

EPA-450/3-76-028b

December 1976

**OPEN SPACE
AS AN
AIR RESOURCE
MANAGEMENT MEASURE
VOLUME II: DESIGN CRITERIA**



**U.S. ENVIRONMENTAL PROTECTION AGENCY
Office of Air and Waste Management
Office of Air Quality Planning and Standards
Research Triangle Park, North Carolina 27711**

EPA-450/3-76-028b

**OPEN SPACE
AS AN
AIR RESOURCE
MANAGEMENT MEASURE
VOLUME II: DESIGN CRITERIA**

by

**R.S. DeSanto, R.A. Glaser, W.P. McMillen,
K.A. MacGregor, and J.A. Miller**

**COMSIS Corporation
972 New London Turnpike
Glastonbury, Connecticut 06033**

Contract No. 68-02-2350

EPA Project Officer: Thomas McCurdy

Prepared for

**ENVIRONMENTAL PROTECTION AGENCY
Office of Air and Waste Management
Office of Air Quality Planning and Standards
Research Triangle Park, North Carolina 27711**

December 1976

This report is issued by the Environmental Protection Agency to report technical data of interest to a limited number of readers. Copies are available free of charge to Federal employees, current contractors and grantees, and nonprofit organizations - in limited quantities - from the Library Services Office (MD35), Research Triangle Park, North Carolina 27711; or, for a fee, from the National Technical Information Service, 5285 Port Royal Road, Springfield, Virginia 22161.

This report was furnished to the Environmental Protection Agency by COMSIS Corporation, Glastonbury, Connecticut 06033, in fulfillment of Contract No. 68-02-2350. The contents of this report are reproduced herein as received from COMSIS Corporation. The opinions, findings, and conclusions expressed are those of the author and not necessarily those of the Environmental Protection Agency. Mention of company or product names is not to be considered as an endorsement by the Environmental Protection Agency.

Publication No. EPA-450/3-76-028b

ACKNOWLEDGEMENTS

We wish to thank Mr. Thomas McCurdy, the E.P.A. project officer for this study, whose assistance and advice was most valuable and greatly appreciated.

STAFFING

Dr. Robert S. DeSanto was project manager and principal investigator for this study at COMSIS CORPORATION - Environmental Services. Mr. Richard A. Glaser, of David A. Crane and Partners, provided interpretations of the literature from the point of view of the landscape architect. He also provided all illustrative material with the exception of the electron micrographs which were provided by Dr. William H. Smith of the Yale University School of Forestry and Environmental Studies. Mr. William P. McMillen and Mr. Kenneth A. MacGregor of COMSIS CORPORATION assisted in all aspects of this study providing engineering and planning overviews and writing much of the text. Dr. Joseph A. Miller, Head Librarian at Yale University School of Forestry and Environmental Studies, executed all library services and guided the numerous processing operations required for document delivery.

Ms. Dana Pumphrey of COMSIS CORPORATION assisted at all levels in the preparation of the report. Her help was broad and very important.

Mrs. Joy Maxfield typed the manuscript entirely alone. Her accuracy and her stamina were important to us and to our successful completion of this Volume. We are grateful to her for her support.

TABLE OF CONTENTS

<u>Chapter</u>	<u>Title</u>	<u>Page</u>
	LIST OF FIGURES	v
	LIST OF TABLES	viii
I	INTRODUCTION, APPROACH AND SUMMARY OF RESULTS	I-1
	A. INTRODUCTION AND ORGANIZATION OF THE REPORT	I-1
	B. SUMMARY OF THE RESULTS	I-4
II	HIGHWAY BUFFER AND RELATED OPEN SPACE	II-1
	A. POLLUTANT IDENTIFICATION.	II-1
	1. Source Emissions	II-1
	2. Transport Mechanisms	II-5
	3. Atmospheric Diffusion	II-10
	B. LITERATURE SEARCH FINDINGS	II-18
	C. POTENTIAL DESIGN ALTERNATIVES	II-42
	1. Summary of Literature Search Findings	II-42
	2. Design Configurations	II-54
III	REGIONAL OPEN SPACE	III-1
	A. POLLUTANT IDENTIFICATION	III-1
	1. Source Emissions	III-3
	2. Pollutant Removal	III-12
	B. LITERATURE SEARCH FINDINGS.	III-17
	C. LAND USE/GREEN BELT ORGANIZATION	III-22
	D. CONVERSION OF LEAF AREA TO GROUND AREA AND WEIGHTED SINK FACTORS	III-28
IV	GLOSSARY	IV-1
V	BIBLIOGRAPHY	V-1
VI	APPENDIX	VI-1
	A. HIGHWAY DIFFUSION MODELS	VI-1
	B. SENSITIVE SPECIES LIST	VI-20
	C. CALCULATION OF LEAF AREAS FOR SELECTED TREES	VI-46
	D. HOLLAND STACK RISE EQUATION.	VI-52

TABLE OF FIGURES

<u>Figure</u>	<u>Title</u>	<u>Page</u>
I-1	SCANNING ELECTRON MICROGRAPH OF THE ADAXIAL SURFACE OF A LONDON PLANETREE LEAF...	I-5
I-2	SCANNING ELECTRON MICROGRAPH OF AGGREGATE PARTICLES ON THE ADAXIAL SURFACE OF A LONDON PLANTREE LEAF... . .	I-6
I-3	SCANNING ELECTRON MICROGRAPH OF A TRICHOME ON THE ADAXIAL SURFACE OF A LONDON PLANETREE LEAF... . . .	I-7
I-4	SCANNING ELECTRON MICROGRAPH OF AGGREGATE PARTICLE BLOCKING A STOMATE OF A LONDON PLANETREE LEAF... . .	I-8
I-5	SCANNING ELECTRON MICROGRAPH OF SUB-MICROMETER PARTICLES ON THE SURFACE OF A LONDON PLANETREE LEAF TRICHOME...	I-9
I-6	SCANNING ELECTRON MICROGRAPH OF POLLEN AND FUNGI ON THE ADAXIAL SURFACE OF A LONDON PLANETREE LEAF... . . .	I-10
II-1	THE INFLUENCE OF WIND SPEED ON GROUND LEVEL POLLUTANT CONCENTRATIONS.	II-6
II-2	SOIL LEVEL OF LEAD QUEEN'S PARK AND SOIL LEVEL OF CADMIUM QUEEN'S PARK	II-8
II-3	LEAD CONTAMINATION OF WHITE PINE TWIGS PLUS NEEDLES SAMPLED FROM TREES GROWING AT VARYING DISTANCES FROM INTERSTATE 95, CONNECTICUT...	II-9
II-4	COORDINATE SYSTEM SHOWING GAUSSIAN DISTRIBUTIONS IN THE HORIZONTAL AND VERTICAL	II-11
II-5	HORIZONTAL DISPERSION COEFFICIENT AS A FUNCTION OF DOWNWIND DISTANCE FROM THE SOURCE	II-14
II-6	VERTICAL DISPERSION COEFFICIENT AS A FUNCTION OF DOWNWIND DISTANCE FROM THE SOURCE	II-15
II-7	ALTERNATE SOLUTION CALIFORNIA LINE SOURCE CROSSWIND MODEL FOR CARBON MONOXIDE CONCENTRATIONS	II-17
II-8	THE SHELTER PROVIDED BY A 16-METRE-HIGH SHELTERBELT OF DECIDUOUS TREES IN SUMMER AND WINTER	II-33

TABLE OF FIGURES (CONTINUED)

<u>Table</u>	<u>Title</u>	<u>Page</u>
II-9	DESIGN PARAMETERS OF BUFFERS FOR SOUND ATTENUATION. . . .	II-41
II-10	DENSITY OF BUFFER RELATED TO REDUCTION OF WIND VELOCITY .	II-46
II-11	EXTENT OF INFLUENCE OF WINDBREAK AND SHELTERBELT PLANTINGS	II-49
II-12	FORM OF BUFFER IS RELATED TO REDUCTION OF WIND VELOCITY .	II-50
II-13	INCREASED DIVERSITY WITHIN EDGE CONDITION MAXIMIZES SINK POTENTIAL.	II-51
II-14	CREATION OF THERMAL CHIMNEYS FOR VENTILATION OF FORESTS AND BUFFERS	II-51
II-15	CO CONCENTRATIONS ADJACENT TO ROADS	II-52
II-16	INCREASING BUFFER EDGES	II-55
II-17	INCREASING BUFFER VENTILATION	II-55
II-18	CHEVRON HEDGEROW	II-56
II-19	PARALLEL HEDGEROW	II-56
II-20	MULTIPLE HEDGEROW	II-57
II-21	MANAGED NATURAL BUFFER	II-57
II-22	VENTILATING ROADWAY CUTS	II-58
II-23	RECREATION FACILITY SETBACK	II-58
II-24	PLANTING EXISTING MEDIANS	II-59
III-1	SCHEMATIC REPRESENTATION OF THE CHEMICAL PROCESSES INVOLVING ENVIRONMENTAL SULFUR...	III-3
III-2	SECTION ALONG 79TH STREET, MANHATTAN ISLAND	III-19
III-3	WEDGES.	III-20
III-4	GREENBELTS.	III-20
III-5	STREET TREE PLANTINGS ARE ENCOURAGED AS PART OF REGIONAL PLANTING AND BUFFER PROGRAM	III-21

TABLE OF FIGURES (CONTINUED)

<u>Table</u>	<u>Title</u>	<u>Page</u>
III-6	DISTANCE OF MAXIMUM CONCENTRATION AND MAXIMUM $\chi\mu/Q$ AS A STABILITY AND EFFECTIVE HEIGHT OF EMISSION.	III-25
III-7	TWO DIMENSIONAL RELATIONSHIPS BETWEEN SOURCE, SINK, AND RECEPTOR LOCATIONS.	III-26
III-8	IDEALIZED POINT SOURCE BUFFERS WITHOUT REGARD TO LAND CONSTRAINTS.	III-27
III-9	IDEALIZED POINT SOURCE BUFFER WITH LAND CONSTRAINTS. . .	III-27

LIST OF TABLES

<u>Table</u>	<u>Title</u>	<u>Page</u>
II-1	KEY TO STABILITY CATEGORIES	II-13
II-2	PLANTS KNOWN FOR THEIR CAPACITY TO RETAIN DUSTS	II-22
II-3	NUMBER OF KERNELS IN ONE CM ³	II-25
II-4	PROCESS OF SULFUR ABSORPTION BY PLANTS	II-30
II-5	ECOLOGICAL CHARACTERISTICS OF COMMERCIAL FORESTS AS CONTRASTED WITH PROTECTIVE GREENBELT VEGETATION	II-36
III-1	SUMMARY OF SOURCES AND ANNUAL EMISSIONS OF ATMOSPHERIC POLLUTANTS.	III-2
III-2	ESTIMATED CARBON MONOXIDE EMISSION SOURCES IN THE UNITED STATES IN 1970	III-6
III-3	KEY TO STABILITY CATEGORIES	III-24
III-4	WEIGHTED SINK AND EMISSION FACTORS FOR AVERAGE SOIL AND AVERAGE VEGETATION...	III-30,31
III-5	SPECIES RELATIONSHIP OF GROUND AREA COVERED TO PLANT SURFACE AREA	III-32
III-6	SELECTED TREES AS POLLUTION SINKS.	III-32,33
VI-1	PLANT SPECIES SENSITIVITY LISTS FLUORINE	VI-22
VI-2	PLANT SPECIES SENSITIVITY LISTS GENERAL POLLUTION	VI-26
VI-3	PLANT SPECIES SENSITIVITY LISTS HYDROGEN CHLORIDE	VI-33
VI-4	PLANT SPECIES SENSITIVITY LISTS NITROGEN DIOXIDE	VI-35
VI-5	PLANT SPECIES SENSITIVITY LISTS OZONE	VI-37

LIST OF TABLES (CONTINUED)

<u>Table</u>	<u>Title</u>	<u>Page</u>
VI-6	PLANT SPECIES SENSITIVITY LISTS PAN	VI-40
VI-7	PLANT SPECIES SENSITIVITY LISTS PARTICULATES-SMOKE	VI-41
VI-8	PLANT SPECIES SENSITIVITY LISTS SULFUR DIOXIDE	VI-42
VI-9	DATA CHARTS OF THE TREE SPECIES USED IN THE MODEL HECTARE	VI-50

I. INTRODUCTION, APPROACH AND SUMMARY OF RESULTS

A. INTRODUCTION AND ORGANIZATION OF THE REPORT

The work undertaken in this project has resulted in the preparation of three separate report volumes and one ~~Appendix~~ Volume. Taken together, they cite and attempt to interpret all of the pertinent and accessible literature from the United States of America, and elsewhere, relating to the potential use of open space as a practical means to mitigate air pollution.

Volume II, this Volume, is entitled Design Criteria and presents the essence of this study in the form of a workbook. It reviews the primary biological and design features which are crucial to the effective utilization of open space to mitigate air pollution. It presents generalized schemes for the design and location of buffer strips and other forms of open space and also illustrates air pollution mitigation by open space by identifying the mathematical procedures necessary in order to permit the incorporation of the appropriate sink factors into four generally used carbon monoxide diffusion models.

Since this project concerns an investigation into the real and potential use of open space, a rather abstract and loosely used phrase, the following definition is given as the frame upon which our work is placed. Open space is an area with a natural cover of soil, water, and plants, where there are usually minimal human activities, and where there are legal restrictions that limit the development of facilities or structures. In a limited sense, open space may be thought of as parks. However, they may also be Resource Open Spaces where the land or water is devoted to some form of non-structural production activity. A forest, range-lands, and water storage lakes or rivers, are examples. Flood control and drainage lands, lands used as waste disposal areas or borrow pits, wildlife refuges, or lands reserved for future urban development, are all examples of Utility Open Spaces. Another major category may be called Green Open Spaces where recreation, or relatively non-structural uses, are sought and where the natural vegetation tends to dominate the landscape. Examples include; national park areas, urban parks, buffers, and the associated greenbelts or green wedges, which may be interspersed with urban development. A fourth major category consists of Corridor Open Spaces where space is allocated for the movement of people and material from one point to another. Examples include, rights-of-way such as highways and streets, or canals and railroads, and the areas associated with the terminals and/or interchanges associated with those rights-of-way.

These, and other categories of open space are more fully described in the literature. DeChiara and Koppelman (1975) include the above definitions and others which may be useful should the reader seek detailed information from the point of view of urban planning and design. However, as explored in this project, open space is limited to those categories defined above.

Open space, in its natural state or manipulated state, can have a varied and far reaching effect on regional air quality. It has been well documented in Volume I of this report that open spaces particularly when planted, as bare soil, or as water bodies, can act as sinks for important air pollutants. Through the natural process of adsorption, absorption, impingement, and deposition, pollutants generated by urban land uses can be entrapped by these areas. From a planning point of view, open space has been used as a buffering device to contain the expansion of urban development and its attendant generation of air pollution. The characterization of open space as land upon which there is minimal human activity makes the phrase an antonym to urban type development. The extent and location of such open space has varied effects on regional air quality. For example, the use of an open space adjacent to a transportation artery (i.e. a roadway,) reduces the ambient levels of automobile generated pollutants. Vegetation in the path of air, laden with particulates, can serve to filter out some of the particulates. This capability can reduce concentrations of particulates which would otherwise impact area residents. The use and design of open space areas on a micro-scale can mitigate pollution transport characteristics. Through the break-up of tunnel or canyon effects, vegetation canopies can encourage air current eddying and thus can cause mixing and the sedimentation of particulates.

The atmosphere should be looked upon as a finite sink for pollutants. It has a limit which we can try and set as an "acceptable" concentration of pollutants. By reducing the density of urban development through the use of open space, the loadings are reduced in a region.

The possible negative effect of open space includes the natural emission factors characteristic of particular plant species. The generation of hydrocarbons by plants produce photochemical oxidants. Depending upon the amount of plant materials, the hydrocarbons emitted can intensify or create oxidant problems. The use of

open space within a comprehensive land use plan can also have negative effects on overall air quality if the entire community infrastructure is not evaluated. For example, if large tracts of open spaces cause an increase in vehicular travel, the associated generation of transportation related pollutants is increased. In addition, some open space uses are marked air polluters. For example, open pit mining and agricultural activities, such as plowing, can significantly increase the particulate loadings in the ambient air.

The knowledge obtained from the investigation of open space as an air quality maintenance strategy should be used to re-evaluate the concept of the atmosphere as a sink. Historically, our view has been to dilute the pollutants with the atmosphere. However, vegetation and open space can be utilized as a sink or filtering device. It would be efficient to concentrate polluting emissions and direct them through an appropriate open space so that they can be filtered. This seems contrary to present day thinking. However, systems planning, value engineering and resource recovery are also relatively new concepts gaining in their acceptance. It is hoped that the information in this report may help make open space an air quality management technique somewhat better understood than was previously the case. It should be actively implemented as an additional strategy available for environmental management.

Volume I is entitled Sink Factors and presents the data collected from the manual and computerized literature searches. Most of the information presented in the other volumes was derived from the data contained in Volume I. Therefore, much cross referencing is made. Volume I contains tables of sink and emission factors which were developed based on the collected data, and it also contains tables of pollution sensitive and pollution resistant plant species derived from the surveyed literature. The separate Appendix Volume for Volume I presents abstracts of the pertinent literature. It was decided to include as many abstracts as possible in order that our work might find as broad a utilization as possible by future researchers.

Volume III is entitled Demonstration Plan and applies our findings in a hypothetical manner to a test city, St. Louis, Missouri. This demonstration plan includes a cost/effectiveness analysis of the combined open space/AQMA plan with that analysis based on the best available data which we were able to secure. It provides the reader with a realistic application and evaluation of using open space as a practical part of the AQMA plan strategy.

B. SUMMARY OF THE RESULTS

Of approximately eight thousand references examined, about two thousand were used because they were directly or indirectly relevant to determining the sink and emission factors of those pollutants under study. Information was collected on: 1) Ammonia, 2) Carbon monoxide, 3) Chlorine, 4) Fluorine, 5) Hydrocarbons, 6) Nitrogen oxides, 7) Ozone, 8) Peroxyacetyl nitrate (PAN), 8) Particulates, and 9) Sulfur dioxide. Sink and emission factors are reported from the literature and, where possible, the average factor is calculated based on a subjective evaluation of the data.

As a result of this study, it is clear that there are very little data available that quantitatively evaluate the function of water bodies as a sink and/or source of air pollutants. Most of the data we reviewed dealt with soil and vegetation relative to sinks and emissions and therefore, the imbalance of data causes this report to make only very general statements concerning the importance of water as a factor in open space mitigation of air pollution. Future research should focus on this area for both qualitative and quantitative analyses.

The present literature is most clear in its conclusion that open space, vegetation in particular, is a filter for all manner of particulates. In fact, the air-pollution-mitigating-capacity of open space is graphically so clear that this Summary of Results has been extended to include the following series of electromicrographs prepared by the Yale University Laboratory of Dr. William H. Smith, a co-author of Volume I - Sink Factors.

Particles are intercepted by vegetation, and the literature also reports absorption of various air polluting gases. These are summarized in Volume I and their conclusions are applied in this Volume. Soil, as a sink for carbon monoxide, is the most effective element of open space in removing noxious gas, as reported in the literature.

With these two simple and well documented findings, it is clear that open space, carefully placed, can effectively function to filter particulates and carbon monoxide from the air. Furthermore, it can be demonstrated from the literature that open space also functions to mitigate numerous other pollutants. The use and predicted mitigation by open space as an air resource management

II. HIGHWAY BUFFER AND RELATED OPEN SPACE

This section of the study is concerned with the control of pollutants from a highway source. It introduces the concept of using highway buffer strips to absorb pollutants transported to the edge of a highway. Initially, a review of pollutants emitted from motor vehicles is presented followed by discussions on transport methodology and diffusion modeling. Next, sink factors are presented for various highway related pollutants. Finally, the literature is reviewed on buffer strips and design alternations.

The section was written to allow the user to initially predict the type and amount of pollutants that will be present adjacent to highways and highway corridors. Following this predictive methodology, one can determine the amount and type of buffer strips that would best absorb these pollutants.

It should be noted that the concepts presented in this chapter are not based on an exact science and should be used only as planning guidance. The sink factors and design alternatives that are presented are based solely on a review of the literature. More practical research is needed on the effectiveness of using these concepts. In addition, before making detailed predictions of the concentrations of pollutants near highways, the user should consult with other publications to determine the best model to use for the actual case with which he is involved.

A. POLLUTANT IDENTIFICATION

1. Source Emissions.

Before developing design concepts for highway buffer strips, it is necessary to review the type and quantities of pollutants that are emitted from a motor vehicle. Air is polluted as a result of combustion and the majority of transportation systems today use the combustion of fossil fuels as their main source of energy. Carbon monoxide (CO), hydrocarbons (HC), and oxides of nitrogen (NO_x) are the three major air pollutants released by motor vehicles. It has been estimated that motor vehicles represent 98% of the sources for CO, 50% of the sources for NO_x and 60% of the sources for HC (Willis, et al., 1973).

In addition to the above, motor vehicles emit a small percentage of two other pollutants usually considered in air pollution problems; sulfur oxides (SO_x) and total suspended particulates (TSP). SO_x is usually considered more of a regional problem associated with individual point sources and it will be discussed in Section III of this study. Although transportation sources are not responsible for any significant portion of TSP emissions, their contribution, especially lead, should and can be considered in designing buffer strips for highway corridors.

Wolsko, et al., (1972) present a description of the fuel combustion process and how pollutants are formed. The majority of emissions come from gasoline powered motor vehicles. When gasoline is mixed with air in proper proportions, a combustible mixture is formed. Because the combustion process is not complete, by-products are formed which are considered pollutants. **This situation is characteristic of any combustion process using fossil fuels (electrical generating stations, space heating, transportation).**

Fuel Combustion Equation for Gasoline

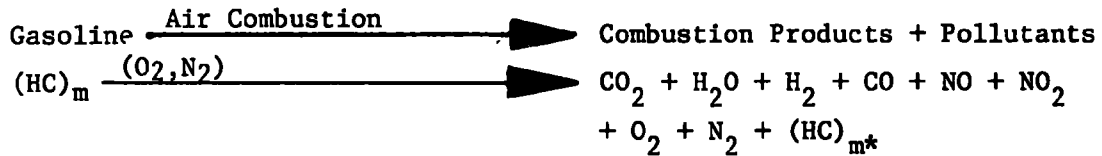

* m = many types

The above equation depicts that carbon dioxide (CO_2), water vapor (H_2O), free hydrogen (H_2), oxygen (O_2) and nitrogen (N_2) make up the bulk of the products of combustion, but carbon monoxide, oxides of nitrogen (NO , NO_2) and unburned hydrocarbons (HC) $_m$ are also produced. More than 200 unburned hydrogens (HC) $_m$ have been detected in vehicle exhaust. (Note: The above equation is representative of the fuel combustion process and does not necessarily balance in a chemical sense).

The amount of each of the pollutants emitted on a highway is dependent on the number of vehicles using the highway as well as the relative efficiency of each automobile's emission system. Because of the many different types of vehicles and their different ages and degrees of operating efficiency, emissions vary widely from vehicle to vehicle. In addition to differences in vehicle emission characteristics, the operating cycle is also an important determinant

of pollutant emissions from transportation sources. Speed, cold starts, acceleration, starts and stops, are factors of the vehicle operating cycle that effect emissions.

The Environmental Protection Agency has published factors which represent the weighted emissions for a standard distribution of vehicles. Using emission factors for each vehicle, it is possible to quantify the total pollutants being emitted along a highway corridor. The necessary data and procedures used to calculate emission factors for motor vehicles are contained in "Supplement No. 5 for Compilation of Air Pollutant Emission Factors" (U.S. EPA, 1975).

In order to determine the total emissions for a given time period, multiply the emission factor obtained from Supplement No. 5 by the total number of vehicles for that same period.

The amount of particulates emitted from a highway source is more difficult to quantify than the gaseous pollutants. Most of the particulate matter comes from two sources: the first being the salts formed in the exhaust and the second being rubber particles from tires and asbestos particles from brake linings. In addition to these sources, the turbulence in the air from a moving vehicle causes dirt particles on the side of the road to be disturbed and emitted into the air.

The particulate from automobiles that has been given most attention is lead. To reduce quantities of lead being emitted, all new cars are made to use lead free gas thereby eliminating the source of the problem. However, it will take years before all older vehicles are phased out and only lead free automobiles are allowed on the highway.

Lead is one of the principal particulates emitted by motor vehicles. Specific estimates of the amount of lead annually introduced to the atmosphere via gasoline combustion includes 98% (National Academy of Sciences, 1972) and 95% (Ewing and Pearson, 1974). Atmospheric, terrestrial and aquatic environments immediately adjacent to roadways are contaminated with lead by motor vehicles combusting leaded gasoline. No controversy surrounds this observation.

Most of the gasoline for vehicles sold prior to 1975 in the United States contains alkyl lead compounds to improve the antiknock quality of the fuel. The amount of lead in gasolines prior to 1975 (in the form of lead alkyls) varied from 2 to 4 g/gal. The average lead content is approximately 2.5 g/gal. (Ewing and Pearson, 1974).

Not all the lead combusted in automobile engines is released into the atmosphere. Hirschler and Gilbert(1964), concluded that 25% of the lead combusted may be held in exhaust system deposits or removed during changes of lubricating oil and oil filters. These investigators further found that the percentage of lead burned in the engine, which is discharged to the atmosphere, varies with driving speed, driving conditions, vehicle age and fuel employed among others. Over many thousands of miles of driving it is generally assumed that approximately 70-80% of the combusted lead will eventually be released to the atmosphere. Assuming average and approximate conditions, automobiles prior to 1975 may release 130 mg of lead per mile per car (81 mg Pb/km) into the roadside environment (Smith, 1975).

$$\frac{2.5\text{gPb/gal} \times 0.80 \text{ emission}}{15 \text{ miles/gal.}} = 0.13 \text{ g. Pb/mile}$$

An average lead emission rate for production vehicles at 108 mg. of lead per mile has been given by Cantwell, et al., (1972). A more conservative average emission rate of 40 mg. of lead per mile has been presented by Haar (1972).

To determine the amount of lead emitted from vehicles along a highway corridor it is suggested that one use 130 mg. Pb/mile and apply this emission rate to the percentage of vehicles using the highway corridor that were manufactured prior to 1975. After 1975, all vehicles are using no-lead gas and thereby, no lead salts are being emitted. The age distribution of vehicles in a particular state is usually available from the local motor vehicle department.

2. Transport Mechanisms.

The concentration of pollutants at a roadway edge (the receptor) depends on more than just the quantity of pollutants emitted at the source. The atmosphere is the agent that transports and dispenses pollutants between sources and receptors and thus its state helps to determine the concentration of pollutants observed at the receptor location. The following paragraphs have been adapted from Epstein, et al. (1974) and are used to briefly review the phenomena of transport mechanisms for gaseous pollutants (CO, HC, NO_x) from a highway source.

In general, three parameters are used to describe atmosphere transport and dispersion processes. These are wind speed, wind direction and atmospheric stability. For a ground level pollutant (the general case for a highway) the concentration of pollutants downwind from a highway source is inversely proportional to wind speed. This phenomenon is illustrated in Figure II-1.

Wind direction is perhaps the most important atmospheric condition influencing the concentration at a given receptor location. For a given wind direction, nearly all the pollutant transport and dispersion will be downwind.

Atmospheric stability is a measure of the turbulent structure of the atmosphere. Epstein explains that "it may be defined in terms of the atmospheric temperature profile where ambient temperature is a function of height above ground level. When the temperature decreases rapidly with height, vertical motions in the atmosphere are enhanced, and the atmosphere is called unstable. ...When the temperature does not decrease rapidly with height, vertical motions are neither enhanced nor repressed and the stability is described as neutral... When the temperature decreases very little, remains the same, or increases with increasing height, the atmosphere is called stable."

FIGURE II-1

THE INFLUENCE OF WIND SPEED ON GROUND LEVEL POLLUTANT CONCENTRATIONS

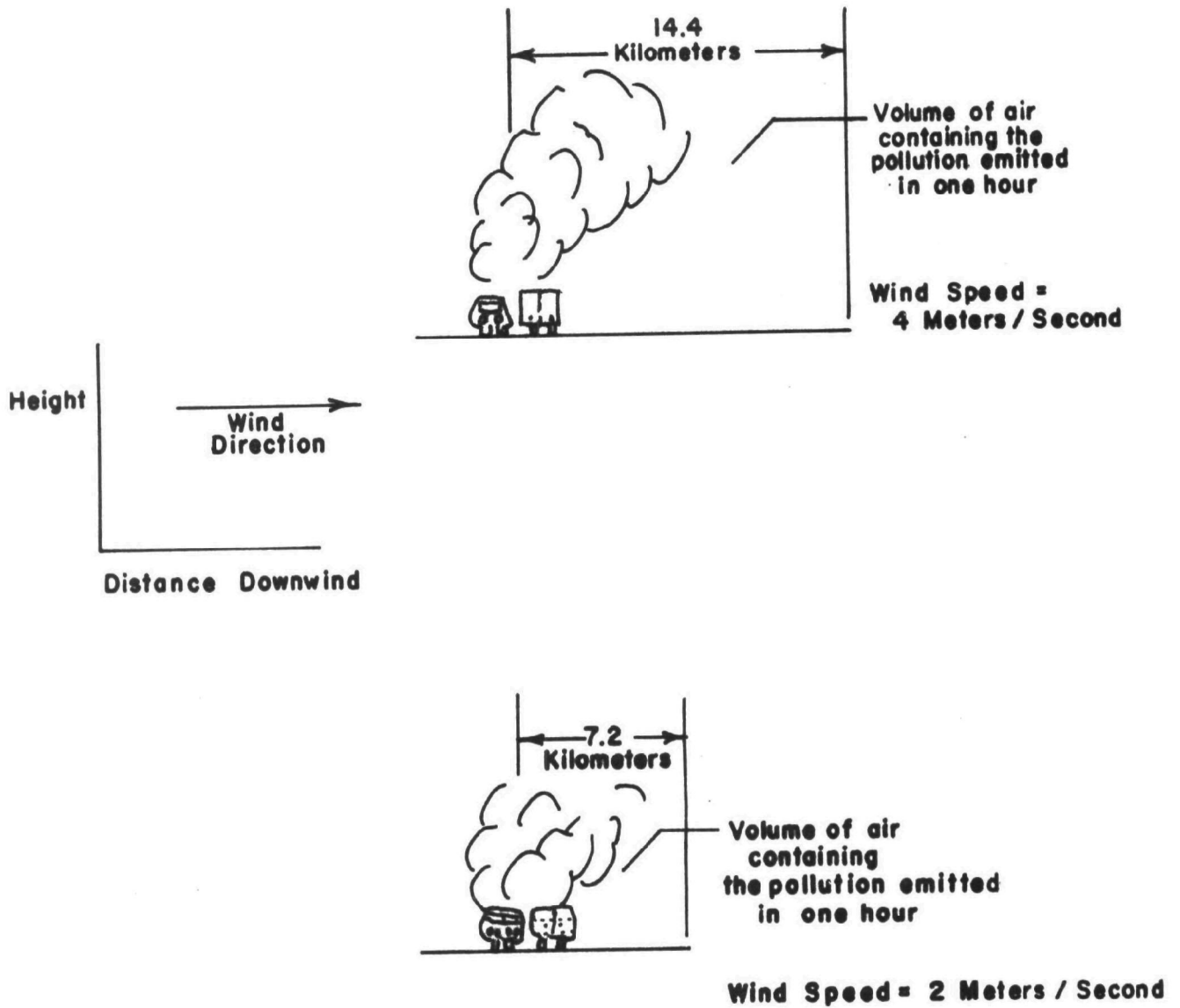

An unstable atmosphere is the best type for dispersing pollutants. A neutral atmosphere allows dispersion of pollutants in the horizontal direction, but not as rapidly in the vertical direction. A stable atmosphere is the worst for air pollutant dispersion as it suppresses the upward movement of rising air. It essentially forms a lid beneath which pollutants can freely disperse horizontally but not vertically.

The available literature on the transport of lead reveals that it is slightly affected by prevailing winds and that most of this contaminant is contained in the particulate fraction of materials generated by the traffic. The distance that the lead particles will be transported depends on size of the particle and the atmospheric conditions prevalent during the time period. Hirschler and Gilbert (1964), suggest that one-half to two-thirds of the lead exhausted in city type driving was in particles 5μ in diameter or less. Only 4 to 12% of the exhaust lead was 1μ or less. Under cruise conditions and at constant speed, Mueller, et al., (1963), found that 62 to 80% of the particulate lead exhausted was less than 2μ in diameter. Of these small particles, 68% were less than 0.3μ .

The roadside environment receives lead particles of all size classes, the large ones by sedimentation and the smaller ones by impaction, precipitation and inhalation. Determining the amount of lead at various distances from a highway source is reflected in literature concerning the lead content of soils and vegetation near the highway. Hutchinson, (1971), has developed experimental data illustrating the soil level of lead adjacent to Queen's Park (Figure II-2). Smith (1971), has studied lead contamination of white pine twigs in Connecticut (Figure II-3), and concluded that the lead content drops drastically as the perpendicular distance from the roadway increases. This conclusion is supported by numerous studies, the finest being that of Daines, et al., (1970), and Shuck and Locke (1970). Between 30 and 150m perpendicular distance from the highways in the above studies, the atmospheric lead rate per 30m was 32% and 23% respectively. In the Daines et al., (1970), study, the lead content of the air decreased 50% between 3 and 46m from the highway. At 533 m perpendicular distance, 50% of the lead containing particles greater than 6.5μ settle out of the air. Little surface deposition, however, of the less than 3.5μ diameter particles occurred in this zone.

FIGURE II-2

SOIL LEVEL OF LEAD IN QUEEN'S PARK AND SOIL

LEVEL OF CADMIUM IN QUEEN'S PARK

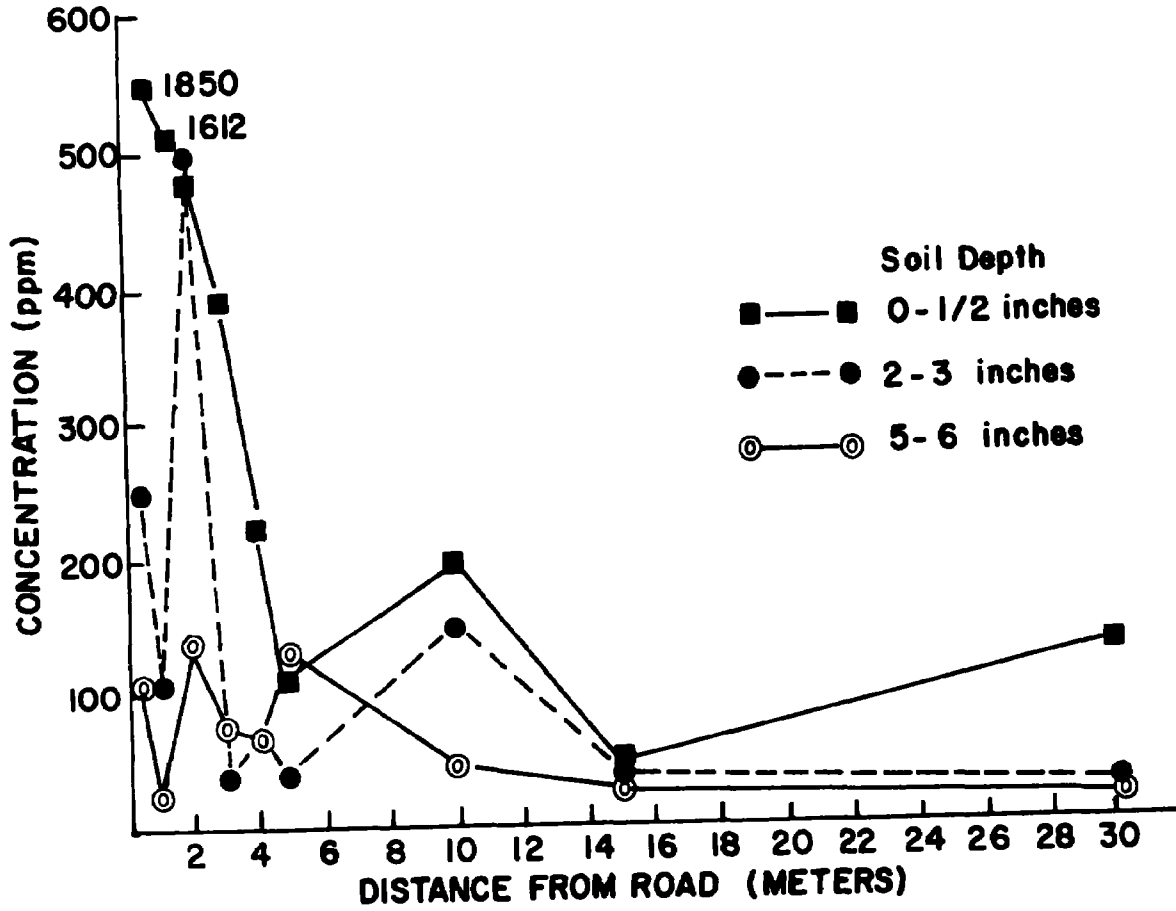
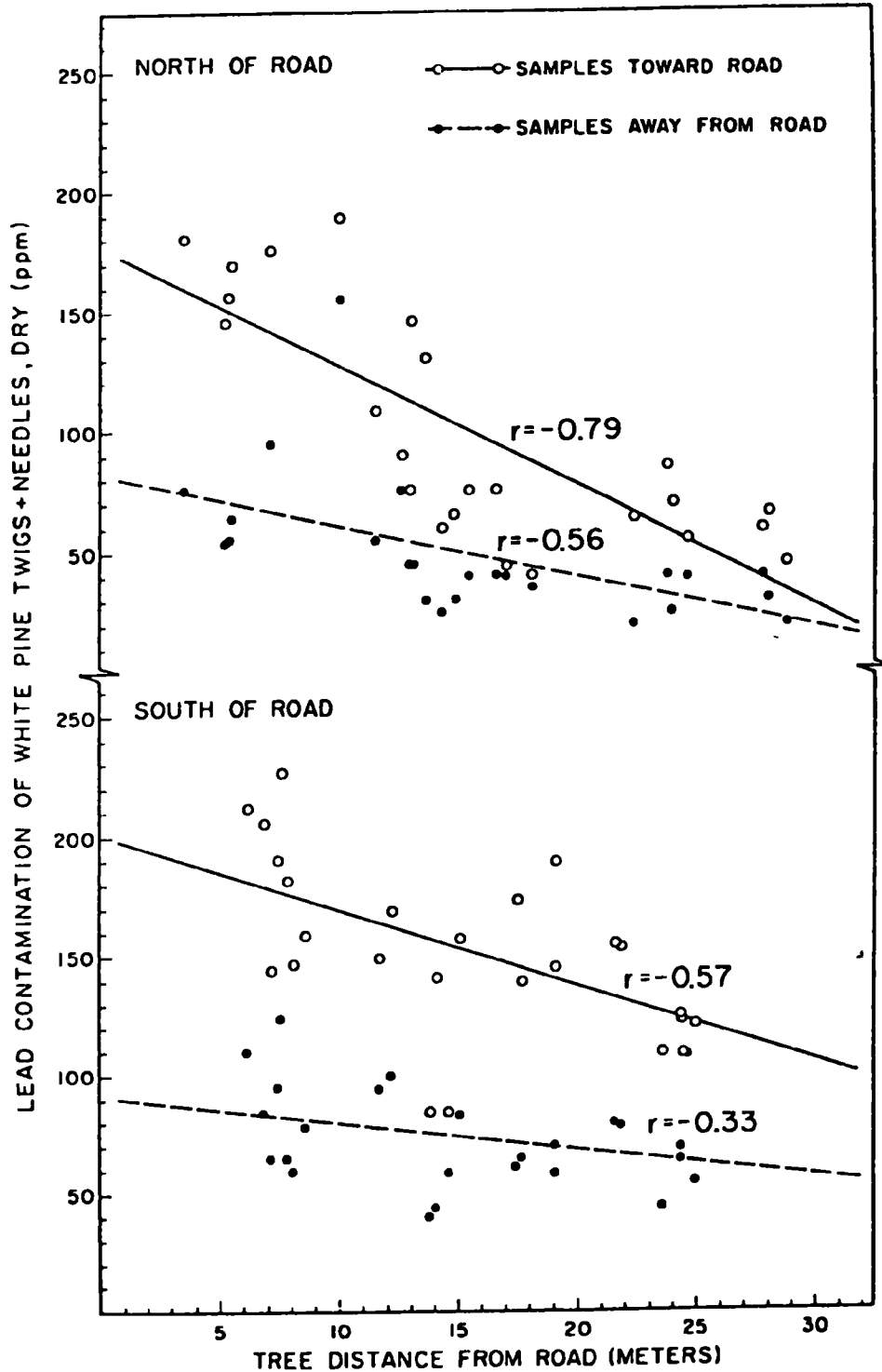

FIGURE II-3

LEAD CONTAMINATION OF WHITE PINE TWIGS PLUS NEEDLES (GROWTH OF PREVIOUS YEAR) SAMPLED FROM TREES GROWING AT VARYING DISTANCES NORTH AND SOUTH OF INTERSTATE 95 IN CONNECTICUT. SAMPLES TOWARD THE ROAD WERE COLLECTED FROM THE TREE BRANCH CLOSEST TO THE HIGHWAY WHILE SAMPLES AWAY FROM THE ROAD WERE COLLECTED FROM THE OPPOSITE SIDE OF THE TREE, FARTHEST FROM THE HIGHWAY.



In addition to distance from the road, numerous other factors influence the lead content of the atmospheric compartment of the roadway environment. Some of the important factors include traffic volume, proximity to other roads, prevailing winds, turbulence, season of the year and time of day. Urban atmospheres over streets may differ significantly from rural atmospheres over roadways. Edwards (1974), has suggested that the canyons formed by multiple story buildings may restrict ventilation and cause high increases in atmospheric lead.

The effect of traffic density is limited to a relatively narrow zone (76m) along busy highways according to the data of Daines et al., (1970). Numerous studies have shown if the prevailing wind direction is perpendicular to the highway, greater amounts of lead will be distributed to the lee side of the road. In seasonal studies, conducted in various United States locations, the fall months consistently exhibit the highest air lead levels. The increasing fall concentrations are generally ascribed to favorable wind patterns and atmospheric mixing occurring at this time of year. Diurnal variations in atmospheric lead burden close to the road generally follow the peak traffic volumes of early morning and late afternoon.

Without further refinement, no exact relationship can be constructed for the amount of lead in the atmosphere versus the perpendicular distance from the highway. However it can be safely concluded that the majority of the lead particles are deposited by some method close to the highway (50m ±). The lighter particles (< 3.5 μ) travel a further distance from the highway source and generally would tend to accumulate on the leeward side of the highway.

3. Atmospheric Diffusion.

The preceding two sections have described the quantities of pollutants emitted from a motor vehicle and the transport mechanisms that influence their dispersion from the source to receptor location. There are numerous mathematical models that simulate the dispersion of CO from a highway source. These models are generally classified into the following categories: Gaussian statistical, box, particle-in-cell, and mass conservation. This section will describe the Gaussian model and its adaption to a highway line source for the prediction of CO.

The Gaussian plume dispersion model has achieved considerable popularity among people attempting to describe the role of atmosphere dispersion. The model is an adaption of the normal distribution curve as a predictive tool to describe the concentration of gaseous pollutants at given distances from a source. The model was originally suggested for use by Pasquill(1961) and modified by Gifford (1961).

The concentration (χ) of gas or aerosols (particles less than about 20 μ diameter) at x,y,z from a continuous source with an effective emission height, H , is given by equation 1 and the coordinate system used in the equation is illustrated in Figure II-4.

FIGURE II-4
COORDINATE SYSTEM SHOWING GAUSSIAN DISTRIBUTIONS
IN THE HORIZONTAL AND VERTICAL

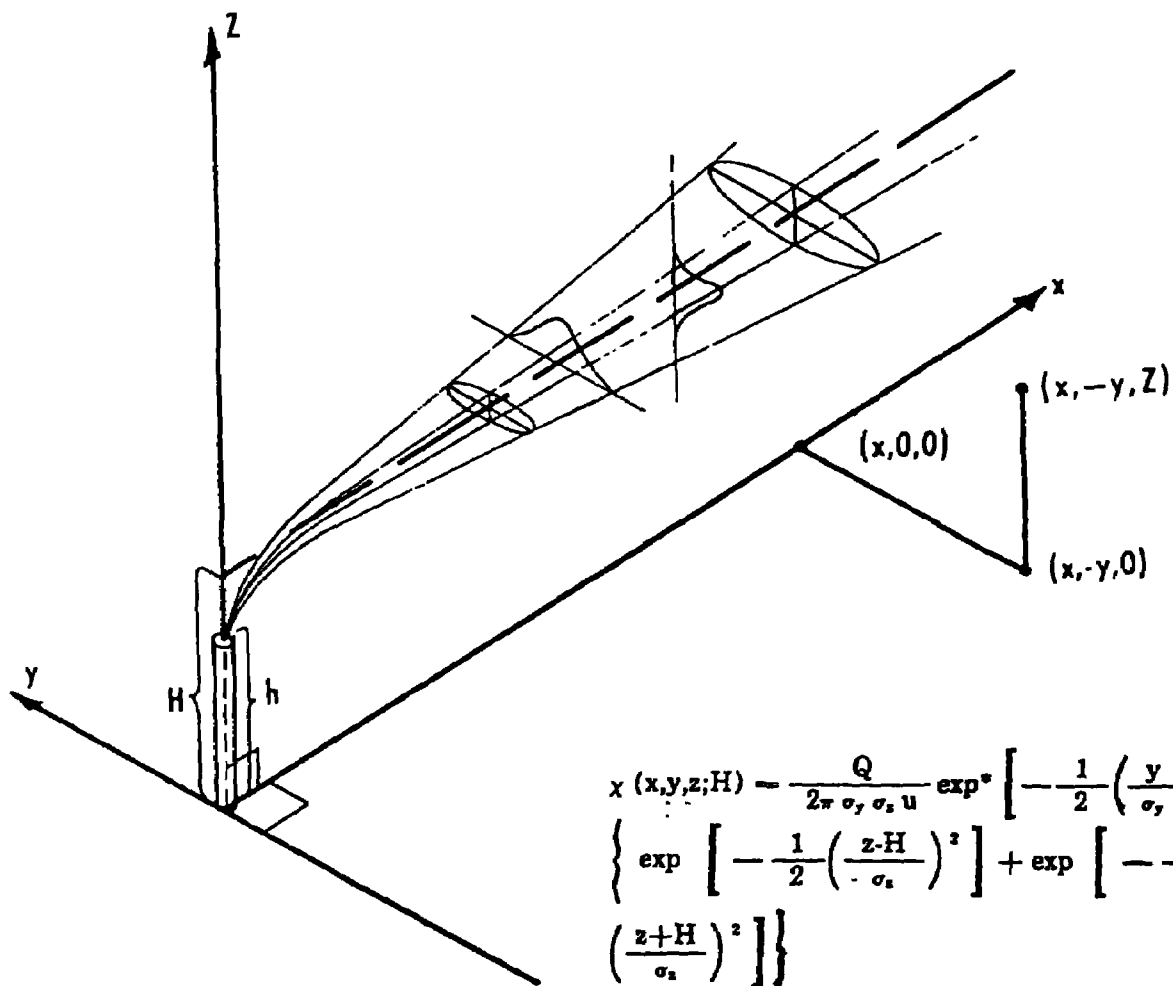

The following assumptions are made in equation (1):

- (1) The plume spread has a Gaussian distribution in both the horizontal and vertical planes, with standard deviations of plume concentration distribution in the horizontal and vertical of σ_y and σ_z , respectively.
- (2) The mean wind speed affecting the plume is μ .
- (3) The uniform emission rate of pollutants is Q .
- (4) Total reflection of the plume takes place at the earth's surface.

Any consistent set of units may be used. The most common is:

x (g m^{-3})
 Q (g sec^{-1})
 μ (g sec^{-1})
 $\sigma_y, \sigma_z, H, x, y,$ and z (m)

For concentrations calculated at ground level, i.e. $z=0$, the equation becomes:

$$\begin{aligned}
 x(x,y,0;H) = \frac{Q}{\pi \sigma_y \sigma_z u} \exp \left[-\frac{1}{2} \left(\frac{y}{\sigma_y} \right)^2 \right] \\
 \exp \left[-\frac{1}{2} \left(\frac{H}{\sigma_z} \right)^2 \right] \quad (2)
 \end{aligned}$$

Where the concentration is to be calculated along the center line of the plume ($y=0$), the equation is simplified to:

$$x(x,0,0;H) = \frac{Q}{\pi \sigma_y \sigma_z u} \exp \left[-\frac{1}{2} \left(\frac{H}{\sigma_z} \right)^2 \right] \quad (3)$$

For ground-level source with no effective plume rise ($H=0$),

$$x(x,0,0;0) = \frac{Q}{\pi \sigma_y \sigma_z u} \quad (4)$$

The values of σ_y and σ_z in the previous equations have produced the major areas of investigation. Turner (1972), developed a procedure to relate σ_y and σ_z to stability classes which is in turn estimated from wind speed at a height of about 10 meters and, during the day, the incoming solar radiation or during the night, the cloud cover. Stability classes are given in Table II-1.

TABLE II-1
KEY TO STABILITY CATEGORIES

Surface Wind Speed (at 10 m), m sec ⁻¹	Day			Night	
	Incoming Solar Radiation			Thinly Overcast or ≥4/8 Low Cloud	≈3/8 Cloud
	Strong	Moderate	Slight		
< 2	A	A-B	B		
2-3	A-B	B	C	E	F
3-5	B	B-C	C	D	E
5-6	C	C-D	D	D	D
> 6	C	D	D	D	D

The neutral class, D, should be assumed for overcast conditions during day or night.

SOURCE: (TURNER, 1972)

Having determined the stability classes, one can estimate σ_y and σ_z as a function of downwind distances from the source, x, using Figures II-5 and II-6.

The Gaussian plume dispersion model can be applied to a continuous line source, such as a highway. Federal Highway Administration (1972) suggests that equation (5) be used to predict downwind ground level concentrations for at grade highways and crosswind conditions:

$$C = \frac{4.24 Q}{K_1 \sigma_z \bar{u} \sin \phi} \quad (5)$$

where:

Q = source strength, grams/meter-second

K_1 = empirical constant = 4.24

\bar{u} = wind speed, m/sec

ϕ = wind angle with respect to road

σ_z = vertical dispersion parameter, meters

FIGURE II-5
HORIZONTAL DISPERSION COEFFICIENT AS A FUNCTION
OF DOWNWIND DISTANCE FROM THE SOURCE

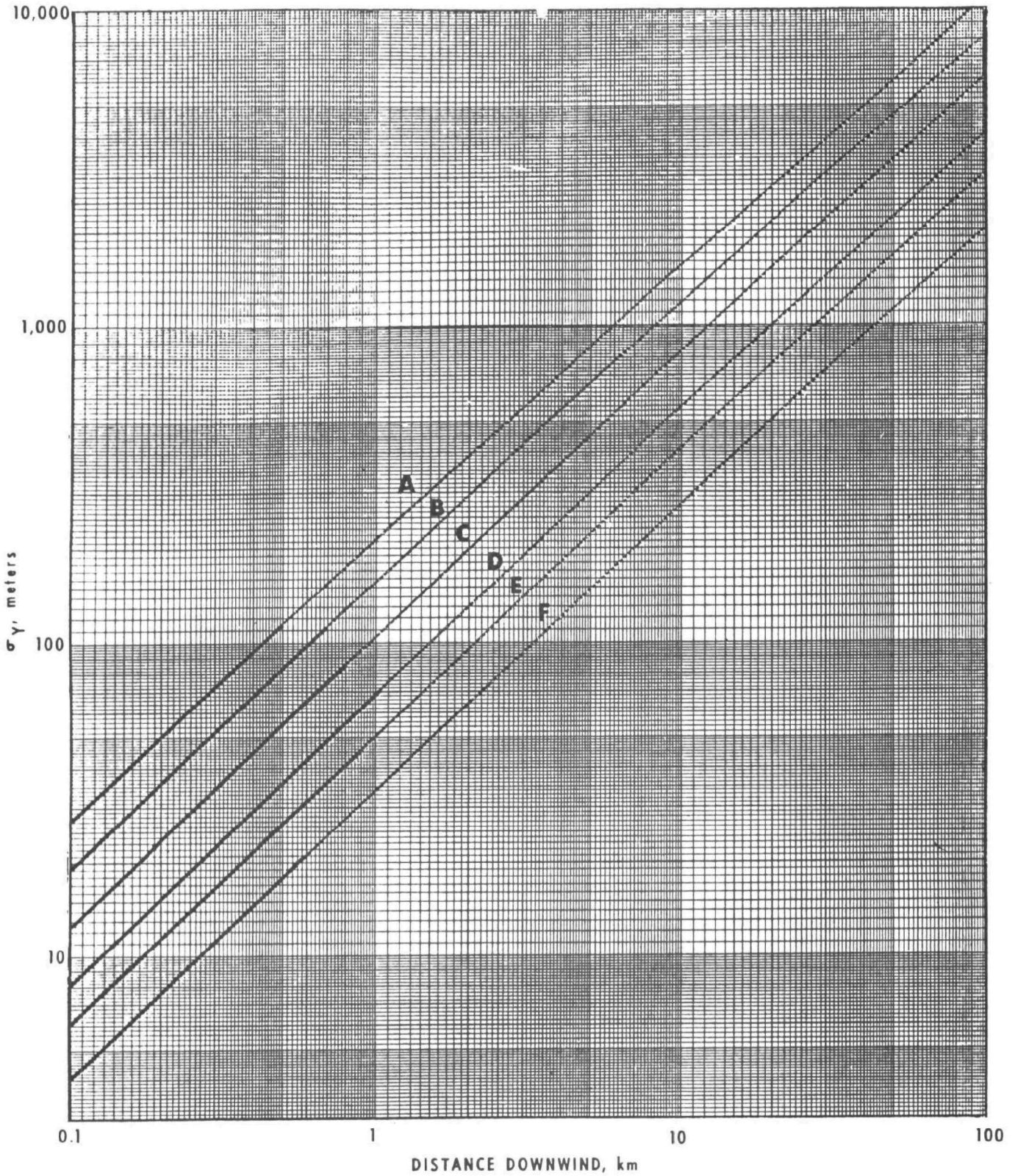
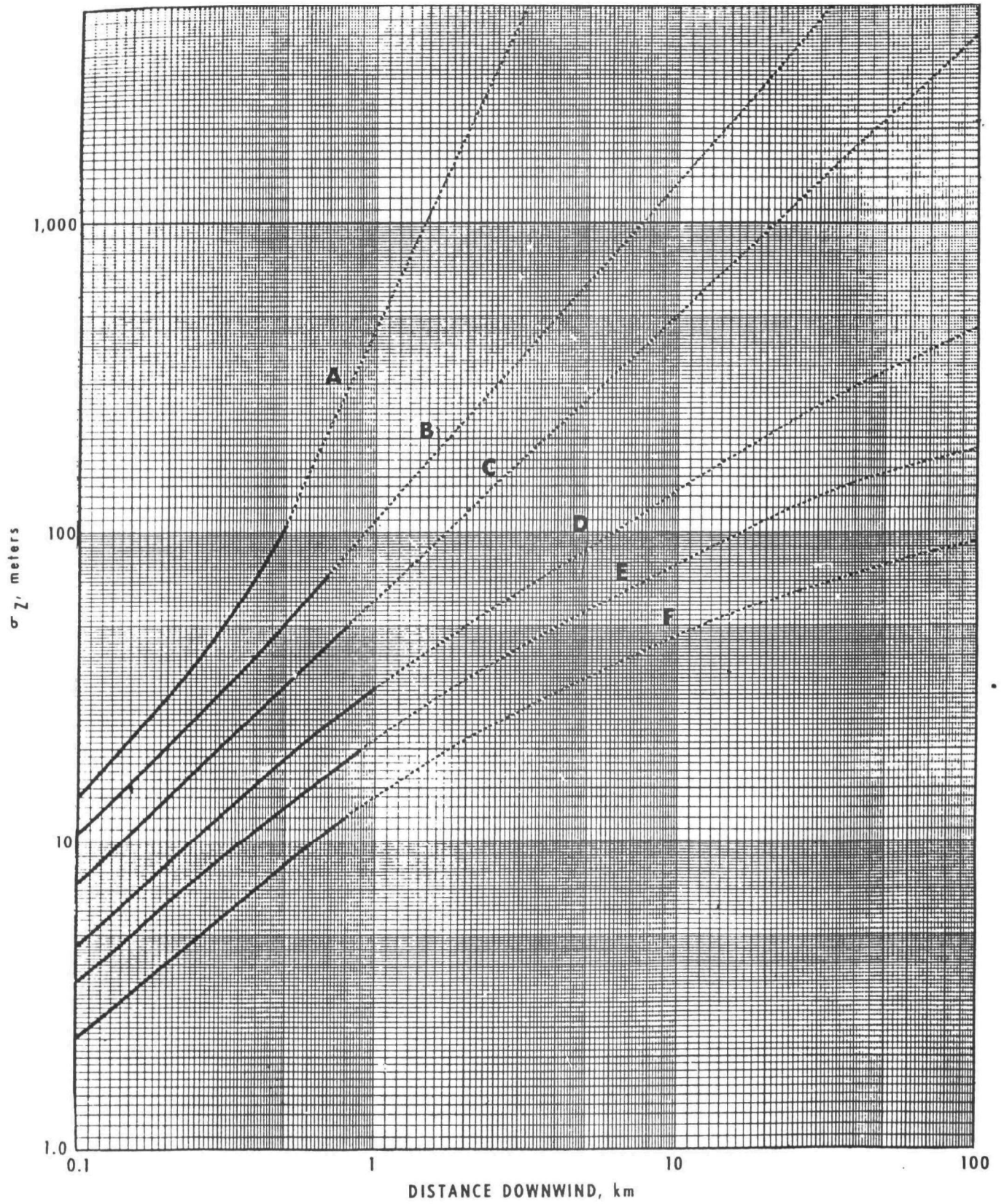

FIGURE II-6

VERTICAL DISPERSION COEFFICIENT AS A FUNCTION
OF DOWNWIND DISTANCE FROM THE SOURCE



Using a technique developed by Noll, et al., (1975) equation (5) can be solved for CO using a nomograph(Figure II-7). Starting at the left axis, there are six meteorology scales labeled A-F and marked off in a wind speed scale in meters/second. These meteorology scales reflect allowable wind speed ranges for each stability class as outlined in Table II-1. To the right of the meteorology lines are next found a scale labeled $\bar{u} \sigma z$, m²/sec and then x, normal distance from the road, meters. Connecting any distance on the x-axis with the desired stability-wind speed combination yields the product $\bar{u} \sigma z$ on the intermediate axis.

The next axis is labeled, ϕ , the wind angle with respect to the road. This axis represents $\sin \phi$, and a line connecting the previously obtained $\bar{u} \sigma z$, through the appropriate value for ϕ (yields the product $\bar{u} \sigma z \sin \phi$, m²/sec on the next axis.)

Having now evaluated the denominator in equation (5), it is now left to evaluate the line source strength, Q, gms/m-sec.

$$Q = (\text{VPH}) (\text{EF}) (1.73 (10.7)) \quad (6)$$

where:

VPH = Traffic volume, veh/hr

EF = emission factor, gms/veh-m

Q = pollutant concentration, gms/m³

The emission factor (EF) is obtained from "Supplement No. 5 for Compliance of Air Pollution Emission Factors", (U.S. EPA, 1975).

However, concentration in parts per million (ppm), by volume is required. Assuming ideal gas behavior, yields at 25°C for CO:

$$\text{ppm CO} = (875) \left(\frac{\text{gms CO}}{\text{m}^3} \right) \quad (7)$$

$$\text{ppm CO} = 1.51 (10^{-4}) \frac{(\text{VPH})(\text{EF})}{\sigma z \bar{u} \sin \phi} \quad (8)$$

Equation 8 is solved graphically by the last four lines of the nomograph in Figure II-7. Connecting the previously described value of $\bar{u} \sigma z \sin \phi$ with a value of emission factor yields an intermediate value on the pivot line. Alignment of this pivot point with a value for traffic volume and extending to the final line yields the desired result, ppm CO.

FIGURE II-7

ALTERNATE SOLUTION CALIFORNIA LINE SOURCE CROSSWIND
MODEL FOR CARBON MONOXIDE CONCENTRATIONS

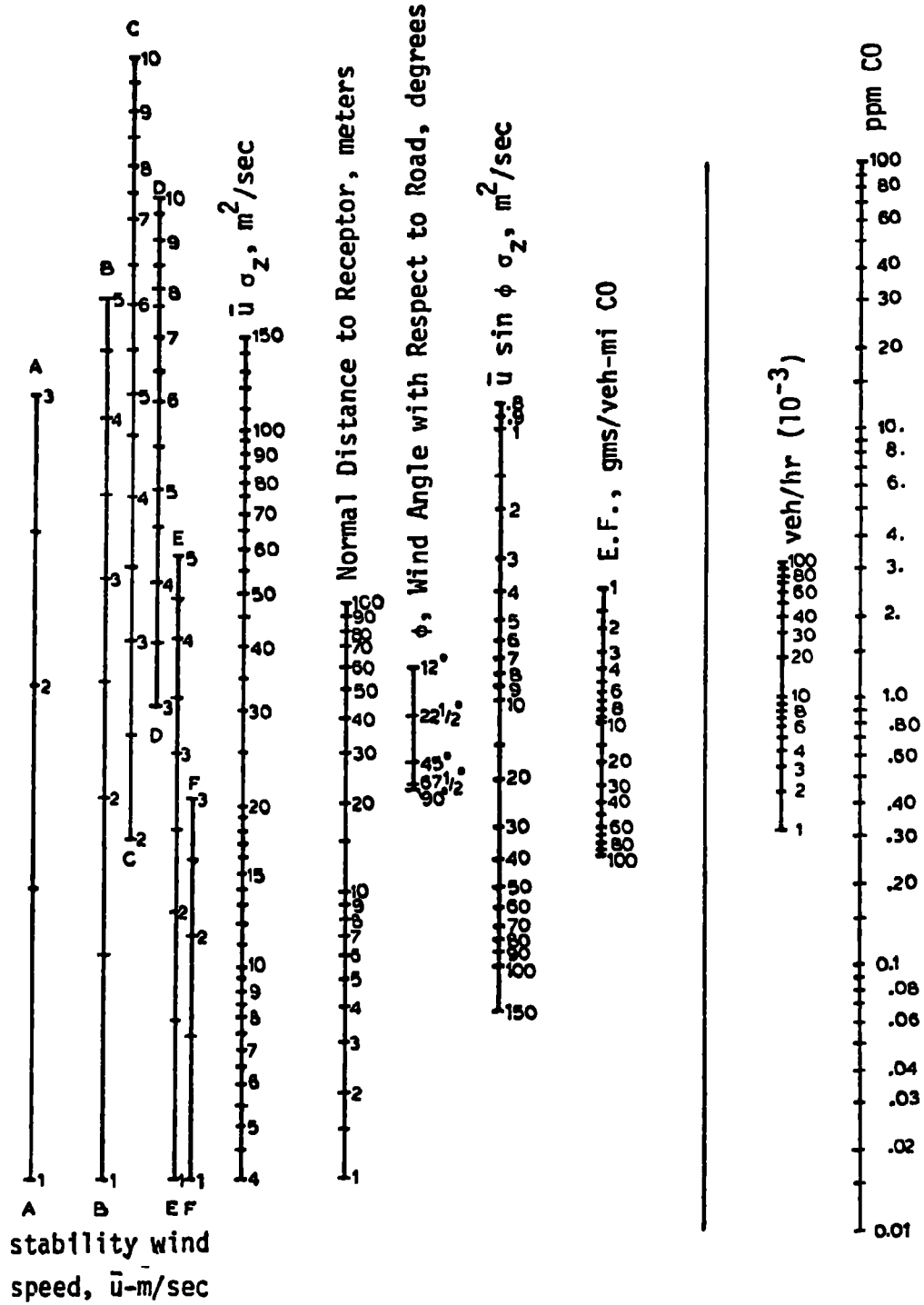

B. LITERATURE SEARCH FINDINGS

This section of Literature Search Findings is composed of those key points which were extracted from the greenbelt literature utilized to derive the landscape architectural information in this Volume. These papers represent a relatively small fraction of the literature obtained for the entire project. An overview of the main body of information about vegetation as sinks and emissions may be gained by referring to the approximately two thousand abstracts appearing in the bibliography of Volume I. The majority of the papers cited in that bibliography were located and read. Those papers that were potentially valuable for the purposes of the landscape architect were then selected. The landscape architect team member decided which were most relevant and most important in his conceptualization of effective greenbelts. Additional papers were sought which augmented the Volume I bibliography. The key bibliography used for this Volume is presented here.

Where possible, the exact words of the various authors are quoted in order to insure accuracy. In other instances, the author's words were paraphrased, but most of the information appears without interpretation. These papers are presented as generally representative of a larger literature and they are interpreted in the following order:

- 1) The value of forests in removing particulates
- 2) Plant mechanisms for absorbing and adsorbing pollutants.
- 3) Organization of plantings.
- 4) Maximizing buffer edges to increase sink potential.
- 5) Ventilation of buffers and woodlots to increase sink potential.
- 6) Importance of local adaptation of plants to local site conditions.
- 7) Ecological approach to roadside treatment.
- 8) Size of buffers.
- 9) Safety factors as design.
- 10) The sound absorbing qualities of buffers.
- 11) Idealized plant material.

1. The value of forests in removing particulates.

It has been frequently stated that plants, in general, forests especially, are excellent agents for reducing ambient air pollutant levels.

Excellent discussions of the functions of forests which produce this phenomenon are found in Keller (1971):

An essential factor for environmental protection, on the other hand, is the filtering action of the forest on dust-shaped air pollution. The most favorable effect in this respect is from loosely structured, step-like forest stands, as can be deduced from Nageli's investigation of windbreak sectors (1943), dense forest stands deflect the wind upwards which also leads to precipitation of dust due to turbulence for irregular tree roof tops. Loosely structured forests, on the other hand, let the wind penetrate and brake it, thereby permitting the dust particles to sedimentate. In addition, it is well known that particles up to 80μ can on impact even adhere to vertically located surfaces of leaves and the like. Forest air is, therefore, especially devoid of dust with the exception of blossom time when noticeable amounts of pollen are discharged into the air. The filtering action of the forest regarding dust can manifest itself even in soil scientific studies. In this way, in the lee of an area of industrial concentration where enormous amounts of soft coal, rich in ash, were burnt, the pH value of the humus layer in pine forests to a distance of about 30km was increased because the tops filtered out alkaline fly ash.

According to Warren (1973), the best deciduous trees for reduction of particulates (according to Russian literature) - are lilac, maple, poplar. Conifers are best for all year filtering - apparently they may remove 34% of the submicroscopic particles compared to 19% removed by deciduous trees.

Bach (1972), further suggests that the best genera for adsorbing particulates are:

Lilac (Syringa)	2.33 g/m ²
Maple (Acer)	1.11 g/m ²
Linden (Tilia)	0.61 g/m ²
Poplar (Populus)	0.26 g/m ²

Also good: sugar maple, sycamore and white ash.

According to Geiger (1950), studies have demonstrated that the reduction of wind velocity by forests and shelterbelts is proportional to tree height; one can expect a 10% reduction in wind speed within a distance equal to three times the tree height on the windward side and twenty times the tree height on the leeward side. Dense plantings, however, seem to reduce this effect due to the turbulence that they create. (See Figure II- 11).

Other studies on the characteristics of particulate distribution within a forest indicate that temperature differential within and above the forest canopy can provide convection currents which move the air (and the pollutants).

Fritschen and Edmonds (date unknown) found:

Inversions in the crown during the daytime and above the crown at night trapped the particles within the stem space. Particles released below the inversion were trapped until they reached a thermal chimney (i.e.; less dense vegetation where solar heating had penetrated to the forest floor) where they escaped above the forest.

Hagevik (1974) refers to:

A study by A.L. Page, et al. examined lead concentrations in 27 varieties of vegetation along highways. They found a direct relation between lead content in the plants and distance from the roadway, although the relationship was most significant at distances less than 150 meters from the highway. Lead content was also found to be influenced by prevailing winds.

Although Warren (1973) feels that this can be reduced by the planting of hedgerows which essentially reduce the velocity of the air to a point where the heavy metal precipitates. In one study cited, a dense hedgerow was responsible for an approximate 40% decline in the lead content behind it.

The World Meteorological Organization (1964) indicated that:

...the measurements of Woodruff & Zingg (1955) with systems of four belts in the wind tunnel show no accumulative effects but an increased degree of turbulence in the air flow after passing the first belt. This indicated that when several parallel belts are planted the interval between them should not increase but should be the same.

It follows then that increased spacing between parallel hedgerows will create increased turbulence and therefore increase the amount of CO and particulates removed.

2. Plant mechanisms for absorbing and adsorbing pollutants.

To understand the functions of the plants to reduce various pollutants, their mechanisms and responses to various pollutants must be understood.

a. Particulates

Smith and Dochinger (1975) state:

Much of the understanding of the mechanics of deposition of particles on natural surfaces has been gleaned from studies with particles in the size range 1-50 μ m and is reviewed in the excellent papers of Chamberlain (1967) and Ingold (1971). Basically, particulates are deposited on natural surfaces by three processes: sedimentation under the influence of gravity, impaction under the influence of eddy currents and deposition under the influence of precipitation. Sedimentation usually results in the deposition of particles on the upper surfaces of plant parts and is most important with large particles. Sedimentation velocity varies with particle density, shape and other factors. Impaction occurs when air flows past an obstacle and the airstream divides, but particles in the air tend to continue straight due to their momentum and strike the obstacle. The efficiency of collection via impaction increases with decreasing diameter of the collecting obstacle and increasing diameter of the particle. Chamberlain (1967), suggested that impaction is the principal means of deposition if; 1) particle size is of the order of tens of microns or greater, 2) obstacle size is of the order of centimeters or less, 3) approach velocity is of the order of meters per second or more and 4) the collecting surface is wet, sticky, hairy or otherwise retentive. Ingold (1971), presented data indicating that leaf petioles are considerably more efficient particulate impacters than either twigs (stems) or the leaf lamina. For particles of dimensions 1-5 μ m impaction is not efficient and interception by fine hairs on vegetation is possibly the most efficient retentive mechanism. The efficiency of washout of particles by rain is high for particles approximately 20-30 μ m in size. The capturing efficiency of raindrops falls off very sharply for particles of 5 μ m or less. Particulate removal by stomatal uptake has been suggested (Jordan 1975), but is of unclear significance. The latter process would probably involve small (< 1 μ m dia) particles.

Heichel and Hankin (1976) found that the pattern of lead accumulation on twigs is unrelated to the pattern or quantity of precipitations falling on a site. It appears that these particles are less easily dislodged from the rough surfaces of twigs than from the waxy, smooth surfaces of needles or leaves.

Wylie and Bell (1973) concluded that the major deposition of lead particles along roadways occurs within the first 25 meters(m) away from the road edge.

Berindan (1969) remarks:

The property of leaves to retain dust is a function of the roughness of their surface. Table III indicates some of the species for which the retention has been tested. This ability is much less in winter. To ensure continuous action, the species in Table III must be combined with Coniferae; yet, considering that the latter are highly sensitive, this combination is no longer effective in cases of mixtures of dusts with SO₂, for example." "Some air pollution studies have focused on the third aspect of dust retention by plants which is the action of swirl of suction, in view of their property for directing pollutants from top to bottom at the level of the respiratory tract. This type of draught is made up behind any barrier which is high enough to hinder the main direction of the wind (22, 39, 56) (Fig. 7).* It is also thought that by using this property, it is possible for dusts carried by the wind behind strips to be drained at the level of the land. In cases of thick clumps, however, the reverse result may be obtained: the current brings the dusts on the targets that are to be protected.

TABLE II-2

PLANTS KNOWN FOR THEIR CAPACITY TO RETAIN DUSTS
(Modified from Berindan, 1969)

Plant Species	Units of Dust Removal
Abies	30
Picea	30
Pinus	30
Ulmus	7.3
Syringa	2.9
Betula	2.5
Tilia	2.4
Acer platanoides	1.9
Populus	1
Platanus	-
Fraxinus	-
Morus	-

(Original units in gr/m.c)

Smith and Dochinger (1975) observed:

Trees may be especially efficient filters of airborne particles because of their large size, high surface to volume ratio of foliage, and frequently hairy or rough leaf, twig or bark surfaces.

* Number 22 refers to Halitsky (1962); number 39 refers to Moses (1964); and number 56 refers to Warren Spring Laboratory (1966). Figure 7 can be located on page 15 of Berindan (1969).

Numerous investigations, reviewed by White & Turner (1970), have indicated that trees catch airborne nutrient particles. These authors found that their mixed deciduous forest was capable of annually removing 125 kilogram/hectare (kg/ha) sodium, 6 kg/ha potassium, 4 kg/ha calcium, 16 kg/ha magnesium and 0.1 kg/ha phosphorous from the atmosphere. Degree of leaf hairiness was inversely correlated with particle retention. Apparently the small droplets employed had insufficient inertia to penetrate the stable boundary layer created by the hairy leaves. Small diameter branches were more efficient particle collectors than large diameter branches in all species examined.

Monteith (1975) states:

Once particles are at rest on a surface, surface tension and other forces hold them, and the drag of the wind is reduced by the viscous sub-layer, so they are not easily disturbed.

Warren (1973), says that concentration of particulates is reduced by 40 - 50% within the first 65' - 85' of forest adjacent to the edge.

Smith and Dochinger (1975) comment:

Many investigators, for example, Raynor et al. (1966), have shown that the concentration of particles carried by an air mass through a woodland decreases rapidly from the edge.

Keller (1971) mentions:

The powerful filter action of the forest in regards to dust makes itself felt most impressively, however, in reports of figures (Handbuch der Staubtechnik, Handbook of Dust Technology, 1955, by Meldau) according to which 1 Hectare (ha) of spruce forest can fix 32 tons, beech forest even 68 tons of dust until the filtering capacity has been exhausted. This means that in an extreme case the forest could fix several times the weight of its tops; however, these figures should be regarded as very maximum, in a way, as the potential dust collecting capacity of the forest.

Podgorow (1967) states:

...considerable quantities of dust are deposited on $1m^2$ of the region which is adjacent to the city. Plantings growing in the vicinity of the city (500 - 1,900m) retain 80.1% of the precipitation/surface of ground dust. From this quantity up to 40.2% can be attributed to the pine needles. Our investigations thus showed that the pine is a good retainer of dust. It is, therefore, necessary to include them in the plantings of parks and wooded areas which are close to industrial centers.

Haupt and Flemming (1973) investigated the efficiency with which dust is filtered out of the air by forests. It is dependent upon the leaf and needle surfaces and their species specific collecting capacity. It was observed that coal dust deposition was less during calm and wet periods and more during turbulent and dry periods. For example, dust deposition during April was 207 times greater than in July. In addition, rates of deposition at any one time were virtually the same whether the collecting surface was vertical or horizontal.

Lampadius (1963) determined that spruce stands on 1 hectare(ha) absorb 67-114 kg of sulfate which reduces the SO₂ content of the air by 18-40 grams. Similarly, a ha spruce stand absorbs 32 tons of dust, pine absorbs 36.4 tons and beech absorbs 68 tons, but no time span is mentioned in this comparative study.

Relative to pollen, Zinke (1967) found that dispersion into a forest is reduced by interception in the canopy. That filter may remove 30% of the pollen grams compared to the concentration in the air over an adjacent open field.

Raynor et al. (1966) concluded that pollen grains are removed from forest air more rapidly at low wind speeds than at higher speeds. Impaction seems important in the first 10 meters of travel into a forest and along the upper canopy surface. Decreased wind speed within the forest allows pollen and other aerosols to settle out by gravitation.

Neuberger et al. (1967) studied concentrations of ragweed pollen within a dense coniferous forest. They found that 80% was removed within the first 100 meters of trees. The efficiency of Aitken nuclei removal by coniferous material averaged 34% while deciduous material averaged 19%.

Weisser (1961) investigated dust contents of forests. One hectare plots of spruce can contain approximately 32 tons of dust, Scotch pine, 35.4 tons, and beech, 45 tons. The average dust settling on a 100 meter square (m²) plot ranges between 3,000 grams per month near a fossil fuel power plant, 1,072 grams per month in a city, and 340 grams per month in a large urban park.

Smith and Dochinger (1975) point out that under controlled wind tunnel conditions, the deposition of particulates on rough, pubescent sunflower leaves was 10 times greater than on smooth waxy, tulip poplar leaves.

Bernatzky (1968) states:

The air in a city is impregnated with a large number of kernels which become the nuclei about which such matter as exhaust gases and radioactive substances gather; eventually they will get into the respiratory organs where they will work havoc. (The kernels which we refer to are particles of pollution of a size measuring from one millionth to one five thousandth of a millimeter.)

TABLE II-3

NUMBER OF KERNELS IN ONE CM³

	Average	Max. of average	Min.	Absolute Maximum
Big cities	147,000	379,000	49,100	4,000,000
Small towns	34,300	114,000	5,900	400,000
Country places	9,500	66,500	1,050	336,000
Coastal areas	9,500	33,000	1,560	150,000
Mountains:				
500-1000m	6,000	36,000	1,390	155,000
1000-2000m	2,130	9,830	450	37,000
above 2000m	950	5,830	160	27,000
Ocean	940	4,680	840	39,800

(A. Landsberg)

Average values of air pollution have been found by Reifferscheidt in Germany shortly after the end of the war to be

	Big cities	Country
Kernels	200,000	8,000 per cm ³
Dust particles	270	7 - 10

Air pollution varies according to hours of the day and to the seasons of the year as well as to the height above ground. We may distinguish three levels:

Just above ground
Roof level (domestic heating)
Level of factory chimneys

This means that high blocks of flats which are much higher than other houses might easily reach their upper storeys into zones that are polluted to a far greater extent and where the amount of pollution is continually kept on a certain level by the factory chimneys as well as the smoke from the houses. The content of kernels and dust particles leads to the formation of a dust dome which is responsible for ultraviolet (U-V) poorness and dimness of sunlight (loss of 20%) in the cities.

The higher the buildings of a city, the more they do to counteract the natural flow of air. To overcome friction, energy is used up, the draught action slows down and thus an air cushion is formed above the city. Oncoming air currents have to rise above this cushion and the result is poor ventilation of the city.

Smith and Dochinger (1975) comment:

The annual mean concentrations of suspended particulate matter in the United States urban areas range from 60 micrograms/cubicmeters (mg/m^3) to $200 \mu\text{g}/\text{m}^3$. The maximum 24 hour average concentration is usually approximately three times the annual mean. Urban areas generally have higher particulate loads in the winter than in the summer (Spirtas and Levin, 1971).

b. Carbon Monoxide (CO)

Carbon monoxide is one of the primary pollutants produced by automobiles. Studies have shown that the most effective receptor for CO are soil microorganisms which apparently metabolize the gas.

Summarizing the findings of a recent study by the General Electric Company on the dispersion characteristics of carbon monoxide cited by Hagevik (1974) it was found that CO exhibits exponential decay with distance as long as the path of the pollution is not obstructed. Also, the concentration of CO at the level of the automobile exhausts is inversely related to traffic speed. As the speed of the traffic increases, the concentration of CO decreases due to the increased efficiency of the vehicles and the increased turbulence. Although the distance required for the removal or decay of CO has been studied, the impact of turbulence and canyon effect on the dispersion of the gas is not clear. Also, the shape and size of surrounding buildings appears to have an effect on dispersion irrespective of wind velocity. The General Electric study indicates that peak values occur at impermeable walls, and the magnitude of CO concentrations are related to traffic volumes on each side of the highway. The example of an open roadway cut is given the maximum concentration occurs at the two walls and the minimum concentration occurs at the center of the roadway. In an example where there is a wall (or cut) along one side of the road and an open area on the opposite side, the maximum concentration occurred along the wall; where both sides of the road are open to ventilation, the maximum concentration occurs in the center of the roadway and decreases in both directions. (See Figure II-15).

H.E. Heggestad is cited by Hagevik (1974) as indicating that soil, apart from vegetation, is important in removing pollutants from the atmosphere, especially gas such as CO and ethylene which are not absorbed by green plants. Apparently, it is fungal microflora which are the primary absorbers of CO. The soil is also a sink for hydrocarbons, a major automotive pollutant.

Inman and Ingersoll (1971) found that non-sterile potting soil reduced CO concentrations in a chamber from 120 parts per million (ppm) to zero within a three hour period. When sterilized, the soil removed no CO. Furthermore, soil absorption of CO was apparently dependent upon high organic matter content and low pH.

c. Ozone (O₃)

Aldaz (1969) reported that bare, dry soil removes about 75% more ozone than when it is moist while the opposite is true when vegetation is present. Relative to water bodies, it was reported that ozone is removed from the atmosphere about 15 times faster over land areas than over sea water.

In 1970 Fesler reported that tobacco plants were generally most sensitive to ozone concentrations coincident with low nitrogen fertilization levels (60 lbs./acre), and high levels least sensitive was found for plants treated with an intermediate level of nitrogen fertilization (120 lbs. N/acre).

Babich and Stotzky (1974) concluded that the removal of ozone from the atmosphere by soil is directly dependent upon the moisture content and surface texture of the soil. Soil compaction and increasing moisture content both decrease exposed soil surfaces and porosity and therefore, decrease the sink capacity of that soil relative to ozone removal. They also feel that the removal process is essentially a physical and chemical process with soil micro-organisms possibly serving as additional active decomposers of ozone.

Smith and Dochinger (1975) report that herbaceous species absorb more ozone than do woody species and that as an example the deposition velocity determined for a petunia species was about 9 times greater than an oak species.

Turner et al. (1974) investigated the dispersion and absorption of ozone as it passes through forested areas. They found a 10% decrease in concentration as the ozone containing air passed through about thirty meters of forest.

Davis (1975) calculated that an average shade tree contains 4,300 square feet of leaf area and that if one assumes an average 8 hour O₃ concentration of 0.17 ppm, and an O₃ diffusion resistance of 0.33 min/cm, about 27% of the ambient O₃ would be removed if the air passed into the canopy at a speed of less than 0.1 miles per hour.

Braun (1974) found that the penetration of solutions under natural conditions occurs mainly through the cuticle and not through the stomata. Therefore, foliar uptake is significantly affected by the chemical composition of the cuticle of each species as well as by the mobility and solubility of the pollutant in question.

Smith and Dochinger (1975) also point out that herbaceous species absorb more ozone than do woody species.

Bennett and Hill. (date unknown) determined that under favorable growing conditions, air pollutants tend to be taken up by vegetation in the exposed and upper portions of dense canopies.

d. Sulfur Dioxide (SO₂)

Sulfur dioxide is a gas produced primarily by the burning of fossil fuels, it is generally considered an industrial pollutant rather than associated with vehicular traffic. It is believed that SO₂ (and other water soluble gases) pass into the plants through the stomata and go into solution within the plant itself.

The following studies cited by Smith and Dochinger (1975) illustrate these processes.

Speeding (1969) investigated the uptake of SO₂ by barley leaves and found a 6-fold increase in average deposition velocity with open stomata compared to closed ones. In related work, Rich and Associates (1970) reported that uptake of ozone (O₃) by bean was regulated by the same factors that control the exchange of water vapor between leaves and the atmosphere. This conclusion is also supported by Thorne and Hanson (1972). Once inside the leaf gases probably become dissolved in water. Hill (1971) compared the rates of uptake of pollutants by alfalfa with the water solubility of the pollutants. Fluorides had the highest water solubility and uptake. As the rates of uptake of pollutants decreased, their water solubility was also reduced. Any factor that affects the stomata influences the uptake rate of gaseous pollutants. Some of the environmental factors that are important in the action of stomata are light, humidity, temperature, wind, and the available supply of soil water.

Atmospheric pollutants themselves are also reported to have an effect on stomatal activity. Majernik and Mansfield (1970) and Unsworth et al. (1972) reported that SO₂ caused stomata to open faster in the light, to achieve a greater aperture, and to close more slowly in darkness. All of these would allow for the absorption of more SO₂.

Berindan (1969) describes the process in the following excerpt:

As regards the action of green spaces on gaseous pollutants, it is much less known since research aiming at determining it has been more restricted and more recent..."

So far the retention of sulphurous gas, fluorine, hydrogen sulphide, and nitrogen oxides has been established. Of all of these mechanisms of action, SO₂ is very well known, its diagram is shown on Table II-4. This table explains the absorption process of sulphur by plants, wherein it can pile up to a given level, which once exceeded, entails the deterioration of the plant.

Blum (1965) in a review of the literature found that a mature beech stand served to filter SO₂ from the air in the vicinity of a smeltery. This beech stand protected an adjacent, enclosed stand of spruce which died in response to removal of the beech trees.

Davis (1975) reported that the use of fertilizers can increase the resistance of plants to SO₂ damage, but that they do not necessarily relate to the rate of SO₂ uptake by this vegetation.

Murphy et al. (1975) determined that the diurnal pattern of SO₂ uptake by plants reflect changing sun light patterns and temperature as they affect stomatal functioning and SO₂ solubility. Seasonal changes in day length and leaf area are key variables and the formation of dew and the vegetation can form a very sizable sink for the transient absorption of SO₂.

e. Gases - General & Miscellaneous

Smith & Dochinger (1975)

In the case of gaseous pollutants, much of the evidence comes from controlled environmental studies with non-woody species. We do not have adequate information to document the ability of trees to remove "meaningful" quantities of pollutants from actual urban atmospheres. Trees have yet to be shown to be capable of reducing a particular air contaminant below a significant threshold of effect for any urban area.

The primary method of vegetative removal of gases from the atmosphere is via uptake through the stomates. Minor methods by which plants remove gaseous pollutants from the atmosphere may include uptake by plant surface microflora, uptake through bark pores and absorption of gases to the surfaces of plant parts.

The processes of transpiration and photosynthesis require that plants exchange gases with the ambient atmosphere through leaf, branch and stem pores. Contaminant gases present in the atmosphere in the vicinity of a plant may be absorbed when the stomates of lenticels are open.

Shelterbelts and windbreaks have traditionally been used to alter microclimate in various ways, primarily by slowing down wind speed and reducing evapotranspiration.

World Meteorological Organization (1964) cites:

....in Canada, after experiments at the Soil Research Laboratory, Dom. Exper. Sta., Swift Current, Saskatchewan, as by Matjakin (1952) and Panfilov in the U.S.S.R. (1937). According to these two an impermeable belt of woodland hardly lets the wind through at all immediately behind the wind is almost completely calm and when it returns to earth in the lee it is very turbulent. A belt of medium permeability with numerous small holes distributed evenly over the entire belt acts as a sieve, preventing turbulence to a large extent.

TABLE II-4

PROCESS OF SULFUR ABSORPTION BY PLANTS

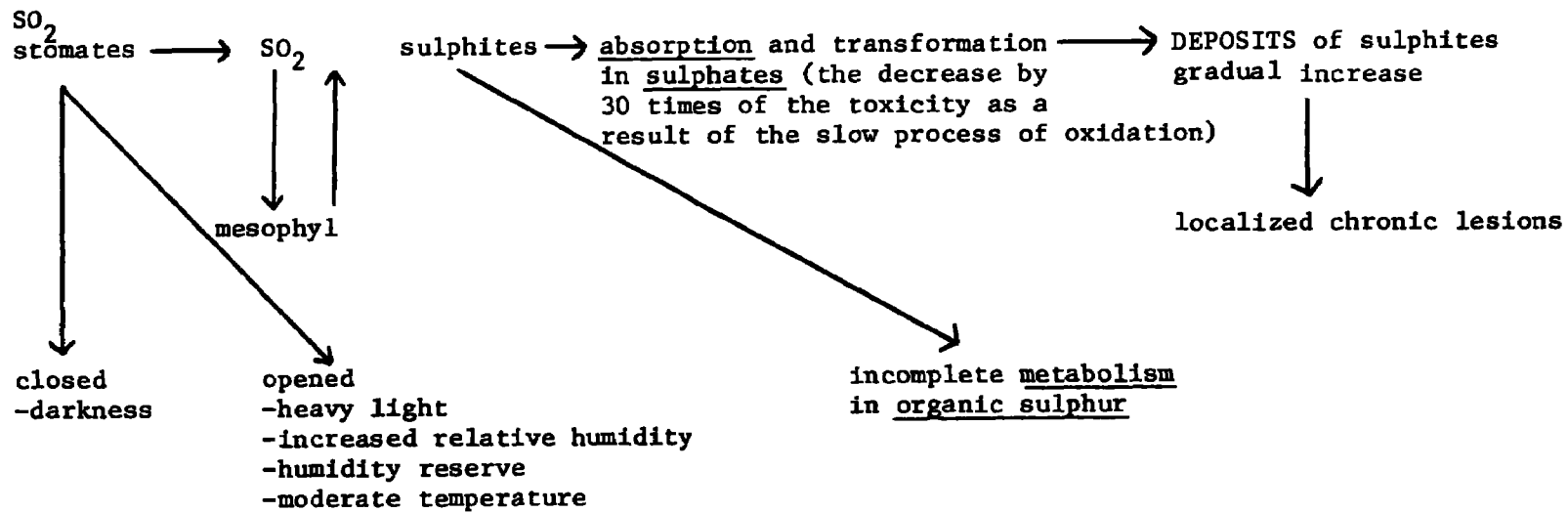

II-30

Thus, by using plant materials to break up the winds, a great amount of exposure of the air currents to the leaf surfaces occurs. This results not only in slowing down the wind and allowing particulates to settle out but enables the gaseous pollutants to be taken up by the leaves. Furthermore, the turbulence created by the air passing through the shelter belt forces the air current down toward the ground where CO can become engaged by soil microorganisms.

Turner et al. (1974) investigated the dispersion and absorption of O₃ as it passes through forested areas. They found a 10% decrease in concentration as the O₃ containing air passed through about thirty meters of pores.

Davis (1975) calculated that an average shade tree contains 4,300 square feet of leaf area and that if one assumes an average 8 hour O₃ concentration of 0.17 parts per million (ppm), and on O₃ diffusion resistance of 0.33 m minute per centimeter (min/cm), about 27% of the ambient O₃ would be removed if this air passed into the canopy at a speed of less than 0.1 miles per hour.

Makarov and Dokuchayev (1970) found that there is a considerable variation in the liberation of nitrogen dioxide (NO₂) during the growing season. Reduced generation rates are associated with treatments which suppress microbial metabolism.

3. Organization of plantings

Factors effecting the efficiency and functioning of buffers are similar to windbreaks and shelterbelts. In both cases the importance of breaking up and slowing down air currents is essential.

World Meteorological Organization (1964) states:

Windbreaks and shelterbelts alter the air flow primarily according to strength, direction, and degree of turbulence.

We can for the moment forget whether a windbreak be artificial or of natural growth. Effective protection and the influence on the windy area are not directly dependent on this.

The deciding factor for wind reduction with shelterbelts is the belts's density permeability.

Immediately behind very dense belts wind reduction is at its greatest; with increased permeability it becomes less. At wind minimum, wind reduction is also a function of permeability, called "covering degree" by Tanaka (1956). With dense belts the position of greatest wind reduction is very close to the belt; yet it is furthest away when the belt is of medium density. According to George (1960) maximum wind reduction occurs immediately in the lee of a belt of 10 rows, shifting to 2.4 x H with 5 to 7 - row belts. Similarly the distance behind belts where wind reductions are still at least 20% is greatest behind belts of medium density and least for very dense and very loose belts.

The different density belts show different curves of wind speed on their leeward side. So it is not permissible to judge the sheltering effect of belts, as Den uyl did (1936) only on measurements taken at small distances. From the curves it can be concluded that where wind reduction extending far behind the belts is required, more than sharp reduction, high belts of medium density are the best (Naegeli, 1946; van der Linde, 1958). The smaller extent of wind reduction with dense belts is a consequence of the stronger displacement flow and the greater power of recovery that this gives the surface wind. The wind recovers speed behind denser belts more quickly than it was reduced.

Blenk & Trienes (1955) also studied the effect of different shapes of belt with four impermeable models 30 millimeters (mm) high in the wind tunnel. One of them was 1 mm wide, the other three 15 mm, of which one was right-angular in cross-section, with sharp edges; the other two were rounded off in different degrees. The model most rounded off on the top edge had the least extent of wind reduction; the one with less had a little greater extent, and the best proved to be the sharp-edged sheet 1 mm wide. (See Figure II- 12).

In the Russian terminology a permeable belt is a wood plantation with large gaps running right through. These belts in the U.S.S.R. mostly have bare, 1 to 2 inch thick trunks without undergrowth or stunted trees.

With such belts eddies would be prevented particularly near the surface by the wind penetrating the lower parts.

A permeability of 40 to 50% can be obtained by various sizes and shapes of opening. According to Naegeli (1946), Nøkkentved (1938), Konstantinov (1950), many small openings are especially effective. Blenk and Trienes (1955) compared three strips 30 mm high with a permeability of 50%, but with different sizes of opening, in the wind tunnel. The wind distribution behind those with openings of 2 and 5 mm diameter was almost equal. The strips with openings of 8 mm reduced wind for a considerably shorter distance.

In the open, where the degree of permeability is hard to estimate, van der Linde (1958) classes well cared for leafy blackthorn or yew hedges as dense, counting belts of Lombardy poplar among those of medium density. Eucalyptus makes equally good belts of medium density in warm, semi-arid areas, but according to Duncan (1950) belts of "thin cottonwood" 20 m high belong to the very loose and least effective.

Shelterbelts of deciduous trees vary in density with the season. According to Flensburg and Nøkkentved (1940) the seasonal differences with loose belts in Denmark were slight; in the autumn dense belts assume the character of medium, and medium that of loose. The protective effect of leafless belts is not to be neglected, however. Figure II-8 shows the wind conditions at a belt of medium density 16m high with and without foliage (Naegeli, 1946).

FIGURE II- 8

THE SHELTER PROVIDED BY A 16-METRE-HIGH SHELTERBELT OF DECIDUOUS TREES IN SUMMER AND WINTER (NAEGELI, 1946)

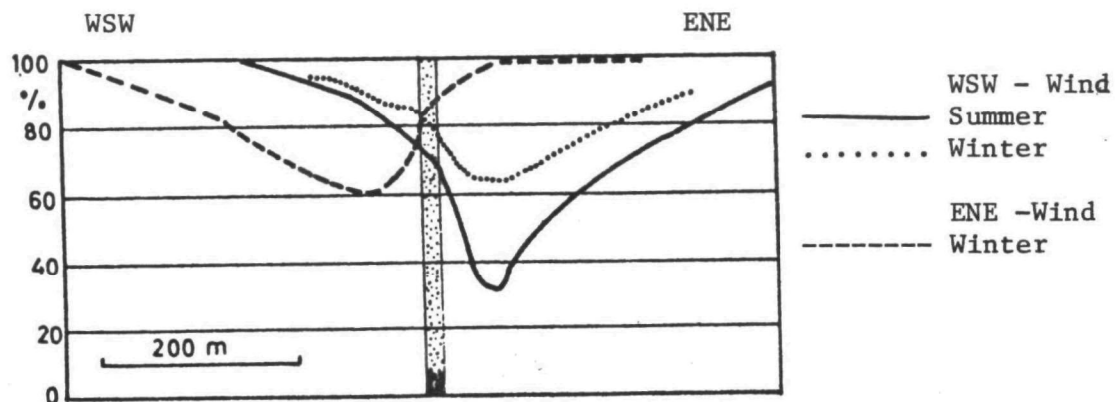

According to Jensen (1954) and Nøkkentved (1938) leafless belts generally gave 60% of the shelter with foliage. In northwest Germany, Franken & Kaps (1957) found about 50% less wind reduction at three, four and seven belts when without leaves. Similar evaluations were made by von Eimern (1957) at a two row belt of maple 12m high with undergrowth.

Berindan (1969) states:

...some guiding concepts may be defined for the planting of green spaces for sanitary protection:

- a) The necessity of a correlation between the type and the concentration of the pollutant and the degree of resistance of plants;
- b) The necessity, in some countries, of checking, through research and experimentation the findings on the resistance of plants, since the uncontrolled implementation of the findings could lead to erroneous or inefficient solutions;
- c) For each situation, the degree of toxicity of the pollutant or the mixture of pollutants must be known in order to select species which have adequate specific resistance;
- d) In so far as the height of the plantings are concerned, in the first place, it must be recommended to plant trees, shrubs and/or to plant some turfs only to supplement their retention capacity. In the last analysis, flowers are used for decorating roads. The same applies to fruit trees, provided however that they are resistant and are not exposed to accumulation of toxics, otherwise planting them will be useless, costly and sometimes even dangerous;

e) Aerated structure plantings, obtained by grouping curtains or rows of trees can better retain dust or even gaseous pollutants, than compact clumps, due to the filtering action of the former. To this end, the form and composition of cross sections of green barriers, function of the effects desired and resulting from the draughts generated are to be closely studied;

f) It is necessary to place dust collecting plants by order of capacity: those that retain large particles are to be placed close to the source; and further off, those which stick to the smallest particles.

4. Maximizing buffer edges to increase sink potential

It is clear that the most diverse and most important part of forests (and buffers) for the purposes of reducing pollutants is the area within the buffer, adjacent to the edge. Warren (1973) previously cited, indicates that the most effective and efficient zone for this purpose lies within 65 - 85 feet of the edge. This is due to the greater diversity of plant materials within this area. Generally the canopy occurs at all elevations not only at the top as it is further into the forest interior (See Figure II- 13).

Obviously in the design of effective buffers, techniques to increase the edges are of great importance. This is true not only for newly planted installations but for existing forests and woodlots as well.

5. Ventilation of buffers and woodlots to increase sink potential

As previously indicated, thermal chimneys within a forest can increase deposition of particulates and absorption of gases by increasing ventilation, and exposing pollution laden air to leaf surfaces high in the interior canopies. Such a phenomenon can be built into buffers or existing forest areas by the creation of openings in the interior forest canopy. (See Figure II-14).

6. Importance of local adaptation of plants to local site conditions

World Meteorological Organization (1964)states:

As the extent of the protective effect of belts is proportional to their height, it is often (in the U.S.S.R. for example) considered an advantage to plant belts which reach a maximum height dependant on soil and climate, for which purpose the types of tree and bush particular to that landscape are selected.

Width and shape of belts are not always decided from the aspect of best wind reduction; forestry also plays a large part. Because of maintenance, care and their possible use for other purposes, wider belts of more than 5 -10m are preferred in many climates. In such belts part of the wood can be used elsewhere without appreciable harming the wind reducing effect, and they are often capable of reducing themselves; filling gaps left by dead wood with new growth. In any case they seldom leave such large gaps that harmful nozzle effects evolve...

Smith and Dochinger (1975) state:

1. Trees selected or bred to provide this amenity function must be tolerant of acute, adverse influences or air pollution. Clearly if the tree is severely damaged or killed by one or an interaction of contaminants utility as a sink will be short-lived. In addition to air pollution tolerance, suitable tree varieties should be capable of withstanding other urban stresses, such as poor soil aeration and drought, nutrient deficiencies and microclimate extremes. A suitable variety should be able to grow vigorously. Vigorous growth will require maximum stomatal aperture and ensure maximum uptake of gaseous pollutants.

2. Coniferous species retaining their foliage year round may appropriately be favored over deciduous species. The atmospheric burden of both particulates and gases is generally higher in the winter than in the summer for most urban areas. It is important, therefore, to have maximum plant surface available for absorption and adsorption during winter months. Since the time of persistence of foliage of evergreens is longer than deciduous foliage, the opportunity for pollutant removal is correspondingly longer. The morphology of coniferous foliage (for example; pine, spruce, fir) results in a high surface to volume ratio which may be instrumental in more efficient removal rates.

3. Since petioles are especially efficient particle receptors, species with long petioles (for example; ash, aspen, maple) may be favored.

4. Surface hairiness on plant parts (leaves, twigs, petioles, buds), may be especially effective for retention of particles. Those species possessing these hairs (for example; oak, birch, sumac) should be considered.

5. Species with small diameter branches and twigs should be selected or bred over species with large diameter branches or twigs as the former are more efficient particle collectors.

6. Since gases are removed from the atmosphere primarily by the stomates, species should be selected or bred with maximum stomatal capacity for absorption. This ability may be related to absolute stomate number per unit of leaf surface, size of stomatal capacity number per unit of leaf surface, size of stomatal aperture and length of time the stomates are open.

7. Species should be selected or bred that have maximum resistance to stomatal closure occasioned by environmental variables such as moisture availability, temperature, wind, light intensity and air pollution.

8. Selection and breeding should consider one relative ability of tree species to utilize pollutant gases as partial sources for required nutrients.

7. Ecological approach to roadside treatment.

Using natural succession as a basis for roadside management....
resulting in increased sink potential, reduced maintenance costs.

Odum (1971)

TABLE II-5

ECOLOGICAL CHARACTERISTICS OF COMMERCIAL FORESTS AS
CONTRASTED WITH PROTECTIVE GREEN BELT VEGETATION

Features	Commercial Forest	Green Belt Vegetation
Species diversity	Low (usually monoculture)	High (mixed species)
Age structure	Even-aged	Multi-aged
Annual growth increment	High	Low
Stratification	One-layered (mostly canopy trees)	Multi-layered (understory, and ground cover well developed)
Mineral cycles	More open (losses from leaching and run off)	More closed (retention and recycling within stand)
Selection pressure	For rapidly growing, sun-adapted species (often softwoods)	For slower-growing, shade tolerant species (more hardwoods)
Maintenance costs (re-planting, fertilization, pest control, thinning, etc.)	High (requires "management")	Low (self-maintaining)
Stability (resistance to outside perturbations such as storms, pest outbreaks, etc.)	Low	High
Overall function	Production of marketable products	Protection of the quality of man's environment

Use of mixed plantings - mixed canopy trees, and shrubs - deciduous and evergreen to increase sink potential, screening headlights of oncoming cars, reducing maintenance costs, protecting wildlife, etc.

Rich (1972) comments:

Many species of roadside trees suffer moderate to severe injury from sodium chloride applied to the highways in winter to prevent ice formation and to aid in snow and ice removal. Trees within 30 feet of the edge of the highway are affected most frequently and most severely..." Canadian hemlock, balsam fir, white and red pine, and sugar and red maple, basswood and American elm are among the most sensitive.

Tolerant species include: red oak, white oak, white ash, black locust, quaking aspen, black cherry, black birch, grey birch, paper birch, yellow birch, Norway maple and red cedar.

Odum (1971) states:

The first and most important consideration in planning and managing the urban greenbelt, then is diversity.

Too often tree plantings in urban and suburban areas end up as even-aged monocultures with no provision for understory young trees that could replace the old ones as they die or become diseased.

A second important ecological consideration involves careful selection of species and varieties that are naturally disease resistant, and adapted to soil, water, light, topographic and other conditions of the microhabitat. When trees are planted outside of their preferred habitat (bottomland trees planted on dry uplands, or vice versa, for example) a lot of maintenance (watering, fertilizing, etc.) may be required.

Also, the metabolic cost of adapting to the suboptimum condition makes the tree vulnerable to disease or drought.

Williston (1971) comments:

Trees will lower right of way maintenance costs. Grasses need to be periodically fertilized to maintain good cover on roadbanks; trees do not, and yet they control erosion well. Trees eliminate the need for weed control and for maintenance mowing, which can cost \$10. or more per acre per year. (Costs are 1971 - add 10%/year).

Odum (1971) states:

Shrubs in the buffers are important.

1. Shrubs, and leafmold they produce, enhance soil moisture, encourage useful soil decomposer organisms, and help in self-fertilization of nutrient recycling.

2. Shrubs, especially evergreen ones, are very effective noise barriers. Robinette (1969), for example, points out that a band of dense shrubs backed by several rows of trees along a highway or street can reduce noise of traffic or garbage collection ten-fold. In such a case sound is not only absorbed by twigs and foliage of shrubs, but it is reflected upward (away from hearer) by trees. Trees alone would have very little value in noise abatement at close range. Since noise pollution is rapidly becoming critical, it could well be that plantings structured to mimic a multi-layered natural forest could be more valuable for noise abatement than for any other purpose.

3. Shrubs and other understory vegetation are absolutely essential for songbird populations. I think we will all agree that pleasant sights and sounds of songbirds are a desirable point of the urban landscape. Among desirable birds only the robin thrives in habitats containing the only tall trees and grass or other ground cover. Most songbirds (mockingbirds, brown thrashers, thrushes, towhees, song sparrow, etc.) require shrubs or understory vegetation for nesting and escape shelter. Contrary to most people's ideas very few songbirds nest high in trees. In a study of bird nesting heights, Preston and Norris (1947) found that 80% of bird nests were between 3 and 18 feet above ground with the median height being 7 feet. For more about the dependency of songbirds on the understory see Odum and Davis (1969).

8. Size of buffers.

Warren (1973) feels that greenbelts should be a minimum of 100 to 120m. wide and should channel the wind to provide a maximum dispersion for the gaseous pollutants. The width must depend on the pollutants and local conditions and could range up to 2,000 feet.

Buffers adjacent to highways should be planted with trees and shrubs as close to the highway as safely possible. Also, forested or planted medians should be provided. They should be at least 15-30m. wide and average 10-20m. tall.

Hagevik (1974) states:

Peter Rydell and Gretchen Schwarz cite a Russian study which concludes 'that the concentration of pollution decreases by about half over 500 meters of planted land'. I.A. Singer also notes a 75% reduction in dust particle count over a 600 foot wide strip of open space.

Frank Cross determined the size requirements for a buffer zone to protect citrus groves from fluoride emitted from a phosphate plant gypsum pond. Based upon a standard where 75 parts per million of fluoride in citrus leaves was considered to be evidence of pollution a one half mile buffer strip was established around the pond to alleviate the fluoride effect. In another case, Cross defined a zone for suspended particles emitted from a dolomite processing plant, and concluded that to reduce the adverse impact of settling particles upon nearby residents, a buffer of 1,500 feet radius around the plant site would be required. A third study by Cross investigated the buffer width needed to restrict ambient air particulate concentrations from a hot mix asphalt plant to 100 micrograms per cubic meter. Results indicated that a buffer zone of one mile radius reduced particulate concentration to the determined level.

Bernatzky (1968) in West Germany feels that to reduce gases the stands need to be 5 times deeper than their height on the windward side and 25 times deeper than their width on the leeward.

Corn (1968) comments:

Numerous studies have found that particulate dispersion is directly related to the source and receptor. It is difficult, however, to establish a specific distance as a guideline for buffer width, since dispersion depends upon factors other than distance alone.

The actual direction of transport is determined by large scale circulation in the atmosphere as well as by the local influences of breezes, the surface features of a specific area, heat sources (such as the higher temperature observed over urban areas) and air masses of differing densities."

9. Safety factors as design considerations.

Williston (1971) states:

Planting areas must be carefully selected lest they interfere with the drivers' safety. Trees growing to a diameter breast height(d.b.h.) of at least 4 inches or larger should be planted 30 feet or more from the edge of the pavement, smaller trees at least 20 feet. Care must be taken that as the trees grow they do not form a tunnel, causing drivers to crowd the centerline. On cut sections, plant at least 6 to 8 feet up the slope from the edge of the ditch and do not plant fills.

Screening headlight glare by planting trees on the median strip is most needed on level ground.

According to Everett (1974) there is a very real danger in exercising in areas of heavy traffic. Many cyclists ride along crowded roads and joggers running along arterials are common. Also many other types of active recreation facility are initially located along roads which are later improved to accommodate high volumes of traffic.

Studies indicated that levels of pollutants in air along such corridors may be as much as 10 times higher than ambient pollution. Heavy exercise in these zones can cause particulates and other harmful pollutants such as lead, and asbestos can be pulled deep into the lungs and deposited there. Also, as a greater volume of gaseous pollutants are pulled over the particulates, the possibility of synergistic reactions is increased.

Buffer strips intended to be used in conjunction with active recreation areas should separate such facilities from heavily traveled roads with heavy planting. Although no specific dimensions have been identified for this purpose, Warren (1973) indicated that 40-50% of concentration of particulates is removed by the first 65 - 80 feet of forest. An 80 foot minimum would probably be reasonable.

10. Sound absorbing qualities of buffers.

It has been adequately shown that plant materials acting as buffers can effectively absorb sound. Hagevik states that, generally, intensities greater than 120 d B(A) may cause pain to the human ear and that physical damage may result at 160 d B(A) especially if the exposure is prolonged.

There apparently are conflicting opinions as to the importance of the sound frequency (cycles per second or c.p.s.) but Embelton (1963) suggests that attenuation is independent of frequency range of 200 - 2000 c.p.s. for all tree types including deciduous trees in full leaf. Gerhard Reethof (1972) indicates that trees 40-50 feet tall planted in a buffer 100' wide can reduce noise by 5-8 dB. His data supported Embleton's conclusions.

Reethof (1972) states:

...other studies point out the difficulty in making definitive statements concerning the value of trees in reducing noise. For instance, assuming that noise reduction in the 300 - 800 c.p.s. range is desirable and that a 25 d B(A) reduction is required, based upon Embelton's data, a dense, coniferous growth, approximately 400 feet wide would be needed; data compiled by F.M. Weiner and D.N. Keast (1959) indicate that a 1,900 foot wide belt would be necessary for the same reduction.

Hagevik (1974) cites two recommendations of Cook and Haverbeke (1971) which indicates the possibility of reducing noise levels to 5-15 dB. Specifically, for high speed vehicular noise, they recommend planting a 65 - 100 foot wide belt of shrubs and trees with the edge of the belt within 50 - 80 feet of the middle of the traffic lane nearest the buffer. Trees in the center of the buffer should be at least 45 feet high.

FIGURE II-9

DESIGN PARAMETERS OF BUFFERS
FOR SOUND ATTENUATION
- AFTER COOK AND HAVERBEKE, (1971)

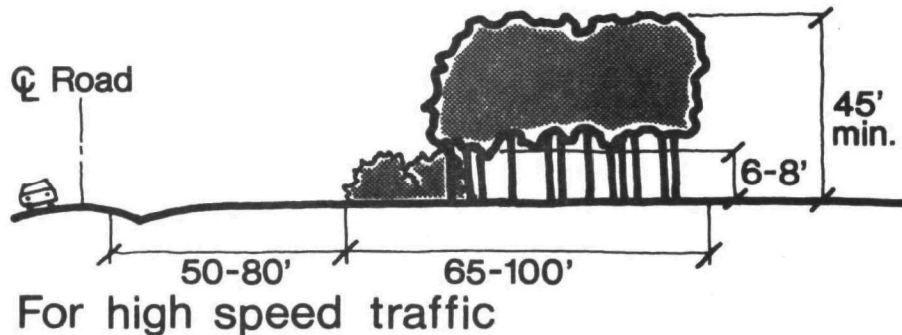
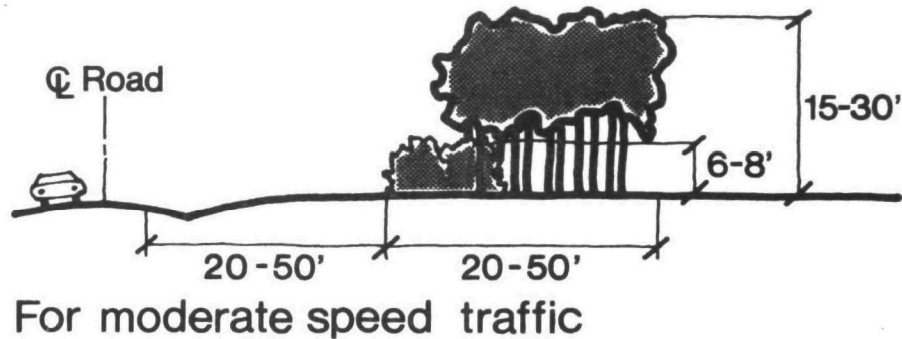

In cases where the traffic speed is moderate, the belts need only be 20 - 50 feet wide with shrubs along the edge. This should be placed 20 - 50 feet from the middle of the nearest lane of traffic. The shrubs should be 6 - 8 feet tall with trees being 15 - 30 feet high. See Illustration II-9.

The characteristics of plantings upon which sound attenuation is dependent are height, density, and width. Hagevik cites a study by Peter Durk which indicates that a 50 meter(m) wide buffer or park can result in a 20 - 30 dB reduction of noise level. Odum (1971) also references the use of vegetation as a buffer for noise (See page II-37).

C. POTENTIAL DESIGN ALTERNATIVES

After reviewing the available literature, certain guidelines for establishing and maintaining healthy, efficient greenbelts become evident. Examples of the authors' recommendations and data may be located in the Literature Search Findings section and also, Sections III and IV of Volume I. The information for creating greenbelts that are efficient sinks of airborne contaminants is summarized below and this material is the basis for the design alternatives of highway buffers.

Summary of Literature Search Findings:

1. *Evaluation of the environment is necessary before selecting or breeding plant species that will compose the greenbelt which functions in the improvement of air quality.*

Two factors which dictate plant growth are climate and soil. The degree of the protective effect of greenbelts is dependent on the amount of growth which is expressed by the vegetation, particularly in terms of height. Vegetative buffers which attain maximum height are generally more efficient in the role of sinks for air pollutants. Since climate and soil greatly influence whether vigorous growth will occur, both of these elements of the environment should be analyzed before determining the most suitable woody plants for a greenbelt. Plant species that are unable to adapt adequately to both the climate and soil will not sufficiently remove airborne pollutants.

Poor soil conditions will cause harmful stresses on even the most tolerant plant species. To alleviate the primary detrimental effects produced by poor soil in terms of plant growth is to relieve any deficiencies in water or nutrients and also, to provide proper aeration of the soil. By taking such measures, the general health of the vegetation may improve and the plants may be capable of more than merely existing; active growth may actually occur. Vigorous growth requires maximum stomatal aperture which ensures optimum uptake of atmospheric pollutants.

However, the energy expended in improving the soil will not produce satisfactory results if the plants are not growing in their preferred habitats. Plants surviving in a suboptimum environment will not significantly

participate in the removal of air pollutants. Also, the metabolic cost of adapting to less than favorable conditions may cause the plants to become more susceptible to disease and drought.

2. Selection or breeding of plant species that can withstand the adverse effects of the air pollutants that are present in their potential habitats is essential to contribute to the health of the greenbelt.

A woody plant that is extremely sensitive to one or a combination of pollutants will be a poor sink due to irreversible damage and even death of that particular plant. The degree of resistance of plants is correlated with the type and the concentration of the pollutant. The Plant Species Sensitivity List, which is located in Volume I and also, in Volume II, this Volume, as Appendix B, provides lists of plant species which are either relatively tolerant or sensitive to some of the primary types of air pollutants: fluorine, hydrogen chloride, nitrogen dioxide, ozone, PAN, particulates - smoke, sulfur dioxide. Since vegetation is usually exposed to a combination of pollutants instead of a single pollutant, lists of relatively resistant and sensitive plants for general pollution also have been developed.

3. Removal rates of air pollutants by vegetation and soil types should be considered in attempting to increase the efficiency of roadside forests and buffers as air pollutant sinks.

General estimates of the removal and emission rates of air pollutants by vegetation and soil types are given in Volume I. These values are arranged in tables headed by the pollutants ammonia, carbon monoxide, fluorine, hydrocarbons, nitrogen oxides, ozone, PAN, particulates, lead, and sulfur dioxide. By reading the literature about air pollution and natural elements and extracting the pertinent information from the research papers, the data was carefully evaluated and limitations of the presently available information were observed.

These limitations of the literature are discussed in the introduction of Section III in Volume I. Therefore, it is essential to recognize that the removal and emission rates are general estimations which are based on information that is very limited.

However, the tables provide some guidelines for mitigating air pollution problems by the utilization of soil and vegetation. A utility factor of 1,2 or 3 was assigned to each given value. The utility factor of 1 means that the research team attempted to measure field conditions and the methods for obtaining the data seemed appropriate. Results that were less applicable to the tables were given utility factors of 2 and the least applicable data was designated as being 3.

Table III-11 on page III-40 of Volume I is a summary table which was developed by selectively averaging the sink and emission factors for each pollutant. The purpose of this table was to find figures which roughly approximate the data obtained from the reviewed publications.

The tables of the section on Sink and Emission Factors for Natural Elements are tools for landscape design in terms of natural removal of air pollution. By referring to these tables and the Plant Species Sensitivity List, the effectiveness of a particular natural element for removing a specific pollutant may be estimated. Also, Table III-11 of Volume I, which provides very rough estimates for absorbing and emitting specific pollutants by vegetation and soil, displays much larger concepts of the effectiveness of natural elements in removing airborne contaminants.

4. Plants that have certain morphological characteristics are relatively more efficient particle and gas receptors.

In addition to selecting or breeding tree and shrub species that are relatively resistant to the types and concentrations of air pollutants present in their potential habitats, the morphological aspects of these species should also be considered. Certain physical characteristics that are especially efficient pollutant receptors have been identified in the literature, particularly

in Smith and Dochinger (1975). These characteristics are listed below and species with several of the features should be selected or bred over species that lack most of the advantageous characteristics.

a. Petioles are effective in the retention of particles and there is a correlation between the length and the collection capacity of the petiole.

b. Surface hairiness on leaves, twigs, petioles, etc. trap the particles more readily than the plant parts that are smooth in texture.

c. Generally, more particulates are deposited on small diameter branches and twigs as compared to large diameter branches and twigs.

d. Maximum stomatal capacity for absorption is a significant characteristic in plants potentially used in greenbelts since the primary mechanisms for removal of gaseous pollutants are by stomatal processes.

e. Species having maximum resistance to stomatal closure caused by environmental variables are preferred for removal of airborne pollutants than species in which stomatal closure occurs due to slight changes in temperature, moisture, light, or air pollution.

f. Plants that more readily metabolize substances extracted from the atmosphere may be considerably more suitable for greenbelts than plants that lack the capacity to utilize contaminated air as a partial source for essential nutrients.

5. *Multi-layered stratification is a characteristic of an efficient roadside forest for absorption and adsorption of air pollutants.*

A stratified forest, formed by developing the understory and ground cover as well as the upper tree layer, is a more effective receptor of air contaminants than an unstratified forest. However, if the strata of a forest, particularly at the edge, grow to such an extent that dense overlapping results, this "natural wall" may drastically hinder the passage of the wind through the forest and the exposure of the air pollutants to the vegetation is reduced. Therefore, the degree of effectiveness of a forest in removing air pollutants is partially dependent on the permeability of that forest. As the diagram on the next page illustrates, moderate permeability is the most favorable condition of a forest

since more vegetative surface area comes in contact with the flow of air than in a forest of maximum permeability and also, less wind deflection occurs than in a forest of minimum permeability.

FIGURE II-10
DENSITY OF BUFFER RELATED TO REDUCTION OF WIND VELOCITY



6 *There are other advantages of maintaining a multi-layered forest in addition to improving air quality.*

Trees are considered to be efficient filters of airborne pollutants because of their large dimensions. Some trees are capable of growing to substantial heights which increases the protective effect of greenbelts. Another important aspect of most trees in terms of the uptake of pollutants is their high surface area to volume ratio.

Although the large dimensions of trees provide greater vegetative surface for absorption and adsorption than other life forms, a forest with a poorly developed understory is less efficient in the removal of pollutants than a stratified forest. Therefore, developing the understory (primarily by opening the tree canopy which will stimulate the growth of the lower plants or by planting shade tolerant species) will increase the effectiveness of the forest.

Also, a stratified forest is valuable in the abatement of noise. Sound may either be absorbed by the twigs and foliage of shrubs or reflected upward by trees. A forest composed of primarily mature trees located near a source of noise pollution, such as adjacent to a highway, is incapable of transferring the sound upward, away from the hearer.

In addition to their role in noise abatement, shrubs can improve the habitat. The leaf matter produced by shrubs as well as trees enhances soil moisture and maintains the populations of the soil decomposer organisms which are essential components of nutrient recycling. Also, wildlife require shrubs

and other understory plants for shelter and food. Many songbirds utilize the understory vegetation for nesting and protection from predators.

7. The use of mixed plantings for reducing levels of pollution should certainly include trees and shrubs which contain deciduous and coniferous plants.

To ensure continuous filtering action, conifers should be planted with the deciduous trees. Compared to deciduous woody plants, conifers possess a longer time of foliage retention which provides a correspondingly greater opportunity for pollutant removal. Another morphological characteristic of conifers that promotes the removal of air pollutants is the high surface area to volume ratio. Both the persistent foliage and the consistently high surface to volume ratio of conifers become increasingly important in urban areas, and possibly along highways, as the winter progresses. Urban areas generally have higher concentrations of atmospheric particulates and gases in the winter as compared to the ambient pollutant concentrations of the summer.

Although conifers may be preferred over deciduous species in terms of absorption and adsorption of pollutants, coniferous species are generally more vulnerable to the adverse effects of atmospheric pollutants than most deciduous trees due to the greater concentrations of pollutants in the foliage of the conifers. Since deciduous trees lose their leaves after the termination of each growing season, the pollutants have less time to accumulate in the living deciduous leaves as opposed to coniferous foliage. In other words, deciduous species have a more rapid mechanism for the disposal of lethal levels of pollutants in their foliage than conifers. That is seasonal leaf senescence.

As a result, mixed plantings of deciduous and coniferous species are recommended since the deciduous trees will protect the conifers by extracting a substantial amount of airborne contaminants present in an area which will lower the pollutant load in the vicinity of the conifers.

8. *A high number of plant species with varying ages is important for developing healthy, efficient greenbelts.*

Many urban plantings are even-aged monocultures in which regeneration is negligible. Since understory young trees are virtually absent, the older, mature trees as they die or become diseased cannot be replaced. Also, in these situations of extremely low plant diversity, the dominant tree species is more susceptible to disease. Two recommendations for improving such urban greenbelts are to increase the diversity index, especially for tree species, and to maintain representatives of all age groups.

9. *Moderate density is the optimum density for the removal of air pollutants.*

Moderate density is achieved when more surface area of the vegetation is exposed to the flow of air through a greenbelt than in a low density condition and when less deflection of the wind occurs than in a high density condition.

10. *There are numerous factors influencing the determination of the minimum width of greenbelts necessary for maximum dispersion of atmospheric pollutants.*

The minimum width of a particular greenbelt which causes maximum dispersion of air pollutants is dependent on numerous factors in addition to that of the distance from the source to the receptor. The large scale circulation of the atmosphere determines the general direction of pollutant transport and deviations may be caused by local breezes, topographical features of a specific area, varying densities of air masses, etc.

Warren (1973) estimates that the minimum width of greenbelts is 100 to 120 meters in which maximum dispersion of airborne pollutants results.

11. *The speed of the wind passing through or over a greenbelt may be influenced by the dimensions and density of that particular greenbelt.*

Decreasing the wind speed by natural barriers allows the ambient substances to settle out onto the vegetation and soil by gravitation. The extent of wind disruption resulting in the deposition of particulates is partly dependent on the height, shape, and permeability of forests and buffers.

The reduction of wind velocity by a greenbelt is correlated to tree height. According to Geiger (1950), the wind speed is reduced 10% within a distance equal to three times the tree height on the windward side and twenty times the tree height on the leeward side. The diagram that follows may illustrate this phenomenon more clearly.

FIGURE II-11

EXTENT OF INFLUENCE OF WINDBREAK AND SHELTERBELT PLANTINGS

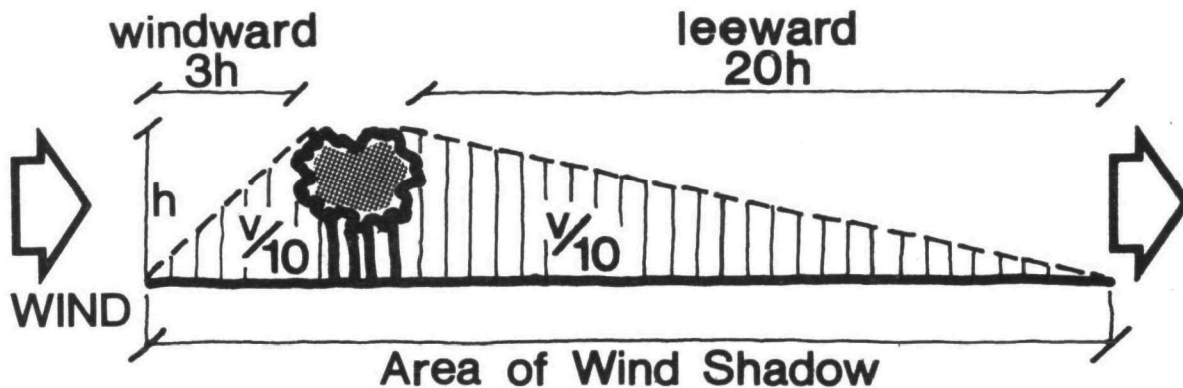

V=Velocity
h=Unit of Length

Wind reduction occurs in the lee of greenbelts regardless of the degree of permeability; however, the location of the area of greatest wind reduction is a function of permeability. Immediately behind a dense greenbelt is the area of greatest wind reduction whereas the position of greatest wind reduction is further away from the boundary of a greenbelt of medium density.

The extent of wind reduction caused by greenbelts of medium density is greater than that caused by dense greenbelts. Also, a natural barrier of medium permeability with openings distributed evenly throughout the greenbelt prevents turbulence in the lee to a larger extent than an impermeable forest or buffer does.

Blenk and Trienes (1955) created models of impermeable plant belts which varied in shape. The rounded model that was devoid of any sharp edges was the least efficient in wind reduction whereas the model that exerted the greatest effect in wind reduction was right-angular in cross section. The diagram on the following page displays three of the models and their differing degrees of wind reduction.

Buffers which are permeable to wind are more efficient in reducing wind velocity than those buffers which are not as permeable.

FIGURE II-12

FORM OF BUFFER IS RELATED TO REDUCTION OF WIND VELOCITY.

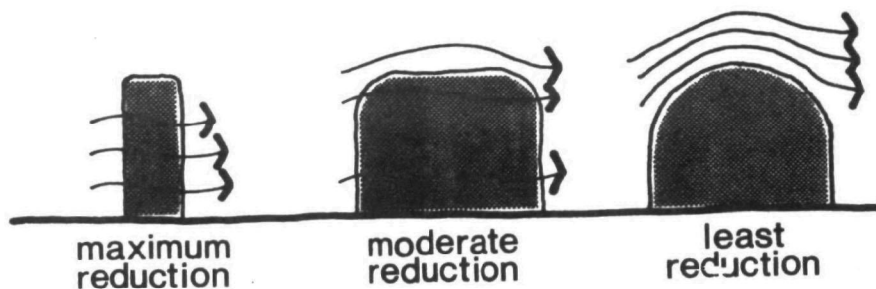

In conclusion, during the process of developing plant belts, there should be some consideration of the conditions influencing wind reduction. The dimensions and permeability of a greenbelt are factors that cause disruption of the air flow which may lower the velocity to such an extent that pollutants filter out of the air onto the vegetation and soil surface.

12. *Increasing the sink potentials of roadside forests and buffers can be accomplished by expanding the length and increasing the diversity of the edge.*

According to Warren (1973), the initial 65 to 85 feet from the edge of a forest can reduce the concentration of particulates by as much as 50%. By increasing the diversity and thereby, increasing the density of the plant species within the first 65 to 85 feet of the greenbelt, the rate of removal of airborne particulates by vegetation composing the edge can be enhanced. The following diagram shows the relative efficiency of the first 65 to 85 feet of a forest for depositing particulates.

Another method for increasing the sink potential of buffers or roadside forests is by clearing to create additional edge. (Figure II-16 on page II-55 of the Design Alternatives demonstrates a pattern for clearing the vegetation to increase the length of edge).

FIGURE II-13

INCREASED DIVERSITY WITHIN EDGE CONDITION MAXIMIZES SINK POTENTIAL

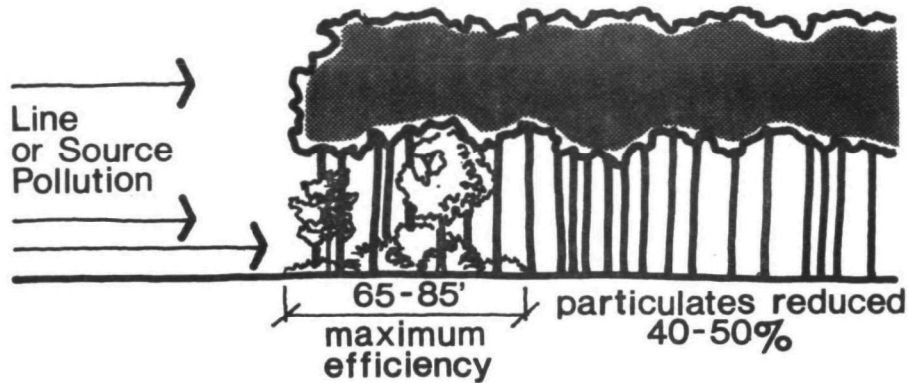

13. *Thermal chimneys within the forest aid in increasing air circulation which causes more exposure of polluted air to the upper leaf surfaces in the interior canopies.*

The installation of thermal chimneys in the forest will allow the airborne particles trapped below the forest canopy to become dispersed in the crowns of the trees since the openings in the canopy will promote the movement of air that will escape above the forest. The diagram below illustrates how a thermal chimney can increase the ventilation of a forest.

FIGURE II-14

CREATION OF THERMAL CHIMNEYS FOR VENTILATION OF FORESTS AND BUFFERS

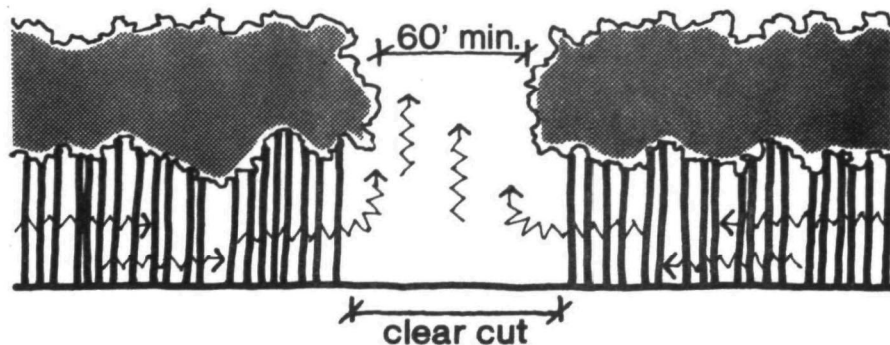

14. Poor ventilation along highways may be caused by steep banks or dense buffers and this adverse condition can be partially removed by alleviating the effect of the natural and artificial barriers.

Steep roadside banks promote localized areas of high carbon monoxide concentrations, especially in areas of high traffic volumes. If the flow of air containing carbon monoxide is not obstructed, the amount of carbon monoxide fallout corresponds to increasing distance from the highway. The dispersion characteristics of carbon monoxide in situations in which the highway is bordered on each side by steep banks are that the maximum concentrations occur in the vicinity of the impermeable walls and the minimum concentrations of carbon monoxide are found at the center of the highway. The peak values of carbon monoxide also occur along the wall in a situation where there is a barrier along one side of the roadway and an open space area on the opposite side. If the sides of the road are open to ventilation, the center of the highway will have the highest content of carbon monoxide while the concentration of carbon monoxide will decrease in both directions. The diagram below displays the three dispersion patterns of carbon monoxide due to the presence or absence of barriers adjacent to the highway.

FIGURE II-15
CO CONCENTRATIONS ADJACENT TO ROADS

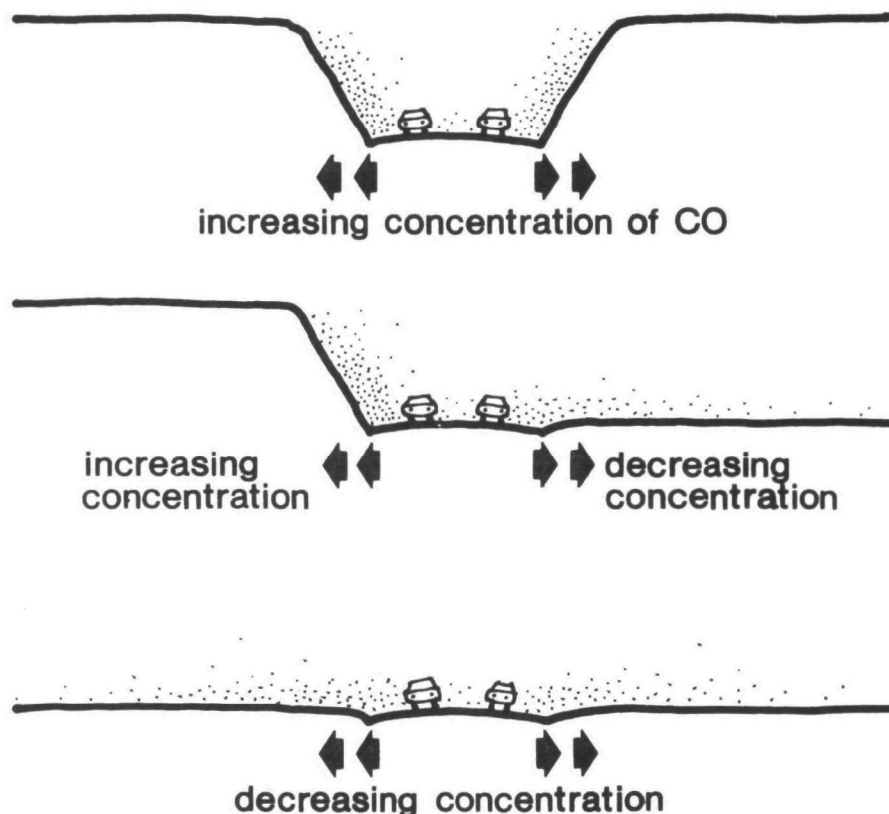

Also, Figure II-22 on page II-58 of the Design Alternatives shows a method for increasing ventilation of a roadway originally bordered by steep banks.

In some instances, dense buffers may hinder adequate ventilation and high concentrations of carbon monoxide may occur. By cutting through the vegetation, the carbon monoxide concentration values will be reduced due to the increased dispersion of this pollutant caused by more ventilation. The technique of increasing buffer ventilation is illustrated in Figure II-17 on page II-55 of the Design Alternatives.

15. *Safety measures that should be included in the design of greenbelts near highways or in urban areas.*

The minimum distance from the edge of the pavement for safely planting trees growing to a diameter breast height (d.b.h.) of 4 inches or larger is 30 feet and for smaller trees is 20 feet.

Persons vigorously exercising near areas of high traffic volumes may be jeopardizing their health. To avoid some of the potentially dangerous effects, it is recommended to establish a buffer which separates areas of high traffic volumes from active recreation sites. This buffer should be at least 65 to 80 feet wide since the percentage of particulate removal as indicated by Warren (1973) is 40 to 50%. Figure II-23 of the Design Alternatives on page II-58 shows the protection of a recreational facility by the use of a buffer that is at least 65 feet wide.

Width is not by any means the only consideration for developing a vegetative barrier that effectively shields actively exercising individuals from the potential dangers of air contaminants emitted by motor vehicles. The buffer should be high enough to hinder the prevailing winds coming from the polluting source. Also, a barrier of high density may cause an adverse effect since the wind will be unable to sufficiently penetrate the thick clumps of vegetation and the deflected current may bring the harmful pollutants in contact with the people that are to be protected.

2. Design Configurations.

The preceding text was a summary primarily concerning the methods for increasing the sink potential of greenbelts. The information can also be found in the Literature Search Findings of Volume II, the Plant Species Sensitivity List in the appendix of Volume II, and the Sink and Emission Factors for Natural Elements of Volume I. This material provided the guidelines for developing the design alternatives which follow.

Each of the designs illustrate ways for increasing the removal rate of atmospheric pollutants by vegetation resulting in the improvement of air quality. Some of the designs for enhancing the sink potential of natural elements involve compiling plants into hedgerows and the most effective arrangement of these hedgerows depends on the direction of the prevailing wind, location of the polluting source, variations in topography, etc. By correctly placing the hedgerows, the wind may be disrupted to such an extent that the airborne particulates settle out onto the vegetation and soil.

In situations where the dense buffers along highways cause inadequate ventilation to such a point that high localized accumulations of carbon monoxide occur, one of the solutions is to divide the vegetation into hedgerows. The design on page II-55 (Figure II-17) shows that gaps in the dense vegetation will channel the polluted air away from the highway. Also, by cutting through the thick vegetation, the edge length will be increased.

Another method for enhancing the edge effect is demonstrated in Figure II-16 on page II-55 which involves cutting gaps at least 65 feet back from the original edge of the buffer. The additional edge will increase the deposition of pollutants by the greenbelt.

The rest of the designs range from improving the sink capacity of a grassy median to ensuring the adequate protection of individuals vigorously exercising in the vicinity of a heavily traveled highway. All of the designs have at least one common characteristic which is increasing the efficiency of highway buffers in extracting harmful air pollutants emitted by motor vehicles.

Increasing Buffer Edges

In cases where buffers or road-side forest cover exist, the sink potential of the vegetation can be increased by clearing to create additional edges. As the first 65 to 85 feet of forest is the most valuable as a receptor for pollutants, this technique will greatly increase the efficiency of the existing buffer, especially for the removal of particulates.

FIGURE II-16

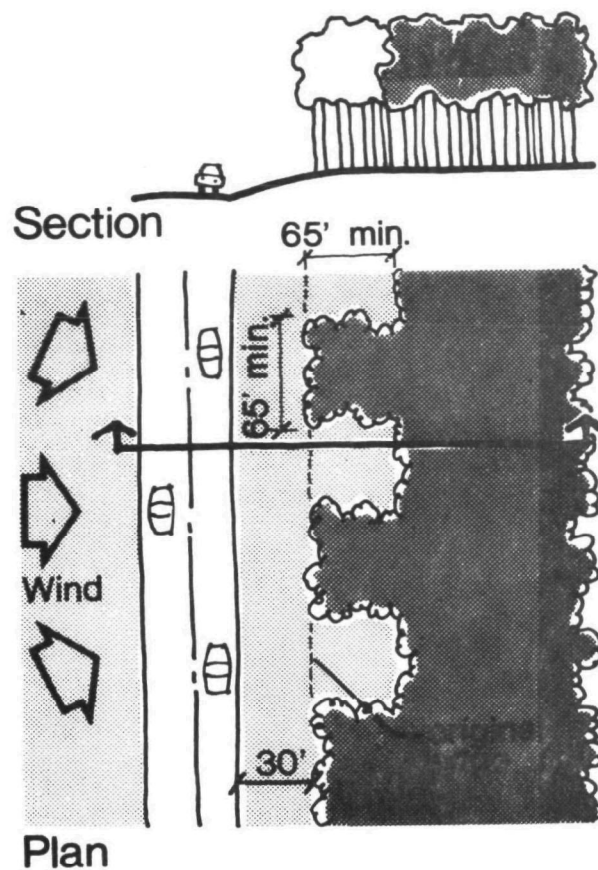

Increasing Buffer Ventilation

Dense buffers along high volume arterials can create high concentrations of CO (as shown in Figure II-15). To reduce CO concentration, cuts through the vegetation will allow ventilation of the roadway and dispersion of CO. This technique also provides increased forest edge thus aiding in the removal of particulates as well as soluble gases.

FIGURE II-17

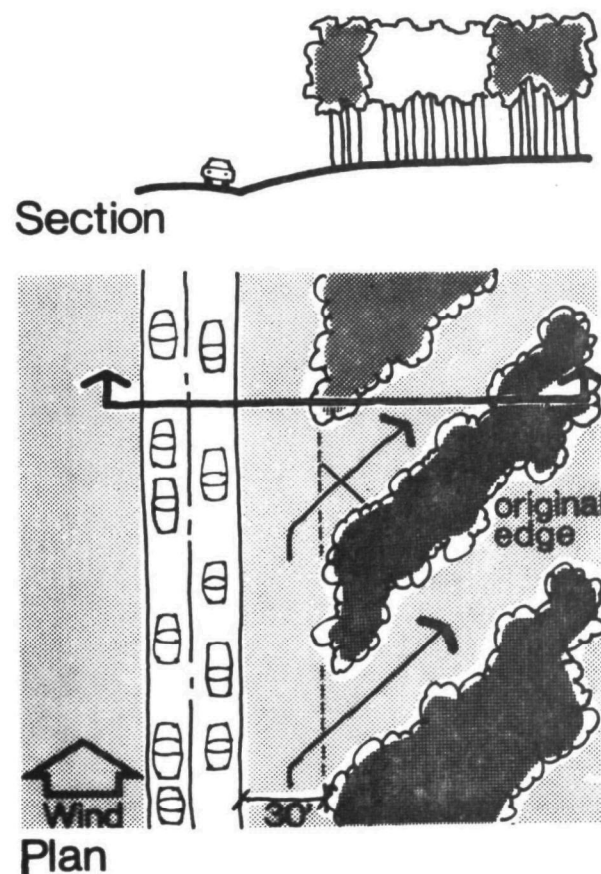

Chevron Hedgerow

The alignment of discontinuous hedgerows in a chevron pattern will provide a large area of leaf surface contact for adsorption of particulates and absorption of soluble gases. The gaps between the plantings provide adequate ventilation for CO dispersion. The belts should be oriented at a 45 degree angle to the road; in the direction of the prevailing winds. A 30' safety setback should be maintained.

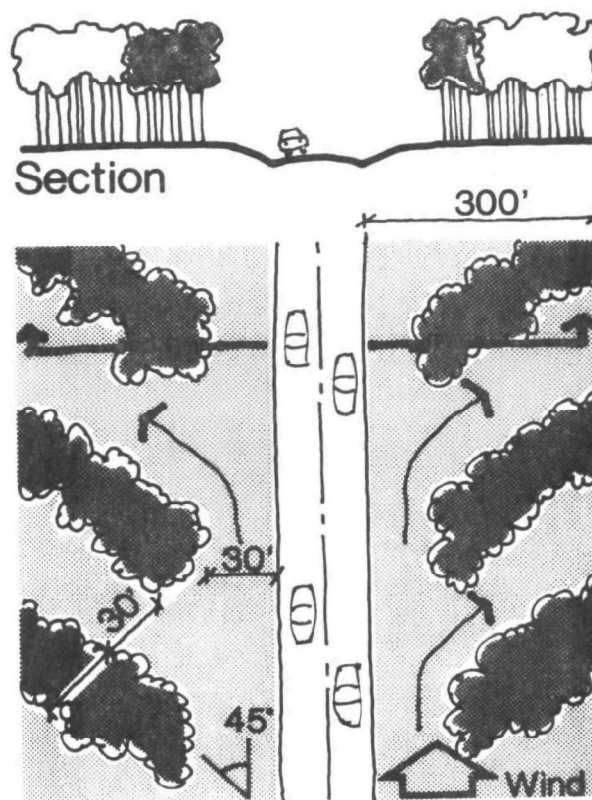

FIGURE II-18 Plan

Parallel Hedgerow

In situations where existing woodlots or buffers are parallel to the road and relatively perpendicular to the prevailing winds, the placement of a discontinuous hedgerow windward of the edge of vegetation, as shown, will increase wind turbulence and decrease wind speed thereby causing particulates to drop out. The polluted air is forced closer to the soil surface where CO can be metabolized by soil organisms. The increased exposure of leaf surfaces further reduces particulates and allows for the absorption of soluble gases. Openings in the hedgerows are located at intervals to limit the buildup of CO. A 30' safety setback should be maintained.

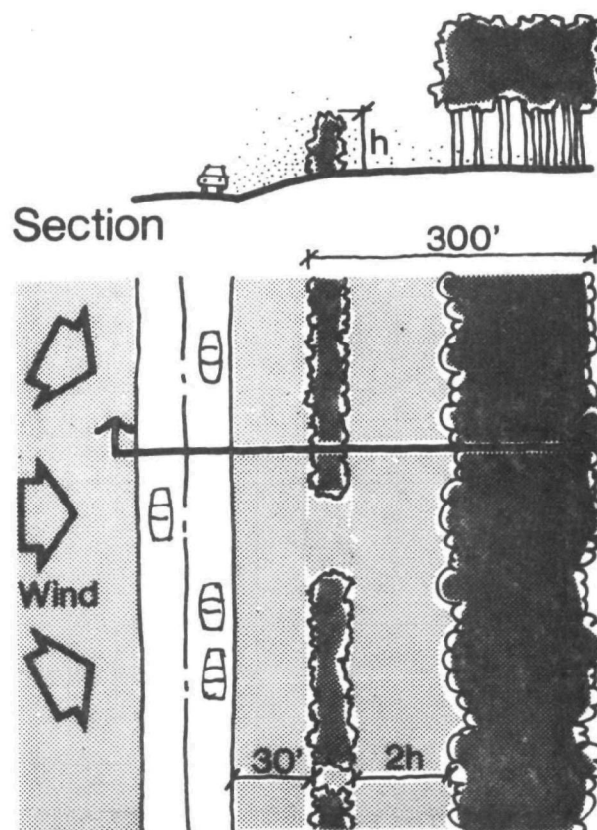

FIGURE II-19

Plan

Multiple Hedgerow

In areas of sloping terrain or where roads are located on fill, an arrangement of multiple hedgerows, parallel to the road and perpendicular to the prevailing winds are recommended. This arrangement provides a maximum disruption of the wind which results in the deposition of particulates as well as maximum exposure of polluted air to leaf and soil surface which reduces CO and soluble gases. The increased spacing between rows will increase turbulence thereby decreasing particulates.

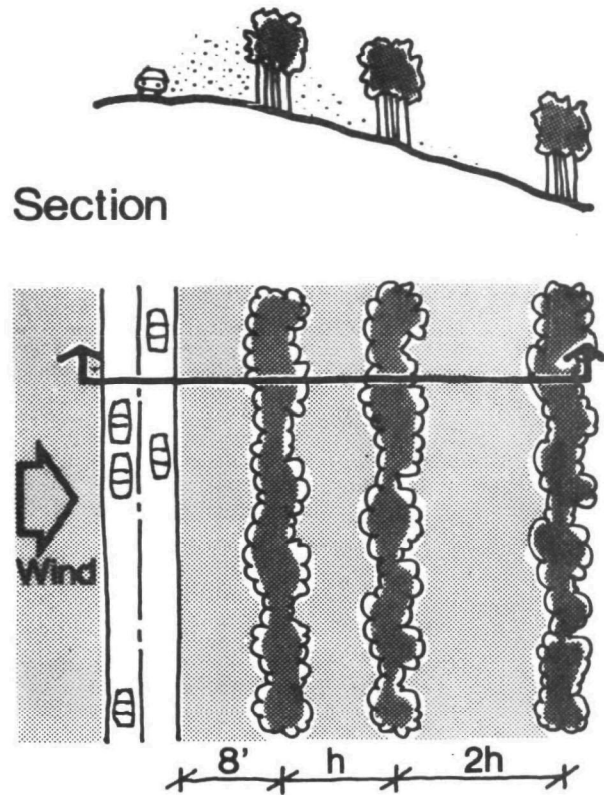

FIGURE II-20 Plan

Managed Natural Buffer

Management of rights of way along roads to stimulate natural plant succession to occur is a useful technique for providing buffers. The development of old fields and forests, or woodlot conditions, will provide increased pollutant sink potential by first reducing wind speed through increased turbulence and by exposure of leaf and twig surface for adsorption of particulates and absorption of soluble gases.

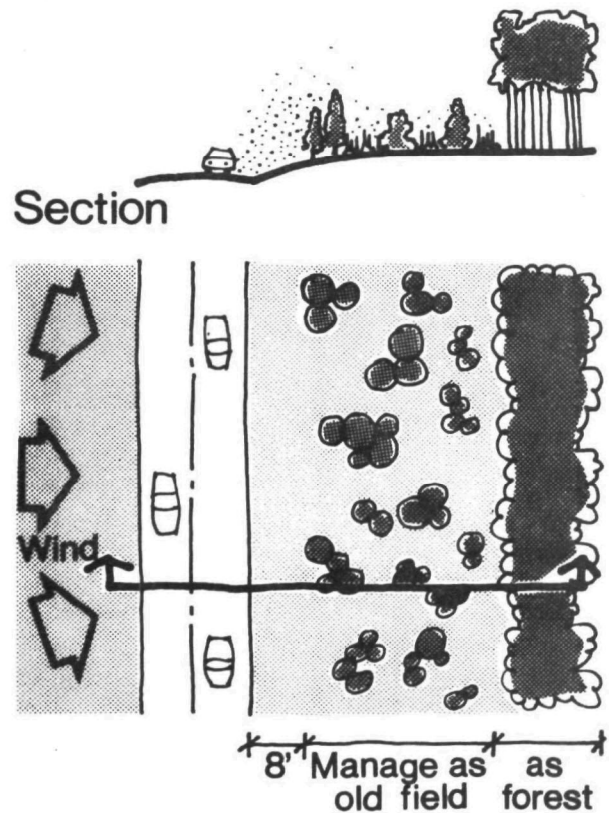

FIGURE II-21 Plan

Ventilating Roadway Cuts

Steep roadside cuts become areas of high concentrations of CO, particularly in areas of high traffic volume (as illustrated in Figure II-15). Cutting back steep banks to more shallow slopes provides better air ventilation to reduce CO levels. Covering the exposed banks with legumes (such as crown vetch) provides soil stability as well as increased sink potential. It also may improve the visual quality of the road experience.

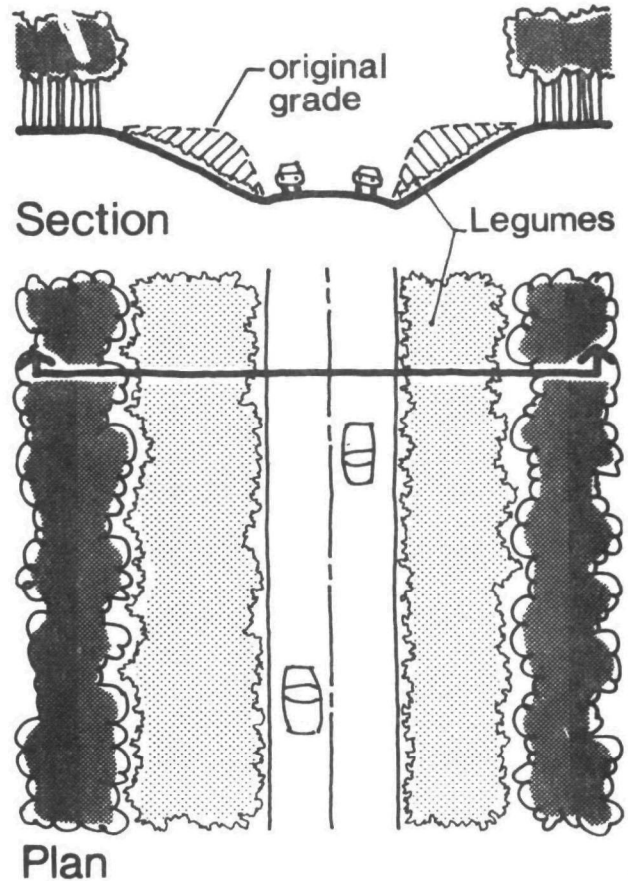

FIGURE II-22

Recreation Facility Setback

Because of the potential dangers of vigorous exercise adjacent to high traffic volumes, it is recommended that active recreation facilities be located at least 65 feet behind the buffer edge.

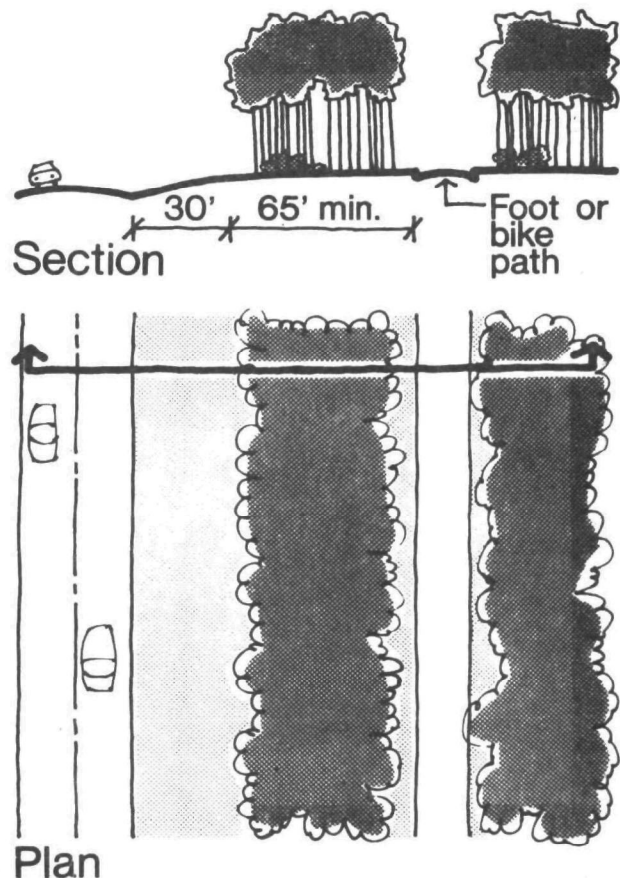

FIGURE II-23

Planting Existing Medians

Roads with medians now planted in maintained grass could greatly reduce the level of pollution by installing a moderately dense mixed planting of trees and shrubs, both evergreen and deciduous. This would also reduce headlight glare and ambient noise levels.



Section

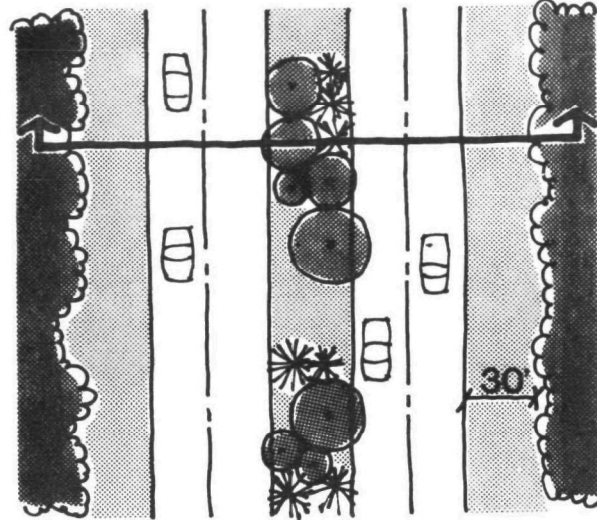

Plan

FIGURE II-24

III. REGIONAL OPEN SPACE

This section of the study is concerned with the regional control of pollutants. Initially, a review of pollutants from both natural and anthropogenic sources is presented including sulfur compounds, nitrogen compounds, carbon monoxide, organic gases (eg. hydrocarbons), asbestos, lead and fluorocarbons. Next, removal processes are discussed to illustrate how regional pollutants interact with the environment. Finally, the literature is reviewed on using open spaces to reduce regional pollutants and several planning concepts are presented.

A. POLLUTANT IDENTIFICATION

Regional scale air pollution problems are generally associated with point sources of pollutants. However, there are numerous natural sources of air pollutants that can be the major cause or that can contribute to regional pollution problems. Ultimately, all air pollutants are from natural sources. However most problems occur when the natural compound is transformed by man into an air polluting compound. As an example, the major source of air polluting sulfur is hydrogen sulfide (H_2S) which, in itself, is not injurious. However, H_2S is rapidly oxidized to sulfur dioxide (SO_2), sulfur trioxide (SO_3), and sulfuric acid (H_2SO_4) which are all considered air pollutants. In the combustion process, SO_2 is produced from elemental sulfur. It is also important to recognize that while sulfur in the form of SO_2 may be considered an air pollutant in industrial areas, crops of various kinds are dependent upon atmospheric sources for a large proportion of their sulfur needs.

Table III-1 is a summary of the annual emissions of various atmospheric pollutants. Careful attention should be directed to the proportion of natural emissions by the anthropogenic sources.

TABLE III-1

SUMMARY OF SOURCES & ANNUAL EMISSIONS
OF ATMOSPHERIC POLLUTANTS

POLLUTANT	MAJOR SOURCE		ESTIMATED EMISSION KILOGRAM	
	ANTHROPOGENIC	NATURAL	ANTHROPOGENIC	NATURAL
SO ₂	combustion of coal and oil	volcanoes	65 x 10 ⁹	2 x 10 ⁹
H ₂ S	chemical processes; sewage treatment	volcanoes; biological decay	3 x 10 ⁹	100 x 10 ⁹
N ₂ O	none	biological decay	none	590 x 10 ⁹
NO	combustion	bacterial action in soil; photo-dissociation of N ₂ O and NO ₂	53 x 10 ⁹ combined with NO ₂	768 x 10 ⁹
NO ₂	combustion	bacterial action in soil; oxidation of NO		
NH ₃	coal burning; fertilizer; waste treatment	biological decay	4 x 10 ⁹	170 x 10 ⁹
CO	auto exhaust; and other combustion processes	oxidation of methane; photodissociation of CO ₂ ; forest fires; oceans	360 x 10 ⁹	3000 x 10 ⁹ (?)
O ₃	none	tropospheric reactions and transport from stratosphere	----	(?)
non-reactive hydrocarbons	auto exhaust; combustion of oil	biological processes in swamps	70 x 10 ⁹	300 x 10 ⁹
reactive hydrocarbons	auto exhaust; combustion of oil	biological processes in forests	27 x 10 ⁹	175 x 10 ⁹
asbestos	insulation, shipbuilding, brake linings	mining	(?)	(?)
lead	auto exhaust, combustion of coal, refuse & sludge incineration	mining	143 x 10 ⁶	(?)
fluorocarbons	aluminum, fertilizer, fuel combustion, steel industries		(?)	(?)

SOURCE: Rasmussen, et al, 1974
(Adapted by COMSIS CORP.1976)

1. Source Emissions.

a. Sulfur Compounds

The element sulfur (S) occurs in a variety of stable compounds that are derived from both the natural environment and from air pollution sources. Among the more common compounds are: hydrogen sulfide (H_2S), sulfur dioxide (SO_2), sulfur trioxide (SO_3) and sulfuric acid (H_2SO_4). H_2S has not, in itself, been considered a pollutant. However, it oxidizes rapidly to SO_2 and further to SO_3 and H_2SO_4 . This chemical reaction is represented in Figure III-1 (Kellogg, et al., 1972).

FIGURE III-1

SCHMATIC REPRESENTATION OF THE CHEMICAL PROCESSES INVOLVING ENVIRONMENTAL SULFUR, WITH INDICATIONS OF THE MEAN LIFETIME OF EACH COMPOUND IN THE LOWER ATMOSPHERE

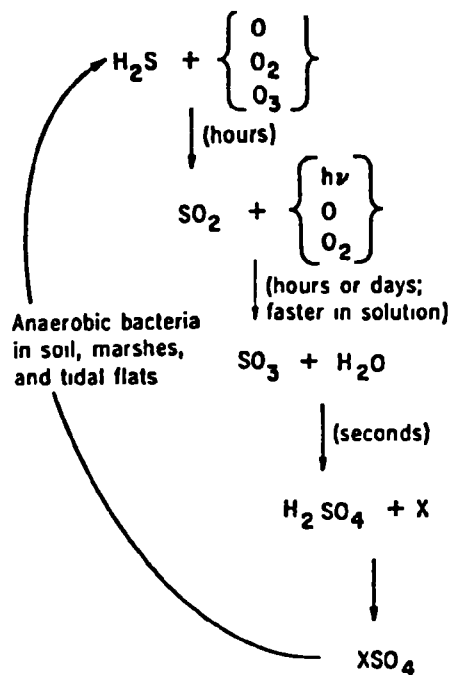

Robinson & Robbins, (1968), have suggested that on an annual basis, 220×10^6 tons of sulfur are discharged into the atmosphere with about one third coming from air pollution sources, mostly in the form of SO_2 , and the rest from natural processes. Kellogg, et al., (1972), estimated that man is contributing about one half as much as nature, but that by AD 2000 he will be contributing about

as much, and in the Northern Atmosphere alone he will more than match the natural generation rate.

Most of the S being emitted by natural sources is in the form of H_2S . It is estimated that H_2S represents one half of the total sulfur now being released to the atmosphere, 100×10^6 tons (Robinson & Robbins, 1968). The primary sources for this natural emission are decaying vegetation in swamps, bogs and other land areas. Estimates of the annual emissions from natural sources vary. Erikson, (1960), suggests decaying vegetation is the source of 112×10^9 kg H_2S per year. Robinson & Robbins, (1968), estimate 70×10^9 kg per year.

The oceans have also been suggested as a source of H_2S . Erikson, (1960), speculated that the annual H_2S emission from the oceans is 202×10^6 tons. Robinson & Robbins, (1968), suggest that it generates 10^6 tons. Kellogg, et al., (1972), dispute both these figures saying that undoubtedly some H_2S is liberated from tidal flats, but probably very little is emitted from the open ocean. Active volcanoes are another source of H_2S , however, no estimates are known of the amount of H_2S emitted. Only small quantities of H_2S are emitted from anthropogenic sources.

Most of the SO_2 and SO_3 compounds in the air are from anthropogenic sources and their contribution to pollution problems can be linked with industrial growth. A good example of this is illustrated by the fact that in 1940 there was an estimated 78×10^9 kg/yr of SO_2 emitted on a global basis (Katz, 1956). Robinson & Robbins, (1968), in Rasmussen et al., (1974), estimated anthropogenic activity in 1968 as the source of 146×10^9 kg SO_2 each year, 70% of which they estimated was due to the combustion of coal, 16% from the combustion of petroleum products, primarily residual fuel oil. The remaining emissions resulted from refining operation (4%) and non-ferrous smelting (10%). Kellogg et al.,(1972), believes an estimate of about 100×10^9 kg SO_2 per year would be reasonable for the same period.

In terms of regional areas, Prince and Russ, (1972), have estimated that SO_2 emissions in Britain have increased from 9.1 to 11.4 mg km^{-2} from 1950 to 1970, an increase of 2.3 mg km^{-2} in 20 years. On the same basis, they estimated emissions in the United States were approaching 2 mg km^{-2} in 1970 and are expected to reach 3.3 mg km^{-2} by 1980 if the fossil fuel becomes available and no steps are taken to reduce emissions.

Most of the natural sources of SO_2 is from volcanic activity. Kellogg, et al., (1972), estimated that the quantity released by volcanoes is about 1.5×10^9 kg/yr. Stoiber and Jepsen (1973), estimated annual volcanic emissions of SO_2 to be 15×10^9 kg. Rasmussen, et al., (1974), determined an average to be 2.0×10^9 kg/yr.

b. Carbon Monoxide

Carbon monoxide (CO), is the most abundant and widely distributed air pollutant found in the atmosphere. CO emissions generally exceed that of all other pollutants combined (excluding carbon dioxide CO_2) particularly in urban atmospheres. Practically all of the CO formed is due to man's technology with more than 90% of the total CO emitted from combustion of fossil fuels being derived from motor vehicle emissions (Jaffe, 1973).

Rasmussen, et al., (1974), has written an excellent review of natural and anthropogenic sources of CO. The following is a synopsis of that material.

By far the largest single anthropogenic source of CO is motor vehicle exhaust. Jaffe (1973), estimated that of a total anthropogenic CO emission source in the United States in 1970 of 132.6×10^9 kg, 96.9×10^9 kg resulted from the burning of gasoline by motor vehicles alone. Other significant contributions to this man-made CO burden are from solid waste disposal (6.5×10^9 kg), industrial process loss (10.3×10^9 kg) and agricultural burning (12.5×10^9 kg). On a global basis, for 1970 Jaffe(1973), estimated CO emissions to be approximately 360×10^9 kg. (See Figure III-2).

The most widely recognized natural source of CO is forest fires which have been estimated as releasing 11×10^9 kg CO into the atmosphere each year (Robinson & Robbins, 1968). Minor amounts of CO have been found to be released from volcanoes and marshes (Flury and Zernik, 1931). CO can also be formed during electrical storms (White, 1932), and by the photo dissociation of CO_2 in the upper atmosphere (Bates and Witherspoon, 1952). Calvert, et al., (1972) has suggested the photo dissociation of formaldehyde as a possible source of CO and recently, Swinnerton, et al., (1971) found CO to be present in rain water in high concentrations.

TABLE III-2
ESTIMATED CARBON MONOXIDE EMISSION SOURCES
IN THE UNITED STATES IN 1970

Source Category	Emissions, 10 ⁶ metric tons
<i>Man-Made Sources</i>	
Fuel combustion in stationary sources	0.7
Steam and electrical	0.1
Industrial	0.1
Commercial and institutional	0.2
Residential	0.3
Transportation, mobile sources	100.6
Motor vehicles, gasoline	86.9
Motor vehicles, diesel	0.7
Railroads	0.1
Watercraft	1.5
Aircraft	2.7
Other nonhighway use	8.6
Solid waste disposal	6.5
Municipal incineration	0.3
On-site incineration	0.4
Open burning	4.1
Conical burning	1.8
Industrial process losses	70.3
Miscellaneous	14.4
Structural fires	0.2
Coal refuse burning	0.3
Agricultural burning	12.5
Prescribed burning	1.4
Total all man-made categories	132.6
<i>Natural Sources</i>	
Forest fires (wild)	2.2

Source: Jaffe, 1973

The ocean was first suggested as a major source of CO by Swinnerton, et al., (1970), who estimated that it can produce up to 220×10^9 kg each year. Robinson & Moser, (1971) suggested that plants could indirectly be the source of about 54×10^9 kg CO by the oxidation of released terpenes. Finally, McConnell, et al., (1971), suggested that approximately 900×10^9 kg CO are produced each year by the oxidation of methane.

Rasmussen, et al., (1974), also points out that Stevens et al., (1972) believes that natural sources of CO could yield about 10 times more CO than all anthropogenic sources in the northern hemisphere. Using that conclusion they estimate the total CO natural emissions to be 3000×10^9 kg per year.

On a regional basis, the emissions from anthropogenic sources far exceed any natural sources. The concentration of this pollutant is well correlated with man's activity and predominantly with the flow of vehicles on urban streets.

c. Nitrogen Oxides

The photochemical smog reaction involving nitrogen oxides, hydrocarbons and sunlight was identified in the early 1950s as the basic mechanism for the characteristic air pollution problem found in Los Angeles. Since that time photochemical smog has been identified as a significant air pollution factor in a number of large urban areas and has focused attention on the role of nitrogen oxides in urban air pollution (Robinson & Moser, 1971).

The main source of N_2O is believed to be the result of bacterial decomposition of other nitrogen compounds in the soil. On a global basis, the quantity of N_2O and NO produced naturally has been estimated as 786×10^6 tons by Robinson & Moser, (1971). Goody & Walshaw, (1953) estimated a global N_2O production rate of about 100×10^{12} kg/year and Robinson & Robbins (1968) suggested that soils produce about 59.2×10^{10} kg N_2O each year by biological action; and of this about 55.4×10^{10} kg (35.3×10^{10} kg N_2O-N) are reabsorbed by the soil and about 3.8×10^{10} kg N_2O (2.4×10^{10} kg N_2O_2-N) travels up to the stratosphere where it is destroyed. Schütz et al., (1970), cited in Rasmussen, et al., (1974) showed a flux of N_2O in the order of 10^{-8} g N_2O/m^2 sec, a level which, if maintained globally, would necessitate on N_2O cycle of about 70 years.

Nitrogen (N) is one of the most abundant elements constituting 78% of our atmosphere. There are a number of compounds of nitrogen, but only 2 are considered pollutants - nitric oxide (NO) and nitrogen dioxide (NO_2). Most other compounds are from anthropogenic sources. Another compound, nitrous oxide (N_2O), is predominantly from natural sources; however it oxidizes to NO_x compounds and therefore should be considered in air pollution calculations. In pollution estimates, the NO and NO_2 are usually considered together and expressed as NO_2 . It is estimated that natural emission of nitrogen as N_2O are approximately 15 times greater than pollutant emissions (768×10^9 kg NO_2 vs. 53×10^9 kg NO_2 , Robinson & Robbins, 1970).

Production rates of NO and NO_2 by soils are much more difficult to predict. McConnell (1973) in Rasmussen, et al., (1974) recently summarized a few of the problems involved in appraising the amount of nitrogen oxides generated by soil. He contends that the soil source is small compared to that produced as a result of the gas phase oxidation of atmospheric ammonia (NH_3) by oxides of nitrogen. He believes this source produces 7×10^{10} kg NO_x-N /year. He offers alternative reaction sequences for NH_3 in the atmosphere. One reaction sequence provides a constant source of NO , the other a sink. If the later occurs in the atmosphere an additional source of NO must be found in order to account for the amount of NO known to be in the atmosphere. In this case, McConnell concedes

that the soil might actually constitute a significant source of NO_x , generations above 10^{11} kg/year.

Estimation of the anthropogenic emissions of NO and NO_2 are lumped together as emission data which rarely distinguishes between the two forms. Robinson and Moser, (1971), estimated that annual production is about 53×10^6 kg with 31% of the total due to coal combustions and 41% due to petroleum production and the combustion of petroleum products. Within the petroleum class, combustion of gasoline and residual fuel oil are the major contributors of NO_2 . For the coal combustion category, power generation and industrial users account for most of the NO_2 emissions. Robinson and Robbins (1970), suggest using the same anthropogenic emission rate of 53×10^9 kg of NO_2 but convert it to 16×10^9 kg NO_2 -N.

Although the natural sources of nitrogen compounds are greater than the anthropogenic sources, the anthropogenic sources are concentrated in industrial sections and thus their contribution is more significant in air pollution problems. There is more than one reason for the build-up of NO_x in urban areas. First, the soil serves as the main sink for NO_x and in urban areas the anthropogenic sources of NO_x usually exceed the capacity of the soil to absorb NO_x . Secondly, although the soil releases great quantities of N_2O , the release occurs at the ground surface thus the same soil can serve as a sink in a dynamic equilibrium.

Most of the anthropogenic sources of NO_2 are released 20-50 meters in the air. Because a soil - gas interface is necessary, the soil has less of a chance to serve as a sink for NO_2 released at height. Therefore, NO_2 remains in the air for a longer period and can contribute to the photochemical smog problem. It is recognized that if the NO_2 were released at the ground level there would be higher concentrations; however the soil could then better serve as a sink and absorb more of the NO_2 .

d. Organic gases (hydrocarbons)

This group of gases represents a major factor contributing to air pollution. It includes all classes of hydrocarbons including those formed when some of the hydrogen of original compound is replaced by other

substituent groups including nitrogen, sulfur or oxygen (Rasmussen, et al., 1974). There are two classifications of organic gases, reactive and non-reactive. In areas where photochemical air pollution is a serious problem, a major concern is with the olefins and other reactive hydrocarbons rather than with the total organic emissions. Using factors derived by the Bay Area Air Pollution Control District in San Francisco, Robinson & Moser, (1971) estimated that approximately one-third of the total hydrocarbon emissions are classed as reactive, or about 27×10^6 tons out of the 88×10^6 total tons of organic materials. The major natural source of reactive hydrocarbons is decaying vegetation and plant metabolic processes.

Since the analytical work of F.W. Went in 1960, an increasing base of information has been developing related to the emissions of air polluting hydrocarbons by vegetation. Particular focus has been made on the presence of aromatic ethers, and some unsaturated material which generally is found in air and is among the prime determinants of our perception of the 'freshness' of the air (Turk and D'Angio, 1962).

The primary volatile organic compounds emitted are the monoterpenes which contain ten carbon atoms and include α -pinene, β -pinene, and limonene and the hemiterpene isoprene which contains five carbon atoms (Rasmussen, 1970, 1972). Other naturally occurring hydrocarbons include Camphene, β -phellandrene, 1, 8-Cineal, Camphor, P-Cymena, Terpinene and Δ^3 -Carene. In effect, these substances serve as tracers for a larger group of lower molecular weight organics which provide material available for reaction with ozone to generate smog through the photochemical reaction of these chemicals.

It has been estimated that 1.7×10^8 tons of volatile hydrocarbons are generated each year by all of the vegetation of the earth as compared with 0.27×10^8 tons of reactive hydrocarbons generated from anthropogenic sources (Eschenroeder, 1974). However, natural emissions from vegetation, because of the low emission densities involved, are not believed to be present in sufficiently high ambient concentrations to result in significant quantities of photochemical oxidants--especially in comparison with ozone levels resulting from anthropogenic precursors.

A cursory examination of the literature reveals that the synthesis of aromatic carbon compounds by plants is an integral part of their cellular

activities. It is logical to anticipate the release of these biosynthetic products in proportion to the potential metabolic activity of the plant species under consideration (Beytia, et.al., 1969). Certain species are far more efficient hydrocarbon generators than others and variations may even be found between clonal variations of the same species (Gerhold and Plank, 1970; Rodwan and Ellis, 1975).

On the other hand, a single species of plant may show marked fluctuation in the generation of hydrocarbons in apparent physiological response to a very wide array of environmental alterations. These alterations include, at a minimum, injury such as from elevated ozone levels (Craker, 1971) or insect attack (Shain and Hillis, 1972). Other alterations include temperature, humidity, nutrient level and any other factor contributing to the cellular environment of the plant under study (DeSanto, personal communication).

There are numerous pollutant sources of reactive hydrocarbons. On a global basis, Robinson and Myers, (1971), have estimated an emission rate of 88×10^6 tons per year. Of this total, 66% is from petroleum usage, 34×10^6 tons from gasoline usage, 6.3×10^6 tons from refinery uperections; 7.8×10^6 tons by transfer losses; petroleum evaporation, and 10×10^6 tons from solvent usage. Other sources of hydrocarbons include incineration and coal combustion.

e. Other pollutants

There are numerous other pollutants emitted by both natural and anthropogenic sources including asbestos, lead and flourocarbons. Most of the sources of these pollutants can be considered minor when compared to the pollutants previously discussed. A brief description of each pollutant is contained below.

1) Asbestos

Asbestos is a generic term covering several fibrous silicate minerals that are found in almost every country in the world. These minerals are classified into two groups: (1) Serpentine - chrysotile and (2) Amphiboles encompassing actinolite, amosite, anthophyllite, crocidolite and tremolite. Chrysotile - the fibrous form of serpentine, the so called white asbestos - is the most widely used type of the mineral, constituting more than 90% of the

world's production. Within the second group, anthophyllite, amosite, and crocidolite are of commercial importance (Hammons and Huff, 1974).

Hammons and Huff, (1974), have reported that in the last 60 years global use of asbestos has increased more than 100 fold—from 30,000 tons to four million tons. The same authors stated that asbestos is used in more than 3,000 products - cement, textiles, yarns and cords, boards and papers, sealing and packing materials, plastics, thermal insulants and fire proofing and friction material for brake linings and many other devices.

Anthropogenic sources of asbestos are mostly industrial that use it as part of their final product. These include ship building, insulation, construction, iron foundries, pharmaceutical and brake lining industries. Natural sources of asbestos include mineral production, weathering of mineral outcrops, and release during farming of asbestos - containing soil. No information could be found on quantities of asbestos being emitted on either a global or regional level.

2) Lead

Lead is a heavy metal that is naturally present in small amounts in soil, rocks, surface waters and the atmosphere. Due to its unique properties, it has been an element widely used by man. This utility has resulted in greatly elevated lead concentrations in certain ecosystems.

The primary source of lead in urban areas is the combustion of gasoline containing lead additives. Specific estimates of the amount of lead annually introduced to the atmosphere via gasoline consumption includes 98% (National Academy of Science, 1972), and 95%, (Ewing and Pearson, 1974). Approximately 136×10^6 kg of lead were released in automotive exhausts in 1970 (U.S. Bureau of Mines, 1971). Since 1970 no-lead and low-lead gasolines have become increasingly available and in 1974 all new cars in the United States were required to use no-lead gasoline. Other sources of lead include coal combustion, refuse and sludge incineration, burning or attrition of lead-painted surfaces and industrial processes.

Lead is a naturally occurring element and therefore small amounts are present in the environment from non-anthropogenic sources. In studies to determine the impact of lead from highways on vegetation it has been reported that

the background lead content of twigs and foilage of shrubs and decidous trees is generally within the range of 1-4 $\mu\text{g/g}$ dry weight of tissue (Smith, 1975).

Other studies have reported that the lead content of the upper soil horizons of unmineralized and uncontaminated areas is approximately 10-20 $\mu\text{g/g}$, dry weight (Smith, 1975). These statistics indicate the amount of lead occurring naturally in the environment.

3) Fluorocarbons

Atmospheric fluorides may be placed into four major categories; gaseous, particulate, soluble and insoluble. The major form of fluorine is hydrogen flouride (HF) and is given off by aluminum, steel and fertilizer processing industries. Coal and shale contain up to 120 - 550 ppm fluorine respectively (Crossley, 1944), and during the combustion process a proportion of this is released as hydro fluoric acid, silicon tetra fluoride and as a form associated with particulate matter (Davison, et al., 1973).

2. Pollutant Removal.

There are numerous mechanisms for removing air pollutants from the atmosphere by natural phenomena. A review of these mechanisms was performed by Rasmussen, et al., 1974, which was based on work by Robinson and Robbins, 1968, and Hidy, 1973. The important mechanisms include:

- (1) Precipitation scavenging in which the pollutant is removed by two modes. The first is "rainout" which involves the absorption of gases and aerosols by clouds. The second is "washout" which involves both gas absorption and particle capture by falling rain drops;
- (2) Chemical reactions in the atmosphere, including the stratosphere, which produce either aerosols or oxidized products such as carbon dioxide and water vapor.
- (3) Dry deposition which involves absorption by aerosols and subsequent deposition on the earth's surface; and
- (4) Absorption by various substances at the earth's surface including vegetation, soil and water bodies.

The remainder of this section will discuss how each of these processes affects the removal of each of the previously mentioned atmospheric pollutants. Particular attention will be given to those processes that contribute to the removal of pollutants using open space measures.

a. Sulfur Compounds

SO_2 is very soluble in water and very reactive either photochemically or catalytically in dilute concentrations in the atmosphere. Accordingly, the main processes for the removal of SO_2 from the atmosphere are: (1) precipitation scavenging (2) chemical conversion and (3) absorption by soil, water, rock and plants.

In precipitation scavenging, the SO_2 will undergo a series of reactions, some catalytic, to ultimately form H_2SO_4 drops or a sulfate salt. In the chemical conversion processes, dry SO_2 in the daytime under low humidity condition, will react with NO_2 and hydrocarbons in the transformation of SO_2 to form a H_2SO_4 aerosol. At night and under high humidity a process involving the absorption of SO_2 by alkaline water droplets and a reaction to form SO_4 within the drop is a well-documented process and can occur at an appreciable rate which removes SO_2 from the atmosphere (Robinson and Robbins, 1968).

In terms of open space measures, SO_2 can be absorbed from the atmosphere directly by vegetation, soil, rocks and water. This technique can be thought of separately or in combination with dry deposition and precipitation scavenging. Vegetation needs elemental sulfur for metabolic processes and much of that sulfur can be obtained from SO_2 especially in areas where the soil is sulfur deficient. Soils readily absorb SO_2 although the removal process is not fully understood. Smith, et al., 1973, suggests that SO_2 absorbed is oxidized to sulfate which may then be subject to leaching and uptake by plants. Thus the soil can remain a renewable sink for SO_2 . Limestone rocks react with H_2SO_4 to form gypsum, thus serving as a sink for SO_2 . Table III-10 of Volume I of this study is a synopsis of sink factors for SO_2 .

b. Carbon Monoxide

For all practical purposes carbon monoxide is insoluble in water. Therefore, the processes of washout and rainout are insignificant in removing it from the air. Gas-phase reactions in the troposphere serve as chemical sinks for CO. In these reactions, CO interacts with the hydroxyl radical to form CO₂ (Rasmussen, et al., 1974). However, there is much debate about this removal process as well as its technical accuracy. It is believed that most of the CO that enters the stratosphere is destroyed (Pressman, et al., 1970).

Soil, and vegetation to a lesser degree, serve as sinks for CO and thus can be utilized in mitigation techniques. Based on laboratory results, it has been proven that soil can act as a significant sink for CO. There are two schools of thought on the subject; Inman and Ingersoll, 1971, believe that the CO is removed by biological activity while Smith, et al., 1973, using sterilized soil in their laboratory concluded that soil could act as a sink by a definitely non-biological pathway. It is evident from the literature that practical research is needed to determine the ability of in situ soils to serve as a sink for CO. Vegetation can reduce CO from the atmosphere but not as effectively as soil. The results of the ability of both to serve as a sink are summarized in Table III-2 of Volume I.

c. Nitrogen Compounds

Of the major nitrogen compounds, N₂O is slightly soluble in water and under normal troposphere conditions, is chemically inert. Therefore there are no significant removal processes. NO is rather insoluble in water and is either oxidized to NO₂ or photolyzed to N₂ in the atmosphere. The NO₂ is then removed primarily by precipitation in the form of nitric acid (HNO₃). It can also be removed by vegetation and soils. The main removal mechanisms for NO and NO₂ are precipitation scavenging, chemical reactions and absorption by plants and soil.

The main removal mechanism for NO_x is precipitation. There is no disagreement with this conclusion. However, there are many theories as to the exact chemical reactions involved. With hydrolysis, the outcome is the same and the nitric acid formed by the reaction of NO_x with rain is absorbed onto hygroscopic particles or it reacts with atmospheric ammonia to form nitrate salt aerosols (Rasmussen, et al., 1974).

NO_x can also be removed by chemical reactions in the atmosphere. The primary reaction is its oxidation by ozone to form NO_2 . It can also be photolyzed to form N which can then react with other NO molecules to form N_2 . NO_2 can also react with ozone to form NO_3 or with the hydroxyl to form nitric acid.

In polluted atmospheres, NO and NO_2 react with SO_2 and hydrocarbons to form aerosols. The most important aerosols formed is atomic oxygen which is free to react with molecular oxygen to form ozone.

In terms of open space techniques for air pollution mitigation, vegetation and soil can serve as a sink for NO and NO_2 . There is no valid evidence of the exact methodology by which vegetation absorbs NO_2 , but from laboratory work it is evident that it serves as a sink for both NO and NO_2 . Soil has long been considered a natural emission for N_2O , but recently it has been discovered that it also can absorb NO and NO_2 . It is believed that the NO_2 absorbed will ultimately be oxidized to nitrate (Nelson and Bremner, 1970). The nitrates eventually decompose and result in the production of NO_2 . NO_2 is also produced from the absorption of NO from the atmosphere, but the reaction is almost instantaneous. However, certain alkaline earth cations can retard this NO_2 production Sundaeson, et al., 1967, found that alkaline earth zeolites readily absorb NO and release it as NO_x and HNO_3 . Much research is needed on the exact mechanisms involved in the use of soil as a sink for NO_x and especially on the role of organic material in the soils to halt or hinder the production of NO_2 .

d. Organic Gases (Hydrocarbons)

Reactive hydrocarbons are completely insoluble in water and therefore cannot be removed by washout or precipitation. The main removal mechanism is chemical reaction where some of the gases are transformed in the troposphere to other gases. For instance, methane has been shown to react with the hydroxyl ion to form CO (Rasmussen, et al., 1974).

In terms of open space techniques, there have been recent laboratory experiments that show that vegetation may be a sink for hydrocarbons and that soil may use them in bacteriological processes. It is also suggested that vegetation may serve to retard the natural release of hydrocarbons to the atmosphere. For instance, tree canopies may prevent sunlight from filtering to a roadway edge where the light would otherwise cause the reactive hydrocarbons to form smog. This is a theoretical possibility but the principal is sound.

e. Other Pollutants

There are numerous papers that discuss the capacity of vegetation and soil to act as sinks for numerous particulates including asbestos, lead and fluorine (in its particulate form). The photographs in the introduction to this volume illustrate this phenomenon.

Lead is introduced into the atmospheric compartment of the roadside environment from exhaust emissions and then transferred to the soil, plant or animal compartment, via sedimentation, impaction, precipitation or inhalation. The roadside environment receives lead particles of all classes, the larger ones by sedimentation and the smaller ones by the latter three processes (Smith, 1975).

Sedimentation and precipitation (washout and washoff) act to deposit lead particles, primarily in the relatively soluble halide form, on the soil surface in the roadside environment. Once the lead enters the soil surface, it is speculated that it may react with soil anions, or with some soil organic or clay complex (Singer and Hanson, 1969 in Smith, 1975). These reactions would indicate that the lead is insoluble in the soil and thus preclude its rapid mobility and restricts plant or microbial uptake.

Lead may also react with sulfuric acid in the atmosphere to form lead sulfate ($Pb SO_4$). This reaction could also occur at the soil-atmosphere interface. Reaction with the sulfate anion may occur in the soil in contact with ground water (Skogorbee, 1974 in Smith, 1975).

Vegetation has been proved (see especially Smith, 1975) to be an effective agent to adsorb lead particulates in the atmosphere. It is accumulated by the vegetative component of roadside ecosystems from both the atmospheric and soil compartments. Contamination of above ground plant parts from the atmospheric compartment may be via gravity settling, impaction (kinetic capture/ or precipitation). Contamination from the atmospheric compartment is also generally considered to be topical (superficial) in nature and largely susceptible to removal by washing (National Academy, 1972 in Smith, 1975).

We found no literature on removal of asbestos from the atmosphere. However, it can be speculated that in the particulate form, it can be removed from the atmosphere in the same manner as lead. Reaction in the soil compartment has not been studied so no conclusions can be made relating to this agent serving as a sink.

There is some evidence that vegetation can serve as a sink for fluorine. The results indicate that fluorine from the air can be adsorbed to the surface of leaves (in its particulate form) as well as accumulated internally (in its gaseous form) and that fluorine in leaves can be translocated outward to the surface as well as upward to the tips. Fluorine remains in a soluble form in plant leaves and maintains the chemical properties of free, inorganic fluorine. The solubility and mobility of fluorine and the ease of removal from plant tissue indicate that irreversible binding to cellular components does not occur (Jacobson, et al., 1966).

B. LITERATURE SEARCH FINDINGS

While there are a number of articles on town planning and buffers to control air quality, relatively little work has been done to quantify these planning proposals. The criteria developed for highway buffers are also applicable to larger (i.e. regional) open space systems. Essentially, the purpose of both is similar and the differences are generally those of scale and proximity to pollutant source.

Berindan (1969) states:

Numerous authors recommend, at present, the necessity of a zone which separates air polluting industries from other urban sectors. This zone is compulsorily provided for in the management plans of towns of certain countries. The idea of planting this zone is to increase its protective efficiency and, consequently, to reduce its surface area, an essential advantage in view of the crisis of urban areas which has become generalized in our time.

An example of such a town in the U.S.S.R. is Volgograd, a new town proposed by Milijutin, considered to be one of the best examples of urban zoning. The plan of the town locates residential, industrial, railroad access, and park land in linear bands perpendicular to the prevailing wind and separates industrial and transportation corridors from residential areas with wide bands of "planted protection zones."

1. Urban parks play an important role in the reduction of pollutant levels.

Sherman (1972) comments:

Dr. Davidson studied the atmospheric concentration of sulphur dioxide (SO₂) in mid-Manhattan, going from the Hudson River to the East River along 79th Street downwind. Remember that this is a single component of the air pollution load, but an important one associated with the burning of coal and oil. The significant feature of this study is the dramatic drop in the SO₂ level created by the presence of Central Park in mid-Manhattan. There are no belching stacks in the park, so being pollution-free itself, it provides an important, perhaps indispensable, dilution of the rest of the community's air pollution load. See Figure III-2.

Bach (1972) states:

For Hyde Park, a recreation area of only one square mile in size in the center of London, an average reduction in the smoke concentration of 27% was found.

Stanley Tankel (1963) advocates the use of green wedges as opposed to greenbelts due primarily to the inflexibility of the greenbelt concept in response to urban growth. Green wedges, radiating from the urban center, can grow with the demand for urban development. Also, they can respond to regional transportation systems and provide access to regional open space. See Figure III-3.

FIGURE III-2

SECTION ALONG 79th STREET, MANHATTAN ISLAND
(AFTER SHERMAN, 1972)

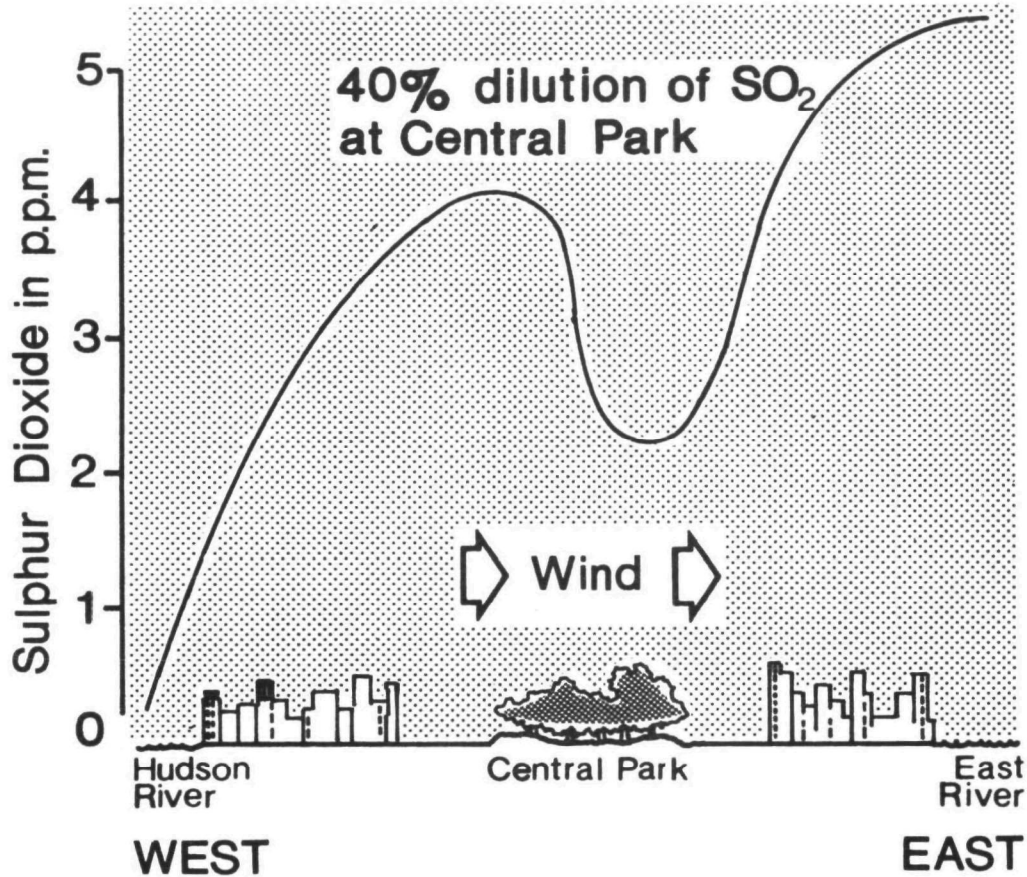

There are apparently no established minimum widths for such wedges. They are generally dependant upon local physiographic features such as river valleys, escarpments, flood plains, etc. However, in Hagevik (1974), literature is cited which observes that a 75% reduction of dust particles occurred within a 600 foot wide greenbelt. Hagevik also cites a study concluding that the concentration of pollutants is decreased by half as they pass over 1500 feet of planted land.

Work was also reported which demonstrated that the pollutants from a phosphorous plant required a buffer of 2540 feet in order to protect a citrus grove from fluoride. In another study, it was determined that suspended particles from a dolomite plant required a buffer of 1500 feet in order to minimize impact.

Wedges

Primary open space:
available natural
features; i.e. rivers,
valleys

Secondary open space:
transportation related

FIGURE III-3
WEDGES

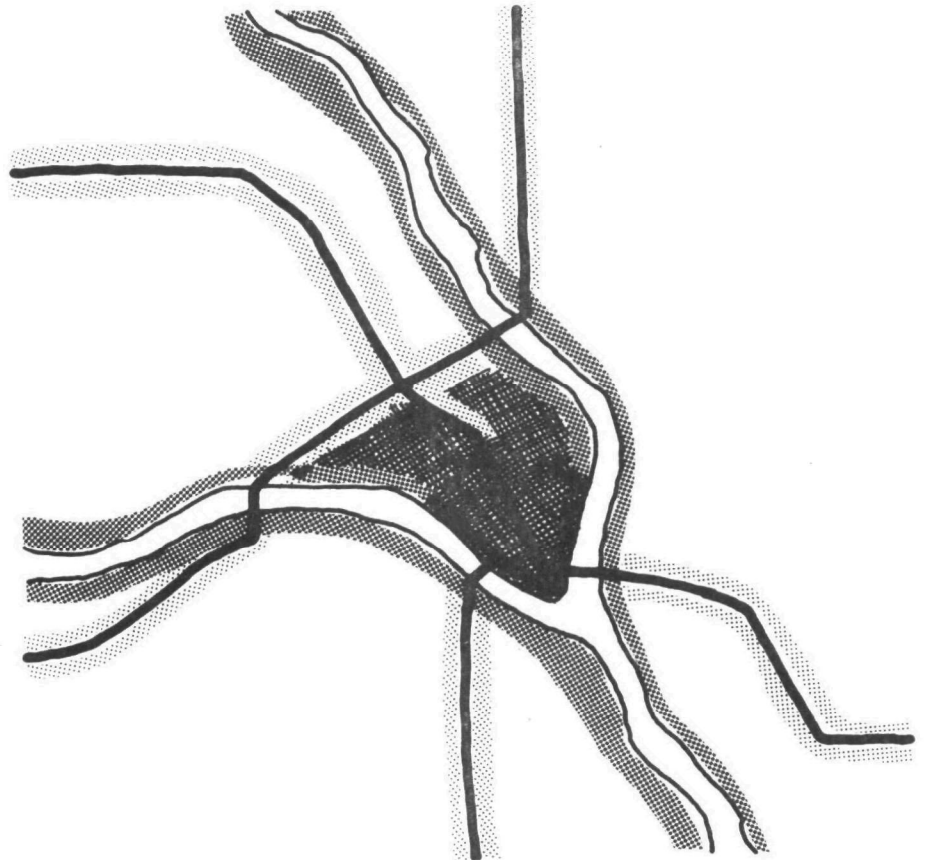

FIGURE III-4
GREENBELTS

Greenbelts

To contain growth and
separate land use
functions.

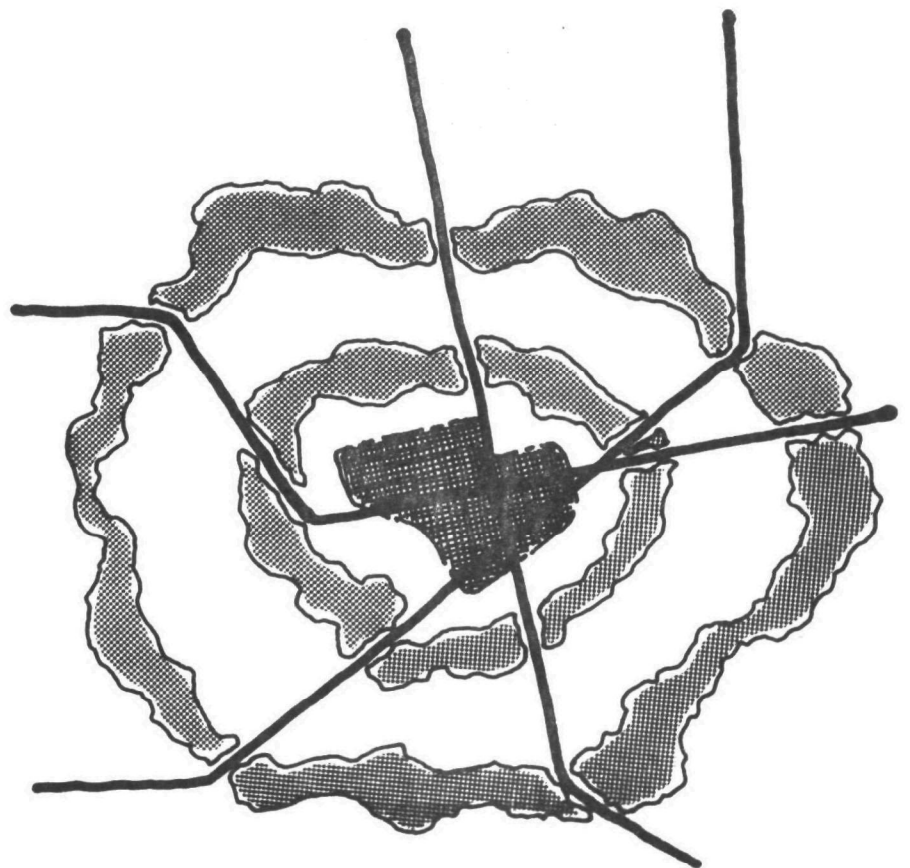
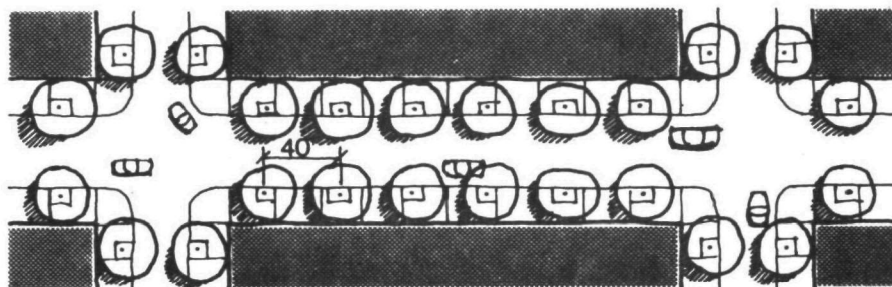

FIGURE III-5

STREET TREE PLANTINGS ARE ENCOURAGED AS
PART OF REGIONAL PLANTING AND BUFFER PROGRAM



It was also proposed that a buffer one mile wide be used around a hot mix asphalt plant in order to minimize particulate pollution.

Such guidelines imply that a great amount of land be used for the regional buffer systems. If the minimum width for such sinks is established between 600 feet and one mile, depending upon the pollutant source and local conditions and opportunities many hundreds of square miles would be involved.

However, there are opportunities for other land uses within the buffer system. Aside from its function as a pollution sink, the following are all compatible:

- .Recreation/Parks
- .Cemetaries/Memorial Parks
- .Education/Agriculture
- .Wildlife Protection
- .Protection of Natural Resources
(flood plains, steep slopes, archeological sites,
historic sites, etc.)
- .Sanitary Landfill
- .Spray Effluent Fields

2. Planning design criteria for regional buffer systems resulting from overall consideration of the literature.

a. Radial wedge system based upon natural land features as primary wedges and planted buffers along major transportation radials augmenting the system.

b. Size of wedges determined by local conditions including pollutant sources and prevailing winds. Minimum width to be set at 600 - 5,000 feet.

Hagevik (1974) feels:

...that the economics of providing buffer zones to improve environmental quality do not justify locating them in the most densely populated urban areas. However, several practical approaches to providing additional sink potential to a region include:

(1) Thinning existing forest areas to increase turbulence and increase leaf surface area. Creating openings in dense canopies in order to provide thermal chimneys and increase exposure of pollution laden air to leaf surface. Clear cutting edges of existing forests to provide additional edge areas.

(2) Urban street tree programs in order to reduce ambient pollutant levels. According to Geiger (1950), streets with trees had 1000 - 3000 dust particles/litre; streets without trees had 10,000 - 12,000 dust particles/litre.

Commonly, in areas where street trees are doing poorly, such as on many city streets, the plants are allowed to die and are not replaced. Instead, additional trees should be planted to reduce the pollutant burden on the existing trees by providing adequate leaf surface area to bring pollutant levels down to a level that can be tolerated by the trees.

C. LAND USE/GREENBELT ORGANIZATION

The literature search findings indicates that the use of greenbelts in urban areas can have multiple benefits. Planners and engineers have, to date, recognized the positive contributions of soil retention, physical separations between non-compatible land uses, climatology, etc. It is now evident that greenbelts can contribute to the air cleansing process or urban pollutants.

The land use planning process has utilized many techniques in order to prepare plans which best serve the interests of the community. Deciding on the amount of acreage and the location of lands to be used for residences, commercial establishments and industries, is a fairly straight forward process. Open space has usually been assigned to serve a recreational need, buffers between different land uses, or it has been identified as land that does not or is not expected to experience developmental pressures.

Now that it is recognized that vegetative plantings within a buffer area can trap particulates and remove other pollutants, the open space land use takes on an increased level of importance. Within current planning processes, sufficient quantities of land are reserved to serve population and development pressures. Ideally, such lands are located in a manner which best serves the interest of the community, e.g. industrial areas near transportation and utility arteries; commercial plots near residential centers, etc. Planners can reserve greenbelt open space lands using comparable planning design criteria. The particular technique that would be utilized requires considerable investigation to allow planners to rationally quantify required areas for greenbelts and to locate them so that they tend to balance urban pollutant loadings.

Planning design in the previous section calls for urban tree programs to reduce ambient pollutant levels. Such programs have usually been haphazardly undertaken based upon vague civic interest. It should be considered that rights-of-way along streets systems be put into an active use by being planted. Such rights-of-way have been used for utility line placement and access, sidewalks, etc. Street plantings for pollution control should be inventoried and planned for just as any other land use.

The planning design criteria also calls for the use of radial wedges to be utilized in consort with major transportation arms and natural land features. The planners should now look to reserving such lands and, more specifically, assign a value to them that is comparable with that normally associated with some of the more dominant land uses.

The value of open space and greenbelts take on added dimension when land use planners specifically identify their use as air pollution sinks. Preservation of open space can significantly contribute to the maintenance of air quality which elevates the value of open space above the historically associated benefits of aesthetics and recreation.

The objectives of this strategy is to locate an open space area within the influence area associated with maximum ground level air pollutants generated from existing stationary sources. The information required in order to establish these areas includes:

- a. The effective height of the emission source (H)
- b. The percentage distribution of wind directions experienced at the given point source of pollution over a period of time (wind rose showing prevailing wind direction).
- c. The Stability Class of the atmosphere - the degree of turbulence that is experienced during the hours of operation of the source of pollution.

The coordinate system in the Figure II-4 is used in the analysis of air pollution dispersion. The point identified as (x, 0, 0) is located where the maximum concentration of pollutants occurs most of the time, given the prevailing winds and the dominant stability class.

In order to determine point (x,0,0) the following must be known:

- a. Effective stack height obtained from area air pollution central agencies or calculated using the Holland stack rise equation as defined in Appendix D.
- b. Prevailing wind direction obtained from area meteorology stations of published reports.
- c. The dominant stability classes obtained from area meteorology stations are determined from the following table:

TABLE III-3

KEY TO STABILITY CATEGORIES						
Surface Wind Speed (at 10 m), m sec ⁻¹	Day			Night		
	Incoming Solar Radiation			Thinly Overcast or ≧4/8 Low Cloud		
	Strong	Moderate	Slight	≧4/8 Low Cloud	≧3/8 Cloud	
< 2	A	A-B	B			
2-3	A-B	B	C	E	F	
3-5	B	B-C	C	D	E	
5-6	C	C-D	D	D	D	
> 6	C	D	D	D	D	

The neutral class, D, should be assumed for overcast conditions during day or night.

One may start the analysis by selecting the prevailing wind direction and stability class for the period of time during which the source usually operates. With these inputs, Figure III-6, may be used in order to determine x Max (x,0,0).

FIGURE III-6

DISTANCE OF MAXIMUM CONCENTRATION AND MAXIMUM χ_u/Q AS A FUNCTION OF STABILITY (CURVES) AND EFFECTIVE HEIGHT (METERS) OF EMISSION (NUMBERS)

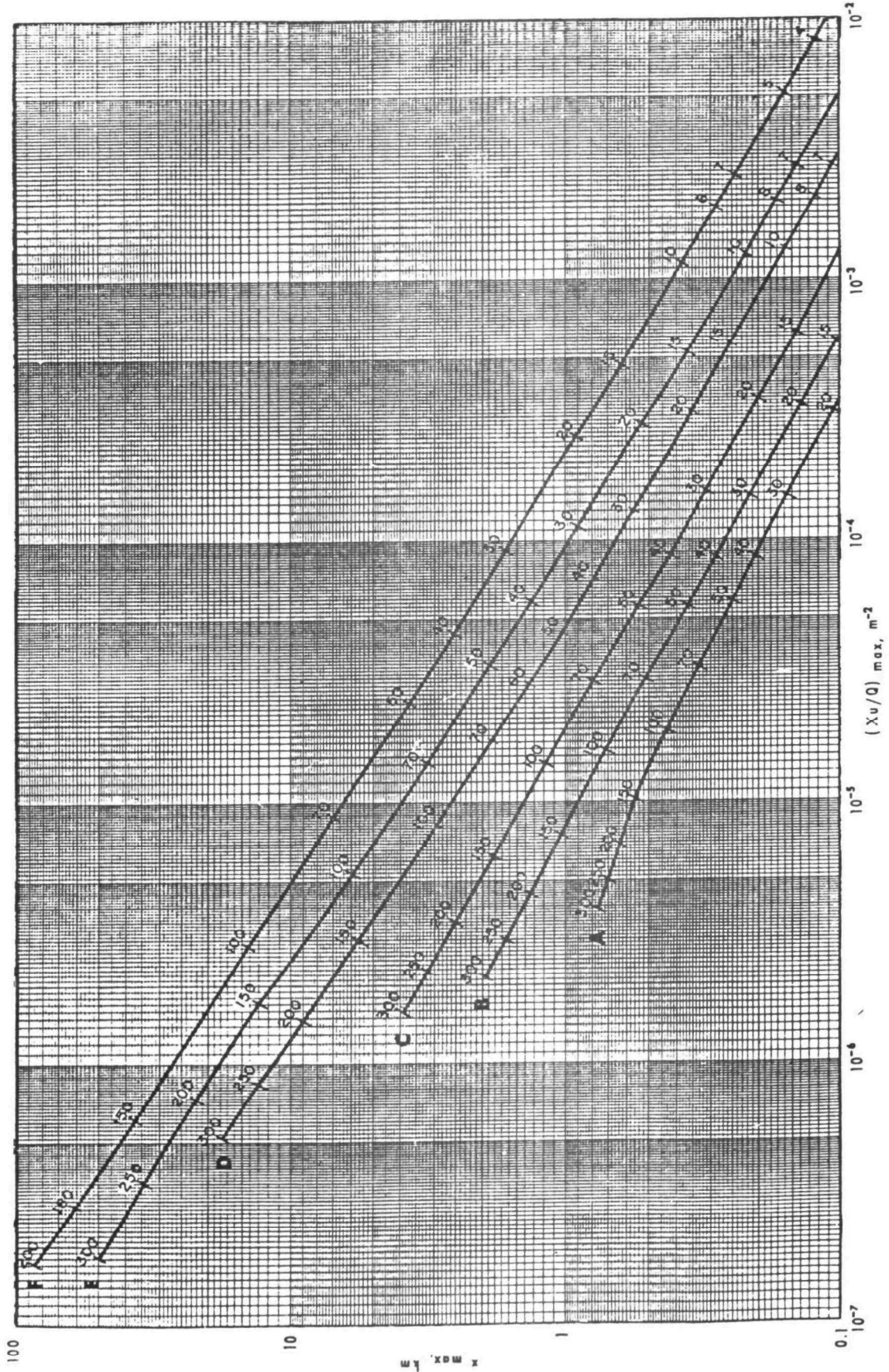

The point x_{Max} merely provides a centroid of pollutant concentrations. Naturally, the pollutants spread downwind and in a crosswind direction around this point. The task of designing the actual buffer involves many inputs. As a starting point, an idealized configuration is as shown in Figure III-7.

FIGURE III-7
TWO DIMENSIONAL RELATIONSHIPS BETWEEN SOURCE,
SINK, AND RECEPTOR LOCATIONS

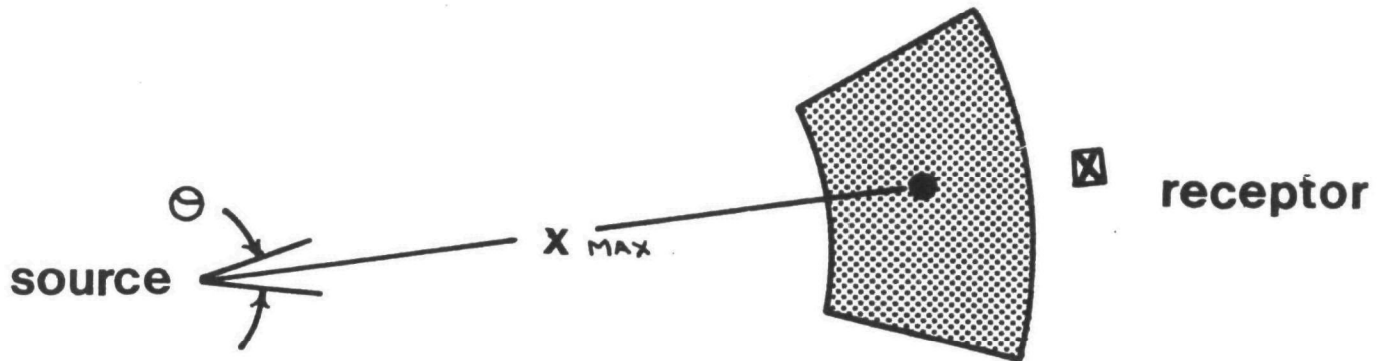

Under ideal circumstances, theta (θ) should represent a sweep angle of predominating winds for the site. Where consistent winds are encountered, (θ) will be smaller than where the winds are less limited in their directions.

The land use planner would need to locate all point sources and determine x_{Max} for each case. The position of sensitive land uses relative to the point sources, would be plotted and the buffer configuration ideally expanded to shield the receptor.

If available open space were not at a premium in an urban area, the logical buffer design would be a series of concentric belts, each with an inside radius equal to the particular x_{Max} , around each point source.

FIGURE III-8

IDEALIZED POINT SOURCE BUFFERS WITHOUT REGARD TO LAND CONSTRAINTS

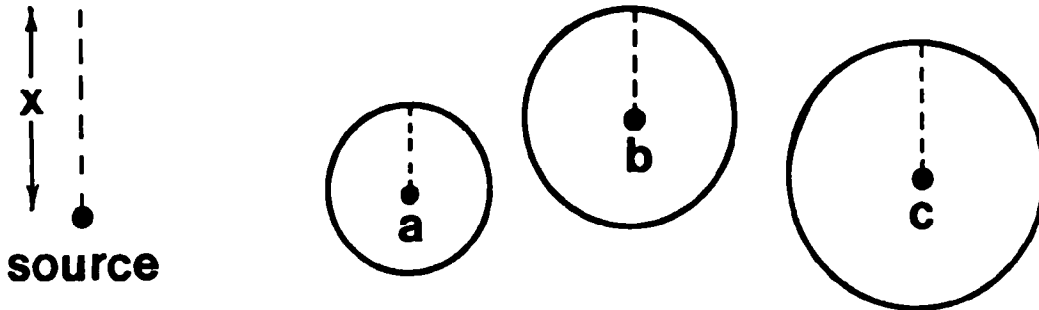

This seems hardly ever feasible. Therefore, we end up with configurations such as shown in Figure III-9 where the open space is designed as arcs.

FIGURE III-9

IDEALIZED POINT SOURCE BUFFER WITH LAND CONSTRAINTS

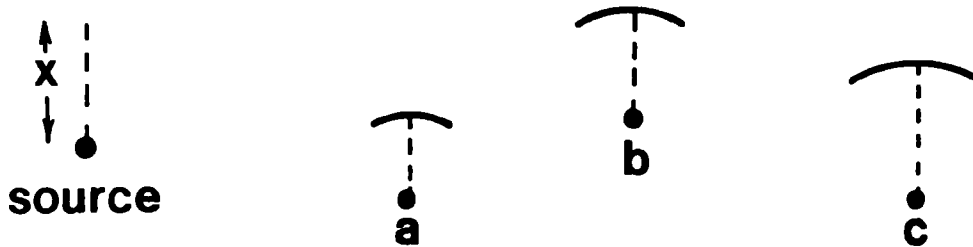

The estimation of horizontal dispersion of the pollutants is necessary in order to determine the arc length of the buffer. The Gaussian dispersion in a y axis helps determine this arc length of the greenbelt as do variations in prevailing wind directions (Θ). Finally, the space available for placing these buffers will determine final configurations.

Planning the location of greenbelts can only be done within the context of the comprehensive land use planning process. The input variables are of such a magnitude that no generalization can be made other than those outlined in the foregoing procedures.

D. CONVERSION OF LEAF AREA TO GROUND AREA AND WEIGHTED SINK FACTORS

The sink and emission factors for soil are reported in this project relative to the surface area of the soil as a unit of measure. Therefore, the relative removal rate or the emission rate for soil is reported as micrograms/square meter/hour. The removal rate or the emission rate, reported for various types of vegetation is also given in units of micrograms/square meter/hour. However, in the case of vegetation, square meters refers to the surface area of the leaves and not the ground area over which the vegetation grows. Therefore, in order to estimate the gross removal rate, or emission for an open space, it is necessary to convert to square meters the canopy area (that is, the ground area shaded by the covering vegetation) to leaf surface area. This requires that one knows the height and canopy diameter of each species of tree growing on the site. It also requires knowledge of the relationship between the particular species of vegetation involved and its leaf area at various stages in its life history. We used the following process in making required adjustments which allow us to draw general conclusions from the available literature. In addition to determining the relationship between canopy area and leaf area, it is also necessary to determine average removal and emission rate for various general types of vegetation. This is important because the literature does not contain much specific information about more than a few species of plants. Taken together then, determination of a typical leaf surface area for an open space, in combination with a typical removal or emission rate for the same area, will allow us to estimate the rate of removal for certain specified pollutants. Table III-11, entitled SUMMARY OF SINK AND EMISSION FACTORS FOR NATURAL ELEMENTS, appeared in Volume I and it has been used here as the basis for a further modification, adapting it more directly to an integrated use in conjunction with estimation of leaf surface areas. That Summary Table is based upon selective averaging of the sink and emission factors for each pollutant under consideration. It was meant as a first rough approximation of the broadest interpretation of the reviewed literature and must be utilized with that caution in mind. It reflects the factors associated with both deciduous and coniferous trees as well as shrubs and various ground covers treated by the literature. Therefore, in order to make the summary table more applicable to an evaluation of woody plants in open spaces, it was determined to modify the Summary Table slightly in the following way.

The average value for vegetation or soil serving as a sink for each of the pollutants, was taken directly from the Table. The detailed tables of emission and sink factors, which also appear in Volume I, Section III, were reviewed and where specific or general averages were available relating to the specific pollutants, these figures were also considered in creating a new average sink rate as shown on Table III-4 in this Volume. The end result is that based on the available literature, the average sink or emission rates are weighted toward the vegetation or soil which we would most likely expect to find in an open space project in St. Louis, Missouri. This project area is further defined in Volume III of this report.

In order to estimate the sink capacity of some representative vegetation, it is necessary to relate total leaf area to canopy diameter. This relationship can be made for several representative trees based upon information provided by Rich (1970) and Monteith (1976). They have reported ratios of the surface area of certain trees to their height and canopy diameters. The logic of our approach to this analysis, and the use of Leaf Area Indexes, is detailed in Appendix C of this Volume. Here, the conclusion of that interpretation has been used to create Table III-5.

TABLE III-4

WEIGHTED SINK AND EMISSION FACTORS FOR AVERAGE SOIL AND
AVERAGE VEGETATION BASED ON DATA REPORTED IN VOLUME I

POLLUTANT	ECOSYSTEM ELEMENT	REMOVAL RATE	REFERENCE	
<u>CARBON MONOXIDE</u>	<u>Vegetation</u>			
	Vol. I (Table III-11)	$2.5 \times 10^3 \mu\text{g m}^{-2}\text{hr}^{-1}$	} Bidwell & Fraser, 1972 Ziegler, 1975	
	Average Unspecified	$2.75 \times 10^3 \mu\text{g m}^{-2}\text{hr}^{-1}$		
	Weighted Average	$2.6 \times 10^3 \mu\text{g m}^{-2}\text{hr}^{-1}$		
	<u>Soil</u>			
	Vol. I (Table III-11) Average	$2.0 \times 10^4 \mu\text{g m}^{-2}\text{hr}^{-1}$	} Heichel, 1973a Heichel, 1973b	
	Forest soil - Charlton	$2.2 \times 10^4 \mu\text{g m}^{-2}\text{hr}^{-1}$		
	Forest/field soil	$8.0 \times 10^3 \mu\text{g m}^{-2}\text{hr}^{-1}$	Heichel, 1973b	
	Columbia, Mo.	$3.82 \times 10^4 \mu\text{g m}^{-2}\text{hr}^{-1}$	Ingersoll, 1972	
	Mt. Olive, Miss.	$1.52 \times 10^4 \mu\text{g m}^{-2}\text{hr}^{-1}$	Ingersoll, 1972	
	Weighted Average	$1.9 \times 10^4 \mu\text{g m}^{-2}\text{hr}^{-1}$		
	<u>NITROGEN OXIDES</u>	<u>Vegetation</u>		
		Vol. 1 (Table III-11) Average	$2 \times 10^3 \mu\text{g m}^{-2}\text{hr}^{-1}$	} Heggstad, 1972 Dochinger, 1974
Unspecified		$7.42 \times 10^2 \mu\text{g m}^{-2}\text{hr}^{-1}$		
Unspecified		$4.09 \times 10^3 \mu\text{g m}^{-2}\text{hr}^{-1}$		
Weighted Average		$2.3 \times 10^3 \mu\text{g m}^{-2}\text{hr}^{-1}$		
<u>Soil</u>				
Vol. 1 (Table III-11) Average		$2.0 \times 10^2 \mu\text{g m}^{-2}\text{hr}^{-1}$		
<u>OZONE</u>		<u>Vegetation</u>		
		Vol. 1 (Table III-11) Average	$8.0 \times 10^4 \mu\text{g m}^{-2}\text{hr}^{-1}$	} Townsend, 1974
		white oak	$6.35 \times 10^4 \mu\text{g m}^{-2}\text{hr}^{-1}$	
	white oak	$1.32 \times 10^5 \mu\text{g m}^{-2}\text{hr}^{-1}$		
	sugar maple	$3.71 \times 10^4 \mu\text{g m}^{-2}\text{hr}^{-1}$		
	sugar maple	$8.63 \times 10^4 \mu\text{g m}^{-2}\text{hr}^{-1}$		
	Ohio buckeye	$3.62 \times 10^4 \mu\text{g m}^{-2}\text{hr}^{-1}$		
	Ohio buckeye	$9.27 \times 10^4 \mu\text{g m}^{-2}\text{hr}^{-1}$		
	sweet gum	$2.78 \times 10^4 \mu\text{g m}^{-2}\text{hr}^{-1}$		
	sweet gum	$8.54 \times 10^4 \mu\text{g m}^{-2}\text{hr}^{-1}$		

<u>POLLUTANT</u>	<u>ECOSYSTEM ELEMENT</u>	<u>REMOVAL RATE</u>	<u>REFERENCE</u>	
<u>OZONE (cont.)</u>	<u>Vegetation</u>			
	red maple	$2.72 \times 10^4 \mu\text{g m}^{-2}\text{hr}^{-1}$	Townsend, 1974	
	red maple	$5.55 \times 10^4 \mu\text{g m}^{-2}\text{hr}^{-1}$	Townsend, 1974	
	white ash	$2.39 \times 10^4 \mu\text{g m}^{-2}\text{hr}^{-1}$	Townsend, 1974	
	white ash	$5.62 \times 10^4 \mu\text{g m}^{-2}\text{hr}^{-1}$	Townsend, 1974	
	Weighted Average	$6.2 \times 10^4 \mu\text{g m}^{-2}\text{hr}^{-1}$		
	<u>Soil</u>			
	Vol. 1 (Table III-11)Average	$1.0 \times 10^9 \mu\text{g m}^{-2}\text{hr}^{-1}$		
	<u>PAN</u>	<u>Vegetation</u>		
		Vol. (Table III-11)Average	$1.2 \times 10^3 \mu\text{g m}^{-2}\text{hr}^{-1}$	{ Jenson, 1973 Hill, 1971
<u>PARTICULATES</u>	<u>Vegetation</u>			
	Vol. 1 (Table III-11)Average	$4.0 \times 10^3 \mu\text{g m}^{-2}\text{hr}^{-1}$		
	hardwood canopy	$1.79 \times 10^3 \mu\text{g m}^{-2}\text{hr}^{-1}$	Dochinger, 1972	
	conifer canopy	$6.28 \times 10^3 \mu\text{g m}^{-2}\text{hr}^{-1}$	Dochinger, 1972	
	chestnut	$2.74 \times 10^3 \mu\text{g m}^{-2}\text{hr}^{-1}$	Chasseraud, 1958	
	tuliptree	$3.0 \times 10^2 \mu\text{g m}^{-2}\text{hr}^{-1}$	Wedding, et al., 1975	
	Weighted Average	$2.5 \times 10^3 \mu\text{g m}^{-2}\text{hr}^{-1}$		
<u>SULFUR DIOXIDE</u>	<u>Vegetation</u>			
	Vol. 1 (Table III-11)Average	$5.0 \times 10^2 \mu\text{g m}^{-2}\text{hr}^{-1}$		
	forest (unspecified)	$3.33 \times 10^3 \mu\text{g m}^{-2}\text{hr}^{-1}$	Davis, 1975	
	vegetation (unspecified)	$1.47 \times 10^4 \mu\text{g m}^{-2}\text{hr}^{-1}$	Dochinger, 1974	
	vegetation (unspecified)	$1.45 \times 10^5 \mu\text{g m}^{-2}\text{hr}^{-1}$	Jensen, 1973	
	Weighted Average	$4.1 \times 10^4 \mu\text{g m}^{-2}\text{hr}^{-1}$		
	<u>Soil</u>			
	Vol. 1 (Table III-11)Average	$1.15 \times 10^7 \mu\text{g m}^{-2}\text{hr}^{-1}$		
	oolitic limestone	$1.68 \times 10^5 \mu\text{g m}^{-2}\text{hr}^{-1}$	Spedding, 1969	
	acid soil (unspecified)	$1.15 \times 10^7 \mu\text{g m}^{-2}\text{hr}^{-1}$	Bohn, 1972	
Weighted Average	$7.7 \times 10^6 \mu\text{g m}^{-2}\text{hr}^{-1}$			

TABLE III-5
SPECIES RELATIONSHIP OF GROUND AREA COVERED TO PLANT SURFACE AREA

SPECIES	HEIGHT	GROUND AREA COVERED	PLANT AREA
Maple (<i>Acer plantanoides</i>)	6m	7.1m ²	36.8m ²
Oak (<i>Quercus robur</i>)	6m	7.1m ²	36.1m ²
Poplar (<i>Populus tremula</i>)	6m	7.1m ²	52.5m ²
Linden (<i>Tilia cordata</i>)	5m	4.5m ²	23.0m ²
Birch (<i>Betula verrucosa</i>)	5m	4.5m ²	27.2m ²
Pine (<i>Pinus sp.</i>)	3m	1.8m ²	4.2m ²

Having weighted sink factors and a relationship of total leaf area to ground area, we can develop the following table:

TABLE III-6
SELECTED TREES AS POLLUTION SINKS

	ug/hr	TYP (tons/yr)
One maple tree (6 m high)		
sulfur dioxide	1.5 x 10 ⁶	1.0 x 10 ⁻²
particulates	9.4 x 10 ⁴	9.0 x 10 ⁻⁴
carbon monoxide	9.6 x 10 ⁴	9.0 x 10 ⁻⁴
nitrogen oxides	8.5 x 10 ⁴	8.0 x 10 ⁻⁴
ozone	2.3 x 10 ⁶	2.0 x 10 ⁻²
PAN	4.4 x 10 ⁴	4.0 x 10 ⁻⁴
One oak tree (6 m high)		
sulfur dioxide	1.5 x 10 ⁶	1.0 x 10 ⁻²
particulates	9.0 x 10 ⁴	9.0 x 10 ⁻⁴
carbon monoxide	9.4 x 10 ⁴	9.0 x 10 ⁻⁴
nitrogen oxides	8.3 x 10 ⁴	8.0 x 10 ⁻⁴
ozone	2.2 x 10 ⁶	2.0 x 10 ⁻²
PAN	4.3 x 10 ⁴	4.0 x 10 ⁻⁴

TABLE III-6(cont)

	ug/hr	TYP (tons/yr)
One poplar tree (6 m high)		
sulfur dioxide	2.2×10^6	2.0×10^{-2}
particulates	1.3×10^5	1.0×10^{-3}
carbon monoxide	1.4×10^5	1.0×10^{-3}
nitrogen oxides	1.2×10^5	1.0×10^{-3}
ozone	3.3×10^6	3.0×10^{-2}
PAN	6.3×10^4	6.0×10^{-4}
One linden tree (5 m high)		
sulfur dioxide	9.4×10^5	9.0×10^{-3}
particulates	5.8×10^4	6.0×10^{-4}
carbon monoxide	6.0×10^4	6.0×10^{-4}
nitrogen oxides	5.3×10^4	5.0×10^{-4}
ozone	1.4×10^6	1.0×10^{-2}
PAN	2.8×10^4	3.0×10^{-4}
One birch tree (5 m high)		
sulfur dioxide	1.1×10^6	1.0×10^{-2}
particulates	6.8×10^4	7.0×10^{-4}
carbon monoxide	7.1×10^4	7.0×10^{-4}
nitrogen oxides	6.3×10^4	6.0×10^{-4}
ozone	1.7×10^6	2.0×10^{-2}
PAN	3.3×10^4	3.0×10^{-4}
One pine tree (3 m high)		
sulfur dioxide	1.7×10^5	2.0×10^{-3}
particulates	1.1×10^4	1.0×10^{-4}
carbon monoxide	1.1×10^4	1.0×10^{-4}
nitrogen oxides	9.7×10^3	9.0×10^{-5}
ozone	2.6×10^5	3.0×10^{-3}
PAN	5.0×10^3	5.0×10^{-5}

*Conversion of $\mu\text{g/hr}$ to tons/yr.
 $\mu\text{g/hr} \times \text{gm}/10^6 \mu\text{g} \times \text{lb}/453.59 \text{ gm}$
 $\times \text{T}/2000 \text{ lbs} \times 24 \text{ hrs/day}$
 $\times 365 \text{ days/yr} = \text{T/yr}$

GLOSSARY

AIR POLLUTION - Contamination of the air by liquids, solids and/or gases at unacceptably high levels (except water in its several phases) or in unnatural, anthropogenic forms. Typical natural contaminants are salt particles from the oceans or dust and gases from active volcanoes. Typical anthropogenic pollutants are waste smokes and gases formed by industrial, municipal, household, and automotive combustion processes.

BUFFER - Used here to mean land used to separate one land usage from another. Especially relating to open space used to insulate one land use from a contiguous land use.

CONIFEROUS - Referring to cone bearing trees. Generally, evergreen needle-leaved vegetation.

D.B.H. - diameter breast height - The diameter of the trunk of a tree measured at approximately 4.5 feet above the ground.

DECIDUOUS - Referring to those plants which shed their leaves seasonally. Generally, plants other than evergreens.

GLABROUS - Smooth, without fuzz or hair.

GREENBELT - In this report, an open space land use within, or around, urban growth and separating one land use from another. Usually, an open space band at least a few hundred feet wide and of variable length.

LENTICLES - Corky spots on young bark, corresponding in function to stomata on leaves (i.e. relating to gas exchange).

LEAF LAMINA - The flattened body of a leaf. A leaf consists of a stem (stalk or petiole) and a lamina.

OPEN SPACE - In this report, a park or natural area unoccupied by formal structures and generally unspoiled and permitting the natural processes of animal and plant growth.

PARTICULATES - Minute and separate particles which may be viable (e.g., pollen, bacteria, viruses, protozoans, etc.) or non-viable, (e.g. mineral dust, metals, etc.) and which are readily transported. Generally, sizes of particulates range between 0.0005 and 500 micrometers in diameter.

PHOTOSYNTHESIS - The process by which green plants convert water and carbon dioxide into sugars and oxygen.

PETIOLE - The stem of a leaf.

SHELTER BELT - A linear planting of shrubs and trees generally parallel to agricultural fields to protect them from winds (i.e. a windbreak).

STOMATES-(vernacular; sing. stoma; pl. stomata) - A microscopic opening generally on the lower surface of leaves, through which there is a gaseous interchange between the atmosphere and the interior of the leaf.

TRANSPIRATION - The movement of water from the internal circulation of a plant through its surfaces (such as the leaves) into the atmosphere as water vapor.

BIBLIOGRAPHY

- Aldaz, L. 1969: "Flux measurements of atmospheric ozone over land and water." J. Geophys. Res., 74(28):6943-6946.
- American Horticultural Society. Transit Planting: A Manual. Urban Mass Transportation Administration, U.S. Dept. of Transportation. Urban Mass Transportation Demonstration, Project #UA-06-0006. (No date).
- Babich, H., and G. Stotzky. 1974. "Air pollution and microbial ecology." Critical Rev. Environ. Control, 4(3):353-421.
- Bach, Wilfred. 1972. "Planning and air pollution control." In: Atmospheric Pollution. McGraw-Hill, New York, pp. 116-130.
- Bates, D.R., and A.E. Witherspoon. 1952. "The photochemistry of some minor constituents of the earth's atmosphere." Mon. Notic. Roy. Astron. Soc., 112: 101-124.
- Bennett, J.H., and A.C. Hill. "Interaction of gaseous air pollutants with canopies of vegetation." Agricultural Environmental Quality Institute, NE Region Agricultural Research Service, USDA, Md., 45pp.(No date).
- Berindan, Cornelia 1969. "Interrelationship between air pollution and green spaces as criteria for protecting industrial cities." Pollution Atmospherique, 11(43): 143-153.
- Bernatzky, A. 1968. "Protection plantings for air purification and improvement of environmental conditions." Tree J., 2:37-42.
- Bernatzky, A., "Climatic influence of the greens and city planning." Garden and Landscape Architect, pp. 29-33. (No date).
- Beytia, E., P. Valenzuela, and O. Cori. 1969. "Terpene biosynthesis: formation of Nerol, Geraniol, and other prenols by an enzyme system from Pinus radiata seedlings." Arch. Biochem. Biophys., 129:346-356.
- Bidwell, R.G.S., and D.E. Fraser. 1972. "Carbon monoxide uptake and metabolism by leaves." Can. J. Botany, 50(7): 1435-1439.
- Blenk, H., and H. Trienes. 1955. "Windschutz. darstellung der strömungen." (Windbreak. description of air-flow). Ein Film. Institute f. wiss. Film, Göttingen. West Germany. Film No. C704.
- Blum, W. 1965. "Air pollution and filtering effectiveness of forests." Forester, 20(10):211-212, 214-215.
- Bohn, H. 1972. "Soil absorption of air pollutants." J. Environ. Quality, 1(4), 5 pp.
- Braun, G. 1974. "Zur verwendung von tabakpflanzen als bioindikatoren waldschadlicher photochemischer immissionen." (The use of tobacco plants as biological indicators of photochemical air pollution affecting forest trees). Forstwiss. Centralbl., 93(4):221-230.

- Caborn, J.M. 1957. "Shelterbelts and microclimate." Forestry Commission, Bulletin No. 29, Dept. of Forestry, Edinburgh Univ., Scotland, 135 pp.
- Caborn, J.M. 1965. "Shelterbelts and windbreaks." Univ. Of Edinburg, 288 pp.
- Calvert, J.G., J.A. Kerr, K.L. Demerjian, and R.D. McQuigg. 1972. "Photolysis of formaldehyde as a hydrogen atom source in the lower atmosphere." Science, 175: 751-752.
- Cantwell, E.N., E.S. Jacobs, W.G. Cunz, Jr., and U.E. Liberi. 1972. "Control of particulate lead emissions from automobiles." IM: Cycling and Controls of Metals, U.S. E.P.A., Cincinnati, Ohio, pp. 95-107.
- Cass, J.S. 1961. "Fluorides: A critical review. IV. Response of livestock and poultry to absorption of inorganic fluorides." J. Occupational Med., 3(10), pp. 451-477.
- Chamberlain, A.C. 1967. "Deposition of particles to natural surfaces." In: Airborne Microbes, P.H. Gregory and J.L. Monteith (eds.), 17th Symp. Soc. Gen. Microbial., Cambridge Univ. Press, London, pp. 138-169.
- Chasseraud, J. 1958. "Influences du milieu un ain sur les vegetaux employes dans les espaces verts: Conclusions et techniques qui en decoulent." (Influence of the urban atmosphere on plants used in parks and gardens: Forthcoming conclusions and techniques). Proc. Intern. Congr. Horticulture, 15(3):60-74.
- Cole, LaMont. 1969. "Wooded highway medians." Bio Science, 19(11). (No page numbers).
- Cook, D.I. and D.F. Van Hauerbeke. 1971. "Trees and shrubs for noise abatement." U.S. Dept. of Agric. Research Bulletin 56-7, No. 246.
- Cook, D.I., and D.F. van Hauerbeke. 1974. "Tree-covered land forms for noise control." U.S.D.A. Research Bulletin #263, Lincoln, Nebraska, 47pp.
- Corn, Morton. 1968. "Nonviable particles in the air." J. Air Pollution, 49. (No page numbers).
- Craker, L.E. 1971. "Ethylene production from ozone injured plants." Environ. Pollut., 1:299-304.
- Cross, Frank L., Jr., and Roger W. Ross. 1969. "New developments fluoride emissions from phosphate processing plants." Jour. Air Pollution Control Assoc., (No volume or page numbers).
- Crossley, H.E. 1944. "Fluorine in Coal." J. Soc. Chem. Ind., 63:289-292.
- Dabberdt, Ludwig, and Johnson. 1972. "Urban diffusion of carbon monoxide in the relationship of land use and transportation planning to air quality management." (No publisher).
- Daines, R.H., H. Molto, and D.M. Chilko. 1970. "Atmospheric lead: its relationship to traffic volume and proximity to highways." Environ. Sci. Technol., 4:318.

- Dasmann, Raymond. 1968. A Different Kind of Country. MacMillan Publishers, New York. (No. of pages unknown).
- Davis, D.D. 1975. "A literature review regarding the ability of woody plants to remove SO₂ and photochemical oxidants from the atmosphere." Order #P5J10 397-J., Part II., EPA, 30 pp.
- Davison, A.W., A.W. Rand, and W.F. Belts. 1973. "Measurement of atmospheric fluoride concentration in urban area." Envir. Pollut.,5:23-33.
- DeChiara and L. Koppleman. 1975. "Urban Planning and Design Criteria." Van Nostrand Reinholdt Co., N.Y. 646 pp.
- Den uyl, D. 1936. "The zone of effective windbreak influence." Journal of Forestry pp. 689-695.
- Dochinger, L.S. 1974. "Atmospheric cleansing of gaseous and particulate pollutants by forest trees." 30 pp. (Publisher unknown).
- Dochinger, L.S. "Improving city air quality with trees." U.S.D.A. Forest Service, Northeastern Forest Expt. Station, Forest Insect and Disease Laboratory, Delaware, Ohio, 17 pp. (Date unknown).
- Duncan, D.P. 1950. "Tree windbreaks for the orchard." Minnesota Horticulturist (March), (No volume number or page numbers).
- Durk, Peter. 1971. "The influence of the forest on the health of man, in Cook and Van Haverbeke." In: Trees and Shrubs for Noise Abatement. David I. Cook and David F. Van Haverbeke (authors). U.S. Dept. of Agric. Research Bulletin 56-7, No. 246, p. 5.
- Edwards, H.W. 1974. "Environmental contamination caused by lead." NSF Interim Report, Colorado State Univ., Fort Collins.
- Embleton, T.F.W. 1963. "Sound propagation in homogeneous deciduous and evergreen woods." J. of the Acoustical Society of America,35:III 9-25.
- Epstein, A.H., C.A. Leary, and S.T. McCandless. 1974. "A guide for considering air quality in urban planning." EPA Contract No. 68-02-0567, Research Triangle Park, North Carolina.
- Erikson, E. 1960. "The yearly circulation of chloride and sulfur in nature: meteorological, geochemical and pedological implications." Tellus,12: 63-109.
- Eschenroeder, A.Q. 1974. "Survey of the state of knowledge of sources of naturally emitted reactive hydrocarbons into the atmosphere." Final Report, Office of Research and Development, EPA Report CR-1-554, 28pp.
- Everett, Michael D. 1974. "Roadside air pollution hazards in recreational land use planning." AIP Journal, pp. 83-87. (No volume number).

- Ewing, B.B., and J.E. Pearson. 1974. "Lead in the environment." Advan. Environ. Sci. Technol., 3:1.
- Federal Highway Administration. 1972. "Mathematical approach to estimating highway impact on air quality." Office of Research, Washington, D.C., Air Quality manual, v. IV, Report No. FHWA-RD-72-36, 63 pp.
- Feder, W.A. 1970. "Modifying the environment." Hort. Science, 5(4):247-249.
- Flemer, William. 1975. "Trees in towns." Journal of the Royal Horticultural Society, 100:22-35.
- Flensburg, C.E. and C.S. Nøkkentved. 1940. "Laevirkningsundersøgelser. fort saate." (Continuation of shelterbelt investigations). Hedeselskabets Tidsskrift, 61:64.
- Flury, F., and F. Zeanik 1931. *Schadliche Gase, Dampfe, Rauch und Staubarten.* Springer, New York, pp. 195-196.
- Franken, E. and D. Kaps, 1957. "Windschutzuntersuchung Emsland 1955." (Investigations on shelterbelts in the Emsland 1955). Berichte Deutscher Wetterd., 5 (33), 37 pp.
- Frenkiel, Francois, N. 1956. "Atmospheric pollution and zoning in an urban area." The Scientific Monthly, 82(4):194-203.
- Fritschen L.J., and R. Edmonds. "Dispersion of fluorescent particles into and within a Douglas fir forest." Univer. of Washington, College of Forest Resources AR-10. (pp. and date unknown).
- Geiger, Rudolf. 1950. "The climate near the ground." Harvard Univ. Press, Boston.
- General Electric Co. 1971. "Final report on study of air pollution aspects of various roadway configurations." Paper #44. (pp. unknown).
- George, E.J. 1960 "The effect of shelterbelts on crop yields." 5th World Forestry Congress, Seattle, Wash., August 29 - September 10, 1960. (pp. unknown).
- Gerhold, H.D., and G.H. Plank. 1970. "Monoterpene variations in vapors from white pines and hybrids." Phytochemistry, 9:1393-1398.
- Gifford, F.A., Jr. 1961. "Uses of routine meteorological observations for estimating atmospheric dispersion." Nuclear Safety, 2:4.
- Goody, R.M., and C.D. Walshaw. 1953. "The origin of atmospheric nitrous oxide." Quart. J. Roy. Meteorol. Soc., 79:496-500.
- Haar, G.T. 1972. "The sources and pathways of lead in environment." Proc. Inter Symp. Environ. Health Aspects of Lead, Amsterdam, (Pages unknown).
- Hagevik G, D. Mandelker, and R. Brail. 1974. "The contribution of urban planning to air quality." Environmental Protection Agency, Research Triangle Park, North Carolina. EPA-450/3-75-038.

- Halitsky, J. 1962. Journal of Air Pollution Control Association; 12(2):74 (Title of publication unknown).
- Hammons, A.S., and J.E. Huff. 1974. "Asbestos - world concern, involvement and Laissez Faire." Intern. J. Env. Stud., 6:247-252.
- Haupt, R., and G. Flemming. 1973. "Sozialhygienische Probleme bei der Gestaltung von Erholungswäldern." (Problems of social hygiene in the planning of recreational forests). Wissen. Z. Tech. Univ. (Dresden), 22(4):688-692.
- Heggstad, H.E. 1972. "How plants fight man-made pollution." The Science Teacher 39(4):21-24.
- Heichel, G.H. 1973. "Removal of carbon monoxide by field and forest soils." J. Environ. Qual., 2(4):419-423.
- Heichel, G.H. 1973. "Soil recycles carbon monoxide." Frontiers of Plant Sciences, 25(2): 4-7.
- Heichel, G.H., and L. Hankin. 1976. "Roadside coniferous windbreaks as sinks for vehicular lead emissions." The Connecticut Agricultural Expt. Station, P.O. Box 1106, New Haven, Ct. 06504.
- Heisler, G.M. 1974. "Trees and human comfort in urban areas." Journal of Forestry, 72(8). (No page numbers).
- Hidy, G.M. 1973. "Removal processes of gaseous and particulate pollutants." Chemistry of the Lower Atmosphere, Plenum Press, New York.
- Highway Research Board. 1966. "The art and science of roadside development: A summary of current knowledge." National Academy of Sciences, National Research Council, Special Report #88, Wash. D.C.
- Hill, A.C. 1971. "Vegetation: a sink for atmospheric pollutants." J. Air Pollut. Cont. Assn., 21:341-346.
- Hill, A.C. 1971. "Vegetation: a sink for atmospheric pollutants." Preprint, Air Pollution Control Assoc., Pittsburgh, Pa. (Presented at the Air Pollution Control Association, Annual Meeting, 64th. Atlantic City. June 27 - July 2, paper 71-66) 37 pp.
- Hirschler, D.A., and L.F. Gilbert. 1964. "Nature of lead in automobile exhaust gas." Arch. Environ. Health, 8:297.
- Hutchinson, T.C. 1972. "The occurrence of lead, cadmium, nickel, vanadium and chloride in soils and vegetation of Toronto in relationship to traffic density." Presented at the Ontario Association of P.E., Int. Aut. Poll. Cont., Toronto, Ontario.
- Hutchinson, T.C. 1971. "The occurrence of lead, cadmium, nickel, vanadium, and chloride in soils and vegetation of Toronto in relation to traffic density." (Presented at the Canadian Botanical Association and the American Institute of Biological Sciences, Joint Meeting, Alberta, June 20-24, 1971). Preprint, Canadian Botanical Assoc. and American Inst. of Biological Sciences, 27 pp.

- Ingersoll, R.B. 1972. "The capacity of the soil as a natural sink for carbon monoxide." (Final Report) Stanford Research Inst., Menlo Park, Coordinating Research Council Contract CAPA-4-68 (1-71), Environmental Protection Agency Contract 68-02-0307, SRI Proj. LSU-1380, Rept. EPA-650/2-73/043, 41 pp.
- Ingold, C.T. 1971. Fungal Spores. Clarendon Press, Oxford, 302 pp.
- Inman, R.E., and R.B. Ingersoll. 1971. "Note on the uptake of carbon monoxide by soil fungi." J. Air Pollution Control Assoc., 21(10):646-647 (Presented at the Air Pollution Control Assoc. Annual Meeting, 64th, Atlantic City, June 1971, Paper 71-65).
- Jacobson, J.S., L.H. Weinstein, D.C. McLure, and A.E. Hitchcock. 1966. "The accumulation of fluorine by plants." J. Air Poll. Con. Assoc., 16(8):412-417.
- Jaffe, L.S. 1973. "Carbon monoxide in the biosphere: Sources, distribution and concentrations." J. Geophys. Res., 78(24):5293-5305.
- Jenson, K.F. 1973. "Absorption, translocation, and soil deposition of aerial pollutants by vegetation." Proc. Soil Conserv. Soc. AM, 28:26-29.
- Jensen, M. 1954. Shelter Effect. Danish Techn. Press., Copenhagen, 265 pp.
- Jordan, M.J. 1975. "Effects of zinc smelter emissions and fire on a chestnut-oak woodland." Ecology, 56:78-91.
- Katz, M. 1956. Air Pollution Handbook, McGraw-Hill, New York. 200 pp.
- Keller, Theodor. 1971. "Die bedeutung des waldes für den umweltschutz." (The importance of the forest for the protection of the environment.) Schweizer Ische Zeitschrift für Forstwesen, 122 (12):600-613.
- Kellogg, W.W., et al. 1972. "The sulfur cycle." Science., 175(4022):587-596.
- Konstantinov, A.R. 1950. "The influence of forest shelterbelts on the wind and on the turbulent exchange in the air layer near the ground." Voprosy gidrometeorologičeskoj effectivnosti polezaščitnogo lesorazvedeniija, Gidrometeoizdat. Leningrad. (pp. unknown).
- Kurtzweg, J.A. 1973. "Urban planning and air pollution control: A review of selected recent research." AIP Journal, pp.83-92. (No volume number).
- Lampadius, F. 1963. "The air-hygiene significance of the forest and its dependence upon harmful air pollution effects upon the forest." Angerwandte Meteorologic, 4(8-10):248-249.
- Lanphear, F.O. 1971. "Urban vegetation: values and stresses." Hort. Science, 6(4):332-334.
- Majernik, O., and T.A. Mansfield. 1970. "Direct effect of SO₂ pollution on the degree of opening stomata." Nature, 227: 377-378.
- Makarov, B.N., and V.V. Dokuchayev. 1970. "Liberation of NO₂ from soils." Soviet Soil Sci., 1:20-25.

- Mastalerz J.W., and Craig S. Oliver. 1974. "Development and application in the urban environment." Hort. Sciences, 9(6):560-563.
- Matjakin, G.I. 1952. "Forest shelterbelts and microclimate." Geografizd, Moscow. (No volume or page numbers).
- McConnell, J.C., M.B. McElroy, and S.C. Wafsy. 1971. "Natural sources of atmospheric CO." Nature, 233: 187-188.
- McConnell, J.C. 1973. "Atmospheric ammonia." J. Geophys. Res., 78(33):7812-7821.
- McHarg, Ian. 1969. Design with Nature. Natural History Press, Garden City, N.Y. (pp. unknown).
- Meldau, R. 1955. Handbuch der Staubtechnik (Handbook of Dust Technology). Dusseldorf, W. Germany, Bd.1. (Publisher and number of pages unknown).
- Monteith, J.L. 1975. Vegetation and the Atmosphere. Vol. 1, Academic Press, New York, 278 pp.
- Monteith, J.L. 1976. Vegetation and the Atmosphere. Vol. 2, Academic Press, New York, 439 pp.
- Moses, H., Carson, J.E., and Strom, G.H. 1964. Nuclear Safety 6:1-19. (Title unknown).
- Mueller, P.K., H.L. Helwig, A.E. Alcour, W.K. Gong, and F.E. Jones. 1963. "Concentration of fine particles and lead in car exhaust." ASTM Special Techn. Publication, No. 352, pp. 60-73.
- Murphy, C.E. Jr., T.R. Sinclair, and K.R. Knoerr. 1975. "A model for estimating air pollutant uptake by forests: calculation of forest absorption of SO₂ from dispersed sources." (Presented at Conference on Metropolitan Physical Environment, Syracuse, New York, August 25-29, 1975).
- Nägeli, W. 1943. Untersuchungen über die Windverhältnisse im Bereich von Windschutzstreifen." Mitt. Schweiz. Anst. forstl. Verswesen, 23(1):223-276.
- Nägeli, W. 1946. "Weitere untersuchungen über die windverhältnisse im Bereich von windschutzanlagen." (Further investigation on wind conditions in the range of shelterbelts). Mitteil. Schweiz. Anstalt Forstl. Versuchswesen, ZURICH, 24:659-737.
- National Academy of Sciences. 1972. "Airborne lead in perspective." Washington, D.C., 330pp. (No date).

- Nelson, O.W., and J.M. Bremner. 1970. "Gaseous products of nitrate decomposition in soils." Soil Bibl. Biochem., 2:203-215.
- Neuberger, H., C.L. Hosler, and W.C. Koemond. 1967. "Vegetation as aerosol filter." Biometeorology, 2(2):693-702.
- Nøkkentved, C. 1938. "Laevirkningsundersøgelser og typebestemmelser af laehegn." (Investigations of shelterbelts and estimation of types of shelterbelts). (Danish) Hedeselskabets Tidsskr. (Heath Soc. J.), 59(4):75-142.
- Noll, K.E., T.L. Miller, R.H. Rainey, and R.C. May. 1975. "Final report on the air monitoring program to determine the impact of highways on ambient air quality." University of Tennessee, Knoxville, Tennessee. (No page numbers).
- Odum, Eugene P. 1967. "Air-land-water." J. Soil, Water Conserv., 24:4-7.
- Odum, Eugene P. 1971. "Ecological principles and the urban forest." In: Symposium on the Role of Trees in the South's Urban Environment, January 31 - February 3, 1971, University of Georgia, Center for Continuing Educ., Athens, Georgia, pp. 78-81.
- Odum, Eugene P., and Sharon Davis. 1969. "More birds in the bushes in the plans." In: Landscape Architecture. (No publisher or page numbers).
- Page, A.L., et al. 1971. "Lead quantities in plants, soil and air near some major highways in Southern California." Hilgardia, 41(1):1-31.
- Panfilov, J.D. 1937. "Forest shelterbelts on the watershed plateau in the mixing zone of the Volga region." Polezascitnye lesnye polösy. VASNIL. (No volume or page numbers).
- Pasquill, F. 1961. "The estimation of the dispersion of windborne material." The Meteorological Magazine, 90:33-49.
- Pittman, S. 1961. "Pollution, parks and plane trees." A paper read at services congress during the session under the auspices of the institute of park administration, pp. 22-26.
- Podgorow, N.W. 1967. "Die Staubfilternde Rolle von Anpflanzungen." (Plantings as Dust Filters). (Translated from German by Belov and Assoc., Denver, Colorado) Lesn. Khoz. Mosk., 20:39-40.
- Pressman, J., L.M. Arin, and P. Warneck. 1970. Mechanisms for removal of carbon monoxide from the atmosphere. U.S. Public Health Service, NAPCA-CKS, final report, contract no. CPA 22-69-36.
- Preston, F.W., and P.T. Norris. 1947. "A study of nesting heights in birds." Ecology 28:241-250.
- Prince, R., and F.F. Ross. 1972. "Sulfur in air and soil." Water, Air and Soil Pollution, 1:286-302.
- Rasmussen, K.H., M. Taheri, and R.L. Kabel. 1974. "Sources and natural removal processes for some atmospheric pollutants." Environmental Protection Agency, Meteorology Laboratory Center, Research Triangle Park, N. Carolina, EPA-650/4-74-032. 122 pp.

- Rasmussen, K.H., et al. 1974. "Sources and natural removal processes for some atmospheric pollutants." Center for Air Environmental Studies, Pennsylvania State University, University Park, CAES Pub. 367 74, EPA/650/4 74 032, 130 pp.
- Rasmussen, R.A. 1970. "Isoprene: Identified as a forest-type emission to the atmosphere." Environ. Sci. Tech., 4(8):667-671.
- Rasmussen, R.A. 1972. "What do the hydrocarbons from trees contribute to air pollution." J. Air Poll. Cont. Assoc., 22(7):537-543.
- Raynor, G.S., L.A. Cohen, J.V. Hayes, and E.C. Ogden. 1966. "Dyed pollen grains and spores as tracers in dispersion and deposition studies." Jour. Appl. Meteor., 5:728-729.
- Raynor, G.S., M.E. Smith, I.A. Singer, L.A. Cohen, and J.V. Hayes. 1966. "The dispersion of ragweed pollen in a forest." 7th National Conf. Agric. Meteorology, Rutgers Univ., New Brunswick, pp. 1-11.
- Reethof, Gerhard. 1972. "Effect of plantings on radiation of highway noise." Presented at Annual Meeting of the Air Pollution Control Assoc. (pp. unknown).
- Reimschuessel, Ernest F. 1970. "A pollution solution - plant trees." presented to the Western Chapter International Shade Tree Conference, , Calif.
- Rich, Avery E. 1972. "Salt injury to roadside trees." Arborist's News, 37(3): 77a-79a.
- Rich, Saul. 1970. "Effects of trees and forests in reducing air pollution." In: Trees and forests in an urbanizing environment. University of Massachusetts Coop. Ext. Serv. Plan. Resour. Dev. Ser. No. 17, pp. 29-33.
- Rich, S., P.E. Waggoner, and H. Tomlinson. 1970. "Ozone uptake by bean leaves." Science, 169:79-80.
- Robinette, Gary O. 1969. "The functional spectrum of plants - sound control." Grounds Maintenance, 4:42-43.
- Robinson, E., and C.E. Moser. 1971. "Global gaseous pollutant emissions and removal mechanisms." Proceedings of the Second International Clean Air Congress, edited by H.M. Englund and W.T. Berry, Academic Press, New York, pp. 1097-1101.
- Robinson, E., and R.C. Robbins. 1968. "Sources, abundance and fate of gaseous atmospheric pollutants." Final Report of Project PR-6755 of the Stanford Research Institute, Menlo Park, California, 123 pp.
- Robinson, E., and R.C. Robbins. 1970. "Gaseous nitrogen compound pollutants from urban and natural sources." J. Air Poll. Control Assoc., 20:303-306.

- Rodwan, M.A., and W.D. Ellis. 1975. "Clonal variation in monoterpene hydrocarbons of vapors of Douglas-fir foliage." Forest Sci., 21(1):63-67.
- Rydell, Peter C., and Schwarz, Gretchen. 1968. "Air pollution and form - a review of current literature." J. Amer. Inst. of Planners, 34. (No page numbers).
- Schuck, E.A., and J.K. Locke. 1970. "Relationship of automotive lead particulates to certain consumer crops." Environ. Sci. Technol., 4:324.
- Schütz, K., C. Junge, R. Breck, and B. Albrecht. 1970. "Studies of atmospheric N₂O." J. Geophys. Res., 75(12):2230-2246.
- Shain, L., and W.E. Hillis. 1972. "Ethylene production in Pinus radiata in response to Sirex-Amylosterem attack." Phytopathology, 62:1407-1409.
- Sherman, James. 1972. Open Land for Urban America. Johns Hopkins Press, Baltimore, Md. 32 pp.
- Singer, I.A. 1959. "An objective method for site evaluation." Presented at the annual meeting of the Air Pollution Control Association.
- Singer, M.J., and L. Hanson. 1969. "Lead Accumulation in soils near highways in the twin cities metropolitan area," Soil Sci. Soc. Amer. Proc., 33:152.
- Skogorbee, R.K., and K.W. Olson. 1974. "Identification of soil lead compounds from automotive sources." Environ. Sci. Technol., 9:227.
- Smith, K.A., J.M. Bremner, and M.A. Tobatabai. 1973. "Sorption of gaseous atmospheric pollutants by soils." Soil Sci., 116(4):313-319.
- Smith, W.H. 1970. "Trees in the city." AIP Journal, pp. 429-436. (No volume number).
- Smith, W.H. 1971. "Lead contamination of roadside white pine." Forest Science, 17:195-198.
- Smith, W.H. 1973. "Metal contamination of urban woody plants." Environ. Sci. Technol., 7:631.
- Smith, W.H. 1975. "Lead contamination of the roadside environment." Presented at 68th Annual Meeting, Air Pollution Control Assoc., Boston Mass.
- Smith, Wm. H., and Leon S. Dochinger. 1975. "Capability of metropolitan trees to reduce atmospheric contaminants." Presented at Better Trees for Metropolitan Landscapes Symposium, U.S. National Arboretum, Wash., D.C.
- Spedding, D.J. 1969. "SO₂ uptake by limestone." Atmos. Environ., 3:683.
- Spedding, D.J. 1969. "Uptake of sulphur dioxide by barley leaves at low sulfur dioxide concentrations." Nature, 224:1229-1237.
- Spirtas, R., and H.J. Levin. 1971. "Patterns and trends in level of suspended particulate matter." J. Air Pollut. Cont. Assoc., 21: 329-333.
- Stevens, C.M., L. Krout, D. Walling, A. Venters, A. Engelkemeir, and L.E. Ross., 1972. "The isotopic composition of atmospheric carbon monoxide." Earth Planet Sci. Lett., 16:147-165.

- Stevens, C.M., L. Krout, D. Walling, A. Venters, A. Engelkemeir, and L.E. Ross. 1972. "The isotopic composition of atmospheric carbon monoxide." Earth Planet Sci. Lett., 16:147-165.
- Stevens, G.R. 1976. Personal communication to William H. Smith, unpublished data. Cited in Smith, William H., and Brian J. Staskawicz. 1976. "Removal of atmospheric particles by leaves and twigs of urban trees: some preliminary observations and assessment of research needs." Environmental Management, 1 (3). (In press).
- Stoiber, R.E., and A. Jepsen, 1973. "Sulfur dioxide contributions to the atmosphere by volcanoes." Science, 182: 577-578.
- Sundareson, B.B., C.I. Harding, F.P. May, and E.R. Henrickson. 1967. "Adsorption of nitrogen oxides from waste gas." Environ. Sci. Tech., 1:151-156.
- Swinerton, J.W., U.J. Linnenbom, and R.A. Lamontagne. 1970. "The ocean: a natural source of carbon monoxide." Science, 167(3920):984-986.
- Swinerton, J.W., R.A. Lamontagne, and V.J. Linnenbom. "Carbon monoxide in rainwater." Science, 172: 943-945.
- Tanaka, S., and T. Tanizawa. 1956. "(7) Design of wood belts and their prevention function." J. Agric. Meteor. (Tokyo), 12(1):9-12.
- Tankel, Stanley B. 1963. "The importance of open space in the urban pattern." In: Cities and Space, Lowdon Wingo, Jr. (ed.), John Hopkins Press. Baltimore, Md. pp. 57-71.
- Thorne, L., and G.P. Hanson. 1972. "Species differences in rates of vegetal ozone absorption." Environ. Pollution, 3: 303-312.
- Townsend, A.M. 1974. "Sorpton of ozone by nine shade tree species." J. Am. Soc. Hort. Sci., 99(3):206-208.
- Turk, A., and C.J. D'Angio. 1962. "Composition of natural fresh air." J. Air Poll. Cont. Assoc., 12(1):29-33.
- Turner, D.B., and J.L. Dicke. 1972. "Atmospheric diffusion computations." In: Air Pollution Meteorology, Research Triangle Park, North Carolina, pp. 3.19-3.46.
- Turner, N.C., P.E. Waggoner, and S. Rich. 1974. "Removal of ozone from the atmosphere by soil and vegetation." Nature, 250(5466):486-489.
- U.S. Bureau of Mines. 1971. Minerals Handbook. U.S. Govt. Printing Office, Washington, D.C. (No pages).
- U.S. Environmental Protection Agency. 1970. "Workbook of atmospheric dispersion estimates." Research Triangle Park, North Carolina.
- U.S. Environmental Protection Agency. 1973. "Compilation of Air Pollutant Emission Factor." Research Triangle Park, North Carolina.

- U.S. Environmental Protection Agency. 1975. Supplement #5 for compilation of air pollution emission factors. Office of Air and Waste Management, Research Triangle Park, North Carolina, 2nd edition, approx. 200 pp.
- University of Mass., U.S.D.A. Forest Service, and Mass. Dept. of Natural Resources. 1970. A symposium on trees and forests in an urbanizing environment, U. of Mass., 168 pp.
- Unsworth, M.H., P.V. Biscoe, and H.R. Pinckney. 1972. "Stomatal responses to sulphur dioxide." Nature, 239:458-459.
- van der Linde, R.J. 1958. "Het probleem van houtopstanden in het cultuurlandschap." (The problem of shelterbelts in cultivated areas). Centrum voor landbouwkundige documentatie, No. 21., 44 pp.
- van Eimern, J. 1957. "Über die Veränderlichkeit der Windschutzwirkung einer Doppelbaumreihe bei verschiedenen meteorol. Bedingungen." (On the variability of shelter effect of a double-tree row at different meteorol. conditions). Berichte Deutsch. Wetterdienst, 5(32), 21pp.
- van Eimern, J., R.Karchon, L.A. Razumova, and G.W. Robertson. 1964. "Windbreaks and shelterbelts." Secretariat of the World Meteorological Organization, Geneva, Technical Note No. 59, 188 pp.
- Voorhees, Alan M. and Associates, Inc. 1971. A Guide for Reducing Air Pollution through Urban Planning. pp. 2-35. (No publisher).
- Wallace, D.A. 1970. Metropolitan Open Space and Natural Process. Univ. of Penn. Press, 199 pp.
- Warren, J.L. 1973. "Green space for air pollution control." North Carolina State Univ., School of Forest Resources, Raleigh, Technical Report #50.
- Warren Spring Laboratory, 1966. Recherches sur la pollution de l'air. The Curwen Press, London. (Number of pages unknown).
- Wedding, J.B., R.W. Carlson, J.J. Stoke., and F.A. Bazzaz. 1975. "Aerosol deposition on plant leaves." Environmental Science & Technology, 9:151-153.
- Weiner, F.M., and D.N. Keast. 1959. "Experimental study of the propagation of sound over ground." Jour. of the Acoustical Society of Amer., 31:724-733.
- Weisser. 1961. "Forests as natural protection barriers against air pollution between adjacent industrial and residential areas." Translated by Edith R. Johnson, 9 pp. (No publisher).
- Went, F.W. 1960. "Blue hazes in the atmosphere." Nature, 187(4738):641-643.
- White, E.J., and F. Turner. 1970. "Method of estimating income of nutrients in catch of airborne particles by a woodland canopy." Jour. Appl. Ecol., 7:441-461.

White, J.J. 1932, "Carbon monoxide and its relation to aircraft." U.S. Nav. Med. Bull., 30:151.

Willis, B.H., J.R. Mahoney, and J.C. Goodrich. 1973. "Hackensack Meadowlands air pollution study - air quality impact of land use planning." EPA Contract No. EHSD 71-39, Research Triangle Park, North Carolina, 139 pp.

Williston, Hamlin L. 1971. "Guidelines for planting and maintaining Loblolly pine and other cover for roadbank stabilization." Tree Planter's Notes, 22(2):14-17.

Wolsko, T.D., M.T. Matthies., and R.E. Wendell. 1972. "Transportation air pollutant emissions handbook." Argonne National Laboratory, Argonne, Illinois. (No page numbers).

Woodruff, N.P., and A.W. Zingg. 1953. "Wind tunnel studies of shelterbelt models." J. of Forestry, 51(3):173-178.

World Meteorological Organization. 1964. "Windbreaks and shelterbelts." Tech. Note No. 59, Geneva, Switzerland, 188 pp.

Wylie, P.B., and L.C. Bell. 1973. "The effect of automobile emissions on the lead content of soils and plants in the Brisbane area." Search, 4(5):161-162.

Young, W.C. 1968. "Ecology of roadside treatment." Jour. of Soil and Water Conservation. 23:2.

Ziegler, L. 1973. "The effect of air-polluting gases on plant metabolism." Environon. Qual. Saf., 2: 182-208.

Zinke, P.J. 1967. "Forest interception studies in the United States." In: Int. Sym. on Forest Hydrology. W.E. Sopper and H.W. Cull, ed., Pergamon Press, Oxford, England, pp. 137-161.

APPENDIX A
HIGHWAY DIFFUSION MODELS

I. INTRODUCTION

The purpose of Appendix A is to investigate the possibilities of incorporating vegetation sink factors for air pollutants into four(4) atmospheric dispersion models that predict carbon monoxide (CO) concentrations from highway sources. These models include 1) the EPA HIWAY model,2) the California Line Source Model,3) the SRI Street Canyon model and, 4)Emp 1, an emperical model.

These models are reviewed by Noll et al.(1975), and a discussion of each follows,

A. EPA MODEL

The EPA HIWAY computer program serves to estimate nonreactive air pollutant concentrations downwind from a highway line source of some specified finite length. Concentration is calculated not as the result of a continuous line source as such, but rather by the approximation of the line source by a finite number of evenly spaced continuous point sources of strength equal to the total line source strength divided by the number of sources used to simulate the line.

The model itself considers each lane of traffic as an individual line source. Thus, traffic estimates for each lane are required. Total concentration is calculated using superposition, i.e., concentrations from the separate line sources are additive.

Because of the physical significance of mechanical mixing above the roadway, some initial values of vertical and horizontal dispersion parameters must be assumed to allow the plume to conform to the actual plume shape encountered. To accomplish this, the point sources are displaced by some virtual distance to the rear such that σ_z and σ_y have an initial value at roadside.

With the exception of receptors directly on the highway or within the cut, the model is applicable for any wind direction, highway orientation, and receptor location. The model was developed for situations where horizontal wind flow occurs. The model cannot consider complex terrain or large obstructions to the flow such as buildings or large trees.

The EPA HIWAY model simulates a highway with a finite number of point sources and calculates the downwind concentration from each point using the Gaussian point source diffusion equation. The total contribution of all points is calculated by a numerical integration of the Gaussian point source equation over a finite length. The coordinates of the end points source equation over a finite length. The coordinates of the end points of a line source of length L, representing a single lane, extending from point A to B (see Figure VI-1) are R_A , S_A , and R_B , S_B . The direction of the line source from A to B is β . The coordinates R, S of any point along the line at the arbitrary distance ℓ from point A are given by:

$$R = R_A + \ell \sin \beta \quad (1)$$

$$S = S_A + \ell \cos \beta \quad (2)$$

Given a receptor at R_k , S_k , the downwind distance, x, and the crosswind distance, y, of the receptor from the point R, S for any wind direction θ is given by:

$$x = (S - S_k) \cos \theta + (R - R_k) \sin \theta \quad (3)$$

$$y = (S - S_k) \sin \theta - (R - R_k) \cos \theta \quad (4)$$

Since R and S are functions of ℓ , x and y are also functions of ℓ . The concentration, χ from the line source is then given by:

$$\chi = \frac{q_\ell}{u} \int_0^L f \, d\ell \quad (5)$$

where for stable conditions or if the mixing height is greater or equal to 5000 meters:

FIGURE VI-1

LINE SOURCE AND RECEPTOR RELATIONSHIPS
FOR EPA HIWAY MODEL

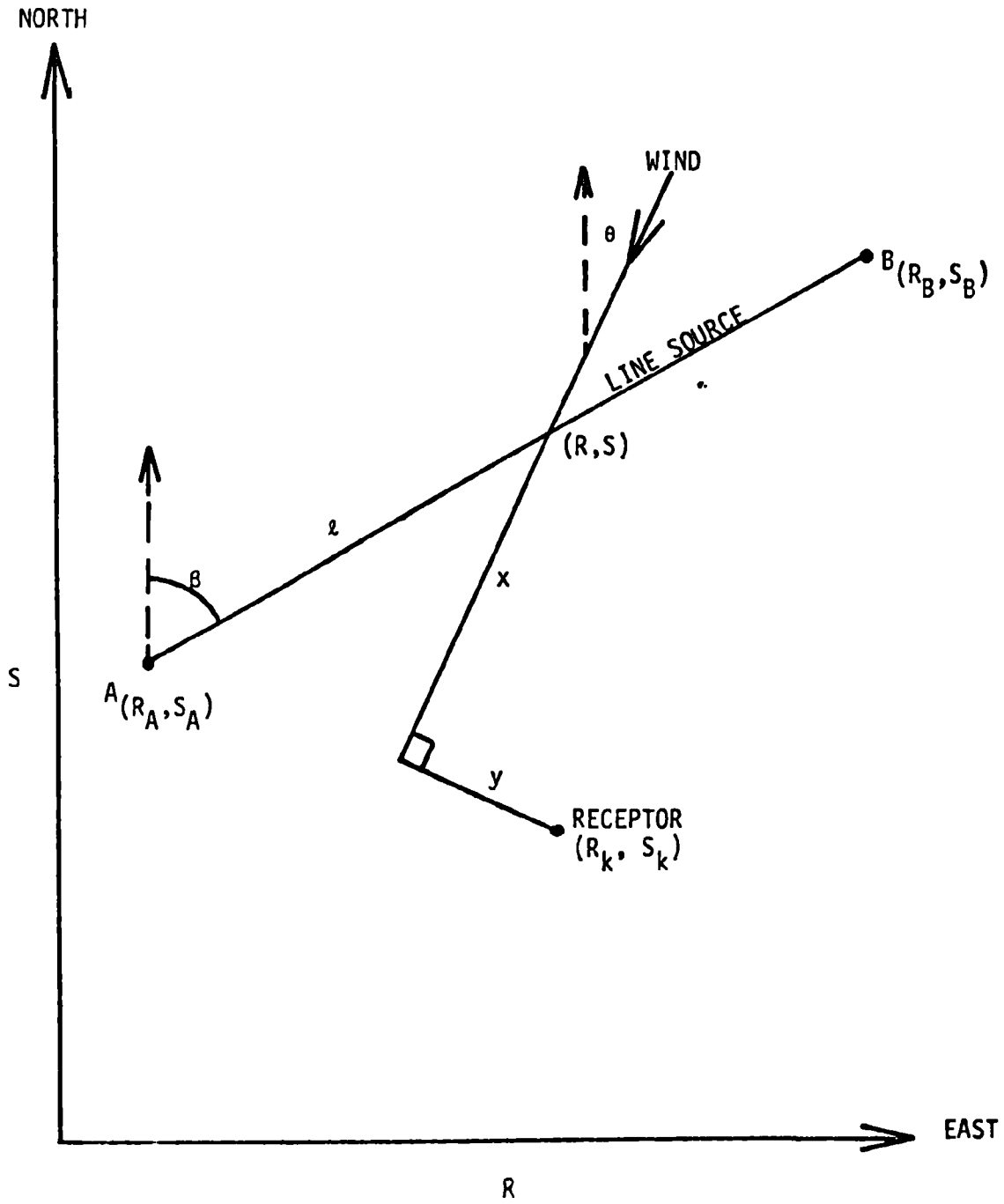

SOURCE: (No11, et al., 1975)

$$f = \frac{1}{2\pi\sigma_y\sigma_z} \exp \left[-\frac{1}{2} \left(\frac{y}{\sigma_y} \right)^2 \right] \left\{ \exp \left[-\frac{1}{2} \left(\frac{z-H}{\sigma_z} \right)^2 \right] + \exp \left[-\frac{1}{2} \left(\frac{z+H}{\sigma_z} \right)^2 \right] \right\} \quad (6)$$

where H = height of the road above ground level, m
 z = height of the receptor above ground level, m
 σ_y & σ_z = horizontal and vertical dispersion parameters, respectively, m.

In unstable or neutral conditions, if σ_z is greater than 1.6 times the mixing height, L , the distribution below the mixing height is uniform with height regardless of source or receptor height provided both are less than the mixing height:

$$f = \frac{1}{\sqrt{2\pi}\sigma_y L} \exp \left[-\frac{1}{2} \left(\frac{y}{\sigma_y} \right)^2 \right] \quad (7)$$

In the above equations, σ_y and σ_z are evaluated for the given stability class and the distance $x + b$ for σ_y and $x + a$ for σ_z . A and b are the virtual distances required to produce the initial σ_z and σ_y respectively.

The value of the integral (Eq. 5) is approximated by use of the trapezoidal rule. Let $\Delta l = L/N$. Then the trapezoidal approximation gives:

$$X = \frac{q\Delta l}{u} \left[\frac{1}{2}(f_0 + f_N) + \sum_{i=1}^{N-1} f_i \right] \quad (8)$$

where f_i is evaluated from the appropriate Equation 6 or 7 for $l + i\Delta l$. x and y are functions of l .

For a given initial choice of the interval length, Δl , the calculation is then successively repeated with twice the number of intervals, that is, with $\Delta l/2$, $\Delta l/4$..., until the concentration estimates converge to within 2 percent of the previous estimate. This value then represents the true value of the integral.

The above evaluation of the integral is repeated for each lane of traffic and the resulting concentrations summed to represent the total concentration from the highway segment.

B. CALIFORNIA MODEL

The California model calculates pollutant concentrations generated by motor vehicles within a microscale highway corridor. The mathematical model, which is based on the Gaussian infinite line source diffusion equation, calculates hourly concentrations of pollutants within a turbulent mixing cell above the highway as well as at receptor points at given distances downwind.

In the crosswind case, the mixing cell concentration is determined by the wind speed and pollutant emission rate of the vehicles. Dispersion downwind is dependent on the atmospheric stability classification. In the parallel wind case, the California model accumulates pollutants within the mixing cell to account for downwind buildup. Pollutants are then dispersed laterally at a rate dominated by stability class. The computerized model is capable of estimating pollutant concentrations where the winds are either parallel or at an angle to the highway alignment and where the highway section may be at grade, elevated or in a cut.

The California model uses separate equations for calculating pollutant concentrations under crosswind and parallel wind conditions. The most general form of the crosswind equation has the form of the Gaussian line source equation:

$$C = \frac{4.24 Q}{2 K \sigma_z U_s \sin \phi} \left[\exp - \frac{1}{2} \left(\frac{z + H}{\sigma_z} \right)^2 + \exp - \frac{1}{2} \left(\frac{z - H}{\sigma_z} \right)^2 \right] \quad (9)$$

where

- C = concentration of pollutant gm/m³
- Q = emission source gm/sec-m
- U_s = wind speed m/sec (1 mph = 0.447 m/sec)
- K = empirical coefficient = 4.24
- φ = angle of wind with respect to highway alignment
- σ_z = vertical dispersion parameter, in meters
- H = height of highway above surrounding terrain, in meters
- z = height of receptor above surrounding ground surface, in meters

For the parallel wind case, the California model accounts for a buildup of pollution concentration within the mixing cell. The estimated concentrations within the mechanical mixing cell for parallel winds, where the ratio of 30.5/W is less than or equal to one, can be determined from the following equation:

$$C = A \frac{Q}{U} \frac{1}{K} \frac{30.5}{W} \quad (10)$$

where

- C = concentration of pollutant (gm/m³) within the mechanical mixing cell
- U = wind speed (m/sec)
- K = empirical coefficient 4.24
- W = width of roadway from edge of shoulder to edge of shoulder, in meters
- A = downwind concentration ratio for parallel winds (accumulation term) is defined as $\frac{C K}{Q} \frac{W}{30.5}$.

30.5 = the initial width (meters) of the highway used for the finite element of area in developing the model for parallel winds

Q = source emission strength (gm/sec)

For parallel winds, the source emission strength (Q) is calculated using the following equation:

$$Q = \{\text{emission factor}\} \times \{\text{vehicles/hour}\} \times \{5.26 \times 10^{-6}\} \quad (11)$$

Where the numerical constant is a factor to convert units of the product (vph) (gm/mi) to gm/sec for a length of highway of 100 feet.

To estimate the ground level pollutant concentration at a distance away from the highway (when the wind is parallel to the alignment) the following equation is used.

$$C = [\text{ppm}]_{\text{mc}} \left[\exp - \frac{1}{2} \left(\frac{Y}{\sigma_y} \right)^2 \right] \times \frac{1}{2} \left[\exp - \frac{1}{2} \left(\frac{z+H}{\sigma_z} \right)^2 + \exp - \frac{1}{2} \left(\frac{z-H}{\sigma_z} \right)^2 \right] \quad (12)$$

where ppm_{mc} = concentration of CO at the highway within the mechanical mixing cell

Y = normal distance in meters from receptor to near edge of highway shoulder

σ_y, σ_z = horizontal and vertical dispersion parameters in meters. These values are obtained from empirical data depending on the receptor's normal distance (Y) from the highway and on the stability class.

The California model reduces to two simpler equations when one solves for at-grade cases. For mixing cell concentrations with crosswinds, equation (9) reduces to:

$$\text{Cmc} = \frac{1.06 Q}{K, \mu \sin \phi}, \text{ grams/cubic meter} \quad (13)$$

where Q = source strength, grams/meter-second

K = empirical constant = 4.24

μ = wind speed, m/sec

ϕ = wind angle with respect to road (90° for winds perpendicular to the road)

For downwind ground level receptors and at grade highways for crosswinds, equation (13) reduces to:

$$C = \frac{4.24 Q}{K \sigma_z \mu \sin \phi} \quad (14)$$

where σ_z = vertical dispersion parameter, meters

C. MAJOR DIFFERENCES IN THE MODELS

The major differences in the two models are outlined

California's model uses a Gaussian line source equation while EPA uses an integrated point source equation. As a result, the California model requires separate equations for predicting under crosswind and parallel wind conditions while EPA's model needs only one equation. The California model uses a wind angle of 12.5° with respect to the road as the boundary separating the two regions within which different equations are used. As a result, a discontinuity occurs at 12.5° between the concentrations predicted by the two equations.

EPA's HIWAY model requires separate traffic and emission data for each lane of the highway. Downwind concentrations are calculated by superimposing the separate pollutant contributions of each traffic lane. California's model uses the total traffic volume and emission rate for all lanes combined, assuming that all emissions are initially dispersed from a uniform "mixing cell" extending from road shoulder to shoulder (for medians <30 ft.).

Initial dispersion of pollutants at the roadside edge is handled differently in the two models. The EPA model uses a virtual source correction providing an initial $\sigma_z = 1.5$ meters. The California model assumes a "mixing cell" with initial $\sigma_z = 4$ meters. (See Figure VI-2).

Downwind dispersion is described by the empirical dispersion coefficients, σ_y and σ_z . Both models use different dispersion coefficients.

D. MODEL ASSUMPTIONS

The following basic assumptions are common to both models.

- 1) The mass of pollutants is conserved throughout the downwind length of the plume. No material is lost by reaction or by sedimentation.
- 2) The ground surface, when encountered, is a perfect plume reflector.
- 3) There exists no wind shear in the vertical direction. The wind velocity used should be representative of the average wind velocity between $\pm \sigma_z$ from the plume centerline in the vertical sense.
- 4) Dispersion occurs only by turbulent diffusion which varies according to Pasquill's atmospheric stability categories.
- 5) Atmospheric stability is constant within the mixing layer containing both sources and receptor.
- 6) There exists no mixing of material in the x axis (i.e., longitudinal mixing).
- 7) Emissions are from continuous sources.
- 8) The dispersion parameters σ_y and σ_z are good for modeling atmospheric dispersion over flat, grassy terrain with no significant aerodynamic roughness nor any artificial vertical instability induced by heat island effects associated with urban areas.

FIGURE VI-2
DISPERSION FROM VIRTUAL IMAGE (EPA MODEL)
AND MIXING CELL (CALIFORNIA MODEL).

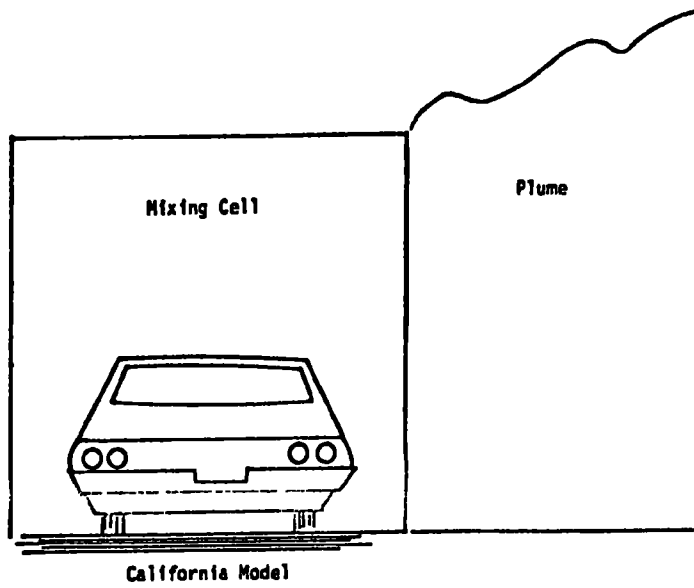
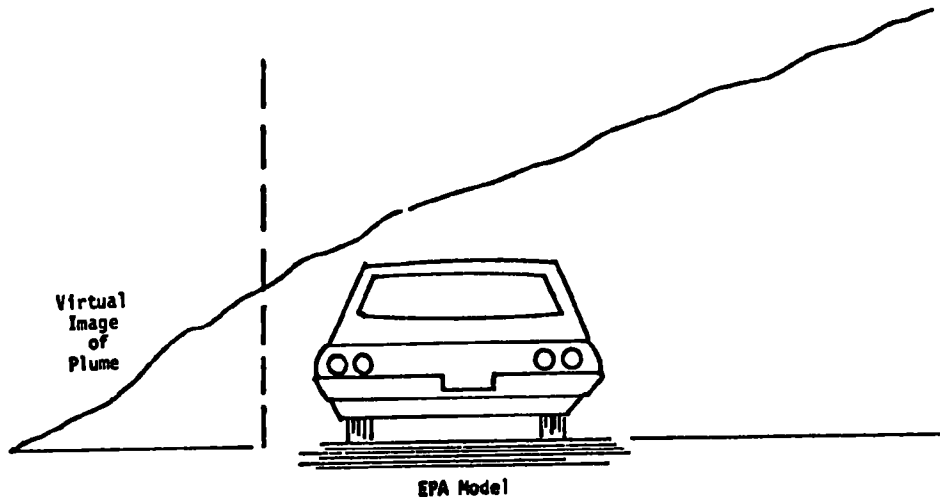

SOURCE: Noll, et al., (1975)

E. SRI STREET CANYON SUBMODEL

Stanford Research Institute's (SRI) Street Canyon Submodel was determined from an experiment conducted by Stanford Research Institute in San Jose, California in 1971 to estimate the dispersion of vehicular carbon monoxide emissions within a city street canyon. For this work air motion within the canyon was believed to be a single-helical circulation. As shown in Figure VI-3, this helical air circulation gives substantially higher concentrations to receptors on the leeward side (right side of the figure) than on the windward side (left side of the figure) because of the reverse flow component across the street, near the surface. This model assumes that the measured concentration, C , at the receptor is derived from two components. One component is contributed from a background concentration, C_{bk} , in the air entering the canyon from above, and the other concentration component, ΔC , is supplied from locally generated vehicular pollutant emissions, Q , in the street. Hence, we have

$$C = C_{bk} + \Delta C \quad (15)$$

This model calculates the concentration component from the vehicular emissions at a given receptor location by three different equations. Different equations are used depending on whether the wind directions are parallel or crosswind with respect to the road angle and whether receptor locations are on the leeward or windward side of a canyon.

1. Leeward Case.

A leeward case equation is employed to calculate concentrations, ΔC , from local vehicular emission for crosswinds (wind directions greater than 30° with respect to the road) and the receptor side of the highway where reverse air movements within the canyon transports vehicular emissions directly to the receptor. This equation can be represented by a simple box model form.

$$\Delta C_L = Q/U_s Y \quad (16)$$

FIGURE VI-3
SRI STREET CANYON DESCRIPTION

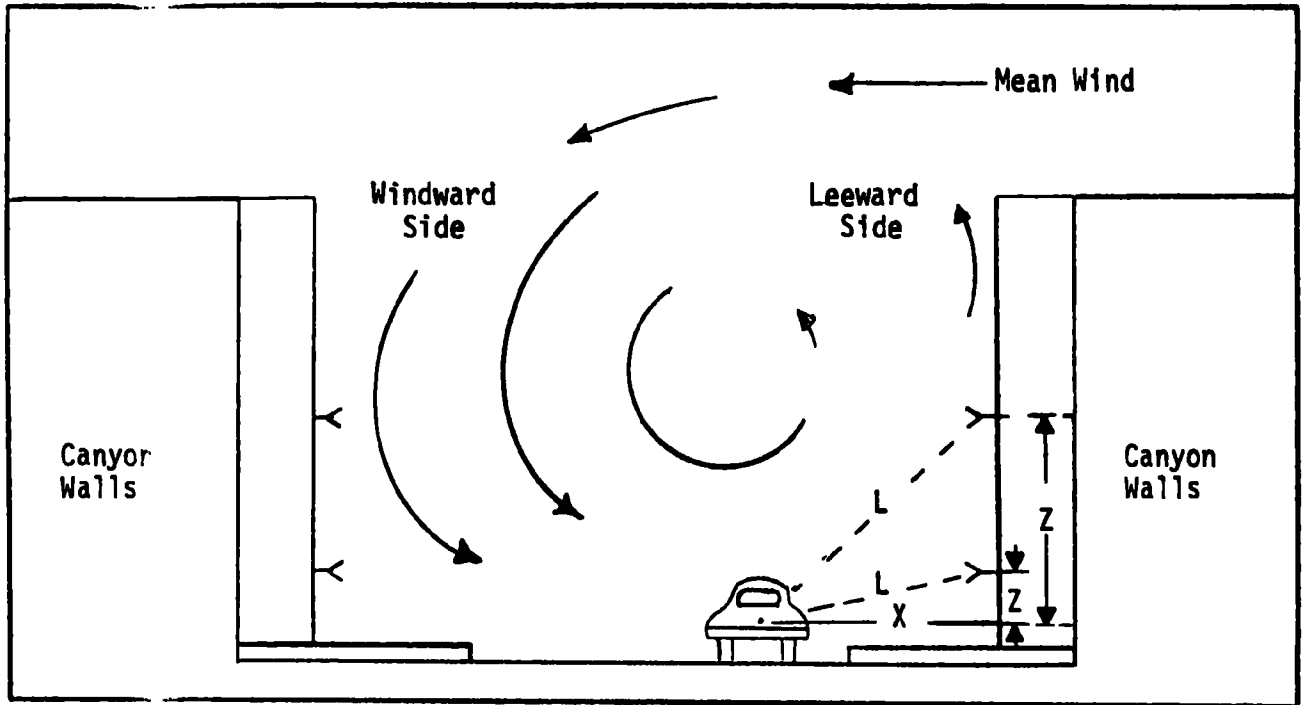

SOURCE: (Noll et al., 1975)

where ΔC_L = concentration component from the vehicular emissions for a receptor on the leeward side of the highway
 Q = rate of vehicular pollutant emissions
 U_s = mean wind speed near the street
 Y = depth of mixing volume

The leeward case model was then determined by SRI to be as follows:

$$\Delta C_L = \frac{K \times Q}{(U + 0.5) \times (X^2 + Z^2)^{\frac{1}{2}} + L_0} \quad (17)$$

where

where

- Q = rate of vehicular pollutant emissions in the street (gm/ (m·sec)).
- U = rooftop wind speed (m/sec.), 0.5 m/sec. is due to the influence of the vehicles forward motion. Therefore, U_s of the box model = $k_1(U + .5)$.
- X = horizontal distance from the receptor to the center of the nearest lane (m).
- Z = vertical distance from the road to the receptor (m).

where $L_0 =$ two meters, the dimension where vehicular emission was assumed completely mixed. Therefore, the depth of mixing volume (Y) from a box model $= k_2((X^2 + Z^2)^{1/2} + L_0)$.

2. Windard Case.

A windward case equation is for crosswind directions and for receptors located on the windward side. Similar to the previous leeward case, a box model concept was also used for fomulation of this equation, where the depth of mixing volume is considered to be constrained by the canyon's size.

$$\Delta C_W = \frac{K \times Q}{W \times (U + .5)} \times \frac{(H - Z)}{H} \quad (18)$$

where $\Delta C_W =$ vehicular emissions concentration component for receptors on the highway's windward side.

$W =$ width of canyon (m).

$H =$ average building height or depth of depressed highway (m).

3. Parallel Case.

A parallel case equation was determined for wind directions within $\pm 30^\circ$ of the highway angle and for prediction of concentrations at receptor locations on either highway side. This equation predicts parallel wind concentrations by taking an average of the leeward and windward equation.

$$\Delta C_I = \frac{1}{2}(\Delta C_L + \Delta C_W) \quad (19)$$

where $\Delta C_I =$ the parallel wind concentration component from the vehicular emissions.

F. EMPRICAL MODEL

As a result of the work accomplished by Noll, et al., (1975) an empirical model was developed to predict CO concentrations from a highway source. This empirical model, called EMP-1, was derived from simple dimensional analysis and has the form:

$$C \propto \frac{k Q}{U (X/\sin \theta)^a} \quad (20)$$

where

- C = concentration at ground level from an at-grade highway, ug/m³
- Q = pollutant emission rate, ug/m-sec
- U = mean wind speed normal to the road, m/sec
- X = distance from center of the road to the receptor
- θ = the angle of the wind with respect to the road, degrees,
- K & a = empirical coefficients

A regression analysis was performed on ln (C/Q) versus ln (X/sin θ) using 524 measurements during perpendicular and oblique wind conditions by Noll, et al., (1975). The values obtained for the slope of the regression line a = -1.106 and the intercept k = 8.18 were used to calibrate the model. The final equation for EMP-1 was

$$C_1 = \frac{8.18Q}{U (X/\sin \theta)^{1.106}} \quad (21)$$

II. INCORPORATION OF SINK FACTORS IN MODELS

The following discussion and calculation are an attempt to incorporate sink factors into the four models previously discussed. A few words of caution are needed before presenting these ideas. First, it should be noted, that the state of the art of using sink factors is not advanced to the point where one can confidently predict the amount of pollution that will be adsorbed or absorbed by a given species of vegetation. Much more research is needed in this area. Secondly, using buffer strips near highways, changes the aerodynamics of the plume generation by the highway. Most of the models discussed in the previous section are valid only for flat terrains with no interference. By using buffer strips, the models themselves are not accurate. Thirdly, once the plume enters the buffer strip area, its characteristics will change drastically. The vegetation will create changing flow patterns as the plume travels amongst the trees. Thermal chimney produced by gaps in the buffer strip will produce additional changes in the plume. Therefore, it is almost impossible to predict the exact characteristics of the plume and its interaction with the vegetation. Given the above considerations, it is easy to conceptualize that incorporating sink factors into mathematical algorithm to predict concentration of CO from highways is no easy task.

The methodology discussed in the remainder of this section for incorporating sink factors into the four models is an initial attempt to perform this task. The models should only be used for planning purposes and not to predict exact concentrations of CO. Further research is needed to collaborate these proposed model modifications.

A. GENERAL THEORY

For the California Line Source Model, the EPA HIWAY Model, and the Empirical Model EMP 1, there are two modifications that must be discussed. The first modification is the determination of the portion of the plume that will enter the buffer. The second modification is the development and incorporation of a pollution sink factor into the highway emission rate.

To determine the portion of the plume that will be effected by the planting of vegetation, it can be seen from the following illustration that Area A of the plume will be unaffected where as Area B will be affected.

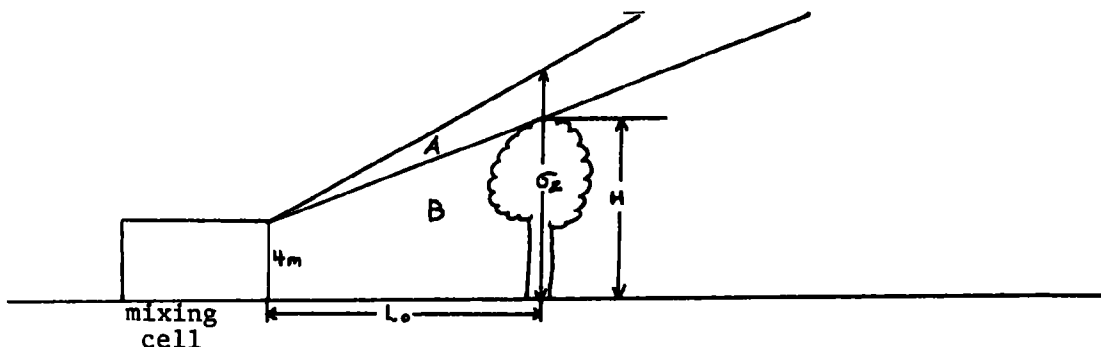

$$\begin{aligned} \text{Area A} &= 4L_0 + \frac{1}{2}L_0 (\sigma_z - 4) - 4L_0 - \frac{1}{2}L_0 (H - 4) \\ &= \frac{1}{2}L_0 (\sigma_z - H) \end{aligned}$$

$$\text{Area B} = 4L_0 + \frac{1}{2}L_0 (H - 4)$$

$$\text{TOTAL AREA} = 4L_0 + \frac{1}{2}L_0 (\sigma_z - 4)$$

$$\text{Fraction of Pollution Entering Trees if } \sigma_z > H = \frac{4L_0 + \frac{1}{2}L_0 (H - 4)}{4L_0 + \frac{1}{2}L_0 (\sigma_z - 4)} \quad (22)$$

The quantity of pollution leaving the buffer (Q_2) can be determined by the inclusion of the buffer sink factor (SLA) into that portion of the highway emission rate (Q_1) that is affected by the buffer strip

$$Q_2 = Q_1 \frac{4L_o + \frac{1}{2}L_o (H-4)}{4L_o + \frac{1}{2}L_o (T_z-4)} - (SLA) \quad (23)$$

where S = Buffer sink rate - gm/sec-m² of vegetation
 L = Depth of Buffer, m
 A = Canopy Area Index, m² canopy area/m² land

In other terms SLA is the quantity of pollution absorbed by a buffer, of a specific depth (L), per length of highway. Essentially, Q₂ is the quantity of pollution remaining in the air as the air leaves the buffer strips.

B. EXAMPLE OF CALIFORNIA MODEL, EPA MODEL AND EMPIRICAL MODEL

The EPA HIWAY Model, the California Line Source Model and the Empirical Model will be evaluated using a hypothetical 2 lane highway with a peak hour traffic volume is 2,000 vehicles. The meteorological conditions used are a 6m/sec wind approaching the highway 22½° adjacent to the road with a stability classification of D.

The buffer of trees used to demonstrate their effectiveness in removing carbon monoxide from the atmosphere will start 10 meters from the highway shoulder and continue to a depth of 100 meters. The receptor will be located 110 meters from the shoulder of the highway.

For the sake of analysis, the make-up of the buffer will consist of 344 deciduous (oak, maple, poplar, birch, linden) and 700 pine trees for every hectare. The absorptive capacity of such a planting for carbon monoxide has been determined to be 6.328 x 10⁻⁶ gr/sec-m² vegetation.

As the plume leaves the highway, part of the plume will escape the influence of the buffer and the remainder of the plume will be trapped by the buffer. To calculate the fraction of the pollution captured by the buffer, the equation (23) and the following data will be used.

$$L_o = 10m \quad H = 6m \quad T_z = 7m$$

By dividing the areas of the two trapezoidal areas between the mixing cell and the buffer, the fraction of entrapment can be calculated.

$$\text{Fraction of entrapment} = \frac{10\text{m} \times 4\text{m} + \frac{1}{2} \times 10\text{m}^2 \times 2\text{m}}{10\text{m} \times 4\text{m} + \frac{1}{2} \times 10\text{m} \times 3\text{m}} = \frac{50}{55} = .909$$

For these specific meteorological conditions, approximately 91% of the pollution being emitted by the highway is being entrapped by the buffer.

Once part of the plume reaches the buffer, the trees start to absorb the carbon monoxide at a hypothetical rate of SLA. For this buffer arrangement (S) has a value of 6.328×10^{-6} gr/sec- m^2 . The buffer depth (L) is 100m and the Canopy Area Index has a value of $1.5 \text{ m}^2/\text{m}^2$. Combining these three parameters yields a value for SLA of 9.49×10^{-4} gr/m-sec.

As previously mentioned the example highway is carrying 2000 vehicles/hour and if each car is emitting 42.8 gr/veh-km, the highway emission rate, Q_1 , will be 0.024 gr/m-sec. Since the Q_1 , SLA, and the fraction of entrapment have been calculated, the emission rate after the buffer (Q_2) can be calculated.

$$Q_2 = .91Q_1 - \text{SLA} \quad (24)$$

Substituting previously defined values of Q_1 , SLA, Q_2 can be calculated to be:

$$\begin{aligned} Q_2 &= .91 (.024) - 9.49 \times 10^{-4} \text{ gr/m-sec} \\ Q_2 &= .0209 \text{ gr/m-sec} \end{aligned}$$

To summarize, the following parameters have been defined for the hypothetical situation:

$$\begin{aligned} U &= 6\text{m/sec} & Q_1 &= .024 \text{ gr/m-sec.} & \text{SLA} &= 9.49 \times 10^{-4} \text{ gr/m-sec} \\ \phi &= 22\frac{1}{2}^\circ & Q_2 &= .0209 \text{ gr/m-sec.} \end{aligned}$$

1. Solution of California Line Source Model.

By determining the vertical dispersion coefficient (σ_z) at .11 km normal to the road to be 13 m, the concentration of carbon monoxide for a bare road side can

be calculated by using equation (14).

$$C = \frac{1.06 Q_1}{4.24 U \sin \phi \sigma_z} \quad (4)$$

$$= \frac{1.06 (.024) (4)}{4.24 (6) (.382) (13)} = 804. \mu\text{g}/\text{m}^3$$

If Q_2 is substituted for Q_1 , the concentration 100m deep in the buffer can be calculated.

$$C = \frac{1.06 Q_2}{4.24 u \sin \phi T_z} \quad 4$$

$$= \frac{1.06 (.0209) (4)}{4.24 (6) (.382) (13)} = 701.4 \mu\text{g}/\text{m}^3$$

As can be noted, a significant hypothetical reduction can be accomplished by 100 meters buffer.

2. Solution of EPA HIWAY Model.

The EPA HIWAY Model was graphically solved for the proposed hypothetical situation. The resultant concentration for an unforested highway is $4000 \mu\text{g}/\text{m}^3$ where a forested highway yields $3483 \mu\text{g}/\text{m}^3$.

Similar answers could be achieved through the numerical integration of the EPA HIWAY equations presented in Section I of this Appendix A.

3. Solution of Empirical Model.

By applying the values of Q_1 , U and θ to equation (21), the concentration 110 meters (x) from non buffered highway can be calculated,

$$C = \frac{8.18 Q_1}{U (x/\sin \theta)} 1.106$$

$$C = \frac{8.18 (.024)}{6(110/.283)} 1.106 = 344 \mu\text{g}/\text{m}^3$$

For a buffered highway, the value of Q_2 is substituted for Q_1 which yields,

$$C = \frac{8.18 Q_2}{U (x/\sin\theta)^{1.106}}$$

$$C = \frac{8.18(.0209)}{6(110/.283)^{1.106}} = 39 \text{ g/m}^3$$

4. Solution of SRI Street Canyon Model.

Instead of the open highway, the SRI Street Canyon Model is applicable to a street surrounded by tall buildings. The tree configuration is also different for this model. There will be a tree every 30 feet on each side of the highway. If 20 ft. maples were used with a canopy area of $7.1 \text{ m}^2/\text{tree}$, the applicable sink rate(s) could be calculated;

$$S = \text{Sink rate} \times \text{canopy area/tree} \times 1/\text{distance between trees} \quad (25)$$

$$S = 6.328 \times 10^{-6} \frac{\text{gr}}{\text{sec m}^2} \times \frac{7.1 \text{ m}^2}{\text{tree}} \times \frac{\text{tree}}{4.57\text{m}} = 2.46 \times 10^{-6} \frac{\text{gr}}{\text{sec m}}$$

The configuration of the street canyon is shown in Figure VI-2. The dimensions of the canyon are chosen to be $Z = 1\text{m}$, $L_0 = 2\text{m}$, $W = 15\text{m}$, $X = 5\text{m}$, $H = 10\text{m}$. When these dimensions and the data from the previous example are entered into equations (17) and (18) the leeward and windward concentrations can be calculated for an unplanted street.

$$\begin{aligned} \Delta C \text{ leeward} &= \frac{7 Q}{(U + .5) ((X^2 + Z^2)^{1/2} + L_0)} \\ &= \frac{7(.024)}{(6.5) ((26)^{1/2} + 2)} = 3640 \text{ } \mu\text{g/m}^3 \end{aligned}$$

$$\begin{aligned} \Delta C \text{ windward} &= \frac{7 Q (H-Z)}{W (U+.5)H} \\ &= \frac{7 (.024) (9)}{(15) (6.5) (10)} = 1550.7 \text{ } \mu\text{g/m}^3 \end{aligned}$$

The concentrations for a planted street can be determined by subtracting S from Q_1 to determine a new emission rate. Subsequently the revised emission rate Q_2 equal .02399 g/m sec. By substituting this revised value into equations (17) and (18) the leeward and windward concentrations can be calculated to be:

$$\begin{aligned} \Delta C \text{ leeward} &= \frac{7 Q_2}{(U + .5) ((X^2 + Z^2)^{\frac{1}{2}} + L_0)} \\ &= \frac{7 (.02399)}{(6.5) ((26)^{\frac{1}{2}} = 2)} = 3639 \mu\text{g}/\text{m}^3 \end{aligned}$$

$$\begin{aligned} \Delta C \text{ windward} &= \frac{7 Q (H-Z)}{W (U + .5) H} \\ &= \frac{7 (.02399) (9)}{(15) (6.5) (10)} = 1550.1 \mu\text{g}/\text{m}^3 \end{aligned}$$

APPENDIX B
SENSITIVE SPECIES LIST

The Plant Species Sensitivity Lists contained in Volume I have been duplicated and placed in this Appendix for convenience. Both the Table and Page numbers which appear in Volume I have been changed, where appropriate, to follow the numerical order of this Volume. Numbers in the Reference column of this list refer to the literature citations listed in Volume I.

TABLE VI-1
PLANT SPECIES SENSITIVITY LISTS

Fluorine

TOLERANT - Trees/Deciduous

Reference

Apple <i>Malus</i> sp.	733
American elm <i>Ulmus americana</i>	1164, 536
American linden (Basswood) <i>Tilia americana</i>	1164, 536
American mountain ash <i>Sorbus domestica</i>	536
American sycamore <i>Platanus occidentalis</i>	733
Basswood (American linden) <i>Tilia americana</i>	1164, 536
Cornelian cherry <i>Cornus mas</i>	1164, 536
Cutleaf birch <i>Betula pendula</i> var. <i>gracilis</i>	536
European black alder <i>Alnus glutinosa</i>	536, 1164
European elder <i>Sambucus nigra</i>	536
European larch <i>Larix decidua</i>	1687
European mountain ash <i>Sorbus aucuparia</i>	1164, 536
European red elder <i>Sambucus racemosa</i>	536
Flowering dogwood <i>Cornus florida</i>	733
Flowering plum <i>Prunus cerasifera</i>	1164, 536
Hackberry <i>Celtis</i> sp.	733
Litte leaf linden <i>Tilia cordata</i>	536
Modesto ash <i>Fraxinus velutina</i>	1164, 536
Norway maple <i>Acer platanoides</i>	733
Oleaster (Russian Olive) <i>Eleagnus angustifolia</i>	536
Oriental cherry <i>Prunus serrulata</i>	536
Pear <i>Fyrus communis</i>	1164
Russian olive (Oleaster) <i>Eleagnus angustifolia</i>	536
Sugar maple <i>Acer saccharum</i>	1164
Tree of heaven <i>Ailanthus altissima</i>	536
Willow <i>Salix</i> sp.	536, 1164
White birch <i>Betula alba</i>	733
White mulberry <i>Morus alba</i>	733

TOLERANT - Trees/Coniferous

American holly <i>Ilex opaca</i>	733
Austrian pine <i>Pinus nigra</i>	1164
Canadian hemlock (Hemlock) <i>Tsuga canadensis</i>	733
Eastern red cedar <i>Juniperus virginiana</i>	525
Hemlock (Canadian hemlock) <i>Tsuga canadensis</i>	733
Juniper <i>Juniperus</i> sp.	1164, 536
Magnolia <i>Magnolia</i> sp.	733
Western hemlock <i>Tsuga heterophylla</i>	1687
White spruce <i>Picea glauca</i>	1164, 536

TOLERANT - Shrubs

Bridal wreath spirea <i>Spirea prunifolia</i>	1164
Currant <i>Ribes</i> sp.	1164
Firethorn <i>Pyracantha</i> sp.	1164

TOLERANT - Herbaceous

Alfalfa <i>Medicago sativa</i>	16
--------------------------------	----

Fluorine (Con't)

TOLERANT - Herbaceous

	<u>Reference</u>
Apricot - vine <i>Passiflora</i> sp.	886C
Celery <i>Spermolepsis</i> sp.	16
Cotton <i>Gossypium</i> sp.	136, 16, 269
Cucumber <i>Sicyos</i> sp.	16
Eggplant <i>Solanum melongena</i>	16
Fescue <i>Festuca elator</i>	890N
Geranium <i>Geranium</i> sp.	16
Gladiolus	886C
Grapevine <i>Vitis</i> sp.	886C
Kentucky bluegrass <i>Poa pratensis</i>	890N
Red Fescue <i>Festuca</i> sp.	890N
Sweet clover <i>Melilotus</i> sp.	16
Tobacco <i>Nicotiana</i> sp.	16

INTERMEDIATE - Trees/Deciduous

Apple <i>Malus</i> sp.	16
Black locust <i>Robinia pseudoacacia</i>	1164, 536
Black walnut <i>Juglans nigra</i>	536
Cutleaf birch <i>Betula pendula</i> var. <i>gracilis</i>	16
English oak <i>Quercus robor</i>	536
English walnut (Persian walnut) <i>Juglans regia</i>	1164, 536
Eugene poplar <i>Populus canadensis</i> var. <i>jugenci</i>	1164, 536
European ash <i>Fraxinus excelsior</i>	1164, 536
European beech <i>Fagus sylvatica</i>	536
European filbert <i>Corylus avellana</i>	536
European hornbeam <i>Carpinus betulus</i>	536
European white birch <i>Betula pendula</i>	536
Green ash <i>Fraxinus pennsylvanica lanceolata</i>	536, 1164
Hedge maple <i>Acer campestre</i>	536, 1164
Japanese larch <i>Larix leptolepsis</i>	1074
Little leaf linden <i>Tilia cordata</i>	1164, 536
Lombardy poplar <i>Populus nigra</i> var. <i>italica</i>	1164, 536
Oriental cherry <i>Prunus serrulata</i>	1164
Oriental plane tree <i>Platanus orientalis</i>	536
Persian walnut (English walnut) <i>Juglans regia</i>	1164, 536
Quaking aspen <i>Populus tremuloides</i>	1164, 536
Red mulberry <i>Morus rubra</i>	536
Servicberry <i>Amelanchier canadensis</i>	1164
Silver maple <i>Acer saccharinum</i>	1164, 536
Smooth sumac <i>Rhus glabra</i>	536
Spanish chestnut <i>Castanea sativa</i>	536

INTERMEDIATE - Trees/ Coniferous

Aborvitae <i>Thuja</i> sp.	536, 1164
Austrian pine <i>Pinus nigra</i>	525
Douglas fir <i>Pseudotsuga menziesii</i>	1074
English holly <i>Ilex aquifolium</i>	1164, 536
Lodgepole pine <i>Pinus contorta</i>	1074

Fluorine (Con't)

INTERMEDIATE - Trees/ Coniferous

	<u>Reference</u>
Noble fir <i>Abies procera</i>	1074
Ponderosa pine <i>Pinus ponderosa</i>	1074
Spruce <i>Picea sp.</i>	1074
Western hemlock <i>Tsuga heterophylla</i>	1074
Western red cedar <i>Juniperus scopulorum</i>	1074
Western white pine <i>Pinus monticola</i>	1074
White fir <i>Abies concolor</i>	1074

INTERMEDIATE - Shrubs

Common lilac <i>Syringa vulgaris</i>	1164
Japanese yew <i>Taxus cuspidata</i>	1164, 536
Rhododendron <i>Rhododendron sp.</i>	1164
Rose <i>Rosa sp.</i>	1074, 1164, 16

INTERMEDIATE - Herbaceous

Buckwheat <i>Fagopyrum</i>	16
Iris <i>Iris sp.</i>	16

SENSITIVE - Trees/Deciduous

Apricot (Flowering apricot) <i>Prunus armeniaca</i>	536, 16, 460
Box elder <i>Acer negundo</i>	536, 1164
Bradshaw plum <i>Prunus domestica 'Bradshaw'</i>	536, 1164
Empress tree <i>Paulownia tomentosa</i>	536
Flowering apricot (Apricot) <i>Prunus armeniaca</i>	536, 16, 460
Hop hornbeam <i>Carpinus betulus</i>	765
Italian prunes <i>Prunus sp.</i>	269
Japanese apricot <i>Prunus mume</i>	363
Maple <i>Acer sp.</i>	765
Moorhead apricot	363
Paulownia (Empress tree) <i>Paulownia tomentosa</i>	536
Plum <i>Prunus sp.</i>	16
Western larch <i>Larix occidentalis</i>	536

SENSITIVE - Trees/ Coniferous

Cascades fir <i>Abies amabilis</i>	1074
Colorado spruce <i>Picea pungens</i>	536, 1164
Douglas fir <i>Pseudotsuga menziesii</i>	525, 536, 1074, 1164
	1687
Eastern white pine <i>Pinus strobus</i>	536
Engelmann spruce <i>Picea engelmannii</i>	1687
Loblolly pine <i>Pinus taeda</i>	1164, 536
Lodgepole pine <i>Pinus contorta</i>	536, 525
Noble fir <i>Abies procera</i>	1687
Nordman's fir <i>Abies nordmanniana</i>	1074, 1687
Norway spruce <i>Picea abies</i>	1074, 1687
Ponderosa pine <i>Pinus ponderosa</i>	536
Scotch pine <i>Pinus sylvestris</i>	525, 1164, 536, 1074

Flourine (Con't)

SENSITIVE - Trees/Evergreen

	<u>Reference</u>
Serbian spruce <i>Picea omorika</i>	1074, 1687
Silver fir <i>Abies pectinata</i>	1687
White fir <i>Abies concolor</i>	1687

SENSITIVE - Shrubs

Blueberry <i>Vaccinium sp.</i>	1164
Common barberry <i>Berberis vulgaris</i>	765
Dwarf alps honeysuckle <i>Lonicera alpigena</i>	765
Dwarf mugo pine <i>Pinus mugo mughus</i>	536
St. Johnswort <i>Hypericum maculatum</i>	1010, 765
St. Johnswort <i>Jupericum perforatum</i>	765

SENSITIVE - Herbaceous

Amaranthus <i>Amaranthus retroflexus</i>	765
Annual blue grass <i>Poa annua</i>	765
Catchfly <i>Silene inflata</i>	765
Colchis (Fall crocus) <i>Colchicum autumnale</i>	765
Common chickweed <i>Stellaria media</i>	765
Corn <i>Zea mays</i>	16
Fall crocus (Colchis) <i>Colchicum autumnale</i>	765
Gladiolus	990, 363, 318, 886C, 16, 136, 269
Goosefoot <i>Chenopodium alba</i>	765
Goosefoot <i>Chenopodium murale</i>	765
Grape <i>Vivis vinifera</i>	765
Iris <i>Iris sp.</i>	990
Mustard <i>Sinapsis arvenis</i>	765
Oat grass <i>Arrhenatherum elatius</i>	765
Orchard grass <i>Dactylis glomerata</i>	765
Oregan grape <i>Vitis sp.</i>	363
Tulip	318

PLANT SPECIES SENSITIVITY LISTS

General Pollution

TOLERANT - Trees/Deciduous

Reference

Alder <i>Alnus sp.</i>	39, 1400
Almond tree <i>Prunus amygdalus</i>	407
American beech (Red beech) <i>Fagus grandifolia</i>	39
Apple <i>Malus sp.</i>	787
Ash <i>Fraxinus sp.</i>	890Q, 39
Balsam poplar <i>Populus balsamifera</i>	890J, 886K, 889A
Birch <i>Betula lenta</i>	889A, 886I, 8900, 1400
Box elder <i>Acer negundo</i>	886K, 890L, 890J, 890L, 886I
Canadian poplar (Carolina poplar) <i>Populus canadensis</i>	890L
Carolina poplar (Canadian poplar) <i>Populus canadensis</i>	890L
Cherry <i>Prunus sp.</i>	890Q, 1501, 407
Eastern poplar <i>Populus deltoides</i>	886N
Elder <i>Sambucus sp.</i>	890Q
Elm <i>Ulmus sp.</i>	886K, 889A, 890J, 890Q
European mountain ash <i>Sorbus aucuparia</i>	890Q
Flowering dogwood <i>Cornus florida</i>	890Q
Gingko (Maidenhair tree) <i>Gingko biloba</i>	1358
Goat willow <i>Salix caprea</i>	890L
Hawthorn <i>Crataegus sp.</i>	889B
Honey locust <i>Gleditsia triacanthos</i>	1976
Japanese larch <i>Larix leptolepsis</i>	787
Japanese pagoda tree <i>Sophora japonica</i>	1976
Juneberry <i>Amelanchier sp.</i>	8900
Larch <i>Larix sp.</i>	1400
London plane tree <i>Platanus acerifolia</i>	1976
Maidenhair tree (Gingko) <i>Gingko biloba</i>	1358
Oak <i>Quercus sp.</i>	889A
Oleaster (Russian olive) <i>Elaeagnus angustifolia</i>	886K, 890J, 890, 889A
Ornamental apple <i>Malus floribunda</i>	890Q
Peach <i>Prunus persica</i>	407
Pear <i>Pyrus communis</i>	809Q
Plum <i>Prunus sp.</i>	407
Poplar <i>Populus sp.</i>	889A, 890Q
Red ash <i>Fraxinus pennsylvanica</i>	890
Red beech (American beech) <i>Fagus grandifolia</i>	39
Redhaw hawthorn <i>Crataegus mollis</i>	890Q
Russian olive (Oleaster) <i>Elaeagnus angustifolia</i>	886K, 890J, 890, 889A
Scarlet elder <i>Sambucus pubens</i>	889B, 890L
Silverberry <i>Elaeagnus commutata</i>	890L
Tree of heaven <i>Ailanthus altissima</i>	1358

TOLERANT - Trees/ Coniferous

Arborvitae <i>Thuja sp.</i>	886N
Austrian pine <i>Pinus nigra</i>	41, 787
Cedar (Eastern red cedar) <i>Juniperus virginiana</i>	890Q
Colorado spruce <i>Picea pungens</i>	886N, 787
Eastern red cedar (Cedar) <i>Juniperus virginiana</i>	890Q
Eastern white pine <i>Pinus strobus</i>	889A
Sitka spruce <i>Picea sitchensis</i>	787
Western red cedar <i>Thuja plicata</i>	787, 890Q

General Pollution (Con't)

TOLERANT - Shrubs

	<u>Reference</u>
Alder buckthorn <i>Rhamnus frangula</i>	886I
Alpine currant <i>Ribes</i> sp.	890Q
Blueberry <i>Vaccinium</i> sp.	407
Common lilac <i>Syringa vulgaris</i>	886K
Hedgerow rose <i>Rosa</i> sp.	890Q
Lilac <i>Syringa</i> sp.	890L, 890Q
Mentor barberry <i>Berberis mentorensis</i>	1501, 886I, 890Q
Spindletree <i>Euonymus</i> sp.	890L
Snowberry <i>Symphoricarpos albus</i>	890L
Sweetbriar <i>Rosa eglantaria</i>	890Q
Tatarian honeysuckle <i>Lonicera tatarica</i>	890L
Viburnum <i>Viburnum</i> sp.	890Q

TOLERANT - Herbaceous

Annual bluegrass <i>Poa annua</i>	407
Barley <i>Hordeum</i> sp.	407
Bean <i>Phaseolus</i>	407
Benoite <i>Geum</i> sp.	407
Blanketflower <i>Gaillardia</i> sp.	1513
Cabbage <i>Brassica napolerassica</i>	407
Cauliflower	407
Chickweed <i>Cerastium triviale</i>	38
Chrysanthemum <i>Chrysanthemum</i>	407
Corn <i>Zea mays</i>	407
Dandelion <i>Taraxacum platicardum</i>	38
Day lily <i>Hemerocallis fulva</i>	38
Hawksbeard <i>Crepis japonica</i>	38
Onion <i>Allium japonica</i>	38
Peas <i>Vigna</i> sp.	407
Pepper	407
Pink satin petunia <i>Petunia</i> sp.	797
Potatoes <i>Solanum jamesii</i>	407
Radish <i>Raphanus</i> sp.	407
Rhubarb <i>Rheum rhaponticum</i>	407
Roth <i>Athyrium nipponicum</i>	38
Siberian pea shrub	886K, 890
Spurge <i>Euphorbia helioscopia</i>	38
Spurge <i>Euphorbia sieboldiana</i>	38
St. Johnswort <i>Hypericum</i> sp.	407
Starwort <i>Stellaria media</i>	38
Strawberry <i>Fragaria</i> sp.	407
Tickseed <i>Coreopsis tinctoria</i>	38
Wheat <i>Triticum aestivum</i>	407
Woodbine <i>Lonicera periclymenum</i>	890Q
Wormwood <i>Artemis vulgaris</i>	38

INTERMEDIATE - Trees/Deciduous

Alder <i>Alnus</i> sp.	886C, 889A
------------------------	------------

General Pollution (Con't)

INTERMEDIATE - Trees/Deciduous

Reference

American linden (Basswood) <i>Tilia americana</i>	886, 733
Apple <i>Malus sp.</i>	1332
Apricot <i>Prunus armeniaca</i>	407
Ash <i>Fraxinus bungeana</i>	38
Ash <i>Fraxinus longicuspis</i>	38
Aspen (Hybrid poplar) <i>Populus sp.</i>	886L, 890E, 886C
Balsam poplar <i>Populus balsamifera</i>	890E, 886L
Basswood (American linden) <i>Tilia americana</i>	886, 733
Black poplar <i>Populus nigra</i>	890E
Box elder <i>Acer negundo</i>	889A
Canoe birch (White birch) <i>Betula papyrifera</i>	886L, 890E
Chestnut oak <i>Quercus dentata</i>	38
Chokecherry <i>Prunus virginiana</i>	733
Elder <i>Sambucus</i>	886C
Elm <i>Ulmus sp.</i>	889A
English oak <i>Quercus robur</i>	886N
European larch <i>Larix decidua</i>	787, 886
Fig <i>Ficus carica</i>	733
Glabbearing oak <i>Quercus glandbearing</i>	38, 886C
Grapefruit <i>Citrus sp.</i>	407
Green ash <i>Fraxinus pennsylvanica var. lanceolata</i>	890E
Hawthorn <i>Crataegus</i>	886C, 733
Hornbeam <i>Carpinus sp.</i>	886C
Hybrid poplar (Aspen) <i>Populus sp.</i>	886L, 890E, 886C
Little leaf linden <i>Tilia cordata</i>	886N
Lombardy poplar <i>Populus nigra var. italica</i>	733
Maple <i>Acer sp.</i>	889A
Mountain ash <i>Sorbus americana</i>	890E
Mulberry <i>Morus sp.</i>	886C
Norway maple <i>Acer platanoides</i>	501
Pubescent birch <i>Betula sp.</i>	886N
Red ash <i>Fraxinus pennsylvanica</i>	886N, 501, 890L
Sawtooth oak <i>Quercus acuta</i>	38
Silver maple <i>Acer saccharinum</i>	501
Tulip poplar (Yellow poplar) <i>Liriodendron tulipifera</i>	501
Walnut <i>Juglans sp.</i>	407
White birch (Canoe birch) <i>Betula papyrifera</i>	886L, 890E
Willow <i>Salix sp.</i>	886C
Yellow poplar (Tulip poplar) <i>Liriodendron tulipifera</i>	501

INTERMEDIATE - Trees/Coniferous

Arborvitae <i>Thuja sp.</i>	889A
Canadian hemlock <i>Tsuga canadensis</i>	787
Colorado spruce <i>Picea pungens</i>	733
Eastern white pine <i>Pinus strobus</i>	886N, 787
Engelmann's spruce <i>Picea engelmanni</i>	889A
False cypress <i>Chameocyparis sp.</i>	889A
Fir <i>Abies sp.</i>	787
Japanese red pine <i>Pinus densiflora</i>	38
Lodgepole pine <i>Pinus contorta</i>	889A

General Pollution (Con't)

INTERMEDIATE - Coniferous

	<u>Reference</u>
Norway pine (Red pine) <i>Pinus resinosa</i>	886N
Pitch pine <i>Pinus rigida</i>	733
Red pine (Norway pine) <i>Pinus resinosa</i>	886N
Serbian spruce <i>Picea omorika</i>	889A

INTERMEDIATE - Shrubs

Common lilac <i>Syringa vulgaris</i>	890J
Filbert <i>Corylus</i> sp.	890L
Forsythia <i>Forsythia intermedia</i>	733, 501
Hedgerow rose <i>Rosa</i> sp.	890E
Japanese barberry <i>Berberis thunbergii</i>	890L
Juniper <i>Juniperus</i> sp.	889A
Spirea <i>Spirea</i> sp.	733
Tatarian honeysuckle <i>Lonicera tatarica</i>	501, 890J
Weigela <i>Weigela florida</i>	501

INTERMEDIATE - Herbaceous

Ageratum <i>Eupatorium coelestinum</i>	407
Bean <i>Phaseolus</i> sp.	407
Bluegrass <i>Poa matsumural</i>	38
Carnation <i>Dianthus</i> sp.	407
Celery <i>Spermolepsis</i> sp.	407
Chrysanthemum <i>Chrysanthemum</i> sp.	407
Common plantago <i>Plantago major</i>	38
Cudweed <i>Gnaphalium multiceps</i>	38
Daisy fleabane <i>Erigeron strigosus</i>	38
Endive <i>Cichorium endivia</i>	407
Grape <i>Vitis vinifera</i>	733
Groundsel <i>Senecio nikoensis</i>	38
Heat lettuce <i>Lactuca</i> sp.	407
Knotweed <i>Polygonum virginianum</i>	38
Lucerne <i>Medicago sativa</i>	407
Maidenhair <i>Adiantum pedatum</i>	38
Nasturtium (Yellow cress) <i>Nasturtium indicum</i>	38
Oat <i>Danthonia</i> sp.	407
Onion <i>Allium</i> sp.	407
Petunia <i>Petunia</i> sp.	407
Rape seed (Turnip) <i>Brassica rapa</i>	407
Siberian pea tree	889A, 890J, 890L
Sorrel <i>Rumex acetosa</i>	38
Sudan grasses	407
Sweet coltsfoot <i>Petasites japonica</i>	38
Turnip (Rape seed) <i>Brassica rapa</i>	407
Violet <i>Viola</i> sp.	38
Yellow cress (Nasturtium) <i>Nasturtium indicum</i>	38
Zinnias <i>Heliopsis elegans</i>	407

General Pollution (Con't)

SENSITIVE - Trees/Deciduous

	<u>Reference</u>
Alder <i>Alnus multinervis</i>	38
Apple (Siberian crabapple) <i>Malus baccata</i>	886L, 311
Ash <i>Fraxinus sp.</i>	889A
Beech <i>Fagus sp.</i>	889A
Birch <i>Betula sp.</i>	886I, 311, 425
Black oak <i>Quercus velutina</i>	733
Box elder <i>Acer negundo</i>	890E
Buckeye <i>Aesculus turbinata</i>	38
Catalpa <i>Catalpa speciosa</i>	311, 425
Chestnut oak <i>Quercus prinus</i>	733
Chokecherry <i>Prunus virginiana</i>	733
Elm <i>Ulmus sp.</i>	811, 425, 1501
Japanese maple <i>Acer palmatum</i>	38, 425
Judas tree <i>Cercis siliquastrum</i>	1501
Larch <i>Larix sp.</i>	890K, 311, 38, 890E
Lichen	1490
Linden <i>Tilia sp.</i>	889A
Lombardy poplar <i>Populus nigra var. italica</i>	311, 425
Mahogany <i>Melia japonica</i>	38
Mulberry <i>Morus microphylla</i>	311
Oak <i>Quercus sp.</i>	425
Orange <i>Citrus sp.</i>	727
Peach <i>Prunus persica</i>	1332, 733
Pear <i>Pyrus communis</i>	311
Pumila Arborea (Turkestan elm) <i>Ulmus turkestanica</i>	890E
Siberian crabapple (Apple) <i>Malus baccata</i>	886L, 311
Tree of heaven <i>Ailanthus altissima</i>	1501
Turkestan elm (Pumila arborea) <i>Ulmus turkestanica</i>	890E
White oak <i>Quercus alba</i>	733
White poplar <i>Populus alba</i>	38
Wild black cherry <i>Prunus serotina</i>	1332

SENSITIVE - Trees/ Coniferous

Austrian pine <i>Pinus nigra</i>	733
Colorado spruce <i>Picea pungens</i>	733
Douglas fir <i>Pseudotsuga menziesii</i>	425, 733
Eastern white pine <i>Pinus strobus</i>	733, 311
Fir <i>Abies sp.</i>	890E, 886N, 886C, 889A
Norway spruce <i>Picea abies</i>	733
Ponderosa pine <i>Pinus ponderosa</i>	311
Scotch pine <i>Pinus sylvestris</i>	733, 886K, 890J, 787, 889A
Spruce <i>Picea sp.</i>	425, 889A, 886N, 39, 890E

General Pollution (Con't)

SENSITIVE - Shrubs

	<u>Reference</u>
Common lilac <i>Syringa vulgaris</i>	733
Oregon holly-grape <i>Mahonia aquifolium</i>	733
Yew <i>Taxus</i> sp.	889A

SENSITIVE - Herbaceous

Aconite <i>Aconitum japonicum</i>	38
Agrimony <i>Agrimonia pilosa</i>	38
Alfalfa <i>Medicago sativa</i>	727, 311
Aster <i>Aster bigelobii</i>	311
Bachelor's button <i>Centaurea cyanus</i>	311
Barley <i>Hordeum vulgare</i>	311
Bean <i>Phaseolus vulgaris</i>	311
Bedstraw <i>Galium strigosum</i>	
Beet <i>Beta vulgaris</i>	311, 407
Bindweed <i>Convolvulus arvensis</i>	311
Bluegrass <i>Poa</i> sp.	886C
Broccoli <i>Brassica oleracea</i>	311
Brussel sprouts <i>Brassica aleracea</i> var. <i>gemmifera</i>	311
Buckwheat <i>Fagopyrum sagittatum</i>	311, 1332
Careless weed <i>Amaranthus palmeri</i>	311
Carrot <i>Daucus carota</i>	311
Catbriar <i>Smilax racemosa</i>	733
Chickweed <i>Stellaria media</i>	407
Cinquefoil <i>Potentilla chinensis</i>	38
Clover <i>Melilotus</i> sp.	311
Clover <i>Trifolium</i> sp.	311
Corn <i>Zea mays</i>	1332
Cosmos <i>Cosmos bipinnatus</i>	311
Cotton <i>Gossypium</i> sp.	311
Curly clock <i>Rumex crispus</i>	311
Endive <i>Cichorium endivia</i>	311
Fleabane <i>Erigeron canadensis</i>	311
Four o'clock <i>Mirabilis jalapa</i>	311
Galinsoga <i>Galinsoga parvifolia</i>	407
Goosefoot <i>Chenopodium album</i>	407
Green beans <i>Phaseolus</i> sp.	727
Gypsy petunia <i>Petunia</i> sp.	797
Horsetail <i>Equisetum arvense</i>	38
Huckleberry <i>Gaylussacia</i> sp.	733
Lettuce <i>Lactuca sativa</i>	311
Lettuce, prickly <i>Lactuca scariola</i>	311
Lima bean <i>Phaseolus limensis</i>	727
Mallow <i>Malva parvifolia</i>	311
Morning glory <i>Ipomoea purpurea</i>	311
Mosses <i>Commelina</i> sp.	1490
Oat <i>Avena sativa</i>	311
Okra <i>Hibiscus esculentus</i>	311
Pea <i>Vigna sinensis</i>	890K
Peanut <i>Arachis</i> sp.	727

General Pollution (Con't)

SENSITIVE - Herbaceous

Reference

Pear tree	889A
Pepper bell, chili <i>Capsicum prutescens</i>	311
Pinto beans	727
Plantain <i>Plantago major</i>	311
Pumpkin <i>Cucurbita pepo</i>	311
Radish <i>Raphanus sativus</i>	311, 407
Ragweed <i>Ambrosia artemisifolia</i>	311
Rape seed (Turnip) <i>Brassica rapa</i>	311
Rhubarb <i>Rheum rhaponticum</i>	311
Rye <i>Secale cereale</i>	311
Solomon's seal <i>Polygonatum latifolium</i>	38
Sorrel <i>Rumex sp.</i>	407
Soybean <i>Glycine max.</i>	311, 727
Spinach <i>Spinacia oleracea</i>	727, 311, 407
Squash <i>Cucurbita maxima</i>	311
Sunflower <i>Helianthus</i>	311
Sweet corn	727
Sweet potato <i>Ipomoea batatas</i>	311
Swiss chard <i>Beta vulgaris var. cicla</i>	311, 407
Thistle <i>Cirsium inoniptum</i>	38
Tomato <i>Lycopersicium esculentum</i>	1332, 727
Turnip (Rape seed) <i>Brassica rapa</i>	311
Velvet-weed <i>Gaura parvifolia</i>	311
Vervain <i>Verbena canadensis</i>	311
Violet <i>Viola sp.</i>	311
Wheat <i>Triticum sp.</i>	311
Wild potato <i>Solanum jamesii</i>	727
Wood nettle <i>Laportea bulbifera</i>	38
Zinnia <i>Zinnia elegans</i>	311

TABLE VI-3
PLANT SPECIES SENSITIVITY LISTS

Hydrogen Chloride

TOLERANT - Trees/deciduous

	<u>Reference</u>
Birch <i>Betula</i> sp.	536
Black Cherry <i>Prunus serotina</i>	536
Cherry <i>Prunus</i> sp.	886C
English walnut (Persian walnut) <i>Juglans regia</i>	886C
Maple <i>Acer</i> sp.	536
Oak <i>Quercus</i> sp.	536
Oleaster (Russian olive) <i>Eleagnus angustifolia</i>	536
Pear <i>Pyrus communis</i>	536
Persian walnut (English walnut) <i>Juglans regia</i>	886C
Red oak <i>Quercus borealis</i>	536
Russian olive (Oleaster) <i>Eleagnus angustifolia</i>	536

TOLERANT - Trees/Coniferous

Arborvitae <i>Thuja</i> sp.	536
Austrian pine <i>Pinus nigra</i>	536, 1104
Balsam fir <i>Abies balsamea</i>	536
Canadian hemlock <i>Tsuga canadensis</i>	536
Eastern white pine <i>Pinus strobus</i>	536
Jack pine <i>Pinus banksiana</i>	536
Loblolly pine <i>Pinus taeda</i>	536
Norway spruce <i>Picea abies</i>	536
Short leaf pine <i>Pinus echinata</i>	536

TOLERANT - Shrub

Yew <i>Taxus</i> sp.	536
----------------------	-----

TOLERANT - Herbaceous

Carrot <i>Daucus carota</i>	187
Grapevine <i>Vitis</i> sp.	886C

INTERMEDIATE - Trees/Deciduous

Black Cherry <i>Prunus serotina</i>	536
Black gum <i>Nyssa sylvatica</i>	536

INTERMEDIATE - Trees/Coniferous

Jack Pine <i>Pinus banksiana</i>	536
Short leaf pine <i>Pinus echinata</i>	536

SENSITIVE - Trees/Deciduous

Apple <i>Malus</i> sp.	536
Box Elder <i>Acer negundo</i>	536
Cherry <i>Prunus</i> sp.	536
Horsechestnut <i>Aesculus hippocastanum</i>	536
Larch <i>Larix</i> sp.	536

Hydrogen Chloride (Con't)

SENSITIVE - Trees/Deciduous

	<u>Reference</u>
Pin oak <i>Quercus palustris</i>	536
Sassafras <i>Sassafras albidum</i>	536
Sugar maple <i>Acer saccharum</i>	536
Sweetgum <i>Liquidambar styraciflua</i>	536
Tree of heaven <i>Ailanthus altissima</i>	536

TABLE VI-4

PLANT SPECIES SENSITIVITY LISTS

Nitrogen Dioxide

TOLERANT - Trees/Deciduous

	<u>Reference</u>
Beech <i>Fagus sp.</i>	16
Ginkgo (Maidenhair tree) <i>Gingko biloba</i>	16
Maidenhair tree (Ginkgo) <i>Gingko biloba</i>	16
Oak <i>Quercus sp.</i>	16

TOLERANT - Trees/Evergreen

Austrian pine <i>Pinus nigra</i>	16
----------------------------------	----

TOLERANT - Herbaceous

Cabbage <i>Brassica sp.</i>	16
Gladiolus	16
Onion <i>Allium sp.</i>	16

INTERMEDIATE - Trees/Evergreen

European larch <i>Larix decidua</i>	536
-------------------------------------	-----

SENSITIVE - Trees/Deciduous

Apple <i>Malus sp.</i>	536
Black locust <i>Robinia pseudoacacia</i>	536
European beech <i>Fagus sylvatica</i>	536
European hornbeam <i>Carpinus betulus</i>	536
European red elder <i>Sambucus racemosa</i>	536
Ginkgo (Maidenhair tree) <i>Gingko biloba</i>	536
Japanese maple <i>Acer palmatum</i>	536
Large leaf linden <i>Tilia grandiflora</i>	536
Little leaf linden <i>Tilia cordata</i>	536
Maidenhair tree (Ginkgo) <i>Gingko biloba</i>	536
Norway maple <i>Acer platanoides</i>	536
Pear <i>Pyrus communis</i>	536

SENSITIVE - Trees/Evergreen

Austrian pine <i>Pinus nigra</i>	536
Colorado spruce <i>Picea pungens</i>	536
Eastern white pine <i>Pinus strobus</i>	536
White spruce <i>Picea glauca</i>	536

SENSITIVE - Shrubs

Dwarf mugo pine <i>Pinus mugo mughus</i>	536
--	-----

SENSITIVE - Herbaceous

Barley <i>Hordeum sp.</i>	16
Begonia <i>Rumex sp.</i>	16
Carrot <i>Daucus carota</i>	16
Kidney beans <i>Phaseolus sp.</i>	16

Nitrogen Dioxide (Con't)

SENSITIVE - Herbaceous

Reference

Lettuce <i>Lactuca</i> sp.	1849, 16
Red clover <i>Trifolium pratense</i>	16
Sweet peas <i>Lathyrus odoratus</i>	16
Tobacco <i>Nicotiana</i> sp.	16

PLANT SPECIES SENSITIVITY LISTS

Ozone

TOLERANT - Trees/Deciduous

	<u>Reference</u>
Acacia <i>Acacia</i> sp.	181
Alder <i>Alnus</i> sp.	1164
American sycamore <i>Platanus occidentalis</i>	1074, 1164, 990
Ash <i>Fraxinus</i> sp.	181
Basswood (Linden) <i>Tilia</i> sp.	1137
Black walnut <i>Juglans nigra</i>	1164, 536
English oak <i>Quercus robor</i>	536, 1164
European mountain ash <i>Sorbus aucuparia</i>	536
European white birch <i>Betula pendula</i>	536, 1164
Fig <i>Ficus carica</i>	181
Flowering dogwood <i>Cornus florida</i>	536, 1164
Giant sequoia <i>Sequoia gigantea</i>	536
Linden (Basswood) <i>Tilia</i> sp.	1137
Little leaf linden <i>Tilia cordata</i>	1164
Maidenhair tree <i>Ginkgo biloba</i>	181
Norway maple <i>Acer platanoides</i>	536, 1164
Plum <i>Prunus</i> sp.	181
Red maple <i>Acer rubrum</i>	536, 1164
Red oak <i>Quercus borealis</i>	1164
Redwood <i>Sequoia sempervirens</i>	536
Shingle oak <i>Quercus imbricaria</i>	536, 1164
Sugar maple <i>Acer saccharum</i>	536, 1137
Weeping willow <i>Salix babylonica</i>	1164
White birch <i>Betula papyrifera</i>	1137

TOLERANT - Trees/Coniferous

Arborvitae <i>Thuja</i> sp.	774, 1164, 536
Balsam fir <i>Abies balsamea</i>	1137, 536, 1164, 774
Black hills spruce <i>Picea glauca densata</i>	774, 1164, 536, 1137
Colorado spruce <i>Picea pungens</i>	1137, 536, 1164, 774
Digger pine <i>Pinus sabiniana</i>	536
Douglas fir <i>Pseudotsuga menziesii</i>	774, 1137, 536, 1164
Eastern red cedar <i>Juniperus virginiana</i>	181
Jack pine <i>Pinus banksiana</i>	1074
Norway pine (Red pine) <i>Pinus resinosa</i>	1137, 1164, 774, 536
Norway spruce <i>Picea abies</i>	1137, 774, 1164, 536
Red pine (Norway pine) <i>Pinus resinosa</i>	1137, 1164, 774, 536
Singleleaf pinyon pine <i>Pinus monophylla</i>	536
Sugar pine <i>Pinus lambertiana</i>	536
Torrey pine <i>Pinus torreyana</i>	536
Virginia pine <i>Pinus virginiana</i>	1074
White fir <i>Abies concolor</i>	774, 1164, 1137
White spruce <i>Picea glauca</i>	536, 1164

TOLERANT - Shrubs

Ivy <i>Hedera</i> sp.	181
-----------------------	-----

TOLERANT - Herbaceous

Bugleweed (Carpet bugle) <i>Ajuga</i> sp.	181
---	-----

Ozone (Con't)

TOLERANT - Herbaceous

Reference

California poppy <i>Eschscholtzia californica</i>	181
Carpet bugle (Bugleweed) <i>Ajuga</i> sp.	181
Lady's slipper <i>Cypripedium</i> sp.	181
Leadwort <i>Ceratostigma plumbaginoides</i>	181
Petunia <i>Petunia</i> sp.	1015, 1074

INTERMEDIATE - Trees/ Coniferous

Big cone Douglas fir <i>Pseudotsuga macrocarpa</i>	536
Coulter pine <i>Pinus coulteri</i>	536
California: Incense-cedar <i>Libocedrus decurrens</i>	536
White fir <i>Abies concolor</i>	536

SENSITIVE - Trees/Deciduous

Alder <i>Alnus</i> sp.	536
American elm <i>Ulmus americana</i>	1164
American sycamore <i>Platanus occidentalis</i>	1074
Black locust <i>Robinia pseudoacacia</i>	1164, 536
Boxelder <i>Acer negundo</i>	536, 1164
California sycamore <i>Platanus racemosa</i>	1074
Catalpa <i>Catalpa speciosa</i>	1164
European larch <i>Larix decidua</i>	990, 1164, 1137, 536
Gambel oak <i>Quercus gambellii</i>	1164, 536
Green ash <i>Fraxinus pennsylvanica lanceolata</i>	536, 1164
Honeylocust <i>Gleditsia triacanthos</i>	1164, 536
Hybrid poplar <i>Populus</i> sp.	--
Japanese larch <i>Larix leptolepsis</i>	1164, 536, 77
Judas tree <i>Cercis siliquastrum</i>	536
Little leaf linden <i>Tilia cordata</i>	536
Mapleleaf mulberry (White mulberry) <i>Morus alba</i>	536
Pin oak <i>Quercus palustris</i>	536, 1164
Quaking aspen <i>Populus tremuloides</i>	536, 1164
Scarlet oak <i>Quercus coccinea</i>	1164, 536
Siberian crab apple <i>Malus baccata</i>	536, 1164
Silver maple <i>Acer saccharinum</i>	536, 1164
Sweetgum <i>Liquidambar styraciflua</i>	1164, 536
Thornless honeylocust <i>Gleditsia triacanthos inermis</i>	1074
Tulip poplar (Yellow poplar) <i>Liriodendron tulipifera</i>	990, 1164, 536, 1074, 1137
Weeping willow <i>Salix babylonica</i>	536
White ash <i>Fraxinus americana</i>	990, 1137, 1074, 536, 1164
White mulberry (Mapleleaf mulberry) <i>Morus alba</i>	536
White oak <i>Quercus alba</i>	1164, 536, 1137
Yellow poplar (Tulip poplar) <i>Liriodendron tulipifera</i>	990, 1164, 536, 1074, 1137

SENSITIVE - Trees/ Coniferous

Austrian pine <i>Pinus nigra</i>	1164, 536, 774, 1137
----------------------------------	----------------------

Ozone (Con't)

SENSITIVE - Trees/ Coniferous

Reference

Canadian hemlock <i>Tsuga canadensis</i>	536, 1137
Eastern white pine <i>Pinus strobus</i>	536, 774, 1137, 532 990, 1164
Jack pine <i>Pinus banksiana</i>	774, 536, 1164
Jeffery pine <i>Pinus jeffreyi</i>	536
Monterey pine <i>Pinus radiata</i>	536
Pitch pine <i>Pinus rigida</i>	1164, 1135, 774, 536
Ponderosa pine <i>Pinus ponderosa</i>	536
Scotch pine <i>Pinus sylvestris</i>	774, 536, 990
Virginia pine <i>Pinus virginiana</i>	536, 774, 1137

SENSITIVE - Shrubs

Bridal wreath spirea <i>Spiraea prunifolia</i>	1164
Camellia <i>Camelia</i> sp.	2
Common lilac <i>Syringa vulgaris</i>	990, 1164
Common privet <i>Ligustrum vulgare</i>	1164
Snowberry <i>Symphoricarpos albus</i>	536

SENSITIVE - Herbaceous

Aster <i>Aster</i> sp.	990
Sage <i>Salvia</i> sp.	990
Tobacco <i>Nicotiana</i> sp.	599

TABLE VI-6
PLANT SPECIES SENSITIVITY LISTS

Pan

TOLERANT - Trees/Deciduous

	<u>Reference</u>
European larch <i>Larix decidua</i>	536
Japanese larch <i>Larix leptolepis</i>	536
Sugar maple <i>Acer saccharum</i>	536

TOLERANT - Trees/ Coniferous

Austrian pine <i>Pinus nigra</i>	536
Canadian hemlock <i>Tsuga canadensis</i>	536
Colorado spruce <i>Picea pungens</i>	536
Eastern white pine <i>Pinus strobus</i>	536
Jack pine <i>Pinus banksiana</i>	536
Pitch pine <i>Pinus rigida</i>	536
White spruce <i>Picea glauca</i>	536

SENSITIVE - Trees/Deciduous

Little leaf linden <i>Tilia cordata</i>	536
Tulip poplar (Yellow poplar) <i>Liriodendron tulipifera</i>	536
Yellow poplar (Tulip poplar) <i>Liriodendron tulipifera</i>	536

SENSITIVE - Herbaceous

Aster <i>Aster sp.</i>	990
Chrysanthemum <i>Chrysanthemum sp.</i>	990
Lettuce <i>Lactuca sp.</i>	1849
Petunia <i>Petunia sp.</i>	990
Primrose <i>Primula sp.</i>	990
Sage <i>Salvia sp.</i>	990
Snapdragon <i>Chaenorrhinum sp.</i>	990

TABLE VI-7
PLANT SPECIES SENSITIVITY LISTS

Particulates - Smoke

TOLERANT - Trees/Deciduous

	<u>Reference</u>
American Elm <i>Ulmus americana</i>	547
European larch <i>Larix decidua</i>	1604
Scarlet elder <i>Sambucus pubens</i>	1390

TOLERANT - Shrub

Cranberry <i>Vaccinium sp.</i>	187
--------------------------------	-----

TOLERANT - Herbaceous

Knotweed <i>Polygonum cilinode</i>	1390
------------------------------------	------

INTERMEDIATE - Trees/Deciduous

Alder <i>Alnus sp.</i>	1604
American beech (Red beech) <i>Fagus grandifolia</i>	1604
American hornbeam <i>Carpinus caroliniana</i>	1604
Birch <i>Betula sp.</i>	1604
English oak <i>Quercus robor</i> (formerly called <i>pendunculata</i>)	1604
Maple <i>Acer sp.</i>	1604
Poplar <i>Populus sp.</i>	1604
Raceme oak <i>Quercus racemosa</i>	1604
Red beech (American beech) <i>Fagus grandifolia</i>	1604
Red oak <i>Quercus borealis</i>	1604
White alder <i>Alnus rhombifolia</i>	1604

INTERMEDIATE - Trees/ Coniferous

Austrian Pine <i>Pinus nigra</i>	1604
Eastern white pine <i>Pinus strobus</i>	1604
Scotch pine <i>Pinus sylvestris</i>	1604

SENSITIVE -Trees/Deciduous

Quaking aspen <i>Populus tremuloides</i>	1390
Single-seeded hawthorne <i>Crataegus monogyna</i>	1675

SENSITIVE - Trees/Coniferous

Black Spruce <i>Picea mariana</i>	1390
Eastern white pine <i>Pinus strobus</i>	1390
Fir <i>Abies sp.</i>	1604
Norway spruce <i>Picea abies (excelsa)</i>	1604
White spruce <i>Picea glauca</i>	1390

SENSITIVE - Herbaceous

Annual bluegrass <i>Poa annua</i>	269
-----------------------------------	-----

TABLE VI-8
PLANT SPECIES SENSITIVITY LISTS

Sulfur Dioxide

TOLERANT - Trees/Deciduous

	<u>Reference</u>
American sycamore <i>Platanus occidentalis</i>	1164
Ash <i>Fraxinus</i> sp.	886C
Basswood (Linden) <i>Tilia</i> sp.	369
Beech <i>Fagus</i> sp.	1187, 886C
Birch <i>Betula</i> sp.	64, 523, 1187
Black gum <i>Nyssa sylvatica</i>	1169, 536
Black locust <i>Robinia pseudoacacia</i>	536
Cottonwood (Eastern poplar) <i>Populus deltoides</i>	1164, 536
Eastern poplar (Cottonwood) <i>Populus deltoides</i>	1164, 536
English oak <i>Quercus robor</i>	1164, 536
European ash <i>Fraxinus excelsior</i>	369
European beech <i>Fagus sylvatica</i>	536
European hornbeam <i>Carpinus betulus</i>	536
European mountain ash <i>Sorbus aucuparia</i>	369
Flowering dogwood <i>Cornus florida</i>	1164, 536
Gingko (Maidenhair tree) <i>Gingko biloba</i>	1164, 369
Green ash <i>Fraxinus pennsylvanica lanceolata</i>	536, 1164
Hedge maple <i>Acer campestre</i>	536, 1164
Hornbeam <i>Carpinus</i> sp.	1187
Larch <i>Larix</i> sp.	44
Linden (Basswood) <i>Tilia</i> sp.	369
Maidenhair tree (Gingko) <i>Gingko biloba</i>	1164, 369
Mountain maple <i>Acer spicatum</i>	1164
Oak <i>Quercus</i> sp.	44
Oriental plane tree <i>Platanus orientalis</i>	1164
Persian walnut <i>Juglans regia</i>	886C
Pin oak <i>Quercus palustris</i>	1164
Poplar <i>Populus</i> sp.	369
Red berried elder <i>Sambucus pubescens</i>	1074
Red maple <i>Acer rubrum</i>	536, 1164
Red oak <i>Quercus borealis</i>	1164, 44
Smooth elm <i>Ulmus glabra</i>	369
Sourwood <i>Oxydendrum arboreum</i>	369
Sugar maple <i>Acer saccharum</i>	1164
Tulip poplar (Yellow poplar) <i>Liriodendron tulipifera</i>	16, 1164, 369
White ash <i>Fraxinus americana</i>	138
Willow <i>Salix</i> sp.	369
Yellow poplar (Tulip poplar) <i>Liriodendron tulipifera</i>	16, 1164, 369

TOLERANT - Trees/ Coniferous

Arborvitae <i>Thuja occidentalis</i>	1164
Austrian pine <i>Pinus nigra</i>	525, 1164, 536
Canadian hemlock <i>Tsuga canadensis</i>	1074
English holly <i>Ilex aquifolium</i>	1164, 536
Lawson false cypress <i>Chamaecyparis lawsoniana</i>	536
Spruce <i>Picea</i> sp.	886C
Western red cedar <i>Thuja plicata</i>	1164
White spruce <i>Picea glauca</i>	1164

Sulfur Dioxide (Con't)

TOLERANT - Shrubs

Dwarf mugo pine *Pinus mugo mughus*
Juniper *Juniperus sp.*

Reference

536
1164, 536

TOLERANT - Herbaceous

Alfalfa *Medicago sativa*
Corn *Zea mays*
Fringed bindweed *Polygonum cilinode*
Galleta *Hilaria jamesii*
Grama grass *Bouteloua barbata*
Heliotrope *Heliotropium sp.*
Meadow fescue *Festuca elatior*
Oats *Avena sp.*
Orchard grass *Dactylus glomerada*
Primrose *Primula sp.*
Sweetpea *Lathyrus odoratus*
Woodwaxen

886C
16
1074
1365
1365
886C
136
886C
136
886C
886C
886C

INTERMEDIATE - Trees/Deciduous

Apple *Malus sp.*
Apricot *Prunus armeniaca*
Balsam poplar *Populus balsamifera*
Bigtooth aspen *Populus grandidentata*
Norway maple *Acer platanoides*

16
16
1164, 536
1164
1164

INTERMEDIATE - Trees/Coniferous

Balsam fir *Abies balsamea*
Douglas fir *Pseudotsuga menziesii*
Lodgepole pine *Pinus contorta*
Scotch pine *Pinus sylvestris*
Silver fir *Abies pectinata*

536, 1164, 525
1164, 525, 536
536, 525
1164
536

INTERMEDIATE - Shrubs

Rose *Rosa sp.*

16

INTERMEDIATE - Herbaceous

Gladiolus
Cotton *Gossypium sp.*
Iris *Iris sp.*

16
16
16

SENSITIVE - Trees/Deciduous

Alder *Alnus*
American elm *Ulmus americana*
American sycamore *Platanus occidentalis*
Apple *Malus sp.*

119, 732
1164
1164
1164

Sulfur Dioxide (Con't)

SENSITIVE - Trees/Deciduous

	<u>Reference</u>
Aspen (Poplar) <i>Populus sp.</i>	732, 1187
Birch <i>Betula sp.</i>	1164, 1119
Blueberry elder <i>Sambucus coerulea</i>	732
Canoe birch (White birch) <i>Betula papyrifera</i>	732
Catalpa <i>Catalpa speciosa</i>	1164
Cherry <i>Prunus sp.</i>	732
Chokecherry <i>Prunus virginiana</i>	938
English walnut (Persian walnut) <i>Juglans regia</i>	1164
European mountain ash <i>Sorbus aucuparia</i>	732, 1187
Horse chestnut <i>Aesculus hippocastanum</i>	44
Hornbeam <i>Carpinus sp.</i>	44
Larch <i>Larix sp.</i>	732, 1164
Lombardy poplar <i>Populus nigra var. italica</i>	1164
Maple <i>Acer sp.</i>	1187
Mazzard cherry <i>Prunus avium</i>	886C
Mountain ash <i>Sorbus americana</i>	1164
Mountain maple <i>Acer spicatum</i>	44
Narrowleaf cottonwood <i>Populus angustifolia</i>	1365
Pear <i>Pyrus communis</i>	1164
Persian walnut (English walnut) <i>Juglans regia</i>	1164
Poplar (Aspen) <i>Populus sp.</i>	732, 1187
Quaking aspen <i>Populus tremuloides</i>	1164, 119
Scarlet hawthorn <i>Crataegus oxyacantha</i>	990
Serviceberry <i>Amelanchier sp.</i>	1164
Texas mulberry <i>Morus microphylla</i>	1164
Utah serviceberry <i>Amelanchier utahensis</i>	1164
White ash <i>Fraxinus americana</i>	773
White birch (Canoe birch) <i>Betula papyrifera</i>	732
Willow <i>Salix sp.</i>	1164, 732

SENSITIVE - Trees/Coniferous

Black spruce <i>Picea mariana</i>	1164
Canadian hemlock <i>Tsuga canadensis</i>	1164
Douglas fir <i>Pseudotsuga menziesii</i>	990
Eastern white pine <i>Pinus strobus</i>	990, 1164, 1074, 563,732,773,119
Engelman's spruce <i>Picea engelmannii</i>	1164
Fir <i>Abies sp.</i>	119
Jack pine <i>Pinus banksiana</i>	1164
Mountain hemlock <i>Tsuga mertensiana</i>	1164
Norway pine (Red pine) <i>Pinus resinosa</i>	16
Ponderosa pine <i>Pinus ponderosa</i>	1164, 1007
Red pine (Norway pine) <i>Pinus resinosa</i>	16
Scotch pine <i>Pinus sylvestris</i>	1074, 525
Sitka spruce <i>Picea sitchensis</i>	732
Virginia pine <i>Pinus virginiana</i>	773
Western red cedar <i>Thuja plicata</i>	1074
Western white pine <i>Pinus monticola</i>	1164

Sulfur Dioxide (Con't)

SENSITIVE - Shrubs

	<u>Reference</u>
Mountain laurel <i>Kalmia latifolia</i>	1164
Ninebark <i>Physocarpus capitatus</i>	1164
Snowberry <i>Symphoricarpos aerophilus</i>	1365
Wild rose <i>Rosa woodsii</i>	1365

SENSITIVE - Herbaceous

Alfalfa <i>Medicago sativa</i>	938, 732
Begonia <i>Rumex venosus</i>	990, 1009
Buckwheat <i>Fagopyrum sp.</i>	16
Celery <i>Spermolepsis sp.</i>	16
Cotton <i>Gossypium sp.</i>	16
Cucumber <i>Sicyos angulatus</i>	16
Eggplant <i>Solanum melongena</i>	16
Evening primrose <i>Oenothera sp.</i>	1365
Geranium <i>Geranium</i>	16
Globe mallow <i>Sphaeralcea munroana</i>	1365
Goosefoot <i>Chenopodium ofrenonti</i>	1365
Grape <i>Vitis sp.</i>	938
Hound's tongue <i>Cynoglossum officinale</i>	1365
Hungarian brome <i>Bromus inpermis</i>	136
Indian rice grass <i>Or'yzopsis hymenoides</i>	1365
Lettuce <i>Lactuca sp.</i>	1844
Locoweed <i>Astragalus utahensis</i>	1365
Lucerne <i>Medicago sativa</i>	1007
Petunia <i>Petunia sp.</i>	1009
Potato <i>Solanum tuberosum</i>	1007
Red clover <i>Trifolium pratense</i>	136
Scarlet Gilia <i>Gilia agregata</i>	1365
Squash <i>Cucurbita sp.</i>	938
Sunflower <i>Helianthus sp.</i>	886C
Sweet clover <i>Melilotus sp.</i>	732, 16
Tobacco <i>Nicotiana sp.</i>	16
Vervain <i>Verbena sp.</i>	990
Violet <i>Viola sp.</i>	990
Wheat <i>Triticum aestivum</i>	1007

APPENDIX C
CALCULATION OF LEAF AREAS FOR SELECTED TREES

A one hectare forested unit of open space is proposed in Volume III. It was developed in order to estimate the amount of pollutants removed from the air by the natural elements of such a standardized forest. The tree species composing this model forest are red oak (*Quercus robur*), Norway maple (*Acer platanoides*), linden (*Tilia cordata*), poplar (*Populus tremula*), birch (*Betula verrucosa*) and pine (*Pinus sp.*). The estimated height and diameter of the canopy for each tree species at age eight (that is, five years after planting three-year-old saplings) were used in calculating the surface area for each tree species. The two dimensions of height, and diameter of the canopy, for each tree species, may be found on Table VI-9.

By knowing the diameter of the canopy of a tree, the canopy area or ground area can be calculated. For example, uncrowded red maple, six meters high, may have a canopy diameter of three meters. Next, it is assumed that the area of a circle, having the diameter of three meters, adequately estimates the ground area covered by that red maple.

$$\begin{aligned} \text{diameter} &= 3 \\ \text{radius} &= 1.5 \end{aligned}$$

Therefore, the area of the circle = $r^2 = (1.5)^2 = 7.1 \text{ m}^2$ and the estimated ground area of this maple = 7.1 m^2 . The total surface area of the plant, however, is much greater. One method for calculating that plant surface area, for a particular tree, is to use its ground area and also, the area index of the tree. That index, is the ratio of total plant surface area to ground area. Monteith (1976) has developed an area index for each of the deciduous tree species used in the model hectare. From that paper, the area index for a seven meter high maple is 5.18. However, the height dimension for the maple growing in the model hectare is six meters. Since the nature of an extrapolation from a seven meter tree to a six meter tree is unknown, the area index we used is unchanged from the literature. It is assumed that the area index for the seven meter maple may be directly used to estimate the area index for the six meter maple. One advantage for not extrapolating the area index given by Monteith is that the calculations we derived can be more easily reconstructed. Once the ground area and area index ratio for the tree is known, the plant surface area can be computed.

$$\begin{aligned}
\text{ground area for maple} &= 7.1 \text{ m}^2 \\
\text{area index for maple} &= 5.18 \\
\text{area index} &= \text{surface area/ground area} \\
5.18 &= \frac{X}{7.1 \text{ m}^2} \\
\text{surface area of maple} &= 36.8 \text{ m}^2
\end{aligned}$$

In multiplying the weighted average sink rate (reported as $\mu\text{g m}^{-2}\text{hr}^{-1}$) of a pollution by vegetation, by the surface area of a tree, the result is the amount of pollutant removed by that tree during one hour. For instance, the surface area of a maple as been calculated as 36.8 m^2 and the weighted average sink rate for SO_2 by vegetation is $4.1 \times 10^4 \mu\text{g m}^{-2}\text{hr}^{-1}$. When these two values are multiplied, the average amount of SO_2 removed by a maple tree is $1.5 \times 10^6 \mu\text{g/hr}$.

One problem with this procedure for determining the amount of pollutant removed by a tree stems from the weighted average sink rate for that pollutant. The removal rates reported in the tables of Volume I were primarily obtained based on studies of the rate of pollutant uptake by foliar material. That is, the pollutant removal rates by woody tissue were usually not considered during the measurements of pollutant removal by vegetation. As a result, the weighted average sink rate for a specific pollutant was primarily obtained from data based on foliar uptake, exclusive of woody tissue uptake.

The area indices reported by Monteith (1976) involve both the foliage and woody areas of the trees. As a result, when the total surface area of a tree is calculated by using the area index and ground area of the tree, the woody surface area is included in the total surface area of the tree. When the latter value is multiplied by the weighted average sink rate of the pollutant, in order to determine the amount of pollutant removal by the tree, the calculation is generally lower than if the surface area were all leaf. The removal rate of the pollutant by the woody surface area is assumed to be comparable to that by foliar surface area. In truth, the uptake rate of gaseous pollutants by the woody surface area is apparently less efficient than the removal rate by a comparable surface area of foliage. The opposite seems to be true when particulates are considered. However, the removal rates for particulates by vegetation may have been primarily obtained from studies

in which the entire plant was evaluated and as a result, the weighted average sink rate for particulates may be more accurate than the other pollutant removal rates since both the foliage and woody areas are considered. Therefore, when the total surface area of a tree is multiplied by the weighted average sink rate for a gaseous pollutant (which primarily defines the foliar uptake), the resulting amount of pollutant removed from the air by the tree may be slightly off. However, if one considers the ratio of the total woody area indices of the five deciduous trees used by Monteith (1976) to the total foliar area indices of the same five species, the amount of woody surface area to that of the foliar surface area is relatively small (0.08:1). Because this ratio is small, any error which it may cause is felt to also be small.

TABLE VI- 9
DATA CHARTS OF THE TREE SPECIES USED IN THE MODEL HECTARE

Maple (*Acer platanoides*)

Height of the tree used in the model hectare	6.0m
Diameter of the canopy of the 6.0 meter tree	3.0m
Canopy area or ground area of the 6.0 meter tree	7.1m ²
Height of the tree used in Monteith's area index	7.0m
Area index of the 7.0 meter tree	5.18m*
Estimated plant surface area of the 6.0 meter tree	36.8m ²

Oak (*Quercus robur*);

Height of the tree used in the model hectare	6.0m
Diameter of the canopy of the 6.0 meter tree	3.0m
Canopy area or ground area of the 6.0 meter tree	7.1m ²
Height of the tree used in Monteith's area index	6.5m
Area index of the 6.5 meter tree	5.08m**
Estimated plant surface area of the 6 meter tree	36.1m ²

Poplar (*Populus tremula*)

Height of the tree used in the model hectare	6.0m
Diameter of the canopy of the 6.0 meter tree	3.0m
Canopy area or ground area of the 6 meter tree	7.1m ²
Height of the tree used in Monteith's area index	10.5m
Area index of the 10.5 meter tree	7.4m***
Estimated plant surface area of the 6.0 meter tree	52.5m ²

*The area index for the 7.0 meter maple is assumed to adequately estimate the actual area index of the 6.0 meter maple used in the model hectare.

**The area index of the 6.5 meter oak is assumed to adequately estimate the actual area index of the 6.0 meter oak used in the model hectare.

***The area index of the 10.5 meter poplar is assumed to adequately estimate the actual area index of the 6.0 meter poplar used in the hectare.

Linden (*Tilia cordata*)

Height of the tree used in the model hectare	5.0m
Diameter of the canopy of the 5.0 meter tree	2.4m
Canopy area or ground area of the 5.0 meter tree	4.5m ²
Height of the tree used in Monteith's area index	11.5m
Area index of the 11.5 meter tree	5.1m*
Estimated plant surface area of the 5.0 meter tree	23.0m ²

Birch (*Betula verrucosa*)

Height of the tree used in the model hectare	5.0m
Diameter of the canopy of the 5.0 meter tree	2.4m
Canopy area or ground area of the 5.0 meter tree	4.5m ²
Height of the tree used in Monteith's area index	7.6m
Area index of the 7.6 meter tree	6.04m**
Estimated plant surface area of the 5.0 meter tree	27.2m ²

Pine (*Pinus sp.*)

Height of the tree used in the model hectare	3.0m
Diameter of the canopy of the 3.0 meter tree	1.5m
Canopy area or ground area of the 3.0 meter tree	1.8m ²
Leaf area index used by Rich (1970)	2.1m***
Estimated woody area index	0.2m****
Total estimated area index	2.3m
Estimated plant surface area of the 3.0 meter tree	4.2m ²

*The area index of the 11.5 meter linden is assumed to adequately estimate the actual area index of the 5.0 meter linden used in the model hectare.

**The area index of the 7.6 meter birch is assumed to adequately estimate the actual area index of the 5.0 meter birch used in the model hectare.

*** The leaf area index used by Rich (1970) does not cite any height specification. As a result, it is assumed that the leaf area index does adequately define the ratio of leaf surface area to ground area of a 3.0 meter high pine.

**** The woody area index for the 3.0 meter high pine was estimated by comparing the surface area measurements of a 12 meter high white pine which were published by Stevens (1976). He found that the foliage surface area of the pine was $15 \times 10^5 \text{cm}^2$ or 150m^2 and the non-foliage or woody surface area was $15 \times 10^4 \text{cm}^2$ or 15m^2 (about 10% of the foliage surface area). In order to estimate the woody area index of the 3.0 meter pine, it was assumed that the woody surface area was 10% of the leaf surface area and this same percentage could be applied to determine the woody area index.

APPENDIX D
HOLLAND STACK RISE EQUATION

The Holland stack rise equation is:

$H =$

$$\Delta H = \frac{v_s d}{u} 1.5 + 2.68 \times 10^{-3} \frac{\Delta T d}{p T_s}$$

where

ΔH = the rise of the plume above the stack (meters)

v_s = stack gas velocity (m/sec)

d = the inside stack diameter (meters)

u = wind speed (m/sec)

p = atmospheric pressure (mb)

T_s = stack gas temperature ($^{\circ}K$)

ΔT = as in equation (1) and

2.68×10^{-3} is a constant having units of ($m^{-1} mb^{-1}$).

TECHNICAL REPORT DATA
(Please read Instructions on the reverse before completing)

1 REPORT NO		2.	3 RECIPIENT'S ACCESSION NO.	
4 TITLE AND SUBTITLE Open Space as an Air Resource Management Measure - Design Criteria - Volume II			5 REPORT DATE December 1976	
			6. PERFORMING ORGANIZATION CODE	
7 AUTHOR(S) Robert S. DeSanto, Richard A. Glaser, Joseph A. Miller William P. McMillen, Kenneth A. MacGregor,			8. PERFORMING ORGANIZATION REPORT NO. H800-II	
9 PERFORMING ORGANIZATION NAME AND ADDRESS COMSIS CORPORATION - Environmental Services 972 New London Turnpike Glastonbury, Connecticut 06033			10. PROGRAM ELEMENT NO.	
			11 CONTRACT/GRANT NO. 68-02-2350	
12 SPONSORING AGENCY NAME AND ADDRESS Strategies and Air Standards Division Office of Air Quality Planning and Standards Environmental Protection Agency Research Triangle Park, North Carolina 27711			13 TYPE OF REPORT AND PERIOD COVERED Final	
			14. SPONSORING AGENCY CODE	
15 SUPPLEMENTARY NOTES				
16 ABSTRACT This report is a workbook which presents the primary biological and design features which are crucial to the effective utilization of open space to mitigate air pollution. It presents generalized schemes for the design and location of buffer strips and other forms of open space. It also illustrates air pollution mitigation by open space by identifying the mathematical procedures necessary in order to permit incorporation of appropriate sink factors into four generally used carbon monoxide diffusion models. Directions and tables are given which may be used to estimate the air pollution removal capacity of various types of vegetation and open space. Leaf area indices are used in order to convert canopy areas to total leaf areas and the associated rates of pollution filtering capacities by selected common tree species.				
17 KEY WORDS AND DOCUMENT ANALYSIS				
a DESCRIPTORS		b. IDENTIFIERS/OPEN ENDED TERMS		c. COSATI Field/Group
Plants Trees Recreation Areas Forests Soils Highways Topographic Interactions		Air Resource Management Open Space Sanitary Zones Air Pollutant Removal Sinks Highway Buffer Strips Greenbelts		
18 DISTRIBUTION STATEMENT		19 SECURITY CLASS (This Report) Unclassified		21. NO. OF PAGES 178
		20 SECURITY CLASS (This page) Unclassified		22. PRICE