

=====

GENERAL PLANNING CONSULTANT
TECHNICAL MEMORANDUM 88.5.3
FINANCIAL OPERATING PLAN NETWORKS
PATRONAGE FORECAST DOCUMENTATION

=====

Prepared for:
Souther California Rapid Transit District

Prepared by:
Schimpeler-Corradino Associates
Cordoba Corporation
Myra L. Frank & Associates

in association with
The Planning Group, Inc.

December 1988

=====

GENERAL PLANNING CONSULTANT

TECHNICAL MEMORANDUM 88.5.3

FINANCIAL OPERATING PLAN NETWORKS

PATRONAGE FORECAST DOCUMENTATION

=====

Prepared for:

Souther California Rapid Transit District

Prepared by:

Schimpeler-Corradino Associates
Cordoba Corporation
Myra L. Frank & Associates

in association with

The Planning Group, Inc.

December 1988

TABLE OF CONTENTS

1.0	Purpose.....	1
2.0	Network Preparation and Demand Forecast Simulation Method.....	3
3.0	Project Alternative Descriptions	
3.1	Minimum Operable Segment.....	8
3.2	Long Beach - Los Angeles Light Rail.....	12
3.3	Century Light Rail	22
3.4	El Segundo extension.....	30
3.5	Harbor Busway.....	34
3.6	Locally Preferred Alternative : MOS-2.....	39
4.0	Network Summary Statistics.....	46
5.0	Network Flowchart and Dataset Directory.....	67
A.1	Appendix.....	92

LIST OF TABLES

<u>TABLE</u>		<u>PAGE</u>
1-1	Networks developed in the context of the FY-88 financial operating plan.....	2
3-1	MOS-1 stations with parking capacity.....	8
3-2	LB-LRT stations with parking capacities.....	12
3-3	Bus-station interface for networks 2,3,6 and the LB-LA light rail.....	18
3-4	LB-LA link travel times.....	21
3-5	Century LRT stations with parking capacities.....	22
3-6	Bus station interface for networks 2,3,6 for Century light rail.....	26
3-7	Century LRT link travel times.....	29
3-8	El Segundo LRT stations with parking capacities....	30
3-9	Bus station interface for networks 2,3,6 El Segundo extension.....	32
3-10	El Segundo LRT link travel times.....	33
3-11	Harbor Busway with parking capacities.....	35
3-12	Bus station interface for networks 2,3,6 Harbor Busway operating plan.....	37
3-13	Locally Preferred Alternative: MOS-2 Stations.....	39
3-14	Locally Preferred Alternative: MOS-2 Bus station Interface.....	42
4-1	Comparative network attributes Year 1990 trip table.....	47

4-2	Comparative network attributes Year 2000 trip table.....	49
4-3.1	Station Index - Network 2.....	51
4-3.2	Daily Station to station trip matrix Network 2 (GOP2VER1).....	52
4-4.1	Station Index - Network 3.....	54
4-4.2	Daily Station to station trip matrix Network 3 (GOP3VER1).....	55
4-5.1	Station Index - Network 3.....	58
4-5.2	Daily Station to station trip matrix Network 3 (GOP3TSM1).....	59
4-6.1	Station Index - Network 6.....	62
4-6.2	Daily Station to station trip matrix Network 6 (GOP6VER1).....	64
5-1	Dataset Directory - Network 2 (GOP2VER1).....	70
5-2	Dataset Directory - Network 3 (GOP3VER1).....	76
5-3	Dataset Directory - Network 3 (GOP3TSM1).....	82
5-4	Dataset Directory - Network 6 (GOP6VER1).....	88
A-1	Other networks developed in the context of the FY-88 operating plan.....	93

LIST OF FIGURES

<u>FIGURE</u>	<u>PAGE</u>
2-1 Financial Operating Plan: Network 1 Rail transit development.....	1
2-2 Financial Operating Plan: Network 2 Rail transit development.....	5
2-3 Financial Operating Plan: Network 3 Rail transit development.....	6
2-4 Financial Operating Plan: Network 6 Rail transit development.....	7
3-1 Null Alternative MOS-1.....	10
3-2 LA-Long Beach light rail Bus rail interface.....	13
3-3 Century Light Rail Bus Rail interface.....	23
3-4 El Segundo light rail Bus Rail interface.....	31
3-5 Harbor Busway operating plan.....	36
3-6.1 Locally Preferred Alternative : MOS-2 Transit system overview.....	40
3-6.2 Locally Preferred Alternative : MOS-2 Bus/Rail interface.....	41
5-1 Financial Operating Plan: Network 2 Simulation Flowchart.....	68
5-2 Financial Operating Plan: Network 3 Simulation Flowchart.....	74
5-3 Financial Operating Plan: Network 3 Simulation Flowchart.....	80

5-4	Financial Operating Plan: Network 6 Simulation Flowchart.....	86
6-1	Financial Operating Plan: Network 4 Transit system overview.....	94
6-2	Financial Operating Plan: Network 4A Transit system overview.....	95
6-3	Financial Operating Plan: Network 4B Transit system overview.....	96
6-4	Financial Operating Plan: Network 5 Transit system overview.....	97
6-5	Financial Operating Plan: Network 5A Transit system overview.....	98
6-6	Financial Operating Plan: Network 5B Transit system overview.....	99

1.0 PURPOSE

This technical memorandum documents base and forecast scenario network simulations as input to the FY-88 five-year financial plan. The District's UTPS transit demand forecast models have been applied to alternative future-year regional transit networks to achieve a series of operating cost and revenue estimates representative of staged project implementation intervals. Projects referred to here are four rapid transit guideways; Metro Rail, the Long Beach - Los Angeles LRT, the Century/El Segundo LRT, and the Harbor busway.

For the purposes of establishing interpolation points for costs and revenues, each transit year-alternative was simulated for both forecast years 1990 and 2000. The full set of alternative bus/rail configurations associated with this task are briefly summarized in Table 1-1. Two network dataset labels appear for each scenario; the first would identify the year 2000 forecast network datasets and the second, the year 1990 network datasets. For the bus only alternative, we have referenced the RTDSEP85 network which was formerly developed by the district and has become the de facto all-bus system.

The 'null' alternative, consisting of MOS-1 with the accomodating background bus scheme was simulated as an independent network alternative. MOS-1 is described in this report as a component to the series of expanded network year-alternatives.

TABLE 1-1

NETWORKS DEVELOPED IN THE CONTEXT OF THE FY-88
FINANCIAL OPERATING PLAN

DESCRIPTION	REFER TO FIGURE	NAMING CONVENTION	YEAR	UTPS LABEL TT2000/ TT1990
BUS ONLY		NETWORK-0	'85	RTDSEP85
BUS + MOS-1	2-1	NETWORK-1	'92	N/A
BUS + MOS-1 + LB-LA-LRT	2-2	NETWORK-2	'92	GOP2VER1/ GOP2YR90
BUS + MOS-1 + LB-LA-LRT + CENTURY/EL SEGUNDO LRT	2-3	NETWORK-3	'94	GOP3VER1/ GOP3YR90 GOP3TSM1
BUS + MOS-2 (LPA) + LB-LA-LRT + CENTURY/EL SEGUNDO LRT	2-4	NETWORK-6	'95	GOP6VER1/ GOP6YR90

2.0 NETWORK PREPARATION AND SIMULATION METHOD

The financial plan networks were prepared in a manner pursuant to ongoing SCRTD network development and simulation practices. For a detailed summary of the transit network simulation process used by the GPC and District Planning Department, refer to Technical Memorandum 86.1.4, Patronage Forecasting Procedures, Barton Aschman Associates, Inc., et. al, April 1987.

Definition of the planned background bus changes associated with each of the guideway projects were provided at the start of this task by the District Planning Department with exception to MOS-1 which was developed in accordance with the bus/rail interface described in Supporting Services Plan, Milestone 9, adopted: May, 1983 and the MOS-2 alternatives which were developed under the Congressionally Ordered Re-engineering Study during FY87 and FY88. In an effort to maintain overall consistency with the C.O.R.E. series of alignment alternative networks, a representative C.O.R.E. network, Candidate Alignment-3 (CORE3CA3) was used as a base for the financial plan or FOP series. To establish a base MOS-1 only network, coding adjustments were applied to the CORE3CA3 lines and links files to retract the MOS-2 alignment and its link attributes and also to reorient the bus network coding to an MOS-1 only rapid transit configuration. The base MOS-1 network then served as the foundation in the incremental coding of rail transit alignments for Networks 2,3, and 6. Figures 2-1 through 2-4 illustrate this progression.

Once the locally preferred alternative in the C.O.R.E. series of alignments was selected, it was used as a base to develop another network for the Financial Operating Plan. This network was also simulated using the 1990 and 2000 year trip tables.

FIGURE 2-1
FINANCIAL OPERATING PLAN
NETWORK-1
MOS-1 ONLY

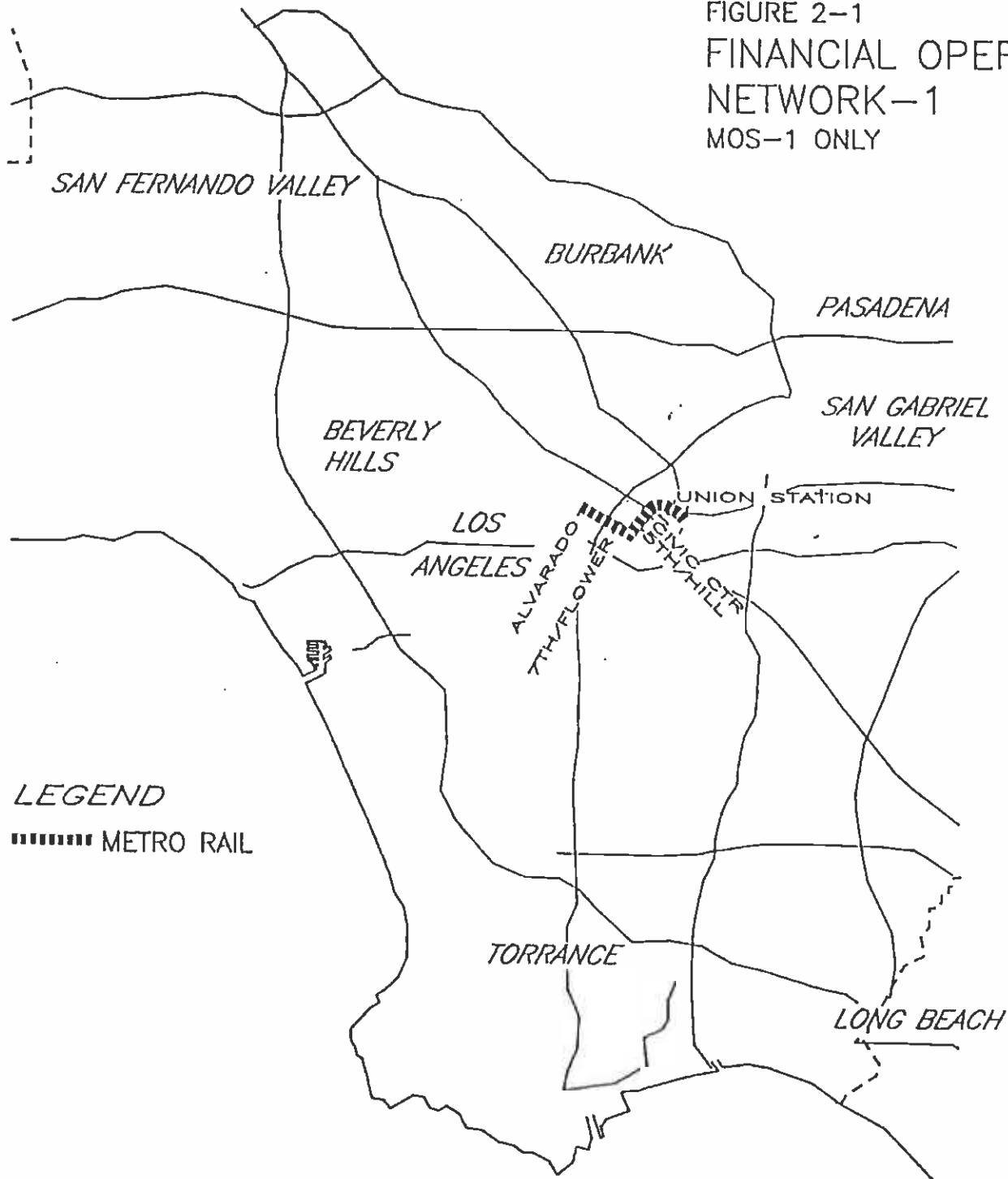
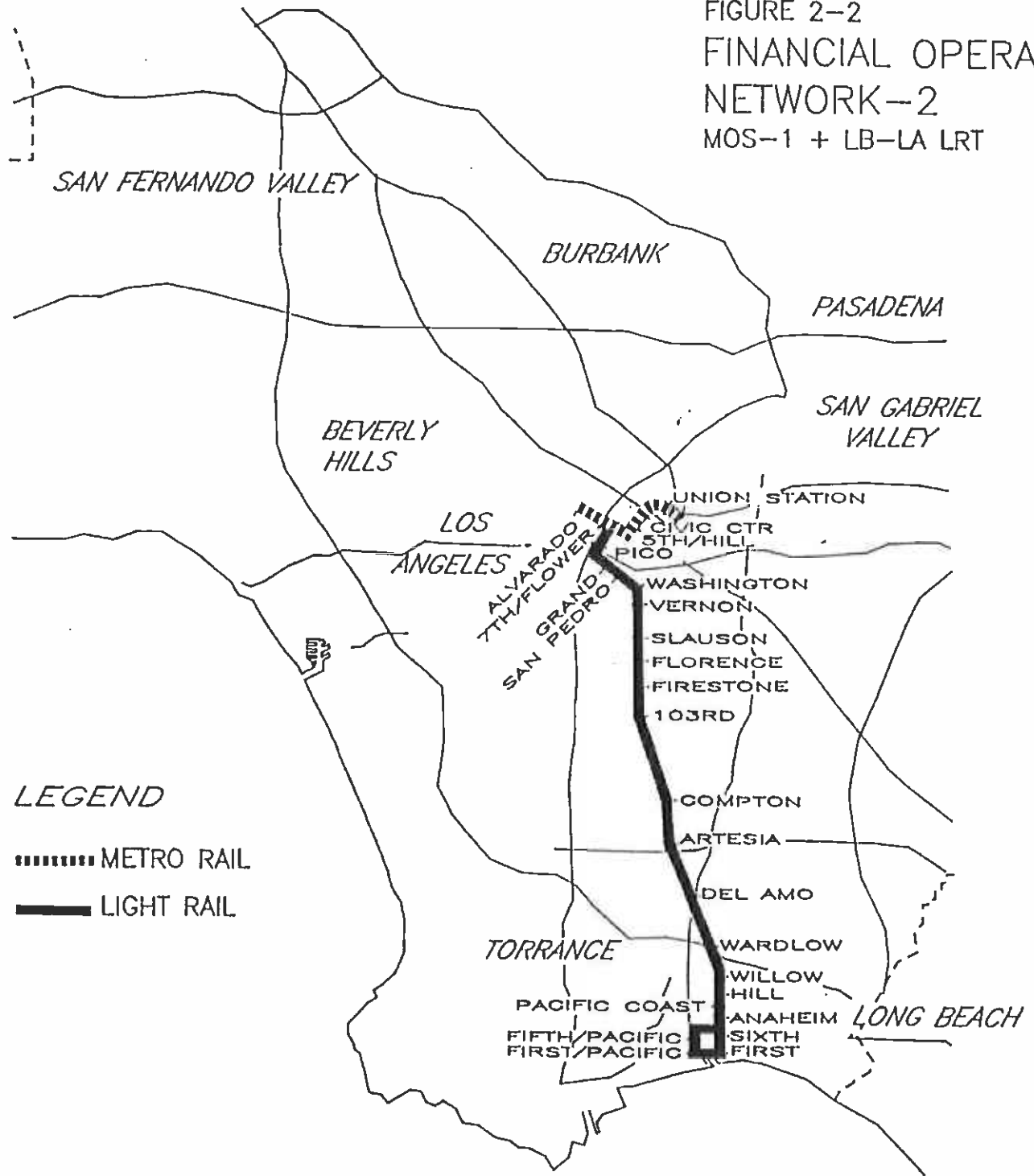

FIGURE 2-2
 FINANCIAL OPERATING PLAN
 NETWORK-2
 MOS-1 + LB-LA LRT

5



S.C.R.T.D. LIBRARY

FIGURE 2-3
 FINANCIAL OPERATING PLAN
 NETWORK-3
 MOS-1 + LB-LA LRT +
 CENTURY/EL SEGUNDO LRT

9

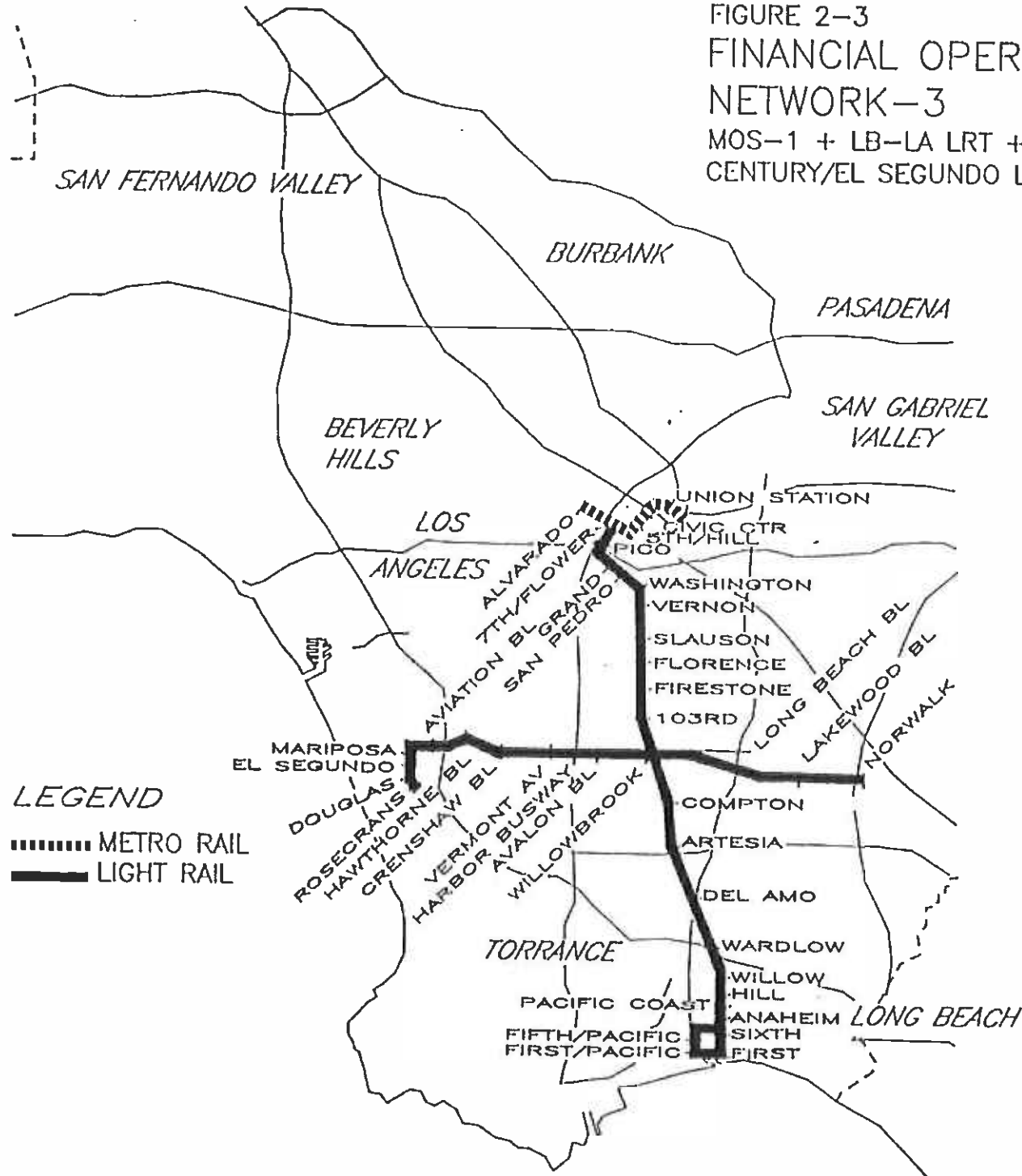
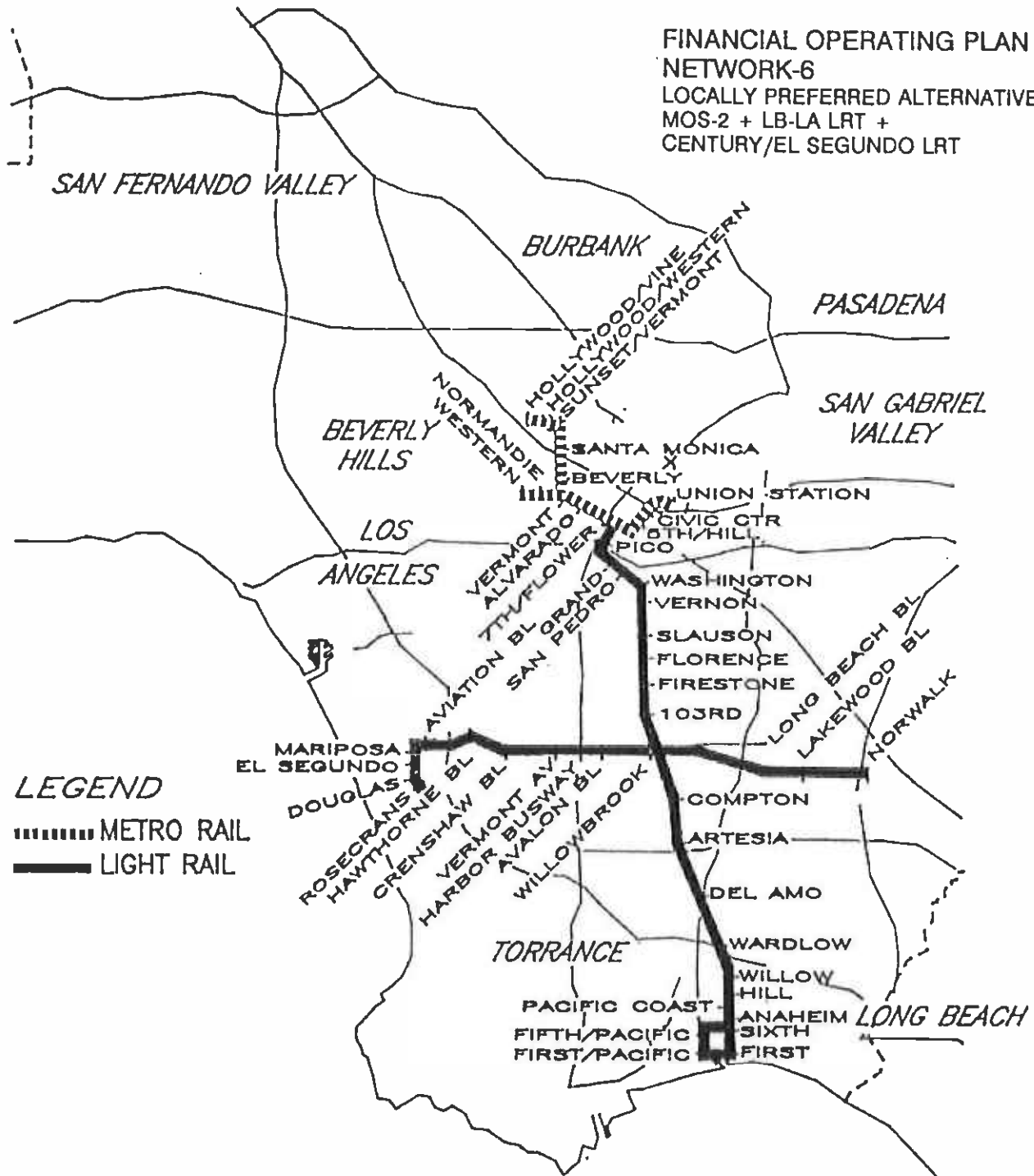

FIGURE 2-4

FINANCIAL OPERATING PLAN
NETWORK-6
LOCALLY PREFERRED ALTERNATIVE
MOS-2 + LB-LA LRT +
CENTURY/EL SEGUNDO LRT



7

3.0 PROJECT ALTERNATIVE DESCRIPTIONS

3.1 MOS-1 (MINIMUM OPERABLE SEGMENT - 1)

MOS-1 consists of five stations extending 4.4 miles from a yard and shop facility south of Union Station to the intersection of Wilshire and Alvarado. MOS-1 is the initial segment of the Original Locally Preferred Alternative defined for funding purposes.

The route for MOS-1 begins at Union Station, where it turns west and south and runs through the CBD along Hill Street. Turning on 7th Street, MOS-1 heads towards the west side of downtown past the Harbor Freeway, to a terminal station at Wilshire/Alvarado. Crossover tracks are located just east of the terminal station at Wilshire/Alvarado to satisfy operational requirements. MOS-1 includes the Metro Rail yard and shop facilities east of Alameda Street. Patronage and operating cost estimates for the MOS-1 alternative are included in the Supplemental Environmental Impact Statement/Subsequent Environmental Impact Report (SEIS/SEIR), November, 1987. The MOS-1 route and the bus-rail interface are shown in Figures 3-1 and 3-1.1 respectively.

TABLE 3-1

MOS-1 STATIONS

UNION STATION P(2500)
CIVIC CENTER (1ST/HILL)
5TH/HILL
7TH/FLOWER
WILSHIRE ALVARADO

P - PARK-AND-RIDE(CAPACITY)

TSM IMPROVEMENTS

The TSM network comprises of MOS-1, the LA-Long Beach light rail, the Century Freeway line including the El Segundo extension, and the Harbor Busway.

The improvements in the TSM network are as follows:

- a. Prohibition of left turns on 7th Street between Alvarado and the Harbor Freeway, increasing 7th street speeds by 15 percent.
- b. Prohibition of left turns on Olympic Boulevard between San Pedro Street and La Cienega Boulevard.
- c. Implementation of reversible lanes on Olympic Boulevard between San Pedro Street and La Cienega Boulevard, increasing speeds by an additional 10 percent.
- d. Implementation of the LADOT computerized signal control system, increasing speeds on the bus routes on Olympic, Wilshire and Cahuenga Boulevards by 7 percent, and increasing auto speeds by 7 percent on all arterial streets in the LADOT program area.
- e. Implementation of the Bus route diversions listed in Technical Memorandum 6.1.3, affecting routes 150, 152, S-170, 160, L-4, S-162, 420, 420A, 421, 422, 423, 424, 425, 426 and 427. (These are the route numbers listed in the Technical Memorandum, some of which may have been changed and some of which may no longer be in operation.)

FIGURE 3-1

NULL ALTERNATIVE (MOS-1)
 CBD/WILSHIRE SUBWAY

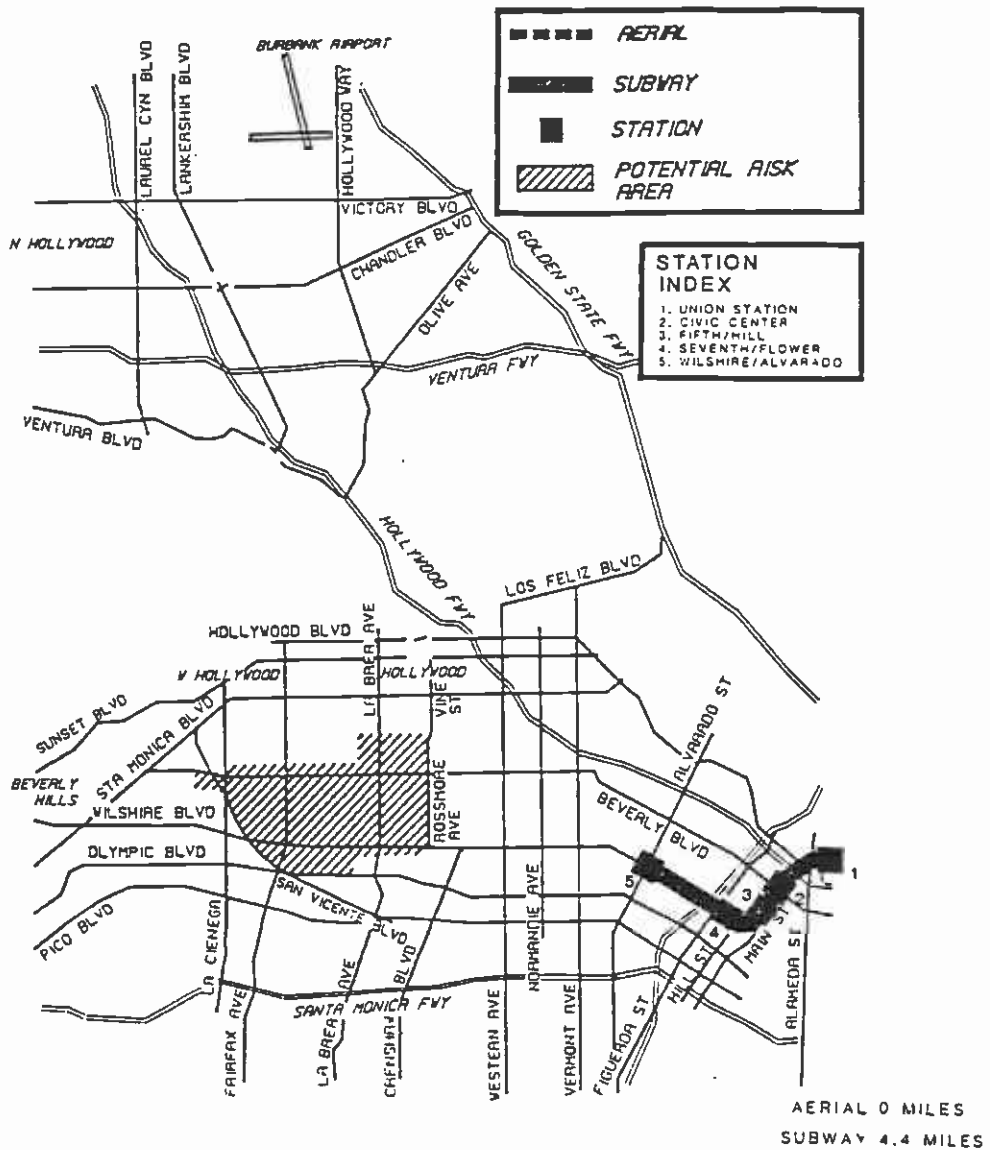

SOURCE: SCRTD

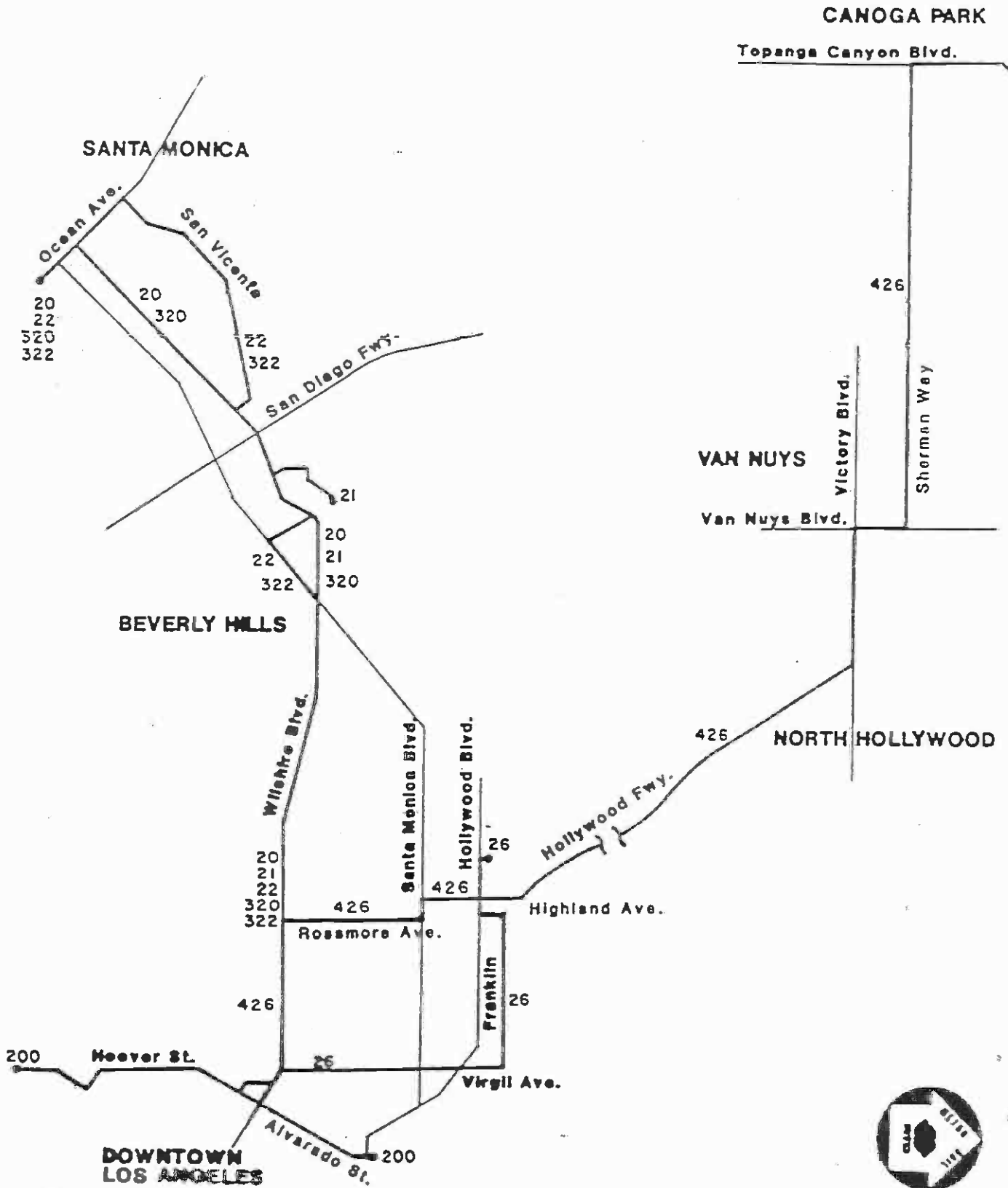

Southern California Rapid Transit District
Metro Rail Project

FIGURE 3-1.1

**Los Angeles Bus Routes
 Serving Metro Rail At
 Wilshire / Alvarado Station**

3.2 LONG BEACH - LOS ANGELES LIGHT RAIL TRANSIT PROJECT

The Long Beach - Los Angeles transit project is a conventional light rail system connecting downtown Los Angeles with downtown Long Beach. The 23 mile alignment will consist of 22 stations (Table 3-2) and will pass through the cities of Compton and Carson with approximately 18 miles of the alignment combining with the Southern Pacific Transportation Company right-of-way. Network coding entailed modifications to the routes of 19 bus lines in addition to the creation of park-and-ride, kiss-and-ride, and walk networks associated with each station.

TABLE 3-2

LB-LA-LRT STATIONS

7TH/FLOWER (ALSO SERVES MOS-1)
PICO/FLOWER
WASHINGTON/GRAND
WASHINGTON/SAN PEDRO
WASHINGTON/LONG BEACH
LONG BEACH/VERNON
SPTC ROW/SLAUSON
SPTC ROW/FLORENCE
SPTC ROW/FIRESTONE
SPTC ROW/103RD
SPTC ROW/IMPERIAL/WILMINGTON (ALSO SERVES THE CENTURY LRT) P(940)
SPTC ROW/COMPTON P(140)
SPTC ROW/ARTESIA P(420)
SPTC ROW/DEL ALMO P(314)
SPTC ROW/WARDLOW P(33)
SPTC ROW/WILLOW P(255)
LONG BEACH/P.C.H.
LONG BEACH/ANAHEIM
LONG BEACH/6TH
LONG BEACH/FIRST
FIRST/PACIFIC
FIFTH/PACIFIC

P - PARK-AND-RIDE(CAPACITY)

Figure 3-2 and Table 3-3 define the bus interface scheme for the LB-LA LRT coding development. Table 3-4 gives the LB-LA LRT link travel times as were coded by direction into the network links.

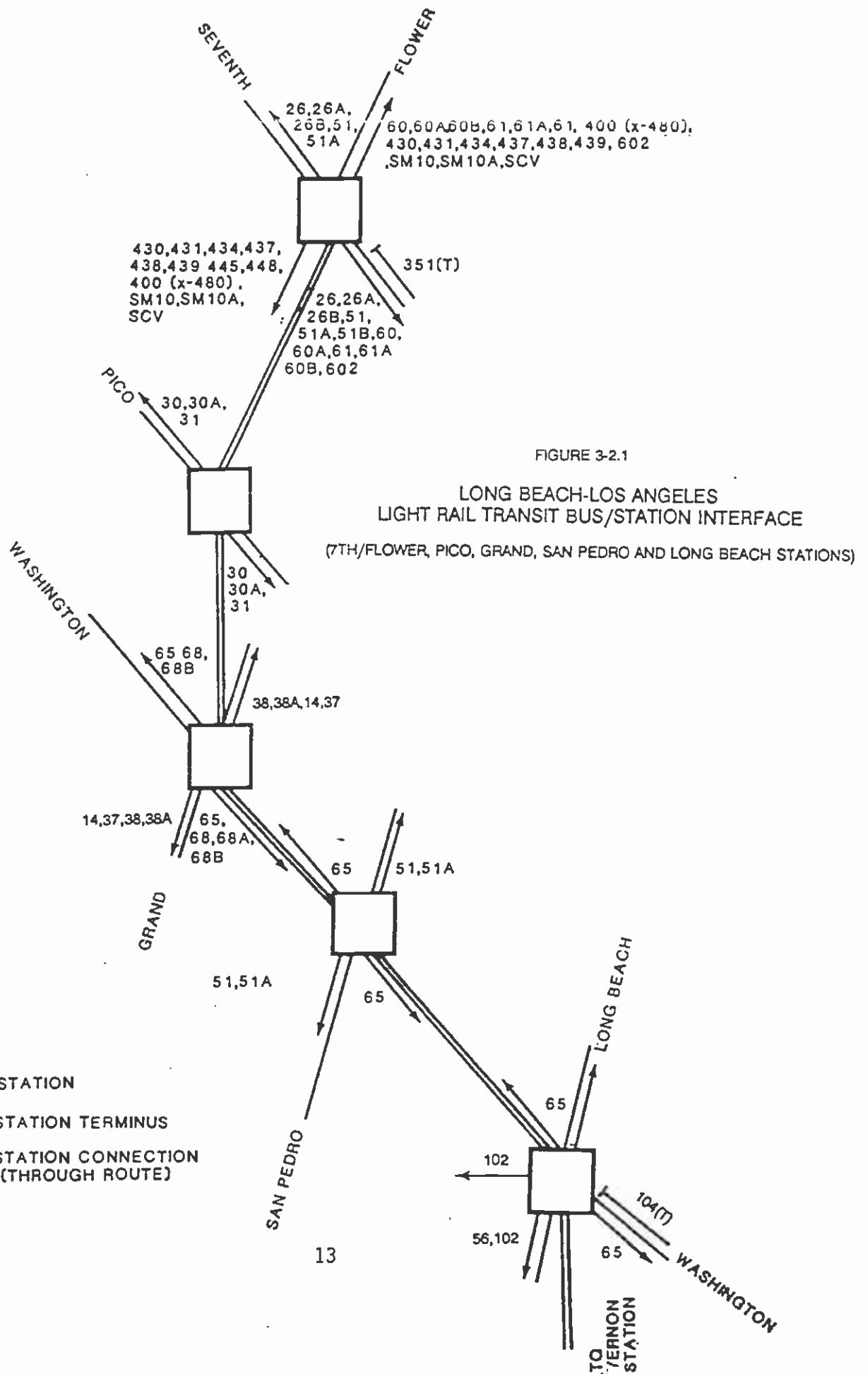



FIGURE 3-2.1

LONG BEACH-LOS ANGELES
LIGHT RAIL TRANSIT BUS/STATION INTERFACE

(7TH/FLOWER, PICO, GRAND, SAN PEDRO AND LONG BEACH STATIONS)

-  STATION
-  STATION TERMINUS
-  STATION CONNECTION (THROUGH ROUTE)

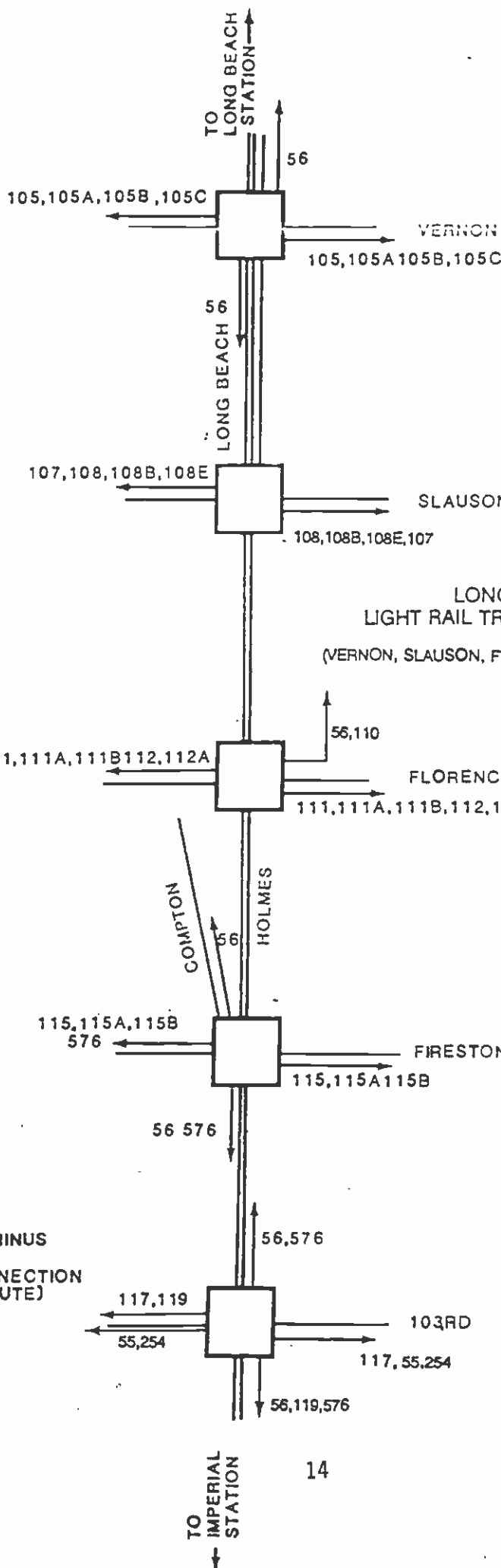

FIGURE 3-2.2
 LONG BEACH-LOS ANGELES
 LIGHT RAIL TRANSIT BUS/STATION INTERFACE
 (VERNON, SLAUSON, FLORENCE, FIRESTONE, AND 103RD STATIONS)

- STATION
- ⊥ STATION TERMINUS
- ← STATION CONNECTION (THROUGH ROUTE)

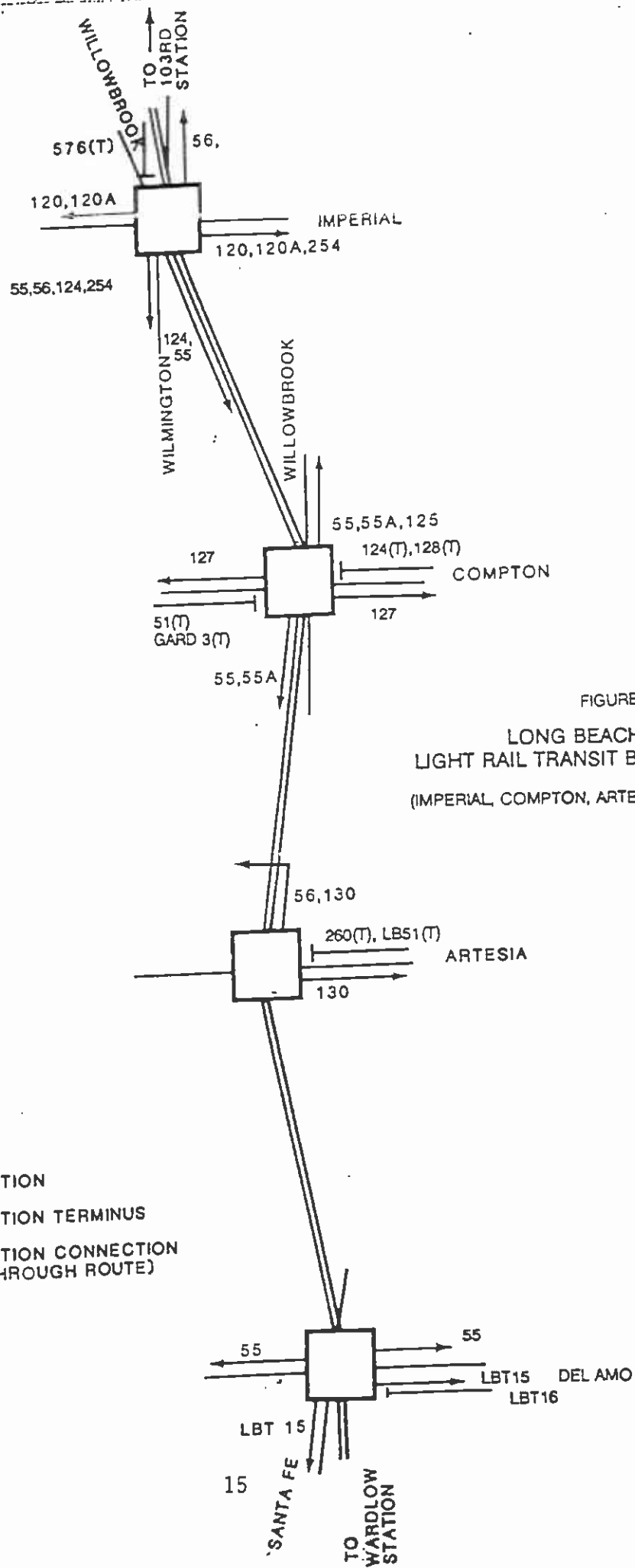
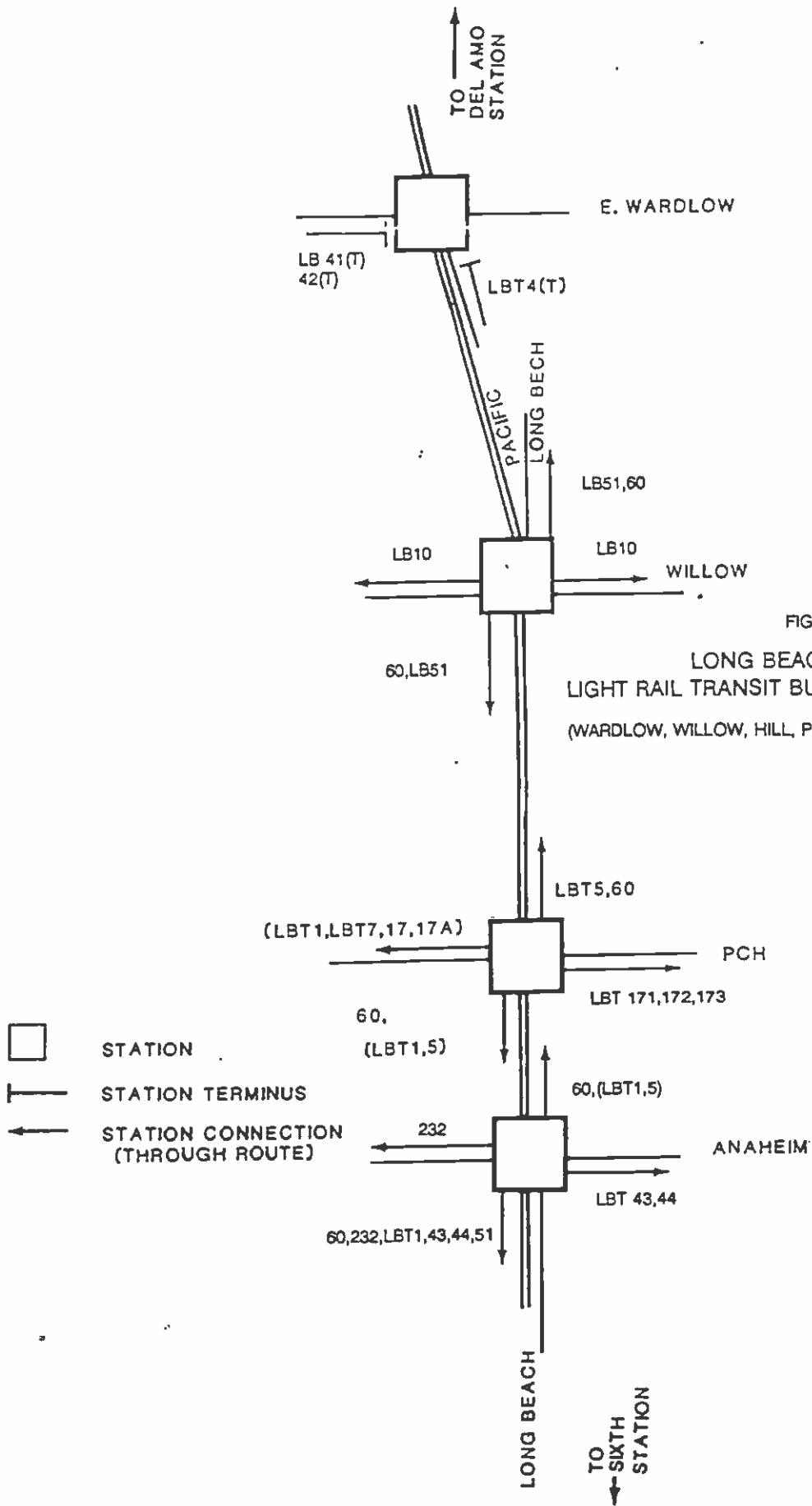

FIGURE 3-2.3

LONG BEACH-LOS ANGELES
 LIGHT RAIL TRANSIT BUS/STATION INTERFAC
 (IMPERIAL, COMPTON, ARTESIA , AND DEL AMO STATION

-  STATION
-  STATION TERMINUS
-  STATION CONNECTION (THROUGH ROUTE)



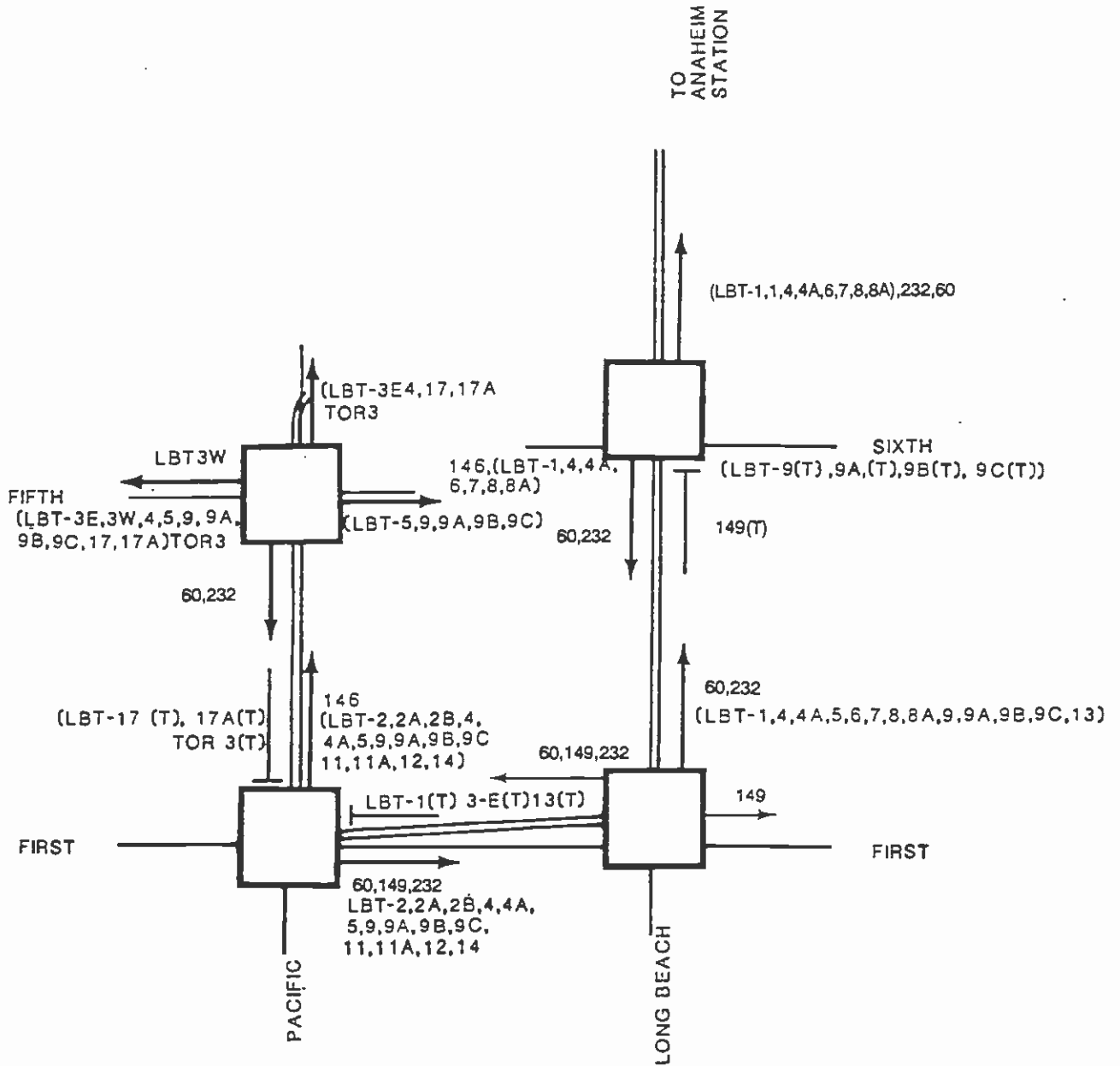

FIGURE 3-2.5

LONG BEACH-LOS ANGELES
LIGHT RAIL TRANSIT BUS/STATION INTERFACE

(SIXTH/LONG BEACH, FIRST/LONG BEACH, FIRST/PACIFIC, AND FIFTH/PACIFIC)

-  STATION
-  STATION TERMINUS
-  STATION CONNECTION (THROUGH ROUTE)

TABLE 3-3

BUS/STATION INTERFACE FOR NETWORKS-2,3,6

LONG BEACH - LOS ANGELES LRT

LINE #	BUS ROUTE / o CODED DESCRIPTION
55	LOS ANGELES, COMPTON, WILMINGTON VIA COMPTON AVE. <ul style="list-style-type: none"> o Extended from Compton via 104th, Grandee, and 103rd to serve the 103rd street station. Also in service to Imperial station, the line is extended north from 119th via Wilmington and Imperial Highway, returning via Willowbrook. rerouted between intersections of Victoria/Susana and Alameda/Del Amo, west on Del Amo to serve the Del Amo station, leaving east on Del Amo and north on Susana.
56	LOS ANGELES, CARSON VIA WILMINGTON AVE. <ul style="list-style-type: none"> o Rerouted from Wilmington on Walnut through the Artesia station, then back to regular routing via Acacia ave and Artesia to Wilmington. It then goes to the 103rd street station via Santa Ana Blvd and Graham Ave, leaving via 103rd and Beach. Its also serves Imperial station.
102	EAST JEFFERSON BLVD - COLISEUM ST <ul style="list-style-type: none"> o Routed north from 41st st to serve the Washington station via Compton Ave, Washington Blvd, and Long Beach Ave.
104	LOS ANGELES - LA MIRADA VIA EAST WASHINGTON BLVD <ul style="list-style-type: none"> o Extended from Washington/Soto via Washington to the Washington station. Present service between Washington/Soto and Olympic/Boyle discontinued
107	FAIRVIEW BLVD - 54TH STREET - SANTA ANA STREET <ul style="list-style-type: none"> o Extended south from 55th to serve the Slauson station operating via Compton, Slauson, and Holmes.
110	GAGE AVE - CENTINELA BLVD - FOX HILLS MALL <ul style="list-style-type: none"> o Routed south off Gage to serve the Florence station via Compton, Florence, and Holmes.

TABLE 3-3 (CONTINUED)

BUS/STATION INTERFACE FOR NETWORKS-2,3,6

LONG BEACH - LOS ANGELES LRT

LINE #	BUS ROUTE / o CODED DESCRIPTION
119	FERNWOOD AVE - 108TH ST. o Service continued northwest on Santa Ana to Graham, north on Graham to the 103rd st. station, leaving via 103rd St and Compton Avenue to resume regular service along 108th st.
124	EL SEGUNDO BLVD - SANTA FE AVE o Line extended to Compton station. also diverted to serve Imperial station, from 119th/Wilmington, north on Wilmington to Imperial Highway, through the Imperial station and south on Willowbrook to 119th.
125	ROSECRANS AVE o Service routed down Willowbrook from Rosecrans to the Compton Station and Compton Transit Center at Palmer.
127	COMPTON BLVD - BELLFLOWER BLVD o Extended north from Compton blvd to the Compton station and Compton Transit Center at Palmer.
128	ALONDRA BLVD o Western terminus extended north from Compton/Willowbrook two blocks to the Compton station and proposed Compton Transit Center
130	ARTESIA BLVD. o Line serves the Artesia station per existing coding.

TABLE 3-3 (CONTINUED)

BUS/STATION INTERFACE FOR NETWORKS-2,3,6

LONG BEACH - LOS ANGELES LRT

LINE #	BUS ROUTE / o CODED DESCRIPTION
254	120TH ST - HUNTINGTON PARK - LORENA AVE o Diverted between 119/Wilmington and Imperial/Mona via Imperial and Wilmington. Extended west from 103rd/Grape, via 103rd and Graham to serve the 103rd station.
260	LONG BEACH - PASADENA - ALTADENA VIA ATLANTIC BLVD o Service south of Artesia and into Long Beach discontinued. line extended west from Atlantic along Artesia and Acacia to the Artesia station.
351	o Limited service deleted.
358	LOS ANGELES - LYNWOOD - PARAMOUNT LIMITED o Deleted from network. Line proposed for cancellation. Service to be assumed by LA-LB LRT and a peak hour extension of line 119.
360	o Limited service deleted.
456	LOS ANGELES - LONG BEACH EXPRESS o Deleted from network. Line proposed for cancellation. Service to be assumed by LA-LB LRT and LBT 51.
457	LOS ANGELES - EAST LONG BEACH EXPRESS o Deleted from network. Line proposed for cancellation. access to LA-LB LRT to be accomodated by Long Beach Transit, east/west lines.
576	SOUTH LOS ANGELES - PACIFIC PALISADES EXPRESS o Line cut-back three blocks from south terminus at 119th/Wilmington to a new terminus at the Imperial station. Also routed by the 103rd St station via Wilmington, Santa Ana Blvd, Graham, 103rd, Beach, Century, and back to present route.

TABLE 3-4

LONG BEACH - LOS ANGELES LINK TRAVEL TIMES

STATION	SOUTHBOUND		NORTHBOUND	
	(MILES)	(MINUTES)	(MILES)	(MINUTES)
	<<READ DOWN>>		<<READ UP>>	
7TH/FLOWER	-	-	0.74	2.13
PICO	0.74	1.98	0.65	3.75
GRAND	0.65	2.47	0.80	2.43
SAN PEDRO	0.80	4.32	0.98	3.93
WASHINGTON	0.98	5.23	1.13	2.42
VERNON	1.13	2.13	1.01	1.87
SLAUSON	1.01	1.90	1.00	3.10
FLORENCE	1.00	3.00	1.01	1.92
FIRESTONE	1.01	1.93	1.16	2.08
103RD	1.16	2.00	1.07	2.07
IMPERIAL	1.07	1.90	2.34	3.38
COMPTON	2.34	3.40	1.43	2.37
ARTESIA	1.43	2.30	2.09	3.05
DEL ALMO	2.09	3.07	2.17	3.33
WARDLOW	2.17	3.23	0.80	1.63
WILLOW	0.80	1.60	1.25	5.13
P.C.H.	1.25	5.47	0.49	2.00
ANAHEIM	0.49	2.13	0.93	7.30
LONG BEACH/SIXTH	0.60	3.77	-	-
LONG BEACH/FIRST	0.33	2.67	-	-
FIRST/PACIFIC	0.24	1.62	-	-
FIFTH/PACIFIC	-	-	0.29	3.52
FIRST/PACIFIC	-	-	-	-

3.3 CENTURY LIGHT RAIL TRANSIT PROJECT

The Century LRT is a 17 mile line which when completed will run from the vicinity of the Los Angeles International Airport on the west to Norwalk on the east, along the median of the Century Freeway. Both freeway and LRT are concurrently under construction. The Century line will consist of 10 stations (Table 3-5) with stops connecting to the proposed Harbor Transitway and the Long Beach-Los Angeles LRT. The line will curve south from it's western extent at I-105 and Aviation into El Segundo; a segment called the El Segundo Extension. The El Segundo Extension is described in Section 3.4.

TABLE 3-5

CENTURY LRT STATIONS

I-105/AVIATION P(1165)
 I-105/HAWTHORNE P(812)
 I-105/CRENSHAW P(539)
 I-105/VERMONT P(274)
 I-105/I-110 P(373)
 I-105/AVALON P(178)
 I-105/IMPERIAL/WILMINGTON (ALSO SERVES LA-LB LRT) P(940)
 I-105/LONG BEACH BLVD P(820)
 I-105/LAKEWOOD P(450)
 I-105/I-605 (NORWALK) P(2058)

 P - PARK-AND-RIDE(CAPACITY)

Figure 3-3 and Table 3-6 describe the bus intercept scheme for the Century LRT coding development. Figure 3-3.1 shows the bus/rail station interface scheme for the Century alignment; Aviation and Hawthorne stations and also includes the four El Segundo Extension Stations. Table 3-7 shows the Century LRT link speeds and conversion to travel time as coded into the network links.

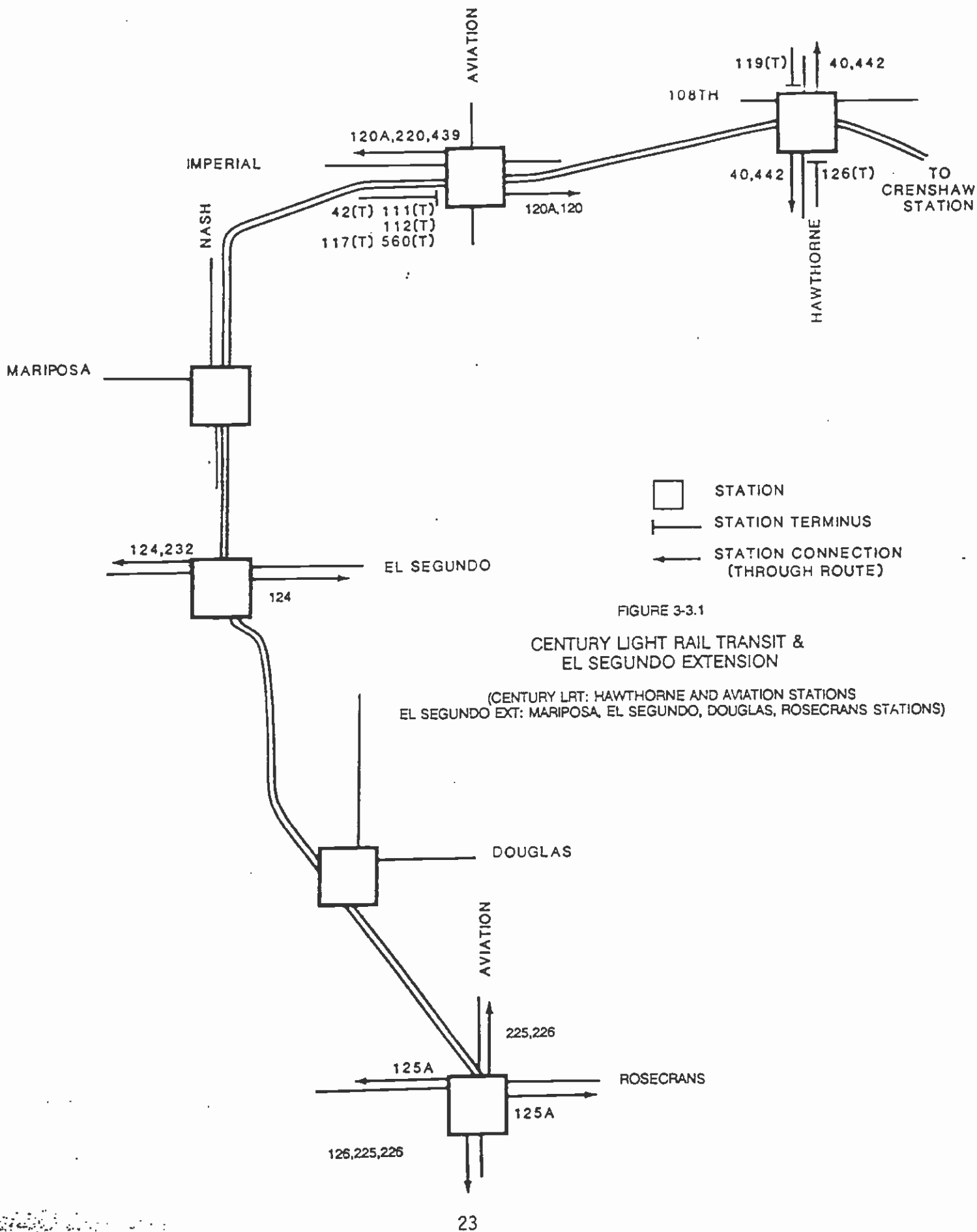

FIGURE 3-3.1

CENTURY LIGHT RAIL TRANSIT & EL SEGUNDO EXTENSION

(CENTURY LRT: HAWTHORNE AND AVIATION STATIONS
EL SEGUNDO EXT: MARIPOSA, EL SEGUNDO, DOUGLAS, ROSECRANS STATIONS)

FIGURE 3-3.2
CENTURY LIGHT RAIL TRANSIT

(CRENSHAW, VERMONT, HARBOR, AVALON, AND WILMINGTON STATIONS)

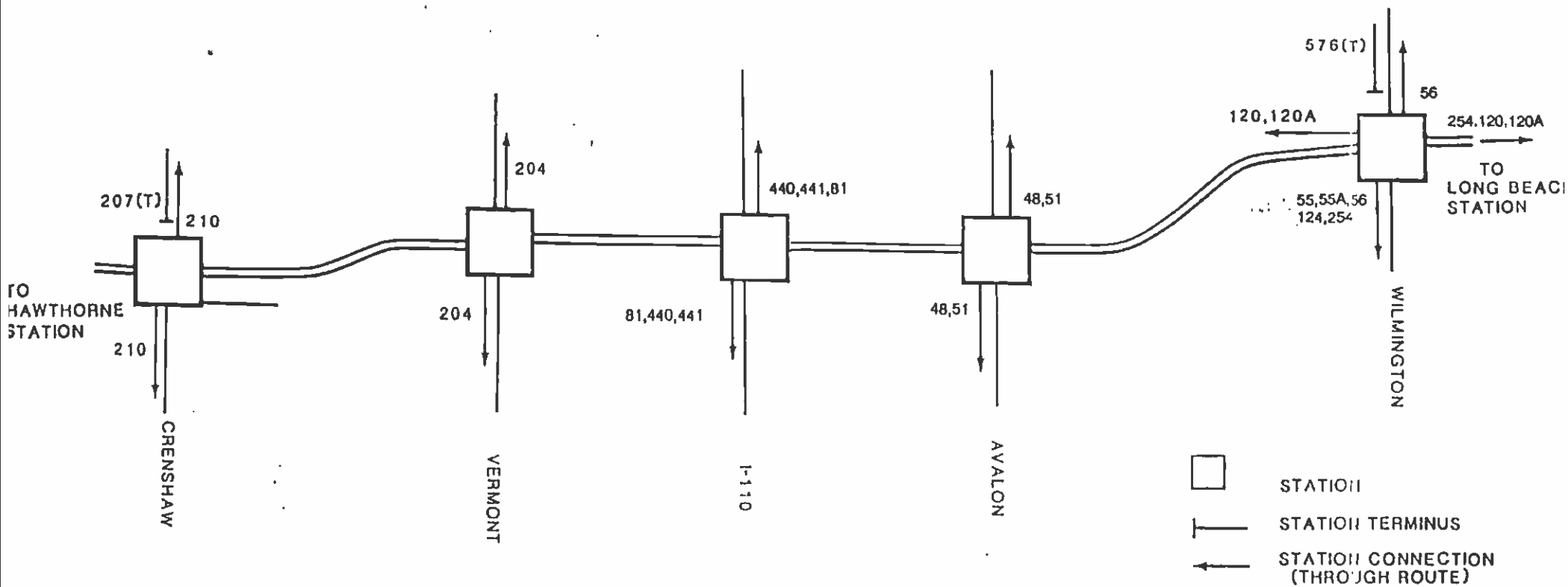

FIGURE 3-3.3

CENTURY LIGHT RAIL TRANSIT

(LONG BEACH, LAKEWOOD, AND NORWALK STATIONS)

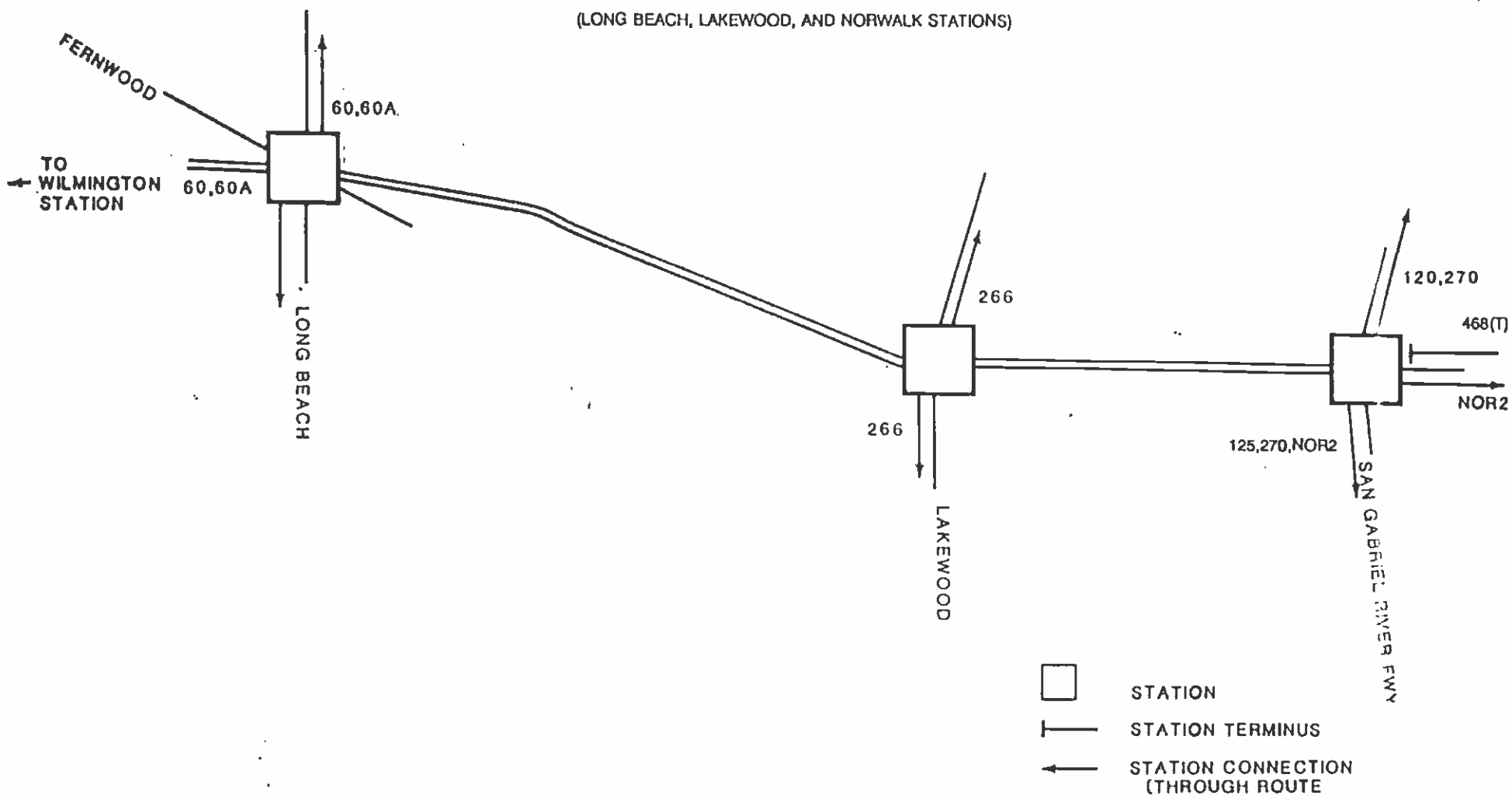

TABLE 3-6

BUS/STATION INTERFACE FOR NETWORKS-2,3,6

CENTURY/EL SEGUNDO LRT

LINE #	BUS ROUTE / o CODED DESCRIPTION
42	LOS ANGELES, WESTCHESTER, REDONDO BEACH o Extended south from LAX Transit Center to terminate at Aviation station.
55	WILMINGTON - LOS ANGELES VIA COMPTON o Extended north from 119th to serve the Imperial station
56	CARSON - LOS ANGELES VIA WILMINGTON o Diverted off Wilmington ave to serve the Imperial station.
111	LAX, FLORENCE AVE, LEFFINGWELL RD o Line extended south from LAX Transit Center to terminate at the Aviation station.
112	LAX, FLORENCE AVE, OTIS ST o Line extended south from LAX transit center to terminate at the Aviation station.
117	CENTURY BLVD o Line extended south from LAX transit center to terminate at the Aviation station.
119	108TH ST, FERNWOOD AVE o Western-most terminus at Hawthorne station

TABLE 3-6 (CONTINUED)

BUS/STATION INTERFACE FOR NETWORKS-2,3,6

CENTURY/EL SEGUNDO LRT

LINE #	BUS ROUTE / o CODED DESCRIPTION
124	EL SEGUNDO BLVD, SANTA FE AVE o Rerouted north of 119th to serve the Imperial station also serves El Segundo station.
125	ROSECRANS AVE o Service rerouted north from Rosecrans to serve the Norwalk Transit Center. It diverts to serve the Rosecrans station in western service extent.
126	YUKON AVE, MANHATTAN BEACH BLVD o This line serves Rosecrans station, and terminates at Hawthorne station.
207	WESTERN AVE o Extended south from its terminal at Imperial/Western to terminate at the Crenshaw station.
220	ROBERTSON BLVD, CULVER CITY, LAX o Extended east from Sepulveda to serve the Aviation Station via Imperial, continuing to the LAX Transit Center.
254	120TH ST, HUNTINGTON PARK, LORENA ST o rerouted north to serve the Imperial station.
270	EL MONTE, CERRITOS o Rerouted west of Studebaker to serve the Norwalk Transit Center.

TABLE 3-6 (CONTINUED)

BUS/STATION INTERFACE FOR NETWORKS-2,3,6

CENTURY/EL SEGUNDO LRT

LINE #	BUS ROUTE / o CODED DESCRIPTION
439	LA, LAX, REDONDO BEACH o Rerouted east from Sepulveda/Imperial to serve the Aviation station.
468	SOUTH LOS ANGELES - PACIFIC PALISADES EXPRESS o New service to operate from Fullerton park-and-ride on Orangethrope near the Santa Ana Fwy. Line 468 will operate on the Santa Ana Fwy to Rosecrans, then west on Rosecrans to Studebaker, north to Norwalk T/C access road. Headways are coded at 12/12/30 minutes (am/pm/midday).
560	LAX, SAN DIEGO FWY, VAN NUYS BLVD o Extended south from the LAX Transit Center to a terminus at the Aviation station.
576	SOUTH LOS ANGELES - PACIFIC PALISADES EXPRESS o Line cut-back three blocks from south terminus at 119th/Wilmington to a new terminus at the Imperial station.

TABLE 3-7

CENTURY LRT LINK SPEEDS

STATION LINK	DISTANCE (MILES)	CODED TRAVEL TIME* (MINUTES)	LINK SPEED (MPH)
NORWALK-LAKEWOOD	2.10	3.13	40.26
LAKEWOOD-LONG BEACH	4.20	5.41	46.58
LONG BEACH-WILMINGTON	1.71	2.70	38.00
WILMINGTON-AVALON	1.57	2.55	36.94
AVALON-HARBOR FWY	0.87	1.78	29.33
HARBOR FWY-VERMONT	0.65	1.55	25.16
VERMONT-CRENSHAW	2.03	3.04	40.07
CRENSHAW-HAWTHORNE	1.58	2.56	37.03
HAWTHORNE-AVIATION	1.58	2.56	37.03
TOTALS	16.29	25.28	

* INCLUDES RUNNING TIME + STATION DWELL TIME

3.4 EL SEGUNDO LRT EXTENSION

The El Segundo extension to the Century LRT will tie into the Century line at the Aviation station. With four additional stations in El Segundo (Table 3-8) , the alignment will run south, south-east to a end-offline near Compton Blvd.

TABLE 3-8

EL SEGUNDO EXTENSION LRT STATIONS

MARIPOSA/NASH
EL SEGUNDO/NASH
DOUGLAS ST P(120)
ROSECRANS/AVIATION P(350)

P- PARK AND RIDE(CAPACITY)

Figure 3-4 and Table 3-9 describe the bus intercept scheme for the Century/ El Segundo extension LRT coding development, including the two initial Century LRT stations. Table 3-10 gives the El Segundo link speeds and conversion to travel time as coded into the appropriate network link records.

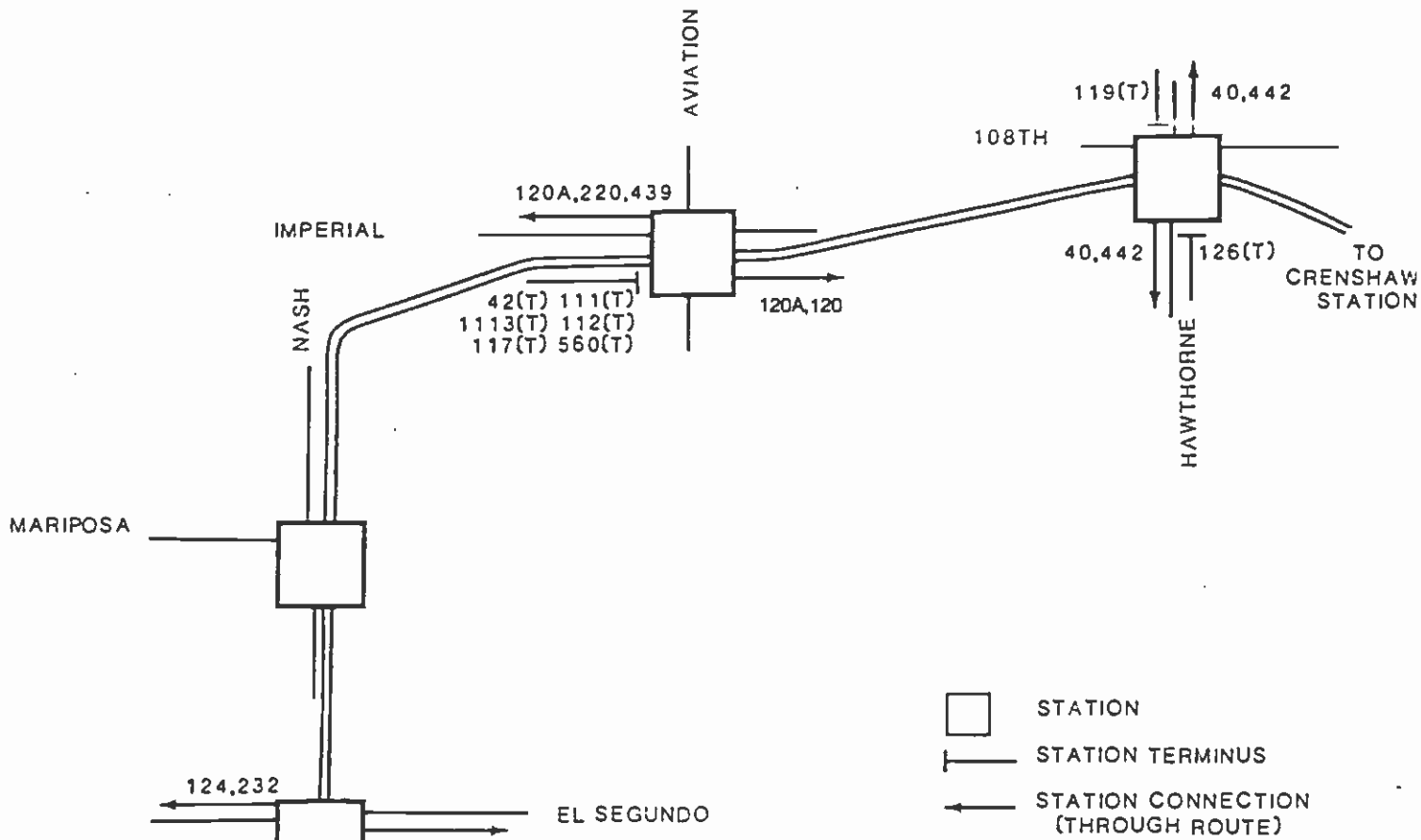

FIGURE 3.4

CENTURY LIGHT RAIL TRANSIT & EL SEGUNDO EXTENSION

(CENTURY LRT: HAWTHORNE AND AVIATION STATIONS
 EL SEGUNDO EXT: MARIPOSA, EL SEGUNDO, DOUGLAS, ROSECRANS STATIONS)

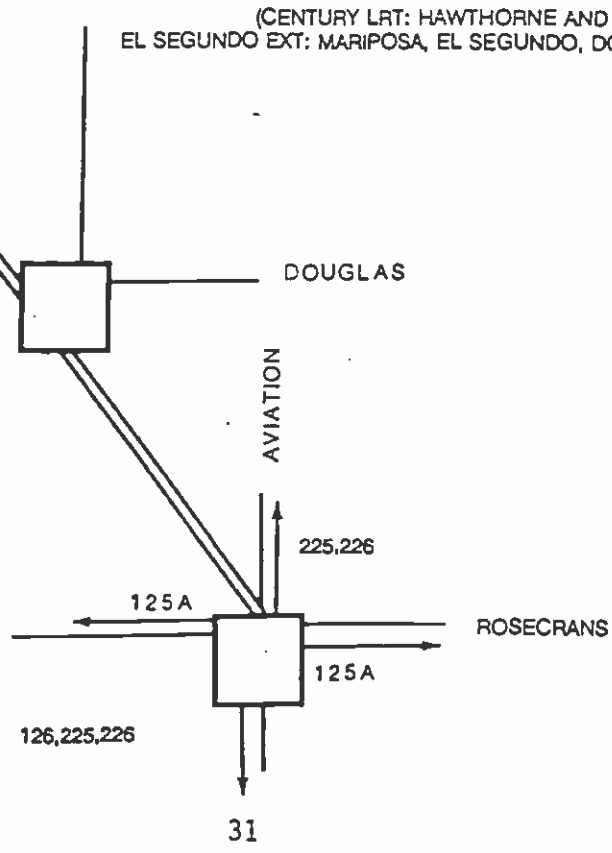

TABLE 3-9

BUS/STATION INTERFACE FOR NETWORKS-2,3,6

CENTURY/EL SEGUNDO LRT

LINE #	BUS ROUTE / o CODED DESCRIPTION
124	EL SEGUNDO BLVD, SANTA FE AVE o Serves the EL Segundo station.
125	ROSECRANS AVE o Serves the Rosecrans station along a short reroute off Rosecrans Avenue.
126	YUKON AVE, MANHATTAN BEACH BLVD o It diverts off Compton Blvd to serve Rosecrans station.
225	AVIATION BLVD, PALOS VERDES DRIVE N., MARINELAND o This is rerouted off Aviation Blvd to serve Rosecrans station.
226	AVIATION BLVD, PALOS VERDES DRIVE N., MARINELAND o It diverts off Aviation to serve the Rosecrans station.
232	LONG BEACH, LAX o It is rerouted from Sepulveda Blvd to serve the El Segundo station.

TABLE 3-10

EL SEGUNDO EXTENSION CODED TRAVEL TIMES AND LINK SPEEDS

STATION LINK	DISTANCE (MILES)	CODED TRAVEL TIME* (MINUTES)	LINK SPEED (MPH)
AVIATION-MARIPOSA	0.95	1.87	30.48
MARIPOSA-EL SEGUNDO	0.61	1.50	24.40
EL SEGUNDO-DOUGLAS	0.66	1.55	25.55
DOUGLAS-COMPTON	0.66	1.55	25.55

3.5 HARBOR BUSWAY

The initial phase of the Harbor Transitway is planned to open around the time of the opening of the Century Freeway and LRT. The Harbor Transitway will connect LA-CBD with points south, operating as an exclusive guideway.

Harbor Busway stations, with parking capacities, as coded into the network for inclusion with the Century/El Segundo LRT, LB-LA LRT, and MOS-1 in Network-3 (GOP3VER1) are listed in Table 3-11. Note, since the busway will not extend below the Artesia Transit Center that those stations south thereof are associated with regular freeway operation speeds coded into the network. Figure 3-5 and Table 3-12 describe the bus intercept scheme for the Harbor Transitway. Express service, coded link speeds were increased to 38 mph, representative of full Transitway completion to the Artesia Transit Center.

TABLE 3-11

HARBOR TRANSITWAY STATIONS AND PARKING CAPACITIES

STATION	LOT CAPACITY

EXPOSITION	200
SLAUSON	200
MANCHESTER	200
I-105	373
ROSECRANS	300
ARTESIA TRANSIT CENTER	1000
CARSON	600
PACIFIC COAST HWY.	500
SAN PEDRO TRANSIT CENTER	700

FIGURE 3-5

HARBOR TRANSITWAY OPERATING PLAN

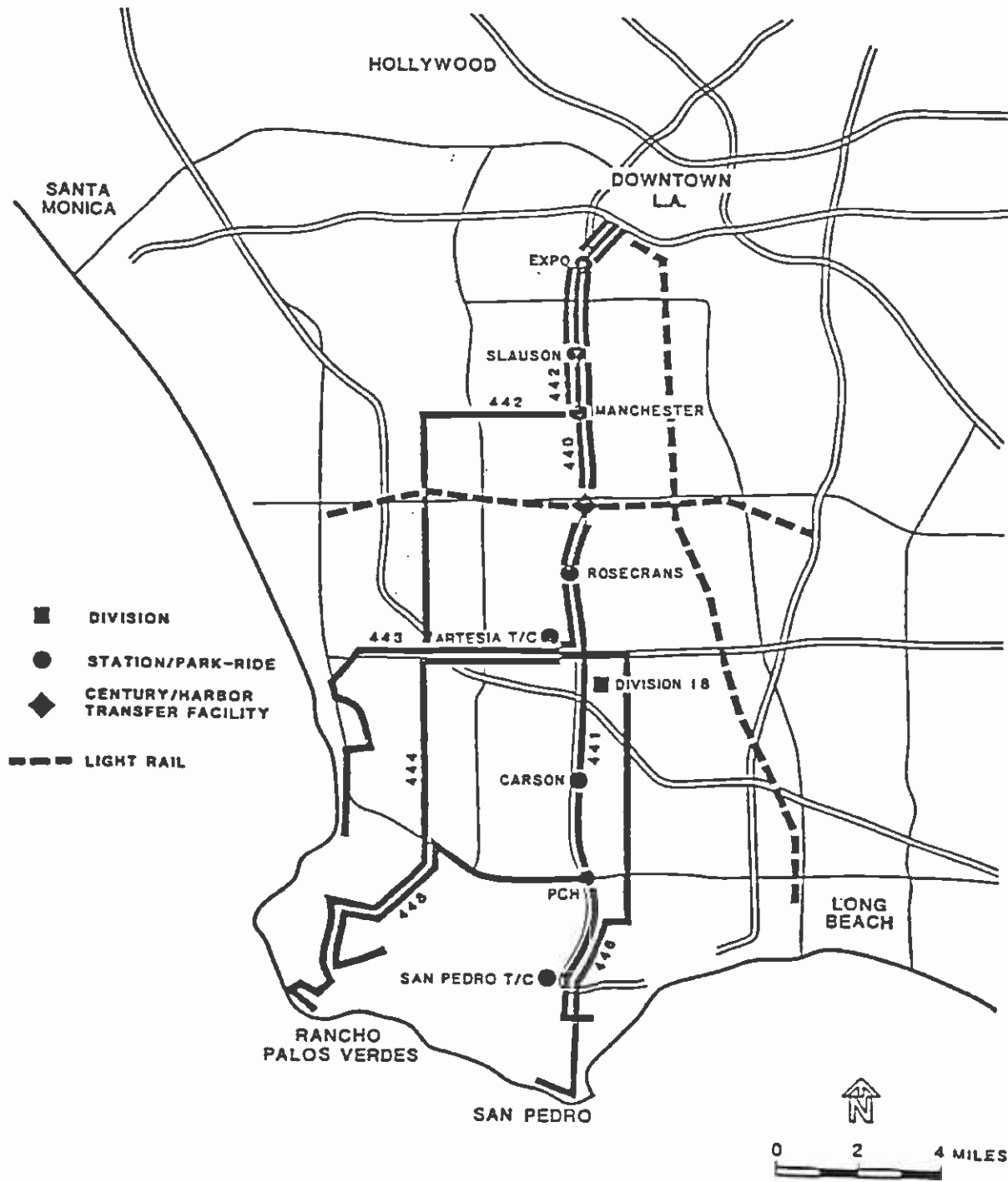

TABLE 3-12

BUS/STATION INTERFACE FOR NETWORK 2,3,6

HARBOR TRANSIT OPERATING PLAN

LINE #	BUS ROUTE / o CODED DESCRIPTION
440	LA, ARTESIA TRANSIT CENTER EXPRESS
	o Service originates at the Artesia Transit Center, operating on the Harbor Transitway to LACBD via Artesia Blvd on/off ramps. Headways are coded at 4/4/20 (am/pm/midday)
441	LA, SAN PEDRO EXPRESS
	o Replaces line 445 service. Operates on the Harbor Transitway at 38 mph. Headways are coded at 9/8/30 (am/pm/midday).
442	LA, HAWTHORNE EXPRESS
	o Service unchanged.
443	LA, TORRANCE, REDONDO BEACH, PALOS VERDES
	o Turned off Aviation at Artesia, routed east on Artesia and terminated at the Artesia Transit Center at Artesia and the Harbor Transitway. Headways are 20/20 (am/pm).
444	LA, WEST TORRANCE, ROLLING HILLS, RANCHO PALOS VERDES
	o Turned off Hawthorne Blvd at Artesia, routed east on Artesia and terminated at the Artesia Transit Center at Artesia and the Harbor Transitway. Headways are 15/15/30 (am/pm/midday).
445	LA, ALPINE VILLAGE, SAN PEDRO PARK-AND-RIDE
	o Service suspended. Replaced by line 441.
446	LA, CARSON, WILMINGTON, SAN PEDRO
	o Line routed west off Avalon on Artesia to a terminus at the Artesia Transit Center. Headways are 8/12/15 minutes (am/pm/midday).
448	LA, PALOS VERDES PENNINSULA EXPRESS
	o Service terminated on Pacific Coast Highway routing at

the PCH transit terminal at the Harbor Transitway.
Headways are coded at 20/20 minutes (am/pm).

3.6 LOCALLY PREFERRED ALTERNATIVE : MOS-2

The MOS-2 configuration of the locally preferred alternative has thirteen stations with temporary terminals at Wilshire/Western and Hollywood/Vine stations. This alignment is shown in Figure 3-6.1.

TABLE 3-13

LOCALLY PREFERRED ALTERNATIVE : MOS-2 STATIONS

Main Branch	Union Station 1st/Hill 5th/Hill 7th/Flower Wilshire/Alvarado Wilshire/Vermont
West Branch	Wilshire Normandie Wilshire/Western
Valley Branch	Vermont/Beverly Vermont/Santa Monica Vermont/Sunset Hollywood/Western Hollywood/Vine

The bus/rail interface for this alternative is shown in Figure 3-6.2. These changes were provided at the start of this task by the District Planning Department.

FIGURE 3-6.2

BUS-RAIL INTERFACE
 LOCALLY PREFERRED ALTERNATIVE: MOS-2

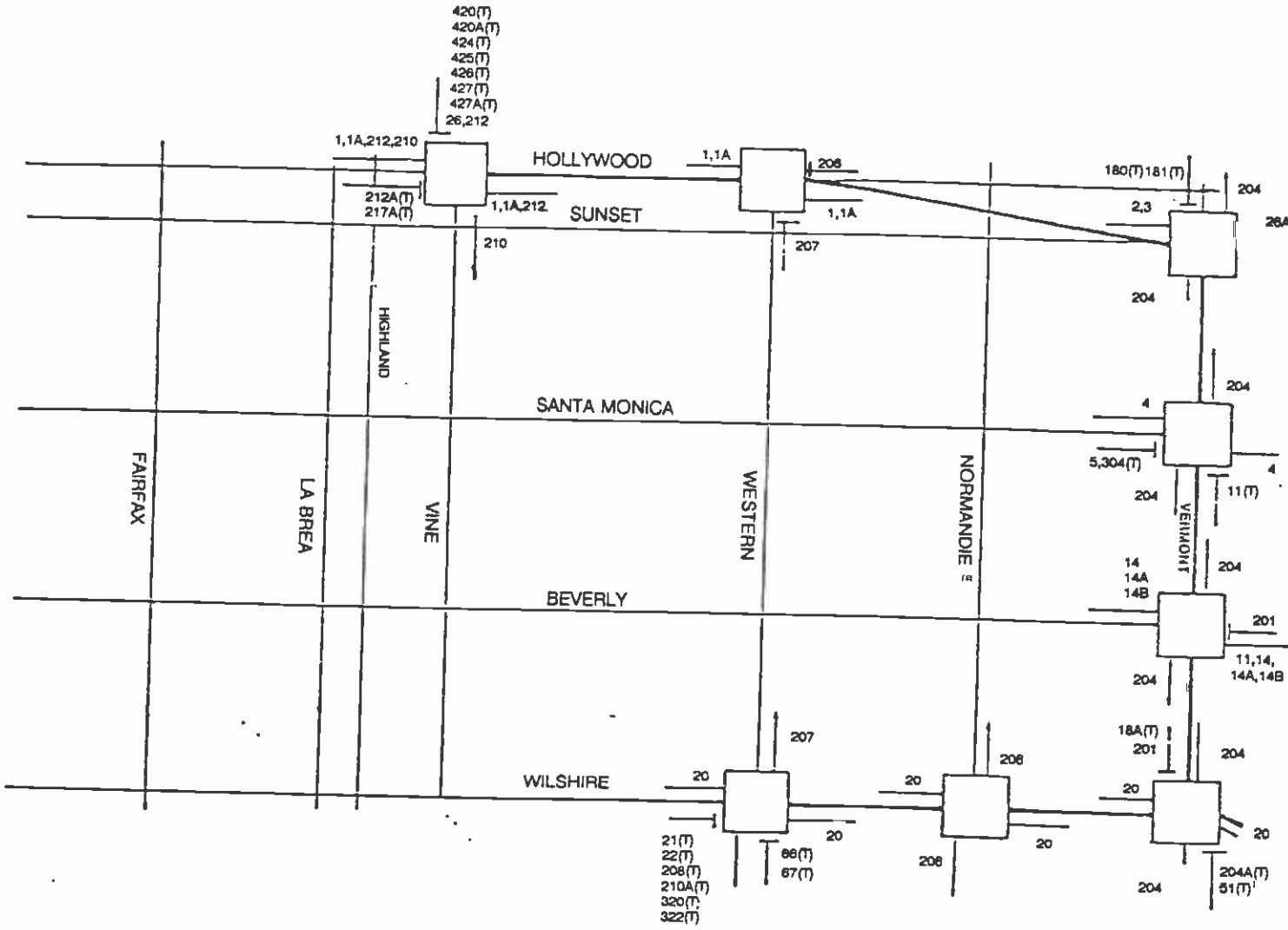

TABLE 3-14

BUS/STATION INTERFACE FOR LOCALLY PREFERRED ALTERNATIVE :MOS-2

LINE #	BUS ROUTE / o CODED DESCRIPTION
5	SANTA MONICA BLVD. - HIGHLAND AVE <ul style="list-style-type: none"> o Replace line 420 service south of Universal City station; operates to Vermont-Santa Monica station via Cahuenga, Highland and Santa Monica.
20	WILSHIRE BLVD. - SANTA MONICA TO LA-CBD <ul style="list-style-type: none"> o Terminating in the LA-CBD, headways are nine minutes for regular service.
21	WILSHIRE BLVD., UCLA - WESTWOOD TO LA-CBD <ul style="list-style-type: none"> o Service terminated at the Wilshire/Western station.
22	WILSHIRE BLVD., UCLA - SANTA MONICA TO LA-CBD <ul style="list-style-type: none"> o Service terminated at the Wilshire/Western station.
26	7TH ST., VIRGIL AVE., FRANKLIN AVE. <ul style="list-style-type: none"> o This line operates on Franklin Ave., turns south on Vine and terminates at the Hollywood/Vine station, accounting for approximately half the service frequency with the other half intercepting the Vermont/Sunset station via Sunset Blvd.
66	OLYMPIC BLVD., 8TH ST. - KOREATOWN TO EAST LA COMMERCE <ul style="list-style-type: none"> o Route extended from its current terminus at 8th/Western to go north on Western to the Wilshire/Western station.
67	OLYMPIC BLVD., 8TH ST. - KOREATOWN TO EAST LA COMMERCE <ul style="list-style-type: none"> o Route extended from its current terminus at 8th/Western, north on Western to the Wilshire/Western station.

TABLE 3-14

BUS/STATION INTERFACE FOR LOCALLY PREFERRED ALTERNATIVE : MOS-2

LINE #	BUS ROUTE / o CODED DESCRIPTION
180	HOLLYWOOD, GLENDALE, PASADENA VIA COLORADO BLVD. o Turned south off Los Feliz on Vermont and terminated at the Vermont/Sunset station.
181	HOLLYWOOD, GLENDALE, PASADENA VIA YOSEMITE DRIVE. o Turned south off Los Feliz on Vermont and terminated at the Vermont/Sunset station.
201	SILVERLAKE BLVD. - GLENDALE TO MID-WILSHIRE o Service from Silverlake operates to the Vermont/Beverly station, than south on Vermont to the Wilshire-Vermont station.
204	VERMONT AVE. - USC TO LA-CBD o Full-frequency service suspended at Wilshire/Vermont station with headways doubled for a short-line operation along Vermont; serving Vermont/Beverly, Vermont/Santa Monica stations and terminating at Hollywood Blvd. Short line is from Wilshire to end from the south.
209	VAN NESS, ARLINGTON AVE. - HANCOCK PARK TO GARDENA o Service turned east from Wilshire/Wilton Pl. (before current turnaround) and routed two blocks east along Wilshire to the Wilshire/Western station.
210	VAN NESS, CRENSHAW BLVD., HOLLYWOOD TO LAWNSDALE o Regular service is turned around at the Hollywood/Highland station.
212	HOLLYWOOD, VINE - TO INGLEWOOD o Short line operates between Inglewood and Hollywood-Vine.

TABLE 3-14 (CONTINUED)

BUS/STATION INTERFACE FOR LOCALLY PREFERRED ALTERNATIVE : MOS-2

LINE #	BUS ROUTE / o CODED DESCRIPTION
304	(LIMITED) SANTA MONICA BLVD. - SANTA MONICA TO LA-CBD o Service to downtown terminates at the Vermont/Santa Monica station.
320	(LIMITED) WILSHIRE BLVD. - SANTA MONICA TO LA-CBD o Service terminates at the Wilshire/Western station.
322	(LIMITED) WILSHIRE BLVD. - SANTA MONICA TO LACBD o Terminates at the Wilshire/Western station.
420	(EXPRESS) LA-CBD, VAN NUYS, NORTHRIDGE o Express service routed south through Cahuenga pass via Hollywood Freeway and Vine street to the Hollywood/Vine station.
423	(EXPRESS) LA, WOODLAND HILLS, WESTLAKE VILLAGE o Routed south on Hollywood Fwy. exiting at Vine street to a terminus at the Hollywood/Vine station.
424	(EXPRESS) LA-CBD, VENTURA BLVD. o Routed south on Hollywood Fwy. exiting at Vine street to a terminus at the Hollywood/Vine station.
425	(EXPRESS) LA-CBD, VENTURA BLVD. o Full service replaced by a local, limited-stop service operation serving the Hollywood/Vine station. Operating via the Hollywood Fwy from Lankeshim to Vine street.

TABLE 3-14 (CONTINUED)

BUS/STATION INTERFACE FOR LOCALLY PREFERRED ALTERNATIVE : MOS-2

LINE # BUS ROUTE / o CODED DESCRIPTION

426 (EXPRESS) LA-CBD, WILSHIRE BLVD., SAN FERNANDO VALLEY

- o Full service replaced by a local, limited stop service feeding the Hollywood/Vine station. Operating via the Hollywood Fwy between Victory Blvd and Vine street.

427 (EXPRESS) LA-CBD, TARZANA, WOODLAND HILLS, CANOGA PARK

- o Routed south on Hollywood Fwy. exiting at Vine street to a terminus at the Hollywood/Vine Station.

4.0 NETWORK SUMMARY STATISTICS

The following tables provide a comparative look at the financial plan alternatives simulated for this task. The main attributes of these alternatives are network layout, transit shares for work and non work, peak-hour vehicle requirements and operating cost. These attributes are presented in the Tables 4-1 and Table 4-2, for year 1990 and 2000 respectively. All the operating costs are in 1980 dollars.

Tables 4-3 through 4-6 give daily station-to-station trip movements in origin-destination format which detail all rail boardings and alightings relative to the station of origin and the station of destination. These matrices are constructed as an intermediate step in the Diamond program sequence and exhibit forecast year 2000 transit trips. These matrices are as large as 50 by 50 (rows and columns), so they had to be continued beyond a single page for a given network year-alternative. Each of the tables are preceded by a station correspondence index which matches the station number (row and column) to the representative station name. In reading these tables, the row labels indicate where station boardings occur. The column headings are stations where the referenced value represents the number of rail trips alighting at that station, having boarded at the station of the corresponding, cross indexed row.

TABLE 4-1

ALTERNATIVE TRIP TABLES HIGHWAY NETWORK SOCIO-ECON FILE	NW01 Y90PA5 Y8221628 SCAG90B	60P2VER1 Y90PA5 Y8221628 SCAG90B	60P3VER1 Y90PA5 Y8221628 SCAG90B	60P3TSM1 Y90PA5 Y8221628 SCAG90B	60P6VER1 Y90PA5 Y8221628 SCAG90B	
LINES BY MODE:	4	202	210	211	212	212
	5	103	83	87	87	89
	6	0	1	1	1	2
	7	0	2	4	4	4
	8	212	215	215	215	212
LINKS BY MODE:	1	N/A	6284	6452	6452	6550
	2	N/A	1018	1577	1577	1588
	3	N/A	1049	849	849	1025
	4	6872	7922	7940	7940	7916
	5	3268	3590	3642	3646	3638
	6	0	8	8	8	24
	7	0	43	69	69	69
	8	6056	6612	6612	6612	6612
HBWORK AUTO DA	5695868	5687465	5670865	5671169	5669959	
AUTO SR2	1221053	1219280	1214900	1214928	1214911	
AUTO SR3+	661232	660157	657723	657751	657599	
TRN (PRSN)	511513	522754	546136	545799	547168	
TOTAL (PRSN)	8089666	8089656	8089624	8089647	8089637	
% (TRN)	0.0632	0.0646	0.0675	0.0675	0.0676	
HO AUTO (VEH)	14383116	14441710	14441071	14440757	14455174	
AUTO (PRSN)	22294263	22385040	22384042	22383561	22405865	
TRN (PRSN)	716480	625640	626632	627131	604810	
TOTAL (PRSN)	23010743	23010680	23010674	23010692	23010675	
% (TRN)	0.0311	0.0272	0.0272	0.0273	0.0263	
OO AUTO (VEH)	5601745	5607913	5607903	5607756	5608923	
AUTO (PRSN)	9528085	9540698	9540622	9540370	9543255	
TRN (PRSN)	145176	132580	132655	132903	130015	
TOTAL (PRSN)	9673261	9673278	9673277	9673273	9673270	
% (TRN)	0.0150	0.0137	0.0137	0.0137	0.0134	
OW AUTO (VEH)	2237462	2240710	2240673	2240611	2241318	
AUTO (PRSN)	3718145	3725318	3725232	3725104	3726896	
TRN (PRSN)	74960	67787	67880	68009	66212	
TOTAL (PRSN)	3793105	3793105	3793112	3793113	3793108	
% (TRN)	0.0198	0.0179	0.0179	0.0179	0.0175	
HOOW AUTO (VEH)	22222323	22290232	22289544	22289037	22305292	
AUTO (PRSN)	35540493	35651132	35649982	35649147	35676124	
TRN (PRSN)	936616	826024	827156	828027	801021	
TOTAL (PRSN)	36477109	36477156	36477138	36477174	36477145	
% (TRN)	0.0257	0.0226	0.0227	0.0227	0.0220	
HWHONH TRN (PRSN)	1448129	1348761	1373303	1373842	1348205	
TOTAL (PRSN)	44566775	44566719	44566687	44566725	44566690	
% (TRN)	0.0325	0.0303	0.0308	0.0308	0.0303	

TABLE 4-1 (CONTINUED)

ALTERNATIVE TRIP TABLES HIGHWAY NETWORK SOCIO-ECON FILE	NW01 Y90PA5 Y82Z1628 SCA6908	GOP2VER1 Y90PA5 Y82Z1628 SCA6908	GOP3VER1 Y90PA5 Y82Z1628 SCA6908	GOP3TSM1 Y90PA5 Y82Z1628 SCA6908	GOP6VER1 Y90PA5 Y82Z1628 SCA6908
AM PRD MD4 BRDG	122730	96194	95836	97976	81082
MD5 BRDG	39371	36542	40204	38304	34951
MD6 BRDG	0	5341	5290	4970	19432
MD7 BRDG	0	4533	8888	8884	9158
MD8 BRDG	24429	23187	23093	23059	22834
TOTAL	186530	165797	173311	173193	167457
PM PRD MD4 BRDG	64472	54855	55173	56020	48086
MD5 BRDG	8993	6672	6601	6307	6292
MD6 BRDG	0	285	265	249	5683
MD7 BRDG	0	878	1903	1797	1878
MD8 BRDG	13911	13145	13227	13152	12820
TOTAL	87376	75835	77169	77525	74759
DAILY...RTD ONLY					
CODED PK VEH	1614	1716	1744	1762	1756
OP VEH	1045	1034	1035	1036	1042
LOADED PK VEH	2185	1797	1846	1792	1536
OP VEH	1114	959	955	975	820
NOMINAL PK VEH	2282	1938	1991	1947	1733
OP VEH	1114	979	978	988	880
MODIFIED PK VEH	2282	1938	1991	1947	1733
OP VEH	1114	979	978	988	880
ANNUALIZED...					
RTDBUS: VHT	8206224	7358256	7434810	7412364	6600292
VMT	109233011	96745474	98310377	96792188	88032069
PSGRS	535956923	455558954	466862028	467787560	397420089
MRTRL: VHT	0	5956	5956	5956	25686
VMT	0	142834	142834	142834	621001
PSGRS	0	18637664	18459584	17342800	67808512
LRT: VHT	0	33172	55798	55798	55798
VMT	0	669831	1389011	1389011	1357989
PSGRS	0	15817854	31014659	31001102	31957038
REGIONAL: VHT	10423484	9618778	9742060	9707534	8909022
VMT	137469663	125761763	128310549	126663874	118292379
PSGRS	626889227	578027039	604245508	603837713	583817611
ANNUAL BUS OPERATING COST	\$552,941,460	\$498,967,882	\$505,291,327	\$502,019,547	\$457,398,174

TABLE 4-2

ALTERNATIVE TRIP TABLES HIGHWAY NETWORK SOCIO-ECON FILE	FOP0VER1 Y00PA5 Y20Z1628 SCAG00B	GOP2VER1 Y00PA5 Y20Z1628 SCAG00B	GOP3VER1 Y00PA5 Y20Z1628 SCAG00B	GOP3TSM1 Y00PA5 Y20Z1628 SCAG00B	GOP6VER1 Y00PA5 Y20Z1628 SCAG00B
LINES BY MODE:	4	210	210	211	212
	5	87	83	87	89
	6	0	1	1	2
	7	0	2	4	4
	8	212	215	215	212
LINKS BY MODE:	1	5982	6284	6452	6452
	2	763	1018	1577	1577
	3	884	1049	849	849
	4	7882	7922	7940	7940
	5	3578	3590	3642	3646
	6	0	8	8	8
	7	0	43	69	69
	8	6612	6612	6612	6612
HBWORK AUTO DA	6648978	6638039	6619770	6620224	6618971
AUTO SR2	1390091	1387200	1382344	1382400	1382375
AUTO SR3+	636594	635104	632785	632828	632676
TRN (PRSN)	559905	575905	601342	600795	602214
TOTAL (PRSN)	9235568	9236248	9236241	9236247	9236236
%(TRN)	0.0606	0.0624	0.0651	0.0650	0.0652
HO AUTO (VEH)	16072919	16079725	16078880	16078538	16094599
AUTO (PRSN)	24913534	24923553	24922238	24921674	24946616
TRN (PRSN)	849518	840665	841976	842540	817600
TOTAL (PRSN)	25763052	25764218	25764214	25764214	25764216
%(TRN)	0.0330	0.0326	0.0327	0.0327	0.0317
DO AUTO (VEH)	6149636	6152156	6152146	6151994	6153276
AUTO (PRSN)	10529010	10534902	10534825	10534510	10538189
TRN (PRSN)	166561	165352	165428	165743	162061
TOTAL (PRSN)	10695571	10700254	10700253	10700253	10700250
%(TRN)	0.0156	0.0155	0.0155	0.0155	0.0151
OW AUTO (VEH)	2512962	2513415	2513362	2513289	2514094
AUTO (PRSN)	4219844	4220902	4220766	4220638	4222958
TRN (PRSN)	93408	92494	92630	92758	90439
TOTAL (PRSN)	4313252	4313396	4313396	4313396	4313397
%(TRN)	0.0217	0.0214	0.0215	0.0215	0.0210
HOODM AUTO (VEH)	24735448	24743611	24742688	24742117	24760265
AUTO (PRSN)	39662330	39675079	39673596	39672609	39703474
TRN (PRSN)	1109463	1098511	1099996	1100989	1070124
TOTAL (PRSN)	40771793	40773596	40773592	40773598	40773598
%(TRN)	0.0272	0.0269	0.0270	0.0270	0.0262
HWHONH TRN (PRSN)	1669392	1674416	1701376	1701836	1672314
TOTAL (PRSN)	50007443	50014116	50014104	50014110	50014099
%(TRN)	0.0334	0.0335	0.0340	0.0340	0.0334

TABLE 4-2 (CONTINUED)

ALTERNATIVE TRIP TABLES HIGHWAY NETWORK SOCID-ECOM FILE	F0P0VER1 Y00PA5 Y20Z1628 SCA600B	G0P2VER1 Y00PA5 Y20Z1628 SCA600B	G0P3VER1 Y00PA5 Y20Z1628 SCA600B	G0P3TSM1 Y00PA5 Y20Z1628 SCA600B	G0P6VER1 Y00PA5 Y20Z1628 SCA600B
AM PRD MD4 BRDG	N/A	113118	112957	115750	94338
MD5 BRDG	N/A	44766	48555	46401	42334
MD6 BRDG	N/A	6520	6410	6006	24199
MD7 BRDG	N/A	5142	10238	10192	10836
MD8 BRDG	N/A	27641	27444	27395	27022
TOTAL	N/A	197187	205604	205744	198729
PM PRD MD4 BRDG	N/A	70786	71438	72359	62086
MD5 BRDG	N/A	9323	9328	8910	8812
MD6 BRDG	N/A	397	378	329	8100
MD7 BRDG	N/A	1126	2531	2440	2468
MD8 BRDG	N/A	16731	16826	16723	16308
TOTAL	N/A	98363	100501	100761	97774
DAILY...RTD ONLY					
CODED PK VEH	N/A	1717	1745	1759	1755
OP VEH	N/A	1035	1035	1034	1041
LOADED PK VEH	N/A	2144	2203	2117	1826
OP VEH	N/A	1209	1185	1197	1035
NOMINAL PK VEH	N/A	2265	2327	2249	2002
OP VEH	N/A	1233	1212	1237	1073
MODIFIED PK VEH	N/A	2265	2327	2249	2002
OP VEH	N/A	1233	1212	1237	1073
ANNUALIZED...					
RTDBUS: VHT	N/A	8998288	8998864	8991790	7877914
VMT	N/A	118171030	118811472	117296680	105140877
PSGRS	N/A	541795196	554364931	556478692	467784260
MRTRL: VHT	N/A	5956	5956	5956	31642
VMT	N/A	142834	142834	142834	771176
PSGRS	N/A	22751600	22367984	20958064	84443056
LRT: VHT	N/A	33172	55798	55798	55798
VMT	N/A	669831	1389011	1389011	1357989
PSGRS	N/A	17943339	35725463	35565345	37812477
REGIONAL: VHT	N/A	11433214	11472920	11453820	10352294
VMT	N/A	149351486	150922270	149236392	137520417
PSGRS	N/A	687361496	716817884	717087901	692399855
ANNUAL BUS OPERATING COST	N/A	\$584,705,759	\$588,282,314	\$584,729,880	\$525,339,494

TABLE 4-3.1

STATION INDEX

NETWORK 2 (GOP2VER1)

STATION / NODE CORRESPONDENCE

STA	NODE	STATION
1	8000	UNION
2	8001	CIVIC CENTER
3	8003	5TH/HILL
4	8004	7TH/FLOWER
5	8006	ALVARADO
6	8077	PICO/FLOWER
7	8078	WASHINGTON/GRAND
8	8150	WASHINGTON/SAN PEDRO
9	8152	WASHINGTON/LONG BEACH
10	8147	SPTC ROW/VERNON
11	8153	SPTC ROW/SLAUSON
12	8154	SPTC ROW/FLORENCE
13	8155	SPTC ROW/FIRESTONE
14	8156	SPTC ROW/103RD
15	8157	SPTC ROW/IMPERIAL
16	8158	SPTC ROW/COMPTON
17	8159	SPTC ROW/ARTESIA
18	8160	SPTC ROW/DEL ALMO
19	8161	SPTC ROW/WARDLOW
20	8099	SPTC ROW/WILLOW
21	8162	LONG BEACH/HILL
22	8163	LONG BEACH/P.C.H.
23	8164	LONG BEACH/ANAHEIM
24	8167	LONG BEACH/6TH
25	8168	LONG BEACH/BROADWAY
26	8166	1ST/PACIFIC
27	8169	6TH/PACIFIC

TABLE 4-3.2
STATION TO STATION MATRIX
NETWORK 2 (GOP2VER1)

I/J	1	2	3	4	5	6	7	8	9	10	11	12	13	14	15	16	17	18	19
1	0	2306	7909	1836	3597	28	32	65	48	41	43	41	28	26	48	47	41	24	11
2	2306	0	0	755	4127	0	0	13	41	99	114	44	81	39	103	83	66	41	13
3	7909	0	0	83	3640	0	0	3	13	27	14	11	13	15	32	24	25	15	5
4	1836	755	83	0	3248	652	117	249	439	632	545	618	549	521	1115	930	440	327	123
5	3597	4127	3640	3248	0	206	65	95	95	134	109	89	105	75	101	74	61	33	12
6	29	0	0	651	206	0	12	287	407	333	226	263	179	219	354	284	135	87	37
7	32	0	0	117	65	12	0	310	168	118	84	107	70	73	125	70	43	29	12
8	65	14	3	249	95	287	309	0	72	147	112	131	100	93	87	51	32	22	8
9	48	40	13	439	95	407	168	71	0	164	86	80	66	55	68	37	30	18	5
10	42	99	27	632	134	333	118	147	163	0	178	167	122	105	108	65	30	17	8
11	43	114	13	546	109	226	84	113	86	178	0	160	86	58	51	23	9	6	2
12	41	44	12	618	89	262	107	131	80	167	160	0	219	246	231	155	87	45	25
13	28	81	12	549	105	179	71	100	66	122	86	220	0	108	176	106	51	29	20
14	26	39	15	521	75	219	72	93	55	105	58	246	109	0	191	148	60	30	18
15	48	102	32	1115	101	353	125	87	68	109	50	231	176	191	0	250	116	58	37
16	47	83	25	930	74	284	70	52	36	65	23	156	106	147	250	0	158	90	48
17	41	67	24	440	61	136	43	31	31	30	9	87	51	61	116	159	0	59	47
18	23	41	15	327	33	87	29	22	18	16	6	45	29	30	58	90	59	0	44
19	11	13	6	123	11	37	12	8	5	8	2	25	19	18	37	48	47	43	0
20	12	29	9	213	26	62	17	16	8	13	1	20	17	19	36	59	39	28	37
21	8	11	4	236	11	50	16	6	4	9	1	22	24	25	38	57	41	39	84
22	29	30	13	373	22	97	30	13	13	21	6	53	33	41	81	94	66	51	111
23	16	28	9	206	21	49	19	14	10	17	6	42	25	21	51	73	50	46	111
24	3	4	0	1	2	4	2	1	1	4	3	6	4	7	13	13	8	13	23
25	21	14	2	21	3	16	17	2	9	13	6	40	44	36	65	84	45	51	117
26	15	18	6	174	17	51	19	10	10	12	3	31	21	22	42	49	32	13	48
27	13	19	8	228	18	55	24	12	7	11	1	22	12	16	25	31	19	0	23
	16289	8078	11880	14631	15985	4092	1578	1951	1953	2595	1932	2957	2288	2267	3602	3104	1790	1214	1029

TABLE 4-3.2 (CONTINUED)

I/J	20	21	22	23	24	25	26	27	ROW TOTAL
1	12	8	29	16	4	21	15	13	16289
2	29	11	30	28	3	14	19	19	8078
3	9	5	12	10	0	3	5	8	11881
4	213	235	374	205	1	21	174	227	14629
5	26	11	22	22	1	3	18	18	15987
6	62	49	97	49	4	16	51	54	4091
7	17	16	30	19	2	17	19	24	1579
8	15	6	14	14	1	2	10	12	1951
9	8	4	12	10	2	9	10	7	1952
10	14	8	22	17	4	13	13	10	2596
11	1	2	6	5	3	5	3	1	1933
12	19	22	53	42	6	40	31	22	2954
13	17	24	33	25	4	44	21	12	2289
14	20	25	41	21	7	37	22	16	2269
15	36	38	81	51	13	64	42	25	3599
16	60	56	94	73	13	84	49	32	3105
17	39	41	66	50	9	44	32	18	1792
18	27	40	51	45	13	52	12	1	1213
19	37	84	111	111	22	117	48	23	1026
20	0	52	132	114	20	98	38	24	1139
21	52	0	219	213	40	354	104	35	1703
22	132	219	0	249	34	332	71	14	2228
23	114	213	250	0	77	541	58	0	2067
24	19	40	34	78	0	0	0	0	283
25	98	354	331	541	0	0	0	0	1930
26	38	104	71	58	0	0	0	0	864
27	24	34	15	0	0	0	0	0	617
	1138	1701	2230	2066	283	1931	865	615	110044

TABLE 4-4.1

STATION INDEX

NETWORK 3 (GOP3VER1)

STATION / NODE CORRESPONDENCE

STA	NODE	STATION
1	8000	UNION
2	8001	CIVIC CENTER
3	8003	5TH/HILL
4	8004	7TH/FLOWER
5	8006	ALVARADO
6	8077	PICO/FLOWER
7	8078	WASHINGTON/GRAND
8	8150	WASHINGTON/SAN PEDRO
9	8152	WASHINGTON/LONG BEACH
10	8147	SPTC ROW/VERNON
11	8153	SPTC ROW/SLAUSON
12	8154	SPTC ROW/FLORENCE
13	8155	SPTC ROW/FIRESTONE
14	8156	SPTC ROW/103RD
15	8157	SPTC ROW/IMPERIAL
16	8158	SPTC ROW/COMPTON
17	8159	SPTC ROW/ARTESIA
18	8160	SPTC ROW/DEL ALMO
19	8161	SPTC ROW/WARDLOW
20	8099	SPTC ROW/WILLOW
21	8162	LONG BEACH/HILL
22	8163	LONG BEACH/P.C.H.
23	8164	LONG BEACH/ANAHEIM
24	8167	LONG BEACH/6TH
25	8168	LONG BEACH/BROADWAY
26	8166	1ST/PACIFIC
27	8169	6TH/PACIFIC
28	8171	I-105/AVIATION
29	8172	I-105/HAWTHORNE
30	8173	I-105/CRENSHAW
31	8174	I-105/VERMONT
32	8175	I-105/I-110
33	8176	I-105/AVALON
34	8178	I-105/LONG BEACH
35	8179	I-105/LAKEWOOD
36	8180	I-105/I-605
37	8181	MARIPOSA/NASH
38	8182	EL SEGUNDO/NASH
39	8183	DOUGLAS
40	8184	ROSECRANS/AVIATION

TABLE 4-4.2
STATION TO STATION MATRIX
NETWORK 3 (GOP3VER1)

I/J	1	2	3	4	5	6	7	8	9	10	11	12	13	14	15	16	17	18	19
1	0	2295	7763	1785	3605	36	30	68	57	38	48	27	34	29	54	35	34	27	10
2	2295	0	0	713	4150	0	0	17	5	26	59	26	38	50	89	56	61	45	19
3	7763	0	0	95	3584	0	0	4	1	5	19	5	10	19	26	22	23	19	6
4	1785	713	95	0	3247	530	128	260	418	509	539	529	504	493	879	647	432	284	120
5	3605	4150	3584	3247	0	196	66	96	61	71	107	63	82	69	92	64	52	37	9
6	36	0	0	531	196	0	12	229	196	216	179	177	154	212	295	218	128	83	41
7	30	0	0	128	65	12	0	320	165	117	94	89	57	63	68	49	40	20	10
8	68	17	4	260	96	230	320	0	93	133	126	137	114	81	81	41	31	19	8
9	57	6	1	417	61	196	164	93	0	169	100	90	73	60	57	30	31	19	8
10	38	26	5	509	71	216	117	133	169	0	199	161	135	92	86	54	30	17	6
11	48	59	19	539	107	179	95	126	100	200	0	177	85	51	38	26	8	4	3
12	27	25	5	529	64	177	89	137	89	161	177	0	257	235	237	122	77	40	22
13	34	38	11	503	81	154	57	114	73	135	85	257	0	101	85	68	39	16	11
14	29	50	18	494	69	212	63	82	59	93	51	235	100	0	129	98	33	13	8
15	54	89	26	878	92	295	68	81	57	86	37	237	86	128	0	153	67	25	17
16	35	56	22	647	65	218	49	41	30	54	26	121	68	98	153	0	134	63	41
17	34	61	23	432	52	128	40	30	32	30	8	77	39	33	67	134	0	55	40
18	26	46	19	284	37	83	21	19	19	17	4	40	16	14	25	62	55	0	43
19	10	19	6	120	9	40	10	8	6	7	3	23	11	8	17	41	41	43	0
20	13	22	7	193	18	50	10	13	6	8	0	22	13	14	22	35	33	28	31
21	11	13	4	198	10	47	11	6	9	7	5	18	14	15	17	50	36	37	82
22	28	30	9	352	21	86	28	13	13	21	6	40	24	28	50	78	62	43	112
23	12	17	7	193	18	37	14	11	8	11	7	36	20	16	29	51	39	47	95
24	5	3	0	3	1	4	4	1	0	3	1	5	6	3	7	10	9	14	17
25	17	12	3	18	5	12	12	3	6	12	7	32	28	29	43	65	43	54	118
26	16	21	8	206	19	60	17	11	13	14	5	33	16	17	21	43	37	12	57
27	18	25	9	363	21	100	21	15	14	16	3	33	12	7	16	41	26	3	35
28	4	0	0	50	3	0	0	6	14	17	6	27	9	8	145	25	18	15	9
29	0	0	0	117	2	0	0	11	11	14	6	21	10	11	112	17	19	9	5
30	4	0	0	69	2	0	0	18	18	23	11	38	13	20	229	38	25	15	12
31	2	0	0	98	0	0	0	10	9	13	5	23	4	12	162	24	11	7	5
32	0	0	0	1	0	0	0	16	12	25	12	48	8	34	336	67	35	31	28
33	0	0	0	12	3	0	1	1	5	9	4	7	2	5	73	14	8	1	0
34	23	0	0	239	24	14	18	26	16	33	18	52	32	31	343	68	43	18	11
35	17	0	0	233	20	14	10	22	10	18	4	10	2	14	55	15	17	4	2
36	30	0	0	368	29	25	14	42	33	26	13	32	12	25	133	44	33	28	19
37	0	0	0	0	0	0	0	0	0	0	0	0	0	0	0	0	0	0	0
38	2	0	0	57	2	0	0	5	6	10	5	23	9	17	99	20	18	14	8
39	0	0	0	0	0	0	0	0	0	0	0	0	0	0	0	0	0	0	0
40	0	0	0	6	0	0	0	0	0	1	0	3	1	1	6	0	2	1	0
	16176	7793	11648	14887	15849	3351	1489	2088	1833	2348	1979	2974	2098	2143	4376	2626	1830	1210	1068

55

TABLE 4-4.2 (CONTINUED)

I/J	20	21	22	23	24	25	26	27	28	29	30	31	32	33	34	35	36	37	38
1	13	11	28	12	6	17	16	18	4	0	4	2	0	0	23	17	30	0	1
2	22	13	30	17	3	12	21	24	0	0	0	0	0	0	0	0	0	0	0
3	7	3	9	7	1	2	8	10	0	0	0	0	0	0	0	0	0	0	0
4	193	199	352	193	2	19	206	363	50	117	69	98	1	13	238	233	368	0	57
5	18	10	20	19	1	5	18	22	3	2	2	0	0	3	24	21	28	0	2
6	50	47	86	37	4	11	60	100	0	0	0	0	1	0	13	14	25	0	0
7	10	11	28	14	4	13	17	22	0	0	0	0	0	1	18	10	14	0	0
8	13	6	13	11	1	2	11	15	5	12	18	11	15	1	26	22	42	0	5
9	6	9	14	8	0	6	13	14	14	10	18	9	12	5	17	9	33	0	5
10	8	7	21	11	2	12	14	16	18	14	23	13	25	9	32	18	27	0	10
11	0	5	6	7	1	7	5	3	6	6	11	5	12	4	18	5	12	0	5
12	22	18	40	36	5	32	34	33	27	21	38	23	48	7	52	10	32	0	23
13	13	14	24	20	6	28	16	12	9	10	13	4	8	2	31	2	12	0	10
14	14	15	27	17	3	28	17	7	8	11	20	13	33	5	32	14	25	0	17
15	22	18	51	28	7	43	22	16	145	112	229	162	336	74	342	55	134	0	99
16	35	49	78	51	9	65	43	41	26	17	38	24	67	13	68	15	44	0	20
17	34	36	62	39	9	43	37	26	18	20	25	11	35	8	44	17	33	0	19
18	28	37	43	47	14	54	13	2	15	8	15	7	31	1	18	3	28	0	13
19	31	83	112	95	17	119	56	36	9	5	12	4	29	1	11	2	18	0	8
20	0	60	122	105	24	96	44	33	11	8	7	5	26	2	7	3	17	0	8
21	60	0	211	181	38	355	133	69	13	8	11	6	24	3	11	7	20	0	9
22	122	211	0	243	32	330	78	38	25	19	24	7	36	3	18	9	28	0	17
23	105	180	243	0	76	541	60	0	11	4	11	6	21	2	10	9	28	0	7
24	24	38	33	76	0	0	0	0	5	1	1	1	10	0	2	5	15	0	1
25	96	355	330	541	0	0	0	0	11	18	18	10	38	7	17	10	30	0	1
26	44	133	78	60	0	0	0	0	14	12	17	8	20	3	13	4	10	0	14
27	34	69	38	0	0	0	0	0	16	8	12	5	29	3	6	4	9	0	20
28	11	13	25	10	5	11	14	17	0	564	450	190	887	84	148	75	178	85	814
29	8	7	19	4	1	18	11	8	564	0	273	165	508	71	93	34	71	0	528
30	7	10	24	11	1	18	17	12	450	273	0	200	673	144	270	143	264	0	439
31	5	6	7	6	1	11	8	5	190	165	200	0	265	98	210	96	148	0	183
32	27	24	36	21	10	38	19	30	887	508	673	265	0	241	657	547	837	0	545
33	2	3	3	2	0	7	3	3	83	71	145	97	242	0	118	33	64	0	72
34	7	11	17	10	2	18	14	6	148	93	270	211	656	118	0	218	348	0	90
35	3	7	10	9	5	9	4	4	75	34	143	96	547	34	217	0	200	0	36
36	16	21	28	28	15	30	10	9	178	72	264	147	837	64	348	200	0	0	68
37	0	0	0	0	0	0	0	0	84	0	0	0	0	0	0	0	0	0	20
38	8	9	16	7	1	1	13	21	814	528	438	184	545	71	91	36	67	20	0
39	0	0	0	0	0	0	0	0	0	0	0	0	0	0	0	0	0	0	206
40	0	1	3	1	0	2	1	1	80	29	18	18	39	5	6	3	6	1	336
	1118	1749	2287	1984	306	2003	1056	1036	4016	2780	3510	2007	6056	1100	3249	1903	3245	106	3708

TABLE 4-4.2 (CONTINUED)

I/J	39	40	ROW TOTAL
1	0	0	16177
2	0	0	7791
3	0	0	11648
4	0	7	14890
5	0	0	15849
6	0	0	3351
7	0	0	1489
8	0	0	2088
9	0	0	1832
10	0	0	2346
11	0	1	1983
12	0	2	2973
13	0	1	2097
14	0	1	2143
15	0	6	4377
16	0	0	2624
17	0	2	1833
18	0	1	1208
19	0	1	1071
20	0	0	1116
21	0	1	1750
22	0	3	2287
23	0	2	1984
24	0	0	308
25	0	2	2003
26	0	0	1056
27	0	1	1032
28	0	80	4018
29	0	30	2778
30	0	18	3509
31	0	17	2006
32	0	40	6058
33	0	5	1098
34	0	6	3252
35	0	3	1903
36	0	6	3247
37	0	1	105
38	207	335	3707
39	0	3	209
40	3	0	574
	210		
		575	141770

TABLE 4-5.1

STATION INDEX

NETWORK 3 (GOP3TSM1)

STATION / NODE CORRESPONDENCE

STA	NODE	STATION
1	8000	UNION
2	8001	CIVIC CENTER
3	8003	5TH/HILL
4	8004	7TH/FLOWER
5	8006	ALVARADO
6	8077	PICO/FLOWER
7	8078	WASHINGTON/GRAND
8	8150	WASHINGTON/SAN PEDRO
9	8152	WASHINGTON/LONG BEACH
10	8147	SPTC ROW/VERNON
11	8153	SPTC ROW/SLAUSON
12	8154	SPTC ROW/FLORENCE
13	8155	SPTC ROW/FIRESTONE
14	8156	SPTC ROW/103RD
15	8157	SPTC ROW/IMPERIAL
16	8158	SPTC ROW/COMPTON
17	8159	SPTC ROW/ARTESIA
18	8160	SPTC ROW/DEL ALMO
19	8161	SPTC ROW/WARDLOW
20	8099	SPTC ROW/WILLOW
21	8162	LONG BEACH/HILL
22	8163	LONG BEACH/P.C.H.
23	8164	LONG BEACH/ANAHEIM
24	8167	LONG BEACH/6TH
25	8168	LONG BEACH/BROADWAY
26	8166	1ST/PACIFIC
27	8169	6TH/PACIFIC
28	8171	I-105/AVIATION
29	8172	I-105/HAWTHORNE
30	8173	I-105/CRENSHAW
31	8174	I-105/VERMONT
32	8175	I-105/I-110
33	8176	I-105/AVALON
34	8178	I-105/LONG BEACH
35	8179	I-105/LAKEWOOD
36	8180	I-105/I-605
37	8181	MARIPOSA/NASH
38	8182	EL SEGUNDO/NASH
39	8183	DOUGLAS
40	8184	ROSECRANS/AVIATION

TABLE 4-5.2
STATION TO STATION MATRIX
NETWORK 3 (GOP3TSM1)

I/J	1	2	3	4	5	6	7	8	9	10	11	12	13	14	15	16	17	18	19
1	0	2261	7754	1794	3492	36	34	67	56	45	45	28	32	24	57	36	33	27	9
2	2261	0	0	697	3565	0	0	16	4	35	65	28	36	52	90	55	61	42	15
3	7754	0	0	97	3344	0	0	4	1	4	21	3	10	21	24	22	24	18	8
4	1794	697	97	0	2668	573	139	253	436	516	551	526	508	500	885	649	439	287	124
5	3492	3565	3344	2667	0	163	47	92	54	52	81	38	53	56	69	56	43	27	8
6	36	0	0	573	163	0	11	221	203	210	183	178	161	228	303	222	138	92	41
7	34	0	0	139	47	11	0	326	164	106	87	91	55	59	66	44	42	22	7
8	66	16	5	253	92	222	325	0	87	132	121	137	113	84	81	44	32	20	7
9	56	4	1	435	54	203	164	87	0	176	99	90	74	58	56	31	28	18	9
10	46	35	4	516	51	210	106	132	176	0	196	156	135	83	94	55	29	18	7
11	44	65	21	551	82	182	88	121	99	196	0	187	88	47	40	23	8	2	5
12	29	28	4	526	38	178	90	137	89	157	187	0	256	232	240	127	72	43	21
13	32	36	10	508	52	162	55	113	75	135	88	256	0	97	91	74	34	18	8
14	24	51	21	499	57	227	59	84	57	83	47	232	97	0	123	94	38	13	10
15	57	90	24	885	69	304	66	82	56	94	39	240	90	123	0	151	63	24	15
16	37	54	22	650	56	222	44	44	31	55	23	127	75	94	150	0	129	62	43
17	33	61	24	439	43	138	41	32	28	29	8	72	34	37	64	128	0	53	42
18	27	42	18	287	27	92	22	19	18	19	2	43	18	13	24	63	53	0	39
19	9	15	8	124	8	41	7	7	9	7	5	21	8	10	15	43	42	39	0
20	9	20	6	193	11	52	12	14	7	9	1	22	11	11	19	39	35	28	33
21	9	16	6	208	8	47	11	6	7	9	2	22	14	12	19	49	37	37	85
22	28	35	7	358	18	85	28	13	18	23	7	45	19	27	44	73	61	48	109
23	11	17	7	197	13	43	15	9	5	12	6	33	17	17	28	55	36	42	94
24	5	5	1	5	1	3	1	1	0	2	1	7	6	6	14	12	10	13	19
25	15	12	4	16	4	13	11	5	7	12	8	31	28	29	41	69	42	53	119
26	11	21	9	200	15	63	16	12	10	16	3	37	12	16	20	45	37	18	59
27	18	23	10	366	19	96	26	17	12	20	2	30	12	11	18	37	26	3	38
28	2	0	0	48	5	0	0	9	12	20	7	25	8	8	147	25	24	11	11
29	2	0	0	119	2	0	0	13	13	14	2	21	12	16	103	25	18	10	5
30	3	0	0	64	0	0	0	18	19	26	13	32	12	19	235	39	24	13	16
31	2	0	0	95	1	0	0	13	11	15	7	21	8	15	161	24	12	7	5
32	0	0	0	0	0	1	0	14	9	21	15	48	6	34	339	62	33	32	26
33	1	0	0	16	1	0	0	2	2	5	4	7	2	5	70	13	10	2	1
34	24	0	0	246	21	14	16	30	17	33	18	52	28	35	336	68	44	15	10
35	18	0	0	236	16	12	9	21	9	22	4	11	5	15	56	14	19	4	2
36	33	0	0	378	28	26	13	40	35	28	14	31	14	27	131	44	36	23	14
37	0	0	0	0	0	0	0	0	0	0	0	0	0	0	0	0	0	0	0
38	3	0	0	57	0	0	1	5	3	11	5	24	8	15	102	20	17	16	10
39	0	0	0	0	0	0	0	0	0	0	0	0	0	0	0	0	0	0	0
40	0	0	0	6	0	0	0	1	1	1	0	2	2	0	5	2	1	0	0
	16025	7169	11407	14448	14071	3419	1457	2080	1840	2350	1967	2954	2067	2136	4360	2632	1830	1200	1074

59

TABLE 4-5.2 (CONTINUED)

I/J	20	21	22	23	24	25	26	27	28	29	30	31	32	33	34	35	36	37	38
1	8	10	28	11	5	15	12	18	2	2	2	2	0	1	24	18	33	0	3
2	21	16	35	16	5	11	21	23	0	0	0	0	0	0	0	0	0	0	0
3	5	6	8	7	1	5	9	9	0	0	0	0	0	0	0	0	0	0	0
4	193	208	358	197	5	16	200	366	49	119	64	96	0	16	246	235	379	0	57
5	11	8	18	13	1	4	15	19	5	3	0	1	0	1	21	17	27	0	1
6	52	47	85	43	3	13	62	97	0	0	0	0	1	0	14	12	26	0	0
7	12	11	28	14	2	11	17	26	0	0	0	0	0	0	16	8	13	0	0
8	14	6	13	9	1	4	12	16	9	12	18	14	14	2	30	22	40	0	6
9	7	6	18	5	0	7	11	12	13	13	18	11	9	3	17	9	35	0	3
10	9	9	23	12	2	13	16	20	19	14	27	15	20	5	32	22	28	0	11
11	1	2	7	6	2	8	2	2	7	2	13	6	16	4	18	4	14	0	6
12	22	22	45	34	7	31	37	30	25	21	32	21	47	7	52	12	30	0	24
13	12	13	20	17	5	28	13	12	8	12	11	9	6	2	28	5	15	0	8
14	11	12	26	17	6	29	16	11	8	16	19	15	34	6	34	15	26	0	15
15	19	20	44	28	14	42	20	17	148	103	235	161	339	70	336	57	131	0	102
16	39	48	73	55	11	69	44	38	24	25	39	24	62	13	68	14	45	0	20
17	35	38	61	36	10	43	37	26	25	17	29	12	33	10	44	19	36	0	18
18	28	37	47	43	13	53	18	2	11	11	13	7	32	2	15	4	23	0	16
19	33	85	109	94	19	119	59	38	11	5	16	5	26	2	9	2	14	0	9
20	0	56	125	106	23	99	43	32	7	7	5	5	25	1	6	6	18	0	10
21	56	0	208	180	38	355	133	67	14	7	11	10	27	2	9	5	17	0	10
22	125	209	0	240	33	331	78	38	26	18	21	9	34	2	19	11	31	0	14
23	106	179	240	0	78	541	60	0	12	7	13	5	26	1	9	9	24	0	7
24	23	38	34	77	0	0	0	0	5	3	2	1	8	1	3	3	11	0	0
25	99	355	330	541	0	0	0	0	12	12	21	10	34	8	16	10	35	0	1
26	43	133	78	60	0	0	0	0	18	13	16	9	25	4	11	7	8	0	14
27	32	68	38	0	0	0	0	0	17	8	14	4	25	2	7	3	9	0	20
28	8	13	26	12	4	12	17	18	0	566	447	193	913	85	151	62	172	83	812
29	7	7	18	7	4	12	14	8	566	0	275	162	505	63	106	32	75	0	524
30	5	11	21	12	2	21	16	13	447	275	0	202	654	141	288	145	254	0	434
31	5	10	9	5	1	10	9	5	193	162	202	0	263	97	198	92	149	0	183
32	25	28	33	26	9	34	24	25	913	505	654	263	0	245	654	538	845	0	545
33	2	1	3	1	1	7	5	2	85	63	141	96	245	0	110	38	67	0	75
34	6	9	19	9	3	17	11	7	150	106	288	199	654	110	0	222	354	0	87
35	5	5	11	9	3	10	6	3	68	33	144	92	538	37	222	0	208	0	35
36	18	17	31	24	11	35	8	9	172	75	254	150	845	67	354	207	0	0	73
37	0	0	0	0	0	0	0	0	83	0	0	0	0	0	0	0	0	0	20
38	10	10	15	7	0	1	14	20	812	523	434	183	546	74	87	35	72	20	0
39	0	0	0	0	0	0	0	0	0	0	0	0	0	0	0	0	0	0	207
40	2	0	1	1	0	1	0	1	75	28	21	16	39	6	6	3	8	2	336
	1109	1753	2286	1974	322	2007	1059	1030	4039	2786	3494	2008	6045	1090	3260	1909	3272	105	3706

TABLE 4-5.2 (CONTINUED)

I/J	39	40	TOTAL
1	0	1	16025
2	0	0	7170
3	0	0	11405
4	0	6	14452
5	0	0	14072
6	0	0	3418
7	0	0	1458
8	0	1	2080
9	0	1	1841
10	0	0	2346
11	0	0	1969
12	0	2	2955
13	0	2	2070
14	0	0	2132
15	0	5	4363
16	0	1	2630
17	0	1	1831
18	0	0	1201
19	0	0	1073
20	0	1	1107
21	0	1	1754
22	0	2	2287
23	0	1	1975
24	0	0	321
25	0	1	2004
26	0	0	1059
27	0	1	1032
28	0	76	4038
29	0	27	2787
30	0	21	3495
31	0	16	2006
32	0	40	6046
33	0	6	1089
34	0	5	3263
35	0	3	1905
36	0	8	3273
37	0	2	105
38	208	336	3704
39	0	3	210
40	3	0	570
	211	570	138521

TABLE 4-6.1

STATION INDEX

NETWORK 6 (GOP6VER1)

STATION / NODE CORRESPONDENCE

STATION #	NODE	STATION
1	8000	UNION
2	8001	CIVIC CENTER
3	8003	5TH/HILL
4	8004	7TH/FLOWER
5	8006	ALVARADO
6	8007	WILSHIRE/VERMONT
7	8008	NORMANDIE
8	8009	WILSHIRE/WESTERN
9	8094	VERMONT/BEVERLY
10	8095	VERMONT/SANTA MONICA
11	8085	VERMONT/SUNSET
12	8111	HOLLYWOOD/WESTERN
13	8058	HOLLYWOOD/VINE
14	8077	PICO/FLOWER
15	8078	WASHINGTON/GRAND
16	8150	WASHINGTON/SAN PEDRO
17	8152	WASHINGTON/LONG BEACH
18	8147	SPTC ROW / VERNON
19	8153	SPTC ROW / SLAUSON
20	8154	SPTC ROW / FLORENCE
21	8155	SPTC ROW / FIRESTONE
22	8156	SPTC ROW / 103RD
23	8157	SPTC ROW / IMPERIAL
24	8158	SPTC ROW / COMPTON
25	8159	SPTC ROW / ARTESIA
26	8160	SPTC ROW / DEL AMO
27	8161	SPTC ROW / WARDLOW
28	8099	SPTC ROW / WILLOW
29	8162	LONG BEACH / HILL
30	8163	LONG BEACH / P.C.H
31	8164	LONG BEACH / ANAHEIM
32	8167	LONG BEACH / 6TH
33	8168	LONG BEACH / BROADWAY
34	8166	1ST / PACIFIC
35	8169	6TH / PACIFIC
36	8171	I-105 / AVIATION
37	8172	I-105 / HAWTHORNE
38	8173	I-105 / CRENSHAW
39	8174	I-105 / VERMONT

TABLE 4-6.1 (CONTINUED)

STATION INDEX

NETWORK 6 (GOP6VER1)

STATION / NODE CORRESPONDENCE

STATION #	NODE	STATION
40	8175	I-105 / I-110
41	8176	I-105 / AVALON
42	8178	I-105 / LONG BEACH
43	8179	I-105 / LAKEWOOD
44	8180	I-105 / I-605
45	8181	MARIPOSA / NASH
46	8182	EL SEGUNDO / NASH
47	8183	DOUGLAS
48	8184	ROSECRANS / AVIATION

TABLE 4-6.2
STATION TO STATION MATRIX
NETWORK 6 (GOP6VER1)

I/J	1	2	3	4	5	6	7	8	9	10	11	12	13	14	15	16	17	18	19
1	0	4952	16106	2883	1353	2385	191	1828	486	585	1058	259	232	117	69	83	65	60	50
2	4952	0	1367	1675	3808	4103	313	2754	635	886	2148	453	564	0	31	31	80	67	68
3	16107	1367	0	1021	5982	5553	334	3798	2152	2032	5928	1350	1284	0	1	0	31	55	38
4	2883	1674	1021	0	5287	4901	397	3295	1626	1474	4630	1391	978	381	122	198	335	367	292
5	1353	3808	5982	5286	0	4119	218	1240	821	730	1241	475	458	363	80	85	50	56	42
6	2385	4103	5553	4902	4119	0	169	1097	1061	1504	2441	955	780	136	54	65	81	80	70
7	191	314	334	397	218	169	0	760	47	36	98	38	30	47	7	7	11	10	6
8	1828	2754	3798	3295	1239	1098	759	0	231	224	247	260	133	93	36	43	48	60	51
9	486	635	2152	1626	821	1061	47	231	0	326	1803	580	481	110	32	32	16	10	9
10	585	886	2032	1474	730	1504	36	223	326	0	800	340	212	111	36	29	18	13	17
11	1058	2147	5928	4630	1241	2442	98	247	1803	800	0	1874	2523	208	65	54	36	30	19
12	259	453	1350	1391	475	954	38	260	580	340	1874	0	513	47	12	12	7	10	6
13	232	564	1284	977	458	780	30	134	481	212	2523	513	0	45	12	15	5	4	3
14	117	0	0	381	363	135	47	93	110	111	208	47	45	0	25	194	184	194	93
15	69	30	2	122	79	54	8	36	32	36	64	12	12	24	0	312	153	103	76
16	83	31	0	199	85	65	7	42	33	29	54	12	15	195	312	0	84	134	114
17	66	80	30	335	50	82	11	48	16	18	36	7	5	183	153	85	0	176	97
18	60	67	55	367	56	79	10	60	11	13	29	10	4	194	103	133	176	0	212
19	50	68	38	293	41	70	6	51	9	16	19	6	3	93	76	114	97	212	0
20	45	53	35	402	43	108	11	56	11	13	24	6	4	162	85	134	90	164	180
21	45	59	59	387	43	86	12	65	12	13	27	8	6	126	56	112	70	131	94
22	41	86	91	403	26	59	8	48	9	10	19	5	2	185	53	76	49	95	44
23	60	169	138	612	39	80	12	86	14	15	28	14	3	243	62	74	57	93	40
24	42	120	108	437	23	42	6	52	10	15	18	5	6	191	43	38	29	49	19
25	36	83	85	324	17	31	4	26	5	9	19	7	2	106	31	28	29	30	6
26	26	56	68	217	9	14	2	18	4	4	9	6	1	68	26	17	15	20	5
27	14	18	25	87	3	6	1	7	3	1	6	3	1	32	11	8	7	5	5
28	14	34	40	153	7	9	1	13	2	5	7	1	0	35	13	9	7	10	1
29	10	29	24	138	4	9	1	11	3	3	7	1	1	38	13	5	7	9	3
30	27	54	52	253	9	14	4	21	2	3	13	5	1	69	25	14	15	17	5
31	16	30	30	125	3	8	3	11	1	4	10	2	0	27	13	11	7	9	6
32	6	2	2	0	1	0	0	0	1	1	1	1	0	3	2	0	1	3	2
33	19	9	4	5	3	4	1	2	2	3	8	1	0	10	11	4	6	12	8
34	20	36	31	134	8	10	3	18	1	2	6	2	1	45	19	11	10	17	5
35	17	51	52	269	7	16	3	19	4	5	12	5	0	73	23	18	13	14	3
36	3	0	0	50	11	2	0	0	2	1	11	1	0	0	0	4	14	17	7
37	3	0	0	107	9	9	0	0	0	1	2	1	0	0	0	11	8	13	6
38	2	0	0	68	5	0	1	0	1	1	0	1	0	0	0	17	15	29	9
39	0	0	0	94	0	1	0	0	0	0	0	0	0	0	0	12	14	13	10
40	1	0	0	3	0	0	0	0	0	0	0	1	0	0	0	21	11	22	12
41	3	0	0	13	3	6	1	5	1	1	2	2	0	0	0	1	3	9	2
42	27	46	23	213	19	36	1	17	6	9	16	4	1	17	17	28	20	31	16
43	24	41	27	205	11	20	2	15	5	7	11	4	2	14	8	21	13	18	7
44	48	82	33	336	17	36	2	21	6	6	22	5	1	29	16	43	32	26	12
45	0	0	0	0	0	0	0	0	0	0	0	0	0	0	0	0	0	0	0
46	7	0	0	57	7	3	0	0	1	4	11	2	0	0	0	5	8	8	5
47	0	0	0	0	0	0	0	0	0	0	0	0	0	0	0	0	0	0	0
48	0	0	0	5	1	0	0	0	0	1	0	1	0	0	0	1	0	1	2
	33319	24991	47959	36351	26733	30163	2798	16708	10566	9509	25490	8676	8304	3820	1753	2215	2027	2506	1777

TABLE 4-6.2 (CONTINUED)

I/J	20	21	22	23	24	25	26	27	28	29	30	31	32	33	34	35	36	37	38
1	45	45	41	60	42	37	25	14	14	9	27	17	6	19	21	16	3	4	2
2	53	59	86	170	120	83	56	18	34	29	54	30	2	9	35	52	0	0	0
3	35	59	91	138	108	85	68	25	40	25	51	30	2	4	32	51	0	0	0
4	402	387	403	612	436	325	217	86	154	137	254	124	0	5	134	269	50	106	68
5	43	43	26	39	23	16	9	4	6	4	9	3	1	3	8	8	11	9	5
6	107	86	59	80	42	32	14	6	9	10	14	7	1	3	11	15	2	9	1
7	11	13	8	12	6	4	2	1	1	4	4	3	0	0	3	3	0	0	0
8	56	65	49	86	52	25	18	7	13	10	21	11	0	3	18	19	0	0	1
9	11	12	9	13	10	5	5	3	2	3	3	1	1	2	2	4	2	0	1
10	13	13	10	15	15	9	4	1	5	3	3	4	0	3	1	6	1	0	1
11	24	27	19	28	18	19	10	6	7	7	13	10	1	8	7	11	11	2	0
12	5	8	5	13	5	8	5	3	1	2	4	3	0	1	2	5	1	1	1
13	4	6	3	3	6	2	1	1	0	1	2	0	0	0	1	0	0	0	0
14	161	127	185	242	191	107	68	32	35	39	69	27	3	10	46	72	0	0	0
15	85	56	53	62	43	31	25	11	12	13	24	13	2	11	19	24	0	0	0
16	134	112	76	74	38	28	17	8	9	5	14	11	0	4	11	18	4	11	16
17	90	70	48	57	29	29	15	7	8	7	14	8	1	6	10	13	13	9	15
18	164	132	95	93	50	30	20	5	10	9	18	8	3	12	17	14	18	12	30
19	180	94	44	40	18	7	4	5	1	3	5	6	2	8	5	3	7	6	9
20	0	248	227	234	126	83	37	23	20	27	47	28	10	29	32	33	18	23	32
21	248	0	102	89	76	38	15	6	10	15	25	17	7	25	15	10	7	5	12
22	227	101	0	127	99	35	13	9	11	16	26	13	5	26	13	12	6	14	18
23	234	90	126	0	155	62	25	15	17	22	40	30	7	44	26	17	141	103	216
24	125	76	99	155	0	134	59	37	43	42	72	52	10	70	45	35	27	22	38
25	83	39	35	62	134	0	51	42	33	37	63	33	8	47	32	25	23	13	27
26	37	15	13	25	59	51	0	47	28	36	42	45	14	56	14	3	12	8	16
27	23	5	10	15	37	42	46	0	35	82	116	88	17	117	57	38	12	5	10
28	20	11	11	17	42	33	28	34	0	58	127	103	21	101	44	32	11	6	6
29	27	14	16	22	42	37	36	83	57	0	212	184	40	354	129	67	9	9	12
30	47	25	26	39	73	63	42	116	127	212	0	240	34	330	77	38	22	16	23
31	28	17	13	31	51	33	45	88	103	183	240	0	77	541	59	0	11	11	11
32	10	7	5	6	11	8	14	17	21	40	34	77	0	0	0	0	3	3	3
33	29	25	26	45	69	48	55	117	102	354	330	541	0	0	0	0	15	13	20
34	32	15	13	26	45	32	14	57	43	129	78	59	0	0	0	0	19	10	16
35	32	11	11	17	35	25	4	38	32	66	38	0	0	0	0	0	19	6	16
36	18	7	7	141	26	24	11	12	12	9	22	10	4	15	19	18	0	565	425
37	24	4	14	103	23	12	9	5	6	9	16	11	2	13	10	7	564	0	249
38	32	12	18	216	38	27	15	10	6	12	23	12	3	19	17	16	425	249	0
39	14	7	13	177	27	17	8	6	4	7	12	7	2	11	7	5	170	130	192
40	52	13	28	359	57	35	32	31	19	25	42	19	5	35	26	28	870	467	599
41	7	2	6	72	18	7	3	4	3	2	4	3	1	8	4	1	86	69	153
42	53	32	29	332	68	41	14	8	9	9	16	10	4	20	8	9	142	95	261
43	14	5	10	57	13	13	6	3	3	6	14	8	5	14	2	2	80	31	124
44	30	14	33	127	33	38	16	16	17	19	26	20	15	33	11	9	174	85	279
45	0	0	0	0	0	0	0	0	0	0	0	0	0	0	0	0	85	0	0
46	27	11	16	94	18	18	15	12	7	8	20	6	0	2	15	20	824	522	429
47	0	0	0	0	0	0	0	0	0	0	0	0	0	0	0	0	0	0	0
48	1	2	0	4	0	1	2	0	0	1	2	1	0	1	2	0	73	29	16
	3097	2222	2217	4429	2627	1839	1198	1079	1128	1743	2290	1933	316	2022	1047	1028	3971	2678	3353

TABLE 4-6.2 (CONTINUED)

I/J	39	40	41	42	43	44	45	46	47	48	TOTAL
1	0	0	3	27	24	48	0	8	0	0	33319
2	0	0	0	46	41	82	0	0	0	0	24994
3	0	0	0	22	27	32	0	0	0	0	47958
4	94	3	13	213	205	336	0	58	0	5	36348
5	0	0	3	19	11	18	0	6	0	1	26735
6	0	0	7	35	20	36	0	3	0	0	30164
7	0	0	0	2	2	2	0	0	0	0	2798
8	0	0	5	17	15	21	0	0	0	0	16708
9	0	0	2	6	5	6	0	1	0	0	10567
10	0	0	1	9	6	7	0	3	0	1	9506
11	0	0	2	17	11	22	0	11	0	1	25494
12	0	0	2	4	3	5	0	2	0	1	8671
13	0	0	0	1	2	2	0	0	0	0	8307
14	0	0	0	17	14	29	0	1	0	0	3822
15	0	0	0	17	8	15	0	0	0	0	1748
16	13	22	1	28	21	44	0	4	0	1	2218
17	14	10	3	20	14	31	0	8	0	0	2027
18	12	23	9	31	17	27	0	8	0	1	2507
19	10	12	2	15	7	12	0	5	0	1	1773
20	15	52	7	53	14	30	0	26	0	2	3102
21	7	13	3	31	6	14	0	11	0	2	2220
22	12	29	5	30	9	34	0	15	0	1	2215
23	177	359	72	332	57	126	0	94	0	4	4430
24	28	57	18	68	13	34	0	18	0	1	2631
25	17	34	7	41	13	37	0	18	0	1	1833
26	7	32	3	15	6	16	0	16	0	1	1202
27	6	31	4	8	4	16	0	11	0	0	1078
28	4	19	3	9	3	16	0	8	0	0	1128
29	7	26	2	9	6	19	0	8	0	1	1744
30	12	42	4	16	14	26	0	20	0	2	2289
31	7	19	3	10	7	20	0	6	0	1	1931
32	2	5	2	4	5	14	0	1	0	0	318
33	11	35	8	20	14	33	0	2	0	1	2025
34	7	26	4	8	3	11	0	15	0	2	1043
35	5	28	1	9	2	9	0	20	0	0	1028
36	170	870	87	142	80	173	85	824	0	73	3972
37	130	467	69	95	30	86	0	522	0	29	2679
38	192	600	153	261	124	279	0	429	0	16	3353
39	0	233	95	167	50	118	0	173	0	13	1809
40	233	0	231	571	466	697	0	523	0	40	5574
41	95	231	0	112	36	74	0	74	0	5	1132
42	167	571	112	0	204	338	0	88	0	6	3193
43	50	466	36	203	0	204	0	34	0	1	1859
44	118	697	74	339	204	0	0	66	0	7	3273
45	0	0	0	0	0	0	0	19	0	1	105
46	173	524	74	88	34	66	20	0	210	336	3707
47	0	0	0	0	0	0	0	210	0	1	211
48	13	40	5	6	1	6	1	336	2	0	557
	1808	5576	1135	3193	1858	3271	106	3705	212	559	357305

5.0 DATASET DIRECTORY AND NETWORK FLOWCHART

The remainder of this volume is an inventory of input and output datasets applicable to each of the financial plan network alternative forecast simulations. The first of the two flowcharts presented for each simulation (Figure 5-1 through 5-16) illustrates steps leading to the Mode-Choice work and Mode-Choice non-work models where transit trip tables are developed. The second of the two flowcharts similarly tracks the remaining job steps which produce the station boarding estimates (Mode-of-Arrival) and the overall transit system patronage and performance statistics (ULOAD/URAP). Attached to each set of flowcharts is a complete, stepwise documentation of the disposition of all input and output datasets cataloged on the district mainframe at the time this memo is being prepared (Tables 5-1 through 5-8).

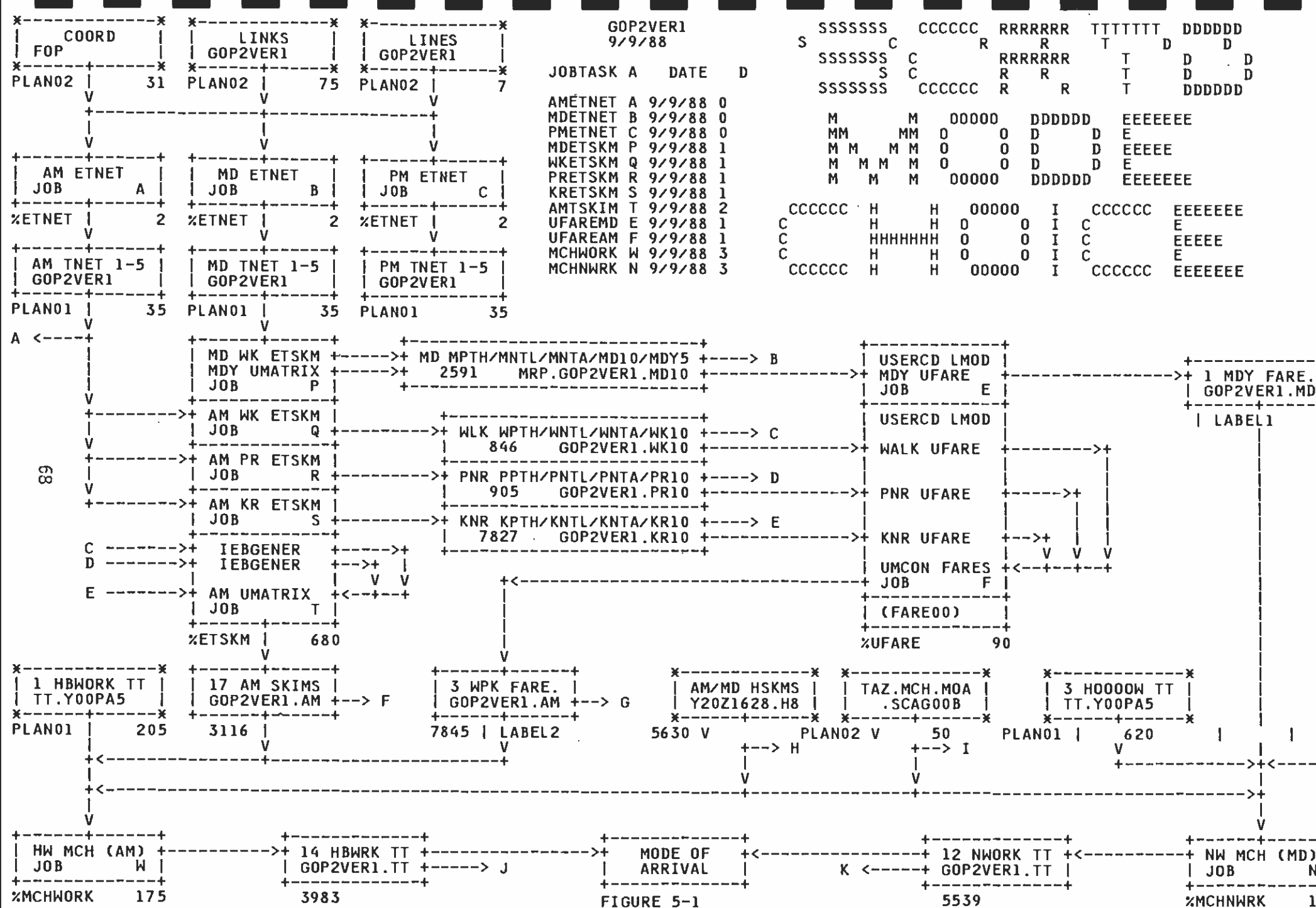
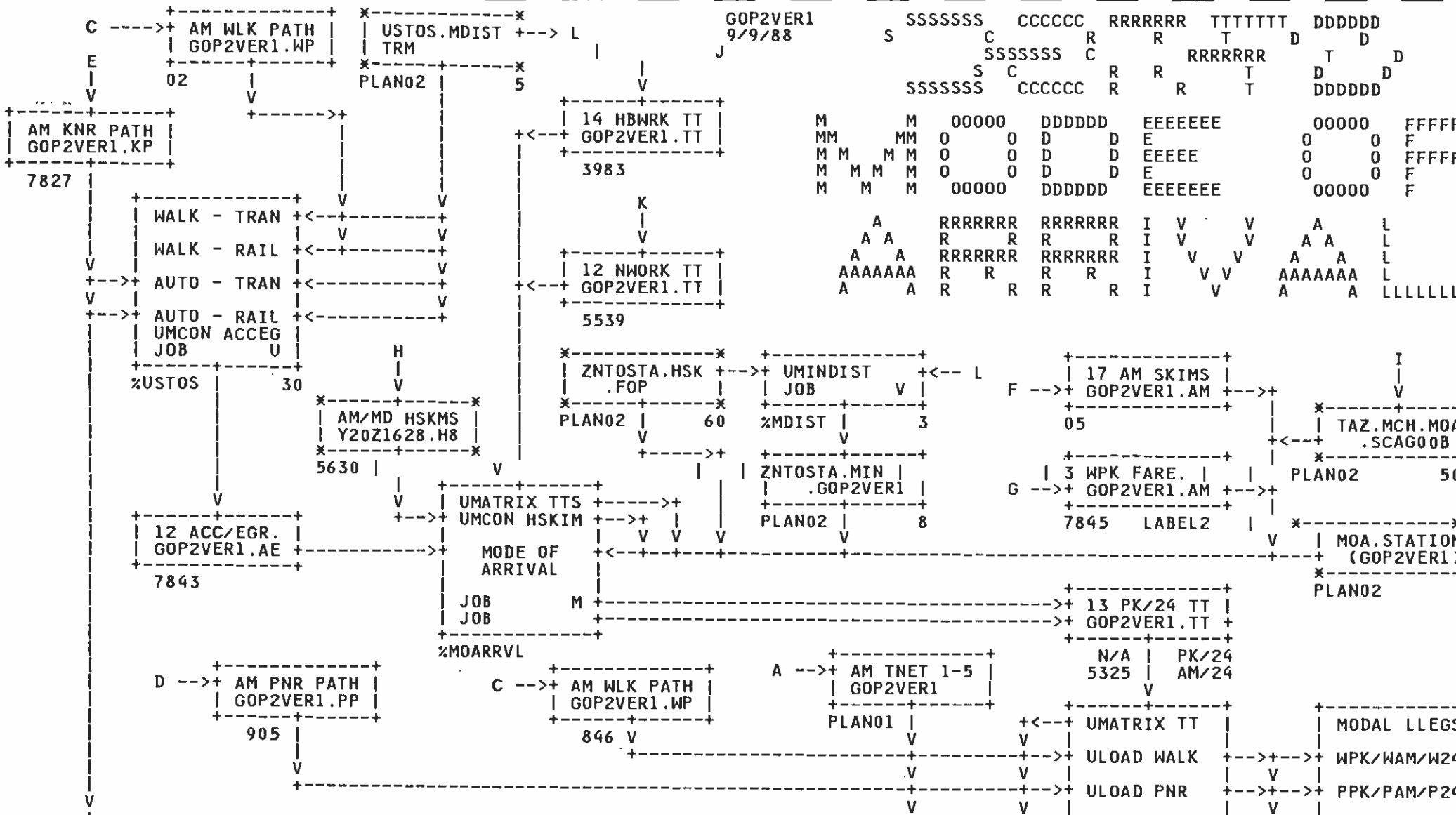

FIGURE 5-1
SIMULATION FLOWCHART
NETWORK 2 (GOP2VER1)



JOBTASK	A	DATE	D
USTOS	U	9/9/88	1
MDIST	V	9/9/88	0
MOAPK	M	9/9/88	3
MOAAP	O	9/9/88	3
ELD3RPK	X	9/9/88	1
ELD3RAM	Y	9/9/88	1
ELD3R24	Z	9/9/88	1

LOAD/URAP	PLAN01	450	%ELD3R	25
TOTAL LLEGS	LL.GOP2VER1			
PK/AM/24 HR	.HPK			
ULOAD/URAP	.HAM			
PGM REPORTS	.H24			

FIGURE 5-1 (CONTINUED)

TABLE 5-1

DATASET DIRECTORY

GOP2VER1

STEP NAME	DATASET	COMMENTS	TAPE/VOL
UNET	(I) MRP.COORD.FOP.DATA	COORDS	PLAN02
	MRP.NETWORK.GOP2VER1.DATA(LINKS)	LINKS FILE	MRP001
	MRP.NETWORK.GOP2VER1.DATA(LINES)	LINES FILE	MRP001
	(O) MRP.TNET.GOP2VER1.AM1.DATA	NETWK FILE	PLAN03
	MRP.TNET.GOP2VER1.AM2.DATA	NETWK FILE	PLAN03
	MRP.TNET.GOP2VER1.AM3.DATA	NETWK FILE	PLAN03
	MRP.TNET.GOP2VER1.AM4.DATA	NETWK FILE	PLAN03
	MRP.TNET.GOP2VER1.AM5.DATA	NETWK FILE	PLAN03
	MRP.TNET.GOP2VER1.MD1.DATA	NETWK FILE	PLAN03
	MRP.TNET.GOP2VER1.MD2.DATA	NETWK FILE	PLAN03
	MRP.TNET.GOP2VER1.MD3.DATA	NETWK FILE	PLAN03
	MRP.TNET.GOP2VER1.MD4.DATA	NETWK FILE	PLAN03
	MRP.TNET.GOP2VER1.MD5.DATA	NETWK FILE	PLAN03
	MDWLKSKM(I)	MRP.TNET.GOP2VER1.MD1.DATA	NETWRK FILE
MRP.TNET.GOP2VER1.MD3.DATA		NETWK FILE	PLAN03
MRP.TNET.GOP2VER1.MD4.DATA		NETWK FILE	PLAN03
(O) MRP.GOP2VER1.MPTH		MIDDAY PATHS	2591
MRP.GOP2VER1.MNTL		MIDDAY PATHS	2591
MRP.GOP2VER1.MNTA		MIDDAY PATHS	2591
MRP.GOP2VER1.MD10		MIDDAY SKIMS	2591
		(10 TABLES)	
MRP.GOP2VER1.MDY5		MIDDAY SKIMS	2591
		(5 TABLES)	
AMWLKSKM(I)	MRP.TNET.GOP2VER1.AM1.DATA	NETWRK FILE	PLAN03
	MRP.TNET.GOP2VER1.AM3.DATA	NETWK FILE	PLAN03
	MRP.TNET.GOP2VER1.AM4.DATA	NETWK FILE	PLAN03
	(O) MRP.GOP2VER1.WPTH	WALK PATHS	846
	MRP.GOP2VER1.WNTL	WALK PATHS	846
	MRP.GOP2VER1.WNTA	WALK PATHS	846
	MRP.GOP2VER1.WK10	MALK SKIMS	846
AMPNRSKM(I)	MRP.TNET.GOP2VER1.AM1.DATA	NETWRK FILE	PLAN03
	MRP.TNET.GOP2VER1.AM3.DATA	NETWK FILE	PLAN03
	MRP.TNET.GOP2VER1.AM4.DATA	NETWK FILE	PLAN03
	(O) MRP.GOP2VER1.PPTH	PNR PATHS	905
	MRP.GOP2VER1.PNTL	PNR PATHS	905
	MRP.GOP2VER1.PNTA	PNR PATHS	905
	MRP.GOP2VER1.PR10	PNR SKIMS	905

TABLE 5-1

DATASET DIRECTORY (CONTINUED)

GOP2VER1

STEP NAME	DATASET	COMMENTS	TAPE/VOL
AMKNRSKM(I)	MRP.TNET.GOP2VER1.AM1.DATA	NETWRK FILE	PLAN03
	MRP.TNET.GOP2VER1.AM3.DATA	NETWK FILE	PLAN03
	MRP.TNET.GOP2VER1.AM4.DATA	NETWK FILE	PLAN03
(O)	MRP.GOP2VER1.KPTH	KNR PATHS	7827
	MRP.GOP2VER1.KNTL	KNR PATHS	7827
	MRP.GOP2VER1.KNTA	KNR PATHS	7827
	MRP.GOP2VER1.KR10	KNR SKIMS	7827
AMSKMSUM(I)	MRP.GOP2VER1.WK10	WLK SKIMS	846
	MRP.GOP2VER1.PR10	PNR SKIMS	905
	MRP.GOP2VER1.KR10	KNR SKIMS	7827
(O)	MRP.GOP2VER1.AM17	MERGED SKIMS (17 TABLES)	3116
FARE00 (I)	MRP.GOP2VER1.MD10	MIDDAY SKIMS	2591
	MRP.GOP2VER1.WK10	WLK SKIMS	846
	MRP.GOP2VER1.PR10	PNR SKIMS	905
	MRP.GOP2VER1.KR10	KNR SKIMS	7827
(O)	MRP.FARE.GOP2VER1.AM.DATA	AM FARES	7845
	MRP.FARE.GOP2VER1.MD.DATA	MD FARES	7845
MCHWORK (I)	MRP.Y20Z1628.H8	HWY SKIMS	005630
	MRP.TT.Y00PA5.HBWORK.DATA	PERSON TT	PLAN01
	MRP.GOP2VER1.AM17	MERGED SKIMS	3116
	MRP.FARE.GOP2VER1.AM.DATA	MD FARES	7845
	MRP.TAZ.MCH.MOA.SCAG00B.DATA(WORK1MOA)	TRIP END	PLAN02
	MRP.TAZ.MCH.MOA.SCAG00B.DATA(WORK2)	TRIP END	PLAN02
	MRP.TAZ.MCH.MOA.SCAG00B.DATA(WORK3)	TRIP END	PLAN02
(O)	MRP.GOP2VER1.TT14	WORK TRIPS	3983
MCHNWRK (I)	MRP.Y20Z1628.H8	HWY SKIMS	005630
	MRP.TT.Y00PA5.H000OW.DATA	PERSON TT	PLAN01
	MRP.GOP2VER1.MDYS	MERGED SKIMS	2591
	MRP.FARE.GOP2VER1.MD.DATA	MD FARES	7845
	MRP.TAZ.MCH.MOA.SCAG00B.DATA(NWRK1)	TRIP END	PLAN02
	MRP.TAZ.MCH.MOA.SCAG00B.DATA(NWRK2)	TRIP END	PLAN02
	MRP.TAZ.MCH.MOA.SCAG00B.DATA(NWRK3)	TRIP END	PLAN02
(O)	MRP.GOP2VER1.TT12	WORK TRIPS	5539

TABLE 5-1

DATASET DIRECTORY (CONTINUED)

GOP2VER1

STEP NAME	DATASET	COMMENTS	TAPE/VOL
MINDIST (I)	MRP.STATION.NODE.DATA(GOP2VER1)	STATION DATA	PLAN02
	MRP.COORD.FOP.DATA	COORDS	PLAN02
(O)	MRP.ZNTOSTA.MIN.GOP2VER1.DATA	MINDIST DATA	PLAN01
USTOS (I)	MRP.GOP2VER1.WPTH	WALK PATHS	2591
	MRP.GOP2VER1.KPTH	KNR PATHS	846
	MRP.GOP2VER1.MPTH	MIDDAY PATHS	905
	MRP.GOP2VER1.AE8	STA. ACC/EGR	7843
		(12 TABLES)	
MOARR (I)	MRP.GOP2VER1.TT14	NONWORK TT	3983
	MRP.GOP2VER1.TT12	WORK TT	5539
	MRP.FARE.GOP2VER1.AM.DATA	MD FARES	7845
	MRP.Y20Z1628.H8	HWY SKIMS	005630
	MRP.ZNTOSTA.MIN.GOP2VER1.DATA	MINDIST DATA	PLAN01
	MRP.TAZ.MCH.MOA.SCAG00B.DATA(WORK1MOA)	TAZ DATA	PLAN02
	MRP.GOP2VER1.AE8	STA ACC/EGR	7843
	MRP.GOP2VER1.AM17	MERGED SKIMS	3116
	MRP.ZNTOSTA.HSK.FOP.DATA	ZN TO STA	PLAN03
	MRP.GOP2VER1.TT13	AM/24HR TRIPS	5325
ELD3R (I)	MRP.GOP2VER1.TT13	AM/24HR TRIPS	5325
	MRP.TNET.GOP2VER1.AM1.DATA	NETWK FILE	PLAN03
	MRP.TNET.GOP2VER1.AM2.DATA	NETWK FILE	PLAN03
	MRP.TNET.GOP2VER1.AM3.DATA	NETWK FILE	PLAN03
	MRP.TNET.GOP2VER1.AM4.DATA	NETWK FILE	PLAN03
	MRP.TNET.GOP2VER1.AM5.DATA	NETWK FILE	PLAN03
	MRP.TNET.GOP2VER1.MD1.DATA	NETWK FILE	PLAN03
	MRP.TNET.GOP2VER1.MD2.DATA	NETWK FILE	PLAN03
	MRP.TNET.GOP2VER1.MD3.DATA	NETWK FILE	PLAN03
	MRP.TNET.GOP2VER1.MD4.DATA	NETWK FILE	PLAN03
	MRP.TNET.GOP2VER1.MD5.DATA	NETWK FILE	PLAN03

TABLE 5-1

DATASET DIRECTORY (CONTINUED)

GOP2VER1

STEP NAME	DATASET	COMMENTS	TAPE/VOL
ELD3R(CONT.)	MRP.GOP2VER1.WPTH	WALK PATHS	846
	MRP.GOP2VER1.WNTL	WALK PATHS	846
	MRP.GOP2VER1.WNTA	WALK PATHS	846
	MRP.GOP2VER1.PPTH	PNR PATHS	905
	MRP.GOP2VER1.PNTL	PNR PATHS	905
	MRP.GOP2VER1.PNTA	PNR PATHS	905
	MRP.GOP2VER1.KPTH	KNR PATHS	7827
	MRP.GOP2VER1.KNTL	KNR PATHS	7827
	MRP.GOP2VER1.KNTA	KNR PATHS	7827
	MRP.GOP2VER1.MPTH	MIDDAY PATHS	2591
	MRP.GOP2VER1.MNTL	MIDDAY PATHS	2591
	MRP.GOP2VER1.MNTA	MIDDAY PATHS	2591
(O)	MRP.LL.GOP2VER1.HAM.DATA	LOADED LEGS	PLAN03
	MRP.GOP2VER1.URAPOUT	RT ANALYSIS	PLAN02
DIAMOND1(I)	MRP.GOP2VER1.TT13	AM/24HR TRIPS	5325
	MRP.GOP2VER1.MPTH	MIDDAY PATHS	2591
	MRP.GOP2VER1.WPTH	WALK PATHS	846
	MRP.GOP2VER1.PPTH	PNR PATHS	905
	MRP.GOP2VER1.KPTH	KNR PATHS	7827
(O)	MRP.GOP2VER1.DIAMOND.AM	S/S A-P TRIPSPLAN02	
	MRP.GOP2VER1.DIAMOND.H24	S/S A-P TRIPSPLAN02	
	MRP.GOP2VER1.DIAMOND.H240D	S/S O-D TRIPSPLAN02	

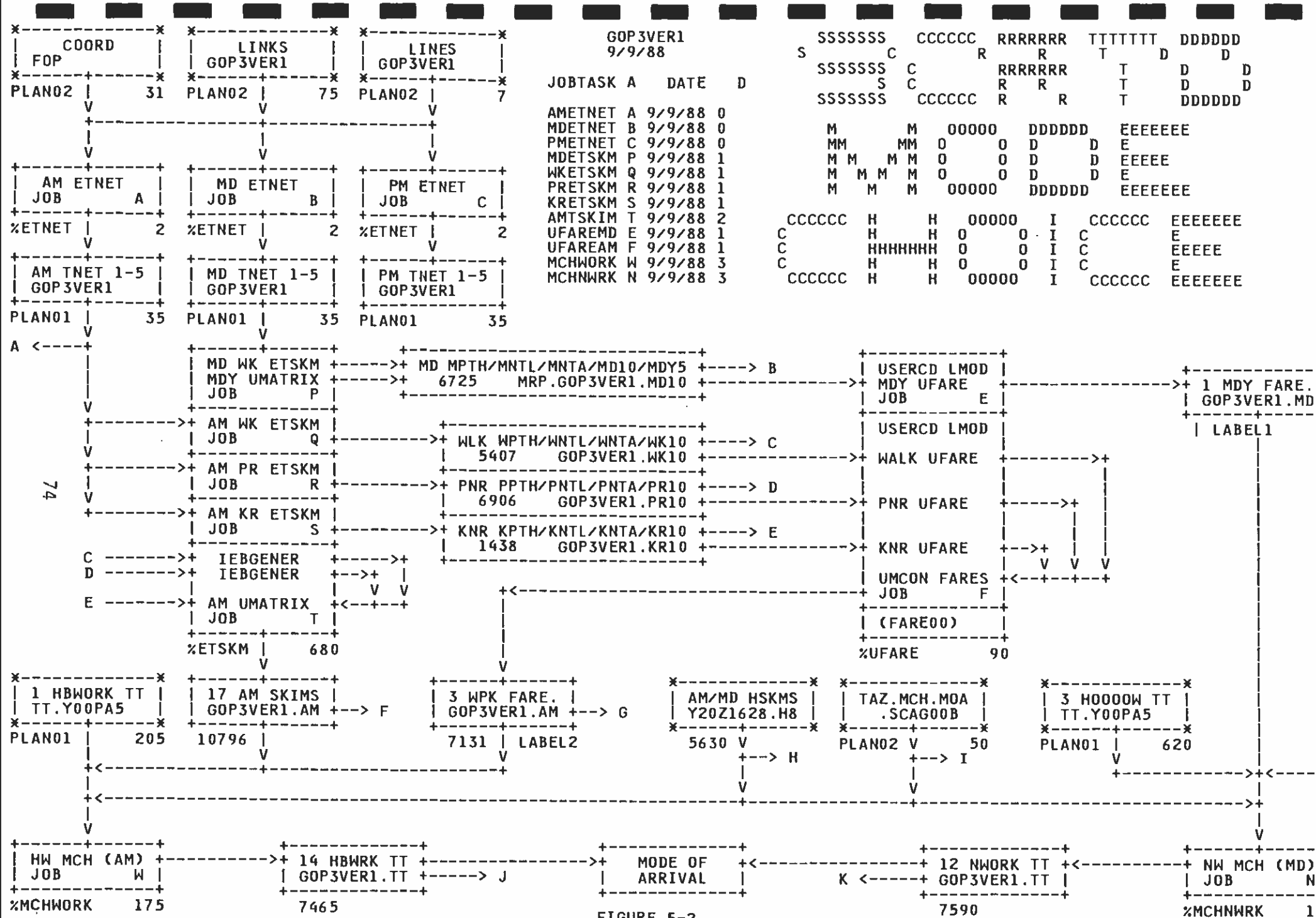

FIGURE 5-2
SIMULATION FLOWCHART
NETWORK 3 (GOP3VER1)

TABLE 5-2

DATASET DIRECTORY

GOP3VER1

STEP NAME	DATASET	COMMENTS	TAPE/VOL
UNET	(I) MRP.COORD.FOP.DATA	COORDS	PLAN02
	MRP.NETWORK.GOP3VER1.DATA(LINKS)	LINKS FILE	MRP001
	MRP.NETWORK.GOP3VER1.DATA(LINES)	LINES FILE	MRP001
	(O) MRP.TNET.GOP3VER1.AM1.DATA	NETWK FILE	PLAN03
	MRP.TNET.GOP3VER1.AM2.DATA	NETWK FILE	PLAN03
	MRP.TNET.GOP3VER1.AM3.DATA	NETWK FILE	PLAN03
	MRP.TNET.GOP3VER1.AM4.DATA	NETWK FILE	PLAN03
	MRP.TNET.GOP3VER1.AM5.DATA	NETWK FILE	PLAN03
	MRP.TNET.GOP3VER1.MD1.DATA	NETWK FILE	PLAN03
	MRP.TNET.GOP3VER1.MD2.DATA	NETWK FILE	PLAN03
	MRP.TNET.GOP3VER1.MD3.DATA	NETWK FILE	PLAN03
	MRP.TNET.GOP3VER1.MD4.DATA	NETWK FILE	PLAN03
	MRP.TNET.GOP3VER1.MD5.DATA	NETWK FILE	PLAN03
	MDWLKSKM(I)	MRP.TNET.GOP3VER1.MD1.DATA	NETWRK FILE
MRP.TNET.GOP3VER1.MD3.DATA		NETWK FILE	PLAN03
MRP.TNET.GOP3VER1.MD4.DATA		NETWK FILE	PLAN03
(O) MRP.GOP3VER1.MPTH		MIDDAY PATHS	6725
MRP.GOP3VER1.MNTL		MIDDAY PATHS	6725
MRP.GOP3VER1.MNTA		MIDDAY PATHS	6725
MRP.GOP3VER1.MD10		MIDDAY SKIMS	6725
		(10 TABLES)	
MRP.GOP3VER1.MDY5	MIDDAY SKIMS	6725	
	(5 TABLES)		
AMWLKSKM(I)	MRP.TNET.GOP3VER1.AM1.DATA	NETWRK FILE	PLAN03
	MRP.TNET.GOP3VER1.AM3.DATA	NETWK FILE	PLAN03
	MRP.TNET.GOP3VER1.AM4.DATA	NETWK FILE	PLAN03
	(O) MRP.GOP3VER1.WPTH	WALK PATHS	5407
	MRP.GOP3VER1.WNTL	WALK PATHS	5407
	MRP.GOP3VER1.WNTA	WALK PATHS	5407
	MRP.GOP3VER1.WK10	WALK SKIMS	5407
AMPNRSKM(I)	MRP.TNET.GOP3VER1.AM1.DATA	NETWRK FILE	PLAN03
	MRP.TNET.GOP3VER1.AM3.DATA	NETWK FILE	PLAN03
	MRP.TNET.GOP3VER1.AM4.DATA	NETWK FILE	PLAN03
	(O) MRP.GOP3VER1.PPTH	PNR PATHS	6906
	MRP.GOP3VER1.PNTL	PNR PATHS	6906
	MRP.GOP3VER1.PNTA	PNR PATHS	6906
	MRP.GOP3VER1.PR10	PNR SKIMS	6906

TABLE 5-2

DATASET DIRECTORY (CONTINUED)

GOP3VER1

STEP NAME	DATASET	COMMENTS	TAPE/VOL
AMKNRSKM(I)	MRP.TNET.GOP3VER1.AM1.DATA	NETWRK FILE	PLAN03
	MRP.TNET.GOP3VER1.AM3.DATA	NETWK FILE	PLAN03
	MRP.TNET.GOP3VER1.AM4.DATA	NETWK FILE	PLAN03
(O)	MRP.GOP3VER1.KPTH	KNR PATHS	1438
	MRP.GOP3VER1.KNTL	KNR PATHS	1438
	MRP.GOP3VER1.KNTA	KNR PATHS	1438
	MRP.GOP3VER1.KR10	KNR SKIMS	1438
AMSKMSUM(I)	MRP.GOP3VER1.WK10	WLK SKIMS	5407
	MRP.GOP3VER1.PR10	PNR SKIMS	6906
	MRP.GOP3VER1.KR10	KNR SKIMS	1438
(O)	MRP.GOP3VER1.AM17	MERGED SKIMS (17 TABLES)	10796
FARE00 (I)	MRP.GOP3VER1.MD10	MIDDAY SKIMS	6725
	MRP.GOP3VER1.WK10	WLK SKIMS	5407
	MRP.GOP3VER1.PR10	PNR SKIMS	6906
	MRP.GOP3VER1.KR10	KNR SKIMS	1438
(O)	MRP.FARE.GOP3VER1.AM.DATA	AM FARES	7131
	MRP.FARE.GOP3VER1.MD.DATA	MD FARES	7131
MCHWORK (I)	MRP.Y20Z1628.H8	HWY SKIMS	005630
	MRP.TT.Y00PA5.HBWORK.DATA	PERSON TT	PLAN01
	MRP.GOP3VER1.AM17	MERGED SKIMS	10796
	MRP.FARE.GOP3VER1.AM.DATA	MD FARES	7131
	MRP.TAZ.MCH.MOA.SCAG00B.DATA(WORK1MOA)	TRIP END	PLAN02
	MRP.TAZ.MCH.MOA.SCAG00B.DATA(WORK2)	TRIP END	PLAN02
	MRP.TAZ.MCH.MOA.SCAG00B.DATA(WORK3)	TRIP END	PLAN02
(O)	MRP.GOP3VER1.TT14	WORK TRIPS	7465
MCHNWRK (I)	MRP.Y20Z1628.H8	HWY SKIMS	005630
	MRP.TT.Y00PA5.H000OW.DATA	PERSON TT	PLAN01
	MRP.GOP3VER1.MDY5	MERGED SKIMS	6725
	MRP.FARE.GOP3VER1.MD.DATA	MD FARES	7131
	MRP.TAZ.MCH.MOA.SCAG00B.DATA(NWRK1)	TRIP END	PLAN02
	MRP.TAZ.MCH.MOA.SCAG00B.DATA(NWRK2)	TRIP END	PLAN02
	MRP.TAZ.MCH.MOA.SCAG00B.DATA(NWRK3)	TRIP END	PLAN02
(O)	MRP.GOP3VER1.TT12	WORK TRIPS	7590

TABLE 5-2

DATASET DIRECTORY (CONTINUED)

GOP3VER1

STEP NAME	DATASET	COMMENTS	TAPE/VOL
MINDIST (I)	MRP.STATION.NODE.DATA(GOP3VER1)	STATION DATA	PLAN02
	MRP.COORD.FOP.DATA	COORDS	PLAN02
(O)	MRP.ZNTOSTA.MIN.GOP3VER1.DATA	MINDIST DATA	PLAN01
USTOS (I)	MRP.GOP3VER1.WPTH	WALK PATHS	6725
	MRP.GOP3VER1.KPTH	KNR PATHS	5407
	MRP.GOP3VER1.MPTH	MIDDAY PATHS	6906
	MRP.GOP3VER1.AE8	STA. ACC/EGR	7606
		(12 TABLES)	
MOARR (I)	MRP.GOP3VER1.TT14	NONWORK TT	7465
	MRP.GOP3VER1.TT12	WORK TT	7590
	MRP.FARE.GOP3VER1.AM.DATA	MD FARES	7131
	MRP.Y20Z1628.H8	HWY SKIMS	005630
	MRP.ZNTOSTA.MIN.GOP3VER1.DATA	MINDIST DATA	PLAN01
	MRP.TAZ.MCH.MOA.SCAG00B.DATA(WORK1MOA)	TAZ DATA	PLAN02
	MRP.GOP3VER1.AE8	STA ACC/EGR	7606
	MRP.GOP3VER1.AM17	MERGED SKIMS	10796
	MRP.ZNTOSTA.HSK.FOP.DATA	ZN TO STA	PLAN03
	MRP.GOP3VER1.TT13	AM/24HR TRIPS	7887
ELD3R (I)	MRP.GOP3VER1.TT13	AM/24HR TRIPS	7887
	MRP.TNET.GOP3VER1.AM1.DATA	NETWK FILE	PLAN03
	MRP.TNET.GOP3VER1.AM2.DATA	NETWK FILE	PLAN03
	MRP.TNET.GOP3VER1.AM3.DATA	NETWK FILE	PLAN03
	MRP.TNET.GOP3VER1.AM4.DATA	NETWK FILE	PLAN03
	MRP.TNET.GOP3VER1.AM5.DATA	NETWK FILE	PLAN03
	MRP.TNET.GOP3VER1.MD1.DATA	NETWK FILE	PLAN03
	MRP.TNET.GOP3VER1.MD2.DATA	NETWK FILE	PLAN03
	MRP.TNET.GOP3VER1.MD3.DATA	NETWK FILE	PLAN03
	MRP.TNET.GOP3VER1.MD4.DATA	NETWK FILE	PLAN03
	MRP.TNET.GOP3VER1.MD5.DATA	NETWK FILE	PLAN03

TABLE 5-2

DATASET DIRECTORY (CONTINUED)

GOP3VER1

STEP NAME	DATASET	COMMENTS	TAPE/VOL
ELD3R(CONT.)	MRP.GOP3VER1.WPTH	WALK PATHS	5407
	MRP.GOP3VER1.WNTL	WALK PATHS	5407
	MRP.GOP3VER1.WNTA	WALK PATHS	5407
	MRP.GOP3VER1.PPTH	PNR PATHS	6906
	MRP.GOP3VER1.PNTL	PNR PATHS	6906
	MRP.GOP3VER1.PNTA	PNR PATHS	6906
	MRP.GOP3VER1.KPTH	KNR PATHS	1438
	MRP.GOP3VER1.KNTL	KNR PATHS	1438
	MRP.GOP3VER1.KNTA	KNR PATHS	1438
	MRP.GOP3VER1.MPTH	MIDDAY PATHS	6725
	MRP.GOP3VER1.MNTL	MIDDAY PATHS	6725
	MRP.GOP3VER1.MNTA	MIDDAY PATHS	6725
(O)	MRP.LL.GOP3VER1.HAM.DATA	LOADED LEGS	PLAN03
	MRP.GOP3VER1.URAPOUT	RT ANALYSIS	PLAN02
DIAMOND1(I)	MRP.GOP3VER1.TT13	AM/24HR TRIPS	7887
	MRP.GOP3VER1.MPTH	MIDDAY PATHS	6725
	MRP.GOP3VER1.WPTH	WALK PATHS	5407
	MRP.GOP3VER1.PPTH	PNR PATHS	6906
	MRP.GOP3VER1.KPTH	KNR PATHS	1438
(O)	MRP.GOP3VER1.DIAMOND.AM	S/S A-P TRIPS	PLAN02
	MRP.GOP3VER1.DIAMOND.H24	S/S A-P TRIPS	PLAN02
	MRP.GOP3VER1.DIAMOND.H240D	S/S O-D TRIPS	PLAN02

GOP3TSM1
9/9/88

S	SSSSSSS	C	CCCCC	R	RRRRRRR	T	TTTTTTT	D	DDDDDD
S	SSSSSSS	C	CCCCC	R	RRRRRRR	T	TTTTTTT	D	DDDDDD
S	SSSSSSS	C	CCCCC	R	RRRRRRR	T	TTTTTTT	D	DDDDDD
M	MM	M	00000	O	0	D	DDDDDD	E	EEEEEEE
MM	MM	M	0	O	0	D	DDDDDD	E	EEEEEEE
M	M	M	0	O	0	D	DDDDDD	E	EEEEEEE
M	M	M	00000	O	0	D	DDDDDD	E	EEEEEEE
C	CCCCC	H	H	00000	I	C	CCCCC	E	EEEEEEE
C	CCCCC	H	H	0	O	I	C	E	EEEEEEE
C	CCCCC	H	H	0	O	I	C	E	EEEEEEE
C	CCCCC	H	H	00000	I	C	CCCCC	E	EEEEEEE

JOBTASK A DATE D
 AMETNET A 9/9/88 0
 MDETNET B 9/9/88 0
 PMETNET C 9/9/88 0
 MDETSKM P 9/9/88 1
 WKETSKM Q 9/9/88 1
 PRETSKM R 9/9/88 1
 KRETSKM S 9/9/88 1
 AMTSKIM T 9/9/88 2
 UFAREMD E 9/9/88 1
 UFAREAM F 9/9/88 1
 MCHWORK W 9/9/88 3
 MCHNWRK N 9/9/88 3

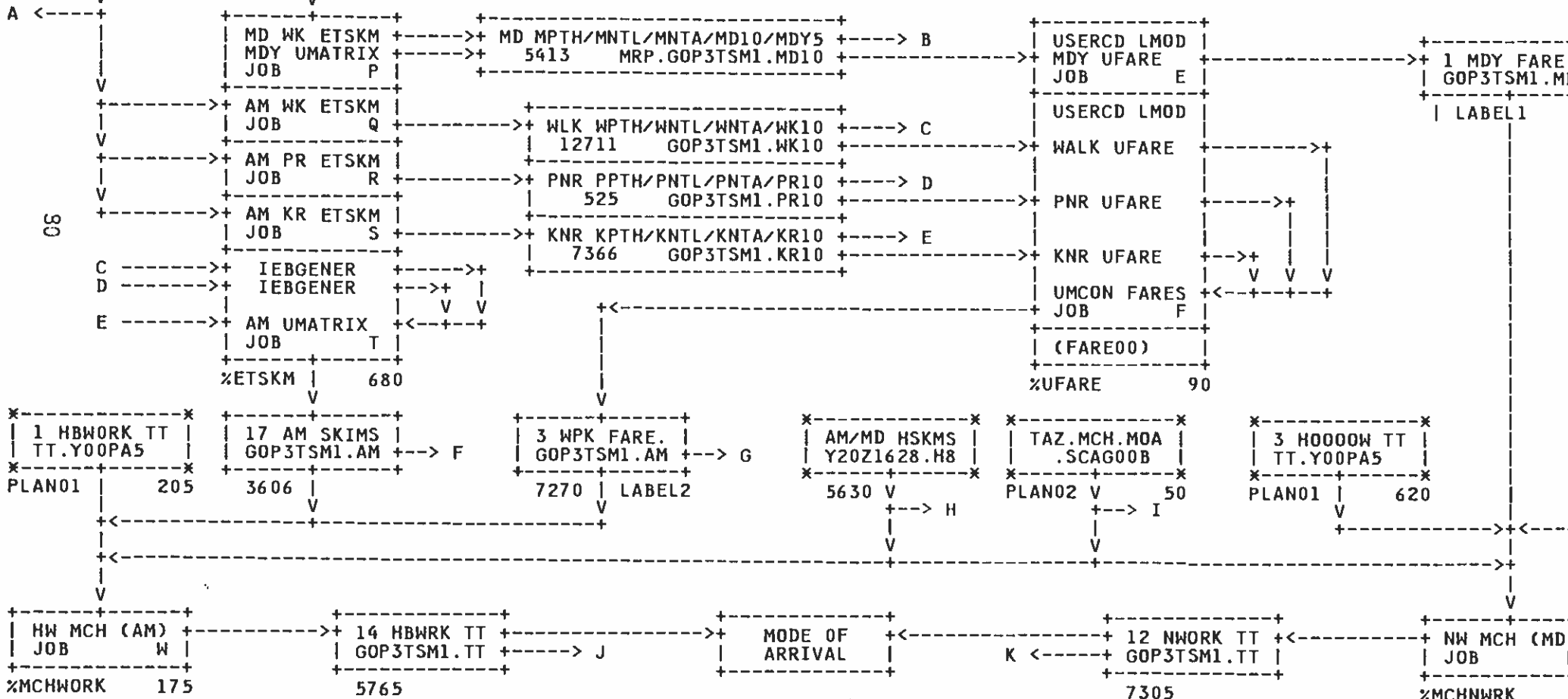
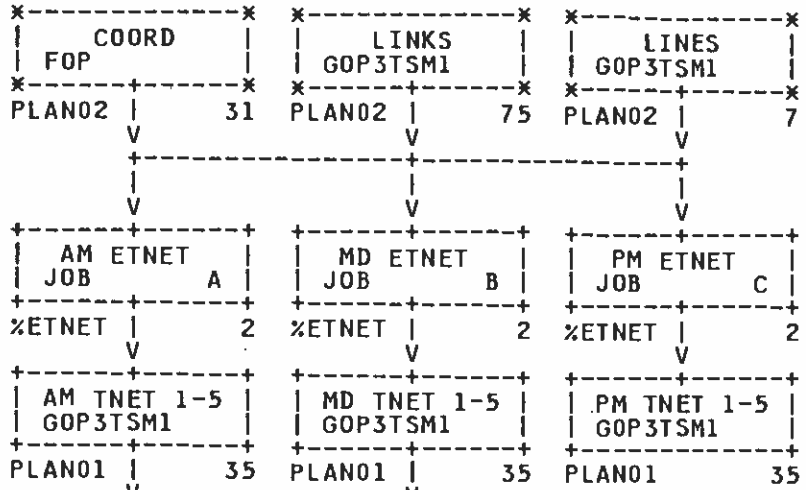
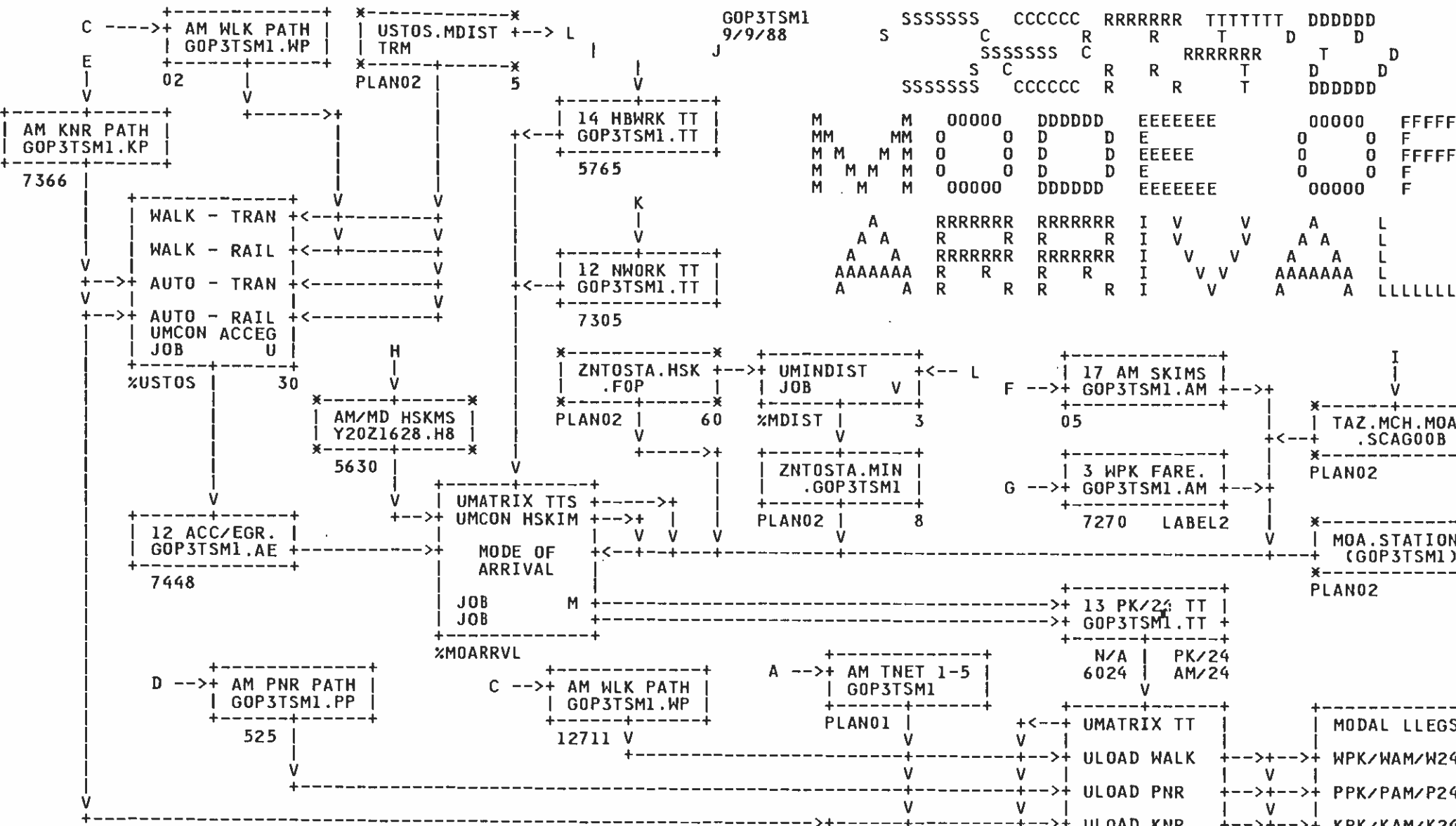

FIGURE 5-3
SIMULATION FLOWCHART
NETWORK 3 (GOP3TSM1)



JOBTASK	A	DATE	D
USTOS	U	9/9/88	1
MDIST	V	9/9/88	0
MOAPK	M	9/9/88	3
MOAAM	O	9/9/88	3
ELD3RPK	X	9/9/88	1
ELD3RAM	Y	9/9/88	1
ELD3R24	Z	9/9/88	1

ULOAD/URAP	PLAN01	450	%ELD3R	25
TOTAL LLEGS	LL.GOP3TSM1	PK/AM/24 HR	.HPK	JOB X
ULOAD/URAP	PLAN01	450	.HAM	JOB Y
ULOAD/URAP	PLAN01	450	.H24	JOB Z

FIGURE 5-3 (CONTINUED)

TABLE 5-3

DATASET DIRECTORY

GOP3TSM1

STEP NAME	DATASET	COMMENTS	TAPE/VOL
UNET	(I) MRP.COORD.FOP.DATA	COORDS	PLAN02
	MRP.NETWORK.GOP3TSM1.DATA(LINKS)	LINKS FILE	MRP001
	MRP.NETWORK.GOP3TSM1.DATA(LINES)	LINES FILE	MRP001
	(O) MRP.TNET.GOP3TSM1.AM1.DATA	NETWK FILE	PLAN03
	MRP.TNET.GOP3TSM1.AM2.DATA	NETWK FILE	PLAN03
	MRP.TNET.GOP3TSM1.AM3.DATA	NETWK FILE	PLAN03
	MRP.TNET.GOP3TSM1.AM4.DATA	NETWK FILE	PLAN03
	MRP.TNET.GOP3TSM1.AM5.DATA	NETWK FILE	PLAN03
	MRP.TNET.GOP3TSM1.MD1.DATA	NETWK FILE	PLAN03
	MRP.TNET.GOP3TSM1.MD2.DATA	NETWK FILE	PLAN03
	MRP.TNET.GOP3TSM1.MD3.DATA	NETWK FILE	PLAN03
	MRP.TNET.GOP3TSM1.MD4.DATA	NETWK FILE	PLAN03
	MRP.TNET.GOP3TSM1.MD5.DATA	NETWK FILE	PLAN03
MDWLKSKM(I)	MRP.TNET.GOP3TSM1.MD1.DATA	NETWRK FILE	PLAN03
	MRP.TNET.GOP3TSM1.MD3.DATA	NETWK FILE	PLAN03
	MRP.TNET.GOP3TSM1.MD4.DATA	NETWK FILE	PLAN03
	(O) MRP.GOP3TSM1.MPTH	MIDDAY PATHS	5413
	MRP.GOP3TSM1.MNTL	MIDDAY PATHS	5413
	MRP.GOP3TSM1.MNTA	MIDDAY PATHS	5413
	MRP.GOP3TSM1.MD10	MIDDAY SKIMS	5413
	MRP.GOP3TSM1.MDY5	(10 TABLES) MIDDAY SKIMS (5 TABLES)	5413
AMWLKSKM(I)	MRP.TNET.GOP3TSM1.AM1.DATA	NETWRK FILE	PLAN03
	MRP.TNET.GOP3TSM1.AM3.DATA	NETWK FILE	PLAN03
	MRP.TNET.GOP3TSM1.AM4.DATA	NETWK FILE	PLAN03
	(O) MRP.GOP3TSM1.WPTH	WALK PATHS	12711
	MRP.GOP3TSM1.WNTL	WALK PATHS	12711
	MRP.GOP3TSM1.WNTA	WALK PATHS	12711
	MRP.GOP3TSM1.WK10	MALK SKIMS	12711
AMPNRSKM(I)	MRP.TNET.GOP3TSM1.AM1.DATA	NETWRK FILE	PLAN03
	MRP.TNET.GOP3TSM1.AM3.DATA	NETWK FILE	PLAN03
	MRP.TNET.GOP3TSM1.AM4.DATA	NETWK FILE	PLAN03
	(O) MRP.GOP3TSM1.PPTH	PNR PATHS	525
	MRP.GOP3TSM1.PNTL	PNR PATHS	525
	MRP.GOP3TSM1.PNTA	PNR PATHS	525
	MRP.GOP3TSM1.PR10	PNR SKIMS	525

TABLE 5-3

DATASET DIRECTORY (CONTINUED)

GOP3TSM1

STEP NAME	DATASET	COMMENTS	TAPE/VOL
AMKNRSKM(I)	MRP.TNET.GOP3TSM1.AM1.DATA	NETWRK FILE	PLAN03
	MRP.TNET.GOP3TSM1.AM3.DATA	NETWK FILE	PLAN03
	MRP.TNET.GOP3TSM1.AM4.DATA	NETWK FILE	PLAN03
(O)	MRP.GOP3TSM1.KPTH	KNR PATHS	7366
	MRP.GOP3TSM1.KNTL	KNR PATHS	7366
	MRP.GOP3TSM1.KNTA	KNR PATHS	7366
	MRP.GOP3TSM1.KR10	KNR SKIMS	7366
AMSKMSUM(I)	MRP.GOP3TSM1.WK10	WLK SKIMS	12711
	MRP.GOP3TSM1.PR10	PNR SKIMS	525
	MRP.GOP3TSM1.KR10	KNR SKIMS	7366
(O)	MRP.GOP3TSM1.AM17	MERGED SKIMS (17 TABLES)	360
FARE00 (I)	MRP.GOP3TSM1.MD10	MIDDAY SKIMS	5413
	MRP.GOP3TSM1.WK10	WLK SKIMS	12711
	MRP.GOP3TSM1.PR10	PNR SKIMS	525
	MRP.GOP3TSM1.KR10	KNR SKIMS	7366
(O)	MRP.FARE.GOP3TSM1.AM.DATA	AM FARES	7270
	MRP.FARE.GOP3TSM1.MD.DATA	MD FARES	7270
MCHWORK (I)	MRP.Y20Z1628.H8	HWY SKIMS	005630
	MRP.TT.Y00PA5.HBWORK.DATA	PERSON TT	PLAN01
	MRP.GOP3TSM1.AM17	MERGED SKIMS	360
	MRP.FARE.GOP3TSM1.AM.DATA	MD FARES	7270
	MRP.TAZ.MCH.MOA.SCAG00B.DATA(WORK1MOA)	TRIP END	PLAN02
	MRP.TAZ.MCH.MOA.SCAG00B.DATA(WORK2)	TRIP END	PLAN02
	MRP.TAZ.MCH.MOA.SCAG00B.DATA(WORK3)	TRIP END	PLAN02
(O)	MRP.GOP3TSM1.TT14	WORK TRIPS	5765
MCHNWRK (I)	MRP.Y20Z1628.H8	HWY SKIMS	005630
	MRP.TT.Y00PA5.H0000W.DATA	PERSON TT	PLAN01
	MRP.GOP3TSM1.MDY5	MERGED SKIMS	5413
	MRP.FARE.GOP3TSM1.MD.DATA	MD FARES	7270
	MRP.TAZ.MCH.MOA.SCAG00B.DATA(NWRK1)	TRIP END	PLAN02
	MRP.TAZ.MCH.MOA.SCAG00B.DATA(NWRK2)	TRIP END	PLAN02
	MRP.TAZ.MCH.MOA.SCAG00B.DATA(NWRK3)	TRIP END	PLAN02
(O)	MRP.GOP3TSM1.TT12	WORK TRIPS	7305

TABLE 5-3

DATASET DIRECTORY (CONTINUED)

GOP3TSM1

STEP NAME	DATASET	COMMENTS	TAPE/VOL
MINDIST (I)	MRP.STATION.NODE.DATA(GOP3TSM1)	STATION DATA	PLAN02
	MRP.COORD.FOP.DATA	COORDS	PLAN02
(O)	MRP.ZNTOSTA.MIN.GOP3TSM1.DATA	MINDIST DATA	PLAN01
USTOS (I)	MRP.GOP3TSM1.WPTH	WALK PATHS	5413
	MRP.GOP3TSM1.KPTH	KNR PATHS	12711
	MRP.GOP3TSM1.MPTH	MIDDAY PATHS	525
	MRP.GOP3TSM1.AE8	STA. ACC/EGR	7448
		(12 TABLES)	
MOARR (I)	MRP.GOP3TSM1.TT14	NONWORK TT	5765
	MRP.GOP3TSM1.TT12	WORK TT	7305
	MRP.FARE.GOP3TSM1.AM.DATA	MD FARES	7270
	MRP.Y20Z1628.H8	HWY SKIMS	005630
	MRP.ZNTOSTA.MIN.GOP3TSM1.DATA	MINDIST DATA	PLAN01
	MRP.TAZ.MCH.MOA.SCAG00B.DATA(WORK1MOA)	TAZ DATA	PLAN02
	MRP.GOP3TSM1.AE8	STA ACC/EGR	7448
	MRP.GOP3TSM1.AM17	MERGED SKIMS	360
	MRP.ZNTOSTA.HSK.FOP.DATA	ZN TO STA	PLAN03
	MRP.GOP3TSM1.TT13	AM/24HR TRIPS	6024
ELD3R (I)	MRP.GOP3TSM1.TT13	AM/24HR TRIPS	6024
	MRP.TNET.GOP3TSM1.AM1.DATA	NETWK FILE	PLAN03
	MRP.TNET.GOP3TSM1.AM2.DATA	NETWK FILE	PLAN03
	MRP.TNET.GOP3TSM1.AM3.DATA	NETWK FILE	PLAN03
	MRP.TNET.GOP3TSM1.AM4.DATA	NETWK FILE	PLAN03
	MRP.TNET.GOP3TSM1.AM5.DATA	NETWK FILE	PLAN03
	MRP.TNET.GOP3TSM1.MD1.DATA	NETWK FILE	PLAN03
	MRP.TNET.GOP3TSM1.MD2.DATA	NETWK FILE	PLAN03
	MRP.TNET.GOP3TSM1.MD3.DATA	NETWK FILE	PLAN03
	MRP.TNET.GOP3TSM1.MD4.DATA	NETWK FILE	PLAN03
	MRP.TNET.GOP3TSM1.MD5.DATA	NETWK FILE	PLAN03

TABLE 5-3

DATASET DIRECTORY (CONTINUED)

GOP3TSM1

STEP NAME	DATASET	COMMENTS	TAPE/VOL
ELD3R(CONT.)	MRP.GOP3TSM1.WPTH	WALK PATHS	12711
	MRP.GOP3TSM1.WNTL	WALK PATHS	12711
	MRP.GOP3TSM1.WNTA	WALK PATHS	12711
	MRP.GOP3TSM1.PPTH	PNR PATHS	525
	MRP.GOP3TSM1.PNTL	PNR PATHS	525
	MRP.GOP3TSM1.PNTA	PNR PATHS	525
	MRP.GOP3TSM1.KPTH	KNR PATHS	7366
	MRP.GOP3TSM1.KNTL	KNR PATHS	7366
	MRP.GOP3TSM1.KNTA	KNR PATHS	7366
	MRP.GOP3TSM1.MPTH	MIDDAY PATHS	5413
	MRP.GOP3TSM1.MNTL	MIDDAY PATHS	5413
	MRP.GOP3TSM1.MNTA	MIDDAY PATHS	5413
(O)	MRP.LL.GOP3TSM1.HAM.DATA	LOADED LEGS	PLAN03
	MRP.GOP3TSM1.URAPOUT	RT ANALYSIS	PLAN02
DIAMOND1(I)	MRP.GOP3TSM1.TT13	AM/24HR TRIPS	6024
	MRP.GOP3TSM1.MPTH	MIDDAY PATHS	5413
	MRP.GOP3TSM1.WPTH	WALK PATHS	12711
	MRP.GOP3TSM1.PPTH	PNR PATHS	525
	MRP.GOP3TSM1.KPTH	KNR PATHS	7366
(O)	MRP.GOP3TSM1.DIAMOND.AM	S/S A-P TRIPSPLAN02	
	MRP.GOP3TSM1.DIAMOND.H24	S/S A-P TRIPSPLAN02	
	MRP.GOP3TSM1.DIAMOND.H240D	S/S O-D TRIPSPLAN02	

TABLE 5-4

DATASET DIRECTORY

GOP6VER1

STEP NAME	DATASET	COMMENTS	TAPE/VOL
UNET	(I) MRP.COORD.FOP.DATA	COORDS	PLAN02
	MRP.NETWORK.GOP6VER1.DATA(LINKS)	LINKS FILE	MRP001
	MRP.NETWORK.GOP6VER1.DATA(LINES)	LINES FILE	MRP001
	(O) MRP.TNET.GOP6VER1.AM1.DATA	NETWK FILE	PLAN03
	MRP.TNET.GOP6VER1.AM2.DATA	NETWK FILE	PLAN03
	MRP.TNET.GOP6VER1.AM3.DATA	NETWK FILE	PLAN03
	MRP.TNET.GOP6VER1.AM4.DATA	NETWK FILE	PLAN03
	MRP.TNET.GOP6VER1.AM5.DATA	NETWK FILE	PLAN03
	MRP.TNET.GOP6VER1.MD1.DATA	NETWK FILE	PLAN03
	MRP.TNET.GOP6VER1.MD2.DATA	NETWK FILE	PLAN03
	MRP.TNET.GOP6VER1.MD3.DATA	NETWK FILE	PLAN03
	MRP.TNET.GOP6VER1.MD4.DATA	NETWK FILE	PLAN03
	MRP.TNET.GOP6VER1.MD5.DATA	NETWK FILE	PLAN03
	MDWLKSKM(I)	MRP.TNET.GOP6VER1.MD1.DATA	NETWRK FILE
MRP.TNET.GOP6VER1.MD3.DATA		NETWK FILE	PLAN03
MRP.TNET.GOP6VER1.MD4.DATA		NETWK FILE	PLAN03
(O) MRP.GOP6VER1.MPTH		MIDDAY PATHS	13255
MRP.GOP6VER1.MNTL		MIDDAY PATHS	13255
MRP.GOP6VER1.MNTA		MIDDAY PATHS	13255
MRP.GOP6VER1.MD10		MIDDAY SKIMS	13255
MRP.GOP6VER1.MDY5		MIDDAY SKIMS (5 TABLES)	13255
AMWLKSKM(I)	MRP.TNET.GOP6VER1.AM1.DATA	NETWRK FILE	PLAN03
	MRP.TNET.GOP6VER1.AM3.DATA	NETWK FILE	PLAN03
	MRP.TNET.GOP6VER1.AM4.DATA	NETWK FILE	PLAN03
	(O) MRP.GOP6VER1.WPTH	WALK PATHS	12999
	MRP.GOP6VER1.WNTL	WALK PATHS	12999
	MRP.GOP6VER1.WNTA	WALK PATHS	12999
	MRP.GOP6VER1.WK10	WALK SKIMS	12999
AMPNRSKM(I)	MRP.TNET.GOP6VER1.AM1.DATA	NETWRK FILE	PLAN03
	MRP.TNET.GOP6VER1.AM3.DATA	NETWK FILE	PLAN03
	MRP.TNET.GOP6VER1.AM4.DATA	NETWK FILE	PLAN03
	(O) MRP.GOP6VER1.PPTH	PNR PATHS	12921
	MRP.GOP6VER1.PNTL	PNR PATHS	12921
	MRP.GOP6VER1.PNTA	PNR PATHS	12921
	MRP.GOP6VER1.PR10	PNR SKIMS	12921

TABLE 5-4

DATASET DIRECTORY (CONTINUED)

GOP6VER1

STEP NAME	DATASET	COMMENTS	TAPE/VOL
AMKNRSKM(I)	MRP.TNET.GOP6VER1.AM1.DATA	NETWRK FILE	PLAN03
	MRP.TNET.GOP6VER1.AM3.DATA	NETWK FILE	PLAN03
	MRP.TNET.GOP6VER1.AM4.DATA	NETWK FILE	PLAN03
(O)	MRP.GOP6VER1.KPTH	KNR PATHS	12916
	MRP.GOP6VER1.KNTL	KNR PATHS	12916
	MRP.GOP6VER1.KNTA	KNR PATHS	12916
	MRP.GOP6VER1.KR10	KNR SKIMS	12916
AMSKMSUM(I)	MRP.GOP6VER1.WK10	WLK SKIMS	12999
	MRP.GOP6VER1.PR10	PNR SKIMS	12921
	MRP.GOP6VER1.KR10	KNR SKIMS	12916
(O)	MRP.GOP6VER1.AM17	MERGED SKIMS (17 TABLES)	13120
FARE00 (I)	MRP.GOP6VER1.MD10	MIDDAY SKIMS	13255
	MRP.GOP6VER1.WK10	WLK SKIMS	12999
	MRP.GOP6VER1.PR10	PNR SKIMS	12921
	MRP.GOP6VER1.KR10	KNR SKIMS	12916
(O)	MRP.FARE.GOP6VER1.AM.DATA	AM FARES	13117
	MRP.FARE.GOP6VER1.MD.DATA	MD FARES	13117
MCHWORK (I)	MRP.Y20Z1628.H8	HWY SKIMS	005630
	MRP.TT.Y00PA5.HBWORK.DATA	PERSON TT	PLAN01
	MRP.GOP6VER1.AM17	MERGED SKIMS	13120
	MRP.FARE.GOP6VER1.AM.DATA	MD FARES	13117
	MRP.TAZ.MCH.MOA.SCAG00B.DATA(WORK1MOA)	TRIP END	PLAN02
	MRP.TAZ.MCH.MOA.SCAG00B.DATA(WORK2)	TRIP END	PLAN02
	MRP.TAZ.MCH.MOA.SCAG00B.DATA(WORK3)	TRIP END	PLAN02
(O)	MRP.GOP6VER1.TT14	WORK TRIPS	3983
MCHNWRK (I)	MRP.Y20Z1628.H8	HWY SKIMS	005630
	MRP.TT.Y00PA5.H0000W.DATA	PERSON TT	PLAN01
	MRP.GOP6VER1.MDY5	MERGED SKIMS	13255
	MRP.FARE.GOP6VER1.MD.DATA	MD FARES	13117
	MRP.TAZ.MCH.MOA.SCAG00B.DATA(NWRK1)	TRIP END	PLAN02
	MRP.TAZ.MCH.MOA.SCAG00B.DATA(NWRK2)	TRIP END	PLAN02
	MRP.TAZ.MCH.MOA.SCAG00B.DATA(NWRK3)	TRIP END	PLAN02
(O)	MRP.GOP6VER1.TT12	WORK TRIPS	5539

TABLE 5-4

DATASET DIRECTORY (CONTINUED)

GOP6VER1

STEP NAME	DATASET	COMMENTS	TAPE/VOL
MINDIST (I)	MRP.STATION.NODE.DATA(GOP6VER1)	STATION DATA	PLAN02
	MRP.COORD.FOP.DATA	COORDS	PLAN02
(O)	MRP.ZNTOSTA.MIN.GOP6VER1.DATA	MINDIST DATA	PLAN01
USTOS (I)	MRP.GOP6VER1.WPTH	WALK PATHS	13255
	MRP.GOP6VER1.KPTH	KNR PATHS	12999
	MRP.GOP6VER1.MPTH	MIDDAY PATHS	12921
	MRP.GOP6VER1.AE8	STA. ACC/EGR	7843
		(12 TABLES)	
MOARR (I)	MRP.GOP6VER1.TT14	NONWORK TT	3983
	MRP.GOP6VER1.TT12	WORK TT	5539
	MRP.FARE.GOP6VER1.AM.DATA	MD FARES	13117
	MRP.Y20Z1628.H8	HWY SKIMS	005630
	MRP.ZNTOSTA.MIN.GOP6VER1.DATA	MINDIST DATA	PLAN01
	MRP.TAZ.MCH.MOA.SCAG00B.DATA(WORK1MOA)	TAZ DATA	PLAN02
	MRP.GOP6VER1.AE8	STA ACC/EGR	7843
	MRP.GOP6VER1.AM17	MERGED SKIMS	13120
	MRP.ZNTOSTA.HSK.FOP.DATA	ZN TO STA	PLAN03
	MRP.GOP6VER1.TT13	AM/24HR TRIPS	5325
ELD3R (I)	MRP.GOP6VER1.TT13	AM/24HR TRIPS	5325
	MRP.TNET.GOP6VER1.AM1.DATA	NETWK FILE	PLAN03
	MRP.TNET.GOP6VER1.AM2.DATA	NETWK FILE	PLAN03
	MRP.TNET.GOP6VER1.AM3.DATA	NETWK FILE	PLAN03
	MRP.TNET.GOP6VER1.AM4.DATA	NETWK FILE	PLAN03
	MRP.TNET.GOP6VER1.AM5.DATA	NETWK FILE	PLAN03
	MRP.TNET.GOP6VER1.MD1.DATA	NETWK FILE	PLAN03
	MRP.TNET.GOP6VER1.MD2.DATA	NETWK FILE	PLAN03
	MRP.TNET.GOP6VER1.MD3.DATA	NETWK FILE	PLAN03
	MRP.TNET.GOP6VER1.MD4.DATA	NETWK FILE	PLAN03
	MRP.TNET.GOP6VER1.MD5.DATA	NETWK FILE	PLAN03

TABLE 5-4

DATASET DIRECTORY (CONTINUED)

GOP6VER1

STEP NAME	DATASET	COMMENTS	TAPE/VOL
ELD3R(CONT.)	MRP.GOP6VER1.WPTH	WALK PATHS	12999
	MRP.GOP6VER1.WNTL	WALK PATHS	12999
	MRP.GOP6VER1.WNTA	WALK PATHS	12999
	MRP.GOP6VER1.PPTH	PNR PATHS	12921
	MRP.GOP6VER1.PNTL	PNR PATHS	12921
	MRP.GOP6VER1.PNTA	PNR PATHS	12921
	MRP.GOP6VER1.KPTH	KNR PATHS	12916
	MRP.GOP6VER1.KNTL	KNR PATHS	12916
	MRP.GOP6VER1.KNTA	KNR PATHS	12916
	MRP.GOP6VER1.MPTH	MIDDAY PATHS	13255
	MRP.GOP6VER1.MNTL	MIDDAY PATHS	13255
	MRP.GOP6VER1.MNTA	MIDDAY PATHS	13255
(O)	MRP.LL.GOP6VER1.HAM.DATA	LOADED LEGS	PLAN03
	MRP.GOP6VER1.URAPOUT	RT ANALYSIS	PLAN02
DIAMOND1(I)	MRP.GOP6VER1.TT13	AM/24HR TRIPS	5325
	MRP.GOP6VER1.MPTH	MIDDAY PATHS	13255
	MRP.GOP6VER1.WPTH	WALK PATHS	12999
	MRP.GOP6VER1.PPTH	PNR PATHS	12921
	MRP.GOP6VER1.KPTH	KNR PATHS	12916
(O)	MRP.GOP6VER1.DIAMOND.AM	S/S A-P TRIPSPLAN02	
	MRP.GOP6VER1.DIAMOND.H24	S/S A-P TRIPSPLAN02	
	MRP.GOP6VER1.DIAMOND.H240D	S/S O-D TRIPSPLAN02	

APPENDIX-1

OTHER ALTERNATIVES CONSIDERED

In the consideration of network alternatives for the horizon year, many other alternatives were coded and simulated. These alternatives are comprised of Alignments 4 or 6, the Long Beach Light Rail, the Century Light Rail and the Harbor Busway. These alternatives are listed in Table A-1 and the respective alignments are depicted in Figures 6-1 through 6-6.

TABLE A-1

OTHER NETWORKS DEVELOPED IN THE CONTEXT OF THE FY-88
FINANCIAL OPERATING PLAN

DESCRIPTION	REFER TO FIGURE	NAMING CONVENTION	YEAR	UTPS LABEL TT2000/ TT1990
BUS + CANDIDATE ALIGNMENT 4: MOS-2 + LB-LA-LRT + CENTURY/EL SEGUNDO LRT	6-1	NETWORK-4	'95	FOP4VER3/ FOP4YR90
BUS + CANDIDATE ALIGNMENT 4: MOS-2A + LB-LA-LRT + CENTURY/EL SEGUNDO LRT	6-2	NETWORK-4A	'95	FOP4AVR1/ FOP4AY90
BUS + CANDIDATE ALIGNMENT 4: MOS-2B + LB-LA-LRT + CENTURY/EL SEGUNDO LRT	6-3	NETWORK-4B	'95	GOP4BVR1/ GOP4BY90
BUS + CANDIDATE ALIGNMENT 6: MOS-2 + LB-LA-LRT + CENTURY/EL SEGUNDO LRT	6-4	NETWORK-5	'95	FOP5YR00/ FOP5YR90
BUS + CANDIDATE ALIGNMENT 6: MOS-2A + LB-LA-LRT + CENTURY/EL SEGUNDO LRT	6-5	NETWORK-5A	'95	FOP5AY00/ FOP5AY90
BUS + CANDIDATE ALIGNMENT 6: MOS-2B + LB-LA-LRT + CENTURY/EL SEGUNDO LRT	6-6	NETWORK-5B	'95	FOP5BY00/ FOP5BY90

FIGURE 6-1

FINANCIAL OPERATING PLAN NETWORK-4

CANDIDATE ALIGNMENT 4:
MOS-2 + LB-LA LRT +
CENTURY/EL SEGUNDO LRT

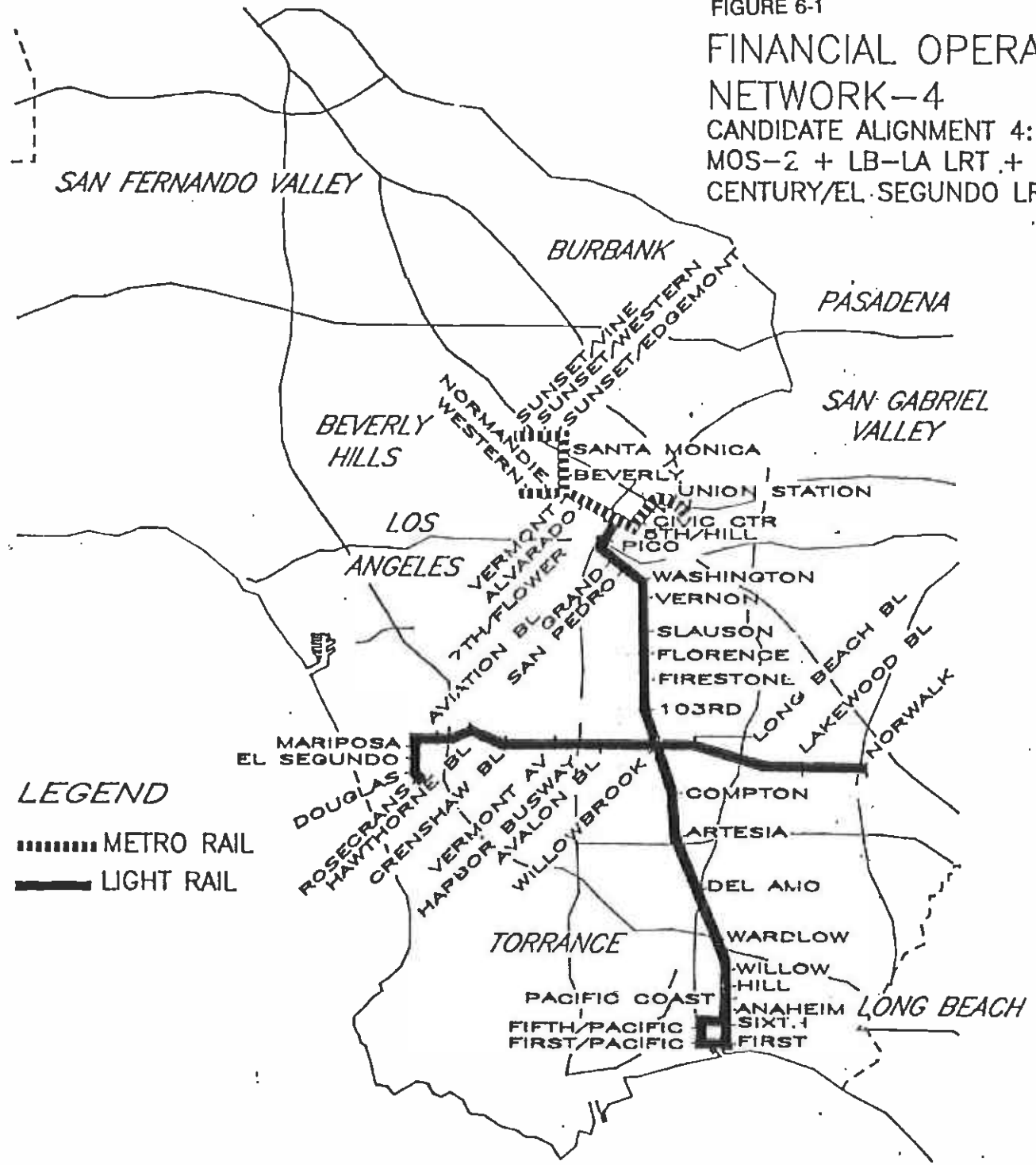

LEGEND

- METRO RAIL
- LIGHT RAIL

FIGURE 6-3

FINANCIAL OPERATING PLAN NETWORK-4B

CANDIDATE ALIGNMENT 4:
MOS-2B + LB-LA LRT +
CENTURY/EL SEGUNDO LRT

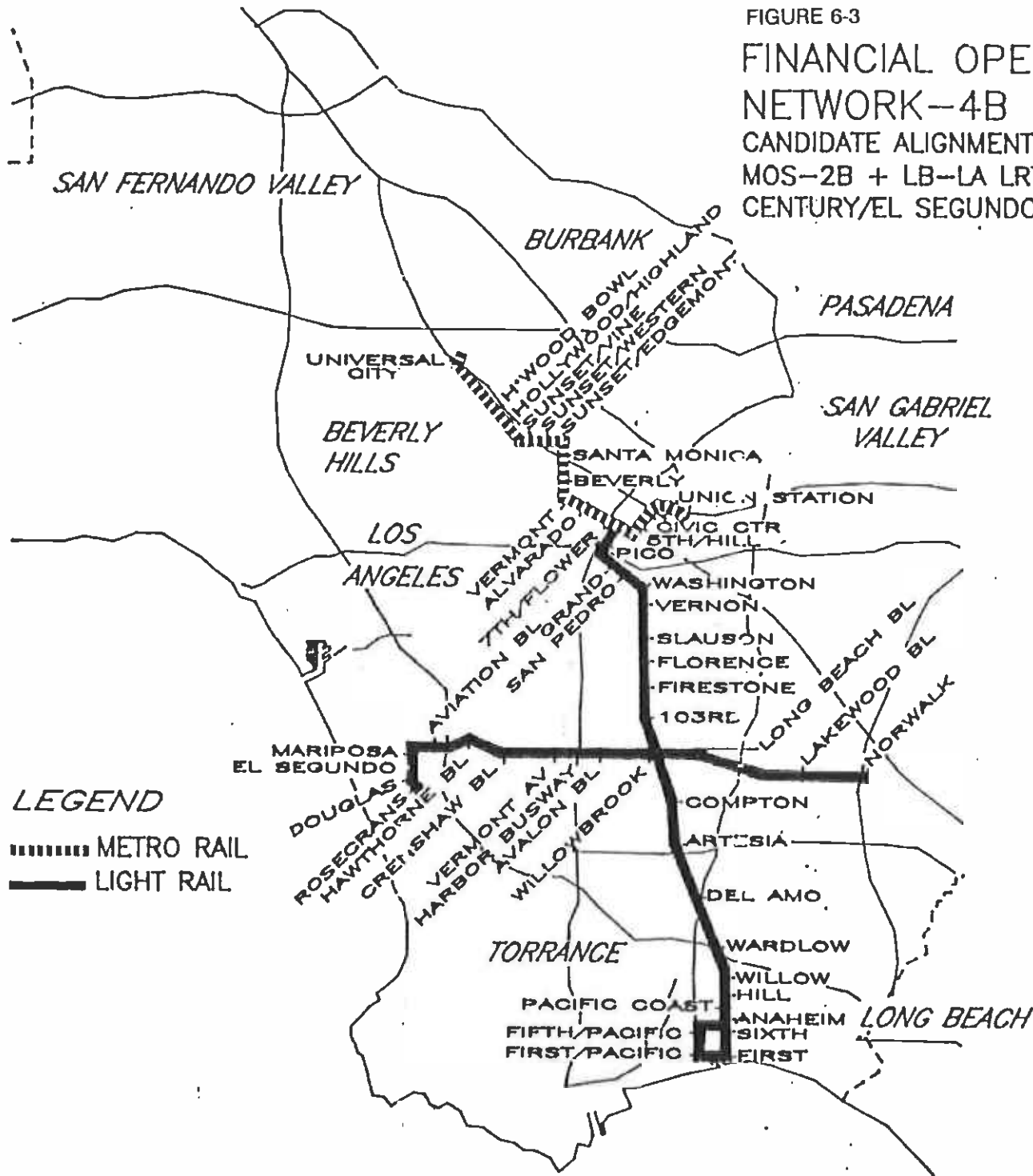

FIGURE 6-5

FINANCIAL OPERATING PLAN

NETWORK-5A

CANDIDATE ALIGNMENT 6:

MOS-2A + LB-LA LRT

CENTURY/EL SEGUNDO LRT

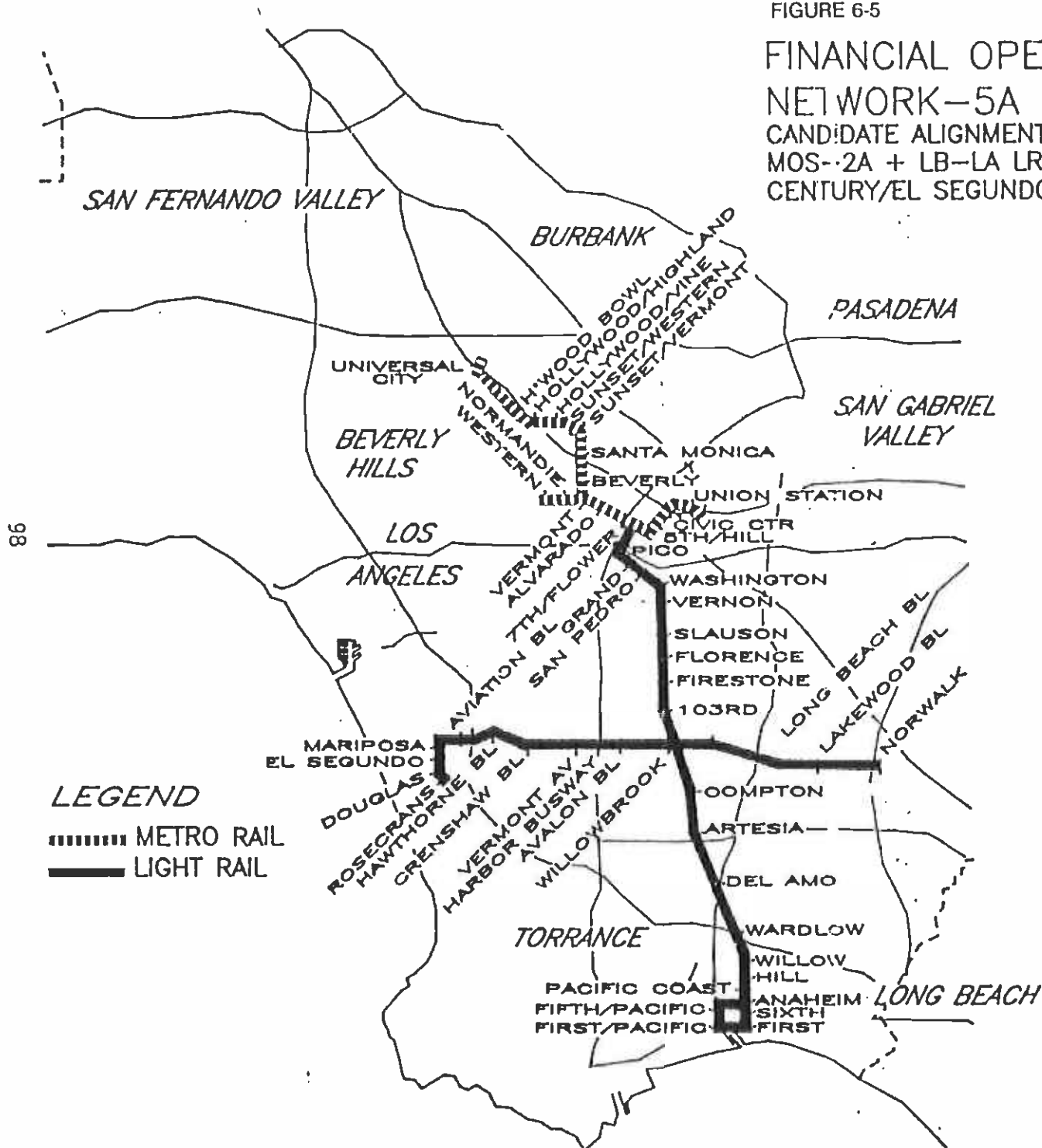

FIGURE 6-6

FINANCIAL OPERATING PLAN NETWORK-5B

CANDIDATE ALIGNMENT 6:
MOS-2B + LB-LA LRT +
CENTURY/EL SEGUNDO LRT

69

LEGEND

-  METRO RAIL
-  LIGHT RAIL

