

Defense Technology Opportunities For First Responders

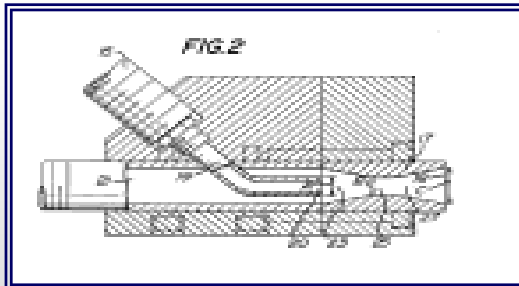

November 2004

STUDY REPORT

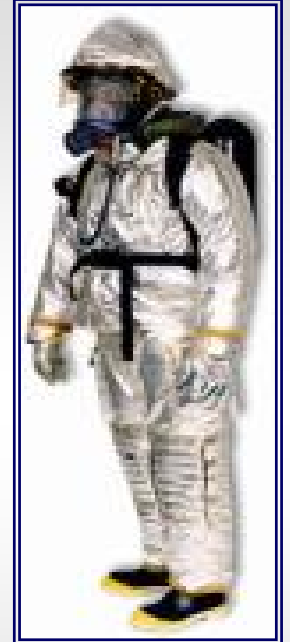
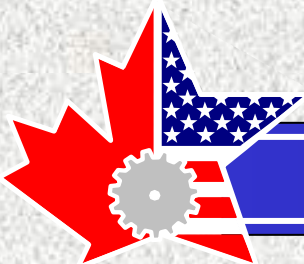

N • A • T • I • B • O

NORTH AMERICAN TECHNOLOGY AND INDUSTRIAL BASE ORGANIZATION

Report Documentation Page

*Form Approved
OMB No. 0704-0188*

Public reporting burden for the collection of information is estimated to average 1 hour per response, including the time for reviewing instructions, searching existing data sources, gathering and maintaining the data needed, and completing and reviewing the collection of information. Send comments regarding this burden estimate or any other aspect of this collection of information, including suggestions for reducing this burden, to Washington Headquarters Services, Directorate for Information Operations and Reports, 1215 Jefferson Davis Highway, Suite 1204, Arlington VA 22202-4302. Respondents should be aware that notwithstanding any other provision of law, no person shall be subject to a penalty for failing to comply with a collection of information if it does not display a currently valid OMB control number.

1. REPORT DATE 00 NOV 2004	2. REPORT TYPE N/A	3. DATES COVERED -			
4. TITLE AND SUBTITLE Defense Technology Opportunities For First Responders, Study Report		5a. CONTRACT NUMBER			
		5b. GRANT NUMBER			
		5c. PROGRAM ELEMENT NUMBER			
6. AUTHOR(S)		5d. PROJECT NUMBER			
		5e. TASK NUMBER			
		5f. WORK UNIT NUMBER			
7. PERFORMING ORGANIZATION NAME(S) AND ADDRESS(ES) Naval Sea Systems Cmd - NSWC, Army Communications - Elec Res, Development and Eng Ctr, NAWC - Aircraft Div, Ofc of Res and Tech Applications, AFRL - Human Effectiveness Dir, Air Force Civil Eng Support Agency - Contingency Support Dir, Fire Protection Div., AFMC - 311 Human Services Wing, Aeromedical Modernization Br., NASC - Systems Eng Div., Enabling Technologies Branch		8. PERFORMING ORGANIZATION REPORT NUMBER			
		10. SPONSOR/MONITOR'S ACRONYM(S)			
9. SPONSORING/MONITORING AGENCY NAME(S) AND ADDRESS(ES)		11. SPONSOR/MONITOR'S REPORT NUMBER(S)			
		12. DISTRIBUTION/AVAILABILITY STATEMENT Approved for public release, distribution unlimited			
13. SUPPLEMENTARY NOTES The original document contains color images.					
14. ABSTRACT					
15. SUBJECT TERMS					
16. SECURITY CLASSIFICATION OF:			17. LIMITATION OF ABSTRACT UU	18. NUMBER OF PAGES 84	19a. NAME OF RESPONSIBLE PERSON
a. REPORT unclassified	b. ABSTRACT unclassified	c. THIS PAGE unclassified			

ACKNOWLEDGEMENTS

Dick Bloomquist	Naval Sea Systems Command – Naval Surface Warfare Center
Trang Bui	Army Communications – Electronics Research, Development and Engineering Center
Paul Fritz	Naval Air Warfare Center – Aircraft Division Office of Research and Technology Applications
Scott Hall	Air Force Research Laboratory – Human Effectiveness Directorate
CmSgt Joe Rivera	Air Force Civil Engineering Support Agency – Contingency Support Directorate, Fire Protection Division
Capt Torrance Salisbury	Air Force Materiel Command – 311 Human Services Wing, Aeromedical Modernization Branch
Joe Wolfe	Naval Air Systems Command – Systems Engineering Division, Enabling Technologies Branch

The authors¹ would also like to acknowledge the Air Force Industrial Base Information Center (IBIC), operated by IITC, for providing a wealth of background information.

In addition, the authors would like to acknowledge all the companies that were part of this study. The phone calls, surveys and site visits required time and effort without which this report would not have been possible.

Distribution Statement A. Approved for public release: distribution is unlimited.

¹ Authors: Rodney White, Department of Defense – US Army; Louis Bédard, Department of National Defence – Canada; Scott Derrah, Department of National Defence – Canada; Maj. Robert Boucher, Canadian Embassy Washington D.C.

DISCLAIMER

The mention of specific products or companies does not constitute an endorsement by the US government or the Canadian government. Use of the information contained in this publication shall be with the user's understanding that neither of the two governments, by the inclusion or exclusion of any company in this document, provides any endorsement or opinion as to the included or excluded companies' products, capabilities, or competencies. The list of companies contained in this document is not represented to be complete or all-inclusive.

EXECUTIVE SUMMARY

NORTH AMERICAN TECHNOLOGY AND INDUSTRIAL BASE ORGANIZATION (NATIBO)

On 30 May, 2001, the United States Department of Defense (DoD) and the Department of National Defence (DND) of Canada entered into a Memorandum of Understanding (MOU) whereby the two departments established an official channel to more efficiently pursue their efforts to improve the defense posture of the North American technology and industrial base. Although the North American Technology and Industrial Base Organization (NATIBO, formerly NADIBO) has existed since 1987, the MOU formalized the organization whose mission is to promote a cost effective, healthy technology and industrial base that is responsive to the national and economic security needs of the United States and Canada.

The objectives of the MOU are to:

- effectively leverage dollars/resources and reduce redundant efforts through bilateral cooperation on studies and projects relating to the defense technology and industrial base of the US and Canada;
- achieve rapid technology insertion and commercialization of emerging technologies that can be used in the manufacture and repair of defense materiel; and
- permit a wide variety of work to be accomplished on a single project, from paper studies and initial research to technology insertion efforts.

These objectives are met through the identification and analysis of key technology and industrial sectors critical to defense, the assessment of the viability of these sectors, the identification of issues and barriers related to the sectors' viability and the development of strategies to enhance and sustain the health of these sectors and their marketplaces.

The NATIBO spearheaded an effort to address the challenges of advancing and maintaining technological superiority in light of reduced government research and development funding. The criteria used for selecting technologies to study through this program are:

- the technology is in an area of high interest;
- the technology has potential for broad military and commercial applications;
- development and/or production exists in both the US and Canada; and
- there is a good window of opportunity for investment and application in the candidate technology.

DEFENSE TECHNOLOGY OPPORTUNITIES FOR FIRST RESPONDERS

Background

In July 2002, Congressman Curt Weldon from Pennsylvania invited representatives from the DoD to talk with him about DoD's developed technologies that were, or could be, made available for civilian first responders, specifically, fire fighters. The intent behind this initiative was to facilitate technology transfer from DoD to industry for commercial production so as to make them available to first responders.

As a result of the meeting, the Deputy Under Secretary of Defense (Advanced Systems and Concepts) Office of Technology Transitions (OTT) requested the Defense laboratories identify technologies that could be transformed into usable products and made available for first responders within 12-18 months. In phase I, the laboratories identified nineteen technologies/products that were at different stages of development/commercialization. Some were at the technology/prototype stage and some had been transferred to a commercial company where products using the technologies were available commercially. At the end of phase I, five technologies were retained as being most mature and useful to the civilian first responders' community. Those five technologies are the subjects of Phase II, which constitute this study.

Current

For this study, the US and Canadian governments assessed the potential for technology transfer of five technologies, which were developed to meet military requirements, to civilian first responders (emergency response teams, police, firefighters, etc). For each of the five technologies identified, the study determined:

- if the technology was already commercialized in North America;
- if competing technology existed and at what stage of development it was (i.e. research, development, commercialization);
- if industrial capability for production was available;
- if barriers existed to the transfer or manufacture of the technology;
- if there was a viable first responders market, or other existing market(s), for the technology; and
- recommendations on ways the US and Canadian Governments could further assist in making the technology available to the first responders.

The current Technology Transfer for First Responders Initiative has multiple parts:

- Phase I has identified and assessed the technologies available. This phase resulted in the down selection of the five technologies to be studied in Phase II.
- Phase II, which resulted in this report, was a Technology and Industrial Base Study to identify the North American manufacturing capabilities, competing technologies, and the barriers and facilitators to the transfer or manufacture of the five technologies down selected in Phase I.
- Phase III, not yet started, will use the recommendations of the Phase II Report to develop a Transition Plan that will include qualification and nonrecurring engineering costs, an outline of who needs to be involved and steps to be taken.

Phase I was completed in late 2003, but it recommended an ongoing identification process within the two Departments to ensure that new technologies are made available to the first responders. Phase I resulted in an initial listing of nineteen technologies. An assessment of the maturity and commercial interest in those technologies was carried out and five technologies were finally identified to pursue in Phase II.

The technologies identified were:

- Effervescent Liquid Fine Mist Apparatus for Extinguishing Fire (ELFMA) – a self contained fire extinguisher that uses chemical reaction to produce a bubbly two-phase (effervescent) flow through a convergent-divergent nozzle. The spray contains non-toxic gas bubbles that provide energy to atomize the water in the nozzle. The resulting fine mist increases suppressant surface area, oxygen displacement and heat dissipation. The system consumes less water than traditional sprinkler systems (thereby minimizing water damage) and is environmentally friendly.
- Joint Firefighter Integrated Response Ensemble (JFIRE) – a first-generation firefighter personal protective suit that provides firefighters with NBC protection while engaged in fighting fires. Previously, firefighters had to remain outside a contaminated building or area and were therefore restricted to containing the fire. Now they can enter the area and attack the fire. To work in a non-firefighting mode in a nuclear, biological or chemical contaminated environment, the firefighter can breathe ambient air through a CW mask that is filtered by a C2 canister. If a firefighter has to enter atmospheres where filtered air is not tenable, they can switch to supplied breathing air to fight fire or perform rescues. This suit is already thoroughly tested and fielded worldwide with military firefighters.
- Panoramic Night Vision Goggles (PNV) – night vision goggles with a wide field of vision to improve situational awareness. Normal goggles have a field of vision in the range of 40 degrees. These goggles have a 100-

degree field of vision. Designed originally for pilots, they would also be useful to first responders.

- Remote Casualty Location Assessment Device (RCLAD) – is a developmental casualty location tool focused toward the search and rescue mission. Using various technologies, including Micro Impulse Radar or Ultra-Wide Band Radar, it locates casualties buried in rubble by remotely sensing heartbeat and breathing. It is intended to be low cost, portable and able to detect minute motion at close range though 10 feet of rubble. This technology was developed because existing heat sensor technology had a very limited range and could not medically assess a casualty, and passive listening devices require all quiet conditions – meaning the stop of all local rescue work.
- Threat Containment Unit – a small (about the size of a refrigerator), lightweight, inexpensive mobile bomb containment and disposal unit intended for one time use. Developed because existing technologies were too large or fixed, thus requiring the suspected package to be moved in unsafe and open conditions to the bomb disposal unit. This new container is small enough to enter buildings and still contain an explosion in a relatively confined space.

Phase II, which resulted in this report, is intended to identify production capabilities, barriers (limited requirement, the technology/item not producible, need not identified, institutional problems, etc.) and the facilitators (what can be done to encourage a production source) to transfer and/or manufacture the five technologies identified.

The methodology for Phase II included data collection from various sources including questionnaires, phone conversations with company representatives and government laboratory personnel, site visits and Internet sites.

For Phase III, the DoD has established a Technology Transfer Center of Excellence for First Responders at the University of Pittsburgh's Institute for Entrepreneurial Excellence, building on their small business development capabilities. This effort is funded at \$500K in year 1 and \$1.5M in year 2, with anticipated funding matching the level of effort in future years. This new Center will work with DND, DoD and civilian first responders in the two countries based on the NATIBO Report results as well as the results of the joint study matching first responders needs and identifying common areas for focus. If no manufacturing capability currently exists for these technologies, the Center will work with companies/new startups to establish a manufacturing capability.

Findings and Recommendations

ELFMA

Due to the simplicity of the design and the material involved in the manufacture of the ELFMA nozzle and fire extinguisher, there are numerous potential manufacturers (more than those that have been identified in this study) for this equipment. There are also numerous manufacturers currently producing nozzles, sprinkler systems and fire extinguishers, which is reflective of a highly competitive market. This situation is a barrier to new competitors that have not yet established a client base, whereas the current manufacturers have no incentive to produce ELFMA nozzles or fire extinguishers because of their established positions in their respective markets. In addition, the cost of introducing a new fire extinguisher in the market is time consuming (24 to 36 months) and costly (more than US\$ 100K) due to testing and certification requirements.

The base ELFMA patent (United States Patent # 5,520,331), which covers the nozzle, has already been licensed to International Aero (IA) for fire suppression throughout the US. This license covers the patent's use in the aerospace industry, the ground transportation industry, the marine industry, the offshore oil industry, and for buildings and other fixed structures. IA is currently concentrating on the aerospace industry, as it is the company's primary market, but they are willing to work with other companies for applications in other markets.

However, the patent for the ELFMA fire extinguisher has not yet been licensed. This patent would be relevant to companies wanting to manufacture fire extinguishers for the first responders market. At a minimum, the companies identified in the sections on the potential "fire extinguisher manufacturers" should be encouraged to pursue that route.

Since the technology involved in ELFMA is within reach of several companies and there are important potential applications for first responders, further licensing agreements should be encouraged to allow companies to manufacture ELFMA nozzles, sprinkler systems and fire extinguishers for the first responders' community.

Another ELFMA application that has not yet been considered and that has potential for further development is to adapt the ELFMA nozzle for forest fire fighting. The first step could be to demonstrate feasibility in a laboratory environment with larger apparatus and water throughput. The laboratory could then develop a prototype kit and have it installed on a test range firefighting vehicle currently part of the US Army inventory. If successful, the vehicle could then be used in a high-risk area for operational testing.

Further development of ELFMA must include consideration of unit cost to make it affordable and widely available to the local/municipal first responders' community.

JFIRE

Due to the lack of a civilian accepted standard (NIOSH) for a CB mask, civilian first responders cannot use the JFIRE mask which uses both a CB canister and a Self Contained Breathing Apparatus (SCBA). This situation limits the marketing of a commercial off-the-shelf (COTS) ensemble for use by both civilian and military first responders.

Many textile manufacturers are bringing their newest textile or component to AFRL Tyndall AFB for subject matter expertise and opinion. While this approach provides some value to the manufacturers, it appears to hold little influence on the developmental direction of the next generation JFIRE.

In the Potential Canadian Manufacturers – JFIRE section, four Canadian companies (Stedfast, Bacou-Dalloz, AirBoss and VRS) were identified as having all complementary components (i.e. textile, garment, boots, gloves, mask) that could either contribute to the Full Spectrum Threat Fire Response Ensemble (FSTFRE) solution or present a different, but complete, solution to the next generation JFIRE requirement. Taken independently, each company could also be aligned with US partners. This also applies to US companies producing complementary components.

From a joint US-Canada military perspective, the next generation JFIRE (possibly the FSTFRE) is where future efforts should be concentrated. Individual suit components were discussed at length to capture the current state of the technology and encourage synergies among the listed companies. Nevertheless, it is recognized that the next iteration of these individual suit components should not be stove-piped independently, but specifically developed with an integration emphasis for the next generation JFIRE. Currently available solutions should not necessarily drive or constrain development (for instance, the bunker suit and Joint Services Lightweight Integrated Suit Technology (JSLIST) could be integrated into a single garment instead of two separate ones).

The Air Force, which has the largest firefighter contingent among the US Services, should accelerate development and finalization of their capability development document, highlighting current JFIRE deficiencies. This document is key to early budgetary identification, development and acquisition funding for all US DoD firefighter ensembles.

There is a need to set a standard for civilian use of CB masks. This would permit civilian first responders, and firefighters in particular, to use the JFIRE. Any future development of the JFIRE CB mask/SCBA should also be acceptable to the civilian first responders' community. This would ensure a COTS solution for both military and civilian personnel, thus reducing unit cost.

Efforts should be better coordinated within the US military and between the US and Canadian militaries in respect to developing a common structural

firefighter/CB ensemble requirement. This would also contribute to reducing the unit cost for all potential users, whether they are civilian or military.

PNVG

PNVGs are at an advanced stage of technology development and the USAF does not hold proprietary rights. The night vision industry in North America is sufficiently large to support the needs of the militaries and the first responders.

The technology currently used in PNVG is an image intensifier tube, commonly called an I² tube. The manufacturers of these tubes are the key players in the industry as the tubes are the critical components of the PNVG. Any other company wanting to manufacture the PNVG would have to get I² tubes from these manufacturers or develop their own. This last strategy would be difficult for the new companies wanting to enter the market because of the investment and specialized skills that are required.

Another type of technology used for night vision is thermal imaging sensors, but the images are not as clear as the images in equipment using I² tube technology. The future trend for this kind of device is to combine both technologies into one system. This will give the end user the best of both worlds. The images will be clearer with the I² tube, but if there is fog or smoke, the user will be able to switch to the thermal imaging sensor, since night vision equipment using an I² tube cannot see through these impediments.

The biggest hurdle to commercializing the PNVG to the first responders' community remains its high cost.

The Department of Homeland Security (DHS) and Public Safety and Emergency Preparedness Canada (PSEPC) should consider acquiring a quantity of PNVGs that could be held in different key locations throughout North America. They could be stored in these locations and made readily available for use by first responders. Adequate training in using these devices should also be delivered to the first responders' community. Larger municipalities may be able to afford their own devices, but for the smaller communities, a regional pool would provide a capability they cannot afford.

Defense departments could also help drive down the cost of production of these systems by a "design to cost" development program for DoD and DND first responders needs. The resulting products could then be procured at an affordable price by other first responder agencies throughout North America.

RCLAD

Time Domain is the only company making RCLAD. RCLAD uses time modulated ultra wideband (TM-UWB) radar technology to detect live victims in rubble up to 23 inches thick. Time Domain is primarily a research company with limited manufacturing capability.

Since no other manufacturer makes live victim location devices of this nature, the companies most capable of making RCLAD-type devices are ground penetrating radar (GPR) manufacturers and through-the-wall surveillance (TWS) manufacturers.

The RCLAD system is being developed by Time Domain Corporation and all the intellectual property associated with the device belongs, or will belong, to the company. Existing Time Domain technology has been made widely available for licensing and it is likely the company will choose that approach to the RCLAD technology or, alternatively, use contract manufacturing.

A similar technology, Micro Impulse Radar (MIR), from Lawrence Livermore National Laboratory (LLNL) may also become available through other UWB Radar companies. It is possible that two or more private-sector sources of similar technology will be available within two to three years if the technology is proven to be technically viable and the cost structure is acceptable.

The commercialization of RCLAD will depend on the technical capabilities of the device, its unit cost and the availability of competing technologies.

One option to help transfer this technology quickly to first responders – assuming that the cost and technical targets are achieved – would be for the DHS to directly acquire some of the devices concurrently with, or prior to, DoD acquisition. These devices could then be made widely available under a grant program to first responders for further testing and evaluation. Direct acquisition by the DHS concurrently with DoD would likely lower the per-unit acquisition cost.

PSEPC could undertake a similar approach. PSEPC is currently setting up several Heavy Urban Search and Rescue (HUSAR) teams across Canada. As part of this endeavor, they are creating a list of standard equipment for these HUSAR teams. It is recommended that they add RCLAD to their list.

TCU

The TCU, designed and patented by the Naval Surface Warfare Center Carderock Division (NSWCCD), is a box-shaped steel shell with an inner liner of rigid polyurethane foam. The bomb or suspect explosive device is placed inside and is tightly packed with additional foam. If a bomb is detonated in the TCU, the foam pulverizes and the liner deforms into an ovoid or cylindroid shape while slowly venting pressure. The NSWCCD TCU is designed for a one-time use. It is small, lightweight and inexpensive.

The deployed units were made in US DoD facilities because the Federal Aviation Administration (FAA) has not licensed the NSWCCD TCU for commercial production. As the FAA is not expected to broaden the NSWCCD TCU usage beyond the airports within its mandate, no license is available.

Nevertheless, there are already several North American companies making products similar to the NSWCCD TCU. The TCUs designed by these companies vary; they can be mobile or fixed and designed for both multiple or single uses. Some are even capable of CB containment.

No further action is recommended on the NSWCCD TCU as there are comparable products already commercially available.

Airport first responders should also consider the acquisition of other technologies suitable to handle threats other than just explosives (i.e. CB).

These technologies should also be considered for urban bomb containment and disposal in crowded outdoor environments and in subways, train stations, large stores and office buildings.

TABLE OF CONTENTS

ACKNOWLEDGMENTS.....	1
DISCLAIMER.....	2
EXECUTIVE SUMMARY.....	3
TABLE OF CONTENTS.....	12
INTRODUCTION.....	14
EFFERVESCENT LIQUID FINE MIST APPARATUS (ELFMA).....	17
OTHER EMERGING TECHNOLOGIES.....	18
MANUFACTURERS.....	19
US MANUFACTURERS – SPRINKLER SYSTEMS.....	19
US MANUFACTURERS – FIRE EXTINGUISHERS.....	21
US MANUFACTURERS – NOZZLE OR SPRINKLER HEAD.....	22
CANADIAN MANUFACTURERS – FIRE EXTINGUISHERS.....	25
MARKET SHARE DATA.....	26
FINDINGS.....	26
RECOMMENDATIONS.....	27
JOINT FIREFIGHTER INTEGRATED RESPONSE ENSEMBLE (JFIRE).....	28
OTHER EMERGING TECHNOLOGIES.....	31
MANUFACTURERS.....	33
US MANUFACTURERS – JFIRE ALUMINIZED SUITS.....	33
US MANUFACTURERS – JOINT SERVICES LIGHTWEIGHT INTEGRATED SUIT TECHNOLOGY (JLIST).....	35
US MANUFACTURERS – JFIRE SELF CONTAINED BREATHING APPARATUS (SCBA).....	36
POTENTIAL CANADIAN MANUFACTURERS – JFIRE.....	38
OTHER POTENTIAL MANUFACTURERS – FABRICS AND GARMENTS.....	41
MARKET SHARE DATA.....	41
FINDINGS.....	42
RECOMMENDATIONS.....	43
PANORAMIC NIGHT VISION GOGGLES (PNVG).....	45
OTHER EMERGING TECHNOLOGIES.....	46
MANUFACTURERS.....	47
US MANUFACTURERS – IMAGE INTENSIFICATION (I ²) TUBE.....	47
US MANUFACTURERS – NIGHT VISION GOGGLES (NVG).....	48
POTENTIAL US MANUFACTURERS – PNVG.....	49
OTHER US MANUFACTURERS – NIGHT VISION DEVICES (NVD).....	50
CANADIAN MANUFACTURERS – NVG.....	51
POTENTIAL CANADIAN MANUFACTURERS – PNVG.....	52
MARKET SHARE DATA.....	53
FINDINGS.....	55
RECOMMENDATIONS.....	55

REMOTE CASUALTY LOCATION ASSESSMENT DEVICE (RCLAD).....	56
OTHER EMERGING TECHNOLOGIES.....	57
MANUFACTURERS.....	58
US MANUFACTURERS – RCLAD.....	58
POTENTIAL US MANUFACTURERS – RCLAD.....	59
POTENTIAL CANADIAN MANUFACTURERS – RCLAD.....	61
MARKET SHARE DATA.....	62
FINDINGS.....	63
RECOMMENDATIONS.....	63
THREAT CONTAINMENT UNIT (TCU).....	65
OTHER BLAST CONTAINMENT TECHNOLOGIES.....	67
MANUFACTURERS.....	68
US MANUFACTURERS – TCU.....	68
CANADIAN MANUFACTURERS – TCU.....	70
OTHER TECHNOLOGY MANUFACTURERS.....	71
MARKET SHARE DATA.....	72
FINDINGS.....	74
RECOMMENDATIONS.....	74
FINDINGS.....	75
RECOMMENDATIONS.....	78
APPENDIX A – ACRONYMS AND DEFINITIONS.....	80

INTRODUCTION

NORTH AMERICAN TECHNOLOGY AND INDUSTRIAL BASE ORGANIZATION (NATIBO)

On 30 May, 2001, the United States Department of Defense (DoD) and the Department of National Defence (DND) of Canada entered into a Memorandum of Understanding (MOU) whereby the two departments established an official channel to more efficiently pursue their efforts to improve the defense posture of the North American technology and industrial base. Although the North American Technology and Industrial Base Organization (NATIBO, formerly NADIBO) has existed since 1987, the MOU formalized the organization whose mission is to promote a cost effective, healthy technology and industrial base that is responsive to the national and economic security needs of the United States and Canada.

The objectives of the MOU are to:

- effectively leverage dollars/resources and reduce redundant efforts through bilateral cooperation on studies and projects relating to the defense technology and industrial base of the US and Canada;
- achieve rapid technology insertion and commercialization of emerging technologies that can be used in the manufacture and repair of defense materiel; and
- permit a wide variety of work to be accomplished on a single project, from paper studies and initial research to technology insertion efforts.

These objectives are met through the identification and analysis of key technology and industrial sectors critical to defense, the assessment of the viability of these sectors, the identification of issues and barriers related to the sectors viability and the development of strategies to enhance and sustain the health of these sectors and their marketplaces.

The NATIBO spearheaded an effort to address the challenges of advancing and maintaining technological superiority in light of reduced government research and development funding. The criteria used for selecting technologies to study through this program are:

- the technology is in an area of high interest;
- the technology has potential for broad military and commercial applications;
- development and/or production exists in both the US and Canada; and

- there is a good window of opportunity for investment and application in the candidate technology.

DEFENSE TECHNOLOGY OPPORTUNITIES FOR FIRST RESPONDERS

Background

In July 2002, Congressman Curt Weldon from Pennsylvania invited representatives from the DoD to talk with him about DoD's developed technologies that were, or could be, made available for civilian first responders, specifically, fire fighters. The intent behind this initiative was to facilitate technology transfer from DoD to industry for commercial production so as to make them available to first responders.

As a result of the meeting, the Deputy Under Secretary of Defense (Advanced Systems and Concepts) Office of Technology Transitions (OTT) requested the Defense laboratories identify technologies that could be transformed into usable products and made available for first responders within 12-18 months. The laboratories identified nineteen technologies/products that were at different stage of development/commercialization. Some were at the technology/prototype stage and some had been transferred to a commercial company where products using the technologies were available commercially. Five technologies were eventually retained as being most mature and useful to the civilian first responders' community. Those five technologies are the subjects of this study.

Current

For this study, the US and Canadian governments assessed the potential for technology transfer of five technologies, which were developed to meet military requirements, to civilian first responders (emergency response teams, police, firefighters, etc). For each of the five technologies identified, the study determined:

- if the technology was already commercialized in North America;
- if competing technology existed and at what stage of development it was (i.e. research, development, commercialization);
- if industrial capability for production was available;
- if barriers existed to the transfer or manufacture of the technology;
- if there was a viable first responders market, or other existing market(s), for the technology; and
- recommendations on ways the US and Canadian governments could further assist in making the technology available to the first responders.

The current Technology Transfer for First Responder Initiative has multiple parts:

- Phase I has identified and assessed the technologies available. This phase resulted in the down selection of the five technologies to be studied in Phase II.
- Phase II, which resulted in this report, was a Technology and Industrial Base Study to identify the North American manufacturing capabilities, competing technologies, and the barriers and facilitators to the transfer or manufacture of the five technologies selected in Phase I.
- Phase III, not yet started, will use the recommendations of this report to develop a Transition Plan that will include qualification and nonrecurring engineering costs, an outline of who needs to be involved and steps to be taken.

Phase I was completed in late 2003, but it recommended an ongoing identification process within the two departments to ensure that new technologies are made available to the first responders. Phase I resulted in an initial listing of nineteen technologies. An assessment of the maturity and commercial interest in those technologies was carried out and five technologies were finally identified to pursue in Phase II.

Phase II, which resulted in this report, is intended to identify production capabilities, barriers (limited requirement, the technology/item not producible, need not identified, institutional problems, etc.) and the facilitators (what can be done to encourage a production source) to transfer and/or manufacture the five technologies identified.

The methodology for Phase II included data collection from various sources including questionnaires, phone conversations with company representatives and government laboratory personnel, site visits and Internet sites.

For Phase III, the DoD has established a Technology Transfer Center of Excellence for First Responders at the University of Pittsburgh's Institute for Entrepreneurial Excellence, building on their small business development capabilities. This effort is funded at \$55K in year 1 and \$1.5M in year 2, with anticipated funding matching the level of effort in future years. This new Center will work with DND, DoD and civilian first responders in the two countries based on the NATIBO Report results as well as the results of the joint study matching first responders needs and identifying common areas for focus. If no manufacturing capability currently exists for these technologies, the Center will work with companies/new startups to establish a manufacturing capability.

EFFERVESCENT LIQUID FINE MIST APPARATUS (ELFMA)

Halon, a fire suppressant material commonly used in sprinkler systems and fire extinguishers, is one of the best fire suppressant materials on the market. Halon is inexpensive, very effective, safe to use around people, and can be used over a wide range of temperatures. Unfortunately, Halon depletes the ozone layer. In 1994, the US, Canada, and most Westernized countries banned new Halon production, referred to as virgin Halon. Halon is obtainable in recycled form, but is becoming scarce. Many companies have tried to use other fire suppressant materials to replace Halon,.

The US Navy developed ELFMA in the late 1990s to address the Halon deficiency. ELFMA is covered by three patents: 6,598,802 and 6,241,164, Effervescent Liquid Fine Mist Apparatus and Method, and 5,520,331, Liquid Atomizing Nozzle. The claims of the two newer patents involve the convergent-divergent nozzle covered in the earlier patent, 5,520,331. ELFMA is a sprinkler system or fire extinguisher that uses water mist as the fire suppressant material.

ELFMA is a low-pressure system (less than 40 psi) that uses a combined stream of gas (i.e. air) and liquid. As the two-phase (effervescent) flow proceeds through the nozzle, the low-pressure compressed gas expands beyond the throat of the nozzle, shearing the low-pressure liquid into small droplets and hurling them out of the nozzle as a high momentum mist (see Figure 1 and Figure 2). The small droplets in the mist increase the suppressant surface area to maximize the efficient absorption of heat, providing rapid cooling. In addition, the small droplets evaporate rapidly and expand to displace oxygen in the proximity of the fire. ELFMA consumes notably less water than traditional high pressure (greater than 500 psi) sprinkler systems, minimizing consequential water damage and conserving water. In addition, high-pressure systems clog easily because of the small apertures required to produce small droplets.

This water mist system has numerous benefits. Relatively inexpensive and safe to use around people, ELFMA combines water and sodium bicarbonate. Spraying a very small amount of water and sodium bicarbonate does not require the same clean up as other fire suppressant materials (i.e. water, foam, or dry chemicals). Additionally, ELFMA effectively extinguishes fires because the fire cannot breathe. The air's normal 21% oxygen level is reduced to 15% and a fire needs at least 16% oxygen to continue burning. Humans can still breathe with a 15% oxygen level, therefore humans can survive, but a fire cannot.

Compared to commercially available atomizing nozzles, the ELFMA convergent-divergent nozzle is more effective. The ELFMA's mist is dispersed with high momentum, which translates to higher effectiveness in dispersion and

firefighting. However, unlike conventional nozzles, this nozzle does not easily clog since it does not utilize small orifices to create the fine mist. The nozzle has cost advantages as well. It can be injection molded, reducing the cost of manufacture. In addition, it operates at reduced pressure (20 psi vs. ~ 2000 psi for COTS). As a result, compressor equipment purchasing and operating costs are lower. In addition, ELFMA has less stringent pressure containment requirements compared to the high-pressure systems currently available on the market. This translates into significant cost savings.

Figure 1 and Figure 2 – ELFMA Nozzle.

U.S. Patent May 28, 1996 5,520,331

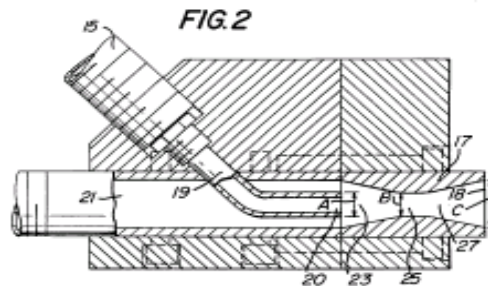
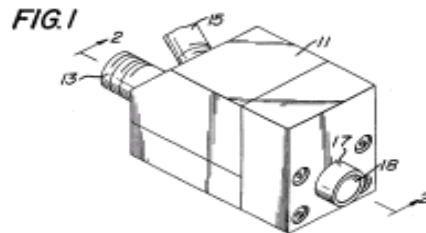

Additional potential application/fields of use for ELFMA include snowmaking equipment, oral drug administration, paint and adhesive sprayers, spray dryers, vehicular fire suppression, agricultural spraying, and chemical/biological decontamination of personnel and vehicles.

OTHER EMERGING TECHNOLOGIES

Water Mist System Combining Water and Polymer

OEKO Tec, a German company, developed a polymer, Hydrex, which surrounds and binds water, thus preventing it from running off or evaporating too quickly. This product holds US Patent 6,386,293 Fire Combating System and Method.

The German Institute for Aeronautical and Space Technology tests show:

- a faster, drastic fire core temperature reduction;
- fire is extinguished in a shorter time using less water;
- a salt crust formation after water evaporation creates a barrier that prevents rapid re-ignition and makes the combustible material flame-resistant;
- creates a cooling barrier against radiated heat;
- a Hydrex-water mixture prevents fire spreading to neighboring objects;
- Hydrex can be used for fighting Class A (ordinary combustibles) fires involving solid combustible materials in closed or open environments; and
- Can be adapted for portable or stationary fire extinguishing equipment.

Aerosols

Pyrogen, a Malaysian company, has developed an aerosol technology that is safe and represents a practical alternative to Halon gas. It is an inert, non-toxic solid that remains stable until electrically or thermally activated. When activated, the system produces a gas-like extinguishing aerosol attacking the fire chemically and physically, giving virtually instant extinguishment and preventing re-ignition. Pyrogen has applications in: offshore drilling rigs, commercial and military aircraft, data rooms, plant machinery and automation equipment, electrical cabinets, military vehicles, and the shipping and marine industry. Pyrogen is certified as having no ozone depleting potential and no global warming potential and is listed by the Environment Protection Act under the Significant New Alternatives Program (SNAP). Pyrogen is certified by the Scientific Services Laboratory as having the lowest extinguishing concentration among commercially available agents, meaning it takes less Pyrogen to extinguish a fire than any other agent.

MANUFACTURERS

US Manufacturers – Sprinkler Systems

The report identifies five potential ELFMA sprinkler system manufacturers in the US. These companies make water mist sprinkler systems, the type most similar

to ELFMA. Companies making other types of sprinkler systems such as water or foam-based are not included in the report, so there may be other capable manufacturers not covered in this report.

Chemetron Fire Systems

4801 Southwick Drive, 3rd Floor
Matteson, IL 60443
Phone: (708) 748-1503
Fax: (708) 748-2847

Chemetron Fire Systems focuses on special hazard fire suppression technology and has been in business for more than 60 years. Chemetron offers an extensive range of products, worldwide distribution network, engineering, technical support, and qualified field service technicians. Chemetron's fire suppression systems come in low and high-pressure carbon dioxide, FM-200 (developed as a Halon replacement), aragonite, and water mist. The Chemetron Water Mist System operates at 350 psi and produces a 110 microns mean droplet size.

Fike Corporation

704 S. 10th Street
Blue Springs, MO 64015
Phone: (816) 229-3405
Fax: (816) 228-9277

Fike Corporation, founded in 1945, employs 350 people in the US, with over 700 employees worldwide. Product lines primarily consist of commercial and industrial fire protection systems, fire detection products, explosion protection, pressure relief solutions, and oil field products. Fike's fire suppression product line includes Halon replacement systems as well as carbon dioxide and water mist systems. The Fike Micromist System operates at 310 psi and is designed to emit a variety of droplet sizes.

Environmental Engineering Concepts Inc. (Owned by Nortec Industries)

1229 South Gene Autry Trail
Palm Springs, CA 92264
Phone: (760) 322-1111
Fax: (760) 322-4341

Environmental Engineering Concepts Inc. (EEC), founded in 1981, custom designs, engineers, and manufactures a wide range of high pressure (1,000 psi) water fogging systems for a variety of residential, commercial, and industrial applications. The company markets its patented product by direct sales and through dealers, both in the US and 40+ overseas markets. EEC is owned by Nortec Industries. Sometimes the company goes by the name Nortec, EEC, or Microcool.

Fogco Systems Inc.

600 South 56th Street, Suite # 9
Chandler, AZ 85226
Phone: (480) 507-6478
Fax: (480) 838-2232

Fogco Systems, Inc., founded in 1989, is one of the world's largest professional mist and fog system suppliers. Fogco Systems' mist and fog systems operate from 250 to 1000 psi and produce water droplets as small as 5 microns.

Securiplex LLC

3710 Lakeside Court
PO Box 91898
Mobile, AL 36691-1898
Phone: (251) 602-6111

Securiplex LLC is a newly formed company owned by Hiller Investments Inc of Mobile (AL) and Integra Applied Technology, LLC, of Allentown (PA). At the time of writing the report, the new company had not started the manufacturing, product support and customer support of the former Canadian Securiplex Inc. product lines. The process of moving the manufacturing operations from Canada to Mobile (AL) was scheduled to be completed by the first half of May 2004.

The former Securiplex Inc. developed and certified a water mist system specifically to protect machinery spaces: the Fire-Scope 2000 Fine Water Spray system. The Fire-Scope 2000 technology is based on a major development in spray nozzle design. A proprietary twin-fluid atomizing nozzle uses minimal quantities of water to suppress most types of fires including oils spills.

Securiplex's twin fluid atomizing nozzle is designed to mix water and air in a mixing chamber for optimum and controlled water droplet size, at a nominal operating pressure of 75 psi. The nozzle contains no moving parts. The water droplet is, instead, generated by the air's shearing effect, when the water is brought into contact with it within the mixing chamber. The combined air and water pressure effect improves the water spray's penetrating capability, an essential element for effective fire suppression.

US Manufacturers – Fire Extinguishers

The report identifies three potential ELFMA fire extinguisher manufactures in the US: Amerex, Larsen's Manufacturing, and Guardian Fire Equipment. These companies make water mist fire extinguishers, the type most similar to ELFMA. Companies making other types of fire extinguishers such as water, dry chemicals

or foam are not included in the report, so there may be other capable manufacturers not covered in this report.

Amerex Corporation

Post Office Box 81, 7595 Gadsden Highway
Trussville, AL 35173-0081
Phone: (205) 655-3271
Fax: (800) 654-5980

Amerex Corporation, founded in 1971, manufactures hand portable and wheeled extinguishers for commercial and industrial applications. Amerex's stored pressure water mist fire extinguisher is for Class A (ordinary combustibles) fires, especially where a potential Class C (electrical equipment) hazard exists. Fine spray from the unique misting nozzle provides safety from electrical shock, enhances the cooling and soaking characteristics of the agent, and reduces scattering of burning materials. The extinguisher works well for hospital environments, telecommunications facilities, and "clean room" manufacturing facilities.

Guardian Fire Equipment Inc.

3430 NW 38th Street
Miami, FL 33142
Phone: (800) 327-6584
Fax: (800) 827-3869

Guardian Fire Equipment Inc. was founded in 1977. It expanded production in 1984 by acquiring the Seco Manufacturing product line. The purchase included manufacturing tools, machines, dies, foundry patterns, match plates, product designs, and engineering data. This acquisition brought new levels of versatility and the ability to respond to special requirements. Guardian is a family owned and operated business. Products include cabinets and accessories, fire hoses and accessories, hose valves, fire department connections, monitors, foam equipment, storage houses and equipment, sprinkler and test equipment, and fire extinguishers.

Larsen's Manufacturing Company

Minneapolis Division
7421 Commerce Lane N.E.
Minneapolis, MN 55342
Phone: (763) 571-1181
Fax: (763) 571-6900

Florida Division
3130 N.W. 17th St.
Ft. Lauderdale, FL 33311
Phone: (954) 486-3325

Fax: (954) 486-3352

Larsen's Manufacturing Company manufactures products for the building construction and fire protection equipment industries. Larsen's manufactures fire rated cabinets, access panels, detention cabinets, and a full line of all-aluminum cabinets as well as water mist fire extinguishers.

US Manufacturers – Nozzle or Sprinkler Head

The report identifies nozzles/sprinkler heads because the technology is integral to the sprinkler system/fire extinguisher.

There are eight potential ELFMA nozzle/sprinkler head manufacturers in the US. These companies make water mist nozzles/sprinkler heads, the type most similar to ELFMA. Companies making other types of nozzles/sprinkler heads such as water or foam are not included in the report. There are potentially hundreds of additional manufacturers making water mist nozzles that could be adapted for fire suppression.

Bete Fog Nozzle, Inc.

Box 1438, 50 Greenfield St.
Greenfield, MA 01302-1438
Phone: (413) 772-2166

Bete Fog Nozzle, Inc. manufactures nozzles for industry, pollution control, and fire protection. Bete is the originator of the Bete "Spiral" or pigtail nozzle that can deliver highly atomized, high velocity spray at low pressure. Bete manufacturers over 20,000 different nozzles and holds many patented nozzle designs.

Central Sprinkler (a Grinnell Corporation, owned by Tyco)

451 North Cannon Ave.
Lansdale, PA 19446
Phone: (215) 362-0700
Fax: (215) 362-4731

Although Tyco is a UK corporation, Central Sprinkler manufactures a variety of nozzles/sprinkler heads in Lansdale, PA.

Evaporator Dryer Technologies, Inc. (EDT)

1805 Ridgeway Street
Hammond, WI 54015
Phone: (715) 796-2313
Fax: (715) 796-2378

EDT is an engineering company providing design and engineering services, and supplies processing equipment and systems to various industries. Fire

suppression systems require fire nozzle strategic placement for ample water deluge to protect equipment from fire. EDT liquid-activated fire suppression nozzles provide a deluge by using specially designed spray heads that fully extend under liquid pressure during fire suppression system activation.

International Aero Inc. (IA)

11817 Westar Lane
Burlington, WA 98233
Phone: (360) 757-2376
Fax: (360) 757-4841

International Aero began as a partnership 15 years ago to provide aircraft interiors to airline companies. While the company has the capability to produce new interiors, much of their business is modifying interiors of existing aircraft. The interior work covers everything outside the cockpit, including galleys and restrooms. The company has the capability to manufacture replacement parts for all brands of aircraft including older versions still in service.

The company is currently in the process of spinning off their research/technology group into a new company called International Aero Technologies. International Aero will become International Aero Interiors.

International Aero stays abreast of all safety issues involving aircraft. In the area of fire fighting the company is investigating aerosols and water mist. The company predicts that aerosols will become prevalent first, but water mist will eventually take over as the preferred technology.

The company has a license for the Navy's ELFMA nozzle and has successfully tested it several times in various situations. With the heavy regulation of the airline industry, introducing new technologies requires time for testing and acceptance.

NNI Inc.

667 N.W. 118th St
Miami, FL 33168-2540
Phone: (305) 756-1102
Fax: (305) 757-1902

NNI manufactures a wide range of fire protection products including multiple sprinkler nozzles.

Potter Roemer

3100 S Susan St.
Santa Ana, CA 92704
Phone: (714) 430-5300
Fax: (714) 545-3552

Manufactures a nozzle used to discharge a water pattern to control fire automatically. Actuated by a heat-sensitive, liquid-filled, glass bulb.

Spraying Systems Co.

P.O. Box 7900
Wheaton, IL 60189-7900
Phone (630) 665-5000
Fax (630) 260-0842

Spraying Systems Co. produces industrial spray products, manufacturing nozzles, accessories, testing services and application assistance. Spraying Systems produces 5 water mist nozzles usable for fire suppression.

The Viking Corporation

210 N. Industrial Park Road
Hastings, MI
Phone: (269) 945-9501
Fax: (269) 945-9599

Viking, in business since 1920, has manufacturing, sales and distribution facilities in the United States and Europe, as well as sales and distribution facilities in Singapore and Hong Kong. In total, Viking is represented in over 50 countries worldwide.

Canadian Manufacturers – Fire Extinguishers

There is one potential ELFMA fire extinguisher manufacturer in Canada. Although this company does not currently manufacture a water mist fire extinguisher, they are actively engaged in developing one.

Strike First Corporation

777 Tapscott Road
Scarborough, ON
M1X 2A2, Canada
Phone: (416) 299-7767
Fax: (416) 299-8039

Created originally as a service company in 1908, Strike First Corporation (SFC) is now the oldest fire extinguisher company in Canada, having manufactured well over one million extinguishers. The company employs about 20 people and has a full product line of portable extinguishers (dry chemical and carbon dioxide, up to 20 lbs), fire hose cabinets and flammable storage cabinets. Among North American companies, SFC is in the bottom third in terms of sales and size, but in the upper half in terms of volume.

Typical of the majority of the companies involved in the fire extinguisher business, SFC specializes in integrating innovative features on already-existing products and places little emphasis on intellectual property protection. While some research and development funding is spent on internal qualification and certification testing costs, SFC's major expense is on listing costs with Underwriters' Laboratories of Canada (ULC), the Canadian affiliate of Underwriters' Laboratories (UL) (both organizations are now harmonizing their standards). The competition is considered aggressive, as exemplified by every manufacturer adding at least one wet chemical Class 'K' extinguisher to its product line every year.

Products developed by SFC are free of Ozone-Depleting Particles (ODP). They are also geared towards meeting the NFPA -10 Standard for Portable Fire Extinguishers.

SFC is developing two new products. The first one is a clean agent fire extinguisher, designed to work with the fluid protection agent NOVEC 1230, hailed as a second-generation Halon gas replacement alternative, and manufactured by 3M. The advantages of this non-ozone depleting compound over an inert gas are that it can be stored in a smaller amount of storage space, and that it is suited for fire extinguishers. This liquid agent can also work in flooding applications as it gasifies during a fire. NOVEC 1230's liquid form allows for shipment in totes and drums, rather than pressurized cylinders, which means that it can be safely stored and shipped over a wide range of temperatures. SFC is incorporating this agent into its fire extinguisher product line.

The company is also developing, in partnership with Terra Nova Marine Co. Ltd., a water mist fire extinguisher. Using the Terra Nova Marine Co. developed technology, the water extinguisher is charged with oxygen vice nitrogen. A separate chamber is inserted to atomize the water into an air mist (Ref: Canadian Patent # 2368082). This extinguisher would be applicable for Class 'C' (electrical) fires.

MARKET SHARE DATA

The only available market share data is for fire products in general, which is a larger segment than water mist sprinkler systems and fire extinguishers. Therefore, meaningful market share data is not available. Nevertheless, the ELFMA technology has outstanding potential for use in first responder applications for both firefighting and decontamination purposes.

FINDINGS

Due to the simplicity of the design and the material involved in the manufacture of the ELFMA nozzle and fire extinguisher, there are numerous potential manufacturers (more than those that have been identified in this study) for these equipments. There are also numerous manufacturers currently producing nozzles,

sprinkler systems and fire extinguishers, which reflects a highly competitive market. This situation is a barrier to new competitors that have not yet established a client base, whereas the current manufacturers have no incentive to produce ELFMA nozzles or fire extinguishers because of their established positions in their respective markets. In addition, the cost of introducing a new fire extinguisher in the market is time consuming (24 to 36 months) and costly (more than US\$ 100K) due to testing and certification requirements.

The base ELFMA patent (United States Patent # 5,520,331), which covers the nozzle, has already been licensed on to International Aero (IA) for fire suppression throughout the United States. This license covers the patent's use in the aerospace industry, the ground transportation industry, the marine industry, the offshore oil industry, and for buildings and other fixed structures. IA is currently concentrating on the aerospace industry, as it is the company's primary market, but they are willing to work with other companies for applications in other markets.

However, the patent for the ELFMA fire extinguisher has not yet been licensed. This patent would be relevant to companies wanting to manufacture fire extinguishers for the first responders market. At a minimum, the companies identified in the sections on the potential "fire extinguisher manufacturers" should be encouraged to pursue that route.

RECOMMENDATIONS

Since the technology involved in ELFMA is within reach of several companies and there are important potential applications for the first responders, further licensing agreements should be encouraged to allow companies to manufacture ELFMA nozzles, sprinkler systems and fire extinguishers for the first responders' community.

Another ELFMA application that has not yet been considered and that has potential for further development is to adapt the ELFMA nozzle for forest fire fighting. The first step could be to demonstrate feasibility in a laboratory environment with larger apparatus and water throughput. The laboratory could then develop a prototype kit and have it installed on a test range firefighting vehicle currently part of the US Army inventory. If successful, the vehicle could then be used in a high-risk area for operational testing.

Further development of ELFMA must include consideration of unit cost to make it affordable and widely available to the local/municipal first responders' community.

JOINT INTEGRATED FIREFIGHTER INTEGRATED RESPONSE ENSEMBLE (JFIRE)

Today's firefighters wear a Chemical/Biological (CB) protective over-garment (OG) under standard firefighting apparel and equipment, which creates severe and debilitating heat stress. The combined bulk and weight of CB protective gear, firefighter apparel and equipment severely limits dexterity, movement and endurance, jeopardizing mission accomplishments.

First generation Joint Firefighter Integrated Response Ensemble (JFIRE) includes the Joint Services Lightweight Integrated Suit Technology (JSLIST) OG as the chemical protective component, firefighter proximity suit, Nomex hood, modified structural Air Rescue Fire Fighters (ARFF) helmet, CB butyl rubber gloves with liners, fire protection gloves, Self Contained Breathing Apparatus (SCBA) with Chemical Warfare (CW) kit, firefighting protective boots and a carrying bag. The ensemble may also contain proximity gloves with built-in CB protection feature instead of the separate butyl rubber gloves and fire protection gloves. Figure 3 shows a sample of the current JFIRE.

Figure 3. Sample JFIRE

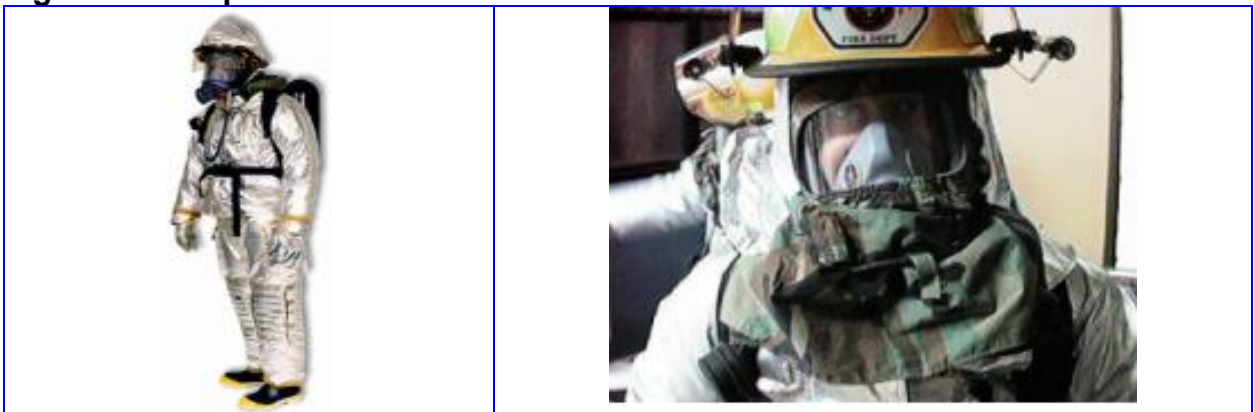

The Air Force has outlined a capability development document that addresses the pros and cons of the current JFIRE system and improvements sought. A key anticipated improvement is a Full Spectrum Threat Fire Response Ensemble (FSTFRE). This new program aims to take advantage of the significant material

improvements in selective permeable membranes against CB agents developed by the industry. The goal is to combine these new materials with Nomex to result in a CB and heat resistant undergarment which would serve many of the functions of the current JLIST OG, but that would be significantly lighter, more breathable, less heat retaining and allow greater mobility. An additional goal for this improved ensemble is to meet the National Fire Protection Association (NFPA) standards.

Currently, there is no national or international commonly accepted standard for firefighter protective clothing ensembles. In the US, NFPA is the most up-to-date organization but only nine states follow their standards. All industrial fire brigades and federal installation fire brigades must follow Occupational Safety and Health Administration (OSHA) standards, even though most OSHA standards are largely out of date due to the rapid evolution of technologies.

The table below provides performance specification data for the current JFIRE.

Table 1. Clothing Items Performance Specification Data.



Environmental: JFIRE items may be worn in every climatic category (including hot, basic, cold, and extreme cold).	
Donning Time	8 minutes
Wear Usage Limitations (clothing only; numbers indicate maximum not to be exceeded, after which item must be replaced):	
JSLIST readiness, uncontaminated environment (whichever comes first)	6 launderings/45 days of wear/120 calendar days after removal from factory vacuum-sealed bag
Butyl rubber gloves wear life once removed from factory bag	30 days
Interspiro CW mask wear life once removed from factory bag	5 years
*Fire protection gloves or fire and chemical protection gloves	24 hours
*Firefighting protective boots	24 hours
*Modified structural Air Rescue Fire Fighters (ARFF) helmet	24 hours
* Usable service life depends on number, type, and degree of exposures, the work environment, frequency of use, and maintenance. JFIRE 24-hour wear life for chemical protective readiness, once chemically contaminated.	





JSLIST is a two-piece OG that was designed to replace the Navy's Chemical Protection OG (CPO). The CPO contained a charcoal impregnated lining. During wear, the lining leached onto the wearer causing inner garments to become coated with charcoal dust plus it would disintegrate when laundered.

JSLIST features state-of-the-art chemical protective lining technology, providing increased chemical protection while giving the wearer more mobility. It can be laundered up to six times. It is a lightweight, front-opening suit that can be worn as an OG or as a primary uniform over underwear. It has an integral hood, a Velcro fastened flap covers the zipper, sleeves have Velcro wrist-closure adjustment tabs and the left sleeve has an outside expandable pocket with flap. The suit also has bellows-type sockets, high-waist trousers, adjustable suspenders, adjustable waistband and a waist-length jacket that enhances comfort and maximizes compatibility with the individual user equipment. The JSLIST liner consists of a non-woven front, laminated to activate carbon spheres and bonded to a knitted back that absorbs chemical agents.

A Nomex hood is worn under the JSLIST OG, with firefighting protective boots worn over the JSLIST OG trouser legs. The firefighting boots provide combined environmental, CB protection, petroleum/oil/lubricants resistance and self-flame extinguishing capability. A CW mask is fitted to the face and a Nomex hood pulled up and fitted around the face-blank. The JSLIST OG hood is secured over the Nomex hood. A CW mask C₂ canister hose is routed across back of shoulders and secured in place with a hose cover strap around the neck. The fire and CB protection butyl rubber gloves are donned at Mission Oriented Protective Posture (MOPP) Level 4. If the fire and chemical protection gloves are unavailable, the fire protection gloves are donned to protect the hands and butyl rubber gloves during fire operations. The proximity suit trousers and coat are donned over the JSLIST OG and secured snugly to the body. The modified structural ARFF helmet is donned over the JSLIST OG hood and the protective shroud is draped over the C₂ canister and around the neck and shoulders to provide thermal protection. Table 2 lists the JFIRE specifications and shows components pictures.

Table 2. JFIRE Components.

<p>JSLIST OG The JSLIST component materials include an outer shell of 50/50 nylon/cotton poplin rip stop with durable water repellent finish. The liner layer has a non-woven front laminated to activated carbon spheres and bonded to a tricot knit back. The OG weighs 5.8 lbs (2.63 kilograms). The suit is expected to have a five-year shelf life, with an estimated total life of 15 years.</p>	
<p>Modified Structural ARFF Helmet The modified structural ARFF helmet is a standard firefighter helmet, one size, adjustable with ratchet. The modified structural ARFF helmet has a gold face shield and a modified aluminized shroud to protect neck area.</p>	

<p>Self Contained Breathing Apparatus (SCBA) with CW Kit The SCBA has a 60-minute air supply canister, regulator unit, backpack/harness assembly, and facemask with breathing valve. In a CW environment a CB protective mask replaces the facemask included in a CW kit. The CW mask is readily switchable between bottled air and filtered air. Air is filtered through a hose to the attached chemical protective C₂ canister. A strap fastened around the neck with hook-and-pile fasteners holds the canister in place. The CW kit modification provides a hose cover and a “beard” fabricated from the JSLIST OG material. A hose cove strap secures the canister. The “beard” fits snugly around the CW mask visor and has a small shroud, which covers the drinking tube, providing protection from gross liquid CW contamination for CW kit rubber components. The JFIRE Basic Sustainment Materiel (BSM) will require an air compressor capable of filling the SCBA canister to 4500 pounds per square inch (psi).</p>	
<p>Nomex Hood The Nomex hood is a balaclava-style hood, of Nomex knit, worn over the head under the JSLIST OG coat to provide increased thermal protection to the head and neck area.</p>	
<p>Firefighter Proximity Suit The firefighter proximity suit consists of aluminized coat and trousers. The proximity suit provides increased thermal and liquid protection required to fight aircraft or chemical and POL fires. The proximity suit is worn over the JSLIST OG.</p>	
<p>Fire and Chemical Protection Gloves The fire and chemical protection gloves are proximity firefighting gloves, which combine fire protection and protection from chemical agents. When available, they are intended to replace the firefighting gloves and butyl rubber CB gloves. The CB glove system is 14-millimeter butyl rubber gloves with cotton liner, worn under fire protection gloves. When available, a combined chemical protection and fire-protection glove may replace fire protection and butyl rubber gloves.</p>	
<p>Firefighting Protective Boots The firefighting protective boot has a tractor tread outer sole, steel toe, and Kevlar/Nomex insulated lining. The firefighting protective boots are worn in place of Green Vinyl Overboots (GVOs), Black Vinyl Overboots (BVOs), or Multipurpose Overboots (MULO) for chemical protection.</p>	
<p>Flyers Kit Bag The flyers kit bag provides a way to carry and store all the JFIRE equipment to ensure accountability during troop movements and when personnel are not required to respond to emergencies.</p>	

OTHER EMERGING TECHNOLOGIES

The US Army Soldier System Center (SSC).

The US Army SSC is developing a next generation protective material based on SPM technology. SPM technology, a one-piece suit with special closure system, would provide increased individual protection, reduced bulk and weight, and a more effective hostile environmental condition barrier. SPM technology allows selective moisture vapor permeation while preventing chemical and biological warfare agent permeation. The Joint Service Protective Aircrew Ensemble (JPACE) and JSLIST Alternative Source Qualification (JASQ) programs are studying SPM based products.

SPM-based clothing is launderable, lighter weight and more comfortable than current over-garments, and has reduced package volume. SPM may become part of other product improvements for items such as butyl rubber boots, gloves, and products similar to OSHA approved Level B and C suits. NSC's current efforts, through the Dual Use Science and Technology (DUST) and WMD Civil Service Response (WMDCSR) programs, investigate the possibility of using SPM technology for other applications.

The Defence Research and Development Canada (DRDC) CB Plus.

DRDC Suffield is the Canadian centre of expertise on CB agents, their toxicology and infectivity, but also on the behaviour of liquids, gases and aerosols released in the atmosphere. DRDC manages the Technology Demonstration Program (TDP), which sponsor the demonstration of different technologies and concepts to meet future military requirements.

Among the projects sponsored by the TDP is the Chemical Biological Plus Combat Duty Uniform (CB Plus) for Broad Spectrum Toxic Hazard Personal Protection. The project is designed for a military requirement, but depending on the outcome of the demonstration, it may also be applicable for civilian first responders. The project's objective is to deliver a combat duty uniform that provides protection against toxic hazards and replaces the need for an additional CB protective suit or over garment. This kind of protection would be particularly useful for both civilian and military fire fighting where toxic hazards are a real or imminent threat. The project is valued at about C\$6M and is to be completed in 2006.

Spiratec® CB Protective System.

Texplor® GmbH (Germany) developed Spiratec® in cooperation with the US Army Soldier System Center. Spiratec® is based on Selectively Permeable Membranes (SPM) technology and provides a barrier function to CB agents while

maintaining its water vapor permeability. An evaporative cooling mechanism reduces heat stress.

Stedair 5000 moisture barrier.

Stedfast Inc. gained expertise through its involvement in the Canadian Department of National Defence's Clothe The Soldier (CTS) Program, where it developed a moisture vapor permeable laminated barrier that allows body heat to escape while protecting against liquid penetration from the outside. Now the company has developed and is introducing its newest Stedair 5000 moisture barrier. As compared to the other Stedair line of products, this material provides enhanced protection against chemical and biological agents and is reported to be currently unmatched. Based on development from the British Ministry of Defence Science and Technology Lab, this material is a reactive barrier that neutralizes toxic chemical agents such as Mustard gas. It has met or exceeded the National Fire Protection Association (NFPA) 1971 and 1994 requirements.

Nanotechnologies.

In March 2002, the Massachusetts Institute of Technology's (MIT) Institute for Soldier Nanotechnologies (ISN) received a \$50M US Army contract to create lightweight molecular uniform and gear materials to shield and protect soldiers against CB agents.

Triton Systems, Inc. (Chelmsford, MA) is also pursuing a nanotechnology that combines polymer-clay nanotechnology with chemically resistant polymers. The materials will provide performance improvements and reduce CB protected tent material costs. The technology will also benefit areas where chemical agent resistance and/or flammability are required, i.e., fabrics in protective clothing, chemical manufacturer worker uniforms and toxic cleanup suits.

Smart Suits

The North Carolina State University's (NCSU) College of Textiles is developing gear to keep first responders safe from biological hazards. The College is trying to create a "smart suit" capable of adapting to its environment. The Smart Suit will incorporate electronics into fibers for communication, location, and sensing body changes or environmental hazards.

The College also has a project that is best described as "spray-on clothes." They have demonstrated that small polymer capsules melted to a cotton candy like consistency could be blown onto a mannequin, resulting in seamless lightweight garment that would not be vulnerable to liquids or toxins.

MANUFACTURERS

US Manufacturers – JFIRE Aluminized Proximity Suits

An aluminized proximity suit is a suit designed to protect firefighters from high radiant fire loads, such as those produced by Jet Petroleum (JP) fuels or other bulk flammable fuels. Civilian and military firefighters, Air Force flightline or Navy flight deck firefighters wear proximity suits manufactured from vacuum deposited aluminized materials that reflect the high radiant loads fire produces.

Chicago Protective Apparel, Inc.

3425 Cleveland Street
Skokie, Illinois 60076-2915
Phone: (847) 674-7900
Fax: (847) 674-7906

Chicago Protective Apparel manufactures aluminized, flame resistant clothing and personal protection apparel.

Fire-Dex®

780 South Progress Drive
Medina, Ohio 44256
Phone: (330) 723-0000
Fax: (330) 723-0035

Fire-Dex® was established in 1983 and initially produced welding gloves. In 1988, the company started the production of firefighting, proximity, and emergency medical service clothing. Structural firefighting gear is Fire-Dex's largest product line. Fire-Dex is one of the four largest firefighter clothing manufacturers in the US.

Fyrepel

202 Pride Lane SW
Decatur, AL 35601
Toll Free: (800) 345-7845
Fax: (256) 350-3011

Fyrepel is owned by Lakeland Industries, a public company. Fyrepel's 700 and 705 Series Proximity Suits are designed to perform maintenance and repairs in high heat areas. Fyrepel's proximity garments have multi-layer construction, with the outer layer composed of high temperature aluminized glass. An additional moisture / steam barrier lining provides protection in areas where exposure to hot liquids, steam, or hot vapor is possible.

Morning Pride Manufacturing, L.L.C.

1 Innovation Court
Dayton, Ohio 45414
Phone: (937) 454-4925

Fax: (937) 264-0075

Morning Pride manufactures proximity gear with head-to-toe blood-borne pathogen protection. The company also manufactures aluminized proximity suits. Morning Pride has 42 US patents, with an additional 36 pending.

Newtex Industries Inc.

8050 Victor-Mendon Rd
Victor, New York 14564
Phone: (585) 924-9135
Fax: (585) 924-4645

Newtex manufactures high-tech, heat resistant products for the industrial and safety markets. Newtex exports products to over 70 countries. The company was established in 1978 to manufacture Zetex, a heat resistant textile for use in their aluminized proximity suit. ZetexPlus is a fabric that safeguards personnel and equipment from temperatures as high as 2000°F (1093°C).

National Safety Apparel (NSA)

3865 West 150th Street
Cleveland, Ohio 44111
Phone: (216) 941-1111
Fax: (216) 941-1130

NSA designs and manufactures personal protective apparel and primarily supplies the automotive & glass industries with proximity suits.

US Manufacturers – JSLIST

Gentex Corporation

P O Box 315
Carbondale, PA 18407
Phone: (570) 282-8511
Fax: (570) 282-8555

Lifetex CB protective OG materials offer lightweight, breathable protection against CB warfare agents. All CD2000 series materials use carbon spherical absorbers that can combine with almost any textile to form a low heat stress and high air permeability composite. The CD2000 series materials can withstand multiple launderings throughout their service life with virtually no loss in any performance characteristic.

CD2560 is used in conventional ground forces and tactical chemical protective OGs. Both OGs have a 50% nylon / 50% cotton rip stop poplin outer shell over a CD2560 liner. A similar ensemble underwent full US Military Operational Testing

(OT) under the JSLIST program. The system is intended to meet all North Atlantic Treaty Organization (NATO) CB protection performance requirements.

Tex-Shield Inc.

2300 M St NW, Suite 800
Washington DC 20037
Phone: (202) 973-2858
Fax: (202) 973-2850

SARATOGA™ proprietary technology is based on activated carbon spheres adhered to fabrics, providing optimal CB agent protection in real-world operational scenarios. CB protective suits made of SARATOGA™ fabric are widely used by North American and foreign first responders. SARATOGA™ CB protective fabric is the only fabric qualified to be used in the DoD's JSLIST OGs. SARATOGA™ is a trademark of the German Company Blucher GmbH, but the fabric is produced under license in North America.

Xymid LLC

1007 Market Street Wilmington
Newark, DE 19898
Phone: (866) 731-5186
Fax: (302) 709-3876
Toll Free: (800) 441-7515

Founded in 1998, Xymid LLC consists of four businesses created by the DuPont Company. LANX is a durable composite fabric containing polymerically encapsulated carbon for the adsorption of chemical warfare agents. LANX fabrics feature excellent stretch properties for good fit and mobility, air permeability that promotes evaporative cooling (reducing heat stress) and enhanced fire protection. LANX fabrics are launderable and have a superior shelf life. The LANX product line includes undergarments, glove liners, boot liners, baklavas, overgarments and gloves.

Current end users of the LANX CPO include the FBI, Pentagon Defense Force, US Marshal Service, New York City Police, Los Angeles Police, Chicago Police, Baltimore Police, San Francisco Police, Evergreen EMS and the Maryland State Police. The LANX CPO was tested and selected as the official protective apparel of the Center for Domestic Preparedness, hosted by the Department of Justice in Anniston, Alabama where first responders across the emergency services spectrum train in live chemical warfare agent environments. The LANX fabric can be combined with a multitude of shell fabrics including nylon, cotton, NYCO and aramids, to provide liquid, vapor and aerosol protection as well as flame resistance.

US Manufacturers – JFIRE SCBA

Interspiro Inc.

31 Business Park Drive
Branford, CT 06405
Phone (203) 481-3899
Fax: (203) 483-1879
Toll Free (800) 468-7788

Interspiro, Inc. is the American division of Interspiro (Sweden), a worldwide supplier of breathing equipment and related products. Interspiro supplies SCBAs, parts, and accessories to many fire departments. Interspiro's customer list includes US Air Force, Navy Sealift, Federal Bureau of Investigation (FBI) and Secret Service. Interspiro's CBRN approved devices include the Spiromatic-S4 and Spirotek-T4. National Institute of Occupational Safety and Health (NIOSH) and Army's Soldier Biological Chemical Command (SBCCOM) tested the Spiromatic-S series SCBA leading to the high-pressure Spiromatic-S4 version's CBRN approval. Tests have exposed SCBA to Mustard and Sarin chemical agents, determining SCBAs ability to withstand exposure without allowing dangerous chemical levels to pass through the mask, and into the face and lungs. Spiromatic-S4 and Spirotek-T4 respirators comply with NFPA 1981 (1997 Edition) qualifying as "all-hazard" SCBAs for fire, immediately dangerous to life or health, and weapons of mass destruction environments.

Mine Safety Appliances (MSA) Company

PO Box 426
Pittsburgh, PA 15230
Phone: (800) 672-2222

MSA has 27 operating companies on five continents. MSA products include respirators, respirator cartridges, gas masks, fire helmets and shields, SCBA, thermal imaging cameras, hard hats, head protection, eye and face protection, monitors, portable instruments and permanent gas detection equipment.

Scott Health and Safety

P.O. Box 569
309 West Crowell Street
Monroe, NC 28111
Phone: (704) 282-8426
Fax: (704) 282-8424

Scott Health & Safety designs high performance respiratory protection systems and other life saving products. Scott Health & Safety's Scott Air-Pak® SCBA models meeting NFPA 1981 (1997 Edition) standard can be upgraded to the new NIOSH voluntary standard for respiratory protection against CBRN incidents.

Survivair

3001 South Susan Street

Santa Ana, CA 92704
Phone: (714) 545-0410
Fax: (800) 201-4407
Toll Free: (800) 375-6020

Survivair, a Bacou-Dalloz company, manufactures respiratory equipment to protect firefighters from smoke, fumes, and toxic gases. Survivair has manufactured respiratory equipment for more than thirty years. Their Panther SCBA is NFPA 1981 (2002 Edition) certified.

Potential Canadian Manufacturers – JFIRE

AirBoss of America, AirBoss – Defense

881 rue Landry
Acton Vale, QC
Canada, J0H 1A0
Phone: (450) 546-2776
Fax: (450) 546-0213

AirBoss – Defense (AD) is a division of Acton International Inc., which is itself a subsidiary of AirBoss of America Corp. (AAC), a corporation specializing in rubber mixing and transformation for the commercial, industrial, transportation and defence markets. AAC bought Acton International Inc. in 1999.

With its two facilities located in Acton Vale, QC (280,000 square foot) and Kitchener, ON (750, 000 square foot), AAC is one of the largest rubber mixing and transformation companies in North America. Both facilities maintain quality assurance programs meeting the ISO 9001 requirements. AAC is traded on the Toronto Stock Exchange (TSX:BOS), employs more than 800 people and had approximately C\$180M of revenues in 2003.

Acton International Inc. develops and manufactures rubber based personnel products like winter boots and firefighters' boots, whereas its AD division (based in Acton Vale) specializes in chemical warfare protective footwear, chemical biological nuclear (NBC) protection gloves, gas masks and extreme cold weather boots. The origins of AD date back to 1928, when Acton International was established, and has been in the NBC protection equipment business for more than 20 years. It supplies its fully decontaminable personnel protection products to armed forces and civilian first responders worldwide. It is also the Canadian representative of the Blücher GmbH's SARATOGA™ biological and chemical protection materials used in the production of NBC suits.

AD capabilities span the whole range of research and development, mixing and manufacture of rubber based products. A partner company, Mold Tech of Buffalo, NY, provides specialized molded products, including all the smaller components of the Canadian C4 Gas Mask. AD has also undertaken advanced polymers research and development projects with DND.

AD is offering potential clients its improved line of NBC protection gloves, boots and gas masks along with its expertise in integrating this equipment with personnel NBC protection suits. In 2004, AD is focusing on providing an integrated solution.

Bacou-Dalloz Protective Apparel Ltd.

4200 St-Laurent Blvd.
Montreal, QC
Canada, H2W 2R2
Phone: (514) 282-0503
Fax: (514) 282-8871

Bacou-Dalloz Protective Apparel Ltd. (BDPAL) is the Canadian subsidiary of Bacou-Dalloz Group (BDG), a worldwide designer, manufacturer and distributor of personal protective equipment. BDG provides head-to-toe protection to the manufacturing, construction, telecommunications and first responders markets. Although BDG operates a total of eight manufacturing plants in the US, BDPAL is the Group's Centre of Expertise for firefighters' protection equipment, including aluminized proximity suits.

First established as Securitex in 1981, BDPAL manufactures and supplies NFPA 1974/1971 protective garments for firefighters and other emergency response workers. In April 2003, BDG bought Securitex, which then became BDPAL. The company employs approximately 165 people in two production facilities, one in Montréal, Canada and the other in Grand Junction, Colorado. The latter was acquired in 1998 (BDG still sells under the FireFlex brand in the US). For 2002, BDPAL had sales of US\$18M.

BDPAL has resident capabilities to design, manufacture and market protective garments for first responders and in particular for firefighters. It has developed a Stress Management System (SMS[®]) that combines optimized layers of specialized lightweight fabrics, working together for maximum flexibility and protection. The company also works with specialty textile manufacturers to offer custom designed solutions.

Stedfast Inc.

230 St-Charles St.

Granby, QC
Canada, J2G 3Y3
Phone: (450) 378-8441
Fax: (450) 378-1558

Stedfast Inc. is a specialty textile developer and manufacturer specializing in protective barrier textile. In operation since 1930, the company has developed several specialty fabrics for the industrial, medical, marine, firefighter and defense markets. Stedfast Inc. employs 90 people at its Granby, QC, 80 000 square foot facility and is the only Canadian textile manufacturer to have a “clean room” for textile lamination.

Over the last few years, the company has worked closely with DND to develop several military fabric applications. For example, in addition to camouflage patterns, Stedfast Inc. has developed camouflage technologies fabrics covering a range of protection that includes UV reflection for snow camouflage, near IR behavior to reproduce the image of a forest for night vision, and thermal reflection to deceive heat sensors. The materials produced at Stedfast are engineered to be rugged, comfortable and dependable.

Stedfast Inc. gained expertise through its involvement in DND’s Clothe The Soldier Program, where it developed a moisture vapor permeable laminated barrier which allows body heat to escape while protecting against liquid penetration from the outside. Now the company is finalizing development and introducing its newest Stedair 5000 moisture barrier. As compared to the other Stedair line of products, this material provides enhanced protection against chemical and biological agents and is reported to be currently unmatched. Based on development from the British Ministry of Defence Science and Technology Lab, this material is a reactive barrier that neutralizes toxic chemical agents such as Mustard gas. It has met or exceeded the NFPA 1971 and 1994 standards.

Vanguard Response Systems Inc.

921 Barton St.
Stoney Creek, ON
Canada, L8E 5P5
Phone: (905) 643-8801

Vanguard Response Systems Inc. (VRS), formerly NBC Team Ltd., develops and markets solutions for the containment and mitigation of Chemical-Biological-Radiological-Nuclear-Explosive (CBRNE) devices and materials. Employing over 80 people, VRS has four main product areas: containment systems, decontamination systems, personal protective equipment and training. VRS benefits from strong manufacturing and business partners like AirBoss – Defense, Tex-Shield Inc., Audio Pack Technology Inc. and 3M.

The company markets proven inter-operable personal protective equipment against chemical agents. VRS is the licensed supplier of the Canadian Forces' C4 military CBRN mask and the PC4 First Responder CBRN mask. It is the Canadian distributor of the SARATOGA™ Hammer chemical protection suits, for civilian first responders, and a distributor of AirBoss – Defense's bio-chemical (BC) protection gloves and Mk V overboots.

VRS manufactures its own chemical protection suit known as the Next to Skin Garment (NTS). It is a close fitting and breathable garment designed to be worn under bomb suits, combat clothing, bunker suits, uniforms and/or civilian clothes to provide very high levels of protection against chemical agent vapor, with minimal thermal load on the user. The NTS is not intended for protection against liquid contamination and therefore needs to be worn beneath clothing that provides liquid protection. The NTS comprises three pieces – a jacket, pants and hood. It is constructed of charcoal knit laminated with polyester knits on both sides and is designed to be worn in conjunction with protective gloves, boots and gas mask.

The NTS offers similar levels of chemical protection as the JFIRE when combined with a bunker suit and a gas mask, while at the same time offering superior mobility and thermal qualities.

VRS also provides customized or standard training on equipment and incident response at their clients' or their own partners' facilities. VRS has trained some of the world's most elite civilian and military response units and is one of the very few organizations in the world able to offer training using live chemical agents.

Incorporated in September 2001, following the purchase of the NBC assets of Irvin Aerospace Ltd., VRS has been publicly traded on the Toronto Stock Exchange since November 2003 (TSX:VRS). It reported sales of C\$10 million in its fiscal year ended September 30th, 2003 and has been profitable since inception. In early 2004, the company purchased Explosive Ordnance Disposal (EOD) Performance Inc., an Ottawa based company that designs and manufactures robots for explosive ordnance disposal, and Bosik Technologies Ltd., an Ottawa based company that designs and manufactures blast containment devices, vehicle barriers, and also conducts ballistic and impact testing. The acquisition of these companies cost approximately C\$18 million and C\$10 million respectively. VRS raised C\$27 million in a share offering to fund the acquisitions and provide working capital.

VRS has provided the equipment listed above to a large mix of military and civilian customers, both domestically and internationally.

Other Potential Manufacturers – Fabrics and Garments

There are potentially several other manufacturers that could produce fabrics, garments, breathing apparels, boots and gloves for the JFIRE, the JSLIST and/or their replacements.

MARKET SHARE DATA

According to a November 2002 study from Business Communications Company (BCC), the protective clothing industry is diverse and involves many areas, each having its own requirements and special materials. The industry includes everything from chemical protective garments and suits to firefighters' turnout gear to bullet-resistant vests to respirators.

Although the protective clothing industry is very fragmented, there are two segments relating to the items in this report:

- chemical protective garments and equipment, including chemical-resistant clothing, chemical warfare and protective suits, and gloves used in industrial applications; and
- heat and flame-resistant clothing, including firefighters' turnout gear for structural, proximity, and woodland fire service, as well as industrial fire-resistant garments for use in electric and gas utilities or industrial applications where electric arc and flash fire may be hazards.

Table 3 displays US Protective Clothing Market data from BCC's report: RGB-142U Protective Clothing and Body Armor Industry: Fire, Chemical and Bullets. Total sales in 2001 for the personal protective clothing industry as it relates to chemical and fire protective garments were \$1.475B, and by 2006, the industry expects to see sales increase to about \$2.0B as the market grows at an average annual growth rate (AAGR) of 6.7% through the forecast period.

The market for chemical resistant garments, such as apparel, gloves, and air-purifying respirators worn by industrial workers, firefighters, HAZMAT teams, emergency medical teams, and the military, will see an AAGR of 6.7% through 2006. The chemical resistant garments market, had estimated sales of \$931M in 2001 and a forecasted increase to nearly \$1.3B by 2006.

The market for fire protective garments includes firefighters' turnout gear for structural firefighting, proximity firefighting, and woodland firefighting, industrial fire resistant garments, and atmosphere-supplying respirators worn by firefighters and industrial workers. In 2001, sales for this combined group were \$544M. Growing at an AAGR of 5.9%, this market is expected to reach \$724M by 2006, market share to slightly decline.

Table 3. US Protective Clothing Market, 2001 and 2006.

Segment	2001 (\$ M)	2001 Market	2006	2006	2001- 2006
---------	----------------	----------------	------	------	---------------

		Share %		AAGR %	
Chemical protective garments and equipment	\$931	63.1%	\$1,288	64.0%	6.7%
Fire protective garments and equipment	\$544	36.9%	\$724	36.0%	5.9%
Total	\$1,475	100%	\$2,012	100%	

FINDINGS

Due to the lack of a civilian accepted standard (NIOSH) for a CB mask, civilian first responders cannot use the JFIRE mask that uses both a CB canister and a SCBA. This situation limits the marketing of a commercial off-the-shelf (COTS) ensemble for use by both civilian and military first responders.

Many textile manufacturers are bringing their newest textile or component to Air Force Research Laboratory – Tyndall AFB for subject matter expertise and opinion. While this approach provides some value to manufacturers, it appears to hold little influence on the developmental direction of the next generation JFIRE.

In the Potential Canadian Manufacturers – JFIRE section, four Canadian companies were identified as having all complementary components (i.e. textile, garment, boots, gloves, mask) that could either contribute to the FSTFRE solution or present a different, but complete, solution to the next generation JFIRE requirement. Taken independently, each company could also be aligned with US partners. This also applies to US companies producing complementary components.

Canadian textile manufacturers, and to a lesser extent garment manufacturers, are disadvantaged in terms of market access by the provisions of the Berry Amendment when trying to enter the US military and first responders markets. No such corresponding restrictions exist for US manufacturers in Canada. The Berry Amendment poses a challenge to Canadian manufacturers and to the North American first responders' communities in general, as Canadian specialized textiles and garments cannot be made readily accessible and available in the US at present.

RECOMMENDATIONS

From a joint US-Canada military perspective, the next generation JFIRE (possibly the FSTFRE) is where future efforts should be concentrated. Individual suit components were discussed at length to capture the current state of the technology and encourage synergies among the listed companies. Nevertheless, it is recognized that the next iteration of these individual suit components should not be stove-piped independently, but specifically developed with an integration emphasis for the next generation JFIRE. Currently available solutions should not

necessarily drive or constrain future development (for instance, the bunker suit and JSLIST could be integrated into a single garment instead of two separate ones).

The Air Force, which has the largest firefighter contingent among the US Services, should accelerate development and finalization of their capability development document, highlighting current JFIRE deficiencies. This document is key to early budgetary identification, development and acquisition funding for all US DoD firefighter ensembles.

There is a need to set a standard for civilian use of CB masks. This would permit civilian first responders, and firefighters in particular, to use the JFIRE. Any future development of the JFIRE CB mask/SCBA should also be acceptable to the civilian first responders' community. This would ensure a COTS solution for both military and civilian personnel, thus reducing unit cost.

Structural barriers, such as the Berry Amendment, which inhibit North American first responders general access to the best textile and garment technologies, should be reviewed and addressed at the political level by the two governments.

Efforts should be better coordinated within the US military and between the US and Canadian militaries in respect to developing a common structural firefighter/CB ensemble requirement. This would also contribute to reducing the unit cost for all potential users, whether they are civilian or military.

PANORAMIC NIGHT VISION GOGGLE (PNVG)

Night vision devices (NVDs) have been around for more than 40 years. They are categorized by generation. Each substantial change in night vision technology establishes a new generation. The US military and the Canadian Forces currently use the latest night vision technology, Generation 3 (Gen III). NVGs are in widespread use for search and rescue and law enforcement activities. Current NVGs provide a narrow 40-degree field of view (FOV). These devices are for sale commercially for a few hundred dollars for Gen I units, to several thousand dollars for Gen III NVGs.

There are two types of technology used in night vision, namely image intensification and thermal imaging. Image intensification works by collecting the tiny amounts of light, including the lower portion of the infrared (IR) light spectrum, that are present but may be imperceptible to human eyes, and amplifying them with an image intensifier (I^2) tube to the point that a person can easily observe the image.

The main advantages of image intensifiers as NVDs are their small size, lightweight, low power requirements (two N-cell or two AA batteries), high resolution and low cost. In addition, image intensification produces a better image resolution than thermal imaging. These attributes have enabled the use of image intensifier goggles for head-worn individual soldier applications that have been procured in the hundreds of thousands by the US Army and several other allied military forces.

Another night vision technology is thermal imaging. In thermal imaging, a special lens focuses the IR light emitted by all the objects in view. The focused light is scanned by a phased array of IR-detector elements. The detector elements create a very detailed temperature pattern called a thermogram. It only takes about one-thirtieth of a second for the detector array to obtain the temperature

information to make the thermogram. Through complex software analysis, the thermogram is transposed into an image.

The main advantages of thermal imaging as NVDs are that they can see through smoke, dust, haze and adverse weather at night, whereas image intensification cannot. However, thermal imaging is bigger and weighs more than image intensification technology. It is used in situations where weight and image clarity are not critical.

The US Air Force Research Laboratory Human Effectiveness Directorate has developed Panoramic Night Vision Goggles (PNVGs), using image intensification, which improve the situational awareness of the user in low light conditions and at night. Originally developed for use by Air Force pilots, PNVGs provide enhanced night vision over a much wider field of view than earlier generation night vision goggles (NVGs). With a 100-degree field of view, Air Force pilots can scan both inside and outside the cockpit using peripheral vision rather than rapid, searching head movements. In addition, digital overlays, video, and symbology can be injected into the system to provide improved information awareness. With PNVGs, first responders could survey wide areas rapidly in low or no-light conditions and identify travel routes, hazards, obstacles, casualties and survivors. This technology is applicable to law enforcement for perimeter control and surveillance where active illumination would betray the presence of the operators. This technology has been prototyped, tested and fielded.

More than 7,000 of these units made by ITT are fielded with the USAF at a cost of between \$3,000 and \$8,000 per unit. Civilian general duty versions are projected to cost about half this price.

The US Army's Advanced Night Vision Goggle (ANVG) program has the same goal as the Air Force's PNVG: to increase the field of view to approximately 100 degrees. This system will utilize four Gen III+ 16mm Pinnacle tubes as opposed to two 18mm Gen III tubes. The ANVG is intended for use by mounted (including heliborne) and dismounted troops. Figure 4 shows front and back view photos of the ANVG.

Figure 4. Front and back view of the ANVG.



OTHER EMERGING TECHNOLOGIES

Fusion Goggle System

Future trends are geared toward the fusion of image intensification and thermal imaging. At least two programs are underway to develop fusion goggle systems. The fusion of these technologies will result in NVGs that merge the strengths of image intensification; a clear, sharp green-tinted (green is the color that the human eye sees most easily) picture, with the advantages of IR; the ability to see under almost any environmental condition.

The first program is the Fusion Goggle System. According to Jane's International Defense Review, May 2002,

“Insight Technology is building two prototypes of the Fusion Goggle System (FGS) under a 10 month contract from US Special Operations Command (USSOCOM), awarded in 2001, worth US \$1.2 million. The FGS is intended as a replacement for the present ITT's F5050 Pirate device and the Northrop Grumman AN/PVS-15. It will be used for target detection, recognition, identification and as a navigation aid following parachute jumps into a variety of hazardous environments. The FGS combines an uncooled long-wave IR (LWIR) thermal imager with an image intensification channel employing Gen IV technology (Gen IV technology is Northrop Grumman's designation on gated filmless tube technology). The operator views the output from both sensors via the same eyepieces and has a control to vary the content from 100% of either to any combination of the two.”

USSOCOM awarded Insight Technology an indefinite delivery/indefinite quantity contract valued at US \$18.1M on March 25, 2003 for FGSs.

The second program is the Electronic Panoramic Thermal Goggle (EPTG), another iteration of fusion technology. This system will use an 8-14 micron dual 640X480 LWIR sensor array with a 100° horizontal field of view. It is designed specifically for SAR missions to reduce observer head motion. It is under development for the US Army by Harsh Environment Applied Technologies. Additional information about EPTG is restricted.

Aviator's Night Vision Imaging System (ANVIS).

ITT Industries first shipped the ANVIS (AN/AVS-6 (V)3) units to the US Army in May 2003. These were the first ANVIS units to be equipped with the new Gen III Pinnacle tubes. The Pinnacle tubes result from thinning the film that prevents ions, generated during normal tube operation, from damaging the photocathode and degrading tube performance. ITT's Pinnacle tubes performed so well during testing that the US Army converted its original contractual (Omnibus V) filmless requirement and accepted the Pinnacle tube. ITT has begun delivery of the AN/PVS-7 NVGs for ground troops in late May 2003. The Army's Omnibus VI contract, for the AN/PVS-7s and the AN/PVS-14s, will feature ITT's Gen III Pinnacle tube technology.

MANUFACTURERS

US Manufacturers – Image Intensification (I²) Tube

There are currently two US companies (ITT Industries and Northrop Grumman Electro-Optical Systems) that make image intensification tubes. These companies produce the critical component of PNVGs. These companies also manufacture NVGs and are included in the section below under US Manufacturers – NVG.

US Manufacturers – NVG

ITT Industries, Inc.

7635 Plantation Road
Roanoke, VA 24019
Phone: (540) 563-0371
Toll Free: (800) 533-5502

ITT Industries Night Vision division is a manufacturer of aviation goggles, I² tubes, ground goggles, monoculars, weapon sights and ground camera systems. While the US Army is ITT's number one customer, the company also supplies night vision equipment to the US Air Force, Navy, Marine Corps and Special Forces. This division of ITT Industries has supplied a large percentage of the US military's Gen III night vision and more than 250,000 of its I² tubes.

Northrop Grumman Electro-Optical Systems (NG EOS)

Northrop Grumman Electronic Systems
1580-A West Nursery Road
Linthicum, MD 21090
Phone: (800) 443-9219

Northrop Grumman Corporation, Electro-Optical Systems
3414 Herrmann Drive
Garland, TX 75041
Telephone: (972) 840-5629

Northrop Grumman Corporation, through mergers and acquisitions, has integrated the assets and resources of five night vision companies into one division, NG EOS. NG EOS (formerly Litton's Electro-Optical Systems) produces a variety of NVG's using Gen II, Gen III or other advanced image intensifiers.

Insight Technology, Inc.

3 Technology Drive
Londonderry, NH 03053.
Phone: (603) 626-4800
Toll Free: (877) 744-4802

Founded in the 1980s, Insight Technology relies on a network of qualified distributors to sell its products to law enforcement and commercial customers. Recently, Insight has partnered with Streamlight Inc. to exclusively facilitate efficient distribution to the law enforcement community. All federal, government, and military sales are conducted directly with Insight Technology.

According to a July 2003 press release by US Senator Gregg (NH), regarding fiscal year 2004 Senate Defense Appropriations Bill, Insight received \$9.5M to fund three programs, including:

- production of IR Target Pointer Illuminator Aiming Lights and Carbine Visible Lasers for US Special Operating Forces;
- continued R&D of the US Army's next generation night vision image intensifier and thermal goggle systems; and
- production of PNVGs.

Vision Systems International (VSI)

641 River Oaks Parkway
San Jose, CA 95134
Phone: (408) 433-9720
Fax: (408) 432-8449

Elbit Systems Ltd. of Israel, through its US subsidiaries EFW Inc. of Fort Worth, Texas and Kaiser Aerospace & Electronics Corporation of Foster City, California, established VSI specifically to pursue worldwide Head Mounted Display systems opportunities. Rockwell Collins subsequently acquired Kaiser Aerospace and Electronics.

VSI has been selected by both Boeing and Lockheed Martin as the supplier of choice for Helmet Mounted Cueing Systems for a wide range of fixed-wing fighter aircraft including the F/A-18, F-15, F-16, and most recently, the F-35 JSF.

Potential US Manufacturers - PNVG

The companies in this section are probably the most technically advanced and might be able to make PNVGs if they received some financial assistance.

Rigel Optics

1510 9th St.

DeWitt, IA 52742
Phone: (563) 659-9761

Rigel offers its own brand name of night vision and other optical products including of night vision binoculars, goggles, riflescopes, and optical glasses. They are currently manufacturing Gen I, Gen I+ and Gen II+ goggles.

Rigel Optics also does business as Night Vision Optics Dot Com. Night Vision Optics Dot Com is a division of Orion Industries, an American engineering company based in Iowa. Night Vision Optics Dot Com is an Internet only dealer and offers a full line of night vision products including the Rigel Optics product line.

Specialized Technical Services (STS)

2794 Indian Ripple Road
Beavercreek, OH.
Phone: (937) 426-2341

STS is a private company formed in 1991 with an emphasis on electro-optical solutions for military and law-enforcement night operations. STS has produced LP/NVGs and related equipment since 1996.

US Night Vision (USNV)

3303 Harbor Blvd., Suite E
Costa Mesa, CA 92626
Phone: (714) 546-4555
Toll Free: (800) 500-4020

USNV is one of the leaders in the night vision industry. In addition to the exclusive line manufactured and assembled at their facility in Costa Mesa, CA, they also carry leading US manufactured products from Northrop Grumman, Raytheon, and ITT Industries. US Night Vision strives to give the best customer service and expert advice in the industry. Their products include digital viewer camera adaptable systems, hands-free goggle systems and weapon sights.

Other US Manufacturers – Night Vision Devices (NVD).

Table 4 lists those companies making Gen I and Gen II devices that do not appear to be technologically advanced enough to produce PNVGs.

Table 4. Other US Manufacturers of NVD.

Company	Product(s)
BE Meyer's	NO Goggles. Claim to make 3 rd generation Image Intensified Microscope System and 3 rd & 4 th generation Multi-Purpose Night Vision Pocketscopes.

Night Owl Optics	They make Gen I and Gen II night vision products. Their goggles are Gen I, with an integrated IR illuminator.
Raytheon Company Electronic Systems	NVGs Gen II. Thermal driving vision enhancers (DVE) and thermal weapon sights (Army and Marines). Although Raytheon has previously made NVGs, they have lately concentrated on sensors. They make the IR sensor for ITT.
Sierra Pacific	Claims to be a manufacturer and a distributor. Unfortunately, they do not identify which products they make and which products they distribute. <ul style="list-style-type: none"> • AN/PVS-7 US Military Goggle/binocular • AN/PVS-7 American Gen III NVG system • ANVIS 6 Aviator's goggles
Sytronics Inc	Thrust is research and testing. Helmet Mounted Systems Technology (HMST) Research. <ul style="list-style-type: none"> • Strike Helmet 21 • VCATS • NVG/PNVG • B1B/HMD
TASCO	Bushnell Performance Optics acquired TASCO on July 3, 2002. They say they are manufacturing two night vision monoculars. They do not specify the generation, but it is either Gen I or Gen II. NV200, NV200W. Popular choice in sports optics.

Canadian Manufacturers - NVG

There are four Canadian companies capable of manufacturing NVGs, but only two of these companies are currently making Gen II or higher NVGs. As opposed to the first two companies listed below, the two companies in the section "Potential Canadian Manufacturers – PNVG" are more technically advanced and would have the capability to make PNVGs.

GSCI – General Starlight Co., Inc.

250 Harding Blvd. West, P.O. Box 32154
Richmond Hill, ON
Canada, L4C 9S3
Phone: (416) 223 6122

Manufactures and markets Night Vision Starlight and IR optical products: the UNITEC Series. The modular NVDs are designed and engineered for a wide variety of activities in low light/total dark conditions. NVDs combine advanced Starlight, IR and Optical technologies. It has multicoated high quality optical lens assemblies and prime grade Image Converter Tubes Gen I, II,III or equivalents.

Newcon Optik

1183 Finch Avenue West, Suite 302
Toronto, ON

Canada, M3J 2G2
Phone: (416) 663 6963

Newcon has a workforce of both R&D engineers and production workers. 90% of their sales are generated through export to over 40 countries. Newcon Optik uses Russian technologies and maintains a single point of contact for marketing, sales, customer service and post sale warranty with warehouses and service depots available in Canada, US and Europe. They also make Gen I and Gen II I² tubes. Although Newcon Optiks has a Canadian address, their manufacturing facility is in Russia.

Potential Canadian Manufacturers – PNVG

The two companies listed below have been assessed as having the capability to manufacture PNVGs, which is conditional on receiving some kind of financial assistance. Their ability to manufacture the PNVG at an affordable price for civilian first responders is hindered by the fact that the I² tubes are produced by a few companies controlling the market and price for those critical items.

ELCAN Optical Technologies

Leitz Road
Midland, ON
Canada, L4R 5B8
Phone: (705) 526-5401

ELCAN, a Raytheon Company, is a fully integrated provider of precision optical and electronic solutions for commercial, industrial, medical, defence, telecommunication and electronics customers. ELCAN employs over 1100 scientists, designers, optical engineers and production staff at facilities in Midland, (ON) Canada, Richardson (TX), USA, and Malaga, Spain.

ELCAN's Midland facility, established in 1952, has 660 employees operating within a 235,000 square foot facility and is capable of performing the design, development, production and testing phases for all of its customers' optical needs. To ensure quality control, ELCAN is ISO 9001 and adheres to Raytheon's Six Sigma quality program.

The majority of ELCAN's business is defence related. For defence and homeland security, ELCAN provides sensor and display components for tactical, airborne and missile systems. Optics by ELCAN can be found in many of the world's advanced combat platforms and imaging and target acquisition systems. ELCAN's line of optical, image intensified and infrared rifle sights are deployed with both the Canadian and US militaries.

ELCAN offers a diverse and comprehensive set of capabilities: new photonics design and development, prototyping and concurrent optical engineering, diamond point turning, optical systems fabrication, thin film coatings, electro/optical/mechanical assembly, testing and qualification.

ELCAN has the capability to design and manufacture the PNVG and most of its components. However, they do not currently possess the capability to manufacture the intensification tubes required for the night vision goggles. These would have to be purchased from a US or European supplier.

Thales Optronics Canada

4868 Levy Street
St-Laurent, QC
Canada, H4R 2P1
Phone: (514) 337-7878

Thales Optronics Canada (TOC) is a division of Thales Canada Inc., which is itself an operating unit of Thales S.A., France. The company designs and manufactures cooled and uncooled optronics systems. TOC currently employs 40 scientists, engineers and production staff at its St-Laurent, QC location. Sales for 2002 totaled C\$30M.

TOC is ISO 9001 registered and operates in a modern 23,000 square foot facility. It is capable of performing the design, production and testing of all its products. The company is production oriented, but has invested more than 7.2% of its 2002 revenues in R&D.

The company's business is exclusively defense related. It has sold 3600 Gen II and Gen III NVG to the Canadian Forces (CF) and performs the Repair and Overhaul (R&O) for the optronics system of the CF's ERYX short-range anti-armor weapon. For the US Armed Forces, the company has delivered its Driver's Vision Enhancer I and, as a result of a successful foreign comparative test (FCT), is delivering thermal imaging modules for the STRYKER and offering its Driver's Vision Enhancer II, which is a highly sensitive thermal system that allows detection of ground disturbance. The company also developed a thermal sniper sight for the European market.

TOC is a system integrator offering the full range of electro-optics capabilities. It develops all of its software and has an expertise in uncooled technologies. It has the capability to design and manufacture the PNVG. Although it does not manufacture the intensification tubes required for the night vision goggles, it has experience in their integration in its systems and benefits from Thales Group global network of suppliers.

MARKET SHARE DATA

Due to the diverse range of products and technologies in the night vision field, the research for market share revealed nothing specific regarding NVGs; all the searches resulted in NVD being part of a larger market share report. Business Communications Company (BCC), Frost & Sullivan, Forecast International, Mindbranch Market Research and Analysis, and Dialog were searched.

The following are quotes from: Electro-Optical (EO) Segment Forecast (Forecast International 3rd Qtr 2003).

“The EO segment of the overall US defense electronics market covers a broad spectrum of applications, from relatively inexpensive, high-volume devices such as thermal viewers to one-of-a-kind, highly sophisticated precision satellite systems and high-energy laser weapons costing hundreds of millions of dollars in both research-development-test and evaluation and procurement funding.”

“A wide variety of manufacturers worldwide are capable of producing the less sophisticated EO systems. The technological resources of most electro-optical/IR equipment – design knowledge, manufacturing facilities and process controls – are well within the financial means of many nations.”

“However, cutting-edge EO technology is a different matter. The number of organizations and even nations that can participate in this technological field – increasingly complicated automatic target acquisition, identification, tracking and weapon delivery systems; high-resolution satellite imaging systems; and weaponized lasers – is limited to a few companies in the US. Export of this advanced technology is limited to close allies that respect licensing agreements. Thus, the tight grip on advanced technology and the sheer costs of developing and employing highly evolved systems limit acquisition of high-end EO equipment to a select few.

In the first responder market, PNV is suited for search and rescue operations, medical evacuation, law enforcement and perimeter security activities where passive observation is preferred. It is an evolutionary enhancement that should be well received by the law enforcement and first responder communities. Current generation night vision technologies are widely available commercially. The PNVG's distinct advantages would allow it to capture a sizeable portion of the market for night vision technology. The only hurdle is cost. The first responder community is very conscious of the cost of procurement and maintenance of its systems. There is no advantage seen for the PNVGs if they cost four times the price of current night vision goggles. In addition, the capability of injecting digital data, symbology and video is not seen as an advantage.

The Federal Aviation Administration does not allow the use of night vision equipment in civilian aircraft. There are a few companies operating under FAA approved exemptions to these rules. One company, Air Methods of Denver,

Colorado, provides critical patient transfer using helicopters and airplanes. It uses 40-degree field of view night vision goggle systems from ITT that cost between \$20,000 and \$35,000 to be fully integrated into its aircraft. This includes acquisition, installation and FAA certification. This company reported that these night vision systems are an essential part of its operations and allow it to perform critical patient transfers from accident sites at night. However, in order to be adopted by the first responders in general, a PNVG would have to be well below that cost target.

Additional civilian markets include hunting, outdoor recreation, navigation and entertainment. These have not been explored here.

FINDINGS

PNVGs are at an advanced stage of technology development and the USAF does not hold proprietary rights. The night vision industry in North America is sufficiently large to support the needs of the militaries and the first responders.

The technology currently used in PNVG is an image intensifier tube, commonly called an I² tube. The manufacturers of these tubes are the key players in the industry as the tubes are the critical components of the PNVG. Any other company wanting to manufacture the PNVG would have to get I² tubes from these manufacturers or develop their own. This last strategy would be difficult for the new companies wanting to enter the market because of the investment and specialized skills that are required.

Another type of technology used for night vision is thermal imaging sensors, but the images are not as clear as the images in equipment using I² tube technology. The future trend for this kind of device is to combine both technologies into one system. This will give the end user the best of both worlds. The images will be clearer with the I² tube, but if there is fog or smoke, the user will be able to switch to the thermal imaging sensor, since night vision equipment using an I² tube cannot see through these impediments.

The biggest hurdle to commercializing the PNVG to the first responders' community remains its high cost.

RECOMMENDATIONS

The Department of Homeland Security (DHS) and Public Safety and Emergency Preparedness Canada (PSEPC) should consider acquiring a quantity of PNVGs that could be held in different key locations throughout North America. They could be stored in these locations and made readily available for use by first responders. Adequate training in using these devices should also be delivered to the first responders' community. Larger municipalities may be able to afford their

own devices, but for the smaller communities, a regional pool would provide a capability they cannot afford.

Defense departments could also help drive down the cost of production of these systems by a “design to cost” development program for DoD and DND first responders needs. The resulting products could then be procured at an affordable price by other first responder agencies throughout North America.

REMOTE CASUALTY LOCATION ASSESSMENT DEVICE (RCLAD)

Ultra wideband (UWB) operates in the 3.1 GHz to 10.6 GHz frequency range or below 960 MHz, which is part of the electromagnetic field regulated by the Federal Communications Commission (FCC). UWB spreads transmissions through the entire range at a low power level. The low power level keeps the signals in the “noise” range, which will avoid interference with narrowband and spread-spectrum radio systems. UWB has the capability to penetrate most construction materials (concrete, stone, drywall, brick, etc.), but it cannot penetrate metals. Applications of UWB include through-the-wall surveillance (TWS), security systems tracking movement, ground penetrating radar (GPR), collision avoidance systems for vehicles, advanced highway construction inspection systems and communications.

GPR is the most widely used application using the UWB radar technology. It has been commercially available for some thirty years. Civilian oil exploration and mining interests use GPR to investigate subsurface conditions and features without drilling, probing or digging. It has also been analyzed for use in mine detection by the military forces.

TWS is a relatively new application for the UWB radar technology. It has been analyzed by the civilian law enforcement industry and the military for the ability to identify the position and location of individuals in a room without gaining entry into the room. The US Army is in the process of developing a system called Soldier Vision to assist military personnel fighting in an urban environment.

In February 2002, Lawrence Livermore National Laboratories (LLNL) demonstrated a prototype Remote Casualty Location and Assessment Device (RCLAD) to the USAF Materiel Command – Human Services Wing – HSW-311 at a test site at Texas A&M University. At that event, LLNL demonstrated a capability of detecting breathing remotely from a distance of 4 feet through 2 feet of rubble and 2 feet of air. The LLNL device was based on Micro Impulse Radar (MIR) technology developed at LLNL.

Subsequently, in December 2002, the USAF Materiel Command – Human Services Wing – HSW-311 posted a Request for Proposals (RFP) for a Remote Casualty Location and Assessment Device. The competitive procurement was a 100 percent small business set-aside. The intent of this program was to develop an RCLAD that is low-cost, portable, and able to detect minute motion at close range through obstructions and at longer ranges without obstruction. The RCLAD should be able to detect motion and breathing rates through rubble, protective clothing and body armor. The device will satisfy two needs for USAF fire rescue personnel and para-rescue specialists: to help find buried victims by using a rubble-penetrating vital signs detector and; to detect and record vital signs through various protective clothing and body armor at short distances. Performance specifications of the device include the detection of breathing and heart rate at 60 feet or more in open air and at 20 feet in rubble, composed of up to 23 inches of actual building materials.

Responses to the RFP resulted in the awarding of a contract to Time Domain Corporation of Huntsville, Alabama, for design, prototyping and delivery of a system. The contract was awarded in July 2003. The contract calls for the delivery of a prototype system within 12 to 14 months of contract issuance and delivery of a complete system for testing within 24 months. The proposed system is based on Time Domain's patented UWB radar technology, which is similar to that developed by LLNL. Time Domain has also developed RadarVision® (See Figure 5) for the detection of motion behind walls using UWB technology that is undergoing testing and verification by the US Army. The current contract work will be an improvement and extension of that technology to meet the requirements of the Air Force solicitation.

The technology is covered by numerous patents with the earliest granted to the founder of Time Domain in 1987. For the RCLAD application, the device should be ready for commercialization in approximately two years (from the date of the report).

Figure 5. RadarVision



OTHER EMERGING TECHNOLOGIES

Micro Impulse Radar (MIR)

The RCLAD system under development by Time Domain potentially has competition from similar technology developed by LLNL. The prototype system developed by LLNL, using their MIR technology and demonstrated during the Texas A&M tests, could be commercialized and provide technology based on very similar UWB technology.

Infrared Scanning System

An existing technology that competes in the same market space as the RCLAD device is the infrared scanning system that detects heat sources in rubble. These devices can quickly and reliably detect heat sources within rubble sometimes at considerable distances. They have three disadvantages as compared to an RCLAD-type system: they cannot assess status since they detect only temperature differences, they cannot detect casualties through more than a minimum amount of rubble and they cannot discriminate between different sources of heat (animal, fire, human, etc).

Passive Listening Device

Another technology that competes with an RCLAD-type system is the passive listening devices that are currently available and widely used. These devices can detect very low noise sources including labored breathing and heartbeat. Passive listening devices can detect sounds in rubble at distances greater than that specified for the RCLAD system. However, they usually cannot detect breathing or heartbeats at those distances. These systems are typically inexpensive and widely available. The primary disadvantage of the passive listening device is its sensitivity to extraneous noises. Because of this sensitivity, its use is limited because all rescue activity must stop during a noise survey.

Continuous Wave (CW) Radar

CW radar penetrates rubble using an L-band signal. The main difference between impulse radar (the technology used in RCLAD) and CW radar is the radio wave emission method. Impulse radar emits radio waves in short pulses; CW radar emits radio waves in a continuous stream. Raytheon created CW radar capable of tracking a person's movements behind a concrete wall (unknown wall dimensions) using this technology. Georgia Tech Research Institute (GTRI) developed CW radar emitting a millimeter wave (MMW) signal capable of detecting a person's breathing through an 8-inch concrete wall.

X-Ray

X-ray systems provide good imagery and rubble penetration, but the technology is limited to short ranges and prolonged exposure is hazardous for humans.

MANUFACTURERS

US Manufacturers – RCLAD

Time Domain Corporation/RadarVision.

Cummings Research Park
7057 Old Madison Pike
Huntsville, AL 35806
Phone: (256) 922-9229
Fax: (256) 922-0387

Time Domain was founded in 1987 by Mr. Larry Fullerton. The privately owned company focuses on UWB technologies, i.e. electromagnetics, optics and acoustics. The company's products use or evaluate UWB equipment and are based on their patented PulsON chips. The company employs 77 people at the home office in Huntsville, AL, where they have a limited manufacturing capability. Vendors are used for production support of large quantities. Chip designs are produced internally, while IBM produces the chip sets. Through the years, the company has amassed 250 patents (awarded or pending). Government contracts account for 80% of company revenues, which were in excess of \$10M in 2003.

Time Domain developed a TWS product called Radar Vision 1000 in 1998 with internal resources. In 2001 the company produced Radar Vision 2000, again with their own funds. Under contract to the US Army, Time Domain modified Radar Vision 2000 into Soldier Vision in 2002 and produced Soldier Vision A1 in 2003.

The Time Domain RCLAD is a variant of Soldier Vision, specifically designed for use in rubble. The company expects the innovations developed in RCLAD will also advance Soldier Vision. Soldier Vision has the capability to operate 10 meters from a structure and penetrate 10 meters into the structure. The technology can penetrate nearly all building material (up to 30 inches) except metals.

The company also produces the PulsON 200 Ultra Wideband Evaluation Kit, which allows product developers to examine the performance, capabilities and properties of ultra-wide band (UWB). The company also produces a Signal Generator/Tag (SG/T) transmit only radio which can be used as an FCC compliant UWB transmitter for various types of analyses independently or in conjunction with the Evaluation Kit.

The company intends to explore the use of UWB for location and communication capabilities in an urban environment.

Potential US Manufacturers – RCLAD

The most similar devices to RCLAD are GPR and TWS. Companies making GPR and TWS could potentially make RCLAD.

Advantaca Corporation, Inc.

1813 Rutan Drive
Livermore, CA 94550
Phone: (925) 447-333
Fax: (925) 447-9999

Advantaca was founded in 2003 by former employees of Lawrence Livermore National Laboratory (LLNL). The products produced by the company leverage years of know-how from the Micropower Impulse Radio (MIR) program at LLNL. The eight-person company embodies a total investment of over \$40M including 17,000 square feet of production area and facilities used to support ongoing development efforts. Institutional applications of their products include stealth radio, breathing/heart rate sensing, container security, electronic tripwire, telemedicine, through-wall imaging, underground imaging, robotic sensors and weapon fusing. Industrial applications include wireless communication, sensing, imaging, camera trigger, electronic fencing and RapidSentry.

Advantaca responded to the Air Force Materiel Command Human Services Wing request for proposal (RFP) for RCLAD, but did not receive a contract for further development.

The company has provided over 100 UWB radar units to the US government under contract to the Defense Advanced Research Projects Agency (DARPA) and others. These units were primarily used outdoors for foliage penetration.

Geophysical Survey Systems, Inc. (GSSI)

13 Klein Drive, PO Box 97
North Salem, NH 03073-0097
Phone: (603) 893-1109
Fax: (603) 889-3984

GSSI develops and manufactures GPR systems. The systems non-destructively explore ground subsurfaces and inspect infrastructure systems for a wide variety of industries. GSSI created the first commercial GPR system. GSSI provides equipment covering all applications from borehole data collection to high-speed highway and railroad data collection. GSSI manufactures custom equipment for specific applications.

GeoRadar Inc.

12996, Somerset Drive
Grass Valley, CA 95975
Phone: (530) 274-4445
Fax: (530) 274-4446

GeoRadar® manufactures Stepped-FM GPR systems used to find and provide images of objects buried in the ground, objects in walls or rebar in concrete. Stepped-FM GPR can find metallic and non-metallic objects, plastic pipe, dead bodies and voids. In order to show an image, buried materials must have different electrical properties than the host material.

Zircon Corporation

1580 Dell Ave.
Campbell, CA 95008
Phone: (408) 866-8600
Fax: (408) 866-9230.

The FCC granted Zircon waivers to operate UWB equipment. Zircon can deploy up to 5,000 units of its radar for detecting the rebar in laid concrete. Unlike other applications, Zircon has no National Telecommunications and Information Administration (NTIA) coordination requirements, as its system operates under the maximum power level allowed by the FCC. That level is similar to what's allowed for personal computers (PCs), or about 500 microvolts per meter. Zircon is developing products with through-the-wall penetration capability.

Potential Canadian Manufacturers – RCLAD

There are no Canadian RCLAD manufacturers. The devices most similar to RCLAD in production now are GPR and TWS. Companies making GPR or TWS could potentially make RCLAD.

Comlab Telecommunications Inc.

2300, Léon-Harmel, suite 220
Québec, QC
Canada, G1N 4L2
Phone: (418) 682-3380
Fax: (418) 682-8996

Comlab Telecommunications Inc. (Comlab) is a private company founded in 1984. The company employs 21 persons. It has wide-ranging expertise in the field of telecommunications and in developing and applying specialized radio frequency technologies for use in the areas of microwaves, antennas and radar.

Among its accomplishments, Comlab has played a major role in the design and development of radar training systems for Lab-Volt Systems Inc. These systems

have been exported to over 20 countries. This patented radar (US 4,975,703; CA 1332846), which uses very low and safe transmitter power to detect short-range targets in a classroom environment, is the precursor of Comlab's developmental UWB TWS radar.

Defence Research and Development Canada (DRDC)-Ottawa awarded three research contracts to Comlab for the development and demonstration of their TWS Radar. As a result of these research contracts, Comlab's is starting the development of an experimental model of an UWB Radar capable of sensing objects and persons through the wall and, ultimately, through rubbles. The company is actively engaged with other government and private partners to secure the funds necessary to complete this project.

Sensors & Software Inc (SSI).

1040 Stacey Court
Mississauga, ON
Canada, L4W 2X8
Phone: 905-624-8909
Fax: 905-624-9365

Sensors & Software Inc. was formed in 1988 with the mandate to commercialize their pulseEKKO GPR technology. This technology focused on geological applications and addressed goals developed by the Geological Survey of Canada during the 1970s. The pulseEKKO systems represented a major shift from conventional GPR at the time and opened up opportunities for GPR in a wide variety of areas not previously deemed practical.

Sensors & Software Inc. employs over 50 staff and has sold GPR systems to customers in over 60 countries. The company has developed GPR for numerous applications, including structural assessment, mining and quarrying, utilities, forensics, archaeology, geology, environmental assessment, glaciology, agriculture, and landmine detection. Their products allow for the integration of GPR instrumentation with various transporting platforms, as well as various positioning, data recording and display devices.

Sensors & Software's newest GPR is the Noggin family of subsurface imaging instruments. Noggin is a fast, affordable and easy-to-use line of GPR. The Noggin combines a rugged, weatherproof assembly with low power, compact size and cutting edge digital electronics. The Noggin provides subsurface image output directly in digital form. The subsurface images appear in real-time and are recorded for scroll-through review. All systems provide marker input as well as time and date stamps on each record. The basic Noggin family also provides the convenience of "point and shoot" operation.

To fully exploit the power of the Noggin family of products, the company has developed a Digital Video Logger (DVL) system to control, display, and record data.

Software is a major part of all of Sensors & Software Inc.'s activities. It has created several simple-to-use software applications that allow users to extract the most information from their GPR data with the least amount of time and effort.

MARKET SHARE DATA

RCLAD products are new and very specialized, making market share data unattainable. Additionally, no meaningful market share data is available for UWB GPR. Business Communications Company (BCC), Frost & Sullivan, Forecast International, Mindbranch Market Research and Analysis, and Dialog were searched, but no result was obtained.

However, the assumption can be made that the market for RCLAD will be highly dependent on the technical capabilities of the developed system and on the system cost. Because these have not yet been determined, no market evaluation could be undertaken for this report. If the technical milestones are achieved at the targeted price of \$2,000 to \$2,500, then there should be a reasonable market for this system. To ascertain the potential market would require a marketing research effort based on different technical and cost assumptions.

FINDINGS

Time Domain is the only company making RCLAD. RCLAD uses time modulated ultra wideband (TM-UWB) impulse radar technology to detect live victims in rubble up to 23 inches thick. Time Domain is primarily a research company with limited manufacturing capability.

Since no other manufacturer makes live victim location devices, the companies most capable of making RCLAD-type devices are GPR manufacturers and TWS manufacturers.

The RCLAD system is being developed by Time Domain Corporation and all the intellectual property associated with the device belongs, or will belong, to the company. Time Domain is a relatively small company that has little internal manufacturing capability. Existing Time Domain technology has been made widely available for licensing and it is likely the company will choose that approach to the RCLAD technology or, alternatively, use contract manufacturing.

A similar technology (MIR) from LLNL may also become available through other UWB Radar companies. It is possible that two or more private-sector sources of similar technology will be available within two to three years if the technology is proven to be technically viable and the cost structure is acceptable.

The commercialization of RCLAD will depend on the technical capabilities of the device, its unit cost and the availability of competing technologies.

RECOMMENDATIONS

One option to help transfer this technology quickly to first responders – assuming that the cost and technical targets are achieved – would be for DHS to directly acquire some of the devices concurrently with, or prior to, DoD acquisition. These devices could then be made widely available under a grant program to first responders for further testing and evaluation. Direct acquisition by the DHS concurrently with DoD would likely lower the per-unit acquisition cost.

PSEPC could undertake a similar approach. PSEPC is currently setting up several Heavy Urban Search and Rescue (HUSAR) teams across Canada. As part of this endeavor, they are creating a list of standard equipment for these HUSAR teams. It is recommended that they add RCLAD to their list.

THREAT CONTAINMENT UNIT (TCU)

Since September 11, 2001 the threat of terrorist attacks on the US has resulted in increased emphasis on technologies and disciplines to improve security measures on the ground and in the air. Many terrorist attacks within the US and abroad have involved a bomb, which is defined as a fused explosive device designed to detonate under specified conditions. An improvised explosive device (IED) is normally devised from non-military components including destructive, lethal, noxious, pyrotechnic, or incendiary chemicals and is designed to destroy, incapacitate, harass or distract. Some IEDs can be prepared from readily available materials.

Various materials (technologies) are used for protecting/mitigating the explosive detonation effects, taking place either on the ground or in the air. Materials consist of layers of high impact steel, various composite materials, blast suppressant chemicals (foams) or specialized fabrics. Material properties typically include high blast resistance or blast suppression and if the blast breaches the material it should not shatter into many pieces. A wide range of applications use these materials including:

- trash containers;
- blast suppression blankets and specialized fabrics;
- luggage/cargo containers; and
- materials that may be part of an interior wall, building exterior, or some form of protective barrier.

Several terms such as bomb box, bomb containment, explosion containment, blast mitigation, suppression container, etc., describe the various technologies. For consistency this report uses the term threat containment unit (TCU) to describe technologies used to contain the effects of explosive detonations. A TCU first contains the suspect item and then removes it to a place where specialists investigate and dispose of the device, thus allowing evacuation from the immediate area without undue risk. The term blast suppressant is used in

this report to describe technologies used to mitigate or lessen the explosive detonation effects.

In 1997, the Federal Aviation Administration (FAA) requested Naval Surface Warfare Center Carderock Division (NSWCCD) to develop a container to use in conjunction with explosive detection system (EDS) equipment being installed at various US airports. The purpose was to provide a safe storage location for an item identified as possibly containing an IED without evacuating large portions of the airport for safety. The FAA chose the NSWCCD to develop a container because the NSWCCD demonstrated an expertise on internal blast phenomenology, structural response to blast loads, and explosive testing, through the anti-terrorism Aircraft Hardening Program.

FAA defined the following container requirements:

- Ability to contain the effects of an explosive, equivalent to five pounds of trinitrotoluene (TNT) detonated inside the container.
- A door and interior large enough to accommodate a piece of luggage 20" wide; 28" High, and 48" in length.
- Ability to be easily deployed to different parts of the airport, including passing through a 36" wide doorway without removing the door from its hinges.
- Light enough in weight to be moved by one or two persons.

As a result, the NSWCCD developed a TCU that is covered by US patent 6,196,107. The NSWCCD TCU is deployed in over a dozen US airports. Figure 6 is a picture of the NSWCCD developed TCU.

Figure 6. NSWCCD Developed TCU

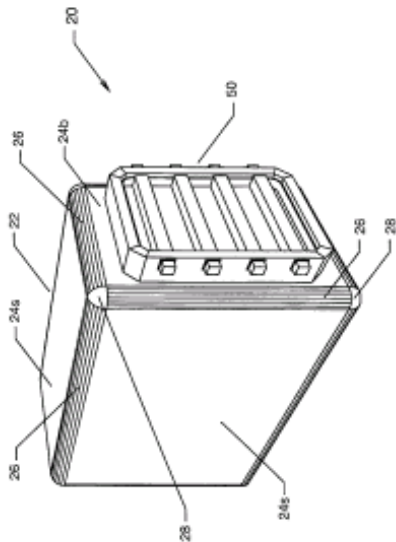

FIG. 1

Canada has also developed a TCU. In the late 1990s, Transport Canada and the Royal Canadian Mounted Police (RCMP) contracted Bosik Technologies Ltd. to develop lightweight TCUs that are reusable explosive containment systems designed to totally contain the explosion within a sealed multi-layer sphere, trapping all resulting gasses, which can then be vented under controlled conditions through an exhaust valve. Two different sized containers resulted: the suspect package containment systems (SPC)-1000, for carry-on luggage, and the SPC-500, a smaller design for letters and small electronic devices. Both are movable by one person, can fit through standard double doors and can be robot-operated in close proximity. Several units have already been sold to Indianapolis International Airport (US), Pierre Elliott Trudeau International Airport (Montreal, QC), Royal Mail (UK) and the US Postal Service. A third design is currently under development, called the SPC-2000, which will be capable of containing checked-in luggage.

OTHER BLAST CONTAINMENT TECHNOLOGIES

Hardened Unit Loading Device (HULD).

After the 1988 Lockerbie bombing, the US and other International agencies started seriously researching an explosion-proof air cargo container or a hardened unit-loading device (HULD) to function as an aircraft luggage or cargo

container. HULDs on the market today are too heavy and costly to replace all existing air cargo containers or unit loading devices (ULDs). In order to get the benefit of the HULD at an affordable price, agencies purchase a few HULDs and put only selected luggage in the container.

The HULD containers that are currently available are made from a ballistic, lightweight material such as aluminum and a fiberglass composite called GLASS-REINFORCED (GLARE) fiber or ballistic composite materials such as Spectra. Composite materials have stronger tensile strength than steel therefore the HULD will bow out or deform, but the explosion will still be contained within the HULD.

Although most US manufacturers will not identify the maximum quantity of explosives that a HULD will contain because it is classified, at least one foreign manufacturer identified the quantity as 1 pound of TNT.

The two industries that would most benefit from TCUs, airport security and federal building security, would not use a HULD for bomb containment and disposal, but would use a TCU.

Universal Containment System (UCS).

The UCS is a reusable, single-person portable multi-panel nylon tent lined with ballistic fabric that can be quickly set up and laid over a device in situ. The tent is then filled, within a few seconds, with one of Vanguard Response System Inc. (VRS)'s two dispersal suppression and decontamination foams (DSF™, DDSF™). These foams, as well as the Surface Decontamination Foam (SDF) and CASCAD™, have the same basic chemical formulae, but they differ in their concentration of CB decontaminant.

The Defence Research and Development Canada (DRDC), the Royal Canadian Mounted Police (RCMP), the National Research Council (NRC) and the DoD first developed the foams in the late 1990s. All these foams were subsequently licensed to VRS for manufacture and distribution. The UCS has been successfully tested on a full-range of live chemical, biological and radiological (CBR) agents and IEDs.

In February 2004, the Canadian government awarded a C\$1.25M contract to VRS to further optimize the blast mitigation and decontamination properties (against chemical, biological and radiological agents) of the company's three dispersal suppression and decontamination foams (The Dispersal Suppressant Foam, or DSF™, Decontaminant Dispersal Suppressant Foam, or DDSF™ and the Surface Decontamination Foam, or SDF™) and the CASCAD™ military decontaminant foam. CASCAD™ is optimized for the military requirement and provides the fastest kill times and the best performance against thickened agents.

Although this technology does not meet the FAA requirements for mobility (stemming from the fact that the device had to be removed from the discovery site) for which the TCU was developed, the UCS is comparable to the TCU in terms of set-up time and portability. In addition, it is reusable and suitable for chemical and biological decontamination.

MANUFACTURERS

US Manufacturers – TCU

Criminalistics Inc.

West Coast Office
1391 Main Ave.
Morton, WA 98356-9726
Phone: (360) 496-6363
Fax: (360) 496-6210

East Coast Office
7560 N.W. 82 St.
Miami, FL 33166-7413
Phone: (305) 885-6444
Fax: 305-885-3330

Criminalistics has been in business for over 35 years. It has manufacturing facilities in Miami, Florida and Morton, Washington. Customers include the New York State Police and the Bureau of Alcohol, Tobacco and Firearms, and the Hazardous Devices School at Redstone Arsenal in Huntsville, Alabama. Criminalistics produces the SID™ which is a transport system designed with a specialized head and replacement inner cylinder. Tested by the US Army at the National Bomb Data Center, the unit safely controlled the detonation of up to 20 pounds of TNT, composition four (C4 Plastic) and high density primers. The unit is 15 ft long, 6 ft 1 in high and 6 ft 3 in wide. The unit weighs 5000 lbs.

DeMil International

221 East Side Square
Huntsville, AL 35801
Phone: (256) 536-6885
Fax: (256) 519-6456

DeMil International offers patented stationary and transportable contained detonation chamber (CDC) units. DeMil has a stationary CDC capable of withstanding detonations of 3 pounds of the explosive called cyclotrimethylenetrinramine (RDX) or its equivalent. This CDC unit is capable of being loaded into the bed of a heavy-duty pick-up truck. DeMil has a transportable system capable of withstanding detonations to 10 pounds of RDX.

DeMil reports that they are designing a transportable CDC system capable of withstanding detonations of up to 50 pounds of equivalent RDX.

Mil-Spec Industries Corp.

10 Mineola Ave.
Roslyn Heights, NY 11577
Phone: (516) 625-5787
Fax: (516) 625-0988

Mil-Spec Industries is a manufacturer and supplier of special chemicals, explosives, propellants, ammunition, pyrotechnics, ordnance components, early warning systems, radars, microwave/radio frequency filters, demilitarization, military, machinery/equipment and law enforcement products.

Mil-Spec claims to make an explosive ordnance device but their website is under construction and the information cannot be verified.

Mistral Group

7910 Woodmont Ave., Suite 820
Bethesda, MD 20814
Phone: (301) 913-9366
Fax: (301) 913-9369

The Mistral Group, founded in 1988, has its headquarters in the Washington, D.C. metro area. The Mistral Group is a holding company composed of five legal entities: Mistral Inc., Mistral Security Inc., Mistral Detection Ltd., Karil International Marketing Ltd., and Karil Protective Systems Ltd. (KPS).

Mistral produces several TCUs, one of which is the ARC-5 Container. Designed and used for EOD and civilian bomb disposal, the ARC-5 can contain 11 pounds of equivalent TNT with repeated detonations. It will limit the dispersal of chemical and biological agents, mitigating the risk of such devices. The hydraulic door can be operated either manually or electrically and has an opening diameter of 21.6 inches. The container is 43.3 inches in diameter and with its stand is 55.2 inches in height and weighs 3300 pounds. The ARC-5 can be trailer mounted and towed at highway speeds.

Nabco Inc.

1501 Reedsdale St, Suite 502
Pittsburgh, PA
Phone: (412) 231-8558

Nabco manufactures TCUs and the All-Terrain Hydraulic Transporter with applications for bomb disposal within the military and airport security sectors. Model SLCV-01 is a luggage containment vessel designed for use in airports. The unit has a door opening of 28 inches x 36 inches and weighs 1200 pounds.

Nabco TCUs are made from 1-1/2 inch high-strength, high-impact steel. Nabco provides disposable baskets for containing and loading suspect devices into the TCU. To eliminate human exposure as much as possible, these baskets can be used in conjunction with all available robotic devices.

Protection Development

1555 Railroad Street
Corona, CA 92880
Phone: (909) 734-7531
Fax: (909) 734-7570

A California corporation marketing/engineering/manufacturing entity whose principals, staff consultants and advisors developed ARMET™: an opaque armor that can be molded and custom built for specialized applications.

Canadian Manufacturers - TCU

Bosik Technologies Ltd.

2495 Del Zotto Avenue
Ottawa, ON
Canada, K1T 3V6
Phone: (613) 822-8898
Fax: (613) 822-3672

Bosik Technologies Ltd. was founded in July 1989 and utilizes integrated engineering analysis, design, fabrication and test competencies to provide business solutions to the safety and security, maintenance, repair and overhaul aerospace industries. Bosik's team of engineers, designers and technicians offers a wide range of services to clients including development of specialized equipment from conceptual design through to construction and commissioning. The company also operates the National Research Council of Canada (NRC) Flight Impact Simulator campus in Ottawa, Ontario, Canada. Their facilities consist of an office and laboratory area including a 75 ft pneumatic cannon, impact testing zone, ballistic test range, machine shop and prototyping area.

Bosik has developed and manufactures a family of TCUs. They are lightweight, reusable explosive containment systems designed to totally contain the explosion within a sealed multi-layer sphere, trapping all resulting gasses, which can then be vented under controlled conditions through an exhaust valve. Bosik offers two different sized containers: the suspect package containment systems (SPC)-1000, for carry-on luggage, and the SPC-500, a smaller design for letters and small electronic devices. Both are movable by one person, can fit through a 36 inch wide doorway and can be robot-operated in close proximity. Several units have already been sold to Indianapolis International Airport (US), Pierre Elliott Trudeau International Airport (Montreal, QC), Royal Mail (UK) and the US Postal

Service. A third design, called the SPC-2000 currently under development, will be capable of containing checked-in luggage.

Bosik Technologies is a profitable private company currently running at approximately \$2 million in revenue with 22 employees. In early 2004, Vanguard Response Systems Inc. acquired Bosik for approximately C\$10 million.

Other Technology Manufacturers

This section is included because of the peculiar technology used in Vanguard Response Systems Inc.'s Universal Containment System (UCS) and because of their recent acquisition of Bosik Technologies Ltd., the Canadian TCU manufacturer.

Vanguard Response Systems Inc.

921 Barton Street
Stoney Creek, ON
Canada, L8E 5P5
Phone: (905) 643-8801
Fax: (905) 643-8824

Vanguard Response Systems Inc. (VRS), formerly NBC Team Ltd., develops and markets solutions for the containment and mitigation of Chemical-Biological-Radiological-Nuclear-Explosive (CBRNE) devices and materials. Employing over 80 people, VRS has four main product areas: containment systems, decontamination systems, personal protective equipment and training. VRS benefits from strong manufacturing and business partners like AirBoss – Defense, Tex-Shield Inc., Audio Pack Technology Inc. and 3M.

VRS is the sole worldwide licensee and supplier of patented technologies developed and owned by the Canadian government for blast mitigation and decontamination of CBR warfare agents, including the Universal Containment System (UCS) and the CASCAD decontamination foam.

The UCS is a reusable, single-person portable multi-panel nylon tent lined with ballistic fabric that can be quickly set up and laid over a device in situ. The tent is then filled, within a few seconds, with one of VRS's two dispersal suppression and decontamination foams (DSF™, DDF™). The foams, including SDF™ and CASCAD™, have the same basic chemical formulae, but they differ in their concentration of decontaminant. The UCS has been successfully tested on a full-range of live CBR agents and Improvised Explosive Devices (IEDs).

SDF™ and CASCAD™ are biodegradable, fresh or sea water-diluted sticky chlorine-based foams used for CBRN decontamination of equipment, vehicles and buildings. They are applied with modular equipment that can be mounted on

small or large vehicular platforms. DSF™, DDF™, SDF™ and CASCAD™ can also be used as suppressants for Class A and B firefighting.

Incorporated in September 2001, following the purchase of the NBC assets of Irvin Aerospace Ltd., VRS has been publicly traded on the Toronto Stock Exchange since November 2003 (TSX:VRS). It reported sales of C\$10 million in its fiscal year ended September 30th, 2003 and has been profitable since inception. In early 2004, the company purchased EOD Performance Inc., an Ottawa based company that designs and manufactures robots for explosive ordnance disposal, and Bosik Technologies Ltd., a company that designs and manufactures blast containment devices, vehicle barriers, and also conducts ballistic and impact testing for the aerospace market.

VRS has provided the equipment listed above to a large mix of military and civilian customers, both domestically and internationally.

MARKET SHARE DATA

A Navy assessment of the TCU market states, “Bomb containment units range in quality and size from single-use units designed to contain 5 pounds of TNT, that are priced at around \$20,000, to reusable units that can handle up to 11 pounds of TNT, that are priced at around \$80,000. The size of the US market, excluding the Transportation Security Administration (TSA) procurement, is estimated at between \$500,000 and \$1M, with the worldwide market being about 200% larger.”

Taking the average price of a TCU times the number of North American airports might derive a better market estimate. In addition, at least in the US, it is reasonable to assume that all federal buildings could contain a TCU. Table 5 shows figures using these assumptions as a baseline. The ‘high’ average TCU cost is based on the known cost of domestic manufacturers’ products as shown in the US Manufacturers – TCU section of this report. The ‘low’ average is based on the US Navy estimate of \$20,000 per unit.

Table 5. Potential TCU Market Share.

Facility	Number	Average TCU Cost Low and High	Estimated Market Low and High
US Commercial Airports	429	\$20,000 - \$36,685	\$9M - \$16M
Canadian Commercial Airports	30	\$20,000 - \$36,685	\$0.6M - \$1.1M
NA Commercial Airports	459	\$20,000 - \$36,685	\$9.6M - \$17.1M
US Certified Carrier Airports	804	\$20,000 - \$36,685	\$16M - \$29M

Canadian Certified Carrier Airports	72	\$20,000 - \$36,685	\$1.4M - \$2.6M
NA Certified Carrier Airports	876	\$20,000 - \$36,685	\$17.4M - \$31.6M
Worldwide Airports	1400	\$20,000 - \$36,685	\$28M - \$51M
US Federal Buildings	500,000	\$20,000 - \$36,685	\$10B - \$18B

Sources: 2002 TSA press release, Bureau of Transportation Statistics 2000 annual report, Mapping.com.

Equipping each of the 500,000 US federal buildings in the US with a TCU would create a market of approximately \$10B (low) to \$18B (high).

If all commercial airports and all federal building purchased at least one TCU, the market would be \$10B (low) to \$34B (high) in the US alone. These numbers are obviously overestimating the potential market, but it gives an order of magnitude and a point of reference. It is the best estimate based on currently available cost information. Using those numbers and spreading the annual market over 20 years breaks down from a low of \$500M per year to a high of \$1.7B per year.

The market for explosion containment devices in many urban settings such as crowded sidewalks, subways, train stations and high-rise buildings resembles that for airports. Wherever first responders are notified of and need to contain suspicious packages, with the minimal disruption of commuters and pedestrians, a potential market exists. The North American market is expected to grow, given increasing homeland security concerns and growing first responders applications.

A number of companies are in the business of providing explosion containment devices, containment walls, other energy absorption systems or blast-related product engineering. Until the Transportation Security Administration (TSA) provides performance data and specifications of the current bomb containment units and offers an RFP, the competitiveness of the Naval Sea Systems Command (NAVSEA) containment unit cannot be fully ascertained and it will likely continue to be a low-profile security project.

FINDINGS

The TCU, designed and patented by the Naval Surface Warfare Center Carderock Division (NSWCCD), is a box-shaped steel shell with an inner liner of rigid polyurethane foam. The bomb or suspect explosive device is placed inside and is tightly packed with additional foam. If a bomb is detonated in the TCU, the foam pulverizes and the liner deforms into an ovoid or cylindroid shape while slowly venting pressure. The NSWCCD TCU is designed for a one-time use. It is small, lightweight and inexpensive.

The deployed units were made in US DoD facilities because the FAA has not licensed the NSWCCD TCU for commercial production. As the FAA is not expected to broaden the NSWCCD TCU usage beyond the airports within its mandate, no license is expected to be awarded.

Nevertheless, there are already several North American companies making products similar to the NSWCCD TCU. The TCUs designed by these companies vary; they can be mobile or fixed and designed for both multiple or single uses. Some even provide protection against chemical and biological weapons.

RECOMMENDATIONS

No further action is recommended on the NSWCCD TCU as there are comparable products already commercially available.

Airport first responders should also consider the acquisition of other technologies suitable to handle threats other than just explosives (i.e. CB).

These technologies should also be considered for urban bomb containment and disposal in crowded outdoor environments, in subways, train stations, large stores and office buildings.

FINDINGS

ELFMA

Due to the simplicity of the design and the material involved in the manufacture of the ELFMA nozzle and fire extinguisher, there are numerous potential manufacturers (more than those that have been identified in this study) for this equipment. There are also numerous manufacturers that are currently producing nozzles, sprinkler systems and fire extinguishers, which reflect a highly competitive market. This situation is a barrier to new competitors that have not yet established

a client base, whereas the current manufacturers have no incentive to produce ELFMA nozzles or fire extinguishers because of their established positions in their respective markets. In addition, the cost of introducing a new fire extinguisher in the market is time consuming (24 to 36 months) and costly (more than US\$ 100K) due to testing and certification requirements.

The base ELFMA patent (United States Patent # 5,520,331), which covers the nozzle, has already been licensed to International Aero (IA) for fire suppression throughout the US. This license covers the patent's use in the aerospace industry, the ground transportation industry, the marine industry, the offshore oil industry, and for buildings and other fixed structures. IA is currently concentrating on the aerospace industry, as it is the company's primary market, but they are willing to work with other companies for applications in other markets.

However, the patent for the ELFMA fire extinguisher has not yet been licensed. This patent would be relevant to companies wanting to manufacture fire extinguishers for the first responders market. At a minimum, the companies identified in the sections on the potential "fire extinguisher manufacturers" could be encouraged to pursue that route.

JFIRE

Due to the lack of a civilian accepted standard (NIOSH) for a CB mask, civilian first responders cannot use the JFIRE mask that uses both CB canister and SCBA. This situation limits the marketing of a commercial off-the-shelf (COTS) ensemble for use by both civilian and military first responders.

Many textile manufacturers are bringing their newest textile or component to AFRL Tyndall AFB for subject matter expertise and opinion. While this approach provides some value to manufacturers, it appears to hold little influence on the developmental direction of the next generation JFIRE.

In the Potential Canadian Manufacturers – JFIRE section, four Canadian companies (Stedfast, Bacou-Dalloz, AirBoss and VRS) were identified as having all complementary components (i.e. textile, garment, boot, glove, mask) that could either contribute to the FSTFRE solution or present a different, but complete, solution to the next generation JFIRE requirement. Taken independently, each company could also be aligned with US partners. This also applies to US companies producing complementary components.

PNVG

PNVGs are at an advanced stage of technology development and the USAF does not hold proprietary rights. The night vision industry in North America is sufficiently large to support the needs of the militaries and the first responders.

The technology currently used in PNVG is an image intensifier tube, commonly called an I² tube. The manufacturers of these tubes are the key players in the industry as the tubes are the critical components of the PNVG. Any other company wanting to manufacture the PNVG would have to get I² tubes from these manufacturers or develop their own. This last strategy would be difficult for the new companies wanting to enter the market because of the investment and specialized skills that are required.

Another type of technology used for night vision is thermal imaging sensors, but the images are not as clear as the images in equipment using I² tube technology. The future trend for this kind of device is to combine both technologies into one system. This will give the end user the best of both worlds. The images will be clearer with the I² tube, but if there is fog or smoke, the user will be able to switch to the thermal imaging sensor, since night vision equipment using an I² tube cannot see through these impediments.

The biggest hurdle to commercializing the PNVG to the first responders' community remains its high cost.

RCLAD

Time Domain is the only company making RCLAD. RCLAD uses time modulated ultra wideband (TM-UWB) impulse radar technology to detect live victims in rubble up to 23 inches thick. Time Domain is primarily a research company with limited manufacturing capability.

Since no other manufacturer makes live victim location devices, the companies most capable of making RCLAD-type devices are GPR manufacturers and TWS manufacturers.

The RCLAD system is being developed by Time Domain Corporation and all the intellectual property associated with the device belongs, or will belong, to the company. Time Domain is a relatively small company that has little internal manufacturing capability. Existing Time Domain technology has been made widely available for licensing and it is likely the company will choose that approach to the RCLAD technology or, alternatively, use contract manufacturing.

A similar technology, Micro Impulse Radar, from LLNL may also become available through other UWB Radar companies. It is possible that two or more private-sector sources of similar technology will be available within two to three years if the technology is proven to be technically viable and the cost structure is acceptable.

The commercialization of RCLAD will depend on the technical capabilities of the device, its unit cost and the availability of competing technologies.

TCU

The TCU, designed and patented by the Naval Surface Warfare Center Carderock Division (NSWCCD), is a box-shaped steel shell with an inner liner of rigid polyurethane foam. The bomb or suspect explosive device is placed inside and is tightly packed with additional foam. If a bomb is detonated in the TCU, the foam pulverizes and the liner deforms into an ovoid or cylindroid shape while slowly venting pressure. The NSWCCD TCU is designed for a one-time use. It is small, lightweight and inexpensive.

The deployed units were made in US DoD facilities because the FAA has not licensed the NSWCCD TCU for commercial production. As the FAA is not expected to broaden the NSWCCD TCU usage beyond the airports within its mandate, no license is expected to be awarded.

Nevertheless, there are already several North American companies making products similar to the NSWCCD TCU. The TCUs designed by these companies vary; they can be mobile or fixed and designed for both, multiple use or single use.

RECOMMENDATIONS

ELFMA

Since the technology involved in ELFMA is within reach of several companies and there are important potential applications for the first responders, further licensing agreements should be encouraged to allow companies to manufacture ELFMA nozzles, sprinkler systems and fire extinguishers for the first responders' community.

Another ELFMA application that has not yet been considered and that has potential for further development is to adapt the ELFMA nozzle for forest fire fighting. The first step could be to demonstrate feasibility in a laboratory environment with larger apparatus and water throughput. The laboratory could then develop a prototype kit and have it installed on a test range firefighting vehicle currently part of the US Army inventory. If successful, the vehicle could then be used in a high-risk area for operational testing.

Further development of ELFMA must include consideration of unit cost to make it affordable and widely available to the local/municipal first responders' community.

JFIRE

From a joint US-Canada military perspective, the next generation JFIRE (possibly the FSTFRE) is where future efforts should be concentrated. Individual suit components were discussed at length to capture the current state of the technology and encourage synergies among the listed companies. Nevertheless, it is recognized that the next iteration of these individual suit components should not be stove-piped independently, but specifically developed with an integration emphasis for the next generation JFIRE. Currently available solutions should not necessarily drive or constrain development (for instance, the bunker suit and JSLIST could be integrated into a single garment instead of two separate ones).

The Air Force, which has the largest firefighter contingent among the US Services, should accelerate development and finalization of their capability development document, highlighting current JFIRE deficiencies. This document is key to early budgetary identification, development and acquisition funding for all US DoD firefighter ensembles.

There is a need to set a standard for civilian use of a CB mask. This would permit civilian first responders, and firefighters in particular, to use the JFIRE. Any future development of the JFIRE CB mask/SCBA should also be acceptable to the civilian first responders' community. This would ensure a COTS solution for both military and civilian personnel, thus reducing unit cost.

Efforts should be better coordinated within the US military and between the US and Canadian militaries in respect to developing a common structural firefighter/CB ensemble requirement. This would also contribute to reducing the unit cost for all potential users, whether they are civilian or military.

PNVG

The DHS and PSEPC should consider acquiring a quantity of PNVGs that could be held in different key locations throughout North America. They could be stored in these locations and made readily available for use by first responders. Adequate training in using these devices should also be delivered to the first

responders' community. Larger municipalities may be able to afford their own devices, but for the smaller communities, a regional pool would provide a capability they cannot afford.

Defense departments could also help drive down the cost of production of these systems by a "design to cost" development program for DoD and DND first responders needs. The resulting products could then be procured at an affordable price by other first responder agencies throughout North America.

RCLAD

One option to help transfer this technology quickly to first responders – assuming that the cost and technical targets are achieved – would be for the DHS to directly acquire some of the devices concurrently with, or prior to, DoD acquisition. These devices could then be made widely available under a grant program to first responders for further testing and evaluation. Direct acquisition by the DHS concurrently with DoD would likely lower the per-unit acquisition cost.

PSEPC could undertake a similar approach. PSEPC is currently setting up several Heavy Urban Search and Rescue teams across Canada. As part of this endeavor, they are creating a list of standard equipment for these HUSAR teams. It is recommended that they add RCLAD to their list.

TCU

No further action is recommended on the NSWCCD TCU as there are comparable products already commercially available.

Airport first responders should also consider the acquisition of other technologies suitable to handle threats other than just explosives (i.e. CB).

These technologies should also be considered for urban bomb containment and disposal in crowded outdoor environments, subways, train stations, large stores and office buildings.

APPENDIX A – ACRONYMS AND DEFINITIONS

ACRONYMS

AAC	AirBoss of America Corporation
AAGR	Average Annual Growth Rate
AD	AirBoss-Defense
AFRL	Air Force Research Laboratory
ANVG	Advanced Night Vision Goggle
ANVIS	Aviators Night Vision Imaging System
ARFF	Air Rescue Fire Fighter

ASD(HD)	Assistant Secretary of Defense Homeland Security
BCC	Business Communications Company
BDG	Bacou-Dalloz Group
BDPAL	Bacou-Dalloz Protective Apparel Ltd
BSM	Basic Sustainment Materiel
BVO	Black Vinyl Over boots
C2	Carbon Dioxide
CB	Chemical/Biological
CBDU	Chemical, Biological Duty Uniform
CBRN	Chemical Biological Radiation Nuclear
CDC	Contained Detonation Chamber
COTS	Commercial Off The Shelf
CPO	Chemical Protection Overgarment
CTS	Clothe the Soldier
CW	Chemical Warfare
CW	Continuous Wave
DDSF TM	Decontamination Dispersal Suppressant Foam
DHS	Department of Homeland Security
DND	Department of National Defence
DoD	Department of Defense
DRDC	Defence Research and Development Canada
DRDC	Defence Research and Development Canada
DSF tm	Dispersal Suppressant Foam
DUST	Dual Use Science and Technology
DVL	Digital Video Logger
EDS	Explosive Detection System
EEC	Environmental Engineering Concepts
ELFMA	Effervescent Liquid Fine Mist Apparatus
EO	Electro Optical
EPA	Environmental Protection Agency
EPTG	Electronic Panoramic Thermal Goggle
FAA	Federal Aviation Administration
FBI	Federal Bureau of Investigation
FCC	Federal Communications Commission
FGS	Fusion Goggle System
FOV	Field of View
FSTFRE	Full Spectrum Threat Fire Response Ensemble
GEN III	Generation III
GLARE	Glass Reinforced
GPR	Ground Penetrating Radar
GSSI	Geophysical Survey Systems Incorporated
GTRI	Georgia Tech Research Institute
GVO	Green Vinyl Overboots
HAZMAT	Hazardous Material

HMST	Helmet Mounted Systems Technology
HULD	Hardened Unit Loading Device
HUSAR	Heavy Urban Search and Rescue
I2	Image Intensification
IED	Improvised Explosive Device
IR	Infra Red
ISN	Institute for Soldier Nanotechnology
JASQ	Joint Alternative Source Qualification
JFIRE	Joint Firefighters Integrated Response Ensemble
JP	Jet Petroleum
JPACE	Joint Service Protective Air Crew Ensemble
JSLIST	Joint Services Lightweight Integrated Suit Technology
kg	kilogram
KPS	Karil Protective Systems
LLNL	Lawrence Livermore National Laboratory
LWIR	Long-Wave Infra Red
mm	Millimeter
MIR	Micro Impulse Radar
MIT	Massachusetts Institute of Technology
MMW	Millimeter Wave
MOU	Memorandum of Understanding
MSA	Mine Safety Appliances
MULO	Multipurpose Overboots
NATIBO	North American Technology and Industrial Base Organization
NATO	North Atlantic Treaty Organization
NAVSEA	Naval Sea Systems Command
NBC	Nuclear Biological Chemical
NCSU	North Carolina State University
NFPA	National Fire Protection Association
NIOSH	National Institute of Occupational Safety and Health
NRC	National Research Council
NSWCCD	Naval Surface Warfare Center Carderock Division
NTS	Next to Skin
NVD	Night Vision Device
OG	Over Garment
OSHA	Occupational Safety and Health Administration
OT	Operational Test
OTT	Office of Technology Transfer
PNVG	Panoramic Night Vision Goggle
POL	Petroleum, Oils, Lubricants
PSEPC	Public Safety and Emergency Preparedness Canada
psi	pounds per square inch
RCLAD	Remote Casualty Location Assessment Device
RCMP	Royal Canadian Mounted Police

RFP	Request for Proposal
SBCCOM	Soldier Biological Chemical Command
SCBA	Self Contained Breathing Apparatus
SDF	Surface Decontamination Foam
SFC	Strike First Corporation
SNAP	Significant New Alternatives Program
SPM	Selectively Permeable Membranes
SSC	System Soldier Center
STS	Specialized Technical Services
TCU	Threat Containment Unit
TDP	Technology Demonstration Program
TM-UWB	Time Modulated Ultra Wide Band
TNT	Trinitrotoluene
TOC	Thales Optronics Canada
TSA	Transportation Security Administration
TWS	Through the Wall Surveillance
UCS	Universal Containment System
ULC	Underwriters Laboratories of Canada
US	United States
USAF	United States Air Force
USNV	US Night Vision
USSOCOM	US Special Forces Command
UWB	Ultra Wide Band
VRS	Vanguard Response Systems
WMD	Weapons of Mass Destruction
WMDCSR	Weapons of Mass Destruction Civil Service Response

DEFINITIONS

NFPA 1971 - Standard on Protective Ensembles For Structural Fire Fighting (ed 2000).

NFPA 1994 - Standard on Protective Ensembles for Chemical/Biological Terrorism Incidents (ed. 2001).