

COPYRIGHT, 1894, BY THE STREET RAILWAY PUBLISHING COMPANY.

VOL. X. NO. 6.

JUNE, 1894.

JUN 4 1894

\$4.00 per Year. Single Copies, 35 Cts.

Entered at New York Post office as second-class matter.

—THE—
STREET RAILWAY JOURNAL,
Havemeyer Building,
New York.

Monadnock Block, Chicago, Ill.
620 Atlantic Ave., Boston, Mass.

Subscriptions \$4 per year, post paid, in the United States, Canada and Mexico. Foreign, \$6 per year, post paid.

EUROPEAN REPRESENTATIVE:
ROBERT W. BLACKWELL,
39 Victoria St., Westminster,
London, Eng.

NEW ADVERTISEMENTS.

JULIUS T. DUDLEY, of New York, mentions his business.
THIEL'S DETECTIVE SERVICE, of New York, urges its claims.
CHARLES M. RUMRILL & BRO., of New York, advertise insulators, etc.
HORSBURGH & SCOTT, of Cleveland, O., advertise their gears and pinions.
THE ST. LOUIS REGISTER CO., of St. Louis, Mo., has a total change in this issue.
THE BERLIN IRON BRIDGE CO., of East Berlin, Conn., has a new illustration.
THE BROWNELL CAR CO., of St. Louis, Mo., has two very entertaining pages.
THE JEWETT CAR CO., of Jewett, O., devotes a half page to its street cars.
THE OHIO BRASS CO., of Mansfield, O., illustrates railway overhead material.
THE WALLACE ELECTRIC CO., of Chicago, draws attention to its rail bond caps.
ALFRED BOX & CO., of Philadelphia, illustrate one of their traveling cranes.
THE WESTON ELECTRICAL INSTRUMENT CO., of NEWARK, N. J., makes a change.
THE LODGE & DAVIS MACHINE TOOL CO., of Cincinnati, advertises machine tools.
THE DEWEY ELECTRIC SIGNAL CO., of New York, explains its car signal system.
LOUIS WARFIELD, of Detroit, Mich., mentions the Detroit motor equipments.
THE PECKHAM MOTOR TRUCK & WHEEL CO., of Kingston, N. Y., has two additional pages.
THE CHANGEABLE ELECTRIC HEADLIGHT CO., of SYRACUSE, N. Y., illustrates its specialty.
THE CENTRAL ELECTRIC HEATING CO., of New York, has a page on its electric heater for cars.
THE DEANE STEAM PUMP CO., of Holyoke, Mass., mentions its pumps and condensing apparatus.
THE ROBINSON ELECTRIC TRUCK & SUPPLY CO., of Boston, Mass., has more about its radial truck.
THE HAMMOND CLEAT & INSULATOR CO., of Boston, illustrates its guard wire and strain insulator.
THE CAR EQUIPMENT CO., of Philadelphia, Pa., has a few words on the merits of the Johnston rail bond.
THE GARVIN MACHINE CO., of New York, has a quarter page devoted to its metal working machinery.
THE WROUGHT IRON BRIDGE CO., of Canton, O., speaks of its business in iron and steel structural work.
THE LEWIS & FOWLER MANUFACTURING CO., of Brooklyn, N. Y., has several pages of new matter in this issue. It illustrates a large number of street car fittings, and has a page showing the popularity of its fare register.

CONTENTS.

Illustrated Articles.

The Cincinnati, Newport & Covington Railway.....	345
Electric Railway Construction in Philadelphia.....	354
The Street Railway System of Terre Haute.....	357
New Suburban Line Near Philadelphia.....	359
William J. Clark.....	368
Editorial Correspondence:—Fort Worth, Dallas.....	369
Track Construction at New Orleans.....	375
The Capital Railway of Frankfort, Ky.....	376
The Johnson-Lundell Surface Contact Electric Railway System	378
The Card Electric Street Railway Motor.....	380
Electric Freight Cars.....	382
Boiler Plant of the Southern Station of the Brooklyn City Ry.	383
San Francisco Cable Sheaves.....	383
The Johnston Rail Bond.....	385
An Electric Headlight.....	385
New Motor Truck.....	385
Works of the Curtis Electric Manufacturing Co.....	386
The Works of a Large Wrought Iron Bridge Co.....	388
New Elliptic Spring Truck.....	389
The Peckham Automatic Life and Wheel Guard.....	390
Compound, Duplex, Double Plunger Pump for Boston.....	390
New "American" Engine.....	391
The Arnold System of Electric Power Station Construction	392
Forty Inch Standard Engine Lathe.....	393
New Electric Heater.....	393
Wooden Faced Brake Shoes.....	393
Car Trimmings.....	394
A Complete Line of Overhead Construction Material.....	396
New Type of Electric Switch.....	396
New Overhead Switch.....	396

Editorial.

Hurry the Bane of Street Railway Operations.....	366
Suggestions Concerning Exhibits at the Atlanta Convention	366
Injury Wrought by Irresponsible Street Railway Promoters.....	366
The Future Prospects of the Electric Railway Business.....	366
Street Railway Companies and the Financial Depression.....	367
The Function of the Street Railway Association.....	367
Our Supplement, "American Street Railway Investments".....	367

Miscellaneous.

The Intrinsic Value of Street Railway Investments.—Sixth Paper.....	360
Suburban Roads in St. Louis.....	375
Wood Paving in Sydney, Australia.....	376
Electric Emergency Ambulances.....	377
Exhibits at the Atlanta Convention.....	382
A Danger Signal for Electric Roads.....	383
New 2,000 H. P. Walker Generators.....	384
Earnings of Street Railroads.....	384
The Brownlee Injector.....	385
Electric Welding of Rails in St. Louis.....	389
\$250 in Prizes.....	393
Annual Report of the Westinghouse Co.....	395
Annual Meeting of the Am. Institute Electrical Engineers	396
Trucks.....	397
Crawford Fenders.....	399
Fenders Adopted in Paterson and Hoboken.....	400
A Well Known Detective Service.....	400
Permanent Pan-American Exhibit.....	401
Electric Launches for Street Railways.....	401
Obituary.....	402
Electric Signals for Street Cars.....	402

Patents.....	403
Quotations of Street Railway Stocks.....	407
Financial.....	410
Street Railway Supply Directory.....	xxxiii
Index to Advertisers.....	v, vi

New Advertisements—Continued.

THE GENERAL ELECTRIC LAUNCH CO., of New York, advertises World's Fair electric launches for sale.
THE VENEER SEATING & CHURCH FURNITURE CO., of Brooklyn, N. Y., returns to the JOURNAL this month.
THE SOUTHWARK FOUNDRY & MACHINE CO., of Philadelphia, gives a new illustration of one of its engines.
THE FULTON TRUCK & FOUNDRY CO., of Cleveland, O., gives a testimonial to the value of the Troy sand box.
THE PHENIX IRON WORKS CO., of Meadville, Pa., has a half page advertisement of the Dick & Church engines.
THE HUBLEY MANUFACTURING CO., of Lancaster, Pa., advertises its various appliances for electric railways.
W. R. BRIXEY, of New York, has four advertisements of Day's Kerite insulation for electric light and power service.
THE PARADIGM CONSTRUCTION CO., of New York, has a page illustrative and descriptive of its system of glass roofing.
THE R. A. CRAWFORD MANUFACTURING CO., of Pittsburgh, Pa., shows the growing popularity of its safety appliances.
THE JOHN SIMMONS CO., of New York, shows the construction of its metallic poles and brackets for electric railways.

AMERICAN STREET RAILWAY ASSOCIATION.

HENRY C. PAYNE, PRESIDENT, Milwaukee, Wis.
W. J. STEPHENSON, FIRST VICE-PRESIDENT, Washington, D. C.
JAMES R. CHAPMAN, SECOND VICE-PRESIDENT, Grand Rapids, Mich.
LEWIS PERRINE, JR., THIRD VICE-PRESIDENT, Trenton, N. J.
WM. J. RICHARDSON, SECRETARY AND TREASURER, Brooklyn, N. Y.
EXECUTIVE COMMITTEE—THE PRESIDENT, VICE-PRESIDENTS, and D. F. LONGSTREET, DENVER, COLO.; THOMAS H. MCLEAN, INDIANAPOLIS, IND.; EDWARD WHITTAKER, ST. LOUIS, MO.; W. Y. SOPER, OTTAWA, CAN.; and E. S. GOODRICH, HARTFORD, CONN.
Next meeting, Atlanta, Ga., third Wednesday in October, 1894. Special committees to report are as follows:
Can the T Rail be Satisfactorily Used in Paved Streets? Joel Hurt, Pres. Atlanta Cons. St. Ry. Co., Atlanta, Ga.; S. Hendrie, Mgr. Wyandotte & Detroit River Ry. Co., Detroit, Mich.; H. J. Crowley, Engr. Atlanta Cons. St. Ry. Co., Atlanta, Ga.
City and Suburban Electric Railways. Elwin C. Foster, Supt. Lynn & Boston R. R., Boston, Mass.
Mail, Express and Freight Service on Street Railway Cars. Richard McCulloch, Elec. Engr. Citizens' Ry. Co., St. Louis, Mo.
The Best Method of Treating Accidents and Complaints. John B. Parsons, Gen. Mgr. West Chicago St. R. R. Chicago, Ill.
Street Car Wheels and Axles. D. S. Cook, Elec. Engr. Trenton Pass. Ry. Co., Trenton, N. J.
Transfers and Commutation. Rodney Curtis, Pres. Denver Tramway Co., Denver, Colo.
The T Rail Construction of the Terre Haute Street Railway Company. M. F. Burke, Supt. Terre Haute St. Ry.
A Standard Form of Street Railway Accounts. H. I. Bettis, Cons. Engr. Atlanta Cons. St. Ry. Co., Atlanta, Ga.
A directory of State Street Railway Associations will be found on page 26.

AMERICAN STREET RAILWAY INVESTMENTS,

A Supplement to the STREET RAILWAY JOURNAL. Ready for Delivery June 15. Price \$5.00, STREET RAILWAY PUBLISHING CO., New York.

THE MEDBERY INSULATION FOR ELECTRIC RAILWAYS.

HIGHEST ELECTRICAL RESISTANCE, AND GREATEST TENSILE STRENGTH. THE BEST IN THE WORLD. EVERY PIECE GUARANTEED.

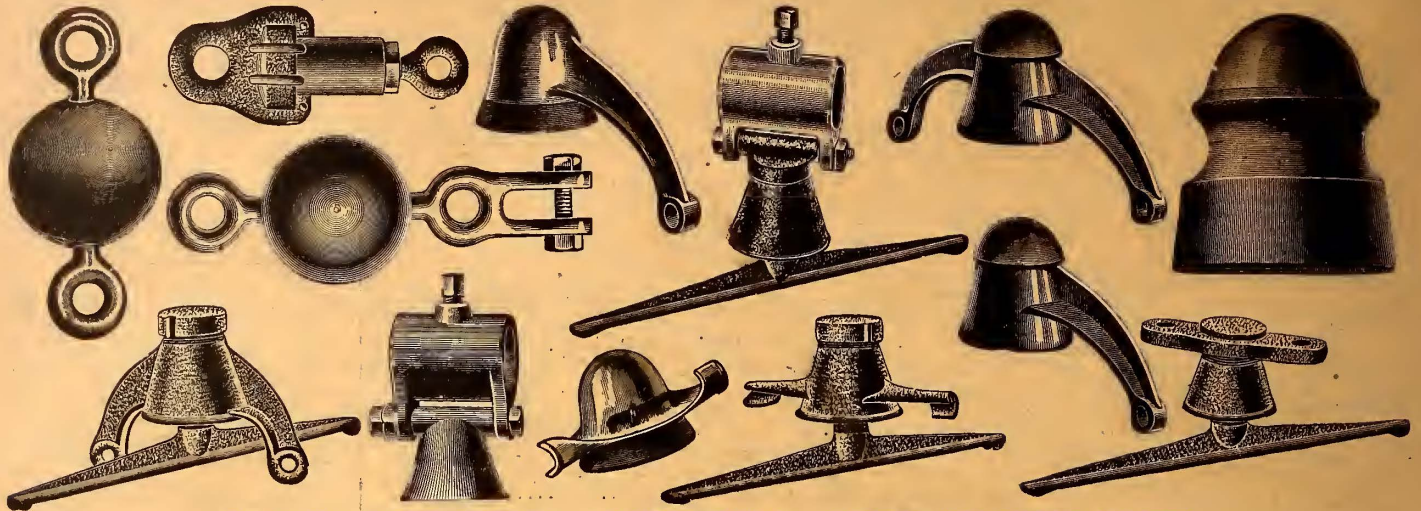

ALL METAL PARTS BRONZE. 5-8 INCH STUDS. ADOPTED AND IN USE BY THE BEST RAILROADS IN THE COUNTRY.

THE FIBERITE CO.,

MECHANICVILLE, N. Y.

Write for Catalogue and Discounts.

SALES AGENTS:

PETTINGELL-ANDREWS CO., BOSTON, MASS., NEW ENGLAND AGENTS,
MASON ELECTRIC CO., CHICAGO, ILL., WESTERN SALES AGENTS.

The Technic Electric Works, Philadelphia, Pa.
H. J. Wightman & Co., Scranton, Pa.
H. C. Willis, Baltimore, Md.

F. P. Little Electric Construction & Supply Co., Buffalo, N. Y.
The Electric Railway Equipment Co., Cincinnati, O.

Central Union Brass Co., St. Louis, Mo.
Southern Electric Supply & Mfg. Co., New Orleans, La.
Reger & Atwater, San Francisco, Cal.
The Mountain Electric Co., Denver, Colo.



GOOD POINTS *Scarritt* STREET CAR SEATS

Has Most Seating Room for Least Space Used.

Is Reversible and Tiltting. Can't Get Out of Order. Simple, Clean, Most Comfortable and Durable Made. THEY ARE "THE BEST." Reversible and Longitudinal Seating. Rattan, Leather or Wood. Our "Reversible" is the same as our popular seat used on steam roads throughout the world. Photographs of many styles furnished. Correspondence solicited. Largest Car Seat Works in the World.

Scarritt Furniture Co., St. Louis, Mo.

THE LATEST.

Guard Wire and Strain Insulator.

Adopted by West End Street Railway Company, Boston, Mass.

THE CHEAPEST.

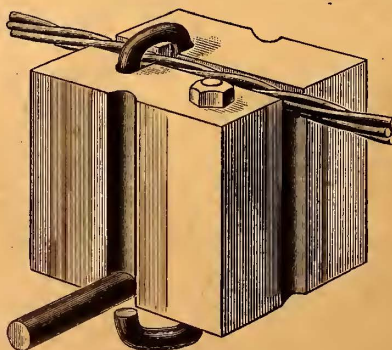

THE SIMPLEST.

Hammond Cleat & Insulator Co.,
15 Custom House St.,
BOSTON, MASS., U. S. A.

Send for Catalogue "A."

THE BEST.

John Simmons Company,

MANUFACTURERS OF

STEEL AND IRON POLES AND BRACKETS

FOR ELECTRIC RAILWAYS.

Wrought, Cast Iron and Steel Pipe and Fittings. Brackets of any Style or Description Made to Order. Supplies for Steam, Water, Gas, Oil and Electric Engineering.

106, 108, 110 Centre Street,

NEW YORK.

AETNA RAILWAY INSULATORS

RECEIVED WORLD'S FAIR AWARD.

ANDERSON LINE MATERIAL.

ALL FULLY GUARANTEED. WILL SAVE CURRENT AND PREVENT "TROUBLE."
IMITATIONS DO NOT BEAR REGISTERED AETNA TRADE MARK.



MANUFACTURED AND SOLD BY

ALBERT & J. M. ANDERSON,

Established 1877.

289-293 A St., Boston, Mass.

THE DEANE,

OF HOLYOKE.

STEAM PUMPS

FOR EVERY PURPOSE.

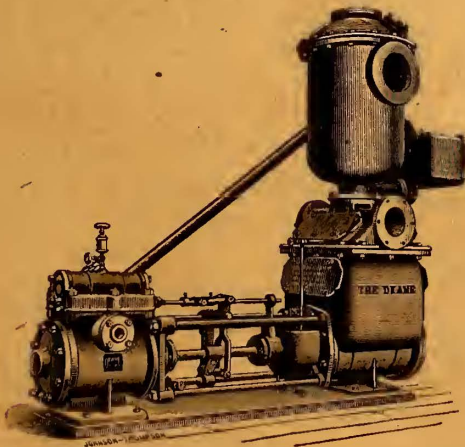

DEANE INDEPENDENT CONDENSING APPARATUS.

DEANE STEAM PUMP CO.,

HOLYOKE, MASS.

New York, Boston, Chicago, Philadelphia, St. Lou's.

The Garvin Machine Co.

Manufacturers of and Dealers in

METAL-WORKING MACHINERY

OF ALL KINDS.

LATHES, PLANERS, SHAPERS, DRILLS, PLAIN AND
UNIVERSAL MILLING MACHINES, SCREW
MACHINES, TURRET LATHES, GRIND-
ING MACHINERY, &c.



LATHES FOR ALL PURPOSES.
11 inch x 4 feet to
36 inch x 16 feet
CONSTANTLY ON HAND.

WE CARRY THE LARGEST STOCK

OF

New and Second - Hand Machinery

ANYWHERE IN THE EAST.

Write for Catalogue and Lists of Machinery
Now Ready for Delivery.

ORDERS FILLED WITHOUT DELAY.

Laight and Canal Sts., NEW YORK, N. Y.

Also 51 North 7th St. Philadelphia, Pa.

Wheeler Condenser & Engineering Co.

39 and 41 CORTLANDT STREET, NEW YORK.

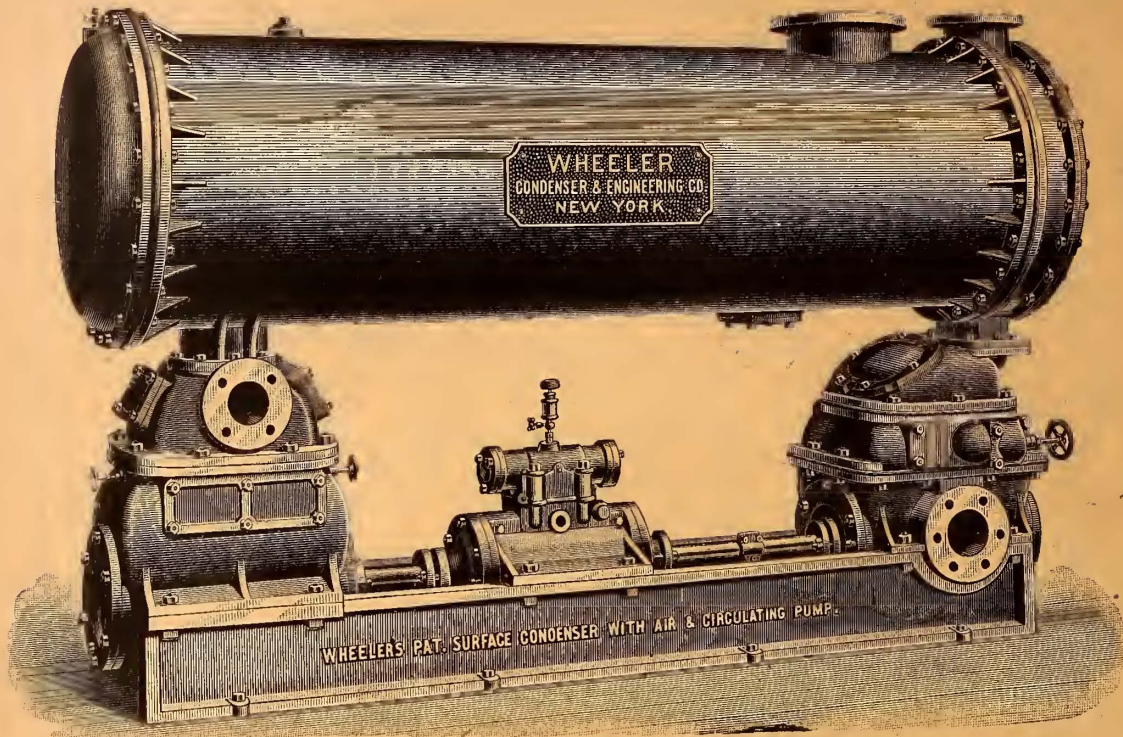

WHEELER'S
 IMPROVED
 SURFACE
 CONDENSER

Combined with Air and Circulating Pumps.



WHEELER-
 ADMIRALTY
 SURFACE
 CONDENSER

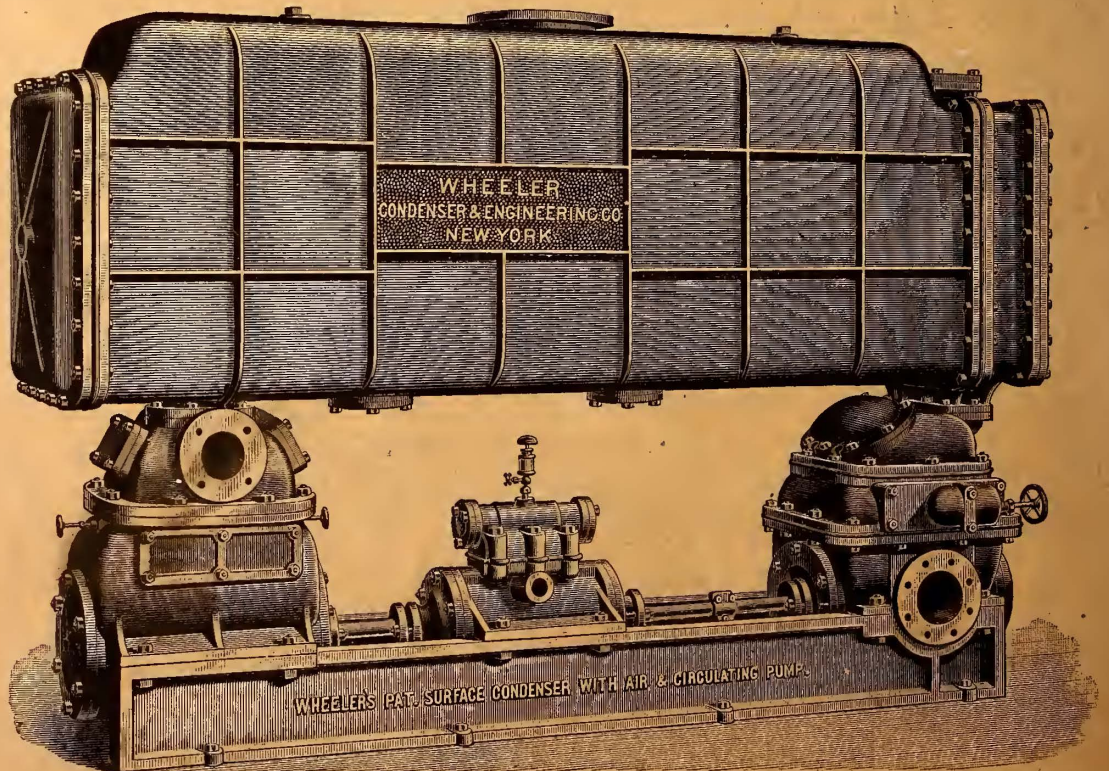

Condensers and Pumps for Mills, Mines, Electric Light and Railway Power Stations.

INDEX TO ADVERTISERS.

Allen, James A., Philadelphia, Pa.	xiv	Dorner & Dutton Manufacturing Co., Cleveland, O.	35, 71
Allis, Edward P., Co., The, Milwaukee, Wis.	52	Dudley, Julius T., & Co., New York.	30
Altoona Manufacturing Co., Altoona, Pa.	49	Eastern Electric Cable Co., Boston, Mass.	27
American Car Co., St. Louis, Mo.	116	Economy Trolley Co., Chicago, Ill.	37
American District Steam Co., Lockport, N. Y.	76	Eddy Electric Manufacturing Co., Windsor, Conn.	xli
American Electrical Works, Providence, R. I.	72	Electric Railway Equipment Co., Cincinnati, O.	76
American Hard Fibre Co., Newark, Del.	77	Electric Storage Battery Co., The, Philadelphia, Pa. ...	45
American Rail Joint Co., Marion, Ind.	61	Elec. & Mechanical Eng. & Trading Co., New York. ...	vii
Ames Iron Works, Oswego, N. Y.	46	Ellis Car Co., Amesbury, Mass.	119
Ames Register Co., Boston, Mass.	88	Eppley, Francis M., New York.	37
Anderson, A. & J. M., Boston, Mass.	iii	Fiberite Co., The, Mechanicville, N. Y.	ii
Anthony, Wm. A., Vineland, N. J.	31	Fibre Conduit Co., New York.	xxxviii
Arnold, B. J., Chicago, Ill.	31	Field & Beattie, New York.	77
Ashley, Frank M., New York.	31	Field, C. J., New York.	411
Babcock & Wilcox, New York.	58	Field Life Guard Co., Providence, R. I.	90
Ball & Wood Co., The, New York.	54	Fishkill Landing Mach. Co., Fishkill-on-Hudson, N. Y. ...	56
Ball Engine Co., Erie, Pa.	51	Fitzgerald-Van Dorn Co., The, Lincoln, Neb.	60
Barbour, Stockwell & Co., Cambridgeport, Mass.	38	Fleming, W. R., & Co., New York.	46
Barney & Smith Car Co., Dayton, O.	108	Floyd, James R., & Sons, New York.	64
Bates Machine Co., Joliet, Ill.	45	Foster Automatic Safety Guard Co., New York.	90
Bemis Car Box Co., The, Springfield, Mass.	70	Fowler, Geo. L., New York.	30
Berlin Iron Bridge Co., East Berlin, Conn.	93	Fowler, J. W., Car Co., Elizabethport, N. J.	122
Bevin Bros. Manufacturing Co., East Hampton, Conn. ...	98	French, S. A., New York.	26
Bickford, J. H., Salem, Mass.	31	Frost Veneer Seating Co., New York.	xxx
Billings & Spencer Co., Hartford, Conn.	44	Fuel Economizer Co., The, Matteawan, N. Y.	57
Blackwell, Robt. W., London, Eng.	30	Fulton Foundry & Machine Works, Brooklyn, N. Y., xxxii	
Box, Alfred, Philadelphia Pa.	xxxviii	Fulton Truck & Foundry Co., Cleveland, O.	xxxvi
Briggs Carriage Company, Amesbury, Mass.	104	Gagnier-Griffin Susp'd Ry. Bridge Co., Chicago, Ill. ...	xxx
Brightman Stoker Co., Cleveland, O.	55	Garvin Machine Co., New York.	iii
Brill, J. G. Co., Philadelphia, Pa.	124, 125	General Electric Co., Schenectady and New York.	xliv, xliii
Brixey, W. R., New York.	x, xi, xii, xiii	General Electric Launch Co., New York.	40
Brooklyn Railway Supply Co., Stamford, Conn.	77	General Incandescent Arc Light Co., New York.	xv
Brownell Car Co., St. Louis, Mo.	112, 113	Genett Air Brake Co., New York and Chicago, Ill.	123
Buckeye Engine Co., Salem, O.	52	Gleason & Bailey Manufacturing Co., New York.	77
Buffalo Forge Co., Buffalo, N. Y.	viii	Globe Iron Works, New York.	67
Burnham & Duggan Ry. Appliance Co., Boston, Mass. ...	56	Goubert Manufacturing Co., The, New York.	57
Burrowes, E. T., Co., The, Portland, Me.	97	Graham Equipment Co., Boston and Philadelphia.	66
California Wire Works, San Francisco, Cal.	78	Groetzinger, A., & Sons, Allegheny Pa.	98
Cambria Iron Co., Philadelphia, Pa.	37	Habirshaw Wire, Yonkers, N. Y.	xxxiv
Car Equipment Co., The, Philadelphia, Pa.	37	Hale & Kilburn Mfg. Co., Phila, N. Y., Chicago.	25
Carleton & Kissam, Boston, New York, etc.	120	Hall, J. P., New York.	31
Central Electric Heating Co., New York.	41	Hallowell, Eli B., & Co., Philadelphia, Pa.	vii
Changeable Elec. Headlight Co., The, Syracuse, N. Y. ...	37	Hammond Cleat & Insulator Co., Boston Mass.	ii
Chester Steel Castings Co., Philadelphia, Pa.	43	Hampson, Edw. P., & Co.	v
Chicago Electric Truck Co., Chicago, Ill.	67	Harrington, Edwin, Son & Co., Incor. Phila. Pa.	61
Clarke, F. H., Springfield, O.	92	Harrington, Robinson & Co., Boston, Mass.	28
Cleveland Construction Co., Akron, O.	31	Harrisburg Foundry & Machine Co., Harrisburg, Pa. ...	46
Clonbrock Steam Boiler Works, Brooklyn, N. Y.	59	Hathaway, Alfred G., Cleveland, O.	81
Colby, C. B. & W. H., Philadelphia, Pa.	31	Hazard Manufacturing Co., Wilkesbarre, Pa.	78
Complete Electric Construction Co., New York.	26	Hazelton, Wm., 3d, New York.	82
Comstock, The Louis K., Co., Chicago, Ill.	31	Heine Safety Boiler Co., St. Louis, Mo.	57
Consolidated Car Heating Co., Albany, N. Y.	96	Higgins, Edward E., New York.	411
Conway, M. W., Brooklyn, N. Y.	30	Hill, W. S., Electric Co., Boston, Mass.	viii
Cooper, C. & G., & Co., Mt. Vernon, O.	28, 49	Hine & Robertson, New York.	28
Corresp. School Mech. & Indust. Sciences, Scranton, Pa. ...	39	Hirsch, L. K., Chicago, Ill.	29
Cradock, George, & Co., Wakefield, England.	80	Hoffmann & Billings Mfg. Co., Milwaukee, Wis.	55
Craig, Wm. P., East Orange, N. J.	30	Hooper, W. E., & Sons, Baltimore, Md.	viii
Crawford, R. A., Manufacturing Co., Pittsburgh, Pa. ...	92	Hooven, Owens & Rentschler Co., Hamilton, O.	51
Creaghead Engineering Co., The, Cincinnati, O.	77	Hoppes Manufacturing Co., The, Springfield, O.	57
Currier, Mayo & Co., Boston, Mass.	50	Horsburgh & Scott, Cleveland, O.	viii
Curtis Electric Mfg. Co., Jersey City, N. J.	xl	Hotel Hanover, Philadelphia, Pa.	xxii
Davidson, M. T., Brooklyn, N. Y.	56	Hubley Manufacturing Co., Lancaster, Pa.	412
Davis, Lewis K., New York.	31	Hunt, C. W., Co., New York.	79
Davis, W. S., & Sons, Concord, N. H.	vii	Hutchinson, A. J., New York.	30
Deane Steam Pump Co., Holyoke, Mass.	iii	Huxley & Hoffman, Boston, Mass.	31
Delaware Hard Fibre Co., Wilmington, Del.	vii	Ide, A. L., & Son, Springfield, Ill.	56
Dewey Electric Signal Co., New York.	38	Insulated Electric Light Wires, New York.	vi
DeWitt, E. F., & Co., Lansingburgh, N. Y.	98	Jackson & Sharp Co., Wilmington, Del.	109
Dick, Kerr & Co., London, Eng.	62	Jewett Car Co., Jewett, O.	96
Dickson Manufacturing Co., Scranton, Pa.	82	Johns, H. W., Manufacturing Co. New York.	72
Dixon, Joseph, Crucible Co., Jersey City, N. J.	28	Jones' Sons, J. M., West Troy, N. Y.	121



EDWARD P. HAMPSON. WILLIAM F. HARING.
EDWARD P. HAMPSON & CO.,
 ENGINEERS AND CONTRACTORS,
36 CORTLANDT STREET, NEW YORK.

Make a Specialty of Equipping and Installing High Class Steam Power Plants for Electric Lighting and Electric Railway Work.
 Over 3,200 Engines in Use in all Parts of the World.
 Correspondence and an Opportunity to Estimate Solicited. Over Thirty Years' Practical Experience.

Keasbey, Robert A., New York.....	44	Rosenbaum, Wm. A., New York.....	31
Keithley, H. R., Chicago, Ill.....	76	Ruff, W. H., Washington, D. C.....	39
Kuhlman, G. C., Co., Cleveland, O.....	98	Rumrill, Charles M., & Bro. New York.....	38
"L. P. & D." Transmitter Co., Montpelier, Vt.....	VII	Safety Car Heating & Lighting Co., New York.....	96
Laclede Car Co., St. Louis, Mo.....	110, 111	Safety Clutch Brake Co., The, Philadelphia, Pa.....	94
Lake, J. H. & D., Co., Massillon, O.....	64	St. Louis Car Co., St. Louis, Mo.....	83, 114, 115
Lane & Bodley Co., The, Cincinnati, O.....	53	St. Louis Register Co., St. Louis, Mo.....	86
Leonard, H. Ward, & Co., New York.....	26	Scarritt Furniture Co., St. Louis, Mo.....	11
Leonhardt Pneumatic Car Fender Co., Baltimore, Md.....	91	Schieren, Chas. A., & Co., New York.....	xxxv
Lewis & Fowler Girder Rail Co., The, Brooklyn, N. Y.....	103	Schumacher, T., Chicago, Ill.....	28
Lewis & Fowler Mfg Co., Bklyn...99, 100, 101, 102, 86 A, 86 B		Scott, Charles, Spring Co., Philadelphia, Pa.....	65
Lewis, Samuel, Brooklyn, N. Y.....	84	Shaw, Benjamin F., Wilmington, Del.....	47
Link-Belt Engineering Co., Nicetown, Pa.....	60	Sheppard Manufacturing Co., Louisville, Ky.....	66
Livingston, Chas. Ludlow, Pittsburgh, Pa.....	30	Shook, Anderson Manufacturing Co., Pittsburgh, Pa..	47
Lobdell Car Wheel Co., Wilmington, Del.....	VII	Shriver, T., & Co., New York.....	61
Lodge & Davis Machine Tool Co., Cincinnati, O.....	44	Shultz Belting Co., St. Louis, Mo.....	60
Loss, C. E., & Co., Chicago, Ill.....	411	Siemens & Halske Electric Co., of America, Chicago, Ill.	29
Loud, H. M., & Sons Lumber Co., Au Sable, Mich....	VII	Simmons, John, Co., New York.....	11
McCarthy, F. E., & Co., Boston, Mass.....	30	Sjoberg, J. P., & Co., New York.....	92
McClure, Chas. L., New York.....	xvii	Smith, Edward & Co., New York.....	xxxiii
McEwen, J. H., Mfg. Co., Ridgway, Pa.....	53	Smith, Josephine D., New York.....	106
McGuire Manufacturing Co., Chicago, Ill.....	69	Smith, Thos. G., Jr., Cincinnati, O.....	
McIntosh, Seymour & Co., Auburn, N. Y.....	50	Société Etablissements Arbel, Rive-de-Gier France...	82
McNally, Thomas, Pittsburgh and Indianapolis.....	30	Solar Carbon & Manufacturing Co., Pittsburgh, Pa...	72
Mailloux, C. O., New York.....	37	Southwark Foundry & Machine Co., Philadelphia, Pa.	52
Maloché, H. J., New Orleans, La.....	31	Standard Paint Co., New York.....	60
Mason Electric Co., Chicago, Ill.....	36	Stanwood Manufacturing Co., Chicago, Ill.....	95
Meaker Manufacturing Co., Chicago, Ill.....	87	Steel Motor Co., Cleveland, O.....	73
Mertes, A., Manufacturing Co., Allegheny, Pa.....	25	Steel Rail Supply Co., New York.....	25
Meyer Julius, New York.....	31	Stephenson, John, Co., Limited, New York.....	126
Moore, Alfred F., Philadelphia, Pa.....	36	Sterling Supply & Manufacturing Co., New York....	89
Morris, Tasker & Co., Philadelphia, Pa.....	xxxii	Stern & Silverman, Philadelphia, Pa.....	31
Morse, C. D., Car Mfg. Co., Millbury, Mass.....	97	Stirling Co., The, Chicago, Ill.....	42, 59
Morse, Williams & Co., Philadelphia, Pa.....	56	Strieby & Foote, Newark, N. J.....	44
Mosher Electric Co., Chicago, Ill.....	43	Sturtevant, B. F., & Co., Boston, Mass.....	55
Mundt & Sons, New York.....	27	Taylor Electric Truck Co., Troy, N. Y.....	68
Munsell, Eugene, New York.....	29	Thayer, William C., Cleveland, O.....	31
Munson, Charles, Belting Co., Chicago, Ill.....	46	Thiel's Detective Service, New York.....	26
Murray, J. D., New Brunswick, N. J.....	30	Time Transfer Printer Mfg. Co., Pittsburgh, Pa.....	84
National Railroad Detective Agency, Newark, N. J...	26	Trenton Iron Co., Trenton, N. J.....	78
Neftel, O'Connor & Co., Incorporated, New York....	30	Trimble, Jas. A., New York.....	92, 107
New Castle Car Manufacturing Co., New Castle, Pa...	117	Tupper, W. W., & Co., New York.....	56
New Haven Car Register Co., New Haven, Conn.....	83	U. S. Steam & St. Ry. Adver'g. Co., Boston, N.Y., etc..	120
New Process Raw Hide Co., The, Syracuse, N. Y.....	75	United Columbian Electric Co., The, New York.....	XLI
New York Electrical Works, New York.....	75	Van Nuis, C. S., New York.....	ix
New York Equipment Co., New York.....	411	Vener Seating & Church Furniture Co., Bklyn, N. Y.	27
Newburyport Car M'fg. Co., Newburyport, Mass.....	98	Vose Spring Co., The, New York.....	64
Nuttall, R. D., Co., Allegheny, Pa.....	75	Vulcanized Fibre Co., New York.....	56
Office Specialty Manufacturing Co., New York.....	97	Wadhams Oil & Grease Co., Milwaukee, Wis.....	25
Ohio Brass Co., Mansfield, O.....	74	Wakefield Electrical Engineering Co., Philadelphia, Pa..	31
Okonite Co. (Ltd.), The, New York.....	xxix	Wales Manufacturing Co., Syracuse, N. Y.....	84
Otto Gas Engine Works, Philadelphia, Pa.....	53	Walker Manufacturing Co., Cleveland, O.....	XLII
Paradigm Construction Co., New York.....	xxxix	Wallace Electric Co., Chicago, Ill.....	xxxviii
Parker, J. W., & Co., Philadelphia, Pa.....	xxviii	Warfield, Louis, Detroit, Mich.....	37
Partridge, Arthur S., St. Louis, Mo.....	105	Washburn & Moen Manufacturing Co., Worcester, Mass	79
Peckham Motor Truck & Wheel Co., Kingston, N.Y., A, B, C, D		Watson & Stillman, New York.....	43
Pennsylvania Iron Works Co., Philadelphia, Pa.....	63	Webster, Warren, & Co., Camden, N. J.....	47
Pepper & Register, Philadelphia, Pa.....	31	West End Street Railway Co., Boston, Mass.....	36
Pfingst, Louis, Boston, Mass.....	91	Westinghouse Electric & Mfg. Co., Pittsburgh, Pa....	76
Philadelphia Engineering Works (Ltd.), Phila., Pa....	45	Westinghouse, Church, Kerr & Co., New York.....	48
Phœnix Iron Works, Cleveland, O.....	61	Weston Electrical Instrument Co., Newark, N. J.....	25
Phœnix Iron Works Co., Meadville, Pa.....	54	Wetherill, Robert, & Co., Chester, Pa.....	53
Phosphor Bronze Smelting Co., Philadelphia, Pa.....	37	Wetmore, A. B., New York.....	xxx
Pierce & Miller Engineering Co., New York.....	50	Wharton, Wm., Jr., & Co. Philadelphia, Pa.....	65
Pitt, Wm. R., Composite Iron Works, New York.....	25	Wheeler Condenser & Engineering Co., New York....	iv
Pittsburgh Steel Hollow Ware Co., Allegheny City, Pa.	74	Wheeler Reflector Co., Boston, Mass.....	25
Pullman's Palace Car Co., Chicago, Ill.....	118	White Manufacturing Co., The, New York.....	67
Railway Register Manufacturing Co., New York.....	85	White Crosby Co., Baltimore, Md.....	411, 412
Ralston & Co., Philadelphia, Pa.....	28	Willcox, E. B., Brooklyn, N. Y.....	xxxii
Rankin, W. L. & Bro., Latta, S. C.....	31	Wilmot & Hobbs Manufacturing Co., New York....	412
Reed & McKibbin, New York.....	411	Woodbridge & Turner Engineering Co., New York...	411
Reliable Detective Agency, The, New York.....	26	Woodman, Joel H., Hoboken, N. J.....	xxxvii
Reliance Gauge Co., Cleveland, O.....	412	Woodman, The R., M'fg & Supply Co., Boston, Mass.viii	
Robinson Electric Truck & Supply Co., Boston, Mass.	68	Wrought Iron Bridge Co., Canton, O.....	43
Roebbling's, John A., Sons Co., Trenton, N. J.....	81	Yeats Engineering Co., Chicago, Ill.....	58
		Young Lock Nut Co., New York.....	36



INSULATED ELECTRIC LIGHT WIRES, 203 Broadway N. Y.

Write for Prices.

Have stood the longest life test. Is the oldest and best known high grade insulation in the market. Is specified by leading architects. Is indorsed by every board of Fire Underwriters and city Electricians in the United States.

LOBDELL CAR WHEEL CO., THE "L. P. & D." SYSTEM

WILMINGTON, DELA.

Makers of all Kinds of Wheels,

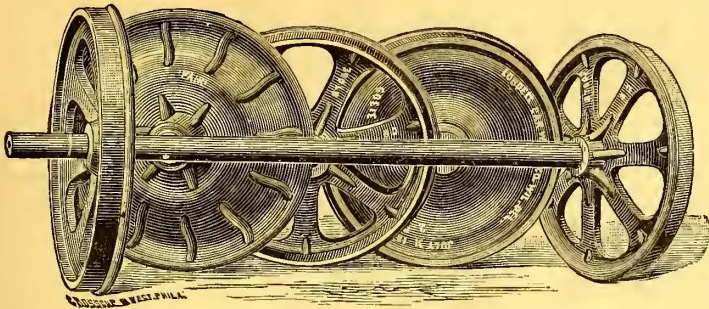

FOR ELECTRIC MOTORS, CABLE CARS, HORSE RAILWAYS AND TRAMWAYS,

Delaware Hard Fibre Co.

The BEST all around

INSULATOR FOR ELECTRICAL WORK.

Send for Catalogue and Samples.

FACTORY, WILMINGTON, DEL.

EUROPEAN STORE, 15 LONG LANE, LONDON, E. C.



"YELLOW PINE" Octagon Poles, Ties

AND CAR SILLS.

Prompt Deliveries. Poles Creosoted and Painted. Correspondence Solicited.

ELI B. HALLOWELL & CO.,

10 South Broad St., Philadelphia.

Of Transmitting Power to Dynamos and Generators,

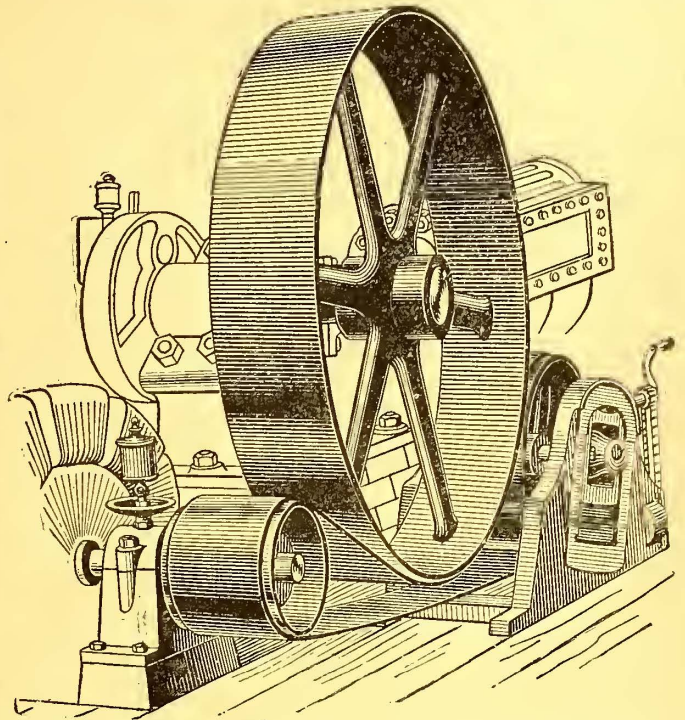

SUCCEEDS WHERE OTHERS FAIL.

SAVES SPACE, POWER AND EXPENSE.

Catalogue, giving full particulars, sent on application.

THE "L. P. & D." TRANSMITTER CO.

MONTPELIER, VT.,

Sole Manufacturers.

G. H. ALMON, 136 Liberty St., New York.

J. W. PARKER & CO., 41 N. 7th St., Philadelphia, Pa.

F. R. DRAVO & CO, Lewis Building, Pittsburgh, Pa.

TOWER WAGON

FOR REPAIRING AND CONSTRUCTING ELECTRIC RAILROADS.

PRICES ON APPLICATION.

MANUFACTURED BY

W. S. Davis & Son,

CONCORD,

N. H.

Patented May 23, 1893.

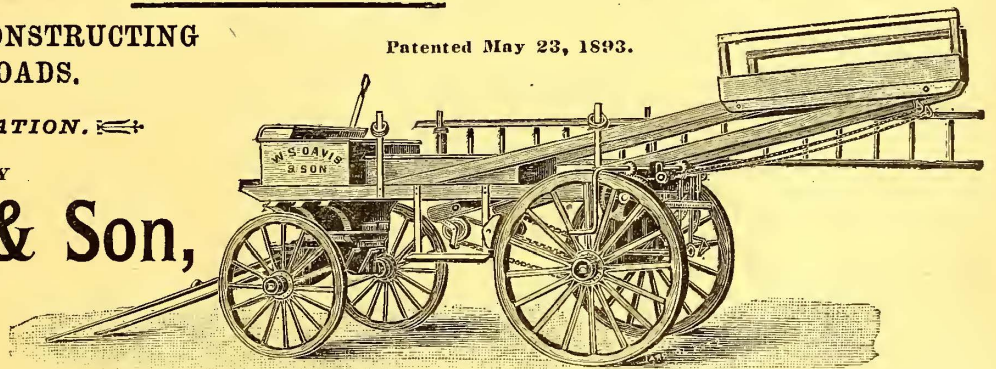

THE N. M. LOUD & SONS LUMBER CO.,

AUSABLE, MICH.

YELLOW ³/₄ MICHIGAN NORWAY PILING.

ROUND ³/₄ OCTAGONAL POLES.

CEDAR TELEGRAPH POLES,

CROSS ARMS ³/₄ TIES.

BRANCH OFFICE: 39 CORTLANDT ST. NEW YORK.

CEDAR POLE

OCTAGONAL POLE

TO ELECTRIC RAILWAY COMPANIES.

Do you lose 20 to 40 per cent. between dynamo and motors?

Our system of complete metallic circuit, fully utilizing track to maximum conductive capacity,

Absolutely stops electrolysis

of Gas and Water Pipes, reduces drop of Potential and raises the entire electric railway system to higher operative economy.

Address,

J. H. VAIL, President

Electrical and Mechanical Engineering and Trading Company,

39 CORTLANDT ST., N. Y.



NOW

Look out for **THUNDER** storms and protect yourselves and apparatus by ordering at once the

DOANE LIGHTNING ARRESTER.

It is absolutely positive, and limits the current following the lightning discharge to an amount that cannot do any possible injury.

If you are in search of **High Grade, Railway, Incandescent, Alternating or Power**

SWITCH-BOARDS AND SWITCHES,

write us, and we can fit you out at short notice. **Rotating and Stationary**

FAN MOTORS

That run noiseless and perfectly cool **WITHOUT THE USE OF OIL.**

RHEOSTATS AND DIMMERS

Of our own design. Send for Catalogue.

W. S. Hill Electric Co.,

133 Oliver St., Boston, Mass.

Represented in New York by the Elson & Brewster Engineering Co., 143 Liberty St.

Buffalo Special Steam Fans

WITH DOUBLE UPRIGHT ENCLOSED ENGINES,
For Forced or Induced Draught.

Burn Hard Coal Screenings or Slack,

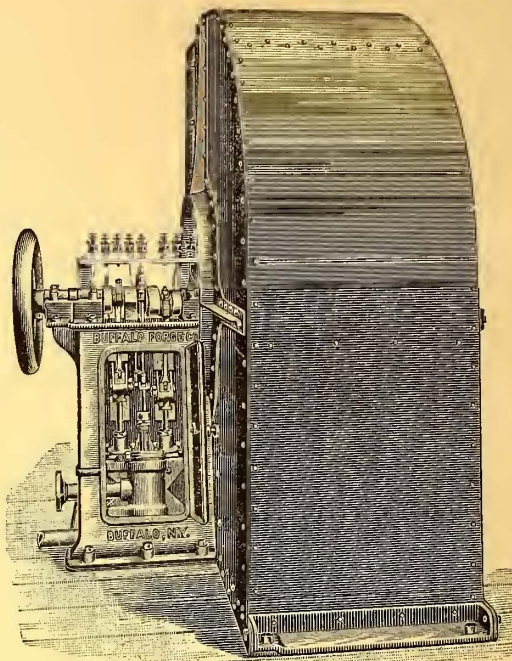

And Save 50 per cent in Cost of Fuel.

THE BUFFALO FAN SYSTEM IS ESPECIALLY ADAPTED TO HEATING CAR SHOPS AND ALL LARGE BUILDINGS.

Plans for installation, specifications and statements as to economy from prominent users, with full construction description, and 288 page catalogue, free on application.

BUFFALO FORGE CO., Buffalo, N. Y., U. S. A.

COTTON ROPE

IN 3/4 INCHES DIAMETER AND SMALLER SIZES FOR

TRANSMISSION of POWER

And Other Purposes.

FOR SALE BY

WM. E. HOOPER & SONS,

MANUFACTURERS,

26 South Frederick Street, Baltimore.

74 BROAD STREET, NEW YORK.

246 MARKET STREET, PHILADELPHIA:

Manufacturers of Woodberry and Druid Mills Cotton Duck, all widths and numbers, Osnaburgs, Seine Twine, Wrapping and Sewing Twines, Lamp, Stove, Candle and Torch Wicks, Banding and Tapes.

DUCK FOR CAR CURTAINS, CAR SEATS AND CAR ROOFS.

Wicks for Lamps and Torches. Cotton Waste.

The R. Woodman Mfg. & Supply Co.

 63 Oliver St., Boston, Mass., U. S. A.

 MANUFACTURERS OF THE

R. Woodman Celebrated Cast Steel Ticket Punches.

Pat. Oct. 2, 1883.

 Almost universally used in this country and abroad on Electric Tram and Cable and Steam Roads for the cancellation of transfer and other tickets, where they give perfect satisfaction. We also manufacture a full line of Patent Lead Seals, Wires and Patent Sealing Presses used in Sealing Electric Meters, Freight Cars, Water Works, and for a number of other purposes. Descriptive circulars of these goods will be sent on application. Correspondence solicited.

HORSBURGH & SCOTT,

CLEVELAND, OHIO.

Manufacturers of

Cast Steel Gears,
Cast Iron Gears,
Steel Pinions
 AND
RAWHIDE PINIONS
 FOR
ELECTRIC MOTORS.

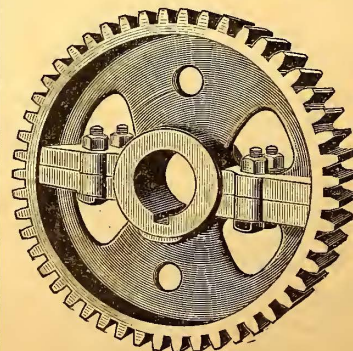

DIRECTORY OF STREET RAILWAYS IN THE UNITED STATES AND CANADA.

COMPILED FROM DATA FURNISHED THE EDITORS OF THE "STREET RAILWAY JOURNAL,"
BY THE OFFICERS OF THE VARIOUS ROADS.

Officials of Street Railways are earnestly requested to observe whether their roads are properly represented in this directory, and if not to send us the facts to make every item correct. For use in the July issue, directory matter must reach us by June 13.

ABBREVIATIONS.—m, miles of track; m s, miles of street; g, gauge; lb r, pounds rail to the yard; c-b r, center-bearing rail; s-b r, side-bearing rail; c, cars; m. c. motor cars; t. c. trolley cars; g. c. grip cars; h, horses; mu, mules.

Officers' addresses are the same postoffice as the company unless otherwise specified.

The figures of track mileage mean entire length of single track, counting one mile of double track as two of single, and counting switches as additional length.

Elec. after name of a road means that the road is operated wholly or partly by electric power. Capital means capital issued unless otherwise expressly stated.

A

ADRIAN, MICH.—Adrian City Electric Belt Ry Co. Elec. 2.8 m, 4-8½ g, 38 lb T r, 4 c, of which 3 are m. c. and 1 t. c. Detroit system. Pres. J. H. Bialn V. Pres. W. A. Jackson, Sec. C. Barker, Treas. M. E. Chittenden. Office, 25 S. Main st. Capital \$50,000. Bonds, \$36,500. 5 2

AKRON, O.—Akron St. R. R. Co. 14 m elec. 4-8½ g, 52 lb girder r, 46 c, of which 25 are m. c. and 21 t. c. Edison system. Pres. J. F. Selberling, V. Pres. I. M. Miller, Sec. & Treas. F. A. Selberling, Gen. Supt. W. D. Chapman. Capital, \$200,000 Bonds, \$185,000. 10 2

ALAMEDA, CAL.—Alameda, Oakland & Piedmont Electric R. R. Co. 6½ m, 3-6 g, 46 lb girder r, 8 m c. T-H system. Ingler & Atkinson cars. Ball engines. Pres. W. M. Rank, V. Pres. E. S. Denison, Sec. & Treas. S. H. Bass, Supt., Pur. Agt. & Elec. L. Wheeler, Ch. Eng. of Power Station, G. S. Ames. Capital, \$500,000. 2 4

ALBANY, GA.—Artesian City R. R. Co. 3¼ m, 4-8½ g, 30 lb T r, 2 c, 4 mu. Pres. & Gen. Man. J. M. Tift, Sec. & Treas. W. E. Mitchell. Capital, \$20,000 authorized, \$100,000. 9 3

ALBANY, N. Y.—The Albany Ry. Elec. 33 m, 4-8½ g, 50 70 lb girder r, 100 m. c. T-H and Westinghouse systems. Gilbert cars. McIntosh & Seymour and Cooper engines. Pres. Robt. C. Pruyn, V. Pres. Anthony N. Brady, Sec. James McCredie, Treas. Gen. Man. & Pur. Agt. John W. McNamara, Asst. Gen. Man. E. S. Fasset, Ch. Engr. T. E. Murray, Elec. H. P. Merriam. Capital \$1,500,000. Bonds \$1,000,000. Office, Albany Co. Bank building. 1 4

ALBANY, ORE.—Albany St. Ry. Co. Steam. 3 m, 3-6 g, 25, 35 lb T r, 4 motor c, 3 h. Pres. L. Flinn V. Pres. S. E. Young, Sec. C. G. Burkhardt, Treas. E. F. Sox, Supt. & Gen. Man. W. Goltra. Capital, \$12,000; authorized \$16,000. 11 2

ALEXANDRIA, VA.—Washington, Alexandria & Mt. Vernon Electric Ry. Co. Elec. 9 m, 4-8½ g, 50, 70 lb girder and T r, 6 m. c. T-H system. Pres. G. E. Abbott, V. Pres. T. A. Reed, Sec. H. K. Whipple, Treas. D. C. Leeds, Supt. W. H. Cooper. Capital, \$500,000. 9 2

ALLEGHENY, PA.—Nunnery Hill Inclined Plane Ry. Co. Elec. 1,100 ft. 5 g, 60 lb T r, 2 c, using wire rope and drum. St. Louis cars. Bentley-Knight motors. Pres. & Treas. Oliver P. Scaife, Sec. A. Kennedy, Supt., Pur. A. t. & Ch. Engr. C. D. Heist. Capital, \$60,000. Office cor. Fairmount & Federal sts. 1 4

Allegheny Traction Co. 7 m, 5-2½ g, 45 lb tram r, 18 c, 100 h & mu. Stephenson cars. Pres. G. B. Hill, Sec. A. M. Neepser, Gen. Man. G. F. Greenwood. Capital \$350,000. Offices, Beaver and Island Aves. Equipping electrically. 4 4

Troy Hill Inclined Plane & Bridge Co. 370 ft. 6 g, 60 lb T r, 2 c. Pres. Jas. D. Callery, Sec. C. S. Wright Treas. Wm. V. Callery, Gen. Man. J. J. Saint. Capital, \$200,000. Office, 448 Liberty Ave. 1 4

ALLENTOWN, PA.—Allentown & Lehigh Traction Co. (Controls and operates Allentown & Bethlehem Rapid Transit Co. and Allentown Electric Light & Power Co.) 29 m, 4-8½ g, 60-70 lb T and girder r, 61 c, of which 32 are m. c. and 29 t. c. T-H and Steel Motor systems. Cooper engines. Pres. A. L. Johnson, Sec. J. K. Page, Gen. Man. J. J. Coleman, Supt. J. G. Honecker. 4 4

ALLIANCE, O.—Alliance St. Ry. Co. 4 m, 4 m s, 4-8½ g, 45, 56 lb T and girder r, 4 m. c. T-H and Short systems. Brill and Laclede cars. Phoenix Iron Works engines. Pres. W. W. Hazzard, Sec. Treas. & Gen. Man. W. H. Whitacre, Electrician G. J. Davis, Ch. Eng. Power Station Frank Bankard. Capital stock \$85,000; authorized \$100,000. Office 11 South Arch Ave. 1 4

ALTON, ILL.—Alton Improvement Association. 3¼ m steam, 4-8½ g, 30 & 40 lb steel T r, 2 Baldwin m. c. Pres. Chas. W. Milnor, Sec. & Treas. H. R. Phinney. Office, 305 W. 2d St. Capital \$25,000. 4 4

Alton & Upper Alton Horse R. R. & Carrying Co 3 m, 4-8½ g, 40, 66 lb steel T & flat r, 7 c, of which 5 are box and 2 open, 24 h. Pres. C. W. Milnor, Sec. Treas. & Supt. H. R. Phinney. Capital, \$42,200; authorized, \$100,000. Office, 305 W. 2d st. 1 4

ALTOONA, PA.—City Pass. Ry. Co. of Altoona Pa. (Controlled by Altoona & Logan Valley Electric Ry Co., which owns 3,600 shares of its stock) 6½ m, 5-3 g, 48½-70 lb. girder r, 25 c, of which 19 are m. c. and 6 t. c. T-H and Westinghouse systems. Brill and Lamokin cars. Altoona Mfg. Co. engines. Pres. J. Lloyd, Sec. & Treas. C. A. Buch, Supt. C. D. Rose, Elec. W. H. Markland. Capital \$200,000; Bonds \$50,000. Office, Chestnut av. below First st. 1 4

Altoona & Logan Valley Ry. Co., controls City Pass. Ry. of Altoona, 10½ m, 5 m s, 5-3 g, 56 and 72 lb T and girder r, 26 c, of which 15 are m. c, 8 t c and 2 double deck cars. Edison system. Brill cars. Altoona Mfg. Co. engines. Pres. John Lloyd, Sec. & Treas. C. A. Buch, Supt. C. L. West, Ch. Engr. A. C. Shand, Elec. W. H. Markland, Ch. Engr. Power Station L. M. Wilson. Capital \$320,500; authorized, \$500,000. Bonds \$300,500. 1 4

AMERICUS, GA.—Americus St. Ry. Co. Elec 5½ m, 4-8½ g, 35 lb T r, 6 m. c. T-H system. Owners T-H Co. Capital \$50,000. Bonds \$50,000. 8 3

AMES, IA.—Ames & College Ry. Co. 2¼ m. Steam 4-8½ g, 30 lb T r, 2 c, 2 steam motors. Pres. E. W. Stanton, V. Pres. D. S. Fairchild, Sec. Gen. Man., Supt. & Pur. Agt. M. K. Smith, Treas. B. J. Shelden. Capital \$20,000; authorized, \$25,000. 1 4

AMESBURY, MASS.—(See Haverhill, Mass and Newburyport, Mass.)

AMSTERDAM, N. Y.—Amsterdam St. Ry. Co. Elec. 4 m. 4-8½ g, 48½ lb. girder r, 13 c, of which 6 are m. c. and 7 t. c, 5 h. Edison system. Pres. J. H. McClement, V. Pres. F. J. Sprague, Sec. & Treas. T. D. Mossrop, Gen. Man. J. R. Snell, Counsel J. S. Wise. Capital, \$250,000. Bonds, \$150,000. Office of Pres. and V. Pres. 42 and 44 Broad St., N. Y. City Office of Supt. 102 E. Main St., Amsterdam. 8 2

ANACONDA, MONT.—Electric Ry., Light & Power Co. 5¼ m, 4-8½ g, 35 & 50 lb. T r, 4 motors, 10 c, of which 4 are m. c. and 6 t. c. T-H system. Pres. M. Daly, Supt. C. R. Holmes. 4 4

ANDERSON, IND.—Anderson Electric St. Ry. Co. 8½ m, 4-8½ g, 40, 50, 60 lb T r, 18 c, of which 10 are m. c. and 8 t. c. Westinghouse, Edison & T-H systems. St. Louis cars. Allis engines. Pres. Treas. & Gen. Man. C. L. Henry, V. Pres. J. F. Wild, Sec. L. M. Cox, Supt. L. Cox, Elec. C. Berry. Capital, \$150,000; authorized \$200,000. Bonds \$100,000; authorized \$150,000. Office, Room 2 P. O. Block. 1 4

ANN ARBOR, MICH.—The Ann Arbor St. Ry. Co. Elec. 5¼ m, 4-8½ g, 45, 48½, 66 lb girder r, 7 c, of which 6 are m. c. and 1 t. c. Edison system. Brill cars. Taylor and straight line engines. Pres. H. P. Glover, Sec. Gen. Man. & Pur. Agt. H. T. Morton, Treas. C. E. Hilscock. Capital, \$93,000; authorized, \$93,000. Bonds, \$100,000. 4 4

Ann Arbor & Ypsilanti St. Ry. Co. Dummy. 9 m 4-8½ g, 40 lb T r, 11 c, of which 5 are pass. c & 6 gravel c; 2 steam motors. Porter and Baldwin engines. Pres. & Gen. Man. J. E. Beal, V. Pres. H. P. Glover, Sec. J. T. Jacobs, Treas. D. L. Quirk, Supt. W. Parker. Capital \$100,000. Bonds \$60,000. 1 4

ANNISTON, ALA.—Anniston City St. Ry. Co. 6 m, 35 lb T r, 9 box c, 35 h. Pres. J. W. Bigsby, Sec., Treas. and Gen. Man. O. E. Edwards. 9 1

Oxford Lake Line Ry. Co. Elec. 7¼ m. 6.7 m s, 4-8½ g, 40 lb T r, 8 c, of which 6 are m. c. and 2 t. c. T-H system. Stephenson cars. Rent power. Pres. Gen. Man. & Pur. Agt. H. W. Sexton, V. Pres. R. P. Thomason, Sec. & Treas. F. M. Light, Elec. A. A. Jett, Ch. Engr. of Power Station H. C. Reid. Capital \$175,000. Bonds \$175,000. Office 915 Wilmer St. 2 4

ANOKA, MINN.—Anoka St. Ry. Co. 3 m, 4-8½ g, 26 lb T r, 3 c, 13 h. Pres. R. Mahany, Sec. J. Mahany Treas. R. Mahany, Jr., Gen. Man. W. W. Mahany Capital, \$15,000. 1 3

APPLETON, WIS.—Appleton Edison Electric Co 3.5 m. 4-8½ g, 33, 60 lb tram and girder r, 9 c, of which 5 are m. c. and 4 t. c. Edison system. Pres. & Treas. A. LeSmith, V. Pres. J. H. Van Nortwick, Sec. C. A. Beveridge, Supt. F. G. King. Office College Ave. 11 2

ASBURY PARK, N. J.—Seashore Elec. Ry. Co. 8½ m, 4 m s, 4-8½ g, 56 lb girder r, 26 m. c. T-H system. Hamilton Corliss engines. Pres. & Treas. J. C. Shaffer, Sec. H. Shaffer, Gen. Man., Pur. Agt. & Elec. A. S. Hickley. Capital, \$200,000; authorized, \$500,000. 1 4

ASHEVILLE, N. C.—Asheville St. Ry. Co. Elec 6½ m, 4-8½ g, 30 & 40 lb c. b. & T r, 14 c of which 12 are m. c. and 2 t. c. T-H and Edison systems. Gilbert cars. Armington & Sims engines. Pres. L. Maddux, V. Pres. W. T. Penniman, Sec. & Treas. B. M. Jones, Supt. J. F. Arthur. Capital, \$100,000; authorized \$250,000. Bonds, \$300,000. 2 3

Asheville & Craggy Mountain Ry. Co. Steam 2½ m, 4-8½ g, 40 lb T r, 2 c. Brill cars. Baldwin engines. Pres. & Gen. Man. W. B. Gwyn. Sec. & Treas. W. W. West. Capital \$24,700; authorized \$500,000. 1 3

Asheville Loan, Construction & Improvement Co. Elec. 1 m, 4-8½ g, 40, 45 lb T & girder r, 2 m. c. T-H system. Pres. & Gen. Man. G. S. Powell, Sec. M. J. Bender, Treas. W. W. Bonnel. Capital, \$296,000; authorized, \$300,000. Bonds, \$20,000. 1 3

West Asheville & Sulphur Springs Ry. Co. Elec. 6 m, 4-8½ g, 40 lb T & girder r, 6 c, of which 5 are m. c. and 1 t. c. T-H system. Ellis and Stephenson cars. Stillwell-Pierce & Smith-Valle turbines. Pres. E. G. Carrier, Sec. Treas. Gen. Man. Supt. Pur. Agt. & Ch. Engr. J. D. Carrier. Capital, \$50,000; authorized \$280,000. Bonds, \$35,000. 1 4

ASHLAND, KY.—Ashland & Catlettsburg St Ry. Co. 6 m, 4-8½ g, 45 & 50 lb Johnson girder & T r, 7 c, of which 4 are m. c. and 3 are t. c. Pres. & Man. W. L. Ringo, Sec. & Treas. John Russell, Jr Capital, \$25,000, authorized, \$200,000. 4 4

AJAX

SWITCHES AND
LIGHTNING ARRESTERS,

136 LIBERTY ST.,
C. S. Van Nuis, NEW YORK.

ASHLAND, PA.—Schuylkill Traction Co. (See Girardville, Pa.)

ASHLAND, WIS.—Ashland Lighting & St. Ry. Co. Elec. 6 m, 4 ms, 4-8 1/2 g, 48, 60 lb T, r, 12 c of which 6 are m c and 6 t c. T-H system. Stephenson cars. 1 de engines. Pres. Gen. Man. & Pur. Agt. G. W. Harrison, Sec. & Treas. G. F. Merrill. Capital \$200,000. Bonds authorized \$250,000. 1 4

ASHUTABULA, O.—Ashutabula City Ry. Co.—4 m 4-8 1/2 g, 40 lb T, r, 9 c, 60 h. Prop'r. J. N. Stewart. Sec. & Treas. S. C. Stewart. Man. H. H. Stewart. Officers and office at Cleveland, O. 1 8

Ashutabula Rapid Transit Co. Elec. 4 1/2 m, 4-8 1/2 g, 47 & 70 lb Johnson girder r, 9 c, of which 5 are m c and 4 t c. T-H system. Pres. F. W. Wagner, V. Pres. R. A. Brown, Sec. & Supt. T. Pricker, Treas. E. W. Savage. Capital \$150,000. 1 4

ASPEN, COLO.—Aspen City Ry. Co. 2 m, 4-8 1/2 g, 16 lb T, r, 2 open c, 3 h, 2 mu. Pres. H. A. Tabor, Sec. M. K. Page, Gen. Man. T. J. Flynn. 5 2

ASTORIA, ORE.—Astoria St. Ry. Co. Elec. 3 m, 3-6 g, 30 lb T, r, 8 c, of which 4 are m c and 4 t c. T-H system. Brownell cars. Pres. J. W. Conn, V. Pres. W. A. Sherman, Sec. & Supt. F. W. Newell, Treas. F. R. Stokes. Capital, \$45,000; authorized, \$200,000. 4 4

ATLANTON, GA.—Atlaton Ry. & Light Co. 8 1/2 m, 4-8 1/2 g, 40 lb T, r, 6 m c, Laclede cars. Gen. Man. B. P. Waggner, Supt. J. A. Bendure. Changing to electricity. 4 4

ATHENS, GA.—Athens Ry. Co. Elec. 6 m, 6 m s, 4-8 1/2 g, 40 lb T, 6 m c, Detroit and T-H systems. Laclede cars, Ball engines. Receiver, C. A. Mell, Supt. T. P. Hunnicutt. 1 4

ATLANTA, GA.—Atlanta Consolidated St. Ry. Co Lines operated, Peachtree st. and North Atlanta, Peachtree st. and Ponce de Leon, Marietta st.—Decatur st., Whitehall st. and West End, Capitol Ave.—North Ave., Wheat st. and Ponce de Leon, Broad st., West End, West View Cemetery and Fulton County St. R. R. 63 m, 4-8 1/2 g, 40, 45 & 56 lb girder & T, r, 104 c, of which 94 are m c, and 10 t c. T-H system. Brill, Lewis & Fowler, Pullman and Stephenson cars. Cooper-Corliss engines. Pres. J. Hurt, V. Pres. E. Woodruff, Sec. T. K. Glenn, Treas. R. J. Lowry, Gen. Supt. H. N. Hurt, Pur. Agt. W. H. Glenn, Elec'n. N. W. L. Brown, Ch. Eng. of Power Station, T. Elliott. Capital, \$2,000,000. Bonds, \$2,000,000. 1 4

Atlanta Traction Co. Elec. 18 1/2 m, 4-8 1/2 g, 40 lb T, r, 24 c of which 21 are m c and 3 t c. Detroit, Edison and Westinghouse systems. American and Brill cars. Russell engines. Pres. T. B. Felder, V. Pres. E. T. Shubrick, Sec. & Treas. — Robinson, Supt. J. T. Voss, Elec'n. E. M. Green, Ch. Engr. of Power Station W. F. Wooden. Capital \$150,000. Office Inman Bldg. 2 4

Collins Park & Belt R. R. Co. Elec. 15 m, 4-8 1/2 g, 56 lb T, r, 9 m c. Short system. Brill cars. Allis engines. Receiver & Man. J. W. Darr. P. O. Box 541. 2 4

Lithia Springs Ry. Co. 6 m, 6 ms, 4-8 1/2 g, 60 lb T and girder r, 5 m c, Bain system. Rent power. St. Louis cars. Pres. H. Camp, V. Pres & Gen. Man. B. F. Curtis, Sec. & Treas. T. Camp. Capital, \$60,000. Bonds \$100,000. 1 4

ATLANTIC CITY, N. J.—Atlantic City Electric Ry. (Operated by Pennsylvania R. R. Co.) 17 m, 4-8 1/2 g, 60 lb T & girder r, 54 c, of which 30 are m c and 24 t c. Edison and Westinghouse systems. Brill cars. Pres. J. S. Roberts, Gen. Foreman, W. K. McAllister. 1 4

ATTLEBORO, MASS.—Attleboro, N. Attleboro & Wrentham St. Ry. Elec. 6 1/2 m 4-8 1/2 g, 40 lb. T, r, 17 c, of which 9 are m c, and 8 are t c. T-H system. Pres. H. M. Daggett, Jr., Treas. C. T. Guild. Capital, \$60,000, bonds \$50,000. 1 4

AUBURN, N. Y.—Auburn City Ry. Co. Elec. 5 1/2 m, 5 1/2 m s, 4-8 1/2 g, 45-47 lb girder & T, r, 14 c, of which 11 are m c and 3 t c. 5 h. T-H system, Jones Rogers and Stephenson cars. McIntosh & Seymour engines. Pres. C. E. Eddy, V. Pres. G. Underwood, Sec. Gen. Man. & Supt. A. H. Underwood, Treas. J. E. Storke, Pur. Agt. Ch. Engr. Elec'n. & Ch. Engr. of Power Station, R. A. Rogers, Jr. Capital, \$50,000, authorized \$150,000. Bonds, 200,000. 1 4

AUGUSTA, GA.—Augusta Ry. Co. Elec. 25 m, 4-8 1/2 g, 35-54 lb T & girder r, 46 c, of which 35 are m c and 11 t c. Edison and T-H systems. Brill and Stephenson cars. Corliss engines. Pres. D. B. Dyer, V. Pres. R. R. Conklin, Sec. C. B. Reavis, Supt. F. A. Roberts. Capital, \$300,000. Bonds, \$400,000. Office, Jarvis-Conklin building. 8 3

AUGUSTA, ME.—Augusta, Hallowell & Gardiner R. R. Co. Elec. 8 m, 4-8 1/2 g, 40 & 55 lb T & Johnson r, 13 c, of which 9 are m c, and 4 t c. T-H, Edison & Detroit systems. Pres. J. M. Haynes, Sec. H. G. Staples, Treas. G. E. Macomber, Supt. & Elec'n. W. G. Meloon. Capital, \$120,000; authorized, \$150,000. Bonds, \$150,000. Office, Hallowell, Me. 1 4

AURORA, ILL.—Aurora St. Ry. Co. Elec. 18 m 12 m s, 4-8 1/2 g, 67 lb. T and 56 lb girder r, 22 m c. Detroit system. Briggs and Gilbert cars. Straight line engines. Pres. & Treas. R. B. Dodson, V. Pres. H. C. Tinker, Gen. Man. & Pur. Agt. D. A. Belden, Ch. Eng. & Ch. Engr. of Power Station, A. S. Hadin, Capital, \$300,000. Bonds, \$300,000. 1 4

AUSTIN, TEX.—Austin Rapid Transit Ry. Co. Elec. 15 m, 4-8 1/2 g, 40 lb girder & T, r, 20 c, of which 12 are m c, and 8 t c. T-H system. Pres. F. H. Watrliss, V. Pres. I. H. Evans. Sec. & Supt. J. K. Urie. Capital \$200,000. 1 4

B

BABYLON, N. Y.—Babylon Street Ry. Co. 1.53 m, 4-9 g, 60 lb T, r, 4 c, of which 3 are box and 1 is open, 3 h. Pres. W. F. Norton, Sec. Jos. F. Sammis Treas. John R. Reid, Supt. David S. S. Sammis Capital \$25,000. 1 4

BAKER CITY, ORE.—Baker City St. Ry. & Motor Co. 2 1/2 m, 3-5 1/2 g, 30 lb T, r, 2 1/2 wheel box c 6 h Pres., Gen. Man. & Supt. C. L. Palmer, Sec. M. D. Abbott, Treas. L. W. Place. Capital, \$50,000. 6 2

BALTIMORE, MD.—Baltimore City Pass. Ry. Co. 59 m, of which 16 are horse, 21 electric and 22 cable, 5-4 1/2 g, 75 lb r, 194 c, of which 50 are m c, 72 g c and 72 t c. Westinghouse system. Brill and Stephenson cars (cable). Allis engines. Pres. & Supt. Oden Bowie, Treas. A. B. Clark, Ch. Engr. A. N. Connett. Capital, \$1,000,000; authorized, \$2,000,000. Bonds, \$2,000,000. Office, Madison Ave., extended. Electric lines in process of change, but considered as completed. 1 4

Baltimore Traction Co. (Includes N. Baltimore Pass. Ry., Baltimore & Curtis Bay St. R. Co. and Baltimore & Powhatan Ry.) 75 m, of which 25 are horse, 15 cable and 35 elec. 5-4 1/2 g, 66, 78, 80 lb girder and T, r, 225 c, of which 100 are h c, 6 g c, 30 m c and 35 t c, 831 lb. Westinghouse system. Brownell and Lewis & Fowler cars. Corliss, McIntosh & Seymour and Westinghouse engines. Pres. F. Brown, V. Pres. J. S. Hagerty, Sec. N. H. Johnson, Treas. F. S. Hamblen, Gen. Man. Wm. A. House, Jr., Ch. Engr. F. H. Hamblen, Elec'n. T. A. Cross, Office, Druid Hill Ave. Extension, Clifton. 1 4

Central Ry. Co. Elec. 13 m, 5-4 1/2 g, 30 lb tram r, 40 c, of which 30 are m c and 10 t c. T-H system. Brill and Stephenson cars. McIntosh & Seymour engines. Pres. G. Blakstone. Treas. N. H. Bell, Supt. J. Hopps, Ch. Engr. J. Burnett, Elec'n. Conway Robinson. Capital, \$300,000; authorized \$3,000,000. Bonds \$700,000. Office 503 E. Preston st. 1 4

City & Suburban Ry. Co. Elec. (Includes Union Pass. Ry., York Road Ry., Baltimore, Catonsville & Ellicott's Mills Ry. and Highlandtown & Point Breeze Ry.) 61 m, 5-4 1/2 g, 25, 45, 65 lb T and girder r, 130 c of which 100 are m c and 30 h c, 300 mu. Gen. Elec. system. Brill, Lewis & Fowler, Laclede and Stephenson cars. McIntosh & Seymour engines. Pres. N. Perin, V. Pres. G. C. Jenkins, Sec. L. Fender, Treas. E. J. Cross, Gen. Man. J. F. Heyward, Ch. Engr. F. H. Sloan. Capital, \$3,000,000. Bonds, \$1,430,000; authorized \$3,000,000. 3 4

Lake Roland Elevated Ry. Co. Elec. 25.68 m 5-4 1/2 g, 52, 60 T and Duplex r, 42 c of which 30 are m c and 3 t c. T-H and Edison systems. Fowler, Lewis & Fowler and Pullman cars. Corliss engines. Pres. J. L. McLane, V. Pres. R. R. Conkin, Sec. E. H. Bouton, Treas. W. C. McHenry, Gen. Man., Supt., Pur. Agt. & Ch. Engr. L. N. Frederick, Elec'n. W. A. McClelland, Ch. Engr. of Power Station, E. Van Gorder. Capital, \$1,000,000. Bonds, \$1,000,000. Office, Roland Park. 1 4

BANGOR, ME.—Bangor St. Ry. (Owned and operated by Public Works Co.) Elec. 8 1/2 m, 4-8 1/2 g, 35 lb tram & T, r; 25 c, of which 22 are m c and 3 t c. T-H system. Newburyport cars. Pres. F. M. Laughton, Sec. J. R. Mason, Treas. and Gen. Man. J. H. Cutler, Supt. Ry. Dept. J. G. Carroll, Pur. Agt. J. H. Green, Chief Eng. J. G. Kimball. Capital, \$200,000. Bonds, \$200,000. 4 4

BANGOR, PA.—Bangor, Pen Argyll & Water Gap Ry. Co.

BATH, ME.—Bath St. Ry. Co. Elec. 4 1/2 m, 4-8 1/2 g, 50 lb T, r, 8 c, of which 6 are m c and 2 t c. Westinghouse system. Lewis & Fowler and Newburyport cars. Ball & Wood engines. Pres. A. H. Shaw, Sec. C. L. Low, Treas. F. H. Twitchell, Gen. Man. A. F. Gerald, Supt. C. E. Gahan, Elec'n. F. Lord, Ch. Engr. of Power Station, J. C. Humphries. 1 4

BATON ROUGE, LA.—Baton Rouge Electric Ry. Co., 5 1/2 m. Gen. Elec. system. Pres. B. F. Meyer, O. P. Steell, Treas. W. J. Knox.

BATTLE CREEK, MICH.—Battle Creek Electric Ry. Co. 8.2 m, 4-8 1/2 g, 42 lb tram r; 18 c, of which 8 are m c and 10 t c. Short system. St. Louis cars. Williams engines. Receiver E. C. Hinman. Capital, \$100,000. Bonds, \$110,000. Office, 15 & 17 Annex Building. 1 4

BAY CITY, MICH.—Bay Cities Consolidated Ry. Co. (Covering Bay City and West Bay City.) 23 m, of which 2 are horse and 21 elec., 19 m s, 4-8 1/2 g, 45, 60 lb tram and T, r, 65 c, of which 15 are h c, 32 m c, 14 t c and 4 hat c, 20 h. Edison and Westinghouse systems. Brill, Illinois and Stephenson cars. Corliss engines. Pres. W. B. McKinley, V. Pres. R. S. Hunter, Sec. W. S. Hood, Treas. D. Slack, Gen. Man. & Pur. Agt. C. C. Rush, Supt. & Elec'n. C. L. Harry, Ch. Engr. of Power Station, L. Rodandsville. Capital \$900,000. Bonds \$470,000. 1 4

BAY RIDGE, MD.—Arundel on the Bay R. R. (Operated by Chesapeake & Columbia Investment Co.) Steam 2 m, 4-8 1/2 g, 30 lb T, r, 4 c, 1 engine. Brill cars, Rhode Island loc. Pres. T. W. Smith, V. Pres. W. P. C. Hazen, Sec. L. Cavanaugh, Treas. N. H. Shea, Gen. Man. D. D. Stone, Supt. L. Cavanaugh. Capital, \$100,000. Office, 1st and Ind. Ave., Washington, D. C. 1 4

BEATRICE, NEB.—Beatrice Rapid Transit & Power Co. Elec. 6 m, 4-8 1/2 g, 38, 52 lb girder & T, r, 8 c, of which 4 are m c and 4 t c. Short system Receiver M. C. Steele, Pres. E. N. Brumback, V. Pres. C. L. Scheel, Sec. L. E. Spencer, Treas. S. K. Davis, Supt. G. M. Johnston. Capital \$250,000. Office Cor Court & 8th Sts. 11 2

BEAUMONT, TEX.—Beaumont St. Ry. Co. 2 1/2 m, 4-8 1/2 g, 25 lb T, r, 3 c, 12 mu. Pres. G. W. Carroll V. Pres. W. R. Caswell, Sec., Treas. Gen. Man. & Pur. Agt. J. H. Rachford. Capital, \$8,200; authorized \$100,000. 1 4

BEAVER FALLS, PA.—Beaver Valley Traction Co. (Includes Central Electric St. R. R. Co. and College & Grand View Co.) Elec. 9 m, 5-2 g, 45, 56, 72 lb girder & T, r, 15 c, of which 12 are m c and 3 t c. T-H system. Brill cars. Buckeye engines. Pres. J. M. Buchanan, V. Pres. T. P. Simpson, Sec. & Gen. Man. H. P. Brown, Treas. S. P. Stone. Capital, \$300,000. Bonds, \$150,000. 1 4

College & Grand View Electric R. R. Co. (Extension of Beaver Valley Traction Co.) 1 1/2 m, 1 1/2 m s, 5-2 g, 52 lb girder r, 2 m c. Westinghouse system. New Castle cars. Hire power from Beaver Valley Traction Co. Pres. C. P. Wallace, V. Pres. G. E. Smith, Sec. A. R. Leyda, Treas. J. B. Sherwood, Gen. Man. & Supt. J. N. Kimmins, Elec'n. F. Mason. Capital, \$15,000. Office 1011 7th Ave. 1 4

BELLAIRE, O.—Bellaire, Bridgeport & Martin's Ferry St. R. R. Co. (See Bridgeport, O.)

BELLEVILLE, ILL.—Belleville electric R. R. Co.

BENSON, NEB.—Benson & Halcyon Heights Ry. Co. Elec. 2 m, 4-8 1/2 g, 20 lb T, r, 2 m c. Westinghouse system. Pres. W. H. Crary, Supt. E. H. Cone 8 3

BEREA, O.—Cleveland & Berea St. Ry. Co. 10 1/2 m, 10 m s, 4-8 1/2 g, 45, 56 T and girder, r, 6 c, of which 5 are m c and 1 t c. 2 h. Pres. & Pur. Agt. C. W. D. Miller, V. Pres. F. T. Pomeroy, Sec. & Treas. A. H. Pomeroy, Supt. A. W. Blshop. Capital, \$30,000 authorized, \$150,000. Bonds, \$73,000. 1 4

BERKLEY, VA.—The Berkley St. Ry. Co. 2 m, 2 ms, 4-8 1/2 g, 20 & 42 lb c. b., & T, r, 7 c, 11 h, 7 mu. Jones and Stephenson cars. Pres. T. H. Synon, Sec. Treas. & Gen. Man. W. Tillotson. Capital, \$8,750; authorized \$75,000. Bonds \$9,000. 1 4

BIDDEFORD, ME.—Biddeford & Saco R.R. Elec. 6 m, 4-8 1/2 g, 35 lb T, r, 18 c, of which 4 are 4-wheel box 7 m c and 7 t c. T-H system. Jones cars. Westinghouse engines. Pres. E. H. Banks, Sec. Treas. & Pur. Agt. Chas. H. Prescott, Ch. Engr. of Power Station J. Hunt, Jr. Capital, \$40,000. Bonds, \$50,000. Office, 154 Main st. 1 4

BINGHAMTON, N. Y.—Binghamton R. R. Co. (Operates all roads in the city) 27 m, of which 12 are horse and 25 elec, 24 1/2 m s, 4-8 1/2 g, 30, 60, 62 1/2, 72 1/2, lb T and girder r, 80 c, of which 6 are h c and 60 m c, 14 t c, 18 h. Edison and T-H systems. Ball & Wood engines. Pres. G. T. Rogers, 1st V. Pres. J. Evans, 2d V. Pres. J. L. Candfield, Sec. C. O. Root, Treas. J. B. Rogers, Gen. Man. Supt. & Pur. Agt. J. P. E. Clark, Ch. Engr. & Ch. Eng. of Power Station H. R. Bowen, Elec'n. W. Merritt. Capital, \$324,060; authorized \$500,000. Bonds, \$340,000. Office, Power Station. 1 4

Court st. & East End R. R. (Operated by Binghamton R. R. Co.)

West Side St. Ry. Co. (Operated by Binghamton R. R. Co.)

BIRMINGHAM, ALA.—Birmingham Ry. & Electric Co. 58 m, of which 48 are steam, and 16 elec 4 1/2 g, 40-58 lb T & Johnson girder r, 104 c, of which 32 are h c, 36 steam, 24 m c and 12 t c, 60 h. T-H system. Pres. T. T. Hillman, V. Pres. & Gen. Man. R. Jemison, Sec. & Treas. Jas. A. Stratton, Supt. J. B. McClary. Capital, \$1,900,000; authorized, \$3,000,000; Bonds, \$927,000. Office, 303 20th St. 1 4

Bessemer & Birmingham R. R. Co. (Owned by Birmingham Ry. & Elec. Co.) 13 1/2 m, 4-8 1/2 g, 40 lb T, r, 15 c, of which 10 are 8 wheel box and 5 8-wheel open, 4 frgt. c, 5 steam motors. Pres. T. T. Hillman, V. Pres. & Gen. Man. R. Jemison, Sec. J. A. Stratton, Supt. J. B. McClary Capital \$250,000. 4 4

Birmingham & Forest City Dummy St. R. R., 4 m, 4-8 1/2 g, 38 lb. r., 2 dummies, 2 coaches. Pres. & Man. E. Eastman. 9

East Birmingham Land & Ry Co., 10 m 7 m s, 4-8 1/2 g, 16 lb T, r, 10 c 3 dummies. Pres. E. T. Martin, Sec. P. Barnett, Treas. R. M. Mulford, Supt. J. H. Heineke. Capital \$1,023,800. Bonds \$50,000.

Highland Ave. & Belt R. R. Co. 29 m, 4-8 1/2 g, 40 lb T and 14 pass. c, 9 engines. Pres. F. M. Billing Treas. & Gen. Man. J. London, Supt. F. T. Bradford, Aud'r L. F. Worl, Gen. Frt. Agt. J. E. Scott. Capital \$1,000,000. Office, 9 N. 20th St. 9 2

North Birmingham St. R. R. Co. 5.75 m, 4 m s, 4-8 1/2 in., 36 lb r 8 c 4 dummies. Pres. E. M. Tutwiler, Sec. & Treas. M. F. Gorman. Capital \$65,000.

BLOOMFIELD, N. J.—Newark & Bloomfield R. R. (See Newark, N. J.)

USE ONLY



INSULATED WIRES AND CABLES FOR AERIAL, SUBMARINE AND UNDERGROUND USE.

W. R. BRIXEY, MFR., 203 BROADWAY, NEW YORK.

BRANCHES:

BLOOMINGTON, ILL.—The Bloomington City Ry. Co. 11 m, 11 m s, 4-8½ g, 45, 47 lb T r, 25 c, of which 15 are m. c. and 10 t. c. Westinghouse and Short systems. St. Louis cars. Buckeye engines. Pres. John J. Patterson, V. Pres. Sec. Treas. Gen. Man. & Pur. Agt. W. H. Patterson, Elecn. D. Barclay, Ch. Engr. of Power Station C. Maguire. Capital, \$600,000. Bonds, \$209,000. 8

BLOUNTSVILLE, ALA.—Blountsville & Bangor Dummy Line Co. 12½ m. Pres. A. E. Fields, V. Pres. W. M. Cote, Sec. J. L. Montgomery, Treas. W. M. Fennell, Gen. Man. C. Ternon, Supt. J. A. B. Lovett. 1 3

BOISE CITY, IDAHO.—Boise City Rapid Transit Co. Elec. 3 m, 4-8½ g, 35 lb T r, 2 m c. Edison system. Brill cars. Pres. G. Ainslie, V. Pres. D. Arnold, Sec. G. E. Gray, Treas. & Gen. Man. G. D. Ellis. Capital \$56,000; authorized \$200,000. Office Main St. 9 3

BOONE, IA.—Boone Electric St. Ry. Light & Power Co. 1½ m, 3 g, 22 lb Tr, 3 c, 9 h. Pres. L. W. Reynolds, V. Pres. D. N. De Tar, Sec. Gen. Man. & Supt. S. T. Stanfield, Treas. C. E. Rice. 1 4

BOSTON, MASS.—Boston & Chelsea R. R. Co. (Leased to West End St. Ry. Co. operated by Lynn & Boston Ry. Co.) 4.154 m, 4-8½ g, 48-56 lb girder r Pres. W. G. Wheilden, Treas. & Clerk. John H. Studley, Jr. Office, 81 Milk st. Capital \$121,000. 1 4

Boston & Revere Electric St. Ry. Co. 4-30 m, 4-8½ g, 56 lb Tr, 16 c, of which 6 are 4-wheel open m. c. and 10 are 4-wheel open t. c. T-H system. Pres. & Man. Washington G. Benedict, Sec. & Treas. Elery I. Garfield. Capital \$50,000. 11 2

East Middlesex St. R. R. Co. (Controlled by Lynn & Boston R. R. Co.) 18.31 m, of which 12.31 are horse and 6 elec, 4-8½ g, 42, 70 lb r, 48 c, of which 39 are h c and 9 m c, 185 h. T-H system. Pres. A. F. Breed, Sec. L. F. Arnold, Treas. D. H. Sweetser, Supt. J. E. Sewell. Capital, \$300,000. Bonds, \$325,000. Office, 35 Congress st. 1 4

Lynn & Boston. (See Lynn, Mass.)

Malden & Melrose R. R. Co. (Owned by West End St. Ry. Co.) 3 4

North Shore Traction Co. (See Lynn, Mass.)

Somerville Horse R. R. Co. (Operated by the West End St. Ry. Co.) 5.4 m, 4-8½ g, 56 lb r Boston pattern. Pres. Jostah Q. Bennett, Somerville, Treas & Clerk, J. H. Studley, Jr. Office, 81 Milk st. Capital, \$153,000. 1 4

West End St. Ry. Co. (Includes Boston & Chelsea, Malden & Melrose, Somerville,) 254 m, of which 71 are horse and 183 are elec., 150 m s, 4-8½ g, 50 to 100 lb. tram & girder r, 2172 c, of which 826 are h c, 1346 m c, 2123 h. T-H system. Brownell, Jones, Pullman, Newburyport, etc. cars. Allis, Arrington & Sims and McIntosh & Seymour engines. Pres. S. Little, V. Pres. P. Cummings, Treas. J. H. Goodspeed, Gen. Man. C. S. Sergeant, Auditor, H. L. Wilson, Pur. Agt. H. F. Woods, M. Meeb. L. J. Hrt, Elecn. R. C. Brown, Ch. Engr. of Power Station C. F. Baker. Capital, \$15,485,000; authorized \$16,400,000. Bonds, \$6,250,000. Office, 81 Milk St. 1 4

Winnimmet R. R. Co. Elec. 2.0153 m, 4-8½ g, 70 lb girder r, T-H system. Pres. T. P. Proctor, Boston, Mass., Treas. & Clerk, E. Francis Oltver, Boston. Capital, \$50,000; authorized, \$75,000. Office 32 Pemberton St. Leased to Lynn & Boston Co. 5 3

BOWLING GREEN, KY.—Park City Ry. Co. 2½ m, 2 m s 5-0½ g, 30 lb T r, 7 c, 10 mu. Brownell and Stephenson cars. Pres. J. D. McGoodwin, V. Pres. & Gen. Man. J. E. Du Bose, Sec. L. R. Porter, Treas. C. G. Smallhouse, Supt. T. J. Smith. Capital \$50,000. Bonds \$5,000. 5 4

BRADDOCK, PA.—Braddock & Turtle Creek St Ry. Co. Elec. 3.7 m, 5-2½ g, 40, 48½ lb T & Johnson girder r, 6 m c, Westinghouse & T-H systems Pres. J. D. Callery, Pittsburgh, Pa., Sec. J. C. Reilly, Pittsburgh, Pa., Treas. J. W. Taylor. Capital \$62,000. Bonds \$50,000. 7 2

Braddock Electric Ry. Co. 3¼ m, 5-2½ g, 48½ lb Johnson girder r, 5 m c. Short system. Pres. A. I. Sallor, V. Pres. J. P. McKelvey, Sec. Treas. & Man. C. F. Ellis. Capital, \$80,000; authorized, \$100,000. Bonds, \$40,000. Office, Bell Ave. 1 4

BRADFORD, PA.—Bradford & Kendall Ry. Co. 1½ m, 4-8½ g, 35 lb T & flat r, 2 c, 5 h. Pres. & Gen. Man. W. S. Wales, Sec. & Supt. M. F. King, Treas G. S. Wales. Capital, \$12,000. 9 2

BRANTFORD, CAN.—Brantford St. Ry. Co. 6¼ m, 6¼ m s, 4-8½ g, 40 lb T r, 10 c, of which 9 are m c and 1 t. c. Gen. Elec. system. Patterson & Corbin cars. Waterous engines. Pres. F. Nicholls, V. Pres. H. P. Dwight, Sec. W. S. Andrews, Gen. Man. & Pur. Agt. J. T. Madden, Supt. Elecn. & Ch. Engr. of Power Station J. Mylin. 4 4

BRIDGEPORT, CONN.—Bridgeport Traction Co. (Controls Bridgeport Ry., Bridgeport Horse R. R. and East End Ry. companies.) 19 m, 4 8½ g, 30, 45, 56 lb T, c b & s b r, 84 c, 435 h. Brill, Jones and Stephenson cars. Pres. & Pur. Agt. N. H. Jeff, V. Pres. E. S. Ward, Sec. T. L. Watson, Treas. W. Scheerer, Supt. A. Radel. Capital \$2,000,000. Bonds authorized \$780,000. 4 4

The East End Ry. Co. (Controlled by Bridgeport Traction Co.) 6 m, 4-8½ g, 35 & 45 lb T r, 27 c, of which 15 are 2-h. and 12 1-h. 200 h. Pres. N. H. Jeff, Treas. W. H. Scheerer, Supt. T. B. Lashar. Capital \$42,550; authorized, \$100,000. Bonds, \$12,000. 5 3

BRIDGEPORT, O.—Bellair, Bridgeport & Martin's Ferry St. R. R. Co. 11½ m, 5-2 g, 63, 83 lb girder r, 13 m c 3 h. T-H system. New Castle cars. Buckeye engines. Pres. J. K. Jolly, V. Pres. P. D. Nicols, Sec. R. T. Howell, Treas. A. R. Leyda, Supt. J. G. Ourey. Capital, \$250,000. Bonds, \$150,000. 9 3

BRISTOL, TENN.—Bristol Belt Line Ry. Co. 7 m, 4-8½ g, 35 lb T r, 7 c, of which 5 a e m c and 2 t c. Short & Edison system. Pres. J. L. Stadelman, Sec. & Gen. Man. W. A. Stadelman, Treas. Aaron Ward Morris. Capital, \$250,000. Bonds, \$75,000. 12 2

BROCKTON, MASS.—Brockton St. Ry. Co. (Includes East Side, Brockton & Holbrook and Whitman Rys.) 35 m, 31 m s, 4-8½ g, 35 40 & 45 lb T r; 75 c, of which 49 are m c and 26 are t c, T-H system. Briggs, Brill, Jones, Newburyport and Stephenson cars. Ball engines. Pres. G. H. Campbell, Treas. A. A. Gasler, Asst. Treas. H. E. Reynolds, Gen. Man. & Pur. Agt. H. B. Rogers, Elecn. E. J. Rauch, Ch. Engr. of Power Station E. C. Baker. Capital, \$250,000. Bonds, \$500,000. Office, 203 Main st. 1 4

BROOKLYN, N. Y.—Atlantic Avenue R. R. Co. of Brooklyn. (Operates Brooklyn, Bath & West End R. R. Co. Controlled by Brooklyn Traction Co.) 141 m, 22 m s 4-8½ g, 90 lb girder r, 415 c. Westinghouse system. Brownell and St. Louis cars. Cooper-Corliss engines. Pres. & Gen. Man. B. Norton, Sec. & Treas. W. J. Richardson, Supt. H. R. Newkirk, Pur. Agt. W. M. Tobias, Elecn. F. Stillman, Jr. Capital, \$2,000,000. Bonds \$4,500,000. Executive office, Franklin Trust Co. Building, Montague St.; Supt's office, cor. Atlantic & Third aves. 4 4

Brooklyn City & Newtown R. R. Co. Elec. 21½ m, 4-8½ g, 58-96 lb girder r, 256 c of which 108 are m c and 148 t c 15 h. Westinghouse system. Brill, Jones and Stephenson cars. Westinghouse, Church, Kerr & Co. engines. Pres. John N. Partridge, V. Pres. L. Fitzgerald, Sec. & Treas. Duncan, B. Cannon, Supt. John L. Heins. Capital, \$1,000,000; authorized \$2,000,000. Bonds, \$1,850,000. General office, 120 Broadway. Executive office, cor. DeKalb & Central aves. 4 4

Brooklyn Elevated R. R. Co. 34.7 m, 16.9 m s, 4-8½ g, 60 lb T r, 242 c, 76 locomotives. Pres. A. Ladenburg, V. Pres. A. Barrett, Sec. & Treas. F. Uhlmann, Gen. Man. & Ch. Eng. O. F. Nichols. Capital \$13,283,600. Bonds \$12,968,000. Office, 31 Sands st. 1 4

Brooklyn Heights R. R. Co. (Lessee of Brooklyn City R. R. and Brooklyn, Queens Co. & Suburban R. R., and controlled by Long Island Traction Co.) 245 m of which 56.1 are horse, 187.8 elec., and 1.1 cable. 4-8½ g, 50 65 lb tram and girder r, 1,968 c of which 1430 are h c, 421 m c, 109 t c and 8 g c, 4,920 h. Curtis, Gen. Elec. and Westinghouse systems. Brill, Jones, Pullman, St. Louis and Stephenson cars. Pres. D. F. Lewis, V. Pres. E. W. Bliss, Sec. & Treas. C. P. Smith, Gen. Man. W. A. H. Bogardus, Supt. of cable division A. Rogers, Ch. Engr. M. G. Starrett, Ch. Engr. of Power Station C. A. Moore. Capital, \$200,000. Bonds, \$250,000. Office, 168 Montague St. 4 4

Brooklyn City R. R. Co. (Leased to Brooklyn Heights R. R. Co.) Capital authorized and issued, \$6,000,000. Bonds, \$3,925,000.

Brooklyn, Queens Co. & Suburban R. R. Co. (Includes Broadway Ferry & Metropolitan Ave. R. R. Co., Broadway R. R. Co., Jamaica & Brooklyn R. R. Co. Operated by Brooklyn Heights R. R. Co. and controlled by Long Island Traction Co.) Pres. C. M. Englis, V. Pres. C. M. Wicker, Sec. H. T. Bragg, Asst. Treas. B. J. Mullin, Supt. C. E. Harris, Elecn. T. M. R. Meikieham. Capital \$2,000,000. Office 21 Broadway. 2 4

Brooklyn Traction Co. Pres. J. P. Ilesley, Sec. & Treas. C. F. Stevens. Capital \$9,000,000. Bonds \$3,000,000. 4 4

Coney Island & Bklyn R.R. Co. Elec. 22 m, of which 16 are horse & 6 elec., 45 & 60 lb r, 4-8½ g, 115 c, of which 40 are box, 61 open and 14 m c., 300 h, T-H and Edison systems. Pres. H. W. Slocum, Sec. & Treas. E. F. Dreyton Supt. D. W. Sullivan. Office, cor. Smith & Huntington sts. Capital, \$500,000. 4 2

Franklin Ave. R. R. Branch of Brooklyn City & Newtown R. R. Co. Elec. 9 m, 4-8½ g, 98 lb girder r, 72 c, of which 40 are 4-wheel box and 32 are 4-wheel open. Westinghouse system. 8 3

Kings County Elevated R. R. Co. 19¼ m, 9 m s, 4-8½ g, 60, 70 lb T r, 138 c, locomotives 43. Pres. J. Jourdan, V. Pres. W. Goodwin, Sec. H. J. Robinson, Treas. J. H. Frothingham, Gen. Man. & Supt. W. T. Goundie. Capital, \$3,250,000; authorized, \$500,000 per mile. Bonds, \$7,188,700. Office, 346 Fulton st. 1 4

Long Island Traction Co., Pres. D. F. Lewis, V. Pres. E. W. Bliss, Sec. & Treas. C. P. Smith, Gen. Man. W. A. H. Bogardus. Capital \$30,000,000. 4 4

Prospect Park & Flatbush R. R. Co. 3 m, 4-8½ g, 34 lb r, 4 box c, 10 h. Pres. H. W. Slocum, Sec. & Treas H. W. Slocum, Jr., Supt. D. W. Sullivan. Office, 45 Broadway. Capital \$50,000. 4 2

Van Brunt St. & Erie Basin R. R. Co. 2¼ m, 4-8½ g, 45 lb s b r, 19 c, 41 h. Pres. Michael Murphy, Sec. & Treas. Wyllys Terry, Supt. T. J. Carey. Capital authorized and issued, \$150,000. Bonds, \$25,000. Offices, 264 Van Brunt st. 9 2

BROWNSTOWN, IND.—Brownstown & Ewing St. R. R. Co. 2 m, 5-4 g, T r, 1 c, 4 h, 2 mu. Pres. & Supt. F. Falk, V. Pres. & Sec. W. L. Bryant, Treas. G. H. Hines. Capital, \$3,500; authorized, \$5,000. 5 3

BRUNSWICK, GA.—Brunswick St. R. R. Co. 9 m, 4-8½ g, 48½ lb T and girder r, 15 c, 50 mu, 1½ m on St. Simon's Island, with 2 connecting steamboat lines. Stephenson cars. Owners. A. J. Crovatt, J. E. Dubignon, A. H. Lane, W. O. Allison, Gen. Man. W. E. Recknagel. Office, Newcastle St. Capital, \$200,000. 6 3

BUFFALO, ILL.—See Mechanicsburg, Ill.

BUFFALO, N. Y.—Buffalo Railway Co. (Operates Crosstown Ry.) 125 m, of which 22 are horse and 103 elec 75 m s, 4-8½ g, 62 lb girder r, 315 c, of which 60 are h c, 185 m c and 100 t c, 450 h. T-H system. Lake Erie engines. Pres. Henry M. Watson, V. Pres. & Gen. Man. H. H. Littell, Sec. & Treas. Joseph S. Baecher, Supt. F. O. Rusling. Capital, 5,370,500; authorized, \$6,000,000. Bonds, \$6,500,000. Office, 178 Main st., Buffalo. 1 4

Crosstown St. Ry. Co. (Operated by Buffalo Ry. Co.) Elec. 52 m, 4-8½ g, 67 lb girder r, 60 m c. T-H system. Pres. & Gen. Man. H. H. Littell, Sec. & Treas. J. S. Baecher, Supt. F. O. Rusling. Capital, \$1,500,000. Bonds, \$1,500,000. 8 3

Buffalo & Tonawanda Electric Ry. Co. 6 m, 4-8½ g, 45 lb T & girder r, 8 c, or which 3 are m c and 5 t c T-H & Edison systems. Pres. E. H. Butler, V. Pres M. Nellany, Sec. & Treas. C. M. Howard, Supt. W. J. Voorhees. Capital, \$125,000; authorized \$250,000. 9 2

Buffalo & Williamsville Electric Ry. Co. (See Williamsville, N. Y.)

Buffalo, Bellevue & Lancaster Ry. Co. (See Lancaster, N. Y.)

Buffalo, Kenmore & Tonawanda Electric Ry. Co. 5.99 m, 5.99 m s, 4-8½ g, 56, 72½ lb T & girder r, 4 m c. T-H system. Brill cars. Noye Engines. Pres. D. F. Callahan, V. Pres. D. F. Mack, Sec. G. H. Frost, Treas. J. L. Donovan, Supt. Pur. Agt. Ch. Engr. Elecn. & Ch. Engr. of Power Station H. E. Heller. Capital \$50,000. 1 4

Buffalo, North Main St. & Tonawanda R. R. Co. Elec. 5¼ m, 4-8½ g, 45-90 T r, 3 m c. Edison system. Brill cars. Pres. L. F. W. Arend, V. Pres. D. Gordon, Sec. E. G. Hoag, Treas. B. A. Cook, Supt. & Elecn. J. W. Towle. Capital \$60,000. Office 110 Franklin st. 4 4

BURLINGTON, IA.—Burlington Electric Ry. Co. 11 m, 10 m s, 4-8½ g, 40 lb T r, 22 c, of which 15 are m c and 7 t c. Westinghouse system. Stephenson cars. Westinghouse engines. Pres. F. G. Jones, V. Pres. H. C. Garrett, Sec. E. G. McInnes, Treas. J. M. Jones, Supt. & Pur. Agt., C. D. Jones. Capital, \$650,000. Bonds, \$425,000. 4 4

BURLINGTON, VT.—Winooski & Burlington St. Ry. Co. 6.38 m, of which 1.50 are horse and 4.88 Elec. 4-8½ g, 50 lb T r, 17 c, of which 8 are m c and 9 h c and t c 24 h. Gen. Elec. system. Gilbert cars. Pres. Elias Lyman, V. Pres. J. A. Powers, Sec. & Treas W. F. Hendee, Supt. T. B. Jones. Capital, \$135,000; authorized, \$300,000. Bonds, \$100,000. Office, 186 College st. 8 3

BUTTE, MONT.—Butte Consolidated Ry. Co. 15 m, of which 1½ are cable, 2 steam and 13½ elec, 4-8½ g, 40 and 50 lb T r, 24 c, of which 5 are steam, 4 g c, 10 m c and 5 t c. Edison system. Pres. W. Bennett, Sec. & Gen. Man. J. R. Wharton, Treas. W. A. Clark. Capital, \$500,000. Office, Main & Park sts. 5 4

C

CAIRO, ILL.—The Delta Electric Co. 4 m, 4-8½ g 45 lb T r, 6 c, of which 4 are m c and 2 t c. Detroit system. St. Louis cars. Russell engines. Pres. W. Kluge, V. Pres. A. Miller, Sec. & Gen. Man. H. Schulze, Treas. H. Hasenjaeger. Capital, \$150,000. Bonds, \$50,000. Office 1010 Washington av. 8 3

CAMDEN, N. J.—Camden & Atlantic R. R. Co Elec. 6¼ m, 4-9 g, 60 lb r, 18 motor & 19 trail c Pres. G. B. Roberts, V. Pres. Wm. J. Sewell, Sec. J R. McClure, Treas. W. Taylor, Supt. A. O. Dayton Office 233 S. 4th st., Phila. 7 1

Camden, Gloucester & Woodbury Ry. Co. Elec. 15 m, 5 g, 80 lb girder r, 42 c, of which 12 are m c and 30 t c. Westinghouse system. Lamokin cars. Westinghouse engines. Pres. J. Willard Morgan, Sec. T. P. Curley, Treas. W. J. Tompson, Engr. J. J. de Kinder, Supt. H. M. Royal. Capital, \$600,000. Bonds, \$250,000. 9 3

USE ONLY **HIGHEST GRADE MANUFACTURED.**

Insulated Switchboard Feeders and Flexible Cords.
W. R. BRIXEY, MFR., 203 BROADWAY, NEW YORK.

Camden Horse R. R. Co. Elec. 28½ m, of which 11½ are horse and 16¼ elec. 5 g., 47, 52, 63½, 80 lb s-b Duplex and girder r, 74 c, of which 28 are h c, 26 m c and 18 t c. 150 h. Edison, T-H and Westinghouse systems. Brill, Lewis & Fowler and Stephenson cars. Westinghouse and Ball engines. Pres. Wm. S. Scull, V. Pres. B. C. Reeve, Sec. Morris W. Hall, Treas. G. G. Browning, Supt. S. J. Fenner. Capital, \$250,000. Bonds, \$150,000. Office, 307 Market st. 8 3

CANANDAIGUA, N. Y.—Canandaigua Electric Lt. & R. R. Co. 2 m, 4-8½ g, 42 lb girder r, 6 c of which 3 are m c and 3 t c. Gen. Elec. system. Payne engines. Pres. M. D. Munger, Sec. & Treas. H. B. Ferguson, Gen. Supt. & Elecn. C. J. Purdy. Capital, \$50,000. 4 4

CANTON, O.—Canton St. Ry. Co. Elec. 6½ m 4 g, 40 & 50 girder & T r, 38 c, of which 24 are m c and 14 t c. Edison system. Pres. & Treas. W. A. Lynch, V. Pres. R. A. Miller, Sec. A. J. Underhill, Supt. T. R. Catlin. Capital \$300,000. Office, 275 W. Tuscarawas st. 3 4

Lakeside St. R. R. Co. Elec. 2½ m, 4 g, 40 lb T r, 12 c, of which 6 are m c. & 6 t c. Summer line. Officers, same as above. 3 4

CAPE MAY, N. J.—Cape May, Delaware Bay & Sewell's Point Electric Ry. Co. 6½ m, 4-8½ g, 45 lb T r, 16 c, of which 10 are m c and 6 t c. Westinghouse system. Brill and Lamokin cars, Ball engines. Pres. G. G. Browning, Sec. & Gen. Man. J. J. Burleigh, Treas. B. C. Reeves, Supt. J. H. Edmunds. Capital, \$150,000. Bonds, \$150,000. Office, Camden. 8 3

CARBONDALE, PA.—Carbondale Traction Co. Elec. 9.4 m, 5-2 g, 48, 50 lb T & girder r, 9 m c. Curtis and T-H systems. Brill and New Castle cars. Frick engines. Pres. J. W. Aitken, Sec. Treas. & Pur. Agt. M. F. Thompson. Gen. Man. & Elecn. W. F. Sadler, Jr., Supt. & Ch. Engr. of Power Station J. Dempsey. Capital, \$150,000. Bonds, \$150,000. 1 4

CARTERSVILLE, MO.—Southwest Missouri Electric Ry. Co. (See Webb City.)

CARTHAGE, MO.—Carthage Horse Ry. Co. 4½ m, 3-6 g, 16-30 lb T r, 5c, of which 4 are box and 1 open, 2h, 18 mu. Pres. J. Guiney, Sec. J. W. Halliburton, Gen. Man. & Supt. E. A. Sexton. Capital \$30,000. Bonds \$10,000. Office, 19 S. Grant st. 1 4

CEDAR RAPIDS, IA.—Cedar Rapids & Marion Ry. Elec. 14 m, 4-8½ g, 45, 58 lb T & girder r, 25c, of which 18 are m c and 7 t c. T-H system. American and St. Louis cars. Allis engines. Pres. P. E. Hall, V. Pres. W. D. Douglas, Sec. J. S. Ely, Treas. C. H. Clark, Supt. F. L. Dierens. 1 4

CENTERVILLE, IA.—People's St. Ry. Co. 1.6 m, 3-8 g, 20 lb T r, 2 4-wheel box c, 14 mu. Robinson & Hit cars. Pres. J. R. Wooden, Sec. & Treas. C. R. Wooden. Capital \$12,000; authorized, \$25,000. 1 4

CENTRALIA, ILL.—Centralia & Central City St. Ry. Co. 3½ m, 4-8½ g, 25 lb T r, 8 c, 14 mu. Pres. S. N. Pierce, V. Pres. J. Grush, Sec. G. P. Duncan, Treas. A. Dunker, Supt. H. M. Johnson. Capital, \$7,950; authorized, \$10,000. 8 3

CHAMPAIGN, ILL.—Urbana & Champaign St. Ry. Co. (Lessee of Champaign Rapid Transit.) Elec. 9 m, 4-8½ g, 40-48 lb T r, 12 c, of which 6 are m c and 6 t c. Westinghouse system. Pres. & Treas. & Gen. Man. B. F. Barris, Jr., Gen. Supt. H. J. Pepper. Capital, \$150,000. Bonds, \$50,000. 11 2

Champaign Rapid Transit Co. Leased to Urbana & Champaign St. Ry. Co. Elec. 3 m, 4-8½ g 50 lb T r, 3 m c. Westinghouse system. Capital, \$50,000. 11 2

CHARLESTON, S. C.—Charleston City Ry. Co. 14½ m, 4-8½ g, 38 & 42 lb c. b. r, 37 c, 153 h and mu. Stephenson cars. Pres. & Pur. Agt. Jno. S. Riggs, Sec. & Treas. Frank F. Whilden, Supt. John Mohlenhoff. Office, 4 Broad st. 1 4

Enterprise R. R. Co. 16 m, 5 g, 30 & 40 lb c b & T r 35 c, 87 h, 16 mu. Brill and Jones cars. Pres. and Gen. Man. T. W. Passallague, Sec. & Treas. P. J. Balaguer. Capital, \$250,000; authorized, \$500,000. Bonds, \$17,000. Office, Cor. Shepard and Meeting Sts. 2 4

Middle Street Sullivan's Island Ry. Co. 2½ m, 4-8½ g, 20 & 30 lb T r, 7 c, 14 mu. Pres. B. Callaghan, Sec. & Treas. Frank F. Whilden, Supt. B. Buckley. Capital \$15,000. Office 4 Broad st. 1 4

CHARLESTON, W. VA.—Charleston St. Ry. Co. 4 m, 4-8½ g, 35 lb s. b. r, 6 open c, 7 h, 12 mu. Sec. E. W. Bridge, Treas. & Gen. Man. J. D. Campbell Supt. W. B. Carder. Capital, \$50,000. Bonds, \$10,000. Office, 215 Kanawha st. 3 2

CHARLOTTE, N. C.—Charlotte St. Ry. Co. Elec 5½ m, 4-8½ g, 40-45 lb T & girder r, 9 c, of which 6 are m c and 3 t c. Edison system. Brill cars. Armstrong & Sims engines. Pres. & Treas. E. D. Latta, V. Pres. E. B. Springs, Supt., Pur. Agt. & Elecn. L. O. Williams, Auditor, F. A. Savin. Capital, \$60,000. Bonds \$100,000 1 4

CHARLOTTESVILLE, VA.—Charlottesville & University St. Ry. Co. 1½ m, 4-8½ g, 16 lb T r, 6 c, 2 h, 18 mu. Lewis & Fowler cars. Pres. & Treas. & Gen. Man. R. P. Valentine, Sec. Geo. Perkins, Supt. H. D. Porter. Capital, \$10,000; authorized, \$100,000. Bonds, \$22,000. 8 3

CHATTANOOGA, TENN.—Chattanooga & North Side St. Ry. Co. (Operates North Chattanooga St. Car line) 6½ m, 3 m, 3 s, 4-8½ g, 56 lb girder & T r. 9 c of which 3 are h c and 6 t c. T-H system. Stephenson cars. Arlington & Sims engines. Pres. & Gen. Man. S. R. Read, V. Pres. N. E. Barker, Sec. & Treas. W. H. Hart, Gen. Man. S. R. Read, Supt, Pur. Agt. Elecn. & Ch. Engr. of Power Station W. C. Teas, Ch. Engr. of Power Station R. C. Henry. Capital, \$40,000. Bonds, \$60,000. Office Read Home. 2 4

North Chattanooga St. Car Co. (Operated by Chattanooga & North Side St. Ry. Co.) 3 m, 3 m s, 4-8½ g, 56 lb T r, 3 m c. Edison system. Stephenson cars. Pres. T. D. Young, Sec. H. C. Beck, Treas. J. Orr, Gen. Man. & Ch. Engr. T. J. Nicholl, Supt. Pur. Agt. Elecn. & Ch. Engr. of Power Station W. T. Teas. 2 4

Chattanooga & Lookout Mountain Ry. Steam 9 m 4-8½ g, 50 lb T r. Supt. W. T. Corby. 2 4

Chattanooga Electric Ry. Co. 40 m, 4-8½ g, 40, 63 lb T & girder r, 36 c, of which 32 are m c and 4 t c T-H, Detroit & Edison systems. Brill and Stephenson cars. Armstrong & Sims and Taylor engines. Pres. Sec. & Treas. W. T. Adams, V. Pres. E. Watkins Supt. C. J. Gustatson, Ch. Engr. of Power Station R. G. Williams. Capital \$1,500,000; authorized \$1,500,000. Bonds, \$1,200,000. Office Richardson Block. 2 4

Chattanooga Union Ry. Co. dummy line, 44 m 4-8½ g, 56 lb r, 59 c, of which 17 are pass. c and 42 freight c. Gilbert and Chattanooga Car & Foundry Co. cars. Baldwin and Rhode Island engines. Pres. H. S. Chamberlain, Sec. & Treas. O. L. Hurlbut, Supt. J. R. Shaler. Capital, \$1,000,000. 5 3

Incline & Narrow Gauge Ry. Co. 3½ m, of which 3 are steam and ½ incline cable, 3 g, 35 lb T r. Pres. D. Woodworth, V. Pres. H. F. Temple, Gen. Man. H. C. Evans, Supt. T. M. Derickson. Capital \$200,000. Office Lookout Mountain. 2 4

CHESTER, PA.—Chester Traction Co. (controls all lines in the city.) Pres. S. Dyer.

Union Ry. Co. (Operates Chester St. Ry. and Chester, Darby & Philadelphia St. Ry.) 30 m 30 m s, 5-2½ g, 60-90 lb T & girder r, 40 m c. Westinghouse system. Brill and Lamokin cars. Wetherill engines. Pres. S. A. Dyer, Sec. Treas. & Pur. Agt. J. G. Dyer, Gen. Man. & Supt. J. MacFayden, Ch. Engr. & Ch. Engr. of Power Station J. Rostrom, Elecn. M. McDowell. Capital, \$450,000. Bonds, \$400,000. 1 4

Chester St. Ry. Co. (Leased to Union Ry. Co.) 7½ m, 7½ m s, 5-2½ g, 60,90 lb girder r. Capital \$150,000. 1 4

Chester, Darby & Philadelphia St. Ry. Co. (Leased to Union Ry. Co.) Elec. 8 m, 4-8½ g, 20 m c. Pres. G. C. Hetzel, Consulting Engr. W. E. Clemens, Wakefield, Mass. 5 3

CHICAGO, ILL.—Chicago City Ry. Co. 159.74 m, of which 93.21 are horse, 34.97 cable and 26.56 elec, 79.87 m s, 4-8½ g, 45-100 lb girder r, 1,763 c, of which 700 are open c, 322 g c, 61 m c and 680 box c, 2,000 h. Own cars. Westinghouse system. Pres. Geo. H. Wheeler, 1st V. Pres. J. C. King, 2d V. Pres. E. M. Phelps, Sec. F. R. Greene, Treas. T. C. Pennington, Supt. M. K. Bowen, Pur. Agt. R. L. Garth, Elecn. G. W. Knox, Ch. Engr. of Power Station, R. G. Hill. Capital, \$9,000,000. Bonds, \$4,619,500. Office, 2,020 State St. 3 4

Calumet Electric St. Ry. Co. Elec. 53 m, 20 m s, 4-8½ g, 78, 80 lb girder r, 106 c, of which 50 are m c and 56 t c. T-H and Detroit systems. American, Lamokin, Pullman and St. Louis cars. Ball and Armstrong & Sims engines. Pres. R. Berger, Sec. & Treas. H. B. White, Gen. Supt. J. Oliphant, Jr. Pur. Agt. F. D. Rusling, Ch. Engr. R. H. Yeats, Elecn. H. McNulta, Ch. Engr. of Power Station W. E. Bevington. Capital, \$500,000. Office, Burnside crossing. 4 4

Chicago North Shore St. Ry. Co. 17 m, 8½ m s, 4-8½ g, 85 lb Johnson girder r, 25 m c. Gen. Electric system. Pullman cars. Wheelock engines. Pres. D. H. Louderbach, V. Pres. J. L. Cochran, Sec. Howard Abel. 8 3

Chicago General St. Ry. Co. (Includes West & South Towns St. Ry. Co.) Elec. 11½ m, 4-8½ g, 80 lb girder r, 5 m c. Sperry system. Pullman cars. Siemens & Halske generators. Pres. L. E. McGann, V. Pres. C. L. Bonney, Sec. & Treas. L. C. Bonney. Capital \$500,000; authorized \$3,000,000. Bonds \$200,000. Office 1032 Lawndale Ave. 1 4

Chicago Pass Ry. Co. 27 m, 4-8½ g, 52 & 60 lb r, 113 c, 480 h. Pres. & Gen. Man. J. B. Parsons, Sec. & Treas. Geo. L. Webb. Leased to West Chicago St. R. R. Co. Office, 89 W. Washington St. 1 4

Cicero & Proviso St. Ry. Elec. 27 m, 4-8½ g, 60 lb Johnson girder r, 54 c, of which 43 are m c and 11 t c. Edison system. American, Pullman and St. Charles cars. Armstrong & Sims, Bullock and Frick engines. Pres. & Gen. Man. G. Butters, V. Pres. E. A. Cummings, Sec. F. E. Ballard, Treas. H. Coombs, Supt. J. T. Hughes, Pur. Agt. D. W. Coan, Elecn. W. C. Fuchs, Ch. Engr. of Power Station, P. Miller. Capital stock, \$1,000,000. Bonds, \$800,000. Office, Oak Park. 1 4

Lake Street Elevated R. R. Co. 16½ m, 8 m s, 5.8½ g, 71 lb T r, 125 c, 25 loc. Gilbert cars. Rhode Island locomotives. Pres. J. A. Roche, V. Pres. H. P. Thompson, Sec. O. W. Brewer, Treas. I. H. Witbeck, Gen. Man. M. H. Alberger, Supt. F. Hedley, Pur. Agt. H. V. DeHart, Ch. Engr. R. J. Sloan. Capital \$10,000,000. Bonds \$4,000,000. Office Security Building. 1 4

North Chicago St. R. R. Co. 83 m, of which 65 are horse, 17 cable and 1 elec., 4-8½ g, 66½ lb girder r, 749 c, of which 570 are h c and c, 177 g c and 2 m c. 1,300 h. Love system. American, Brownell, and Stephenson cars. Fraser & Chalmers engines. Pres. Chas. T. Yerkes, 1st V. Pres. W. F. Furbeck, 2d V. Pres. Gen. Man. & Pur. Agt. J. M. Roach, Sec. & Treas. J. W. Helm, Supt. Fred L. Threedy, Asst. Supt. E. W. Sherman, Ch. Engr. S. Potis, Ch. Engr. of Power Station W. W. Roach. Capital, \$5,500,000; authorized, \$10,000,000. Bonds, \$3,000,000. Office, 444 N. Clark st. 1 4

South Chicago City Ry. Co. Elec. 30 m, 16 m s, 4-8½ g, 75, 85 lb girder r, 91 c, of which 51 are m c and 40 t c. Edison and Westinghouse systems. Brownell, Pullman and St. Louis cars. Allis engines. Pres. D. F. Cameron, V. Pres. D. M. Cummings, Sec. & Pur. Agt. O. S. Gaither, Supt. R. D. Rowe, Ch. Engr. C. W. Thiel. Capital, \$1,200,000. Bonds, \$1,200,000. Office, Chicago. 1 4

West Chicago St. R. R. Co. (Includes Chicago Pass Ry.) 185 m, of which 151 are horse and 34 cable, 4-8½ g, 43-90 lb flat & girder r, 1,815 c, of which 1,475 are h c, 225 t c and 200 g c, 4,025 h. Pres. Chas. T. Yerkes, V. Pres. & Gen. Man. John B. Parsons, Sec. & Treas. C. A. Yuille, Asst. Sec. & Treas. L. S. Owsley, Supt. C. F. Nagel, Pur. Agt. E. A. Bloodgett. Capital, \$12,000,000. Office of Pres. & Supt. 89 W. Washington st. 9 3

CHILLICOTHE, ILL.—People's Street Ry. Co 3½ m, 4-8½ g, 16, 20, 25 lb T r, 6 c, 12 mu. Lessee & Gen. Man. J. Kinloch. Capital, \$8,000. 1 4

CHILLICOTHE, O.—Chilllicothe Electric Ry. & Lighting Co. 4½ m, 4-8½ g, 60 lb T r, 13 c, of which 8 are m c and 5 t c. T-H and Edison systems. Pres. M. Cahll, Treas. William Poland, Receiver & Gen. Man. A. H. Reutinger. Capital \$100,000. Bonds, \$100,000. 8 3

CINCINNATI, O.—Cincinnati Inclined Plane Ry Co. Elec. 16 m, 1920 ft. of which are cable and 16 m elec, 5-2½ g, 56, 58½, 63 lb girder r, 42 c, of which 40 are m c. and 2 incline plane cable, 5 h. Edison system. Pres. H. H. Littell, V. Pres. St. John Boyle, Sec. J. M. Doherty, Gen. Man. H. P. Bradford. Capital, \$725,000; authorized, \$1,000,000. Bonds, \$500,000. 4 4

Cincinnati St. Ry. Co. Elec, cable and horse. 139½ m, 8 m cable, 60 electric, 5-2 g, 42-52 lb tram and Johnson r, 370 c of which 91 are m c, 36 grip, 72 t c. 70 open. T-H system. 1,200 to 1,500 h. Pres. & Gen. Man. John Kilgour, Sec. Jas. A. Collins, Treas. R. A. Dunlap, Gen. Supt. Jno. Harris, Pur. Agt. A. G. Starr, Elec. Engr. B. L. Kilgour. Mech. Engr. B. L. Baldwin, Supt. of Machinery H. C. Rolf, Audr. W. R. Avery. Office, 2d floor Apollo bldg. 1 4

Mt. Adams & Eden Park Inclined Ry. Elec. 25 m of which 8 are cable and 17 elec, 5-2½ g, 52-100 lb r 160 c, of which 32 are g c, 50 m c and 78 t c. T-H system. Brill, Laclede, Pullman and Stephenson cars. Pres. John Kilgour, Sec. & Treas. James A. Collins, Pur. Agt. & Auditor, A. G. Starr, Supt. John C. Weaver. Office, 5th & Walnut, sts. 3 3

Mt. Auburn Cable Ry. Co. 8½ m, cable, 5-2 g, 56 lb girder r, 42 c, of which 21 are g c. & 21 t c. Pres. Henry Martin, V. Pres. R. Wurlitzer, Sec. and Treas. A. Hill Supt. G. Levins. Capital \$300,000; authorized, \$600,000. Bonds, \$370,000. Office, Highland ave. & Saunders st. 8 3

Pendleton, Mt. Lookout & E. Walnut Hill Ry. Co 2 m, 5.2 g, 40 lb T r; 7 c., of which 2 are dummy, 2 m c. and 3 t c. T-H system. Pres. & Gen. Man. C. H. Kilgour, Sec. Supt. & Pur. Agt. A. H. Meler, Treas. C. G. Gove, Elecn. B. Kilgour. Capital authorized \$150,000. Office Station C. 4 4

Price Hill Inclined Planes, 2 planes, each 800 ft 5-6 g, 60 & 85 lb T r, 2 c on each plane. Pres. M. W. Oliver, Gen. Man. Rees E. McDuffie, Sec. & Treas Geo. T. McDuffie. Capital, \$400,000. Office, Price Hill 4 4

So. Covington & Cincinnati. (See Covington, Ky.)

CITY ISLAND, N. Y.—Pelham Park R. R. Co 3½ m, 3-6 g, 30-57 lb T and s br, 8 c, of which 6 are 4-wheel box and 2 4-wheel open, 15 h. Pres. H. D. Carey, V. Pres. W. R. Lamberton, Sec. & Treas. E. N. Anable, Supt. Jesse Titus. Capital \$50,000. Office, City Island, N. Y., and 16 & 18 Exchange Place, New York City. 1 4

CLARKSVILLE, TENN.—Clarksville St. Ry Co. 4.2 m, 4-8 g, 18 lb T r, 7 c, 32 mu. Pres. W. M. Dantial, V. Pres. F. P. Gracey, Sec. J. P. Polk, Supt. T. A. Small. Brownell and Stephenson cars. Capital \$16,500. Bonds, \$11,000. Office, 211 S. 10th St. 4 4

CLEVELAND, O.—Cleveland City Ry. Co. (Includes Woodland Ave. & West Side R. R., Superior St., Payne & Lexington Ave. and St. Clair st. lines.) 72 m, of which 19 are cable and 53 elec. 82-98 lb girder r, 346 c, of which 47 are g c, 140 m c. and 159 t c. Westinghouse and Short systems. Brill and Jones cars. Globe engines. Pres. M. A. Hanna, V. Pres. F. De H. Robinson, Sec. & Pur. Agt. J. B. Hanna, Gen. Supt. George G. Mulhern. Capital, \$7,000,000. Bonds \$2,000,000. Office, Western Reserve Bldg. 4 4

Cleveland Electric Ry. Co. 120 m, 4-8½ g, 62-98 lb girder r, 482 c, of which 240 are m c and 242 t c. General Electric and Steel Motor systems. Brill and Jones cars. Allis engines. Pres. H. E. Andrews, V. Pres. H. A. Everett, Sec. R. A. Harman, Asst. Sec. L. E. Bellstein, Treas. J. Parmelee, Elecn. & Pur. Agt. C. W. Watson, Gen. Supt. J. J. Stanley. Capital \$12,000,000. 4 4

USE ONLY

HIGHEST GRADE MANUFACTURED.

Submarine and Aerial Feeders for Street Railway and Power Service.

W. R. BRIXEY, MFR., 203 BROADWAY, NEW YORK.



East Cleveland, Euclid & Wickliffe St. Ry. Co. Elec. 3 m, 4-8 1/2 g, 52 lb girder r, 4 c of which 2 are m c and 2 t c. Edison system. (Same officers as Cleveland Elec. Ry. Co.) 4 4

Lake View & East Cleveland St. Ry. Co. Elec. 12.68 m, 4-8 1/2 g, 52 lb girder r, 8 c, of which 4 are m c and 4 t c. Edison system. (Same officers as Cleveland Elec. Ry. Co.) 4 4

CLEVELAND, TENN.—Cleveland St Ry. Co. 2 m, 4-9 g, 32 lb T r, 2 4-wheel box c, 4 mu. Pres. L. D. Campbell, Sec. & Treas. L. L. Harle, Supt. J. T. Johnston. Capital \$4,000. 6 2

CLINTON, IA.—Lyons & Clinton Horse R. R. Co. (See Lyons.)

State Electric Co. 14 m, of which 2 are horse and 12 elec. 4-8 1/2 g, 45, 54 lb girder & T r, 20 c, of which 2 are h c 12 m c and 6 t c, 6 h, 4 mu. T-H and Westinghouse systems. Pullman cars. Ideal engines. Pres. E. C. Walsh, V. Pres. D. Langan, Sec. C. C. Coan, Treas. A. L. Stone, Gen. Man. J. P. Calman, Supt. W. H. Calnan. Capital, \$500,000. 9 3

CLINTON, MASS.—Clinton St. Ry. Co. Elec. 2 1/2 m, 4-8 1/2 g, 58 lb T r, 2 m c. Pres. H. Parker, V. Pres. H. A. Wallis, Sec. W. R. Dane, Treas. A. J. Witherall, Auditor, B. F. Wallace. Capital \$30,000. 9 3

CLINTON, MO.—Clinton St. Ry. Co. 3 m, 4 g Z T & crescent r, 5 c, 8 mu. Pres. A. P. Frowein, V. Pres. J. T. Ruffin, Sec. & Treas. H. P. Paris, Supt. G. C. Haysler. Capital, \$12,000. 4 4

COLORADO SPRINGS, COLO.—Colorado Springs Rapid Transit Ry. Co. Elec. 28 m, 4-8 1/2 g, 30 lb T r, 42 c, of which 25 are m c and 17 t c. Edison system. Pullman and Woerber cars. Frick and Reynolds Corliss engines. Pres. F. L. Martin, V. Pres. E. J. Eaton, Sec. & Treas. A. L. Lawton, Gen. Man. & Auditor, A. A. McGovney, Supt., Pur. Agt. & Elec. D. L. Macaffree, Ch. Engr. of Power Station C. Bibb. Capital, \$500,000. Bonds, \$350,000. 4 4

COLUMBIA, PA.—Columbia & Ironville St. Ry. Pass. Co. (Operated by Columbia TrACTION Co.) 8 m, 4 m s, 5-2 1/2 g, 56 lb girder r, 4 m c. Westinghouse system. Brill cars. Ball & Wood and Westinghouse engines. Pres. F. S. Given, Sec. Gen. Man. Supt. & Pur. Agt. F. S. Given, Treas. J. Janson, Ch. Engr. E. N. Smith, Elec. J. Cramen, Ch. Engrs. of Power Station F. Lawlor & J. Hughes. Capital, \$75,000; authorized, \$100,000. Bonds, \$75,000. Office 22 1/2 Locust ave. 1 4

Columbia & Donegal Ry. Co. (Operated by Columbia TrACTION Co.) 7 m, 5-2 1/2 g, 56 lb T r & girder r, 4 m c. Westinghouse system. Lamokin cars. Westinghouse engines. Pres. W. B. Given, Sec. & Gen. Man. F. S. Given, Treas. H. L. Haldeman. Capital, \$75,000. 9 3

COLUMBIA, S. C.—Columbia Electric St. Ry. Light & Power Co. Elec. 21 m, 4-8 1/2 g, 48 lb T r, 6 m c. Short system. Pres. & Gen. Man. J. Q. Marshall, V. Pres. W. A. Clark, Sec. W. G. Cbilds, Supt. A. Wallace. Capital, \$50,000. Office, 85 Gervais st. Changing to elec. 6 3

COLUMBUS, GA.—Columbus R. R. Co. 17 m, of which 5 are horse and 12 steam, 4-8 1/2 & 4-9 g, 25 & 40 lb T r, 27 c, of which 9 are dummy and 1 1/2 h c, 10 h 50 mu. Brill cars. Porter engines. Pres. & Ch. Engr. J. F. Flournoy, Sec. & Treas. Cliff B. Grimes, Supt. J. H. Henderson. Capital, \$25,000. Bonds \$100,000. 4 4

North Highlands R. R. Co. Elec. 3 1/2 m, 4-8 1/2 g, 45 lb T r, 6 c, of which 3 are m c. and 3 t c. T-H system. Brill and Ellis cars. Arlington & Sims engines. Pres. & Gen. Man. S. A. Carter, V. Pres. E. J. Rankin, Sec. & Treas. R. Browne, Supt. F. E. Knapp. Capital \$31,000; authorized, \$200,000. Office, Front St. 4 4

COLUMBUS, IND.—Crump's St. Ry. 7 m, of which 1/2 m is horse and 6 1/2 elec. 4-8 1/2 g, 30 lb T r, 9 c of which 1 is h c, 4 m c and 4 t c. American Car Co. and Brownell cars. Ideal engines. John S. Crump, proprietor; Man. R. F. Gottschalk, Supt. J. W. Crump, Jr. 1 4

COLUMBUS, MISS.—Columbus St. Ry. & Power Co. Dummy. 2 m, 4-1/2 g, 40 lb T r, 2 c. Pres. E. Cahn, Sec. & Gen. Man. C. E. Rodenburg, Treas. R. T. Williams. Capital, \$25,000. 9 2

COLUMBUS, O.—Columbus St. Ry. Co. (Operates Glenwood & Greenlawn St. Ry.) Elec. 5 1/2 m, 3 1/2 m s, 5-2 g, 52-93 lb T r & girder r, 150 c, of which 120 are m c and 30 t c. T-H system. Brill, Brownell and Stephenson cars. Buckeye and McIntosh & Seymour engines. Pres. E. McMillin, 1st V. Pres. Treas. & Gen. Man. E. K. Stewart, 2d V. Pres. H. E. Sheldon, Sec. P. V. Burlington, Gen. Supt. Pur. Agt. & Elec. W. F. Kelly, Ch. Engr. of Power station F. Nussbaum. Capital, \$3,000,000. Bonds \$3,000,000. Office 12 N. High St. 1 4

Glenwood & Greenlawn St. Ry. Co. (Operated by Columbus St. Ry. Co.) Elec. 5 m, 5-2 g, 5-2 g, 45 lb girder & T r, 14 c, of which 8 are m. c. and 6 t. c. Edison and Westinghouse systems. 8 3

Worthington, Clintonville & Columbus St. Ry. Co. 4 m, 5-4 g, 45 lb. T r, 2 m c. Westinghouse system. Brill cars. Pres. O. W. Aldrich, V. Pres. D. H. Welling, Sec. Supt. & Pur. Agt. R. M. Weaver, Treas. H. C. Cooke. Capital, \$22,000; authorized \$40,000. Office 11 Wesley Block 2 4

CONCORD, N. C.—Concord Ry. Co. Steam. 2.65 m, 48 1/2 g, 40 lb T r, 3 c. Owned by J. P. Allison, A. B. Young and W. M. Smith.

CONCORD, N. H.—Concord St. Ry. Co. Elec. 10 1/2 m, 3 g, 35, 45 & 50 lb T r, 24 c, of which 18 are m c and 6 t c. T-H system. Rollins and Swamscott engines. Pres. J. H. Albin, Sec. N. E. Martin, Treas. A. B. Cross, Supt. H. E. Chamberlin, Elec. D. W. White. Capital, \$100,000; authorized \$150,000. Bonds \$85,000. Office, Main st. 4 4

CONY ISLAND, N. Y.—Sea View R. R. Co. Elevated. 2.3 m, 1 m s, 4-8 1/2 g, 56 lb T r, 7 c, 7 locomotives. Brill and Felgel cars. Baldwin engines. Pres. F. A. Schroeder, Sec. Gen. Supt. & Pur. Agt. W. Finley, Treas. I. M. Bonn. Capital, \$191,000; authorized \$250,000. Bonds \$27,500. Office, Flatbush. 1 4

CONNELLSVILLE, PA.—Connellsville, New Haven & Lisenring St. Ry. Co. Elec. 4 1/2 m s, 5 2 1/2 g, 52 lb girder r 7 m c. Edison & Westinghouse systems. Brill cars. Taylor engines. Pres. J. D. Frisbee, Sec. J. K. Ewing, Jr., Treas. E. T. Norton, Supt. Pur. Agt. Ch. Engr. & Elec. J. L. Gans, Ch. Engr. of Power Station D. S. Farnwait. Capital, \$70,000; authorized, \$100,000. Bonds, \$30,000. 1 4

CORPUS CHRISTI, TEX.—Corpus Christi improvement Co. Dummy. 6 1/2 m, 4-8 1/2 g, 30 lb T r 4 c, 2 steam motors. Pres. E. H. Ropes, V. Pres. J. M. Ropes, Sec. W. B. Newkirk, Treas. & Supt. H. Keller. Capital, \$100,000. 2 3

Gussett St. Ry. 4 m, 4-8 1/2 g, 25-30 lb T r, 6 c, 16 mu. Proprietor, N. Gussett. Capital \$25,000. 9 1

CORSICANA, TEX.—Corsicana St. Ry. Co. 4 1/2 m, 4-8 1/2 g, 16 lb T r, 6 c, 28 mu. Pres. & Gen. Man. B. G. McKie, V. Pres. J. E. Whiteside, Sec. & Treas. W. J. McKie. Capital, \$50,000. 5 3

CORTLAND, N.Y.—Cortland & Homer Horse R. R. Co. 4.1 m, 4-8 1/2 g, 25-30 lb flat & T r, 8 c, of which 4 are box and 4 open, 26 h. Pres. C. H. Garrison, V. Pres. S. E. Welch, Sec. & Treas. Gen. Man. & Supt. L. D. Garrison. Capital, \$40,000. Office, 19 Main St. 1 4

CORVALLIS, ORE.—The Corvallis St. Ry. Co. 2 m, 3 m s, 3-6 g, 30 lb steel T r, 2 box c, 2 h. Pres. Gen. Man. Supt. & Pur. Agt. M. W. Wilkins, Sec. M. O. Wilkins, Treas. M. G. Wilkins. Capital \$50,000; authorized, \$50,000. Bonds, \$10,000. 1 4

COTTAGE CITY, MASS.—Cottage City St. Ry. Co. 5 m, 4-8 1/2 g, 40 lb T r, 10 c. Briggs and Ellis cars. Pres. W. C. Van Derrip, V. Pres., Sec. & Gen. Man. W. A. Boland, Supt. H. S. Kemp. Capital, \$15,000; authorized, \$25,000. Office of Gen. Man. 610 Exchange Bldg, Boston. 9 3

COTTONWOOD FALLS, KAN.—Consolidated St. Ry. Co. 1 1/2 m, 3-6 g, 36 T lb steel T r, 2 4-wheel box c, 5 h, 3 mu. Pres. H. S. F. Davis, V. Pres. W. Adare, Sec. E. W. Tanner, Treas. C. J. Lantry, Supt. N. P. Martin. Capital \$10,000. 4 4

COUNCIL BLUFFS, IA.—Omaha & Council Bluffs Ry. & Bridge Co. Elec. High steel bridge spans the Missouri river. 20 m, 20 m s, 4-8 1/2 g, 40, 45 & 56 lb girder & T r, 56 c, of which 36 are m c & 20 t c. T-H & Edison systems. Pullman cars. Westinghouse engines. Pres. G. C. Barton, V. Pres. J. J. Brown, Sec. C. T. Stewart, Treas. J. H. Millard, Gen. Supt. W. S. Dimmock, Elec. L. Lovett, Ch. Engr. of Power Station W. B. Tarkington. 4 4

COVINGTON, GA.—Covington & Oxford St. R. R. Co. 6 m, 4-8 1/2 g, 25 lb T r, 6 c, 8 mu. Pres. I. W. Brown, Sec. & Treas. J. G. Lester, Gen. Man. & Supt. R. O. Usher. Capital, \$16,000, authorized \$20,000. 1 4

COVINGTON, KY.—South Covington & Cincinnati St. Ry. Co. Elec. 4 1/2 m, 35 m s, 5-2 1/2 g, 65, 80 lb T r & girder r, 120 m c, 40 h. Westinghouse system. Brownell, Jones, Laclede and Stephenson cars. Cleveland Ship Bldg Co. and Lane & Bodley engines. Pres. J. J. Shipherd, V. Pres. & Gen. Man. S. Bigstaff, Sec. & Treas. G. M. Abbott, Supt. T. M. Jenkins, Elec. C. C. Benson, Ch. Engr. of Power Station M. Kelly. Capital, \$500,000; Bonds \$500,000. Office, 402 Scott st. 1 4

CUMBERLAND, MD.—Cumberland Electric Ry. Co. 6 m, 4-8 1/2 g, 54 lb girder r, 14 c, of which 9 are m c and 5 t c. Edison and Westinghouse systems. Brill cars. Pres. G. L. Wellington, V. Pres. L. Lowndes, Sec. & Treas. J. H. Holzshu, Supt. W. Minor Roberts, Jr. Capital \$70,000; authorized \$100,000. Bonds \$30,000. Office North Centre St 3 4

CUYAHOGA FALLS, O.—Akron & Cuyahoga Falls Rapid Transit Co. Elec. 8 m, 4-8 1/2 g, 52, 66 lb T r, 11 m c. Gen. Elec. system. Capital, \$300,000. Address, R. J. Randolph, Cuyahoga Falls. 6 3

D

DALLAS, TEX.—Dallas Consolidated Traction Ry. Co. Elec. 26 3-16 of which 16 are horse and 10 2-16 elec, 4-8 1/2 g, 30-40 lb girder & T r, 82 c, of which 67 are h. c. and 15 m. c, 3 b, 200 mu. T-H & Edison systems. Laclede, St. Louis and Stephenson cars. Receiver, S. P. Cochran, Gen. Man. for Receiver K. Kurtz. Capital, \$1,000,000. Office, 135 Main St. 5 8

Dallas & Oak Cliff Ry. Co. Steam. 11 m, 4-8 1/2 g, 35 & 65 lb T r, 4 m, 15 c. Pres. & Man. T. L. Marsalls, V. Pres. J. T. Elliott, Sec. & Treas. E. L. Snodgrass. Capital \$460,000. Room 5 Knepply Bldg. 11 2

Dallas Rapid Transit Ry. Co. Elec. 13 m, 13 m s, 4-8 1/2 g, 35 & 45 lb steel T r, 10 m c. Edison system. Receiver, C. F. Freeman, Supt. Geo. D. Hartson, Ch. Engr. of Power Station. Capital, \$300,000. Office, 303 North Texas Bank Bldg. 1 4

North Dallas Circuit Ry. Co. Elec. 4 m, 4-8 1/2 g 40 lb T r, 4 m c. T-H system. St. Louis cars. Pres. J. C. Schneider, V. Pres. & Gen. Man. Royal A. Ferris, Sec. E. T. Moore, Treas. N. A. McMillin. Capital, \$100,000. Bonds, \$100,000. 2 3

Queen City Ry. Co. 10.02 m, 7.54 m s, 4-8 1/2 g, 45 lb T r, 18 m c. T-H system. American and St. Louis cars. Pres. & Gen. Man. A. W. Childress, V. Pres. J. S. Armstrong, Sec. Treas. & Pur. Agt. C. L. Wakefield, Supt. R. S. Wakefield, Elec. W. C. Ure. Office 263 Elm st. 4 4

DANBURY, CONN.—Danbury & Bethel Horse Ry. Co. 6 1/2 m, 4-8 1/2 g, 25 lb T r, s and c, b, r, 20 c, of which 13 are 4-wheel box and 7 4-wheel open, 130 h Pres. S. C. Holly, V. Pres. S. H. Wagner, Sec. & Treas M. H. Griffing, Gen. Supt. G. H. Kilzing. Office 23 South st. Capital, \$100,000. 1 4

DANVILLE, ILL.—Danville Gas, Elec. Light & St. Ry. Co. 8 m, 4-8 1/2 g, 50 lb T r, 21 c, of which 11 are m c. and 10 t c. T-H system. St. Louis cars. Ide engines. Pres. F. W. Penwell, V. Pres. A. C. Daniel, Sec & Treas. W. P. Cannon, Supt. M. Connor. Capital, \$250,000. 6 3

DANVILLE, VA.—Danville St. Car Co. Elec 2.06 m, 4-8 1/2 g, 38 lb girder r 5 m c. T-H system. Lamokin cars. Taylor engines. Pres. P. R. Jones, V. Pres. L. C. Berkeley Jr., Sec. & Treas. H. S. Lanier Gen. Man. & Supt. N. W. Berkeley Jr. Capital, \$50,000 authorized \$300,000. Office, 820 Craighead st. 1 3

DAVENPORT, IA.—Davenport & Rock Island Ry. Co. Elec. 43 m, of which 5 are horse and 38 elec. 4-8 1/2 g, 52 lb girder r, 111 c, of which 7 are h c, 54 m c and 50 t c. T-H system. St. Louis cars. "Ideal" engines. Pres. J. H. Louderback, V. Pres. J. J. Mitchel, Sec. & Treas. J. F. Lardner, Supt. H. Schlichtger, Ch. Engr. of Power Station T. Gowling. Capital, \$335,000; authorized, \$1,500,000. Bonds \$600,000. Office, 2d & Rock Island sts., Davenport, Ia. 1 4

DAYTON, KY.—Cincinnati, Newport & Covington St. Ry. Co., Dayton Division (See Covington, Ky.)

DAYTON, O.—City Ry. Co. (Owns and operates Dayton St. R. R., Third St., Fifth St., Green and Dayton & Soldiers' Home lines) 18 1/2 m, of which 14 1/2 are horse and 4 elec, 9 1/2 m s, 4-8 1/2 g 70, 90 lb girder r, 66 c, of which 60 are horse, 4 m c and 2 t c, 212 h, 48 mu. Gen. Elec. and Westinghouse systems. Pres. D. B. Corwin, V. Pres. C. B. Clegg, Sec. W. H. Sims, Supts. A. W. Anderson, T. C. Howell. Capital, \$1,500,000. Office, W. 3d st. 4 4

Dayton St. R. R. Co. (Owned and operated by City Ry. Co.)

Dayton & Soldiers' Home Electric R. R. Co. Extension of west end of Fifth st. R. R. (Owned and operated by City Ry. Co.)

Fifth St. R. R. Co. (Owned and operated by City Ry. Co.)

Home Avenue R. R. Co. Steam 3 m, 4-8 1/2 g, 40 lb T r, 6 c, 3 motors. Barney, Smith & Co. cars. Porter engines. Pres. J. Applegate, V. Pres. W. P. Callahan, Sec. & Treas. C. W. Dustin, Gen. Man. & Supt. W. F. Stark. Capital, \$100,000. Office, N. Man St. 4 4

Oakwood St. Ry. Co. 8 m, 4-8 1/2 g, 60, 72 lb girder r, 18 box c, 80 h. Pres. Charles B. Clegg, V. Pres. A. L. Stout, Sec. V. Winters, Treas. 4th Nat. Bank, Gen Man. H. P. Clegg, Supt. William Jones. Capital \$300,000. Office, cor. Brown & Fallground av. 1 4

Wayne & Fifth St. R. R. Co. 7 m, 3 1/2 m s, 4-8 1/2 g, 60, 70, 90 lb girder r, 13 c, 80 h. St. Louis cars. Pres. Geo. W. Shaw, V. Pres., Gen. Man. & Pur. Agt. Ezra Bimm, Sec. & Treas. Eugene Wulfbet, Supt. N. Rutzahn. Capital \$100,000. Office 29 Wayne av. 4 4

White Line St. R. R. Co. Elec. 11 1/2 m, 4-8 1/2 g 42 lb steel girder r, 34 c, of which 22 are m c and 12 t c. T-H and Westinghouse systems. Pres. J. A. McMahon, V. Pres. A. G. Clark, Sec. J. E. Lowes, Treas. & Gen. Man. M. A. Nipgen, Supt. & Pur. Agt. W. Beach, Ch. Engr. & Ch. Engr. of Power Station, C. Orain, Elec. J. Cook. Capital, \$300,000. 4 4

DECATUR, ALA.—Decatur St. Ry. Co. 4 m, 3 1/2 m s, 4-8 1/2 g, 20 lb T r, 5 c, 31 mu. Pres. W. W. Hedges, V. Pres. A. C. Hartsborne, Sec. & Gen. Man. A. Bibb. Capital \$100,000. 1 4

USE ONLY



HIGHEST GRADE MANUFACTURED

—FOR—

STREET RAILWAY FEED WIRES AND CABLES.

W. R. BRIXEY, MFR., - 203 BROADWAY, NEW YORK.

BRANCHES: BOSTON, ELECTRIC GAS LIGHTING CO.

DECATUR, ILL.—City Electric Ry. Co. 13 1/2 m 12 m 2, 4-8 1/2 g, 40, 42, 48, 50 lb T & girder r, 25 c, of which 19 are m c and 6 t c. T-H and Westinghouse systems. Pullman, St. Louis and Stephenson cars. Ide engines. Pres. D. S. Shellabarger, Sec., Treas. & Pur. Agt. W. L. Shellabarger, Gen. Man. W. L. Ferguson, Ch. Engr. & Ch. Engr. of Power Station S. Ray, Elec. G. I. Nitsche. Capital \$300,000. Bonds \$175,000. 4 4

DEERFIELD, N. Y.—Deerfield & Utica R. R. Co. 2 m, 2 m s, 4-8 1/2 g, 42 lb flat and T r, 3 box c, 9 h. Stephenson cars. Pres. & Gen. Man. F. G. Weaver, Sec. & Treas. J. R. Swan. Capital \$12,000. Bonds \$12,000. 1 4

DEFIANCE, O.—The Defiance Light & Power Co. Elec. 3 1/2 m, 60 lb T r, 6 c, of which 3 are m c and 3 t c. Westinghouse system. Brownell and Pullman cars. Russell engines. Receiver G. W. Bechel, Pres. W. B. McKinley, Elec. C. Miller, Ch. Engr. of Power Station G. Butler. Capital stock, \$100,000. 4 4

DELAWARE, O.—Delaware Electric St. Ry. Co. 5 1/2 m, 4-8 1/2 g, 45 lb girder r, 7 m c. Westinghouse system. Brill cars. Pres. J. K. Newcomer, V. Pres. J. D. Van Deman, Sec. L. L. Hudson, Treas. V. T. Hills, Supt. F. P. Welch. Capital, \$60,000. 1 4

DENISON, TEX.—Denison Rapid Transit Ry. Co. 6 1/2 m, 4-8 1/2 g, 35 lb T r, 6 c, 2 dummies. Pres. & Man. B. J. Derby, Sec. C. F. Rose, Treas. S. Star. Owned and operated by the Denison Land & Improvement Co. 4 1

Denison Street & Belt Line Ry. Co. 13 m, of which 5 1/2 are horse and 7 1/2 steam. 4-8 1/2 g, 16, 35 lb T r, 17 c, of which 11 are h. c. and 6 steam, 2 engines, 42 mu. Baldwin engines. Pres. F. C. Churchill, V. Pres. A. H. Coffin, Sec. A. Zintgraf, Treas. E. H. Hanna, Gen. Man. B. J. Derby. Capital, \$150,000. Bonds, \$75,600. 1 4

DENISON, O.—The United Electric Co. 2 m, 4-8 1/2 g, 45 lb girder r, 3 m c, T-H system. Lamokin cars. Russell and Westinghouse engines. Pres. T. H. Wilson, Sec. E. E. Elvin, Treas. W. H. Smith, Gen. Man. R. F. Gardner. Capital \$23,000; authorized \$100,000. Office Grant St. 8 3

DENVER, COL.—Colfax Electric Ry. Co. 10 1/2 m 3-6 g, 30 lb T r, 32 c, of which 12 are m. c. and 20 t. c. Edison system. Pres. D. Fletcher, V. Pres. Sec. & Gen. Man. S. M. Perry, Treas. T. S. Hayden, Supt. F. A. Perry. Capital, \$150,000. Office, 1738 Curtis st. 4 4

Denver & Westminster Ry. Co. Elec. 18 m, 4-8 1/2 g. Pres. H. J. Mayhew, V. Pres. K. W. Woodbury, Sec. J. Downing, Engr. F. H. Whiting. Capital, \$1,000,000. Office, 1643 Curtis St. 2 3

Denver, Lakewood & Golden R. R. Co. Elec. and Steam, 20 m, of which 15 are steam and 5 elec, 4-8 1/2 g, 60, 76 lb T r, 12 c, of which 4 are m. c, 4 t c and 4 steam c. T-H system. Woebler cars. Sioux City engines. Pres. C. C. Welch, V. Pres. W. F. R. Mills, Sec. J. Q. Adams, Treas. W. A. H. Loveland, Supt. T. E. Mitten. Capital, \$1,000,000. Bonds, \$250,000. Offices, 1427 Arapahoe St. 8 3

Denver Consolidated Tramway Co. (Includes Denver Cable, Denver & Berkeley Park, So. Denver Cable, University Park and Metropolitan.) 9 6 1/2 m, 3-6 g, 48 lb T r, 26c, of which 125 are m c and 138 t c. T-H, Westinghouse and Edison systems. Brill, St. Louis and Woebler cars. Hamilton-Corriss and Wetherill engines. Pres. Rodney Curtis, V. Pres. Jno. J. Rietzman, Sec. Wm. G. Evans, Treas. F. A. Keener, Gen. Supt. C. K. Durbin. Pur. Agt. J. C. Curtis, Elec. A. M. Ballou. Capital, \$3,000,000. Bonds \$3,400,000. Gen. Offices, Broadway and Colfax and Railroad Bldg. 1 4

Denver City Cable Ry. Co. 45 m, of which 5 are horse, 30 cable and 10 elec, 23 m s, 3-6 and 4-8 g, 50 lb T r, 200 c of which 8 are h. c, 52 g, 17 m c and 113 t c, 30 h. Laclede and Woebler cars. Allis, Armstrong & Sims and Wright engines. Pres. Geo. H. Hoff, Sec. & Treas. G. D. L'Hullier, Gen. Man. Supt. & Pur. Agt. G. E. Randolph, Ch. Engr. of Power Station, W. F. Smith. Capital, \$3,000,000. Bonds, \$3,500,000. Office, 18th & Lawrence Sts. 1 4

Thirty-fourth Ave. Ry. 1 1/4 m, 3-6 g, 25 lb T r, 1 c, 6 h. Owner, J. Cook, Jr., P. O. Box 528. 1 4

West End St. Ry. Co. Elec. 10 1/2 m, 4-8 1/2 g, 50 lb r, 17 m c. Edison system. Laclede and Woebler cars. Armstrong & Sims engines. Pres. J. Wilbour, V. Pres. & Gen. Man. D. F. Longstreet, Sec. E. M. Dexter. Supt. & Pur. Agt. S. R. Wright. Capital, \$500,000. Bonds, \$300,000. Office Prospect Ave. 8 3

DEPTFORD, TENN.—Deptford & South Pittsburg St. Ry. Co. Dummy. 2 1/2 m, 4-8 1/2 g, 40 lb T r, 3 c, 8 mu. Stephenson cars. Pres. L. W. Barringer, V. Pres. J. G. Kelly, Sec. Treas. & Gen. Man. J. Bright. Capital, \$12,000. Office, Deptford. 4 4

DERBY, CONN.—Derby Street Ry. Co. Elec. 4 m, 4-8 1/2 g, 45 lb girder and flat r; 11 c, of which 6 are m c and 5 t c. T-H system. Pres. H. Holton Wood, V. Pres. Chas. F. Bliss, Sec. Geo. O. Schneller, Treas. Chas. E. Clark, Supt. B. W. Porter, Elec. G. N. Kennedy, Ch. Engr. of Power Station H. Schmitz. Capital stock \$50,000; authorized \$200,000. Bonds \$3,500 1 4

DES MOINES, IA.—Des Moines City Ry. Co. Elec. 35 m, 27 m s, 4-8 1/2 g, 45, 50, 62 lb T girder & r, 51 c, of which 49 are m. c. and two t c. T-H system. St. Louis cars. Lane & Bodley engines. Pres. J. S. Polk, V. Pres. G. M. Hippee, Sec. G. H. Huttonlocker, Treas. & Gen. Man. Geo. B. Hippee, Ch. Engr. J. S. Goodsell, Elec. W. G. Owens. Capital \$1,000,000. Authorized, \$3,000,000. Bonds, \$1,150,000. Office, 201 5th St. 1 4

DETROIT, MICH.—Fort Wayne & Belle Isle Ry. Co. Elec. 23 1/2 m, 4-8 1/2 g, 48-90 s b girder & grooved r, 86 c, of which 29 are m. c. and 57 t c. Gen. Elec. system. Brill cars. Allis engines. Pres. E. H. Butler, Sec. N. W. Goodwin, Treas. E. S. Heine-man, Supt. G. S. Hazard. Capital \$250,000. Bonds \$324,000. Office, Room 12 Kanten Bldg. 1 4

Detroit Citizens' St. Ry. Co. (Includes Grand River St. Ry. and Hamtramck & Grosse Point Ry. Leases Highland Park Ry.) Elec. 67 m, of which 37 are horse and 30 elec, 4-8 1/2 g, 45, 66, 78 lb tram and girder r, 245 c, of which 174 are h c, 59 m c and 12 t c, 1,575 h. T-H, Detroit and Westinghouse systems. Brownell, Jones, Lewis & Fowler, Pullman and Stephenson cars. Westinghouse, Church, Kerr & Co. engines. Pres. D. M. Ferry, V. Pres. W. C. Colburn, Sec. J. R. Stirling, Treas. G. H. Russell, Gen. Man. J. D. Hawks, Supt. J. H. Fry. Elec. J. C. Liggett, Ch. Engr. of Power Station C. Mery. Office 12 Woodward Ave. 4 4

Detroit, Rouge River & Dearborn St. Ry. Co. Elec. 1 1/2 m, 4-8 1/2 g, 66 lb T r, 1 m c. Edison system. Pres. E. J. Owen, V. Pres. J. R. McLoughlin, Sec. S. Hendrie, Treas. R. J. McLoughlin. Office, Moffat Building. 9 3

Detroit Suburban Ry. Co. (Leased to Detroit Citizens' St. Ry. Co.) 3.75 m, 3 m s, 4-8 1/2 g, 60 lb T r, 3 m c. Detroit system. Pres. W. C. McMillan, Sec. H. M. Campbell, Treas. G. H. Russell, Gen. Man. J. D. Hawks. Capital, \$50,000. Office, 904 Hammond Building. 1 4

DOVER, N. H.—Union St. Ry. Co. Elec. 14 m 4-8 1/2 g, 40 lb T r, 19 c, of which 10 are m c and 9 t c T-H system. Pres. H. Haley, V. Pres. & Treas. H. W. Burgett, Sec. R. W. Burwell, Supt. F. A. Christy. Capital \$150,000. Leased by Consolidated Light & Power Co. 1 4

DUBLIN, TEX.—Dublin St. R. R. Co. 5 m, (1/2 in operation), 4 g, 20 lb T r, 3 c, 20 mu. Pres. H. A. Smith, V. Pres. R. H. McCain, Sec. & Gen. Man. J. E. Chapman, Treas. A. A. Chapman. Capital stock \$10,000. 1 4

DU BOIS, PA.—Du Bois Traction Passenger Ry. Co. 3 m, 2 1/2 m s, 4-8 1/2 g, 50 lb girder r, 5 m c. Wightman and Gen. Electric systems. Brill and Stephenson cars. McEwen and Bail engines. Pres. M. D. Wayman, V. Pres. & Sec. A. C. Bailey, Pur. Agt., Gen. Man. & Supt. S. R. Smith, Treas. G. E. Grier, Ch. Engr. Power Station, W. L. Shawkey. Capital authorized, \$85,000. Bonds, \$45,000. 1 4

DU QUAIN, ILL.—Du Quain St. R. R. Co. 3 m 4-8 1/2 g, 57 lb T r, 3 c, 3 h. Pres. & Gen. Man. P. D. Miffien, V. Pres. C. Horn, Sec. D. White, Treas. P. N. Pope. Capital, \$5,375. 1 3

DU BUQUE, IA.—Dubuque St. R. R. Elec. 15 m 4-8 1/2 g, 52 lb girder r, 25 c, of which 15 are m. c. and 10 t c. Gen. Elec. System. Brill cars. Sioux City engines. Pres. & Gen. Man. J. A. Rhomberg, Sec. C. H. Meyer, Treas. & Supt. J. H. Rhomberg. Capital \$375,000; authorized \$500,000. Bonds \$250,000. 9 3

Dubuque Light & Traction Co. 12 m, 4-8 1/2 g, 50 lb Johnson girder r, 16 c, of which 12 are m c and 4 t c. Edison system. St. Louis cars. Pres. G. K. Wheeler, V. Pres. W. J. Ballard, Sec. E. W. Duncan, Treas. P. H. Anderson. Capital, \$500,000. 4 4

Eighth St. & West Dubuque St. Ry. Co. Elec. 2 1/2 m, 4-8 1/2 g, 52 lb girder r, 6 c, of which 4 are m c and 2 t c. Edison system. Northern Car Co. cars. Fairbanks, Morse & Co. engines. Pres. L. H. Blgelow, V. Pres. E. P. Griswold, Treas. W. H. Doane, Supt. H. J. Dressel. Capital, \$100,000. Office, foot of 8th st. 5 3

DULUTH, MINN.—Duluth St. Ry. Co. 42 m, of which 1.13 are cable and 40.87 elec, 21 m s, 4-8 1/2 g, 45, 60 lb girder & T r, 71 c, of which 2 are g c, 66 m c and 3 t c. T-H system. Laclede and Northern cars. Allis engines. Pres. L. Mendenhall, V. Pres. G. G. Hartley, Sec. & Treas. T. W. Hoopes, Gen. Man. Supt. & Pur. Agt. H. Warren, Ch. Engr. & Ch. Engr. of Power Station M. Noble, Elec. L. E. Fairchild, T. Armstrong, Gen. Man. A. W. M. Dimont, Asst. Gen. Man. H. A. Douglas. Capital, \$300,000; authorized, \$1,500,000. Bonds, \$750,000. Office, 209 First Nat. Bank Bldg. 4 4

Lakeside Ry. Co. Elec. 4 m, 4-8 1/2 g, 45 lb T r, Pres. D. G. Cash, Sec. Treas. & Man. W. C. Sargent. Capital, \$100,000. Operated by Duluth St. Ry. Co. 8 2

Minnesota Point St. Ry. 3 1/2 m, 3-6 g, 28 lb T r, 8 c 16 h. Pres. J. J. Hibbard, V. Pres. R. P. Edson, Sec., Gen. Man. & Supt. W. Warner, Treas. B. Silberstein, Capital \$60,000; authorized \$100,000. 9 3

Motor Line Improvement Co. Elec. 6 m, 4-8 1/2 g 45 lb T r, 4 m c. T-H system. Laclede cars. Pres. G. G. Hartley, V. Pres. J. D. Stryker, Sec. T. W. Hoopes, Treas. A. R. Macfarlane, Gen. Mans. Mendenhall & Hoopes. Capital, \$150,000; authorized \$300,000. Bonds, \$200,000. Office 12 3d Ave. W. 4 4

DURANGO, COLO.—Durango Ry. & Realty Co. 2 m, 2 m s, 4 c, of which 2 are m c and 2 t c, 3 g, 30 lb T r. Westinghouse system. Woebler cars. Ide engines. Pres. T. C. Graden, V. Pres. C. M. Williams, Sec. W. S. Pickett, Treas. & Supt. H. J. Arnold. Capital, \$250,000. 1 4

DURHAM, N. C.—Durham St. Ry. Co. 2 m, 4-8 1/2 g, 16 lb T r, 4 box c, 4 mu. Pres. J. S. Carr, V. Pres. A. B. Anderson, Sec. R. H. Wright. 8 3

E

EAST LIVERPOOL, O.—East Liverpool & Wellsville R. R. Co. Elec. 8 1/2 m, 4-8 1/2 g, 56 lb T and 81 lb girder r, 20 m c. Short and Westinghouse systems. Brill and Stephenson cars. Pres. & Gen. Man. A. L. Johnson, Sec. & Treas. C. H. J. Davis, Supt. R. L. Andrews. 4 4

EAST WAREHAM, MASS.—East Wareham Onset Bay & Point Independence St. Ry. Co. 2.779 m 4-8 1/2 g, 25 & 35 lb T r, 14 c, 15 h. Pres. T. B. Griffith, Sec. B. F. Gibbs, Treas. & Supt. I. B. Eldridge. Capital, \$20,600; authorized, \$26,000. 4 4

EASTON, PA.—Easton Transit Co. Elec. 10 m, of which 3 are horse and 7 elec, 5-2 1/2 g, 68 lb girder r, 20 c, of which 10 are h c and 10 m c, 26 h. Westinghouse system. Brill cars. Pres. H. Ruick Sec. & Treas. A. D. Childsey, Gen. Man. F. Knight, Supt. W. M. Williams. Capital, \$150,000; authorized \$500,000. Office, 60 Centre sq. 1 4

Easton & Bangor Electric Ry. Co. 16 m, 5-2 1/2 g, 48 lb r. Pres. J. M. Young, Sec. & Treas. D. W. Nevin. Capital, \$100,000. 9 3

Pennsylvania Motor Co. 2 1/2 m, elec. 5-2 1/2 g, 36-56 lb flat & T r, 8 m c. Wightman system. Pres. H. E. Hand, Sec. Treas. & Gen. Man. D. W. Nevin, Supt. L. Richter. Capital, \$120,000. Bonds, \$60,000 1 3

EAU CLAIRE, WIS.—Eau Claire St. Ry. Lt. & Power Co. 8 m, 4-8 1/2 g, 35, 42 & 45 lb c & s b r, 13 m c Edison and Detroit systems. Pres. & Gen. Man. G. B. Wheeler, V. Pres. E. Horan, Treas. W. G. Maxcy Supt. D. E. Pepin. Capital, \$100,000. 1 4

EL PASO DE ROBLES, CAL.—El Paso de Robles St. Ry. 5 m, 3 g, 16 lb T r, 2 box c, 6 h Proprietors, Putnam & Hord. Cost, \$10,000. Office Adams Block, cor Spring & 12th sts. 4 4

EL PASO, TEX.—El Paso & Juarez Ave. St. Ry. Co. 6 1/2 m, 6 1/2 m s, 4-8 1/2 g, 30 lb T r, 14 c, 40 mu. Pres. Z. T. White, Sec. J. J. Bruck, Supt. & Pur. Agt. A. Larmour. 4 4

San Antonio & Magoffin St. Ry. Co. 4 m, 4-8 1/2 g, 30 lb T r, 3 c, 9 mu. Pres. J. Magoffin, Treas. H. B. Scaevens, Sec. & Pur. Agt. A. Larmour. 4 4

ELGIN, ILL.—Eigin City Ry. Elec. 13 m, 4-8 1/2 g 40 & 45 lb T & girder r, 22 c, of which 13 are m c and 9 t c. Edison system. Pres. W. Grote, V. Pres. J. B. Lane, Sec. & Treas. A. B. Church, Gen. Man. C. Wuestenfeld. Capital, \$250,000. 1 3

ELIZABETH, N. J.—Elizabeth St. Ry. Co. 3 1/2 m, 5-2 1/2 g, 38 & 52 lb Johnson girder r, 13 box c, 42 h. Pres. F. L. Heidritter, V. Pres. A. Heidritter, Sec. & Treas. E. C. Woodruff, Supt. J. C. Hubbard. Capital \$50,000. Office, foot of East Jersey st. 1 4

ELKHART, IND.—Elkhart Electric & Ry. Co. Elec. 7 m, 4-8 1/2 g, 35 lb T & tram, 11 c, of which 7 are m c & 4 t c. Detroit system. Pres. L. Warfield, V. Pres. J. McNaughton, Sec. J. W. Ellis, Treas. T. Muir, Supt. C. T. Goodrich. Capital, \$99,000; authorized, \$100,000. Bonds, \$65,000. 9 2

ELMIRA, N. Y.—Elmira & Horseheads Ry. Co. Elec. 15.7 m, of which 7.15 are horse and 15 elec, 4-8 1/2 g, 45-78 lb T & girder r, 49 c, of which 18 are h. c, 19 m. c, and 12 t c, 8 h. Gen. Elec. and Westinghouse systems. Brill and Stephenson cars. McIntosh & Seymour engines. Pres. R. Leland, Sec. E. Spencer, Treas., Gen. Man. & Pur. Agt. C. H. Baldwin, Elec. I. Mack, Ch. Engr. of Power Station F. A. Cheney. Capital, \$400,000. Bonds, \$400,000. 4 4

West Side R. R. Co. Elec. 7 1/2 m, 6 m s, 4-8 1/2 g, 70 lb girder r, 22 c, of which 21 are m c and 1 t c. T-H system. Brill and Stephenson cars. Bates-Corriss engines. Pres. C. M. Tompkins, V. Pres. A. E. Ockley, Sec. & Treas. H. H. Hallock, Gen. Man. W. Cole, Asst. Supt. W. J. Jones, Ch. Engr. & Ch. Engr. of Power Station P. Kaufert, Elec. J. Hendricks. Capital \$100,000; authorized \$300,000. Office 123 Baldwin st. 4 4

EMPORIA, KAN.—Emporia City Ry. Co. 3 1/2 m, 3-6 g, 20 lb r, 8 c, 24 h. Pres. Van K. Holmes, Treas. A. F. Crowe, Sec. & Man. J. D. Holden. 11 2

ENSLEY, ALA.—Ensley Ry. Co. (Consolidated with Birmingham Ry. & Elec. Co.)

STAMPED & ENGRAVED METAL PLATES for Electrical Apparatus. **BADGES** FOR CONDUCTORS, MOTORMEN, Etc. **JAS. A. ALLEN,** 244 ARCH ST., PHILADELPHIA. SEND FOR CATALOGUE.

ERIE, PA.—Erie City Passenger Ry. Elec. (Operated by Erie Elec. Motor Co.)

Erie Elec. Motor Co. 25 m, 4-8½ g, 52 lb Johnson girder r, 174c, of which 87 are h c, 77 m c and 10 t c, 4 h and mu. Edison system. Pres. J. S. Casement, V. Pres. J. C. Brady, Sec. & Treas. J. L. Sternberg, Supt. H. F. Wilbur. Capital \$700,000. Bonds \$350,000. Office 202 State st. 5 3

ESSEX, MASS.—(See Salem, Mass.)

EUREKA, CAL.—Eureka St. R.R. Co. 4½ m, 4-8½ g, 14 & 36 lb T & flat r, 6 box c, 13 h, 7 mu. Holt and N. B. & M. Ry. cars. Pres. & Gen. Man. R. M. Fernald, Supt. J. A. Clark. Capital \$60,000. 9 3

EUREKA SPRINGS, ARK.—Eureka Springs Elec. St. Ry. Co. 2½ m, 4-8½ g, 35 lb T r, 5 c, 17 mu. St. Louis cars. Pres., Sec. & Gen. Man. J. D. Jordan, V. Pres. C. F. Ellis, Treas. T. N. Clifton, Supt. W. J. Wallace. Capital \$17,000; authorized, \$20,000. Bonds \$3,700. 8 3

EVANSVILLE, IND.—Evansville St. Ry. Co. 25 m, 15 ms, 4-8½ g, 60 lb T r, 77 c, of which 35 are m c and 42 t c. Westinghouse system. Brownell and St. Louis cars. Westinghouse engines. Pres. J. J. Shipherd, V. Pres. G. H. Stockwell, Sec. H. D. Moran, Treas. S. Krutz, Supt. & Pur. Agt. W. L. Stockton, Ch. Engr. Power Station G. Wilson. Capital \$500,000. Bonds, \$850,000. Office, 102 Main St. 12 3

EVERETT, WASH.—Everett Ry. & Electric Co. 7.42 m, 7.42 m s, 4-8½ g, 40 lb girder r, 5 m c. Westinghouse system. American cars. Ball engines. Pres. S. Duryee, V. Pres. G. Colby, Sec. U. A. Schenck, Treas., Gen. Man. & Elec. A. R. Whitney, Jr. Capital, \$200,000. P. O. Box 118. 4 4

F

FAIRHAVEN, WASH.—Fairhaven & New Whatcom Ry. Co. Elec. 18½ m, 4-8½ g, 40, 56 lb T r, 16 m c. T-H system. Brill cars. Ide engines. Pres. H. Eldridge, V. Pres., Gen. Man. & Supt. E. Cosgrove, Sec. J. A. Kerr, Treas. C. C. Fisher. Capital, 500,000; authorized, \$600,000. 6 3

FALL RIVER, MASS.—Globe St. Ry. Co. Elec. 26½ m, 4-8½ g, 45, 48½, 75 lb girder & s b r, 88 c, of which 72 are m c and 16 t c. T-H system. Felgel, Jones, Newburyport and Stephenson cars. McIntosh & Seymour engines. Pres. Frank S. Stevens, Sec. M. G. B. Swift, Treas. R. S. Goff, Supt. John H. Bowker, Ch. Engr. & Ch. Engr. Power Station G. B. Esterly, Elec. G. W. Palmer, Jr. Capital \$650,000. Bonds \$1,425,000. Office, 182 N. Main st. 4 4

FINDLAY, O.—Findlay St. Ry. Co. (Operated by Northern Ohio & Lake Erie Ry., Lt. & Power Co.) Elec. 12½ m, of which 4 are horse and 8½ elec., 8 m s 4-8½ g, 35 & 60 lb T r, 22 c, of which 7 are h c, 10 m c and 5 t c, 4 h, 32 mu. Westinghouse system. Laclede cars. Buckeye engines. Pres. G. B. Kerper, V. Pres. J. N. Klinney, Sec. J. Strader, Treas. C. D. Klinney, Gen. Man. & Pur. Agt. C. Smith, Ch. Engr. W. Nusbaum, Elec. W. Twining. Capital, \$300,000; Bonds, \$100,000. Office N. Main St. 1 4

Northern Ohio & Lake Erie Ry., Lt. & Pow. Co. (Operates Findlay St. Ry. and Tiffin Elec. Ry.)

FISHKILL-ON-HUDSON, N. Y.—Citizens' St R. R. Co. 3½ m, 3 m s, 4-8½ g, 45, 54 lb T & girder r, 9 m c. T-H system. Gilbert cars. Fishkill Landing engines. Pres. Gen. Man. & Pur. Agt. J. T. Smith, V. Pres. H. G. Wolcott, Sec. S. K. Phillips, Treas. W. H. Southard, Supt. W. E. Havens, Ch. Engr. of Power Station, W. E. Blakney. Capital \$75,000. Bonds, \$75,000. 1 4

FITCHBURG, MASS.—Fitchburg & Leominster St. Ry. Co. 13.214 m, of which 247 are horse and 10.10 elec., 11.70 m s, 4-8½ g, 58 lb T r, 30 c, of which 16 are h c and 14 m c, 42 h. Westinghouse system. Brill, Jones & Newburyport cars. Pres. H. A. Willis, V. Pres. H. I. Wallace, Sec. C. F. Baker, Treas. B. F. Wallis, Gen. Man. & Pur. Agt. W. W. Sargent. Capital \$185,000; authorized \$250,000. Bonds \$30,000. 1 4

FLUSHING, N. Y.—Flushing & College Point St. Ry. Co. 4 m, 4 m s, 4-8½ g, 47 lb s. b. r, 9 c, of which 5 are m c and 4 t c. Westinghouse system. Brill, Jones and Stephenson cars. N. Y. Safety engines. Pres. D. Master, V. Pres. G. Rople, Sec. H. Clement, Treas. J. Hepburn, Supt. W. G. Rock, Elec. C. Banghart, Ch. Engr. of Power Station W. F. Russell. Capital \$60,000. 1 4

FOND DU LAC, WIS.—Fond du Lac St. Ry. Co. Elec. 5 m, 4-8½ g, 35 lb T & tram r, 8 c, of which 6 are m c and 2 t c. Westinghouse system. Pullman cars. Ball engines. Pres. & Gen. Man. W. G. De Celle, Treas. W. H. Cole, Asst. Gen. Man. G. A. Voorhees, Supt. L. Marlon. Capital, \$125,000. 8 3

FORT MADISON, IA.—Fort Madison St. Ry. Co. 4 m, 4-8½ g, 20 & 40 lb T & tram r, 8 c, 5 h 28 mu. Pres. & Gen. Man. D. A. Morrison, V. Pres. R. S. Johnson, Sec. H. Jones, Treas. J. C. Brewster, Supt. F. H. Weber. Capital, \$100,000. Office, Santa Fe Ave. 1 4

FORT MEADE, FLA.—Fort Meade St. Ry. Co. 2 m, 2 m s., 3 g, 25 lb T r, 2 c, 2 mu. Pres. F. N. Varn, V-Pres H. L. Rockner, Sec. W. Jackson, Treas. & Pur. Agt. M. Reif. Capital \$6,000. 1 4

FORT SCOTT, KAN.—Fort Scott Rapid Transit Co. Elec. 8½ m, of which 1¼ are horse & 7 elec. 4 g, 35 lb T r, 16 c, of which 3 are h c and 8 m c. Edison system. Operated by Davenport & Fort Scott Investment Co. Pres. H. H. Anderson, Sec. F. H. Griggs, Supt. W. D. Mitchell. Elec. L. R. Harris, Ch. Engr. of Power Station J. Hunt. Capital, \$250,000; authorized \$500,000. Bonds \$100,000. Office Katzung & Malin Block. 1 4

FORT SMITH, ARK.—Fort Smith St. Ry. Co. 8½ m, 3-6 g, 38 & 45 lb girder r, 22 c, 80 mu. Brownell and Laclede cars. Pres. Gen. Man. & Supt. Sam'l McLoud, V. Pres. Benj. T. Duval, Sec. & Treas. Geo. T. Sparks. Capital, \$150,000. Bonds, \$35,000. Office, Cor. Third & A sts. 4 4

FORT WAYNE, IND.—C. L. Centlivre St. Ry. Co. 2 m, 4-8½ g, 18 lb T r, 6 c, of which 2 are 4 wheel box and 4 4-wheel open, 24 h. Pres. L. A. Centlivre V. Pres. & Sec. C. F. Centlivre. Treas. J. B. Reuss, Gen. Man. Le Meyers. Capital, \$30,000. d 3 2

Fort Wayne Electric Ry. 18½ m, 4-8½ g, 40, 60 lb T & tram r, 67 c, of which 57 are m c and 10 t c, 5 h. Own system. Jones cars. Pres. J. H. Bass, V. Pres. & Treas. M. S. Robison, Jr., Sec. J. M. Barrett, Supt. L. D. McNutt. 8 3

Lakeside Electric Ry. 1 m, 52 lb s b Duplex & T r. Gen. Elec. system. Gen. Man. J. D. McDonald. 8 3

FORT WORTH, TEX.—North Side St. R. Co. Elec. 14 m, of which 1¼ are horse and 12½ elec, 12½ m s, 4 g, 30 lb T & girder r, 19 c of which 15 are m c and 4 t c. T-H system. Brownell cars. Hamilton-Corliss engines. Receiver, N. Harding, Sec. J. Vanarsdell, Gen. Man. & Pur. Agt. G. B. Hendricks, Supt. J. W. Rentro, Ch. Engr. & Ch. Engr. of Power Station C. Bode, Elec. W. Godfrey. Capital, \$200,000. Bonds, 150,000. Office, 409½ Main St. 1 4

Fort Worth & Arlington Heights St. Ry. Co. Elec. 6½ m, 4 g, 35 lb T r, 5 m. c. Edison system Pres. H. W. Tallant, V. Pres. A. W. Chamberlin Supt. S. Horn. Capital, \$300,000. 9 3

City Ry. Co. Elec. 7½ m, 4 g, 30, 35 lb T r, 16 c, of which 14 are m c and 2 t c. Detroit system. Pullman cars. Ide engines. Pres. L. Warfield, V. Pres. & Sec. J. C. Terrall, Jr., Treas. J. C. Harrison, Gen Man. Supt. & Pur. Agt. W. P. Quigg, Ch. Engr. of Power Station W. A. Andrew. Capital stock, \$400,000. 4 4

Polytechnic St. Ry. Co. 2½ m, 4 g, 20 lb T r, 2 c, 10 mu. Pres. W. D. Hall, V. Pres. R. Vickery, Sec. M. F. Lomer, Treas. G. E. Tandy. 4 2

FRAMINGHAM, MASS.—Framingham Union St. Ry. Co. 7.35 m, 4-8½ g, 30 & 35 lb T & s. b. r, 17 c 40 h. Pres. Jas. R. Entwistle, Sec. I. B. Forbes, Treas. F. E. Gregory, Supt. J. J. Hennessy. Capital \$60,000 & \$50,000 bonds. Office, S. Framingham. 5 3

FRANKFORT, N. Y.—Frankfort & Ilon St. Ry. Co. 2½ m, 5 g, 25 lb T r, 5 c, of which 4 are box and 1 open. 6 h. Pres. J. H. Hoard, V. Pres. P. A. Skiff, Sec. W. I. Piper, Treas. W. W. Crosby, Supt J. Myers. Capital, \$20,000. Office, Frankfort. 1 4

FREDONIA, N. Y.—Dunkirk & Fredonia R. R. Co. 3½ m, 3½ m s, 4-8½ g, 42-48 lb c. b. and girder r, 9 c, of which 3 are m c and 6 t c. Edison and Westinghouse systems. Pres. W. McKinstry, Sec., Treas Pur. Agt. & Man. M. M. Fenner, Ch. Engr. Power Station John Kresnliska. Capital, \$73,450; authorized, \$75,000. Bonds, \$36,000; authorized, \$40,000. 1 4

FREEPORT, ILL.—Freeport St. Ry. Co. 4 m, 4-8½ g, 30 lb s. b. r, 6 4-wheel box c, 24 h. Pres. Jacob Krohn, V. Pres. F. C. Platt, Sec. W. G. Barnes, Treas & Gen Man. John B. Taylor. Capital, \$45,000. 1 2

FREMONT, NEB.—City St. Ry. Co. 6½ m, 4-8½ g, 16-40 lb T r, 7 c, 24 h. Pres. F. Fowler, V. Pres. F. Meyer, Sec., Treas. & Gen. Man, E. N. Morse. Capital \$45,000. 1 4

FREMONT, O.—Fremont St. Ry. Co. 1½ m 4-8½ g, 40 lb flat r, 2 4-wheel box c, 8 h. Pres. F. N. Carter, 29 Euclid ave., Cleveland, O., Treas. T. M Irvine, Cleveland, O., Supt. E. J. Carter. Capital \$125,000. Office, 307 Croghan st. 1 4

FRESNO, CAL.—Fresno R. R. Co. 4½ m, 4-8½ g, 20 lb r, 7 c, 7 h. Pres. Dr. L. Leach, V. Pres. R. E. Hughes, Sec. N. I. Baldwin, Treas. L. Einstein. Capital, \$200,000. 11 0

Fresno, Belmont & Yosemite R. R. Co. 4 m. 4-8½ g, 20 lb steel T r, 6 c, 12 h, 6 mu. Stockton cars. Pres. T. C. White, V. Pres. H. P. Hedges, Sec. J. P. Vincent, Gen. Man. C. L. Walter. Capital, \$500,000. Leased to C. L. Walter. 9 3

FRYBURG, ME.—Fryburg Horse R. R. Co. 3 m, 4 8½ g, 16 lb steel T r, 5 c, 1 h. Pres, Freeman Hatch, Clerk, Gen. Man. & Supt. Seth W. Fife. Treas. John Locke. Capital \$5,075, authorized \$10,000. 1 4

FULTON, N. Y.—Fulton & Oswego Falls St. Ry. Co. 1.14 m, 1.14 m s, 4-8½ g, 42½ lb r, 4 c, of which 3 are box and 1 open, 8 h. Pres. Joseph Walker, Jr., V. Pres. N. N. Stranahan, Sec. & Treas. Charles Lyman, Supt. E. Quirk. Capital, \$15,000. Bonds \$15,000. Office, 15 Broad st., New York. 1 4

G

GADSDEN, ALA.—Gadsden & Attala Union Ry. Co. Dummy, 13½ m, of which 2 are horse and 11½ steam, 4-8½ g, 40 lb T r, 14 c, 6 motors, 6 h. Brill cars, Baldwin engines. Pres. J. M. Elliott, Jr., V. Pres. C. A. Lyster, Sec. Treas., Gen. Man. Supt. & Pur. Agt. M. L. Foster, Engr. & M. M. J. L. Curry. Capital, \$2,000. Office 123 N. 4th st. 1 4

GAINESVILLE, GA.—Gainesville & Hall Co. St. R. R. Co. 5 m, 4-8½ g, 20 lb crescent r, 3 c, 3 h, 4 mu. Pres. Sec. & Treas. H. H. Dean, V. Pres. A. D. Candler. Capital, \$15,000. Leased to G. F. Boone for three years from Oct. 1, 1891. Office, 10 Spring st. 4 4

GAINESVILLE, TEX.—Gainesville St. Ry. Co. 3½ m, 4-8½ g, 36 lb T r, 8 c, 16 mu. Pres. J. M. Lindsay Gen. Man. & Supt. G. W. Lindsay. Capital \$40,000. Office, Fort Worth. 2 3

GALESBURG, ILL.—Galesburg Electric Motor & Power Co. 8 m, 7 m s, 4-8½ g, 50 lb T r, 19 c, of which 6 are h c, 8 m c and 5 t c. Westinghouse system. Pullman cars. Westinghouse engines. Pres. W. Seacord, V. Pres. & Treas. R. Chappell, Sec. & Pur. Agt. H. F. Arnold, Ch. Engr. of Power Station R. W. Whipple. Capital \$210,000. Bonds \$111,000. Office 540 Main St. 1 4

GALLIPOLIS, O.—Gallipolis St. Ry. Co. Elec 3 m c, T-H system. 10 2

GALVESTON, TEX.—Galveston City R. R. Co (Controls and operates Gulf City Ry. & Real Estate Co.) 33 m, 4-8½ g, 40, 52 lb T r, 84 c, of which 22 are h c, 52 m c and 10 t c. T-H and Westinghouse systems. Laclede and St. Louis cars. Buckeye and Cooper engines. Pres. & Gen. Man. Wm. H. Sinclair, Sec. & Treas. H. Keilner, Supt. W. H. Griffin, Pur. Agt. M. Dwyer, Ch. Engr. & Ch. Engr. of Power Station F. Gwartney. Capital, \$318,673.50; authorized, \$1,000,000. Bonds, \$750,000. Office, I and Center Sts. 1 4

Gulf City St. Ry. & Real Estate Co. (Operated by Galveston City R. R. Co.) 11 m, of which 8 are horse & 3 elec. 4-8½ g, 25-40 lb T r, 22 c, 32 mu. Westinghouse system. Own cars. Pres. J. H. Burnett, V. Pres. & Sec. P. S. Wren. Capital \$109,000. Bonds \$80,000. Office Ave. 1 & 21st St. 1 4

GEORGETOWN, KY.—Georgetown St. Ry. Co. 1½ m, 4-8½ g, 20 lb T r, 2 c, 6 mu. Pres. S. M. Davis Sec. W. Z. Thomson, Treas. A. H. Sinclair. Capital \$6,000. Leased to John Cole. 1 4

GETTYSBURG, PA.—Gettysburg Electric Ry. Co. 8 m, 4-8½ g, 56 lb T r, 6 c, of which 3 are m c and 3 t c. Brill cars. Pres. Gen. Man. & Supt. E. M. Hoffer, Sec. H. G. Walmer, Treas. G. P. Hoffer. 9 3

GIRARDVILLE, PA.—Schuylkill Traction Co. (Lessee of Mahanoy, Shenandoah Girardville & Ashland St. Ry.) 22 m, 10 m s, 4-8½ g, 50, 60, 70 lb T r, 22 m c. Westinghouse system. Lamok cars, Frick engines. Pres. W. F. Harity, Sec. & Treas. J. A. Johann, Gen. Man. & Pur. Agt. E. W. Ash. 4 4

GLENS FALLS, N. Y.—Glens Falls, Sandy Hill & Fort Edward St. R. R. Co. Elec. 8 m, 4-8½ g, 40 lb T r, 14 c, of which 10 are m c and 4 t c. Westinghouse system. Pres. J. M. Coillidge, V. Pres. L. Allen, Sec. & Treas. B. B. Fowler, Supt. J. A. Powers. Capital authorized \$150,000. Bonds \$150,000. 1 4

GLOUCESTER, MASS.—Gloucester St. Ry. Co. Elec. 9 m, 4-8½ g, 40-60 lb T & Johnson r, 13 m c T-H and Detroit systems. Pres. W. B. Ferguson, V. Pres. J. H. Cunningham, Sec. D. S. Presson, Treas. A. D. Bosson, Supt. A. R. Hallowell. Capital, \$180,000. Bonds, \$60,000. Office, Gloucester st. 1 3

GLOVERSVILLE, N. Y.—Cayadutta Electric R. R. Co. (Leases Johnstown, Gloversville & Kingsboro Horse R. R.) 20 m, 10½ m s, 4-8½ g, 56, 80 lb T & girder r, 21 c of which 14 are m c and 7 t c. Gen. Elec. and Westinghouse systems. Brill, Ellis and Gilbert cars. Russell Engines. Pres. J. H. Decker, V. Pres. R. Wempie, Sec. H. Dudley, Treas. J. E. Ashe, Gen. Man. R. T. McKeever, Supt. T. C. Freneyar, Mast. Mech. F. D. Havens, Ch. Engr. of Power Station T. H. Cliperly. Capital \$335,000; authorized \$350,000. Bonds \$266,000. Office 1 St. Main St. 4 4

Johnstown, Gloversville & Kingsboro Horse R. R. Co. (Leased to Cayadutta Electric R. R. Co.) 4.1 m, 3.9 m s, 4-8½ g, 45 lb T & girder r, 7 c, of which 4 are m c and 3 t c. Gilbert cars. Gen. Elec. system. Pres. G. C. Burr, V. Pres. J. Hees, Sec. J. M. Russel, Treas. J. H. Place. Capital \$50,000. Bonds \$50,000. 1 4

GRAND ISLAND, NEB.—Grand Island St. Ry. Co. 7 m, 4-6 g, 16 & 20 lb T r, 11 c, 52 h & mu. St. Louis cars. Pres. A. H. Baker, V. Pres. H. A. Koenig Sec. O. B. Thomson, Treas. W. A. Hagge, Gen. Man. & Supt. W. C. Lamom. Capital, \$50,000. 2 3

GRAND JUNCTION, COL.—Grand Junction St. Car Co. 2 m, 3 g, 22 lb T r, 2 4-wheel box c, 4 & Pres. G. Wheeler, V. Pres. B. Cannon, Sec. h. Treas. T. B. Crawford, Gen. Man. & Supt. B. K. Kennedy. Capital \$25,000. h 3 1

General Incandescent Arc Light Co., BEST RAILWAY LAMPS, 572 to 578 First Ave., NEW YORK.

S. BERGMAN, President.

GRAND RAPIDS, MICH.—Consolidated St. Ry. Co. 44 m, 25.7 m s, 4-8½ g, 45, 66 & 78 lb girder r; 183 c, of which 138 are m c and 45 t c. Edison and Detroit systems. Hamilton and Wheelock engines. Pres. A. J. Bowne, V. Pres. & Gen. Man. J. R. Chapman, Sec. J. M. Hagar, Asst. Sec. & Treas. B. S. Hancock, Jr., Supt. D. Campbell, Gen. Elec. S. Barnes, Ch. Engr. of Power Station J. Cooper. Capital \$1,500,000; authorized \$2,000,000. Bonds \$2,380,000; authorized \$3,000,000. 1 4

GREAT FALLS, MONT.—Great Falls St. Ry. Co. 10.8 m, 10.4 m s, 4-8½ g, 45 lb T & girder r, 11 c, of which 7 are m. c. and 4 t. c. T-H system. Water power. Pres. A. S. Bigelow, V. Pres. L. Lewesohn, Sec. & Treas. T. Nelson, Supt. & Pur. Agt. W. D. Dickinson, Ch. Engr. of Power Station G. H. Jay. Capital, \$200,000. Bonds \$120,000. 1 4

GREENBUSH, N. Y.—North & East Greenbush St. Ry. Co. 1.7 m, 4-8½ g, 6 c, 22 h. Pres. & Treas. A. Blecker Banks. Capital \$50,000. Office, 473 Broadway, Albany. 3 2

GREEN CASTLE, IND.—Green Castle City St. Ry. Co. 3 m, 4-8½ g, 40 lb T r, 3 c, 10 mu. Pres. J. W. Welk, V. Pres. J. S. Dowling, Sec. & Treas. F. G. Gilmore, Pur. Agt. J. H. Deltrick. Capital \$32,000; authorized \$50,000. Office Crystal Palace cor. Vine and Walnut sts. 4 4

GREENSBURG, PA.—Greensburg & Hempfield Electric St. Ry. 2.4 m elec., 4-8½ g, 35 & 45 lb girder & T r, 3 m c. Westinghouse system. Lamokin cars. Phoenix Iron Works engines. Pres. W. W. Jamison, Sec. & Treas. J. E. Keenan, Gen. Man. F. Y. Clopper, Supt. Pur. Agt. & Elec. R. C. Reamer. Capital \$59,250; authorized \$60,000. Bonds, \$39,250. Office, Huff Building. 1 4

GREENVILLE, S. C.—St. Ry. Co. of the City of Greenville. 2½ m, 5 g, 16 lb crescent r, 6 c, 3 mu T. C. Gower & Son, proprs. Pres. T. C. Gower, Sec. G. G. Wells, Supt. A. G. Gower. Capital \$10,000. Office, 104 Washington st. 1 4

GREENVILLE, MISS.—Greenville St. Ry. Co. 6 m, 4-8½ g, 25-30 lb T r, 9 c, 15 mu. Pres. J. M. Jayne, Sec. & Treas. J. E. Negus, Supt. C. H. Wheat. Capital, \$35,000; authorized, \$100,000. 1 4

Suburban St. Ry. of Greenville. 2 m, 4-8½ g, T r 2 c, 4 mu. Pres. & Man. H. Wilczinski, V. Pres. N. Wilczinski, Sec. & Treas. L. Wilczinski. Capital \$25,000. 3 2

H

HALIFAX, N. S.—Nova Scotia Power Co. (Lim.) 7 m, 4-8½ g, 45-60 lb T r, 25 c, 100 h. Pres. John White, Sec. & Treas. H. Freeman, Supt. J. Adams. Office, 138 Hollis st. Halifax, N. S. Office of Supt. Richmond. 11 0

HAMILTON, O.—Hamilton and Lindenwald Electric Transit Co. 9 m, 4-8½ g, 40, 45 lb T and girder r, 23 c, of which 15 are m. c. and 8 t. c. Edison system. Stephenson cars. Hamilton engines. Pres. Thos. Millikin, V. Pres. C. Benninghofen, Sec. & Gen. Man. Ira S. Millikin, Treas. P. Benninghofen. Capital, \$100,000. Bonds \$100,000 1 4

HAMILTON, ONT.—Hamilton St. Ry. Co. 22 m, 11 m s, 4-8½ g, 62, 69 lb girder r, 75 c. Westinghouse system. Jones Cars. Corliss and Wheelock engines Pres. B. E. Charlton, V. Pres. E. Martin, Sec. Gen. Man. & Pur. Agt. J. B. Griffith, Elec. W. W. Dean. Capital \$205,000. Office 6 James St., South. 1 4

HAMMOND, IND.—Hammond, Whiting & East Chicago Electric Ry. Co., 8 m, 8 m s, 4-8½ g, 62 lb girder r, 6 m c. Westinghouse system. Pullman cars. Ball engines. Pres. C. F. Griffin, V. Pres. N. M. Kaufman, Sec. & Treas. A. M. Turner, Supt. J. S. Ward. Capital, \$100,000. 2 4

HAMPTON, VA.—Hampton & Old Point Ry. Co. 4 m, 1½ m s, 4-8½ g, 50-69 lb T & girder r, 14 c, of which 7 are m c and 7 t c. Edison system. Brill cars. Frick engines. Pres. Gen. Man. Supt. & Pur. Agt. F. W. Darling, V. Pres. J. McMenamin, Sec. & Treas. H. L. Schmelz, Elec. J. B. Crankshaw. Ch. Engr. of Power Station F. L. Small. Capital, \$37,500 authorized \$100,000. Bonds \$140,000. 1 4

HANNIBAL, MO.—Hannibal Ry. Co. Elec 2½ m 4-8½ g, 36.40 lb T & c b r, 5 c, of which 3 are m. c. and 2 t. c. T-H system. Pres. & Supt. M. Doyle Sec. & Treas. James O'Hern. Capital \$25,000. Office 300 Market st. 1 4

HARRISBURG, PA.—Harrisburg City Passenger Ry. Co. (Leased to East Harrisburg Pass. Ry. Co.) Elec. 5½ m, 5-2½ g, 70 lb girder r. T-H system. Pres. H. A. Kelker, V. Pres. G. R. Fleming, Sec. A. Roberts, Treas. W. L. Gorgas. Capital \$125,000. Office, 27 South 2d st. 9 3

Citizens' Passenger Ry. Co. Elec. 9 m, 5-2½ g, 75 lb girder r, 16 m c. Baxter, Curtis and Westinghouse systems. Ide engines. Pres. B. F. Meyers, V. Pres. J. A. Dunkle, Sec. & Treas. A. W. Dunkle, Supt. F. H. Alleman. Capital, \$200,000. 6 3

East Harrisburg Pass. Ry. Co. 30 m, 8 m s, 5-2½ g 52, 78, 92 lb girder and T r, 63 c, of which 48 are m c and 15 t c. Gen. Elec. system. Brill and Lamokin cars. Wetherill engines. Pres. John Q. Denney, V. Pres. T. G. Greenaway, Sec. & Treas. W. J. Calder. Supt., Pur. Agt. & Elec. F. B. Musser. Capital \$500,000; authorized \$1,000,000. Office, 5 Market square. 4 4

HARTFORD, CONN.—Hartford St. Ry. Co. Elec. 35 m, of which 20 are horse and 15 elec, 4-8½ g, 45-60 lb T, & girder r, 127 c, of which 108 are m c and 19 t c, 468 h. Gen. Elec. and Westinghouse systems. Pres. E. S. Goodrich, Sec. & Treas. Dan'l R. Howe. Capital \$200,000; authorized \$2,000,000. Bonds \$500,000. Office, 346 Main st. 4 4

East Hartford & Glastonbury Horse R. R. Co. Elec 5 m, 4-8½ g, 50 lb T r, 4 m c. Short system. Pres D. R. Howe, V. Pres. I. Broadhead, Sec. G. D. Curtis Treas. E. M. White, Gen. Man. E. S. Goodrich. 11 2

HARVEY, ILL.—Harvey Transit Co. Elec. 3 m c, 4-8½ g, T r, 3 m c. Short system. Laclede cars. Ide engines. Pres. A. G. Spalding, V. Pres. A. C. Badger, Gen. Man. W. J. McCorkinole, Supt. H. E. Geyer. Capital \$150,000. Bonds \$150,000 4 4

HASTINGS, NEB.—Citizens' St. Ry. Co. 5½ m, 4-8½ g, 16 & 32 lb T & flat r, 6 box c, 8 h. Pres. Gen. Man. & Supt. R. A. Batty, Sec. Rose E. Shedd, Treas. J. Hornshaw. Capital \$65,000; authorized, \$100,000. 9 3

HAVERTHILL, MASS.—Lowell, Lawrence & Havert Hill St. Ry. Co. (See Lawrence, Mass.)

Havert Hill & Amesbury St. Ry. Co. Elec. 32 m, of which 8½ are horse, 5½ steam & 18 elec, 4-8½ g, 35 50, 70 lb T & girder r, 65 c, of which 20 are h c, 32 m c and 13 t c. T.H and Westinghouse systems. Briggs, Ellis and Newburyport cars. Pres. & Gen. Man. E. P. Shaw, Treas. A. C. Pond, Supt. W. Wentworth. Capital, \$150,000; authorized, \$250,000. Bonds, \$300,000. 1 3

HAZLETON, PA.—Lehigh Traction Co. 14 m, 4 m s, 4-8½ g, 60 lb T r, 30 c, of which 11 are m c, 4 t c, and 4 coal c. Westinghouse system. Brill and Lamokin cars. Westinghouse engines. Pres. C. W. Kline, V. Pres. H. Dryfoos, Sec. E. S. Doud, Treas. N. C. Yost, Supt. & Elec. J. E. Gilles. Ch. Engr. A. E. Hess. Capital \$500,000; authorized, \$1,000,000. Bonds, \$350,000. 2 4

HELENA, ARK.—Citizens' St. Ry. Co. 2½ m. ½ m s, 4-8½ g, 20 & 40 lb T & Johnson r, 7 c, of which 4 are 4-wheel box & 3 truck c, 12 mu. St. Louis cars. Pres. H. S. Hornor, V. Pres. D. T. Hargraves, Sec. Gen. Man. & Pur. Agt. J. H. Thompson, Treas. S. H. Hornor. Capital \$30,000. 1 4

HELENA, MONT.—Helena Electric Ry. Co. 9 m, 4-8½ g, 38-48 lb girder & T r, 16 c, of which 8 are m c and 8 t c. T-H & Westinghouse systems. Pullman and Stephenson cars. Corliss engines. Pres. H. M. Parchen, V. Pres. W. A. Chessman, Sec. & Treas. H. L. Walker. Capital, 250,000. Office, Main St. & 6th Ave. 4 4

Helena Rapid Transit R.R. Elec. 15 m, 15 m s, 4-8½ g, 35, 45, 50 lb T & girder r, 9 m c. T-H system. Northern cars. Russell engines. Pres. & Gen. Man. R. Lockey, V. Pres. P. Winne, Sec. J. T. Hoag, Foreman F. G. Montgomery, Elec. A. H. Noyes, Ch. Eng. of Power Station, N. B. Nason. Capital, \$500,000. Office, Lockey Bldg, 6th ave. 1 4

HENDERSON, KY.—Henderson St. Ry. Co. 6½ m, 4-8½ g, 20 lb steel T r, 12 c, 2 h, 44 mu. St. Louis cars. Pres. & Gen. Man. E. G. Sebree, Jr., Sec. & Treas. D. Bank, Jr., Supt. J. W. O'Brien. Authorized capital, \$100,000. 4 4

HENDERSONVILLE, N. C.—Hendersonville St. Ry. Co. 3 m, 4-8½ g, 30 lb T r, 3 c, of which 1 ls 4-wheel box and 2 4-wheel open, 1 h, 2 mu. Stephenson cars. Owner & Gen. Man. S. V. Pickens. Capital, \$6,000. Office, 1 S. End Main st. 4 4

HOBOKEN, N. J.—North Hudson County Ry Co. (Includes Pavonia Horse R.R.) 60 m, of which 23 are horse and 32 elec, 4 6½, 4-8½ g, 56, 67, 78 lb c. b. girder and T r, 250 c, of which 171 are h c, and 179 m c, 930 h. T-H system. Brill, Gilbert and Stephenson cars. Ball, Phila-Corliss and Watts-Campbell engines. Pres. M. Tierny, V. Pres. H. J. Bonn, Sec. T. J. Mallory, Treas. J. F. W. Mangels, Gen. Man. E. W. Starr, Supt. Nicholas Goetz, Elec. A. K. Bonta, Ch. Engr. of Power Station C. A. Dennis. Capital, \$1,000,000. Bonds \$3,000,000. Office, 21 Hudson Place. 2 3

HOLYOKE, MASS.—Holyoke St. Ry. Co. Elec \$1 m, 4-8½ g, 56 lb T r, 82 c, of which 20 are m c and 12 t c. T-H and Westinghouse systems. Pres. Levi Perkins, Treas. & Gen. Man. Wm. S. Loomis, Supt. G. Hunter. Capital \$250,000. Office 23 Canal St. 1 4

HORNELLSVILLE, N. Y.—Hornellsville Electric Ry. Co. 4 m, 4-8½ g, 56 lb girder r, 10 c of which 5 are m c and 5 t c. Edison system. Pres. C. Adsit, V. Pres. F. D. Sherwood, Sec. D. M. Page, Treas. G. T. Rehn, Supt. & Ch. Engr. C. H. Wickham, Elec. Dr. Haven. Capital \$50,000. Bonds \$50,000. Office, 119 Main St. 4 4

Hornellsville & Canisteo Ry. Co. Elec. 5 m, 4-8½ g, 40 lb T r, 4 c, of which 3 are m c and 1 t c. Edison system. Brill cars. Pres. D. M. Page, V. Pres. F. D. Sherwood, Sec. C. Adsit, Treas. G. T. Rehn, Supt. & Ch. Engr. C. H. Wickham, Elec. Dr. Haven. Capital \$50,000. Bonds \$50,000. Office 119 Main st. 4 4

HOT SPRINGS, ARK.—Hot Springs Electric St Ry. Co. 15.4 m, of which 2 are horse and 13.4 elec, 4-8½ g, 48 lb T r, 35 c, of which 10 are h c 10 m c and 15 t c. T-H system. American cars. Pres. S. W. Fordyce, Sec. C. E. Maurice, Treas., Man. & Pur. Agent C. G. Convers. Capital, \$500,000. Office, 615 Park Ave. 9 3

Fountain & Suburban R. R. Co. Elec. 4½ m, 4 g 35 lb T r R. Murray, own-r & manager, Williamson Block, Valley st., at Malvern Crossing. Capital \$20,000. 8 2

HOT SPRINGS, S. DAK.—Hot Springs & Chautauqua R. R. Co. Elec. 1½ m, 2 m c. Short system 10 1

HOUSTON, TEX.—Houston City St. Ry. Co. (Operates Bayou City and Houston Heights Rys.) Elec. 35 m, 4-8½ g, 40, 45 lb T & flat r, 55 c, of which 45 are m c and 10 t c, Edison and T-H systems. Brill, Brownell, St. Louis and Stephenson cars. Allis engines. Pres. O. M. Carter, V. Pres. & Gen. Man. H. F. MacGregor, Sec. & Treas. C. A. McKinney, Supt. F. Mundes. Capital, \$1,000,000. Office, 502-4 Travis st. 3 4

HUDSON, N. Y.—Hudson Elec. Ry. Co. 1½ m elec, 4-8½ g, 35 lb T r, 5 m c. T-H system. Pres. H. Mc Gonegal, Vice-Pres. A. J. Rowles, Sec. E. J. Hodge, Treas. S. D. Lake. Capital stock \$50,000. 5 3

HULL, MASS.—Hull St. Ry. Co. 2 m, 2 m s, 4-8½ g, 40 lb T r, 8 c, 4 of which are m c and 4 t c. Gen. Elec. system. Newburyport cars. Pres. E. P. Shaw, Treas. J. W. Hobart, Supt. W. A. Larrabee. Capital, \$20,000. Bonds, \$20,000. Office, 53 State St., Boston. 2 4

HUNTINGTON, L. I., N. Y.—Huntington R. R. Co. 3 m, 4-8½ g, 30 lb T r, 3 c, 10 h. Pres. E. D. Davidson, V. Pres. Temple Prime, Sec. Geo. M. Thieston Treas. D. Conklin, Gen. Man. I. Rogers. Capital \$30,000. Bonds, \$26,000. 4 4

HUNTINGTON, W. VA.—Consolidated Light & Ry. Co. Elec. 11 m, of which 4 are horse and 7 elec, 4-8½ g, 42, 52 lb girder & T r, 13 c, of which 7 are m c and 6 t c. Short system. Laclede and Jones cars. Taylor and Buckeye engines. Pres. J. L. Caldwell, V. Pres. T. T. McCullough, Sec. & Gen. Man. F. L. Doolittle, Treas. C. L. Hafner, Sr. Capital, \$250,000. Bonds, \$100,000. Office, 919 2d Ave. 9 3

HUNTSVILLE, ALA.—Huntsville Belt Line & Monte Sano Ry. Co. 12 m steam, 4-8½ g, 60 lb T r, 20 c. Pres. J. F. O'Shaughnessy, 36 Wall st. New York Capital, \$200,000. Bonds, \$150,000. Office, Jefferson st. 2 2

HUTCHINSON, KAN.—Hutchinson St. Ry. Co. 12 m, 4-6 g, 20 lb T r, 6 c, 30 h, 20 mu. Brownell and Laclede cars. Pres. & Gen. Man. L. A. Bigger, V. Pres. J. B. Brown, Sec. L. Taylor, Treas. & Supt. S. Bigger. Capital, \$50,000. Office, 8 E. Sherman St. 9 3

INDEPENDENCE, MO.—Kansas City, Independence & Park Dummy Line. (See Kansas City.)

INDIANAPOLIS, IND.—Citizens' St. R. R. Co. 100 m, 4-8½ g, 38 to 95 lb Johnson girder r, 160 c, Gen. Elec. and Westinghouse systems. Pres. A. L. Mason, V. Pres. W. L. Elder, Sec. & Treas. W. F. Mithland, Pur. Agt. S. F. Hazclrigg, Gen. Man. T. H. McLean. Capital \$5,000,000. Bonds \$1,000,000. Room 11 Fair Block. 4 4

IRONTON, O.—The Ironton & Petersburg St. Ry. Co. 8 m, 4-8 g, 32 lb T & flat r, 13 c, 42 h. Pres. C. H. Harman, Sec. & Treas. Wm. M. Kerr, Supt. T. T. Johnson. Capital, \$100,000. Bonds, \$65,000. Office, 32 Nassau St., New York. 1 3

IRONWOOD, MICH.—Twin City Ry. Co. 5½ m, 5½ m s, 4-8½ g, 45 lb T r, 4 m c. T-H system. Allis engines. Pres. & Gen. Man. E. D. Nelson, V. Pres. H. M. Byllesby, Sec. & Treas. H. F. Jahn, Supt. and Pur. Agt. M. Kinch. 4 4

ITHACA, N. Y.—Ithaca St. Ry. Co. Elec. 6 m, 4-8½ g, 45, 60 lb T r, 18 c, of which 12 are m c and 6 t c. T-H system. Brill and Gilbert cars. Ball engines. Water power. Pres. H. E. Hand, V. Pres. A. Hand, Sec. Treas. & Gen. Man. H. Bergholtz. Supt. J. A. Maxwell. Capital, \$175,000; authorized, \$250,000. Office 16 East State st. 4 4

J

JACKSON, MICH.—Jackson Street Ry. Co. Elec 7 m, 4-8½ g, 45 T & lb girder r, 16 c, of which 8 are m c and 8 t c. Edison system. Brill cars. Pres. H. H. Smith, V. Pres. D. S. Smith, Sec. J. B. Corliss, Treas. & Gen. Man. H. H. Smith, Jr. Capital, \$140,000; authorized, \$150,000. Office, Main and Horton Sts. 9 3

JACKSON, MISS.—Jackson City R.R. 1 1/2 m 4-8 1/2 g, 4-4 wheel box c, 10 h. Pres. P. W. Peoples of Jackson Bank. Capital, \$5,000. 3 2

JACKSON, TENN.—Jackson & Suburban St. R. R. Co. 7 m, 4 g, 30 lb tram r, 9 4-wheel box c, 30 mu Pres. & Gen. Man. J. L. Wisdom, V. Pres. J. H. Duke Sec. C. G. Bond, Supt. T. F. Dalbey, Treas. 1st Nat Bank. Capital, \$50,000. Office, Royal St. at Five Points. 5 3

JACKSONVILLE, FLA.—Main St. R. R. Co. Elec. 3 m, 3 m s, 5 g, 40 lb T r, 4 c of which 2 are m c and 2 t c. General Electric system. Stephenson cars. Pres. S. B. Hubbard; V. Pres. J. M. Schumacher, Sec. & Treas. A. F. Perry, Elecn. C. S. Hammatt, Ch. Engr. of Power Station C. O. Patterson. Capital, \$15,000. Bonds \$4,400. Office, 26 Main st. 1 4

Jacksonville St. R. R. Co. 12 m, 5 g, 25 & 30 lb T & 35 lb c b r, 33 c, 137 mu. Pres. H. S. Haines, Savannah, Ga.; V. Pres. Geo. R. Foster, Jacksonville, Fla.; Treas. J. M. Lee, Savannah; Supt. G. W. Haines, Brunswick, Ga.; Agent & Eng. M. H. Motte, Jacksonville. Office, Commercial st. c 9 0

JACKSONVILLE, ILL.—Jacksonville Ry. Co. Elec. 5 m, 4-8 1/2 g, 25-45 lb r, 21 c, of which 9 are m c, 12 t c, 5 h. T-H & Detroit systems. Pres. Wm. S. Hook, Sec. Marcus Hook, Treas. Fannie Hook, Supt. B. F. Sibert. Capital \$50,000. 6 2

JAMAICA, N. Y.—Jamaica & Brooklyn Road Co. (See Brooklyn, Queens Co. & Suburban R. R. Co., Brooklyn, N. Y.)

JAMESTOWN, N. Y.—Jamestown St. Ry. Co. Elec. 20 m, 4-8 1/2 g, 30-70 lb T & girder r, 32 c, of which 27 are m c and 5 t c, 7 h. Short and Westinghouse systems. Brill cars. Noye and Phoenix engines. Pres. A. N. Broadhead, V. Pres. L. B. Warner, Sec. W. S. Cameron, Treas. S. B. Broadhead, Supt. & Pur. Agt. G. E. Maltby. Capital \$250,000. Bonds \$300,000. 9 3

JANESVILLE, WIS.—Janesville St. Ry. Co. 7 m, 5 m s, 4-8 1/2 g, 35 lb T r, 9 c, of which 5 are m c and 4 t c. Short system. Calumet and St. Louis cars. Arlington & Silms engines. Pres. George W. Blabon, V. Pres. A. Graham, Sec., Treas. & Gen. Man. W. R. Proudfoot, Elecn. R. W. Bryan, Ch. Engr. of Power Station A. Gibson. Capital \$125,000. Bonds \$75,000. Office, Power House, Academy st. 4 4

JEFFERSONVILLE, IND.—Jeffersonville City Ry. Co. 5 m, 4-8 1/2 g, 20 & 35 lb steel T r, 11 c, 35 mu. Pres. Sec. & Treas. E. J. Howard, V. Pres. G. J. Long, Supt. E. Frazer. Capital stock, \$50,000. Office, 57-59 Spring st. 1 3

JERSEY CITY, N. J.—Jersey City & Bergen R. R. Co. (Controlled by Consolidated Traction Co. of New Jersey.) 40 m, of which 30 are horse and 10 elec. 4-10 1/2 g, 50 & 78 lb c. b. & girder r, 163 c, of which 136 are h c and 27 m c, 819 h, 66 mu. Curtis and Westinghouse systems. Stephenson and Trimble cars. Pres. Chas. B. Thurston, 1st V. Pres. G. F. Perkins, 2d V. Pres. & Gen. Man. D. Young, Sec. H. C. Ross, Treas. Joseph S. Vanzandt, Supt. Thos. M. Sayre. Capital \$1,000,000. Bonds, \$258,000. Office, No. 1 Exchange Pl. 9 3

Consolidated Traction Co., of New Jersey. (See Newark, N. J.)

JOHNSON CITY, TENN.—Johnson City & Carnegie St. Ry. Co. Elec. 4 m, 4-8 1/2 g, 45 lb T r, 4 m c. T-H system. Ellis cars. Power rented. Pres. E. Day, V. Pres. F. A. Stratton, Sec., Treas. & Gen. Man. E. H. Stevens. Capital \$50,000. 1 4

JOHNSTOWN, PA.—Johnstown Pass. Ry. Co. 15 m, 4-8 1/2 g, 73 lb girder r, 31 c, of which 19 are m c and 12 t c. Westinghouse motors. Ball and Westinghouse engines. Stephenson cars. Pres. Tom. L. Johnson, V. Pres. & Man. John B. Hoefgen, Sec. S. E. Young. Capital, \$250,000. Office Johnstown. 4 4

JOLIET, ILL.—Joliet St. Ry. Co. Elec. 16 m 4-8 1/2 g, 38, 40, 58 lb girder & T r; 30 c, of which 16 are m c & 14 t c. T-H system. Pres. & Gen. Man. J. A. Henry, V. Pres. & Supt. J. W. Folk, Sec. & Treas. J. Hulsizer. Capital, \$150,000; authorized, \$300,000. Bonds, \$75,000. Office, S. W. corner Jefferson & Ottawa Sts. 1 3

JOPLIN, MO.—Joplin Electric Ry. & Motor Co. 5 m, 5 m s, 4-8 1/2 g, 56 lb girder r, 10 c, of which 8 are m c and 2 t c. T-H system. St. Louis cars. Ide engines. Pres. John N. Boffinger, V. Prests. B. F. Hammett, J. C. Stewart, Sec. & Treas. D. R. Powell, Gen. Man. H. L. Newnam, Supt., Pur. Agt. & Elecn. C. H. Belden, Ch. Engr. of Power Station C. Knowles. Capital, \$150,000. Office, East Broadway. 4 4

Southwest Missouri Electric Ry. Co. (See Webb City, Mo.)

K

KALAMAZOO, MICH.—Citizens' St. Ry. Co. Elec. 12 m, 4-8 1/2 g, 50 lb. T r, 25 c, of which 14 are m c. and 11 t c. General Electric system. Pres. T. P. Bailey, V. Pres. G. J. Kobusch, Sec. & Supt. E. E. Downs, Treas. J. W. Johnson, Gen. Man. G. K. Wheeler. 1 4

KANKAKEE, ILL.—Kankakee Electric Ry. Co. 6 m, 4-8 1/2 g, 50 lb T, girder & T r, 4 m c. Westinghouse system. Pullman cars. Pres. & Gen. Man. C. H. Cobb, V. Pres. H. K. Wheeler Sec. & Treas, T. W. Adams. Capital, \$50,000; authorized, \$60,000. 9 3

North Kankakee Elec. Lt. & Ry. Co. 4.2 m, 4-8 1/2 g, 40, 57 lb T & girder r, 3 m c. Detroit and T-H Systems. St. Louis cars. Phoenix engines. Pres. E. F. Uran, Sec. E. E. Day, Treas. A. D. Ehrlich, Gen. Man. & Supt. E. Powell. Capital \$70,000; Bonds, \$25,000. 9 3

KANSAS CITY, KAN.—Kansas City Elevated Ry. Co. (Operates Kensington Ry.) Elec. 20 m, 4-8 1/2 g, 40, 50, 62 lb T & Duplex r, 34 m c. T-H, Edison and Westinghouse systems. Pullman and St. Louis cars. Corliss engines. Pres. C. W. Blair, V. Pres. & Gen. Man. R. Gillham, Sec. D. D. Hoag, Treas. A. H. Callf. Capital, \$3,600,000. 1 4

West Side R. R. Co. Elec. 10 m, 4-8 1/2 g, 45, 54 lb T & girder r, 16 c, of which 12 are m c. and 4 t c. Westinghouse system. St. Louis cars. Sioux City Corliss engines. Pres. W. N. Coler, Jr., Sec. C. F. Hutchings, Supt. J. P. Clark, Capital, \$500,000. Bonds \$150,000. 6 3

KANSAS CITY, MO.—Kansas City Cable Ry. Co. 20 1/2 m cable, 4-8 1/2 g, 42, 56 & 63 lb flat & Johnson girder r, 190 c, of which 119 are open and 71 g, c Brownell, Laclede and Stephenson cars. Pres. & Gen. Man. Wm. J. Smith, V. Pres. Jas. A. Blair, Sec. W. H. Lucas, Treas. J. T. Thornton, Asst. Gen. Man. F. C. Peck, Pur. Agt. W. A. Satterlee, Elecn. T. Griffin. Capital, \$1,575,000. Bonds \$1,350,000. Office, 433 E. Ninth st. 4 4

Grand Ave. Ry. Co. 22.518 m, of which 3,500 are horse, 17,144 cable & 1,874 steam, 12,129 m s, 56 lb T & c b r, 89 c, of which 7 are h c, 80 cable comb'n and 2 steam c, 40 h. Brownell cars. Allis engines. Pres. W. H. Holmes, V. Pres. V. B. Buck, Sec. D. B. Holmes, Treas. W. B. Clarke, Gen. Man. C. F. Holmes, Supt. T. Barratt, Auditor, T. J. Fry, Ch. Engr. of Power Station D. W. Dozler. Capital, \$1,200,000. Bonds, \$1,200,000. Office, 1500 Grand ave. 1 4

Kansas City & Independence Rapid Transit Ry. Co. 18 m steam, 4-8 1/2 g, 40 lb T r, 28 c, of which 18 are pass. c, 9 flat c and 1 express c, 6 steam motors. Laclede cars. Baldwin engines. Pres. W. H. Holmes, V. Pres. C. L. Hutchinson, Sec. D. B. Holmes, Treas. W. B. Clarke, Gen. Man. C. F. Holmes, Auditor, T. J. Fry, Pur. Agt. V. W. Flowerree. Capital, \$1,000,000. Office 1,500 Grand Ave. 1 4

Kensington Ry. Co. (Operated by Kansas City Elevated Ry. Co.) Steam. 4 m, 4-8 1/2 g, 50 lb T r. Pres. A. P. Smith, V. Pres. K. S. Miner, Sec. J. E. Brady, Treas. W. A. Bunker. Capital \$50,000. Bonds \$50,000. 4 4

Metropolitan St. Ry. Co. 42.387 m, of which 24,814 are cable, 9,345 horse and 8,228 elec., 4-8 1/2 g, 60 lb c b r, 289 c of which 42 are h c, 76 g c, 20 m c and 151 t c, 175 h and mu. T-H system. Laclede and Pullman cars. Arlington & Silms and Hooven, Owens & Rentschler engines. Pres. & Treas. C. F. Morse, V. Pres. G. H. Nettleton, Sec. J. A. Harder, Gen. Man. & Ch. Engr. R. J. McCarty, Asst. Gen. Man. F. M. Bernardin, Ch. Engr. of Power Station A. E. Delbert. Capital \$2,800,000; authorized \$3,600,000. Bonds \$2,000,000. Office, 9th & Broadway. 4 4

North East St. Ry. Co. Elec. 7 m, 3 1/2 m s, 4-8 1/2 g, 52 lb girder r; 20 c of which 10 are h c and 10 m c. T-H and Westinghouse systems. Centropolis cars. Pres. E. A. Phillips, Sec. W. C. Scarritt, Gen. Man. R. Gillham, Supt. J. Houlehan, Pur. Agt. A. J. McDonald. Capital \$260,000. Bonds \$260,000. Office, St. John and Elmwood Aves. 1 4

People's Cable Ry. Co. 6.8 m, 4-8 1/2 g, 58 1/2 lb r, 35 c, of which 15 are g c. and 20 t c. Auditor & Cashier, W. C. Phillips, Supt. F. Phillips. Capital \$750,000. 3 2

South Suburban Ry. Co. Elec. 3.25 m, 4-8 1/2 g, 35-56 lb flat & girder r, 6 m c. T-H system. St. Louis cars. Pres. G. K. Wheeler, V. Pres. & Gen. Man. D. J. Hafl, Sec. C. A. Ross, Treas. I. C. Hubbell, Supt. C. Grover. Capital, \$150,000. Bonds \$100,000. Office, 829 N. Y. Life Ins. Bldg. 6 3

KEARNEY, NEB.—Kearney Electric Co. 5 1/2 m Elec. 4-8 1/2 g, 40 lb T r, 6c, of which 4 are m c. and t c. T-H & Edison systems. Pres. Geo. W. Frank Sec. & Treas. C. M. Rice, Supt. G. W. Frank Jr. Capital \$250,000. 1 4

KENOSHA, WIS.—Kenosha Electric St. Ry. Co. Pres. & Gen. Man. J. W. Munson. Capital \$100,000. (Not in operation) 4 4

KEOKUK, IA.—Gate City Electric St. Ry. Co. 6 1/2 m, 4-8 1/2 g, 38-45 lb T & girder r, 14 c, of which 8 are m c and 6 t c. Edison and Westinghouse systems. Receiver H. C. Helner. Capital authorized, \$130,000. Bonds \$85,000. 1 4

KEY WEST, FLA.—Key West Street Car Association, 5 m, 4-8 1/2 g, 50 lb r, 12 c, 75 mu. Brill cars. Pres. J. Albertas, Sec. G. B. Paterson, Treas. Key West St. Car Co., Supt. A. Orchueta. Capital, \$150,000. 6 2

KEYPORT, N. J.—Keyport & Matawan St. Ry Co. 3 1/2 m, 4-8 1/2 g, 35 lb girder s-b r, 6 4-wheel box c 24 h. Pres. R. R. Brown, Sec. & Treas. A. M. Brown, Supt. W. C. Smith. Capital, \$30,000. 4 4

KINGSTON, N. Y.—Colonial City Electric Ry. Co. 6 m, 6 m s, 4-8 1/2 g, 80 lb girder r, 12 c, of which 6 are m c, and 6 t c. United Columbian system. St. Louis cars. Ball & Wood engines. Pres. E. H. Loughran, V. Pres. W. Goodwin, Sec. & Gen. Man. N. C. Powelson, Treas. F. Swift, Ch. Engr. E. B. Codwise, Ch. Engr. of Power Station F. Brown. Capital, \$175,000. Bonds \$150,000. Office 29 Wall St. 2 4

Kingston City R. R. Co. (See Rondout, N. Y.)

KINGSTON, ONT., CAN.—Kingston St. Ry Co. 8 m, 3 g, 44 lb r, 15 c, 45 h. Pres. & Gen. Man B. W. Folger, V. Pres. M. H. Folger, Sec. F. R. Sargent, Treas. B. W. Folger, Jr., Supt. A. Beacance Capital \$60,000. Bonds \$60,000. 6 2

KNOXVILLE, TENN.—Knoxville Electric Ry. Co. 17 m, of which 13 are electric, 4 8 1/2 g, 45 lb girder & T & 25 lb tram r, 26 c, 12 m c. T-H system Receiver, J. C. Duncan, Supt. W. B. Palmer. 7 3

Fountain Head Ry. Co. 6 m, 4-8 1/2 g, 45 lb T r, 11 c of which 7 are passenger and 4 freight, 3 dummies Pres. G. Borgfeldt, V. Pres. G. F. Pfeiffer, Treas. J. Kahle, Gen. Man. M. O. French, Supt. R. T. Baker Capital \$200,000. Office, 91 W. Depot st. 4 4

West End St. Ry. Co. 4 m, 4 m s, 4-8 1/2 g, 20 24 lb c. b. and T r, 3 m c. T-H System. Stephenson cars. Pres. R. M. Rhea, V-Pres. W. P. Chamberlain, Sec. Treas. Gen. Man. & Pur. Agt. T. J. Thomas, Elecn. W. P. Hickman. Capital \$25,000; authorized \$50,000. Bonds \$9,600. 1 4

KOKOMO, IND.—Kokomo City St. Ry. Co. Elec 4 1/2 m, 4-8 1/2 g, 35 lb T r, 13 c, of which 9 are m c, and 4 t c. Detroit system. Brownell cars. Dick & Church engines. Pres. F. E. Snow, V. Pres. W. A. Jackson, Sec. & Treas. F. Woodruff, Supt. & Elecn. F. H. Allen. Capital \$100,000. 1 4

L

LACONIA, N. H.—Laconia & Lakeport St. Ry. 3.62 m, 3 g, 35 lb T r, 11 c, 25 h. Pres. J. C. Moore, V. Pres. & Gen. Man. Henry Tucker, Treas. Edmund Little, Supt. B. S. Kenniston. Capital \$50,000. 1 4

LA CROSSE, WIS.—La Crosse City Ry. Co. 10 1/2 m, of which 1/2 is horse and 10 1/2 elec., 4-8 1/2 g, 40-66 lb girder & T r, 30 c, of which 5 are h c, 11 m c and 14 t c, 20 h. Gen. Elec. system. St. Louis cars. Allis engines. Pres. B. E. Edwards, V. Pres. W. W. Cargill, Sec. H. E. West, Treas. Geo. H. Clark, Supt. Peter Valler, Ch. Engr. C. C. Smith, Elecn. J. Johnson, Ch. Engr. of Power Station S. J. Prentiss. Capital \$200,000. Bonds \$125,000. Office, 3d and La Crosse Sts. 1 4

LA SALLE, ILL.—City Electric Ry. Co. 9 1/2 m, elec. 4-8 1/2 g, 51 1/2 lb s b & girder r, 9 c, of which 6 are m c and 3 t c. Edison system. Pres. Sec. F. X. Kilduff, Treas. L. B. Merrifield, Supt. E. S. Enyart. Capital \$125,000. 3 2

LAKE CHARLES, LA.—Lake Charles St. Ry Co. 1 1/2 m, 1 1/2 m s, 4-8 1/2 g, 30 lb T r, 4 c, 14 mu. Pres. P. Crowley, V. Pres. J. Ryan, Sec., Treas. & Gen. Man. W. Meyer, Treas. A. Meyer. Capital, \$10,000; authorized \$50,000. 4 4

LAFAYETTE, IND.—Lafayette St. Ry. Elec 10 m, 4-8 1/2 g, 56 lb T & girder r, 31 c, of which 19 are m c and 2 t c. Edison system. Brill cars. Hamilton-Corliss engines. Pres. Frank M. Ritter, V. Pres. T. J. Levering, Sec. & Treas. J. T. Henderson, Gen. Man. & Elecn. J. S. Hill. Capital \$150,000. 1 4

LAMPASAS SPRINGS, TEX.—Lampasas Springs St. R. R. Co. 3 m, 3 m s, 4-8 1/2 g, 35 lb T r, 6 c, 16 mu. Pres. R. E. Maddox, V. Pres. E. R. Maddox, Sec. W. Little, Treas. Gen. Man. Supt. & Pur. Agt. E. P. Maddox, Ch. Engr. E. Day. Capital \$20,000; authorized, \$20,000. Office, Elm st. 1 4

LANCASTER, N. Y.—Buffalo, Bellevue & Lancaster Ry. Co. 14 m, 13 1/2 m s, 4-8 1/2 g, 45.54, 66 T and girder r, 24 c of which 10 are m c and 14 t c. T-H system. Brill and Stephenson cars. Ball engines. Pres. H. W. Box, Sec. J. A. Roberts, Treas. J. L. Williams, Supt. & Pur. Agt. R. E. Danforth, Elecn. F. D. Jackson, Ch. Engr. of Power Station, W. A. Davison. Capital \$90,000; authorized \$100,000. Bonds \$200,000. 1 4

LANCASTER, O.—Lancaster Electric Ry. Co. 7 m, bonded for elec. service, 4-8 1/2 g, 52 lb girder r, 7 c, 16 h. Pres. Wm. Duffy, V. Pres. G. Mussee, Sec. C. F. Nestor, Treas. & Gen. Man. A. Baumann. 9 3

LANCASTER, PA.—Pennsylvania Traction Co. (Operates Columbia & Donegal, Columbia & Ironville, Lancaster & Columbia and Lancaster City railways.) 50 m, 5-2 1/2 g, 62, 60 lb girder & T r, 50 c, of which 40 are m c and 10 t c, 7 h. Gen. Elec. system. Brill cars. Ball & Wood and Reynolds engines. Pres. J. J. Patterson, Sec. & Treas. J. Hertzler. 2 4

Lancaster & Lititz Ry. Co. Elec. 8 m, 5-2 1/2 g, Pres. J. A. Coyle, Sec. & Treas. J. E. Ackley. 8 2

ROUND "BELL CORD." LEATHER Jas. Lyon's Superior Quality in Coils. Send for Samples and Prices. **CHAS. L. McCLURE, Manufacturer's Agent,** 415 Broadway, Room 522, New York.

LANSING, MICH.—Lansing City Ry. Co. Elec 8 m, 4-8 1/2 g, 35 & 45 lb s b & T r, 17 c, of which 12 are m c, and 5 t, c. Westinghouse system. Pres. G. Macdonald, V. Pres. C. Osbound, Sec. J. P. Lee, Gen. Man. S. L. Keighley. Capital \$50,000. Office, 1 106 Washington Ave., South Lansing. 9 3

LARCHMONT, N. Y.—Larchmont Horse R. R. Co. 1 1/2 m, 4-8 1/2 g, 25 & 33 lb T & girder r, 3 box c, 12 h. Stephenson cars. Pres. C. H. Murray, V. Pres. E. E. Flint, Sec. Treas. & Supt. W. H. Campbell. Capital \$25,000. 1 4

LAREDO, TEX.—International Bridge & Tramway Co. 2 m, 3-9 g, 20 lb T r, 2 c, 10 mu. Brill cars. Pres. P. Ornelas, Sec. T. W. Smith, Supt. K. Varela. 4 4

Laredo Electric & Ry. Co. 3 1/2 m, 4 g, 25 lb T r, 6 m c. Edison system. Brill cars. Armington & Sims engines. Pres. B. M. Hammond, V. Pres., Treas. & Gen. Man. C. F. Drake, Sec. Supt. & Pur. Agt. C. F. Yaeger, Ch. Engr. and Ch. Engr. of Power Station J. E. Emly, Elec. G. D. Hand. Capital, \$100,000. Office, Salinas & Farragut sts. 4 4

LAWRENCE, KAN.—Lawrence Transportation Co. 5 1/2 m, 4-1 g, 33 lb Johnson girder r, 9 c, of which 6 are 4-wheel box and 3 4-wheel open, 54 h. Pres. & Treas. H. Tisdale, V. Pres. J. W. Parker, Sec. H. B. Lawton, Supt. W. McElheny. Capital \$35,000. 4 4

LAWRENCE, MASS.—Lowell, Lawrence & Haverhill St. Ry. Co. 53 m, 4-8 1/2 g, 60, 70 lb T and girder r, 94 c, of which 6 are h c, 71 m c and 17 t c. Gen. Elec. system. Brill, Jones, Lewis & Fowler and Newburyport cars. McIntosh & Seymour and Providence engines. Pres. G. H. Campbell, Treas. C. A. Stone, Asst. Treas. W. A. Fisher, Audr. G. E. Tripp, Supts. (Lawrence division) N. E. Morton, (Haverhill division) F. Woodman. Offices 104 Ames Bldg., Boston, 246 Essex st., Lawrence. 4 4

LEAVENWORTH, KAN.—Leavenworth Electric Ry. Co. 15 m, of which 5 are horse and 10 elec, 4-8 1/2 g, 56 lb T r, 28 c, of which 14 are h. c. 9 steam c. 3 m. c. and 2 t. c. 15 h 32 mu. Stephenson cars. Baldwin and Porter engines. Receiver & Pur. Agt. L. M. Erb, Atty. W. Dill, Elec. C. W. White. Capital, \$300,000. 1 4

LEBANON, MO.—Lebanon Light & Water Co. Elec. 1/2 m, 4-8 1/2 g, 48 lb T r, 1 m. c. Westinghouse system. Pres. E. F. Hobart, V. Pres. E. B. Loveland Sec. & Treas. W. P. Heath, Gen. Man. & Supt. J. E. Fulkerson. Capital \$250,000. Bonds, \$100,000. 9 3

LEBANON, PA.—Lebanon & Anville St. Ry. Co. Elec. 20m, 5-2 1/2 g, 40-80 lb girder & T r, 14 m c Edison system. Lebanon Mfg. Co., Lewis & Fowler and Stephenson cars. Ball and Ide engines. Pres. & Gen. Man. J. M. Sherk, V. Pres. S. F. Light, Sec. H. H. Light, Treas. F. H. Reineohi, Supt. C. H. Smith Capital \$100,000. Bonds \$100,000. 1 4

Lebanon & Myerstown St. Ry. Co. Pres. J. N. Sherk. Sec. S. L. Brightbill. Treas. G. D. Rice. 3 4

LEWISTON, ME.—Lewiston & Auburn Horse R. R. Co. 14 m, 4-8 1/2 g, 35, 45, 50 lb T and c b r, 15 c, 80 h. Jones and Stephenson cars. Pres. C. F. Woodward, Treas. H. C. Little, Gen. Man. E. W. Gross, Supt. II. Yates, Pur. Agt. E. E. Proctor. Capital \$97,000; authorized \$100,000. Bonds \$85,000. 4 4

LEXINGTON, KY.—Passenger & Belt Ry. Co. Elec. 13 m, 12 m s, 4-8 1/2 g 50 lb T r; 33 c, of which 25 are m c and 8 t c. Edison and T-H systems. Ohio Falls and Pullman cars. Armington & Sims and Lane & Bodley engines. Pres. & Gen. Man. C. H. Stoll, V. Pres. W. J. Longbridge, Sec. T. D. Murray, Treas. R. P. Stoll, Supt. Pur. Agt. & Elec. E. J. Richards, Ch. Engr. of Power Station J. McKeever. Capital \$1,000,000. Office, Main and Cheapside sts. 1 4

LEXINGTON, MO.—Lexington & Kansas City Land & Investment Co. 2 1/2 m, 4-4 g, 30 lb r, 2 c, 8 h. Pres. R. G. Estell, V. Pres. W. Z. Hickman, Sec. & Treas. Jas. Wentworth. 5 3

LIMA, O.—The Lima Electric Ry. Co. 7 m, 4-8 1/2 g 66 lb girder r, 10 c, of which 7 are m c and 3 t c T-H system. New Castle cars. Pres. A. E. Townsend, V. Pres. & Treas. W. W. Hazzard, Sec. Miss M. L. Hill, Supt. H. M. Ingold, Elec. J. C. Huffer. Capital, \$200,000. Bonds, \$100,000. 1 4

LINCOLN, NEB.—Lincoln St. Ry. Co. Elec. 50 m, 4-8 1/2 g, 40, 56, 70 lb T & girder r, 80 c, of which 40 are m c and 40 t c. T-H generators, Westinghouse and Short motors. Pres. F. W. Little, Sec. W. H. Clark Treas. & Gen. Man. C. C. Upham. Capital, \$1,200,000; authorized \$2,000,000. Bonds, \$600,000. Office 9 and K sts. 4 4

LITTLE ROCK, ARK.—Capital St. Ry. Co. (Leased and operated by City Electric Ry. Co.

The City Electric Ry. Co. (Operates Capital St. Ry.) 19.51 m, of which 1.30 is horse and 18.21 tlec. 4-8 1/2 g, 35, 38 & 43 lb T & girder r, 72 c, of which 4 are h c 28 m c and 40 t c. T-H system. Various cars. Hamilton-Corliss engines. Receivers T. W. Fordyce and A. N. Johnson, Gen. Man. Pur. Agt. & Ch. Engr. H. G. Fleming, Supt. A. S. Grooms, Ch. Engr. of Power Station R. F. Baise. Capital \$500,000. Bonds, \$600,000. 1 4

LOCKPORT, N. Y.—Lock City Electric R. R. Co. 7 m, 4-8 1/2 g, 77 lb s b r, 12 c, of which 6 are m. c. and 6 t. c. Brill and St. Louis cars. Pres. W. Goodwin, Sec. W. Spalding, Treas. F. Swift. Capital, \$150,000. 9 3

LOGANSPOUT, IND.—Logansport Ry. Co. Elec 5 1/2 m, 4 g, 40 lb T r, 8 m. c. Edison and T-H systems. St. Louis cars. McIntosh & Seymour engines. Pres. S. Spencer, Sec. & Treas. R. D. Lankford, Gen. Man. & Pur. Agt. J. T. McNary, Ch. Engr. of Power Station C. A. Herring. Office 414 1/2 Broadway. 1 4

LONDON, ONT.—London St. Ry. Co. 11 1/2 m, of which 1 is horse and 10 1/2 elec. 7 m s, 4-8 1/2 g, 35, 36 lb flat r, 36 c, of which 35 are h c and 1 m c. Westinghouse system. Toronto Ry. cars. Pres. H. A. Everett, V. Pres. E. M. Moore, Sec., Treas. & Gen. Man. S. R. Break, Supt. H. T. Smith. Capital \$100,000. Office Dundas st. East. 4 4

LONG ISLAND CITY, N. Y.—Steinway Ry. Co. of Long Island City. 32.25 m, of which 12 are horse and 20.25 elec. 4-8 1/2 g, 47, 66, 70 lb Duplex r 100 c, of which 48 horse and 52 m c, 200 h. Pres. R. T. McCabe, V. Pres. Stephen Peabody, Sec. & Treas. H. D. Babcock, Asst. Treas. W. A. Pease, Gen. Man. G. Chambers. Capital, \$2,500,000. Bonds \$1,300,000; authorized \$1,500,000. 29 Broadway, New York. 1 4

Long Island City & Newtown Ry. Co. Elec. 6 1/2 m, 4-8 1/2 g, 45-55 lb r, 27 c, 7 m. c. Edison system. Pres Isaac Buchanan, N. Y. City, Sec. Geo. S. Crawford Brooklyn, N. Y., Treas. Patrick J. Gleason, Sec Thomas Burke, Supt. Michael Conway. Capital \$150,000. Offices, 112 Front st. 3 1

LONGVIEW, TEX.—Longview & Junction St. Ry. 5 1/2 m, of which 1 1/2 are horse and 4 cable; 3-6 g 16 lb r, 2 c, 4 mu. Pres. W. S. Mayfield, Sec. & Treas. W. D. Stallings, Gen. Man. T. H. Huffman. Capital \$4,500. 3 2

LOS ANGELES, CAL.—Los Angeles Consolidated Electric Railway Co. (Controls all roads in Pasadena except Pasadena & Mt. Wilson Ry.) 87 m, of which 21 are horse and 21 cable, 3-6 and 4-8 1/2 g, 40, 45 lb girder r, 209 c, of which 34 are h c, 50 g c, 65 m c and 60 t c, 125 h, 82 mu. Westinghouse and Edison systems. Brill and Stockton C. H. & A. cars. Golden State & Miners' Iron Works engines. Pres. M. H. Sherman, V. Pres. & Gen. Man. E. P. Clark, Sec. F. V. McDonald, Supt. J. J. Akin. Office, Central ave. and Wilde st. 4 4

Main St. & Agricultural Park R. R. Co. 9.72 m, 3-6 g, 16 lb T, r, 31 c, 105 h. Pres. W. J. Brodrick, V Pres. T. E. Rowan, Sec. A. C. Taylor, Treas. Farmers' & Merchants' Bank, Supt. Wm. Hawks, Capital \$200,000, Office, 234 N. Main St. 4 4

Temple St. Cable Ry. Co. 4 1/2 m, 3-6 g, 38 lb Johnson girder r, 10 c. 10 dummies Pres. & Gen. Man. F. W. Wood, V. Pres. O. Morgan, Sec. W. N. Hamaker, Treas. Frank A. Gibson, Supt. J. Fowler. Capital \$400,000. Bonds \$100,000. Office, 129 Temple St. 4 4

LOUISVILLE, KY.—Louisville Ry. Co (includes all lines in the city). Elec. 150 m, of which 50 are horse and 100 elec, 5 g, 58 1/2, 78, 100 lb girder r, 490 c, of which 200 are h. c, 175 m c and 115 t c, 1300 mu. Gen. Elec. system. Allis, Ball and Williams engines. Pres. J. B. Speed, V. Pres. St. John Boyle, Sec. & Treas. R. H. Watts, Gen. Man. T. J. Minary, Supt. J. O. Haddock, Ch. Engr. and Elec. H. B. DuPont. Capital \$6,000,000. Bonds \$6,000,000. Office, 500 Twelfth st. 4 4

Louisville Terminal Ry. Co. 2 1/2 m, 4-9 g, 56 lb T r, 2 c, of which 1 is m c and 1 t c. Pullman cars. Pres. G. L. Danforth, Sec. & Treas. C. C. McClarty, Receiver H. V. Harris. Capital \$60,000. Office, Columbia Bldg. 3 4

LOWELL, MASS.—Lowell & Suburban Ry. Co. Elec. 49 m, 4-8 1/2 g, 45, 50, 60, 90 lb T, girder and tram r, 105 c, of which 53 are m c and 52 t c Bentley Knight, T-H & Westinghouse systems. Brill Jones, Newburyport and Stephenson cars. Pres. E. M. Tucke, V. Pres. A. Fels, Sec. & Gen. Man. P. F. Sullivan, Treas. P. Parker, Elec. G. F. Wells. Capital, \$500,000. Bonds \$1,000,000. 4 4

Lowell, Lawrence & Haverhill. (See Lawrence, Mass.)

LYNCHBURG, VA.—Lynchburg Electric Co. 5 1/2 m, 2 1/2 m s, 4-8 1/2 g, 35-42 lb T & tram r, 3 m c Eickemeyer and Westinghouse systems. Lewis & Fowler cars. Ball engines. Pres. Stephen Adams, Sec. & Treas. J. F. Lewis, Gen. Man. & Pur. Agt. C. H. Harman, Supt. B. Flanagan, Ch. Engr. & Ch. Engr. of Power Station H. S. Hall, Elec. S. Cochran C. P. Poole. Capital \$100,000. Office, Park ave. 4 4

Lynchburg & Rivermont Electric Ry. Co. 4 1/2 m, 1 1/2 m s, 4-8 1/2 g, 31, 56 lb T and girder r, 7 m c. Edison and Westinghouse systems. Brill and Lewis & Fowler cars. Green and Russell engines. Pres. J. P. Pettyjohn, V. Pres. W. I. Owen, Supt. & Pur. Agt. J. A. Humphries, Ch. Engr. of Power Station J. Barnard. Capital, \$20,000. 4 4

LYNN, MASS.—Lynn & Boston R. R. Co. (Includes Essex, Naumkeag & Lynn Belt Line Rys., and controls East Middlesex Ry. Co. under a 99 year lease. Controlled by North Shore Traction Co.) 150 m, 4-8 1/2 g, 35, 45, 50, 58, 90 lb tram, T & girder r, 475 c, of which 45 are h c, 450 h. T-H system. Pres. Amos F. Breed, V. Pres. & Clerk, E. Francis Oliver, Treas. C. Williams, Gen. Man. Elwin C. Foster, Auditor, A. S. Palfray, Pur. Agt. H. Grover, Elec. M. Hoopes. Capital, \$1,000,000. Bonds, \$1,890,500; authorized \$4,000,000. Office, 333 Union st. 4 4

North Shore Traction Co. (Controls Lynn & Boston Ry. Co.) Pres. John P. Isley, Sec. Wm. Stiles, Treas. C. Ford Stevens. Capital, \$6,000,000. Bonds, \$2,445,000. Office, Camden, N. J. 1 4

M

MACON, GA.—Consolidated St. Ry. Co. Elec. 25 3/4 m, 4-8 1/2 g, 20, 30, 40 lb T r, 37 c, of which 21 are m c and 16 t c. T-H system. 5 3

Macon & Indian Spring Electric Ry. Co. 6 1/2 m, 4-8 1/2 g, 30, 40 lb T r, 8 m c. T-H system. American and Lamokin cars. Ball engines. Pres. & Gen. Man. T. J. Carling, Sec. & Treas. J. H. Herley, Supt. & Elec. J. T. Nyhan, Pur. Agt. G. Margen. Capital \$60,000. 4 4

McKEESPORT, PA.—McKeesport & Reynoldton Pass. Ry. Co. Elec. 9 m, 5-2 1/2 g, 38 & 52 lb Johnson girder r, 16 c, of which 13 are m c and 3 t c. Gen. Elec. and Westinghouse systems. Russell engines. Pres. J. C. Smith, V. Pres. W. P. Wampler, Sec. W. B. Peters, Treas. E. F. Woods, Supt. W. L. Osborne, Pur. Agt. J. C. Smith. Capital \$180,000; authorized \$300,000. Office, 105 5th ave. 4 4

MADISON, IND.—Madison St. Ry. Co. 2 1/2 m, 4 g, 15 lb tram r, 8 c, 4 h, 16 mu. Pres. & Treas. J. W. Thomas, Sec. J. A. Mercer, Supt. J. Wendel. Capital \$13,000; authorized \$15,000. Office 301 Front st. 5 3

MADISON, WIS.—Madison City Ry. Co. Elec. 8 m, 4-8 1/2 g, 40, 50 lb T r, 13 c, of which 9 are m c and 4 t c. T-H system. St. Louis cars. Pres. W. Lamprecht, Sec. & Treas. H. C. Welch, Gen. Man. G. H. Shaw. Capital \$100,000. Bonds \$150,000. Office Main & Baldwin sts. 2 4

MALDEN, MASS.—East Middlesex St. Ry. Co. 16.13 m, 4-8 1/2 g, 35 & 40 lb T & tram & Richards r, 58 c, of which 23 are box and 35 open, 204 h. Pres Amos F. Breed, Treas. D. H. Sweetser, Supt. J. Sewall. Capital, \$300,000. Office, 35 Congress st., Boston. 12 2

MANCHESTER, N. H.—Manchester Street Ry Co. 12 m, 3 g, 35 lb tram r, 39 c, 189 h. Pres. C. Williams, Treas. C. H. Bartlett, Gen. Man. N. H. Walker. Capital, \$25,000. Office Depot St. 9 3

MANISTEE, MICH.—Manistee, Flier City & East Lake Ry. Co. Elec. 11 m, 4-8 1/2 g, 45 lb T r, 16 c, of which 8 are m c and 8 t c. Gen. Elec. system. St. Louis cars. Ide engines. Pres. & Treas. G. A. Hart, V. Pres. F. F. Davidson, Sec. W. F. Davidson, Supt. F. J. Hinton, Pur. Agt. G. A. Hart. Capital, \$150,000. Office, 418 River St. 1 4

MANKATO, MINN.—Mankato St. Ry. Co. 3 1/2 m, 3-6 g, 27 lb steel r, 5 c, of which 3 are m. c, 16 h Brownell cars. Pres. S. Lamm, Sec. & Treas. John C. Noe, Gen. Man. W. M. Farr. Capital, \$50,000. Office, 121 Hickory st., Mankato. 1 4

MANSFIELD, O.—Citizens' Elec. Ry., Lt. & Power Co. 7 1/2 m, 4-8 1/2 g, 45, 50, 60 lb girder & T r, 13 m. c. Westinghouse system. Akron, Brill and Laclede cars. Buckeye and Cooper engines. Pres. S. N. Ford, V. Pres. M. D. Harter, Sec. S. G. Cummings, Treas. & Gen. Man. R. Carpenter, Supt. S. Hennesfauth. Capital \$80,000; authorized \$125,000. Office, Power Station, N. Main st. 4 4

MARINETTE, WIS.—Marquette Gas, Elec. Lt. & St. Ry. Co. 5 m, 4-3 1/2 g, 32, 35, 52 lb T & tram r 15 c, of which 6 are h c, 7 m c and 2 t c. T-H system. St. Louis cars. Hoffman-Billings Co. engines. Pres. & Gen. Man. H. C. Higgins, V. Pres. A. C. Merryman, Sec. G. W. Hanley, Treas. J. F. Hancock Capital \$100,000. Bonds \$50,000. Office 1511 Main St. 2 3

MARION, IND.—Marion St. Ry. Co. Elec. 10 1/2 m, 4-8 1/2 g, 35, 38 lb T and girder r, 11 c, of which 6 are m c and 5 t c. T-H system. Pres. Eli Halderman, V. Pres. J. A. Halderman, Sec. & Treas. C. W. Halderman, Supt. W. C. Whitney. Capital, \$80,000. 5 3

Queen City Electric Ry. Co. 5 m, 4-8 1/2 g, 45, 52 lb T & girder r, 16 c, of which 14 are m c and 2 t c. T-H system. Jones and Pullman cars. Phoenix engines. Pres. R. B. Harrison. Sec. L. Wallace, Jr., Gen. Man. & Supt. A. A. Boyd. Capital, \$180,000. Office cor. 13th st. & Buffalo ave. Eastern office 1 Broadway, New York. 9 3

MARION, O.—Marion St. Ry. Co.

MARLBORO, MASS.—Marlboro St. R. R. Co. Elec. 3,322 m, 4-8 g, 38, 48 lb T and girder r, 9 m c Edison system. Ellis and Newbury port cars. Pres. E. R. Alley, V. Pres. S. H. Howe, Sec. F. L. Clafin, Treas. T. T. Robinson, Gen. Man. & Supt. H. B. Bradford. Capital \$50,000. Bonds \$50,000. Office 88 Maple st. 1 4

MARQUETTE, MICH.—Marquette City & Presque Isle Ry. Co. Elec. 5 m, 4-8½ g, 50 lb Johnson girder r, 5 c, of which 3 are m c & 2 t c. T-H system. Laclede cars. Hamilton-Corliss engines. Pres. F. O. Clark, Sec. M. E. Asire, Treas. J. Connolly, Supt. C. Retaillic. Capital, \$200,000. 9 3

MARSHALLTOWN, IA.—Marshalltown Light Pow. & Ry. Co. 3½ m, 3½ m s, 4-8½ g, 40 lb T r, 5 c, of which 4 are m c and 1 t c. T-H system. Brill and Pullman cars. Ide and St. Louis engines. Pres. C. D. Jones, Sec. S. B. Hovey, Treas. M. W. Hovey, Supt. J. J. Roe, Pur. Agts. Jones & Hovey, Elecn. W. G. Bowe. Capital \$250,000. Bonds \$125,000. 4 4

MARTINSBURG, W. VA.—Martinsburg St. Ry. Co. 3½ m, 40 lb T r, 6 c of which 3 are m c and 3 t c. Edison system. Brill cars. McIntosh & Seymour engines. Pres. & Treas. J. B. Wilson. Sec. J. W. Walker. Capital, \$50,000; authorized \$100,000. 9 3

MARYSVILLE, CAL.—M'ville & Yuba City St. R. R. Co. 4 m, 3-6 g, 16 lb T r, 5 c, 4 h, 14 mu. Pres. D. E. Knight, V. Pres. S. H. Bradley, Sec. W. T. Ellis, Jr Supt. L. Graves. Capital \$40,000. Office, cor. D & 1st sts. 4 4

MAYSVILLE, KY.—Maysville St. R. R. & Transfer Co. Elec. 4 m, 4-8½ g, 40 lb T r, 12 c, of which 5 are m c and 7 t c. Pres. A. M. J. Cochran, Sec. Treas. & Gen. Man. R. A. Cochran, Jr., Supt. of lines cars, &c., J. Limbrick. Capital \$30,900; authorized \$100,000. Bonds \$65,000. Office, Court st. 4 4

MECHANICSBURG, ILL.—Mechanicsburg & Buffalo Ry. Co. 7½ m, 3-10 g, 16 & 20 lb T r, 3 4-wheel open c, 4 mu. Pres. J. B. Hunter, V. Pres. H. Thompson, Sec. J. T. Fullenwider, Treas. A. T. Thompson. Capital, \$12,000. b 7 1

MEMPHIS, TENN.—Citizens' St. R. R. Co. (Owns City & Suburban Ry.) 50 m, 4-8½ g, 60, 76 lb T & girder r, 125 c, of which 65 are m c and 60 t c. Edison system. Lamokin cars. Ide engines. Pres. C. H. Ruddock, Sec. & Treas. L. R. Godwin, Gen. Man. & Pur. Agent, G. F. Jones. Office, 29 Hernandez st. 4 4

City & Suburban Ry. Co. Owned by Citizens' St. R. R. Co.) Elec. m, 4-8½ g, 45 & 52 lb T and tram r, 10 c, of which 5 are m c and 5 t c. T-H system. St. Louis cars. Pres. F. G. Jones, Sec. L. R. Godwin, Treas. R. L. Benson. Capital stock, \$150,000; authorized, \$165,000. Office, 56 E Court st. 10 2

East End Ry. Co. 5½ m steam, 4-8½ g, 35-50 lb steel T r, 8 c, 4 steam dummies. Ohio Falls cars. Baldwin engines. Pres. J. Overton, Jr. V. Pres. B. M. Stratton, Sec. J. E. Wade, Treas. W. D. Bethel, Gen. Man. J. C. Sneed. Capital \$150,000. Bonds \$150,000. Office, 310 2nd st. 9 3

Raleigh Springs Ry. Co. 11 m, 4-8½ g, 60 lb girder & T r, 15 c, of which 9 are m c and 6 t c. T-H system. Brill cars. Allis and Hampson engines. Pres. B. L. Duke, V. Pres. & Gen. Man. W. R. Hall, Sec. S. L. Finley, Treas. C. B. Buchanan. Capital \$264,100; authorized \$265,000. Office, 10 W. Court st. 10 3

MEMONIEE, MICH.—Menominee Elec. Ry. & Pow. Co. 6.9 m, 4-8½ g, 40 lb T r, 12 c, of which 8 are m c & 4 t c. Edison system. Pres. A. Spies, V. Pres. P. A. Van Bergen, Sec., Treas. & Gen. Man. E. Daniell. Capital \$110,000. Bonds \$54,000. 4 4

MERIDEN, CONN.—Meriden Horse R. R. Co 7 m, 4-8½ g, 35 & 40 lb T r, 21 c, 90 h. Pres. Geo. R. Curtis, Sec. & Treas. Chas. L. Rockwell, Capital, \$80,000. Bonds, \$70,000. 5 2

MERIDIAN, MISS.—Meridian St. Ry. Co. 6 m of which 1½ are steam and 4½ horse, 4-8½ g, 25 & 36 lb T & flat r, 10 c, 50 mu. Pres. Geo. S. Covert, Sec. J. M. Kelley, Supt. & Gen. Man. J. L. Handley. Capital, \$30,000. 3 1

Meridian Dummy Line Ry. Co. 2 m, 4-8½ g, 40 lb T r, 6 c. Pres. J. H. Wright, V. Pres. C. C. Coffee, Sec. & Treas. G. Q. Hall, Engr. N. M. Brandon. Capital \$20,000. 5 3

MERRILL, WIS.—Merrill Ry. & Lighting Co Elec. 1½ m, 4-8½ g, 38 lb Johnson girder r, 3 m c. Pres. F. P. Hixon, V. Pres. R. Werdner, Sec., Treas. & Gen. Man. E. S. King. Capital, \$20,000. Bonds, \$40,000. Office, 990 Main St. 5 3

MICHIGAN CITY, IND.—Lake Cities Electric Ry. Co. 4 m, 4-8½ g, 22 lb flat & T r, 5 c, 15 h. Laclede cars. Pres. R. B. Harrison, Sec. L. Wallace, Jr., Man. F. H. Root. Capital, \$200,000. Eastern office, 1 Broadway, New York. 1 4

MIDDLETOWN, CONN.—Middletown Horse R. R. Co. 3½ m, 4-8½ g, 36 & 38 lb Johnson & T r, 7 c, 40 h. Pres. John M. Douglas, V. Pres. A. C. Allison, Sec. & Treas. J. K. Guy, Gen. Man. & Supt. W. A. Larrabee. Capital, \$23,000; authorized, \$50,000. Office, 265 Main st. 9 3

MIDDLETOWN, N. Y.—Middletown-Goshen Traction Co. 3½ m, 4-8½ g, 60, 70 lb T and girder r, 6 m c. Gen. Elec. system. Jewett and St. Louis cars. Payne engines. Pres. J. C. Hinchliffe, V. Pres. & Elecn. M. J. Wightman, Sec. E. G. Wightman, Treas. & Gen. Man. W. B. Rockwell, Supt. F. D. La Bar, Ch. Engr. of Power Station G. Hess. Capital, \$200,000. P. O. Box 401. 5 4

MIDDLETOWN, O.—Middletown & Madison St. R. R. Co. 2 m, 4-8½ g, 45 lb girder r, 6 c, 6 h. Receiver D. B. Bnydy. Capital \$50,000. Bonds \$20,000. 4 4

MILFORD, MASS.—Milford & Hopedale St. Ry. Co. Elec. 6 m, 4-8½ g, 30 & 60 lb tram r, 6 4-wheel box c. Hopedale storage battery system. Pres. & Gen. Man. E. P. Usher, Treas. A. G. Morse. Capital \$60,000. Bonds, \$60,000. Office, 23 Court st, room 618 Boston. 9 2

MILLERSVILLE, PA.—Lancaster & Millersville St. R. R. Co. (See Lancaster, Pa.)

MILWAUKEE, WIS.—Milwaukee St. Ry. Co. 138 m, 4-8½ g, 45, 70 lb girder r, 273 c, of which 263 are m c and 10 t c, 100 h. T-H and Edison systems. Brill, Brownell, Jones and St. Charles cars. Allis engines. Pres. W. N. Cromwell, V. Pres. H. C. Payne, Sec. & Treas. C. A. Spofford, Asst. Sec. & Treas. G. O. Wheatcroft, Gen. Man. C. D. Wyman, Gen. Supt. G. W. Hommel, Asst. Supt. G. M. Kimmmerlein, Pur. Agt. C. L. Jones, Supt. of repairs, A. W. Lynn, Auditor, W. L. Mason, Elecn, O. M. Rau, Ch. of Construction of Power Station R. S. Stikeman. Office 209-11 W. Water St. 1 4

Milwaukee & Wauwatosa Electric Co. 12 m, 4-8½ g, 65 lb girder r, 4 m c. Edison system. Allis engines. Pres. C. Stuckney, Sec. & Treas. G. Pabst, Gen. Man. E. D. Hoyt, Supt. & Elecn. T. F. Grover. Capital \$75,000. Office 917 Chestnut st. 1 4

Milwaukee & Wauwatosa Motor Ry. Co. Steam. 12 m, 4-8½ g, 56 lb girder r, 9 c, of which 3 are steam and 6 t c. Pres. J. F. Petley, V. Pres. J. W. Bingham, Sec. & Treas. A. B. Meyers, Supt. H. Mortimer. Capital, \$300,000. Office, 371 Broadway. 9 3

MINNEAPOLIS, MINN.—Twin City Rapid Transit Co. Elec. (Includes Minneapolis St. Ry. and St. Paul City Ry.) Minneapolis Division. 127 m, 4-8½ g, 47, 60, 73 lb T & girder r, 500 c, of which 300 are m c, and 200 t c. Edison and T-H systems. Pres. Thos. Lowry, V. Pres. C. G. Goodrich, Treas. M. B. Koon, Gen. Man. W. J. Held, Supt. B. W. Martindale, Mast. Mech. W. Cooper, Audr. J. F. Calderwood. Capital \$5,000,000. Office, 200 3d ave. N. 5 3

St. Paul Division 120 m, of which 5 are cable and 115 elec. 4-8½ g, 40-76 lb Johnson girder & T r, 265 c, of which 25 are g c, 110 m c and 117 t c. Edison and T-H systems. Allis engines. Pres. Thos. Lowry, V. Pres. C. G. Goodrich, Sec. J. F. Calderwood, Treas. W. R. Merriam, Gen. Man. W. J. Held, Supt. F. S. Hoskins. Capital \$5,000,000. Office Globe Bldg. 4th st. 2 4

MOBILE, ALA.—Mobile St. Ry. Co. 20½ m, 16 m s, 45-70 lb T & girder r, 40 c, of which 20 are m c and 20 t c. Gen. Elec. system. Stephenson cars. McIntosh & Seymour engines. Pres. J. C. Morris, V. Pres. F. J. Gasquet, Sec. R. B. Owen, Treas. & Gen. Man. R. Semmes, Elecn. & Ch. Engr. of Power Station J. F. McAviney. Capital, \$500,000. Office, Anthony and Royal Sts. 1 4

Mobile & Spring Hill Ry. Co. Steam and Elec. on same track. 7 m, 7 m s, 4-8½ g, 35 lb T r, 10 c of which 5 are m c and 5 t c, 2 dummies. Winkler system. St. Louis cars. Rent power. Pres. W. Goodwin, V. Pres. F. Switt, Gen. Man. J. H. Bleo. 3 4

Mobile Light & Ry. Co. 7½ m, 4-8½ g, 45 lb T r, 20 c, of which 9 are m c and 11 t c. T-H and Westinghouse systems. Brill and Stephenson cars. Pres. J. Wilson, V. Pres. & Gen. Man. J. H. Wilson, Sec. A. J. Peaper. Capital, \$500,000. 9 3

MOHAWK, N. Y.—Mohawk & Ilion Horse R.R. Co. 1½ m, 4-8½ g, 30 lb flat & T r, 5 c, (Cars towed by contract.) no h. Pres. J. B. Rafer, V. Pres. C. W. Carpenter, Sec. H. D. Alexander, Treas. Supt. & Pur. Agt. R. M. Devendorf. Capital, \$15,000. No bonds. 1 4

Herkimer & Mohawk St. Ry. Co. 1½ m, 4-8½ g, 30-40 lb T r, 4 c, of which 3 are 4-wheel box and 1 is 4-wheel open, 8 h. Pres., Treas. & Man. H. D. Alexander, V. Pres. H. Delmel, Sec. E. L. Prince. Capital \$17,000; authorized \$20,000. Office Mohawk, N. Y. 1 4

MOLINE, ILL.—Moline Central St. Ry. Co. Elec. 4 m, 4-8½ g, 35, 50 & 57 lb T & Wharton girder r, 8 c, of which 4 are m c. and 4 t c. Edison and Westinghouse systems. Pres. S. H. Velle, V. Pres. L. S. McCabe, Sec. & Gen. Man. E. H. Guyer, Treas. C. F. Hemenway, Supt. G. H. Moon. Capital \$33,000; authorized \$100,000. Bonds \$17,500; authorized \$48,000. Secretary's office, Rock Island, Ill. 1 4

MONTREY, CAL.—Monterey & Pacific Grove St. Ry. & Elec. Pow. Co. 5 m, 3-6 g, 20 lb T r, 8 c, 45 h. Fitzgerald cars. Pres. O. S. Trimmer, V. Pres. H. A. Greene, Sec. & Gen. Man. J. Malarin, Treas. J. S. Metteer, Supt. A. J. Haynes. 4 4

MONTGOMERY, ALA.—Montgomery St Ry. Co 9 m, of which 2 are horse and 7 elec., 4-8½ g, 45-51 T and girder r, 9 c, of which 2 are h c and 7 m c. T-H system. New Castle cars. Armington & Sims, Atlas and Corliss engines. Pres. J. W. Dimmick, V. Pres. John D. Roquemore, Sec. J. C. Virden, Treas. G. W. Craik, Gen. Man. E. L. Coolahan, Elecn. R. P. Scott, Ch. Engr. of Power Station J. W. Lutz. Capital \$250,000. Bonds \$240,000. Office, 5½ Dexter Ave. 2 4

West End & Riverside Park Electric St. Ry. Co. 4 m, 4-8½ g, 56 lb girder & T r, 5 m c. Westinghouse system. Brill cars. Westinghouse engine, Pres. S. D. Seelye, Sec. J. N. Browder. Office 14 Dexter Ave. 2 4

MONTREAL, CAN.—Montreal St. Ry. Co. Elec 59.35 m, of which 47.35 are horse & 12 elec. 4-8½ g, 44 lb r, 200 c, 100 sleighs, 75 buses, 1200 h. Royal, Edison and Westinghouse systems. Pres. L. J. Forget, Sec. & Treas. E. Lusher, Supt. J. J. Franklin, Engr. & Acting Man., G. C. Cunningham. Capital authorized \$2,000,000. Bonds, \$300,000; authorized, \$1,000,000. 11 2

Montreal Park & Island Ry. Co. 8 m, 2 m s, 4-8½ g, 56 lb T r, 2 m c. Royal and Westinghouse systems. Brill cars. Pres. L. Beaubien, V. Pres. J. R. Thibaudeau, Asst. Sec. A. Cinq-Mars, Treas. R. L. Gault, Gen. Man. W. S. Williams, Ch. Engr. J. R. Roy, Elecn. L. E. Marple, Ch. Engr. of Power Station L. Goulland. Capital authorized, \$500,000. Bonds \$48,000. Office, 17 Place d'Armes Hill. 1 4

MT. CLEMENS, MICH.—Mt. Clemens St. Ry. Co., Ltd. 3½ m, 4-8½ g, 35 lb tram r, 5 c, 12 h. Jones and Stephenson cars. Pres. M. L. Williams, Sec. G. A. Skinner, Treas. & Gen. Man. M. Stush. Capital, \$25,000. General office, Berea, O. 9 3

MT. VERNON, N. Y.—Mount Vernon & East Chester Ry. Co. 4 m, 4-8½ g, 48 lb c. b. r, 14 c, 33 h. Pres. C. Strauss, Sec. W. H. Martens Treas. D. O'Brien, Supt. J. H. Small. Capital, \$60,000. Bonds \$75,000 1 3

MUNCIE, IND.—Muncie St. Ry. Co. (Owned by Citizens' St. Ry. Co.) 8 m steam 4-8½ g, 35 lb T r, 14 c, 4 steam motors. Baldwin and Porter motors. 5 3

Citizens' St. Ry. Co. Elec. 6 m, 4-8½ g, 48-60 lb T r, 16 c, of which 12 are m c. and 4 t c. Gen. Elec. system. St. Louis cars. Ide engines. Pres. J. S. Talley, V. Pres. C. W. Talley, Sec. G. F. McCulloch, Treas. C. F. Miller, Gen. Man. J. W. Hillings, Supt. W. C. Gotshall. Capital, \$250,000. 6 3

MUSCATINE, IA.—Muscatine Electric Ry. Co. 7½ m, 4-8½ g, 45 lb T r, 7 c of which 5 are m c and 2 t c. Gen. Elec. system. American Car Co. Ideal engines. Pres. G. W. Seever, Sec. & Treas. H. W. Seever, Gen. Man. T. S. Seever. Capital, \$300,000. 9 3

MUSKEGON, MICH.—Muskegon Ry. Co. Elec 15 m, 4-8½ g, 30, 38 lb T & girder r, 33 c, of which 18 are m c and 15 t c. Short system. Pres. F. A. Nims, V. Pres. J. W. Moon, Sec. D. P. Erwin, Treas. Wm. B. McLaughlin, Supt. F. W. Thompson. Capital \$100,000. Office, Michigan and Franklin Sts. 2 3

N

NASHUA, N. H.—Nashua St. Ry. Co. 10 m, 3 g, 35, 38 lb T, tram & girder r, 27 c, 100 h. Pres. G. H. Knowles, V. Pres. J. A. Fisher, Sec. & Treas. J. D. Chandler, Supt. H. F. Webster. Office 85 Kinsey st. 5 3

NASHVILLE, TENN.—Nashville St. Ry. Co 52 m, 5 g, 35, 45 lb T & girder r, 69 m c. Edison, T-H & Westinghouse systems. Pres. W. H. Jackson, V. Pres. T. M. Steger, Sec. & Treas. R. F. Jackson, Gen. Man. E. G. Connette. Capital, \$1,000,000. 4 4

Citizens' Rapid Transit Co. Elec. 5 m, 4-11½ g, 40, 45 lb T & girder r, 5 m c. Edison system. Stephenson cars. Pres. W. H. Mitchell, Sec., Treas. & Gen. Man. Wm. S. Jones. Capital stock \$15,000. Bonds \$75,000. 1 3

Nashville & West Nashville St. Ry. Co. Dummy Line, 7 m, 4-8½ g, 46 lb T & Johnson r, 8 c, 4 engines. Pres. L. H. Davis, V. Pres. M. S. Cockrill, Sec. J. Woods, Jr. Capital, \$81,000. 11 2

Overland Ry. Co. 9½ m of which 3 are steam and 6½ elec. 4-11½ g, 35-45 lb T & girder r, 12 c, of which 7 are m c and 5 t c 5 dummies. T-H system. St. Louis cars. Pres. & Gen. Man. F. W. Hunter, V. Pres. J. Compton, Sec. & Treas. T. Taylor, Supt. J. K. Spicer. Capital, \$125,000. Bonds, \$210,000. 9 3

Richland Ry. Co. Steam. 8 m, 2.6 m s, 4-8½ g, 46 lb girder & T r, 8 c, 4 engines. Brill cars. Baldwin engines. Pres. L. H. Davis, V. Pres. J. C. Rodemer, Sec. Treas. Gen. Man. Supt. & Pur. Agt. J. Woods, Jr. Capital, \$87,300; authorized, \$100,000. Office, 217 Union St. 4 4

NATCHEZ, MISS.—Natchez St. Ry. Co. 5 m 4-8½ g, 25-52 lb girder, flat & T r, 7 c, 20 mu. Pres & Supt. Maurice Moses, Sec. & Treas. A. Moses. Capital, \$25,000; authorized, \$100,000. Office Natchez Savings Bank. Main & Pearl sts. 4 4

Bluff City Ry. Co. 2 m, of which 800 ft. is double track incline plane, 6-2 g, incline 3-6 g remainder, 24c, 1 h, 4 mu, 4 engines. Pres. S. E. Rumble, V. Pres. R. C. Learned, Sec. & Treas. T. V. Wensei, Gen. Man. & Supt. J. C. Montleith. Capital \$100,000. Office, Main and Broadway. 1 4

NATICK, MASS.—Natick & Cochituate St. Ry. 6 m, 3 ms, 3 m, 4-8½ g, 35 lb T & flat r, 7 c, of which 5 are m c and 2 t c, 1 h. Westinghouse system. Pres. H. Harwood, Clerk F. H. Hayes, Treas. W. H. Bent, Supt. Geo. F. Keep. Capital, \$31,500. 4 4

Natick Electric St. Ry. Co. 6 m, 4-8½ g, 45 lb T r 9 m c. T-H & Short systems. Pres. A. C. Pond, Sec. & Treas. T. T. Robinson, Supt. H. W. True Capital \$60,000. 11 2

NEBRASKA CITY, NEB.—Nebraska City St Ry. Co. 7 m, 4-8½ g, 20, 40 & 45 lb T and girder r, 4 c, 2 h, 20 mu. Pres. & Gen. Man. H. H. Bartling, V. Pres. J. T. Teten, Sec. J. C. Watson, Treas. F. W. Rodenbrock. Capital, \$17,500; authorized \$50,000. 1 4

NEENAH, WIS.—Menasha & Neenah St. Ry. Co. 4 m, 4-8½ g, 35 lb tram r, 2 c, 10 h. Pres. & Treas. F. Schumacher, Sec. C. Griggs, Gen. Man. T. Schumacher. Capital, \$125,000; authorized \$300,000. Bonds, \$25,000. 4 4

NEGAUNEE, MICH.—Negaunee & Ishpeming St. Ry. Co. 4 m c. T-H system. 12 2

NEW ALBANY, IND.—New Albany Ry. Co. 7 m, 4-8½ g, 52 lb T r, 30 c, of which 17 are h c, 9 m c and 4 t c. Gen. Elec. system. St. Louis cars. Receiver J. MacLeod, Sec. & Treas. H. W. Heazlitt, Supt. G. MacLeod, Ch. Engr. R. H. Young, Elecn. B. Schlater. 4 4

Highland R. R. Co. 2 m, 3 m c. Edison system. Pres. J. F. Gebhart, Sec. & Treas. W. W. Tuley. 1 4

NEW BEDFORD, MASS.—Union St. Ry. Co. Elec. 18 m, of which 13 are horse and 5 elec. 4-8½ g, 38-80 lb girder & T r, 84 c, of which 64 are h c, and 20 m c, 229 h. T-H system. Pres. & Gen. Man. A. P. Smith, V. Pres. J. Irvine, Sec. & Treas. G. R. Phillips. Capital \$260,000. Bonds, \$100,000. Office, Five Cent Savings Bank Bldg. Purchase St. 9 3

NEW BRITAIN, CONN.—Central Ry. & Electric Co. 12 m, 4-8½ g, 56 lb T r, 18 c, of which 16 are m c and 2 t c. Gen. Elec. system. Brill cars. Allis & Harrisburg engines. Pres. A. M. Young, Sec. C. S. Landers, Treas. F. G. Platt, Gen. Man. & Supt. E. S. Breed, Capital, \$1,000,000. 4 4

NEW BRUNSWICK, N. J.—New Brunswick City Ry. Co. 4½ m, 4-8½ g, 43 lb c. b. & girder r, 13 c, 45 h. Pres. H. Congar, V. Pres. A. Le Massena, Jr., Sec. & Treas. W. B. Price, Supt. W. F. Price. Capital \$100,000. Bonds, \$25,000. Office, Sanford st. 6 3

NEW CASTLE, PA.—New Castle Electric St. Ry. Co. 2½ m, 4-8½ g, 45½-66 lb girder r, 4 m c. T-H & Westinghouse systems. New Castle cars. Pres. T. W. Phillips, V. Pres. & Gen. Man. W. M. Brown, Sec. & Treas. S. S. Hamilton, Supt. L. D. McClusky. Capital stock, \$40,000. 9 3

NEW DECATUR, ALA.—Decatur St. Ry. Co. 3½ m, 3½ m s, 4-8½ g, 20 lb T r, 5 4-wheel box c, 31 mu. St. Louis cars. Pres. W. W. Hedges, V. Pres. A. C. Hartshorne, Sec. Treas. & Gen. Man. W. A. Bibb. Capital, \$100,000. 1 4

NEW HAVEN, CONN.—Fair Haven & Westville R. R. Co. 15 m, 8½ ms, 4-8½ g, 50, 70 lb T r, 63 c Westinghouse system. Brill, Lewis & Fowler and Stephenson cars. Allis engines. Pres. & Pur. Agt. H. S. Parmelee, V. Pres. S. Hemingway, Sec. & Treas. L. Candee, Supt. Walter A. Graham. Capital, \$400,000. Office 730 Chapel st. 4 4

New Haven & Centreville Horse R.R. Co. 2½ m 4-8½ g, 46 lb c b r, 16 c, 62 h. Pres. & Gen. Man. C. Pierpont, Supt. T. R. Hull. Capital \$31,000; authorized \$40,000. Office, 1 Broadway. 9 3

New Haven St. Ry. Co. (Includes New Haven & Morris Cove Ry., State Street Horse R. R. and Whitney Avenue Ry.) 9½ m, 4-8½ g, 42, 50 lb T and c b r, 24 m c, 86 h. Pres. D. Correy, V. Pres. C. A. Warren, Sec. & Treas. G. A. W. Dodge. Office, 16 Exchange Bldg. 2 4

State Street Horse R. R. Co. (Operated by New Haven St. R. R. Co.)

Winchester Ave. R. R. Co. (Owns and operates New Haven & West Haven R. R.) 16 m, 4-8½ g, 50, 56, 60 lb T r, 65 c, of which 49 are m c and 16 t c. Short & Westinghouse systems. Brill, Jones, Lewis & Fowler, Newburyport and Stephenson cars. Westinghouse engines. Pres. A. C. Pond, Sec. Treas. & Gen. Man. I. A. Kelsey, Supt. A. E. Pond. Capital, \$40,000; authorized, \$60,000. In addition to \$100,000 of New Haven & West Haven road. Bonds, \$600,000. 1 4

NEW LONDON, CONN.—New London St. Ry. Co. 8 m, 7 m s, 4-8½ g, 48 lb T r, 13 m c. Gen. Elec. system. Newburyport cars. McIntosh & Seymour engines. Pres. E. P. Shaw, Sec. W. Learned, Treas. W. A. Tucker, Gen. Man. & Pur. Agt. E. P. Shaw, Jr., Supt. L. Bentley, Elecn. E. A. Brown. Capital \$150,000. Bonds \$110,000. 4 4

NEW ORLEANS, LA.—Canal & Chalborne R. R. Co. 13½ m, 5-2½ g, 37 45 & 5 1 lb tram & girder r, 40 box c, 20 mu. Pres. E. J. Hart, Sec. Gen. Man. & Supt. Jos. H. DeGrange. Capital, \$240,000. Bonds \$150,000. Office 6 Camp st. 1 4

Algiers & Gretna Ry. Co. 3.75 m, 3 g, 30 lb T r, 4 c, 24 h. Stephenson cars. Pres. Gen. Man. & Supt. A. M. Halliday, Sec. & Treas. W. Royal. Capital \$25,000. Bonds \$25,000. Office Canal St. Ferry. 6 3

New Orleans & Carrollton R. R. Co. Elec. 19 m, 4-8½ g, 50, 60, 70 lb T & girder r, 70 m c. T-H system. St. Louis cars. Lane & Bodley Corliss engines. Pres. J. Lennes, Sec. & Treas. Walter V. Crouch, Gen. Man. & Supt. Chris. V. Halle. Capital \$1,200,000. Bonds \$600,000. Office Jeannette and Dublin Sts. 6 3

New Orleans Traction Co. (operates Crescent City and New Orleans City & Lake Rys.) Pres. J. H. Maury, Sec. & Treas. H. Selligman, Gen. Man. H. M. Littell. 3 3

Crescent City R. R. Co. (Operated by New Orleans Traction Co.) Elec. 26 m, 5-2½ g, 35-47 lb c. b. & T r, 25 c. Pres. H. M. Littell, Sec. & Treas. A. H. Ford, Supt. B. B. Gilman. Capital, \$1,150,000; authorized, \$2,000,000. Bonds, \$140,000. 5 3

New Orleans City & Lake R.R. Co. 66 m, 5-2½ g, 42, 46 lb flat & T r, 218 c, of which 182 are h c and 36 steam coaches, 7 locomotives, 867 mu. Pres. H. M. Littell, Sec. & Treas. A. H. Ford, Supt. B. B. Gilman. Capital, \$1,500,000. Office 102 Canal st. 5 3

Orleans R. R. Co. 9½ m, 5 g, 35-40 lb T r, 32 c, 135 h, 5 mu. Pres. Gen. Man. Supt. & Pur. Agt. A. Cassard, Sec. & Treas. P. Cougot. Capital \$185,000. Authorized \$500,000. Bonds \$19,000. Office, cor. White & Laharpe sts. 1 4

St. Charles St. R. R. Co. Operates 3 lines. 11½ m, 11, 4 m s, 5-2½ g, 40 lb s b r, 66 4-wheel box c, 65 h, 218 mu. Stephenson cars. Pres. & Supt. Alden McLellan, Sec. N. Riviere. Capital, \$594,350; authorized \$1,000,000. Bonds \$120,000. Office, cor. Carondelet & 8th sts. 1 4

NEW ROCHELLE, N. Y.—New Rochelle Ry & Transit Co. 8 m, 4-8½ g, 38 lb Johnson r, 14 c, of which 10 are 4-wheel box & 4 4-wheel open, 40 h Pres. Thos. E. Crimmins, Sec. & Treas. C. Strauss Supt. Frank Ryan. 3 2

NEW WESTMINSTER, B. C.—New Westminster & Vancouver Tramway Co. 16½ m, 5 m s, 4-8½ g, 40 lb T r, 13 c of which 11 are m c and 2 t c. Edison system. Brill cars. Ball and Ide engines. Pres. D. Oppenheimer, V. Pres. B. Douglas, Sec. & Treas. L. N. Smith, Traffic Man. G. F. Gibson, Supt. G. Lubke, Ch. Engr. of Power Station J. Robertson. Capital, \$1,000,000. Office, Columbia st. 4 4

NEW WHATCOM, WASH.—Bellingham Bay Electric Ry. Co. 4 m, 4-8½ g, 40 lb T r, 6 c, of which 4 are m c and 2 t c. T-H system. Pres. H. Eldridge, 1st V. Pres. P. B. Cornwell, 2nd V. Pres. C. L. Roth, Sec. E. B. Leaming, Treas. V. A. Roeder, Gen. Man. & Supt. E. Cosgrove, Capital, \$200,000. 1 4

NEW YORK, N.Y.—Central Crosstown R. R. Co. (Includes Christopher & Tenth St.) 11.7 m, 4-8½ g, 52 lb r, 94 box c, 608 h Pres. Geo. S. Hart, V. Pres. A. Cammack, Sec. Milton I. Masson, Treas. E. Burton Hart. Office, 170 Christopher st. Capital, \$600,000. Bonds, \$250,000. 1 4

Christopher & Tenth St. R. R. Co. (Leased to and operated by Central Crosstown R. R. Co.) Pres. A. Wagstaff, V. Pres. I. Hendrix, Sec. & Treas. Geo. W. Lynch. 1 4

Dry Dock, East Broadway & Battery R.R. Co. 18½ m, 4-8½ g, 181 c, 60, 90 lb c b & girder r. Pres. R. Kelly, Sec. E. T. Landon, Treas. J. Byrns, Supt. Fred F. White. Capital, \$1,200,000. Bonds, \$840,000. Office, 605 Grand st. 1 4

Eighth Ave. R.R. Co. 20 m, 4-8½ g, 60 lb r, 165 c of which 125 are box and 40 open, 1155 h. Pres. Geo. Law, V. Pres. Jacob Hays, Sec. & Treas. James G. Affleck, Supt. E. R. Sherman. Capital \$1,000,000. Bonds \$1,000,000. Office, Eighth Ave. & 50th st. 1 4

Forty-second St., Manhattanville & St. Nicholas Avenue Ry. Co. 24.20 m, 4-8½ g, 47-60 lb r, 119 c, 1,023 h. Pres. John S. Foster, Sec. C. F. Naething, Treas. Jacob Fleischhauer, Supt. S. M. Slsson. Capital \$2,500,000. Bonds, \$2,700,000. Office, 118 E. 42 st. 1 4

Manhattan (Elevated) R. R. Co. 100 m, 36 m s, 4-8½ g, 50-90 lb T r, 1076 c, 334 locomotives. Pres. G. J. Gould, Sec. & Treas. D. W. McWilliams, Gen. Man. & 2nd V. Pres. F. K. Hahn, Auditor E. F. J. Gaynor, Ticket Agt. C. P. McFaddin, Ch. Engr. J. Waterhouse, Asst. Engr. L. Moss, Master Mechanic T. W. Peoples. Capital \$29,902,980; authorized \$30,000,000. Bonds \$19,675,000. Office 71 Broadway. 1 4

Metropolitan St. Ry. Co. (Includes Chambers St. & Grand St. Ferry R. R. Co., Houston St., West St., and Pavana Ferry R. R., Broadway R. R. Co., and South Ferry R. R. Co., also operates Broadway & Seventh Ave., Sixth Ave. Ninth Ave. and 23d St. Rys.) 13 m, owned, 23 m, leased, 4 8½ g, 60 lb c b r, 45 box c, 370 h. Pres. & Gen. Man. H. H. Vreeland, 1st V. Pres. D. B. Hasbrouck, 2d V. Pres., H. A. Robinson, Sec. C. E. Warren, Treas. H. S. Beattie, Pur. Agt. A. C. Tully. Capital, \$8,200,000. Bonds, \$500,000. Office, 621 Broadway. 4 4

Broadway & Seventh Ave. R.R. Co. (Leased to Metropolitan St. Ry. Co.) 23 m, of which 10 are cable and 13 h. 4-8½ g, 47-60 lb r, 225 c, of which 160 are g c and 65 h c. Laclede and Stephenson cars. Penna. Iron Works engines. Pres. E. A. Wickes, V. Pres. J. P. O'Brien, Sec. & Treas. J. W. Ritchie, Supt. Henry A. Newell, Pur. Agt. A. C. Tully, Ch. Engr. F. S. Pearson Capital, \$2,100,000. Bonds, \$1,500,000, first consolidated mortgage. Office, 621 Broadway. 4 4

Ninth Ave. R. R. Co. (Leased to Metropolitan St. Ry. Co.) 16 m, 4-8½ g, 45 & 60 lb T r, 60 c, of which 40 are 4-wheel box and 20 4-wheel open, 542 h. Pres. Geo. Law, V. Pres. Jacob Hays, Sec. & Treas. J. G. Affleck. Capital \$800,000. No bonds. Offices 814 Ninth Ave. 4 4

Sixth Ave. R.R. Co. (Leased to Metropolitan St. Ry. Co.) 9½ m, 4-8½ g, 60 lb r, 122 c, of which 102 are box and 20 open, 925 h. Pres. Frank Curtiss, Sec. & Treas. E. H. Garrison. Capital \$1,500,000. Bonds, \$500,000. Office 768 6th ave. 7 3

Twenty-third St. Ry. Co. (Leased to Metropolitan St. Ry. Co.) 14½ m, 4-8½ g, 50 lb c b & tram r, 101 c, 946 h. Brill, Jones, Lewis & Fowler, Pullman and Stephenson cars. Pres. H. H. Vreeland, V. Pres. D. B. Hasbrouck, Sec. C. E. Warren, Treas. H. S. Beattie. Capital, \$600,000. Bonds, 400,000; Broadway Surface Bonds, \$375,000. Office, 621 Broadway. 4 4

Metropolitan Crosstown Ry. Co. (Operates 42d St. & Grand St. Ferry R.R. and Central Park, North & East River R.R.) 4-8½ g, 60 lb girder r, 30 c. Pres. E. H. Vreeland, V. Pres. D. B. Hasbrouck, Sec. C. E. Warren, Treas. H. S. Beattie. Pur. Agt. A. C. Tully. Capital, \$300,000. Bonds, 1st mtg., \$600,000; 2d mtg., \$300,000. Office, 621 Broadway. 1 4

Central Park North & East River R.R. Co. (Leased to Metropolitan Crosstown Ry. Co.) 26 m, 4-8½ g, 60 lb r, 196 c, of which 136 are box and 60 open, 1,157 h. Pres. H. H. Vreeland, V. Pres. D. B. Hasbrouck, Sec. C. E. Warren, Treas. H. S. Beattie, Supt. J. Sittler. Office, 621 Broadway. Capital, \$1,800,000. Bonds, \$1,200,000. 4 4

Forty-second Street & Grand Street Ferry R.R. Co. (Leased to Metropolitan Crosstown Ry. Co.) 10.25 m, 4-8½ g, 60 to 64 lb r, 72 c, of which 52 are box and 20 open, 480 h. Pres. H. H. Vreeland, V. Pres. D. B. Hasbrouck, Sec. C. E. Warren, Treas. H. S. Beattie. Pur. Agt. A. C. Tully. Capital, \$748,000; authorized, \$750,000. Bonds, \$236,000. Office, 621 Broadway. 4 4

Metropolitan Traction Co. (Controls Metropolitan St. Ry., Broadway & Seventh Avenue, Ninth Avenue, Sixth Avenue, and 23d Street railways, which are operated by the Metropolitan St. Ry. Co. Also controls Metropolitan, Crosstown, Central Park, North & East River, and 42d Street & Grand Street Ferry Rys., which are operated by Metropolitan Crosstown R. R. Co.) Pres. C. R. Henderson, V. Pres. P. A. B. Wildener, Sec. & Treas. C. E. Warren, Ch. Engr. F. S. Pearson. Capital, \$30,000,000. Office, 621 Broadway. President's office Mutual Life Bldg., 32 Liberty st. 4 4

New York & Harlem R.R. Co. 17½ m, 87-12 m s, 4-8½ g, 47-64, lb r, 187 box c, 1,646 h. Pres. C. Vanderbilt, V. Pres. C. C. Clarke, Sec. & Treas. Ed. V. W. Rossiter, Supt. Alfred Skitt, Pur. Agt. A. Bourn. Capital, \$10,000,000. Bonds, \$12,000,000. Office, Grand Central Depot 4 4

North & East River R. R. Co. 3 m, 1½ m s, 4-8½ g, 45 lb, s-b r, 12 c, 54 h. Pres. E. T. McLaughlin, V. Pres. Gen. Robert Avery, Sec. F. C. Gaffney, Treas. T. F. Carney, Supt. W. Farrell. Capital, \$300,000. Bonds, \$125,000. Office, 232-1 Front St. 1 4

Second Ave. R.R. Co. 28 m, 4-8½ g, 60 lb r, 352 c, of which 169 are box and 168 open h c, and 15 are Waddell-Entz storage cars, 1938 h. Pres. G. S. Hart, V. Pres. C. F. Cox, Sec. J. B. Underhill, Treas. H. E. Doremus. Capital \$1,860,000, authorized \$2,500,000. Bonds \$1,750,000. Office, Second ave. cor. 96th st. 1 4

Third Ave. R. R. Co., 28½ m cable, 14 m s, 4-8½ g, 80 lb r 568 c, of which 256 are h c & 60 t c, 252 g c; 1600 h. Pres. A. J. Elias, V. Pres. Henry Hart, Sec. Alfred Lazarus, Treas. J. Beaver, Supt. John H. Robertson, Ch. Engr. R. P. Tomassek, Ch. Eng. of Power Station C. G. Bliss. Capital, \$7,000,000. Bonds \$5,000,000. Office, 65th St. & Third ave. 1 4

Twenty-eighth & Twenty-ninth sts. R. R. Co. 9.13 m, 4-8½ g, 60 lb steel grooved r, 40 c. Pres. J. H. Crane, V. Pres. D. D. Conover, Sec. D. J. Appar Treas. J. H. Davis. Capital \$500,000. Bonds, \$500,000. Office, 45 William st. 4 4

Union Ry. Co. of New York City. Elec. 24 m, 4-8½ g, 72½, 90 lb girder r, 110 m c. T-H and Westinghouse systems. Gilbert and St. Louis cars. Cooper engines. Pres. Gen. Man. & Pur. Agt. E. A. Maher, V. Pres. C. A. Stadler, Sec. & Treas. T. W. Olcott, Supt. J. Carrigan, Elecn. F. A. Wardlaw, Ch. Engr. of Power Station E. W. Van Brunt. Capital, \$3,000,000. Bonds, \$2,000,000. Office, 2389 3d ave. 4 4

NEWARK, N. J.—Newark Passenger Ry. Co. (Includes Rapid Transit Ry. and controlled by Consolidated Traction Co. of New Jersey), 75 m, of which 45 are horse and 30 elec, 5-2½ g, 50, 57 & 60 lb tram & girder r, 277 c, of which 200 are h c, 5 c and 77 m c, 300 h, T-H and Edison systems. Office, Prudential Building. 9 2

Consolidated Traction Co. of New Jersey. (Controls Newark Passenger and Jersey City & Bergen railroads) Pres. E. F. C. Young, J. O'Rourke, Sec. T. J. George, Treas. R. F. Bower, Gen. Man. D. Young, Audr. W. J. Ramsey, Pur. Agt. C. H. Thorne, Supts. (Newark) D. W. Sharpe, (Jersey City), T. Sayre, Roadmasters (Newark), A. W. Pratt, (Jersey City), J. W. Leahy. 6 3

Newark & S. Orange, St. Ry. Co. Elec. 13 m, 5-2½ g, 90 lb girder r, 30 m. c. Westinghouse system. Pres. E. S. Ward, V. Pres. G. Kreuger, Sec. & Treas. W. Scheerer, Gen. Man. & Supt. A. Radel. Capital \$1,500,000. Bonds, \$1,500,000. Office S. Orange Ave and S. 19th st. 1 3

NEWARK, O.—Newark & Granville Elec. St. Ry. Co. (Includes Newark City Ry.) 13 m, 4-8½ g, 30-51½ lb T & girder r, 22c, of which 10 are m c & 12 t c. T-H and Edison systems. Gilbert & Lamokin Cars. Hamilton and Russell & Taylor engines. Pres. R. Scheidler, V. Pres. J. A. Flory, Sec. & Gen. Man. W. C. Christian, Treas. F. A. Crane, Supt. H. R. Scheidler, Pass. Agt. W. C. Weiss. Capital, \$73,000. Authorized \$100,000. Bonds \$120,000. 9 3

NEWBURGH, N. Y.—Newburgh St. Ry. Co. 5 m 4-8½ g, 40 lb T r, 13 c, of which 11 are box and 2 open 72 h. Pres. M. H. Hirschberg, V. Pres. J. C. Adams Sec. & Treas. Wm. Moores, Gen. Man. & Supt. W. P. Rayland. Office, 246 Broadway. 1 4

NEWBURYPORT, MASS.—Newburyport & Amesbury St. R. Co. 19,729 m, 18,046 m s, 4-8½ g, 35, 40 lb T and flat r, 41 c of which 24 are m c and 17 t c, 6 h. T-H system. Ellis and West End cars. McIntosh & Seymour engines. Pres. & Treas. Chas. Odell, Sec. R. G. Calaf, Supt. & Pur. Agt. C. F. Dennis, Ch. Engr. A. G. Dickerman, Ch. Engr. of Power Station O. W. Morrison. Capital, \$90,000. Bonds, \$350,000. Office, 32 Market sq. 4 4

NEWPORT, KY.—Cincinnati, Newport & Covington Ry. Co., Newport Division. (See Covington, Ky.)

NEWPORT, R. I.—Newport St. Ry. Co. Elec. 4,17 m, 4-8½ g, 45 lb T r, 15 c, of which 9 are m c and 6 t c. T-H system. Ellis and Newburyport cars. Pres. & Gen. Man. A. C. Titus, Sec. & Treas. Francis Burdick, Asst. Man. R. G. Lee, Elec. G. E. Levan. Capital \$101,000; authorized, \$110,000. Bonds, \$50,000. Office, 237 Spring st. 4 4

NEWTON, MASS.—Newton St. Ry. Co. Elec. 8,280 m. Capital \$23,725. c r 1 4

NEWTONVILLE, MASS.—Newton & Boston St. Ry. Co. 5,11 m, 5,11 m s, 4-8½ g, 56 lb T r, 16 m. c. Gen. Elec. system. Hollingsworth and Trimble cars. Westinghouse engines. Pres. Gen. Man. & Pur. Agt. H. B. Parker, V. Pres. A. R. Mitchell, Sec. R. A. Sears, Treas. J. L. Richards, Supt. F. G. L. Henderson, Ch. Engr. & Ch. Engr. of Power Station G. H. Leonard, Elec. L. H. McLain. Capital, \$100,000; authorized, \$250,000. Bonds, \$50,000. 4 4

Newtonville & Watertown St. Ry. Co., Elec. 2,142 m. Capital \$50,000. c r 1 4

NIAGARA FALLS, N. Y.—Niagara Falls & Suspension Bridge Ry. Co. Elec. 13 m, 4-8½ g, 60 lb girder r, 23 c, of which 15 are m c and 8 t c. T-H system. Pres. C. B. Gaskill, V. Pres. H. L. Taylor, Sec. & Treas. Chas. B. Hill, Supt. J. C. Brewster. Capital, \$400,000; Bonds, \$400,000. 4 4

NIAGARA FALLS, ONT.—Niagara Falls, Wesley Park & Clifton Tramway Co. 4 m, 4-8½ g, 30 & 45 lb T r, 10 c, of which 8 are 4-wheel box & 2 4-wheel open, 25 h. Pres. J. N. Mooney, Treas. John N. Hayward, Supt. C. Black. Capital \$50,000. 6 3

Niagara Falls, Park & River Ry. Co. Elec. 14 m, 4-8½ g, 56 lb T r, 40 c, of which 24 are m c and 16 t c. T-H system. Pres. E. B. Oslter, V. Pres. W. Hendrie, Sec. & Treas. R. A. Smith. Gen. Man. R. Mackenzie. 4 4

NILES, O.—Mineral Ridge & Niles Electric Ry. Co. 3½ m, 3½ m s 4-8½ g, 45 lb T & girder r, 4 m. c. Edison system. American cars. Allis-Corliss engines. Receiver E. J. Ohi, Elec. E. H. Bowman, Ch. Engr. of Power Station, H. Williams. Capital, \$50,000. Bonds, \$40,000. 4 4

NORFOLK, NEB.—Norfolk St. Ry. Co. 4½ m 4-6 g, 16 lb T r, 5 c, of which 4 are h c and 1 m c, 10 h, 4 mu. Edison system. Pres. R. A. Stewart, V. Pres. Dr. A. Bear, Sec. N. A. Rainbolt, Treas. C. B. Burrows. Capital, \$51,000. Office, 400 Main st. 9 2

NORFOLK, VA.—Norfolk City R. R. Co. 5½ m 5-2 g, 45, 50, 65 lb tram, girder & s b r, 32 c, 125 h. Pres. W. H. Taylor, Sec. & Treas. H. C. Whitehead Supt. Jas. J. Ferris. Capital, \$100,000; Bonds, \$125,000. Office, 125 Main st. 9 3

The Suburban & City Ry. & Improvt Co. 3½ m, 3 ½ m s, 5-2 g, 80 lb girder r, 15 c, of which 9 are 4-wheel box and 6 4-wheel open, 56 h. Pres. Jas. W. McCarrick, Sec. & Treas. H. C. Whitehead, Supt. E. W. Savage, Elec. J. F. Macartney. Capital \$50,000. Bonds \$75,000. Office, 125 Main st. 4 4

NORRISTOWN, PA.—Citizens' Pass. Ry. Co. 6m, 6 m s, 5-2½ g, 60 lb girder r, 8 m c. Curtis system Lewis & Fowler cars. Pres. John Singluff, V. Pres. J. W. Shepp, Sec. Geo. R. Kite, Treas. G. Shannon, Supt. I. D. B. Spatz. Capital \$80,000. 4 4

Norristown, Bridgeport & Conshohocken Traction Co. (Leases Norristown Pass. Ry. and Montgomery County Pass. Ry.) 5½ m, 5-2½ g, 47, 66 lb girder r, 11 c, of which 6 are closed and 5 open. Westinghouse system. Buckeye engine. Pres. C. Gallagher, V. Pres. M. Willis, Sec. & Treas. E. S. Perot. Gen. Supt. I. H. Passmore. Capital \$125,000. Office Trust Bldg. 4 4

Norristown Pass. Ry. Co. (Operated by Norristown, Bridgeport & Conshohocken Traction Co.) 4 m, 5-2½ g, 45 & 50 lb tram & girder r, 9 c, of which 8 are 4-wheel box and 1 4-wheel open, 23 h, 6 mu. V. Pres. C. Gallagher, Sec. & Treas. H. Freedley, Supt. Louis Heck. Capital, \$45,000. 4 4

NORTH ABINGTON, MASS.—Rockland & Abington St. Ry. Co. 11 m, 11 m s, 4-8½ g, 45, 56, 60 lb T & girder r, 14 m. c. Gen. Elec. system. Jones cars. Pres. E. P. Reed, V. Pres. M. N. Arnold, Sec. G. W. Kelley, Treas. C. N. Cobb, Gen. Man. Supt. Pur. Agt. & Elec. A. H. Walcott, Ch. Engr. C. W. Howland, Ch. Engr. of Power Station L. McCarty. Capital \$120,000. 4 4

NORTH ADAMS, MASS.—Hoosac Valley St. Ry. Co. Elec. 6 m, 4-8½ g, 40 lb T & flat r 13 c, of which 7 are m c and 6 t c T-H system. Brill and Newburyport cars. Fitchburg engines. Pres. & Treas. C. Q. Richmond, Gen. Man. H. A. Fitzsimons. Capital \$50,000. 4 4

NORTH TONAWANDA, N. Y.—Tonawanda Electric R. R. Co. of Tonawanda, Erie Co. 6 m, 4-8½ g, 45 lb T & girder r, 8 c, of which 3 are m. c. and 5 t c. T-H system. Brill cars. Noye engines. Pres. E. H. Butler, V. Pres. M. Nellany, Sec. & Treas. C. M. Howard, Gen. Man. G. P. Smith, Supt. H. R. Wellman. Capital, \$125,000; authorized \$250,000. 4 4

Tonawanda St. R. Co. Elec. 3½ m, 4-8½ g, 56, 62 lb T & girder r, 5 m c. T-H system. Pres. & Gen. Man. G. P. Smith, Sec. A. J. Hathaway, Treas. G. C. Herschell, Supt. H. R. Wellman. Capital \$250,000. Bonds \$40,000. Office, Main st. 1 4

NORTH WOBURN, MASS.—North Woburn St. Ry. Co. 7.5 m, 35, 48 lb tram & T r, 12 c, 53 h. Pres. A. F. Breed, Lynn, Mass., Sec. & Treas. D. H. Sweetser, Supt. W. L. Brockway. Capital \$100,000; authorized \$200,000. 4 4

NORTHAMPTON, MASS.—Northampton St. Ry. Co. 4½ m, 4 8½ g, 40, 58 lb T r, 19 c of which 12 are m c and 7 t c, 2 h. T-H system. Jones cars. Hamilton-Corliss engines. Pres. J. Olmstead, Treas. D. N. Winter, Supt. E. C. Clark Jr., Ch. Engr. of Power Station T. J. Murray. Capital \$150,000. Bonds \$25,000. 1 4

NORWALK, CONN.—Norwalk Horse R. R. Co. 3½ m, 4-10 g, 56 lb T r, 8 c, 43 h. Pres. E. I. Hill, Sec. W. F. Acton, Supt. Edwin G. Hoyt. Capital \$50,000 1 4

Norwalk Tramway Co. Elec. 3½ m, 4-8½ g, 60 lb T r, 4 m c. Pres. G. N. McKibbin, Sec. G. W. Mansfield, Supt. G. M. Pierce. Capital \$70,000. Office South Norwalk. 4 4

NORWICH, CONN.—Norwich St. Ry. Co. 14½ m, 13 m s, 4-8½ g, 45, 50 lb T r, 46 c, of which 26 are m c and 20 t c, 5 h. Gen. Electric system. Newburyport cars. Pres. C. P. Cogswell, Sec., Gen. Man. & Pur. Agt. E. P. Shaw, Jr., Treas. W. A. Tucker, Electrician W. L. Adams, Ch. Eng. Power Station Geo. Bennett. Capital \$250,000; authorized \$600,000. Bonds, \$255,000. 1 4

OAKLAND, CAL.—Consolidated Piedmont Cable Co. Elec. 24 m, of which 6 are horse, 13 cable and 5 elec. 3-6 & 5 g, 25 & 40 lb girder r, 52 c, of which 17 are h c, 25 g c, 5 m c and 5 t c, 120 h. Pres. E. A. Heron, V. Pres. J. L. Bradbury, Gen. Man. & Supt. H. P. Garthwaite. Capital, \$1,500,000; authorized, \$2,000,000. Bonds, \$600,000. 6 3

Central Avenue Ry. Co. Elec. 5½ m, 2½ m s, 3-8 g, 40 lb compound r, 6 m c. T-H system. Ingler & Atkinson cars. S. F. Tool Co. engines. Pres. W. F. Beck, V. Pres. A. H. Clough, Sec. Treas. & Gen. Man. W. F. Rudolph, Supt. & Ch. Engr. S. B. Lennegan, Elec. P. J. Brandt. Capital, \$19,000, authorized, \$1,000,000. Office 12th and Kirkman sts. 1 4

East Oakland St. Ry. Co. Elec. 6 m, 4-8½ g, 45 lb combination r, 11 m c. T-H system. Pres. C. E. Wilson, V. Pres. & Gen. Man. E. P. Vandervoek, Supt. A. G. Briggs. Capital \$250,000. Office, 458 9th St. 4 4

Highland Park & Fruit Vale R. R. 10½ m, 6 m s, 4-8½ g, 40-50 lb girder & T r, 8 double deck m c. T-H system. Pullman cars. Pres. E. C. Sessions, Sec. & Treas. F. J. Woodward, Gen. Man. Pur. Agt. & Supt. J. E. Morris, Elec. H. E. Richards. Capital, \$500,000. Bonds, \$150,000. Office 118 Broadway. 1 4

Oakland Consolidated St. Ry. Co. Elec. 36 m, 16 m s, 3-6 g, 35, 40 lb girder r, 28 m c. T-H system. Pres. F. M. Smith, V. Pres. J. W. Coleman, Sec. & Supt. A. K. Grimm, Treas. 1st Nat. Bank, Elec. J. Sparks, Ch. Engr. of Power Station J. A. Munroe. Capital, \$1,000,000. Bonds, 500,000. Office 47th st & Grove. P. O. Box 126. 1 4

Oakland R. R. Co. (Owned by Southern Pacific Ry. Co. of San Francisco) Elec. 16.2 m, of which 5.2 are cable and 11 elec. 3 g, 40, 72 lb girder r, 32 c of which 12 are cable and 20 m c. T-H system. Supt. Geo. Y. Loring. Office, San Pablo and 20th sts. 6 3

Oakland, San Leandro & Haywards Ry. Co. 25 m, of which 2 are horse and 23 elec. 19 m s, 3-6 g, 35, 40 lb T and girder r, 33 c, of which 2 are h c and 31 m c. T-H system. Carter cars. Ball and McIntosh & Seymour engines. Pres. H. W. Meek, V. Pres. W. J. Landers, Sec. A. L. Stone, Treas. C. E. Palmer, Supt. F. M. Leland, Ch. Engr. E. DeGroat. Capital, \$500,000. Bonds, \$250,000. Office, 908 Broadway. 1 4

OGDEN, UTAH.—Ogden City St. Ry. Co. Elec. 10 m, 4-8½ g, 30 lb T r, 20 c, of which 12 are m c and 8 t c. Pres. W. H. Rowe, V. Pres. H. M. Jarvis, Sec. & Supt. R. M. Spivey, Treas. S. L. Conklin. Capital, \$350,000. Office Power House, 1920 Washington Ave. 4 4

OGDENSBURG, N. Y.—Ogdensburg St. Ry. Co. 5 m, 4-8½ g, 25 lb T r, 7 c, 19 h. Pres. W. H. Daniels, V. Pres. & Gen. Man. H. B. Howard, Sec. E. A. Newell, Treas. A. E. Smith. Capital, \$30,000. 4 4

OIL CITY, PA.—Oil City St. Ry. Co., 2½ m, 2 m s, 4-8½ g, 56 lb girder r, 6 m c. Curtis system, New Castle cars. Pres. & Gen. Man. J. B. Smithman, Sec. G. S. Bredin, Treas. G. W. Parker. Capital \$52,000; authorized \$90,000. 12 3

OLEAN, N. Y.—Olean St. Ry. Co. 2.45 m, 3-6 & 4-8½ g, 25-50 lb T r, 4 box c, 14 h. Pres. & Supt. John Fobes, V. Pres. C. S. Carey, Sec. & Treas. G. H. Strong. Capital, \$16,000. Office, 264 Union st. 11 2

OLYMPIA, WASH.—Olympia Light & Power Co. Elec. 4 m, 4-8½ g, 40 lb T r, 5 m c. T-H system. Brill and Pullman cars. Water power. Pres. G. D. Shannon, V. Pres. R. Frost, Sec. & Gen. Man. A. H. Chambers, Supt. C. McClelland, Pur. Agt. T. B. Faulker, Elec. H. C. Ranft, Ch. Engr. of Power Station. F. M. Cooper. Capital, \$250,000. Bonds \$150,000. Office 5th & Chestnut Sts. 4 4

OMAHA, NEB.—Omaha St. Ry. Co. Elec. 89½ m, of which 18 are horse 6½ cable and 65 elec. 4-8½ g, 45, 58½ lb T & girder r, 270 c of which 42 are h c, 29 g c, 36 m c and 110 t c, 75 h. T-H, Edison and Westinghouse systems. American, LaClede, Pullman and Stephenson cars. Allis, Wright and Westinghouse engines. Pres. Frank Murphy, V. Pres. Guy C. Barton, Sec. D. H. Goodrich, Treas. W. W. Marsh, Gen. Man. W. A. Smith, Supt. F. A. Tucker. Capital, \$5,000,000. Bonds, \$2,250,000. 4 4

Dundee Place Car Line. 1½ m, 4-8½ g, 35 lb T r 2 m c. Detroit system. Pres. R. W. Patrick, Man. W. A. Smith. 9 3

East Omaha St. Ry. Co., 4.2 m, 4-8½ g, 40, 45 lb. T and girder r, 14 c, of which 7 are in c and 7 t c. Westinghouse system. Pres. A. S. Potter, V. Pres. D. Smith, Sec. & Gen. Man. A. B. De Long, Treas. H. W. Yates. Office 16th and Furman Sts. 3 4

ONEIDA, N. Y.—Oneida Ry. Co. 1½ m, 1 m s, 4-8½ g, 47 lb c, br, 3 box c, 10 h. Stephenson cars. Pres. W. E. Northrup, Sec. Treas. & Gen. Man. H. C. Stone, Supt. G. Leggett. Capital, \$13,500; authorized \$15,000. 1 4

ONEONTA, N. Y.—Oneonta St. R. R. Co. 2½ m 4-8½ g, 35 & 38 lb T & flat r, 4 c of which 3 are 4-wheel box and 1 4-wheel open, 12 h. Pres. & Supt. Geo. I. Wilber, V. Pres. D. F. Wilber, Sec. & Treas. T. D. Tallmadge, Jr. Capital \$20,000. 4 4

ONTARIO, CAL.—Ontario & San Antonio Heights Ry. Co. 8½ m, 4-8½ g, 30 lb T r, 24-wheel open c, 4 h. Pres. C. E. Harwood, V. Pres. & Gen. Man. C. Frankish, Sec. W. E. Collins. Capital \$150,000. 9 3

ORANGE, N. J.—Orange Crosstown and Bloomfield St. Ry. Co. 7 m, 5-2 g, 38 lb Johnson girder rail, 13 box c, 86 h. Pres. & Gen. Man. Francis M. Eppley, Sec. Thos. Marsh, Treas. Edw. A. Pearson Supt. J. Waller. Capital stock, \$60,000; bonds, \$60,000 4 4

Suburban Traction Co., 7 m, of which 3½ are horse and 3½ elec. 7 m s, 5-2½ g, 80 lb girder r, 21 c of which 13 are h c, and 5 m c, 50 h. Brill & Stephenson cars. Pres. & Pur. Agt., F. W. Child, V. Pres. J. L. Seward, Sec. A. W. Kissam, Treas. A. P. Foster, Supt. W. Henkerson, Jr., Elec. H. F. Tildman. Capital, \$1,500,000. Bonds, \$400,000. 4 4

Orange Mountain Cable Co. 8000 ft, 8 g, 56 lb. m. p. r, 2 c. Roebbling engines. Pres. A. Z. Mason, V. Pres. & Gen. Man. F. W. Child, Sec. Treas. & Pur. Agt. W. Kissam, Supt. W. Condon. Capital, \$350,000. Bonds, \$350,000. Office Orange Nat. Bank Bldg. 1 4

ORANGEBURG, S. C.—Oranburg City St. Ry. Co. 2½ m, 4-8½ g, 40 lb T r, 6 c, 2 h, 4 mu. Pres. & Gen. Man. J. W. H. Duker, V. Pres. N. H. Bull, Sec. & Treas. B. H. Moss. Capital, \$11,000. 1

ORLANDO, FLA.—Orlando St. Ry. 3 m, 4-9 g, 30, 40 lb T r, 7 c, 5 mu. Pres. & Gen. Man. H. W. Moulton, Sec. J. M. Cheney, Treas. M. D. Brooks. Capital \$10,000; authorized \$50,000. 3 4

OSHKOSH, WIS.—Oshkosh St. R. R. Co. 8½ m, 4-8½ g, 30 lb, tram r, 13 c, of which 10 are 4 wheel box & 3 4-wheel open, 57 h. Pres. Chas. Barber, V. Pres. J. H. Porter, Sec. & Treas. J. H. Jenkins, Gen. Man. & Supt. C. E. Montgomery. Office, 222 Main st. 4 4

OSKALOOSA, IA.—Oskaloosa St. Ry. & Land Co 5 m, 4 g, 16, 40, 50 lb tram, T & girder r, 4 c, 14 h. Minneapolis and St. Louis cars. Pres. W. M. Peatman, Sec. C. Winter, Treas. W. G. Clark, Supt. J. M. Powell. Capital \$30,000. Office, 100 High Ave., West. 9 3

OSWEGO, N. Y.—Oswego St. Ry. Co. 7½ m, 4 m s, 4-8½ g, 51-72 lb T & girder r, 12 c, of which 7 are m c and 5 t c. T-H system. Brill cars. Power Is rented. Pres. & Pur. Agt. M. E. Graves, V. Pres. L. Clancy, Sec. W. A. Fineran, Treas. & Man. M. McGowan, Supt. & Ch. Engr. F. E. Prichard. Capital, \$125,000. Office, East First & Bridge sts. 1 4

OTTAWA, ILL.—Ottawa Electric St. Ry. 8 m 4-8½ g, 56 lb girder r, 8 motor and 4 trailer, T-H system. Pres. T. J. Evans, Sec. & Treas. T. P. Bailey Gen. Man. H. A. Kin. Capital, \$100,000. 6 2

OTTAWA, ONT.—Ottawa Electric Ry. Co. 20 m 10 m s, 4-8½ g, 53, 56, 60 lb girder & T r, 48 m c, Westinghouse systems. Ottawa cars. Water power. Pres. J. W. McRae, V. Pres. G. P. Brophy, Sec. & Treas. J. D. Fraser, Gen. Man. T. Ahearn, Supt. J. E. Hutcheson. Capital, \$500,000. Office, 337 Albert St. 1 4

OTTUMWA, IA.—Ottumwa Electric Ry. Co. 7.25 m, 7 m s, 4-8½ g, 38 & 40 lb girder & T r, 12 c, of which 11 are m c and 1 t c. Gen. Elec. and Westinghouse systems. Pullman and St. Louis cars. Allis and Ball engines. Pres. & Gen. Man. W. R. Daum, V. Pres. J. B. Sax, Sec. T. H. Eaton, Treas. C. F. Blake, Supt. of Car Service, E. M. Campbell, Ch. Engr. & Ch. Engr. Power Station W. M. Evans, Elec'n. W. J. Jones. Capital, \$300,000; authorized, \$500,000. Bonds \$200,000. Office, 102 S. Market st. 6 3

OWENSBORO, KY.—Owensboro City R. R. Co. Elec. 10 m, 4-8½ g, 40 lb T r, 25 c, of which 12 are m c and 13 t c. T-H system. Stephenson cars. Harrisburg engines. Pres. W. E. Whitley, Sec. R. A. Miller. Treas. J. H. Parish, Gen. Man. J. N. Ainsop, Supt. R. H. Neely. Capital \$50,000. Bonds, \$25,000. 9 3

P

PADUCAH, KY.—Paducah St. Ry. Co. Elec. 8½ m, 4-8½ g, 35, 54 lb T r, 22 c, of which 14 are m c and 8 t c Edison system. Pres. Geo. C. Thompson, V. Pres. C. Dallam, Sec. & Treas. T. J. Flournoy, Gen. Supt. A. S. Thompson, Elec'n & Supt. Mo. Pow. D. B. Simon. Capital, \$115,000; authorized, \$200,000. Bonds, \$112,000. Office, 1342 Broadway. 4 4

PAINESVILLE, O.—Painesville, Fairport & Richmond St. Ry. Co. 6¼ m, 4-8½ g, 52, 60 lb girder r, 7 c, of which 5 are m c and 2 t c. Gen. Elec. system. Ball engines. Pres. & Gen. Man. I. K. Pierson, V. Pres. F. C. Moodey, Sec. & Treas. E. W. Rudder. Capital \$50,000; authorized \$150,000. Bonds \$150,000. 4 4

PALATKA, FLA.—Palatka & Heights St. Ry. Co. 2 m, 3 g, 30 lb centre bearing r, 2 c, 3 mu. Pres Wm. P. Craig, Sec. Marcus Loab, Treas. E. S. Crill, Gen. Man. W. C. Snow. Capital, \$10,000. 4 4

PARIS TEX.—Paris Elec. Lt. & Ry. Co. 5 m, 4-8½ g, 22 & 36 lb T & flat r, 10 c, of which 8 are 4-wheel box & 2 4-wheel open, 45 mu. Pres. J. J. Walsh, V. Pres. S. J. Wright, Sec. & Treas. B. J. Baldwin, Jr., Supt. R. F. Grimes. Capital, \$200,000; authorized, \$300,000; Bonds, \$150,000. Office over Farmers' & Merchants' Bank. 2 3

PARKERSBURG, W. VA.—Park City St. R. R. Co. 5 m, 4 8½ g, 40 lb flat & T r, 7 c, 14 h, 14 mu. Pres. D. Gould, V. Pres., & Sec. R. Covert, Treas W. H. Wolfe, Gen. Man. & Supt. W. A. McCosh. Capital, \$40,000; authorized \$75,000. Office 332 Juliana st. 1 4

PASADENA, CAL.—City Ry. Co. (Controlled by Los Angeles Consolidated Electric Ry. Co.) 5½ m, 3-6 and 4-8½ g, 16, 20, 30 lb T & flat r, 5 c, of which 2 are 4-wheel box & 3 4-wheel open; 10 h, 4 mu. Baker cars. V. Pres. C. W. Buchanan, Sec. Treas. & Gen. Man. M. D. Painter. Capital, \$20,300; authorized, \$50,000. 1 4

Alhambra & Pasadena St. Ry. Co. (See Alhambra, Cal.)

Colorado St. Ry. Co. 5½ m, 3-6 g, 16 lb. T r, 5 c, 9 h. V. Pres. T. P. Lukens, Sec. E. E. Jones. Capital, \$50,000. Office, 50 South Los Robles Ave. 1 4

Pasadena & Mt. Wilson Ry. Co. 3½ m, of which 3 are elec. and ½ cable 2 c. Edison system. Pelton water wheels. Pres. T. S. C. Lowe, V. Pres. P. M. Green, Sec. A. P. West, Treas. T. W. Brotherton. 6 3

Pasadena St. Ry. Co. (Controlled by Los Angeles Consolidated Electric Ry. Co.) 3½ m, 3-6 g, 16 lb T r, 5 box c, 8 h. Baker cars. Pres. & Gen. Man. W. Thomson, V. Pres. G. R. Thomas, Sec. P. G. Wooster, Treas. P. M. Green. Capital, \$20,300; authorized, \$50,000. Office, Wooster Block. 10 3

PATERSON, N. J.—Paterson Ry. Co. Elec. 36 m, 4-8½ g, 58½ lb c b & T r, 75 c, of which 60 are m c and 15 t c. T-H, Westinghouse and Edison systems. Gilbert and Stephenson cars. Ball engines. Pres. Garrett A. Hobart, V-Pres. H. Romaine, Sec. A. A. Wilcox, Treas. E. T. Bell, Gen. Man. M. R. McCAdoo, Supt. M. Pettigrew. Capital \$1,250,000. Bonds \$1,250,000 1 4

Jersey City, Hoboken & Rutherford. 15 m, 11 m s, 4-8½ g, 90 lb girder r, 20 c, of which 15 are m c and 5 t c. Westinghouse system. St. Louis cars, Pres. C. A. Johnson, V. Pres. J. A. Morrisse, Sec. J. T. Maginnis, Treas. L. Fitzgerald, Gen. Man. & Ch. Engr. T. McCann, Supt. R. DeBoise. Capital \$300,000. 4 4

Paterson Central Electric R. R. Co. 4 m, 4-8½ g, 45, 58½ lb T & girder r, 18 c. Westinghouse system. Gilbert cars. Pres. T. H. Bakewell, V. Pres. F. C. Vandike, Sec. J. J. Scanlon, Treas. J. A. Morrisse, Gen. Man. & Supt. W. Ring. 6 3

Paterson, Passaic & Rutherford Electric Ry. Co. (Includes Paterson & Little Falls, Grand St. Elec. Ry., People's Park Elec. Ry. Paterson & Passaic Elec. Ry. and Passaic, Rutherford & Carlstadt Ry. Cos.) 20 m, 13 m s, 4-8½ g, 70, 90 lb T and girder r, 24 c, of which 15 are m c and 9 t c. Westinghouse system. Brill, Laconia and St. Louis cars. Rent power. Pres. C. A. Johnson, 1st V. Pres. & Asst. Treas. J. A. Morrisse, 2d V. Pres. F. C. Van Dyk. Sec. J. J. Scanlon, Supt. W. Ring. Capital \$800,000. Office Cor. Main and Ward sts. 4 4

PAWTUCKET, R. I.—Pawtucket St. Ry. Co. Elec. 15 m, of which 6.5 are horse and 8.5 elec; 4 g, 54-60 lb Prov. girder & T r, 50 c, of which 35 are h c and 15 m c, 142 h. T-H system. Pres. N. W. Aldrich, V. Pres. L. B. Goff, Sec. & Gen. Man. C. F. Luther, Treas. E. N. Littlefield. Capital \$200,000. Office, 54 Broad st. 9 3

Interstate St. Ry. Co. Elec. 24 m, 4-8½ g, 50 lb T r, 40 c, of which 23 are m c and 17 t c. T-H system. Briggs and Newburyport cars. Pres. & Gen. Man. H. M. Daggett, Jr., Sec. G. E. Webster, Treas. W. N. Otis, Pur. Agt. E. Holmes, Elec'n. J. Tregoning. Capital, \$362,500; authorized, \$500,000. 4 4

PEORIA, ILL.—Central Ry. Co. 24 m, 12 m s 4-8½ g, 48, 80 lb girder r, 89 c, of which 47 are m c and 42 t c. T-H system. American, Laclede and St. Louis cars. Cortiss engines. Pres. W. Barker, V. Pres. S. Clark, Sec. J. N. Ward, Treas. E. Callender, Gen. Man. & Pur. Agt. J. Finley, Supt. P. Brady, Ch. Engr. A. L. Kellogg, Elec'n. D. E. Flynn. Capital, \$600,000. Bonds \$200,000. Office, 622 S. Adams st. 4 4

Fort Clark St. Ry. Co. Elec. 14 m, 4-8½ g, 38, 50, 75 lb girder & T r, 34 c, of which 14 are m c and 20 t c. T-H system. St. Louis cars. Ball and Ide engines. Pres. F. W. Horne, Sec. & Treas. J. A. Trawick, Supt. W. D. Allison. Capital, \$250,000; authorized, \$500,000. Bonds, \$250,000. Office, Abington & Monroe Sts. 4 4

PETERSBURG, VA.—Petersburg St. Ry. Elec. 3½ m, 3¼ m s, 4-8½ g, 45 & 47 lb c b r, 12 c, of which 2 are h c and 10 are m c. T-H system. Jones cars. Receiver R. Gilham, Supt. G. Beadle. Capital, \$100,000. Bonds, \$100,000. 4 4

Petersburg & Asylum Ry. Co. Dummy. 3¼ m, 4-8½ g, 50 lb T r, 1 Baldwin engine, 4 c. Receiver R. Gilham, Supt. G. Beadle. Capital \$20,000. Bonds \$30,000. 4 4

PHILADELPHIA, PA.—Citizens' Pass. Ry. Co. (Leased by Electric Traction Co.)

Electric Traction Co., includes Lombard & South Sts. Pass. Ry., Lehigh Ave. Ry., Frankford & Southwark City Pass. Ry., Citizens' Pass. Ry., and Second & Third Sts. Pass. Ry.) 129 m, 5-2 g, 45, 47, 50, 78, 93 lb. girder & Tram r, 253 c, 1,705 h, 10 steam dummies. Gen. Elec. and Curtis systems. McIntosh & Seymour and Porter-Alien engines. Pres. J. J. Sullivan, V. Pres. G. S. Gandy, Sec. F. Weckerly, Treas. R. C. Brewster, Supt. W. H. Janney, Ch. Engr. E. B. Ives. Capital \$1,875,000. Office, 2501 Kensington ave. Engr's office, 11th & Colona sts. 12 3

Frankford & Southwark City Pass. Ry. Co. (Leased to Electric Traction Co.)

Lehigh Ave. Ry. Co. (Owned by Frankford & Southwark Phila. Pass. R. R. Co.)

Lombard & South Sts. Pass. Ry. Co. (Owned by Frankford & Southwark Ry.)

Second & Third Sts. Pass. Ry. Co. (Owned by Frankford & Southwark Phila. City Pass. R. R. Co.)

Hestonville, Mantua & Fairmount Pass. R. R. Co. 17.78 m, 10 m s, 5-2½ g, 47 lb r, 82 c, 537 h. Pres. J. Hopkins, V. Pres. I. Blum, Sec., Treas. & Pur. A. T. W. R. Benson, Ch. Engr. A. L. Johnston. Capital, \$39,322; authorized, \$41,000. Bonds \$499,500, Office, 4300 Lancaster ave. 4 4

People's Pass. Ry. Co. (Lessee of Germantown Pass. and Green & Coates Rys. and is controlled by People's Traction Co.) 49 m, 49 m s, 5-2 g, 49 m s, 93 lb girder r, 173 c, 1475 h. Gen. Elec. system. Allis engines. Own cars. Pres. H. C. Moore, Sec. & Treas. David C. Golden, Gen. Supt. J. C. Lugar, Ch. Engr. L. H. McIntyre. Capital, \$2,250,000. Bonds \$750,000. Office, 5th & Dauphin sts. 4 4

People's Traction Co. (controls People's Pass. Ry. Co.) Lamokin and St. Louis cars. Pres. J. Lowber Welch, Sec. & Treas. C. Kruger, Ch. Engr. & Gen. Man. L. H. McIntire. 4 4

Germantown Pass. Ry. Co. (Leased to People's Pass. Ry. Co.)

Green & Coates R. R. Co. (Leased to People's Pass. Ry. Co.)

Philadelphia City Pass. Ry. Co. 12.417 m, 5-2½ g, girder r. Pres. Wm. W. Colket, Sec. & Treas. T. W. Pennypacker. Capital, \$1,000,000. Office, 202 Walnut place. Leased to W. Phila. Pass. Ry. Co. 4 4

Philadelphia & Darby Ry. Co. (Leased to Phila City Pass. Ry. Co.)

Philadelphia Traction Co. (Lessee of Empire Pass. Phila. & Gray's Ferry, Ridge Ave., 17th & 19th Sts., 13th & 15th Sts., 12th and 16th Sts., Phila. City Pass. Schuylkill River Pass., the Continental Pass., Catherine & Bainbridge Pass., Phila. & Darby, 22d St. & Allegheny Ave., Union Pass. and West Phila. Rys.,) 250 m, of which 126 are horse, 90 elec. and 34 cable, 5-2½ g, 47, 78, 90 lb r, 116 c, of which 406 are h. c. 575 m. c. and 135 g c, 3622 h. Brill and Laclede cars. Westinghouse and Wetherill engines. Pres. P. A. B. Widener, 1st V. Pres. W. L. Elkins, 2d V. Pres. G. D. Widener, Sec. & Treas. D. W. Dickson, Gen. Man. J. T. Gorman. Capital, \$6,000,000. Office, n w cor. 41st and Haverford sts. V. Pres, office 423 Walnut st. 4 4

Empire Pass. Ry. Co. 8½ m, 5-2 g, 45 lb r. Pres James McManes, Sec. and Treas. D. W. Dickson Capital, \$600,000. Office, N. E. cor. 41st & Haverford sts. Leased to Phila. Traction Co. 1 4

Philadelphia & Gray's Ferry Pass. R. R. Co. (Leased to Phila. Traction Co.)

Ridge Ave. Pass. Ry. Co. (Leased to Phila. Traction Co.)

Seventeenth & Nineteenth Sts. Pass. Ry. Co. (Leased to Phila. Traction Co.)

Thirteenth & Fifteenth Sts. Pass. Ry. Co. (Leased to Phila. Traction Co.)

Union Pass. Ry. Co. (Leased to Phila. Traction Co.)

West Philadelphia Pass. Ry. Co. (Leased to Phila. Traction Co.)

Schuylkill River Pass. Ry. Co. Leased to Phila delphia & Gray's Ferry Pass R. R. Co. 12 3

PHENIX, ARIZ. T.—Phoenix City Ry. Co. 10 m, of which 5 are horse and 5 elec. 3-6 and 4-8½ g, 20, 30, 35 lb T r. Pres. M. H. Sherman, Sec. & Man. B. N. Pratt. 6 3

PIERRE, S. DAK.—Pierre City Ry. Co. 4.1 m 4-8½ g, 27-35 lb r, 5 open c, 7 h, 16 mu. Pres. W. G. Warden, V. Pres. Randal Morgan, Sec., Supt. & Gen. Man. S. B. Wallace. Capital \$75,000. 6 3

PINE BLUFF, ARK.—The Citizens' St. Ry. Co. 12½ m, 4 & 4-8½ g, 20, 35, 45 lb T r, 28 m. c. 4 h, 140 mu. Pres. T. S. James, Sec. A. Murray, Treas. & Gen. Man. & Supt. W. Jones, Capital \$200,000. Bonds \$90,000. Office, 207½ Main St. 11 2

PIQUA, O.—Miami Valley Ry. Co. 14 m, 4-8½ g, 85, 48 lb T r, 12 c, of which 8 are m c and 4 t c. Edison and T-H systems. Pres. W. P. Orr, V. Pres. & Man. A. M. Orr, Sec. & Treas. L. M. Flesch, Gen. Supt. F. C. Davies. Capital \$300,000. Bonds \$200,000. 3 4

PITTSBURGH, PA.—Birmingham, Knoxville & Allentown Traction Co. 1.4 m. horse and 1,600 ft. cable, 5 g, 45 lb steel & T r, 9 c, 24 h. Pres. H. S. A. Stewart, Sec. Danl. Beech Treas. T. H. Given, Supt. M. S. Holden. Capital, \$100,000. 11 1

Central Traction Co. 8½ m, of which 5 are cable & 3½ elec. 5-2½ g, 65 lb girder r, 26 c, of which 18 are g c and 8 m c. Westinghouse system. Brill and Pullman cars. Wetherill and Westinghouse engines. Pres. Geo. I. Whitney, V. Pres. T. A. Gillespie, Sec. J. F. Miller, Treas. G. F. Wright, Supt. W. C. Smith. Capital, \$1,500,000; bonds \$375,000. Office 33d st. & Herron Avenue, 4 4

Citizens' Traction Co. 30 m of which 6 are horse, 12 cable and 12 elec. 5-2½ g, 54 & 65 lb girder & tram r-90 c, of which 4 are h c, 66 c and 20 m c, 28 h. West, inghouse system. Gilbert, Pullman and Stephenson cars. Buckeye and Wetherill engines. Pres. Jno. G. Holmes, V. Pres. H. S. A. Stewart, Sec. J. G. Bright, Treas. N. Holmes, Jr., Gen. Man. J. E. Rugg. Capital \$3,000,000. Bonds \$1,250,000. General Office 537 Penn Ave., business office 3404 Penn Ave. 4 4

Duquesne Inclined Plane Co. 1,586 ft., 5 g, 60 lb T r 2 c. Pres. S. Severance, V. Pres. F. B. Nimick, Sec. K. Q. Brigham, Treas. S. Severance, Jr., Supt. Geo. L. Holliday. Capital, \$50,000. 9 2

Duquesne Traction Co. Elec. 23 m, 5-2½ g, 48 lb girder r, 60 m c, T-H system. Pres. C. L. Magee, V. Pres. _____, Sec. Jas. L. McDevitt, Treas. Jno F. Steel. Capital, \$3,000,000. Bonds, \$1,500,000 Leased to Pittsburgh Traction Co. 9 2

Federal St. & Pleasant Valley Ry. Co. Elec. 28 m, 4-8½ g, 50, 52, 66 lb girder and tram r, 75 m c, 13 h. Edison and Westinghouse systems. Brill and Pullman cars. Buckeye and Westinghouse engines. Pres. D. F. Henry, V. Pres. R. H. King, Sec. Wm. H. Graham, Treas. R. F. Ramsey, Gen. Man. & Elec'n. W. M. Ramsey, Supt. W. H. Foster, Ch. Engr. of Power Station J. Johnston. Capital \$1,400,000. Bonds \$1,250,000. Office 42 6th. Ave. 2 4

Fort Pitt Inclined Plane Ry. Co. 350 ft., 10 g, 2 c Pres. Wm. Flinn, Sec. & Supt. S. H. French, Treas. F. L. Stephenson. Capital, \$60,000. Office 125 Fourth Ave. 3 2

Knoxville Inclined Plane Co. 2,640 ft. 9 g, 60 lb. T r, 2 c. Capital \$150,000. Office 96 Diamond st.

WHEN IN PHILADELPHIA, "HOTEL HANOVER," ARCH AND TWELFTH STREETS. Stop at the New BEST EQUIPPED \$2.50 AMERICAN PLAN HOUSE IN THE WORLD.

Monongahela Inclined Plane Ry. Co. 2 planes, 640 ft, 5 & 12 g, 45 & 80 lb T r, 2 pass. 2 freight c. Pres. Jas. M. Bailey, Sec. Treas. & Supt. John L. Awi Capital, \$200,000 3 2

Penn. Inclined Plane Ry. 840 ft, 10 g, 60 lb T r Pres. Joshua Rhodes, 1st ave. 1 4

Pittsburgh & Manchester Traction Co. Elec. 18 m, of which 1 1/2 are horse and 16 1/2 elec. 52 1/2 g, 63 lb girder r, 72 c of which 1 is h c, 61 are m c, and 10 t c. T-H system. Pres. J. H. Dalzell, V. Pres. Joshua Rhodes, Sec. A. M. Neepner, Treas. W. Montgomery Gen. Man. G. F. Greenwood. Capital, \$3,000,000. Bonds, \$1,500,000. Office, S. Market & Liberty sts. and Beaver st & Island ave, Allegheny. 1 4

Pittsburgh & Birmingham Traction Co. Elec. 13 m 5-2 1/2 g, 63 1/2 lb girder r, 42 m c. Westinghouse system. Gilbert cars. Hamilton-Corliss engines. Pres. H. S. McKee, Sec. F. J. Tener, Treas. Daniel Beach, Gen. Supt. Miller Elliott. Capital \$3,000,000. Bonds \$1,500,000. Office, 30th & Carson sts. 4 4

Pittsburgh & Castle Shannon R. R. Cable. (Includes 2 inclines). 6 1/2 m, 3-4 g, 60 lb T r, 4 c. Incline No. 1, 1,375 ft, 10 g, 60 lb T r, 2 c. Incline No. 2, 2,112 ft, 10 g, 60 lb T r, 2 c. Jackson & Sharp cars. Pittsburgh Loco. Works engines. Pres. Walter Chess, V. Pres. J. M. Bailey, Sec. & Treas. E. J. Reamer, Supt. & Pur. Agt. O. A. Rogers. Capital, \$481,000. Bonds, \$200,000. 1 4

Pittsburgh & West End Pass. Ry. Co. 16 m, 8 m s 6-2 1/2 g, 78 lb tram r, 44 c of which 18 are h c and 26 m c 6 h. Westinghouse system. Laclede and Stephenson cars. Russell engines. Pres. John C. Reilly, V. Pres. Thomas S. Bigelow, Sec. W. V. Callery, Treas. & Gen. Man. William J. Burns, Ch. Engr. & Elecn. M. Murphy. Capital, \$1,500,000. Bonds \$500,000. Office, Carson st. and Point Bridge. 4 4

Pittsburgh Traction Co. 12 m, of which 10 are cable and 2 elec, 7 m s, 5-2 g, 65 lb girder r, 74 c, of which 72 are g c and 2 m c. Atwood system. Brill and Philadelphia Traction Cars. Wetherill engines. Pres. Geo. W. Elkins, V. Pres. C. L. Magee, Sec. and Treas. J. G. Traggardh, Gen. Man. & Pur. Agt. W. L. Elkins, Ch. Engr. J. M. Gorman. Capital \$1,900,000; authorized \$2,500,000. Bonds \$750,000. Office, 6006 Penn ave. 1 4

St. Clair Incline Plane Ry. Co. 40 m, 5 g, 56 lb T r, 2 box c. Pres. & Supt. W. S. Hughes, Sec. W. S. Jones, Treas. R. B. Mellon. Capital, \$150,000. Bonds \$75,000. Office, 514 Smithfield St. 9 3

Schenley Park & Highlands Ry. Co. Elec. 3 1/2 m, 5-2 1/2 g, 40, 45, 60 lb T & girder r, 5 m c. Dart system Gilbert cars. Pres. R. G. Wood, V. Pres. & Gen. Man. S. J. MacFarren, Sec. J. H. Adams, Treas. T. A. Noble Capital \$100,000. Bonds \$50,000. Office 415 Lewis Block. 2 4

Second Avenue Pass. Ry. Co. Elec. 10 1/2 m, 5-2 1/2 g 54 lb Johnson & T r. T-H & Westinghouse systems Pres. Jas. D. Caffery, Sec. C. G. Minor, Treas. John W. Taylor, Gen. Man. W. J. Burns, Supt. John Murphy. Capital, \$300,000. Bonds \$150,000. Office Glenwood, 23d Ward. 9 2

Suburban Rapid Transit St. Ry. Co. 7 m, 4 m s, 5-2 1/2 g, 52 lb girder r, 16 m c. Sperry, Westinghouse and United Columbian systems. Laclede and Lewis & Fowler cars. Fisher and Green engines. Pres. H. Miller, Sec., Treas. & Gen. Man. Thos. A. Noble, Supt. & Elecn. J. F. Saltz, Ch. Engr. of Power Station M. McLachen. Capital \$100,000; authorized, \$120,000. Bonds \$100,000. 1 4

PITTSFIELD, MASS.—Pittsfield Electric St. Ry Co. 3 1/2 m, 4-8 1/2 g, 56 lb flat r, 10 c of which 5 are m c, and 5 t c, 3 h. Westinghouse system. Pres. Jos. Tucker, Sec. J. M. Stevenson, Treas. & Gen. Man. P. C. Dolan. Capital \$40,000. Office Seymour & Wahconah Sts. 12 3

PLAINFIELD, N. J.—Plainfield St. Ry. Co. 3 1/2 m, 3 1/2 m s, 5-2 1/2 g, 72 lb tram r, 5 m c. T-H system. Brill cars. Westinghouse engines. Pres. T. N. Nevins, V. Pres. T. J. Fritts, Sec. & Treas. C. W. Riker, Gen. Man., Supt., Pur. Agt. & Elecn. J. H. Adelman, Ch. Engr. & Ch. Engr. of Power Station, M. McClurg. Capital, \$100,000. Office West 14th St. 4 4

PLYMOUTH, MASS.—Plymouth & Kingston Ry. Co. 9 m, 9 m s, 4-8 1/2 g, 35, 42 lb T r, 12 c, of which 11 are m c and 1 t c, 1 h. T-H system. Briggs and Newburyport cars. Pres. J. H. Cunningham, Sec. T. Loring, Treas. J. D. Thurber, Gen. Man. Supt. Pur. Agt. & Ch. Engr. C. E. Barnes. Capital \$70,000; authorized, \$100,000. Bonds \$35,000. 1 4

POMONA, CAL.—Orange Grove St. R. R. Co. 4 m 3-6 g, 16 lb T r, 3 c, 8 mu. Pres. & Treas. B. B. Nesbitt, Sec. C. E. Rice Gen. Man. & Supt. P. C. Towner. Capital \$25,000. 11 2

PORT ARTHUR, ONT.—Port Arthur Electric St. Ry. 8 m, 8 m s, 4-8 1/2 g, 40 lb T r, 3 m c. Edison system. Patterson & Corbin cars. Goldie & McCulloch engines. Capital \$115,000. J. M. Neefin, Chairman of the Elec. Ry. Committee, Treas. J. McTague, Supt. & Elecn, G. Lowe. Bonds \$115,000. 4 4

PORT HURON, MICH.—City Electric Ry. Co. 9 m, 4-8 1/2 g, 45 lb T r, 23 c, of which 18 are m c and 5 t c, T-H system. Ellis and St. Louis cars. Rent power. Pres. W. Canham, Sec. & Treas. F. J. Dixon, Gen. Man. A. Dixon, Supt. H. A. Dickson, Elecn. H. Ludwig. Capital \$100,000. Bonds \$50,000. Office 316 Huron ave. 1 4

PORT NORFOLK, VA.—Port Norfolk Electric Ry. Co. 3 1/2 m s, 3 1/2 m s, 4-8 1/2 g, 40 lb T r, 6 c, of which 5 are h c and 1 t c, 1 steam motor. Pres. W. H. Stewart, V. Pres. Treas. & Gen. Man. M. W. Mason, Sec. E. T. Powell. Capital \$50,000; authorized \$500,000. Bonds 60,000. Office Mt. Vernon Ave. 1 4

PORT RICHMOND, S. I., N. Y.—Port Richmond & Prohibition Park R. R. Co. Elec. 2 m, 4-8 1/2 g, 56 lb girder r, 10 c, of which 5 are m c and 5 t c. Edison system. Stephenson cars. Ball engines. Pres. C. A. Starbuck, V. Pres. J. C. Thompson, Sec. & Treas. R. C. Vilas, Gen. Man. & Supt. H. C. Vilas. Capital \$100,000. Bonds \$75,000. 1 4

PORT TOWNSEND, WASH.—Port Townsend St. Ry., Light & Power Co. 4 1/2 m, 4-8 1/2 g, 38 & 40 lb T & girder r. Not in operation. 3 4

Port Townsend Belt Ry. Co. 4 m, 2 m c. Edison system. 12 2

PORTLAND, CONN.—Portland R. R. Co.

PORTLAND, ME.—Ocean St. R. R. Co. Operated by Portland R. R. Co.

Portland R. R. Co. 20.14 m, of which 11.42 are horse and 8.72 elec. 16.53 m s, 4-8 1/2 g, 35, 48, 58, 72 lb, T tram and girder r, 68 c, of which 42 are h c, 18 m c, and 8 t c, 240 h. T-H system. Ball and McIntosh & Seymour engines. Pres. W. R. Wood, Sec., Treas., Gen. Man., Pur. Agt. & Supt., E. A. Newman, Elecn. J. A. Hutt, Ch. Engr. of Power Station, C. M. Thompson. Capital \$300,000; authorized \$500,000. Bonds \$150,000. Office 471 Congress st. 4 4

PORTLAND, ORE.—Barnes Heights & Cornell Mt. Ry. Co. 3 1/2 m, 3 m c. T-H system. 12 2

Portland Cable Co. 7 1/2 m, 3 1/2 m s, 3-6 g, 22, 38 comb. r, 24 c. Stockton cars. Hamilton-Corliss engines. Receiver & Gen. Man. F. I. Fuller. Bonds \$400,000. Office Mill & Chapman Sts. 1 4

City & Suburban Ry. Co. Elec. 46 m, of which 35 are elec. and 11 steam, 3-6 g, 30, 40 lb T & girder r, 56 c, of which 52 are m c and 4 t c, 7 steam motors, 13 coaches. T-H system. Pullman cars. Baldwin engines. Pres. H. Failing, V. Pres. T. Woodward, Sec. & Treas. C. F. Swlgert, Gen. Man. H. C. Campbell. Capital, \$1,000,000. 9 3

City & West Portland Park Motor Co. 7 m, of which 6 are steam and 1 elec. 4-8 1/2 g, 45, 50 T r, 17 c, 2 steam motors. Edison system. Pres. E. T. Johnson, V. Pres., Treas. & Gen. Man. T. A. Wood, Sec. W. H. Wood. Capital \$100,000. Bonds \$100,000. Office Room 1, I. O. O. F. Temple. 9 3

East Side Ry. Co. (Includes Mt. Tabor R. R.) Elec. 22 m of which 4 1/2 are steam and 17 1/2 elec. 4-8 1/2 g, 30, 40 lb T r, 19 c of which 15 are m c and 4 t c, 3 steam motors. Edison and T-H systems. Baldwin engines. Pres. & Gen. Man. G. A. Steel, V. Pres. & Treas. J. Steel, Sec. J. B. Cleland. Capital \$195,300; authorized \$250,000. Bonds \$153,000. Office 212 Madison St. 4 4

Portland Consolidated St. Ry. Co. 32 m, 13 1/2 m s 3-6, 4-8 1/2 g, 35, 40 lb T r, 79 c, of which 74 are m c, and 5 t c. Gen. Elec. and Westinghouse systems. Brill, Hand and Stephenson cars. Ball and Beck engines. Pres. G. B. Markie, V. Pres. J. Steel, Sec. D. F. Sherman, Treas. J. L. Hartman, Supt. & Pur. Agt. J. E. Thelsen, Elecn. H. Rustin. Capital, \$525,000; authorized \$1,000,000. Bonds \$660,000. Office 100 Front st. 4 4

Portland St. Ry. Co. 2 m, 4-8 1/2 g, 30 lb tram r, 4 c, 30 h. Pres. J. Holladay, V. Pres. G. W. Weldier, Sec. T. Gray. 4 4

PORTSMOUTH, O.—Portsmouth St. R. R. & Lt. Co. 5 m, 5 m s, 4-8 1/2 g, 45 lb T & girder r, 6 c, of which 4 are m c and 2 t c. Westinghouse and Curtis systems. St. Louis cars. Ball & Wood engines. Pres. L. D. York, V. Pres. H. S. Grimes, Sec. Treas. & Pur. Agt. S. B. Timmonds, Gen. Man. Floyd L. Smith, Supt. & Elecn. S. P. Baird, Ch. Engr. W. Williamson, Ch. Engr. of Power Station C. Hood. Capital \$125,000. Bonds \$83,000. 1 4

PORTSMOUTH, VA.—Portsmouth St. Ry. Co. 4, 7 m, 4, 7 m s, 4-8 1/2 g, 30 lbs b r, 8 c, 10 h, 15 mu. Pres. L. R. Watts, V. Pres. H. L. Page, Sec. J. L. Watson, Treas. J. L. Blissley, Supt. L. C. W. Page. Capital \$50,000. Bonds, \$50,000. n 4 4

POTTSTOWN, PA.—Pottstown Passenger Ry. Co. 6 m, 3 m s, 4-8 1/2 g, 48, 63 lb T & girder r, 14 c, of which 10 are m c and 4 t c. Westinghouse system. Brill and Jackson & Sharp cars. Ball engines. Pres. G. Maltzberger, Sec. & Treas. C. Fegely, Gen. Man. & Supt. L. P. Muthart, Elecn. D. Laferity. 1 4

POTTSVILLE, PA.—People's Ry. Co. 4 1/2 m, of which 3 1/2 are steam and 1 elec., 4-8 1/2 g, 52 lb girder and 60 lb T r, 8 c. Short system. Pres. T. A. Reilly Sec. & Supt. Wm. D. Pollard. Office, 221 S. Centre st. 1 4

Schuylkill Electric Railway Co. 8 1/2 m, 4-8 1/2 g, 48 1/2 lb T & girder r, 15 c, of which 14 are m c and 1 t c. Short system. Brill and Lamokin cars. Ball engines. Pres. J. K. Sigfried, V. Pres. F. G. Yuengling, Sec. J. Newlin, Treas. J. F. Zerby, Supt. W. Conrad, Elecn. C. Swan. Capital, \$150,000. Bonds, \$25,000. 4 4

POUGHKEEPSIE, N. Y.—City R. R. Co. 4 1/2 m 4-8 1/2 g, 42 lb s b & c b r, 10 c, 49 h. Pres. J. W. Hinckley, Sec. I. DeGroof, Treas. J. Doheny, Supt. C. M. Davis. Capital \$50,000. Office, 491 Main st. 1 4

PROVIDENCE, R. I.—Union R. R. Co. 87 m 4-8 1/2 g, 54, 70, 90 lb girder r, 303 m c. T-H system. Jones and Newburyport cars. Providence engines. Pres. N. W. Aldrich, V. Pres. C. W. Perkins, Sec. Henry V. A. Joslin, Treas. C. A. Babcock, Gen. Man. & Pur. Agt. A. T. Potter, Ch. Engr. G. C. Tingley, Elecn. W. D. Wright, Ch. Engr. of Power Station M. H. Bronson. Capital, \$3,000,000; authorized, \$3,000,000. Office, 32 Westminster St. 4 4

Providence Cable Tramway Co. Cable. 3.2 m, 3.2 m s, 4-8 1/2 g, 38 & 50 lb girder r, 58 c of which 14 are g c and 44 t c, 168 h. Own and Stephenson cars. Harris-Corliss engines. Pres. N. W. Aldrich, Sec. H. V. A. Joslin, Treas. C. A. Babcock, Gen. Man. & Pur. Agt. A. T. Potter, Supt. M. H. Bronson. Capital, \$300,000; authorized, \$400,000. (Stock held by Union R. R. Co.) Office, 32 Westminster St. 1 4

PUEBLO, COLO.—Pueblo City Ry. Co. Elec. 25 m, 4 g, 35 & 40 lb T r, 40 c, of which 24 are m c and 16 t c. T-H system. Woebler cars. Allis engines. Pres. J. E. Downey, V. Pres. F. J. Chamberlain, Sec. Supt. & Elecn. W. A. Martin, Treas. G. H. Hard, Receiver & Pur. Agt. H. E. Chubbuck. Capital, \$500,000. 4 4

PUNXSUTAWNEY, PA.—Punxsutawney St. Pass. Ry. Co. Elec. 2 m, 4-8 1/2 g, 51 1/2 lb girder r, 3 m c. Westinghouse system. Newcastle cars. Greene engines. Pres. S. E. Wilson, V. Pres. J. K. North, Sec. A. J. Trull, Treas., Gen. Man. & Supt. L. C. Myers. Capital, \$18,000. Bonds, \$14,000. 8 3

PUT-IN-BAY, O.—Put-In-Bay Water Works, Light & Ry. Co. 2 m, 4-8 1/2 g, 75 lb T r, 8 c, of which 4 are m c, and 4 t c. Westinghouse system. St. Louis cars. Pres. G. H. Ketcham, V. Pres. and Gen. Man. J. K. Tillotson, Sec. and Treas. F. M. Ohl. 3 4

Q

QUEBEC, CAN.—Quebec St. Ry. Co. 3 m, 4-8 1/2 g, 45 lb Phila. r, 12 c, 8 busses, 11 sleighs, 62 h. Pres Chas. St. Michel, V. Pres. W. Hossack, Sec., Treas Supt. & Man. F. T. Boomer. Capital \$50,000. Authorized \$100,000. Box 74, Crown St. 6 3

St. John St. Ry. Co. Llm. 1 1/2 m, 4-8 1/2 g, 35 lb s.b. r, 4 4-wheel box c, 24 h. Run a bus service out 4 m, from city limits, connecting with car service Pres. A. Robertson, V. Pres. W. DeQuincy Sewell, Sec. & Man. W. W. Martin. Capital, \$30,000. Office, 564-6 St. John St. 6 3

QUINCY, ILL.—Quincy Horse Ry. & Carrying Co., 11 1/2 m, 5 g, 38, 45 lb T & girder r, 27 c, of which 20 m c & 7 t c, 4 mu, T-H system. St. Louis cars. Hamilton-Corliss engines. Pres. W. S. Warfield, V. Pres. E. J. Parker, Sec. Supt. & Pur. Agt. E. K. Stone, Jr., Treas. F. W. Meyer, Elecn. J. L. Miswander, Ch. Engr. of Power Station I. L. Fawcett. Capital \$160,000. 4 4

QUINCY, MASS.—Quincy St. R. R. Leased to Quincy & Boston St. Ry. Co.

Quincy & Boston St. Ry. Co. Elec. 14 m, 4-8 g, 35, 58 lb T & flat r, 20 m c. T-H system. Pres. J. R. Graham, Sec. & Treas. F. H. Smith, Supt. B. J. Weeks. Capital, \$50,000. 9 3

R

RACINE, WIS.—Belle City St. Ry. Co. Elec. 15 m, 4 g, 45, 52 lb T & girder r, 26 c, of which 20 are m c and 6 t c. Detroit system. American, Lamokin and St. Louis cars. Bullock-Corliss, McIntosh & Seymour and Westinghouse engines. Pres. & Treas. C. H. Holmes, V. Pres. Sec. & Gen. Man. A. Shevmon. Capital \$100,000; authorized \$300,000. Bonds \$300,000. Office, 233 Main St. 1 4

RALEIGH, N. C.—Raleigh St. Ry. Co. Elec 11 m, 3 m s (In city) 4-8 1/2 g, 30 lb T and girder r, 21 c, of which 9 are m c and 12 t c. Edison system. Brill cars. Allis & Hampson engines. Receivers Grosvenor & Tate, Act. Sec. H. S. Trezevant, Supt. & Elecn. J. Erickson, Pur. Agt. S. Tate, Ch. Engr. of Power Station W. J. Whitfield. Capital stock, \$25,000. Bonds \$125,000. 4 4

RAPID CITY, S. DAK.—Rapid City St. Ry. Co. 4 m, 2 m s, 4 g, 25 lb r, 2c, 4 h. Pres. E. B. Chapman, V. Pres. James Hailey, Sec. Treas. & Supt. J. W. Leedy. Capital \$100,000. 1 4

READING, PA.—Reading City Pass. Ry. Co. (Operated by Reading Traction Co.)

East Reading Electric Ry. Co. (Operated by Reading Traction Co.)

Neversink Mountain R. R. Elec. 12 m, 2 m s, 4-8 1/2 g, 56 lb T r, 13 c, of which 7 are m c and 6 t c. Edison system. Brill and Pullman cars. Water power. Pres. H. T. Kendall, V. Pres. G. Brooke, Sec. M. C. McIlrain, Treas. D. W. Stehman, Gen. Man., Pur. Agt. & Elecn., Paul D. Mihoiland, Ch. Engr. & Ch. Engr. of Power Station, B. F. Kraft. Capital \$150,000. Office, 586 Pine St. 4 4

Reading & South Western St. Ry. Co. Elec. 5½ m, 1½ m, 4-8½ g, 40-56 lb T and grder r, 14 c, of which 8 are m c and 6 t c. Curtis and Gen. Elec. systems. Brill, Lewis & Fowler and Stephenson cars. Ball engines. Pres. J. W. Shepp, V. Pres. J. B. Sterley, Sec. & Treas. V. S. Seltzer, Gen. Man. Supt. & Pur. Agt., G. W. Keim, Electn. W. T. Kautner. Capital, \$130,000. Office, Water st., below Chestnut. 4 4

Reading Traction Co. (Operates Reading City Pass. Ry. and East Reading Electric Ry.) 28 m, of which 5 are horse and 23 elec. 26 m s, 5-2½ g, 60, 90, 93 lb grder r, 124 c, of which 34 are h c, 54 m c and 86 t c, 141 h. Brill and St. Louis cars. Green and Lake Erie engines. Pres. Gen. Man. & Pur. Agt. J. A. Riggs, Sec. & Treas. M. C. Aulenbach, Supt. S. E. Riggs, Ch. Engr. of Power Station J. L. Boyer. Capital \$1,000,000. Bonds \$100,000. 3 4

RED CLOUD, NEB.—Red Cloud Street Ry. 1 m, 3 c, 6 mu. Proprietor, L. Crabill. 2 3

REDLANDS, CAL.—Redlands St. Ry. Co. 2½ m, 2½ m, 4-2½ g, 20 lb T r, 1 open c, 7 mu. Baker Iron Works cars. Pres. A. E. Sterling, V. Pres. S. J. Hayes, Treas. First National Bank, Gen. Man. Supt. & Pur. Agt. A. E. Stuting. Capital, \$50,000. 1 4

RED OAK, IA.—Red Oak St. R.R. Co. 1½ m, 4-2½ g, 20 lb flat r, 1 c, 2 mu. Pres. Gen. Man. & Supt. M. Bonham, V. Pres. J. Hayes, Sec. F. M. Byrket. Capital \$75,000. 3 4

RICHMOND, IND.—Richmond City Elec. St. Ry. Co. 11 m, 4-8½ g, 40, 60 lb T r, 24 c, of which 14 are m c and 10 t c. T-H system. Pres. J. P. Miller, Sec. R. B. Harrison, Treas. D. G. Reid, Receiver & Gen. Man. A. D. Titsworth, Elec. Supt. E. Kessler. Capital \$200,000. 3 4

RICHMOND, VA.—Richmond Ry. & Electric Co. 50 m, 4-8½ g, 45-55 lb flat and c b r, 112 c. Edison and Westinghouse systems. Pres. J. P. Munn, Treas. & Gen. Man. G. E. Fisher; Supt. City Division C. Selden; Supt. Union Division, J. W. Wilbur; Supt. Manchester Division, B. R. Selden. Capital, \$1,250,000; authorized \$2,000,000. Office, 909 Bank st. New York office, 261 Broadway. 3 3

RIVERSIDE, CAL.—Riverside & Arlington St. Ry. 12½ m, 4-6 g, 22-34 lb T r, 6c, of which 3 are 4-wheel box & 3 4-wheel open, 20 mu. St. Louis cars. Pres. S. C. Evans, V. Pres. O. Backus, Sec. F. A. Miller, Treas. Riverside Banking Co., Gen. Man. G. O. Newman, Supt. J. C. Little. Capital \$40,000; authorized \$200,000. 6 3

ROANOKE, VA.—Roanoke St. Ry. Co. 23m, 21½ m s, 4-8½ g, 50 lb T r, 14 c, of which 9 are m c, and 5 t c, 2 h. Westinghouse and Edison systems. Brill and Gilbert cars. Arlington & Sims engines. Pres. S. W. Jamison, V. Pres. & Treas. J. T. Engleby, Sec. G. C. McCahan, Gen. Man. Supt. & Electn. W. F. Carr, Ch. Engr. of Power Station W. J. Updyke. Capital, \$300,000; authorized, \$500,000. Bonds, \$200,000. Office, 301 Terry Bldg. 4 4

ROCHESTER, PA.—People's Electric St. Ry. Co. 3.7 m, 1½ m s, 4 m, 5-2½ g, 45 lb T & grder r, 4 m c. T-H system. Laclade cars. Phoenix engines. Pres. H. P. Brown, Sec. J. P. Stone, Treas. C. H. Bentel, Gen. Man. & Pur. Agt. P. Bentel. Ch. Engr & Electn. A. L. Fickel. Capital, \$150,000. Bonds \$50,000. 4 4

ROCHESTER, N. Y.—Rochester Ry. Co. (Controls Rochester & Irondequoit R. R. Co., and Rochester Electric Ry. Co.) 77.45 m, 4-8½ g, 40, 78 lb grder & T r, 207 c, of which 151 are m c and 56 t c, 80 h. Short and Westinghouse systems. Pres. John N. Beckley, V. Pres. W. C. Barry, Sec. W. D. Ellwanger, Treas. F. Cook, Supt. W. Rosborough. Capital, \$5,000,000. Bonds \$3,275,000. Office, 267 State st. 11 2

Rochester & Irondequoit R. R. Co. (Controlled by Rochester Ry. Co.) 10 m, 4-8½ g, 56 lb T r, 10 m c. Gen. Elec. system. Stephenson cars. Pres. J. N. Beckley, V. Pres. W. C. Barry, Sec. W. D. Ellwanger, Treas. F. Cook. 4 4

Rochester Electric Ry. Co. (Controlled by Rochester Ry. Co.) 8.88 m, 4-8½ g, 40 lb T r, 23 c, of which 12 are m c and 11 t c. T-H system. Gilbert and Stephenson cars. Arlington & Sims and Woodbury engines. Pres. A. Luetchford, V. Pres. J. N. Beckley, Sec. & Treas. M. H. Briggs, Gen. Man. & Pur. Agt. C. A. Derr, Electn. G. Meglhan, Ch. Engr. of Power Station J. Farnan. Capital, \$200,000. Office Charlotte. 1 4

Grand View Beach Railway Co. Elec. 9½ m, 4-8½ g, 40 lb T r, 7 c, of which 5 are m c and 2 t c. Gen. Elec. system. Newburyport cars. McIntosh & Seymour engines. Pres. H. H. Craig, V. Pres. Sec. Treas. & Gen. Man. M. Boyle, Supt. W. H. Gillette. Capital, \$100,000. Bonds, \$200,000. 9 3

ROCK ISLAND, ILL.—Rock Island & Milan St. Ry. Co. 6½ m, 4-8½ g, 20, 30 & 40 lb r, 8 pass c, 8 ft c 7 h, 2 motors, Pres. H. C. Connelly, Sec. J. M. Buford. Treas. P. Fries, Supt. J. Huntton. p 1 3

ROCKAWAY, N. Y.—The Rockaway Village Ry. Co. 1 m, 4-8½ g, 47 lb c, b, r, 3 c, of which 2 are box and 1 open, 10 h. Pres. C. A. Cheever, V. Pres. J. D. Cheever, Sec. J. S. Auerbach, Treas. D. L. Haight. Capital \$25,000. Bonds \$25,000. Office, 13 Park Row, New York. 9 3

ROCKFORD, ILL.—Rockford City Ry. Co. Elec 15 m, 4-8½ g, 40-45 lb tram & T r; 20 c, of which 18 are m c, and 2 t c, 4 h. T-H system. Laclade and St. Louis cars, Ball and Ide engines. Pres. R. N. Bayliss, Sec. F. W. McAssey, Treas. W. H. McCutchen, Gen. Man. Supt. & Pur. Agt. T. M. Ellis, Electn. H. J. Termoehlen. Capital \$150,000. Bonds \$120,000. 1 4

West End St. Ry. Co. 10.20 m, 10, 20 m s, 4-8½ g, 40, 45 lb T & grder r, 17c, of which 13 are m. c. and 4 t c. Short system. Northern and Stephenson cars. Ide engines. Pres. Treas. Gen. Man. & Pur. Agt. J. S. Ticknor, V. Pres. H. B. Andrews, Sec. Treas. & Supt. F. A. Ticknor, Electn. F. L. Colby, Ch. Engr. of Power Station—Kipp. Capital, \$57,000; authorized, \$75,000. Bonds, \$100,000. Office, 205 S. Main st. 1 4

ROCKLAND, MASS.—Rockland & Abington St. Ry. Co. (See North Abington, Mass.)

ROCKLAND, ME.—Rockland, Thomaston & Camden St. Ry. Co. Elec. 14½ m, 4-8½ g, 50 lb T r, 23 c. Edison system. Briggs cars. Hamilton-Corliss engines. Pres. & Gen. Man. G. E. Macomber, V. Pres. H. L. Shepherd, Sec. H. M. Heath, Treas. A. D. Bird, Supt. H. C. Weston. Capital, \$300,000. 9 3

ROCKPORT, TEX.—Aransas Pass St. Ry. Co. 4 m, 4 g, 20 lb T r, 2 c, 4 mu. Pres. H. W. Davis V. Pres. W. P. Poland, Sec. & Treas. C. W. Booth. Capital, \$25,000. Address Box 129, P. O. 1 4

ROME, GA.—Rome St. R. R. Co. (Operates North & South St. Ry.) 5 m, 5 m s, 4-8½ g, 40, 45 lb T r, 10 c, of which 4 are m c and 6 t c. Edison system. Brill and Lamokin cars. Ball engines. Pres. & Gen. Man. John S. Lawrence, Sec. L. A. Dean, Treas. & Pur. Agt. J. King, Supt. C. M. Fouché, Ch. Engr. of Power Station J. R. Waits. Capital, \$100,000. Bonds, \$100,000. Office, East First St. 2 4

ROME, N. Y.—Rome City St. Ry. Co. Elec. 6½ m 4-8½ g, 35½ lb grder r, 14 c, 15 h. Stephenson cars. Pres. J. S. Wardwell, V. Pres. A. C. Kessinger, Sec. & Treas. W. P. Rayland. Capital, \$50,000. Bonds, \$125,000. Offices, 115 John st. 9 3

RONDOU, N. Y.—Kingston City R. R. Co. Elec 2.77 m, 4-8½ g, 72 lb grder r, 6 m c. Gen. Elec. system. Pullman cars. Payne engines. Pres. S. D. Coykendall, Sec. & Treas. Peter E. Schoonmaker, Auditor Oscar L. Eastman, Gen. Man. & Pur. Agt. Geo. Coykendall. 4 4

ROXBOROUGH, PA.—Manayunk & Roxborough Incline Plane & Ry. Co. 7½ m, 5-2½ g, 48 lb r, 5 c, 36 h. Pres. G. M. Brill, Sec. F. Pearson, Treas. C. J. McGlinchay, Supt. J. Bramble. Capital, \$58,475. Office, Roxborough. 9 3

RUTLAND, VT.—Rutland St. Ry. Co. 8 m, 4-8½ g, 20 lb Tr 10 c, of which 8 are 4-wheel box & 2 4-wheel open, 30 h. Brill and Stephenson cars. Pres. J. W. Cramton, Sec. S. M. Willison, Treas. N. K. Chaffee, Supt. M. McKeough. Capital \$50,000. Bonds \$28,000. Office 60 State St. 4 4

S

SACRAMENTO, CAL.—Central St. Ry. Co. Elec. (Includes Sacramento City and Highland Park. Controlled by Sacramento Elec. Lt. & Power Co.) 19½ m, 4-8½ g, 30 to 65 lb grder & T r, 27 c, of which 24 are m c and 3 t c. T-H and Edison systems. Pres. A. Gallatin, Sec. J. Baker, Treas. National Bank (D. O. Mills & Co.). Gen. Man. J. B. Edson, Supt. G. P. Kingsbury. Capital \$500,000. Bonds \$265,000. Office 28 and N. sts. 1 4

SAGINAW, MICH.—City of Saginaw St. R. R. Co. 3½ m, 4-8½ g, 42 lb c. b. r, 16 c, of which 9 are 4-wheel box & 7 4-wheel open, 80 h. Pres. David H Jerome, Sec. & Treas. Geo. L. Burrows, Supt. Fred G. Benjamin. Capital \$30,000. Office, 426 N. Hamilton st. 1 4

Saginaw Union St. Ry. 30 m, 25 m s, 4-8½ g, 35, 40 lb T and tram r, 45 c, of which 1 is h c, 27 m c and 17 t c, 12 h. Detroit system. Brill, Gilbert, Jones and Pullman cars. Bartlett-Corliss engines. Pres. F. E. Snow, V. Pres. W. A. Jackson, Sec. L. T. Durany, Treas. J. M. Nichol, Gen. Man. Pur. Agt. & Ch. Engr. W. J. Hart. Capital, \$300,000. Bonds, \$325,000. 4 4

ST. CATHARINE'S, ONT.—St. Catharine's, Merritton & Thorold St. Ry. Co. Elec. 8½ m, 4-8½ g, 30 lb T & flat r, 10 c, of which 8 are m c, and 2 t c. Van Depoelle system. Pres. W. B. Gilleland, V. Pres. & Gen. Man. T. Nihan, Sec. & Treas. T. E. Nihan, Jr. Capital, \$80,000. Office, St. Paul st. 3 2

ST. CLOUD, MINN.—St. Cloud City St. Car Co. Elec. 10 m, 4-8½ g, 40 lb T r, 8 m c. T-H system. St. Louis cars. Pres. H. M. Byrlesly, V. Pres. C. K. Stearns, Sec. W. P. Johnson, Treas. G. C. Duffie, Supt. C. S. Benson. Capital \$100,000. Bonds, \$125,000. 9 3

St. Cloud & Sauk Rapids Ry. Co. 3 m, 2 m c. T-H system. 9 3

ST. JOHN, N. B.—The Consolidated Electric Co., Ltd., 5 m, 4-8½ g, 45-60 lb r, 5 m c. Edison system. Pres. John F. Zebley, Sec. H. B. Zebley, Gen. Man. C. D. Jones, Supts. A. R. Bliss, J. R. Purdy. 4 3

ST. JOSEPH, MICH.—St. Joseph & Benton Harbor Electric Ry. & Light Co. 5½ m, 4-8½ g, 45 & 52 lb T & and grder r, 12 c, of which 6 are m c and 6 t c. T-H system. Brill cars. Williams engines. Pres. Gen. Man. & Pur. Agt. W. W. Bean, Sec. W. H. Hull, Treas. W. G. Keith, Supt. H. C. Mason. Capital, \$100,000. Bonds \$200,000. 1 4

ST. JOSEPH, MO.—St. Joseph Traction & Lighting Co. 33 m, 4-8½ g, 30, 35, 38, 40, 47, 52 lb T and grder r, 61 c, of which 49 are m c and 12 t c, 3 h, 2 mu. Edison, T-H, Westinghouse and Wightman systems. Brill, Brownell, Gilbert, Lewis & Fowler, St. Louis and Stephenson cars. Arlington & Sims engines. Pres. J. T. Gardner, V. Pres. J. R. Owens, Sec. S. S. Terry, Treas. N. Fish, Asst. Treas. G. L. Rollins, Gen. Supt. W. T. Van Brunt. 3 4

ST. LOUIS, MO.—Baden & St. Louis R. R. 3 m, 4-10 g, 24.28, 42½ lb T & tram r, 10 c, 27 h. Pres. & Gen. Man. Geo. S. Case, V. Pres. F. J. McMaster Supt. H. Nelson. Capital, \$50,000. Office, Broadway near Baden ave. 1 4

Cass Avenue & Fair Grounds Ry. Co. (Includes Northern Central and Union Rys.) 35 m, 4-10 g, 85 lb grder r, 210 c, of which 70 are m c and 140 t c. T-H system. Pres. D. G. Hamilton (Chicago), V. Pres. & Gen. Man. Robt. McCulloch, Sec. & Treas. C. N. Duffy. Capital \$2,500,000. Bonds, \$2,000,000. Office 3,820 Easton Ave. 1 4

Citizens' Ry. Co. 16 m, 10 of which are cable, 3 elec. and 3 horse, 4-10 g, 63 lb grder r, 246 c, of which 55 are g c, 54 m c and 137 t c, 67 h & mu. Pres. D. G. Hamilton (Chicago), V. Pres. & Gen. Man. Robt. McCulloch, Sec. & Treas. C. N. Duffy. Capital \$1,500,000. Office, 3,820 Easton Ave. 1 4

Fourth St. & Arsenal Ry. Co. 5 m, 4-10 g, 78 lb grder r, 15 c. Pres. Chas. Green, V. Pres. & Gen. Man. J. Mahoney, Acting Sec. D. J. Mahoney. Capital \$150,000. Office 1,801 Park ave. 12 3

Jefferson Ave. Ry. Co. 5.7 m, 4-10 g, 56 lb tram r 40 c, of which 20 are box & 20 open, 190 mu. Pres P. C. Maffit, Sec. W. D. Henry, Supt. T. W. Murphy, Gen. Man, J. Scullin. Capital \$112,000. Office, Jefferson ave. & Gravois road. 1 4

Lindell Ry. Co. Elec. 50 m, 4-10 g, 78, 81 lb grder r, 245 m c and t c. Edison, Short and Westinghouse systems. Brill and St. Louis cars. Porter-Allen engines. Pres. E. Whitaker, V. Pres. C. D. McLure, Sec. & Treas. Jas. Adkins, Gen. Man. Geo. W. Baumhoff. Capital, \$2,500,000. Bonds \$1,600,000. Office, 2330 Chouteau Ave. 1 4

Compton Heights, Union Depot & Merchants' Terminal Ry. Co. (Operated by Lindell Ry. Co.) Capital \$1,000,000. Bonds, \$500,000. 1 4

Taylor Avenue St. Ry. Co. (Operated by Lindell Ry. Co.) Capital \$500,000. 1 4

Missouri R.R. Co. Elec. 27.52 m, 9.06 of which are cable and 18.46 elec. 4-10 g, 63 lb grder r, 290 c, of which 40 are g c, 44 m c and 206 t c. T-H system. American, Brill and Brownell cars. Harris & Hamilton engines. Pres. & Gen. Man. P. C. Moffit, V. Pres. J. R. Lionberger, Sec. & Treas. F. R. Henry, Supt. James F. Davidson. Capital \$2,300,000; authorized \$2,400,000. Office, 10 S. Compton Ave. 1 4

Forest Park & Laclade Ave. & Fourth St. Ry. Co. Elec. Operated by Missouri R. R. Co.

People's R. R. Co. Cable. 9½ m, 4-10 g, 78 lb grder r 120 c, of which 40 are g c and 80 t c, 12 h. Brownell and Stephenson cars. Hooven, Owens & Rentschler engines. Pres. Chas. Green, V. Pres. & Gen. Man. J. Mahoney, Asst. Sec. & Treas. D. J. Mahoney. Capital, \$300,000; authorized, \$1,000,000. Office, 1,801 Park ave. 1 4

St. Louis County Ry. Co. Pres. J. B. Greensfelder Central P. O.

St. Louis R. R. Co. Cable. 14½ m, 4-10 g, 78 lb grder r, 240 c, of which 80 are g c, 80 box & 80 open c. Pres. D. G. Hamilton (Chicago), V. Pres. C. Pepper, Sec. & Treas. R. B. Jennings, Gen. Man. Robt. McCulloch. Capital, \$2,000,000. 1 4

St. Louis & East St. Louis Electric Ry. Co. 2 m, 1 m s, 4.10 g, 48-56 lb grder r, 8 m c, T-H system. Brownell and St. Louis cars. Pres. D. R. Powell, V. Pres. C. C. Carroll, Sec. D. T. Breck. Asst. Supt. W. H. Williams. Capital \$250,000. Bonds \$75,000. Office, 115 N. 3d st. 4 4

St. Louis & Suburban Ry. Co. (Operates Midland St. Ry.) 28 m, 4-10 & 3 g, 35.40, 69 lb T & grder r, 120 c, of which 60 are m c and 60 t c. T-H system. Pres. C. H. Turner, V. Pres. S. McKennard, Sec. & Treas. S. D. Barlow, Jr., Gen. Supt. T. F. Sneed. Capital, \$2,500,000. Office, DeHodiamont. 1 4

Midland St. Ry. Co. (Operated by St. Louis & Suburban Ry. Co.) 3 m, 4-10 g, 35 lb T r, c, of which 1 is m c and 2 t c. T-H system. Pres. F. Kuhn, V. Pres. E. C. Robbins, Sec. & Treas. G. Kingsland, Gen. Man. E. H. Benoit. Capital \$20,000. Office, 823 N. 2d St. 1 4

Southern Electric Ry. Co. Elec. 16 m, 4-10 g, 78 lb grder r, 120 c, of which 40 are m c and 80 t c. T-H system. Allis and Ball engines. Pres. Tom L. Johnson, Sec. Treas. & Gen. Man. Jos. S. Minary, Supt. J. C. Allen. Office, 4,041 So. Broadway. 1 4

Union Depot R. R. Co. (Controls Benton, Bellefontaine and Mound City Rys.) 67 m, 4-8½ g, 78 lb grder r; 381 c, of which 215 are m c and 166 t c. Gen. Elec. system. Pres. J. Scullin, V. Pres. & Gen. Man. H. Scullin, Sec. Jas. H. Roach, Supt. T. W. Murphy. Capital \$1,000,000. Bonds \$3,500,000. Office Geyer & Missouri aves. 1 4

ST. PAUL, MINN.—Twin City Rapid Transit Co (see Minneapolis, Minn).

St. Paul & White Bear Ry. Co. 11 1/2 m, 4-8 1/2 g, 50 lb T r, 13 c, of which 9 are m c and 4 t c. T-H system. Laclede and Pullman cars. Baldwin engines. Pres. & Gen. Man. H. M. Byllesby; V. Pres. H. C. Lewis, Sec. & Treas. W. Ruan, Supt. S. B. Livermore. Capital, \$200,000. Bonds, \$200,000. 9 3

ST. THOMAS, CAN.—St. Thomas St. R. R. Co. 2 m, 3-6 g, 30 lb tram r, 4 c, 8 h. Pres. Cameron Currie, V. Pres. J. Winter, Sec. C. W. Smith, Treas. S. Hendrie, Supt. S. Chambers. Office, St. Thomas Ont. 2 4

SALEM, MASS.—(See Lynn).

SALEM, N. C.—Winston-Salem Ry. & Elec. Co (See Winston, N. C.)

SALEM, O.—Salem Electric Ry. Co. 3 1/2 m, 4-8 1/2 g 45 lb Johnson girder r, 6 c, of which 4 are m c and 2 t c. T-H system. Buckeye engines. Pres. & Treas. M. Davis, V. Pres. J. M. Evans, Sec. D. L. Davis, Supt. & Pur. Agt. L. Davis, Elecn. W. Snaifer, Ch. Engr. of Power Station J. Wolf. Capital, \$100,000. Bonds, \$50,000. Office, 210 E. Main st. 4 4

SALEM, ORE.—Salem Consolidated St. Ry. Co. 8 m, 8 s, 4-8 1/2 g, 40 lb T r, 9 m c. Edison system. Brill, Pullman and Stockton cars. Beck, Sioux City and Westinghouse engines. Pres. C. B. Markle, V. Pres. E. P. McCormack, Sec. F. H. Page, Treas. A. P. Fuller, Gen. Man. Pur. Agt. & Ch. Engr. F. R. Anson, Supt. & Elecn. L. McGrew, Ch. Engr. of Power Station L. Kibel. Capital, \$259,900; authorized, \$500,000. Bonds, \$250,000. Office, 179 Commercial St. 2 4

SALT LAKE CITY, UTAH.—Salt Lake City R. R. Co. Elec. 42 m, 4-8 1/2 g, 30, 35, 40, 72, lb T r, 63 c, of which 57 are m c and 6 t c. Westinghouse, T-H & Edison systems. Stephenson cars. Fraser & Chalmers engines. Pres. A. W. McCune, V. Pres. R. C. Chambers, Sec. & Treas. Joseph S. Wells, Supt. Walter P. Read. Capital, \$650,000; authorized \$1,000,000. Bonds \$650,000. Office Hooper building. 4 4

Salt Lake Rapid Transit Co., Elec. 32 m, 26 m s 4-8 1/2 g, 35, 40, 79 lb T & girder r, 41 c, of which 30 are m c and 11 t c. 3 h. T-H Edison and Westinghouse systems. Stephenson and Woerber cars. Ide engines. Pres. & Gen. Man. J. S. Cameron, V. Pres. J. M. Donnellan, Sec. C. B. Jock, Treas. G. S. Gannett, Supt. & Pur. Agt. A. M. Hinckley, Ch. Engr. of Power Station C. M. Dunlap. Capital, \$500,000. Office, 176 State st., Rooms 14, 15, 16. 4 4

West Side Rapid Transit Co. Elec. & Steam. 8 m, of which 6 are steam and 2 elec, 4-8 1/2 g, 30 lb T r, 4 c. T-H system. Pres. & Gen. Man. J. G. Jacobs Treas. E. W. Wilson. Capital \$300,000. Bonds, \$400,000. Office Eagle Block. 1 4

SAN ANTONIO, TEX.—San Antonio St. Ry. Co. Elec. 43 m, 40, 45, 56 lb T r, 45 c, of which 39 are m c and 6 t c. T-H system. St. Louis cars. Arrington & Sims engines. Pres. & Treas. W. H. Weiss, V. Pres. C. H. Weiss, Sec. C. A. Buford, Supt. J. W. Greer, Ch. Engr. & Ch. Engr. of Power Station, W. H. Rowley. Capital, \$200,000; authorized, \$1,000,000. Bonds, \$300,000. Office 81 1/2 W. Houston St. 1 4

Citizens' Electric Power & St. Ry. Co. 13 m, 4-8 1/2 g, 40, 48 lb T r, 20 c, of which 10 are m c and 10 t c. T-H system. Lewis & Fowler cars. Pres. W. J. Clark, V. Pres. H. E. Barnard, Sec. & Treas. A. H. Dollard, Gen. Man. C. E. Harris, Supt. S. F. Walker. Capital, \$300,000; authorized \$600,000. Bonds \$300,000. Office, 415 Navarro St. 9 3

San Antonio Rapid Transit St. Ry. Co. 5 m, 4 1/2 m s, 4-8 1/2 g, 40 lb T r, 5 c of which 3 are m c and 2 t c. T-H system. Brill cars. Bullock engines. Pres. J. W. B. Patterson, V. Pres. R. H. Russell, Sec. & Gen. Man. G. S. Limons, Treas. C. W. Ogden, Supt. Pur. Agt. & Ch. Engr. B. W. Randall, Elecn. B. Parker. Capital, \$100,000; authorized \$200,000. Bonds, \$100,000. Office 25 E. Houston St. 1 4

West End St. Car Co. Elec. 5 1/2 m, 4-0 g, 30 lb T r, 6 c, of which 3 are m c and 3 t c. T-H system. Pres. & Gen. Man. G. W. Russ, V. Pres. F. H. Baldwin, Sec. J. N. Grosbeck, Treas. Thad. W. Smith, Gen. Man. G. W. Russ, Supt. F. M. Dowden. Office, 285 Commerce St. 11 2

SAN BERNARDINO, CAL.—Southern California Motor Road Co. 12 m, 4-8 1/2 g, 40 lb T r, 6 c, 3 Baldwin motors. Receiver J. A. Muir, Sec. & Treas. W. S. Hooper, Supt. H. C. Guiteau. Capital, \$1,000,000. Office, 3rd & E Sts. 4 4

San Bernardino St. Ry. Co. 1 1/2 m, 3 ft g, 20 lb T r, 2 c, 2 h. Pres. I. R. Brunn, Sec. & Treas. W. S. Hooper. Capital \$50,000. 6 3

SAN DIEGO, CAL.—San Diego Cable Ry. Co. 10 1/2 m, 3-6 g, 20-30 Z & T r, 14 c of which 10 are comb'n & 4 open. Receiver, G. H. Hensley. 11 2

San Diego Electric Ry. Co. 20 m, of which 5 are horse and 15 elec, 4-8 1/2 g, 38, 40, 52 1/2 lb T & girder r, 40 c, of which 30 are h c and 10 m c. T-H system Pres. A. B. Spreckels, V. Pres. E. S. Babcock, Sec., Treas. & Gen. Man. J. A. Flint. Capital \$500,000 authorized \$350,000. Office E and Arctic sts. 9 3

San Diego, Old Town & Pacific Beach R. R. Co. Dummy. 1 1/2 m, 4-8 1/2 g, 35, 40 lb T r, 11 passenger c, and 3 motors. Pres. & Gen. Man. H. Dabury, Sec. R. P. Dabury. Capital, \$250,000. 11 2

SAN FRANCISCO, CAL.—California Street Cable R.R. Co. 11 m, 5 1/2 m s, 8-6 g, 38 lb s-b r, 60 c. Pres. J. B. Stetson, V. Pres. Antoine Borel, Sec. Albert Stetson Treas. A. Borel & Co., Gen. Man. Supt. & Pur. Agt. J. W. Harris, Ch. Engr. of Power Station A. D. McLean. Office, Cor. California & Hyde sts. 1 4

Geary St., Park & Ocean R.R. Co. 9 m, of which 8 are cable and 1 steam, 4 1/2 m s, 4-8 1/2 g, 5 g, 40, 72 girder and T r, 85 c, of which 31 are g c, 10 comb'n c, 37 t c and 7 motors and coaches. Union Iron Works engines. Pres. C. F. Crocker, V. Pres. A. Grant, Sec. & Gen. Man. J. J. Willcutt, Treas. N. T. Smith, Supt. A. W. Barron, Man. of Purchases and Supplies, R. P. Schwerin. Capital, \$1,000,000. Bonds, \$71,000. Office, 4th & Townsend Sts. 2 4

Market St. Ry. Co. (Controls Central, City, Ferries & Cliff House, North Beach & Mission, Omnibus and Potrero & Bay View Railroads) 158 1/2 m, of which 56 are horse, 68.5 cable, 18.3 steam, elec. (op. by horses) 15.7, 89.1 m s, 3, 3-6, 4-8 1/2 and 5 g, 37-72 lb c b, 3 b, girder and T r, 729 c, of which 264 are h c, 408 comb'n c, 57 motors and coaches. Union Iron Works engines. Pres. C. F. Crocker, V. Pres. H. E. Huntington, Sec. & Controller J. L. Willcutt, Treas. N. T. Smith, Act. Man. (Transp'n. Dept.) M. D. Stein, Div. Supts. A. W. Barron, J. C. Skinner, J. F. Clark, H. O. Rogers. Man. of Purchases and Supplies, R. P. Schwerin, Engr. G. H. Fairchild. Capital, \$17,892,000; authorized, \$18,750,000. Bonds, \$7,035,000. Office, 4;h & Townsend sts. 2 4

Metropolitan St. Ry. Co. 11 m, 5 1/2 m s, 5 g, 40 lb girder r, 22 m c. T-H system. Risdon Iron Works engines. Pres. W. Easton, V. Pres. P. Lillenthal, Sec. C. G. Minife, Treas. Anglo-Californian Bank, Supt. H. A. Iddings, Elecn. F. Vanatta, Ch. Engr. of Power Station, T. Mirk. Office 317 Carl St. 1 4

Presidio & Ferries R. R. Co. 11 1/2 m of which 7 1/2 are cable, 2 horse & 2 steam, 5 g, 40 & 42 lb c b r, 30 c of which 5 are h c and 25 c, 30 h. Pres. G. A. Newhall, V. Pres. H. M. A. Miller, Sec. John B. Leighton, Treas. J. C. Johnson, Supt. I. F. Kydd. Capital \$10,000. Bonds \$250,000. Office, 1,111 Union St. 6 3

San Francisco & San Mateo Ry. Co. 24 m, 17 m s 4-8 1/2 g, 50 lb T & comb'n r, 33 c, of which 30 are m c and 3 t c. T-H system. O'Brien caas. Risdon I. W. engines. Receiver, S. Bennett, Pres. & Gen. Man. B. Joost, V. Pres. C. C. Butler, Sec. G. T. Smith, Treas. Nevada Bank of San Francisco, Supt. Ch. Engr. Elecn. & Ch. Engr. of Power Station F. Hoffmeister, Pur. Agt. W. A. Andrews. Capital \$2,000,000 Bonds \$1,100,000. Office 30th St. & San Jose Ave. 4 4

Sutter St. Ry. Co. 13 m, of which 1 is horse & 12 cable, 5 1/2 m s, 5 g, 42 lb girder r, 50 c, of which 2 are h c and 48 c, 90 h. Own cars. Union Iron Works engines. Pres. R. F. Morrow, V. Pres. J. L. Schmitt Sec. A. K. Stevens, Treas. M. Schmitt, Supt. & Pur. Agt. J. Reynolds, Ch. Engr. F. E. Mason. Capital \$2,000,000. Bonds \$900,000. Office, corner Sutter & Polk sts. 1 4

SAN JOSE, CAL.—San Jose & Santa Clara R.R. Co Elec. 12 m, of which 1 is horse & 11 elec. 3 g, 20 & 35 lb T r, 29 c, of which 4 are h c, 17 c and 9 t c. T-H & Edison systems. Pres. J. H. Henry, V. Pres. & Gen. Man. J. P. Burke, Sec. J. T. McGeoghegan, Supt. W. Skinner. Capital \$500,000. Bonds \$200,000. Office The Alameda. 1 4

First St. R. R. Elec. 10 m, 3 g, 30 lb steel T r, 12 c of which 7 are m c and 5 t c. T-H system. Jacob Rich, Sole Owner; Sec. E. M. Rosenthal. 3 4

Willow Glen R.R. 2 1/2 m, 3 g, 20 lb steel T r, 3 c, 20 h Sole owner Jacob Rich. Sec. E. M. Rosenthal. 3 4

SAN LUIS OBISPO, CAL.—San Luis St. Ry Co. (Owned by West Coast Land Co.) 2 1/2 m, 3 g, 16 lb T r, 5 c, of which 2 are 4-wheel box & 3 4 wheel open, 10h. Pres. J. L. Howard, Man. C. O. Johnson Office, Higura St. 4 4

SANDUSKY, O.—Sandusky St. Ry. Co. Elec. 11 1/2 m, 4-8 1/2 g, 45 lb T and girder r, 14 c, of which 12 are m c and 2 t c. Westinghouse system. Brownell and Gilbert cars. Pres. A. J. Stoll, V. Pres. C. Moss, Sec. & Treas. G. F. Anderson, Supt. E. G. Schmidt. Capital \$119,000; authorized \$150,000. Bonds \$40,000. 4 4

People's Electric Railway Co. 6 1/2 m, 4-8 1/2 g, 40-45 lb T & girder r, 8 m c. Westinghouse system. Pres. H. C. Post, V. Pres. G. Barney, Sec. & Treas. A. W. Prout, Gen. Man. T. Wood, Supt. E. L. Crawford Capital \$80,000; authorized \$100,000. Bonds \$31,500 Office 122 Lawrence st. 2 3

Sandusky, Milan & Norwalk Electric Ry. Co. Receiver, J. C. Gilchrist, Jr. Capital, \$80,000; authorized \$100,000. Office, 122 Lawrence St. n 1 4

SANFORD, ME.—Moussam River R. R. Co. Elec 2 1/2 m, 2 1/2 m s, 4-8 1/2 g, 60 lb T r, 4 c, of which 2 are m c and 2 t c, 1 elec. frt. loco. Westinghouse system. Amesbury and Briggs cars. Swampscott-Corliss engines. Humphrey water wheel. Pres. E. M. Goodall, V. Pres. & Treas. L. B. Goodall, Sec. G. B. Goodall, Gen. Man. Supt. Pur. Agt. & Elecn. E. K. Day, Ch. Engr. of Power Station S. Splinney. Capital, \$75,000. 4 4

SANTA ANA, CAL.—Santa Ana, Orange & Tustin St. Ry. Co. 10 m, 3-6 g, 16 & 25 lb steel T r, 6 c, 10 h, 6 mu. Pres., Supt. & Gen. Man. M. J. Bundy, V. Pres. Noah Palmer, Treas. Commercial Bank, Sec. Miss. M. A. Ross-Lewin. Office, 419 North Main St Capital \$35,660; authorized \$50,000. 4 4

SANTA BARBARA, CAL.—Santa Barbara St. R.R. Co. and Citizens' St. R. R. Co. of Santa Barbara. 7 m, 3-6 g, 20 lbs T r, 7 c, 36 mu. Pres. Warren Gilliten, Sec. & Supt. C. R. Diver, Treas. G. H. Bonebrake. Capital \$50,000; bonds \$50,000. Office, State st. 6 3

SANTA CRUZ, CAL.—Santa Cruz Electric Ry. Co. (Operates Pacific Ave. R. R.) 7 m, 3-2 g, 35, 40 lb girder & T r, 8 m c. T-H system. Pres. J. H. Logan, V. Pres. E. G. Green, Sec. W. T. Jeter, Treas. Bank of Santa Cruz County, Gen. Man. F. W. Ely. Capital \$500,000. 4 4

SANTA ROSA, CAL.—Santa Rosa, St. R. R. Co. 1 1/2 m, 3-6 g, 12 lb T r, 5 c, 4 h, 3 mu. Pres. M. L. McDonald, Sec. & Treas. M. L. McDonald, Jr. Capital, \$25,000. 4 4

Central St. Ry. Co. 3 m, 3-6 g, 24, 35 lb flat r, 4 c. Pres. J. D. Barnett, V. Pres. W. D. Reynolds, Sec. J. W. Warboys, Treas. W. Prindle, Supt. W. H. Lee. Capital, \$25,000. 1 4

Union St. Ry. Co. 4 m, 3-6 g, 35 lb flat r, 8 c. Pres. B. M. Spencer, Sec. J. M. Farnham, Treas. J. H. Bush. Capital, \$50,000. 1 4

SARATOGA, N. Y.—Union Electric Ry. of Saratoga. 10 m, 4-8 1/2 g, 50 lb T r, 20 c, of which 8 are m c and 12 t c. T-H system. Pres. C. E. Arnold Sec. M. Nussbaum, Treas. E. J. Stattery. Capital \$300,000. Bonds, \$100,000. 9 2

SARNIA, ONT.—Sarnia St. Ry. Co. 4 m, 4-8 1/2 g, 40 lb T r, 9 c, 21h. Patterson & Corbin cars. Pres. & Treas. Jas. S. Symington, V. Pres. James Smith, Sec. & Gen. Man. H. W. Mills. Capital, \$50,000. Office, Front St., 4 4

SAUGATUCK, CONN.—Westport & Saugatuck Horse R. R. Co. (See Westport, Conn.)

SAULT STE. MARIE, MICH.—Sault Ste. Marie St. Ry. Co. Elec. 4.25 m, 4-8 1/2 g, 20 lb T r, 5 m c. Detroit system. Pres. Thos. Ryan, V. Pres. B. F. McEvoy, Sec. & Treas. James R. Ryan, Gen. Man. Lorenzo G. Cody, Supt. G. A. Cody. Capital, \$25,300. Cash paid in to equip, \$60,000. 2 3

SAVANNAH, GA.—City & Suburban R. R. Co. Elec. 14 m, of which 5 are steam and 9 elec., 5 g, 35-52 lb c b & T r, 24 c, of which 6 are steam c, 12 m c and 6 t c. T-H system. Brill and St. Louis cars. Cooper-Corliss engines. Pres. J. H. Johnston, V. Pres. H. Parsons, Sec. E. J. Thomas, Treas. E. Schmitt, Asst. Supt. J. E. Lewis, Ch. Engr. of Power Station ——— McIntire. Capital, \$50,000. Office 2d Ave. & Whitaker St. 1 4

The Electric Ry. Co. 25 m, 4-8 1/2 g, 50 lb T and girder r 52 c of which 40 are m c and 12 t c. T-H, Edison and Westinghouse systems. Brill cars. Arrington & Sims engines. Pres. J. S. Collins, Sec. & Treas. T. G. Read, Supt. J. W. McFarland. 1 4

Savannah, Thunderbolt & Isle of Hope Ry. Co. 8 m, 5 g, 45, 50 lb T r, 11 m c. T-H system. Brill and St. Louis cars. Cooper engines. Pres. & Treas. J. H. Johnston, V. Pres. H. Parsons, Sec. E. J. Thomas. Office Bolton st. 2 4

SCHENECTADY, N.Y.—Schenectady St. Ry. Co 4 1/2 m, 4 1/2 m s, 4-8 1/2 g, 45 lb Lewis & Fowler and Johnson girder r, 15 c, of which 12 are m c and 3 t c Edison system. Gilbert and Jones cars. Westinghouse and Arrington & Sims engines. Pres. John Kreusi, Sec. A. MacAndrew, Treas. W. E. Gilmore, Gen. Man. & Pur. Agt. H. S. Cooper Capital authorized and issued \$300,000. Bonds \$300,000. Office, 224 State st. 1 4

SCRANTON, PA.—People's St. Ry. Co. Elec (Operates Nayaug, Crosstown, Scranton & Suburban and Scranton Passenger). 30 m, 4-8 1/2 g, 40 & 52 lb girder & T r, 88 m c. Westinghouse system. Dickson-Corliss engines. Pres. F. S. Page, V. Pres. & Gen. Man. H. H. Archer, Sec. & Treas. Horace E. Hand, Supt. C. H. Smith. Capital, \$600,000. 9 3

Scranton Passenger Ry. Co. Westinghouse system. Capital, \$50,000. Bonds, \$100,000. Owned and operated by People's St. Ry. Co. 9 3

Scranton & Suburban Ry. Co. (Merged with Nayaug and Crosstown Ry.) Westinghouse system. Capital, \$100,000. Bonds \$200,000. Leased to and operated by People's St. Ry. Co. 9 3

Scranton Traction Co. (Operates People's, Nayaug, Crosstown, Scranton & Suburban and Scranton Pass. Rys.) Pres. ——— V. Pres. J. P. Hsley, Sec. & Treas. C. F. Stevens, Gen. Man. H. H. Archer, Gen. Supt. C. H. Smith, Audr. J. H. Gormley. Capital \$2,000,000. Bonds \$1,000,000. 9 3

SEARCY, ARK.—Searcy & West Point R.R. Co 8 1/2 m, of which 3 1/2 are horse & 5 steam, 4-8 1/2 g, 35 lb T r, 4 c, 1 mu. St. Louis cars. Porter engines. Pres. W. H. Lightie, Sec. W. S. Lay, Treas., Gen. Man. & Pur. Agt., J. Hicks, Ch. Engr., J. M. Finley, Capital \$75,000. 4 4

SEATTLE, WASH.—Grant Street Electric Ry. Co. 7 m, 3½ g, 56 lb girder & T r, 12 m c. Sander cars. Westinghouse engines. Pres. & Gen. Man. F. E. Sander, V. Pres. N. B. Sander, Sec. & Treas. L. D. Bruns, Supt. R. E. Sander. Capital, \$200,000. Bonds, \$125,000. 9 3

Madison St. Cable Ry. Co. (Controls South Seattle Cable Ry.) 7½ m, 3-6 and 4-8½ g, 38 lb girder r, 19 c of which 16 are g and 3 fr. t c. S. C. H. & A. Works cars. Hoovens, Owen & Rentscher engines. Pres. H. G. Struve, V. Pres. R. H. Denny, Sec. M. McMillen, Treas. J. Furth, Asst. Sec. W. B. Goodrich, Supt. S. Gibson. Capital \$750,000. Office Madison St. Power House. 1 4

Rainier Avenue Electric Ry. Co. 8 m, 1 m s, 4-8½ g, 30-45 lb T & girder r, 20 c, of which 4 are m c and 16 t c. T-H system. Northern cars. Corliss type engine. Pres. J. K. Edmlston, Sec. & Treas. A. C. Marconnier, Supt. Pur. Agt. & Ch. Engr. W. M. Camp, Elecn. J. D. Chase, Ch. Engr. of Power Station J. O. Fisher. Capital, \$250,000. Office at Columbia City, Wash. 1 4

Seattle City Ry. Co. Cable. 5 m, 5 m s, 3 g, 16 lb T r, 27 c, of which 12 are g c and 15 t c. Receiver W. A. Underwood, 40 Wall st., New York, Gen. Man. Supt. & Pur. Agt. F. A. Haas, Ch. Engr. of Power Station C. A. Johnston. Capital \$600,000. Bonds \$1,000,000. Office Power House, Yessier Ave. 1 4

Seattle Consolidated St. Ry. Co. (Controls Front St. Cable, Green Lake Electric, North Seattle Cable and Rainier Ry. & Power Co.) Elec. 13.7 m, 4-8½ g, 30, 40, 44, 46 lb T & girder r, 27 c, of which 23 are m c and 4 t c. Gen. Elec and Westinghouse systems. Jones, Pullman and own cars. Reynolds-Corliss engines. Pres. D. T. Denny, V. Pres. J. B. Denny, Sec. V. H. Smith, Treas. R. R. Spencer, Gen. Man. & Pur. Agt. C. S. Clark, Audr. A. Dunn, Ch. Engr. of Power Station W. D. Gordon. Capital, \$1,200,000; authorized \$1,500,000. Bonds \$861,000. Office, 200 Pike st. 3 4

Green Lake Electric Ry. Co. (Leased to Seattle Consolidated St. Ry. Co.) 4½ m elec. 4-8½ g, 40 lb T r, 4 c, of which 2 are m c and 2 t c. T-H system. Pullman cars. Pres. W. D. Wood, V. Pres. J. Leddy, Sec. & Treas. C. A. Kilbourne, Gen. Man. E. C. Kilbourne. Capital, \$60,000; authorized, \$70,000. Bonds, \$50,000. Office, 815 Second St. 1 4

Union Trunk Line. 15 m, of which 13.64 are elec and 1.36 cable; 3-6 g, 56 lb T and girder r, 24 c, of which 16 are m c and 8 g c. Gen. Elec. system. Lane & Bodley engines. Pres. E. F. Wittler, V. Pres. F. E. Sander, Sec. J. D. Lowman, Treas. R. R. Spencer, Elec. D. Bunce, Ch. Engr. of Power Station J. C. Blegert, Gen. Supt. E. E. Hussey. Capital, \$1,000,000. Office James St. Power station. 4 4

West Seattle Cable Ry. Co. 2 m, 3-6 g, 4 c. Wheelock engines. Pres. T. Ewing, Man. J. H. Watson. Capital \$150,000. 12 1

West St. & North End Electric Ry. Co. 8 m, 4-8½ g, 35 & 45 lb T & girder r, 14 c, of which 13 are m c and 1 t c. T-H system. Northern Car Co. cars. Hamilton-Corliss engines. Pres. J. Leary, V. Pres. B. Pelly, Sec. E. C. Kellogg, Treas. W. R. Ballard, Gen. Man. & Supt. T. Imeson. Capital, \$1,000,000. Office, cor. Alva & 3d ave. E. 4 4

Woodland Park Electric Ry. Co. 1½ m, 4-8½ g, 60 lb T r, 1 m c. T-H system. Brill cars. Pres. & Gen. Man. G. C. Flinney, Sec. & Treas. C. J. Brenton. Office 110 Seneca St. 4 3

SEDALIA, MO.—The Electric Ry., Light & Power Co. of Sedalia. 12 m, 12 m s, 4-8½ g, 35 lb T r, 20 c, of which 10 are m c and 10 t c. Edison system. Pres. W. E. Sterne, V. Pres. R. R. Moore, Sec. Treas. & Man. D. C. Metzker, Supt. Chas. Carroll. Office, 500 E. 9th St. 4 4

SELMA, ALA.—Selma St. & Suburban Ry. Co. Dummy, 8 m, of which 2½ are horse and 5½ steam 4-8½ g, 20 & 35 lb T r, 10 c, of which 6 are h c and 4 t c, 1 steam motor, 20 m. Pres. S. H. March, Sec. Treas. & Gen. Man. R. H. McFaddin. Capital, \$30,000. 11 2

SENECA FALLS, N. Y.—Seneca Electric Ry Co 3½ m, 4-8½ g, 40 lb T r, 6 c, of which 2 are m c & 4 t c. T-H system. Brill cars. Pres. S. L. Phillips, V. Pres. & Treas. J. H. Gould, Sec. C. H. Williams, Supt. E. F. Slack. Capital, \$50,000. 2 3

SHAMOKIN, PA.—Shamokin Electric St. Ry. Co 3 m, 5-2 g, 35, 48½ lb T and girder r, 6 c, of which 4 are m c and 2 t c. T-H system. Brill cars. — engines. Pres. R. S. Auicker, Sec. S. Heckert, Treas. M. Markle, Gen. Man. & Supt. G. Marshall. Capital \$50,000; authorized, \$80,000. Bonds, \$22,500 6 3

Shamokin & Mt. Carmel Electric Ry. Co. 15 m, 4-8½ g, 50 lb. T r, 12 c, of which 6 are m c and 6 t c. Pres. E. C. Hamilton, Sec. D. J. Lewis, Treas. H. S. Robins. Office, 321 Independent St. 9 3

SHARON, PA.—Shenango Valley St. Ry. Co. Elec 4½ m, 5-2½ g, 45 lb T & girder r, 4 m c. T-H system New Castle cars. Phoenix engines. Pres. J. C. Whittle, V. Pres. H. W. Reeves, Sec. & Gen. Man. M. L. Knight, Treas. F. G. Barker, Supt. J. O. Patterson. Capital, \$150,000. 9 3

SHEBOGAN, WIS.—Sheboygan City R. R. 8 m, 7 m s, 4-8½ g, 35-40 tram r, 11 c, 30 h, 30 mu. Laclede cars. Pres. J. M. Semmann, Sec. & Treas. F. Semmann, Supt. C. F. Bacon. Capital, \$50,000. 4 4

SHEFFIELD, ALA.—Sheffield St. Ry. Co. 9 m, 4-8½ g, 35 lb steel r, 5 c, 2 steam motors. Pres. H. B. Tompkins, Supt. W. S. White, Asst. Supt. P. N. Totten, Sec. M. McTyler, Treas. C. D. Woodson. Capital \$50,000. p 12 2

SHERMAN, TEX.—Sherman City R. R. Co. 4 m 4-8½ g, 20, 35 lb T r, 9 c, 50 mu. Pres. Gen. Man. & Owner C. W. Batsell, Sec. J. M. Batsell, Treas. C. W. Batsell Jr. Capital, \$50,000. 8 3

College Park Rapid Transit Co. Elec. 4½ m, 4-8½ g 25 lb T r, 5 m c. Edison system. Pres. J. M. Cullers, V. Pres. J. R. Cole, Sec. C. W. Lewis, Treas J. P. Harrison, Supt. H. C. Morrow. Capital, \$24,000 authorized, \$100,000. 11 2

SHREVEPORT, LA.—Shreveport City R.R. Co. 1½ m, 4-4 g, 46 lb r, 6 c, 14 h. Pres. S. Levy, Jr., V. Pres. P. J. Trezovant, Sec. Jules Dreyfuss. 9

Shreveport Ry. & Land Improvement Co. Elec. 5½ m, 4-8½ g, 40-45 T & Johnson girder r, 8 c, of which 4 are m c & 4 t c. T-H system. Pres. S. B. McCutchen, Sec. W. B. Jacobs, Gen. Man. J. R. Jones, Supt. J. G. Keller. Capital, \$32,000; authorized \$100,000. Bonds \$100,000. Office 525 Spring St. 9 2

SIASCONSET, MASS.—Siasconset St. Ry. Co. 2 m, 2 m s, 4-8½ g, 35 lb T r, 2 c, 16 h. Pres. H. H. Pratt, Treas. J. F. Timmins, Gen. Man. T. E. Macy. Capital \$30,000; authorized \$100,000. Bonds authorized \$100,000. None issued. 1 4

SING SING, N. Y.—Ossining Electric Ry. Co. 3 m, 4-8½ g, 50 lb T r, 10 m c. T-H system. Gilbert cars. Ball & Wood and McIntosh & Seymour engines. Pres. A. S. Underhill, V. Pres. J. V. Cockcroft, Sec. F. L. Young, Treas. S. E. Tompkins, Supt. & Elecn. F. A. Cole, Pur. Agt. J. Champlain, Ch. Engr of Power Station J. Kay. Capital, \$100,000. Bonds \$100,000. 4 4

SIoux CITY, IA.—Sioux City St. Ry. Co. Elec 17 m, 4 g, 30, 40, 45 & 58½ lb girder r, 50 c, of which 27 are m. c. and 23 t. c. T-H, Westinghouse & Edison systems. Pullman cars. Allis engines. Receiver, J. C. French, Cashier, F. L. Brown, Supt. I. B. Walker. Capital, \$300,000; authorized \$1,500,000. Office, 510 United Bank Bldg. 4 4

Riverside Park Ry. Co. 9 m elec., 4-8½ g, 40 lb steel T r, 20 c, of which 6 are m. c. 8 t. c. and 6 freight c Westinghouse system. Northern Car Co. cars. Westinghouse engines. Pres. A. M. Coffman, V. Pres. Jas. E. Booge, Sec. & Treas. C. M. Swan, Supt. Pur. Agt. & Elecn. B. J. Jones, Ch. Engr. of Power Station E. Doollittle. Capital \$250,000. Office, Masonic Bldg. 4 4

Sioux City & Morning Side Ry. Co. Dummy. 6 m, 4-8½ g, 50 lb T r, 6 c. Pres. J. N. Jackson, Sec. T. C. Prescott, Treas. D. L. Pratt. Capital \$100,000. 6 3

Sioux City & Leeds Electric Ry. Co. 5.6 m. 4-8½ g 45 lb T r, 5 m c. Detroit system. Pres. A. M. Coffman V. Pres. C. C. Pierce, Sec. W. M. Stevens, Treas. E. W. Skerry, Supt. C. J. Lever. Capital, \$300,000. 6 3

Sioux City Cable Ry. Co. 7 m, 4-8½ g, 45 lb Johnson girder r, 34 c, of which 14 are g c and 20 t c. Laclede and Trimble cars. Williams engines. Pres. J. Pearce, Sec. D. T. Hedges, Treas. W. V. Hedges, Gen. Man. & Supt. C. Moller. Capital, \$250,000. 2 3

Sioux City Rapid Transit Co. Steam. 5½ m, of which 2 m are elevated track; 4-8½ g, 35 & 50 lb T r, 6 c, 2 engines. Northern cars. Porter engines. Pres. E. Haakinson, V. Pres. A. M. Jackson, Sec. A. V. Larimer, Treas. E. C. Peters, Gen. Man. C. E. Haakinson, Supt. T. L. Miller. Capital, \$1,000,000. Office, Chamber of Commerce Bldg. 2 3

Washington Park & Spring Grove Ry. Co. 4½ m, 4-8½ g, 50 lb T r, 3 c. Porter Engines. Pres. E. Haakinson, V. Pres. D. T. Hedges, Sec. & Treas. C. E. Haakinson. Capital, \$250,000. 8 3

SIoux FALLS, S. DAK.—City St. Ry. Co. 9 m 4-8½ g, 30 lb r, 6 c, 20 h 20 mu. Pres. R. F. Pettigrew, V. Pres. L. T. Dunning, Sec. & Treas. S. L. Tate, Supt. D. P. Beach. 11 2

S. Dakota Rapid Transit & Ry. Co. Elec. 7½ m, 4-8½ g, 35, 45 lb T & tram r, 5 c, of which 3 are m c and 2 t c. Edison system. Pullman cars. Armstrong & Sims engines. Pres. W. R. Kingsbury, V. Pres. C. W. Hubbard, Sec. J. H. Voorhees, Treas. & Gen. Man. F. H. Files, Supt. R. L. Wells. Capital, \$100,000. Bonds, \$75,000. 4 4

SOUTH BEND, IND.—South Bend & Mishawaka St. Ry. Co. Elec. 14 m, of which 9½ are horse and 4½ elec; 4-8½ g, 35, 65 lb T r, 22 c, of which 4 are h c, 10 m c and 8 t c, 10 h. T-H system. Stephenson cars. Allis engines. Pres. J. McM. Smith, V. Pres. O. H. Lawrence, Sec. & Treas. I. B. Newcombe. Capital, \$200,000; authorized, \$250,000. Bonds, \$250,000. 6 3

SOUTH CHICAGO, ILL.—See Chicago.

SOUTHINGTON, CONN.—Southington & Plantsville Tramway Co. Elec. 2.8 m, 4-8½ g, 25 lb T r, 2 m c. T-H system. Stephenson cars. Russell engine. Pres. & Elecn. J. H. Osborne, V. Pres. R. W. Cowles, Sec. Gen. Man. & Pur. Agt., L. E. Southworth, Treas. S. Walkley, Supt., Ch. Eng. & Ch. Engr. of Power Station, T. L. Dawson. Capital, \$20,000. Bonds, \$16,000. Office, Centre st. 4 4

SPOKANE WASH.—Spokane & Montrose Motor R. R. Co. Elec. 3½ m, 3-6 g, 30 & 35 lb T r, 4 m c T-H and Short systems. Pres. & Treas. Francis H. Cook, V. Pres. E. A. Routh, Sec. L. C. Cook. Capital \$50,000. Bonds \$40,000. 3 2

Arlington Heights Motor Ry. Co. 2 m, 4-8½ g, 30 lb r, 1 m c. Edison system. Pres. W. Hughson. Capital, \$50,000. 3 3

City Park Transit Co. Elec. 7 m, 4-8½ g, 35 lb T r, 5 m c. T-H system. Pres. D. Glass, Sec. & Treas. C. Glass, Supt. E. J. Comley. Capital \$250,000. 3 3

Ross Park St. Ry. Co. Elec. 12 m, 4-8½ g, 35 lb T r, 8 m c. T-H system. Pullman cars. Water power. Pres. H. N. Belt, Sec. & Gen. Man. W. S. Norman, Treas. J. D. Sherwood, Supt. E. E. Knowles, Auditor C. S. Smith. 4 4

Spokane St. Ry. Co. (Controlled by Washington Water Power Co. includes Spokane Electric Ry. and Spokane Cable Ry.) 83 m, of which 1½ are cable and 31½ elec., 4-8½ g, 30, 35, & 40 lb T r, 20 c, of which 2 are g c, and 18 m c. T-H and Edison systems. Brill cars. Water power. Pres. H. Bolster, V. Pres. H. Brook, Sec. & Gen. Man. W. S. Norman, Treas. J. D. Sherwood, Supt. & Pur. Agt. E. E. Knowles, Ch. Engr., Elecn. & Ch. Engr. of Power Station J. B. Fiske. Capital, \$500,000. Bonds \$350,000. Office, Hazel Block. 2 4

SPRINGFIELD, ILL.—Springfield Consolidated Ry. Co. (Comprises Springfield City Ry. Co. and People's Elec. Ry. Co.) 22 m, 22 m s, 4-8½ g, 40, 60 lb T r, 51 c, of which 33 are m c and 18 t c. T-H and Detroit systems. Bates-Corliss engines. Pres. T. J. Minary, V. Pres. B. Wilson, Treas. & Gen. Man. C. K. Minary, Supt. F. P. McNeil. Capital, \$750,000. Bonds, \$650,000. 4 4

SPRINGFIELD, MASS.—Springfield St. Ry. Co. Elec. 33 m, 4-8½ g, 56 lb T r, 110 c, of which 100 are m c and 10 t c. T-H system. Pres. John Olmsted, Treas. & Man. A. E. Smith. Capital \$1,000,000. Office cor. Main & Carew sts. 6 3

SPRINGFIELD, MO.—Metropolitan Electric Ry. Co. 17 m, 4-8½ g, 45 lb Johnson girder r, 30c of which 16 are m c, and 14 t c. Westinghouse system. Pres. B. F. Hobart, Sec. & Gen. Man. Frank B. Smith. Capital, \$550,000; authorized, \$600,000. Bonds, \$550,000. 6 3

SPRINGFIELD, O.—Springfield Ry. Co. Elec. 25 m, 4 g, 45, 60 lb girder & T r, 25 m c. Westinghouse system. Brownell, Laclede and St. Louis cars. Russell & Co. engines. Pres. W. B. McKinley, V. Pres. R. S. Hunter, Sec. B. Hood, Treas. D. W. Slack, Gen. Man. S. L. Nelson, Supt. C. E. Milley. Capital, \$1,000,000. Bonds, \$500,000. 8 3

STANFORD, CONN.—Stamford Street R. R. Co. 7 m, 4-8½ g, 25, 60 lb T r, 11 c, 48 h. Feigel, Jones and Stephenson cars. Pres. & Treas. R. A. Foslidge, V. Pres. Wm. W. Gillespie, Sec. L. J. Curtis, Supt. G. W. Pierce. Capital \$92,500; authorized \$100,000. Bonds \$32,000. Office, Fessenden Block. 4 4

STATEN ISLAND, N. Y.—Staten Island Belt Line R. R. Co. 9 m, 4-8½ g, 25 lb T r, 10 c, 3 h. Receiver James D. Van Hoevenberg, 189 Broadway New York, Pres. M. E. Graves. Office, Tompkinsville 4 4

STAUNTON, VA.—City St. Car Co. 5½ m, 4-8½ g 25 & 42 lb T & girder r, 13 4-wheel box c, 70 mu Pres. E. K. Sibley, New York; V. Pres. D. D. Parmlay, Treas. Andrew Spotts, New York; Gen. Man. R. D. Apperson, Staunton, Va. Capital \$50,000. 1 3

STEBENVILLE, O.—Stebenville St. Ry. Co. 2½ m, 2½ m s, 4-8½ g, 35 lb girder r, 6 m c. Edison system. Richmond L. & M. Works cars. Pres. D. B. Toucey, V. Pres. W. B. Donaldson, Sec. & Treas. T. N. Motley, Gen. Man. Supt., Pur. Agt., Ch. Engr., Elecn. & Ch. Engr. of Power Station J. F. Flood. Capital, \$70,000. Office, 921 Sixth Ave. 4

STILLWATER, MINN.—Stillwater St. Ry. Co. Elec. 5 m, 4-8½ g, 30 lb T & tram r, 8 m c. Edison system. Receiver W. M. Hewitt. Office, Davenport, Ia. 4 4

STILLWATER, N. Y.—Stillwater & Mechanicville St. Ry. Co. 4½ m, 4-8½ g, 25-30 lb T & flat r, 6 c, 13 h. Jones cars. Pres. A. E. Powers, V. Pres. W. L. Denison, Sec. Treas. & Supt. H. O. Bailey. Capital \$11,775; authorized, \$30,000. Bonds, \$17,500. 4 4

STOCKTON, CAL.—Stockton Electric Ry. Co. Elec. 12 m, 3-6 g, 45 lb, s. b & T r, 22 c, of which 11 are m c. and 11 t c. Westinghouse and T-H systems. Stockton cars. Pres. I. S. Bostwick, Sec. J. Fyfe, Treas. E. R. Hedges, Supt. G. E. Ladd. Capital \$500,000. 8 3

STREATOR, ILL.—Streator Ry. Co. 5½ m, 4-8½ g, 56 lb T & girder r, 3 m c. T-H system. Laclede cars. Armstrong & Sims engines. Pres. F. F. Barr, V. Pres. D. Heenan, Sec. W. Reeves, Treas. J. C. Barlow, Gen. Man. C. C. Barr, Supt. & Pur. Agt. C. D. Hagerty. Capital \$250,000. 4 4

STROUDSBURG, PA.—Stroudsburg Passenger Ry. Co. 1½ m, 4-8½ g, 28-30 lb T r, 3 box c, 9 h 3 mu. Pres. & Treas. J. Lantz, Sec. Jacob Houser Gen. Man. W. Kistler. Capital, \$25,600. 3 1

SUNBURY, PA.—Sunbury & Northumberland St. Ry. Co. Elec. 3½ m, 5-2 g, 50 lb girder r, 4 m c. Westinghouse system. Stephenson cars. Harrisburg Fdry. & Mach. Co. engines. Pres. D. Coolidge, Sec. & Treas. S. P. Wolvorton, Gen. Man. C. M. Clement Supt. M. Withington. Capital \$125,000. 4 4

SYRACUSE, N. Y.—People's R. R. Co. 4 m, 4-8½ g, 47, 57, 66½ lb r, 72 c, of which 31 are box and 41 open, 300 h. Pres. A. N. Palmer, Sec. H. H. Durr, Treas. F. W. Barker, Gen. Man. J. H. Moffitt. Capital, \$1,000,000. 5 3

Syracuse, Eastwood Heights & De Witt R. R. Co. Elec. 10 m, 4-8½ g, 40 lb T r, 2 m c. Short system. Pres. N. S. Williams, Treas. G. B. Leonard, Supt. L. A. Williams. 6 3

Syracuse Consolidated St. Ry. Co. (includes Fifth Ward, Fourth Ward, Genesee & Water St., Seventh Ward, Syracuse & Geddes, Third Ward and Woodlawn & Butternut railways). Elec. 36 m, of which 16 are horse and 20 elec, 4-8 g, 35 to 6 3/4 lb girder, s b & T r, 100 c, of which 52 are box, 17 open and 31 m c, 320 h. T-H system. Receiver F. J. Mack, Pres. W. W. Hazzard, V. Pres. P. T. Brady, Sec. W. P. Gannon, Treas. W. R. Kimball, Gen. Man. E. F. Rice, Supt. J. H. Moffett. Capital, \$1,250,000. Office, 3 Syracuse Sav. Bank Bldg. 4 2

T

TACOMA, WASH.—Tacoma Ry. & Motor Co. Elec. 43 m, of which 46 are elec. and 2 cable, 3-6 g, 40, 45, 60, 66 lb T & girder r, 31 c, of which 26 are m c and 5 g c. T-H and Edison systems. Pullman cars. Corliss, Frick and Stearns engines. Pres. Paul Schulze, V. Pres. S. Z. Mitchell, Sec. P. H. Kershaw, Treas. T. B. Wallace, Supt. J. H. Davis, Audr. G. W. Bird. Capital \$750,000. Office, A & 13th sts. 4 4

Point Defiance, Tacoma & Edison Ry. Co. (Operates Tacoma & Puyallup Ry.) 13 m, 13 m s, 3-6 g, 40 lb T r, 14 c, of which 13 are m c and 1 t c. Gen. Elec. system. Brill and Pullman cars. Pres. A. C. Mason, Treas. T. B. Wallace, Supt. N. Lawson, Audr. E. S. Shull, Jr. Capital \$500,000. Office, 915 Railroad st. 4 4

Tacoma & Puyallup (Operated by Point Defiance Tacoma & Edison Ry. Co.) steam. 15 m, 3-6 g, 40 lb T r, 9 c. 3 Porter motors. 4 4

TAMPA, FLA.—Tampa St. Ry. & Power Co. Elec. 5 m, 4-8 1/2 g, 25, 30 lb T r, 10 m c. General Elec. system. Brill cars. Porter engines. Receiver T. C. Tallaferro. Capital \$500,000; authorized \$600,000. Bonds \$250,000. Office, Gulf Bank Bldg. 8 3

TAUNTON, MASS.—Taunton St. Ry. Co. Elec. 14 m, 4-8 1/2 g, 40, 45, 60 lb T & girder r, 47 c, of which 23 are h c and 24 m c. Jones and Stephenson cars. McIntosh & Seymour engines. Pres. J. N. Beckley, Sec. O. A. Barker, Treas. S. M. Thomas, Supt. Geo. C. Morse. Capital, \$100,000. 8 3

TERRE HAUTE, IND.—Terre Haute St. Ry. Co. Elec. 16 m, 4-8 1/2 g, 40, 45, 60 lb T & Johnson girder r, 37 c, of which 28 are m c and 9 t c. Westinghouse system. Centropolis and Pullman cars. Westinghouse engines. Pres. R. B. Harrison, V. Pres. W. Kidder, Treas. L. D. Thomas, Asst. Sec. & Treas. P. P. Thomas, Supt. M. F. Burke. Capital, \$200,000. Office 100 N. Ninth st. 1 4

TEXARKANA, ARK.—Texarkana St. Ry. Co. Elec. 5 m, 4-g, 30 lb T r, 8 c, of which 6 are 4-wheel box & 2 4-wheel open, 38 mu. Pres. J. Deutschman V. Pres. B. Collins, Sec. F. W. Offenhauser, Treas. G. W. Fouke, Supt. B. M. Foreman. Capital \$40,000. 1 4

TIFFIN, O.—Tiffin & Interurban Consolidated Electric Ry. Co. 24 m, of which 6 are horse and 18 elec, 4-8 1/2 g, 67-83 lb T and girder r, 24 c, of 18 are h c and 6 m c, 50 h. Westinghouse system. Laclede cars. Pres. & Gen. Man. R. M. Brown, V. Pres. A. Betts, Sec. N. W. Miller, Treas. T. T. Rosendale, Supt. J. Murphy. 5 4

TOLEDO, OHIO.—Toledo Consolidated St. Ry. Co. Elec. 65 m, 4-8 1/2 g, 48 1/2, 56, 70, 75 lb girder r, 120 c, of which 109 are m c and 11 t c. Westinghouse system. Hooven, Owens & Rentschler engines. Pres. Norman B. Ream (Chicago), V. Pres. Albion E. Lang, Sec. Chas. L. Wight, Treas. W. E. Hale, Capital \$1,500,000. Bonds \$1,500,000. Office, 336 Summit st. 1 4

Toledo Electric St. Ry. Co. 27 m, 4-8 1/2 g, 45, 52, 85 90 lb Johnson girder & T r, 80 m c, 9 h. T-H and Westinghouse systems. Brill cars. Cooper engines. Pres. D. Robison, Jr., V. Pres. L. S. Baumgardner, Sec. & Gen. Man. J. J. Robison, Treas. W. F. Robison, Div. Supts. C. L. Hulbut, E. F. Adler. Capital, \$800,000. Bonds \$800,000. Office, cor. Madison & Summit Sts. 1 4

TOPEKA, KAN.—Topeka Ry. Co. 35 m of which 1 is horse and 34 elec, 25 m s, 4 & 4-8 1/2 g, 35, 52 lbs. T & girder r, 66 c, of which 36 are m c and 30 t c. T-H system. Laclede, St. Louis and Stephenson cars. Allis engines. Pres. C. C. Baker, V. Pres. M. A. Low, Sec. & Treas. R. M. Gage, Gen. Man. & Elecn. J. M. Patten. Capital \$1,290,000. Office, 807 Kansas Ave. 2 4

Topeka Belt Ry. Co. Steam. 4 m, 4-8 1/2 g, 45 lb T r, 11 c, 2 Baldwin motors. Pullman cars. Pres. Chas. S. Glead, Sec. & Treas. J. Mackenzie, Supt. E. H. Littlefield. Capital, \$1,000,000. Office, 110 W. 10th st. 6 3

West Side Circle Ry. Co. Steam. 6 1/2 m, 4 8 1/2 g, 40 lb T & girder r, 2 c, 3 Baldwin motors. Pres. C. S. Glead, Sec. & Treas. G. H. Nolte, Asst. Sec. & Treas. F. H. Poole. Capital, \$50,000; authorized, \$100,000. Bonds, \$50,000. Office, Knox Building. 4 4

TORONTO, ONT.—Toronto Ry. Co. 80 m, of which 20 are horse and 60 elec, 45 m s, 4-10 1/2 g, 70 lb girder r, 850 c, of which 80 are h c, 120 m c and 150 t c. Own cars. Armington & Sims engines. Pres. W. McKenzie, V. Pres. H. A. Everett, Sec. & Treas. J. C. Grace, Supt. James Gunn, Ch. Engr. & Elecn. W. E. Davis, Ch. Engr. of Power Station D. C. McLean. Capital, \$6,000,000. Bonds, \$1,700,000. Offices Canada Life Assurance Bldg., King st., west. 4 4

Metropolitan St. Ry. Co. 4 1/2 m, 4 1/2 m s, 4-10 1/2 g, 56 lb T r, 5 c, of which 3 are m c, and 2 t c. T-H system. Jones and St. James cars. Goldie & McCulloch engines. Pres. C. D. Warren, Sec. & Treas. R. Jenkins, Gen. Man. J. W. Moyes. Capital, \$130,000; authorized \$250,000. Deer Park P. O. Ontario. 4 4

Toronto & Scarboro Electric Ry. Lt. & Pow. Co. 3 m, 4-8 1/2 g, 56 lb T r, 2 m c. T-H system. Patterson & Corbin cars. Pres. D. G. Stephenson, V. Pres. J. J. Foy, Sec. & Gen. Man. A. W. Dingman, Supt. C. A. Crawford. Capital, \$50,000; authorized \$400,000. Office, 38 King St. 8 3

TRENTON, N. J.—Trenton Pass. Ry. Co. Elec. 37 m, of which 19 are horse and 18 elec.; 78-90 lb girder r, 85 c, of which 53 are h c and 32 m c, 175 h. 6 mu. Gen. Elec. and Short systems. St. Louis and Stephenson cars. Watts-Campbell engines. Pres. Gen. Man. & Pur. Agt. L. Perrine, Jr., V. Pres. S. K. Wilson, Sec. J. H. Solomon, Treas. W. S. Cook, Supt. P. E. Hurley, Ch. Engr. & Ch. Engr. of Power Station J. Hyde, Jr., Elecn. D. S. Cook. Office cor. Greenwood and S. Clinton Aves. 1 4

TROY, N. Y.—Troy City Ry. Co. (Lessee of Troy & Lansingburgh and Watford & Cohoes Rys.) 29 1/2 m, of which 4 are horse and 25 1/2 elec, 19 1/2 m s, 4-8 1/2 g, 63 1/2 lb girder & s. b. r, 150 c, of which 46 are h. c. and 98 m. c. Gen. Elec. system. Gilbert and Jones cars. Greene-Corliss engines. Pres. C. Clemmishaw, 1st V. Pres. A. N. Brady, 2d V. Pres. J. B. Carr, Sec. & Treas. J. J. Hagen, Supt. C. H. Smith. Capital, \$2,000,000. Bonds \$2,000,000. Office, 361 River St. 4 4

Troy & Lansingburgh R. R. Co. (Leased to Troy City Ry. Co.)

TUSCALOOSA, ALA.—Tuscaloosa St. Ry. Co (Owned by Tuscaloosa & Castle Hill Real Estate & Mfg. Co.) 4 m, 4-8 1/2 g, 20, 25 lb T r, 9 box c, 8 mu. Stephenson cars. Pres. Jas. H. Fitts, Sec. Treas. & Gen. Man. S. F. Alston. Capital, \$100,000. Office, Main st. 1 4

Tuscaloosa Belt Ry. Co. 4 1/2 m, 4-8 1/2 g, 35 lb. T r 1 c, 1 steam motor. Pres. W. C. Jemison, Sec. & Treas. J. L. Wallace, Supt. J. T. Cochrane. Capital \$100,000. 1 4

TYLER, TEX.—Tyler St. Ry. Co. 3 1/2 m, 3 1/2 m s, 4-8 1/2 g, 20, 40 lb T & flat r, 4 c, 9 mu. Pres. Sec. Treas. & Gen. Man. W. C. Scott, V. Pres. J. P. Douglas. Capital, \$12,000. 1 4

U

UNION SPRINGS, ALA.—Union Springs St. Car Co. 2 m, 5-1 g, 20 lb T r, 4 flat c for freight, 1 or 2 for pass., 4 mu. Pres. Wm. Stakley, Sec. & Treas. T. H. Mabson, Jr., Supt. A. D. Fielder. Capital, \$10,000. p 12 2

UNIONTOWN, PA.—Uniontown St. Ry. Co. 3 1/2 m, 5-2 1/2 g, 68 lb girder & T r, 6 c, of which 5 are m c, and 1 t c. Edison system. Brill cars. Buckeye engines. Pres. W. C. McCormick, Sec. & Treas. R. F. Hopwood, Gen. Man. & Pur. Agt. G. A. McCormick, Supt. & Ch. Eng. R. A. Smith. Capital, \$50,000. 1 4

UTICA, N. Y.—Onondaga St. R. R. Co. 1 1/2 m, 4-8 1/2 g, 35 lb c b r, 3 c, of which 2 are box and 1 open, 8 h. Pres. & Gen. Man. Henry Ney, V. Pres. Dan'l L. Jones, Jr., Sec. & Treas. Wm. C. Willcox. Capital \$40,000. Office, 69 Genesee st. 11 2

Deerfield & Utica. (See Deerfield.)

Utica & Mohawk R. R. Co. Elec. 3 1/2 m, 4-8 1/2 g, 40, 45 lb T r, 14 c, of which 8 are m c and 6 t c. Edison system. Stephenson cars. Pres. & Gen. Man. Jas. F. Mann, V. Pres. R. W. Sherman, Sec. Wm. E. Lewis, Treas. Geo. D. Dimon, Supt. F. L. Everts. Capital \$51,000. Bonds \$75,000. Office Mann Bldg. 1 4

Utica Belt Line St. R. R. Co. Elec. (Operates Utica, Clinton & Binghamton St. R. R.) 23 m, 4-8 1/2 g, 40-85 T, girder and flat r, 25 m c, 6 h. T-H system. Receiver, C. E. Benton, Gen. Counsel & V. Pres. J. W. Boyle, Supt. R. G. Young. Capital, \$150,000. Bonds, \$570,000. 1 4

Utica, Clinton & Binghamton St. R. R. Pres. Jas. J. Scollard, Sec. & Treas. Robt. S. Williams. Capital \$849,485. Leased to and operated by Utica Belt Line St. R. R. Co. Office, 157 Genesee st. 1 4

V

VANCOUVER, B. C.—Vancouver Electric Ry. & Light Co. Ld. 7 1/2 m, 4-8 1/2 g, 40 lb T r, 10 c, of which 9 are m. c. and 1 t. c. T-H & Westinghouse systems Pres. J. Oppenheimer, V. Pres. T. Dunn, Sec. H. T. Cepuley, Treas. & Business Manager, W. E. Brown Supt. C. F. Hutchings. Capital, \$300,000; authorized \$500,000; Bonds \$300,000. Office, 523 Hastings st. W. 10 2

VANCOUVER, WASH.—Columbia Land & Improvement Co. 3 m, 3-6 g, 30 lb T r, 2 c, Th. Pres. J. Gibbon, V. Pres. & Gen. Man. L. M. Hadden, Sec. C. Brown, Treas. 1st Nat. Bank. Capital \$280,000. Address, P. O. Box 44. 3 2

VERNON, IND.—North Vernon & Vernon St. R. R. Co. 2 m, 5-2 g, 35 lb girder r, 3 c, 5 h, 2 mu. Laclede cars. Pres. S. H. Grinstead, Jr., V. Pres. L. T. Wilkerson, Sec. & Pur. Agt. E. L. Wagner, Treas. J. C. Cope. Capital \$15,000. 1 4

VICTORIA, B. C.—National Electric Tramway & Lighting Co. 14 m, 4-8 1/2 g, 40 lb girder & T r, 16 c of which 14 are m c and 2 t. c. T-H, Edison & Westinghouse systems. Pres. & Gen. Man. D. W. Higgins, V. Pres. T. L. Jones, Sec. C. T. Dupont, Supt. F. W. McCrady. Capital \$205,000; authorized \$1,000,000. Office Store st. 9 3

VICKSBURG, MISS.—Vicksburg consolidated Electric St. Ry. Co. Receiver T. M. Smedes, n 3 4

VINCENNES, IND.—Citizens' St. Ry. Co. 5 m, 5 m s, 4-8 1/2 g, 40, 55 lb T & girder r, 16 c, of which 7 are m. c. and 9 t. c, 2 mu. Westinghouse system. Calumet and Ellis cars. Westinghouse engines. Pres. A. Tindolph, Sec. Gen. Man. Supt. Pur. Agt. & Elecn. E. F. Tindolph, Treas. B. G. Hudnut, Ch. Engr. & Ch. Engr. of Power Station, T. P. Agnew. Capital \$15,050. Bonds \$100,000. Office, 16 Fair View ave. 1 4

W

WACO, TEX.—Citizens' Ry. Co. 16 m, 14 m s, 4-8 1/2 g, 30, 40 & 45 lb girder & T r, 13 m c. Westinghouse system. St. Louis cars. Hamilton Engines. Pres. & Gen. Man. H. C. Scott, Sec. & Supt. J. L. Griffith. Capital, \$350,000. Bonds, \$350,000. Office, 4th & Washington sts. 1 4

Waco Electric Ry. & Lt. Co. 10 m, 4-8 1/2 g, 35 lb T r, 10 c, of which 8 are m c and 2 t c. T-H system. St. Louis cars. Armington & Sims and Stouh City engines. Pres. W. J. Hobson, V. Pres. B. Moore, Sec. & Supt. S. A. Hobson, Treas. & Gen. Man. C. W. Hobson. Capital, \$250,000. Bonds, \$200,000. 2 3

WAKEFIELD, MASS.—Wakefield & Stoneham St. Ry. Co., 10 m, 10 m s, 4-8 1/2 g, 50 lb T r, 13 c, of which 8 are m c and 5 t c. Westinghouse system. Jones and Newburyport cars. Power is rented. Pres. & Gen. Man. C. F. Woodward, Sec. E. M. Southworth, Treas. J. F. Shaw, Pur. Agt. E. P. Shaw, Ch. Engr. J. A. Bancroft, Electr'n Robt. J. Lawder. Capital authorized \$300,000; issued \$100,000. Bonds authorized \$300,000; issued none. 1 4

WALLA WALLA, WASH.—Walla Walla St. Ry. & Investment Co. 4 m, 3-6 g, 30 & 35 lb T r, 6 4-wheel box c, 24 h. Pres. W. P. Winans, V. Pres. Miles C. Moore, Sec. J. W. Langdon, Treas., Supt. & Man. J. M. Hill. Capital \$72,000; authorized \$100,000. 1 4

WARREN, O.—Trumbull Electric R. R. Co. 7 m, 7 m s, 4-8 1/2 g, 66, 70 lb girder r, 8 m c, T-H system. Brill and Ellis cars. Phoenix Iron Works engines. Pres. H. C. Christy, V. Pres. A. R. Sillman, Sec. & Treas. E. D. Kennedy, Gen. Man. & Pur. Agt. J. W. Packard, Supt. J. H. Donnelly, Elecn. & Ch. Engr. of Power Station — Brocklehurst. Capital authorized \$150,000. Bonds \$88,000. 1 4

WARREN, PA.—Warren St. Ry. Co. 2 m, 4-8 1/2 g, 45 lb T & girder r, 2 m c. Westinghouse system. New Castle cars. Pres. T. B. Clawson, Sec. J. Roy, Treas. & Gen. Man. D. H. Siggins. Capital \$12,000; authorized \$25,000. Office 342 Water st. 8 3

WASHINGTON, D. C.—Belt Ry. Co. 13 1/2 m, 4-8 g, 80 lb girder r, 72 c, 308 h. Pres. H. Munnikhuysen, Sec. & Treas. H. K. Gray, Supt. Andrew Glass. Office, 3d & B sts. S. W. 3 4

Anacostia & Potomac River Ry. Co. 15.3 m, 4-8 1/2 g, 62 lb grooved girder r, 46 c, 200 h. Jones cars. Pres. Pur. Agt. & Supt. H. A. Griswold, Sec. & Treas. J. B. Pitcher. Capital \$100,000. Bonds \$300,000. Office, Anacostia, D. C. 1 4

Brightwood Ry. Co. 11.9 m, 5.5 m s, 4-8 1/2 g, 50 lb T & 70 lb girder r, 23 c of which 13 are m. c. and 10 t. c. Gen. Electric & Westinghouse systems. Laclede cars. Clark Bros. of Belmont N. Y., engines. Pres. H. S. Cummings, V. Pres. E. O. McNair, Sec. Victor B. Deyber, Treas. C. P. Williams, Supt. & Pur. Agt. Thomas O'Brien. Capital, \$108,500. Bonds, \$350,000. 1 4

Columbia R. R. Co. 6 m, 4-8 1/2 g, 36 & 68 lb girder r, 44 c, 180 h. Pres. R. T. Baker, V. Pres. E. G. Davis, Sec. & Treas. James B. Adams, Supt. Wm. C. Bateler, Capital, \$400,000. Office, 15th & H sts., N. E. 1 4

Eckington & Soldiers' Home Ry. Co. Elec. 9 m, of which 2 1/2 are horse and 6 1/2 elec, 4-8 1/2 g, 80 lb girder r, 39 c, of which 12 are h c, 14 m c and 13 t c, 54 h. T-H and Westinghouse systems. Brill, Robinson and Stephenson cars. Armington & Sims and Ball engines. Pres. H. Munnikhuysen, V. Pres. Gen. Man. & Pur. Agt. W. K. Schoepf, Sec. & Treas. H. K. Gray, Supt. & Elecn. R. I. Todd. Capital, \$352,000. Bonds, \$129,000. Office, McGill Bldg., 908-914 G St., N. W. 1 4

Georgetown & Tenalleytown Ry. Co. Elec. 9 1/2 m, 4 1/2 m s, 4-8 1/2 g, 45, 60 lb groove & T r, 19 m c. T-H system. Brill, Gilbert, Jones and Stephenson cars. Frick and Harrisburg Foundry & Machine Co.'s engines. Pres. M. W. Offutt, V. Pres. H. Bradley Davidson, Sec. & Treas. J. E. Beall, Supt. & Pur. Agt. & Elecn. J. H. Mills, Ch. Engr. Power Station L. J. Garner. Capital \$200,000. Bonds \$200,000. Office, Power House, 32d st. 1 4

Glen Echo R. R. Co. 6 1/2 m, 3 m s, 4-8 1/2 g, 40 lb T r 8 c, of which 6 are m c and 2 t c. Westinghouse system. Brill cars. Westinghouse engines. Pres. Edwin Balzley, V. Pres. F. W. Pratt, Sec. Edward Balzley, Treas. J. C. Pratt. Capital, \$100,000. Office, Room 7 Sun Bldg. 1 4

Metropolitan R. R. Co. 19.44 m, 4-8 1/2 g, 62 lb grooved r, 150 c, 653 h. Pres. & Pur. Agt. W. J. Stephenson, V. Pres. A. A. Wilson, Sec. & Treas. Wm. J. Wilson, Supt. W. E. Lowry. Capital \$732,000; authorized \$1,000,000. Office, 2411 P st. N. W. 1 4

Rock Creek Ry. Co. of District of Columbia, 15 m, 11 1/2 m s, 4-8 1/2 g, 50, 62 lb T & groove r, 22 c, of which 16 are m c and 6 t c. Love conduit and T-H systems. Lamokin and Stephenson cars. Ball & Wood McIntosh & Seymour and N. Y. Safety engines. Pres. H. E. Davis, V. Pres. E. J. Stellwagen, Sec. H. S. Nyman, Treas. T. M. Gale, Supt. H. Claude, Elecn. R. M. Palmer, Ch. Engr. of Power Station W. D. Hogan. Capital \$800,000. 2 4

Washington & Arlington Ry. Co. Elec. 3 m, 4-8 1/2 g, 50 lb T r, 4 m c. Edison system. Brill cars. Phoenix engines. Pres. D. L. King, Sec. & Treas. W. Hazlett, Gen. Man. & Supt. W. Chapman. Capital \$500,000. Bonds authorized \$300,000. Office 95-96 Corcoran building. 1 3

Washington and Georgetown R.R. Co. Cable. 22 m 4-8 1/2 g, 80 lb English groove girder r, 389 c, of which 94 are g c and 295 t c, 30 h. Pres. H. Hurt, V. Pres G. T. Dunlop, Sec. & Treas. C. M. Koonen, Gen. Supt C. C. Sailer, Engr. D. S. Carll. Capital, \$500,000. Bonds, \$3,500,000. Offices Central Power Station 14th & E sts. N. W. 1 4

WASHINGTON, PA.—Washington Electric St Ry. Co. Elec. 3 1/2 m, 5-2 1/2 g, 45 lb girder r, 5 m c, Westinghouse system. Pres. A. E. Townsend, Sec. J. F. Bristol, Treas. Brit Hart, Supt. F. G. Marshall. Capital \$40,000; authorized \$60,000. Bonds \$8,000. 8 3

WATERBURY, CONN.—Waterbury Traction Co. 6 1/2 m, 4-8 1/2 g, 40 lb T r, 29 c, 125 h. Brill, Lewis & Fowler and Stephenson cars. Pres. D. S. Plume, Sec. A. M. Young, Supt. & Gen. Man. E. A. Bradley. Capital \$50,000; authorized \$1,000,000. Bonds \$50,000. 1 4

WATERLOO, IA.—Waterloo St. Ry. Co. 2 m, 3 g, 23, 35 lb T r, 3 c, 8 h. Pres. J. E. Sedgwick, V. Pres G. A. Whitney, Sec. & Treas. A. A. Hungerford Capital, \$40,000. Office, 183 1/2 Bridge St. 4 4

WATERLOO, ONT.—Berlin & Waterloo St. Ry. Co. 2 3/4 m, 4-8 1/2 g, 25 & 30 lb flat & T r, 8 c, 16 h. Pres. & Treas. Thos. M. Burt, Sec. Alex. Millar. Office, Waterloo. Capital, \$40,000. Bonds \$20,000. 1 4

WATERLOO, N. Y.—See Seneca Falls, N. Y.

WATERTOWN, S. DAK.—Watertown & Lake Kampeska Ry. Co. Dummy. 6 1/2 m, 4-8 1/2 g, 30 lb T r 1 c. Pullman car. Baldwin engine. Ch. Engr. F. L. Burdeck. Office, Kemp ave. & Oak st. 4 4

WATERTOWN, N. Y.—Watertown St. Ry. Co. 6 m, 6 m s, 4-8 1/2 g, 50 lb girder & T r, 19 c, of which 11 are m c, and 8 t c. Edison system. Stephenson cars. Water power. Pres. J. C. Thompson, V. Pres C. A. Starbuck, Sec. & Treas. E. S. Goodale, Asst. Sec. & Treas. G. F. Clark, Gen. Man. Supt. & Pur. Agt. G. W. Adams, Ch. Engr. Elec. & Ch. Engr of Power Station E. A. Barber. Capital \$40,000. Bonds \$75,000. Office, 172 Main St. 2 4

WATERVILLE, ME.—Waterville & Fairfield Ry. & Lt. Co. Elec. 5m, 4-8 1/2 g, 35 lb T r, 8 c, of which 3 are m c and 5 t c. Westinghouse system Pres. & Gen. Man. A. F. Gerald, Sec. H. M. Heath Treas. H. D. Bates. Capital, \$200,000. Bonds, \$175,000 Office, Fairfield. 9 2

WAXAHACHIE, TEX.—Waxahachie St. Ry Co 2 m, 4-8 1/2 g, 2 1/2 lb T r, 3 c, 16 h. Pres. T. A. Ferris, V. Pres. W. F. Lewis, Sec., Treas. & Gen. Man. O Goodwin. Capital, \$24,000. 4 4

Lake Park St. Ry. Co. 2 m, 4-8 1/2 g, 20 lb T r, 4 c 14 mu. Pres. & Gen. Man. J. F. Strickland, V. Pres. W. F. Lewis, Sec. J. F. Phillips, Treas. W. G. Williams, Supt. W. J. Stevenson. Capital, \$8,000; authorized, \$20,000. 8 3

WEATHERFORD, TEX.—Weatherford City & Suburban R. R. Co. 3 1/2 m, 2 1/2 m s, 4-8 1/2 g, 16 & 20 lb T r 6c, 17 mu. Pres. G. P. Levy, Supt. G. B. Willbanks. Capital, \$100,000. 1 4

WEBB CITY, MO.—Southwest Missouri Electric Ry. Co. Connecting Joplin, Webb City, Carter, ville and Prosperity 10 m, 4-8 1/2 g, 48, 75 lb T & girder r, 12 c. T-H and Westinghouse systems. Laclede cars, Cooper engines. Pres. A. H. Rogers, V. Pres. E. Z. Wallower, Sec. & Treas. W. M. Donaldson, Supt. J. M. Maret, Ch. Engr. of Power Station, E. J. Pratt. Capital, \$500,000. Bonds, \$100,000 authorized, \$200,000. Offices Centerville, Mo., and Harrisburg, Pa. 1 4

WEST BAY CITY, MICH.—(See Bay City, Mich.)

WEST CHESTER, PA.—West Chester St. Ry. Co. Elec. 6 1/2 m, 1 1/2 m s, 5-2 1/2 g, T and flat r, 9 c, of which 5 are m c, and 4 t c. Edison and Westinghouse systems. Brill cars. Pres. W. M. Hayes, Sec. W. S. Harris, Treas. F. W. Wollerton, Gen. Man. & Pur. Agt. J. W. Andrews, Elec. J. Early, Ch. Engr. of Power Station J. Pyle. Capital, \$60,000. Bonds \$60,000. 3 4

WEST NEWTON, MASS.—Newton St. Ry. Co 8 1/2 m, 8 1/2 m s, 4-8 1/2 g, 45, 56 lb T r, 31 c, of which 25 are m c and 3 t c. T-H system. Jones and Newburyport cars. Armington & Sims engines, contract for power. Pres. H. B. Parker, V. Pres. E. Stearns, Sec. J. C. Lane, Treas. C. W. Smith, Supt. & Pur. Agt. F. G. L. Henderson. Capital \$125,000. Bonds \$100,000. Office, West Newton, Mass. 1 4

WEST SUPERIOR, WIS.—Superior Rapid Transit Ry. Co. Elec. 26 m, 3-6g, 35 lb T r, 35 c, of which 25 are m c and 10 t c. T-H system. Pres. & Gen. Man. S. T. Norvell, Treas. F. W. Hanson, Supt. H. M. Sloan. Capital, \$1,000,000. 1 4

WESTFIELD, MASS.—Woronoco St. Ry. Co. 2,016 m, 1,70 m s, 4-8 1/2 g, 52 lb T r, 6 c, 30 h. Jones cars. Pres. C. N. Yeamans. Sec. S. B. Campbell, Treas. O. B. Parke, Gen. Man. Supt. & Pur. Agt. J. Fennell. Capital, \$25,000. 4 4

WESTPORT, CONN.—Westport & Saugatuck Horse R. R. Co. 1 1/2 m, 4-8 g, 40 lb r, 4 c, 6 h. Pres. A. S. Huributt, Sec. and Treas. B. L. Woodworth Supt A. F. Downes. 3 2

WHEELING, W. VA.—Wheeling Ry. Co. 17 m, 15 m s, 5-2 g, 35, 78, 85 lb girder r, 35 c, of which 30 are m c and 5 t c. T-H system. Brill & St. Louis cars. Ball engines. Pres. W. Erskine, Sec. & Treas. W. A. Shirley, Gen. Man. & Pur. Agt. A. M. Jolly, Supt. M. Loftus, Elec. W. H. Tucker, Ch. Engr. of Power Station W. S. Wright. Capital, \$700,000. Bonds \$500,000. 2 4

Wheeling & Elm Grove R. R. Dummy. 8 1/2 m, 4-8 1/2 g, 60 lb T r, 23 c, of which 20 are pass, c, 2 freight c and 1 baggage c, 4 Baldwin motors, 1 h. Pres. A. Reymann, Sec. & Treas. J. Roemer, Gen. Man. H. E. Welsger Capital, \$250,000; authorized, \$300,000. Office, 16th st 6 3

WHITMAN, MASS.—(See Brockton, Mass.)

WICHITA, KAN.—Wichita Electric Ry. & Lt. Co. 25 m, 4-8 1/2 g, 35 & 46 lb T & Johnson r, 30 c, of which 22 are m c and 8 t c. T-H system. Pres. C. E. Dustin, V. Pres. A. T. Batchelder, Sec. & Gen. Man. J. W. O'Neill, Treas. G. A. Litchfield, Supt. F. W. Sweet. Capital, \$450,000. Office, 100 W. Douglas Ave. 1 4

WILKESBARRE, PA.—Wilkesbarre & Wyoming Valley Traction Co. (Owns and operates all lines in the city). 41 m, 4-8 1/2 g, 40, 60, 70 lb T and girder r, 88 c. Baxter, Gen. Elec., Short and Westinghouse systems. Brill & St. Louis cars. Pres. B. F. Myers, Sec. W. G. Eno, Treas. & Gen. Man. J. Graham, Supts. (East Side division) J. Clifford, (West Side division) J. C. Meixell, Elec. Engr. J. Fagan. 1 4

WILLIAMSPORT, PA.—Williamsport Pass. Ry. Co. 7 1/2 m, 6 1/2 m s, 4-8 1/2 g, 60 lb c b r, 12 m c. Westinghouse system. Lamokin cars. Westinghouse engines. Pres. ———. Sec. J. F. Starr, Treas. J. Lawshe, Supt. & Elec. H. C. Young. Capital \$250,000; authorized \$600,000. Bonds \$125,000. Office 760 W. 4th st. 2 4

WILLIAMSVILLE, N. Y.—Buffalo & Williams-ville Electric Ry. Co. 5 m, 4-8 1/2 g, 60 lb T r, 6 c, of which 4 are m c and 2 t c. T-H system. Laclede cars. Noyes engines. Pres. Gen. Man. & Supt. J. Blocher, V. Pres. J. Chalmers, Sec. A. C. Rinewalt, Treas. L. L. Grove, Ch. Engr. of Power Station C. Summers. Capital, \$75,000 1 4

WILMINGTON, DEL.—Front & Union St. Pass. Ry. Co. (Operated by Wilmington City Ry.) 1 1/2 m 5-2 g, 32 & 63 lb tram & girder r, 10 c, 80 h. Pres. W. W. Pusey, V. Pres. P. Lea, Sec. & Treas. F. L. Kurtz Capital, \$50,000. Office, Front & Union sts. 2 13

Wilmington City Ry. Co. Elec. 22 m, 5-2 g, 58, 90 lb. T and girder r, 61 m c. Westinghouse system. Pres. P. Lea, V. Pres. W. Sausburg, Sec. Gen. Man. & Pur. Agt. W. S. Heger, Treas. C. G. Blandy. Office, Delaware ave. & Dupont st. 4 4

WILMINGTON, N. C.—The Wilmington St. Ry. Co. 6 m, of which 1 1/2 m is steam and 4 1/2 elec., 5 m s, 4-8 1/2 g, 45, 60 lb T & girder r, 16 c of which 12 are m c and 4 t c. T-H system. Lewis & Fowler and Stephenson cars. Ball engines. Pres. C. A. Lieb, V. Pres. & Gen. Man. J. H. Barnard, Sec. B. F. O'Connor, Treas. C. H. Wilson, Supt. M. T. Heskell, Ch. Engr. G. Hires. Capital, \$100,000; authorized, \$400,000. Bonds \$250,000. Office 29 Broadway, New York. 2 4

WINDSOR, ONT.—Windsor Electric St. Ry. Co. 1 1/2 m, 3-6 g, 25 lb T r, 1 motor, 4 c, 9 h. T-H system. Steam power. Pres. W. M. Boomer, Sec. & Treas. M. A. S. Boomer. Office, cor. Mercer & Sandwich sts. W. 11 2

Sandwich, Windsor & Amherstburg Ry Co. Elec 10 m, 4-8 1/2 g, 56 lb girder & T r, 14 c, of which 10 are m c. and 4 t c. Westinghouse system. Brill, Laclede, Ottawa and St. Louis cars. Brown & Robb engines. Pres. J. Coventry, V. Pres. G. M. Hendrix, Sec. & Treas. W. I. Pulling, Supt. R. Canfield. Capital, \$315,000; authorized \$500,000. 9 3

WINFIELD, KAN.—Union St. Ry. Co. 5 m, 4 g, 16-20-35 lb T & Johnson r, 5 c, 20 mu. Pres. Wm Mathewson, Sec. W. J. Kennedy, Treas. Geo. M Robinson, Gen. Man. W. J. Kennedy Capital 25,000. 1 4

WINNIPEG, MAN.—The Winnipeg Electric St. Ry. Co. 9 m, of which 5 are horse & 4 elec, 4-8 1/2 g, 35 40lb r, 23 c, of which 15 are h c, 5 m c and 3 t c, 80 h. Edison system. Pres. Jas. Austin, Sec. & Man. Albert W. Austin, Supt. Geo. A. Young. Capital \$100,000. 1 3

WINONA, MINN.—Winona City Ry. Co. (Owned by Winona General Electric Co.) Elec. 4 m, 4-8 1/2 g, 40 lb r, 7 m c. T-H system. Pres. G. C. Duffie, Sec. & Treas. W. H. Moore. Office, 403 Sibley st., St. Paul. 3 3

WINSTON, N. C.—Winston-Salem Ry. & Elec. Co. (Operated and leased by Twin City Construction Co.) 8 2 m, 8 m s, 4-8 1/2 g, 45 lb Johnson girder r, 12 c, of which 9 are m c and 3 t c. Edison system. Brill cars. Ball engines. Pres. J. H. McClement, V. Pres. F. J. Sprague, Sec. & Treas. R. G. Day, Asst. Sec. Treas. & Pur. Agt. W. H. Barham, Supt. Ch. Eng. Elec. & Ch. Engr. of Power Station, F. W. McClement. Capital, \$100,000; authorized, \$200,000. 2 4

WOODLAND, CAL.—Woodland St. Ry. Co. 1 m, 3 g, 30 lb T r, 3 c, 3 h. Pres. T. Ross, V. Pres. G. D. Fiske, Sec. L. W. Hilliker, Treas. T. Armstrong Gen. Man. M. McCutcheon, Supt. J. D. Lawson. Capital \$30,000. 4 4

WOONSOCKET, R. I.—Woonsocket St. Ry. Co. 6.65 m, of which 2.65 are horse and 4 elec, 4-8 1/2 g, 35 to 50 lb T r, 17 c, of which 2 are h c, 6 m c and 9 t c 20 h. T-H system. Pres. J. P. Ray, Sec. W. Kent Treas. W. Whittlesley, Gen. Man. E. K. Ray, Supt H. M. Young. Capital, \$100,000. Bonds, \$160,000. Office, 6 S. Main St. 4 4

WORCESTER, MASS.—Worcester Consolidated St. Ry. Co. (Controlled by Worcester Traction Co.) 30 1/2 m, 25 m s, 4-8 1/2 g, 90 lb girder r, 125 c, of which 62 are h c and 63 m c, 25 h. General Electric and Westinghouse systems. Laclede, Jones and Stephenson cars. Lake Erie engines. Pres. Chas. B. Pratt, Sec. T. C. Barr, Asst. Sec. & Treas. A. H. Stone, Gen. Man. J. N. Akarman. Capital \$700,000. Bonds \$650,000. Office, 15 Market st. 4 4

North End St. Ry. Co. Elec. 5 1/2 m, 4-8 1/2 g, 45, 55, 65 lb T r, 12 c, of which 11 are m c, 5 and 1 t c. Westinghouse system. Jones, Lewis & Fowler and Stephenson cars. Pres. & Gen. Man. W. P. Searls, V. Pres. G. A. Barnard, Sec. G. F. Barnard, Treas. G. A. Smith, Supt. C. L. West. Capital, \$80,000; authorized, \$110,000. 6 3

Worcester & Millbury St. Ry. Co. 7.439 m, 4-8 1/2 g, 70 lb girder & T r, 14 c, of which 8 are m c and 6 t c. T-H system. Pres. S. Winslow, Sec. & Treas. T. T Robinson, Supt. J. B. Gorman. Capital, \$150,000. 9 3

Worcester & Shrewsbury St. Ry. Co. 3,300 ft. 3,300 ft. s, 4-8 1/2 g, 58 lb T r, 2 m c. Edison system. Lewis & Fowler cars. Pres. & Treas. H. H. Bigelow, Supt. & Pur. Agt. I. E. Bigelow. Capital \$20,000. Office 19 Foster st. 2 4

Worcester, Leicester & Spencer St. Ry. Co. Elec. 13 m, 4-8 1/2 g, 48 lb T r, 26 c, of which 23 are m c. and 8 t c. T-H & Detroit systems. Pres. & Gen. Man. S. Winslow, Treas. & Clerk, T. T. Robinson, Supt. J. B. Gorman. Capital \$250,000. 9 3

Worcester Traction Co. (Owns all the stock of the Worcester Consolidated St. Ry. Co.) Pres. C. B. Pratt, Sec. T. C. Barr, Treas. A. H. Stone, Gen. Man. J. N. Akarman. Capital \$5,000,000. Bonds \$150,000. 4 3

WYMORE, NEB.—Wymore & Blue Springs Ry. Co. 3 1/2 m, 3 1/2 m s, 3-6 g, 22 lb T r, 4 wheel box c, 10 h. Pres. J. H. Reynolds, V. Pres. Gen. Man. & Ch. Engr. A. Stewart, Sec. Treas. & Pur. Agt. E. P. Reynolds, Jr., Supt. T. Bauman. Capital, \$36,700; authorized \$50,000. 1 4

Y

YARMOUTH, N. S.—Yarmouth St. Ry. Co. 2 m, 4 g, 45 lb T r, 5 c, of which 2 are m c and 3 t c. Edison system. Pres. R. Cate, V. Pres. W. D. Lovitt, Sec., Treas. & Gen. Man. B. B. Law, Supt. J. W. Burton. Capital \$40,000; authorized, \$100,000. 1 3

YONKERS, N. Y.—Yonkers St. Ry. Co. Elec. 8 1/2 m, 7 1/2 m s, 4-8 1/2 g, 42-48 lb r, 24 c, of which 9 are h c, 12 m c and 3 t c, 88 h. Field and Westinghouse systems. Stephenson cars. Ball & Wood engines, Pres Gen. Man. & Pur. Agt. C. H. Montague, Sec. T. W. Smith, Treas. G. E. Ketcham, Supt. Ch. Engr. & Elec. S. L. Montague 2d, Ch. Engr. of Power Station C. A. Lewis. Capital, \$125,000; authorized \$200,000. Bonds \$125,000. 2 4

YORK, PA.—York St. Ry. Co. 8 1/2 m, 6 1/2 m s, 4-8 1/2 g, 45, 70 lb girder r, 25 c, of which 17 are m c and 8 t c. T-H system. Brill and Lamokin cars. Russell Corliss engines. Pres. W. H. Lanus, V. Pres. D. K. Trimmer, Sec. G. S. Schmidt, Treas. Geo. W. Bell, Supt. & Pur. Agt. C. E. Long, Elec. F. D. Connelly. Capital, \$141,150; authorized, \$200,000. Office, 27 E. Market St. 2 4

YOUNGSTOWN, O.—Youngstown St. Ry. Co. 15 m, 13 m s, 4-8 1/2 g, 48, 70 lb girder r, 49 c, of which 34 are m c. and 15 t c. Sperry system. New Castle and Pullman cars. Allis and Hamilton-Corliss engines. Pres. James Parmelee, V. Pres. H. M. Garlick, Sec. Treas. Gen. Man. & Pur. Agt. A. A. Anderson, Supt. S. F. Hazlerigg. Capital \$300,000. Bonds, \$300,000. 1 4

Z

ZANESVILLE, O.—Zanesville St. Ry. Co. Elec 8 m, 5-2 1/2 g, 48 1/2, 50 lb girder & T r, 21 c, of which 11 are m c and 10 t c. Edison system. Lamokin cars. Pres. A. L. Conger, V. Pres. F. M. Atterhot, Sec. F. A. Wilcox, Treas. & Gen. Man. F. A. Seiberling, Supt. A. H. Johnson. Capital \$200,000. Bonds \$180,000. 2 3

J. W. PARKER & CO., 41 N. Seventh St., Philadelphia, ENGINEERS AND CONTRACTORS FOR COMPLETE STEAM POWER PLANTS. Our Specialties: Ball Automatic Engines, Case Vertical Engines, L. P. & D. Belting Systems.



WILLARD L. CANDEE, {
H. DURANT CHEEVER. } Managers.

W. H. HODGINS, Secretary.
GEO. T. MANSON, Gen'l Supt.



THE FACT THAT

OUR COMPETITORS CLAIM THAT THEIR PRODUCT IS
JUST AS GOOD AS OKONITE,

PROVES THAT

OKONITE  **IS THE STANDARD**

OF PERFECT INSULATION.

OUR FEED WIRES AND CABLES

ARE THE BEST,

**AND ARE USED BY THE LEADING ELECTRIC
STREET RAILWAY COMPANIES.**

THE OKONITE COMPANY, LIMITED,

13 PARK ROW, NEW YORK.

A. B. WETMORE. LUMBER AT WHOLESALE.

Wants of Street Car Builders a Specialty.

The Best Grades of Whitewood, Ash and White Oak, up to 26 ft. and 28 ft. long.
 WHITEWOOD PANELS, 16 ft. to 26 ft., of the CHOICEST GRADE.

OCTAGON TROLLEY POLES.
 YELLOW PINE AND WHITE OAK TIES.

CORRESPONDENCE SOLICITED. 10 WEST 23d ST., NEW YORK.

FROST VENEER SEATING COMPANY,

MANUFACTURERS OF

VENEER CAR CEILINGS,
 CAR SEATS AND BACKS.

Advertising Racks and Frames for Street and Steam Cars.

SETTEES AND SEATINGS FOR RAILROAD STATIONS,

FACTORIES AT

New York,
 Newport, Vt.
 Sheboygan, Wis.

208 CANAL STREET,

New York.

CUTTING MILLS AT

Newport, Vt.,
 Antigo, Wis.,
 Elcho and Elmhurst, Wis.

W. P. SEQUINE, Manager of R. R. Dept.

THE

Gagnier - Griffin Suspended Railway Bridge Co.,

INCORPORATED.

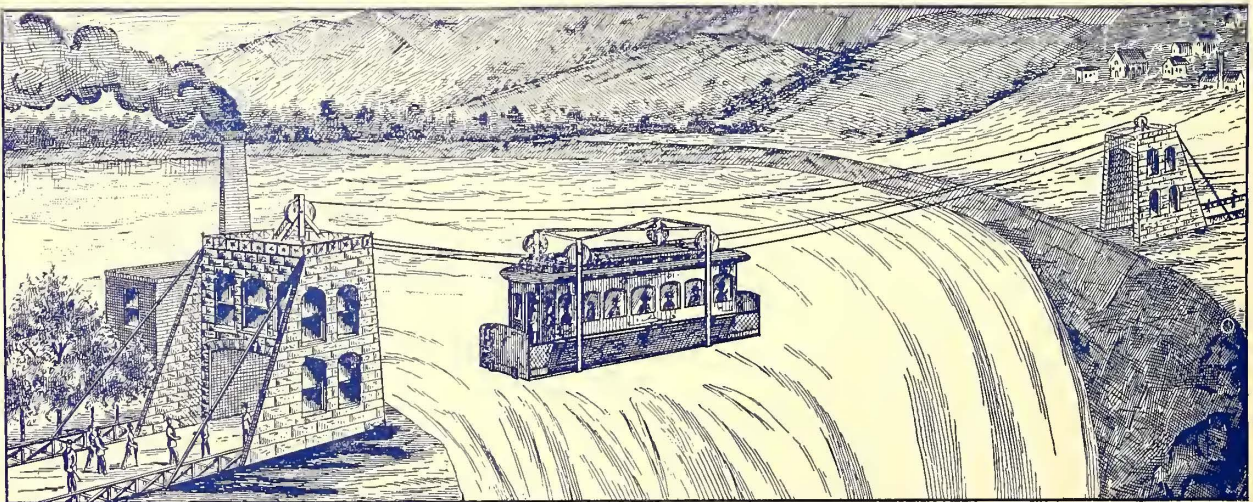

CAPITAL, \$1,000,000.

J. S. CHADWICK,
 Secretary.

OFFICES :

1026-1027 Masonic Temple, Chicago.

Contractors and Builders of Suspended Cable Railway Bridges, for the transmission of Passengers, Freight, Coal, Ore, or for Ferry purposes. For the transmission of Horse and Railway Cars, at any distance, from 200 feet to half a mile, with perfect safety.

Bridges on this plan, can be built on sixty per cent. less than any other plan, as described.

W. E. HAYCOX, Pres. and Gen'l Man.

M. B. BUSHNELL, Vice-Pres.

C. J. LANGDON, Sec. and Treas.

THE FULTON TRUCK AND FOUNDRY CO.

CLEVELAND AND MANSFIELD, OHIO.

Address Cleveland Office.

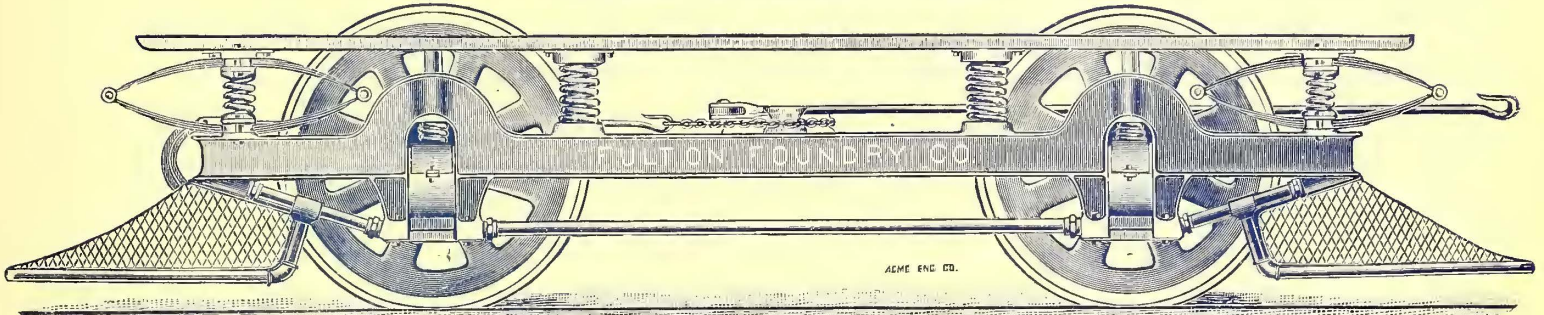

SINGLE STEEL TRUCK "IMPERIAL."

The Best Standard Motor Truck Ever Made for Single Truck Cars.

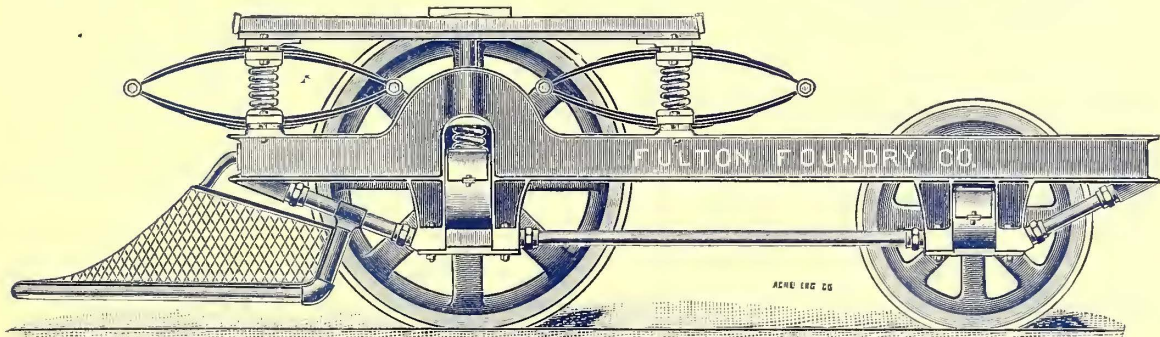

DOUBLE STEEL TRUCK "IMPERIAL."

This Truck has no Equal for Strength, Durability and Easy Riding.
WRITE FOR PRICES, BLUE PRINTS, ETC.

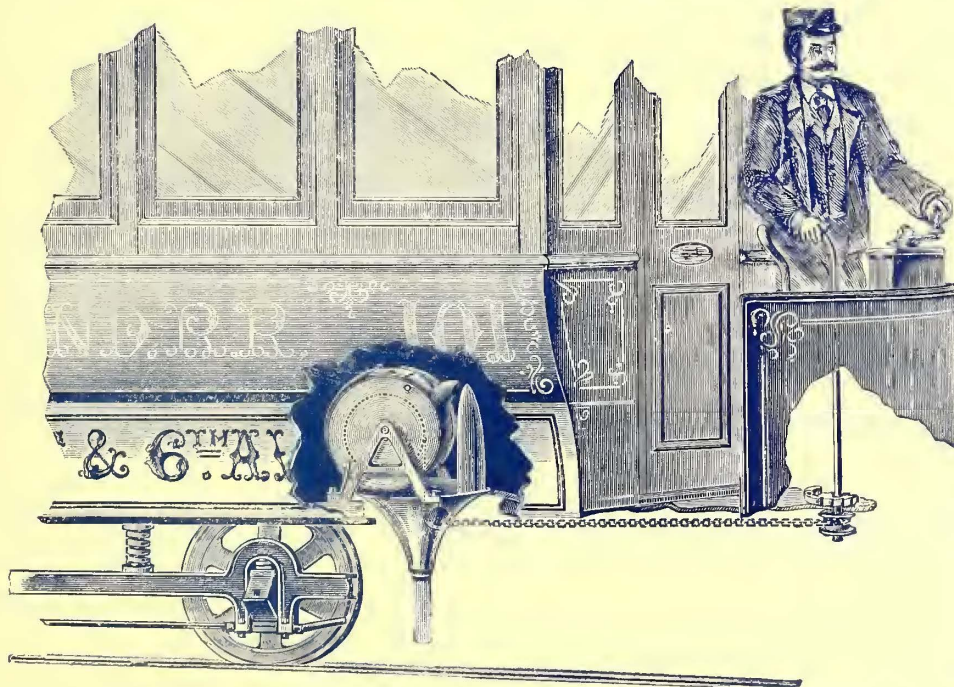

For your next cars specify the

Troy Sand Box,

(Patented June 22, 1893.)

And accept no other.

READ WHAT THEY SAY OF IT:
TROY CITY RAILWAY CO.,
TROY, N. Y., Nov. 8, 1893.
THE FULTON TRUCK & FOUNDRY CO.,
CLEVELAND, O.

Gentlemen:—We have been using the Troy Sand Box on our road since last February, during which time it has been in use on our Albia division, running a portion of the way on a 9 per cent. grade, and it has given us such satisfaction that we are now equipping all the cars on this division.

Respectfully yours,
(Signed) C. H. SMITH, Supt.

THE FULTON TRUCK & FOUNDRY COMPANY.

General Eastern Office, Havemeyer Building, 26 Cortlandt St., New York, WM. HAZELTON, 3d, Agent.

—• E. B. WILLCOX, •—

Fulton Foundry and Machine Works,

FINE MACHINERY IRON CASTINGS.

Tool and Pattern Making, General Machinists, Die, Press and
Interchangeable Work, Plain and Ornamental
Japanning. Sewing Machine Needles,

(B. N. W.)
BRAND.

Electrical Castings a Specialty.

21 FURMAN STREET, Near Fulton Ferry, BROOKLYN, N. Y.

TELEPHONE, BROOKLYN, 1413.

CABLE ADDRESS, EDWIN B. BROOKLYN.

1821.



1888.

MORRIS, TASKER & CO.,

INCORPORATED.

Offices, 222 and 224 So. Third Street, Philadelphia, Pa.

MANUFACTURERS OF

Boiler Tubes, Wrought Iron Pipe and Fittings.

ELECTRIC LIGHT AND

Street Railway Pipe Poles

A SPECIALTY.

PASCAL IRON WORKS. Philadelphia, Pa.

DELAWARE IRON WORKS, New Castle, Del.

DIRECTORY

OF

MANUFACTURERS AND DEALERS IN STREET RAILWAY SUPPLIES.

NOTE.—For reference to the advertisements, see alphabetical index on page V.

ADVERTISING RACKS.

Frost Veneer Seating Co., New York.
U.S. Steam & Street Ry. Advertising Co., Boston,
New York, etc.

AIR PUMPS.

Philadelphia Engineering Works (Ltd.), Phila., Pa.
Davidson, M. T., Brooklyn, N. Y.

AUTOMATIC SWITCHES.

Dorner & Dutton Mfg. Co., Cleveland, O.
Fulton Truck & Foundry Co., Cleveland, O.
Lewis & Fowler Mfg. Co., Brooklyn, N. Y.
Pennsylvania Iron Works Co., Philadelphia, Pa.
Wharton, Wm. Jr., & Co., Philadelphia, Pa.
White Manufacturing Co., The, New York.

AXLES.

Brill, J. G. Co., Philadelphia, Pa.
Dorner & Dutton Mfg. Co., Cleveland, O.
Fulton Truck & Foundry Co., Cleveland, O.
Lewis & Fowler Mfg. Co., Brooklyn, N. Y.
Peckham Motor Truck & Wheel Co., Kingston, N. Y.
Stephenson, Jno., Co. Ld., New York.
White Manufacturing Co., The, New York.
Whitney, A., & Sons, Philadelphia, Pa.

BADGES.

Allen, James A., Philadelphia, Pa.
Wales Manufacturing Co., Syracuse, N. Y.

BEARINGS.

Bemis Car Box Co., Springfield, Mass.
Brill, J. G. Co., Philadelphia, Pa.
Dorner & Dutton Mfg. Co., Cleveland, O.
Electric Railway Equipment Co., Cincinnati, O.
Fulton Truck & Foundry Co., Cleveland, O.
Lewis & Fowler Mfg. Co., Brooklyn, N. Y.
Nuttall, R. D., Co., Allegheny, Pa.
Peckham Motor Truck & Wheel Co., Kingston, N. Y.
Stephenson, John, Co., Ld., New York.
Taylor Electric Truck Co., Troy, N. Y.
Wharton, Wm. Jr., & Co., Philadelphia, Pa.
White Manufacturing Co., The, New York.

BELL CORD.

McClure, Chas. L., New York.
Schleren, Chas. A., & Co., New York.
Smith, J. D., New York.

BELLS, CAR.

Brill, J. G., Co., Philadelphia, Pa.
Lewis & Fowler Mfg. Co., Brooklyn, N. Y.
Pittsburgh Steel Hollow Ware Co., Allegheny
City, Pa.

BELTING.

Link-Belt Engineering Co., Nicetown, Pa.
Munson, Charles, Belting Co., Chicago, Ill.
Schleren, Chas. A., & Co., New York.
Shultz Belting Co., St. Louis, Mo.

BELTING, LEATHER LINK.

Shultz Belting Co., St. Louis, Mo.

BENDING MACHINES.

Barbour, Stockwell Co., Cambridgeport, Mass.
Wharton, Wm. Jr., & Co., Philadelphia, Pa.

BLINDS.

Brill, J. G., Co., Philadelphia, Pa.
Frost Veneer Seating Co., New York.
Sjoberg, J. P., & Co., New York.
Trimble, Jas. A., New York.

BOILER & PIPE COVERINGS.

Johns, H. W., Manufacturing Co., New York.
Keasbey, Robert A., New York.

BOILERS.

Babcock & Wilcox, New York.
Buckeye Engine Co., Salem, O.
Clonbrock Steam Boiler Works, Brooklyn, N. Y.
Dickson Manufacturing Co., Scranton, Pa.
Fleming, W. R. & Co., New York.
Helne Safety Boiler Co., St. Louis, Mo.
Jarvis Engineering Co., Boston, Mass.
Parker, J. W. & Co., Philadelphia, Pa.
Pennsylvania Iron Works Co., Philadelphia, Pa.
Southwark Foundry & Machine Co., Philadelphia,
Pa.
Stirling Co., The, Chicago, Ill.
Wetherill, Robert, & Co., Chester, Pa.
Woodbridge & Turner Engineering Co., New York.

BOLTS, FISH PLATES, ETC.

Barbour, Stockwell Co., Cambridgeport, Mass.
Cambria Iron Co., Philadelphia, Pa.
Craig, Wm. P., New York.
Dick, Kerr & Co., London, Eng.
Dorner & Dutton Mfg. Co., Cleveland, O.
Fulton Truck & Foundry Co., Cleveland, O.
Harrington, Robinson & Co., Boston, Mass.
Lewis & Fowler Mfg. Co., Brooklyn, N. Y.

New York Equipment Co., New York.
Pennsylvania Iron Works Co., Philadelphia, Pa.
Ralston & Co., Philadelphia, Pa.
Steel Rail Supply Co., The, New York.
Wharton, Wm., Jr. & Co., Philadelphia, Pa.

BOXES, JOURNAL.

Bemis Car Box Co., Springfield, Mass.
Brill, J. G. Co., Philadelphia, Pa.
Dorner & Dutton Mfg. Co., Cleveland, O.
Fowler, J. W., Car Co., Elizabethport, N. J.
Fulton Truck & Foundry Co., Cleveland, O.
Harrington, Robinson & Co., Boston, Mass.
Lewis & Fowler Mfg. Co., Brooklyn, N. Y.
Peckham Motor Truck & Wheel Co., Kingston, N. Y.
Stephenson, Jno., Co. Ld., New York.
Taylor Electric Truck Co., Troy, N. Y.
White Manufacturing Co., The, New York.

BRAKE HANDLES.

Brill, J. G., Co., Philadelphia, Pa.
Fowler, J. W., Car Co., Elizabethport, N. J.
Lewis & Fowler Mfg. Co., Brooklyn, N. Y.
Safety Clutch Brake Co., Philadelphia, Pa.
Stephenson, Jno., Co. Ld., New York.
White Manufacturing Co., New York.

BRAKE RODS.

Fowler, J. W., Car Co., Elizabethport, N. J.
Brill, J. G., Co., Philadelphia, Pa.
Lewis & Fowler Mfg. Co., Brooklyn, N. Y.
Peckham Motor Truck & Wheel Co., Kingston, N. Y.
Stephenson, Jno., Co. Ld., New York.
Taylor Electric Truck Co., Troy, N. Y.

BRAKE SHOES.

Brill, J. G., Co., Philadelphia, Pa.
Dorner & Dutton Mfg. Co., Cleveland, O.
Fowler, J. W., Car Co., Elizabethport, N. J.
Fulton Truck & Foundry Co., Cleveland, O.
Lewis & Fowler Mfg. Co., Brooklyn, N. Y.
Peckham Motor Truck & Wheel Co., Kingston, N. Y.
Pennsylvania Iron Works Co., Philadelphia, Pa.
Stephenson, Jno., Co. Ld., New York.
Taylor Electric Truck Co., Troy, N. Y.
Wharton, Wm. Jr., & Co., Philadelphia, Pa.
White Manufacturing Co., The, New York.

BRAKES.

Brill, J. G., Co., Philadelphia, Pa.
Dorner & Dutton Mfg. Co., Cleveland, O.
Fowler, J. W., Car Co., Elizabethport, N. J.
Genett Air Brake Co., Chicago, Ill.
Lewis & Fowler Mfg. Co., Brooklyn, N. Y.
Peckham Motor Truck & Wheel Co., Kingston, N. Y.
Safety Clutch Brake Co., Philadelphia, Pa.
Stephenson, Jno., Co. Ld., New York.
Taylor Electric Truck Co., Troy, N. Y.

BRAKES, RATCHET.

Brill, J. G., Co., Philadelphia, Pa.

BRAKES, TRACK.

Brill, J. G., Co., Philadelphia, Pa.
Stephenson, Jno., Co. Ld., New York.

BRIDGES, IRON.

Berlin Iron Bridge Co., East Berlin, Conn.
Wrought Iron Bridge Co., Canton, O.

BRIDGES, SUSPENDED.

Gagnier-Griffin Suspended Ry. Bridge Co., Chicago,

BUILDINGS, IRON.

Berlin Iron Bridge Co., East Berlin, Conn.
Wrought Iron Bridge Co., Canton, O.

CABLE DRIVING MACHINERY.

Dickson Manufacturing Co., Scranton, Pa.
Pennsylvania Iron Works Co., Philadelphia, Pa.
Walker Manufacturing Co., The, Cleveland, O.
Wharton, Wm. Jr., & Co., Philadelphia, Pa.

CAR LIGHTING.

Safety Car Heating & Lighting Co., New York.

CABLE GRIPS.

Pennsylvania Iron Works Co., Philadelphia, Pa.
Walker Manufacturing Co., The, Cleveland, O.

CABLE RAILWAY PLANTS.

Pennsylvania Iron Works Co., Philadelphia, Pa.
Walker Manufacturing Co., The, Cleveland, O.

CABLE ROADS AND MATERIALS.

Conway, M. W., Brooklyn, N. Y.
Dick, Kerr & Co., London, Eng.
Fowler, Geo. L., New York.
McCarthy, F. E., & Co., Boston, Mass.
New York Equipment Co., New York.
Pennsylvania Iron Works Co., Philadelphia, Pa.
Walker Manufacturing Co., The, Cleveland, O.
Washburn & Moen, Mfg. Co., Worcester, Mass.
Wharton, Wm., Jr., & Co., Philadelphia, Pa.

CABLE YOKES.

Johnson Co., Johnstown, Pa.
Pennsylvania Iron Works Co., Philadelphia, Pa.
Walker Manufacturing Co., The, Cleveland, O.
Wharton, Wm., Jr., & Co., Philadelphia, Pa.

CABLES, ELECTRIC LIGHT & POWER

Brixey, W. R., New York.
Creaghead Engineering Co., Cincinnati, O.
Eastern Electric Cable Co., Boston, Mass.
General Electric Co., Schenectady and New York
Habitshaw Wire, Yonkers, N. Y.
Hill, W. S., Electric Co., Boston, Mass.
Insulated Electric Light Wires, New York.
Moore, Alfred F., Philadelphia, Pa.
New York Electrical Works, New York.
Okonite Co. (Ltd.), The, New York.
Roebling's, John A., Sons Co., Trenton, N. J.
Washburn & Moen Mfg. Co., Worcester, Mass.

CABLES, ROPES.

California Wire Works, San Francisco, Cal.
Cradock, George, & Co., Wakefield, England.
Hazard Manufacturing Co., Wilkesbarre, Pa.
Roebling's, John A., Sons Co., Trenton, N. J.
Trenton Iron Company, Trenton, N. J.
Walker Manufacturing Co., Cleveland, O.
Washburn & Moen Mfg. Co., Worcester, Mass.

CABLES, TELEPHONE & TELEGRAPH

Creaghead Engineering Co., Cincinnati, O.
Eastern Electric Cable Co., Boston, Mass.
General Electric Co., Schenectady and New York
Habitshaw Wire, Yonkers, N. Y.
Hill, W. S., Electric Co., Boston, Mass.
Moore, Alfred F., Philadelphia, Pa.
Mosher Electric Co., Chicago, Ill.
New York Electrical Works, New York.
Okonite Co. (Ltd.), The, New York.
Roebling's, John A., Sons Co., Trenton, N. J.
Wallace Electric Co., Chicago, Ill.
Washburn & Moen Mfg. Co., Worcester, Mass.

CAR CEILINGS.

Brill, J. G., Co., Philadelphia, Pa.
Fowler, J. W., Car Co., Elizabethport, N. J.
Frost Veneer Seating Co., N. Y.
Lewis & Fowler Mfg. Co., Brooklyn, N. Y.
Stephenson, Jno., Co. Ld., New York.
Woodman, Joel H., Hoboken, N. J.

CAR CHANNELS.

Cambria Iron Co., Philadelphia, Pa.
Johnson Co., Johnstown, Pa.
Wharton, Wm., Jr., & Co., Philadelphia, Pa.

CAR COUPLERS.

Fitzgerald-Van Dorn Co., The, Lincoln, Neb.

CAR CURTAINS.

Brill, J. G., Co., Philadelphia, Pa.
Burrows, E. T., Co., The, Portland, Me
Davis Car Shade Co., Portland, Me.

CAR GATES & GUARDS.

Brill, J. G., Co., Philadelphia, Pa.
Pitt, Wm. R., Composite Iron Works, New York.

CAR LININGS.

Brill, J. G., Co., Philadelphia, Pa.
Woodman, Joel H., Hoboken, N. J.

CAR LUMBER.

Jackson & Sharp Co., Wilmington, Del.
Wetmore, A. B., New York.

CAR PANELS.

Brill, J. G., Co., Philadelphia, Pa.
Fowler, J. W., Car Co., Elizabethport, N. J.
Lewis & Fowler Mfg. Co., Brooklyn, N. Y.
Stephenson, Jno., Co., New York.
Trimble, Jas. A., New York.
Woodman, Joel H., Hoboken, N. J.

CAR ROOFS.

Frost Veneer Seating Co., New York.
Sjoberg, J. P., & Co., New York.
Trimble, Jas. A., New York.
Woodman, Joel H., Hoboken, N. J.

CAR SEATS.

Brill, J. G., Co., Philadelphia, Pa.
Frost Veneer Seating Co., New York.
Hale & Kilburn Mfg. Co., Phila., New York and
Chicago.
Lewis & Fowler Mfg. Co., Brooklyn, N. Y.

EDWARD SMITH & CO., COLORS AND VARNISHES, TIMES BUILDING, NEW YORK,

Scarritt Furniture Co., St. Louis, Mo.
Sjoberg, J. P., & Co., New York.
Stephenson, Jno., Co. Ld., New York.
Trimble, Jas. A., New York.
Veneer Seating & Church Furniture Co., Brooklyn, N. Y.
Woodman, Joel H., Hoboken, N. J.

CAR SHADES.

Brill, J. G. Co., Philadelphia, Pa.
Burrowes, E. T., Co., The, Portland, Me.

CAR SIDES AND ENDS.

Brill, J. G., Co., Philadelphia, Pa.
Frost Veneer Seating Co., New York.
Sjoberg, J. P., & Co., New York.
Trimble, Jas. A., New York.
Woodman, Joel H., Hoboken, N. J.

CAR STOVES.

Brill, J. G., Co., Philadelphia, Pa.
Fowler, J. W., Car Co., Elizabethport, N. J.
Lewis & Fowler Mfg. Co., Brooklyn, N. Y.

CAR TRIMMINGS.

Brill, J. G., Co., Philadelphia, Pa.
Fowler, J. W., Car Co., Elizabethport, N. J.
Lewis & Fowler Mfg. Co., Brooklyn, N. Y.
Stephenson, Jno., Co., Ld., New York.

CARBON BRUSHES.

General Electric Co., Schenectady and New York.
Mason Electric Co., Chicago Ill.
Ohio Brass Co., Mansfield, O.
Solar Carbon & Manufacturing Co., Pittsburgh, Pa.

CARBONS.

Solar Carbon & Manufacturing Co., Pittsburgh, Pa.

CARRIAGES.

Briggs Carriage Co., Amesbury, Mass.

CARS, NEW.

American Car Co., St. Louis, Mo.
Barney & Smith Car Co., Dayton, O.
Blackwell, Robert W., London, England.
Briggs Carriage Co., Amesbury, Mass.
Brill, J. G., Co., Philadelphia, Pa.
Brownell Car Co., St. Louis, Mo.
Ellis Car Co., Amesbury, Mass.
Fowler, J. W., Car Co., Elizabethport, N. J.
Gilbert Car Co., Troy, N. Y.
Jackson & Sharp Co., Wilmington, Del.
Jewett Car Co., Jewett, O.
Jones, J. M., Sons, West Troy, N. Y.
Kuhlman, G. C., Co., Cleveland, O.
Laclede Car Co., St. Louis, Mo.
Lewis & Fowler Mfg. Co., Brooklyn, N. Y.
Morse, C. D., Car Mfg. Co., Millbury, Mass.
New Castle Car Manufacturing Co., New Castle, Pa.
New York Equipment Co., New York.
Newburyport Car Mfg. Co., Newburyport, Mass.
Phillman's Palace Car Co., Chicago, Ill.
Ralston & Co., Philadelphia, Pa.
Steel Rail Supply Co., The, New York.
Stephenson, John, Co., Ld., New York.
St. Louis Car Co., St. Louis, Mo.
Trimble, James A., New York.
Woodbridge & Turner Engineering Co., New York.

CARS, SECOND HAND.

Hirsch, L. K., Chicago, Ill.
New York Equipment Co., New York.
Ralston & Co., Philadelphia, Pa.
Steel Rail Supply Co., The, New York.
Third Ave. R. R. Co., New York.
Thursby, James E., New York.
West End Street Railway Co., Boston, Mass.

CASTINGS.

Chester Steel Castings Co., Philadelphia, Pa.
Dorner & Dutton Mfg. Co., Cleveland, O.
Fulton Foundry & Machine Co., Brooklyn, N. Y.
Fulton Truck & Foundry Co., Cleveland, O.
Lewis & Fowler Mfg. Co., Brooklyn, N. Y.
Pennsylvania Iron Works Co., Philadelphia, Pa.
Ralston & Co., Philadelphia, Pa.
Shriver, T., & Co., New York.
Wharton, Wm., Jr., & Co., Philadelphia, Pa.
White Manufacturing Co., The, New York.
Willcox, E. B., Brooklyn, N. Y.

CASTINGS (SPECIAL), FOR WATER AND GAS.

Floyd, James R. & Sons, New York.

CHAIRS.

Barbour, Stockwell Co., Cambridgeport, Mass.
Burnham & Duggan Railway Appliance Co., Boston, Mass.
Johnson Co., Johnstown, Pa.
Lewis & Fowler Mfg. Co., Brooklyn, N. Y.
New York Equipment Co., New York.
Pennsylvania Iron Works Co., Philadelphia, Pa.
Steel Rail Supply Co., The, New York.
Wharton, Wm., Jr., & Co., Philadelphia, Pa.

CHIMNEYS, STEEL PLATE.

Philadelphia Engineering Works (Ltd.), Phila., Pa.

COMMUTATOR BARS.

Billings & Spencer Co., Hartford, Conn.
General Electric Co., Schenectady and New York.
Ohio Brass Co., Mansfield, O.

COMPRESSORS.

Philadelphia Engineering Works (Ltd.), Phila., Pa.

CONDENSERS.

Philadelphia Engineering Works (Ltd.), Phila., Pa.
Deane Steam Pump Co., Holyoke, Mass.
Davidson, M. T., Brooklyn, N. Y.
Wheeler Condenser & Engineering Co., New York.

CONDUCTORS' CAPS.

Brill J. G., Co., Philadelphia, Pa.
French, S. A., New York.
Wales Manufacturing Co., Syracuse, N. Y.

CONTRACTORS.

Ashley, Frank M., New York.
Bickford, J. H., Salem, Mass.
Cleveland Construction Co., Akron, O.
Complete Electric Construction Co., New York.
Comstock, The Louis K., Co., Chicago, Ill.
Conway, M. W., Brooklyn, N. Y.
Craig, Wm. P., East Orange, N. J.
Craghead Engineering Co., The, Cincinnati, O.
Davis, Lewis K., New York.
Dick, Kerr & Co., London, England.
Electric Railway Equipment Co., Cincinnati, O.
Electrical & Mechanical Engineering & Trading Co., New York.
Field, C. J., New York.
Fowler, Geo. L., New York.
Hall, J. P., New York.
Hampson, Edw. P., & Co., New York.
Hutchinson, A. J., New York.
Huxley & Hoffman, Boston, Mass.
Lane & Bodley Co., The, Cincinnati, O.
Leonard, H. Ward, & Co., New York.
Livingston, Chas. Ludlow, Pittsburgh, Pa.
Loss, C. E., & Co., Chicago, Ill.
McCarthy, F. E., & Co., Boston, Mass.
McNally, Thomas, Pittsburgh & Indianapolis.
Mailloux, C. O., New York.
Meyer, Julius, New York.
Murray, J. D., New Brunswick, N. J.
Nettel, O'Connor & Co., Incorp., New York.
Parker, J. W. & Co., Philadelphia, Pa.
Pennsylvania Iron Works Co., Philadelphia, Pa.
Pepper & Register, Philadelphia, Pa.
Ralston & Co., Philadelphia, Pa.
Reed & McKibbin, New York.
Smith, Thos. G., Jr., Cincinnati, O.
Stern & Silverman, Philadelphia, Pa.
Wakefield Electrical Engineering Co., Philadelphia, Pa.
Westinghouse, Church, Kerr & Co., New York.
Westinghouse Elec. & Mfg. Co., Pittsburgh, Pa.
White-Crosby Co., Baltimore, Md.
Woodbridge & Turner Engineering Co., New York.
Yeats Engineering Co., Chicago, Ill.

CONVEYORS, COAL AND ASHES.

Hunt, C. W., Co., New York.
Link-Belt Engineering Co., Nictown, Pa.

CRANES, TRAVELING.

Box, Alfred, Philadelphia, Pa.
Harrington, Edwin, Son & Co., Incorporated, Philadelphia, Pa.
Phoenix Iron Works, Cleveland, O.
Shriver, T., & Co., New York.

CROSSINGS, FROGS AND SWITCHES.

Barbour, Stockwell Co., Cambridgeport, Mass.
Dick, Kerr & Co., London, Eng.
Dorner & Dutton Mfg. Co., Cleveland, O.
Floyd, James R., & Sons, New York.
Fulton Truck & Foundry Co., Cleveland, O.
Harrington, Robinson & Co., Boston, Mass.
Lewis & Fowler Mfg. Co., Brooklyn, N. Y.
New York Equipment Co., New York.
Pennsylvania Iron Works Co., Philadelphia, Pa.
Steel Rail Supply Co., The, New York.
Wharton, Wm., Jr., & Co., Philadelphia, Pa.
White Manufacturing Co., The, New York.

CURVED RAILS.

Barbour, Stockwell Co., Cambridgeport, Mass.
Craig, Wm. P., East Orange, N. J.
Floyd, James R., & Sons, New York.
Fulton Truck & Foundry Co., Cleveland, O.
Harrington, Robinson & Co., Boston, Mass.
Lewis & Fowler Mfg. Co., Brooklyn, N. Y.
New York Equipment Co., New York.
Steel Rail Supply Co., The, New York.
Wharton, Wm., Jr., & Co., Philadelphia, Pa.

DETECTIVE SERVICE.

National Railroad Detective Agency, Newark, N. J.
Reliable Detective Agency, The, New York.
Thiel's Detective Service, New York.

DERMAGLUTINE.

Groetzinger, A., & Sons, Allegheny, Pa.

DROP FORGINGS.

Billings & Spencer Co., Hartford, Conn.
Strieby & Foote, Newark, N. J.

ECONOMIZERS.

Brightman Stoker Co., The, Cleveland, O.
Fuel Economizer Co., The, Matteawan, N. Y.

ELECTRIC RAILWAYS.

Bickford, J. H., Salem, Mass.
Cleveland Construction Co., Akron, O.
Complete Electric Construction Co., New York.
Comstock, The Louis K., Co., Chicago, Ill.
Craghead Engineering Co., Cincinnati, O.
Dick, Kerr & Co., London, Eng.
General Electric Co., Schenectady and New York.
McCarthy, F. E., & Co., Boston, Mass.

McNally, Thomas, Pittsburgh & Indianapolis.
Murray, J. D., New Brunswick, N. J.
Nettel, O'Connor & Co., Incorporated, New York.
Pennsylvania Iron Works Co., Philadelphia, Pa.
Ralston & Co., Philadelphia, Pa.
Reed & McKibbin, New York.
Smith, Thos. G., Jr., Cincinnati, O.
Wakefield Electrical Engineering Co., Philadelphia, Pa.
Westinghouse Electric & Mfg. Co., Pittsburgh, Pa.
Wharton, Wm., Jr., & Co., Philadelphia, Pa.
White-Crosby Co., Baltimore, Md.
Woodbridge & Turner Engineering Co., New York.
Yeats Engineering Co., Chicago, Ill.

ELECTRICAL INSTRUMENTS.

General Electric Co., Schenectady and New York.
Western Electrical Instrument Co., Newark, N. J.
Westinghouse Electric & Mfg. Co., Pittsburgh, Pa.

ELECTRICAL SUPPLIES.

Anderson, A. & J. M., Boston, Mass.
Billings & Spencer Co., Hartford, Conn.
Blackwell, Robert W., London, England.
Craghead Engineering Co., Cincinnati, O.
Curtis Electric Mfg. Co., Jersey City, N. J.
Dick, Kerr & Co., London, Eng.
Dudley, Julius T., & Co., New York.
Eastern Electric Cable Co., Boston, Mass.
Eddy Electric Manufacturing Co., Windsor, Conn.
Electric Railway Equipment Co., Cincinnati, O.
Fberrie Co., The, Mechanicville, N. Y.
General Electric Co., Schenectady and New York.
Glenwood Works, Yonkers, N. Y.
Groetzinger, A. & Sons, Allegheny, Pa.
Hill, W. S., Electric Co., Boston, Mass.
Hubley Manufacturing Co., Lancaster, Pa.
Johns, H. W., Manufacturing Co., New York.
Mason Electric Co., Chicago, Ill.
Moore, Alfred F., Philadelphia, Pa.
Moshier Electric Co., Chicago.
Nettel, O'Connor & Co., Incorporated, New York.
New York Electrical Works, New York.
New York Equipment Co., New York.
Ohio Brass Co., Mansfield, O.
Okonite Co. (Ltd.), The, New York.
Partridge, Arthur S., St. Louis, Mo.
Ralston & Co., Philadelphia, Pa.
Rumrill, Charles M., & Bro., New York.
Solar Carbon & Mfg. Co., Pittsburgh, Pa.
Standard Paint Co., New York.
Steel Motor Co., The, Cleveland, O.
United Columbian Electric Co., New York.
Van Nuis, C. S., New York.
Wales Manufacturing Co., Syracuse, N. Y.
Wallace Electric Co., Chicago, Ill.
Washburn & Moen Mfg. Co., Worcester, Mass.
Westinghouse Electric & Mfg. Co., Pittsburgh, Pa.
Western Electrical Instrument Co., Newark, N. J.
Woodridge & Turner Engineering Co., New York.

ELECTROTYPING.

Field & Beattie, New York.

ELEVATORS.

Link-Belt Engineering Co., Nictown, Pa.
Morse, Williams & Co., Philadelphia, Pa.

ENGINEERS, ELECTRICAL.

Anthony, W. A., Vineland, N. J.
Arnold, B. J., Chicago, Ill.
Ashley, Frank M., New York.
Bickford, J. H., Salem, Mass.
Blackwell, Robert W., London, England.
Cleveland Construction Co., Akron, O.
Complete Electric Construction Co., New York.
Comstock, The Louis K., Co., Chicago, Ill.
Craghead Engineering Co., Cincinnati, O.
Davis, Lewis K., New York.
Dick, Kerr & Co., London, Eng.
Electrical & Mechanical Engineering & Trading Co., New York.
Field, C. J., New York.
General Electric Co., Schenectady and New York.
Hall, J. P., New York.
Higgins, Edward E., New York.
Hutchinson, A. J., New York.
McCarthy, F. E., & Co., Boston, Mass.
Leonard, H. Ward, & Co., New York.
Livingston, Chas. Ludlow, Pittsburgh, Pa.
Mailloux, C. O., New York.
Maloche, H. J., New Orleans, La.
Meyer, Julius, New York.
Murray, J. D., New Brunswick, N. J.
Nettel, O'Connor & Co., Incorporated, New York.
Parker, J. W., & Co., Philadelphia, Pa.
Pepper & Register, Philadelphia, Pa.
Ralston & Co., Philadelphia, Pa.
Reed & McKibbin, New York.
Siemens & Halske Electric Co. of America, Chicago.
Smith, Thos. G., Jr., Cincinnati, O.
Stern & Silverman, Philadelphia, Pa.
Thayer, William C., Cleveland, O.
Van Nuis, C. S., New York.
Wakefield Electrical Engineering Co., Philadelphia, Pa.
Walker Manufacturing Co., Cleveland, O.
White-Crosby Co., Baltimore, Md.
Woodbridge & Turner Engineering Co., New York.
Yeats Engineering Co., Chicago, Ill.

ENGINEERS, MECHANICAL.

Ashley, Frank M., New York.
Bickford, J. H., Salem, Mass.
Colby, C. B. & W. H., Philadelphia, Pa.
Dick, Kerr & Co., London, Eng.
Electrical & Mechanical Engineering & Trading Co., New York.
Fowler, Geo. L., New York.
Hampson, Edw. P., & Co., New York.

Hutchinson, A. J., New York.
 Lane & Bodley Co., The, Cincinnati, O.
 McCarthy, F. E. & Co., Boston, Mass.
 Meyer, Julius, New York.
 Parker, J. W., & Co., Philadelphia, Pa.
 Pepper & Register, Philadelphia, Pa.
 Pennsylvania Iron Works Co., Philadelphia, Pa.
 Shook, Anderson Mfg. Co., Pittsburgh, Pa.
 Smith, Thos. G., Jr., Cincinnati, O.
 Walker Manufacturing Co., The, Cleveland, O.
 Westinghouse, Church, Kerr & Co., New York.
 Wheeler Condenser & Engineering Co., New York.
 Woodbridge & Turner Engineering Co., New York.
 Yeats Engineering Co., Chicago, Ill.

ENGINEERS' SETS.

Wilnot & Hobbs, New York, and Bridgeport, Conn

ENGINES.

Allis, The Edward P. Co., Milwaukee, Wis.
 Altoona Manufacturing Co., Altoona, Pa.
 Ames Iron Works, Oswego, N. Y.
 Ball & Wood Co., The, New York.
 Ball Engine Co., Erie, Pa.
 Bates Machine Co., Joliet, Ill.
 Buckeye Engine Co., Salem, O.
 Cooper, C. & G., & Co., Mt. Vernon, O.
 Currier, Mayo & Co., Boston, Mass.
 Dickson Manufacturing Co., Scranton, Pa.
 Fishkill Landing Machine Co., Fishkill-on-Hudson
 Fleming, W. R. & Co., New York.
 Harrington, Edw. P. & Co., New York.
 Harrisburg Foundry & Machine Co., Harrisb'g, Pa.
 Hoffman & Billings Mfg. Co., Milwaukee, Wis.
 Hooven, Owens & Rentschler, Hamilton, O.
 "I. A. L. & Son, Springfield, Ill.
 "L. P. & D." Transmitter Co., Montpelier, Vt.
 Lane & Bodley Co., The, Cincinnati, O.
 McEwen, J. H., Mfg. Co., Ridgway, Pa.
 McIntosh, Seymour & Co., Auburn, N. Y.
 New York Equipment Co., New York.
 Otto Gas Engine Works, Philadelphia, Pa.
 Parker, J. W., & Co., Philadelphia, Pa.
 Pennsylvania Iron Works Co., Philadelphia, Pa.
 Philadelphia Engineering Works (Ltd.), Phila., Pa.
 Phoenix Iron Works, Cleveland, O.
 Phoenix Iron Works Co., Meadville, Pa.
 Pierce & Miller Engineering Co., New York.
 Southwark Foundry & Machine Co., Phila., Pa.
 Walker Manufacturing Co., The, Cleveland, O.
 Westinghouse, Church, Kerr & Co., New York.
 Wetherill, Robert, & Co., Chester, Pa.
 Woodbridge & Turner Engineering Co., New York.

ENGINES, BLOWING.

Philadelphia Engineering Works (Ltd.), Phila., Pa

ENGINES, HOISTING.

Dickson Manufacturing Co., Scranton, Pa.
 Walker Manufacturing Co., The, Cleveland, O.

ENGRAVING.

Field & Beattie, New York.

EYE BOLTS.

Billings & Spencer Co., Hartford, Conn.
 Creaghead Engineering Co., Cincinnati, O.

FANS, STEAM.

Buffalo Forge Co., Buffalo, N. Y.
 Sturtevant, B. F., & Co., Boston, Mass.

FARE BOXES.

Brill, J. G. Co., Philadelphia, Pa.
 Brownell Car Co., St. Louis, Mo.
 Lewis & Fowler Mfg. Co., Brooklyn, N. Y.
 New York Equipment Co., New York.
 Stephenson, John, Co., Ltd., New York.
 Wales Manufacturing Co., Syracuse, N. Y.

FARE COLLECTORS.

Lewis & Fowler Mfg. Co., Brooklyn, N. Y.

FARE REGISTERS.

Ames Register Co., Boston, Mass.
 Brill, J. G. Co., Philadelphia, Pa.
 Fowler, J. W., Car Co., Elizabethport, N. J.
 Lewis & Fowler Mfg. Co., Brooklyn, N. Y.
 Meaker Mfg. Co., Chicago, Ill.
 New Haven Car Register Co., New Haven, Conn.
 Railway Register Mfg. Co., New York.
 St. Louis Car Co., St. Louis, Mo.
 St. Louis Register Co., St. Louis, Mo.
 Sterling Supply & Manufacturing Co., New York.
 Wales Manufacturing Co., Syracuse, N. Y.

FEED WATER HEATERS.

Fuel Economizer Co., The, Matteawan, N. Y.
 Goubert Manufacturing Co., The, New York.
 Hoppes Manufacturing Co., Springfield, O.
 Philadelphia Engineering Works (Ltd.), Phila., Pa.
 Webster, Warren, & Co., Camden, N. J.

FEED WATER PURIFIERS (Live Steam).

Davis, I. B., & Son, Hartford, Conn.
 Goubert Manufacturing Co., New York.
 Hoppes Manufacturing Co., Springfield, O.
 Webster, Warren, & Co., Camden, N. J.

FENDERS AND GUARDS.

Clarke, F. H., Springfield, O.
 Crawford, R. A., Mfg. Co., Pittsburgh, Pa.
 Field Life Guard Co., Providence, R. I.
 Foster Automatic Safety Guard Co., New York.
 Leonhardt Pneumatic Safety Car Fender Co., Baltimore, Md.
 Pfingst, Louis, Boston, Mass.

FIBRE CONDUIT.

Fibre Conduit Co., New York

FORGINGS.

Dorner & Dutton Mfg. Co. Cleveland, O.

FRICTION CLUTCHES AND COUPLINGS.

Falls Rivet & Machine Co., Cuyahoga Falls, O.
 Lake, J. H. & D. Co., Massillon, O.
 Walker Manufacturing Co., Cleveland, O.

FURNACES.

Fleming, W. R., & Co., New York.
 Philadelphia Engineering Works (Ltd.), Phila., Pa

GEARING.

Chester Steel Castings Co., Philadelphia, Pa.
 Dickson Manufacturing Co., Scranton, Pa.
 Dorner & Dutton Mfg. Co., Cleveland, O.
 Electric Railway Equipment Co., Cincinnati, O.
 Fulton Truck & Foundry Co., Cleveland, O.
 General Electric Co., Schenectady and New York.
 Grotzinger, A. & Sons, Allegheny, Pa.
 Horsburgh & Scott, Cleveland, O.
 Mertes, A., Manufacturing Co., Allegheny, Pa.
 New Process Raw Hide Co., The, Syracuse, N. Y.
 Nuttall, R. D. Co., Allegheny, Pa.
 Pennsylvania Iron Works Co., Philadelphia, Pa.
 Shriver, T., & Co., New York.
 Steel Motor Co., The, Cleveland, O.
 Walker Manufacturing Co., The, Cleveland, O.
 Wharton, Wm., Jr., & Co., Philadelphia, Pa.
 Woodbridge & Turner Engineering Co., New York.

GENERATORS.

Complete Electric Construction Co., New York.
 Creaghead Engineering Co., Cincinnati, O.
 Curtis Electric Mfg. Co., Jersey City, N. J.
 Eddy Electric Mfg. Co., Windsor, Conn.
 General Electric Co., Schenectady and New York.
 Hill, W. S., Electric Co., Boston, Mass.
 Mosher Electric Co., Chicago, Ill.
 New York Equipment Co., New York.
 Siemens & Halske Electric Co. of America, Chicago
 Steel Motor Co., The, Cleveland, O.
 United Columbian Electric Co., New York.
 Walker Manufacturing Co., Cleveland, O.
 Wallace Electric Co., Chicago, Ill.
 Westinghouse Electric & Mfg. Co., Pittsburgh, Pa.

GONGS, CABLE AND CAR.

Bevin Bros. Manufacturing Co., East Hampton, Conn.
 Brill, J. G., Co., Philadelphia, Pa.
 Fowler, J. W., Car Co., Elizabethport, N. J.
 Johnson Electric Co., Cleveland, O.
 Lewis & Fowler Mfg. Co., Brooklyn, N. Y.
 New York Equipment Co., New York.
 Pittsburgh Steel Hollow Ware Co., Allegheny, Pa.

GRATE BARS, SECTIONAL.

Tupper, W. W., & Co., New York.

GRATES, SECTIONAL.

Tupper, W. W., & Co., New York.

GRIP DIES.

Pennsylvania Iron Works Co., Philadelphia, Pa.
 Walker Manufacturing Co., The, Cleveland, O.

GRIPS.

Pennsylvania Iron Works Co., Philadelphia, Pa.

GUTTERS.

Barbour, Stockwell Co., Cambridgeport, Mass.
 Dorner & Dutton Mfg. Co., Cleveland, O.
 Wharton, Wm., Jr., & Co., Philadelphia, Pa.

HEADLIGHTS.

Brill, J. G., Co., Philadelphia, Pa.
 Changeable Elec. Light Co., The, Syracuse, N. Y.
 New York Equipment Co., New York.
 Ohio Brass Co., Mansfield, O.
 Rumrill, Charles M., & Bro., New York.
 Smith, J. D., New York.
 Wales Manufacturing Co., Syracuse, N. Y.
 Wheeler Reflector Co., Boston, Mass.

HEATERS, CAR.

Brill, J. G. Co., Philadelphia, Pa.
 Central Electric Heating Co., New York.
 Consolidated Car Heating Co., Albany, N. Y.
 Fowler, J. W., Car Co., Elizabethport, N. J.
 Lewis & Fowler Mfg. Co., Brooklyn, N. Y.
 Safety Car Heating & Lighting Co., New York.
 Sterling Supply Co., New York.

HEATERS, ELECTRIC.

Brill, J. G., Co., Philadelphia, Pa.
 Central Electric Heating Co., New York.
 Consolidated Car Heating Co., Albany, N. Y.

HYDRAULIC JACKS.

Schaffer, The J. T., Mfg. Co., Rochester, N. Y.
 Walker Manufacturing Co., The, Cleveland, O.
 Watson & Stillman, New York.

INDICATORS.

Hine & Robertson, New York.
 Ohio Brass Co., Mansfield, O.

INSPECTORS.

Colby, C. B. & W. H., Philadelphia, Pa.

INSULATORS.

Anderson, A. & J. M., Boston, Mass.
 Blackwell, Robert W., London, England.
 Burnham & Duggan Railway Appliance Co., Boston, Mass.
 Creaghead Engineering Co., Cincinnati, O.
 Curtis Electric Mfg. Co., Jersey City, N. J.
 Delaware Hard Fibre Co., Wilmington, Del.
 Electric Railway Equipment Co., Cincinnati, O.
 Fiberite Co., The, Mechanicville, N. Y.
 Fibre Conduit Co., New York.
 General Electric Co., Schenectady and New York.
 Hammond Cleat & Insulator Co., Boston, Mass.
 Johns, H. W., Manufacturing Co., New York.
 Mason Electric Co., Chicago, Ill.
 Mosher Electric Co., Chicago, Ill.
 Ohio Brass Co., Mansfield, O.

Rumrill, Charles M., & Bro., New York.
 Standard Paint Co., New York.
 Steel Motor Co., The, Cleveland, O.
 Wales Manufacturing Co., Syracuse, N. Y.
 Wallace Electric Co., Chicago, Ill.
 Walworth Mfg. Co., Boston, Mass.

INSULATORS, MICA.

Creaghead Engineering Co., Cincinnati, O.
 Johns, H. W., Manufacturing Co., New York.

IRON STRUCTURAL WORK.

Berlin Iron Bridge Co., East Berlin, Conn.

KNEES AND OTHER TRACK CASTINGS.

Barbour, Stockwell Co., Cambridgeport, Mass.
 Craig, Wm. P., New York.
 Dorner & Dutton Mfg. Co., Cleveland, O.
 Floyd, James R., & Sons, New York.
 Fulton Truck & Foundry Co., Cleveland, O.
 Harrington, Robinson & Co., Boston, Mass.
 Lewis & Fowler Mfg. Co., Brooklyn, N. Y.
 New York Equipment Co., New York.
 Pennsylvania Iron Works Co., Philadelphia, Pa.
 Steel Rail Supply Co., The, New York.
 Wharton, Wm., Jr., & Co., Philadelphia, Pa.

LAMPS.

Brill, J. G., Co., Philadelphia, Pa.
 Lewis & Fowler Mfg. Co., Brooklyn, N. Y.
 Smith, J. D., New York.
 Stephenson, John, Co., Ltd., New York.
 Wheeler Reflector Co., Washington, D. C.
 Wilnot & Hobbs, New York, and Bridgeport, Conn.

LAMPS, ELECTRIC.

Creaghead Engineering Co., Cincinnati, O.
 General Electric Co., Schenectady and New York.
 General Incandescent Arc Light Co., New York.
 Mosher Electric Co., Chicago, Ill.
 Wallace Electric Co., Chicago, Ill.
 Wheeler Reflector Co., Boston, Mass.

LAW.

Eppley, Francis M., New York.

LIGHTNING ARRESTERS.

General Electric Co., Schenectady and New York.
 Hill, W. S., Electric Co., Boston, Mass.
 Mason Electric Co., Chicago, Ill.
 Ohio Brass Co., Mansfield, O.
 Van Nuis, C. S., New York.

LOCK NUTS.

Young Lock Nut Co., New York.

LOCOMOTIVES.

Dickson Manufacturing Co., Scranton, Pa.
 Steel Rail Supply Co., The, New York.

LUBRICANTS.

Dixon, Joseph, Crucible Co., Jersey City, N. J.
 Wadhams Oil & Grease Co., Milwaukee, Wis.

LUMBER, CAR BUILDERS'.

Rankin, W. L. & Bro., Latta, S. C.
 Wetmore, A. B., New York.

MACHINE TOOLS

Garvin Machine Co., New York.
 Harrington, Edwin, Son & Co., Incorporated, Philadelphia, Pa.
 Lodge & Davis Machine Tool Co., Cincinnati, O.
 Ralston & Co., Philadelphia, Pa.
 Schaffer, The J. T., Mfg. Co., Rochester, N. Y.

MAGNESIA SECTIONAL COVERINGS.

Keasbey, Robert A., New York.

MAGNETIC CUT-OUTS.

General Electric Co., Schenectady and New York.

MATTING, WOOD.

Brill, J. G. Co., Philadelphia, Pa.
 Lewis, Samuel, Brooklyn, N. Y.

MEDBERY INSULATION.

Fiberite Co., The, Mechanicville, N. Y.

METERS, ELECTRIC.

General Electric Co., Schenectady and New York.

MICA.

Munsell, Eugene, New York.

MOTORS, ELECTRIC.

Complete Electric Construction Co., New York
 Creaghead Engineering Co., Cincinnati, O.
 Curtis Electric Mfg. Co., Jersey City, N. J.
 Eddy Electric Manufacturing Co., Windsor, Conn.
 General Electric Co., Schenectady and New York.
 Hill, W. S., Electric Co., Boston, Mass.
 Mason Electric Co., Chicago, Ill.
 Mosher Electric Co., Chicago, Ill.
 New York Equipment Co., New York.
 Siemens & Halske Electric Co. of America, Chicago
 Steel Motor Co., The, Cleveland, O.
 United Columbian Electric Co., New York.
 Walker Manufacturing Co., Cleveland, O.
 Wallace Electric Co., Chicago, Ill.
 Warfield, Louis, Detroit, Mich.
 Westinghouse Electric & Mfg. Co., Pittsburgh, Pa.
 Woodbridge & Turner Engineering Co., New York.

OFFICE SPECIALTIES.

Office Specialty Manufacturing Co., New York.

OILERS.

Wilnot & Hobbs, Manufacturing Co., New York, and Bridgeport, Conn.

ROUND "BELL CORD" LEATHER oak Tanned for **Chas. A. Schieren & Co.** **Street Cars.** **MANUFACTURERS.** New York, 47 Ferry St. Philadelphia, 226 N. 3d St. Boston, 119 High St. Chicago, 46 & 48 S. Canal St.

PAINT, GRAPHITE.

Dixon, Joseph, Crucible Co., Jersey City, N. J.

PAINT, PRESERVATIVE, FOR IRON.

Standard Paint Co., New York.

PAINTS.

Johns, H. W., Manufacturing Co., New York.
Valentine & Co., New York.

PATENT SOLICITORS, ETC.

Rosenbaum, Wm. A., New York.
Ruff, W. H., Washington, D. C.

PEDESTALS.

Brill, J. G. Co., Philadelphia, Pa.
Fowler, J. W., & Co., Elizabethport, N. J.
Lewis & Fowler Mfg. Co., Brooklyn, N. Y.
Stephenson, John, Co., Ltd., New York
Wharton, Wm., Jr., & Co., Philadelphia, Pa.
White Manufacturing Co., The, New York.

PERFORATED METALS.

Mundt & Sons, New York.

PHOSPHOR BRONZE.

Phosphor Bronze Smelting Co., Philadelphia, Pa.

PINIONS, METALLIC.

Chester Steel Castings Co., Philadelphia, Pa.
Dickson Manufacturing Co., Scranton, Pa.
Dorner & Dutton Manufacturing Co., Cleveland, O.
Electric Railway Equipment Co. Cincinnati, O.
General Electric Co., Schenectady and New York.
Horsburgh & Scott, Cleveland, O.
Mertes, A., Manufacturing Co., Allegheny, Pa.
Nuttall, R. D., Co., Allegheny, Pa.
Pennsylvania Iron Works, Philadelphia, Pa.
Steel Motor Co., The, Cleveland, O.
Walker Manufacturing Co., Cleveland, O.
Wharton, Wm., Jr., & Co., Philadelphia, Pa.

PIPES.

Shook, Anderson Mfg. Co., Pittsburgh, Pa.

POLE BRACKETS.

Creaghead Engineering Co., Cincinnati, O.
Ohio Brass Co., Mansfield, O.
Simmons, John, Co., New York.

POLES, METAL.

Berlin Iron Bridge Co., East Berlin, Conn.
Blackwell, Robert W., London, England.
Creaghead Engineering Co., Cincinnati, O.
Electric Railway Equipment Co., Cincinnati, O.
Morris, Tasker & Co., Philadelphia, Pa.
Nettel, O'Connor & Co., Incorporated, New York.
New York Electrical Works, New York.
New York Equipment Co., New York.
Nuttall, R. D., Co., Allegheny, Pa.
Ohio Brass Co., Mansfield, O.
Partridge, Arthur S., St. Louis, Mo.
Ralston & Co., Philadelphia, Pa.
Simmons, John, Co., New York.
Wrought Iron Bridge Co., Canton, O.

POLES, WOODEN.

Creaghead Engineering Co., Cincinnati, O.
Hallowell, Ell B. & Co., Philadelphia, Pa.
Loud, H. W., & Sons Lumber Co., Au Sable, Mich.
New York Equipment Co., New York.
Nuttall, R. D., Co., Allegheny, Pa.
Ohio Brass Co., Mansfield, O.
Ralston & Co., Philadelphia, Pa.
Rankin, W. L., & Bro., Latta, S. C.
White-Crosby Co., Baltimore, Md.

POWER TRANSMISSION.

General Electric Co., Schenectady and New York.
"L. P. & D." Transmitter Co., Montpelier, Vt.
Link-Belt Engineering Co., Nicetown, Pa.
Walker Manufacturing Co., Cleveland, O.
Washburn & Moen, Mfg. Co., Worcester, Mass.

PRESSES, COPYING.

Shriver, T. & Co., New York.

PRESSES, LEVER, HYDRAULIC, ETC.

Schaffer, J. T., Manufacturing Co., Rochester, N. Y.
Walker Manufacturing Co., The, Cleveland, O.
Watson & Stillman, New York.

PRESSES, WHEEL.

Dorner & Dutton Mfg. Co., Cleveland, O.
Fulton Truck & Foundry Co., Cleveland, O.
Hathaway, Alfred G., Cleveland, O.
Schaffer, J. T., Manufacturing Co., Rochester, N. Y.
Watson & Stillman, New York.

PULLEYS.

"L. P. & D." Transmitter Co., Montpelier, Vt.

Lane & Bodley Co., The, Cincinnati, O.
Shriver, T. & Co., New York.
Walker Manufacturing Co., The, Cleveland, O.

PULLEYS, CABLE.

Walker Manufacturing Co., The, Cleveland, O.
Wharton, Wm., Jr. & Co., Philadelphia, Pa.

PUMPS.

Davidson, M. T., Brooklyn.
Deane Steam Pump Co., Holyoke, Mass.
Dickson Manufacturing Co., Scranton, Pa.
Schaffer, J. T., Manufacturing Co., Rochester, N. Y.
Shook, Anderson Mfg. Co., Pittsburgh, Pa.
Southwark Foundry & Machine Co., Philadelphia, Pa.
Walker Manufacturing Co., The, Cleveland, O.
Wheeler Condenser & Engineering Co., New York.

RAIL BONDS.

Car Equipment Co., Philadelphia, Pa.
Electrical & Mechanical Engineering & Trading Co., New York.
General Electric Co., Schenectady and New York.
Keithley, H. R., Chicago, Ill.
New York Electrical Works, New York.
New York Equipment Co., New York.
Ohio Brass Co., Mansfield, O.
Rumrill, Charles M., & Bro., New York.

RAIL JOINTS.

American Rail Joint Co., Marlon, Ind.
Cambria Iron Co., Philadelphia, Pa.
Harrington, Robinson & Co., Boston, Mass.
New York Equipment Co., New York.
Pennsylvania Iron Works Co., Philadelphia, Pa.
Wharton, Wm. Jr. & Co., Philadelphia, Pa.

RAILS, GIRDER.

Barbour, Stockwell Co., Cambridgeport, Mass.
Dick, Kerr & Co., London, Eng.
Harrington, Robinson & Co., Boston, Mass.
Hirsch, L. K., Chicago, Ill.
Lewis & Fowler Girder Rail Co., Brooklyn, N. Y.
New York Equipment Co., New York.
Pennsylvania Iron Works Co., Philadelphia, Pa.
Ralston & Co., Philadelphia, Pa.
Steel Rail Supply Co., The, New York.
Wharton, Wm., Jr., & Co., Philadelphia, Pa.
Woodbridge & Turner Engineering Co., New York.

RAILS, SECOND HAND.

Hirsch, L. K., Chicago, Ill.
New York Equipment Co., New York.
Ralston & Co., Philadelphia, Pa.

RAILS, TURNOUTS, CURVES, ETC.

Barbour, Stockwell Co., Cambridgeport, Mass.
Cambria Iron Co., Philadelphia, Pa.
Craig, Wm. P., East Orange, N. Y.
Dick, Kerr & Co., London, Eng.
Dorner & Dutton Mfg. Co., Cleveland, O.
Fulton Truck & Foundry Co., Cleveland, O.
Harrington, Robinson & Co., Boston, Mass.
Hirsch, L. K., Chicago, Ill.
Lewis & Fowler Girder Rail Co., Brooklyn, N. Y.
Lewis & Fowler Mfg. Co., Brooklyn, N. Y.
New York Equipment Co., New York.
Pennsylvania Iron Works Co., Philadelphia, Pa.
Ralston & Co., Philadelphia, Pa.
Steel Rail Supply Co., The, New York.
Wharton, Wm., Jr., & Co., Philadelphia, Pa.
Woodbridge & Turner Engineering Co., New York.

RAILWAY ADVERTISING.

U. S. Steam & Street Railway Advertising Co.
New York and Boston.

RAILWAY FEED WIRES.

Brixey, W. R., New York.
Creaghead Engineering Co., Cincinnati, O.
Curtis Electric Mfg. Co., Jersey City, N. J.
General Electric Co., Schenectady and New York.
Eastern Electric Cable Co., Boston, Mass.
Electric Railway Equipment Co., Cincinnati, O.
Hablshaw Wire, Yonkers, N. Y.
Bill, W. S., Electric Co., Boston, Mass.
Mason Electric Co., Chicago, Ill.
New York Equipment Co., New York.
Okonite Co., The, Ltd., New York.
Partridge, Arthur S., St. Louis, Mo.
Roebbing's, John A., Sons Co., Trenton, N. J.
Wallace Electric Co., Chicago, Ill.
Washburn & Moen Mfg. Co., Worcester, Mass.

RAW HIDE PINIONS.

Groetzinger, A. & Sons, Allegheny, Pa.
Horsburgh & Scott, Cleveland, O.
New Process Raw Hide Co., Syracuse, N. Y.
Nuttall, R. D. Co., Allegheny, Pa.
Steel Motor Co., The, Cleveland, O.

REFLECTORS.

Smith, Josephine D., New York.
Wheeler Reflector Co., Boston, Mass.

ROOFING.

Johns, H. W., Manufacturing Co., New York.

ROOFING, GLASS.

Paradigm Construction Co., New York.

ROOFS, IRON.

Berlin Iron Bridge Co., East Berlin, Conn.

ROPE WHEELS.

Philadelphia Engineering Works (Ltd.), Phila., Pa.

ROPES, COTTON.

Walker Manufacturing Co., The, Cleveland, O.

ROTATING SIGNS.

Wheeler Reflector Co., Washington, D. C.

RUNNING GEAR.

Barney & Smith Car Co., Dayton, O.
Bemis Car Box Co., Springfield, Mass.
Blackwell, Robert W., London, England.
Brill, J. G. Co., Philadelphia, Pa.
Brownell Car Co., St. Louis, Mo.
Chicago Electric Truck Co., Chicago, Ill.
Dorner & Dutton Mfg. Co., Cleveland, O.
Fowler, J. W., Car Co., Elizabethport, N. J.
Fulton Truck & Foundry Co., Cleveland, O.
General Electric Co., Schenectady and New York.
Graham Equipment Co., Boston and Philadelphia.
Laclede Car Co., St. Louis, Mo.
Lewis & Fowler Mfg. Co., Brooklyn, N. Y.
McGuire Manufacturing Co., Chicago, Ill.
Peckham Motor Truck & Wheel Co., Kingston, N. Y.
Robinson Electric Truck & Supply Co., Boston, Mass.
St. Louis Car Co., St. Louis, Mo.
Sheppard Manufacturing Co., Louisville, Ky.
Stephenson, John, Co., Ltd., New York.
Taylor Electric Truck Co., Troy, N. Y.
Wharton, Wm., Jr., & Co., Philadelphia, Pa.

SALT DISTRIBUTORS.

Brill, J. G. Co., Philadelphia, Pa.
Dewitt, E. F. & Co., Lansingburgh, N. Y.

SAND BOXES.

Brill, J. G. Co., Philadelphia, Pa.
Crawford, R. A., Manufacturing Co., Pittsburgh, Pa.
Dewitt, E. F., & Co., Lansingburgh, N. Y.
Fulton Truck & Foundry Co., Cleveland, O.
Peckham Motor Truck & Wheel Co., Kingston, N. Y.
Sterling Supply & Manufacturing Co., New York.

SASHES.

Frost Veneer Seating Co., New York.
Sjoberg, J. P., New York.
Trimble, Jas. A., New York.
Woodman, Joel H., Hoboken, N. J.

SCHOOLS.

Correspondence School of Mechanics & Industrial Sciences, Scranton, Pa.

SEATING, RAILROAD.

Frost Veneer Seating Co., New York.
Woodman, Joel H., Hoboken, N. J.

SECURITIES.

Eppley, Francis M., New York.
Hutchinson, A. J., New York.
New York Equipment Co., New York.

SEPARATORS.

Goubert Mfg. Co., (Stratton Separator) The, New York.
Webster, Warren, & Co., Camden, N. J.

SIGNAL LIGHTS.

Brill, J. G. Co., Philadelphia, Pa.
Smith, J. D., New York.
Stephenson, Jno., Co. Ltd., New York.

SIGNALS, ELECTRIC.

Dewey Electric Signal Co., New York.

SILICON BRONZE WIRE.

Roebbing's, John A., Sons Co., New York.

SILVERED CORRUGATED REFLECTOR GLASS.

Smith, J. D., New York.

SKYLIGHTS.

Paradigm Construction Co., New York.

SNOW PLOWS.

Brill, J. G. Co., Philadelphia, Pa.
Brooklyn Railway Supply Co., Stamford, Conn.
Dorner & Dutton Mfg. Co., Cleveland, O.
Floyd, James R., & Sons, New York.
Fowler, J. W., Car Co., Elizabethport, N. J.
General Electric Co., Schenectady and New York.
Lewis & Fowler Manufacturing Co., Brooklyn, N. Y.
Morse, C. D., Car Mfg. Co., Millbury, Mass.
New York Equipment Co., New York.
Wales Manufacturing Co., Syracuse, N. Y.
White Manufacturing Co., The, New York.

SPIKES AND FASTENINGS.

Fulton Truck & Foundry Co., Cleveland, O.
Harrington, Robinson & Co., Boston, Mass.
New York Equipment Co., New York.
Steel Rail Supply Co., The, New York.

SPRINKLERS, TRACK AND ROAD.

Brill, J. G. Co., Philadelphia, Pa.

SPRINGS, CAR.

Brill, J. G. Co., Philadelphia, Pa.
Fowler, J. W., Car Co., Elizabethport, N. J.
Lewis & Fowler Mfg. Co., Brooklyn, N. Y.
Railway Equipment Co., Chicago, Ill.
Scott, Charles, Spring Co., Philadelphia, Pa.
Stephenson, Jno., Co. Ltd., New York.
Vose Spring Co., The, New York.

STEAM FITTING.

Shaw, Benjamin F., Wilmington, Del.

STEAM PLANTS.

Altoona Manufacturing Co., Altoona, Pa.
 Bates Machine Co., Joliet, Ill.
 Brightman Stoker Co., Cleveland, O.
 Buckeye Engine Co., Salem, O.
 Dickson Manufacturing Co., Scranton, Pa.
 Grant, J. A., & Co., New York.
 Hampson, Edw. P., & Co., New York.
 Huxley & Hoffman, Boston, Mass.
 Lane & Bodley Co., The Cincinnati, O.
 McIntosh, Seymour & Co., Auburn, N. Y.
 Neffel, O'Connor & Co., Incorporated, New York.
 New York Equipment Co., New York.
 Parker, J. W., & Co., Philadelphia, Pa.
 Phoenix Iron Works Co., Meadville, Pa.
 Pierce & Miller Engineering Co., New York.
 Smith, Thos. G., Jr., Cincinnati, O.
 Walker Manufacturing Co., Cleveland, O.
 Westinghouse, Church, Kerr & Co., New York.
 Wetherill, Robert, & Co., Chester, Pa.
 Woodbridge & Turner Engineering Co., New York.

STEAM SUPPLY (UNDERGROUND.)

American District Steam Co., Lockport, N. Y.

STEEL CASTINGS.

Chester Steel Castings Company, Philadelphia, Pa.

STEEL STEPS.

Stanwood Manufacturing Co., Chicago, Ill.

STOCKS AND BONDS.

Eppley, Francis M., New York.
 Higgins, E. E., New York.

STORAGE BATTERIES.

Electric Storage Battery Co., The, Philadelphia, Pa.

STOKERS, MECHANICAL.

Brightman Stoker Co., Cleveland, O.

SURFACE CONDENSERS.

Philadelphia Engineering Works (Ltd.), Phila, Pa.

SWEEPERS.

Brill, J. G., Co., Philadelphia, Pa.
 Brooklyn Railway Supply Co., Stamford, Conn.
 Fowler, J. W., Car Co., Elizabethport, N. J.
 General Electric Co., Schenectady and New York.
 Lewis & Fowler Mfg. Co., Brooklyn, N. Y.
 Morse, C. D., Car Mfg. Co., Millbury, Mass.
 White Manufacturing Co., The, New York.

SWITCH TONGUES.

Chester Steel Castings Co., Philadelphia, Pa.
 Harrington, Robinson & Co., Boston, Mass.
 Wharton, Wm., Jr., & Co., Philadelphia, Pa.
 White Manufacturing Co., The, New York.

SWITCHES.

Craig, Wm. P., East Orange, N. J.
 Dorner & Dutton Mfg. Co., Cleveland, O.
 Fulton Truck & Foundry Co., Cleveland, O.
 Harrington, Robinson & Co., Boston, Mass.
 Lewis & Fowler, Brooklyn, N. Y.
 Steel Rail Supply Co., The, New York.
 Wharton, Wm., Jr., & Co., Philadelphia, Pa.

SWITCHES, ELECTRIC.

Craghead Engineering Co., Cincinnati, O.
 General Electric Co., Schenectady and New York.
 Hill, W. S., Electric Co., Boston, Mass.
 Mason Electric Co., Chicago, Ill.
 Ohio Brass Co., Mansfield, O.
 Wallace Electric Co., Chicago, Ill.

TICKET PUNCHES.

French, S. A., New York.
 Wales Manufacturing Co., Syracuse, N. Y.
 Woodman, The R., Mfg. & Supply Co., Boston, Mass.

TIES.

Hallowell, Eli B., & Co., Philadelphia, Pa.
 Loud, H. M., & Sons Lumber Co., Au Sable, Mich.

TIME TRANSFER PRINTERS.

Time Transfer Printer Mfg. Co., Pittsburgh, Pa.

TOWER WAGONS.

Briggs Carriage Co., Amesbury, Mass.
 Davis, W. S. & Sons, Concord, N. H.

TRACK CLEANERS AND SCRAPERS.

Barbour, Stockwell Co., Cambridgeport, Mass.
 Brill, J. G. Co., Philadelphia, Pa.
 Dorner & Dutton, Cleveland, O.
 Fowler, J. W., Car Co., Elizabethport, N. J.
 Fulton Truck & Foundry Co., Cleveland, O.
 Lewis & Fowler Manufacturing Co., Brooklyn, N. Y.

TRACK DRILLS.

Ohio Brass Co., Mansfield, O.

TRACK WRENCHES.

Chester Steel Castings Co., Philadelphia, Pa.
 Wharton, Wm., Jr., & Co., Philadelphia, Pa.

TRACKMEN'S TOOLS.

Wharton, Wm., Jr., & Co., Philadelphia, Pa.

TRANSFER TABLES.

Barbour, Stockwell Co., Cambridgeport, Mass.
 Brill, J. G. Co., Philadelphia, Pa.
 Burnham & Duggan Railway Appliance Co., Boston, Mass.
 Dorner & Dutton Mfg. Co., Cleveland, O.
 Fulton Truck & Foundry Co., Cleveland, O.
 Harrington, Robinson & Co., Boston, Mass.
 Hathaway, Alfred G., Cleveland, O.
 Lewis & Fowler Mfg. Co., Brooklyn, N. Y.
 Morse, C. D., Car Mfg. Co., Millbury, Mass.
 Wharton, Wm., Jr., & Co., Philadelphia, Pa.
 White Manufacturing Co., The, New York.

TRANSFORMERS.

General Electric Co., Schenectady and New York.

TROLLEY BRACKETS, ADJUSTABLE.

Burnham & Duggan Railway Appliance Co., Boston, Mass.

TROLLEY BUSHINGS.

Electric Railway Equipment Co., Cincinnati, O.
 General Electric Co., Schenectady and New York.
 New York Electrical Works, New York.
 Nuttall, R. D., Co., Allegheny, Pa.
 Steel Motor Co., The, Cleveland, O.

TROLLEY HANGERS.

Anderson, A. & J. M., Boston, Mass.
 Burnham & Duggan Railway Appliance Co., Boston, Mass.
 Craghead Engineering Co., Cincinnati, O.
 Curtis Electric Mfg. Co., Jersey City, N. J.
 General Electric Co., Schenectady and New York.
 Johns H. W., Manufacturing Co., New York.
 Mason Electric Co., Chicago, Ill.
 New York Electrical Works, New York.
 Nuttall, R. D., Co., Allegheny, Pa.
 Ohio Brass Co., Mansfield, O.
 Steel Motor Co., The, Cleveland, O.
 Wales Manufacturing Co., Syracuse, N. Y.
 Wallace Electric Co., Chicago, Ill.
 Walworth Manufacturing Co., Boston, Mass.

TROLLEY SWITCHES.

Anderson, A. & J. M., Boston, Mass.
 Craghead Engineering Co., Cincinnati, O.
 General Electric Co., Schenectady and New York.
 Hill, W. S., Electric Co., Boston, Mass.
 Mason Electric Co., Chicago, Ill.
 New York Electrical Works, New York.
 Nuttall, R. D., Co., Allegheny, Pa.
 Ohio Brass Co., Mansfield, O.
 Rumrill, Charles M., & Bro., New York.
 Steel Motor Co., The, Cleveland, O.

TROLLEYS AND TROLLEY WHEELS.

Adams, W. L., & Co., Chicago, Ill.
 Anderson, A. & J. M., Boston, Mass.
 Blackwell, Robert W., London, England.
 Curtis Electric Mfg. Co., Jersey City, N. J.
 Economy Trolley Co., Chicago, Ill.
 General Electric Co., Schenectady and New York.
 Hill, W. S., Electric Co., Boston, Mass.
 Hubley Manufacturing Co., New York.
 New York Electrical Works, New York.
 Nuttall, R. D., Co., Allegheny, Pa.
 Ohio Brass Co., Mansfield, O.
 Steel Motor Co., The, Cleveland, O.
 Wales Manufacturing Co., Syracuse, N. Y.
 Wallace Electric Co., Chicago, Ill.
 Wharton, Wm., Jr. & Co., Philadelphia, Pa.
 Yeats Engineering Co., Chicago, Ill.

TRUCKS.

Barney & Smith Car Co., Dayton, O.
 Bemis Car Box Co., Springfield, Mass.
 Blackwell, Robert W., London, England.
 Brill, J. G., Co., Philadelphia, Pa.
 Chicago Electric Truck Co., Chicago, Ill.
 Dorner & Dutton Mfg. Co., Cleveland, O.
 Fulton Truck & Foundry Co., Cleveland, O.
 General Electric Co., Schenectady and New York.
 Graham Equipment Co., Boston and Philadelphia.
 Laclede Car Co., St. Louis, Mo.
 Lewis & Fowler Mfg. Co., Brooklyn, N. Y.
 McGuire Mfg. Co., Chicago.
 New York Equipment Co., New York.
 Peckham Motor Truck & Wheel Co., Kingston, N. Y.
 Robinson Electric Truck & Supply Co., Boston, Mass.
 Sheppard Manufacturing Co., Louisville, Ky.
 St. Louis Car Co., St. Louis, Mo.
 Stephenson, John, Co., New York.
 Taylor Electric Truck Co., Troy, N. Y.
 Warfield, Louis, Detroit, Mich.
 Wharton, Wm., Jr. & Co., Philadelphia, Pa.
 Woodbridge & Turner Engineering Co., New York.
 Yeats Engineering Co., Chicago, Ill.

TRUCKS, RADIAL.

Robinson Electric Truck & supply Co., Boston.
 Taylor Electric Truck Co., Troy, N. Y.
 White Manufacturing Co., The, New York.

TURNTABLES.

Brill, J. G. Co., Philadelphia, Pa.
 Dick, Kerr & Co., London, Eng.
 Dorner & Dutton Mfg. Co., Cleveland, O.
 Fulton Truck & Foundry Co., Cleveland, O.

Hathaway, Alfred G., Cleveland, O.
 Lewis & Fowler Mfg. Co., Brooklyn, N. Y.
 New York Equipment Co., New York.
 Wharton, Wm., Jr., & Co., Philadelphia, Pa.
 White Manufacturing Co., The, New York.

UNIFORM SUPPLIES.

Brill, J. G., Co., Philadelphia, Pa.
 French, S. A., New York.
 Wales Manufacturing Co., Syracuse, N. Y.

VALVES AND GATES.

Shook, Anderson Mfg. Co., Pittsburgh, Pa.

VARNISHES.

Johns, H. W., Manufacturing Co., New York.
 Smith, Edward, & Co., New York.

VENEERS.

Frost Veneer Seating Co., New York.
 Veneer Seating & Church Furniture Co., Brooklyn, N. Y.
 Woodman, Joel H., Hoboken, N. J.

VOLTMETERS AND AMMETERS.

General Electric Co., Schenectady and New York.
 Weston Electrical Instrument Co., Newark, N. J.
 Westinghouse Electric & Mfg. Co., Pittsburgh, Pa.

VULCABESTON.

Johns, H. W., Manufacturing Co., New York.

VULCANIZED FIBRE.

Vulcanized Fibre Co., 14 Dey st., New York.

WAGONS.

Briggs, Carriage Co., Amesbury, Mass.

WAGONS, WRECKING.

Gleason & Bailey Manufacturing Co., New York.

WATER COLUMNS.

Rellance Gauge Co., Cleveland, O.

WHEELS.

Brill, J. G. Co., Philadelphia, Pa.
 Chester Steel Castings Co., Philadelphia, Pa.
 Dorner & Dutton Mfg. Co., Cleveland, O.
 Fulton Truck & Foundry Co., Cleveland, O.
 Hazelton, Wm., 3d, New York.
 Lewis & Fowler, Mfg. Co., Brooklyn, N. Y.
 Loddell Car Wheel Co., Wilmington, Del.
 Peckham Motor Truck & Wheel Co., Kingston, N. Y.
 Societe Anonyme Industrielle des Etablissements
 Arbel, Rive-de-Gier (Loire), France.
 Stephenson, Jno., Co. Ld., New York.
 Taylor Electric Truck Co., Troy, N. Y.
 White Manufacturing Co., The, New York.
 Whitney, A., & Sons, Philadelphia, Pa.

WIRE.

American Electrical Works, Providence, R. I.
 California Wire Works, San Francisco, Cal.
 Eastern Electric Cable Co., Boston, Mass.
 General Electric Co., Schenectady and New York.
 Habirshaw Wire, Yonkers, N. Y.
 Hazard Manufacturing Co., Wilkesbarre, Pa.
 Hill, W. S., Electric Co., Boston, Mass.
 Mason Electric Co., Chicago, Ill.
 Moore, Alfred F., Philadelphia, Pa.
 New York Equipment Co., New York.
 Nuttall, R. D., Co., Allegheny, Pa.
 Ohio Brass Co., Mansfield, O.
 Okonite Co. (Ltd.), The, New York.
 Partridge, Arthur S., St. Louis, Mo.
 Ralston & Co., Philadelphia, Pa.
 Roebbling's, John A., Sons Co., Trenton, N. J.
 Rumrill, Charles M., & Bro., New York.
 Trenton Iron Co., Trenton, N. J.
 Walker Manufacturing Co., The, Cleveland, O.
 Wallace Electric Co., Chicago, Ill.
 Washburn & Moen Mfg. Co., Worcester, Mass.

WIRE, INSULATED.

Allen Electric & Supply Co., Philadelphia, Pa.
 American Electrical Works, Providence, R. I.
 Brixey, W. R., New York.
 Craghead Engineering Co., Cincinnati, O.
 Eastern Electric Cable Co., Boston, Mass.
 General Electric Co., Schenectady and New York.
 Habirshaw Wire, Yonkers, N. Y.
 Hill, W. S., Electric Co., Boston, Mass.
 Insulated Electric Light Wires, New York.
 Mason Electric Co., Chicago, Ill.
 Moore, Alfred F., Philadelphia, Pa.
 Mosher Electric Co., Chicago, Ill.
 Neffel, O'Connor & Co., Incorporated, New York.
 New York Equipment Co., New York.
 Nuttall, R. D., Co., Allegheny, Pa.
 Ohio Brass Co., Mansfield, O.
 Okonite Co. (Ltd.), The, New York.
 Partridge, Arthur S., St. Louis, Mo.
 Ralston & Co., Philadelphia, Pa.
 Roebbling's, John A., Sons Co., Trenton, N. J.
 Rumrill, Charles M., & Bro., New York.
 Steel Motor Co., The, Cleveland, O.
 Wallace Electric Co., Chicago, Ill.
 Washburn & Moen Mfg. Co., Worcester, Mass.

WOODWORK, CAR.

Brill, J. G., Co., Philadelphia, Pa.
 Kuhlman, G. C., Co., Cleveland, O.
 Morse, C. D., Car Mfg. Co., Millbury, Mass.
 Sjoberg, J. P., & Co., New York.
 Trimble, James A., New York.
 Wetmore, A. B., New York.

VENEER CAR LININGS and SEATS, Joel H. Woodman, HOBOKEN, NEW JERSEY.

Rail Bond Cap.

—PATENTED.—

SIMPLE.

DURABLE.



ECONOMICAL.

EASILY APPLIED.

100,000 Sold Since Feb. 1, 1894.

PERFECT CONNECTION.

MOISTURE PROOF CONTACT.

This Improved Cap obviates all former difficulties experienced in rail bonding. It insures a waterproof joint, and makes a perfect electrical contact on all sides of the wire. When in use it is practically one piece of the rail—cap and wire.

WALLACE ELECTRIC CO.,

307 DEARBORN ST.,

CHICAGO, ILL.

HIGH SPEED POWER TRAVELING CRANES

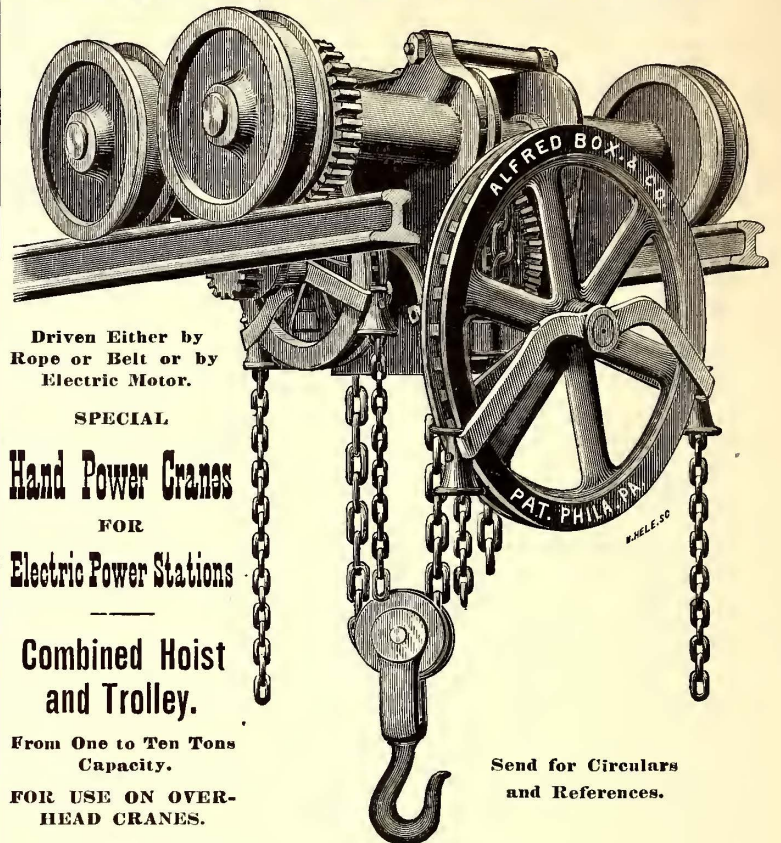

Driven Either by Rope or Belt or by Electric Motor.

SPECIAL

Hand Power Cranes

FOR

Electric Power Stations

Combined Hoist and Trolley.

From One to Ten Tons Capacity.

FOR USE ON OVER-HEAD CRANES.

Send for Circulars and References.

ALFRED BOX & CO.,

Front, Poplar & Canal Sts., Philadelphia, Pa.

When Ordering

From firms whose names appear in the STREET RAILWAY JOURNAL our friends will confer a favor on our advertisers and ourselves by mentioning this paper.

Very respectfully,

Street Railway Publishing Co.

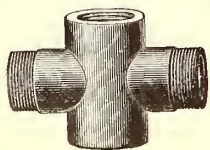

FIBRE CONDUIT.

The Best Underground Conduit for Electric Cables.

LIGHT, STRONG AND DURABLE.

NOT AFFECTED BY ACIDS OR ALKALIES.

A PERFECT INSULATOR.



Write for Information.

Manufactured Exclusively, under Basic Patents, by

THE FIBRE CONDUIT COMPANY, - - - 257 Broadway, New York.

WORKS, ORANGEBURGH, N. Y.

PARADIGM SKYLIGHTS.

The "PARADIGM" SYSTEM of Glass Roofing for Skylights, Greenhouses, etc., now being introduced by us is unquestionably the Strongest, Best and Most Durable and Economical ever invented, and is especially adapted for Skylights for

CAR SHEDS, POWER HOUSES, WORKSHOPS, ETC.,

The Main Bars being made of CHANNEL STEEL give a strength and durability entirely lacking in Skylights of other makes, while the cost is moderate compared with the substantial character of the work. These Skylights can be put up by any intelligent mechanic. No soldering is required, all the parts being bolted together. The steel bars are cut, punched, mitred, painted and numbered at the factory, and shipped to any part of the world f. o. b. cars or steamship—or put in place on the building.

DESCRIPTION.

The astragal or channel bar is made of strong steel, varying in width from one to two inches, depending on the distance between the roof purlins to which said astragals are bolted by means of angles, as shown in sketch.

About every fifteen inches apart, one-quarter inch square holes are made in the sides of the steel skylight bar into which is secured the cross bolt "B" and eye bolt "C." These bolts secure the glass in place by means of cap "D" and the

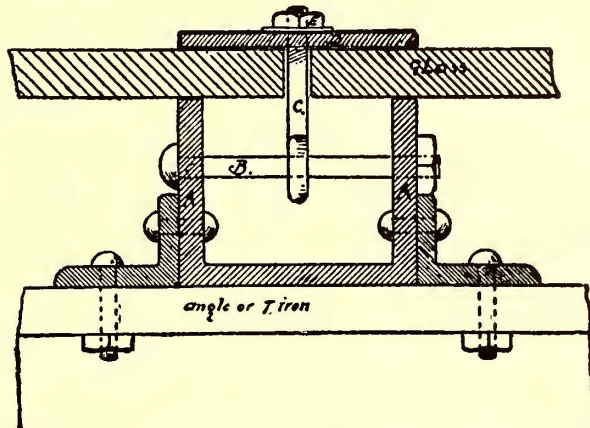

DESCRIPTION.

nut "E." This cap can be made of a bent piece of sheet copper or other metal or narrow pieces of flat iron covered with lead, like sketch.

The cross bars, which can be made of copper or other sheet metal, are fitted into slots cut in the sides of the steel channel bars, 1½ inches long by ½ inch deep, and they are made the exact width of the glass, and lap over the channel bar so that all condensation, water, etc., finds its way into the main channel bar.

A FEW REASONS WHY Engineers, Architects and others may decide to adopt the new "Paradigm" Skylight System.

1. The main bar being made of strong steel, greater strength is necessarily obtained than in the cheaply constructed sheet metal bars now being used all over the country.
2. The steel bars are not exposed to the weather at all, being entirely and completely covered by the glass and "caps," and they can be kept painted and will last as long as the building.
3. The "caps" are the only part of the patent "Paradigm" Skylight System exposed to the weather, and as these can be made of strong copper or lead, it will be readily conceded that a skylight or glass roof constructed on this system should outlast an ordinary galvanized iron skylight many years.
4. It is the most economical skylight system, by reason of the fact that we can supply the steel bar, lead cap, and copper cross bars at a price that will almost compete with the cheaply constructed and galvanized iron skylights. The cost of maintenance and repairs is reduced to a minimum.
5. As the steel channel bar is so strong, averaging from one-eighth to one-quarter inch thick, a less number of roof purlins are required; for instance, purlins need not be less than five to eight feet centers.
6. Broken panes of glass can be replaced more easily and quickly than by any other method.
7. The skylight bars are usually made in one length, up to forty feet if necessary, so that defects, through careless soldering and consequent leakage, as in the sheet metal bars, are an impossibility.
8. The method used for making a watertight joint at the junction where two panes of glass meet, which permits the glass to be butted instead of being lapped, will commend itself to all. The cross bar is usually made of strong copper or other sheet metal.

The Engineers for the Trustees of the New York and Brooklyn Bridge have adopted the "Paradigm" Skylight System for the big skylights on the new Terminal Stations now being built on each side of the East River—New York and Brooklyn—about 45,000 sq. ft., and contracts have been made with General Contractors for the work.

PARADIGM CONSTRUCTION COMPANY,

Caution Infringements will be Vigorously Prosecuted.

41 Pine Street, New York.

AGENTS WANTED IN EVERY TOWN.

CURTIS ELECTRIC MANUFACTURING CO.

Electric Motor Car Equipments.

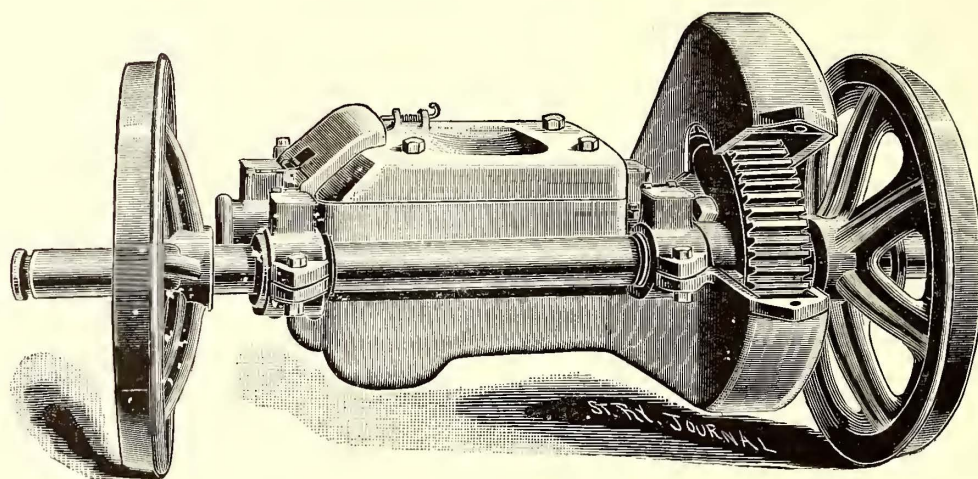

CURTIS STANDARD (30 H. P.) MOTOR

The Brooklyn City Railroad Co. has had 25 Double 30 H. P. Curtis Equipments in service with hundreds of motors of two other leading makes. They have recently ordered 120 additional Curtis Motors and Controlling Apparatus.

These Motors, and the Curtis Series Multiple Platform Controllers, etc., have been in constant service on many street railroads, and have invariably given perfect satisfaction. We refer, among others, to

Brooklyn City Railroad Co.,	- - - -	Brooklyn, N. Y.
Consolidated Traction Co.,	- - - -	Jersey City, N. J.
Citizens' Passenger Railway Co.,	- - - -	Norristown, Pa.
Reading & Southwestern Railway Co.,	- - - -	Reading, Pa.
Portsmouth Street Railroad & Light Co.,	- - - -	Portsmouth, O.
Oil City Street Railway Co.,	- - - -	Oil City, Pa.

EFFICIENCY.—Tests made officially by two railway companies have shown that the Curtis equipments are more efficient—consume less current—than either of the other well-known types of street car equipment.

The Improved Motor made by this Company, and shown above, is lighter per unit of guaranteed horse power capacity than any so called light weight motor now in the market.

SEND FOR
DESCRIPTIVE
CATALOGUE.

CURTIS ELECTRIC MFG. CO., Pacific Ave., Jersey City, N. J.

THE UNITED COLUMBIAN ELECTRIC CO.

MANUFACTURERS OF
ELECTRIC RAILWAY APPARATUS.

FREEDOM FROM
OSCILLATION

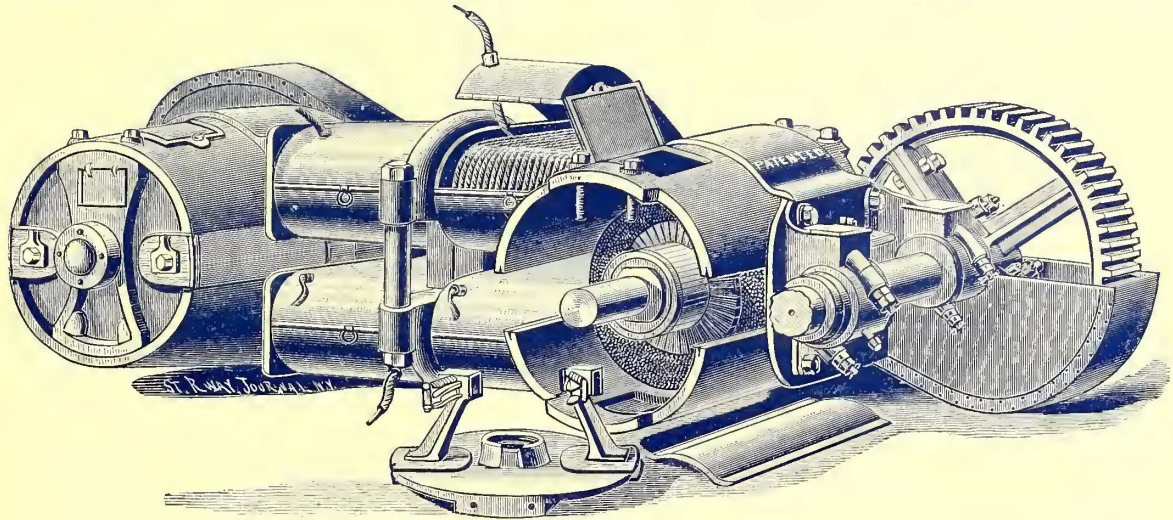

AMPLE ROOM FOR FIELD
WINDINGS.

50 H. P. TWIN SERIES MOTOR.
WINKLER PATENTS.

The only double equipment equalizing load between the two armatures. One armature geared to each axle.
Maximum traction, efficiency and power.

GENERAL OFFICE, 280 BROADWAY, NEW YORK.

TELEPHONE 4703, CORTLANDT.

FACTORY, KINGSTON, N. Y.

PHILADELPHIA OFFICE, 1430 So. Penn Sq., Philadelphia, Pa.

Eddy Power Generators

FOR
ELECTRIC STREET
RAILWAYS.

THIS COMPANY MAKES A SPECIALTY OF THE POWER
BUSINESS IN ITS VARIOUS BRANCHES.

We Guarantee

Highest Possible Efficiency, Perfect Regulation and

Workmanship Seldom Equalled but Never Excelled.

WRITE FOR PARTICULARS, OR IF IN THE MARKET,
SEND US YOUR SPECIFICATIONS.

Havemeyer Building, New York.
1417 & 1418 Monadnock Building, Chicago.
30 Oliver Street, Boston.
170 Second Street, Portland, Ore.
506 Commerce Street, Philadelphia, Pa.
Cuyahoga Building, Cleveland, O.
135 Seneca Street, Buffalo.
249 Second Ave. South, Minneapolis.

THE EDDY ELECTRIC MFG. CO.

WINDSOR, CONN.

THE WALKER MFG. CO.

Engineers, Founders and Machinists,
CLEVELAND, OHIO, U. S. A.

THIS MOTOR WILL

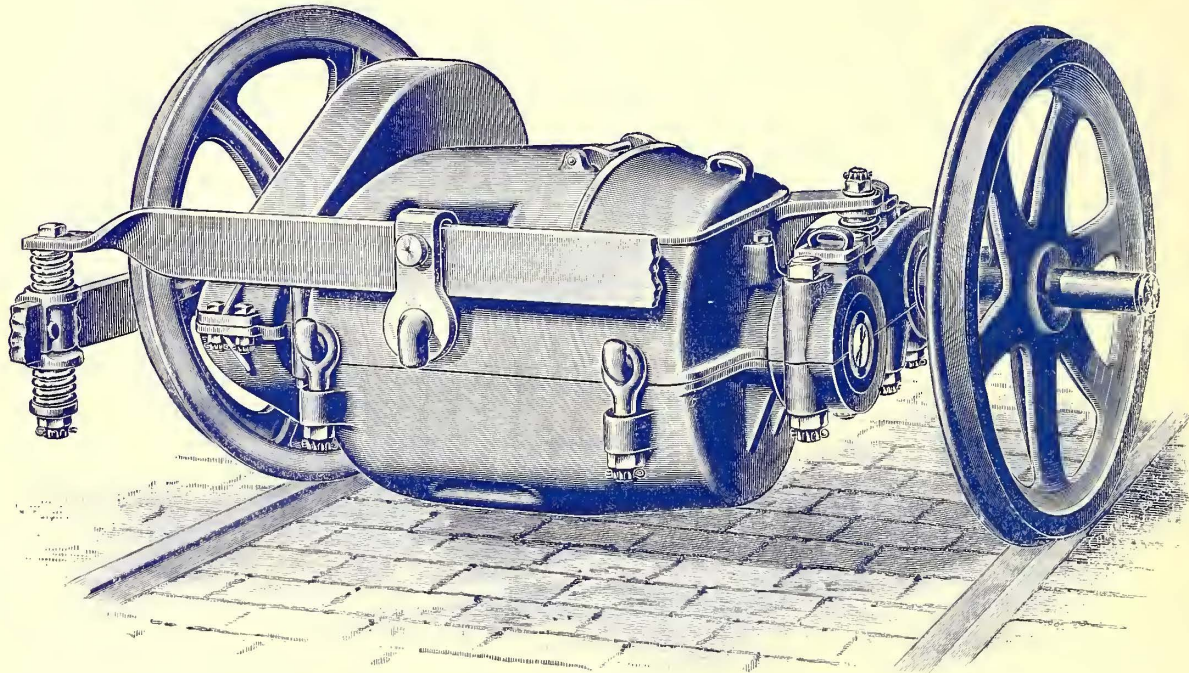

SAVE YOUR RAIL JOINTS.

SPRING MOUNTED STEEL MOTOR. WEIGHT, 1,500 LBS.

Electric and General Power Transmitting Machinery

Electric Generators and
Motors. Cable Rail-
way Machinery.

EXCLUSIVE MANUFACTURERS

Walker Patent
Differential Cable Drums and
Friction Clutches.

Machine Molded and Cut
Gearing of all Sizes
a Specialty.

GENERAL OFFICE AND WORKS,
CLEVELAND, OHIO.

BRANCH OFFICES :

913-914 Postal Telegraph Bldg., New York
1120 Betz Bldg., Philadelphia, Pa.
1417 Monadnock Bldg., Chicago.

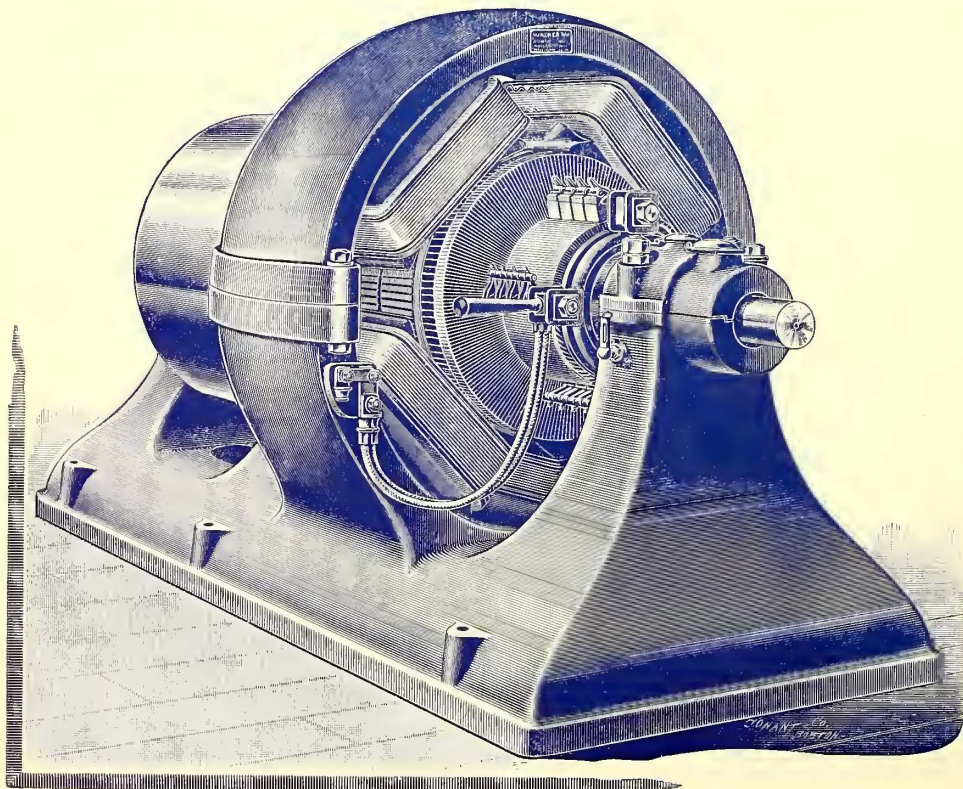

HEAVY MACHINERY OF ALL KINDS.

GENERAL ELECTRIC CO.

MULTIPOLAR RAILWAY GENERATORS

DIRECT CONNECTED OR BELT DRIVEN.

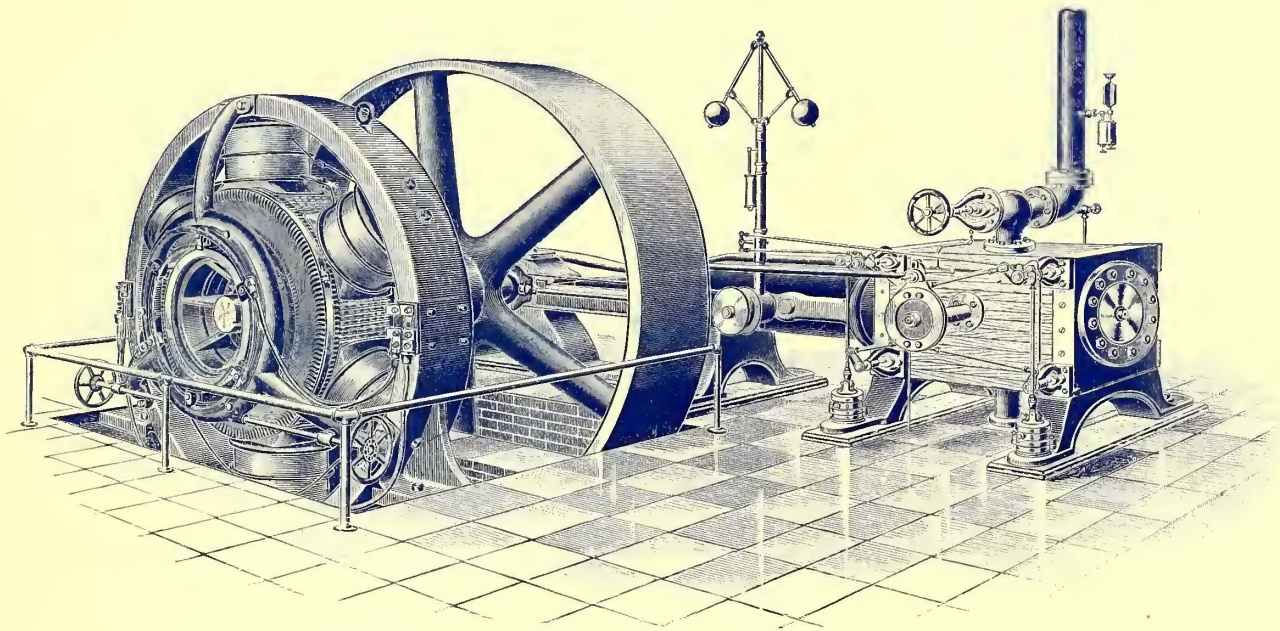

Direct Connected Multipolar Railway Generator.

PERFECT IN DESIGN,
 HIGHEST IN EFFICIENCY,
 ECONOMICAL IN OPERATION,
 OCCUPY SMALL SPACE,
 RUN AT SLOW SPEED.

—OUR—

ELECTRIC RAILWAY SUPPLIES

ARE THE STANDARD SUPPLIES OF THE WORLD.

Every Street Railway Manager should write for our new Railway Catalogue.

PRINCIPAL SALES OFFICES:

MAIN OFFICE, - - - SCHENECTADY, N. Y.

180 Summer Street, Boston, Mass.
 44 Broad Street, New York.
 224 W. Fayette Street, Syracuse, N. Y.
 Erie County Savings Bank Bldg., Buffalo.
 509 Arch Street, Philadelphia, Pa.
 425 Wood Street, Pittsburgh, Pa.
 18 South Street, Baltimore, Md.

1333 F Street, N. W., Washington, D. C.
 Equitable Building, Atlanta, Ga.
 264 West Fourth Street, Cincinnati, O.
 510 Cuyahoga Building, Cleveland, O.
 Monadnock Building, Chicago, Ill.
 309 So. Thirteenth Street, Omaha, Neb.
 New York Life Building, Kansas City, Mo.
 Bailey Building, Seattle, Wash.

Wainwright Building, St. Louis, Mo.
 Cor. Field and Main Streets, Dallas, Tex.
 Masonic Temple, Denver, Col.
 15 First Street, San Francisco, Cal.
 403 Sibley Street, St. Paul, Minn.
 Electric Building, Helena, Montana.
 Front and Ankeney Streets, Portland, Ore.

FOR ALL BUSINESS OUTSIDE THE UNITED STATES AND CANADA; THOMSON-HOUSTON INTERNATIONAL ELECTRIC COMPANY, SCHENECTADY, N. Y. AND 44 BROAD STREET, N. Y.

FOR CANADA; CANADIAN GENERAL ELECTRIC COMPANY, LTD., TORONTO, CANADA.

G. ♦ E. ♦ 800.

THE MOST SUCCESSFUL, EFFICIENT AND COMPACT
RAILWAY MOTOR EVER CONSTRUCTED.

OVER 800 SOLD

DURING THE

First Two Weeks in May, 1894.

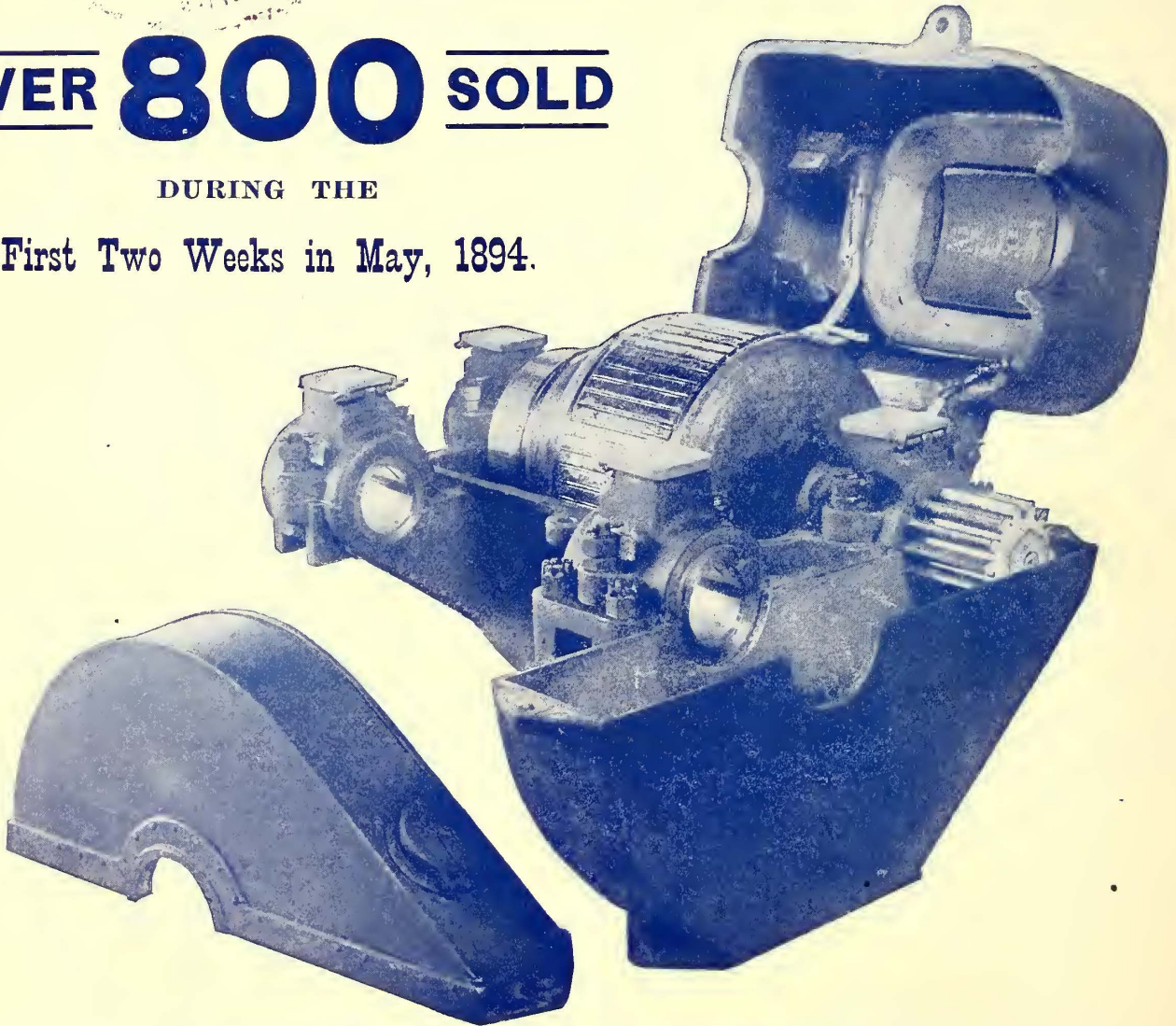

ALL PARTS EASILY ACCESSIBLE.

Every Railway which has tried the G. E. 800 Motor has expressed unqualified approval of its merits, and has ordered additional motors; while Controllers of other manufacturers are being replaced by our Type K.

The only SERIES PARALLEL CONTROLLER which
will not burn out is our

TYPE K CONTROLLER.

GENERAL ELECTRIC COMPANY.

For Addresses of Sales Offices, see Page XLIII.

WHY

Peckham's "Cantilever Extension" Trucks

ARE SUPERIOR TO OTHER TRUCKS.



1st. Because THEIR "CANTILEVER BRIDGE TRUSS" CONSTRUCTION gives the greatest strength with the least weight of metal.

2d. Because THEY ARE MACHINE MADE; all parts being carefully machine fitted to Steel Templets.

3d. Because THEY ARE CONSTRUCTED WITH HOT RIVETS, driven by skilled boiler makers.

4th. Because THEY ARE POSITIVELY NON-OSCILLATING, NOISELESS AND EASY RIDING, whether light or heavily loaded.

5th. Because they require NO REPAIRS, cost of maintenance being reduced to actual wear of brake shoes and wheels.

6th. Because THEIR ELASTIC SUPPORT UPON JOURNAL BOXES BY GRADUATED SPIRAL SPRINGS prevents shocks to car bodies and motors, and relieves rail joints.

Guarantee:

TRUCK FRAMES AGAINST BREAKAGE FOR FIVE YEARS.
AXLES AND SPRINGS FOR TWO YEARS.
WHEELS, 35,000 MILES ON GOOD TRACK.

Descriptive Catalogue, Testimonials and Price Lists Furnished upon Application to

The Peckham Motor Truck & Wheel Co.

GENERAL SALES OFFICE:

Havemeyer Building, 26 Cortlandt St., New York.

BOSTON, 53 State Street.
CHICAGO, Monadnock Building.

PHILADELPHIA, 420 Walnut Street,
SAN FRANCISCO, 123 California Street.



SEE CUTS OF TRUCKS ON
OPPOSITE PAGE.



PECKHAM'S "CANTILEVER EXTENSION" TRUCKS.

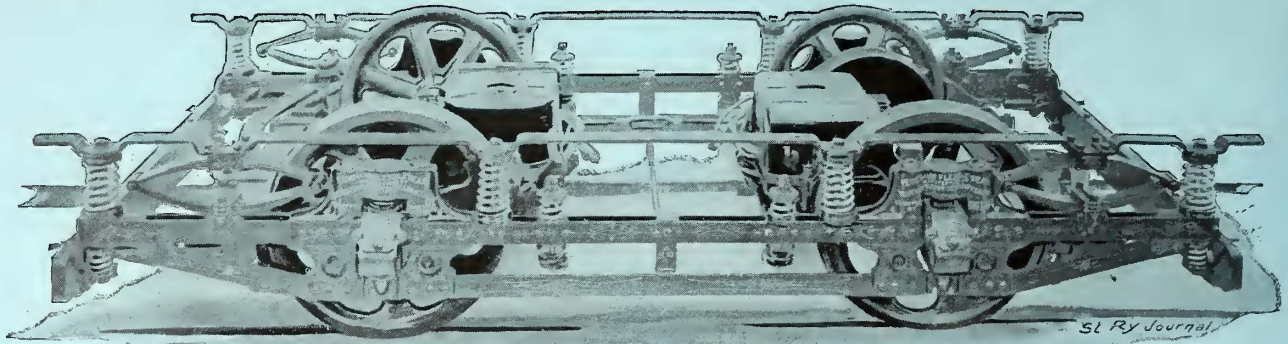

Standard 6 C, as Constructed for Standard Motors.

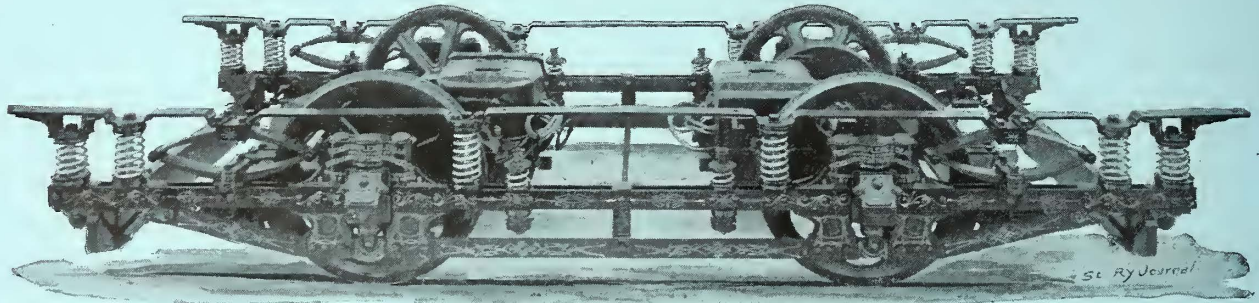

Extra Long 6 D--Designed Expressly for 20 ft. Closed Cars.

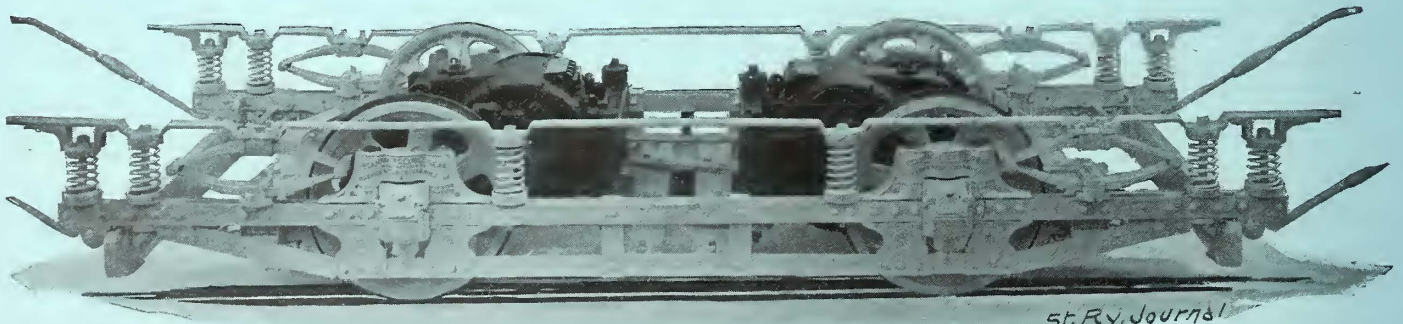

Extra Long 6 D X, with Double Extension for 30 ft. Open Cars.

**The Strongest, Easiest Riding, and Most Economically
Maintained Truck in Use.**

Adopted as Standard by all of the Electric and Cable Railways in New York,
Brooklyn, Jersey City, Hoboken and Long Island.

OVER 1,000 IN USE IN BROOKLYN ALONE.

Price List, Blue Print, Testimonials and Descriptive Catalogue
Furnished upon Application.

THE PECKHAM MOTOR TRUCK & WHEEL CO.,

GENERAL SALES OFFICE:

Havemeyer Building, 26 Cortlandt St., New York.

BOSTON, 53 State Street.
CHICAGO, Monadnock Building.

PHILADELPHIA, 420 Walnut St.
SAN FRANCISCO, 123 California St.



TURN OVER.



Peckham's Cantilever Extension Trucks.

Have been Adopted as Standard by the following Electric and Cable
Railways in the Vicinity of New York, because of their
EASY RIDING, PREVENTION OF OSCILLATION
AND SAVING IN COST OF
MAINTENANCE.



<p>The Brooklyn Heights Railroad Co., Brooklyn, N. Y. The Brooklyn, Queens County & Suburban R. R. Co., Brooklyn, N. Y. The Atlantic Avenue Railroad Co., Brooklyn, N. Y. The Coney Island & Brooklyn Railroad Co., Brooklyn, N. Y. The Broadway & 7th Avenue R. R. Co., New York City. The Consolidated Traction Co., Jersey City, N. J. The North Hudson County Railroad Co., Hoboken, N. J. The Union Railway Co., Harlem, New York City. The Steinway Railway Co., Long Island. The Newburgh & Orange Lake Railroad Co., Newburgh, N. Y.</p>
--



OVER 1,500 TRUCKS IN USE ON THE ABOVE
NAMED ROADS AND GIVING
SATISFACTION.

IF YOU DON'T BELIEVE IT,

“ASK THEM.”

Price List, Blue Print, Testimonials and Descriptive
Catalogue Furnished upon Application.

The Peckham Motor Truck & Wheel Co.

GENERAL SALES OFFICE:

Havemeyer Building, 26 Cortlandt St., New York.

Boston, 53 State Street.
Chicago, Monadnock Building.

Philadelphia, 420 Walnut Street.
San Francisco, 123 California Street.

Works, at Kingston, N. Y.

 TURN OVER. 

PECKHAM'S "EXTRA LONG" CANTILEVER EXTENSION TRUCK

Guaranteed to prevent Oscillation of 22 ft. Closed or 32 ft. Open Electric or Cable Cars.

WITH FLEXIBLE ADJUSTABLE LIFE AND WHEEL GUARDS, DESIGNED
EXPRESSLY FOR PECKHAM'S EXTENSION TRUCKS.

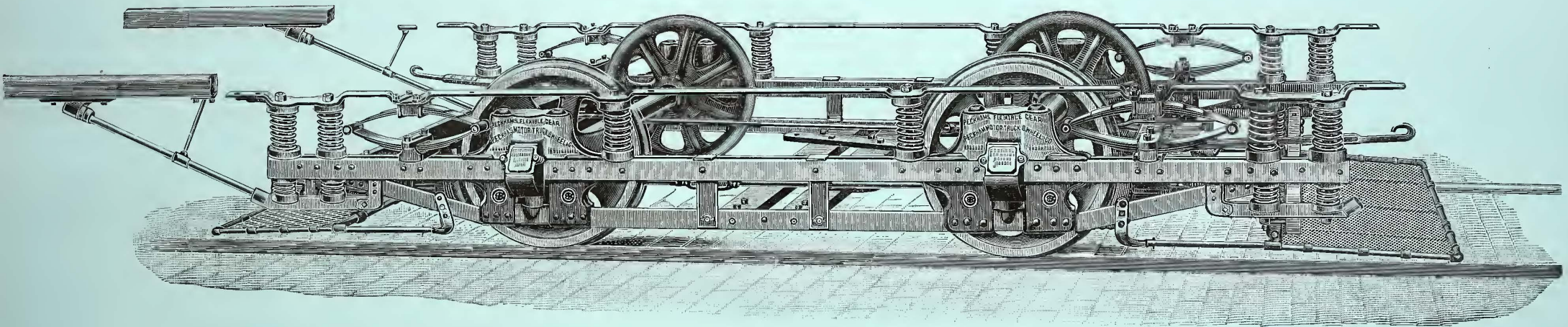

The Strongest, Easiest Riding and Longest Spring Base Truck in Use

COST OF MAINTENANCE LESS THAN ANY OTHER TRUCK.

Adopted as Standard by the Brooklyn City Railroad Co., of Brooklyn, N. Y.
OVER 1,000 FURNISHED TO THIS COMPANY ALONE.

For Price List, Blue Prints and Catalogues, apply to

THE PECKHAM MOTOR TRUCK & WHEEL CO., Kingston, N. Y.

GENERAL SALES OFFICE:

HAVEMEYER BUILDING, 26 CORTLANDT STREET, NEW YORK.

Boston Office, Exchange Building, 53 State Street.
Chicago Office, 1137 & 1138 Monadnock Bldg.

Philadelphia Office, 420 Walnut St.
San Francisco Office, 123 California St.

Wadhams Graphite Curve Grease

For Use on ELECTRIC and CABLE RAILWAYS.

Made soft, easily applied with a stiff brush or paddle, and is the 'slickest Grease you ever saw' for curves, switch plates and sliding surfaces.

We quote from letters received:

"It is the best we ever used." "I heartily recommend it."

"We have tried various kinds, and find yours the more economical."

"Our cars seem to round the curves easier, and with less friction than when using other Greases."

"We have been unable to find a cheap substitute, and consider it by far the best and most economical material we have ever found for our curves, etc."

Price in bbls. of about 400 lbs., per lb., 3 cents.
Delivered price on application.

MANUFACTURED ONLY BY

WADHAMS OIL & GREASE CO., Milwaukee, Wis.

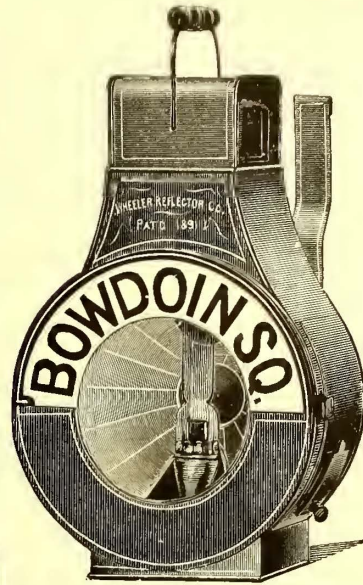

STYLE 167.

ROTATING SIGNS,

Showing immediate destination of car.

OIL OR ELECTRIC.

Send for Catalogue.

Wheeler Reflector Co.,
18 WASHINGTON ST.,
BOSTON, MASS.

STEEL RAILS.

COMPLETE OUTFIT FOR LOGGING, MINING,
PLANTATION AND

STREET RAIL AND TRAM ROADS.

LIGHT SECTIONS RAILS AND SPIKES IN STOCK.

LOCOMOTIVES, MOTORS, CARS, ETC.

NEW AND SECOND HAND.

THE STEEL RAIL SUPPLY CO.,

HUMPHREYS & SAYCE, Managers.

No. 10 Wall St., - - - - NEW YORK.

THE WESTON STANDARD

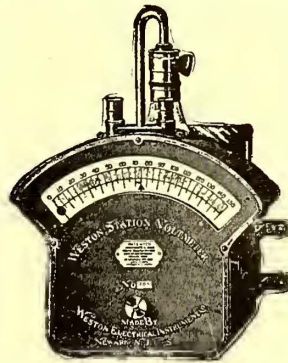

Portable Direct Reading Voltmeters, Millivoltmeters, Ammeters and Milliammeters.

Wattmeters, and Voltmeters for Alternating and Direct Current Circuits.

Our portable instruments are recognized as standards throughout the civilized world.

ILLUMINATED

DIAL STATION INSTRUMENTS.

These instruments are based upon the same general principle, and are just as accurate as our regular Standard Portable Direct Current Voltmeters and Ammeters, but are much larger, and the working parts are inclosed in a neatly designed, dust-proof, cast-iron case which effectively shields the instruments from disturbing influences of external magnetic fields.

WESTON'S STANDARD ILLUMINATED DIAL STATION VOLTMETER STYLE A.

WESTON ELECTRICAL INSTRUMENT CO.,
114-120 William Street, NEWARK, N. J.

A. MERTES MFG. CO.

MANUFACTURERS OF

ELECTRIC

MOTOR

Pinions AND Gears

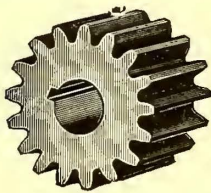

OF ALL KINDS

AND FOR ALL SYSTEMS,

OUR FACILITIES ARE UNEQUALLED.

Isabella and Sandusky Sts., Allegheny, Pa.

THE LATEST

For Electric and Cable Cars.

STREET CAR SEATS

OF EVERY DESCRIPTION.

With or without springs, covered with Carpet, Plush and Rattan.

HUNDREDS OF REFERENCES. THOUSANDS IN USE.

A Regular Reversible Seat Adapted for Street Cars. Catalogues, Estimates and Samples on Application.

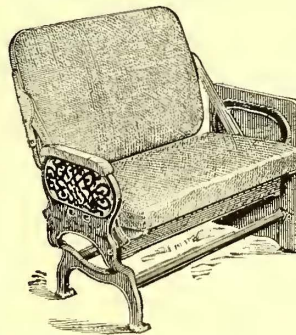

THE HALE & KILBURN MFG. CO.,

PHILADELPHIA.
NEW YORK. CHICAGO.

THE PITT PATENT FOLDING GATES.

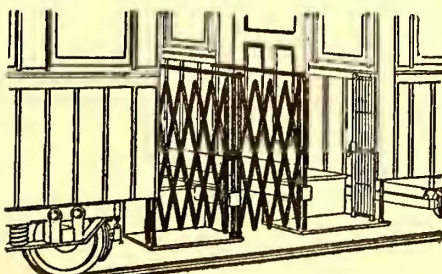

The "Pitt" Patent is the most approved Steel Folding Gate now in use for Street and Railway Cars. We also make Iron Gates and Iron Guards for cars. All work of ours is first class and our prices are low. New Pitt Composite Iron Works

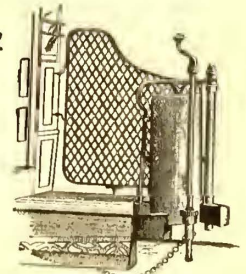

5th Avenue and 25th St., New York City.



HAVEMEYER BUILDING, NEW YORK. MONADNOCK BUILDING, CHICAGO.

Directory of State Street Railway Associations.

NEW YORK STATE STREET RAILWAY ASSOCIATION.

President, DANIEL B. HASBROUCK, New York City; first vice-president, G. TRACY ROGERS, Binghamton, N. Y.; second vice president, JAMES H. MOFFITT, Syracuse, N. Y., secretary and treasurer, WILLIAM J. RICHARDSON, Brooklyn, N. Y. Executive Committee: JOHN N. BECKLEY, Rochester; DANIEL F. LEWIS, Brooklyn; CHAS. CLEMENSHAW, Troy.

Next regular meeting, Syracuse, third Tuesday in September, 1894.

OHIO STATE TRAMWAY ASSOCIATION.

ALBION E. LANG, Toledo, President; W. J. KELLY, Columbus, Vice-President; J. B. HANNA, Cleveland, Secretary and Treasurer; W. A. LYNCH, Canton, Chairman Executive Committee.

Next meeting, Toledo, fourth Wednesday in September, 1894.

MASSACHUSETTS STATE STREET RAILWAY ASSOCIATION.

President, J. H. CUNNINGHAM, Boston; First Vice-President, AMOS F. BREED, Lynn; Second Vice-President, FRANK S. STEVENS, Fall River; Third Vice-President, SAMUEL WINSLOW, Worcester; Secretary and Treasurer, A. E. BUTLER, Lawrence; Executive Committee, ALFRED A. GLAZIER, Boston; P. F. SULLIVAN, Lowell; E. C. FOSTER, Lynn; PRENTISS CUMMINGS, Boston; CHAS. ODELL, Salem; E. P. SHAW, Newburyport; R. S. GOFF, Fall River.

THE STREET RAILWAY ASSOCIATION OF THE STATE OF NEW JERSEY.

President, THOS. C. BARR, Newark; vice-President, W. S. SCULL, Camden; Secretary and Treasurer, CHARLES Y. BAMFORD, Trenton; Executive Committee, OFFICERS and C. B. THURSTON, Jersey City; H. ROMAINE, Paterson.

PENNSYLVANIA STATE STREET RAILWAY ASSOCIATION.

President, _____; first vice-president, Williamsport; R. L. JONES, Secretary, S. P. LIGHT, Lebanon; treasurer, W. H. LANIUS, York.

Next meeting, Reading, first Wednesday in September, 1894.

THE MAINE STREET RAILWAY ASSOCIATION.

President, W. R. WOOD, Portland; Secretary and Treasurer, E. A. NEWMAN, Portland. Executive Committee, W. R. WOOD, Portland, H. TWITCHELL, Bath; A. F. GERALD, Waterville; J. HAYNES, Augusta; G. E. MACOMBER, Rockland; E. H. BANKS, Biddeford; E. K. DAY, Sanford; F. N. LAUGHTON, Bangor; F. W. DANA, Lewiston.

The midsummer meeting (1894) will be held in Rockland.

JOHN A. SEELY, Pres. and Gen'l Man.
C. O. BAKER, JR., Treasurer.

W. H. BAKER, Vice-President.
MILLS H. LANDON, Auditor.

— THE —

Complete Electric Construction Co.

General Offices,
121 Liberty Street, New York.

ELECTRIC OR STEAM RAILROAD CONSTRUCTION
A SPECIALTY.

Chicago Office, - Monadnock Building.
CLIFT WISE, Manager.

CONNECTICUT STATE STREET RAILWAY ASSOCIATION.

President, H. H. WOOD, Derby; Vice-President, H. S. PARMELEE, New Haven; Secretary, R. A. FOSDICK, Stamford; Treasurer, E. S. GOODRICH, Hartford. Executive Committee, A. M. YOUNG, Waterbury; G. A. W. DODGE and I. A. KELSEY, New Haven. Next meeting, New Haven, third Wednesday in November, 1894.

THE TEXAS STREET RAILWAY ASSOCIATION.

President, W. H. SINCLAIR, Galveston; vice-president, J. K. URIE, Austin; secretary and treasurer, S. A. HOBSON, Waco. Executive Committee and officers: A. W. CHILDRESS, Dallas; W. H. WEISS, San Antonio. Committee on Membership: C. DRAKE, Laredo; J. K. URIE, Austin; A. W. CHILDRESS, Dallas; C. A. MCKINNEY, Houston.

ESTABLISHED 1850.

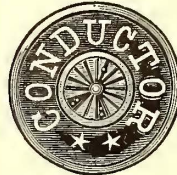

UNIFORM CAPS.
METAL CAP BADGES.
COAT BADGES.
UNIFORM BUTTONS.
TICKET PUNCHES.



UNIFORM SUPPLIES AND RAILROAD SPECIALTIES.

S. A. FRENCH,
108 West 28th St. NEW YORK.

ESTABLISHED 1873.

Thiel's Detective Service.

— OFFICES. —

St. Louis, Mo., Odd Fellows Building. Chicago, "The Temple."
New York, Fulton Building. Kansas City, Mo., Masonic Building.
St. Paul, Minn., Germania Life Bldg. Denver, Colo., Mining Exchange Bldg.
Portland, Ore., Chamber of Commerce Building.

STREET RAILWAYS CHECKED OR MANNED.

Skilled employes for any railway position.

BEST SERVICE. REASONABLE CHARGES. REFERENCES
TO 200 CORPORATIONS.

F. W. FRIIS'
National Railroad Detective Agency,

176 BROADWAY,
NEW YORK.
Telephone, 1511 Cortlandt.

PRUDENTIAL BUILDING,
NEWARK, N. J.
Telephone, 734 Newark.

Trustworthy and experienced male and female operators sent to any part of the country for a reasonable charge.

SATISFACTORY RESULTS GUARANTEED.

For terms and references, address to headquarters.

THE RELIABLE DETECTIVE AGENCY.

ESTABLISHED 1876.

P. J. SALOSCHIN,
General Manager.

853 BROADWAY, NEW YORK.

Experienced operators male and female, furnished on short notice.
SURFACE R. R. WORK A SPECIALTY.

Telephone 893A Cortlandt.

Electrical Exchange Bldg.
136 Liberty Street.

H. Ward Leonard & Co.
Bulk Electrical Contractors
and Consulting Electrical Engineers
New York.

THE "CLARK" WIRE

Insulation Guaranteed Wherever Used, Aerial, Underground, or Submarine.

In a Letter from the Inspector of the Boston Fire Underwriters' Union, he states :

"A THOROUGHLY RELIABLE AND DESIRABLE WIRE IN EVERY RESPECT."

The Rubber used in insulating our Wires and Cables is especially Chemically Prepared, and is Guaranteed to be waterproof, and will not deteriorate, oxidize, or crack, and will remain flexible in extreme cold weather, and is not affected by heat. The Insulation is protected from mechanical injury by one or more braids, and the whole slicked with Clark's Patent Compound, and Special Extra finish, which we have now adopted for all our solid wires as an Extra Weatherproof Protection, and also Preventing Chafing and Abrasion, which is Water, Acid, and to a very great extent, Fireproof. Our insulation will prove durable when all others fall. We are prepared to furnish Single Wires of all Gauges and Diameter of Insulation for Telegraph and Electric Lights from stock. Cables made to order. We are now prepared to furnish our Clark Wire with a white outside finish for ceiling cleat work as well as our Standard Color.

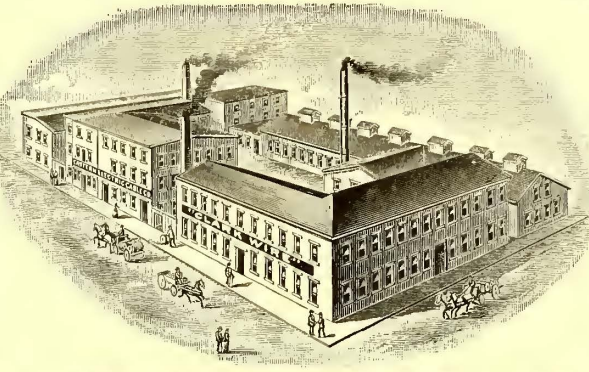

For Railway and Motor Use, We Make All Sizes of Stranded and Flexible Wire and Cables with Clark's Insulation.

WE GUARANTEE OUR INSULATION WHEREVER USED, AERIAL, UNDERGROUND, OR SUBMARINE,

and our net prices are as low, if not lower than any other First-class insulated Wire.

We shall be pleased to mail Catalogues with Terms and Discounts for Quantities.

EASTERN ELECTRIC CABLE CO.,

61 and 63 Hampshire St., Boston, Mass.

HENRY A. CLARK, Treas. and Gen. Manager.

HERBERT H. EUSTIS, Pres. and Electrician.

Western Agent, **GREAT WESTERN MFG. CO., Chicago, Ill.**

VENEER SEATING & CHURCH FURNITURE CO.
 129 Degraw St. - Brooklyn, N.Y.
 RAILWAY CAR AND DEPOT SEATINGS - VENEER ADVERTISING RACKS AND FRAMES.

CHARES MUNDT & SONS,
 MANUFACTURERS OF
PERFORATED SHEET METALS,
 Steel, Iron, Brass, Copper, Zinc, Tin, &c.
 88 & 90 WALKER STREET, NEW YORK.

Engravings OF ALL KINDS AT
 BOTTOM RATES.
 Send for estimates.
 Street Railway Publishing Co., Havemeyer Bldg., New York.

—RUSSELL'S—
Scientific Horseshoeing
 FOR THE DIFFERENT DISEASES OF THE FOOT.

Second Edition, Enlarged and Fully Illustrated.

Sent by mail, prepaid, on receipt of the price, \$3.00.

The author of this work has been a practising farmer for more than forty years. His record is one of rare success, and he has long been recognized by the leading horsemen of this country as the foremost shoeing smith of the age. This book aims to give the practical details of the most approved and rational plans and principles of horseshoeing in the plainest and most complete manner possible. A large share of the work is devoted to the diseases of the foot, and the subject of pathological shoeing is fully treated.

ADDRESS,

STREET RAILWAY PUBLISHING CO.,
 WORLD BUILDING, NEW YORK.

A VALUABLE BOOK.
STREET RAILWAYS;

Their Construction, Operation and Maintenance.

"TRAMS."

A Practical Handbook for Street Railway Men.

By C. B. FAIRCHILD, Editor Street Railway Journal.

PRICE, POSTAGE PREPAID, \$4.00.

Remit by P. O. money order, draft, registered letter or express money order. Orders can be sent in at once. Address

STREET RAILWAY PUBLISHING CO.,
 HAVEMEYER BUILDING, NEW YORK.

SPECIAL NOTICES.

POSITIONS WANTED.

WANTED.—Engineer, one who thoroughly understands the care and management of electric railway power station, will take position, in any part of country. Good reference. Address, J. T. POCKWELL, P. O. Box 184 Hoboken, N. J.

MONEY SAVED TO RAILROAD EMPLOYERS.—A car builder with 15 years' experience, wants position as general repairer, electric, cable, steam or horse cars; suitable for small road anywhere in United States or Canada. Address "A. B. C.," Station S, Brooklyn, N. Y.

WANTED.—A position as Superintendent of a street railroad company. Have had five years' experience in all branches of management, also thoroughly understand track laying. Will furnish satisfactory evidence of ability. Address "H. B. B.," care of STREET RAILWAY JOURNAL, New York.

WANTED.—A position as electrician or superintendent of an electric railway. I have been connected with some of the best managed and equipped roads in the country. Am a good manager and buyer. Will be at liberty April 1st. Address W. S., care of STREET RAILWAY JOURNAL, New York.

WANTED.—Situation to take charge of electric street railway, power or lighting station, by a man familiar with the application and construction of both steam and electric plants. Have constructed several large stations and am familiar with the details in office and repair shops. Thoroughly understands the construction and operation of any of the above plants. I am at present electrical engineer and superintendent of a lighting power and street railway plant. Good reason for wanting to change. With best of reference from present employers. "ALL AROUND MAN," Care of STREET RAILWAY JOURNAL.

FOR SALE.

FOR SALE.—30 twelve-foot cars, one-end type, with one fare box; in fair order. Gauge 4 ft. 8½ in. For all particulars apply to METROPOLITAN RAILROAD Co., Washington, D. C.

WANTED---TRACK FOREMEN.

Four first class track foremen thoroughly acquainted with the laying of street railway tracks and special work. Best of references required. State wages wanted and experience. Address

H. M. LITTELL, - - New Orleans, La.

FOR SALE.

One 150 H. P. Ball Engine and Two 80 H. P., D-62 T.-H. Railway Generators.

All in good condition. Will be sold at a low price. For particulars, address

CLEVELAND CONSTRUCTION COMPANY, Akron, Ohio.

FOR SALE.

THREE ENGINES, 22x48 ins.

Extra heavy built for street railway work. One new. Two used about three months; good as new. A bargain. Consolidation and the use of larger units dispensed with their use. Address

C. & G. COOPER & COMPANY, Mt. Vernon, Ohio.

RAILS Joint Fastenings, Tie Rods, Knees, Bolts, Spikes, &c. Curved Rail and Special Switch and Frog Work a Specialty.
Harrington, Robinson & Co.,
10 OLIVER ST., BOSTON.

INDICATORS.

Robertson-Thompson Improved Straight Line, \$40.00 each.

Everything good that can be said of ANY Indicator can be truthfully said of these. Our catalogue tells of several improvements you will be glad to see in the one YOU are GOING to buy. It also shows the best Reducing Wheels, Planimeters, Three-way Cocks and twenty-five other high grade steam specialties.

HINE & ROBERTSON CO., 63 Cortlandt Street, New York.

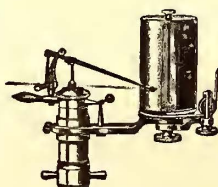

CARS FOR SALE.

2 Double Deck Open and Closed Cars—used less than 60 days.
2 Double Deck Closed Car Bodies—new.
15 Vestibuled Closed Car Bodies—3 years old.
All in excellent condition and great bargains.
Write us for prices on all your material.

RALSTON & CO.,
202 WALNUT PLACE, PHILADELPHIA, PA.

THOSE ENGAGED IN BUILDING ELECTRIC RAILWAYS, MAY FIND

A Rare Opportunity for Investment,

BY APPLYING TO

F. SCHUMACHER,

1347 Monadnock Bldg., Chicago, Ill.,

For the purchase of the Menasha & Neenah Street Railway, to be connected with Appleton and Kaukauna, Wis., and villages and cities between.

FOR SALE.

About one hundred and twenty-five sixteen foot

Second-Hand Street Cars

Thirty-four forty seat

OPEN CARS.

About Eight Hundred Sets of Harness,

Three hundred and fifty sets of bars, one hundred poles, also stable fixtures, &c., &c.

THIRD AVENUE RAILROAD DEPOT,

65th St. and Third Ave., N. Y. City.

CARS FOR SALE.
Second-Hand Street Cars.
All Styles. Lowest Prices.
JAMES E. THURSBY,
Railway Equipment.
45 BROADWAY, NEW YORK,

FREE A Scientific and Practical Pamphlet on Lubrication is sent free to all who wish it. It contains interesting and valuable information.

JOS. DIXON CRUCIBLE CO.,
JERSEY CITY, N. J.

Siemens & Halske Electric Company of America,

Siemens & Halske: Berlin, Charlottenburg, Vienna, St. Petersburg.

—MANUFACTURERS OF—

DIRECT CURRENT MULTIPOLAR DYNAMOS AND GENERATORS.

These machines are constructed with outside revolving armatures, without and with special commutator, as desired. They have proved remarkably efficient and economical. Used largely in European Central Stations. They are slow-speed machines, made for direct connection to engine without belting, and in sizes from 20 H. P. to 1,500 H. P.

HIGH-SPEED BELTED SIEMENS DYNAMOS

Are copied extensively in this country as "Drum Type." We are building these machines in sizes from 1 H. P. to 150 H. P.

ALTERNATING AND MULTIPHASE CURRENT DYNAMOS

With laminated field and armature, in sizes from 1 H. P. to 4,000 H. P., for belted or direct coupling.

MOTORS

Of every speed for direct, alternating or multiphase current, in sizes from 1-10 H. P. up to 4,000 H. P. Durable and economical in operation.

SIEMENS BAND LAMPS

For direct and alternating current, for constant potential and series machines.

SIEMENS ARC LIGHT CARBONS

With either solid or soft cores, which are the most economical in the world and give a steady light.

ALL INSTRUMENTS

Requisite for the regulation of electric apparatus; also the Siemens Voltmeters and Ammeters and Automatic devices made in Berlin.

New York Office, 136 Liberty Street.

Cincinnati Office, Perlin Building.

Salt Lake City Office, Dooly Block.

Buffalo, N. Y., Office, Erie County Bank Bldg.

Philadelphia Office, 531 Chestnut Street.

GENERAL OFFICES:

Monadnock Building, Chicago.

Toledo, O., Office, 518 Summit Street,

Boston Office, 31 Milk Street.

Sau Francisco Office, 508 California Street.

Denver Office, 614 Boston Block.

St. Louis Office, Bank of Commerce Bldg.

New Orleans Office, 42 Union Street.

Pittsburgh Office, 830 Liberty Avenue.

Troy, N. Y., Office, 43 Fourth Street.

MICA

All Sizes and Qualities for Electrical Purposes.
Eugene Munsell & Co., 218 Water St., New York.
W. H. SILLS, 83 Lake St., Chicago, Ill.

"MICANITE"

PERFECT INSULATOR.

**NEW AND
RE-LAYING
RAILS.**



**SPLICE BARS
BOLTS
AND SPIKES.**

549 THE ROOKERY,
CHICAGO, ILL.

Material off of the Pier Movable Sidewalk for Sale Cheap,

CONSISTING OF

1,000 park benches.

50 turnstiles.

500 squares of corrugated roofing.

30 lb. second-hand steel T rails.

3 inch angle iron, and all the lumber; also all the electrical appliances that ran the plant, consisting of rheostats, wire hangers, switches; in fact everything that ran the cars.

FOR SALE.

FOR IMMEDIATE DELIVERIES, SPECIAL BARGAINS IN NEW
AND SECOND-HAND STEEL RAILS.

100 tons 20 lb. re-laying Tees with Splices.

400 tons re-laying 35 lb. Steel Tees with Splices.

300 tons new 25 lb. Steel " " "

1,000 tons re-laying 52 lb. Steel Johnson Girder.

2,000 " re-laying 60 lb. Steel Tees with Splices.

400 " " 38 lb. " " "

3,000 tons re-laying Flat and Tram Steel Tees of different weights.

Will make exchange, taking old ones for new or relaying rails.

Can also give you any weight you wish in new steel Tees, in which I can save you some money.

I have also on hand a large number of second-hand Cars, Motors and Locomotives of all descriptions.

Will buy anything you have in the way of re-laying rails or scrap, or make trade, giving you different weights in exchange. Rails cut to lengths for building purposes. I have a large quantity of corrugated iron roofing that is in first-class order, and considered as good as new. Will be pleased to hear from you if you are in the market to purchase or sell anything in this line. Kindly mention paper.

L. K. HIRSCH, 549 Rookery Bldg, Chicago.

ROBERT W. BLACKWELL, M. I. E. E.

39 Victoria Street, Westminster,
London, England.

EUROPEAN AND COLONIAL AGENT

AMERICAN TRAMWAY MATERIAL,

CARS, TRUCKS, ETC.

Line Insulation, Trolleys, Special Tools and Supplies
for Electric Traction.

CABLE ADDRESS, "KURKEE-LONDON."

J. D. MURRAY,

NEW BRUNSWICK, N. J.

Contractor and Builder of Street Railways.

THOMAS McNALLY,
GENERAL CONTRACTOR.

Railroad Work, Paving, Grading, Masonry, Bulder
and Pile Driving.

STREET RAILWAY WORK A SPECIALTY.

Estimates Furnished on Application.

Have constructed 150 miles of Electric and 17 miles of Cable Road Track Work.

NO. 5531 DAYS STREET, PITTSBURGH, PA.

NO. 75 WEST GEORGIA STREET, INDIANAPOLIS, IND.

F. E. McCARTHY & CO.,**CONTRACTORS**

FOR THE

CONSTRUCTION OF STREET RAILWAYS,

Operated by Horse or Mechanical Power. Large ex-
perience in railroad building. Material furnished
and estimates given on short notice.

RESIDENCE,

1558 Tremont Street, Boston, Mass.

A. J. HUTCHINSON,

Contractor and Bulder of Street and Electric
Railways. Materials Furnished, etc.

137 BROADWAY, NEW YORK, Rooms 39 and 40.

A Thorough Knowledge of the Different Systems of Girder Rail Construction,
and Bulder of the following Street Railroads :

34th St. Branch, 4th Ave. Line, New York, 1863, Central Cross Town R. R. Co.
Atlantic Ave. Rapid Transit, Brooklyn, N. Y., Waterbury Horse Railway,
Waterbury, Conn., Asbury Park Electric Railway, Asbury Park, N. J., Observa-
tory Hill Electric Railway, Allegheny, Pa.

M. W. CONWAY,
CONTRACTOR

For the Construction of Street Railways Operated by Horse or
Mechanical Power. Girder Rail Construction a Specialty.
Twenty-five Years' Experience in Railroad Building.

MATERIAL FURNISHED. ESTIMATES GIVEN. CURVES
AND SWITCHES LAID AT SHORT NOTICE.

Office and Residence, 487 Monroe St., BROOKLYN, N. Y.

WM. P. CRAIG,**Street Railway Builder**

And Dealer in Supplies. Groove Rail with the Necessary Castings
Furnished at Short Notice. Complicated Work,
Car Houses, &c., a Specialty.

Office and Residence: 22 BURNET ST., E. ORANGE, N. J.

GEO. L. FOWLER,**Consulting Mechanical Engineer,**

Room 27, No. 53 Broadway,
NEW YORK.

Special attention paid to Estimates, Designs and Superintendence of Con-
struction of new Electric Power and Cable Plants for Street Railways, and the
testing for efficiency of those already in operation.

JULIUS T. DUDLEY & CO.,

136 Liberty Street, New York City.

RAILWAY EQUIPMENT SUPPLIES

Bought, Sold and Exchanged.

CORRESPONDENCE SOLICITED.

NEFTEL, O'CONNOR & COMPANY,

INCORPORATED,

ELECTRICAL ENGINEERS,

Electric Railways, Light, Power and Steam
Plants Designed and Constructed.

126 Liberty Street, NEW YORK

CHAS. LUDLOW LIVINGSTON,

ELECTRICAL ENGINEER AND CONTRACTOR,

713 PENN AVENUE,

PITTSBURGH, PA.

CONTRACTS TAKEN FOR THE CONSTRUCTION AND COMPLETE
EQUIPMENT OF ELECTRIC STREET RAILWAYS.

Station and Overhead Construction a Specialty.

ANTHONY, WM. A.,
 Consulting Electrical Engineer
 and Electrical Expert.
 Examinations and Reports, Plans and Specifications for Power Transmission and Electric Lighting. Tests of Instruments, Machinery and Entire Plant.
 VINELAND, N. J.

ARNOLD, B. J.,
 M. Am. Inst. of Elec. Eng.,
 Consulting and Constructing Engineer.
 SPECIALTY: Electric Railways, Power Stations,
 565 ROOKERY, CHICAGO.

ASHLEY, FRANK M.,
 Consulting Engineer and Contractor.
 Machinery for Special Purposes designed and Construction Superintended. Estimates Furnished for Entire Steam and Electric Power Plants. Inventions Perfected.
 136 Liberty St., NEW YORK CITY.

CLEVELAND CONSTRUCTION CO.
 Complete Equipment of Electric
 Street Railways.
 244 SOUTH HOWARD STREET, AKRON, OHIO.

COLBY, C. B. & W. H.,
 Inspectors of Iron and Steel for Bridges and
 Buildings, Railway Track Material, Ship and Boiler
 Plate, Pipe, etc.
 328 CHESTNUT ST., PHILADELPHIA, PA.

COMSTOCK, THE LOUIS K., CO.,
 Electrical Engineers and Contractors.
 Electric Railways. Power Plants. Isolated Plants.
 MONADNOCK BUILDING, CHICAGO, ILL.

DAVIS, LEWIS K.,
 Consulting Engineer,
 Power Plants and Electric Street Railways. Plans, specifications, and estimates prepared. Examinations made and work superintended.
 1 BROADWAY, NEW YORK.

HALL, J. P.,
 Electrical Contractor.
 Isolated and Steamship Work a Specialty.
 CENTRAL BUILDING, 143 Liberty St., NEW YORK.

JULIUS MEYER,
 PRUSSIAN GOVERNMENT ENGINEER.
 Late Chief Engineer of the Milwaukee Street Railway Company,
 of Milwaukee, Wis., and Consulting Engineer of the
 North American Company, of New York.
**FINANCES, PRELIMINARIES AND CONSTRUCTION OF
 ELECTRIC RAILWAYS.**
 Commercial and Technical Reports on Electrical Properties.
 Office, Temple Court, New York.

HUXLEY & HOFFMAN,
 Construction and Power Contractors.
 Agents Buckeye Engine Co. Plans and specifications furnished.
 W. H. HOFFMAN, Consulting Engineer.
 John Hancock Building, 178 Devonshire St., BOSTON, MASS.

MALOCHÉE, H. J.,
 Consulting Electrical Engineer,
 Reports, Specifications, Designs. Expert Examinations and Supervision
 of Light and Power Work.
 23 Imperial Bldg., Cor. Gravier and Carondelet, New Orleans, La.

PEPPER & REGISTER,
 General Contractors.
 Electric Street Railways a specialty.
 PROVIDENT BLDG., 4th & Chestnut Sts., PHILADELPHIA.

ROSENBAUM, WM. A.,
 Electrical Expert and Patent Solicitor.
 Successor to the Patent Business formerly conducted
 by the W. J. Johnston Co., Ltd.
 Room 177 TIMES BUILDING, NEW YORK CITY.

SMITH, THOS. G., Jr., M. E.
 Mem. Amer. Soc. Mec. Eng.
 Consulting and Supervising Engineer.
 Electric Railway, Light and Power Plants. Equipment of Buildings.
 11 Hammond Building, CINCINNATI, O.

STERN & SILVERMAN,
 Designers and Builders of
 Electric Railway, Light and Power Plants.
 No. 707 ARCH STREET, PHILADELPHIA, PA.

THAYER, WILLIAM C.,
 Consulting and Constructing
 Electrical Engineer.
 Plans, Specifications and Estimates furnished on short notice, and Construction supervised. Wiring of all kinds neatly done. Designing, Draughting and Blue Printing a Specialty.
 110 Wilbur St., CLEVELAND, O.

WAKEFIELD ELECTRICAL ENG. CO.,
 Contracting Engineers.
 Steam, Electric Light, Railway and Power Plants. Correspondence Solicited.
 No. 731 Reading Terminal Building, PHILADELPHIA.

W. L. RANKIN & BRO.,
 LATA, S. C.
 MANUFACTURERS OF
**YELLOW PINE OCTAGON POLES, TIES, CAR STUFF
 AND BRIDGE TIMBERS.**
 —CORRESPONDENCE SOLICITED.—

When Ordering

From firms whose names appear in the Street Railway Journal, our friends will confer a favor on our advertisers and ourselves by mentioning this paper.

Very respectfully,
STREET RAILWAY PUBLISHING CO.

J. H. BICKFORD,

CONSULTING AND CONSTRUCTING ENGINEER.

SURFACE AND ELEVATED ELECTRIC RAILWAYS.

POWER PLANTS, STEAM PLANTS, LIGHTING PLANTS.

PLANS, SPECIFICATIONS AND ESTIMATES. DESIGNS AND SUPERVISION, EFFICIENCY TESTS.
 COMMERCIAL AND TECHNICAL REPORTS, PRELIMINARIES.

—RECENT WORK.—

North Shore Traction Co., Salem, Mass., Lynn & Boston R. R. Co., Lynn, Mass., Scranton Traction Co., Scranton, Pa., Reading Traction Co., Reading, Pa., Steinway Railway Co., Long Island City, N. Y., Metropolitan Electric Co., Reading, Pa., Alton St. Ry. Co., Alton, Ill.

PRINCIPAL OFFICE, NEAL BLOCK, SALEM, MASS.

NEW YORK OFFICE, 29 BROADWAY, Room 203.

AMERICAN STREET RAILWAY INVESTMENTS

A SUPPLEMENT TO THE

Street Railway Journal.

WILL BE READY FOR DELIVERY ON JUNE 15th.

PRICE, - - - - \$5.00.

IT CONTAINS

A careful and authoritative description of the capitalization and operating statistics of over 1,000 street railway systems, operating in 600 cities and towns.

Accurate descriptive and statistical matter concerning the value, as street railway centers, of about 75 cities and towns.

A large number of maps of the principal street railway systems.

NO SUCH COMPLETE AND VALUABLE MANUAL HAS EVER BEFORE APPEARED IN THIS FIELD.

Cut out and send in the following order blank :

AMERICAN Street Railway Investments <small>A SUPPLEMENT TO THE</small> STREET RAILWAY JOURNAL.	<p>—THE—</p> <h2>Street Railway Publishing Co.,</h2> <p>Havemeyer Building, New York.</p>
	<p style="text-align: right;">.....189</p> <p><i>Gentlemen :—Please send</i></p> <p>American Street Railway Investments, <i>(Edition 1894) for which I agree to pay.....\$5.00</i></p> <p>American Street Railway Investments, <i>(Edition 1894) and the Street Railway Journal for</i> <i>one year, beginning with the issue of.....</i> <i>189....., for which I agree to pay.....\$7.50</i></p> <p style="text-align: center;"><i>Name.....</i></p> <p style="text-align: center;"><i>Address.....</i></p> <p>\$.....</p>

SEE OPPOSITE PAGE.

SAMPLE PAGE FROM AMERICAN STREET RAILWAY INVESTMENTS.

Operation. —Year ending June 30,		1892.	1893.
Receipts from passengers.....	\$263,953		\$407,854
“ other sources.....	1,940		7,337
“ total.....	265,893		415,191
Operating expenses.....	161,111		241,459
Earnings from operation.....	\$104,782		\$173,732
Deductions from earnings.....	59,216		87,420
Net income.....	\$45,566		\$86,312
Dividends paid, 6 per cent.....	45,000		52,499
To surplus account.....	566		33,813
Total surplus account,.....def.	16,166	surp.	17,002
Per cent. O. E. to total receipts.....	60.5		58.1

Balance Sheet.—Date June 30, 1893.

Assets.		Liabilities.	
Cost of road and equip. \$1,802,633		Capital stock.....	\$1,000,000
Cash assets..... 36,261		Funded debt.....	730,000
Other assets..... 1,757		Bills and accounts payable.....	91,015
		Other liabilities.....	2,633
		Profit and loss.....	17,002
Total..... 1,840,650		Total.....	1,840,650

Plant and Equipment.

		Owned.	Leased.
Miles of main line.....	12.6		8.4
“ second track and sidings.....	4.0		7.1
“ track (electricity).....	16.6		15.5

Gauge, 4 ft. 8½ in.; 50 lb. and 70 lb. girder rail; 100 motor cars, McL. & S. and Cooper Corliss engines, B. & W. boilers, Gen. Elec; dynamos, Gen. Elec. and West. motors, Gilbert cars, Taylor trucks.

Officers.—Pres. Robt. C. Pruyn, V. Pres. A. N. Brady, Treas. Gen. Man. & Purch. Agt. John W. McNamara, Sec. James McCredie, Asst. Gen. Man. Edgar S. Fassett, Chf. Eng. Thomas E. Murray, Elec. Engr. H. P. Merriam. General Office, Broadway and State Streets.

LOUISVILLE, KY.

MUNICIPAL STATISTICS AND INFORMATION.

Location.—Louisville is situated in the northern central part of Kentucky, on the Ohio River—the dividing line between Kentucky and Indiana. It is the county seat of Jefferson County.

Suburbs.—The townships of Crescent Hill, Parkland and South Louisville are connected with Louisville by street railway lines. The cities of New Albany and Jeffersonville are across the river in Indiana, but are not connected with Louisville.

Population.—The population in 1880 was 123,758, and in 1890, 161,129, an increase of 30 per cent. The total present population of the city and suburbs named is approximately 200,000.

Railroad Connections.—The Newport News & Mississippi Valley R. R., the Louisville & Nashville R. R., the Louisville, Evansville & St. Louis R. R., the Louisville, New Albany & Chicago R. R., the Ohio & Mississippi R. R., the Louisville, St. Louis & Texas R.R., the Louisville Southern, the Queen & Crescent route (to New Orleans and all Southern points) and the Pennsylvania Company connect Louisville with all parts of the country. A number of river steamers ply between Louisville and the different points on the Ohio and Mississippi River.

Manufacturing and Commercial Interests.—A capital of about \$31,000,000 is employed in the various industries of the city, the principal productions being chewing and smoking tobacco, cigars, sole leather, furniture, agricultural implements, water and gas pipes, wagons and manufactured iron. Louisville is the largest whiskey market in the world, the taxes alone amounting to over \$20,000 per day, and the city's commerce exceeds \$150,000,000 per annum. About 25,000 hands are employed in the manufacturing industries, receiving in wages about \$11,000,000 per annum, and the value of the manufactured product is about \$45,000,000 per annum.

Banking Capital.—There are now (1894) 9 national banks, with a combined capital and surplus of about \$5,000,000; 12 state banks, with capital and surplus of about \$9,000,000; 1 loan and investment company, with capital and surplus of about \$715,000, and 2 savings banks, with surplus of about \$39,000. The total banking capital is approximately \$15,000,000, equivalent to about \$93 per capita.

Assessed Valuation.—The assessed valuation of real estate is (1893) \$84,600,000 the property being assessed at about 80 per cent. of its real value. The assessed valuation of the personal property is \$5,725,000. The total valuation of real and personal property is \$90,325,000, equivalent to \$561 per capita.

Municipal Debt.—The municipal debt of the city less sinking funds is (1893) \$9,212,000, equivalent to \$57 per capita.

Tax Rate.—The tax rate is (1893) \$23.05 per \$1,000.

STREET RAILWAY SYSTEM—Descriptive.

Louisville is built on a plateau about 70 ft. above the river, and

is laid out upon a regular geometrical pattern. The city covers an area of about 35 square miles, the population density being about 4,600 inhabitants per square mile. The street railway system is extensive and well developed, is under the control of a single corporation, and gives an excellent service to every part of the city and suburbs. Of the 160 miles of track 100 miles are operated by electricity and 60 miles by horses.

STREET RAILWAY SYSTEM—Present Companies.

Louisville Railway Co.—Chartered, April 9, 1893. Annual meeting third Wednesday in Feb. This is a consolidation of the following companies: Louisville City Ry. Co., Central Passenger R. R. Co., Kentucky Street Ry. Co., Beargrass Ry. Co. and Crescent Hill Ry. Co. This company owns and operates the entire street railway system of Louisville.

Capital Stock.—Common stock, authorized and issued (Jan. 1894), \$4,000,000; par value \$100 per share. Preferred stock, authorized and issued, \$2,000,000; par value \$100 per share. Conditions of preference, 5 p. c. cumulative dividends.

Funded Debt.—First consolidated mortgage gold bonds, authorized, \$6,000,000; issued, \$4,600,000; in escrow, \$1,400,000 (see Note), coupon, but may be registered; dated July 1, 1890, due 1930; denom. \$1,000; int. 5 p. c., payable Jan. and July in Louisville and New York (Seligman & Co.); trustee of mortgage, Fidelity Trust & Safety Vault Co. of Louisville, Ky.

Note.—The company has reserved \$1,400,000 of consolidated mortgage bonds to retire an equal amount of prior issues as follows:

First mortgage bonds Louisville City Ry. Co., original issue, \$300,000, now outstanding, \$137,000; dated July 1864, due 1894; denom. \$500; int. 6 p. c., payable Jan. and July, at office of Continental Nat'l Bank, New York, and in Louisville; trustee of mortgage, J. G. Barrett, of Louisville.

Mortgage bonds Louisville City Ry. Co., original issue \$250,000, now outstanding, \$79,000; dated July 1877, due 1897; denom. \$100 and upwards; int. 6 p. c., payable Jan. and July, at office of Continental Nat'l Bank, New York, and in Louisville; trustee of mortgage, William Mix, of Louisville.

Mortgage bonds Louisville City Ry. Co., original issue and now outstanding, \$609,000; dated July 1884, due 1909; denom. \$50 and upwards; int. 6 p. c., payable Jan. and July, at office of Louisville Trust & Safety Vault Co., trustee of mortgage,

First mortgage bonds Central Passenger Ry. Co., authorized \$400,000, now outstanding, \$95,000; dated Nov. 1883, due 1902; denom. \$1,000; int. 6 p. c., payable May and Nov. in Louisville; trustee of mortgage, J. M. Duncan, of Louisville.

Mortgage bonds Central Passenger Ry. Co., authorized, \$400,000, now outstanding, \$305,000; dated Nov. 1888, due 1908; denom. \$1,000; int. 6 p. c., payable May and Nov., in Louisville; trustee of mortgage, Louisville Safety Vault & Trust Co.

First mortgage bonds Citizens' Passenger Ry. Co., original issue, \$200,000, now outstanding, \$175,000; dated Jan. 1867, due 1897; denom. \$1,000; int. 6 p. c., payable Jan. and July in Louisville; trustee of mortgage, J. M. Duncan, of Louisville.

Franchises.—The franchises for a part of the system are granted for 99 years from 1893, the balance are granted without time limit.

Operation.—Year ending Dec. 31, 1893.

Receipts from passengers.....	\$1,265,202
“ other sources.....	16,791
“ total.....	1,281,993
Operating expenses and taxes, 63 p. c.....	807,056

Earnings from operation.....	474,937
Interest on bonds.....	314,000
Net income.....	160,937
Dividends paid.....	87,500

To Surplus account..... 73,437

Balance Sheet.—Date, Dec. 31, 1893.

Assets.		Liabilities.	
Cost of road.....	\$11,559,17	Capital stock.....	\$6,000,000
“ equipment.....	1,376,175	Funded debt.....	6,000,000
Cash assets.....	163,106	Bill payable.....	10,000
Other assets.....	220,124	Other liabilities.....	333,347
		Surplus.....	975,235
Total.....	13,318,582	Total.....	13,318,582

Plant and Equipment.

Miles of main line 90, of second track 60, of sidings and other track 10, total track 160; track operated by horses 60, by electricity 100. Gauge, 5 ft., 100 miles 78 and 100 lb girder rail construction, 30 miles T rail construction, 30 miles miscellaneous construction; no. of horses, 1,258, of horse cars, 180, of motor cars, 200, of trail cars, 100; horse power of engines, 3,000, Gen. Elec. dynamos and motors.

Officers. Pres. J. B. Speed, Vice-Pres. St. John Boyle, Sec. & Treas. R. A. Watts, Gen. Man. T. J. Minary, Supt. J. O. Haddox, Chief Eng. & Elec. A. B. Du Pont. General office, 12th and Jefferson Sts.

A VALUABLE BOOK.

THE MOST IMPORTANT WORK TO STREET RAILWAY MEN THAT HAS BEEN PUBLISHED.

THE FIRST PRACTICAL BOOK COVERING
AMERICAN STREET RAILWAY
PRACTICE OF TO-DAY.

STREET RAILWAYS;

THEIR

CONSTRUCTION,

OPERATION AND

MAINTENANCE.

"TRAMS."

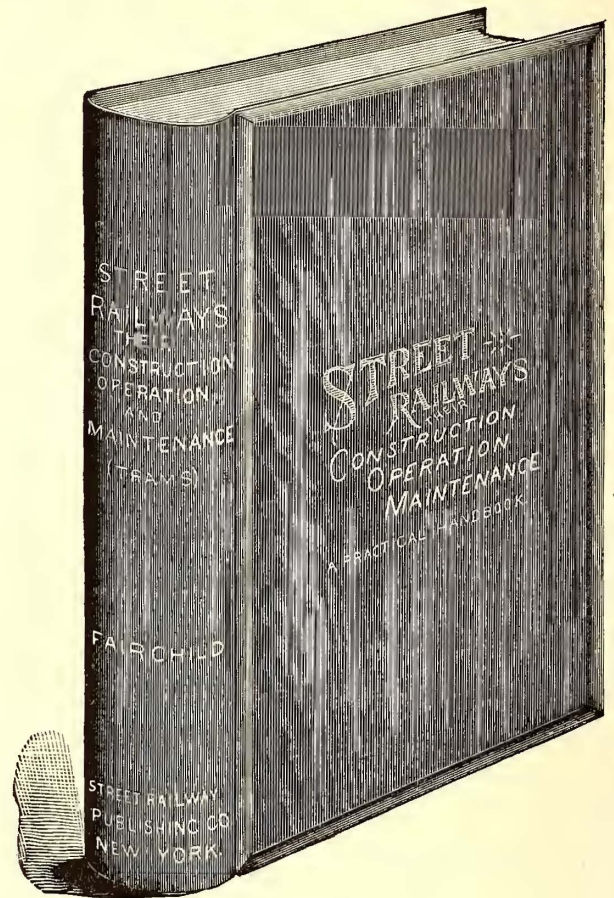

A Practical Handbook for Street Railway Men.

By C. B. FAIRCHILD, Editor Street Railway Journal.

A BOOK bearing the above title, profusely illustrated, has been issued from the press of the STREET RAILWAY JOURNAL. This work has been carefully compiled from the series of articles entitled "Trams," which, for a year past, have appeared in the STREET RAILWAY JOURNAL. These articles have been submitted to the criticism of experts in each of the different departments treated, and have been revised, enlarged and corrected, and it is confidently believed that the book will be accepted by street railroad men as a standard work, and will prove invaluable to all interested in the subject.

It treats fully of Electric, Cable, Horse and other surface roads, including those operated by Steam, Air and Gas Motors, also Elevated, Inclined plane and Rack Rail Systems. A whole chapter is devoted to track construction for each method of traction; with an itemized bill of cost. Another treats of Franchises and Corporations and Laws relating to the same. A third relates to discipline, and gives a classified set of rules for the guidance of conductors and drivers, which have been compiled from the best practice.

The book is quarto in form, handsomely printed, and bound in a most substantial manner. It contains nearly 500 pages and over 750 illustrations.

PRICE, POSTAGE PREPAID:—Cloth, \$4.00; Leather and Gilt, \$5.00.

Remit by P. O. money order, draft, registered letter or express money order.

ADDRESS **STREET RAILWAY PUBLISHING CO.,**
Havemeyer Building, New York.

Copies can also be obtained at our Western Office, **Monadnock Block, Chicago.**

THE DORNER & DUTTON MFG. CO.

—✦ CLEVELAND, O., ✦—

MANUFACTURERS OF

**ELECTRIC,
CABLE
AND
TRAIL CAR**

TRUCKS

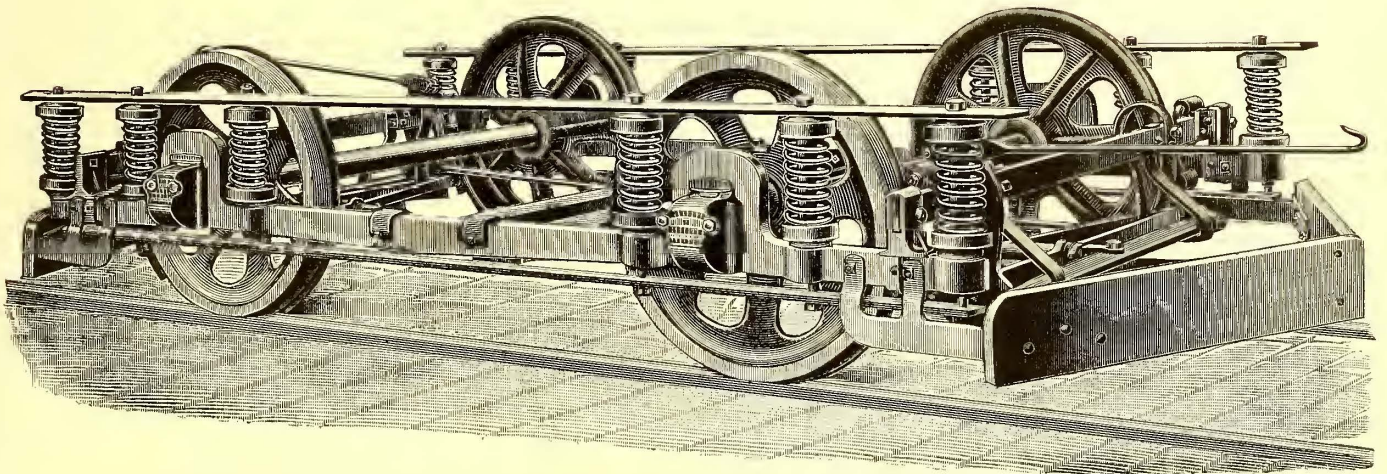

SOLID FORGED MOTOR TRUCK, No. 20,
For Car Bodies, 16 to 20 Feet Long.

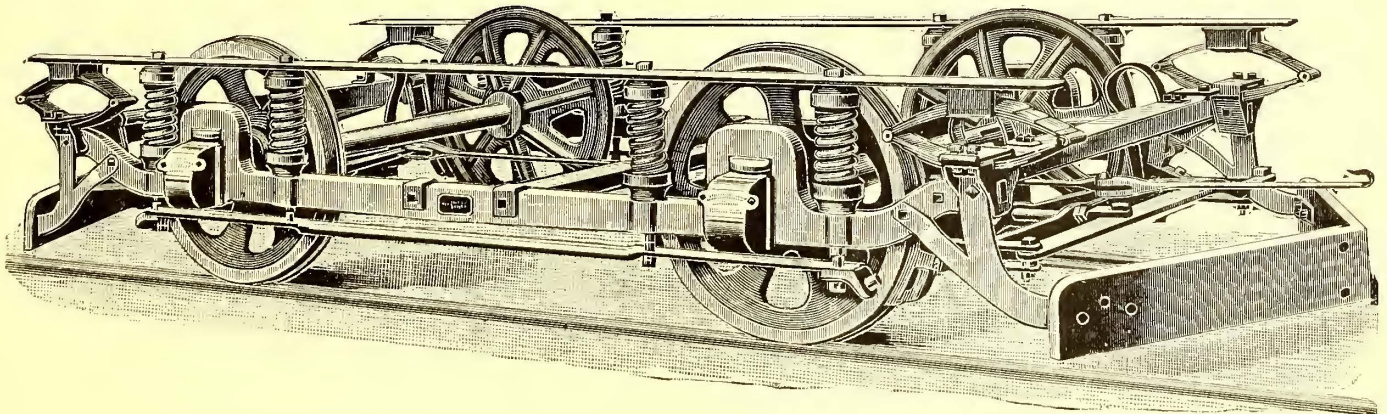

SOLID FORGED MOTOR TRUCK, No. 25.
For Car Bodies, 18 to 26 Feet Long. (Exclusive of Platforms.)

FOR SALE

SECOND-HAND STREET CARS

Open and Closed Cars, with or without electrical equipment, ready for service.
 Various parts new and second-hand F 30 electrical equipment, at very low prices.
 Also, one second-hand McIntosh & Seymour 250 H. P. Engine in good order.
 Photographs of cars sent on application. Address

H. F. WOODS,

Purchasing Agent West End Street Railway Co. **BOSTON, MASS.**

ECONOMY. EFFICIENCY. LONGEVITY.

THE YOUNG LOCK NUT CO.,
 150 Broadway, New York City.

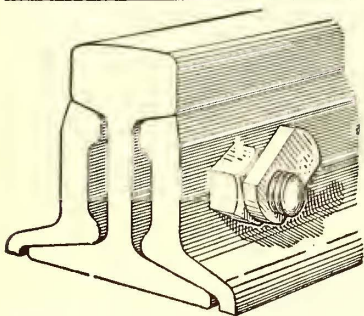

WASHINGTON & GEORGETOWN RAILROAD CO.

WASHINGTON, D. C., February 15, 1894.

Gentlemen:—Replying to yours of the 14th inst., would state that the Young lock nut is giving us entire satisfaction where used. We are using these locks on the bolts that fasten our grip guards to their brackets around curves. We formerly had a jam nut on these bolts and they were continually getting loose; but since using the Young lock nut they have given us no trouble at all.

(Signed)

D. S. CARLL, Chief Engineer.

THE STREET RAILWAY JOURNAL, - - \$4.00 PER YEAR.

ESTABLISHED 1820

Alfred F. Moore
 MANUFACTURER OF
INSULATED ELECTRIC WIRE

ALFRED F. MOORE.
 CHAS. C. KING.
 A. BOURNONVILLE.

FLEXIBLE CORDS,
 CABLES & C.

PHILADELPHIA
 PA.

NORTH EAST WEST SOUTH

CHICAGO, MILWAUKEE AND ST. PAUL RAILWAY.

MINN. IOWA MO. KANSAS

CHICAGO, ILL.

GEO. H. HEAFFORD, General Passenger Agent.
 J. H. HILAND, General Freight Agent.

WESTERN NEW YORK & PENNSYLVANIA RAILROAD CO.

The Short and Popular Route from Buffalo to Olean, Bradford, Dunkirk, Mayville, Titusville, Oil City, Pittsburgh, Philadelphia, Baltimore, Washington and the South,

THE ONLY LINE RUNNING SOLID TRAINS WITH PULLMAN BUFFET AND SLEEPING CARS DAILY BETWEEN BUFFALO, OIL CITY AND PITTSBURGH.

Gen'l Office, 84 Exchange St., Buffalo, N. Y.
 Trains Leave N. Y. C. & H. R. R. R. Depot

R. BELL, General Superintendent. J. A. FELLOWS, General Passenger Agent.

The Economy Trolley Wheel Co.

1244 UNITY BUILDING, CHICAGO.

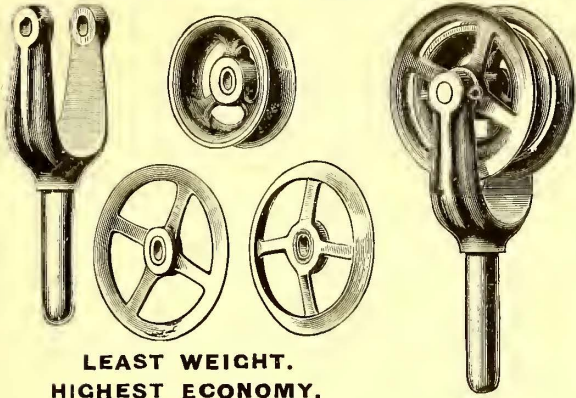

LEAST WEIGHT.
HIGHEST ECONOMY.

Flanges and Rims are Steel. Center Pulley is Brass. All turn independently on splined. Worn part CHEAPLY RENEWED. The LIGHTEST, most PRACTICAL, and ECONOMICAL TROLLEY WHEEL, on the market. Are made for cable purposes.

Changeable Electric Headlight Co.

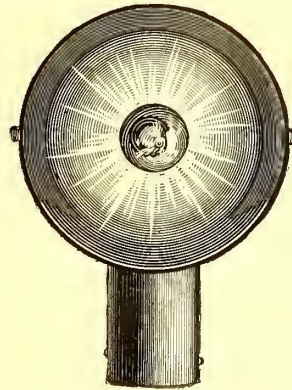

Front View.

No Oil.
No Broken
Chimneys.
Costing Nothing
for Maintenance.

OFFICE:
406 BASTABLE,
SYRACUSE, N. Y.

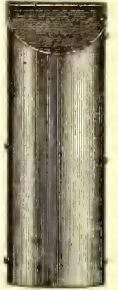

Rear View.

MOTORS

Detroit Standard

Motor Equipments (New)
Complete Including
TRUCKS.

Lowest Prices. Write for
Particulars.

L. Warfield, Agt., Detroit, Mich.

ELEPHANT BRAND. PHOSPHOR BRONZE.

<p>ALL GENUINE INGOTS & MANUFACTURES BEAR OUR REG. TRADE MARKS.</p> <p>"Phosphor Bronze"</p>	<p>PHOSPHOR-BRONZE INGOTS, CASTINGS, WIRE, SHEET &c. THE PHOSPHOR BRONZE SMELTING CO. LIMITED 2200 WASHINGTON AVE. PHILADELPHIA, PA. ORIGINAL MANUFACTURERS OF PHOSPHOR- BRONZE IN THE UNITED STATES AND SOLE MAKERS OF "ELEPHANT BRAND" PHOSPHOR-BRONZE</p>
--	---

CAMBRIA STEEL

STREET RAILS. CAR CHANNELS

Address,

CAMBRIA IRON CO.,
218 SO. FOURTH ST., PHILADELPHIA, PA.

FRANCIS M. EPPLEY, ATTORNEY & COUNSELLOR-AT-LAW

—AND—
SOLICITOR OF PATENTS.

PRESIDENT OF THE ORANGE CROSS TOWN STREET RAILWAY.

New York Office, 140 Nassau St.
New Jersey Office, 303 Washington St., Orange, N. J.

Special Attention to all Matters and Negotiations appertaining to
Street Railway Properties.

10 Times the Area of the Wire for Contact

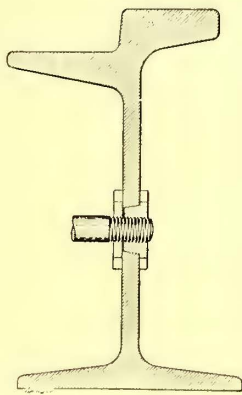

Is what the electrical law requires, but you have been compelled to ignore this and be satisfied with getting the area of the wire, and often not that. The Johnston Rail Bond, by utilizing the contact against the side of the rail, affords **12 times the area of the Bond Wire for contact.** It is durable and the contact indestructible. An ignorant laborer cannot bungle it; it can be applied in about 5 minutes. You can with this bond operate your road under the highest economy and reduce the loss of 30 to 40 per cent. between dynamos and motors. Write for cross section and prices.

THE CAR EQUIPMENT CO.,

741 Drexel Building, = = = Philadelphia, Pa.

ELECTRIC RAILWAYS.

PLANS, SPECIFICATIONS, ESTIMATES;
CONSTRUCTION SUPERVISED;

UNDER ANY OR ALL SYSTEMS.

C. O. MAILLOUX, Consulting Electrical Engineer,

No. 45 William St., NEW YORK.

CHARLES M. RUMRILL & BRO.,

—MANUFACTURERS OF—

HIGH GRADE INSULATORS

FOR LINE CONSTRUCTION,

AND APPLIANCES FOR TRACK OR OVERHEAD WORK.

109 Liberty Street,

NEW YORK.

SEND SPECIFICATIONS.

BARBOUR, STOCKWELL CO.,

MANUFACTURERS OF

MATERIAL AND SUPPLIES FOR STREET RAILWAYS.



205 Broadway, Cambridgeport, Mass.

THE Dewey Electric Signal System

FOR CARS PROPELLED BY ELECTRICITY.

ACCIDENTS AVOIDED.

SAFETY ASSURED.

CONVENIENCE ATTAINED.

ALARM GONG operated by simple pressure of motorman's foot on push button. Gong rings continuously if desired.

NO CONFUSING UP AND DOWN MOVEMENT OF THE FOOT. SIGNAL BELLS operated by push buttons conveniently located in car and at each end under the hood.

NO BATTERY. CURRENT TAKEN DIRECTLY FROM MAIN LINE OR TROLLEY.

Electric Railway Companies are particularly invited to inspect the system before placing their orders for new cars.

Detailed information given on application.

THE DEWEY ELECTRIC SIGNAL CO.,

Havemeyer Building, 26-28 Cortlandt St., New York.

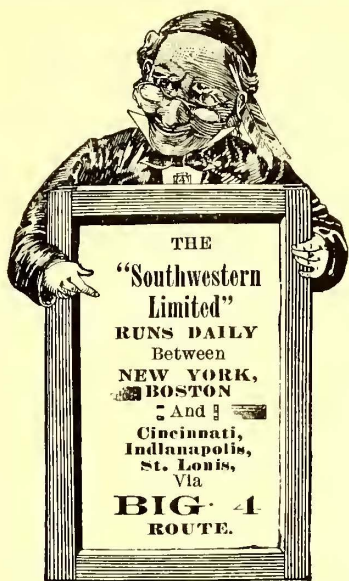

E. O. McCORMICK, Passenger Traffic Mgr., CINCINNATI, O. D. B. MARTIN, Gen'l Passenger & Ticket Agt., CINCINNATI, O.

INSTRUCTION ^{BY} MAIL

In Architecture, Architectural Drawing, Plumbing, Heating and Ventilation, Mechanics, Mechanical Drawing,

Bridge Engineering, Electrical Engineering, Surveying and Mapping, Mining, English Branches and

RAILROAD ENGINEERING.

Diplomas awarded. To begin, students need only know how to read and write. Send for FREE Circular of Information, stating the subject you think of studying to

THE CORRESPONDENCE SCHOOL OF MECHANICS AND INDUSTRIAL SCIENCES.

SCRANTON, PA.

4000 STUDENTS.

W. H. RUFF,
COUNSELLOR AT LAW IN PATENT CAUSES

—AND—

SOLICITOR OF AMERICAN AND FOREIGN PATENTS.
Washington Loan and Trust Company Building,
WASHINGTON, D. C.

ESTABLISHED 1882.

CIRCULAR FURNISHED ON APPLICATION.

Mason Electric Co.,

Electric Railway

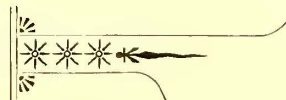

Supplies **ONLY.**

THE PIONEER HOUSE SELLING ONLY THE BEST EQUIPMENT. AGENTS FOR HOLMES BOOTH & HAYDENS WIRES, GARTON LIGHTNING ARRESTERS, SAFETY CLUTCH BRAKE, PARTRIDGE CARBON BRUSHES, GRIFFITH'S IMPROVED TROLLEY.

Medbery Overhead Material.

SEND FOR CATALOGUE AND PRICES.

MASON ELECTRIC CO.

608 PULLMAN BUILDING, CHICAGO.

W. R. MASON, General Manager.

WORLD'S FAIR ELECTRIC LAUNCHES AT A BARGAIN.

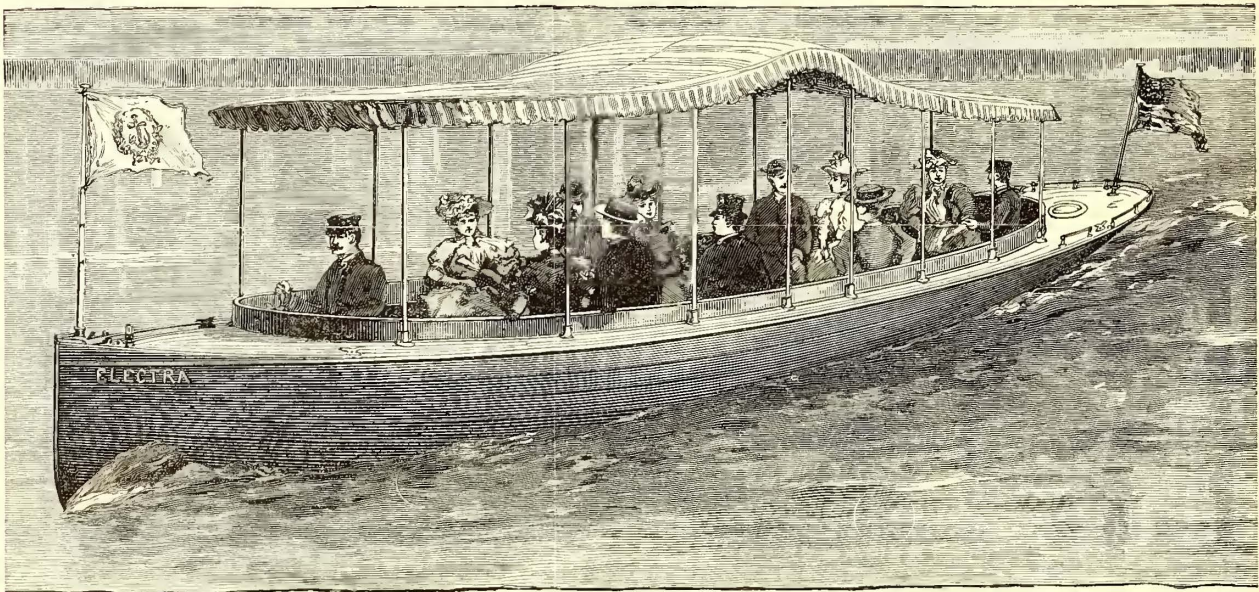

STREET RAILROADS WILL FIND IT A GREAT ADVANTAGE TO HAVE THEM ON THEIR WATER TERMINI.

May be Charged from Trolley or Arc Circuit.

WILL SEAT 30 PASSENGERS.

Beautiful Effects at Night when Launches are Lighted by their Own Electric Power.

MAY NOW BE SEEN AT MORRIS HEIGHTS ON
THE HARLEM RIVER.

General Electric Launch Co.,
44 Broad Street, New York.

The American Electric Car Heaters

Have Passed the Experimental Stage.

NO PASSENGER SPACE OCCUPIED.

NO PASSENGER SPACE OCCUPIED.

Economy.

By continual experience in actual use on a large number of cars, have been proven the most efficient, most durable, most economical and most simple Electric Heater made. Investigate this system before ordering new cars. It saves expense to have cars wired during their course of construction.

Efficiency.

Turn on Switch,
Heat Begins Immediately.

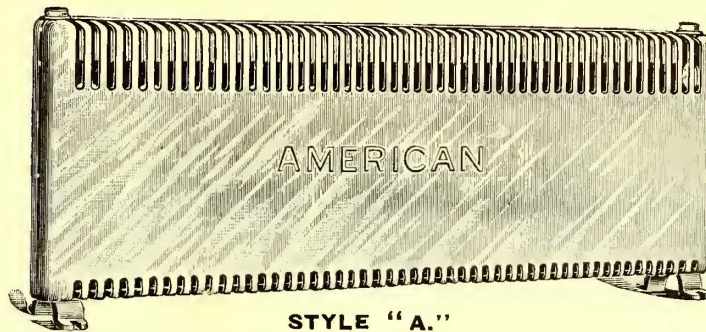

Turn off Switch,
All Expense Ceases.

STYLE "A."

Durability.

During the past winter careful and complete tests of the American Electric Heaters have been made on cars under varying conditions of temperature and weather. Copies of series of these tests will be mailed on application.

Cleanliness.

FOR PRICES, ESTIMATES, CATALOGUES OR OTHER INFORMATION, WRITE TO

CENTRAL ELECTRIC HEATING CO.,

26-28 CORTLANDT STREET, NEW YORK.

Every Vital Claim Ever Made for the STIRLING WATER TUBE SAFETY BOILER Confirmed in the Following WORLD'S FAIR AWARD:

UNITED STATES:

Department F.—Machinery:

1647

Exhibitor—Stirling Co., Address Chicago, Ill.

Group 69 Class 413.

Exhibit—Water Tube Steam Boilers.--

AWARD

Furnishing steam for use of Exhibition. One of the chief characteristics lies in the simplicity and consequent low cost of construction. Boilers consist merely of four cylindrical shells or drums, connected by tubes which form major portion of heating surface. Tubes are expanded into drum, and practically the only machine work required upon entire structure is that employed upon the manhole frame in the head of each drum, which is of the simplest character. Tubes are located in a position slightly inclined from a vertical and the tendency of sediment to collect on either the exterior or interior surfaces is thereby reduced to a minimum. The large mud-drum, located below the current produced by circulation, insures quiet water in which mud, scale and other impurities may settle. Drum favorably located at bottom of rear bank of tubes for receiving deposits which require high temperature to be precipitated. Examination of these boilers in operation where water used contained large quantities of lime salts, demonstrated that a small amount of labor was required to maintain them in a clean condition, and that they operated with the highest efficiency in this most important feature and possessed marked advantage. Arrangement of division plates is such that exit for waste gases is over surfaces where the cold feed water is just entering, insuring low flue temperature. Use of a fire-brick arch covering grate enables high furnace temperature to be maintained. These boilers are proportioned so that the ratio of horse power to grate is about fifty to one, ample for economical result. Boilers exhibited show that they gave practically dry steam. Inner and outer rows of tubes slightly curved. A chain scraper is passed through when deposits form on surfaces. The tubes are accessible from outside. A single workman disconnected the four manhole plates and exposed every tube in the boiler within a period of five minutes.

Extreme simplicity and low cost of construction of water tube boilers. Excellence of design in features pertaining to fuel economy, and singular adaptability to situations requiring the use of impure feed water.

(Signed) Geo. H. Barrus, Individual Judge.

Approved: John A. Roche, President Departmental Committee.

Approved: [Signature] Chairman Executive Committee on Awards.

Copyist A. M. C. Date February 26, 1894.

Subject to change of grammatical and typewritten inaccuracies:

THE STIRLING COMPANY,

GENERAL OFFICES: PULLMAN BUILDING, CHICAGO, ILL.

New York Office, 126 Liberty St. Boston Office, 8 Oliver St. Philadelphia Office, 418 Walnut St. Pittsburgh Office, Conestoga Bldg. Cleveland Office, Cuyahoga Bldg. Cincinnati Office, 38 W. Third St. Toledo Office, Arbuckle, Ryan & Co. New Orleans Office, C. S. Burt Co. Minneapolis Office, Lumber Exchange.

STEEL CASTINGS

From 1 to 40,000 Pounds Weight.
 OF OPEN HEARTH, CHESTER OR
 BESSEMER STEEL.
True to Pattern. Sound. Solid.
 Gearing of All Kinds, Crank Shafts,
 Knuckles for Car Couplers.
 CROSS-HEADS, ROCKERS, PISTON-HEADS,
 ETC., FOR LOCOMOTIVES.
Steel Castings of Every Description.
CHESTER STEEL CASTINGS CO.

WORKS:—CHESTER, PA. Office:—407 Library St., Philadelphia, Pa.

HYDRAULIC WHEEL PRESSES

BOTH HAND AND BELT POWER.

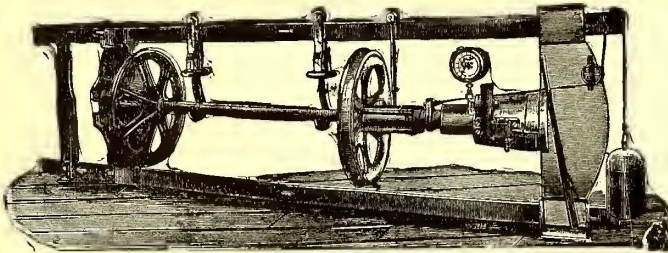

HYDRAULIC JACKS

To lift or push from 4 to 150 tons. Large Jacks Rented by the day, week or month.

All Sizes and Styles of Screw Jacks, Track Jacks, Traverse Jacks, &c., &c. Punches and Shears, Polishing and Buffing Machinery.

WATSON & STILLMAN,

204 to 210 East 43d Street. NEW YORK.

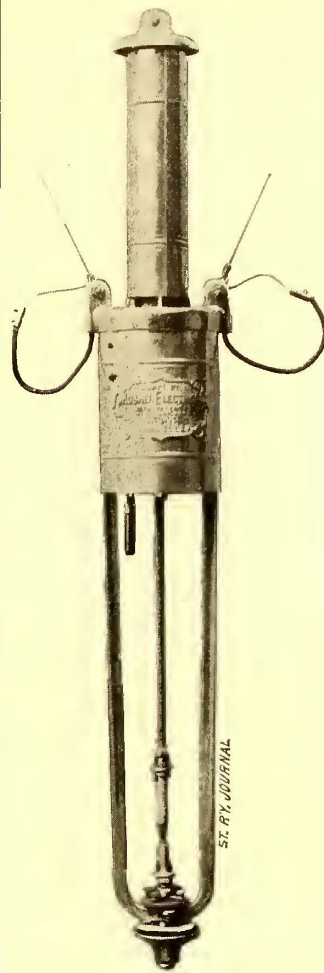

MOSHER Arc Lamp,

FOR Street Railway Work.

Fully Guaranteed.

PRICES REDUCED.

Lamps Sent on Trial for Thirty Days.

It Will Pay to Try it.

Mosher Electric Co.

125 Ontario Street, Chicago, Ill.

View of Lamp Wired in Use.

IRON BUILDINGS, IRON ROOFS,

RAILWAY AND HIGHWAY BRIDGES.

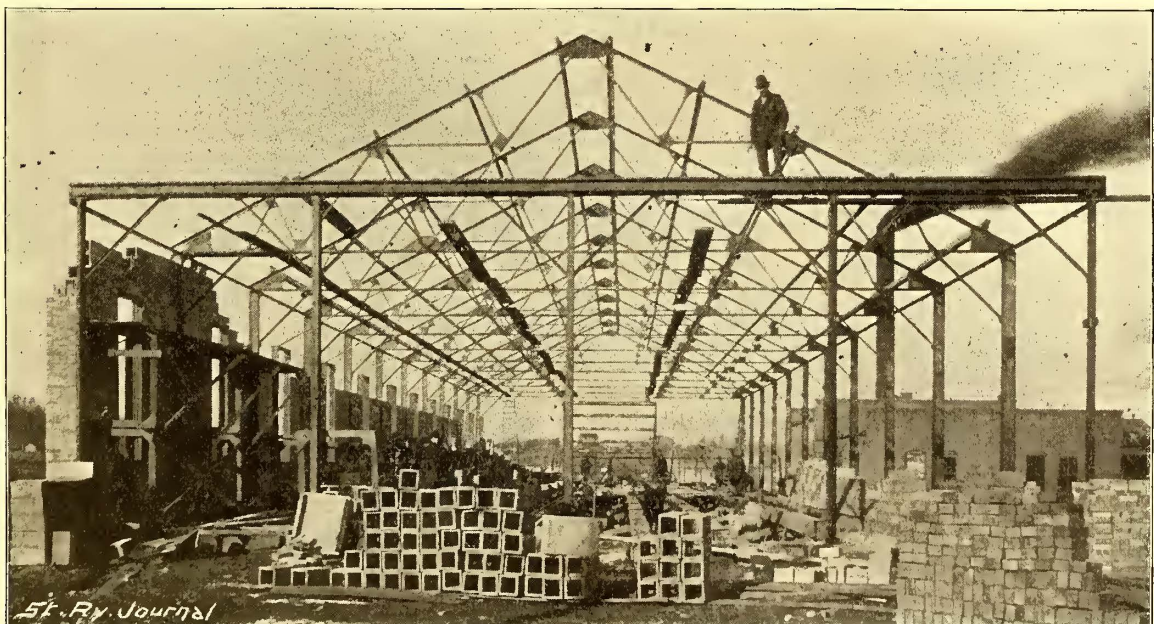

GENERAL STRUCTURAL WORK IN IRON AND STEEL, FOR POWER HOUSES, CAR SHEDS, ETC.
 POLES FOR TROLLEY WIRES, ELECTRIC LIGHTS, ETC.

WROUGHT IRON BRIDGE CO.,

Principal Office:
CANTON, OHIO.

PLEASE COMMUNICATE WITH
 NEAREST OFFICE.

New York Office, Electrical Exchange Building.
 Central Office, Chicago, Ill.
 Western Office, Kansas City, Mo.

The Billings Patent

Commutator Bars.

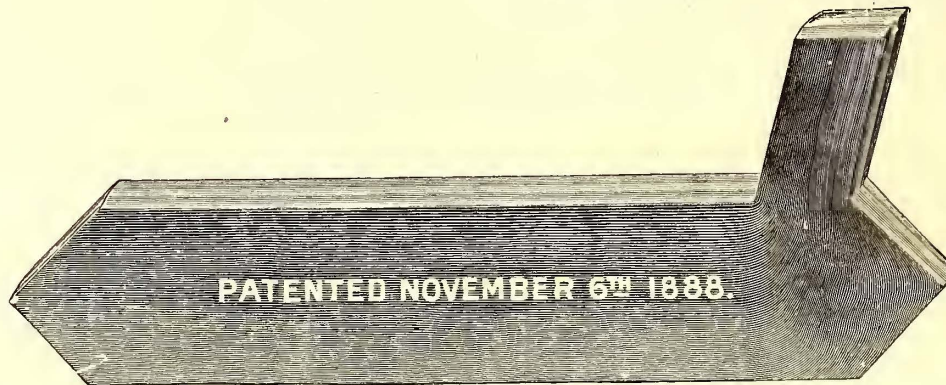

USED BY THE PRINCIPAL MAKERS OF ELECTRIC DYNAMOS AND MOTORS
AND THE LEADING ELECTRIC RAILWAYS.

THE BILLINGS & SPENCER COMPANY,
HARTFORD, CONN.

Drop Forgings of Every Description.

ST. LOUIS, ARTHUR S. PARTRIDGE, BANK OF COMMERCE BUILDING.

CLEVELAND, THE EASTERN ELECTRICAL EQUIPMENT CO., 5 WATER ST.

EASTERN AGENTS, PETTINGELL-ANDREWS CO., 72 74 FEDERAL ST., BOSTON.

GET DRY STEAM for your engine.

There are two ways: A separator will remove the EFFECT of condensation;
MAGNESIA Pipe Covering, the CAUSE. Which is the better method?



ROBERT A. KEASBEY, 54 Warren St., New York.

Long Distance Telephone 1515 Cortlandt.

BRANCH OFFICE: 119 Franklin St., Buffalo, N. Y.
Telephone Call 1844.

STRIEBY & FOOTE, DROP FORGINGS.

295-301 Ogden St., Newark, N. J.

TURNBUCKLES, POLE-CLAMPS,
AND SPECIAL FORGINGS FOR ELECTRICAL RAILWAY CONSTRUCTION.

THE LODGE & DAVIS MACHINE TOOL CO.,

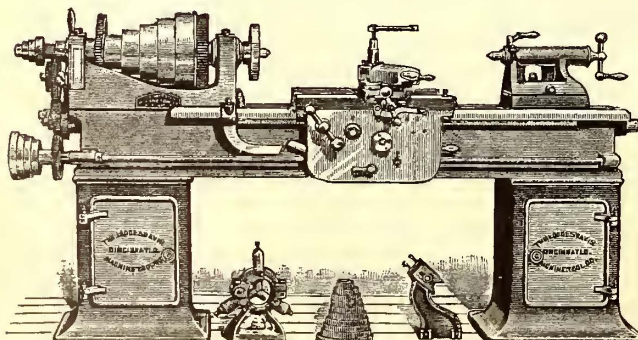

BUILDERS OF

COMPLETE EQUIPMENTS FOR

Street Railway Shops,

Including Engine Lathes, Planers, Drill Presses,
Shapers, Screw Machines, Milling Machines,
Turret Lathes, Bolt Cutters, &c., &c.

Works: **CINCINNATI, OHIO, U. S. A.**

NEW YORK,
110 Liberty St.

CHICAGO,
68-70 S. Canal St.

PITTSBURGH,
Cor. Market & Water Sts.

ST. LOUIS,
823 N. Second St.

BOSTON,
23-25 Purchase St.

BATES-CORLISS BATES MACHINE CO.

JOLIET, ILL.

SOLE MANUFACTURERS.

Simple and Compound.

The only Liberating Valve Gear Without Springs or Hook Block,
All Joints have Wrist Pin Bearings.

BRANCH OFFICE, CUYAHOGA BUILDING, CLEVELAND, O.

AGENCIES:

FROST MFG. CO., Galesburg, Ill.	KEATING IMP. & MACH. CO., Dallas, Tex.
ENGLISH SUPPLY & ENG. CO., Kansas City, Mo.	SMITH-COURTNEY CO., Richmond, Va.
E. C. WELLS, 49 Rutland Square, Boston, Mass.	

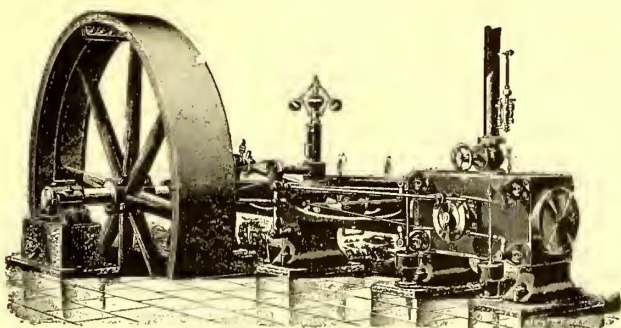

—PHILADELPHIA CORLISS ENGINES.—
AIR PUMPS AND CONDENSERS.
BAND AND FLY WHEELS. STEEL-PLATE CHIMNEYS.
—BLOWING ENGINES.—

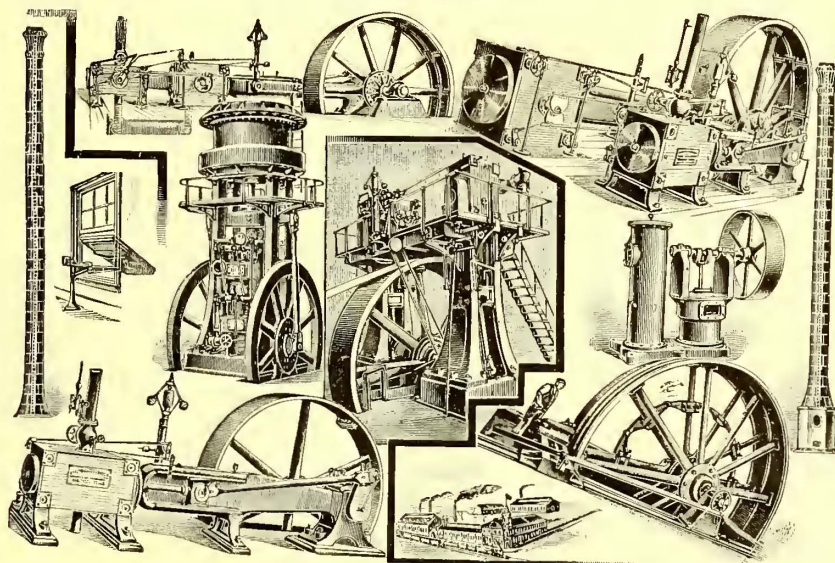

BUILT BY

PHILADELPHIA ENGINEERING WORKS, Limited,
Mifflin Street, East of Front, Philadelphia, Pa.

Chicago, W. F. PARISH MACHINERY CO., Home Insurance Building.
New York, WM. M. POWER, 121 Liberty St.

A TREATISE ON English Methods of Street Railway Track Construction.

BY

JAMES MORE,

*Assoc. M. Inst. C. E., Engineer to
Dick, Kerr & Co., Ltd.,*

AND

ALEX. McCALLUM.

Paper Covers. Price 35 Cts.

FOR SALE BY THE

Street Railway Publishing Co.,

HAVEMEYER BUILDING,

26 CORTLANDT ST., NEW YORK.

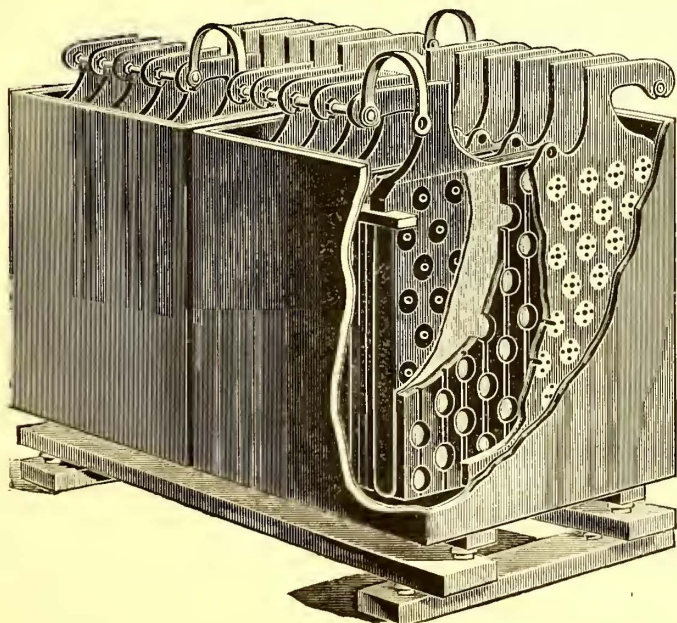

—THE— Electric Storage Battery Co.

SOLE MANUFACTURERS OF

THE CHLORIDE ACCUMULATOR.

Elements of all sizes, from one
hundred up to ten thousand watt
hours capacity each, or larger if
required.

TRACTION CELLS A SPECIALTY.

Electric Launch Equipments,
Telegraph, Phonograph, Surgi-
cal, and all Special Cells.

Address,

**Drexel Bldg.,
Philadelphia, Pa.**

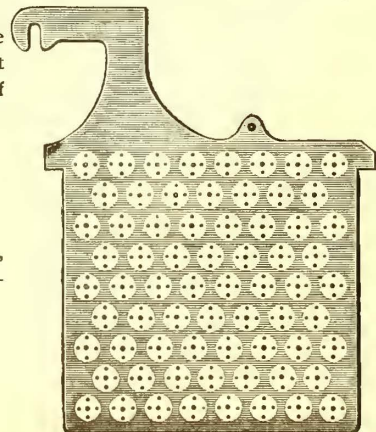

WHEN YOU SEE



THIS TRADE MARK

ON LEATHER BELTING, YOU
SEE ALSO THE

BEST BELTING.

CHAS. MUNSON BELTING CO.,

Chicago, 22 to 36 So. Canal St.
Pittsburgh.

HARRISBURG Foundry and Machine WORKS

GENERAL OFFICE AND WORKS:

HARRISBURG, PA., U. S. A.

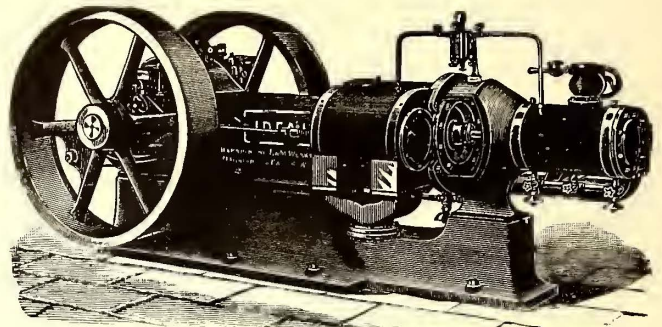

The Harrisburg Ideal Tandem Compound Engine.

Automatic Lubrication. Superior Regulation. Perfect
Equilibrium in Action. Highest Economy.

SELLING AGENTS:

W. R. FLEMING & CO.,
New York and New England.
New York Office,
Mail and Express Building.
Boston Office, 620 Atlantic Ave.
(Walter W. Jones, Manager.)

F. E. BAILEY, Philadelphia.
701 Betz Building.
H. E. BALDWIN, Cincinnati.
Perwin Bldg., 5th and Race Sts.

IMPROVED HEAVY DUTY ENGINES

FOR ELECTRIC RAILWAY SERVICE.

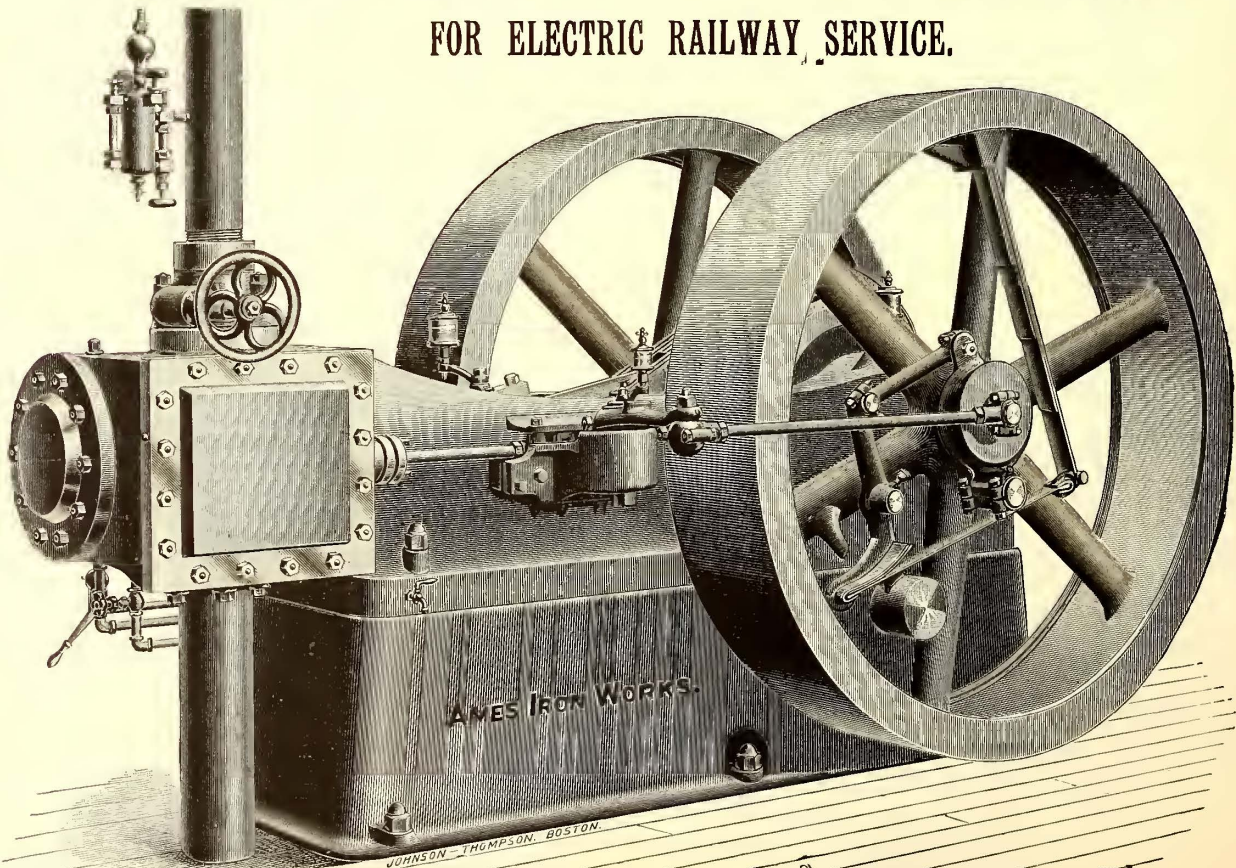

Branch Offices and Salesrooms:
38 Cortlandt Street, New York City.
18 South Canal Street, Chicago, Ill.
50 Oliver Street, Boston, Mass.
518 Arch St., Philadelphia, Pa.

MANUFACTURED BY

AMES IRON WORKS, OSWEGO, N. Y.

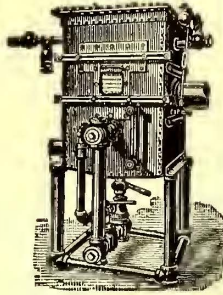

350,000 HORSE-POWER

of our Vacuum Feed Water Heaters and Purifiers could not have been installed unless the constant investigations had clearly demonstrated their saving capabilities. Our Catalogue will fully enlighten you, and will be sent if desired. We also build the Webster Separator and Williams Vacuum System of Steam Heating.

WARREN WEBSTER & Co..

NEW YORK, 126 Liberty Street.
CHICAGO, Monadnock Building.

NO. 1.

CAMDEN, N. J.

LONG DISTANCE TELEPHONE 651.

HIGH PRESSURE WORK A SPECIALTY.

**ELECTRIC LIGHT WORK.
STEAM HEATING.
ELECTRIC RAILWAY
POWER HOUSE WORK.
COPPER PIPES OF ALL SHAPES
MADE TO ORDER.**

BENJAMIN F. SHAW

Steam Fitter and Steam Expert,
313-315 Orange St., WILMINGTON, DEL.
—CORRESPONDENCE SOLICITED.—

SHOOK, ANDERSON MFG. CO.,

INCORPORATED,

PITTSBURGH, PA.

Engineers, Pipe Fitters

AND Machinists.

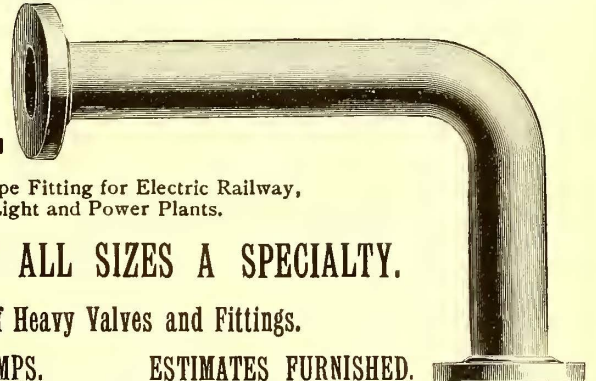
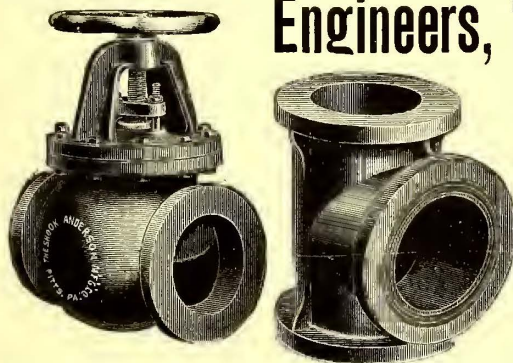

High Pressure Pipe Fitting for Electric Railway,
Electric Light and Power Plants.

PIPE BENDING OF ALL SIZES A SPECIALTY.

Manufacturers of Heavy Valves and Fittings.

AGENTS FOR STEAM PUMPS.

ESTIMATES FURNISHED.

NOW READY.

Economic Legislation of all the States.

THE LAW OF INCORPORATED COMPANIES

OPERATING UNDER MUNICIPAL FRANCHISES,

Such as Street Railway Companies, Illuminating Gas Companies, Fuel Gas Companies,
Electric Central Station Companies, Telephone Companies, Water Companies, Etc.

PRECEDED BY A SUGGESTIVE DISCUSSION OF THE ECONOMIC PRINCIPLES INVOLVED IN THE
OPERATION, CONTROL, AND SERVICE OF SUCH COMPANIES.

THREE OCTAVO VOLUMES OF OVER 3,000 PAGES. PRICE, \$15.00 NET.

SENT BY MAIL, PREPAID, ON RECEIPT OF PRICE.

BY ALLEN RIPLEY FOOTE,

CHARLES E. EVERETT, Editing Attorney,

Address, THE STREET RAILWAY PUBLISHING CO,

WESTINGHOUSE, CHURCH, KERR & CO., ENGINEERS.

WE DESIGN AND CONSTRUCT PLANTS FOR
MECHANICAL DRAFT

EXHAUSTING THROUGH ECONOMIZERS.

BRIEFLY THE ADVANTAGES ARE :

- Perfect control of combustion, regardless of fuel or barometer.
- Very great increase in boiler capacity.
- Perfect smokelessness when combined with mechanical stoking.
- Temperature of flue gases down to 200°.
- Temperature of feed water up to 300°.
- From which results the large net economy of fuel due to this system.
- Moreover the first cost of Mechanical Draft, including the Economizer, seldom exceeds, and with bad foundations is always much less than that of an equivalent brick chimney, in which the flue gases are wasted at 400° to 600°.

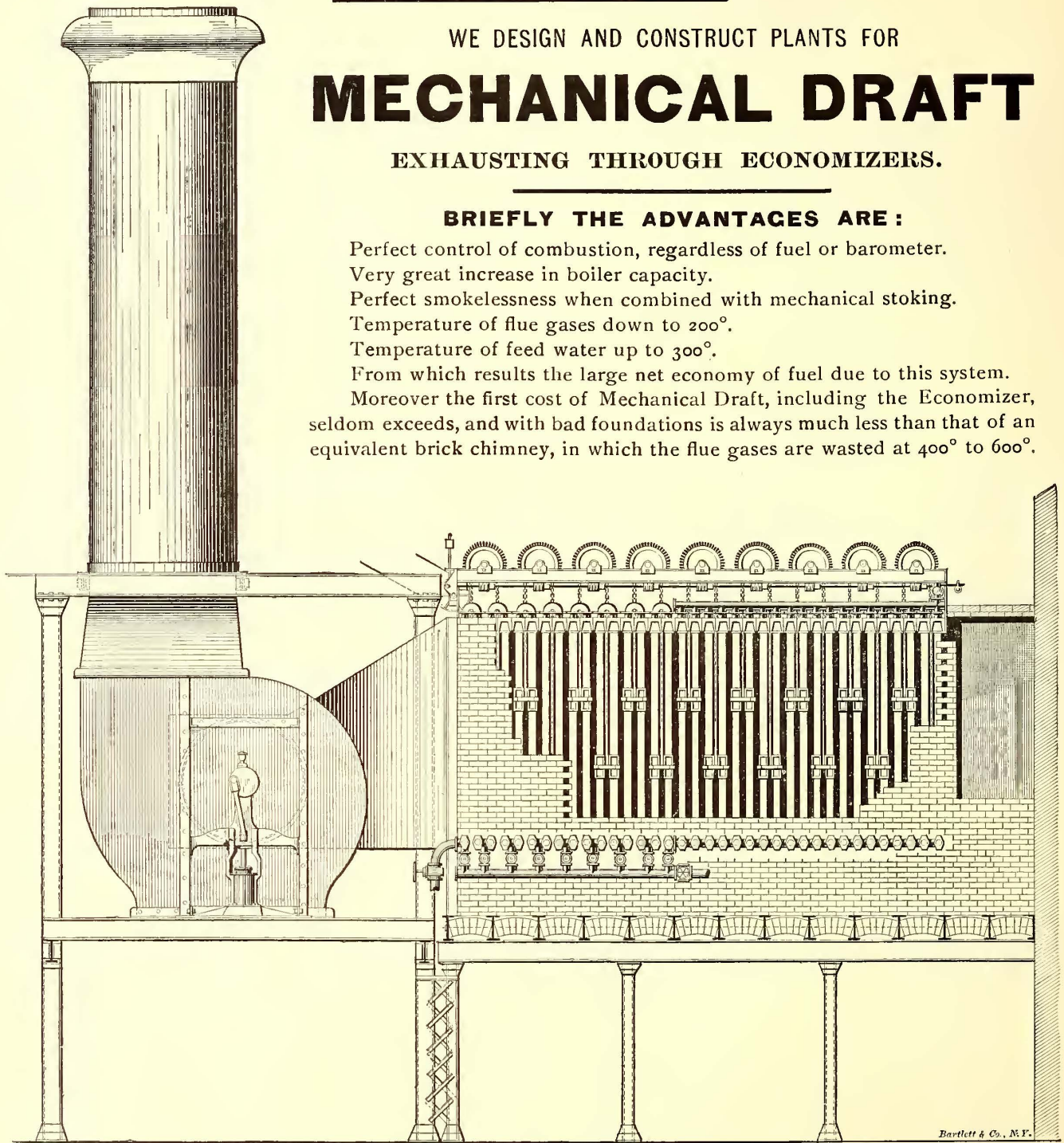

We refer to plants in use or under construction as follows :

Curtis, Davis & Co., Cambridgeport, Mass., Soap Works.....	1,200	H. P.
Arc Light & Power Co., Chicago, Ill.....	1,000	"
Winchester Avenue Railway, West Haven, Conn.....	1,000	"
Boston & Maine Railroad, New Terminal Station, Boston.....	2,000	"
Massachusetts General Hospital, Boston.....	1,200	"
Holyoke Card & Paper Co., Springfield, Mass.....	1,000	"
W. G. Warden, Philadelphia, Pa.....	1,200	"
Electric Traction Co., Philadelphia, Pa.....	1,200	"
Cincinnati Street Railway Co., Cincinnati, O.....	4,000	"
Philadelphia Traction Co., 33d Street Station, Philadelphia, Pa.....	6,000	"
Philadelphia Traction Co., 13th Street Station, Philadelphia, Pa.....	7,500	"

ADDRESS,

26 CORTLANDT STREET, NEW YORK.
620 ATLANTIC AVENUE, BOSTON.
DREXEL BUILDING, PHILADELPHIA.

171 LA SALLE STREET, CHICAGO.
COMMERCIAL BUILDING, ST. LOUIS.
WESTINGHOUSE BUILDING, PITTSBURGH.

C. & G. COOPER & CO. BUILDERS OF CORLISS ENGINES
 MT. VERNON, O. COMPOUND, CONDENSING AND HIGH PRESSURE.

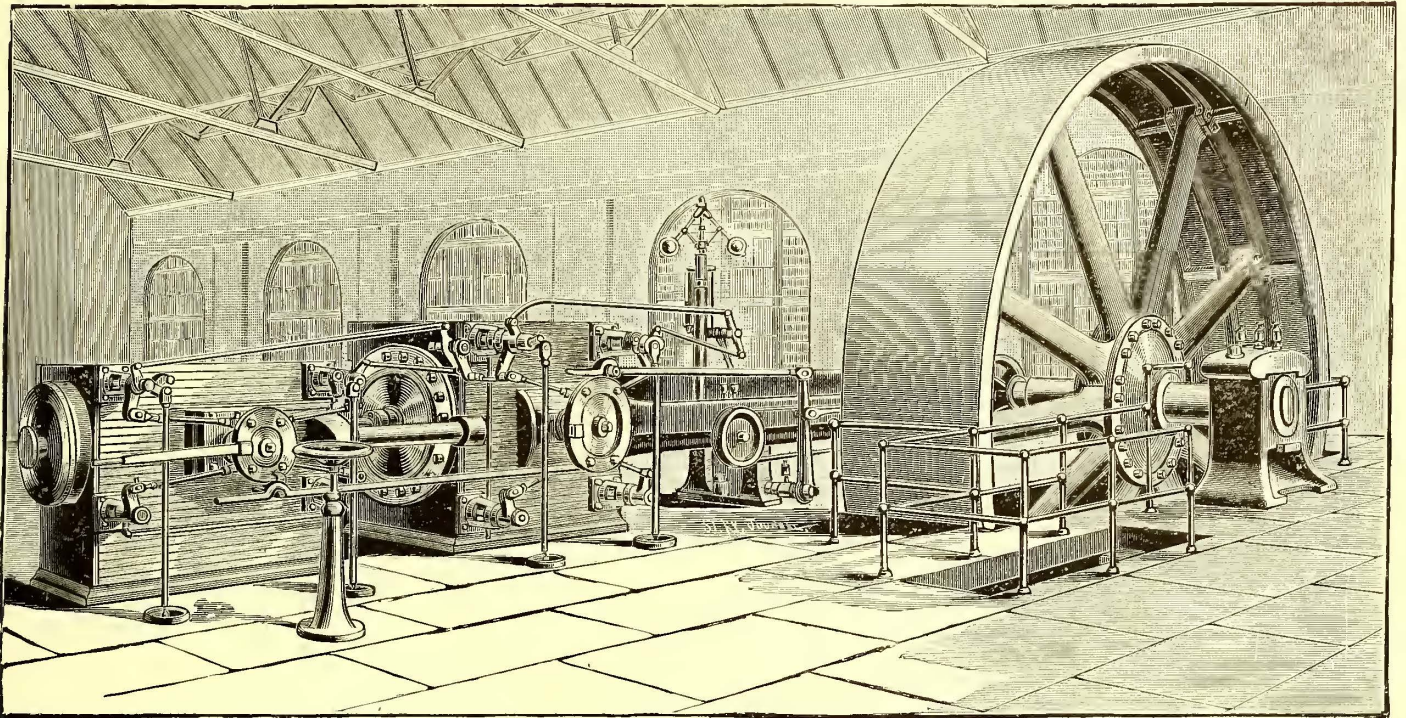

C. & G. COOPER & CO.'S TANDEM COMPOUND CONDENSING CORLISS ENGINE FOR ELECTRIC STREET RAILWAY WORK.

EXTRA HEAVY PATTERNS for STREET RAILWAY WORK

THE

"M. A. GREEN" IMPROVED RAILWAY ENGINE.

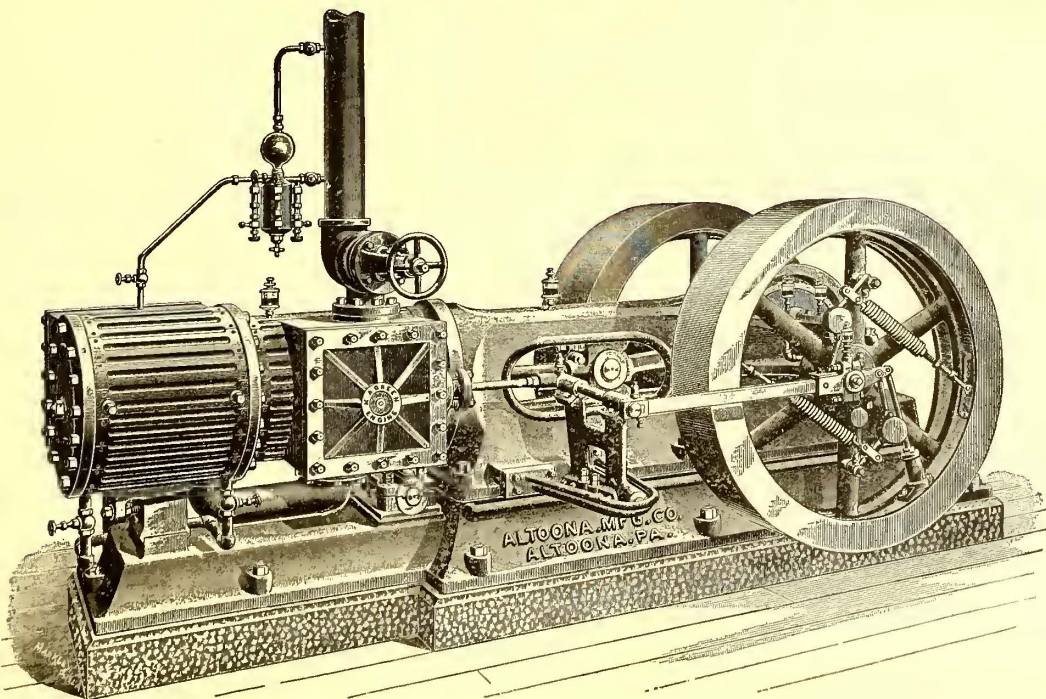

REPRESENTED BY

EDW. F. AUSTIN,
51 Schuidt Bldg., Pittsburgh, Pa.

T. T. BURCHFIELD & CO.,
55 N. Seventh St., Philadelphia.

J. L. LUDWIG,
913-914 Postal Telegraph Bldg.,
New York City.

FISHER & PORTER,
1025 Monadnock Block, Chicago.

HOLMES HARRISON,
74 Baronne St., New Orleans, La.

W. H. RAMSDELL,
2 Varney St., Lowell, Mass.

G. T. MILLS,
44 Colman Bldg., Seattle, Wash.

BUILT BY THE

Altoona Manufacturing Co., - Altoona, Pa.

THE MCINTOSH & SEYMOUR

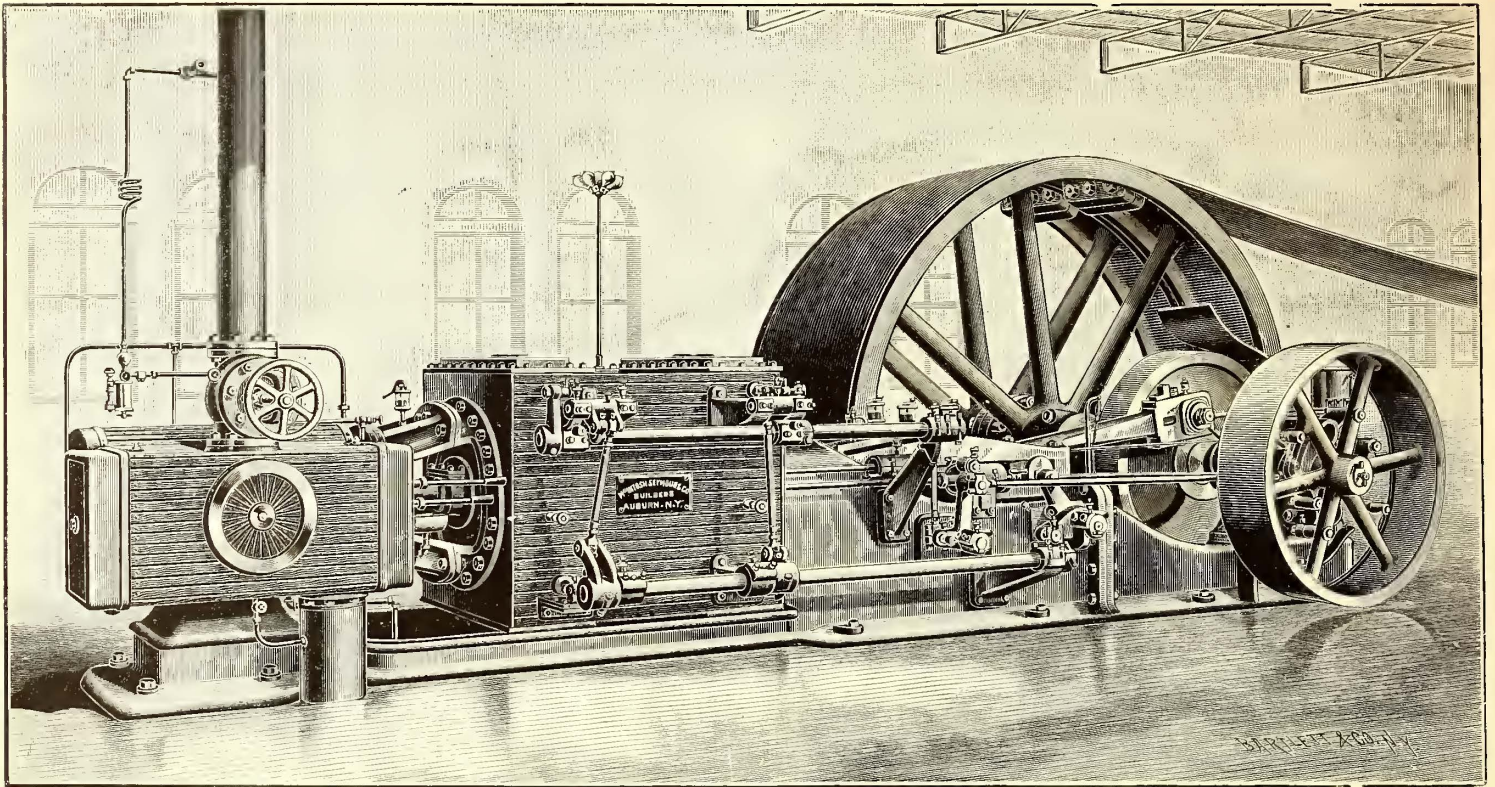

The above cut represents a 700 horse power engine; cylinders 20 and 36 x 36; shaft is 14 ins. in diameter in the bearings, 16 ins. in the middle; the bearings are 30 ins. long; everything else in proportion. Weight 188,000 lbs.; wheel 65,000 lbs. Revolutions 110. The low pressure cylinder is fitted with our gridiron valves at four points, making the clearance less than with any other valves—about one-half that of a cylinder fitted with Corliss valves. The Brooklyn City Railway Co., Brooklyn, N. Y., has three of these in its Ridgewood Power Station. We are making three of them for the City & Suburban Railway, Baltimore, Md., and four for the Cincinnati Street Railway Co., Cincinnati, O.

WORKS:
AUBURN, N. Y., U. S. A.

McINTOSH, SEYMOUR & CO.

— SELLING AGENTS. —

NEW YORK.

**PIERCE & MILLER
ENGINEERING
COMPANY,**

42 Cortlandt St., NEW YORK.

**Engineers and
Contractors**

FOR

**COMPLETE POWER PLANTS. ELEC-
TRIC RAILROADS BUILT
AND EQUIPPED.**

BOSTON.

CURRIER, MAYO & CO.

8 OLIVER STREET,

AGENTS,

NEW ENGLAND

AND

MARITIME PROVINCES.

CONTRACTORS

FOR

Complete Power Plants.

32,870 H. P. Sold to Electric Railways.

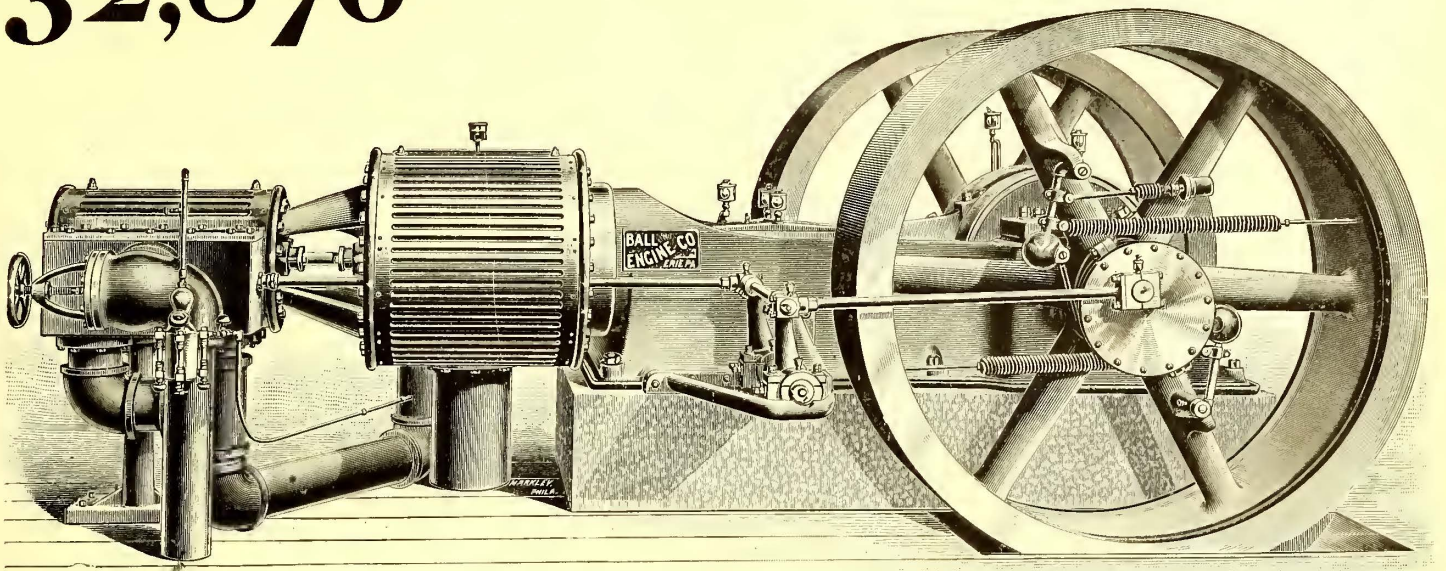

The Improved Ball Engines

— ARE UNEXCELLED. —

They are correctly designed, beautiful in appearance, thoroughly constructed, heavy and strong. The governor is especially adapted for street railway service, and gives unequalled regulation.

BALL ENGINE COMPANY, Erie, Pa.

Chicago Office, Rookery Building.

HAMILTON CORLISS ENGINES.

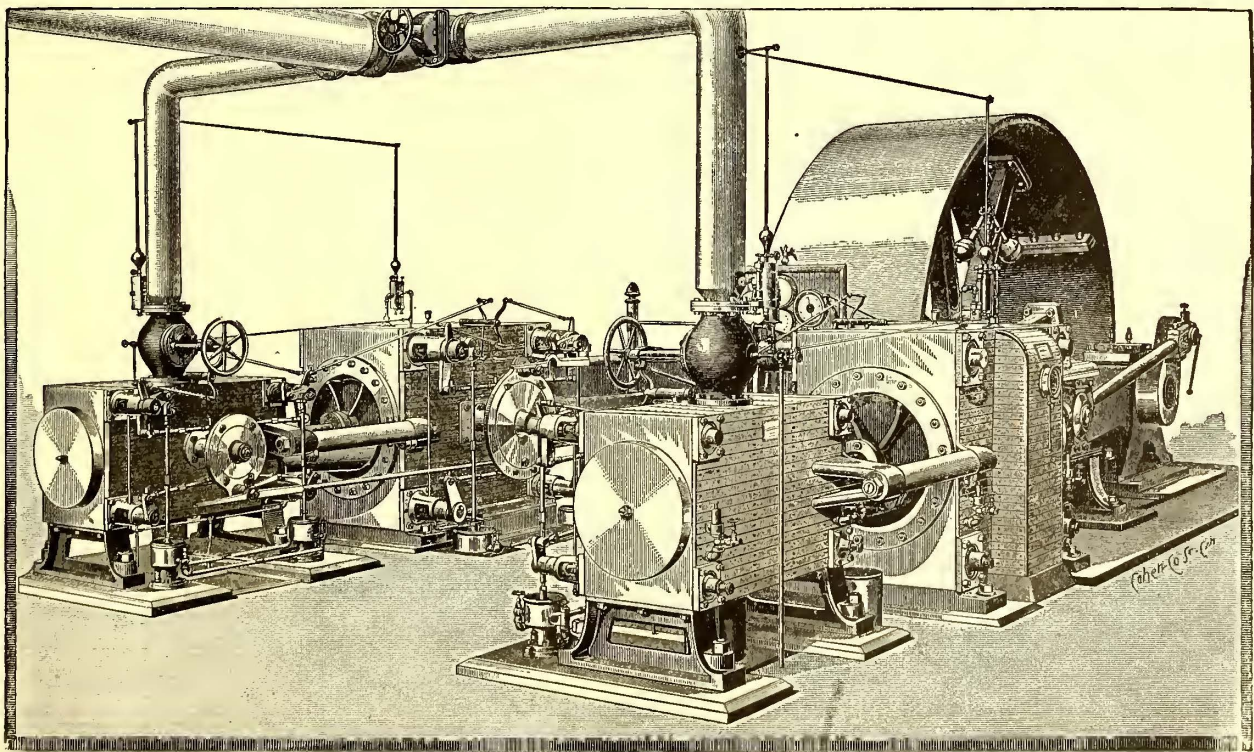

OVER 800 IN DAILY USE.

OVER 100 IN STREET RAILWAY SERVICE.

Following are a few of the Principal Lines having our Engines in use:

- | | |
|---|---|
| DENVER TRAMWAY CO., Denver, Col. | CONSOLIDATED STREET RAILWAY CO., Cincinnati, O. |
| PITTSBURGH & BIRMINGHAM TRACTION CO., Pittsburgh, Pa. | NAUMKEAG STREET RAILWAY CO., Salem, Mass. |
| MISSOURI R. R. CO., St. Louis, Mo. | WICHITA ELECTRIC R. R. CO., Wichita, Kans. |
| ST. LOUIS & SUBURBAN R. R. CO., St. Louis, Mo. | CITY ELECTRIC RAILWAY CO., Little Rock, Ark. |
| UNION DEPOT R. R. CO., St. Louis, Mo. | QUINCY HORSE RAILWAY & CARRYING CO., Quincy, Ill. |
| TOLEDO CONSOLIDATED STREET RAILWAY CO., Toledo, O. | |

THE HOOVEN, OWENS & RENTSCHLER CO., HAMILTON, OHIO.

SOUTHWARK FOUNDRY & MACHINE CO.

SOLE MAKERS OF THE
PORTER-ALLEN AUTOMATIC ENGINE,
Simple, Compound or Triple Expansion.
ADAPTED TO ELECTRIC LIGHT AND STREET
RAILWAY SERVICE.

PHILADELPHIA, PA.

Chicago,
554 Rookery.

St. Louis,
32 Laeclde Bldg.

Close
Regulation.
High
Economy.

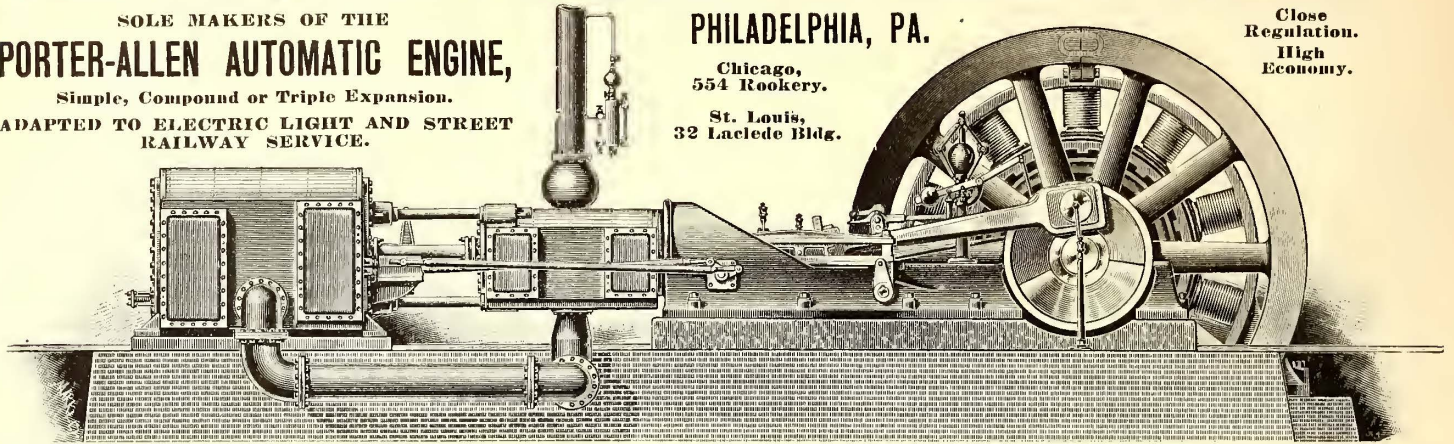

THE EDWARD P. ALLIS CO.

MILWAUKEE, WIS.

**HIGH DUTY
PUMPING
ENGINES.**

Vertical and Horizontal,
Triple Expansion
and
Compound.

SPECIAL SEWAGE AND IRRIGATING PUMPS.

BUILDERS OF HIGHEST GRADE CORLISS ENGINES FOR ALL PURPOSES.

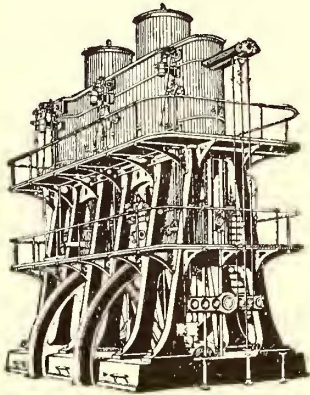

CHICAGO, 509 Home Insurance Bldg.
J. B. ALLAN.

NEW YORK, Room 1111, 26 Cortlandt St.
F. A. LARKIN.

MINNEAPOLIS, 416 Corn Exchange.
J. F. HARRISON.

THE BUCKEYE AUTOMATIC CUT-OFF ENGINES.

Slow Speed, Medium Speed and High Speed Engines. Simple, Compound and Triple Expansion Engines, High Pressure Boilers.

COMPLETE STEAM POWER PLANTS OF HIGHEST ATTAINABLE EFFICIENCY.

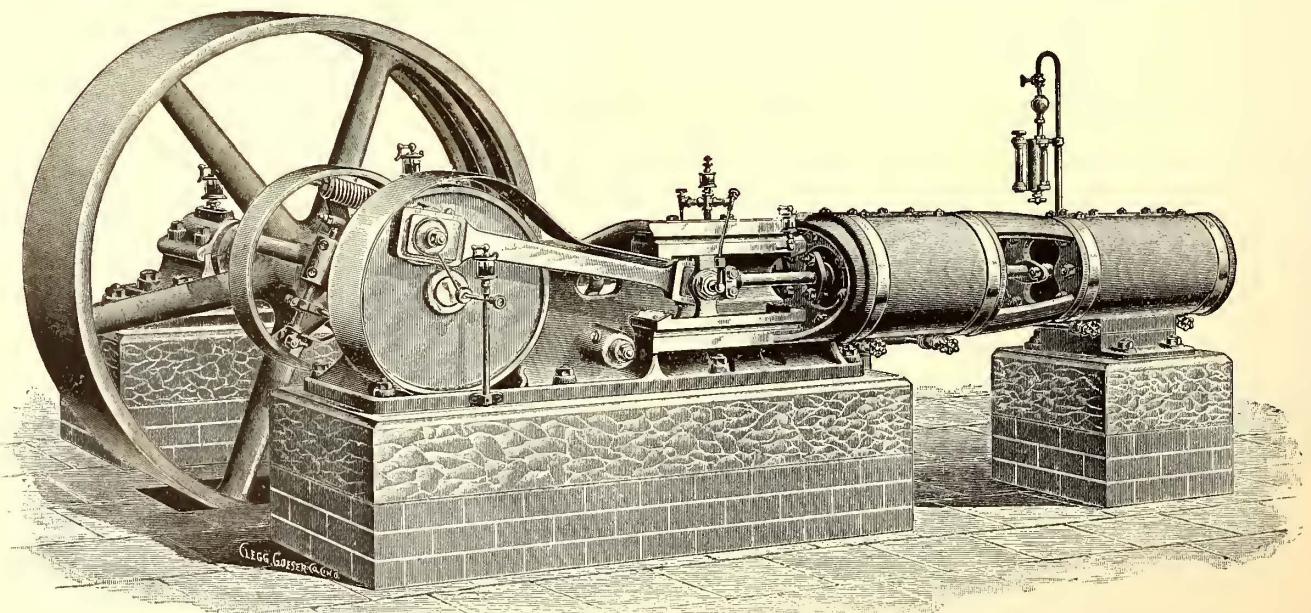

Address **BUCKEYE ENGINE COMPANY,**
25 FRANKLIN AVENUE, SALEM, OHIO.

10 Telephone Building, New York City.
303 Neave Building, Cincinnati, O.
605 Penn Building, Pittsburgh, Pa.

SALES AGENTS:

N. W. ROBINSON, 97 Washington St. Chicago, Ill.
ROBINSON & CARY CO., St. Paul, Minn.
JAMES P. CREIGHTON, 635 First St., Louisville, Ky.
A. M. MORSE, 511 Commercial Building, St. Louis, Mo.
HUXLEY & HOFFMAN, 401 John Hancock Building, Boston, Mass.

OTTO GAS ENGINE WORKS,

245 Lake St.
CHICAGO.

PHILADELPHIA.

18 Vesey St.,
NEW YORK.

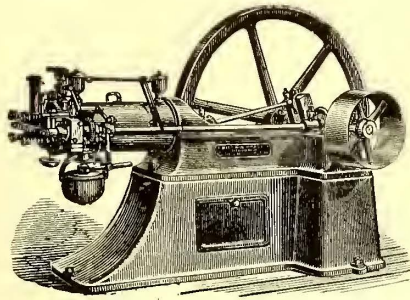

OTTO GAS ENGINES Working Without Boiler, Steam or Engineer. Started at Once.

SIZES: 1-3 TO 100 HORSE POWER.

BEST POWER FOR USE IN STREET CAR STABLES.—Running Elevators, Cutting Fodder, Etc.

UNEXCELLED FOR ELECTRIC LIGHT WORK.—As Expense of Running is Limited to Time of Use Only.

THE LANE & BODLEY CO.

CINCINNATI, OHIO.

CORLISS ENGINES.

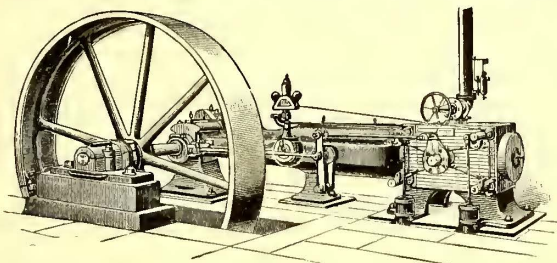

HEAVY SHAFTING, STANDS, TIGHTENERS AND PULLEYS.

ELECTRIC LIGHT AND STREET RAILWAY PLANTS

—A SPECIALTY.—

ROBT. WETHERILL & Co.

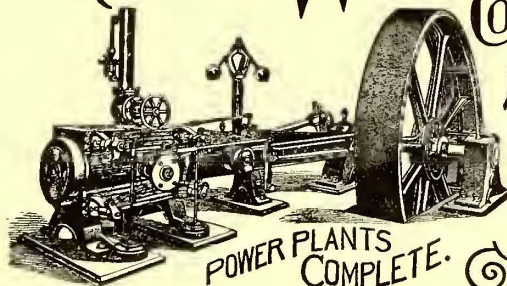

CONSTRUCTING Improved ENGINEERS HIGH PRESSURE CONDENSING AND COMPOUND CORLISS ENGINES. BOILERS. CHESTER, PENNA.

POWER PLANTS COMPLETE.

J. H. McEwen Mfg. CO., BUILDERS OF High Grade Automatic Engines.

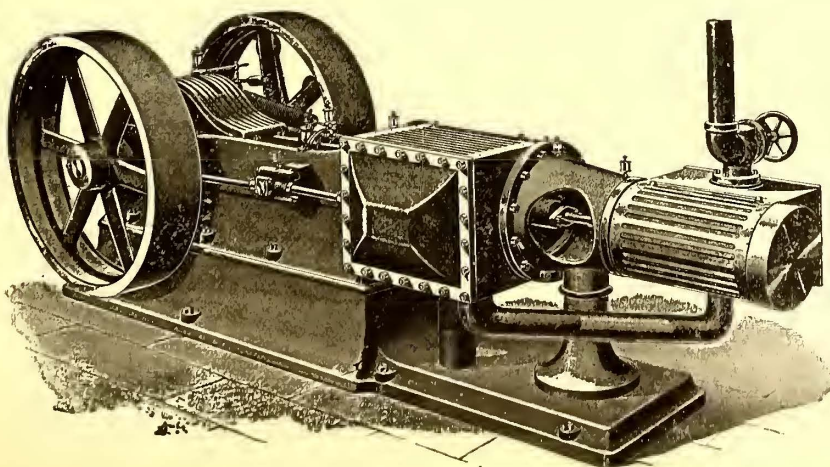

Simple and Compound of the Horizontal Type, from 25 to 600 H. P.

Compound and Triple Expansion of the Vertical Type, from 100 H. P. to any size.

These Engines are especially adapted to any work that requires close regulation, and particularly for Electric Street Railway work where sudden and extreme change of load takes place.

OUR GUARANTEE.

The engine shall not run one revolution slower when fully loaded than when running empty, and a reduction of boiler pressure from the greatest to that necessary to do the work will not reduce the speed of engine one revolution. Any engine failing to meet this guarantee becomes the property of the purchaser upon payment of one dollar.

Main Office and Works, RIDGWAY, PA.

Branch Offices: { New York. 141 Liberty St. Chicago, Ill. 937 Monadnock Block.

THE BALL & WOOD ENGINE

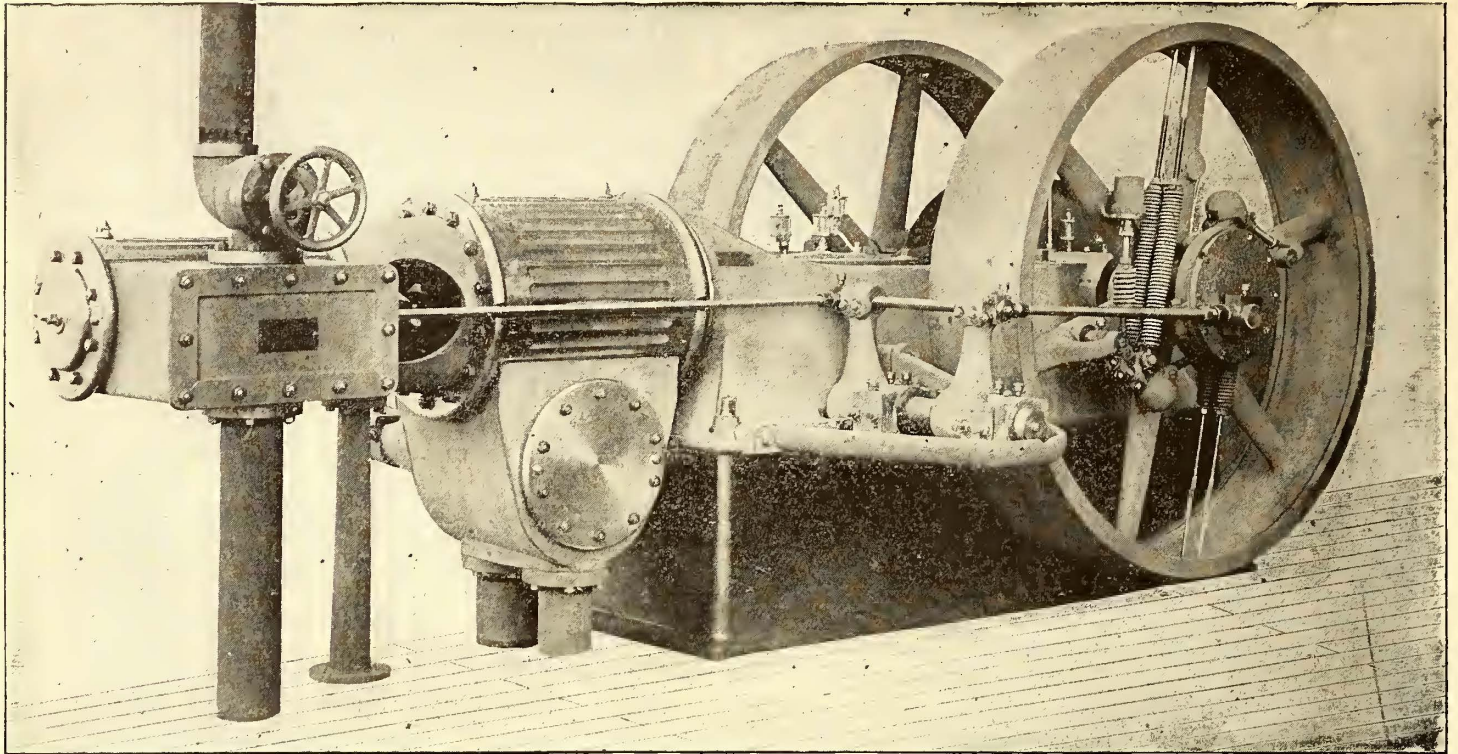

TANDEM COMPOUND TYPE.

Works, Elizabeth, N. J.

Office, 15 Cortlandt St., New York

DICK & CHURCH

SIMPLE,
COMPOUND,
TRIPLE EXPANSION

ENGINES.

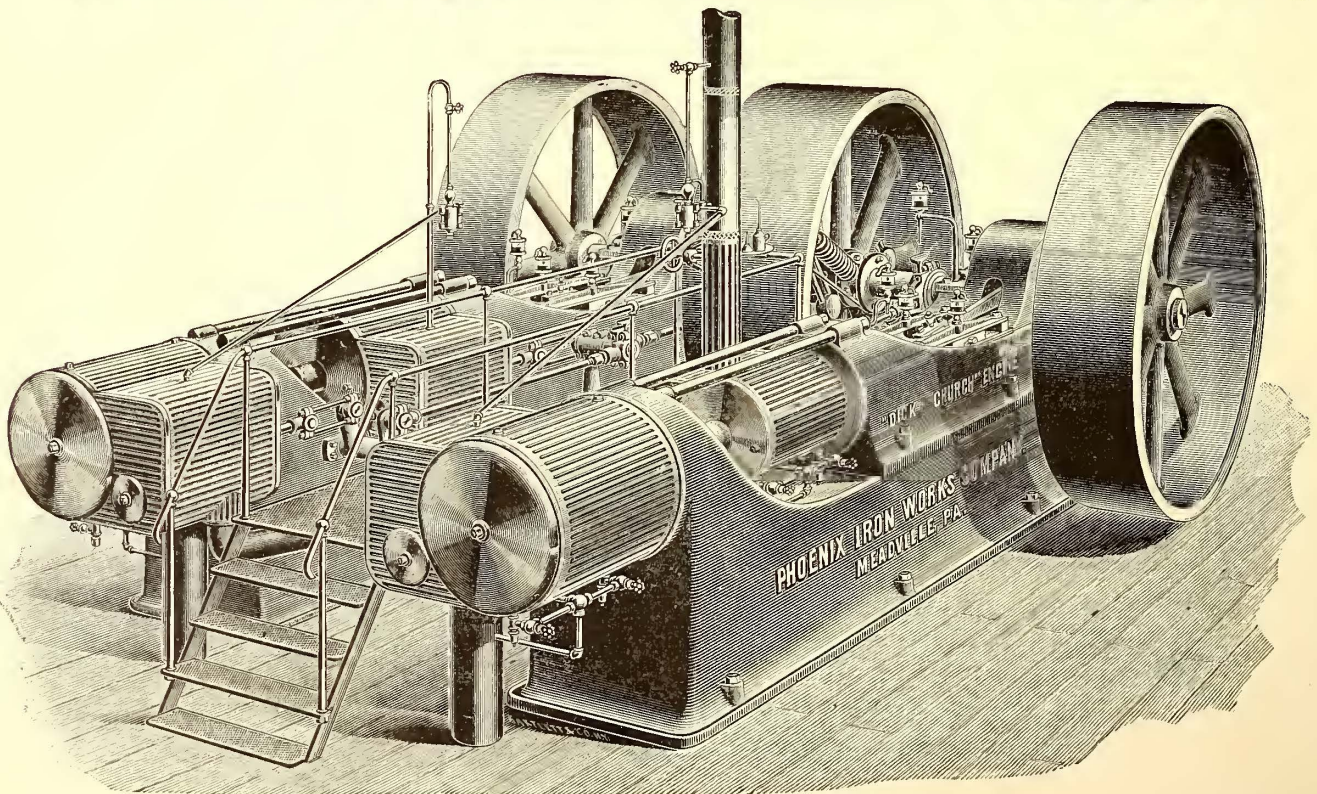

FOUR-CYLINDER TRIPLE EXPANSION.

PHOENIX IRON WORKS CO., Meadville, Pa. 15 CORTLANDT ST., NEW YORK. 519 "THE ROOKERY," CHICAGO.

THE BEST BOILER FURNACE IN THE WORLD!

THE BRIGHTMAN MECHANICAL STOKER and Smoke Preventing Furnace for Steam Boilers is more Economical than any other Boiler Furnace in use. Over 300,000 H. P. now in operation. Send for our illustrated descriptive pamphlet. We design and construct **MECHANICAL DRAFT** appliances and **ECONOMIZERS**, with or without Mechanical Stokers, and for either new or old boiler plants.

THE BRIGHTMAN STOKER COMPANY, ENGINEERS AND CONTRACTORS, 17 Michigan Street, Cleveland, Ohio.

HOFFMANN & BILLINGS MFG. CO.,

1892 FRAME.

MILWAUKEE, WIS.

BUILDERS OF

IMPROVED CORLISS ENGINES.

Non-Condensing, Condensing and Compound.

Economy. - Efficiency. - Reliability.

WRITE FOR CUTS AND OTHER PARTICULARS.

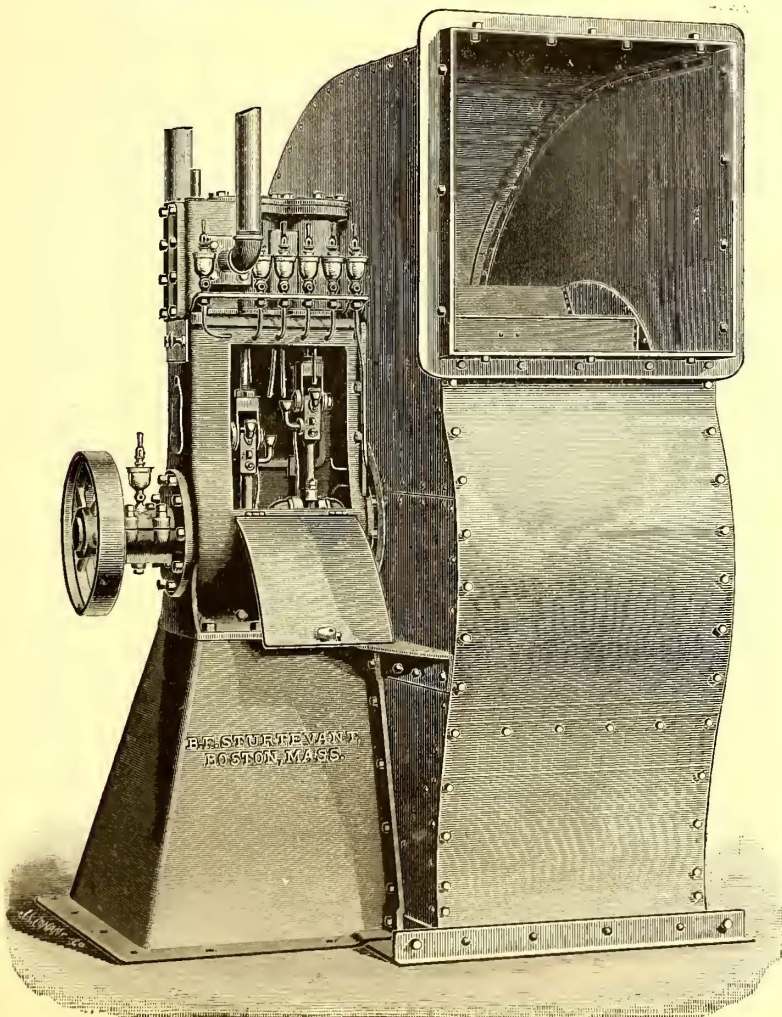
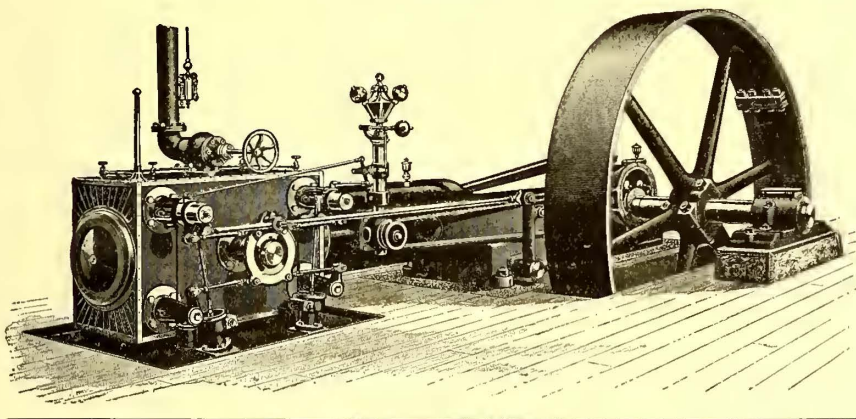

THE

STURTEVANT

SPECIAL STEEL PLATE

STEAM FAN

DOUBLE ENCLOSED ENGINE, CYLINDERS ABOVE THE SHAFT.

::: FOR :::

FORCED

—OR—

Induced Draft.

Built to Order for Special Requirements.

CATALOGUES, PLANS AND ESTIMATES CHEERFULLY FURNISHED.

B. F. STURTEVANT CO.,

BOSTON, MASS.

BRANCH STORES: { 91 Liberty Street, New York.
16 S. Canal Street, Chicago.
135 N. Third Street, Philadelphia.
75 Queen Victoria Street, London.

**MORSE,
WILLIAMS
& CO.**

Morse Elevator Works.

MANUFACTURERS AND BUILDERS OF
**ELECTRIC, HYDRAULIC, BELT and HAND
POWER PASSENGER and FREIGHT
ELEVATORS.**

1105 Frankford Ave., Philadelphia. 108 Liberty St., New York
1116 E. St., N. W., Washington, D.C. 33 Lincoln St., Boston.
425 Spruce St., Scranton, Pa. 82 Church St., New Haven.
Omaha Building, Chicago, Ill.

W. W. TUPPER & CO.
Patent Sectional Grate and Grate Bars.

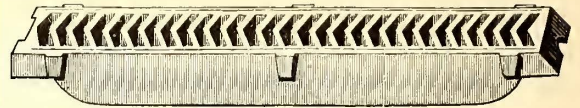

SHAKING AND DUMPING GRATES
For all kinds of coal. Send for circular.
39-41 Cortlandt St., Taylor Building, New York.

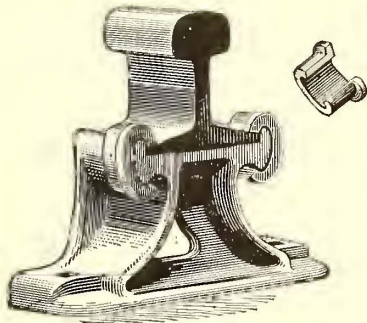

Burnham & Duggan

RY. APPLIANCE CO.

70 Kilby St., Boston, Mass.

MANUFACTURERS AND DEALERS IN

Rail Chairs, Adjustable Trolley Wire Brackets,
Transfer Tables, Insulators, Railway Supplies.

SEND FOR CIRCULARS AND PARTICULARS.

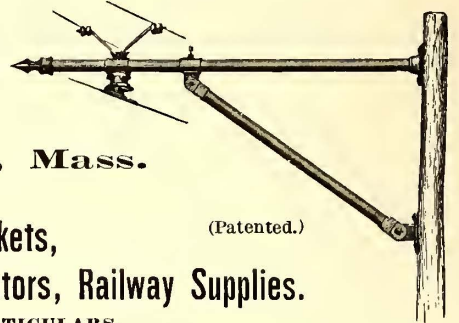

(Patented.)

VULCANIZED FIBRE CO.

ESTABLISHED 1873.

SOLE MANUFACTURERS OF

HARD VULCANIZED FIBRE,

In Sheets, Tubes, Rods, Sticks and Special Shapes to order. Colors, Red, Black and Gray.
SEND FOR CATALOGUE AND PRICES.

FACTORY: WILMINGTON, DEL. THE STANDARD ELECTRICAL INSULATING MATERIAL OF THE WORLD. OFFICE: 14 DEY ST., N. Y.

DAVIDSON CONDENSERS

FOR
ELECTRIC
RAILWAYS
AND
POWER
STATIONS.

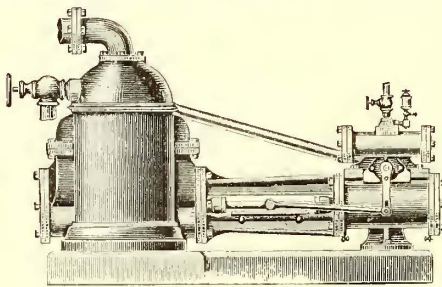

M. T. DAVIDSON,

BRANCHES:
77 Liberty St., New York.
50 Oliver St., Boston.

43-53 Keap St.,
BROOKLYN, N. Y.

—THE IMPROVED—
FISHKILL CORLISS ENGINE

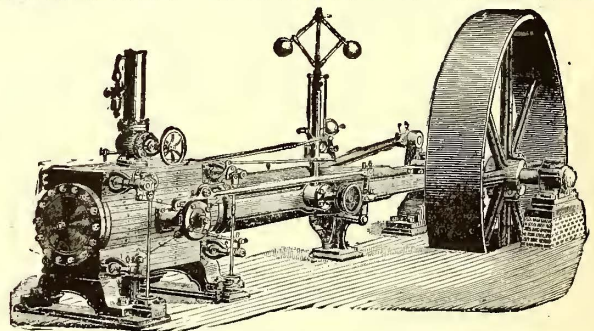

High Economy, Close Regulation, Noiseless Operation.

FISHKILL LANDING MACHINE CO.,

FISHKILL-ON-THE-HUDSON, N. Y.

ROBT. J. HALGIN, Pres. W. F. SAGE, Vice-Pres. JAS. L. TELLER, Sec'y

IDEAL ENGINES

FOR
Street Railways.

740 consecutive hours' running with one application of oil, without one stoppage, is our World's Fair record.

The Ideal Engine is the only successful horizontal self-oiling engine on the market.

A. L. IDE & SON,
BUILDERS,
SPRINGFIELD, ILL.

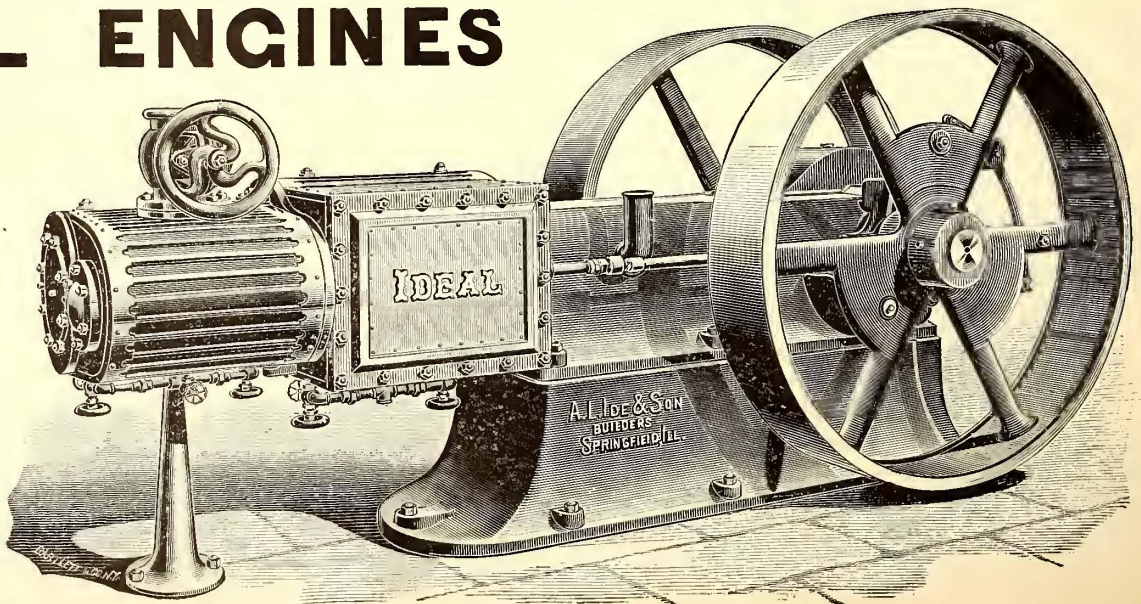

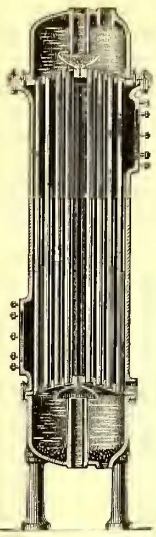

THE GOUBERT FEED-WATER HEATER,

Specially adapted to
CONDENSING ENGINES, and in use in the
largest CABLE and ELECTRIC
RAILWAY PLANTS in
the United States.

ALL SIZES, 50 TO 5,000 H. P.

Meets the requirements of
High Pressure, Free Exhaust,
Great Durability.

Agencies in all Principal Cities.

COUBERT MFG. CO.

14 & 16 Church St., Cor. Cortlandt, New York.

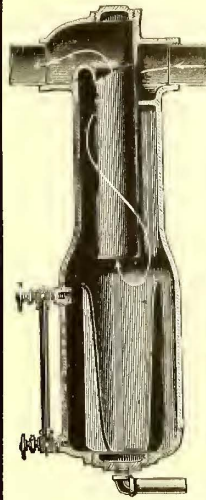

A BREAKDOWN OF YOUR ENGINE

Means the stoppage of traffic on the entire line.
NINE-TENTHS OF THE BREAKDOWNS
are due to Water in the Cylinder.

The Stratton Separator

Removes all Water in the Steam
and Delivers

ABSOLUTELY DRY STEAM

To your Engine. It is A POSITIVE
SAFEGUARD as well as a Source
of Economy. Send for
Catalogue to

The Goubert Manufacturing Co.,

Sole Manufacturers,

14 & 16 Church St., Cor. Cortlandt, New York.

Heine Safety Boiler Co.

St. Louis, Mo.

High Class

Water-tube Boilers.



A TEXTBOOK OF

MODERN BOILER PRACTICE FREE.

SOME STREET RAILWAYS USING

HOPPES PURIFIERS.

Rochester (N. Y.) Railway Co.....	2000	H. P.
Columbus (O.) Street Railway Co.....	1000	"
Calumet Electric Street Railway Co., Burnside Crossing, Ills.....	1000	"
Springfield (O.) Railway Co.....	300	"
Cincinnati (O.) Street Railway Co.....	300	"
Cincinnati (O.) Incline Plane Railway Co.....	250	"
Bay City (Mich.) Union Railway Co.....	400	"
Topeka (Kans.) Railway Co.....	500	"
Kansas City (Mo.) Cable Railway Co.....	800	"
City Electric Railway Co., Little Rock, Ark.....	750	"
Rapid Transit Street Ry., San Antonio, Tex.....	250	"
San Antonio Street Ry. Co., San Antonio, Tex.....	250	"
Houston (Tex.) City Railway Co.....	200	"

THE FUEL ECONOMIZER CO.

OF MATTEAWAN, N. Y.

Sole Makers in the United States of

Green's Patent Fuel Economizer.

Being Applied to Work with NATURAL DRAFT by
the Following Electric Railroad Companies.

Brooklyn City Railroad Co., Brooklyn, N. Y.....	12,000	H. P.
Intramural Railroad Co., World's Fair.....	3,500	"
Montreal Street Railroad Co., Montreal, P. Q.....	3,000	"
Union Railroad Co., Providence, R. I.....	2,000	"
South Chicago City Railroad Co., Chicago, Ill.....	900	"
Terre Haute Street Railroad Co., Terre Haute, Ind.....	250	"
Lake Cities Electric Railroad Co., Michigan City.....	150	"

Head Office and Works, Matteawan, N. Y.

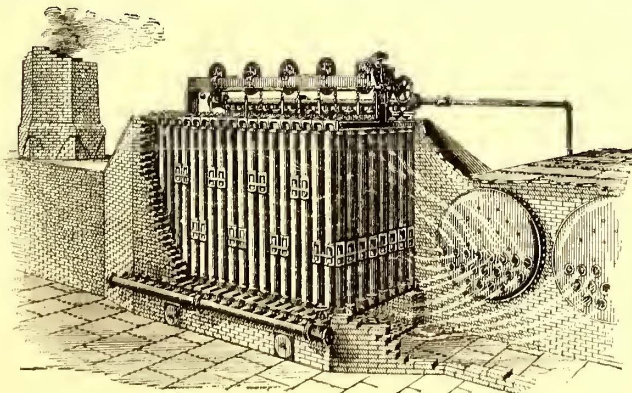

SEND FOR THIS BOOK
FREE ON APPLICATION.

THE BABCOCK & WILCOX CO. WATER TUBE STEAM BOILERS

30 CORTLANDT ST. N.Y.

BOSTON, MASS. 8 OLIVER ST.
PHILADELPHIA, PA. 32 N. 5TH ST.
PITTSBURGH, PA. 408 LEWIS BLOCK
CLEVELAND, O. 412 PERRY-PAYNE BLDG.
CHICAGO, ILL. 45 S. JEFFERSON ST.
MINNEAPOLIS, MINN. 604 CORN EX.
NEW ORLEANS, LA. 57 CARONDELLET ST.
HAYAMA, CUBA. 116 CALLE DELA HIGUANA.

BRANCH OFFICES
SAN FRANCISCO, CALIF. 305 CALIFORNIA ST.
SAN DIEGO, CALIF. 100 W. BROADWAY
SAN ANTONIO, TEX. 100 W. BROADWAY
SAN JOSE, CALIF. 100 W. BROADWAY
SAN LUIS OBISPO, CALIF. 100 W. BROADWAY
SAN MARINO, CALIF. 100 W. BROADWAY
SAN JOAQUIN, CALIF. 100 W. BROADWAY
SAN JOSE, CALIF. 100 W. BROADWAY
SAN JOSE, CALIF. 100 W. BROADWAY
SAN JOSE, CALIF. 100 W. BROADWAY

MANUFACTORIES IN UNITED STATES, SCOTLAND, FRANCE, GERMANY & AUSTRIA.

LIST OF
BABCOCK AND WILCOX BOILERS
In use on Electric and Cable Railroads, Nov. 1, 1893.

	H. P.		H. P.		
West End Ry. Co., Boston.....	4 orders, '89-'92....	9,500	Market Street Elec. Ry. Co., San Francisco, Cal.....	3 orders.....	2,208
The Albany Ry. Albany, N. Y.....	3 orders, '89-'92....	1,000	Cincinnati, Newport & Covington Ry. Newport, Ky.....		600
The Crosstown St. Ry. Co., Buffalo, N. Y.....	3 orders, '90-'93....	4,500	Union Ry. Co., Providence, R. I.....	December, 1892....	1,500
Cincinnati St. Ry. Co., Cincinnati, O.....	5 orders, '90-'93....	3,300	Atlantic Improvement Co., Long Island City, N. Y.....	February, 1893....	1,000
Pittsburgh & Birmingham Traction Co., Pittsburgh, Pa.....	July, 1890....	1,000	Philadelphia Traction Co., Philadelphia.....	March, 1893....	6,000
Columbus Elec. St. Ry. Co., Columbus, O.....	4 orders.....	1,807	Camden, Gloucester & Woodbury Elec. Co., Gloucester, N. J.....		750
Aurora St. Ry. Co., Aurora, Ill.....	2 orders, '90-'92....	832	Union Depot Ry. Co., St. Louis, Mo.....		1,000
People's St. Ry. Co., St. Joseph, Mo.....	2 orders, '89-'93....	1,040	Haverhill & Groveland St. Ry. Co., Haverhill, Mass.....	1892....	630
Duluth St. Ry. Co., Duluth, Minn.....	4 orders, '90-'93....	1,312	Columbus Elec. Ry. Co., Columbus, O.....	1890....	692
Brooklyn City Ry. Co., Brooklyn, N. Y.....	6 orders, '91-'93....	16,500	New York & Brooklyn Bridge, Brooklyn.....	3 orders, '82-'91....	1,248
Rochester St. Ry. Co., Rochester, N. Y.....	2 orders, '91-'92....	808	Washington & Georgetown R. R., Washington, D. C.....	4 orders.....	1,923
Merrimac Valley R. R. Co., Lawrence, Mass.....	3 orders, '91-'93....	896	Cleveland City Cable Ry. Co., Cleveland, O.....	March, 1890....	1,086
Citizens' Ry. Co., Indianapolis, Ind.....	August, 1891....	600	Valley City St. & Cable Ry. Co., Grand Rapids, Mich.....		781
Union R. R. Co., New York.....	2 orders, '91-'92....	1,500	Chicago City R. R. Co., Chicago, Ill.....	April, 1881....	1,000
Lynn & Boston R. R., Boston, Mass.....	3 orders, '91-'92....	4,000	Grand Ave. R. R. Co., Kansas City, Mo.....	2 orders, '86-'88....	800
Globe St. Ry. Co., Fall River, Mass.....	February, 1892....	675	Metropolitan St. Ry. Co., Kansas City, Mo.....	3 orders, '86-'88....	1,800
Houston City Ry. Co., Houston, Tex.....	2 orders, '90-'92....	492	Denver City Cable Ry. Co., Denver, Colo.....	2 orders, '89-'91....	1,600
City & Suburban Ry. Co., Savannah, Ga.....	March, 1892....	500	The Melbourne Tramways, Melbourne, Australia.....	1884-1885....	1,040
Seashore Elec. Ry., Asbury Park, N. J.....	May, 1892....	640	And Others.		
Atlantic Ave. Ry. Co., Brooklyn, N. Y.....	3 orders, '92-'93....	3,000			
Carrollton Elec. Ry. Co., New Orleans, La.....	May, 1892....	624			
Intramural Elec. Ry. Co., World's Fair.....	1892-1893....	3,500			

—THE—
Yeats Engineering Co.
937-938 Monadnock Bldg.,
CHICAGO, ILL.

CHICAGO TROLLEY.

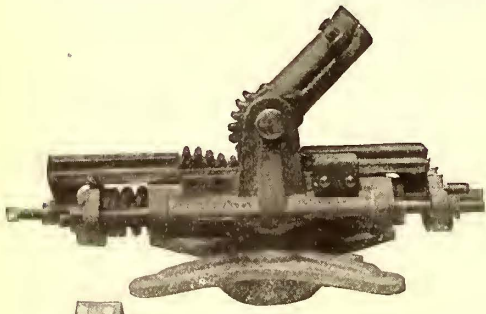

No Chain to Break. Strong, Cheap and Durable. Warranted in every Particular.

CONTRACTORS FOR COMPLETE STREET RAILWAY INSTALLATION.

Sole Agents for the Chicago Trolley.
Special Agents for the Chicago Truck.

Exclusive Eastern Agents:
NEW YORK ELECTRICAL WORKS.

A VALUABLE BOOK.

The Most Important Work to Street Railway Men that Has Been Published.

THE FIRST PRACTICAL BOOK COVERING AMERICAN STREET RAILWAY PRACTICE OF TO-DAY.

STREET RAILWAYS;

THEIR
Construction, Operation and Maintenance.

—TRAMS.—

A PRACTICAL HANDBOOK FOR STREET RAILWAY MEN.

—BY—
C. B. FAIRCHILD, Editor Street Railway Journal.

A book bearing the above title, profusely illustrated, has been issued from the press of the STREET RAILWAY JOURNAL. This work has been carefully compiled from the series of articles entitled "Trams," which, for a year past, have appeared in the STREET RAILWAY JOURNAL. These articles have been submitted to the criticism of experts in each of the different departments treated, and have been revised, enlarged and corrected, and it is confidently believed that the book will be accepted by street railway men as a standard work, and will prove invaluable to all interested in the subject.

It treats fully of Electric, Cable, Horse and other Surface Roads, including those operated by Steam, Air and Gas Motors, also Elevated, Inclined Plane and Rack Rail Systems. A whole chapter is devoted to track construction for each method of traction; with an itemized bill of cost. Another treats of Franchises and Corporations and Laws relating to the same. A third relates to Discipline, and gives a classified set of rules for the guidance of conductors and drivers, which have been compiled from the best practice.

The book is quarto in form, handsomely printed, and bound in a most substantial manner.

It contains nearly 500 pages and over 750 illustrations.
PRICE, POSTAGE PREPAID, Cloth, \$4.00; Leather and Gilt, \$5.00. Remit by P. O. money order, draft, registered letter or express money order. Address

The Street Railway Publishing Co.,
Havemeyer Building, 26 Cortlandt St., New York.

P. & B.

**Armature and Field Coil Varnish,
Tape and Motor Curtain Cloth.**

THE STANDARD PAINT CO., Sole Manufacturers,
2 Liberty Street, New York.

New England Agents, PETTINGELL-ANDREWS CO., Boston.

Western Agents, METROPOLITAN ELECTRIC CO., Chicago.

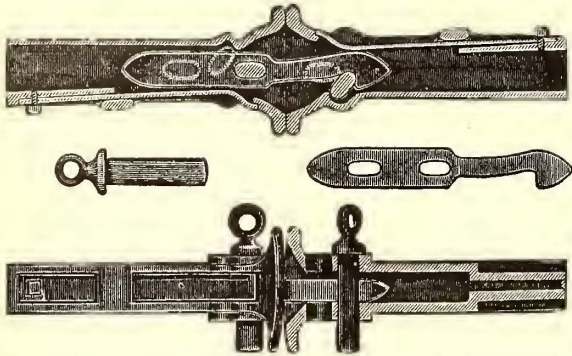

VAN DORN AUTOMATIC Cable and Motor Coupler

For Cable and Electric Cars and Elevated Roads.

Our Coupler has been adopted and is now in use on more than forty Electric Roads and three Cable Roads. It has also been adopted as the Coupler for the World's Fair Elevated Railroad. It is the only Coupler ever produced that is giving satisfactory results. **Correspondence Solicited.** Address

FITZGERALD-VAN DORN CO.,

W. T. VAN DORN,
General Manager.

LINCOLN, NEB.

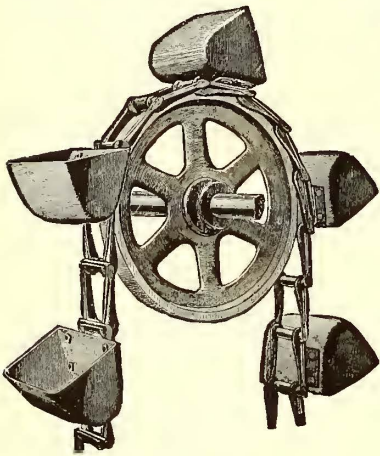

THE LINK-BELT ENGINEERING CO.

NICETOWN, PHILADELPHIA.—49 DEY ST., NEW YORK.

COAL AND ASH HANDLING MACHINERY

FOR POWER STATIONS, DESIGNED AND ERECTED.

ELEVATORS AND CONVEYORS.

EWART DETACHABLE LINK BELTING AND DODGE CHAINS.

MANILA ROPE POWER TRANSMISSIONS.

Chicago—Link-Belt Machinery Company.

SHULTZ PATENT WOVEN LEATHER (LINK) BELTING

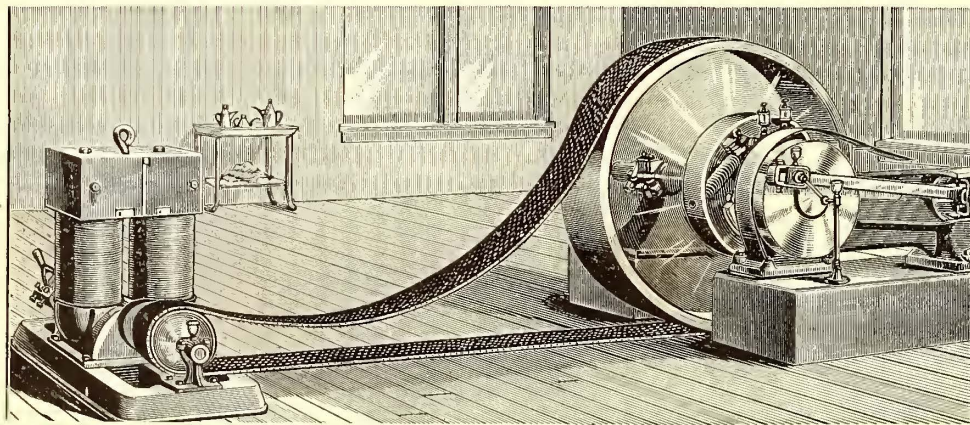

From a Photograph of a Shultz Patent Woven Leather (Link) Belt, Running at the St. Louis Electric Power Company's Plant, 210 Lucas Ave., St. Louis, Mo.

St. Louis & Suburban Railway Co.
Room 13, Turner Building.

St. Louis, Mo., May 14, 1892.

SHULTZ BELTING Co., St. Louis, Mo.,

Gentlemen:—In answer to your inquiry, will say we are running two of your 72-inch main driving belts, each 154 feet long; two 24-inch, and ten 16-inch generator belts, all heavy, double, and we are happy to state that we have never been stopped or delayed one moment on account of the belts. They are giving us entire satisfaction, running noiseless, straight, smooth, and driving full power.

The 72-inch developing from 200 to 300 horse power more than your guarantee; in fact we believe that we have as good, if not the best belted power station in this country,

Yours truly,

Signed) CHAS. H. TURNER, Pres't.

ALL RAWHIDE LEATHER—NO IRON.

NO HINGE, BECAUSE FLEXIBLE WITHOUT.

STRONG. DURABLE. PERFECT CONTACT.

SEND FOR DESCRIPTIVE CIRCULAR "J" TO

SHULTZ BELTING COMPANY,

ST. LOUIS, MO.

NEW YORK, N. Y., 113 Liberty St., A. B. LAURENCE, Manager.
BOSTON, MASS., 164 Summer St., GEO. J. KELLEY, Manager.

PHILADELPHIA, PA., 140 N. 3d St., JAS. GARNETT, Manager.
LONDON, ENGLAND, Charles Churchill & Co., 21 Cross St., Finsbury.

HOW DO YOU LIFT Machine Moulded Gears and Pulleys

YOUR
DYNAMOS
AND
MOTORS?

The Best, Safest and Most
Economical way
is to get a

**HARRINGTON
DOUBLE CHAIN
SCREW HOIST.**

Traveling Cranes.
Overhead Tramway.

Complete System for Lift-
ing Cars from Trucks.

Edwin Harrington

SON & CO., Inc.,

MANUFACTURERS OF
MACHINE TOOLS.

1513 Penna. Ave., Phila., Pa.

Mention this paper.

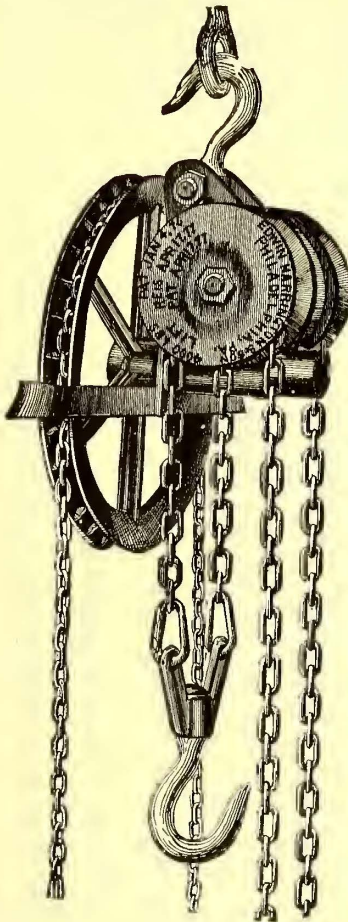

OF ALL KINDS AND SIZES.

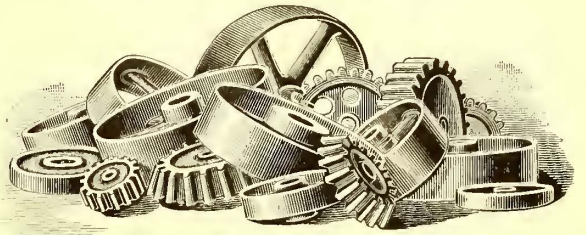

T. SHRIVER & CO.,

IRON, BRASS AND ALUMINUM FOUNDERS.
MACHINISTS.

333 E. 56th St., N. Y. City.

CORRESPONDENCE SOLICITED.

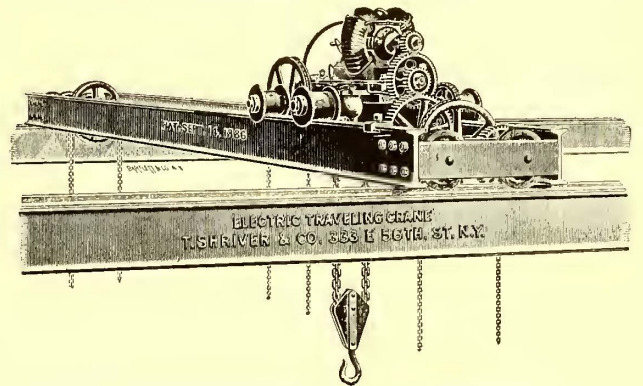

CRANES, ELECTRIC AND
HAND POWER.

JNO. J. SHIPHERD, Pres.

WM. RUSSELL, V. Pres. and Man.

L. C. SHIPHERD, Sec. and Treas.

THE PHOENIX IRON WORKS CO.

WASON STREET, CLEVELAND, O.

POWER HOUSE CRANES

FOR ELECTRIC RAILWAY, ELECTRIC LIGHT AND CABLE RAILWAY POWER HOUSES.

CORRESPONDENCE SOLICITED.

PATENTS APPLIED FOR ON TRAVELING CRANE.

AMERICAN RAIL JOINT CO.

MARION, IND.

NO BOLTS.

A Perfect Suspended Joint.
Can be Used on Present
Construction as well
as New Work.

Pronounced a most thorough
success after a year's constant
use on Cable and Electric Street
Railways. Address.

AMERICAN RAIL JOINT

COMPANY,

MARION, - IND.

JAY WILLARD CLARK,
Manager.

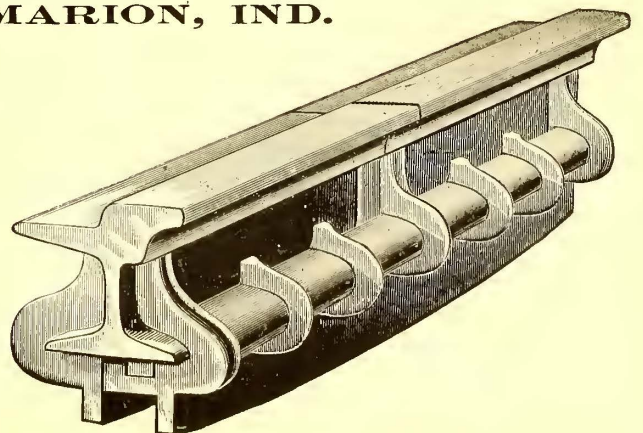
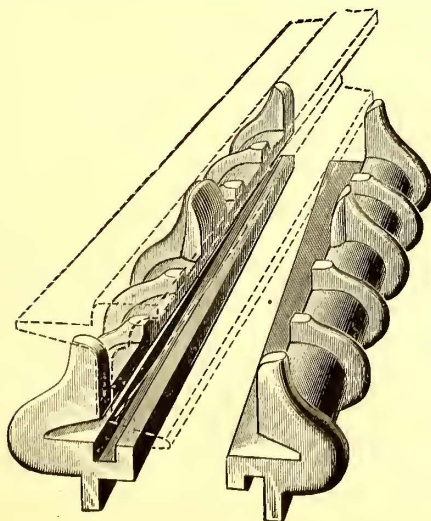

DICK. KERR & CO., LIMITED,

Engineers and Contractors,

101 LEADENHALL ST., LONDON, E. C.

WORKS: BRITANNIA ENGINEERING WORKS.

KILMARNOCK, N. B.

CONTRACTORS
FOR
CONSTRUCTION
AND
EQUIPMENT
OF
HORSE
TRAMWAYS,
ELECTRIC
TRAMWAYS,
STEAM
TRAMWAYS.

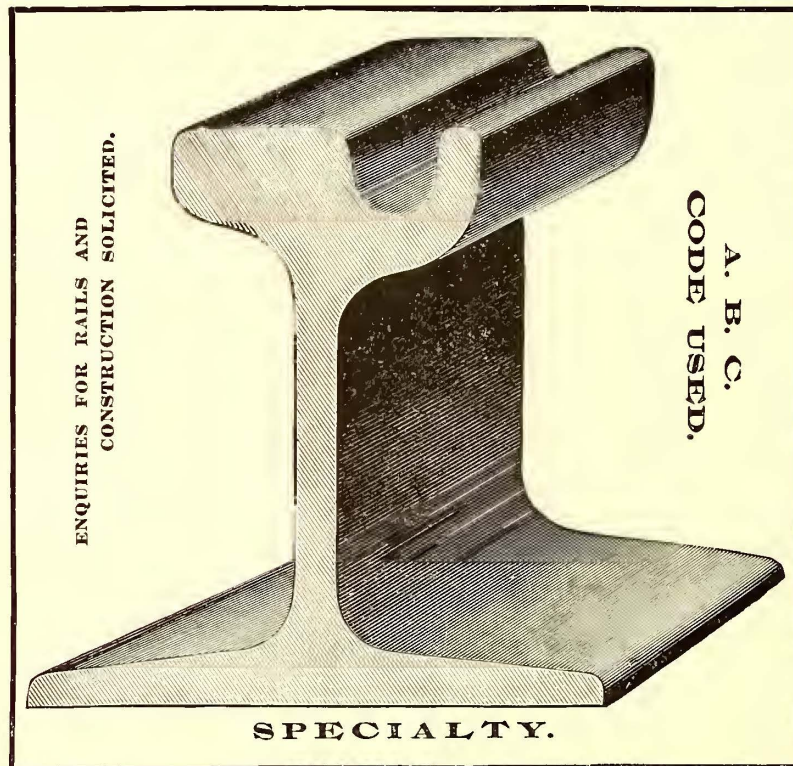

POINTS
AND
CROSSINGS.
—
TURNTABLES
AND
TRAVERSERS

CONTRACTORS FOR
CABLE TRAMWAYS,
STEEL GIRDER TRAMWAY RAILS,
WITH GROOVE ANY SHAPE,
From 35 lb. to 105 lb. Per Yard.
AND ALL ACCESSORIES.

Pennsylvania Iron Works Co.

General Offices and Works, 50th St. and Lancaster Ave.,

PHILADELPHIA, PA.

NEW YORK OFFICES :

Rooms 1118 and 1119 Havemeyer Building, 26 Cortlandt St.

BUILDERS OF COMPLETE

CABLE RAILROAD PLANTS

ENGINES, WINDING AND DRIVING MACHINERY.

Sole Licensees for the Manufacture and Sale of

Walker's Patent Differential Drums, Friction Clutches

AND OTHER CABLE RAILWAY DEVICES,

For the New England, Middle and South Atlantic States.

Agents for the Westinghouse Electric & Manufacturing Co.

Complete Equipment for Electric Street Railways.

STREET AND CABLE RAILROADS.

Will Survey Routes, Make Plans and Estimates

Free of Cost to Customers.

CONTRACTING ENGINEERS.

RAILROAD SWITCH, FROG AND TRACK WORK.

CORRESPONDENCE SOLICITED.

THE VOSE SPRING COMPANY,

Room 108 Taylor Building, 39 Cortlandt St., New York City.

MANUFACTURERS OF

Street Railway and Machinery Springs.

VOSE "GRADUATED,"
PLAIN COIL, ELLIPTIC,

AND SPRINGS OF ALL DESCRIPTIONS. ALSO RUBBER
SPRINGS, CUSHIONS AND WASHERS.

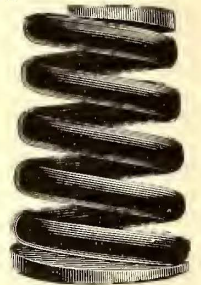

GET OUR PRICES BEFORE YOU BUY. CORRESPONDENCE SOLICITED.

GUS SUCKOW, Sales Agent.

JNO. C. N. GUIBERT, Sec'y-Manager.

JAMES R. FLOYD & SONS,

531-543 West 20th St.,
New York.

CROSSINGS, FROGS, SWITCHES, CURVED RAILS, KNEES, SPIKES AND CHANNEL PLATES.

This Work Under the Direction of Eugene Haldeman.

ALL KINDS OF REGULAR AND SPECIAL CASTINGS FOR WATER AND GAS, 3 INS. TO 36 INS.

J.H. & D. LAKE, Co.
MASSILLON, O. U.S.A.
 MFRS. OF
 FRICION CLUTCH PULLEYS;
 PLAIN OR SPLIT PULLEYS,
 SHAFTING,
 HANGERS, Etc.
 ALSO
 CUT-OFF COUPLINGS,
 PLAIN OR SPLIT;
 COUNTER SHAFTS
 COMPLETE.
 FORMERLY OF HORNELLSVILLE, N.Y.

CHARLES SCOTT SPRING CO.

PHILADELPHIA, PA.

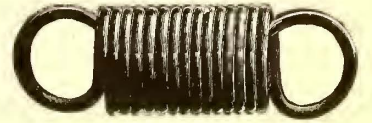
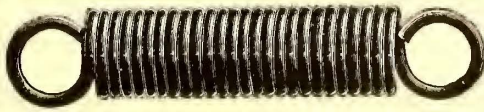

BRUSH HOLDER SPRINGS.



POSITIVELY GUARANTEED BEST AND CHEAPEST IN THE MARKET.

Springs of all Descriptions, for Street Cars, Either
Cable, Electric or Horse.

Springs for all Standard Trucks Kept in Stock.

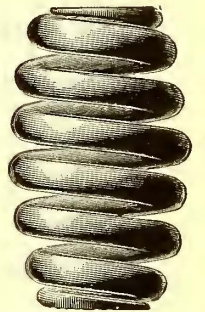
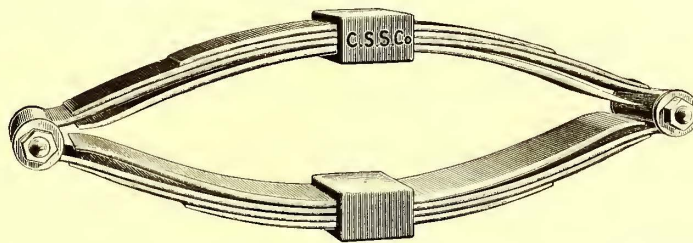
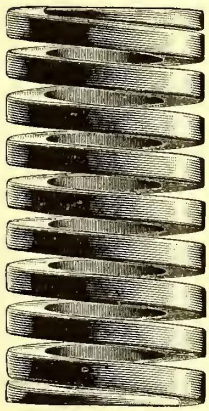

We Call Special Attention to our Light Elliptic Springs for Fast Running Trucks.

We will take pleasure in quoting you on any
Springs you may require.

—BUSINESS ESTABLISHED IN 1859.—

WM. WHARTON, JR., & CO.,

INCORPORATED.

Manufacturers of Everything Entering into the Track Construction of
ELECTRIC RAILWAYS,

CABLE RAILWAYS,

HORSE RAILWAYS,

Including all the latest and most approved appliances and appurtenances.

ALL KINDS OF

Street Rails,
Girder Rails,
Flat Tram Rails,
Slot Rails,

Curved Rails,
Railway Castings,
Switches,
Frogs,

Crossings,
Turntables,
Transfer Tables,
Derailing Switches.

We particularly direct attention to our Patented "INTEGRAL" Special Work, used by
the leading railroads, and by them considered the best ever made.

FROG, SWITCH AND CURVE WORKS,
25th Street. & Washington Ave.
PHILADELPHIA, PA.

FURNACES, STEEL WORKS AND ROLLING MILLS,
North Branch Steel Company,
DANVILLE, PA.

GRAHAM TRUCK.

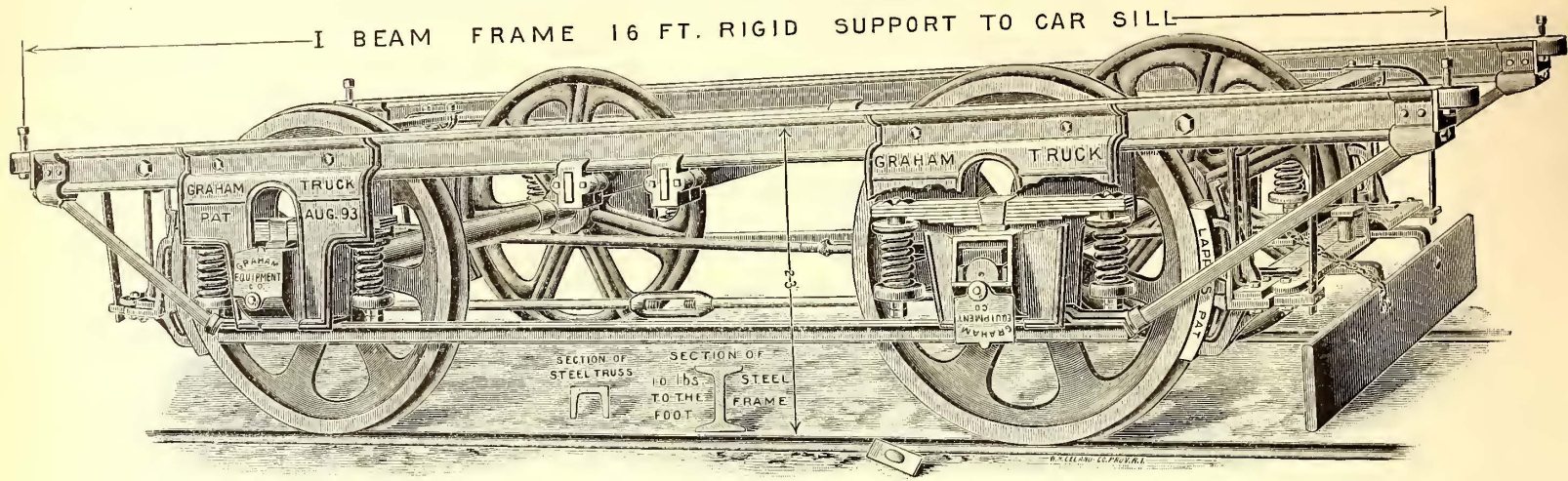

GRAHAM EQUIPMENT COMPANY, 258 WASHINGTON STREET, BOSTON.
741 DREXEL BUILDING, PHILADELPHIA.

**GALLOUPE'S
GENERAL INDEX TO ENGINEERING PERIODICALS.**

FROM 1888 TO 1892 INCLUSIVE.

CLOTH, 8VO. . . 396 PAGES. . . \$3.00.

By **FRANCIS E. GALLOUPE, M.E.**

Mass. Institute Technology: Member American Society Mechanical Engineers.

This Index embraces five years of work in engineering, railroads, science, manufactures and technical trades. It includes thousands of references to periodicals, of which some twenty-five are carefully indexed, and use is made of over one hundred others. The references to electrical work and investigations are specially full and numerous. Sent to any address, postage free on receipt of price, by

THE STREET RAILWAY JOURNAL, - - - - **Havemeyer Building, New York.**

A. B. DU PONT, President.

S. C. SHEPPARD, Gen. Mgr.

SHEPPARD MANUFACTURING CO.
(INCORPORATED.)

313, 315, 317 Ninth St., Louisville, Ky.

—MANUFACTURERS OF THE—

LOUISVILLE TRUCK,

(PATENTED.)

FOR MOTOR, TRAIL, CABLE AND HORSE CARS.

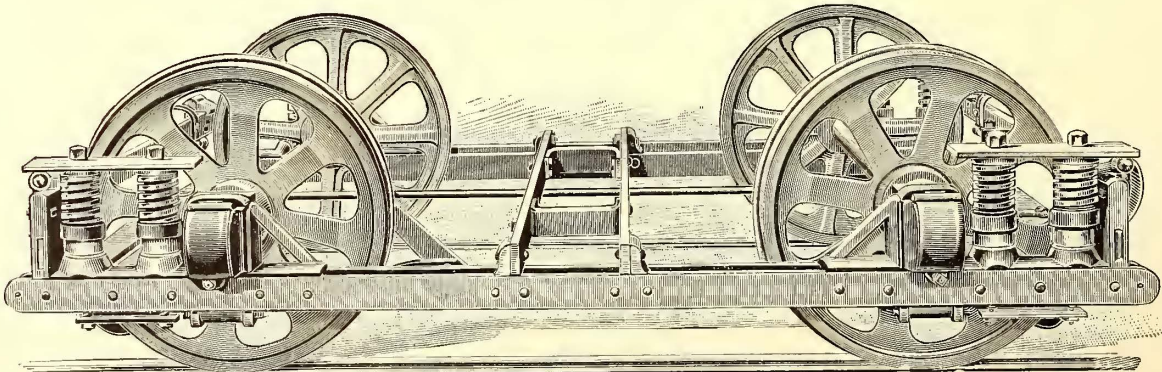

Simplicity of Construction.
Great Strength.
Ease of access to parts.
Few parts; no bolts except in removable parts.

Wheels easily and rapidly removed.
Long spring base relative to wheel base—no oscillation.
Low car floor—ample spring room.
Any wheel base, any spring base, any gauge, any motor.

THE 

CHICAGO

 **TRUCK.**

LATEST AND BEST.

CHICAGO ELECTRIC TRUCK CO.

1436 Monadnock Building, Chicago.

“WEST END” 4-WHEEL TRUCK

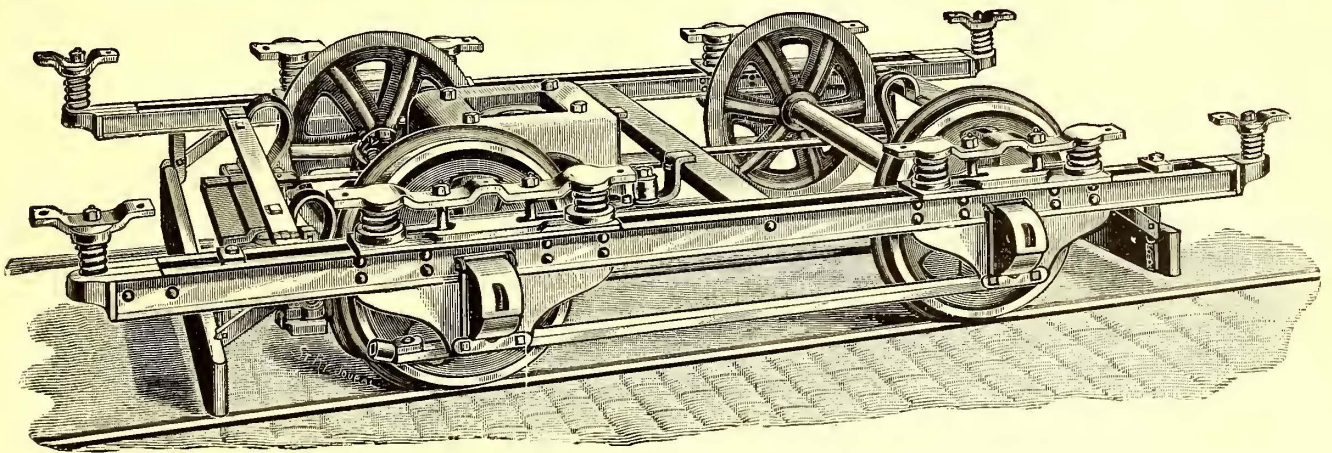

OVER 900 NOW IN USE.

SIMPLICITY AND DURABILITY.

GLOBE IRON WORKS.

THE WHITE MFG. CO.,

556 West 34th St.,

NEW YORK.

ROBINSON RADIAL TRUCK

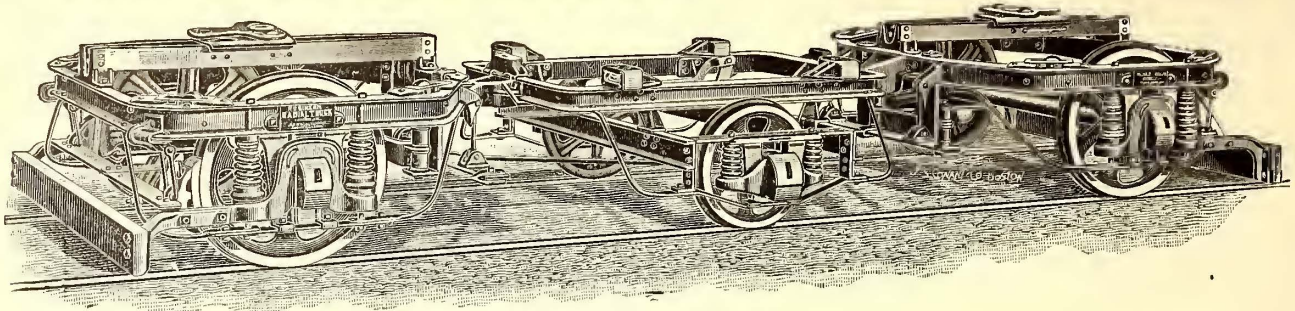

WHEELS: Some of the Robinson Radial Trucks, in constant use since January 1, 1891, on the West End Railway, Boston, are still running **with some of the original wheels then put on.** What other truck can show such a record?

“The Radial Truck turns the sharpest curves as readily and as rapidly as if it were on a straight track.”—
D. W. HIGGINS, *Pres. National Electric Light & Tramway Co., Victoria, B. C.*

“It has always given us satisfaction.”—HENRY M. WHITNEY, *Pres. West End St. Ry. Co., Boston.*

“I regard the ROBINSON RADIAL as the best truck in the world.”—JOHN SCULLIN, *Pres. Union Depot R. R. Co., St. Louis, Mo.*

**IN USE FROM MAINE TO CALIFORNIA, FROM BRITISH
COLUMBIA TO BRAZIL; ALSO IN EUROPE.**

The Robinson “Ajax” Four Wheel Truck will be illustrated in the July JOURNAL.
A Radically New Departure in Truck Building. Look for it.

ROBINSON ELECTRIC TRUCK & SUPPLY COMPANY,
620 Atlantic Avenue, BOSTON, MASS. WM. ROBINSON, General Manager.

TAYLOR ELECTRIC TRUCK CO.

TROY, N. Y.

BUILDERS OF HIGHEST GRADE

SINGLE AND DOUBLE TRUCKS.

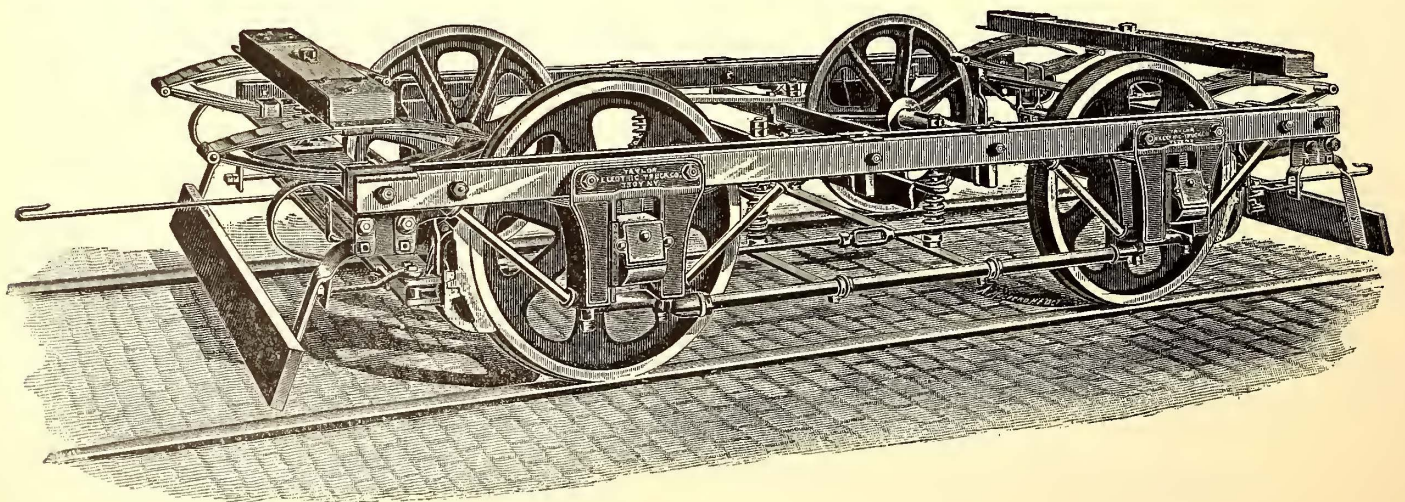

WRITE FOR CATALOGUE AND PRICES.

HIGHEST MEDAL AND DIPLOMA
 Awarded by the World's Columbian Exposition, 1893,
 for Single and Double Trucks.
COLUMBIAN TRUCK
 PATENTED.

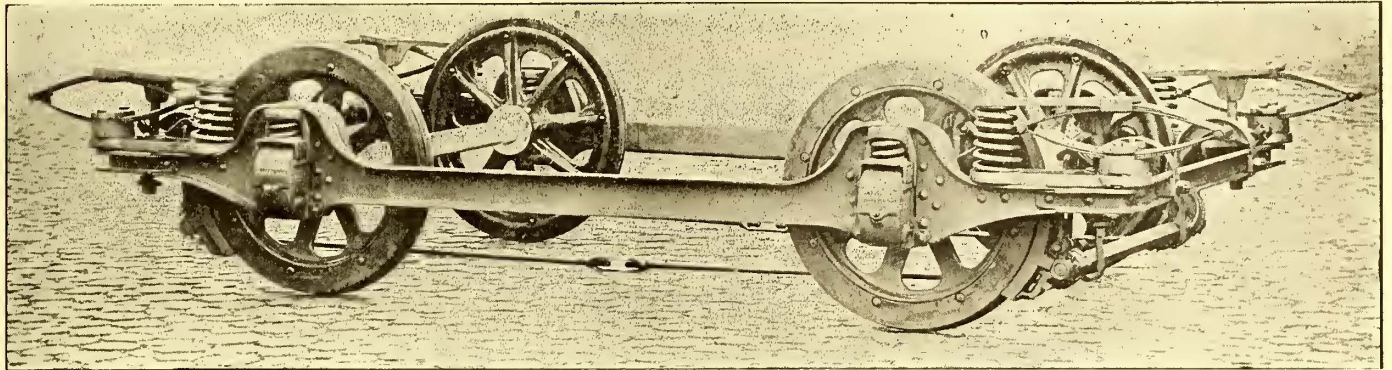

PATENTED SOLID PRESSED STEEL FRAMES.

IN USE ON 293 ROADS IN THIS COUNTRY, EUROPE AND CANADA.

Adopted as the standard of over 200 roads in this country, because they require practically no repairs, and largely reduce the repairs on MOTORS and the ROADBED. Ride easy and give entirely satisfactory service.

WORTH READING.

OFFICE OF
 ROCHESTER RAILWAY COMPANY.

ROCHESTER, N. Y., November 24, 1893.

McGUIRE MANUFACTURING COMPANY,
 122 NORTH SANGAMON STREET, CHICAGO, ILL.

GENTLEMEN:—In response to your inquiry as to the cost of maintenance, braking and riding qualities of your truck, I take pleasure in stating:

The eighty-five trucks which were purchased from your company, of the type called "Columbia," have been for some time in use under our eighteen foot vestibule bodies, and have given us entire satisfaction, both in regard to riding qualities and cost of repairs. I believe this truck to be the best riding truck in this company's service, and the brake is both efficient and durable. The repairs upon these trucks have been less than the repairs upon any other type of truck which we are using. In brief, they are in all respects satisfactory.

Very truly yours,
 J. N. BECKLEY.

NEW ORLEANS & CARROLLTON RAILROAD COMPANY.

NEW ORLEANS, April 1, 1893.

McGUIRE MANUFACTURING COMPANY, CHICAGO, ILL.

GENTLEMEN:—We have in use forty of your trucks; we bought them because we believed they were the best trucks made. They are better than we thought they were. The best proof of the entire satisfaction which they have given us, is that we have just ordered twenty more. The "Boss" truck. Yours truly,

CHRIS. V. HAILLE, Superintendent.
 W. N. SHEAFF, Superintendent Motive Power.

THE TOLEDO CONSOLIDATED STREET RAILWAY
 COMPANY.

TOLEDO, O., April 26, 1893.

McGUIRE MANUFACTURING COMPANY, CHICAGO, ILL.

GENTLEMEN:—We are so well pleased with the twenty "Columbian" trucks recently purchased of you, that you may now enter our order for ten additional trucks of the same pattern.

Respectfully yours,
 (Signed) ALBION E. LANG, Vice-President and General Manager.

SECOND AVENUE PASSENGER RAILWAY COMPANY.

GLENWOOD STATION, PITTSBURGH, PA., MARCH 10, 1893.

McGUIRE MANUFACTURING COMPANY, CHICAGO, ILL.

Your "Columbia" truck gives us perfect satisfaction and solves the problem of an easy riding truck on a rough track; also I think it is the most substantial truck in the market.

JOHN MURPHY, Superintendent.

YOUNGSTOWN STREET RAILWAY COMPANY.

YOUNGSTOWN, O., February 23, 1893.

McGUIRE MANUFACTURING COMPANY,
 122 NORTH SANGAMON STREET, CHICAGO, ILL.

GENTLEMEN:—Your trucks have been in use on our road ever since the change from horse to electric power some two years ago, and we have found them easy riding, simple in construction and exceedingly durable; we are using your trucks with seven foot wheel base, and running them around short curves, one of which has a radius of only thirty-three feet. We consider this as good a test as any truck could be put to.

Yours very truly,
 F. WAYLAND BROWN, General Manager.

MILWAUKEE, Wis., July, 21, 1893.

McGUIRE MANUFACTURING COMPANY,
 122 NORTH SANGAMON STREET, CHICAGO, ILL.

GENTLEMEN:—It gives us pleasure to state that your "Columbian Truck," which we are now using on our system, has given us the best of satisfaction, and we can conscientiously commend it to all street railways purchasing new equipment.

Yours very truly,
 H. C. PAYNE, Vice-President.

WILLIAMSPORT PASSENGER RAILWAY COMPANY.

WILLIAMSPORT, PA., January 3, 1893.

McGUIRE MANUFACTURING COMPANY, CHICAGO, ILL.

GENTLEMEN:—We have been using your make of trucks for the past eighteen months, making from 110 to 130 miles per car, and during that time the cost for repairs has been nominal. They are strong, easy riding, and are about all that could be required, and we have no suggestions to make concerning their improvement.

I enclose photograph of a car equipped with your truck, taken at our car house. Yours very truly,

H. R. RHOADS, President.

CHICAGO CITY RAILWAY COMPANY.

CHICAGO, ILL., December 16, 1893.

McGUIRE MANUFACTURING COMPANY,
 122 NORTH SANGAMON STREET, CHICAGO, ILL.

GENTLEMEN:—It gives us pleasure to say, unsolicited, that your "Columbian" trucks have been in use under seventy twenty-one foot motor cars operated on our lines since June 1, and that they have given excellent service and satisfaction. We have had no trouble with them, even during the extremely heavy travel of the World's Fair season.

Yours truly,
 M. K. BOWEN, Superintendent.

McGUIRE MANUFACTURING CO., 122-132 N. Sangamon St., Chicago.

Eastern Agency McGuire Mfg. Co.
 Chicago, Ill.

DANIEL J. DOWDNEY,

New York Office, 171 Broadway.
 Telephone, 3362 Cortlandt.

THE BEMIS CAR BOX CO.

SPRINGFIELD, MASS.

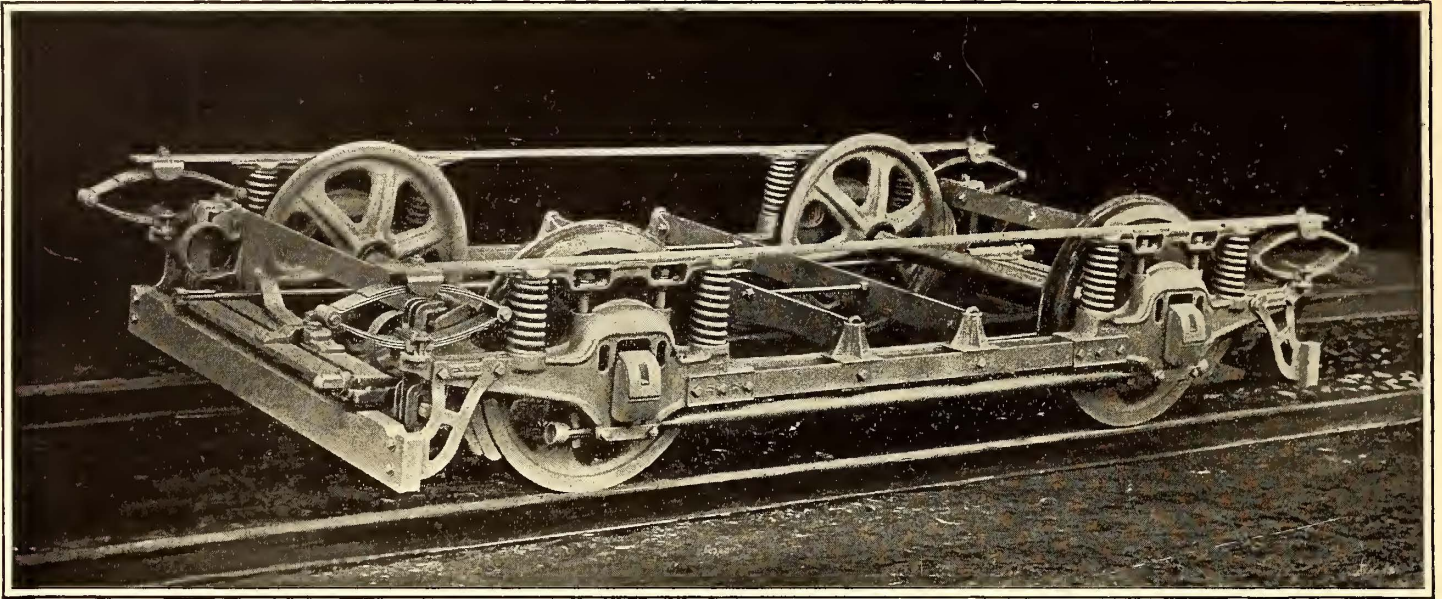

THE STANDARD MOTOR TRUCK.

Few Parts, Light, Strong and Durable ;
Powerful, Quick Acting and Noiseless Brake ;
Has the Bemis Journal Box.

For Service under 16 to 20 foot box and long open cars.

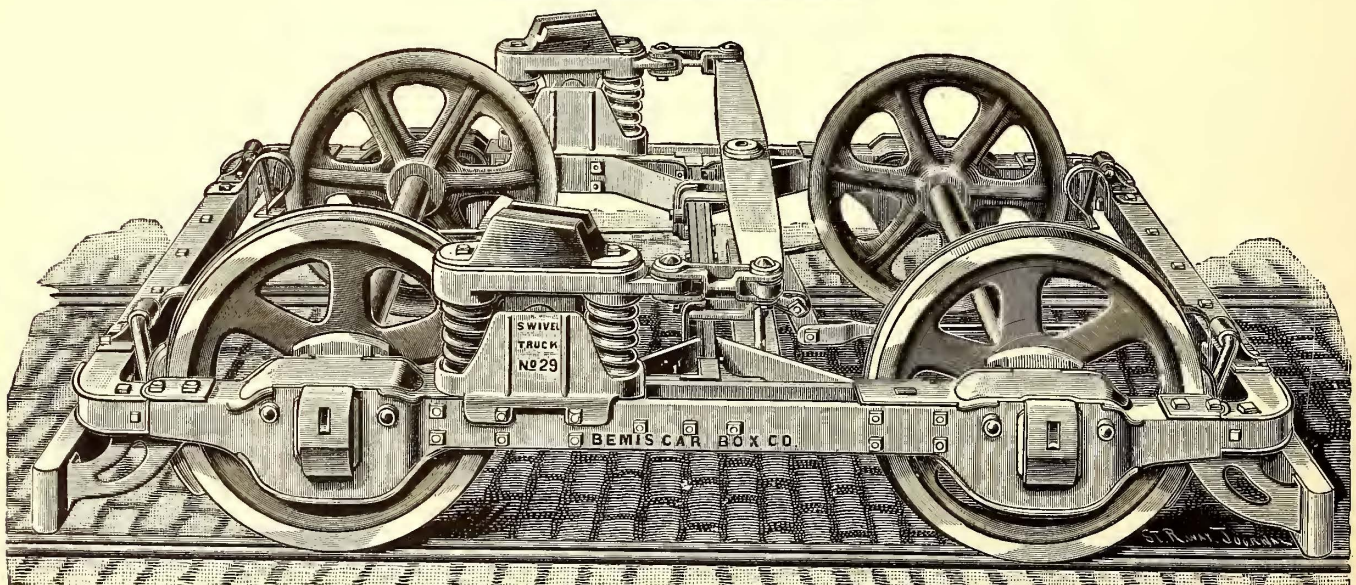

THE BEMIS NO. 29 TRACTION MOTOR TRUCK.

Increased traction on motor axles. Swivels from its center. Has standard size wheels on both axles. This gives light draught and good brake power, without increasing height of car above truck. No part of the truck over the motor. Short wheel base.

THE DORNER & DUTTON MFG. CO.

CLEVELAND, O.

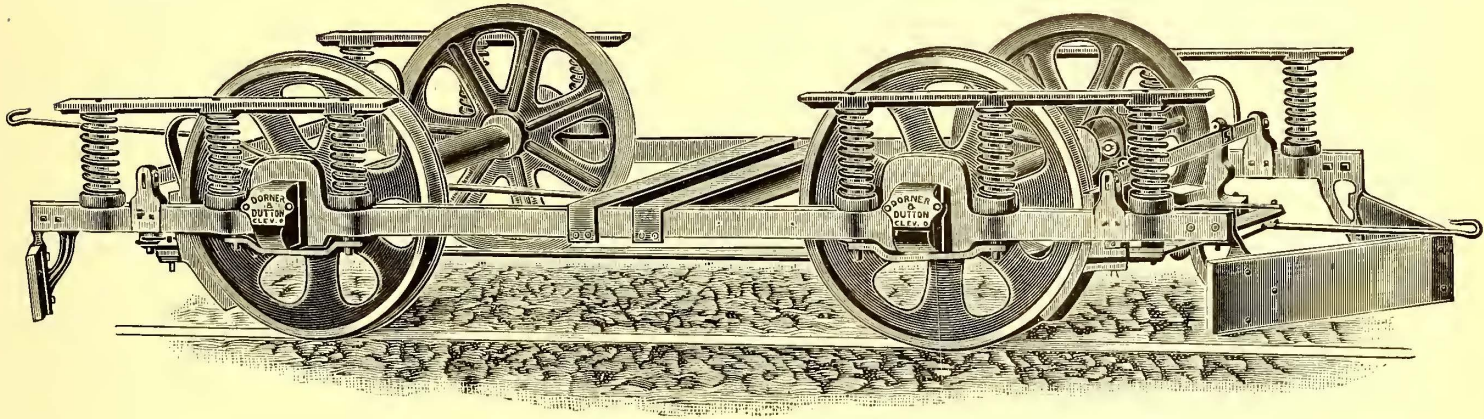

SOLID FORCED MOTOR TRUCK, No. 20,

For Car Bodies, 16 to 20 Feet Long.

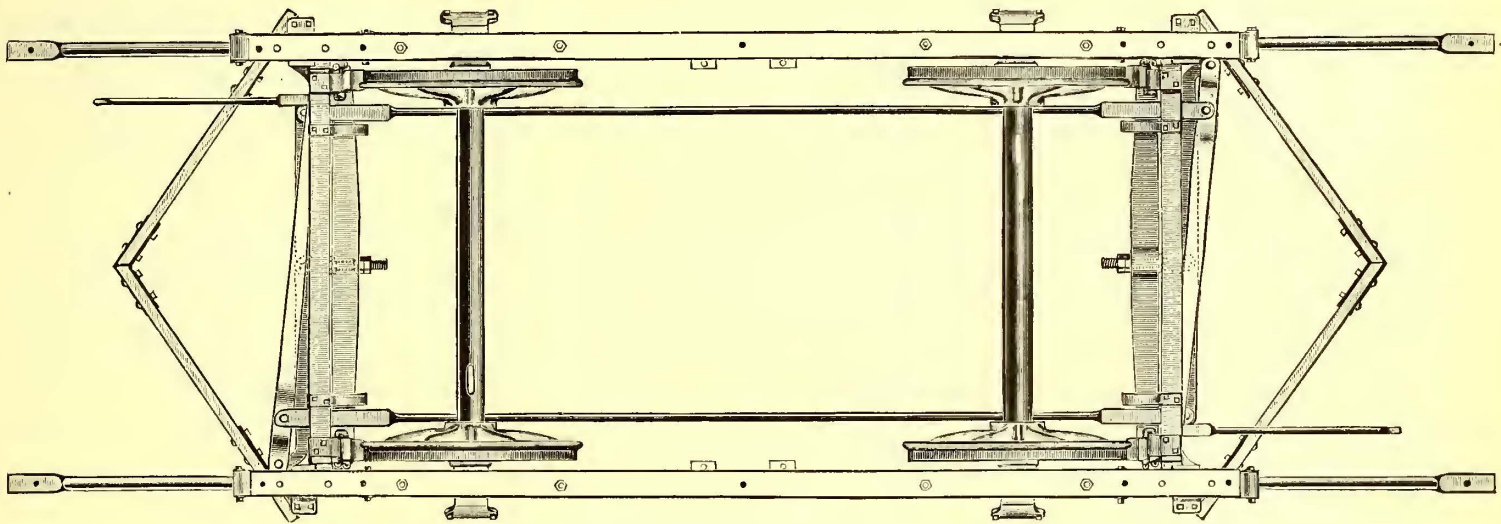

TOP VIEW.

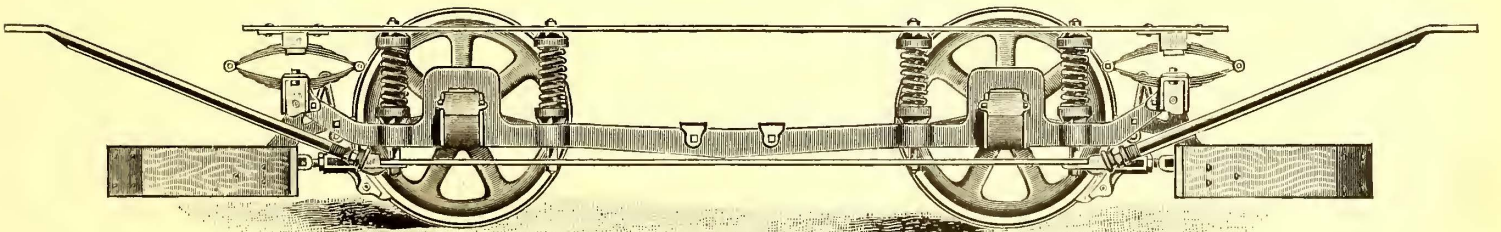

SIDE VIEW.

SOLID FORCED MOTOR TRUCK, No. 25 C.

For Car Bodies, 18 to 26 Feet Long. (Exclusive of Platforms.)

EUGENE F. PHILLIPS, President.

W. H. SAWYER, Sec'y and Electrician.

AMERICAN * ELECTRICAL * WORKS,

PROVIDENCE, R. I.

RAILWAY FEEDER AND TROLLEY WIRE

Electric Light Line Wire, Incandescent and Flexible Cords,
Americanite, Magnet, Office and Annunciator Wires.

FARADAY CABLES.

NEW YORK OFFICE, 10 Cortlandt St.

MONTREAL BRANCH; Eugene F. Phillips' Elec. Works.

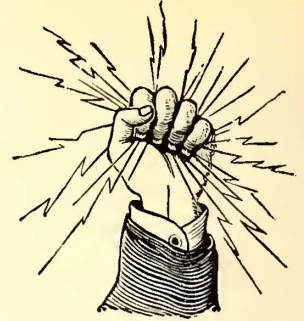

SOLAR CARBON & MFG. CO.,

MANUFACTURERS OF

CARBON BRUSHES. -:- BATTERY CARBONS.

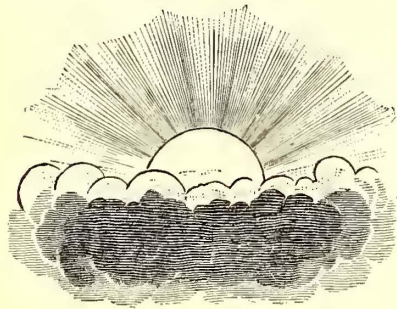

SOLID ELECTRIC LIGHT CARBONS,

For any system, of any degree of hardness.

SOFT CORED CARBONS, (Not Hollow),

For Arc Lamps on Incandescent and Railway Circuits.

SOLAR CARBON & MANUFACTURING CO.

95 FIFTH AVENUE, PITTSBURGH, PA.

MOULDED MICA FOR LINE INSULATORS.

Long service on many electric lines proves the reliability of Moulded Mica Insulation for **Safety, Durability and Strength.**

A FULL LINE OF

Hangers, Pull-offs,
Strain Insulators, Ears,
Section Insulators,
Insulated Crossings,
Switches, Tree Insulators, &c.

Insulated Gas and Side Cutting Pliers.
Insulated Screw Drivers, &c.
Weather-proof Moulded Mica Incandescent Lamp Sockets and Rosettes.

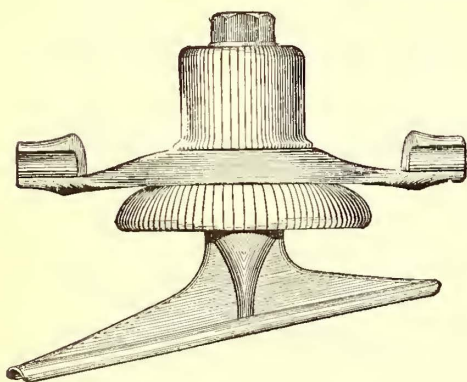

SWIVEL HANGER, NO. 131.

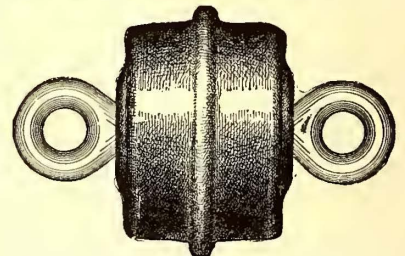

NO. 1. GIANT STRAIN INSULATOR,
NO. 830. AVERAGE BREAKING
STRAIN 6,500 LBS.

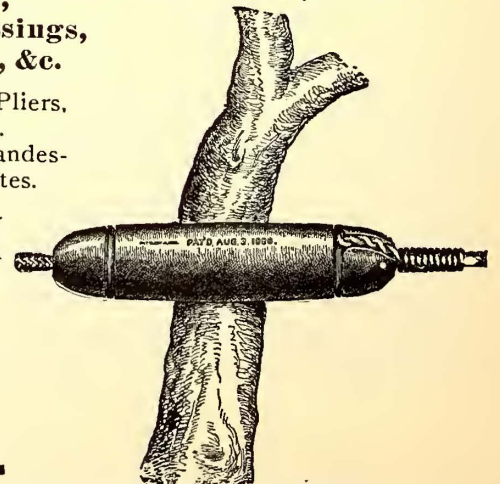

TREE INSULATOR. BEST PROTECTION FOR
ALL SIZES OF ELECTRIC LIGHT
AND FEEDER WIRES.

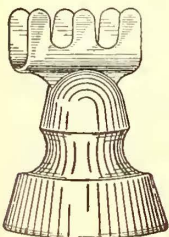

IRON CLAD FEEDER
WIRE INSULATOR
for 500,000 CIRC.
MILLS. (NEW.)

VULCABESTON

Heat-proof Insulation for Magnet Spools, Bushings, Controller parts, Insulating Sheets and special parts.

SEND FOR THE APRIL ISSUE OF OUR REVISED
"INSULATION" PRICE LIST.

H. W. Johns Mfg. Co.

87 Maiden Lane, New York.

CHICAGO.

PHILADELPHIA.

BOSTON.

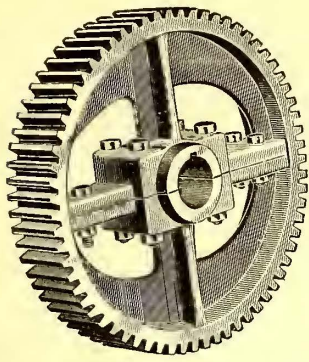

THE
Steel Motor Co.

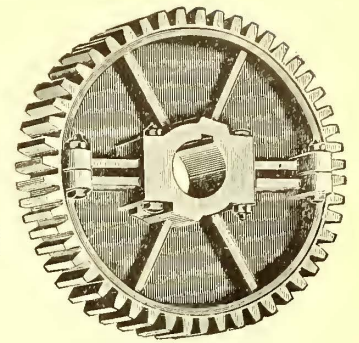

STANTON ST. AND C. P. R. R.

CLEVELAND, OHIO, U. S. A.

MANUFACTURERS OF

THE "STEEL CLAD" RAILWAY MOTOR

AND IMPROVED

SERIES MULTIPLE CONTROLLER.

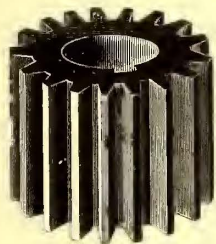

HARRIS TRUCKS, HARRIS TROLLEYS

AND

SUPPLIES FOR ALL SYSTEMS.

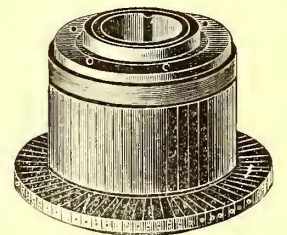

SPECIAL BARGAINS!

WE OFFER THE FOLLOWING

STANDARD SUPPLIES

FOR ELECTRIC RAILWAYS.

T-H. S. R. G. Armatures Complete, - - - \$175.00	T-H. F. 20 Armature Shafts, - - - - \$7.50
Edison No. 6 Armatures Complete, - - - 105.00	T-H. F. 30 Armature Shafts, - - - - 7.50
Short 15 H. P., D. R., Armatures Complete, - 100.00	T-H. F. 30 Intermediate Shafts, - - - - 7.50
T-H. D. 62 Generator Armatures Complete, - 475.00	Short 15 H. P. Armature Shafts, - - - - 6.75
Edison No. 32 Generator Armatures Complete, - 425.00	Harris Anti-Friction Trolleys, - - - - 20.00
T-H. F. 30 Brass Shell Commutators Complete, - 30.00	Improved Trolley Harp, - - - - 1.00
Edison No. 6 Brass Shell Commutators Complete, - 25.00	Improved Trolley Wheels, - - - - .60
Edison No. 6 Iron Shell Commutators Complete, - 22.50	Sleet Trolley Wheels, - - - - .70
T-H. S. R. G. Field Coils Complete, - - - 48.00	Boston Trolley Wheels, - - - - .80
Westinghouse S. R. Field Coils, - - - - 19.60	3 Section Steel Trolley Poles, - - - - 1.25

All Goods New and Guaranteed First-Class.

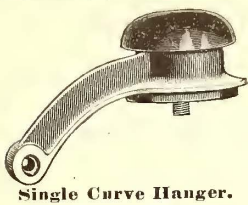

Single Curve Hanger.

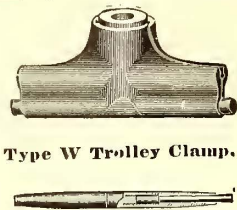

Type W Trolley Clamp.

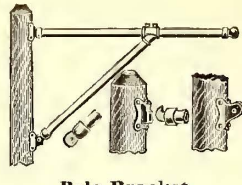

Pole Bracket.

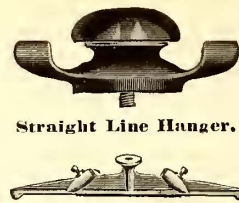

Straight Line Hanger.

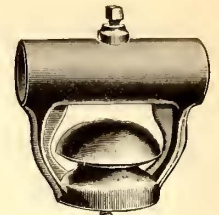

Pipe Bracket Hanger



Strain Insulator.

Trolley Splicer.

Splicing Ear.



Feeder Wire Splicer.

The Ohio Brass Co., MANSFIELD, OHIO.
MANUFACTURERS
 ELECTRIC RAILWAY SUPPLIES, CONSTRUCTION MATERIAL, LINE DEVICES, CAR APPLIANCES.
 Write for Illustrated Catalogue No. 2.

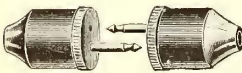

Trailer Connector.



Soldered Ear.



Section Insulator.



Feeder Ear.



Banding Cap.



Double Strain Ear.



Adjustable Switch.

When Ordering

From firms whose names appear in the STREET RAILWAY JOURNAL our friends will confer a favor on our advertisers and ourselves by mentioning this paper.

Very respectfully,

Street Railway Publishing Co.

ROLLED STEEL GONGS

FOR ELECTRIC, CABLE AND MOTOR CARS.

Adopted by all the Leading Car Builders.

THE LEWIS & FOWLER MANUFACTURING CO.

Office 28 Sandford St.,

Brooklyn, N. Y., U. S. A., Dec. 26, 1893.

(Dictated)

Pittsburgh Steel Hollow Ware Co.,

Allegheny, Pa.

GENTLEMEN:--We have used your gongs in large quantities, and are pleased to state that we have found them most satisfactory in all particulars.

Yours very truly,

THE LEWIS & FOWLER MFG. CO.

George W. Myers, Sec'y.

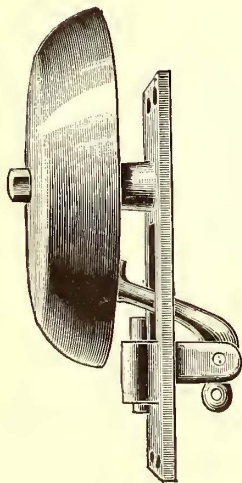

BLACK OR NICKEL FINISH.

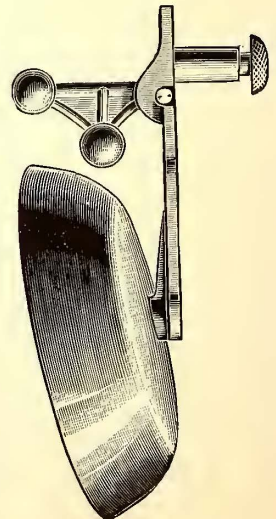

BLACK OR NICKEL FINISH.

Write for Prices and send for Samples before ordering elsewhere.

PITTSBURGH STEEL HOLLOW WARE CO.

ALLEGHENY CITY, PA.

San Francisco Office, 216 Bush St. - - McLure & Kaufman, Agents.

"It is dangerous for a street railway manager to permit himself to lapse into such satisfaction with his achievements in securing the introduction of mechanical traction, as to neglect opportunities for improvements in the many little details that please the patrons, increase the income, and place the business on a substantial financial basis. The operations of every system should be broadened so as to embrace all features which will tend to make the business popular, and to increase the income more rapidly than the expenses."—*From editorial in Street Railway Journal for April.*

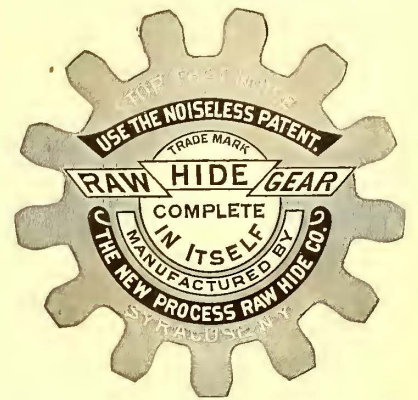

New Process Raw Hide Pinions are Noiseless, Cleanly and Economical.

The New Process Raw Hide Co.

PATENTEES AND SOLE MANUFACTURERS.

SYRACUSE, N. Y.

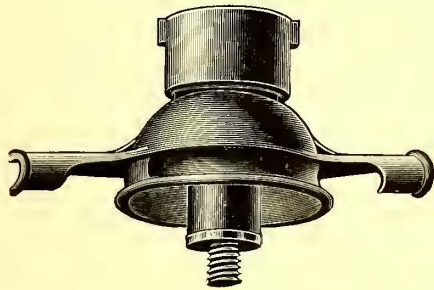

NEW YORK ELECTRICAL WORKS,

161 Washington St., New York.

MANUFACTURERS OF

PATENT AND SPECIAL

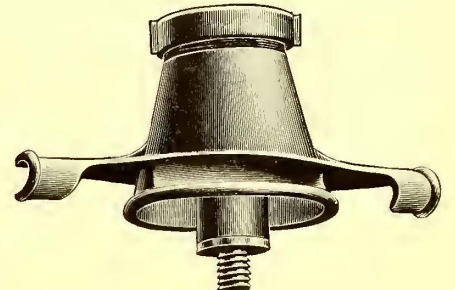

OVERHEAD FITTINGS FOR ELECTRIC RAILWAYS.

SECTION INSULATORS, HANGERS, SWITCHES AND CROSSOVERS, MECHANICAL EARS, SOLDER EARS, SPLICE AND STRAIN EARS, INSULATED TURNBUCKLES, POLE RATCHETS, GLOBE INSULATORS, FEED WIRE INSULATORS, HAULING CLAMPS, EYE BOLTS, GUARD WIRE HANGERS, ETC.

F. A. ESTEP, President & Treasurer.

J. R. MCGINLEY, Vice-President.

F. S. MARTIN, Supt. of Works.

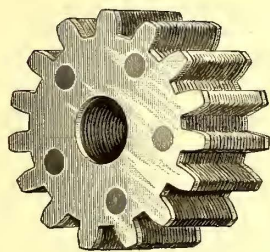

GEARS and PINIONS

FOR

ALL ELECTRIC RAILWAY SYSTEMS.

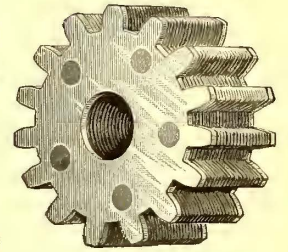

Gears made of Cast Iron or steel. Pinions made of Steel, Bronze, Tempered Copper or Rawhide.

All our Gears and Pinions are made on the latest and most improved machinery. Our castings are free from all imperfections. All Gears and Pinions are Accurately Cut, and Each one is given a most rigid test before leaving our works.

We are prepared to cut gears for all systems, and of any desired diameter, pitch and face. Our Cast Steel Gears are unequalled.

Our Trolleys are in General Use and Known Everywhere.

Have You Tried Them?

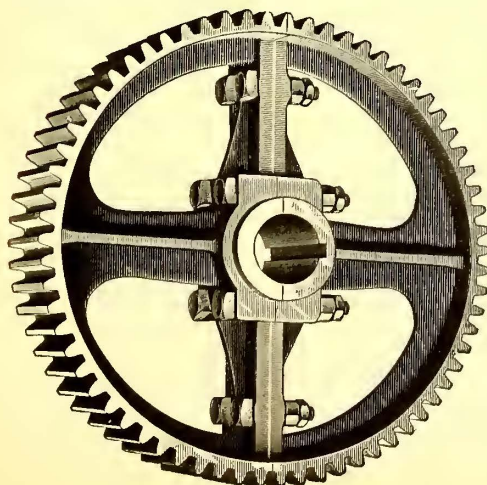

R. D. Nuttall Co.

179 GRANT AVENUE.

ALLEGHENY, PA.

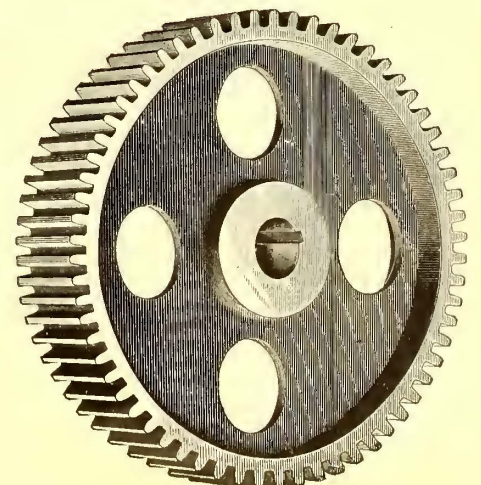

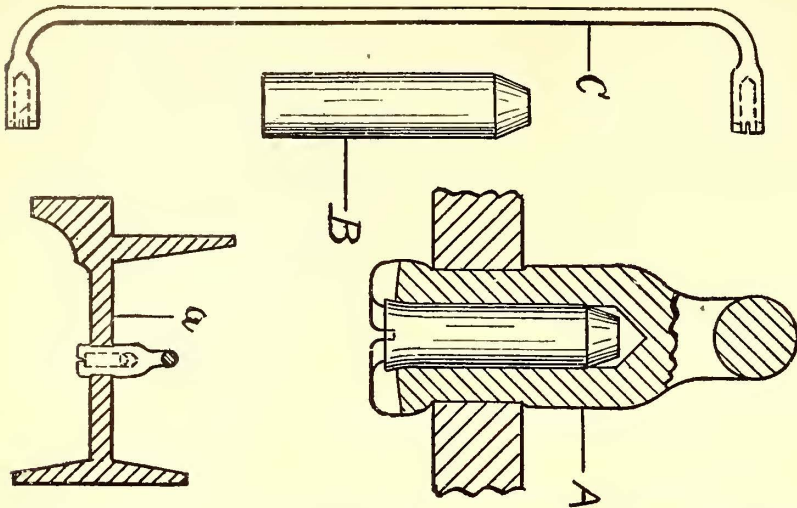

—THE—
Chicago Rail Bond.

The Bonding Question Solved at Last. The Contact of the connection will remain perfect as long as the rail will last.

With the Chicago Rail Bond you can make a perfect all-rail, metallic return circuit. Can be furnished any length or size, from 0 to 0000.

H. R. KEITHLEY,
107-109 Lake St., Chicago, Ill.
Care Washburn-Moen Mfg. Co.

—THE—

ELECTRIC RAILWAY EQUIPMENT CO.,

81-83 E. FRONT ST., CINCINNATI, O.

MANUFACTURERS

WROUGHT IRON AND STEEL TUBULAR POLES, GEARS AND PINIONS, OVER-HEAD LINE MATERIAL, BEARINGS AND BRASSES, TROLLEY HANGERS AND WHEELS, AND REPAIR PARTS FOR ALL SYSTEMS.

WESTINGHOUSE ELECTRIC & MFG. CO.

PITTSBURGH, PA.

WE MANUFACTURE COMPLETE INSTALLATIONS OF

Electrical Apparatus for Electric Railways.

CENTRAL STATION ELECTRIC LIGHTING, LONG DISTANCE POWER TRANSMISSION AND ISOLATED PLANTS.

BRANCH OFFICES IN ALL LARGE CITIES.

ELECTRICITY FREE OF COST

At Central Stations.

Many Companies pay all expenses back on the dynamo from the sale of their EXHAUST STEAM.

This they do by the **HOLLY SYSTEM** of Underground Steam Distribution, which heats dwellings, stores, offices, churches and public buildings from the sale of a by-product, which other companies are allowing to go to waste. It is a legitimate source of revenue and helps pay dividends. For particulars, address

AMERICAN DISTRICT STEAM CO.

LOCKPORT, N. Y.

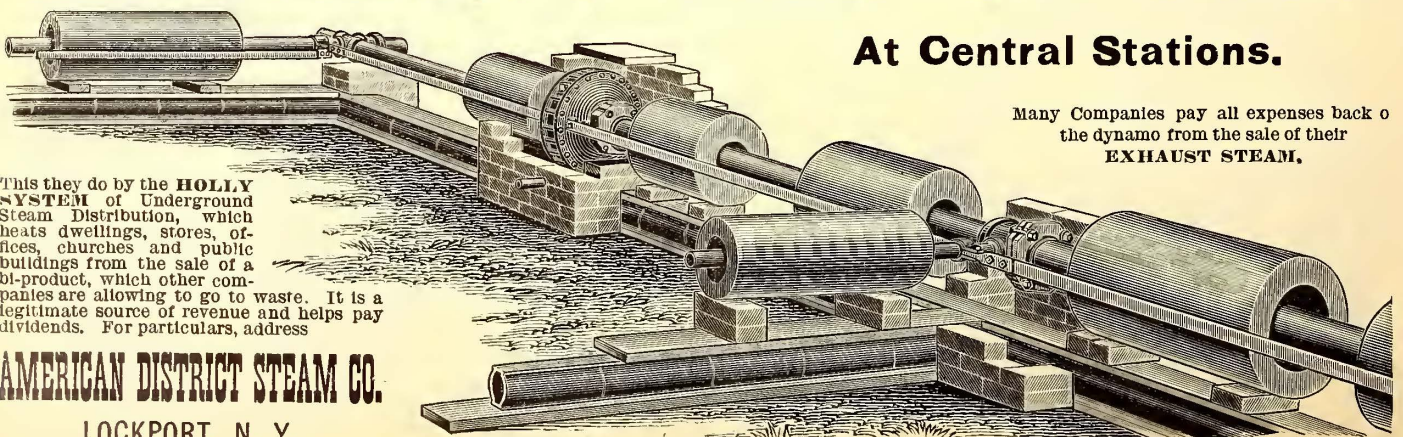

Pole Brackets,

Trolley Insulators,
Trolley Switches,
Trolley Ears.

A FLEXIBLE SUPPORT FOR
TROLLEY WIRE.

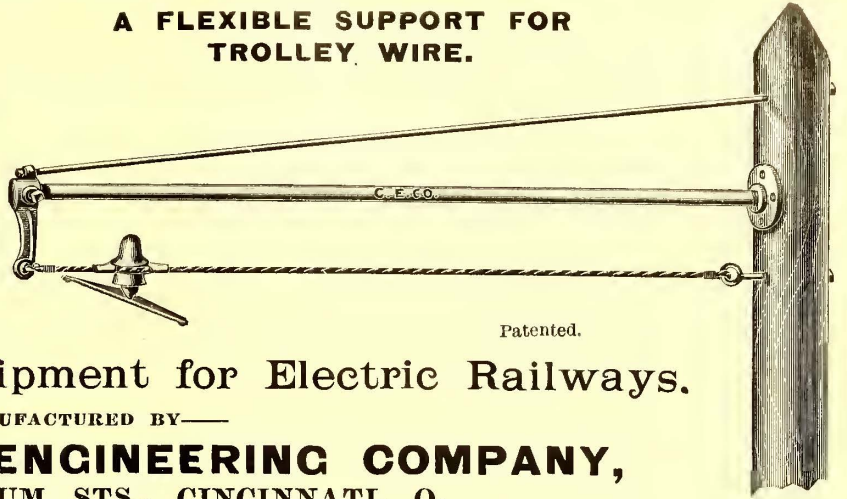

Complete Overhead Equipment for Electric Railways.

—MANUFACTURED BY—

THE CREACHEAD ENGINEERING COMPANY,
EIGHTH AND PLUM STS., CINCINNATI, O.

AMERICAN HARD FIBRE CO.

NEWARK, DELAWARE,

—MANUFACTURERS—

HARD AND FLEXIBLE FIBRE,

In Sheets, Rods and Tubes, for Electrical, Mechanical
and Manufacturing purposes.

QUALITY WARRANTED. LOWEST PRICES.

SEND FOR SAMPLES AND CATALOGUE.

FILD & BATE
Engravers
ELECTROTYPERS.
113 FULTON ST.
NEW YORK. N.Y.

THE BROOKLYN RAILWAY SUPPLY CO.
STAMFORD, CONN.
Formerly of Brooklyn.

ALL KINDS SWEEPING MACHINERY
For Horse, Cable and Electric Railways.

TRACK SWEEPERS. RAIL SWEEPERS. TWO-HORSE SWEEPERS.
Revolving Rail Sweepers for Street Car Attachment.

The Walkaway Snow Plow, for Removing Heavy Snow, Excels
any Plow Ever Made.

—CORRESPONDENCE SOLICITED.—

WRECKING WAGON FOR STREET RAILWAYS.



Here is just the thing for any Electric or Cable road. The cut shows facsimile of wagons recently built for the Cable System, New York City. We also build one hundred different styles of wagons and other rolling stock for Underwriters, Fire and Police Departments. Send for estimates and photographs.

GLEASON & BAILEY MFG. CO.,

FOUNDED IN 1840.

SHOPS,
SENECA FALLS, N. Y.

Cor. Mercer and Houston Streets, New York City,

Opposite Broadway Cable
Power House.

THE
TRENTON IRON COMPANY
 MANUFACTURERS OF
IRON AND STEEL WIRE
 AND
WIRE ROPE
 OF EVERY DESCRIPTION.
STEEL CABLES
 FOR
STREET RAILWAYS
 EITHER LANG LAY OR ORDINARY LAY.
 OFFICE AND WORKS
TRENTON NEW JERSEY.
 NEW YORK OFFICE
 COOPER HEWITT & CO. 17 BURLING SLIP.
 CHICAGO OFFICE
 502 WESTERN UNION BUILDING.

ESTABLISHED 1848.

The Hazard Manufacturing Co.
 MANUFACTURERS OF
 IRON, STEEL AND GALVANIZED
Wire Rope.



Steel Cables for Street Railways.

GENERAL OFFICE AND WORKS:
WILKES - BARRE, PA.

New York Office, 87 Liberty Street.

CALIFORNIA WIRE WORKS,

509 & 511 Market St., San Francisco, Cal.

MANUFACTURERS OF
IRON, STEEL
 AND
GALVANIZED ROPES.

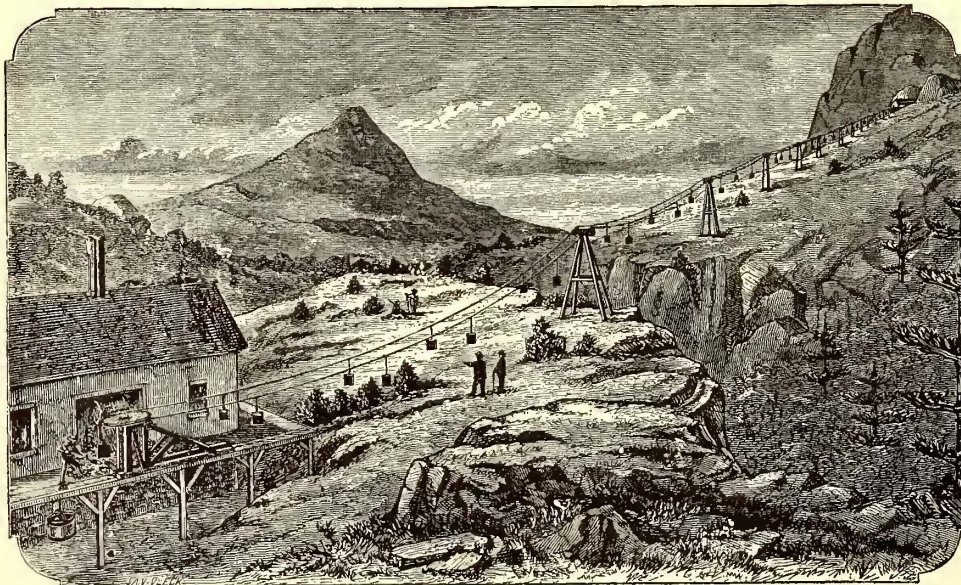

HALLIDIE'S PATENT WIRE ROPEWAY.

Simplest and Most Economical Means of Transportation.

SEND FOR ILLUSTRATED CATALOGUE.

Manufacturers of Wire of all kinds. Barbed Wire, Wire Nails, Wire Cloth and Netting.

THE RECORD OF OUR CABLES STANDS UNSURPASSED.



CRUCIBLE STEEL CABLES
 For Street Railways.

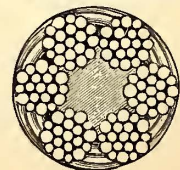

WASHBURN & MOEN MFG. CO.

WORCESTER, MASS.

Makers of Iron, Steel and Copper,

AND MANUFACTURERS OF

IRON, STEEL AND COPPER WIRE FOR ALL PURPOSES.

WIRE ROPE AND CABLE

CORRESPONDENCE SOLICITED.



ORDERS RECEIVE PROMPT ATTENTION.

OF EVERY DESCRIPTION.

Crucible Cast Steel Cables for Cable Railways a Specialty.
SEMAPHORE STRAND AND EXTRA FLEXIBLE STEEL RHEOSTAT CABLES.

Hard and Soft Drawn **BARE AND INSULATED COPPER WIRE** For Electric Railways.

HARD DRAWN TROLLEY WIRE, FEEDER WIRES, ARC AND INCANDESCENT LIGHT WIRE, ETC.

Makers of the "SALAMANDER" Fire and Water-Proof Insulated Wire.

STEEL MILLS AND FACTORIES:—WORCESTER, MASS.; WAUKEGAN, ILL.

OFFICES AND WAREHOUSES:

WORCESTER, MASS.; NEW YORK, N. Y.; CHICAGO, ILL.; SAN FRANCISCO, CAL.; HOUSTON, TEXAS.

C. W. HUNT COMPANY,

45 BROADWAY, NEW YORK.

MANUFACTURERS OF THE

HUNT NOISELESS CONVEYOR

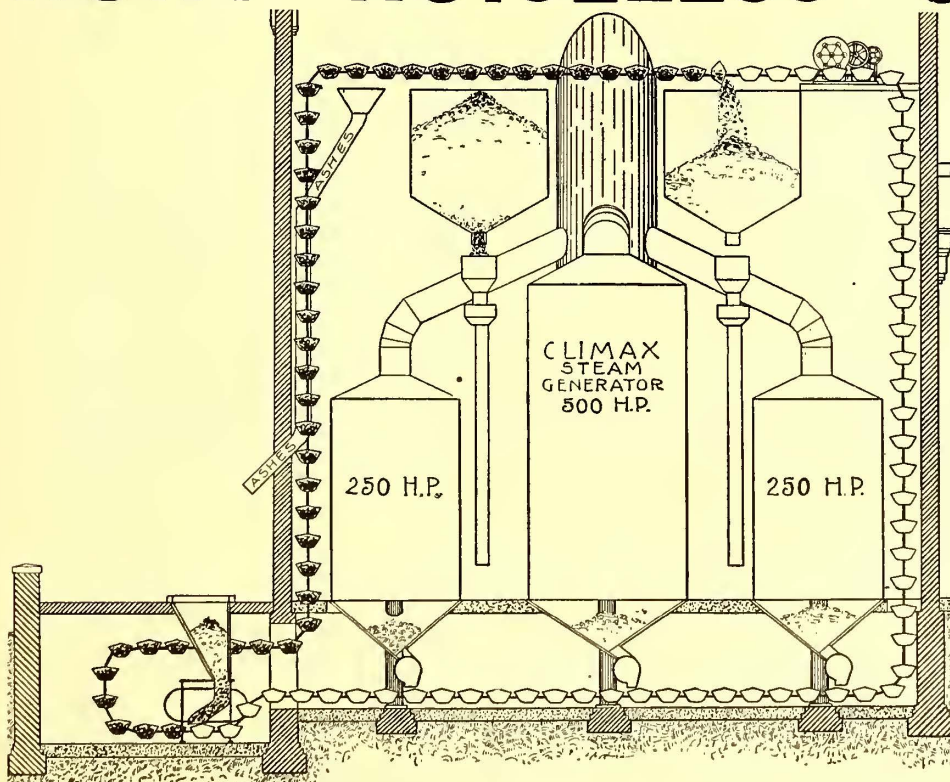

For HANDLING COAL AND ASHES
AT ELECTRIC LIGHT AND
POWER HOUSES.

Hunt Conveyor arranged for
handling both coal and ashes at
Edison Electric Illuminating Co.'s
Third District Station, Brooklyn,
N. Y.

GEORGE CRADOCK & CO.

Wire Rope Works and Wire Drawing Mills,
WAKEFIELD, ENGLAND.

LONDON OFFICES, 7 East India Avenue, E. C. - HEAD OFFICES, Wakefield.

TELEGRAPHIC ADDRESS, "CRADOCK, WAKEFIELD."

A B C AND ENGINEERING TELEGRAPH CODES USED.

Chicago Exhibition—Award Received.

MANUFACTURERS OF EVERY DESCRIPTION OF

Steel and Iron Wire Ropes,

FOR CABLE TRAMWAYS, MINES, COLLIERIES, AERIAL ROPEWAYS,
CRANES, HOISTS AND AGRICULTURAL PURPOSES.

Our Cable Tramway Ropes, made on Lang's Lay, and of our own Improved Patent Crucible Steel Wire, have given specially good results. Following illustrations, taken from Cables, show condition after being in service:

Cable supplied The Melbourne Tramway & Omnibus Company, Melbourne, Australia; 30,000 feet long by $3\frac{3}{8}$ in. cir. Ran on St. Kilda Line 116 weeks and 3 days. Speed 10 miles per hour. Total run, 134,951 miles. First splice lasted 84 weeks. Best record.

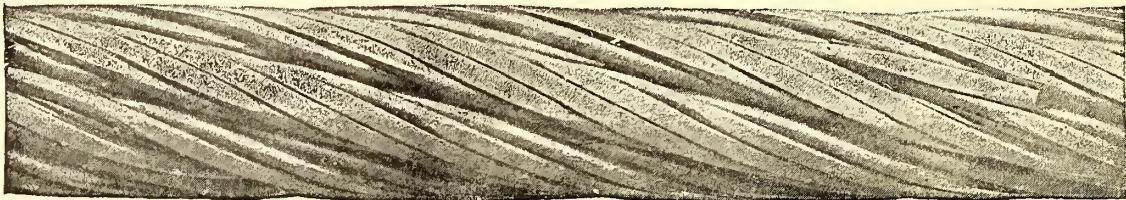

Cable supplied North Chicago Street R. R. Co., Chicago, U. S. A.; 9,670 feet long by $1\frac{3}{8}$ in. diam. Run on Loop Line 98 days. Best record.



St. Ry. Journal

Original Manufacturers of Lang's Patent Wire Rope.

All wire used in the Manufacture of our Ropes is drawn by ourselves from specially prepared Wire Rods exclusively for our own use, and on no account whatever do we supply the Trade.

T. A. WIGHAM, Agent for United States,
714 Bort Building, 17 to 21 Quincy Street, Chicago, Ill.

Soft Bare Copper Wire.

Insulated Feeder Wire.

Heavy Stranded Feeder Conductors.

Lead Covered Underground Cables,

Rubber Insulated Wire.

Span Wire, Bare and Insulated.

Magnet Wire for Armature Repairs.

Iron and Steel Telegraph Wire.

Hard Drawn Copper Telephone Wire.

Copper Rods for Station Work.

ORDERS EXECUTED PROMPTLY.

Large Stock on Hand.

HARD COPPER AND SILICON BRONZE TROLLEY WIRE.

Correspondence Solicited as per Address in Wire Rope Circle.



ALFRED G. HATHAWAY

SOLE MANUFACTURER,

G. HATHAWAY PATENT TRANSFER TABLES,

Cuyahoga Building, Cleveland, Ohio.

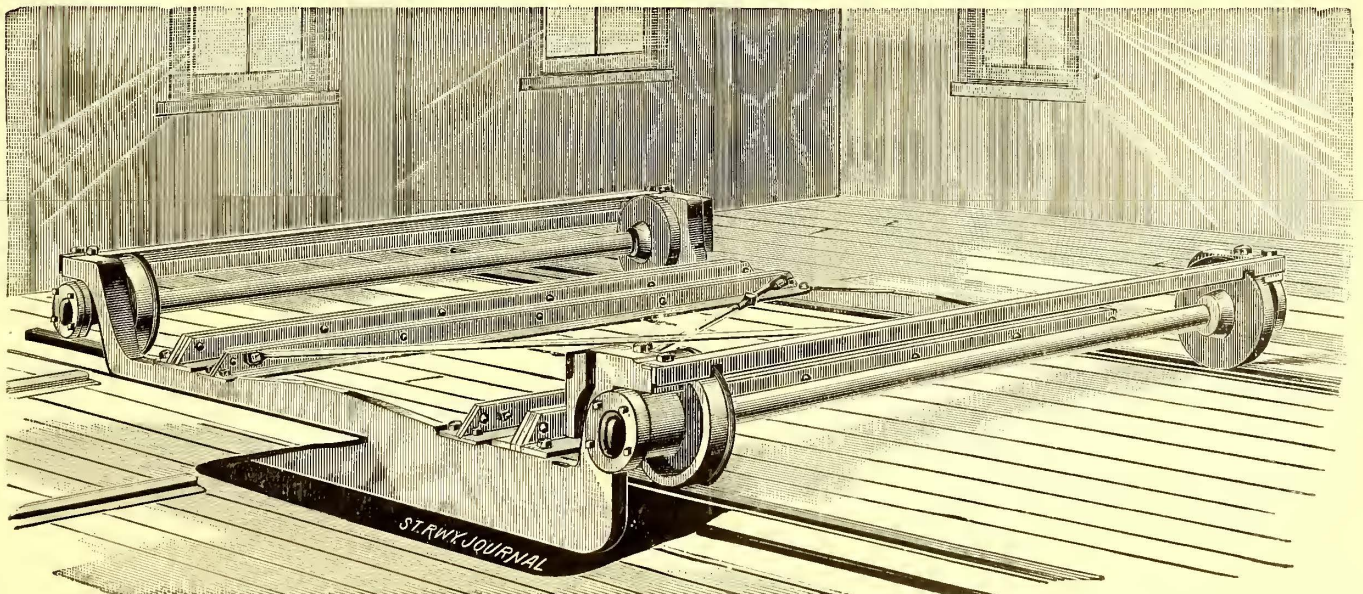

NO PIT, ANTI-FRICTION RUNNING GEARS AND CAPACITY 15 TONS.

KEEP A LARGE SUPPLY OF TRANSFER TABLES AND TURN TABLES CONSTANTLY ON HAND.

Send for Circular of Hathaway Improved Hydraulic Wheel Press.

SOCIÉTÉ ANONYME INDUSTRIELLE DES ETABLISSEMENTS ARBEL,

WORKS:—RIVE-DE-GIER (LOIRE), FRANCE.

Manufacturers of Wrought-Iron Forged Wheel Centres with Steel Tires for Street Railway Service.

Sample Wheels
ON
Exhibition
IN
Our New York
Office.

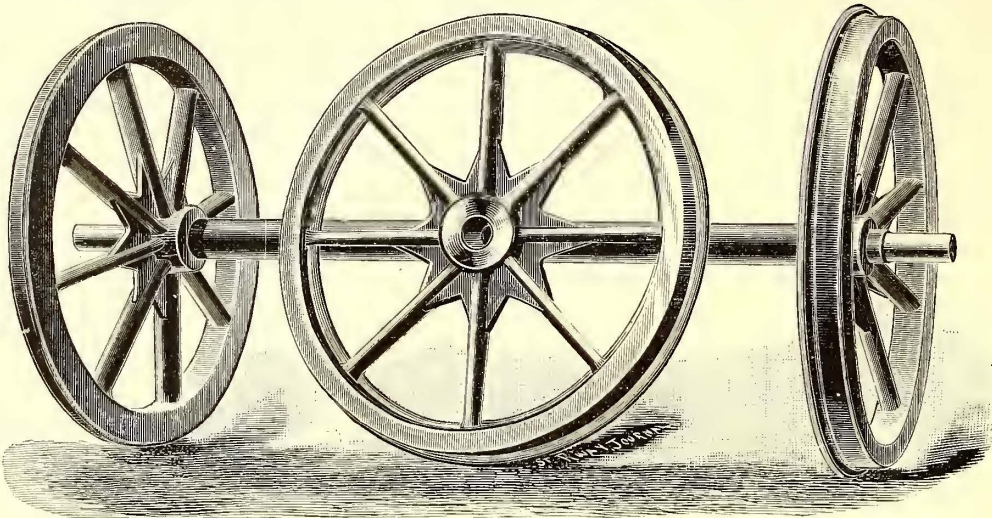

Catalogues
AND
Blue Prints
ON
Application.

We Guarantee our Wrought-Iron Centres for Cable and Electric Railway Service for 5 years.

ADDRESS ALL CORRESPONDENCE,

W. M. HAZELTON, 3d.

OUR EXCLUSIVE AGENT FOR THE UNITED STATES FOR SALE OF
STREET RAILWAY WROUGHT IRON WHEELS.

Havemeyer Building, . . . 26 Cortlandt St., New York.

THE

DICKSON MANUFACTURING CO.,

SCRANTON AND WILKES-BARRE, PA.

LOCOMOTIVES FOR ALL KINDS OF SERVICE. BLAST ENGINES FOR IRON AND STEEL
WORKS. BESSEMER STEEL PLANT MACHINERY. STATIONARY ENGINES.
HORIZONTAL AND VERTICAL, HIGH PRESSURE, CONDENSING
AND COMPOUND, AUTOMATIC CUT-OFF ENGINES AND

CABLE MACHINERY.

HOISTING ENGINES, DRUMS AND MACHINERY. COLLIERY MACHINERY. COAL AND
PHOSPHATE BREAKERS WITH PATENT REMOVABLE STEEL TEETH.

MACHINE CUT GEARS OF ALL SIZES.

Pumping Engines of High Duty Types. Cornish Pumping Engines. Pumps and Boilers
of Every Kind and Size. Heavy Machinery of all Kinds.

General Office, **SCRANTON, PA.**

The "New Haven" Fare Register

THE WINNER OF THE HIGHEST AND ONLY MEDAL AND DIPLOMA
Awarded on Stationary Fare Registers at the World's Columbian Exposition.

These Registers are a Marvel in Completeness of Registration, Reliability, Compactness, Beauty of Design and Finish, and are Attracting World Wide Attention among Practical Railroad Men, and have been placed on over 75 roads within the past year.

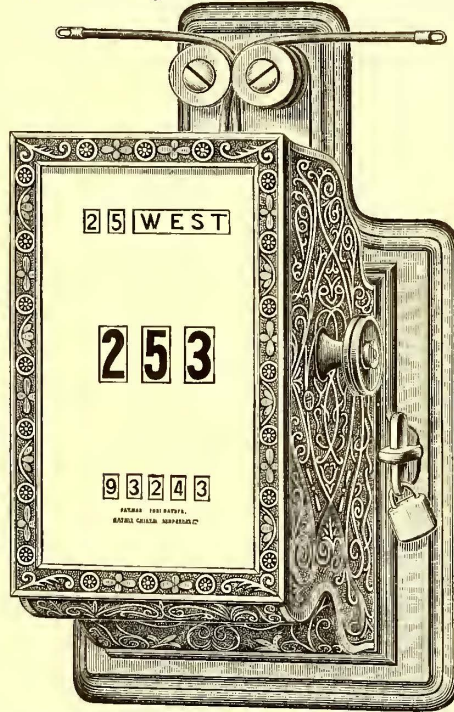

The ONLY Register that cannot be beaten, which will show at a glance if the attempt is made.

The ONLY Register which registers up to one thousand fares on a trip in prominent numerals.

The ONLY Register which registers the number of the trip as well as the direction, from which the daily mileage can be computed.

MANUFACTURERS,

THE NEW HAVEN CAR REGISTER CO., New Haven, Ct., U. S. A.

TOM L. JOHNSON'S
NOW

St. Louis Car Company's IMPROVED FARE BOX.

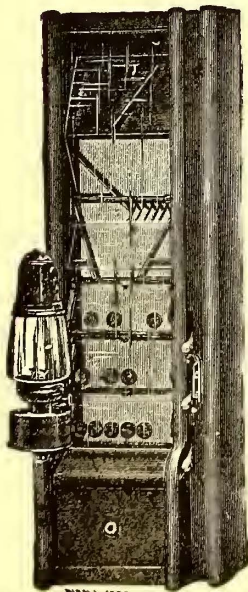

BOX NO. 1.

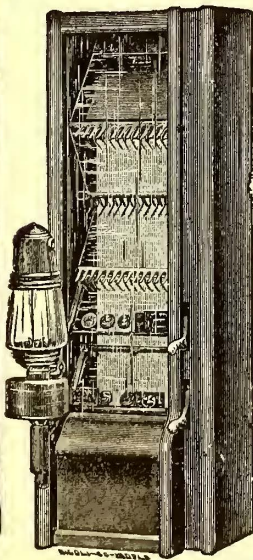

BOX NO. 2.

Patented Oct. 14, 1873.

CHEAPEST AND BEST.

Fares Cannot be Extracted or boxes Robbed without violence.
Roads Equipped with Boxes on Trial, and if not satisfactory, returned without any expense to the company trying them.

Ornamental to any Car.
Special Sizes built to order.

NOTICE.—All parties are cautioned against using fare boxes recently placed on the market which are direct infringements on our patents.

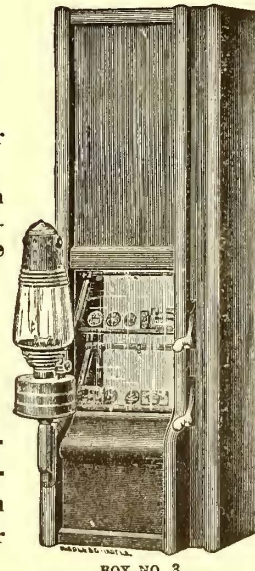

BOX NO. 3.

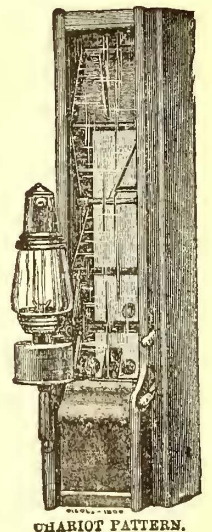

CHARIOT PATTERN.

REDUCED PRICES.

Write for Descriptive Circular and Price List.

St. Louis Car Company,

MANUFACTURERS OF ALL KINDS OF HORSE, ELECTRIC, CABLE AND ALL OTHER MOTOR CARS.
3023 North Broadway, St. Louis, Mo. See Pages 114-115.



“PAY HERE.”

THE WALES FARE BOX

SO WELL KNOWN AND LARGELY USED IN THIS AND FOREIGN COUNTRIES.

SPECIALTIES AND NOVELTIES,
INSULATOR, SELF-OILING TROLLEY WHEEL,
ELECTRIC HEADLIGHTS.

TICKET PUNCHES, UNIFORM BUTTONS, CAPS AND BADGES.
SEND FOR CATALOGUE.

WALES MANUFACTURING CO.,
SYRACUSE, N. Y.

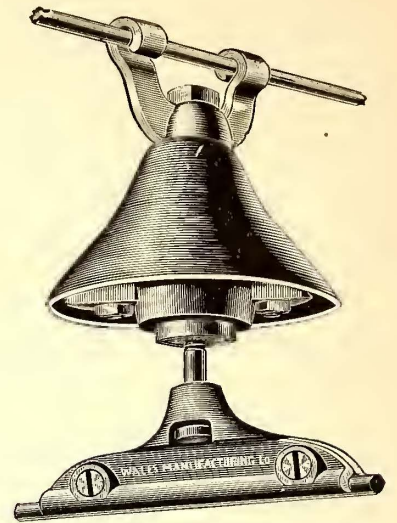

SAMUEL LEWIS,

ORIGINATOR AND MANUFACTURER

—OF—

LEWIS' PATENT WOOD MATS.

LIGHTEST,
STRONGEST,
CHEAPEST,
CLEANLIEST,

MAT
EVER DESIGNED
FOR
STREET CARS.

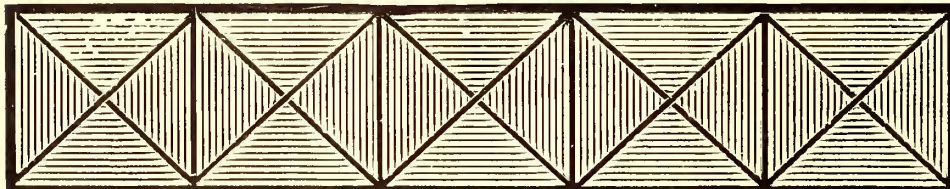
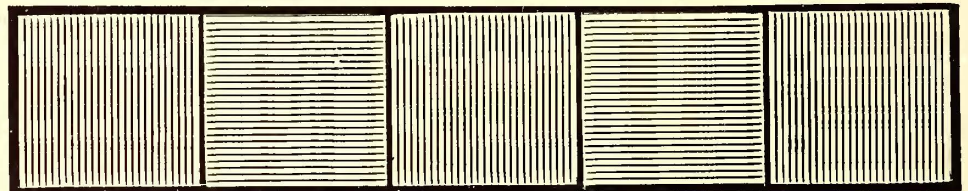

PRICES REDUCED

AND

MANY IMPROVEMENTS ADDED.

Prompt attention will be given to any orders, and information cheerfully furnished on application.

These mats are interchangeable and reversible, made of well-seasoned maple-wood slats, assembled with strong screw-rods which cut their own thread, rendering infiltration of dust or liquids impossible, maintain them smooth and prevent warping, so that the underlying material is not injured; these screw-rods give great strength and insure durability to the mats, some have been worn by usage until the screw-rods in the middle of the slats were exposed without decreasing their firmness and strength. They are easily repaired by screwing two half slats in the place of the one broken.

10 to 18 Lorimer Street, near Broadway, Brooklyn, N. Y., U. S. A.

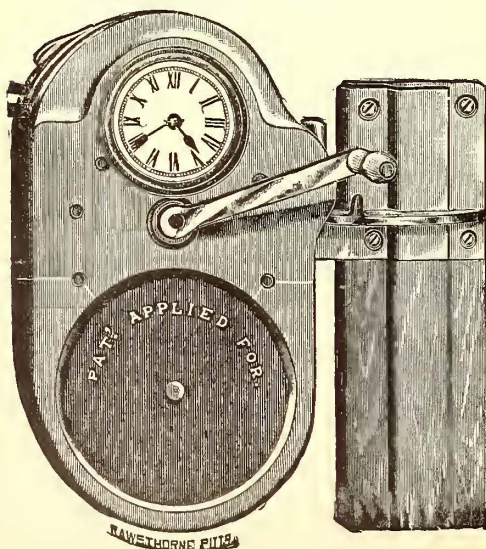

THE NEW SYSTEM of ISSUING TRANSFERS.

The accompanying cut is one-quarter size of the Time Transfer Printer. By this system only the tickets actually needed are printed. The time is automatically and accurately recorded on each ticket, and mistakes are impossible.

GREAT SAVING OF TIME, LABOR AND MONEY.

FOR FULL PARTICULARS APPLY TO

THE TIME TRANSFER PRINTER MFG. CO.,
Schmidt Bldg., 95 5th Ave., Pittsburgh, Pa.

RAILWAY REGISTER

MANUFACTURING

MANUFACTURERS AND OWNERS OF THE Latest Designs, Improvements and Inventions in Registers, Indicators, Classifiers and Punches, for the Recording of Fares Collected on Street and Steam Railroads.



COMPANY.

This company owns over 100 Patents embracing all the Valuable Features of Fare Registers, Indicators, etc., and was awarded three Medals at the Chicago Exposition of Railway Appliances. Latest Improved Model Register.

The Alarm Registering Punch.

This Register, which is so generally used throughout the United States and Europe, we claim to be the most perfect check that has ever been placed before the public for the Collection and Registration of Fares on Street Railroads, especially where different rates

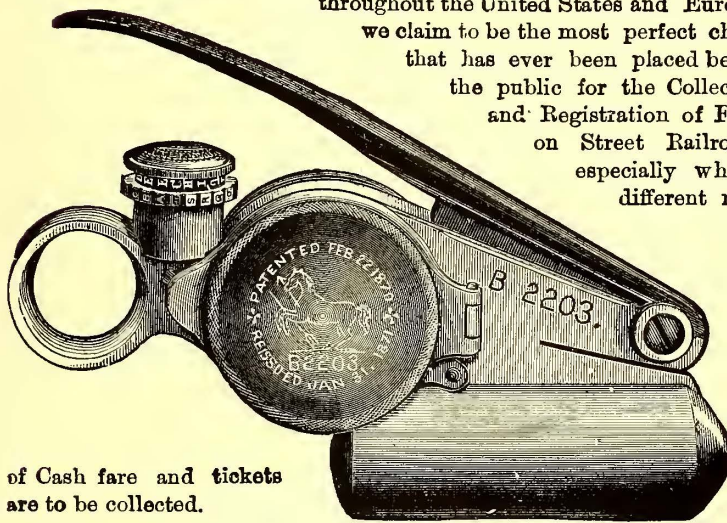

of Cash fare and tickets are to be collected.

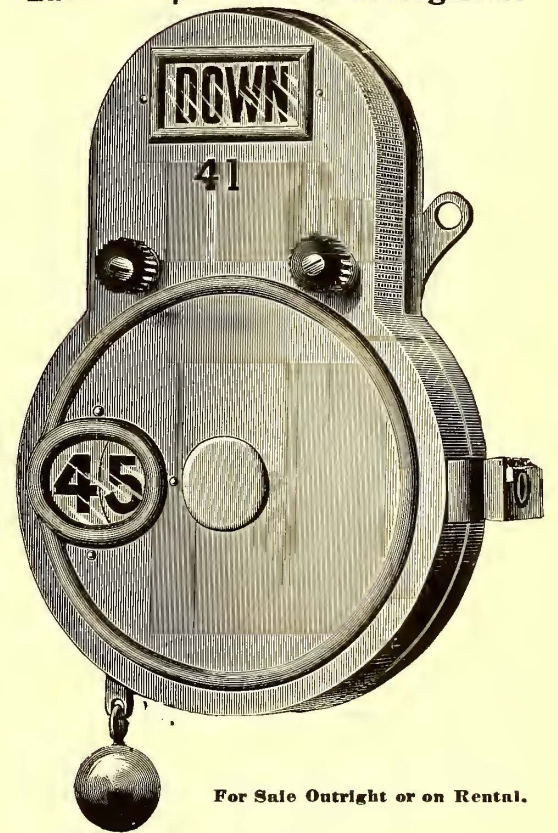

For Sale Outright or on Rental.

The Monitor Register.

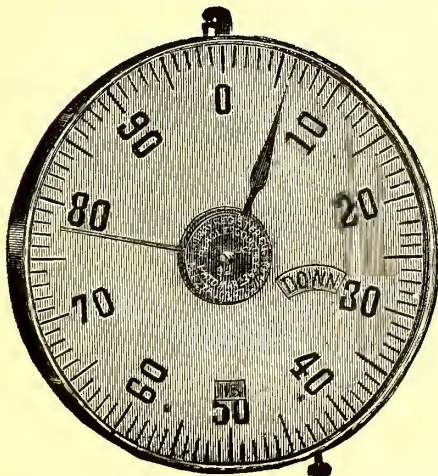

For Sale Outright or on Rental.

Railway companies desiring to use a Stationary Register will consult their own interest by examining this Register before adopting any of the cheap devices now offered as it is the most Reliable Register of its kind. For further particulars address

The Pond Register.

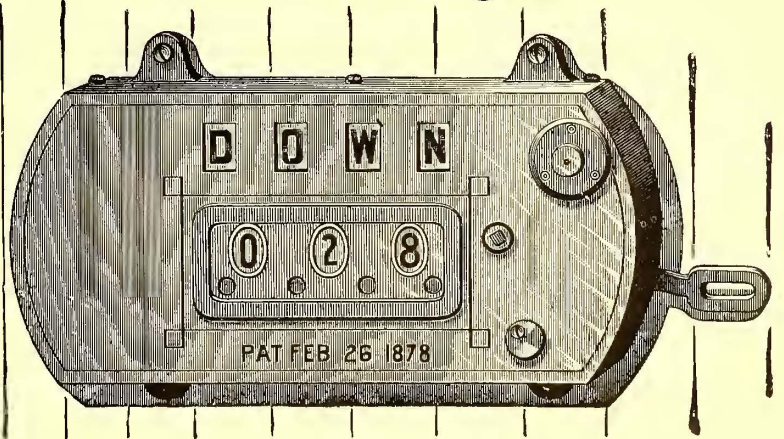

For Sale Outright or on Rental.

SPECIAL ATTENTION PAID TO EXPORT ORDERS.

EDWARD BEADLE, Manager, 1193 Broadway, New York City, N. Y.

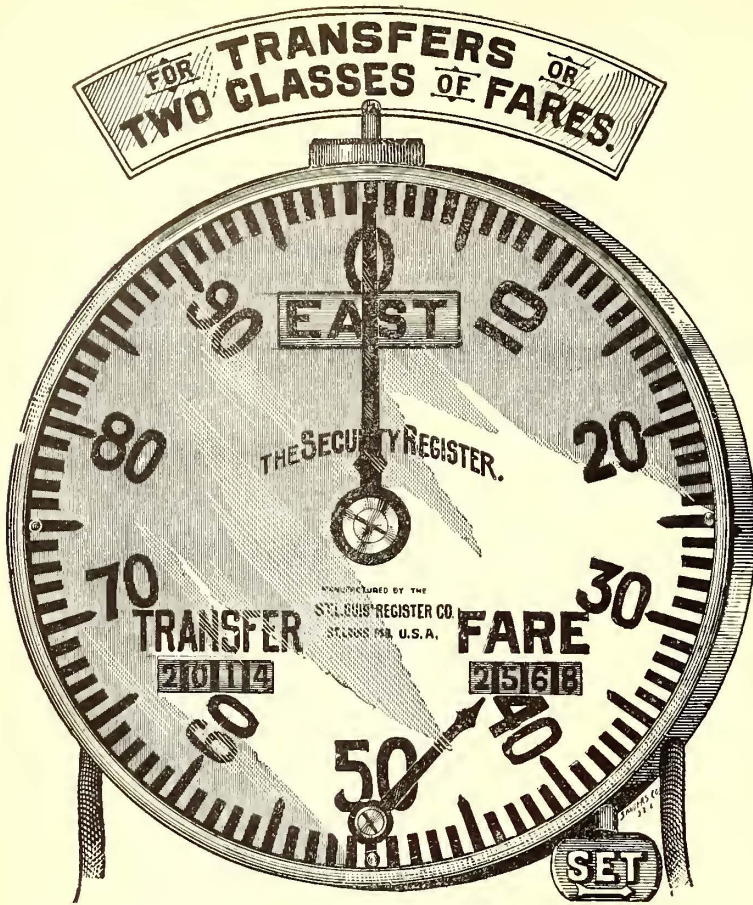

This is the only device on the market that shows on one dial Full Fares and Transfers, or two classes of fares. The red hand always points to last fare rung up. The register has two bells of different tones, and two totalizers, keeping the records separate and distinct. It is as simple in its construction as our Security Register, and absolutely accurate and durable.

We refer to a few of the principal roads who are using our Security Registers.

The West End Road, of Boston, Mass.
 The Philadelphia Traction Co., of Philadelphia, Pa.
 The Scranton Traction Co., of Scranton, Pa.
 New Orleans & Carrollton Ry., of New Orleans, La.
 Denver Tramway Co., of Denver, Colo.

Lindell Railway, of St. Louis, Mo.
 St. Louis & Suburban Railway, of St. Louis, Mo.
 South St. Louis Electric Road, of St. Louis, Mo.
 Missouri Railway, of St. Louis, Mo.
 Benton-Bellefontaine Railway, of St. Louis, Mo.

We claim Superiority for the Security Register on the following points.

Simplicity of Mechanism.

Absolute Accuracy of Registration.

The only Register Locked at all Times During its Action.

The Only Register that can be placed in the hands of Conductors without case or dial, and defy Manipulation.

A liberal basis of exchange will be made with railway companies dissatisfied with the device they are now using.

ST. LOUIS REGISTER CO.,
 703 Houser Bldg., St. Louis.

SECURITY REGISTER.

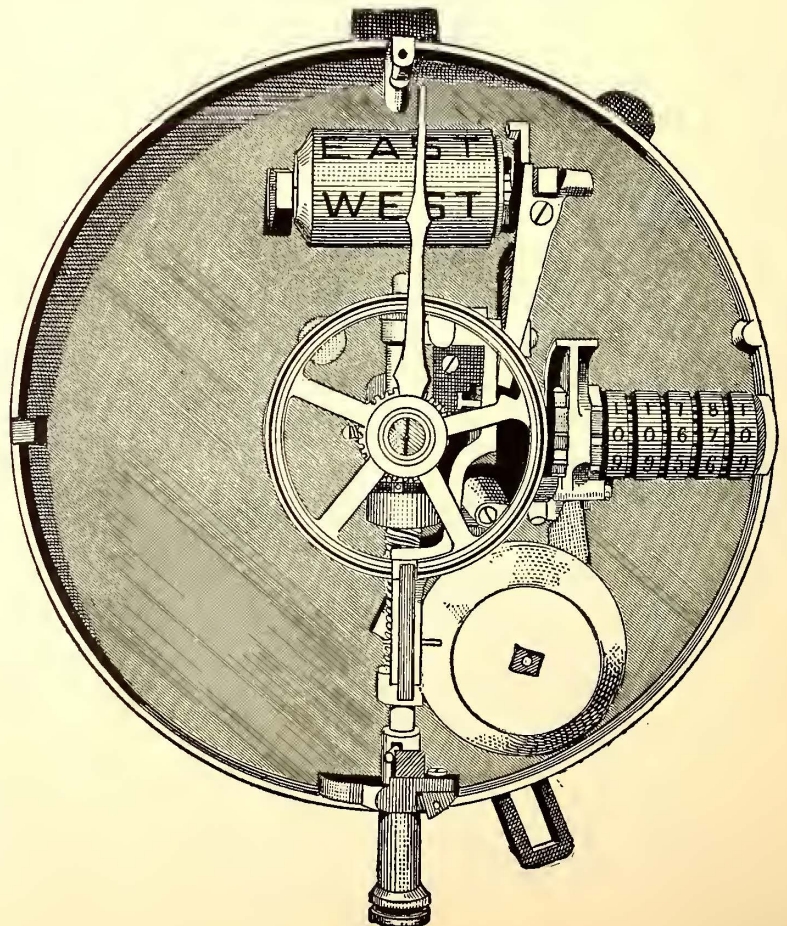

Certificate of Merit.

The story of the **FARE REGISTER** is a very interesting one. Much has been said regarding it that might be styled "cheap talk," but we believe all street railway men are interested in knowing the

EXACT FACTS.

The **Lewis & Fowler Register** is in use to-day on nearly **600** street railways in the United States and Canada. That means **19,000 Registers** of our make in **daily** use. Every Register is thoroughly tested by being rung up **100,000** times before leaving our works.

SIMPLICITY of construction is not desirable in a Fare Register where absolute security is demanded.

AS TO DURABILITY

We can furnish the names of Street Railway companies who are to-day operating our registers that were put in use more than **SIXTEEN YEARS** ago, and every attempt to tamper with them or beat them, has proved an entire failure.

THE LEWIS & FOWLER MANUFACTURING CO.,
Office, 28 Sanford Street, Brooklyn, N. Y.

THE
LEWIS & FOWLER MFG. CO.

28 Sanford St., Brooklyn, N. Y.

Patentees and Sole Manufacturers of the

Improved "Alarm" Passenger Register

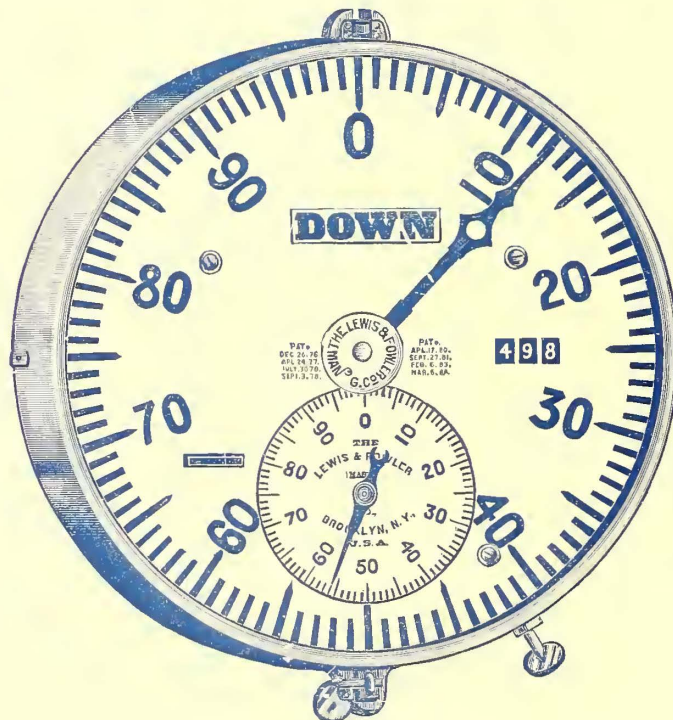

ACKNOWLEDGED TO BE THE SAFEST AND MOST
COMPLETE REGISTER IN THE WORLD.

Over Eighteen Thousand (18,000) in Daily Use

—BY OVER—

500 RAILROAD COMPANIES.

SEND FOR PRICES.



Our Registers Will Totalize Up to 100,000 if Required.



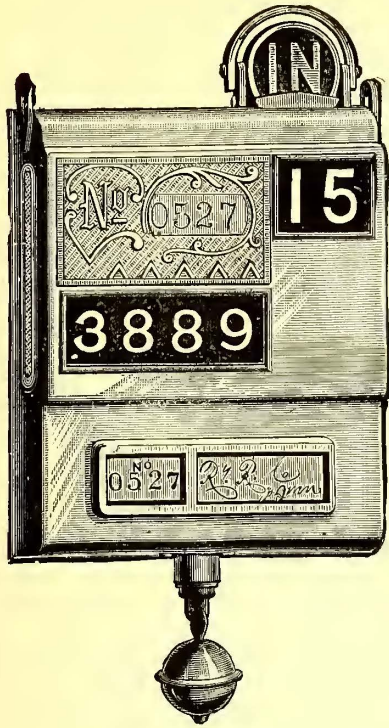

— THE —
MEAKER
 PORTABLE and STATIONARY
 REGISTERS

SIMPLE! DURABLE! RELIABLE!

THIS is a Double Register, being so constructed that the statement (settlement numbers) may be visible or not, at will, by the simple use of a key. It is impossible to change the direction signal without cancelling the fares recorded at the trip window, and said cancellers can only be removed by a return to zero. It is also impossible to ring the bell without registering, or register without ringing the bell. The pull cords will be placed on both sides of the car, without extra charge, if desired. The machine is made strong in all its parts, and being constructed without wheels, is not subject to the same wear as cogged devices.

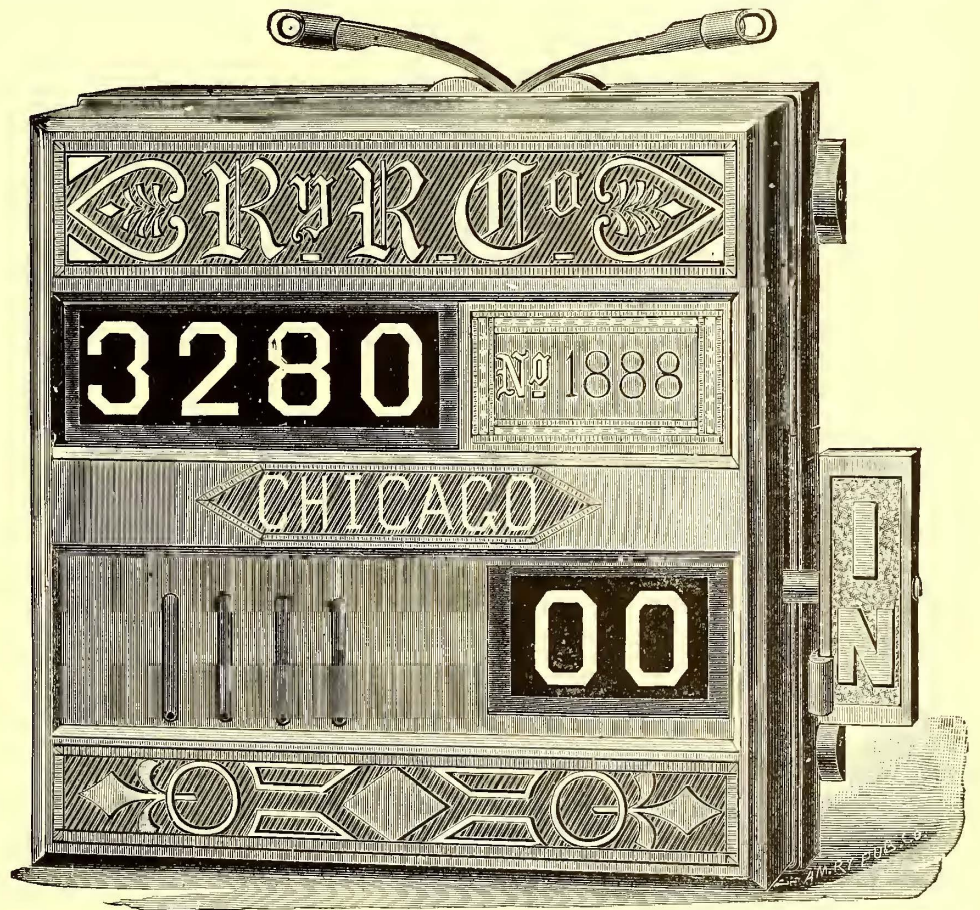

THE IMPROVED STATIONARY.

Our Registers have been adopted by over Sixty Street Railway Companies. For Reference, Terms, Etc., address

THIS Register can be read correctly from any part of the car.

MEAKER MANUFACTURING CO.,

Fac-simile of Figures Used,

134 WEST WASHINGTON STREET,

CHICAGO.



Successors to Railway Register Company.

THE AMES REGISTER COMPANY'S COMBINED PORTABLE and STATIONARY REGISTER

The attention of street railway officials is called to this new departure in car registers. It is the only one in the market combining the portable and stationary register.

A small interchangeable portable register is furnished the conductor and used in any car having the stationary register.

It is inserted in the stationary register by the conductor, the fares registered, and returned by him whenever required.

It shows the fares registered each trip, day or other desired length of time. It is accurate and cannot be altered, changed or tampered with. No inspectors are required in the car stations or elsewhere where the register is used.

It is well and substantially made, and will sustain severe usage without liability of getting out of order.

It is protected by broad patents and is fully guaranteed.

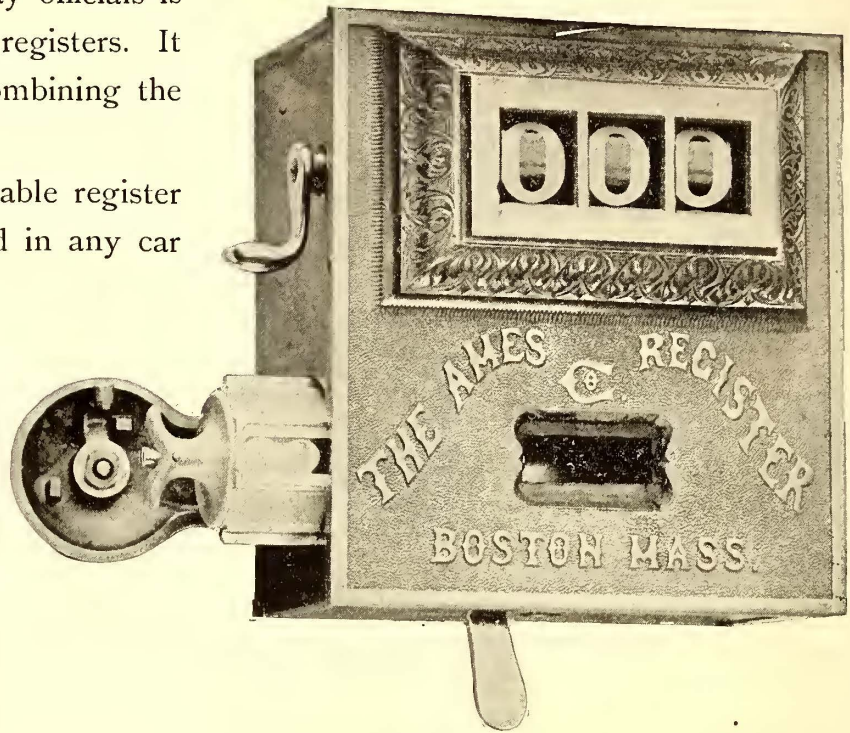

THE PORTABLE REGISTER PARTIALLY IN PLACE.



THE PORTABLE REGISTER.

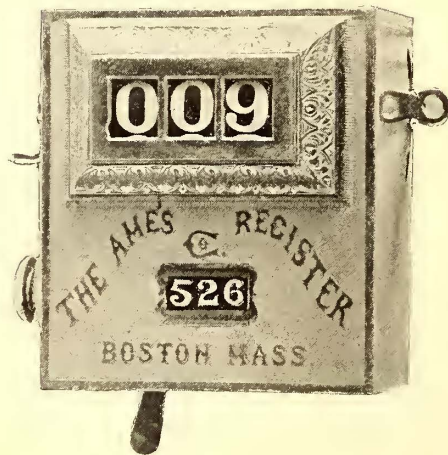

THE REGISTER READY FOR USE.

For further information, address the Company or General Manager.

OAKES. A. AMES, President.

—MANUFACTURED BY—

A. C. TITCOMB, Treasurer.

THE AMES REGISTER COMPANY,

LOUIS PFINGST, General Manager,
53 State St., Boston, Mass.

89 State Street, Boston, Mass.

STYLE NO. 1.

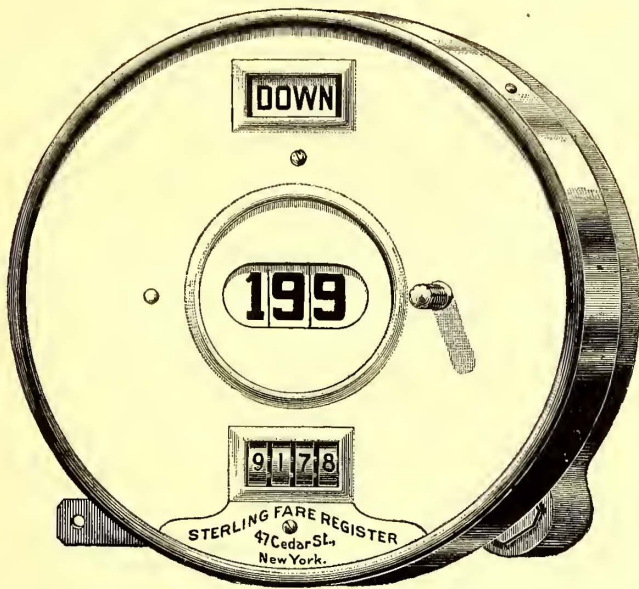

Used on Broadway (N. Y.) Cable Road.

STYLE NO. 2.

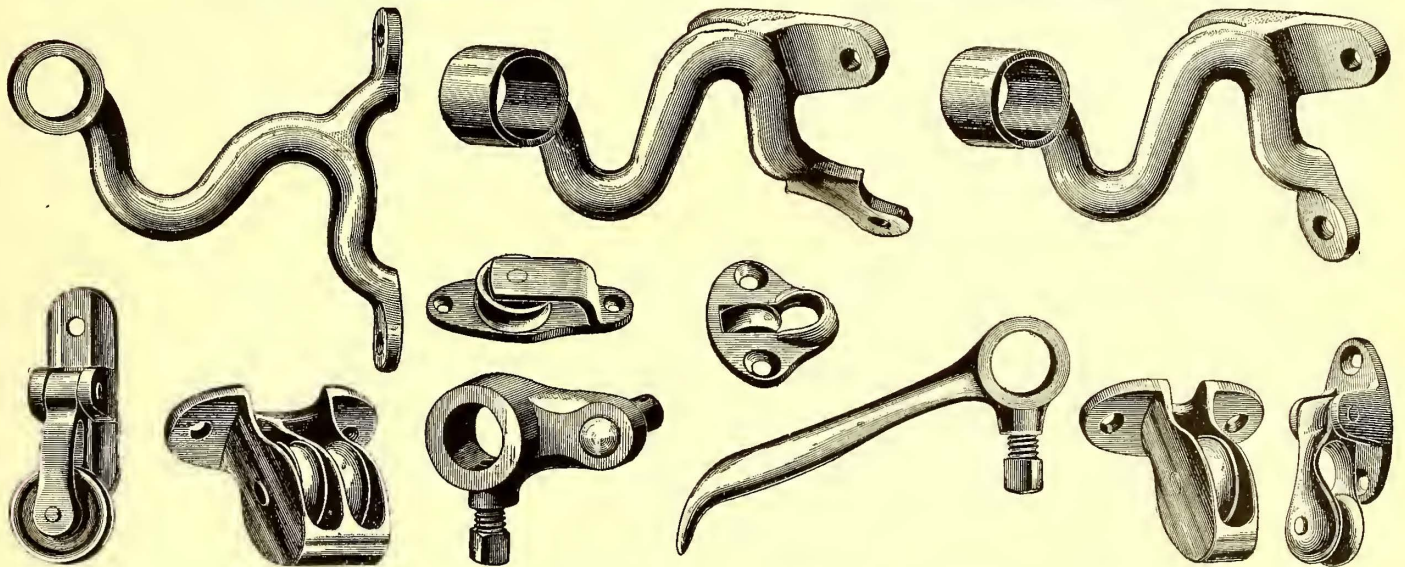
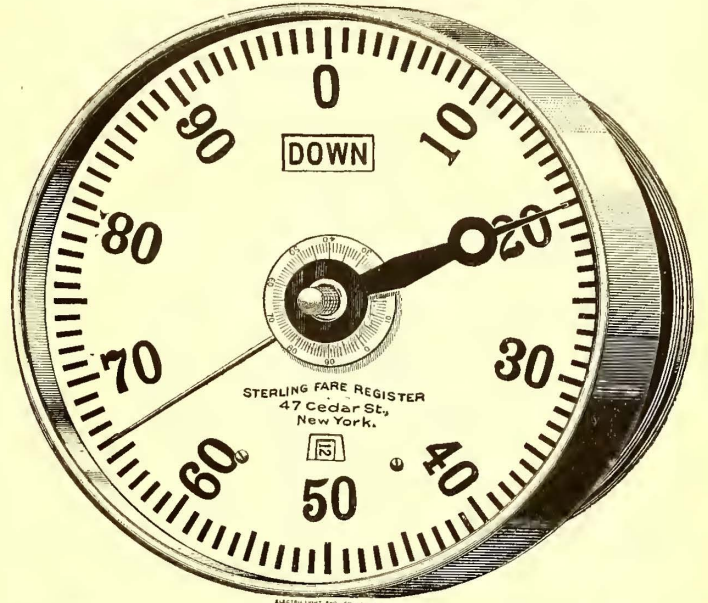

STYLE NO. 3.

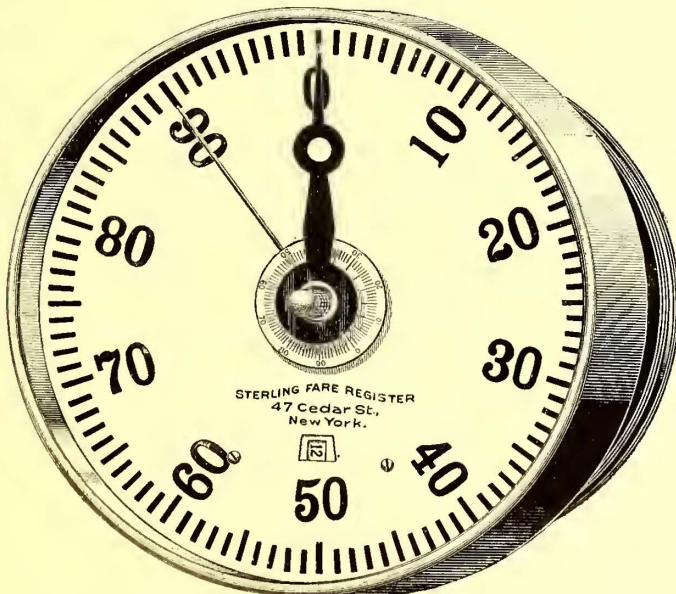

Used on Third Ave. (N. Y.) Railway 18 Years.

STYLE NO. 4.

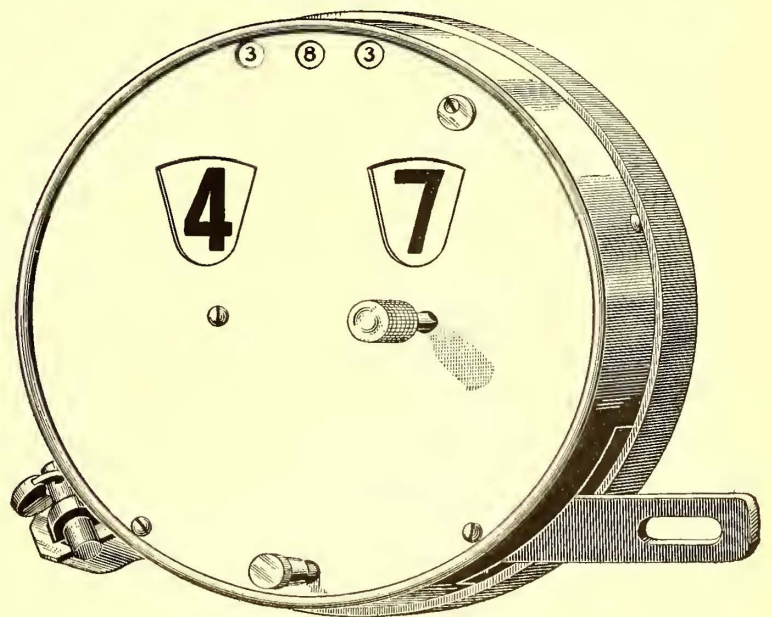

Used on 23d St. Railway (N. Y.) 10 Years.

Sterling Supply and Manufacturing Co.,

MANUFACTURERS OF STREET RAILWAY SUPPLIES, STERLING FARE REGISTERS.

97 BANK STREET,

(Ross Building.)

NEW YORK.

TELEPHONE 233 SPRING.

THE FOSTER AUTOMATIC SAFETY GUARD CO.

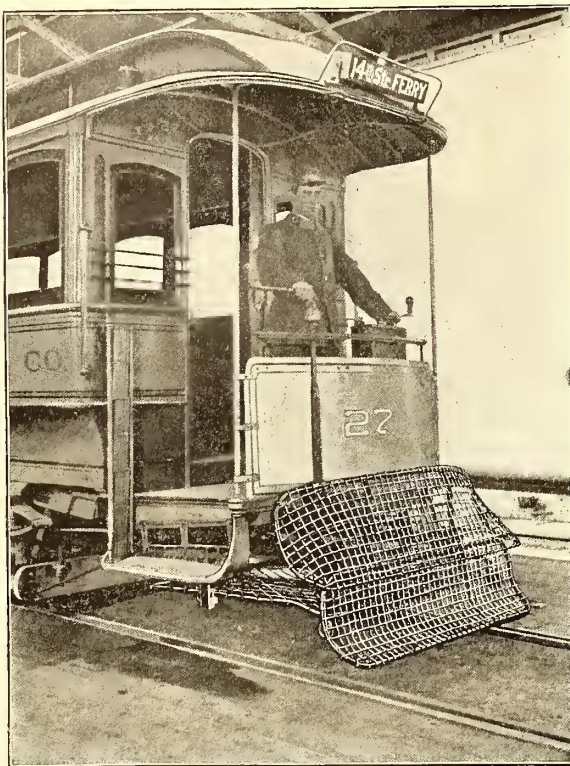

150
Broadway,
New York.



Our Fender has been adopted by the North Hudson County Street Railway Co., of Hoboken, N. J., and all the Street Railway Companies in Paterson, N. J., after a long series of competitive trials with other fenders.

Can be Made to Run Flush with the Dashboard.
Runs Only Three Inches or Less Above the Track.
Cars Can be Trailed Without Removing Fender.
All Tests Have Been Made With Human Beings.

The Car Fender Which is a Life Saver

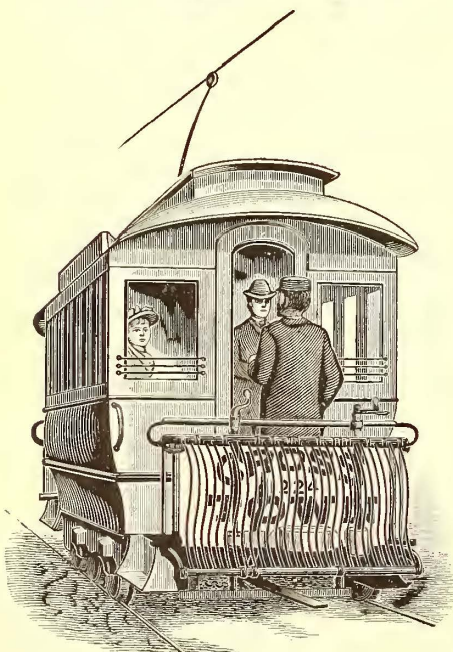

REAR VIEW.

Perfectly Satisfactory
Results from the
Most Severe
Tests.

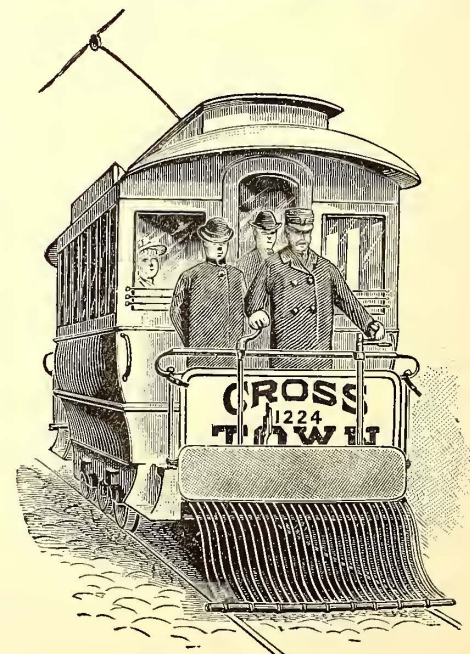

FRONT VIEW.

Impossible for a person or object to get under the wheels of cars equipped with our fenders. Practical Tests Given. Address

FIELD LIFE GUARD COMPANY,
430 Butler Exchange, PROVIDENCE, R. I.

THE PFINGST FENDER.

ADOPTED BY THE BROOKLYN CITY RAILROAD,
WHICH HAS ORDERED 1,000 CARS
EQUIPPED WITH THIS FENDER.

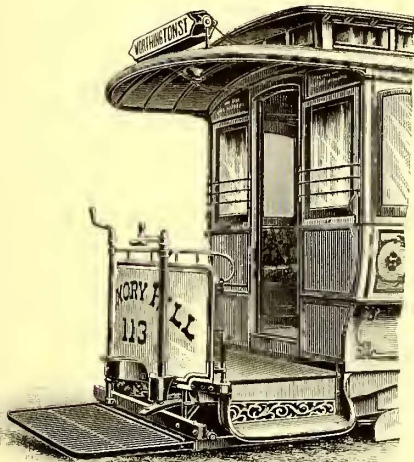

Also in use in
BOSTON, MASS.
SPRINGFIELD, MASS.
HOLYOKE, MASS.
PATERSON, N. J.

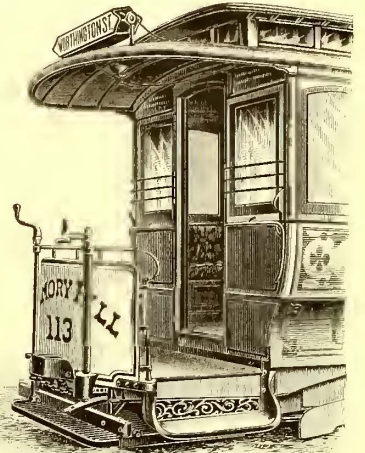

—MANUFACTURED BY—

LOUIS PFINGST, 53 State St., Boston, Mass.

THE ONLY PNEUMATIC CAR FENDER.

STRONG AND SIMPLE IN CONSTRUCTION.

AUTOMATIC IN ACTION.



ALL PARTS INTERCHANGEABLE.

A POSITIVE SAVER OF LIFE AND LIMB.
Quickly Transferred from One End of Car to the Other.

CORRESPONDENCE SOLICITED.

CLARKE'S CAR WHEEL FENDERS

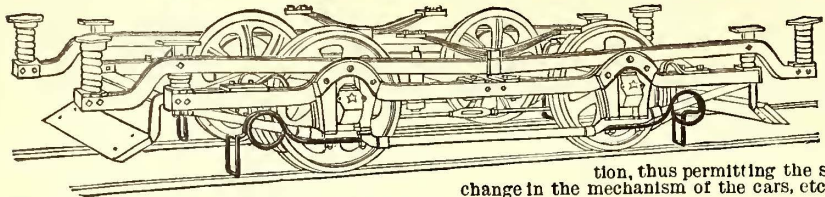

To Prevent Accidents by the Wheels of **ELECTRIC, CABLE and HORSE CARS, Switch and Locomotive Engines, Suburban, Passenger and Freight Cars.**
SIMPLE, CHEAP and EFFECTIVE,

Our devices are constructed of one piece of spring steel, so designed as to be placed close above the rail and directly in front of the wheel. The bottom is formed into a loop placed oblique to the rail, thus effectually preventing any body or limb passing under the wheel, and with a tendency to remove them to the outside of the track. The coil is designed to provide, with certainty, for an ample lateral yield in case of the fender striking a fixed obstruction, thus permitting the safe running of the car. These devices can be applied without any change in the mechanism of the cars, etc., being attached by bolts now in use.

Manufactured by **F. H. CLARKE, Springfield, O.**

New York Office, 1267 Broadway, Room 7.

When Ordering

From firms whose names appear in the **Street Railway Journal**, our friends will confer a favor on our advertisers and ourselves by mentioning this paper.

Very respectfully,
STREET RAILWAY PUBLISHING CO.

JAMES A. TRIMBLE,

MANUFACTURER OF

Rail Road Car Wood Work,

PLAIN AND CARVED MOULDINGS,

Doors, Sashes, Blinds, Pillars and Sills,

ALL PATTERNS.

Nos. 220 & 222 East 28th St., bet. 2d & 3d Aves.

NEW YORK.

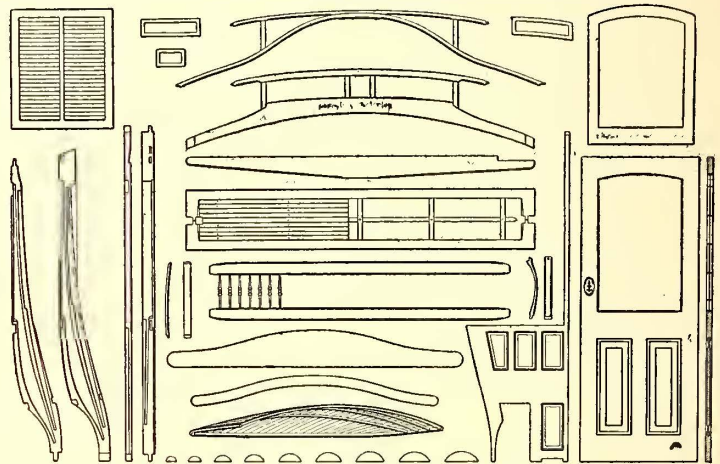

J. P. SJOBERG & CO.,
MANUFACTURERS OF STREET CAR WOOD WORK.
155 and 157 Eleventh Ave., New York.

THE LEADING STREET RAILWAY SAFETY APPLIANCES.

CRAWFORD'S
Wheel Guard Fender Board.

OUR LIST OF ORDERS FOR
ALL CARS.

CRAWFORD'S
PICK-UP FENDER.

WHEEL GUARDS.

- Philadelphia (Pa.) Traction Co.
- Terre Haute (Ind.) Street Ry. Co.
- Williamsport (Pa.) Passenger Ry. Co.
- IN PITTSBURGH, PA.
- Pittsburgh Traction Co.
- Duquesne Traction Co.
- Central Traction Co.
- Citizens' Electric Traction Co.

PICK-UP FENDERS.

- Pittsburgh & Birmingham Traction Co.
- Pittsburgh & West End Pass. Ry. Co.
- Second Ave. Passenger Ry. Co.
- Rochester (N. Y.) Ry. Co.
- Citizens' Street Ry. Co., Indianapolis.
- New Orleans (La.) Traction Co.
- Tarentum (Pa.) Traction Pass. Ry. Co.

OUR LIST OF REFERENCES:

- Geo. D. Widener, Vice-President Philadelphia Traction Co.
- J. T. Gorman, General Superintendent Philadelphia Traction Co.
- H. A. Newell, Superintendent Broadway Line, New York.
- A. N. Connitt, Chief Engineer Baltimore City Passenger Railway Co.
- Geo. W. Elkins, President Pittsburgh & Duquesne Traction Co.
- E. McDowell, Superintendent Pittsburgh & Duquesne Traction Co.
- Miller Elliott, Superintendent Pittsburgh & Birmingham Traction Co.
- W. C. Smith, Superintendent Central Traction Co., Pittsburgh, Pa.
- J. E. Rugg, General Manager Citizens' Traction Co., Pittsburgh, Pa.
- Many Others.

LIVES SAVED SINCE FEB. 1st.

PICK-UP FENDER 6,
WHEEL GUARD 8.

PICK-UP FENDER—FOLDED POSITION.



PICK-UP FENDER—POSITION IN USE.



WRITE FOR ANY INFORMATION, PRICES, ETC.

R. A. CRAWFORD MFG. CO., 35 Water St., Pittsburgh, Pa.

F. A. LAWSON & CO., Coast Agents, San Francisco, Cal.

THE BERLIN IRON BRIDGE CO.

CHAS. M. JARVIS, President and Chief Engineer.
FRANK L. WILCOX, Treasurer.

BURR K. FIELD, Vice-President.
GEO. H. SAGE, Secretary.

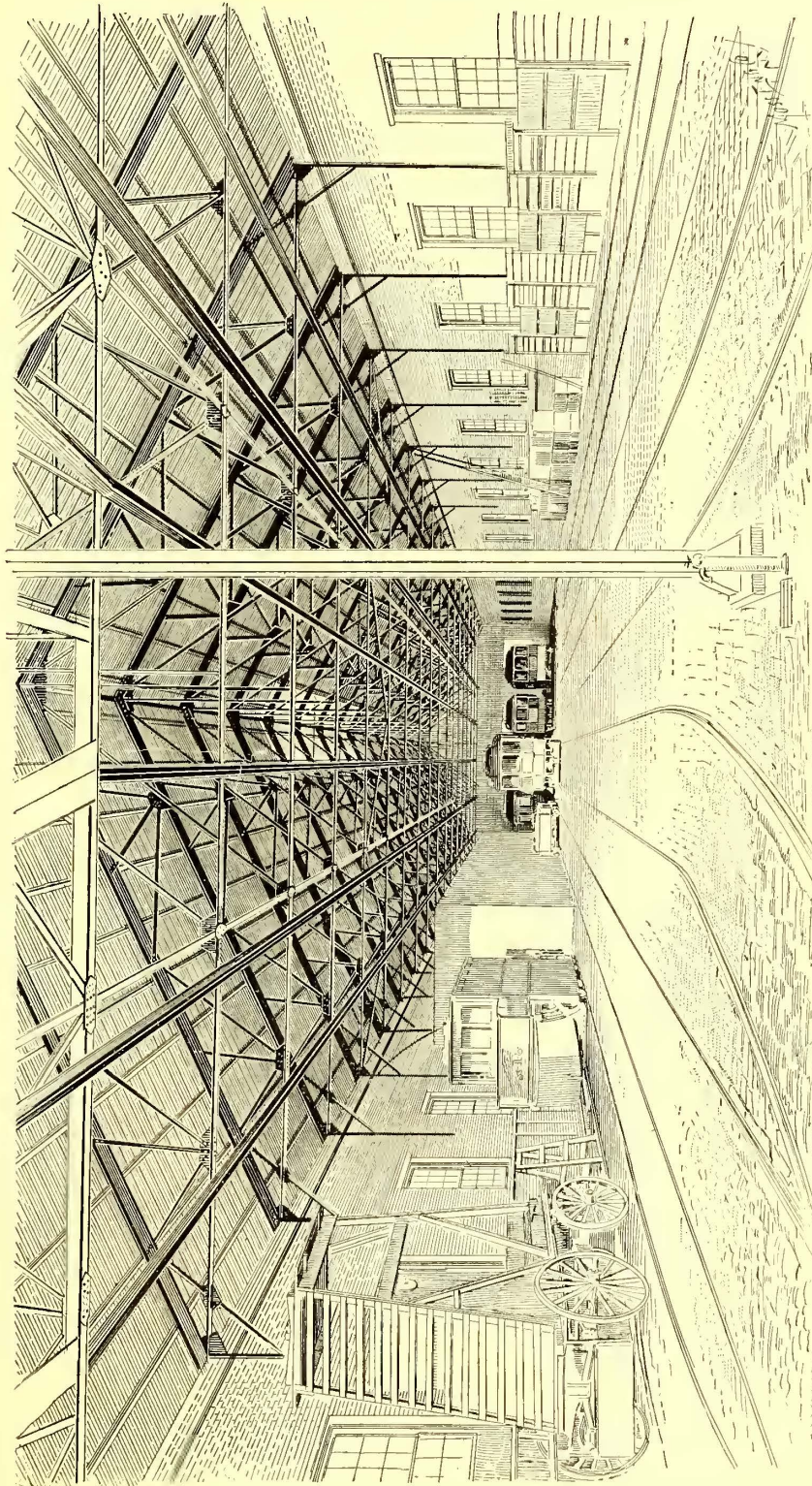

The above illustration is taken direct from a photograph and shows the interior of a Car Shed designed and built by us for the Wilmington City Railway Co., at Wilmington, Del.

Send for Illustrated Catalogue of Over 300 Pages, Describing Iron and Steel Buildings, Car Sheds, Power Houses, etc.

Office and Works: - - East Berlin, Conn.

L. BACHENHEIMER, President,
C. E. BAIRD, Vice-President and Manager.

E. M. FIELDS, Secretary and Treasurer.
C. W. ARMSTRONG, Superintendent.

THE SAFETY CLUTCH BRAKE CO.

725 SANSOM ST., PHILADELPHIA.

83 TENTH AVENUE, NEW YORK, F. C. FRIES, Agent.

A NEW ELECTRIC CAR BRAKE.

SAFE**S**T.
STRO**N**G**E**ST.
SIM**P**LE**S**T.

WILL STOP A CROWDED CAR
IN HALF ITS LENGTH.

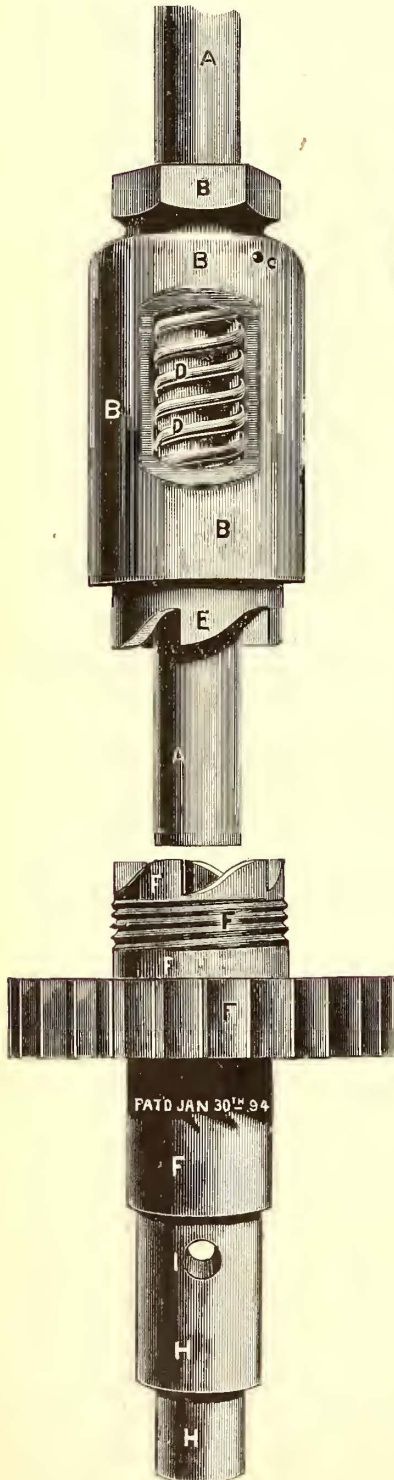

BRAKE OPEN.

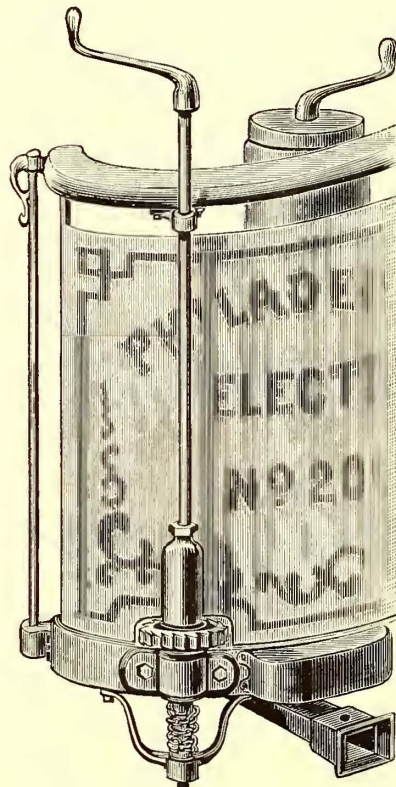

AS IT LOOKS ON A CAR.

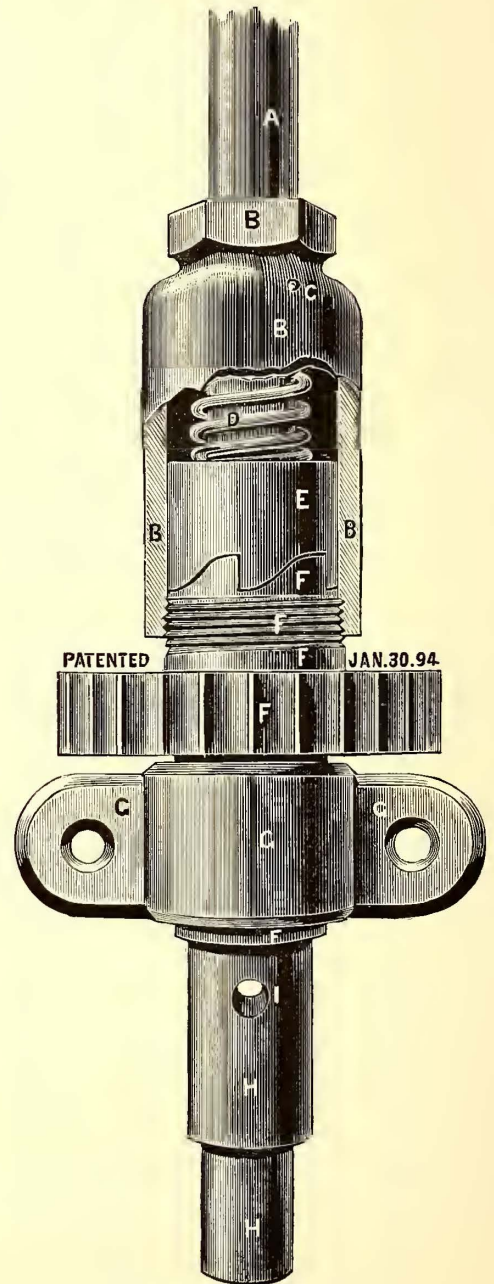

BRAKE CLOSED.

- A.—Brake shaft operating slip-clutch E and extending down through F to centre of sprocket.
- B.—Movable casing which screws onto thread of F, protecting connections from dirt and retaining lubricant.
- C.—Hole in B for oiling and exhausting air.
- D.—Strong spiral spring which forces E into coupling with teeth of F.
- E.—Slip-clutch, with five or more bearings operated by A and D, giving absolute and immediate control of car.
- F.—One casting forming lower clutch and sprocket wheel, with thread for B.
- G.—Box or bearing to be bolted to front of car platform, fastening F, in perfectly rigid position.
- H.—Brake chain shaft driven and pinned into F meeting A at centre of sprocket wheel F with square butt. The lower end of this shaft is fitted with a sufficient brace to prevent springing or bending.
- I.—Hole for brake chain.

SEND FOR DESCRIPTIVE CIRCULAR AND SAMPLE BRAKE.

STANWOOD MFG. CO.

MANUFACTURERS OF THE

“Stanwood Steel Step.”



In Use on 468 Street Railways.

WE REPAIR ELECTRICAL APPARATUS.

From the Most Delicate Instruments to the
Largest Dynamos and Motors.

WORKMANSHIP GUARANTEED.

REPAIR ORDERS EXECUTED PROMPTLY.

EARL ATKINSON, Superintendent Electrical Department.

Stanwood Manufacturing Co.

17th and Clark Streets, Chicago, Ill.

CONSOLIDATED CAR-HEATING Co.

GENERAL OFFICES AND FACTORY:

936 BROADWAY, ALBANY, N. Y.

BRANCH OFFICES:

CHICAGO,
200 Phenix Building.

NEW YORK,
114 Broadway.

CANADA,
Coaticooke, P. Q.

ELECTRIC HEATERS.—Regulating Switch. Five different intensities of heat. Leading lines already equipped in Albany, N. Y.; Troy, N. Y.; Rochester, N. Y.; Cleveland, Ohio; Chicago, Ill.; Montreal, Toronto, Hamilton, Canada; Holyoke, Mass.; Cincinnati, Ohio, and New York City.

SEND FOR CATALOGUE.

THE PINTSCH GAS LIGHTING SYSTEM

HAS BEEN ADOPTED AS THE

STANDARD LIGHT

By the Broadway and the Third Avenue Cable Lines. Also by sixty of the most prominent railways, and by the Pullman and Wagner Palace Car Companies in the United States.

It has been the Standard Lighting System in Europe for many years, and is applied to 55,000 cars in Europe, United States, South America, India and Australia.

FOR PARTICULARS, ADDRESS

THE SAFETY CAR HEATING & LIGHTING CO., - 160 Broadway, New York.

JEWETT CAR CO.,

OF JEWETT, HARRISON COUNTY, O.

—MANUFACTURERS OF—

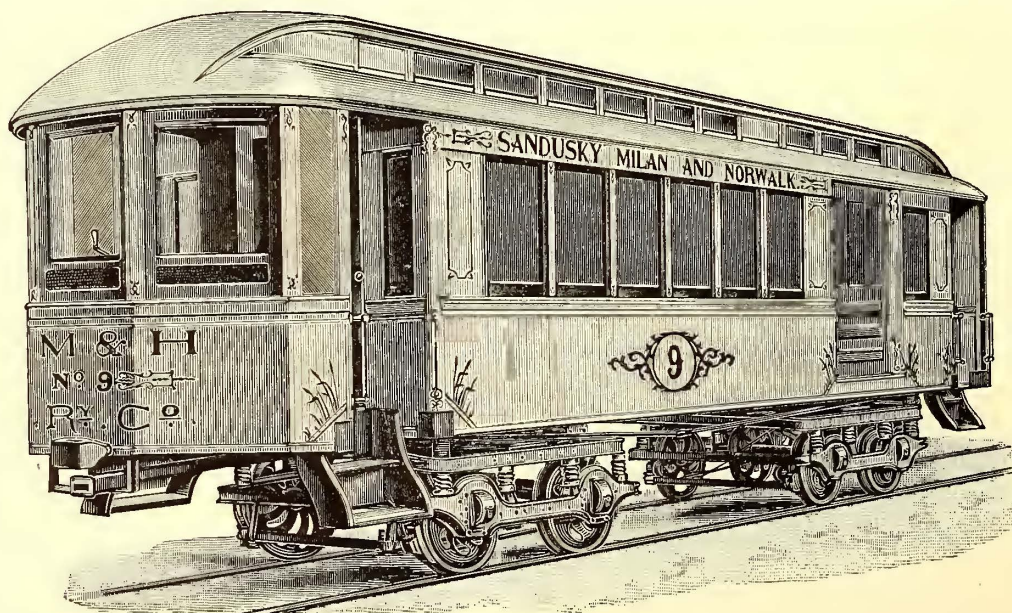

— STREET CARS —

OF EVERY DESCRIPTION.

HORSE — ELECTRIC — CABLE.

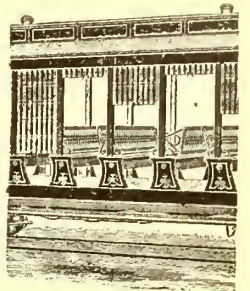
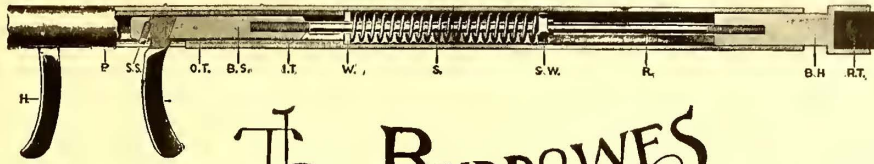

Send for Descriptive Pamphlet.

The BURROWES AUTOMATIC CAR CURTAINS,

Largest Factories in the World.

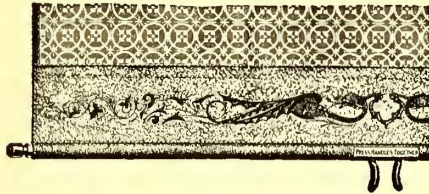

For Open or Closed Cars.
Highest Award at Chicago.

MADE BY
The E. T. BURROWES
PORTLAND, MAINE, U.S.A.

Trade "Oakette" Mark
Our new Waterproof, leather coated, Curtain Material makes the best and in fact the only Durable Curtain. Prices Very Reasonable.

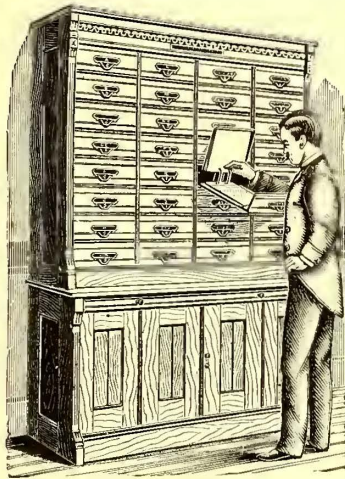

ABSOLUTE SECURITY.

QUICKEST REFERENCES, THE SHANNON FILING CABINET.

THE MOST PERFECT SYSTEM!

TIME, LABOR, PATIENCE, AND DOLLARS SAVED BY THIS SYSTEM. RAPID AND RELIABLE.

200 LETTERS COPIED IN 10 MINUTES

—BY THE—

RAPID ROLLER COPIERS.

IT HAS NO EQUAL. SEND FOR CATALOGUE.

OFFICE SPECIALTY MFG. CO.,
ROCHESTER, N. Y.

Makers of Shannon Letter Files, Loose Sheet Letter Files, Document Files and Document Cabinets, Desks, Schlicht's Standard Indexes, Metal Roller Book Shelves, Vault Fixtures, etc.

BRANCH: 77 CHAMBERS STREET, NEW YORK.



C. D. MORSE CAR MFG. CO.

MILLBURY, MASS.

BUILDERS OF ALL KINDS OF STREET RAILWAY CARS.

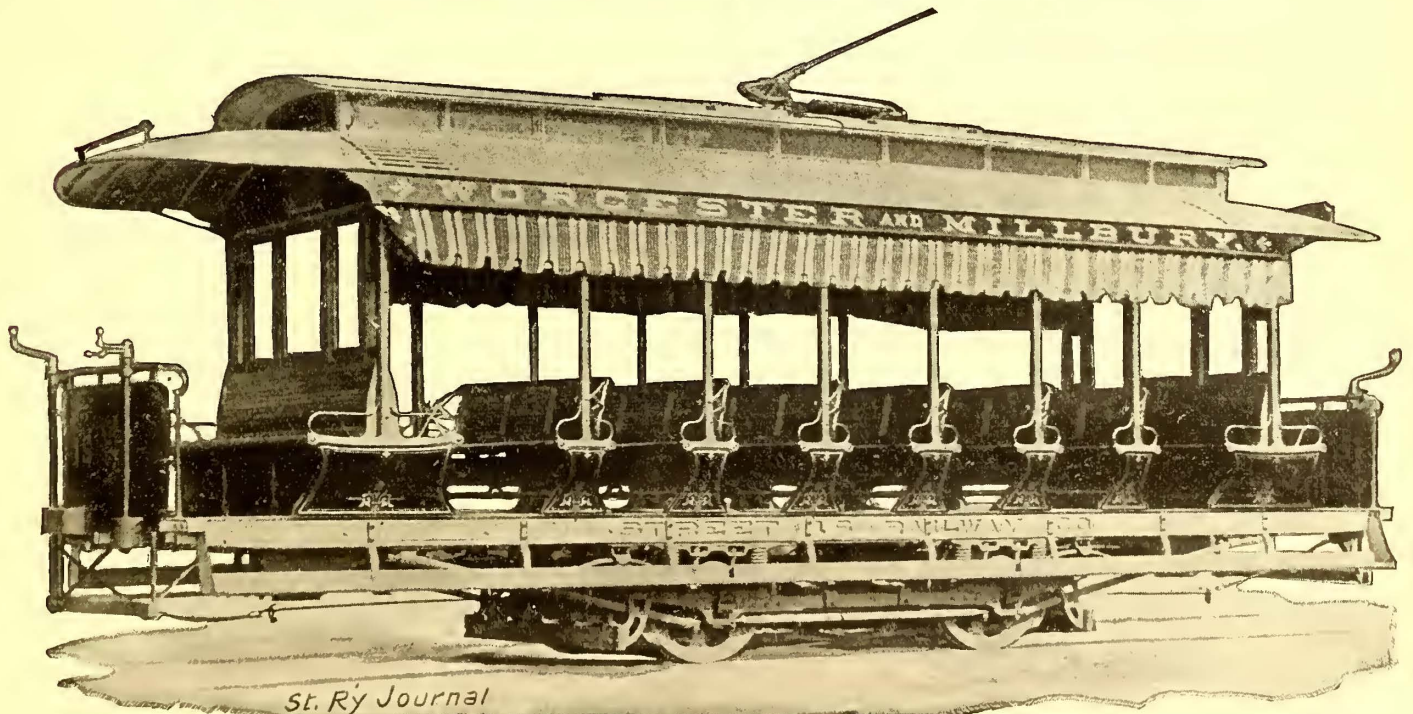

Highest Grade Work at Reasonable Prices. Car Wood Work Done to Order. Builders of Transfer Tables and Snow Plows. Send for Prices and Photographs. Standard 20 ft. Open and Closed Electric Cars in Stock.

G. C. KUHLMAN CO. BUILDERS OF STRYCARS CLEVELAND OHIO.

When Ordering

From firms whose names appear in the **Street Railway Journal**, our friends will confer a favor on our advertisers and ourselves by mentioning this paper.

Very respectfully,
STREET RAILWAY PUBLISHING CO.

DE WITT'S COMMON SENSE SAND BOX

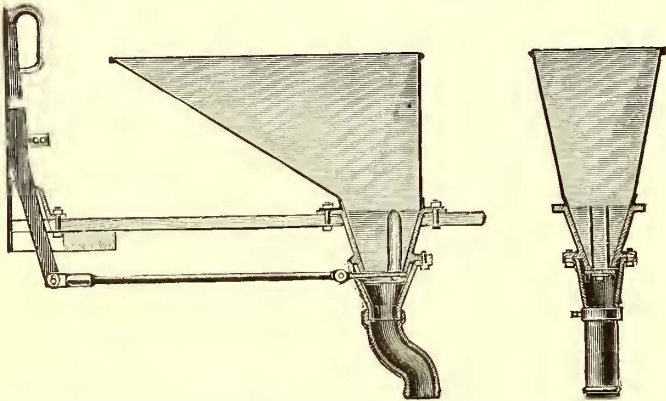

Has Worked Two Winters Under All Conditions of Weather and Sand Without Failure.

Has been adopted as "Standard" by the Metropolitan Traction Co., of New York City, after the severest tests extending over eleven months.

Made to last. It will stand longer than the car body to which it is applied. Cars equipped with either four or two boxes to operate by lever or foot power, as desired.

CORRESPONDENCE IS INVITED.

E. F. DE WITT & CO.,
 LANSINGBURGH, N. Y.

DERMAGLUTINE !

NOISELESS AND EQUAL TO STEEL.

IMPROVED PROCESS RAWHIDE FOR ELECTRIC STREET CAR AND MECHANICAL PURPOSES.

MANUFACTURED ONLY BY

A. GROETZINGER & SONS,
 271 RIVER AVE., ALLEGHENY CITY, PA.

Wearing qualities unsurpassed by any other similar article on the market. Actual service has demonstrated it superior to steel. Send for catalogue and price list. All orders will receive prompt attention. Excellent facilities for the manufacture of this article on a large scale. Give it a trial.

NO MORE CRACKED GONGS !

OVERHEAD GONG
 CONSTRUCTED

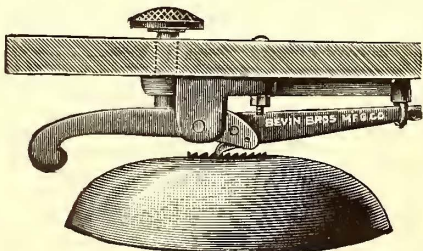

SAME PLAN,
 ON

Patented January 30, 1894.

THE LATEST THING OUT FOR

CABLE AND ELECTRIC CARS.

THE GONG ROTATES with each pressure of the foot, causing the hammer to strike in a new place each time. No bother about REPAIRS. Write us for prices and further particulars.

BEVIN BROS. MFG. CO., - East Hampton, Conn.
 (Mention this paper.)

E. P. SHAW, Pres. EBEN SUMNER, Treas.

NEWBURYPORT Car Manufacturing Co.

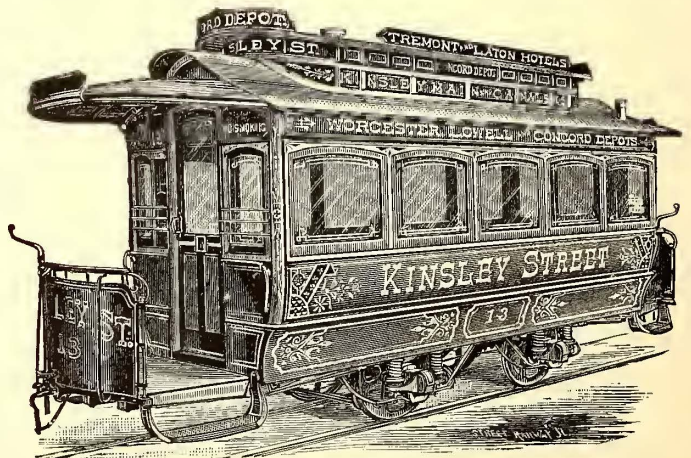

BUILDERS OF

Electric, Cable and Street Railway

CARS

OF EVERY DESCRIPTION.

Photographs and Prices Sent upon Application.

NEWBURYPORT, MASS.

THE LEWIS & FOWLER MFG. CO.

BROOKLYN, N. Y.

MANUFACTURERS OF

Open and Closed Street Cars,

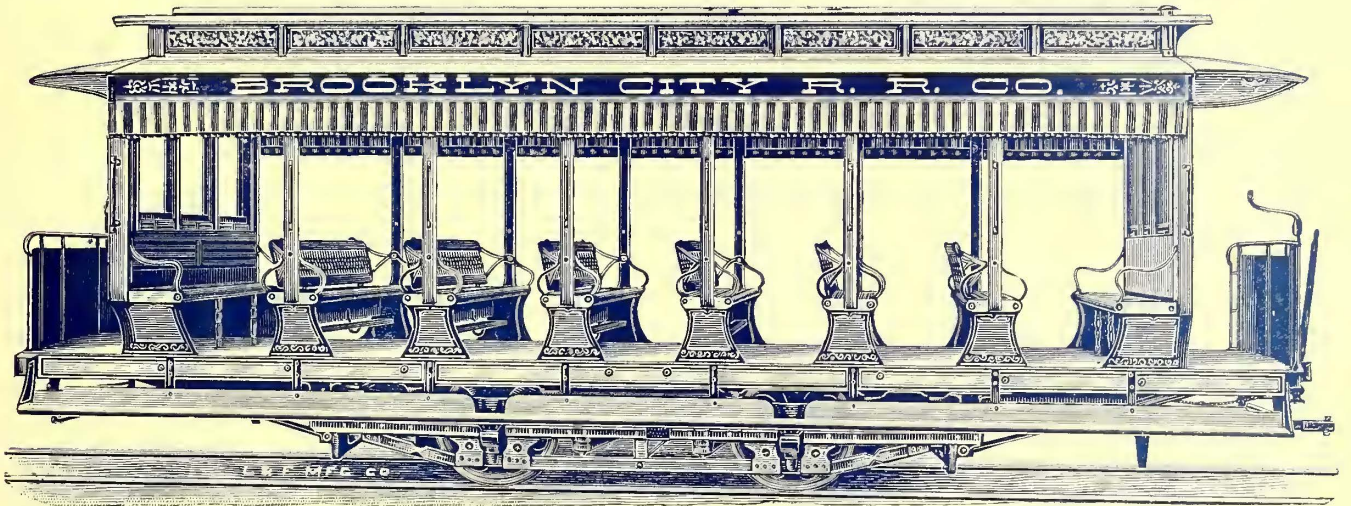

FOR ELECTRIC OR CABLE SYSTEMS.



PROMPT DELIVERIES ON SHORT NOTICE.

The Best Workmanship Guaranteed.

SEND FOR FULL PARTICULARS AND PHOTOGRAPHS.

THE

LEWIS & FOWLER MFG. CO.

BROOKLYN, N. Y.

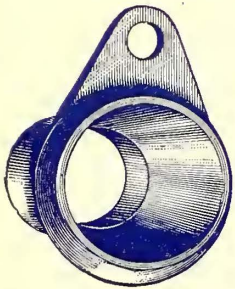

THIMBLE.

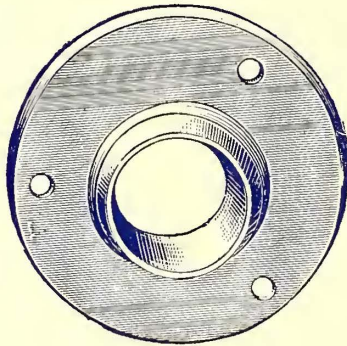

STRAP GUIDE.

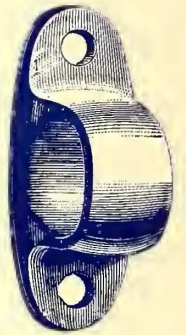

STRAP GUIDE.

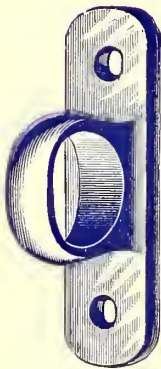

STRAP GUIDE.

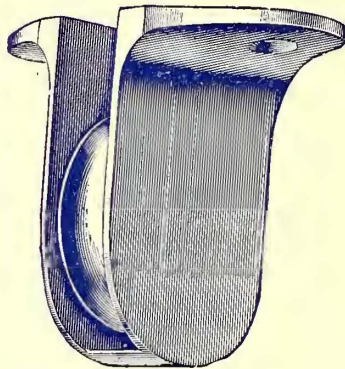

SINGLE ROLLER SHEAVE.



STRAP FASTENER.

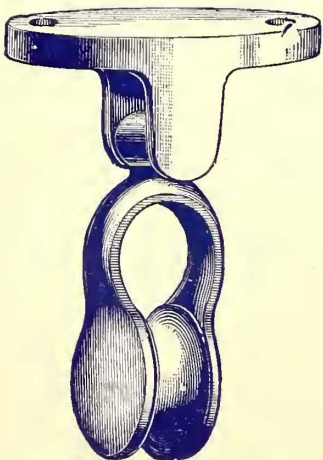

SWINGING BRACKET.



DOUBLE ROLLER SHEAVE.



ROLLER BRACKET.

— ||| THE ||| —

LEWIS & FOWLER MFG. CO.

BROOKLYN, N. Y.

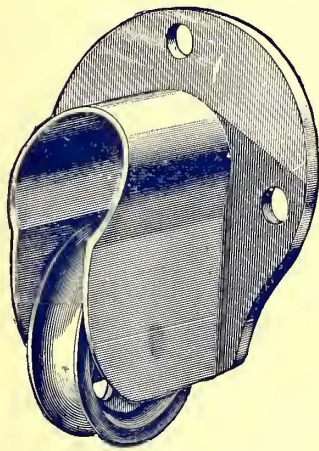

HOUSING SHEAVE.

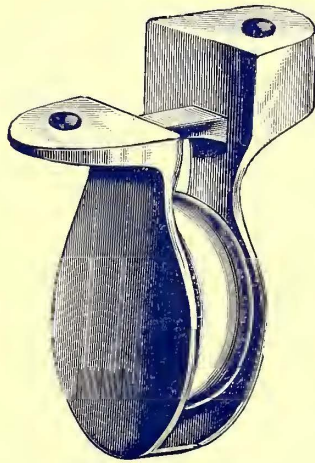

SINGLE ROLLER SHEAVE—SPECIAL.

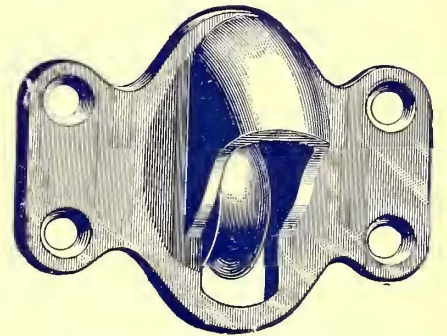

HOUSING SHEAVE.

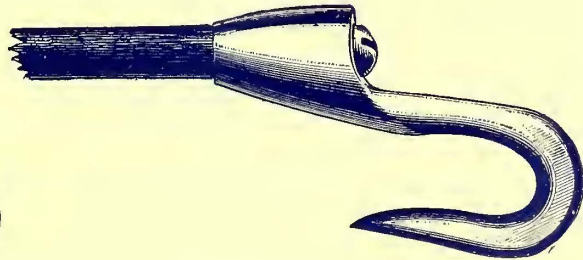

BELL CORD HOOK.

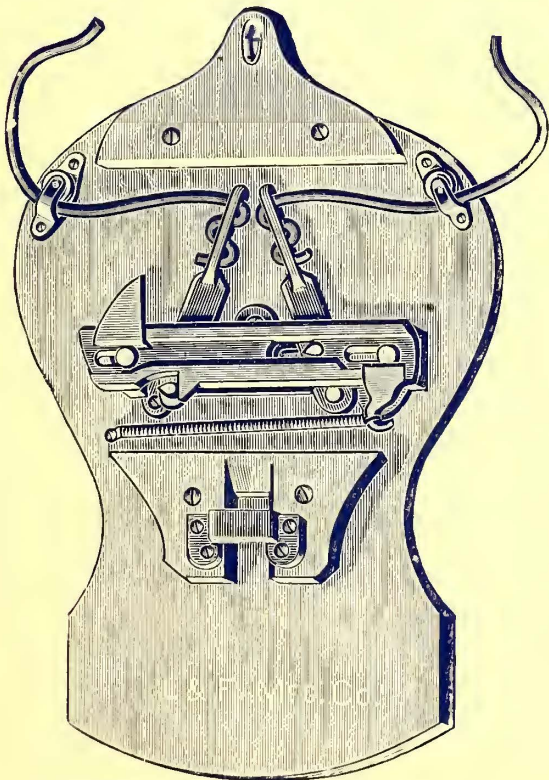

REGISTER BLOCK FOR OPEN CAR.
RINGING DEVICE.

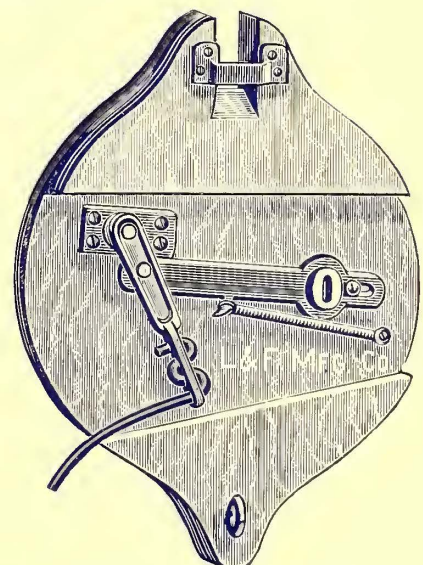

REGISTER BLOCK FOR CLOSED CAR.
RINGING DEVICE.

THE LEWIS & FOWLER MFG. CO.

Office, 28 Sanford St., Brooklyn, N. Y.





BRONZE TRIMMINGS



OF ALL DESCRIPTIONS FOR

Open and Closed Electric, Cable or Horse Cars.

We have Unequalled Facilities, which Enable us to Fill
Orders at the Shortest Notice and
Lowest Prices.

**We Make No Charge for Patterns of Special
Designs for Bronze Car
Trimmings.**

Estimates Furnished for Single Piece or
Complete Set as Desired.

It Will Pay You to Consult Us Before Placing Your Order Elsewhere

ANNOUNCEMENT

—* OF THE *—

Lewis & Fowler Girder Rail Co.

Ready for Spring, 1894, Delivery
—Our Nine Inch Box
Girder Rail.

THE ONLY GIRDER RAIL CONSTRUCTION

—* INSURING *—

SECURE JOINTS AND PERMANENT FASTENINGS, AND
PRESENTING A SMOOTH VERTICAL FACE
AGAINST WHICH TO LAY PAVING.

Our Special Work, such as Frogs, Switches, Mates, Runouts, Crossings, etc., etc., are made of the same Rail. Thus making a complete system of Steel Rail Girder Construction.

SEND FOR CATALOGUE AND LIST OF RAILROAD
COMPANIES USING OUR RAIL.

OFFICE, 28 SANFORD STREET, BROOKLYN, N. Y.

Electric Car Bodies

— OF ALL DESCRIPTIONS. —

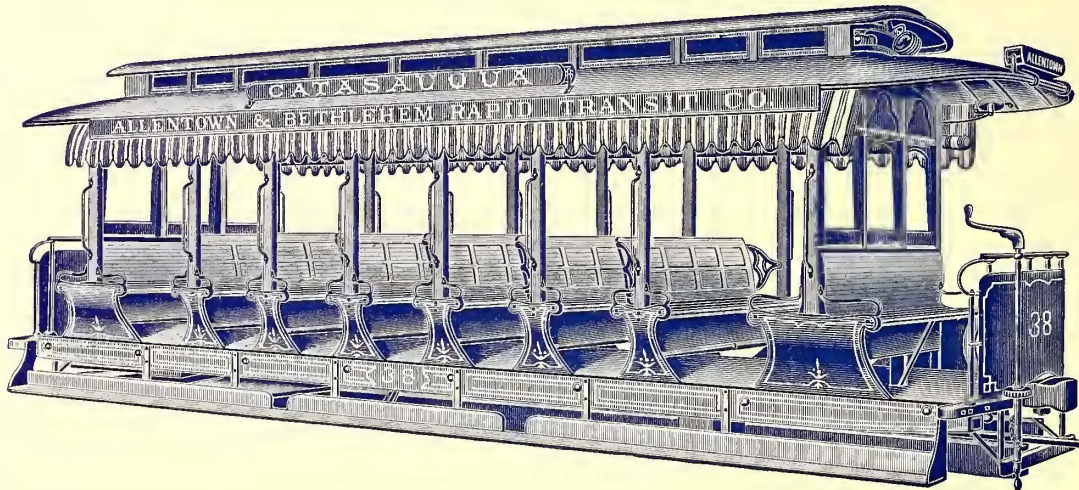

We can furnish from stock at short notice, 40, 45 and 50 passenger open or closed end car bodies.

WE MAKE A SPECIALTY OF TRAILER CARS.

Write for particulars and prices.



BRIGGS CARRIAGE CO.

AMESBURY, MASS.

Estimates Furnished on Buyer's Specifications

IF YOU WANT

SPECIAL LOW PRICES

ON

BARE COPPER WIRE,

MAGNET WIRE,

FEEDER AND TROLLEY WIRE,

OR

STEEL AND IRON POLES,

WRITE TO

ARTHUR S. PARTRIDGE,

ST. LOUIS, MO.

SMITH'S NEW YORK

J. D. SMITH,

350 & 352 PEARL ST. NEW YORK.

ESTABLISHED OVER HALF A CENTURY.

SHADES
GLOBES
CHIMNEYS
BURNERS
WICKS
REFLECTOR
GLASS

CENTRE
LAMPS
SIDE
LAMPS
END
LAMPS
HEAD
LIGHTS
ETC

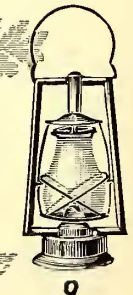
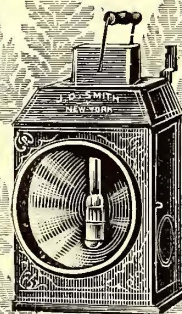
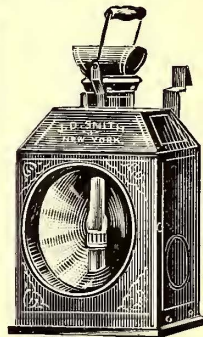
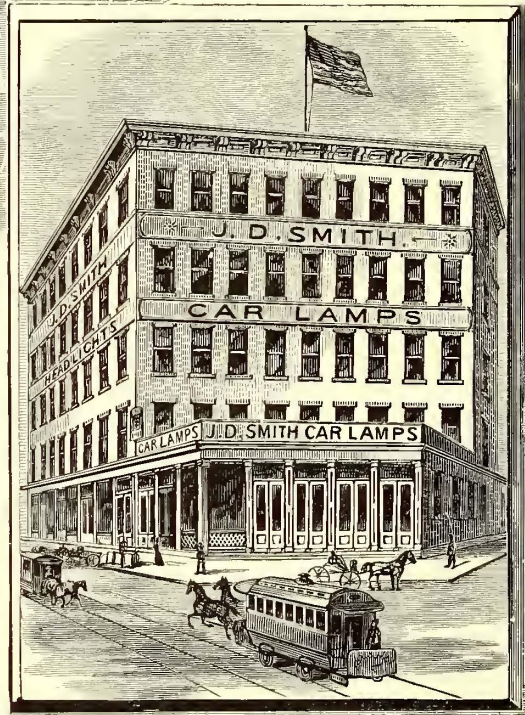
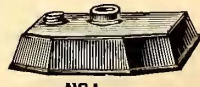
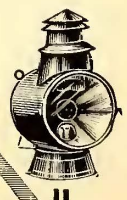
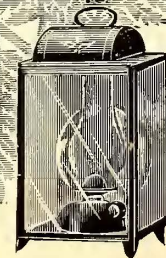
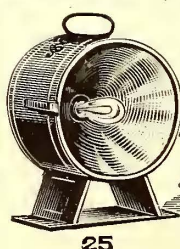
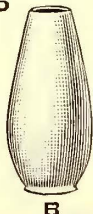
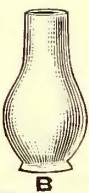
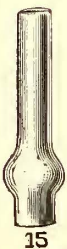
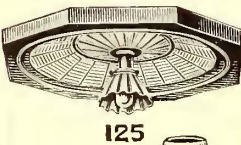
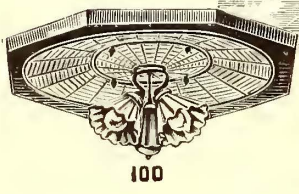
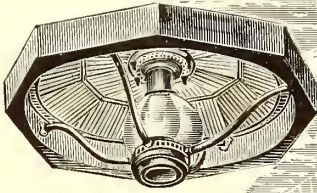
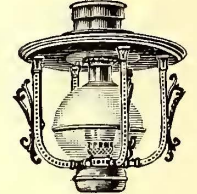
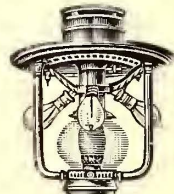
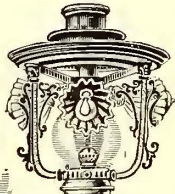
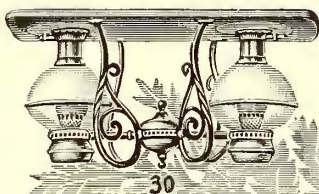
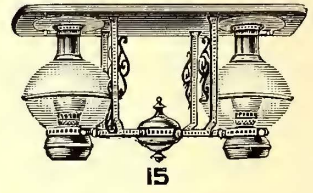
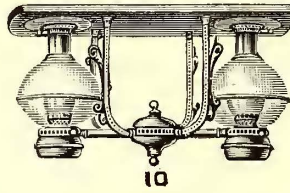
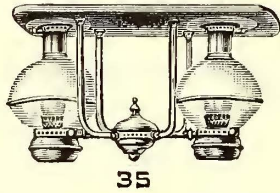
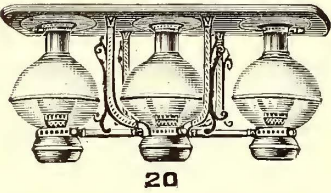

JAMES A. TRIMBLE,



**C
A
R
S**

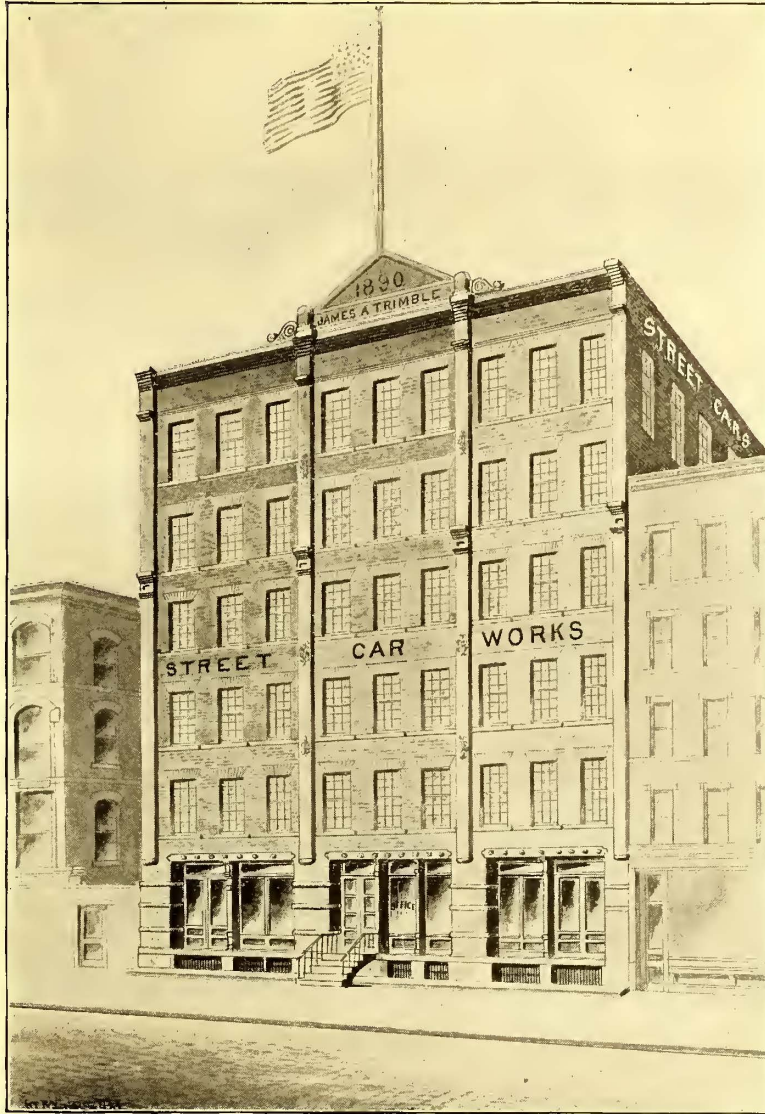

**Horse,
Cable,
Electric**

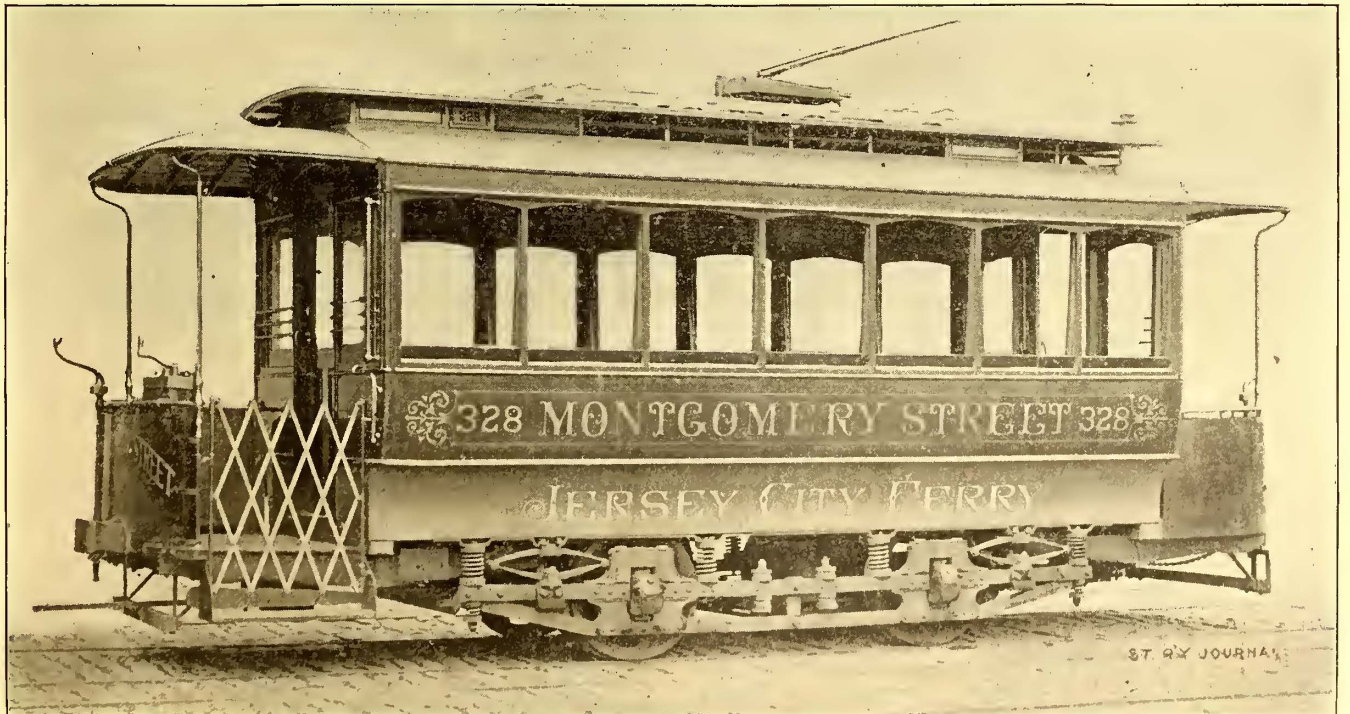

218 East 28th St., New York.

THE BARNEY & SMITH CAR CO.

DAYTON, OHIO.

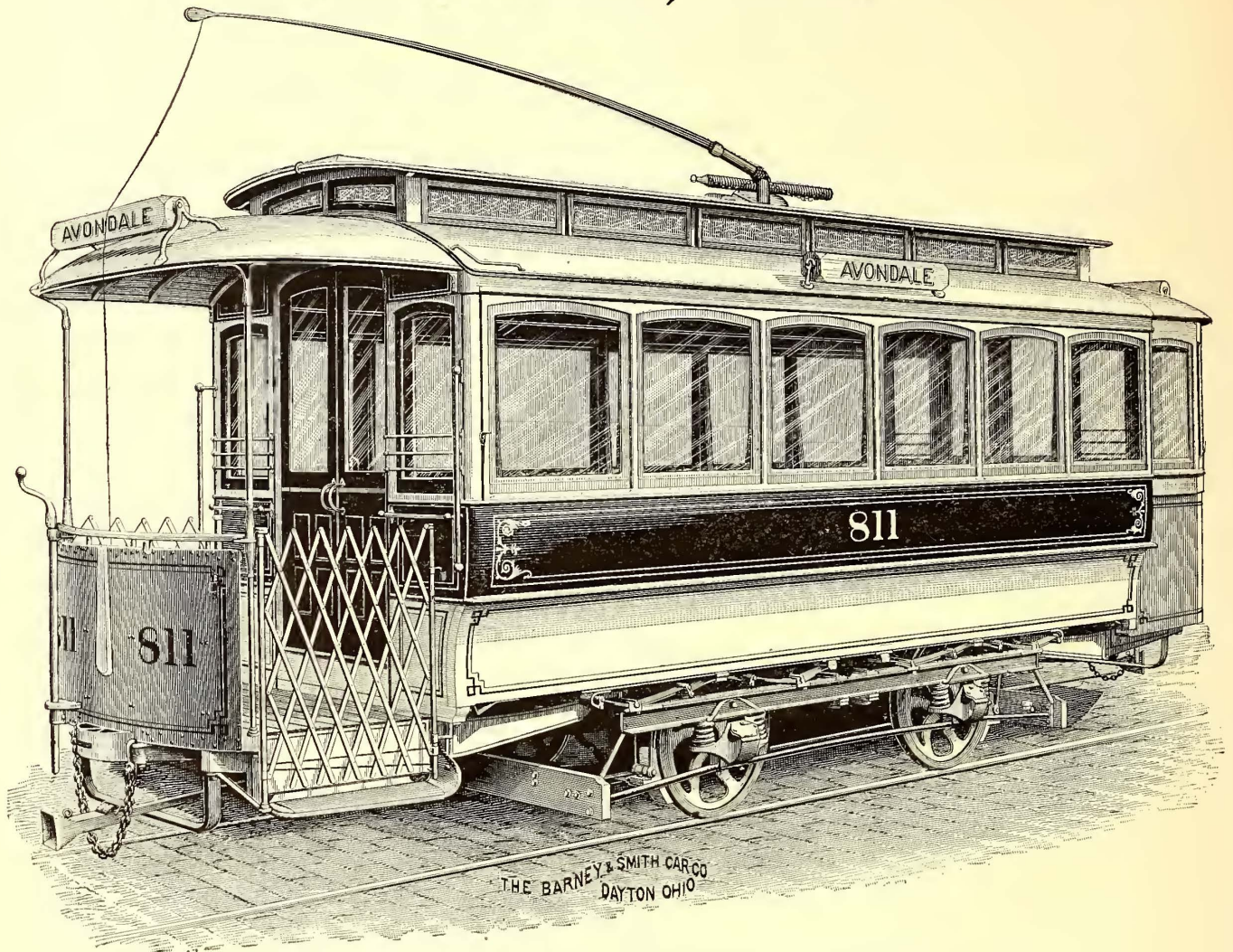

THIS IS ONE OF THE CARS BUILT BY US FOR USE ON THE
CONSOLIDATED LINES IN CINCINNATI, O.

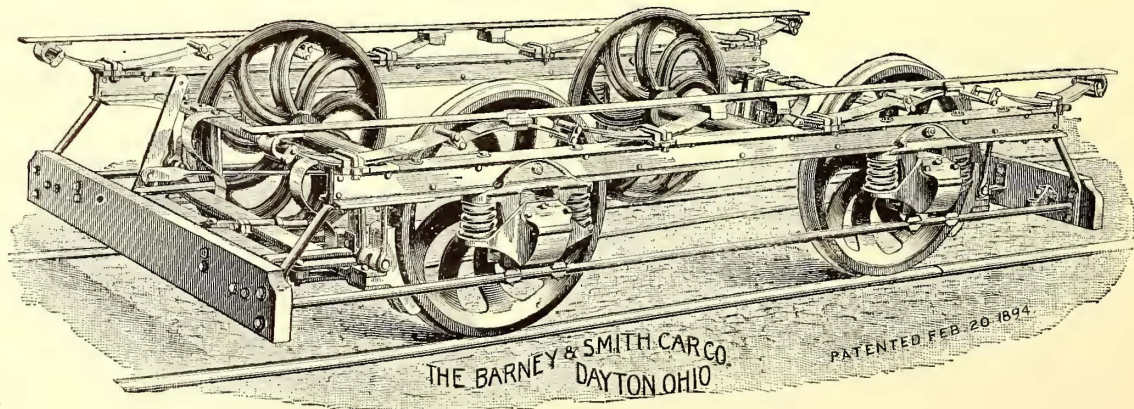

PATENTED FEBRUARY 20, 1894.
OUR STANDARD TRUCK FOR CLOSED CARS.

BUILDERS OF HIGH CLASS
ELECTRIC, CABLE AND HORSE CARS.
SEND FOR CATALOGUE.

Jackson & Sharp Co.

**DELAWARE CAR WORKS,
WILMINGTON, - DELAWARE,**

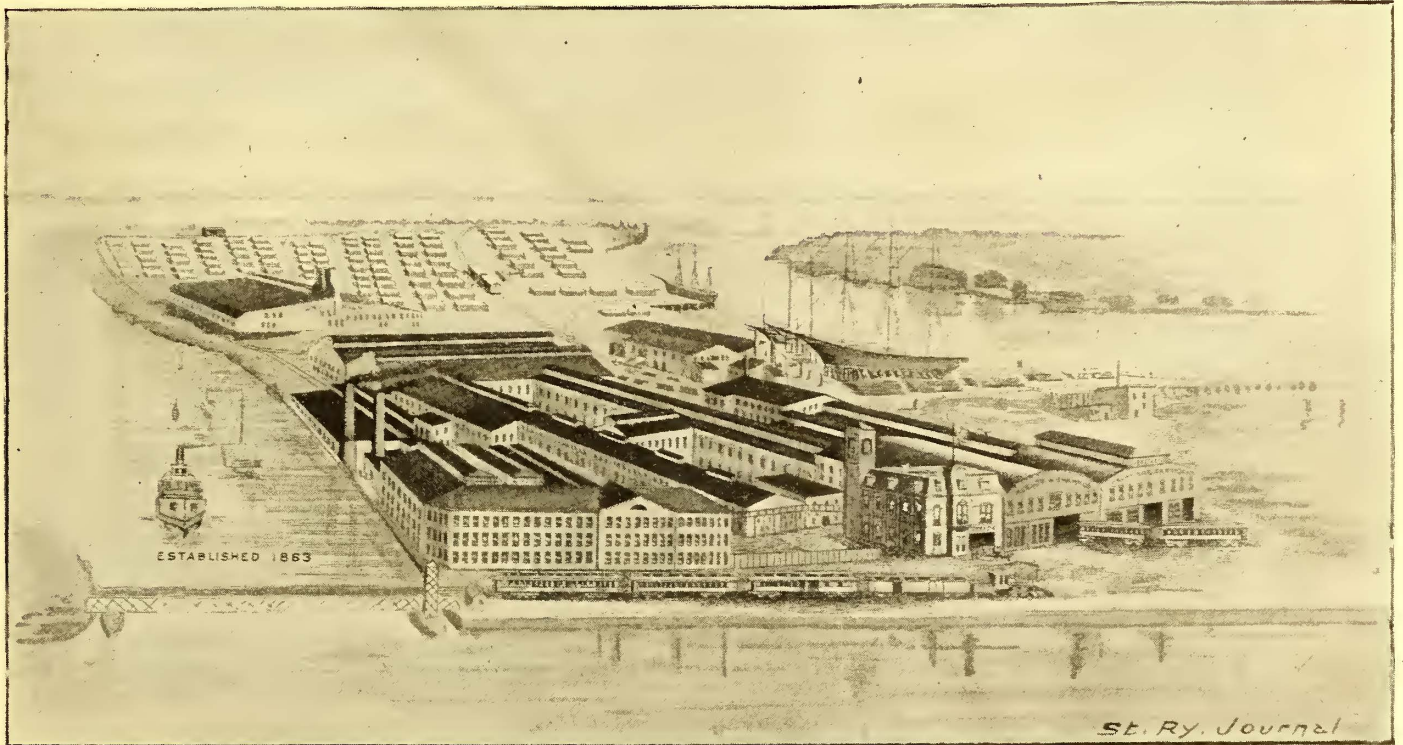

BUILDERS OF

STREET RAILWAY CARS

OF ALL KINDS.

Between 6,000,000 and 7,000,000 feet of thoroughly dry and seasoned lumber of all kinds constantly on hand, and 2,000,000 feet under cover.

Extraordinary facilities and large experience give us many advantages.

WRITE FOR DRAWINGS AND PRICES.

THE LACLEDE CAR CO.,

— ST. LOUIS, MO. —

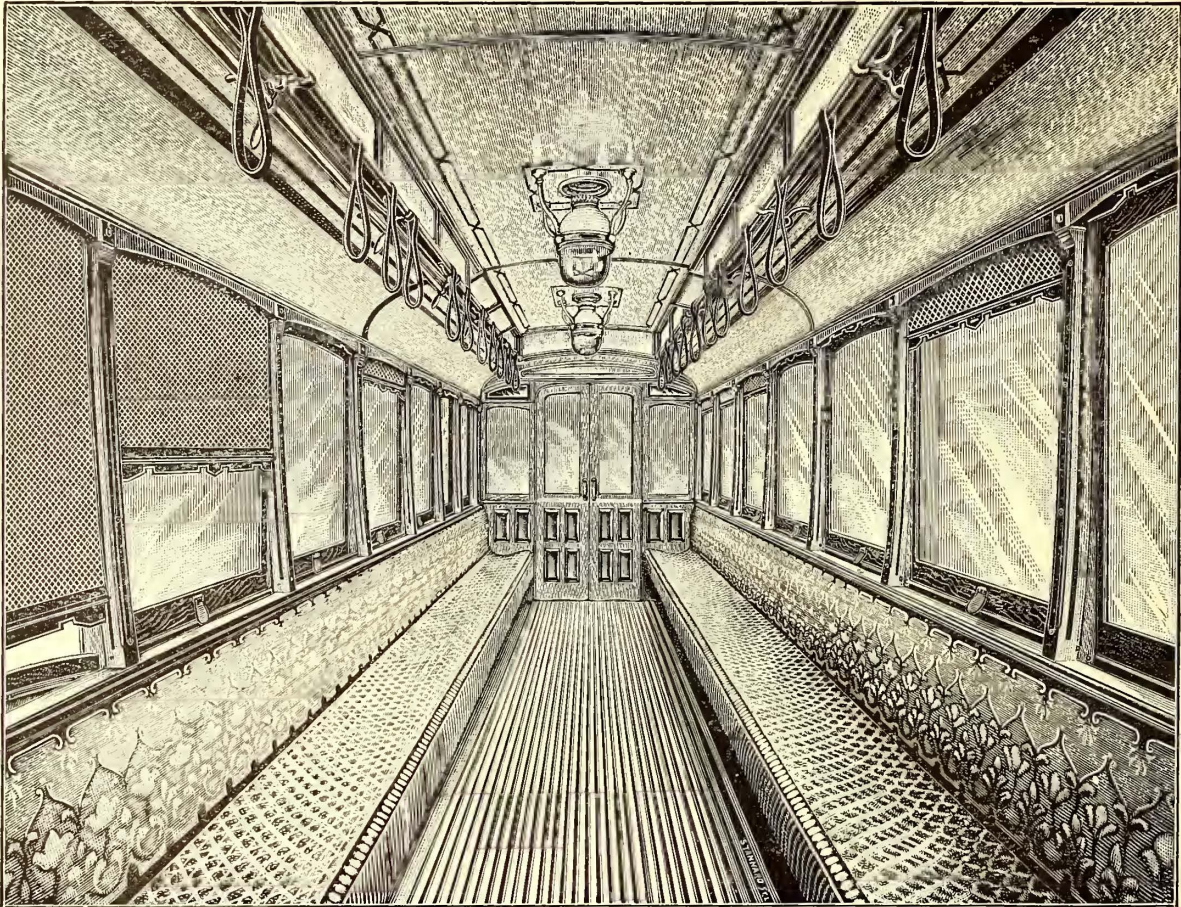

INTERIOR OF CAR BUILT FOR THE BROADWAY CABLE LINE, NEW YORK CITY.

Builders of Street Cars of Every Description.

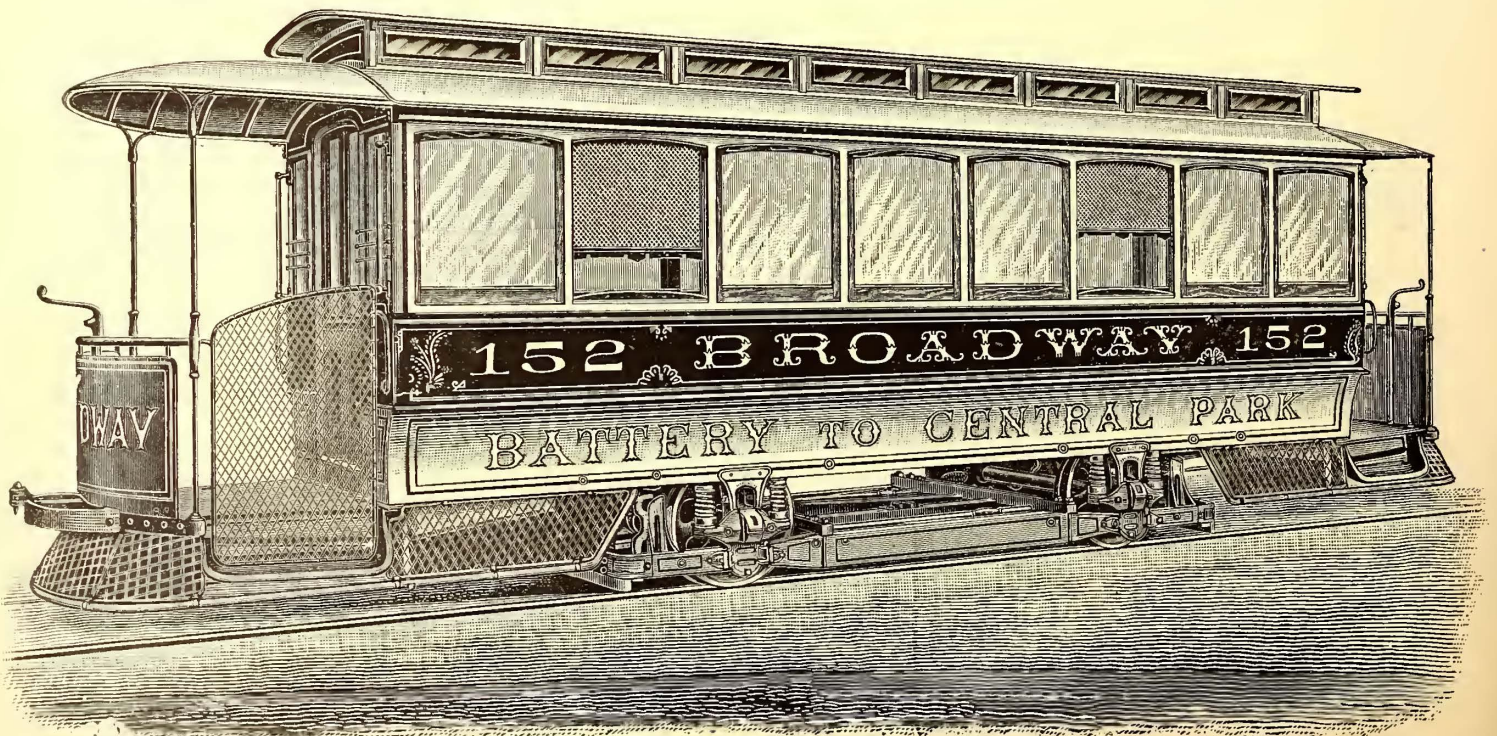

THIS CUT REPRESENTS ONE OF THE CARS BUILT FOR THE BROADWAY CABLE LINE OF NEW YORK CITY.

The Laclede Car Co., ST. LOUIS, MO.

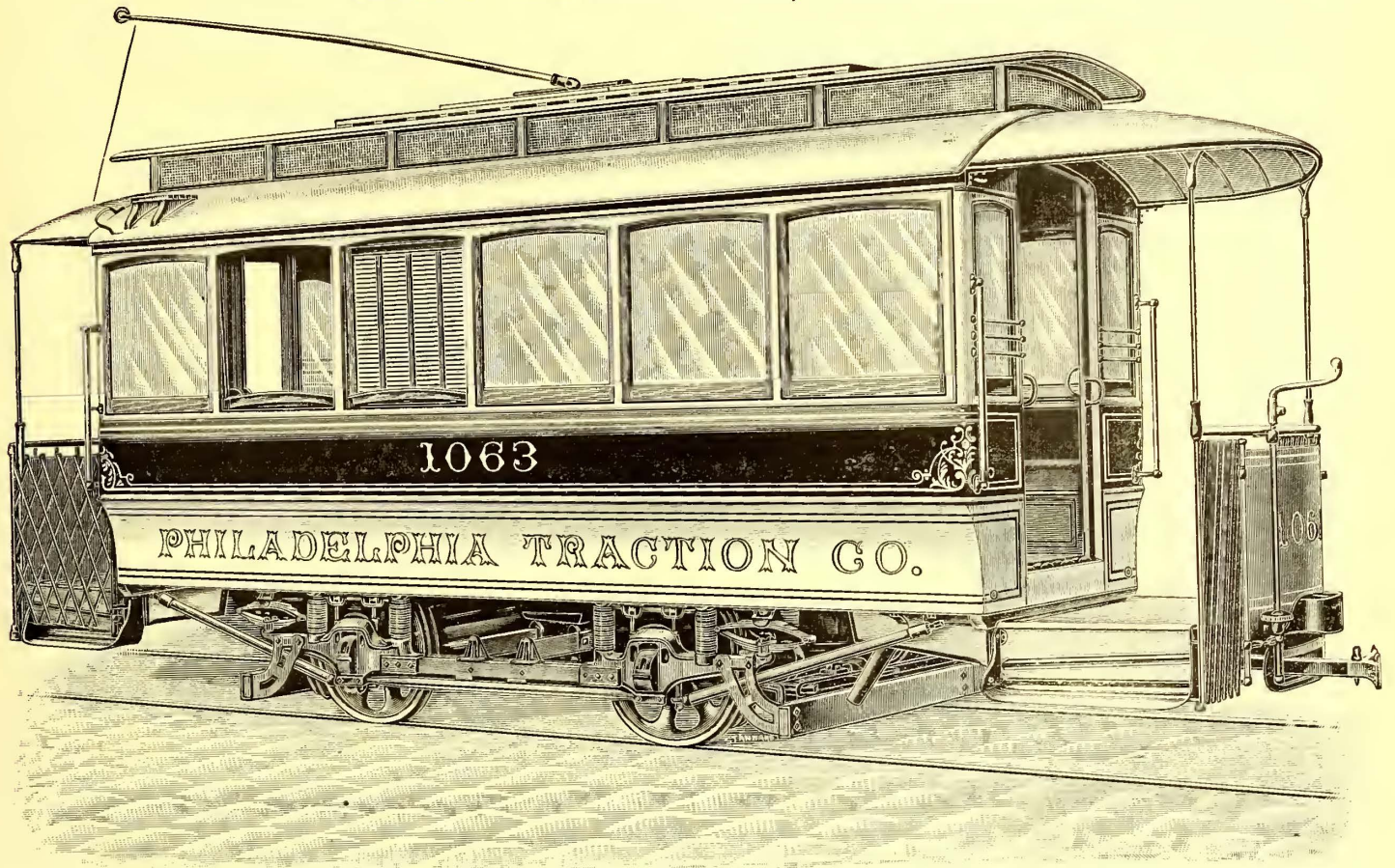

THIS CUT REPRESENTS ONE OF THE 200 CLOSED CARS WE ARE FURNISHING
THE PHILADELPHIA TRACTION CO.

Builders of Street Cars of Every Description.

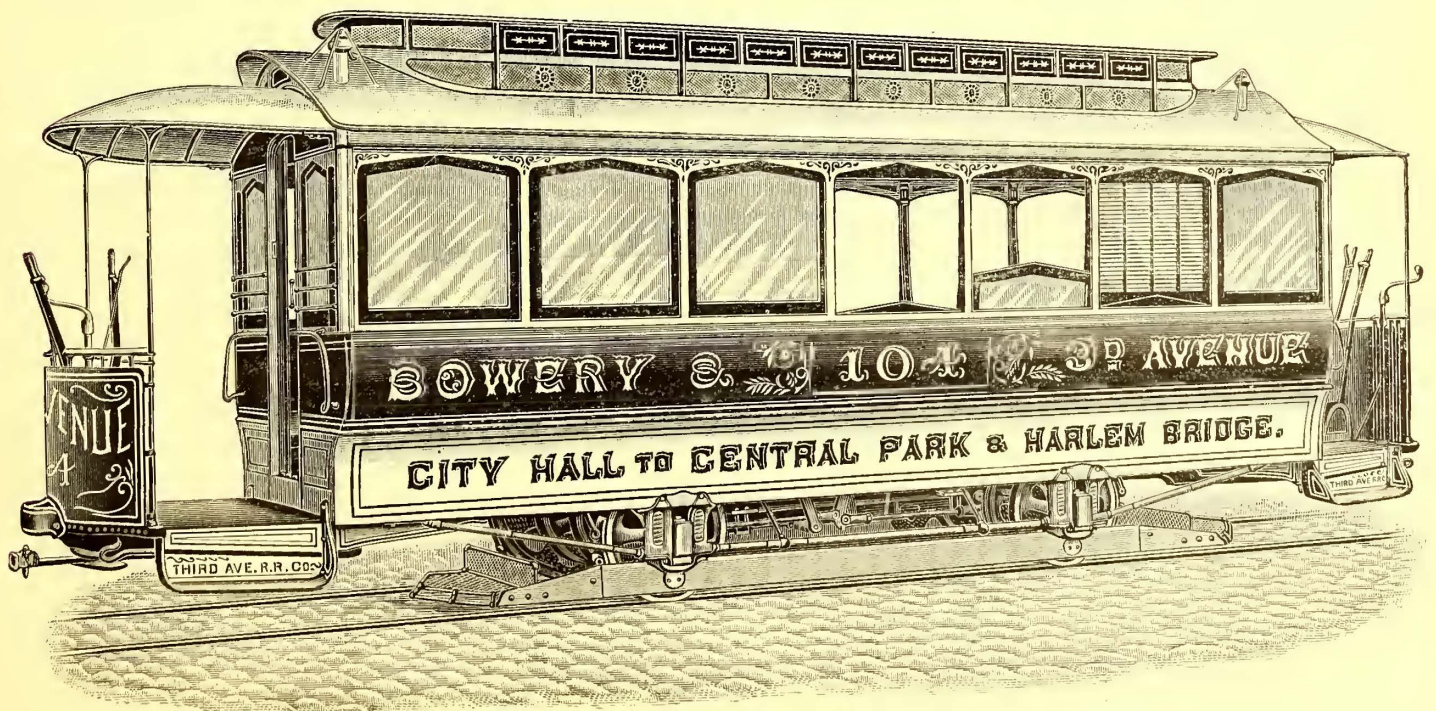

THIS CUT REPRESENTS ONE OF THE 200 CARS BUILT FOR THE THIRD
AVENUE R. R. CO., OF NEW YORK CITY.

BIG JOKE ON RAILROAD MEN!

Three years ago this month, May, '91, a Railroad President—peace to his ashes—asked us for some device to carry more passengers and let 'em on and off in less time.

We ought to have thought of it first ourselves—it's our business to do such things, and we do 'em generally—we made the first reversible seat with no arms, and now we've got a reversible folding seat, like a theater chair; we'll tell of it shortly if it turns out to be good-for-anything—sorry we didn't think of it. No matter—he did; and we got the thing up and patented it.

The man who does the inventing gets the patent, not the man that wants the inventing done.

We were fool enough to show him how we did it, the road we took. We widened the doorway; put in two doors—a really pretty arrangement—all the Conductor had to do was to touch one door, and both flew open or shut. We tried to think we had done it. No; it was something else. It worked like a jack-in-the-box; but it wouldn't carry more people or let 'em on and off faster.

We put the door at the step, and it carried 20 per cent. more people and let 'em on and off so fast that we got about 10 per cent. more speed in the safest and most agreeable way, by shortening stops.

We got our patent but lost our customer—we can afford to laugh at the joke, for we've got the world by the tail in spite of him.

He took up with our jack-in-the-box twin-door arrangement, and went to somebody else for his cars; and, being a great big man—at least in a great big place—four-fifths of the railroad men have gone after him! There's actually a run on twin doors! The car builders who have no patents, yell "steboy!" And the railroad men do the running.

Meanwhile we are building Accelerators, and railroad men who kept their wits are buying 'em. 20 per cent. more passengers on at a time and 10 per cent. more speed and trips are too much for a jack-in-the-box twin-door I-move-without-touching car.

We build good cars at fair prices—all we want is all we can do at fair prices—we build all through as we build outside; and we make the prettiest cars this side of Jerusalem.

Gentlemen, you have lost your way, don't all come at once.

BROWNELL CAR COMPANY.

SAINT LOUIS, MISSOURI.

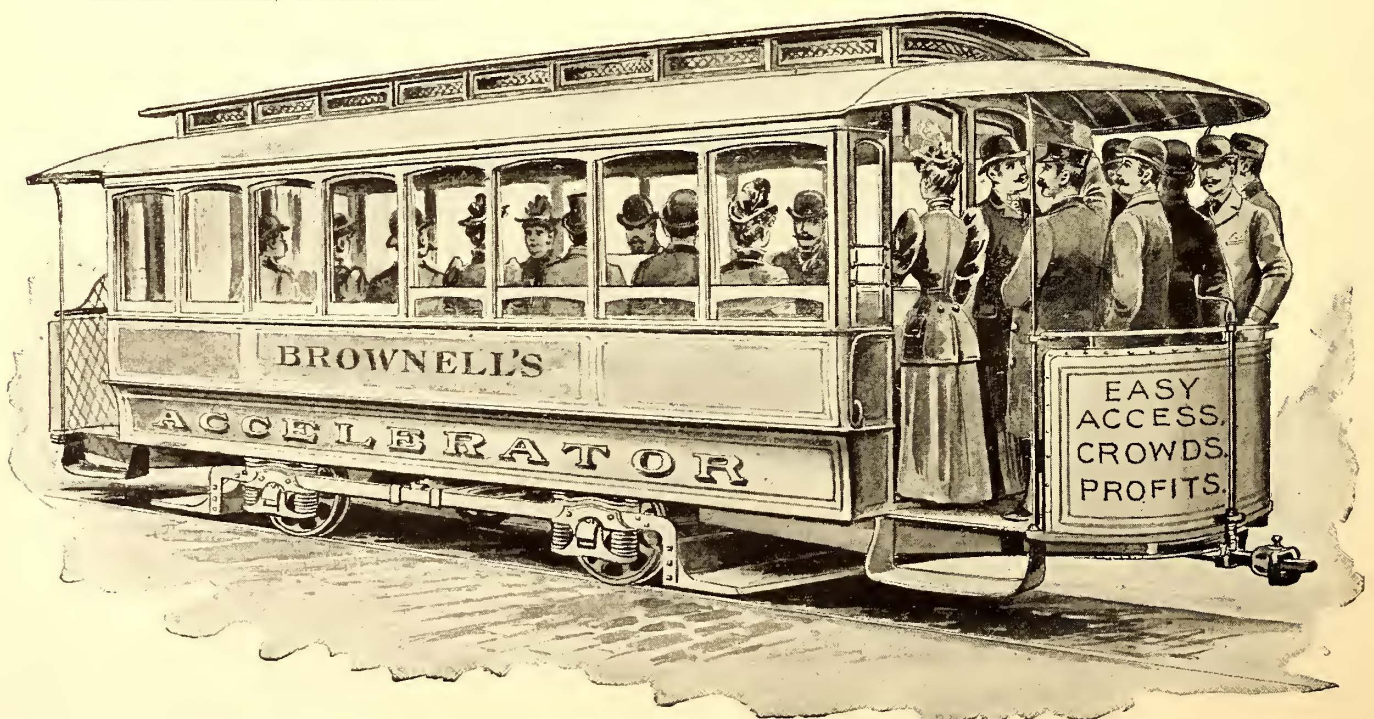

If we should fill that car as full of passengers as you will when you have it, and the passengers want to ride, you couldn't see it half so clearly. There's room for twenty or thirty men on the platform, without obstructing the path between door and sidewalk. A woman with a baby in her arms can get on, without touching a man on the platform; and the Conductor is right at the step to help her.

May 7th last we received this telegram :

“ First open car in service to-day. It is a bird. I congratulate you on your exquisite taste, and myself on my nerve to give you *carte blanche* order. We are the people. The best, East, West, North, South, can't catch us.”

JOHN J. SHIPHERD.

And three days later, this letter :

“ Our \$250 to \$300 a day increase in Newport and Covington this year over last, while Cleveland is not keeping up in receipts, shows that the bright attractive equipment should have credit. I believe it is the true way to do the street railroad business.”

JOHN J. SHIPHERD.

They were the spontaneous expressions of gratification over the last lot of cars we had made for him.

We quote from his first order from memory—it was spoken, not written :

“ We want to show the people that we are going to give them the best service they ever had. We want the best and finest cars you can build. If it is necessary to spend \$200 more on a car, I want to do it. I understand from our General Manager that you are a man we can deal with in this way.”

He had just bought a road in Toledo with which we had made a contract for cars a few days before ; and that is how he treated our contract. It was in 1884.

It is not necessary to deal in this extremely generous way to get good cars ; but we print (without permission) the telegram, letter and speech, to show that a buyer is safe in dealing with us, no matter how he deals—and he may as well deal agreeably.

He was a total stranger to us ; there was nothing personal in the case. We had been making ears for the road since 1873, and had the good-will of the officers of it. That's all the foundation he had.

One road wants one sort of equipment, another another. One wants fine ears ; another durable ones—we never heard of a road that wanted mean ones or weak ones.

We have no difficulty in making exactly such ears as the buyer wants ; and this is how we go about it :

We reckon the costs of the stuff and the work—of the grade that is wanted—put on the profit we want—and put 'em together. That is our price for the ears. The buyer pays it ; and we are good friends forever after.

On the next large order we have, we are going to make an extra car to be *inspected*. There's only one way to inspect a ear ; that is to knock it to pieces and see what it was made of and how it was made.

The car to inspect will be drawn by lot ; and you shall be there to see the show, if you like. We'll give due notice of time and place.

We have never been suspected, so far as we know, of making poor ears, or of cheating inside, or of anything else that might be supposed to call for ocular proof of how we make all cars ; but we have a substantial reason for giving an extra car to be inspected now and then—for we mean to do it occasionally—and the reason is ; we want a larger and readier market ; we want more money. Our cars are worth it ; we want it.

We have a good deal more to say ; but this will do for once.

BROWNELL CAR COMPANY.

SAINT LOUIS, MISSOURI.

The Largest and Most Complete Street Car Factory in the World.

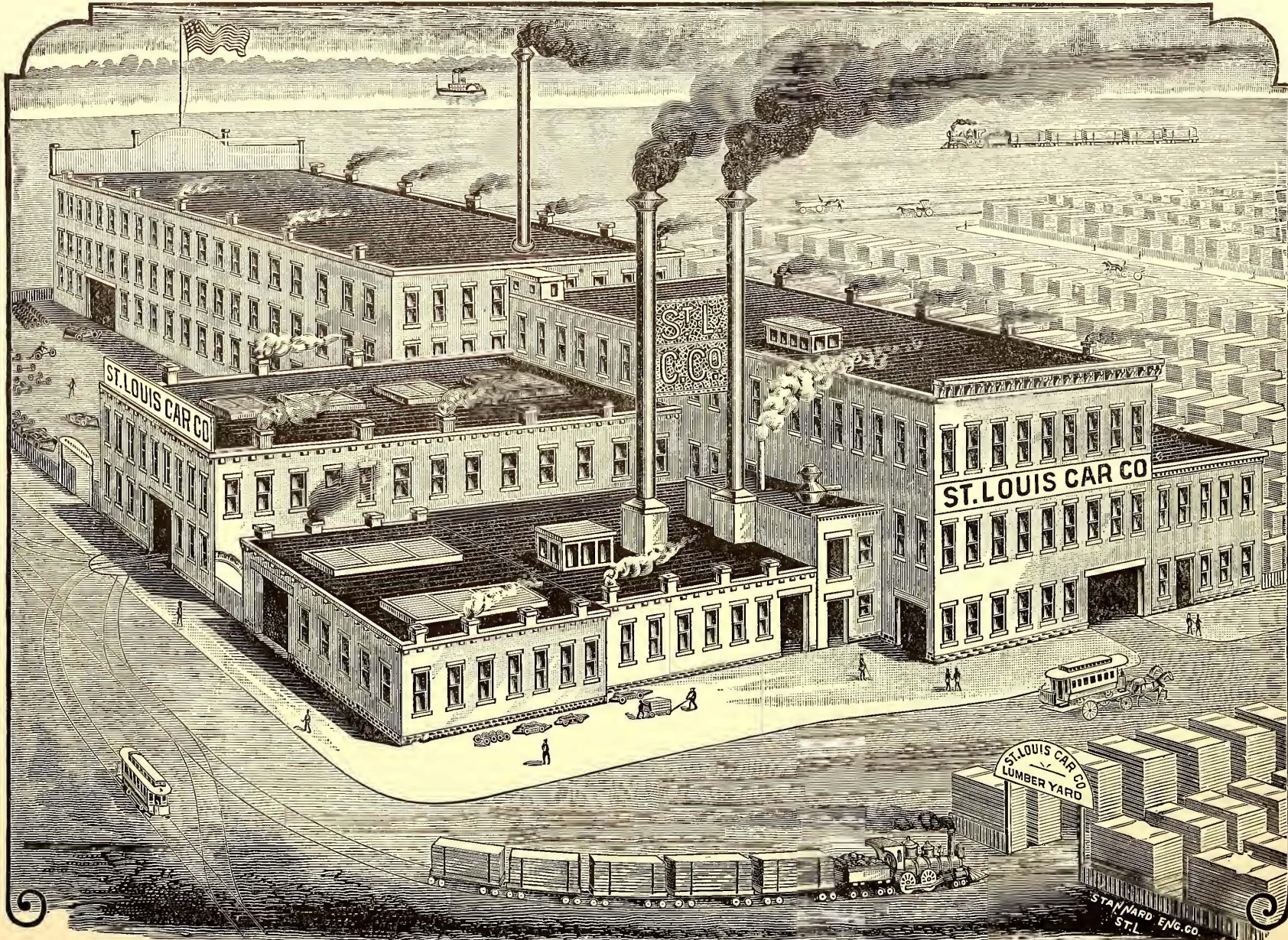

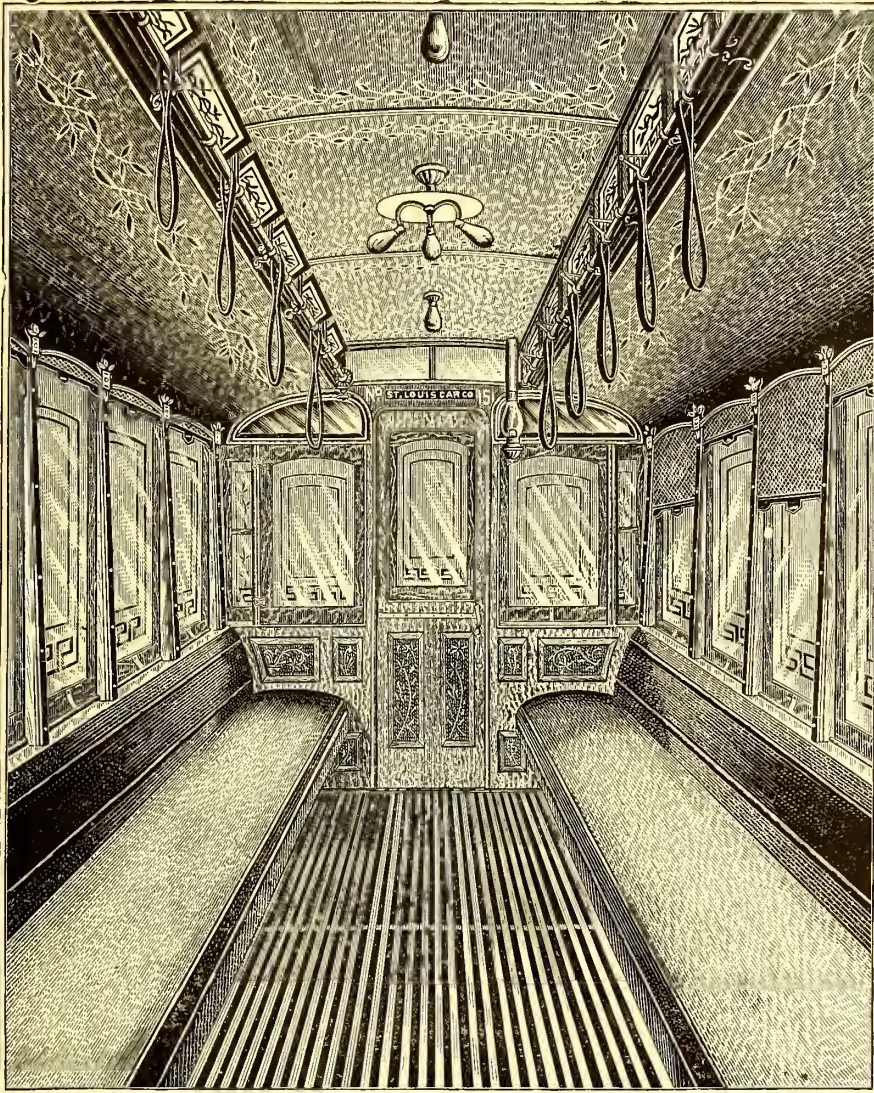

EASTERN AGENTS:
EDMUND D. SMITH & CO.,
208 S. 4th St., Philadelphia, Pa.

PERSPECTIVE VIEW OF THE NEW WORKS OF THE ST. LOUIS CAR CO.



INTERIOR FINISH OF FANCY ELECTRIC CAR

ST. LOUIS 

 **CAR CO.,**

Manufacturers of all kinds of

MOTOR CARS,

ELECTRIC CARS

AND TRUCKS

A SPECIALTY.

OFFICE:

**3,023 N. Broadway,
ST. LOUIS.**

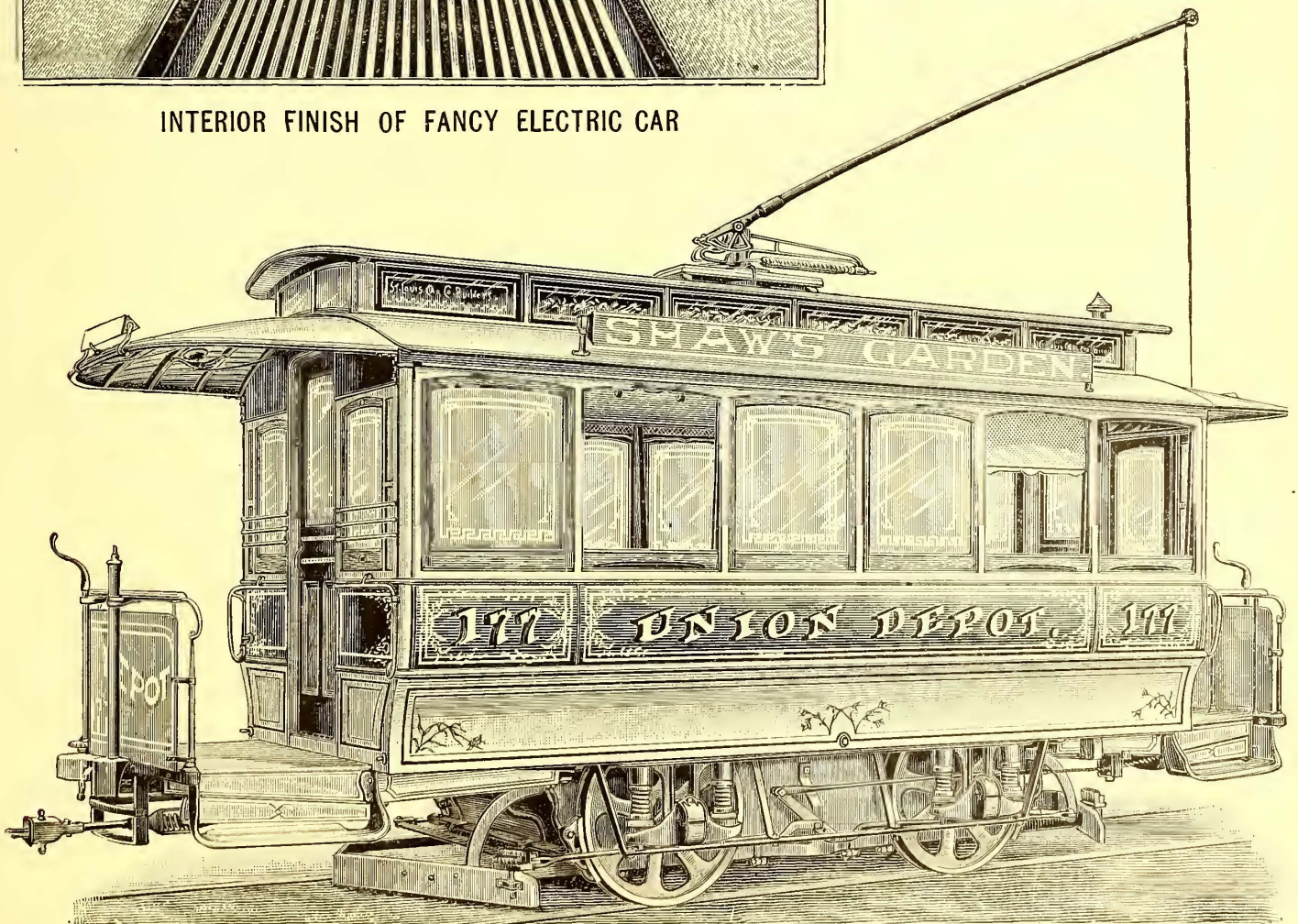

16 FOOT CLOSED CAR MOUNTED ON PATENT ENCLOSED ELECTRIC TRUCK.

AMERICAN CAR CO.

WM. SUTTON, President.
EMIL ALEXANDER, Secretary.

STRICTLY
HIGH CLASS
ELECTRIC,
CABLE AND
HORSE
CARS

FOR

Early Delivery

Extensive Shops.

New Machinery.

Correspondence Invited.

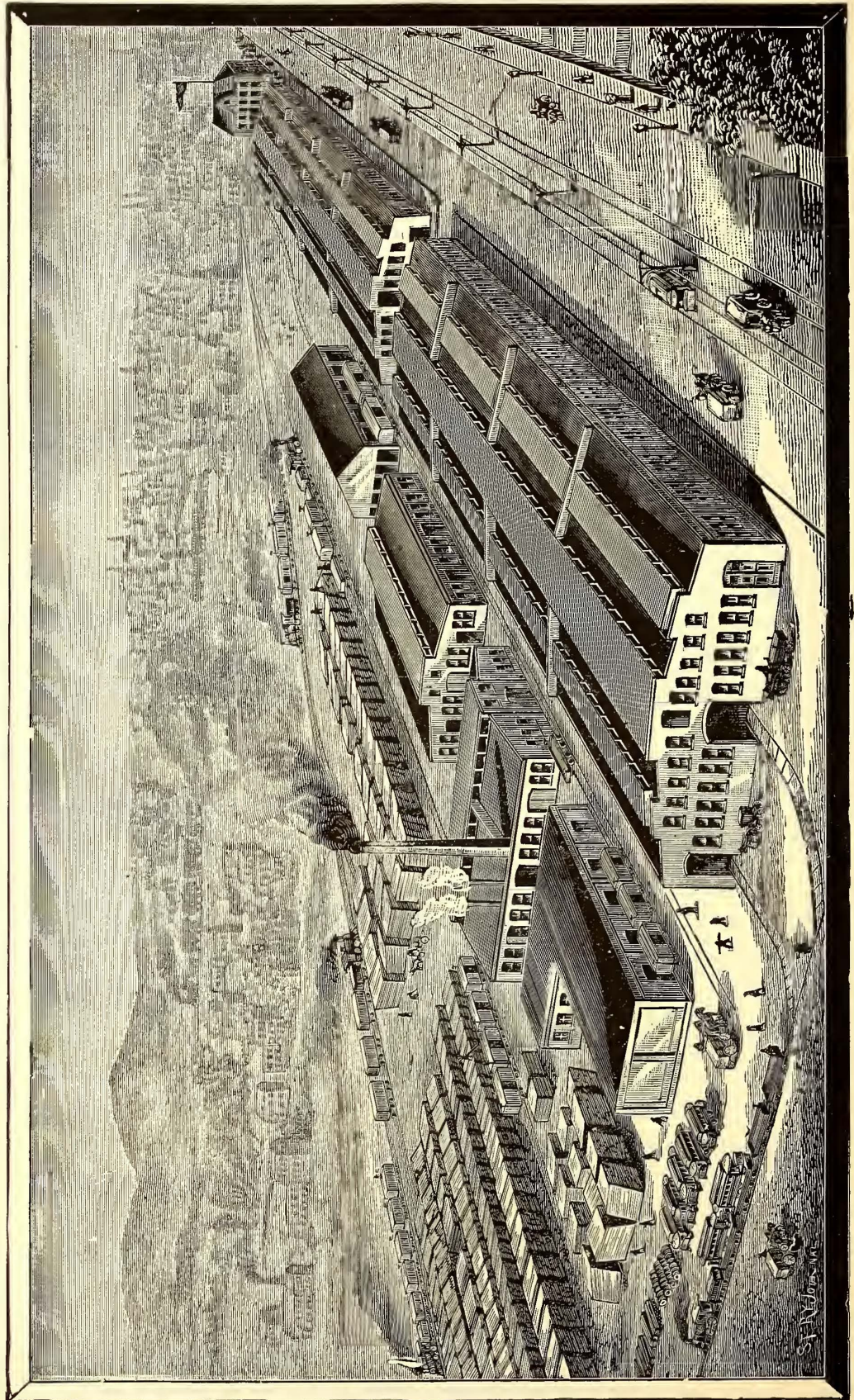

Works, Old Manchester Road, near Tower Grove Ave. 626 CHESTNUT ST., ST. LOUIS, MO.

) THE (

NEW CASTLE CAR MFG. CO.

NEW CASTLE, PA.

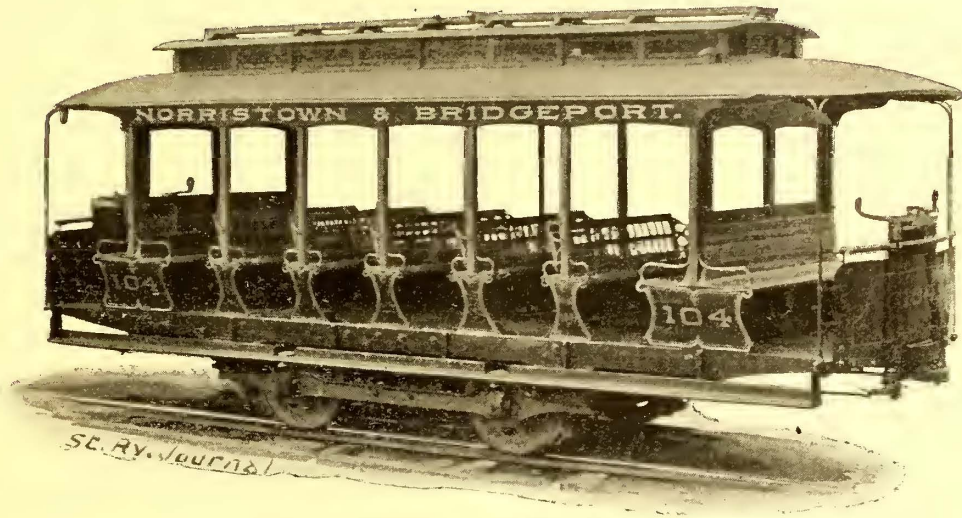

BUILDERS OF ALL KINDS OF

STREET RAILWAY CARS

Orders Filled Promptly and with Care.



Material and Workmanship Guaranteed.

≡ SEND FOR CATALOGUE. ≡

Pullman's Palace Car Co.,

Manufacturers
of

RAIL-
ROAD

CARS.

Pullman, Illinois.

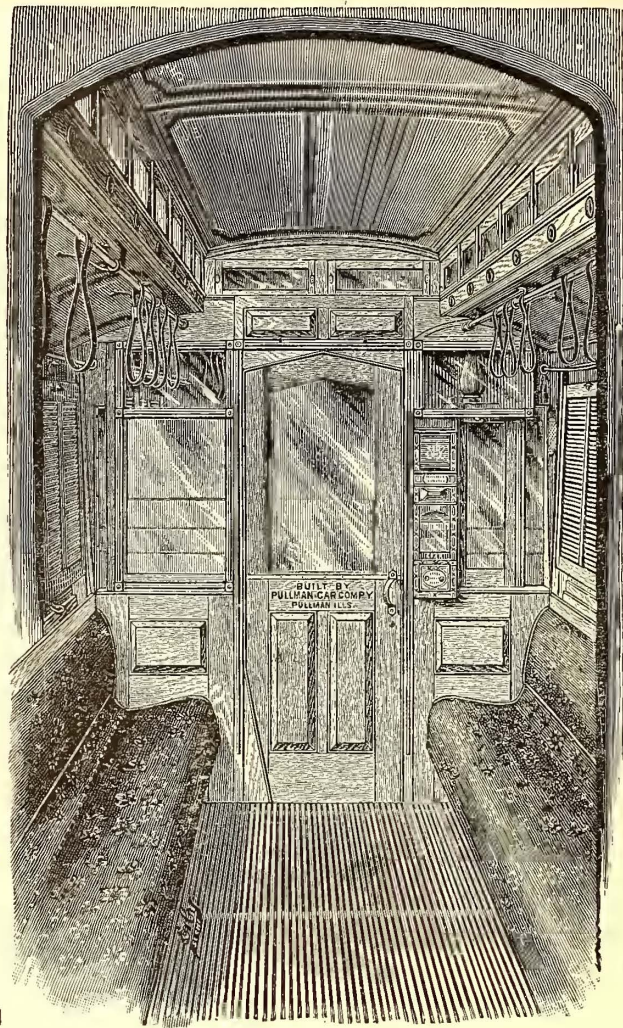

Make a Specialty of

Street, Cable Grip
& Electric Motor

CARS.

Detroit, Michigan.

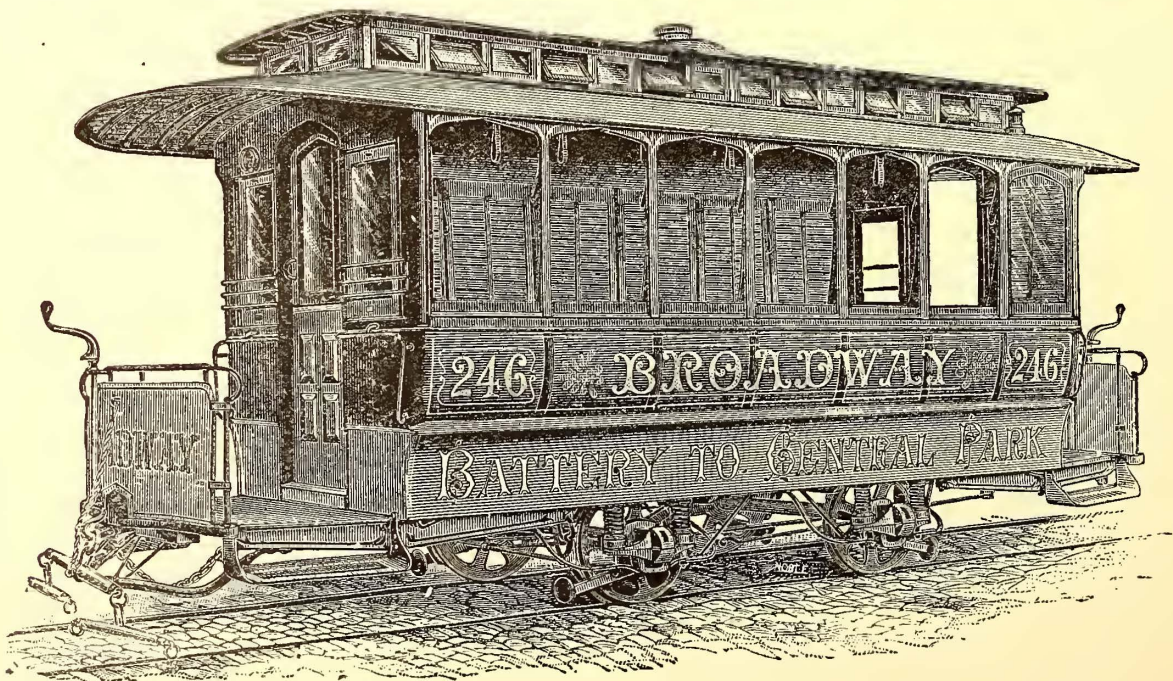

Address all Correspondence

Contracting Agent, Chicago, Ill.

THERE ARE MANY

CAR BUILDERS

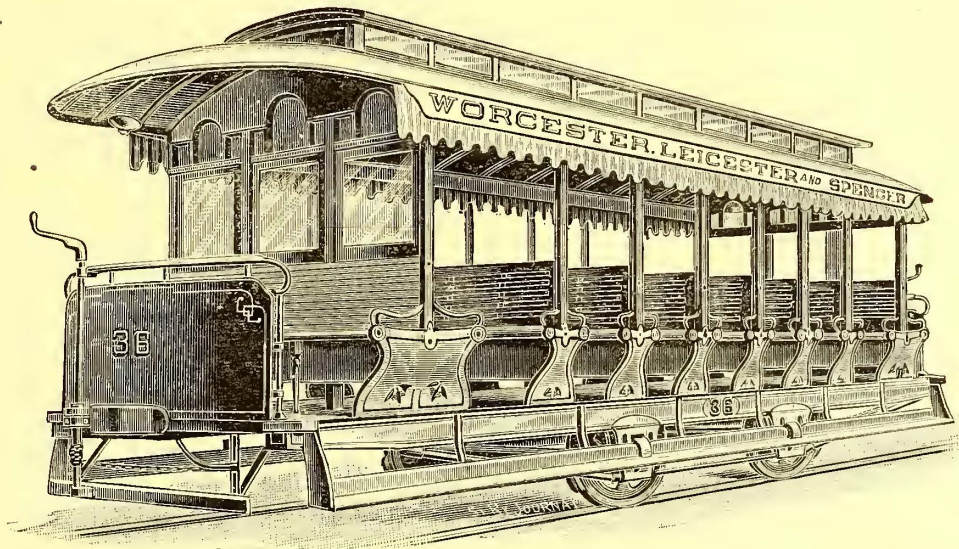

BUT IF YOU THINK OF BUYING CARS YOU OUGHT
TO BE SURE TO GET PRICES
AND ESTIMATES OF

THE ELLIS CAR CO.

AMESBURY, MASS.

N. B.—We have in stock that we can ship on short notice, the following car bodies: Five 9 bench open car bodies with closed ends, ten 10 bench open car bodies with closed ends, five 16 foot box car bodies, five 19 foot box car bodies and one 25 foot box car body.

CARLETON & KISSAM

LARGEST STREET CAR ADVERTISING CONCERN IN THE WORLD!

WILLIAM F. CARLETON.
BOSTON, MASS.

GEORGE KISSAM.
NEW YORK, N. Y.

MAIN OFFICE:

NEW YORK OFFICE:

50 Bromfield St., Boston.

Postal Telegraph Building.

BRANCH OFFICES:

Chicago, Cincinnati, Minneapolis, St. Paul, Pittsburgh, Buffalo, Rochester, Columbus, Duluth,
Denver, Milwaukee, Newark, Providence, Albany, Hamilton, Canada.

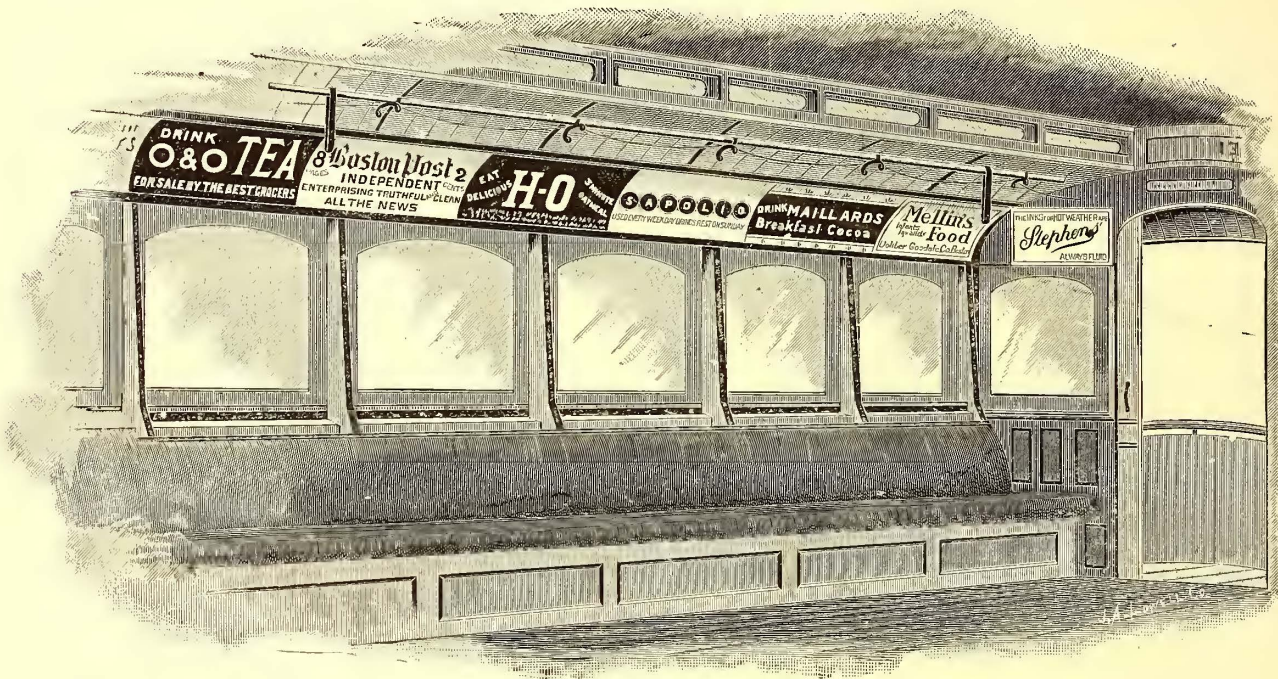

CONTROLS THE ADVERTISING PRIVILEGE IN

1000 Cars of the West End Co., Boston, Mass.	44 Cars of the Pittsburgh & West End Pass. Ry. Co., Pittsburgh, Pa.
50 " " Boston, Revere Beach & Lynn R. R., Boston, Mass.	850 " " West Chicago Street Railway, Chicago, Ill.
50 " " Lynn & Boston Railway, Boston, Mass.	75 " " Chicago Passenger Railway Co.
75 " " Lynn & Boston Railway, Lynn, Mass.	400 " " North Chicago Street Railway, Chicago, Ill.
50 " " Naumkeag Street Railway, Salem, Mass.	225 " " Third Avenue Railway, New York.
50 " " Globe Street Railway, Fall River, Mass.	65 " " 125th St. & 10th Ave. Cable Railway, New York.
50 " " Brockton Street Railway, Brockton, Mass.	47 " " Central Crosstown Railway, New York.
40 " " Merrimac Valley Railroad Co., Lawrence, Mass.	41 " " Christopher & 10th St. Railway Co., New York.
40 " " Lowell Railroad Co., Lowell, Mass.	200 " " Brooklyn City & Newtown Ry., Brooklyn, N. Y.
40 " " Haverhill & Groveland St. R. R. Co., Haverhill, Mass.	50 " " South Covington & Cincinnati Railway Co.
169 " " Union Railroad, Providence, R. I.	50 " " Newark & South Orange Ry. Co., Newark, N. J.
500 " " Consolidated Cincinnati Railways, Cincinnati, O.	175 " " Rochester Railway Co., Rochester, N. Y.
250 " " New Jersey Traction Co., Newark, N. J.	250 " " Buffalo Street and Crosstown St. Ry. Cos., Buffalo, N. Y.
70 " " Citizens' Traction Co., Pittsburgh, Pa.	200 " " Minneapolis St. Railway Co., Minneapolis, Minn.
60 " " Pittsburgh Traction Co., Pittsburgh, Pa.	20 " " New Jersey Traction Co., Elizabeth, N. J.
200 " " St. Paul City Railway Co., St. Paul, Minn.	50 " " Patterson Railway Co., Paterson, N. J.
100 " " Consolidated Street Railroad Co., Columbus, O.	18 " " Hamilton & Lindenwald Elec. Transit Co., Hamilton, O.
13 " " Elizabeth Street Railway Co., Elizabeth, N. J.	13 " " New Brunswick City Ry. Co., New Brunswick, N. J.
50 " " Duluth Street Railway Co., Duluth, Minn.	27 " " Springfield Railway Co., Springfield, O.
25 " " Superior Rapid Transit Ry. Co., West Superior, Wis.	25 " " Second Avenue Pass. Railway Co. Pittsburgh, Pa.
20 " " Citizens' Street Railway Co., Kalamazoo, Mich.	107 " " Albany Railway, Albany, N. Y.
25 " " N. F. & Susp. Bridge Ry. Co., Niagara Falls, N. Y.	5 " " Plainfield St. Ry. Co., Plainfield, N. J.
200 " " Milwaukee Street Railway Co., Milwaukee, Wis.	6 " " Buffalo, Bellevue & Lancaster Ry., Buffalo, N. Y.
10 " " Buffalo & Tonawanda Ry. Co., Tonawanda, N. Y.	6 " " Stillwater & Mechanicville St. Ry. Co., Mec'ville, N. Y.
17 " " West End Street Railway Co., Denver, Colo.	14 " " Madison City Ry. Co., Madison, Wis.
170 " " Denver City Cable Ry. Co., Denver, Colo.	42 " " Mt. Auburn Cable Ry. Co., Cincinnati, O.
40 " " Cicero & Proviso Railway Co., Chicago, Ill.	52 " " Steinway Railway Co., Long Island City, N. Y.
60 " " Hamilton Street Railway Co., Hamilton, Canada.	15 " " Newport Street Railway Co., Newport, R. I.
13 " " North & East River Railway Co., New York.	47 " " Pittsburgh & Birmingham Traction Co., Pittsburgh, Pa.

290 CARS OF THE BROOKLYN UNION ELEVATED R. R. CO., Brooklyn, N. Y., After May 1, 1895.

And has Special Contracts with many other Companies.

References: Presidents of all the above Roads.

This Company is prepared to negotiate for long time leases with first-class roads in any part of the United States.

—ESTABLISHED 1839.—

J. M. JONES' SONS,
STREET RAILWAY
CAR BUILDERS,
West Troy, N. Y.

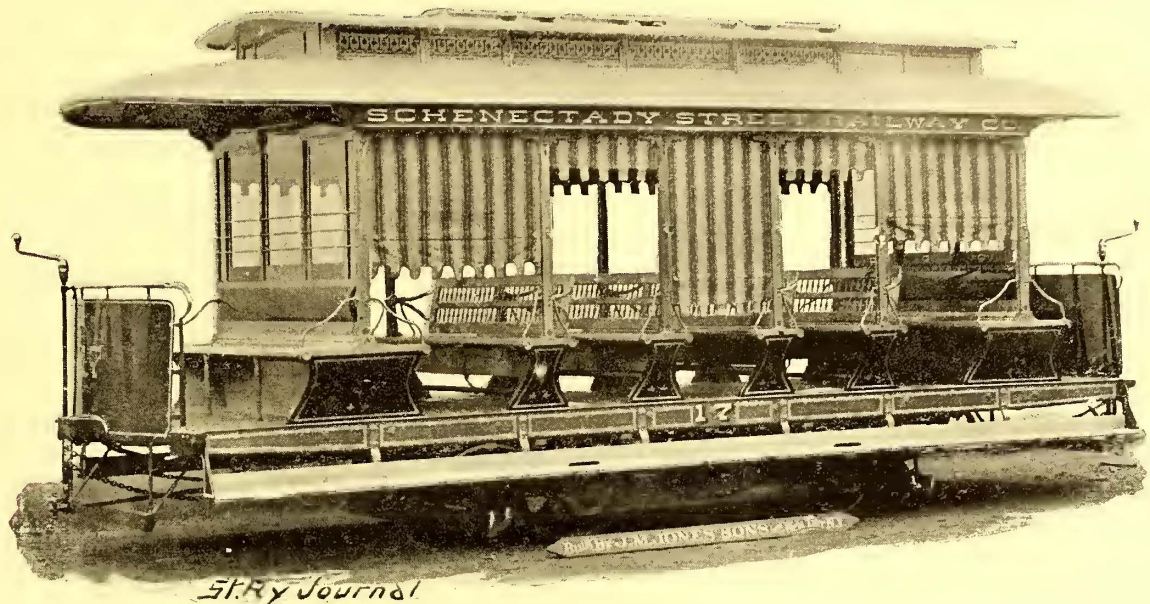

St. Ry Journal

— **ORDERS FILLED PROMPTLY.** —



SPECIAL ATTENTION GIVEN TO

CARS FOR ELECTRIC AND CABLE SERVICE.

CARS

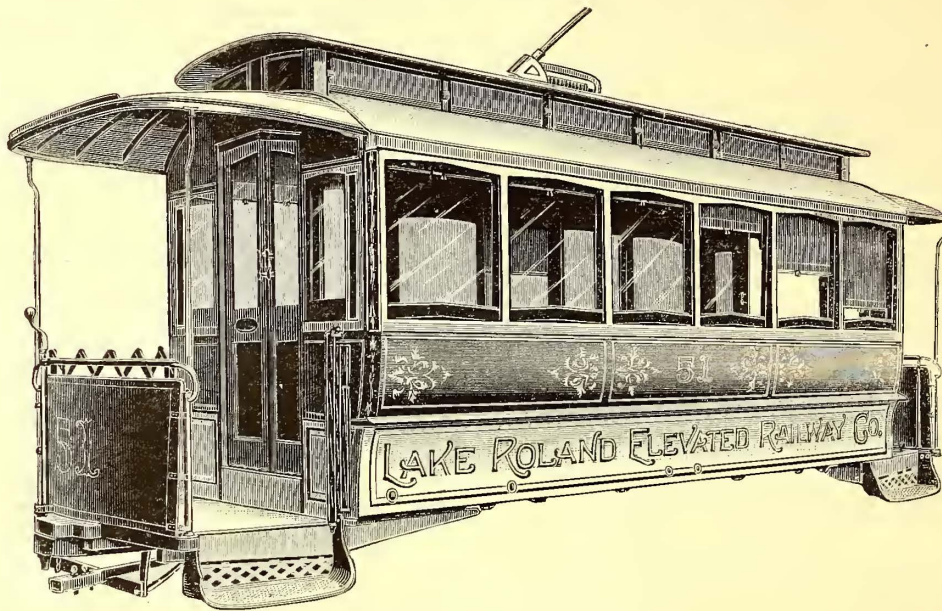

J. W. FOWLER CAR CO

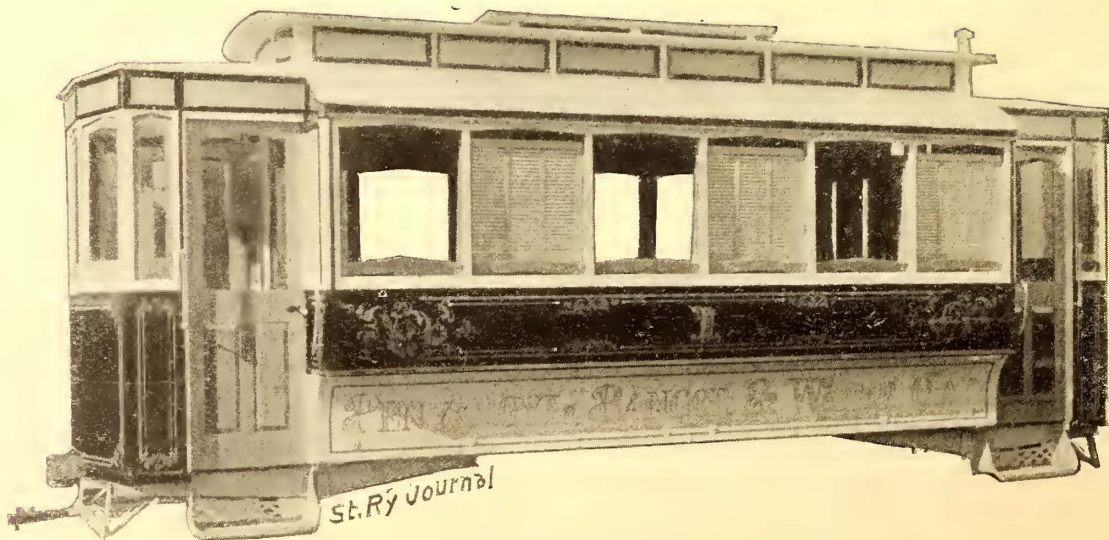

GENERAL OFFICE AND WORKS:

ELIZABETHPORT, N. J.

GENETT AIR BRAKE.

RECEIVED THE HIGHEST AWARD AT THE WORLD'S COLUMBIAN EXPOSITION.

The only reliable and economical brake adapted for all kinds of **Trolley and Cable Cars**, with and without trailers. Trailers broken up from motor car. Cars instantly stopped or slowed down as required, regardless of speed. A boon for motormen. Efficient service and economy secured.

ACCIDENTS REDUCED TO A MINIMUM.

INSTANTANEOUS. POWERFUL AND RELIABLE. SIMPLE IN CONSTRUCTION.

EASILY UNDERSTOOD AND OPERATED.

No Possibility of Accident or Delay through failure of apparatus. Its action is entirely uniform. Braking power is under perfect control, and can be applied with any degree of force desired. **Especially Adapted to Heavy Grades.** Thoroughly tested by actual use, and pronounced a success by leading street railway men.

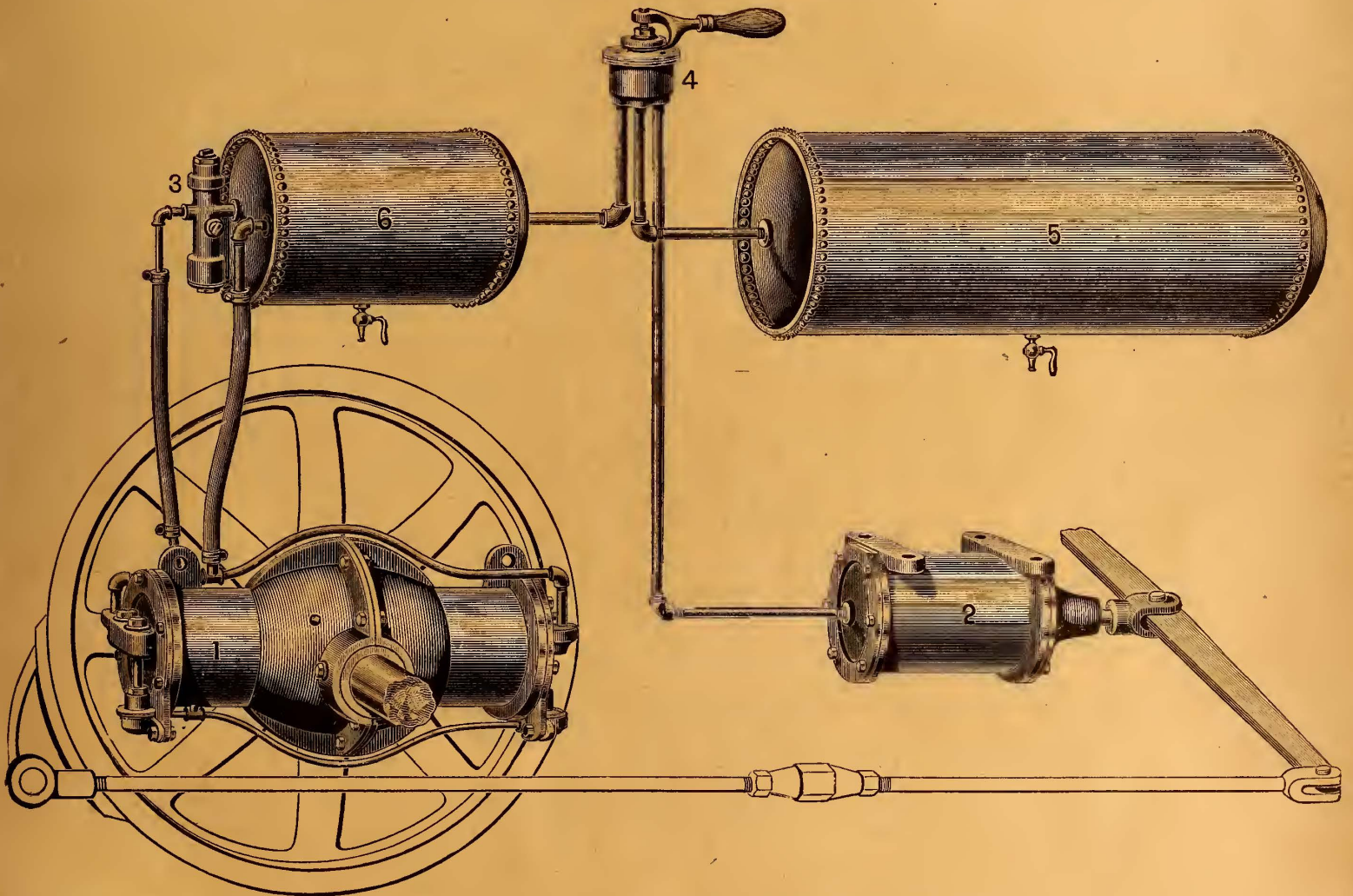

WE GUARANTEE THE GENETT AIR BRAKE AND EVERY CLAIM WE MAKE FOR IT.

It is manufactured under our own supervision. Every part thoroughly tested.

NOW IN ACTUAL OPERATION

ON A NUMBER OF THE MOST PROMINENT STREET RAILWAYS.

ALL ORDERS PROMPTLY ATTENDED TO.

GENETT AIR BRAKE CO.

New York Office,

Office & Factory 11-23 S. Jefferson St., Chicago.

PHILADELPHIA

J. G. BRILL COMPANY,

—BUILDERS OF—

Railway, Tramway and Electric Car Bodies of all Classes and Descriptions.

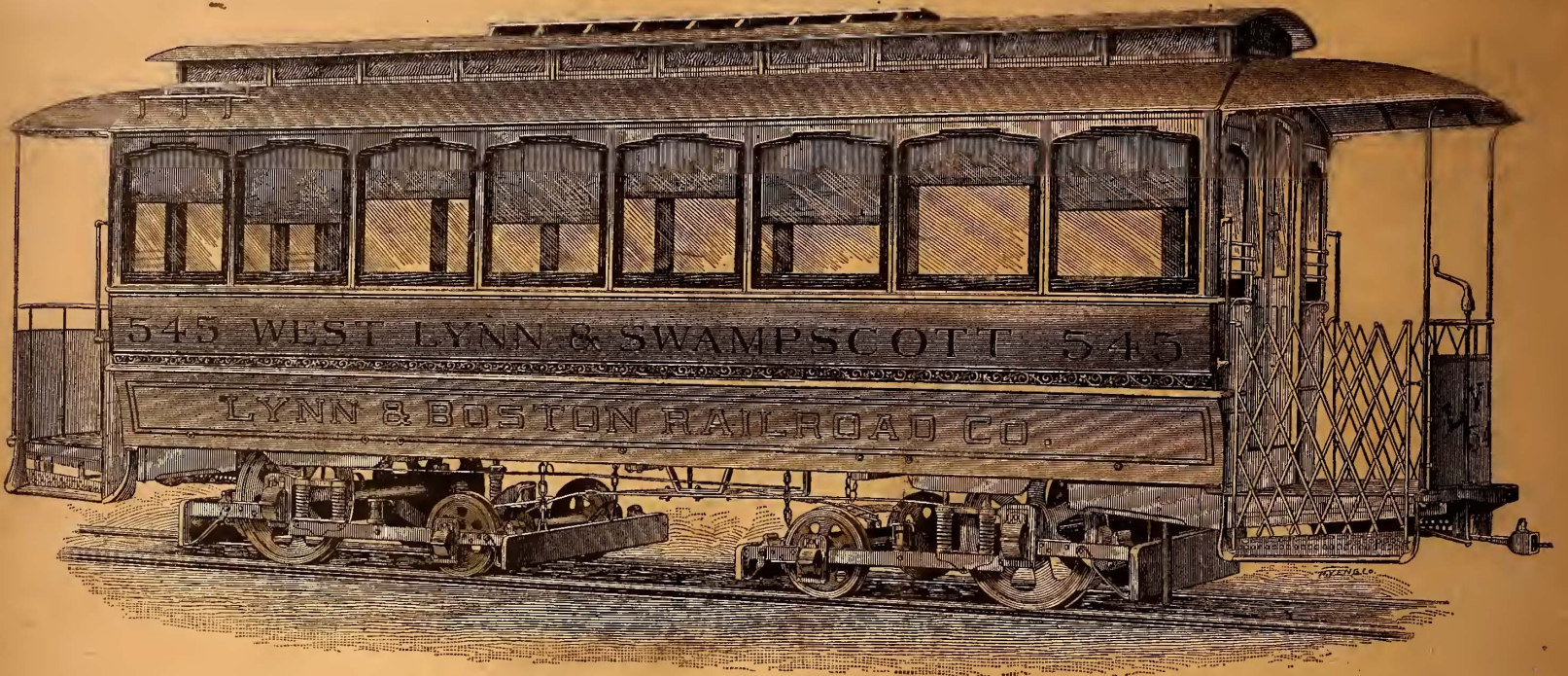

23 ft. 6 in. Electric Motor Car Body, Mounted on Eureka Maximum Traction No. 22 Trucks.

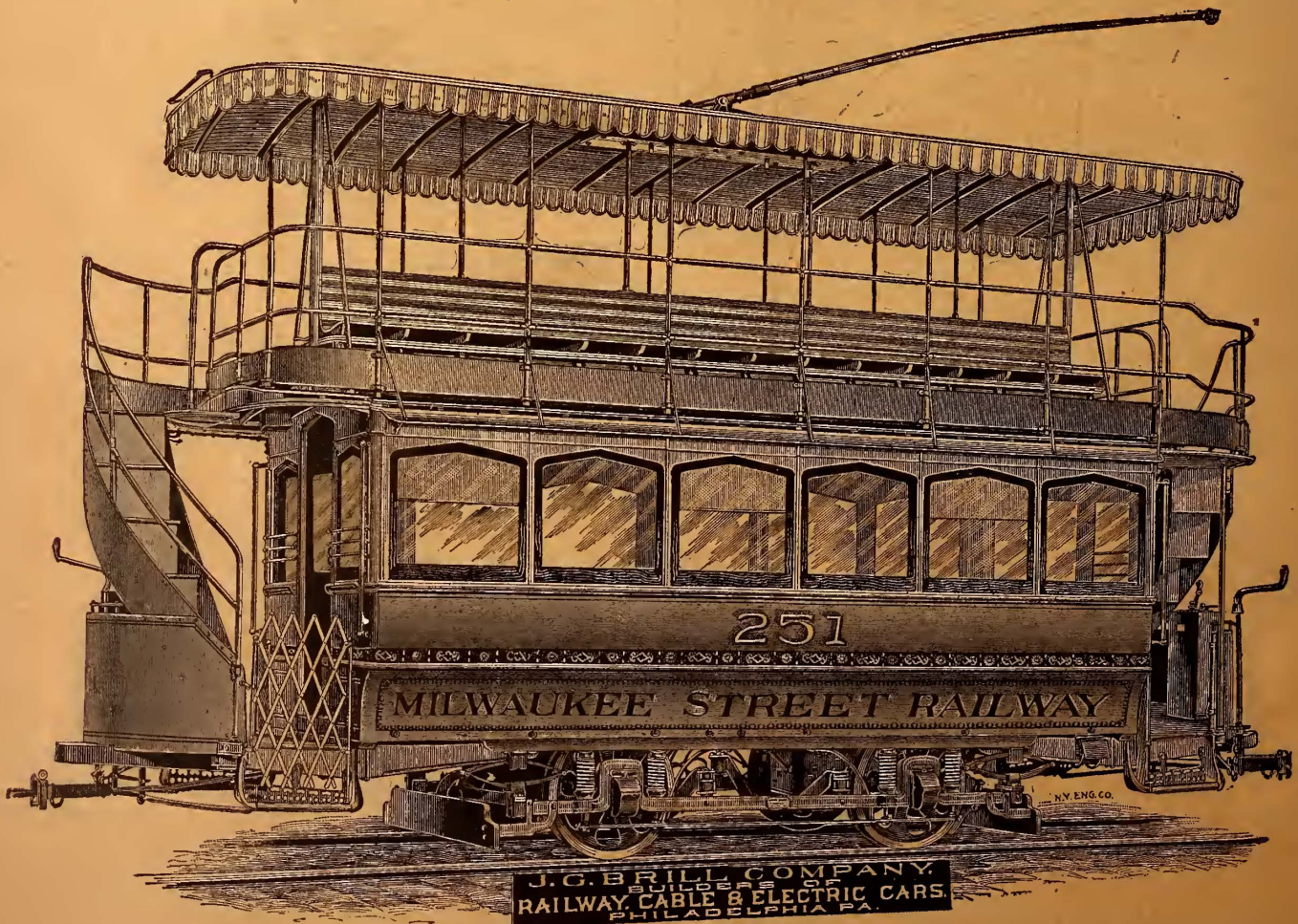

J. G. BRILL COMPANY,
BUILDERS OF
RAILWAY, CABLE & ELECTRIC CARS,
PHILADELPHIA, PA.

Double Deck Electric Motor Body Mounted on Brill No. 21 Independent Rigid Trucks Having Solid Forged Axle Box Frame.

PRICES, CATALOGUES AND INFORMATION FURNISHED ON APPLICATION.

WESTERN OFFICE, MONADNOCK BUILDING, CHICAGO, ILL.

CAR WORKS.

J. G. BRILL COMPANY,

—BUILDERS OF—

Electric, Cable, Grip and Suburban Car Trucks.

Special Attention Given to Construction of Electric Cars of Special Design.

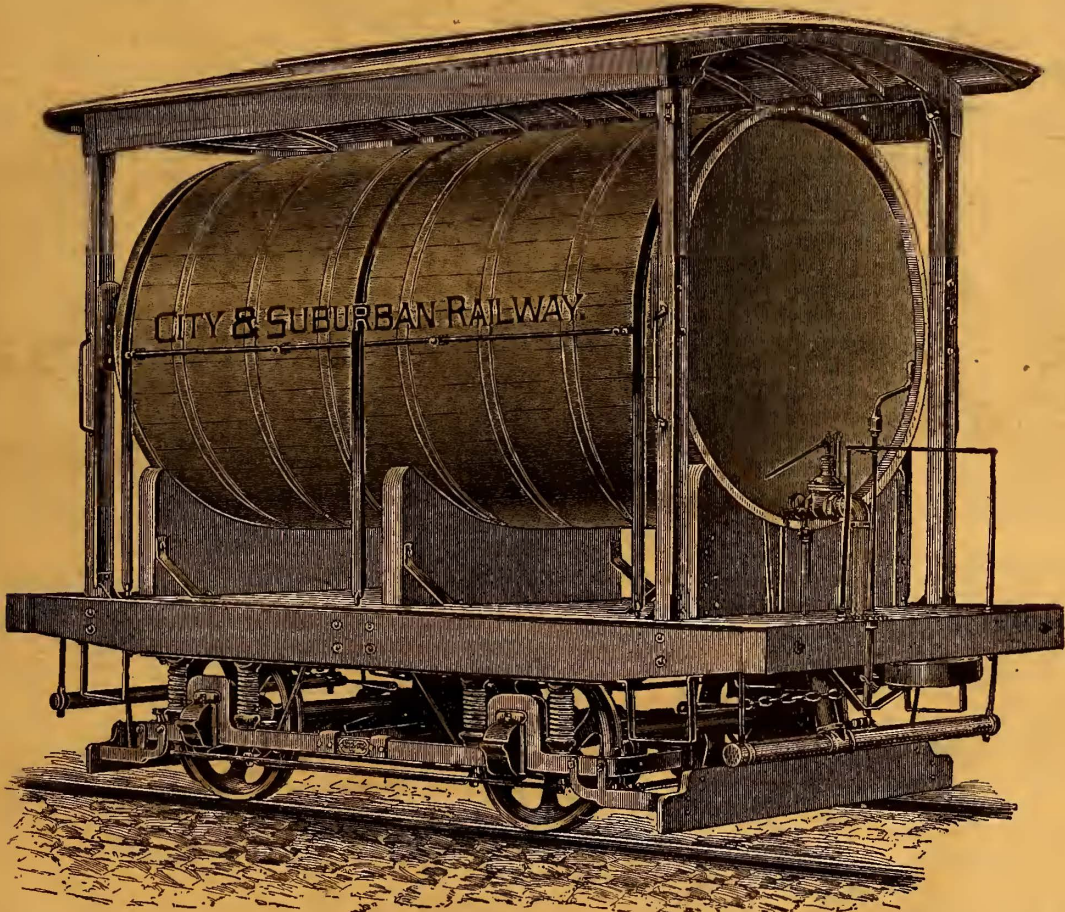

Sprinkling Car Body, Capacity 2,390 gallons, and Mounted on Brill No. 7 Truck, with Forged Axle Box Frame.

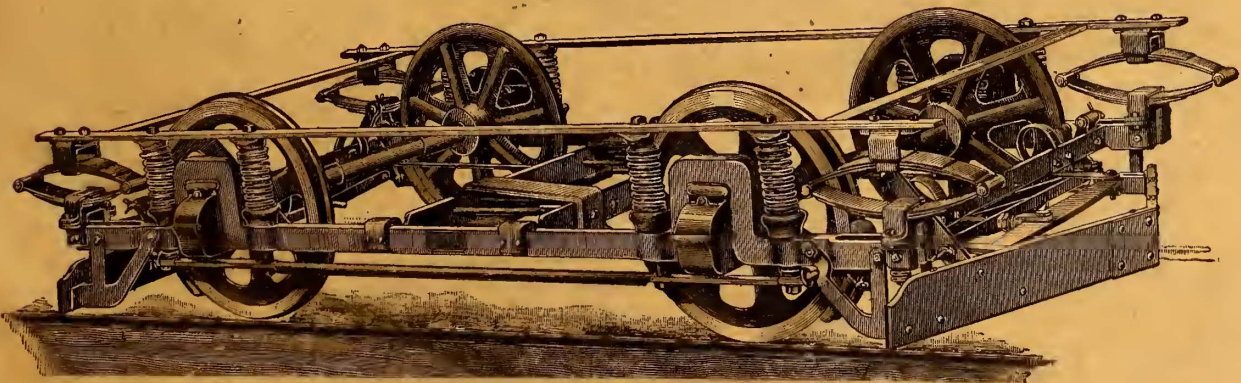

Brill No. 21 Independent Rigid Electric Motor Truck, Embodying Simplicity of Construction, Most Powerful Brakes, Upper "Chord" Holding Truck and Car Body in Square. **Solid Wrought Forged Axle Box Frame**, Elliptic Spring Buffers being Auxiliary in their Action to the Coil Springs, Overcoming Oscillation.

Works Situated on Lines of Penn'a. R. R. and B. & O. R. R., Ten Minutes from Philadelphia.

1831.

1893.

JOHN STEPHENSON
 LIMITED,
NEW YORK.
CO.,

CARS

HORSE * ELECTRIC * CABLE.



Plain==Practical==Permanent.

Twin Automatic Doors, Affording Largest
 Capacity for Entrance and Exit.

LIGHT. * ELEGANT. * DURABLE.