

# Link Union Station

Final Drainage and Water Quality Technical Reports

January 2026

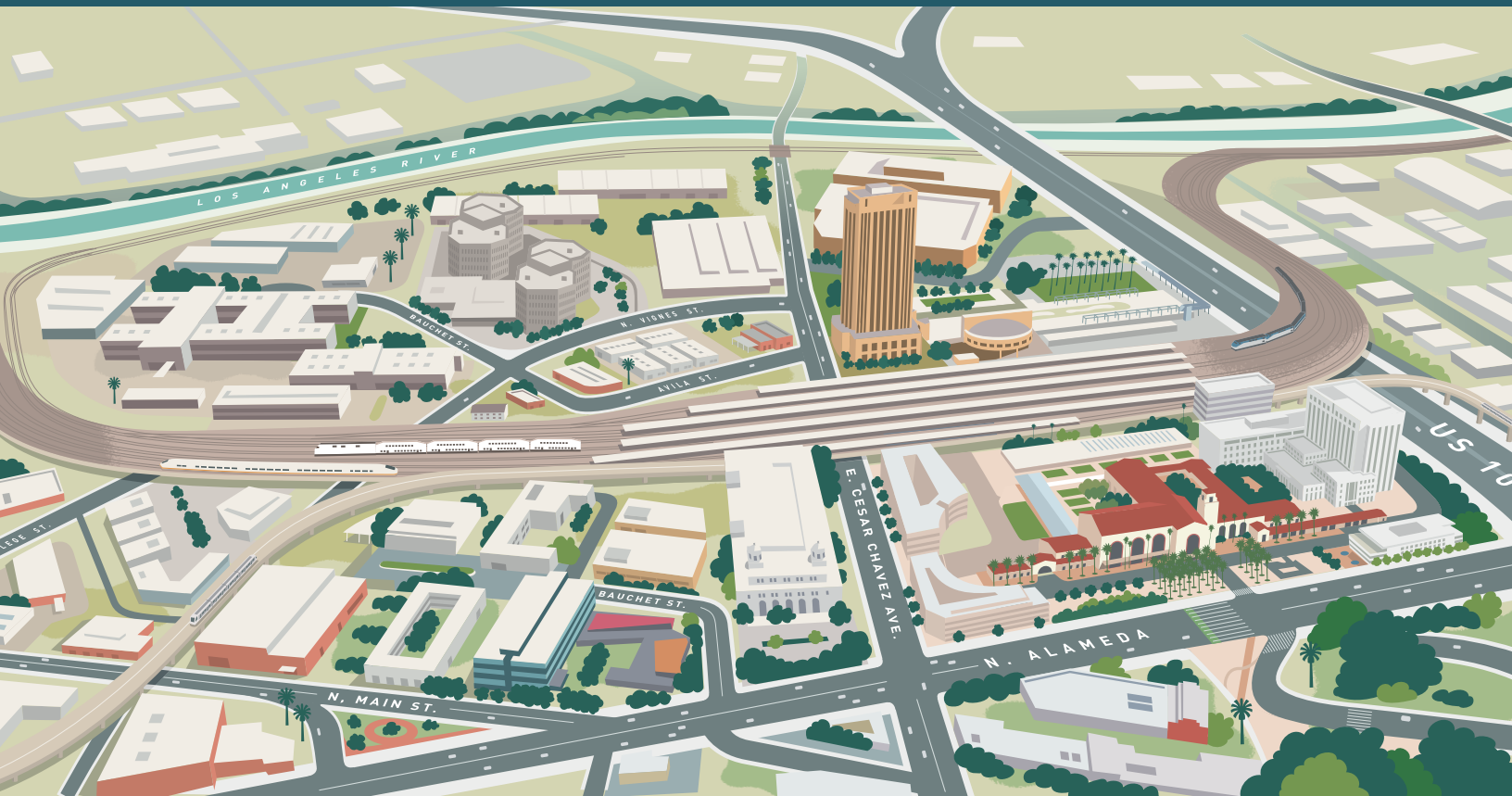

The environmental review, consultation, and other actions required by applicable Federal environmental laws for this project are being, or have been, carried out by the State of California pursuant to 23 U.S.C. 327 and a Memorandum of Understanding dated July 23, 2019, renewed July 22, 2024, and executed by the Federal Railroad Administration and the State of California.

**(THIS PAGE INTENTIONALLY BLANK)**



**(THIS PAGE INTENTIONALLY BLANK)**

**CONTENTS**

**ES.0 Executive Summary ..... v**

**1.0 Introduction ..... 1**

1.1 Purpose ..... 2

1.2 Need ..... 2

1.3 Project Location and Study Area ..... 2

1.4 Project Alternatives ..... 9

1.4.1 No Action Alternative ..... 9

1.4.2 Build Alternative ..... 10

1.4.3 Rail Yard Canopy Design Options ..... 11

1.5 Project Implementation Approach ..... 11

1.5.1 Interim Condition (Phase A) ..... 11

1.5.2 Full Build-Out Condition (Phase B) ..... 12

1.6 Report Purpose ..... 13

1.7 Approach to Water Quality Assessment ..... 13

**2.0 Regulatory Setting ..... 17**

2.1 Federal Laws and Requirements ..... 17

2.1.1 Clean Water Act (1972) ..... 17

2.1.2 National Flood Insurance Act (1968) ..... 18

2.1.3 Flood Disaster Protection Act (1973) ..... 19

2.1.4 Federal Antidegradation Policy ..... 19

2.1.5 Executive Order 11988 – Floodplain Management (1977) ..... 19

2.1.6 Department of Transportation Order 5650.2 – Floodplain Management and Protection (1979) ..... 19

2.2 State Laws and Regulations ..... 19

2.2.1 Porter-Cologne Water Quality Control Act (1969) ..... 19

2.2.2 Cobey-Alquist Flood Plain Management Act (Cal. Water Code, Section 8400 et seq.) (1965) ..... 20

2.2.3 Water Quality Control Plan, Los Angeles Region (2014) ..... 20

2.2.4 California Toxics Rule (1994) ..... 20

2.2.5 State Requirements under Section 402 of the Clean Water Act ..... 21

2.3 Regional and Local Requirements ..... 24

2.3.1 Municipal National Pollutant Discharge Elimination System Permit (2021) ..... 24

2.3.2 Enhanced Watershed Management Program for the Upper Los Angeles River Watershed ..... 27

2.3.3 Southern California Regional Rail Authority Design Criteria Manual (2014) ..... 32

2.3.4 Water Quality Compliance Master Plan for Urban Runoff (2009) ..... 32

2.3.5 City of Los Angeles Municipal Code (1998) ..... 32

2.3.6 City of Los Angeles General Plan Conservation Element (2001) ..... 32

2.3.7 City of Los Angeles General Plan Safety Element (1996) ..... 32

2.3.8 General Waste Discharge Requirements for Dewatering (2013) ..... 33

2.3.9 General Waste Discharge Requirements for Dewatering from Contaminated Activities (2013) ..... 33

**3.0 Existing Conditions ..... 35**

3.1 General Environmental Setting ..... 35

3.1.1 Population and Land Use ..... 35

3.1.2	Topography .....	35
3.1.3	Hydrology .....	35
3.1.4	Geology/Soils .....	56
3.1.5	Biological Communities .....	57
<b>4.0</b>	<b>Environmental Consequences .....</b>	<b>59</b>
4.1	Introduction .....	59
4.2	Potential Effects on Water Quality.....	59
4.2.1	Anticipated Changes to the Physical/Chemical Characteristics of the Aquatic Environment .....	59
4.2.2	Anticipated Changes to the Biological Characteristics of the Aquatic Environment.....	66
4.2.3	Anticipated Changes to the Human Use Characteristics of the Aquatic Environment .....	67
4.2.4	Short-Term Effects during Construction.....	67
4.2.5	Long-Term Effects during Operation and Maintenance.....	69
<b>5.0</b>	<b>Mitigation Measures .....</b>	<b>71</b>
5.1	California Department of Transportation .....	72
5.2	Non-California Department of Transportation.....	72
<b>6.0</b>	<b>References.....</b>	<b>73</b>

**TABLES**

Table 2-1.	Total Maximum Daily Loads Applicable to the Upper Los Angeles River Enhanced Watershed Management Programs .....	31
Table 3-1.	Surface Water Quality Objectives.....	49
Table 3-2.	Groundwater Quality Objectives.....	52
Table 3-3.	Los Angeles River Water Quality - 2005 Results .....	53
Table 3-4.	2020–2022 Clean Water Act Section 303(d) Listed Waterbodies and Pollutants of Concern.....	55

**FIGURES**

Figure 1-1.	Project Location and Regional Vicinity .....	5
Figure 1-2.	Project Study Area .....	7
Figure 1-3.	Overview of Project Footprint (Maximum Extent of Physical Disturbance).....	15
Figure 2-1.	Upper Los Angeles River Enhanced Watershed Management Programs Area .....	29
Figure 3-1.	Regional Hydrology.....	37
Figure 3-2.	Watersheds and Surface Waters (CalWater Watersheds).....	41
Figure 3-3.	Flood Insurance Rate Map of Project Study Area.....	47

**ACRONYMS**

bgs	below ground surface
BMP	Best Management Practice
Caltrans	California Department of Transportation
CFR	Code of Federal Regulations
CGP	Construction General Permit
CHSRA	California High-Speed Rail Authority
CWA	Clean Water Act
EIS	Environmental Impact Statement
EO	Executive Order
EPA	Environmental Protection Agency
EWMP	Enhanced Watershed Management Program
FDPA	Federal Disaster Protection Act
FEMA	Federal Emergency Management Agency
FIRM	Flood Insurance Rate Map
FRA	Federal Railroad Administration
HSA	Hydrologic Subarea
HSR	High-Speed Rail
HU	Hydrologic Unit
IGP	Industrial General Permit
LAUS	Los Angeles Union Station
LID	Low Impact Development
Link US	Link Union Station
Metro	Los Angeles County Metropolitan Transportation Authority
mg/L	milligrams per liter
MS4	Municipal Separate Storm Sewer System
NEPA	National Environmental Policy Act
NFIP	Nation Flood Insurance Program
NPDES	National Pollutant Discharge Elimination System
POC	Pollutant of Concern
Project	Link Union Station Project
RCP	Reinforced Concrete Pipe
ROW	Right-of-Way
RWQCB	Regional Water Quality Control Board

SCRRA	Southern California Regional Rail Authority (SCRRA or Metrolink)
SUSMP	Standard Urban Stormwater Mitigation Plan
SWMP	Stormwater Management Plan
SWPPP	Stormwater Pollution Prevention Plan
SWRCB	State Water Resources Control Board
TMDL	Total Maximum Daily Load
ULAR	Upper Los Angeles River
U.S.	United States
US-101	United States Highway 101
WQAR	Water Quality Assessment Report

## ES.0 Executive Summary

This Link Union Station (Link US) Project (Project or proposed action) Water Quality Assessment Report (WQAR) includes an evaluation of the proposed infrastructure within California Department of Transportation (Caltrans) right-of-way (ROW) (United States Highway 101 [US-101] Viaduct) and outside of Caltrans ROW, utilizing the Project footprint for the Build Alternative.

The purpose of this WQAR is to provide the technical analysis to support the environmental evaluation pursuant to the National Environmental policy Act (NEPA) and provide information for future National Pollutant Discharge Elimination System (NPDES) permitting.

During construction, excavated soil would be exposed, and there would be an increased potential for soil erosion compared with existing conditions. Chemicals, liquid products, petroleum products (e.g., paints, solvents, and fuels), and concrete-related waste may be spilled or leaked as part of construction and have the potential to be transported via storm runoff into receiving waters. In addition, if the excavated underlying soil contains hazardous materials, there is a possibility those materials could enter the stormwater runoff.

A Storm Water Pollution Prevention Plan (SWPPP) would be prepared and implemented during construction. The SWPPP would identify the specific best management practices (BMP), such as good housekeeping, erosion control, and sediment control, to be implemented during construction so as not to cause or contribute to an exceedance of any applicable water quality standards contained in the Los Angeles Regional Water Quality Control Board (RWQCB) Basin Plan. These BMPs would be designed to meet the technology requirement as stipulated in the construction general permit (CGP).

Implementation of the Build Alternative would result in a permanent increase in impervious surfaces and a permanent increase in runoff and pollutant loading. Pollutants of concern (POC) from the railroad include sediments, heavy metals, oil and grease, trash and debris, pesticides, and organic compounds. For the Build Alternative, the total existing and maximum proposed impervious surface areas are 47.10 and 52.40 acres, respectively, which equates to 5.30 acres of new impervious surface area.

Within Caltrans ROW, the impervious surface area increases under the Build Alternative. The total existing and maximum proposed impervious surface areas in Caltrans ROW are 6.72 and 6.86 acres, which results in a net increase of 0.14 acre. Additional areas calculated within the Caltrans ROW include disturbed soils area (2.82 acres), replaced impervious surface (1.24 acres), new impervious surface (1.38 acre), and post construction treatment area (2.95 acres).

Currently, runoff from the Project study area is untreated. Source control and treatment BMPs would be incorporated into the design of proposed infrastructure consistent with the *Long Form - Stormwater Data Report* (Caltrans ROW) and Low Impact Development (LID) Plan (non-Caltrans ROW) to address operational POCs.

Proposed source control BMPs include:

- Education of property owners;
- Activity restrictions;
- Spill contingency plans;
- Employee training and education program;
- Common area BMP inspection;
- Storm drain signage;
- Trash storage areas and litter control; and
- Alternative building materials (e.g., concrete instead of wood ties).

Proposed treatment control BMPs would be consistent with the *Project Planning and Design Guide* (Caltrans ROW) and City of Los Angeles *Planning and Land Development Handbook for Low Impact Development* (LID Manual) (City of Los Angeles 2016) (non-Caltrans ROW). Proposed treatment control BMPs include underground cisterns to reduce runoff volumes and associated pollutants to downstream waterbodies. As compared with the existing condition, any excess runoff is attributed to the proposed increase in impervious surfaces under the Build Alternative. Similarly, capture and use (Tier 2) BMPs and bioretention (Tier 3) BMPs are incorporated in the design to treat the runoff prior to discharge to the local storm drain system. These BMPs are an intermediate tier of LID required by the City of Los Angeles. The preferred tier (Tier 1) of LID, infiltration and associated infiltration-type BMPs, is not proposed, given the potential for contaminated soils in the Project study area (Metro 2025c).

The Build Alternative would result in no adverse effect on water quality with implementation of the following mitigation measures:

- **WQ-1: Prepare and Implement a SWPPP.** This measure would reduce potential construction-related adverse effects on the substrate and on water quality caused by suspended particulates (turbidity); oil, grease, and chemical pollutants; trash and debris; and erosion and accretion patterns.
- **WQ-2: Comply with Local Dewatering Requirements.** This measure would reduce potential construction-related adverse effects caused by dewatering activities.
- **WQ-3: Comply with Local Dewatering Requirements for Contaminated Sites.** This measure would reduce potential construction-related adverse effects caused by dewatering activities on contaminated sites.
- **WQ-4: Final Water Quality BMP Selection (Caltrans ROW).** Compliance with the Caltrans Municipal Separate Storm Sewer System (MS4) Permit as it applies to the US-101 overhead viaduct improvements would reduce potential adverse effects caused by suspended particulates (turbidity) and oil, grease, and chemical pollutants in the Caltrans ROW during operations.

- **WQ-5: Final Water Quality BMP Selection (Railroad ROW).** Compliance with the Small MS4 permit for areas within the railroad ROW would reduce potential adverse effects caused by increased stormwater runoff, suspended particulates (turbidity), and oil, grease, and chemical pollutants during operations.
- **WQ-6: Final Water Quality BMP Selection (City of Los Angeles).** Compliance with the Los Angeles and Ventura County MS4 permit as it applies to areas outside of the Caltrans and railroad ROW would reduce potential adverse effects caused by increased stormwater runoff, suspended particulates (turbidity), oil, grease, and chemical pollutants, trash and debris, and erosion and accretion patterns during operations.
- **WQ-7: Prepare and Implement Industrial SWPPP for Relocated, Regulated Industrial Uses.** Compliance with the Industrial General Permit (IGP) for demolished, relocated, or new industrial-related properties would reduce potential construction-related adverse effects caused by oil, grease, and chemical pollutants.

(THIS PAGE INTENTIONALLY LEFT BLANK)

## 1.0 Introduction

The Los Angeles County Metropolitan Transportation Authority (Metro), as the owner of Los Angeles Union Station (LAUS), is proposing the infrastructure improvements associated with the Link Union Station (Link US) Project (Project or proposed action) to address existing capacity constraints at LAUS. For the purposes of the National Environmental Policy Act (NEPA), Metro is serving as the local Project sponsor and joint lead agency.

Pursuant to 23 United States Code (USC) Section 327 and a memorandum of understanding (MOU) between the Federal Railroad Administration (FRA) and the State of California, effective July 23, 2019, under a program known as NEPA Assignment, the California High-Speed Rail Authority (CHSRA) is responsible for the federal review and approval of environmental documents for projects on the high-speed rail (HSR) system and other passenger rail projects that directly connect to the HSR system, including the Link US Project. For the purposes of the environmental impact statement (EIS) being prepared, CHSRA is serving as the federal lead agency with NEPA responsibilities pursuant to the requirements of the NEPA Assignment MOU. CHSRA and Metro are preparing the EIS in compliance with NEPA (42 USC Section 4321 et seq.), the Council on Environmental Quality (CEQ) regulations implementing NEPA (40 Code of Federal Regulations [CFR] Parts 1500–1508), FRA's Procedures for Considering Environmental Impacts (FRA's Environmental Procedures) (*Federal Register* [FR] 64(101), 28545-28556, May 26, 1999), 23 USC Section 139, and the NEPA Assignment MOU.<sup>1, 2</sup>

Pursuant to the MOU requirements between FRA and the State of California, FRA's Environmental Procedures are being used to determine environmental effects of the No Action Alternative and the Build Alternative.

Below is an overview of the purpose and need, the Project study area, the No Action Alternative, and the major components associated with the on-site infrastructure improvements proposed at and within the vicinity of LAUS that are associated with the Build Alternative considered in the EIS.

---

<sup>1</sup> While this environmental document was being prepared, FRA adopted new NEPA compliance regulations (23 CFR 771). Those regulations only apply to actions initiated after November 28, 2018. See 23 CFR 771.109(a)(4). Because this environmental document was initiated prior to that date, it remains subject to FRA's Environmental Procedures rather than the Part 771 regulations.

<sup>2</sup> The CEQ issued new regulations, effective April 20, 2022, updating the NEPA implementing procedures at 40 CFR Parts 1500–1508. However, because this environmental document was initiated prior to the effective date, it is not subject to the new regulations and CHSRA is relying on the regulations as they existed on the date of the initial Notice of Intent, May 31, 2016. Therefore, all citations to CEQ regulations in this environmental document refer to the 1978 regulations and the 1986 amendment, 51 *Federal Register* 15618 (April 25, 1986).

## 1.1 Purpose

The purpose of the proposed action is to increase the regional and intercity rail service capacity of LAUS and to improve schedule reliability at LAUS through the implementation of a run-through tracks configuration and elimination of the current stub end tracks configuration while preserving current levels of freight rail operations, accommodating the planned HSR system in Southern California, increasing the passenger/pedestrian capacity and enhancing the safety of LAUS through the implementation of a new passenger concourse, meeting the multi-modal transportation demands at LAUS.

## 1.2 Need

The need for the proposed action is generated by the forecasted increase in regional population and employment; implementation of federal, state, and regional transportation plans (RTP) that provide for increased operational frequency for regional and intercity trains; and introduction of the planned HSR system in Southern California. Localized operational, safety, and accessibility upgrades in and around LAUS will be required to meet existing demand and future growth.

## 1.3 Project Location and Study Area

The Build Alternative consists of infrastructure improvements in Downtown Los Angeles in the vicinity of LAUS (Figure 1-1). LAUS is located at 800 Alameda Street in the City of Los Angeles, California. LAUS is bounded by United States Highway 101 (US-101) to the south, Alameda Street to the west, Cesar Chavez Avenue to the north, and Vignes Street to the east. The northern Project limit is at North Main Street (Mile Post 1.18) and the southern Project limit is in the vicinity of Control Point (CP) Olympic, south of Interstate 10 and Olympic Boulevard (Mile Post 142.70).

Figure 1-2 depicts the Project study area, which is generally used to characterize the affected environment, unless otherwise specified, and provide a geographic context for the existing and proposed infrastructure improvements at and within the vicinity of LAUS. The Project study area includes three main segments (Segment 1: Throat Segment, Segment 2: Concourse Segment, and Segment 3: Run-Through Segment). The existing conditions within each segment are summarized north to south below:

- **Segment 1: Throat Segment** – This segment, known as the LAUS throat, includes CP Chavez and the area north of the platforms at the LAUS rail yard, from North Main Street at the north to Cesar Chavez Avenue at the south. In the throat segment, all arriving and departing trains are required to traverse through a complex network of lead tracks, switches, and crossovers. Five lead tracks provide access into and out of the rail yard, except for one location near the Vignes Street Bridge, where it reduces to four lead tracks. Currently, special track work consisting of multiple turnouts and double-slip switches are used in the throat to direct trains into and out of the appropriate assigned terminal platform tracks. The Garden Tracks (stub-end tracks where private train cars are currently stored) are also located just north of the platforms. Land uses in the vicinity of the throat segment are residential, industrial, and institutional.

- **Segment 2: Concourse Segment** – This segment is between Cesar Chavez Avenue and US-101 and includes LAUS, the rail yard, the East Portal Building, the baggage handling building with associated parking areas and access roads, the ticketing/waiting halls, and the 28-foot-wide pedestrian passageway with connecting ramps and stairways below the rail yard. Land uses in the vicinity of the concourse segment are residential, commercial, and public.
- **Segment 3: Run-Through Segment** – This segment is south of LAUS and extends east to west from Alameda Street to the west bank of the Los Angeles River and north to south from Keller Yard to CP Olympic. This segment includes US-101, the Commercial Street/Ducommun Street corridor, Metro Red and Purple Lines Maintenance Yard (Division 20 Rail Yard), BNSF Railway (BNSF) West Bank Yard, Keller Yard, the main line tracks on the west bank of the Los Angeles River from Keller Yard to CP Olympic, and the Amtrak lead track connecting the main line tracks with Amtrak’s Los Angeles Maintenance Facility in the vicinity of 8th Street. Land uses in the vicinity of the run-through segment are primarily industrial and manufacturing.

The Project study area has a dense street network ranging from major highways to local city streets. The roadways within the Project study area include the El Monte Busway, US-101, Bolero Lane, Leroy Street, Bloom Street, Cesar Chavez Avenue, Commercial Street, Ducommun Street, Jackson Street, East Temple Street, Banning Street, First Street, Alameda Street, Garey Street, Vignes Street, Main Street, Aliso Street, Avila Street, Bauchet Street, and Center Street.

(THIS PAGE INTENTIONALLY LEFT BLANK)

Figure 1-1. Project Location and Regional Vicinity

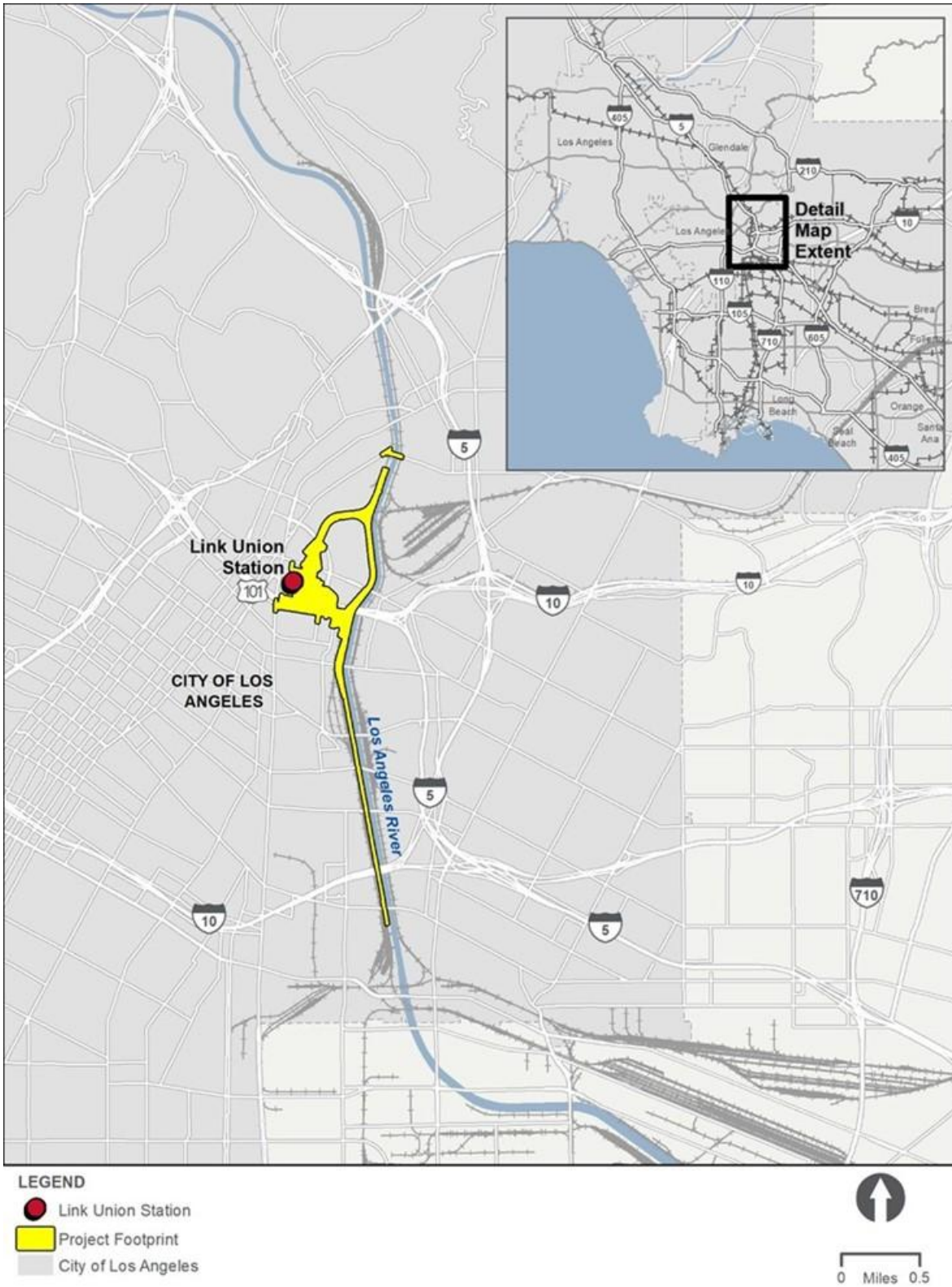

(THIS PAGE INTENTIONALLY LEFT BLANK)

Figure 1-2. Project Study Area

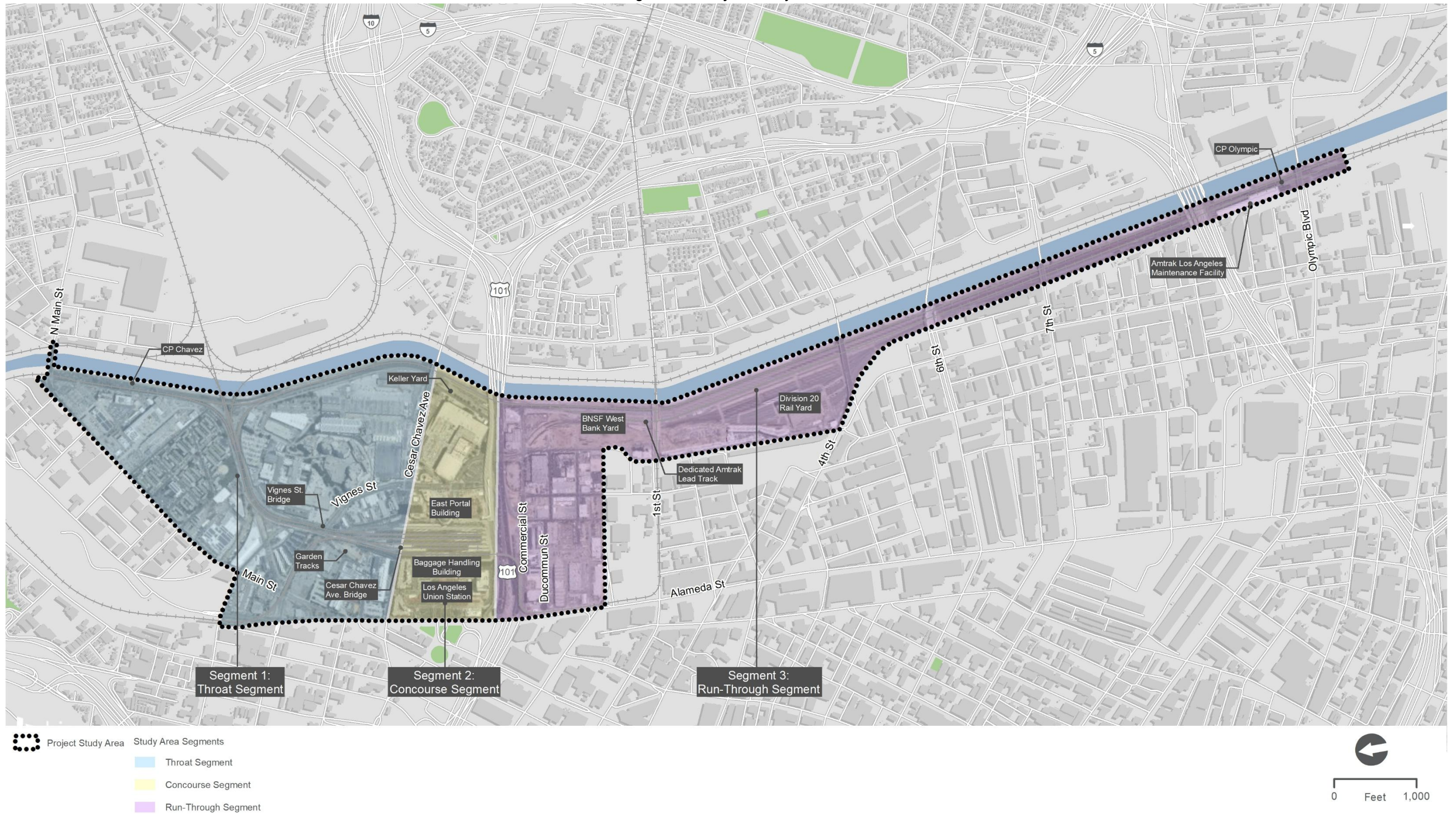

(THIS PAGE INTENTIONALLY LEFT BLANK)

## 1.4 Project Alternatives

The EIS includes an evaluation of the No Action Alternative and one build alternative (Build Alternative). The Build Alternative would include, but not be limited to, new lead tracks north of LAUS (Segment 1: Throat Segment), an elevated throat and rail yard with concourse-related improvements at LAUS (Segment 2: Concourse Segment), and 10 run-through tracks south of LAUS (Segment 3: Run-Through Segment).

### 1.4.1 No Action Alternative

NEPA (40 CFR 1502.14(d)) requires federal agencies to include an analysis of “the alternative of no action.” For NEPA purposes, the No Action Alternative is the baseline against which the effects of implementing the Build Alternative is evaluated against to determine the extent of environmental and community effects. For the No Action Alternative, the baseline year is 2016, and the horizon year is 2040.

The No Action Alternative represents the future conditions that would occur if the proposed infrastructure improvements and the operational capacity enhancements at LAUS were not implemented. The No Action Alternative reflects the foreseeable effects of growth planned for the area in conjunction with other existing, planned, and reasonably foreseeable projects and infrastructure improvements in the Los Angeles area, as identified in planning documents prepared by Southern California Association of Governments (SCAG), Metro, and/or Metrolink, including the 2023 Federal Transportation Improvement Program (FTIP) (SCAG 2023), *Final 2008 Regional Comprehensive Plan* (SCAG 2008), and the 2020 RTP/Sustainable Communities Strategy (SCS): Connect SoCal (SCAG 2020).

Conditions in the Project study area would remain similar to the existing condition, as described below:

- **Segment 1: Throat Segment** – Trains would continue to operate on five lead tracks that do not currently accommodate the planned HSR system. The tracks north of LAUS would remain at the current elevation, and the Vignes Street Bridge and Cesar Chavez Avenue Bridge would remain in place.
- **Segment 2: Concourse Segment** – LAUS would not be transformed from a stub-end tracks station into a run-through tracks station, and the 28-foot-wide pedestrian passageway would be retained in its current configuration. No modifications to the existing passenger circulation routes or addition of vertical circulation elements (escalators and elevators) at LAUS would occur.
- **Segment 3: Run-Through Segment** – Commercial Street would remain in its existing configuration, and implementation of active transportation improvements would likely be implemented along Center Street in concert with the *Connect US Action Plan* (Metro 2015). No modifications to the BNSF West Bank Yard would occur.

## 1.4.2 Build Alternative

The key components associated with the Build Alternative are summarized north to south below:

- **Segment 1: Throat Segment (lead tracks and throat track reconstruction)** – The Build Alternative includes subgrade and structural improvements in Segment 1 of the Project study area (throat segment) to increase the elevation of the tracks leading to the rail yard. The Build Alternative includes the addition of one new lead track in the throat segment for a total of six lead tracks to facilitate enhanced operations for regional/intercity rail trains (Metrolink/Amtrak) and operations for HSR trains within a shared track alignment. Regional/intercity and HSR trains would share the two western lead tracks in the throat segment. The existing railroad bridges in the throat segment at Vignes Street and Cesar Chavez Avenue would also be reconstructed. North of CP Chavez on the west bank of the Los Angeles River, the Build Alternative also includes safety improvements at the Main Street public at-grade railroad crossing (medians, restriping, signals, and pedestrian and vehicular gate systems) to facilitate future implementation of a quiet zone by the City of Los Angeles.
- **Segment 2: Concourse Segment (elevated rail yard and expanded passageway)** – The Build Alternative includes an elevated rail yard and expansion of the existing 28-foot-wide pedestrian passageway in Segment 2 of the Project study area (concourse segment). The rail yard would be elevated approximately 15 feet. New passenger platforms would be constructed on the elevated rail yard with associated vertical circulation elements (stairs, escalators, and elevators) to enhance safety elements and improve Americans with Disabilities Act (ADA) accessibility. Platform 1, serving the Gold Line, would be lengthened, and elevated to optimize east to west passenger circulation. The pedestrian passageway would be expanded at the current grade to a 140-foot width to accommodate a substantial increase in passenger capacity with new functionally modern passenger amenities while providing points of safety to meet applicable California Building Code (CBC) and National Fire Protection Association (NFPA) 130 Standards for Fixed Guideway Transit Systems. The expanded passageway and associated concourse improvements would facilitate enhanced passenger circulation and provide space for ancillary support functions (back-of-house uses, baggage handling, etc.), transit-serving retail, and office/commercial uses while creating an opportunity for an outdoor, community-oriented space with new plazas east and west of the elevated rail yard (East and West Plazas). Amtrak ticketing and baggage check-in services would be enhanced, and new baggage carousels would be constructed in a centralized location under the rail yard. A canopy would be constructed over the West Plaza up to 70 feet in height, and two design options are considered for canopies that would extend over the rail yard (Section 1.4.3).
- **Segment 3: Run-Through Segment (10 run-through tracks)** – The Build Alternative includes 10 new run-through tracks south of LAUS in Segment 3 of the Project study area (run-through segment). The Build Alternative includes common rail infrastructure from LAUS to the west bank of the Los Angeles River (vicinity of First Street

Bridge) to support run-through tracks for both regional/intercity rail trains and HSR trains. At the BNSF West Bank Yard, dedicated lead tracks for Amtrak trains and BNSF trains, in combination with implementation of common rail infrastructure would result in permanent loss of freight rail storage track capacity at the north end of BNSF West Bank Yard (5,500 track feet).

The Build Alternative would also require modifications to US-101 and local streets (including potential street closures and geometric modifications); improvements to railroad signal, positive train control (PTC), and communication systems; modifications to the Gold Line light rail platform and tracks; modifications to the main line tracks on the west bank of the Los Angeles River; modifications to the Amtrak lead track; addition of access roadways to the railroad right-of-way (ROW); land acquisitions; addition of utilities; utility relocations, replacements, and abandonments; and addition of drainage facilities/water quality improvements.

### 1.4.3 Rail Yard Canopy Design Options

Two design options for canopies over the elevated platforms in the rail yard are considered in conjunction with the concourse-related improvements as part of the Build Alternative.

- **Rail Yard Canopy Design Option 1 (individual canopies)** – This design option would include replacing the existing historic butterfly canopies with individual canopies above each platform. New individual canopies would extend up to 25 feet above each platform and would be similar in form to the existing butterfly canopies but sized to fit the widened and lengthened platforms. Platform lengths would vary between 450 and 1,445 feet. Platforms would be up to 30 feet wide.
- **Rail Yard Canopy Design Option 2 (grand canopy)** – This design option would include replacing the existing historic butterfly canopies with a large grand canopy that would extend up to 75 feet above the elevated rail yard platforms. The grand canopy would be up to 1,500 feet long and wide enough to provide cover over all elevated platforms in the rail yard.

## 1.5 Project Implementation Approach

The implementation of infrastructure improvements would generally occur in two main phases that are evaluated as scenario years in the EIS: the interim condition and the full build-out condition. The infrastructure improvements for each of these scenarios are described below.

### 1.5.1 Interim Condition (Phase A)

The interim condition (also referred to as Phase A) is when the run-through track infrastructure south of LAUS and the associated signal modifications, property acquisitions, and civil/structural improvements to facilitate new run-through service would be implemented. The interim condition does not include new lead tracks north of LAUS, or the elevated rail yard and new concourse-related improvements at LAUS. The interim condition aligns with a construction completion date as early as 2026.

A summary of the proposed activities associated with the interim condition is provided below.

- Acquire properties south of LAUS within the Project footprint.
- Relocate utilities north and south of LAUS.
- Acquire a portion of the BNSF West Bank Yard (majority north of First Street) and remove 5,500 feet of existing storage tracks at BNSF West Bank Yard.
- Construct special track work and modify signal/communication infrastructure north of LAUS.
- Construct a run-through track ramp on the southern extent of Platform 4 at LAUS.
- Construct a common viaduct/deck over US-101.
- Construct a common embankment from Vignes Street to Center Street south of LAUS.
- Construct common Center Street Bridge south of LAUS.
- Construct common embankment or new common bridge from Center Street to Amtrak Bridge south of LAUS.
- Construct common Amtrak Bridge south of LAUS.
- Construct Division 20 access road.
- Construct common rail embankment on the west bank of the Los Angeles River (from Amtrak Bridge to First Street Bridge).
- Construct new dedicated lead tracks for BNSF freight trains and Amtrak trains.
- Construct two run-through tracks from Platform 4 at LAUS to the main line tracks along the west bank of the Los Angeles River.

Some embankments and/or bridges south of LAUS could be constructed in a phased manner.

### **1.5.2 Full Build-Out Condition (Phase B)**

The full build-out condition (also referred to as Phase B) is when new lead tracks and the elevated throat north of LAUS, along with the elevated rail yard and concourse-related improvements at LAUS would be implemented. The full build-out condition aligns with a construction completion date as early as 2031.

A summary of the proposed activities associated with the full build-out condition is provided below.

- Construct new compatible lead tracks and reconstruct throat north of LAUS.
- Construct new bridges over Vignes Street and Cesar Chavez Avenue north of LAUS.

- Construct elevated rail yard, concourse-related improvements, and East/West Plazas at LAUS.
- Construct remaining run-through tracks for regional/intercity rail operations on previously constructed structures south of LAUS.

The full build-out condition includes the common rail infrastructure for the planned HSR system that would be located throughout the Link US Project limits, including improvements at LAUS. Operation of HSR trains would occur on two lead tracks north of LAUS, Platforms 2 and 3 and associated Tracks 3 through 6 at LAUS, and on HSR run-through tracks supported by common rail bridges and embankments south of LAUS. Operation of the planned HSR system is or will be considered in CHSRA’s environmental documentation for the Burbank to Los Angeles and Los Angeles to Anaheim Project Sections.

## 1.6 Report Purpose

The purpose of the WQAR is to:

- Provide the technical analysis to support the environmental evaluation pursuant to NEPA.
- Provide information for future NPDES permitting.

## 1.7 Approach to Water Quality Assessment

This WQAR includes an analysis of potential water quality effects of the Build Alternative, utilizing the area encompassing the maximum extent of physical disturbance (Project footprint). Figure 1-3 depicts the Project footprint for the Build Alternative.

The WQAR includes a discussion of the major Project components, general environmental setting of the Project study area, and regulatory framework with respect to water quality. It also provides data on surface water and groundwater resources within the Project study area and the water quality of these waters, describes water quality impairments and beneficial uses, identifies potential water quality effects/benefits associated with the Build Alternative considered, and identifies mitigation measures that are proposed to avoid and/or minimize effects on water quality.

This WQAR has been prepared in accordance with the *Water Quality Assessment Report Content and Recommended Format* (Caltrans 2017) and the Standard Environmental Reference. The Standard Environmental Reference applies to all transportation projects developed under the auspices of Caltrans and all local agency highway or local streets and roads projects with funding or approvals by the Federal Highway Administration. The recommended format has been modified to meet the needs of the Project. Being a multi-stakeholder project, the approach is for the WQAR to reflect requirements of Metro, Southern California Regional Rail Authority (SCRRA), CHSRA, City of Los Angeles, and Caltrans.

(THIS PAGE INTENTIONALLY LEFT BLANK)

Figure 1-3. Overview of Project Footprint (Maximum Extent of Physical Disturbance)

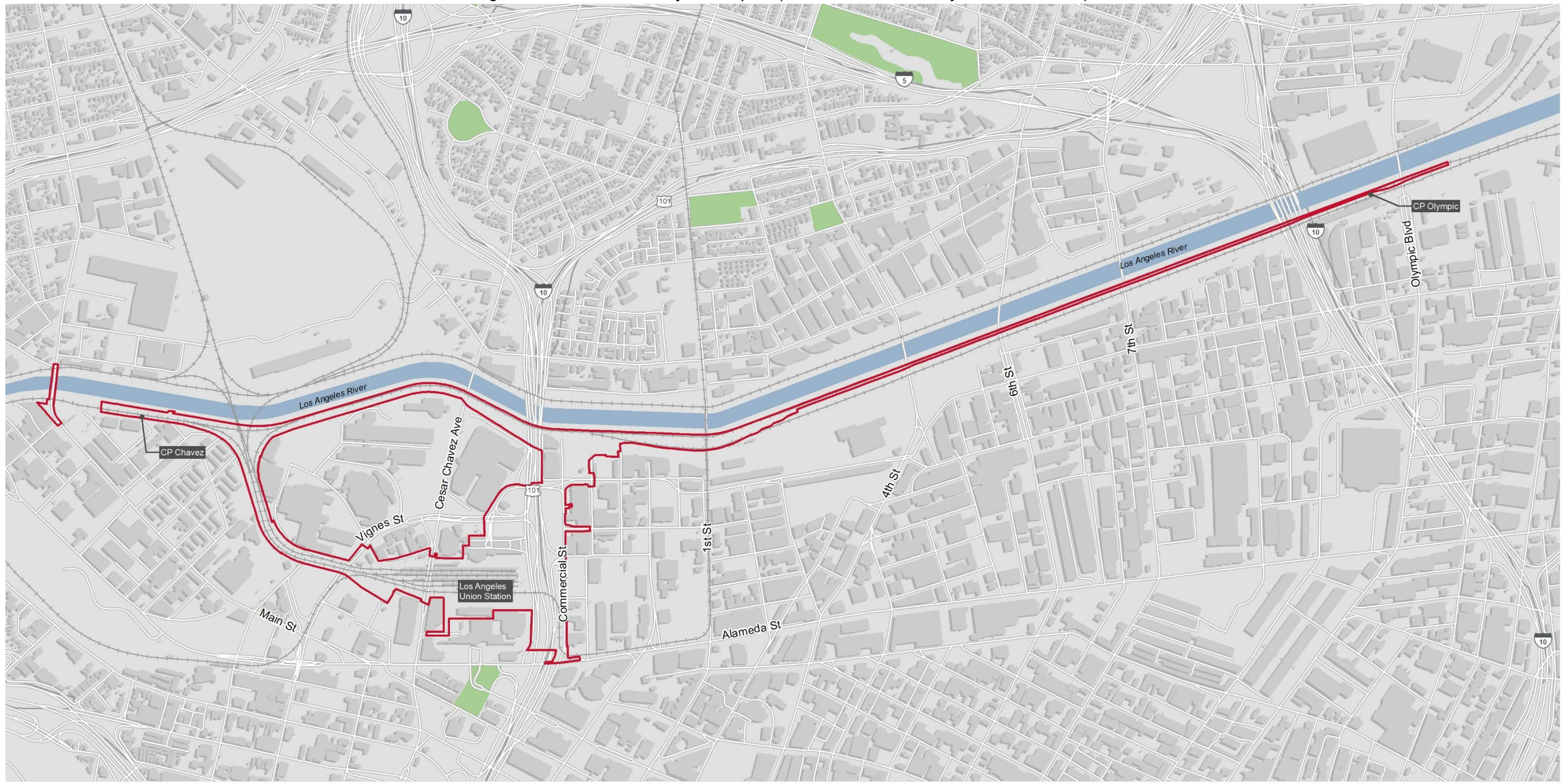

LEGEND

 Project Footprint

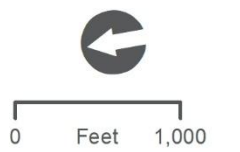

(THIS PAGE INTENTIONALLY LEFT BLANK)

## 2.0 Regulatory Setting

### 2.1 Federal Laws and Requirements

#### 2.1.1 Clean Water Act (1972)

In 1972, Congress amended the Federal Water Pollution Control Act, making the addition of pollutants to the waters of the U.S. from any point source unlawful unless the discharge complies with a National Pollutant Discharge Elimination System (NPDES) permit. Currently known as the Clean Water Act (CWA), it has been amended by Congress several times. The objective of the CWA is “to restore and maintain the chemical, physical, and biological integrity of the Nation’s waters.”

In the 1987 amendments, Congress directed dischargers of stormwater from municipal and industrial/construction point sources to comply with the NPDES permit program. Important CWA sections are as follows:

- Section 102 states that parties involved prepare or develop comprehensive programs for preventing, reducing, or eliminating the pollution of the navigable waters and ground waters and improving the sanitary condition of surface and underground waters.
- Sections 303 and 304 require states to promulgate water quality standards, criteria, and guidelines.
- Section 402 establishes the NPDES, a permitting system for the discharges (except for dredge or fill material) of any pollutant into waters of the U.S. The U.S. Environmental Protection Agency (EPA) delegated to the California State Water Resources Control Board (SWRCB) the implementation and administration of the NPDES program in California. The SWRCB established nine RWQCBs. The SWRCB enacts and enforces the federal NPDES program, as well as all water quality programs and regulations that cross regional boundaries. The nine RWQCBs enact, administer, and enforce all programs, including NPDES permitting, within their jurisdictional boundaries. Section 402(p) requires permits for discharges of stormwater from industrial, construction, and MS4s.

The State Water Resource Control Board and RWQCBs are responsible for establishing the water quality standards (objectives and beneficial uses) required by the CWA and regulating discharges to ensure compliance with the water quality standards.

The U.S. Army Corps of Engineers issues two types of Section 404 permits: General and Individual. There are two types of General permits: Regional and Nationwide. Regional permits are issued for a general category of activities when they are similar in nature and cause minimal environmental effect. Nationwide permits are issued to authorize a variety of minor project activities with no more than minimal effects. Based on the results of the Link US *Natural Environmental Study (Minimal Impact)* (Metro 2025b), no waters of the U.S. are located within the

Project study area; therefore, Sections 401 and 404 of the CWA are not applicable to the proposed action.

CWA Section 402(p) and the implementing regulations make a distinction between Large and Medium MS4s, which are commonly referred to as Phase I MS4s-and Small MS4s, referred to as Phase II MS4s. There are important differences in how Phase I and Phase II MS4s are regulated.

Large and Medium MS4s are called Phase I because they were included in the U.S. EPA’s first round of MS4 regulations in 1990. Large and Medium MS4s are subject to the same permitting requirements under the CWA, although some state permitting programs may have slightly different requirements for each. Phase I MS4s are classified based on the population served in the 1990 U.S. Census.

The Phase I (Large MS4) regulations include incorporated places with populations of 250,000 or more based on the 1990 U.S. Census, or counties with unincorporated urbanized areas with populations of 250,000 or more based on the 1990 U.S. Census. The Phase I (Medium MS4) regulations include incorporated places with populations between 100,000 and 250,000 based on the 1990 U.S. Census, or counties with unincorporated urbanized areas with populations between 100,000 and 250,000 based on the 1990 U.S. Census. Nationwide, there are approximately 855 Phase I MS4s covered by 250 Individual Permits.

Small MS4s are defined as any MS4 that does not meet the definition of a Large or Medium MS4. They are often called Phase II MS4s because they were included in the U.S. EPA’s second round of MS4 regulations in 1999. Small MS4s include smaller cities, towns, and counties. MS4s operated by other types of federal, state, or local governmental entities, such as military bases, public universities, prisons, and state highway agencies, also are classified as Small MS4s. Most of the 6,695 Phase II MS4s are covered by statewide General Permits; however, some states use individual permits (U.S. EPA 2018).

An important distinction from Phase I MS4s is that not all Small MS4s are regulated. Some Small MS4s or portions of Small MS4s are not required to obtain NPDES permit coverage. A Small MS4 must obtain an NPDES permit only in two situations: if it (1) is within a Census designated urbanized area or (2) has been designated by the permit authority as requiring a permit.

## **2.1.2 National Flood Insurance Act (1968)**

The Federal Emergency Management Agency (FEMA) National Flood Insurance Act of 1968 (42 USC 4001 et seq.) is legislation that created the National Flood Insurance Program (NFIP). FEMA administers the NFIP to provide subsidized flood insurance to communities that comply with FEMA regulations that limit development in floodplains. FEMA also issues flood insurance rate maps (FIRMs) that identify which land areas are subject to flooding and flood hazard zones in the community. The design standard for flood protection covered by the FIRMs is established by FEMA, with the minimum level of flood protection for new development determined to be the 1-in-100 (0.01) annual exceedance probability (i.e., the 100-year flood event).

### **2.1.3 Flood Disaster Protection Act (1973)**

The Flood Disaster Protection Act (FDPA) (42 USC 4001 to 4128) is a law that expanded the NFIP and required flood-prone communities and property owners to participate in it. The law aimed to reduce flood-related losses and provide financial assistance to flood victims through insurance rather than loans. The law also mandated financial institutions to require flood insurance on loans secured by improved real estate in special flood hazard areas designated by FEMA. The law also encouraged local officials to adopt and enforce minimum floodplain management standards to minimize future flood damage.

### **2.1.4 Federal Antidegradation Policy**

The Federal Antidegradation Policy (40 CFR Section 131.12) is designed to protect existing uses, water quality, and national water resources.

### **2.1.5 Executive Order 11988 – Floodplain Management (1977)**

Executive Order (EO) 11988 (42 CFR 26971) requires that federal agencies avoid or minimize adverse effects of occupancy and modifications of floodplains and to avoid direct and indirect support of development in floodplains if there is a practicable alternative.

### **2.1.6 Department of Transportation Order 5650.2 – Floodplain Management and Protection (1979)**

On April 23, 1979, the Department of Transportation issued Order 5650.2 regarding floodplain management and protection with the purpose of avoiding and mitigating adverse floodplain effects in agency actions, planning programs, and budget requests.

## **2.2 State Laws and Regulations**

### **2.2.1 Porter-Cologne Water Quality Control Act (1969)**

California's Porter-Cologne Water Quality Control Act, enacted in 1969 (California Water Code Section 13000 et seq.), provides the legal basis for water quality regulation within California. This act requires a Report of Waste Discharge for any discharge of waste (liquid, solid, or gaseous) to land or surface waters that may impair beneficial uses for surface and/or groundwater of the state. It predates the CWA and regulates discharges to waters of the state. Waters of the state include more than just waters of the U.S., such as groundwater and surface waters not considered waters of the U.S. Additionally, it prohibits discharges of waste as defined, and this definition is broader than the CWA definition of pollutant. Discharges under the Porter-Cologne Water Quality Control Act are permitted by waste discharge requirements and may be required even when the discharge is already permitted or exempt under the CWA.

The SWRCB and RWQCBs are responsible for establishing the water quality standards, as required by the CWA, and regulating discharges to protect beneficial uses of waterbodies. Details regarding water quality standards in a project area are contained in the applicable RWQCB basin

plan. In California, regional boards designate beneficial uses for all waterbody segments in their jurisdictions and then set standards necessary to protect those uses. Consequently, the water quality standards developed for particular waterbody segments are based on the designated use and vary depending on such use. Waterbody segments that fail to meet standards for specific pollutants are included in a statewide list in accordance with CWA Section 303(d). If a regional board determines waters are impaired for one or more constituents and the standards cannot be met through point source or nonpoint source controls (NPDES permits or waste discharge requirements), the CWA requires the establishment of total maximum daily loads (TMDL). TMDLs specify allowable pollutant loads from all sources (point, nonpoint, and natural) for a given watershed. The SWRCB implemented the requirements of CWA Section 303(d), and it includes specific TMDLs and associated stakeholders.

### **2.2.2 Cobey-Alquist Flood Plain Management Act (Cal. Water Code, Section 8400 et seq.) (1965)**

The Cobey-Alquist Floodplain Management Act encourages local governments to plan, adopt, and enforce floodplain management regulations (California Water Code Section 8400, et seq.). Where a federal flood control project report has been issued designating floodway boundaries, the Department of Water Resources or the State Reclamation Board will not appropriate money in support of the project unless the applicable agency has enacted floodplain regulations. Those regulations must provide that construction of structures in the floodway that may endanger life or significantly reduce its carrying capacity shall be prohibited. Development will be allowed within the “restrictive zone” between the floodway and the limits of the floodplain as long as human life and the carrying capacity of the floodplain are protected (California Water Code Section 8410).

### **2.2.3 Water Quality Control Plan, Los Angeles Region (2014)**

The Water Quality Control Plan for the Los Angeles Region prepared by the RWQCB (Region 4) outlines the regulatory process for the protection of the beneficial uses of all regional waters. According to the Basin Plan, the beneficial uses for surface waters and groundwater established for the Los Angeles Region that includes both Project study areas are municipal, agricultural supply, industrial service supply, industrial process supply, groundwater recharge, water contact recreation, non-water contact recreation, warm freshwater habitat, and wildlife habitat.

### **2.2.4 California Toxics Rule (1994)**

Under the California Toxics Rule, the U.S. EPA has proposed water quality criteria for priority toxic pollutants for inland surface waters, enclosed bays, and estuaries. These federally promulgated criteria create water quality standards for California waters and satisfy CWA requirements.

## 2.2.5 State Requirements under Section 402 of the Clean Water Act

### National Pollutant Discharge Elimination System Program

The Project is located within the Lower Los Angeles River Watershed (Chavez Ravine-Los Angeles River) and is within the jurisdiction of several entities.

### Caltrans Municipal Separate Storm Sewer System Permit (2022)

Section 402(p) of the CWA requires the issuance of NPDES permits for five categories of stormwater discharges, including MS4s. An MS4 is defined as “any conveyance or system of conveyances (roads with drainage systems, municipal streets, catch basins, curbs, gutters, ditches, human-made channels, and storm drains) owned or operated by a state, city, town, county, or other public body having jurisdiction over storm-water, that is designed or used for collecting or conveying storm-water.” The SWRCB has identified Caltrans as an owner/operator of an MS4 under federal regulations. Caltrans’ MS4 permit covers all respective ROWs, properties, facilities, and activities in the state, including the portion of Caltrans ROW in the Project footprint for the Build Alternative. The SWRCB or RWQCB issues NPDES permits for 5 years, and permit requirements remain active until a new permit has been adopted.

Caltrans’ MS4 Permit (Order Number 2022-0033-DWQ) and Time Schedule Order (Order Number 2022-0089-DWQ) was adopted June 22, 2022, and became effective January 1, 2023. The permit has three basic requirements:

- Caltrans must comply with the requirements of the CGP (see below).
- Caltrans must implement a year-round program in all parts of the state to effectively control stormwater and non-stormwater discharges.
- Caltrans’ stormwater discharges must meet water quality standards through implementation of permanent and temporary (construction) BMPs, to the maximum extent practicable, and other measures the SWRCB determines to be necessary to meet the water quality standards.

To comply with the permit, Caltrans developed the statewide stormwater management plan (SWMP) to address stormwater pollution controls related to highway planning, design, construction, and maintenance activities throughout California. The SWMP assigns responsibilities within Caltrans for implementing stormwater management procedures and practices, as well as training, public education and participation, monitoring and research, program evaluation, and reporting activities. The SWMP describes the minimum procedures and practices that Caltrans uses to reduce pollutants in stormwater and non-stormwater discharges. It outlines procedures and responsibilities for protecting water quality, including the selection and implementation of BMPs.

The guidelines and procedures outlined in the latest SWMP would be reviewed to address Project-related stormwater runoff.

The Build Alternative is subject to the Caltrans MS4 Permit for the portion of the overhead viaduct crossing US-101 within Caltrans ROW.

### **California Department of Transportation Encroachment Permit (2020)**

An encroachment permit is required from Caltrans for a permittee to enter state highway ROW to construct, alter, repair, improve facilities, or conduct specified activities. An encroachment permit must be obtained prior to commencement of proposed activities for placement of encroachments within, under, or over the state highway ROW. Based on the cost (over \$3 million), project funding (funding source other than the State Highway Fund), project type (public transit), and complexity, Metro would follow the oversight project process to obtain the encroachment permit from Caltrans. Part of that complexity is reflected in the need for the Project Study Report/Project Report for the Project as well a Stormwater Data Report. Currently being updated, the cooperative agreement between Caltrans and Metro for this project is part of an overall master agreement between the two agencies. As a result, double permits are required for contractors performing work under these agreements. A copy of the fully executed agreement and approved plans would be delivered to the District Encroachment Permits Office before an encroachment permit is issued to Metro for work within state highway ROW. For additional information on Caltrans encroachment permit requirements, refer to the Encroachment Permits Manual, dated February 2020.

### **Industrial General Permit (2014)**

The Statewide General Permit for Stormwater Discharges Associated with Industrial Activities, Order 2014-0057-DWQ (IGP), as amended by Order no. 2015-0122-DWQ, implements the federally required stormwater regulations in California for stormwater associated with industrial activities discharging to waters of the U.S. The IGP regulates discharges associated with 10 federally defined categories of industrial activities. The IGP requires the implementation of BMPs, a site-specific SWPPP, and a monitoring plan. The IGP also includes criteria for demonstrating no exposure of industrial activities or materials to stormwater and no discharges to waters of the U.S.

It is assumed the BNSF West Bank Yard and Keller Yard have an active IGP permit. South of LAUS, the Build Alternative would also require demolition and relocation of commercial, industrial, and manufacturing-related businesses that may also have an active IGP-related permit with the SWRCB.

### **Construction General Permit (2022)**

The CGP (Order Number 2009-0009-DWQ), adopted September 2, 2009, became effective July 1, 2010. This permit has since been amended twice by Order Nos. 2010-0014-DWQ and 2012-0006-DWQ, which are currently in effect. However, during construction of the Project, Order Number 2022-0057-DWQ may be in effect. This permit was adopted on September 8, 2022, and will become effective on September 1, 2023. The permit regulates stormwater discharges from construction sites that result in a disturbed soil area of 1 acre or greater and/or are smaller sites that are part of a larger common plan of development. By law, all stormwater discharges associated with construction activity where clearing, grading, and excavation result in soil

disturbance of at least 1 acre must comply with the provisions of the CGP. Construction activity that results in soil disturbances of less than 1 acre is subject to this CGP if there is potential for significant water quality impairment resulting from the activity as determined by the RWQCB. Operators of regulated construction sites are required to develop SWPPPs; implement sediment, erosion, and pollution prevention control measures; and obtain coverage under the CGP.

The 2009 CGP separates projects into Risk Levels 1, 2, and 3. Risk levels are determined during the planning and design phases and are based on potential erosion and transport to receiving waters. Requirements apply according to the risk level determined. For example, a Risk Level 3 (highest risk) project would require compulsory stormwater runoff pH and turbidity monitoring, as well as before and after construction aquatic biological assessments during specified seasonal windows. For all projects subject to the permit, applicants are required to develop and implement an effective SWPPP. In accordance with the Caltrans standard specifications, a water pollution control plan is necessary for projects with a disturbed soil area less than 1 acre (Caltrans 2003).

Additionally, the CGP requires that all dischargers comply with certain post-construction runoff reduction and stormwater quality requirements unless they are located within an area subject to post-construction standards of an active Phase I or II MS4 permit that has an approved SWMP (such as the one related to Los Angeles County NPDES MS4 Permit, Order Number R4-2021-0105, NPDES Permit Number CAS004004). These post-construction requirements would normally apply to Metro and SCRRA projects within their property; however, the Project is being designed to comply with the LID ordinance requirements (as required by the SWMP) for the City of Los Angeles (Los Angeles County NPDES MS4 Permit, Order Number R4-2021-0105), which are typically more stringent than the applicable MS4s. See Section 2.3 for additional information.

### **Small Municipal Separate Storm Sewer System Phase II Permit (2014)**

MS4 permits were issued in two phases. Under Phase I, which started in 1990, the RWQCBs adopted NPDES stormwater permits for medium (serving between 100,000 and 250,000 people) and large (serving 250,000 or more people) municipalities. The City of Los Angeles, along with other cities in Los Angeles County, has been issued a Phase I MS4 permit as a group. See Section 2.3.1 for additional information.

On April 30, 2003, as part of Phase II, SWRCB issued a General Permit for the Discharge of Stormwater from Small MS4s (Water Quality Order Number 2003-0005-DWQ) to provide permit coverage for smaller municipalities (population less than 100,000), including nontraditional Small MS4s, which are facilities such as military bases, public campuses, and prison and hospital complexes. The Phase II Small MS4 General Permit covers Phase II permittees statewide. On February 5, 2013, the current Phase II Small MS4 General Permit (Order Number 2013-0001-DWQ) was adopted, and it became effective July 1, 2013.

One of the nontraditional Small MS4 categories included in the permit are local transportation planning agencies, such as Amtrak, Bay Area Rapid Transit, CalTrain, Golden Gate Bridge

(Highway and Transportation District), Metropolitan Transit System, North County Transit District, and Valley Transportation Authority. These categories and agencies are reflected in Attachment B of the permit. Metro was not included in the permit as a nontraditional Small MS4; however, CHSRA was designated on August 22, 2014, as being included under the Phase II Small MS4 General Permit.

On August 24, 2014, the SWRCB designated CHSRA as a nontraditional permittee under the Phase II MS4 permit (Order Number 2013-0001-DWQ). This order is the only MS4 permit for which CHSRA has obtained coverage as a nontraditional permittee. CHSRA must follow the discharge, program, and monitoring requirements described in Section F of the Phase II MS4 permit within its ROW in Los Angeles County (Los Angeles RWQCB jurisdiction) and Orange County (Santa Ana RWQCB jurisdiction). CHSRA's MS4 permit replaces county-/city-specific MS4 permits that would otherwise be applicable to the Project. If runoff enters another agency's MS4 (i.e., Caltrans) or if the Project extends into local ROWs (i.e., county or city), the jurisdictional agency's MS4 permit applies. LID design standards and a post-construction stormwater management program are required under the MS4 permit.

## 2.3 Regional and Local Requirements

### 2.3.1 Municipal National Pollutant Discharge Elimination System Permit (2021)

The City of Los Angeles is a permittee under the Phase I NPDES Permit and Waste Discharge Requirements for MS4 Discharges within the Coastal Watersheds of Los Angeles and Ventura Counties, Order Number R4-2021-0105 (NPDES Number CAS004004). The NPDES permit prohibits discharges, sets limits on pollutants being discharged into receiving waters, and requires implementation of technology-based standards.

Under the NPDES permit, the City of Los Angeles, as a permittee, is responsible for the management of storm drain systems within its jurisdiction. Cities are required to implement management programs, monitoring programs, implementation plans, and all BMPs outlined in the Municipal Stormwater Management Program and take any other actions as may be necessary to protect water quality to the maximum extent practicable. In addition, each city is required to implement a municipal stormwater management program and develop a long-term assessment strategy for effectiveness of the municipal stormwater management program.

On July 23, 2021, the Los Angeles RWQCB adopted Order Number R4-2021-0105, the NPDES Stormwater Permit for the County of Los Angeles and Ventura and cities within (NPDES Number CAS004004). The permit was issued to Los Angeles County (principal permittee) and 95 cities (permittees) to reduce pollutants discharged from their MS4 to the maximum extent practicable statutory standard. The permit became effective September 11, 2021.

The permit required development and implementation of a number of stormwater management programs designed to reduce pollutants in stormwater and urban runoff. One of these programs, the Development Planning Program focuses on preventing pollutants that could be generated

from new development and redevelopment projects from reaching stormwater conveyance systems and receiving waters. The Development Planning Program is comprised of, in order of priority, an LID plan, standard urban stormwater mitigation plan (SUSMP), and/or a site-specific mitigation plan. These requirements are spelled out in the *Development Best Management Practices Handbook, Low Impact Development Manual, Part B Planning Activities 4th Edition*, dated June 2011 (LID Manual).

Under this program, the RWQCB developed requirements for the SUSMP, which requires specific development and redevelopment categories to manage stormwater runoff. In 2002, the City of Los Angeles implemented the SUSMP program requiring all categories of affected land development projects to capture or treat stormwater runoff. Category projects include:

- Single-family hillside residences;
- 100,000 square feet of impervious surface area of industrial/commercial developments;
- Automotive service facilities;
- Retail gasoline outlets;
- Restaurants;
- Ten or more-unit homes (includes single-family homes, multifamily homes, condominiums, and apartments);
- Parking lots with 5,000 square feet or more of surface area or 25 or more parking spaces; and
- Projects located in or directly adjacent to or discharging directly to an environmentally sensitive area.

A relatively recent stormwater management approach aimed at achieving this goal is the use of LID, which is a stormwater management strategy that seeks to mitigate the effects of increases in runoff and stormwater pollution as close to its source as possible. LID comprises a set of site design approaches and BMPs that promote the use of natural systems for infiltration, evapotranspiration, and use of stormwater. These LID practices can effectively remove nutrients, bacteria, and metals from stormwater while reducing the volume and intensity of stormwater flows. With respect to urban development and redevelopment projects, it can be applied on site to mimic the site's predevelopment drainage characteristics. Through the use of various infiltration techniques, LID is geared toward minimizing impervious surface area that produces large amounts of runoff and does not allow water to infiltrate into the ground. Where infiltration is infeasible, the use of bioretention, rain gardens, vegetated rooftops, and rain barrels that would store, evaporate, detain, and/or treat runoff can be used.

In November 2011, the City of Los Angeles adopted the Stormwater LID Ordinance (Ordinance #181899) to amend and expand on the existing SUSMP requirements by incorporating LID practices and principles, as well as expanding the applicable development categories. The LID Ordinance has the stated purpose of:

- Requiring the use of LID standards and practices in future developments and redevelopments to encourage the beneficial use of rainwater and urban runoff;
- Reducing stormwater/urban runoff while improving water quality;
- Promoting rainwater harvesting;
- Reducing off-site runoff and providing increased groundwater recharge;
- Reducing erosion and hydrologic effects downstream; and
- Enhancing the recreational and aesthetic values in communities.

The LID Ordinance requires stormwater mitigation for a larger number of development and redevelopment categories that was previously required under the SUSMP. All development and redevelopment projects that create, add, or replace 500 square feet or more of impervious area need to comply with the LID Ordinance. If applicable to the LID Ordinance, project applicants would also be required to prepare an LID plan.

On August 25, 2015, the City of Los Angeles adopted an updated Stormwater LID Ordinance (Ordinance #183833) to amend and expand on the LID requirements. Subsequently, on May 9, 2016, the City of Los Angeles, Board of Public Works, adopted an update to the LID Manual (formally retitled *Planning and Land Development Handbook for Low Impact Development, Part B Planning Activities 5th Edition*, dated May 9, 2016) and corresponding revisions to Section 64.72 of the Los Angeles Municipal Code, approved by Ordinance Number 183833. The LID Manual was made publicly available via the City of Los Angeles website in October 2016. The updated LID Manual removed the requirement for a SUSMP and site mitigation plan; now, the only required LID document is the LID plan.

According to the LID Manual, project applicants for all new development and redevelopment projects who are required to prepare an LID plan fall into two categories: small-scale residential development projects (four units or less) and all other developments (residential developments of five units or more and nonresidential developments). The Project would fall under the “all other developments” category. An LID plan is required to demonstrate that stormwater runoff would be infiltrated, evapotranspired, captured and used, and/or treated through high removal efficiency BMPs on site and stormwater management techniques. The on-site stormwater management techniques must be properly sized, at a minimum, to infiltrate, evapotranspire, store for use, and/or treat through a high removal efficiency biofiltration/biotreatment system, without any stormwater runoff leaving the site, to the maximum extent feasible. This documentation must demonstrate the feasibility or infeasibility of LID-focused BMPs. If partial or complete on-site compliance of any type is technically infeasible, the Project and LID plan are required to maximize

on-site compliance. Under this option, a mechanical/hydrodynamic unit may be used. Any remaining runoff that cannot feasibly be managed on site would be managed off site.

Metro and SCRRRA are not permittees of the municipal NPDES permit. However, because the Project requires permits from the City of Los Angeles, compliance with the LID Ordinance is required. Pursuant to 40 Code of Federal Regulations 122.26(a), the Los Angeles RWQCB has the authority to require noncooperating entities to adhere to the requirements of the NPDES permit or issue individual discharge permits to those entities.

The Link US *Preliminary Low Impact Development Report* serves as the preliminary LID plan for the Project. The preliminary LID plan applies to portions of the Project outside of the jurisdiction of the Caltrans NPDES MS4 permit, which applies to the ROW for US-101. The Project would be designed to be consistent with the guidelines and standards outlined in the City of Los Angeles LID Ordinance. Consequently, Section 2.4 of the LID Manual states that agencies, such as Metro, must prepare an LID plan for non-roadway transportation projects, rail lines, and stations and implement stormwater mitigation measures. The Link US *Preliminary Low Impact Development Report* was prepared to be consistent with City of Los Angeles LID Ordinance Number 183833 (LID Ordinance) and specifies BMPs to be implemented during the post-construction phase.

### **2.3.2 Enhanced Watershed Management Program for the Upper Los Angeles River Watershed**

The MS4 Permit Order Number R4-2021-0105 (Permit) for Los Angeles County provides an innovative approach to permit compliance through development of enhanced watershed management programs (EWMP). Through a collaborative approach, an EWMP for the Upper Los Angeles River (ULAR) Watershed Management Area (EWMP area) was developed by the ULAR EWMP group. The ULAR EWMP group is comprised of the Cities of Los Angeles (lead coordinating agency), Alhambra, Burbank, Calabasas, Glendale, Hidden Hills, La Canada Flintridge, Montebello, Monterey Park, Pasadena, Rosemead, San Fernando, San Marino, South El Monte, South Pasadena, and Temple City, the County of Los Angeles (Unincorporated County), and the Los Angeles County Flood Control District. By electing to comply with the optional compliance pathway in the MS4 Permit, the ULAR EWMP Group has leveraged this program to facilitate a robust, comprehensive approach to stormwater management for the Los Angeles River watershed to address the priority water quality conditions in the EWMP area.

The planning area for the ULAR EWMP is the largest of all the EWMPs being developed in the Los Angeles region, representing 485 square miles of watershed (Figure 2-1) and over 50 miles of main stem Los Angeles River from its headwaters to just above the estuary. The Los Angeles River watershed has been the subject of numerous water quality planning and compliance efforts, and the EWMP leveraged those efforts and identified additional projects to address water quality issues in the ULAR.

The vision for the EWMP development was to utilize a multipollutant approach that maximizes the retention and use of urban runoff as a resource for groundwater recharge and irrigation while creating additional benefits for the communities in the ULAR watershed. This EWMP presents

distributed and regional watershed control measures to address applicable stormwater quality regulations, including LID, green streets, regional projects, and institutional control measures.

This Project is within Region 4 (Los Angeles) of the RWQCB. The Project is adjacent to Reach 2, consistent with the Los Angeles RWQCB Basin Plan. Major tributaries to Reach 2 include Rio Hondo Reaches 2 and 3, as well as Compton Creek.

Figure 2-1. Upper Los Angeles River Enhanced Watershed Management Programs Area

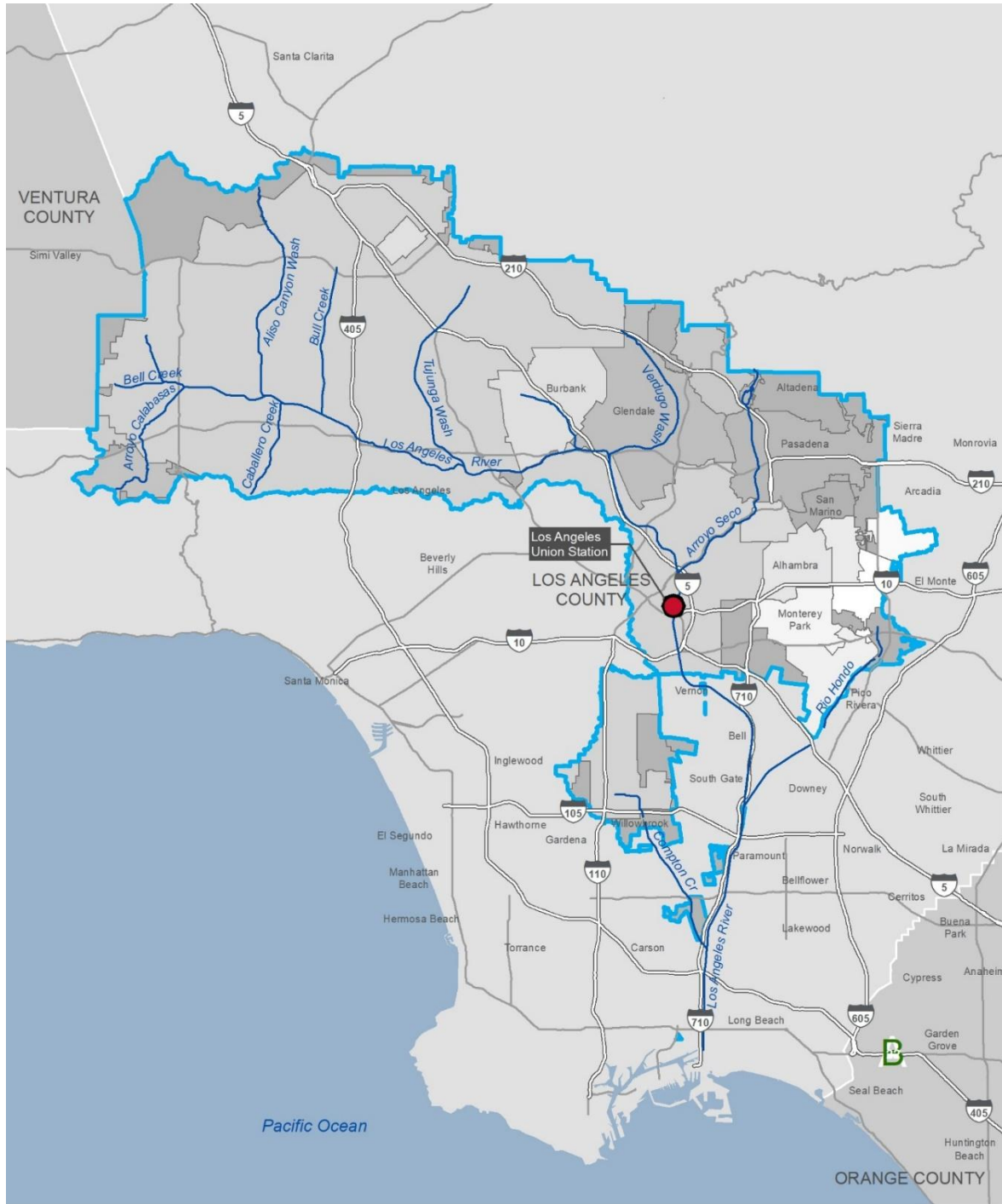

LEGEND

- Project Location
- Upper LA River EWMP
- Waterbody



(THIS PAGE INTENTIONALLY LEFT BLANK)

The 2021 Los Angeles County MS4 Permit contains effluent limitations, receiving water limitations, minimum control measures, and TMDL provisions, as well as outlines the process for developing watershed management programs, including the EWMP. The MS4 Permit incorporates the TMDL waste load allocations applicable to dry and wet weather as water quality-based effluent limits and/or receiving water limitations. Section V.A of the permit requires compliance with the water quality-based effluent limits as outlined by the respective TMDLs. The EWMP provides a compliance pathway for attaining these limitations.

A primary driver of the extent and scheduling of control measures that make up the EWMP implementation strategy are the applicable TMDLs in the Los Angeles River watershed. Section 303(d) of the CWA requires states to prepare a list of waterbodies that do not meet water quality standards and establish for each of these waterbodies load and waste load allocations (loads refers to pollutants [i.e., a TMDL that would ensure attainment of water quality standards]). A TMDL represents an amount of pollution that can be released by anthropogenic and natural sources of a watershed into a specific waterbody without causing a decline in water quality and beneficial uses. Unlike federal law, state law requires regional boards to include an implementation plan for TMDLs, and these plans generally include compliance schedules.

Table 2-1 presents the TMDLs developed for waterbodies within the ULAR EWMP area. For more information, refer to the EWMP for the ULAR watershed, dated March 29, 2016, as approved by the Los Angeles RWQCB on April 20, 2016.

**Table 2-1. Total Maximum Daily Loads Applicable to the Upper Los Angeles River Enhanced Watershed Management Programs**

<b>TMDL</b>	<b>Los Angeles RWQCB Resolution Number</b>	<b>Effective Date and/or U.S. EPA Approval Date</b>
Los Angeles River nitrogen compounds and related effects (ammonia, nitrate, nitrite)	2003-009	03/23/2004
	2012-010 (amended)	08/07/2014
Los Angeles River trash (nonpoint source, surface runoff, urban runoff/storm drains)	2007-012	09/23/2008
Los Angeles River metals TMDL (natural and anthropogenic sources; cadmium, copper, lead, nickel, mercury, thallium, zinc)	2007-014	10/29/2008
	2010-003 (amended)	11/03/2011
Los Angeles River bacteria TMDL (E. coli)	2010-007	03/23/2012

**Notes:**  
**RWQCB=Regional Water Quality Control Board; TMDL=total maximum daily load; U.S. EPA=United States Environmental Protection Agency**

### **2.3.3 Southern California Regional Rail Authority Design Criteria Manual (2014)**

SCRRA has established engineering criteria for track and bridges under its jurisdiction, which requires that culverts conveying cross-track flood flows be designed to freely pass low flows and accommodate high-water conditions. New and replacement bridge and culvert openings will be sized for two high-water design discharge events: designated low chord/soffit event and subgrade event. If insufficient channel area exists to meet SCRRA's criteria, even with maximum widening, consideration will be given to adding relief structures on the overbank floodplain, raising the SCRRA grade, or other reasonable alternatives.

### **2.3.4 Water Quality Compliance Master Plan for Urban Runoff (2009)**

In 2009, the City of Los Angeles adopted the Water Quality Compliance Master Plan for Urban Runoff, a 20-year strategy for clean stormwater and urban runoff. The Water Quality Compliance Master Plan for Urban Runoff was developed by Los Angeles Bureau of Sanitation and Watershed Protection Division to develop a water quality master plan with strategic directions for planning, budgeting, and funding to reduce pollution from urban runoff in the City. The Water Quality Compliance Master Plan for Urban Runoff seeks a broad watershed-based perspective to improve water quality and bring the City into compliance with the CWA.

### **2.3.5 City of Los Angeles Municipal Code (1998)**

Stormwater discharge is regulated under Chapter VI Public Works and Property, Article 4.4 – Stormwater and Urban Runoff Pollution Control of the City of Los Angeles Municipal Code. Under Article 4.4, discharge of non-stormwater is permissible only when connection to the storm drain system is made in accordance with a valid city permit, approved construction plan, or an NPDES permit and/or Notice of Intent. In addition, projects within the City of Los Angeles are required to comply with the requirements of the CGP and Municipal NPDES Permit, which includes preparation of an SWPPP and implementation of construction and post-construction BMPs.

### **2.3.6 City of Los Angeles General Plan Conservation Element (2001)**

The Conservation Element in part, provides goals, objectives, policies, and programs related to conservation of fossil fuels and protection of petroleum resources. Policy 1 provides information about energy conservation and petroleum reuse and Policy 3 addresses protection of neighborhoods from accidents associated with drilling, extraction, and transport operations.

### **2.3.7 City of Los Angeles General Plan Safety Element (1996)**

The Safety Element in part provides goals, objectives, policies, and programs related to hazards mitigation, emergency response, and disaster recovery and implementation to carry out these

policies. The Safety Element provides specifics as to selected urban life and secondary hazards, such as oil fields, areas with known shallow methane accumulation, natural gas transmission and distribution lines, and areas with concentrations of post-1946 high-rise buildings (greater than eight stories).

### **2.3.8 General Waste Discharge Requirements for Dewatering (2013)**

On June 6, 2013, the Los Angeles RWQCB adopted the General Waste Discharge Requirements for Discharges of Groundwater from Construction and Project Dewatering to Surface Waters in Coastal Watersheds of Los Angeles and Ventura Counties (Order Number R4-2013-0095, NPDES Number CAG994004) (Dewatering Permit). This permit covers discharge of groundwater and non-stormwater construction dewatering discharges in the Los Angeles and Ventura region. For coverage under this permit, a discharger is required to submit a Notice of Intent to the Los Angeles RWQCB. Under this permit, discharges must comply with discharge specifications, receiving water limitations, and monitoring and reporting requirements detailed in the permit. The Project would be subject to the requirements of the Dewatering Permit because groundwater dewatering discharges are anticipated during construction.

### **2.3.9 General Waste Discharge Requirements for Dewatering from Contaminated Activities (2013)**

On March 7, 2013, the Los Angeles RWQCB adopted the General Waste Discharge Requirements for Discharges of Treated Groundwater from Investigation and/or Cleanup of Volatile Organic Compounds-Contaminated Sites to Surface Waters in Coastal Watersheds of Los Angeles and Ventura Counties (Order Number R4-2013-0043, NPDES Number CAG914001) (Dewatering Permit for Contaminated Activities), effective April 7, 2013. This permit covers discharge of groundwater and non-stormwater construction dewatering waste contaminated in the Los Angeles and Ventura region. For coverage under this permit, a discharger is required to submit a Notice of Intent to the Los Angeles RWQCB. Under this permit, discharges must comply with discharge specifications, receiving water limitations, and monitoring and reporting requirements detailed in the permit. The Project would be subject to the requirements of the Dewatering Permit for Contaminated Activities because groundwater and other non-stormwater discharge that are contaminated are anticipated to be encountered during construction. According to the Link US *Phase I Environmental Site Assessment* (Metro 2016), the Project study area is known to contain contaminated soils.

(THIS PAGE INTENTIONALLY LEFT BLANK)

## 3.0 Existing Conditions

This section provides a description of the existing conditions in the Project study area relative to this water quality evaluation.

### 3.1 General Environmental Setting

The Project is located within a densely developed commercial and industrial area within the incorporated boundaries of the City of Los Angeles located within the Los Angeles Hydrologic Unit (HU); one of eight defined units within the Los Angeles Basin. Within this HU, the Project is located within the approximately 824-square-mile Los Angeles River watershed. This watershed discharges into the Pacific Ocean through the Los Angeles/Long Beach Harbor. The Project study area is located on the west side of the Los Angeles River, close to the point where US-101 crosses it.

#### 3.1.1 Population and Land Use

Land use within the Project study area reflects a mixture of transportation-related land uses and other developed uses, including educational, residential, institutional, industrial, and commercial uses. Residential land uses in the Project study area are limited. There are no natural features or open space areas with native habitat within the Project study area, including along the concrete-lined portion of the Los Angeles River (adjacent to the Project study area).

#### 3.1.2 Topography

The Project study area is located on flat terrain in an urbanized and heavily developed area. Regionally, the topography slopes southward and toward the Los Angeles River. Elevation within the Project study area ranges from approximately 274 to 295 feet above mean sea level (Metro 2025a).

#### 3.1.3 Hydrology

##### Regional Hydrology

This Project study area lies within the Los Angeles River watershed, which includes the Los Angeles River. The western portion of the watershed includes the Santa Monica Mountains, Simi Hills, and Santa Susana Mountains, while the eastern portion includes the San Gabriel Mountains (U.S. EPA 2020). The watershed encompasses, and is shaped by, the path of the Los Angeles River, which flows from its headwaters in the Simi Hills and Santa Susana Mountains, to the Santa Monica Mountains, and eastward to the northern corner of Griffith Park. Here, the channel turns southward through the Glendale Narrows before it flows across the coastal plain and into San Pedro Bay near Long Beach (Figure 3-1). The Los Angeles River has evolved from an uncontrolled, meandering river providing a valuable source of water for early inhabitants to a major flood protection waterway. The Los Angeles River watershed covers more than 824 square miles (Los Angeles RWQCB 2014).

(THIS PAGE INTENTIONALLY LEFT BLANK)

Figure 3-1. Regional Hydrology

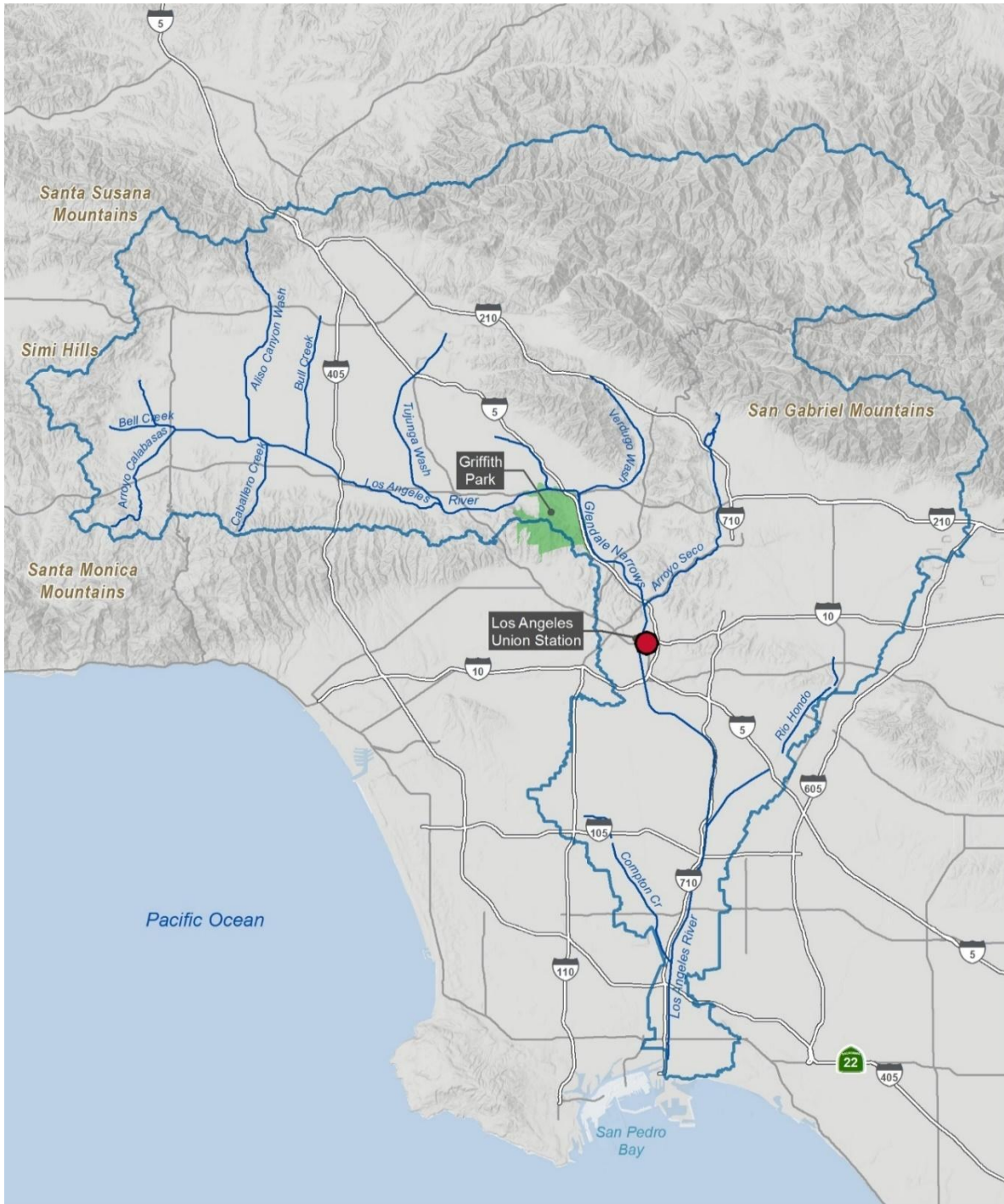

LEGEND

- Project Location
- Los Angeles River Watershed
- Waterway
- Griffith Park



0 Miles 5

(THIS PAGE INTENTIONALLY LEFT BLANK)

### ***Hydrology within California Department of Transportation ROW***

Based on the Caltrans Water Quality Planning Tool (Caltrans 2018b), as it relates to the adjacent US-101, the associated watershed information of the Project study area is included below.

#### *CalWater Watershed*

- HU: Los Angeles River
- Hydrologic Area: Los Angeles
- Hydrologic Sub-Area Name: undefined
- Hydrologic Sub-Area Number: 412.10
- Hydrologic Region: South Coast
- Planning Watershed: 4412100000

See Figure 3-2 for more information.

#### *Watershed Boundary Dataset*

- Watershed: Los Angeles River (Reach 2)
- Sub-Watershed: Lower Los Angeles River hydrologic area (Chavez Ravine hydrologic subarea [HSA] and Compton Creek HSA)
- HU Codes: 180701050401, 180701050402, 180701050403, 180701050404

The digital watershed delineation information from Los Angeles RWQCB is not consistent with the Los Angeles RWQCB Basin Plan or the associated Overlay #1 Exhibit in Appendix 2 of that plan. This Overlay #1 Exhibit shows different watershed codes (refer to Basin Plan discussion below). When discussing issues related to Caltrans ROW, this Water Quality Assessment Report uses watershed codes developed by CalWater.

### ***Hydrology within Non-California Department of Transportation ROW***

Based on the Basin Plan (Water Quality Control Plan, Los Angeles Region), the Los Angeles River watershed (18070105) is divided into HSAs that are subdivided into hydrologic areas all within a specific HU. The Project is located in Reach 2 of the Los Angeles River (Carson Street to Figueroa Street), in the Lower Los Angeles River hydrologic area (50400), and in the Chavez Ravine HSA (50401) and Compton Creek HSA (50402). These water codes are from Tables 1-1, 2-1, and 2-1a of the Basin Plan, which are different from CalWater. When discussing issues related to non-Caltrans ROW, this report uses watershed codes developed by the Basin Plan.

(THIS PAGE INTENTIONALLY LEFT BLANK)

Figure 3-2. Watersheds and Surface Waters (CalWater Watersheds)

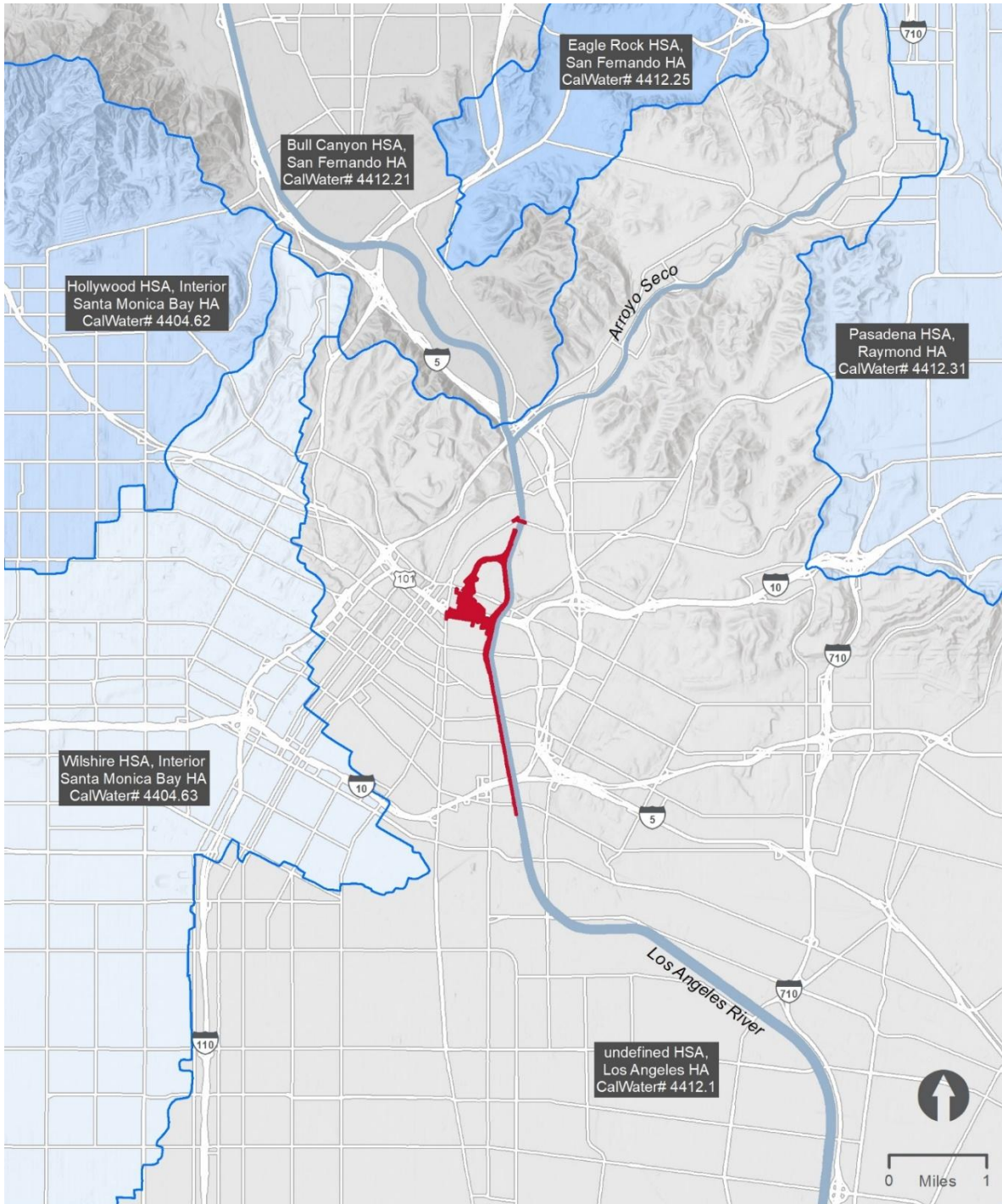

LEGEND

- |   |   |   |
|---|---|---|
|  Project Footprint |  Bull Canyon HSA, San Fernando HA            |  Pasadena HSA, Raymond HA                  |
|  Surface Waters    |  Eagle Rock HSA, San Fernando HA             |  Wishire HSA, Interior Santa Monica Bay HA |
|   |  Hollywood HSA, Interior Santa Monica Bay HA |  Undefined HSA, Los Angeles                |

(THIS PAGE INTENTIONALLY LEFT BLANK)

## Local Hydrology

As Figure 3-2 shows, the Los Angeles River is immediately east of the Project study area and is the primary drainage facility in the area and facilitates alluvial groundwater recharge through spreading basins. The portion of the Los Angeles River adjacent to the Project study area is entirely concrete lined. This portion of the river is designated as Reach 2 in the Basin Plan (from Figueroa Street, City of Los Angeles [upstream], to Carson Street, City of Long Beach [downstream]) and as Reach 3 in the Los Angeles River Revitalization Master Plan (from Arroyo Seco [upstream] to Washington Boulevard [downstream]). As this WQAR relies heavily on the Basin Plan, it is important to note from this point forward, reference is made to Reach 2 unless noted otherwise. Runoff from the Project study area is discharged to various storm drain systems, some of which cross portions of the Project study area, and eventually to Reach 2 of the Los Angeles River. Runoff within Caltrans ROW enters a 138-inch reinforced concrete arch in US-101, which connects to the existing municipal storm drain system and discharges to the Los Angeles River.

## Precipitation and Climate

Local climate conditions are characterized by warm summers, mild winters, infrequent rainfall, moderate humidity, and moderate breezes during the daytime. Periods of hot weather, winter storms, and Santa Ana winds occasionally disrupt the mild climate. Precipitation generally occurs as rainfall during major storms, with snowfall occurring at higher elevations. The average annual rainfall for the City of Los Angeles is approximately 18.63 inches (U.S. Climate Data 2023).

## Drainage and Flood Control Improvements

Attachment B of the City of Los Angeles *Emergency Operations Plan (City of Los Angeles 2018)* identifies the Project study area as located within a dam inundation area. The majority of drainage and flood control structures and improvements within the Project study area are under the jurisdiction of the following entities: City of Los Angeles Department of Public Works, Los Angeles Bureau of Engineering, Caltrans, and SCRRA. Facilities that are under the jurisdiction of Los Angeles County within the Project study area, including Bolero Lane and Leroy Street near Mission Tower in Segment 1 (throat segment), are proposed to be protected in place, and are not anticipated to be affected as part of the Project.

As shown in Appendix A of the *Link US Preliminary Low Impact Development (Metro 2025c)*, there are six major storm drains within the Project study area. Drainage in the Project study area is managed by Metro (and SCRRA), the City of Los Angeles, and Caltrans. Runoff in the area is generated from a combination of hard surfaces, including roadways, buildings, and bridges. A network of underground facilities collects runoff (e.g., curbside catch basins and inlets) and directs the flows to the Los Angeles River. Drainage from LAUS is directed to a 108-inch reinforced concrete pipe (RCP) within Cesar Chavez Avenue, which subsequently drains into the Los Angeles River. Drainage from the El Monte Busway and US-101 is managed by Caltrans and distributed into two major systems. The first consists of a large box structure that extends along Vignes Street and then easterly along Ducommun Street, before discharging into the Los Angeles River. A second system enters a lift station that enters a 75-inch underground pipe system along

Alameda Street and drains southerly and ultimately to the Los Angeles River, between 4th and 6th Streets. Runoff along Commercial Street enters a 42-inch RCP system along Ducommun Street and ultimately discharges to the Los Angeles River and the Pacific Ocean.

### ***Floodplains***

Floodplains for the Project study area are shown on Panel 060137-163G of the FIRM (FEMA 1998). This panel was revised in December 1998 and as shown on Figure 3-3, the 100-year flood boundary does not extend over the west bank of the river in the Project study area. The entirety of the Project study area is located in Zone X, Areas of Minimal Flooding.

### ***Municipal Supply***

The regional potable water supply is delivered by the Los Angeles Department of Water and Power. The supply is comprised of a mixture of local groundwater resources, recycled water from local water reclamation facilities, and imported water. Approximately 46 percent of the water demand is met through the imported water bought from the Metropolitan Water District (LADWP 2023).

### ***Surface Waters***

The Los Angeles River is highly modified, with concrete lining the majority of its length, including within the Project study area. Along the middle and lower sections of the river, it is unlined and supports natural habitat for fish and other wildlife species. However, carries urban runoff, tertiary-treated effluent from several municipal wastewater treatment plants, and illegally dumped material. This activity contributes to the impaired water quality in the Los Angeles River and its tributaries.

### ***Surface Water Quality Objectives/Standards and Beneficial Uses***

Beneficial uses of water are defined in the Water Quality Control Plan for the Los Angeles River Basin, Region 4 (Basin Plan) as those uses necessary for the survival or well-being of humans, plants, and wildlife. Examples of beneficial uses include drinking water supplies, swimming, industrial and agricultural water supply, and support of freshwater and marine habitats and their organisms.

As identified in Table 2-1 of the Basin Plan, the surface water beneficial uses for Reach 2 of the Los Angeles River, where the Project study area is located, are as follows:

- Municipal (MUN)
- Groundwater Recharge (GWR)
- Industrial (IND)
- Water Contact Recreation (REC1)
- Noncontact Water Recreation (REC2)

- Warm Freshwater Habitat (WARM)
- Wildlife Habitat (WILD)

(THIS PAGE INTENTIONALLY LEFT BLANK)

Figure 3-3. Flood Insurance Rate Map of Project Study Area

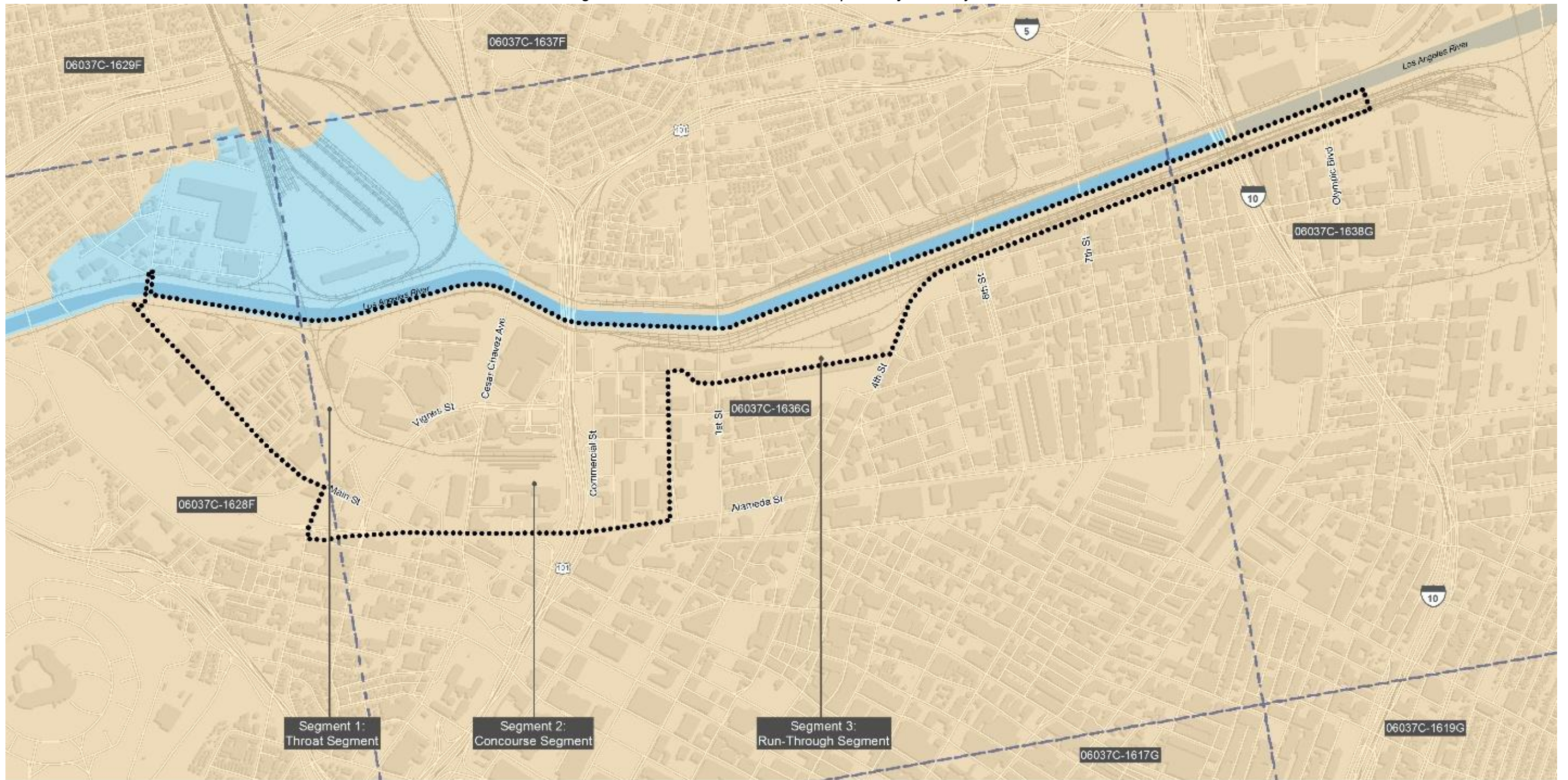

**LEGEND**

- Project Study Area
- 1% Annual Chance Flood Hazard (Zones A, AE, AH, AO, V, VE)
- 0.2% Annual Chance Flood Hazard (Zone X)
- FEMA - FIRM Panels

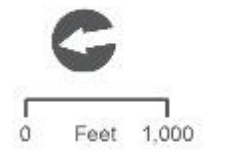

(THIS PAGE INTENTIONALLY LEFT BLANK)

The above beneficial uses are also the same for US-101 within the Project study area, as identified on the Caltrans Water Quality Planning Tool website with the exception of WET (Wetland Habitat). These uses are related to the Los Angeles River, between Figueroa Street and Los Angeles River Estuary (Willow Street), which include Reach 2.

Water quality objectives, as defined by California Water Code Section 13050(h), are the “limits or levels of water quality constituents or characteristics, which are established for the reasonable protection of beneficial uses or the prevention of nuisance within a specific area.”

The stipulated surface water quality objectives for inland surface waters, which include streams, rivers, lakes, and wetlands as identified in the Basin Plan, are listed in Table 3-1.

The numeric and narrative water quality objectives for Los Angeles River (as related to US-101), which include streams, rivers, lakes, and wetlands, are included in Table 3-1. These narrative water quality objectives include color, floating material, oil and grease, pH, radioactive substances, settleable material, suspended material, suspended solids, taste and odor, temperature, toxicity, and turbidity. This applies to the entire Project study area, for both the Caltrans and non-Caltrans portions.

**Table 3-1. Surface Water Quality Objectives**

Constituent	Concentrations
Ammonia, un-ionized	Discharges for 4-day average concentration will not exceed 0.035 mg/L; 1-hour average concentration will not exceed 0.233 mg/L.
Bacteria, Coliform	In waters designated for nonwater contact recreation (REC-2) and not designated for water contact recreation (REC-1), the fecal coliform concentration will not exceed a log mean of 2,000/100 milliliter (based on a minimum of not less than four samples for any 30-day period), nor will more than 10 percent of samples collected during any 30-day period exceed 4,000/100 milliliter.
Bioaccumulation	Toxic pollutants will not be present at levels that will bioaccumulate in aquatic life to levels that are harmful to aquatic life or human health.
Biochemical oxygen demand	Waters will be free of substances that result in increases in the biochemical oxygen demand that adversely affect beneficial uses.
Biostimulatory substances	Waters will not contain biostimulatory substances in concentrations that promote aquatic growth to the extent that such growth causes nuisance or adversely affects beneficial uses.
Chloride	Chloride will not exceed 190 mg/L.
Chlorine (residual)	Chlorine residual in wastewater discharged to inland surface waters will not exceed 0.1 mg/L.
Color	Waters will be free of coloration that causes nuisance or adversely affects beneficial uses.

**Table 3-1. Surface Water Quality Objectives**

Constituent	Concentrations
Exotic vegetation	Exotic vegetation will not be introduced around stream courses to the extent that such growth causes nuisance or adversely affects beneficial uses.
Floatables	Waste discharges will not contain floating materials, including solids, liquids, foam, or scum, that cause a nuisance or adversely affect beneficial uses.
Fluoride	Surface waters designated as MUN will not exceed 2 mg/L as a result of controllable water quality factors, depending on air temperature.
Methylene blue activated substances	Waters designated as MUN will not exceed 0.05 mg/L as a result of controllable water quality factors.
Nitrogen (Nitrate, Nitrite)	Waters will not exceed 10 mg/L nitrogen as nitrate-nitrogen plus nitrite-nitrogen, 45 mg/L as nitrate, 10 mg/L as nitrate-nitrogen, or 1 mg/L as nitrite-nitrogen.
Oil and grease	Waters will not contain oils, greases, waxes, or other materials in concentrations that result in a visible film or coating on the surface of the water or objects in the water, or that cause nuisance or otherwise adversely affect beneficial uses.
Oxygen (dissolved)	At a minimum (see specifics below), the mean annual dissolved oxygen concentration of all waters will be greater than 7 mg/L, and no single determination will be less than 5 mg/L, except when natural conditions cause lesser concentrations. The dissolved oxygen content of all surface waters designated as WARM will not be depressed below 5 mg/L as a result of waste discharges.
Pesticides	No individual pesticide or combination of pesticides will be present in concentrations that adversely affect beneficial uses. There will be no increase in pesticide concentrations found in bottom sediments or aquatic life.
pH	The pH of inland surface waters will not be depressed below 6.5 or raised above 8.5 as a result of waste discharges. Ambient pH levels will not be changed more than 0.5 units from natural conditions as a result of waste discharge.
Polychlorinated biphenyls	<p>The purposeful discharge of polychlorinated biphenyls (the sum of chlorinated biphenyls whose analytical characteristics resemble those of Aroclor-1016, Aroclor-1221, Aroclor-1232, Aroclor-1242, Aroclor-1248, Aroclor-1254, and Aroclor-1260) to waters of the region, or at locations where the waste can subsequently reach waters of the region, is prohibited.</p> <p>Pass-through or uncontrollable discharges to waters of the region, or at locations where the waste can subsequently reach water of the region, are limited to 70 picograms/liter (30-day average) for protection of human health and 14 nanograms/liter and 30 nanograms/liter (daily average) to protect aquatic life in inland fresh waters and estuarine waters, respectively.</p>
Radioactivity	Radioactive materials will not be present in the waters of the region in concentrations that are deleterious to human, plant, or animal life. Waters designated MUN will meet the limits specified in the California Code of Regulations, Title 22.

**Table 3-1. Surface Water Quality Objectives**

Constituent	Concentrations
Solids (suspended and settleable)	Waters will not contain suspended or settleable material in amounts that cause nuisance or adversely affect beneficial uses as a result of controllable water quality factors.
Sulfate	Sulfates will not exceed 350 mg/L.
Taste and odor	Waters will not contain taste or odor-producing substances in concentrations that impart undesirable tastes or odors to fish flesh or other edible aquatic resources, cause nuisance, or adversely affect beneficial uses.
Temperature	The natural receiving water temperature of all regional waters will not be altered unless it can be demonstrated to the satisfaction of the regional board that such alteration in temperature does not adversely affect beneficial uses. For waters designated WARM, water temperature will not be altered by more than 5 degrees Fahrenheit above the natural temperature. At no time will these WARM-designated waters be raised above 80 degrees Fahrenheit as a result of waste discharges.
Total dissolved solids	Total dissolved solids will not exceed 1,500 mg/L.
Toxic substances	Toxic substances will not be discharged at levels that will bioaccumulate in aquatic resources to levels that are harmful to human health. The concentrations of contaminants in waters that are existing or potential sources of drinking water will not occur at levels that are harmful to human health. Concentrations of toxic pollutants in the water column, sediments, or biota will not adversely affect beneficial uses.
Turbidity	Waters will be free of changes in turbidity that cause nuisance or adversely affect beneficial uses. Increases in natural turbidity attributable to controllable water quality factors will not exceed the following limits: where natural turbidity is between 0 and 50 nephelometric turbidity units, increases will not exceed 20 percent. Where natural turbidity is greater than 50 nephelometric turbidity unit, increases will not exceed 10 percent.

Source: Los Angeles RWQCB 2014; Caltrans 2018b

Notes:

mg/L=milligrams per liter; pH=potential of hydrogen

## Groundwater Hydrology and Quality

The Coastal Plain of Los Angeles (Central) Groundwater Basin (Basin Number 4-11.04 of the South Coast Hydrologic Region) is the major groundwater basin located in the Project study area. The general quality of groundwater in the Project study area has been degraded because of land use, as contaminants seep into the subsurface. Commercial and industrial activities include leaking aboveground and underground storage tanks containing various of hazardous materials that are discharging these contaminants and presenting themselves as inorganic and organic pollutants. Inadequate storage, handling, and disposal practices also contribute to pollution. Pesticides and fertilizers also degrade groundwater quality. Overloaded or improperly treated septic tanks and illegal discharges are also sources of bacteria and pollutants.

Groundwater in the Project study area is generally considered drinking-water quality for inorganic constituents but is likely to contain organic contaminants from solvent and petroleum hydrocarbon pollution associated with industrial activities in the area.

Based on the *Link US Preliminary Geotechnical Report* (Metro 2025a), the groundwater levels within the Project study area range between depths of approximately 14 and 48 feet below ground surface (bgs). Historical groundwater depths as shallow as 13.5 feet bgs have been reported (Cordoba Corporation 1994; Catellus Urban Development Corporation 1998), but more recent measurements indicate a steady groundwater level decline. The groundwater quality within the Project study area is not specifically known, but the groundwater may contain inorganic constituents, as well as organic contaminants from solvent and petroleum hydrocarbon pollution associated with industrial activities in the area (Caltrans 2005). Developers of underground facilities, as well as temporary excavations during construction, should anticipate encountering groundwater if greater than approximately 20 feet bgs. The *Link US Phase I Environmental Site Assessment* (Metro 2016) includes additional information regarding potential groundwater contamination.

**Groundwater Quality Objectives/Standards and Beneficial Uses**

The following beneficial uses are identified in the Basin Plan for the Coastal Plain of Los Angeles (Central) Groundwater basin.

- Municipal and Domestic Supply (MUN)
- Agricultural Supply (AGR)
- Industrial Service Supply (IND)
- Industrial Process Supply (PROC)

The stipulated water quality objectives for groundwater, as identified in the Basin Plan, are listed in Table 3-2. The narrative water quality objectives for Los Angeles River (as related to US-101) identified only chlorine and polychlorinated biphenyl in the Caltrans Water Quality Planning Tool (Caltrans 2018).

**Table 3-2. Groundwater Quality Objectives**

Constituent	Concentrations
Bacteria	In groundwaters used for domestic or MUN supply, the concentration of coliform organisms over any 7-day period will be less than 1.1/100 milliliter.
Boron	Boron will not exceed 1.0 mg/L.
Chemical constituents and radioactivity	Groundwaters designated for use as domestic or MUN supply will not contain concentrations of chemical constituents and radionuclides in excess of the limits specified in California Code of Regulations, Title 22. Groundwaters will not contain concentrations of chemical constituents in amounts that adversely affect any designated beneficial use.

**Table 3-2. Groundwater Quality Objectives**

Chloride	Chloride will not exceed 150 mg/L.
Nitrogen (Nitrate, Nitrite)	Groundwaters will not exceed 10 mg/L nitrogen as nitrate-nitrogen plus nitrite-nitrogen, 45 mg/L as nitrate, 10 mg/L as nitrate-nitrogen, or 1 mg/L as nitrite-nitrogen.
Sulfate	Sulfates will not exceed 250 mg/L.
Taste and odor	Groundwaters will not contain taste or odor-producing substances in concentrations that cause nuisance or adversely affect beneficial uses.
Total dissolved solids	Total dissolved solids will not exceed 700 mg/L.

Source: Los Angeles RWQCB 2014

Notes:

mg/L=milligrams/liter

### Existing Water Quality

The surface water ambient monitoring program maintains water quality stations along the Los Angeles River. The most recent water quality data collection near the Project study area occurred on June 29, 2005. Table 3-3 summarizes water quality measurements collected by the surface water ambient monitoring program at Site Numbers 412CE0104 and 412LAR007 for Los Angeles River (HU Code 18070105) for selected constituents, compared with water quality objectives provided in the Basin Plan.

**Table 3-3. Los Angeles River Water Quality - 2005 Results**

Analyte	Unit	Basin Plan Water Quality Objectives	Los Angeles Random Site 7 Station Code 412LAR007	Los Angeles River ~ 0.8 mile below Highway 110 Station Code
Specific conductivity, total	microsiemens/centimeter	—	1323	945
Oxygen, dissolved, total	mg/L	> 5	21.31	12.5
Temperature	Degrees Celsius	< 26.67	29.81	25.1
Velocity	feet/second	—	—	0
Salinity, total	parts per thousand	< 1	0.65	0.4
Turbidity, total	nephelometric turbidity unit	< 5	4.7	—

**Table 3-3. Los Angeles River Water Quality - 2005 Results**

Analyte	Unit	Basin Plan Water Quality Objectives	Los Angeles Random Site 7 Station Code 412LAR007	Los Angeles River ~ 0.8 mile below Highway 110 Station Code
Oxygen, saturation, total	percentage	—	284.2	—
pH	units	> 6.5, < 8.5	9.7	—
Nitrite as N, dissolved	mg/L	< 1	1.42	—
OrthoPhosphate as P, dissolved	mg/L	—	0.343	—
Chloride, dissolved	mg/L	< 190	107	—
Hardness as calcium carbonate, total	mg/L	—	332	—
Ammonia as N, total	mg/L	<0.233	0.059	—
Nitrogen, total Kjeldahl, total	mg/L	< 8	2.86	—
Phosphorus as P, total	mg/L	—	0.597	—
Nitrate as N, dissolved	mg/L	< 10	2.6	—
Chlorophyll a, particulate	micrograms/liter	—	63.7	—
Sulfate, dissolved	mg/L	< 350	226	—

Source: California Environmental Data Exchange Network 2018 and Basin Plan

Notes:

mg/L=milligrams per liter; pH=potential of hydrogen

## Regional Water Quality

Pollutants from dense clusters of residential, industrial, and other urban activities in the Los Angeles Basin have impaired water quality in the immediate vicinity of the Project study area. Added to this complex mixture of pollutant sources (in particular, pollutants associated with urban and stormwater runoff) is the high number (in the thousands) of point source industrial, construction, and municipal permits issued north and south of the Project study area (California Water Boards, 2007).

### Section 303(d) List of Impaired Waters

Within the Chavez Ravine and Compton Creek HSAs of the Lower Los Angeles River hydrologic area, included within the Los Angeles HU, the Los Angeles River is the receiving waterbody listed as an impaired waterbody on the 2020–2022 CWA Section 303(d) list (California SWRCB 2022). A summary of the hydrologic information, Section 303(d) listed waterbodies and their associated POCs, TMDLs, and targeted design constituents are shown in Table 3-4.

**Table 3-4. 2020–2022 Clean Water Act Section 303(d) Listed Waterbodies and Pollutants of Concern**

Jurisdiction	HU	Hydrologic Area	HSA #	Waterbody	POC
Los Angeles RWQCB <sup>1</sup>	Los Angeles	Lower Los Angeles River	Chavez Ravine and Compton Creek	Los Angeles River (Reach 2)	Ammonia <sup>3</sup> , Indicator Bacteria <sup>4</sup> , Copper <sup>5</sup> , Lead <sup>6</sup> , Nutrients (Algae) <sup>7</sup> , Oil <sup>8</sup> , Trash <sup>9</sup>
Los Angeles RWQCB (Caltrans) <sup>2</sup>	Los Angeles River <sup>10</sup>	Los Angeles <sup>10</sup>	412.10 <sup>10</sup>	Los Angeles River (Reach 2)	Ammonia <sup>3</sup> , Coliform Bacteria <sup>4</sup> , Copper <sup>5</sup> , Lead <sup>6</sup> , Nutrients (Algae) <sup>7</sup> , Oil <sup>8</sup> , Trash <sup>9</sup>

Source: SWRCB 2022.

**Notes:**

<sup>1</sup> 2018 Section 303(d) Approved List.

<sup>2</sup> Caltrans 2018b.

<sup>3</sup> Pollutants of concern with an EPA-approved TMDL, USEPA TMDL Approved Date, 2004-03-18

<sup>4</sup> Pollutants of concern with an EPA-approved TMDL, USEPA TMDL Approved Date, 2012-03-23

<sup>5</sup> Pollutants of concern with an EPA-approved TMDL, USEPA TMDL Approved Date, 2005-12-22

<sup>6</sup> Pollutants of concern with an EPA-approved TMDL, USEPA TMDL Approved Date, 2005-12-22

<sup>7</sup> Pollutants of concern with an EPA-approved TMDL, USEPA TMDL Approved Date, 2004-03-18

<sup>8</sup> Pollutants of concern with an EPA-approved TMDL, Expected TMDL Completion Date, 2019

<sup>9</sup> Pollutants of concern with an EPA-approved TMDL, USEPA TMDL Approved Date, 2008-07-24.

<sup>10</sup> Based on CalWater Watershed Data.

Caltrans=California Department of Transportation; HSA=hydrologic subarea; HU= Hydrologic Unit; POC=pollutant of concern; RWQCB=Regional Water Quality Control Board; TMDL=total maximum daily load; U.S. EPA=United States Environmental Protection Agency

A targeted design constituent is a pollutant that has been identified during Caltrans runoff characterization studies to be discharging with a load or concentration that commonly exceeds allowable standards and is considered treatable by currently available Caltrans-approved treatment BMPs. It is a requirement of the Caltrans NPDES Permit to provide treatment of the Caltrans-identified targeted design constituents.

### Areas of Special Biological Significance

Areas of special biological significance are a subset of state water quality protection areas and require special protection as determined by the SWRCB pursuant to the California Ocean Plan. The Project study area is not located within an area of special biological significance.

### 3.1.4 Geology/Soils

#### Geology

The Project study area is located within the Los Angeles Basin near the boundary of the Transverse Ranges Province and the northern Peninsular Ranges Geomorphic Province. The mountain ranges include the Santa Monica and San Gabriel Mountains located to the northwest and northeast of the Project study area, respectively, and the Palos Verdes Hills toward the southwest. The Transverse Ranges are characterized by an east-to-west trending complex group of mountain ranges and valleys. The Transverse Ranges are comprised predominantly of sedimentary rocks, Mesozoic granitic rocks, and ancient Precambrian rocks of all types. The northern Peninsular Ranges are characterized by a series of northwest-to-southwest trending mountains and faults. These mountain ranges are composed of metamorphosed sedimentary and volcanic rocks of Jurassic age that have been intruded by mid-Cretaceous plutonic rocks of the Southern California batholith and rimmed by Cenozoic sedimentary rocks (Gastil and Krummenacher 1981; Schoellhamer et al. 1981; Metro 1981).

The Project study area is located west of the Los Angeles River on a gently sloping alluvial surface. In general, the Project study area is underlain by varying amounts of artificial fill and Holocene- and Pleistocene-age alluvium deposits consisting of silty sands, sands, and silts with varying amounts of gravel and cobbles. Beneath the alluvium layers, Miocene Puente marine sedimentary formations are encountered within the Project study area.

#### Soils

Based on existing geotechnical data, geologic maps, reports, and other pertinent information, the Project study area is underlain by varying amounts of artificial fill and younger alluvium deposits ranging from loose to medium dense materials such as silty sands/sandy silts, silt, and sands with varying amounts of gravel and cobbles. The artificial fill varies in composition but is generally known to contain construction debris, as well as imported natural earth materials. The compaction of this layer is uncertain, and, therefore, this layer of fill is categorized as uncertified fill. In Los Angeles County, in general, uncertified fill may not be used to support loads from structures, and the removal and recompaction of this layer should be anticipated for construction.

The artificial fill layer varies from approximately 5 to 15 feet in thickness but may extend to depths as great as approximately 30 feet bgs in some locations. In Segment 2 of the Project study area, the artificial fill ranges from approximately 20 to 30 feet bgs. The younger alluvium deposit thickness within the Project study area limits ranges from approximately 40 to 70 feet; however, for the concourse area, young alluvium deposit thickness ranges from approximately 65 to 75 feet (Metro 2016).

According to the *Link US Phase I Environmental Site Assessment* (Metro 2016), the Project study area is expected to have variable potential for contamination because of legacy site use and historical development. These uses have released contaminants into soil and groundwater. Field

results and desktop research indicate chemicals, methane, and volatile gases are present in the soil. It is assumed that the entire Project study area is underlain with contaminated soils.

### **Soil Erosion Potential**

Due to the lack of unpaved soils within the immediate Project study area, the erosion potential under natural conditions is low. According to the National Resources Conservation Service soil survey (USDA 2023), the soil erodibility factor within the Project study area limits is approximately 0.24, on a scale of 0.02 to 0.65, which is low to moderate for erosion potential. The estimates are based primarily on a percentage of silt, sand, and organic matter; soil structure; and saturated hydraulic conductivity of the soil. The higher the value, the more susceptible the soil is to sheet and rill erosion by water.

### **3.1.5 Biological Communities**

The Los Angeles area supports a variety of plant communities and wildlife species. Native vegetation includes grasslands, coastal sage scrub, chaparral, oak woodland, riparian, pinyon juniper, and timber conifer. The Project study area, however, is highly developed with essentially no remaining native vegetation. There are no natural communities present within the Project study area that would support native and special-status plant and wildlife species. Nonnative, ornamental, and weedy plant species are present in landscaped areas and vacant lots.

### **Aquatic Habitat**

Reach 2 of the Los Angeles River (the portion adjacent to the Project study area) is concrete-lined and supports no functional aquatic habitat.

### **Special-Status Species**

There are no special-status species present within the Project study area.

### **Stream/Riparian Habitats**

There are no stream or riparian habitats present within the Project study area.

### **Wetlands**

There are no jurisdictional wetlands within the Project study area.

### **Fish Passage**

There are no fish passages present within the Project study area.

(THIS PAGE INTENTIONALLY LEFT BLANK)

## 4.0 Environmental Consequences

### 4.1 Introduction

This section discusses the potential environmental effects related to water quality that may occur upon implementation of the Build Alternative and identifies mitigation measures that would reduce potential effects during construction and throughout operation. Under the No Action Alternative, the Build Alternative would not be implemented, and existing conditions in the Project study area would remain. No effect on water quality would occur.

Based on the *Link US Phase I Environmental Site Assessment*, the majority of the soil where physical disturbance would occur is contaminated and not suitable for infiltration (Tier 1). Therefore, unlined landscaping improvements, including irrigation, are not feasible for the Build Alternative. Tier 2 (capture and use) and Tier 3 (bioretention) are viable approaches to meet LID requirements and are incorporated into the design of the Build Alternative, as summarized below.

- In Segment 1: Throat Segment, a structural stormwater vault would address the area north of Vignes Street; a capture and use BMP (cistern) would address the rest of this segment, including a portion of the concourse area (Segment 2: Concourse Segment). Implementation of the City of Los Angeles Green Street Standards would be applied at this location, similar to the BMPs proposed in Segment 3: Run-Through Segment.
- In Segment 2: Concourse Segment, capture and use BMP (cisterns) are proposed. The extent of BMPs in the concourse area would be refined in final design.
- In Segment 3: Run-Through Segment, south of US-101, bioretention BMPs are proposed for the Build Alternative. City of Los Angeles Green Street Standard Plans may be used and modified with bioretention features and impermeable liners to convey the underdrains to a nearby storm drain system. This approach would require concurrence from the City of Los Angeles. For the Build Alternative, a structural BMP (Contech Jellyfish Filter) would address the area south of Ducommun Street, where tracks would be supported by cellular concrete.

### 4.2 Potential Effects on Water Quality

#### 4.2.1 Anticipated Changes to the Physical/Chemical Characteristics of the Aquatic Environment

##### Substrate

##### *California Department of Transportation ROW*

During construction, there would be minor contact with the substrate at the columns of the US-101 Viaduct. Although exposure to the substrate to accommodate the column foundations is limited and not considered substantial, adverse effects may occur if not properly managed.

Implementation of Mitigation Measure WQ-1 (described in Section 5.0) would reduce adverse effects on the substrate; therefore, no effect would occur.

During operation, the Build Alternative would result in a slight increase of impervious surfaces within Caltrans ROW (0.14 acre of net new impervious surface). This increase in impervious surface has the added benefit of not exposing more substrate. No effect would occur.

Under the No Action Alternative, the existing conditions in the Project study area would remain. No effect on water quality would occur.

### ***Non-California Department of Transportation ROW***

During construction, there would be contact, albeit minor, with the substrate at various locations and depths. Adverse effects may occur if not properly managed. The SWPPP would identify construction BMPs to be implemented to address this activity within the substrate. Implementation of Mitigation Measure WQ-1 (described in Section 5.0) would reduce adverse effects on the substrate; therefore, no effect would occur.

During operation, the Build Alternative would result in a permanent increase of impervious surfaces within non-Caltrans ROW. This increase in impervious surface has the added benefit of not exposing more substrate, which would limit erosion and the need for additional sediment control. Therefore, no effect would occur.

Under the No Action Alternative, the existing conditions in the Project study area would remain. No effect on water quality would occur.

## **Currents, Circulation, or Drainage Patterns**

### ***California Department of Transportation ROW***

The Build Alternative is not located in a coastal area that would affect ocean currents or circulation. Implementation of the Build Alternative would result in a 0.14-acre increase in impervious surface, with 1.24 acres of Replaced Impervious Surface, within Caltrans ROW. Because the US-101 overhead viaduct is a non-Caltrans structure proposed within Caltrans ROW and would act as a roof to a small portion of the highway, the runoff generated from the non-Caltrans structure would offset the reduced runoff along the highway. Therefore, the runoff associated with the US-101 overhead viaduct would not exceed the capacity of the tributary Caltrans system below. The Build Alternative is designed to preserve existing drainage patterns and time of concentration to the extent practicable associated with the tributary US-101 storm drain system. By preserving existing drainage system routing, changes to hydrology would be minimized, and no effect would occur.

Under the No Action Alternative, the existing conditions in the Project study area would remain. No effect on water quality would occur.

***Non-California Department of Transportation ROW***

The Build Alternative is not located in a coastal area that would affect currents or circulation. Implementation of the Build Alternative would increase impervious surfaces in the Project study area by 5.30 acres. A breakdown of these areas per jurisdiction is provided in the *Link US Preliminary Low Impact Development Report* (Metro 2025c). The Build Alternative would be designed to preserve existing drainage patterns that pass through the Project site. An overall increase in storm runoff is anticipated to result from increased impervious surface area, which would increase the volume of flow and could exceed the capacity of some on-site drainage systems if not properly managed, and potentially result in an adverse effect. Where net increases in runoff would occur, BMPs are proposed in accordance with Mitigation Measures WQ-5 and WQ-6 (described in Section 5.0) to reduce adverse effects by attenuating the flow prior to entering the drainage conveyance system. For the Build Alternative, this would be addressed through the incorporation of cisterns into the design of proposed infrastructure to capture the volume so as not to overtax the existing storm drain systems. The cisterns would be designed to control peak flows to match existing conditions.

Under the No Action Alternative, the existing conditions in the Project study area would remain. No effect on water quality would occur.

**Suspended Particulates (Turbidity)**

***California Department of Transportation ROW***

Construction activities within Caltrans ROW would disturb soil from the foundations of the US-101 overhead viaduct columns. Total disturbed soil area within Caltrans ROW is calculated to be 2.82 acres. Generation of suspended particles and sediment during construction is expected to be minor, although it could result in an adverse effect if not properly managed. Generation of suspended particles may be conveyed in runoff along the storm drain system and ultimately to the Los Angeles River, in which the turbid runoff may affect wildlife and aquatic habitats. During construction, the contractor would be required to comply with the requirements of the CGP (Mitigation Measure WQ-1 [described in in Section 5.0]). Under this permit, a SWPPP would be required to be implemented for the Build Alternative, of which Caltrans ROW is a portion, to be prepared and implemented throughout construction. The SWPPP would identify construction BMPs to be implemented to address suspended solids and turbidity. Construction BMPs would include, but not be limited to, erosion control and sediment control BMPs designed to minimize erosion and retain sediment on site. Implementation of Mitigation Measure WQ-1 would reduce the potential for adverse effects.

During operation, increase in sediment load is not expected along US-101 and the associated overhead viaduct because this impervious surface would not be subject to erosion. Only during a maintenance activity that disturbs the underlying soil would there be a potential for suspended particles and turbidity, but this is expected to be minor due to the requirements to implement standard BMPs. Periodic maintenance of the proposed drain inlet(s) along the US-101 overhead viaduct would be required to ensure that turbid runoff does not discharge into the existing drainage

system along US-101, which is considered an adverse effect. Implementation of Mitigation Measure WQ-4 (described in Section 5.0) would reduce the potential for adverse effects.

Under the No Action Alternative, the existing conditions in the Project study area would remain. No effect on water quality would occur.

### ***Non-California Department of Transportation ROW***

Construction activities would disturb soil and increase the potential for soil erosion and suspended particles to be generated as a result of construction vehicles operating on a roadway and rail cars operating on the tracks and platforms. This is considered an adverse effect.

During construction, the contractor would be required to comply with the requirements of the CGP for work outside Caltrans ROW (Mitigation Measure WQ-1 [described in Section 5.0]). Mitigation Measure WQ-1 requires implementation of construction BMPs including, but not limited to, erosion control and sediment control BMPs designed to minimize erosion and retain sediment on site. Implementation of Mitigation Measure WQ-1 would reduce the potential for adverse effects.

During operation, increased impervious surfaces associated with cellular concrete, impermeable liners for all soil-contaminated areas, platforms, and access roads increase the volume and velocity of runoff during a storm event, which transports pollutants to receiving waters and may lead to downstream erosion and increases in suspended particles and sediment. Maintenance activities may also generate suspended particles and sediment. An increase in suspended particles and sediment would directly increase the turbidity. This is considered an adverse effect. Implementation of Mitigation Measures WQ-5 and WQ-6 (described in Section 5.0) would reduce this potential adverse effect.

Under the No Action Alternative, the existing conditions in the Project study area would remain. No effect on water quality would occur.

### **Oil, Grease, and Chemical Pollutants**

Heavy metals, pesticides, petroleum hydrocarbons (oil and grease), and organic compounds can be toxic to aquatic life. Some of these compounds can bioaccumulate over several years, resulting in health problems for the affected organism. POCs during construction include petroleum products and chemicals. Chemicals, liquid products, petroleum products (e.g., paints, solvents, and fuels), and concrete-related waste may be released and transported via storm runoff into receiving waters. During operation, oil, grease, and toxic organic compounds are POCs. These pollutants can be generated from general maintenance activities, as well as rail cars operating on the facility.

### ***California Department of Transportation ROW***

Construction activities within Caltrans ROW would require use of chemical liquid products, petroleum products (e.g., paints, solvents, and fuels) and generate concrete-related waste.

Generation of oil, grease, and chemical pollutants during construction is expected to be minor, although they could result in adverse effects if not properly managed.

During construction, the contractor would be required to comply with the requirements of the CGP (Mitigation Measure WQ-1 [described in Section 5.0]). Mitigation Measure WQ-1 requires implementation of construction BMPs including, but not limited to, non-stormwater management and waste management BMPs designed to minimize oil, grease, and chemical pollutants on site. Implementation of Mitigation Measure WQ-1 would reduce this potential adverse effect.

During operation, minor amounts of oil and grease would originate from train cars could discharge oil, grease, and other chemical pollutants into existing drainage systems. This is considered an adverse effect. Post-construction BMPs (Mitigation Measure WQ-4 [described in Section 5.0]) are required to treat the runoff prior to discharge to the local storm drain system through capture and use, bioretention, and structural BMPs. Implementation of Mitigation Measures WQ-1 and WQ-4 would reduce this potential adverse effect.

Under the No Action Alternative, the existing conditions in the Project study area would remain. No effect on water quality would occur.

#### ***Non-California Department of Transportation ROW***

During construction, chemicals, liquid products, petroleum products (e.g., paints, solvents, and fuels), and concrete-related waste may be released and transported via storm runoff into receiving waters. This is considered an adverse effect. During construction, the contractor would be required to comply with the requirements of the CGP (Mitigation Measure WQ-1 [described in Section 5.0]). Under this permit, the contractor would be required to prepare an SWPPP and implement construction BMPs including, but not limited to, good housekeeping BMPs to prevent spills, leaks, and discharge of construction oil, grease, and chemical pollutants into receiving waters. Implementation of Mitigation Measure WQ-1 would reduce this potential adverse effect.

During operation, generation of oil, grease, and chemical pollutants in runoff during a storm event may result in the transport of pollutants to receiving waters and lead to a downstream impairment. Maintenance activities may also generate oil, grease, and chemical pollutants. This is considered an adverse effect. The Build Alternative includes capture and use BMPs, bioretention BMPs, and structural BMPs that would provide permanent stormwater treatment. Mitigation Measure WQ-5 (described in Section 5.0) would require implementation of post-construction BMPs in accordance with the NPDES General Permit. Implementation of Mitigation Measure WQ-6 (described in Section 5.0) would memorialize the post-construction BMPs in accordance with the City of Los Angeles *Planning and Land Development Handbook for Low Impact Development*. Implementation of Mitigation Measures WQ-5 and WQ-6 would reduce this potential adverse effect.

Also, during operation, the Project would result in acquisition of parcels with current manufacturing and industrial processes permitted by the IGP. These processes include treating stormwater discharges that include pollutants. Upon implementation of the Build Alternative, if these

processes are not continued, industrial stormwater may not be treated and could adversely affect the storm drain system. Implementation of Mitigation Measure HWQ-7 (described in Section 5.0) requires Metro to comply with the NPDES General Permit for Stormwater Discharges Associated with Industrial Activities for demolished, relocated, or new industrial-related properties impacted by the Project. This will include preparation of industrial SWPPP(s), as applicable. As such, treatment of stormwater discharge associated with the IGPs would continue. Implementation of Mitigation Measure WQ-7 (described in Section 5.0) would reduce this potential adverse effect.

Under the No Action Alternative, the existing conditions in the Project study area would remain. No effect on water quality would occur.

### **Temperature, Oxygen Depletion, and Other Parameters**

This section applies to both Caltrans and non-Caltrans ROW.

Temperature is not typically considered a POC during construction or operation of a rail facility. However, water detained on a construction site has the potential to reach ambient air temperature, which could cause an increase in surface water temperature if discharged during a storm event. Non-stormwater discharges, such as groundwater dewatering, could also change surface water temperatures. In addition, during operation, stormwater falling on or flowing over warm pavement can increase the temperature of runoff. A discharge of water with increased temperature would not be considered an adverse effect because Los Angeles River does not have documented marine habitat.

Nutrients are typically composed of phosphorus and/or nitrogen, and elevated levels of these nutrients in surface waters could cause algal blooms and excessive vegetative growth. As nutrients are absorbed, the vegetative growth decomposes, depleting oxygen in the process and reducing dissolved oxygen levels. Dissolved oxygen is critical for the support of aquatic life. The ammonium form of nitrogen commonly found in wastewater discharges converts to nitrite and nitrate in the presence of oxygen and further depletes the dissolved oxygen levels in water. Nutrients are not a POC during construction and are not expected because proposed landscaping is expected to be minimal. Therefore, nutrients are not expected during construction and no adverse effect would occur.

Trash and debris can interfere with aquatic life respiration and can be harmful or hazardous to aquatic animals that mistakenly ingest floating debris. During construction, trash and debris are potential pollutants from construction activities. During operation, trash and debris are POCs from maintenance activities and rail cars operating on the rail facility. This is considered an adverse effect.

During construction, the contractor would be required to comply with the requirements of the CGP (Mitigation Measure WQ-1 [described in Section 5.0]). Under this permit, the contractor would be required to prepare an SWPPP and implement construction BMPs including, but not limited to, good housekeeping BMPs to prevent spills, leaks, and discharge of construction debris and waste into receiving waters. The SWPPP and Project specifications would also include provisions for

keeping the Project site clean of debris to the extent possible and keeping all food-related trash items enclosed in sealed containers with regular removal from the Project site. Implementation of Mitigation Measure WQ-1 would reduce this potential adverse effect.

During operation, trash and debris in storm runoff may result in the transport of pollutants to receiving waters. The Build Alternative includes capture and use BMPs, bioretention BMPs, and structural BMPs that would capture trash as part of their treatment. Mitigation Measure WQ-6 (described in Section 5.0) would memorialize the post-construction BMPs in accordance with the City of Los Angeles *Planning and Land Development Handbook for Low Impact Development*. Implementation of Mitigation Measure WQ-6 would reduce this potential adverse effect.

Under the No Action Alternative, the existing conditions in the Project study area would remain. No effect on water quality would occur.

### **Flood Control Functions**

This section applies to both Caltrans and non-Caltrans ROW.

As discussed above, a comprehensive drainage system upgrade would be implemented, including longitudinal drainage systems and a combination of inlets and/or grated line drains to intercept stormwater runoff that is ultimately conveyed to the Los Angeles River. As detailed in the *Preliminary Low Impact Development Report* (Metro 2025c) prepared for the Project, the capacities of the storm drain systems were analyzed to compare with the existing and proposed condition.

To minimize the effect on the existing drainage systems, cisterns were deemed necessary at locations where the Project stormwater runoff was anticipated to exceed the existing conveyance facility's capacity. In addition, new, and in some cases, larger diameter drainage systems would be necessary at various locations based on tributary flow rates and length of pipe needed to connect into an existing drainage system. With the installation of cisterns and new drainage systems, the Build Alternative would have no adverse effect on flood control facilities.

Under the No Action Alternative, the existing conditions in the Project study area would remain. No effect on water quality would occur.

### **Erosion and Accretion Patterns**

This section applies to both Caltrans and non-Caltrans ROW.

During construction, excavated soil would be exposed, and there would be increased potential for soil erosion. This is considered an adverse effect. The contractor would be required to implement standard erosion control practices as part of the SWPPP to reduce potential effects during construction. Implementation of Mitigation Measure WQ-1 (described in Section 5.0) would reduce this potential adverse effect.

During operation, increases in impervious area would decrease infiltration and cause an increase in the volume of runoff during a storm event, which can lead to changes in downstream erosion

and accretion patterns. However, this would be minimized during operations by capturing the increased volume in cisterns and controlling the release of runoff at a predevelopment level. Implementation of Mitigation Measure WQ-6 (described in Section 5.0) would reduce this potential adverse effect.

Under the No Action Alternative, the existing conditions in the Project study area would remain. No effect on water quality would occur.

### **Aquifer Recharge/Groundwater**

This section applies to both Caltrans and non-Caltrans ROW.

During construction, it is assumed that groundwater dewatering may be required. These groundwater dewatering activities are considered temporary, and water would only be extracted from the upper aquifer, which is not currently used for potable uses. If groundwater dewatering is not appropriately managed and disposed of (including discharge back to the groundwater), an adverse effect on the groundwater quality could occur. Implementation of Mitigation Measures WQ-2 and WQ-3 (described in Section 5.0) would reduce this potential adverse effect.

Operation of the Build Alternative would not require groundwater extraction; therefore, would not substantially deplete groundwater supplies or substantially interfere with groundwater recharge. Also, there are no groundwater recharge facilities in the Project study area. Therefore, no effect would occur.

Under the No Action Alternative, the existing conditions in the Project study area would remain. No effect on water quality would occur.

### **Baseflow**

This section applies to both Caltrans and non-Caltrans ROW.

Baseflow is streamflow that results from precipitation that infiltrates into the soil and eventually moves through the soil to the stream channel. Given that the Project study area is already largely comprised of impervious surfaces, the Build Alternative would not substantially reduce the current level of baseflow that naturally occurs in the Project study area. Therefore, no effect related to baseflow would occur.

Under the No Action Alternative, the existing conditions in the Project study area would remain. No effect on water quality would occur.

## **4.2.2 Anticipated Changes to the Biological Characteristics of the Aquatic Environment**

Given the urbanized nature of the Project study area, changes to the biological characteristics of the aquatic environment are not anticipated. The Build Alternative would have no effect on special aquatic sites, habitat for fish and other aquatic organisms, wildlife habitat, or endangered or threatened species, as well as no effect associated with invasive species.

Under the No Action Alternative, the existing conditions in the Project study area would remain. No effect on water quality would occur.

### **4.2.3 Anticipated Changes to the Human Use Characteristics of the Aquatic Environment**

#### **Existing and Potential Water Supplies/Water Conservation**

Due to the presence of contaminated soils, the Build Alternative would be designed to avoid infiltration to the underlying groundwater table. Landscaping pockets are proposed as bioretention areas in limited areas. These limited areas would use irrigation water secondary to harvested water from capture and use BMPs. Landscaped areas would be vegetated with drought-tolerant plants that do not require consistent and substantial levels of irrigation. There are no other demands for harvested water. Therefore, no adverse effect related to water supply/conservation would occur.

Under the No Action Alternative, the existing conditions in the Project study area would remain. No effect on water quality would occur.

#### ***Recreational or Commercial Fisheries***

The receiving waters in the Project study area are not used for commercial fishing. Implementation of the Build Alternative would not affect commercial fishing. No effect related to recreational or commercial fisheries would occur.

Under the No Action Alternative, the existing conditions in the Project study area would remain. No effect on water quality would occur.

#### ***Other Water-Related Recreation***

The receiving waters in the Project study area are not used for recreation. Implementation of the Build Alternative would not affect other water-related recreation. No effect related to other water-related recreation would occur.

Under the No Action Alternative, the existing conditions in the Project study area would remain. No effect on water quality would occur.

### **4.2.4 Short-Term Effects during Construction**

#### **Physical/Chemical Characteristics of the Aquatic Environment**

POCs during construction include sediments, trash, petroleum products, concrete waste (dry and wet), sanitary waste, and chemicals. During construction, excavated soil would be exposed, and there would be increased potential for soil erosion. In addition, excavated soils would be contaminated, and the contractor would be required to follow protocol consistent with the Link US *Phase I Environmental Site Assessment* (Metro 2016) or forthcoming Phase II Environmental Site Assessment for disposal of the soils. In addition, chemicals, liquid products, petroleum products

(e.g., paints, solvents, and fuels), and concrete-related waste may be spilled or leaked and have the potential to be transported via stormwater runoff into receiving waters. Construction of the safety improvements at the North Main Street at-grade public crossing may require some minor grading, excavation, and other site preparation activities. If not properly managed, sediments, petroleum products, and concrete-related waste may be spilled or leaked and have the potential to be transported via stormwater into the Los Angeles River.

Due to the depth to groundwater, groundwater dewatering is anticipated during construction. Other non-stormwater dewatering discharges are not anticipated during construction.

Under the CGP, the contractor would be required to prepare an SWPPP and implement construction BMPs. Construction BMPs would include, but not be limited to, erosion and sediment control BMPs designed to minimize erosion and retain sediment on site, and good housekeeping BMPs to prevent spills, leaks, and discharge of construction debris and waste into receiving waters.

The requirements of the CGP are based on the Project risk level. The overall risk level is based on two factors: receiving water risk and sediment risk. Runoff from the Project site would not discharge to a Section 303(d) listed waterbody impaired for sediment, or discharge to a waterbody with designated beneficial uses of SPAWN, COLD, or MIGRATORY. As calculated in the Stormwater Data Report (July 2019), the receiving water risk is classified as low because the location's receiving water bodies are not listed on the 2014-2016 303(d) list for sediment, nor do they have a TMDL for sediment. The estimated Isoerodent R-Factor is 146, using the U.S. EPA's Construction Rainfall Erosivity Worksheet. The hillslope-length (L) to hillslope-gradient (S) LS Factor value is 1.4 and the estimated soil-erodibility K-Factor is 0.32, taken from Caltrans CGP maps. The calculated Sediment Risk is rated as medium at 65.41 tons per acre. The combined medium sediment risk and low receiving water risk indicate a combined Risk Level of 2. The risk level was determined by the Individual Method (U.S. EPA Rainfall Erosivity Calculator and Individual Data), indicating a combined Risk Level of 2 for the Build Alternative.

Under the No Action Alternative, the existing conditions in the Project study area would remain. No effect on water quality would occur.

### ***California Department of Transportation***

The construction risk level is 2.

Implementation of the mitigation measures described in Section 5.0 would reduce short-term, Project-related effects during construction.

Under the No Action Alternative, the existing conditions in the Project study area would remain. No effect on water quality would occur.

### ***Non-California Department of Transportation***

The construction risk level is 2.

Implementation of the mitigation measures described in Section 5.0 would reduce short-term, Project-related effects during construction.

Under the No Action Alternative, the existing conditions in the Project study area would remain. No effect on water quality would occur.

### **Biological Characteristics of the Aquatic Environment**

Because there are no aquatic resources in the Project study area, the Build Alternative would have no effect on biological characteristics of the aquatic environment. No short-term water quality effect would occur.

Under the No Action Alternative, the existing conditions in the Project study area would remain. No effect on water quality would occur.

### **Human Use Characteristics of the Aquatic Environment**

Because there are no aquatic resources in the Project study area, the Build Alternative would have no effect on human use characteristics of the aquatic environment. No short-term water quality effect would occur.

Under the No Action Alternative, the existing conditions in the Project study area would remain. No effect on water quality would occur.

## **4.2.5 Long-Term Effects during Operation and Maintenance**

### **Physical/Chemical Characteristics of the Aquatic Environment**

Primary POCs are pollutants that are expected or have potential to result in project runoff and which also have been identified as causing impairment of receiving waters on the most recent Section 303(d) list or have an established TMDL. POCs during project operation include suspended solids/sediments, nutrients, pesticides, heavy metals, oil and grease, toxic organic compounds, and trash and debris. These pollutants can be generated from maintenance activities, as well as from locomotives operating at LAUS.

#### ***California Department of Transportation***

During operation, minor amounts of oil and grease would originate from train cars during operation, which could discharge oil, grease, and other chemical pollutants into the existing drainage system along US-101. Post-construction BMPs (Mitigation Measure WQ-4 [described in Section 5.0]) are required to reduce this adverse effect. Provisions for management of oil, grease, and chemical pollutants would be addressed by Mitigation Measure WQ-4 (described in Section 5.0) in the form of post-construction BMPs. Implementation of Mitigation Measures WQ-1 and WQ-4 would reduce this adverse effect.

Under the No Action Alternative, the existing conditions in the Project study area would remain. No effect on water quality would occur.

### ***Non-California Department of Transportation***

As discussed above, the approach to addressing post-Project water quality is to treat the runoff prior to discharge to the local storm drain system through capture and use, bioretention, and structural BMPs. Implementation of the Build Alternative would increase impervious surfaces by 5.30 acres (conservative estimate).

With incorporation of proposed design features and implementation of mitigation measures identified in Section 5.0, no long-term, effects during operations would occur.

Under the No Action Alternative, the existing conditions in the Project study area would remain. No effect on water quality would occur.

### **Biological Characteristics of the Aquatic Environment**

As indicated above, with implementation of the mitigation measures outlined in Section 5.0, there would be no long-term water quality effects on the biological characteristics of the aquatic environment.

Under the No Action Alternative, the existing conditions in the Project study area would remain. No effect on water quality would occur.

### **Human Use Characteristics of the Aquatic Environment**

Although the receiving waters in the vicinity of the Project study area have designated beneficial uses, they are not anticipated to be affected during Project operations with implementation of the mitigation measures described in Section 5.0. Therefore, no long-term water quality effects on human use characteristics would occur.

Under the No Action Alternative, the existing conditions in the Project study area would remain. No effect on water quality would occur.

## 5.0 Mitigation Measures

The following mitigation measures are proposed to reduce effects related to water quality:

- WQ-1 Prepare and Implement a SWPPP:** During construction, Metro shall comply with the provisions of the NPDES General Permit for Stormwater Discharges Associated with Construction and Land Disturbance Activities (Order Number 2009-0009-DWQ, NPDES Number CAS000002), and any subsequent amendments (Order Number 2010-0014-DWQ and Order Number 2012-0006-DWQ), which are currently in effect. However, during construction of the Project, Order Number 2022-0057-DWQ may be in effect. This permit was adopted on September 8, 2022, and became effective on September 1, 2023. Construction activities shall not commence until a waste discharger identification number is received from the Stormwater Multiple Application and Report Tracking System. The contractor shall implement all required aspects of the SWPPP during Project construction. Metro shall comply with the Risk Level 2 sampling and reporting requirements of the CGP. A rain event action plan shall be prepared and implemented by a qualified SWPPP developer within 48 hours prior to a rain event of 50 percent or greater probability of precipitation according to the National Oceanic and Atmospheric Administration. A Notice of Termination shall be submitted to the SWRCB within 90 days of completion of construction and stabilization of the site.
- WQ-2 Comply with Local Dewatering Requirements:** The contractor shall comply with the provisions of the General Waste Discharge Requirements for Discharges of Groundwater from Construction and Project Dewatering to Surface Waters in Coastal Watersheds of Los Angeles and Ventura Counties (Order Number R4-2013-0095, NPDES Permit Number CAG994004), effective July 6, 2013 (known as the Dewatering Permit), as they relate to discharge of non-stormwater dewatering wastes. The two options to discharge shall be to the local storm drain system and/or to the sanitary sewer system, and the contractor shall obtain a permit from the RWQCB and/or the City of Los Angeles.
- WQ-3 Comply with Local Dewatering Requirements for Contaminated Sites:** The contractor shall comply with the provisions of the General Waste Discharge Requirements for Discharges of Treated Groundwater from Investigation and/or Cleanup of Volatile Organic Compounds-Contaminated Sites to Surface Waters in Coastal Watersheds of Los Angeles and Ventura Counties (Order Number R4-2013-0043, NPDES Permit Number CAG914001), effective April 7, 2013 (known as the Dewatering Permit for contaminated sites), for discharge of non-stormwater dewatering wastes from contaminated sites affected during construction. The two options to discharge shall be to the local storm drain system and/or to the sanitary sewer system, and the contractor shall require a permit from the RWQCB and/or the City of Los Angeles.

## 5.1 California Department of Transportation

**WQ-4 Final Water Quality BMP Selection (Caltrans ROW):** Metro shall comply with the provisions of the Caltrans MS4 Permit (Order Number 2022-0033-DWQ) and Time Schedule Order (Order Number 2022-0089-DWQ) that was adopted June 22, 2022, and became effective January 1, 2023, and any applicable provisions of the Caltrans SWMP for long-term BMPs. This post-construction requirement would only apply to the US-101 overhead viaduct improvements. Metro shall prepare a stormwater data report for the plans, specifications, and estimate phase that will address post-construction BMPs for the US-101 overhead viaduct in accordance with the Caltrans *Project Planning and Design Guide* (latest edition).

## 5.2 Non-California Department of Transportation

**WQ-5 Final Water Quality BMP Selection (Railroad ROW):** For the portion of the Project outside Caltrans ROW and not under the jurisdiction of the City of Los Angeles, Metro shall comply with the NPDES General Permit for Waste Discharge Requirements for Stormwater Discharges from Small MS4 (Order Number 2013-0001-DWQ, NPDES Number CAS000004), effective July 1, 2013 (known as the Phase II permit).

**WQ-6 Final Water Quality BMP Selection (City of Los Angeles):** Metro shall comply with the NPDES Waste Discharge Requirements for MS4 Discharges within the Coastal Watersheds of Los Angeles and Ventura Counties (Order Number R4-2021-0105, NPDES Number CAS004004), effective September 11, 2021. This post-construction requirement shall apply to the entire Project except for those portions under the jurisdiction of the Caltrans MS4 Permit and the Phase II Permit. Metro shall prepare a final LID report in accordance with the City of Los Angeles *Planning and Land Development Handbook for Low Impact Development* (LID Manual), May 9, 2016. This document shall identify the required BMPs to be in place prior to Project operation and maintenance.

**WQ-7 Prepare and Implement Industrial SWPPP for Relocated, Regulated Industrial Uses:** Metro shall comply with the NPDES General Permit for Stormwater Discharges Associated with Industrial Activities (IGP; Order Number 2014-0057-DWQ, as amended by Order No. 2015-0122-DWQ, NPDES No. CAS000001), for demolished, relocated, or new industrial-related properties affected by the Project. This shall include preparation of industrial SWPPP(s), as applicable.

## 6.0 References

- California Department of Transportation (Caltrans). 2003. Stormwater Quality Handbooks, Construction Site Best Management Practices.
- . 2005. *Final Environmental Impact Report/Environmental Impact Statement*. Los Angeles Union Station Run-Through Tracks Project.
- . 2017. Stormwater Quality Handbooks, Project Planning and Design Guide, CTSW-RT-10-254.03.
- . 2018a. *California State Rail Plan: Connecting California*. <https://dot.ca.gov/programs/rail-and-mass-transportation/2018-california-state-rail-plan>.
- . 2018b. Caltrans Water Quality Planning Tool. Accessed October 2018: <http://svctenvims.dot.ca.gov/wqpt/wqpt.aspx>.
- California Environmental Data Exchange Network. 2018. Hydrologic Unit Code 18070105 Los Angeles River. <http://ceden.org/>.
- California High-Speed Rail Authority (CHSRA). 2022. *2022 Business Plan*. [hsr.ca.gov/wp-content/uploads/2022/05/2022-Business-Plan-FINAL-A11Y.pdf](https://www.chsra.gov/wp-content/uploads/2022/05/2022-Business-Plan-FINAL-A11Y.pdf).
- California Water Boards. 2007. Water Quality and Watersheds. December 2007. [https://www.waterboards.ca.gov/losangeles/water\\_issues/programs/regional\\_program/watershed/](https://www.waterboards.ca.gov/losangeles/water_issues/programs/regional_program/watershed/).
- Catellus Urban Development Corporation. 1998. Geotechnical Engineering and Groundwater Study, Proposed Two Level Subterranean Parking Garage and Four Story Office. Prepared by J. Byer Group, Inc.
- City of Los Angeles. 2016. *Planning and Land Development Handbook for Low Impact Development*. [http://www.lastormwater.org/wp-content/files\\_mf/lidmanualfinal.pdf](http://www.lastormwater.org/wp-content/files_mf/lidmanualfinal.pdf).
- Cordoba Corporation. 1994. Report of Phase I Environmental Site Assessment, Alameda District Plan, Los Angeles, California. Prepared by Law/Crandall, Inc.
- Federal Emergency Management Agency (FEMA). 1998. Flood Map Service Center. <https://msc.fema.gov/portal/home>.
- Gastil, G., and Krummenacher, D. 1981. The Tectonic History of Peninsular California and Adjacent Mexico, *The Geotechnical Development of California*. Rubey Vol. I, Prentice-Hall, Inc. Englewood Cliffs, NJ, pp. 285-306.
- Los Angeles County Metropolitan Transportation Authority (Metro). 1981. Geology of the Northern Santa Ana Mountains, California: U.S. Geological Survey Professional Paper 420-D. U.S. Geological Survey, Denver, CO.
- . 2015. *Connect US Action Plan*. [http://media.metro.net/projects\\_studies/union\\_station/images/LAUSMP\\_Action\\_Plan\\_Final\\_100515.pdf](http://media.metro.net/projects_studies/union_station/images/LAUSMP_Action_Plan_Final_100515.pdf).
- . 2016. *Link US Phase I Environmental Site Assessment*. Prepared by HDR Engineering, Inc.
- . 2025a. *Preliminary Geotechnical Report*. Prepared by HDR Engineering, Inc.

——— 2025b. *Natural Environmental Study (Minimal Impact)*. Prepared by HDR Engineering, Inc.

——— 2025c. *Link US Preliminary Low Impact Development*. Prepared by HDR Engineering, Inc.

Los Angeles Department of Water and Power (LAWDP). 2023. Briefing Book 2022-23. Available online at [https://ladwp-jtti.s3.us-west-2.amazonaws.com/wp-content/uploads/sites/3/2023/05/18120930/2022-23\\_Briefing\\_Book\\_Online.pdf](https://ladwp-jtti.s3.us-west-2.amazonaws.com/wp-content/uploads/sites/3/2023/05/18120930/2022-23_Briefing_Book_Online.pdf). Accessed June 27, 2023.

Los Angeles Regional Water Quality Control Board (RWQCB). 2014. Basin Plan for the Coastal Watersheds of Los Angeles and Ventura Counties. Accessed January 2020. [https://www.waterboards.ca.gov/losangeles/water\\_issues/programs/basin\\_plan/basin\\_plan\\_documentation.html](https://www.waterboards.ca.gov/losangeles/water_issues/programs/basin_plan/basin_plan_documentation.html).

Schoellhamer, J. E., Woodford, A. O., Vedder, J. G., Yerkes, R.F., Andkinney, D.M. 1981. Geology of the Northern Santa Ana Mountains, California. U.S. Geological Survey Professional Paper 420-D. U.S. Geological Survey, Denver, CO, 109p.

Southern California Association of Governments (SCAG). 2008. *Final 2008 Regional Comprehensive Plan*.

——— 2023. Federal Transportation Improvement Program.

——— 2020. *2020 Regional Transportation Plan/Sustainable Communities Strategy: Connect So Cal*. <https://scag.ca.gov/read-plan-adopted-final-connect-social-2020>.

State Water Resources Control Board (SWRCB). 2012. 2012 Integrated Report, Clean Water Act Sections 303(d) and 305(b). Accessed on June 26, 2015: [https://www.waterboards.ca.gov/water\\_issues/programs/tmdl/docs/ir\\_staffreport\\_final.pdf](https://www.waterboards.ca.gov/water_issues/programs/tmdl/docs/ir_staffreport_final.pdf).

——— 2022. California Water Quality Planning Tool. 2020-2022 303(d) List. <http://svctenvims.dot.ca.gov/wqpt/wqpt.aspx>.

United States (U.S.) Climate Data. 2020. Los Angeles, California. Accessed January 2020. <https://www.usclimatedata.com/climate/los-angeles/california/united-states/usca1339/2019/1>.

United States (U.S.) Department of Agriculture (USDA). 2023. National Resources Conservation Service Web Soil Survey. <https://websoilsurvey.nrcs.usda.gov/app/>

United States (U.S.) Environmental Protection Agency (EPA). 2012. Los Angeles River Watershed. Accessed January 2020. <https://www.epa.gov/sites/production/files/2014-07/documents/Map-LA-2014.pdf>.

——— 2018. Urbanized Area Maps for NPDES MS4 and Phase II Stormwater Permits. <https://www.epa.gov/npdes/urbanized-area-maps-npdes-ms4-phase-ii-stormwater-permits>.

# Link Union Station

Final Preliminary Low Impact Development Report

January 2026

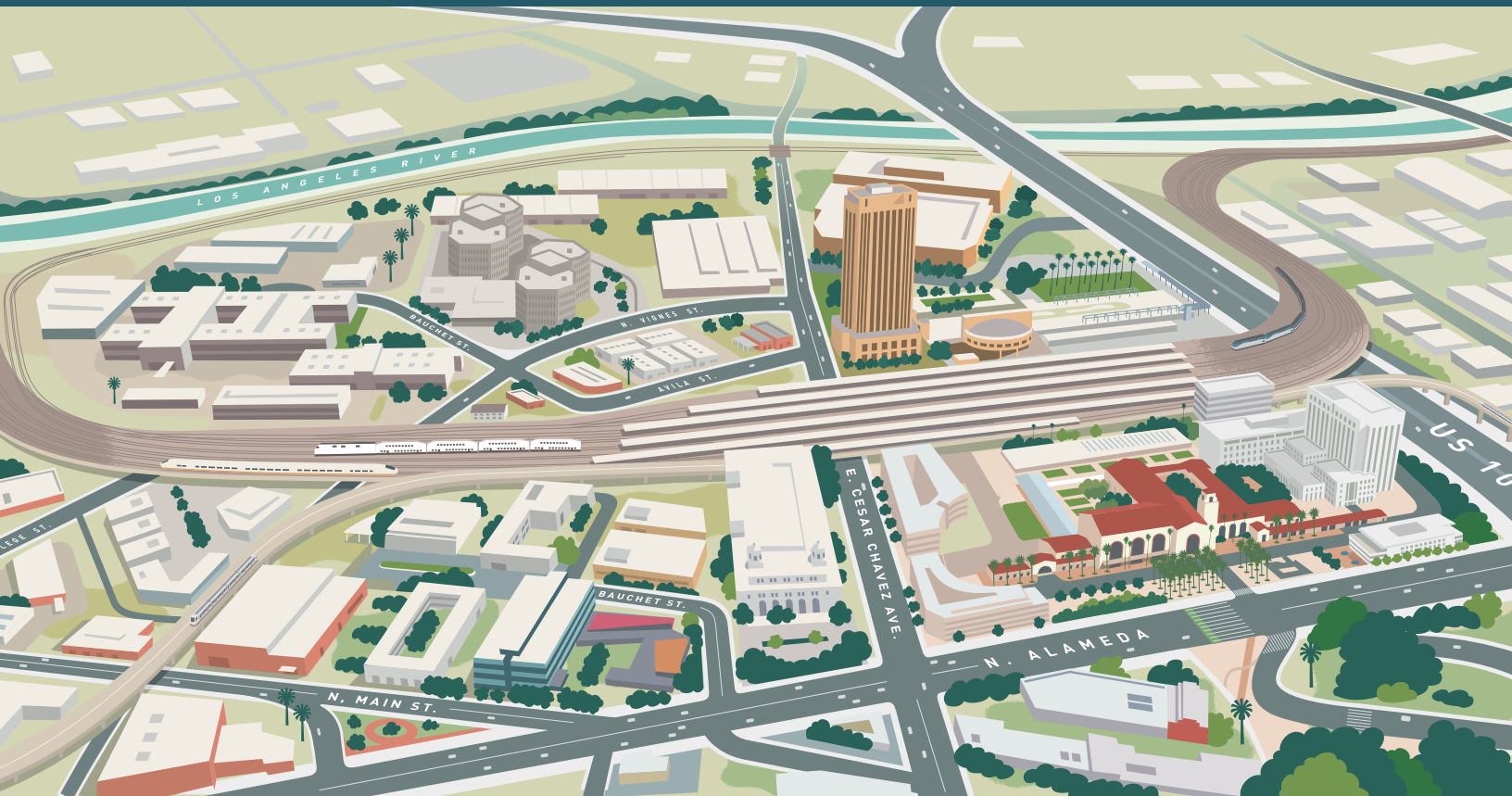

The environmental review, consultation, and other actions required by applicable Federal environmental laws for this project are being, or have been, carried out by the State of California pursuant to 23 U.S.C. 327 and a Memorandum of Understanding dated July 23, 2019, renewed July 22, 2024, and executed by the Federal Railroad Administration and the State of California.

**(THIS PAGE INTENTIONALLY BLANK)**

## CONTENTS

<b>ES.0</b>	<b>Executive Summary .....</b>	<b>v</b>
<b>1.0</b>	<b>Introduction .....</b>	<b>1</b>
1.1	Purpose .....	2
1.2	Need .....	2
1.3	Project Location and Study Area .....	2
1.4	Project Alternatives .....	9
1.4.1	No Action Alternative .....	9
1.4.2	Build Alternative .....	10
1.4.3	Rail Yard Canopy Design Options .....	11
1.5	Project Implementation Approach .....	11
1.5.1	Interim Condition (Phase A).....	11
1.5.2	Full Build-Out Condition (Phase B).....	12
1.6	Baseline Assumptions.....	13
<b>2.0</b>	<b>Agency Requirements and Methodology.....</b>	<b>15</b>
2.1	Agency Standards and Guidelines .....	15
2.2	Methodology .....	15
2.2.1	Regulatory Setting .....	15
2.2.2	Low Impact Development Compliance .....	16
2.2.3	Hydromodification.....	16
2.2.4	Prioritization of Best Management Practice Selection.....	16
2.2.5	Other Stormwater Management Measures .....	18
<b>3.0</b>	<b>Pollutants of Concern .....</b>	<b>19</b>
<b>4.0</b>	<b>Post Construction Drainage .....</b>	<b>23</b>
4.1	Drainage Areas for Post-Construction Conditions – Build Alternative.....	27
4.1.1	Drainage Area A.....	27
4.1.2	Drainage Area D.....	29
4.1.3	Drainage Area E.....	29
4.1.4	Drainage Area F.....	30
4.1.5	Drainage Area G .....	30
4.1.6	Drainage Area H.....	30
4.1.7	Drainage Area I.....	31
4.1.8	Drainage Area J .....	31
4.2	California Department of Transportation Right-of-Way.....	31
4.3	Stormwater Quality Calculations .....	31
<b>5.0</b>	<b>Best Management Practice Selection .....</b>	<b>35</b>
5.1	Best Management Practice Selection – Build Alternative .....	35
5.2	Capture and Use (Cistern) .....	35
5.2.1	Description .....	35
5.2.2	Cistern Sizing .....	37
5.3	Biofiltration .....	37
5.4	Other Best Management Practices .....	39
5.5	Summary .....	39
<b>6.0</b>	<b>Recommendations .....</b>	<b>41</b>

7.0 References .....43

**TABLES**

Table 1-1. Summary of Impervious Surfaces – Build Alternative ..... 14  
Table 4-1. Low Impact Development Stormwater Quality Calculations – Build Alternative ..... 33  
Table 5-1. Summary of Cistern Sizing (Low Impact Development) for Tributary Area A –  
Build Alternative ..... 37  
Table 5-2. Bioretention with Underdrain Sizing Parameters ..... 38  
Table 5-3. Summary of Biofiltration Sizing – Build Alternative ..... 39

**FIGURES**

Figure 1-1. Project Location and Regional Vicinity ..... 5  
Figure 1-2. Project Study Area ..... 7  
Figure 3-1. Los Angeles River Watershed Map ..... 21  
Figure 4-1. Overview of Major Drainage Areas for Post-Construction Conditions ..... 25  
Figure 4-2. Hydrology Map Showing 85th Percentile, 24-hour Rainfall, and Soil Type ..... 32

**APPENDICES**

Appendix A: Low Impact Development Exhibits for the Build Alternative  
Appendix B: Cistern Details  
Appendix C: Biofiltration Sizing for the Build Alternative  
Appendix D: Contech StormFilter  
Appendix E: Existing and Proposed Impervious Area Exhibit for the Build Alternative  
Appendix F: Stormwater Quantity Calculations for the Build Alternative  
Appendix G: Stormwater Process Diagram  
Appendix H: Meeting Minutes

**ACRONYMS**

BMP	best management practice
Caltrans	California Department of Transportation
CHSRA	California High-Speed Rail Authority
EIS	environmental impact statement
FRA	Federal Railroad Administration
HSR	High-Speed Rail
LAUS	Los Angeles Union Station
LID	low impact development
Link US	Link Union Station
Metro	Los Angeles County Metropolitan Transportation Authority
MOU	Memorandum of Understanding
MS4	Municipal Separate Storm Sewer System
NEPA	National Environmental Policy Act
No.	number
NPDES	National Pollution Discharge Elimination System
Project	Link Union Station Project
RCP	reinforced concrete pipe
ROW	right-of-way
SCRRA	Southern California Regional Rail Authority (SCRRA or Metrolink)
U.S.	United States
US-101	United States Highway 101
UV	ultraviolet

(THIS PAGE INTENTIONALLY LEFT BLANK)

## ES.0 Executive Summary

This Preliminary Low Impact Development (LID) Report serves as the preliminary LID plan for the Link Union Station (Link US) Project (Project or proposed action). The preliminary LID plan applies to portions of the Project in the vicinity of Los Angeles Union Station (LAUS) that would occur outside of the railroad ROW and outside of the jurisdiction of the California Department of Transportation's (Caltrans) National Pollution Discharge Elimination System (NPDES) Municipal Separate Storm Sewer System (MS4) permit, which applies to the right-of-way (ROW) for United States Highway 101 (US-101). The Project would be designed to be consistent with City of Los Angeles LID Ordinance Number (No.) 183833 (LID Ordinance). The LID Ordinance is consistent with Los Angeles County NPDES MS4 Permit Order No. R4-2021-0105. Consequently, City of Los Angeles Section 2.4 of the *Planning and Land Development Handbook for Low Impact Development* (LID Manual) states that agencies such as the Los Angeles County Metropolitan Transportation Authority (Metro) must prepare an LID Plan for non-roadway transportation projects, rail lines, and stations and implement stormwater mitigation measures.

This Preliminary LID Report was prepared to:

- Identify stormwater pollutants of concern in the Project study area (non-Caltrans ROW) that address the post-construction phase;
- Conduct preliminary stormwater quality calculations; and
- Recommend a conceptual best management practice (BMP) approach for the post-construction phase.

This report includes an analysis of existing and proposed drainage systems and stormwater management BMPs utilizing the area encompassing the maximum extent of physical disturbance associated with build alternative considered (Project footprint). This report reflects the quantities and exhibits associated with the Build Alternative.

Key assumptions and findings of this report are summarized below:

- 100 percent imperviousness is assumed for elevated tracks on cellular concrete fill;
- Tracks at-grade are assumed to be 15 percent imperviousness;
- Reconstructed street improvements are assumed to be 91 percent imperviousness; and
- For the Build Alternative, the total area within the Project footprint is 85.7 acres, of which 47.3 acres (55 percent) is considered impervious surface in the existing condition. For the proposed condition, 52.6 acres (61 percent) is considered to be impervious surface.

In accordance with the LID Manual, the Project falls under the All Other Developments category. The LID Manual specifies BMPs to be implemented in the following priority order: infiltration (Tier 1), capture and use (Tier 2), biofiltration/bioretention (Tier 3), or a combination of any of the above. Based on the Link US *Phase I Environmental Site Assessment* (Metro 2016), the majority of the

soil where physical disturbance would occur is contaminated and not suitable for infiltration (Tier 1). Therefore, unlined landscaping improvements, including irrigation, are not feasible for the Project. Tier 2 (capture and use) and Tier 3 (biofiltration/bioretenion) are viable approaches to meet LID requirements. To mitigate for stormwater quality effects, the preferred conceptual BMP approach is proposed.

- In Segment 1: Throat Segment, a structural stormwater vault would address the area north of Vignes Street; a capture and use BMP (cistern) would address the rest of this segment, including a portion of the concourse area (Segment 2: Concourse Segment).
- In Segment 2: Concourse Segment, capture and use BMP (cisterns) are proposed. The extent of BMPs in the concourse area would be refined in final design.
- In Segment 3: Run-Through Segment, south of US-101, biofiltration BMPs are proposed for the Build Alternative. City of Los Angeles Green Street Standard Plans may be used and modified with biofiltration/ features and impermeable liners to convey the underdrains to a nearby storm drain system. This approach would require concurrence from the City of Los Angeles. For the Build Alternative, a structural BMP (e.g., Contech Jellyfish Filter) would address the area where the run-through tracks are supported by cellular concrete in the vicinity of the main line.

Preliminary options for the types, sizes, and placement of BMPs are described in Section 5.2, Section 5.3, and Appendix A, Appendix B, Appendix C, and Appendix D of this LID Report. However, the following are recommended for further evaluation during final design:

- Conduct water demand analysis for capture and use cisterns. If further analysis determines 100 percent of the water quality design volume cannot be managed through capture and use, the remaining volume is proposed to be managed through biofiltration/bioretenion BMPs.
- Conduct further exploration of other BMP options as the engineering design progresses.
- Update this Preliminary LID Report after the selection of post-construction BMP designs and consideration of operations and maintenance costs for each BMP.

## 1.0 Introduction

The Los Angeles County Metropolitan Transportation Authority (Metro), as the owner of Los Angeles Union Station (LAUS), is proposing the infrastructure improvements associated with the Link Union Station (Link US) Project (Project or proposed action) to address existing capacity constraints at LAUS. For the purposes of the National Environmental Policy Act (NEPA), Metro is serving as the local Project sponsor and joint lead agency.

Pursuant to 23 United States Code (USC) Section 327 and a memorandum of understanding (MOU) between the Federal Railroad Administration (FRA) and the State of California, effective July 23, 2019, under a program known as NEPA Assignment, the California High-Speed Rail Authority (CHSRA) is responsible for the federal review and approval of environmental documents for projects on the high-speed rail (HSR) system and other passenger rail projects that directly connect to the HSR system, including the Link US Project. For the purposes of the environmental impact statement (EIS) being prepared, CHSRA is serving as the federal lead agency with NEPA responsibilities pursuant to the requirements of the NEPA Assignment MOU. CHSRA and Metro are preparing the EIS in compliance with NEPA (42 USC Section 4321 et seq.), the Council on Environmental Quality (CEQ) regulations implementing NEPA (40 Code of Federal Regulations [CFR] Parts 1500–1508), FRA's Procedures for Considering Environmental Impacts (FRA's Environmental Procedures) (*Federal Register* [FR] 64(101), 28545-28556, May 26, 1999), 23 USC Section 139, and the NEPA Assignment MOU.<sup>1, 2</sup>

Pursuant to the MOU requirements between FRA and the State of California, FRA's Environmental Procedures are being used to determine environmental effects of the No Action Alternative and the Build Alternative.

Below is an overview of the purpose and need, the Project study area, the No Action Alternative, and the major components associated with the on-site infrastructure improvements proposed at and within the vicinity of LAUS that are associated with the Build Alternative considered in the EIS.

---

<sup>1</sup> While this environmental document was being prepared, the Federal Railroad Administration (FRA) adopted new National Environmental Policy Act (NEPA) compliance regulations (Code of Federal Regulations [CFR] Title 23, Part 771). Those regulations only apply to actions initiated after November 28, 2018. See 23 CFR 771.109(a)(4). Because this environmental document was initiated prior to that date, it remains subject to FRA's Environmental Procedures rather than the Part 771 regulations.

<sup>2</sup> The Council on Environmental Quality (CEQ) issued new regulations, effective April 20, 2022, updating the NEPA implementing procedures at 40 CFR Parts 1500-1508. However, because this Project initiated the NEPA process before April 20, 2022, it is not subject to the new regulations. The California High-Speed Rail Authority (CHSRA) is relying on the regulations, as they existed prior to April 20, 2022. Therefore, all citations to CEQ regulations in this environmental document refer to the 1986 amendment, 51 *Federal Register* 15618 (April 25, 1986).

## 1.1 Purpose

The purpose of the proposed action is to increase the regional and intercity rail service capacity of LAUS and to improve schedule reliability at LAUS through the implementation of a run-through tracks configuration and elimination of the current stub end tracks configuration while preserving current levels of freight rail operations, accommodating the planned HSR system in Southern California, increasing the passenger/pedestrian capacity and enhancing the safety of LAUS through the implementation of a new passenger concourse, meeting the multi-modal transportation demands at LAUS.

## 1.2 Need

The need for the proposed action is generated by the forecasted increase in regional population and employment; implementation of federal, state, and regional transportation plans (RTP) that provide for increased operational frequency for regional and intercity trains; and introduction of the planned HSR system in Southern California. Localized operational, safety, and accessibility upgrades in and around LAUS will be required to meet existing demand and future growth.

## 1.3 Project Location and Study Area

The Build Alternative consists of infrastructure improvements in Downtown Los Angeles in the vicinity of LAUS (Figure 1-1). LAUS is located at 800 Alameda Street in the City of Los Angeles, California. LAUS is bounded by United States Highway 101 (US-101) to the south, Alameda Street to the west, Cesar Chavez Avenue to the north, and Vignes Street to the east.

Figure 1-2 depicts the Project study area, which is generally used to characterize the affected environment at and within the vicinity of LAUS. The Project study area includes three main segments (Segment 1: Throat Segment, Segment 2: Concourse Segment, and Segment 3: Run-Through Segment). The existing conditions within each segment are summarized north to south below:

- **Segment 1: Throat Segment** – This segment, known as the LAUS throat, includes the area north of the platforms at the LAUS rail yard, from Main Street at the north to Cesar Chavez Avenue at the south. In the throat segment, all arriving and departing trains are required to traverse through the LAUS throat, which includes a complex network of lead tracks, switches, and crossovers. Five lead tracks provide access into and out of the rail yard, except for one location near the Vignes Street Bridge, where it reduces to four lead tracks. Currently, special track work consisting of multiple turnouts and double-slip switches are used in the throat to direct trains into and out of the appropriate assigned terminal platform tracks. The Garden Tracks (stub-end tracks where private train cars are currently stored) are also located just north of the platforms. Land uses in the vicinity of the throat segment are residential, industrial, and institutional.
- **Segment 2: Concourse Segment** – This segment is between Cesar Chavez Avenue and US-101 and includes LAUS, the rail yard, the East Portal Building, the baggage handling

building with associated parking areas and access roads, the ticketing/waiting halls, and the 28-foot-wide pedestrian passageway with connecting ramps and stairways below the rail yard. Land uses in the vicinity of the concourse segment are residential, commercial, and public.

- **Segment 3: Run-Through Segment** – This segment is south of LAUS and extends east to west from Alameda Street to the west bank of the Los Angeles River and north to south from Keller Yard to Control Point (CP) Olympic. This segment includes US-101, the Commercial Street/Ducommun Street corridor, Metro Red and Purple Lines Maintenance Yard (Division 20 Rail Yard), BNSF Railway (BNSF) West Bank Yard, Keller Yard, the main line tracks on the west bank of the Los Angeles River from Keller Yard to CP Olympic, and the Amtrak lead track connecting the main line tracks with Amtrak’s Los Angeles Maintenance Facility in the vicinity of 8th Street. Land uses in the vicinity of the run-through segment are primarily industrial and manufacturing.

The Project study area has a dense street network ranging from major highways to local city streets. The roadways within the Project study area include the El Monte Busway, US-101, Bolero Lane, Leroy Street, Bloom Street, Cesar Chavez Avenue, Commercial Street, Ducommun Street, Jackson Street, East Temple Street, Banning Street, First Street, Alameda Street, Garey Street, Vignes Street, Main Street, Aliso Street, Avila Street, Bauchet Street, and Center Street.

(THIS PAGE INTENTIONALLY LEFT BLANK)

Figure 1-1. Project Location and Regional Vicinity

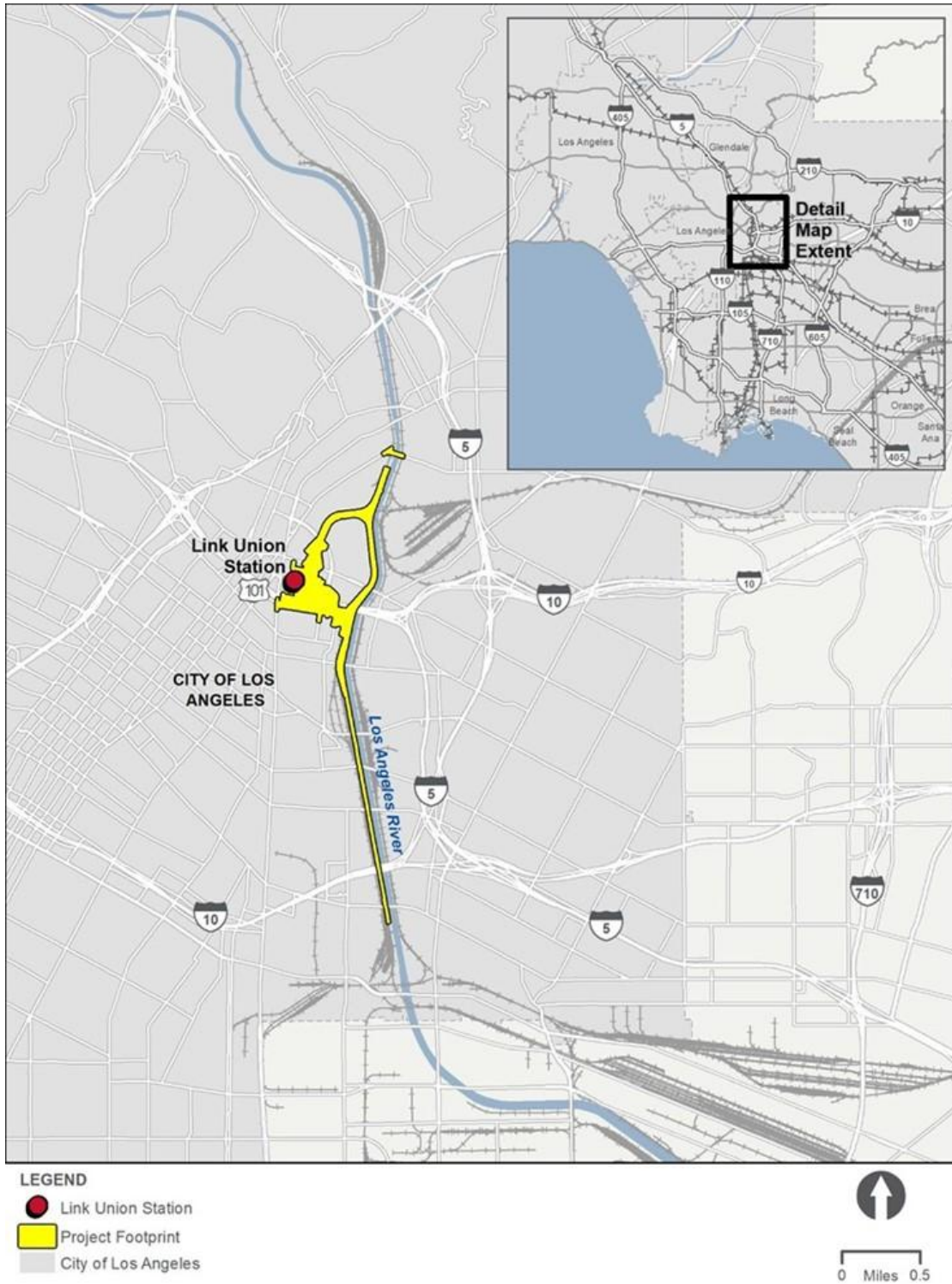

(THIS PAGE INTENTIONALLY LEFT BLANK)

Figure 1-2. Project Study Area

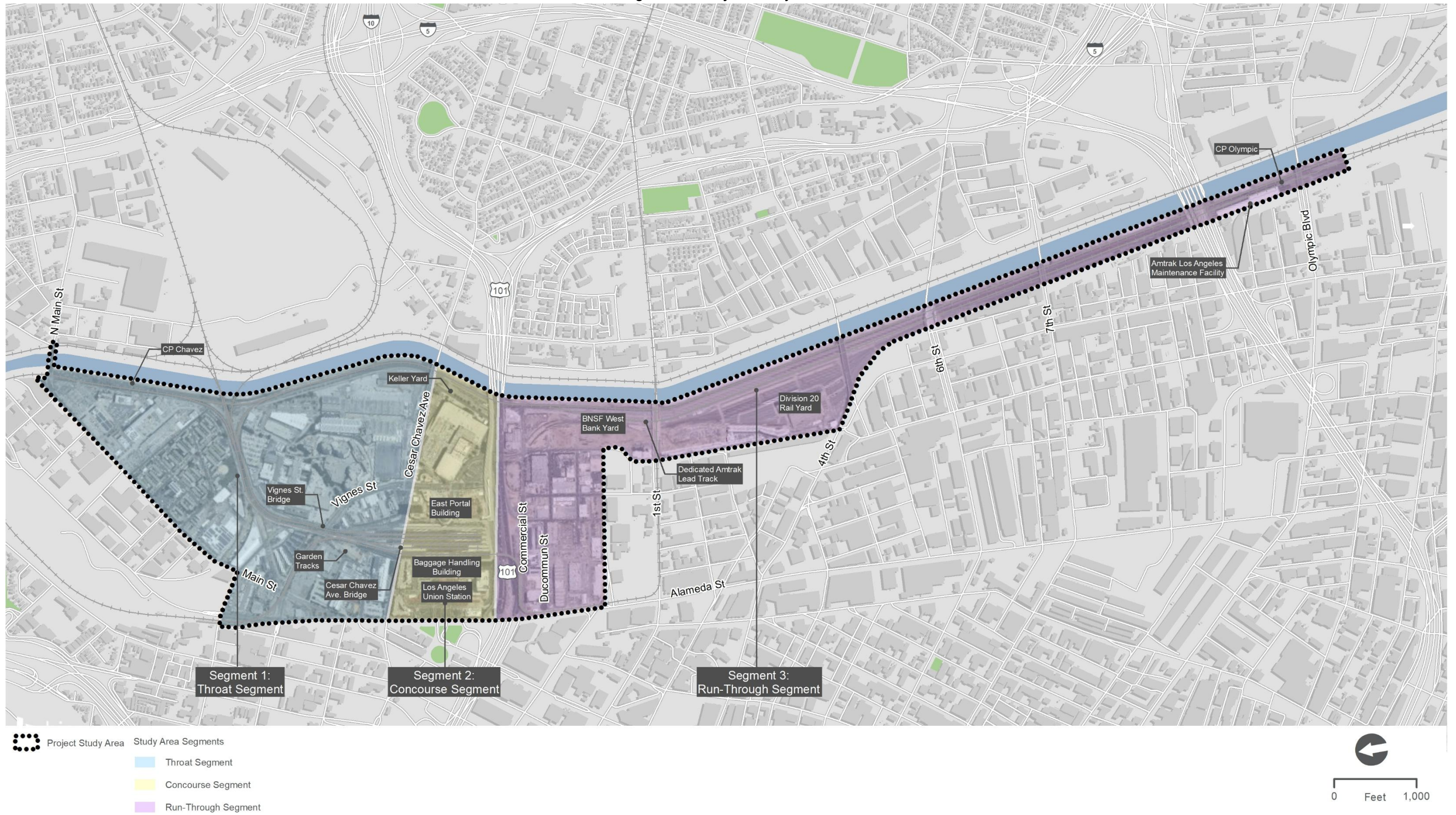

(THIS PAGE INTENTIONALLY LEFT BLANK)

## 1.4 Project Alternatives

The EIS includes an evaluation of the No Action Alternative and one build alternative. The Build Alternative would include, but not be limited to, new lead tracks north of LAUS (Segment 1: Throat Segment), an elevated throat and rail yard with concourse-related improvements at LAUS (Segment 2: Concourse Segment), and up to 10 run-through tracks south of LAUS (Segment 3: Run-Through Segment).

### 1.4.1 No Action Alternative

NEPA (40 CFR 1502.14(d)) requires federal agencies to include an analysis of “the alternative of no action.” For NEPA purposes, the No Action Alternative is the baseline against which the effects of implementing the Build Alternative is evaluated against to determine the extent of environmental and community effects. For the No Action Alternative, the baseline year is 2016, and the horizon year is 2040.

The No Action Alternative represents the future conditions that would occur if the proposed infrastructure improvements and the operational capacity enhancements at LAUS were not implemented. The No Action Alternative reflects the foreseeable effects of growth planned for the area in conjunction with other existing, planned, and reasonably foreseeable projects and infrastructure improvements in the Los Angeles area, as identified in planning documents prepared by Southern California Association of Governments (SCAG), Metro, and/or Metrolink, including the 2023 Federal Transportation Improvement Program (FTIP) (SCAG 2023), *Final 2008 Regional Comprehensive Plan* (SCAG 2008), and the 2020 RTP/Sustainable Communities Strategy (SCS): Connect SoCal (SCAG 2020).

Conditions in the Project study area would remain similar to the existing condition, as described below:

- **Segment 1: Throat Segment** – Trains would continue to operate on five lead tracks that do not currently accommodate the planned HSR system. The tracks north of LAUS would remain at the current elevation, and the Vignes Street Bridge and Cesar Chavez Avenue Bridge would remain in place.
- **Segment 2: Concourse Segment** – LAUS would not be transformed from a stub-end tracks station into a run-through tracks station, and the 28-foot-wide pedestrian passageway would be retained in its current configuration. No modifications to the existing passenger circulation routes or addition of vertical circulation elements (escalators and elevators) at LAUS would occur.
- **Segment 3: Run-Through Segment** – Commercial Street would remain in its existing configuration, and implementation of active transportation improvements would likely be implemented along Center Street in concert with the *Connect US Action Plan* (Metro 2015). No modifications to the BNSF West Bank Yard would occur.

## 1.4.2 Build Alternative

The key components associated with the Build Alternative are summarized north to south below:

- **Segment 1: Throat Segment (lead tracks and throat track reconstruction)** – The Build Alternative includes subgrade and structural improvements in Segment 1 of the Project study area (throat segment) to increase the elevation of the tracks leading to the rail yard. The Build Alternative includes the addition of one new lead track in the throat segment for a total of six lead tracks to facilitate enhanced operations for regional/intercity rail trains (Metrolink/Amtrak) and operations for HSR trains within a shared track alignment. Regional/intercity and HSR trains would share the two western lead tracks in the throat segment. The existing railroad bridges in the throat segment at Vignes Street and Cesar Chavez Avenue would also be reconstructed. North of CP Chavez on the west bank of the Los Angeles River, the Build Alternative also includes safety improvements at the Main Street public at-grade railroad crossing (medians, restriping, signals, and pedestrian and vehicular gate systems) to facilitate future implementation of a quiet zone by the City of Los Angeles.
- **Segment 2: Concourse Segment (elevated rail yard and expanded passageway)** – The Build Alternative includes an elevated rail yard and expansion of the existing 28-foot-wide pedestrian passageway in Segment 2 of the Project study area (concourse segment). The rail yard would be elevated approximately 15 feet. New passenger platforms would be constructed on the elevated rail yard with associated vertical circulation elements (stairs, escalators, and elevators) to enhance safety elements and improve Americans with Disabilities Act (ADA) accessibility. Platform 1, serving the Gold Line, would be lengthened, and elevated to optimize east to west passenger circulation. The pedestrian passageway would be expanded at the current grade to a 140-foot width to accommodate a substantial increase in passenger capacity with new functionally modern passenger amenities while providing points of safety to meet applicable California Building Code (CBC) and National Fire Protection Association (NFPA) 130 Standards for Fixed Guideway Transit Systems. The expanded passageway and associated concourse improvements would facilitate enhanced passenger circulation and provide space for ancillary support functions (back-of-house uses, baggage handling, etc.), transit-serving retail, and office/commercial uses while creating an opportunity for an outdoor, community-oriented space with new plazas east and west of the elevated rail yard (East and West Plazas). Amtrak ticketing and baggage check-in services would be enhanced, and new baggage carousels would be constructed in a centralized location under the rail yard. A canopy would be constructed over the West Plaza up to 70 feet in height, and two design options are considered for canopies that would extend over the rail yard (Section 1.4.3).
- **Segment 3: Run-Through Segment (10 run-through tracks)** – The Build Alternative includes 10 new run-through tracks south of LAUS in Segment 3 of the Project study area (run-through segment). The Build Alternative includes common rail infrastructure from LAUS to the west bank of the Los Angeles River (vicinity of First Street

Bridge) to support run-through tracks for both regional/intercity rail trains and HSR trains. At the BNSF West Bank Yard, dedicated lead tracks for Amtrak trains and BNSF trains, in combination with implementation of common rail infrastructure would result in permanent loss of freight rail storage track capacity at the north end of BNSF West Bank Yard (5,500 track feet).

The Build Alternative would also require modifications to US-101 and local streets (including potential street closures and geometric modifications); improvements to railroad signal, positive train control (PTC), and communication systems; modifications to the Gold Line light rail platform and tracks; modifications to the main line tracks on the west bank of the Los Angeles River; modifications to the Amtrak lead track; addition of access roadways to the railroad right-of-way (ROW); land acquisitions; addition of utilities; utility relocations, replacements, and abandonments; and addition of drainage facilities/water quality improvements.

### 1.4.3 Rail Yard Canopy Design Options

Two design options for canopies over the elevated platforms in the rail yard are considered in conjunction with the concourse-related improvements as part of the Build Alternative.

- **Rail Yard Canopy Design Option 1 (individual canopies)** – This design option would include replacing the existing historic butterfly canopies with individual canopies above each platform. New individual canopies would extend up to 25 feet above each platform and would be similar in form to the existing butterfly canopies but sized to fit the widened and lengthened platforms. Platform lengths would vary between 450 and 1,445 feet. Platforms would be up to 30 feet wide.
- 1. **Rail Yard Canopy Design Option 2 (grand canopy)** – This design option would include replacing the existing historic butterfly canopies with a large grand canopy that would extend up to 75 feet above the elevated rail yard platforms. The grand canopy would be up to 1,500 feet long and wide enough to provide cover over all elevated platforms in the rail yard.

## 1.5 Project Implementation Approach

The implementation of infrastructure improvements would generally occur in two main phases that are evaluated as scenario years in the EIS: the interim condition and the full build-out condition. The infrastructure improvements for each of these scenarios are described below.

### 1.5.1 Interim Condition (Phase A)

The interim condition (also referred to as Phase A) is when the run-through track infrastructure south of LAUS and the associated signal modifications, property acquisitions, and civil/structural improvements to facilitate new run-through service would be implemented. The interim condition does not include new lead tracks north of LAUS, or the elevated rail yard and new concourse-related improvements at LAUS. The interim condition aligns with a construction completion date as early as 2026.

A summary of the proposed activities associated with the interim condition is provided below.

- Acquire properties south of LAUS within the Project footprint.
- Relocate utilities north and south of LAUS.
- Acquire a portion of the BNSF West Bank Yard (majority north of First Street) and remove 5,500 feet of existing storage tracks at BNSF West Bank Yard.
- Construct special track work and modify signal/communication infrastructure north of LAUS.
- Construct a run-through track ramp on the southern extent of Platform 4 at LAUS.
- Construct a common viaduct/deck over US-101.
- Construct a common embankment from Vignes Street to Center Street south of LAUS.
- Construct common Center Street Bridge south of LAUS.
- Construct common embankment or new common bridge from Center Street to Amtrak Bridge south of LAUS.
- Construct common Amtrak Bridge south of LAUS.
- Construct Division 20 access road.
- Construct common rail embankment on the west bank of the Los Angeles River (from Amtrak Bridge to First Street Bridge).
- Construct new dedicated lead tracks for BNSF freight trains and Amtrak trains.
- Construct two run-through tracks from Platform 4 at LAUS to the main line tracks along the west bank of the Los Angeles River.

Some embankments and/or bridges south of LAUS could be constructed in a phased manner.

### **1.5.2 Full Build-Out Condition (Phase B)**

The full build-out condition (also referred to as Phase B) is when new lead tracks and the elevated throat north of LAUS, along with the elevated rail yard and concourse-related improvements at LAUS would be implemented. The full build-out condition aligns with a construction completion date as early as 2031.

A summary of the proposed activities associated with the full build-out condition is provided below.

- Construct new compatible lead tracks and reconstruct throat north of LAUS.
- Construct new bridges over Vignes Street and Cesar Chavez Avenue north of LAUS.

- Construct elevated rail yard, concourse-related improvements, and East/West Plazas at LAUS.
- Construct remaining run-through tracks for regional/intercity rail operations on previously constructed structures south of LAUS.

The full build-out condition includes the common rail infrastructure for the planned HSR system that would be located throughout the Link US Project limits, including improvements at LAUS. Operation of HSR trains would occur on two lead tracks north of LAUS, Platforms 2 and 3 and associated Tracks 3 through 6 at LAUS, and on HSR run-through tracks supported by common rail bridges and embankments south of LAUS. Operation of the planned HSR system is or will be considered in CHSRA's environmental documentation for the Burbank to Los Angeles and Los Angeles to Anaheim Project Sections.

## 1.6 Baseline Assumptions

The analysis included in this report was based on the following assumptions:

- This report was prepared to be consistent with City of Los Angeles LID Ordinance.
- This report reflects the quantities and exhibits associated with the Build Alternative. This drainage nexus extends similarly to the stormwater quality approach. The elevated rail yard would be supported on cellular concrete fill. Tracks on cellular concrete are assumed to be 100 percent impervious. For a conservative approach in this preliminary plan, all track and platform surfaces and the concourse building footprint are considered to be impervious.
- Throat tracks are supported on cellular concrete fill up to the proposed tie-in location to existing tracks. Tracks at-grade are assumed to be 15 percent impervious, according to Appendix D (Proportion Impervious Data) of the Los Angeles County Hydrology Manual.
- As part of the existing condition, LAUS is identified as railroads with open storage to account for the platforms and canopies. Railroads with open storage utilize a percent impervious value of 66 percent.
- A few pockets of lots adjacent to the proposed run-through track structures south of US-101 would be re-graded and are assumed to be vacant undifferentiated type, utilizing a percent impervious value of 1 percent.

Appendix E depicts the existing and proposed impervious surface where Project-related effects would occur for the Build Alternative. The impervious surfaces for the Build Alternative is also broken down by ROW under different jurisdictions. The estimate of total impervious surfaces for the existing and future conditions for the Build Alternative are shown in Table 1-1.

The total area within Project footprint for the Build Alternative is 85.7 acres.

**Table 1-1. Summary of Impervious Surfaces – Build Alternative**

Condition	Area (acres)	Impervious Surface (%)	Impervious Surface (acres)
Existing	35.62	91	32.41
	14.42	66	9.52
	35.61	15	5.34
Existing Total	85.70	55	47.27
Proposed	32.70	100	32.70
	16.35	91	14.88
	33.42	15	5.01
	3.32	1	0.03
Proposed Total	85.70	61	52.62

Source: HDR 2023

## 2.0 Agency Requirements and Methodology

This section provides an overview of associated agency standards and guidelines that would shape the scope of the stormwater quality design, and the methodology to be used in this analysis.

### 2.1 Agency Standards and Guidelines

The following agency standards and guidelines were used to prepare this Preliminary LID Report:

- *County of Los Angeles Hydrology Manual*, 2006 (County of Los Angeles 2006)
- *Planning and Land Development Handbook for Low Impact Development, Part B Planning Activities, Watershed Protection Division* (City of Los Angeles 2016)
- *Development Best Management Practices Handbook, Part A Construction Activities, Watershed Protection Division* (City of Los Angeles 2004)
- *Low Impact Development Standards Manual* (County of Los Angeles 2014)
- Leadership in Energy and Environmental Design (U.S. Green Building Council 2013)
- California Green Building Standards Code (California Building Standards Commission 2013)
- Technical Manual for Stormwater BMP in the County of Los Angeles (County of Los Angeles 2004)

### 2.2 Methodology

#### 2.2.1 Regulatory Setting

There are several related entities whose jurisdictions intersect with the Project. Refer to the Link US *Water Quality Assessment Report* (Metro 2025) for additional information.

Construction General Permit (Order No. 2009-0009-DWQ), adopted on September 2, 2009, became effective on July 1, 2010. This permit has since been amended twice by Orders No. 2010-0004-DWQ and 2012-0006-DWQ. However, during construction of the Project, Order Number 2022-0057-DWQ may be in effect. This permit was adopted on September 8, 2022, and will become effective on September 1, 2023. The permit regulates stormwater discharges from construction sites that result in a Disturbed Soil Area of 1 acre or greater, and/or are smaller sites that are part of a larger common plan of development. The permit also includes post-construction stormwater standards that apply to jurisdictions not subject to a Phase I or II MS4 jurisdiction.

The City of Los Angeles is a permittee under the Phase I NPDES Permit and Waste Discharge Requirements for MS4 Discharges within the Coastal Watersheds of Los Angeles and Ventura Counties, Order No. R4-2021-0105 (NPDES No. CAS004004), effective September 11, 2021. The NPDES permit prohibits discharges, sets limits on pollutants being discharged into receiving waters, and requires implementation of technology-based standards. These requirements are

outlined in the LID Manual, Part B Planning Activities, Watershed Protection Division (City of Los Angeles 2016).

The portion of the Project within Caltrans ROW is to be subject to NPDES Statewide Stormwater Permit Waste Discharge Requirements for Caltrans adopted on September 19, 2012 (as amended). This is a Phase I permit that applies statewide.

On February 5, 2013, the State Water Resources Control Board renewed the Phase II General Permit for the Discharge of Stormwater from Small MS4s General Permit (Order No. 2013-0001-DWQ) to provide permit coverage for smaller municipalities (population less than 100,000), including nontraditional Small MS4s, which are facilities such as military bases, public campuses, prisons, and hospital complexes. It became effective on July 1, 2013. The Phase II Small MS4 General Permit covers Phase II permittees statewide. Metro is not a Phase II permittee yet; however, for the purpose of this evaluation, this permit will eventually be applicable to the portion of the Project within the railroad ROW.

### **2.2.2 Low Impact Development Compliance**

The Project falls under All Other Developments category which is not Small Scale Residential Development Projects. For development that results in an alteration of at least 50 percent or more of the impervious surface of an existing developed site, the entire site would be consistent with the City of Los Angeles LID Ordinance. The Build Alternative would result in alteration of 61 percent of impervious area, per Table 1-1, based on the assumptions identified in Section 1.0, and therefore, the entire site of the Project would be designed to be consistent with the requirements of the LID Manual.

### **2.2.3 Hydromodification**

Projects that drain into the natural drainage systems in a small part of the Upper Los Angeles River Area would apply hydromodification control. Per Appendix I of the LID Manual, which shows the extents of the Upper Los Angeles River Area, the Project study area is not located in the Upper Los Angeles River Area. Furthermore, the Los Angeles River adjacent to the Project study area is entirely concrete lined. Hydromodification control is not required for the Project.

### **2.2.4 Prioritization of Best Management Practice Selection**

According to the LID Manual, the following is the priority order for implementing BMPs:

1. Infiltration Systems
2. Stormwater Capture and Use
3. High Efficiency Biofiltration/Bioretenion Systems
4. Combination of Any of the Above

## **Infiltration Feasibility Screening**

Infiltration systems are the first priority type of BMP improvements, as they provide for percolation and infiltration of the stormwater into the ground, which not only reduces the volume of stormwater runoff entering the MS4, in some cases they can also contribute to groundwater recharge. If stormwater infiltration is not possible based on the site conditions, the developer would utilize the next priority BMP.

According to the Link US *Phase I Environmental Site Assessment* (Metro 2016), there are active oil and gas reserves located through the City of Los Angeles. Adjacent to the Project is the Union Station Oil Field. Naturally occurring oil seeps have also been documented throughout the Project study area. Surface oil stains were also noted within the railroad tracks on the ballast material. Groundwater samples taken from the U.S. Postal Service Terminal Annex property, located adjacent to Segment 1: Throat Segment, detected total petroleum hydrocarbons, volatile organic compounds, and chlorinated solvents, which are contaminants of concern. Based on these considerations, the majority of the soil in the Project study area is contaminated and not suitable for proposed infiltration. Therefore, unlined landscaping improvements, including irrigation, are not feasible.

The area where existing tracks are currently at-grade would still be able to support infiltration.

## **Capture and Use Feasibility Screening**

Capture and use, commonly referred to as rainwater harvesting, collects and stores stormwater for later use, thereby offsetting potable water demand and reducing pollutant loading to the storm drain system. Sufficient landscaped area with appropriate water demand, to which the captured runoff can be directed, is needed. Partial capture and use can also be achieved as part of a treatment train by directing the overflow to a bioretention system. This can provide additional volume-reduction and water quality treatment in instances where the quantity of runoff from a storm event exceeds the volume of the collection tank.

In the City of Los Angeles, the use of collected stormwater is primarily limited to landscape irrigation. Landscape soil must contain suitable fill material. Excavation and replacement of contaminated or otherwise inadequate soil may be required. Use of landscaped areas for the collection of stormwater is subject to review and approval via the City of Los Angeles Land Development Plan Check procedure.

It is anticipated that the proposed capture and use system would supply water for landscape irrigation only. Water for toilet flushing may be considered as an option for use of stormwater during final design, as there may be insufficient landscape area to meet capture and use requirements. Other uses for treated stormwater, such as toilet flushing or cooling tower makeup, would require further study and compliance with city, regional, and/or state codes. This would be investigated further during the plan, specification, and estimate phase.

A cistern is proposed as the capture and use BMP system. Please see Section 5.2 below for a detailed description of cisterns.

### **Biofiltration: Bioretention with Underdrain with an Impermeable Liner**

Projects that have demonstrated that 100 percent of the water quality design volume cannot be managed on site through Tier 1 (infiltration) and/or Tier 2 (capture and use) may utilize Biofiltration/Bioretention for the remaining volume. Biofiltration/Bioretention BMPs would need to capture 1.5 times the design volume not managed through capture and use. Bioretention facilities are landscaped shallow depressions that capture and filter stormwater runoff. As stormwater passes down through the planting soil, pollutants are filtered, adsorbed, and bio-degraded by the soil and plants.

As stated above, the Project site is contaminated; therefore, it does not pass the infiltration screening. An impermeable liner would be needed to prevent incidental infiltration.

## **2.2.5 Other Stormwater Management Measures**

### **Natural Areas**

There are no natural areas within the Project footprint for the Build Alternative.

### **Slopes and Channels**

The Los Angeles River runs directly east of the Project study area. The portion of the Los Angeles River adjacent to the Project study area is entirely concrete lined. No modifications to the Los Angeles River Channel would be required.

Slopes would be vegetated within the Project footprint for the Build Alternative.

### **Storm Drain Stenciling and Signage**

Storm drain stencils would be provided at all new or affected drain inlets and catch basins within the Project footprint for the Build Alternative.

### **3.0 Pollutants of Concern**

The Project is located within the Los Angeles River Watershed (Figure 3-1), Los Angeles River Reach 2. The pollutants of concern for Los Angeles River Reach 2, as determined by the 2020-2022 303(d) list are:

- Ammonia
- Copper
- Indicator bacteria
- Lead
- Nutrients (algae)
- Oil
- Trash

(THIS PAGE INTENTIONALLY LEFT BLANK)



(THIS PAGE INTENTIONALLY LEFT BLANK)

## 4.0 Post Construction Drainage

The site has eight major drainage areas, which are identified as Areas A, D, E, F, G, H, I, and J for LID evaluation and are shown on Figure 4-1 for the Build Alternative. Drainage subareas for each major drainage area are detailed in Appendix A, Preliminary LID exhibit. Under the No Action Alternative, the Project would not be implemented, and existing conditions in the Project study area would remain. No changes to drainage would occur.

Details regarding BMPs proposed for each area/subarea are provided in Section 5.0.

(THIS PAGE INTENTIONALLY LEFT BLANK)

Figure 4-1. Overview of Major Drainage Areas for Post-Construction Conditions

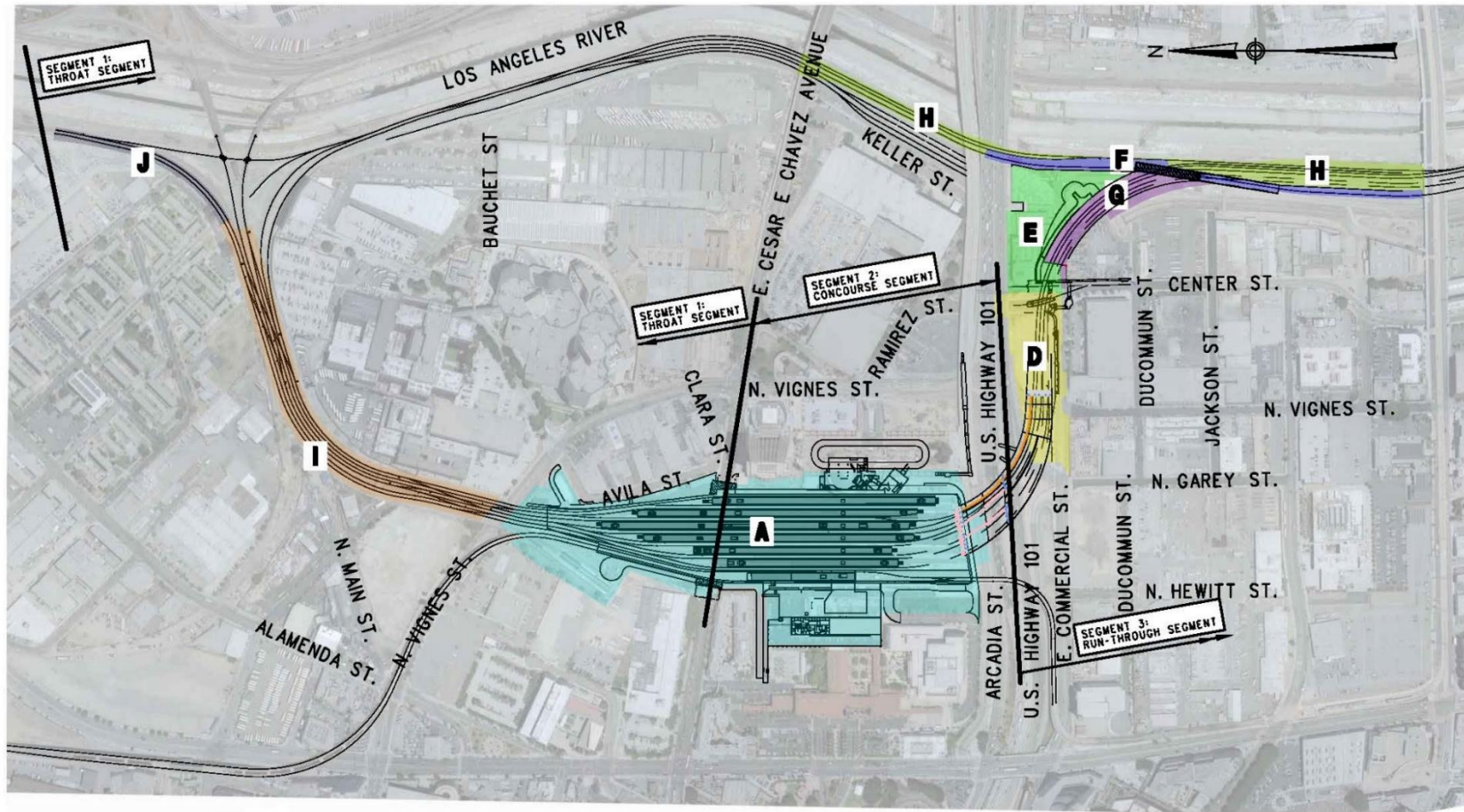

**LEGEND:**

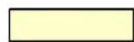
	AREA A		AREA E		AREA G		AREA I
	AREA D		AREA F		AREA H		AREA J

(THIS PAGE INTENTIONALLY LEFT BLANK)

## 4.1 Drainage Areas for Post-Construction Conditions – Build Alternative

### 4.1.1 Drainage Area A

To maintain the existing drainage pattern and implement a stormwater treatment system, Tributary Area A was divided into eight sub-areas in order to analyze the capture and conveyance of stormwater to the appropriate location for treatment.

Specific descriptions of each sub-area are provided below. The study area has two points of connection to the existing municipal storm drain system:

1. 108-inch reinforced concrete pipe (RCP) in Cesar Chavez Avenue, to the east of the Cesar Chavez Bridge
2. 138-inch reinforced concrete arch in US-101

Both existing systems ultimately discharge to the Los Angeles River.

Runoff from the rail yard area would drain into a ballasted track bed supported by a cellular concrete slab on-grade. The cellular concrete slab on-grade would slope away from the tracks and direct runoff into the underdrains (8-inch-diameter perforated corrugated metal pipes) running adjacent and parallel to the tracks. These underdrains would be connected to a cross-drain line (36-inch RCP) that would then connect to a stormwater capture system (cistern). Details on the proposed cistern are in Section 5.2. The stormwater capture system would treat stormwater for use and detain and attenuate overflow before conveyance to one of the two existing municipal storm drain systems previously mentioned. All stormwater that is not detained on site would be discharged to the municipal storm drain system.

Runoff from the rail yard north of the pedestrian passageway (Sub-Areas A1, A2, and A4) is tributary to the Garden Track Cistern (Appendix A provides details of the location) and would be discharged to the municipal storm drain in Cesar Chavez Avenue. The rail yard south of the pedestrian passageway, the west plaza, the baggage handling building, and adjacent parking areas (Sub-Areas A3, A5, A6, A7, and A8) are tributary to the West Plaza Cistern Appendix A provides details of the location) and would be discharged to the municipal storm drain in US-101.

- **Sub-Area A1** – Sub-Area A1 primarily encompasses the throat portion of the rail yard and the portion of the rail yard known as the garden track area, both located north of Cesar Chavez Avenue. Precipitation that falls in these two areas would be collected and conveyed to the proposed Garden Track Cistern, located north of Cesar Chavez Avenue in the Garden Track area, for treatment and detention. Treated runoff and overflow would be conveyed to the existing municipal storm drain system in Avila Street, which eventually outlets to the 108-inch City of Los Angeles storm drain pipe in Cesar Chavez Avenue.
- **Sub-Area A2** - Sub-Area A2 encompasses the portion of the main rail yard between Cesar Chavez Avenue and the existing pedestrian passageway that connects to the East Portal

building. Precipitation that falls in this area of the rail yard would be collected and conveyed to the proposed Garden Track Cistern for treatment and detention. Treated runoff and overflow would be conveyed from the cistern to the existing municipal storm drain system in Avila Street, which connects to the 108-inch City of Los Angeles storm drain pipe in Cesar Chavez Ave, and ultimately discharges to the Los Angeles River.

- **Sub-Area A3** – Sub-Area A3 encompasses the portion of the rail yard between the existing pedestrian passageway and the access road along the southern end of the platforms. Precipitation that falls in this area would be collected and conveyed to the proposed West Plaza Cistern for treatment and detention. Treated runoff and overflow would be conveyed to the existing 138-inch arch pipe in US-101, which ultimately discharges to the Los Angeles River.
- **Sub-Area A4** – Sub-Area A4 is primarily made up of the slope to the east of the garden track and west of the postal annex building. The area slopes to the west, away from the LAUS property. Runoff from this area would be collected and conveyed to the proposed Garden Track Cistern for treatment and detention. As the design progresses, the method of conveyance to the cistern would need to be further assessed. Overflow and treated runoff would be conveyed to the existing storm drain system in Avila Street, which connects to the 108-inch City of Los Angeles storm drain pipe in Cesar Chavez Ave, and ultimately discharges to the Los Angeles River.
- **Sub-Area A5** – Sub-Area A5 encompasses the west plaza, the baggage handling building, adjacent parking, and the proposed loading dock. Precipitation that falls into this area would be collected and conveyed to the proposed West Plaza Cistern for treatment and detention. Overflow and treated runoff would be conveyed to the existing 138-inch arch pipe in US-101, which ultimately discharges to the Los Angeles River.
- **Sub-Area A6** – Sub-Area A6 encompasses the slope to the south of the west plaza between the Metropolitan Water District of Southern California building and the access road. Precipitation that falls in this area would be collected and conveyed to the proposed West Plaza Cistern for treatment and detention. Overflow and treated runoff would be conveyed to the existing 138-inch arch pipe in US-101, which ultimately discharges to the Los Angeles River.
- **Sub-Area A7** – Sub-Area A7 primarily includes the walkway along the west side of Patsaouras Transit Plaza. This area is not tributary to the rail yard, but rather is part of the Patsaouras Transit Plaza drainage system. This area is included in the analysis as the area is affected by the proposed improvements. As a result of the proposed improvements, the area of Sub-Area A7 would be reduced from 1.1 acre in the preconstruction condition to 0.7 acre in the post-construction condition. The difference of 0.4 acre, which is tributary to Patsaouras Transit Plaza in the preconstruction condition, becomes tributary to the rail yard in the post-construction condition. This reduction in area reduces the total runoff flow and directs it to the West Plaza Cistern for treatment and detention, effectively improving the drainage condition in the Patsaouras Transit Plaza drainage system.

- **Sub-Area A8** – Sub-Area A8 encompasses a small portion of the viaduct crossing over US-101. Precipitation in this area would drain to the West Plaza Cistern for treatment and detention in the catch basins on the access road under the viaduct.

#### 4.1.2 Drainage Area D

Area D encompasses the area west of Center Street, east of Garey Street, and south of US-101. For the Build Alternative, deck drainage from the overhead viaduct would be tied into existing drainage systems. The Build Alternative includes:

- **Retained fill Section 1 between US-101 and Center Street Bridges** – A retained earthen fill section (embankment) is planned to connect the US-101 Viaduct to the Center Street Bridge. The fill section consists of retaining walls on the north and south faces that would be constructed on shallow foundations and filled with engineered fill material.
- **Center Street Bridge** – A new bridge over Center Street is proposed to support the run-through tracks as they cross over the existing Red Line tunnel and Center Street. The eastern abutment of this bridge marks the beginning of Retained Fill Section 2 (see Drainage Area G below).

As part of the Build Alternative, a structural stormwater vault is recommended at Drainage Area D on the west side of Center Street, under the proposed Center Street Bridge, if space is not available for biofiltration at Area D.

The drainage pattern and area acreages stay the same at this area. Underdrains are proposed to collect the runoff from the retained fill section, where it would then be conveyed to rock-lined pervious ditches at ground level. The area outside the retained fill section would be re-graded to maintain the same drainage pattern as the existing condition. The re-graded area is assumed to be vacant undifferentiated type, utilizing a percent impervious value of 1 percent. The deck drainage from the bridge would be connected to existing storm drainage system within the same drainage area.

#### 4.1.3 Drainage Area E

Commercial Street, east of Center Street, is proposed to be vacated. The area north of the proposed SCRRA maintenance ramp would be re-graded to preserve the same drainage pattern as the existing condition. The portion of the existing 22-inch vitrified clay pipe storm drain under proposed Retained Fill Section 2 would be re-routed and replaced with a 22-inch RCP. The runoff from the SCRRA maintenance ramp would be collected at the proposed inlet at the base of the ramp and would be conveyed to the re-aligned 22-inch RCP. The area east of Retained Fill Section 2 and the wall supporting the Amtrak Bridge would be re-graded to drain into a proposed inlet which would connect to existing downstream portion of 22-inch RCP, which drains to Los Angeles River. As part of the Build Alternative, a biofiltration basin is recommended north of vacated Commercial Street at Drainage Area E.

#### 4.1.4 Drainage Area F

Drainage Area F encompasses a Metro-owned property that includes Metro's Division 20 Red Line Portal Trench Project, which is a separate but adjacent project, and its associated parking lot. Runoff within this area drains to the existing 138-inch arch pipe system, which discharges to the Los Angeles River. Treatment of runoff from this area is not proposed as part of the Link US Project.

- **Amtrak Bridge** - The proposed bridge over the Amtrak lead track spans about 40 feet, allowing for the run-through tracks to cross over the restored Amtrak yard lead track, which must be lowered to accommodate the crossing of the bridge above. The single-span bridge is the divider between Retained Fill Section 2 to the northwest and Retained Fill Section 3 to the southeast.

The lowering of the Amtrak lead to accommodate the run-through track structure would create a sump condition under the bridge, with the Amtrak profile elevation at the sump at approximately 252 feet (Project datum) at top of rail. An underdrain is proposed to drain the runoff along the lowered lead track. The only viable storm drain to connect the track underdrain to is the existing 138-inch arch pipe. Other components contributing to drainage Area F are the same as existing, including the new Red Line portal trench, per the Division 20 Project, and adjacent surface parking area, existing street flow, and adjacent building runoff.

#### 4.1.5 Drainage Area G

- **Retained Fill Section 2** - With an average width of 100 feet, length of 690 feet, and maximum height of 28 feet above existing ground, the proposed Retained Fill Section 2 extends from the easterly abutment of the Center Street Bridge on the west, bends towards the south, and terminates at the easterly abutment of the proposed Amtrak Bridge, adjacent to the Los Angeles River. The fill section is currently proposed to be supported on two rows of secant piles restrained by deadman anchors, with a T-wall system or similar wall construction method above grade. A slope is proposed on the northern side of the retained fill section. Beneath the fill section, a protection slab supported on micropiles is proposed to reduce surcharge loading onto the existing 138-inch arch pipe and a parallel 42-inch RCP system.

An existing 21-inch RCP is in conflict with the proposed fill section thereby requiring the facility to be routed to the west side of the fill section and replaced with a 24-inch RCP. This existing 21-inch RCP drains a portion of the Division 20 rail yard. Underdrains are proposed to drain the runoff from the tracks sitting on the retained fill section, which would connect to the proposed 24-inch RCP.

#### 4.1.6 Drainage Area H

- **Retained Fill Section 3** - This retained fill section would support the run-through tracks as they transition down to grade along the west bank of the Los Angeles River to join the

existing main line tracks to the south. This retained fill section would be an approximate length of 1,000 feet and an average width of 80 feet. The fill would begin at the southern abutment of the Amtrak Bridge, at a maximum retained height of 31 feet. The fill would extend southward, decreasing in height to match existing grade north of First Street. The proposed fill section consists of mechanically stabilized walls filled with lightweight cellular concrete fill material. Deep foundations or other solutions may be required for the western section of the wall due to limited clearance above the Los Angeles River.

Drainage Area H is smaller than existing due to the Amtrak Bridge runoff being discharged to an 138-inch arch pipe and contributed to Drainage Area F. Underdrains are proposed to collect the track runoff from on the fill section, which would connect to an existing 24-inch RCP, which discharges to the Los Angeles River. As part of the Build Alternative, a structural BMP (Contech Jellyfish Filter) would address the runoff for Drainage Area H south of Ducommun Street.

#### **4.1.7 Drainage Area I**

Proposed lead tracks in the throat and rail access roads north of Vignes Street are located within this area. The majority of the southern portion of the track bed would be supported by a cellular concrete slab on-grade that is sloped away from the tracks and designed to direct runoff into perforated underdrains located adjacent to the tracks. A new storm drain is proposed along the rail access roads that would collect the runoff from the underdrains and drain runoff south, to the 66-inch RCP at Vignes Street. A Contech StormFilter (stormwater vault with filter cartridges) is proposed to treat runoff in Drainage Area I.

#### **4.1.8 Drainage Area J**

Area J encompasses the northernmost tracks for the Build Alternative, parallel to Bolero Lane, north of Bloom Street. An existing 30-inch RCP collects the runoff from an existing funnel intake and an existing concrete ditch located along Bolero Lane and discharges to the Los Angeles River. Track underdrains collecting track runoff drain to this existing 30-inch RCP.

### **4.2 California Department of Transportation Right-of-Way**

Stormwater collected on the common structure/deck over US-101 would be collected through a series of inlets in the center of the structure and then directed, untreated, to the Caltrans on-site drainage system through one of the structure's columns. It is assumed that only a very small amount of stormwater north of the Caltrans ROW would be added to this area. The BMP approach for the stormwater within Caltrans ROW would be further investigated during plan, specification, and estimate phase, in cooperation with Caltrans.

### **4.3 Stormwater Quality Calculations**

LID calculations for the water quality volume and flow are based on the City of Los Angeles LID Manual (City of Los Angeles 2016), and County of Los Angeles Department of Public Works, LID, *Standards Manual* (County of Los Angeles 2014).

Current water quality requirements are based on treating a specific volume of stormwater runoff from the Project site (Stormwater Quality Design Volume). By treating the Stormwater Quality Design Volume, it is expected that pollutant loads, which are typically higher during the beginning of storm events, would be reduced during discharge or prevented from reaching the receiving waters. The design storm, from which the Stormwater Quality Design Volume is calculated, is defined as the greater of the 0.75-inch, 24-hour rain event; or the 85th percentile, 24-hour rain event as determined from the Los Angeles County 85th percentile precipitation isohyet map.

According to the Los Angeles County 85th percentile precipitation isohyet map (County of Los Angeles n.d.), the 85th percentile 24-hour rainfall equals 1.0 inch and soil type 006 (Figure 4-2).

Figure 4-2. Hydrology Map Showing 85th Percentile, 24-hour Rainfall, and Soil Type

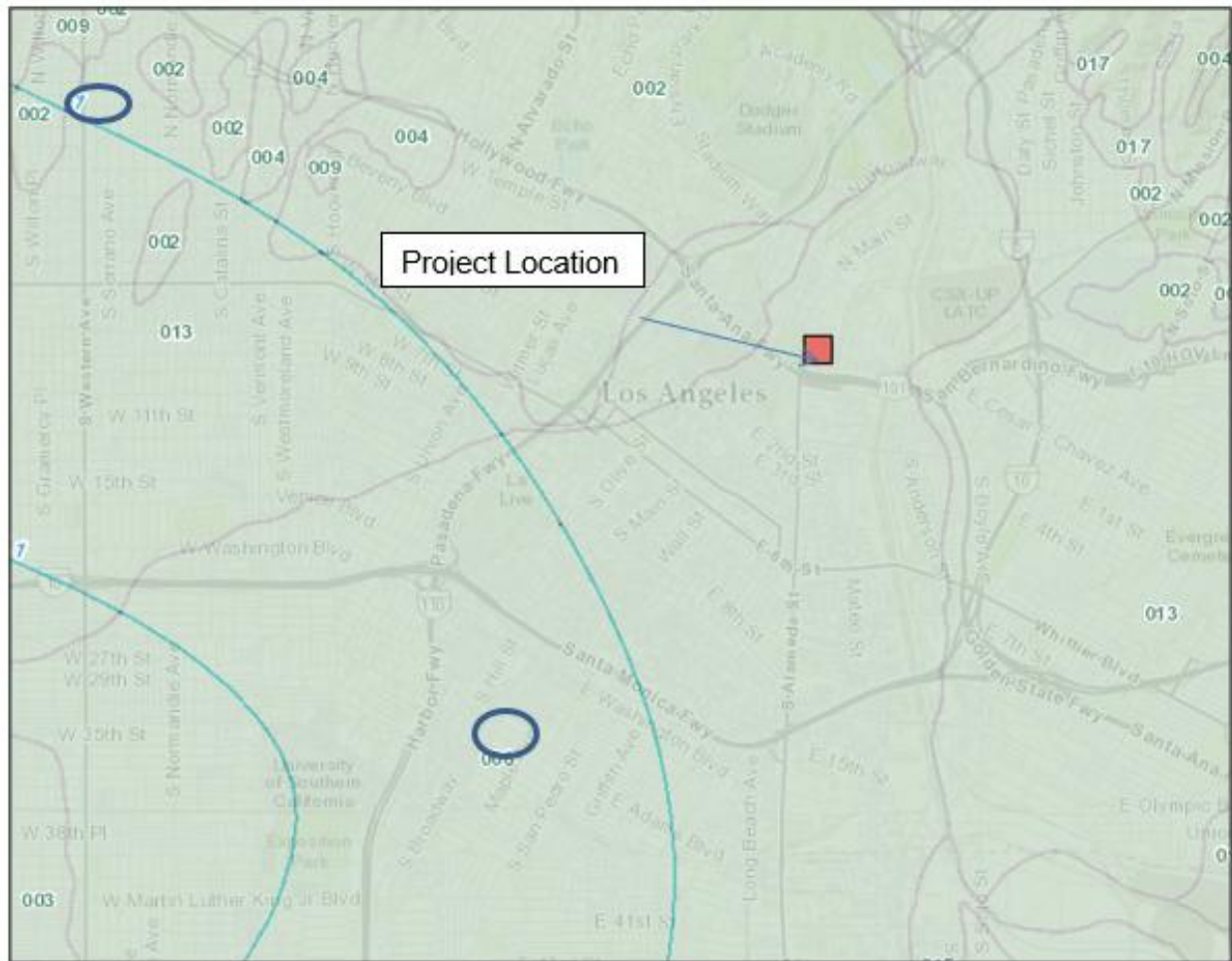

Source: County of Los Angeles 2006

The HydroCalc program was used to calculate the Stormwater Quality Design Volume.

Table 4-1 details the mitigated water quality flow and volume for each area, and Appendix F details the supporting calculations.

**Table 4-1. Low Impact Development Stormwater Quality Calculations – Build Alternative**

Area Identification	Sub-Area	Area (acres)	Impervious Surface (%)	Water Quality Flow (cubic feet per second)	Water Quality Runoff Volume (cubic feet)
A	A1	7.38	100	1.66	23,912
	A2	5.48	100	1.36	17,755
	A3	6.66	100	1.71	21,579
	A4	0.57	100	0.16	1,847
	A5	2.61	100	0.67	8,456
	A6	0.70	100	0.20	2,268
	A7	0.71	91	0.16	2,300
	A8	0.39	100	0.13	1,264
	Total	24.50	—	6.05	79,381
D	D	3.62	76	0.82	9,227
	Total	3.62	76	0.82	9,227
E	E	3.36	18	0.18	2,951
	Total	3.36	18	0.18	2,951
F	F	1.81	19	0.10	1,642
	Total	1.81	19	0.10	1,642
G	G	1.70	35	0.14	2,325
	Total	1.70	35	0.14	2,325
H	H	3.80	17	0.11	3,230
	Total	3.80	17	0.11	3,230
I	I	5.01	63	0.63	10,894
	Total	5.01	63	0.63	10,894
J	J	0.86	15	0.03	681
	Total	0.86	15	0.03	681

Source: Metro 2020

(THIS PAGE INTENTIONALLY LEFT BLANK)

## 5.0 Best Management Practice Selection

Section 5.0 summarizes BMPs for the Build Alternative. Under the No Action Alternative, the Project would not be implemented, and existing conditions in the Project study area would remain. No BMPs are proposed under the No Action Alternative.

### 5.1 Best Management Practice Selection – Build Alternative

Section 5.1 summarizes BMP recommendations for the Build Alternative in the portion of the Project located outside of Caltrans ROW and includes a preferred conceptual BMP approach to advance into preliminary engineering. Sections 5.2 and 5.3 provide details regarding the recommended cisterns and biofiltration BMPs.

The recommended BMPs for the Build Alternative are summarized below:

- In Segment 1, a structural stormwater vault would address the area north of Vignes Street as there is no good location for capture and use or biofiltration BMPs given that it is within the railroad ROW; a capture and use BMP (cistern) would address the rest of this segment, including a portion of concourse area (Segment 2). Segment 1 includes the portion of Drainage Area A that is north of Cesar Chavez Avenue, and Drainage Areas I and J.
- In Segment 2, the concourse area, capture and use BMP (cisterns) would be considered. The extent of BMPs in the concourse area would be refined in final design. Segment 2 includes the portion of Drainage Area A that is south of Cesar Chavez Avenue and north of US-101.
- For Segment 3 south of US-101, a structural stormwater vault is recommended at Drainage Area D on the west side of Center Street under the proposed Center Street Bridge, if space is not available for biofiltration. A biofiltration basin is recommended north of vacated Commercial Street at Drainage Area E. A structural BMP (Contech Jellyfish Filter) would address the runoff for Drainage Area H south of Ducommun Street. The selection of BMP type and design would be finalized during subsequent proposed action phases. Segment 3 also includes Drainage Areas F and G.

## 5.2 Capture and Use (Cistern)

### 5.2.1 Description

Stormwater from the tributary areas would discharge into a water quality unit for pre-treatment prior to discharging into the cistern for storage. A mechanical skid unit would manage the distribution of the captured stormwater for use (i.e., for irrigation). The mechanical skid, being the brain of the system, activates the pump to convey water to the irrigation system when it detects water in the cistern. If water uses inside the proposed passenger concourse are pursued,

post-treatment (filter and ultraviolet [UV] system) would be required. In the UV system, UV light sterilizes the pretreated water; this is described further at the end of this section.

Capture volume must be equal to or less than the Estimated Total Water Usage from October 1 to April 30, as prescribed by a landscape architect. According to the LID Manual, the use of treated stormwater is primarily limited to irrigation of landscaped surfaces that have an impermeable lining. Excavation and replacement of new fill material may be required because of the potential for contaminated soils.

As new guidelines and guidance become available, the potential use of graywater for irrigation and/or flushing toilets may be considered. The demands for graywater would be dictated by fixture unit counts, as defined by the plumbing engineer. In order for water to be utilized in fixture units, the water must comply with California Code of Regulations Title 22 regulations, Section 60301.230 Disinfected Tertiary Recycled Water Code requirements.

For the first year after installation of the cistern, it is recommended that the system be inspected quarterly. After the first year, annual inspections are recommended. Inspections should include checking of the inlet, outlet, and cistern overflow for potential blockages and accumulated sediment.

### **Pre-Treatment (Baffle Boxes)**

Baffle boxes are a possible pre-treatment measure that could also be implemented. Baffle boxes are concrete or fiberglass structures containing a series of sediment settling chambers separated by baffles. The primary function of baffle boxes is to remove sediment, suspended particles, and associated pollutants from stormwater. Baffle boxes may also contain trash screens or skimmers to capture larger materials, trash, and floatables.

### **Post-Treatment (Ultraviolet System)**

The UV system is a possible post-treatment for the Project. In the UV system, UV sterilizers expose water to a specific wavelength of UV light that destroys the DNA of organisms present and keeps the water sterile. Sizing of the UV system is critical to maintain sufficient exposure rates to keep the water sterile.

The advantages of UV sterilization are that chemicals are not used to kill pathogens, systems typically require minimal maintenance, and they are often less expensive than chlorination systems. If pursued, the UV system would be used in addition to the pre-treatment system.

### 5.2.2 Cistern Sizing

The following are preliminary dimensions for each cistern unit. Appendix G shows the Stormwater Process Diagram and illustrates the treatment train for the proposed cisterns. Appendix B contains cistern details from a sample manufacturer.

- Width = 7 feet
- Length = 15 feet
- Depth = 14 feet

The cistern manufacturer is still being determined because the Project is at the preliminary stage. A cistern manufacturer analysis would be conducted in the future to assist Metro in selection of a cistern manufacturer. For the time being, the cistern sizes of 12,028 gallons (1,608 cubic feet) provided by OldCastle’s StormCapture Tank would be used as a reference. The required design volume is 77,081 cubic feet, which is shown in Table 5-1; in addition to the number of cistern units required for the concourse area (Exhibit 2 in Appendix E). The manufacturer may need to be National Sanitation Foundation-350 certified for use of treated water inside the building (i.e., flushing toilets).

Sub-Area	Required Volume (cubic feet)	Receiving Cistern
A1	23,912	Garden Track
A2	17,755	Garden Track
A3	21,579	West Plaza
A4	1,847	Garden Track
A5	8,456	West Plaza
A6	2,268	West Plaza
A8	1,264	West Plaza
Total	77,081	—

Source: Metro 2020

### 5.3 Biofiltration

Bioretention with underdrains fall within the biofiltration category in Section 4.6.1 of the City’s LID Manual and are proposed in landscaped shallow depressions that capture and filter stormwater runoff. As the Project site is contaminated, an impermeable liner (i.e., no infiltration) would be

included for each bioretention BMP with an underdrain to convey overflow to a nearby existing storm drain system.

This BMP is proposed for Drainage Areas D and E. A structural stormwater vault is recommended at Drainage Area D on the west side of Center Street, under the proposed Center Street Bridge, if space is not available for biofiltration at Area D. A biofiltration basin is recommended north of vacated Commercial Street at Drainage Area E.

Calculations were based on the LID Manual (see Appendix F for City of Los Angeles LID Sample Design Calculation).

$$A_{min} = \frac{V_{Design}}{\left[ \left( \frac{T_{fill} \times K_{Sat,Design}}{12} \right) + d_p \right]}$$

Table 5-2 shows input parameters.

Table 5-2. Bioretention with Underdrain Sizing Parameters				
Parameters	Symbol	Value	Unit	Notes
Mitigated Volume	VM	—	cubic feet	Value per HydroCalc
Measured Infiltration Rate	Ksat, media	5	inch/hour	Assumed 5 inches/hour
Factor of Safety	FS	6	—	FS=2 if soil infiltration test and geotechnical report from professional geotechnical engineer is done; FS=6 if only a boring was done; soil infiltration rate to be determined by geotechnical engineer.
Design Infiltration Rate	Ksat, design	2.5	inch/hour	—
Time to fill	Tfill	3	hours	T=3 hours, unless a hydrologic routing model is used
Maximum Ponding Depth	dp, max	1	feet	18 inches or 12 inches
Design Volume	Vdesign	2.5	inch/hour	—

Source: Metro 2020

See Table 5-3 for the estimated biofiltration footprint to meet LID requirements, for the Build Alternative. Appendix C details sizing calculations. A ponding depth of 12 inches is assumed for this preliminary sizing.

**Table 5-3. Summary of Biofiltration Sizing – Build Alternative**

Area	Footprint (square feet)	Biofiltration BMP
D	8,100	Bioretention with Underdrain
E	2,600	Bioretention with Underdrain

Source: Metro 2020

Notes:

BMP=best management practice

## 5.4 Other Best Management Practices

For the Build Alternative, Drainage Area I is challenging because of its location. There is no good location for capture and use or biofiltration/bioretention BMP given that it is within the railroad corridor. Therefore, capture and use and biofiltration/bioretention BMP are infeasible. It is proposed to use a Contech StormFilter (stormwater vault with filter cartridges) for Drainage Area I. See Appendix D for more information.

For the Build Alternative, no BMP is evaluated for Drainage Area J, which is composed of tracks on grade.

Drainage Area H is on cellular concrete fill, and it has the same constraints posed by Drainage Area I. It is proposed to use a high flow pretreatment and membrane filtration, such as Contech Jellyfish Filter. See Appendix D for more information.

## 5.5 Summary

The proposed BMP approach for the Build Alternative is summarized as follows:

- In Segment 1: Throat Segment, a structural stormwater vault would address the area north of Vignes Street; a capture and use BMP (cistern) would address the rest of this segment, including a portion of the concourse area (Segment 2: Concourse Segment).
- In Segment 2: Concourse Segment, capture and use BMP (cisterns) are proposed for the Build Alternative. The extent of BMPs in the concourse area would be refined in final design. The BMPs would not result in physical impacts outside the footprint of the Build Alternative.
- In Segment 3: Run-Through Segment, south of US-101, biofiltration BMPs are proposed for the Build Alternative. City of Los Angeles Green Street Standard Plans may be used and modified with biofiltration features and impermeable liners to convey the underdrains to a nearby storm drain system. This approach would require concurrence from the City of Los Angeles. A structural BMP (Contech Jellyfish Filter) would address the area south of Ducommun Street where the tracks sit on the cellular concrete.

(THIS PAGE INTENTIONALLY LEFT BLANK)

## 6.0 Recommendations

The Project team has met with the City of Los Angeles Bureau of Engineering to discuss the city's LID requirements and to present the preferred conceptual BMP approach. See the meeting minutes in Appendix H.

This Preliminary LID Report highlights preliminary stormwater quality analysis and BMP options. Tier 1 (infiltration) is not feasible because of site constraints; however, Tier 2 (capture and use) and Tier 3 (biofiltration) are viable approaches to meet LID requirements.

The following are recommended for further evaluation:

- Conduct water demand analysis for capture and use cisterns. If after further analysis determines 100 percent of the water quality design volume cannot be managed through capture and use, the remaining volume is proposed to be managed through biofiltration BMPs.
- Conduct further exploration of other BMP options within the limits of the Project footprint of the Build Alternative.
- Update this Preliminary LID Report after selection of post-construction BMP designs and consideration of operations and maintenance costs for each BMP.

(THIS PAGE INTENTIONALLY LEFT BLANK)

## 7.0 References

- California Building Standards Commission. 2013. *California Green Building Standards Code*. <https://codes.iccsafe.org/public/document/details/toc/645>
- California Department of Transportation (Caltrans). 2016. Conceptual Drainage Study Report for Link Union Station Project. Prepared by WKE.
- 2018a. *California State Rail Plan: Connecting California*. <https://dot.ca.gov/-/media/dot-media/programs/rail-mass-transportation/documents/rail-plan/00-toc-and-introcsrpfinal.pdf>.
- 2018b. Draft Stormwater Data Report (PA and ED). Prepared by WKE.
- California Stormwater Quality Association. 2009. Stormwater BMP Handbook Portal: Construction.
- City of Los Angeles. 2004. *Development Best Management Practices Handbook*, Part A Construction Activities, Watershed Protection Division. September 2004.
- 2016. *Planning and Land Development Handbook for Low Impact Development*. [http://www.lastormwater.org/wp-content/files\\_mf/lidmanualfinal.pdf](http://www.lastormwater.org/wp-content/files_mf/lidmanualfinal.pdf)
- County of Los Angeles. n.d. Hydrology Map viewer. <http://dpw.lacounty.gov/wrd/hydrologygis/>
- 2004. Technical Manual for Stormwater Best Management Practices in the County of Los Angeles, February 2004.
- 2006. Los Angeles County Hydrology Manual.
- 2014. Low Impact Development Standards Manual. Department of Public Works.
- Los Angeles County Metropolitan Transportation Authority (Metro). 2015. *Connect US Action Plan*. [http://media.metro.net/projects\\_studies/union\\_station/images/LAUSMP Action Plan Final\\_100515.pdf](http://media.metro.net/projects_studies/union_station/images/LAUSMP_Action_Plan_Final_100515.pdf)
- 2016. *Link US Phase I Environmental Site Assessment*. Prepared by HDR Engineering, Inc.
- 2025. *Link US Water Quality Assessment Report*. Prepared by HDR Engineering, Inc.
- Southern California Association of Governments. 2020. *Connect SoCal*. <https://www.connectsocial.org/Documents/Adopted/0903fConnectSoCal-Plan.pdf>
- 2023. Federal Transportation Improvement Program.
- State Water Resources Control Board. 2022. California Water Quality Planning Tool. 2020-2022 303(d) List. <http://svctenvims.dot.ca.gov/wqpt/wqpt.aspx>
- United States (U.S.) Green Building Council. 2013. *Leadership in Energy and Environmental Design*, Version 4.

(THIS PAGE INTENTIONALLY LEFT BLANK)

# **Appendix A: Low Impact Development Exhibits for the Build Alternative**





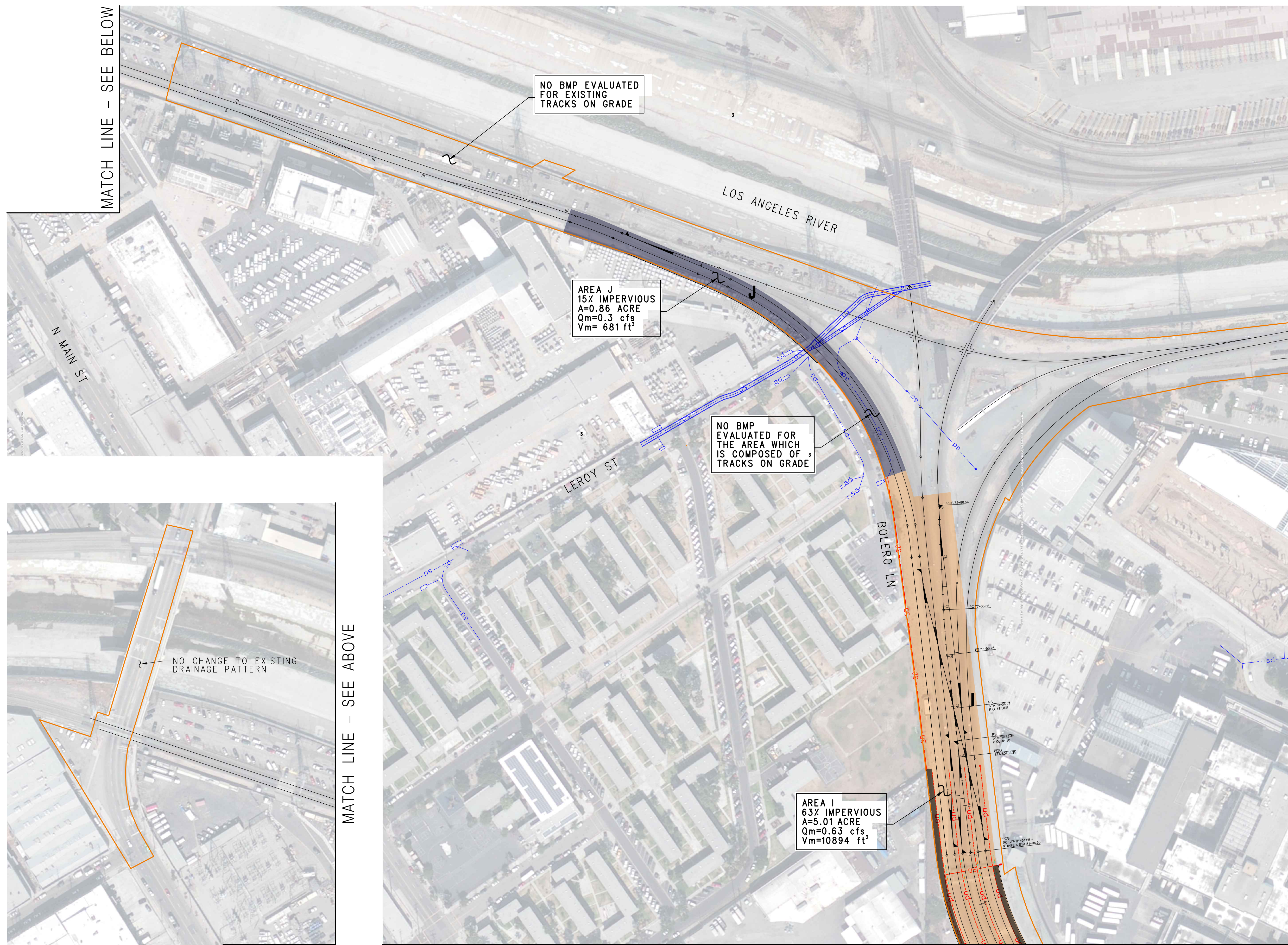

(THIS PAGE INTENTIONALLY LEFT BLANK)

3/22/2023 1:36:23 PM  
c:\pwworking\src\dl068890\SUSMPL.dgn  
p:\pwworking\src\dl068890\SUSMPL\Drawings\01829\000000000232098\13.00\_CAD\_CAD\_BIM\13.01\_CAD\_Data\PRJ\_CAD\_Std\PlotDev\PlotStamp.tbl  
c:\pwworking\src\dl068890\SUSMPL.dgn  
p:\pwworking\src\dl068890\SUSMPL\Drawings\01829\000000000232098\13.00\_CAD\_CAD\_BIM\13.01\_CAD\_Data\PRJ\_CAD\_Std\PlotDev\PlotStamp.tbl



MATCH LINE  
SEE EXHIBIT 3 OF 7

LEGEND:

-  AREA I
-  AREA J
-  EXISTING STORM DRAIN
-  DRAINAGE SUB-AREA BOUNDARY
-  PROJECT FOOTPRINT
-  TRACK UNDERDRAIN

**D R A F T**

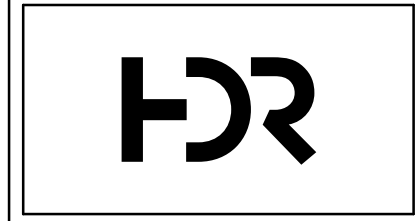

LINK UNION STATION PROJECT  
BUILD ALTERNATIVE  
PRELIMINARY LID EXHIBIT  
SHEET 1 OF 7







SCALE: 1"=100'  
DATE: 03-22-2023

SEE EXHIBIT 1 OF 7  
MATCH LINE

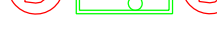

MATCH LINE  
SEE EXHIBIT 4 OF 7

**LEGEND:**

-  AREA I
-  PROPOSED STORM DRAIN
-  EXISTING STORM DRAIN
-  DRAINAGE SUB-AREA BOUNDARY
-  PROJECT FOOTPRINT
-  STORMFILTER VAULT
-  TRACK UNDERDRAIN

**D R A F T**

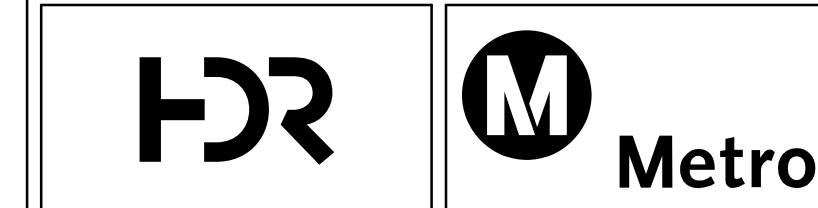

LINK UNION STATION PROJECT  
BUILD ALTERNATIVE  
PRELIMINARY LID EXHIBIT  
SHEET 2 OF 7

SCALE: 1"=100'  
DATE: 03-22-2023

3/22/2023 1:44:23 PM  
c:\pwworking\src\dl068890\SUSIMP2.dwg  
P:\pwworking\src\dl068890\SUSIMP2.dwg  
c:\pwworking\src\dl068890\SUSIMP2.dwg  
c:\pwworking\src\dl068890\SUSIMP2.dwg





3/22/2023 1:48:42 PM  
c:\pwworking\src\dl068890\SUSMP3.dwg  
p:\pwworking\src\dl068890\SUSMP3.dwg  
c:\pwworking\src\dl068890\SUSMP3.dwg

SEE EXHIBIT 1 OF 7  
MATCH LINE

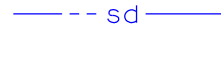

MATCH LINE  
SEE EXHIBIT 5 OF 7

**LEGEND:**

-  AREA H
-  EXISTING STORM DRAIN
-  DRAINAGE SUB-AREA BOUNDARY
-  PROJECT FOOTPRINT
-  TRACK UNDERDRAIN

**D R A F T**

MATCH LINE  
SEE EXHIBIT 4 OF 7

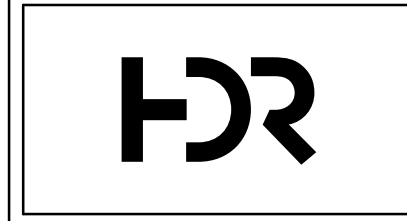

LINK UNION STATION PROJECT  
BUILD ALTERNATIVE  
PRELIMINARY LID EXHIBIT  
SHEET 3 OF 7

SCALE: 1"=100'  
DATE: 03-22-2023

SEE EXHIBIT 3 OF 7  
MATCH LINE

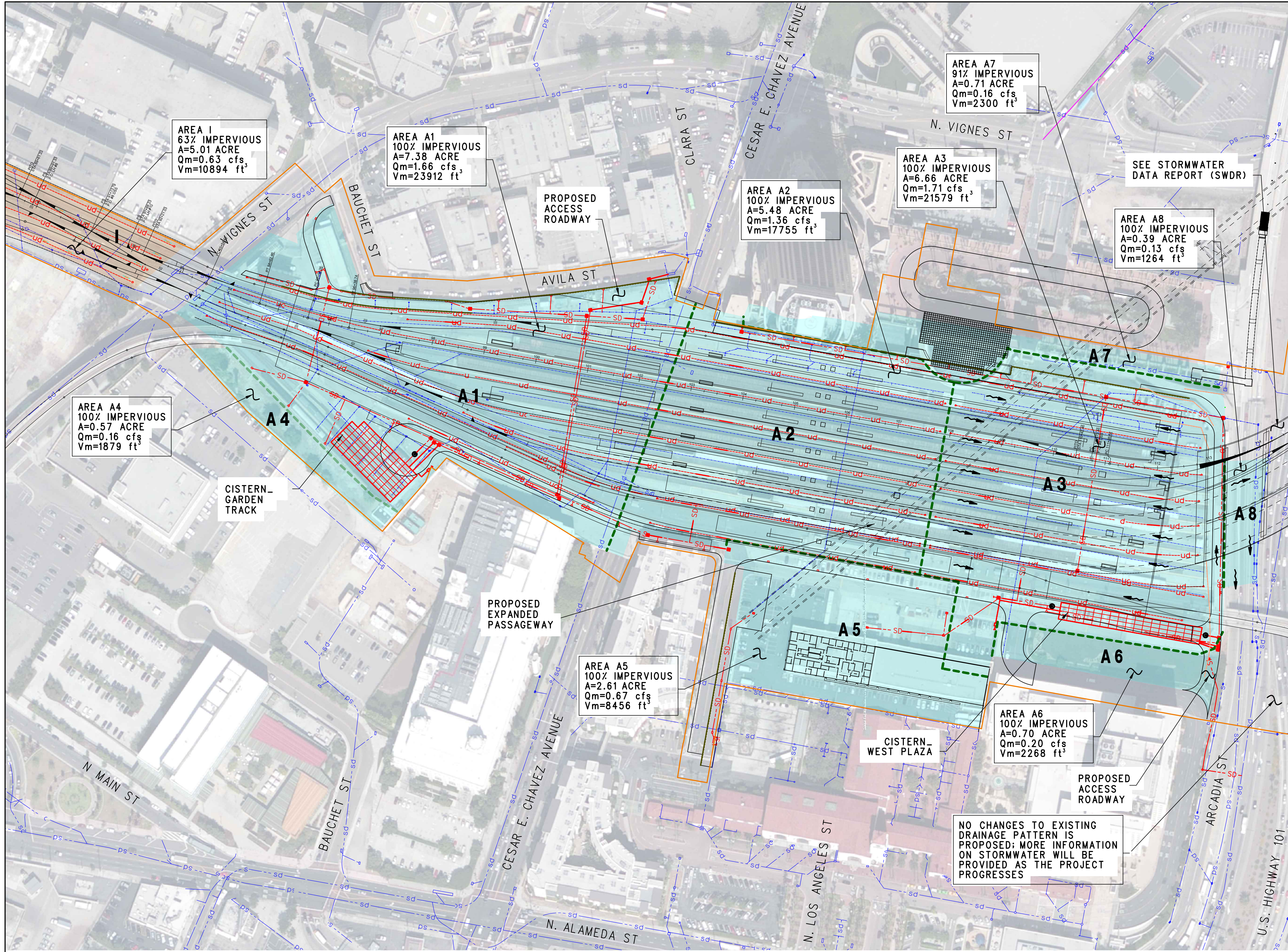
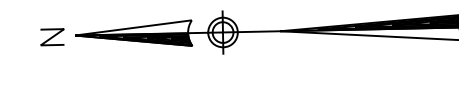

SEE EXHIBIT 2 OF 7  
MATCH LINE

MATCH LINE  
SEE EXHIBIT 5 OF 7

- LEGEND:**
- AREA I
  - AREA A (A1, A2, A3, A4, A5, A6, A7, A8)
  - PROPOSED STORM DRAIN
  - EXISTING STORM DRAIN
  - DRAINAGE SUB-AREA BOUNDARY
  - CISTERN
  - PROJECT FOOTPRINT
  - TRACK UNDERDRAIN

D R A F T

		LINK UNION STATION PROJECT BUILD ALTERNATIVE PRELIMINARY LID EXHIBIT SHEET 4 OF 7	SCALE: 1"=100' DATE: 03-22-2023
--	--	--	------------------------------------

3/22/2023 1:59:17 PM  
 c:\pwworking\hrc\project\link\station\build\alternatives\lids\exhibit\lids\exhibit\_4.dwg  
 p:\pwworking\hrc\project\link\station\build\alternatives\lids\exhibit\lids\exhibit\_4.dwg  
 c:\pwworking\hrc\project\link\station\build\alternatives\lids\exhibit\lids\exhibit\_4.dwg

3/22/2023 2:13:00 PM  
 c:\pwworking\src\dl068890\SUSIMP5.dwg  
 p:\pwworking\src\dl068890\SUSIMP5.dwg  
 c:\pwworking\src\dl068890\SUSIMP5.dwg

SEE EXHIBIT 4 OF 7  
 MATCH LINE

SEE EXHIBIT 3 OF 7  
 MATCH LINE

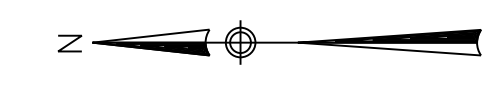
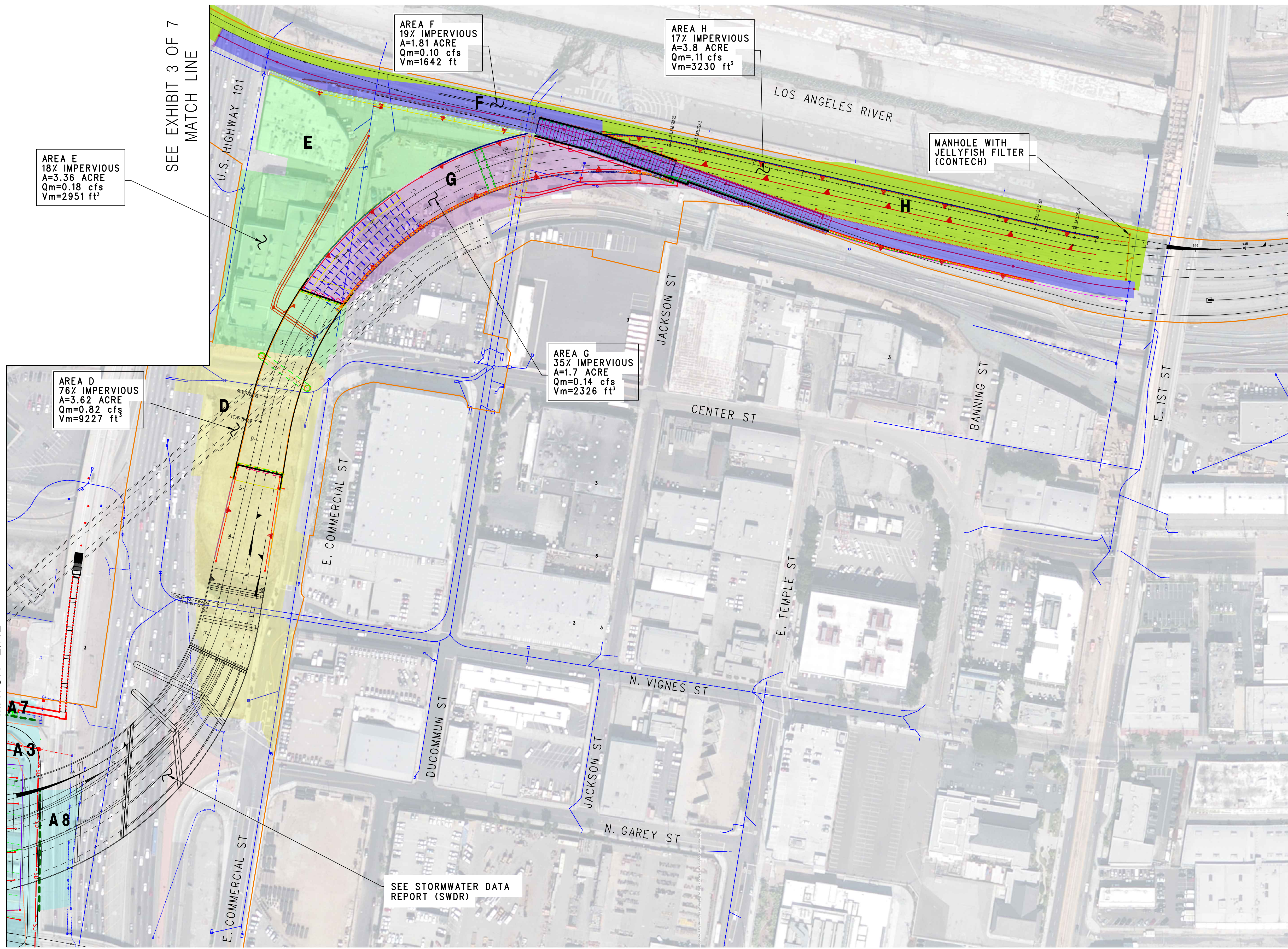

AREA E  
 18% IMPERVIOUS  
 A=3.36 ACRE  
 Qm=0.18 cfs  
 Vm=2951 ft<sup>3</sup>

AREA F  
 19% IMPERVIOUS  
 A=1.81 ACRE  
 Qm=0.10 cfs  
 Vm=1642 ft<sup>3</sup>

AREA H  
 17% IMPERVIOUS  
 A=3.8 ACRE  
 Qm=.11 cfs  
 Vm=3230 ft<sup>3</sup>

AREA D  
 76% IMPERVIOUS  
 A=3.62 ACRE  
 Qm=0.82 cfs  
 Vm=9227 ft<sup>3</sup>

AREA G  
 35% IMPERVIOUS  
 A=1.7 ACRE  
 Qm=0.14 cfs  
 Vm=2326 ft<sup>3</sup>

SEE STORMWATER DATA  
 REPORT (SWDR)

**NOTE:**  
 LOCATIONS OF BIORETENTION WITH  
 UNDERDRAIN NOT SHOWN FOR EACH  
 DRAINAGE AREA

- LEGEND:**
- AREA A (A3, A7, A8)
  - AREA D
  - AREA E
  - AREA F
  - AREA G
  - AREA H
  - PROPOSED STORM DRAIN
  - EXISTING STORM DRAIN
  - DRAINAGE SUB-AREA BOUNDARY
  - PROJECT FOOTPRINT
  - TRACK UNDERDRAIN

D R A F T

		LINK UNION STATION PROJECT BUILD ALTERNATIVE PRELIMINARY LID EXHIBIT SHEET 5 OF 7	SCALE: 1"=100' DATE: 03-22-2023
--	--	--	------------------------------------

3/22/2023 2:23:23 PM  
c:\pwworking\src\dl068890\SUSMP6.dgn  
p:\pwworking\src\dl068890\SUSMP6.dgn  
c:\pwworking\src\dl068890\SUSMP6.dgn

SEE EXHIBIT 5 OF 7  
MATCH LINE

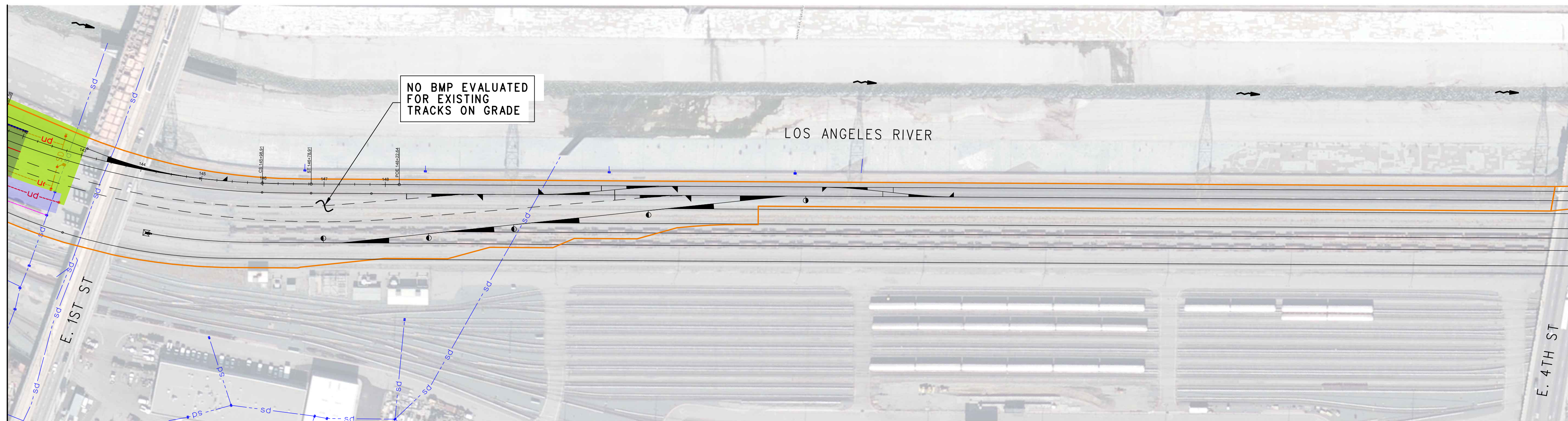

MATCH LINE  
SEE BELOW LEFT

SEE ABOVE RIGHT  
MATCH LINE

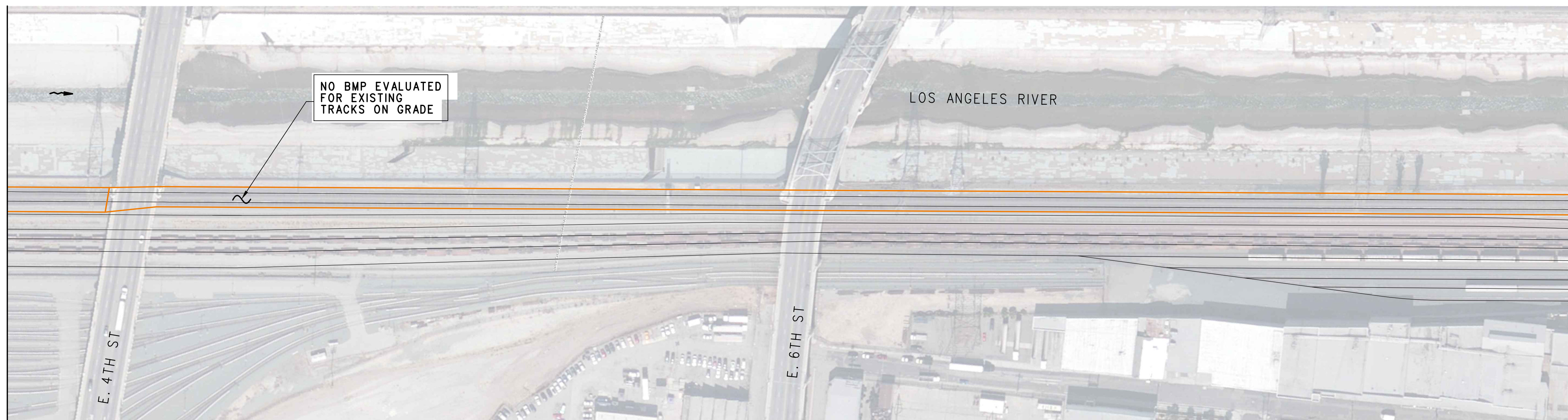

MATCH LINE  
SEE EXHIBIT 7 OF 7

LEGEND:

- sd--- EXISTING STORM DRAIN
- PROJECT FOOTPRINT

D R A F T



LINK UNION STATION PROJECT  
BUILD ALTERNATIVE  
PRELIMINARY LID EXHIBIT  
SHEET 6 OF 7

SCALE: 1"=100'  
DATE: 03-22-2023

3/22/2023 2:29:20 PM  
c:\pwworking\src\dl068890\SUSMP7.dgn  
p:\pwworking\src\dl068890\SUSMP7.dgn  
c:\pwworking\src\dl068890\SUSMP7.dgn

SEE EXHIBIT 6 OF 7  
MATCH LINE



MATCH LINE  
SEE BELOW LEFT

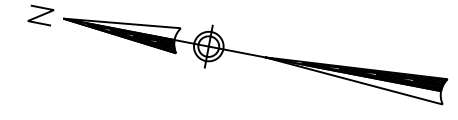

SEE ABOVE RIGHT  
MATCH LINE

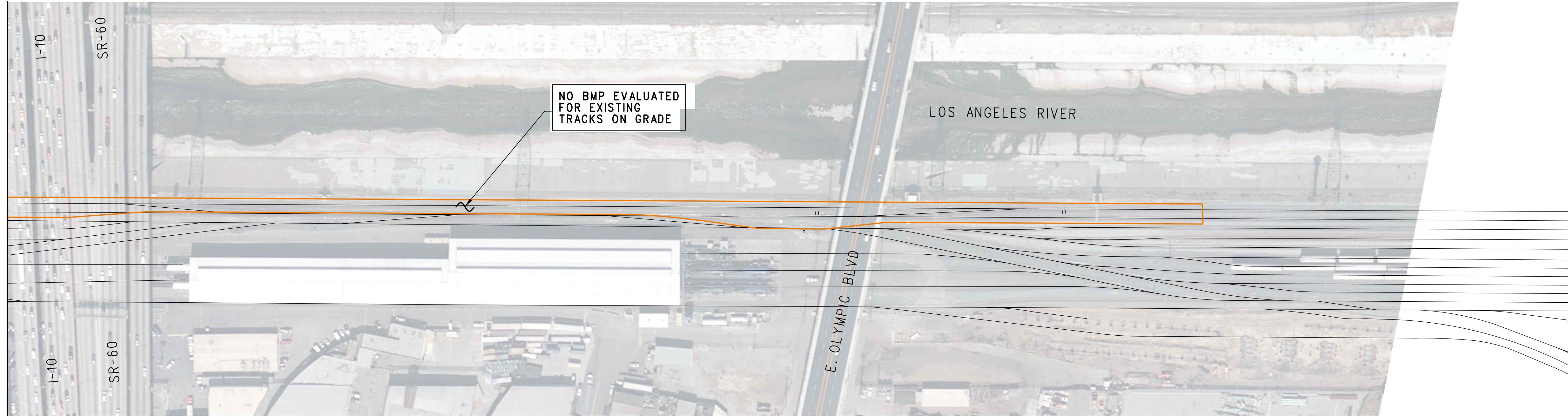

LEGEND:

— PROJECT FOOTPRINT

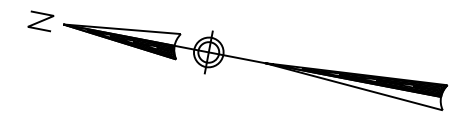

D R A F T

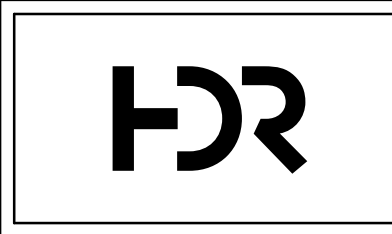

LINK UNION STATION PROJECT  
BUILD ALTERNATIVE  
PRELIMINARY LID EXHIBIT  
SHEET 7 OF 7

SCALE: 1"=100'  
DATE: 03-22-2023

(THIS PAGE INTENTIONALLY LEFT BLANK)

## **Appendix B: Cistern Details**

The cistern details are used as a reference for preliminary design purposes only and are subject to change.

(THIS PAGE INTENTIONALLY LEFT BLANK)

# STORMCAPTURE<sup>®</sup>

*StormCapture Modular Stormwater Management System  
for Infiltration, Detention, Retention and Treatment*

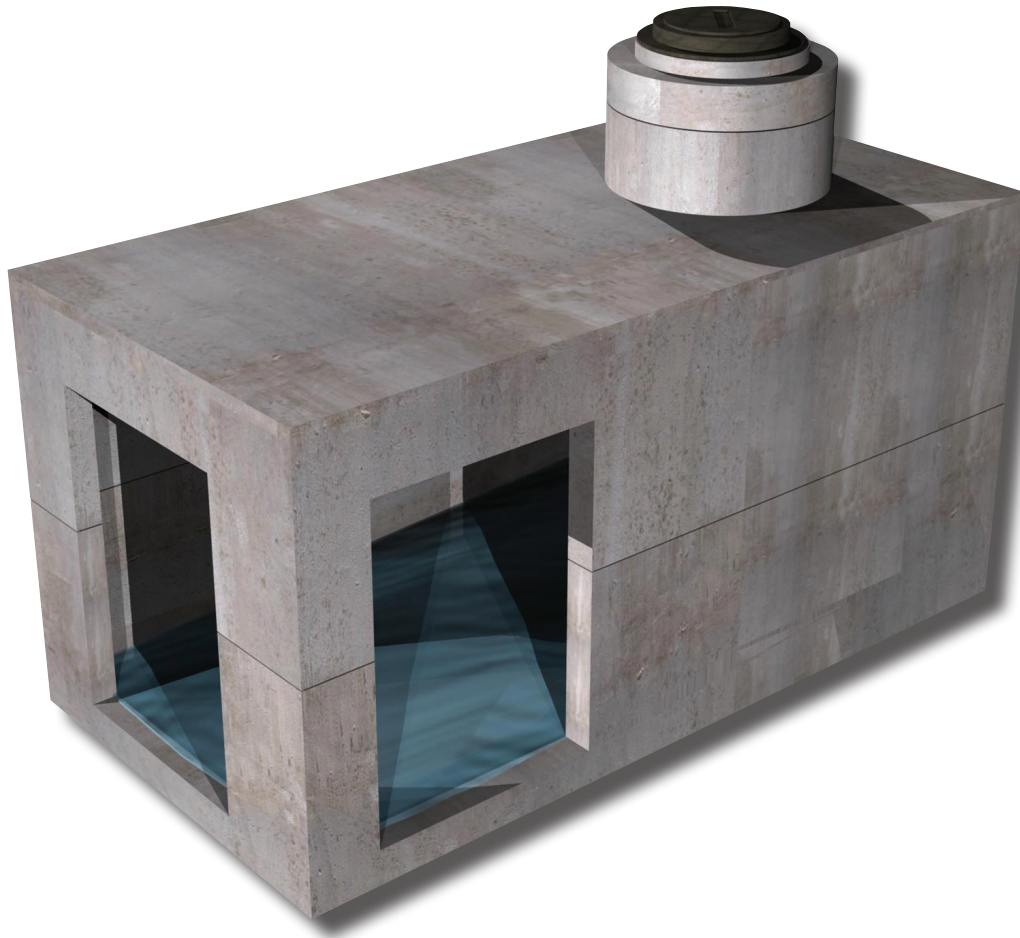

Call us today **(800) 579-8819** or visit our website for detailed product information, drawings and design tools at [www.oldcastlestormwater.com](http://www.oldcastlestormwater.com)

# StormCapture<sup>®</sup> Module

---

## Large Storage Capacity

Smaller system footprint for greater design flexibility.

## Traffic Loading

Only requires 6" of cover.

## Modular Design

Precast concrete modules measure 8' wide by 16' long OD, (7' x 15' ID), with customizable heights.

## Custom Sizes

Available in internal heights from 2' to 14' to best-fit site needs.

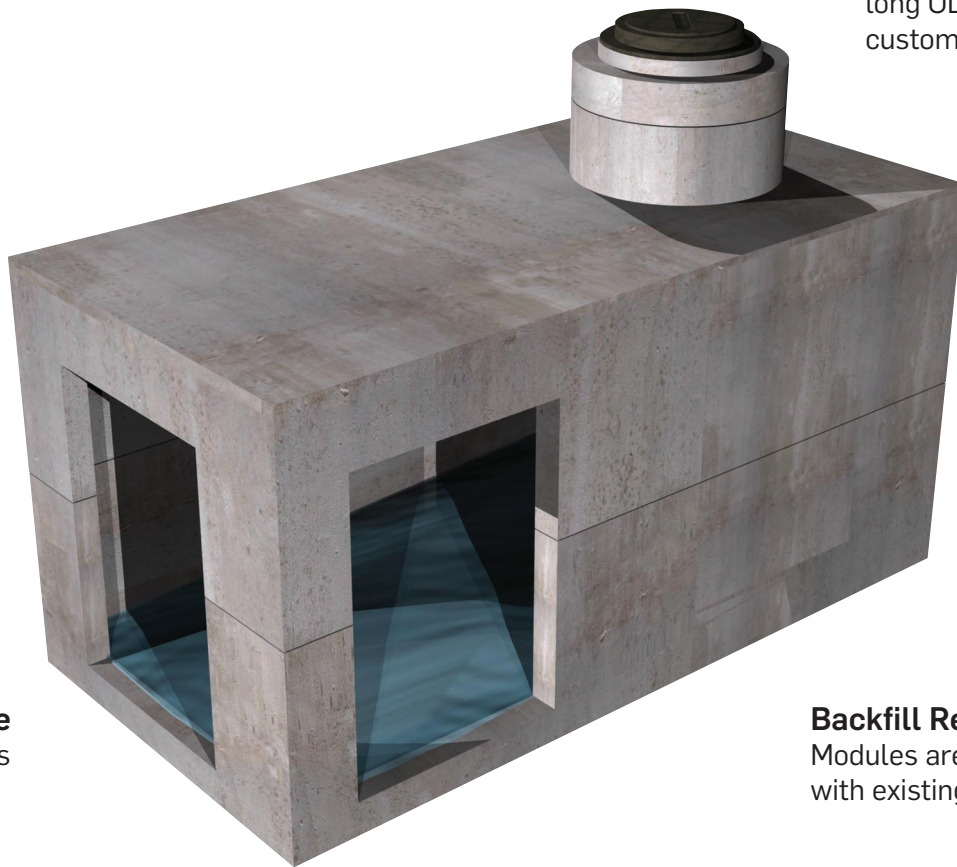

## Easy to Install

Fast installation with minimal handling.

## Design Assistance

Let our professionals customize for your specific needs.

## Backfill Requirements

Modules are typically backfilled with existing site materials.

## Treatment Train

Available with pre-treatment, post-treatment, or both.

## Construction Site Friendly

Contractor does not have to relinquish any ground on the site once the StormCapture system is installed.



INSTALLED IN JUST ONE DAY

## Module Sizes

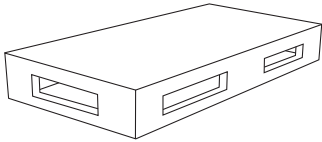

**SC1** - Single piece modules can be used for applications from 2' to 7' tall. Appropriate for cisterns, infiltration, detention and retention systems. SC1 modules are typically installed on minimally compacted gravel base, depending on specific project requirements.

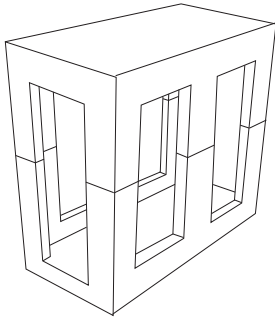

**SC2** - Two piece modules can be used for applications from 7' to 14' tall for maximum storage capacity in a condensed footprint. Appropriate for cisterns, infiltration, detention and retention systems. SC2 modules are typically installed on compacted native subgrade.

### Module Sizes & Capacities

Modules are 8'x16' outside dimensions. Capacity varies by configuration of openings.

Inside Dimensions (ft)	Capacity Range (ft <sup>3</sup> )	Inside Dimensions (ft)	Capacity Range (ft <sup>3</sup> )
7x15x2	210-212	7x15x9	945-1,027
7x15x3	315-325	7x15x10	1,050-1,140
7x15x4	420-442	7x15x11	1,155-1,257
7x15x5	525-559	7x15x12	1,260-1,374
7x15x6	630-676	7x15x13*	1,365-1,491
7x15x7	735-793	7x15x14*	1,470-1,608
7x15x8	840-910		

\* Special design considerations required and limited availability

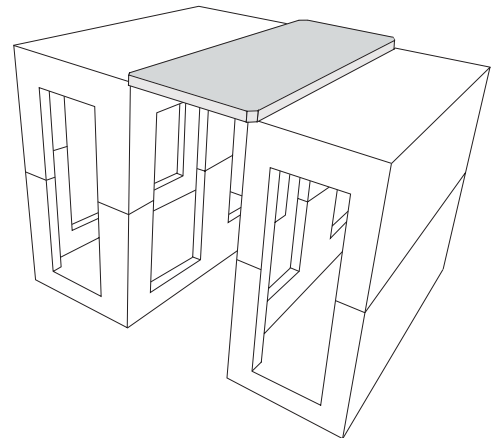

**Link Slab** - Unique design allows for significant reduction in the quantity of modules and associated costs, while providing maximum storage capacity.

## Endless Configurations

Contact us today to start designing your system!

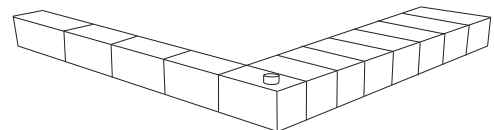
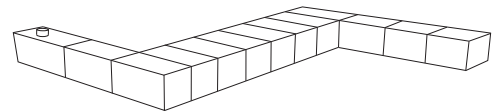
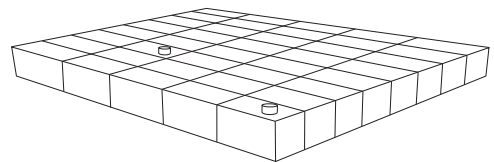

(THIS PAGE INTENTIONALLY LEFT BLANK)

## **Appendix C: Biofiltration Sizing for the Build Alternative**

(THIS PAGE INTENTIONALLY LEFT BLANK)

## Build Alternative

LINK Union Station  
Preliminary Low Impact Development Report

### LINK US BIORETENTION Sizing Area D

$$A_{\min} = V_{\text{Design}} / [(T_{\text{fill}} \times K_{\text{Sat, Design}}) / 12 + d_p]$$

Parameters	Parameters	Notes	
Mitigated Volume (ft <sup>3</sup> )	$V_m$	Per HydroCalc	9,227
Design Volume (ft <sup>3</sup> )	$V_{\text{design}} = 1.5 V_m$	Biofilterion facilities to be sized to capture and treat 150% of the design capture volume	13,840
Measured Infiltrate Rate (in/hr)	$K_{\text{sat, media}}$	Assumed 5 in/hr	5.0
Factor of Safety	<b>FS</b>	FS=2 if soil infiltration test and geotechnical report from professional GE is done, FS= 6 if only a boring was done.	6.0
Design Infiltrate Rate (in/hr)	$K_{\text{sat, design}}$		0.8
Time to fill (hrs)	$T_{\text{fill}}$	$T_{\text{fill}} = 3$ hrs, unless a hydrologic routing model is used	3.0
Maximum Ponding Depth (ft)	$d_{p, \text{max}}$	Maximum = 18 in	1.5
Design Infiltration Area (sf)	$A_{\min}$	$A_{\min} = V_{\text{Design}} / [(T_{\text{fill}} \times K_{\text{Sat, Design}}) / 12 + d_p]$	8,101

## Build Alternative

LINK Union Station  
Preliminary Low Impact Development Report

### LINK US BIORETENTION Sizing Area E

$$A_{\min} = V_{\text{Design}} / [(T_{\text{fill}} \times K_{\text{Sat,Design}}) / 12 + d_p]$$

Parameters	Parameters	Notes	
Mitigated Volume (ft <sup>3</sup> )	$V_m$	Per HydroCalc	2,951
Design Volume (ft <sup>3</sup> )	$V_{\text{design}} = 1.5 V_m$	Biofilterion facilities to be sized to capture and treat 150% of the design capture volume	4,427
Measured Infiltrate Rate (in/hr)	$K_{\text{sat, media}}$	Assumed 5 in/hr	5.0
Factor of Safety	<b>FS</b>	FS=2 if soil infiltration test and geotechnical report from professional GE is done, FS= 6 if only a boring was done.	6.0
Design Infiltrate Rate (in/hr)	$K_{\text{sat, design}}$		0.8
Time to fill (hrs)	$T_{\text{fill}}$	$T_{\text{fill}} = 3$ hrs, unless a hydrologic routing model is used	3.0
Maximum Ponding Depth (ft)	$d_{p,\text{max}}$	Maximum = 18 in	1.5
Design Infiltration Area (sf)	$A_{\min}$	$A_{\min} = V_{\text{Design}} / [(T_{\text{fill}} \times K_{\text{Sat,Design}}) / 12 + d_p]$	2,592

## Appendix D: Contech StormFilter

(THIS PAGE INTENTIONALLY LEFT BLANK)

I:\STORMWATER\COM\OPS\10 STORMFILTER\40 STANDARD DRAWINGS\VAULTS\F0806-DTL.DWG 1/23/2014 10:15 AM

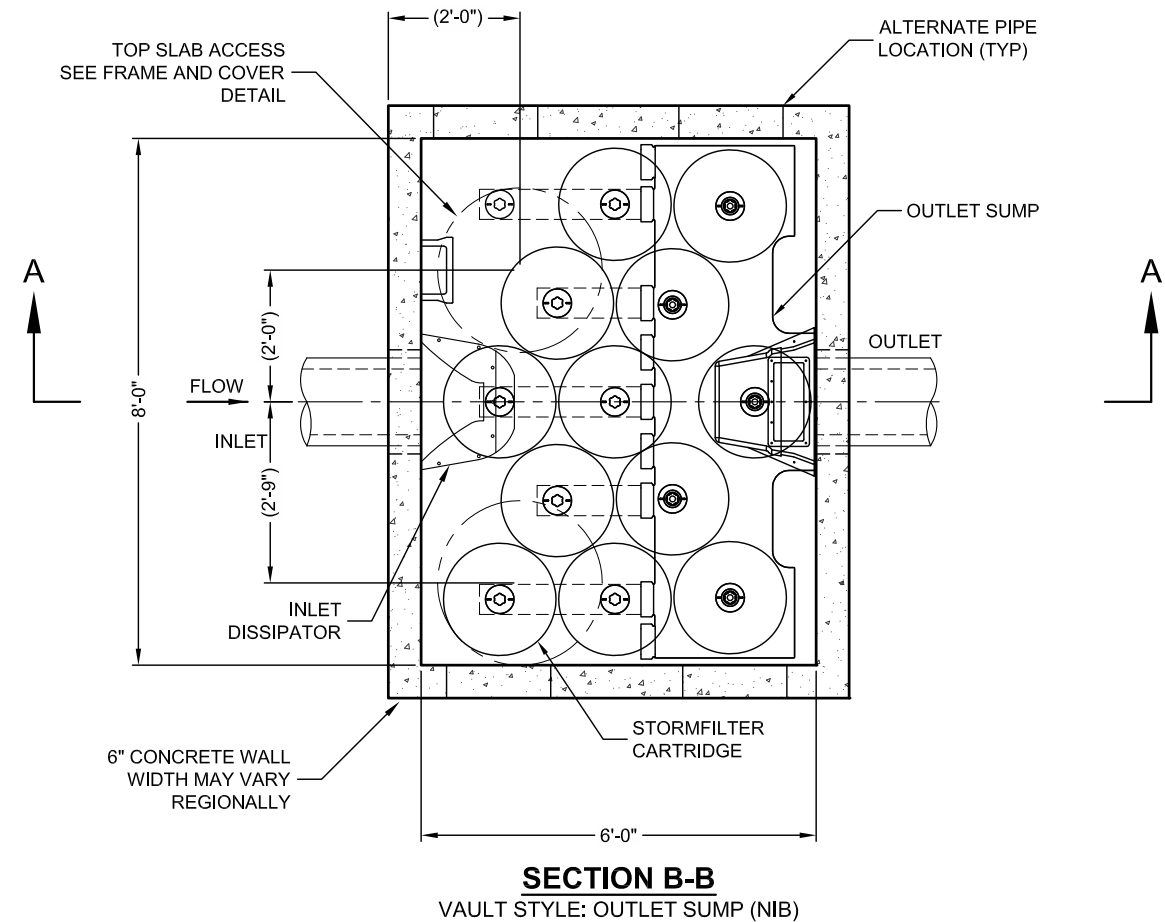

**SECTION B-B**  
VAULT STYLE: OUTLET SUMP (NIB)

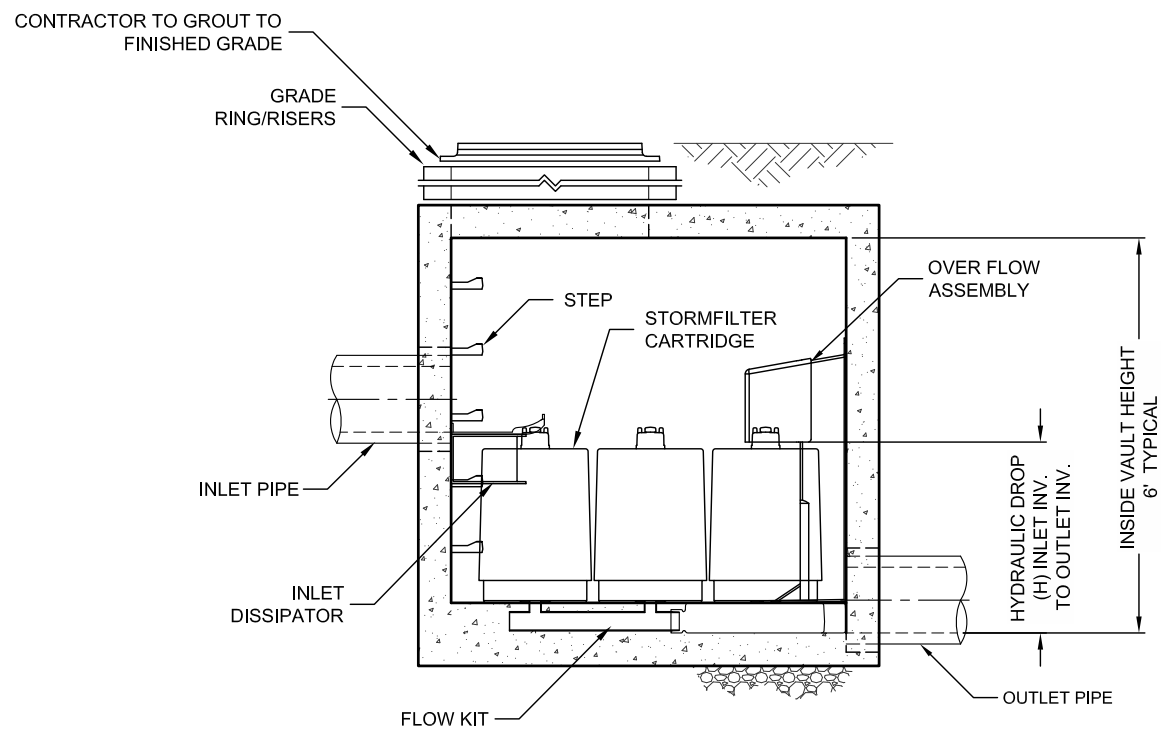

**SECTION A-A**



THIS PRODUCT MAY BE PROTECTED BY ONE OR MORE OF THE FOLLOWING U.S. PATENTS: 5,322,228; 5,344,476; 5,717,477; 5,848,765; 6,022,009; 6,049,040; 6,071,411; 6,071,412; 6,071,413; 6,071,414; 6,071,415; 6,071,416; 6,071,417; 6,071,418; 6,071,419; 6,071,420; 6,071,421; 6,071,422; 6,071,423; 6,071,424; 6,071,425; 6,071,426; 6,071,427; 6,071,428; 6,071,429; 6,071,430; 6,071,431; 6,071,432; 6,071,433; 6,071,434; 6,071,435; 6,071,436; 6,071,437; 6,071,438; 6,071,439; 6,071,440; 6,071,441; 6,071,442; 6,071,443; 6,071,444; 6,071,445; 6,071,446; 6,071,447; 6,071,448; 6,071,449; 6,071,450; 6,071,451; 6,071,452; 6,071,453; 6,071,454; 6,071,455; 6,071,456; 6,071,457; 6,071,458; 6,071,459; 6,071,460; 6,071,461; 6,071,462; 6,071,463; 6,071,464; 6,071,465; 6,071,466; 6,071,467; 6,071,468; 6,071,469; 6,071,470; 6,071,471; 6,071,472; 6,071,473; 6,071,474; 6,071,475; 6,071,476; 6,071,477; 6,071,478; 6,071,479; 6,071,480; 6,071,481; 6,071,482; 6,071,483; 6,071,484; 6,071,485; 6,071,486; 6,071,487; 6,071,488; 6,071,489; 6,071,490; 6,071,491; 6,071,492; 6,071,493; 6,071,494; 6,071,495; 6,071,496; 6,071,497; 6,071,498; 6,071,499; 6,071,500; 6,071,501; 6,071,502; 6,071,503; 6,071,504; 6,071,505; 6,071,506; 6,071,507; 6,071,508; 6,071,509; 6,071,510; 6,071,511; 6,071,512; 6,071,513; 6,071,514; 6,071,515; 6,071,516; 6,071,517; 6,071,518; 6,071,519; 6,071,520; 6,071,521; 6,071,522; 6,071,523; 6,071,524; 6,071,525; 6,071,526; 6,071,527; 6,071,528; 6,071,529; 6,071,530; 6,071,531; 6,071,532; 6,071,533; 6,071,534; 6,071,535; 6,071,536; 6,071,537; 6,071,538; 6,071,539; 6,071,540; 6,071,541; 6,071,542; 6,071,543; 6,071,544; 6,071,545; 6,071,546; 6,071,547; 6,071,548; 6,071,549; 6,071,550; 6,071,551; 6,071,552; 6,071,553; 6,071,554; 6,071,555; 6,071,556; 6,071,557; 6,071,558; 6,071,559; 6,071,560; 6,071,561; 6,071,562; 6,071,563; 6,071,564; 6,071,565; 6,071,566; 6,071,567; 6,071,568; 6,071,569; 6,071,570; 6,071,571; 6,071,572; 6,071,573; 6,071,574; 6,071,575; 6,071,576; 6,071,577; 6,071,578; 6,071,579; 6,071,580; 6,071,581; 6,071,582; 6,071,583; 6,071,584; 6,071,585; 6,071,586; 6,071,587; 6,071,588; 6,071,589; 6,071,590; 6,071,591; 6,071,592; 6,071,593; 6,071,594; 6,071,595; 6,071,596; 6,071,597; 6,071,598; 6,071,599; 6,071,600; 6,071,601; 6,071,602; 6,071,603; 6,071,604; 6,071,605; 6,071,606; 6,071,607; 6,071,608; 6,071,609; 6,071,610; 6,071,611; 6,071,612; 6,071,613; 6,071,614; 6,071,615; 6,071,616; 6,071,617; 6,071,618; 6,071,619; 6,071,620; 6,071,621; 6,071,622; 6,071,623; 6,071,624; 6,071,625; 6,071,626; 6,071,627; 6,071,628; 6,071,629; 6,071,630; 6,071,631; 6,071,632; 6,071,633; 6,071,634; 6,071,635; 6,071,636; 6,071,637; 6,071,638; 6,071,639; 6,071,640; 6,071,641; 6,071,642; 6,071,643; 6,071,644; 6,071,645; 6,071,646; 6,071,647; 6,071,648; 6,071,649; 6,071,650; 6,071,651; 6,071,652; 6,071,653; 6,071,654; 6,071,655; 6,071,656; 6,071,657; 6,071,658; 6,071,659; 6,071,660; 6,071,661; 6,071,662; 6,071,663; 6,071,664; 6,071,665; 6,071,666; 6,071,667; 6,071,668; 6,071,669; 6,071,670; 6,071,671; 6,071,672; 6,071,673; 6,071,674; 6,071,675; 6,071,676; 6,071,677; 6,071,678; 6,071,679; 6,071,680; 6,071,681; 6,071,682; 6,071,683; 6,071,684; 6,071,685; 6,071,686; 6,071,687; 6,071,688; 6,071,689; 6,071,690; 6,071,691; 6,071,692; 6,071,693; 6,071,694; 6,071,695; 6,071,696; 6,071,697; 6,071,698; 6,071,699; 6,071,700; 6,071,701; 6,071,702; 6,071,703; 6,071,704; 6,071,705; 6,071,706; 6,071,707; 6,071,708; 6,071,709; 6,071,710; 6,071,711; 6,071,712; 6,071,713; 6,071,714; 6,071,715; 6,071,716; 6,071,717; 6,071,718; 6,071,719; 6,071,720; 6,071,721; 6,071,722; 6,071,723; 6,071,724; 6,071,725; 6,071,726; 6,071,727; 6,071,728; 6,071,729; 6,071,730; 6,071,731; 6,071,732; 6,071,733; 6,071,734; 6,071,735; 6,071,736; 6,071,737; 6,071,738; 6,071,739; 6,071,740; 6,071,741; 6,071,742; 6,071,743; 6,071,744; 6,071,745; 6,071,746; 6,071,747; 6,071,748; 6,071,749; 6,071,750; 6,071,751; 6,071,752; 6,071,753; 6,071,754; 6,071,755; 6,071,756; 6,071,757; 6,071,758; 6,071,759; 6,071,760; 6,071,761; 6,071,762; 6,071,763; 6,071,764; 6,071,765; 6,071,766; 6,071,767; 6,071,768; 6,071,769; 6,071,770; 6,071,771; 6,071,772; 6,071,773; 6,071,774; 6,071,775; 6,071,776; 6,071,777; 6,071,778; 6,071,779; 6,071,780; 6,071,781; 6,071,782; 6,071,783; 6,071,784; 6,071,785; 6,071,786; 6,071,787; 6,071,788; 6,071,789; 6,071,790; 6,071,791; 6,071,792; 6,071,793; 6,071,794; 6,071,795; 6,071,796; 6,071,797; 6,071,798; 6,071,799; 6,071,800; 6,071,801; 6,071,802; 6,071,803; 6,071,804; 6,071,805; 6,071,806; 6,071,807; 6,071,808; 6,071,809; 6,071,810; 6,071,811; 6,071,812; 6,071,813; 6,071,814; 6,071,815; 6,071,816; 6,071,817; 6,071,818; 6,071,819; 6,071,820; 6,071,821; 6,071,822; 6,071,823; 6,071,824; 6,071,825; 6,071,826; 6,071,827; 6,071,828; 6,071,829; 6,071,830; 6,071,831; 6,071,832; 6,071,833; 6,071,834; 6,071,835; 6,071,836; 6,071,837; 6,071,838; 6,071,839; 6,071,840; 6,071,841; 6,071,842; 6,071,843; 6,071,844; 6,071,845; 6,071,846; 6,071,847; 6,071,848; 6,071,849; 6,071,850; 6,071,851; 6,071,852; 6,071,853; 6,071,854; 6,071,855; 6,071,856; 6,071,857; 6,071,858; 6,071,859; 6,071,860; 6,071,861; 6,071,862; 6,071,863; 6,071,864; 6,071,865; 6,071,866; 6,071,867; 6,071,868; 6,071,869; 6,071,870; 6,071,871; 6,071,872; 6,071,873; 6,071,874; 6,071,875; 6,071,876; 6,071,877; 6,071,878; 6,071,879; 6,071,880; 6,071,881; 6,071,882; 6,071,883; 6,071,884; 6,071,885; 6,071,886; 6,071,887; 6,071,888; 6,071,889; 6,071,890; 6,071,891; 6,071,892; 6,071,893; 6,071,894; 6,071,895; 6,071,896; 6,071,897; 6,071,898; 6,071,899; 6,071,900; 6,071,901; 6,071,902; 6,071,903; 6,071,904; 6,071,905; 6,071,906; 6,071,907; 6,071,908; 6,071,909; 6,071,910; 6,071,911; 6,071,912; 6,071,913; 6,071,914; 6,071,915; 6,071,916; 6,071,917; 6,071,918; 6,071,919; 6,071,920; 6,071,921; 6,071,922; 6,071,923; 6,071,924; 6,071,925; 6,071,926; 6,071,927; 6,071,928; 6,071,929; 6,071,930; 6,071,931; 6,071,932; 6,071,933; 6,071,934; 6,071,935; 6,071,936; 6,071,937; 6,071,938; 6,071,939; 6,071,940; 6,071,941; 6,071,942; 6,071,943; 6,071,944; 6,071,945; 6,071,946; 6,071,947; 6,071,948; 6,071,949; 6,071,950; 6,071,951; 6,071,952; 6,071,953; 6,071,954; 6,071,955; 6,071,956; 6,071,957; 6,071,958; 6,071,959; 6,071,960; 6,071,961; 6,071,962; 6,071,963; 6,071,964; 6,071,965; 6,071,966; 6,071,967; 6,071,968; 6,071,969; 6,071,970; 6,071,971; 6,071,972; 6,071,973; 6,071,974; 6,071,975; 6,071,976; 6,071,977; 6,071,978; 6,071,979; 6,071,980; 6,071,981; 6,071,982; 6,071,983; 6,071,984; 6,071,985; 6,071,986; 6,071,987; 6,071,988; 6,071,989; 6,071,990; 6,071,991; 6,071,992; 6,071,993; 6,071,994; 6,071,995; 6,071,996; 6,071,997; 6,071,998; 6,071,999; 6,072,000.

**STORMFILTER DESIGN NOTES**

STORMFILTER TREATMENT CAPACITY IS A FUNCTION OF THE CARTRIDGE SELECTION AND THE NUMBER OF CARTRIDGES. THE STANDARD VAULT STYLE IS SHOWN WITH THE MAXIMUM NUMBER OF CARTRIDGES (12). VAULT STYLE OPTIONS INCLUDE OUTLET BAY (7).

STORMFILTER 8X6 PEAK HYDRAULIC CAPACITY IS 1.8 CFS. IF THE SITE CONDITIONS EXCEED 1.8 CFS AN UPSTREAM BYPASS STRUCTURE IS REQUIRED.

**CARTRIDGE SELECTION**

CARTRIDGE HEIGHT	27"		18"		LOW DROP	
RECOMMENDED HYDRAULIC DROP (H)	3.05'		2.3'		1.8'	
SPECIFIC FLOW RATE (gpm/sf)	2 gpm/ft <sup>2</sup>	1 gpm/ft <sup>2</sup>	2 gpm/ft <sup>2</sup>	1 gpm/ft <sup>2</sup>	2 gpm/ft <sup>2</sup>	1 gpm/ft <sup>2</sup>
CARTRIDGE FLOW RATE (gpm)	22.5	11.25	15	7.5	10	5

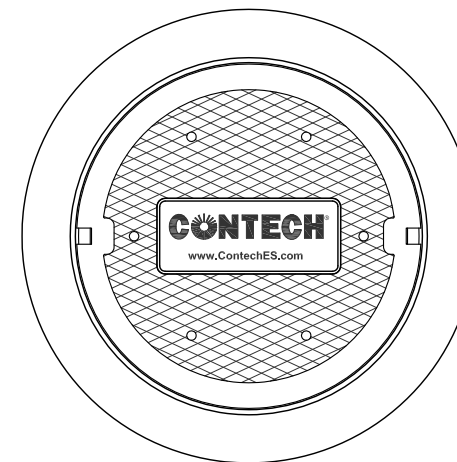

**FRAME AND COVER**  
(DIAMETER VARIES)  
N.T.S.

**SITE SPECIFIC DATA REQUIREMENTS**

STRUCTURE ID	*		
WATER QUALITY FLOW RATE (cfs)	*		
PEAK FLOW RATE (cfs)	*		
RETURN PERIOD OF PEAK FLOW (yrs)	*		
# OF CARTRIDGES REQUIRED	*		
CARTRIDGE FLOW RATE	*		
MEDIA TYPE (CSF, PERLITE, ZPG, GAC, PHS)	*		
PIPE DATA:	I.E.	MATERIAL	DIAMETER
INLET PIPE #1	*	*	*
INLET PIPE #2	*	*	*
OUTLET PIPE	*	*	*
UPSTREAM RIM ELEVATION	*		
DOWNSTREAM RIM ELEVATION	*		
ANTI-FLOTATION BALLAST	WIDTH	HEIGHT	
	*	*	
NOTES/SPECIAL REQUIREMENTS:			
* PER ENGINEER OF RECORD			

**GENERAL NOTES**

- CONTECH TO PROVIDE ALL MATERIALS UNLESS NOTED OTHERWISE.
- DIMENSIONS MARKED WITH ( ) ARE REFERENCE DIMENSIONS. ACTUAL DIMENSIONS MAY VARY.
- FOR SITE SPECIFIC DRAWINGS WITH DETAILED VAULT DIMENSIONS AND WEIGHTS, PLEASE CONTACT YOUR CONTECH REPRESENTATIVE. [www.ContechES.com](http://www.ContechES.com)
- STORMFILTER WATER QUALITY STRUCTURE SHALL BE IN ACCORDANCE WITH ALL DESIGN DATA AND INFORMATION CONTAINED IN THIS DRAWING.
- STRUCTURE SHALL MEET AASHTO HS20 AND CASTINGS SHALL MEET AASHTO M306 LOAD RATING, ASSUMING GROUNDWATER ELEVATION AT, OR BELOW, THE OUTLET PIPE INVERT ELEVATION. ENGINEER OF RECORD TO CONFIRM ACTUAL GROUNDWATER ELEVATION
- FILTER CARTRIDGES SHALL BE MEDIA-FILLED, PASSIVE, SIPHON ACTUATED, RADIAL FLOW, AND SELF CLEANING. RADIAL MEDIA DEPTH SHALL BE 7-INCHES. FILTER MEDIA CONTACT TIME SHALL BE AT LEAST 39 SECONDS.
- SPECIFIC FLOW RATE IS EQUAL TO THE FILTER TREATMENT CAPACITY (gpm) DIVIDED BY THE FILTER CONTACT SURFACE AREA (sq ft).

**INSTALLATION NOTES**

- ANY SUB-BASE, BACKFILL DEPTH, AND/OR ANTI-FLOTATION PROVISIONS ARE SITE-SPECIFIC DESIGN CONSIDERATIONS AND SHALL BE SPECIFIED BY ENGINEER OF RECORD.
- CONTRACTOR TO PROVIDE EQUIPMENT WITH SUFFICIENT LIFTING AND REACH CAPACITY TO LIFT AND SET THE STORMFILTER VAULT (LIFTING CLUTCHES PROVIDED).
- CONTRACTOR TO INSTALL JOINT SEALANT BETWEEN ALL VAULT SECTIONS AND ASSEMBLE VAULT.
- CONTRACTOR TO PROVIDE, INSTALL, AND GROUT PIPES. MATCH OUTLET PIPE INVERT WITH OUTLET BAY FLOOR.
- CONTRACTOR TO TAKE APPROPRIATE MEASURES TO PROTECT CARTRIDGES FROM CONSTRUCTION-RELATED EROSION RUNOFF.



[www.ContechES.com](http://www.ContechES.com)  
9025 Centre Pointe Dr., Suite 400, West Chester, OH 45069  
800-338-1122 513-645-7000 513-645-7993 FAX

SF806  
STORMFILTER  
STANDARD DETAIL

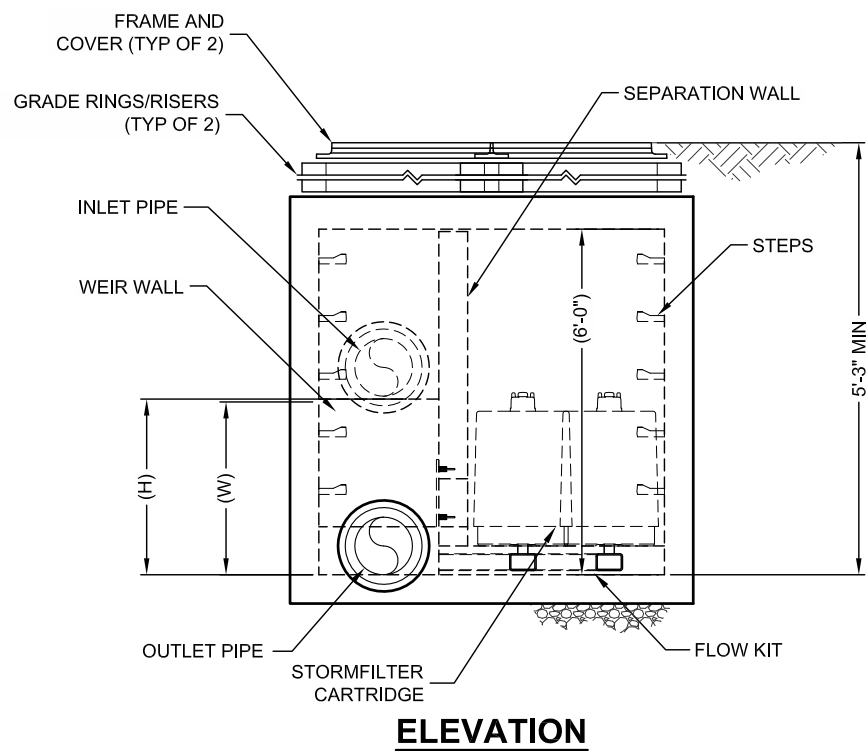
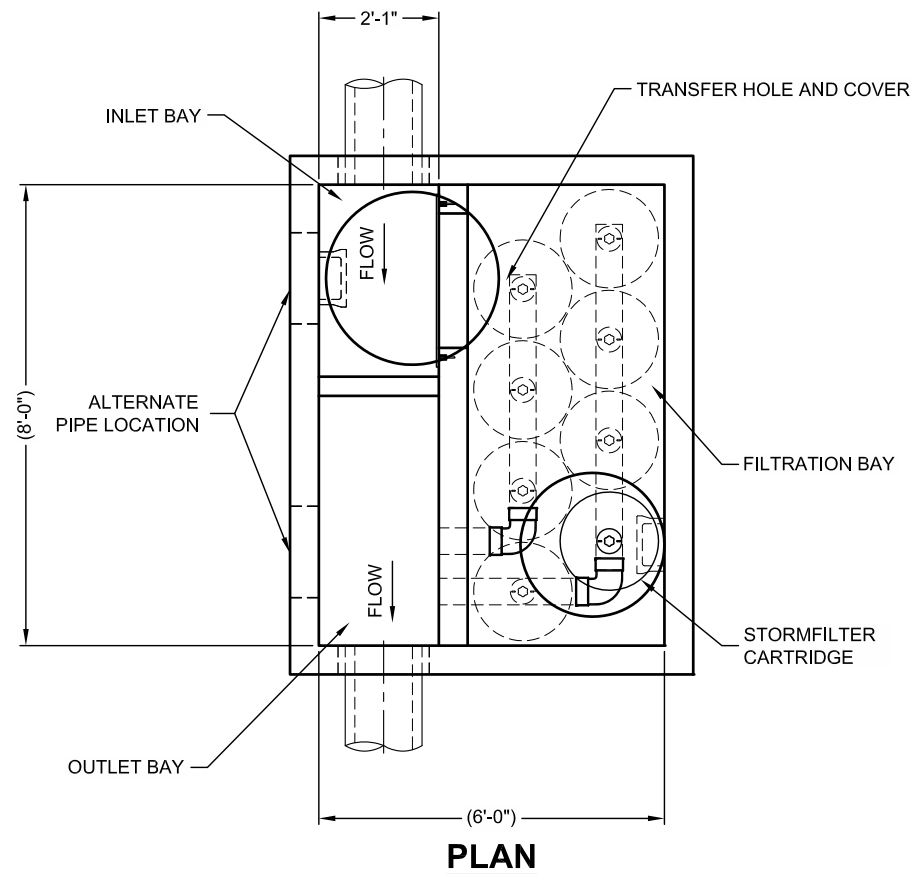

### STORMFILTER DESIGN TABLE

- THE 8' x 6' PEAK DIVERSION STORMFILTER TREATMENT CAPACITY VARIES BY CARTRIDGE COUNT AND LOCALLY APPROVED SURFACE AREA SPECIFIC FLOW RATE. PEAK CONVEYANCE CAPACITY TO BE DETERMINED BY ENGINEER OF RECORD.
- THE PEAK DIVERSION STORMFILTER IS AVAILABLE IN A LEFT INLET (AS SHOWN) OR RIGHT INLET CONFIGURATION.
- ALL PARTS AND INTERNAL ASSEMBLY PROVIDED BY CONTECH UNLESS OTHERWISE NOTED.

CARTRIDGE HEIGHT	27"		18"		LOW DROP	
SYSTEM HYDRAULIC DROP (H - REQ'D. MIN.)	3.05'		2.3'		1.8'	
HEIGHT OF WEIR (W)	3.00'		2.25'		1.75'	
TREATMENT BY MEDIA SURFACE AREA	2 gpm/ft <sup>2</sup>	1 gpm/ft <sup>2</sup>	2 gpm/ft <sup>2</sup>	1 gpm/ft <sup>2</sup>	2 gpm/ft <sup>2</sup>	1 gpm/ft <sup>2</sup>
CARTRIDGE FLOW RATE (gpm)	22.5	11.25	15	7.5	10	5

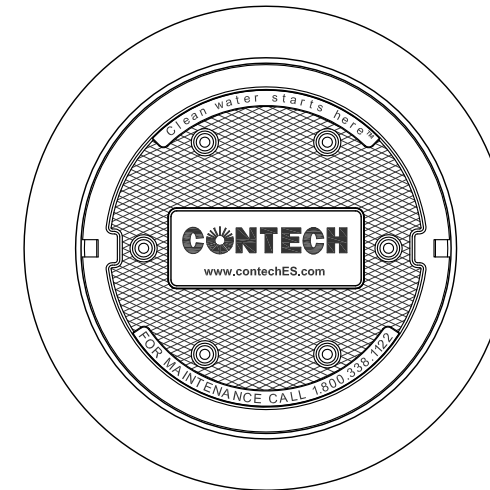

**FRAME AND COVER**  
(DIAMETER VARIES)  
N.T.S.

SITE SPECIFIC DATA REQUIREMENTS			
STRUCTURE ID	*		
WATER QUALITY FLOW RATE (cfs)	*		
PEAK FLOW RATE (cfs)	*		
RETURN PERIOD OF PEAK FLOW (yrs)	*		
# OF CARTRIDGES REQUIRED	*		
CARTRIDGE FLOW RATE	*		
MEDIA TYPE (CSF, PERLITE, ZPG)	*		
PIPE DATA:	I.E.	MATERIAL	DIAMETER
INLET PIPE	*	*	*
OUTLET PIPE	*	*	*
INLET BAY RIM ELEVATION	*		
FILTER BAY RIM ELEVATION	*		
ANTI-FLOTATION BALLAST	WIDTH	HEIGHT	
	*	*	
NOTES/SPECIAL REQUIREMENTS:			

#### PERFORMANCE SPECIFICATION

FILTER CARTRIDGES SHALL BE MEDIA-FILLED, PASSIVE, SIPHON ACTUATED, RADIAL FLOW, AND SELF CLEANING. **RADIAL MEDIA DEPTH SHALL BE 7-INCHES**. FILTER MEDIA CONTACT TIME SHALL BE AT LEAST **37 SECONDS**. SPECIFIC FLOW RATE SHALL BE **2 GPM/SF (MAXIMUM)**. SPECIFIC FLOW RATE IS THE MEASURE OF THE FLOW (GPM) DIVIDED BY THE MEDIA SURFACE CONTACT AREA (SF). MEDIA VOLUMETRIC FLOW RATE SHALL BE **6 GPM/CF OF MEDIA (MAXIMUM)**.

#### GENERAL NOTES

1. CONTECH TO PROVIDE ALL MATERIALS UNLESS NOTED OTHERWISE.
2. DIMENSIONS MARKED WITH ( ) ARE REFERENCE DIMENSIONS. ACTUAL DIMENSIONS MAY VARY.
3. FOR FABRICATION DRAWINGS WITH DETAILED STRUCTURE DIMENSIONS AND WEIGHTS, PLEASE CONTACT YOUR CONTECH REPRESENTATIVE. [www.ContechES.com](http://www.ContechES.com)
4. STORMFILTER WATER QUALITY STRUCTURE SHALL BE IN ACCORDANCE WITH ALL DESIGN DATA AND INFORMATION CONTAINED IN THIS DRAWING. CONTRACTOR TO CONFIRM STRUCTURE MEETS REQUIREMENTS OF PROJECT.
5. STRUCTURE SHALL MEET AASHTO HS20 LOAD RATING, ASSUMING EARTH COVER OF 0' - 5' AND GROUNDWATER ELEVATION AT, OR BELOW, THE OUTLET PIPE INVERT ELEVATION. ENGINEER OF RECORD TO CONFIRM ACTUAL GROUNDWATER ELEVATION. CASTINGS SHALL MEET AASHTO M306 AND BE CAST WITH THE CONTECH LOGO.

#### INSTALLATION NOTES

- A. ANY SUB-BASE, BACKFILL DEPTH, AND/OR ANTI-FLOTATION PROVISIONS ARE SITE-SPECIFIC DESIGN CONSIDERATIONS AND SHALL BE SPECIFIED BY ENGINEER OF RECORD.
- B. CONTRACTOR TO PROVIDE EQUIPMENT WITH SUFFICIENT LIFTING AND REACH CAPACITY TO LIFT AND SET THE STORMFILTER STRUCTURE (LIFTING CLUTCHES PROVIDED).
- C. CONTRACTOR TO INSTALL JOINT SEALANT BETWEEN ALL SECTIONS AND ASSEMBLE STRUCTURE.
- D. CONTRACTOR TO PROVIDE, INSTALL, AND GROUT PIPES. MATCH OUTLET PIPE INVERT WITH OUTLET BAY FLOOR.
- E. CONTRACTOR TO TAKE APPROPRIATE MEASURES TO PROTECT CARTRIDGES FROM CONSTRUCTION-RELATED EROSION RUNOFF.
- F. CONTRACTOR TO REMOVE THE TRANSFER HOLE COVER WHEN THE SYSTEM IS BROUGHT ONLINE.



THIS PRODUCT MAY BE PROTECTED BY ONE OR MORE OF THE FOLLOWING: U.S. PATENT NO. 8,322,228; U.S. PATENT NO. 8,348,172; U.S. PATENT NO. 8,353,100; U.S. PATENT NO. 8,353,101; U.S. PATENT NO. 8,353,102; U.S. PATENT NO. 8,353,103; U.S. PATENT NO. 8,353,104; U.S. PATENT NO. 8,353,105; U.S. PATENT NO. 8,353,106; U.S. PATENT NO. 8,353,107; U.S. PATENT NO. 8,353,108; U.S. PATENT NO. 8,353,109; U.S. PATENT NO. 8,353,110; U.S. PATENT NO. 8,353,111; U.S. PATENT NO. 8,353,112; U.S. PATENT NO. 8,353,113; U.S. PATENT NO. 8,353,114; U.S. PATENT NO. 8,353,115; U.S. PATENT NO. 8,353,116; U.S. PATENT NO. 8,353,117; U.S. PATENT NO. 8,353,118; U.S. PATENT NO. 8,353,119; U.S. PATENT NO. 8,353,120; U.S. PATENT NO. 8,353,121; U.S. PATENT NO. 8,353,122; U.S. PATENT NO. 8,353,123; U.S. PATENT NO. 8,353,124; U.S. PATENT NO. 8,353,125; U.S. PATENT NO. 8,353,126; U.S. PATENT NO. 8,353,127; U.S. PATENT NO. 8,353,128; U.S. PATENT NO. 8,353,129; U.S. PATENT NO. 8,353,130; U.S. PATENT NO. 8,353,131; U.S. PATENT NO. 8,353,132; U.S. PATENT NO. 8,353,133; U.S. PATENT NO. 8,353,134; U.S. PATENT NO. 8,353,135; U.S. PATENT NO. 8,353,136; U.S. PATENT NO. 8,353,137; U.S. PATENT NO. 8,353,138; U.S. PATENT NO. 8,353,139; U.S. PATENT NO. 8,353,140; U.S. PATENT NO. 8,353,141; U.S. PATENT NO. 8,353,142; U.S. PATENT NO. 8,353,143; U.S. PATENT NO. 8,353,144; U.S. PATENT NO. 8,353,145; U.S. PATENT NO. 8,353,146; U.S. PATENT NO. 8,353,147; U.S. PATENT NO. 8,353,148; U.S. PATENT NO. 8,353,149; U.S. PATENT NO. 8,353,150; U.S. PATENT NO. 8,353,151; U.S. PATENT NO. 8,353,152; U.S. PATENT NO. 8,353,153; U.S. PATENT NO. 8,353,154; U.S. PATENT NO. 8,353,155; U.S. PATENT NO. 8,353,156; U.S. PATENT NO. 8,353,157; U.S. PATENT NO. 8,353,158; U.S. PATENT NO. 8,353,159; U.S. PATENT NO. 8,353,160; U.S. PATENT NO. 8,353,161; U.S. PATENT NO. 8,353,162; U.S. PATENT NO. 8,353,163; U.S. PATENT NO. 8,353,164; U.S. PATENT NO. 8,353,165; U.S. PATENT NO. 8,353,166; U.S. PATENT NO. 8,353,167; U.S. PATENT NO. 8,353,168; U.S. PATENT NO. 8,353,169; U.S. PATENT NO. 8,353,170; U.S. PATENT NO. 8,353,171; U.S. PATENT NO. 8,353,172; U.S. PATENT NO. 8,353,173; U.S. PATENT NO. 8,353,174; U.S. PATENT NO. 8,353,175; U.S. PATENT NO. 8,353,176; U.S. PATENT NO. 8,353,177; U.S. PATENT NO. 8,353,178; U.S. PATENT NO. 8,353,179; U.S. PATENT NO. 8,353,180; U.S. PATENT NO. 8,353,181; U.S. PATENT NO. 8,353,182; U.S. PATENT NO. 8,353,183; U.S. PATENT NO. 8,353,184; U.S. PATENT NO. 8,353,185; U.S. PATENT NO. 8,353,186; U.S. PATENT NO. 8,353,187; U.S. PATENT NO. 8,353,188; U.S. PATENT NO. 8,353,189; U.S. PATENT NO. 8,353,190; U.S. PATENT NO. 8,353,191; U.S. PATENT NO. 8,353,192; U.S. PATENT NO. 8,353,193; U.S. PATENT NO. 8,353,194; U.S. PATENT NO. 8,353,195; U.S. PATENT NO. 8,353,196; U.S. PATENT NO. 8,353,197; U.S. PATENT NO. 8,353,198; U.S. PATENT NO. 8,353,199; U.S. PATENT NO. 8,353,200; U.S. PATENT NO. 8,353,201; U.S. PATENT NO. 8,353,202; U.S. PATENT NO. 8,353,203; U.S. PATENT NO. 8,353,204; U.S. PATENT NO. 8,353,205; U.S. PATENT NO. 8,353,206; U.S. PATENT NO. 8,353,207; U.S. PATENT NO. 8,353,208; U.S. PATENT NO. 8,353,209; U.S. PATENT NO. 8,353,210; U.S. PATENT NO. 8,353,211; U.S. PATENT NO. 8,353,212; U.S. PATENT NO. 8,353,213; U.S. PATENT NO. 8,353,214; U.S. PATENT NO. 8,353,215; U.S. PATENT NO. 8,353,216; U.S. PATENT NO. 8,353,217; U.S. PATENT NO. 8,353,218; U.S. PATENT NO. 8,353,219; U.S. PATENT NO. 8,353,220; U.S. PATENT NO. 8,353,221; U.S. PATENT NO. 8,353,222; U.S. PATENT NO. 8,353,223; U.S. PATENT NO. 8,353,224; U.S. PATENT NO. 8,353,225; U.S. PATENT NO. 8,353,226; U.S. PATENT NO. 8,353,227; U.S. PATENT NO. 8,353,228; U.S. PATENT NO. 8,353,229; U.S. PATENT NO. 8,353,230; U.S. PATENT NO. 8,353,231; U.S. PATENT NO. 8,353,232; U.S. PATENT NO. 8,353,233; U.S. PATENT NO. 8,353,234; U.S. PATENT NO. 8,353,235; U.S. PATENT NO. 8,353,236; U.S. PATENT NO. 8,353,237; U.S. PATENT NO. 8,353,238; U.S. PATENT NO. 8,353,239; U.S. PATENT NO. 8,353,240; U.S. PATENT NO. 8,353,241; U.S. PATENT NO. 8,353,242; U.S. PATENT NO. 8,353,243; U.S. PATENT NO. 8,353,244; U.S. PATENT NO. 8,353,245; U.S. PATENT NO. 8,353,246; U.S. PATENT NO. 8,353,247; U.S. PATENT NO. 8,353,248; U.S. PATENT NO. 8,353,249; U.S. PATENT NO. 8,353,250; U.S. PATENT NO. 8,353,251; U.S. PATENT NO. 8,353,252; U.S. PATENT NO. 8,353,253; U.S. PATENT NO. 8,353,254; U.S. PATENT NO. 8,353,255; U.S. PATENT NO. 8,353,256; U.S. PATENT NO. 8,353,257; U.S. PATENT NO. 8,353,258; U.S. PATENT NO. 8,353,259; U.S. PATENT NO. 8,353,260; U.S. PATENT NO. 8,353,261; U.S. PATENT NO. 8,353,262; U.S. PATENT NO. 8,353,263; U.S. PATENT NO. 8,353,264; U.S. PATENT NO. 8,353,265; U.S. PATENT NO. 8,353,266; U.S. PATENT NO. 8,353,267; U.S. PATENT NO. 8,353,268; U.S. PATENT NO. 8,353,269; U.S. PATENT NO. 8,353,270; U.S. PATENT NO. 8,353,271; U.S. PATENT NO. 8,353,272; U.S. PATENT NO. 8,353,273; U.S. PATENT NO. 8,353,274; U.S. PATENT NO. 8,353,275; U.S. PATENT NO. 8,353,276; U.S. PATENT NO. 8,353,277; U.S. PATENT NO. 8,353,278; U.S. PATENT NO. 8,353,279; U.S. PATENT NO. 8,353,280; U.S. PATENT NO. 8,353,281; U.S. PATENT NO. 8,353,282; U.S. PATENT NO. 8,353,283; U.S. PATENT NO. 8,353,284; U.S. PATENT NO. 8,353,285; U.S. PATENT NO. 8,353,286; U.S. PATENT NO. 8,353,287; U.S. PATENT NO. 8,353,288; U.S. PATENT NO. 8,353,289; U.S. PATENT NO. 8,353,290; U.S. PATENT NO. 8,353,291; U.S. PATENT NO. 8,353,292; U.S. PATENT NO. 8,353,293; U.S. PATENT NO. 8,353,294; U.S. PATENT NO. 8,353,295; U.S. PATENT NO. 8,353,296; U.S. PATENT NO. 8,353,297; U.S. PATENT NO. 8,353,298; U.S. PATENT NO. 8,353,299; U.S. PATENT NO. 8,353,300; U.S. PATENT NO. 8,353,301; U.S. PATENT NO. 8,353,302; U.S. PATENT NO. 8,353,303; U.S. PATENT NO. 8,353,304; U.S. PATENT NO. 8,353,305; U.S. PATENT NO. 8,353,306; U.S. PATENT NO. 8,353,307; U.S. PATENT NO. 8,353,308; U.S. PATENT NO. 8,353,309; U.S. PATENT NO. 8,353,310; U.S. PATENT NO. 8,353,311; U.S. PATENT NO. 8,353,312; U.S. PATENT NO. 8,353,313; U.S. PATENT NO. 8,353,314; U.S. PATENT NO. 8,353,315; U.S. PATENT NO. 8,353,316; U.S. PATENT NO. 8,353,317; U.S. PATENT NO. 8,353,318; U.S. PATENT NO. 8,353,319; U.S. PATENT NO. 8,353,320; U.S. PATENT NO. 8,353,321; U.S. PATENT NO. 8,353,322; U.S. PATENT NO. 8,353,323; U.S. PATENT NO. 8,353,324; U.S. PATENT NO. 8,353,325; U.S. PATENT NO. 8,353,326; U.S. PATENT NO. 8,353,327; U.S. PATENT NO. 8,353,328; U.S. PATENT NO. 8,353,329; U.S. PATENT NO. 8,353,330; U.S. PATENT NO. 8,353,331; U.S. PATENT NO. 8,353,332; U.S. PATENT NO. 8,353,333; U.S. PATENT NO. 8,353,334; U.S. PATENT NO. 8,353,335; U.S. PATENT NO. 8,353,336; U.S. PATENT NO. 8,353,337; U.S. PATENT NO. 8,353,338; U.S. PATENT NO. 8,353,339; U.S. PATENT NO. 8,353,340; U.S. PATENT NO. 8,353,341; U.S. PATENT NO. 8,353,342; U.S. PATENT NO. 8,353,343; U.S. PATENT NO. 8,353,344; U.S. PATENT NO. 8,353,345; U.S. PATENT NO. 8,353,346; U.S. PATENT NO. 8,353,347; U.S. PATENT NO. 8,353,348; U.S. PATENT NO. 8,353,349; U.S. PATENT NO. 8,353,350; U.S. PATENT NO. 8,353,351; U.S. PATENT NO. 8,353,352; U.S. PATENT NO. 8,353,353; U.S. PATENT NO. 8,353,354; U.S. PATENT NO. 8,353,355; U.S. PATENT NO. 8,353,356; U.S. PATENT NO. 8,353,357; U.S. PATENT NO. 8,353,358; U.S. PATENT NO. 8,353,359; U.S. PATENT NO. 8,353,360; U.S. PATENT NO. 8,353,361; U.S. PATENT NO. 8,353,362; U.S. PATENT NO. 8,353,363; U.S. PATENT NO. 8,353,364; U.S. PATENT NO. 8,353,365; U.S. PATENT NO. 8,353,366; U.S. PATENT NO. 8,353,367; U.S. PATENT NO. 8,353,368; U.S. PATENT NO. 8,353,369; U.S. PATENT NO. 8,353,370; U.S. PATENT NO. 8,353,371; U.S. PATENT NO. 8,353,372; U.S. PATENT NO. 8,353,373; U.S. PATENT NO. 8,353,374; U.S. PATENT NO. 8,353,375; U.S. PATENT NO. 8,353,376; U.S. PATENT NO. 8,353,377; U.S. PATENT NO. 8,353,378; U.S. PATENT NO. 8,353,379; U.S. PATENT NO. 8,353,380; U.S. PATENT NO. 8,353,381; U.S. PATENT NO. 8,353,382; U.S. PATENT NO. 8,353,383; U.S. PATENT NO. 8,353,384; U.S. PATENT NO. 8,353,385; U.S. PATENT NO. 8,353,386; U.S. PATENT NO. 8,353,387; U.S. PATENT NO. 8,353,388; U.S. PATENT NO. 8,353,389; U.S. PATENT NO. 8,353,390; U.S. PATENT NO. 8,353,391; U.S. PATENT NO. 8,353,392; U.S. PATENT NO. 8,353,393; U.S. PATENT NO. 8,353,394; U.S. PATENT NO. 8,353,395; U.S. PATENT NO. 8,353,396; U.S. PATENT NO. 8,353,397; U.S. PATENT NO. 8,353,398; U.S. PATENT NO. 8,353,399; U.S. PATENT NO. 8,353,400; U.S. PATENT NO. 8,353,401; U.S. PATENT NO. 8,353,402; U.S. PATENT NO. 8,353,403; U.S. PATENT NO. 8,353,404; U.S. PATENT NO. 8,353,405; U.S. PATENT NO. 8,353,406; U.S. PATENT NO. 8,353,407; U.S. PATENT NO. 8,353,408; U.S. PATENT NO. 8,353,409; U.S. PATENT NO. 8,353,410; U.S. PATENT NO. 8,353,411; U.S. PATENT NO. 8,353,412; U.S. PATENT NO. 8,353,413; U.S. PATENT NO. 8,353,414; U.S. PATENT NO. 8,353,415; U.S. PATENT NO. 8,353,416; U.S. PATENT NO. 8,353,417; U.S. PATENT NO. 8,353,418; U.S. PATENT NO. 8,353,419; U.S. PATENT NO. 8,353,420; U.S. PATENT NO. 8,353,421; U.S. PATENT NO. 8,353,422; U.S. PATENT NO. 8,353,423; U.S. PATENT NO. 8,353,424; U.S. PATENT NO. 8,353,425; U.S. PATENT NO. 8,353,426; U.S. PATENT NO. 8,353,427; U.S. PATENT NO. 8,353,428; U.S. PATENT NO. 8,353,429; U.S. PATENT NO. 8,353,430; U.S. PATENT NO. 8,353,431; U.S. PATENT NO. 8,353,432; U.S. PATENT NO. 8,353,433; U.S. PATENT NO. 8,353,434; U.S. PATENT NO. 8,353,435; U.S. PATENT NO. 8,353,436; U.S. PATENT NO. 8,353,437; U.S. PATENT NO. 8,353,438; U.S. PATENT NO. 8,353,439; U.S. PATENT NO. 8,353,440; U.S. PATENT NO. 8,353,441; U.S. PATENT NO. 8,353,442; U.S. PATENT NO. 8,353,443; U.S. PATENT NO. 8,353,444; U.S. PATENT NO. 8,353,445; U.S. PATENT NO. 8,353,446; U.S. PATENT NO. 8,353,447; U.S. PATENT NO. 8,353,448; U.S. PATENT NO. 8,353,449; U.S. PATENT NO. 8,353,450; U.S. PATENT NO. 8,353,451; U.S. PATENT NO. 8,353,452; U.S. PATENT NO. 8,353,453; U.S. PATENT NO. 8,353,454; U.S. PATENT NO. 8,353,455; U.S. PATENT NO. 8,353,456; U.S. PATENT NO. 8,353,457; U.S. PATENT NO. 8,353,458; U.S. PATENT NO. 8,353,459; U.S. PATENT NO. 8,353,460; U.S. PATENT NO. 8,353,461; U.S. PATENT NO. 8,353,462; U.S. PATENT NO. 8,353,463; U.S. PATENT NO. 8,353,464; U.S. PATENT NO. 8,353,465; U.S. PATENT NO. 8,353,466; U.S. PATENT NO. 8,353,467; U.S. PATENT NO. 8,353,468; U.S. PATENT NO. 8,353,469; U.S. PATENT NO. 8,353,470; U.S. PATENT NO. 8,353,471; U.S. PATENT NO. 8,353,472; U.S. PATENT NO. 8,353,473; U.S. PATENT NO. 8,353,474; U.S. PATENT NO. 8,353,475; U.S. PATENT NO. 8,353,476; U.S. PATENT NO. 8,353,477; U.S. PATENT NO. 8,353,478; U.S. PATENT NO. 8,353,479; U.S. PATENT NO. 8,353,480; U.S. PATENT NO. 8,353,481; U.S. PATENT NO. 8,353,482; U.S. PATENT NO. 8,353,483; U.S. PATENT NO. 8,353,484; U.S. PATENT NO. 8,353,485; U.S. PATENT NO. 8,353,486; U.S. PATENT NO. 8,353,487; U.S. PATENT NO. 8,353,488; U.S. PATENT NO. 8,353,489; U.S. PATENT NO. 8,353,490; U.S. PATENT NO. 8,353,491; U.S. PATENT NO. 8,353,492; U.S. PATENT NO. 8,353,493; U.S. PATENT NO. 8,353,494; U.S. PATENT NO. 8,353,495; U.S. PATENT NO. 8,353,496; U.S. PATENT NO. 8,353,497; U.S. PATENT NO. 8,353,498; U.S. PATENT NO. 8,353,499; U.S. PATENT NO. 8,353,500; U.S. PATENT NO. 8,353,501; U.S. PATENT NO. 8,353,502; U.S. PATENT NO. 8,353,503; U.S. PATENT NO. 8,353,504; U.S. PATENT NO. 8,353,505; U.S. PATENT NO. 8,353,506; U.S. PATENT NO. 8,353,507; U.S. PATENT NO. 8,353,508; U.S. PATENT NO. 8,353,509; U.S. PATENT NO. 8,353,510; U.S. PATENT NO. 8,353,511; U.S. PATENT NO. 8,353,512; U.S. PATENT NO. 8,353,513; U.S. PATENT NO. 8,353,514; U.S. PATENT NO. 8,353,515; U.S. PATENT NO. 8,353,516; U.S. PATENT NO. 8,353,517; U.S. PATENT NO. 8,353,518; U.S. PATENT NO. 8,353,519; U.S. PATENT NO. 8,353,520; U.S. PATENT NO. 8,353,521; U.S. PATENT NO. 8,353,522; U.S. PATENT NO. 8,353,523; U.S. PATENT NO. 8,353,524; U.S. PATENT NO. 8,353,525; U.S. PATENT NO. 8,353,526; U.S. PATENT NO. 8,353,527; U.S. PATENT NO. 8,353,528; U.S. PATENT NO. 8,353,529; U.S. PATENT NO. 8,353,530; U.S. PATENT NO. 8,353,531; U.S. PATENT NO. 8,353,532; U.S. PATENT NO. 8,353,533; U.S. PATENT NO. 8,353,534; U.S. PATENT NO. 8,353,535; U.S. PATENT NO. 8,353,536; U.S. PATENT NO. 8,353,537; U.S. PATENT NO. 8,353,538; U.S. PATENT NO. 8,353,539; U.S. PATENT NO. 8,353,540; U.S. PATENT NO. 8,353,541; U.S. PATENT NO. 8,353,542; U.S. PATENT NO. 8,353,543; U.S. PATENT NO. 8,353,544; U.S. PATENT NO. 8,353,545; U.S. PATENT NO. 8,353,546; U.S. PATENT NO. 8,353,547; U.S. PATENT NO. 8,353,548; U.S. PATENT NO. 8,353,549; U.S. PATENT NO. 8,353,550; U.S. PATENT NO. 8,353,551; U.S. PATENT NO. 8,353,552; U.S. PATENT NO. 8,353,553; U.S. PATENT NO. 8,353,554; U.S. PATENT NO. 8,353,555; U.S. PATENT NO. 8,353,556; U.S. PATENT NO. 8,353,557; U.S. PATENT NO. 8,353,558; U.S. PATENT NO. 8,353,559; U.S. PATENT NO. 8,353,560; U.S. PATENT NO. 8,353,561; U.S. PATENT NO. 8,353,562; U.S. PATENT NO. 8,353,563; U.S. PATENT NO. 8,353,564; U.S. PATENT NO. 8,353,565; U.S. PATENT NO. 8,353,566; U.S. PATENT NO. 8,353,567; U.S. PATENT NO. 8,353,568; U.S. PATENT NO. 8,353,569; U.S. PATENT NO. 8,353,570; U.S. PATENT NO. 8,353,571; U.S. PATENT NO. 8,353,572; U.S. PATENT NO. 8,353,573; U.S. PATENT NO. 8,353,574; U.S. PATENT NO. 8,353,575; U.S. PATENT NO. 8,353,576; U.S. PATENT NO. 8,353,577; U.S. PATENT NO. 8,353,578; U.S. PATENT NO. 8,353,579; U.S. PATENT NO. 8,353,580; U.S. PATENT NO. 8,353,581; U.S. PATENT NO. 8,353,582; U.S. PATENT NO. 8,353,583; U.S. PATENT NO. 8,353,584; U.S. PATENT NO. 8,353,585; U.S. PATENT NO. 8,353,586; U.S. PATENT NO. 8,353,587; U.S. PATENT NO. 8,353,588; U.S. PATENT NO. 8,353,589; U.S. PATENT NO. 8,353,590; U.S. PATENT NO. 8,353,591; U.S. PATENT NO. 8,353,592; U.S. PATENT NO. 8,353,593; U.S. PATENT NO. 8,353,594; U.S. PATENT NO. 8,353,595; U.S. PATENT NO. 8,353,596; U.S. PATENT NO. 8,353,597; U.S. PATENT NO. 8,353,598; U.S. PATENT NO. 8,353,599; U.S. PATENT NO. 8,353,600; U.S. PATENT NO. 8,353,601; U.S. PATENT NO. 8,353,602; U.S. PATENT NO. 8,353,603; U.S. PATENT NO. 8,353,604; U.S. PATENT NO. 8,353,605; U.S. PATENT NO. 8,353,606; U.S. PATENT NO. 8,353,607; U.S. PATENT NO. 8,353,608; U.S. PATENT NO. 8,353,609; U.S. PATENT NO. 8,353,610; U.S. PATENT NO. 8,353,611; U.S. PATENT NO. 8,353,612; U.S. PATENT NO. 8,353,613; U.S. PATENT NO. 8,353,614; U.S. PATENT NO. 8,353,615; U.S. PATENT NO. 8,353,616; U.S. PATENT NO. 8,353,617; U.S. PATENT NO. 8,353,618; U.S. PATENT NO. 8,353,619; U.S. PATENT NO. 8,353,620; U.S. PATENT NO. 8,353,621; U.S. PATENT NO. 8,353,622; U.S. PATENT NO. 8,353,623; U.S. PATENT NO. 8,353,624; U.S. PATENT NO. 8,353,625; U.S. PATENT NO. 8,353,626; U.S. PATENT NO. 8,353,627; U.S. PATENT NO. 8,353,628; U.S. PATENT NO. 8,353,629; U.S. PATENT NO. 8,353,630; U.S. PATENT NO. 8,353,631; U.S. PATENT NO. 8,353,632; U.S. PATENT NO. 8,353,633; U.S. PATENT NO. 8,353,634; U.S. PATENT NO. 8,353,635; U.S. PATENT NO. 8,353,636; U.S. PATENT NO. 8,353,637; U.S. PATENT NO. 8,353,638; U.S. PATENT NO. 8,353,639; U.S. PATENT NO. 8,353,640; U.S. PATENT NO. 8,353,641; U.S. PATENT NO. 8,353,642; U.S. PATENT NO. 8,353,643; U.S. PATENT NO. 8,353,644; U.S. PATENT NO. 8,353,645; U.S. PATENT NO. 8,353,646; U.S. PATENT NO. 8,353,647; U.S. PATENT NO. 8,353,648; U.S. PATENT NO. 8,353,649; U.S. PATENT NO. 8,353,650; U.S. PATENT NO. 8,353,651; U.S. PATENT NO.

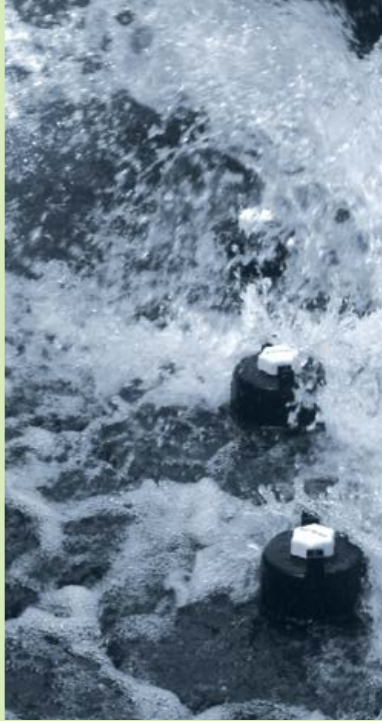

**CONTECH**<sup>®</sup>  
ENGINEERED SOLUTIONS

# The Stormwater Management StormFilter<sup>®</sup>

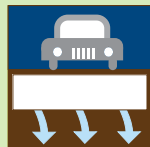
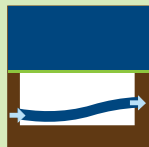

Solutions  
Guide



# Stormwater Filtration



Selecting the right stormwater solution just got easier...

It's simple to choose the right low impact development (LID) solution to achieve your runoff reduction goals with the Contech UrbanGreen® Staircase. First, select the runoff reduction practices that are most appropriate for your site, paying particular attention to pretreatment needs. If the entire design storm cannot be retained, select a treatment best management practice (BMP) for the balance. Finally, select a detention system to address any outstanding downstream erosion.

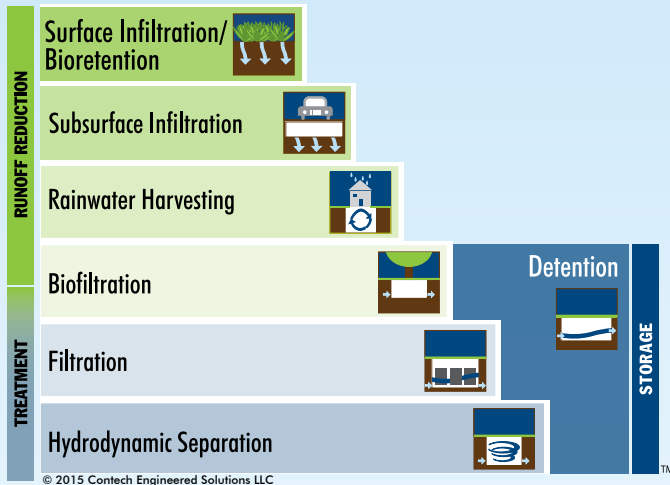

## Highly Effective Pollutant Removal

Stormwater quality standards are becoming increasingly complex, especially with the advent of total maximum daily load (TMDL) requirements. Meeting pollutant reduction goals typically requires a technology that is highly effective at removing solids and associated pollutants from stormwater. In some cases, the technology must also be capable of removing dissolved pollutants such as metals and phosphorus. Using a variety of media, filtration systems can meet that need.

For almost two decades the Stormwater Management StormFilter® has helped you meet the most stringent stormwater requirements. The system has been continually tested and refined to ensure maximum reliability and performance.

Learn more about filtration at [www.ContechES.com/stormfilter](http://www.ContechES.com/stormfilter)

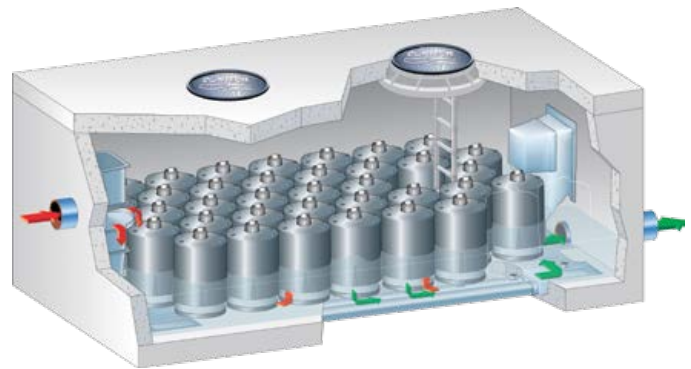

The Stormwater Management StormFilter helps you meet the most stringent stormwater requirements ❖❖❖

# Choosing the Right System

## The Fundamentals of Filtration

The performance and longevity of media filtration systems is governed by a number of variables that must be carefully considered when evaluating systems, including media type, media gradation, hydraulic loading rate. Understanding these variables requires careful testing and development of performance and longevity data to support proper filter design.

### Media Surface Area

Filtration flow rates are typically expressed as a surface area specific operating rate such as gallons per minute per square foot (gpm/ft<sup>2</sup>) of surface area. Lower specific operating rates translate to better performance and longer maintenance cycles. Specific operating rates higher than 2 gpm/ft<sup>2</sup> of media surface area negatively impact performance and longevity.

### Surface vs. Radial Cartridge Filtration

When assessing filtration systems, it is important to consider whether filtration occurs primarily at the media surface or throughout a bed of media like in radial-cartridge filters. All else equal, radial-cartridge filters are longer lasting, since pollutants are captured and stored throughout the bed, as opposed to predominantly on the media surface. Radial cartridge filters capture more mass of pollutants per unit area of filter surface. Surface filters, such as membranes, are prone to rapid failure due to clogging, as pollutants occlude the media surface which requires frequent backwashing.

### Media Hydraulic Conductivity and Flow Control

Filtration media is able to pass more flow per unit of media when it is new versus when it has been in operation for a while. With time, pollutants accumulate in the media bed and reduce its hydraulic capacity. It is critical that filtration devices are designed with excess hydraulic capacity to account for this loss. Also, finer media gradations remove finer particles, but have lower hydraulic capacity and occlude more rapidly. High performance and superior longevity can be achieved by controlling the flow through a more coarse media bed.

### Performance: Laboratory Testing

Laboratory testing provides a means to generate hydraulic and basic performance data, but should be complimented with long-term field data. Laboratory performance trials should be executed with a fine sediment gradation such as Sil-Co-Sil 106 which has a median particle size of 22 microns. Testing with coarser gradations is not likely to be representative of field conditions.

### Performance: Field Testing

Long-term field evaluations should be conducted on all filtration devices. Field studies should comply with the Technology Acceptance Reciprocity Partnership (TARP), Environmental Technology Verification (ETV) or the Technology Assessment Protocol – Ecology (TAPE) protocols. Testing should be overseen by a reputable third-party to be considered valid.

### Longevity

It is essential that loading trials be conducted to evaluate the longevity of a media filter. These trials must be executed with “real” stormwater solids and not silica particles. Reliance on silica particles to assess longevity grossly overstates the loading capacity of the media and the results of such trials should not be relied on. Knowing how much mass a media filter can capture before failure allows it to be sized for a desired maintenance interval by estimating the pollutant load that will be delivered to the filter.



# The Stormwater Management StormFilter®

A best management practice (BMP) designed to meet stringent regulatory requirements; the Stormwater Management StormFilter removes the most challenging target pollutants – including fine solids, soluble heavy metals, oil, and total nutrients – using a variety of media. For more than two decades, StormFilter has helped clients meet their regulatory needs and through product enhancements the design continues to be refined for ease of use.

## Here's Why StormFilter is the Best Filter Available:

### Superior Hydraulics

- External bypass – Protects treatment chamber from high flows and ensures captured pollutants are not lost during low frequency, high intensity storm events
- Multiple cartridge heights – Minimize head loss to fit within the hydraulic grade line and shrink system size, reducing install costs
- Over 30 StormFilter configurations in use across the country

### Reliable Longevity

- Unique surface-cleaning mechanism – Prevents surface blinding, ensures use of all media, and prolongs cartridge life
- One to two-year maintenance cycles - Fewer maintenance events compared to similar products reduces costs over the lifetime of the system
- 15-years of maintenance experience – Predictable long-term performance comes standard

### Proven Performance

- Only proven filter on the market - Performance verified by the WA Ecology and NJ DEP, and system approved for use with numerous local agencies
  - Qualifies for LEED® Sustainable Site Credit 6.2 – Stormwater Quality Control
- Achieve water quality goals with confidence – Easy approval speeds permitting
- 8th Generation Product – Design refined and perfected over two decades of research and experience
- Full-scale testing at more than 10 sites around the United States

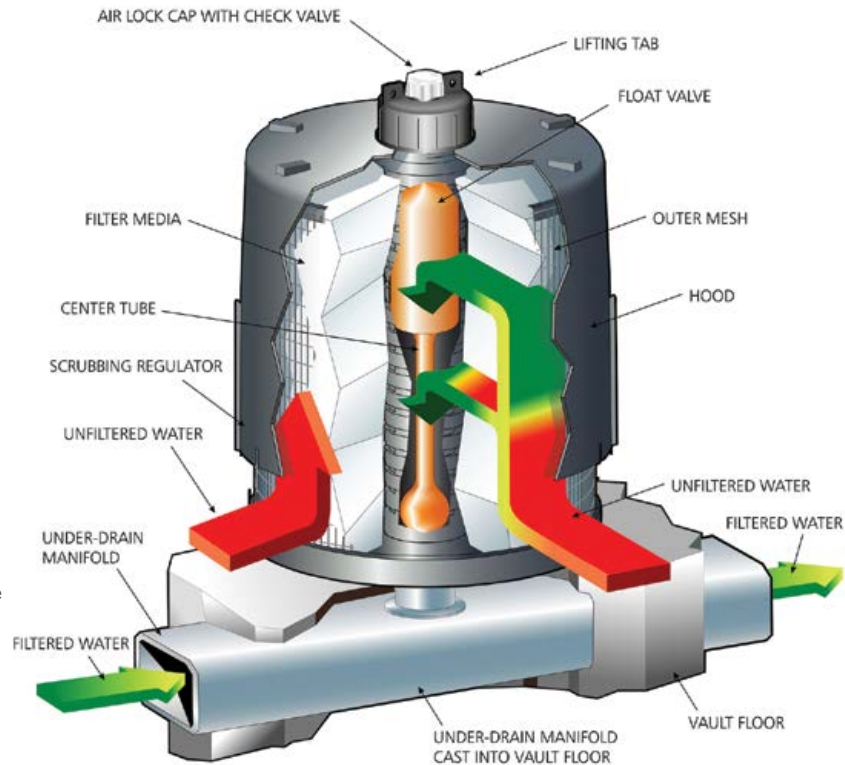

### Underground System Maximizes Land Use and Development Profitability

- Save land space, allow denser development and reduce sprawl
- Add parking, increase building size, develop outparcels by eliminating aboveground systems
- Compact design reduces construction and installation costs by limiting excavation

## Patented Siphon-Actuated Filtration

During a storm, runoff passes through the filtration media and starts filling the cartridge center tube. Air below the hood is purged through a one-way check valve as the water rises. When water reaches the top of the float, buoyant forces pull the float free and allow filtered water to drain.

After the storm, the water level in the structure starts falling. A hanging water column remains under the cartridge hood until the water level reaches the scrubbing regulators at the bottom of the hood. Air then rushes through the regulators releasing water and creating air bubbles that agitate the surface of the filter media, causing accumulated sediment to drop to the vault floor. This patented surface-cleaning mechanism helps restore the filter's permeability between storm events.

See the StormFilter in action at [www.ContechES.com/stormfilter](http://www.ContechES.com/stormfilter)



Unique surface-cleaning mechanism prevents surface blinding, ensures use of all media, and prolongs cartridge life



For even more information, check out the StormFilter Animation available at [www.conteches.com/videos](http://www.conteches.com/videos)

# Configurations and Applications

The StormFilter technology can be configured to meet your unique site requirements. Here are a few of the most common configurations, however many other configurations are available. Please contact your Contech Project Consultant to evaluate the best options for your site or find out more in the [StormFilter Configuration Guide available on www.ContechES.com/stormfilter](http://www.ContechES.com/stormfilter).

## Upstream Treatment Configurations

The following suite of StormFilter configurations are easily incorporated on sites where LID site design is recommended. These low-cost, low-drop, point-of-entry systems also work well when you have a compact drainage area.



### CatchBasin StormFilter

- Combines a catch basin, a high flow bypass device, and a StormFilter cartridge in one shallow structure
- Treats sheet flow
- Uses drop from the inlet grate to the conveyance pipe to drive the passive filtration cartridge
- No confined space required for maintenance

CatchBasin StormFilter



### Curb Inlet

- Accommodates curb inlet openings from 3 to 10 feet long
- Uses drop from the curb inlet to the conveyance pipe to drive the passive filtration cartridges

Curb Inlet



### Linear Grate

- Can be designed to meet volume based sizing requirements
- Can be installed in place of and similar to a typical catch basin
- No confined space entry required for maintenance
- Accommodates up to 29 StormFilter cartridges

Linear Grate

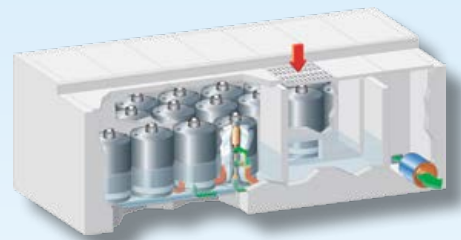

## Infiltration/Retrofit Configuration

### Infiltration

- Provides treatment and infiltration in one structure
- Available for new construction and retrofit applications
- Easy installation



Infiltration

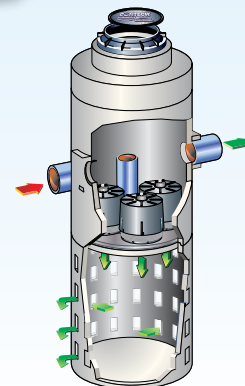

# Roof Runoff Treatment Configuration



## DownSpout

- Easily integrated into existing gutter systems to treat pollution from rooftop runoff
- Fits most downspout configurations and sizes; single or dual-cartridge models available
- Treats up to 14,000 square feet of rooftop area per dual-cartridge system

DownSpout StormFilter



## Downstream Treatment Configurations

Conventional stormwater treatment involves collecting, conveying and treating stormwater runoff with an end of pipe treatment system before discharging off-site. StormFilter configurations suitable for these applications are listed below and can be engineered to treat a wide range of flows.

### Vault / Manhole

- Treats small to medium sized sites
- Simple installation - arrives on-site fully assembled
- May require off-line bypass structure

Vault

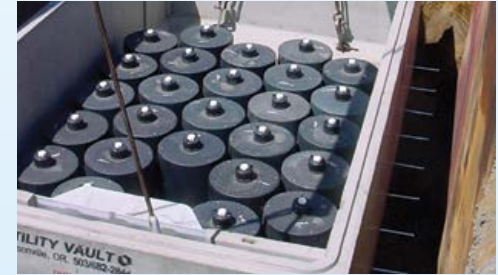

### High Flow

- Treats flows from large sites
- Consists of large, precast components designed for easy assembly on-site
- Several configurations available, including: CON/SPAN®, Panel Vault, Box Culvert, or Cast-In-Place

High Flow



### Volume

- Meets volume-based stormwater treatment regulations
- Captures and treats specific water quality volume (WQv)
- Provides treatment and controls the discharge rate
- Can be designed to capture all, or a portion, of the WQv

Manhole



### Peak Diversion

- Provides off-line bypass and treatment in one structure
- Eliminates material and installation cost of additional structures to bypass peak flows
- Reduces the overall footprint of the treatment system, avoiding utility and right-of-way conflicts
- Internal weir allows high peak flows with low hydraulic head losses
- Accommodates large inlet and outlet pipes (up to 36") for high flow applications

Peak Diversion

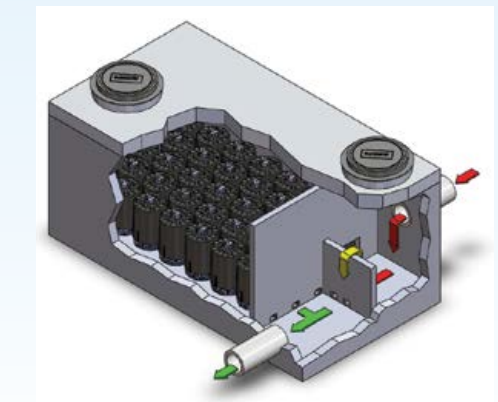

# Media Options

Our filtration products can be customized using different filter media to target site-specific pollutants. A combination of media is often recommended to maximize pollutant removal effectiveness.



**PhosphoSorb®** is a lightweight media built from a Perlite-base that removes total phosphorus (TP) by adsorbing dissolved-P and filtering particulate-P simultaneously.



**Perlite** is naturally occurring puffed volcanic ash. Effective for removing TSS, oil and grease.



**CSF® Leaf Media** and **MetalRx™** are created from deciduous leaves processed into granular, organic media. CSF is most effective for removing soluble metals, TSS, oil and grease, and buffering acid rain. MetalRx, a finer gradation, is used for higher levels of metal removal.



**Zeolite** is a naturally occurring mineral used to remove soluble metals, ammonium and some organics.



**GAC (Granular Activated Carbon)** has a micro-porous structure with an extensive surface area to provide high levels of adsorption. It is primarily used to remove oil and grease and organics such as PAHs and phthalates.

	PhosphoSorb	Perlite	CSF	MetalRx	Zeolite	GAC
Sediments	•	•	•			
Oil and Grease	•	•	•	•		
Soluble Metals	•		•	•	•	
Organics			•	•		•
Nutrients	•	•	•	•	•	
Total Phosphorus	•					

Note: Indicated media are most effective for associated pollutant type. Other media may treat pollutants, but to a lesser degree.

ZPG™ media, a proprietary blend of zeolite, perlite, and GAC, is also available and provides an alternative where leaf media cannot be used.

## Focus on Phosphorous

Stormwater runoff with elevated phosphorus concentration can significantly impair water quality. More stringent stormwater regulations calling for higher levels of phosphorus removal are currently being implemented. To meet these requirements, more than just the physical separation of particulate P is needed. That's where the PhosphoSorb media can help.

A cost-effective, lightweight, adsorptive filtration media, PhosphoSorb offers the effective adsorption capacity of dissolved phosphorus and retention capacity of particulate phosphorus. Initial field results suggest removal of greater than 65% of the total phosphorus load can be expected when influent concentrations exceed 0.1 mg/l, and the media can remain in operation for more than 1 year without requiring maintenance due to media occlusion.

## Dissolved Phosphorus

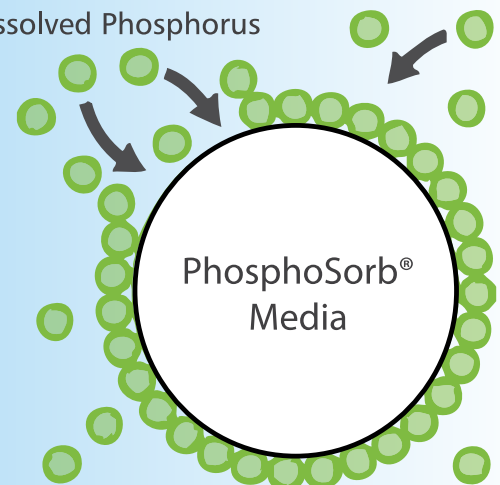

# Cartridge Options

With multiple cartridge heights available, you have a choice when fitting a StormFilter system onto your site.

The 27" cartridge provides 50% more treatment per square foot of system than the 18" cartridge. So, you are meeting the same treatment standards with fewer cartridges, which means a smaller system.

If you are limited by hydraulic constraints, choose our low drop cartridge, which provide filtration treatment with only 1.8 feet of headloss.

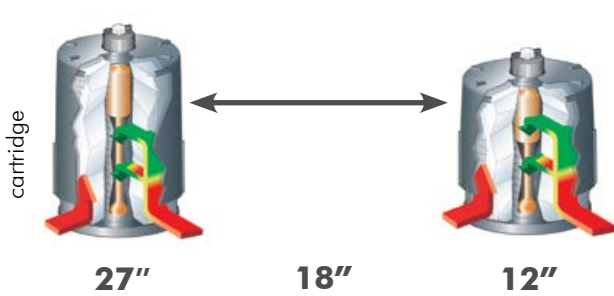

## Cartridge Flow Rates

Cartridge Type	Hydraulic Drop	Treatment Capacity (gpm)	
		1 gpm/ft <sup>2</sup>	2 gpm/ft <sup>2</sup>
StormFilter 27"	3.05 feet	11.25	22.5
StormFilter 18"	2.3 feet	7.5	15
StormFilter Low Drop	1.8 feet	5	10
MFS 22"	2.3 feet	9	18
MFS 12"	1.4 feet	5	10

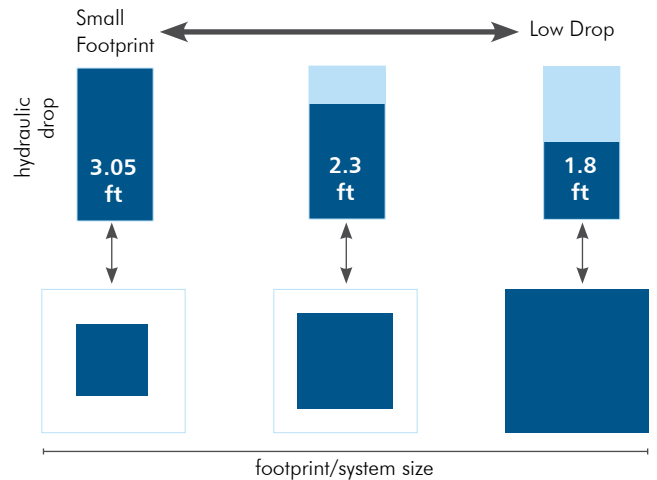

Multiple cartridge heights are available to meet your hydraulics needs ❖❖❖

# StormFilter Accessories

## Drain-Down

- Provides complete dewatering of the StormFilter vault by gradually removing residual water in the sump after the storm event
- Aids in vector control by eliminating mosquito-breeding habitat
- Eliminates putrefaction and leaching of collected pollutants
- Lowers maintenance cost by reducing decanting and disposal volume

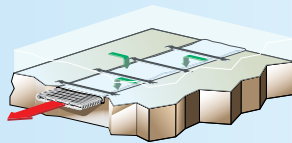

## Sorbent Hood Cover

- Absorbs free surface oil and grease on contact
- Will not release captured oil, even when saturated
- Made from recycled synthetic fiber



## Cartridge Lifting Hook

- Specially designed to help you easily lift cartridges during maintenance



# Maintenance

Longevity is a function of applying existing filtration physics to the maximum extent possible in order to decrease maintenance frequency without sacrificing performance. Maintenance is an integral part of ensuring long term effectiveness of a filter system. The quality of treatment can only be guaranteed by a well maintained structure, whether it is proprietary or nonproprietary. The notion that some BMPs, including low impact development (LID) structures, have no maintenance cost burden is a misconception.

## Longer Maintenance Intervals Reduce Life Cycle Costs

Maintenance intervals can be a large unseen cost for developers and owners. Including a maintenance interval in the product specification will ensure that no one is surprised with high long term costs.

The Stormwater Management StormFilter can be designed with up to a 2 year maintenance interval, proven by over a decade of installations, which can greatly reduce costs. Our filter cartridges are made with 60% of recyclable material.

## Ease of Maintenance Matters

The StormFilter has been optimized over time to make maintenance easy. Cartridges feature a 1/4 turn connector, so they can be quickly removed and installed. A removable hood allows for effortless access to spent media, especially compared to sealed systems that require cutting the cartridge hood. Finally, all StormFilter structures can be accessed without restriction for inspection, media replacement, and washing of structure.

## Experience Counts

Contech has over 120,000 StormFilter cartridges in use throughout the country. We have a plant dedicated to the production of filtration cartridges based in Portland, OR, that supports maintenance events with exchange of full cartridge and maintenance contracts. All cartridge components go through a QA/QC review at the refilling point to ensure that the correct media gradation is supplied and that it is packed properly which provides reliable operation and performance.

## Not All Stormwater Filtration Systems are the Same

When you choose the Stormwater Management StormFilter, you are choosing the industry leading technology. Our experienced design engineers can help you design the system that will work for your site and your budget.

### Maintenance Required If:



Greater than 4" of sediment is on the structure floor



Greater than 1/4" of sediment is on the top of the cartridges



Greater than 4" of standing water in vault for more than 24 hours after a storm

Annual StormFilter vault inspection is recommended and it doesn't require confined space entry ❖❖❖



**Pollutants must be removed to restore the StormFilter to its full efficiency and effectiveness.**

Spent filter media can be dumped directly onto the structure floor, so the emptied lightweight cartridges can be easily removed, thus eliminating the need for handling heavy units.



**Easy to access treatment system can make a difference in maintenance expenses.**



**StormFilter structures can be accessed without confined space for inspection.**

The quality of treatment can only be guaranteed by a well maintained structure





## LEARN MORE

- Access project profiles, photos, videos and more online at [www.ContechES.com/stormfilter](http://www.ContechES.com/stormfilter)

## CONNECT WITH US

- Call us at 800-338-1122
- Contact your local rep at [www.ContechES.com/localresources](http://www.ContechES.com/localresources)

## START A PROJECT

- Submit your system requirements on our product Design Worksheet [www.ContechES.com/start-a-project](http://www.ContechES.com/start-a-project)

## USE OUR ONLINE TOOLS

- Low Impact Development Site Planner [www.ContechES.com/LIDsiteplanner](http://www.ContechES.com/LIDsiteplanner)



## COMPLETE SITE SOLUTIONS

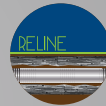
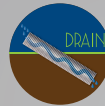

### TREATMENT SOLUTIONS

Helping to satisfy stormwater management requirements on land development projects

- Stormwater Treatment
- Detention/Infiltration
- Rainwater Harvesting
- Biofiltration/Bioretenation

### PIPE SOLUTIONS

Meeting project needs for durability, hydraulics, corrosion resistance, and stiffness

- Corrugated Metal Pipe (CMP)
- Steel Reinforced Polyethylene (SRPE)
- High Density Polyethylene (HDPE)
- Polyvinyl Chloride (PVC)

### STRUCTURES SOLUTIONS

Providing innovative options and support for crossings, culverts, and bridges

- Plate, Precast & Truss bridges
- Hard Armor
- Retaining Walls
- Tunnel Liner Plate



©2017 Contech Engineered Solutions LLC, a QUIKRETE Company  
800-338-1122  
[www.ContechES.com](http://www.ContechES.com)

All Rights Reserved. Printed in the USA.

Contech Engineered Solutions LLC provides site solutions for the civil engineering industry. Contech's portfolio includes bridges, drainage, sanitary sewer, stormwater and earth stabilization products. For information on other Contech division offerings, visit [ContechES.com](http://ContechES.com) or call 800.338.1122

The product(s) described may be protected by one or more of the following US patents: 5,707,527; 5,788,848; 5,985,157; 6,027,639; 6,350,374; 6,406,218; 6,641,720; 6,511,595; 6,649,048; 6,991,114; 6,998,038; 7,186,058; 7,296,692; 7,297,266 related foreign patents or other patents pending.

The Stormwater Management StormFilter, MFS and CDS are trademarks, registered trademarks, or licensed trademarks of Contech Engineered Solutions LLC. LEED is a registered trademark of the U.S. Green Building Council.

Get Social With Us!



NOTHING IN THIS CATALOG SHOULD BE CONSTRUED AS A WARRANTY. APPLICATIONS SUGGESTED HEREIN ARE DESCRIBED ONLY TO HELP READERS MAKE THEIR OWN EVALUATIONS AND DECISIONS, AND ARE NEITHER GUARANTEES NOR WARRANTIES OF SUITABILITY FOR ANY APPLICATION. CONTECH MAKES NO WARRANTY WHATSOEVER, EXPRESS OR IMPLIED, RELATED TO THE APPLICATIONS, MATERIALS, COATINGS, OR PRODUCTS DISCUSSED HEREIN. ALL IMPLIED WARRANTIES OF MERCHANTABILITY AND ALL IMPLIED WARRANTIES OF FITNESS FOR ANY PARTICULAR PURPOSE ARE DISCLAIMED BY CONTECH. SEE CONTECH'S CONDITIONS OF SALE (AVAILABLE AT [WWW.CONTECHES.COM/COS](http://WWW.CONTECHES.COM/COS)) FOR MORE INFORMATION.

## StormFilter Configuration Guide



# The Stormwater Management StormFilter®

The Stormwater Management StormFilter (StormFilter) is a passive, flow-through, stormwater filtration system. The system is comprised of one or more structures that house rechargeable, media-filled cartridges which trap particulates and adsorb materials such as dissolved metals, hydrocarbons, and nutrients in polluted runoff.

The StormFilter system comes in a variety of configurations and sizes to meet any site need. A variety of filter media is available and can be customized for each site to remove the desired pollutants.

## Basic Design

The StormFilter is sized to treat the peak flow of a water quality design storm. The peak flow or WQv is determined from calculations based on the contributing watershed hydrology and from a design storm magnitude set by the local stormwater management agency. The StormFilter system is modular and each unit is designed with the number of cartridges required to meet the peak design flow rate, WQv or cap.

The flow rate through each filter cartridge is set to meet the jurisdictional performance requirements, allowing control over the amount of contact time between the influent and the filter media. The maximum flow rate through each cartridge can be adjusted, between 0.26 gpm/ft<sup>2</sup> and 2 gpm/ft<sup>2</sup> of surface area, using a calibrated restrictor disc at the base of each filter cartridge. Adjustments to the cartridge flow rate will affect the number of cartridges required to treat the peak flow or WQv.

Please contact your local Contech representative for site-specific design assistance.

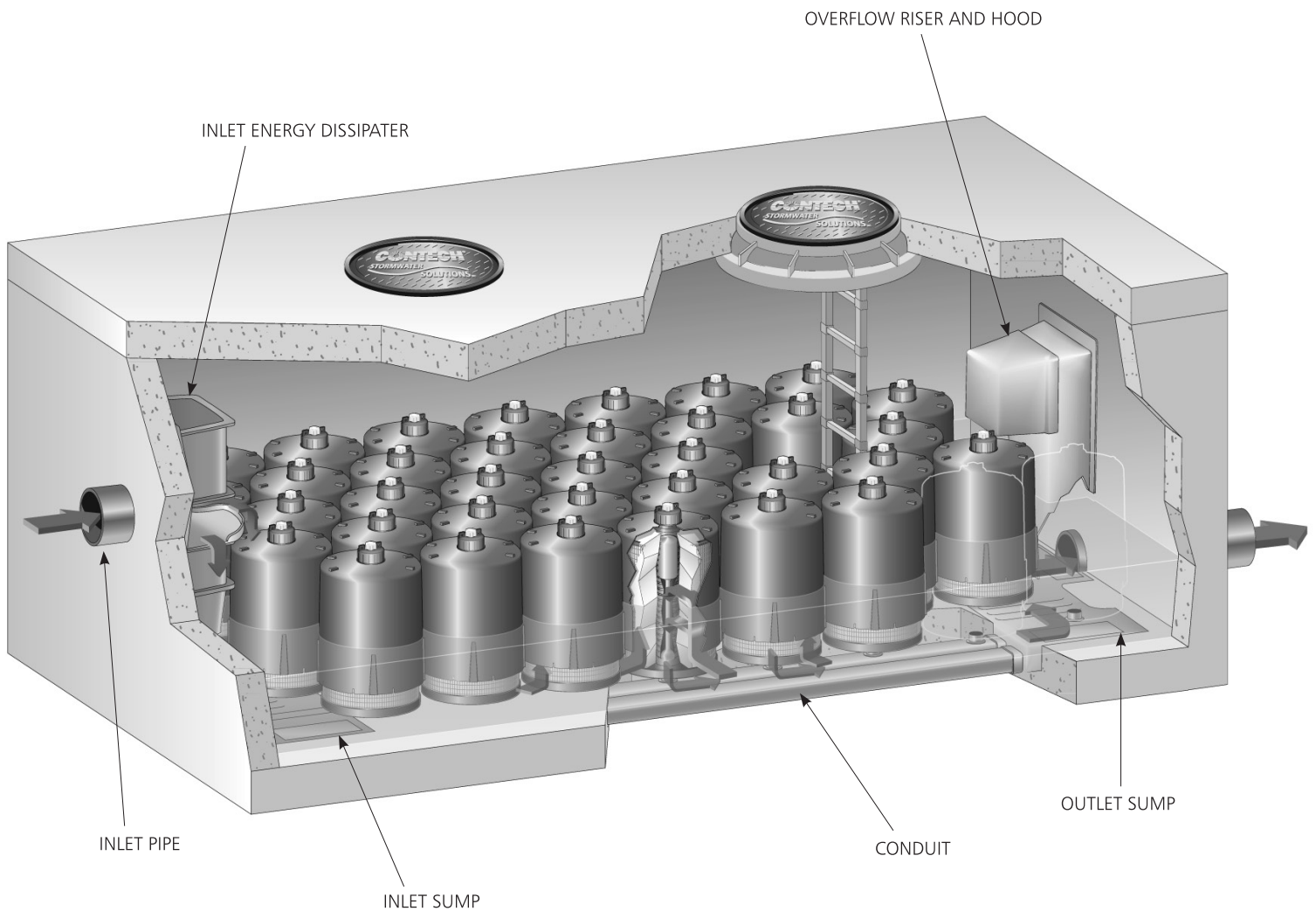

## Basic Operation

### Priming System Function

The system is designed to siphon stormwater runoff through the StormFilter cartridge. Stormwater enters a StormFilter cartridge, percolates horizontally through the cartridge's filter media and collects in the center tube where the float valve is in a closed (downward) position.

As water passes through the filter media and into the cartridge's center tube, the air in the cartridge is displaced by the water and purged from beneath the filter hood through the one-way check valve located in the cap. Once the center tube is filled with water, there is enough buoyant force to open the float valve and allow the treated water in the center tube to flow into the under-drain manifold. This causes the check valve to close, initiating a siphon that draws polluted water throughout the full surface area and volume of the filter. Thus, the entire filter cartridge is used to filter water throughout the duration of the storm, regardless of the water surface elevation in the unit. This siphon continues until the water surface elevation drops to the elevation of the hood's scrubbing regulators, and the float returns to a closed position. Utilizing the hydraulic potential in the cartridge, the scrubbing regulators cause the filter surface to be clean of attached sediments thus extending the filter's operational life.

### Flow and Valve Control

The filtration rate through a typical StormFilter cartridge can be adjusted so that it has a maximum flow rate of 2 gpm/ft<sup>2</sup> at

the design driving head. The flow rate is individually controlled for each cartridge by a restrictor disc located at the connection point between the cartridge and the under-drain manifold. Consisting of a simple orifice disc of a specific diameter, the flow rate through the cartridges can be adjusted to a level that coincides with your treatment requirements by using a disc with the appropriate orifice diameter.

A reduction in flow rate affects the performance of the StormFilter system with regards to both sediment and soluble pollutants. For solids, Stokes' Law predicts the movement of sediment in a fluid and it has been proven that a reduction in the flow velocity through the system will facilitate increased settling and capture of sediments. In addition, some media types have the ability to remove soluble pollutants through chemical processes, like ion exchange. A reduction in the flow velocity through the StormFilter cartridge will increase the contact time between the stormwater and the media, thereby increasing the removal efficiency by increasing the time for a chemical process to take place.

Media type can be changed, but flow rate adjustment requires engineering consultation to ensure hydraulic demands are satisfied.

Through routine maintenance, a media filtration system can adjust the media type to target or update the system to treating specific pollutants, new TMDLs, or changing pollutants of concern. The media change out can provide a long-term solution to changing regulatory requirements.

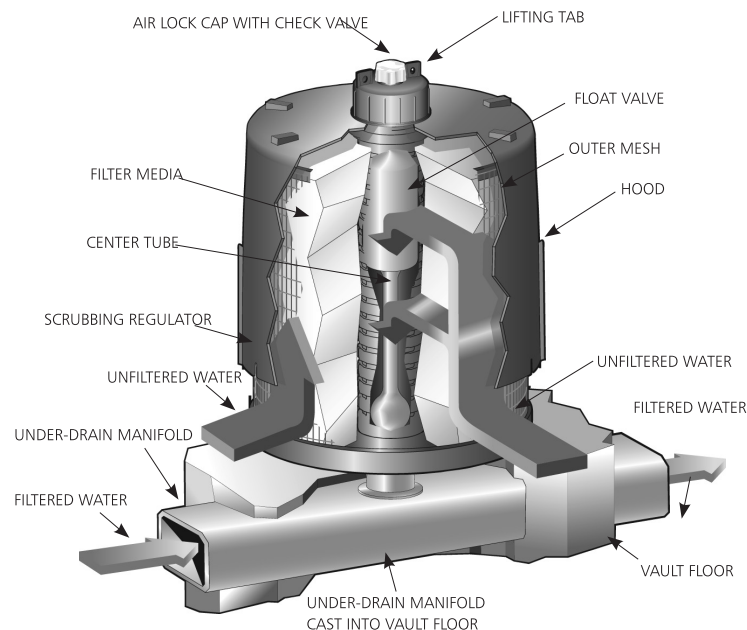

## StormFilter Configurations

The StormFilter technology can be configured to meet your unique site requirements.

## Downstream Treatment Configurations

Conventional stormwater treatment involves collecting, conveying and treating stormwater runoff with an end of pipe treatment system before discharging off-site. StormFilter configurations suitable for these applications are listed below and can be engineered to treat a wide range of flows.

## Vault/Manhole

The Vault/Manhole consists of one or more precast concrete structures ranging from 48" manholes to 8' x 24' vaults. The largest unit treats water quality design flows up to 3.75 cfs, and can be placed in series or in parallel to treat higher flows if needed.

A Vault/Manhole configuration can be installed online or offline from storm system, where the unit has internal overflow bypass. These systems can also be installed offline, where high flows are bypassed around the treatment system and there is no internal overflow. However, if detention, pretreatment, or bypassing is required, it can be installed offline of the storm system.

## Basic Operation

Vault/Manhole systems are housed in either a vault or manhole. Stormwater first enters the structure through the inlet pipe where it is directed through the energy dissipator. This gently spreads the flow to minimize re-suspension of previously captured pollutants.

Once in the filtration area, the stormwater begins to pond and percolate horizontally through the media contained in the filter cartridges. After passing through the media, treated water that has collected in the cartridge center tube is directed into the outlet sump by an under-drain manifold. The treated water in the outlet sump is then discharged through the outlet pipe.

Precast StormFilter systems have an internal bypass capability from 1.0 cfs to 2.0 cfs, depending upon the size of the system. If peak flows to the system exceed 2.0 cfs, an offline high flow bypass is needed.

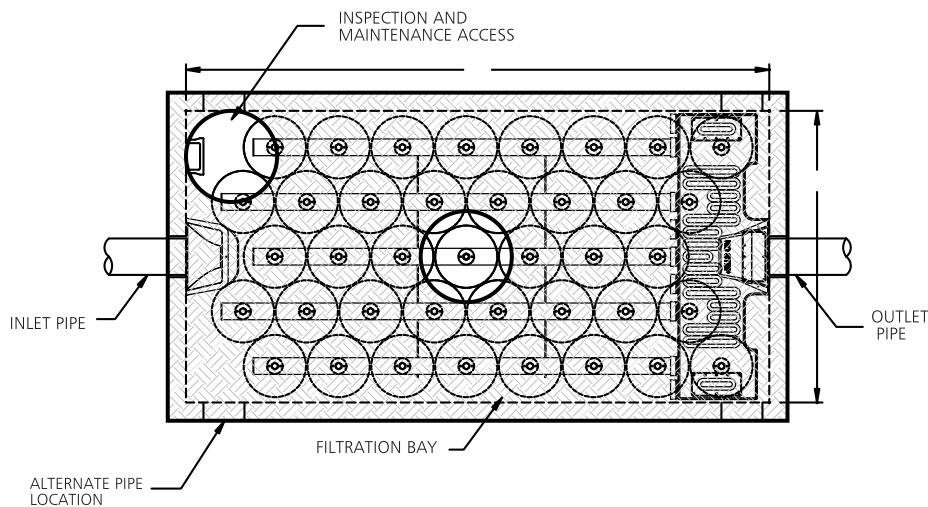
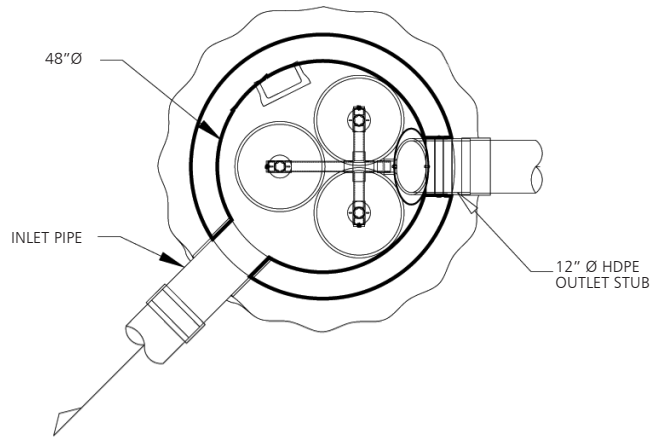

**Vault/Manhole StormFilter**

## High Flow StormFilter

High Flow StormFilter systems can be designed within a variety of structures to meet local requirements and streamline installation. These systems are designed for large sites and large flows. Too big for standard precast structures, they are usually built from precast components that are assembled on site. The High Flow StormFilter is available in several configurations: CON/SPAN®, Panel Vaults, Box Culverts, or Cast-In-Place.

### Basic Operation

The High Flow StormFilter design has the same basic configuration and components as the Precast StormFilter but operates on a larger scale.

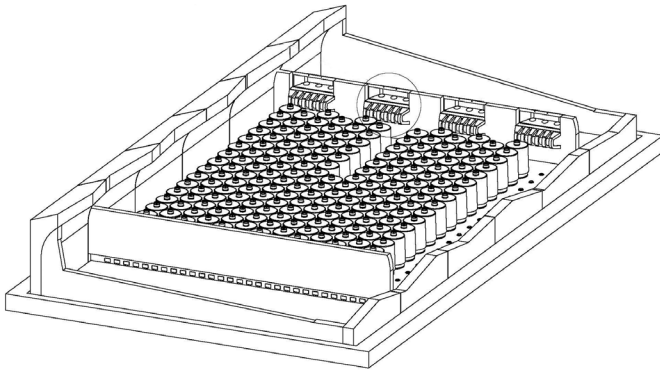

**High Flow StormFilter**

## Peak Diversion StormFilter

The Peak Diversion StormFilter includes a treatment chamber and offline by-pass capability in one precast vault. Sizes range from 8'x11" to 8'x24" in most areas. Larger units can treat up to 2.5 cfs depending on cartridge height and the approved flow rate of regulatory jurisdiction. The integrated off-line bypass eliminates upstream flow splitters, downstream junction structures, and additional piping to save space and reduce the overall foot print. This lowers materials and installation cost while reducing potential conflicts with right of way (ROW) boundaries and utilities.

### Basic Operation

Stormwater enters the structure through one or two inlet pipes into the inlet bay and low flows are directed to the filtration bay through a transfer opening. Once in the filtration area, the stormwater begins to pond and percolate horizontally through the media contained in the filter cartridges. After passing through the media, treated water that has collected in the cartridge center tube is directed into the outlet bay by an under-drain manifold. The treated water in the outlet sump is then discharged through the outlet pipe.

During large storm events greater than the treatment capacity, peak flows are diverted across the overflow weir directly to the outlet. Even during high flows the cartridges are still operating and water is entering the filtration bay from the inlet bay. This continuous flow into the filter bay helps ensure pollutants can not be washed out during high flow events.

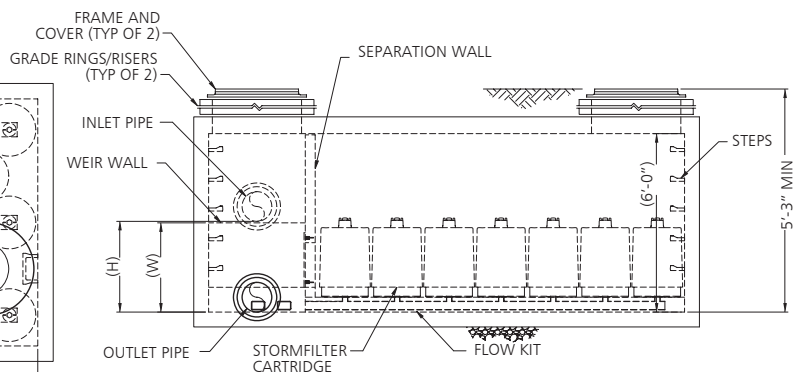
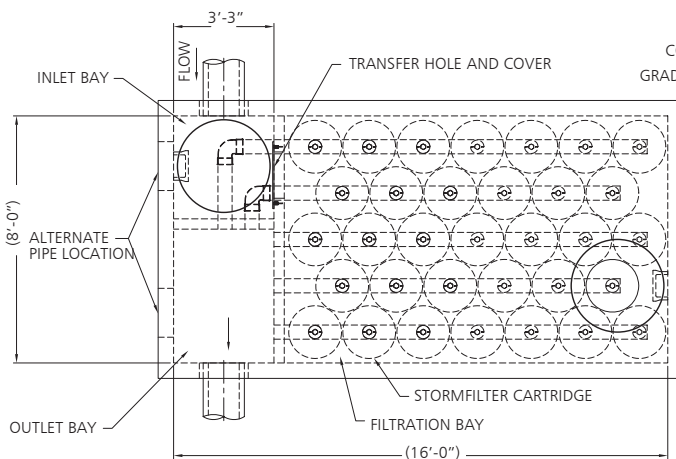

**Peak Diversion StormFilter**

## Volume StormFilter

The Volume StormFilter is designed to meet volume-based regulations where a specific water quality volume (WQv) must be captured and treated. In addition to the treatment, the structure can be sized to capture all or a portion of the WQv.

Restrictor discs inside each cartridge can be used to control the discharge rate from the system. The size of the disc is calibrated to provide the design filtration rate at a live storage depth. Because of these discs (and the airlock cap with a one way vent) water can be impounded above the cartridges in the treatment bay.

Structures range in size from a 48" manhole to CON/SPAN sections with a 24' x 10' cross section built to length. In many cases smaller structures are combined with outboard storage, such as pipe, to provide the WQv storage.

The Volume StormFilter can be designed with or without an internal bypass. If peak flows to the system exceed the internal bypass, or external bypass. If peak flows to the system exceed the internal bypass, or external bypass is required, a high flow bypass is needed. The system can also be installed online or offline and uses a traffic-bearing lid.

## Basic Operation

The Volume StormFilter is typically configured in one of two ways.

A three bay system that incorporates internal storage for the WQv and includes: the storage bay, the filtration bay, and the outlet bay. Water first enters the storage bay (a portion of which includes dead storage) which facilitates pretreatment (gravity separation) and storage of the WQv. The stormwater is then directed into the filtration bay for full treatment and additional storage. The storage bay can be designed with a baffle to trap floatables, oils, and surface scum. Cartridges in the filtration bay treat the stormwater and control the discharge rate. Once in the filtration bay, the stormwater percolates horizontally through the media contained in the filter cartridges. After passing through the cartridge, treated water is directed to the outlet bay by an under-drain manifold where it is discharged through an outlet pipe.

A two bay, precast vault bases system similar to the Vault StormFilter where pretreatment and live storage are provided upstream.

Providing WQv storage in an outboard storage facility such as storage pipe provides the versatility to meet most footprint and elevation requirements.

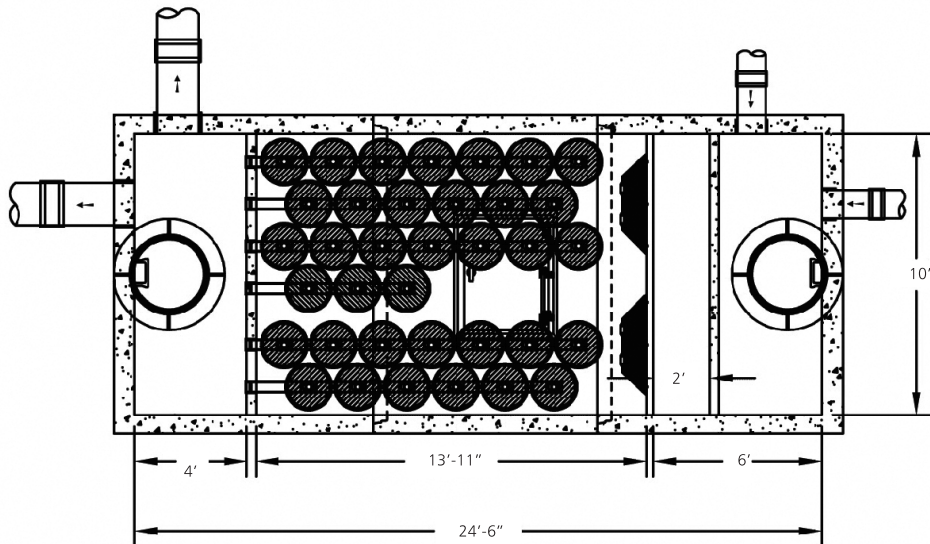

Volume StormFilter

## Upstream Treatment Configurations

Low Impact Design (LID) involves managing runoff close to the source using small, decentralized system. The following suite of StormFilter configurations are easily incorporated on sites where LID site design is recommended. These low-cost, lowdrop, point-of-entry systems also work well when you have a compact drainage area.

### CatchBasin StormFilter

The CatchBasin StormFilter (CBSF) consists of a multi-chamber steel, concrete, or plastic catch basin unit that contains up to four StormFilter cartridges. The steel CBSF is offered both as a standard and as a deep unit.

The CBSF is installed flush with the finished grade and is applicable for small drainage areas from roadways and parking lots, and retrofit applications. It can also be fitted with an inlet pipe for roof leaders or similar applications.

The CBSF unit treats water quality design flows up to 0.20 cfs, coupled with an internal weir overflow capacity of 1.0 cfs for the standard steel and concrete units and 1.8 cfs for the deep steel units. Non-traffic rated plastic CBSF units have an internal weir overflow capacity of 0.5 cfs.

### Basic Operation

The CBSF acts as the primary receiver of runoff, similar to a standard, grated catch basin. The steel and concrete CBSF units each have an H-20 rated, traffic-bearing lid that allows the filter to be installed in parking lots and take up no land area. Plastic CBSF units can be used in landscaped areas and for other non-traffic bearing applications.

The CBSF consists of a sumped inlet chamber and cartridge chamber(s). Runoff enters the sumped inlet chamber either by sheet flow from a paved surface or from an inlet pipe discharging directly to the unit. The inlet chamber's internal baffle traps debris and floating oil, and houses an overflow weir. Heavier solids settle into the deep sump, while lighter solids and soluble pollutants are directed under the baffle and into the cartridge chamber through a port between the baffle and the overflow weir. Once in the cartridge chamber, polluted water ponds and percolates horizontally through the media in the filter cartridges. Treated water collects in the cartridge's center tube from where it is directed by an under-drain manifold to the outlet pipe on the downstream side of the overflow weir and discharged.

When flows into the CBSF exceed the water quality design value, excess water spills over the overflow weir, bypassing the cartridge bay, and discharges to the outlet pipe.

The CBSF is particularly useful where small flows are being treated or for sites that are flat and have little available hydraulic head to spare. The unit is ideal for applications in which standard catch basins are to be used. Both water quality and catchment issues can be resolved with the use of the CBSF.

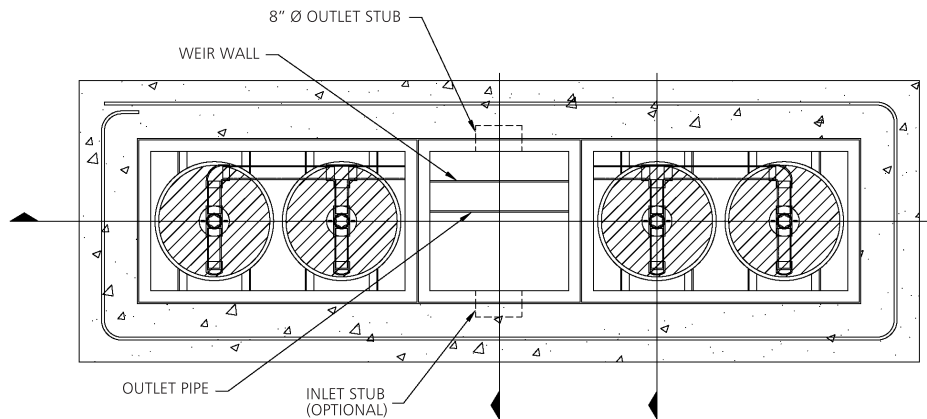

CatchBasin StormFilter

## Curb Inlet StormFilter

The Curb Inlet StormFilter consists of a precast concrete vault ranging from 6'x8' to 8'x16' in size. These units can treat water quality design flows up to 1.2 cfs. The system is installed online and includes an internal offline overflow bypass around the filtration chamber. The internal bypass capability is based on depth of the structure. The standard bypass capacity is 15 cfs but is larger for deeper units. A traffic-bearing lid is placed underneath the median or sidewalk adjacent to the roadway.

### Basic Operation

The Curb Inlet StormFilter is composed of three bays: the inlet bay, the filtration bay, and the outlet bay. Stormwater enters the inlet bay through the curb inlet opening. The design flow is directed through a transfer opening to the filtration bay for full treatment.

Once in the filtration bay, the stormwater percolates horizontally through the media in the filter cartridges to the center tube. Treated water in the cartridge center tube is directed into the outlet bay by an under-drain manifold and discharged through the outlet pipe. Outlet pipes can be placed parallel, perpendicular, or up to 45° to the roadway. Overflow is directed over a weir wall between the inlet bay and the outlet bay, bypassing the filtration bay leaving accumulated pollutants undisturbed.

### Curb Inlet Openings

Every Curb Inlet StormFilter is designed to meet local regulations governing the geometry of the curb inlet. This can be accomplished in two ways. One way is with an integrated face plate – the vault lid includes the face plate which is tied into the curb. Another way is with a cast-in-place face plate – the entire face plate is constructed by the contractor pouring the curb. Curb inlet openings can be 4', 7', or 10' in length.

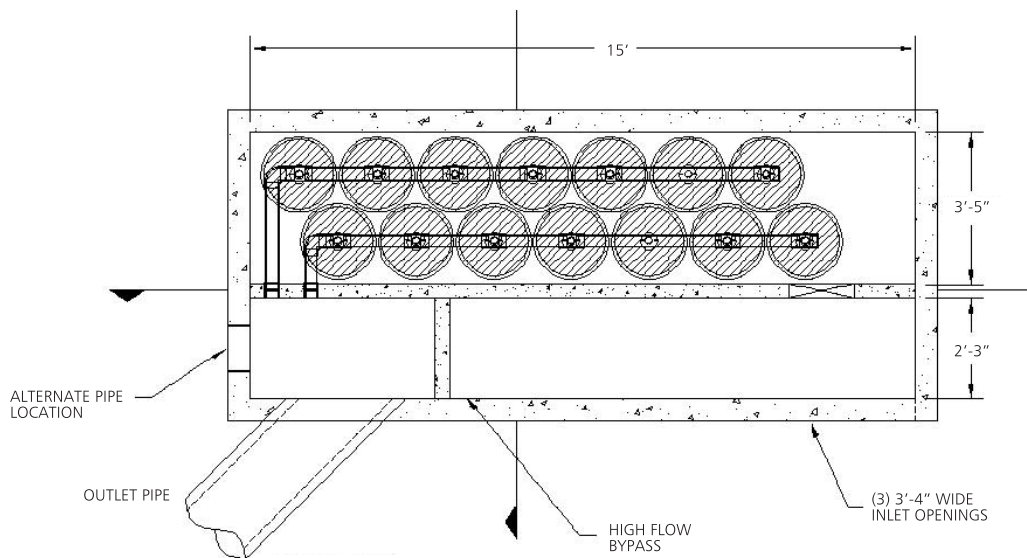

**Curb Inlet StormFilter**

## Linear Grate StormFilter

The Linear Grate StormFilter is a precast vault that acts as the primary receiver of runoff, similar to a standard grated catch basin. The unit has H-20 rated traffic bearing lids that allow the filter to be installed under parking lots. The system consists of an inlet bay, filtration bay, and an outlet bay. Providing treatment as it enters the conveyance system reduces the overall head loss because the vertical drop from the finished grade into the conveyance system is also used to provide hydraulic pressure on the filter cartridges.

### Basic Operation

Runoff enters the inlet bay by sheet flow from a paved surface or from an inlet pipe discharging directly to the unit. The inlet bay's internal baffle traps debris and floating oil and denser pollutants are directed into the filtration bay. Once in the cartridge chamber, polluted water ponds and percolates through a radial media filter cartridge. Treated water collects in the cartridge's center tube where it is directed by an underdrain manifold to the outlet pipe on the downstream side of the overflow weir. When flow rates exceed the water quality design value, excess water spills across the overflow weir, bypassing the cartridge bay and proceed directly to the outlet pipe. The integrated offline bypass ensures pollutants captured in the filtration bay are not washed downstream during peak flow events.

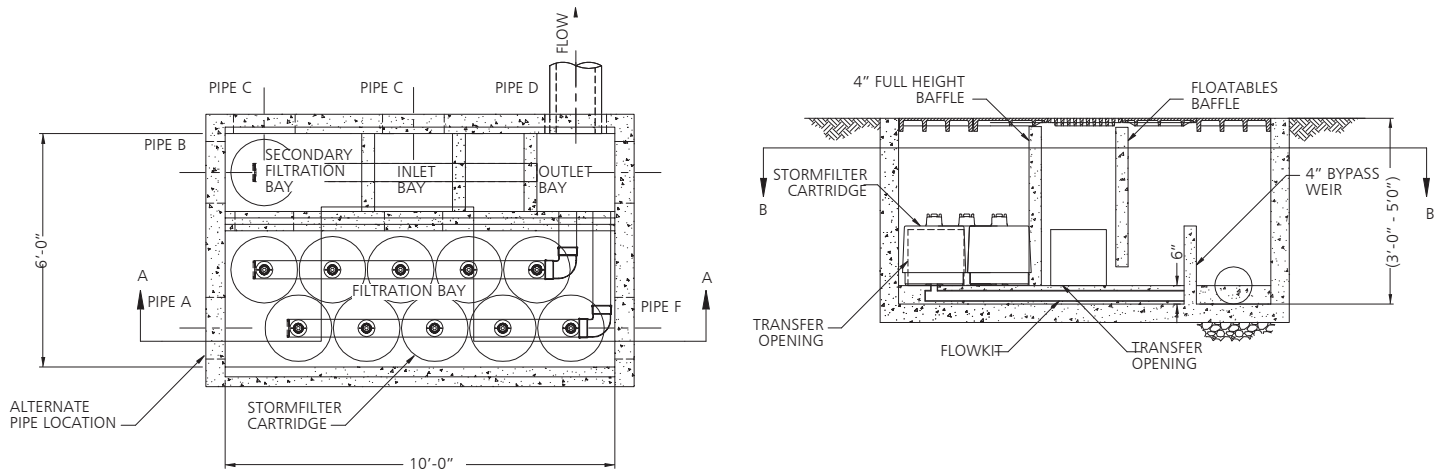

**Linear Grate StormFilter**

### Grated Inlet Openings

The number of inlet grates and the size of the inlet bay are designed to capture the peak flow rates from the drainage area. The remaining area is devoted to the filtration bay and the outlet bay which are covered with removable plates for access during maintenance. The entire inlet bay, filtration bay, and outlet bay can be opened at one time allowing full access. In many cases, due to the shallow nature of the design, confined space entry is not required for maintenance.

### Linear StormFilter

The Linear StormFilter consists of one or two precast concrete channels that are 10' or 20' in length and 2' 9" in width.

The Linear StormFilter is installed flush with the finished grade, functioning similar to a catch basin or trench drain. The top of the unit has either covers or doors for easy access. The Linear StormFilter is typically installed online like the precast StormFilter.

The Linear StormFilter unit treats water quality design flows up to 0.27 cfs.

### Basic Operation

The Linear StormFilter can be installed either as the primary receiver of runoff, similar to a grated catch basin, or with an inlet stub and doors to receive runoff collected upstream.

The system is equipped with an internal overflow weir to ensure that there is no local flooding for storm events in excess of the design treatment flow. Maintenance costs for the unit are typically less because there are no confined space entry requirements, and access is quick and easy.

The Linear StormFilter is particularly useful where small flows are being treated or where the site is very flat and there is little available hydraulic head to spare.

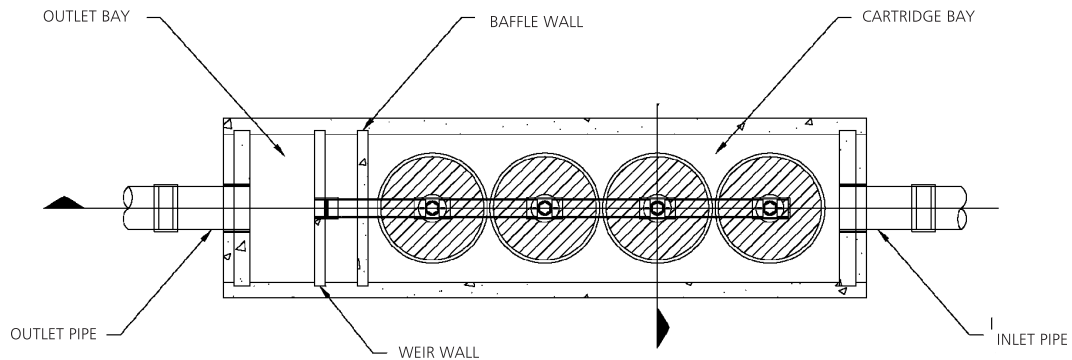

**Linear StormFilter**

# Infiltration Configuration

## Dry Well StormFilter

The Dry Well StormFilter provides treatment, infiltration and groundwater protection in a single structure. The system is designed to treat conveyed flow or sheet flow from small drainages. Multiple units can be installed to treat any size site. Because it provides treatment and infiltration in a single unit, the total number of structures and the amount of pipe required for the stormwater system are reduced.

The Dry Well StormFilter system is available in 48", 60" and 72-" pre-cast manhole top sections that are designed to be stacked on top of dry well infiltration risers. The StormFilter portion of the unit arrives fully assembled and ready to install, including an integrated concrete deck for the StormFilter cartridges. The system can also be retrofitted into existing 48" manhole dry wells.

### Basic Operation

Stormwater enters the dry well unit through one or more entry pipes or channels at its top. It then percolates through the media in the StormFilter cartridge to the center tube. Treated water in the cartridge center tube is discharged to the infiltration section below, and then infiltrates into the surrounding soils through a number of small exit openings at the sides and bottom.

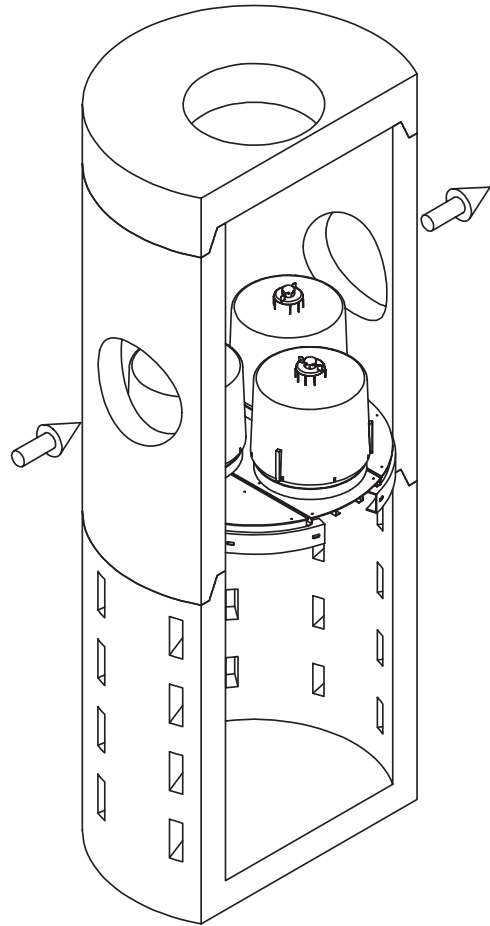

**DryWell StormFilter**

# Roof Runoff Treatment Configuration

## Downspout StormFilter

The Downspout StormFilter is an aboveground configuration that can be easily integrated into existing gutter systems to eliminate pollution from rooftop runoff. It typically occupies 2.5' x 5' footprint, and can fit most downspout configurations and sizes. Each unit holds two StormFilter cartridges, and single- and dual-stage options are available. It treats up to 14,000 square feet of rooftop area per dual-cartridge system.

## StormFilter Cartridges

There are three cartridge heights available for StormFilter systems: 27", 18", and Low Drop. The most economical is the 27" tall cartridge. It can treat the highest flow rate per cartridge, which creates the smallest system with the lowest installed cost. The 27" cartridge requires 3.05' of driving head to operate. For sites with less driving head available, the 18" cartridge is the next best option. Lower flow rates per cartridge increase the footprint of the overall system but only 2.3' of driving head is required. For sites with very limited drop, the Low Drop cartridge only requires 1.8' of driving head.

**Cartridge Flow Rates**

Cartridge Type	Hydraulic Drop	Treatment Capacity (gpm)	
		1 gpm/ft <sup>2</sup>	2 gpm/ft <sup>2</sup>
StormFilter 27"	3.05'	11.25	22.5
StormFilter 18"	2.30'	7.5	15
StormFilter Low Drop	1.80'	5	10

## StormFilter Media

The removal of site-specific pollutants can be maximized with the variety of filtration media available. In many cases, different media types can be combined so as to target a wide spectrum of pollutants. This ability to combine and use various media types allows the system to be easily adjusted to meet ever-changing site conditions and increasingly stringent regulatory requirements.

### PhosphoSorb®

PhosphoSorb, a lightweight media comprised of Perlite (a heat-expanded volcanic rock) and activated alumina, removes total phosphorus (TP) by absorbing dissolved-P and filtering particulate-P simultaneously. The Perlite provides the capability to remove suspended solids while the activated alumina absorbs soluble phosphorus absorption.

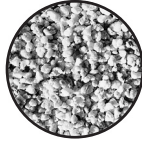

PhosphoSorb is composed of a slightly finer gradation than the field proven ZPG™ (Zeolite, Perlite, Granular Activated Carbon) media and will provide equivalent - or even better - removal of suspended solids. Initial field tests have indicated an increase in the TSS removal efficiency up to 10% over the field-proven ZPG media. The StormFilter with ZPG media has already received a General Use Level Designation for basic treatment in the State of Washington.

### Perlite

Perlite is a natural, volcanic ash, similar in composition to glass and similar in appearance to pumice. To use perlite as a filter medium, it must first go through a heating process to yield a lightweight, multicellular, expanded form. This expanded form has a coarse texture, very low-density, high surface area, and stable, inert chemistry, all of which make perlite an excellent physical filtration medium.

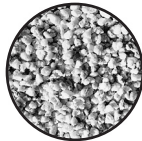

Perlite has proven to be our media of choice for sediment and oil removal. The multicellular nature of expanded perlite is the key to its excellent ability to trap sediments and adsorb oil. The coarse texture of the expanded perlite creates a bed of material with a very high porosity, which allows perlite to have the highest sediment and oil storage capacity of all of the available media options.

### Zeolite

The term zeolite defines a family of both natural and synthetic, hydrous aluminosilicate materials with a highly porous mineral matrix that holds light, alkali metal cations (ideally sodium ions).



Zeolite has the ability to use a cation exchange reaction that removes other cations such as zinc, copper, lead, and ammonia from water. In the cation exchange reaction, the light metal cations in the zeolite matrix are displaced by the heavier metal cations, such as copper, in the water.

The zeolite used in our system is clinoptilolite, which has a cation exchange capacity (CEC) of approximately 100 to 220 meq/100 g. Clinoptilolite has inert characteristics that make it an excellent metals removal media option when CSF media cannot be used. It can be combined with other media such as GAC and perlite when metals are not of exclusive concern.

### CSF® Leaf Media

CSF Leaf Media is a patented filtration media composed of composted deciduous leaves originating from the City of Portland, Oregon. Contech Engineered Solutions purchases the mature, stable, deciduous leaf compost and then processes it into an odorless, pelletized compost product with physical and chemical characteristics desirable for stormwater filtration.



The patented compost process creates a material with excellent flow-through characteristics and stability in water. Not only do CSF Leaf Media consist of 100% recycled, all natural materials, but it also provides good removal of sediments and excellent removal of a wide range of toxic contaminants.

CSF Leaf Media provides the multitude of beneficial water treatment properties typical of soil in a form that is compatible with the compact, modular, media-based design of the StormFilter system. In addition to the physical filtration provided by the granular nature of the CSF Leaf Media, the complex chemistry of the compost also provides chemical filtration as well.

Sediment and total nutrients are removed through physical filtration. Oil, complexed metals, and anthropogenic organic contaminants such as herbicides and pesticides are removed through adsorption, the physical partitioning of organic compounds, such as pesticides, to carbon-rich materials, such as the compost.

Soluble metals are removed by cation exchange, as well as by complexation of metal ions to the organic chelating agents present in compost. CSF Leaf Media is an excellent, cost-effective, all-purpose media that epitomizes the potential value of recycled materials.

### GAC

GAC (Granular Activated Carbon) is a widely accepted water filtration media used for the removal of organic compounds. It consists of pure carbon (originating from coal or charcoal) whose micro-porous structure has been enhanced through steam or acid "activation."



The high carbon content and porous nature of GAC accounts for its excellent ability to remove organic compounds through adsorption. Since adsorption is the physical partitioning of organic compounds to high carbon surfaces, the "activation" of the carbon (which creates GAC) endows it with an enormous surface area upon which adsorption can take place.

In situations where anthropogenic organic contaminants are of exclusive concern, GAC media provide the highest level of stormwater treatment compared to other available media options. However, because it is not very often the case that anthropogenic organic contaminants are of exclusive concern, GAC is usually combined with another media such as perlite or zeolite for the treatment of additional contaminants.

Combination of GAC with perlite constitutes the most cost-effective configuration, as the effectiveness of GAC is drastically reduced if it is coated with high concentrations of heavy oil or sediment, which can restrict access via surface pores to the interior of the GAC granules.

### ZPG™ (Zeolite, Perlite, GAC blend)

This proprietary blend of zeolite, perlite, and granular activated carbon media is used to provide an alternative for CSF media for installations where leaf media cannot be used.



### Laboratory and Field Testing

The StormFilter system is designed to meet the most stringent regulatory requirements. The field-proven performance of the StormFilter has led to hundreds of regulatory agency approvals nationwide as a standalone BMP.

The Stormwater Management StormFilter® is the first manufactured BMP to receive stand-alone approval through field testing and satisfying the total suspended solids treatment requirements in Washington and New Jersey.

Log on to [www.conteches.com/stormfilter](http://www.conteches.com/stormfilter) to view the following reports in full.

## Field Monitoring Reports

Field Proven Performance of the StormFilter using the Technology Assessment Protocol - Ecology (TAPE) and Technology Acceptance Reciprocity Partnership (TARP) Tier II Protocol

1. Washington
  - a. Washington State Department of Ecology General Use Level Designation for Basic Treatment
  - b. Technical Evaluator Engineering Report (TEER). Gary Minton, Ph.D., P.E.
2. New Jersey
  - a. New Jersey State Department of Environmental Protection Final Certification
  - b. New Jersey Corporation for Advanced Technology (NJCAT) Field Verification Report

## Laboratory Reports

### ***Total Suspended Solids (TSS) Removal Using Different Particle Size Distributions with the Stormwater Management StormFilter.***

#### ***Influences on TSS removal efficiency***

Influence of analytical method, data summarization method, and particle size on total suspended solids (TSS) removal efficiency of the StormFilter

#### ***StormFilter removal efficiency with coarse/fine perlite media***

Evaluation of the removal of silt loam TSS using coarse/fine perlite at 28 L/min (7.5 gpm).

#### ***StormFilter removal efficiency with ZPG media***

Evaluation of the removal of SIL-CO-SIL 106 using ZPG media at 28 L/min (7.5 gpm)

#### ***StormFilter removal efficiency with coarse perlite***

Evaluation of the removal of sandy loam TSS using coarse perlite at 57 L/min (15 gpm)

#### Support

- Drawings and specifications are available at [contechstormwater.com](http://contechstormwater.com).
- Site-specific design support is available from Contech Stormwater Design Engineers.

©2015 Contech Engineered Solutions LLC

Contech Engineered Solutions LLC provides site solutions for the civil engineering industry. Contech's portfolio includes bridges, drainage, sanitary sewer, stormwater and earth stabilization products. For information on other Contech division offerings, visit [contech-cpi.com](http://contech-cpi.com) or call 800.338.1122

NOTHING IN THIS CATALOG SHOULD BE CONSTRUED AS AN EXPRESSED WARRANTY OR AN IMPLIED WARRANTY OF MERCHANTABILITY OR FITNESS FOR ANY PARTICULAR PURPOSE. SEE THE CONTECH STANDARD CONDITIONS OF SALE (VIEWABLE AT [WWW.CONTECHES.COM/COS](http://WWW.CONTECHES.COM/COS)) FOR MORE INFORMATION.

The product(s) described may be protected by one or more of the following US patents: 5,322,629; 5,624,576; 5,707,527; 5,759,415; 5,788,848; 5,985,157; 6,027,639; 6,350,374; 6,406,218; 6,641,720; 6,511,595; 6,649,048; 6,991,114; 6,998,038; 7,186,058; 7,296,692; 7,297,266; related foreign patents or other patents pending.



**CONTECH**<sup>®</sup>  
ENGINEERED SOLUTIONS

# Jellyfish<sup>®</sup> Filter

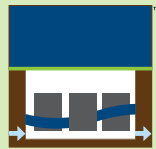

**Solutions  
Guide**



# Stormwater Solutions from Contech



## Selecting the Right Stormwater Solution Just Got Easier...

It's simple to choose the right stormwater solution to achieve your goals with the Contech Stormwater Solutions Staircase. First, select the runoff reduction practices that are most appropriate for your site, paying particular attention to pretreatment needs. If the entire design storm cannot be retained, select a treatment best management practice (BMP) for the balance. Finally, select a detention system to address any outstanding downstream erosion.

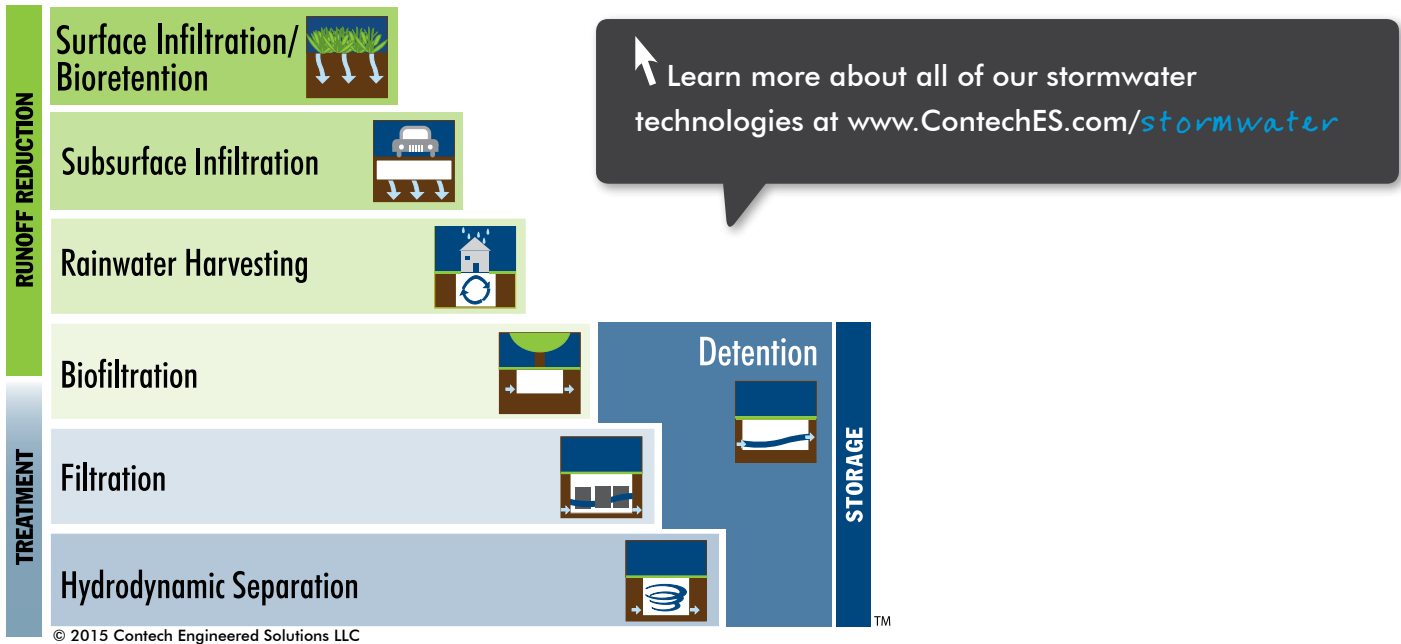

## Learn About the Jellyfish<sup>®</sup> Filter

Go online and watch our animation to learn how the Jellyfish Filter works. The animation also highlights important features of the Jellyfish Filter including...

- Applications
- Performance test results
- Inspection and maintenance
- Regulatory approvals

To view the Jellyfish Filter animation, visit: [www.conteches.com/jellyfish](http://www.conteches.com/jellyfish)



**Jellyfish<sup>®</sup> Filter**

# Filtration as a Stormwater Management Strategy

Stormwater regulations are increasingly calling for more robust treatment levels. In addition to the removal of suspended solids, many regulations now require best management practices to remove significant amounts of nutrients, metals, and other common pollutants found in stormwater runoff. Meeting these regulations often requires the use of a filtration solution.

Low Impact Development (LID) and Green Infrastructure (GI) are complimented by filtration solutions. Benefits of LID and GI systems include retaining runoff and aesthetic appeal. Keeping LID and GI sites free from fine sediments, oils, trash, and debris while functioning as designed can be time consuming and costly.

As a result, the practice of combining LID and GI with filtration is becoming more common. Providing a single point of maintenance promotes proper system functionality and increases the aesthetic appeal by removing unsightly trash and debris.

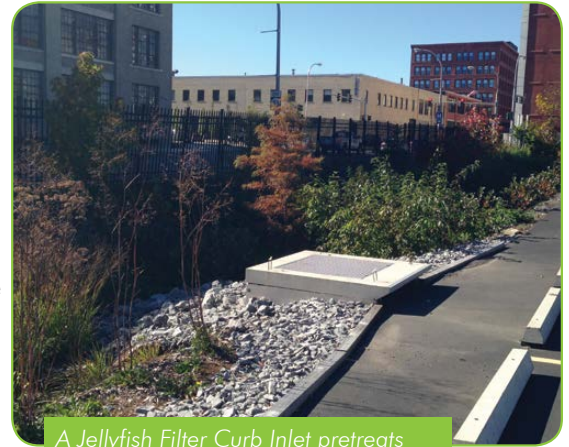

A Jellyfish Filter Curb Inlet pretreats runoff entering a bioretention system

## The Jellyfish<sup>®</sup> Filter - Setting New Standards in Stormwater Treatment

The Jellyfish Filter is a stormwater quality treatment technology featuring high surface area and high flow rate membrane filtration at low driving head. By incorporating pretreatment with light-weight membrane filtration, the Jellyfish Filter removes floatables, trash, oil, debris, TSS, fine silt-sized particles, and a high percentage of particulate-bound pollutants; including phosphorus and nitrogen, metals and hydrocarbons.

The high surface area membrane cartridges, combined with up flow hydraulics, frequent backwashing, and rinsable/reusable cartridges ensures long-lasting performance.



The Jellyfish Filter.



# Jellyfish® Filter Features and Benefits

FEATURES	BENEFITS
1. High surface area, high flow rate membrane filtration	1. Long-lasting and effective stormwater treatment
2. Highest design treatment flow rate per cartridge (up to 80 gpm (5 L/S))	2. Compact system with a small footprint, lower construction cost
3. Low driving head (typically 18 inches (457 mm) or less)	3. Design Flexibility, lower construction cost
4. Lightweight cartridges with passive backwash	4. Easy maintenance and low life-cycle cost
5. 3 <sup>rd</sup> party verified field performance per TARP Tier II protocol	5. Superior pollutant capture with confidence

# Jellyfish® Filter Applications

- Urban development
- Highways, airports, seaports, and military installations
- Commercial and residential development, infill and redevelopment, and stormwater quality retrofit applications
- Pretreatment for Low Impact Development (LID), Green Infrastructure (GI), infiltration, and rainwater harvesting and reuse systems
- Industrial sites



A Jellyfish Filter pretreats a bioretention/bioswale system at a commercial site in Ontario, Canada.



A catch basin Jellyfish Filter is installed in a commercial development in Virginia.



A Jellyfish Filter provides treatment at an Industrial Park in Lake Tahoe, Nevada.

# Jellyfish® Filter Field Performance Test Results

POLLUTANT OF CONCERN	% REMOVAL
Total Trash	99%
Total Suspended Solids (TSS)	89%
Total Phosphorus (TP)	59%
Total Nitrogen (TN)	51%
Total Copper (TCu)	>80%
Total Zinc (TZn)	>50%
Turbidity (NTU)	<15%

Sources:

TARP II Field Study – 2012 JF 4-2-1 Configuration

MRDC Floatables Testing – 2008 JF6-6-1 Configuration



## Jellyfish® Filter Approvals

The Jellyfish Filter is approved through numerous state and federal verification programs, including:

- New Jersey Corporation for Advanced Technology (NJCAT) – Field Performance Verification per TARP Tier II Protocol
- Washington State Department of Ecology (TAPE –CULD)
- Maryland Department of the Environment (MD DOE)
- Texas Commission on Environmental Quality (TCEQ)
- Virginia Department of Environmental Quality (VA DEQ)
- New York Department of Environmental Conservation (DEC)
- City of Denver
- Los Angeles County
- Canada ISO 14034 Environmental Management – Environmental Technology Verification (ETV)
- Ontario Ministry of the Environment – New Environmental Technology Evaluation (NETE) – Certification



Learn more at [www.ContechES.com/jellyfish](http://www.ContechES.com/jellyfish)



# Jellyfish® Filter Configurations

The Jellyfish Filter is available in a variety of configurations. Typically, 18 inches (457 mm) of driving head is designed into the system. For low drop sites, the designed driving head can be less.

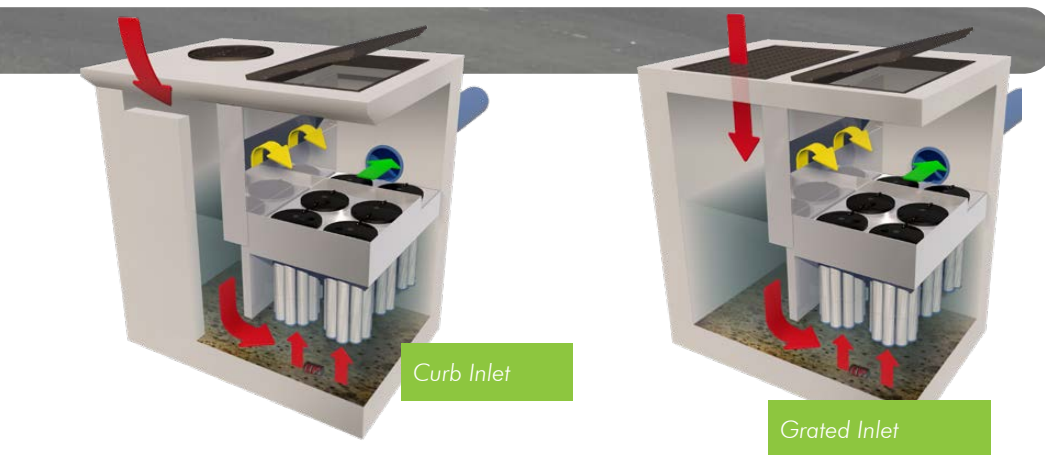
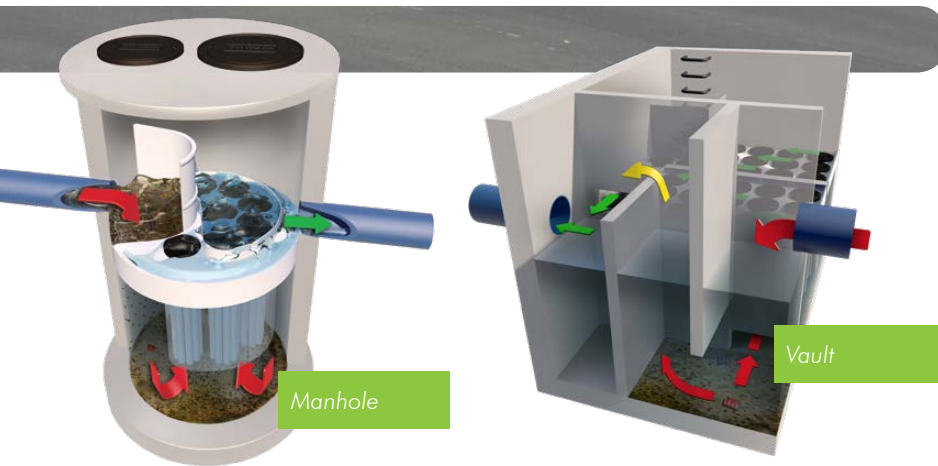

## Lightweight Jellyfish Filter Configurations

Custom configurations include Jellyfish Filter tanks made from fiberglass for site specific applications.



A Jellyfish Filter was constructed from fiberglass to reduce the weight of the system, allowing for a suspended installation above an underground parking structure. The reduced weight eliminated the need for structural changes, and suspending the Jellyfish resulted in no loss of parking space, maximizing real-estate value.

# Jellyfish® Filter Maintenance

Inspection and maintenance activities for the Jellyfish Filter typically include:

- Visual inspection of deck, cartridge lids, and maintenance access wall.
- Vacuum extraction of oil, floatable trash/debris, and sediment from manhole sump.
- External rinsing and re-installing of filter cartridges.
- Replacement of filter cartridge tentacles as needed. Cartridge replacement intervals vary by site; replacement is anticipated every 2-5 years.



The Jellyfish Filter tentacle is light and easy to clean.

## Jellyfish® Filter Inspection and Maintenance Video

Inspecting and maintaining the Jellyfish Filter is easier than you may think. Watch the Jellyfish inspection and maintenance video at [www.ContechES.com/jellyfish](http://www.ContechES.com/jellyfish)





### LEARN MORE

- Access project profiles, photos, videos and more online at [www.ContechES.com/jellyfish](http://www.ContechES.com/jellyfish)

### CONNECT WITH US

- Call us at 800-338-1122
- Contact your local rep at [www.ContechES.com/localresources](http://www.ContechES.com/localresources)

### START A PROJECT

- Submit your system requirements on our product Design Worksheet [www.ContechES.com/start-a-project](http://www.ContechES.com/start-a-project)

### USE OUR ONLINE TOOLS

- Low Impact Development Site Planner [www.ContechES.com/LIDsiteplanner](http://www.ContechES.com/LIDsiteplanner)



## COMPLETE SITE SOLUTIONS

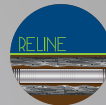
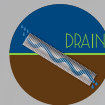

#### TREATMENT SOLUTIONS

Helping to satisfy stormwater management requirements on land development projects

- Biofiltration/Bioretenention
- Stormwater Treatment
- Detention/Infiltration
- Rainwater Harvesting

#### PIPE SOLUTIONS

Meeting project needs for durability, hydraulics, corrosion resistance, and stiffness

- Corrugated Metal Pipe (CMP)
- Steel Reinforced Polyethylene (SRPE)
- High Density Polyethylene (HDPE)
- Polyvinyl Chloride (PVC)

#### STRUCTURES SOLUTIONS

Providing innovative options and support for crossings, culverts, and bridges

- Plate, Precast & Truss Bridges
- Hard Armor
- Retaining Walls
- Tunnel Liner Plate

NOTHING IN THIS CATALOG SHOULD BE CONSTRUED AS AN EXPRESSED WARRANTY OR AN IMPLIED WARRANTY OF MERCHANTABILITY OR FITNESS FOR ANY PARTICULAR PURPOSE. SEE THE CONTECH STANDARD CONDITION OF SALES (VIEWABLE AT [WWW.CONTECHES.COM/COS](http://WWW.CONTECHES.COM/COS)) FOR MORE INFORMATION.



© 2018 Contech Engineered Solutions LLC, a QUIKRETE Company  
800-338-1122 | [www.ContechES.com](http://www.ContechES.com)  
All Rights Reserved. Printed in the USA.

Get Social With Us!



# **Appendix E: Existing and Proposed Impervious Area Exhibit for the Build Alternative**

(THIS PAGE INTENTIONALLY LEFT BLANK)

3/22/2023 10:50:27 AM  
 c:\pwworking\src\dl068890\Existing\Impervious - Street 1.dgn  
 p:\pwworking\src\dl068890\Existing\Impervious - Street 1.dwg  
 c:\pwworking\src\dl068890\Existing\Impervious - Street 1.dwg  
 c:\pwworking\src\dl068890\Existing\Impervious - Street 1.dwg

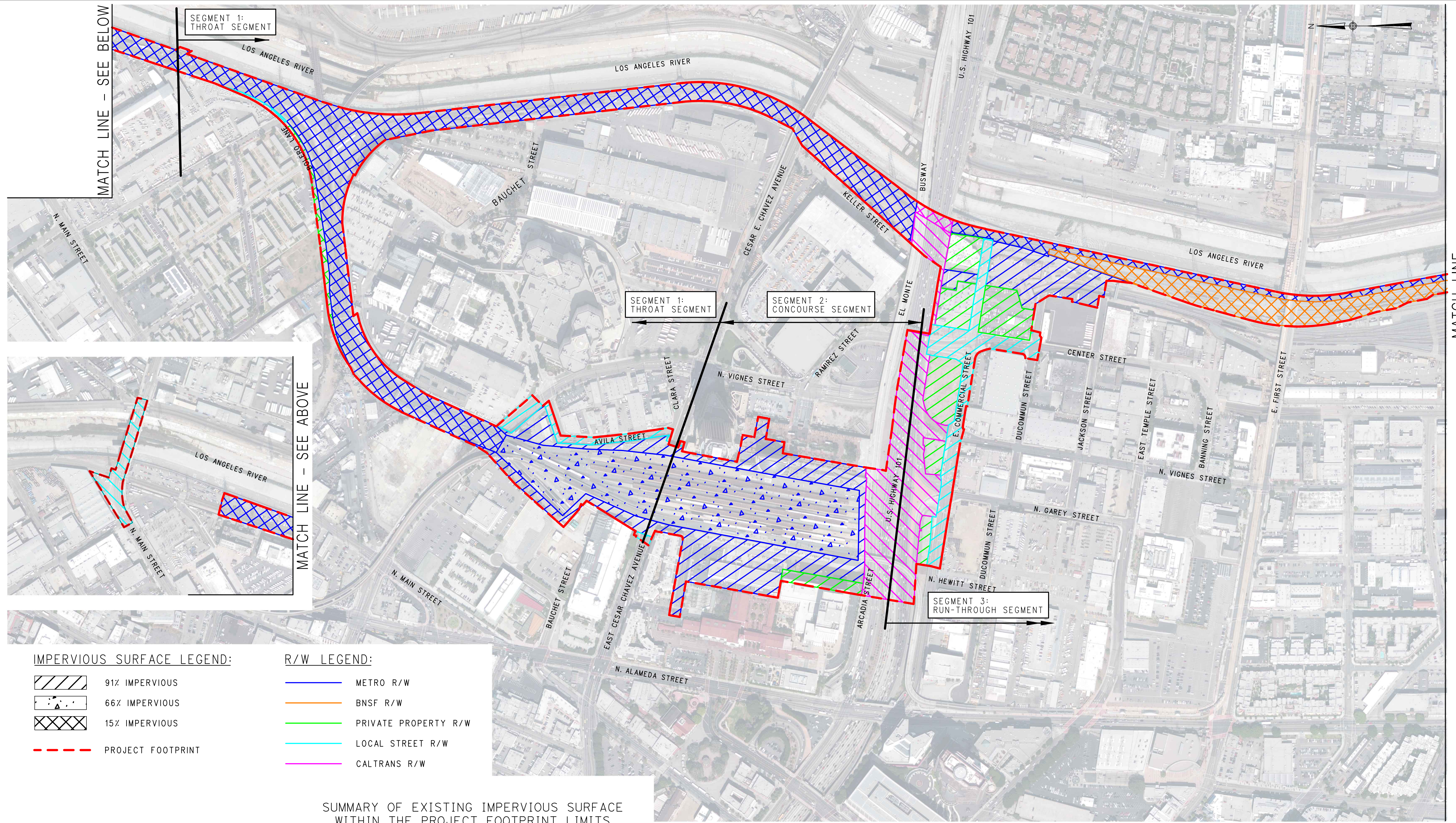

- IMPERVIOUS SURFACE LEGEND:**
- 91% IMPERVIOUS
  - 66% IMPERVIOUS
  - 15% IMPERVIOUS
  - PROJECT FOOTPRINT
- R/W LEGEND:**
- METRO R/W
  - BNSF R/W
  - PRIVATE PROPERTY R/W
  - LOCAL STREET R/W
  - CALTRANS R/W

SUMMARY OF EXISTING IMPERVIOUS SURFACE WITHIN THE PROJECT FOOTPRINT LIMITS

SUBAREA	METRO R/W	BNSF R/W	PRIVATE PROPERTY R/W	LOCAL STREET R/W	CALTRANS R/W	TOTAL	IMPERVIOUS SURFACE (%)	IMPERVIOUS SURFACE AREA (ACRES)
	(ACRES)							(ACRES)
	14.28	-	5.98	6.39	8.99	35.62	91	32.41
	14.42	-	-	-	-	14.42	66	9.52
	29.23	5.26	0.70	0.13	0.31	35.61	15	5.34
<b>TOTAL</b>	<b>57.92</b>	<b>5.26</b>	<b>6.67</b>	<b>6.51</b>	<b>9.29</b>	<b>85.70</b>		<b>47.27</b>

**NOTE:**  
 CITY AND STATE RIGHT OF WAY LINES SHOWN ARE SUBJECT TO CHANGE PENDING FURTHER INVESTIGATION

LINK UNION STATION PROJECT  
 BUILD ALTERNATIVE  
 EXISTING IMPERVIOUS SURFACE EXHIBIT  
 SHEET 1 OF 2

SCALE: 1"=250'  
 DATE: 03-22-2023

MATCH LINE - SEE EXHIBIT 2 OF 2

MATCH LINE - SEE BELOW

MATCH LINE - SEE ABOVE

3/22/2023 2:35:49 PM c:\pwworking\src\dl068890\Existing\_Impervious\_Street\_2.dgn  
 P:\pwworking\src\dl068890\Existing\_Impervious\_Street\_2.dgn  
 c:\pwworking\src\dl068890\Existing\_Impervious\_Street\_2.dgn

D R A F T

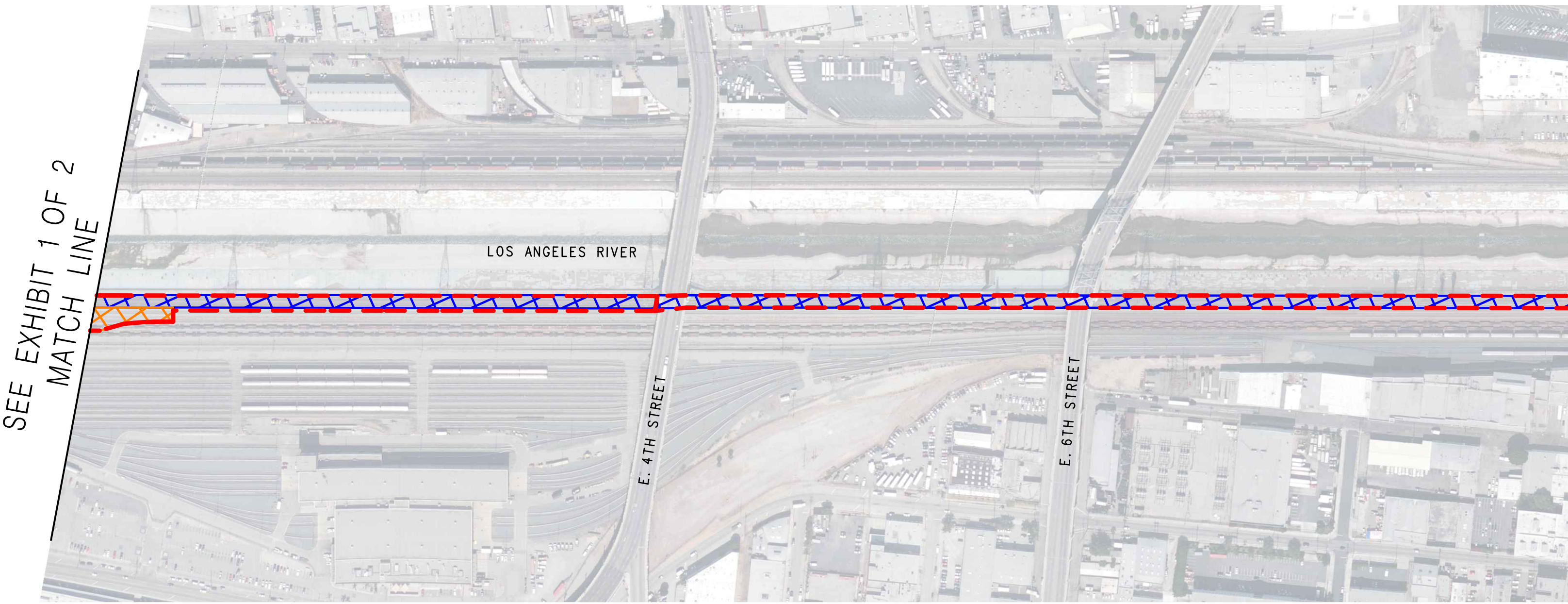

SEE EXHIBIT 1 OF 2  
MATCH LINE

MATCH LINE  
SEE BELOW LEFT

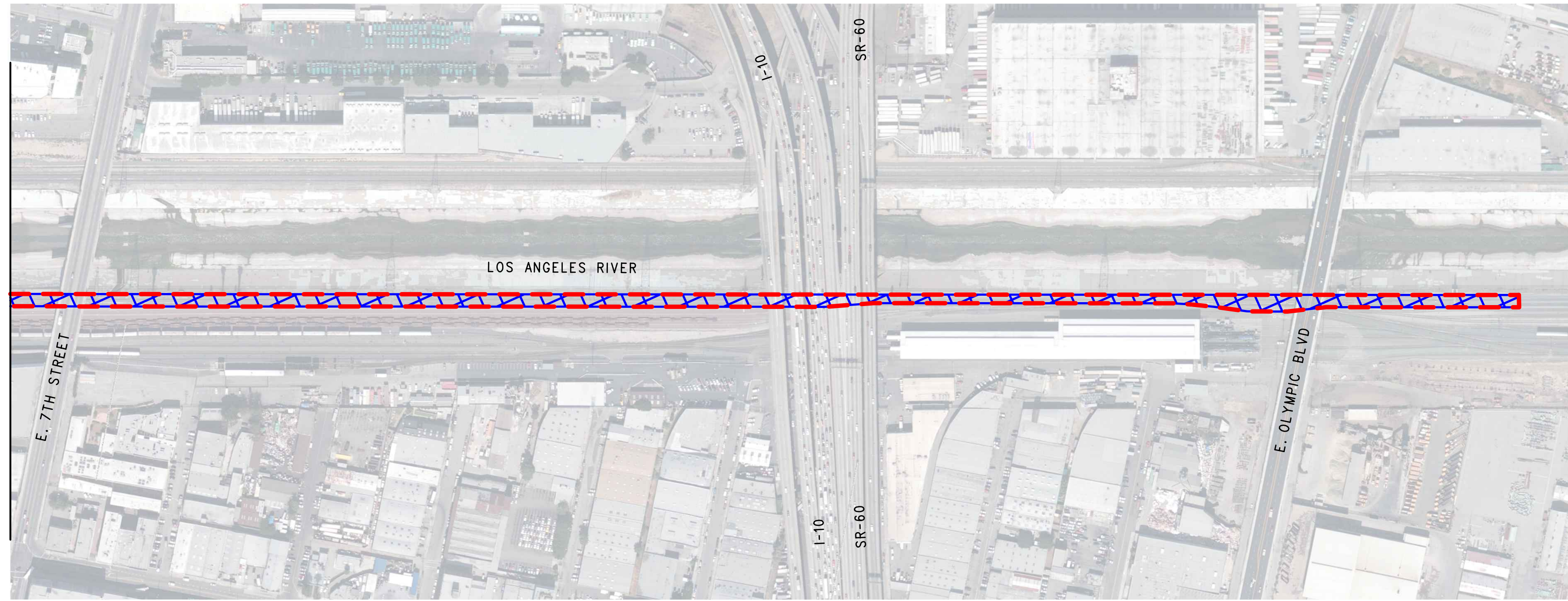
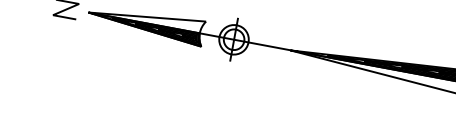

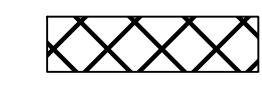
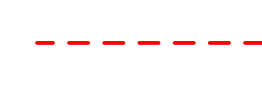

SEE ABOVE RIGHT  
MATCH LINE

IMPERVIOUS SURFACE LEGEND:

-  15% IMPERVIOUS
-  PROJECT FOOTPRINT

R/W LEGEND:

-  METRO R/W
-  BNSF R/W

NOTE:

CITY AND STATE RIGHT OF WAY LINES SHOWN ARE SUBJECT TO CHANGE PENDING FURTHER INVESTIGATION

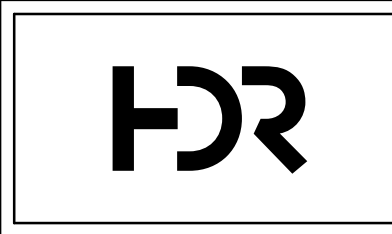
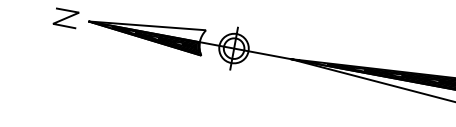

LINK UNION STATION PROJECT  
 BUILD ALTERNATIVE  
 EXISTING IMPERVIOUS SURFACE EXHIBIT  
 SHEET 2 OF 2

SCALE: 1"=250'  
 DATE: 03-22-2023

3/22/2023 11:19:59 AM  
 c:\pwworking\hrc\project\68990\Proposed\Impervious\_Sheet\_1.dgn  
 p:\pwworking\hrc\project\68990\Proposed\Impervious\_Sheet\_1.ctb  
 c:\pwworking\hrc\project\68990\Proposed\Impervious\_Sheet\_1.dgn  
 c:\pwworking\hrc\project\68990\Proposed\Impervious\_Sheet\_1.ctb

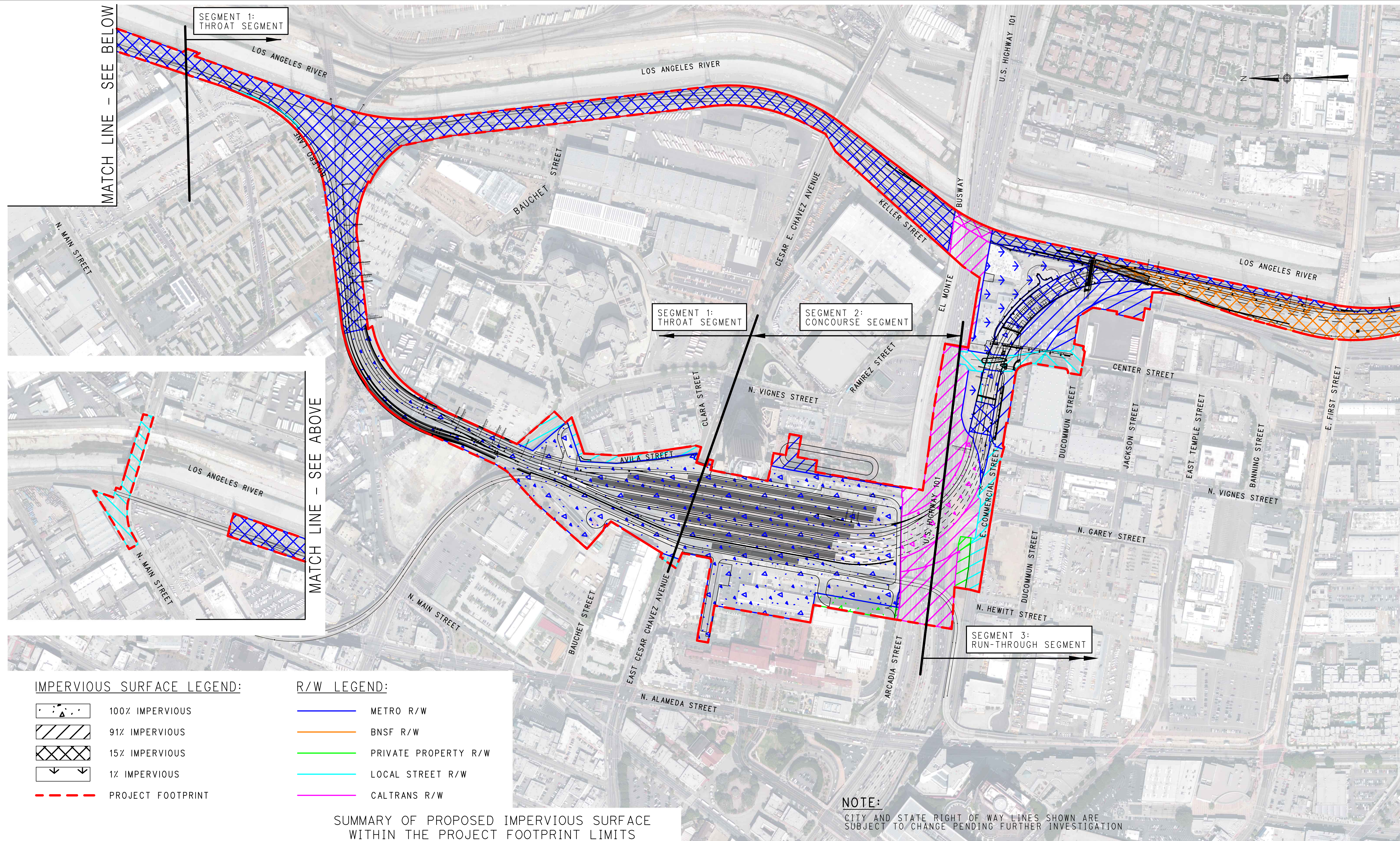

**IMPERVIOUS SURFACE LEGEND:**

- 100% IMPERVIOUS
- 91% IMPERVIOUS
- 15% IMPERVIOUS
- 1% IMPERVIOUS
- PROJECT FOOTPRINT

**R/W LEGEND:**

- METRO R/W
- BNSF R/W
- PRIVATE PROPERTY R/W
- LOCAL STREET R/W
- CALTRANS R/W

**SUMMARY OF PROPOSED IMPERVIOUS SURFACE WITHIN THE PROJECT FOOTPRINT LIMITS**

SUBAREA	METRO R/W	BNSF R/W	PRIVATE PROPERTY R/W	LOCAL STREET R/W			TOTAL	IMPERVIOUS SURFACE (%)	IMPERVIOUS SURFACE AREA (ACRES)
				LOCAL STREET R/W	CALTRANS R/W	TOTAL			
	29.55	0.06	0.61	0.27	2.20	32.70	100	32.70	
	4.28	-	0.38	4.69	7.00	16.35	91	14.88	
	27.79	5.20	-	0.13	0.31	33.42	15	5.01	
	3.23	-	-	-	-	3.23	1	0.03	
<b>TOTAL</b>	<b>64.85</b>	<b>5.26</b>	<b>0.99</b>	<b>5.09</b>	<b>9.51</b>	<b>85.70</b>		<b>52.62</b>	

**NOTE:**  
CITY AND STATE RIGHT OF WAY LINES SHOWN ARE SUBJECT TO CHANGE PENDING FURTHER INVESTIGATION

MATCH LINE  
 SEE EXHIBIT 2 OF 2

LINK UNION STATION PROJECT  
 BUILD ALTERNATIVE  
 PROPOSED IMPERVIOUS SURFACE EXHIBIT  
 SHEET 1 OF 2

SCALE: 1"=250'  
 DATE: 03-22-2023

3/22/2023 11:27:58 AM  
 c:\pwworking\sac\dl068890\Proposed\_Impervious\_Sheet\_2.dgn  
 p:\pwworking\sac\dl068890\Proposed\_Impervious\_Sheet\_2.dgn  
 c:\pwworking\sac\dl068890\Proposed\_Impervious\_Sheet\_2.dgn

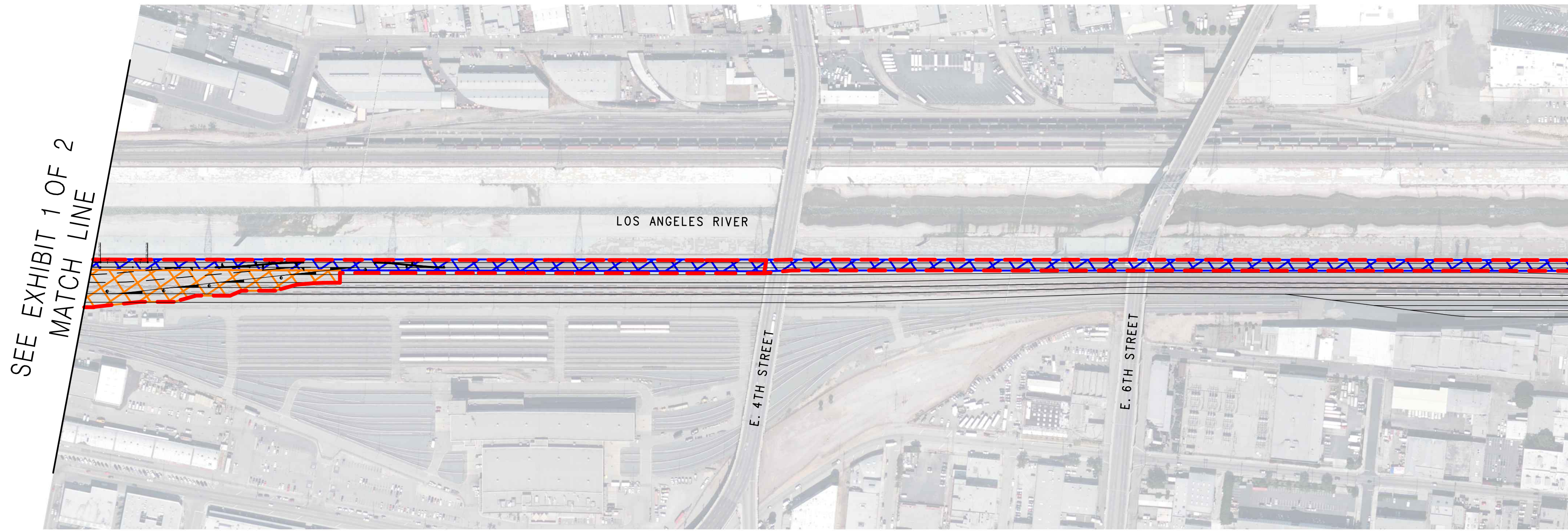



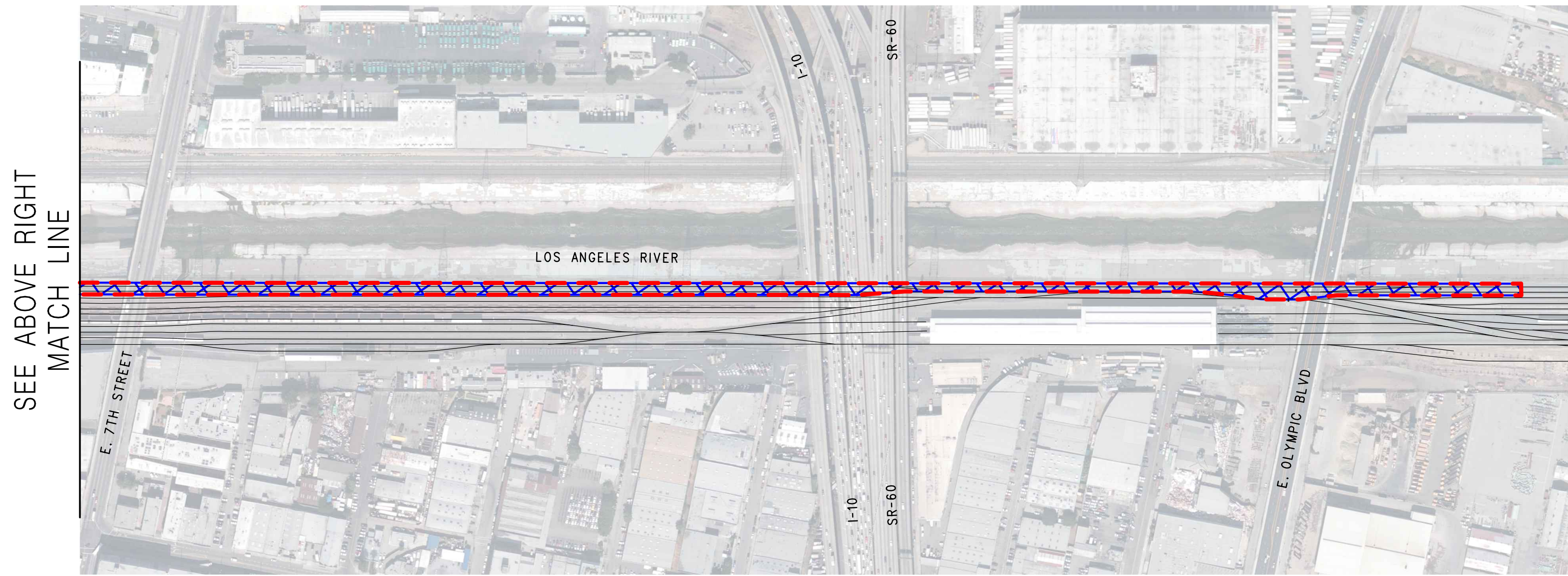
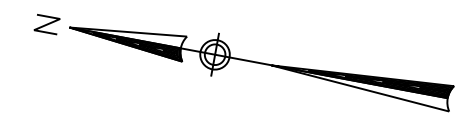

SEE EXHIBIT 1 OF 2  
MATCH LINE

MATCH LINE  
SEE BELOW LEFT



SEE ABOVE RIGHT  
MATCH LINE

IMPERVIOUS SURFACE LEGEND:  
 15% IMPERVIOUS  
 PROJECT FOOTPRINT

R/W LEGEND:  
 METRO R/W  
 BNSF R/W

NOTE:  
 CITY AND STATE RIGHT OF WAY LINES SHOWN ARE  
 SUBJECT TO CHANGE PENDING FURTHER INVESTIGATION

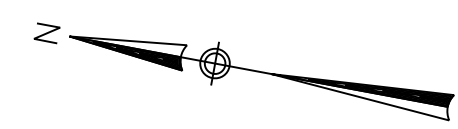

LINK UNION STATION PROJECT  
 BUILD ALTERNATIVE  
 PROPOSED IMPERVIOUS SURFACE EXHIBIT  
 SHEET 2 OF 2

SCALE: 1"=250'  
 DATE: 03-22-2023

# Appendix F: Stormwater Quantity Calculations for the Build Alternative

(THIS PAGE INTENTIONALLY LEFT BLANK)

## Peak Flow Hydrologic Analysis

File location: C:/Users/vrodriguez/Desktop/Link Union Station - Subarea A1 (LID).pdf  
Version: HydroCalc 0.3.0-beta

### Input Parameters

Project Name	Link Union Station
Subarea ID	Subarea A1 (LID)
Area (ac)	7.38
Flow Path Length (ft)	1000.0
Flow Path Slope (vft/hft)	0.02
85th Percentile Rainfall Depth (in)	1.0
Percent Impervious	1.0
Soil Type	6
Design Storm Frequency	85th percentile storm
Fire Factor	0
LID	True

### Output Results

Modeled (85th percentile storm) Rainfall Depth (in)	1.0
Peak Intensity (in/hr)	0.2493
Undeveloped Runoff Coefficient (Cu)	0.1
Developed Runoff Coefficient (Cd)	0.9
Time of Concentration (min)	32.0
Clear Peak Flow Rate (cfs)	1.6561
Burned Peak Flow Rate (cfs)	1.6561
24-Hr Clear Runoff Volume (ac-ft)	0.5489
24-Hr Clear Runoff Volume (cu-ft)	23911.5128

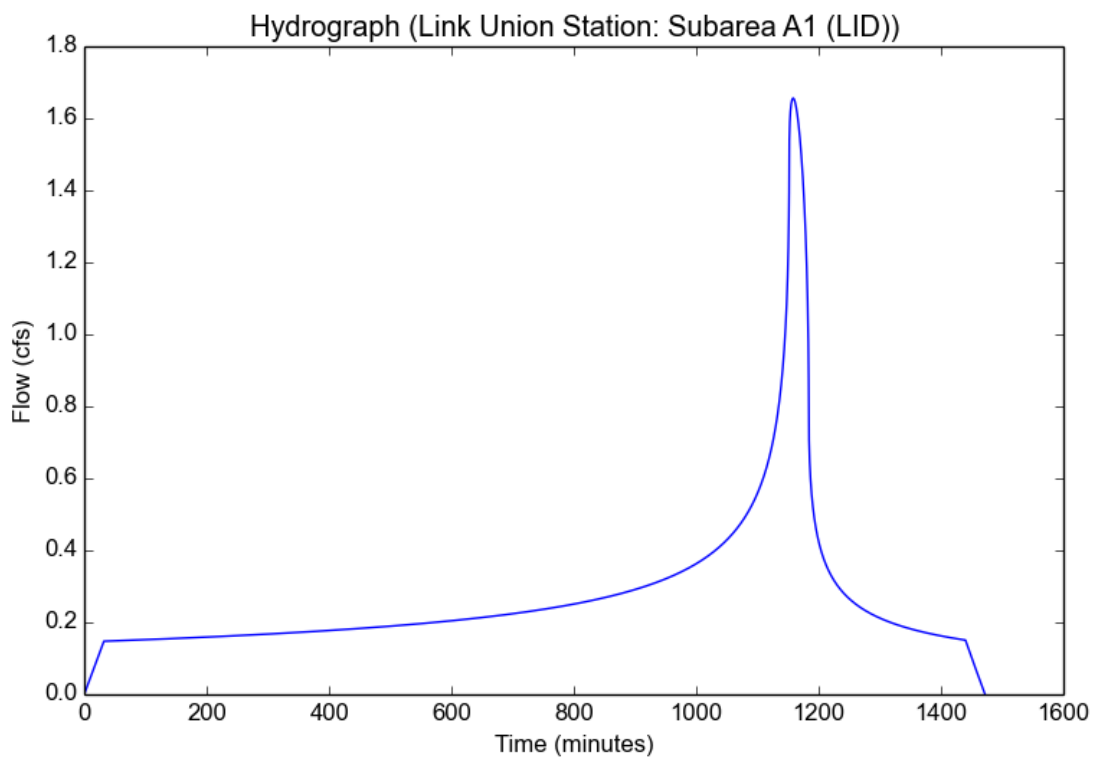

## Peak Flow Hydrologic Analysis

File location: C:/Users/vrodriguez/Desktop/Link Union Station - Subarea A2 (LID).pdf  
Version: HydroCalc 0.3.0-beta

### Input Parameters

Project Name	Link Union Station
Subarea ID	Subarea A2 (LID)
Area (ac)	5.48
Flow Path Length (ft)	700.0
Flow Path Slope (vft/hft)	0.02
85th Percentile Rainfall Depth (in)	1.0
Percent Impervious	1.0
Soil Type	6
Design Storm Frequency	85th percentile storm
Fire Factor	0
LID	True

### Output Results

Modeled (85th percentile storm) Rainfall Depth (in)	1.0
Peak Intensity (in/hr)	0.2749
Undeveloped Runoff Coefficient (Cu)	0.1
Developed Runoff Coefficient (Cd)	0.9
Time of Concentration (min)	26.0
Clear Peak Flow Rate (cfs)	1.3558
Burned Peak Flow Rate (cfs)	1.3558
24-Hr Clear Runoff Volume (ac-ft)	0.4076
24-Hr Clear Runoff Volume (cu-ft)	17755.3527

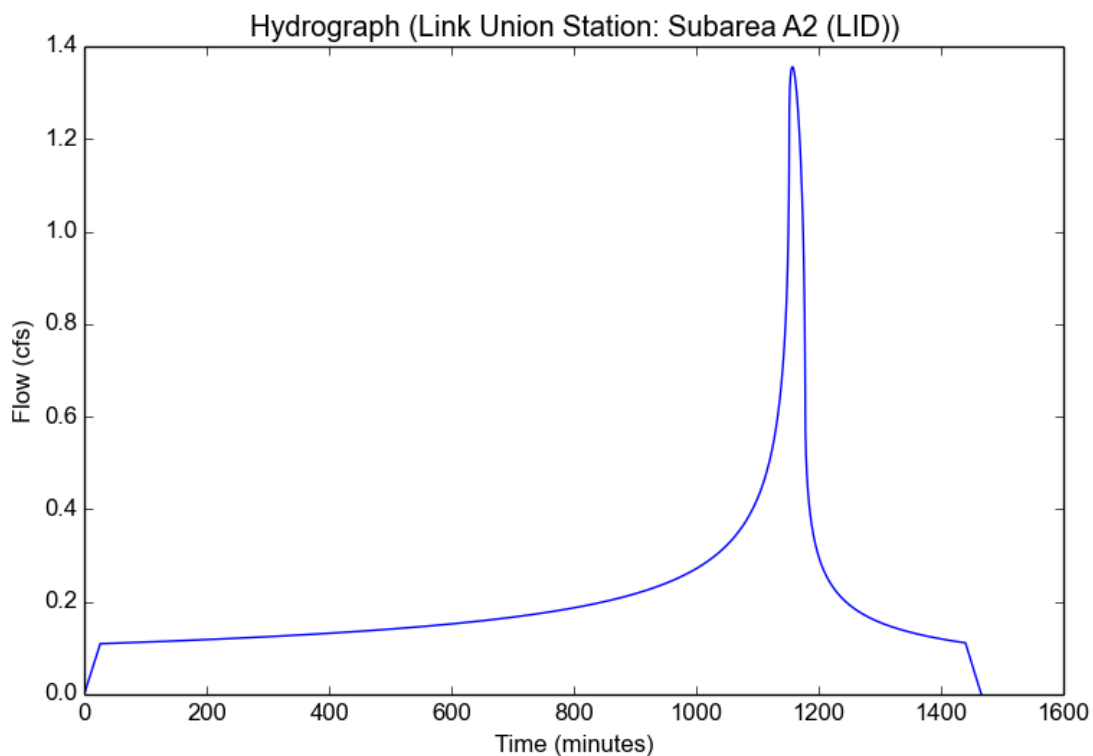

## Peak Flow Hydrologic Analysis

File location: C:/Users/vrodriguez/Desktop/Link Union Station - Subarea A3 (LID).pdf  
Version: HydroCalc 0.3.0-beta

### Input Parameters

Project Name	Link Union Station
Subarea ID	Subarea A3 (LID)
Area (ac)	6.66
Flow Path Length (ft)	650.0
Flow Path Slope (vft/hft)	0.02
85th Percentile Rainfall Depth (in)	1.0
Percent Impervious	1.0
Soil Type	6
Design Storm Frequency	85th percentile storm
Fire Factor	0
LID	True

### Output Results

Modeled (85th percentile storm) Rainfall Depth (in)	1.0
Peak Intensity (in/hr)	0.2854
Undeveloped Runoff Coefficient (Cu)	0.1
Developed Runoff Coefficient (Cd)	0.9
Time of Concentration (min)	24.0
Clear Peak Flow Rate (cfs)	1.7109
Burned Peak Flow Rate (cfs)	1.7109
24-Hr Clear Runoff Volume (ac-ft)	0.4954
24-Hr Clear Runoff Volume (cu-ft)	21578.5579

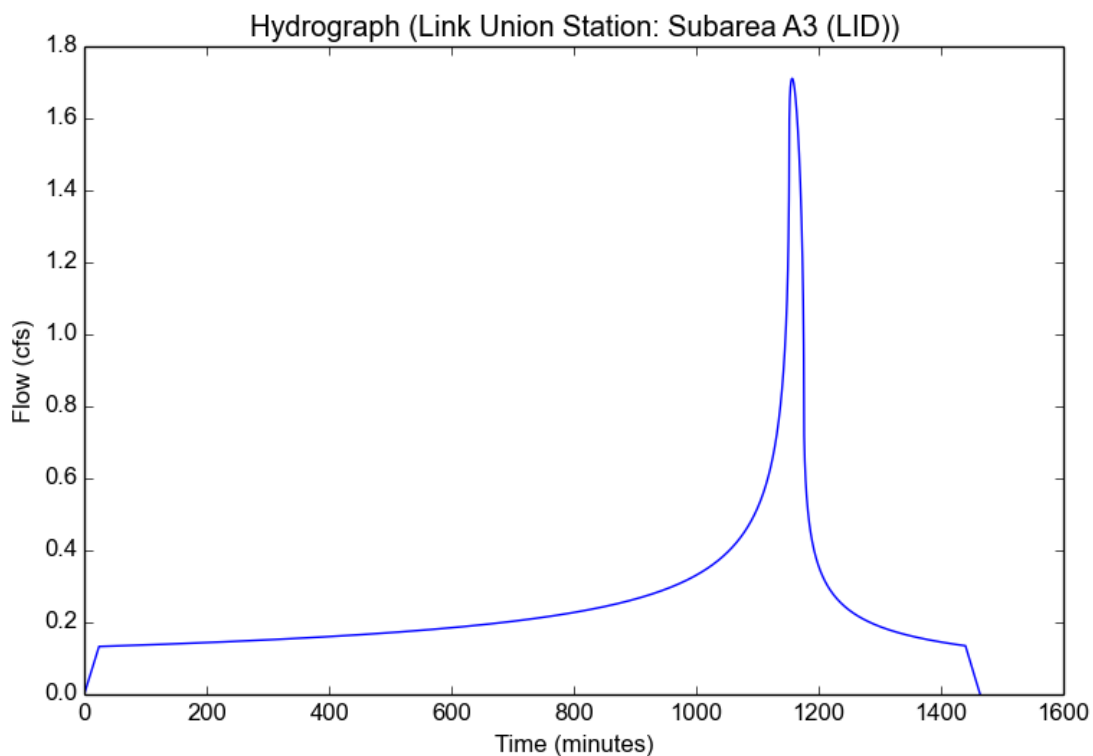

## Peak Flow Hydrologic Analysis

File location: C:/Users/vrodriguez/Desktop/Link Union Station - Subarea A4 (LID).pdf  
Version: HydroCalc 0.3.0-beta

### Input Parameters

Project Name	Link Union Station
Subarea ID	Subarea A4 (LID)
Area (ac)	0.57
Flow Path Length (ft)	500.0
Flow Path Slope (vft/hft)	0.02
85th Percentile Rainfall Depth (in)	1.0
Percent Impervious	1.0
Soil Type	6
Design Storm Frequency	85th percentile storm
Fire Factor	0
LID	True

### Output Results

Modeled (85th percentile storm) Rainfall Depth (in)	1.0
Peak Intensity (in/hr)	0.3039
Undeveloped Runoff Coefficient (Cu)	0.1
Developed Runoff Coefficient (Cd)	0.9
Time of Concentration (min)	21.0
Clear Peak Flow Rate (cfs)	0.1559
Burned Peak Flow Rate (cfs)	0.1559
24-Hr Clear Runoff Volume (ac-ft)	0.0424
24-Hr Clear Runoff Volume (cu-ft)	1846.8103

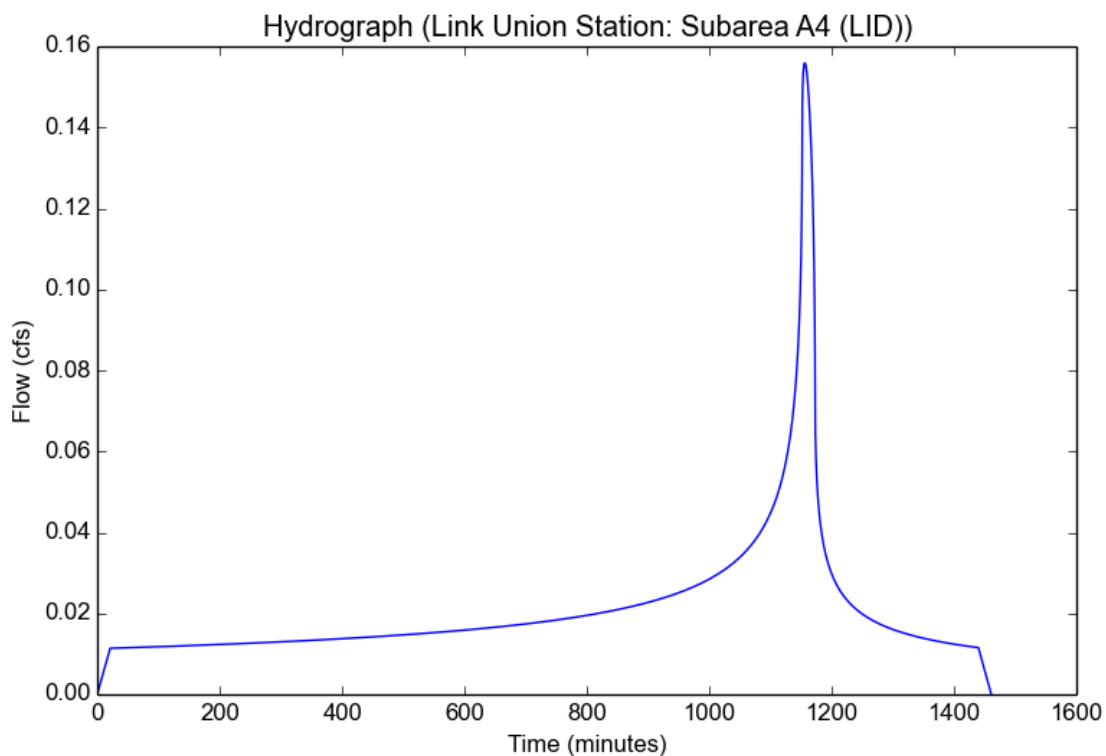

## Peak Flow Hydrologic Analysis

File location: C:/Users/vrodriguez/Desktop/Link Union Station - Subarea A5 (LID).pdf  
Version: HydroCalc 0.3.0-beta

### Input Parameters

Project Name	Link Union Station
Subarea ID	Subarea A5 (LID)
Area (ac)	2.61
Flow Path Length (ft)	620.0
Flow Path Slope (vft/hft)	0.02
85th Percentile Rainfall Depth (in)	1.0
Percent Impervious	1.0
Soil Type	6
Design Storm Frequency	85th percentile storm
Fire Factor	0
LID	True

### Output Results

Modeled (85th percentile storm) Rainfall Depth (in)	1.0
Peak Intensity (in/hr)	0.2854
Undeveloped Runoff Coefficient (Cu)	0.1
Developed Runoff Coefficient (Cd)	0.9
Time of Concentration (min)	24.0
Clear Peak Flow Rate (cfs)	0.6705
Burned Peak Flow Rate (cfs)	0.6705
24-Hr Clear Runoff Volume (ac-ft)	0.1941
24-Hr Clear Runoff Volume (cu-ft)	8456.4619

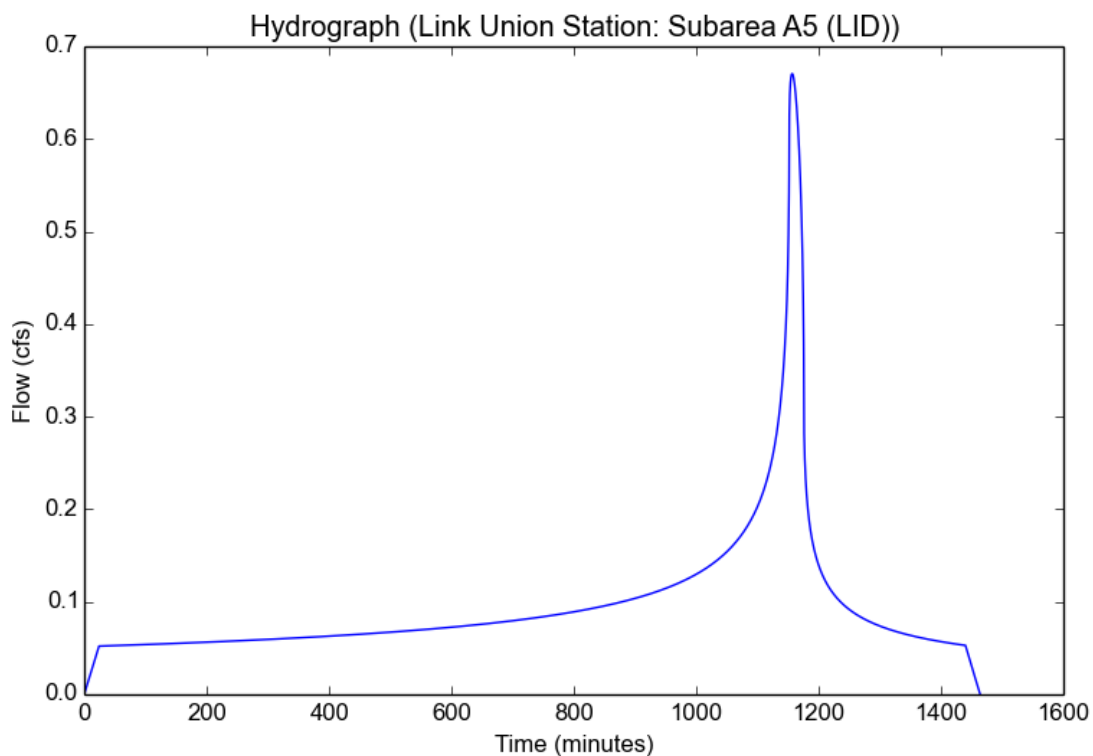

## Peak Flow Hydrologic Analysis

File location: C:/Users/vrodriguez/Desktop/Link Union Station - Subarea A6 (LID).pdf  
Version: HydroCalc 0.3.0-beta

### Input Parameters

Project Name	Link Union Station
Subarea ID	Subarea A6 (LID)
Area (ac)	0.7
Flow Path Length (ft)	480.0
Flow Path Slope (vft/hft)	0.02
85th Percentile Rainfall Depth (in)	1.0
Percent Impervious	1.0
Soil Type	6
Design Storm Frequency	85th percentile storm
Fire Factor	0
LID	True

### Output Results

Modeled (85th percentile storm) Rainfall Depth (in)	1.0
Peak Intensity (in/hr)	0.311
Undeveloped Runoff Coefficient (Cu)	0.1
Developed Runoff Coefficient (Cd)	0.9
Time of Concentration (min)	20.0
Clear Peak Flow Rate (cfs)	0.1959
Burned Peak Flow Rate (cfs)	0.1959
24-Hr Clear Runoff Volume (ac-ft)	0.0521
24-Hr Clear Runoff Volume (cu-ft)	2268.0115

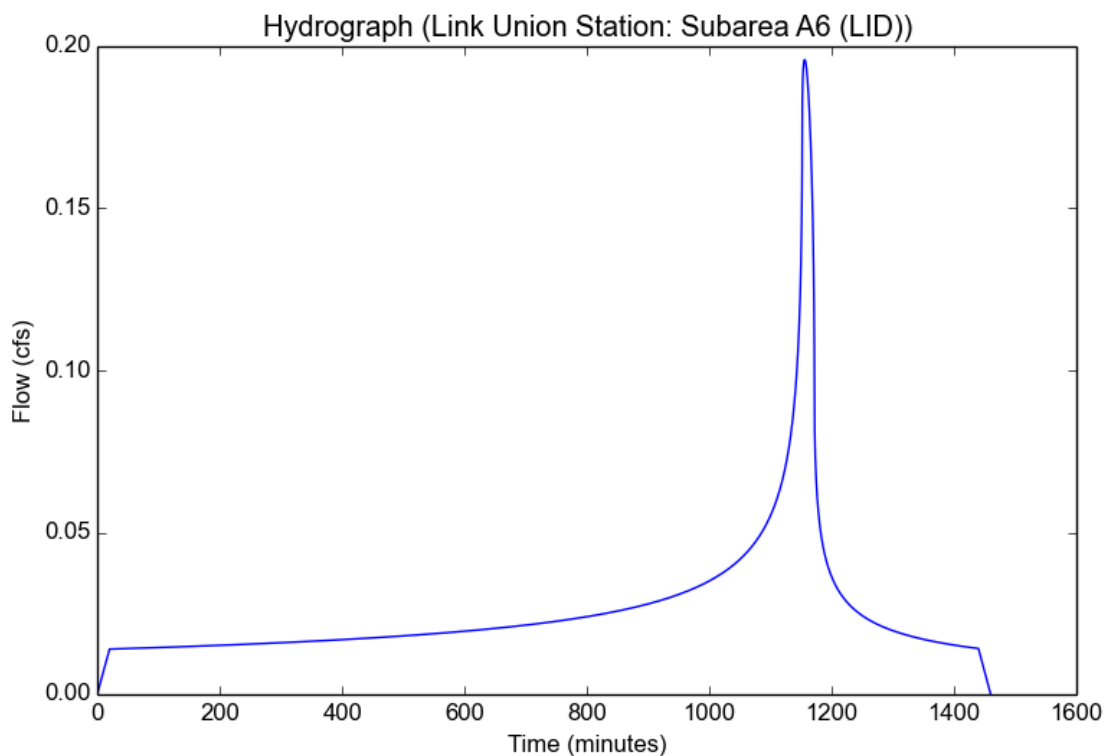

## Peak Flow Hydrologic Analysis

File location: C:/Users/vrodriguez/Desktop/Link Union Station - Subarea A7 (LID).pdf  
Version: HydroCalc 0.3.0-beta

### Input Parameters

Project Name	Link Union Station
Subarea ID	Subarea A7 (LID)
Area (ac)	0.71
Flow Path Length (ft)	910.0
Flow Path Slope (vft/hft)	0.02
85th Percentile Rainfall Depth (in)	1.0
Percent Impervious	1.0
Soil Type	6
Design Storm Frequency	85th percentile storm
Fire Factor	0
LID	True

### Output Results

Modeled (85th percentile storm) Rainfall Depth (in)	1.0
Peak Intensity (in/hr)	0.257
Undeveloped Runoff Coefficient (Cu)	0.1
Developed Runoff Coefficient (Cd)	0.9
Time of Concentration (min)	30.0
Clear Peak Flow Rate (cfs)	0.1642
Burned Peak Flow Rate (cfs)	0.1642
24-Hr Clear Runoff Volume (ac-ft)	0.0528
24-Hr Clear Runoff Volume (cu-ft)	2300.4264

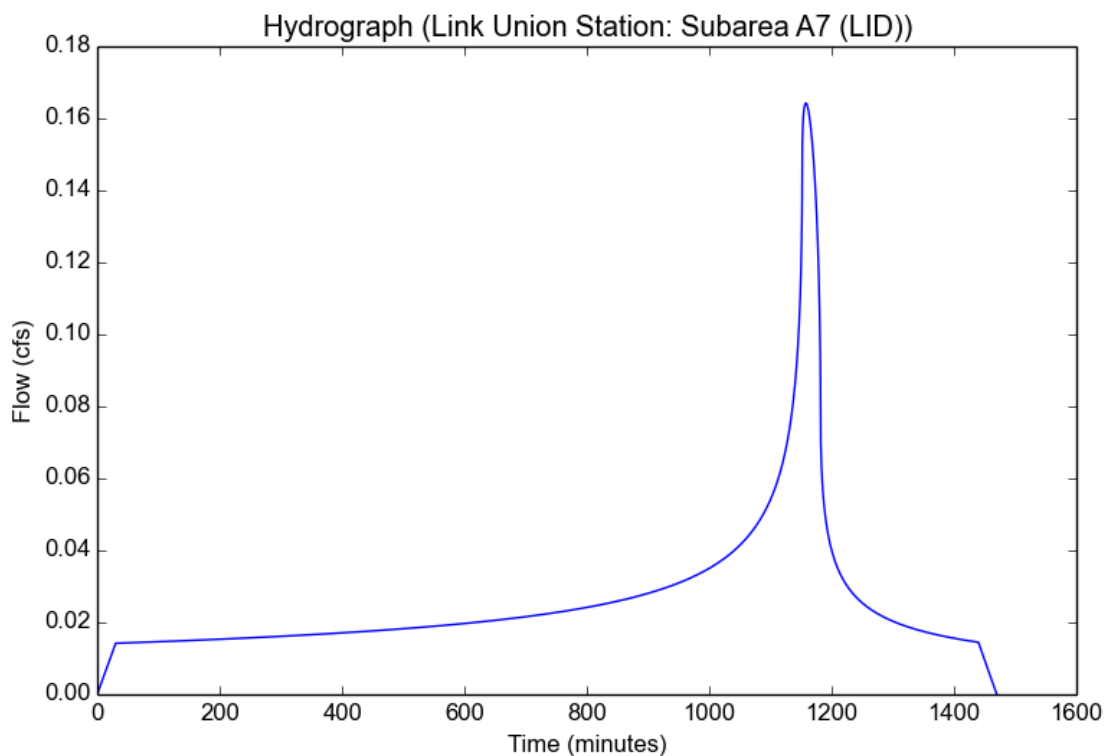

## Peak Flow Hydrologic Analysis

File location: C:/Users/vrodriguez/Desktop/Link Union Station - Subarea A8 (LID).pdf  
Version: HydroCalc 0.3.0-beta

### Input Parameters

Project Name	Link Union Station
Subarea ID	Subarea A8 (LID)
Area (ac)	0.39
Flow Path Length (ft)	300.0
Flow Path Slope (vft/hft)	0.02
85th Percentile Rainfall Depth (in)	1.0
Percent Impervious	1.0
Soil Type	6
Design Storm Frequency	85th percentile storm
Fire Factor	0
LID	True

### Output Results

Modeled (85th percentile storm) Rainfall Depth (in)	1.0
Peak Intensity (in/hr)	0.356
Undeveloped Runoff Coefficient (Cu)	0.1
Developed Runoff Coefficient (Cd)	0.9
Time of Concentration (min)	15.0
Clear Peak Flow Rate (cfs)	0.125
Burned Peak Flow Rate (cfs)	0.125
24-Hr Clear Runoff Volume (ac-ft)	0.029
24-Hr Clear Runoff Volume (cu-ft)	1263.6036

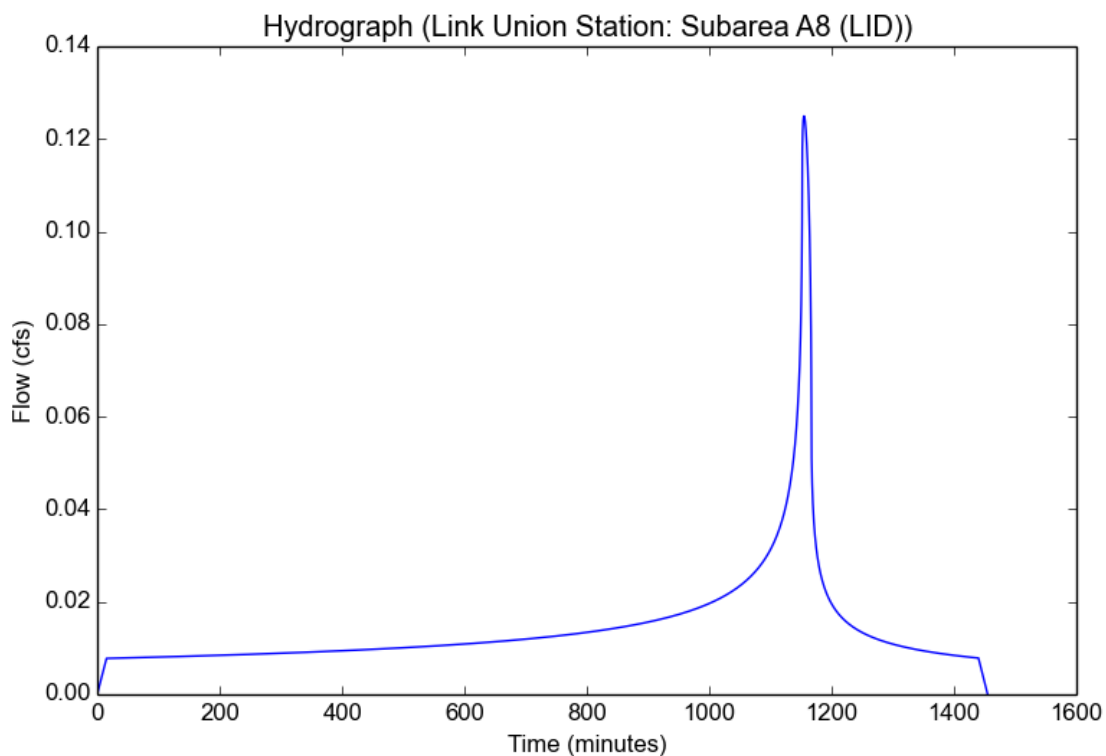

## Peak Flow Hydrologic Analysis

File location: C:/Users/vrodriguez/Desktop/Link US/Calculations/HydroCalc/Link Union Station Report.pdf  
Version: HydroCalc 0.3.0-beta

### Input Parameters

Project Name	Link Union Station
Subarea ID	Subarea D (LID)
Area (ac)	3.62
Flow Path Length (ft)	285.18
Flow Path Slope (vft/hft)	0.01
85th Percentile Rainfall Depth (in)	1.0
Percent Impervious	0.76
Soil Type	6
Design Storm Frequency	85th percentile storm
Fire Factor	0
LID	True

### Output Results

Modeled (85th percentile storm) Rainfall Depth (in)	1.0
Peak Intensity (in/hr)	0.3186
Undeveloped Runoff Coefficient (Cu)	0.1
Developed Runoff Coefficient (Cd)	0.708
Time of Concentration (min)	19.0
Clear Peak Flow Rate (cfs)	0.8165
Burned Peak Flow Rate (cfs)	0.8165
24-Hr Clear Runoff Volume (ac-ft)	0.2118
24-Hr Clear Runoff Volume (cu-ft)	9226.6982

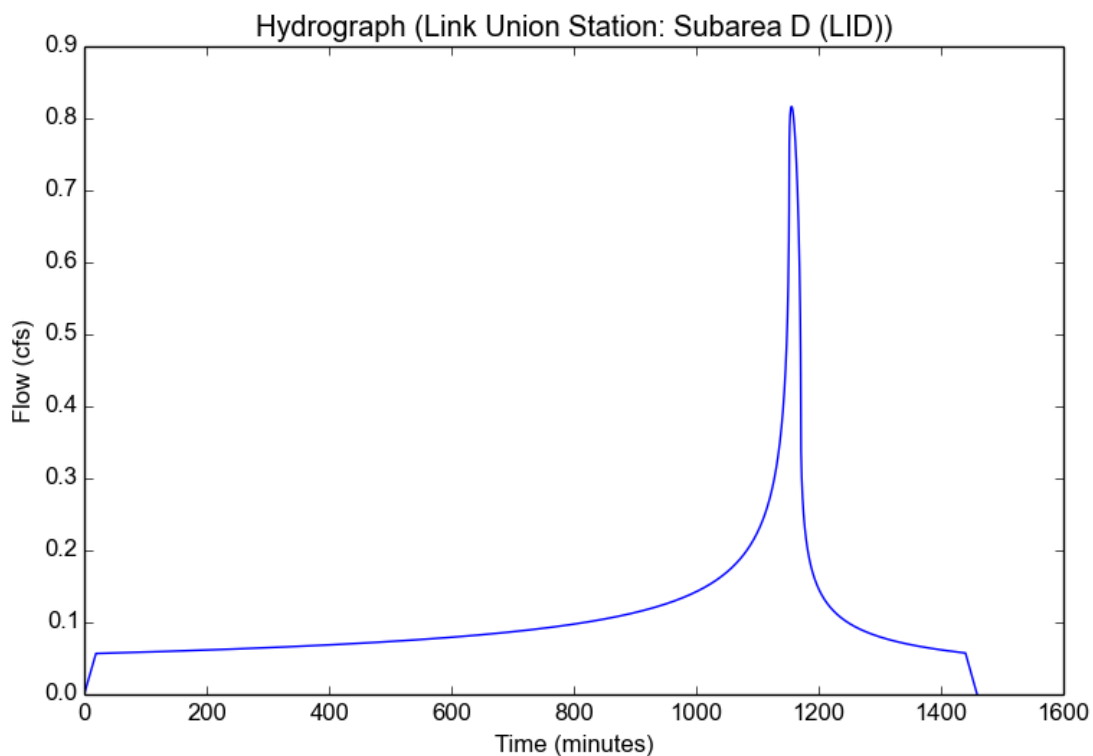

## Peak Flow Hydrologic Analysis

File location: C:/Users/vrodriguez/Desktop/Link US/Calculations/HydroCalc/Link Union Station Report.pdf  
Version: HydroCalc 0.3.0-beta

### Input Parameters

Project Name	Link Union Station
Subarea ID	Subarea E (LID)
Area (ac)	3.36
Flow Path Length (ft)	294.56
Flow Path Slope (vft/hft)	0.01
85th Percentile Rainfall Depth (in)	1.0
Percent Impervious	0.18
Soil Type	6
Design Storm Frequency	85th percentile storm
Fire Factor	0
LID	True

### Output Results

Modeled (85th percentile storm) Rainfall Depth (in)	1.0
Peak Intensity (in/hr)	0.2219
Undeveloped Runoff Coefficient (Cu)	0.1
Developed Runoff Coefficient (Cd)	0.244
Time of Concentration (min)	41.0
Clear Peak Flow Rate (cfs)	0.1819
Burned Peak Flow Rate (cfs)	0.1819
24-Hr Clear Runoff Volume (ac-ft)	0.0678
24-Hr Clear Runoff Volume (cu-ft)	2951.4878

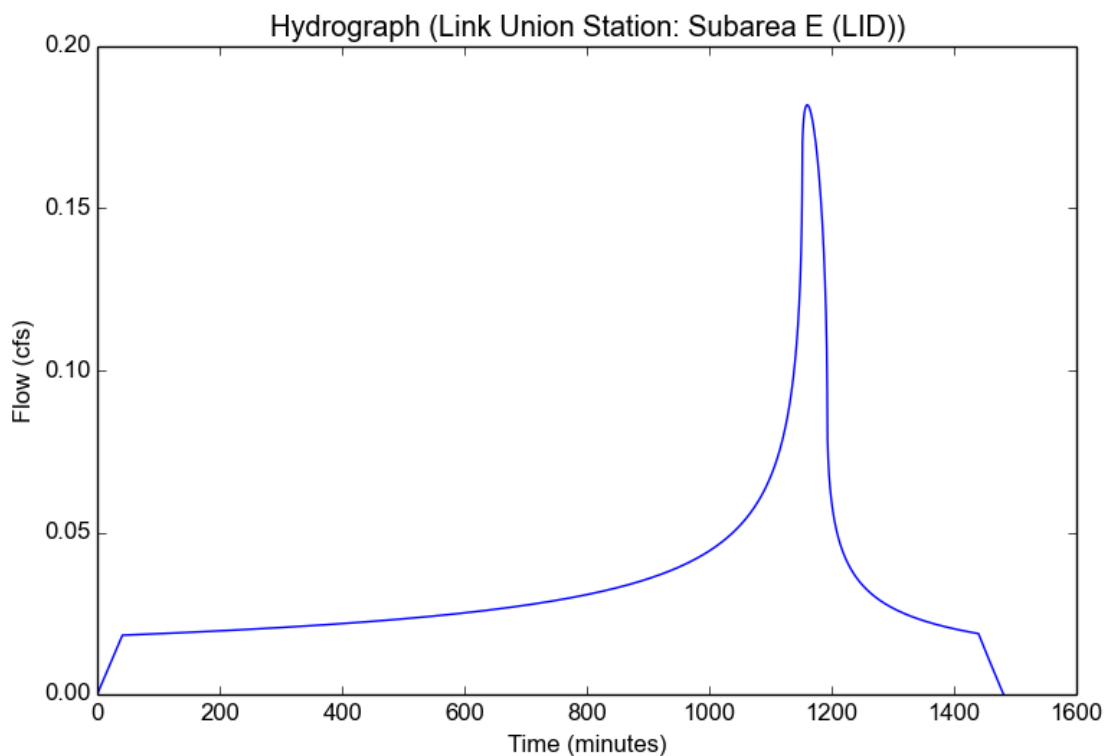

## Peak Flow Hydrologic Analysis

File location: C:/Users/vrodriguez/Desktop/Link US/Calculations/HydroCalc/Link Union Station Report.pdf  
Version: HydroCalc 0.3.0-beta

### Input Parameters

Project Name	Link Union Station
Subarea ID	Subarea F (LID)
Area (ac)	1.81
Flow Path Length (ft)	355.81
Flow Path Slope (vft/hft)	0.02
85th Percentile Rainfall Depth (in)	1.0
Percent Impervious	0.19
Soil Type	6
Design Storm Frequency	85th percentile storm
Fire Factor	0
LID	True

### Output Results

Modeled (85th percentile storm) Rainfall Depth (in)	1.0
Peak Intensity (in/hr)	0.2245
Undeveloped Runoff Coefficient (Cu)	0.1
Developed Runoff Coefficient (Cd)	0.252
Time of Concentration (min)	40.0
Clear Peak Flow Rate (cfs)	0.1024
Burned Peak Flow Rate (cfs)	0.1024
24-Hr Clear Runoff Volume (ac-ft)	0.0377
24-Hr Clear Runoff Volume (cu-ft)	1642.0657

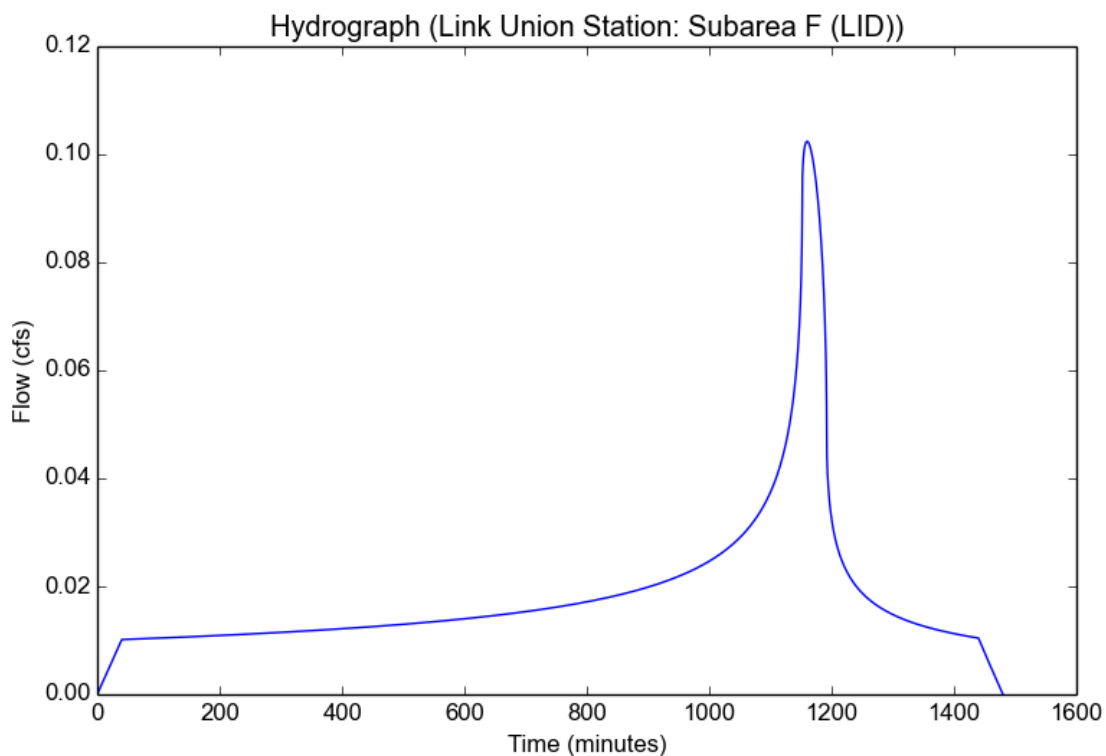

## Peak Flow Hydrologic Analysis

File location: C:/Users/vrodriguez/Desktop/Link US/Calculations/HydroCalc/Link Union Station Report.pdf  
Version: HydroCalc 0.3.0-beta

### Input Parameters

Project Name	Link Union Station
Subarea ID	Subarea G (LID)
Area (ac)	1.7
Flow Path Length (ft)	677.25
Flow Path Slope (vft/hft)	0.02
85th Percentile Rainfall Depth (in)	1.0
Percent Impervious	0.35
Soil Type	6
Design Storm Frequency	85th percentile storm
Fire Factor	0
LID	True

### Output Results

Modeled (85th percentile storm) Rainfall Depth (in)	1.0
Peak Intensity (in/hr)	0.2124
Undeveloped Runoff Coefficient (Cu)	0.1
Developed Runoff Coefficient (Cd)	0.38
Time of Concentration (min)	45.0
Clear Peak Flow Rate (cfs)	0.1372
Burned Peak Flow Rate (cfs)	0.1372
24-Hr Clear Runoff Volume (ac-ft)	0.0534
24-Hr Clear Runoff Volume (cu-ft)	2325.6607

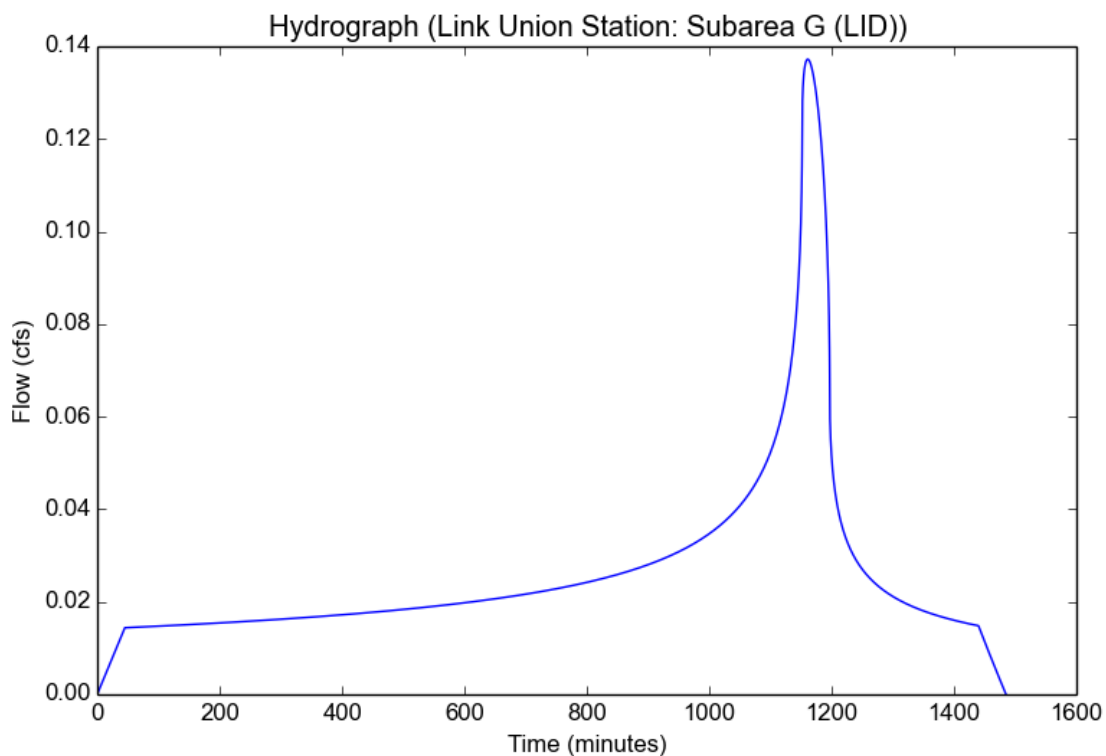

## Peak Flow Hydrologic Analysis

File location: C:/Users/vrodriguez/Desktop/Link US/Calculations/HydroCalc/Link Union Station Report.pdf  
Version: HydroCalc 0.3.0-beta

### Input Parameters

Project Name	Link Union Station
Subarea ID	Subarea H (LID)
Area (ac)	3.8
Flow Path Length (ft)	2753.72
Flow Path Slope (vft/hft)	0.02
85th Percentile Rainfall Depth (in)	1.0
Percent Impervious	0.17
Soil Type	6
Design Storm Frequency	85th percentile storm
Fire Factor	0
LID	True

### Output Results

Modeled (85th percentile storm) Rainfall Depth (in)	1.0
Peak Intensity (in/hr)	0.1191
Undeveloped Runoff Coefficient (Cu)	0.1
Developed Runoff Coefficient (Cd)	0.236
Time of Concentration (min)	154.0
Clear Peak Flow Rate (cfs)	0.1069
Burned Peak Flow Rate (cfs)	0.1069
24-Hr Clear Runoff Volume (ac-ft)	0.0741
24-Hr Clear Runoff Volume (cu-ft)	3229.5427

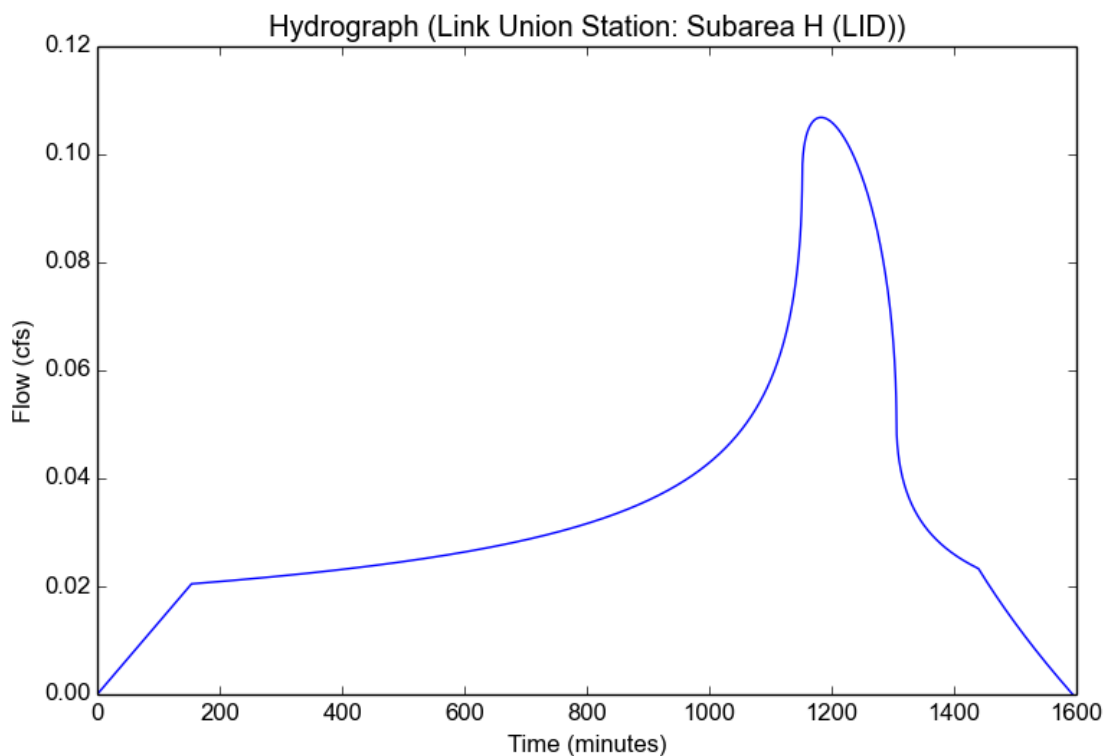

## Peak Flow Hydrologic Analysis

File location: C:/Users/vrodriguez/Desktop/Link Union Station - Subarea A1 (LID).pdf  
Version: HydroCalc 0.3.0-beta

### Input Parameters

Project Name	Link Union Station
Subarea ID	Subarea A1 (LID)
Area (ac)	7.38
Flow Path Length (ft)	1000.0
Flow Path Slope (vft/hft)	0.02
85th Percentile Rainfall Depth (in)	1.0
Percent Impervious	1.0
Soil Type	6
Design Storm Frequency	85th percentile storm
Fire Factor	0
LID	True

### Output Results

Modeled (85th percentile storm) Rainfall Depth (in)	1.0
Peak Intensity (in/hr)	0.2493
Undeveloped Runoff Coefficient (Cu)	0.1
Developed Runoff Coefficient (Cd)	0.9
Time of Concentration (min)	32.0
Clear Peak Flow Rate (cfs)	1.6561
Burned Peak Flow Rate (cfs)	1.6561
24-Hr Clear Runoff Volume (ac-ft)	0.5489
24-Hr Clear Runoff Volume (cu-ft)	23911.5128

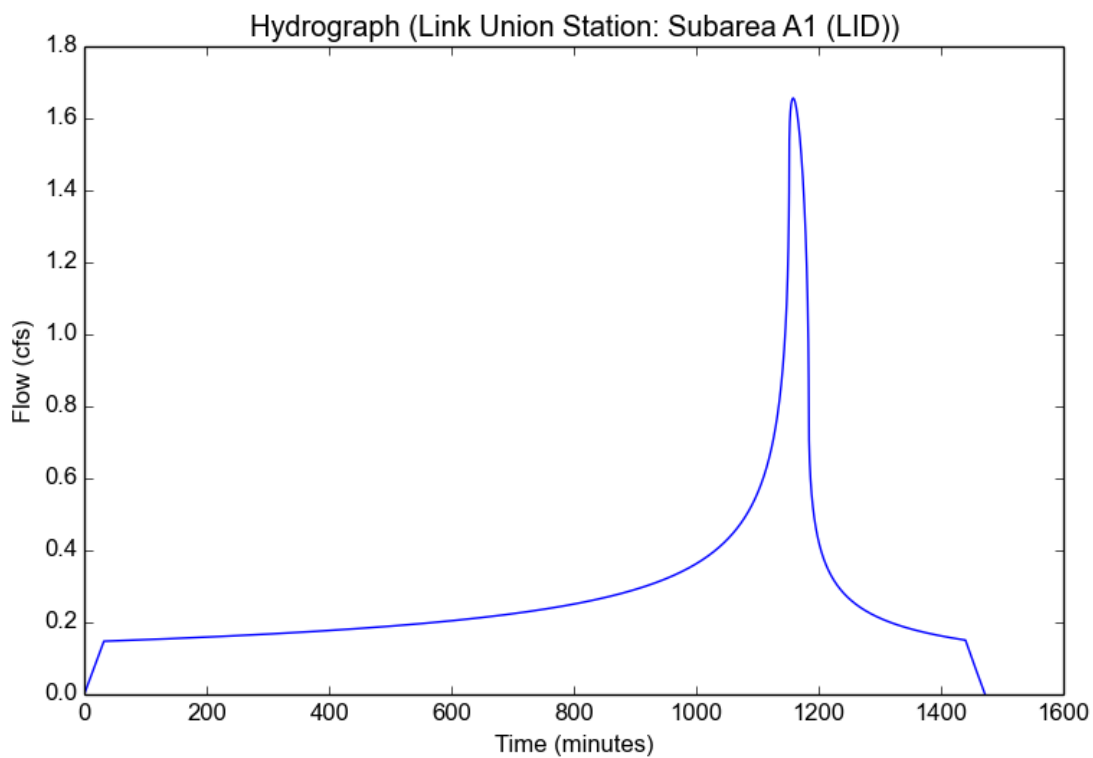

## Peak Flow Hydrologic Analysis

File location: C:/Users/vrodriguez/Desktop/Link Union Station - Subarea A2 (LID).pdf  
Version: HydroCalc 0.3.0-beta

### Input Parameters

Project Name	Link Union Station
Subarea ID	Subarea A2 (LID)
Area (ac)	5.48
Flow Path Length (ft)	700.0
Flow Path Slope (vft/hft)	0.02
85th Percentile Rainfall Depth (in)	1.0
Percent Impervious	1.0
Soil Type	6
Design Storm Frequency	85th percentile storm
Fire Factor	0
LID	True

### Output Results

Modeled (85th percentile storm) Rainfall Depth (in)	1.0
Peak Intensity (in/hr)	0.2749
Undeveloped Runoff Coefficient (Cu)	0.1
Developed Runoff Coefficient (Cd)	0.9
Time of Concentration (min)	26.0
Clear Peak Flow Rate (cfs)	1.3558
Burned Peak Flow Rate (cfs)	1.3558
24-Hr Clear Runoff Volume (ac-ft)	0.4076
24-Hr Clear Runoff Volume (cu-ft)	17755.3527

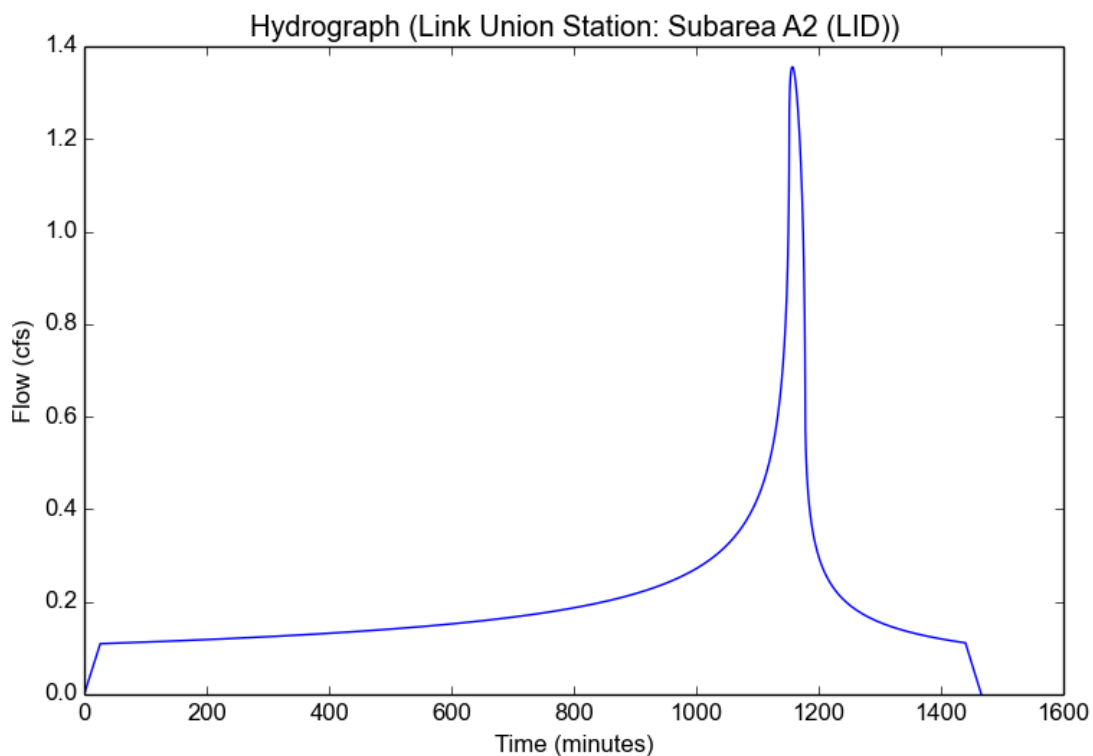

## Peak Flow Hydrologic Analysis

File location: C:/Users/vrodriguez/Desktop/Link Union Station - Subarea A3 (LID).pdf  
Version: HydroCalc 0.3.0-beta

### Input Parameters

Project Name	Link Union Station
Subarea ID	Subarea A3 (LID)
Area (ac)	6.66
Flow Path Length (ft)	650.0
Flow Path Slope (vft/hft)	0.02
85th Percentile Rainfall Depth (in)	1.0
Percent Impervious	1.0
Soil Type	6
Design Storm Frequency	85th percentile storm
Fire Factor	0
LID	True

### Output Results

Modeled (85th percentile storm) Rainfall Depth (in)	1.0
Peak Intensity (in/hr)	0.2854
Undeveloped Runoff Coefficient (Cu)	0.1
Developed Runoff Coefficient (Cd)	0.9
Time of Concentration (min)	24.0
Clear Peak Flow Rate (cfs)	1.7109
Burned Peak Flow Rate (cfs)	1.7109
24-Hr Clear Runoff Volume (ac-ft)	0.4954
24-Hr Clear Runoff Volume (cu-ft)	21578.5579

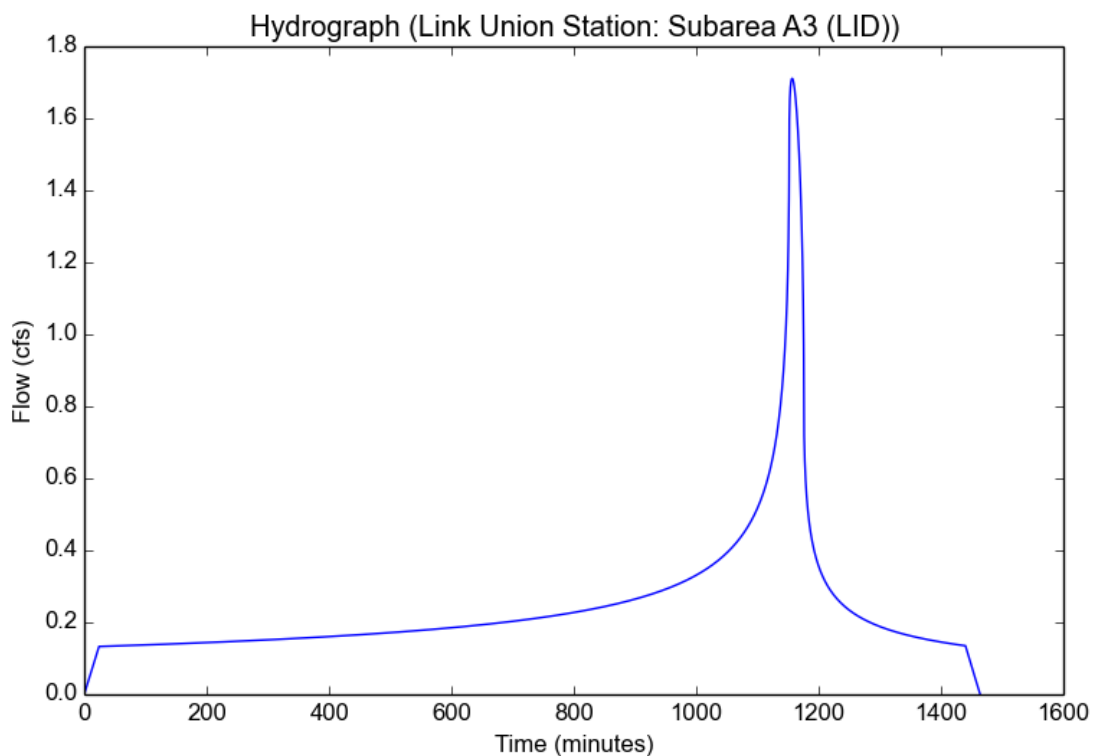

## Peak Flow Hydrologic Analysis

File location: C:/Users/vrodriguez/Desktop/Link Union Station - Subarea A4 (LID).pdf  
Version: HydroCalc 0.3.0-beta

### Input Parameters

Project Name	Link Union Station
Subarea ID	Subarea A4 (LID)
Area (ac)	0.57
Flow Path Length (ft)	500.0
Flow Path Slope (vft/hft)	0.02
85th Percentile Rainfall Depth (in)	1.0
Percent Impervious	1.0
Soil Type	6
Design Storm Frequency	85th percentile storm
Fire Factor	0
LID	True

### Output Results

Modeled (85th percentile storm) Rainfall Depth (in)	1.0
Peak Intensity (in/hr)	0.3039
Undeveloped Runoff Coefficient (Cu)	0.1
Developed Runoff Coefficient (Cd)	0.9
Time of Concentration (min)	21.0
Clear Peak Flow Rate (cfs)	0.1559
Burned Peak Flow Rate (cfs)	0.1559
24-Hr Clear Runoff Volume (ac-ft)	0.0424
24-Hr Clear Runoff Volume (cu-ft)	1846.8103

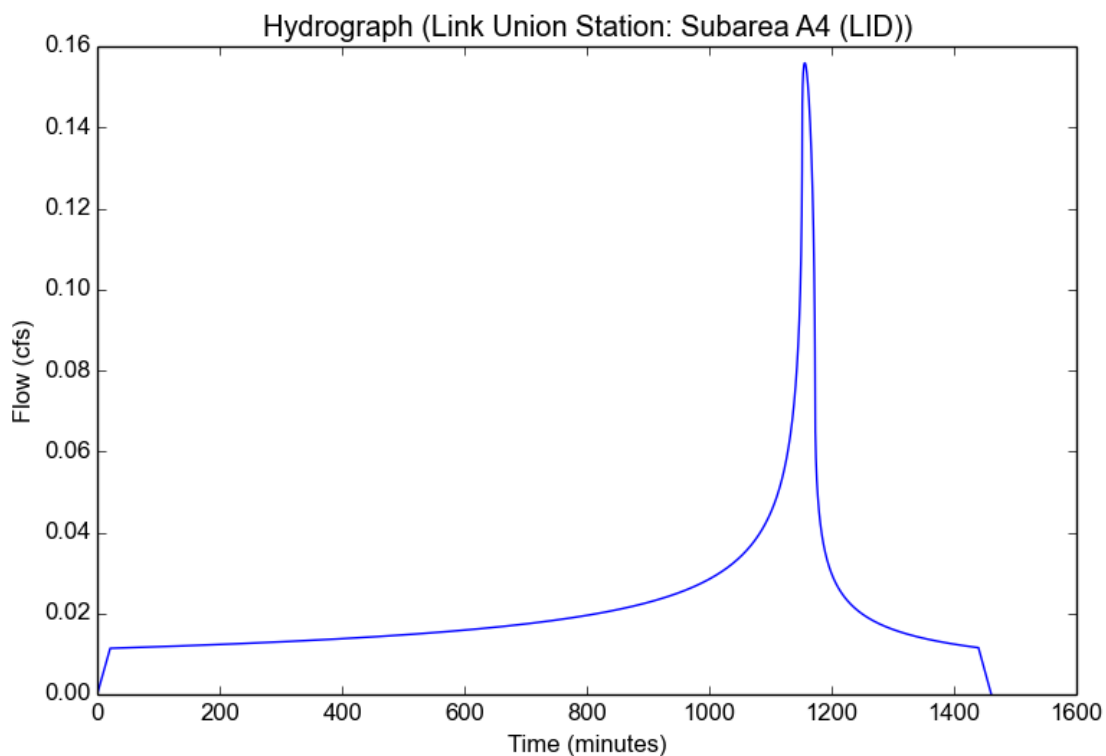

## Peak Flow Hydrologic Analysis

File location: C:/Users/vrodriguez/Desktop/Link Union Station - Subarea A5 (LID).pdf  
Version: HydroCalc 0.3.0-beta

### Input Parameters

Project Name	Link Union Station
Subarea ID	Subarea A5 (LID)
Area (ac)	2.61
Flow Path Length (ft)	620.0
Flow Path Slope (vft/hft)	0.02
85th Percentile Rainfall Depth (in)	1.0
Percent Impervious	1.0
Soil Type	6
Design Storm Frequency	85th percentile storm
Fire Factor	0
LID	True

### Output Results

Modeled (85th percentile storm) Rainfall Depth (in)	1.0
Peak Intensity (in/hr)	0.2854
Undeveloped Runoff Coefficient (Cu)	0.1
Developed Runoff Coefficient (Cd)	0.9
Time of Concentration (min)	24.0
Clear Peak Flow Rate (cfs)	0.6705
Burned Peak Flow Rate (cfs)	0.6705
24-Hr Clear Runoff Volume (ac-ft)	0.1941
24-Hr Clear Runoff Volume (cu-ft)	8456.4619

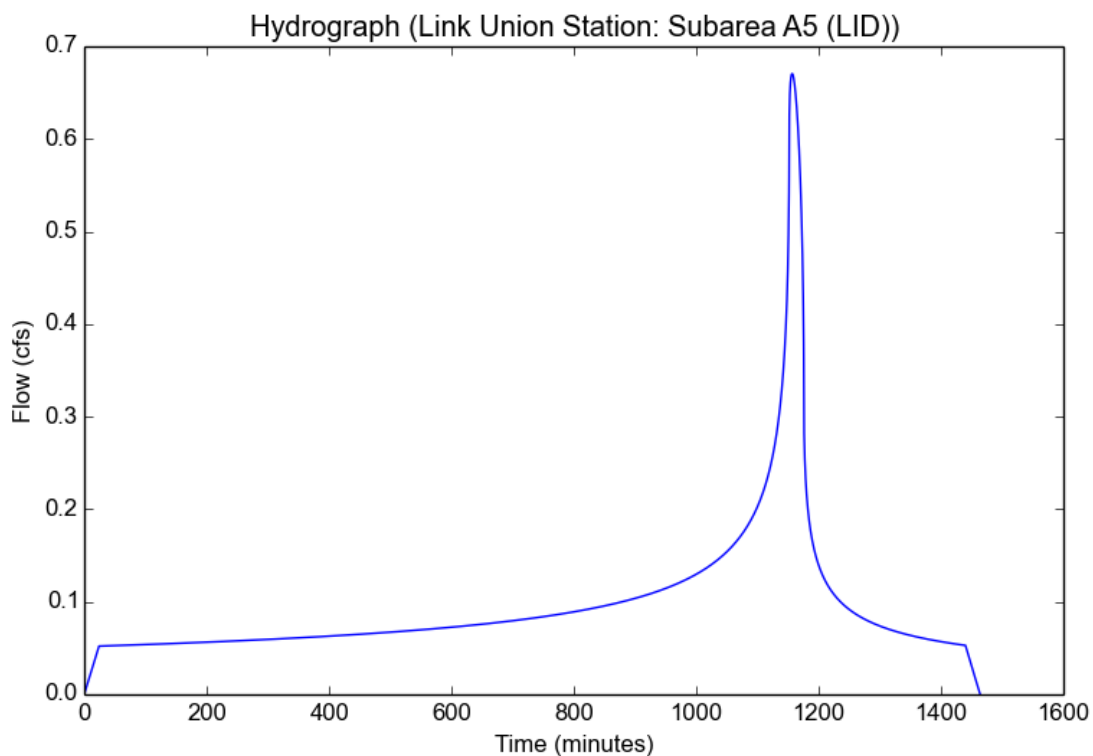

## Peak Flow Hydrologic Analysis

File location: C:/Users/vrodriguez/Desktop/Link Union Station - Subarea A6 (LID).pdf  
Version: HydroCalc 0.3.0-beta

### Input Parameters

Project Name	Link Union Station
Subarea ID	Subarea A6 (LID)
Area (ac)	0.7
Flow Path Length (ft)	480.0
Flow Path Slope (vft/hft)	0.02
85th Percentile Rainfall Depth (in)	1.0
Percent Impervious	1.0
Soil Type	6
Design Storm Frequency	85th percentile storm
Fire Factor	0
LID	True

### Output Results

Modeled (85th percentile storm) Rainfall Depth (in)	1.0
Peak Intensity (in/hr)	0.311
Undeveloped Runoff Coefficient (Cu)	0.1
Developed Runoff Coefficient (Cd)	0.9
Time of Concentration (min)	20.0
Clear Peak Flow Rate (cfs)	0.1959
Burned Peak Flow Rate (cfs)	0.1959
24-Hr Clear Runoff Volume (ac-ft)	0.0521
24-Hr Clear Runoff Volume (cu-ft)	2268.0115

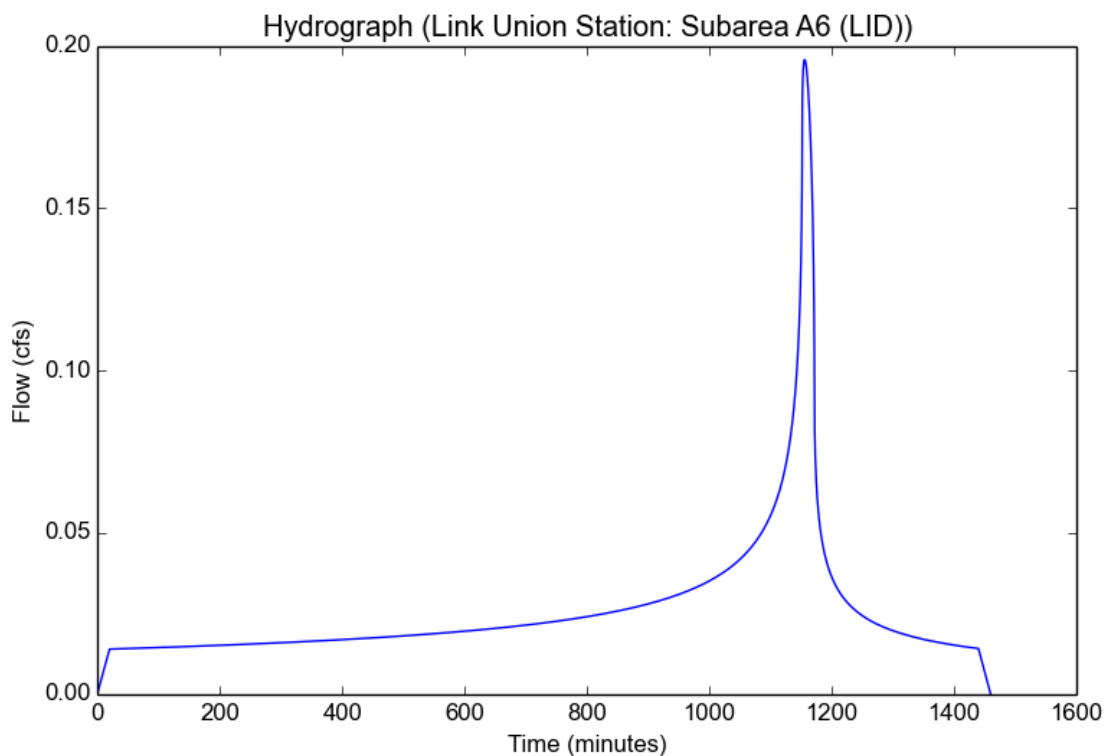

## Peak Flow Hydrologic Analysis

File location: C:/Users/vrodriguez/Desktop/Link Union Station - Subarea A7 (LID).pdf  
Version: HydroCalc 0.3.0-beta

### Input Parameters

Project Name	Link Union Station
Subarea ID	Subarea A7 (LID)
Area (ac)	0.71
Flow Path Length (ft)	910.0
Flow Path Slope (vft/hft)	0.02
85th Percentile Rainfall Depth (in)	1.0
Percent Impervious	1.0
Soil Type	6
Design Storm Frequency	85th percentile storm
Fire Factor	0
LID	True

### Output Results

Modeled (85th percentile storm) Rainfall Depth (in)	1.0
Peak Intensity (in/hr)	0.257
Undeveloped Runoff Coefficient (Cu)	0.1
Developed Runoff Coefficient (Cd)	0.9
Time of Concentration (min)	30.0
Clear Peak Flow Rate (cfs)	0.1642
Burned Peak Flow Rate (cfs)	0.1642
24-Hr Clear Runoff Volume (ac-ft)	0.0528
24-Hr Clear Runoff Volume (cu-ft)	2300.4264

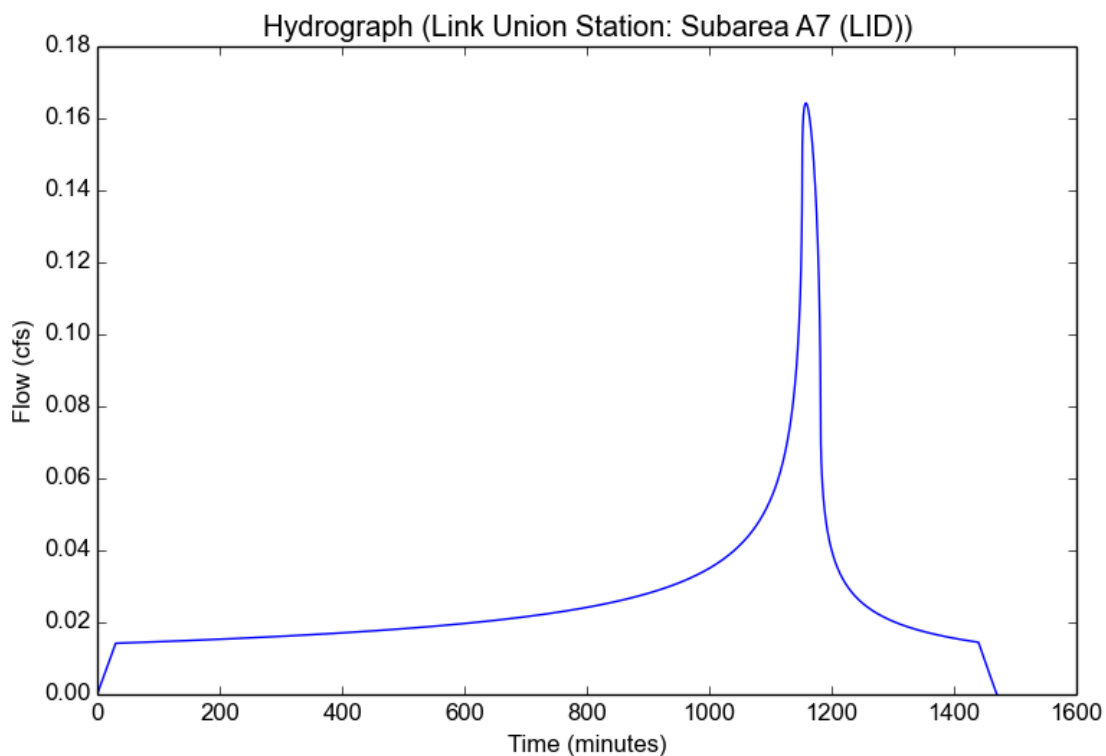

## Peak Flow Hydrologic Analysis

File location: C:/Users/vrodriguez/Desktop/Link Union Station - Subarea A8 (LID).pdf  
Version: HydroCalc 0.3.0-beta

### Input Parameters

Project Name	Link Union Station
Subarea ID	Subarea A8 (LID)
Area (ac)	0.39
Flow Path Length (ft)	300.0
Flow Path Slope (vft/hft)	0.02
85th Percentile Rainfall Depth (in)	1.0
Percent Impervious	1.0
Soil Type	6
Design Storm Frequency	85th percentile storm
Fire Factor	0
LID	True

### Output Results

Modeled (85th percentile storm) Rainfall Depth (in)	1.0
Peak Intensity (in/hr)	0.356
Undeveloped Runoff Coefficient (Cu)	0.1
Developed Runoff Coefficient (Cd)	0.9
Time of Concentration (min)	15.0
Clear Peak Flow Rate (cfs)	0.125
Burned Peak Flow Rate (cfs)	0.125
24-Hr Clear Runoff Volume (ac-ft)	0.029
24-Hr Clear Runoff Volume (cu-ft)	1263.6036

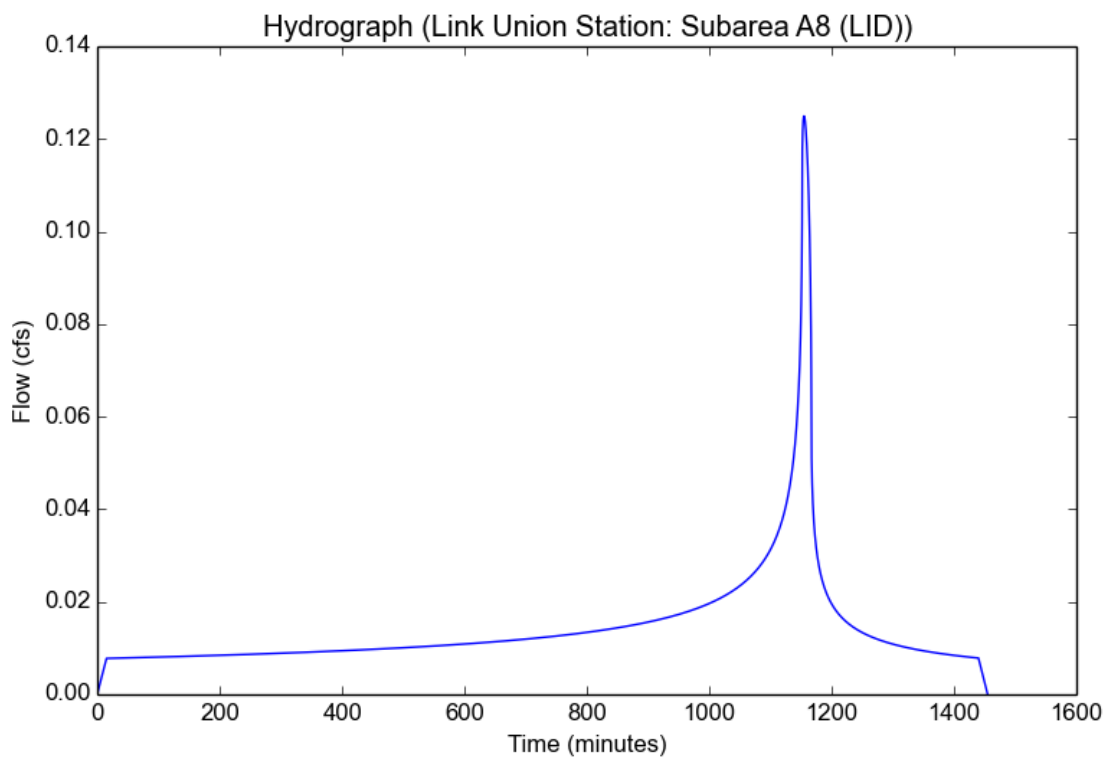

## Peak Flow Hydrologic Analysis

### Input Parameters

Project Name	LinkUS LID
Subarea ID	Subarea D1
Area (ac)	1.17
Flow Path Length (ft)	390.0
Flow Path Slope (vft/hft)	0.003
85th Percentile Rainfall Depth (in)	1.0
Percent Impervious	0.54
Soil Type	6
Design Storm Frequency	85th percentile storm
Fire Factor	0
LID	True

### Output Results

Modeled (85th percentile storm) Rainfall Depth (in)	1.0
Peak Intensity (in/hr)	0.2391
Undeveloped Runoff Coefficient (Cu)	0.1
Developed Runoff Coefficient (Cd)	0.532
Time of Concentration (min)	35.0
Clear Peak Flow Rate (cfs)	0.1488
Burned Peak Flow Rate (cfs)	0.1488
24-Hr Clear Runoff Volume (ac-ft)	0.0514
24-Hr Clear Runoff Volume (cu-ft)	2240.8191

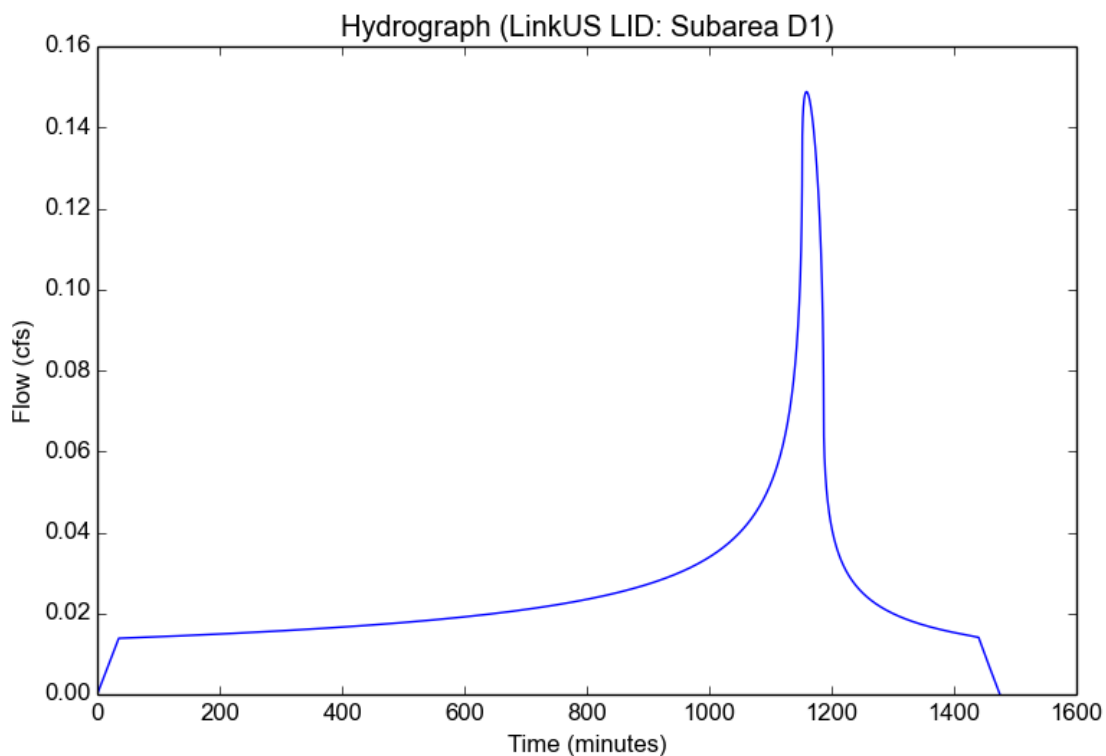

## Peak Flow Hydrologic Analysis

### Input Parameters

Project Name	LinkUS LID
Subarea ID	Subarea D2
Area (ac)	0.81
Flow Path Length (ft)	125.0
Flow Path Slope (vft/hft)	0.2
85th Percentile Rainfall Depth (in)	1.0
Percent Impervious	0.01
Soil Type	6
Design Storm Frequency	85th percentile storm
Fire Factor	0
LID	True

### Output Results

Modeled (85th percentile storm) Rainfall Depth (in)	1.0
Peak Intensity (in/hr)	0.2854
Undeveloped Runoff Coefficient (Cu)	0.1
Developed Runoff Coefficient (Cd)	0.108
Time of Concentration (min)	24.0
Clear Peak Flow Rate (cfs)	0.025
Burned Peak Flow Rate (cfs)	0.025
24-Hr Clear Runoff Volume (ac-ft)	0.0072
24-Hr Clear Runoff Volume (cu-ft)	314.9303

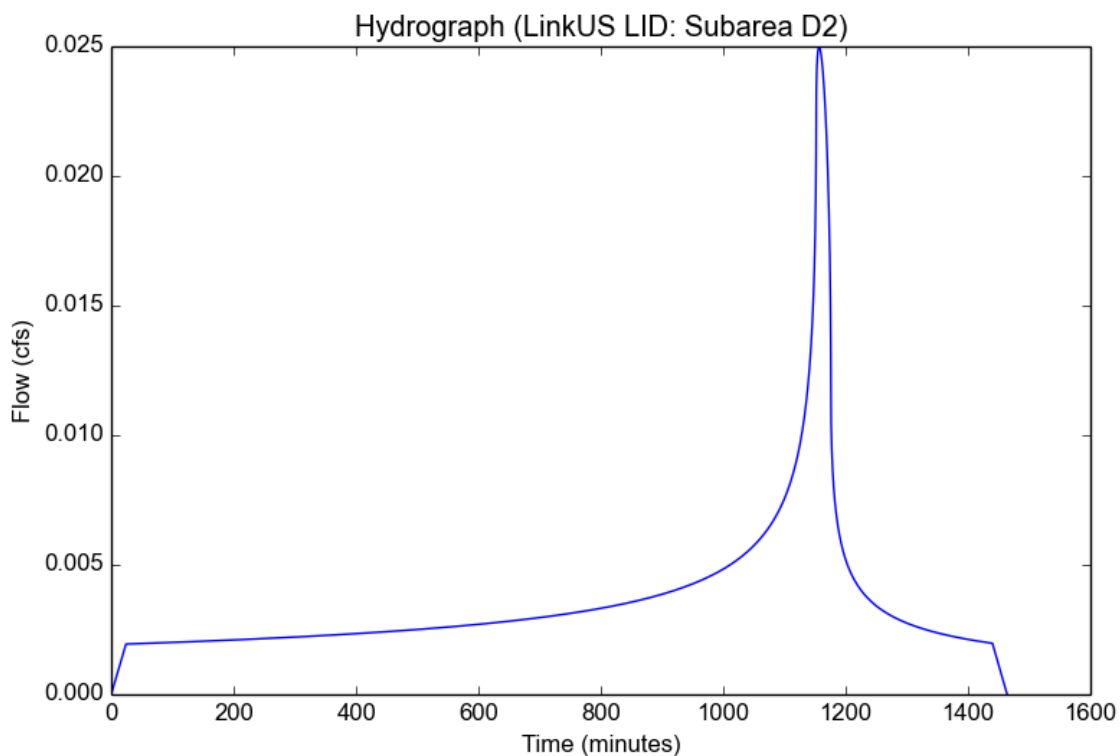

## Peak Flow Hydrologic Analysis

### Input Parameters

Project Name	LinkUS LID
Subarea ID	Subarea D3
Area (ac)	2.43
Flow Path Length (ft)	388.0
Flow Path Slope (vft/hft)	0.005
85th Percentile Rainfall Depth (in)	1.0
Percent Impervious	0.91
Soil Type	6
Design Storm Frequency	85th percentile storm
Fire Factor	0
LID	True

### Output Results

Modeled (85th percentile storm) Rainfall Depth (in)	1.0
Peak Intensity (in/hr)	0.2854
Undeveloped Runoff Coefficient (Cu)	0.1
Developed Runoff Coefficient (Cd)	0.828
Time of Concentration (min)	24.0
Clear Peak Flow Rate (cfs)	0.5743
Burned Peak Flow Rate (cfs)	0.5743
24-Hr Clear Runoff Volume (ac-ft)	0.1663
24-Hr Clear Runoff Volume (cu-ft)	7243.397

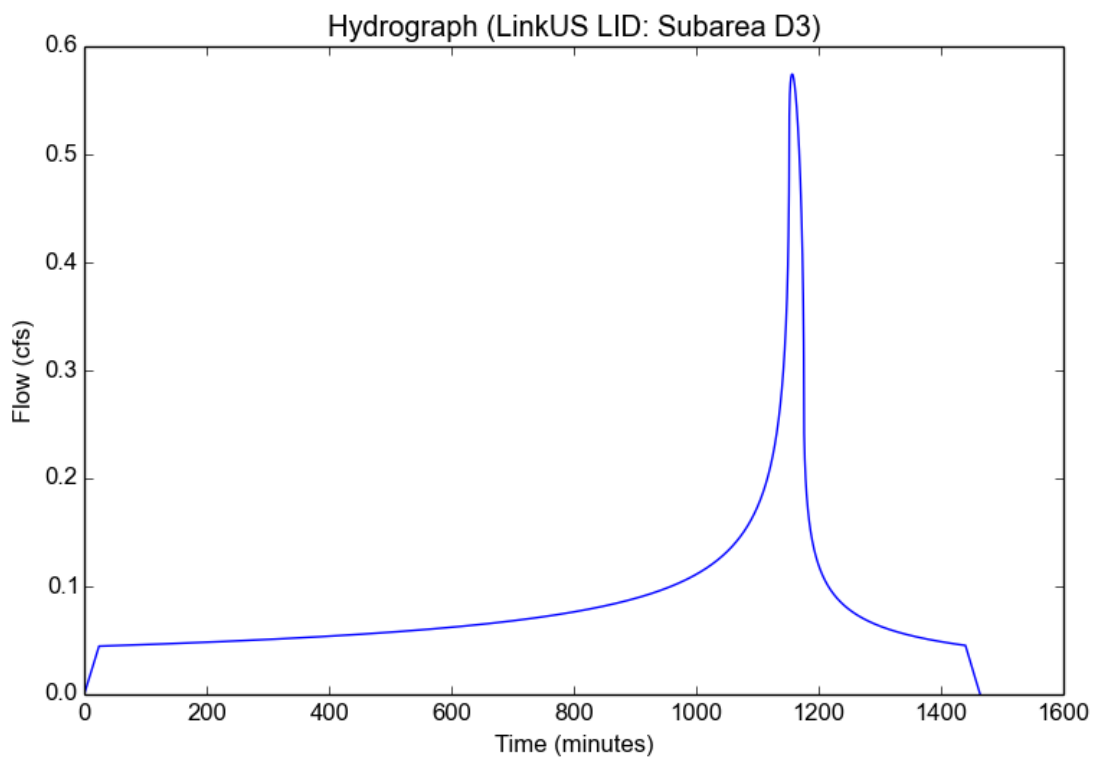

## Peak Flow Hydrologic Analysis

### Input Parameters

Project Name	LinkUS LID
Subarea ID	Subarea E1
Area (ac)	1.12
Flow Path Length (ft)	295.0
Flow Path Slope (vft/hft)	0.013
85th Percentile Rainfall Depth (in)	1.0
Percent Impervious	0.01
Soil Type	6
Design Storm Frequency	85th percentile storm
Fire Factor	0
LID	True

### Output Results

Modeled (85th percentile storm) Rainfall Depth (in)	1.0
Peak Intensity (in/hr)	0.175
Undeveloped Runoff Coefficient (Cu)	0.1
Developed Runoff Coefficient (Cd)	0.108
Time of Concentration (min)	68.0
Clear Peak Flow Rate (cfs)	0.0212
Burned Peak Flow Rate (cfs)	0.0212
24-Hr Clear Runoff Volume (ac-ft)	0.01
24-Hr Clear Runoff Volume (cu-ft)	435.4823

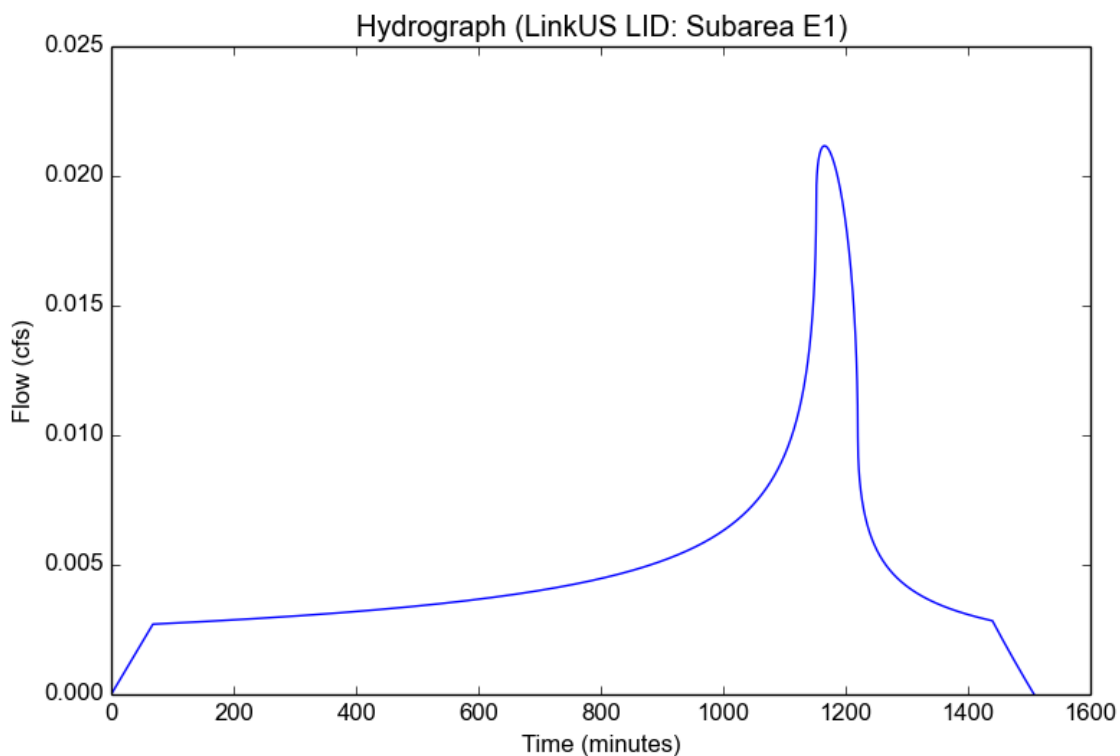

## Peak Flow Hydrologic Analysis

### Input Parameters

Project Name	LinkUS LID
Subarea ID	Subarea E2
Area (ac)	1.79
Flow Path Length (ft)	439.0
Flow Path Slope (vft/hft)	0.026
85th Percentile Rainfall Depth (in)	1.0
Percent Impervious	0.62
Soil Type	6
Design Storm Frequency	85th percentile storm
Fire Factor	0
LID	True

### Output Results

Modeled (85th percentile storm) Rainfall Depth (in)	1.0
Peak Intensity (in/hr)	0.2854
Undeveloped Runoff Coefficient (Cu)	0.1
Developed Runoff Coefficient (Cd)	0.596
Time of Concentration (min)	24.0
Clear Peak Flow Rate (cfs)	0.3045
Burned Peak Flow Rate (cfs)	0.3045
24-Hr Clear Runoff Volume (ac-ft)	0.0882
24-Hr Clear Runoff Volume (cu-ft)	3840.6521

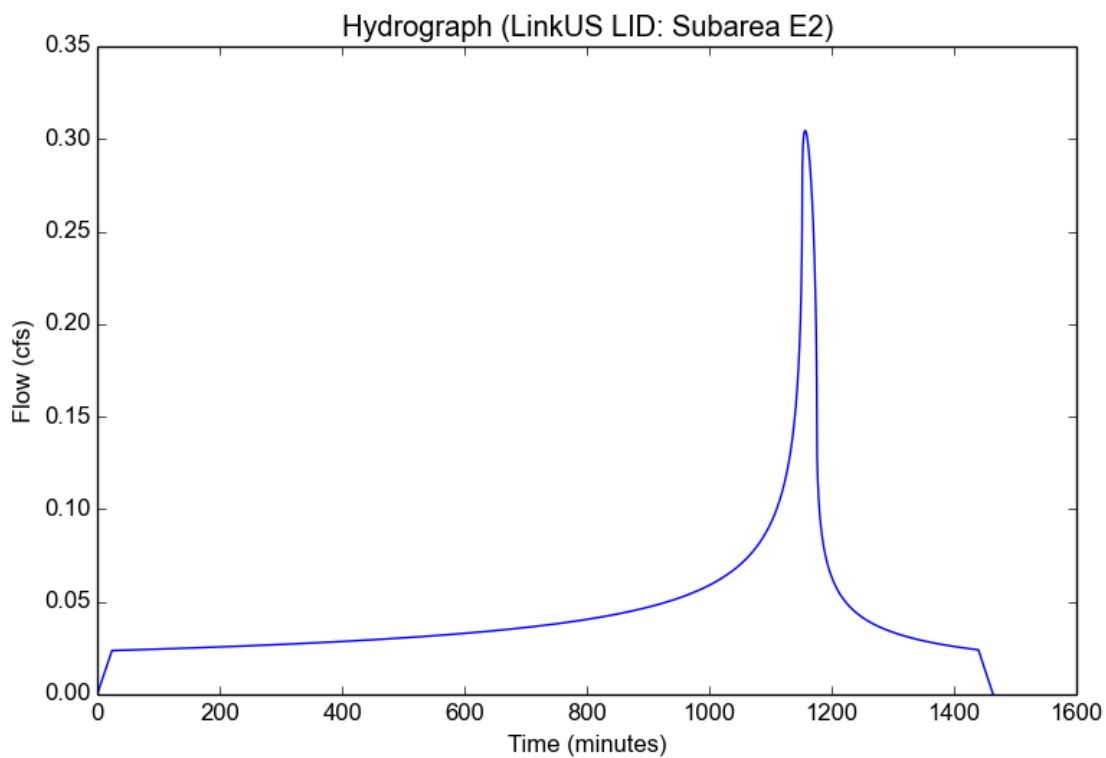

## Peak Flow Hydrologic Analysis

### Input Parameters

Project Name	LinkUS LID
Subarea ID	Subarea F1
Area (ac)	1.49
Flow Path Length (ft)	140.0
Flow Path Slope (vft/hft)	0.038
85th Percentile Rainfall Depth (in)	1.0
Percent Impervious	0.47
Soil Type	6
Design Storm Frequency	85th percentile storm
Fire Factor	0
LID	True

### Output Results

Modeled (85th percentile storm) Rainfall Depth (in)	1.0
Peak Intensity (in/hr)	0.3954
Undeveloped Runoff Coefficient (Cu)	0.1436
Developed Runoff Coefficient (Cd)	0.4991
Time of Concentration (min)	12.0
Clear Peak Flow Rate (cfs)	0.294
Burned Peak Flow Rate (cfs)	0.294
24-Hr Clear Runoff Volume (ac-ft)	0.0587
24-Hr Clear Runoff Volume (cu-ft)	2556.8011

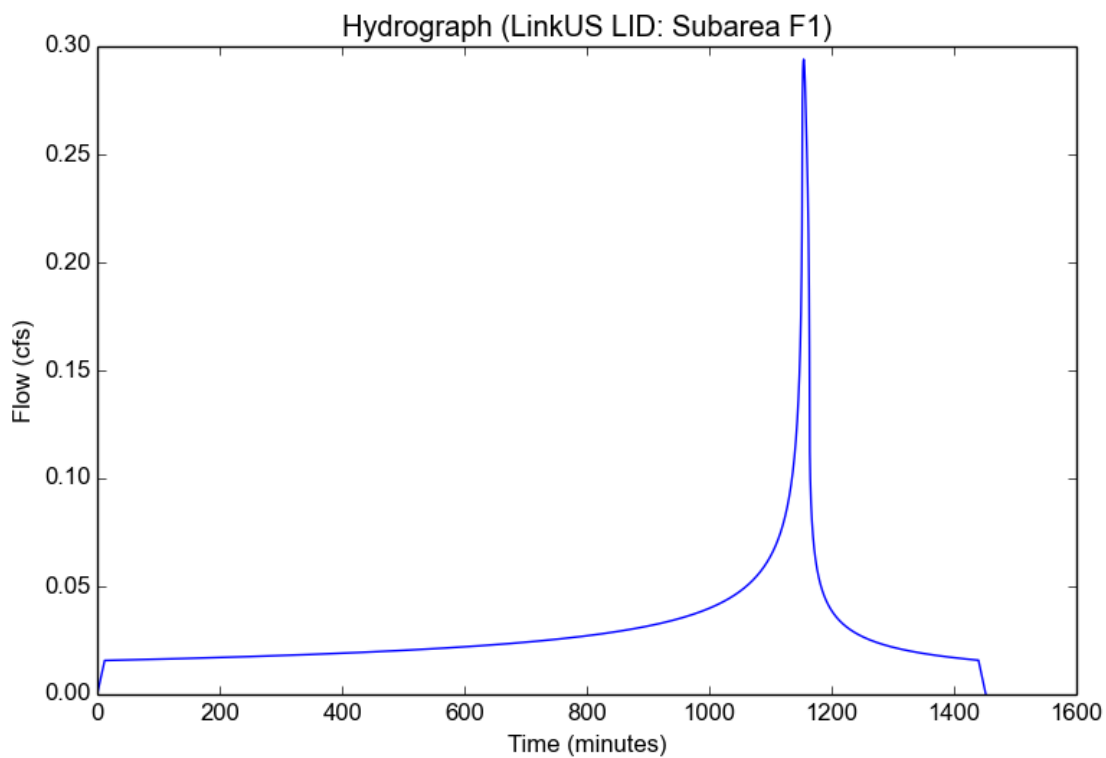

## Peak Flow Hydrologic Analysis

### Input Parameters

Project Name	LinkUS LID
Subarea ID	Subarea F2
Area (ac)	1.07
Flow Path Length (ft)	214.0
Flow Path Slope (vft/hft)	0.006
85th Percentile Rainfall Depth (in)	1.0
Percent Impervious	0.91
Soil Type	6
Design Storm Frequency	85th percentile storm
Fire Factor	0
LID	True

### Output Results

Modeled (85th percentile storm) Rainfall Depth (in)	1.0
Peak Intensity (in/hr)	0.3454
Undeveloped Runoff Coefficient (Cu)	0.1
Developed Runoff Coefficient (Cd)	0.828
Time of Concentration (min)	16.0
Clear Peak Flow Rate (cfs)	0.306
Burned Peak Flow Rate (cfs)	0.306
24-Hr Clear Runoff Volume (ac-ft)	0.0732
24-Hr Clear Runoff Volume (cu-ft)	3189.4663

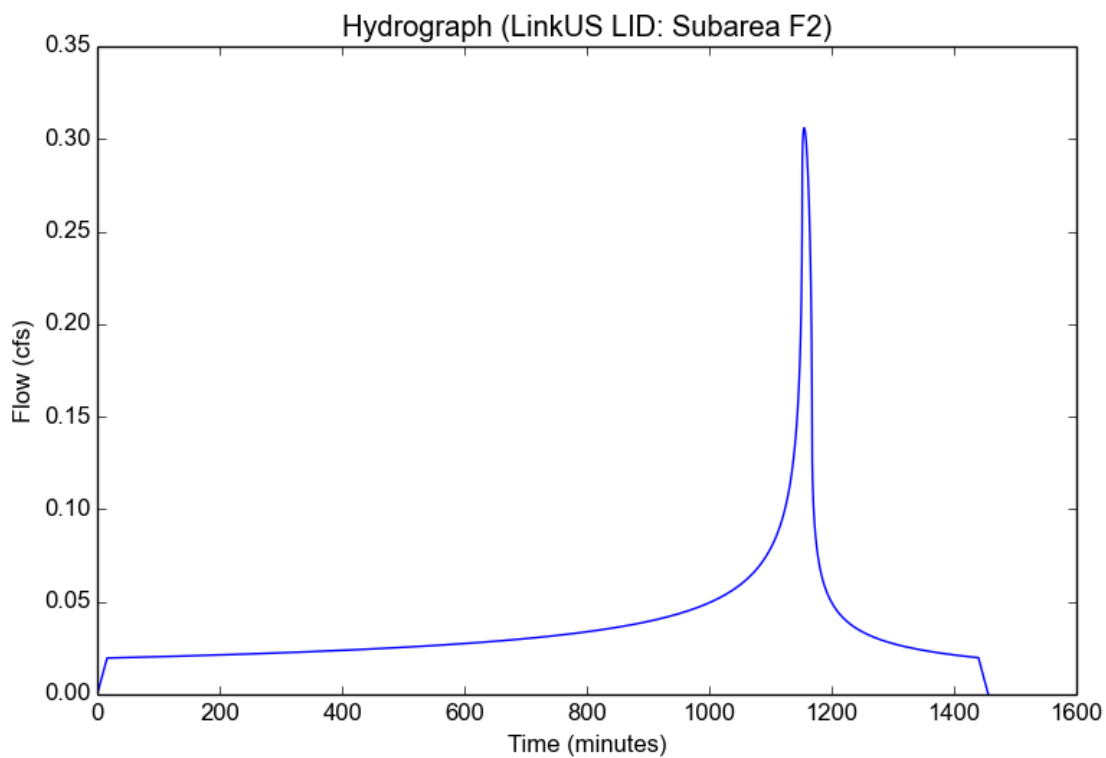

## Peak Flow Hydrologic Analysis

### Input Parameters

Project Name	LinkUS LID
Subarea ID	Subarea G1
Area (ac)	0.65
Flow Path Length (ft)	111.0
Flow Path Slope (vft/hft)	0.029
85th Percentile Rainfall Depth (in)	1.0
Percent Impervious	0.12
Soil Type	6
Design Storm Frequency	85th percentile storm
Fire Factor	0
LID	True

### Output Results

Modeled (85th percentile storm) Rainfall Depth (in)	1.0
Peak Intensity (in/hr)	0.3039
Undeveloped Runoff Coefficient (Cu)	0.1
Developed Runoff Coefficient (Cd)	0.196
Time of Concentration (min)	21.0
Clear Peak Flow Rate (cfs)	0.0387
Burned Peak Flow Rate (cfs)	0.0387
24-Hr Clear Runoff Volume (ac-ft)	0.0105
24-Hr Clear Runoff Volume (cu-ft)	458.6426

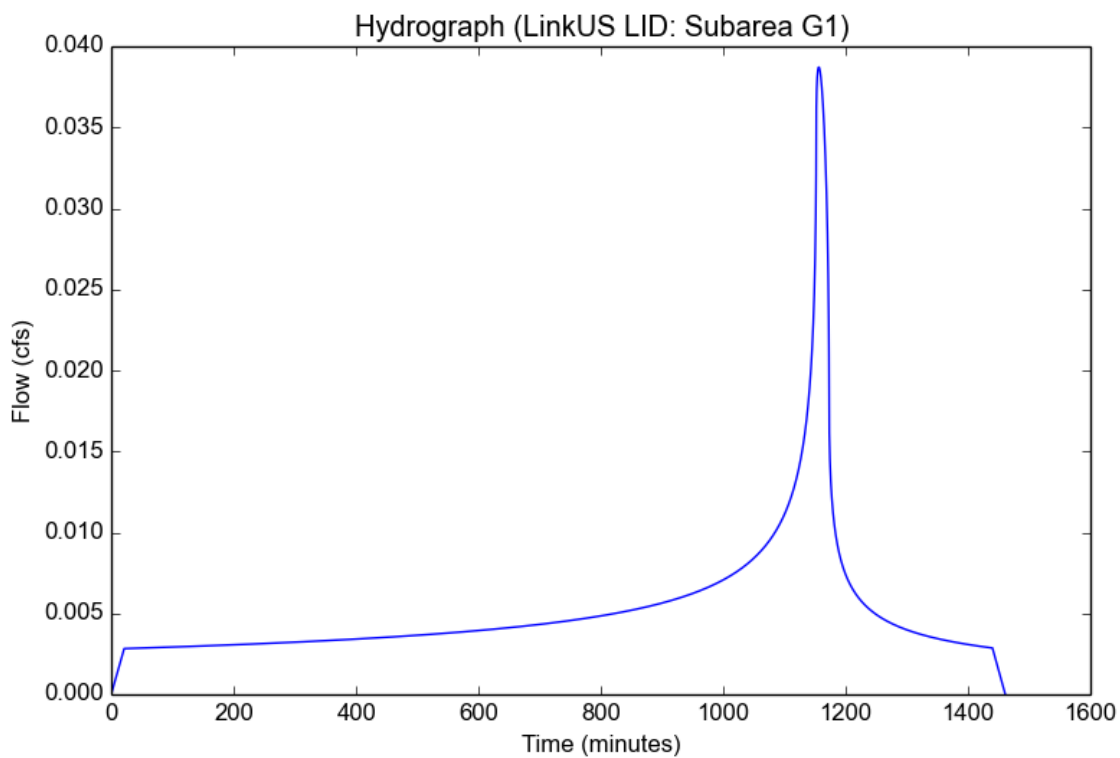

## Peak Flow Hydrologic Analysis

### Input Parameters

Project Name	LinkUS LID
Subarea ID	Subarea G2
Area (ac)	1.95
Flow Path Length (ft)	140.0
Flow Path Slope (vft/hft)	0.152
85th Percentile Rainfall Depth (in)	1.0
Percent Impervious	0.01
Soil Type	6
Design Storm Frequency	85th percentile storm
Fire Factor	0
LID	True

### Output Results

Modeled (85th percentile storm) Rainfall Depth (in)	1.0
Peak Intensity (in/hr)	0.2701
Undeveloped Runoff Coefficient (Cu)	0.1
Developed Runoff Coefficient (Cd)	0.108
Time of Concentration (min)	27.0
Clear Peak Flow Rate (cfs)	0.0569
Burned Peak Flow Rate (cfs)	0.0569
24-Hr Clear Runoff Volume (ac-ft)	0.0174
24-Hr Clear Runoff Volume (cu-ft)	758.167

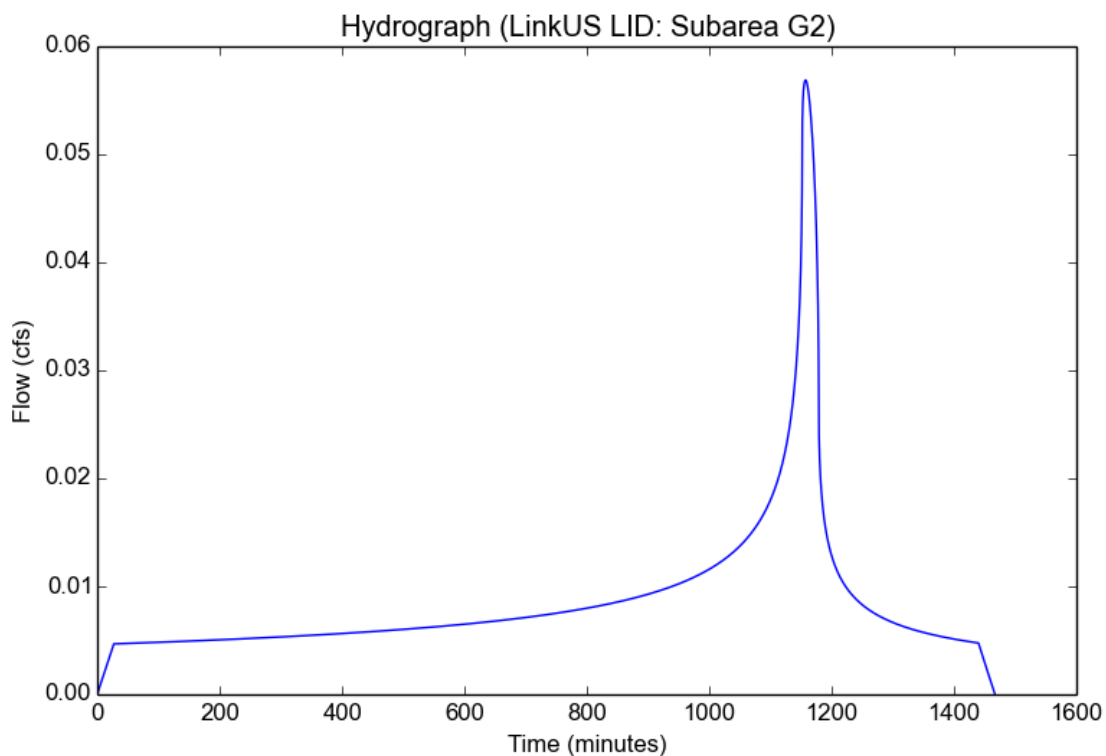

## Peak Flow Hydrologic Analysis

### Input Parameters

Project Name	LinkUS LID
Subarea ID	Subarea G3
Area (ac)	0.94
Flow Path Length (ft)	383.0
Flow Path Slope (vft/hft)	0.005
85th Percentile Rainfall Depth (in)	1.0
Percent Impervious	0.91
Soil Type	6
Design Storm Frequency	85th percentile storm
Fire Factor	0
LID	True

### Output Results

Modeled (85th percentile storm) Rainfall Depth (in)	1.0
Peak Intensity (in/hr)	0.2854
Undeveloped Runoff Coefficient (Cu)	0.1
Developed Runoff Coefficient (Cd)	0.828
Time of Concentration (min)	24.0
Clear Peak Flow Rate (cfs)	0.2222
Burned Peak Flow Rate (cfs)	0.2222
24-Hr Clear Runoff Volume (ac-ft)	0.0643
24-Hr Clear Runoff Volume (cu-ft)	2801.9725

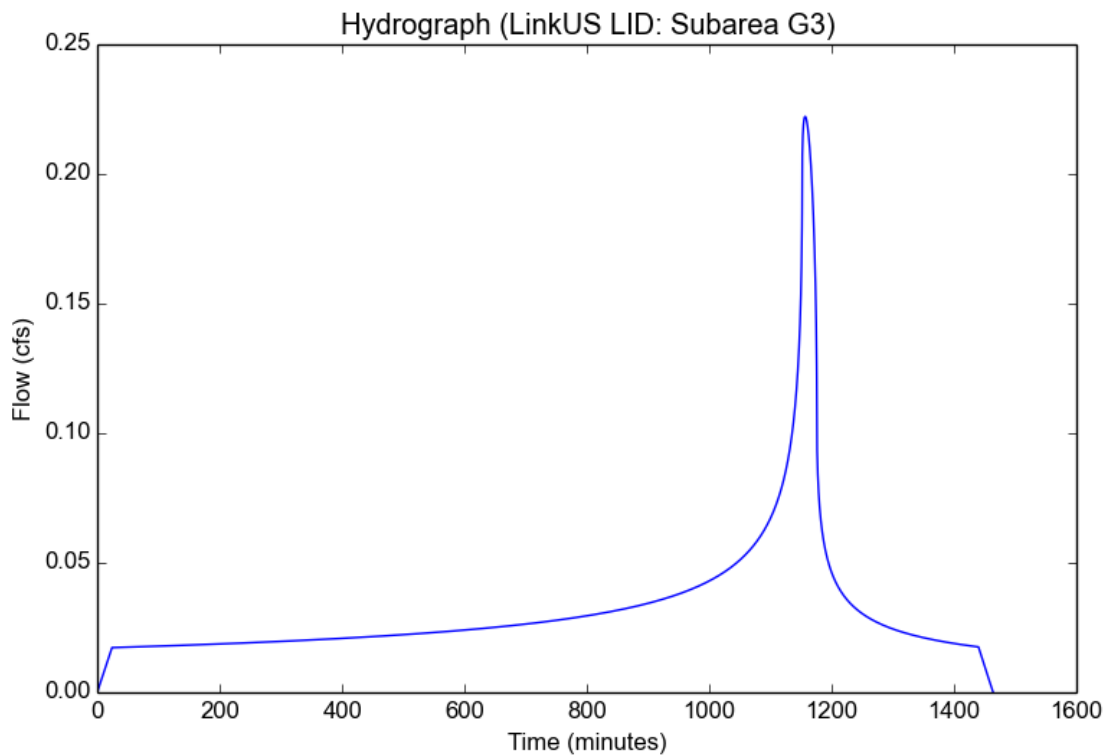

## Peak Flow Hydrologic Analysis

### Input Parameters

Project Name	LinkUS LID
Subarea ID	Subarea G4
Area (ac)	3.43
Flow Path Length (ft)	1362.0
Flow Path Slope (vft/hft)	0.007
85th Percentile Rainfall Depth (in)	1.0
Percent Impervious	0.15
Soil Type	6
Design Storm Frequency	85th percentile storm
Fire Factor	0
LID	True

### Output Results

Modeled (85th percentile storm) Rainfall Depth (in)	1.0
Peak Intensity (in/hr)	0.1319
Undeveloped Runoff Coefficient (Cu)	0.1
Developed Runoff Coefficient (Cd)	0.22
Time of Concentration (min)	124.0
Clear Peak Flow Rate (cfs)	0.0995
Burned Peak Flow Rate (cfs)	0.0995
24-Hr Clear Runoff Volume (ac-ft)	0.0624
24-Hr Clear Runoff Volume (cu-ft)	2717.1276

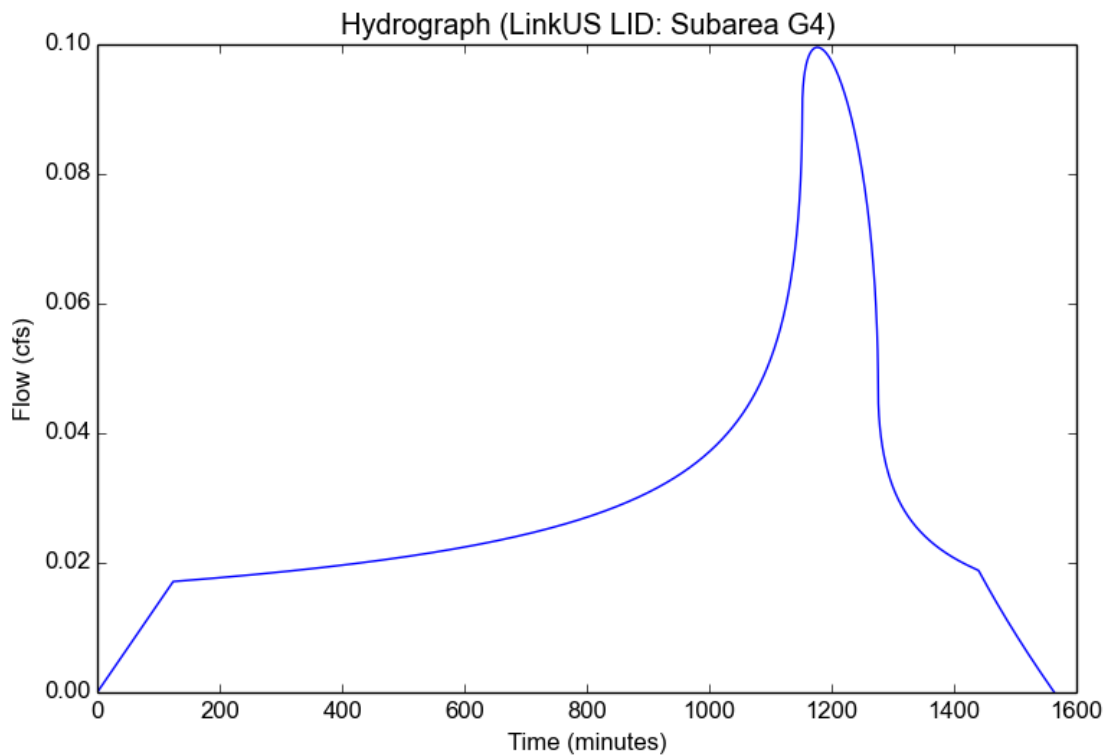

## Peak Flow Hydrologic Analysis

### Input Parameters

Project Name	LinkUS LID
Subarea ID	Subarea H
Area (ac)	0.97
Flow Path Length (ft)	1045.0
Flow Path Slope (vft/hft)	0.03
85th Percentile Rainfall Depth (in)	1.0
Percent Impervious	0.15
Soil Type	6
Design Storm Frequency	85th percentile storm
Fire Factor	0
LID	True

### Output Results

Modeled (85th percentile storm) Rainfall Depth (in)	1.0
Peak Intensity (in/hr)	0.1612
Undeveloped Runoff Coefficient (Cu)	0.1
Developed Runoff Coefficient (Cd)	0.22
Time of Concentration (min)	81.0
Clear Peak Flow Rate (cfs)	0.0344
Burned Peak Flow Rate (cfs)	0.0344
24-Hr Clear Runoff Volume (ac-ft)	0.0176
24-Hr Clear Runoff Volume (cu-ft)	768.3065

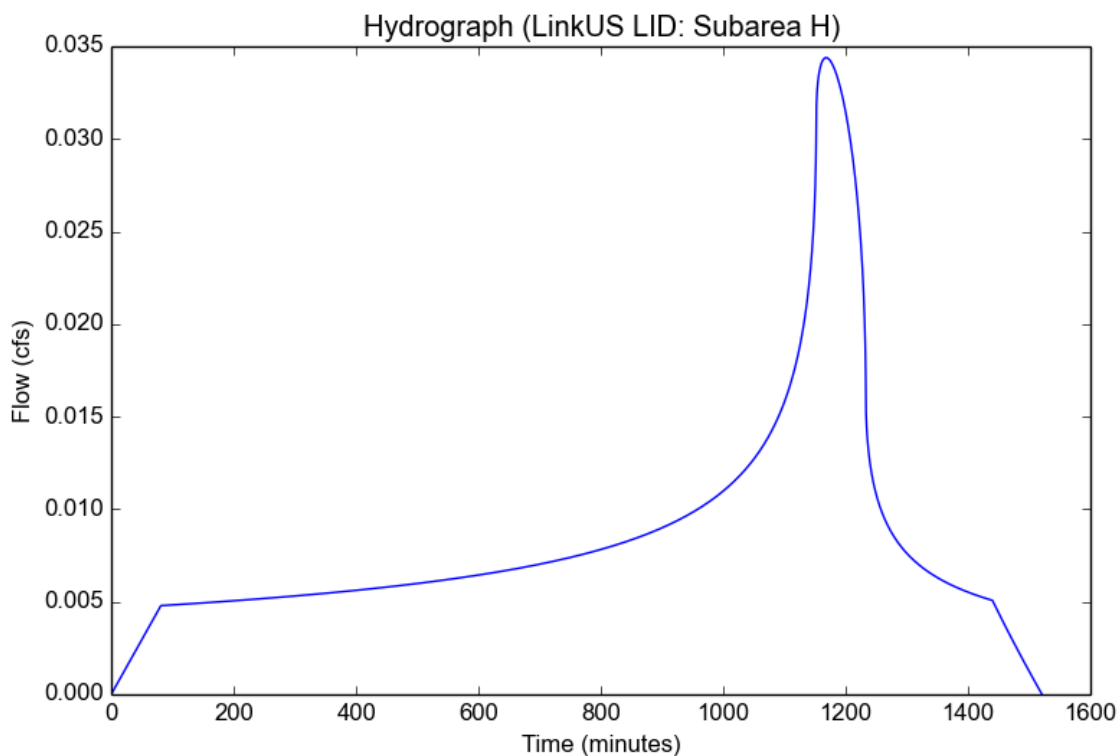

## Peak Flow Hydrologic Analysis

### Input Parameters

Project Name	LinkUS LID
Subarea ID	Subarea I
Area (ac)	5.01
Flow Path Length (ft)	649.0
Flow Path Slope (vft/hft)	0.0023
85th Percentile Rainfall Depth (in)	1.0
Percent Impervious	0.63
Soil Type	6
Design Storm Frequency	85th percentile storm
Fire Factor	0
LID	True

### Output Results

Modeled (85th percentile storm) Rainfall Depth (in)	1.0
Peak Intensity (in/hr)	0.2081
Undeveloped Runoff Coefficient (Cu)	0.1
Developed Runoff Coefficient (Cd)	0.604
Time of Concentration (min)	47.0
Clear Peak Flow Rate (cfs)	0.6298
Burned Peak Flow Rate (cfs)	0.6298
24-Hr Clear Runoff Volume (ac-ft)	0.2501
24-Hr Clear Runoff Volume (cu-ft)	10894.0544

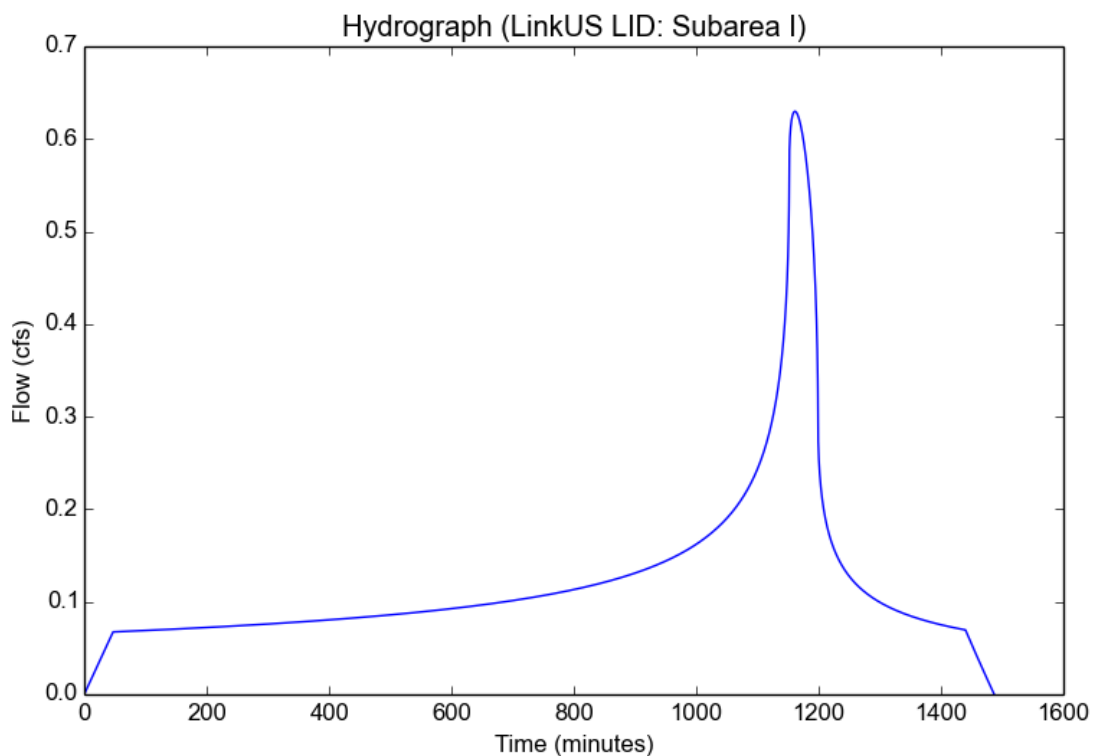

## Peak Flow Hydrologic Analysis

### Input Parameters

Project Name	LinkUS LID
Subarea ID	Subarea J
Area (ac)	0.86
Flow Path Length (ft)	850.0
Flow Path Slope (vft/hft)	0.0023
85th Percentile Rainfall Depth (in)	1.0
Percent Impervious	0.15
Soil Type	6
Design Storm Frequency	85th percentile storm
Fire Factor	0
LID	True

### Output Results

Modeled (85th percentile storm) Rainfall Depth (in)	1.0
Peak Intensity (in/hr)	0.1384
Undeveloped Runoff Coefficient (Cu)	0.1
Developed Runoff Coefficient (Cd)	0.22
Time of Concentration (min)	112.0
Clear Peak Flow Rate (cfs)	0.0262
Burned Peak Flow Rate (cfs)	0.0262
24-Hr Clear Runoff Volume (ac-ft)	0.0156
24-Hr Clear Runoff Volume (cu-ft)	681.2351

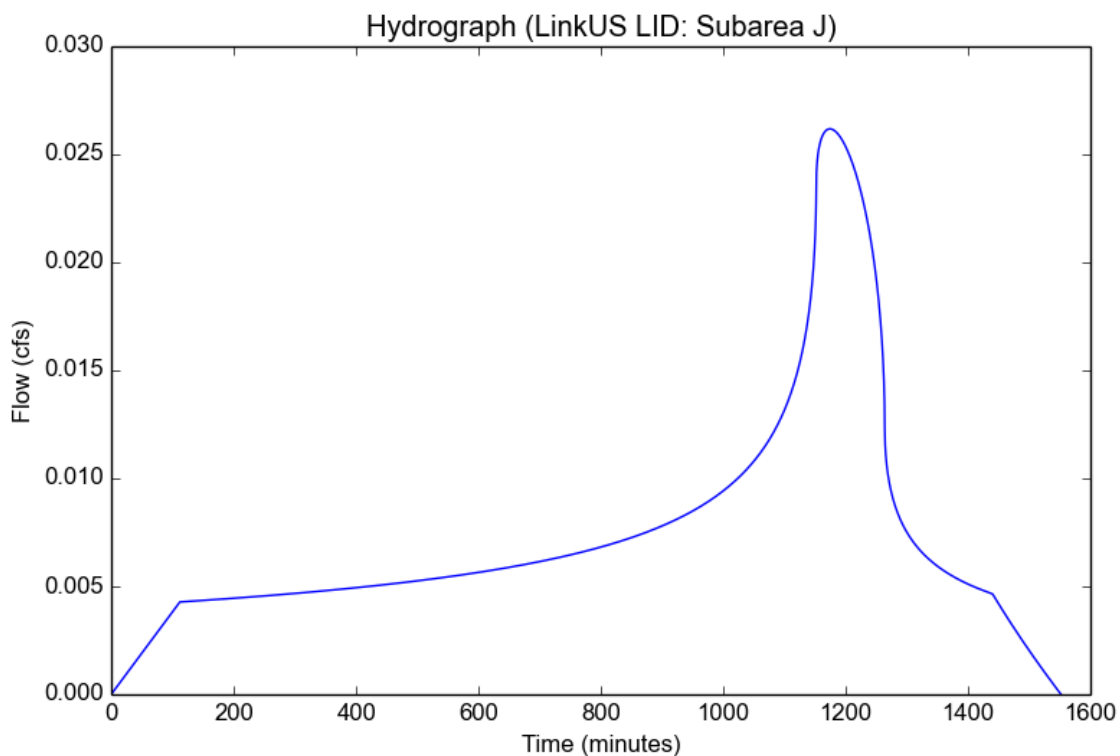

(THIS PAGE INTENTIONALLY LEFT BLANK)

## Appendix G: Stormwater Process Diagram

(THIS PAGE INTENTIONALLY LEFT BLANK)

# Link Union Station Stormwater Process Diagram

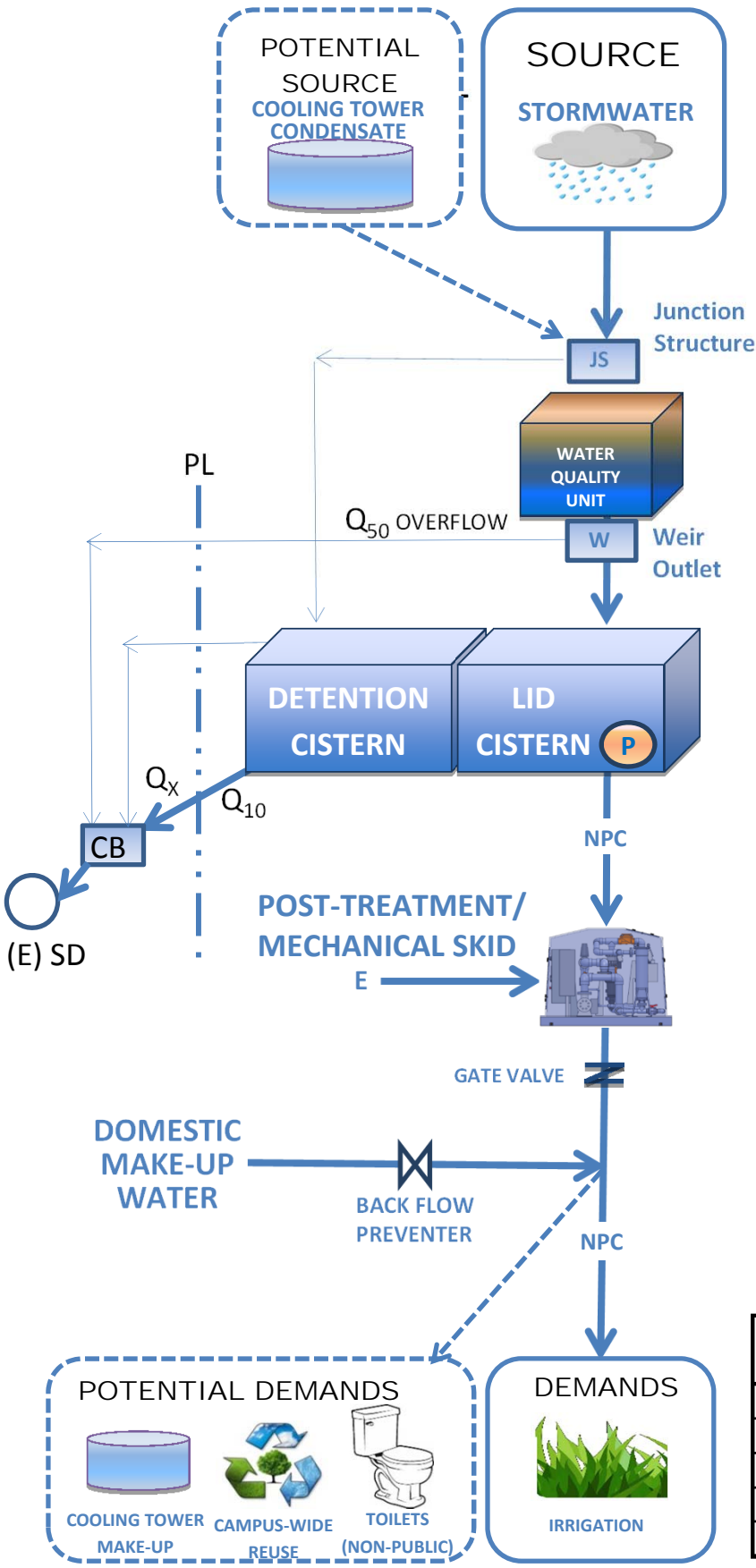

Source	Volume Per Design Storm	
	cu-ft	gal
Stormwater (Q50)	470,779	3,521,425

Condensate is not considered at this time

LID (85th)	Volume		Flow
	cu-ft	gal	cfs
	77,178	577,288	5.88

LID (85th)

10-Year Pre 50-Year Post Delta (50yr - 10yr)	Volume		Flow
	cu-ft	gal	cfs
	242,655	1,815,057	33.98
	470,779	3,521,425	64.77
	228,124	1,706,368	30.79

- Notes:
1. Assumes public line is Q10
  2. Qx size to be verified after property line
  3. Post-treatment includes UV disinfection and microfiltration
  4. NPC = Non-Potable Cistern
  5. PL = Property Line
  6. CB = Catch Basin
  7. Detention cistern sizing will be the difference of the total detention and LID sizing

Demands	Volume / Day	
	cu-ft	gal
Irrigation		
Cooling Tower		
Campus-wide reuse		
Toilets (non-Public)		
Total		

(THIS PAGE INTENTIONALLY LEFT BLANK)

## Appendix H: Meeting Minutes

(THIS PAGE INTENTIONALLY LEFT BLANK)



acquisition of the properties along the south side of the street between Garey and Center Streets.

### **3. Work to be Completed as Part of Current Contract**

HDR indicated that their current contract with Metro for the Link US project includes the following major project elements:

- Preparation of EIR/EIS for the proposed project
- Preparation of preliminary engineering/architectural plans and Design-Build procurement documents for the proposed project.

The Draft EIR/EIS is scheduled to be circulated in April of 2017, with certification of the environmental document planned for November of 2017. The preliminary design package is estimated to be complete by April of 2018, with work to be completed as part of the Design-Build contract to be initiated in early 2019.

### **4. Proposed Onsite Improvements at LAUS and Throat Area**

HDR provided an overview of the analysis completed to determine the most appropriate approach for treating onsite stormwater runoff at the proposed station yard and throat area. HDR noted that the entire station yard and throat area was assumed to be impervious for the purpose of this analysis as the tracks in this area will either be supported on the concourse roof structure or on cellular concrete fill. The limits of the onsite area were assumed to extend from US-101 to the south to Vignes Street to the north. The following were key items related to this discussion:

- Passenger concourse and egress plaza
  - The existing ridge conditions within the existing Station Yard were used to divide the site into three on-site tributary areas. The total on-site disturbed on-site area is approximately 23 acres.
- Proposed LEED certification and applicability of City LID criteria
  - The stormwater system for Link US must conform to LEED Silver requirements. Further analysis is needed to determine if the City of Los Angeles LID requirements will also meet LEED credit requirements.
- Overall goals related to water quality and stormwater treatment
  - The BMP system will comply with the Municipal Storm Water Permit issued by the California Regional Water Quality Board. A pre-treatment system is proposed to remove pollutants before stormwater enters into a cistern system.
- Potential Tier 1 and Tier 2 BMP's considered
  - According the City of Los Angeles LID Manual, the following is the priority order for implementing BMPs:

- Tier 1: Infiltrate
    - Tier 2: Capture and Use
    - Tier 3: Biofiltration
  - Tier 1 is not feasible because infiltration cannot occur underneath railyard track or within 25 feet of structures. Also, based on preliminary geotechnical investigation, the water table, soil condition, and hazardous material are not favorable for infiltration.
  - Therefore, Tier 2 is proposed.
- Proposed cisterns and their location, size and function
  - Three cistern locations are proposed. One for each tributary area. Two of the cisterns are located west of the yard track (Cisterns #2 and #3), while the other is currently placed underneath the tracks (Cistern #1). Cistern #1 may be relocated to another location within the tributary area.
  - Cisterns will be sized at a minimum to meet LID requirements, 85<sup>th</sup> percentile storm (1.0 inch rain depth for project site).
  - Stormwater from the site will flow into a water quality unit for pre-treatment prior to discharging into the cistern for storage. A mechanical skid unit will manage the distribution of the captured stormwater for re-use; i.e. for irrigation. If non-potable uses are pursued, then a post treatment (filter and UV system) will be required as well as clearance from LA County Department of Public Health.
  - The water balance analysis is ongoing and will continue to be updated as the project progresses in its design. The current program is to collect stormwater and HVAC condensate to the cistern, and supply the landscape irrigation and toilet demands.
  - Based on this meeting, the City of Los Angeles (BOS) concurs with the concept of a cistern as an on-site BMP. There will be a follow-up meeting next week to discuss cistern and drainage in more detail.

## 5. Proposed Local Street Improvements

HDR and BOE discussed the applicability of the City's LID/green street requirements as they related to the offsite work south of LAUS within City of LA jurisdiction, which includes the new run-through track viaduct structure and the associated local street modifications. The following items of note were discussed as part of this agenda item:

- LABOE feels that based on current City policy, Metro would be treated as a developer with regard to the need to meet the City's LID guidelines for the local street reconstruction included as part of the Link US Project. Meeting the City's LID guidelines would involve the implementation and maintenance of City approved stormwater treatment BMP's as part of the street reconstruction. Metro disagreed with the City's position with regard to the maintenance and stated that they should not be responsible for the maintenance costs of the BMP's, which would be in perpetuity. Metro cited the agreement between the City of LA and Metro that was adopted as part of the Crenshaw LRT project for the construction and maintenance

of the stormwater treatment BMP's included as part of the Crenshaw Boulevard street reconstruction. This agreement stipulates that Metro will be responsible for the cost of the maintenance of the BMP's constructed as part of the project for a five year period, after which maintenance responsibilities will be relinquished to the City via a mutually agreed upon approach between Metro and the City.

- HDR noted that conventional BMP's involving infiltration such as curb cuts/planter boxes would not be applicable for use along the Commercial Street corridor due to the likelihood for soil contamination, existing soil impermeability, and high groundwater.
- Metro suggested considering an approach for treating project runoff that takes advantage one of the adjacent acquired parcels which could be converted into a pocket park or some other public space as part of the project. A stormwater treatment BMP could be incorporated into the design of a pocket park or other public space where stormwater is captured and reused to provide for landscaping irrigation. Another option would be to incorporate some sort of biofiltration BMP into the design of the park's landscaping elements. HDR agreed to explore this approach.

## 6. Next Steps

The group agreed to switch the day/time of the planned biweekly coordination meetings with BOE staff to alternate Wednesday afternoons so that Ammar can participate. The next meeting was scheduled for Wednesday September 28<sup>th</sup>.

### Meeting Action Item Summary

No.	Action Item	Responsibility	Due Date
1	Metro and City of LA to continue discussions regarding maintenance cost responsibilities for any offsite stormwater BMP's included as part of Link US Project.	Metro/BOE	
2	HDR to consider potential BMP's for offsite stormwater treatment that could be integrated into potential pocket parks or other uses that could be considered for properties to be acquired along Commercial Street corridor?	HDR	