

Archival Collections Library

CALIFORNIA

HIGHWAYS AND PUBLIC WORKS



*Scenic on State Highway No. 1 (Coast Route)
through Gaviota Pass, Santa Barbara County*

PER
TE
24
.C2
C2

Official Journal of the Department of Public Works
JANUARY • 1936

Table of Contents



| | PAGE |
|--|-----------|
| Governor Merriam Announces Public Works Program of 28,000,000 Man Hours Work..... | 1 |
| <i>By Frank F. Merriam, Governor of California</i> | |
| \$994,000 Tower Bridge at Sacramento Opened by Governor Merriam..... | 2 |
| Tower Bridge Dedication Day Scenes..... | 3 |
| New San Marcos Pass Highway Completed..... | 4 |
| <i>By L. E. McDougal, District Office Engineer</i> | |
| Views of New San Marcos Pass Highway..... | 5 |
| Tabulation of Highway Projects for Next 18 Months..... | 7 |
| U. S. Road Chief Suggests Highway Safety Plan..... | 8 |
| <i>By Thos. H. MacDonald, Chief, U. S. Bureau of Public Roads</i> | |
| Measuring Stability and Cohesion of Bituminous Paving..... | 10 |
| <i>By T. H. Stanton, Jr., and F. N. Hveem of Research Laboratory</i> | |
| Illustrations of Hveem Stabilometer and Cohesimeter..... | 11 and 23 |
| Redding Highway Bridge Project Completed and Dedicated..... | 14 |
| Illustrations of Redding Bridge and Highway Project..... | 15 |
| State Highway Traffic Count Being Made Monthly..... | 17 |
| Bay Bridge to be Opened in Eleven Months..... | 18 |
| Lifting Bridge Roadway Sections from Midbay Pictured..... | 19 |
| "Money Well Spent" Says RFC Chairman Jones..... | 20 |
| Photo of Chairman Jones and Group on Catwalk..... | 21 |
| Monthly Water Resources Report of State Engineer..... | 24 and 25 |
| Burning Off Sunset Boulevard Surface for Repaving..... | 26 |
| <i>By J. M. Lackey, Assistant District Construction Engineer</i> | |
| Illustrations of Sunset Boulevard Burning Operations..... | 27 |
| Old Timers' Card Competition..... | 28 |
| Highway Bids and Awards..... | 30-32 |

Governor Merriam Announces

Public Works Program Providing for

28,000,000 Man Hours Work

During the Next Eighteen Months

By **FRANK F. MERRIAM**, Governor of California

LOOKING forward in this opening month of the year 1936 at the prospects for relieving the unemployment situation in California while securing important construction and improvement benefits for the State, I am greatly heartened by the report of Director Earl Lee Kelly of the Department of Public Works detailing the program of work planned by the three divisions of that department for the remaining months of the current biennium.

The activities of the Highway, Architecture and Water Resources divisions touch more closely, perhaps, the daily lives of our people than any other units of our State government. They are engaged in the construction and development of great public works for which the State and Federal governments apportion millions of dollars for expenditures within the State, thereby providing work and pay rolls for many thousands of our citizens.

It gives me great joy to be able to announce from the information in Mr. Kelly's report that the program of the Department of Public Works for which money may be anticipated under the present financial set-up of State and Federal funds will provide a total

of approximately 28,000,000 man hours work during the remaining 18-month period of the current biennium, extending from January 1, 1936, to June 30, 1937.

This figure includes 10,000,000 man hours of work that the engineers estimate will be afforded by the Central Valley Water Project

being constructed under the supervision of the U. S. Bureau of Reclamation.

From the Division of Highways, however, will come the largest share of the work that will be done by the State with State and Federal funds during the remainder of this biennial period. The development of California's State highways to high engineering standards which provide adequate facilities for the ever increasing volume of traffic is the earnest desire of my administration.

Substantial progress toward such development has been accomplished

during the past year and the State highway organization is continuing into the new year the advancement of construction programs as established by the California Highway Commission's budget and the Federal unemployment relief allocations made to California for highway work.



GOVERNOR FRANK F. MERRIAM

(Continued on page 6)

Governor Merriam Opens \$994,000 Tower Bridge at M Street, Sacramento

UNEXCELLED for its architectural and engineering beauty and constituting an impressive western gateway to the Capital City, the unique and imposing Tower Bridge spanning the Sacramento River from the foot of M Street in the city of Sacramento formally was dedicated and opened to traffic by Governor Frank F. Merriam on the afternoon of Sunday, December 15, 1935.

Constructed at a cost of \$994,000, the new structure, the only vertical lift span bridge on the California Highway System, replaces the old steel swing span built by the Sacramento Northern Railway in 1910. During the twenty-five years that the original M street bridge was in use, Sacramento's population expanded from 45,000 to approximately 100,000 and traffic increased 700 per cent in volume and 500 per cent in speed, making the old bridge with its nine-foot roadway cantilevered out from the trusses on either side of the structure not only entirely inadequate, but dangerous as well.

A COOPERATIVE PROJECT

The Tower Bridge, built by the State Department of Public Works in cooperation with the city and county of Sacramento and the Federal government, is 737 feet long, has a fifty-two foot roadway and two sidewalks, a thirteen-foot roadway in the center for the tracks of the Sacramento Northern Railway and two lanes for one-way traffic on each side of the tracks. Representing all that is modern in engineering skill, it will stand as an enduring monument to transportation progress and relieve traffic problems that had become a matter of grave concern to the state as well as to the city and the county of Sacramento.

Construction work on the Tower Bridge began in July, 1934, and was hailed by Sacramento and Yolo counties as the beginning of a new and greater bond between them.

At the outset, a problem of paramount importance that confronted Director Earl Lee Kelly of the State Department of Public Works, his engineers and the bridge contractors was that of detouring. The old M street bridge, built by the Sacramento North-

ern Railroad, carried a fifty-year franchise. It was necessary to provide not only for highway traffic but for a river crossing for the railway while the Tower Bridge was in course of construction.

After considering all feasible plans, the State spent approximately \$12,000 in widening certain parts of the I Street Bridge to accommodate automobile traffic and built a temporary detour bridge about seventy-five feet north of the Tower Bridge to take care of the Sacramento Northern. This structure, built entirely of timbers with the exception of four spans of steel girders, rented for the purpose, cost \$90,000.

Economizing to the utmost, the engineers made the grade of the detour bridge as low as possible, placing the steel girders just above normal high water. Exceptional rains last winter raised the Sacramento river to a point where, for a few days, driftwood endangered the temporary bridge, but this danger passed and there was no delay to railway traffic.

The Tower Bridge consists of a combination of steel and concrete spans. The central lift span is a 209 foot truss supported by two vertical towers 160 feet high. The approach span on the east consists of one 167 foot steel truss span and one 30 foot girder span. On the west, there is one 193 foot steel truss span and four 34 foot girder spans.

LIFT SPAN COUNTERWEIGHTED

The central lift span in its extreme high position has a clearance of 100 feet above high water and a horizontal clearance of 172 feet between the fenders. The total load of the lift span proper is estimated at 2,300,000 pounds. To avoid the necessity of lifting this great weight as a direct load, it is counterweighted by steel frames, filled with concrete. One of these frames is in each tower. They move in a direction opposite from that which the span moves. In raising the span, therefore, only enough electric energy is required to overcome the friction of the moving parts.

(Continued on page 12)

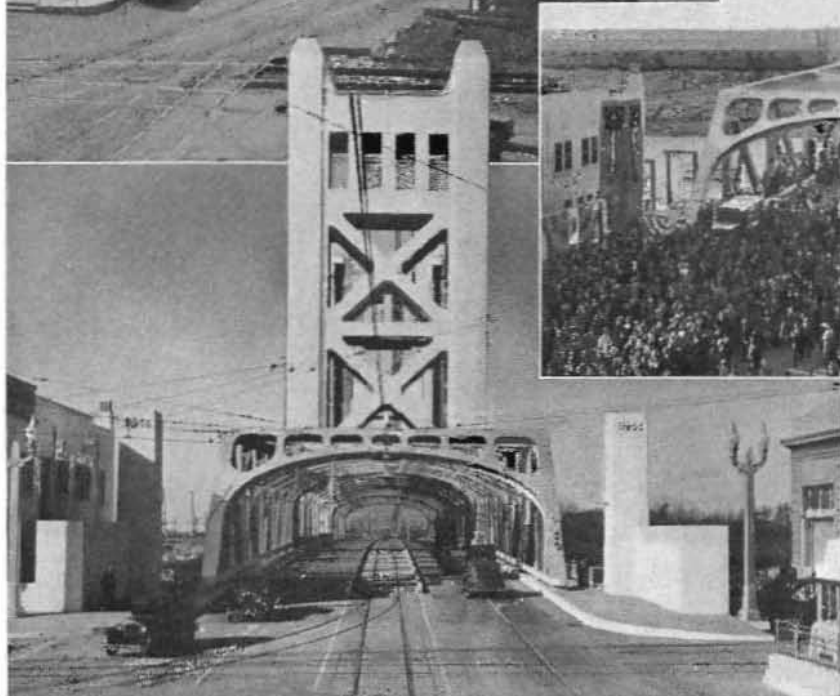
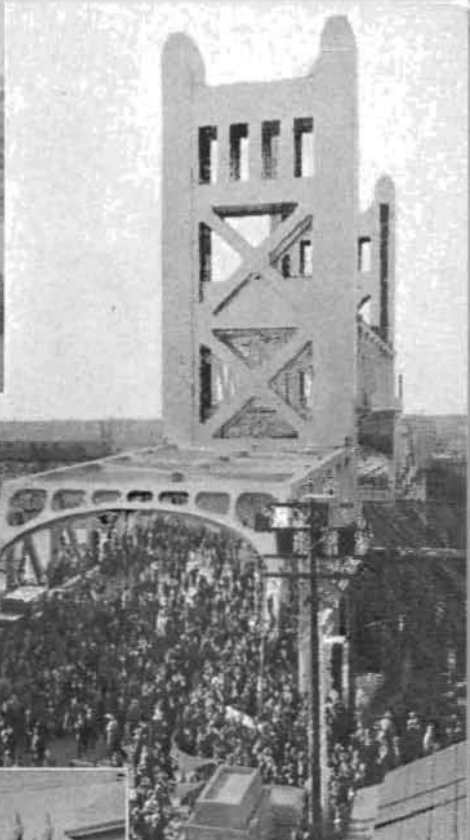

TOWER BRIDGE DEDICATION SCENES—A view of the narrow old M Street swing span structure contrasts with several views of the modern new Tower Bridge with central vertical lift span that replaces it. The view of the dedication day crowd shows the lift span raised. In the official group, left to right, are: Director of Public Works Earl Lee Kelly; Mayor Ferguson; Governor Merriam; Assemblyman Desmond; President McCurry, Chamber of Commerce; Assemblyman Nielsen; Commander Kunz, American Legion; Secretary Dudley, Chamber of Commerce. Governor Merriam is shown releasing one of a thousand pigeons carrying messages to mayors of California.

Highway Completed Through Historic San Marcos Pass on New Alignment

By L. E. McDOUGAL, District Office Engineer

ON a dismal rainy Christmas Day 89 years ago General Fremont led a small band of sturdy soldiers through the San Marcos Pass and pushed down the rugged brush-covered slopes of the Santa Ynez Mountains and captured the then small mission settlement of Santa Barbara.

This attack from over the mountains completely surprised the Spanish defenders who lay in ambush some 35 miles westward in the picturesque Gaviota Gorge with the intention of waylaying and destroying the attackers.

Were Fremont and his men to reappear at San Marcos Pass today, they would find, for their convenience, a modern oil surfaced highway carved for 5.8 miles out of the westerly slope of the Santa Ynez Range and dropping down almost into their objective, the city of Santa Barbara.

OVER SANTA YNEZ RANGE

The San Marcos Pass Road (State Route 80) was taken into the State system in 1931 and extends northerly from the Coast Highway at a point about two and one-half miles westerly from Santa Barbara. The old road, which ascended the Santa Ynez Range up a sharp ridge, was steep, very crooked, and had several dangerous hairpin turns. The road crosses the summit through the San Marcos Pass and thence generally follows down the Santa Ynez Valley through the towns of Santa Ynez and Los Olivos, rejoining the State Highway at Zaca, about 50 miles north of Santa Barbara.

This route is some 10 miles shorter than the regular main highway and provides an attractive alternate for the motorist, as the road traverses a truly delightful country. As one descends the mountains back of Santa Barbara, a beautiful panorama unfolds, embracing the city, the Santa Barbara Channel and the distant islands of the same name; and in the wooded canyons immediately adjacent are spotted numerous summer homes and cottages.

Extensive use of the road as an alternate route has been impeded mainly by the torridous and dangerous condition presented by the old route up to the San Marcos Pass from the vicinity of Santa Barbara.

As soon as possible after the inclusion of the route in the State system, plans were formulated whereby the San Marcos Grade and other portions of the road could be brought to more modern standards and eliminate the dangers prevalent along the old route.

With this in mind, \$500,000 was allocated for expenditure during the past biennium for the relocation of the highway from Santa Barbara to a point near the summit; and so, for the past year or more, power shovels and huge scrapers have been gnawing away at the sidehill overlooking Santa Barbara; and have excavated nearly 1,000,000 cubic yards of material and placed it in the adjoining gigantic fills.

The new road is a complete realignment from the old, and situated some distance easterly, has its junction with the Coast Highway about one and one-half miles closer to Santa Barbara than the old road; close to the intersection of the recently completed Santa Barbara Through Traffic Boulevard.

HEAVY GRADING A FEATURE

The new road is of 24-foot roadbed width and the maximum grade is 6.6% with a ruling grade of about 5% in the mountainous section. Surfacing for the present will consist of local material oil mixed and sealed 20 feet wide.

A feature of the work, aside from the heavy grading, was the constructing of large box culverts and placing of large drainage pipes at almost inaccessible locations far up the side of the mountain range. Rough temporary roads had to be bulldozed along the line ahead of the regular grading in order that the culvert materials might be transported to the drainage site.

Also, in conjunction with the project, there has been constructed across San Antonio Creek a combination timber and concrete bridge, 192 feet long, with a 24-foot clear roadway and consisting of eight standard 19-foot timber spans and one 40-foot concrete and steel girder span. Three large reinforced concrete arch culverts were constructed, the larger having 102 square feet of opening at Maria Ygnacio Creek.

(Continued on page 16)



SAN MARCOS PASS highway just completed on new alignment over the Santa Ynez mountains.



HEAVY SIDE HILL CUT one of several that permitted elimination of hairpin turns and steep grades.



CONSTRUCTION SCENE showing character of heavy grading work on fill leading to two 100 foot cuts.

Financial Set-up Provides \$21,914,000

(Continued from page 1)

Provision for major construction in the sum of \$21,545,400 was made in the revised biennial budget for the Division of Highways which received my approval on September 12, last. This budget was aimed to provide for continued development of the State Highway System, even with the curtailment of the State's share of gas tax revenue to one and one-half cents as a result of the granting of a second one-quarter cent to incorporated cities.

Since the approval of the budget, the Commission, due to increased gas tax revenue, has been able to raise the major construction allocation by some \$1,913,100, making a construction budget total of approximately \$23,458,500 from State and regular Federal aid funds for the period from July 1, 1935, to June 30, 1937.

In addition to this amount, Works Progress Administration funds for highway construction and grade crossing elimination in the amount of \$15,234,290 were apportioned to California by the Federal Government, \$7,747,428 being provided for road work and \$7,486,362 for grade crossing elimination.

SIX MONTHS RECORD

Of the \$21,232,300 in construction work orders issued by the Division of Highways during the last six months of 1935, some \$6,923,500 provided for work budgeted under the revised State Highway program, \$9,855,100 provided for work authorized under the two Works Progress programs, and \$4,453,700 in work was financed from minor improvement, maintenance and previous biennium funds.

The \$9,855,100 in projects put under way from the \$15,234,290 in Federal funds allocated to California from Works Program Highway and Works Program Grade Crossing funds, leaves some \$5,379,000 for unemployment relief contracts still to be advertised and awarded in the coming months of 1936.

From the Division of Highways budget, prepared upon the basis of estimated revenues from the State gas tax and motor vehicle license fees and from regular Federal Aid provided by Congress, the work put under way during the past six months in the sum of

\$6,923,500 leaves a balance of \$16,535,000 in major project construction for the remaining eighteen months of the biennium.

FUTURE WORK FUNDS

The sum of these two balances provides for future work in the amount of approximately \$21,914,000.

This amount of construction funds is contingent upon gas tax collections continuing at their present level and upon the appropriation by Congress of the regular Federal Aid funds. For the fiscal year ending June 30, 1937, California's share of Federal Aid is estimated at some \$4,792,000.

While provision was made in the Hayden-Cartwright act of 1934 for the "1937 Federal Aid" funds, at the time of the passage of the bill Congress only appropriated sufficient money for the 1936 apportionment. The appropriation of funds for the 1937 apportionment has not yet been made by Congress.

In his message to Congress accompanying the budget, the President recommended that this Federal Aid appropriation be deferred one year. If such action be taken, it will mean that the major construction projects included in the regular State Highway budget will be reduced by some \$4,792,000, leaving only about \$11,743,000 for the programmed work during the remaining eighteen months of the biennium. Revision of the budget to meet such a reduction will of necessity eliminate approximately 25 per cent of the projects now programmed.

HIGHWAY MAN HOURS

Translated into hours of work the \$21,914,000 anticipated for construction during the next year and a half will mean about 12,270,000 man hours for California labor. This total is obtained from 3,010,000 man hours on the Works Program projects and 9,260,000 man hours on the projects included in the revised budget.

Should the 1937 Federal Aid appropriation be withheld by Congress, it will mean the elimination of 2,684,000 man hours, leaving only 6,576,000 man hours for the budgeted program.

(Continued on page 13)

Major Highway Projects Planned for Construction in Next 18 Months

| County | Location | Route | Miles | Amount | Type |
|------------------------|---|--------------------------------------|-------|-----------|----------------------------|
| Humboldt | Salmon Creek to Bucksport and Trinidad to McNeil | Redwood Highway | 9.4 | \$290,000 | Grade and surface |
| Mendocino | Outlet Creek to Reeves Creek and Eleven Oaks Road to Willits | Redwood Highway | 5.3 | 256,000 | Grade, surface and bridge |
| Del Norte | Between Winton Corner and State Line | Crescent City-Marshfield Road | 5.1 | 140,000 | Grade and surface |
| Tehama | Pacific Highway to 1.5 mi. East of Dales | Red Bluff-Susanville Lateral | 13.8 | 175,000 | Surface |
| | Richfield to Red Bluff | Pacific Highway (West Side) | 13.0 | 270,000 | Grade and pave |
| Shasta | Near Shasta to near Redding | Trinity Lateral | 5.0 | 220,000 | Grade and surface |
| Yolo, Colusa | Dunnigan to Arbuckle | Pacific Highway (West Side) | 8.9 | 180,000 | Grade and surface |
| Yolo | Causeway to "M" Street Subway | Sacramento-San Francisco Rd. | 3.5 | 170,000 | Grade and pave |
| El Dorado | Kyburz to Strawberry | Placerville-Tahoe Road | 9.0 | 115,000 | Surface |
| Santa Cruz | Scott Valley to Santa Cruz | Los Gatos-Santa Cruz Road | 3.9 | 220,000 | Grade and surface |
| Santa Clara | Alviso Road to San Jose | Bay Shore Highway | 3.7 | 425,000 | Grade and pave and bridge |
| Marin | Waldo to Golden Gate Bridge | Golden Gate Bridge Approach | 3.5 | 1,780,000 | Grade, pave and structures |
| San Francisco, Alameda | Approaches to Bay Bridge | Bay Bridge Approaches | | 978,000 | Grade, pave and structures |
| Contra Costa | Between Oakland and Walnut Creek | Oakland-Walnut Creek Road | | 325,000 | Grade and surface |
| Monterey | Soledad to Gonzales | Coast Route | 3.0 | 168,000 | Grade and pave |
| Monterey | Bradley to 6 mi. South of San Ardo | Coast Route | 6.8 | 335,000 | Grade, pave and bridge |
| Santa Barbara | Tajiguas Creek to 1½ mi. W. Arroyo Hondo; Rincon Creek to Carpinteria; Richfield Tower to Santa Maria River; and Sheffield Drive to Olive Mill Road | Coast Route | 7.9 | 503,000 | Grade, pave and bridge |
| Fresno | Fresno to Ashlan Ave. | Valley Route | 4.0 | 275,000 | Grade and pave |
| Madera | Kelshaw to Coarsegold | Wawona Road | 3.0 | 230,000 | Grade and surface |
| Kern | Tehachapi to Mojave | Tehachapi Lateral (portions) | | 100,000 | Grade and surface |
| Los Angeles | Scoville Ave. to Osborne Ave. | Foothill Boulevard | | 235,000 | Grade, pave and bridge |
| Los Angeles, Ventura | Calabasas-Conejo Grade | Coast Route (portions) | | 200,000 | Grade and pave |
| Ventura | Big Sycamore Creek Line Change and Oxnard to Hueneme Road | Roosevelt Highway | 5.9 | 223,000 | Grade, pave and bridge |
| Orange | Seal Beach to Newport Beach | Roosevelt Highway | 10.3 | 150,000 | Pavement |
| Los Angeles | N and O Sts. and Wilmington Blvd. to Alameda St. | Roosevelt Highway | 1.5 | 150,000 | Grade and pave |
| Los Angeles | Rio Hondo Bridge | Los Angeles-Pomona Lateral | | 160,000 | Bridge |
| Los Angeles | Culver City to Centinella | Sepulveda Blvd. | 1.2 | 85,000 | Grade and pave |
| Orange | Gypsum Creek to East Boundary | Santa Ana Canyon Route | 2.6 | 175,000 | Grade, pave and bridges |
| Los Angeles | Los Angeles River Bridge and Approaches at Atlantic Blvd. | Alhambra-Long Beach Route | | 271,000 | Bridge and pavement |
| Los Angeles | Rosemead Avenue | Pasadena-Long Beach Route (portions) | | 222,300 | Grade and pavement |
| Los Angeles | Sepulveda Boulevard | Sepulveda Boulevard (portions) | | 195,800 | Grade, pave and structures |
| San Bernardino | Santa Ana River to Redlands | Los Angeles-El Centro Route | 5.5 | 111,000 | Grade, pave and structures |
| San Bernardino | Mountain Pass to State Line | Los Angeles-Salt Lake Road | 15.3 | 415,000 | Grade and surface |
| San Bernardino | Colton to Waterman Ave. | Los Angeles-Redlands Road | 1.9 | 330,000 | Grade, pave and bridge |
| Riverside | North Boundary to Beaumont | Imperial Valley Route | 1.5 | 77,000 | Grade and pave |
| Riverside | West Boundary to Prado | Route 43 | 3.0 | 205,000 | Grade and pave |
| Inyo | Big Pine to Keogh Hot Springs | Owens Valley Route | 8.0 | 150,000 | Grade and surface |
| Mono | 2 mi. S. Rush Creek to 3 mi. S. Mono Inn | Owens Valley-Tahoe Route | 7.5 | 125,000 | Grade and surface |
| San Diego | Del Mar to Encinitas, Las Flores Underpass to San Mateo Creek and Santa Margarita Bridge | Coast Route | 16.8 | 988,500 | Grade, pave and bridge |
| Imperial | Holtville to Brawley | Route 187 (portions) | | 104,000 | Surface |
| Imperial | Midway Wells to Calexico | Route 202 (portions) | | 100,000 | Grade, surface and bridge |

U. S. Road Chief Suggests Plan to Meet Problem of Safety on Highways

Increasing motor vehicle accidents on public highways, the necessity for preventive measures and all aspects of safety precautions designed to lessen the great loss of life featured addresses delivered by prominent speakers at the recent annual convention of American Association of State Highway Officials at Miami, Florida. An outstanding paper, "The Right to Pass—In Safety," presented by Thos. H. MacDonald, Chief, U. S. Bureau of Public Roads, is herewith reproduced in part.

By THOS. H. MACDONALD, Chief, U. S. Bureau of Public Roads

IN OUR ways and means of meeting the problems of safety of travel on the highway, we lag far behind the advance that has been made in dealing with similar problems of travel by rail and ship. This comparison applies to all aspects of the problem—the operating officials, the laws and enforcement organizations, and even the facilities themselves.

The perfecting of each of these factors through consistent effort and experience in meeting these problems results in the inevitable record for ships and railways. Certainly it would be possible to draw comparisons leading to the conclusion, and the subsequent excuse, that the conditions to be met are so different in highway transportation—some so exaggeratedly different—that a comparable degree of safety for our streets and highways is beyond any reasonable possibility.

Fortunately, we are not now in the dark as to many things which need to be done to increase highway safety. An evaluation of the present status of ways and means that, if given the opportunity, will advance the cause of highway safety, discloses a very definite foundation on which to proceed. * * *

Records of the Bureau of Census show that there was an increase in fatalities in 1934 over 1933 of 4738, and in 1934 total fatalities of 36,101. In the 95 cities of over 10,000 population the total fatalities in 1934 were 10,361, an increase of 918 over the previous year.

The fatalities in these cities were 28.7 per cent of the total. It is evident, therefore, that if we are to better this record materially we must look to the smaller towns and the rural districts. * * *

With a background as to the need and method of securing the vital and necessary facts, including the number, kinds and results of major and minor disasters on our highways, on which to base corrective action, the problem becomes one of organization and administration plus public education.

A natural transportation safety program is essential—definite in character and fixed

in the responsibility resting upon officials for its various phases. The principal criticism that can now be made is that in general we are not reducing to effective action what we know to be sound and are not carrying on adequate research to clear our blind spots in traffic control.



Copyright Underwood and Underwood, Inc.
THOS. H. MACDONALD

MacDonald Proposes Federal and State Safety Committees

(Continued from preceding page)

To bring a sound safety program into definite form and then to place it in effective operation in all its ramifications, is the only policy that carries any hope of progress. The remarkable advance in the attainment of industrial safety has rested upon a definite program and fixed responsibilities. In the public safety field the same general principle must be followed.

Until recently there have been only State laws giving authority to officials to operate in the safety field. Now limited authority has been reposed in the Interstate Commerce Commission to make rules and regulations applying to certain types of vehicles moving in interstate commerce. We will have, within a short time, then an entry into the field of traffic regulations in a moderate way by the Federal government. We must depend, however, for the major advance in the actual attainment of safer conditions on our streets and highways upon the States and their local subdivisions.

PLAN OF ORGANIZATION

Without any claim as to novelty, the following plan of organization necessary for effective administration is advanced. There would be two principal divisions in the major organization: First, Federal, and second, State. In turn, each of these divisions would consist of two branches. First, an official committee appointed by the Chief Executive, or through legislation, consisting of those elective or appointive officers who have the legal responsibility and authority to act in this field. The second very important branch would be an advisory committee on safety consisting of representatives of organizations and individuals who are now engaged in safety work.

The Federal official committee* should be headed by a cabinet officer and consist of the heads of those divisions or bureaus which have legal authority now to act upon matters directly related to transportation safety—in addition to the representatives of the Federal bureaus, the President of the American Association of Motor Vehicle Administrators and the President of the American Association of State Highway Officials.

The Federal advisory committee on transportation safety would include organizations such as the American Automobile Association, the National Safety Council and other groups which now are engaged in safety work.

OFFICIAL STATE COMMITTEES

The State official committee should be headed by the Motor Vehicle Administrator and there should be associated with him the heads of State departments who have legal responsibilities in this field,

* Such a committee could very well be composed of representatives of the Interstate Commerce Commission, the Bureau of the Census, the Bureau of Navigation, the Bureau of Aeronautics, the Bureau of Public Roads and the Bureau of Standards; and the Presidents of the American Association of Motor Vehicle Administrators and of the American Association of State Highway Officials.

CONVENTION OF HIGHWAY OFFICIALS URGES PRESIDENT TO EFFECT SAFETY PROGRAM

The following resolution was adopted at the annual convention of the American Association of State Highway Officials at Miami, Florida, December 9, 1935:

"Whereas, Accidents on the public highways, and fatalities resulting therefrom have continued to increase, as evidenced by the published records for 1934; and

Whereas, These records indicate a condition seriously disturbing to the public mind, to the public officials administering the traffic regulations, to those engaged in promoting highway safety, to those responsible for the construction and maintenance of public highways and to the motor industry; and

Whereas, It is considered of the utmost importance not only from the humanitarian standpoint, but also from the point of view of efficient and satisfactory highway construction, maintenance and operation that every phase of the existing conditions be thoroughly examined and all possible immediate and related steps be taken to correct the present conditions; now, therefore, be it

Resolved, That the American Association of State Highway Officials urgently recommends that the Federal and State governments take prompt action to correlate the efforts of all public and civic agencies now engaged in highway accident prevention; and be it further

Resolved, That this association specifically recommends to the President of the United States and to the governors of the several states that they use their executive authority at once to appoint advisory groups and direct existing official agencies to effect the cooperative action necessary to accomplish the desired results."

such as the chief highway executive, the superintendent of public education and the head of any State safety group.

The State advisory committee would be composed of the representatives of branches of national organizations and individuals who are now engaged in the safety field.

The functions of the official committees, State and Federal, would be to formulate regulations and policies and to administer these. The functions of the advisory committee would be to encourage and support the public officials and their law enforcement officers, to suggest regulations and legislation, to help secure and sustain these and to carry on a constant campaign of education in every possible form to the end that the public shall become safety conscious. The importance of these advisory committees can not be overemphasized. Unless the official groups, Federal and State, have the backing of an intelligent and vigorous support, their work can not be effective.

Such an organization can be put into effect on executive order and would make use of existing legal authority and organization which must in the end be responsible for results.

(Continued on page 16)

Measuring Stability and Cohesion of Bituminous Paving Mixtures by Machines

By THOS. E. STANTON, Jr.* and F. N. HVEEM†

WHEN the first oil mixed road surfacing was constructed by the State of California in 1926, it marked the beginning of an inexpensive type of pavement which now carries millions of vehicles annually, and covers a vast mileage of primary and secondary highways in this and other western states.

The development of this type of surfacing has required that many problems be solved, and a full share of these has fallen to the testing and research laboratory of the Division of Highways.

In order to retain the fundamental low-cost feature of such construction, it is essential that, whenever possible, cheap local materials be utilized. It is poor economy, however, to use materials of questionable quality and thus incur an immediate high annual maintenance charge just to obtain extremely low first cost. Therefore, to insure stable, traffic-resistant construction and to discriminate between good and bad materials, it is necessary that there be suitable laboratory tests to determine quality prior to construction.

TESTING FOR STABILITY

One of the important properties of a bituminous pavement is that of stability. The term "stability" is intended to express that quality of bituminous pavements which tends to resist plastic deformation. Unstable pavements are those that corrugate or groove under the action of traffic. A pavement which ravel and disintegrates due to abrasion or which fails from water action may not be fundamentally unstable.

Though a number of laboratory machines have been designed for testing stability, most of such stability measuring devices were developed for testing mixtures of the sheet asphalt or asphaltic concrete type, in which the binding medium consists of a relatively hard asphaltic cement. The oil mix type of pavement, in which the binder is a fuel oil or

liquid asphalt, does not show high stability values in testing machines which primarily measure the cohesion or tensile strength of the mixture.

NEW MACHINE NECESSARY

Samples of oil mix surfacing, which had been known to withstand traffic successfully, gave results so low in these testing machines as to be almost negligible when compared to standards considered acceptable for asphaltic mixtures.

Inasmuch as many of these oil roads had successfully carried automobile and truck traffic, it appeared reasonable that a proper stability test should record the superior qualities of the low cost road as well as of the harder type of asphaltic concrete mixtures, and, furthermore, the test should indicate higher stability for a stable oil mix road than for an inferior asphaltic concrete mixture which had proved to be unstable by waving and rutting under the action of traffic.

In analyzing the action responsible for this pavement distortion, it appears that the prime force is the weight of the vehicle. The vehicle tends to sink into the pavement surface, and when in motion pushes one side of the depression forward in front of the wheel. (Fig. 1.)

Presumably, in a perfectly uniform and homogeneous mixture, and with the vehicle traveling at a uniform rate, any wave or ripple thus formed should proceed ahead of the vehicle indefinitely, or at least for the complete length of the pavement.

MOVEMENT OF SURFACE

Bituminous pavements, however, are rarely of uniform quality, nor do vehicles proceed at uniform speed. Several factors probably contribute to the formation of transverse waves or ripples which may become quite extensive and of considerable magnitude under certain conditions.

Figure 1 shows a diagram of a pavement surface, with a loaded wheel displacing a small wave or ridge in the direction of travel.

Figure 2 is a diagram illustrating the type of movement within the mass of the pavement under load. These lines of flow have

* Materials and Research Engineer, California Division of Highways.

† Associate Physical Testing Engineer, California Division of Highways.

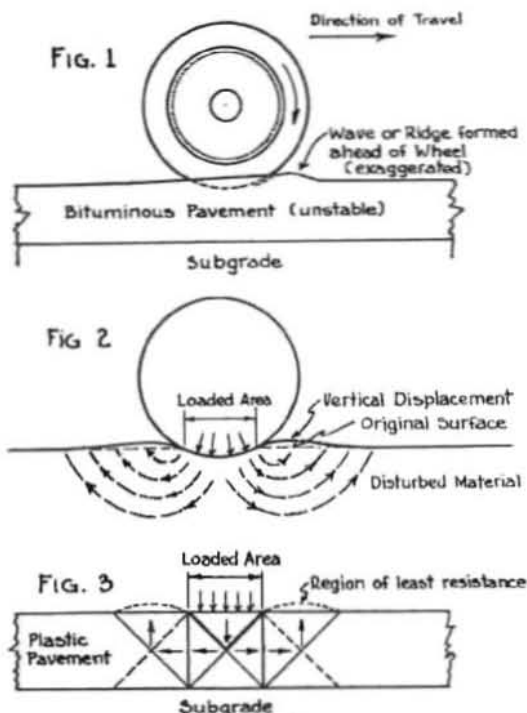

been photographed and demonstrated experimentally.† There is ample evidence, both experimental and theoretical, that the effect of a load on a plastic surface is to force downward a conelike or wedge-shaped body of the material.

CAUSE OF UPHEAVAL

From a study of the diagram, Figure 3, it is evident that distortion or flow in a plastic solid in which the loaded area covers only a small portion of the exposed upper surface consists of a cone-shaped mass of the material being forced downward, meeting the resistance of an adequate support (subgrade) and the resultant forces are diverted horizontally and radially against the surrounding mass outside the loaded area.

The lines of least resistance naturally trend upward toward the unloaded surface surrounding the loaded area, so that when the load exceeds the resistance of the plastic solid, an upheaval occurs around the loaded area.

In producing the movement thus described, work is done principally in overcoming friction between the solid particles of the mass, and partially in overcoming adhesion in certain areas. (This last resistance varies with the speed of action.) The pressure horizontally transmitted to the side limits of the prism beneath the load will be less per unit area than the load pressure applied, so long as any internal friction exists.

MEASURE OF STABILITY

In other words, asphaltic paving mixtures may be classed as plastic solids; hence, a measure of resistance to plastic deformation should be a measure of stability.

The necessity for reliable laboratory tests to determine in advance the probable tendency of the pavement to shove and distort under traffic led to the development in the Materials and Research Department of

† Part II, Proceedings of the Fourteenth Annual Meeting of the Highway Research Board, page 140.

DIAGRAMMATIC SKETCH OF THE HVEEM STABILOMETER

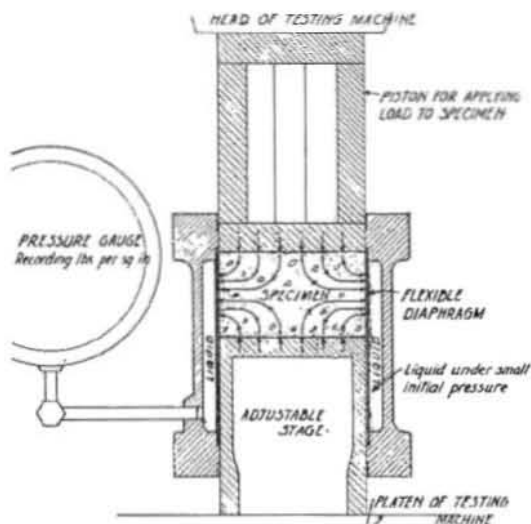

NOTE:
Specimen given lateral support by flexible side wall which transmits horizontal pressure to liquid. Magnitude of pressure may be read on gauge.

Fig. 5

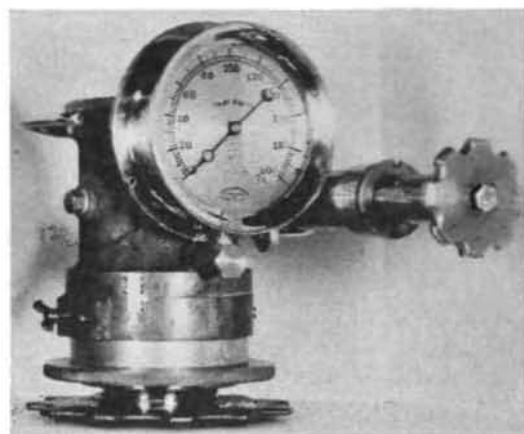

HVEEM STABILOMETER as it looks completely assembled.

the California Division of Highways of the special equipment hereinafter described.

The stabilometer is a form of plastometer, and consists essentially of an outer metal shell of cylindrical form within which is secured a rubber tube of smaller diameter. The rubber is clamped to the cylinder at each end in such a manner as to form a water-tight chamber between the outside of the rubber tube and the inner side of the metal cylinder. This water-tight chamber is filled with any suitable liquid, and connected with a pressure gauge to register the pressure to which the liquid is subjected. (See Fig. 5.)

A compacted test specimen is formed to fit snugly within the rubber tube, and any lateral expansion of

(Continued on page 23)

Lift Span Moving Load, 5,000,000 Lbs.

(Continued from page 2)

The pull of the counterweights is attached to the four corners of the lift span by ninety-six steel wire ropes, twenty-four of them at each corner. Each rope is two inches in diameter. As the combined weight of the two counterweights equals that of the lift span, the total moving load, including the span counterweights, the wire rope cables and the fittings, is about 5,000,000 pounds.

When a river vessel passes through the span it is necessary for the operator to judge the height of the craft and then raise the span sufficiently to provide a suitable margin of safety above the highest point of the boat. An advantage of this type of movable span is that it is not necessary to fully open the span except for a few vessels. Immediately after the passage of a boat, the span is lowered and roadway traffic can be resumed.

OPERATED BY ELECTRICITY

A complex electrical system for operating the span was installed at a cost of about \$100,000. The power for controlling the huge span and operating and lighting it is provided by an electric current taken on to the bridge by cable. The voltage is reduced for light and control purposes by means of transformers in the control house. Switches for all purposes are on switchboards and control desks in the control house.

When an approaching vessel signals for passage-way it is answered from the bridge by an electrically operated signal. Automatic signals immediately are set to stop all approaching trains and derail switches are set to stop any trains that might overrun the stop signals. When this is done, it is possible to unlock the rail locks on the bridge and energize the control desk for operating the span. Sirens at each end of the bridge sound immediately, stop signals used at street intersections are lighted at both ends of the structure and bells and illuminated signs warn traffic the span is about to open. The vehicular and pedestrian gates close automatically and sirens blow continuously until the gates are closed.

EIGHT SAFETY GATES

There are eight such gates and when the last is closed it is possible to raise the central lift span. When the vessel has passed the bridge operation is reversed and traffic resumed.

The new bridge can be fully opened or closed in approximately one and one-half minutes. Highway traffic will be stopped for only a small part of the time that was required for opening and closing the old bridge swing span.

The two great towers of the bridge rest upon two concrete cylinders built to a depth of fifty feet below water. In building the piers, two circular wells of timber sheet piling, each thirty feet in diameter, were driven into the river bed, sixty feet of piling having been used to provide safe freeboard above low water. After the cofferdams were completed, excavation with a clamshell bucket handled from a crane on a floating barge was undertaken.

The bottoms of the cofferdams were sealed by pouring concrete through a flexible pipe, reaching

down into the water near the point of deposit. It was necessary to pour a sufficient amount of concrete inside the cofferdams to offset the hydrostatic pressure from the water outside. This required a seal twenty-four feet thick—about 650 yards of concrete—for each well.

The concrete in the piers, caps, paving, railings and walls amounted to more than 5,000 cubic yards. A total of 6,500,000 pounds of steel was required. Fifty-eight thousand feet of fir went into the 922 piles, varying in length from fifty to ninety feet. Excavation for the bridge and roadways totaled 23,000 cubic yards.

In excavating for the abutment on the Sacramento shore twenty feet below the present street level, the contractor discovered and removed complete sections of the Central Pacific Railroad laid there seventy years ago. There are 4600 lineal feet of concrete pilings in the bridge.

One of the chief hindrances to motor vehicle and pedestrian traffic on the old bridge was caused by switching trains on Front Street at the east end of the structure. There were several railroad tracks to be crossed at this point. The Southern Pacific, in a spirit of cooperation, has eliminated one track and Front Street has been repaved thus providing a smooth and easy crossing for highway traffic.

WIDE, EASY APPROACHES

Highway curves on the west approach have been eased off and pavement widened to connect with the Tower Bridge. The Sacramento Northern has rearranged its freight switching movements over the bridge so as to facilitate highway traffic.

Formal dedication of the bridge by Governor Merriam on December 15, last year, was witnessed by thousands of Sacramentans and visitors from other counties. The ceremonies began at 1.30 p.m. when the state's executive led a parade from Ninth and M streets to the bridge.

The procession was headed by bearers of the national and American Legion colors, commanders of Sacramento American Legion posts and the American Legion band. Automobiles bearing Governor Merriam and Director of Public Works Kelly, under whose supervision the bridge was built, followed. Behind them came cars bearing state, city and county officials and leaders of local civic bodies and citizens escorted by a drum corps. The dedication and opening of the bridge were arranged by the Sacramento Chamber of Commerce through a committee of which R. L. Moore was the chairman.

SPEAKERS ON PROGRAM

The celebration at the bridge began at 2 p.m. with flag raising ceremonies participated in by the Boy Scouts. Following rendition of "The Star Spangled Banner" by the American Legion Band, opening remarks were made by M. B. Kunz, commander of the American Legion city council. Brief talks were made by Mayor Arthur Ferguson of Sacramento; H. J. McCurry, president of the Sacramento Chamber of Commerce; John Keema, chairman of the Sacramento

**MAINTENANCE ENGINEER
GIVES TIMELY AID TO
MOTORISTS IN ACCIDENT**

**MUTUAL CREDIT FOUNDATION
RIALTO BUILDING**

San Francisco, California

Chairman Highway Commission,
Sacramento, California.

Dear Sir:

On September 17, 1935, at about 9 a.m., the writer had the misfortune to become involved in an automobile accident at a point just opposite the Point Sur Lighthouse and just north of the schoolhouse on that road. Only the writer's car was involved; it having turned over once on its top and settled on its left side facing south. The writer crawled out through a window and pulled out two other occupants, the instant the car had settled; however, the danger of fire was averted by the ignition key having been pushed in.

I wish to especially commend to you and your good service Mr. Brown, your District Maintenance Engineer, who was heading north and stopped his car picking all three of us up and proceeding without delay to the Peninsular Community Hospital at Carmel where he awaited the arrival of a doctor. He then proceeded to Carmel proper and left word with the garage there to proceed to the scene of the accident with a tow car giving them all necessary details.

While probably anyone else would have done the same thing, yet Mr. Brown's attitude was helpful, sympathetic and understanding and had the effect of calming us all down. In addition, he offered his services to any other extent we might need.

Kindly accept my sincerest thanks and may I ask that some official word be passed on to Mr. Brown as an expression of gratitude of myself and family.

Sincerely yours,

(Signed) Gilbert O. Roos.

GOVERNOR MERRIAM OPENS BRIDGE

(Continued from preceding page)

Board of Supervisors; William Russell, chairman of the Yolo County Board of Supervisors; George G. Pollock, general contractor for the bridge, and Director of Public Works Kelly.

Governor Merriam then formally dedicated the new bridge and entered his official car in which he led a parade across the great span. As the radiator of his automobile broke the ribbon stretched across the eastern bridge entrance, the siren on the central towers announced the opening of the structure to traffic and factory whistles throughout the city, automobile horns and sirens on river craft joined in the chorus.

Simultaneously, 1000 homing pigeons bearing tidings of the occasion to all sections of California were released.

*State Water Plan
Work to Approximate
10,000,000 Man Hours*

(Continued from page 6)

An accompanying tabulation sets forth a few of the larger projects included in the work planned to be begun by the Division of Highways during the remainder of the biennium.

WATER RESOURCES PROGRAM

The Division of Water Resources will employ during the ensuing 18 months close to 200 technical and non-technical employees in the administration of water rights, water resources investigations, snow surveys, water master service, irrigation investigations, supervision of dams, cooperative stream gaging and topographic mapping, flood control construction, bank protection and the maintenance and operation of the Sacramento Flood Control Project, at an expenditure excluding materials and supplies, of approximately \$600,000, representing roughly 840,000 man hours of employment.

In addition to the above, approximately 200 WPA relief workers will be employed intermittently during the ensuing 18 months under the direction of the Division of Water Resources on flood control construction and maintenance and operation of the Sacramento Flood Control Project, representing 468,000 man hours of employment at an expenditure of approximately \$160,000.

CENTRAL VALLEY PROJECT

This does not include the Central Valley Water Project being constructed under the supervision of the United States Bureau of Reclamation on which an expenditure of approximately \$15,000,000 is estimated during the next 18 months, including materials and supplies. It is not possible to accurately estimate the man hours on this project as it is not known when the peak employment will be reached, however indications are that it will provide approximately 10,000,000 man hours of employment.

The estimate for WPA relief work during the ensuing 18 months on flood control construction and maintenance and operation of the Sacramento Flood Control Project is made contingent upon relief work being carried out on this project on a comparable basis to that in effect in 1935.

(Continued on page 29)

Notable Highway and Bridge Project at Redding Completed and Dedicated

By M. FREDERICKSON, Resident Engineer

The new highway and Sacramento River bridge at the north entrance to the city of Redding was officially dedicated and opened to public use by the Director of Public Works, Earl Lee Kelly, on December 18, 1935.

The dedicatory ceremonies, participated in by public officials and civic leaders, were held on the south end of the new bridge spanning the Sacramento River, with President Harry E. Thompson, of the Redding Chamber of Commerce, presiding. Speeches were given and the traditional silken ribbon severed.

barrier that officially opened the road and bridge to public use.

This major improvement to the State highway system begins at the intersection of Market and Trinity streets in Redding and follows Market Street to the intersection of Riverside Drive. From this point, instead of turning left on a sharp curve to cross the Sacramento River more than one-half of a mile upstream, the new alignment turns slightly to the right and immediately crosses the river over a new bridge of modern design, and continues straight across the flat north of

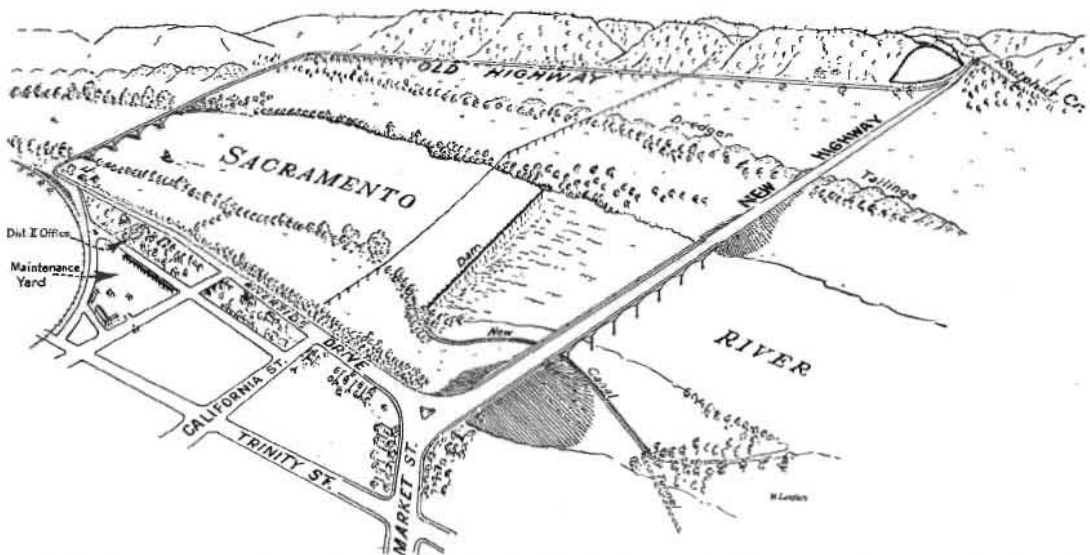

SKETCH MAP by W. Landers, Engineering Draftsman of District II shows how new Redding Bridge across Sacramento shortens distance more than one mile.

Those participating in the exercises in addition to Director Kelly and President Thompson were: Mayor William Menzel, representing the city of Redding; G. T. McCoy, Assistant State Highway Engineer; F. W. Haselwood, District Engineer; F. W. Panhorst, Bridge Engineer; and Richard E. Wilson, Office Engineer.

RIBBON BARRIER CUT

Miss Barbara Hellesoe, daughter of Mr. and Mrs. G. F. Hellesoe of Redding, assisted Mr. Kelly in the final act of cutting the ribbon

the river to rejoin the existing highway near the Sulphur Creek Bridge.

SAVES OVER MILE

The entire length of the new road is 1.05 miles; whereas, the distance between the same limits over the old road was 2.2 miles.

The project has long been a dream in the minds of engineers, a cherished hope of the citizens of Redding and Shasta County, and the marked improvement in traffic service will benefit all who travel into or through that

(Continued on page 22)



STRAIGHT ACROSS THE SACRAMENTO at Redding goes the realigned State highway over a new 795-foot bridge with a 34-foot roadway and wide, easy approaches.



RIVER VIEW of the new steel girder type bridge consisting of six 108-foot continuous plate-girder spans and two 45-foot cantilever end spans on concrete piers.



OFFICIAL GROUP at night dedication ceremonies (left to right) Office Engineer R. H. Wilson, Division of Highways; District Construction Engineer, G. F. Hellesoe; Acting Bridge Engineer, F. W. Panhorst; Mayor W. B. Menzel of Redding; District Engineer F. W. Haselwood; Director of Public Works Earl Lee Kelly; Barbara Hellesoe who cut the ribbon; Assistant State Highway Engineer G. T. McCoy; President H. E. Thompson, Chamber of Commerce.

Highway Design for Safety Outlined

(Continued from page 9)

The first action would be to develop a detailed program and assign definitely the different activities proposed. We would then have for the first time a coordinated plan in which both State and Federal governments can function in harmony.

The same type of organization can well be extended into the city and major local subdivisions of government. * * *

The studies which the Bureau of Public Roads has made in cooperation with the highway departments and other agencies, and other studies, indicate a failure of around one-third of highway users to obey traffic signals.

The degree of disregard varies widely and this is not intended to convey the impression that one-third of the drivers on highways are careless or disobedient of regulations. Competent motor vehicle administrators place the percentage of really dangerous drivers as low as 5 per cent. The fact, however, that not more than 20 States have a highway patrol organization of even reasonably adequate character indicates the distance we have to go to establish law enforcement on our highways.

EMERGENCY HIGHWAY IMPROVEMENTS

In harmony with these suggestions but without delay there are two types of activities to which the highway departments should give greater attention. The first we may term the emergency improvements that may be undertaken quickly and that should prove effective in eliminating dangerous conditions. Such activities include placing of non-skid surfaces, the clearing of obstructions to lengthen sight distances, the elimination of hazard at points where accidents have occurred, if due to faults of the road, and the immediate marking of all curves for their safe speed of travel.

It is a fairly well established fact that the obvious danger points are not responsible for the greatest number of accidents. Where they are due to faults of road design, accidents usually result from some faulty detail not disclosed until too late.

For the long-time program, highway design must recognize the trend to higher speeds and provide for those to the extent they may reasonably be expected to become established by the public usage. This involves the recognition of two general classes of highways: those for through or main line traffic and those for local and tributary service. This classification follows the trend of public usage and human behavior. For the first class, ample width of traffic lanes, safe sight distances, easy curvature, super-elevation, non-skid surfaces and clear vision of intersecting roads are essentials of proper design.

MULTIPLE LANE SEPARATION

Where multiple lanes are necessary it is recognized that in general the two opposing directions should be separated.

A serious fault existing in many otherwise high-class highways is the inclusion of short sections of highway in which the design as to curvature, sight

distance or other details, falls below the general standard of the road. A very substantial contribution can be made by the highway engineering profession to the safety of highway use by adequately designing all component parts of the highway structure for safe travel, not only at the speed with which traffic moves at the present time, but in so far as possible for the speed which observation of the general trend indicates will be the average for the greater percentage of highway traffic in the years to come. Practically one-half of the fatal accidents are to pedestrians.

On these through highways, footpaths and sidewalks, which will actually be used by pedestrians, must be an integral part of the design.

Such elaboration of design necessary for those roads which fall into the general-use, long-distance, high-speed traffic class will be unnecessary for the tributary roads where traffic instinctively proceeds with less haste and more caution, and this distinction must be applied. Otherwise, the expense becomes too great a burden.

THE IMMEDIATE PROBLEM

In this discussion no attempt has been made to approach the subject from the angle of a traffic expert. The problem at this time is one of administration and organization. Such an approach will undoubtedly have the full support of the American Association of State Highway Officials because of their recognition, through their own experience, of its validity.

Unfortunately, because of the lack of organization, adequate administration and popular education in this field, much of the splendid effort and to an extent the great investment that has been made in highway improvement are being partially depreciated by the selfish and uncontrolled action of a relatively small percentage of the users of the highways.

Our highways are a proud possession. Over them each individual has the right to pass, but we must add the qualification, with due regard to the rights and safety of others.

HIGHWAY BUILT OVER HISTORIC SAN MARCOS PASS

(Continued from page 4)

It is expected that the road will be completed and opened some time this month and will afford the motorist a delightful and scenic alternative route when traveling the Coast Highway and certainly offers a striking contrast between riding along this modern road in the luxury of an automobile to that of not many years ago when a weary group of soldiers pushed their way down these same slopes through dense rain-soaked brush and mud.

State Highway Traffic Count to Be Made Monthly at 38 Key Stations

FOR several years it has been customary for the Division of Highways to make, on the Sunday and Monday nearest to the middle of the months of January and July, two 16-hour traffic counts at approximately 1400 traffic stations. This procedure is to be revised with respect to the winter traffic count. Instead of occupying 1400 stations on the Sunday and Monday nearest the middle of January, 38 stations will be occupied one Monday in each month throughout the year.

The most important reason for the change is that a monthly count at the smaller number of stations will effect a considerable saving in cost and at the same time furnish a more reliable basis for the estimation of seasonal traffic throughout the State.

MARKED SEASONAL FLUCTUATIONS

In the immediate vicinity of the larger cities the monthly fluctuation in volume of traffic is not pronounced, but it is marked in rural areas. There is also considerable range in fluctuation between different parts of the State.

The Redwood Highway (U. S. 101) in Del Norte County and U. S. 80 in Imperial County are typical of the extremes encountered in traffic fluctuation. In Del Norte County the traffic in July or August is approximately seven times as great as the traffic in January. On the other hand, July traffic at Fort Yuma approximates only 85 per cent of the January traffic. At Fort Yuma, peak traffic occurs during December and January.

Uncertainty of weather conditions in January was a secondary reason for the present revision of the traffic count. Over a period of years there is a fairly constant relationship between winter and summer counts made in a given locality. However, since rural traffic is greatly influenced by the weather, comparisons of winter counts limited to two successive years sometimes produce misleading results.

The monthly counts at a large majority of the 38 key stations listed below will be taken for 24 hours, the first count being made on January 13. Vehicles will be classified, as heretofore, by type and according to the

number passing each hour. The records of these stations will be used in conjunction with the regular state-wide census which will be made in July.

LIST OF KEY STATIONS

ROUTE 1—Tiburon Junction, junction Routes 1 and 52. North of Ukiah, at junction with Route 15. Fernbridge, at junction with Route 56. Crescent City, at junction with Route 71.

ROUTE 2—Del Mar, at Santa Fe Railroad Crossing. Serra, at junction with Route 60. Los Angeles, at junction with Route 166 (Whittier Boulevard and Indiana Street). West of El Rio, at junction with Route 60. South of San Lucas, at junction with Route 10. Palo Alto, at Federal Telegraph Station.

ROUTE 3—12 Mile House, at junction with Folsom Road. North of Weed.

ROUTE 4—Tunnel Station, junction of Weldon Canyon and Tunnel Road (Junction Routes 4, 23, and 157). Famoso, at junction with Route 33. Califa, at junction with Route 32.

ROUTE 5—Mossdale, at junction with Route 66.

ROUTE 7—South of Williams.

ROUTE 8—Petaluma Creek Bridge.

ROUTE 9—Junction of Routes 9 and 190, Los Angeles County.

ROUTE 11—Isleton Bridge, junction of Routes 11 and 53. 14 Mile Post (Headquarters Camp).

ROUTE 12—Whitestar, west of Jacumba, at junction with Route 200. West of El Centro, at junction with Route 26.

ROUTE 23—3.25 miles south of Palmdale, at junction with county road. South of Lone Pine, at junction with Route 127. Leevining, at junction with Route 40.

ROUTE 26—Whitewater, at junction with Route 187.

ROUTE 28—East of Canby, at junction Malin-Klamath Falls Road.

ROUTE 29—3 miles west of Chester, at junction with Route 83.

ROUTE 31—Cajon, at junction with Swartout Valley Road (Route 59). Barstow, at junction with Route 58 at Mojave River.

ROUTE 43—Olive, at junction with Route 178. Mt. Anderson, at junction with Route 188.

ROUTE 55—Junction of Routes 55 and 56 (Salada Beach Road).

ROUTE 60—Junction of Routes 60 and 174 (Lincoln Boulevard and Manchester).

ROUTE 68—Burlingame, junction with Broadway.

ROUTE 72—Northeast of Weed.

ROUTE 77—Temecula, junction with Route 78.

"About this girl you want to marry—has she good connections?"

"Well, she never came apart when I was with her."

San Francisco-Oakland Bay Bridge

Will be Opened to Traffic in 11 Months

ONLY eleven months more and the construction of the world's largest bridge will be California history.

This is the essence of the 1936 New Year's Day report to Governor Frank F. Merriam, chairman of the California Toll Bridge Authority, by State Director of Public Works Earl Lee Kelly.

Despite the pace of the 30-hour week and the obstacles which nature places in the way when man seeks to set new engineering frontiers in defiance to the hazards of deep water and dizzy heights, the world's largest bridge will finish ahead of schedule. By November, 1936, Chief Engineer C. H. Purcell expects to have finished the paved decks so that the bridge may be opened to traffic during November.

these great bridges and California is the special beneficiary.

"The engineering wonders of these two record-breaking structures have turned the eyes of the world on America, on California, and on San Francisco Bay—just as Boulder Dam has turned the spotlight on Los Angeles. The State Department of Public Works is proud to present to California this San Francisco-Oakland Bay Bridge, which, eminent authorities have said, will hold its place as the greatest bridge in the world for one thousand years.

"During its first year we expect the bridge to carry 6,000,000 vehicles, and full prosperity only needs to return to give the bridge an annual passenger traffic of 50,000,000 persons."

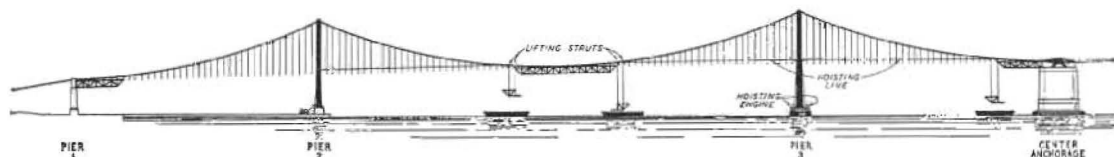

FERRIED ON BARGES roadway trusses for the Bay Bridge are lifted from midbay into position and fastened to suspender cables as shown in sketch.

\$40,000,000 EXPENDED TO DATE

Thus far approximately \$40,000,000 has been expended on bridge and approaches. During 1936, the bridge and its approaches—representing \$62,600,000 at present estimates—will have been completed and the remaining \$15,000,000 worth of work which represents the cost of the interurban railway on the bridge will, if present negotiations with the railroads and RFC are successful, be well under way. The railway portion will not be completed until after the highway decks have been opened to the traveling public.

"The building of this world's greatest \$77,600,000 bridge between San Francisco and Oakland," Director of Public Works Kelly said, "and its sister bridge, the \$35,000,000 Golden Gate Structure, sets in motion the tidal wave of public interest in California which is to produce a tremendous exposition on a specially made island in San Francisco Bay in 1938. The entire west is tributary to

PROGRESS SCHEDULE FOR 1936

The report to Governor Merriam set forth the following schedules for completion of units of the San Francisco-Oakland Bay Bridge in 1936:

BERKELEY UNDERPASS—now complete.

EAST BAY DISTRIBUTION VIADUCTS—complete April 1.

MAINTENANCE BUILDINGS IN OAKLAND TIDELANDS—complete July 1.

EAST BAY BRIDGE—cantilever closed March 7.

PAVING EAST BAY—complete May 7.

YERBA BUENA ISLAND—upper deck of tunnel and all island work, including the tunnel—complete June 1.

WEST BAY BRIDGE—(The twin suspension bridges, East Bridge and West Bridge, over the West Bay Channel, between San Francisco and Yerba Buena Island)—The west bridge will be completed first, with all of its spans hung from the cables by March 15, and the steel floor in by April 15. The East Bridge, between the concrete center anchorage and the island, 28½ inch cables for which are now being spun, will have its decks

(Continued on page 20)

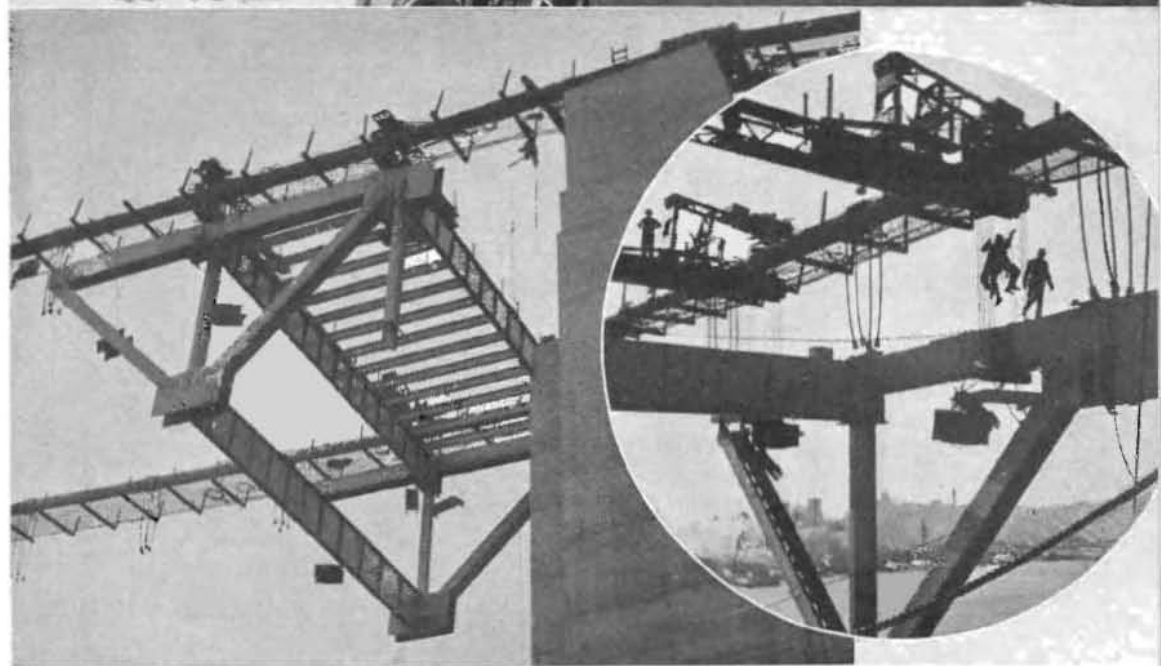
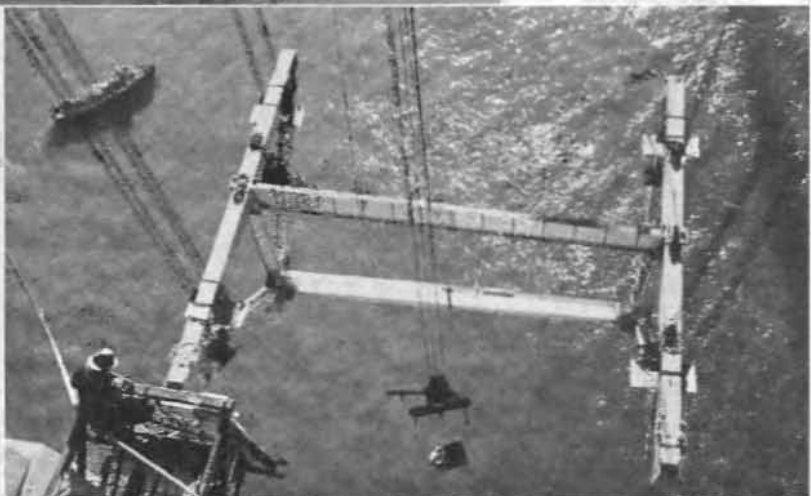
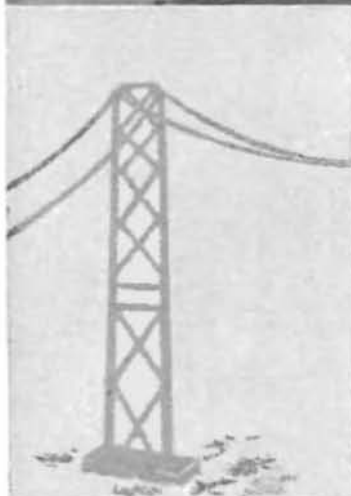

FROM THE WATER UP go steel sections of the San Francisco-Oakland Bay Bridge roadway to be hung in position on suspender cables. These sections consist of about 90 feet of truss measuring the full 66-foot width of the bridge and weighing as much as 210 tons. They are ferried out to the bridge on barges as shown in the top photo and lifted into position by steel lifting lines operated by engines at the base of the towers as seen in the center picture. At bottom is shown one section just six feet below final position 250 feet above the Bay and in inset workmen are sliding down from the main cables to attach socketed suspender cables, four of which can be seen dangling over each end of the truss.

Bridge Deck Sections Hung from Cables

(Continued from page 13)

hung by June 15 and its floor steel in by July 15; and all paving in the West Bay will be complete by September 15.

SAN FRANCISCO APPROACHES—complete by July 1.

ENTIRE BRIDGE (exclusive of railways)—paved by September 15 and cleaned up ready for traffic by November, 1936.

Work completed in 1935 is listed as follows:

PROGRESS MADE IN 1935

EAST BAY. Five 504-foot through truss spans, east and west cantilever anchor arms, west cantilever arm, completed in 1935.

YERBA BUENA ISLAND. Three 300-foot deck truss spans over the east side of the island completed in 1935 together with towers supporting them. The vehicular tunnel through Yerba Buena Island was fully excavated and lined with concrete by the end of 1935 and construction of the upper deck started. At the beginning of 1935 the vehicular tunnel was in the stage where three small excavations (two at the bottom and one at the crown) had been bored through the wall and the concrete footings for part of the side walls poured.

Therefore, during 1935 it may be said that save for three pilot tunnels, entire excavation of the Yerba Buena Island tunnel was accomplished. In the category of concrete work, all but the footings for the side walls were poured during the year 1935—the footings having been laid in the fall of 1934. Similarly, all the concrete viaduct at the east portal of the tunnel, a section of the bridge approximately 800 feet long, was built during 1935.

SUPERSTRUCTURE COMPLETED

WEST BAY. At the start of 1935, the last of the foundation work was being done; some concrete was still being poured at Pier A near Beale Street, San Francisco; and the concrete center anchorage, a mile off the San Francisco shore, was being raised by the superstructure contractor to the height where it was to be taken over by the Columbia Steel Company for cable spinning. The superstructure contractor had erected Towers W-2, W-3, and W-6; and had raised W-5 to 155 feet with approximately 350 feet to go. The fenders for Pier W-4 and W-3 were not yet complete.

"MONEY WELL SPENT!" SAYS CHAIRMAN JONES OF RFC ON VISIT TO BAY BRIDGE

Jesse Jones, chairman of the Reconstruction Finance Corporation recently visited San Francisco to see for himself what is being done with the \$61,000,000 Uncle Sam loaned to span the bay.

He asked not only to be told about the progress of the work on the San Francisco-Oakland Bay bridge, but the opportunity to see for himself—and got it!

Taken to Yerba Buena Island, he eagerly scaled the span catwalk, braving a lashing rain and tugging winds, and walked far out over the green waters.

A half hour later he descended and gazed at the great vehicular and train bore through the island, and exclaimed:

"That's what I call money well spent!"

He expressed surprise at the rapidity of construction, admiration for the engineering skill represented by the massive bridge works, and reiterated a previously expressed belief the span will pay for itself within 20 years.

After the catwalk visit, Jones was taken for an automobile ride on the completed concrete viaduct on the East Bay section of the bridge.

His hosts included Earl Lee Kelly, State Director of Public Works representing Governor Merriam; Leland W. Cutler, president of the exposition board and vice chairman of the financial advisory committee for the bridge, Charles H. Purcell, chief bridge engineer and Joseph A. Moore, State Harbor Commissioner.

Eyebars on both the San Francisco and Yerba Buena Island Anchorages had been set up and were practically ready for cable spinning, and locker posts at Pier W-1 on the Embarcadero and at Yerba Buena Island Anchorage were under way.

During 1935, catwalks on both the West Bridge and East Suspension Bridge were built and the spinning machinery erected. Spinning was completed during the year on the West Bridge between San Francisco and the Center Anchorage; and half completed on the East Bridge between the Center Anchorage and Yerba Buena Island. Cable bands were bolted around the suspension cables and the first sections of the actual decks of the bridge were being hung from the cables in the last month of 1935.



"MONEY WELL SPENT!" declared Chairman Jesse Jones of RFC viewing Bay Bridge progress from a swaying catwalk. Left to right are: Leland F. Cutler, Director Earl Lee Kelly, Chief Engineer C. H. Purcell, and Mr. Jones.

Bay Bridge Roadway Trusses Being Erected

(Continued from preceding page)

Two weeks before New Year's Day, January, 1935, the \$835,000 field painting contract had been awarded, and half of this gigantic painting job was completed in 1935.

Contracts for construction of the Toll House and Maintenance Buildings were awarded in July, 1935, and are now well under way. Also, in July, 1935, the contract for the lighting of the bridge and electrical work was awarded and construction of the units is now going on.

Contract for the San Francisco Approach was let in January, 1935, and is now half complete.

In April, 1935, the contract for interlacing viaducts of the East Bay Distribution Structure in Emeryville was awarded and is half complete.

In June, 1935, the contract for the Folger Avenue Underpass in Berkeley was awarded and that contract is now complete.

In October, 1935, the contract for the San Pablo Underpass was awarded and is now in its early stage of construction.

The erection of the roadway trusses of the west suspension bridge started during December. Prior to that time all of the cable bands

and suspenders were hung from the cables. In the meantime, the assembly yard at Islais Creek had been put in order. Here the sections of trusses are assembled somewhat like automobiles are put together on an assembly line. These sections consist of about ninety feet of truss the full 66-foot width of the bridge, and some weigh as much as 210 tons. When they reach the end of the assembly line they have been riveted up and ready to take their place in the bridge.

A barge is floated under the end sections. By pumping the water out of the hull, the barge rises and lifts the steel section free from its supports. The barge is then towed out to a position under the cables of the bridge.

From this point the truss section is lifted vertically and attached to the suspenders which are looped over the cable. This lifting is accomplished by engines placed at the base of the steel towers. The lifting lines from the engines are carried up about two-thirds the height of the tower and thence horizontally out to lifting struts which are securely fastened to the cables. From the lifting struts the lifting line is dropped down and attached to the truss.

CALIFORNIA HIGHWAYS AND PUBLIC WORKS

Official journal of the Division of Highways of the Department of Public Works, State of California; published for the information of the members of the department and the citizens of California.

Editors of newspapers and others are privileged to use matter contained herein. Cuts will be gladly loaned upon request.

EARL LEE KELLY.....Director
JOHN W. HOWE.....Editor

Address communications to California Highways and Public Works, P. O. Box 1499, Sacramento, California.

Vol. 14 JANUARY, 1936 No. I

GAS TAX DIVERSION

In their own interest the people must prevent the diversion of the gasoline tax money to other purposes than road building. The gasoline tax belongs to the roads and to the roads alone by original policy. It was levied originally on motorists for the purpose of providing good roads on which motorists could run. The purpose justified the tax and has kept it popular. If the money is diverted to any other purpose the tax is no longer justified.

This generation owes much to the invention of the gasoline tax. This excise has built two of the most important industries in the country. These are the petroleum and the automobile industries.

The chain of cause and effect is clear. The gasoline tax built and is building the roads. Good roads alone made possible the automobile for everybody. The automobile, by the demand it set up for gasoline, developed the petroleum industry to a pitch not dreamed of before.

The gasoline tax belongs to the roads. It is the motorists' money, cheerfully given up by them for the roads but NOT for any other purpose.

So far the people of California have vigilantly warded off every attempt to seize the gas tax money for other purposes than the roads. In an unguarded moment, however, the fund might be looted. It will be well to put a double lock on it by a constitutional ban on using it for any purpose but the roads.—*San Francisco Chronicle*.

New Redding Highway Bridge and Alignment Saves Mile in Travel

(Continued from page 14)

vast area of northern California and southern Oregon, appropriately known as the Shasta Cascade Wonderland.

Few State projects result as does this one, in a saving in distance equal to its length. The result will be a direct saving of many dollars in fuel cost alone to the traveling public. In addition to this monetary saving, the value of the increased driving safety and comfort which was brought about by the elimination of a hazardous stretch of road is incalculable.

BRIDGE 795 FEET LONG

The construction work was performed under two contracts: One, covering the major portion of the bridge, and the other, the approaches and end spans to the bridge.

The bridge, of continuous steel girder type, is 795 feet in length, has a driveway width of 34 feet and three feet sidewalks. The central and major part of the bridge, consisting of six 108 feet continuous plate-girder spans and two 45 feet cantilever end spans, on concrete piers, was constructed at a cost of approximately \$180,000.

This work was started on July 5, 1934, and completed on April 2, 1935. A. L. Richardson was resident engineer on the bridge contract.

The approaches to the bridge, including the two 28½ feet end spans, were constructed at a cost of approximately \$97,500. This work was started on February 23, 1935, and completed on December 17, 1935.

STREET WIDENED AND PAVED

A large item in this contract was the widening and repaving of a portion of Market Street in the city of Redding. The width of this portion was increased from 60 to 80 feet, and the roadway 56 feet wide was paved with Portland cement concrete.

The approaches to the bridge were constructed to a gross width of 50 feet and paved with a bituminous road-mix surfacing, 32 feet wide on the south approach to the bridge and 22 feet wide on the north approach.

Fingerprints have been urged as a requisite for obtaining a license to drive an automobile in California.

Stabilometer and Cohesimeter Built for Pavement Tests

(Continued from page 11)

the loaded test specimen transmits pressure to the liquid through the flexible rubber walls, the resulting lateral pressure being recorded by the test gauge.

DETAILS OF TEST

Laboratory test specimens may be prepared by tamping, compression, or any suitable means of compaction designed to give as nearly as possible the same efficiency of consolidation as is obtained from rolling or traffic. We have found that efficiency of consolidation is not always accurately indicated by density determinations.

Under the conditions of this test, a frictionless liquid specimen transmits lateral pressure equivalent to the applied load per unit area. A rigid solid transmits no lateral pressure. Lateral pressures of plastics or semisolids will, of course, range somewhere between the liquid and the solid.

For simplicity, stability results are reported in a scale ranging from 0 to 100 per cent, in which 0 equals a liquid condition, and 100 per cent is the equivalent of a solid with no measurable lateral reaction under the test loads employed.

APPLICATION TO PAVEMENTS

Correlation with pavements under traffic indicates that a stability value of 30 per cent to 35 per cent represents a bordering condition. In other words stability values of less than 30 per cent indicate a pavement which will to some degree displace under traffic, which mixtures showing stability values above 35 per cent have so far shown satisfactory service value. Traffic and local conditions vary sufficiently, however, to make precise comparison difficult.

Stabilometer results are not consistently higher on mixtures using hard asphalt than on those using fuel oil or liquid asphalt. In order to measure differences which do exist between oil mix and asphaltic concrete pavements, an instrument was built to measure the tensile strength or cohesion of a compacted specimen. (See Fig. 6.)

The tensile strength of a bituminous pavement is, of course, due chiefly to the adhesion of the asphalt to the aggregate particles, and the cohesive strength of the bituminous film. While the quality is described as tensile strength for the sake of simplicity, it must be recognized that more precisely it is the rate of flow with time, and hence characteristic of the consistency of the bituminous binder, and also of the fineness, or surface area equivalent, of the aggregate.

TENSILE STRENGTH DIFFERENCES

It was found that the cohesimeter could measure definite and consistent differences between oils and asphalts of varying consistency. A given specimen with "D" grade asphalt may give as much as 50 times the "tensile" strength of a mix using fuel oil.

An attempt to correlate tensile strength values with

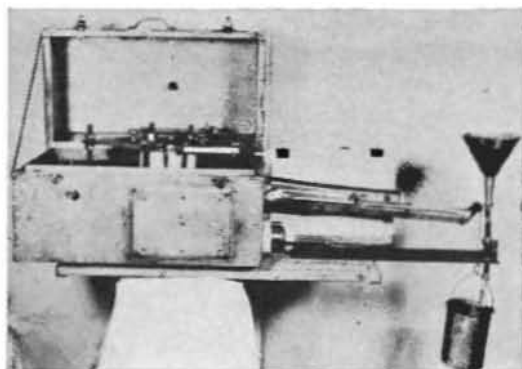

HVEEM COHESIMETER for measuring tensile strength of bituminous pavement. Broken briquette is seen in center of box.

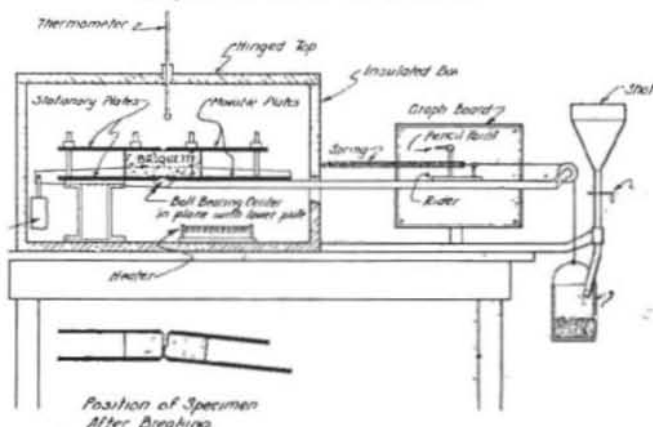
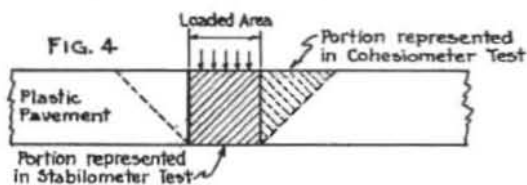

FIG. 6—DIAGRAM showing construction and operation of Hveem Cohesimeter.



pavement performance shows very uncertain agreement. The fact that mixtures of very low tensile strength can and do remain smooth under traffic, and also that mixtures of quite high tensile strength have been known to become wavy and ratted, is proof that this quality is not essential for the pavement to resist the distorting effects of vehicles, although it is true that if the pavement mixture is lubricated to such a degree that it has a tendency to distort, the time required for roughness to become evident will depend to a great degree on the tensile strength, or more precisely the rate of flow of the bitumen serving as binder.

FUNCTIONS OF MACHINES

The stabilometer measures the tendency of the portion of the pavement under load to expand or flow laterally against the surrounding pavement.

The cohesimeter measures the cohesion or chief property by which the surrounding pavement tends to restrain the lateral flow. (See Fig. 4.)



The Central Valley Project, one of the largest and most worthy undertakings for water conservation in the United States, plans for which have been formulated by the Water Resources Division of the Department of Public Works of California, is rapidly nearing the stage of actual construction. Under a new order issued by President Roosevelt, officially announced at Washington on December 10th, an initial allocation of \$15,000,000 from the Emergency Relief Appropriation of 1935 has been authorized to begin construction of the project.

Detailed surveys are now being made by the Bureau of Reclamation in preparation for actual construction, and contract plans and specifications are being prepared by the Denver office. A board of consulting engineers consisting of Dr. W. F. Durand, Mr. Charles H. Paul and Mr. R. V. Meikle, in company with Dr. Charles P. Berkey, Consulting Geologist, and Mr. J. L. Savage, Chief Designing Engineer for the Bureau, have just completed a five-day field inspection and study of the project with respect to the plans and program for immediate construction. It is expected that initial contracts will be advertised for bids and construction will be active under way early this year.

STATE IS COOPERATING

The Water Project Authority of the State of California is highly satisfied with the proposed program and the progress which is being made. The State Department of Public Works is cooperating in every possible way with the Bureau of Reclamation in speeding the work on the project.

The areas to be served by the Central Valley Project are National assets and the preservation of agricultural and industrial production in those areas and the social life dependent thereon and business created thereby is of National concern. It is a project of first and prime importance to the State of California.

IRRIGATION DISTRICTS

To date the Reconstruction Finance Corporation has authorized loans in the total amount of \$35,686,401 to 37 California irrigation districts for refinancing an indebtedness of \$63,778,993. Of the amount authorized, about \$17,000,000 have been disbursed in refinancing over \$30,000,000 of indebtedness. In addition to loans for refinancing, the R.F.C. has granted about \$2,000,000 in loans to irrigation districts for improvements in their canal and distribution systems.

California Districts Securities Commission.

Among the matters which came before the Commission for consideration, the following were approved:

1. Petition of the Paradise Irrigation District for consent to new plan of debt readjustment and for authority for filing petition under the provisions of the Federal Bankruptcy Act.

2. Expenditures totaling \$48,892 by the following irrigation districts, operating under Section 11 of the Securities Commission Act, were approved: Citrus Heights; Carmichael, West Side and San Dieguito districts.

FLOOD CONTROL AND RECLAMATION

Maintenance of Sacramento Flood Control Project.

A crew of 20 men has been engaged in clearing brush from the Tisdale By-pass, to assist in the rectification of the channel at the westerly end of the by-pass.

Relief Labor Work.

Six relief labor projects are now in operation, on which 252 men are employed. The work being done consists of clearing and improving flood channels, most of the activity being in Sutter and Yuba counties. One project is operating in Yolo County, employing 35 men in the Sacramento By-pass.

Sacramento Flood Control Project.

This division has proceeded with the work of installing pipes and doing other incidental construction in connection with right of way for the south levee of the American River near Perkins. Construction was commenced on December 16th under contract with the California Debris Commission.

The Division is now working on the installation of pipes in four road crossings in the borrow pit on the

Three Levee Units to Be Constructed

(Continued from preceding page)

property of Burr Mitchell north of Colusa, and the crossings are being raised.

Good progress is being made in construction of three new drainage pumping plants in the Sutter Bypass, under contract with the California Debris Commission.

A conference was held December 4th between representatives of the State and the U. S. War Department with General Pillsbury, Assistant Chief of Engineers, with the result that a decision has been rendered on the points at issue in the controversy. This decision upholds the contention of the State on all major points and will lead to immediate advertisement for bids for three important and urgent levee units. The three levees scheduled for immediate construction are on the west side of the Sacramento River from Wohlfrons to Princeton, on the east side of the Sacramento from Colusa to Moulton Weir, and on the east side of the Feather River above Starr Bend.

San Joaquin River.

The contract for constructing three units of levee in Reclamation District No. 2064 on the San Joaquin River, was completed on December 6th. A total of 57,677 cubic yards was placed at a cost of \$8,075, the unit price being 14 cents per yard.

Flood Measurements and Gages.

The flood gaging stations and automatic recorders maintained by this office are now in operation, and arrangements are complete for making measurements of flood discharges should this be required.

DAMS

1. Construction of the Cajalco Dam of the Metropolitan Water District in Riverside County is progressing satisfactorily.

2. Work is progressing on San Gabriel Dam Number 1 of the Los Angeles County Flood Control District.

3. The Calero, Guadalupe, Stevens Creek and Vasona Dams of the Santa Clara Valley Water Conservation District have been completed. The fill at the Almaden Dam has been raised to its ultimate height. Work is now under way on the concreting of the spillway channel. The work remaining to be done at the Coyote Dam consists of placing the rock blanket and concreting of the spillway channel.

4. Work on the West Valley Dam of the South Fork Irrigation District in Modoc County and the Arcata Waterworks Dam of the city of Arcata in Humboldt County has been closed down for the winter.

5. Excavation for the abutments and spillway for the enlargement of the O'Shaughnessy Dam of the city of San Francisco is progressing satisfactorily.

6. Repair and alteration of the American River Head Dam and the Lake Francis Dam of the Pacific Gas and Electric Company is proceeding satisfactorily and will be completed shortly.

7. Repairs on the St. Helena Lower Dam, consisting of the placing of an upstream blanket and outlet tower, are under way.

SACRAMENTO-SAN JOAQUIN WATER SUPERVISOR

Work during the past month has been in the office on compilation of the 1935 Report covering the diversions, stream flow, and return flow in the Sacramento-San Joaquin territory and salinity in the Delta.

The flow of the Sacramento River at Sacramento is about 9500 second feet and there has been little variation during the past month.

California Cooperative Snow Surveys.

Work during the past month has been principally in the office bringing up to date the computation of normals for both precipitation stations and snow courses and compiling natural stream flow records for correlating the past snow survey data.

WATER RIGHTS

Supervision of Appropriation of Water.

Twenty-five applications to appropriate water were received during the month of November; 14 applications were approved and 8 were denied, while 17 permits were revoked and 4 passed to license. Mining continues to be the predominant activity among appropriators.

On October 1st reports of progress were requested in connection with 1310 projects which are under permit and on December 1st, 887 reports had been filed.

On October 15th reports of status were requested in connection with 477 projects which are under license and on December 1st a total of 370 of these reports had been filed.

FEDERAL COOPERATION—TOPOGRAPHIC MAPPING

Field work was completed during November on the Paynes Creek Quadrangle in Tehama County and the Sebastopol Quadrangle in Sonoma County.

Some further progress was made toward completion of the field work on the Burney Quadrangle in Shasta County and the Kreyenhagen Hills Quadrangle in Fresno County. Progress was also made on the office work in connection with the Cucamonga No. 4 Quadrangle in San Bernardino County.

South Coastal Basin Investigation.

Work has been going on in a routine way on the South Coastal Basin Investigation. Preparations are being made for the annual report on change in water levels and other hydrology.

Sunset Boulevard Surfacing Removed by Burners Covering 900 Yards a Day

By J. M. LACKEY, Assistant District Construction Engineer

NOT many years ago building a State Highway meant moving out into the country or the mountains and for over a period of many months constructing a narrow roadbed, sometimes paving it with a 20 foot strip of concrete. But times have changed, particularly in District VII, for most likely the job will be the reconstruction of a busy city street or an important trunk highway in a thickly populated district with curbs and gutters and pavement 40 to 76 feet in width.

One of the latest projects of this kind to be completed was the resurfacing of portions of Sunset Boulevard between La Veta Terrace and Santa Monica Boulevard in the City of Los Angeles. The existing pavement was 5 inch portland cement concrete surfaced with asphaltic concrete which varied from 1½ to 4 inches in thickness. Several years of heavy traffic had developed many irregularities and the pavement became slippery when wet.

OLD SURFACE PROBLEM

The plans provided for the removal of portions of the old surfacing to permit laying a 1½ inch asphaltic concrete wearing surface. Removal of the irregular thickness of the old asphalt surface was no easy problem, as, under years of traffic the asphalt had become hard and tough. The special provisions of the contract provided that where an excessive quantity was removed the contractor should replace it at his own expense. An added complication was that a variable height crown was used, often changing several times in the distance of a block.

The old surface was removed by burning. At the beginning of the work two pavement burners were obtained from the City of Los Angeles, each unit being mounted on a truck. A single distillate burner covered with a 6 x 9 foot hood was suspended from cantilever arms from the rear of the chassis. A separate gasoline motor on the chassis operated air pumps attached to the burners.

NEW BURNERS CONSTRUCTED

Progress was so slow, however, with these burners that the contractor constructed two much larger outfits. Each unit consisted

of six burners operated under a 9 x 15 foot hood mounted on wheels and towed by a two-cylinder road roller, both burners being operated together. A small compressor furnished air to both units. The procedure was as follows:

Grade points were set at from 10 to 20 feet intervals in the old surfacing and the amount of the cut painted near the point. The burners were then set to work, remaining stationary for from 3 to 5 minutes, depending on the thickness of the surfacing to be removed, then moving about 3 feet.

This operation was followed up with a tractor and grader which windrowed material loosened by the burning for loading into trucks. The surface was then checked, high spots marked and burned with the units obtained from Los Angeles City.

SMALL FUEL COST

From 550 to 900 square yards of surfacing were covered by the two large burners per 10 hour day. The area covered depended on the thickness of the old surface to be removed. Kerosene required for 10 hours of burning totaled 400 gallons, which, at a cost of 5 cents per gallon, amounted to from \$0.025 to \$0.036 per square yard for fuel.

On account of street cars, the burners could not operate within several feet of the rails, and a strip 17 feet wide was burned by direct application of distillate to the surface. In this manner, 200 to 300 square yards were burned per day, using about 300 gallons of distillate at a cost of 3½ cents per gallon, a total of \$10.50, or \$0.035 to \$0.0525 per square yard.

The section paved was all outside the street car tracks and consisted of 27 feet of asphaltic concrete surfacing and a 2-foot cement concrete gutter on each side of the street. A 20-foot section out from the gutter was spread and finished with a finishing machine and the remaining 7-foot spread and raked by hand.

On the hand-raked section a concrete float was used after the hand raking in much the same manner as used on concrete pavement, with excellent results.

(Continued on page 29)

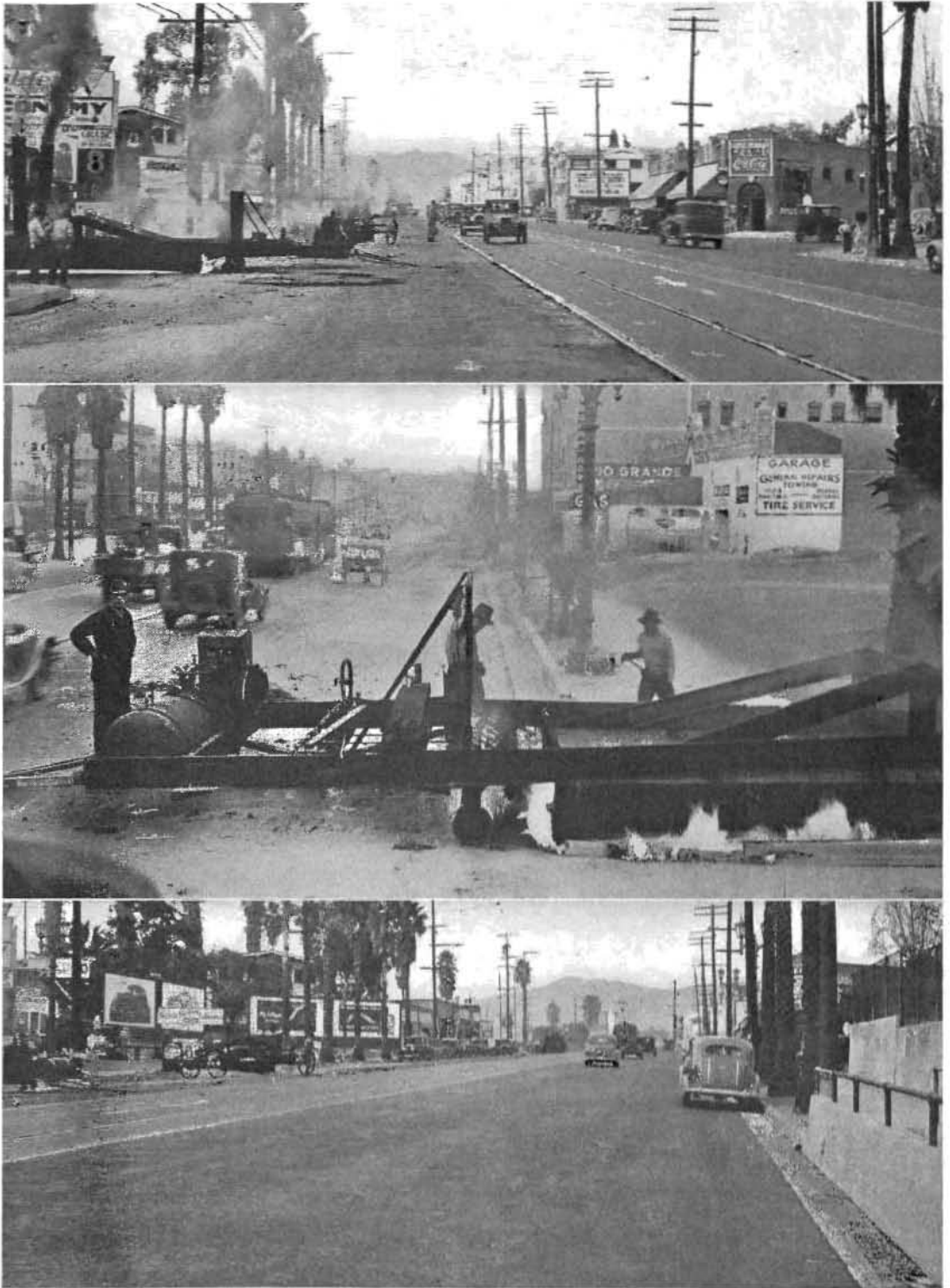

BURNING OPERATIONS on Sunset Boulevard resurfacing job in Los Angeles were carried on expeditiously without interruption of daily traffic of 20,000 to 23,000 autos per day in addition to suburban and interurban trains. Two large burners removed old asphaltic concrete surfacing at rate of from 550 to 900 square yards per day at cost of 2½ to 3 cents per yard for fuel.

Old Timer, Do You Hold a Card to Beat This?

RETENTION of the honor of being head man in the Old Timers' Club of the State Division of Highways is getting to be rather difficult.

Each month since the club was started last July by E. M. Cameron, Construction Engineer, District 1, the oldest member in the organization has been displaced by some veteran whose appointment by the first California Highway Commission antedated that of the reigning charter member.

The only membership requirement is possession of one of the identification cards issued by the old Highway Commission in 1912 and thereafter to every man appointed on the staff of a division engineer.

Last month, E. J. Bassett, District Office Engineer, District 11, competed with Thomas H. Dennis, Maintenance Engineer of the Division of Highways, for the distinction of being the oldest member. Both hold identification cards issued on March 21, 1912.

But this month, both had to relinquish the honor to George Mattis of Emeryville, one of the Resident Engineers of the San Francisco-Oakland Bay Bridge, which is being built by the Department of Public Works. Mr. Mattis produced his ancient identification card showing he was appointed Chief Assistant of the old Division V of the Highway Commission on February 1, 1912.

CAN'T FIND CARD

A close runner-up is H. F. Holley of Los Angeles, now Assistant Chief Engineer of the Automobile Club of Southern California, whose membership application must be passed upon because, unfortunately, while Highway Commission records reveal he was named as an instrumentman attached to Division 1 on February 10, 1912, Mr. Holley, after much rummaging, has been unable to find his identification card.

W. V. Brady of Garden Grove, Orange County, also applied for membership, but is



GEORGE MATTIS of Berkeley, now a resident engineer of the San Francisco-Oakland Bay Bridge, takes leading place in the Old Timers competition this month with an appointment card dated February 1, 1912.

in the same category with Mr. Holley in that he can not locate his card. Mr. Brady says he was given the post of an assistant to J. B. Woodson, Division Engineer of Division VII, Fresno, by Austin B. Fletcher, California's first Highway Engineer, in February or March, 1912.

In his application letter, Mr. Mattis, forwarding his credentials, writes:

"I do not know whether I am eligible to the Old Timers' Club since my services were not continuous, but I feel just as old in years and service as if it had been continuous."

Mr. Mattis is eligible. He continues:

LEFT SERVICE IN 1919

"I served as Assistant Division Engineer in San Luis Obispo from February, 1912, to April, 1917, and then was transferred as Assistant Division Engineer to District (then Division) IV, San Francisco. After leaving the Highway Commission in September, 1919, I served one year as Assistant Engineer, California Railroad Commission, and two years as City Engineer of Oakland.

During the past two years I have been Resident Engineer on several units of the East Bay approach of the San Francisco-Oakland Bay Bridge, reporting to Col. Skeggs and Mr. P. O. Harding, and delighted to have the opportunity of again serving in the organization which meant so much to me in the past. I still remember the time when Mr. Dennis reported for duty at San Luis Obispo."

Mr. Holley writes expressing disappointment over his failure to find his identification card. He adds:

TEACHER THANKS HIGHWAY FIRE FIGHTERS FOR SAVING THE DECKER SCHOOLHOUSE

Appreciation of the efforts of employees of the State Division of Highways who, on October 23, 1935, saved the Decker District schoolhouse from destruction in the disastrous Malibu forest fire in Los Angeles County, is expressed in a letter received from Mrs. Helena K. Weaver, principal of the school, by Maintenance Superintendent Bernard M. Gallagher, who sent members of his crew to the scene of the fire. A stirring account of the battle against the flames, written by Mr. Gallagher, appeared in the November issue of California Highways and Public Works. In her letter, Mrs. Weaver said:

"The children and residents of the Decker School District wish to thank Mr. Roy Alley, Mr. John Schorr and the men who were with them (whose names we do not know) for their timely and able assistance in protecting and saving our school from destruction by fire on Wednesday, October 23, 1935. We are very grateful for their help and take this opportunity to express our appreciation."

The Division of Highway employees who assisted Mr. Alley and Mr. Schorr are C. F. Saman, William Dresher, Norton, Flores, Dituri, Kanchi, Smith, Housman, Bradley and Albanex. Mr. Schorr's own home was burned down while he was engaged in helping to save the school.

23,000 Daily Traffic Count Street Kept Open During Construction

(Continued from page 26)

One feature of the job was the use of a mortar-supported side form for support of the spreading machine on the side opposite the gutter. The forms which were only 1½ inches by 6 inches laid flatwise, were secured by driving a large spike through the plank into a wooden plug which had been wedged into a 2 inch hole drilled into the old P. C. C. pavement. The side form was then shimmed up to grade and the space underneath filled with a 1 to 5 cement mortar.

These side forms took a terrific pounding from traffic with very little damage and the maintenance cost was small. In a few places the mortar became reduced to a powder, probably due to using too dry a mix which dried out too soon.

Traffic on this street is very heavy at all times. Traffic counts taken in January, April and July, 1934, showed that Sunday traffic amounted to 15,000 to 19,000 cars per day and week day traffic from 20,000 to 23,000 cars daily. Street railway traffic is also heavy, carrying both interurban and local cars.

CARD HELD BY OLD TIMER

(Continued from preceding page)

"I was appointed Instrumentman attached to Division I on February 10, 1912. I reported to Mr. W. S. Caruthers in Willits on the same date. Our location party was organized and we immediately left Willits for "Mountain House," Mendocino County, where we established camp. On February 15, 1912, we started the survey for the Cloverdale-Hopland road, beginning at the Sonoma-Mendocino county line.

CLAIMS FIRST STAKE

"In view of the fact that most of the first survey parties were organized on February 15, 1912, and started work some time thereafter, I believe our party drove the first stake on the California State Highway System."

Mr. Brady regrets he can not find his card and writes:

"I believe I had the honor to be the first one appointed in Division VII after Mr. Woodson. I have had varied and interesting experiences since that job, but sometimes wish I had stayed with the good old State Highway Department. They are a fine bunch of fellows."

"Was your bachelor party a success?"

"Rather, we had to postpone the wedding three days."

[GOVERNOR MERRIAM ANNOUNCES WORK PROGRAM

(Continued from page 13)

The program of the Division of Architecture provides for construction of 18 new State building projects at an estimated total cost of \$4,924,500, with an additional \$600,000 for minor construction, improvements and equipment at various State institutions, colleges, prisons and armories.

It is estimated this program will supply directly and indirectly approximately 4,900,000 man hours work.

Of all the sad surprises
There's nothing to compare
With treading in the darkness
On a step that isn't there.

She (gushingly): "Will you love me when I am old?"

He: "Love you? I shall idolize you. I shall worship the ground under your little feet. I shall—um—er—You are not going to look like your mother, are you?"—*Pathfinder*.

Highway Bids and Awards

for December, 1935

ALAMEDA COUNTY—Undergrade crossing under Sacramento Northern Railway in Oakland, 2 concrete abutments and steel sup. str. 416' Rdy. Gr. & A. C. Pave. District IV, Mountain Boulevard Crossing. H. C. Vensano & Co., San Francisco, \$60,438; M. B. McGowan, Inc., San Francisco, \$51,108; Lindgren & Swinerton, Inc., Oakland, \$50,782; Heafey-Moore Co., Oakland, \$55,699. Contract awarded to A. Seda & Son, Oakland, \$49,469.50.

ALAMEDA COUNTY—12th Street in Oakland, between 20-29th Avenue, Gr. and Pave. Asp. Conc. Remove and Relay R. R. Tracks. District IV, Route 105, Section Oak. Union Paving Co., San Francisco, \$25,757; Independent Const. Co., Oakland, \$26,857. Contract awarded to Heafey-Moore Co., Oakland, \$41,238.45.

ALAMEDA COUNTY—In Oakland, Undergrade Xing Sac. No. Ry. 2 Conc. Abts., 1 Conc. Pier, Steel Sup. Str. 0.34 mi. Rd. Grade P. C. C. Pav. 0.24 mi. Rd. Grade, Pl Mix surf. District IV, Roadway Terrace Xing. Heafey-Moore Co., Oakland, \$119,155; N. M. Ball Sons, Berkeley, \$104,895; Barrett & Hilp, San Francisco, \$111,737; H. C. Vensano, San Francisco, \$129,343. Contract awarded to Lindgren & Swinerton, Inc., San Francisco, \$103,386.50.

ALAMEDA COUNTY—At Jackson St. Under Gr. Xing, W. P. R. R. R. C. Abuts., Steel Sup. Str., 0.15 mi. rd. Grade, P. C. C. Pav. District IV, Route 105, Section Hay, McDonald & Kahn Co., Ltd., San Francisco, \$92,372; Barrett & Hilp, \$95,502. Contract awarded to Peninsula Paving Co., San Francisco, \$87,161.

ALAMEDA COUNTY—Near San Leandro under grade Xing W. P. R. R. at Wash. Ave. 2 R. C. Abuts. St. Sup. Str. 0.26 mi. Grade and P. C. C. Pav. District IV, Route 69, Section B. Peninsula Paving Co., San Francisco, \$154,560; Barrett & Hilp, San Francisco, \$150,844; MacDonald & Kahn Co., Ltd., San Francisco, \$171,914. Contract awarded to Bodenhamer Const. Co., Oakland, \$149,371.30.

BUTTE COUNTY—Between 3.4 mi. E. of Butte Creek and Cherokee Canal, 2.9 mi. Grade, Un'tr. C. G. or S. District II, Route 45, Section A. Claude C. Wood, Stockton, \$17,210; Leo F. Piazza, San Jose, \$18,465; Heafey Moore Co., Oakland, \$19,500; Hemstreet and Bell, Marysville, \$21,052. Contract awarded to C. B. Bishop, Orland, \$17,092.75.

CALAVERAS COUNTY—Bet. S. Fork Mokelumne R. and Herberts Rch. 1.3 mi. Grade and R. C. Bridge. District X, West Point Feeder Road. Contract awarded to Biasotti, Willard & Biasotti and Rocca and Co., Stockton, \$146,939.

COLUSA COUNTY—Between Williams and N. boundary, portions of four existing concrete bridges to be removed and disposed of. District III, Route 7, Section B. C. Leo F. Piazza, San Jose, \$2,881; Hemstreet & Bell, Marysville, \$6,980; Geo. Pollock Co., Sacramento, \$5,990; Nelson Hyde Chick, Berkeley, \$7,570; F. H. Neilson, Orland, \$3,746; M. G. McGowan, Inc., San Francisco. Contract awarded to M. A. Jenkins, Sacramento, \$2,888.

FRESNO COUNTY—O. H. Xing over A. T. & S. Fe at Calwa 158' Tr. Spans 28-40' Conc. Gir. Spans on Conc. Piers & Abut. Approaches P. C. C. Pav. District VI, Route 4, Section B. Bodenhamer Const. Co., Oakland, \$194,867; F. O. Bohnett Co., Campbell, \$214,106; Oscar Oberg, Los Angeles \$195,652; Rocca & Co., San Rafael, \$209,008. Contract awarded to R. R. Bishop, Long Beach, \$184,766.

FRESNO COUNTY—Between Junction Rt. 41 and 1 1/2 miles West 1.6 mile long Graded. District VI, route Sand Creek Road. Contract awarded to Stewart & Nuss & John Jurovich, Fresno, \$30,244.

IMPERIAL COUNTY—Between 3 miles E. of Imperial and 0.5 E. of Brawley 9.3 miles. Grade, gravel and road mix surface treatment and timber bridge. District XI, Route 301, Section B. Geo. Herze & Co., San Bernardino, \$56,454; V. R. Dennis Constr. Co. San Diego, \$55,282; Oswald Bros., Los Angeles, \$48,707. Contract awarded to R. E. Hazard & Sons, San Diego, \$45,505.

INYO COUNTY—Between 1.8 mile N. of Bishop and 1.4 mi. N. of Laws, 2.6 miles to be graded. District

IX, Route 76, Section A. Contract awarded to Basich Brothers, Torrance, \$16,973.

KERN COUNTY—A grade separation proj. under the tracks of the S. P. R. R. consisting of two reinf. conc. abut. and a steel girder strot. for carrying the tracks of the R. R. together with incid. strot., the const. of a reinf. conc. bridge across Poso Cr., the grading and paving of approx. 2.2 miles of St. Hwy. and the const. of incidental struct. District VI, Route 4, Sec. E. Bodenhamer Construction Co. Oakland, \$304,023; J. E. Haddock, Pasadena, \$303,365. Contract awarded to Griffith Co., Los Angeles, \$295,611.

KERN COUNTY—Two miles SW. of Searles to Rademacher Road. Mix surface treatment to be applied for a distance of about 5 miles. District IX, Route 145, Section A-B. A. S. Vinell Co., Los Angeles, \$6,003; Basich Bros., Torrance, \$6,902. Contract awarded to Oilfields Trucking Co., Bakersfield, \$5,215.

KERN COUNTY—Between the Easterly entrance to Kern County Park and 1 1/2 mi. Easterly about 1.3 mi. in length to be graded. District VI, Park Road, Rexroth and Rexroth, Bakersfield, \$35,620; Oilfields Trucking Company, Bakersfield, \$37,922; Basich Brothers, Torrance, \$40,639. Contract awarded to Stewart and Nuss, Inc., and John Jurkovich, Fresno, \$34,328.

KERN COUNTY—Between 4 mi. S. of Shafter and Shafter, 5.1 Mi. lg. Grade and Rd. Mix Surf. District VI, Route 139, Section B. C. Union Paving Co., San Francisco, \$71,881; N. M. Ball Sons, Berkeley, \$81,718; Basich Brothers, Torrance, \$81,607; Dimmitt and Taylor, Los Angeles, \$86,237. Contract awarded to Southern California Roads Co., Los Angeles, \$67,509.50.

LAKE COUNTY—Two (2) standard timber cattle passes, between Upper Lake and Sweet Hollow Summit. District I, Route 15, Section B. Alfred T. Howe, Santa Rosa, \$4,745. Contract awarded to Smith Bros. Co., Eureka, \$2,713.55.

LOS ANGELES COUNTY—An undergrade crossing under the A. T. & S. F. Ry. at Hobart. District VII, Route 167, Section A. Griffith Co., Los Angeles, \$148,335; Bannister-Field Co., Ltd., Fred E. Potts Co., Los Angeles, \$156,757; Mundo Engr. Co., Los Angeles, \$158,986; T. A. Allen Constr. Co., Los Angeles, \$156,268; Oswald Bros., Los Angeles, \$154,923; J. E. Haddock, Ltd., Pasadena, \$162,419; R. E. Campbell, Los Angeles, \$174,769; Basich Bros., Torrance, \$152,417. Contract awarded to John Strona, Pomona, \$146,122.50.

LOS ANGELES COUNTY—Between San Fernando Rd. and Central Ave., 0.6 mi. lg. A. C. Pavement. District VII, Route 161, Section Gnd. Oswald Bros., Los Angeles, \$23,261; J. L. McClain, Los Angeles, \$23,117; George R. Curtis Paving Co., Los Angeles, \$19,032. Contract awarded to Southwest Paving Co., Roscoe, \$18,529.25.

LOS ANGELES COUNTY—Steel and Conc. Overhead Xing A. T. & S. Fe at Wilmington 4-61.5' Spans, 2-42' Spans & 2-39' spans. Approaches Grade A. C. and P. C. C. paving. Mitty Bros. Const. Co., Los Angeles, \$240,281; R. R. Bishop, Long Beach, \$223,889; Bodenhamer Const. Co., & C. F. Robbins, Oakland and Los Angeles, \$216,555; Griffith Co., Los Angeles, \$212,637; Sander Pearson, Santa Monica, \$228,306; Oswald Bros., Los Angeles, \$218,786; Shafner & Gordon, Los Angeles, \$242,994. Contract awarded to Sharp & Fellows, Contr. Co., Los Angeles, \$202,941.30.

LOS ANGELES COUNTY—At Firestone Blvd., Undergrade Xing Pacific Electric Ry. District VII, Route 174, Section B. Griffith Company, Los Angeles, \$139,201; Lynch-Cannon Eng. Co., Los Angeles, \$122,984; Carlo Bongiovanni Const. Co., Hollywood, \$122,224; Basich Bros., Torrance, \$124,107; Byerts & Dunn, Los Angeles, \$123,936; Herbert M. Baruch Corp., Ltd., Los Angeles, \$129,715; Oscar Oberg, Los Angeles, \$119,422. Contract awarded to Shofner & Gordon, Los Angeles, \$106,024.

LOS ANGELES AND ORANGE COUNTIES—Between Luitwieler Ave. and La Mirada Ave. about 2.5 miles in length to be graded and surfaced with selected material base. District VII, Imperial Highway. J. E. Haddock, Pasadena, \$333,199; Oswald Bros., Los Angeles, \$335,561; Basich Bros., Torrance,

Highway Bids and Awards

(Continued from preceding page)

\$359,968. Contract awarded to R. E. Campbell, Los Angeles, \$332,995.

LOS ANGELES COUNTY—Between Spring Street and Hathaway Ave., 2.5 mile Grade and Timber bridge. District VII, Somerset Avenue. Oswald Bros., Los Angeles, \$62,812; Sully Miller Contr. Co., Long Beach, \$62,936. Contract awarded to R. E. Campbell, Los Angeles, \$61,182.

LOS ANGELES COUNTY—Drainage sumps to be excavated, and backfilled with sand, between 1½ miles NW. and 1½ SE. of Norwalk. District VII, Route 174, Section B. Kovacevich & Price, Inc., South Gate, Paul R. Hughes, Long Beach, \$3,320; Owl Truck & Materials Co., Compton, \$2,362; Anso Constructing Co., Long Beach, \$3,618; The Price Company, Santa Monica, \$4,510; Kuhn Bros., Inc., Manhattan Beach, \$4,752; Geo. J. Bock Co., Los Angeles, \$4,892; John Oberg, Los Angeles, \$7,576; V. Lovrich & L. B. Konjevod, Los Angeles, \$8,350. Contract awarded to Theodore G. Smith, South Gate, \$2,772.

MENDOCINO COUNTY—At the Oaks and at Clow Creek, 1.75 mi. lg. Grade, Surf. Cr. R. Gr., Ldg. Asp. Tr. District I, Route 43, Sections A & B. Hemstreet & Bell, Marysville, \$42,943; Claude C. Wood, Stockton, \$43,493. Contract awarded to N. M. Ball Sons, Berkeley, \$38,488.

MENDOCINO COUNTY—One standard timber cattle pass, Sta. 172—between Hopland and Ukiah, Mendocino County. District I, Route 1, Section B. Alfred T. Howe, Santa Rosa \$3,162. Contract awarded to Smith Bros. Co., Eureka, \$1,723.

MODOC COUNTY—Between 2½ miles west of Cedarville Nevada State Line, 11.8 miles Grade, Pentr. Oil Tr. District II, Route 28, Section C. Hemstreet & Bell, Marysville, \$92,574. Contract awarded to C. F. Fredrickson & Sons, Lower Lake, \$79,235.40.

MONTEREY COUNTY—An undergrade crossing, under the tracks of the S. P. R. District V, Route 2, Section Sal. M. B. McGowan, Inc., and C. W. Caletti & Co., San Francisco, \$254,638; MacDonald & Kahn Co., Ltd., San Francisco, \$276,365; Union Paving Co., San Francisco, \$261,332. Contract awarded to F. O. Bohnett Co., Campbell, \$249,108.05.

MONTEREY COUNTY—Undergrade King of S. P. R. R. at Soledad. Roadway paved with P. C. C. and Rd. Mix Surf. District V, Route 2, Section D. McDonald & Kahn Co., Ltd., San Francisco, \$185,912; Barrett & Hlip, San Francisco, \$193,252; Peninsula Paving Co., San Francisco, \$161,453. Contract awarded to Paul J. Tyler, Lord & Bishop, Sacramento, \$155,187.40.

ORANGE COUNTY—At Northam Under grade King, A. T. & S. F. Ry. 2 Conc. Abts., W. Ws and Steel Sup. Str. Slope Pav. 0.86 mile Rd. Grade and P. C. C. Pave. District VII, Route 171, Section B. J. E. Haddock, Pasadena, \$106,484; Oswald Bros., Los Angeles, \$106,309; Basich Bros., Torrance, \$107,601. Contract awarded to Mundo Engineering Co., Los Angeles, \$104,729.

ORANGE COUNTY—Batavia Street in the city of Orange between Walnut Avenue and La Veta Ave., about 1 mile to be graded and a Road-mix surface treatment to be applied. District VII, Batavia Street Feeder. C. F. Robbins, Los Angeles, \$10,460; Paul R. Hughes, Long Beach, \$11,035; A. S. Vinell Co., Los Angeles, \$11,388. Contract awarded to Square Oil Co., Los Angeles, \$6,681.

ORANGE COUNTY—Between Bay Boulevard and Boisa Chica Rd. 2.9 mi. lg. Grade, Sel. Mtl. Surf., Bit. Mac. Armor Coat. District VII, Route 183, Sections S1.B & A. Martin Bros. Trucking Co., Long Beach, \$52,489; J. E. Haddock, Ltd., Pasadena, \$57,695; Oswald Bros., Los Angeles, \$51,252; J. L. McClain, Los Angeles, \$63,073; Sharp & Fellows Cont. Co., Los Angeles, \$48,824; Gogo & Rados, Los Angeles, \$53,881. Contract awarded to Sully-Miller Contracting Co., Long Beach, \$44,651.50.

PLACER COUNTY—Various locations between Lincoln and Newcastle 1.5 mi. Grade, portion Cr. Run Base and Seal Coat. District III, Route 91, Section A. A. Teichert & Son, Inc., Sacramento, \$28,879; Kennedy Construction Co., Oakland, \$34,863; L. C. Seidel, Sacramento, \$28,490; J. R. Reeves, Sacramento, \$28,278; Leo P. Piazza San Jose, \$23,501; Claude C. Wood, Stockton, \$23,519. Contract awarded to Hemstreet & Bell, Marysville, \$28,131.30.

PLUMAS COUNTY—Between Ede's Ranch and Beckworth Pass about 5.5 miles in length to be graded, road-mix surface treatment and seal coat to be applied. District II, Route 21, Section G. Hemstreet & Bell, Marysville, \$73,821; Dunn & Baker, Klamath Falls, \$69,656. Contract awarded to A. Teichert & Son, Inc., Sacramento, \$67,265.

RIVERSIDE COUNTY—2.9 miles west of Indio over S. P. tracks O. H. King 1-61' span 2-45.5' Spans. Grade Pave P. C. C. 0.54 mile. District XI, Route 26, Section E. Lynch Cannon Engr. Co., Los Angeles, \$105,836; Griffith Co., Los Angeles, \$120,202; J. E. Haddock, Ltd., Pasadena, \$118,477; John Strona, Pomona, \$128,403; Dimmitt & Taylor, Los Angeles, \$109,062; Match Bros., Elsinore, \$111,163; Oswald Bros., Los Angeles, \$111,595. Contract awarded to B. G. Carroll, San Diego, \$105,829.

RIVERSIDE COUNTY—Between 1.4 mile south of Thermal and Junction Rt. 26 5.4 miles long. Plant mix surf. District XI, Route 187, Section F. Oswald Bros., Los Angeles, \$39,957; Gibbons & Reed Co., Burbank, \$48,737. Contract awarded to R. E. Hazard & Sons, San Diego, \$28,456.

RIVERSIDE COUNTY—O. H. Str. over S. P. R. R. 1-70' st. pl. gird, sp. & 4-47' st. beam sps. on conc. piers with tim. pile founds. District VIII, Route 19, Section D. Shannahan Bros., Inc., Los Angeles, \$59,400; Oscar Oberg, Los Angeles, \$59,237; Lynch Cannon Eng. Co., Los Angeles, \$53,997; R. R. Bishop, Long Beach \$51,909; Lindgren & Swinerton, Inc., Los Angeles, \$53,205; T. A. Allen Const. Co., Los Angeles, \$52,309. Contract awarded to Byerts & Dunn, Los Angeles, \$51,828.

SACRAMENTO COUNTY—At 16th Street, Sacramento, the existing undergrade crossing to be widened. District III, Route 3, Section Sac. Charles Kupping, Lakeport, \$39,007. Contract awarded to Lord & Bishop, Sacramento, \$39,026.25.

SACRAMENTO COUNTY—Between Walnut Grove and Freeport, 16.4 mi. lg. Grade, C. R. B. widening, portions resurf. Pl. mix Surf. District III, Route 11, Section E.F. Union Paving Co., San Francisco, \$139,523; J. A. Casson, Hayward, \$147,680; Peninsula Paving Co., San Francisco, \$148,899. Contract awarded to A. Teichert & Son, Inc., Sacramento, \$131,857.80.

SAN BERNARDINO COUNTY—Between Westley Boundary and Rt. 59 4.7 mi. grade, Road mix, Surf. Treat. District VIII, Route 61, Section A. Gibbons & Reed Co., Burbank, \$144,234; V. R. Dennis Constr. Co., San Diego, \$158,158; J. E. Haddock, Ltd., Pasadena, \$153,012. Contract awarded to Basich Bros., Torrance, \$130,317.50.

SAN BERNARDINO COUNTY—Between 1 mi. N. W. of Lake Arrowhead and L. Arrowhead Dam 2.5 mi. lg. Grade and Road Mix Surface Treat. District VIII, Route 59, Section E. Geo. Herz & Co., San Bernardino, \$84,925; J. E. Haddock, Ltd., Oswald Bros., Los Angeles, \$97,447; Sharp & Fellows Contr. Co., Los Angeles, \$83,961; Basich Bros., Torrance, \$91,115; Lewis Constr. Co., Los Angeles, \$109,766; Gibbons & Reed Co., Burbank, \$94,237. Contract awarded to Geo. J. Bock Co., \$80,512.30.

SAN BERNARDINO COUNTY—Eight miles west of Needles, an overhead crossing over the tracks of A. T. & S. F. Railroad consisting of 1-56', 2-53'6", 2-17'6" spans on concrete piers; and a bridge across a drainage channel consisting of 4-19' timber spans on timber pile foundations to be constructed. Approx. 0.57 mile to be graded and surfaced with Road-mix surfacing. District VIII, Route 55, Section N. Match Bros., Elsinore, \$75,709; A. S. Vinell Co., Los Angeles, \$52,861; R. E. Campbell, Los Angeles, \$78,898. Contract awarded to Basich Bros., Torrance, \$54,142.

SAN BERNARDINO COUNTY—L. A. Co. line to Pipe Line Ave., 2.7 miles lg. Grade, Ldg. Asp. Treat. Tim. Pile Trestle. District VIII, Route 77, Section A. V. R. Dennis Construction Co., San Diego, \$73,331; George J. Bock Co., Los Angeles, \$63,757; Match Bros., Elsinore, \$66,500; A. S. Vinell Co., Los Angeles, \$63,952; Basich Bros., Torrance, \$63,905; Oswald Bros., Los Angeles, \$64,425. Contract awarded to Dimmitt & Taylor, Los Angeles, \$62,278.60.

SAN BERNARDINO COUNTY—An undergrade crossing under the tracks of the A. T. & S. F. railway near Verdemon consisting of 2 concrete abutments with steel and concrete superstructure and grading and surfacing approx. 0.57 mile of highway with plant-mixed surfacing (slow curing type). District

(Continued on page 32)

Highway Bids and Awards

(Continued from page 31)

VIII, Route 31, Section A. George J. Bock Co., Los Angeles, \$65,962; R. E. Campbell, Los Angeles, \$89,786; C. F. Robbins, Los Angeles, \$75,875; Bannister Field Co., Ltd., and Fred E. Potts Co., Los Angeles, \$72,748. Contract awarded to Geo. Herz & Co., San Bernardino, \$66,898.30.

SAN FRANCISCO COUNTY—Widen Un. Gr. Xing, at Army Street under S. P. R. R. District IV, Army St. Xing, Barrett & Hilt, San Francisco, \$49,629; Alfred H. Vogt, Co., Inc., San Francisco, \$42,785; H. C. Vensano & Co. San Francisco, \$44,976; Eaton & Smith, San Francisco, \$45,616; McDonald Kahn Co., Ltd., San Francisco, \$45,746. Contract awarded to M. B. McGowan, Inc., San Francisco \$38,969.

SAN FRANCISCO COUNTY—Widening O. H. Xing over S. P. R. R., Williams St., San Francisco, 1-42' and 1-43' St. I Spans, St. Bent, Conc. Absts. & W. W. District IV, Williams St. Xing, Eaton & Smith, San Francisco, \$31,562; Chas. L. Harney, San Francisco, \$31,325; MacDonald & Kahn, Co., Ltd., San Francisco, \$29,506; Alfred H. Vogt, San Francisco, \$23,675; H. C. Vensano & Co., San Francisco, \$35,015; Barrett & Hilt, San Francisco, \$31,595; Lindgren & Swinerton, Inc., San Francisco, \$31,292. Contract awarded to F. C. Amoroso & Sons, San Francisco, \$28,940.

SAN JOAQUIN COUNTY—An undergrade Xing under tracks of S. P. R. R. and W. P. R. R. at Charter Way, 0.29 mile to be graded and paved with P. C. C. District X, Route 5, Section Stockton. Paul J. Tyler, Lord & Bishop, Sacramento, \$289,064; C. W. Caletti & Co., San Rafael, \$282,194; Bodenhamer Construction Co., Oakland, \$285,250; Union Paving Co., San Francisco, \$279,991; MacDonald & Kahn Co., Ltd., San Francisco, \$310,201. Contract awarded to Biasotti, Willard & Biasotti and Rocca & Co., Stockton, \$267,421.15.

SAN JOAQUIN COUNTY—Const. an overhd. crossing over the tracks of the S. P. R. R. $\frac{1}{2}$ mi. east of Tracy, consisting of one 81 ft. and two 48 ft. plate girder spans, two 52 ft. steel beam spans and twenty-nine 48 ft. reinf. conc. girder spans on conc. bents and abutments with wingwalls on timber pile foundations. Approx. three-tenths (0.3) mile to be graded and paved with P. C. C. Pavt. District X, Route 5, Section A. F. O. Bohnett, Campbell, California, \$225,373; Bodenhamer Const. Co., Oakland, \$225,638; Rocca & Co., San Rafael, \$225,955; McDonald & Kahn Co., Ltd., San Francisco, \$239,876; Union Paving Co., San Francisco, \$241,010; Paul J. Tyler, Lord & Bishop, Sacramento, \$245,692; M. B. McGowan, Inc., & C. W. Caletti & Co., San Francisco, \$249,538; Healy, Tibbitts Const. Co., San Francisco, \$242,123. Contract awarded to Lindgren & Swinerton, Inc., Oakland, \$223,255.74.

SAN LUIS OBISPO COUNTY—Between 1 mile E. Cholame & Kern Co. line 6.6 miles long, Grade C. R. Base, Rd. mix Surf. District V, Route 125, Section D. Peninsula Paving Co., San Francisco, \$206,133; Granfield, Farrar & Carlin, San Francisco, \$202,649; George Pollock Co., Sacramento, \$237,364; Union Paving Co., San Francisco, \$206,910. Contract awarded to A. Telchert & Son, Inc., Sacramento, \$177,031.

SANTA BARBARA COUNTY—A reinforced Conc. girder bridge extension on Las Positas Rd. over the S. P. R. R. at Santa Barbara. District V, Las Positas Crossing. Robert D. Paterson, Santa Barbara, \$13,458; D. A. Loomis, Glendale, \$15,380. Contract awarded to Parish Bros., Los Angeles, \$12,425.50.

SANTA BARBARA COUNTY—Between 1 mile E. Santa Ynez and Los Olivos 5.4 mi. lg. Grade Gravel Base, Rd. mix Surf. District V, Route 80, Section A. C. F. Fredericksen & Sons, Lower Lake, \$108,152; Basich Brothers, Torrance, \$115,247; Gogo & Rados, Los Angeles, \$107,890; Gibbons & Reed Co., Burbank, \$114,117; M. J. B. Construction Co., Stockton, \$132,002; Granfield, Farrar & Carlin, San Francisco, \$119,983. Contract awarded to Oswald Bros., Los Angeles, \$94,078.

SANTA CLARA COUNTY—An undergrade crossing under the tracks of the Southern Pacific R. R. at Embarcadero Road in Palo Alto consisting of 2 abutments and steel superstructure and approx. 0.21 mile of roadway to be graded and paved with P. C. C. District IV Embarcadero Road Crossing. F. O. Bohnett, Campbell, \$155,316; Union Paving Co., San Francisco, \$152,797; Barrett & Hilt, San Francisco, \$134,986; Rocca & Co., San Rafael, \$164,313; A. J. Ralsch & A. G. Ralsch, San Francisco, \$164,195. Contract

awarded to Eaton & Smith, San Francisco, \$132,213.59.

SANTA CRUZ COUNTY—Through Ben Lomond about 0.5 mile to be graded, surfaced with bit. mac. on crush. run base and 2 hrs. constructed. District IV, Route 116, Section A. Peninsula Paving Co., San Francisco, \$61,677. Contract awarded to Lord & Bishop, Sacramento, \$55,835.75.

SHASTA COUNTY—Between $\frac{1}{2}$ mi. East of Bella Vista & Diddy Hill, about 7.7 mi. in length to be graded and surfaced with crusher run base and plant-mix surfacing. District II, Route 28, Section A. A. Telchert and Son, Inc., Sacramento, \$228,172; Hemstreet & Bell, Marysville, \$199,945; Union Paving Co., San Francisco. Contract awarded to Peninsula Paving Co. San Francisco, \$197,656.50.

SONOMA COUNTY—Bet. Stony Pt. Rd. and Cotati 1.8 mile lg. Grade, R. R. Base, Bit. Mac. Surf. District IV, Route 104, Section C. Union Paving Co., San Francisco, \$63,639; C. F. Fredericksen and Sons, Lower Lake, \$66,671; Pacific States Construction Co., San Francisco, \$73,717; C. W. Caletti and Co., San Rafael, \$76,579; Granfield, Farrar and Carlin, San Francisco, \$77,402; A. G. Ralsch, San Francisco, \$77,325. Contract awarded to N. M. Ball Sons, Berkeley, \$60,856.70.

STANISLAUS COUNTY—Between Riv. Rd. and 2 mi. W. of Gatos Rd. 3.1 mile Grade, Rd. mix Surf. Tr. and Bridge. District X, Route 110, Section A. C. W. Caletti and Co., San Rafael, \$187,857; N. M. Ball Sons, Berkeley, \$168,519; Paul J. Tyler-Lord and Bishop, Sacramento, \$183,556. Contract awarded to Pacific Bridge Co., San Francisco, \$152,973.50.

TEHAMA COUNTY—Between southerly boundary and 3 mi. N. of Los Molinos, 14.8 miles long, Rd. Wdg. Untr. Cr. Gr. or stone base-plant mix surf. District II, Route 3, Sections A & D. Peninsula Paving Company, San Francisco, \$185,607; A. Telchert & Son, Inc., Sacramento, \$146,714; J. A. Casson, Hayward, \$184,991; Pacific States Construction Co., San Francisco, \$165,278; Union Paving Co., San Francisco, \$146,605; Heafey-Moore Co., Oakland, \$178,006. Contract awarded to Hemstreet & Bell, Marysville, \$146,014.70.

TULARE COUNTY—Between Yokohi and 1 mi. N. Lemon Cove, 6.6 mi. lg. Grade, C. R. Base, Rd. mix surf. District VI, Route 10, Section D. A. Telchert & Son, Inc., Sacramento, \$152,182; Basich Brothers, Torrance, \$159,971. Contract awarded to Union Paving Co., San Francisco, \$147,771.90.

TUOLUMNE COUNTY—Between Sullivan Creek and $\frac{3}{4}$ mi. Easterly about three and four-tenths mis. in length to be graded and surfaced with road-mix surfacing on untr. crushed gravel or stone base. District X, Route 13, Section C. Hemstreet & Bell, Marysville, \$116,916; Peninsula Paving Co., San Francisco, \$129,979; Biasotti, Willard and Biasotti, Stockton, \$108,649; M. J. B. Construction Co., Stockton, \$116,785. Contract awarded to Union Paving Co., San Francisco, \$104,232.20.

VENTURA COUNTY—Bet. W. Casitas Pass & E. Casitas Pass, 2.4 mile long, Grade, Road-mix Surf. Treat. District VII, Route 151, Section B. Granfield, Farrar & Carlin, San Francisco, \$109,712; Basich Bros., Torrance, \$102,270; Sharp & Fellows Contr. Co., Los Angeles, \$99,646; J. E. Haddock, Ltd., Pasadena, \$115,835; Gibbons & Reed, Burbank, \$107,468. Contract awarded to Daley Corp., San Diego, \$97,129.50.

VENTURA COUNTY—Between Somis and Saticoy, 5.9 miles lg. Grade and pl. mix surf. District VII, Route 9, Section A R. C. F. Robbins, Los Angeles, \$61,057; Southwest Pav. Co., Poscos, \$58,409; Basich Brothers, Torrance, \$52,808; A. S. Vinell Co., Los Angeles, \$59,801. Contract awarded to Oswald Bros., Los Angeles, \$51,208.90.

"Shay, waiter, find my hat!"

"It's on your head, sir."

"Don't bother, then, I'll look for it myself."

Father: "Fancy a big boy like you being afraid to sleep in the dark."

Five-Year-Old: "It's all very well for you, you've got mother to look after you."

STATE OF CALIFORNIA
Department of Public Works

Headquarters: Public Works Building, Eleventh and P Sts., Sacramento

FRANK F. MERRIAM.....Governor

EARL LEE KELLY.....Director

JUSTUS F. CRAEMER.....Assistant Director

EDWARD J. NERON.....Deputy Director

DIVISION OF HIGHWAYS

CALIFORNIA HIGHWAY COMMISSION

HARRY A. HOPKINS, Chairman, Taft
TIMOTHY A. REARDON, San Francisco
PHILIP A. STANTON, Anaheim
CHARLES D. HAMILTON, Banning
C. H. PURCELL, State Highway Engineer, Sacramento
JULIEN D. ROUSSEL, Secretary

HEADQUARTERS STAFF, SACRAMENTO

G. T. MCCOY, Assistant State Highway Engineer
J. G. STANDLEY, Principal Assistant Engineer
R. H. WILSON, Office Engineer
T. E. STANTON, Materials and Research Engineer
FRED J. GRUMM, Engineer of Surveys and Plans
C. S. POPE, Construction Engineer
T. H. DENNIS, Maintenance Engineer
F. W. PANHORST (Acting), Bridge Engineer
L. V. CAMPBELL, Engineer of City and Cooperative
Projects
R. H. STALNAKER, Equipment Engineer
E. R. HIGGINS, Comptroller

DISTRICT ENGINEERS

J. W. VICKREY, District I, Eureka
F. W. HASELWOOD, District II, Redding
CHARLES H. WHITMORE, District III, Marysville
JNO. H. SKEGGS, District IV, San Francisco
L. H. GIBSON, District V, San Luis Obispo
R. M. GILLIS, District VI, Fresno
S. V. CORTELYOU, District VII, Los Angeles
E. Q. SULLIVAN, District VIII, San Bernardino
S. W. LOWDEN (Acting), District IX, Bishop
R. E. PIERCE, District X, Stockton
E. E. WALLACE, District XI, San Diego
General Headquarters, Public Works Building,
Eleventh and P Streets, Sacramento, California

DIVISION OF WATER RESOURCES

EDWARD HYATT, State Engineer, Chief of Division
J. J. HALEY, Jr., Administrative Assistant
HAROLD CONKLING, Deputy in Charge Water Rights

A. D. EDMONSTON, Deputy in Charge Water
Resources Investigation
R. L. JONES, Deputy in Charge Flood Control and
Reclamation
GEORGE W. HAWLEY, Deputy in Charge Dams
SPENCER BURROUGHS, Attorney
EVERETT N. BRYAN, Hydraulic Engineer, Water
Rights
A. N. BURCH, Irrigation Investigations
H. M. STAFFORD, Sacramento-San Joaquin Water
Supervisor
GORDON ZANDER, Adjudication, Water Distribution

DIVISION OF ARCHITECTURE

GEORGE B. McDOUGALL, State Architect, Chief of
Division
P. T. POAGE, Assistant Chief
W. K. DANIELS, Administrative Assistant

HEADQUARTERS

H. W. DeHAVEN, Supervising Architectural Drafts-
man
C. H. KROMER, Principal Structural Engineer
CARLETON PIERSON, Supervising Specification
Writer
J. W. DUTTON, Principal Engineer, General Con-
struction
W. H. ROCKINGHAM, Principal Mechanical and
Electrical Engineer

**DIVISION OF CONTRACTS AND
RIGHTS OF WAY**

C. C. CARLETON, Chief
CLARENCE W. MORRIS, Attorney, San Francisco
FRANK B. DURKEE, General Right of Way Agent
C. R. MONTGOMERY, General Right of Way Agent
ROBERT E. REED, General Right of Way Agent

DIVISION OF PORTS

Port of Eureka—William Clark, Sr., Surveyor

MAP SHOWING STATE HIGHWAY SYSTEM

LEGEND
 Primary Roads 
 Secondary Roads 

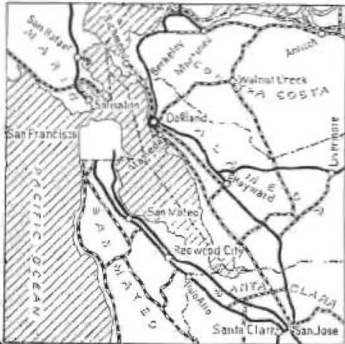

SAN FRANCISCO AND VICINITY



LOS ANGELES AND VICINITY