

Transportation Librarian's Toolkit

From the Transportation Library Connectivity
Pooled Fund Study – TPF-5(105)

Second edition – September 2009



WISCONSIN DOT
Wisconsin Department of Transportation Research & Library Unit

NOTICE:

This research was funded by the Wisconsin Department of Transportation, the Federal Highway Administration and other participating agencies under Transportation Pooled Fund #TPF-5(105) and WisDOT Project 0092-06-31. The information reported is the result of research performed under the auspices of the Transportation Library Connectivity Pooled Fund Project. The contents of this report reflect the views of the authors, who are responsible for the facts and the accuracy of the data presented herein. The contents do not necessarily reflect the official views of the Wisconsin Department of Transportation or the Federal Highway Administration at the time of publication.

This document is disseminated under the sponsorship of the Department of Transportation in the interest of information exchange. The United States Government assumes no liability for its contents or use thereof. This report does not constitute a standard, specification or regulation.

The United States Government does not endorse products or manufacturers. Trade and manufacturers' names appear in this report only because they are considered essential to the object of this document.

Technical Report Documentation Page

1. Report No.	2. Government Accession No	3. Recipient's Catalog No	
4. Title and Subtitle Transportation Librarian's Toolkit, Second Edition		5. Report Date September 2009	
		6. Performing Organization Code	
7. Authors Maggie Sacco, CTC & Associates LLC		8. Performing Organization Report No.	
9. Performing Organization Name and Address CTC & Associates LLC 4805 Goldfinch Dr. Madison, WI 53714		10. Work Unit No. (TRAIS)	
		11. Contract or Grant No. 0092-06-31	
12. Sponsoring Agency Name and Address Transportation Library Connectivity Pooled Fund #TPF-5(105) Lead State: Wisconsin Department of Transportation 4802 Sheboygan Avenue Madison, WI 53707		13. Type of Report and Period Covered	
		14. Sponsoring Agency Code 0092-06-31	
15. Supplementary Notes			
16. Abstract The <i>Transportation Librarian's Toolkit, Second Edition</i> , is a product of the Transportation Library Connectivity pooled fund study, TPF-5(105), a collaborative effort by transportation libraries to enhance information accessibility and professional expertise to serve the transportation community. At the time of publication study members included state DOT libraries in Arizona, California, Connecticut, Idaho, Iowa, Kansas, Louisiana, Michigan, Minnesota, Mississippi, Missouri, Montana, New York State, Ohio, Oregon, Pennsylvania, Tennessee, Washington and Wisconsin; Los Angeles County Metropolitan Transportation Authority; University of Minnesota Center for Transportation Studies; and the Wisconsin Transportation Center at the University of Wisconsin-Madison. The Technical Advisory Committee members of the pooled fund study were instrumental in creating this toolkit, which is a product of the collective work of the study. The purposes of this toolkit are to ease the learning curve of those new to librarianship and/or transportation; to pull together the collective wisdom of study members on topics that the study has addressed through its work of connecting and networking transportation libraries; to serve as a living document, updated frequently in print and online; to capture some of the institutional memory that is leaving the DOTs as waves of retirements loom; and to give transportation librarians of varying experience levels and work situations some tools to inspire, enhance and streamline librarians' work and library operations.			
17. Key Words Transportation Library, Transportation Librarian, Knowledge, Information, Transportation Information Management, Online Transportation Catalogs, Transportation Data Access, Transportation Networking, Transportation Data Exchange, Transportation Information Services, Reauthorization, Information Architecture, Knowledge Management, Strategic Planning, Institutional Memory, Information Capture, Transportation Information Retrieval		18. Distribution Statement No restriction. This document is available to the public through the National Technical Information Service 5285 Port Royal Road Springfield VA 22161	
18. Security Classif.(of this report) Unclassified	19. Security Classif. (of this page) Unclassified	20. No. of Pages	21. Price

Table of Contents

Acknowledgments	v
Foreword	vi
Introduction	1
I. Library Services	3
Reference and Literature Searches	3
Internet and Intranet Pages	4
Web 2.0	4
Cataloging	5
Interlibrary Loan and Document Delivery	7
News Alerts	7
News Clips and Newsletters	7
Table of Contents and Journal Distribution	8
Vertical Files	8
Training	8
Web Conferencing.....	8
II. Collection Development	9
Reference Collection	9
Monograph Collection.....	9
Serials Collection	9
Transportation Reports	10
Online Resources.....	10
Open Access	12
Subscription Databases.....	12
III. Data Management	14
The Librarian as Data Broker	14
Data Catalog	14
IV. Space Planning	16
WSDOT Remodel: Doing More with Less	16
V. Best Practices	18
Mission Statement	18
Budgeting	18
Library Policies	19
Copyright.....	19
Selecting an Integrated Library System.....	20
Collection Development.....	21
Managing Electronic Resources	22
Performance Measures	22
VI. Outreach and Marketing	25
Know Your Audience.....	25
Establish a Library Committee	25
Develop Library Marketing Collateral	25
Brand Yourself	26
VII. Network, Network, Network	27
Professional Organizations and Resources	27
VIII. The Transportation Landscape	29
Federal Transportation Agencies and Organizations.....	29
Nonprofit Organizations.....	30

TRB	31
Directory of Transportation Libraries.....	31
Directory of State Highway and Transportation Department Libraries.....	31
TRB Special Report 284.....	31
NCHRP 20-75	32
Transportation Abbreviations and Acronyms.....	32
Looking Ahead: Libraries and Networks.....	33
Appendices	34
Appendix A: TLCat Libraries	A-1
Appendix B: Online Computer Library Center Regional Service Providers.....	B-1
Appendix C: Sample Core Journal Collection (Minnesota DOT Library).....	C-1
Appendix D: Shelving Layouts, WSDOT Library Remodel (Before and After)	D-1
Appendix E: Sample Library Policies (Iowa DOT Library).....	E-1
Appendix F: Pooled Fund Libraries' ILS, OPAC and Web Sites.....	F-1
Appendix G: Sample Collection Development Policy (Minnesota DOT Library).....	G-1
Appendix H: Statistical Tracking Tools (National TKN Resource Sharing Project, MTKN).....	H-1
Appendix I: Return on Investment Formula (Jerry Baldwin, Minnesota DOT Library).....	I-1
Bibliography	

Acknowledgments

Technical Advisory Committee

This study was proposed by the Wisconsin Department of Transportation as the lead state for the Transportation Library Connectivity pooled fund study, TPF-5(105). The work was guided by a Technical Advisory Committee chaired by Ann Pahnke and previously by Nina McLawhorn, WisDOT. Other members of the TAC are Betty Ambler, Connecticut DOT; Matthew Barrett, Los Angeles County Metropolitan Transportation Authority; Jason Bittner, Wisconsin Transportation Center at UW-Madison; Sandy Brady, Louisiana Transportation Research Center; Alexandra Briseno, Michigan DOT; Mara Campbell, Missouri DOT; John Cherney, Wisconsin DOT; Janet Coles, Caltrans; Bonnie Fields, Pennsylvania DOT; Sheila Hatchell, Minnesota DOT; Sandra Hoff, Tennessee DOT; Inez Adele Hopkins, Idaho Transportation Department; Zona Kahkonen Keppler, Ohio DOT; Marie Manthe, Kansas DOT; Arlene Mathison, University of Minnesota Center for Transportation Studies; Jane Minotti, New York State DOT; Sue Sillick, Montana DOT; Dale Steele, Arizona DOT; Kathy Szolomayer, Washington State DOT; James Watkins, Mississippi DOT; Laura Wilt, Oregon DOT; and Hank Zaletel, Iowa DOT.

Research Managers and Others

The DOT research managers who assisted in the administrative oversight of this study included Daniel Yeh, WisDOT; Teresa Adams, Wisconsin Transportation Center at UW-Madison; Christine Azevedo, Caltrans; Randy Battey, Mississippi DOT; Mara Campbell, Missouri DOT; Frank Darmiento, Arizona DOT; Monica Del Toro, Los Angeles County Metropolitan Transportation Authority; Monique Evans, Ohio DOT; Bonnie Fields, Pennsylvania DOT; Gary Frederick, New York State DOT; Sandra Hoff, Tennessee DOT; Bob Johns, University of Minnesota Center for Transportation Studies; Bernie Jones, Oregon DOT; Sandra Larson and Carol Culver, Iowa DOT; Sue Lodahl and Deb Fick, Minnesota DOT; Dick McReynolds, Kansas DOT; Leni Oman, Washington State DOT; Ned Parrish, Idaho Transportation Department; Skip Paul and Glynn Cavin, Louisiana Transportation Research Center; Calvin Roberts, Michigan DOT; Sue Sillick, Montana DOT; James Sime, Connecticut DOT; and ex officio members Amanda J. Wilson, National Transportation Library; Jerry Baldwin, Minnesota DOT (ret.); Sandy Tucker, Texas A&M University; Bob Cullen, AASHTO; and Barbara Post, Transportation Research Board.

Foreword

The Transportation Library Connectivity pooled fund study has seen tremendous growth since the first edition of the Toolkit in 2007. Our membership has doubled, and our expanded and diversified Technical Advisory Committee now includes 22 members who have created this toolkit by sharing their best practices and innovative approaches to providing valuable services and collections to their customers. The goal of the second edition is to update previous information and add new content that reflects the dynamic nature of library services and information technology. New information such as data management, Web 2.0 tools, policies and space planning experience are presented in this edition. The learning curve in transportation can be steep and we hope the Toolkit will continue to serve as a guide for new transportation librarians and seasoned professionals alike. The collective wisdom of our members covers everything from well-established practices of cataloging and controlled vocabularies to the latest uses of Web 2.0 and social networking tools to deliver information wherever users reside. The pooled fund continues to address all of the topics in these pages through its work of connecting and networking transportation libraries. Our members hope the toolkit will be an indispensable tool for transportation libraries of all types.

“Transportation as a discipline is still in its infancy. While other disciplines, such as medicine, agriculture or philosophy, have been around for centuries, the study of the transportation discipline as a serious endeavor is probably barely one century old. The transportation information milieu is one that draws upon many others, including engineering, chemistry, psychology, medicine, ecology and more. To succeed in this profession, librarians and information services personnel need the tools and processes to reach a wide variety of resources in quick fashion. This toolkit will go far in attaining this crucial goal.”

—*John Cherney, head librarian, Wisconsin DOT*

“We need to adjust to operate in a complex environment where we provide services to a multigenerational user population with widely varying expectations and information-seeking behaviors and skills. We also have to continually confront and challenge ourselves to master new technologies and processes. What we do as librarians and the intellectual processes behind that haven't changed that much over the years, but the tools and the environment are in constant flux.”

—*Janet Coles, supervising librarian, Caltrans*

“To be a librarian, I believe you must possess three characteristics: One is that you must be endlessly curious, the second is a deep understanding of complex organization, and the third is the genuine desire to help people.”

—*Cheryl Bodan, librarian, Pennsylvania DOT*

“Never send anyone away empty-handed. They won't come back. We participate in the AASHTO e-mail distribution list so we can ask other DOTs when there is no published information to be found. We use our academic network OhioLINK particularly when we need answers fast, like e-books, academic databases, online reference sources, etc. We call upon our regional (MTKN) and professional networks when there are no holding libraries willing to lend or we need additional ideas for finding answers. And we have a materials budget to back us up when we need to purchase resources necessary to supply our patrons with what they've asked for.”

—*Janet Bix, library administrator, Ohio DOT*

“With the first-ever joint meeting of the TKNs in June of this year, transportation librarians are, at long last, making progress toward fulfilling a recommendation first made more than 40 years ago in a report dated March 1967, commissioned by the U.S. Department of Commerce. The report encouraged the development of a resource sharing network by ‘establishing service agreements and communication linkages among the major transportation collections to evolve into a national transportation information system.’ The primary role of the transportation librarian is to understand and meet the information needs of the staff of their own organization. The most critical role is developing the knowledge and contacts necessary to tap into the various nodes of the world's transportation information networks to acquire the specific information and resources required to meet those needs. While each of the transportation libraries needs to be unique to meet the needs of its parent organization, the pooled fund has provided funding and staff needed to develop resources and services addressing issues common to all libraries including training, communications, resource sharing and cataloging. The most important of these is the Transportation Librarian's Toolkit.”

—*Jerry Baldwin, library director (1972-2008), Minnesota DOT*

Introduction

The Transportation Library Connectivity pooled fund study is a collaborative, grass-roots effort by transportation libraries to enhance information accessibility and professional expertise to serve the transportation community. We are a group of 22 state agencies, two universities and one metropolitan transportation authority. Members currently include state DOTs in Arizona, California, Connecticut, Idaho, Iowa, Kansas, Louisiana, Michigan, Minnesota, Mississippi, Missouri, Montana, New York State, Ohio, Oregon, Pennsylvania, Tennessee, Washington and Wisconsin (lead state), as well as the Los Angeles County Metropolitan Transportation Authority, University of Minnesota Center for Transportation Studies and the Wisconsin Transportation Center at the University of Wisconsin-Madison.

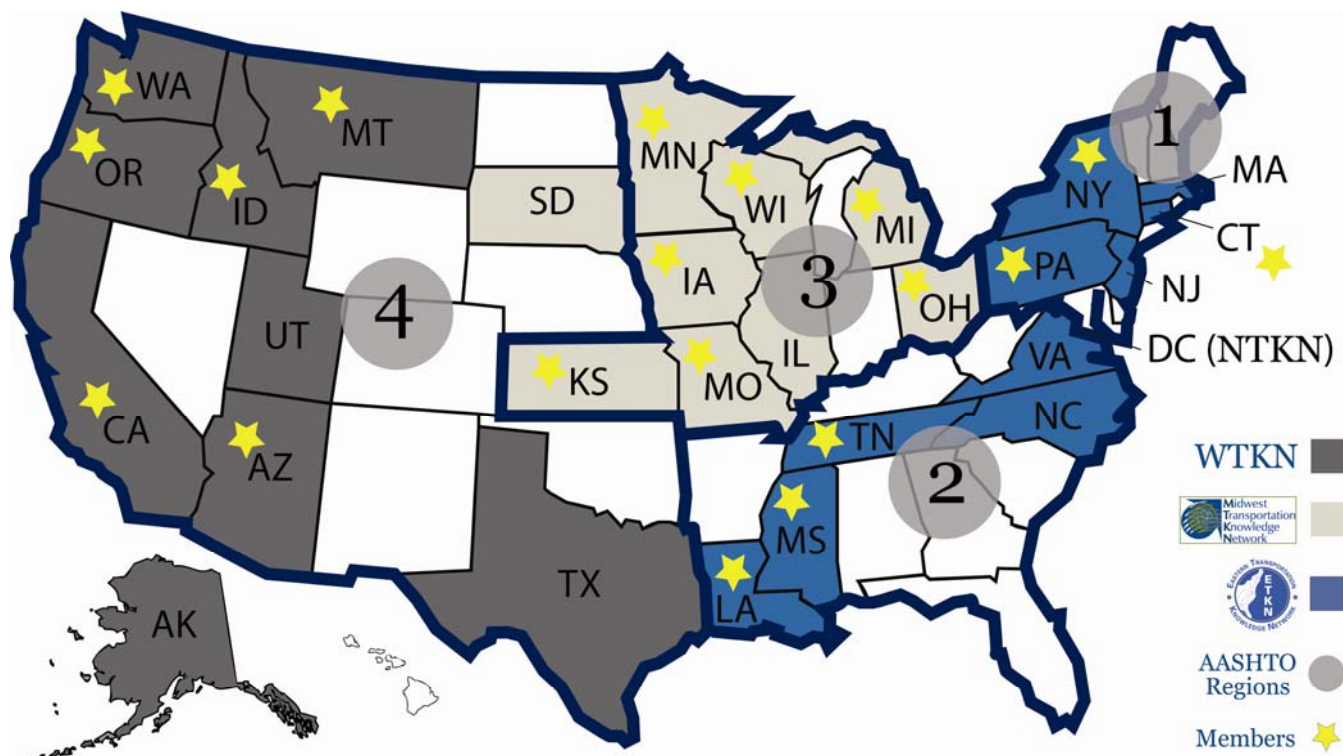

This map shows the membership of the three regional TKNs, the pooled fund and their geographical relationship to the four AASHTO regions.

The Transportation Library Connectivity pooled fund study aims to follow the recommendations of TRB Special Report 284, *Transportation Knowledge Networks: A Management Strategy for the 21st Century*,¹ with respect to improving library services and the need for Transportation Knowledge Networks. The report envisions the creation of regional networks connected by a national coordinating body in its first recommendation: “Transportation knowledge networks (TKNs) should be established in every region of the United States and at the federal level.”² The purpose of these networks is to improve library services in the following ways:

¹ At the request of AASHTO’s Standing Committee on Research, TRB conducted a study on how transportation information should be managed and delivered. The resulting report, *Transportation Knowledge Networks: A Management Strategy for the 21st Century* (TRB Special Report 284), makes recommendations for sustainable funding and administrative structures for a national TKN. <http://onlinepubs.trb.org/onlinepubs/sr/sr284.pdf>.

² *Transportation Knowledge Networks: A Management Strategy for the 21st Century*, Committee for a Future Strategy for Transportation Information Management, Transportation Research Board of the National Academies, 2006, p. 5. <http://onlinepubs.trb.org/onlinepubs/sr/sr284.pdf>. 5 March 2007.

- Identification of key information provider and user groups
- Sharing of information and services
- Coordination of collections
- Interlibrary loan
- Sharing of catalogs through TLCat
- Reference services
- Professional capacity building for members³

The pooled fund study focuses on library technical services, outreach and advocacy. Our study partners' goals are to improve access to resources through networks, promote the value of transportation libraries and raise awareness at all levels of government about the benefits of viable TKNs.

This toolkit is intended as a guide for transportation librarians with varying levels of experience who are challenged with delivering quality information services to their agencies on a modest budget. Delivering the best services possible within budget constraints while advocating for more resources and justifying the expenditures is a challenge in the transportation sector. Librarians continue to be asked to do more with fewer staff and reduced resources. One of the greatest challenges in this environment is to perform at the highest level possible while not perpetuating the misperception that adequate funding has been achieved.

We developed this guide from the body of work of the Transportation Library Connectivity pooled fund study and other sources we have found to be useful as we explored the benefits of working cooperatively. We realized that this knowledge and experience could be organized and preserved to meet the often-expressed need for a guide to help new and/or solo librarians deliver top-notch information services to their departments. The pooled fund study members include librarians with diverse backgrounds and levels of experience in transportation who have expressed the need for a toolkit for effective transportation information services.

The target audience is any information professional serving the transportation sector, although the guide itself is written from a state DOT library perspective. Whether the librarian is a recent graduate from library school; experienced but new to transportation; or a veteran who would like to enhance his or her services, implement new technologies or supplement staff training, this toolkit aims to provide answers to some of the most challenging aspects of transportation librarianship in the age of downsizing and the myth of the intrinsic value of information found on the Internet.

While this guide is focused on state DOT libraries, there are common threads in services and selection of transportation resources as well as some basic best practices of special librarianship. We hope to provide information and tools that can be tailored to the numerous unique requirements of any transportation library.

Getting started in a transportation library is often described as climbing a steep learning curve for both new and experienced librarians. These librarians bring the tools of their profession and adapt them to a new environment while trying to collect the essential knowledge needed to be conversant in the transportation community.

³ Ibid., p. 56.

I. Library Services

Many people believe libraries are repositories for collections. But in truth, libraries are places with highly trained staff offering a diverse set of services that may or may not involve the use of a physical collection. Typical library services include reference; literature searching; interlibrary loan and document delivery; creation of bibliographies; e-mail alerts; news clips; and in some libraries, design and maintenance of the library's intranet and Internet sites. Some DOT libraries run their map reproduction services; others manage photo collections. By helping customers get needed information quickly, the library becomes an essential partner in meeting department goals.

The Big Picture of Library Services

1. Assess the informational requirements of the DOT community on a continuing basis by formal and informal interaction with all other elements of the transportation community.
2. Select from available information those resources most applicable to the requirements of the DOT community.
3. Acquire, organize and arrange these informational resources in a manner and in a physical setting most conducive to their use.
4. Promote a range of informational and educational services to increase library benefits for all members of the DOT community.
5. Provide enhanced informational resources and services by active collaboration with other institutions through interlibrary loan, information networks and cooperative arrangements.
6. Study the operations and services provided by the library to assure effective use of available resources.
7. Present and interpret the library's fiscal and other needs to funders.
8. Provide an environment in which to develop and maintain an informed and capable staff.
9. Anticipate and plan for future developments in the informational needs and services that are likely to affect the DOT community.⁴

Reference and Literature Searches

Reference and literature searching are two key public services in any library. While it is sometimes difficult to know for statistical purposes what qualifies as a reference question, many agree on the American Research Library definition, which is a guide for collecting reference statistics:

A reference transaction is an information contact that involves the knowledge, use, recommendations, interpretation or instruction in the use of one or more information sources by a member of the library staff. The term includes information and referral service. Information sources include (a) printed and nonprinted material; (b) machine-readable databases (including computer-assisted instruction); (c) the library's own catalogs and other holdings records; (d) other libraries and institutions through communication or referral; and (e) persons both inside and outside the library. When a staff member uses information gained from previous use of information sources to answer a question, the transaction is reported as a reference transaction even if the source is not consulted again. If a contact includes both reference and directional services, it should be reported as one reference transaction. Duration should not be an element in determining whether a transaction is a reference transaction.⁵

A literature search differs from reference transactions in its objectives, depth, duration and the tools consulted. While the goal of a reference transaction is to provide a factual answer to a question, the objective of a literature search is to survey the published articles on a topic and provide customers with a set of bibliographic citations, abstracts or articles from which they can select for further research. Using search alerts or running saved searches helps customers who require the most up-to-date published articles in their specialty. Literature alerts are automated searches that are set up and run on a designated schedule (e.g., daily, weekly, monthly) to scan selected databases that meet the search criteria for new articles. These can be delivered directly to customers' e-mail addresses or to the librarian for editing and packaging prior to distribution. Literature search alerts often allow librarians to use high-end database aggregators like Dialog at a fraction of the cost of normal searching.

⁴ Adapted from *Library Services in Theory and Context*, Michael Buckland. 2nd ed., 1999. <http://sunsite.berkeley.edu/Literature/Library/Services/>. 12 March 2007.

⁵ *ARL Statistics 2004-2005: A Compilation of Statistics from the One Hundred and Twenty-Three Members of the Association of Research Libraries*, 2006, p. 102. <http://www.arl.org/bm~doc/arlstat05.pdf>. 12 March 2007.

Internet and Intranet Pages

Maintaining the library's intranet and extranet pages is an excellent opportunity to promote resources and services to internal and external customers. Depending on an agency's IT rules and time and staff resources, the optimal library Web presence is one that mirrors the physical library. Any service or digital resource available to customers in the library should also be accessible on the library's Web pages. Patrons should be able to access databases and search the library catalog if possible. (The department's Internet security policies or subscription licenses may prevent these options.) Reference services can be transacted by e-mail via the Web page or using the agency's network chat or instant messaging program—a virtual reference desk.

An excellent example of a well-designed DOT library Web site that our members find useful is the Wisconsin DOT site at <http://www.dot.wisconsin.gov/library/>.

The philosophy behind the WisDOT Library Web site is threefold: comprehensiveness, partnership and a focus on Wisconsin transportation. The library staff is able to create, edit and upload Web pages live through an agreement with the department's Information Technology Bureau, allowing the content to be more dynamic and responsive to users' needs. The site reflects the multidisciplinary nature of transportation such as technical publications, transportation law, online journals and newsletters, full-text reports, maps and forms. While there are sections dedicated to Wisconsin transportation, the focus remains national. In addition, the site tries to incorporate resource links to databases, statistics and journals from other disciplines that overlap with transportation.

A unique aspect of the WisDOT Library Web site is the philosophy of partnership with different areas and personnel within the department. Currently more than a dozen staff members have Web author rights to maintain separate areas of the library site by contributing their subject expertise to the design and content of the original site. The Office of General Counsel, Office of Public Affairs, Division of Motor Vehicles, Division of State Patrol, Bureau of Highway Operations, Research section, to name a few, all have rights and separate areas within the library site which they maintain. The result is the library as a central conduit and repository for others within the department.

Web 2.0

Web 2.0 is a common term for the technology and applications that facilitate interactive information sharing, such as blogs, YouTube, Twitter, Flickr, Facebook and Wikipedia. Realizing that social and information-seeking habits and workforce demographics are changing and that more people rely on Web 2.0 applications for information and communication, transportation agencies are beginning to adopt Web 2.0 applications as a means of collaborating and delivering information wherever and whenever it is needed. In the transportation sector, early adopters of this technology are targeting four key areas: wikis, social media, social networking and mashups. Web 2.0 provides transportation agencies more tools to deliver information to users—where, when and how they need it.

The term Web 2.0 was first used in 2004 by Tim O'Reilly of computer book publisher O'Reilly Media, Inc. to describe applications that harnessed the networking capabilities of the Internet and allowed for more user participation. He described Web 2.0 as a platform for sharing and collaboration:

“Web 2.0 is the business revolution in the computer industry caused by the move to the Internet as platform, and an attempt to understand the rules for success on that new platform. Chief among those rules is this: Build applications that harness network effects to get better the more people use them.”⁶

The two-way exchange of information using Web 2.0 applications has the potential to improve collaboration with the inherent participatory nature of the tools themselves. “Transportation agencies that promote themselves and their services with Web 2.0 applications are more likely to engage their audience in an active dialogue, rather than a passive interaction. People will feel more enfranchised with the services offered and be more informed, and perhaps enthusiastic, users.”⁷

The challenge facing transportation is network security concerns, particularly in the state DOTs. Even as federal transportation agencies like U.S. DOT, TSA, RITA, NTL and more than 50 others have begun using Web 2.0 tools such as wikis, Twitter and Second Life, states have been reluctant to allow these sites through their firewalls because

⁶ *What is Web 2.0: Design Patterns and Business Models for the Next Generation of Software*, Tim O'Reilly. <http://www.oreillynet.com/pub/a/oreilly/tim/news/2005/09/30/what-is-web-20.html>.

⁷ Mashtrans, Kendra K. Levine. <http://www.mashtrans.org>.

of perceived security issues, terms of service agreements, legal jurisdiction and concerns about advertising on the sites.⁸ The General Services Administration signed agreements with Facebook, Flickr, YouTube, Vimeo and blip.tv that allow federal agencies to use new media tools while meeting their legal requirements.⁹ Twitter was already allowed as the GSA found no disagreement with its terms of use.

Another challenge is communicating how you plan to use these tools to enhance library services and productivity.

When the Louisiana Transportation Research Center (LTRC) opened a new building in 2007, space was set aside for a much-needed library. Building a library mostly from scratch has allowed it to easily integrate a number of Web 2.0 applications into everyday operations. There were few preconceived notions of how things should be done, and quick solutions to needs and problems were often required.

- Web-based word processor and spreadsheet applications from Google Docs (<http://docs.google.com>) were used to create and store documents before a permanent computer was available. Having documents accessible online remains useful when moving from office to library, remote office hours or an out of town conference.
- Delicious.com (<http://delicious.com/>) and Box.net (<http://box.net>) have been used as alternative ways to provide research information to patrons. Delicious.com allows online bookmarking, tagging and commenting on relevant Web sites. Box.net allows files, documents and images to be uploaded to a free online storage site. All materials can then be accessed and downloaded at the patron's convenience, preventing e-mail box overload.
- A number of options have been employed to facilitate communication between the library and patrons. Photos of the library's progress and growth are housed on Flickr, the photo sharing Web site: <http://www.flickr.com/photos/ltrc-tteclibrary/>. LTRC-TTEC Library News is a blog used as to communicate research news and new materials with patrons. Often e-mails are lost or deleted, but blog entries are always available: <http://www.flickr.com/photos/ltrc-tteclibrary/>. Finally, a "meebo me" widget has been incorporated directly on the library Web page. The widget allows any library patron to chat directly with the librarian through this box without needing to have or log into any instant message account. Look for the "Chat with Librarian" box: <http://www.ltrc.lsu.edu/library.html>.
- As a temporary solution to cataloging materials so they can be organized and found easily, LibraryThing—an online alternative to the library catalog—is being used. Eventually a more robust Integrated Library System will be acquired, but until then, LibraryThing allows inclusion of the most basic and necessary information such as titles, authors, publishers and call numbers. It also allows for exporting of data into a spreadsheet which can then be imported into an ILS. <http://www.librarything.com/catalog/LTRCTTEC>.

Web 2.0 sites and tools have many network security issues. They are inherent in the collaborative functions of these tools because of the client-side processes like Ajax or widgets.¹⁰ IT departments do need to control what is downloaded and accessed, as most people don't read user agreements and often can't tell if an application is legitimate or malicious. Network security experts agree that deploying Web 2.0 tools requires continual auditing and adjustments in security measures, but that the continual evolution of the Web as a virtual workplace requires IT departments to be nimble and adaptable to meet the challenges of the networked environments they manage. The continued adoption of new media by government agencies and the Gen Y work force is one of the most important areas for librarians to watch.

Cataloging

Cataloging is often thought of as purely a technical service, but in fact, it is among the most valuable public services a library can provide. The work of cataloging is invisible to customers, but adherence to high cataloging standards results in maximum access and use of the library's collection. It is what enables librarians and patrons to find print

⁸ *Federal Agencies and Web 2.0*, Miller, Ellen. The Sunlight Foundation. <http://blog.sunlightfoundation.com/2009/02/03/federal-agencies-and-web-20/>, 3 February 2009.

⁹ GSA Signs Agreements with Web 2.0 Providers, Beizer, Doug. *Federal Computer Week*, <http://www.fcw.com/Articles/2009/03/25/web-GSA-agreement.aspx>. March 25, 2009.

¹⁰ Web 2.0 Security: Getting Collaborative Peace of Mind, McClure, Marji. *EContent*, November 2008.

and electronic resources in your library. The pooled fund libraries use a variety of classification schemes in their collections, sometimes more than one. For instance, a library may have the bulk of its collection classified according to Dewey or Library of Congress, but use a sequential date/numbering system for AASHTO publications. In addition to using Dewey or LC subject headings, many transportation libraries also use the Transportation Research Thesaurus for classification. TRT terms are added to the bibliographic record for improved indexing and retrieval of resources in the library's catalog.

Some cataloging resources the pooled fund members have found helpful are:

Library of Congress Classification Web—This is a subscription service from LC that frees up the cumbersome print LC classification scheme. (Think of the shelf space!)

<http://classificationweb.net/>

Library of Congress Online Catalog—You can use the LC catalog to find records for similar items to the one you have in hand. This tool is very useful for getting started with assigning subject headings.

<http://catalog.loc.gov/cgi-bin/Pwebrecon.cgi?DB=local&PAGE=First>

OCLC Bibliographic Formats & Standards—Machine Readable Cataloging variable fields, fixed field data, indicators—it's all there to help you create high-quality records in proper Online Computer Library Center format.

<http://www.oclc.org/us/en/bibformats/en/default.shtm>

Cataloging Calculator—This tool will help you generate Cutter numbers, fixed data codes, country codes and more. It's also linked to the OCLC Bibliographic Formats & Standards to help you with MARC variable fields.

<http://calculate.alptown.com/>

Special Libraries Cataloguing Cheat Sheets—SLC makes their templates freely available online.

<http://www.slc.bc.ca/cheats/>

The pooled fund Technical Advisory Committee recommends that transportation libraries become OCLC members and add their holdings to the Transportation Libraries catalog. At present, TLCat offers holdings from 36 transportation libraries. TLCat is a subset of WorldCat, the OCLC union catalog that has more than 136 million bibliographic records and 1 billion individual items¹¹. These resources dramatically improve members' access to resources for sharing and copy cataloging, thus positively impacting the library's materials expenditures and workflow. For a complete list of participating TLCat libraries, see Appendix A.

MARC is desirable but not essential to facilitate including a library's holdings in WorldCat and TLCat. For example, if librarians are cataloging with labeled or text fields in catalogs such as InMagic, they can batch-load records into OCLC, which will convert them to OCLC-formatted MARC records. Cataloging with OCLC increases librarians' ability to locate and use bibliographic records for copy cataloging, but original catalog records enrich both the union and group catalogs because much of the value that comes from contributing holdings to TLCat is the uniqueness of individual transportation collections. Becoming a member of OCLC is easy. Most libraries will join through their OCLC Regional Service Providers. These regional library cooperatives are not part of OCLC, but independent library consortia. In addition to managing OCLC subscriptions, they offer training opportunities and many other subscription resources, often at discounted group rates.

¹¹ OCLC Web site: WorldCat, a global catalog. <http://www.oclc.org/worldcat/catalog/default.htm>. 19 March 2009.

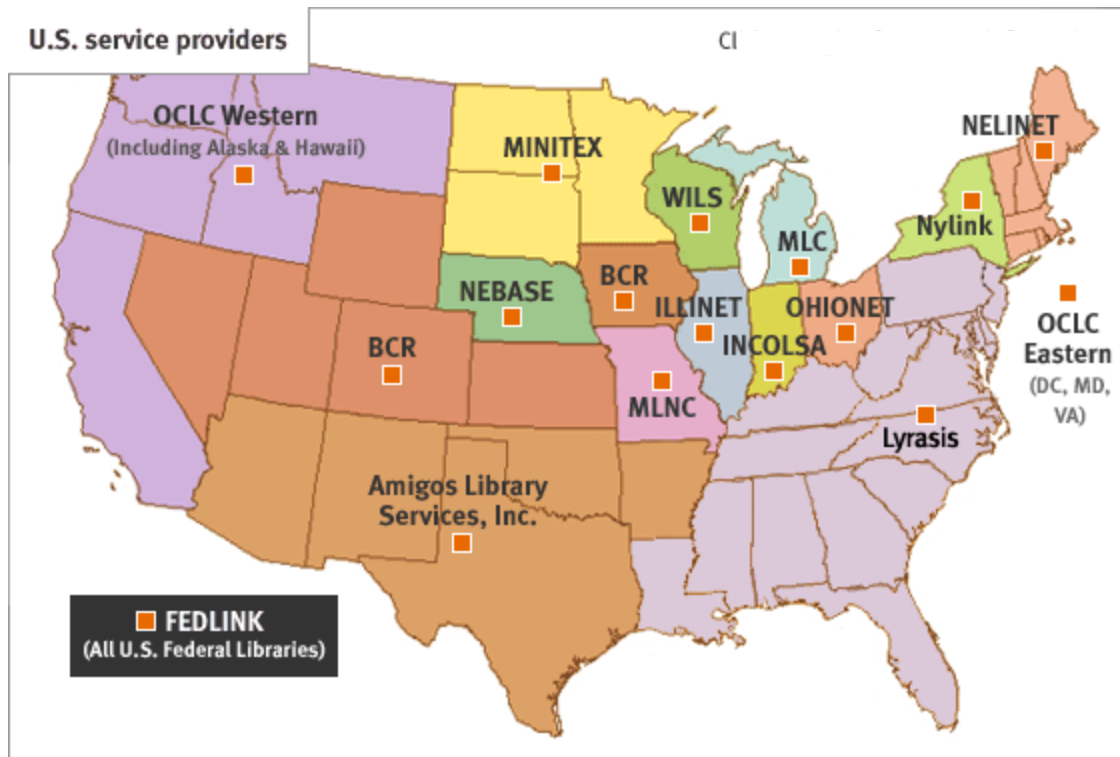

Note: OCLC Western and Eastern are now OCLC. NELINET will become part of Lyrisis. See Appendix B for a Regional Service Provider contact list.

Interlibrary Loan and Document Delivery

Borrowing items and requesting copies of documents from other libraries increases the breadth of information available to customers. After all, no library can own everything it may need to satisfy customers' requests for information. Borrowing from other libraries usually implies that a library will lend resources or supply copies of documents when requested. Resource sharing networks like OCLC make a vast catalog of resources available and allow libraries to focus their collection development budgets on what they really must have in the library. Libraries Sharing Transportation Resources is an OCLC Group Access Capability group for nonprofit transportation libraries that was started in 2006. The LSTR participant agreement is available at <http://www.tfhr.gov/library/lstr.htm>.

The National TKN Resource Sharing Pilot Project began in 2008. This collaborative project between the NTL, regional TKNs and the pooled fund has funded new OCLC Resource Sharing subscriptions and covers the costs of mailing items via FedEx to all participating libraries. Participants are keeping statistics and reporting them with RITA's Sharepoint system. The project will run through June 2010. For more information on the project, visit http://ntl.bts.gov/networking/TKN_ILL_Guidelines.html. To view the latest metrics, visit <http://www.transportationresearch.gov/NTL/NTKN/metrics.aspx>.

News Alerts

Industry and agency news alerts are excellent ways to serve library clients. Some clients need to stay abreast of happenings in industries that are related to transportation. Subscribing to RSS feeds such as those offered by BTS, UMTRI and Caltrans allow librarians to push timely information to their customers either by compiling them and sending via e-mail or by helping customers sign up for RSS feeds and showing them how to use RSS feed readers.

News Clips and Newsletters

Another way libraries can reach out to customers is to keep them informed about information of interest regarding your agency or other topics of interest. Librarians compile related news items from RSS feeds, alerting services and other sources and then e-mail the selected links and attachments to distribution lists at their agencies. News clips are often more frequent (daily, weekly) and contain headlines and links. Newsletters are less frequent (monthly) and contain annotations or abstracts along with links to articles. WSDOT sends out daily e-mail news clips with items of interest from local, statewide and national news sources. Iowa DOT produces a monthly newsletter highlighting

library services, resources and new items. To see the latest newsletter, visit <http://www.iowadot.gov/research/library-newsletter/index.html>.

Table of Contents and Journal Distribution

An increasing number of publishers are making RSS feeds available for their journal titles. Librarians can use RSS feeds to track and distribute the latest tables of contents with direct links or instructions for obtaining articles through the library. E-mail or RSS TOCs distribution is often preferable to circulating physical journals and allows the same current awareness service for print and online subscriptions. It also allows librarians to push information out to customers whose jobs depend on obtaining the latest information in their discipline. This is another approach to increasing current awareness essential to potential customers who routinely bypass the library in favor of informal networks of information exchange. In transportation, what you don't know could be critical to safety and efficiency outcomes. Librarians who routinely distribute these see a dramatic rise in circulation and interlibrary loan statistics. An efficient way to gather the TOCs is ticTOCs from JISC. Free and easy to use, ticTOCs includes more than 11,000 journal titles and allows you to gather your selected TOCs online and link directly to articles through your subscriptions or Open Access. You can also export TOC RSS feeds to popular feedreaders such as Google Reader and Bloglines, as well as obtain an API or a tab-delimited file on the site to load into compatible serials management systems and online public access catalogs¹². Visit www.tictocs.ac.uk/ for more information.

Circulating journals among staff via routing lists is an easy way for the library to reach out to agency staff members who may prefer not to receive electronic TOCs via e-mail. Each library has its own way of routing journals. For some it is very informal, with a typed list of names attached to the cover. Each person on the list reviews the journal, then crosses out his name and passes the journal along until it reaches the end of the list, which is the library. Others may choose to use the journal routing function in their ILS, which is highly recommended because it is a more efficient tracking method.

Vertical Files

Vertical files can be populated with valuable information sources generally considered ephemeral that don't fit neatly into the main library collection. The Iowa DOT library provides a newspaper article updating service to its patrons. Iowa and national papers are reviewed daily for topics that relate to Iowa, its transportation and government. This information is then routed to staff manually or by e-mail to those who have requested it. These articles provide the nucleus of the Iowa DOT library vertical file, which also contains magazine articles, brochures, reports and other materials. It is a source of information for library users that cannot be found anywhere else. The file, which is updated daily, has been maintained by the library for the last 25 years. The collection is arranged alphabetically, and a printed thesaurus of file titles is available for use by in-house users.

Training

Many of the pooled fund libraries offer training on library services and resources. If offered in an appealing and engaging way, library training is both an educational and an outreach tool that can help grow a research-savvy customer base and highlights the value of the library. However, library outreach and training can be a challenge. Experience tells us that library users don't want to have to sit through a presentation or online training for using the library catalog or other resources. Be creative and consider developing webinars that are geared on specific topics or communities of practice. New employee orientation, supervisor training, district meetings, peer exchanges and other meetings can be great opportunities to showcase the library's services and resources.

Web Conferencing

Web conferencing applications are great for delivering training to off-site customers. Live video and audio, instant messaging, whiteboards, shared files and desktop sharing allow librarians to reach colleagues in regional offices for live training that offers convenience and saves on travel costs while reaching more potential library users. Some of these programs are by subscription and are used by many transportation agencies. WebEx, Adobe Connect and GoToMeeting are a few. There are some excellent free Web conferencing applications offering similar functionality and provide alternatives to costly subscription meeting programs. Dimdim, Yugma and vRoom are just a few.

¹² *Transforming Current Awareness Through RSS: How Two Projects (ticTOCs and Gold Dust) are Using RSS to Improve the Information Landscape for the 21st Century Researcher*, Rogers, Lisa J., Simon Hodson and Roddy MacLeod. 2009. In European Library Automation Group Conference (ELAG 09), University Library in Bratislava, 22-24 April 2009. [Conference Proceedings]. <http://eprints.rclis.org/16060/>.

II. Collection Development

A useful collection doesn't happen by accident. In today's transportation libraries, just as in academic, public and other special libraries, there is a need for resources that cater to customers' needs, and one of the things they want is electronic information. The current buzzword seems to be "seamless searching," that elusive single interface that allows the researcher to move between library catalogs and between databases with minimal mouse clicks and no perception of the changing resources.

Portals and federated searching are the closest tools we have, yet they are still not truly seamless or reasonably inclusive in most cases. With the strong preference for online resources in mind, a useful collection should include resources of value without regard to format. This is where the librarian's expertise regarding resources intersects with the need to educate the customer in order to serve them. A collection will include print and online reference and monographic sources, serials, databases, aggregators and Web resources. It should contain the materials internal customers require to help them do their jobs effectively. If the library is open to the public, the collection should include agency-produced materials so that the public can access the information financed by their taxes.

The following is a breakdown of a core collection in a DOT library. There are many resources individual transportation librarians find useful in their work. As a practical matter, this discussion is not all-inclusive but includes information about resources that the majority of our study partners find valuable.

For an online guide to transportation resources, visit the WisDOT Research & Library Web site at <http://www.dot.wisconsin.gov/library/research/resources/index.htm>.

See the NTL Web site for research tools, statistics, dictionaries, information management standards, directories and legislative resources at <http://ntl.bts.gov/tools.html>.

Reference Collection

A well-rounded reference collection would ideally include the most frequently consulted reference works in the interdisciplinary sciences of transportation as well as some of the more general resources found in any library, such as current dictionaries, encyclopedias, directories, statistics, TRT, atlases and reference works for librarians such as publisher directories and periodical indexes. Legal reference materials, such as state codes and statutes, and management and training materials are other valuable subject areas.

Monograph Collection

Subject areas for a library's monograph collection include engineering (mechanical, civil); materials; chemistry; modal (auto, aeronautics, pedestrian, bicycle, public transit); roads, bridges, ferries, waterways, freight and rail; weather; geology; geography; environmental; and planning.

Serials Collection

The pooled fund libraries all maintain fairly extensive serials collections. For reference, a list of core titles used by the Minnesota DOT library is given in Appendix C. Yet even with an extensive on-site collection, researchers in the interdisciplinary sciences in transportation have a strong preference for online research¹³. For this reason, electronic subscriptions are recommended wherever possible to meet customers' needs and expectations.

Serials are synonymous with change. Price increases, changes by publishers (titles, subtitles, ISSNs), and vendors' services all make managing online and print subscriptions challenging. Often the print subscription comes with the online version at no additional cost, so there are two formats to manage. The serials module of an ILS or a third-party vendor tool such as Serials Solutions (<http://www.serialssolutions.com/>) or Ebsco's Serials A-to-Z (<http://www2.ebsco.com/en-us/ProductsServices/atoz/Pages/index.aspx>) or the open source CUFTS Serials Management tool (<http://researcher.sfu.ca/cufts>) are some options for managing unruly serials collections.

¹³ *Understanding Research Behaviors, Information Resources, and Service Needs of Scientists and Graduate Students: A Study by the University of Minnesota Libraries*, June 2007. https://conservancy.umn.edu/bitstream/5546/1/Sciences_Assessment_Report_Final.pdf. 9 October 2007.

Transportation Reports

State DOT publications are the foundation of a collection of reports, and it's a good idea to set up a system whereby copies of all in-house publications are automatically deposited in the library. Many reports are now born digital, and they often get posted on a department Web site without formal announcement to the library. Setting up a system of searching the Web for new titles to add to a library's catalog may be worthwhile, depending on staff resources and time. Publications from other state DOTs are also important and for reasons of relevance and space, some libraries focus mostly on neighboring states. TRB's complete list of publications, NCHRP, AASHTO and U.S. DOT publications should be included. Most libraries have a small collection of foreign transportation agency reports.

Online Resources

The following is a list of online resources, both proprietary and free to the public, which the pooled fund study librarians find useful in their work. For information on managing online resources, see Chapter V, "Best Practices."

Free Resources

NTL Digital Repository

http://ntl.bts.gov/about_ntl.html

The NTL collection is entirely digital. Electronic resources for the NTL Digital Repository are selected according to the NTL's Collection Policy (see <http://ntl.bts.gov/colldev.html>). The NTL Digital Repository is a permanent archive. It includes primarily statistical, technical, research and policy documents provided by federal, state, local, tribal and other government agencies that are required by researchers and decision-makers.

RiP

http://rip.trb.org/search/advanced_search.asp

TRB's Research in Progress database contains more than 9,500 current or recently completed transportation research projects. Most of the RiP records are projects funded by federal and state DOTs. University transportation research is also included.

RNS

<http://rns.trb.org>

TRB's Research Needs Statements database contained some 700 transportation research needs statements at its premiere in October 2007. The new database provides a central location that makes searching and sharing statements easy. Organizations, agencies, universities, students, consultants and others who fund and conduct transportation research can now quickly and confidently identify where the focus of their critical resources is most needed. The database will be updated continuously by TRB's standing committees.

Sources of Information in Transportation

<http://ntl.bts.gov/ref/biblio/>

Sources of Information in Transportation is compiled by members of the Transportation Division, Special Libraries Association, and published by U.S. DOT, Bureau of Transportation Statistics, NTL. Many of the pooled fund librarians find the "Highways" section (<http://ntl.bts.gov/ref/biblio/highways/>) quite valuable. Pooled fund librarian Janet Bix, Ohio DOT, is a contributor.

TRIS Online

<http://ntlsearch.bts.gov/tris/index.do>

TRIS Online is a public-domain, Web-based version of the Transportation Research Information Services bibliographic database. TRIS Online is published as a collaborative effort by the NTL and TRB. The TRIS Online database contains more than half a million records of published transportation research, including technical reports, books, conference proceedings and journal articles. Currently the database has almost 24,000 TRIS records with links to electronic copies of the full text.

TLCat

<http://ntl.bts.gov/cgi-bin/fs.scr>

TLCat is the Transportation Library group catalog, and is a subset of the OCLC WorldCat union catalog. TLCat was created through the joint efforts of NTL, the Midwest Transportation Knowledge Network and OCLC. Currently 36 transportation libraries have their holdings in TLCat. Although the catalog is a paid subscription, anyone can search it through the guest view.

TRT

<http://trt.trb.org/>

The Transportation Research Thesaurus is a tool developed by TRB to improve the indexing and retrieval of transportation information. The thesaurus covers all modes and aspects of transportation. TRT's continued development aims to provide a common and consistent language between those who produce transportation information and those who use it. Many transportation libraries use the thesaurus terms as further subject analysis in bibliographic records to enhance to the classification scheme they use throughout their collections.

Google Co-op Custom Search Engines

Individual States

<http://google.com/coop/cse?cx=016923400724939679832%3Avmv2xow5buq>

Search transportation sites in individual states. An excellent example is the Wisconsin Transportation Information Search. WTIS includes more than 50 transportation sites in Wisconsin, including the DOT site, university sites in Wisconsin, MPO and RPC sites, and nonprofit Wisconsin transportation sites.

LTAP and TTAP Centers

<http://www.google.com/coop/cse?cx=010809592348763093458%3Ar3i0biypw1u>

Search all 58 LTAP and TTAP Center Web sites.

Metropolitan Planning Organizations

<http://www.google.com/coop/cse?cx=006511338351663161139%3Aktu1nltiojg>

Search the Web sites of metropolitan planning organizations. Sites included in this search were taken from the AMPO membership list.

Public Transit Search

<http://www.google.com/coop/cse?cx=012995479145342077058%3Aipxox2lxkha>

Meta search all major transit agency and transit-related organization Web sites for fares, routes, data, reports, research, press releases, budgets, policies, programs and other transit industry information.

State DOTs

<http://www.google.com/coop/cse?cx=006511338351663161139%3Acnk1qdck0dc>

Search the DOT Web sites of the 50 states and the District of Columbia. The search engine has received more than 100,000 queries since December 2006.

U.S. State Public Utilities Commissions

<http://www.google.com/coop/cse?cx=004890854172713559008%3A3vjc7enw1du>

Search the Web sites of public utilities commissions in all 50 states, plus the National Association of Regulatory Utility Commissioners.

UTCs

<http://www.google.com/coop/cse?cx=010809592348763093458:3jsikrwi874>

Search for transportation research located on university transportation center Web sites, including the U.S. DOT Research & Innovative Technology Administration's University Transportation Center program and the Council of University Transportation Centers.

Google Scholar

http://scholar.google.com/advanced_scholar_search?hl=en&lr=

Google Scholar provides a simple way to search for scholarly literature on the Web. It provides simple and advanced searching options to locate peer-reviewed papers, books, citations, abstracts, articles and theses. Google Scholar sorts articles the way researchers do—by weighing the full text of each article, the author, the publication that printed the article and the number of citations in other scholarly literature. The most relevant results will always appear on the first page.

Open Access

Open access is a trend that is gaining momentum in scholarly publishing. OA provides immediate, free and unrestricted online access to peer-reviewed research articles in scholarly journals. There are two main currents in the OA movement:

1. **OA self-archiving:** Authors publish in a subscription journal, but in addition make their articles freely accessible online, usually by depositing them in an institutional or central repository. This can be as postprints or as non-peer-reviewed preprints.
2. **OA publishing:** Authors publish in OA journals that make their articles freely accessible online immediately upon publication.¹⁴

Directory of Open Access Journals

<http://www.doaj.org/>

The DOAJ covers free, full-text, quality-controlled scientific and scholarly journals. Although a limited number of transportation-specific titles are available at this time, there are several in the interdisciplinary areas, such as materials and engineering, that make this a resource worth consulting.

Subscription Databases

There are some subscription databases that transportation librarians consider essential to the provision of the most complete and timely information services to their customers. The following list is not comprehensive, but is representative of databases in use in many of the pooled fund libraries:

American Society of Civil Engineering Online Research Library

<http://www.ascelibrary.org/>

The research library includes ASCE conference proceedings beginning in 1998, and all 30 ASCE journal and periodical volumes published since 1995. Technical and professional interest areas include transportation, materials, structural, engineering mechanics, geotechnical, infrastructure, urban planning, computing in civil engineering and professional issues. The ASCE journal archive goes back to 1993. This full-text database contains more than 24,000 journal and 8,700 proceedings papers.

Compendex

<http://www.ei.org>

Compendex is a comprehensive interdisciplinary literature database for engineers. It is a vital resource for current awareness, new product information and technological forecasting. The database has more than 9 million records from more than 5,000 scholarly journals, trade magazines and conference proceedings.

Dialog

<http://www.dialog.com/products/productline/dialog.shtml>

More than 600 databases are available through Dialog, including comprehensive, global coverage of chemicals, computer science, energy and environment, and mechanical and civil engineering. Dialog can be very cost-effective if searches are run through the alerting service.

Elsevier E-Select

<http://www.ebsco.com/e-select/>

Specifically designed for institutions with small print journal collections, E-Select E-journals provide individual online-title access to more than 1,300 titles searchable on the ScienceDirect platform.

Elsevier SCOPUS

<http://info.scopus.com/overview/what/>

Scopus is the largest abstract and citation database with more than 15,000 peer-reviewed titles from more than 4,000 international publishers, including coverage of OA journals, conference proceedings, trade publications, books, abstracts and references. Scopus also covers 250 million quality Web sources, including 12.7 million patents.

¹⁴ Open Access Overview, Peter Suber. June 19, 2007. <http://www.earlham.edu/~peters/fos/overview.htm>. 3 January 2008.

Engineering Village

<http://www.engineeringvillage2.org/controller/servlet/Controller>

Engineering Village is a Web-based database designed to meet the information needs of the engineering community. It has powerful search tools and an intuitive user interface. Engineering Village provides access to several important engineering databases such as Compendex, NTIS, Inspec and Engineering Index Backfile through one single interface. Useful features include alerts and RSS feeds, links to full text using CrossRef, and links to document delivery services.

IngentaConnect

<http://www.ingentaconnect.com>

IngentaConnect.com is Ingenta's flagship online Web service, providing the most comprehensive collection of academic and professional publications online. It allows users to register and manage online journal subscriptions and receive seamless access, where available, to full-text electronic articles. There are more than 10,000 online titles; and 20,000 fax and Ariel-delivered titles; and more than 20 million articles. Users can link at the title or article level, making the experience seamless within the library Web site or OPAC.

McGraw-Hill Digital Engineering Library

<http://www.digitalengineeringlibrary.com/index.asp>

The McGraw-Hill Engineering Library has more than 185 titles in aerospace engineering, bioengineering, chemical engineering, civil engineering, construction and architectural engineering, electrical engineering, engineering math and science, environmental engineering, industrial engineering, materials science and engineering, and mechanical engineering.

TRANSPORT on Ovid/Silverplatter

<http://www.ovid.com/site/catalog/DataBase/157.jsp?top=2&mid=3&bottom=7&subsection=10>

TRANSPORT consists of two component bibliographic databases produced by the world's leading transportation research organizations: the International Transport Research Documentation and the Transportation Research Information Services database produced by the TRB. Together, the databases feature published research in transportation systems and their components: highways, construction, traffic, transport, road safety, intermodal transport, environmental effects of transport, transport economics, transport policy and social sciences of transportation.

TRISworld

<http://trisworld.trb.org/index.aspx>

TRISworld is a new product for TRB Sponsors that combines the records from TRB's TRIS Database and the English language records from the OECD's ITRD (International Transport Document Database). TRISworld provides access to more than 700,000 records of published transportation research worldwide.

III. Data Management

Libraries are often the first point of contact for internal databases, maps, archives, records management and historical materials. Given the importance of research data in transportation, libraries can position themselves as a key partner with research and IT by bringing key skills like metadata to the data management goals of their agencies. Many librarians are already engaged in data management by helping researchers manage and maintain their data and data sets by describing them and providing centralized access in the library. Working with data managers in transportation agencies is an indispensable collaboration that ensures information and knowledge aren't hidden away.

The Librarian as Data Broker

Internal data management issues have been a nontraditional area for librarians to be involved (as opposed to published information and licensed databases) but their traditional skill sets of reference assistance and information organization can be readily applied.

In the role of data broker, the librarian facilitates access to nontraditional, unpublished forms and sources of information. From a librarian's perspective, this makes perfect sense. In essence, a librarian is performing the traditional duties of organizing and increasing access to information. But it is the type of information that is nontraditional. The formats and types of data are almost as numerous as various topics they cover. The formats can include anything from internal databases (Oracle, DB2, Access); spreadsheets; word processing documents; PDF files; paper records; correspondence; archival photographs; video footage; CADD files; and mainframe screens. The topic areas of the data, for example, range from traffic volume counts, traffic accident records, state patrol pursuits, highway video footage, financial data, economic and other planning data, geographic information systems data, historical legal documents and departmental design manuals.

The librarian can also assist with the organization and storage of these data types along with the data stewards and level of access associated with them. They can reside informally on a local or shared network drive, on the intranet, or other internal file and web servers.

What does this mean for the transportation librarian in the role of data broker or the larger topic of data management?

- **Library/librarian as data power user:** In this role, the library has received an authorized copy or has been authorized to access an internal database (behind a firewall, not on the extranet), and can perform basic searches or execute basic queries for an external customer. The librarian receives basic training or instruction to understand and operate the database at this level, and becomes familiar with the unique vocabulary associated with this database. The ability to answer basic customer questions is a time-saving feature for the data stewards and their staff, and fits in with the librarian's traditional role of reference.
- **Library/librarian as data conduit:** This role draws upon the traditional informational organizational skills of the librarian. Here the librarian as data broker uses the library's tools and resources to be a conduit to the department's internal data warehouse. In this scenario, the data steward wishes to retain complete control of the database but will consent to make contact information made available on a library Web site or portal. This portal ideally would consist of a data catalog or guide, where information about each database is described, contact information given for each, format of information, any subject terms or metadata, as well as level of access.
- **Library/librarian as data steward:** In this scenario, the library/librarian is given, or takes complete control and ownership (and thus maintenance) of, a particular internal database.

Data Catalog

The data catalog concept, as mentioned earlier, combines all of the above databases associated with the above scenarios and compiles them into a Web site/portal. This portal should also list related resources that patrons can access without library assistance (i.e., Internet or extranet sites) to create a more meaningful grouping of resources on an available topic associated with any particular internal database.

- **Metadata function:** Another facet of a data catalog compilation should be the creation of a vocabulary or glossary (or the combination of the data steward's various glossaries). A compilation of these unique data

set/database vocabularies into either a glossary or controlled vocabulary would greatly aid the researcher or customer.

- Access function: In describing all of the different internal databases, a field indicating level of access should be stated. It could be an e-mail to contact the data steward or a direct link to the database itself on an internal server.

A data catalog or compilation/description of internal databases is a good first step toward a full-scale, departmentwide data integration project. These projects are time-consuming and expensive, but a good data catalog could save time and duplication in identifying various databases and any access barriers that exist before embarking on the data integration project.

IV. Space Planning

The pooled fund libraries vary widely in their physical spaces, but all make the most of the space they have. Lack of square footage should not deter librarians from envisioning and creating an efficient library environment. Using compact shelving and eliminating cubicle walls can be very effective in maximizing available space. Each library has individual needs, and there is no one-size-fits-all solution.

Library space planning isn't just preparation for new facilities or relocation. It is an ongoing process of evaluating space needs against availability. Library managers often have to prove their requests for additional space are legitimate and necessary, and frequently have to defend their turf against other departments' encroachment.

Below are guidelines for preparing a space-needs assessment:

- **Collection survey:** Collections should be measured by counting the number of ranges, sections and shelves and then listing them by collection categories represented in the number of shelves per collection (e.g., reference, bound journals, current periodicals, reports, etc.). These measurements should be based on actual space in use, not the capacity of the shelving. A realistic growth factor should be used to project shelving needs for each collection. Collection usage statistics are useful here to make the case for keeping or tossing hard copies. The projected shelving needs should then be converted to a square-footage requirement.¹⁵
- **Measurements:** When working with facilities personnel, it is important to use linear feet to measure shelving as that is the unit of measurement library space planners use. Also, two square footage measurements are needed to determine overall footprint related to library furniture, shelving and equipment: the actual square footage that the item (i.e., shelving unit) occupies in terms of floor space, or the actual footprint; and the square footage the item will need to function properly. For shelving and other library space functional areas, the extra square footage of floor space needed involves accounting for Americans with Disabilities Act requirements at a minimum, along with general comfort of the library user, such as an aisle wide enough for browsing, or for a reading table, enough room for chairs to be pulled out and not in the way of other functions of the library.
- **Staff requirements:** A list that reflects agency workstation standards (e.g., professional staff is assigned to a 6-foot by 6-foot workstation; however this may not be practical or desirable in all libraries) must be created. Some exceptions will exist, such as catalogers who need more space to perform their work, and these should be identified and explained. The number of staff should reflect current head count with room to grow. At least one additional work space should be available for contract or temporary workers.¹⁶
- **Functional areas:** This category includes areas such as technical services, copy machines, microfiche readers, collaboration areas and PC workstations for patron use.¹⁷

The Minnesota DOT Library floor plan is on its Web site: <http://www.dot.state.mn.us/library/libfloorplan.html>.

WSDOT Remodel: Doing More with Less

The Washington State DOT Library at the main headquarters building had been slated for a move to a larger remodeled space as part of a buildingwide facilities upgrade. In 2007 the plan was to add to the approximately 1,150 square feet the library occupied and had outgrown. However, because of organizational realignments, the library was remodeled in the existing space. Because the shelf space for the collection was overcrowded, new acquisitions and historic items were kept on carts and stored in boxes throughout the library space, including in the aisles between stacks. Stacks were not securely anchored and posed a hazard should the area experience an earthquake of any significance, and the space barely complied with ADA minimum clearance guidelines in some places and was noncompliant in others. Safety was also compromised because library staff was constantly shifting books and moving boxes to access needed items from the shelves. Additionally, workstations were located in areas with limited lines of sight to the entrance, and although close to the stacks, in an emergency such as an earthquake, egress could have been severely hampered by shifting or falling stacks and books.

¹⁵ Finnerty, Chuck. *Library Space Planning in the Electronic Era: Are the Stacks Necessary?* *Information Outlook*, 6(8), August 2002, p. 6-13. <http://www.sla.org/content/memberonly/infoonline/2002/aug02/finnerty.cfm>. 6 April 2007.

¹⁶ Ibid.

¹⁷ Ibid.

The WSDOT Library staff faced a challenge to redesign the existing space to accommodate a growing collection, ADA requirements, seismic stability concerns and also aesthetics. They wanted a welcoming, efficient space that combined safety and accessibility with room to grow. The key ingredient to the successful balance of form and function was compact mobile shelving. Working with a local vendor, library staff looked at the existing space as a blank slate and designed a radically new layout that increased shelf space by more than 50 percent on a smaller footprint than the original shelving. Mobile stacks were built on carriages powered by gears that move 1,000 pounds for each pound of force exerted, and the ranges can be “compacted” together and locked, or opened up for aisle space approaching 6 feet. Additionally, existing shelves were reused in the new design, which saved money and allowed for an upgrade to welded frames better suited to withstand seismic events. Borrowing from the Wisconsin iCommons, WSDOT has acquired some additional space near the newly reconfigured library for closed stacks to hold older and fragile items that are infrequently used, but are important parts of the collection.

The WSDOT Library’s new configuration is brighter, more comfortable for visitors and much more efficient in terms of collection access and workstation layout. Shelf space is available for anticipated collection growth for the next five to seven years, and finding items no longer requires moving boxes out of the way. The new space plan proves that with careful planning and design, amazing results can be achieved—a fitting conclusion for a transportation library redesign. To see the before and after shelving layouts of the WSDOT Library floor plan, see Appendix D. Photos of the remodel of the WSDOT Library can be found at: <http://picasaweb.google.com/wsdotlibrary/>.

V. Best Practices

There are best practices for practically every aspect of librarianship. There are policies and procedures that make our work manageable. We will touch upon a few that are common to most of the pooled fund libraries and DOT libraries. Sharing best practices in library networks is one of the greatest benefits of membership because it raises and equalizes standards among member libraries and eliminates the need to reinvent the wheel. Pooled fund member libraries have learned a great deal from one another by sharing best practices, further proof that libraries work better when they work together.

Mission Statement

Special libraries need mission statements to communicate their purpose to the individuals in management who may not be familiar with the library and its services. This is vital for transportation libraries, which have been severely undervalued historically. Compared with other major sectors of the economy, such as agriculture and health—both of which have national libraries and networks—the transportation sector devotes relatively few resources to library and information services.¹⁸ *Special Report 284* points out that “the services offered by librarians are frequently not known, particularly at the DOT leadership level.”¹⁹ A clear mission statement, when supported by effective outreach and high-quality, value-added information services, is one of the ways to protect the library from being considered for downsizing.

Library management continually re-evaluates priorities to meet customers’ needs and managers’ expectations. What are the *actual* goals of the organization and how cost-effective is it to achieve them? The mission statement should communicate a library’s goals concisely, inform others of its purpose and communicate the library’s priorities to staff. An excellent example is this mission statement from the Caltrans library:

Caltrans Library Mission Statement

The California Department of Transportation Library and History Center supports the Department’s staff statewide in working to preserve and improve the state’s transportation infrastructure and shape its future. The Library is dedicated to providing high-quality reference, research and other information services for transportation planning and traffic safety, highway and bridge design and construction, environmental impact research, current and past state transportation policy, state transportation history, professional development and other subjects of interest.

As part of its mission the Library builds and sustains physical and digital library and archival collections and services designed to meet the Department’s current information needs and document its history. To effectively deliver these collections and services, the Library creates and maintains Web-based information systems and databases that are easily accessed by all Department staff.

The Library is committed to developing networks within the Department and the wider transportation community, to ensure that its systems and services are relevant, innovative and accessible.

Budgeting

Most of the pooled fund libraries do not have a budget of their own. Their expenditures are part of their departmental budgets, often the research unit. However, whether or not staff is asked to develop a budget for the library or simply pay as expenses arise until told otherwise, tracking is critical so that expenditures can be justified, if necessary. A simple spreadsheet with a basic sum formula is an easy way to monitor your expenses and have a detailed report at hand.

About 50 percent to 70 percent of a library’s costs are staff salaries and benefits. The next largest expenditure is materials and subscriptions (the collection). A general rule of thumb is to spend at least as much as was spent the year before, if possible. If librarians underspend, they run the risk of losing available budget dollars as senior managers could infer that the library does not need the funding. Again, this is where monitoring comes in very handy.

¹⁸ *Special Report 284*, p. 3.

¹⁹ *Ibid.*

Library Policies

Interlibrary loans, circulation and collection development are some areas where having written policies are beneficial. Written policies help both staff and customers eliminate confusion and keep operations running smoothly. For example, most libraries do not charge for interlibrary loan and document delivery, although some do. Individual libraries must decide whether they will impose fees on borrowers. Interlibrary loan policies are especially useful to transportation libraries that have unique or historical information not suitable for lending. Lending periods and materials that do or do not circulate should be clearly understood. Clear, established and accessible policies will go along way toward eliminating any surprises or misunderstandings. The Iowa DOT Library has clearly stated policies for library services ranging from acquisitions to special collections and makes them available on its Web site: http://www.iowadot.gov/research/lib_services.htm. Some examples from the Iowa DOT Library are given in Appendix E.

Copyright

There is a lot of confusion about copyright, and for good reason—it's very complicated. Many state government libraries believe copyright is not an issue for most of the materials in their collections, as "government information is taxpayer-funded, and as such, is not subject to copyright." While it is true that federal government-produced information is not subject to copyright law, many states do copyright some or all of their documents. The use or reproduction of these documents should be clarified with the producing agency. Transportation libraries also have materials and online resources produced by commercial publishers and are protected by copyright law, as outlined in the U.S. Code. In state DOTs and other nonprofit libraries, the use of copyrighted materials for research is covered by the Fair Use section, Title 17, of the U.S. Code, known as Fair Use (17USC§ 108):

Limitations on exclusive rights: Reproduction by libraries and archives

Notwithstanding the provisions of sections 106 and 106A, the fair use of a copyrighted work, including such use by reproduction in copies or phonorecords or by any other means specified by that section, for purposes such as criticism, comment, news reporting, teaching (including multiple copies for classroom use), scholarship or research, is not an infringement of copyright. In determining whether the use made of a work in any particular case is a fair use, the factors to be considered shall include:

1. the purpose and character of the use, including whether such use is of a commercial nature or is for nonprofit educational purposes;
2. the nature of the copyrighted work;
3. the amount and substantiality of the portion used in relation to the copyrighted work as a whole; and
4. the effect of the use upon the potential market for or value of the copyrighted work.

The fact that a work is unpublished shall not itself bar a finding of fair use if such finding is made upon consideration of all the above factors.²⁰

This explanation includes some outdated terminology, such as "phonorecordings." The copyright laws have been driven by technology for more than two centuries; Title 17 was written prior to the development and use of the digital technology we use to publish, transmit and communicate information today. The Digital Millennium Copyright Act of 1998 addressed areas that older laws would cover as new technology emerges. The entirety of the DMCA potentially affects library operations as it covers everything from transitory communications, system caching, information storage on systems or networks at direction of users, and information location tools. Section 404 of the DMCA amends the exemptions in 108USC for nonprofit libraries to allow digital preservation:

²⁰ United States Code, 2000 ed., supplement 4. <http://www.gpoaccess.gov/uscode/index.html>. 24 October 2007.

Exemption for Nonprofit Libraries and Archives

Section 404 of the DMCA amends the exemption for nonprofit libraries and archives in section 108 of the Copyright Act to accommodate digital technologies and evolving preservation practices. Prior to enactment of the DMCA, section 108 permitted such libraries and archives to make a single facsimile (i.e., not digital) copy of a work for purposes of preservation or interlibrary loan. As amended, section 108 permits up to three copies, which may be digital, provided that digital copies are not made available to the public outside the library premises. In addition, the amended section permits such a library or archive to copy a work into a new format if the original format becomes obsolete—that is, the machine or device used to render the work perceptible is no longer manufactured or is no longer reasonably available in the commercial marketplace.²¹

Section 405 is also of potential interest to libraries as it amends the Digital Performance Right in Sound Recordings Act of 1995 to allow Webcasting, specifically streaming audio. Some new exemptions appeared in 2006, such as Ebooks for the visually impaired and making video clip compilations for specific classroom instruction, and making backup copies of obsolete software.²² Reapplication for these exemptions must occur every three years. Interestingly, in 2006 the Copyright Office passed on allowing an exemption for “space shifting”—moving legally obtained digital material from one device to another, like from a CD to an iPod.

What does all this mean to the library? Libraries must comply with the provisions of the copyright laws that pertain to them and must inform their patrons of the restrictions regarding fair use. Posting the copyright law in its brief form on or above copy machines is the most common practice in libraries. Here is a sample text for making a sign:

Warning concerning copyright restrictions

The copyright law of the United States (Title 17, United States Code) governs the making of photocopies or other reproductions of copyrighted material.

Under certain conditions specified in the law, libraries and archives are authorized to furnish a photocopy or other reproduction. One of these specified conditions is that the photocopy or reproduction is not to be “used for any purpose other than private study, scholarship, or research.” If a user makes a request for, or later uses, a photocopy or reproduction for purposes in excess of “fair use,” that user may be liable for copyright infringement.

This department reserves the right to refuse to accept a copying order if, in its judgment, fulfillment of the order would involve violation of Copyright Law.²³

Selecting an Integrated Library System

During their tenure, some librarians will have the opportunity to instate an integrated library system or migrate from one ILS to another. This is a great opportunity to dramatically improve the operations and work flow of the library. It is also one of the most challenging processes a librarian may encounter. In 2008, Mississippi DOT received approval to migrate from the Microsoft FoxPro database to its first ILS. The department required a request for proposal and together, we followed the steps below. Links and resources have been provided both here and in the bibliography for further research. Preparation is the key; librarians are encouraged to do their homework when choosing a vendor, and then let the vendor guide them through the preparation and transfer of a database as well as the implementation of the new ILS. The pooled fund libraries are using various ILSs. See Appendix F for a list with links to their OPACs.

These steps will help guide libraries in selecting an ILS:

²¹ Digital Millennium Copyright Act of 1998. <http://www.copyright.gov/legislation/dmca.pdf>. 21 October 2007.

²² Rulemaking on Exemptions from Prohibition on Circumvention of Technological Measures that Control Access to Copyrighted Works. November 27, 2006. <http://www.copyright.gov/1201/>. 23 October 2007.

²³ Adapted from UCLA Copyright Policy. <http://www2.library.ucla.edu/copyright/2135.cfm>. 22 October 2007.

1. Do your research. Do a literature search for articles on ILSs and special libraries; put out a call for feedback from users on listservs; search the Web; talk to vendors if you are at a conference. From research, you can formulate the questions you should ask vendors and current users.
2. Create a needs assessment. Decide what features are essential and what are nice extras. Interview library staff such as catalogers, circulation clerks and reference librarians. What do they need in an ILS to perform their jobs effectively? Essential features are likely to be cataloging, circulation and acquisitions modules. RSS feeds, resource linking and federated searching are useful extras if they are available.
3. Make a short list of vendors that offer products that meet your criteria.
4. Call the vendors and ask tough questions about anything you see lacking in the product. Pay particular attention to the libraries the vendors highlight as success stories. How do those institutions compare to yours in terms of need, collection, staff, etc.?
5. Gather system specifications for the products on your short list.
6. If your department requires it, send out a Request for Proposal, which lays out the specific needs the library has for an ILS and invites vendors to submit proposals describing how they would meet your needs. RFPs are frequently part of the bid process in government agencies. Your agency may have a form for writing RFPs; if not, search the Web for sample library ILS RFPs.
7. Visit other libraries that already use the systems on your short list and ask them how they like them. These site visits can be very enlightening. Users will tell you about bugs as well as the good features of the product.
8. Invite vendors to come to your library to demonstrate their products and answer questions.

Remember that while many of the popular systems can meet the needs of a state DOT library, open source is becoming a part of the library software landscape.²⁴ WisDOT has been looking into the open source ILS options. The most widely used are:

- *Evergreen* is an enterprise-class open source ILS that runs on the GNU operating system. It is freely licensed under the GNU General Public License. <http://www.open-ils.org/>
- *Koha*, an enterprise-class ILS that runs on Linux, is also distributed under the GPL. <http://koha.org/>
- The Library Technology Guides blog is a good resource for information about library automation. It has no affiliation with any library automation company. It is also a great source of current developments in library technology. <http://www.librarytechnology.org/>

Collection Development

Collection development is the selection and acquisition of library materials in all formats that will best serve a library's current customer needs. It also involves some forecasting as trends emerge or change. Like a road map, a collection development policy will help you stay on track with your collection development goals. It doesn't need to be overly elaborate or lengthy for smaller collections with well-defined customers.

The mission and priorities of the agency are the most important factors of collection development in transportation libraries. Collection development is a continuous process that requires policy revision from time to time based on changes in customers and their needs. For example, do new graduates use the library differently? What are the research habits of the scientific community served? Is there a new government in place with different priorities? According to a study recently published by the University of Minnesota libraries, "Scientists are generally comfortable with a wide array of technological tools and demand access to online resources—journal articles, reports, conference proceedings, data sets and more. Online resources are now seen as indispensable to effective

²⁴ An Industry Redefined: Private Equity Moves into the ILS, and Open Source Support Emerges, Marshall Breeding. *Library Journal*, April 1, 2007. <http://www.libraryjournal.com/article/CA6429251.html>. 21 October 2007.

research, especially for collaborative research and fieldwork.”²⁵ Regarding students, online resources are also strongly favored, and in some cases, used exclusively.²⁶ New graduates in the interdisciplinary sciences of transportation are bringing this bias to the DOT, and the demand for online research tools is only going to grow. These electronic resources will figure prominently in the library’s collection development. For a sample collection development policy, see Appendix G.

Managing Electronic Resources

Managing electronic resources entails three major considerations (aside from recurrent costs; in this context we are assuming the library is past the point of purchase):

- **Licensing**—The library has not purchased the content of the database or aggregator, only access to it. Even though the vendor or publisher licenses may look daunting and full of legal absolutes, they can often be modified at the librarian’s request. If the terms of the license are confusing or unclear, your agency’s in-house legal office can help. Often the boilerplate license is overly restrictive and can be amended to satisfy the library’s needs. Work with your vendors to define the terms that work for your library. Yale University has created a helpful resource for understanding and negotiating digital content licenses. Liblicense: Licensing Digital Information, <http://www.library.yale.edu/~llicense/index.shtml>, has standard publisher licenses, legal terminology, software links, author licenses, a searchable archive of the LIBLICENCE-L discussion group and other licensing resources.
- **Authentication**—Vendors offer two forms of authentication: identification and password, or IP. Sometimes libraries will have a choice, sometimes not. Some multiuser licenses are very costly and the library can only purchase a single use license, which designates the library as the user and customers must use the online resource in the library. If a sitewide or multiuser license is in effect, libraries can easily obtain the IP range of their network from their IT department. The standard setup is quite simple and the vendor tech support can walk you through it if you have problems.
- **Troubleshooting**—Invariably, as with everything electronic in the library, technical difficulties with the online resources will arise. If other Internet resources are accessible, the problem may be on the vendor’s end. Vendors usually let customers know of downtimes and problems via e-mail. If the library and vendor networks appear fine, passwords may be invalid or IP addresses incorrect. If all else fails, bring in your IT people!

Performance Measures

What to Measure and Why

Performance measurement allows librarians to gather data and draw conclusions about the overall success or impact of library services. Tracking activities of the library will provide data for senior management (CEOs, decision-makers, managers, etc.) to have a clearer picture of the daily functioning of the library, its impact on the agency and the value of library services.

Librarians should approach performance measurement as though they are reporting to people who rarely use the library and don’t understand that it is a vital unit within their agency, as this is frequently the case. To present a clear picture of the library as a busy unit supporting the agency’s mission statement and the professionals whose work they understand, librarians have to keep good statistics of the work they do. That is the quantitative component of the performance measurement task. There is a qualitative component, too, and using customer feedback or “success stories” has a real impact on senior managers. Library services don’t lend themselves to scientific measurements, but we can make assumptions based on solid facts. We use what we know factually and from experience to extrapolate certain conclusions.

The members of MTKN began collecting statistics for performance measurement in 2009. They decided to keep it simple and track the following:

²⁵ *Understanding Research Behaviors, Information Resources, and Service Needs of Scientists and Graduate Students: A Study by the University of Minnesota Libraries*. June 2007. p. 9.
https://conservancy.umn.edu/bitstream/5546/1/Sciences_Assessment_Report_Final.pdf. 19 October 2007.

²⁶ *Understanding Research Behaviors*, p. 22.
https://conservancy.umn.edu/bitstream/5546/1/Sciences_Assessment_Report_Final.pdf. 23 October 2007.

Circulation to include:

- Books
- Magazines and routed magazines
- Electronic journals
- Tables of contents
- Books and magazines read only in the library
- AV/media
- Informal document delivery
- Images document URLs

Reference:

- Short/ready reference—less than 15 minutes
- Detailed—longer than 15 minutes

See Appendix H for the MTKN Performance Measures Matrix.

The facets of performance measurement:

- Quantitative—recording statistics, outputs
- Qualitative—success stories, letters of appreciation, return on investment calculations

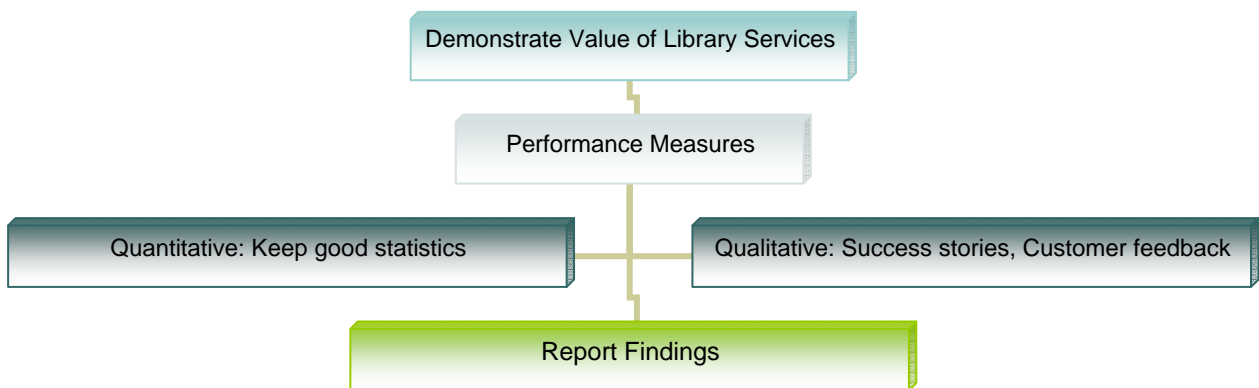

Quantitative Data

Many ILSs will track materials checked out, new items added to the database and interlibrary loan/document delivery activity. Librarians can create reports that are presented clearly, often with charts and graphs from these ILS modules. Many libraries track reference statistics, literature searches and interlibrary loan statistics in Excel, which allows librarians to tabulate and present data in charts and graphs. The MTKN and NTL have been collecting performance measurement and their data collection matrixes can be found in Appendix H.

Qualitative Data

Success Stories

According to our pooled fund librarians, customer testimonials have tremendous impact on senior management, and several librarians save customer testimonials for use in reporting. Here is an example of a high-impact success story:

When the Minnesota Department of Transportation was developing the MnPAVE pavement design software, Senior Engineer John Siekmeier and his colleagues needed specific data about the material properties for each standard classification of soil—such as gravel, sand, loam, and clay. Obtaining all of the data needed would

involve years of laboratory analysis. Siekmeier contacted the Minnesota DOT Library and received a series of reports presenting the results of laboratory tests by the University of Illinois between 1976 and 1989 on 50 Illinois soils.

The material properties were directly applicable to the MnPAVE project. One call saved the agency hundreds of thousands of dollars and sped up the development of the MnPAVE design software by several years.²⁷

Customer Surveys

Several of the pooled fund libraries have conducted surveys of their customers to determine factors such as awareness of library services, satisfaction with services and areas that need improvement. Iowa DOT library has developed a survey using Survey Monkey, a cost-effective Web-based survey tool that is a good example of a library customer survey.

Return on Investment

Qualitative data is also important when demonstrating the return on investment of library services to senior managers. Several studies claim that libraries return at least four to six times the investment.²⁸ Recent Outsell research shows that government libraries topped the time-saved metric with an average of 12.2 hours saved per transaction.²⁹ Government end-users were also in the lead for reliance on their libraries for decision support.³⁰ Jerry Baldwin (Minnesota DOT) has developed an ROI formula that many people have adapted for their own use that demonstrates reduced costs and added-value ratios. (See Appendix I.)

Reporting

Statistics, expenditures, ROI and success stories should all be part of the reports to management. Reporting informs the decision-makers of the role of the library within the organization and allows library staff members to step back and review their progress. A good rule of thumb for reports is to include the mission statement up front, to inform the reader of the library's purpose and follow with statistics and narrative illustrating how the mission was fulfilled and what factors may have interfered with the library's objectives. The report should also include a summary of customer populations (percentage of civil engineering staff, planning, research); which parts of the collection get the most use; most frequently used services; and the results of a customer survey.

²⁷ Making Transportation Libraries and Information Services a Priority. Mark Linsenmayer. *TR News*, Number 261, March-April 2009. <http://onlinepubs.trb.org/onlinepubs/trnews/trnews261.pdf>.

²⁸ International Federation of Library Associations and Institutions, Alexandria Manifesto on the Information Society in Action, October 2006. <http://archive.ifla.org/III/wsis/AlexandriaManifesto.html>.

²⁹ "ROI for Libraries Remains High," Roger Strouse, Outsell Inc. August 29, 2007. <http://www.outsellinc.com/store/insights/3538>. 1 December 2007.

³⁰ Ibid.

VI. Outreach and Marketing

Marketing library services is limited only by the staff's imagination. Our pooled fund members have exchanged some creative ideas to reach out to customers and raise awareness and communicate the value of their libraries to the senior managers in their organizations such as:

- Presentation at new employee orientations
- Creation of folios
- Mobile new materials cart
- Customized takeaways: bookmarks, rulers, notepads and pens
- News clips
- Stories in department newsletter

Know Your Audience

Identifying the library's users is critical to the services, resources and best practices discussed in this guide. The vast majority of transportation libraries are within government agencies. As administrations change, so do priorities. Regardless of administration, most DOT library customers are research managers, senior-level managers, CEOs, elected officials and their staff, agency employees, consultants and the public. Library users in private industry are primarily an internal customer base of staff and consultants, while university transportation center libraries support faculty and student researchers.

Establish a Library Committee

A library advocacy committee is often beneficial. It should include representatives with influence from various divisions within the organization. The library committee can create plans for increasing awareness of the library, its services and its collections. It can assist librarians in developing general and targeted presentations for meetings and events, and make the librarian aware of opportunities within different units to promote library services, including training, reference, literature searches, alerts and synthesis reports. All of these activities are aimed at better serving customers and getting buy-in from management.

The Research and Library Advisory Committee at WisDOT has been focusing on issues such as strategic planning for the library and making sure the activities are aligned with the overall mission, vision and strategic plan of the entire organization. Other RLAC activities include getting buy-in and direction from top management for broad library activities, such as topical research and collection development focus, and targeting user groups to survey. Caltrans, Minnesota DOT and WSDOT also have library committees or library advisory boards.

Develop Library Marketing Collateral

The pooled fund libraries have created a lot of useful and creative internal marketing collateral. Useful objects such as pens, pencils, bookmarks, notepads, rulers and magnifying cards branded with the library logo are popular giveaways. WSDOT develops and maintains a folio collection with important departmental information, and hands out magnifying rulers with the librarians' business cards in the sleeve. The pooled fund has also designed customizable marketing collateral for National Library Week, like this bookmark from NYDOT:



The WisDOT Research and Library unit produced a video to promote the Library and Information Commons Learning Center. The video was produced in-house at a low cost and features interviews with the deputy secretary and practitioners who describe how they use the library to fulfill the WisDOT mission. Librarian John Cherney discusses the services and collections available to WisDOT employees and the public.

Visit the pooled fund Web site to see some of our members' marketing collateral:
<http://www.libraryconnectivity.org/promotionresources.html>.

Brand Yourself

In the library, our services are our products. We need to brand ourselves and our products—the results of literature searches, reports, answers to reference questions—anything we send electronically or put on paper. If you know your way around graphics and desktop publishing programs like Dreamweaver or Adobe Illustrator, you can do this yourself, within departmental guidelines, of course. You can also enlist the help of your graphics and communications colleagues for help. Attach the library logo to your e-mail signature or footer and to everything you produce and send—electronically and in print. The result is a consistent and polished presentation of your work. Here are some of our pooled fund members' logos:



VII. Network, Network, Network

Professional organizations and conferences are vital for those who work in small libraries. Solo librarians often staff transportation libraries. Getting involved with national, state and local consortia or networks can open up a network of colleagues to learn from and exchange ideas with, ensuring that the library's methods and practices do not develop in a vacuum. Library consortia exist on regional, state and local levels. Membership in one or more of these organizations as well as volunteering for a committee offers great benefits for both cost savings and professional networking.

Membership in regional, state and local library networks offers substantial cost savings on subscription resources like OCLC products and services, and a wide array of databases. These networks are also the best place to turn to for training and professional development classes, often for a very reasonable fee. Library consortia may also offer technical support for the products they offer or will liaise with the vendor on a library's behalf. Regular meetings at local consortia often feature speakers or highlight new technologies to keep professionals current.

Find your state library at <http://lists.webjunction.org/libweb/usa-state.html>, and your regional, state and local library consortia at <http://lists.webjunction.org/libweb/usa-consortia.html>.

Professional Organizations and Resources

Special Libraries Association

<http://www.sla.org/>

SLA is an international association representing the interests of thousands of information professionals from more than 80 countries worldwide. Founded in 1909 in New York state, SLA defines special librarians as "information resource experts who collect, analyze, evaluate, package and disseminate information to facilitate accurate decision-making in corporate, academic and government settings." The SLA annual conference is a fantastic place to network and learn about new technologies in the information services field.

SLA Transportation Division

<http://wiki.sla.org/display/SLATRAN/SLA+Transportation+Division>

SLA's Transportation Division is celebrating its 65th birthday in 2008. More than 200 librarians from universities; corporations; and regional, state, provincial and national government organizations make up the Transportation Division. International in scope and interests, the division promotes the exchange of knowledge and information among members interested in the development and use of information resources in transportation in general or in one of its many subdivisions, including air, highway, rail, urban and water transport, and multimodal transportation. The division publishes a quarterly newsletter, maintains a listserv and organizes programs for the SLA annual conference.

SLA Solo Librarians Division

<http://units.sla.org/division/dsol/>

SLA's Solo Librarians Division provides a forum to share ideas, problems and solutions unique to the solo librarian.

NTL

<http://ntl.bts.gov/>

NTL offers many resources and services to transportation libraries and is actively involved in establishing and sustaining regional TKNs. It is the administrator of TLCat and TRIS Online.

Transportation Librarians Roundtable

<http://ntl.bts.gov/networking/roundtable.html>

NTL hosts monthly Web conferences with featured speakers from the transportation library and information community. TLR provides opportunities for transportation librarians to learn more about issues of mutual concern and interest, and to have a new means of regular communication among members of that community.

Eastern Transportation Knowledge Network

<http://www.etkn.org/index.html>

The Eastern Transportation Knowledge Network is a newly forming network that will be open to all interested transportation libraries or organizations interested in transportation information in the Eastern states.

Midwest Transportation Knowledge Network

<http://www.mtkn.org/index.htm>

MTKN was founded in 2001 as a network of state DOT and academic transportation libraries in the Midwest. Sponsored by NTL, the network is a forum to pool resources and share expertise and best practices while serving as a model for a national TKN.

Western Transportation Knowledge Network

<http://wtkn.org/>

The Western Transportation Knowledge Network is currently under development. Membership is open to any transportation library or entity interested in transportation information in the Western states.

Transportation Library Connectivity Pooled Fund Study

<http://www.libraryconnectivity.org/>

The pooled fund is moving into its second phase and welcomes new members. It can assist any transportation library with information about getting started with OCLC subscriptions, regional TKNs, TLCat, best practices, etc.

TRB Library and Information Science for Transportation Committee

<http://trblist.tamu.edu/>

TRB's Library and Information Science for Transportation Committee serves as a forum for transportation librarians and the transportation research community about developments in information science and their applicability to transportation. The committee facilitates diffusion of national library and information science innovations throughout the transportation community by monitoring the use of new resources and tools in the transportation arena, defining critical research and training issues related to their implementation, and promoting the benefits of these capabilities.

AASHTO RAC TKN Task Force

This task force is under the auspices of AASHTO Research Advisory Committee. AASHTO's Standing Committee on Research and RAC realize the importance of providing access to current information which is critical for researchers and practitioners to use in addressing the needs of our agencies. The task force is composed of librarians and research managers, and has been holding monthly teleconferences and meetings at the annual RAC meeting. The first project the task force worked on was the U.S. DOT's Climate Change Clearinghouse by submitting important resources for inclusion in the clearinghouse. You can visit the clearinghouse at <http://climate.dot.gov/>.

VIII. The Transportation Landscape

Learning all of the state and federal departments, offices, agencies, nonprofits and acronyms and how they are related can be daunting to people who are new to the transportation industry. This section is by no means comprehensive, but will give new staff members a good start in acclimating to their new professional environment.

Federal Transportation Agencies and Organizations

The diagram below shows the hierarchical relationship between administrations in U.S. DOT that interact most frequently with transportation librarians. Brief descriptions of some of the primary offices and agencies within U.S. DOT also are listed.

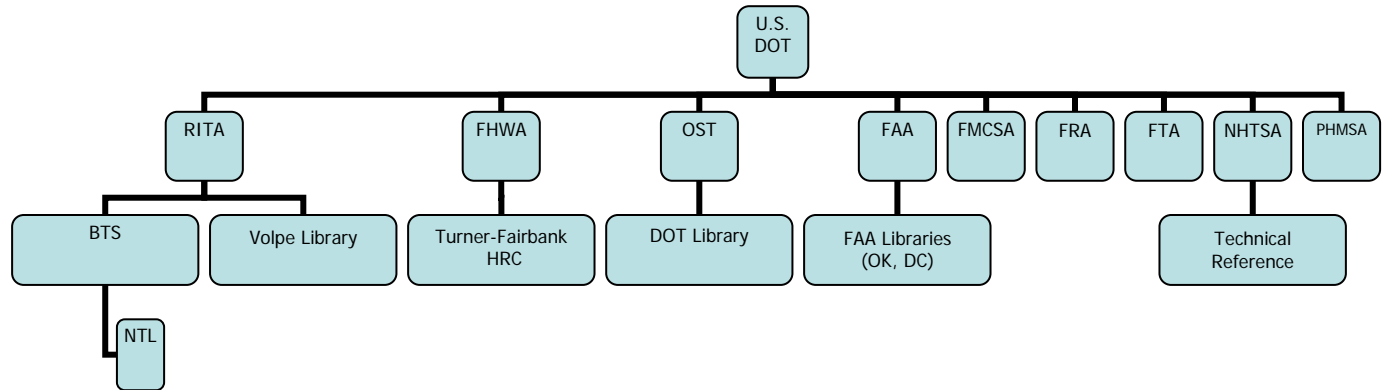

U.S. DOT

<http://www.dot.gov/>

U.S. DOT employs almost 60,000 people in agencies, offices and bureaus across the country. (See <http://www.dot.gov/DOTagencies.htm> for a list of agencies.) Some of these organizations house transportation libraries. Key agencies include:

FAA	Federal Aviation Administration (FAA libraries in Oklahoma and the District of Columbia)
FHWA	Federal Highway Administration (includes the Turner-Fairbank Highway Research Center)
FMCSA	Federal Motor Carrier Safety Administration
FRA	Federal Railroad Administration
FTA	Federal Transit Administration
NHTSA	National Highway Traffic Safety Administration (a Technical Reference Center)
OIG	Office of Inspector General
OST	Office of Secretary of Transportation (where the U.S. DOT library resides)
RITA	Research and Innovative Technology Administration (includes the Volpe National Transportation Systems Center)
STB	Surface Transportation Board

Research and Innovative Technology Administration

http://www.rita.dot.gov/about_rita/

RITA coordinates U.S. DOT's research programs and is charged with "advancing the deployment of cross-cutting technologies" to improve the nation's transportation system. RITA is composed of BTS, Volpe National Transportation Systems Center, Transportation Safety Institute and the Office of Intermodalism.

Bureau of Transportation Statistics

<http://www.bts.gov/about/>

BTS was established as a statistical agency in 1992 to administer data collection, analysis and reporting and to ensure the most cost-effective use of transportation-monitoring resources. BTS is part of RITA and administers the NTL in cooperation with its federal, state and local partners.

National Transportation Library

<http://ntl.bts.gov/>

In 2008 a new NTL was created through a merger with the U.S. DOT Library. Located in the former U.S. DOT Library, it continues to offer the same resources and services, and to be open for use to the general public. The new NTL maintains a substantial presence in both digital and traditional library environments. Its mission continues as a provider of transportation-related information needed by federal, state and local decision-makers, and to increase timely access to the information that supports transportation policy, research, operations and technology transfer activities. NTL was established in 1998 through the Transportation Equity Act for the 21st Century. NTL activities include network leadership; creation and provision of technology and tools for access; electronic document collection for preservation and access; a digital repository; reference and referral services; and the establishment of metadata and document exchange standards.

Federal Highway Administration

<http://www.fhwa.dot.gov/>

FHWA carries out the federal highway programs in partnership with state and local agencies to meet the nation's transportation needs. FHWA adds value to the delivery of the federal highway programs by administering and overseeing these programs to ensure that federal funds are used efficiently. In administering these funds, FHWA applies flexible and innovative financing techniques permissible under the law, such as pooled funds. FHWA advances the state of the art in transportation by working cooperatively with governmental agencies, industry and research community partners to research, develop, test and implement the latest proven technological advancements, including intelligent transportation systems.

Nonprofit Organizations

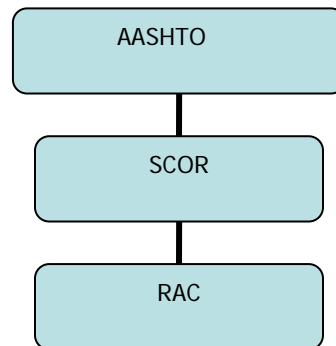

AASHTO

<http://www.transportation.org/>

The American Association of State Highway and Transportation Officials is a nonprofit, nonpartisan association representing highway and transportation departments in the 50 states, the District of Columbia and Puerto Rico. It represents all five transportation modes: air, highways, public transportation, rail and water. AASHTO's primary goal is to foster the development, operation and maintenance of an integrated national transportation system.

SCOR

<http://research.transportation.org/?siteid=55&pageid=853>

The Standing Committee on Research makes reports and recommendations on the National Cooperative Highway Research Program and other activities to the AASHTO board of directors. In its capacity to study and foster transportation research, SCOR is engaged in many activities, including working with AASHTO committees and subcommittees to identify research needs, define research areas and utilize research findings; solicit problem statements from member departments and FHWA; monitor TRB's performance as program manager for NCHRP as well as monitor NCHRP; and coordinate highway and other transportation research.

RAC

<http://research.transportation.org/?siteid=55&pageid=863>

AASHTO created the Research Advisory Committee to facilitate SCOR's work. RAC's functions include participating in establishing the NCHRP and rating problem statements, working with member departments to

facilitate development of research problem statements, maintaining an overview of state-related highway and other federally funded transportation research and providing advice on transportation research matters to SCOR and the AASHTO executive and policy committees.

AASHTO Regions



TRB

<http://www.trb.org/>

TRB is a division of the National Research Council, which serves as an independent adviser to the federal government and others on scientific and technical questions of national importance. TRB conducts its work through its standing committees and task forces addressing all modes and aspects of transportation; publication and dissemination of reports and peer-reviewed technical papers on research findings; management of cooperative research and other research programs; administration of special studies on transportation policy issues at the request of the U.S. Congress and government agencies; operation of an online computerized file of transportation research information; and hosting an annual meeting that typically attracts 10,000 transportation professionals from throughout the United States and abroad.

Directory of Transportation Libraries

<http://ntl.bts.gov/tldir/>

This is the eighth edition of BTS' directory and the first edition on the Web. Entries can be searched or browsed, and libraries outside North America now are included. Entries provide address and contact information, collection size and scope, and links to library Web pages, where available. BTS does not claim to have a complete listing of transportation libraries, but it is a place to start while the NCHRP 20-75 project is under way (described below), which includes a comprehensive directory of transportation libraries and information centers in North America. This new directory is under way with the help of the SLA Transportation Division, regional TKNs and the pooled fund.

Directory of State Highway and Transportation Department Libraries

<http://www.dot.state.mn.us/library/dotlist.html>

This is a list compiled by the Minnesota DOT library of state DOT libraries and contacts, plus the TRB and AASHTO libraries.

TRB Special Report 284

Transportation Knowledge Networks: A Management Strategy for the 21st Century

<http://onlinepubs.trb.org/onlinepubs/sr/sr284.pdf>

Known simply as SR 284, this TRB special report was presented at the TRB annual meeting in January 2006. Concerned about library downsizing and closures as well as increased demand for information services utilizing new technologies, SCOR requested that TRB re-examine how transportation information should be managed and

provided. The TRB study committee developed this report, which provides strategic advice to the federal government and the states on core information services needs along with a sustainable administrative structure and funding mechanism to meet the defined needs.

NCHRP 20-75

Transportation Knowledge Networks: Shaping the Future of Transportation Information Access

<http://www.cts.umn.edu/Research/Featured/NCHRP20-75/>

In response to recommendations of SR 284, Project 20-75 is developing a business plan for TKNs. The formation of TKNs is intended to improve access and information sharing using new institutional arrangements and current technology. The business plan is in development as this toolkit is being published. The research team (Spy Pond Partners and the Center for Transportation Studies) states:

The business plan seeks to be sufficiently compelling to gain champions for TKNs across all modes and functions of the national transportation enterprise—especially policymakers and decision-makers for the information user and information provider communities in the myriad federal, state, local, university, association and private sector stakeholders and service providers—resulting in long-term commitments of legislative, funding and staffing support for TKNs.³¹

An interim report is expected in late 2007. When the project concludes in April 2008, the team will produce a finalized business plan and a comprehensive directory of transportation libraries in all sectors.

Transportation Abbreviations and Acronyms

<http://www.bts.gov/dictionary/index.xml>

Both seasoned transportation librarians and those new to the field often comment on the proliferation of abbreviations and acronyms in transportation. The BTS online Dictionary of Transportation Acronyms includes more than 6,000 terms and acronyms related to transportation.

³¹ *Transportation Knowledge Networks: Shaping the Future of Transportation Information Access*.
<http://www.cts.umn.edu/Research/Featured/NCHRP20-75/>. 27 June 2007.

Looking Ahead: Libraries and Networks

After decades of proposals, studies, position papers and grass-roots efforts, an NTKN is becoming a reality. 2009 saw the first NTKN meeting, growth in the pooled fund and increased networking among regional TKN members. Collaboration between the pooled fund, TKNs, NTL and the AASHTO RAC TKN Task Force has delivered projects that benefit the whole community. We are building the infrastructure for a vibrant national network of transportation information service providers. So, what's next?

To keep this momentum going, we must continue our outreach efforts to managers, market our services to engineers and push for access to Web 2.0 tools. We need to continue our commitment to the volunteer efforts that have propelled TKNs this far. When the pooled fund grew out of MTKN in 2005, the map of the United States had only one TKN. There are now three vibrant and growing networks that cover the country. The expanded role of NTL and its merger with the U.S. DOT Library has created a thriving organization that stands ready to link the three regional networks together under one umbrella while preserving their regional focus.

This momentum is driven by viability within our organizations. Librarians have always been ahead of the curve with technology, and transportation librarians—particularly in DOTs—need to be the leaders once again to bring new, collaborative social networking tools to the field of transportation.

The Transportation Library Connectivity pooled fund study members will continue to operate on the principle that we work better together, and we will work to bring more tools, products and ideas to the table for the benefit of the entire transportation community.

Appendices

Please note that sample policies and tools are intended to help librarians design and formulate tools and policies that serve their own library's and management's needs. Although some of the details may not fit individual library situations, we hope that these samples will help to get librarians started or enhance their current efforts.

Appendix A

TLCat Libraries

Appendix B

Online Computer Library Center Regional Service Providers

Appendix C

Sample Core Journal Collection (Minnesota DOT Library)

Appendix D

Shelving Layouts, WSDOT Library Remodel (Before and After)

Appendix E

Sample Library Policies (Iowa DOT Library)

Appendix F

Pooled Fund Libraries' ILS, OPAC and Web Sites

Appendix G

Sample Collection Development Policy (Minnesota DOT Library)

Appendix H

Statistical Tracking Tools (National TKN Resource Sharing Project, MTKN)

Appendix I

Return on Investment Formula (Jerry Baldwin, Minnesota DOT Library)

Appendix A—TLCat Libraries

TLCat is a subset of Online Computer Library Center's WorldCat union catalog. It is a group catalog of transportation libraries' holdings. Currently, there are 36 libraries participating by adding their holdings to TLCat.

Members as of July 2009

Institution	OCLC Symbol
Alaska DOT	AKDOT
California DOT*	CDT
Connecticut DOT*	RHT
Geophysical Institute of International Arctic Res	GIKBM
Illinois DOT	IZA
Iowa DOT*	UIG
Kansas DOT*	KSDOT
Los Angeles County Metropolitan Transit Auth.*	CRD
Massachusetts DOT	TLB
Michigan DOT*	EEV
Minnesota DOT*	MDT
Missouri DOT*	MODOT
Montana DOT*	DMY
National Transportation Library NTL*	NATTR
Nebraska Department of Roads	NC6
New Jersey DOT Library	TJQ
New York DOT*	NY2
Northwestern University Transportation Library	JCR
Ohio DOT*	OHDOT
Oregon DOT*	OTT
PACCAR, Inc. Library	PCR
Pennsylvania DOT*	P3T
South Dakota DOT	SDDOT
Transportation Research Board TRB*	TPO
University of California, Berkeley ITS HED Library	CBT
University of Michigan, Transportation Research Institute	U2T
U.S. DOT FHWA Technical Reference Center	FHATR
U.S. DOT Library	TRL
U.S. DOT, Volpe Transportation Systems Center	TRS
U.S. FAA Aeronautical Center	OUR
U.S. FAA CAMI	OUT
U.S. FAA Tech Center	FAA
U.S. Merchant Marine Academy	VYM
Virginia DOT/VTRC	TDG
Washington State DOT*	WDT
Wisconsin DOT*	WOY

*Pooled fund libraries and partners.

Appendix B—Online Computer Library Center Regional Service Providers

Name	Region	Web Site	Contact
Amigos Library Services	AZ, AR, NM, OK, TX	www.amigos.org	1-800-843-8482
BCR (Bibliographic Center for Research)	CO, IA, KS, NV, UT, WY	www.bcr.org	1-800-397-1552
INCOLSA	IN	www.incolsa.net	1-800-733-1899
ILLNET	IL	www.cyberdriveillinois.com/departments/library/who_we_are/OCLC/home.html	1-800-665-5576
MINITEX Library Information Network	MN, ND, SD	www.minitex.umn.edu	1-800-462-5348
MLC (Michigan Library Consortium)	MI	www.mlcnet.org	1-800-530-9019
MLNC (Missouri Library Network Corporation)	MO	www.mlnc.org	1-800-969-6562
NELINET	CT, ME, MA, NH, RI, VT	www.nelinet.net	1-800-NELINET
Nylink	NY	www.nylink.org	1-800-342-3353
OCLC (formerly Eastern and Western)	AK, CA, DC, HI, ID, MD, MT, OR, VA, WA	http://www.oclc.org/us/en/about/default.htm	
OHIONET	OH, WV, Western PA	www.ohionet.org	1-800-686-8975
Lyrasis	AL, DE, FL, GA, KY, LA, MD, MS, NJ, NC, PA, SC, TN, VA, Caribbean	www.lyrasis.org	1-800-999-8558
WiLS	WI	www.wils.wisc.edu/	1-608-263-5051
FEDLINK	U.S. Federal Libraries	www.loc.gov/flicc/	1-202-707-4800

For an interactive map with regional service provider contacts and training links, visit OCLC's Web site at <http://www.oclc.org/contacts/regional/us.htm>.

Appendix C—Sample Core Journal Collection (Minnesota DOT Library)

AASHTO Journal. Weekly Transportation Report
Access: Research at the University of California Transportation Center
ACI Materials Journal
ACI Structural Journal
ACRP Report (Airport Cooperative Research Program)
ACSM Bulletin
Advanced Imaging
Appraisal Journal
APWA Reporter
ASCE International Journal of Geomechanics
ASCE Journal of Bridge Engineering
ASCE Journal of Composites for Construction
ASCE Journal of Computing in Civil Engineering
ASCE Journal of Construction Engineering and Management
ASCE Journal of Engineering Mechanics
ASCE Journal of Environmental Engineering
ASCE Journal of Geotechnical & Geoenvironmental Engineering
ASCE Journal of Hydraulic Engineering
ASCE Journal of Hydrologic Engineering
ASCE Journal of Infrastructure Systems
ASCE Journal of Irrigation and Drainage Engineering
ASCE Journal of Management in Engineering
ASCE Journal of Materials in Civil Engineering
ASCE Journal of Performance of Constructed Facilities
ASCE Journal of Professional Issues in Engineering Education & Practice
ASCE Journal of Structural Engineering
ASCE Journal of Surveying Engineering
ASCE Journal of Transportation Engineering
ASCE Journal of Urban Planning and Development
ASCE Leadership and Management in Engineering
ASCE Natural Hazards Review
ASCE Practice Periodical on Hazardous, Toxic and Radioactive Waste Management
ASCE Practice Periodical on Structural Design & Construction
ASCE Water Resources Planning and Management Journal
ASCE Waterway, Port, Coastal, and Ocean Engineering Journal
Asphalt
Aviation Week and Space Technology
Better Roads
Bicycling
Bridge Design and Engineering
Bus Transit Systems Newsletter
Civil Engineering
Commercial Carrier Journal
Computers
Concrete Construction
Concrete International
Concrete Pavement Progress
Concrete Pipe News

Corrosion
ENR
Environment
Environmental Science and Technology
Federal Register
General Aviation News
Geo World
Geomatica
Geosynthetics
Governing
Government and Regulation
Government Executive
GPS World
Ground Engineering
Growth and Change
Heavy Duty Trucking
Highway and Vehicle Safety Report
Highway Builder
Highway Focus
Highways and Highway Engineering
HMAT Hot Mix Asphalt Technology
HPC Bridge Views
IATSS Research: International Association of Traffic and Safety Science
Ignition: News From TRB's IDEA Programs
In Transit
Innovation Briefs
Inside ITS
Intercity Rail Passenger Systems Update
Intersection Decision Support E-News
ITE Journal
ITS International
Journal for Quality and Participation
Journal of Advanced Transportation
Journal of Protective Coatings & Linings
Journal of Public Transportation
Journal of the Air & Waste Management Association
Journal of the American Planning Association
Journal of the Transportation Research Forum
Journal of Transportation and Statistics
Journal of Transportation Law, Logistics and Policy
Land and Water
Land Management/Appraisal
Landscape Architecture
LRT News
Mass Transit
Materials Performance
Metro
Modern Steel Construction
NCHRP IDEA Annual Progress Report (PDF)
NCHRP Legal Research Digest
NCHRP Progress Report

NCHRP Quarterly Progress Reports
NCHRP Report
NCHRP Research Results Digest
NCHRP Summary of Progress
NCHRP Synthesis of Highway Practice
Newsline: Current Research in Public Transportation
Nordic Road & Transport Research
Passenger Transport
Pipeline and Gas Journal
Pipelines
Planning
Planning Magazine: Journal of the American Planning Association
Policy Studies Journal
Politics and Policy
Pollution Engineering Online
Professional Safety
Progressive Railroading
Public Administration Review
Public Manager
Public Roads
Public Works
Public Works Management and Policy
Quality Management
Quality Progress
Railway Age
Railway Gazette International
Railway Track and Structures
Railways
Research and Technology Transporter
Review of Policy Research
Right of Way
Roads and Bridges
Routes/Roads
Safety
Signs of the Times
Status Report: Insurance Institute for Highway Safety
Stone, Sand & Gravel Review
Surveying and Land Information Science
Surveying and Photogrammetry
TCRP Annual Report of Progress
TCRP Legal Research Digest
TCRP Report
TCRP Research Results Digest
TCRP Synthesis
Texas Transportation Researcher
Thinking Highways
Traffic Engineering
Traffic Engineering and Control
Traffic Safety
Traffic Technology International
Traffic World: The Logistics News Weekly

TranScan
Transit
Transport Topics
Transportation
Transportation Journal
Transportation Management + Engineering
Transportation Research Board Special Report
Transportation Research Circular
Transportation Research News
Transportation Research Record
Transportation Research: Part A-Policy and Practice
Transportation Research: Part B-Methodological
Transportation Research: Part C-Emerging Technologies
Transportation Research: Part D-Transport and Environment
Transportation Research: Part E-Logistics and Transportation Review
Transportation Research: Part F-Traffic Psychology and Behavior
Transportation Science
Trenchless Technology
Trend Letter
TRL News
TRL Research Alert
Trucks and Trucking
Tunneling
Tunnels and Tunneling International
UMTRI Research Review: University of Michigan Transportation Research Institute
Urban Transport News
Urban Transportation Monitor
Waterways Journal
Work Boat
World Highways

Appendix D—Shelving Layouts, WSDOT Library Remodel (Before and After)

TRA-1107-A

Existing shelving configuration

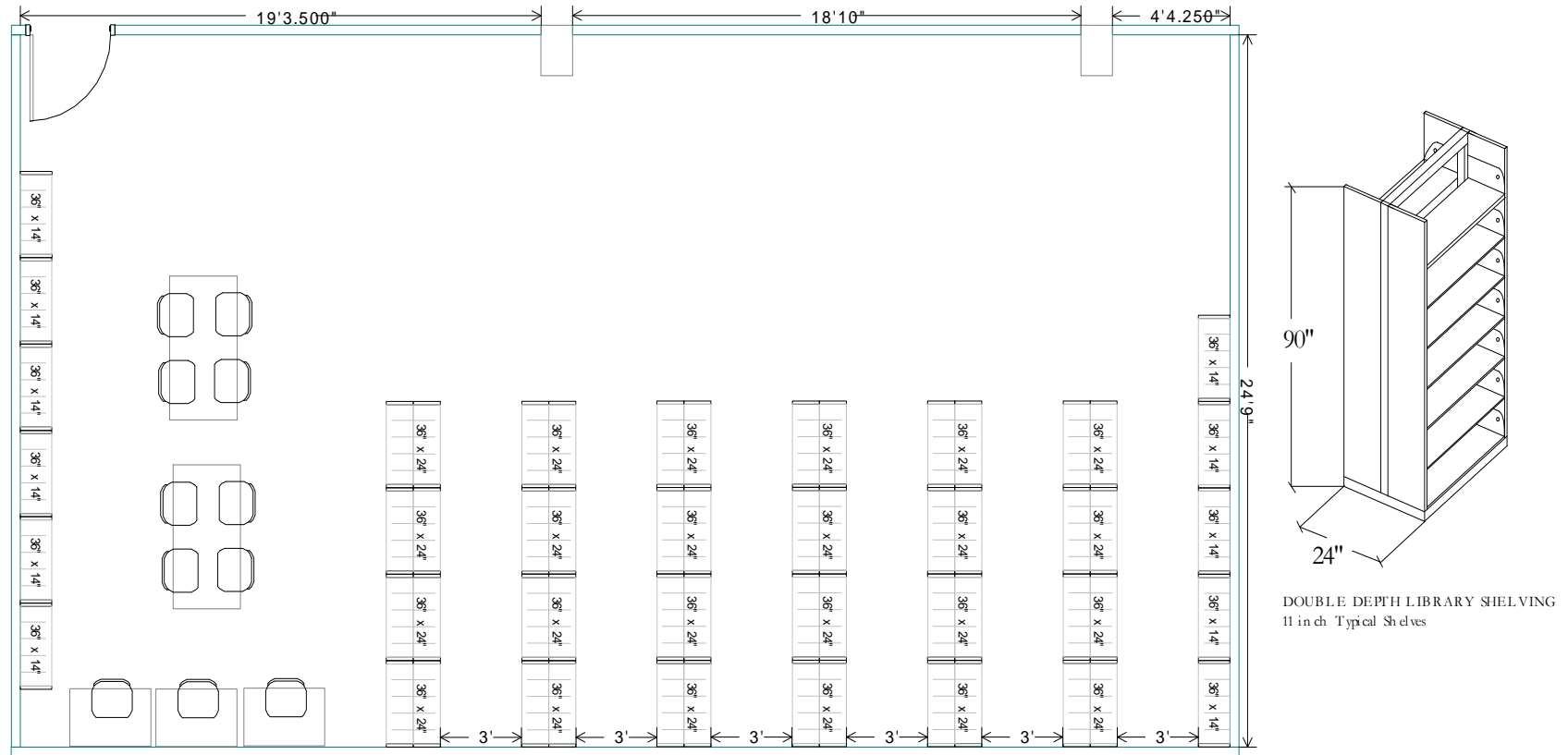

Correctional Industries
 Department of Corrections
 PO Box 41115
 Olympia, WA 98504-1115
 Customer Service 1.800.628.4738

Department of Transportation
 WSDOT Library
 Michele Brady
 Melanie Worf

all designs represented by this drawing are confidential and should not be disclosed without written permission from correctional industries

Appendix D—Shelving Layouts, WSDOT Library Remodel (Before and After)

TRA-1107-B

NEW Mobile shelving configuration

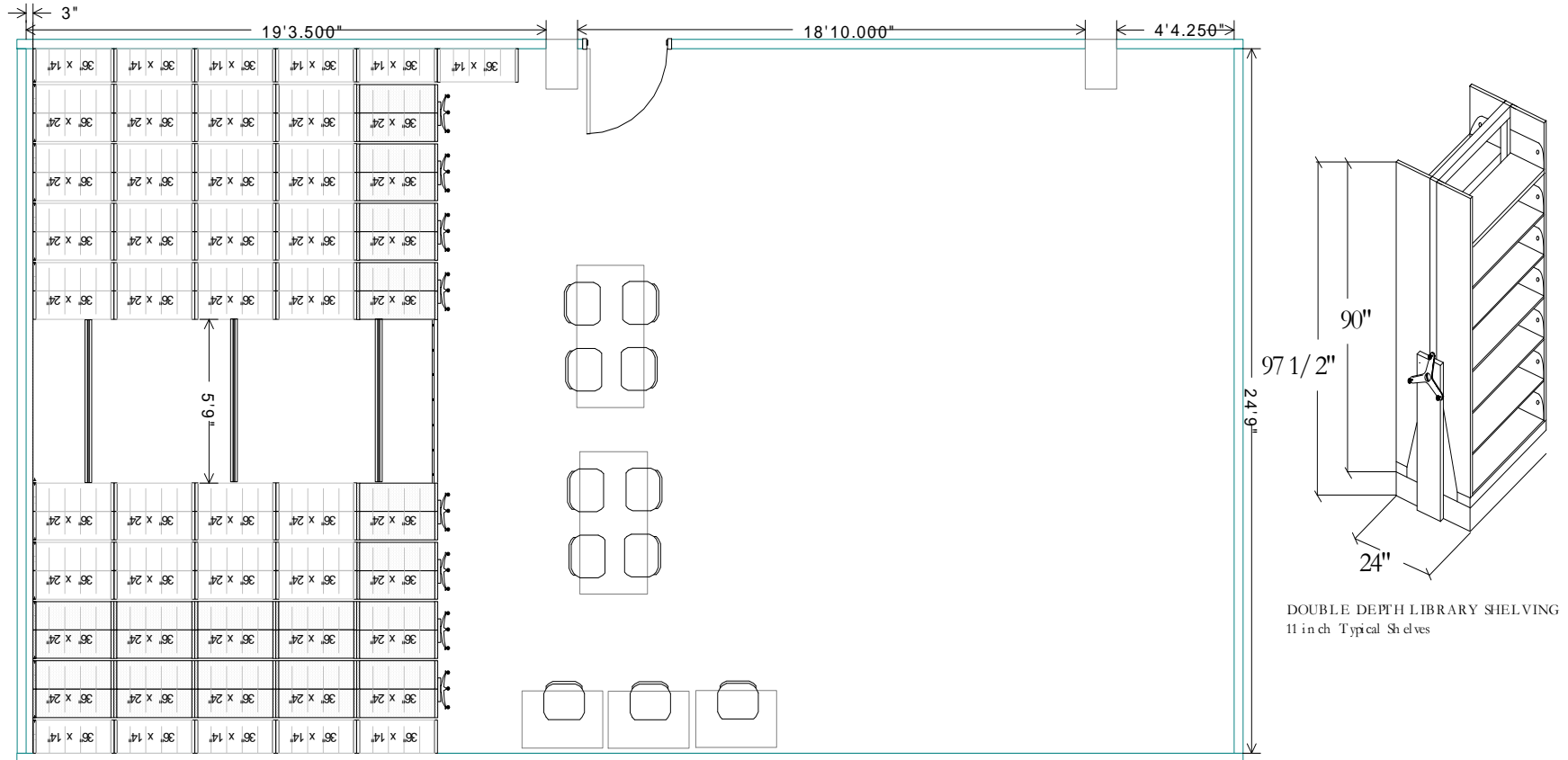

- = Existing shelving with new seismic welded frames
- = New shelving with seismic welded frames

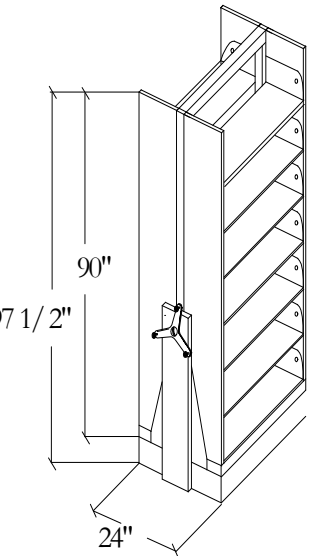

DOUBLE DEPTH LIBRARY SHELVING
11 inch Typical Shelves



Correctional Industries
 Department of Corrections
 PO Box 41115
 Olympia, WA 98504-1115
 Customer Service 1.800.628.4738

Department of Transportation
 WSDOT Library
 Michele Brady
 Melanie Worf

all designs represented by this drawing are confidential and should not be disclosed without written permission from correctional industries

Appendix E—Sample Library Policies (Iowa DOT Library)

Ordering Books for DOT Staff

All purchases of books, manuals, subscriptions, prerecorded audio, videotapes or CDs, and related items from outside sources must be verified and approved by the library. The requester shall complete Form 130501, Publication Request, attach order information to the form, and submit the form and attachments to the library. The library will return the approved form to the requestor for processing, will forward the approved form to Purchasing for processing, or the library will order the publication.

Because of a state book contract, the library can purchase most mass-market books and paperbacks at discounts of up to 45 percent. Please consult the librarian in regard to the selection and purchase of these items.

Gifts

The library reserves the right to accept or discard any donated materials as it sees fit. It will not photocopy materials unless there is copyright clearance.

Discards

The library considers discarding books when their information becomes obsolete, when it is replaced by a newer edition, when room size restrictions require a smaller collection, or when the items are not used or they are damaged beyond repair.

Catalog

The library's holdings will be classified and cataloged using the Library of Congress and Swank classification schemes. This database will be accessed through DOTNET and the Internet.

Circulation

Iowa DOT and state government employees, faculty, staff and students at Iowa universities and colleges, city and county transportation officials, and the public may borrow circulating items from the library.

The standard loan period is one month. The borrower may renew items providing no one else has requested them.

Clientele

The Iowa DOT Library is open to the public; however, some services are restricted.

The standard loan period is one month. The borrower may renew items providing no one else has requested them.

Interlibrary Loan

The library will attempt to borrow material from other libraries for Iowa DOT staff and CTRE personnel through the interlibrary loan service. Fees for services above \$10 will be discussed with the patron. Clients requesting an interlibrary loan must provide complete and accurate bibliographic information about the items they want to borrow.

Literature Searches

Literature searches may be requested by employees of Iowa DOT, state of Iowa or local governments. Call the DOT Library. Before requesting a search, consider the following issues:

- The main topic of my literature search is ...
- Key words to search for are ...
- Limit the search by date published
- Search these media (you may check more than one): books, articles, videos, CDs, conference proceedings, training materials
- The date this search is needed by is ...

Reference Services

The library responds to transportation-related reference questions from anyone; questions from Iowa DOT staff receive the highest priority. Iowa DOT staff may ask for information on any job-related topic. The library works with the requestor to determine the best way to deliver the answer: telephone calls; in-person visits to the library; fax; e-mail; interagency mail; or U.S. Postal Service.

Appendix F—Pooled Fund Libraries’ ILS, OPAC and Web Sites

(Pooled fund members’ Integrated Library System vendors and products; TLCat membership status and OCLC symbols; library Web sites and Web 2.0 sites; and Online Public Access Catalog URLs)

Arizona DOT/Arizona Transportation Research Center

ILS/Catalog: InMagic DB Textworks

TLCat: No

OCLC Symbol: AZF

Library Web site: <http://www.azdot.gov/TPD/ATRC/library/index.asp>

OPAC: <http://www.azdot.gov/dbtw-wpd/cat020411.asp>

California DOT

ILS/Catalog: SydneyPlus for MS-SQL (intranet only)

TLCat: Yes

OCLC Symbol: CDT

Connecticut DOT

ILS/Catalog:

TLCat: Yes

OCLC Symbol: RHT

OPAC: <http://conndot.worldcat.org>

Idaho Transportation Department

ILS/Catalog: N/A

TLCat: Yes

OCLC Symbol: IDITD

Iowa DOT

ILS/Catalog: SirsiDynix Horizon

TLCat: Yes

OCLC Symbol: UIG

Library Web site: http://www.iowadot.gov/research/lib_home.htm

OPAC:

<http://iowa.ipac.dynixasp.com/?session=KU21277753116.89422&profile=statelib&logout=true&startover=true#focus>

Kansas DOT

ILS/Catalog: No ILS at this time

TLCat: Yes

OCLC Symbol: KSDOT

KDOT Research Reports Catalog: <http://www.ksdot.org/burmatres/kdotlib2.asp>

Los Angeles County Metropolitan Transportation Authority

ILS/Catalog: CyberTools for Libraries

TLCat: Yes

OCLC Symbol: CRD

Library Web site: http://www.metro.net/about_us/library/library.htm

OPAC: <http://maple.cybertoolsforlibraries.com/cgi-bin/CyberHTML?MTADHO>

Twitter: <http://twitter.com/metrolosangeles>

Blog: Los Angeles Transportation Headlines, <http://losangelestransportation.blogspot.com/>

MySpace: <http://www.myspace.com/mtalibrary>

YouTube: <http://www.youtube.com/profile?user=metrolibrarian>

Flickr: <http://www.flickr.com/photos/metrolibraryarchive/>

Scribd: <http://www.scribd.com/metrolibraryandarchive>

Louisiana DOT

ILS/Catalog: LibraryThing (temporary)
OCLC Symbol: LADOT
Library Web site: <http://www.ltrc.lsu.edu/library.html>
OPAC: <http://www.librarything.com/catalog/LTRCTTEC>
Blog: <http://ltrc-tteclibrary.blogspot.com/>
Flickr: <http://www.flickr.com/photos/ltrc-tteclibrary/>
Chat with the Library (meebo): <http://www.ltrc.lsu.edu/library.html>

Michigan DOT

ILS/Catalog (Vendor/Product): Cuadra STAR
TLCat: Yes
OCLC Symbol: EEV
Library Web site: http://www.michigan.gov/mdot/0,1607,7-151-9623_10724_48681-195709--,00.html

Minnesota DOT

ILS/Catalog: Ex Libris ALEPH 500
OCLC Symbol: MDT
Library Web site: <http://www.dot.state.mn.us/library/>
OPAC: <http://mdt.mnpals.net>

Mississippi DOT

ILS/Catalog: EOS.Web Express
TLCat: No
OCLC Symbol: N/A

Missouri DOT

ILS/Catalog: Innovative Interfaces, Inc./WebPAC PRO
TLCat: Yes
OCLC Symbol: MODOT
OPAC: <http://arthur.missouri.edu/search~S7>

Montana DOT

ILS/Catalog: SirsiDynix Unicorn
TLCat: Yes
OCLC Symbol: DMY
Library Web site: <http://www.mdt.mt.gov/research/unique/services.shtml>
OPAC: <http://mtscprod.msl.mt.gov/uhtbin/cgiisirs/HLsTCOuRRW/MT-DOT/149200379/60/1180/X>

New York State DOT

ILS/Catalog:
TLCat: Yes
OCLC Symbol: NY2

Ohio DOT

ILS/Catalog: Innovative Interfaces Inc. Millenium
TLCat: Yes
OCLC Symbol: OHDOT
Library Web site: <http://www.dot.state.oh.us/Divisions/TransSysDev/Library/Pages/default.aspx>
OPAC: <http://slonet.state.oh.us/>

Oregon DOT

ILS/Catalog: EOS.Web Express
OCLC Symbol: OTT
TLCat: Yes
Library Web site: <http://69.63.217.28/O10019Staff/OPA/index.asp#CATALOG>
OPAC: <http://www.oregon.gov/ODOT/CS/BSS/library.shtml>

Pennsylvania DOT

ILS/Catalog:

TLCat: Yes

OCLC Symbol: P3T

Library Web site: <http://www.dot.state.pa.us/Internet/Bureaus/pdPlanRes.nsf/InfoLibrary>

Tennessee DOT

ILS/Catalog: SydneyPlus for Oracle

TLCat: Yes

OCLC Symbol: TNTDT

Washington State DOT

ILS/Catalog: Innovative Interfaces, Inc. Millenium

OCLC Symbol: WDT

Library Web site: <http://www.wsdot.wa.gov/Library/>

OPAC: <http://www.secstate.wa.gov/library/catalog.aspx>

Wisconsin DOT

ILS/Catalog: InMagic DB Textworks (intranet), Autographics Agent (Internet)

TLCat: Yes

OCLC Symbol: WOY

Library Web site: <http://www.dot.wisconsin.gov/library/>

OPAC: <http://www.wiscat.net/agent/SearchPages.asp?myses=5413369&w=A&cuid=stwi&cusrvr=damia&s=LD>

University of Minnesota Center for Transportation Studies

ILS/Catalog:

TLCat: Yes

OCLC Symbol: MNU

Library Web site: <http://www.cts.umn.edu/LibraryServices/>

OPAC: <http://mdt.mnpals.net>

University of Wisconsin-Madison Midwest Regional University Transportation Center

ILS/Catalog: This research center does not have a catalog.

TLCat: Yes

OCLC Symbol: WIRUT

Center Web site: <http://www.mrutc.org/>

Appendix G—Sample Collection Development Policy (Minnesota DOT Library)

Minnesota DOT Library Collection Development Policy April 2006

Background

Minnesota DOT Library had a materials and services budget of approximately \$90,000 for FY05. The largest portion of this, \$63,000, was spent on periodical subscriptions, with the remainder spent on other formats. The library currently includes collections of information resources in the following formats:

Books and “hard copy” reports	18,000 titles (28,000 volumes)
Reports on microfiche	35,000 titles
Periodicals	350 active titles (700 total)
Audio tapes	300 cassettes
Video tapes	1,000 titles
CD-ROM and DVD	300 titles
Vertical File	18 linear feet (newspaper clippings, pamphlets, brochures, and articles on various subjects of current interest to the department)

Since one of the roles of the library is to provide Minnesota DOT staff access to a broad range of information needed to monitor developments and trends potentially affecting the department, acquisition or retention of any particular item does not constitute an endorsement of any concepts or opinions advanced by or expressed in the publication.

Items for inclusion in library collections are selected from resources acquired through purchase, received via controlled distribution lists (i.e., TRB, AASHTO, FHWA publications, etc.), and donations to the library. Because of the changing needs of the department and the rapidity with which many kinds of information resources become outdated, the library discards almost as many items as it acquires. Each year, over 1,000 books and reports and more than 100 linear feet of periodicals are removed from the collections.

As the largest expenditure and the basis for our routing system, periodicals receive particularly close monitoring in acquisition decisions. Titles are continuously added and dropped from our subscription lists as new issues and periodicals emerge, and others are no longer of interest. During the last four years, we have added approximately 50 titles, and dropped approximately 35 from our subscription lists.

Decisions regarding the acquisition and retention of specific materials are made by the library staff in response to, or in anticipation of, explicit and/or implicit needs of Minnesota DOT staff. Materials are acquired and discarded with an eye towards developing a strong, up-to-date collection of reference and research materials in the field of transportation and other subjects of current interest to the department. At the discretion of the library director, the library also retains resources which provide retrospective information on the activities of the department, the U. S. Department of Transportation, the American Association of State Highway and Transportation Officials, the Transportation Research Board, and other organizations.

The library does not act as a purchasing agent for the department. However, at the discretion of library staff, and within budget constraints, single purchases of a particular item costing no more than twenty dollars may be made for the convenience of the person or office requesting the item. Purchase of other materials for the exclusive use of an individual or unit within the department will be handled by the office requiring the resource. At the discretion of the library director, and within budget constraints, materials for the use of several units within the department may be purchased and retained by the library.

In order to reduce the department's overall costs for subscriptions to serial and periodical publications, the library maintains and operates a periodical routing service. Publications for the routing service are selected and retained in the same manner as other materials covered by this policy. Users of the routing service are periodically surveyed to ensure that materials routed remain consistent with their changing information needs. Within budget constraints, the library purchases sufficient copies of a subscription to ensure that no more than ten individuals are on the routing list for a single copy of any subscription. Subscriptions to publications no longer in demand on the routing service may be cancelled at the discretion of the library director.

See attached library policy statement for further details.

**Minnesota DOT Library
Collection Development Plan
July 2001**

Policy Statement

The library will develop a collection of print, audio/visual, and electronic information resources in order to provide state employees and the general public with convenient and efficient access to transportation-related information. In addition, resources will be collected to support current activities in other fields of interest to the department.

The collection is intended to serve primarily the reference and research needs of the department's engineering, management, planning, and other professional personnel.

Primary consideration for additions to the collection will be given to resources in the following areas:

- Transportation engineering
- Transportation planning
- Transportation management
- Transportation research
- Transportation construction
- Transportation safety
- Minnesota DOT publications
- TRB publications
- AASHTO publications

Secondary areas for consideration include:

- Civil engineering
- Materials engineering
- Surveying and mapping
- Regional, city, and land use planning
- Public administration

Resources in the following areas, along with others of interest to the department, will also be considered for addition to the collection in support of current department activities:

- Business and finance
- Management
- Human resources
- Computers and data processing
- Training
- Office administration
- Communications
- Laws and regulations

Selection Criteria

In selecting any given resource for inclusion in the collections of the library, the following criteria will be considered:

- Explicit or implicit need for access to the information by department personnel
- Cost
- Relationship of the item to the existing collections
- Availability of similar information within other state agency collections
- Availability of the resource by loan from other collections

Retention Guidelines

Minnesota DOT publications	Permanent retention
TRB publications	Permanent retention
AASHTO publications	Permanent retention
U.S. Government depository publications	Retention will be in accordance with depository regulations
Periodicals	Retention will vary by title from one month to permanent in accordance with department needs and provisions of U.S. Copyright Law and American Library Association interlibrary loan guidelines
All other materials	Retention will be reviewed periodically using the same criteria as for selection of resources for inclusion in the collections

Appendix H—Statistical Tracking Tools

National TKN Resource Sharing Network Project Statistics Log

NTKN Resource Sharing Project Statistics Log	
Library Name or OCLC Symbol:	
Month:	
Borrowing	monthly tally
Total Number Requested (all libraries):	
Total Number Received (all libraries):	
Number Requested from TKN Libraries:	
Number Received from TKN Libraries:	
Lending	monthly tally
Total Number Lent (all libraries):	
Number Lent by TKN:	
ETKN:	
MTKN:	
WTKN:	
Number Lent To TKNs by Method:	
Mail:	
Unfilled Requests (all libraries):	
Total Unfilled (all libraries):	
Unfilled Requests by Reason (all libraries):	
at bindery:	
checked-out:	
not on shelf/missing:	
non-circulating:	
poor condition:	
not owned/withdrawn:	
not found as cited:	
volume/issue not yet available:	
other:	

MTKN Performance Measures Matrix

MTKN Libraries	ILL--In	ILL--Out	Copy Cataloging	Original Cataloging	Circulation	Reference
Iowa DOT Library						
Hanson Engineering						
Illinois DOT Library						
Kansas DOT Library						
Michigan DOT Library						
Minnesota DOT Library						
Missouri DOT Library						
Northwestern University Library						
PCA Library						
University of Michigan						
Wisconsin DOT Library						
Wiss, Janney						

Appendix I—Return on Investment Formula (Jerry Baldwin, Minnesota DOT Library)

The following is adapted from “Mn/DOT Library Accomplishments” by Jerry Baldwin (see http://www.dot.state.mn.us/library/mndot_library_benefits.html).

In FY01 Minnesota DOT Library services provided an estimated total of \$8,386,500 in reduced costs and added value for a benefits-to-cost ratio of 12:1.

Minnesota DOT Library Reduced Costs

- 4,500 information resources were provided in response to specific requests for an estimated savings of \$191,250. NOTE: Library networks were used to borrow about 500 of these resources for use by Minnesota DOT employees from 175 other organizations in 45 states and 3 foreign countries.
- 3,600 requests for information on specific topics were responded to for an estimated savings of \$468,000.
- Reduction in duplicate subscriptions provided by the library’s centralized magazine subscription and routing service saved an estimated \$180,000.

Minnesota DOT Library Added Value

- Minnesota DOT employees’ reading of the 4,500 requested information resources provided by the library provided an estimated value of \$5,100,000.
- Minnesota DOT employees’ reading of the 40,000 information resources provided through the library’s routing services provided an estimated value of \$2,400,000.
- Viewing and use of Minnesota DOT Library’s Web pages provided an estimated value of \$47,250.

Estimates of Annual Minnesota DOT Cost Savings and Cost Avoidance Attributable to Minnesota DOT Library Services

Reference Services (Savings of Customer’s Time)

	600	In-depth reference questions handled each year
Times	16	Estimate of hours of customer’s time saved per
	question	
Times	<u>\$30.00</u>	Estimate of hourly value of customer’s time
Savings	\$288,000.00	
	3,000	Quick reference questions handled each year
Times	2	Estimate of hours of customer’s time saved per
	question	
Times	<u>\$30.00</u>	Estimate of hourly value of customer’s time
Savings	\$180,000.00	

Document Delivery (Savings of Customer’s Time and Avoidance of Purchase Costs)

	1,500	Articles downloaded or photocopied
Plus	1,000	Interlibrary loans
Plus	2,000	Publications checked out from collections
Times	1	Estimate of hours of customer’s time saved per article
Times	<u>\$30.00</u>	Estimate of hourly value of customer’s time
Savings	\$135,000.00	

	1,500	Articles downloaded or photocopied
Plus	1,000	Interlibrary loans
Plus	2,000	Publications checked out from collections
Times	\$50.00	Estimate of costs per item of acquiring through other channels if library did not exist (price + purchase order processing, payment, etc.)
Times	0.25	Estimate of percent of materials that would be acquired if not available from the library
Savings	\$56,250.00	

Routing Service (Avoidance of Purchase Costs)

	400	Periodicals subscriptions
Times	\$150.00	Average cost per subscription through other channels if library did not exist (price + purchase order processing, payment, etc.)
Times	3	Average multiple subscriptions if sharing through routing service did not exist
Savings	\$180,000.00	

Total Savings and Avoided Costs \$839,250.00

NOTE: These are measures of only the time and dollars saved in acquiring information. They do not measure the actual value of the information itself or the benefits derived from application of the information acquired.

Estimate of Annual Added Value Attributable to Minnesota DOT Library Services

	1,500	Articles downloaded or photocopied
Plus	1,000	Interlibrary loans
Plus	2,000	Publications checked out from collections
Plus	4,000	Publications from collections used in the library
Times	0.75	Percent of items that would not be read if library did not exist
Times	\$600.00	Average value per reading (Griffith & King, 1993)*
Value Added	\$5,100,000.00	
	40,000	Resources distributed through routing service
Times	0.1	Estimate of number of routed items that add value
Times	\$600.00	Average value per reading (Griffith & King, 1993)*
Value Added	\$2,400,000.00	
	27,000	Annual visitors to Minnesota DOT Library websites
Times	3.5	Average minutes spent viewing pages per visitor
Divided by	60	Minutes per hour
Times	\$30.00	Estimate of hourly value of customer's time
Value Added	\$47,250.00	

* Professionals report substantial savings as a result of reading; average savings are nearly \$600 per reading of journals, books and internal reports. These savings, relative to the cost of acquiring and using information, yield a return-on-investment ratio of about 10.2 to 1. (*Special Libraries: Increasing the Information Edge*, Jose-Marie Griffiths and Donald W. King, 1993.)

Benefits and Return on Investment

	\$839,250.00	Savings and Avoided Costs
Plus	\$7,547,250.00	Value Added
Divided by	<u>\$700,000.00</u>	Library Costs (salaries, supplies, equipment, space)
Benefits to Cost Ratio	12:1	

	\$839,250.00	Savings and Avoided Costs
Plus	\$7,547,250.00	Value Added
Total Benefits	\$8,386,500.00	
Minus	<u>\$700,000.00</u>	Library Costs (salaries, supplies, equipment, space)
Annual ROI	\$7,686,500.00	

Note: This analysis does not include additional benefits derived from the library. No value estimates can be readily calculated for many potential measures. These include the value of creating metadata describing Minnesota DOT publications. This metadata is added to WorldCat, which makes information created by Minnesota DOT more accessible to transportation practitioners around the world. Also, it is difficult to estimate the “goodwill” value created by the loan of information resources to at least 179 organizations in 46 states, five Canadian provinces and five other countries in FY01 alone.

Numbers Used in the ROI Analysis**Citable Source**

Average value per reading: *Special Libraries: Increasing the Information Edge*, Jose-Marie Griffiths and Donald W. King, 1993.

Minnesota DOT Library Customer Surveys

Estimate of hours of customer’s time saved

Minnesota DOT Library Statistics

Reference questions handled
 Articles downloaded or photocopied
 Interlibrary loans
 Publications checked out from collections
 Periodicals subscriptions
 Resources distributed through routing service
 Annual visitors to Minnesota DOT Library Web sites
 Average minutes spent viewing pages per visitor

Professional Judgment or Informed Estimates

Estimate of hourly value of customer’s time
 Estimate of percent of materials that would be acquired if not available from the library
 Average multiple subscriptions if sharing through routing service did not exist
 Percent of items that would not be read if library did not exist
 Estimate of number of routed items that add value
 Publications from collections used in the library

Professional Knowledge and Experience

Estimate of costs per item of acquiring through other channels if library did not exist (price plus cost of purchase order processing and payment)
 Average cost per subscription through other channels if library did not exist (price plus cost of purchase order processing and payment)³²

³² Jerry Baldwin, excerpted from ROI documents presented at First Annual Pooled Fund Meeting, October 2005.

Bibliography

Association of Research Libraries. *ARL Statistics 2004-2005: A Compilation of Statistics from the One Hundred and Twenty-Three Members of the Association of Research Libraries*. Washington, D.C.: ARL, 2006. <http://www.arl.org/bm~doc/arlstat05.pdf>.

Baldwin, Jerome C. *Return on Investment at Mn/DOT Library*. Excerpted from ROI documents presented at First Annual Pooled Fund Meeting, October 2005. http://www.dot.state.mn.us/library/mndot_library_benefits.html.

British Library. *Measuring Our Value: Results of an Independent Economic Impact Study Commissioned by the British Library to Measure the Direct and Indirect Value to the UK Economy*. British Library, 2003. <http://www.bl.uk/pdf/measuring.pdf>.

Buckland, Michael. *Library Services in Theory and Context*, 2nd ed. 1999. <http://sunsite.berkeley.edu/Literature/Library/Services/>.

Bureau of Transportation Statistics Web site: <http://www.bts.gov/>.

Ciracella, Jill. *You and Me and Google Makes Three: Welcoming Google into the Reference Interview Library Philosophy and Practice*, 2007. <http://libr.unl.edu:2000/LPP/lpp2007.htm>.

Clark, John R. The Internet Connection: Open Source Library Software—Ready for Prime Time? *Behavioral & Social Sciences Librarian*, 1544-4546, Volume 27, Issue 3, 2008.

Committee for a Future Strategy for Transportation Information Management, Transportation Research Board of the National Academies. *Transportation Knowledge Networks: A Management Strategy for the 21st Century*. Washington, D.C.: TRB, 2006. www.trb.org/publications/sr/sr284.pdf.

Eastern Transportation Knowledge Network Web site: <http://www.etkn.org/index.html>.

Evans, Rita. Libraries in a Digital Age: An Essential Resource for Research and Information. *TR News*, Number 261, March-April 2009.

Farcas, Meredith G. *Social Software in Libraries: Building Collaboration, Communication and Community Online*. Medford, N.J.: Information Today, 2007.

Finnerty, Chuck. *Library Space Planning in the Electronic Era: Are the Stacks Necessary?* *Information Outlook*, 6(8), August 2002. <http://www.sla.org/content/memberonly/infoonline/2002/aug02/finnerty.cfm>.

GAO Enlists New Technologies to Report its Findings. Press Release, July 7, 2009. http://www.gao.gov/press/gao_enlists_new_technologies2009jul07.pdf.

Gold, Anna. Cyberinfrastructure, Data, and Libraries, Part 2. Libraries and the Data Challenge: Roles and Actions for Libraries. *D-Lib Magazine*, September/October 2007, Volume 13 Number 9/10 <http://www.dlib.org/dlib/september07/gold/09gold-pt2.html>.

Interlibrary Loan Code for the United States. American Library Association, 2001. <http://www.ala.org/Template.cfm?Section=Home&template=/ContentManagement/ContentDisplay.cfm&ContentID=31579>.

International Federation of Library Associations and Institutions. *Alexandria Manifesto on Libraries*, the Information Society in Action, IFLA Headquarters, The Hague, Netherlands, 2006. <http://www.ifla.org/III/wsis/AlexandriaManifesto.html>.

International Federation of Library Associations and Institutions. *Recommendations and Best Practices for Libraries of Government Departments: Guidelines for Library Development*. IFLA, Draft, August 2007.

Library Success: A Best Practices Wiki: http://www.libsuccess.org/index.php?title=Main_Page.

Linsenmayer, Mark and Patrick Casey. Making Transportation Libraries and Information Services a Priority. *TR News*, Number 261, March-April 2009.

McClure, Marji. Web 2.0 Security: Getting Collaborative Peace of Mind. *EContent*, November 2008.

Midwest Transportation Knowledge Network Web site: <http://www.mtkn.org>.

Miller, Ellen. *Federal Agencies and Web 2.0*. The Sunlight Foundation. 3 February 2009. <http://blog.sunlightfoundation.com/2009/02/03/federal-agencies-and-web-20/>

National TKN Resource Sharing Project: http://ntl.bts.gov/networking/TKN_ILL_Guidelines.html.

Research Data—Libraries of the Future (JISC): <http://www.jisc.ac.uk/whatwedo/campaigns/librariesofthefuture/research.aspx>.

Rogers, Lisa J., Simon Hodson and Roddy MacLeod. *Transforming Current Awareness Through RSS: How Two Projects (ticTOCs and Gold Dust) are Using RSS to Improve the Information Landscape for the 21st Century Researcher*. 2009. In European Library Automation Group Conference (ELAG 09), University Library in Bratislava, 22-24 April 2009. [Conference Proceedings]. <http://eprints.rclis.org/16060/>.

Strouse, Roger. "ROI for Libraries Remains High." <http://www.outsellinc.com/store/insights/3538>.

Suber, Peter. Open Access Overview, June 19, 2007. <http://www.earlham.edu/~peters/fos/overview.htm>.

Transportation Information Resource Management: Articles and Reports: <http://www.dot.state.mn.us/library/access.html>.

UCLA Copyright Policy: <http://www2.library.ucla.edu/copyright/2135.cfm>.

Understanding Research Behaviors, Information Resources, and Service Needs of Scientists and Graduate Students: A Study by the University of Minnesota Libraries, June 2007. http://conservancy.umn.edu/bitstream/5546/1/Sciences_Assessment_Report_Final.pdf.

Van Boheemen, Peter. Using TicToc RSS feed collection. http://internal.ulib.sk/indico/elag/prezentacie/van_boheemenl.pdf.

Western Transportation Knowledge Network Web site: <http://wtkn.org/>.

Winter, Ken, Shirley Morin and Barbara Post. The Momentum of Transportation Information: A History of TRB's Transportation Research Information Services. *TR News*, Number 261, March-April 2009.

Wisconsin Department of Transportation
Research & Library Unit
4802 Sheboygan Avenue, Room 104
P.O. Box 7915
Madison, WI 53707

www.libraryconnectivity.org