

- LEGEND**
- = BUS/TRAM DEDICATED LANE
 - = BUS/TRAM MIXED FLOW
 - = S/W NARROWING OR WIDENING
 - = EXISTING STOP
 - = PROP./UPGRADED STATION
 - = REMOVED STOP

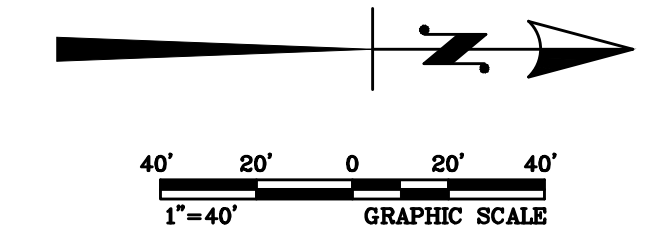

REV	DATE	BY	APP	REG. NO.	EXPIRES	SEAL HOLDER	DESCRIPTION

DESIGNED BY	
DRAWN BY	
CHECKED BY	
IN CHARGE	
DATE	

Metro LOS ANGELES COUNTY METROPOLITAN TRANSPORTATION AUTHORITY

EAST SAN FERNANDO VALLEY TRANSIT CORRIDOR
 BUS RAPID TRANSIT ALTERNATIVE
 MEDIAN RUNNING
 VENTURA BLVD TO MAGNOLIA BLVD

CONTRACT NO.	PS-4370-2622
DRAWING NO.	ALT2-1
SCALE	1"=40'
SHEET NO.	

MATCHLINE - SEE ABOVE RIGHT

MATCHLINE - SEE BELOW LEFT

MATCHLINE - SEE ABOVE RIGHT

MATCHLINE - SEE SHEET ALT2-1

MATCHLINE - SEE BELOW LEFT

MATCHLINE - SEE SHEET ALT2-1

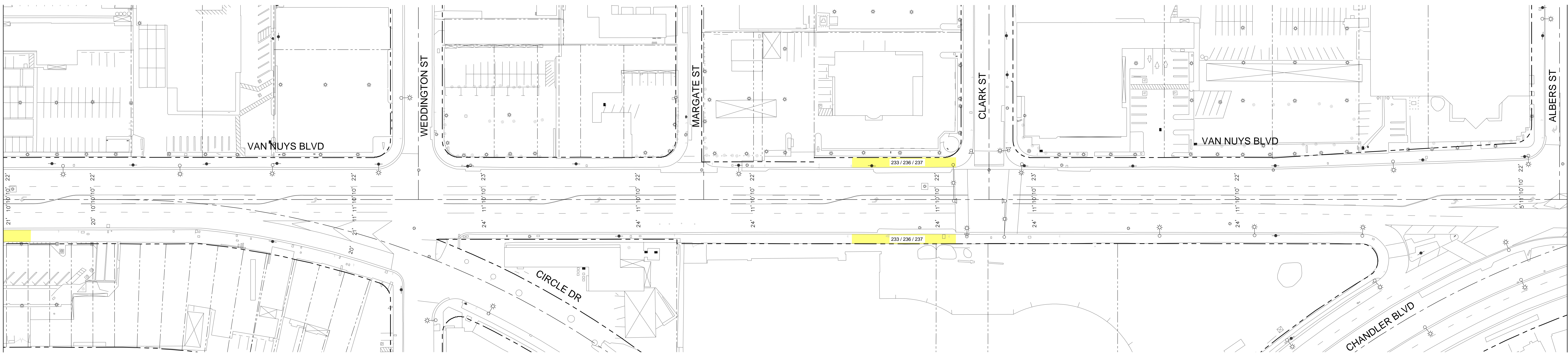

MATCHLINE - SEE BELOW LEFT

MATCHLINE - SEE ABOVE RIGHT

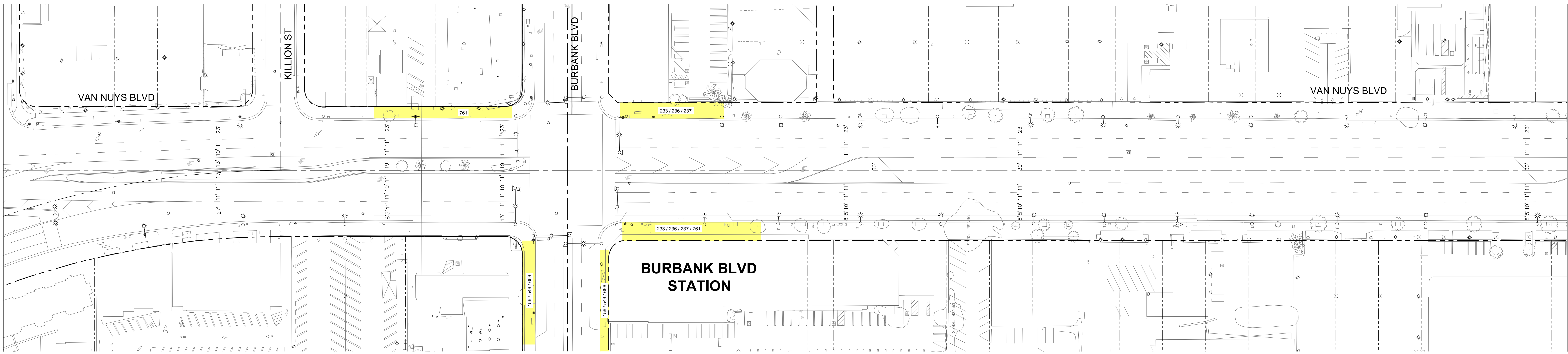

MATCHLINE - SEE BELOW LEFT

MATCHLINE - SEE ABOVE RIGHT

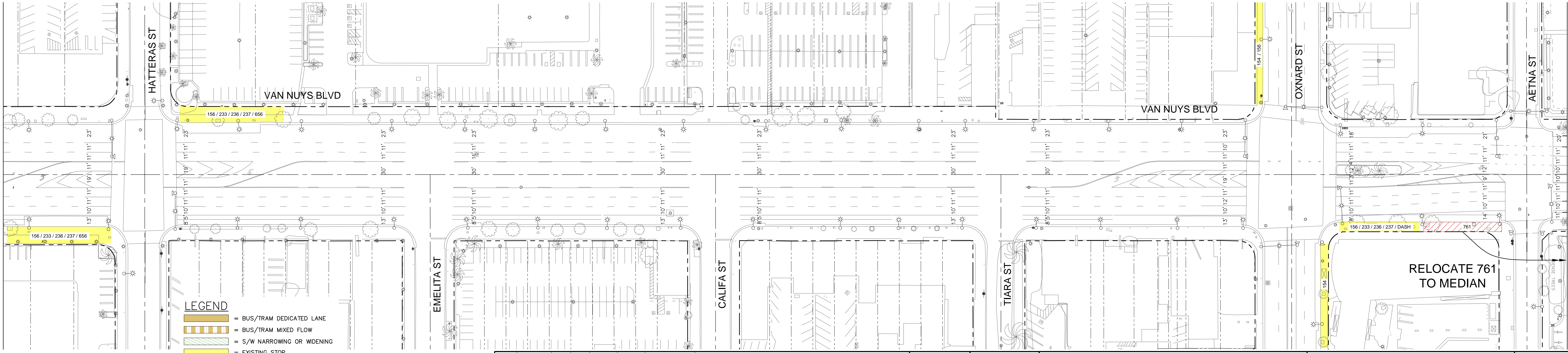

MATCHLINE - SEE SHEET ALT2-3

- LEGEND**
- = BUS/TRAM DEDICATED LANE
 - = BUS/TRAM MIXED FLOW
 - = S/W NARROWING OR WIDENING
 - = EXISTING STOP
 - = PROP./UPGRADED STATION
 - = REMOVED STOP

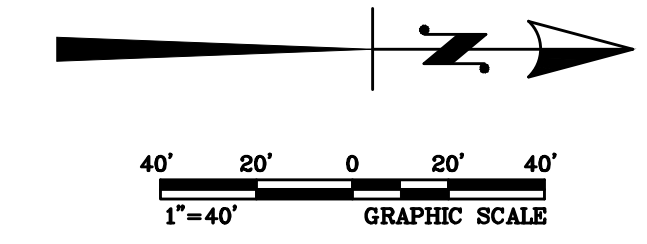

REV	DATE	BY	APP	REG. NO.	EXPIRES	SEAL HOLDER	DESCRIPTION

DESIGNED BY	
DRAWN BY	
CHECKED BY	
IN CHARGE	
DATE	

Metro LOS ANGELES COUNTY METROPOLITAN TRANSPORTATION AUTHORITY

EAST SAN FERNANDO VALLEY TRANSIT CORRIDOR
 BUS RAPID TRANSIT ALTERNATIVE
 MEDIAN RUNNING
 MAGNOLIA BLVD TO AETNA ST

CONTRACT NO.	PS-4370-2622
DRAWING NO.	ALT2-2
SCALE	1"=40'
SHEET NO.	

Last Revised: Thu Aug 04, 2016 - 4:53pm. User: Rishad, Thu Aug 04, 2016 - 4:53pm. Printed By: vrodgers. Drawings: A:\2010\B0105 Metro Van Nuys Corridor Response\Exhibit\036 Concept Exp\Meridian Exhibit\A2 - Exhibiting

MATCHLINE - SEE SHEET ALT2-2

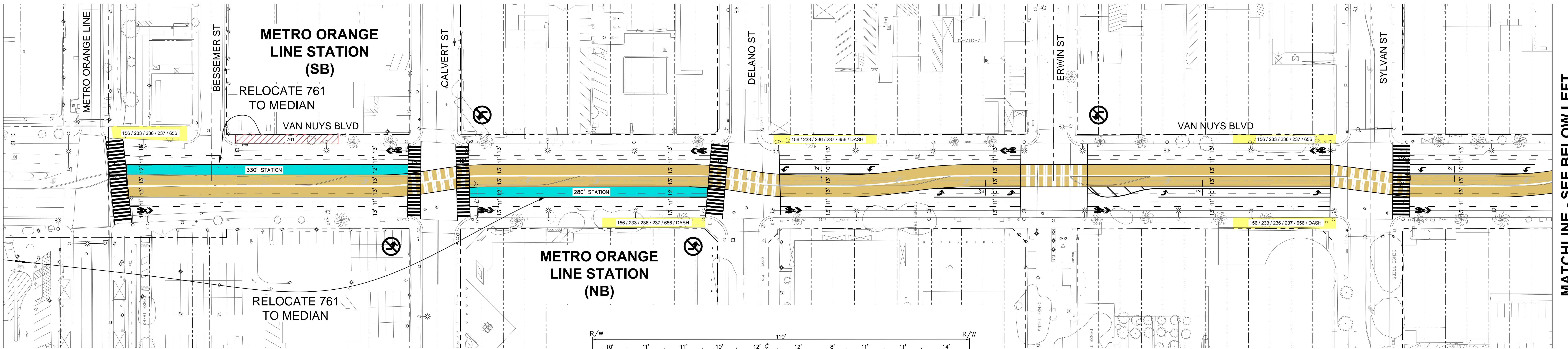

MATCHLINE - SEE BELOW LEFT

MATCHLINE - SEE ABOVE RIGHT

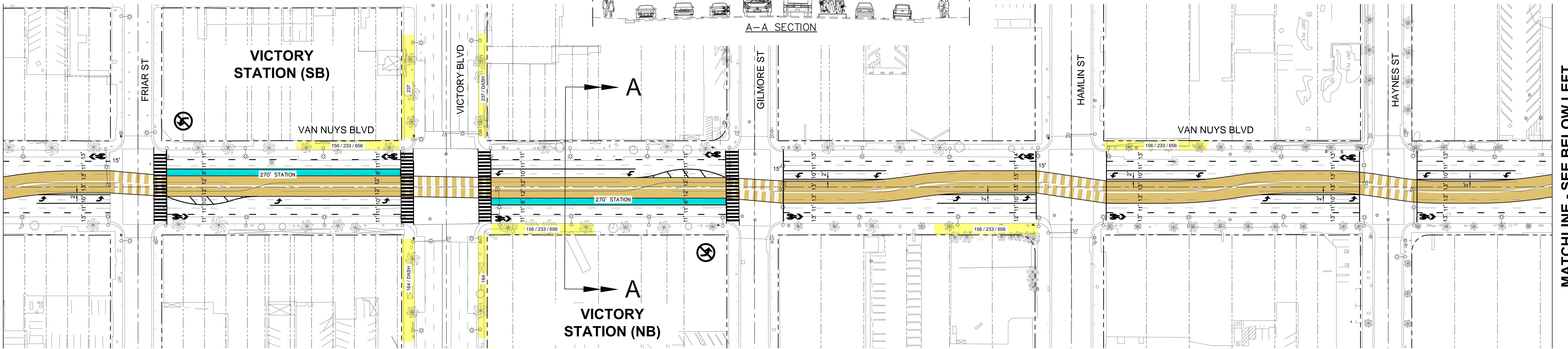

MATCHLINE - SEE BELOW LEFT

MATCHLINE - SEE ABOVE RIGHT

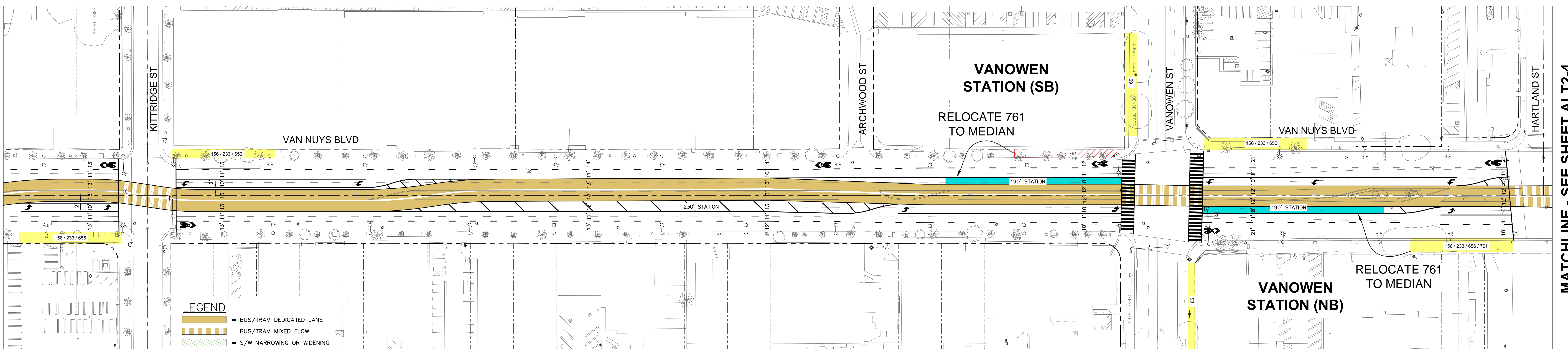

MATCHLINE - SEE SHEET ALT2-4

- LEGEND**
- = BUS/TRAM DEDICATED LANE
 - = BUS/TRAM MIXED FLOW
 - = S/W NARROWING OR WIDENING
 - = EXISTING STOP
 - = PROP./UPGRADED STATION
 - = REMOVED STOP

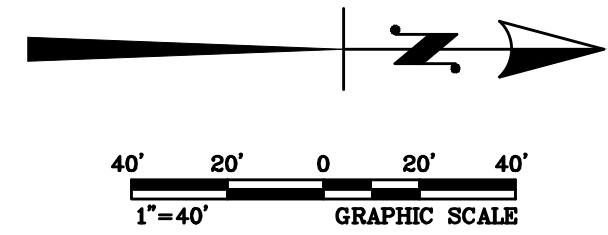

REV	DATE	BY	APP	REG. NO.	EXPIRES	SEAL HOLDER	DESCRIPTION

DESIGNED BY	
DRAWN BY	
CHECKED BY	
IN CHARGE	
DATE	

Metro LOS ANGELES COUNTY METROPOLITAN TRANSPORTATION AUTHORITY

EAST SAN FERNANDO VALLEY TRANSIT CORRIDOR
 BUS RAPID TRANSIT ALTERNATIVE
 MEDIAN RUNNING
 AETNA ST TO HARTLAND ST

CONTRACT NO.	PS-4370-2622
DRAWING NO.	ALT2-3
SCALE	1"=40'
SHEET NO.	

Last Revised: Thu Aug 04, 2016 - 4:53pm. User: Rbaker. Thu Aug 04, 2016 - 4:53pm. Printed by: vrodgers. Drawings: 3/20/10/08/10/05 Metro Van Nuys Corridor Response/Alt2/3/03 Concept Exp/Med/Station/Alt2 - 2 - E:\bldg

MATCHLINE - SEE SHEET ALT2-3

MATCHLINE - SEE ABOVE RIGHT

MATCHLINE - SEE ABOVE RIGHT

MATCHLINE - SEE BELOW LEFT

MATCHLINE - SEE BELOW LEFT

MATCHLINE - SEE SHEET ALT2-5

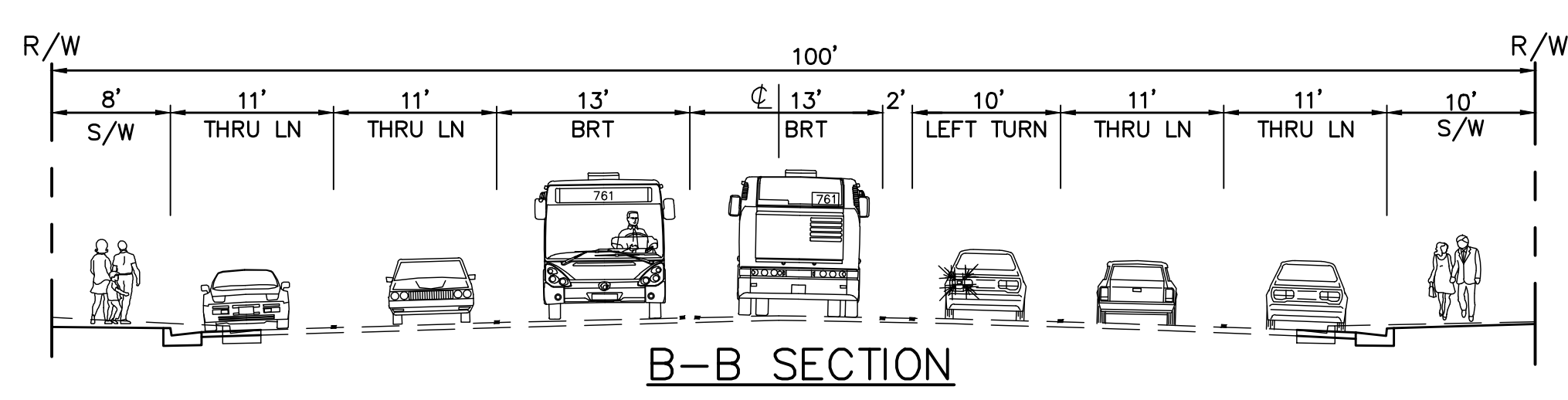
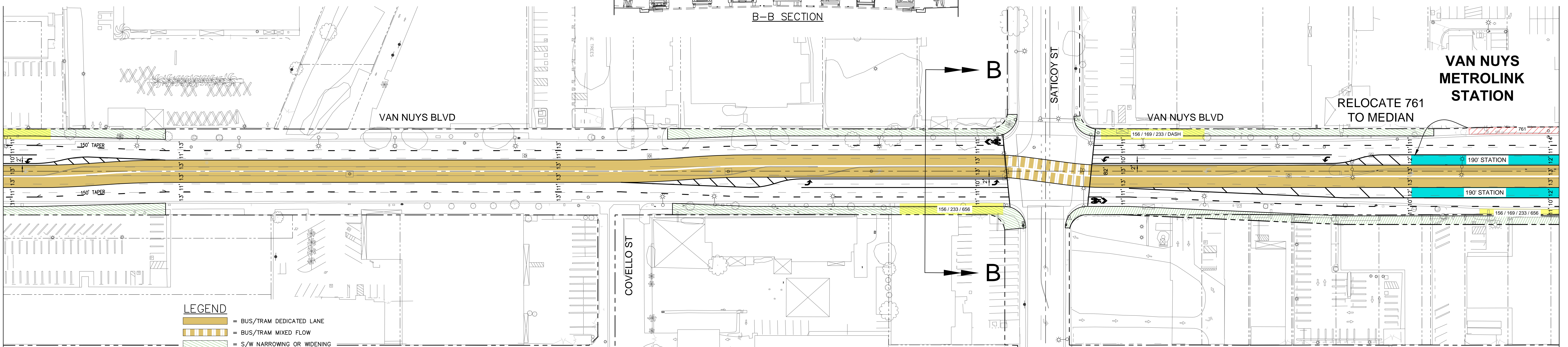
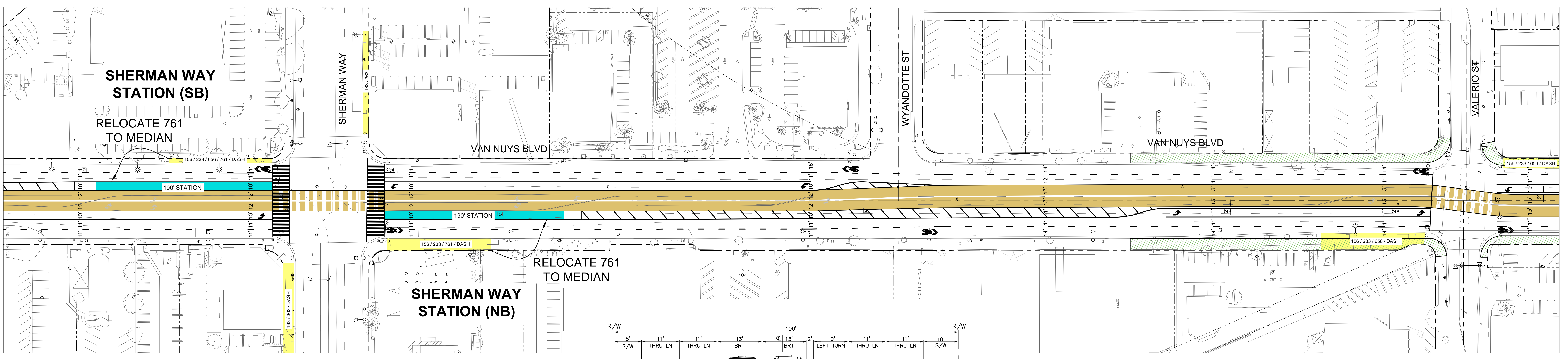
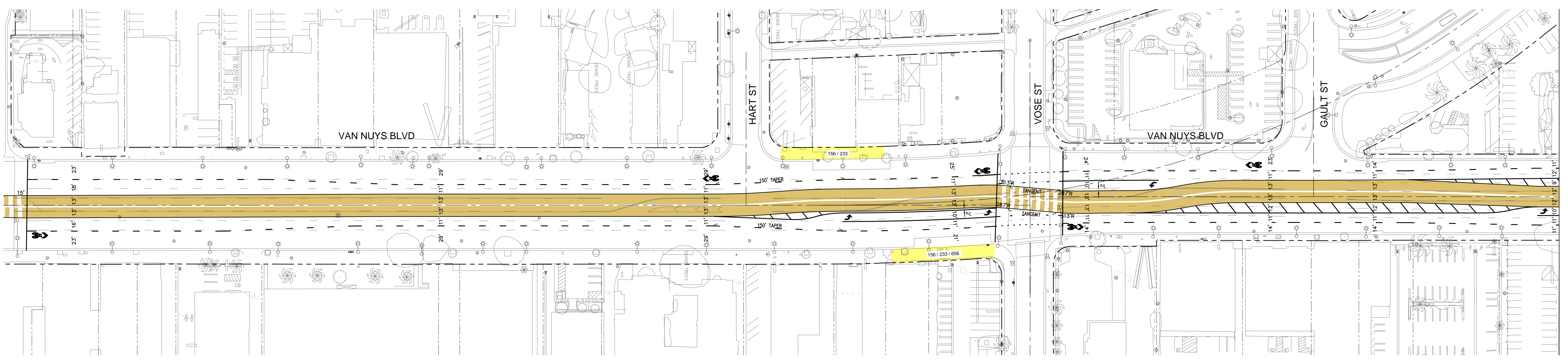

- LEGEND**
- = BUS/TRAM DEDICATED LANE
 - = BUS/TRAM MIXED FLOW
 - = S/W NARROWING OR WIDENING
 - = EXISTING STOP
 - = PROP./UPGRADED STATION
 - = REMOVED STOP

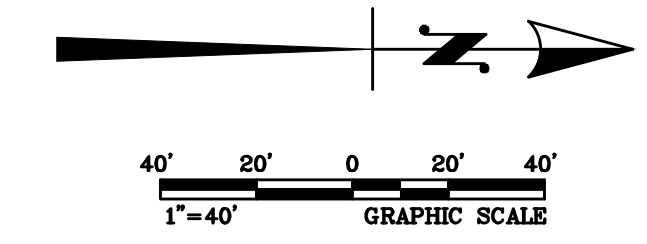

REV	DATE	BY	APP	REG. NO.	EXPIRES	SEAL HOLDER	DESCRIPTION

DESIGNED BY	
DRAWN BY	
CHECKED BY	
IN CHARGE	
DATE	

Metro LOS ANGELES COUNTY METROPOLITAN TRANSPORTATION AUTHORITY

EAST SAN FERNANDO VALLEY TRANSIT CORRIDOR
 BUS RAPID TRANSIT ALTERNATIVE
 MEDIAN RUNNING
 HARTLAND ST TO SATICOY ST

CONTRACT NO.	PS-4370-2622
DRAWING NO.	ALT2-4
SCALE	1"=40'
SHEET NO.	

Last Revised: Thu Aug 04, 2016 - 4:53pm. User: Rbaker. Thu Aug 04, 2016 - 4:53pm. Printed By: vdwagner. Drawings: A:\2016\080105 Metro Van Nuys Corridor Response\Exhibit\03 Concept Exp\Meridian Exhibit\Alt 2 - Exhibiting

MATCHLINE - SEE SHEET ALT2-4

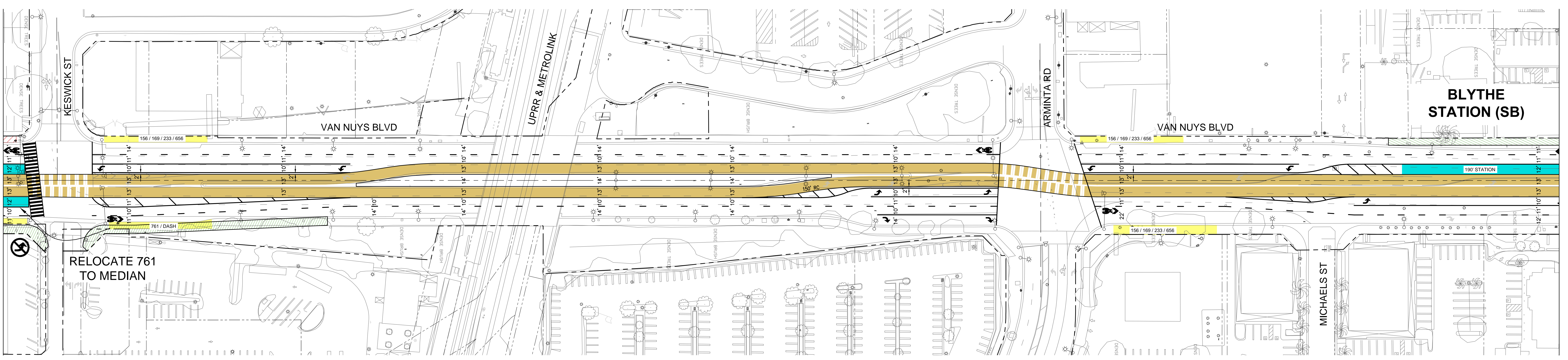

MATCHLINE - SEE BELOW LEFT

MATCHLINE - SEE ABOVE RIGHT

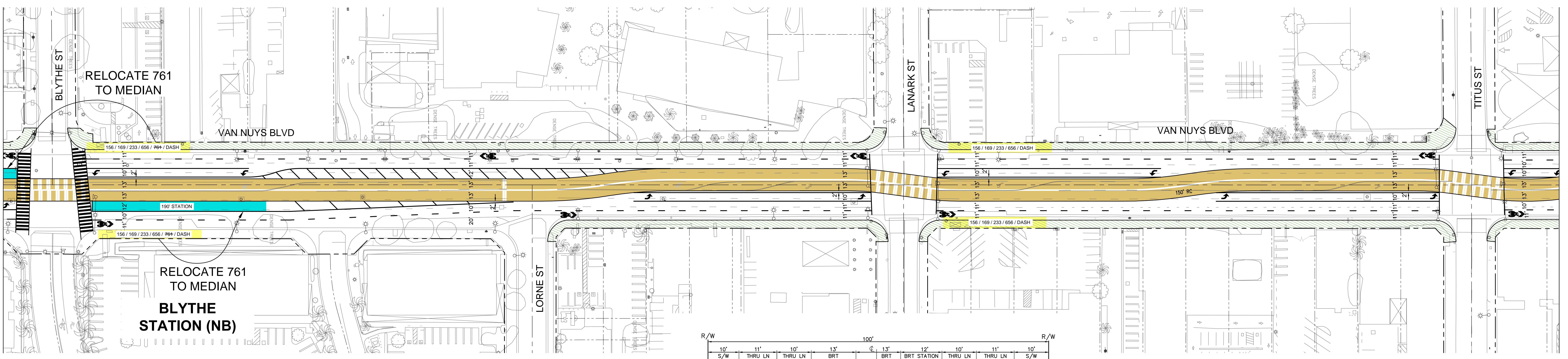

MATCHLINE - SEE BELOW LEFT

MATCHLINE - SEE ABOVE RIGHT

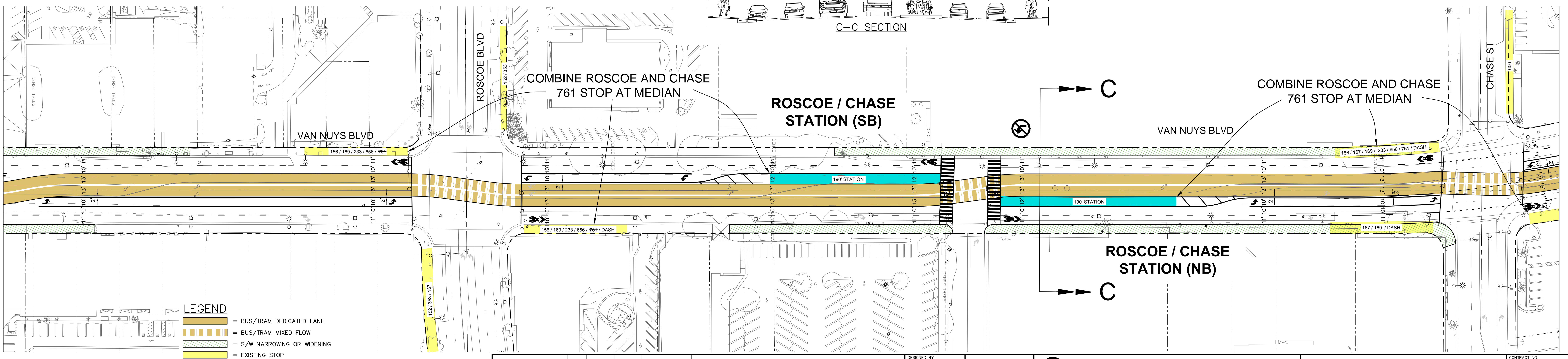

MATCHLINE - SEE SHEET ALT2-6

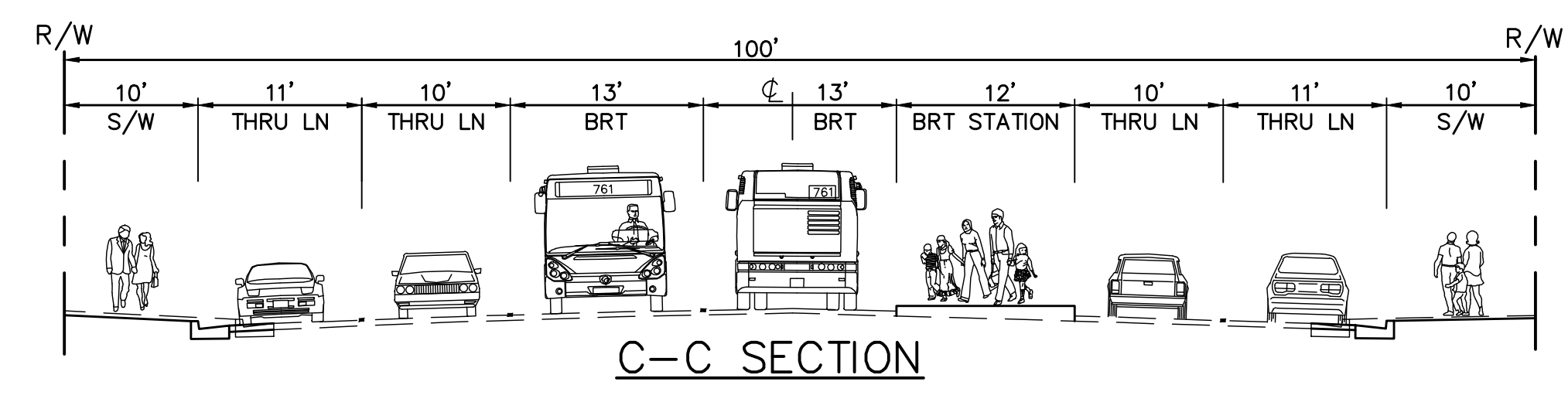

- LEGEND**
- = BUS/TRAM DEDICATED LANE
 - = BUS/TRAM MIXED FLOW
 - = S/W NARROWING OR WIDENING
 - = EXISTING STOP
 - = PROP./UPGRADED STATION
 - = REMOVED STOP

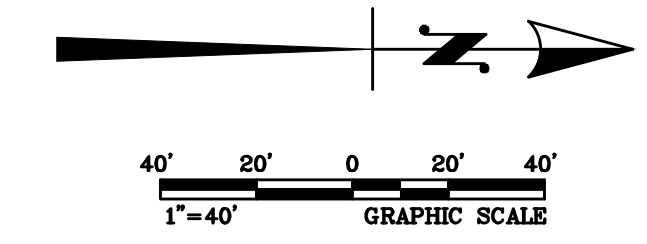

REV	DATE	BY	APP	REG. NO.	EXPIRES	SEAL HOLDER	DESCRIPTION

DESIGNED BY
DRAIN BY
CHECKED BY
IN CHARGE
DATE

Metro LOS ANGELES COUNTY METROPOLITAN TRANSPORTATION AUTHORITY
EAST SAN FERNANDO VALLEY TRANSIT CORRIDOR
BUS RAPID TRANSIT ALTERNATIVE
MEDIAN RUNNING
SANTICOY ST TO CHASE ST

CONTRACT NO. PS-4370-2622
DRAWING NO. ALT2-5
SCALE 1"=40'
SHEET NO. REV 0

Last Revised: Thu Aug 04, 2016 4:51pm
 User: Rbaker
 Thu Aug 04, 2016 4:53pm
 Printed By: vrbogdan
 Drawings: A:\2016\08041605 Metro Van Nuys Corridor Response\Drawings\030 Concept_Est\Meridian Exhibit\A2 - Exhibit

MATCHLINE - SEE SHEET ALT2-5

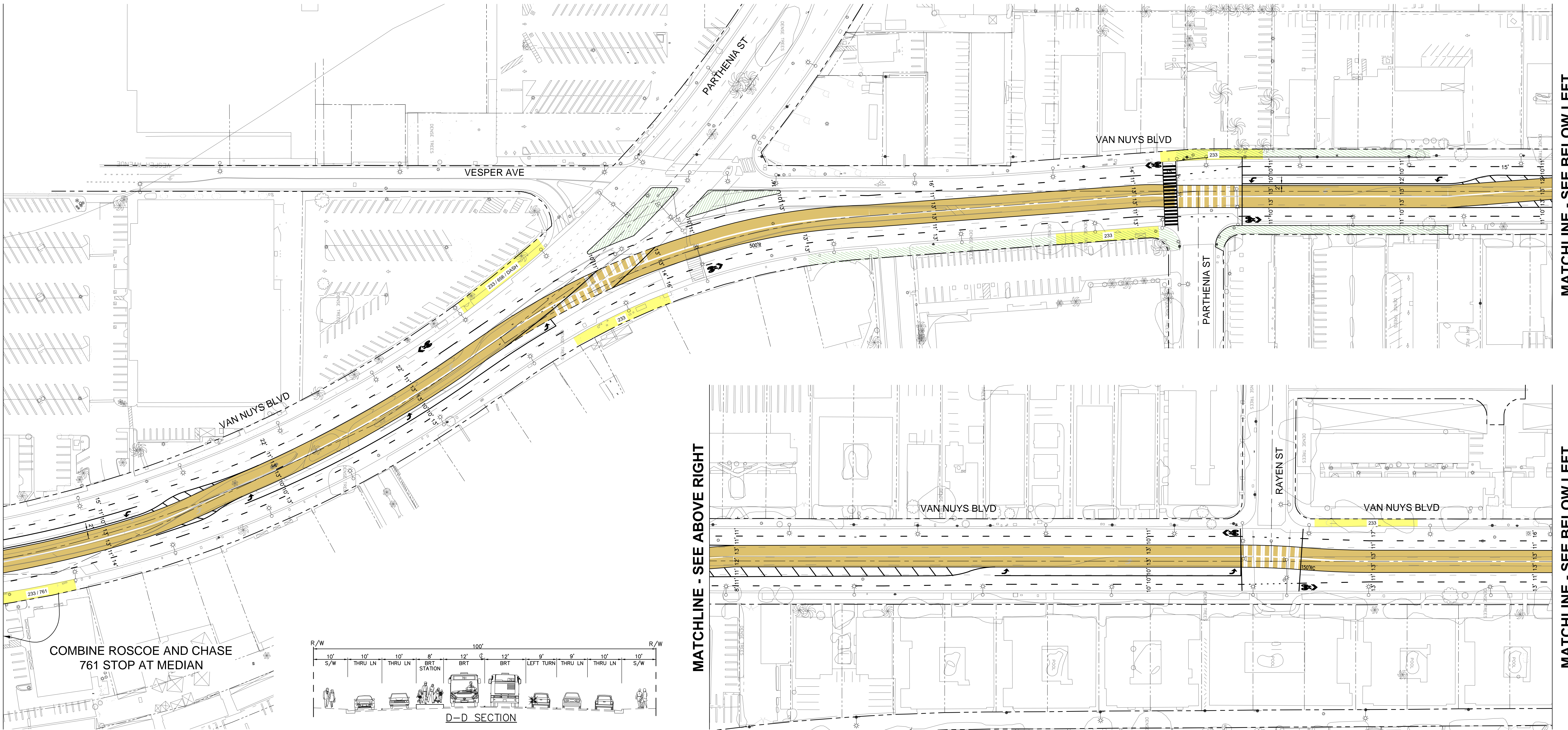

MATCHLINE - SEE BELOW LEFT

MATCHLINE - SEE ABOVE RIGHT

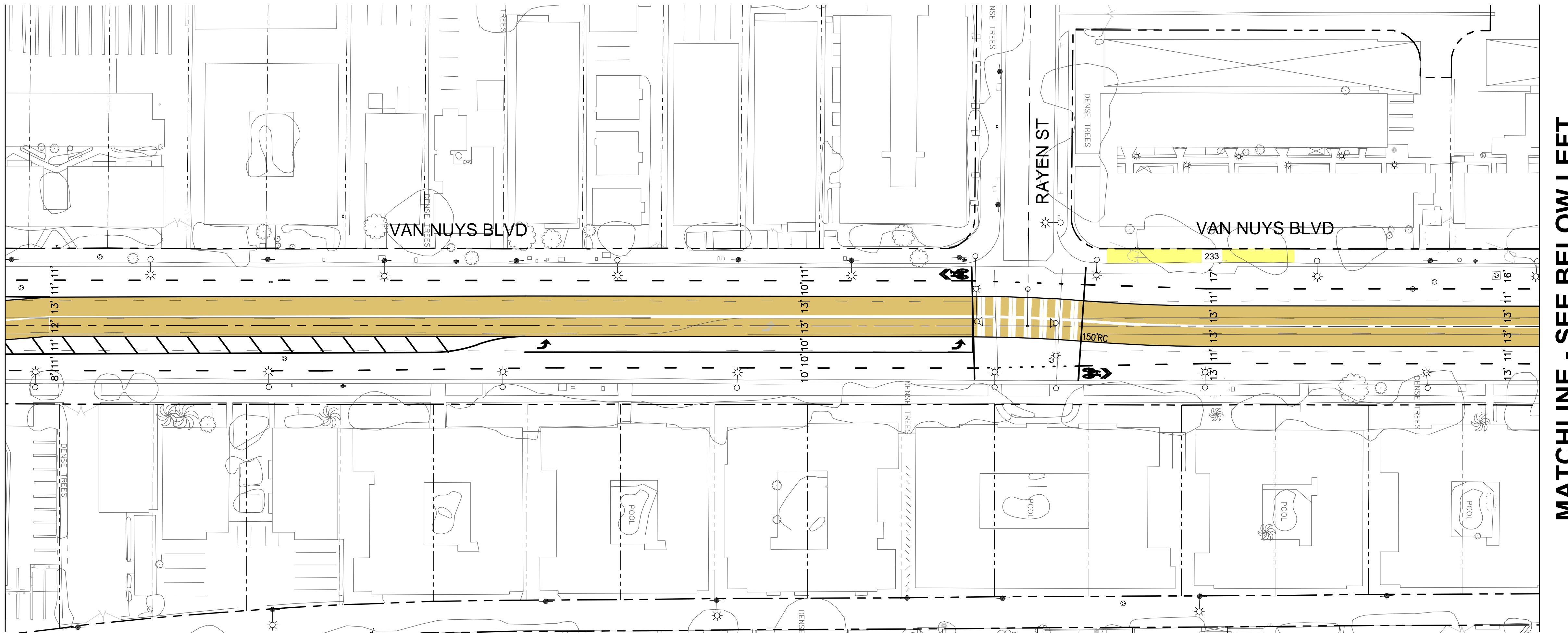

MATCHLINE - SEE BELOW LEFT

MATCHLINE - SEE ABOVE RIGHT

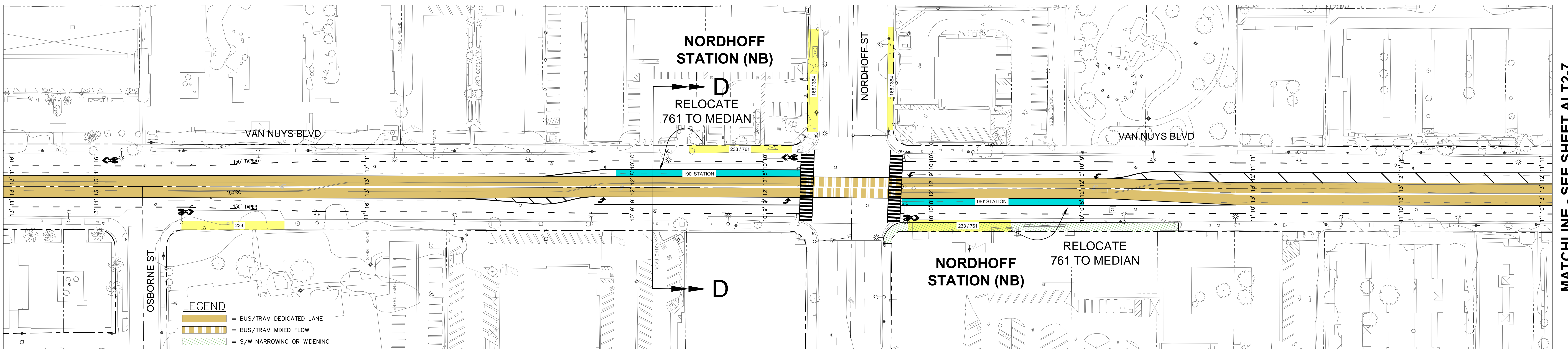

MATCHLINE - SEE SHEET ALT2-7

REV	DATE	BY	APP	REG. NO.	EXPIRES	SEAL HOLDER	DESCRIPTION

DESIGNED BY	
DRAWN BY	
CHECKED BY	
IN CHARGE	
DATE	

Metro LOS ANGELES COUNTY METROPOLITAN TRANSPORTATION AUTHORITY

EAST SAN FERNANDO VALLEY TRANSIT CORRIDOR
 BUS RAPID TRANSIT ALTERNATIVE
 MEDIAN RUNNING
 CHASE ST TO NORDHOFF ST

CONTRACT NO.	PS-4370-2622
DRAWING NO.	ALT2-6
SCALE	1"=40'
SHEET NO.	

MATCHLINE - SEE SHEET ALT2-6

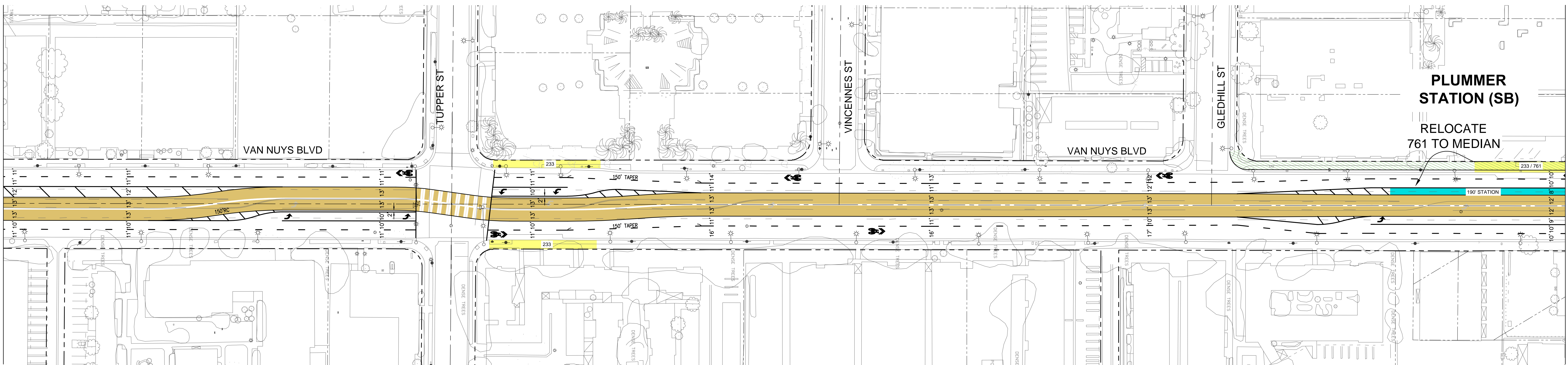

MATCHLINE - SEE BELOW LEFT

MATCHLINE - SEE ABOVE RIGHT

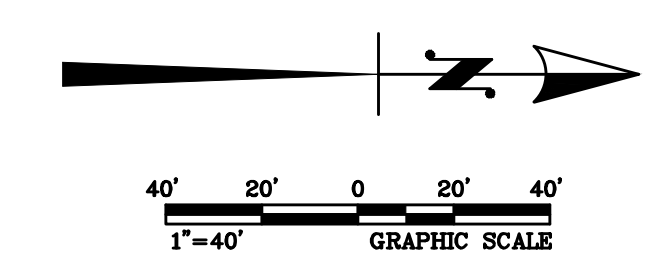
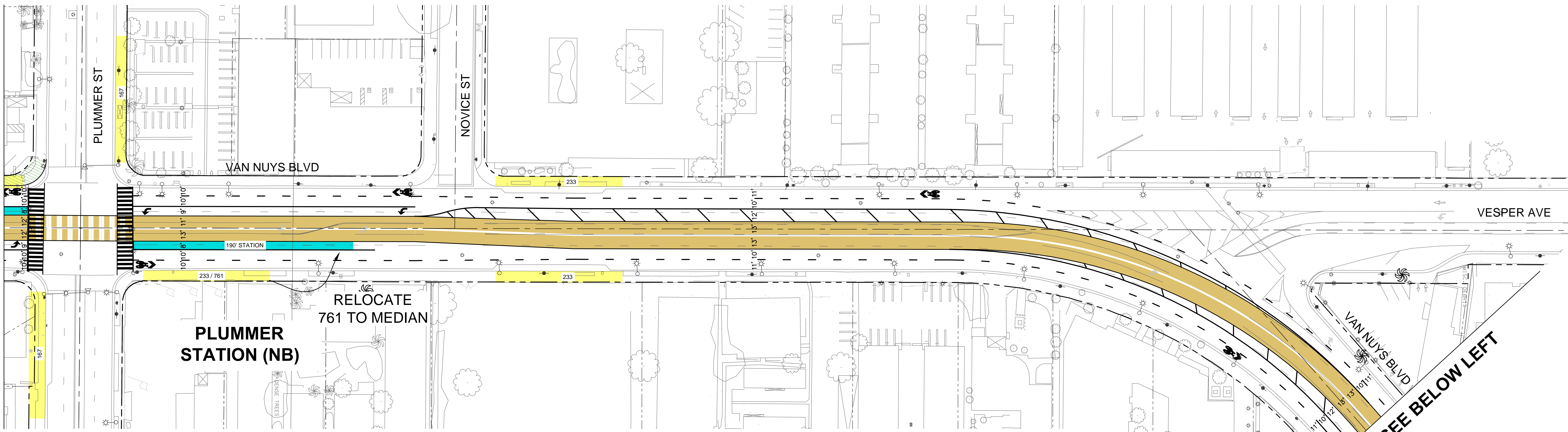

MATCHLINE - SEE BELOW LEFT

MATCHLINE - SEE ABOVE RIGHT

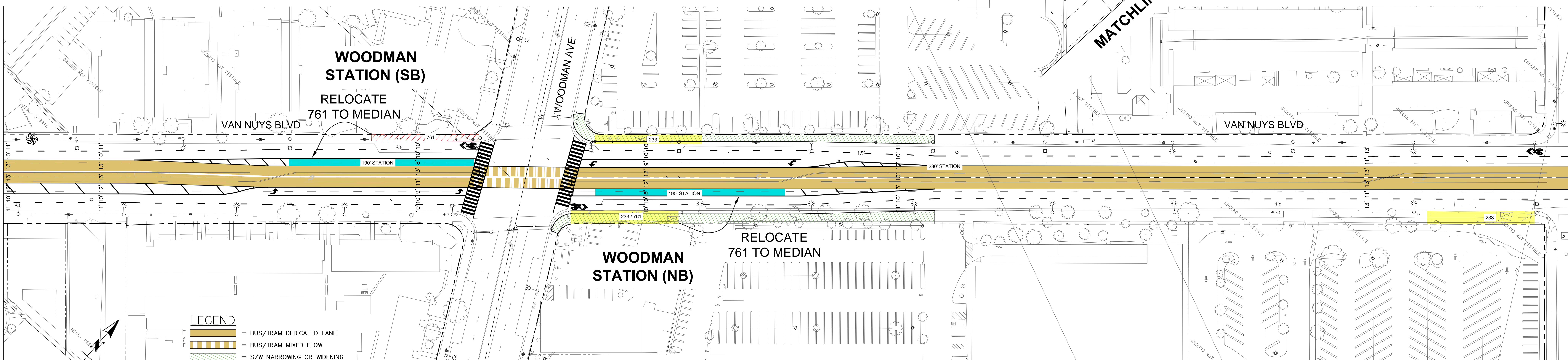

- LEGEND**
- = BUS/TRAM DEDICATED LANE
 - = BUS/TRAM MIXED FLOW
 - = S/W NARROWING OR WIDENING
 - = EXISTING STOP
 - = PROP./UPGRADED STATION
 - = REMOVED STOP

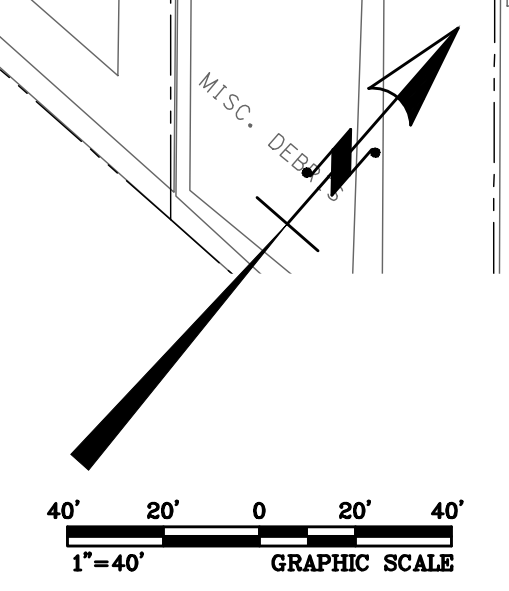

MATCHLINE - SEE SHEET ALT2-8

REV	DATE	BY	APP	REG. NO.	EXPIRES	SEAL HOLDER	DESCRIPTION

DESIGNED BY	
DRAWN BY	
CHECKED BY	
IN CHARGE	
DATE	

Metro LOS ANGELES COUNTY METROPOLITAN TRANSPORTATION AUTHORITY

EAST SAN FERNANDO VALLEY TRANSIT CORRIDOR
 BUS RAPID TRANSIT ALTERNATIVE
 MEDIAN RUNNING
 NORDHOFF ST TO CANTERBURY AVE

CONTRACT NO.	PS-4370-2622
DRAWING NO.	ALT2-7
SCALE	1"=40'
SHEET NO.	

Last Revised: Thu Aug 04, 2016 - 4:53pm. User: Risher, Thu Aug 04, 2016 - 4:53pm. Printed By: vrodgers. Drawings: A:\2016\B01005 Metro Van Nuys Corridor Response\Exhibit\03 Concept Exp\Meridian Exhibit\Alt 2 - Exhibit.dwg

MATCHLINE - SEE SHEET ALT2-7

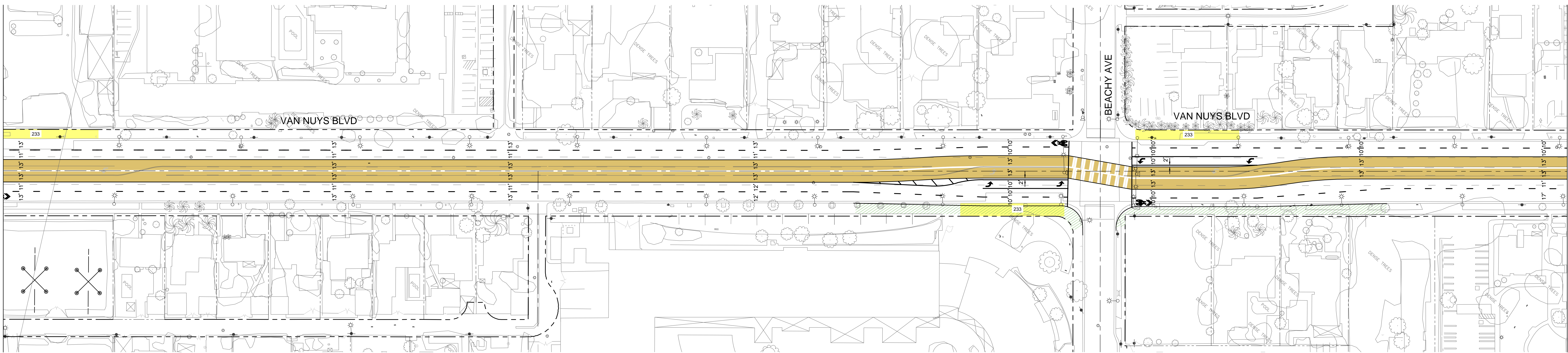

MATCHLINE - SEE BELOW LEFT

MATCHLINE - SEE ABOVE RIGHT

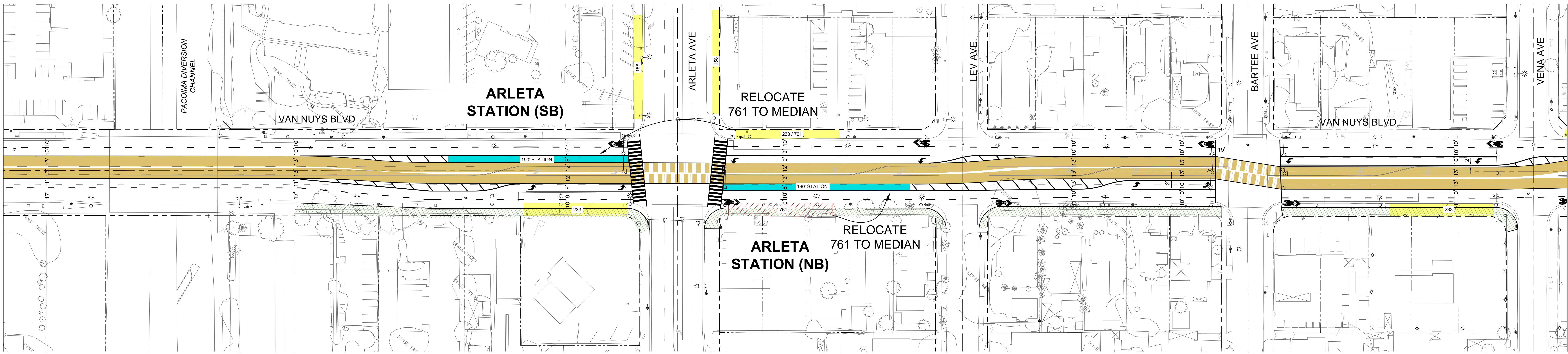

MATCHLINE - SEE BELOW LEFT

MATCHLINE - SEE ABOVE RIGHT

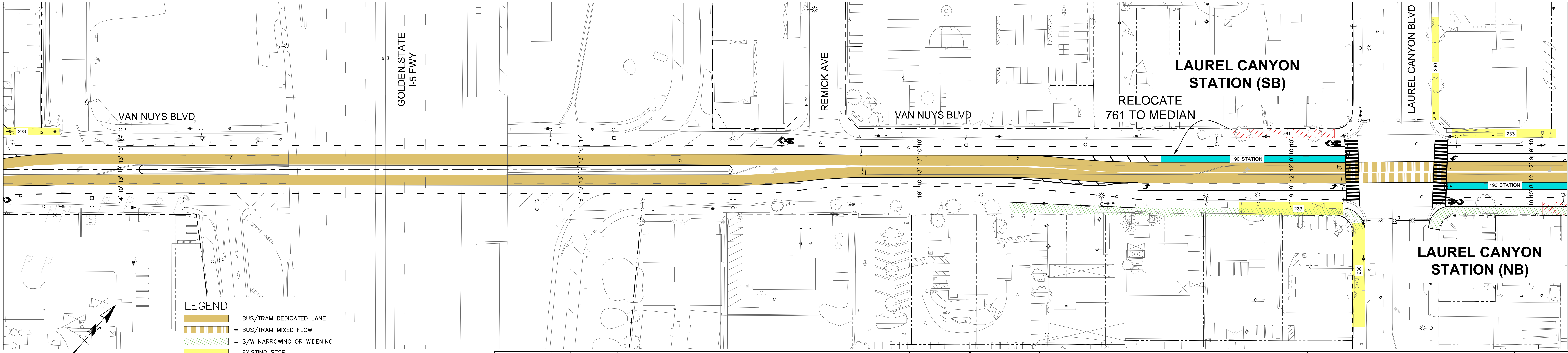

MATCHLINE - SEE SHEET ALT2-9

- LEGEND**
- = BUS/TRAM DEDICATED LANE
 - = BUS/TRAM MIXED FLOW
 - = S/W NARROWING OR WIDENING
 - = EXISTING STOP
 - = PROP./UPGRADED STATION
 - = REMOVED STOP

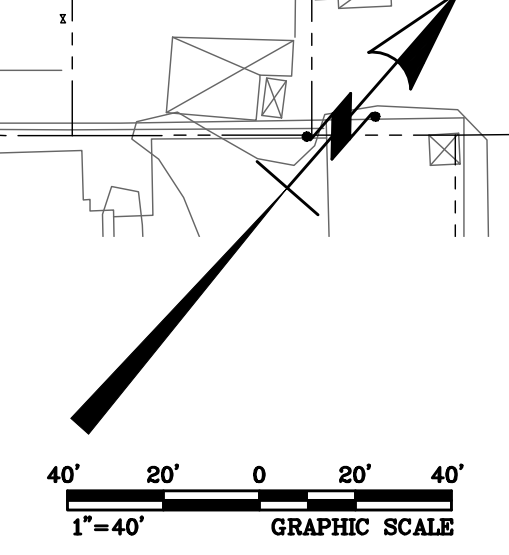

REV	DATE	BY	APP	REG. NO.	EXPIRES	SEAL HOLDER	DESCRIPTION

DESIGNED BY	
DRAWN BY	
CHECKED BY	
IN CHARGE	
DATE	

Metro LOS ANGELES COUNTY METROPOLITAN TRANSPORTATION AUTHORITY

EAST SAN FERNANDO VALLEY TRANSIT CORRIDOR
 BUS RAPID TRANSIT ALTERNATIVE
 MEDIAN RUNNING
 CANTERBURY AVE TO LAUREL CANYON BLVD

CONTRACT NO.	PS-4370-2622
DRAWING NO.	ALT2-8
SCALE	1"=40'
SHEET NO.	

Last Revised: Thu Aug 04, 2016 - 4:53pm. User: Rishad, Thu Aug 04, 2016 - 4:53pm. Printed By: vrd@metro.net. Drawings: A:\2010\080105 Metro Van Nuys Corridor - Bussing\Exhibit\030 Concept Exp\Alternatives Exhibit\Alt 2 - Exhibiting

MATCHLINE - SEE SHEET ALT2-8

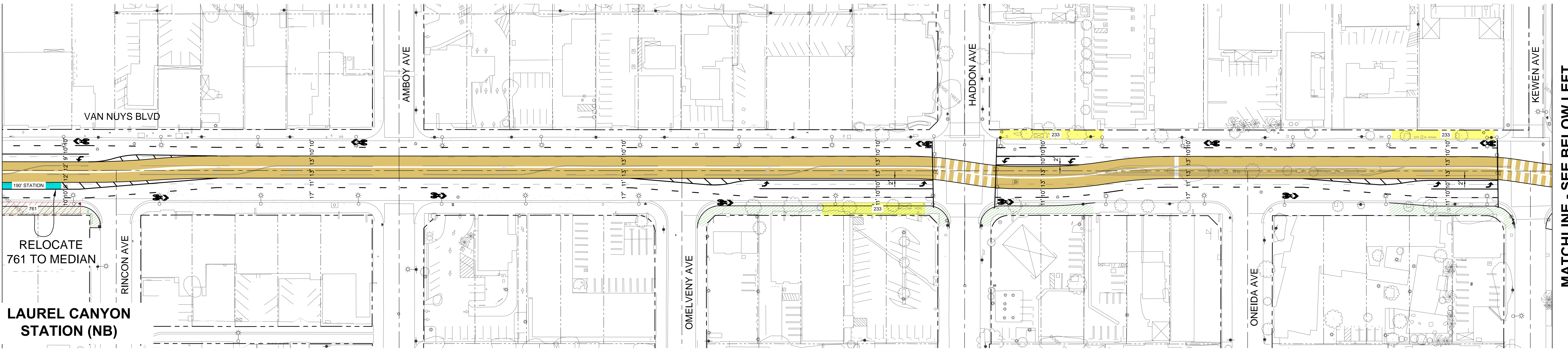

MATCHLINE - SEE BELOW LEFT

MATCHLINE - SEE ABOVE RIGHT

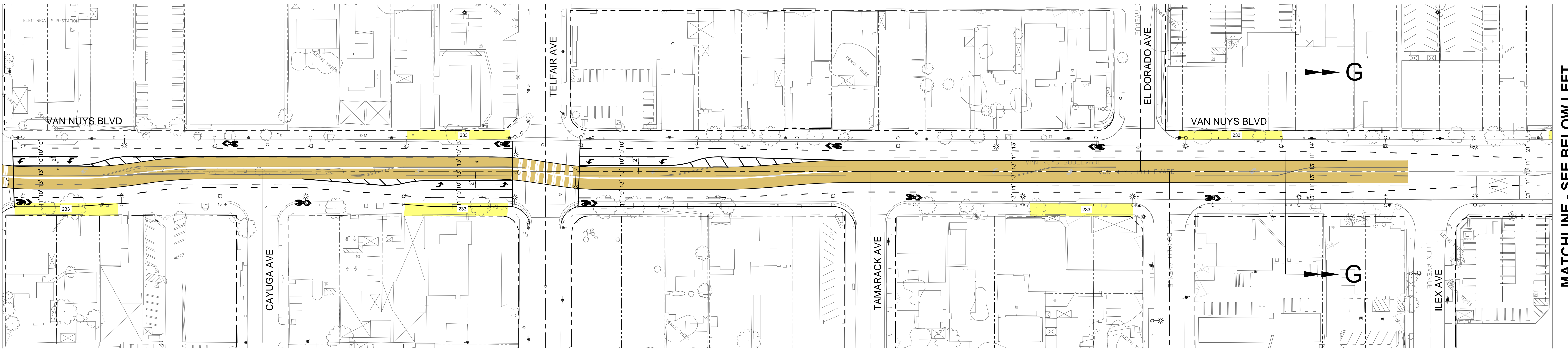

MATCHLINE - SEE BELOW LEFT

MATCHLINE - SEE ABOVE RIGHT

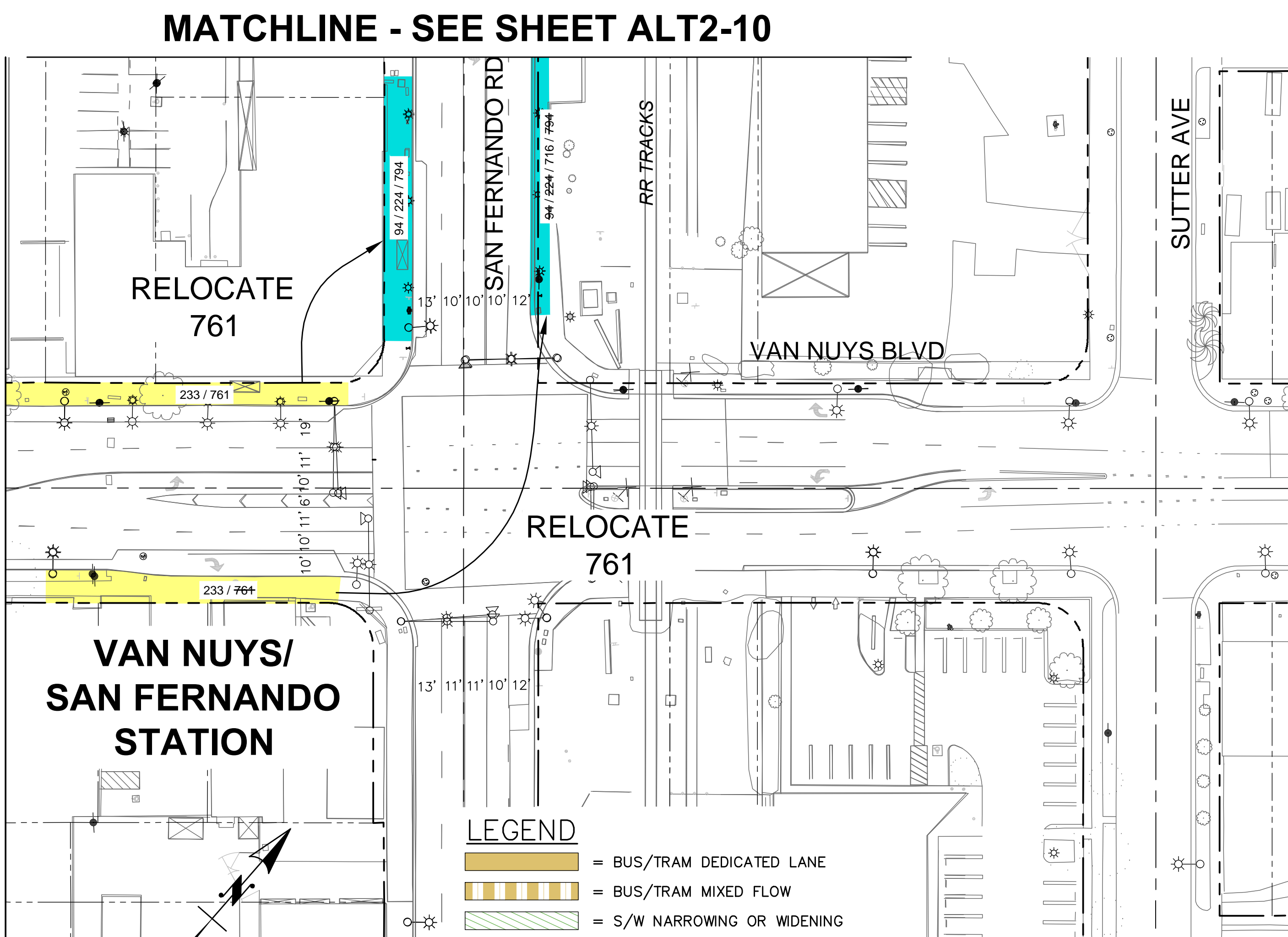

- LEGEND**
- = BUS/TRAM DEDICATED LANE
 - = BUS/TRAM MIXED FLOW
 - = S/W NARROWING OR WIDENING
 - = EXISTING STOP
 - = PROP./UPGRADED STATION
 - = REMOVED STOP

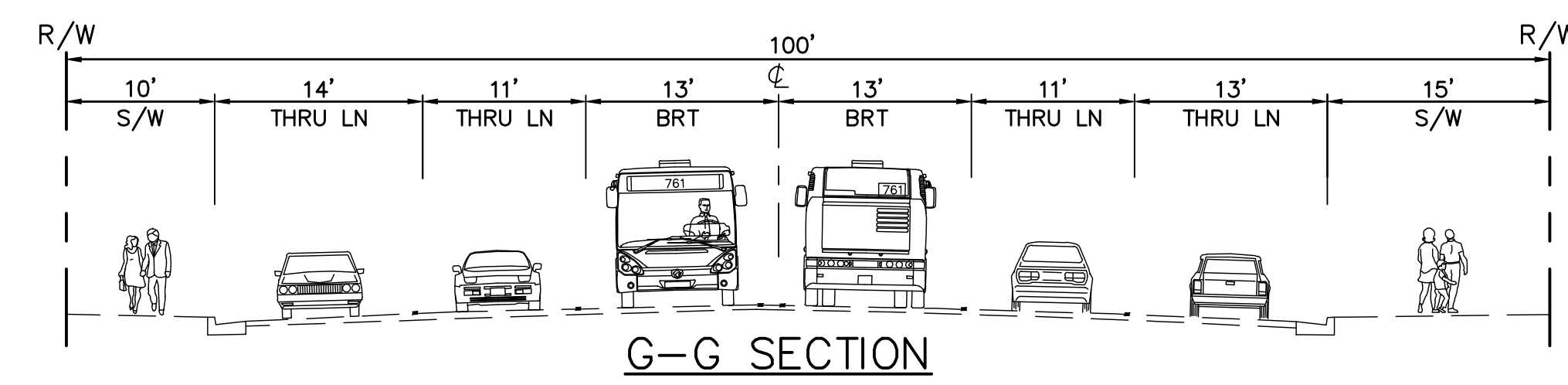

MATCHLINE - SEE SHEET ALT2-10

GRAPHIC SCALE
1"=40'

REV	DATE	BY	APP	REG. NO.	EXPIRES	SEAL HOLDER	DESCRIPTION

DESIGNED BY	
DRAWN BY	
CHECKED BY	
IN CHARGE	
DATE	



LOS ANGELES COUNTY METROPOLITAN
TRANSPORTATION AUTHORITY

EAST SAN FERNANDO VALLEY TRANSIT CORRIDOR
BUS RAPID TRANSIT ALTERNATIVE
MEDIAN RUNNING
LAUREL CANYON BLVD TO SUTTER AVE

CONTRACT NO. PS-4370-2622
DRAWING NO. ALT2-9
SCALE 1"=40'
SHEET NO. 0

PROJECT MANAGER

MATCHLINE - SEE SHEET ALT2-9

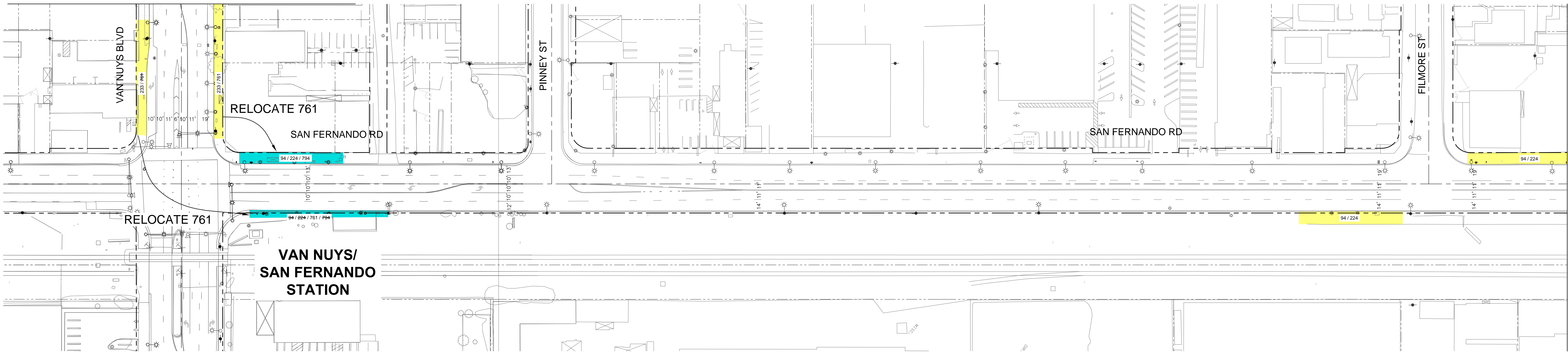

MATCHLINE - SEE BELOW LEFT

MATCHLINE - SEE ABOVE RIGHT

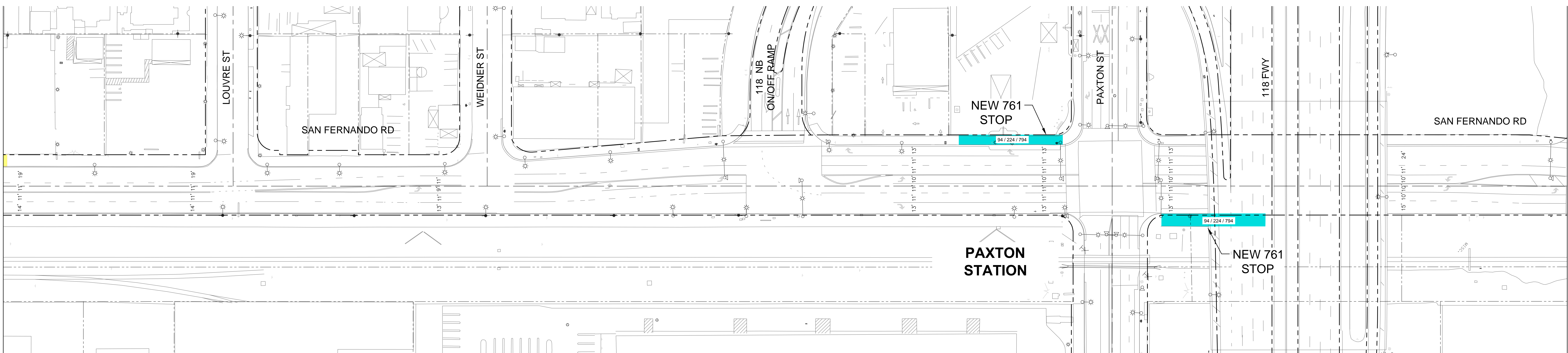

MATCHLINE - SEE BELOW LEFT

MATCHLINE - SEE ABOVE RIGHT

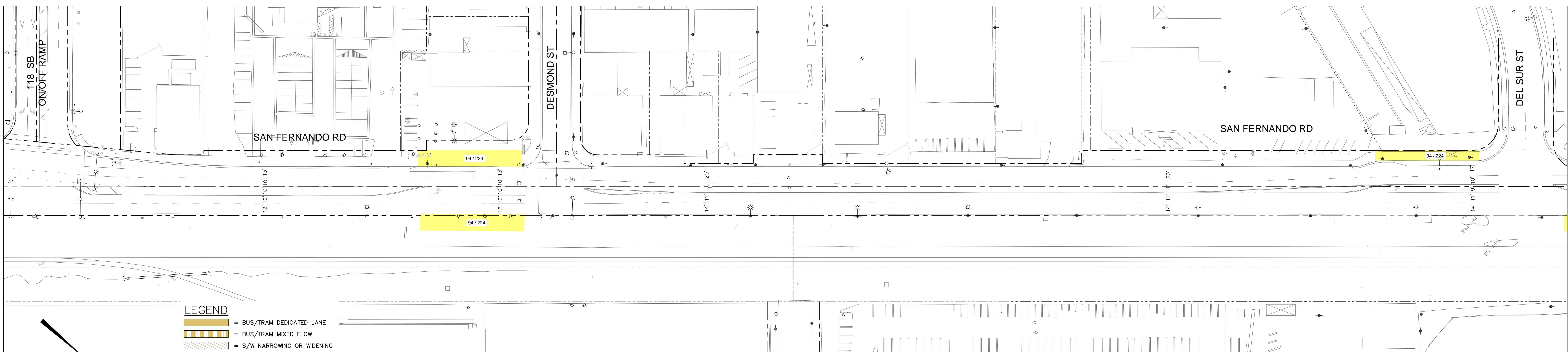

MATCHLINE - SEE ALT2-11

- LEGEND**
- = BUS/TRAM DEDICATED LANE
 - = BUS/TRAM MIXED FLOW
 - = S/W NARROWING OR WIDENING
 - = EXISTING STOP
 - = PROP./UPGRADED STATION
 - = REMOVED STOP

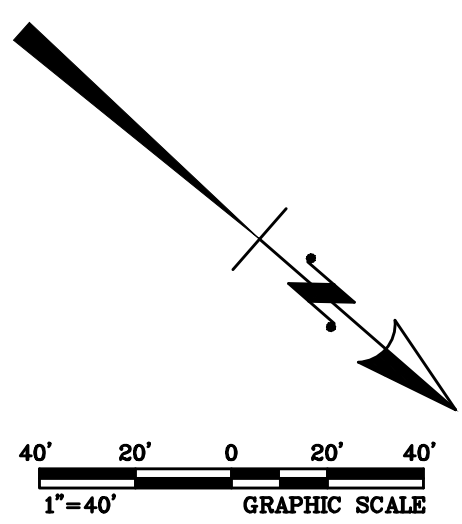

REV	DATE	BY	APP	REG. NO.	EXPIRES	SEAL HOLDER	DESCRIPTION

DESIGNED BY	
DRAWN BY	
CHECKED BY	
IN CHARGE	
DATE	



LOS ANGELES COUNTY METROPOLITAN TRANSPORTATION AUTHORITY

EAST SAN FERNANDO VALLEY TRANSIT CORRIDOR
 BUS RAPID TRANSIT ALTERNATIVE
 MEDIAN RUNNING
 VAN NUYS BLVD TO DEL SUR ST

CONTRACT NO. PS-4370-2622
 DRAWING NO. ALT2-10
 SCALE 1"=40'
 SHEET NO. REV 0

PROJECT MANAGER

Last Revised: Thu Aug 04, 2016 - 4:53pm. User: Risher, Thu Aug 04, 2016 - 4:53pm. Printed By: vordogone. Drawings: A:\2016\080105 Metro Van Nuys Corridor Response\Exhibit\03 Concept Exp\Alternatives\Exhibit\2 - Exhibiting

MATCHLINE - SEE ALT2-10

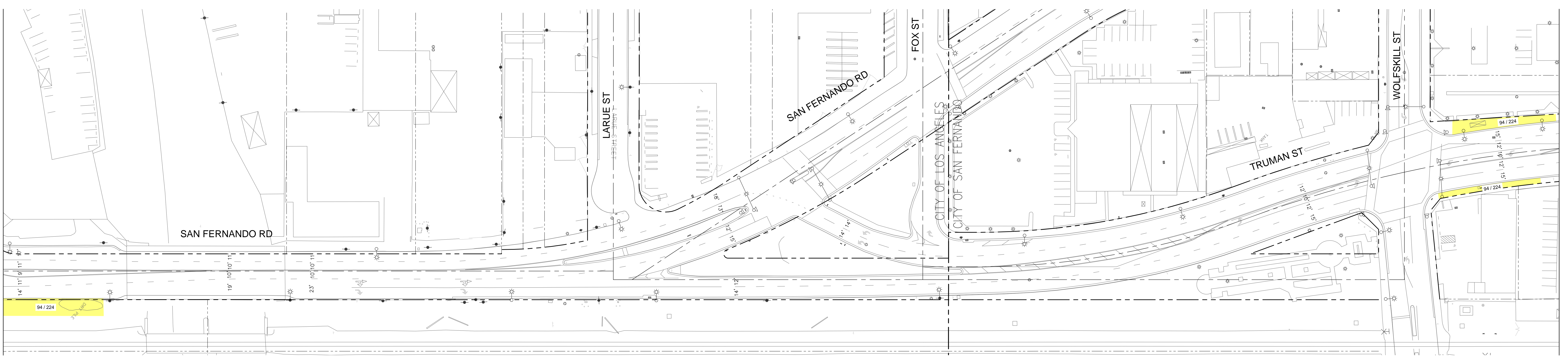

MATCHLINE - SEE BELOW LEFT

MATCHLINE - SEE ABOVE RIGHT

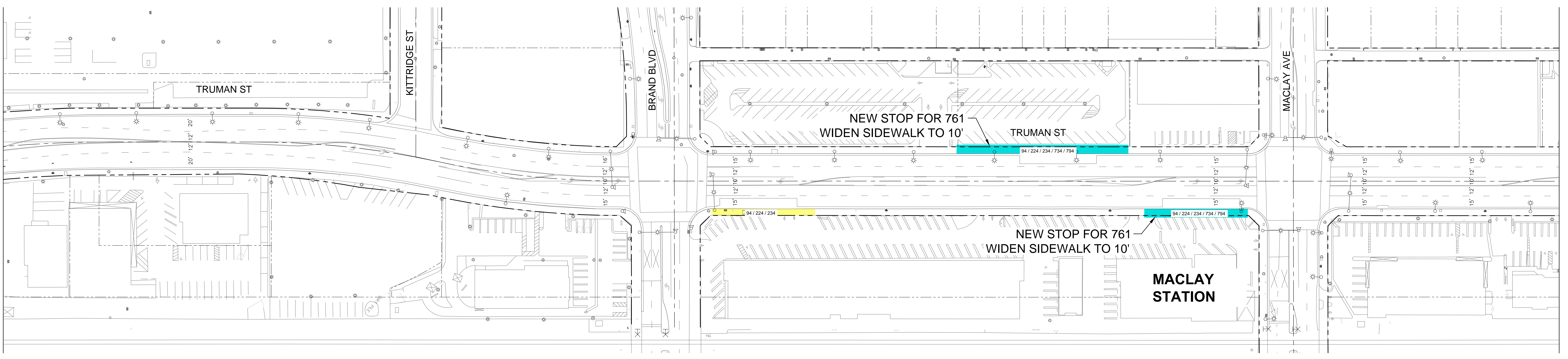





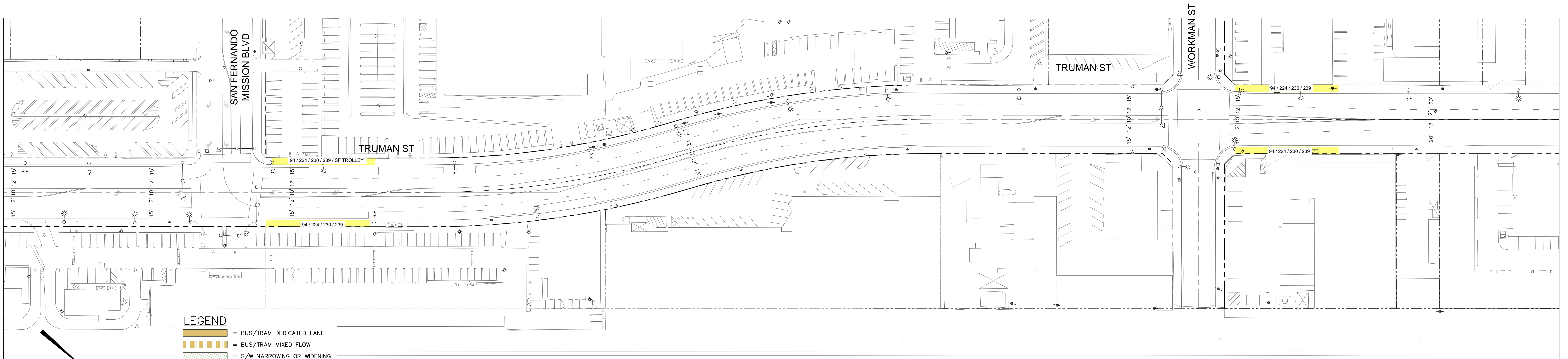

MATCHLINE - SEE BELOW LEFT

MATCHLINE - SEE ABOVE RIGHT

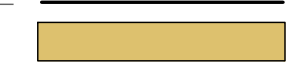

MATCHLINE - SEE ALT2-12

LEGEND

-  = BUS/TRAM DEDICATED LANE
-  = BUS/TRAM MIXED FLOW
-  = S/W NARROWING OR WIDENING
-  = EXISTING STOP
-  = PROP./UPGRADED STATION
-  = REMOVED STOP

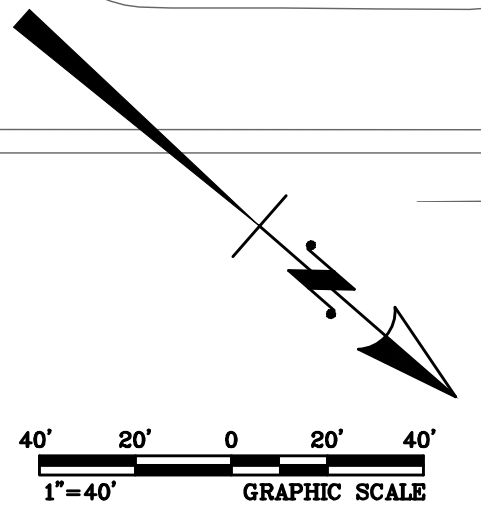

REV	DATE	BY	APP	REG. NO.	EXPIRES	SEAL HOLDER	DESCRIPTION

DESIGNED BY	
DRAWN BY	
CHECKED BY	
IN CHARGE	
DATE	



**LOS ANGELES COUNTY METROPOLITAN
TRANSPORTATION AUTHORITY**

EAST SAN FERNANDO VALLEY TRANSIT CORRIDOR
BUS RAPID TRANSIT ALTERNATIVE
MEDIAN RUNNING
DEL SUR ST TO WORKMAN ST

CONTRACT NO. PS-4370-2622
DRAWING NO. ALT2-11
SCALE 1"=40'
SHEET NO. REV 0

PROJECT MANAGER

MATCHLINE - SEE ALT-11



MATCHLINE - SEE BELOW LEFT

MATCHLINE - SEE ABOVE RIGHT

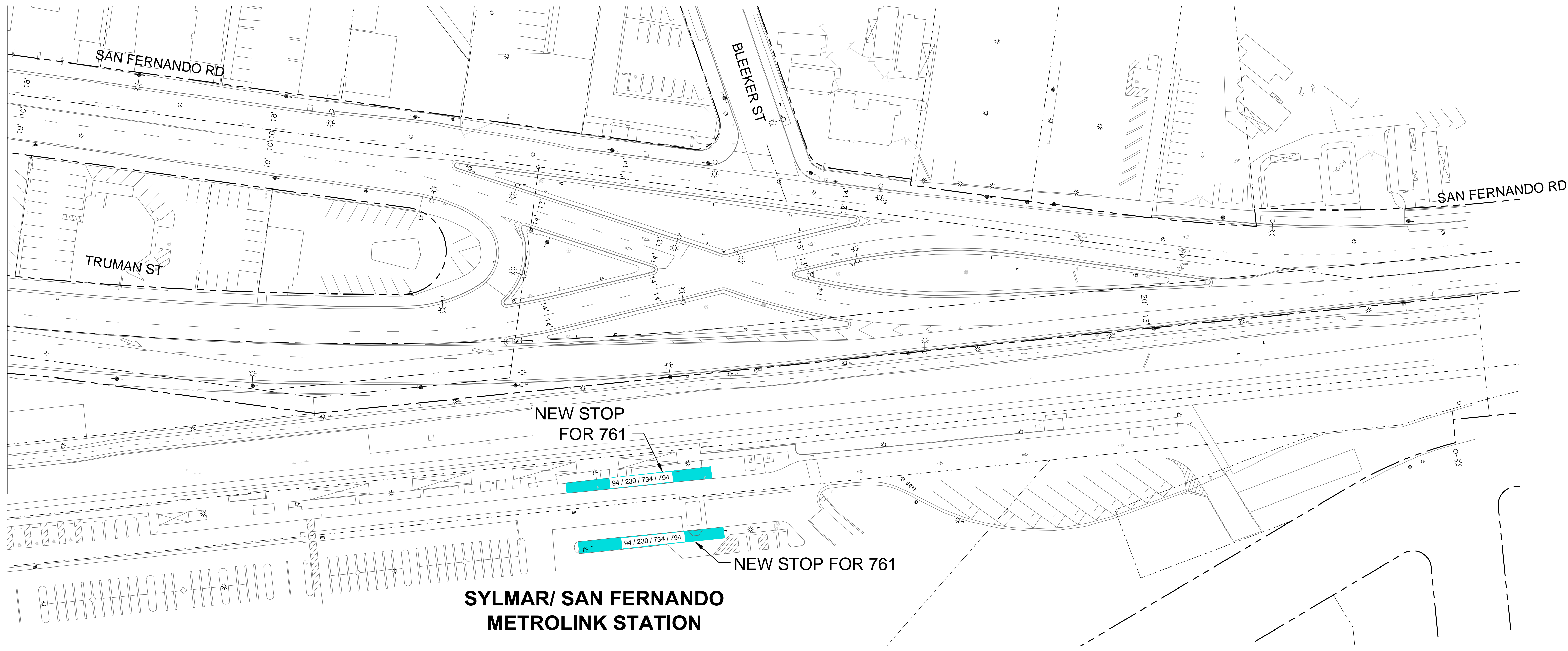

LEGEND

- = BUS/TRAM DEDICATED LANE
- = BUS/TRAM MIXED FLOW
- = S/W NARROWING OR WIDENING
- = EXISTING STOP
- = PROP./UPGRADED STATION
- = REMOVED STOP

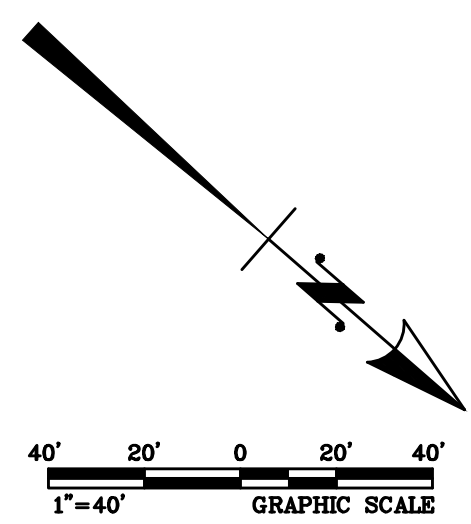

REV	DATE	BY	APP	REG. NO.	EXPIRES	SEAL HOLDER	DESCRIPTION

DESIGNED BY	
DRAWN BY	
CHECKED BY	
IN CHARGE	
DATE	



**LOS ANGELES COUNTY METROPOLITAN
TRANSPORTATION AUTHORITY**

EAST SAN FERNANDO VALLEY TRANSIT CORRIDOR
 BUS RAPID TRANSIT ALTERNATIVE
 MEDIAN RUNNING
 WORKMAN ST TO BLEEKER ST

CONTRACT NO.	PS-4370-2622
DRAWING NO.	ALT2-12
SCALE	1"=40'
SHEET NO.	

PROJECT MANAGER

REV 0