

*Readers' Guidance:*

*This chapter reflects modifications to the proposed project that occurred subsequent to issuance of the Draft EIR/EIS in April 2004. Changes are shown in ~~strikeout~~ and underline format so that the reader can compare updated information to that shown in the draft environmental document.*

THIS PAGE INTENTIONALLY BLANK

## CHAPTER 2 - ALTERNATIVES

### Background

Transportation improvements for the San Gabriel Valley and adjoining areas have been the subject of study for several decades. Among past efforts was the creation of I-210, the Foothill Freeway, for which planning was initiated in 1955. Implementation of that freeway plan continues today.

As early as 1980, transportation planners envisioned the use of the former Atchison Topeka-Santa Fe Railroad's Pasadena Subdivision alignment as part of a countywide rapid rail network. The first outgrowth of this vision was the initiation of planning for Phase I of the Gold Line in the late 1980's.

Local governments have been keenly interested in how that right-of-way might be best used to improve mobility. In light of the pending acquisition of the former Atchison Topeka-Santa Fe railroad right-of-way (completed in 1992 with Proposition C funds), the Los Angeles County Metropolitan Transportation Authority (LACMTA), in cooperation with the Foothill Cities Transportation Task Force and the San Bernardino Associated Governments prepared a study that resulted in issuance of the *Northern San Gabriel-San Bernardino Valley Transportation Corridor Preliminary Planning Study* in 1992. In 1993, LACMTA and the Foothill Task Force Cities commissioned an Environmental Impact Report (EIR) to evaluate the impacts of light rail and commuter rail east of the planned Sierra Madre Villa LRT station. The EIR was completed in 1994.

After implementation of Phase I of the Gold Line began in 1999, attention was again focused on potential use of the remainder of the former Pasadena Subdivision railroad right-of-way to extend service eastward from Pasadena. The ~~Los Angeles to Pasadena Metro Blue Line Construction Authority~~ Metro Gold Line Foothill Extension Construction Authority and the San Gabriel Valley Association of Governments, with the participation of cities along the rail right-of-way, initiated an Alternatives Analysis study to bring corridor planning up to date.

This chapter begins with an overview of the Alternatives Analysis process, conducted during 2001 and 2002, during which numerous alternatives were considered and evaluated. The outcome of the Alternatives Analysis process was a Locally Preferred Alternative (LPA-AA), which is now the focus of the Build Alternatives evaluated in this EIS/EIR. The remainder of this chapter describes the Alternatives that are evaluated in this EIS/EIR for the Gold Line ~~Phase II-Foothill~~ Extension Project. ~~Four-Three~~ Alternatives are presented in this chapter: (1) the No-Build Alternative, (2) ~~the Full-Build LRT Alternative~~ Full Build (Pasadena to Montclair) Alternative, and (3) ~~the Build LRT to Maintenance Facility Alternative~~ Build LRT to Azusa Alternative. Subsequent to the Draft EIS/EIR, the TSM Alternative was eliminated from consideration by selection of an LPA (See Section 2-3). **Figure 2-1** shows the 13-city study area and the study corridor along either side of the rail right-of-way.

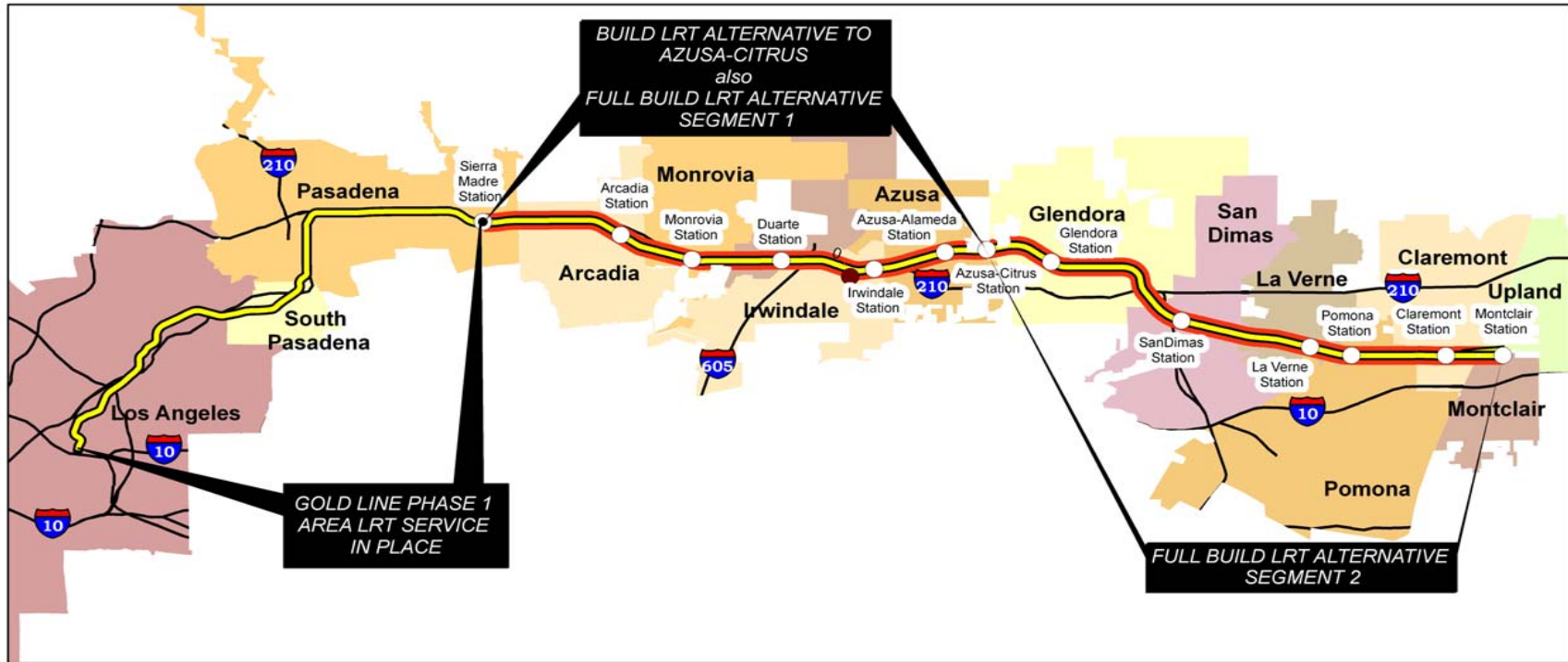

Sources: U.S. Census TIGER Data, 2000; Jones & Stokes Associates; PBQD, 2005

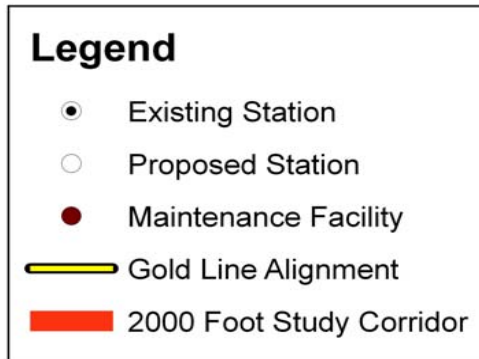
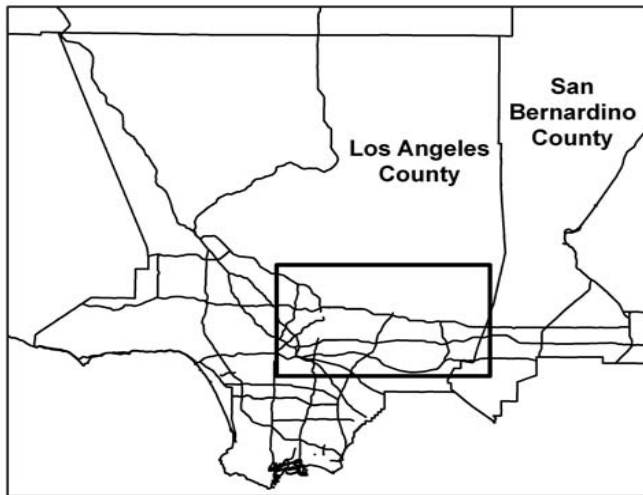
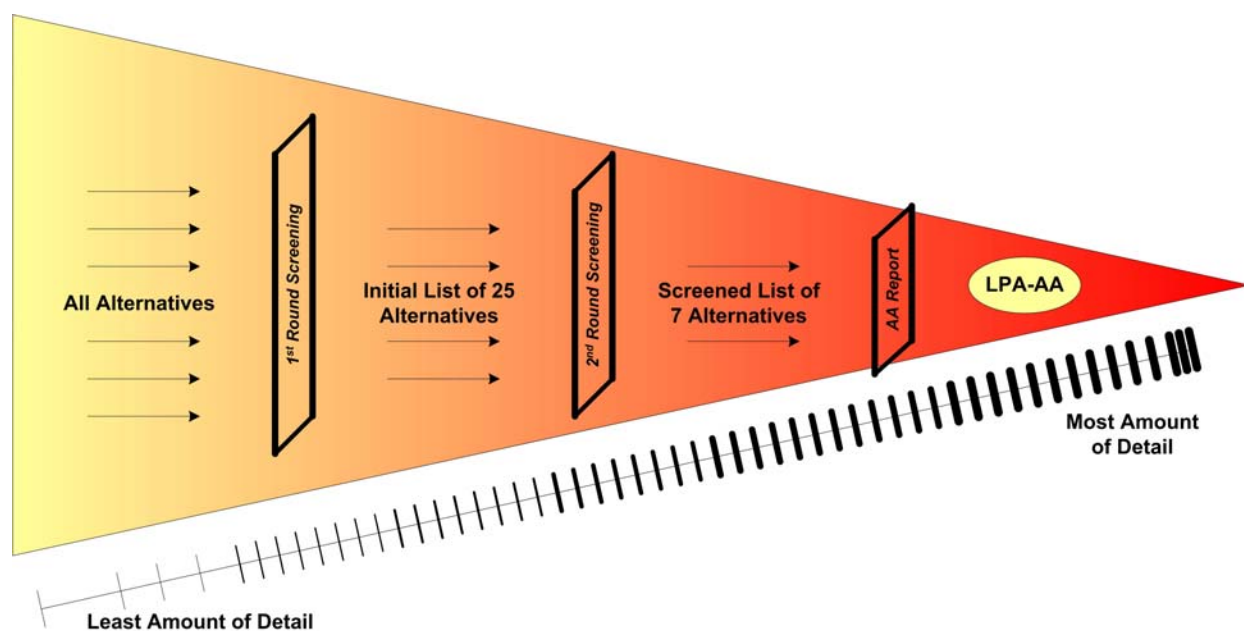

Figure 2-1: Gold Line Foothill Extension Study Area and Study Corridor

## 2-1 ALTERNATIVES ANALYSIS

A number of alternatives were initially evaluated during the Alternatives Analysis portion of this study (*Gold Line Phase II Extension Pasadena to Claremont Alternatives Analysis, Final Draft Report*, dated January 9, 2003). Conducted during 2002, the Alternatives Analysis process essentially was a three-tiered screening process where a full range of alternatives was narrowed down during three levels of screening to ultimately arrive at a LPA-AA. **Figure 2-2** illustrates this process. As the number of alternatives decreased, the level of technical detail with which the alternatives were analyzed and evaluated increased.



*Figure 2-2: The Alternatives Analysis Process*

### 2-1.1 Alternatives Analysis Process

#### 2-1.1.1 Initial List of Alternatives

The Alternatives Analysis looked at a wide range of alignment and technology options aimed at serving the study corridor's transportation needs. The initial list of 25 alternatives was identified from all

possible alternatives using the 1993 EIR<sup>1</sup> produced for this corridor as a guide, as well as input from the public. These included a No-Build Alternative, a TSM Alternative, as well as various modal alternatives: Bus Rapid Transit (BRT), Light Rail Transit (LRT), Commuter Rail, High Occupancy Vehicle (HOV) Lanes, and other guideway-based alternatives. **Table 2-1** outlines the extensive initial list of alternatives as described in the Alternatives Analysis Report, which is incorporated and made a part of this EIS/EIR.

As **Table 2-1** illustrates, these alternatives encompassed a variety of options, including differing technologies, alignments, and operations. Technologies looked at in the initial analysis included enhanced bus service, BRT, LRT, commuter rail, diesel multiple units (DMUs), HOV lanes, and other fixed guideway technologies. The alignment alternatives included the existing railroad right-of-way, Interstate 210 (I-210), and local major arterials. Operations alternatives varied by mode or utilized a combination of technologies.

| <b>TABLE 2-1<br/>INITIAL LIST OF ALTERNATIVES<br/>TO ADDRESS CORRIDOR TRANSPORTATION PROBLEMS<br/>(ALTERNATIVES ANALYSIS REPORT)</b> |                  |                         |  |  |
|--|------------------|-------------------------|--|--|
| Alternative  |                  | Technology              | Description  | Western Terminus / Eastern Terminus  |
| 0  | Baseline/<br>TSM |                         | Future bus network with Foothill Transit Express Bus on I-210, plus other transportation improvements in Regional Transportation Plan, Package G | Sierra Madre Villa Ave./Indian Hill Blvd.  |
| 1  | BRT-1            | Bus Rapid Transit (BRT) | Widen I-210 for BRT lanes  | Sierra Madre Villa Ave./Indian Hill Blvd.  |
| 2  | BRT-2            | BRT                     | Elevated BRT lanes on I-210  | Sierra Madre Villa Ave./Indian Hill Blvd.  |
| 3  | BRT-3            | BRT                     | BRT on I-210 Shoulder  | Sierra Madre Villa Ave./Indian Hill Blvd.  |
| 4  | BRT-4            | BRT                     | BRT-only HOV lanes   | Sierra Madre Villa Ave./Indian Hill Blvd.  |
| 5  | BRT-5            | BRT                     | BRT on I-210 and street right-of-way   | Sierra Madre Villa Ave./ Claremont Metrolink Station   |
| 6  | BRT-6            | BRT                     | Rapid bus on streets   | Local Streets from Pasadena to Claremont   |
| 7  | BRT-7            | BRT                     | BRT on exclusive street right-of-way   | Foothill Blvd. from Pasadena to Huntington Blvd. to Foothill Blvd. (Azusa) to Alostia Ave. to Lone Hill Ave. to Arrow Highway/Claremont. |

<sup>1</sup> Northern San Gabriel-San Bernardino Rail Transit Corridor Draft Environmental Impact Report, SCH# 93021062, September 1993. Los Angeles County Metropolitan Transportation Authority.

**TABLE 2-1  
INITIAL LIST OF ALTERNATIVES  
TO ADDRESS CORRIDOR TRANSPORTATION PROBLEMS  
(ALTERNATIVES ANALYSIS REPORT)**

| Alternative |       | Technology                  | Description   | Western Terminus / Eastern Terminus  |
|-------------|-------|-----------------------------|---|--|
| 8           | BRT-8 | BRT                         | BRT on I-210 and rail right-of-way  | Sierra Madre Villa Ave. on I-210, exit at Irwindale into rail right-of-way/Claremont |
| 9           | BRT-9 | BRT                         | BRT on rail right-of-way (two lanes)<br>Bus on pavement<br>Guided bus   | Rail right-of-way/Claremont  |
| 10          | LRT-1 | Light Rail Transit (LRT)    | LRT single track using existing rail for both LRT and freight with new sidings  | Rail right-of-way/Claremont  |
| 11          | LRT-2 | LRT                         | LRT double track (may include some sections of single track)<br>With no freight—buy remaining interests<br>With freight—run freight operations off-peak<br>Test a Segment 1 Minimum Operable Segment that extends LRT to, for example, Irwindale, with DMU to Claremont on double track | Rail right-of-way/Claremont  |
| 12          | LRT-3 | LRT                         | LRT double track and dedicated freight track<br>Test a Segment 1 Minimum Operable Segment that extends LRT to, for example, Irwindale, with DMU to Claremont on double track  | Rail right-of-way/Claremont  |
| 13          | LRT-4 | LRT/BRT                     | LRT on rail right-of-way and Express buses use sections of the rail right-of-way  | Rail right-of-way/Claremont  |
| 14          | CR-1  | Conventional Commuter Rail  | Conventional Metrolink-type commuter rail using rail right-of-way   | Rail right-of-way/Claremont  |
| 15          | CR-2  | Diesel Multiple Units (DMU) | FRA-compliant single track using existing rail for both DMU and freight with new sidings  | Rail right-of-way/Claremont  |
| 16          | CR-3  | DMU                         | FRA non-compliant double track<br>With no freight—buy remaining interests<br>With freight—run freight operations off-peak   | Rail right-of-way/Claremont  |

| <b>TABLE 2-1<br/>                     INITIAL LIST OF ALTERNATIVES<br/>                     TO ADDRESS CORRIDOR TRANSPORTATION PROBLEMS<br/>                     (ALTERNATIVES ANALYSIS REPORT)</b> |            |                                  |   |  |
|---|------------|----------------------------------|---|--|
| Alternative   |            | Technology                       | Description   | Western Terminus / Eastern Terminus          |
| 17  | CR-4       | DMU                              | FRA non-compliant double track and dedicated freight track                      | Rail right-of-way/Claremont                  |
| 18  | CR-5       | DMU                              | FRA-compliant double track with occasional single track in narrow sections      | Rail right-of-way/Claremont                  |
| 19  | HOV-1      | High Occupancy Vehicle (HOV)     | HOV Direct Connector to Sierra Madre Villa Station (Gold Line Phase I Terminus) | Sierra Madre Villa Ave. to Indian Hill Blvd. |
| 20  | HOV-2      | HOV with Bus                     | Bus operations in HOV lanes with online stations                                | I-210 to end of HOV Lane                     |
| 21  | HOV-3      | HOV with Bus                     | Bus operations in HOV lanes with offline stations and new connector ramps       | I-210 to end of HOV Lane                     |
| 22  | Guideway-1 | Monorail                         | Monorail using rail right-of-way  | Sierra Madre Villa Ave./Claremont            |
| 23  | Guideway-2 | Maglev                           | Magnetic Levitation System using rail right-of-way                              | Sierra Madre Villa Ave./Claremont            |
| 24  | Guideway-3 | Automated Guideway Transit (AGT) | AGT using rail right-of-way   | Sierra Madre Villa Ave./Claremont            |
| 25  | Guideway-4 | Personal Rapid Transit (PRT)     | PRT using rail right-of-way   | Sierra Madre Villa Ave./Claremont            |
| Source: Gold Line Phase II Extension, Pasadena To Claremont Alternatives Analysis, Final Draft Report, Metro Blue Line Construction Authority. January 8, 2003.                                     |            |                                  |   |  |

### 2-1.1.2 Screened List of Alternatives

Once the initial list of potential alternatives was developed (**Table 2-1**), alternatives were screened for flaws that would prevent their implementation, or that would seriously limit their ability to service the needs of the study corridor. Screening criteria were created and applied to the 25 potential alternatives during this second round of screening. The basis for eliminating alternatives in this round of screening included these basic reasons:

- Was estimated not to be cost-effective
- Posed significant environmental disadvantages
- Offered no advantages over less-costly technologies
- Would not be likely to meet projected travel demand
- Would not be likely to reduce travel times



- Would be more costly to construct and/or operate than TSM or 10 build alternatives
- Would not meet or would conflict with goals and objectives established for the Alternatives Analysis.

During the second round of screening, as shown previously in **Figure 2-2**, alternatives were also analyzed using a number of additional factors, including engineering or environmental “fatal flaws,” potential to service existing land uses, transit-oriented development potential, implementation time, and financial capacity. Refer to the Development and Screening Analysis Report, dated November 30, 2001, for more information.

As a result of the second round screening analysis and input from the Technical Advisory Committee, which had been established for the Alternatives Analysis process, the list of 25 alternatives was reduced to seven, as outlined in **Table 2-2**. All seven alternatives utilize a single alignment on property currently owned by the LACMTA and used by the Burlington Northern Santa Fe (BNSF) Railway for freight rail service to a small number of customers along the alignment.

| <b>TABLE 2-2<br/>SCREENED LIST OF ALTERNATIVES</b> |  |                   |   |  |
|--|--|-------------------|---|--|
| <b>Alternative</b>                                 |  | <b>Technology</b> | <b>Description</b>  | <b>Route / Western Terminus / Eastern Terminus</b>                   |
| 1  | Baseline/<br>TSM                       | Baseline          | Future bus network with Foothill Transit Express Bus on I-210, plus other transportation improvements in Regional Transportation Plan, Package G  | Existing street network<br>Sierra Madre Villa Ave./Indian Hill Blvd. |
| 2  | (BRT-9)<br>BRT on rail right-of-way    | BRT               | BRT on Rail right-of-way (two lanes)<br>Bus on pavement<br>Guided bus   | Rail right-of-way<br>Sierra Madre Villa Ave./Claremont               |
| 3  | (LRT-2)<br>LRT no Freight              | LRT               | LRT double track (may include some sections of single track)<br>With no freight—buy remaining interests<br>With freight—run freight operations off-peak<br>Test a Segment 1 Minimum Operable Segment that extends LRT to, for example, Irwindale, with DMU to Claremont on double track | Rail right-of-way<br>Sierra Madre Villa Ave./Claremont               |
| 4  | (LRT-3)<br>LRT on Two Tracks + Freight | LRT               | LRT double track and dedicated freight track<br>Test a Segment 1 Minimum Operable Segment that extends LRT to, for example, Irwindale, with DMU to Claremont on double track  | Rail right-of-way<br>Sierra Madre Villa Ave./Claremont               |

| TABLE 2-2<br>SCREENED LIST OF ALTERNATIVES  |   |            |   |  |
|---|---|------------|---|--|
| Alternative   |   | Technology | Description   | Route / Western Terminus / Eastern Terminus            |
| 5   | (CR-3)<br>Non-compliant DMU shared with Freight | DMU        | FRA non-compliant double track<br>With no freight—buy remaining interests<br>With freight—run freight operations off-peak | Rail right-of-way<br>Sierra Madre Villa Ave./Claremont |
| 6   | (CR-4)<br>Non-compliant DMU + Separated Freight | DMU        | FRA non-compliant vehicle, double tracked, and dedicated freight track  | Rail right-of-way<br>Sierra Madre Villa Ave./Claremont |
| 7   | (CR-5)<br>Compliant DMU + Single Track Sections | DMU        | FRA-compliant double track with occasional single track in narrow sections  | Rail right-of-way<br>Sierra Madre Villa Ave./Claremont |
| Source: Gold Line Phase II Extension, Pasadena To Claremont Alternatives Analysis, Final Draft Report, Metro Blue Line Construction Authority, January 8, 2003. |   |            |   |  |

These seven alternatives were analyzed using criteria developed for the proposed project and identified in the Alternatives Analysis Report.

### 2-1.1.3 Locally Preferred Alternative from Alternatives Analysis

Utilizing the findings of the Alternatives Analysis Report, the Technical Advisory Committee identified Alternative 4, double track LRT with either a separate freight track or with no freight as the preferred alignment and mode choice in June 2002. Subsequently, this preference was defined in the Draft EIS/EIR document as the “Double Track Configurations” for both the LRT Full Build Alternative and the Build LRT to Maintenance Facility. Subsequent to the Draft EIS/EIR, the Double Track Configuration terminology was dropped from usage, but the Final EIS/EIR is based upon a configuration of two LRT tracks throughout the project alignment.

## 2-1.2 Alternatives Screening Process

### 2-1.2.1 Public Input Into Defining Alternatives for Consideration

As a part of the federal and local project development and environmental clearance process, the Scoping process was initiated to begin the environmental analysis of this proposed project. A component of the Scoping meetings was to ask the public about alternatives to be considered. A very aggressive public outreach effort to support the Scoping meetings was begun, including newspaper notices and mailings to approximately 23,000 residents, elected officials, government officials, and interested parties. The Scoping process was initiated with the cooperation of the Federal Transit Administration (FTA). Required public notifications were made through publication of a Notice of Intent by FTA in the Federal Register (July 9, 2003) and issuance of the state-required Notice of Preparation (June 27, 2003) by the Construction Authority. The purpose of the intensive Scoping process was to invite interested

individuals, organizations, and federal, state, and local agencies to participate in defining the alternatives to be evaluated in the EIS/EIR and identify any significant social, economic, or environmental issues related to the alternatives. The study area was defined in the Scoping information booklets and the seven alternatives resulting from Alternative Analysis were shown at the Scoping meetings.

Four community Scoping meetings were noticed and conducted on July 15, 16, 17, and 21, 2003. A separate governmental agency Scoping meeting was conducted on July 22, 2003, at the Construction Authority offices. More than 200 persons attended the five meetings, and the comments are fully documented in the Scoping Meeting Summary Report dated September 5, 2003.

### 2-1.2.2 Screening of Technologies

The range of technologies initially considered included BRT, LRT, commuter rail, DMUs, HOV lanes, and fixed guideway facilities. After the long list of alternatives was screened down to seven, the three technologies associated with the remaining alternatives and evaluated in the Alternatives Analysis Report were BRT, LRT, and DMU. The preferred alignment and mode utilized LRT technology as an extension of the existing Gold Line light rail line from downtown Los Angeles to Pasadena. It was selected for the following reasons:

- LACMTA is familiar with this type of transit technology, and has successfully implemented three light rail services within the last 20 years (Blue, Green, and Gold Lines). LACMTA has invested substantial amounts in the supporting maintenance and operating infrastructure for LRT service.
- ~~Phase II~~ The Foothill Extension is an extension of the existing Gold Line light rail service, thus eliminating transfers between modes. Avoiding transfer increases the potential for shifting patrons from automobile to transit.

The two other technologies (BRT and DMU) were dismissed mainly due to the fact that the existing technology of Phase I is LRT. Transferring to a different mode at the beginning or end of the ~~Phase II~~ Foothill Extension corridor ~~impacted~~ negatively affected projected travel times and service levels when modeled. Street-running BRT would not offer the travel time savings that LRT could offer, and a dedicated BRT lane, BRT alignment on the right-of-way, or DMU would offer service similar to the LRT but include a mode transfer at Sierra Madre Villa Station. The three technologies evaluated are described below.

#### *a. Bus Rapid Transit*

BRT utilizes buses to provide high-quality, rapid transportation in a defined corridor and primarily on dedicated bus lanes. As the FTA describes it,<sup>2</sup> BRT “combines the quality of rail transit and the flexibility of buses.” BRT takes advantage of such innovations as intelligent transportation systems technologies, signal priority for transit vehicles, convenient fare collection systems, and integration with local land use policies, all with the goal of reducing travel time. BRT often, but not necessarily, include busways, which are exclusive lanes for buses or separate rights-of-way. In Los Angeles County, a modified system of BRT called the Metro Rapid runs along several routes, such as the Wilshire Corridor. This modified BRT does not have dedicated lanes, but does utilize priority traffic signals and limited stops.

---

<sup>2</sup> FTA. BRT Reference Guide. Available at: [www.fta.dot.gov/brt](http://www.fta.dot.gov/brt).

BRT provides fast, longer distance trips, as well as collection and distribution functions. Buses can pick up and distribute passengers, get on the busway, and proceed to other destinations before exiting the busway again. Therefore, BRT alignments can be used by local bus routes as well as longer commute-type routes. At grade crossings, the busway alternative would include gates as an added safety measure.

### *b. Light Rail Transit*

LRT uses lightweight passenger railcars operating on tracks. Along the proposed project corridor, a dedicated right-of-way ensures that the LRT would be separated from vehicular traffic; however, LRT vehicles can also be street running. LRT is an electrically powered system, obtaining its power using an overhead wire. In Los Angeles County, the Metro Blue Line, Green Line, and Gold Line Phase I, all completed within the last decade, are LRT systems.

LRT vehicles can accelerate and decelerate quickly and, therefore, can efficiently serve closely spaced stations. Because of their lighter weight, LRT vehicles can often be accommodated on bridges designed for automobile traffic.

### *c. Diesel Multiple Units*

DMUs are diesel-powered, self-propelled passenger cars operating on rail tracks. Since a power unit is located in the undercarriage of each passenger car, a locomotive is not needed. A DMU looks much like a passenger railcar, but without a locomotive to pull it. DMU systems accelerate and decelerate much like LRT systems. Cars can be coupled together or run individually, depending upon required capacity. They tend to be more efficient than conventional commuter rail alternatives for smaller passenger loads because they do not require a locomotive to pull only one or two cars.

DMUs are classified into two categories: Federal Railroad Administration (FRA)-compliant or FRA non-compliant. Operating DMUs on the same time schedule and on the same tracks as freight operations requires that the DMU be FRA-compliant, meaning that the DMU meets the FRA safety standards (structural strength) for crashworthiness. Otherwise, DMU and freight operations must be time-separated in order to avoid potential accidental crashes.

## 2-1.2.3 Screening of Primary Alignments

Several alignments were considered in the Alternatives Analysis process, including using the rail right-of-way formerly owned by BNSF and currently owned by LACMTA, running on I-210, or utilizing local major arterials.

The rail right-of-way alignment was deemed the most promising for development of transit service for the following reasons:

- A limited amount of land acquisition would be necessary to support rail service along the existing right-of-way.
- Implementing service would maximize the previous investment made in purchasing the right-of-way.
- Rail service would be consistent with the goals of locating stations that facilitate many corridor cities' vision for land use and development around transit stations and adjoining activity centers.
- Rail service on existing right-of-way would have relatively shorter construction time than on new right-of-way.

- Use of a pre-existing right-of-way that included current train movements would generate fewer and less significant impacts on existing natural and manmade environments than on new right-of-way.

The freeway alignment was not considered for further analysis for the following reasons: high costs associated with widening the freeway; inability to implement transit by the goal service date of 2008 due to extensive widening and construction; significant impacts to the natural and manmade environment; inconsistency with the goal of locating stations that facilitate corridor cities' vision for land use and development around transit stations and adjoining activity centers within cities' downtowns; and community resistance to further construction on I-210, which has been ongoing for a number of years. Communities along the proposed project corridor are resistant to additional right-of-way and construction impacts.

The local major arterials alignments were not considered further for the following reasons: no reduction in travel times; high costs associated with widening local streets; significant impacts to environmental and community resources associated with widening streets; and impacts to residential neighborhoods along local streets during construction and potentially during operation.

#### *a. Rail Right-of-Way*

In 1991, LACMTA acquired BNSF's Pasadena subdivision right-of-way. This rail right-of-way is the historic link between San Gabriel Valley cities. Amtrak service connected from downtown Los Angeles through Pasadena to San Bernardino County and beyond along this route up until the late 80s. BNSF continues to run limited freight operations along the portion of this line between Monrovia and Montclair.

#### *b. I-210 Freeway*

Expanding I-210 to accommodate bus or HOV lanes would entail widening the freeway right-of-way, elevating a busway above the freeway, or running buses on the shoulders or in the HOV lanes.

#### *c. Local Major Arterials*

The BRT and Metro Rapid Alternatives were examined that utilized local major arterials, dedicated local streets, or a combination of freeway and local streets in an east-west orientation. Specific routes are described further in the Alternatives Analysis Report.

### 2-1.3 Candidate Alternatives for Environmental Analysis

Based on input from the community, FTA, Construction Authority, LACMTA technical staff, and the consultant team, a No-Build Alternative, ~~a TSM Alternative~~, and two fixed-guideway Build Alternatives were developed for technical analysis. These alternatives include a refinement and expansion of Alternatives 3 and 4 from Table 2-2. They are summarized below. The detailed project descriptions for each alternative are covered in Section 2-2.

The **No-Build Alternative** includes all highway and transit projects and operations that the region and LACMTA expect to be in place in 2025 (the horizon year for this EIS/EIR). These include improvements to the local bus system and regional commuter rail system (Metrolink), as well as planned highway improvements in the region. A TSM Alternative was developed for the Draft EIS/EIR. Subsequent to the Draft EIS/EIR, a TSM Alternative was dropped from further consideration since it did not well meet the Purpose and Need (Chapter 1) established for the corridor.

The TSM Alternative was eliminated from consideration by selection of an LPA (see Section 2.3). The two Build Alternatives utilize existing LACMTA Construction Authority-owned right-of-way through the San Gabriel Valley for LRT lines from Sierra Madre Villa Station to the east. The major difference between the two Build Alternatives is the terminus: the Full Build LRT Alternative Full Build (Pasadena to Montclair) Alternative extends 24 miles east from the Sierra Madre Villa Station in Pasadena to the City of Montclair in San Bernardino County, while the Build LRT to Maintenance Facility Alternative Build LRT to Azusa Alternative extends about 11 miles from the Sierra Madre Villa Station to the eastern boundary of the City of Irwindale-Azusa.

### 2-1.3.1 Screening of Station Locations

Station locations were determined through discourse with each city along the proposed route. Meetings with the cities took place during both the Alternatives Analysis process and the EIS/EIR process. Cities called attention to a number of important issues related to the location of a station. For the most part, the alignment runs through the downtown areas of each city, which creates a natural location for a station. Additionally, many cities have historic depots from the original passenger and freight line that used to run through this area. The cities of Monrovia, Azusa, San Dimas, and Claremont plan to utilize their historic structure in some manner as a part of their LRT station areas. Other cities, without this historic resource, have plans for transit plazas, mixed-use or joint development, or other methods of incorporating the new station into the community.

For the most part, cities came to the meetings entered the environmental process with a first choice station location identified, and in most cases, this was a location that was technically acceptable to the consultant team's engineers, planners, and architects. For cities that had a number of station location options, some were screened out for the following reasons:

- Track curvature, horizontal alignment, or vertical alignment did not allow for conformance with LACMTA Design Criteria and/or Americans with Disabilities Act (ADA) regulations.
- The neighborhood in which the station was to be located was not conducive for transit use (i.e., residential and/or industrial).
- The right-of-way was too narrow at the proposed location, thus requiring additional land to be purchased.

In some cases, cities have two or three potential station locations that were identified and analyzed within this the Draft EIS/EIR. In such cases, the city was unable to identify a single acceptable location, and requested that the study look at a number of options. This will allow the city to make a decision on the station location later in the environmental process, when the impacts associated with the site options (such as those reported in this DEIS/DEIR) are known to them. Subsequent to the Draft EIS/EIR, those cities with options reached decisions on the locations of LRT stations. These locations are reported below, and environmental impacts of the selected locations are discussed in Chapter 3.

### 2-1.3.2 Freight Rail Considerations

The two LRT-Build Alternatives utilize an existing BNSF right-of-way currently owned by LACMTA the Construction Authority. BNSF runs daily freight operations between Montclair and Irwindale, and weekly operations between Irwindale and Monrovia, with the majority of freight heading to the Miller Brewing Company facility in Irwindale. Freight operations are governed by a Shared Use Agreement between BNSF and LACMTA, and by regulations of the federal Surface Transportation Board. The

dispatch of freight trains is managed by the Southern California Regional Rail Authority. Safety issues are governed by the California Public Utilities Commission and the Federal Railroad Administration.

~~Both Build Alternatives include three operational configuration options for handling the existing freight traffic while also implementing LRT:~~

~~Triple Track Configuration: This operational configuration was developed that would provide two light rail tracks and one freight rail track for most of the alignment length. Two light rail tracks would extend from the existing Sierra Madre Villa Station to the proposed terminus at Montclair.~~

~~The existing single freight track between Irwindale and Pomona / Claremont would have to be relocated within the right of way in order to provide room for the two light rail tracks. Between La Verne, Claremont and Montclair, the rail right of way includes two tracks jointly used by Metrolink and BNSF. In the segment, which is a wide right of way, the LRT tracks would be located on the northern portion of the right of way, while Metrolink/freight tracks would be located on the southern portion.~~

~~Double Track Configuration without Freight: This operational configuration assumes that the freight interests along this corridor would be negotiated to move to other modes of access. This would result in there being two LRT tracks along the corridor from Sierra Madre Villa Station to the eastern border of the City of La Verne. East of La Verne, freight would continue to operate on the existing Metrolink/freight tracks that share the right of way.~~

~~Double Track Configuration with Freight: This operational configuration would have freight and light rail vehicles sharing the same tracks along the right of way between Monrovia and La Verne. Freight operations would occur during a time-separated window from when LRT services would be occurring. LRT operations are assumed to begin at approximately 4 a.m. and end at about 2 a.m.; freight operations would typically be restricted to hours when LRT service is not in operation. Under this operational configuration, freight service to the east of La Verne would operate on the existing (and separate) Metrolink/freight tracks, and would not be required to be time separated.~~

~~All three options will be examined and analyzed in this EIS/EIR.~~

Currently, the western-most freight customer is located in Monrovia. The City of Monrovia Redevelopment Agency has plans to relocate this freight customer, allowing for the elimination of the freight track between Monrovia and Irwindale. Following the removal of the freight track to Monrovia, a single freight rail track would extend from Irwindale to the Pomona / Claremont border, where it would link with the existing double BNSF freight tracks (also used by Metrolink).

The freight rail track would be located on the south side of the right-of-way between the Miller Brewing Company in Irwindale and Virginia Avenue in Azusa. At this point, the LRT would “fly-over” the freight rail and the street, so that the configuration east of Virginia Avenue would have the freight track on the north and the LRT tracks on the south side of the right-of-way. This configuration extends from Azusa to Towne Avenue in Pomona, where the LRT tracks again “fly-over” the freight track and the street, resulting in the LRT on the north side of the right-of-way, and the freight track on the south. This positions the freight track to merge with the Metrolink tracks, located to the south of the alignment at this point. Adjacent to the Pomona / Claremont border, the freight tracks merge with the Metrolink tracks, resulting in two LRT and two Metrolink / freight tracks through Claremont and Montclair.

## 2-2 DETAILED DESCRIPTION OF ALTERNATIVES

~~Four candidate~~ Three alternatives are examined in this Final EIS/EIR. These include:

- No-Build Alternative
- ~~Full Build LRT Alternative~~ Full Build (Pasadena to Montclair) Alternative
- ~~Build LRT Alternative to the Maintenance Facility~~ Build LRT to Azusa Alternative.

### 2-2.1 No-Build Alternative

The No-Build Alternative as defined by FTA should represent the baseline case consisting of existing and committed elements of the region's transportation plan. The No-Build Alternative for the proposed project assumes that no extension to the Gold Line would be built. The No-Build Alternative includes all highway and transit projects and operations that the region and MTA expect to be in place by 2025. This section includes descriptions of the general types of projects included in the No-Build Alternative and describes some of the larger projects, along with those located very close to the Gold Line ~~Phase II~~ Foothill Extension Project.

#### 2-2.1.1 Transportation Projects in the No-Build Alternative

The No-Build Alternative includes transportation projects throughout Los Angeles County that are approved and funded. Transportation projects include transit projects, freeway improvements, new smart street projects, and arterial improvement projects. The No-Build Alternative is LACMTA's Long Range Transportation Plan 2025 (LRTP 2025) Constrained Alternative (Package G). This alternative/package includes a balance of vehicle and transit improvements, including an expanded bus network. Projects within LRTP 2025 that are relevant to the proposed project are stated below:

~~Transit projects include countywide (Los Angeles and San Bernardino Counties) bus service improvements; commuter rail (Metrolink) improvements; Gold Line Phase I LRT service at planned headways of 5 minutes peak, 10 minutes off peak (currently operating at 10 minutes peak and 12 minutes off peak); and the construction of the Gold Line Eastside Extension with service headways of 5 minutes peak and 10 minutes off peak.~~

~~Freeway improvements include projects on freeways, such as the extension of State Route 30/I-210 from Foothill Boulevard to Sierra Avenue (now completed), and the continuing extension from Sierra Avenue to Interstate 215 (I-215) in the future.~~

~~Smart street projects include improvements such as synchronized traffic signals, on street parking removal, frontage road and grade separation construction, and key intersection improvements to improve traffic flow.~~

~~Arterial improvement projects include improvements to existing roadways.~~

Details can be found in Appendix B of LRTP 2025, adopted by the LACMTA in April 2001.



*a. Transit Service Under No-Build Alternative*

Gold Line Phase I Light Rail Transit

Phase I of the Gold Line opened in July 2003 to better than expected ridership. Extending from Union Station north to Pasadena's Sierra Madre Villa Station, the 13.7 miles of Phase I traverse numerous neighborhoods such as Chinatown and Highland Park, and the cities of South Pasadena and Pasadena. Currently operating 2-car trains at 10-minute headways, this line was designed and environmentally cleared for ultimate operations of 3-car trains at 5-minute headways. The Operating Plan for Gold Line Phase I and the Eastside LRT Extension (see below) will be 2 to 3-car trains at 5-minute headways once the Eastside project is completed in 2009. This Operating Plan dictates the basis for the Phase II-Foothill Extension impact analyses. The environmental impacts of Phase I were addressed through a series of documents prepared by LACMTA and the Construction Authority that met the requirements of the California Environmental Quality Act (CEQA). Since the first phase of LRT construction on the Gold Line did not include federal funds, no National Environmental Policy Act (NEPA) documents were required. Phase ~~I~~ of the Gold Line traverses 13 stations during its 36-minute run time from downtown Los Angeles to East Pasadena.

Gold Line Eastside Light Rail Transit Extension

Currently ~~out to bid for~~ in design/build construction, the Eastside Extension of the Gold Line extends from Union Station along First and Third Streets to a terminus at Pomona Boulevard/Atlantic Boulevard in East Los Angeles. Partly tunnel and partly street running, the Eastside LRT Extension is projected, and environmentally cleared, to ultimately run at headways of 5 minutes peak and 10 minutes off-peak. This LRT line is projected to begin operation in 2009.

Countywide Bus Service Improvements

L RTP 2025 calls for additional countywide bus service improvements (including a total countywide fleet of approximately 4,400 buses), and to implement 22 additional Metro Rapid bus lines. Refer to **Figures 2-3 through 2-7** for existing bus service routes.

SCRRA Metrolink Service Improvements

The Southern California Regional Rail Authority (SCRRA) has planned for future Metrolink commuter rail service expansions along the San Bernardino line. This commuter rail service is currently expanding to six-car platforms and SCRRA is building double tracking through the eastern end of the study corridor (i.e., east of La Verne).

*b. Highway/Roadway Improvements Under No-Build Alternative*

Proposed freeway improvements and gap closures in or affecting the proposed project area under L RTP 2025 include the I-210 Gap Closure to I-215 and HOV projects. HOV lanes are proposed for State Route 60 from Interstate 605 (I-605) to Brea Canyon Road, for I-10 from Baldwin Avenue in El Monte to the San Bernardino County line, and for I-605 from the Orange County line to South Street in Cerritos. Noise barriers, project development support, highway operations, freeway rehabilitation, and environmental enforcement and mitigation are also included in L RTP 2025.

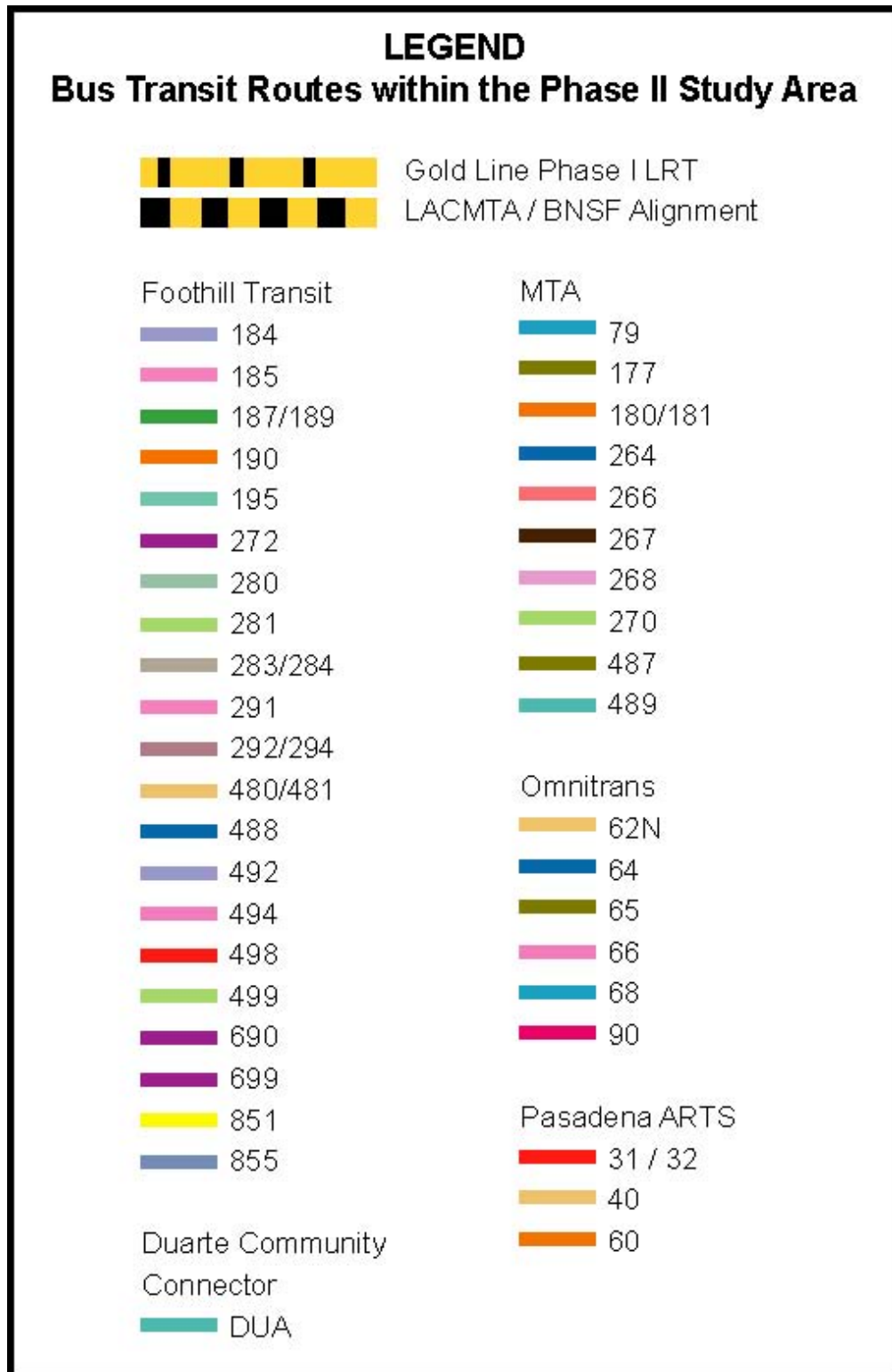

Figure 2-3: Legend for Figures 2-4 to 2-7

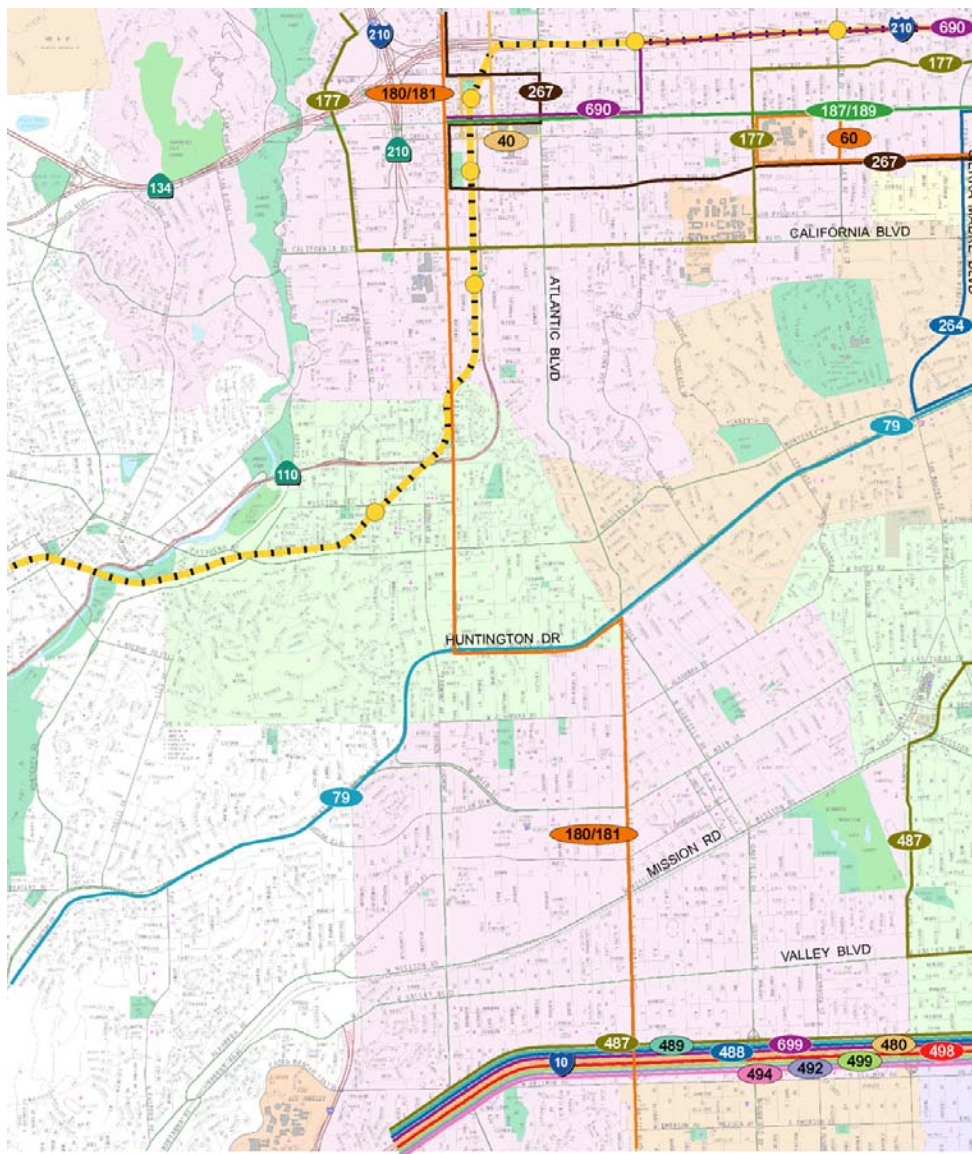

Figure 2-4: Transit Service Map, Segment 1: No Build Alternative

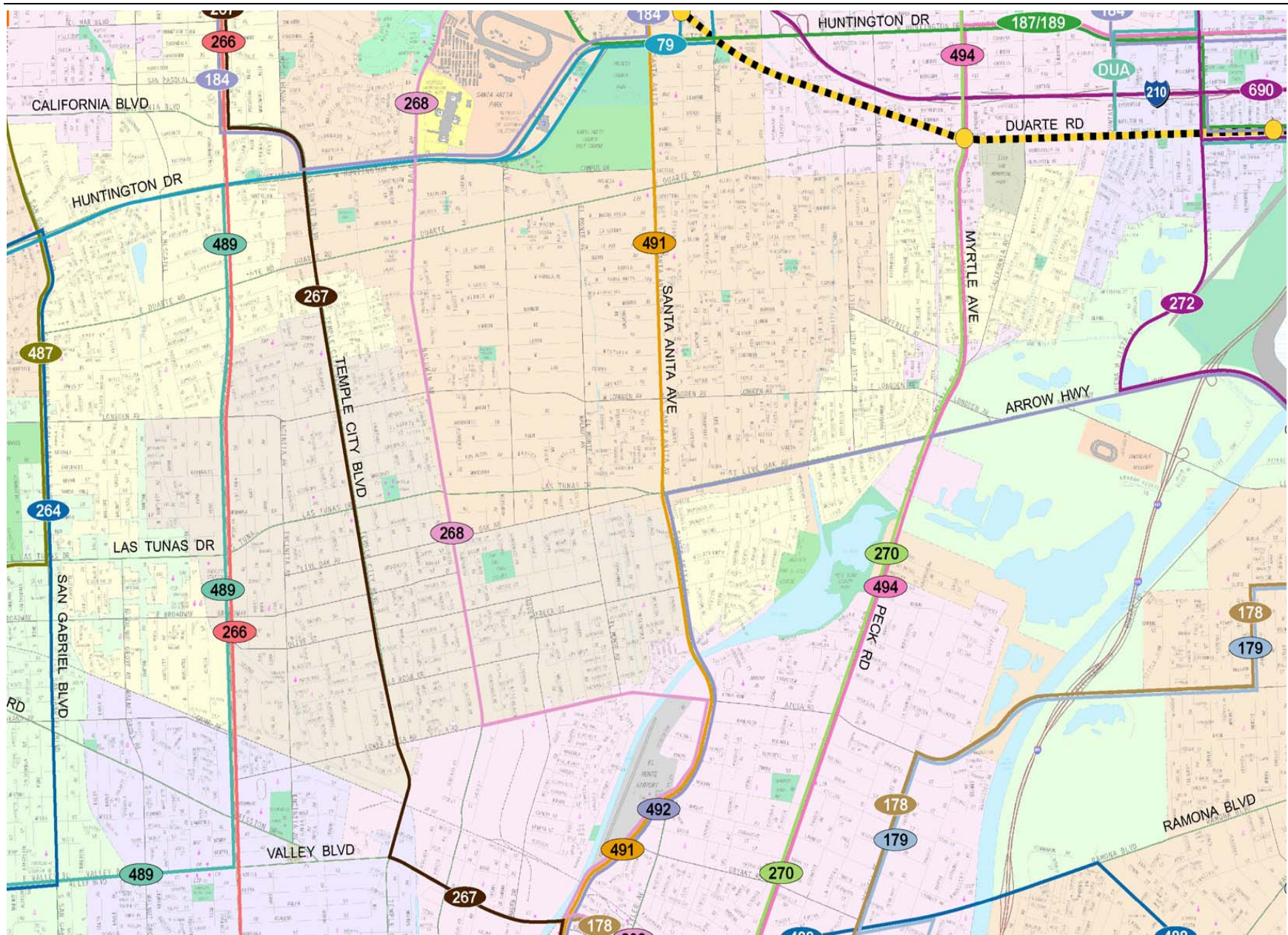

Figure 2-5: Transit Service Map, Segment 2: No Build Alternative

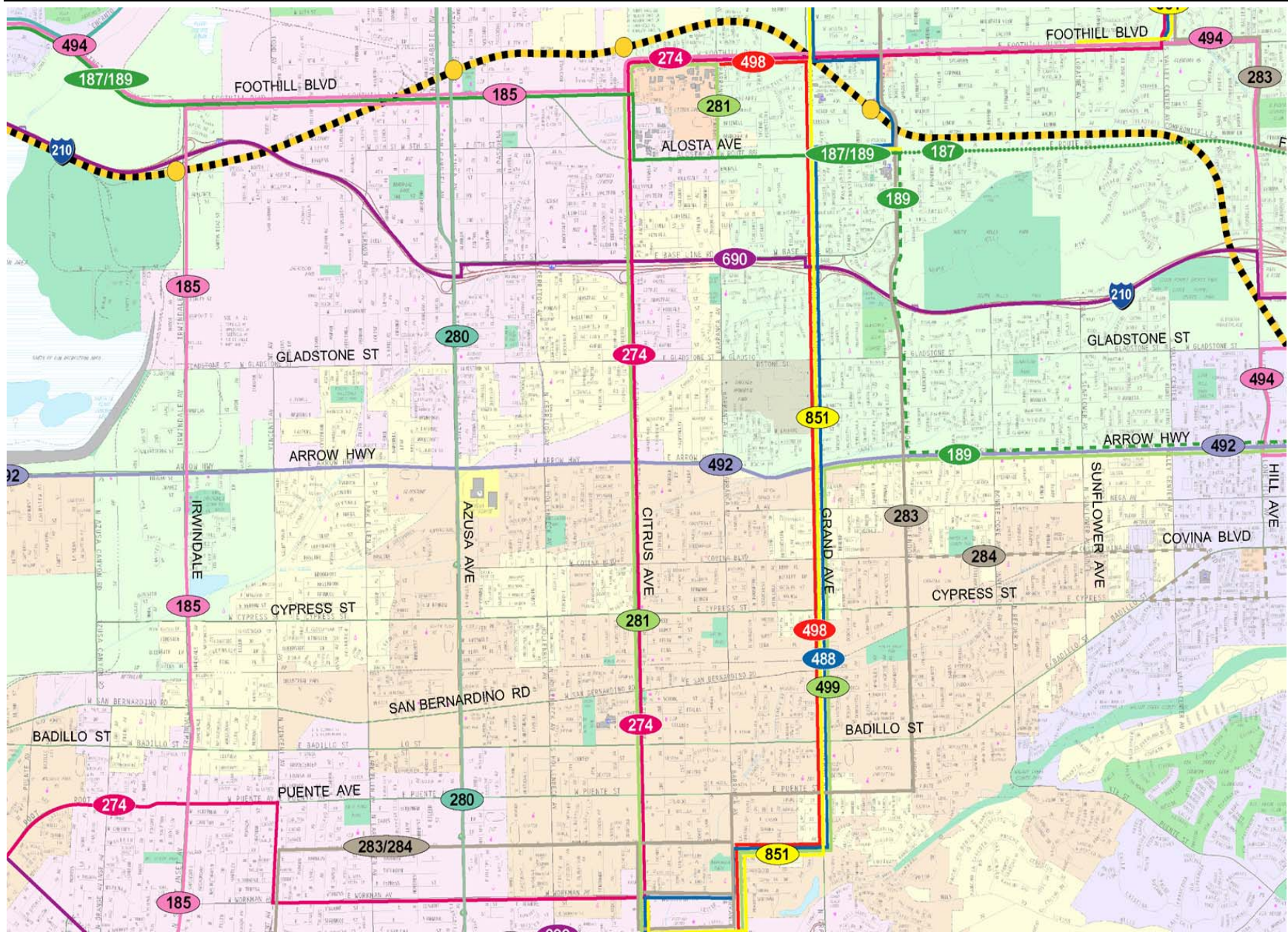

Figure 2-6: Transit Service Map, Segment 3: No Build Alternative

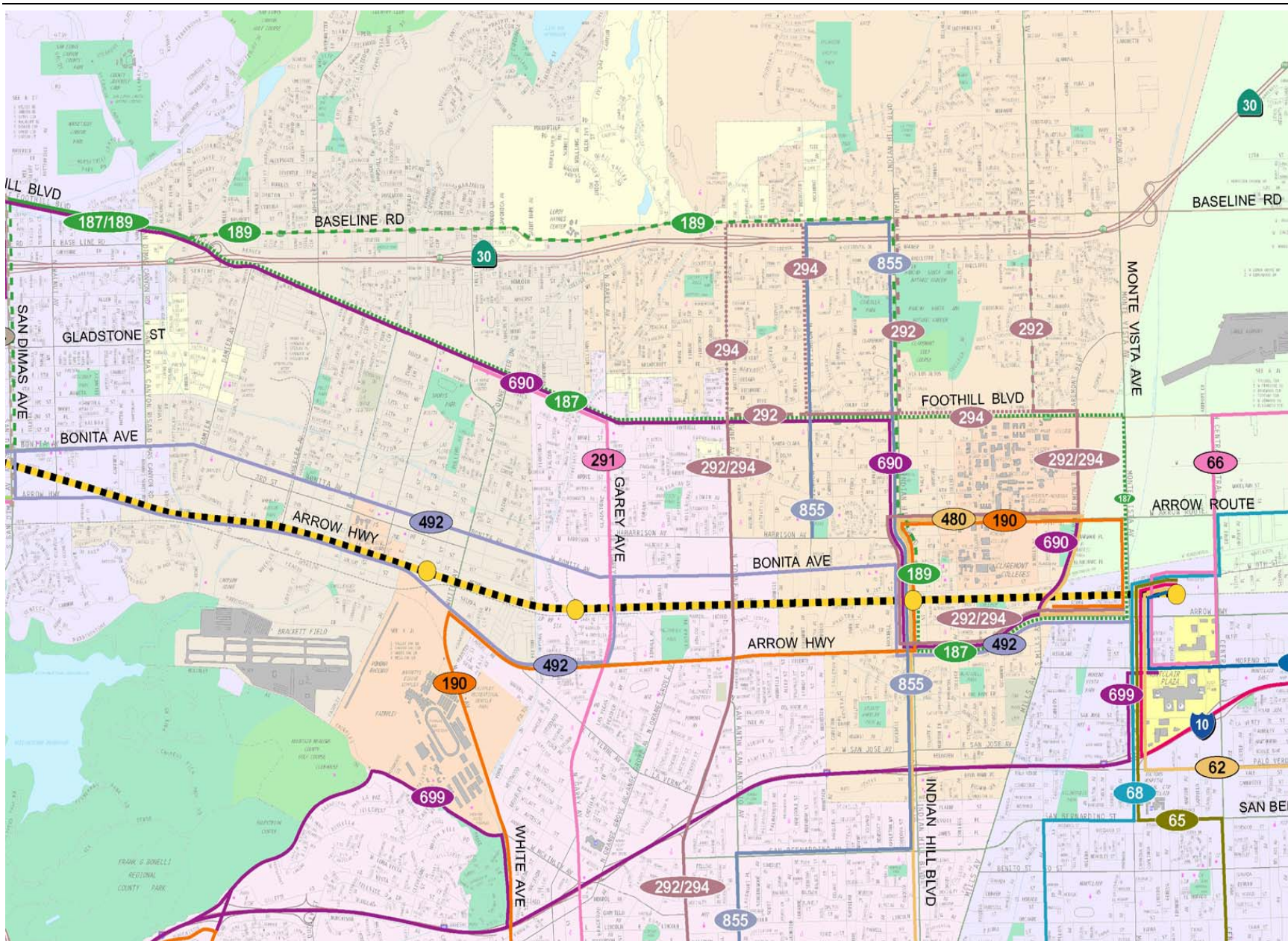

Figure 2-7: Transit Service Map, Segment 4: No Build Alternative

*c. Other Committed Transportation Improvements*

There are no other committed transportation projects that affect the overall study area or study corridor. In the past, there were plans for a bikeway along this Corridor between San Dimas and Claremont. However, the project has evolved into a network of on-street routes and is no longer would utilize rail right-of-way. While it is of interest to some commuters and local cyclists, this project does not have committed funding or a construction date at this time.

2-2.1.2 Non-Transportation Projects in the No-Build Alternative

Non-transportation projects in the No-Build Alternative consist of land development projects within the corridor cities that have been funded and approved and are scheduled for development. These projects include those that will be undertaken or have been approved by the corridor cities, the County of Los Angeles, and the County of San Bernardino.

*a. Station Square Development – Monrovia*

The Redevelopment Agency of Monrovia is in the planning stages of a transit village to be located near the historic Monrovia train depot. A transit village located at the site of the historic Monrovia train depot is in the planning stages by the Redevelopment Agency of Monrovia. The Station Square development will have mixed-use housing, neighborhood commercial, office, and high-tech manufacturing. It will be focused around a Transit Center, currently under construction, and will include approximately 200 to 300 parking spaces, a bus plaza, and the restored Santa Fe Depot.

*b. Monrovia Nursery Site/Rosedale Development—Azusa/Glendora*

A Specific Plan and EIR for the development of the 500-acre former Monrovia Nursery site, located northwest of the intersection of Foothill Boulevard/Citrus Avenue, has been ~~submitted to~~ approved by the City of Azusa. Portions of the proposed development are within the boundaries of the City of Glendora. The development would contain up to 1,250 residential units; a K-8 school; a system of parks, open spaces, and trails; and 50,000 square feet of commercial uses. ~~The project has been approved in concept by the Azusa City Council and the EIR is underway.~~ The developer plans to create a transit plaza near Citrus Avenue ~~with to complement the proposed~~ an LRT station and parking. The developer also plans to grade separate both Palm and Citrus Avenues, such that automobile traffic would pass underneath the railroad tracks.

*c. Diamond Ridge Specific Plan – Glendora*

The Diamond Ridge Specific Plan is a planned redevelopment on 29 acres located west of the existing Glendora Marketplace in the City of Glendora. The 360,000 square foot development would include, retail shopping, dining, and a theatre facility, as well as over 2,000 parking spaces. A Final EIR has been approved for the Diamond Ridge Specific Plan.

d. Costco – San Dimas

A Final EIR was prepared for a proposed Costco Commercial Complex on 22.83 acre in the City of San Dimas. The project site is located on the southeast corner of Gladstone Street and Lone Hill Avenue and on the east by the former Atchison, Topeka, and Santa Fe Railway Company (ATSF) right-of-way. The Costco Commercial Complex includes a Costco warehouse/retail facility with a tire center and a gasoline service station and 61,000 square feet of retail and restaurant space. Much of the proposed project site lies on vacant, undeveloped, or underdeveloped land and is within the jurisdiction of the San Dimas Redevelopment Agency.

e. Hutton Mixed-Use Development—Upland

Hutton Development is currently planning a mixed-use development in the City of Upland, located in the block south of Arrow Route, west of Monte Vista Avenue, north of the old Union Pacific right-of-way, and east of the San Bernardino County line. This development is directly adjacent to the existing Montclair Transcenter. The proposed development will include approximately 450 apartments, 50 single-family homes, and a hotel, office space, and a commercial center on 37 acres. A draft EIR for the proposed project is in progress.

## 2-2.2 Full Build (Pasadena to Montclair) Alternative

### 2-2.2.1 Physical Components

A Full Build (Pasadena to Montclair) Alternative that encompasses Segments 1 and 2 of the proposed project would extend the current Gold Line system from Sierra Madre Villa Station to the Montclair Transcenter (approximately 24 miles). Segment 1 lies between the current Sierra Madre Villa Station and ~~the proposed Maintenance and Operating Facility site in Irwindale~~ the eastern boundary of the City of Azusa. Segment 2 is between ~~the proposed Maintenance and Operating Facility site eastern boundary of the City of Azusa~~ and the existing Montclair Transcenter. **Figure 2-198** provides an overview of Segments 1 and 2, and the location of the proposed maintenance and operations (M&O) facility site. Volume ~~III~~ 4 of this EIR/EIS contains the plan/profiles for the Full Build (Pasadena to Montclair) Alternative. That document includes plans, profiles, station layouts, and bridge analysis. The Full Build (Pasadena to Montclair) Alternative will use the same LRT technology and the same types of system components would be used as are in the existing Phase I segment from Los Angeles to Pasadena, and in the ~~soon-to-be-built~~ Eastside Extension. The Eastside Extension will run from Union Station to Pomona Boulevard /Atlantic Boulevard Station in East Los Angeles.

The Full Build (Pasadena to Montclair) Alternative would include 12 new stations, subject to the approval of the individual cities, with at least one in or serving each of the cities along the corridor. ~~Potential Station locations, including two optional ones,~~ have been defined in consultation with the corridor cities. Parking facilities would be provided at each new station. The Full Build (Pasadena to Montclair) Alternative consists of two LRT tracks extending from Sierra Madre Villa Station in Pasadena along the LACMTA/BNSF alignment Construction Authority-owned right of way through the San Gabriel Valley to the Montclair Transcenter. ~~Several options are described in more detail throughout this section, including freight, station location, Metrorail, and alignment options.~~ Freight service between Irwindale and Montclair would be maintained; current freight service between Irwindale and Monrovia would be eliminated. ~~Freight options include Double or Triple Track; with freight operations on the third track in the Triple Track option.~~ Refer to Section 3-12, Railroad Operations, for a discussion of freight operations. The station descriptions in the following section begin with the “base case” for the station location in each city. Following this description, any options for the station location and alignment in that



city are outlined. A brief summary of the options is provided at the beginning of the station description section.

The location of the Maintenance and Operating Facility is proposed to be on now-vacant property west and south of the Miller Brewing facility. ~~and the proposed Irwindale Station .~~ Approximately ~~24~~ 16 traction power substations (TPSS) would be constructed along the route in order to provide electrical power to the line. ~~Where possible, TPSS sites would be located near a station.~~ TPSS sites would be located within existing rail right-of-way or within properties to be acquired for stations or parking, where possible. Refer to ~~Figures 2-19 through 2-41~~ Figures 2-8 through 2-30 for the LRT alignment.

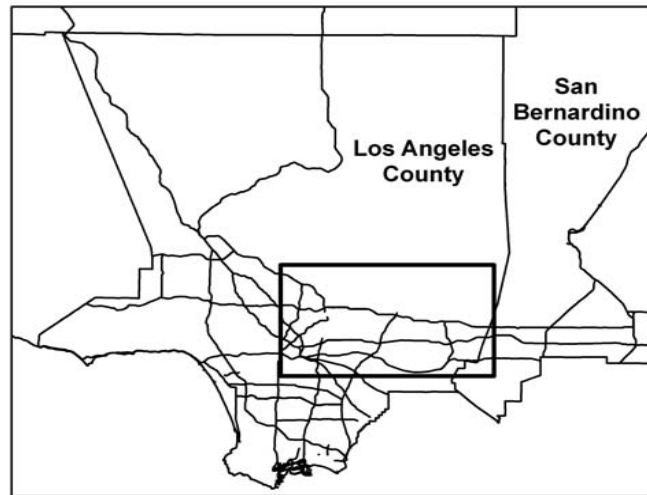
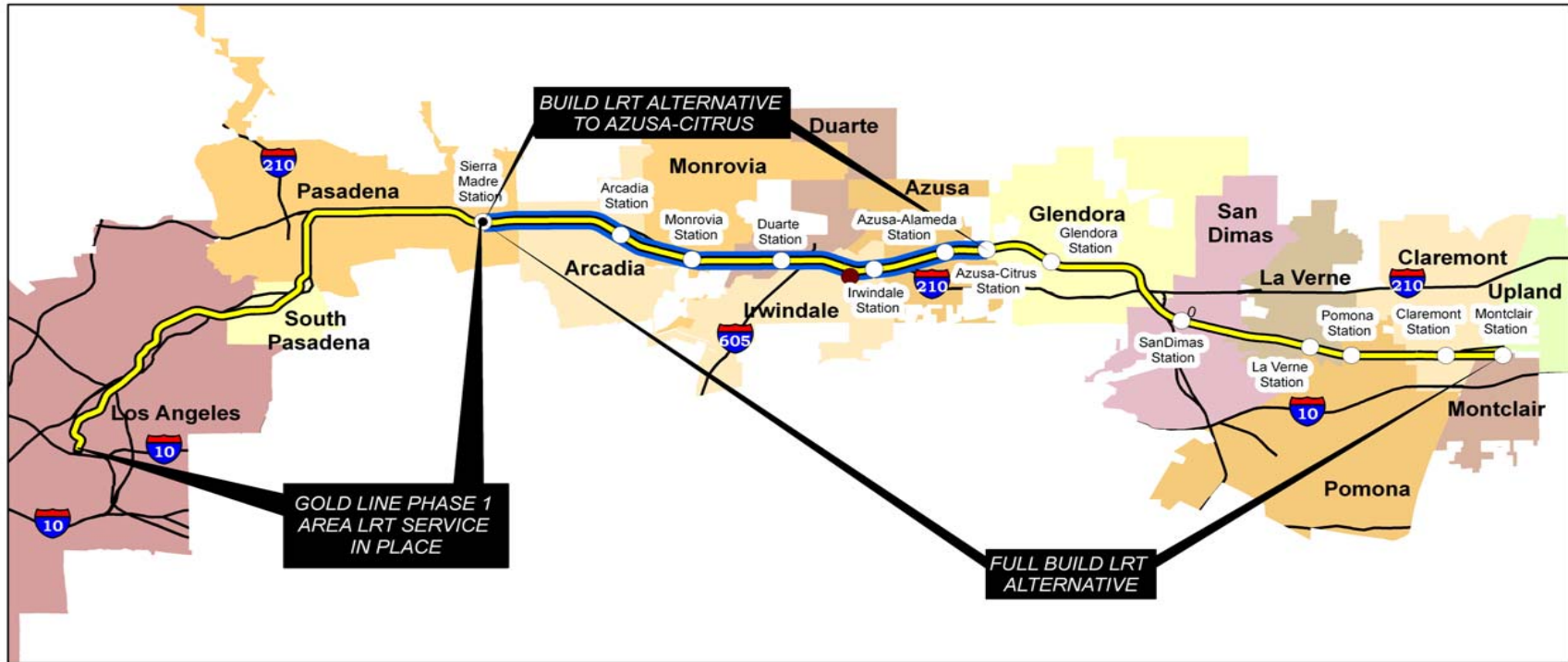

Sources: U.S. Census TIGER Data, 2000; Jones & Stokes Associates; PBQD, 2005

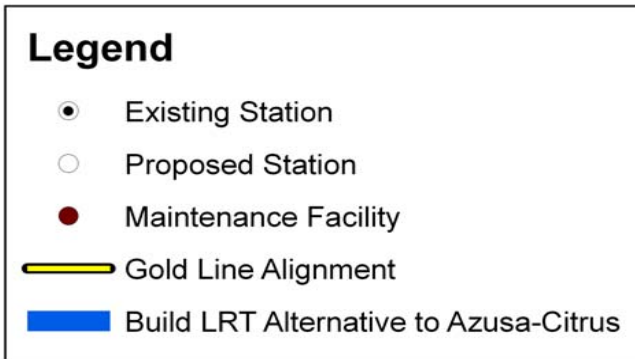

Figure 2-8: Gold Line Foothill Extension Build Alternatives

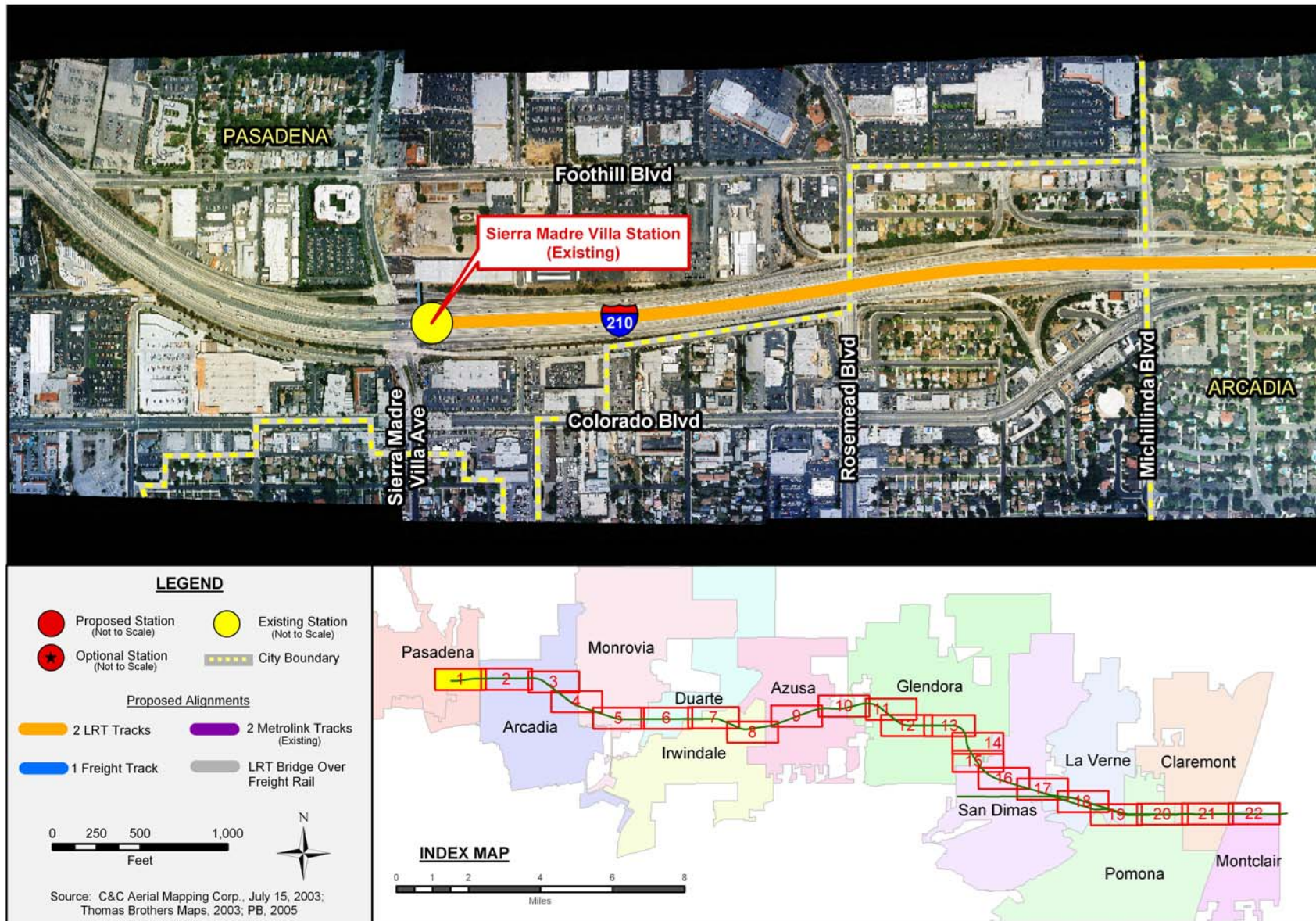

Figure 2-9: Full Build Alternative (1 of 22)



Figure 2-10: Full Build Alternative (2 of 22)



Figure 2-11: Full Build Alternative (3 of 22)

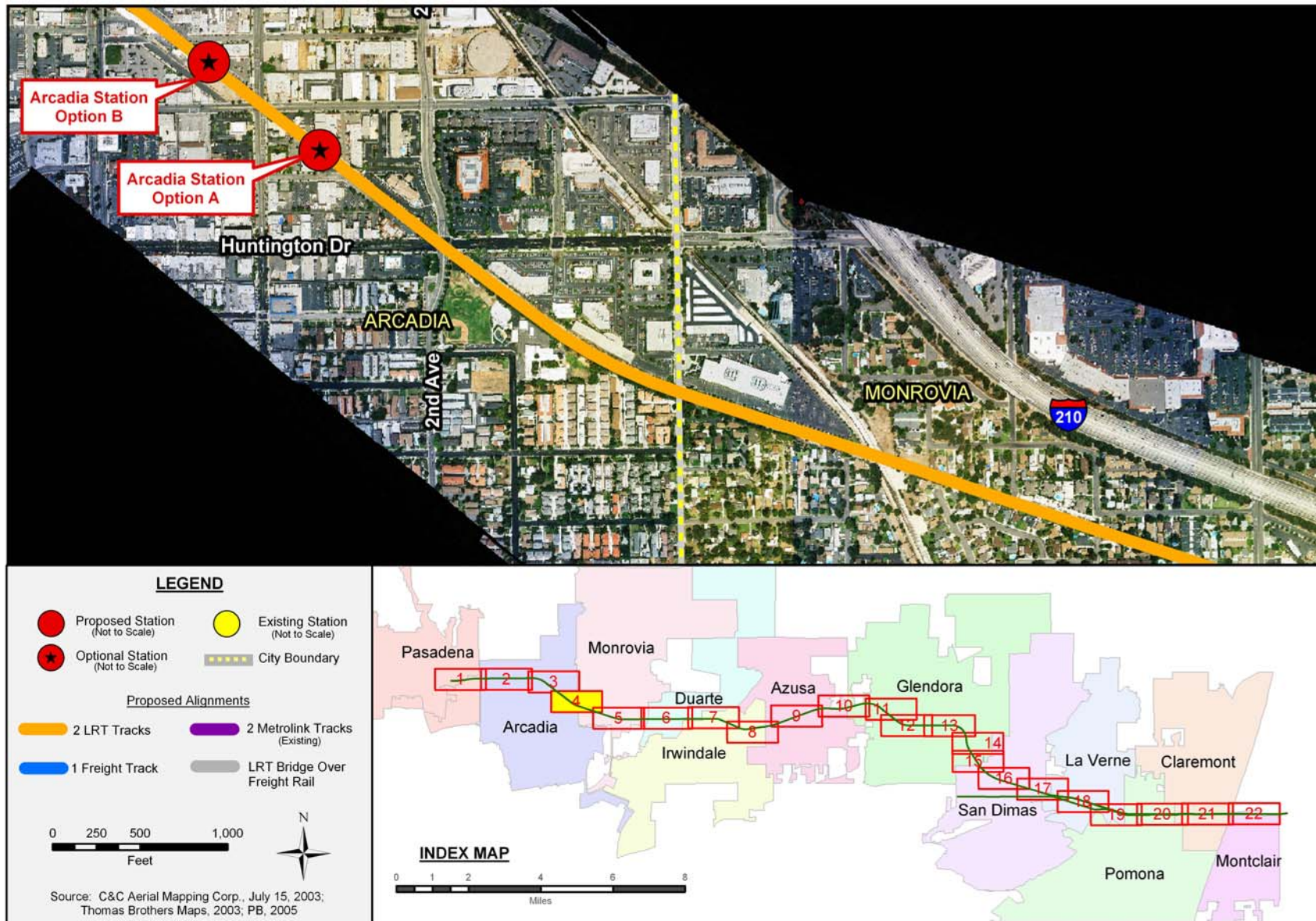

Figure 2-12: Full Build Alternative (4 of 22)

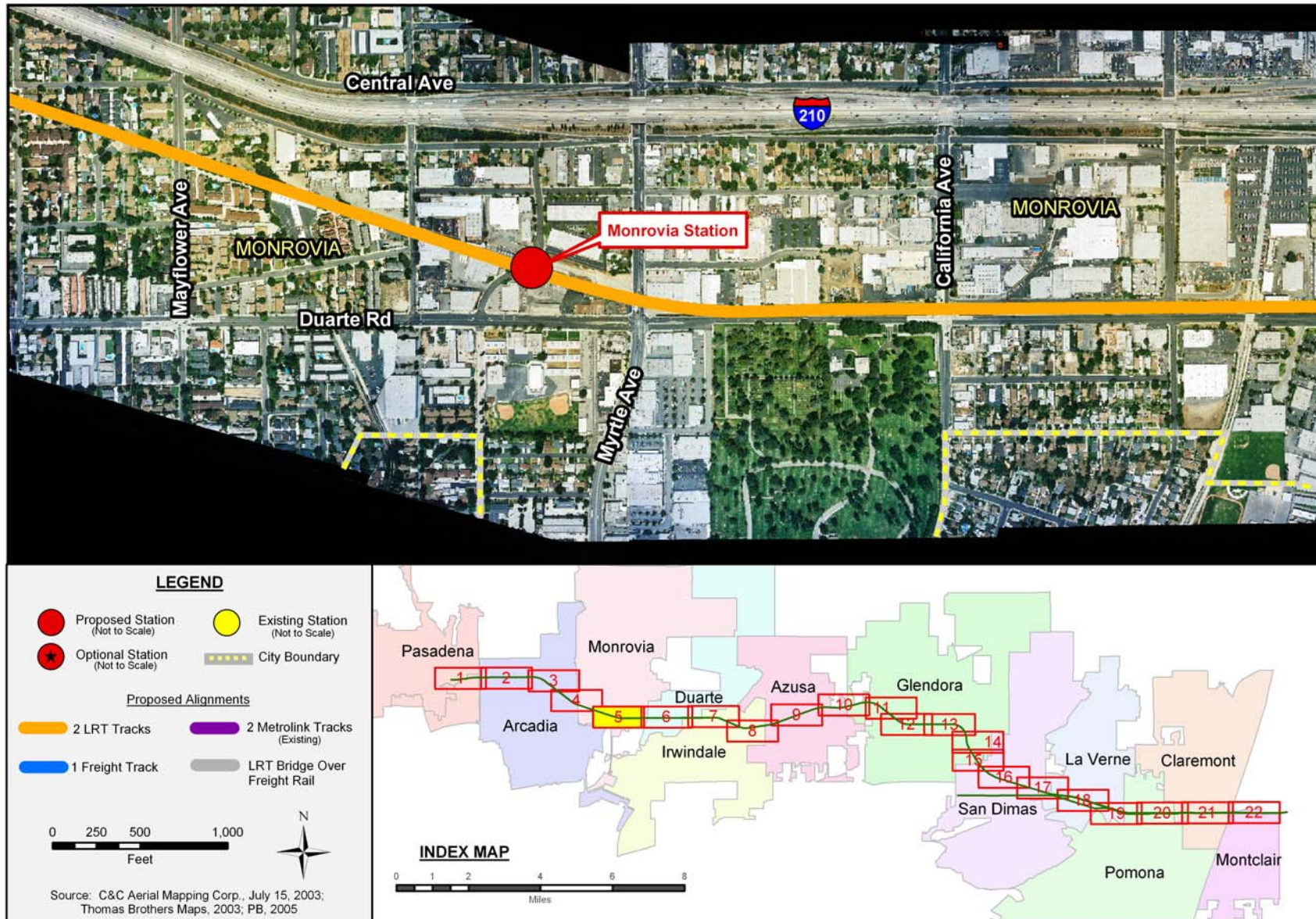

Figure 2-13: Full Build Alternative (5 of 22)

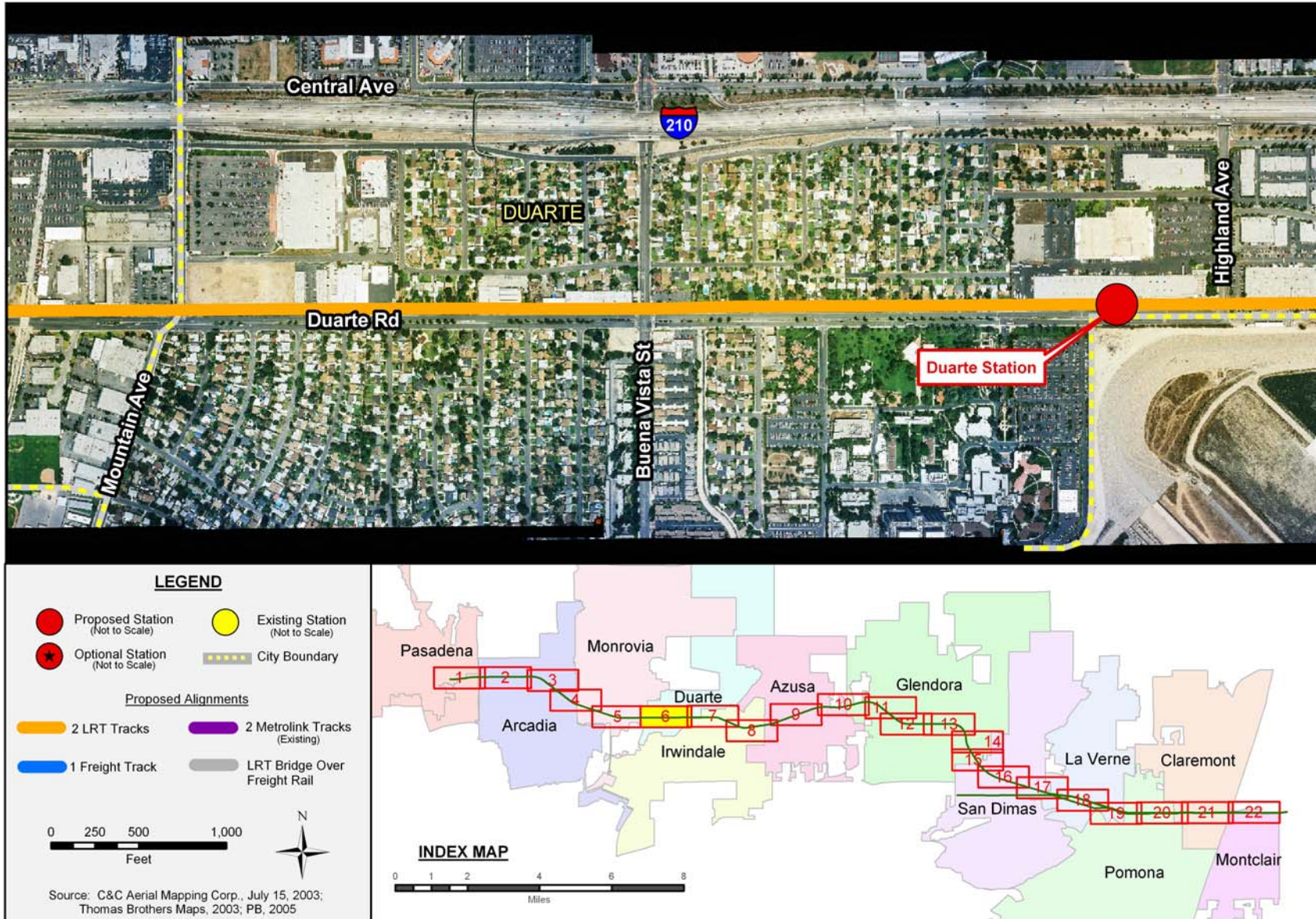

Figure 2-14: Full Build Alternative (6 of 22)



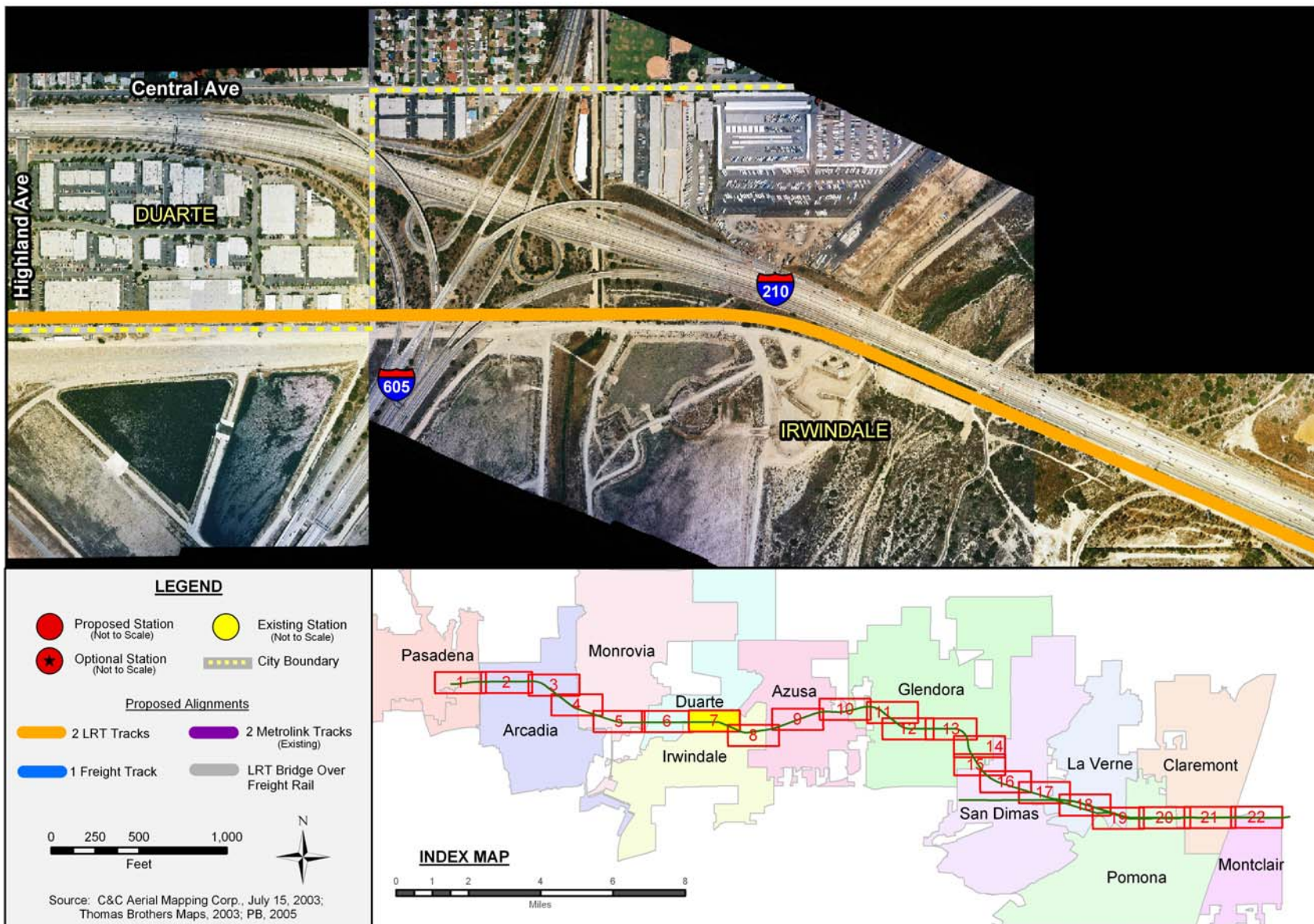

Figure 2-15: Full Build Alternative (7 of 22)

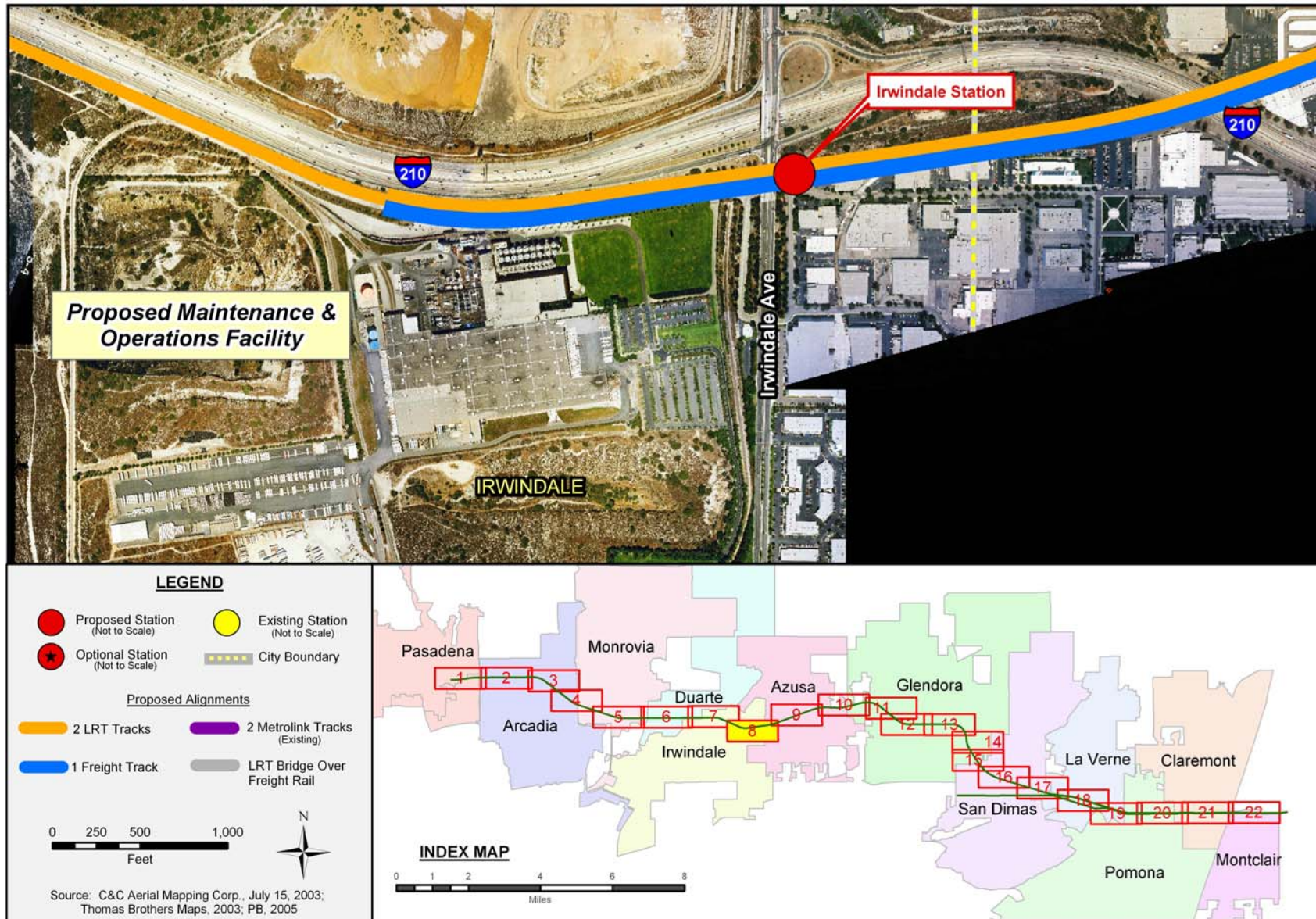

Figure 2-16: Full Build Alternative (8 of 22)

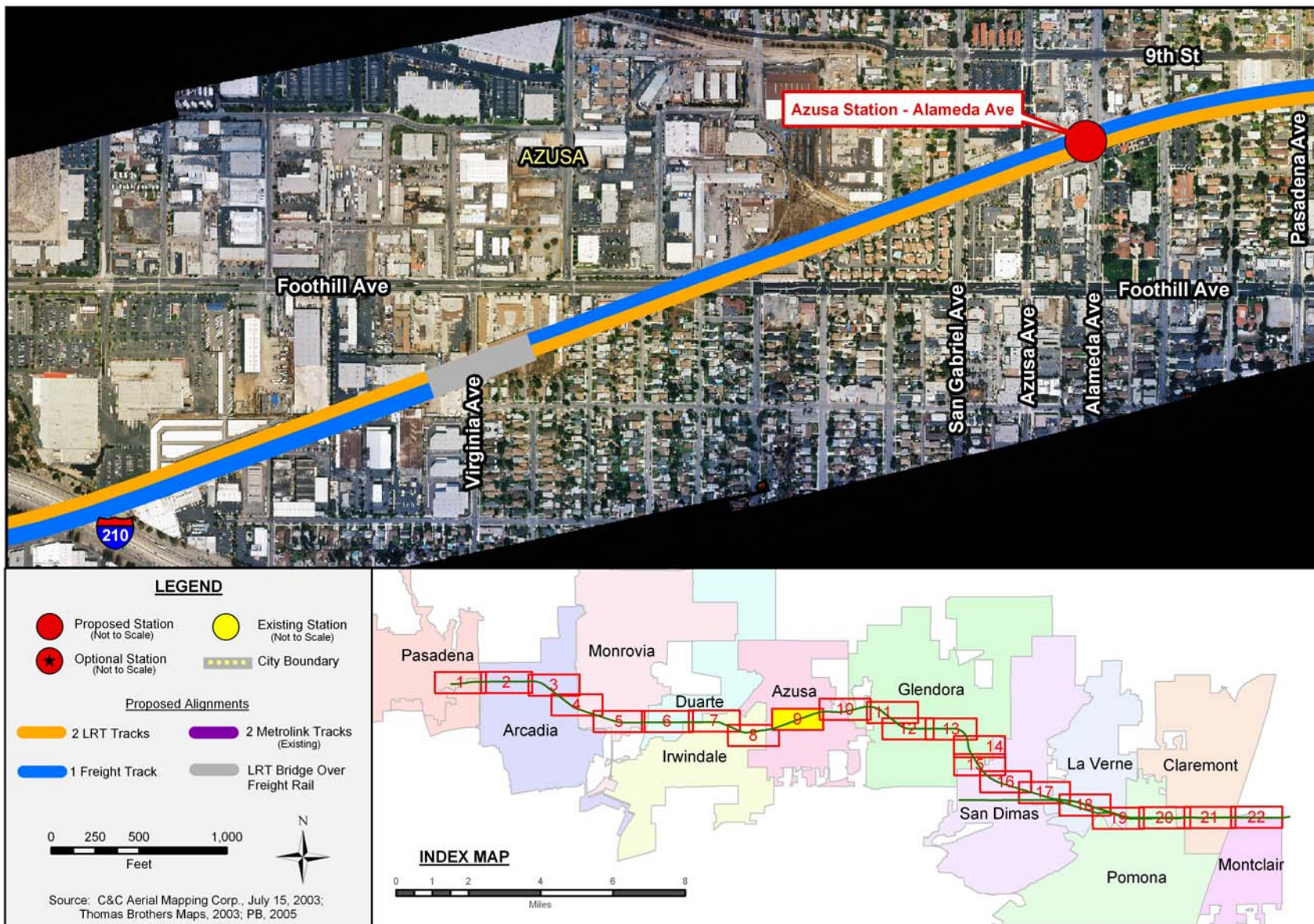

Figure 2-17: Full Build Alternative (9 of 22)

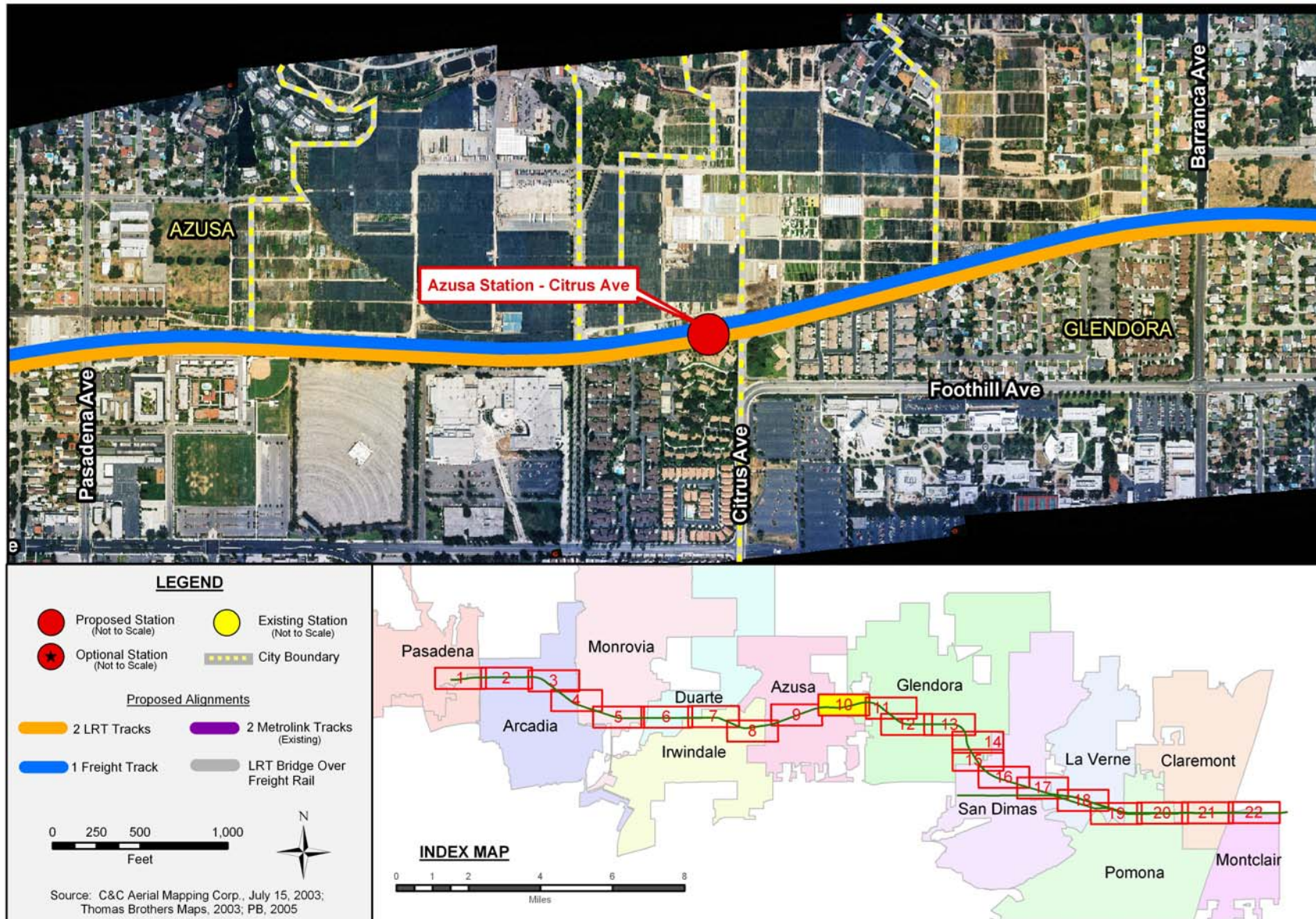

Figure 2-18: Full Build Alternative (10 of 22)

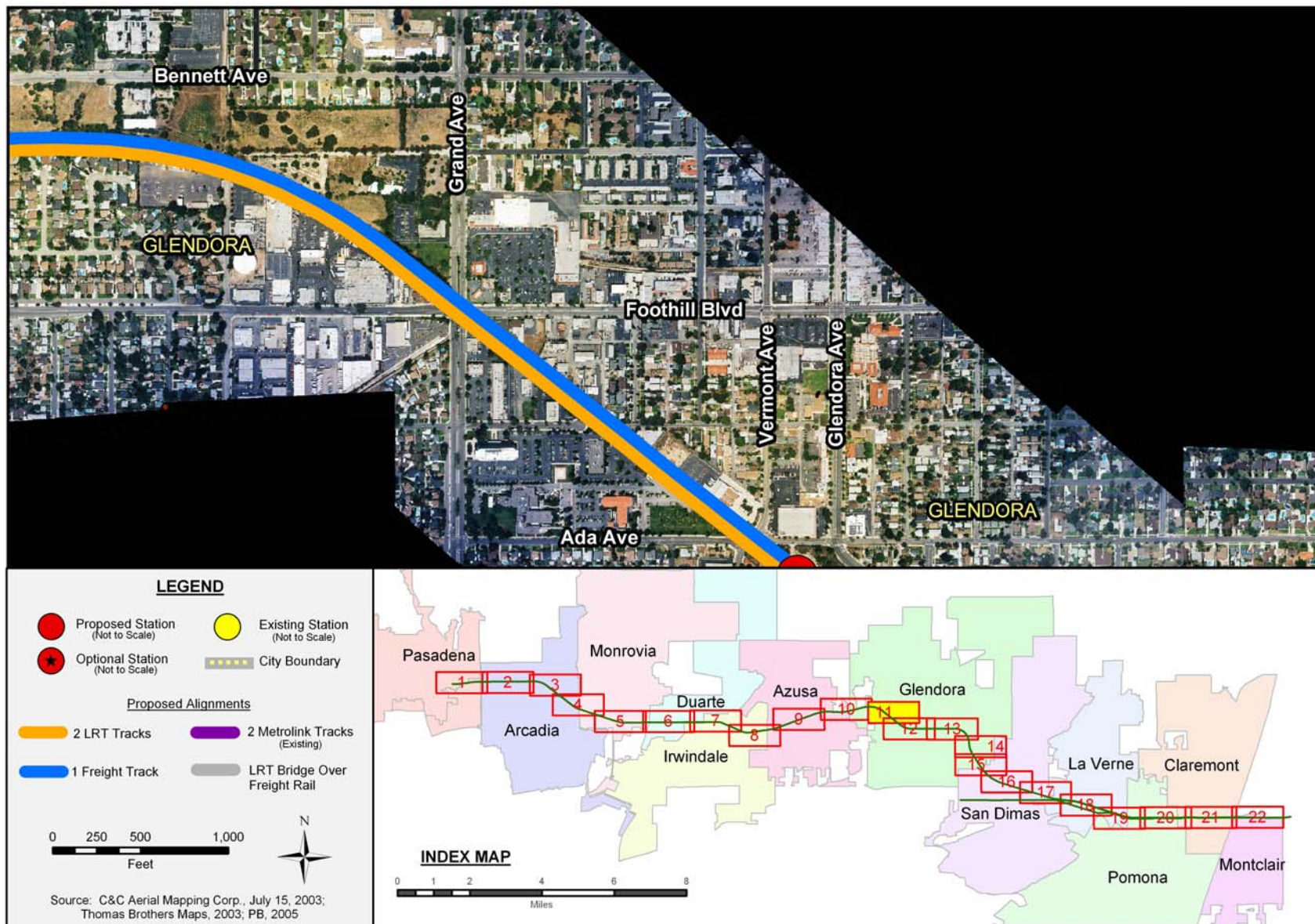

Figure 2-19: Full Build Alternative (11 of 22)

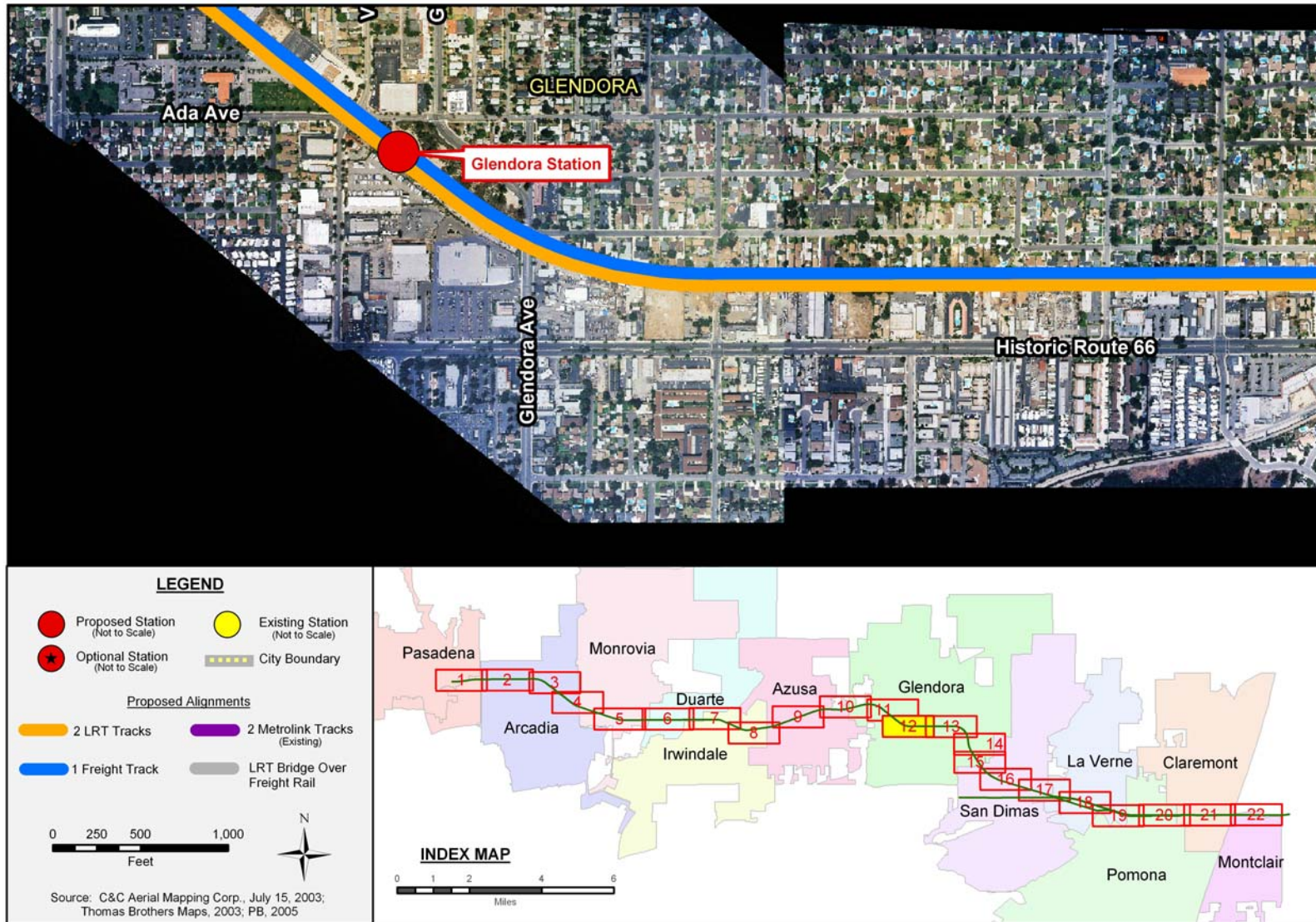

Figure 2-20: Full Build Alternative (12 of 22)

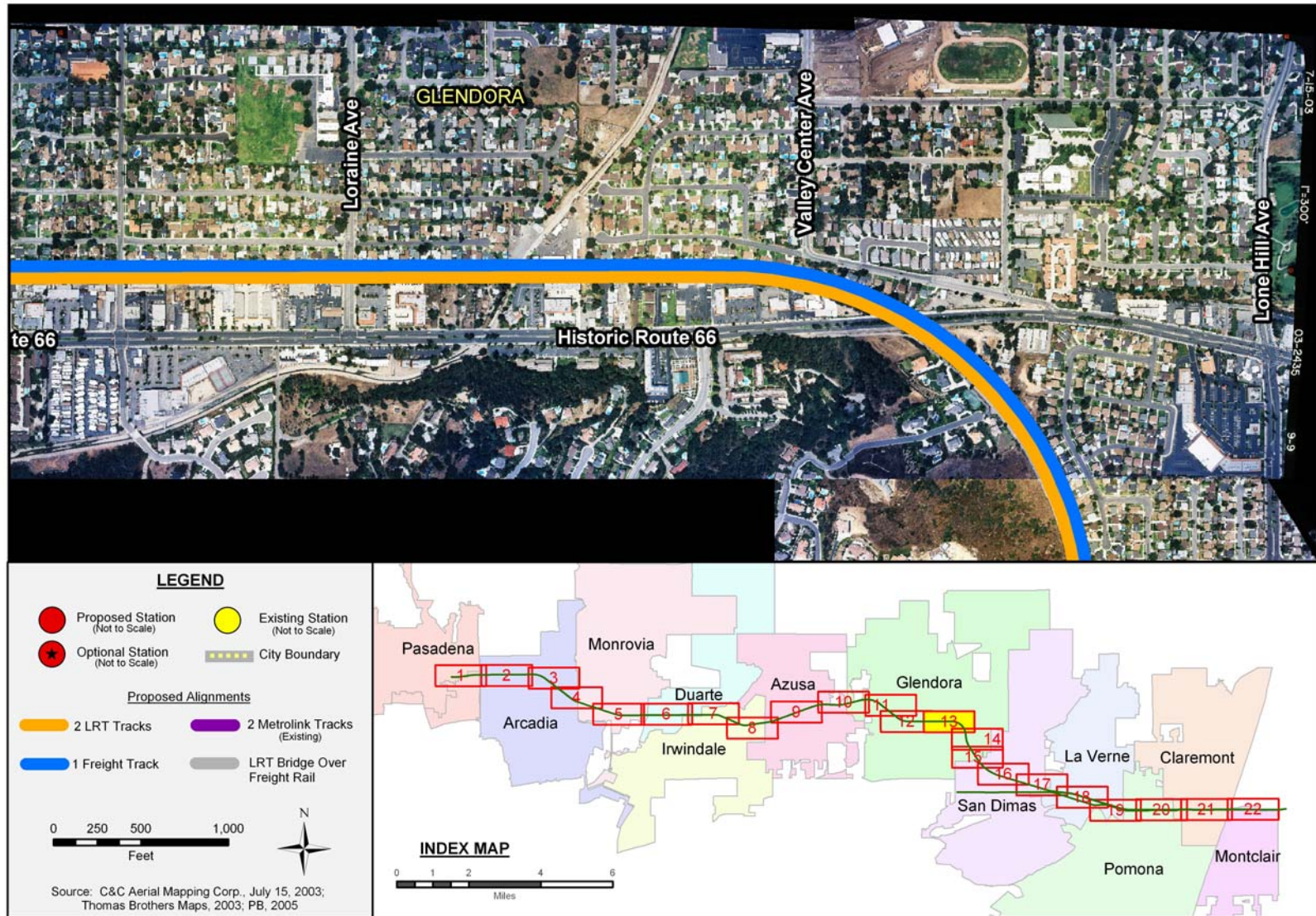

Figure 2-21: Full Build Alternative (13 of 22)

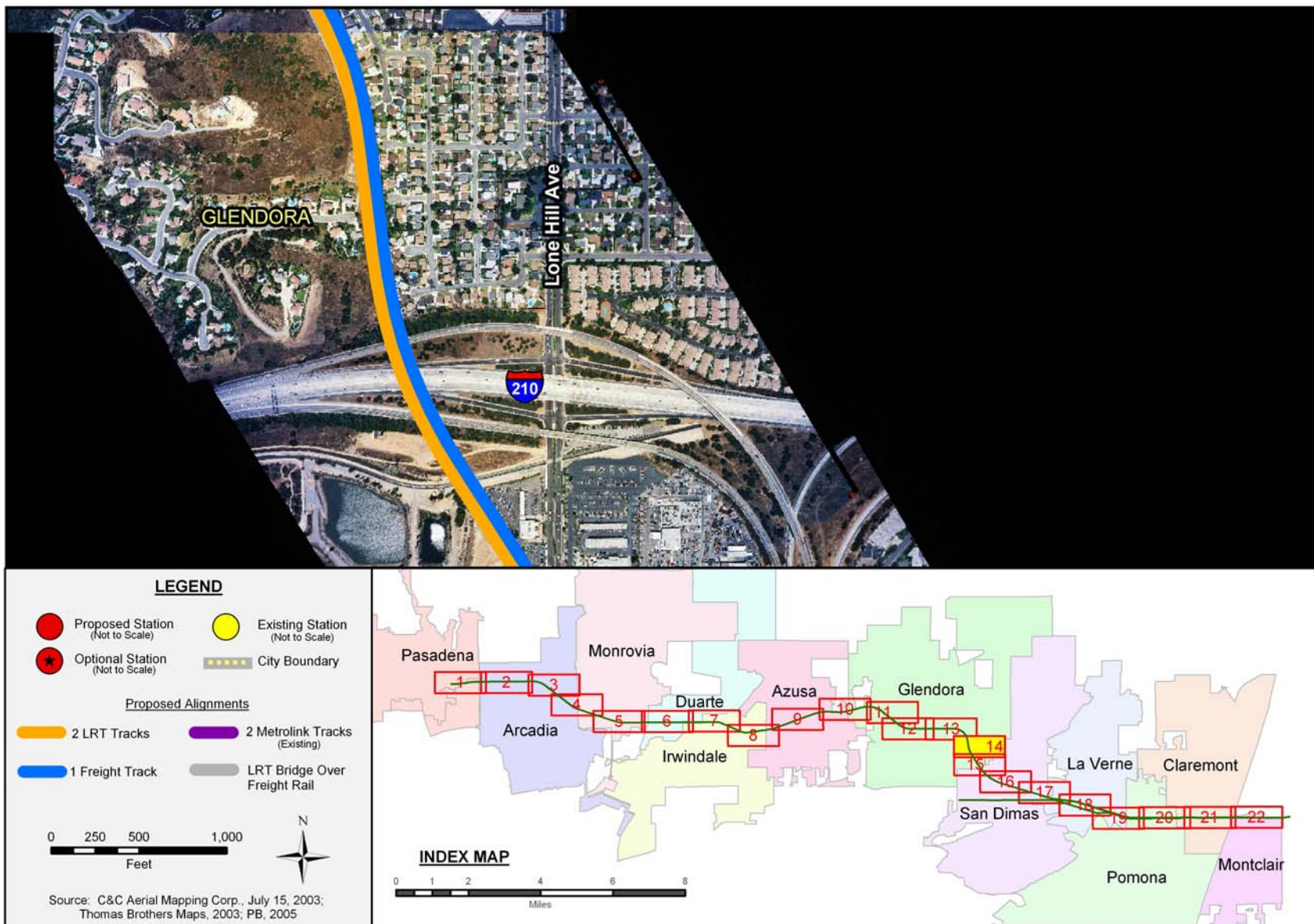

Figure 2-22: Full Build Alternative (14 of 22)



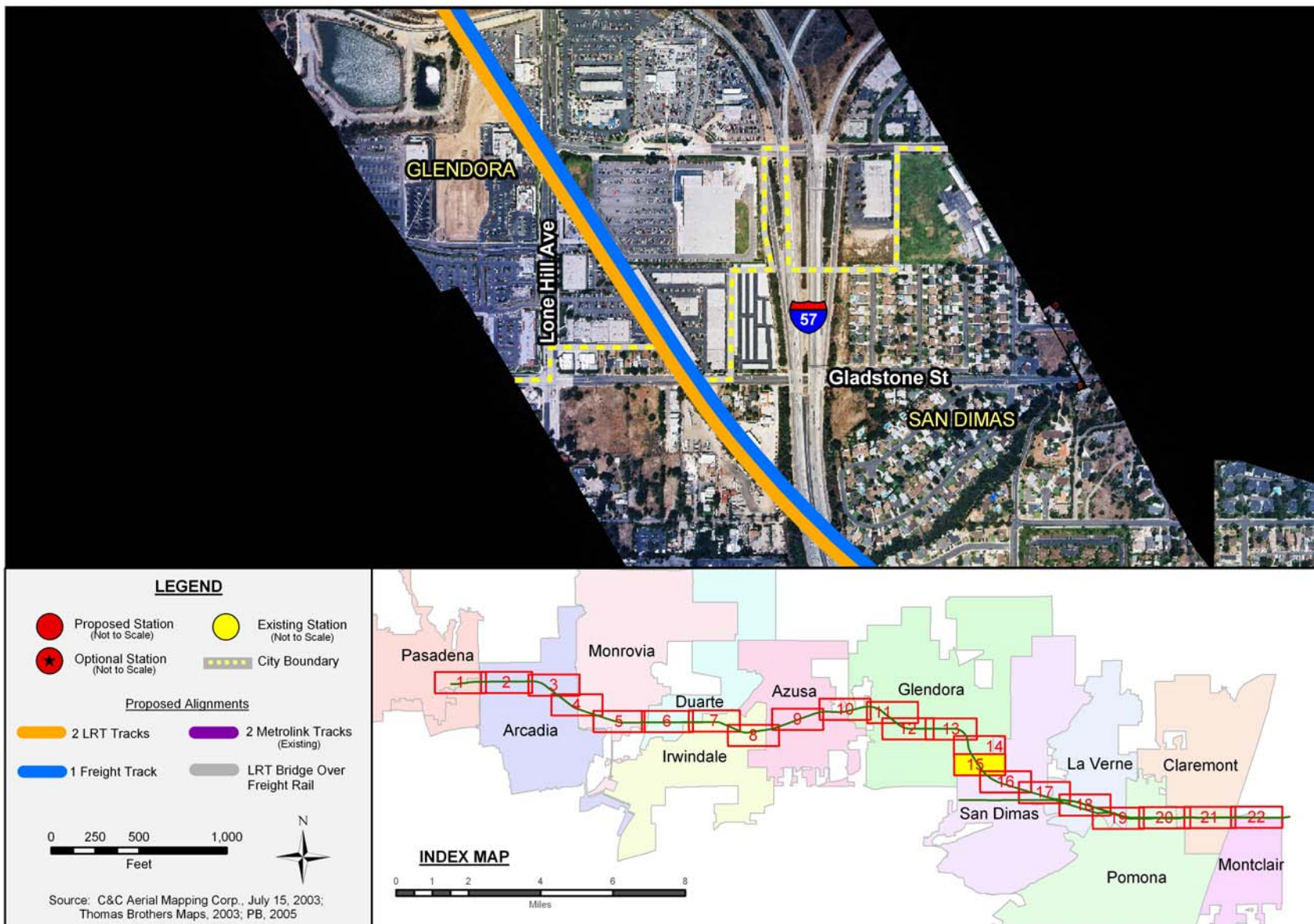

Figure 2-23: Full Build Alternative (15 of 22)

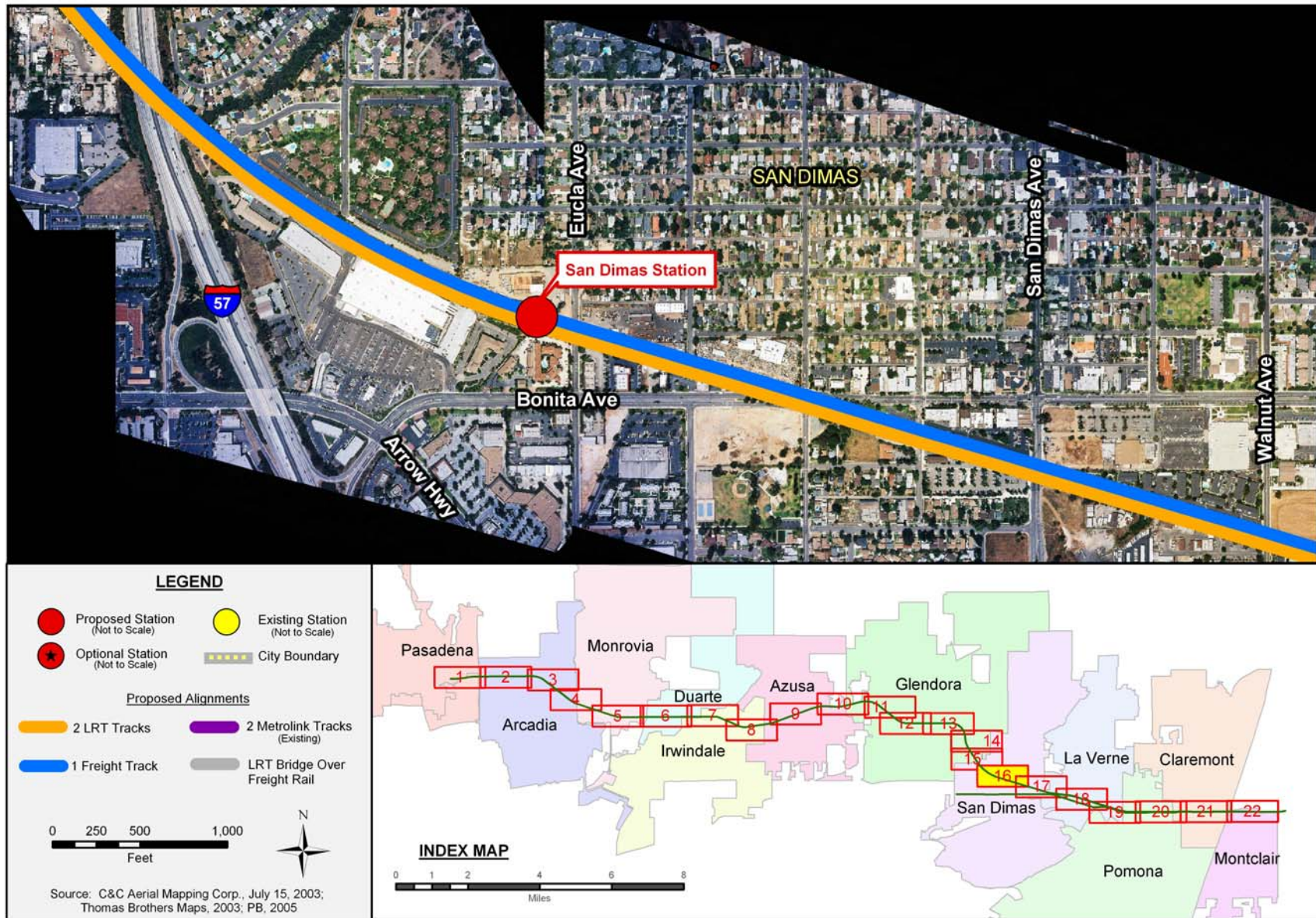

Figure 2-24: Full Build Alternative (16 of 22)

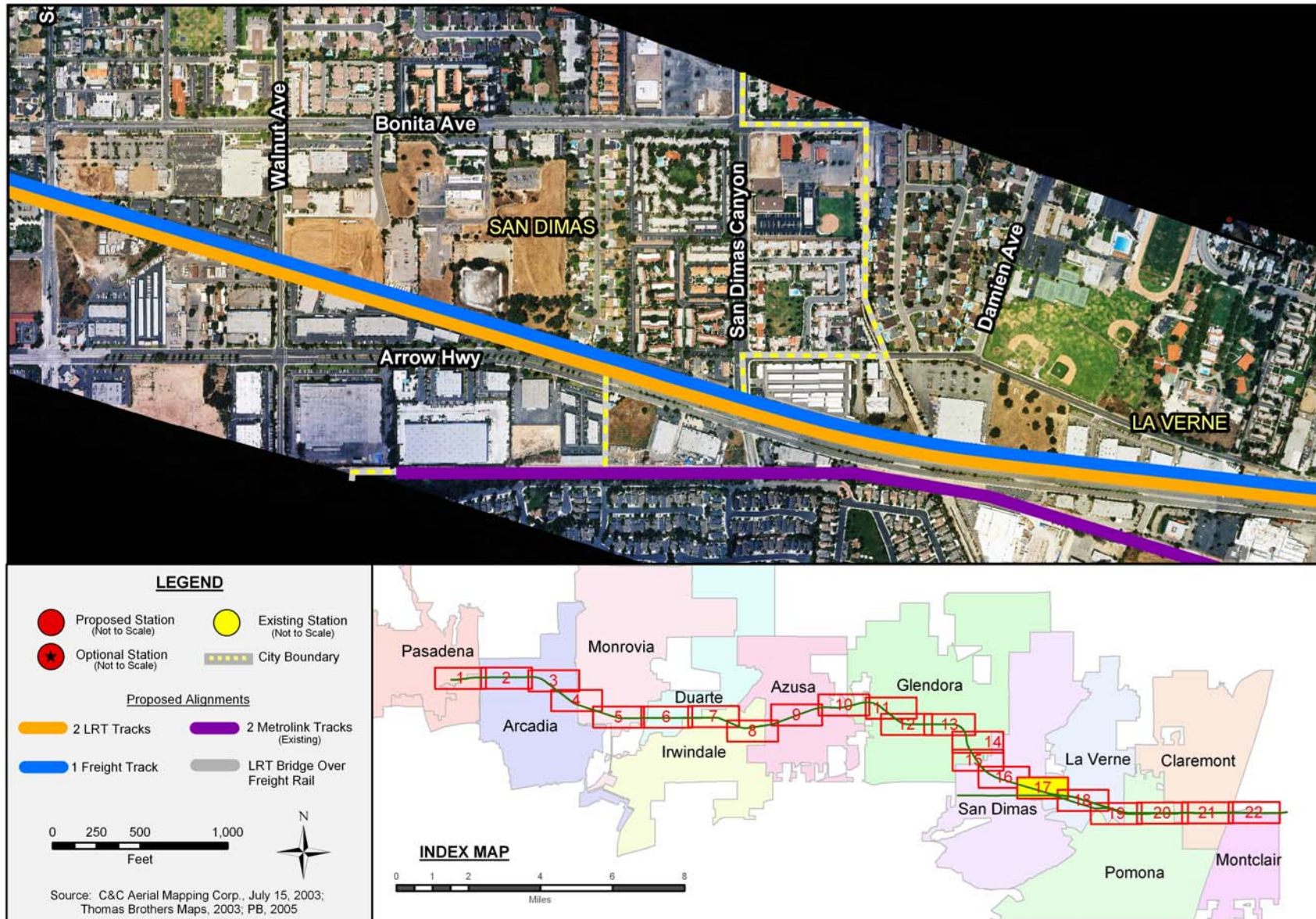

Figure 2-25: Full Build Alternative (17 of 22)

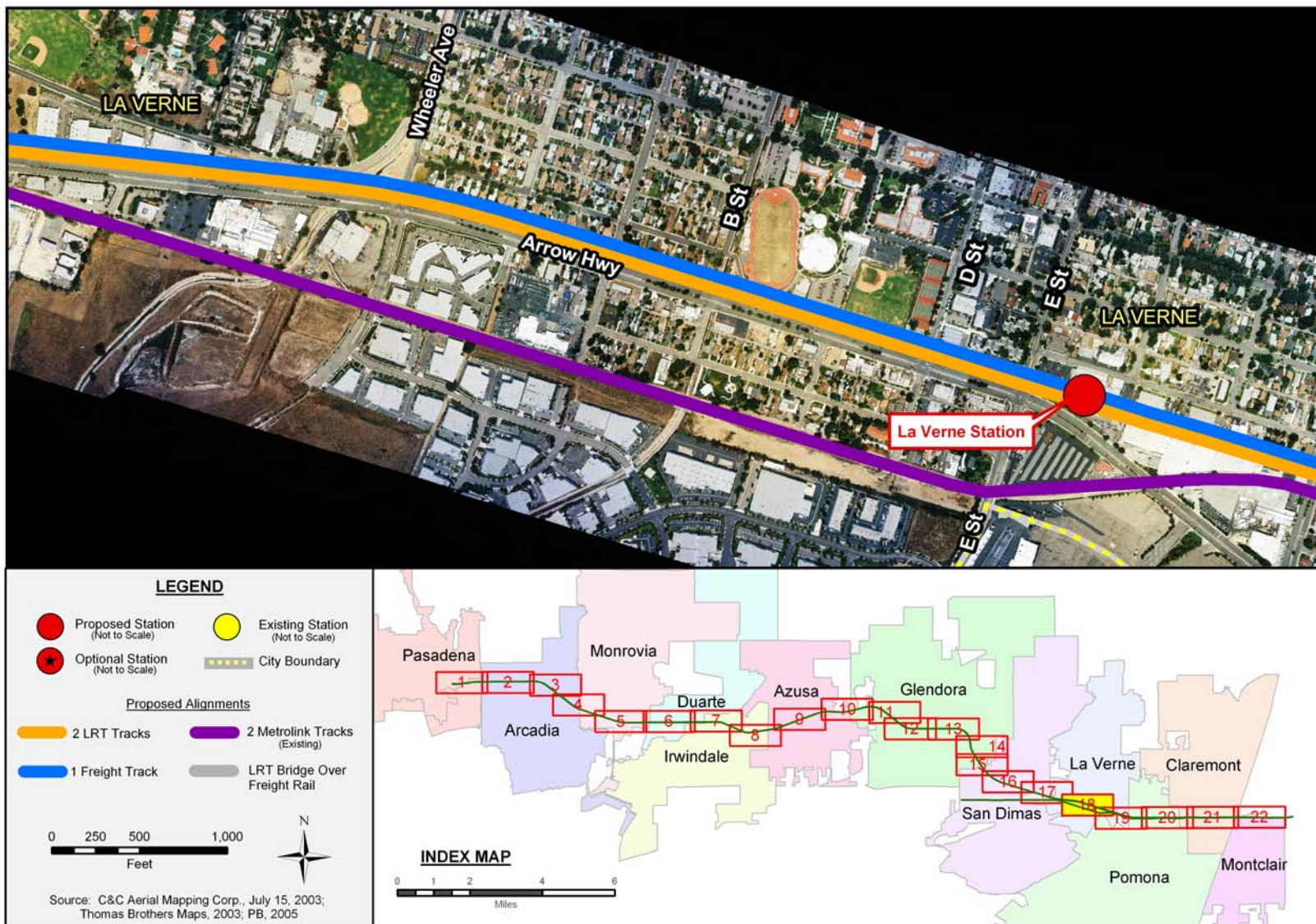

Figure 2-26: Full Build Alternative (18 of 22)

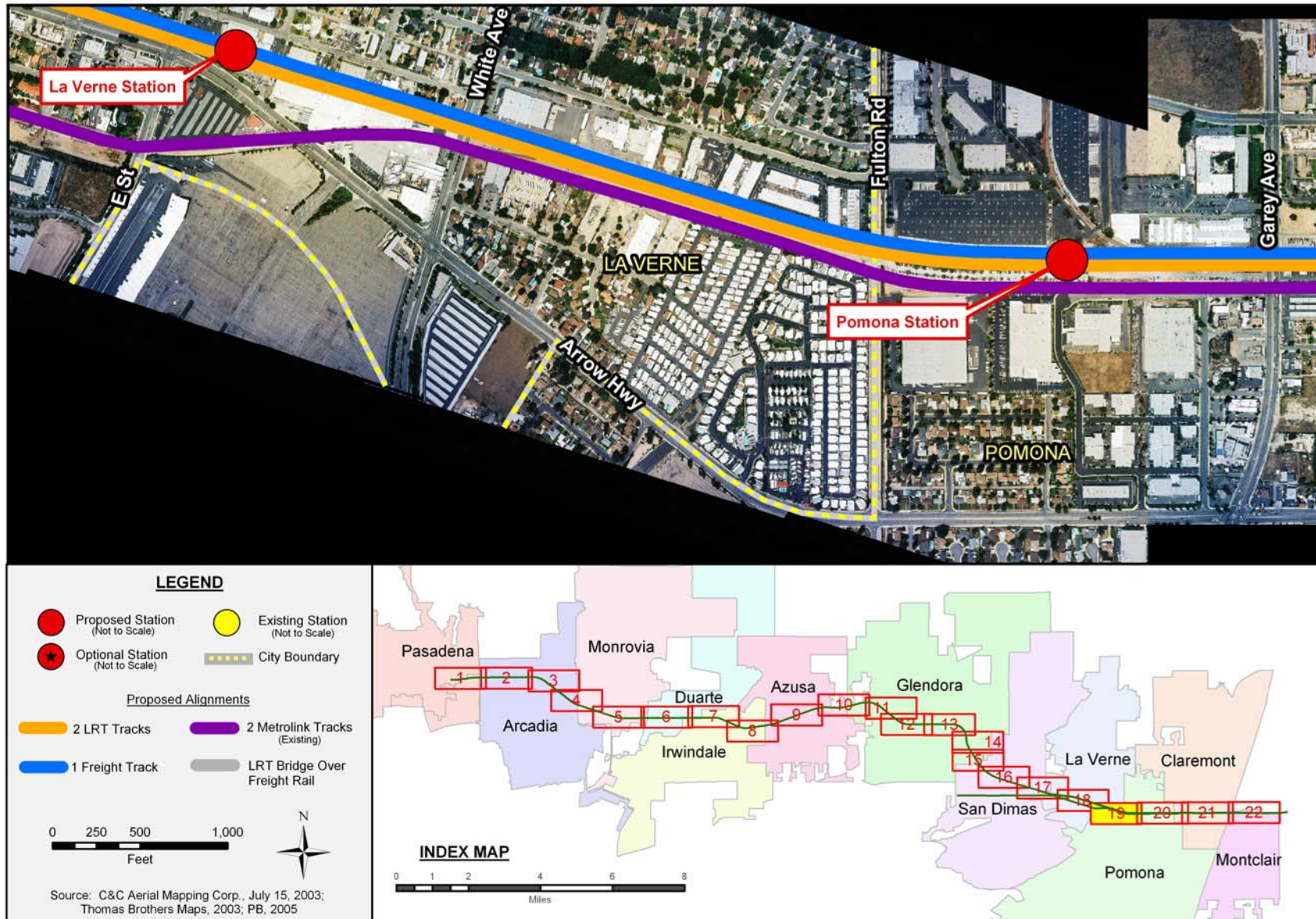

Figure 2-27: Full Build Alternative (19 of 22)

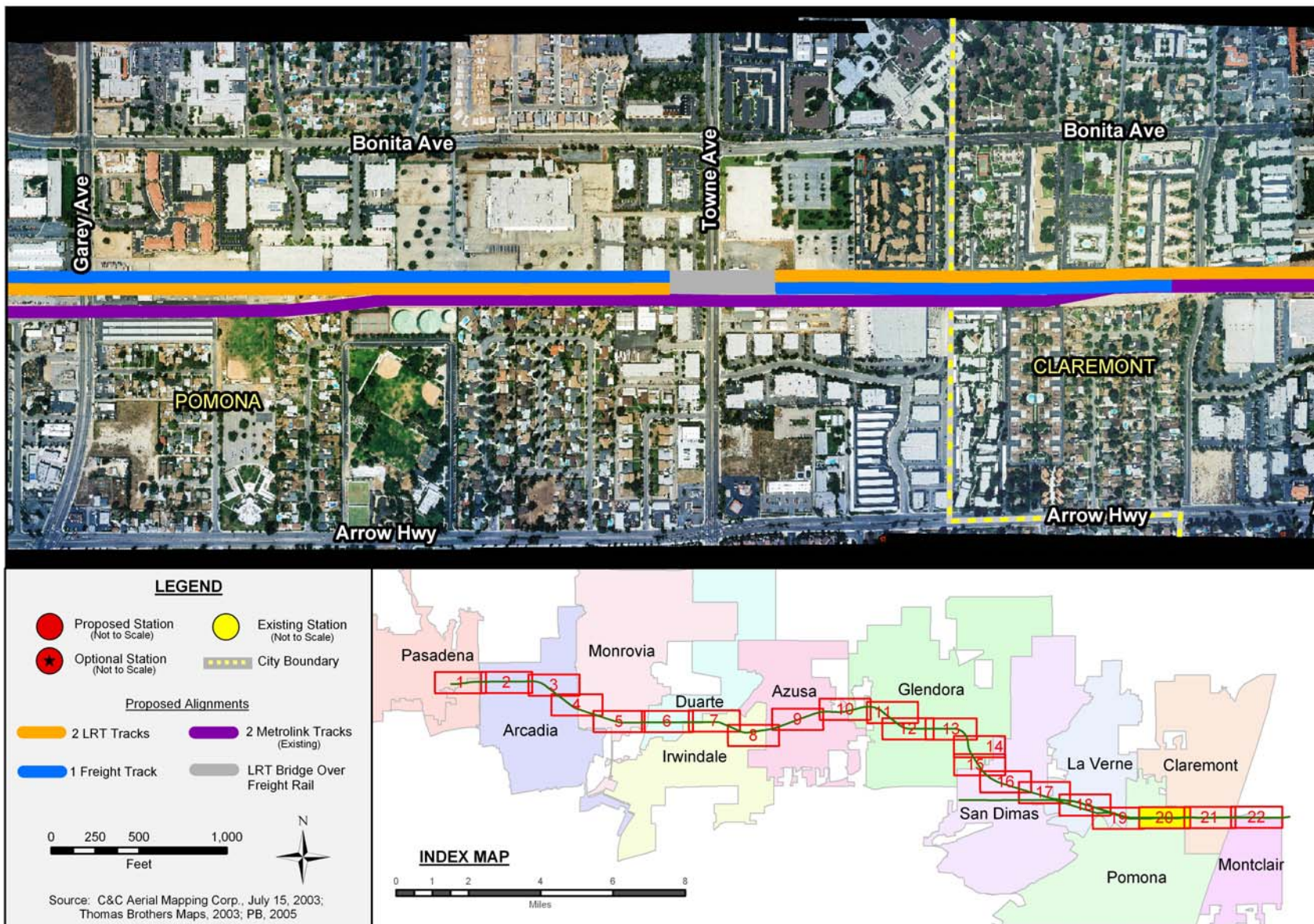

Figure 2-28: Full Build Alternative (20 of 22)

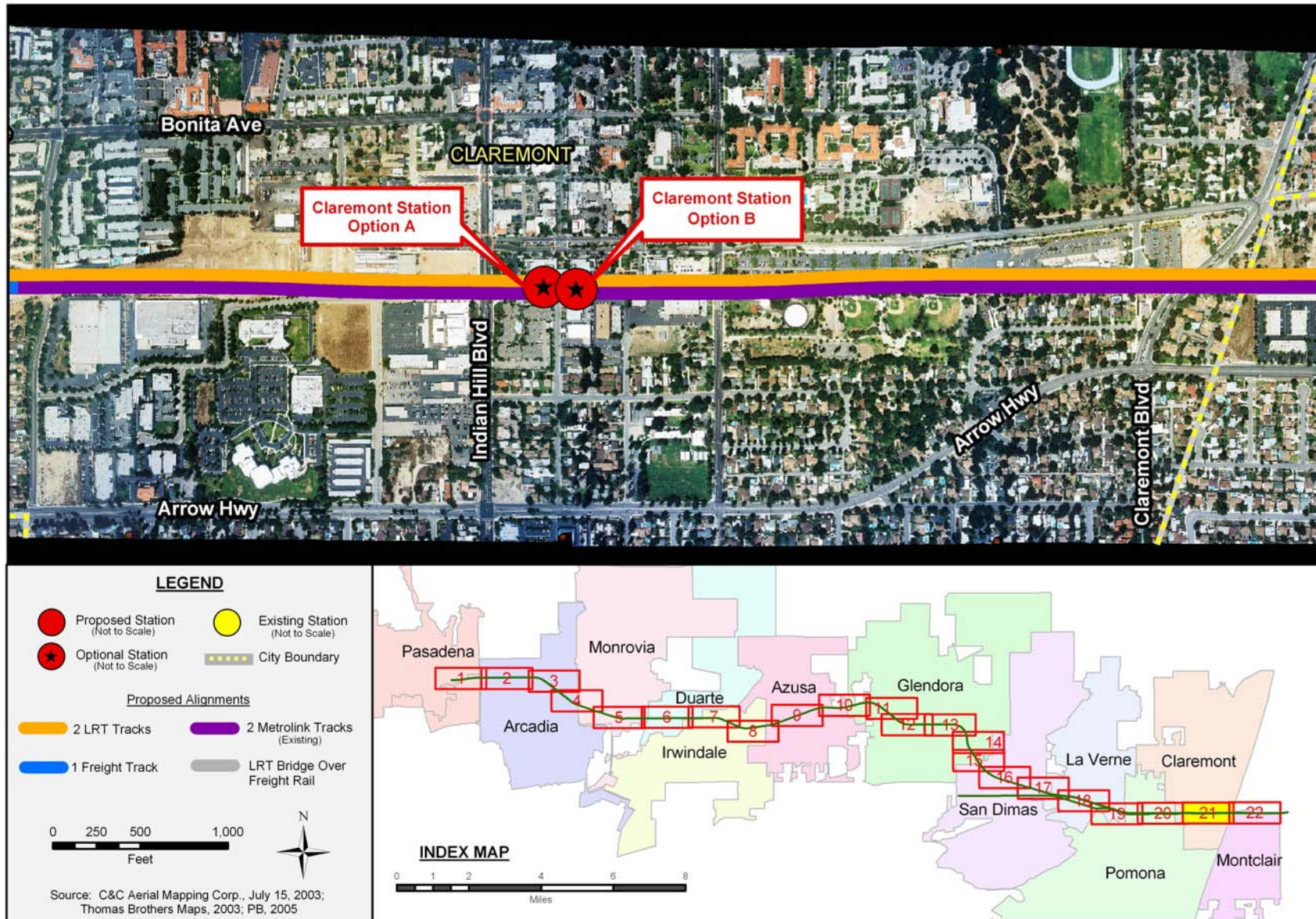

Figure 2-29: Full Build Alternative (21 of 22)

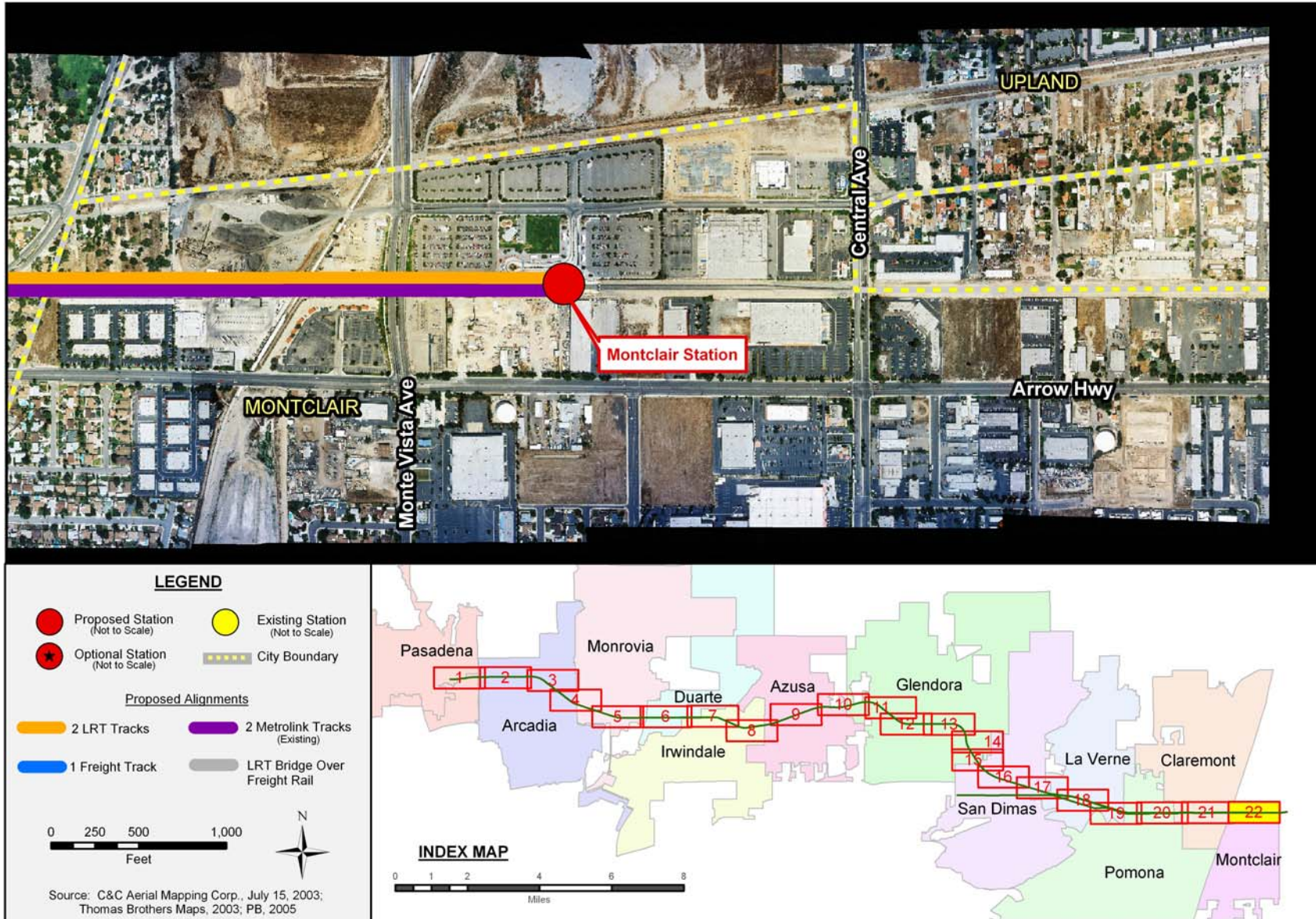

Figure 2-30: Full Build Alternative (22 of 22)



*a. Stations*

The Full Build (Pasadena to Montclair) Alternative would include a total of 12 new stations, ~~subject to the approval of as approved by the individual cities in the Final Project Definition Reports which have been developed in conjunction with the individual cities.~~ All of these stations would contain one or two platforms, 270 feet long, to accommodate LRT trains with up to three cars. Platforms would be approximately ~~14-12~~ feet wide for side-platform stations and ~~18-16~~ feet wide for center-platform stations. The conceptual design of proposed stations is based on the LRT stations created for Phase I. See **Figures 2-42-31 through 2-45-44 34** for examples of typical station types that would be used for the Full Build (Pasadena to Montclair) Alternative.

~~Station platforms would be either at grade or elevated above grade. Station platforms would be designed to accommodate high-floor LRT vehicles, with the platform level approximately 3 feet above the level of the tracks. Grade changes between the platform and the surrounding land would be addressed with ramps, sloped walks, and stairs that meet ADA requirements. Aerial stations would be located approximately 30 feet above grade, and would require elevators, escalators, and other access equipment to meet ADA requirements and MTA design criteria. No aerial stations are planned. Stations would be configured with center platforms or side platforms. Center-platform stations have a single platform located between the tracks and would serve trains traveling in both directions. Refer to Figures 2-31 and 2-33. Passengers would access the stations by using a crosswalk and a sloping walkway between the LRT tracks. For street-level stations, and stairs and elevators (and possibly escalators) at elevated stations. Side-platform stations have separate platforms for each track to serve trains traveling in opposite directions. Refer to Figures 2-32 and 2-34. For elevated stations, passengers traveling from one platform to the other would need to take the stairs or elevators (or escalators, if provided) to another level and then back to the platform level once they had crossed. For at grade stations, passengers would need to go down the ramp from the platform to a designated crosswalk, cross the tracks, and then go back up the ramp or stairs to the other platform. Passenger access to the at-grade platforms would be at one or both ends, connecting to existing or new sidewalks, or along the outside of the platform. During the conceptual design of the alignment, center platform stations were looked at first. If the site characteristics (such as a narrow right of way entering or exiting the site) ruled out a center platform, then a side-platform station was designed.~~

LACMTA design guidelines state that stations are to be at least 180 feet from the nearest street in order to allow for safe emergency stopping of LRT vehicles shy of the roadway. In some locations, waivers may need to be obtained for non-conforming station locations due to existing street configurations. To be granted a waiver, it would have to be demonstrated that safety would not be substantially compromised by allowing a station to be closer than 180 feet from the nearest street. These waivers, if granted, would not have any environmental impacts.

Consistent design and equipment layout would be used throughout the system, as initiated in the Phase I construction, for the convenience of transit passengers and to control capital, operations, and maintenance costs. Signage, maps, fixtures, furnishings, lighting, and communication equipment would have consistent design throughout the system. However, opportunities are being provided during the engineering and ~~would be provided during~~ later stages of project development for stations to have individual and community identities through the integration of artwork, placement and color of the standard station canopy, and selection of unique colors and patterns for the platform, created by design of other station components, such as roof canopies guardrails, floor finishes station furniture, plaza and entrance areas, artwork, vertical finishes, and related items. Station Design and Art Review Committees (SDAR) were created by the Construction Authority for each City in conjunction with City staff. During the spring of 2005, the committees selected a station design artist and identified design themes for each

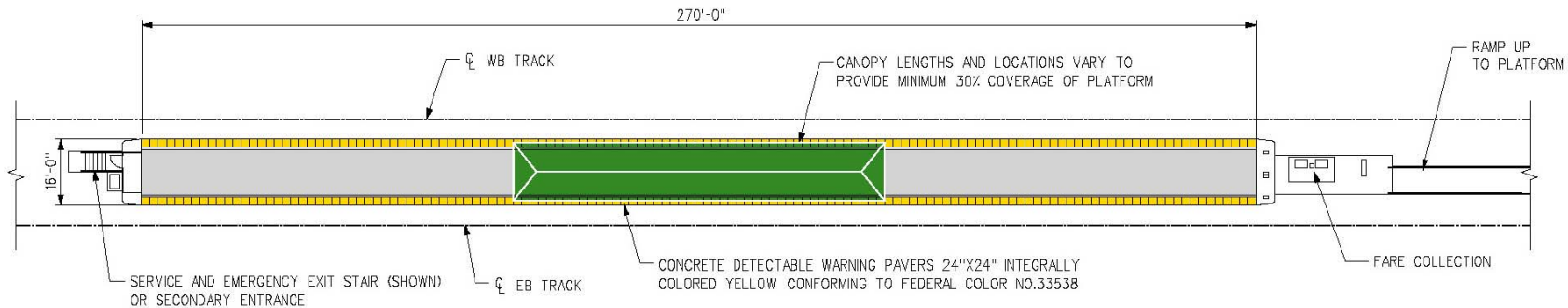

PROTOTYPICAL PLATFORM PLAN

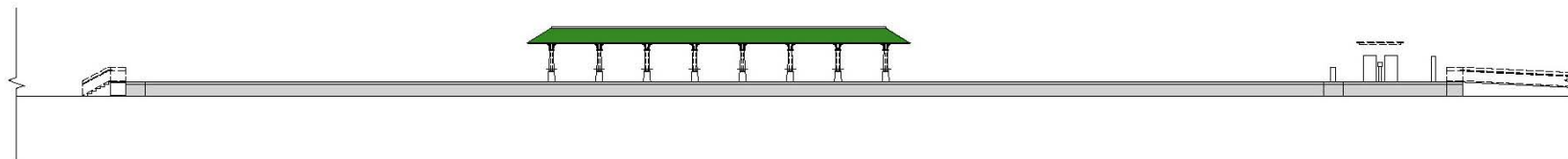

PROTOTYPICAL ELEVATION

**Figure 2-31: Typical Station Layout: Center Platform**

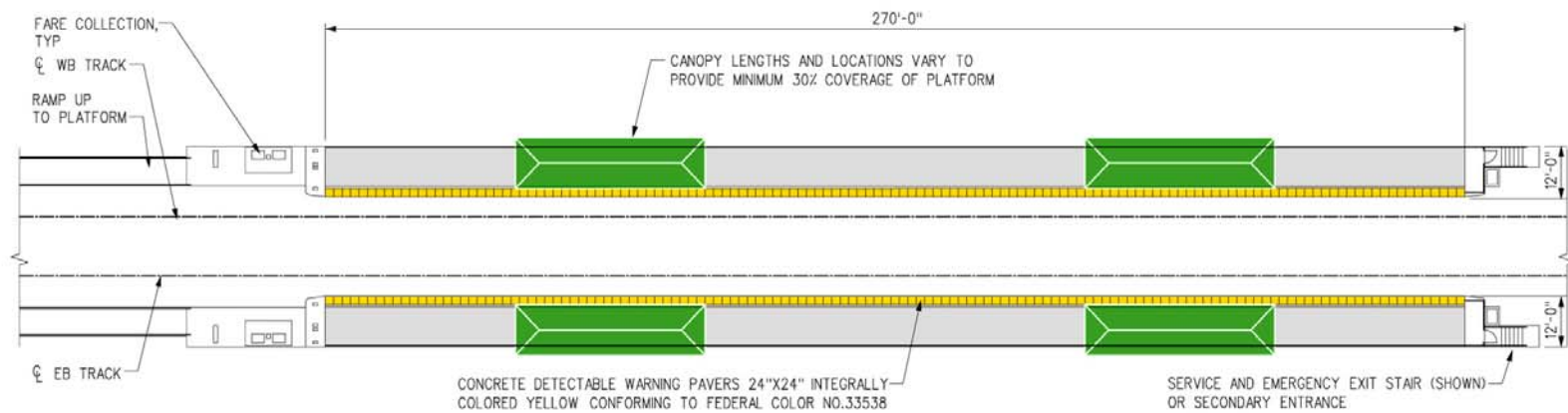

PROTOTYPICAL PLATFORM PLAN



PROTOTYPICAL ELEVATION

Figure 2-32: Typical Station Layout: Side Platform

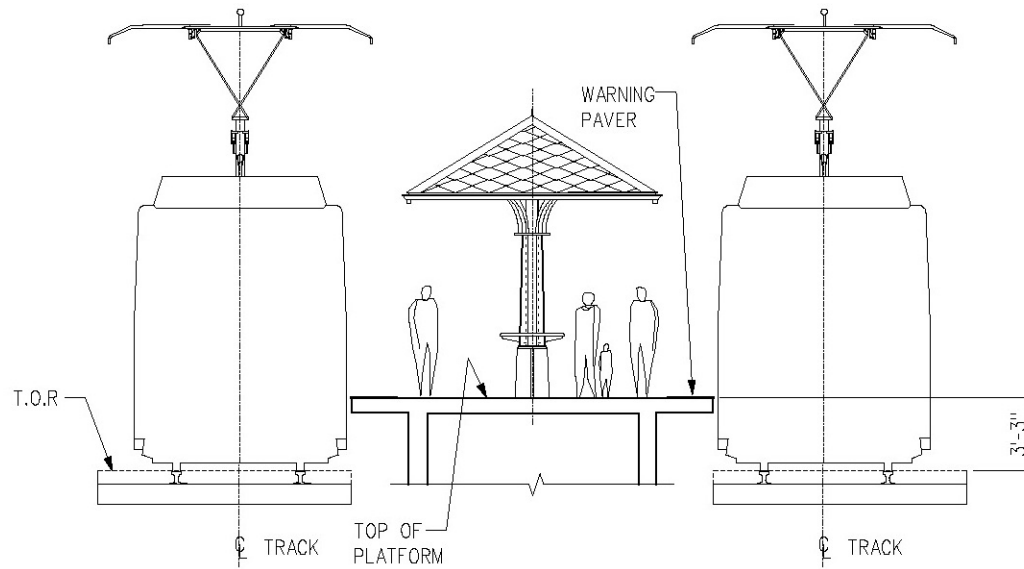

Figure 2-33: Prototypical Center Platform Cross Section

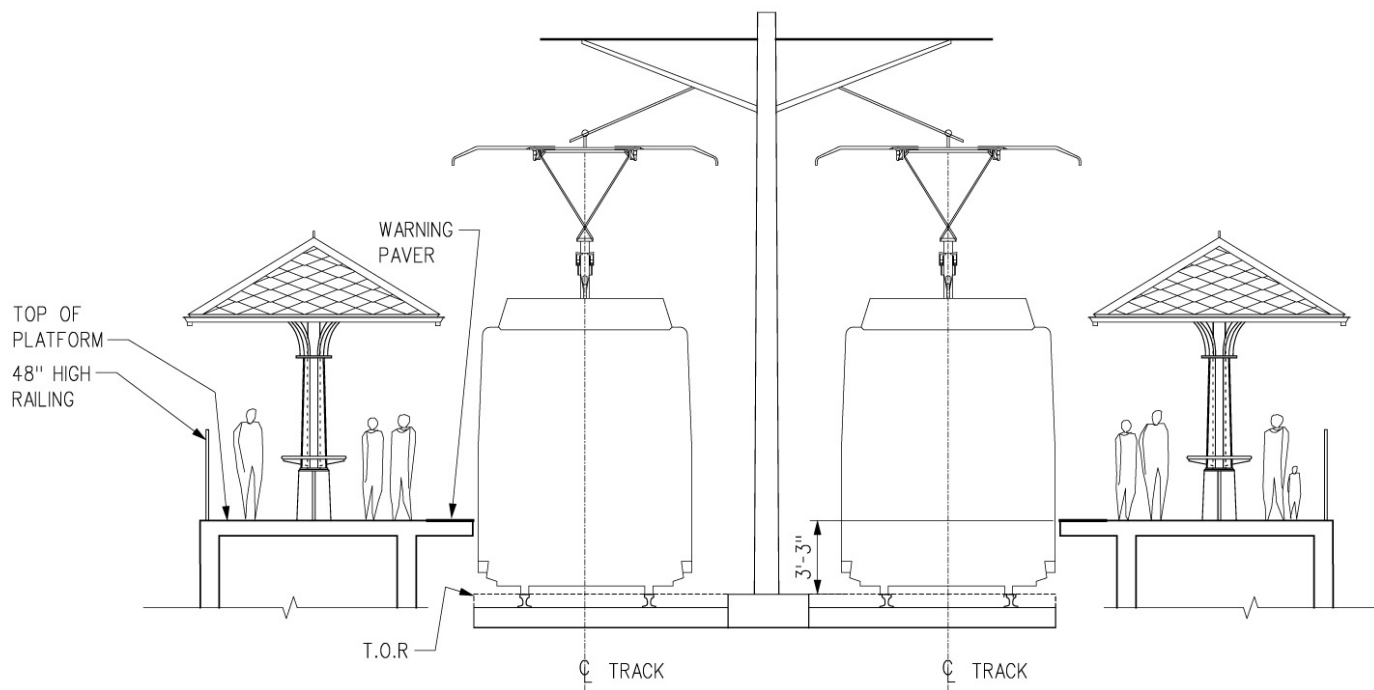

Figure 2-34: Prototypical Side Platform Cross Section

station. The final design of stations would result from a combination of LACMTA-standard system components and design enhancements provided by individual cities.

An area for fare collection and transit information posting would be provided on the platforms, similar to the existing LRT systems in Los Angeles County. Parking at each station would be necessary to accommodate patrons using the LRT service. Parking facilities would be provided at each station based on the results of travel demand modeling. It is currently estimated that more than 7,000 parking spaces would be required at the 12 stations along the alignment. It should be noted that the demand for parking has been established from the transportation modeling process for ~~2010~~ 2009 and for 2025. Although proposed locations for parking have developed based on the 2025 demand forecast, it is assumed that staged implementation of parking is likely to occur. Staged implementation would enable existing or new surface lots to serve initial ridership, with parking structures being created over time as ridership increases. For the purpose of environmental analysis, the impacts of 2025 parking demand (i.e., the likely worst-case scenario) have been assessed. It is also assumed that parking at any of the stations might be provided as part of transit-oriented development that may be implemented by the individual cities.

Table 2-4 lists the options for station locations and alignment. These are described further in the specific station descriptions. Subsequent to the Draft EIS/EIR, the station and alignment options were eliminated from consideration by selection of an LPA, with the exception of Arcadia, where the City requested that an alternative remain in consideration. Also subsequent to the Draft EIS/EIR, the City of Claremont added a station option.

Based on meetings with each city, preliminary station layouts and parking locations have been identified and analyzed. The proposed station and parking sites in each city are described below. Figures are provided for station layouts by city. Based on meetings with each city, station layouts and parking locations have been identified, analyzed, and approved by the cities. The proposed station and parking sites in each city are described below. Additional detail is available in the engineering drawings in Volume 4 and in the March 2005 Project Definition Report (see Appendices on compact disc).

### Arcadia

The City of Arcadia has two potential station sites, both located near the stated their preference for a station site southeast of the diagonal crossing of the intersection of North First Avenue and East Santa Clara Avenue. The City of Arcadia also requested a grade separation at Santa Anita Avenue (to be built at City expense), which would require the station to be located southeast of the North First Avenue and East Santa Clara Avenue intersection. The location east of North First Avenue is necessary in order to provide sufficient distance between Santa Anita and North First Avenue for the LRT to be at-grade when crossing North First Avenue. If the Santa Anita Avenue crossing remains at-grade, the station would remain southeast of the North First Avenue and East Santa Clara Avenue intersection.

The LRT platforms would be located southeast of the North First Avenue and East Santa Clara Street intersection. Due to narrowing of the railroad right-of-way, this option would have offset side platforms, and access would be provided from the north at the aforementioned intersection. This location would be implemented for either at-grade operation of the LRT line across Santa Anita Avenue, or for a grade separation of the LRT line above Santa Anita Avenue, which is at the request of the City of Arcadia.

The City of Arcadia requested that an alternative platform location northwest of the diagonal crossing of the intersection of North First Avenue and East Santa Clara Avenue also be considered. This station location would have a center platform. This option would require that the crossing at Santa Anita Avenue be at-grade.

Parking for both options would utilize rail right-of-way along Front Street, as well as requiring acquisition of commercial property northwest of the Front Street and East Santa Clara Avenue intersection. The parking structure would include approximately 300 spaces (on opening day) on two levels and the property could incorporate a transit/passenger drop-off and a pedestrian plaza as well.

Parking for both options would take advantage of the city owned parking lot located south of Wheeler Avenue between North Santa Anita Avenue and North First Avenue, and the land in the vicinity of the rail right-of-way and Front Street northwest of the intersection of North First Avenue and East Santa Clara Avenue. The City owned lot is currently utilized by customers of local shops and as parking for employees. This lot could be used with the construction of a parking structure in the future as transit ridership develops. The land in the vicinity of the rail right of way and Front Street would be available for parking and/or transit/passenger drop off. In 2025, 800 parking spaces are forecasted as necessary for the Arcadia station; opening day would require approximately 300 spaces. Creation of the parking structure would require the acquisition and demolition of commercial structures. Refer to **Figures 2-46 through 38 2-35 and 2-36** for the proposed Arcadia station layouts.

Under base conditions, the LRT station would be located northwest of the North First Avenue/East Santa Clara Avenue intersection, within the rail right of way next to Front Street, as shown in **Figure 2-46**. This location would utilize a center platform with entry from the southern end at the intersection of North First Avenue/East Santa Clara Avenue. The platform begins 180 feet from the street curb to comply with California Public Utilities Commission regulations. Potential parking or passenger drop off would be located adjacent to the station at Front Street.

Option A would be located southeast of the North First Avenue and East Santa Clara Street intersection of North First Avenue and East Santa Clara Street. Due to the narrowing of the railroad right of way, this option would have side platforms, and access would be provided from the north at the aforementioned intersection. Option A could be implemented for either at grade operation of the LRT line across Santa Anita Avenue, or for a grade separation of the LRT line above Santa Anita Avenue, which is at the request of the City of Arcadia. Refer to **Figure 2-47**.

The City of Arcadia has also expressed interest in having grade separations at Santa Anita Avenue and at the intersection of First Avenue and Santa Clara Avenue. This would require an aerial station in this area, which is Option B. The station in Option B would be located in the same location as the initial station, but would be elevated approximately 30 feet above grade. Refer to Figures 2-44 and 2-45 for typical aerial station layouts. **Figure 2-48** shows the Arcadia aerial station layout.

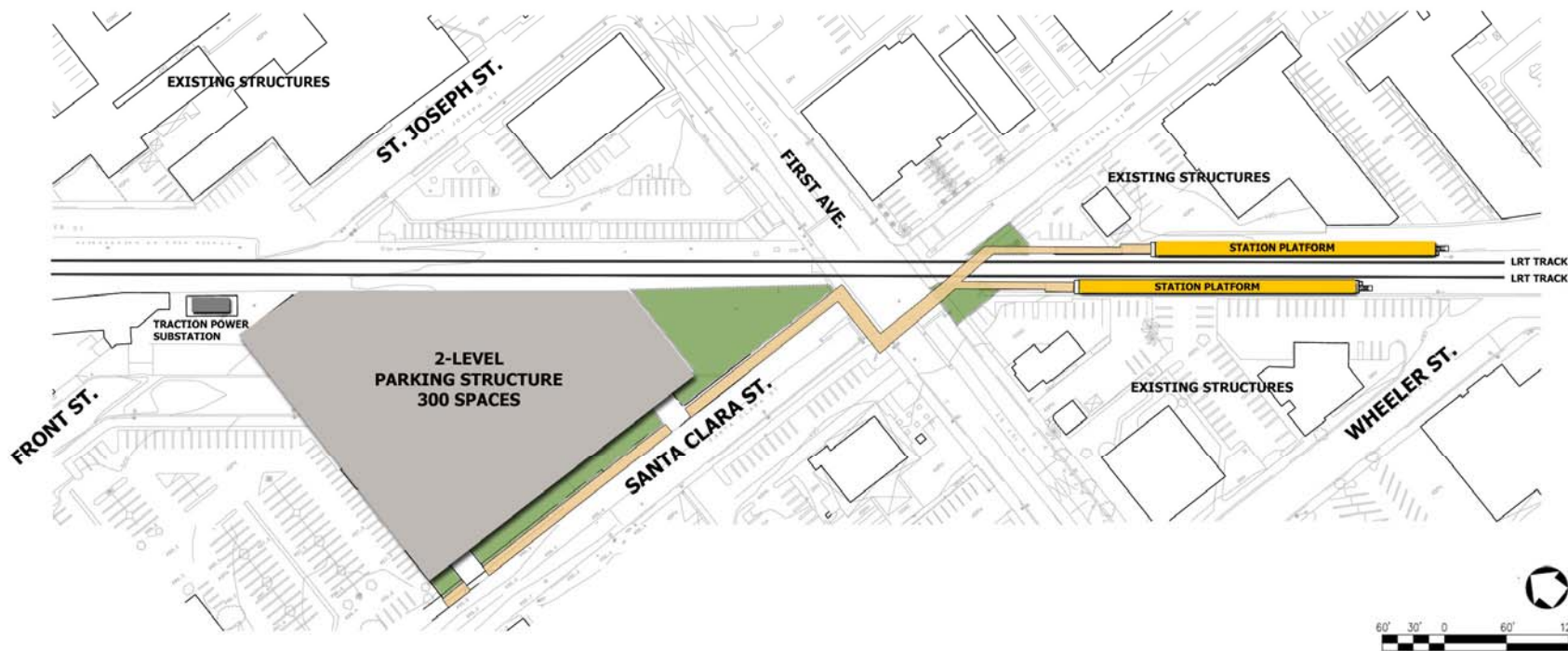

Figure 2-35: Site Plan: City of Arcadia Station, Option A



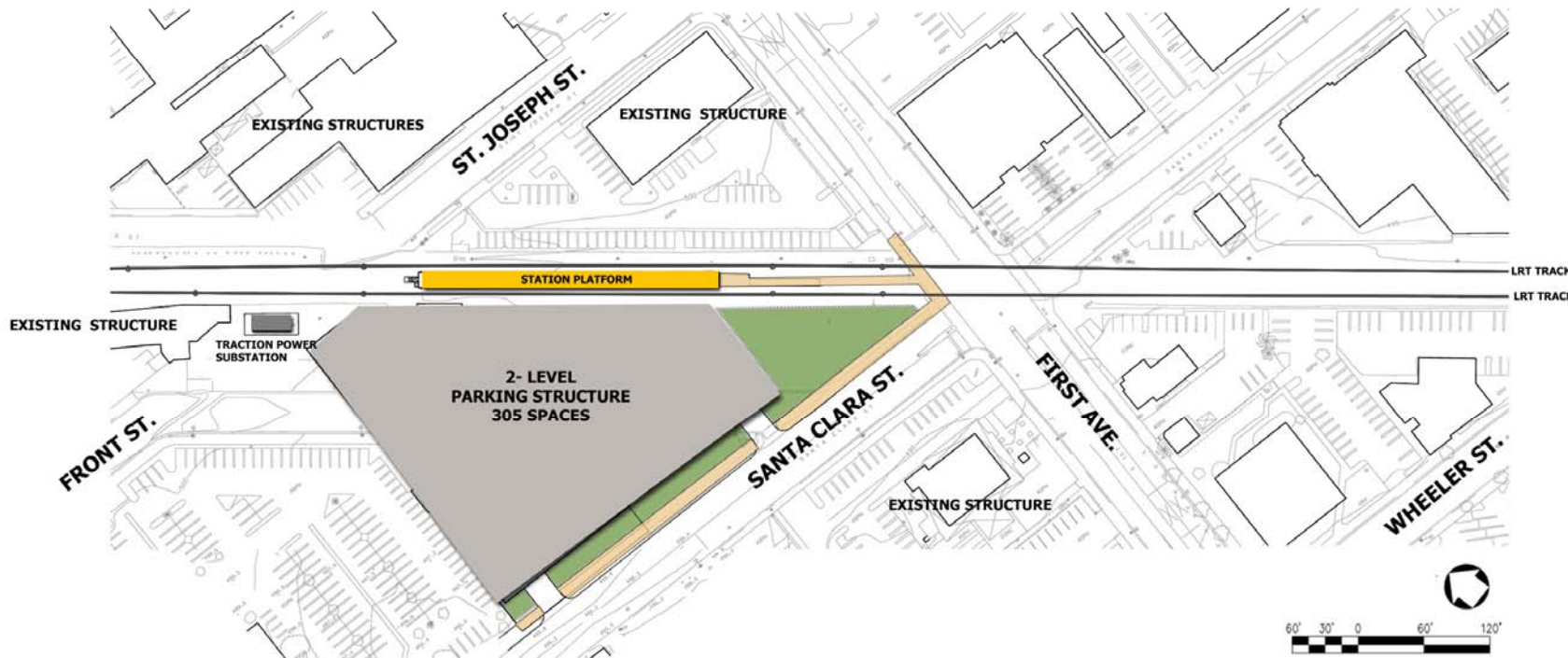

Figure 2-36: Site Plan: City of Arcadia Station, Option B

Monrovia

The City of Monrovia has a historic Santa Fe depot located on Myrtle Avenue just south of West Pomona Avenue. The City is in the process of restoring the depot and creating a new transit center, including a surface parking lot of ~~205~~ approximately 200 spaces. Foothill Transit will provide bus service to the transit center in addition to the proposed Gold Line LRT station.

The station would be located just west of the historic depot, adjacent to and connected to the new transit center. ~~For the Double Track Configurations, The station would be a side-platform station, with access from the east end of the platforms. For the Triple Track Configuration, the station is a center platform station (as shown in Figure 2-42) closer to the existing Santa Fe Depot. Refer to Figures 2-47-37 and 2-50 for illustrations of the alternate station layout. Approximately 350 parking spaces are estimated to be required on opening day; 600 parking spaces would be required at the Monrovia station in 2025. Parking demand associated with LRT service would be accommodated by the new transit center lot and proposed parking structure on the south side of the alignment within the proposed mixed-use development that the City of Monrovia Redevelopment Agency is planning for this area. Creation of the parking structure would require the acquisition and demolition of commercial structures to the southwest of the station.~~

Duarte

~~The City of Duarte station would be sited near the City of Hope Medical Center just north of Duarte Road, approximately 500 feet west of Highland Avenue. The City of Hope is an internationally recognized hospital and is a major destination in Duarte. The rail right-of-way is at its narrowest at this point (just under 50 feet in width)., and, thus, the station site would require expansion into the parking lane of Duarte Road if the Triple Track Configuration were implemented. For the Double Track Configurations, expansion in the parking lane would not be necessary. Parking is currently not allowed along this stretch of Duarte Road, as per the City of Duarte. A center platform is proposed for this location with entry from both ends of the platform. The Duarte station requires 125 parking spaces on opening day and 250 parking spaces by 2025. Approximately 125 parking spaces are proposed to be accommodated in a surface parking lot located north of the proposed station with vehicular access via Business Center Drive. A 500-foot pedestrian walkway would connect the parking with the station due to the narrow right-of-way. The estimated 250 parking spaces that are forecasted to be required by 2025 are proposed to be accommodated in a parking structure located on City of Hope property. The proposed structure would be located on a current surface parking area, and would be jointly utilized by transit patrons and City of Hope visitors and staff. Refer to Figure 2-48-38.~~

Irwindale

~~The station platform for the City of Irwindale would be located east of the Irwindale Avenue overpass. A side platform station is proposed in this location due to constraints of the Irwindale Avenue overpass support columns and the adjacent freight tracks (both mainline and sidings). Access to the platforms would be via both the eastern and western ends.~~

~~Approximately 700 parking spaces would be required by 2025, with approximately half (350 parking spaces) required on opening day. Parking is proposed to be located in the "South Kincaid Pit," north of the platforms between the alignment and the I-210 freeway. Vehicular access for the station would be provided via Irwindale Boulevard and Adelante Street, which connects to a frontage road. The frontage road would be realigned to accommodate a vehicular tunnel that would pass under the rail right-of-way to access the surface parking on the north side of the alignment. Refer to Figure 2-49-39. The station location for the City of Irwindale would be located adjacent to the Miller Brewing facility, west of~~

~~Irwindale Boulevard. Vehicular access for the station would be provided via Irwindale Boulevard and a frontage road called Montoya Road. Approximately 700 parking spaces would be required by 2025. These parking spaces would be provided in a parking structure, to be located on a vacant site south of the station .~~

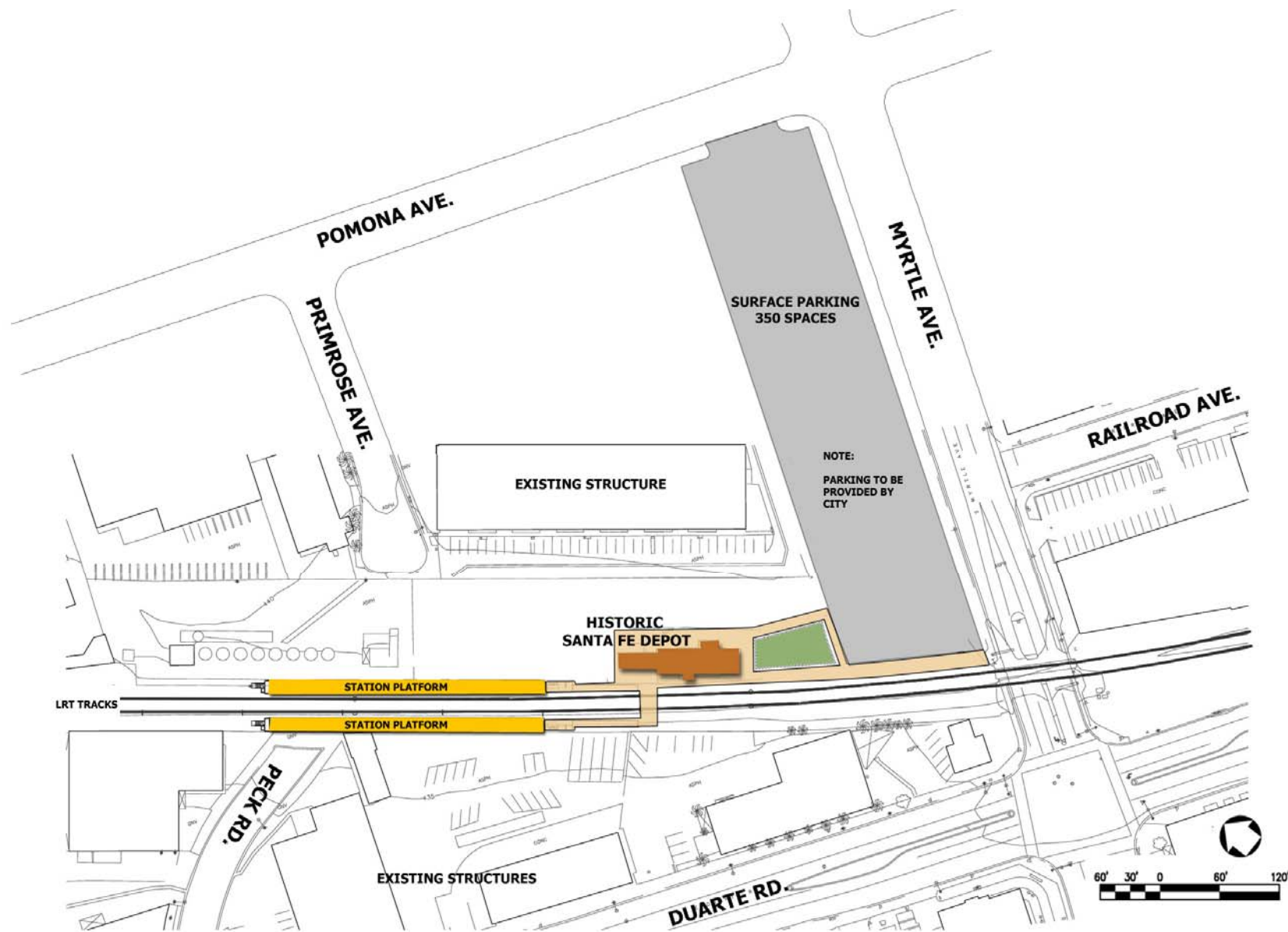

Figure 2-37: Site Plan: City of Monrovia Station

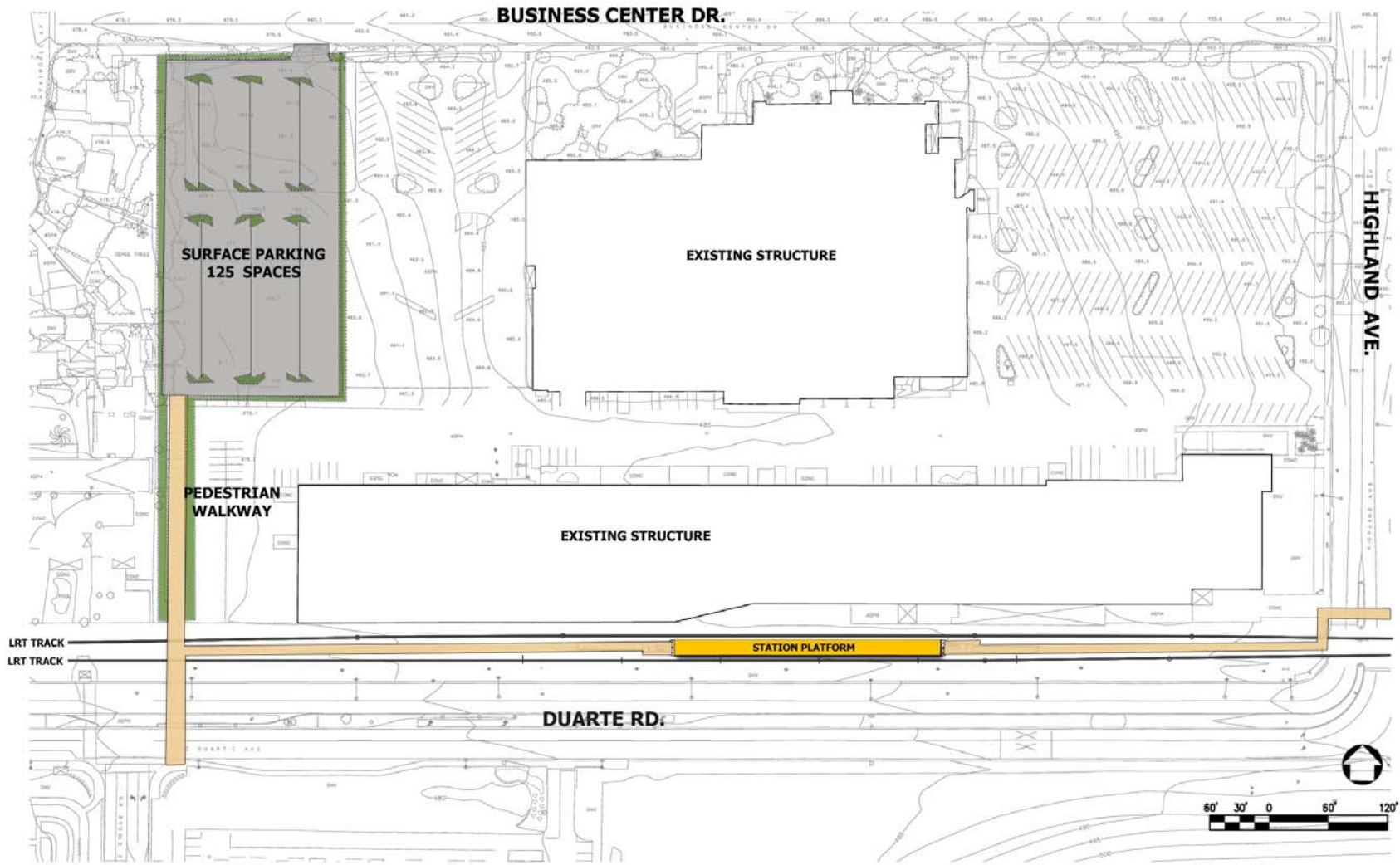

Figure 2-38: Site Plan: City of Duarte Station

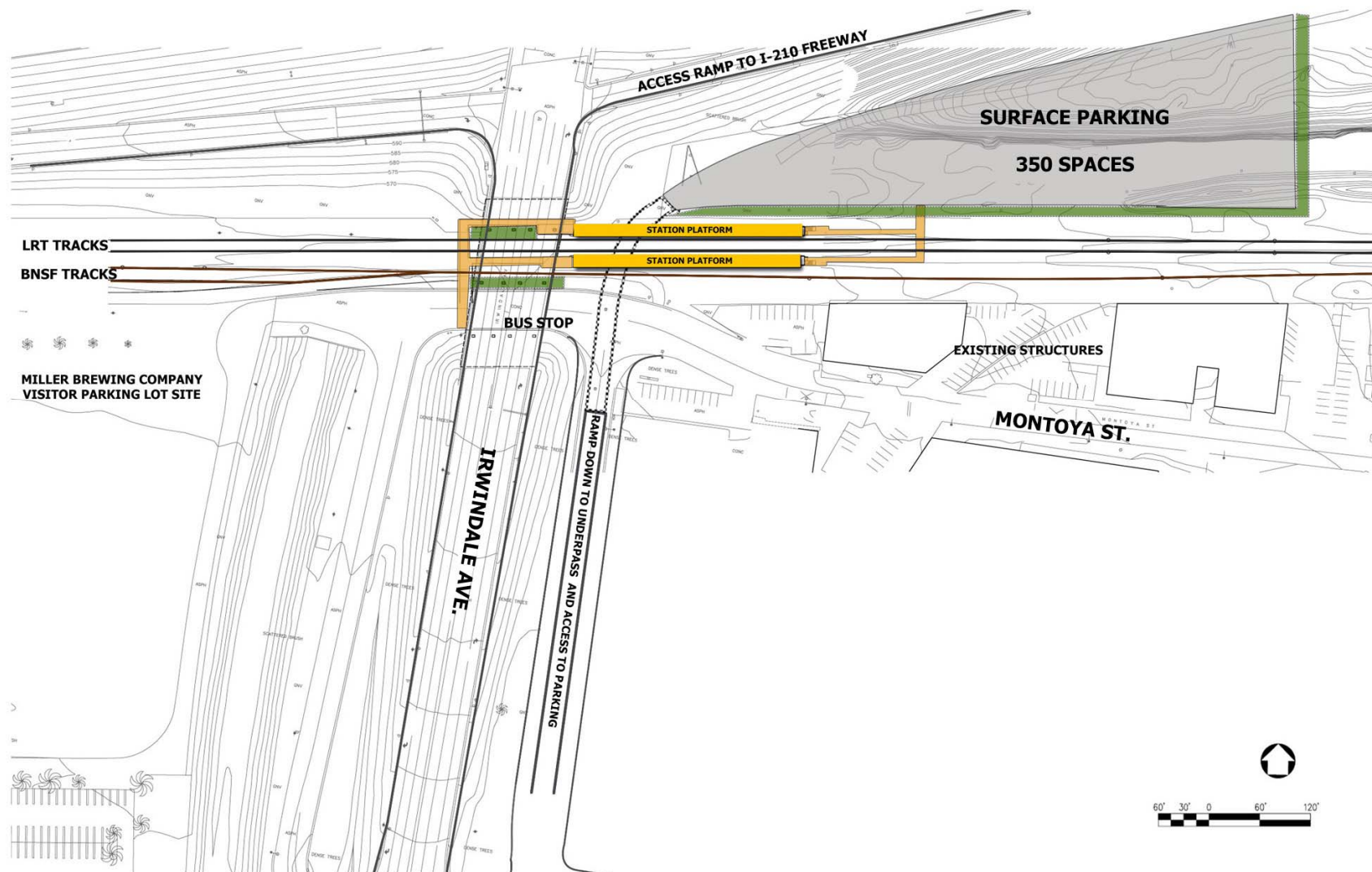

Figure 2-39: Site Plan: City of Irwindale Station

## Azusa

The City of Azusa would have two stations: one located in the downtown center near the historic Santa Fe depot and one located at the proposed ~~Monrovia Nursery~~ Rosedale development. Refer to **Figures 2-50 and 2-51** ~~2-40 and 2-41~~.

The downtown station would be located at North Alameda Avenue, which would be closed across the rail right-of-way. This location takes advantage of the existing historic Santa Fe depot that is located just east of North Alameda Avenue, as well as the adjacent City Hall and downtown businesses. See **Figure 2-50 40**. This station would have a center platform and would be accessed via the western end of the platform. The downtown Azusa station would need approximately 400 parking spaces in 2025, half of which would be required on opening day. Parking is proposed within the rail right-of-way and ~~in a parking structure on a surface lot~~ that would be built on the block bounded by North Alameda Avenue, 9<sup>th</sup> Street, and North ~~Dalton~~ Azusa Avenue. Creation of the parking ~~structure~~ facility would require the acquisition and demolition of commercial structures. The City has expressed interest in combining the parking with a mixed-use development on this site. That potential mixed-use development is not part of the proposed Foothill Extension project and would be subject to a separate EIR prepared by the City.

The Azusa/Citrus Avenue station site at ~~Monrovia Nursery~~ the Rosedale development would be part of a transit-oriented mixed-use development just west of Citrus Avenue and north of the rail right-of-way. Located between Palm Drive and the future Citrus Avenue extension, the LRT station would have a center platform with access from the east end of the platform. Approximately 200 parking spaces would be required on opening day at the Citrus station, and 350 parking spaces would be required by 2025. Construction Authority would purchase a one-acre parcel for parking near the proposed station location to accommodate a two-level parking structure containing approximately 200 parking spaces. A transit plaza is also proposed adjacent to the station and parking. This location would have side platforms (as shown in Figure 2-43) due to the close proximity of the future grade-separated crossing at Citrus Avenue (part of the Monrovia Nursery redevelopment project). The developer would incorporate approximately 350 parking spaces into the transit center design. Refer to **Figure 2-51 41**.

## Glendora

The City of Glendora station would be sited on a parcel located between Glendora Avenue on the east and northeast, East Ada Street on the north, and Vermont Avenue on the west. A center platform station would be located near Vermont Avenue (as shown in **Figure 2-52- 42**), 180 feet from the curb. Access would be provided from both ends of the platform to allow entry from both the street and the parking area, as required by the California Public Utilities Commission in the Double Track Configurations. For the Triple Track Configuration, shown in Figure 2-56, side platforms (as shown in Figure 2-43) would be required.

Surface parking would be provided on the remainder of the Construction Authority-owned property, site. Approximately 400 parking spaces would be required in 2025 at this location; 200 spaces would be required on opening day. There is room for additional parking on the south side of the alignment, which could be used for future parking needs. Currently, the City and the Authority are considering proposals for joint development on this parcel. Should joint development occur, parking for the opening day will be provided as a part of the project. Parking is also proposed to be provided on a parcel located north of the rail right of way and Vermont Avenue. Creation of the parking structure would require the acquisition and demolition of commercial buildings.



Figure 2-40: Site Plan: City of Azusa, Alameda Avenue Station



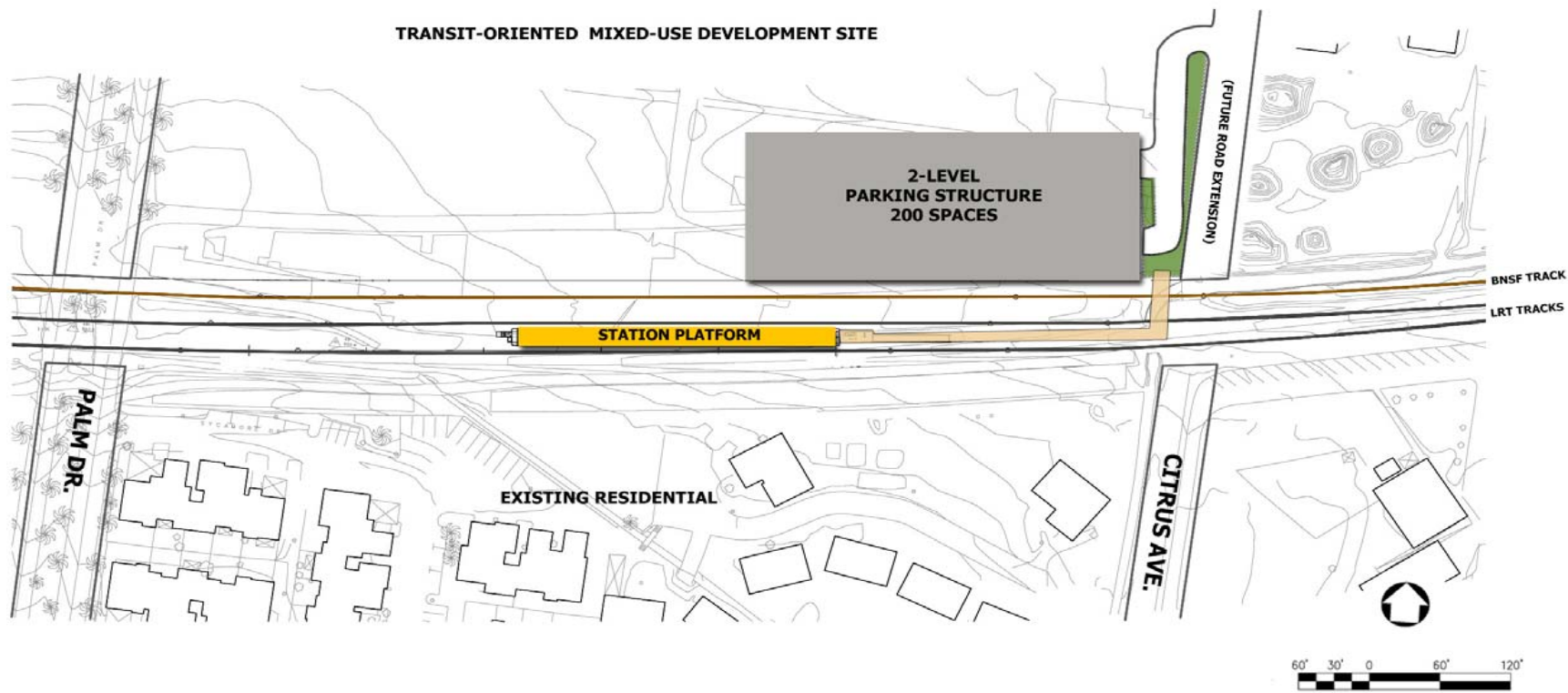

Figure 2-41: Site Plan: City of Azusa, Citrus Avenue Station



Figure 2-42: Site Plan: City of Glendora

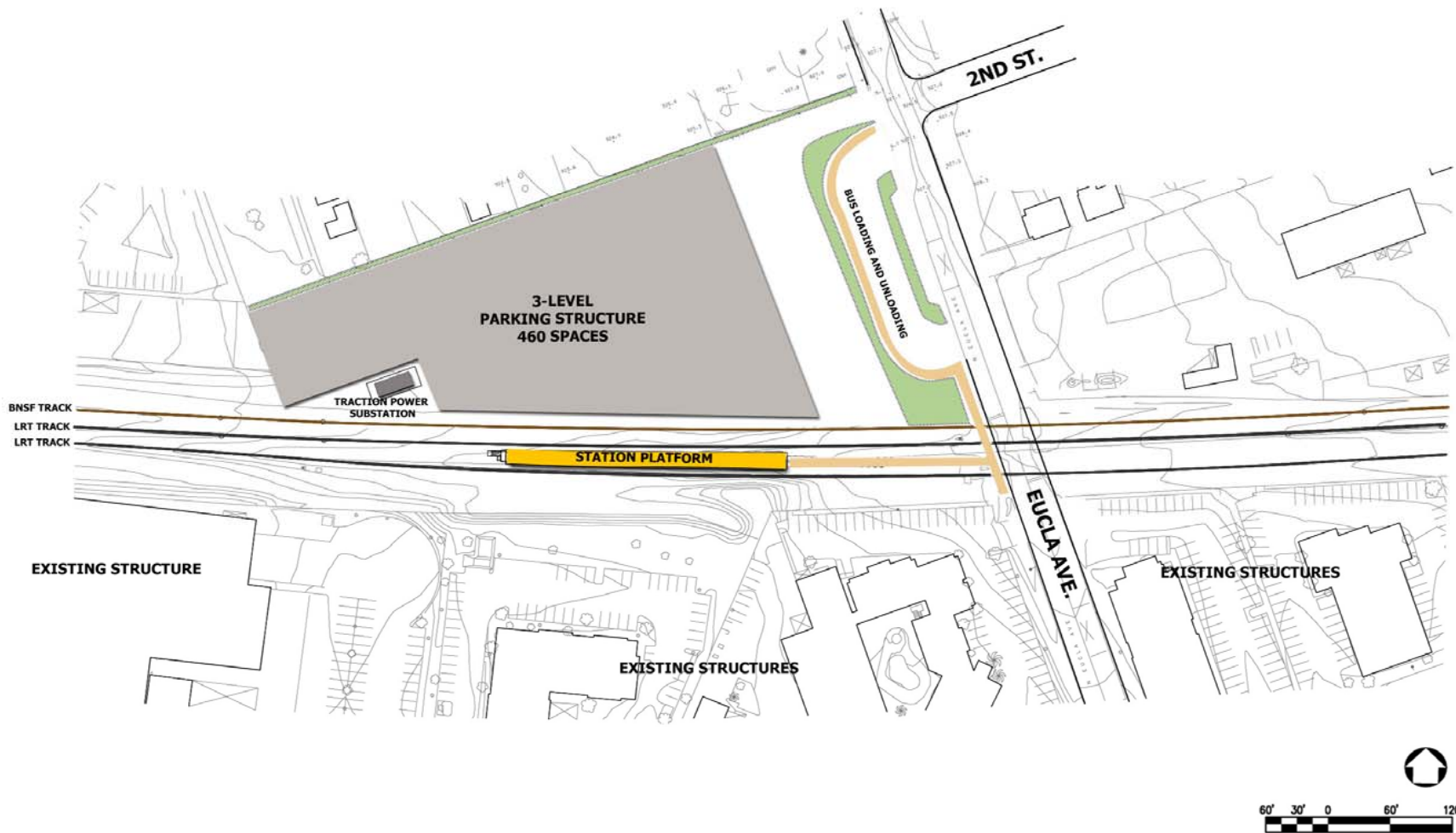

Figure 2-43: Site Plan: City of San Dimas Station

San Dimas

Two station site options have been identified for the City of San Dimas. The station siting choice is complicated by the rail alignment crossing two major arterials on the diagonal in the center of town. For the Double Track Configurations, the station would be located near the historic Santa Fe Depot on the south side of Bonita Avenue, east of Cataract Avenue. The side platforms at this location would need to be offset in order to accommodate the 180-foot distance requirement at intersections. The station would be accessed via both the northern and southern ends of the side platforms. The Triple Track Configuration requires a wider right of way in order to fit three tracks and a station. The location of the Double Track station does not allow for this third track due to the constraints of the existing historic depot. Locating the Triple Track station at the same location would require moving or cutting into a historic structure and community facility, which is quite invasive. For the Triple Track Configuration, the station would be located north of Bonita Avenue and west of Cataract Avenue. For the Double Track Configuration, refer to **Figure 2-58** for the Triple Track Configuration.

The Foothill Extension station in the City of San Dimas would be located west of Eucla Avenue and North of Bonita Avenue. Access to this center platform station would be at the eastern end, directly adjacent to Eucla Avenue. Refer to **Figure 2-53 43.**

Approximately 460 parking spaces would be required for opening day, and 750 parking spaces would be needed at the San Dimas station in 2025. Parking would be provided in a three-level structure located west of Eucla Avenue and north of the Authority alignment. A bus transfer area would also be located in this area. Construction of the station parking facility would require the acquisition and demolition of commercial buildings.

~~Approximately 460 parking spaces are required for opening day, and 750 parking spaces would be needed at the San Dimas station in 2025/2030. Parking would be provided in a three-level structure located west of Eucla Avenue and north of the Authority alignment. The structure would accommodate approximately 420 parking spaces. Additional surface parking (50 spaces) would be provided between the structure and the platform. A bus transfer area would also be located in this area. For the LRT station at the historic depot, some parking demand could be met at the existing park and ride lot that is located nearby, east of Monte Vista Avenue. Three other locations were identified by the city as possible locations for parking. Surface parking could be provided at one of these sites, which is located west of Cataract Avenue and north of Bonita Avenue. This site includes the historic La Verne Orange Association building, which would remain on the site. Two locations for parking structures were identified. The first of these is located west of Acacia Avenue, at its intersection with First Street. The second is located west of Eucla Avenue, at its intersection with Second Street. Either of Construction of the station the parking facility structure locations would require the acquisition and demolition of commercial buildings.~~

La Verne

The station for the City of La Verne would be located east of E Street, just north of Arrow Highway. This location would have a center platform (as shown in **Figure 2-42**), and is illustrated in **Figure 2-54 44**. Pedestrian access to the platform would be from the west end, adjacent to E Street.

The La Verne station would require 300 parking spaces on opening day, and 600 parking spaces by 2025. The Fairplex has agreed to provide 600 parking spaces on opening day for use by Foothill Extension patrons. This parking would be located approximately 1,200 feet away from the station on Fairplex property. Access to the station would be via a 5-minute walk along Arrow Highway to E Street.

In addition, there are several options for the station site.

~~Option C, for the Double Track Configurations, and Option E, for the Triple Track Configuration, would be located west of D Street, adjacent to the University of La Verne campus and just north of Arrow Highway. This location would have a center platform (as shown in Figure 2-42), and is illustrated in **Figure 2-60**. This figure illustrates Option C, Double Track, and gives a good view of Option E, Triple Track. Option E is identical except for an additional through track to the south of the LRT tracks.~~

~~Option D, for the no freight configuration, and Option F, for the freight on Metrolink configuration, would be located adjacent to a potential multimodal transfer facility that would be built on the triangle of land south of the rail right-of-way between E and White Streets, and bordered on the southwest by Arrow Highway and on the southeast by the Metrolink right-of-way. This location would have a center platform (as shown in Figure 2-42) for LRT operations. Refer to **Figure 2-61**. This figure illustrates Option D and gives a good view of Option F. Option F is identical in that freight will share the Metrolink track on the south. This facility is tentatively planned to contain a light rail station, a Metrolink station, a bus transfer facility, patron parking, and kiss and ride access. The City of La Verne, the City of Pomona, the Fairplex, Foothill Transit, Metrolink, and the Construction Authority are in discussions regarding the potential for such a regional transportation facility.~~

~~If the multimodal facility were built (Options D and F), instead of following the current Metrolink right-of-way and turning southwest at White Street, the Metrolink tracks would continue west along a shared Gold Line alignment parallel to and north of Arrow Highway until approximately San Dimas Canyon Road. At this point, Metrolink tracks would cross over Arrow Highway and reunite with the Metrolink right-of-way on the south side of Arrow Highway. Additional parking, beyond that identified for LRT stations, may be required by Metrolink and Foothill Transit, according to their planning requirements. Those needs are not known at this time and would be developed in response to service demands. Funding issues and partnering agreements would be worked out separately between the various groups involved.~~

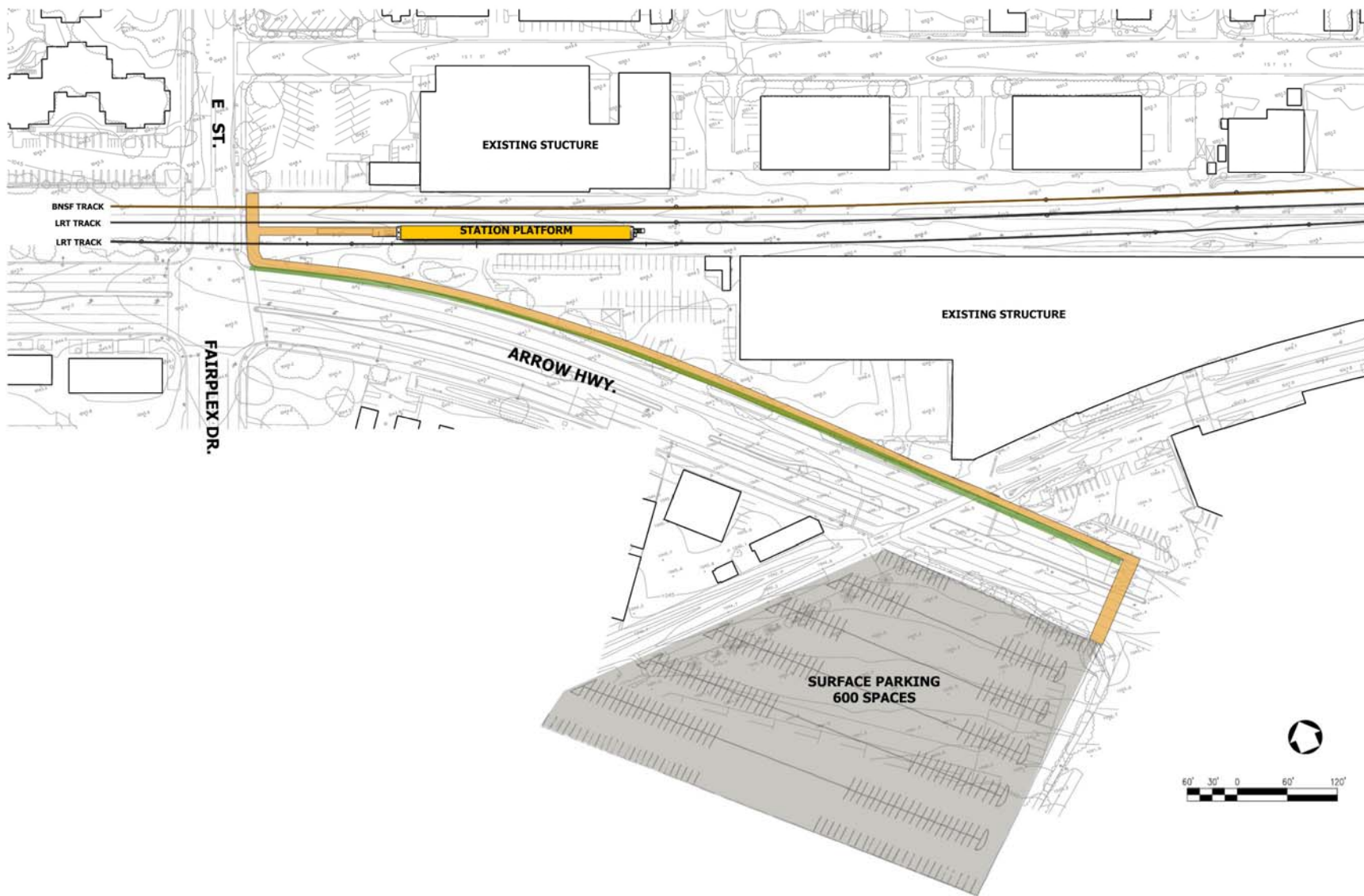

Figure 2-44: Site Plan: City of La Verne Station

## Pomona

The San Bernardino Metrolink line stops in Pomona at a passenger station located west of Garey Avenue and accessible via West Santa Fe Street. The proposed LRT station (**Figure 2-62-45**) site is located ~~adjacent north of~~ the existing Metrolink facility. This location would have a center platform. ~~as shown in Figure 2-41.~~

~~Approximately 800-530 parking spaces would be required at the Pomona station on opening day; 800 spaces would be needed by 2025. Current Metrolink surface parking is fairly limited, and at capacity. A nearby vacant lot located north of the alignment is proposed for a parking structure. Vehicular access to the parking structure would be from Bonita Avenue. Pedestrian access from the parking area to the platform would be via a pedestrian walkway and bridge over the freight tracks—a layout designed to allow freight trains to continue using the area for shunting cars while also allowing unrestricted access from the parking facility to the station area. Metrolink is has double tracks in this area, so there would be a total of more than four-five tracks in this area (one freight track on the north, as well as several switching tracks, two LRT tracks, and two Metrolink tracks on the south/freight).~~

~~Due to the proximity of the Garey Avenue site to the proposed La Verne Fairplex Station, the Pomona station must be moved east to allow sufficient separation between the two stations. An option for the Pomona station as a part of Options D or F (**Figure 2-63**) is located to the east of Towne Avenue. This station alternative would be part of a package of stations with the La Verne Fairplex Station, described previously (Options D or F). This location would have an at grade, center platform. To the north of the alignment and east of Towne Avenue is a vacant industrial site that is identified as a potential location for surface parking.~~

## Claremont

Claremont has a thriving transit center focused on its historic restored Santa Fe depot, located north of the tracks to the east of Indian Hill Boulevard. There are two options for the platform location.

~~Metrolink has a newly expanded and renovated commuter rail station at this location. The Gold Line LRT station Option A is proposed to be located between Indian Hill Boulevard and the just south of the west end of the existing Metrolink station, with easy access between the two systems. The center platform station would be accessed via the east. Within the rail right-of-way, there would be two LRT tracks and two Metrolink/freight track, with two new side Metrolink platforms. Due to the narrow right-of-way between Indian Hill Boulevard and College Avenue, property would have to be acquired on the south side of the right-of-way between approximately Bucknell Avenue and east of College Avenue.~~

The Option B LRT station location would to be located east of College Avenue, south of the proposed parking structure. The station would be accessed via the west. This side platform station would require slightly less property acquisition through the existing station area. There would be two LRT tracks and two Metrolink/freight tracks, with two new side Metrolink platforms.

The Claremont station would require approximately 700 parking spaces for LRT patrons in 2025; about 300 parking spaces would be needed opening day. On opening day, parking would be provided in a 5-level structure to be built on the existing Metrolink surface parking lot. The parking structure could accommodate approximately 700 parking spaces. There would be a total of 400 parking spaces for Metrolink patrons (to replace the existing surface parking lot) and 300 parking spaces for Foothill Extension patrons. Two locations for parking have been identified. The current transit center parking lot, located west of College Avenue, is under capacity and could be utilized for additional LRT parking or a future structure.

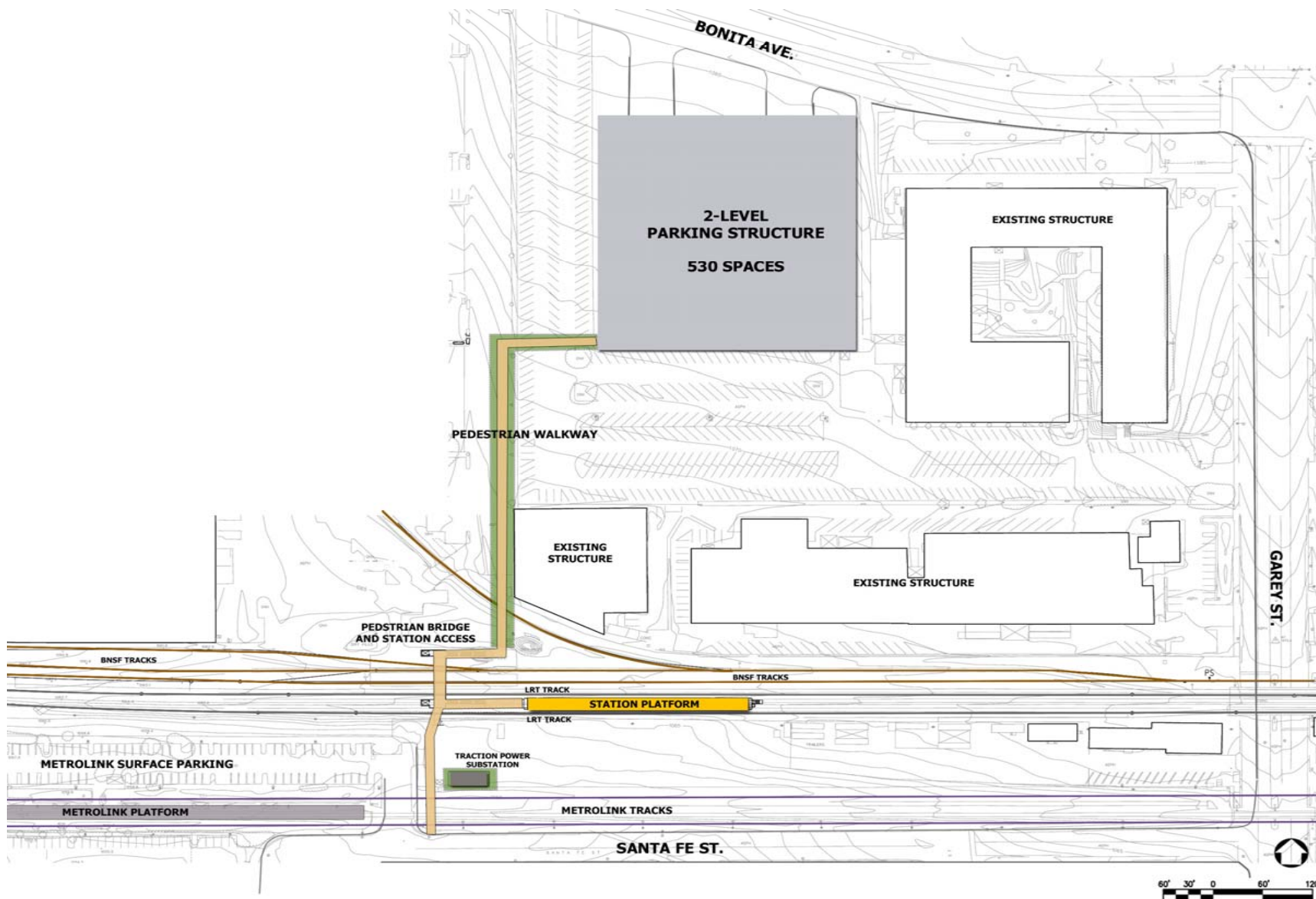

Figure 2-45: Site Plan: City of Pomona Station



~~A second option would be to provide a parking structure that would be located to the west of Indian Hill Boulevard at what is currently a vacant lot. Refer to **Figures 2-46 and 2-47.**~~

## Montclair

The terminus station in the City of Montclair (which would also serve the City of Upland) is located at the Montclair Transcenter. The Montclair Transcenter provides a transfer location between Metrolink and Foothill Transit, and contains ample parking for all current and planned operations. The LRT service would require approximately 800 parking spaces in 2025. This demand can be accommodated within the existing Transcenter parking.

The City of Montclair has a specific plan process underway for the Transcenter and the adjoining neighborhood directly south of the site. The focus of the specific plan is increased connectivity between the Transcenter and the Montclair Mall, which is located about two blocks south of the rail right-of-way. The station would be located on the ~~north~~ south side of the Transcenter. This location would have a center platform ~~(as shown on Figure 2-42)~~ and access would be provided from ~~the western~~ both ends of the platform. The existing Metrolink station and future pedestrian tunnel would not be affected by the construction of the Foothill Extension, and coordination has ensured that the pedestrian tunnel would merely have to be extended, not relocated, with the construction of the LRT platform. Refer to **Figure 2-48.**

~~In order to reach the north side of the Transcenter, the LRT alignment would turn northward to the east of the Claremont station and transition into abandoned rail right of way that is owned by the San Bernardino Associated Governments (SANBAG). This right of way is typically referred to as the Union Pacific right of way or the Pacific Electric right of way. Option G would locate the LRT station on the south side of the Transcenter, just west of the existing Metrolink station. This location would have side platforms and have access from the eastern end of the LRT platforms. The existing Metrolink station would need to be relocated to the south side of the rail right of way in order for the LRT tracks to be placed on the north side of the right of way. The southern LRT platform would be located immediately next to a relocated Metrolink side platform. Refer to **Figure 2-66.**~~

~~The City of Upland, located directly to the north of the Transcenter, has a number of housing and commercial developments in the planning stages for the land adjacent to the north side of the Transcenter.~~

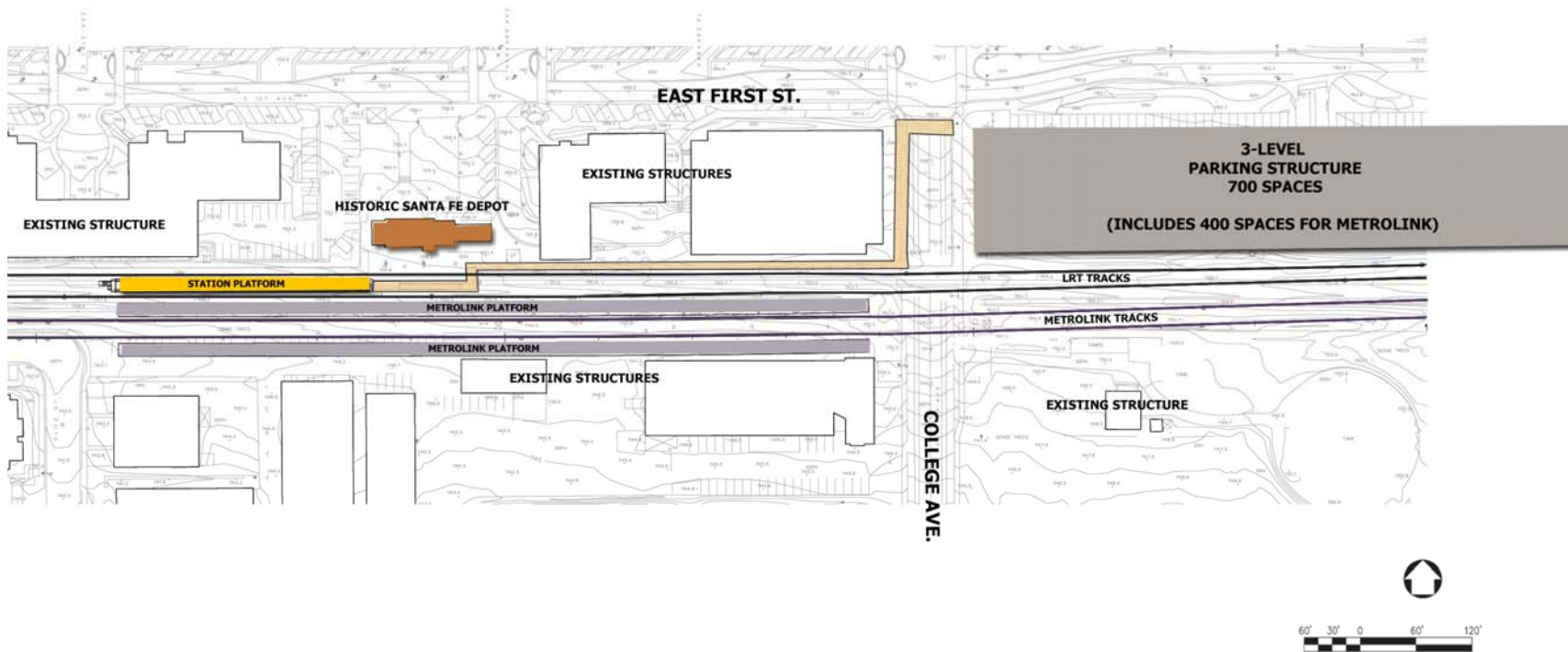

Figure 2-46: Site Plan: City of Claremont Station, Option A

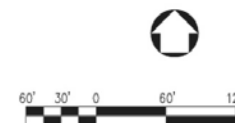
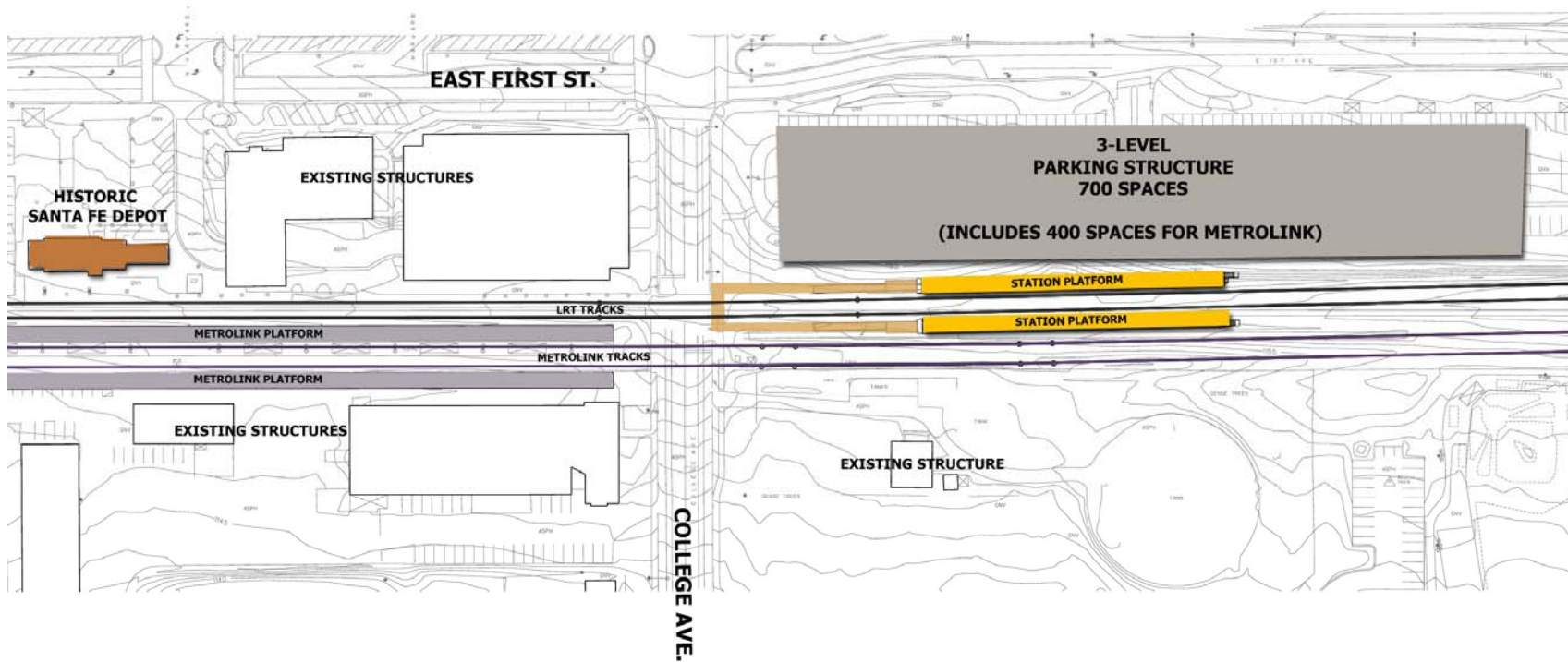

Figure 2-47: Site Plan: City of Claremont Station, Option B

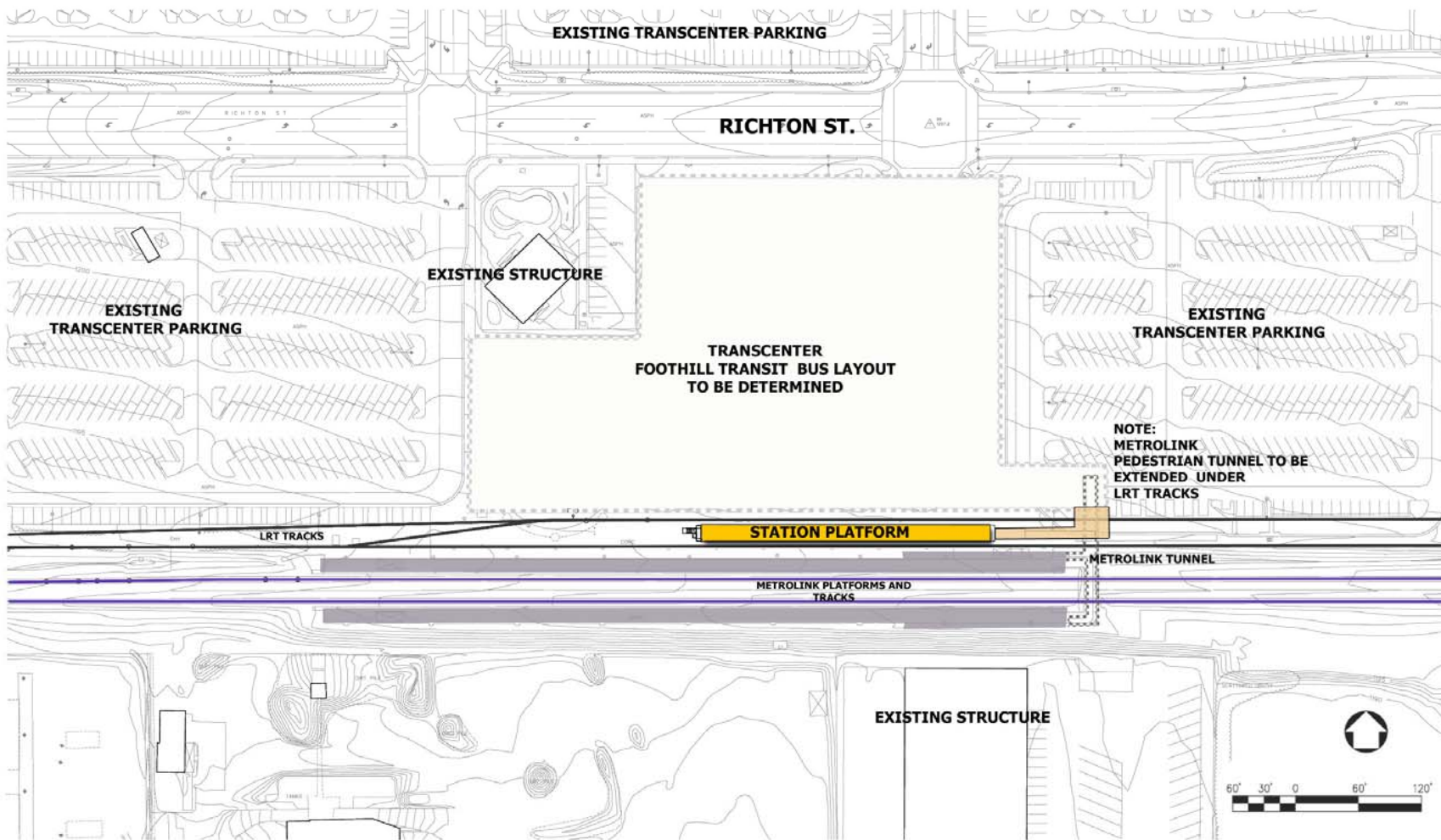

Figure 2-48: Site Plan: City of Montclair Station

*b. Maintenance and Operations Facility*

The Irwindale Maintenance and Operations Facility is proposed to be located on Miller Brewing Company property that is currently vacant, or that is leased for truck storage. Refer to Volume II of the EIS/EIR for the Maintenance and Operations Facility layout and **Figure 2-67** for a site plan. The proposed Maintenance and Operations Facility site is west of the brewing facility. It would utilize heretofore “unusable” elongated and irregular segments of property that abut an abandoned gravel quarry that is both sizable and deep (reaching a maximum depth of approximately 250 feet), as well as a heavily secured area used for liquor tax calculations for outgoing product shipments from the Miller Brewing facility. The proposed 33-acre site would not interfere with the present rail operations serving the brewery. Access to the proposed site would be grade-separated from the railroad operations that now occur, and may occur, on the proposed LRT alignment. There is also a potential for expanding the facility an additional 8 or 9 acres, which would encompass the northerly swath of land adjacent to the LACMTA Construction Authority owned railroad right-of-way.

In conjunction with the Foothill Extension, a storage yard and Maintenance and Operations Facility is proposed to be constructed on a site of approximately 24 acres that is owned by the Miller Brewing Company in Irwindale. Rail access to the yard would be via tracks that lead from the BNSF mainline on the west side of the Miller property. These new lead tracks would be on United States Corps of Engineers (USCOE) property that is also part of the Santa Fe Dam Recreational site.

The conceptual design of the Maintenance and Operations Facility has been based on a need to adequately handle all fleet requirements for an ultimate Gold Line operation that would include the Eastside Extension, Phase I, and Phase II. The conceptual design of the Maintenance and Operations Facility has been based on a need to adequately handle all fleet requirements for an ultimate Gold Line operation that would include the Eastside Extension, Phase I, and Phase II. The yard and facility would be constructed to meet the requirements for the Foothill Extension, with the capability to be expanded for future LACMTA Metro requirements (Gold Line Phase I and Eastside Extension). Power for rail operations within the yard would be by TPSS-16, which would be on the south side of the yard. Refer to **Figure 2-49**.

The impacts associated with the site are discussed in Chapter 3, and are entirely “owned” by Phase II. Capital costs for the facility would be shared between the Eastside Extension, Phase I, and Phase II. The proposed site would be conveniently located at about the midpoint of this combined route. Vehicular access to accommodate delivery of goods and supplies is very close to the I-210/Irwindale Avenue interchange.

**Brief Description of Facility**

The terrain of the proposed site slopes slightly downward (in the order of 1 percent) in a southwesterly direction from the proposed LRT mainline. The area best suited for maintenance, due to its broader expanse and proximity to goods and supplies, is located about 3,000 feet away and about 30 feet lower than the LRT mainline (which is at approximately elevation of 556.5 feet). The main entrance to the facility would be off of West First Street (an elevation of 523.5 feet) at the southeasterly corner of the property. The maintenance area would be level at an elevation of 526.5 feet, and the first 1,800 feet of the storage yard would be constructed with a slight northerly ascending grade of 0.20 percent, followed by a descending grade of 0.24 percent to the LRT mainline. At this point, the yard lead tracks would be about 21 feet lower than the proposed LRT mainlines, making it convenient to grade separate the railroad by way of an underpass. There are three underpasses under the freight line, for two inbound tracks and one outbound track between the yard and the mainline.



Figure 2-49: Site Plan: Maintenance and Operations Facility, Irwindale

## Rail Access to the LRT Mainline

In designing the track connections to the LRT mainline, two options were considered that would allow a single-track connection in each direction along the mainline, while also maintaining grade separation from the railroad. Option 1 provided aerial structures over the railroad and Option 2 called for railroad underpasses. After extensive analysis, including costing, construction phasing, railroad operations, and site conditions, the railroad underpass option had little or no adverse slope to contend with and turned out to be slightly less costly and have greater overall benefits than the aerial option.

Time saving measures, such as 48-hour freight railroad closures to quickly construct the required underpasses using precast concrete tunnel segments, would seem appropriate since the brewery generally operates six days a week and the effective closure for brewery shipping would only be one day. This matter was discussed with BNSF personnel who cited similar examples on the recently completed Alameda Corridor Project. It should be noted that constructing aerial structures would likely call for long periods of "slow order" railroad operations, which would only add to the cost differential of the two options.

Building on Option 2, an Option 3 was subsequently developed that added a second east connector that would allow separate dedicated inbound and outbound tracks for vastly improved operations to and from the facility.

## Operational Capabilities

The Irwindale Maintenance and Operations Facility site would be a stand-alone facility capable of performing all levels of maintenance on the LRT vehicle fleet based there. When completed, it would handle approximately 171 railcars, enough to cover the requirements of the Eastside Extension and Phases I and II, and would include the following:

A storage yard for approximately 171 ~~80~~ light rail vehicles, with an adjacent 30,000-square-foot transportation building complete with recreational facilities, an eating and food service area, a meet and greet area (train operator/maintenance personnel interface), offices, and its own parking facility (213 spaces) that would also accommodate visitors.

A maintenance area (that would be sufficient to store an additional 50 vehicles) that would include a 100,000-square-foot maintenance building with facilities for daily servicing, preventive maintenance, running repairs, heavy repairs, blowdown, wheel truing, parts storage and material control, component troubleshooting and repair, maintenance administration, and employee welfare and support areas.

An approximately 8,000-square-foot paint shop and paint prep (body shop) with associated sheet metal, welding, and paint storage areas.

A 35,000-square-foot operations center (as a second floor to a portion of the maintenance building) to house rail operations, maintenance and operation training, and the signals and communications department. The overall maintenance area would have its own parking facility (161 spaces).

A 12,000-square-foot maintenance-of-way building to serve the track department that will include a storage track and lay-down area.

A TPSS for the yard and shop.

Approximately 40 percent of the capital cost of the Maintenance and Operations Facility is attributable to the Phase II extension. Refer to Section 5-1.2 for additional cost information.

## Facility Access

The conceptual layout for rail access to the facility calls for one egress track (to inject light rail vehicles into the mainline) and one ingress track (to remove them from the mainline). These two tracks would tie directly into the Irwindale station platform area. A third track going to the west would normally serve as an ingress track, but could be used as an egress track in emergencies. The access tracks would continue in a southerly direction leading first to an eight track storage yard (with run-around tracks on each side) and eventually to the maintenance complex (that would include a maintenance of way facility). Refer to **Figure 2-67** for a site plan.

The main entrance to the facility for vehicular access would be from West First Street at its southeastern corner. The two-lane roadway (26 feet wide) would follow along the southerly and westerly edges of the maintenance area, passing the parking entrance for this area and continuing to the parking area for the storage yard. This main road would have no grade crossings with LRT tracks. The main highway vehicle entrance would be at 1<sup>st</sup> Street, on the south side of the Miller property. This entrance would be manned at all times for security reasons. A 22-foot-wide road leading to the main facility paralleling the BNSF tracks along the south and west side of the property would be constructed. An additional 7 acres from the Miller Brewing facility property would be required for this entrance road.

## Storage Yard

The overall site of the storage yard is a generally L-shaped section of land that covers approximately 17 acres on the south and east side of the large quarry that occupies the northwest quadrant of the Miller Brewing Company property. The site would include an area to accommodate the Maintenance and Operations Facility building, Blow Down building, future Body Shop building, future Maintenance-of-Way building, vehicle storage, and necessary paved areas for highway vehicle delivery and parking.

Rail access to the site would be by two yard leads from the LRT mainline and would traverse property to be acquired from the United States Corps of Engineers (USCOE). Adding these yard leads would make the overall site a U-shape. Approximately 7 acres of USCOE property would be required for the yard leads. Immediately before entering the yard, the vehicles will pass through a Car Wash building which would tentatively be built on USCOE property.

A two-track cleaning area with a center platform would be located on the southwest corner of the storage yard site. Vehicles would pass into this cleaning area after exiting the Car Wash building. The cleaning platform would be long enough to accommodate a three-car train on either side. A run-around track (third track) would allow LRT vehicles access to/from the yard vehicle storage without having to pass through the cleaning platforms and the car wash.

From the cleaning platform, the tracks would lead directly to the storage tracks that would occupy the southeast side of the yard. Storage tracks would also occupy the L-shaped portion that turns to the north along the eastern edge of the property. Initial construction would include two storage tracks plus a run-around track to meet the vehicle requirements for the Foothill Extension. The run-around track and the storage tracks would have a direct connection to the LRT mainline at the north end, but access would be used in emergency situations only. However, portions of this emergency track would be used to turn the vehicles around for exiting the yard. Normal operation would require all vehicles exiting the yard to use the lead tracks on the west side of the facility.

Two tracks would come out from the yard lead track after the car wash to provide access to the Maintenance Facility building. Two additional tracks would be added to these tracks, which are needed in the operation of the facility (one of these tracks would be constructed to serve the future expansion of the facility). Vehicles leaving the facility would have access to the Blow Down building, future Maintenance-of-Way building and future Body Shop building, and the most westerly storage track.



Two storage tracks and a turn-around track which is capable of storing as many as 20 vehicles would be included in the initial construction. Future expansion would add as many as seven additional tracks to the yard and would accommodate up to an additional 48 vehicles, for a total of 68 vehicles in the storage yard itself. The total vehicle storage capacity of the yard including storage on all future tracks, car cleaning platform, Maintenance Facility, Blow Down and Body Shop but excluding the turn-around track would accommodate as many as 85 vehicles. Possible construction of storage tracks on the north side would further increase the storage capacity of the yard.

A perimeter road that ranges from 12 to 22 feet wide would be provided for service and inspection of the yard by highway vehicles. A 4-foot service road would be provided between every other track for maintenance carts to service the vehicles.

All turnouts in the storage yard would be 190-foot-radius turnouts as defined in the LACTMA design guidelines, and would be similar to the current turnouts installed at the Phase I Midway Yard in Los Angeles. The minimum curve radius is 100 feet. Track center spacing would be alternatively 13 feet and 18 feet in the storage yard to allow for walkways and emergency access.

### Maintenance and Shop Facility

The Maintenance and Shop Facility's initial construction would occupy a rectangular area of approximately 44,550 square feet of floor space (135 feet by 330 feet) and would occupy three levels, with the second level mainly used for administrative offices and the third floor on the east end of the building serving as a yard control center. A wheel-truing machine, plus four pits for inspection and heavy repair would occupy the floor space over three tracks passing through the building. The Maintenance and Shop Facility would have 5-ton and 10-ton hydraulic cranes that would move the length of the building over all three tracks. The Maintenance and Shop Facility would also have a truck, wheel and axle, traction motor, coupler, brake and sheet metal shops. Initial construction would also include a Car Wash building of approximately 4,500 square feet (30 feet by 150 feet) and a Blow Down building of approximately 5,550 square feet (30 feet by 185 feet).

Future expansion could add one additional run-through track and floor space of 9,900 square feet (30 feet by 330 feet) at the Maintenance and Shop Facility, as well as an optional Body Shop building of 3,900 square feet (30 feet by 130 feet). An option to build a Maintenance-of-Way building on the site could accommodate the needs of future Gold Line and Eastside Extension expansion, with a building size of 6,000 square feet (40 feet by 150 feet). This building would house equipment, and spare parts for replacement and repair of the right-of-way.

### *c. Traction Power Substations*

In order to provide electrical power to the light rail vehicles, the proposed project requires a series of TPSS sites along the alignment. Typically, ~~these~~ TPSSs are pre-fabricated buildings, approximately 14 feet wide by 43 feet long and 16 feet high. Around this building there would be a perimeter ground mat, access for equipment, and parking. The overall property requirement would be 40 feet by 70 feet (2,800 square feet), not including roadway access. Refer to **Figure 2-68 50**. The TPSS sites would be located within the existing right-of-way where possible; a few substations would be located on vacant properties immediately adjacent to the existing right-of-way. They would be designed to be compatible with the surrounding land uses through the use of architectural treatments, landscaping, and other means as appropriate for the individual locations. Locations of the TPSS sites are independent of the station option locations described previously.



**Figure 2-50: Typical Existing TPSS Facility Located on Gold Line Phase I**

The Full Build (Pasadena to Montclair) Alternative would require ~~24~~16 TPSS sites along the 24 miles of the alignment, including one in the proposed Maintenance and Operations Facility. This number of TPSS locations was obtained after an analysis of the ultimate light rail operations of 3-car trains at ~~5~~10-minute headways. These headways are consistent with LACMTA's planned operating plan for Phase I after construction of the Eastside Extension. Two types of criteria were utilized in the analysis: electrical criteria and other criteria, such as right-of-way, visual intrusion, and proximity of primary feeders. Refer to ~~Figures 2-69 through 2-83~~ **Figures 51 through 2-66** for the locations of TPSS sites along the alignment. ~~When information was available, these criteria were used in the selection of the TPSS locations. Further refinements will be made during the preliminary engineering phase, when additional technical information that is needed to finalize locations would be available. TPSS spacing for all TPSS (except the two end of line TPSS) is estimated at 6,500 feet for the operation of three car trains at 5-minute headways. The estimated number and location of traction power supply substations for the Full Build (Pasadena to Montclair) Alternative are provided below in **Table 2-3.**~~

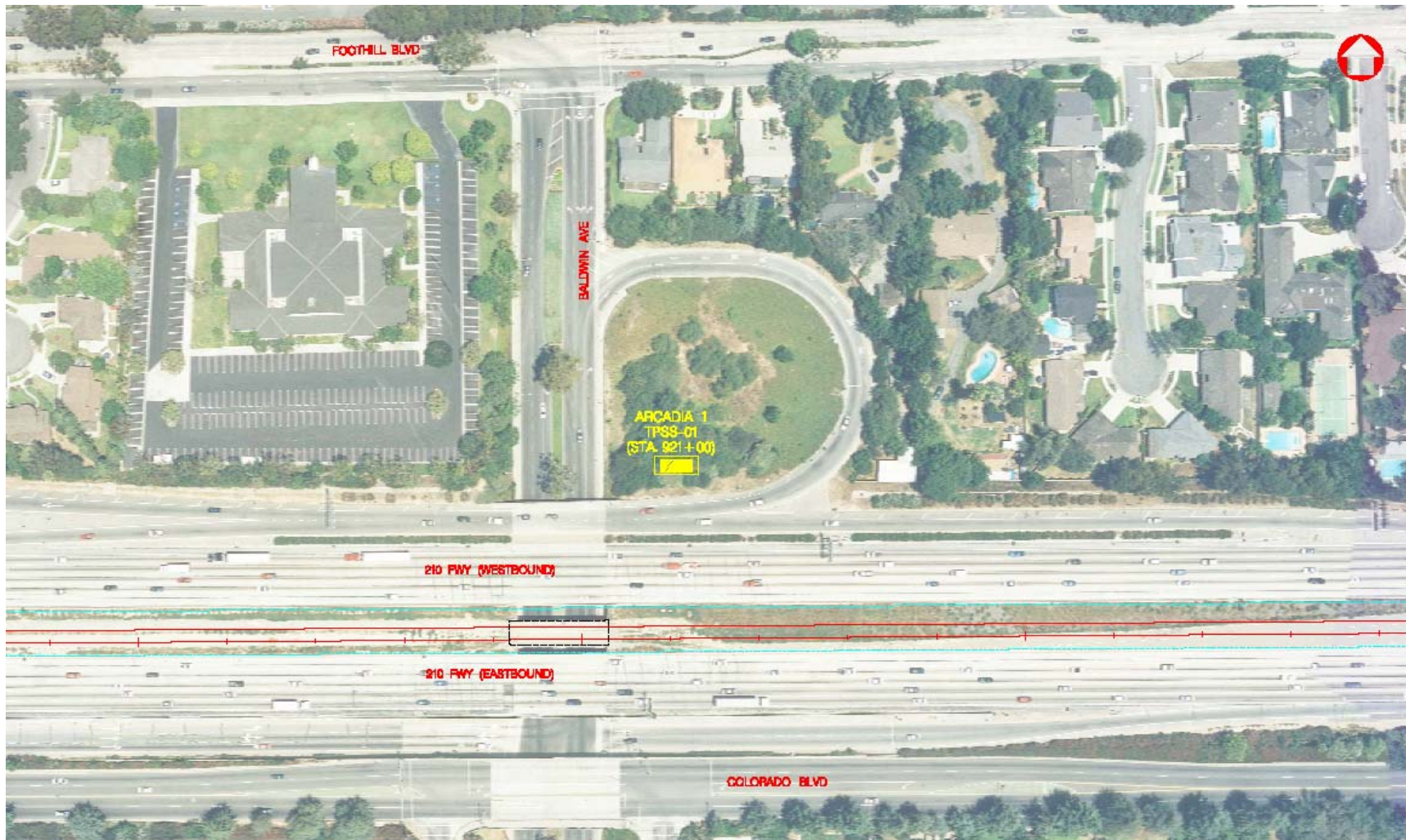

Figure 2-51: Traction Power Substation Sites, City of Arcadia (1 of 16)

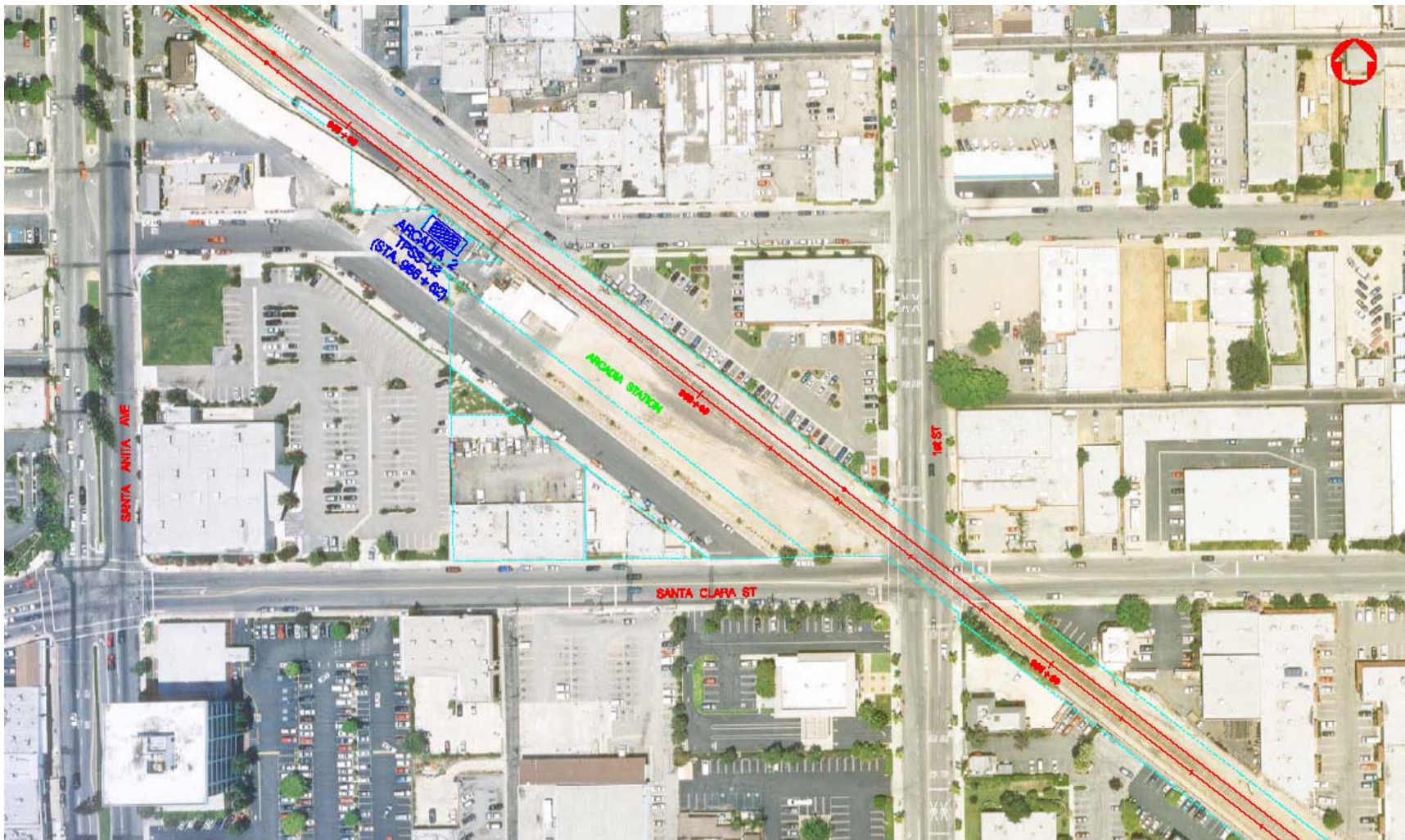

Figure 2-52: Traction Power Substation Sites, City of Arcadia (2 of 16)



Figure 2-53: Traction Power Substation Sites, City of Monrovia (3 of 16)

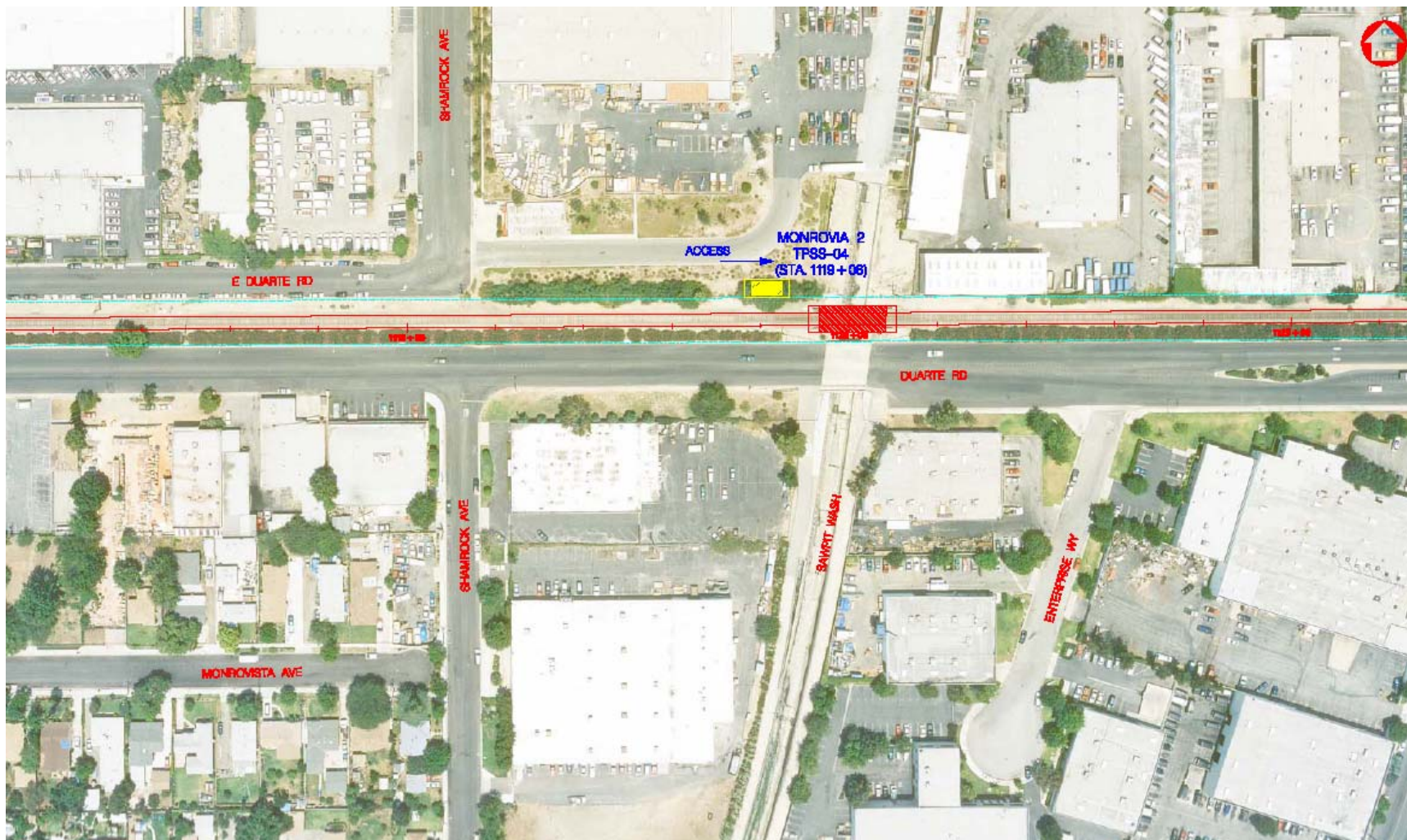

Figure 2-54: Traction Power Substation Sites, City of Monrovia (4 of 16)

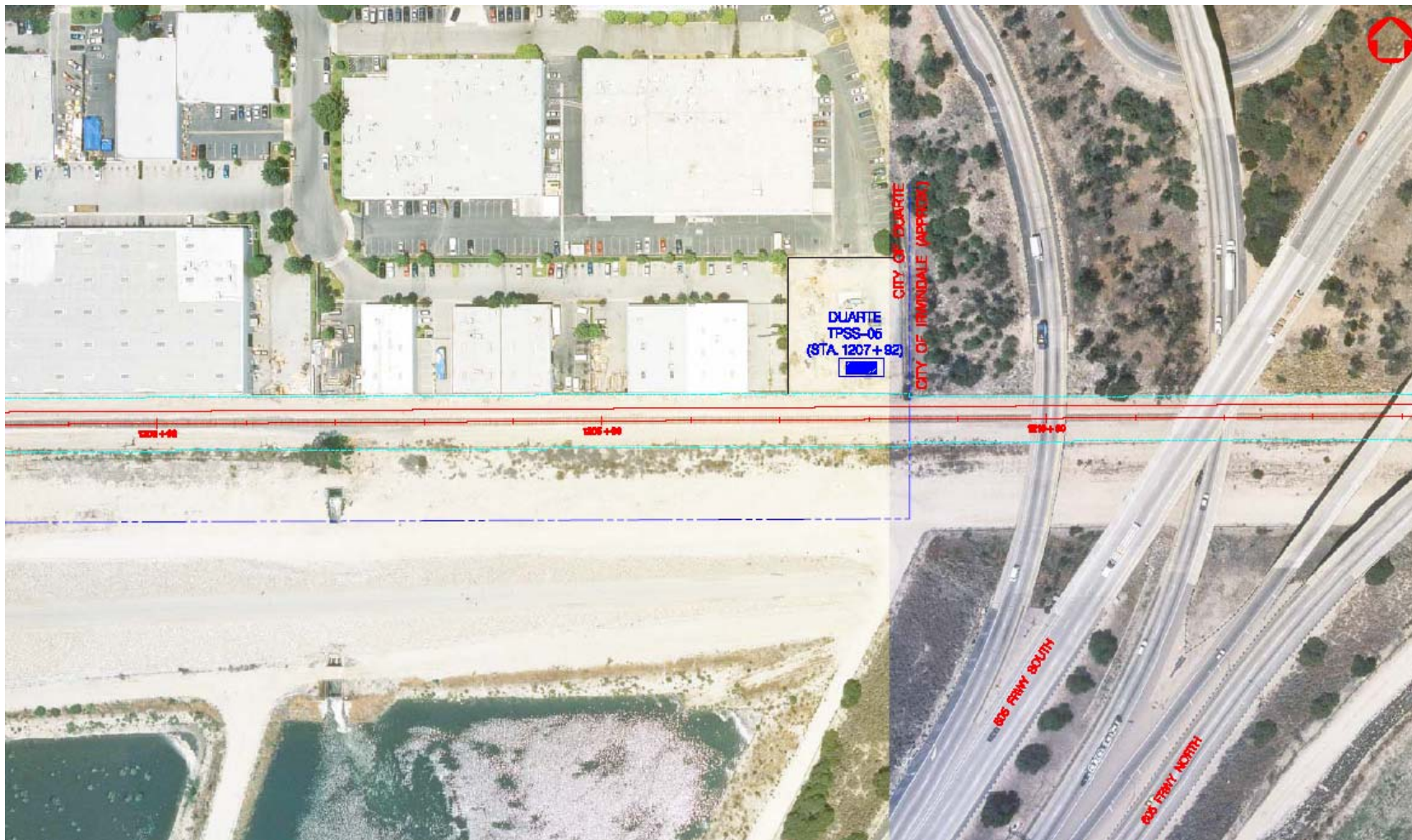

Figure 2-55: Traction Power Substation Sites, City of Duarte (5 of 16)



Figure 2-56: Traction Power Substation Sites, City of Irwindale (6 of 16)



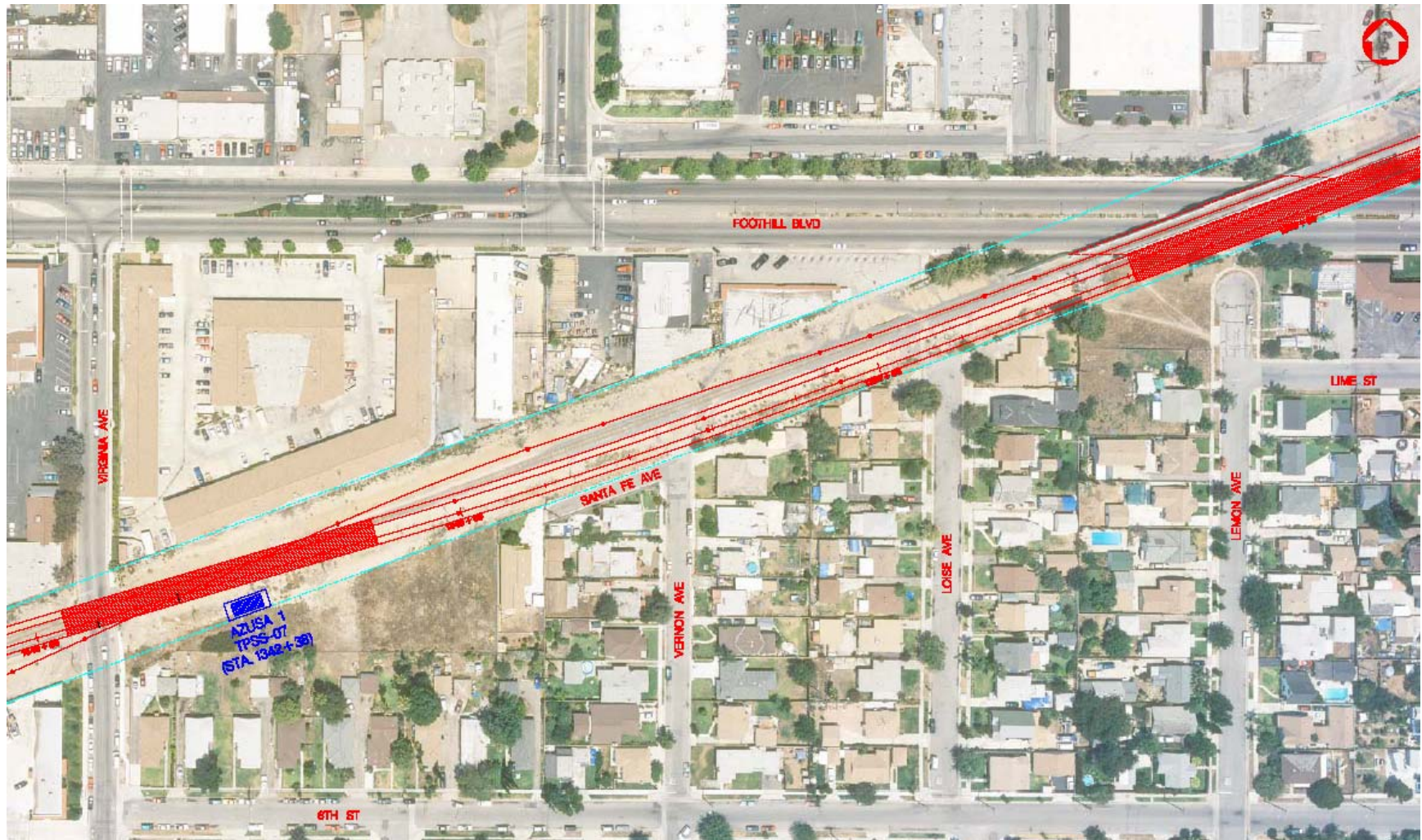

Figure 2-57: Traction Power Substation Sites, City of Azusa (7 of 16)

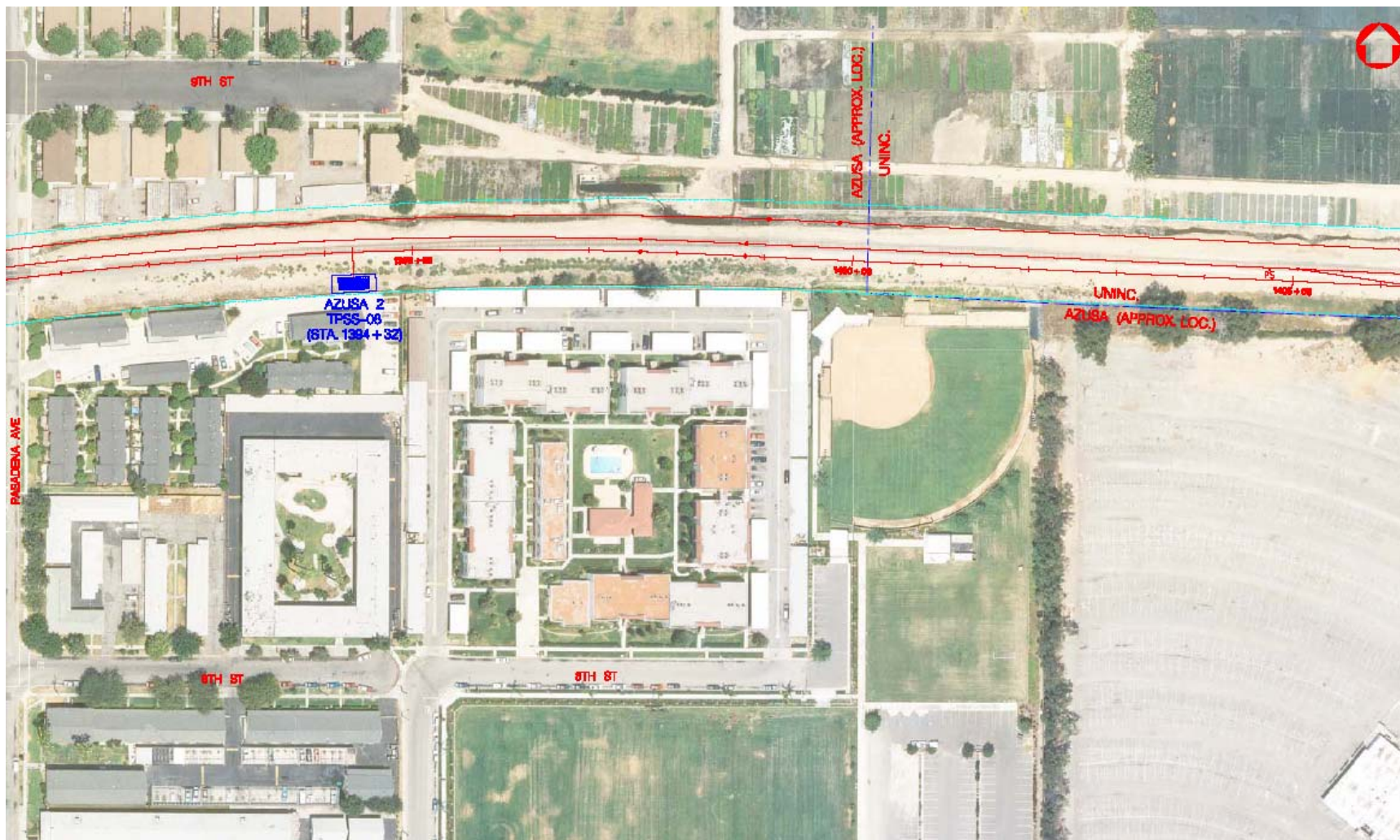

Figure 2-58: Traction Power Substation Sites, City of Azusa (8 of 16)

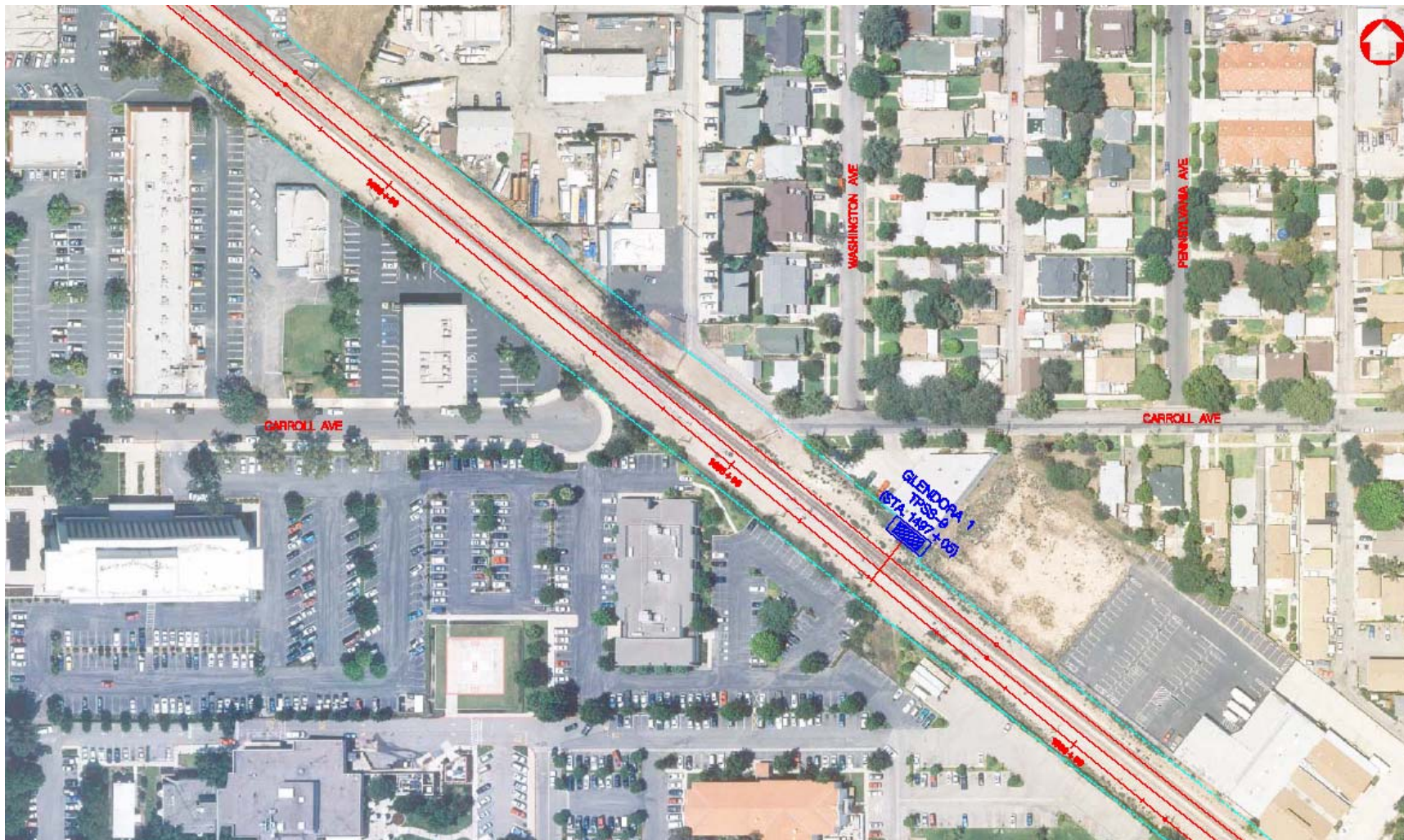

Figure 2-59: Traction Power Substation Sites, City of Glendora (9 of 16)

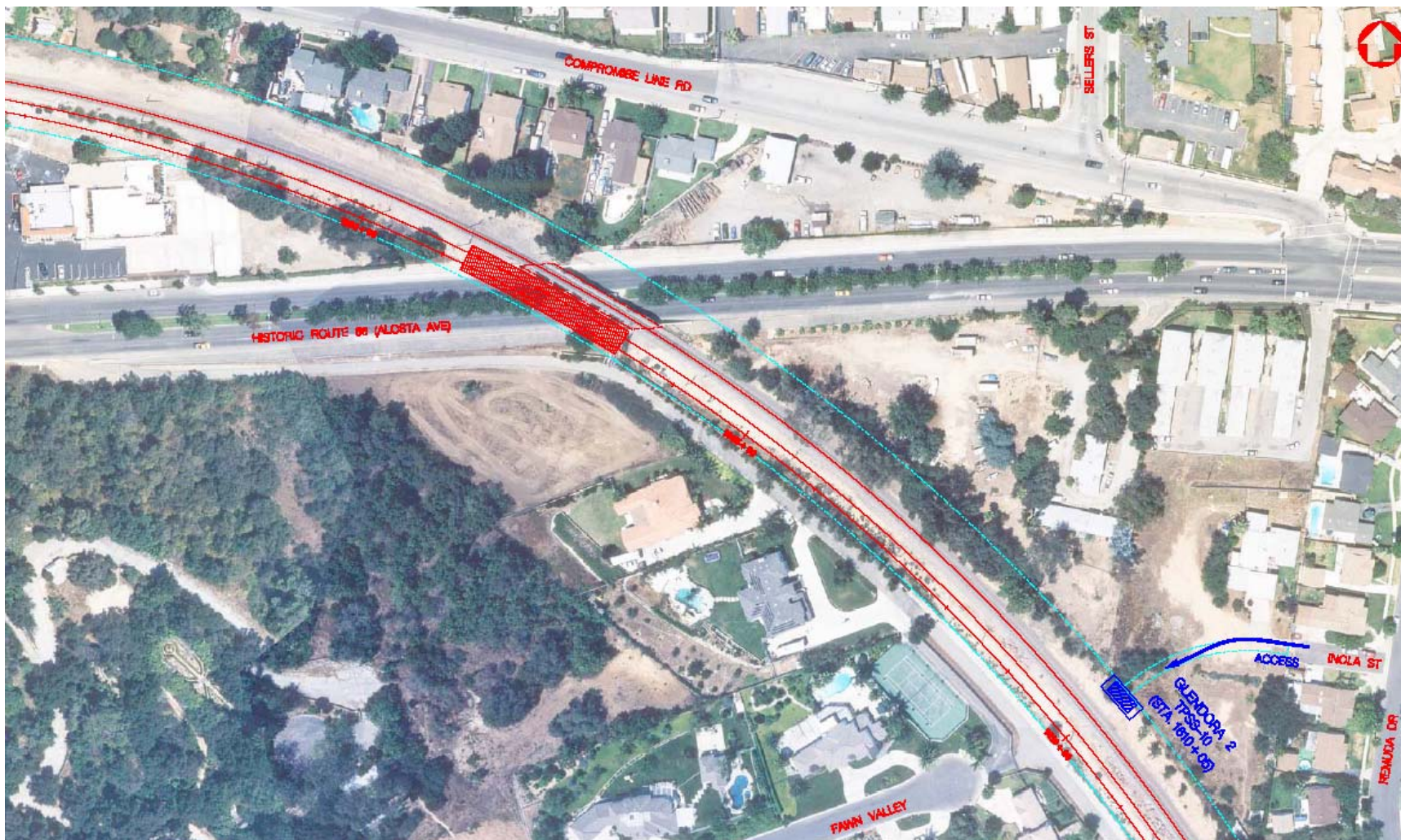

Figure 2-60: Traction Power Substation Sites, City of Glendora (10 of 16)



Figure 2-61: Traction Power Substation Sits, City of San Dimas (11 of 16)

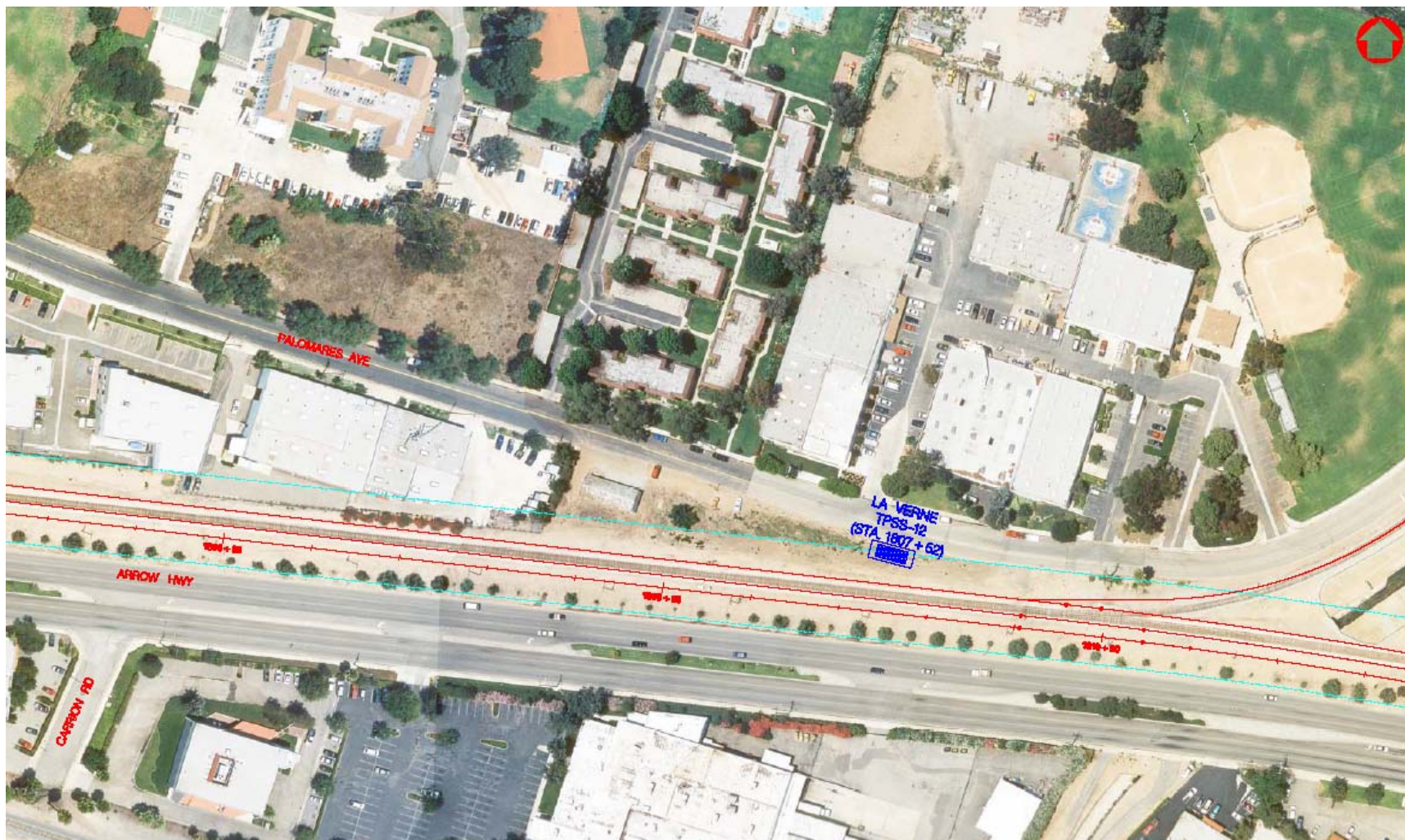

Figure 2-62: Traction Power Substation Sites, City of La Verne (12 of 16)



Figure 2-63: Traction Power Substation Sites, City of Pomona (13 of 16)

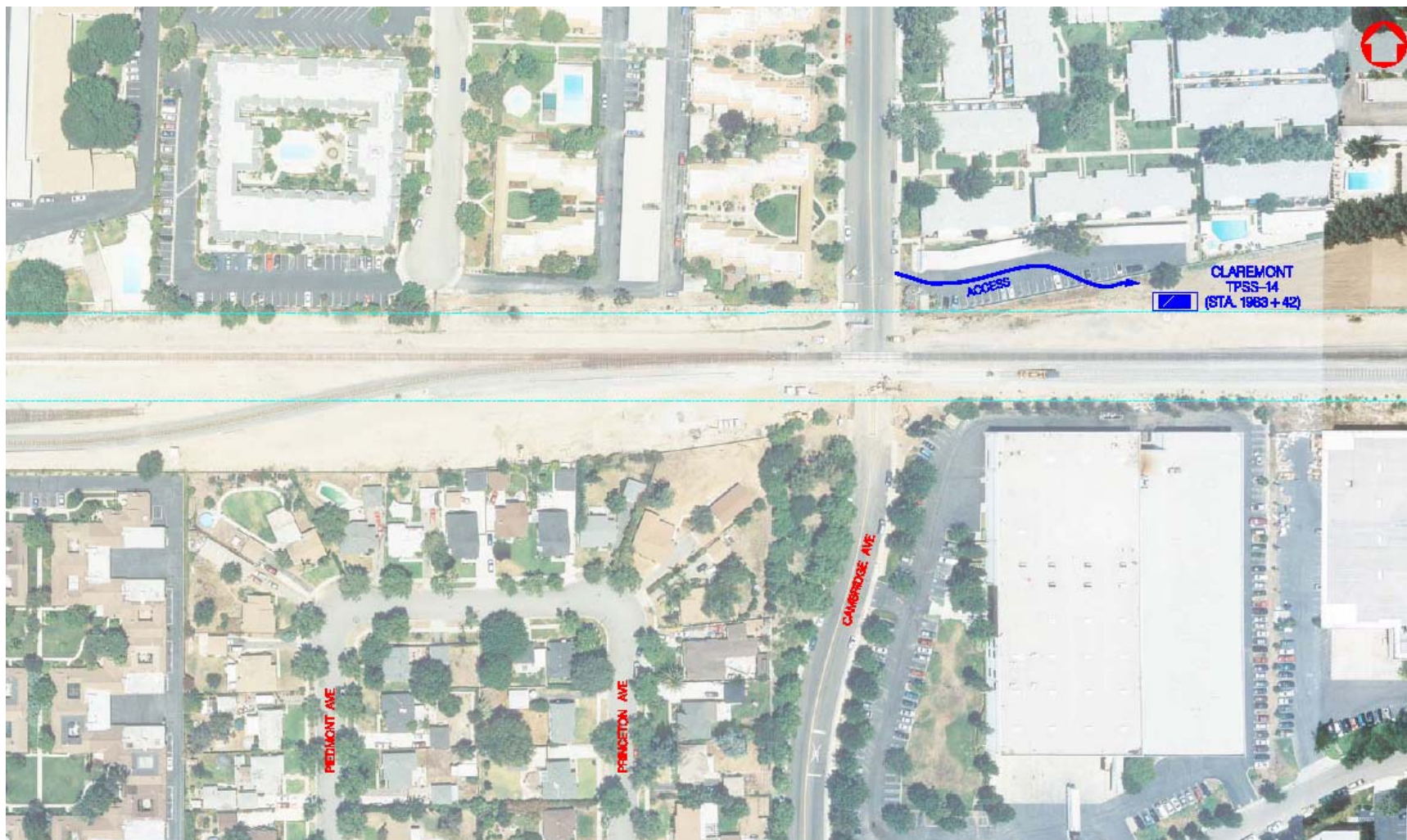

Figure 2-64: Traction Power Substation Sites, City of Claremont (14 of 16)





Figure 2-65: Traction Power Substations, City of Montclair (15 of 16)

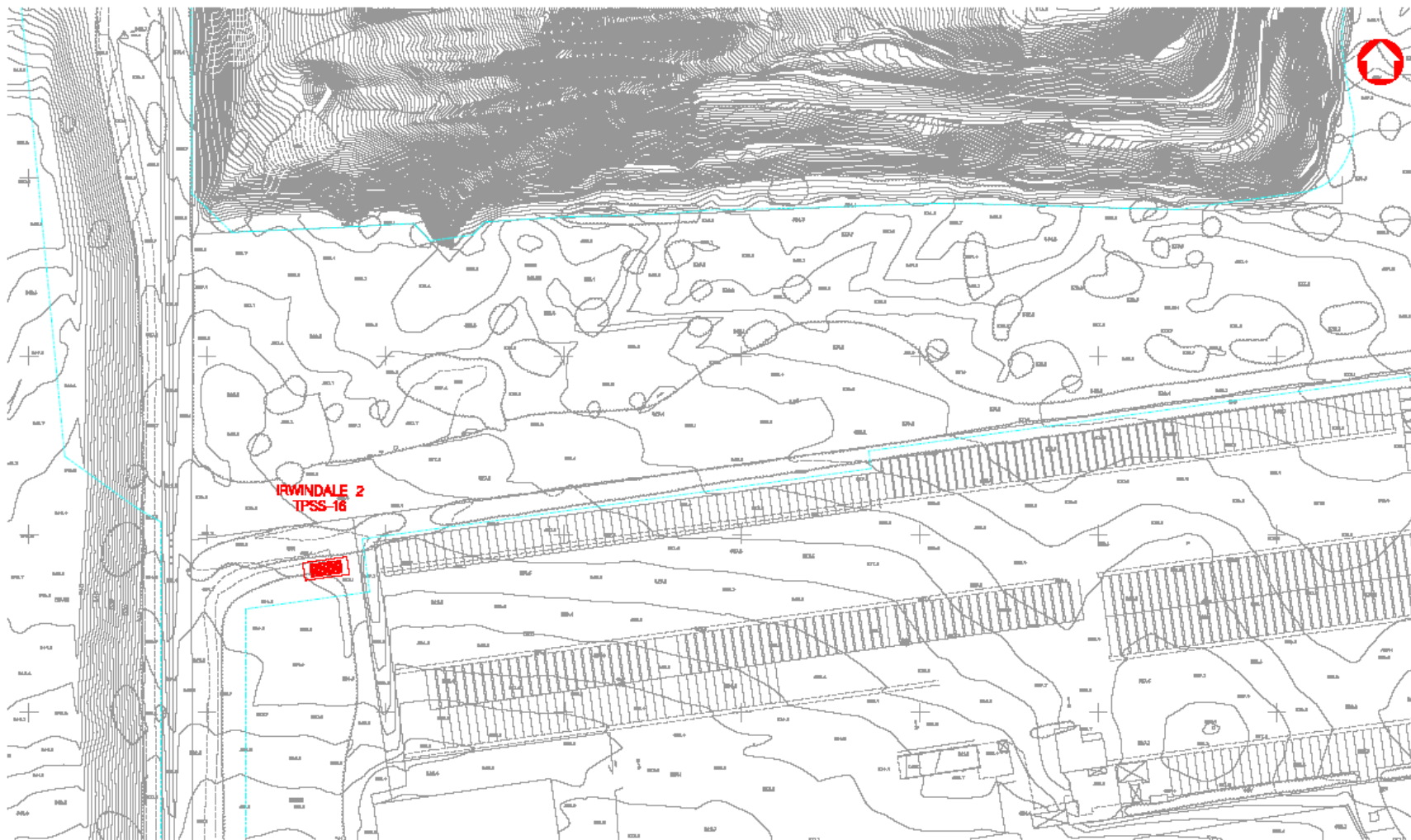

Figure 2-66: Traction Power Substation Sites: Maintenance and Operations Facility, Irwindale (16 of 16)

**TABLE 2-3  
LOCATION OF TRACTION POWER SUBSTATIONS,  
FULL BUILD (PASADENA TO MONTCLAIR) ALTERNATIVE**

| <u>TPSS Number</u> | <u>City</u>                | <u>TPSS Number</u>                              | <u>City</u>      |
|--------------------|----------------------------|---|------------------|
| <u>0</u>           | <u>Pasadena (existing)</u> | <u>9</u>  | <u>Glendora</u>  |
| <u>1</u>           | <u>Arcadia</u>             | <u>10</u>                                       | <u>Glendora</u>  |
| <u>2</u>           | <u>Arcadia</u>             | <u>11</u>                                       | <u>San Dimas</u> |
| <u>3</u>           | <u>Monrovia</u>            | <u>12</u>                                       | <u>La Verne</u>  |
| <u>4</u>           | <u>Monrovia</u>            | <u>13</u>                                       | <u>Pomona</u>    |
| <u>5</u>           | <u>Duarte</u>              | <u>14</u>                                       | <u>Claremont</u> |
| <u>6</u>           | <u>Irwindale</u>           | <u>15</u>                                       | <u>Montclair</u> |
| <u>7</u>           | <u>Azusa</u>               | <u>16 (Maintenance and Operations Facility)</u> | <u>Irwindale</u> |
| <u>8</u>           | <u>Azusa</u>               |   |                  |

Source: Parsons Brinckerhoff, 2005.

*d. Parking at Stations*

Estimates of parking needs at stations in 2025 were obtained from the regional model runs. **Table 2-6 4** shows the number of spaces that would be required at each station in 2025. Locations for parking at each station were identified through discussions with City staff and via field visits. Parking that is built as part of the proposed project would be managed by LACMTA.

**TABLE 2-64  
PARKING AT STATIONS  
FULL BUILD (PASADENA TO MONTCLAIR) ALTERNATIVE**

| <u>Station</u>           | <u>Parking Space Estimate<br/>(Opening Day)</u> | <u>Parking Space Estimate<br/>2025</u> |
|--------------------------|---|--|
| Pasadena <sup>1</sup>    | <u>1,000 existing</u>                           | 1,000                                  |
| Arcadia                  | <u>300</u>                                      | 800                                    |
| Monrovia                 | <u>350</u>                                      | 600                                    |
| Duarte                   | <u>125</u>                                      | 250                                    |
| Irwindale                | <u>350</u>                                      | 700                                    |
| Azusa (Downtown station) | <u>200</u>                                      | 400                                    |
| Azusa Citrus station)    | <u>200</u>                                      | 350                                    |
| Glendora                 | <u>200</u>                                      | 400                                    |
| San Dimas                | <u>460</u>                                      | 750                                    |
| La Verne                 | <u>300</u>                                      | 600                                    |
| Pomona                   | <u>530</u>                                      | 800                                    |
| Claremont                | <u>300</u>                                      | 700                                    |
| Montclair <sup>1</sup>   | <u>800</u>                                      | 800                                    |

<sup>1</sup> Will utilize existing parking facility.

Source: Parsons Brinckerhoff, 2003, revised 2005.

2-2.2.2 Track Configurations

The Draft EIS/EIR considered several options for accommodating the freight and light rail interface, including a Triple Track layout, a Double Track (No Freight) configuration, and a Double Track (Freight and Time Separation) option. The adoption of the LPA included the decision to utilize a Triple Track layout, with two LRT tracks along the entire alignment, and one freight track from Irwindale to Claremont. In Claremont, the single freight track would join up with the double Metrolink tracks and continue through Montclair.

2-2.2.3 Operational Assumptions

The headways for the initial travel forecasts for the Full Build (Pasadena to Montclair) Alternative would be 10-minute peak service and 20-minute off-peak service. This would mean that every other train would proceed from the Sierra Madre Villa Station to the Montclair Transcenter. Two LRT operating lines would be operated for the Gold Line service for this alternative. The operations would be (1) Line 1 from the Pomona Boulevard/Atlantic Boulevard Station to Sierra Madre Villa Station (10-minute peak/20-minute off-peak) and (2) Line 2 from the Pomona Boulevard/Atlantic Boulevard Station to the Montclair Transcenter (10-minute peak/20-minute off-peak). The travel time for Line 1 (Pomona Boulevard /Atlantic Boulevard Station to Sierra Madre Villa Station [Eastside Extension + Phase I]) would be approximately 53 minutes for the 20-mile distance. The travel time from Union Station to Sierra Madre Villa Station would be approximately 36 minutes for the 13.7 miles (current Phase I operation). The travel time from Sierra Madre Villa Station to the Montclair Transcenter is estimated to be 35 minutes for the 24-mile ~~Phase II~~ Foothill Extension. The stations, distances, and estimated travel times are shown in **Table 2-7 5**.

| <b>TABLE 2-7 5<br/>                     TRAVEL FORECAST DATA<br/>                     FULL BUILD (PASADENA TO MONTCLAIR) ALTERNATIVE</b> |                                   |                                    |  |                               |
|--|-----------------------------------|------------------------------------|--|-------------------------------|
| Station  | Distance Between Stations (miles) | Cumulative Travel Distance (miles) | Travel Time Between Stations (minutes) | Elapsed Travel Time (minutes) |
| Sierra Madre Villa   |                                   |                                    |  |                               |
|  | 3.13                              |                                    | 4.22                                   |                               |
| Arcadia  |                                   | 3.13                               |  | 4.22                          |
|  | 1.70                              |                                    | 2.67                                   |                               |
| Monrovia   |                                   | 4.83                               |  | 6.89                          |
|  | 1.47                              |                                    | 2.41                                   |                               |
| Duarte   |                                   | 6.30                               |  | 9.30                          |
|  | 2.38                              |                                    | 3.41                                   |                               |
| Irwindale  |                                   | 8.68                               |  | 12.71                         |
|  | 1.75                              |                                    | 2.71                                   |                               |
| Azusa (Alameda Ave.)   |                                   | 10.43                              |  | 15.42                         |
|  | 0.91                              |                                    | 1.80                                   |                               |

**TABLE 2-7 5  
TRAVEL FORECAST DATA  
FULL BUILD (PASADENA TO MONTCLAIR) ALTERNATIVE**

| Station             | Distance Between Stations (miles) | Cumulative Travel Distance (miles) | Travel Time Between Stations (minutes) | Elapsed Travel Time (minutes) |
|---------------------|-----------------------------------|------------------------------------|--|-------------------------------|
| Azusa (Citrus Ave.) |                                   | 11.34                              |  | 17.22                         |
|                     | 1.64                              |                                    | 2.60                                   |                               |
| Glendora            |                                   | 12.98                              |  | 19.82                         |
|                     | 4.15                              |                                    | 5.34                                   |                               |
| San Dimas           |                                   | 17.13                              |  | 25.16                         |
|                     | 2.12                              |                                    | 3.12                                   |                               |
| La Verne            |                                   | 19.25                              |  | 28.28                         |
|                     | 1.24                              |                                    | 2.16                                   |                               |
| Pomona              |                                   | 20.49                              |  | 30.44                         |
|                     | 1.92                              |                                    | 2.91                                   |                               |
| Claremont           |                                   | 22.41                              |  | 33.35                         |
|                     | 1.50                              |                                    | 1.55                                   |                               |
| Montclair           |                                   | 23.91                              |  | 34.90                         |
| Total               | 23.91                             |                                    | 34.90                                  |                               |

Source: Parsons Brinckerhoff, 2003.

#### 2-2.2.4 Operational Alternatives

~~Options for freight railroad track configurations/operations were studied to compare the impacts of maintaining or removing the existing freight service between Monrovia and Montclair. There are currently daily freight movements between Irwindale and Montclair, and weekly movements to five locations between Monrovia and Montclair.~~

~~Three freight rail configurations/operations were studied for the Full Build Alternative: (1) triple track with two tracks for LRT and one track for freight service; (2) LRT double track with freight service removed; and (3) LRT double track with time separation for freight operation on the LRT tracks. In the areas where Metrolink provides service (i.e., between La Verne and Montclair), the Metrolink track will be maintained and relocated as needed.~~

#### 2-2.2.5 Bus Service

The bus network in the study area for the Full Build (Pasadena to Montclair) Alternative would be similar to the No-Build ~~and TSM~~ Alternative and would include the addition of community feeder service to the stations when there is no local service provided by Foothill Transit, Omnitrans, or LACMTA. Additionally, peak and off-peak service ~~was~~ would be added to LACMTA Routes 177 and 188 and Foothill Transit Routes 184, 187, 189, and 690. Refer to Table 2-6.

| TABLE 2-6<br>BUS SERVICE HEADWAYS<br>ALL ALTERNATIVES |          |          |                                    |          |                    |          |
|---|----------|----------|------------------------------------|----------|--------------------|----------|
|   | No-Build |          | Full Build (Pasadena to Montclair) |          | Build LRT to Azusa |          |
|   | Peak     | Off-Peak | Peak                               | Off-Peak | Peak               | Off-Peak |
| MTA 177   | 30       | 60       | 20                                 | 40       | 20                 | 40       |
| MTA 188   | 45       | 60       | 20                                 | 40       | 20                 | 40       |
| FT 184  | 60       | 60       | 30                                 | 30       | 30                 | 30       |
| FT 187 (W)  | 30       | 60       | 30                                 | 40       | 30                 | 40       |
| FT 187 (E)  | -        | -        | -                                  | -        | 20                 | 40       |
| FT 189 (W)  | 30       | 60       | 30                                 | 40       | 30                 | 40       |
| FT 189 (E)  | -        | -        | -                                  | -        | 20                 | 40       |
| FT 494  | 30       | 0        | 30                                 | 0        | 30                 | 0        |
| FT 690 (W)  | 30       | 0        | 20                                 | 30       | 20                 | 30       |
| FT 690 (E)  | -        | -        | -                                  | -        | 15                 | 30       |

MTA – Los Angeles County Metropolitan Transportation Authority (LACMTA)  
 FT – Foothill Transit  
 W – West of Irwindale  
 E – East of Irwindale  
 Source: Parsons Brinckerhoff, 2005.

## 2-2.3 Build LRT to Azusa Alternative

The Draft EIS/EIR included an alternative to construct Segment 1 of the project, from Sierra Madre Villa Station to the Maintenance and Operations Facility in Irwindale. Following the public comment period and the adoption of the Locally Preferred Alternative, the decision was reached by the Construction Authority Board in conjunction with the JPA and the TAC to extend the limits of Segment 1 to include the City of Azusa. Thus, the second build alternative considered in this study is the Build LRT to Azusa Alternative.

### 2-2.3.1 Physical Components

A second Build Alternative that encompasses only Segment 1 would extend the current Gold Line LRT system from the existing Sierra Madre Villa Station to the ~~proposed Irwindale-Azusa-Citrus~~ Station (approximately ~~8.7~~ 11.4 miles). Volume H 4 of this EIR/EIS is the plan/profiles for the ~~Build LRT to Maintenance Facility~~ Build LRT to Azusa Alternative. That document includes plans, profiles, station layouts, and bridge analysis. The ~~Build LRT to Maintenance Facility~~ Build LRT to Azusa Alternative would use the same LRT technology and the same types of system components ~~would be used as~~ are in the existing Phase I segment from Los Angeles to Pasadena, and in the soon-to-be built Eastside Extension. This Build LRT to Azusa Alternative would include ~~four-six~~ LRT stations (Arcadia, Monrovia, Duarte, ~~and Irwindale,~~ and two in Azusa). The ~~proposed~~ locations of the stations would be the same as described under the Full Build (Pasadena to Montclair) Alternative. Parking facilities would be provided at each new station, and in the same locations as identified for the Full Build (Pasadena to Montclair) Alternative. ~~The location of the Maintenance and Operations Facility would be the same as~~

~~identified for the Full Build (Pasadena to Montclair) Alternative. Seven-Eight TPSS sites would be constructed along the route in order to provide electrical power to the line, in addition to one TPSS at the Maintenance and Operations Facility. The Build LRT to Maintenance Facility Build LRT to Azusa Alternative alignment can be seen in Figures 2-20 through 2-27 Figures 2-9 through 2-16, shown previously for the Full Build (Pasadena to Montclair) Alternative. An overview of this alternative is shown in Figure 2-19- 2-8. In general, the Build LRT to Maintenance Facility Build LRT to Azusa Alternative is the same as the Full Build (Pasadena to Montclair) Alternative but only extends 8.7 11.4 miles east from Sierra Madre Villa Station to the Irwindale-Azusa-Citrus Station.~~

*a. Stations*

~~The Build LRT to Maintenance Facility Build LRT to Azusa Alternative would include a total of four-six new stations. The proposed stations would be the same locations as described under the Full Build (Pasadena to Montclair) Alternative for the cities of Arcadia, Monrovia, Duarte, and Irwindale, and Azusa (Alameda and Citrus stations). Parking demand at stations under the Build LRT to Maintenance Facility Build LRT to Azusa Alternative would be the same as under the Full Build (Pasadena to Montclair) Alternative. Refer to Figures 2-35 through 2-41 for the proposed stations (and options) in Phase II Foothill Extension Segment 1.~~

*b. Traction Power Substations*

~~The Build LRT to Maintenance Facility Build LRT to Azusa Alternative would require eight TPSS sites along the 11 miles of the alignment, including one in the maintenance yard. This number of TPSS locations was obtained after an analysis of the ultimate light rail operations of three-car trains at 5 10-minute headways. This level of operation would extend the operating plan developed by LACMTA for Phase 1, following completion of the Eastside Extension. Two types of criteria were utilized in the analysis: electrical criteria and other criteria, such as right of way, visual intrusion, and proximity of primary feeders. Refer to Figure 2-68- 50 for a typical TPSS from Phase I.~~

~~Further refinements will be made during the preliminary engineering phase, when additional technical information that is needed to finalize locations would be available. TPSS spacing for all TPSS (except the two end of line TPSS) is estimated at 6,500 feet for the operation of three car trains at 5 minute headways. The estimated number and locations of eight TPSS sites for the Build Alternative to Maintenance Facility- Build LRT to Azusa Alternative are shown in Table 2-8-7. Refer to Figures 2-51 through 2-58 for the locations of TPSS sites in Phase II Foothill Extension Segment 1 cities and to Figure 2-66 for the location of the TPSS at the M&O Maintenance and Operations facility.~~



**TABLE 2-7  
LOCATION OF TRACTION POWER SUBSTATIONS,  
~~BUILD LRT TO MAINTENANCE FACILITY ALTERNATIVE~~  
BUILD LRT TO AZUSA ALTERNATIVE**

| TPSS Number | Figure Number City              | TPSS Number | Figure Number City         |
|-------------|---------------------------------|-------------|----------------------------|
| 0           | <u>Pasadena</u> (existing), N/A | 5           | <del>2-73-</del> Duarte    |
| 1           | <del>2-60</del> <u>Arcadia</u>  | 6           | <del>2-74-</del> Irwindale |
| 2           | <del>2-70</del> <u>Arcadia</u>  | 7           | <del>2-75-</del> Azusa     |
| 3           | <del>2-71</del> <u>Monrovia</u> | <u>8</u>    | <del>2-76-</del> Azusa     |
| 4           | <del>2-72</del> <u>Monrovia</u> |             |                            |

Source: Parsons Brinckerhoff, 2003; revised 2005.

*c. Parking at Stations*

Parking demand at stations under the Build LRT to Azusa Alternative would be the same as under the Full Build (Pasadena to Montclair) Alternative.

2-2.3.2 Track Configurations

Track configuration along the alignment under the Build LRT to Azusa Alternative would be the same as under the Full Build (Pasadena to Montclair) Alternative between Pasadena and Azusa-Citrus.

2-2.3.3 Operational Assumptions

The headways for the initial travel forecasts for the ~~Build LRT to Maintenance Facility~~ Build LRT to Azusa Alternative would be 10-minute peak service and 20-minute off-peak service. This would mean that every other train would proceed from the Sierra Madre Villa Station to the ~~Irwindale-Azusa-Citrus~~ station. Two LRT operating lines would be operational for the Gold Line for this alternative. The operations would be (1) Line 1 from the Pomona Boulevard/Atlantic Boulevard Station to Sierra Madre Villa Station (10-minute peak/20-minute off-peak) and (2) Line 2 from the Pomona Boulevard/Atlantic Boulevard Station to the ~~Irwindale-Azusa-Citrus~~ station (10-minute peak/20-minute off-peak). The travel time for Line 1 (Pomona/Atlantic to Sierra Madre Villa Station [Eastside Extension and Phase I]) would be approximately 53 minutes for the 20-mile distance. The travel time from Union Station to Sierra Madre Villa Station would be approximately 36 minutes for the 13.7 miles (current Phase I operation). The travel time from Sierra Madre Villa Station to the ~~Irwindale-Azusa-Citrus~~ station is estimated to be approximately ~~13-18~~ minutes for the ~~8.7~~ 11.4 miles. The stations, distances, and estimated travel times are shown in ~~Table 2-9~~ 2-8.

**TABLE 2-8  
TRAVEL FORECAST DATA,  
~~BUILD LRT TO MAINTENANCE FACILITY ALTERNATIVE~~  
BUILD LRT TO AZUSA ALTERNATIVE**

| Station            | Distance Between Stations (miles) | Cumulative Travel Distance (miles) | Travel Time Between Stations (minutes) | Elapsed Travel Time (minutes) |
|--------------------|-----------------------------------|------------------------------------|--|-------------------------------|
| Sierra Madre Villa |                                   |                                    |  |                               |
|                    | 3.13                              |                                    | 4.22                                   |                               |
| Arcadia            |                                   | 3.13                               |  | 4.22                          |
|                    | 1.70                              |                                    | 2.67                                   |                               |
| Monrovia           |                                   | 4.83                               |  | 6.89                          |
|                    | 1.47                              |                                    | 2.41                                   |                               |
| Duarte             |                                   | 6.30                               |  | 9.30                          |
|                    | 2.38                              |                                    | 3.41                                   |                               |
| Irwindale          |                                   | 8.68                               |  | 12.71                         |
|                    | <u>1.75</u>                       |                                    | 2.71                                   |                               |
| Azusa-Alameda      |                                   | 10.43                              |  | 15.42                         |
|                    | 0.91                              |                                    | 1.80                                   |                               |
| Azusa-Citrus       |                                   | 11.34                              |  | 17.22                         |
| Total              | <del>8.68</del> <u>11.34</u>      |                                    | <del>12.71</del> <u>17.22</u>          |                               |

Source: Parsons Brinckerhoff, 2003.

#### 2-2.3.4 Bus Service

The bus network in the study area for the ~~Build LRT to Maintenance Facility~~ Build LRT to Azusa Alternative will be similar to the No-Build Alternative but would include the addition of community feeder service to the ~~four~~ six proposed stations when there is no local service provided by Foothill Transit or LACMTA. In order to provide bus service to the balance of ~~Phase II~~ the Foothill Extension alignment, Foothill Routes 187, 189, and 690 would be modified to provide increased frequencies east of ~~Irwindale~~ Azusa and provide connections to the proposed ~~Irwindale-Azusa-Citrus~~ station for all trips. ~~These routes are described in detail in the TSM Alternative (Section 2-2.2).~~ These routes are described in detail below.

Foothill Transit Routes 187/189 travel throughout the San Gabriel Valley in an east-west direction from Pasadena through Arcadia, Monrovia, Glendora, San Dimas, and La Verne to Claremont. Departing from Raymond Avenue and Walnut Street in Pasadena, Routes 187/189 do a counter-clockwise loop west on Walnut Street, south on Fair Oaks Avenue, and then east on Colorado Boulevard, past Pasadena City College. At San Gabriel Boulevard, the route turns north to meet up with the Phase I terminus station at Sierra Madre Villa Avenue and Foothill Boulevard. It then travels south on Sierra Madre Villa Avenue, turning east on Colorado Boulevard through Arcadia. At Santa Anita Avenue, Colorado Boulevard merges into Huntington Drive, and the route continues through Duarte on Huntington Drive into Azusa, where it becomes Foothill Boulevard. At Citrus College, the route turns south on Citrus Avenue, then east again on Historic Route 66. At the intersection of Glendora Avenue and Historic Route 66, Route

187 continues east while Route 189 heads south on Glendora Avenue. Route 187 continues east on Historic Route 66 (which becomes Foothill Boulevard), turns south on Monte Vista Avenue in San Bernardino County, stops at the Montclair Transcenter, and terminates at the Claremont Transcenter by way of a loop on Arrow Highway and Indian Hill Boulevard. Route 189 travels south on Glendora Avenue, turns east on Gladstone Street, jogs down Lone Hill Avenue to continue east on Arrow Highway to Bonita Avenue, and then heads north on San Dimas Avenue. At Foothill Boulevard, Route 189 turns southeast until it meets up with Baseline Road. The route travels east on Baseline Road, then south on Indian Hill Boulevard to terminate at the Claremont Transcenter on First Street.

Foothill Transit Route 690 offers express service from Montclair to Pasadena, roughly paralleling the I-210 corridor. Traveling westbound in the mornings and eastbound in the evenings, Route 690 begins at the Montclair Transcenter, travels north on Monte Vista Avenue, west on Arrow Highway, and south into Claremont on Claremont Boulevard. Traveling west through the Claremont Colleges area on First Street, the route turns north on Indian Hill Boulevard up to Foothill Boulevard, where it turns west again. Route 690 runs west on Foothill Boulevard through the cities of Pomona and La Verne, where it meets up with I-210 and continues west. At San Dimas Avenue, the route exits the freeway and loops south on San Dimas Avenue, west on Allen Avenue (Auto Center Drive), north on Lone Hill Avenue, and then rejoins the freeway. Route 690 continues west on I-210 to meet the Grand Avenue Park-and-Ride in Azusa, and then travels west on Baseline Road to Azusa Avenue. At this point, it rejoins I-210 to reach Pasadena, where it heads south on Lake Avenue, west on Union Street, and north on Fair Oaks Avenue before rejoining I-210 and reversing the trip for the eastbound route.

The headways on Routes 187 and 189 would be changed to be 20 minutes peak/40 minutes off-peak east of Irwindale and 30 minutes peak/40 minutes off-peak west of Irwindale. Route 690 would be changed to provide two-way all-day service east of Irwindale, with 15-minute peak/30 minute off-peak service. The Route 690 service would provide the same service west of ~~Irwindale-Azusa~~ as provided in the Full Build (Pasadena to Montclair) Alternative. **Table 2-8 2-6** illustrates the bus service headways for all of the alternatives.

## 2-3 CONSTRUCTION SCENARIOS

The two Build Alternatives have similar construction scenarios. ~~while the No-Build Alternative requires no physical construction.~~

### 2-3.1 No-Build Alternative

The No-Build Alternative does not require any construction by the proposed project, as all improvements are either operational improvements or to be implemented by others.

### 2-3.2 Build Alternatives

The construction of either Build Alternative would involve conventional construction techniques and equipment used in the southern California region. Major project elements would include:

- Demolition of existing structures
- Roadway improvements

- Relocation of the existing freight lines
- Construction of new bridges and renovation/widening of existing bridges
- Construction of at-grade trackwork and stations
- Construction of aerial station and pedestrian tunnels
- Installation of specialty system work, such as overhead contact electrification systems and communications and signaling systems
- Construction of TPSS
- Construction of parking lots and parking structures
- Sub-grade preparation and placement of rail ballast.

All work would conform to industry specifications and standards. The equipment used in construction would include pile drilling and trenching equipment, bulldozers, rollers, cranes, concrete trucks, pumping equipment, flatbed trucks, dump trucks, and rail-mounted equipment. Temporary traffic detours and truck routes would be required during construction. The total time that would be required to construct the Full Build (Pasadena to Montclair) Alternative would be 8 to 10 years, with expected completion by 2014. Construction of the ~~Build LRT to Maintenance Facility~~ Build LRT to Azusa Alternative would take 3 to 5 years, with expected completion in 2009.

The required construction easements (i.e., the areas needed temporarily in addition to the actual project footprint during the construction period) would vary depending on the type of construction and the adjacent land use. Generally, easements would be minimized as much as possible to avoid impacts to adjacent traffic and land uses, and right-of-way already owned by the Construction Authority would be utilized as much as possible. Lane and/or road closures would be scheduled so as to be least disruptive, and traffic management plans would be approved by the individual cities prior to construction. Freight movements would be impacted as little as possible. Construction staging areas would be identified during preliminary engineering.

The Full Build (Pasadena to Montclair) Alternative would be constructed during an approximate 8 to 10 year period. Construction would occur simultaneously at several locations along the selected route. Construction of the project would follow all applicable local, state, and general laws for building and safety. Working hours would be varied to meet special circumstances. Standard construction methods would be used for traffic control and noise, vibration, and dust control, consistent with all applicable laws and as described in the following paragraphs. Actual durations for construction activities would be dependent upon such variables as final designs, the contractors' means and methods, project funding, and restrictions on working hours and other variables. Durations estimated below are based on similar projects and the conceptual designs.

## 2-3.2.1 At-Grade Construction

### *a. Demolition of Existing Structures*

In some locations, demolition and the associated reconstruction of existing structures would be required to accommodate widened cross sections within the right-of-way. Demolition would comply with applicable regulations, and disposal and/or recycling of material would be performed in accordance with standard construction practices. For further discussion of the disposal of hazardous materials, refer to Chapter 3 of this EIS/EIR. Demolition activities are estimated to be completed over 18 months at several locations.

### *b. Utility Relocations*

Both aboveground and underground utilities would need to be relocated, modified, or protected in place in some portions of the build alternatives' construction area if they would interfere with construction or if they become damaged during construction. In some cases, major utilities, such as water supply and distribution lines and sewer mains, may need to be relocated to maintain access and appropriate spacing. Most of this work would be completed before other construction work commenced. Chapter 3, Section 3-16, includes more information about the types and locations of utilities that would be affected. Utility relocation, including relocation of major utilities, would take about 18 months to complete ahead of rail, street, or station construction in the area.

### *c. Street Improvements*

In some segments of both Build Alternatives, particularly in the City of Duarte near the Duarte station, the narrow right-of-way will require taking the northern parking lane of Duarte Road (currently a no-parking zone). This work would begin before the construction of the actual rail components to allow the maximum room for detouring traffic during construction. The period of time necessary for street construction would be about one year ahead of rail construction in the area.

At the final stage in the construction of both Build Alternatives, streets and crossings would be restored to their preconstruction conditions. In some cases, street improvements would be made, such as new site modifications, cul-de-sacs, landscaping, traffic control modifications, signage, and lighting. Some of these improvements would be accomplished simultaneously with other construction activities and would require about two years to complete.

### *d. Trackwork*

Both Build Alternatives would be located within the existing right-of-way. Trackwork construction would involve relocating the existing freight line (for the Triple Track Configuration) or removing it altogether (Double Track Configurations), preparing the track bed and ballast, and installing rails. In areas where the rail alignment runs next to and parallel to a local street, periodic lane closures may be required for delivery of materials. Minor cross streets may be temporarily closed, but access to adjacent properties would be maintained through detours or alternative access routes. Major cross streets would require partial closures of half of the street at a time. Bridges shorter than 200 feet long would have ballasted trackways, while bridges longer than 200 feet in length would use direct fixation track. Trackwork is anticipated to take up to two years to complete.

*e. Stations*

Stations could be constructed simultaneously with the various aspects of the Build Alternatives. At-grade station construction involves removing existing surface materials, preparing subgrade, forming and constructing an elevated concrete platform, ramps and stairs, as well as installing the station furnishings, such as the canopy, hand railings, lighting, signage, and ticket vending machines. Design and installation would be according to LACMTA Design Criteria, and similar to that constructed for Phase I. Construction would take up to 6 months per station, but several could be constructed concurrently.

*f. Operating Systems Installation*

The operating systems for the Build Alternatives would include communications, train control, and traction power supplied through an overhead contact system. The overhead contact system would consist of poles connected to drilled shaft foundations with overhead wires to supply power to the trains. (See also Traction Power Substations, described on the following pages.) In addition, communications and control systems would be installed along the alignment. The installation of the operating systems would occur simultaneously with other construction, and would require up to 18 months to complete and test.

*g. Special Construction Issues*

The Build Alternatives cross a number of freeways along the length of the corridor. The Full Build (Pasadena to Montclair) Alternative runs in the median of I-210, crosses over I-210 EB twice and over I-210 WB once, under I-210 once, crosses under I-605, and crosses under State Route 57. Coordination with Caltrans would be required for each crossing. In Caltrans right-of-way, Caltrans design and construction standards, as well as approvals, are typically required.

2-3.2.2 Elevated Construction

~~The City of Arcadia desires a grade separation over Santa Anita Avenue, which would result in an above-grade station near N. First Street. If an above-grade station were selected, the following construction scenarios are identified. There are two elevated “flyover” structures planned for the Full Build (Pasadena to Montclair) Alternative as well as a potential grade separation of Santa Anita Avenue by the City of Arcadia. The “flyover” structures would allow the freight track to switch from the south side of the alignment to the north side of the alignment in Azusa, and then switch back to the south side of the alignment in Pomona, where it would meet up with the existing Metrolink track.~~

*a. Demolition of Existing Structures*

~~If Option B, the elevated rail segment in Arcadia, were selected in either Build Alternative is constructed, a limited amount of property acquisition would occur, requiring removal of some existing structures. This demolition would take less than 2 months. No property acquisition would be required for the “flyovers” in Azusa and Pomona.~~

*b. Utility Relocations*

~~Some utility relocation, modification, and protection in place would be required for these elevated portions of the Build Alternatives structures, but the amount of such work would be limited to areas where there are conflicts with the existing overhead utilities and the underground utilities that would be~~

affected by the foundations of columns ~~and the street level entrance to the Arcadia Option B station and retaining walls.~~

*c. Foundations and Support Columns*

~~If Options A or B were to be selected in either Build Alternative,~~ Portions of the track ~~and possibly a station~~ will be elevated on columns and earth-fill sections at these elevated structures. Construction of the column foundations for the elevated portions of the track would use cast-in-place drilled shafts, rather than driven piles. These shafts could be 80 to 100 feet deep. Temporary or permanent steel casings may be required to support the drilled holes where the water table is high. After the pile steel reinforcement is placed, the concrete would be placed. Once these foundations are complete, the columns themselves would be formed and cast in place on the shafts. Foundations and support columns would be constructed in alternate blocks to limit traffic impacts. The construction period of the columns is included with that of the overhead structure (superstructure) or filled section.

*d. Superstructure*

The elevated superstructure itself could be constructed using either cast-in-place concrete or precast concrete elements that would be erected and installed at the site. Because multiple construction activities would be simultaneously occurring along the length of the elevated structure, the construction period of the superstructure, along with the support columns, would vary from about 18 to 24 months, depending on the construction method used. ~~Construction of the platform of the elevated Arcadia Option B station would also be included in this construction period.~~

*e. Installation of Other System Components*

Once construction of the superstructure is completed, most work on the remaining elements of the elevated portions would be accomplished from on top of the structure. Trackwork, the catenary system, station furnishings, and other components would be installed during a construction period of about one year.

*f. Transitions*

The transitions from an at-grade alignment to the elevated alignment would require the placement of retained fill on both sides of the aerial guideway. Much of this construction could occur at the same time as other components of the elevated portions ~~of either Build Alternative of the project~~. Foundations and retaining walls would be constructed, fill materials would be imported and placed, the track bed would be constructed, and the track would be laid. Necessary safety features and other minor components would be installed. Construction of these transitions would require up to nine months.

**2-3.2.3 Maintenance and Operations Facility**

Construction of the Maintenance and Operations Facility would require clearing and grubbing (removal of plant and root materials), followed by site grading, paving, installation of track overhead contact systems and signaling equipment, construction of maintenance buildings, and construction of perimeter walls or fences. Construction methods to be used would be similar to those for typical industrial building site construction, with the addition of site work and trackwork. Construction of the Maintenance and Operations Facility is estimated to require approximately two years.

The location of the Maintenance and Operations Facility necessitates an elevated portion of track above the existing Miller Brewery facility rail yard. For the construction of the underpass for the Miller yard, construction of a temporary rail detour (shoo-fly) around the portion of track affected by the underpass may be required. The underpass would be constructed by cut-and-cover construction methods, where a box shape trench is excavated and supported as necessary, a top is constructed, the freight tracks are returned to their original location within the box section, and the rail detour is demolished. Alternatively, because the Miller Brewery receives six shipments a week, it may be possible to fast-track construction of the underpass within 48 hours, and limit the impact on Miller operations. These alternatives would be explored further during Preliminary Engineering.

#### 2-3.2.4 Traction Power Substations

Each TPSSs would require approximately a ~~4,000~~ 2,800 square-foot footprint. Preliminary planning has placed ~~the~~ each TPSSs within existing railroad right-of-way or on property to be acquired for stations/parking or the proposed Maintenance and Operation facility. Each of these sites would include a substation concrete slab with grounding mat. The TPSS itself would be a prefabricated structure approximately 14 feet wide by 43 feet long and 16 feet high. It would be delivered to the site, connected to the slab, and connected to the utilities. Fencing would be installed around the perimeter of the site and architectural and landscaping treatments could be provided, as appropriate. Construction of a TPSS would require about three months. A typical TPSS is shown in **Figure 2-68 50**.

## 2-4 LOCALLY PREFERRED ALTERNATIVE AS IDENTIFIED BY AUTHORITY STAFF

The previous sections identified the alternatives considered during the environmental process. Several key decision points occurred during this process, namely in August 2004, March 2005, and June 2005. This section identifies these decision points and presents the Authority staff recommendation to the Board for the Locally Preferred Alternative.

### 2-4.1 LPA Decision – August 2004

Following the release of the Draft EIS/EIR, the public comment period, and input from the cities along the alignment, the Construction Authority Board approved a Locally Preferred Alternative (LPA) in August 2004. This LPA included the Triple Track Alternative (2 LRT and 1 Freight track), a station in each City, and the location of the Maintenance and Operations Facility.

### 2-4.2 Project Definition Report – March 2005

The Draft Project Definition Report (PDR) was submitted to the TAC (Technical Advisory Committee), the JPA (Joint Powers Authority), and the Authority’s Board in January. The PDR identified the results of Draft Environmental Impact Statement/Report (Draft EIS/EIR) comments and their impacts on refined station and parking lot locations, grade crossings, and traction power substation locations. During February and early March, each of the corridor City Councils along the Foothill Extension alignment approved the PDR with some caveats. Comments from each of the Cities were incorporated into the Final Project Definition Report and the Authority Board approved the document on March 23, 2005. The Final EIS/EIR and engineering work that support the Final EIS/EIR are based on the project as identified in the Final PDR (March 2005), with the following modifications: Following the PDR, the Authority Board



approved a Revised LPA in June 2005. Between March and August 2005, station options in Arcadia and Claremont were added.

The Revised LPA in June 2005 also included the construction of the maintenance and operations facility in conjunction with the second segment of the project.

### 2-4.3 Staff Recommendation

Based on the comments received, the preliminary engineering activities, and the other technical studies conducted, as well as the extensive communication with the Corridor Cities, the Authority staff has concluded that the Build LRT to Azusa Alternative is the option that best responds to the direction of the Board and the comments received.

The Build LRT to Azusa Alternative is as described in the previous sections (and is presented in more detail throughout the Final EIS/EIR). The following options are included in the staff recommendation:

- Santa Anita grade separation
- Arcadia Station Option A

Based on the comments received, the engineering definitions, and the other technical studies conducted, as well as the extensive communication with the Corridor Cities, the Authority staff has concluded that the Build LRT to Azusa Alternative is the option that best responds to the direction of the Board, the comments received, and the stated purpose and need.

The Build LRT to Azusa Alternative is presented in more detail throughout the Final EIS/EIR.

THIS PAGE INTENTIONALLY BLANK