

Ms. Lisa Levy Buch
Mr. Ray Tellis
February 2, 2011
Page 4

Hon. Diane DuBois
Hon. John Fasana
Hon. José Huizar
Hon. Richard Katz
Hon. Gloria Molina
Hon. Ara Najarian
Hon. Pam O'Connor
Hon. Mark Ridley-Thomas
Hon. Rita Robinson
Hon. Zev Yaroslavsky
Arthur T. Leahy, Metro Chief Executive Officer

From: [Tom Helliwell](#)
To: [Lisa Levy Buch](#)
Subject: Support for Gold Line Extension
Date: Tuesday, February 01, 2011 8:39:04 PM

Dear Ms. Buch,

I am writing in support of extending the Gold Line from Azusa to Montclair. My wife and I are residents of Claremont who make frequent trips into Pasadena, and would definitely prefer to go by train rather than fighting traffic.

My sister and brother-in-law live in Altadena, and on our visits to her she could pick us up at a stop in Pasadena, and in her visits to us we could pick her up at the stop in Claremont.

I sometimes attend seminars at Caltech, and would again prefer to go to Pasadena and back by train. The Caltech seminars typically end about 5:30 pm, and by that time the rush hour traffic heading east on the 210 is already very heavy. There is no question that I would take the train both ways, and walk from the train stop to Caltech and back.

My wife and I are members of the Huntington Museum and Gardens, and because of heavy traffic on weekdays we have been constrained to travel there and back during an approximately three-hour window in mid day. It would be much more convenient if we could go in at different hours for special events.

Apart from the convenience to us, we are also very concerned about both local and global impacts of having so many cars on the road, and have been a strong supporter of public transportation as a way to reduce the combustion of fossil fuels. I currently chair the Claremont Interfaith Sustainability Committee, a consortium of Christian Churches, Jewish Temples, and Muslim Mosques, who share information about how to make our congregations more knowledgeable about environmental issues and also take action to make our campuses greener. We are all strong supporters of public transportation, and would strongly urge extension of the Gold Line.

Thank you for this opportunity to submit public comments.

Sincerely,

- Thomas M. Helliwell

From: [Glenn Trost](#)
To: [Lisa Levy Buch](#)
Subject: Support for the Azusa to Montclair Extension
Date: Monday, January 24, 2011 6:33:42 PM

Dear Friends,

My wife and I have lived in Claremont at Pilgrim Place the last four years. We support the Azusa to Montclair extension of the Gold Line as soon as possible. We regret that there seem to be endless delays in moving ahead with its completion. I am Chair of our Environmental Concerns Committee at Pilgrim Place where there is definite support of this project. Sincerely, Glenn Trost, Environmental Concerns Chair, Pilgrim Place, 615 Leyden Lane, Claremont, California.

Appendix J

Written Agency Public Comments



Preserving America's Heritage

February 1, 2011

Mr. Habib Balian
Metro Gold Line Foothill Extension Construction Authority
406 E. Huntington Drive, Suite 202
Monrovia, CA 91016-3633

**REF: EIS/EIR for the Metro Gold Line Foothill Extension Azusa to Montclair
Los Angeles and San Bernardino Counties, California**

Dear Mr. Balian:

On January 11, 2011, the Advisory Council on Historic Preservation (ACHP) received your invitation to participate in the environmental review process for the referenced undertaking pursuant to Section 6002 of the *Safe, Accountable, Flexible, Efficient Transportation Equity Act: A Legacy for Users* (SAFETEA-LU). At this time, we do not expect to attend meetings or provide formal comments at environmental review milestones. However, we retain the right to become involved in the environmental review for this action in the future if, based on information provided by you or other consulting parties, we determine that our involvement is warranted.

In order to ensure compliance with Section 106 of the *National Historic Preservation Act*, the ACHP encourages your agency to initiate the Section 106 process by notifying, at your earliest convenience, the appropriate State Historic Preservation Officer (SHPO) and/or Tribal Historic Preservation Officer (THPO), Indian tribes, and other consulting parties pursuant to our regulations, "Protection of Historic Properties" (36 CFR Part 800). Through early consultation your agency will be able to determine the appropriate strategy to ensure Section 106 compliance for this undertaking.

The agency should continue consultation with the appropriate SHPO/THPO, Indian tribes, and other consulting parties to identify and evaluate historic properties and to assess any potential adverse effects on those historic properties. If your agency determines through consultation with the consulting parties that the undertaking will adversely affect historic properties, or that the development of a Programmatic Agreement is necessary, the agency must notify the ACHP and provide the documentation detailed at 36 CFR § 800.11(e). In the event that this undertaking is covered under the terms of an existing Programmatic Agreement, you should follow the process set forth in the applicable Programmatic Agreement.

Should you have any questions as to how your agency should comply with the requirements of Section 106, please contact me by telephone at (202) 606-8527, or by e-mail at lbrodnitz@achp.gov.

Sincerely,

Louise Dunford Brodnitz
Historic Preservation Specialist
Office of Federal Agency Programs

ADVISORY COUNCIL ON HISTORIC PRESERVATION

1100 Pennsylvania Avenue NW, Suite 803 • Washington, DC 20004
Phone: 202-606-8503 • Fax: 202-606-8647 • achp@achp.gov • www.achp.gov



United States Department of the Interior

FISH AND WILDLIFE SERVICE

Ecological Services
Carlsbad Fish and Wildlife Office
6010 Hidden Valley Road, Suite 101
Carlsbad, California 92011



In Reply Refer To:
FWS-LA-09B0202-11TA0239

JAN 26 2011

Lisa Levy Buch
Director of Public Affairs
Metro Gold Line Foothill Extension Construction Authority
406 E. Huntington Drive, Suite 202
Monrovia, California 91016-3633

RECEIVED

JAN 31 2011

MGL FOOTHILL EXT.
CONSI. AUTHORITY

Subject: Notice of Intent (NOI) to prepare an Environmental Impact Statement (EIS) for Metro Gold Line Foothill Light Rail Project, Azusa to Montclair, Los Angeles County, California

Dear Ms. Levy Buch:

We have reviewed the NOI for the proposed construction of a light rail transit line to connect to the Metro Gold Line Eastside Extension, linking communities farther east of Los Angeles to the regional transit network. We offer the following comments pursuant to the Endangered Species Act of 1973 (Act), as amended (16 U.S.C. 1531 *et seq.*), and in keeping with our agency's mission to work "with others to conserve, protect, and enhance fish, wildlife, and plants and their habitats for the continuing benefit of the American people."

Our main concern regarding the proposed project is the potential for impacts to federally listed species and sensitive habitat types in the eastern half of the SR-60 Light Rail Transit Alternative. Please be aware that we have data records for federally endangered least Bell's vireo (*Vireo bellii pusillus*), and Nevin's barberry (*Berberis nevinii*), federally threatened coastal California gnatcatcher (*Polioptila californica californica*), and Federal candidate for listing Brand's phacelia (*Phacelia stellaris*) in this area. In addition we are concerned regarding the location of the proposed future park and ride facilities at the stations along this route and request that the environmental impacts of these facilities be defined and considered within the EIS as interrelated and interdependent actions.

To facilitate evaluation of the proposed project from the standpoint of fish and wildlife protection, we recommend that the EIS include a description of the proposed project and the environment in the vicinity of the project, from both local and regional perspectives, including all practicable alternatives that have been considered to avoid and/or reduce project impacts to federally listed and other sensitive species and habitat types. Specific acreages and descriptions of the types of wetlands, riparian, and other sensitive habitats that may be affected by the project alternatives should be included, as well as aerial photographs, maps, and tables that summarize

TAKE PRIDE[®]
IN AMERICA 

this information. Please also include detailed information on the number and distribution of all Federal candidate, proposed, and listed species; State-listed species; and locally sensitive species that may be affected within the footprint or near the proposed project alternatives. The EIS should address the entire footprint of all project alternatives, including borrow and fill sites, construction staging areas, and fuel modification zones, as well as impacts from future right-of-way maintenance and areas that may be restored to offset project impacts.

We appreciate the opportunity to participate in the transportation planning process and look forward to our continued coordination on this project. If you have any questions regarding this letter, please contact Katy Kughen of this office at (760) 431-9440, extension 201.

Sincerely,



 Karen A. Goebel
Assistant Field Supervisor

cc

Lisa Treichel, Office of Environmental Policy and Compliance, Washington DC (by email)
Stephanie Nash, U.S. Fish and Wildlife Service, Arlington, VA (by email)
Tracy Davis, U.S. Fish and Wildlife Service, Sacramento, CA (by email)
Diane Elam, U.S. Fish and Wildlife Service, Sacramento, CA (by email)
Scott Sobiech, U.S. Fish and Wildlife Service, Carlsbad, CA (by email)
Jaime Hotz, U.S. Fish and Wildlife Service, Carlsbad, CA (by email)



UNITED STATES ENVIRONMENTAL PROTECTION AGENCY
REGION IX
75 Hawthorne Street
San Francisco, CA 94105

February 2, 2011

Ray Tellis
Federal Transit Administration
888 South Figueroa Street, Suite 1850
Los Angeles, CA 90017

Subject: Scoping Comments and Response to Participating Agency Request for the Metro Gold Line Foothill Extension Azusa to Montclair, Los Angeles and San Bernardino Counties, California

Dear Mr. Tellis:

The U.S. Environmental Protection Agency (EPA) has reviewed the Notice of Intent published in the Federal Register December 27, 2010, requesting comments on the Federal Transit Administration (FTA) proposal to prepare a Draft Environmental Impact Statement (EIS) for the Metro Gold Line Foothill Extension Azusa to Montclair. Our comments are provided pursuant to the National Environmental Policy Act (NEPA), Council on Environmental Quality (CEQ) regulations (40 CFR Parts 1500-1508) and Section 309 of the Clean Air Act.

Additionally, we have enclosed our comments on the 2004 DEIS for an earlier version of this project. In those comments, EPA made recommendations addressing the scope of analysis, air quality, water resources, biological resources, hazardous materials and hazardous waste, and impacts of freight delivery restrictions. Where they remain relevant, we recommend the upcoming DEIS address these issues.

FTA has also invited EPA to become a "Participating Agency" (as defined in 23 USC 139 Safe, Accountable, Flexible, Efficient Transportation Equity Act: A Legacy for Users (SAFETEA-LU)). EPA accepts this invitation and agrees to engage in this project as a Participating Agency. EPA's participation as a Participating Agency does not constitute a formal or informal approval of any independent review of the Draft and Final EISs pursuant to Section 309 of the Clean Air Act. We look forward to working with you to ensure that the SAFETEA-LU implementation procedures assist both our agencies in meeting our statutory missions.

We appreciate the opportunity to provide comments on the preparation of the Draft EIS. As a participating Agency, EPA will provide comments on the Draft EIS, the Final EIS, and at other milestones where we believe we can contribute to avoidance and minimization of potential environmental and human health impacts during the development of the EIS.

When the Draft EIS is released for public review, please send one hard copy and one disc copy to the address above (mail code CED-2). If you have any questions, please contact me at 415-947-4121 or ganson.chris@epa.gov.

Sincerely,



Chris Ganson
Environmental Protection Specialist
Environmental Review Office (CED-2)

Enclosure: EPA's Detailed Comments
EPA Comments on 2004 Draft Environmental Impact Statement/Draft
Environmental Impact Report for the Gold Line Phase II Light Rail Transit
(LRT) Extension Project

CC: Leslie Rogers, Federal Transit Administration
Ray Sukys, Federal Transit Administration
Lisa Levy Buch, Metro Gold Line Foothill Extension Construction Authority

Range of Alternatives

The Draft Environmental Impact Statement (DEIS) should explore and objectively evaluate a range of reasonable alternatives, including the No Action Alternative, and briefly discuss the reasons for eliminating some alternatives from further evaluation (40 CFR 1502.14). EPA recommends that the DEIS include a summary of the screening methodology that was used to determine the Range of Alternatives for inclusion in the DEIS. The methodology summary should include information about which criteria and measures were used at each screening level and how they were integrated in a comprehensive evaluation. The DEIS should also include a description of alternatives that were considered but withdrawn with a summary of why they were eliminated.

The DEIS should also identify opportunities for the alternatives to avoid or minimize adverse environmental impacts while fulfilling the project purpose. This may include alignment shifts, buffers, localized design modifications, changes in construction practices, or spanned crossings of sensitive biological resources.

Air Quality

The proposed project is located in the South Coast Air Basin (SCAB). The South Coast Air Quality Management District (SCAQMD) implements local air quality regulations in the SCAB to carry out Federal Clean Air Act (CAA) requirements, as authorized by the EPA. The current SCAB nonattainment designations under the CAA are as follows: 8-hour ozone - severe nonattainment; particulate matter with a diameter of 10 microns or less (PM₁₀) - serious nonattainment; and particulate matter with a diameter of 2.5 microns or less (PM_{2.5}) - nonattainment. The SCAB has the worst 8-hour ozone and PM_{2.5} problems in the nation, and attainment of these NAAQS will require massive reductions from mobile sources, given the rapid growth in this emissions category and the long lifespan of diesel engines. Because of the air basin's nonattainment status, it is important to reduce emissions of ozone precursors, mobile source air toxics (MSAT) and particulate matter from this project to the maximum extent.

Recommendations:

- **Ambient Conditions:** The DEIS should include a detailed discussion of ambient air conditions (i.e., baseline or existing conditions), the area's attainment or nonattainment status for all NAAQS, and potential air quality impacts (including cumulative and indirect impacts) from the construction and operation of the project for each fully evaluated alternative. The DEIS should include estimates of all criteria pollutant emissions and diesel particulate matter (DPM). EPA also recommends that the DEIS disclose the available information about the health risks associated with construction and truck emissions and how the proposed project will affect current emission levels.
- **Relevant Requirements:** The DEIS should describe any applicable local, state, or federal requirements. The DEIS should describe applicable requirements for Federal Actions that require FTA or Federal Highway Administration (FHWA) funding or approval and are

subject to the Transportation Conformity requirements in 40 CFR part 93, subpart A and for Federal Actions that are subject to the General Conformity requirements in 40 CFR part 93, subpart B.

- Conformity: The DEIS should ensure that the emissions from both the construction and the operational phases of the project conform to the approved State Implementation Plan and do not cause or contribute to violations of the NAAQS. To meet the transportation conformity requirements, the DEIS should demonstrate that the project is included in a conforming transportation plan and transportation improvement program.
- Construction: The responsible agency should include a Construction Emissions Mitigation Plan in the DEIS and adopt this plan in the Record of Decision (ROD). In addition to all applicable local, state, or federal requirements, EPA recommends that the following mitigation measures be included in the Construction Emissions Mitigation Plan in order to reduce impacts associated with emissions of particulate matter (PM) and other toxics from construction-related activities:

Fugitive Dust Source Controls:

- Stabilize open storage piles and disturbed areas by covering and/or applying water or chemical/organic dust palliative where appropriate. This applies to both inactive and active sites, during workdays, weekends, holidays, and windy conditions.
- Install wind fencing and phase grading operations where appropriate, and operate water trucks for stabilization of surfaces under windy conditions.
- When hauling material and operating non-earthmoving equipment, prevent spillage and limit speeds to 15 miles per hour (mph). Limit speed of earth-moving equipment to 10 mph.

Mobile and Stationary Source Controls:

- Minimize use, trips, and unnecessary idling of heavy equipment.
- Maintain and tune engines per manufacturer's specifications to perform at EPA certification levels, where applicable, and to perform at verified standards applicable to retrofit technologies. Employ periodic, unscheduled inspections to limit unnecessary idling and to ensure that construction equipment is properly maintained, tuned, and modified consistent with established specifications. The California Air Resources Board has a number of mobile source anti-idling requirements which could be employed. See their website at: <http://www.arb.ca.gov/msprog/truck-idling/truck-idling.htm>
- Prohibit any tampering with engines and require continuing adherence to manufacturer's recommendations.
- If practicable, lease new, clean (diesel or retrofitted diesel) equipment meeting the most stringent of applicable Federal¹ or State Standards². In general, commit to the best available emissions control technology. Tier 4 engines should be used for project construction equipment to the maximum extent feasible³. Lacking availability of non-

¹ EPA's website for nonroad mobile sources is <http://www.epa.gov/nonroad/>.

² For ARB emissions standards, see: <http://www.arb.ca.gov/msprog/offroad/offroad.htm>.

³ Diesel engines < 25 hp rated power started phasing in Tier 4 Model Years in 2008. Larger Tier 4 diesel engines will be phased in depending on the rated power (e.g., 25 hp - <75 hp: 2013; 75 hp - < 175 hp: 2012-2013; 175 hp - < 750 hp: 2011 - 2013; and ≥ 750 hp 2011- 2015).

road construction equipment that meets Tier 4 engine standards, GSA should commit to using the best available emissions control technologies on all equipment.

- Utilize EPA-registered particulate traps and other appropriate controls where suitable to reduce emissions of diesel particulate matter and other pollutants at the construction site.

Administrative controls:

- Identify all commitments to reduce construction emissions and update the air quality analysis to reflect additional air quality improvements that would result from adopting specific air quality measures.
- Identify where implementation of mitigation measures is rejected based on economic infeasibility.
- Prepare an inventory of all equipment prior to construction and identify the suitability of add-on emission controls for each piece of equipment before groundbreaking. (Suitability of control devices is based on: whether there is reduced normal availability of the construction equipment due to increased downtime and/or power output, whether there may be significant damage caused to the construction equipment engine, or whether there may be a significant risk to nearby workers or the public.) Meet CARB diesel fuel requirement for off-road and on-highway (i.e., 15 ppm), and where appropriate use alternative fuel sources such as natural gas and electric power.
- Identify sensitive receptors in the project area, such as children, elderly, and infirm, and specify the means by which you will minimize impacts to these populations. For example, locate construction equipment and staging zones away from sensitive receptors and fresh air intakes to buildings and air conditioners.

Greenhouse Gas Emissions and Sustainable Communities Strategies

The State of California has increased its focus on potential climate change and impacts of increasing greenhouse gas emissions. Specifically, the Global Warming Solutions Act of 2006 and Executive Order S-3-05 recognize the impact that climate change can have within California and provide direction for future reductions of greenhouse gases. In fact, the Natural Resources Agency recently adopted Amendments to the California Environmental Quality Act (CEQA) Guidelines for greenhouse gas emissions on December 30, 2009, which became effective on March 18, 2010⁴. Senate Bill 375 (SB 375) is aimed at curbing sprawl and reducing vehicle miles traveled in an effort to cut greenhouse gas emissions. SB 375 requires Metropolitan Planning Organizations (MPOs) to develop a “sustainable communities strategy” (SCS), which demonstrates how the region will meet greenhouse gas emissions reduction targets set by CARB.

Under the Partnership for Sustainable Communities, EPA, the U.S. Department of Housing and Urban Development, and the U.S. Department of Transportation are working together to help improve access to affordable housing, provide more transportation options, and lower transportation costs while protecting the environment in communities nationwide.

⁴ Amendments to the CEQA Guidelines for greenhouse gas emissions are available on-line at: <http://ceres.ca.gov/ceqa/guidelines/>.

Recommendations:

- EPA strongly recommends that the DEIS identify the cumulative contributions to and cumulative savings of greenhouse gas emissions that will result from implementation of the project.
- EPA also recommends that the DEIS discuss how the project may support the principles of the Partnership for Sustainable Communities and development of the regional SCS.

Climate Change Adaptation

We recommend that the DEIS discuss the potential impacts of climate change on the project. For example, the DEIS should discuss design features that will allow the proposed infrastructure to withstand an increase in extreme precipitation events, and drought tolerant landscaping should be used to prepare for water shortages. We suggest the DEIS discuss adaptation to climate change in context, by describing how the project meets the intent of statewide and national sustainability initiatives and goals to develop sustainable communities.

Integration with Existing Facilities

The DEIS should explore the extent to which proposed alternatives will integrate with existing transportation facilities. The document should discuss how the project will impact existing bus and rail transit, surface vehicle traffic, bicycle lanes and pedestrian paths due to project construction and operation. Measures to minimize or mitigate impacts to bicycle lanes and pedestrian paths should be addressed in the DEIS.

Green Design and Construction

Green Infrastructure

EPA encourages Caltrans to implement “green infrastructure,” such as bioretention areas, vegetated swales, porous pavement, and filter strips in any onsite stormwater management features. These features can serve as both stormwater treatment and visual enhancements. More detailed information on these forms of “green infrastructure” can be found at http://cfpub.epa.gov/npdes/home.cfm?program_id=298.

Industrial Materials Reuse and Recycling

For the construction of new infrastructure, EPA recommends industrial materials recycling, or the reusing or recycling of byproduct materials generated from industrial processes. Nonhazardous industrial materials, such as coal ash, foundry sand, construction and demolition materials, slags, and gypsum, are valuable products of industrial processes. Industrial materials recycling preserves natural resources by decreasing the demand for virgin materials, conserves energy and reduces greenhouse gas emissions by decreasing the demand for products made from energy intensive manufacturing processes, and saves money by decreasing disposal costs for the generator and decreasing materials costs for end users. EPA recommends that, for any new construction proposed, the DEIS identify how industrial materials recycling can be incorporated into project design. More information can be found at: <http://www.epa.gov/epawaste/conserva/rrr/imr/index.htm>.

Environmental Justice and Community and User Outreach

The DEIS should identify whether the proposed alternatives may disproportionately and adversely affect low income or minority populations in the surrounding area and should provide appropriate mitigation measures for any adverse impacts. Executive Order 12898 addresses Environmental Justice in minority and low income populations, and the Council on Environmental Quality has developed guidance concerning how to address Environmental Justice in the environmental review process (<http://ceq.eh.doe.gov/nepa/regs/ej/justice.pdf>). Community involvement activities supporting the project should include opportunities for incorporating public input, especially in Environmental Justice communities, into the facility area design process to promote context sensitive design. In addition, the DEIS should demonstrate compliance with Title VI of the Civil Rights Act of 1964 which, in part, would include analyses for service equity and fare equity.

Recommendations:

- Identify whether the proposed alternatives may disproportionately and adversely affect low-income or minority populations and provide appropriate mitigation measures for any adverse impacts. Assessment of the project's impacts should reflect consultation with affected populations and mitigation measures should be considered where feasible to avoid, mitigate, minimize, rectify, reduce, or eliminate impacts associated with a proposed project (See 40 C.F.R. § 1508.20). Mitigation measures identified in the DEIS should reflect the needs and preferences of the affected low-income and minority populations to the extent practicable.
- Document the process used for community involvement and communication, including all measures to specifically outreach to potential environmental justice communities. Include an analysis of results achieved by reaching out to these populations. EPA has developed a model plan for public participation that may assist Caltrans in this effort. *The Model Plan for Public Participation*, EPA OECA, February 2000, is available at: <http://www.epa.gov/compliance/ej/resources/publications/nejac/model-public-part-plan.pdf>.
- In the DEIS, discuss possible impacts to community cohesion the project may cause, and include mitigation measures for those impacts.

Waters of the United States

The DEIS should identify if the project will involve the discharge of dredged or fill material into jurisdictional wetlands and waterways. Discharges of dredged or fill material into waters of the U.S. require authorization by the U.S. Army Corps of Engineers (Corps) under Section 404 of the Clean Water Act (CWA). The Federal Guidelines at 40 CFR Part 230 promulgated under CWA Section 404 (b)(1) provide substantive environmental criteria that must be met to permit such discharges into waters of the U.S. These criteria require a permitted discharge to: (1) be the least environmentally damaging and practicable alternative (LEDPA); (2) avoid causing or contributing to a violation of a State water quality standard; (3) avoid

jeopardizing a federally listed species or adversely modifying designated critical habitat for a federally listed species; (4) avoid causing or contributing to significant degradation of the waters of the U.S.; and (5) mitigate for unavoidable impacts to waters. A fully integrated DEIS that adequately addresses these criteria would facilitate the CWA Section 404 permit review process.

Avoidance, Minimization and/or Mitigation Measures

To demonstrate compliance with CWA Guidelines, the DEIS should identify measures and modifications to avoid and minimize impacts to water resources. Temporary and permanent impacts to waters of the U.S. for each alternative studied should be quantified; for example, acres of waters impacted, etc. For each alternative, the DEIS should report these numbers in table form for each impacted water and wetland feature.

On April 10, 2008, EPA and the Corps issued revised regulations, “Compensatory Mitigation for Losses of Aquatic Resources; Final Rule” (Mitigation Rule) (40 CFR 230), governing compensatory mitigation for authorized impacts to wetlands, streams, and other waters of the U.S. under Section 404 of the Clean Water Act. These regulations are designed to improve the effectiveness of compensatory mitigation to replace lost aquatic resource functions and area and include a mitigation hierarchy with an inherent preference for mitigation banks and in-lieu fee programs before the use of an on-site mitigation site.

Recommendations:

- If it is determined that waters of the United States will be impacted, include discussion in the DEIS to reflect current regulations. The link to the final Mitigation Rule, which went into effect on June 9, 2008, can be found at <http://www.epa.gov/EPA-WATER/2008/April/Day-10/w6918a.pdf>. Ensure that all mitigation proposed for waters of the U.S. is in compliance with the Mitigation Rule.
- Discuss mitigation for temporary and unavoidable indirect impacts. Temporary impact mitigation should consider additional compensatory mitigation for temporal loss of functions as well as establishing numeric criteria and monitoring of the temporary impact site to ensure that aquatic functions are fully restored. Indirect impact mitigation should consider opportunities to reduce any potential effects from shading and to compensate for possible wetland habitat fragmentation.



reading file

UNITED STATES ENVIRONMENTAL PROTECTION AGENCY
REGION IX
75 Hawthorne Street
San Francisco, CA 94105-3901

June 21, 2004

Ray Sukys
Office of Planning and Program Development
Federal Transportation Administration
Region 9
210 Mission Street, Suite 2210
San Francisco, CA, 94105

Subject: Draft Environmental Impact Statement/Draft Environmental Impact Report for the Gold Line Phase II Light Rail Transit (LRT) Extension Project, Los Angeles and San Bernardino Counties, CA [CEQ# 040214]

Dear Mr. Sukys:

The Environmental Protection Agency (EPA) has reviewed the above-referenced document pursuant to the National Environmental Policy Act (NEPA), Council on Environmental Quality (CEQ) regulations (40 CFR Parts 1500-1508) and Section 309 of the Clean Air Act (CAA).

Based on the procedures EPA uses to evaluate the potential effects of proposed actions and the adequacy of the information in the Draft Environmental Impact Statement/Draft Environmental Impact Report (Draft EIS), the project will be listed in the *Federal Register* in the category EC-2 (Environmental Concerns, Insufficient Information). This rating means that the review identified environmental impacts that should be avoided in order to fully protect the environment, and the Draft EIS does not contain sufficient information to thoroughly assess environmental impacts that should be avoided to fully protect the environment (see enclosed "Summary of Rating Definitions"). Our concerns are based on the scope of the analysis, potential impacts to air, water, and biological resources, hazardous materials management, and socioeconomic impacts of removing freight service. Our detailed comments are enclosed.

EPA is supportive of the Gold Line Light Rail project, especially the goal to provide transit services and strategies to reduce congestion and associated motor vehicle emissions in the South Coast Air Basin. We appreciate the opportunity to review this Draft EIS. When the Final EIS is completed, please send two copies to me at the address above (Mail Code: CMD-2). If you have any questions or comments, please feel free to contact me or Connell Dunning, the primary staff person working on this project. Connell Dunning can be reached at 415-947-4161 or dunning.connell@epa.gov.

Sincerely,

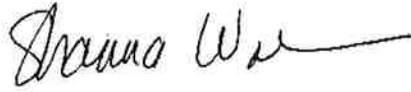

for

Lisa B. Hanf, Manager
Federal Activities Office

Attachments:

Summary of EPA Rating Definitions
EPA's Detailed Comments

cc:

Habib F. Balian, Los Angeles to Metro Blue Line Construction Authority

DETAILED COMMENTS ON THE DRAFT ENVIRONMENTAL IMPACT STATEMENT/ DRAFT ENVIRONMENTAL IMPACT REPORT FOR THE GOLD LINE PHASE II LIGHT RAIL TRANSIT PROJECT, LOS ANGELES AND SAN BERNARDINO COUNTIES, JUNE 21, 2004

Scope of Analysis

Both the double and the triple track options in the Draft Environmental Impact Statement/Draft Environmental Impact Report (Draft EIS) for the Gold Line Phase II Light Rail Project (Gold Line) will require the replacement of the existing 6,000-foot siding area for the Burlington Northern Santa Fe (BNSF) rail to another location on the BNSF line. The Draft EIS does not identify where the relocation will occur and what the resulting potential environmental impacts will be. Relocating this 6,000-foot siding area is a requirement of each build alternative for the Gold Line, therefore the relocation is a connected action (40 CFR Part 1508.25(a)) and all direct, indirect, and cumulative impacts of this and any additional connected actions should be analyzed through the environmental review process.

Recommendation:

Describe the design and location of the proposed relocation of the 6,000-foot siding area required on the BNSF line and disclose the direct, indirect, and cumulative impacts that the relocation will have on environmental resources.

Air Quality

Los Angeles County and San Bernardino County are designated as nonattainment for the federal 1-hour and 8-hour National Ambient Air Quality Standards (NAAQS) for ozone, carbon monoxide, and particulate matter under 10 microns (PM₁₀). EPA revised the ozone NAAQS on July 18, 1997 (62 FR 38856) by promulgating an ozone standard of 0.08 parts per million (ppm) as measured over an 8-hour period. EPA's final rule designating non-attainment areas under the 8-hour NAAQS was published in the *Federal Register* on April 30, 2004. On that date, EPA announced the designation of parts of Los Angeles and San Bernardino Counties in the project area as severe non-attainment areas for the new national 8-hour ozone standard, effective June 15, 2004. EPA intends to revoke the 1-hour ozone standard on June 15, 2005. In accordance with Clean Air Act Section 176(c)(6), the conformity requirements for projects located within the newly designated ozone non-attainment areas do not apply until one year from the effective date of the area's designation.

Recommendation:

Correct Section 3-2 to disclose that the project area is designated as severe nonattainment for the federal 8-hour ozone standard.

The Draft EIS describes the Air Quality Management Plan and Regional Transportation Plan (RTP), but states that the proposed project is listed as a recommended major transit

investment in the draft 2004 RTP which is scheduled for adoption in April 2004. Because the project is in nonattainment for the criteria pollutants listed above, the project must be included in a conforming plan and transportation improvement program.

Recommendation:

Address whether the project is included in a conforming plan and transportation improvement program.

One of the double track options, the Double Track Configuration Without Freight, will require removing existing freight service utilizing the BNSF line between the Sierra Madre Station and the city of La Verne. Current and future freight delivery on the BNSF rail line in this area will be required to be delivered through a different mode, presumably via trucks. The Draft EIS does not analyze the indirect air quality impacts of transferring existing and future freight operation service in this area to trucks.

Recommendation:

Analyze the air quality impacts from transferring current and future rail freight service to truck-delivered freight operations and disclose the estimated increase in pollutants.

Water Resources

In addition to crossing over underground channels, the proposed project will cross several bridged channels indicated as "blue-line" streams on United States Geological Survey (USGS) maps: Sawpit Wash (Monrovia), San Gabriel River and an unnamed wash west of San Gabriel (Irwindale), Big Dalton Wash and San Dimas Wash (San Dimas), Live Oak Creek (La Verne), Thompsom Creek (Pomona), San Antonio Creek (Montclair/Upland). "Blue-line" streams flow for most or all of the year and are marked on topographic maps with a solid blue line. Other jurisdictional waters not depicted as blue-line streams may occur in the project area. The Draft EIS does not identify all jurisdictional waters crossed by the proposed project and does not provide an estimate of the total acres of impacts to waters or a description of potential mitigation.

Recommendations:

Identify all jurisdictional waters of the U.S. that are directly and indirectly affected by the project. Disclose the total number of acres of impacts to jurisdictional waters of the United States due to the proposed project, including any jurisdictional waters not identified as blue-line streams on USGS maps. Update the listings of channels/drainages included within each city area to include jurisdictional waters that are not identified as blue-line streams on the USGS maps referenced. Include a reference to a jurisdictional determination that has been completed by the Army Corps of Engineers. Describe potential mitigation, including on-site restoration, for any impacts to waters where it is feasible.

Impaired Waters

Surface waterways in the project area are currently degraded. All alternative alignments cross many channels that terminate in the San Gabriel River Estuary, one of several impaired water bodies crossed by the proposed Gold Line (page 3-18-8). Therefore, any new streambed alterations should avoid and minimize further impacts to water quality. The Draft EIS lists Best Management Practices from the *California Storm Water Best Management Practices Handbook* (1993). The Draft EIS also states that requirements for streambed alteration agreements from the California Department of Fish and Game (CDFG) are listed in "Section 4.15 Natural Resources" (page 3-18-16). No such section is included in the Draft EIS and there is no description of the additional measures required by CDFG.

Recommendations:

Describe the proposed methods for avoiding and minimizing impacts to the San Gabriel River and other streams and channels that will be crossed by the build alternatives. Correct the reference to the CDFG Streambed Alteration Agreements by identifying what additional requirements FTA will be committing to regarding necessary permits from CDFG for projects requiring streambed alterations.

San Gabriel River Wildlife Corridor

The Cumulative Impacts Analysis indicates that the San Gabriel River wildlife movement corridor would not be affected by the proposed project (page 4-7); however, the Triple Track Configuration would require bridge retrofits with the potential for additional footings within the riverbed. The Draft EIS does not identify potential impacts due to construction within the wildlife corridor and does not indicate mitigation measures to minimize construction impacts to species from the required retrofit construction over the San Gabriel River.

Recommendations:

Disclose the potential impacts from bridge retrofits to the species that utilize the San Gabriel River wildlife corridor. Include a more thorough description of how impacts to wildlife utilizing the wildlife corridor can be minimized.

Biological Resources

The Draft EIS acknowledges the impacts of all alternatives on the alluvial fan coastal sage scrub and riparian scrub. The impacted resources are native habitats found within a highly urbanized environment, and as such, they are sensitive resources. The Cumulative Impacts Analysis indicates that the habitat lost in the urbanized area is marginal (page 4-7); however, it does not provide a clear historic baseline or the percentage of historic loss of these habitats from which to compare the impacts of the proposed activities. The Draft EIS indicates that there would be permanent loss of habitat to endangered species, but does not indicate the percentage of the species' habitats that will be permanently lost.

Recommendations:

Disclose the historic loss of alluvial fan coastal sage scrub and riparian scrub habitat as well as the total remaining habitat. Identify the percentage of remaining habitat lost due to the proposed action. Identify any mitigation measures to minimize the loss of habitat.

Hazardous Materials and Hazardous Waste

All build alternatives will require the construction of the Maintenance and Operations Facility in Irwindale, including an approximately 8,000 square foot paint shop and body shop with associated sheet metal, welding, and paint storage areas. The Draft EIS does not address the potential impacts associated with the operation of the new paint and body shop. A hazardous materials management plan can potentially reduce the volume and/or toxicity of waste requiring subsequent management as hazardous waste under the Resource Conservation and Recovery Act (RCRA) and California's RCRA implementation provisions.

Recommendations:

Address potential impacts due to the use of hazardous materials in construction and operation, and the expected types and volumes of hazardous materials, specifically associated with the Maintenance and Operations Facility. Evaluate alternate processes potentially using a smaller volume of hazardous materials and/or less toxic materials, especially as project mitigation and identify expected storage, disposal, and management plans. Address the proposed methods to control and remediate any spill or discharge of hazardous materials into the environment. Address the applicability of Federal hazardous waste requirements and also California's requirements that are approved by EPA under RCRA.

Mitigation and Pollution Prevention

The Draft EIS states that long term impacts would be eliminated or reduced to less than adverse levels by complying with the federal and state regulatory requirements related to hazardous materials (page 3-9-13). NEPA does not require that an impact be significant before mitigation can be presented in an EIS. Rather, "all relevant, reasonable mitigation measures that could improve the project are to be identified. Mitigation measures must be considered even for impacts that by themselves would not be considered significant. Once the proposal itself is considered as a whole to have significant effects....mitigation measures must be developed where it is feasible to do so." (see Council on Environmental Quality (CEQ), 1981, "Forty Most Asked Questions Concerning CEQ's National Environmental Policy Act Regulations"). CEQ also issued guidance on integrating pollution prevention measures in NEPA documents and NEPA decisions (1993 Memorandum on Pollution Prevention and NEPA). Many strategies can reduce pollution and protect resources, including using fewer toxic inputs, altering construction and facility maintenance processes, and conserving energy.

Recommendation:

Consistent with CEQ's guidance, present all reasonable mitigation and pollution prevention features in the Final EIS. Evaluate the feasibility of mitigation to avoid, reduce or compensate for adverse environmental impacts from construction and operation.

Socioeconomic Impacts of Freight Delivery Restrictions

The double track options would either require existing freight operations to occur during the non-operational Gold Line hours, estimated as between 2:00 am and 4:00 am (Double Track Configuration with Freight), or would transfer all existing freight operations to an entirely separate mode, presumably trucks (Double Track Configuration without Freight). The Draft EIS does not fully assess the option of requiring freight operators to operate between 2:00 am and 4:00 am. The Draft EIS does not address the long-term socioeconomic impacts of removing the potential for future freight delivery on the BNSF line proposed in the Double Track Configuration without Freight option.

Recommendations:

Discuss the feasibility and impacts of limiting all freight operations between the hours of 2:00 am and 4:00 am, including how light rail maintenance between 2:00 am and 4:00 am would be compatible with freight delivery utilizing the same tracks. Describe the long-term socioeconomic impacts of permanently removing the ability for freight to be delivered on the BNSF line between the Sierra Madre Station and the city of La Verne.



UNITED STATES ENVIRONMENTAL PROTECTION AGENCY
REGION IX
75 Hawthorne Street
San Francisco, CA 94105

February 2, 2011

Ray Tellis
Federal Transit Administration
888 South Figueroa Street, Suite 1850
Los Angeles, CA 90017

Subject: Scoping Comments and Response to Participating Agency Request for the Metro Gold Line Foothill Extension Azusa to Montclair, Los Angeles and San Bernardino Counties, California 

Dear Mr. Tellis:

The U.S. Environmental Protection Agency (EPA) has reviewed the Notice of Intent published in the Federal Register December 27, 2010, requesting comments on the Federal Transit Administration (FTA) proposal to prepare a Draft Environmental Impact Statement (EIS) for the Metro Gold Line Foothill Extension Azusa to Montclair. Our comments are provided pursuant to the National Environmental Policy Act (NEPA), Council on Environmental Quality (CEQ) regulations (40 CFR Parts 1500-1508) and Section 309 of the Clean Air Act.

Additionally, we have enclosed our comments on the 2004 DEIS for an earlier version of this project. In those comments, EPA made recommendations addressing the scope of analysis, air quality, water resources, biological resources, hazardous materials and hazardous waste, and impacts of freight delivery restrictions. Where they remain relevant, we recommend the upcoming DEIS address these issues.

FTA has also invited EPA to become a "Participating Agency" (as defined in 23 USC 139 Safe, Accountable, Flexible, Efficient Transportation Equity Act: A Legacy for Users (SAFETEA-LU)). EPA accepts this invitation and agrees to engage in this project as a Participating Agency. EPA's participation as a Participating Agency does not constitute a formal or informal approval of any independent review of the Draft and Final EISs pursuant to Section 309 of the Clean Air Act. We look forward to working with you to ensure that the SAFETEA-LU implementation procedures assist both our agencies in meeting our statutory missions. 

We appreciate the opportunity to provide comments on the preparation of the Draft EIS. As a participating Agency, EPA will provide comments on the Draft EIS, the Final EIS, and at other milestones where we believe we can contribute to avoidance and minimization of potential environmental and human health impacts during the development of the EIS.

When the Draft EIS is released for public review, please send one hard copy and one disc copy to the address above (mail code CED-2). If you have any questions, please contact me at 415-947-4121 or ganson.chris@epa.gov.

Sincerely,



Chris Ganson
Environmental Protection Specialist
Environmental Review Office (CED-2)

Enclosure: EPA's Detailed Comments
EPA Comments on 2004 Draft Environmental Impact Statement/Draft
Environmental Impact Report for the Gold Line Phase II Light Rail Transit
(LRT) Extension Project

CC: Leslie Rogers, Federal Transit Administration
Ray Sukys, Federal Transit Administration
Lisa Levy Buch, Metro Gold Line Foothill Extension Construction Authority

Range of Alternatives

The Draft Environmental Impact Statement (DEIS) should explore and objectively evaluate a range of reasonable alternatives, including the No Action Alternative, and briefly discuss the reasons for eliminating some alternatives from further evaluation (40 CFR 1502.14). EPA recommends that the DEIS include a summary of the screening methodology that was used to determine the Range of Alternatives for inclusion in the DEIS. The methodology summary should include information about which criteria and measures were used at each screening level and how they were integrated in a comprehensive evaluation. The DEIS should also include a description of alternatives that were considered but withdrawn with a summary of why they were eliminated.

The DEIS should also identify opportunities for the alternatives to avoid or minimize adverse environmental impacts while fulfilling the project purpose. This may include alignment shifts, buffers, localized design modifications, changes in construction practices, or spanned crossings of sensitive biological resources.

Air Quality

The proposed project is located in the South Coast Air Basin (SCAB). The South Coast Air Quality Management District (SCAQMD) implements local air quality regulations in the SCAB to carry out Federal Clean Air Act (CAA) requirements, as authorized by the EPA. The current SCAB nonattainment designations under the CAA are as follows: 8-hour ozone - severe nonattainment; particulate matter with a diameter of 10 microns or less (PM₁₀) - serious nonattainment; and particulate matter with a diameter of 2.5 microns or less (PM_{2.5}) - nonattainment. The SCAB has the worst 8-hour ozone and PM_{2.5} problems in the nation, and attainment of these NAAQS will require massive reductions from mobile sources, given the rapid growth in this emissions category and the long lifespan of diesel engines. Because of the air basin's nonattainment status, it is important to reduce emissions of ozone precursors, mobile source air toxics (MSAT) and particulate matter from this project to the maximum extent.

Recommendations:

- Ambient Conditions: The DEIS should include a detailed discussion of ambient air conditions (i.e., baseline or existing conditions), the area's attainment or nonattainment status for all NAAQS, and potential air quality impacts (including cumulative and indirect impacts) from the construction and operation of the project for each fully evaluated alternative. The DEIS should include estimates of all criteria pollutant emissions and diesel particulate matter (DPM). EPA also recommends that the DEIS disclose the available information about the health risks associated with construction and truck emissions and how the proposed project will affect current emission levels.
- Relevant Requirements: The DEIS should describe any applicable local, state, or federal requirements. The DEIS should describe applicable requirements for Federal Actions that require FTA or Federal Highway Administration (FHWA) funding or approval and are

subject to the Transportation Conformity requirements in 40 CFR part 93, subpart A and for Federal Actions that are subject to the General Conformity requirements in 40 CFR part 93, subpart B.

- **Conformity:** The DEIS should ensure that the emissions from both the construction and the operational phases of the project conform to the approved State Implementation Plan and do not cause or contribute to violations of the NAAQS. To meet the transportation conformity requirements, the DEIS should demonstrate that the project is included in a conforming transportation plan and transportation improvement program.
- **Construction:** The responsible agency should include a Construction Emissions Mitigation Plan in the DEIS and adopt this plan in the Record of Decision (ROD). In addition to all applicable local, state, or federal requirements, EPA recommends that the following mitigation measures be included in the Construction Emissions Mitigation Plan in order to reduce impacts associated with emissions of particulate matter (PM) and other toxics from construction-related activities:

Fugitive Dust Source Controls:

- Stabilize open storage piles and disturbed areas by covering and/or applying water or chemical/organic dust palliative where appropriate. This applies to both inactive and active sites, during workdays, weekends, holidays, and windy conditions.
- Install wind fencing and phase grading operations where appropriate, and operate water trucks for stabilization of surfaces under windy conditions.
- When hauling material and operating non-earthmoving equipment, prevent spillage and limit speeds to 15 miles per hour (mph). Limit speed of earth-moving equipment to 10 mph.

Mobile and Stationary Source Controls:

- Minimize use, trips, and unnecessary idling of heavy equipment.
- Maintain and tune engines per manufacturer's specifications to perform at EPA certification levels, where applicable, and to perform at verified standards applicable to retrofit technologies. Employ periodic, unscheduled inspections to limit unnecessary idling and to ensure that construction equipment is properly maintained, tuned, and modified consistent with established specifications. The California Air Resources Board has a number of mobile source anti-idling requirements which could be employed. See their website at: <http://www.arb.ca.gov/msprog/truck-idling/truck-idling.htm>
- Prohibit any tampering with engines and require continuing adherence to manufacturer's recommendations.
- If practicable, lease new, clean (diesel or retrofitted diesel) equipment meeting the most stringent of applicable Federal¹ or State Standards². In general, commit to the best available emissions control technology. Tier 4 engines should be used for project construction equipment to the maximum extent feasible³. Lacking availability of non-

¹ EPA's website for nonroad mobile sources is <http://www.epa.gov/nonroad/>.

² For ARB emissions standards, see: <http://www.arb.ca.gov/msprog/offroad/offroad.htm>.

³ Diesel engines < 25 hp rated power started phasing in Tier 4 Model Years in 2008. Larger Tier 4 diesel engines will be phased in depending on the rated power (e.g., 25 hp - <75 hp: 2013; 75 hp - < 175 hp: 2012-2013; 175 hp - < 750 hp: 2011 - 2013; and \geq 750 hp 2011- 2015).

road construction equipment that meets Tier 4 engine standards, GSA should commit to using the best available emissions control technologies on all equipment.

- Utilize EPA-registered particulate traps and other appropriate controls where suitable to reduce emissions of diesel particulate matter and other pollutants at the construction site.

Administrative controls:

- Identify all commitments to reduce construction emissions and update the air quality analysis to reflect additional air quality improvements that would result from adopting specific air quality measures.
- Identify where implementation of mitigation measures is rejected based on economic infeasibility.
- Prepare an inventory of all equipment prior to construction and identify the suitability of add-on emission controls for each piece of equipment before groundbreaking. (Suitability of control devices is based on: whether there is reduced normal availability of the construction equipment due to increased downtime and/or power output, whether there may be significant damage caused to the construction equipment engine, or whether there may be a significant risk to nearby workers or the public.) Meet CARB diesel fuel requirement for off-road and on-highway (i.e., 15 ppm), and where appropriate use alternative fuel sources such as natural gas and electric power.
- Identify sensitive receptors in the project area, such as children, elderly, and infirm, and specify the means by which you will minimize impacts to these populations. For example, locate construction equipment and staging zones away from sensitive receptors and fresh air intakes to buildings and air conditioners.

Greenhouse Gas Emissions and Sustainable Communities Strategies

The State of California has increased its focus on potential climate change and impacts of increasing greenhouse gas emissions. Specifically, the Global Warming Solutions Act of 2006 and Executive Order S-3-05 recognize the impact that climate change can have within California and provide direction for future reductions of greenhouse gases. In fact, the Natural Resources Agency recently adopted Amendments to the California Environmental Quality Act (CEQA) Guidelines for greenhouse gas emissions on December 30, 2009, which became effective on March 18, 2010⁴. Senate Bill 375 (SB 375) is aimed at curbing sprawl and reducing vehicle miles traveled in an effort to cut greenhouse gas emissions. SB 375 requires Metropolitan Planning Organizations (MPOs) to develop a “sustainable communities strategy” (SCS), which demonstrates how the region will meet greenhouse gas emissions reduction targets set by CARB.

Under the Partnership for Sustainable Communities, EPA, the U.S. Department of Housing and Urban Development, and the U.S. Department of Transportation are working together to help improve access to affordable housing, provide more transportation options, and lower transportation costs while protecting the environment in communities nationwide.

⁴ Amendments to the CEQA Guidelines for greenhouse gas emissions are available on-line at: <http://ceres.ca.gov/ceqa/guidelines/>.

Recommendations:

- EPA strongly recommends that the DEIS identify the cumulative contributions to and cumulative savings of greenhouse gas emissions that will result from implementation of the project.
- EPA also recommends that the DEIS discuss how the project may support the principles of the Partnership for Sustainable Communities and development of the regional SCS.

Climate Change Adaptation

We recommend that the DEIS discuss the potential impacts of climate change on the project. For example, the DEIS should discuss design features that will allow the proposed infrastructure to withstand an increase in extreme precipitation events, and drought tolerant landscaping should be used to prepare for water shortages. We suggest the DEIS discuss adaptation to climate change in context, by describing how the project meets the intent of statewide and national sustainability initiatives and goals to develop sustainable communities.

Integration with Existing Facilities

The DEIS should explore the extent to which proposed alternatives will integrate with existing transportation facilities. The document should discuss how the project will impact existing bus and rail transit, surface vehicle traffic, bicycle lanes and pedestrian paths due to project construction and operation. Measures to minimize or mitigate impacts to bicycle lanes and pedestrian paths should be addressed in the DEIS.

Green Design and Construction

Green Infrastructure

EPA encourages Caltrans to implement “green infrastructure,” such as bioretention areas, vegetated swales, porous pavement, and filter strips in any onsite stormwater management features. These features can serve as both stormwater treatment and visual enhancements. More detailed information on these forms of “green infrastructure” can be found at http://cfpub.epa.gov/npdes/home.cfm?program_id=298.

Industrial Materials Reuse and Recycling

For the construction of new infrastructure, EPA recommends industrial materials recycling, or the reusing or recycling of byproduct materials generated from industrial processes. Nonhazardous industrial materials, such as coal ash, foundry sand, construction and demolition materials, slags, and gypsum, are valuable products of industrial processes. Industrial materials recycling preserves natural resources by decreasing the demand for virgin materials, conserves energy and reduces greenhouse gas emissions by decreasing the demand for products made from energy intensive manufacturing processes, and saves money by decreasing disposal costs for the generator and decreasing materials costs for end users. EPA recommends that, for any new construction proposed, the DEIS identify how industrial materials recycling can be incorporated into project design. More information can be found at: <http://www.epa.gov/epawaste/conserves/rrr/imr/index.htm>.

Environmental Justice and Community and User Outreach

The DEIS should identify whether the proposed alternatives may disproportionately and adversely affect low income or minority populations in the surrounding area and should provide appropriate mitigation measures for any adverse impacts. Executive Order 12898 addresses Environmental Justice in minority and low income populations, and the Council on Environmental Quality has developed guidance concerning how to address Environmental Justice in the environmental review process (<http://ceq.eh.doe.gov/nepa/regs/ej/justice.pdf>). Community involvement activities supporting the project should include opportunities for incorporating public input, especially in Environmental Justice communities, into the facility area design process to promote context sensitive design. In addition, the DEIS should demonstrate compliance with Title VI of the Civil Rights Act of 1964 which, in part, would include analyses for service equity and fare equity.

Recommendations:

- Identify whether the proposed alternatives may disproportionately and adversely affect low-income or minority populations and provide appropriate mitigation measures for any adverse impacts. Assessment of the project's impacts should reflect consultation with affected populations and mitigation measures should be considered where feasible to avoid, mitigate, minimize, rectify, reduce, or eliminate impacts associated with a proposed project (See 40 C.F.R. § 1508.20). Mitigation measures identified in the DEIS should reflect the needs and preferences of the affected low-income and minority populations to the extent practicable.
- Document the process used for community involvement and communication, including all measures to specifically outreach to potential environmental justice communities. Include an analysis of results achieved by reaching out to these populations. EPA has developed a model plan for public participation that may assist Caltrans in this effort. *The Model Plan for Public Participation*, EPA OECA, February 2000, is available at: <http://www.epa.gov/compliance/ej/resources/publications/nejac/model-public-part-plan.pdf>.
- In the DEIS, discuss possible impacts to community cohesion the project may cause, and include mitigation measures for those impacts.

Waters of the United States

The DEIS should identify if the project will involve the discharge of dredged or fill material into jurisdictional wetlands and waterways. Discharges of dredged or fill material into waters of the U.S. require authorization by the U.S. Army Corps of Engineers (Corps) under Section 404 of the Clean Water Act (CWA). The Federal Guidelines at 40 CFR Part 230 promulgated under CWA Section 404 (b)(1) provide substantive environmental criteria that must be met to permit such discharges into waters of the U.S. These criteria require a permitted discharge to: (1) be the least environmentally damaging and practicable alternative (LEDPA); (2) avoid causing or contributing to a violation of a State water quality standard; (3) avoid

jeopardizing a federally listed species or adversely modifying designated critical habitat for a federally listed species; (4) avoid causing or contributing to significant degradation of the waters of the U.S.; and (5) mitigate for unavoidable impacts to waters. A fully integrated DEIS that adequately addresses these criteria would facilitate the CWA Section 404 permit review process.

Avoidance, Minimization and/or Mitigation Measures

To demonstrate compliance with CWA Guidelines, the DEIS should identify measures and modifications to avoid and minimize impacts to water resources. Temporary and permanent impacts to waters of the U.S. for each alternative studied should be quantified; for example, acres of waters impacted, etc. For each alternative, the DEIS should report these numbers in table form for each impacted water and wetland feature.

On April 10, 2008, EPA and the Corps issued revised regulations, “Compensatory Mitigation for Losses of Aquatic Resources; Final Rule” (Mitigation Rule) (40 CFR 230), governing compensatory mitigation for authorized impacts to wetlands, streams, and other waters of the U.S. under Section 404 of the Clean Water Act. These regulations are designed to improve the effectiveness of compensatory mitigation to replace lost aquatic resource functions and area and include a mitigation hierarchy with an inherent preference for mitigation banks and in-lieu fee programs before the use of an on-site mitigation site.

Recommendations:

- If it is determined that waters of the United States will be impacted, include discussion in the DEIS to reflect current regulations. The link to the final Mitigation Rule, which went into effect on June 9, 2008, can be found at <http://www.epa.gov/EPA-WATER/2008/April/Day-10/w6918a.pdf>. Ensure that all mitigation proposed for waters of the U.S. is in compliance with the Mitigation Rule.
- Discuss mitigation for temporary and unavoidable indirect impacts. Temporary impact mitigation should consider additional compensatory mitigation for temporal loss of functions as well as establishing numeric criteria and monitoring of the temporary impact site to ensure that aquatic functions are fully restored. Indirect impact mitigation should consider opportunities to reduce any potential effects from shading and to compensate for possible wetland habitat fragmentation.

CALIFORNIA ENERGY COMMISSION

1516 NINTH STREET
SACRAMENTO, CA 95814-5512
www.energy.ca.gov



January 21, 2011

Ms. Lisa Levy Buch
Director of Public Affairs
Metro Gold Line Foothill Extension Construction Authority
406 E. Huntington Drive, Suite 202
Monrovia, CA 91016-3633

Dear Ms. Levy Buch:

The California Energy Commission (Energy Commission) has received the Metro Gold Line Foothill Extension Construction Authority's letter dated January 6, 2011, regarding the invitation to participate in the environmental review process for the Metro Gold Line Foothill Extension Azusa to Montclair EIS/EIR for comments due by February 2, 2011. After careful review of the project scoping information packet, the Energy Commission does not elect to become a participating agency. The Energy Commission would, however, like to make you aware of the *Energy Aware Planning Guide*.

The Energy Commission's *Energy Aware Planning Guide* is available as a tool to assist in your land use planning and other future projects. The purpose of the *Energy Aware Planning Guide* is to provide technical information to local governments seeking to improve energy efficiency, reduce energy use and greenhouse gas emissions, and enhance renewable energy resources. For further information on how to utilize this guide, please visit www.energy.ca.gov/energy_aware_guide/index.html.

Thank you for providing us the opportunity to be a participating agency in the environmental review process of your proposed project. We hope the *Energy Aware Planning Guide* will be a helpful resource for evaluating your project.

If you have any further questions, please contact John Sugar in Special Projects Office of Fuels and Transportation Division at (916) 654-4563.

Sincerely,

MELISSA JONES
Executive Director

RECEIVED

JAN 27 2011

MGL FOOTHILL EXT.
CONST. AUTHORITY

Lisa Levy Buch

From: Helen Birss [HBIRSS@dfg.ca.gov]
Sent: Tuesday, January 11, 2011 11:34 AM
To: Habib Balian
Cc: Lisa Levy Buch
Subject: Re: Invitation to Become a Participating Agency in the Metro Gold Line Foothill Extension Azusa to Montclair EIS/EIR

Hi Habib,

I am unable to attend the meeting, however, Kelly Schmoker will be attending.

Please add me to the e-mail list.

Thanks,
Helen

Helen Birss
Environmental Program Manager
California Department of Fish and Game
South Coast Region
Habitat Conservation (North/Central)
4665 Lampson Avenue
Los Alamitos, CA 90720
805-448-3432 (Cell)
805-569-6863 (Santa Barbara Office)
562-342-7151 (Los Alamitos)
hbirss@dfg.ca.gov

>>> Habib Balian <HBalian@foothillextension.org> 1/6/2011 5:27 PM >>>

The Metro Gold Line Foothill Extension Construction Authority (Construction Authority), in cooperation with the Federal Transit Administration (FTA), is initiating the preparation of Environmental Impact Statement/Environmental Impact Report (EIS/EIR) for the proposed Metro Gold Line Foothill Extension Azusa to Montclair Project. The proposed project is located in Los Angeles and San Bernardino Counties encompassing seven adjoining cities that lie along I-210 and a railroad right-of-way, between the eastern boundary of Azusa on the west and Montclair on the east. The study area is a 12.6 mile corridor that includes the cities of Azusa, Glendora, San Dimas, La Verne, Pomona, and Claremont in Los Angeles County. In San Bernardino County, it includes the city of Montclair.

The purpose of this project is to improve mobility in western Los Angeles County and eastern San Bernardino County by introducing high-frequency transit service; enhance the regional transit network by interconnecting existing and planned rapid transit lines; provide an alternative mode of transportation for commuters who currently use the congested I-210 corridor; improve transit accessibility for residents and employees who live and/or work along the corridor; and encourage a mode shift to transit, reducing air pollution and greenhouse gas (GHG) emissions. The enclosed scoping information packet provides more details, including a preliminary schedule.

Section 6002 of the Safe, Accountable, Flexible, Efficient, Transportation Equity Act: A Legacy for Users (SAFETEA-LU) establishes an enhanced environmental review process for certain FTA projects, improving the transparency of the process, and increasing opportunities

**DEPARTMENT OF HOUSING AND COMMUNITY DEVELOPMENT
OFFICE OF THE DIRECTOR**

1800 Third Street, Room 450
Sacramento, CA 95811
www.hcd.ca.gov
(916) 445-4775
Fax (916) 324-5107



February 2, 2011

Ms. Lisa Levy Buch
Director of Public Affairs
Metro Gold Line Foothill Extension Construction Authority
406 E. Huntington Drive, Suite 202
Monrovia, CA 91016

RE: Metro Gold Line Foothill Extension, Azusa to Montclair EIS/EIR

Dear Ms. Buch:

This letter is written to convey acceptance by the California Department of Housing and Community Development of the January 7, 2011, invitation to become a "Participating Non-Federal Agency" in the Metro Gold Line Foothill Extension, Azusa to Montclair EIS/EIR Project. The project is located in Los Angeles and San Bernardino Counties, encompassing several adjoining cities that lie along I-210 and a railroad right-of-way, including the cities of Azusa, Glendora, San Dimas, La Verne, Pomona, Claremont and Montclair.

The interests of the Department relate to the project objectives of improving transit accessibility for residents and employees; encouraging mode shift to transit, and reducing air pollution and greenhouse gas (GHG) emissions. In particular, the Department is interested in the prospective impacts of the project on siting of new housing or residential mixed-use development, or rehabilitation of such developments, to support the project objectives, as well as to address housing goals and objectives of State laws including integration of housing and transportation planning.

Thank you for the opportunity to participate in this project. Please forward questions or further information, meeting notices, or the status of the project to me at (916) 445-4775 or via e-mail at lwheaton@hcd.ca.gov.

Sincerely,

A handwritten signature in black ink that reads "Linda M. Wheaton". The signature is written in a cursive, flowing style.

Linda Wheaton
Assistant Director of Local Government Affairs

PUBLIC UTILITIES COMMISSION

320 WEST 4TH STREET, SUITE 500
LOS ANGELES, CA 90013



January 25, 2011

Lisa Levy Buch
Metro Gold Line Foothill Extension Construction Authority
406 E. Huntington Drive, Suite 202
Monrovia, CA 91016

Dear Ms. Buch:

Re: SCH# 2011121069; Gold Line Foothill Extension Azusa to Montclair (Phase 2B)

Thank you for providing us with a copy of your Notice of Preparation (NOP) for a Project Environmental Impact Report (EIS/EIR) for the Gold Line Foothill Extension Azusa to Montclair Phase 2B. The California Public Utilities Commission (CPUC or Commission) provides the following comments:

The project is subject to a number of rules and regulations involving the CPUC. These may include: Sections 1201 et al, and 99152 of State of California Public Utilities Code, which requires Commission authority to construct rail lines over existing streets. The design criteria of the proposed project must comply with CPUC General Orders (GOs), such as, GO 72-B rules governing the construction and maintenance of crossings at grade of railroads with public streets, roads and highways; GO 75-D regulations governing standards for warning devices for at-grade highway-rail crossings; GO 143-B Safety Rules and Regulations governing Light-Rail Transit; and GO 164-D regulations governing State Safety Oversight of Rail Fixed Guideway Systems.

As part of its mission to reduce hazards associated with at-grade crossings, the Commission's policy is to reduce the number of at-grade crossings on rail corridors. In acquiring Commission approval for construction of at-grade rail crossings, Metro Gold Line Foothill Extension Construction Authority has two options: (1) Filing a Rail Crossing Hazard Analysis Report (RCHAR), or (2) Filing formal applications in accordance with the Commission's Rules of Practice and Procedure. These options are contained in greater detail in Commission GO 164-D.

The Build Alternative described in your NOP passes through high density commercial, residential and industrial areas of the greater Los Angeles Metropolitan Area. High density areas near rail tracks lead to a high amount of pedestrians around the tracks. Constructing tracks at the existing Right of Way elevations is likely to result in trespassing issues and pedestrian conflicts similar to those currently experienced along other Metro Rail corridors in Los Angeles. Elevating or lowering the tracks would mitigate this concern. Additionally, fencing any remaining at-grade portions of the rail alignment selected should be a requirement of the project.

While we understand the cost of grade separating a highway-rail at-grade crossing makes for a perceived detriment to your project, the CPUC normally does not take cost into its consideration of the practicability of grade separating a crossing.

We understand that this is a highly complex and challenging project with funding, design and environmental approval for the greater Los Angeles area. It is imperative that the CPUC be involved with the details of this project from its inception in order to be informed and to be of greater assistance in the future. The CPUC will need to provide applicable regulatory oversight for all phases of the project. This will require early consultation with not only Metro Gold Line Foothill Extension Construction Authority staff but contracted consultants as well in order to provide early consultation on all proposed design and engineering of the proposed project improvements on the corridor.

This will also assist with the review of the environmental documents and final CEQA approval of the project by the CPUC, since we are a responsible agency under CEQA section 15381 with regard to this project and in complying with any and all General Order requirements as they apply to the Phase 2B of the Gold Line Foothill Extension Azusa to Montclair Project.

Thank you very much for the opportunity to review and comment on your NOP for the Gold Line Foothill Extension Azusa to Montclair Project Phase 2B Project (EIS/EIR). Commission staff is available to meet with you and discuss our concerns.

We look forward to working with the Metro Gold Line Foothill Extension Construction Authority staff on this project. Should you have any questions, please contact Jose Pereyra, responsible Engineer at (213) 576 – 7083 or email at jfp@cpuc.ca.gov or myself at rxm@cpuc.ca.gov, 213-576-7078.

Sincerely,

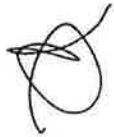

Rosa Muñoz, PE
Senior Utilities Engineer
Rail Crossings Engineering Section
Consumer Protection & Safety Division

C: Vijay Khawani, Metro
John C. Miller, PE, Metro

DEPARTMENT OF TRANSPORTATION

DISTRICT 7, Division of Environmental Planning
100 South Main Street, Suite 100
LOS ANGELES, CA 90012-3606
PHONE (213) 897-0703
FAX (213) 897-0685
TTY (213) 897-4937



*Flex your power!
Be Energy efficient!*

January 27, 2011

Lisa Levy Buch
Director of Public Affairs
Metro Gold Line Foothill Extension
Construction Authority
406 E. Huntington Drive, Suite 202
Monrovia, CA 91016

Re: Metro Gold Line Foothill Extension Azusa to Montclair Acceptance to become Participating Agency

Dear Lisa Levy Buch:

We accept your invitation to become a Participating Agency for the Metro Gold Line Foothill Extension Azusa to Montclair segment. In response to your invitation for the above referenced segment, our office is currently reviewing the material provided by you. We look forward to working with you on this important transportation project and would like to provide any environmental assistance within State the right-of-way. This would include proposed alignments and alternatives adjacent to, or intersecting with the California Department of Transportation (Caltrans) Highway System. As a NEPA delegated agency, Caltrans would represent you as the Federal Agency status for this project and would sign in behalf of FHWA.

As this project moves forward please be aware, the California High Speed Rail Authority (CHSRA) is also looking at alternatives in this region for the LA to San Diego segment. We highly recommend coordinating with that agency. Potential concerns are hazardous waste sites, noise and vibration impacts, right-of-way requirements and potential modifications to our bridge structures.

Additionally, please add Deborah Robertson, Deputy District Director from Caltrans, Division of External Affairs to your mailing list. She can be reached at 213-897-0362 or via email at deborah_robertson@dot.ca.gov

We hope that you will continue to inform our office of any future meetings and we look forward to working with you. If you have any questions, please feel free to contact me at (213) 897-0703 or Dawn Kukla, Branch Chief, at (213) 897-3643.

Sincerely,

A handwritten signature in black ink that reads "Ron Kosinski".

RON KOSINSKI
Deputy District Director
Division of Environmental Planning
Caltrans-District 7

DEPARTMENT OF TRANSPORTATION

PLANNING DIVISION
464 WEST FOURTH STREET, SIXTH FLOOR MS 1221
SAN BERNARDINO, CA 92401-1400
PHONE (909) 383-4147
FAX (909) 383-4364
TTY 711
www.dot.ca.gov/dist8



*Flex your power!
Be energy efficient!*

January 28, 2011

Mr. Habib Balian
Chief Executive Officer
Metro Gold Line Foothill Extension
Construction Authority
406 E. Huntington Drive, Suite 202
Monrovia, CA 91016-3633

Dear Mr. Balian:

This letter is in response to your letter dated January 6th inviting Caltrans District 8 to become a participating agency in the Metro Gold Line Foothill Extension EIR/EIS process.

Due to the importance of the project and since it will extend into San Bernardino County, Caltrans District 8 accepts the invitation and will participate in this environmental review process.

Mr. Mark Roberts, of my staff will attend future scoping meetings on behalf of Caltrans for this environmental determination. You may contact me at (909) 383-4147 or Mark at (909) 383-6040 regarding this information. Mark's email address is: mark.roberts@dot.ca.gov.

Sincerely,

A handwritten signature in cursive script that reads "William A. Mosby".

WILLIAM A. MOSBY
Deputy District Director
Chief, Division of Planning

RECEIVED

FEB 01 2011

MGL FOOTHILL EXT.
CONST. AUTHORITY

DEPARTMENT OF TRANSPORTATION
DISTRICT 7, REGIONAL PLANNING
IGR/CEQA BRANCH
100 SO. MAIN ST.
LOS ANGELES, CA 90012
PHONE (213) 897-6536
FAX (213) 897-1337
E-Mail: NersesYerjanian@dot.ca.gov



*Flex your power!
Be energy efficient!*

Ms. Lisa Levy Buch
Metro Gold Line
Foothill Extension Construction Authority
406 E. Huntington Drive
Monrovia, CA. 91016-3633

RE: IGR/CEQA # 110116/NY
Metro Gold Line Foothill Extension
Phase IIB, Azusa to Montclair
LA/210, 57,30

SCH# 2010121069

January 18, 2011

Dear Ms. Buch;

Thank you for including the California Department of Transportation (Caltrans) in the environmental review process for the Metro Gold Line Foothill Extension Phase IIB, Azusa to Montclair project in San Gabriel Valley.

Based on our evaluation of the information received, this project should receive encroachment permit review by Caltrans. We recommend that your agency, at its earliest convenience, submit six (6) complete sets of plans including two (2) sets of all engineering documents to the Caltrans Permits Office for review.

Storm water run-off is a sensitive issue for Los Angeles and Ventura counties. Please be mindful of your need to discharge clean run-off water.

An Encroachment Permit from the Department of Transportation may be needed for this project. Any encroachment into, on or over State right-of-way needs a Department Encroachment Permit.

Please prepare and submit engineering plans including drainage plans, for our review so we can determine whether an encroachment exists.

We would like to remind you that any transportation of heavy construction equipment and/or materials which requires the use of oversized-transport vehicles on State highways will require a Caltrans transportation permit. We recommend that large size truck trips be limited to off-peak commute periods.

RECEIVED

JAN 25 2011

MGL FOOTHILL EXT.
CONST. AUTHORITY

If you have any questions regarding this response, please call the Project Engineer/Coordinator Mr. Yerjanian at (213) 897-6536 and refer to IGR/CEQA # 110116/NY.

Sincerely,



For: Dianna Watson
IGR/CEQA Branch Chief
Regional Transportation Planning
Caltrans, District 7

Lisa Levy Buch

From: Joan Sollenberger [joan_sollenberger@dot.ca.gov]
Sent: Thursday, January 20, 2011 4:46 PM
To: Lisa Levy Buch
Cc: Habib Balian; Jay Norvell
Subject: RE: Invitation to Become a Participating Agency in the Metro Gold Line Foothill Extension Azusa to Montclair EIS/EIR

Hi Lisa - I have been around the process for awhile and have never actually gotten an invitation like this. Based on the Section 6002 reference and that Ron is involved, Ron's counterpart in Caltrans HQ is Jay Norvell, Division Chief for Environmental Analysis. So I am taking a chance that he is the one...he wasn't in his office when I went to ask about this....so I am trying an e-mail to see if he is the right unit. The HQ Division of Mass Transportation may also be interested in this project. Let's see what we hear back from this e-mail.

Regards, Joan

Joan Sollenberger, Chief
Office of System Management Planning
Division of Traffic Operations
CA Department of Transportation
1120 N Street, Sacramento, Room 4203
(916)653-4575
(916) 838-5465 (cellular)

Lisa Levy Buch <LLevyBuch@foothillextension.org>

01/20/2011 12:17 PM

To Joan Sollenberger <joan_sollenberger@dot.ca.gov>
cc Habib Balian <HBalian@foothillextension.org>
Subject RE: Invitation to Become a Participating Agency in the Metro Gold Line Foothill Extension Azusa to Montclair EIS/EIR

Joan,

Thank you for following up on the e-mail.

Yes, we have sent an invitation to District 7 staff. Ron Kosinski attended our agency coordination meeting last week, as did Deborah Robertson. We have not received a formal letter in response; however, there is still time for them to do so.

Since you are not the correct contact, is there anyone else in Sacramento that should receive the invitation?

Let me know if you need any additional information and if we should send the information to a different HQ contact.

Best,

Lisa

Lisa Levy Buch
Director of Public Affairs
Metro Gold Line Foothill Extension Construction Authority
406 E. Huntington Drive, Suite 202
Monrovia, CA 91016
626-305-7004 (office)

626-471-9049 (fax)

From: Joan Sollenberger [mailto:joan_sollenberger@dot.ca.gov]
Sent: Thursday, January 20, 2011 12:12 PM
To: Habib Balian
Cc: Lisa Levy Buch
Subject: Re: Invitation to Become a Participating Agency in the Metro Gold Line Foothill Extension Azusa to Montclair EIS/EIR

Hello Habib - I am just catching up with e-mails. I am not the proper contact for this request. Have you also sent this to the Caltrans D-7, Los Angeles office and received a reply? thanks, Joan

Joan Sollenberger, Chief
Office of System Management Planning
Division of Traffic Operations
CA Department of Transportation
1120 N Street, Sacramento, Room 4203
(916)653-4575
(916) 838-5465 (cellular)
Habib Balian
<HBalian@foothillextension.org>

01/06/2011 05:27 PM

To
cc Lisa Levy Buch <LLevyBuch@foothillextension.org>
Subject Invitation to Become a Participating Agency in the Metro Gold Line Foothill Extension Azusa to Montclair EIS/EIR

The Metro Gold Line Foothill Extension Construction Authority (Construction Authority), in cooperation with the Federal Transit Administration (FTA), is initiating the preparation of Environmental Impact Statement/Environmental Impact Report (EIS/EIR) for the proposed Metro Gold Line Foothill Extension Azusa to Montclair Project. The proposed project is located in Los Angeles and San Bernardino Counties encompassing seven adjoining cities that lie along I-210 and a railroad right-of-way, between the eastern boundary of Azusa on the west and Montclair on the east. The study area is a 12.6 mile corridor that includes the cities of Azusa, Glendora, San Dimas, La Verne, Pomona, and Claremont in Los Angeles County. In San Bernardino County, it includes the city of Montclair.

The purpose of this project is to improve mobility in western Los Angeles County and eastern San Bernardino County by introducing high-frequency transit service; enhance the regional transit network by interconnecting existing and planned rapid transit lines; provide an alternative mode of transportation for commuters who currently use the congested I-210 corridor; improve transit accessibility for residents and employees who live and/or work along the corridor; and encourage a mode shift to transit, reducing air pollution and greenhouse gas (GHG) emissions. The enclosed scoping information packet provides more details, including a preliminary schedule.

Section 6002 of the Safe, Accountable, Flexible, Efficient, Transportation Equity Act: A Legacy for Users (SAFETEA-LU) establishes an enhanced environmental review process for certain FTA projects, improving the transparency of the process, and increasing opportunities for participation. The requirements of Section 6002 apply to the project that is the subject of this e-mail. As part of the environmental review process for this project, the lead agencies must identify, as early as practicable, any other Federal and non-Federal agencies that may have an interest in the project and invite such agencies to become participating agencies in the environment review process.

Your agency has been identified preliminarily as one that may have an interest in this project, because of the public facilities located in many parts of this corridor. Accordingly, you are invited to become actively involved as a participating agency in the environmental review process for the project.

As a participating agency, you will be afforded the opportunity, together with the public, to be involved in defining the purpose of and need for the project, as well as in determining the range of alternatives to be considered for the project. In addition you will be asked to:

- Provide input on the impact assessment methodologies and level of detail in your agency's area of expertise;
- Participate in coordination meetings, conference calls, and joint field reviews, as appropriate; and
- Review and comment on sections of the pre-draft or pre-final environmental documents to communicate any concerns of your agency on the adequacy of the document, the alternatives considered, and the anticipated impacts and mitigation.

If you elect to become a participating agency, you must accept this invitation in writing. Your acceptance may be transmitted electronically to Lisa Levy Buch, Director of Public Affairs, Metro Gold Line Foothill Extension Construction Authority at llevybuch@foothillextension.org. Please include the title of the official responding.

In order to give your agency adequate opportunity to weigh the relevance of your participation in this environmental review process, written responses to this invitation are not due until after the interagency scoping meeting, which will be held:

- **Thursday, January 13, 2011, at 2:00 PM** at the Glendora Teen and Family Center, 241 West Dawson Street, Glendora, CA. You or your delegate is invited to represent your agency at this meeting. We request that your written response accepting designation as a participating agency be transmitted no later than **February 2, 2011**.

Attached to this e-mail is a copy of the Federal Register Notice of Intent (NOI), Study Area map, and copies of the scoping meeting boards, which provide information on the project background, study area, and proposed alternatives. The Agency Coordination Plan, prepared in accordance with the Section 6002 of SAFETEA-LU, includes the project schedule, and will be available on the Construction Authority's website (<http://www.foothillextension.org>) when finalized. The NOI also provides details on how to submit initial scoping comments if you would like to do so. As noted in the NOI, all scoping comments should be submitted on or before February 2, 2011. All scoping information is also available at www.foothillextension.org.

If you have any questions regarding this invitation, please contact Lisa Levy Buch, Director of Public Affairs, Metro Gold Line Foothill Extension Construction Authority, 406 E. Huntington Drive, Monrovia, CA 91016-3633; llevybuch@foothillextension.org.

In the coming days, you will receive a hard copy of this correspondence in the mail.

Sincerely,

Habib F. Balian
Chief Executive Officer
Metro Gold Line Foothill Extension Construction Authority

Attachments (3):

1. Federal Register NOI
2. Study Area Map
3. Copies of Scoping Meeting Boards



THE METROPOLITAN WATER DISTRICT
OF SOUTHERN CALIFORNIA

Office of the General Manager

RECEIVED

JAN 26 2011

MGL FOOTHILL EXT.
CONST. AUTHORITY

January 19, 2011

Via E-Mail and Regular Mail

Ms. Lisa Levy Buch
Director of Public Affairs
Metro Gold Line Foothill Extension
Construction Authority
406 E. Huntington Drive, Suite 202
Monrovia, CA 91016

Dear Ms. Buch:

Invitation to Become Participating Agency in the
Metro Gold Line Foothill Extension Azusa to Montclair EIS/EIR Project

The Metropolitan Water District of Southern California (Metropolitan) received an invitation to become a participating agency on the Metro Gold Line Foothill Extension Azusa to Montclair Environmental Impact Statement/Environmental Impact Report (EIS/EIR) (Project). The Federal Transit Administration and the Metro Gold Line Foothill Extension Construction Authority are the lead agencies under the National Environmental Policy Act (NEPA). The project proposes to extend the existing Metro Gold Line utilizing light rail transit, from the city of Azusa to the city of Montclair. The project will affect the cities of Azusa, Glendora, San Dimas, La Verne, Pomona, Claremont, and Montclair, within Los Angeles and western San Bernardino County. The following is Metropolitan's response to the Public Notice as a potentially-affected public agency.

While Metropolitan appreciates the invitation, we will respectfully decline the opportunity to become a participating agency in the Agencies' environmental review process. We will continue to review the Agencies' environmental documents during the formal public review process and provide comments as appropriate. From our preliminary review of the materials provided, we have identified several issues that we would like to see addressed in the draft EIS/EIR.

Metropolitan reviewed the project description of the proposed project, study area map, and the Federal Register Notice of Intent and have the following comments. The following Metropolitan facilities are within the proposed project areas:

- The Orange County Feeder is a 42-inch diameter precast concrete pipeline that runs in a northerly to southerly direction along Wheeler Avenue. The Metro Gold Line Foothill Extension route would intersect the Orange County Feeder at Wheeler Avenue.

- The Middle Feeder is a 72-inch diameter steel pipeline that runs in a south-westerly to easterly direction along Bonita Avenue. The Metro Gold Line Foothill Extension route would intersect the Middle Feeder at Bonita Avenue.
- The Upper Feeder is a 140-inch diameter precast concrete pipeline that runs in a north-westerly to south-easterly direction between Fulton Road and North Garey Avenue. The Metro Gold Line Foothill Extension route would intersect the Upper Feeder near North Garey Avenue.
- The Yorba Linda Feeder is a 102-inch diameter steel pipeline that runs in a northerly to southerly direction along A Street. The Metro Gold Line Foothill Extension route would intersect the Yorba Linda Feeder at A Street.

The enclosed map shows these facilities in relation to the proposed project. It will be necessary for the Agencies to consider these facilities in its project planning. We are concerned with potential impacts to these facilities associated with future excavation, construction, utilities or any redevelopment that may occur as a result of proposed activity under the proposed Project. Development and redevelopment associated with the proposed Project must not restrict any of Metropolitan's day-to-day operations and/or access to its facilities. Metropolitan must be allowed to maintain its rights-of-way and requires unobstructed access to our facilities and properties at all times in order to repair and maintain our system.

In order to avoid potential conflicts with Metropolitan's rights-of-way, we require that any design plans for any activity in the area of Metropolitan's pipelines or facilities be submitted for our review and written approval. Approval of the Project where it could impact Metropolitan's property should be contingent on Metropolitan's approval of design plans for the Project. Detailed prints of drawings of Metropolitan's pipelines and rights-of-way may be obtained by calling Metropolitan's Substructures Information Line at (213) 217-6564. To assist in preparing plans that are compatible with Metropolitan's facilities, easements, and properties, we have enclosed a copy of the "Guidelines for Developments in the Area of Facilities, Fee Properties, and/or Easements of The Metropolitan Water District of Southern California." Please note that all submitted designs or plans must clearly identify Metropolitan's facilities and rights-of-way.

Additionally, Metropolitan encourages projects within its service area to include water conservation measures. While Metropolitan continues to build new supplies and develop means for more efficient use of current resources, projected population and economic growth will increase demands on the current system. Water conservation, reclaimed water use, and groundwater recharge programs are integral components to regional water supply planning. Metropolitan supports mitigation measures such as using water efficient fixtures, drought-tolerant landscaping, and reclaimed water to offset any increase in water use associated with the proposed project.

Ms. Lisa Levy Buch
Page 3
January 19, 2011

We appreciate the opportunity to provide input to your planning process and we look forward to receiving the Draft EIS/EIR and future environmental documentation on this Project. If we can be of further assistance, please contact Ms. Brenda S. Marines at (213) 217-7902.

Very truly yours,



John Shamma
Manager, Environmental Planning Team

BSM/bsm
(EPT Task No.2011011208)

Enclosures: **Map**
Guidelines

The Metropolitan Water District of Southern California
 And The Metro Gold Line Foothill Extension Azusa to Montclair EIS/EIR

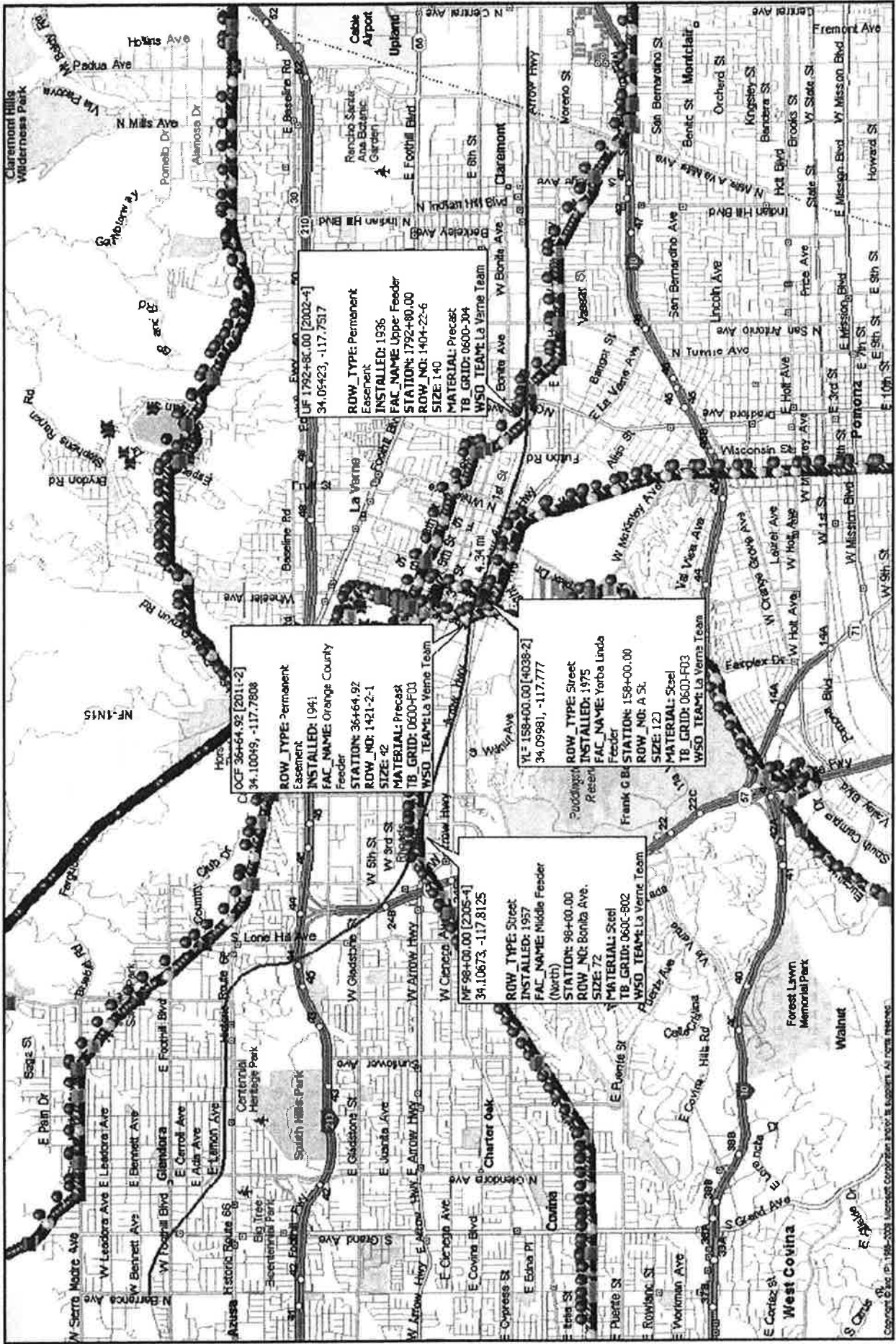

The Metropolitan Water District of Southern California.

Guidelines for Developments in the
Area of Facilities, Fee Properties, and/or Easements
of The Metropolitan Water District of Southern California

1. Introduction

a. The following general guidelines should be followed for the design of proposed facilities and developments in the area of Metropolitan's facilities, fee properties, and/or easements.

b. We require that 3 copies of your tentative and final record maps, grading, paving, street improvement, landscape, storm drain, and utility plans be submitted for our review and written approval as they pertain to Metropolitan's facilities, fee properties and/or easements, prior to the commencement of any construction work.

2. Plans, Parcel and Tract Maps

The following are Metropolitan's requirements for the identification of its facilities, fee properties, and/or easements on your plans, parcel maps and tract maps:

a. Metropolitan's fee properties and/or easements and its pipelines and other facilities must be fully shown and identified as Metropolitan's on all applicable plans.

b. Metropolitan's fee properties and/or easements must be shown and identified as Metropolitan's with the official recording data on all applicable parcel and tract maps.

c. Metropolitan's fee properties and/or easements and existing survey monuments must be dimensionally tied to the parcel or tract boundaries.

d. Metropolitan's records of surveys must be referenced on the parcel and tract maps.

3. Maintenance of Access Along Metropolitan's Rights-of-Way

a. Proposed cut or fill slopes exceeding 10 percent are normally not allowed within Metropolitan's fee properties or easements. This is required to facilitate the use of construction and maintenance equipment, and provide access to its aboveground and belowground facilities.

b. We require that 16-foot-wide commercial-type driveway approaches be constructed on both sides of all streets crossing Metropolitan's rights-of-way. Openings are required in any median island. Access ramps, if necessary, must be at least 16-foot-wide. Grades of ramps are normally not allowed to exceed 10 percent. If the slope of an access ramp must exceed 10 percent due to the topography, the ramp must be paved. We require a 40-foot-long level area on the driveway approach to access ramps where the ramp meets the street. At Metropolitan's fee properties, we may require fences and gates.

c. The terms of Metropolitan's permanent easement deeds normally preclude the building or maintenance of structures of any nature or kind within its easements, to ensure safety and avoid interference with operation and maintenance of Metropolitan's pipelines or other facilities. Metropolitan must have vehicular access along the easements at all times for inspection, patrolling, and for maintenance of the pipelines and other facilities on a routine basis. We require a 20-foot-wide clear zone around all above-ground facilities for this routine access. This clear zone should slope away from our facility on a grade not to exceed 2 percent. We must also have access along the easements with construction equipment. An example of this is shown on Figure 1.

d. The footings of any proposed buildings adjacent to Metropolitan's fee properties and/or easements must not encroach into the fee property or easement or impose additional loading on Metropolitan's pipelines or other facilities therein. A typical situation is shown on Figure 2. Prints of the detail plans of the footings for any building or structure adjacent to the fee property or easement must be submitted for our review and written approval as they pertain to the pipeline or other facilities therein. Also, roof eaves of buildings adjacent to the easement or fee property must not overhang into the fee property or easement area.

e. Metropolitan's pipelines and other facilities, e.g. structures, manholes, equipment, survey monuments, etc. within its fee properties and/or easements must be protected from damage by the easement holder on Metropolitan's property or the property owner where Metropolitan has an easement, at no expense to Metropolitan. If the facility is a cathodic protection station it shall be located prior to any grading or excavation. The exact location, description and way of protection shall be shown on the related plans for the easement area.

4. Easements on Metropolitan's Property

a. We encourage the use of Metropolitan's fee rights-of-way by governmental agencies for public street and utility purposes, provided that such use does not interfere with Metropolitan's use of the property, the entire width of the property is accepted into the agency's public street system and fair market value is paid for such use of the right-of-way.

b. Please contact the Director of Metropolitan's Right of Way and Land Division, telephone (213) 250-6302, concerning easements for landscaping, street, storm drain, sewer, water or other public facilities proposed within Metropolitan's fee properties. A map and legal description of the requested easements must be submitted. Also, written evidence must be submitted that shows the city or county will accept the easement for the specific purposes into its public system. The grant of the easement will be subject to Metropolitan's rights to use its land for water pipelines and related purposes to the same extent as if such grant had not been made. There will be a charge for the easement. Please note that, if entry is required on the property prior to issuance of the easement, an entry permit must be obtained. There will also be a charge for the entry permit.

5. Landscaping

Metropolitan's landscape guidelines for its fee properties and/or easements are as follows:

a. A green belt may be allowed within Metropolitan's fee property or easement.

b. All landscape plans shall show the location and size of Metropolitan's fee property and/or easement and the location and size of Metropolitan's pipeline or other facilities therein.

c. Absolutely no trees will be allowed within 15 feet of the centerline of Metropolitan's existing or future pipelines and facilities.

d. Deep-rooted trees are prohibited within Metropolitan's fee properties and/or easements. Shallow-rooted trees are the only trees allowed. The shallow-rooted trees will not be permitted any closer than 15 feet from the centerline of the pipeline, and such trees shall not be taller than 25 feet with a root spread no greater than 20 feet in diameter at maturity. Shrubs, bushes, vines, and ground cover are permitted, but larger shrubs and bushes should not be planted directly over our pipeline. Turf is acceptable. We require submittal of landscape plans for Metropolitan's prior review and written approval. (See Figure 3).

e. The landscape plans must contain provisions for Metropolitan's vehicular access at all times along its rights-of-way to its pipelines or facilities therein. Gates capable of accepting Metropolitan's locks are required in any fences across its rights-of-way. Also, any walks or drainage facilities across its access route must be constructed to AASHTO H-20 loading standards.

f. Rights to landscape any of Metropolitan's fee properties must be acquired from its Right of Way and Land Division. Appropriate entry permits must be obtained prior to any entry on its property. There will be a charge for any entry permit or easements required.

6. Fencing

Metropolitan requires that perimeter fencing of its fee properties and facilities be constructed of universal chain link, 6 feet in height and topped with 3 strands of barbed wire angled upward and outward at a 45 degree angle or an approved equal for a total fence height of 7 feet. Suitable substitute fencing may be considered by Metropolitan. (Please see Figure 5 for details).

7. Utilities in Metropolitan's Fee Properties and/or Easements or Adjacent to Its Pipeline in Public Streets

Metropolitan's policy for the alinement of utilities permitted within its fee properties and/or easements and street rights-of-way is as follows:

a. Permanent structures, including catch basins, manholes, power poles, telephone riser boxes, etc., shall not be located within its fee properties and/or easements.

b. We request that permanent utility structures within public streets, in which Metropolitan's facilities are constructed under the Metropolitan Water District Act, be placed as far from our pipeline as possible, but not closer than 5 feet from the outside of our pipeline.

c. The installation of utilities over or under Metropolitan's pipeline(s) must be in accordance with the requirements shown on the enclosed prints of Drawings Nos. C-11632 and C-9547. Whenever possible we request a minimum of one foot clearance between Metropolitan's pipe and your facility. Temporary support of Metropolitan's pipe may also be required at undercrossings of its pipe in an open trench. The temporary support plans must be reviewed and approved by Metropolitan.

d. Lateral utility crossings of Metropolitan's pipelines must be as perpendicular to its pipeline alignment as practical. Prior to any excavation our pipeline shall be located manually and any excavation within two feet of our pipeline must be done by hand. This shall be noted on the appropriate drawings.

e. Utilities constructed longitudinally within Metropolitan's rights-of-way must be located outside the theoretical trench prism for uncovering its pipeline and must be located parallel to and as close to its rights-of-way lines as practical.

f. When piping is jacked or installed in jacked casing or tunnel under Metropolitan's pipe, there must be at least two feet of vertical clearance between the bottom of Metropolitan's pipe and the top of the jacked pipe, jacked casing or tunnel. We also require that detail drawings of the shoring for the jacking or tunneling pits be submitted for our review and approval. Provisions must be made to grout any voids around the exterior of the jacked pipe, jacked casing or tunnel. If the piping is installed in a jacked casing or tunnel the annular space between the piping and the jacked casing or tunnel must be filled with grout.

g. Overhead electrical and telephone line requirements:

1) Conductor clearances are to conform to the California State Public Utilities Commission, General Order 95, for Overhead Electrical Line Construction or at a greater clearance if required by Metropolitan. Under no circumstances shall clearance be less than 35 feet.

2) A marker must be attached to the power pole showing the ground clearance and line voltage, to help prevent damage to your facilities during maintenance or other work being done in the area.

3) Line clearance over Metropolitan's fee properties and/or easements shall be shown on the drawing to indicate the lowest point of the line under the most adverse conditions including consideration of sag, wind load, temperature change, and support type. We require that overhead lines be located at least 30 feet laterally away from all above-ground structures on the pipelines.

4) When underground electrical conduits, 120 volts or greater, are installed within Metropolitan's fee property and/or easement, the conduits must be incased in a minimum of three inches of red concrete. Where possible, above ground warning signs must also be placed at the right-of-way lines where the conduits enter and exit the right-of-way.

h. The construction of sewerlines in Metropolitan's fee properties and/or easements must conform to the California Department of Health Services Criteria for the Separation of Water Mains and Sanitary Services and the local City or County Health Code Ordinance as it relates to installation of sewers in the vicinity of pressure waterlines. The construction of sewerlines should also conform to these standards in street rights-of-way.

i. Cross sections shall be provided for all pipeline crossings showing Metropolitan's fee property and/or easement limits and the location of our pipeline(s). The exact locations of the crossing pipelines and their elevations shall be marked on as-built drawings for our information.

j. Potholing of Metropolitan's pipeline is required if the vertical clearance between a utility and Metropolitan's pipeline is indicated on the plan to be one foot or less. If the indicated clearance is between one and two feet, potholing is suggested. Metropolitan will provide a representative to assist others in locating and identifying its pipeline. Two-working days notice is requested.

k. Adequate shoring and bracing is required for the full depth of the trench when the excavation encroaches within the zone shown on Figure 4.

1. The location of utilities within Metropolitan's fee property and/or easement shall be plainly marked to help prevent damage during maintenance or other work done in the area. Detectable tape over buried utilities should be placed a minimum of 12 inches above the utility and shall conform to the following requirements:

1) Water pipeline: A two-inch blue warning tape shall be imprinted with:

"CAUTION BURIED WATER PIPELINE"

2) Gas, oil, or chemical pipeline: A two-inch yellow warning tape shall be imprinted with:

"CAUTION BURIED _____ PIPELINE"

3) Sewer or storm drain pipeline: A two-inch green warning tape shall be imprinted with:

"CAUTION BURIED _____ PIPELINE"

4) Electric, street lighting, or traffic signals conduit: A two-inch red warning tape shall be imprinted with:

"CAUTION BURIED _____ CONDUIT"

5) Telephone, or television conduit: A two-inch orange warning tape shall be imprinted with:

"CAUTION BURIED _____ CONDUIT"

m. Cathodic Protection requirements:

1) If there is a cathodic protection station for Metropolitan's pipeline in the area of the proposed work, it shall be located prior to any grading or excavation. The exact location, description and manner of protection shall be shown on all applicable plans. Please contact Metropolitan's Corrosion Engineering Section, located at Metropolitan's F. E. Weymouth Softening and Filtration Plant, 700 North Moreno Avenue, La Verne, California 91750, telephone (714) 593-7474, for the locations of Metropolitan's cathodic protection stations.

2) If an induced-current cathodic protection system is to be installed on any pipeline crossing Metropolitan's pipeline, please contact Mr. Wayne E. Risner at (714) 593-7474 or (313) 250-5085. He will review the proposed system and determine if any conflicts will arise with the existing cathodic protection systems installed by Metropolitan.

3) Within Metropolitan's rights-of-way, pipelines and carrier pipes (casings) shall be coated with an approved protective coating to conform to Metropolitan's requirements, and shall be maintained in a neat and orderly condition as directed by Metropolitan. The application and monitoring of cathodic protection on the pipeline and casing shall conform to Title 49 of the Code of Federal Regulations, Part 195.

4) If a steel carrier pipe (casing) is used:

(a) Cathodic protection shall be provided by use of a sacrificial magnesium anode (a sketch showing the cathodic protection details can be provided for the designers information).

(b) The steel carrier pipe shall be protected with a coal tar enamel coating inside and out in accordance with AWWA C203 specification.

n. All trenches shall be excavated to comply with the CAL/OSHA Construction Safety Orders, Article 6, beginning with Sections 1539 through 1547. Trench backfill shall be placed in 8-inch lifts and shall be compacted to 95 percent relative compaction (ASTM D698) across roadways and through protective dikes. Trench backfill elsewhere will be compacted to 90 percent relative compaction (ASTM D698).

o. Control cables connected with the operation of Metropolitan's system are buried within streets, its fee properties and/or easements. The locations and elevations of these cables shall be shown on the drawings. The drawings shall note that prior to any excavation in the area, the control cables shall be located and measures shall be taken by the contractor to protect the cables in place.

p. Metropolitan is a member of Underground Service Alert (USA). The contractor (excavator) shall contact USA at 1-800-422-4133 (Southern California) at least 48 hours prior to starting any excavation work. The contractor will be liable for any damage to Metropolitan's facilities as a result of the construction.

8. Paramount Right

Facilities constructed within Metropolitan's fee properties and/or easements shall be subject to the paramount right of Metropolitan to use its fee properties and/or easements for the purpose for which they were acquired. If at any time Metropolitan or its assigns should, in the exercise of their rights, find it necessary to remove any of the facilities from the fee properties and/or easements, such removal and replacement shall be at the expense of the owner of the facility.

9. Modification of Metropolitan's Facilities

When a manhole or other of Metropolitan's facilities must be modified to accommodate your construction or reconstruction, Metropolitan will modify the facilities with its forces. This should be noted on the construction plans. The estimated cost to perform this modification will be given to you and we will require a deposit for this amount before the work is performed. Once the deposit is received, we will schedule the work. Our forces will coordinate the work with your contractor. Our final billing will be based on actual cost incurred, and will include materials, construction, engineering plan review, inspection, and administrative overhead charges calculated in accordance with Metropolitan's standard accounting practices. If the cost is less than the deposit, a refund will be made; however, if the cost exceeds the deposit, an invoice will be forwarded for payment of the additional amount.

10. Drainage

a. Residential or commercial development typically increases and concentrates the peak storm water runoff as well as the total yearly storm runoff from an area, thereby increasing the requirements for storm drain facilities downstream of the development. Also, throughout the year water from landscape irrigation, car washing, and other outdoor domestic water uses flows into the storm drainage system resulting in weed abatement, insect infestation, obstructed access and other problems. Therefore, it is Metropolitan's usual practice not to approve plans that show discharge of drainage from developments onto its fee properties and/or easements.

b. If water must be carried across or discharged onto Metropolitan's fee properties and/or easements, Metropolitan will insist that plans for development provide that it be carried by closed conduit or lined open channel approved in writing by Metropolitan. Also the drainage facilities must be maintained by others, e.g., city, county, homeowners association, etc. If the development proposes changes to existing drainage features, then the developer shall make provisions to provide for replacement and these changes must be approved by Metropolitan in writing.

11. Construction Coordination

During construction, Metropolitan's field representative will make periodic inspections. We request that a stipulation be added to the plans or specifications for notification of Mr. _____ of Metropolitan's Operations Services Branch, telephone (213) 250-_____, at least two working days prior to any work in the vicinity of our facilities.

12. Pipeline Loading Restrictions

a. Metropolitan's pipelines and conduits vary in structural strength, and some are not adequate for AASHTO H-20 loading. Therefore, specific loads over the specific sections of pipe or conduit must be reviewed and approved by Metropolitan. However, Metropolitan's pipelines are typically adequate for AASHTO H-20 loading provided that the cover over the pipeline is not less than four feet or the cover is not substantially increased. If the temporary cover over the pipeline during construction is between three and four feet, equipment must be restricted to that which

imposes loads no greater than AASHTO H-10. If the cover is between two and three feet, equipment must be restricted to that of a Caterpillar D-4 tract-type tractor. If the cover is less than two feet, only hand equipment may be used. Also, if the contractor plans to use any equipment over Metropolitan's pipeline which will impose loads greater than AASHTO H-20, it will be necessary to submit the specifications of such equipment for our review and approval at least one week prior to its use. More restrictive requirements may apply to the loading guideline over the San Diego Pipelines 1 and 2, portions of the Orange County Feeder, and the Colorado River Aqueduct. Please contact us for loading restrictions on all of Metropolitan's pipelines and conduits.

b. The existing cover over the pipeline shall be maintained unless Metropolitan determines that proposed changes do not pose a hazard to the integrity of the pipeline or an impediment to its maintenance.

13. Blasting

a. At least 20 days prior to the start of any drilling for rock excavation blasting, or any blasting, in the vicinity of Metropolitan's facilities, a two-part preliminary conceptual plan shall be submitted to Metropolitan as follows:

b. Part 1 of the conceptual plan shall include a complete summary of proposed transportation, handling, storage, and use of explosions.

c. Part 2 shall include the proposed general concept for blasting, including controlled blasting techniques and controls of noise, fly rock, airblast, and ground vibration.

14. CEQA Requirements

a. When Environmental Documents Have Not Been Prepared

1) Regulations implementing the California Environmental Quality Act (CEQA) require that Metropolitan have an opportunity to consult with the agency or consultants preparing any environmental documentation. We are required to review and consider the environmental effects of the project as shown in the Negative Declaration or Environmental Impact Report (EIR) prepared for your project before committing Metropolitan to approve your request.

2) In order to ensure compliance with the regulations implementing CEQA where Metropolitan is not the Lead Agency, the following minimum procedures to ensure compliance with the Act have been established:

a) Metropolitan shall be timely advised of any determination that a Categorical Exemption applies to the project. The Lead Agency is to advise Metropolitan that it and other agencies participating in the project have complied with the requirements of CEQA prior to Metropolitan's participation.

b) Metropolitan is to be consulted during the preparation of the Negative Declaration or EIR.

c) Metropolitan is to review and submit any necessary comments on the Negative Declaration or draft EIR.

d) Metropolitan is to be indemnified for any costs or liability arising out of any violation of any laws or regulations including but not limited to the California Environmental Quality Act and its implementing regulations.

b. When Environmental Documents Have Been Prepared

If environmental documents have been prepared for your project, please furnish us a copy for our review and files in a timely manner so that we may have sufficient time to review and comment. The following steps must also be accomplished:

1) The Lead Agency is to advise Metropolitan that it and other agencies participating in the project have complied with the requirements of CEQA prior to Metropolitan's participation.

2) You must agree to indemnify Metropolitan, its officers, engineers, and agents for any costs or liability arising out of any violation of any laws or regulations including but not limited to the California Environmental Quality Act and its implementing regulations.

15. Metropolitan's Plan-Review Cost

a. An engineering review of your proposed facilities and developments and the preparation of a letter response

giving Metropolitan's comments, requirements and/or approval that will require 8 man-hours or less of effort is typically performed at no cost to the developer, unless a facility must be modified where Metropolitan has superior rights. If an engineering review and letter response requires more than 8 man-hours of effort by Metropolitan to determine if the proposed facility or development is compatible with its facilities, or if modifications to Metropolitan's manhole(s) or other facilities will be required, then all of Metropolitan's costs associated with the project must be paid by the developer, unless the developer has superior rights.

b. A deposit of funds will be required from the developer before Metropolitan can begin its detailed engineering plan review that will exceed 8 hours. The amount of the required deposit will be determined after a cursory review of the plans for the proposed development.

Metropolitan's final billing will be based on actual cost incurred, and will include engineering plan review, inspection, materials, construction, and administrative overhead charges calculated in accordance with Metropolitan's standard accounting practices. If the cost is less than the deposit, a refund will be made; however, if the cost exceeds the deposit, an invoice will be forwarded for payment of the additional amount. Additional deposits may be required if the cost of Metropolitan's review exceeds the amount of the initial deposit.

16. Caution

We advise you that Metropolitan's plan reviews and responses are based upon information available to Metropolitan which was prepared by or on behalf of Metropolitan for general record purposes only. Such information may not be sufficiently detailed or accurate for your purposes. No warranty of any kind, either express or implied, is attached to the information therein conveyed as to its accuracy, and no inference should be drawn from Metropolitan's failure to comment on any aspect of your project. You are therefore cautioned to make such surveys and other field investigations as you may deem prudent to assure yourself that any plans for your project are correct.

17. Additional Information

Should you require additional information, please contact:

Civil Engineering Substructures Section
Metropolitan Water District
of Southern California
P.O. Box 54153
Los Angeles, California 90054-0153
(213) 217-6000

JEH/MRW/lk

Rev. January 22, 1989

Encl.

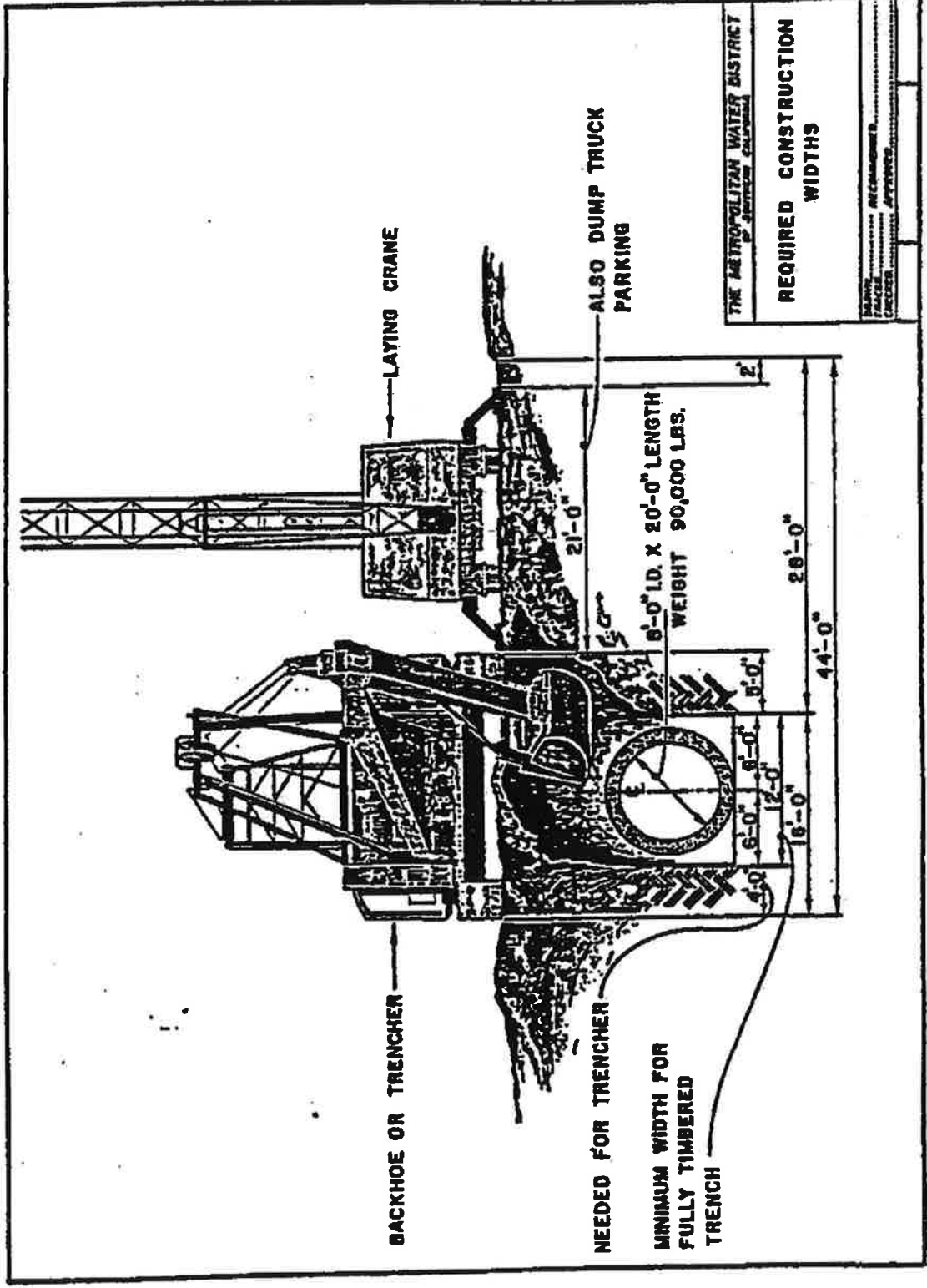
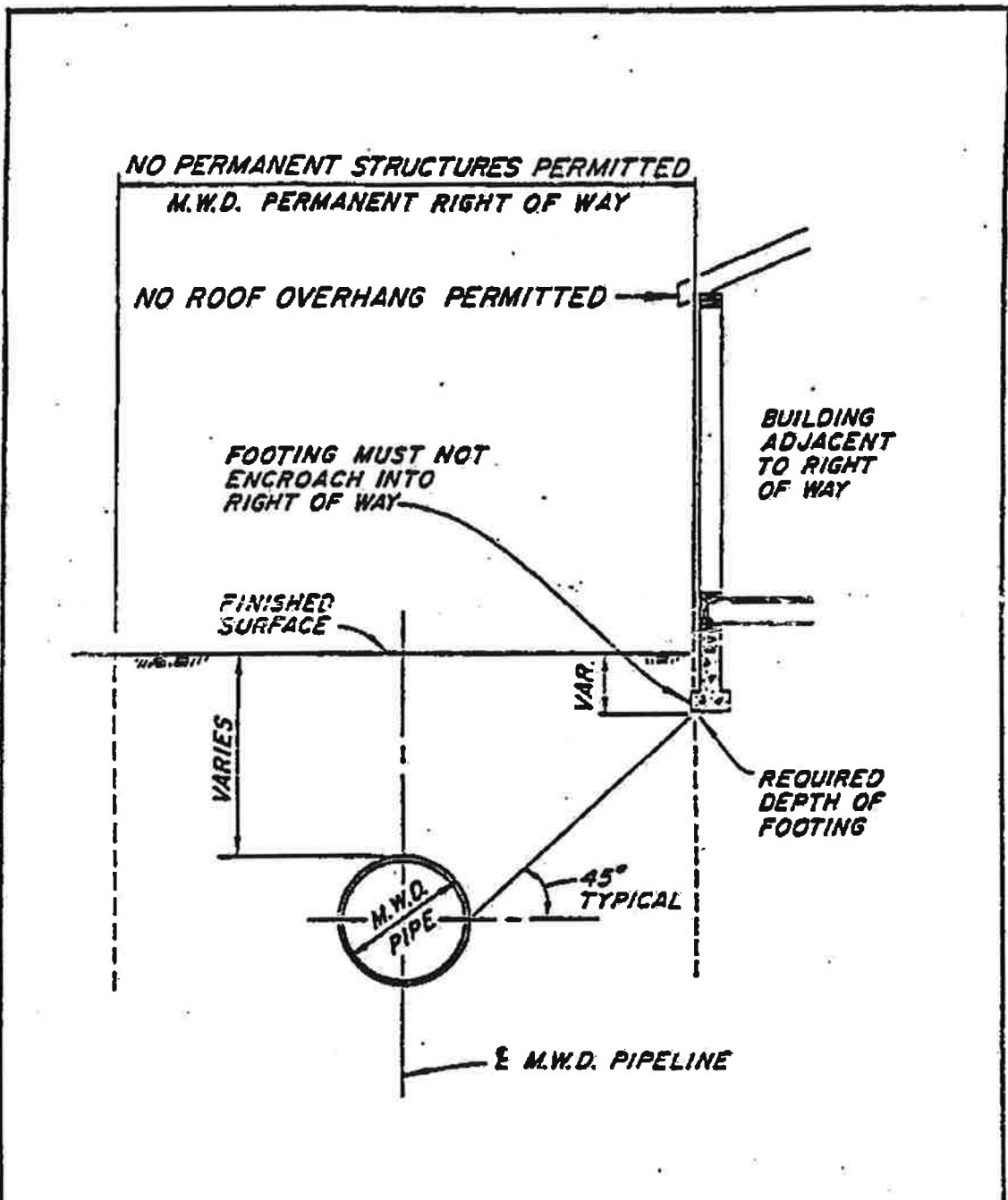

FIGURE 1

11-97 DISTRICT...POST ELEVATION 1000



NOTE: M.W.D. PIPELINE SIZE, DEPTH, LOCATION AND WIDTH OF PERMANENT RIGHT OF WAY VARIES.

THE METROPOLITAN WATER DISTRICT OF DISTRICT OF COLUMBIA	
REQUIREMENTS FOR BUILDINGS AND FOOTINGS ADJACENT TO M.W.D. RIGHT OF WAY	
DESIGNED BY _____	REVISIONS _____
CHECKED BY _____	APPROVED _____

FIGURE 2

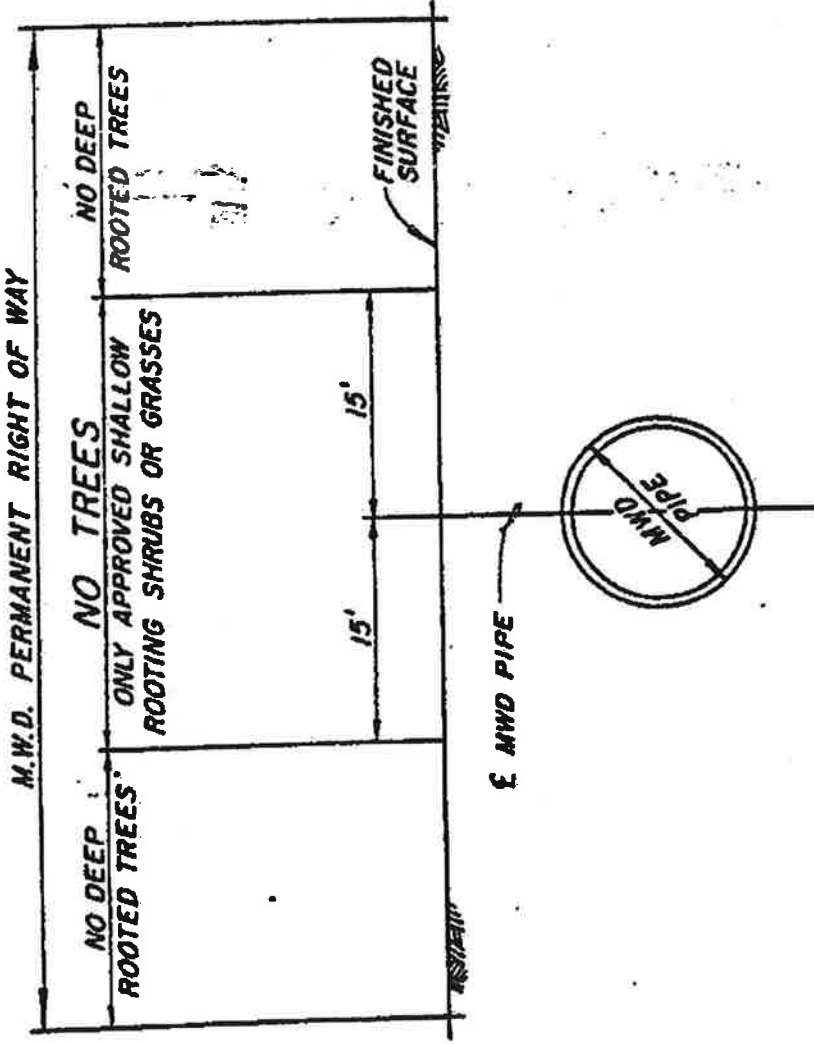

THE METROPOLITAN WATER DISTRICT OF DISTRICT OF CALIFORNIA

LANDSCAPE GUIDELINES FOR M.W.D. RIGHT OF WAY

REVIEWED BY: _____
DATE: _____
APPROVED BY: _____
DATE: _____

FIGURE 3

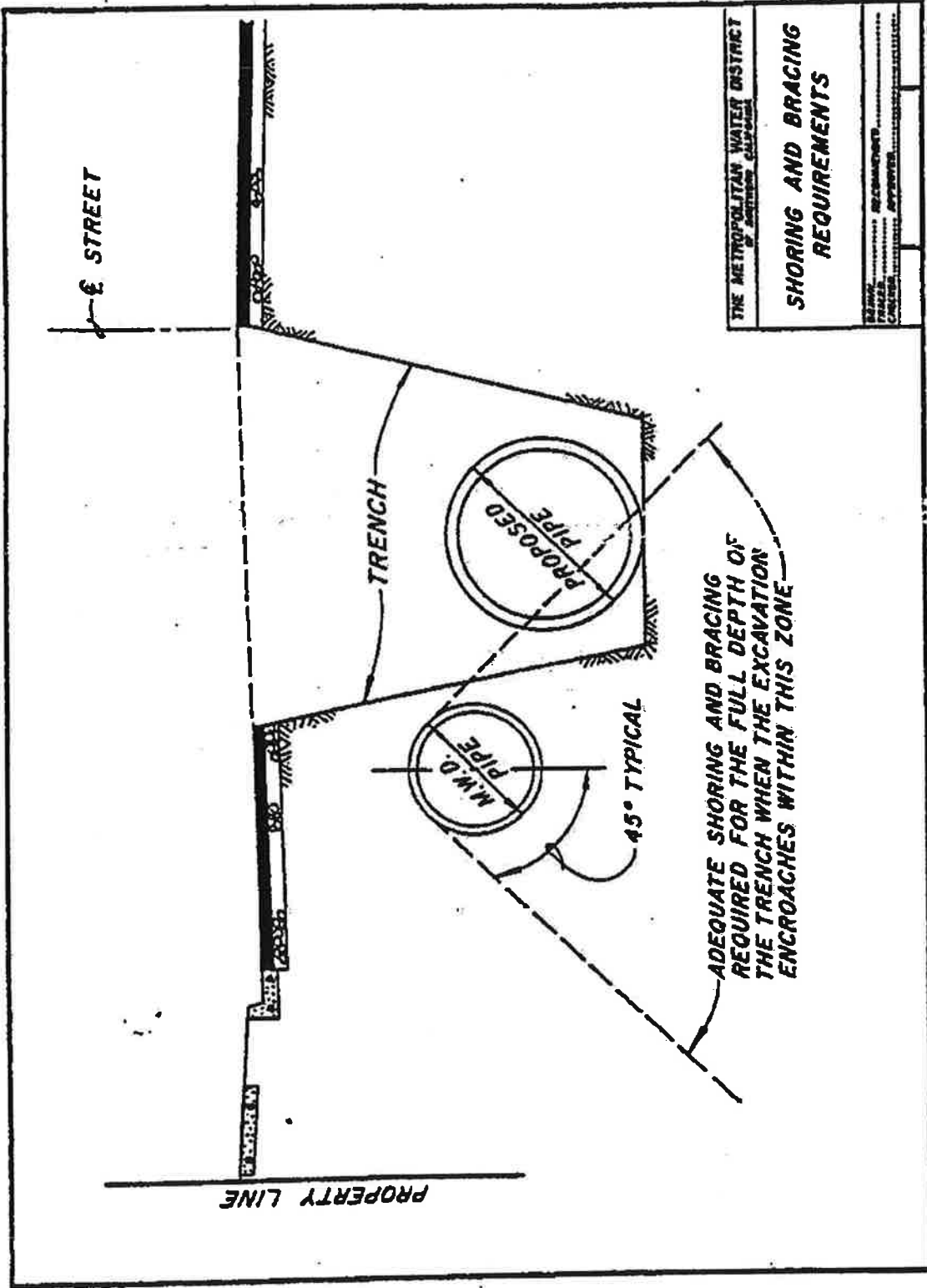
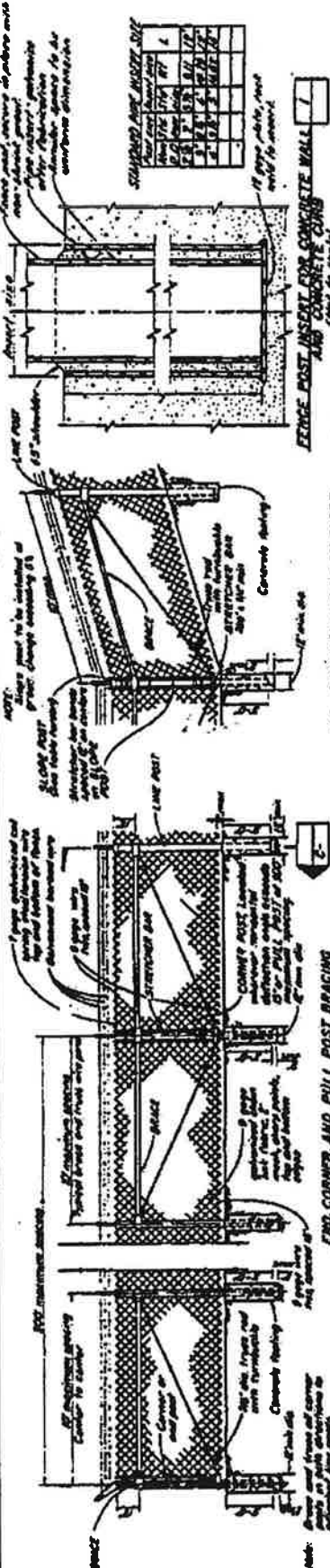

FIGURE 4

SPECIFICATIONS NO.

SHEET NO.



Type	Size	Qty	Unit Price	Total Price
Also				
Also	2 1/2	2,875	0.39	
Also	2	1,275	0.65	
Also	0.5	4,000	0.7	
Also	6	6,000	0.97	
Also	4	8,625	0.70	
Also	2	2,125	0.61	
Also	2	2,000	0.78	
Also	2	1,000	0.40	
Also	2	1,000	0.40	
Also	2	1,000	0.40	
Also	2	1,000	0.40	

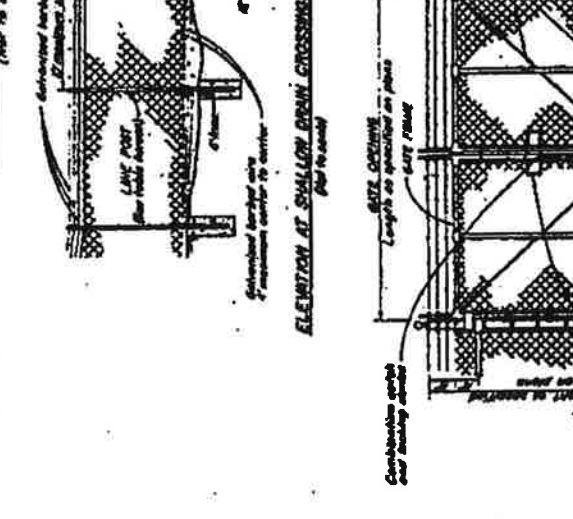
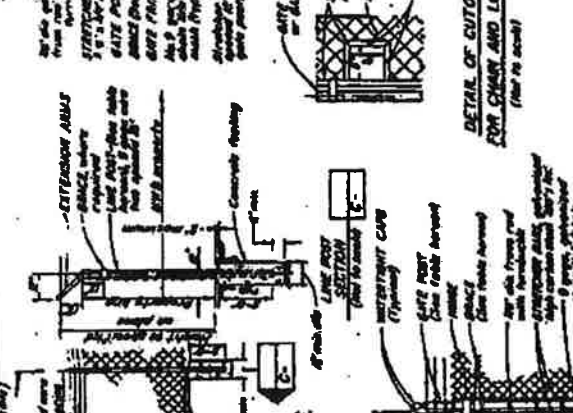
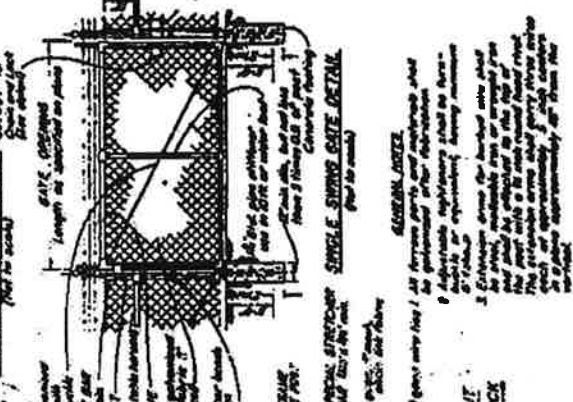

THE METROPOLITAN WATER DISTRICT
OF DISTRICT OF COLUMBIA
DISTRICT ENGINEER

CHAIN LINK
FENCE DETAILS

NO.	DATE	REVISION	BY	CHK.

FIGURE 5

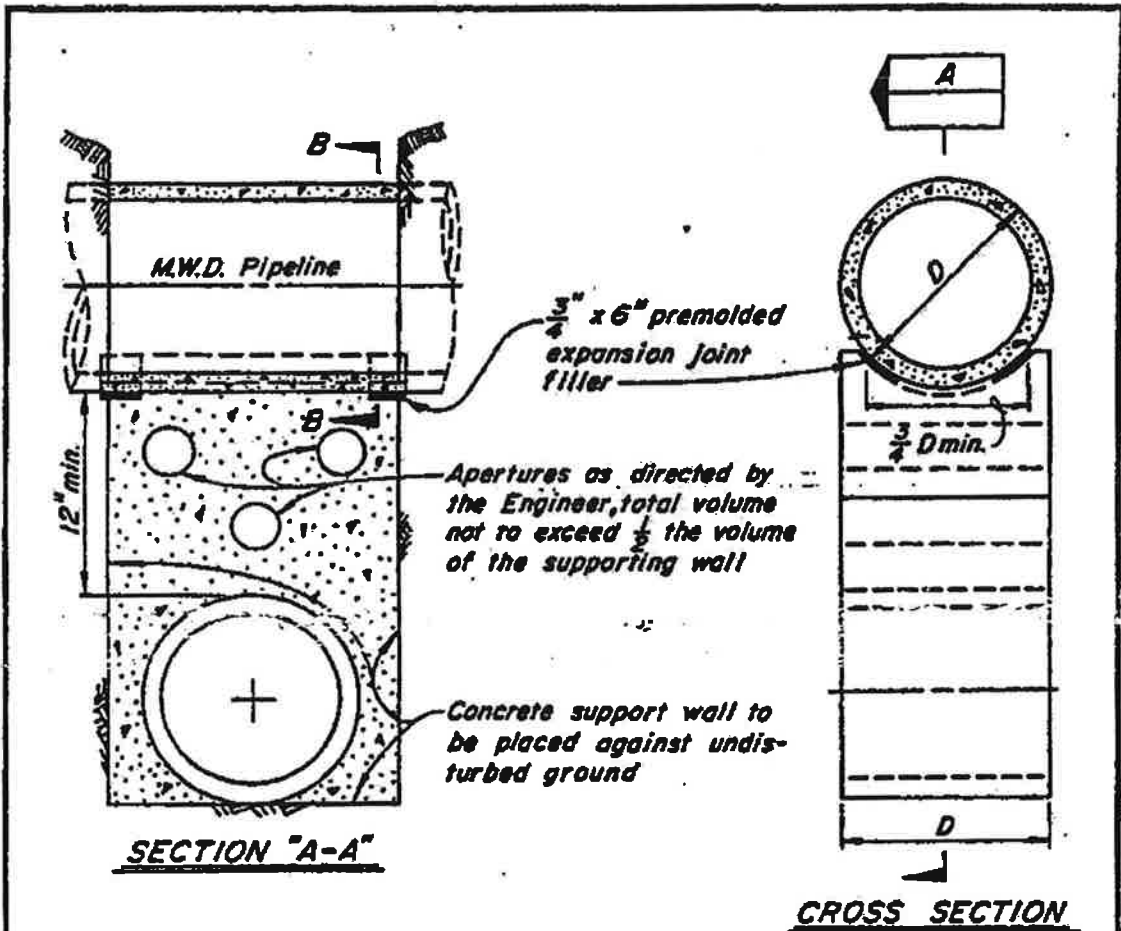

1. Supporting wall shall have a firm bearing on the subgrade and against the side of the excavation.
2. Premolded expansion joint filler per ASTM D-1751-73 to be used in support for steel pipe only.
3. If trench width is 4 feet or greater, measured along centerline of M.W.D. pipe, concrete support must be constructed.
4. If trench width is less than 4 feet, clean sand backfill, compacted to 90% density in accordance with the provisions of ASTM Standard D-1557-70 may be used in lieu of the concrete support wall.

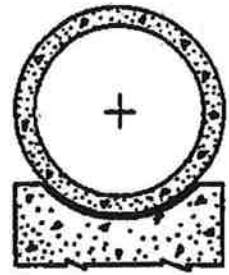

THE METROPOLITAN WATER DISTRICT <small>OF SOUTHERN CALIFORNIA</small>	
TYPICAL SUPPORT FOR M.W.D. PIPELINE	
DRAWN _____ TRACES _____ CHECKED _____	RECORDED _____ APPROVED _____
C-9547	

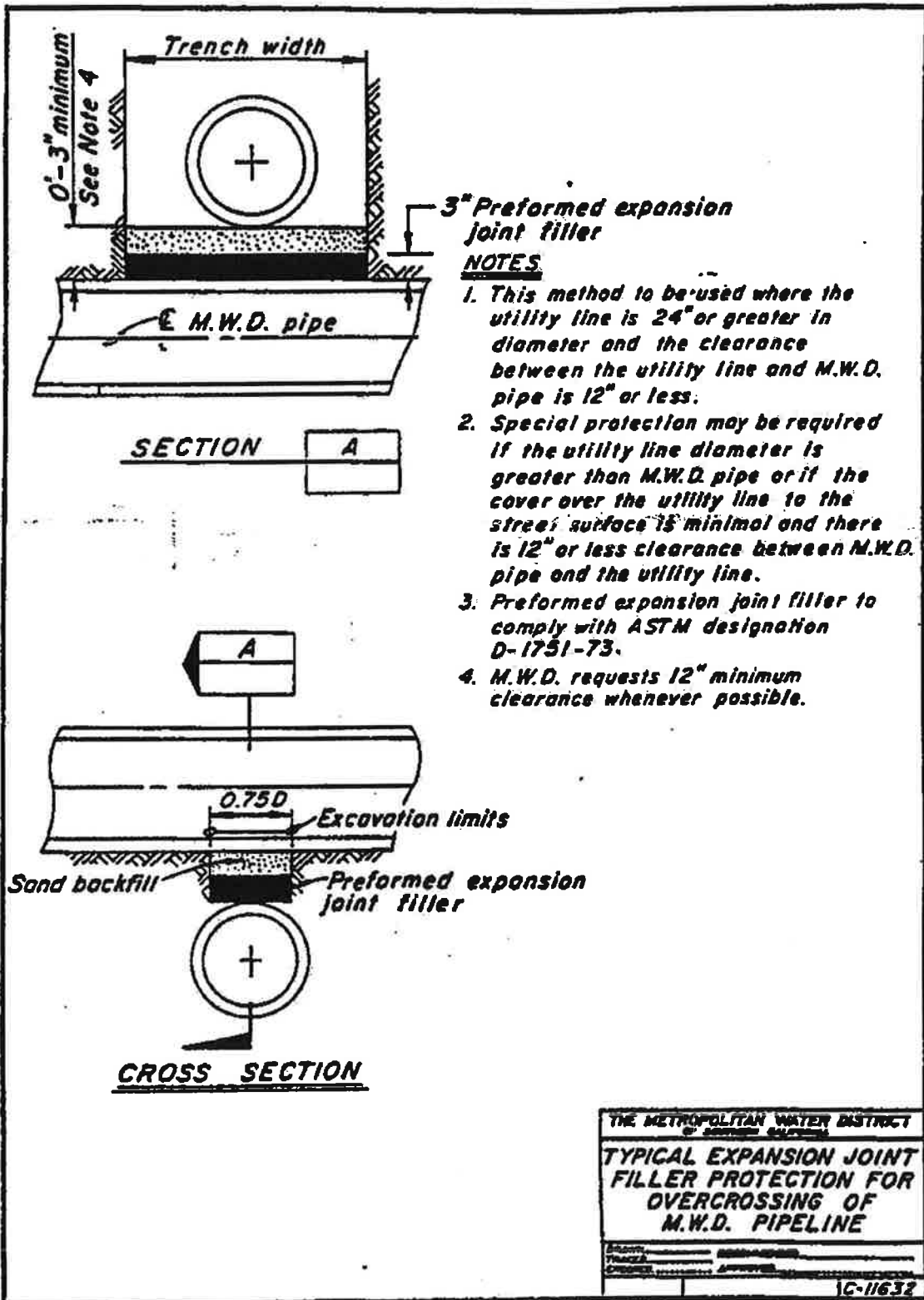

THE METROPOLITAN WATER DISTRICT
 OF DENVER, COLORADO
TYPICAL EXPANSION JOINT FILLER PROTECTION FOR OVERCROSSING OF M.W.D. PIPELINE

DESIGNED BY: _____
 CHECKED BY: _____
 APPROVED BY: _____

16-11632



Gallagher & Quentin LLP
100 New Bridge Street
San Francisco, CA 94077
Tel: 555-555-1221
Fax: 555-555-1222
www.gallagherquentin.com

December 2007
Newsletter #40

ENVIRONMENTAL IMPACT

Environmental Growth in US (by region)
Population growth is only one measure of environmental impact. According to the 2000 Census, the Western and Southern Regions of the United States had double-digit growth, while the Northeast and the Midwest grew by less than 10 percent. The chart captures by region population growth (bar height) and its corresponding environmental impact (bar width). While the West grew th

In areas where these agreements have been put in place and have been successfully monitored, the impact to the habitat has been minimal and even beneficial. Species have adapted and in some cases flourished as a result of the conscientious and measured approach to the management of their habitat.

Companies in almost every industry have found that environmental laws and policies more often than not have application to their daily operations. As environmental issues and climate change discussions top the national agenda, more businesses will be faced with difficult and potentially

Gallagher & Quentin has organized a practice group that is oriented towards proactive environmental law, focusing on meaningful solutions in the face of increased regulations. We have a sensible approach to environmental law, using proactive measures to prevent problems from occurring. We counsel clients on the environmental aspect of climate change, corporate disclosure and governance, litigation and government relations.

Our attorneys have extensive litigation experience and an array of resources and specialists available to effectively defend or prosecute any type of environmental

SUPERIOR COURT OF SOUTH CAROLINA
FIRST DISTRICT

INTERROGATORIES

1. State the name, job title, business name, address and telephone number of the person to whom this discovery is directed herein above and the person who is assisting in answering or answering these discovery requests.
2. State the name, job title, business name, address and telephone number of each person whom you may call as a witness to testify at the trial of the above-entitled action.
3. Identify and describe all documents that you believe support the allegations contained in the Complaint, Answer and Counterclaim.
4. Identify and describe all documents that you intend or expect to introduce at the trial of this matter.
5. Describe in detail all facts supporting the claims contained in the Complaint, Answer and Counterclaim.
6. Identify by name, job title, business name, address and telephone number all individuals who assisted in the preparation of the answers to these Interrogatories.
7. Identify and describe all documents that you reviewed and/or relied upon to assist you in preparing the answers to these Interrogatories.

James L. Peterson, Esq.

Networked office productivity for an exceptional value
Get print speeds up to 30 ppm and a fast first page out with Instant-on Technology plus Ethernet networking—at a great price.

Sleek, space-saving design
Compact printer fits almost any workspace.

Easy to set-up, use, and manage
Save hours with fast setup, hassle-free use, and convenient supplies reordering.

Use original HP LaserJet print cartridges for worry-free, professional quality printing every time

- Designed together with the printer for consistently outstanding results
- Easy to use and replace for low-maintenance printing
- Compatible with a range of HP professional-quality everyday papers and specialty papers that fit the way you work

 Print up to 30 PPM Ltr./A4	10/100 network ¹ 	Instant-on Technology
	 HI-SPEED CERTIFIED USB	Parallel port ²

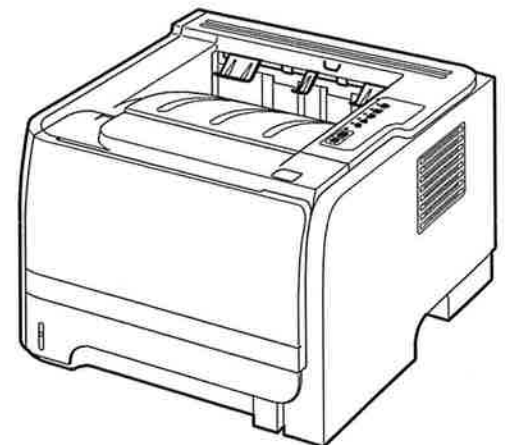

¹ Available on network models only

² Available on base model only



City of Arcadia

Development Services Department

Jason Kruckeberg
*Assistant City Manager,
Development Services
Director*

February 4, 2011

Ms. Lisa Levy Buch, Director of Public Affairs
Metro Gold Line Foothill Extension Construction Authority
406 East Huntington Drive, Suite 202
Monrovia CA 91016

SUBJECT: Notice of Preparation of Environmental Impact Report

Dear Ms. Buch:

Thank you for this opportunity to review and comment on the Notice of Preparation of the Environmental impact report for Metro Gold Line Foothill Extension Phase 2B. We support the project and your efforts to environmentally clear this important extension.

We have some comments to be considered. The impacts on the operational capabilities of the stations and parking structures in the Phase 2A segment should be given serious consideration when developing the Phase 2B project scope. How will the Phase 2B project address impacts on Phase 2A facilities? As part of the Phase 2B project, will a new ridership forecast be done? If the new forecast is significantly different from the one that was done as part of Phase 2A project, some mechanisms need to be put in place to remedy any impact on the Phase 2A segment (station, parking, etc.).

Again, we thank you for this opportunity and look forward to the continued progress on the project.

Sincerely,

Philip A. Wray
Deputy Director of Development Services/City Engineer

PAW:pa

cc: Jason Kruckeberg, Assistant City Manager/Development Services
Director
Linda Hui, Transportation Services Manager



CITY OF CLAREMONT

Community Development Department

City Hall
207 Harvard Avenue
P.O. Box 880
Claremont, CA 91711-0880
FAX (909) 399-5327
www.ci.claremont.ca.us

Building • (909) 399-5471
Planning • (909) 399-5470
Engineering • (909) 399-5465
Community Improvement • (909) 399-5467
Administration • (909) 399-5321

February 2, 2011

Ms. Lisa Levy Buch
Director of Public Affairs
Metro Gold Line Foothill Extension
Construction Authority
406 E. Huntington Drive, Suite 202
Monrovia, CA 91016-3633

Dear Ms. Buch:

We have received your invitation to participate in the Metro Gold Line Foothill Extension Azusa to Montclair EIS/EIR.

The City of Claremont accepts your invitation to become a participating agency in this proposed project.

Very truly yours,

Craig Bradshaw
City Engineer



CITY OF GLENDORA CITY HALL

(626) 914-8200

116 East Foothill Blvd., Glendora, California 91741
www.ci.glendora.ca.us

February 2, 2011

Habib Balian, Chief Executive Officer
Metro Gold Line Foothill Extension Construction Authority
406 E. Huntington Drive, Suite 202
Monrovia, CA 91016

RE: Gold Line Phase 2B NOI for EIS/EIR Participating Agency Preliminary Comments

Dear Mr. Balian,

Thank you for inviting the City of Glendora to become a Participating Agency in the EIS/EIR for the Metro Gold Line Foothill Phase 2B Extension from Azusa to Montclair. The delegate for the City of Glendora as a Participating Agency for the project will be Chris Jeffers, City Manager and/or his designees.

The City of Glendora supports the intent of the project to provide high-frequency transit service through the San Gabriel Valley that will serve the City of Glendora and other communities along the San Gabriel foothills. We appreciate being able to comment at this early phase of the project to ensure that the project will address Glendora's interests, needs and concerns. The following list of issue areas should not be considered a definitive or complete list but will outline the issues discussed with Gold Line Authority staff in the past. We understand that discussions and possible modifications to the project to address our comments will be on-going.

Preliminary Comments for the EIR/EIS:

Station Parking

The Gold Line Authority entered into an MOU with the City agreeing to provide adequate parking for the Glendora station which is located between Glendora Avenue and Vermont Avenue. Authority staff has provided concept sketches showing a parking structure along the south side of the proposed station with access possibly from Vermont and Glendora Avenues. The City has concerns regarding the location of the parking structure, traffic conflicts with ingress/egress so close to the rail crossings at Glendora and Vermont Avenues and aesthetic impacts of a narrow, tall, utilitarian structure on surrounding views and properties within the Historic Preservation Overlay Zone adjacent to the subject station property. Please provide detailed site plans, floor plans, elevations and traffic analysis for the proposed parking including any plans for expanding parking to meet future demand pursuant to the MOU for City review and comment.

Station Pedestrian Access

We have had some discussion with Gold Line Authority staff to remind them that the City will require pedestrian access through the property north of the Station from Glendora Avenue which provides a direct link to bus stop service on Glendora Avenue and pedestrian access north to the Downtown Village area. Please ensure that the station location and pedestrian access can accommodate this goal.

Street Closures

In 2005, the City was notified that the Gold Line Authority was considering eliminating crossings at several streets in Glendora including Pasadena Avenue, Glenwood Avenue and Elwood Avenue. The City notified the Authority at that time that closure of these streets at the railroad right of way would cause significant emergency access problems for the City. Recently, Authority staff indicated that the closure issue had been reduced to considering either Glenwood Avenue or Elwood Avenue. The City would like to continue discussions regarding the advisability of closing either of these streets at the railroad crossing and the impact on providing emergency services to the area.

Noise Impacts

Noise impacts from the future commuter rail line have been an on-going concern for the citizens of Glendora. Notes provided by Authority staff after a scoping meeting held with the City on January 13, 2011 indicate that the project would provide 15,575 feet of sound walls in Glendora. Please provide detailed maps showing the locations of these sound walls along with elevation views for City review and comment.

Horn soundings and crossing gate bells may also create noise impacts for adjacent residents and businesses. Please provide more detail on mitigation planned to reduce these impacts for City review and comment.

Traffic Impacts

The City has concerns regarding traffic impacts at important intersection crossings in the City. Of particular concern are the intersections of Foothill and Grand Avenue, Vermont Avenue, Glendora Avenue, and Lone Hill Avenue. Please provide a detailed traffic impact analysis for all at-grade crossings with particular attention to the listed intersections for City review and comment.

TSS Facilities

Authority staff has indicated that there will be two or three transformer substations located in Glendora to serve the light rail system. Apparently the locations for these TSS facilities is still under review. Please provide detailed information on the locations for City review and comment.

Public Works Street access

The City's Public Works Street Yard access off of Loraine Avenue is located on the railroad right of way. Discussions with Authority staff indicate that the Loraine access will not be impacted. The City respectfully requests that the Authority confirm that the Loraine access to the Street Yard will be maintained as part of the Phase 2B project.

Route 66 Bridge

The Gold Line commuter line will require an additional bridge across Route 66. It is unclear from documents provided whether the existing bridge for the freight line will also need to be rebuilt. While the bridge is not considered an historic structure, it does provide an opportunity for the City to provide historic identification of the community as "Pride of the Foothills." Please provide detailed plans and elevations of the new bridge and modifications to the existing bridge if proposed for City review and comment.

We look forward to working with the Gold Line Authority on this exciting and important transit project serving the San Gabriel Valley foothill communities. Please call Dianne Walter at 626-914-8218 or email dwalter@ci.glendora.ca.us if you have any questions.

Sincerely,



Dianne Walter,
Planning Manager

Cc: Chris Jeffers, City Manager
Jeff Kugel, Director, Planning and Redevelopment
Dave Davies, Director, Public Works
Jerry Burke, City Engineer



CITY OF GLENDORA CITY HALL

(626) 914-8200

116 East Foothill Blvd., Glendora, California 91741
www.ci.glendora.ca.us

February 2, 2011

Habib Balian, Chief Executive Officer
Metro Gold Line Foothill Extension Construction Authority
406 E. Huntington Drive, Suite 202
Monrovia, CA 91016

RE: Gold Line Phase 2B NOI for EIS/EIR Participating Agency Preliminary Comments

Dear Mr. Balian,

Thank you for inviting the City of Glendora to become a Participating Agency in the EIS/EIR for the Metro Gold Line Foothill Phase 2B Extension from Azusa to Montclair. The delegate for the City of Glendora as a Participating Agency for the project will be Chris Jeffers, City Manager and/or his designees.

The City of Glendora supports the intent of the project to provide high-frequency transit service through the San Gabriel Valley that will serve the City of Glendora and other communities along the San Gabriel foothills. We appreciate being able to comment at this early phase of the project to ensure that the project will address Glendora's interests, needs and concerns. The following list of issue areas should not be considered a definitive or complete list but will outline the issues discussed with Gold Line Authority staff in the past. We understand that discussions and possible modifications to the project to address our comments will be on-going.

Preliminary Comments for the EIR/EIS:

Station Parking

The Gold Line Authority entered into an MOU with the City agreeing to provide adequate parking for the Glendora station which is located between Glendora Avenue and Vermont Avenue. Authority staff has provided concept sketches showing a parking structure along the south side of the proposed station with access possibly from Vermont and Glendora Avenues. The City has concerns regarding the location of the parking structure, traffic conflicts with ingress/egress so close to the rail crossings at Glendora and Vermont Avenues and aesthetic impacts of a narrow, tall, utilitarian structure on surrounding views and properties within the Historic Preservation Overlay Zone adjacent to the subject station property. Please provide detailed site plans, floor plans, elevations and traffic analysis for the proposed parking including any plans for expanding parking to meet future demand pursuant to the MOU for City review and comment.

Station Pedestrian Access

We have had some discussion with Gold Line Authority staff to remind them that the City will require pedestrian access through the property north of the Station from Glendora Avenue which provides a direct link to bus stop service on Glendora Avenue and pedestrian access north to the Downtown Village area. Please ensure that the station location and pedestrian access can accommodate this goal.

Street Closures

In 2005, the City was notified that the Gold Line Authority was considering eliminating crossings at several streets in Glendora including Pasadena Avenue, Glenwood Avenue and Elwood Avenue. The City notified the Authority at that time that closure of these streets at the railroad right of way would cause significant emergency access problems for the City. Recently, Authority staff indicated that the closure issue had been reduced to considering either Glenwood Avenue or Elwood Avenue. The City would like to continue discussions regarding the advisability of closing either of these streets at the railroad crossing and the impact on providing emergency services to the area.

Noise Impacts

Noise impacts from the future commuter rail line have been an on-going concern for the citizens of Glendora. Notes provided by Authority staff after a scoping meeting held with the City on January 13, 2011 indicate that the project would provide 15,575 feet of sound walls in Glendora. Please provide detailed maps showing the locations of these sound walls along with elevation views for City review and comment.

Horn soundings and crossing gate bells may also create noise impacts for adjacent residents and businesses. Please provide more detail on mitigation planned to reduce these impacts for City review and comment.

Traffic Impacts

The City has concerns regarding traffic impacts at important intersection crossings in the City. Of particular concern are the intersections of Foothill and Grand Avenue, Vermont Avenue, Glendora Avenue, and Lone Hill Avenue. Please provide a detailed traffic impact analysis for all at-grade crossings with particular attention to the listed intersections for City review and comment.

TSS Facilities

Authority staff has indicated that there will be two or three transformer substations located in Glendora to serve the light rail system. Apparently the locations for these TSS facilities is still under review. Please provide detailed information on the locations for City review and comment.

Public Works Street access

The City's Public Works Street Yard access off of Loraine Avenue is located on the railroad right of way. Discussions with Authority staff indicate that the Loraine access will not be impacted. The City respectfully requests that the Authority confirm that the Loraine access to the Street Yard will be maintained as part of the Phase 2B project.

Route 66 Bridge

The Gold Line commuter line will require an additional bridge across Route 66. It is unclear from documents provided whether the existing bridge for the freight line will also need to be rebuilt. While the bridge is not considered an historic structure, it does provide an opportunity for the City to provide historic identification of the community as "Pride of the Foothills." Please provide detailed plans and elevations of the new bridge and modifications to the existing bridge if proposed for City review and comment.

We look forward to working with the Gold Line Authority on this exciting and important transit project serving the San Gabriel Valley foothill communities. Please call Dianne Walter at 626-914-8218 or email dwalter@ci.glendora.ca.us if you have any questions.

Sincerely,

A handwritten signature in cursive script that reads "Dianne Walter".

Dianne Walter,
Planning Manager

Cc: Chris Jeffers, City Manager
Jeff Kugel, Director, Planning and Redevelopment
Dave Davies, Director, Public Works
Jerry Burke, City Engineer



CITY OF LA VERNE CITY HALL

3660 "D" Street, La Verne, California 91750-3599
www.ci.la-verne.ca.us

January 25, 2011

Habib Balian, Chief Executive Officer
Metro Gold Line Foothill Extension
Construction Authority
406 Huntington Drive, Suite 202
Monrovia, CA 91016-3633

Re: City of La Verne Acceptance as Participating Agency
For Gold Line Foothill Extension Azusa to Montclair
Project Environmental Review Process

Dear Mr. Balian:

This letter shall serve as the City of La Verne's acceptance to become a "Participating Agency" in the environmental review process for the Gold Line Foothill Extension Azusa to Montclair project.

As noted in your invitation, we acknowledge that "designation as a 'participating agency' does not imply that the participating agency supports the proposed project or has any jurisdiction over, or special expertise concerning the proposed project or its potential impacts."

The City of La Verne's elected official representatives regarding the Gold Line project remain Council member Robin Carder (primary) and Steve Johnson (alternate), with staff member representatives being Community Development Director Hal Fredericksen and Associate Planner Amy Altomare.

Please don't hesitate to contact me should you have any need at (909) 596-8726 or at brussi@ci.la-verne.ca.us.

Sincerely,

Bob Russi
City Manager

Cc: Mayor and City Council

RECEIVED

JAN 26 2011

MGL FOOTHILL EXT.
CONST. AUTHORITY





CITY OF LA VERNE CITY HALL

3660 "D" Street, La Verne, California 91750-3599
www.ci.la-verne.ca.us

January 31, 2011

RECEIVED

FEB 01 2011

Lisa Levy Buch
Director of Public Affairs
Metro Gold Line Foothill Extension Construction Authority
406 East Huntington Drive, Suite 202
Monrovia, CA 91016

MGL FOOTHILL EXT.
CONST. AUTHORITY

RE: City of La Verne Response to Scoping Sessions for Phase IIB Metro Gold Line Foothill Environmental

To Whom It May Concern:

City of La Verne representatives attended the Intergovernmental agency scoping session in Glendora, CA, as well as the public scoping session in Pomona, CA for the Metro Gold Line Foothill Extension Azusa to Montclair project. Based on the current project and previous City review, the City of La Verne has the following comments:

A. At-Grade Crossings

The City of La Verne is aware of the potential of CPUC closing several at-grade crossings along the Gold Line Corridor in La Verne. The City strongly disagrees with these recommendations. A, D, and E Streets in La Verne and Fulton Road at the La Verne/Pomona border should all remain open and continue to be through streets. To close these crossings presents significant safety concerns and potentially disenfranchises whole neighborhoods. Below are more detailed comments:

1. Emergency Services – With the City Public Safety headquarters located on 3rd Street between C and D Streets, both A Street and D Streets are primary routes for response to emergencies in the area south of the railroad tracks. E Street is also a primary route for emergency service to Fairplex, Brackett Field and the large industrial complex south of Arrow Highway. Closure of any of these streets could severely affect response times. The Fire Department estimates that closure of A Street would



General Administration 909/596-8726 • Water Customer Service 909/596-8744 • Parks & Community Services 909/596-8700
Public Works 909/596-8741 • Finance 909/596-8716 • Community Development 909/596-8706 • Building 909/596-8713
Police Department 909/596-1913 • Fire Department 909/596-5991 • General Fax 909/596-8737

increase response times to areas south of Arrow Highway between Wheeler Avenue and E Street by approximately 1 minute and closure of D and E would increase response times up to 3 minutes. Not only does this compromise the Fire Department's ability to provide fire and emergency medical services in a timely fashion, it would also compromise the safety of first responders due to rerouting through numerous intersections. The difference of even 1 – 3 minutes is particularly critical for medical aid response to heart attacks, strokes, drownings, etc. and eliminates alternative routes if at-grade crossings were blocked.

2. Pedestrian Diversion – There is significant pedestrian activity at each crossing given the interaction of the housing and employment centers south of the tracks and the University of La Verne and the downtown commercial area north of the tracks. We understand the rail right-of-way will be fenced to prevent trespassing. However, experience has shown that openings get cut in fences and pedestrians cross at locations where they do not have the protection afforded by gates, warning lights, etc. at established crossings.
3. Vehicular Diversion – Information presented in the Gold Line Extension February 2007 Final Environmental Impact Report (FEIR) shows that the current daily traffic volumes are 1150, 6346, 5813 and 2162 on A Street, D Street, E Street and Fulton Road, respectively. Closure of these streets would cause diversion through residential areas to Wheeler Avenue and White Avenue, which is unacceptable from a neighborhood preservation perspective and unnecessary environmental impacts. Closure of either D Street or E Street would cause a diversion to the other that would cause a near-capacity condition on the street that is left open. E Street is particularly important due to the Gold Line Station being located at E Street and Arrow Highway. To potentially close the at-grade crossing at E Street and Arrow Highway would serve as barricade to the station and preclude parking for any La Verne residents traveling from north of the station.
4. Downtown Viability – The downtown commercial area and the University of La Verne are the primary traffic generators in the area affected by the proposed closures. They rely on Arrow Highway for east-west access for their students/patrons. D Street provides the primary connection to this major route for both entities.
5. Unusable Property – The property currently occupied by the streets would be of little value because the existing underground and overhead infrastructure would preclude building on it. It would become another maintenance burden for the City. Utility companies probably would block any attempt to vacate the property.

6. Fulton Road – Fulton Road, shared by the Cities of Pomona and La Verne, is a designated truck route. Closure would force trucks to travel through residential areas to reach areas in east La Verne and west Pomona. Fulton is also the primary access route for La Verne residents to the Garey Avenue Metrolink Station. The importance of Fulton is demonstrated in the DEIS as it identifies signalization at the Bonita Avenue and Arrow Highway intersections as a mitigation measure for the project.

B. Signalization

There should be additional studies undertaken to investigate which signals would be warranted at White Avenue between First Street and Bonita Avenue. The City would ask that only the appropriate intersections be signaled and not have excessive traffic signals along White Avenue. While one signal in this three block stretch is needed, more than one signal is evaluated as excessive.

C. Parking

The City of La Verne would like to have additional parking studies undertaken to investigate the parking needed for the La Verne station and possible funding that will be made available to the City, particularly if the La Verne Station becomes a temporary terminus on the Gold Line route. More research is needed and should be conducted on parking obligations researching different scenarios with the completion of the Phase IIB extension.

D. Noise

The City requests noise studies to be conducted to investigate the noise that comes from the alarm systems at the Gold Line at-grade crossings. The Gold Line extension travels along residential areas and noise disturbance should be minimized to these residential areas.

Should you have any questions, please contact me at (909) 596-8706.

Sincerely,



Bob Russi
City Manager

C: Hal G. Fredericksen, Community Development Director
Amy Altomare, Associate Planner



CITY OF LA VERNE CITY HALL

3660 "D" Street, La Verne, California 91750-3599
www.ci.la-verne.ca.us

January 31, 2011

Lisa Levy Buch
Director of Public Affairs
Metro Gold Line Foothill Extension Construction Authority
406 East Huntington Drive, Suite 202
Monrovia, CA 91016

RE: City of La Verne Response to Scoping Sessions for Phase IIB Metro Gold Line Foothill Environmental

To Whom It May Concern:

City of La Verne representatives attended the Intergovernmental agency scoping session in Glendora, CA, as well as the public scoping session in Pomona, CA for the Metro Gold Line Foothill Extension Azusa to Montclair project. Based on the current project and previous City review, the City of La Verne has the following comments:

A. At-Grade Crossings

The City of La Verne is aware of the potential of CPUC closing several at-grade crossings along the Gold Line Corridor in La Verne. The City strongly disagrees with these recommendations. A, D, and E Streets in La Verne and Fulton Road at the La Verne/Pomona border should all remain open and continue to be through streets. To close these crossings presents significant safety concerns and potentially disenfranchises whole neighborhoods. Below are more detailed comments:

1. Emergency Services – With the City Public Safety headquarters located on 3rd Street between C and D Streets, both A Street and D Streets are primary routes for response to emergencies in the area south of the railroad tracks. E Street is also a primary route for emergency service to Fairplex, Brackett Field and the large industrial complex south of Arrow Highway. Closure of any of these streets could severely affect response times. The Fire Department estimates that closure of A Street would



General Administration 909/596-8726 • Water Customer Service 909/596-8744 • Parks & Community Services 909/596-8700
Public Works 909/596-8741 • Finance 909/596-8716 • Community Development 909/596-8706 • Building 909/596-8713
Police Department 909/596-1913 • Fire Department 909/596-5991 • General Fax 909/596-8737

increase response times to areas south of Arrow Highway between Wheeler Avenue and E Street by approximately 1 minute and closure of D and E would increase response times up to 3 minutes. Not only does this compromise the Fire Department's ability to provide fire and emergency medical services in a timely fashion, it would also compromise the safety of first responders due to rerouting through numerous intersections. The difference of even 1 – 3 minutes is particularly critical for medical aid response to heart attacks, strokes, drownings, etc. and eliminates alternative routes if at-grade crossings were blocked.

2. Pedestrian Diversion – There is significant pedestrian activity at each crossing given the interaction of the housing and employment centers south of the tracks and the University of La Verne and the downtown commercial area north of the tracks. We understand the rail right-of-way will be fenced to prevent trespassing. However, experience has shown that openings get cut in fences and pedestrians cross at locations where they do not have the protection afforded by gates, warning lights, etc. at established crossings.
3. Vehicular Diversion – Information presented in the Gold Line Extension February 2007 Final Environmental Impact Report (FEIR) shows that the current daily traffic volumes are 1150, 6346, 5813 and 2162 on A Street, D Street, E Street and Fulton Road, respectively. Closure of these streets would cause diversion through residential areas to Wheeler Avenue and White Avenue, which is unacceptable from a neighborhood preservation perspective and unnecessary environmental impacts. Closure of either D Street or E Street would cause a diversion to the other that would cause a near-capacity condition on the street that is left open. E Street is particularly important due to the Gold Line Station being located at E Street and Arrow Highway. To potentially close the at-grade crossing at E Street and Arrow Highway would serve as barricade to the station and preclude parking for any La Verne residents traveling from north of the station.
4. Downtown Viability – The downtown commercial area and the University of La Verne are the primary traffic generators in the area affected by the proposed closures. They rely on Arrow Highway for east-west access for their students/patrons. D Street provides the primary connection to this major route for both entities.
5. Unusable Property – The property currently occupied by the streets would be of little value because the existing underground and overhead infrastructure would preclude building on it. It would become another maintenance burden for the City. Utility companies probably would block any attempt to vacate the property.

6. Fulton Road – Fulton Road, shared by the Cities of Pomona and La Verne, is a designated truck route. Closure would force trucks to travel through residential areas to reach areas in east La Verne and west Pomona. Fulton is also the primary access route for La Verne residents to the Garey Avenue Metrolink Station. The importance of Fulton is demonstrated in the DEIS as it identifies signalization at the Bonita Avenue and Arrow Highway intersections as a mitigation measure for the project.

B. Signalization

There should be additional studies undertaken to investigate which signals would be warranted at White Avenue between First Street and Bonita Avenue. The City would ask that only the appropriate intersections be signaled and not have excessive traffic signals along White Avenue. While one signal in this three block stretch is needed, more than one signal is evaluated as excessive.

C. Parking

The City of La Verne would like to have additional parking studies undertaken to investigate the parking needed for the La Verne station and possible funding that will be made available to the City, particularly if the La Verne Station becomes a temporary terminus on the Gold Line route. More research is needed and should be conducted on parking obligations researching different scenarios with the completion of the Phase IIB extension.

D. Noise

The City requests noise studies to be conducted to investigate the noise that comes from the alarm systems at the Gold Line at-grade crossings. The Gold Line extension travels along residential areas and noise disturbance should be minimized to these residential areas.

Should you have any questions, please contact me at (909) 596-8706.

Sincerely,



Bob Russi
City Manager

C: Hal G. Fredericksen, Community Development Director
Amy Altomare, Associate Planner

Lisa Levy Buch

From: Michael Hudson [mudson@cityofmontclair.org]
Sent: Friday, January 21, 2011 7:46 AM
To: Habib Balian
Cc: Lisa Levy Buch; Steve Lustro; Marilyn Staats; Edward C. Starr
Subject: Invitation to Become a Participating Agency in the Metro Gold Line Foothill Extension Azusa to Montclair EIS/EIR

Good morning Habib

Please include the City of Montclair as a participating agency in the environmental review process for the extension of the Gold Line from Azusa to Montclair. The City strongly supports this extension project and looks forward to its becoming a reality.

Michael C. Hudson
City Engineer
City of Montclair
909-625-9441

From: Habib Balian [mailto:HBalian@foothillextension.org]
Sent: Thursday, January 06, 2011 5:27 PM
Cc: Lisa Levy Buch
Subject: Invitation to Become a Participating Agency in the Metro Gold Line Foothill Extension Azusa to Montclair EIS/EIR

The Metro Gold Line Foothill Extension Construction Authority (Construction Authority), in cooperation with the Federal Transit Administration (FTA), is initiating the preparation of Environmental Impact Statement/Environmental Impact Report (EIS/EIR) for the proposed Metro Gold Line Foothill Extension Azusa to Montclair Project. The proposed project is located in Los Angeles and San Bernardino Counties encompassing seven adjoining cities that lie along I-210 and a railroad right-of-way, between the eastern boundary of Azusa on the west and Montclair on the east. The study area is a 12.6 mile corridor that includes the cities of Azusa, Glendora, San Dimas, La Verne, Pomona, and Claremont in Los Angeles County. In San Bernardino County, it includes the city of Montclair.

The purpose of this project is to improve mobility in western Los Angeles County and eastern San Bernardino County by introducing high-frequency transit service; enhance the regional transit network by interconnecting existing and planned rapid transit lines; provide an alternative mode of transportation for commuters who currently use the congested I-210 corridor; improve transit accessibility for residents and employees who live and/or work along the corridor; and encourage a mode shift to transit, reducing air pollution and greenhouse gas (GHG) emissions. The enclosed scoping information packet provides more details, including a preliminary schedule.

Section 6002 of the Safe, Accountable, Flexible, Efficient, Transportation Equity Act: A Legacy for Users (SAFETEA-LU) establishes an enhanced environmental review process for certain FTA projects, improving the transparency of the process, and increasing opportunities for participation. The requirements of Section 6002 apply to the project that is the subject of this e-mail.

As part of the environmental review process for this project, the lead agencies must identify, as early as practicable, any other Federal and non-Federal agencies that may have an interest in the project and invite such agencies to become participating agencies in the environment review process.

THE CITY OF
POMONA

Office of the City Manager

LINDA C. LOWRY
City Manager



January 13, 2011

Ms. Lisa Levy-Buch, Director of Public Affairs
Metro Gold Line Foothill Extension Construction Authority
406 E. Huntington Drive
Monrovia, CA 91016

**Subject: Acceptance of Invitation to Become a Participating Agency in the Metro Gold Line
Foothill Extension Azusa to Montclair EIS/EIR**

Dear Ms. Levy-Buch:

On behalf of the City of Pomona, we gladly accept the invitation to become a participating agency in the Metro Gold Line Foothill Extension Azusa to Montclair EIS/EIR.

Ati Eskandari, P.E., City Engineer, will represent the Public Works Department and Brad Johnson, Planning Manager, will represent the Community Development Department.

We look forward in developing a balanced project with your team and improving the transit accessibility in our area.

Should you have any questions or concerns, please contact Ati Eskandari at (909) 620-2440 or Brad Johnson at (909) 620-2346.

Sincerely,

Linda C. Lowry
City Manager

RECEIVED

JAN 18 2011

MGL FOOTHILL EXT.
CONST. AUTHORITY

THE CITY OF POMONA

Office of the City Manager

LINDA C. LOWRY
City Manager

February 1, 2011



Ms. Lisa Levy Buch
Director of Public Affairs
Metro Gold Line Foothill Extension Construction Authority
406 E. Huntington Drive, Suite 202
Monrovia, CA 91016

SUBJECT: GOLD LINE FOOTHILL EXTENSION / POMONA STATION

Dear Ms. Levy Buch:

The City of Pomona would like to take this opportunity to support preparation of a new focus EIS/EIR for this leg of the project to identify and mitigate project impacts to local communities as result of proposed rail operation and alignment. The following comments illustrate Pomona's concerns regarding the project's environmental impact and suggest further analysis and consideration in order to build a balanced project for the community.

Traffic Analysis (Station and Rail)

The following comments are based on the review of Metro Gold Line Phase II Traffic and Transportation Section of the FEIR document dated February 2007, and proposed design modifications currently under consideration:

1. The FEIR did not state how many trains/day currently block crossings in Pomona. The FEIR should describe the maximum vehicle queue length caused by these blockages including the average duration of the blockages and estimated number of affected vehicles/day.
2. Impacts of the potential elimination of Fulton Road ingress/egress at the existing/future Metrolink parking lot need to be addressed.
3. Impacts to Garey Avenue as a result of the potential Fulton Road cul-de-sacs need analysis and mitigation or a revised proposal. The local preferred alternative is to consider a grade separation at the Garey Avenue crossing.
4. The potential Fulton Road closure and cul-de-sacs need police, fire, and City of La Verne's review with any comments being addressed.
5. The SCAG travel demand model should be used to adjust existing counts for future traffic scenarios based on growth rates from each city.

6. The FEIR traffic volume forecast does not appear to have considered the cumulative projects to determine an accurate traffic forecast.
7. It is not clear that the study considered increases in BNSF freight traffic and Metrolink service in the evaluation of build-out intersection delay analysis. The new traffic analysis should address this issue clearly.
8. The new study should provide expected queue length and delays for traffic stopped at all crossings.
9. The new study should consider and analyze potential traffic diversion to other arterials as a result of an at-grade crossing blockage. Diverted traffic from Garey Avenue could potentially trigger impacts at Fulton Road/Arrow Hwy and Towne Avenue/Arrow Hwy.
10. The proposed Pomona Light Rail Station is about ½ mile from the Pomona Fairplex. Currently, Metrolink operates special train service to this station during the LA County Fair. Discussion about the traffic impact to and from the Fairplex and a future Pomona Gold Line station is recommended.
11. The current study does not consider potential traffic impacts of shuttles that would likely be used to link the Gold Line Station near Garey Avenue to various activity centers.
12. The study should evaluate the impact to police, fire, and ambulance response times at proposed crossings. There is a fire station on Bonita Avenue about ¼ mile east of Garey Avenue. Response times of emergency vehicles from the fire station would be affected by blockages of Garey Avenue resulting from at-grade crossing.
13. The study should evaluate the safety and impact to pedestrians at proposed crossings.
14. Impacts to Garey Avenue, Bonita Avenue, Towne Avenue, and Santa Fe Street need further analysis and potential modifications to proposed improvements.

Visual Quality/Aesthetics (Station and Rail)

1. Project impacts to visual resources by obstructing views along the portion near Towne Avenue where elevated grade separation is being proposed should be addressed. The local alternative is to consider a below grade rail separation at this location.
2. Poles for power, communications, and similar installations need to be painted in green, brown, or a similar City approved color to minimize visual impact.
3. Proposed landscaping in City approved palette (drought-tolerant, native, etc.) should be illustrated.
4. Walls and screening should be incorporated.

Station Design Alternative

1. Preliminary design of the Pomona Station location does not appear to accommodate pedestrians within the track. Also the platform location does not appear to provide free and

unobstructed accessibility. The local alternative is to construct a station/platform on the north side of the outside rail.

2. The long-narrow parking structure in the middle of the tracks appears to be a practical/possible alternative.
3. Pedestrian crossings of tracks should be avoided, reduced and/or improved.
4. Access: ingress, egress and movement on site appears overly restrictive for this area.
5. Identify access and rights to the property for the north parking structure

Rail and Related Transit Operation

1. Considering the projected frequency of rail traffic at the proposed crossings, the City of Pomona would strongly recommend a joint agreement between Metrolink, Gold Line, and the applicable Freight Operators to establish acceptable train daily minimum and maximum separation at crossings, thereby limiting the long-term impact to the community.
2. Bus and similar transit connectivity (on-site bus access and turn-around) is needed.

General Design

1. If any electrical sub-station (transformer bank or similar power installation) is needed, then the proposed site of the electrical installation needs to be provided with the design to address aesthetics, noise, and related matters.
2. Please see the attached exhibit of residential areas in Pomona relative to the above comments.
3. Further analysis of noise considerations and mitigation measures is needed.

Thank you for your consideration of our comments in this matter.

Sincerely,

Linda C. Lowry
City Manager

Attachment: Exhibit of Residential Areas in Pomona

cc: Jennifer Flores, Project Administrator
Mark Lazzaretto, Community Development Director
Daryl Grigsby, Public Works Director

Pomona North Rail Line Residential Neighborhoods

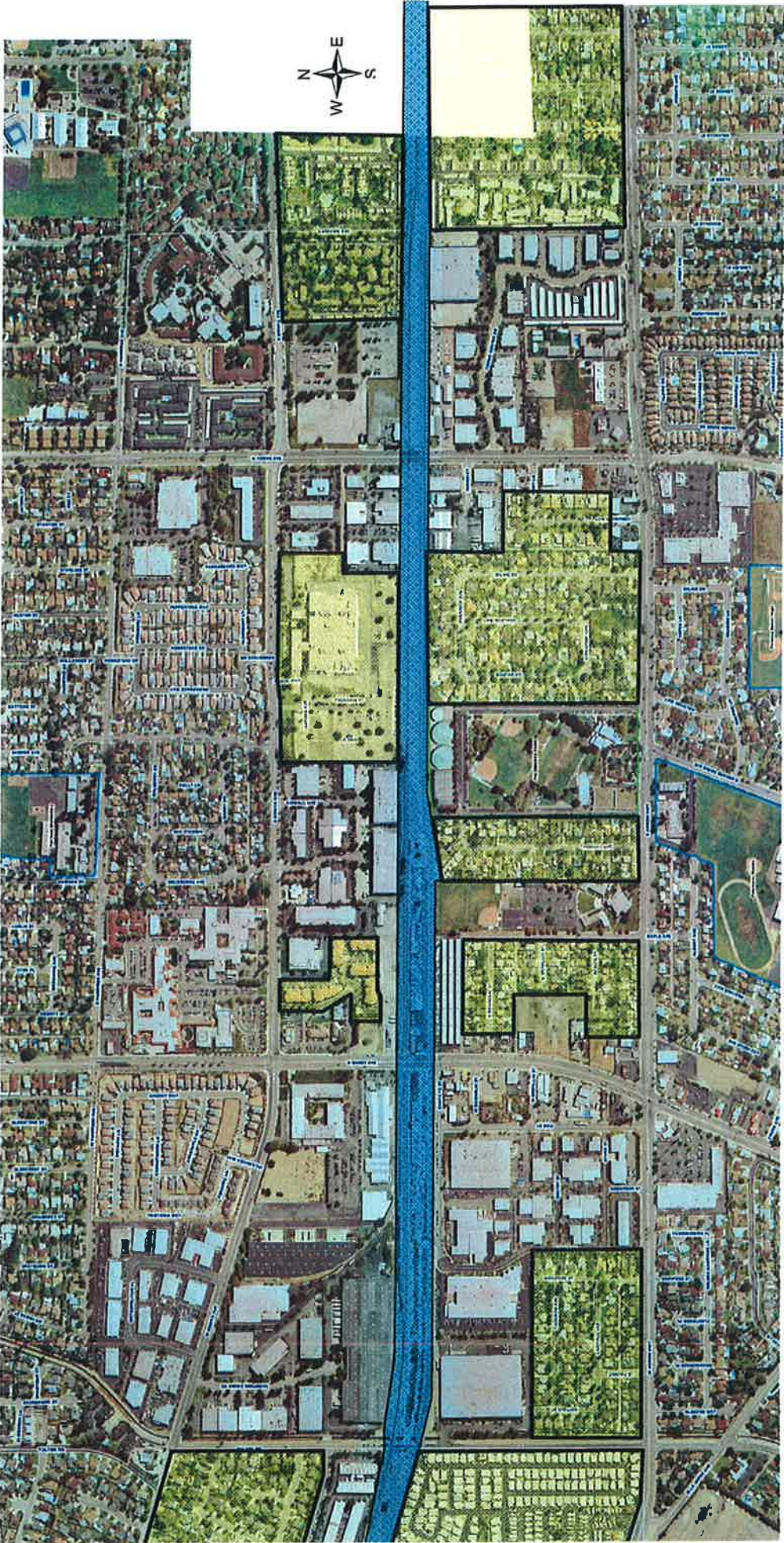

City Council
CURTIS W. MORRIS, Mayor
DENIS BERTONE, Mayor Pro Tem
EMMETT BADAR
JEFF TEMPLEMAN
JOHN EBINER

City Manager
BLAINE M. MICHAELIS

Assistant City Manager / Treasurer
KENNETH J. DURAN

City Attorney
J. KENNETH BROWN



**Assistant City Manager of
Community Development**
LAWRENCE STEVENS

Director of Public Works
KRISHNA PATEL

**Director of Development
Services**
DAN COLEMAN

**Director of Parks
and Recreation**
THERESA BRUNS

City Clerk
INA RIOS

January 27, 2011

Ms. Lisa Levy Buch, Director of Public Affairs
Metro Gold Line Foothill Extension Construction Authority
406 E Huntington Drive, Suite 202
Monrovia, California 91016

SUBJECT: Metro Gold Line Foothill Extension Azusa to Montclair -
Environmental Impact Report

Dear Ms. Levy Buch:

Following the January 20, 2011 Public Scoping Meeting for Phase II of the Pasadena to Montclair Extension held at Ekstrand Elementary, the City of San Dimas has the following issues and concerns that need to be addressed and analyzed in the preparation of the Environmental Impact Report (EIR) for Phase II of the Project.

1) Traffic

Since the rail line at Bonita Avenue/Cataract Avenue crosses the intersection in a diagonal entry from the northwest corner and crossing to the southwest corner, considering the (approximately 300 foot) long diagonal rail crossing and its intersection geometry. It is the City's belief this intersection will be experiencing almost 40 to 50 seconds delays of closure every 5 minutes when considering the estimated train frequency of 12 trains per hour in both directions. Therefore in addition to signal stoppage delays, the intersection would most likely result in all automobile operations being stopped during the Light Rail Transit (LRT) crossing every 5 minutes. This delay or closure would significantly impact traffic operations and adversely impact traffic in the heart of downtown San Dimas. The City requests the authority conduct a detailed grade crossing analysis that evaluates the feasibility of a grade separation in order to mitigate the traffic concerns, together with a study of aesthetics and a visual impact plan for this intersection and other LRT crossing intersections in the City.

2) Aesthetics

The equipment and the necessary housing of a power traction system to operate the LRT has the potential of creating negative aesthetic impacts throughout the City, but especially the City's Frontier Village area. In addition, the poles and the overhead wiring system, along the entire length of the rail right-of-way will have an adverse impact to the community.

3) Traffic/Land Use

Impacts associated with the development of an intermodal station in the City located between San Dimas Avenue and Walnut Avenue, including parking structures that is limited

RECEIVED

JAN 28 2011

MGL FOOTHILL EX
CONST. AUTHORIT

to 2 levels of parking with a maximum of 400 parking spaces as per the attached letter dated 12/17/2008

4) Hydrology

The EIR should address and analyze the impact created on existing undersized and aging storm drains and culvert system crossing the proposed project.

5) Noise and Vibration

Noise and vibration will be a significant issue. All feasible mitigation measures should be addressed including mitigation measures that consider landscaping within the railroad right-of-way.

6) Miscellaneous

The EIR should analyze the following:

- 1) The feasibility of relocating the existing abandoned spur/siding line located at the southwest corner of Bonita Avenue and Cataract Avenue.
- 2) The project mitigation should consider the viability of expanding bus services, bikeways, pedestrian and vehicular areas at the station as well as other parts of the City.
- 3) It is our understanding that the EIR/EIS intends to utilize the 2008 SCAG Growth Forecast. The City of San Dimas has continually objected to these forecasts as being unrealistic for our City. As SCAG is preparing for the upcoming 2012 Growth Forecast, they have acknowledged these unrealistic projections and current drafts of the 2012 Growth Forecast reflect housing, population and jobs projections more consistent with the built-out conditions in the City. These updated projections are substantially lower than those in the 2008 Forecast. The EIR/EIS should take these differences into consideration.

Should you wish to discuss this matter further, please contact Mr. Krishna Patel, Director of Public Works at (909) 394-6245 or Mr. Larry Stevens, Assistant City Manager for Community Development at (909) 394-6281.

Sincerely,



Curtis Morris
Mayor

Attachment:

kp/jam/01-11-17

cc: Krishna Patel, Director of Public Works
Larry Stevens, Assistant to City Manager for Community Development
Blaine Michaelis, City Manager
David Dreier, Congressman

San Dimas

City Council
CURTIS W. MORRIS, Mayor
EMMETT BADAR, Mayor Pro Tem
DENIS BERTONE
JOHN ERINER
JEFF TEMPLEMAN

City Manager
BLAINE M. MICHAELIS

Assistant City Manager / Treasurer
KENNETH J. DURAN

City Attorney
J. KENNETH BROWN

Assistant City Manager of
Community Development
LAWRENCE STEVENS

Director of Public Works
KRISHNA PATEL

Director of Development
Services
DAN COLEMAN

Director of Parks
and Recreation
THERESA BRUNS

City Clerk
INA RIOS, CMC

December 17, 2008

Habib F. Balian
Chief Executive Officer
Metro Gold Line Foothill Extension Authority
406 E. Huntington Drive, Suite 202
Monrovia, CA 91016-3633

RE: Gold Line Station – City of San Dimas

Dear Mr. Balian:

At its meeting of December 9, 2008, the San Dimas City Council determined that it would support a Gold Line Station in San Dimas pursuant to the following criteria:

- Station to be located in area bounded by San Dimas Avenue on the west, Arrow Highway on the south, Walnut Avenue on the east and the railroad tracks on the north.
- Parking to support that station to be limited to a maximum of 400 parking spaces.

The City will be evaluating zoning in this area as part of its Downtown Specific Plan review tentatively scheduled for hearings in Spring 2009. We look forward to working with the Authority on a site meeting these criteria as you progress through environmental and funding reviews in the upcoming months.

Please contact Larry Stevens, Assistant City Manager for Community Development, if you have questions or require additional assistance in these upcoming reviews.

Sincerely,

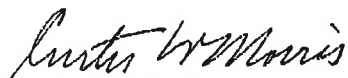
Curtis W. Morris,
Mayor

cc: San Dimas City Council
Blaine Michaelis, City Manager
Larry Stevens, Assistant City Manager for Community Development

Lisa Levy Buch

From: Sparks, Ann [Sparks@bonita.k12.ca.us]
Sent: Thursday, January 27, 2011 4:38 PM
To: Lisa Levy Buch
Subject: FW: Participating Agency

From: Sparks, Ann
Sent: Thursday, January 27, 2011 4:37 PM
To: 'llevybuch@foothiiiextension.org'
Subject: Participating Agency

Lisa – The Bonita Unified School District wishes to become a participating agency in the Foothill Extension project. I will be the contact person for the District. My address and phone number are listed below.

Ann Sparks
Assistant Superintendent – Business Services
115 W. Allen Avenue
San Dimas, CA 91773

909-971-8320 ext 5200

Lisa Levy Buch

From: Bruce Spena [bruce_spena@cuc.claremont.edu]
Sent: Tuesday, February 01, 2011 9:51 AM
To: Lisa Levy Buch
Cc: Tim Morrison
Subject: The Claremont Colleges

Dear Ms Buch, The Claremont University Consortium, on behalf of The Claremont Colleges, requests that we be included among the participant agencies in the EIS/EIR for the Gold Line. Thank you.

Bruce Spena
Director of Central Facilities Services
Claremont University Consortium
bruces@cuc.claremont.edu
909-621-8441

Ontario-Montclair School District

950 West D Street, Ontario, California 91762 • (909) 418-6366 • FAX (909) 459-2550
FACILITIES PLANNING AND OPERATIONS

January 25, 2011

Lisa Levy Buch
Director of public Affairs
Metro Gold line Foothill Extension Construction Authority
406 E. Huntington Drive, Suite 202
Monrovia, CA 91016-3633

BOARD OF TRUSTEES

Paul Vincent Avila
Kristen Brake
Samuel Crowe
Maureen Mendoza
Elvia Rivas

James Q. Hammond, Ed.D.
Superintendent

Casey Cridelich
*Assistant Superintendent
Business Services*

Craig E. Misso
*Director, Facilities Planning and
Operations*

**RE: Invitation to Become a Participating Agency in the Metro Gold Line Foothill
Extension Azusa to Montclair EIS/EIR**

Dear Ms. Buch:

This letter is to inform you of the Ontario-Montclair School District's interest in being a participating agency in the Metro Gold Line Foothill Extension Azusa to Montclair EIS/EIR project.

Please send all future notifications and correspondence to me as I will be serving as the District's representative.

Sincerely,

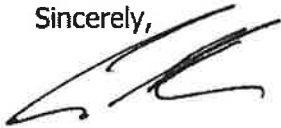

Craig Misso
Director, Facilities Planning and Operations
craig.misso@omsd.k12.ca.us

Lisa Levy Buch

From: Ruiz, Lupe H [Lupe.H.Ruiz@pomona.k12.ca.us]
Sent: Tuesday, January 25, 2011 11:53 AM
To: Lisa Levy Buch
Subject: Participating Agency

Lisa Levy Buch
Director fo Public Affairs
Metro Gold Line Foothill Extension Construction Authority

Pomona Unified School District is interested in participating in the environment review process for the Metro Gold Line Foothill Extension Azusa to Montclair Project. Leslie Barnes (Assistant Superintendent, CFO, Business Services) will represent Pomona Unified School District at the meetings. Please send future meeting notifications to leslie.barnes@pusd.org and cc lupe.h.ruiz@pusd.org.

Please reply to confirm that you received this email. If you require additional information, please do not hesitate to contact me at the number listed below.

Thank you,

Lupe H. Ruiz
Administrative Secretary, Fiscal Services
Pomona Unified School District
(909) 397-4800, ext. 3890
FAX (909) 622-5895
Lupe.H.Ruiz@pusd.org

Lisa Levy Buch

From: Lisa Levy Buch
Sent: Wednesday, February 02, 2011 3:54 PM
To: Lisa Levy Buch
Subject: FW: Participating Agency Request

Donna Lee
Regional Manager
Local Public Affairs
800 West Cienega Avenue
San Dimas, CA 91771
(909) 592-3723
Donna.Lee@sce.com

From: Alexander.Pugh@sce.com [<mailto:Alexander.Pugh@sce.com>]
Sent: Wednesday, February 02, 2011 3:49 PM
To: Lisa Levy Buch
Cc: Donna.Lee@sce.com; Ben.Wong@sce.com
Subject: Participating Agency Request

Good Afternoon Lisa,

SCE would like to be a participating agency. For right now, please include me and Donna Lee on your contact list for future meetings. We will make sure that the correct staff from SCE are in attendance in the case of a technical matter.

Thanks,
Alex

Alexander G. Pugh
Senior Project Manager
Policy & Project Management
Southern California Edison
(626) 302-3819 (Office)
(626) 419-8262 (Cell)
(626) 302-9821 (Fax)