

SR 710 North Study

Parts 2/3 – Project Report/Environmental Studies Documentation Phase

# Advanced Conceptual Engineering Report Light Rail Transit Alternative

Prepared for



**Metro**

Los Angeles County  
Metropolitan Transportation Authority

April 2014

**CH2MHILL**®

1000 Wilshire Boulevard  
Suite 2100  
Los Angeles, CA 90017



# Contents

---

	Page
Acronyms and Abbreviations .....	vii
Introduction.....	1-1
1.1 Study Area .....	1-1
1.2 Purpose and Need .....	1-1
1.2.1 Purpose of the Project.....	1-1
1.2.2 Need for the Project.....	1-1
1.3 Purpose of this Report .....	1-3
Background.....	2-1
2.1 Project Description .....	2-1
2.1.1 Light Rail Transit Alternative.....	2-1
LRT Design .....	3-1
3.1 Design Criteria .....	3-1
3.2 Operating Plan.....	3-1
3.2.1 Operating Assumptions.....	3-1
3.3 LRT Alternative – Engineering Considerations .....	3-4
3.3.1 Third Street to I-710 ROW .....	3-4
3.3.2 I-710 ROW.....	3-4
3.3.3 Valley Boulevard to SR 110 .....	3-5
3.3.4 SR 110/Raymond Fault Crossing .....	3-5
3.3.5 SR 110 to Fillmore Street.....	3-5
3.4 Track Design .....	3-5
3.4.1 Horizontal Alignment.....	3-6
3.4.2 Vertical Alignment.....	3-6
3.4.3 Storage Tracks.....	3-7
3.4.4 Exceptions to Design Criteria.....	3-7
3.5 Trackwork.....	3-7
3.5.1 Direct Fixation Track.....	3-7
3.5.2 Ballasted Track.....	3-7
3.5.3 Track Gauge .....	3-7
3.6 Special Trackwork .....	3-8
3.6.1 Crossovers.....	3-8
3.6.2 Turnouts.....	3-8
3.7 Track Material.....	3-8
3.7.1 Running Rail .....	3-8
3.7.2 Direct Fixation Rail Fasteners.....	3-9
3.7.3 Bonded Insulated and Bonded Standard Rail Joints.....	3-9
3.7.4 Restraining Rails .....	3-9
3.7.5 Rail Lubricators.....	3-10
3.7.6 Ballasts.....	3-10
3.7.7 Sub Ballasts .....	3-10
3.8 Civil.....	3-10
3.8.1 Utilities.....	3-10
3.8.2 Drainage.....	3-12
3.8.3 Traffic.....	3-12

Geological Conditions .....	4-1
4.1 Exploration Program .....	4-1
4.2 Subsurface Conditions .....	4-2
4.2.1 Regional Setting .....	4-2
4.2.2 Geological Setting.....	4-2
4.2.3 Faulting and Seismicity .....	4-3
4.2.4 Mineral Resources.....	4-5
4.2.5 Hazardous Materials.....	4-5
4.3 Properties of Concern .....	4-6
4.3.1 Former Blanchard Landfill.....	4-6
Aerial Structures .....	5-1
5.1 Design Criteria and Stations .....	5-1
5.2 Bridge and Guideway Alignments.....	5-1
5.2.1 LRT Alternative .....	5-1
5.3 Types.....	5-2
5.3.1 Aerial Guideway .....	5-2
5.3.2 Aerial Stations .....	5-4
5.3.3 Aerial Support Columns and Bents.....	5-5
5.4 Limits and Clearances .....	5-5
Underground Excavation and Ground Support .....	6-1
6.1 Tunnel Design Summary .....	6-1
6.1.1 Bored Tunnel Internal Configuration and Clearances .....	6-1
6.1.2 Bored Tunnel Separation .....	6-2
6.1.3 Cross Passages .....	6-2
6.1.4 Tunnel Excavation Methods.....	6-3
6.1.5 Concepts for Tunnel and Cross Passage Lining .....	6-6
6.1.6 Fault Crossings .....	6-7
6.2 Station and Portal Excavation and Ground Support .....	6-8
6.2.1 TBM Portal Excavation and Support.....	6-8
6.2.2 Underground Station and Excavation and Ground Support .....	6-9
6.2.3 Headwall Support and Ground Improvements.....	6-9
6.3 Zone of Potential Settlement Disturbance.....	6-10
6.3.1 Introduction .....	6-10
6.3.2 Ground Surface Settlement Resulting from Tunneling .....	6-10
6.3.3 Ground Surface Settlement Resulting from Portal and Underground Station Excavations.....	6-11
6.3.4 Preliminary Results.....	6-12
Station Architecture.....	7-1
7.1 General.....	7-1
7.2 Station Locations .....	7-1
7.2.1 Mednik Station.....	7-1
7.2.2 Floral Station.....	7-2
7.2.3 Cal State LA Station .....	7-2
7.2.4 Alhambra Station.....	7-2
7.2.5 Huntington Station .....	7-2
7.2.6 South Pasadena Station .....	7-3
7.2.7 Fillmore Station.....	7-3

Systems Requirements .....	8-1
8.1 General Requirements .....	8-1
8.2 Fare Collection .....	8-1
8.3 Train Control .....	8-1
8.4 Rail Vehicles .....	8-2
8.5 Communications .....	8-2
8.5.1 Rail Operations Center (ROC) .....	8-3
8.5.2 Cable Transmission System (CTS) .....	8-3
8.5.3 Telephone System .....	8-4
8.5.4 Radio System .....	8-5
8.5.5 Transit Passenger Information System (TPIS) .....	8-5
8.5.6 Closed Circuit Television (CCTV) System .....	8-6
8.5.7 Intrusion Detection and Controlled Access System (IDCAS) .....	8-6
8.5.8 Fire Alarm Detection System .....	8-7
8.5.9 Gas Detection and Alarm System .....	8-8
8.5.10 Seismic Detection System .....	8-8
8.5.11 Tunnel Portal Surveillance and Alarm System .....	8-9
8.5.12 Supervisory Control and Data Acquisition Remote Terminal Unit .....	8-10
8.5.13 (SCADA RTU) .....	8-10
8.5.14 Facilities Emergency Management (FEM) System .....	8-10
8.5.15 Universal Fare Collection System (UFCS) .....	8-12
8.5.16 Communications Uninterruptable Power Supply System .....	8-12
8.6 Ventilation System .....	8-13
8.6.1 Design Conditions for Normal Operation in Stations .....	8-13
8.6.2 Design Conditions for Normal Operation in Tunnels .....	8-13
8.6.3 Design Conditions for Emergency Operation in Stations .....	8-13
8.6.4 Emergency Ventilation System (EVS) in Stations .....	8-13
8.6.5 Design Conditions for Emergency Operation in Tunnels .....	8-13
8.6.6 Emergency Ventilation System (EVS) in Tunnels .....	8-14
8.6.7 Maintenance Operation Criteria .....	8-14
8.7 Traction Power and Distribution .....	8-14
8.7.1 Traction Power Substations .....	8-14
8.7.2 DC power Distribution System .....	8-15
8.7.3 Overhead Contact System .....	8-15
8.8 Safety/Security .....	8-15
8.8.1 Safety .....	8-15
8.8.2 Security .....	8-16
Mechanical .....	9-1
9.1 Elevators .....	9-1
9.2 Escalators .....	9-1
9.3 Fire Protection Systems .....	9-1
Electrical .....	10-1
10.1 Power Sources .....	10-1
10.2 Temporary Construction Power .....	10-1
10.3 Power Supply Reliability .....	10-1
10.4 Power Distribution System .....	10-1
10.5 Grounding .....	10-1
10.6 Supply Voltage and Voltage Drop .....	10-1
10.7 Lighting .....	10-2

Right of Way .....	11-1
11.1 Right of Way Criteria and Limits .....	11-1
11.2 Right of Way Informational Requirements .....	11-1
11.3 Affected Facilities and Right of Way .....	11-1
11.3.1 Caltrans ROW .....	11-1
11.3.2 Cal State Los Angeles .....	11-1
11.3.3 Flood Control Facilities .....	11-2
Constraints and Issues to be Resolved in Next Phase .....	12-1
12.1 Civil, Alignment and Track Work .....	12-1
12.1.1 Maintenance Yard Layout .....	12-1
12.1.2 Mednik Station Location .....	12-1
12.1.3 Mednik Station Crossover .....	12-1
12.2 Geotechnical Investigations .....	12-2
12.3 Tunnel Excavation and Ground Support .....	12-2
12.3.1 Building Foundation Records Search Reconnaissance .....	12-2
12.3.2 Settlement Estimates and Building Protection .....	12-3
12.3.3 Additional Geotechnical Information .....	12-4
12.4 Station Architecture .....	12-4
12.4.1 Station Layouts .....	12-4
12.4.2 Architectural Design .....	12-5
12.5 Systems .....	12-5
12.6 Mechanical .....	12-5
12.6.1 Ventilation .....	12-5
12.6.2 Fire Protection Requirements .....	12-5
12.7 Electrical .....	12-5
12.8 Construction .....	12-6
Project Cost .....	13-1
13.1 General Approach .....	13-1
13.2 Cost Estimating Assumptions .....	13-1
13.3 Adequacy of Cost Estimates .....	13-1
References .....	13-1

## Appendix

Appendix A: Conceptual Plans and Profile Drawings

Appendix B: LRT Preliminary Operating Plan

## Tables

Table 3-1: Metro LRT Span of Service .....	3-1
Table 3-2: Metro LRT Service Frequency.....	3-2
Table 3-3: LRT Alternative Station-to-Station Run Times.....	3-3
Table 3-4: LRT Alternative Operating Requirements .....	3-4
Table 4-1: Summary of SR 710 North Study LRT Alternative Explorations .....	4-1
Table 4-2: Summary of Technical Study Borings Utilized in the SR 710 North Study, LRT Alternative .....	4-1
Table 4-3: Previous Geotechnical Explorations Utilized in the SR 710 North Study, LRT Alternative .....	4-2
Table 5-1: Operational Description of the LRT Alternative .....	5-1

## Figures

Figure 1-1: SR 710 Study Area .....	1-2
Figure 2-1: LRT Alternative .....	2-2
Figure 5-1: Typical Aerial Structure Cross Section .....	5-3
Figure 5-2: Typical Aerial Station Cross Section .....	5-4
Figure 6-1: Cross Section of Bored Tunnel .....	6-1
Figure 6-2: Cross Section of Typical LRT Cross Passage .....	6-2
Figure 6-3: Plan of LRT Tunnels at Location of Cross Passage .....	6-3
Figure 6-4: Preliminary Grain Size Analysis Curves, per Geologic Unit .....	6-5
Figure 6-5: Precast Concrete Segmental Lining, University-Link LRT Tunnel .....	6-7
Figure 6-6: Typical Surface Settlement above Two Tunnels .....	6-10
Figure 12-1: Relationship of Damage to Angular Distortion & Horizontal Strain (Boscardin and Cording, 1989) .	12-3

DRAFT





# Acronyms and Abbreviations

AA	Alternatives Analysis
AASHTO	American Association of State Highway and Transportation Officials
AC	Alternating Current
ACE	Advanced Conceptual Engineering
ADA	Americans with Disabilities Act
ADL	Aerially-Deposited Lead
ADM	Add Drop Multiplexers
APEQFZ	Alquist-Priolo Earthquake Fault Zone
AREMA	American Railway Engineering and Maintenance-of-Way Association
ATEL	Administrative Telephone
BRT	Bus Rapid Transit
Caltrans	California Department of Transportation
CCTV	Closed Circuit Television
CDCS	Central Data Collection System
CEQA	California Environmental Quality Act
CGS	California Geological Survey
CIDH	Cast-in-Drilled-Hole
CMP	Corrugated Metal Pipe
CPUC	California Public Utilities Commission
CTS	Cable Transmission System
CWR	Continuous Welded Rail
DC	Direct Current
DEIS/DEIR	Draft Environmental Impact Statement/Draft Environmental Impact Report
DVR	Digital Video Recorder
EMP	Emergency Management Panels
EPB	Earth Pressure Balance
EPDM	Ethylene Propylene Diene Monomer
ETEL	Emergency Telephone
ETS	Emergency Trip Station
EVS	Emergency Ventilation System
F&EM	Facilities Emergency Management Systems
FACP	Fire Alarm Control Panels
FD	Final Design
FEIS/FEIR	Final Environmental Impact Statement/Final Environmental Impact Report
FEM	Facilities Emergency Management
FLAC	Fast Lagrangian Analysis of Continua
FHWA	Federal Highway Administration
FOCT	Fiber Optics Cable Transmission
FRP	Forced Reduced Performance
FTA	Federal Transit Administration
FY	Fiscal Year
GIS	Geographical Information System
GRP	Glass-Reinforced Plastic
GTEL	Gate Telephones
I-5	Interstate 5
I-10	Interstate 10
I-210	Interstate 210

I-605	Interstate 605
I-710	Interstate 710
IDCAS	Intrusion Detection and Control Access System
IP	Internet Protocol
ISA	Initial Site Assessment
LACFCD	Los Angeles county Flood Control District
LADPW	Los Angeles County Department of Public Works
LED	Light-Emitting Diode
LFRD	Local and Resistance Factor Design
L RTP	Long Range Transportation Plan
LRT	Light Rail Transit
LRV	Light Rail Vehicle
LTEL	Elevator Telephones
MCC	Motor Control Centers
Metro	Los Angeles County Metropolitan Transportation Authority
MDF	Main Distribution Frame
MPH	Miles Per Hour
MSE	Mechanically Stabilized Earth
MTEL	Maintenance Telephones
MWD	Metropolitan Water District
NATM	New Austrian Tunneling Method
NAVD	North American Vertical Datum
NEMA	National Electrical Manufacturers Association
NEPA	National Environmental Policy Act
NFPA	National Fire Protection Association
OCS	Overhead Catenary System
OSHA	Occupational Safety and Health Administration
OSP	Outside Plant
OWS	Operator Work Station
PA	Public Announcement
PE	Preliminary Engineering
PGR	Preliminary Geotechnical Report
PLC	Programmable Logic Controller
PTEL	Passenger Assistance Telephones
RCB	Reinforced Concrete Box
RCP	Reinforced Concrete Pipe
REMP	Remote Emergency Management Panel
ROC	Rail Operations Center
ROM	Rough Order of Magnitude
ROW	Right-of-Way
RTU	Remote Terminal Unit
SCADA	Supervisory Control and Data Acquisition
SCC	Standardized Cost Categories
SEM	Sequential Excavation Method
SR 22	State Route 22
SR 57	State Route 57
SR 60	State Route 60
SR 91	State Route 91
SR 134	State Route 134
SR 710	State Route 710
SUSMP	Standard Urban Run-off Mitigation Plan

---

TBM	Tunnel Boring Machine
TC&C	Train Control and Communications
TDM	Transportation Demand Management
TPIS	Transit Passenger Information System
TPSS	Traction Power Substation
TE	Tractive Effort
TRU	Transformer-Rectifier Unit
TSM	Transportation System Management
TVA	Threat and Vulnerability Analysis
TWC	Train-To-Wayside Communication
UBC	Uniform Building Code
UEPBT	Upper Elysian Park Blind Thrust
UFS	Universal Fare System
UFCS	Universal Fare Collection System
UPS	United Postal Service
USG	Union Station Gateway
VMS	Visual Message Sign
VPI	Vertical Point of Intersection
VDC	Volts Direct Current

DRAFT



# Introduction

---

## 1.1 Study Area

The California Department of Transportation (Caltrans), in cooperation with the Los Angeles County Metropolitan Transportation Authority (Metro) proposes transportation improvements to improve mobility and relieve congestion in the area between State Route 2 (SR 2) and Interstates 5, 10, 210 and 605 (I-5, I-10, I-210, and I-605, respectively) in east/northeast Los Angeles and the western San Gabriel Valley. The study area for the State Route 710 (SR 710) North Study as depicted on Figure 1-1 is approximately 100 square miles and generally bounded by I-210 on the north, I-605 on the east, I-10 on the south, and I-5 and SR 2 on the west. Caltrans is the Lead Agency under the National Environmental Policy Act (NEPA) and the California Environmental Quality Act (CEQA).

## 1.2 Purpose and Need

### 1.2.1 Purpose of the Project

Due to the lack of continuous north-south transportation facilities in the study area, there is congestion on freeways, cut-through traffic that affects local streets, and low-frequency transit operations in the study area. Therefore, the following project purpose has been established.

The purpose of the proposed action is to effectively and efficiently accommodate regional and local north-south travel demands in the study area of the western San Gabriel Valley and east/northeast Los Angeles, including the following considerations:

- Improve efficiency of the existing regional freeway and transit networks.
- Reduce congestion on local arterials adversely affected due to accommodating regional traffic volumes.
- Minimize environmental impacts related to mobile sources.

### 1.2.2 Need for the Project

The study area is centrally located within the extended urbanized area of Southern California. With few exceptions, the area from Santa Clarita in the north to San Clemente in the south (a distance of approximately 90 miles [mi]) is continuously urbanized. Physical features such as the San Gabriel Mountains and Angeles National Forest on the north, and the Puente Hills and Cleveland National Forest on the south, have concentrated urban activity between the Pacific Ocean and these physical constraints. This urbanized area functions as a single social and economic region that is identified by the Census Bureau as the Los Angeles-Long Beach-Santa Ana Metropolitan Statistical Area (MSA).

There are seven major east-west freeway routes:

- State Route 118 (SR 118)
- United States Route 101 (US-101)/State Route 134 (SR 134)/I-210
- I-10
- State Route 60 (SR 60)
- Interstate 105 (I-105)
- State Route 91 (SR 91)
- State Route 22 (SR 22)

Figure 1-1: SR 710 Study Area

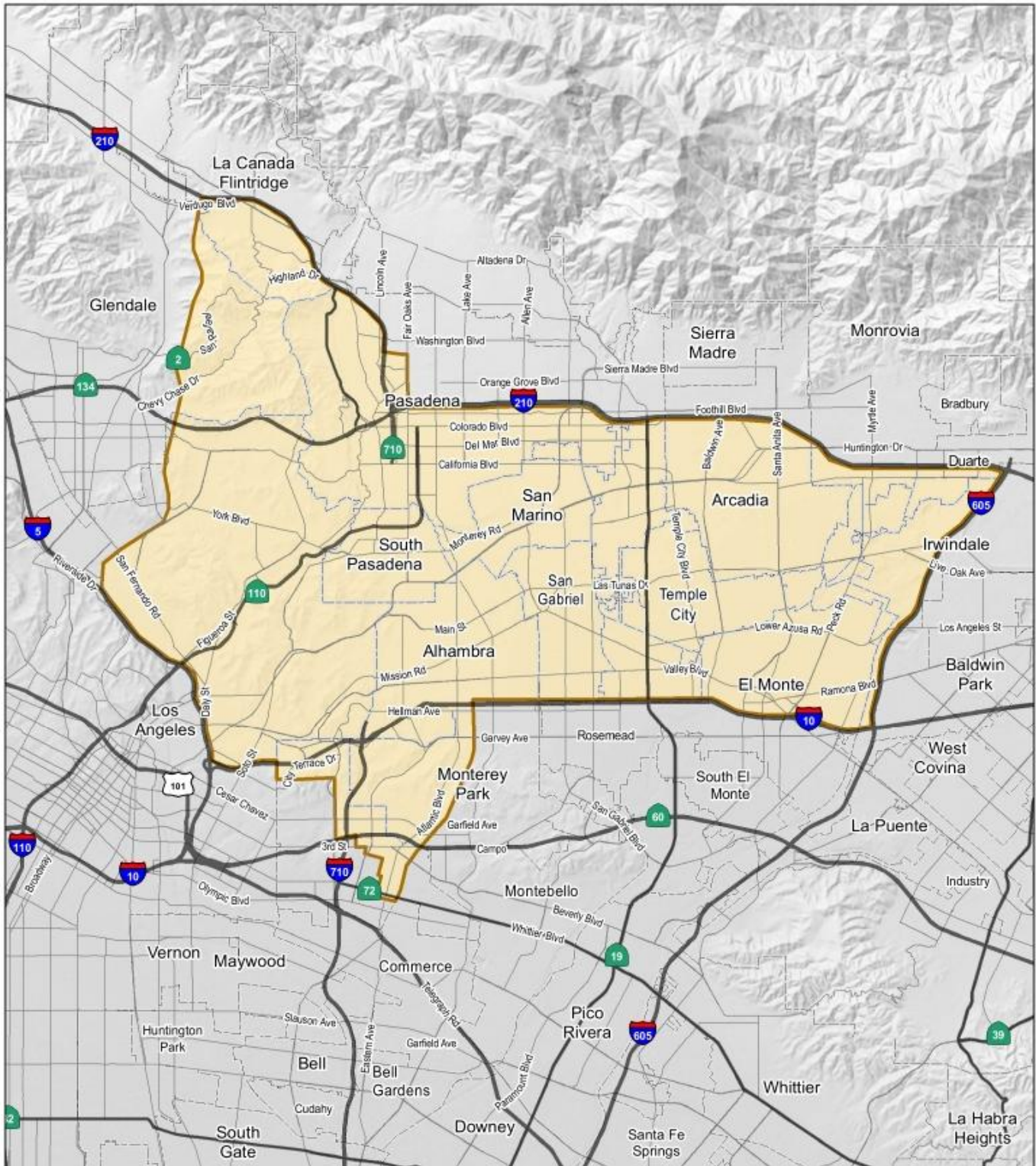

There are seven major north-south freeway routes:

- Interstate 405 (I-405)
- US-101/State Route 170 (SR 170)
- I-5
- Interstate 110 (I-110)/State Route 110 (SR 110)
- Interstate 710 (I-710)
- I-605
- State Route 57 (SR 57)

All of these major routes are located in the central portion of the Los Angeles-Long Beach-Santa Ana MSA. Of the seven north-south routes, four are located partially within the study area (I-5, I-110/SR 110, I-710, and I-605), two of which (I-110/SR 110 and I-710) terminate within the study area without connecting to another freeway. As a result, a substantial amount of north-south regional travel demand is concentrated on a few freeways, or diverted to local streets within the study area. This effect is exacerbated by the overall southwest-to-northeast orientation of I-605, which makes it an unappealing route for traffic between the southern part of the region and the urbanized areas to the northwest in the San Fernando Valley, the Santa Clarita Valley, and the Arroyo-Verdugo region.

The lack of continuous north-south transportation facilities in the study area has the following consequences, which have been identified as the elements of need for the project:

- Degradation of the overall efficiency of the larger regional transportation system
- Congestion on freeways in the study area
- Congestion on the local streets in the study area
- Poor transit operations within the study

### 1.3 Purpose of this Report

This Advanced Conceptual Engineering (ACE) report builds on the conceptual engineering from the Alternatives Analysis (AA) study and relates the additional engineering effort to further define the project and assists in the evaluation of the alternatives. The purpose of the ACE work is to allow the engineering to proceed as rapidly as possible through Preliminary Engineering (PE) and Final Design (FD) and to minimize changes, disruptions or delays in these later phases. The goal of ACE is to achieve a point where there is consensus amongst stakeholders regarding the scope of the project in order to allow significant design progress to be achieved in PE and FD.





# Background

---

## 2.1 Project Description

The SR 710 Study is the culmination of a long history of efforts to address north-south mobility in the western San Gabriel Valley and east and northeast Los Angeles. A wide range of possible transportation alternatives were identified during the Alternative Analysis Report (CH2M HILL, 2012), including input from past studies, comments received during the “SR 710 Conversations” from elected officials, stakeholders, city and agency staff, and the community. The resulting alternatives were evaluated and refined through a three-step screening process to identify the alternatives that best meet the Need and Purpose of the study. The details of the screening process, selection criteria, and the alternatives selected for further conceptual engineering and initial environmental analysis evaluation are presented in the Alternative Analysis Report.

Using the alternatives analysis process a total of five alternatives were selected for conceptual engineering and environmental evaluation. The set of alternatives considered for conceptual engineering includes a No Build alternative, a Transportation System Management (TSM)/Travel Demand Management (TDM) alternative, Bus Rapid Transit (BRT) alternative, Light Rail Transit (LRT) alternative, and a freeway tunnel alternative. The LRT alternative is described in detail in this report. The TSM/TDM and BRT alternative improvements are documented in their respective alternative ACE reports. The freeway tunnel alternative is documented in the Draft Project Report, as appropriate for a proposed Caltrans facility. The Draft Project Report also documents impacts of the LRT Alternative on Caltrans facilities.

### 2.1.1 Light Rail Transit Alternative

The LRT Alternative would include passenger rail operated along a dedicated guideway, similar to other Metro light rail lines. The LRT alignment is approximately 7.5 mi long, with 3 mi of aerial segments and 4.5 mi of bored tunnel segments. Figure 2-1 illustrates the LRT Alternative.

The LRT Alternative would begin at an aerial station on Mednik Avenue adjacent to the existing East Los Angeles Civic Center Station on the Metro Gold Line. The alignment would remain elevated as it travels north on Mednik Avenue, west on Floral Drive, north across Corporate Center Drive, and then along the west side of I-710, primarily in Caltrans ROW, to a station adjacent to the California State University, Los Angeles (Cal State LA). The alignment would descend into a tunnel south of Valley Boulevard and travel northeast to Fremont Avenue, north under Fremont Avenue, and easterly to Fair Oaks Avenue. The alignment would then cross under SR 110 and end at an underground station beneath Raymond Avenue adjacent to the existing Fillmore Station on the Metro Gold Line.

Two directional tunnels are proposed with tunnel diameters approximately 20 ft each, located approximately 60 ft below the ground surface. Other supporting tunnel systems include emergency evacuation cross passages for pedestrians, a ventilation system consisting of exhaust fans at each portal and an exhaust duct along the entire length of the tunnel, fire detection and suppression systems, communications and surveillance systems, and 24-hour monitoring, similar to the existing LRT system.

Trains would operate at speeds of up to 65 miles per hour (mph) every 5 minutes during peak hours and 10 minutes during off-peak hours.

Seven stations would be located along the LRT alignment at Mednik Avenue in East Los Angeles, Floral Drive in Monterey Park, Cal State LA, Fremont Avenue in Alhambra, Huntington Drive in South Pasadena, Mission Street in South Pasadena, and Fillmore Street in Pasadena. The Fremont Avenue Station, the Huntington Drive Station, the Mission Street Station, and the Fillmore Street Station would be underground stations. New Park-and-Ride facilities would be provided at all of the proposed stations except for the Mednik Avenue, Cal State LA, and Fillmore Street stations.

Figure 2-1: LRT Alternative

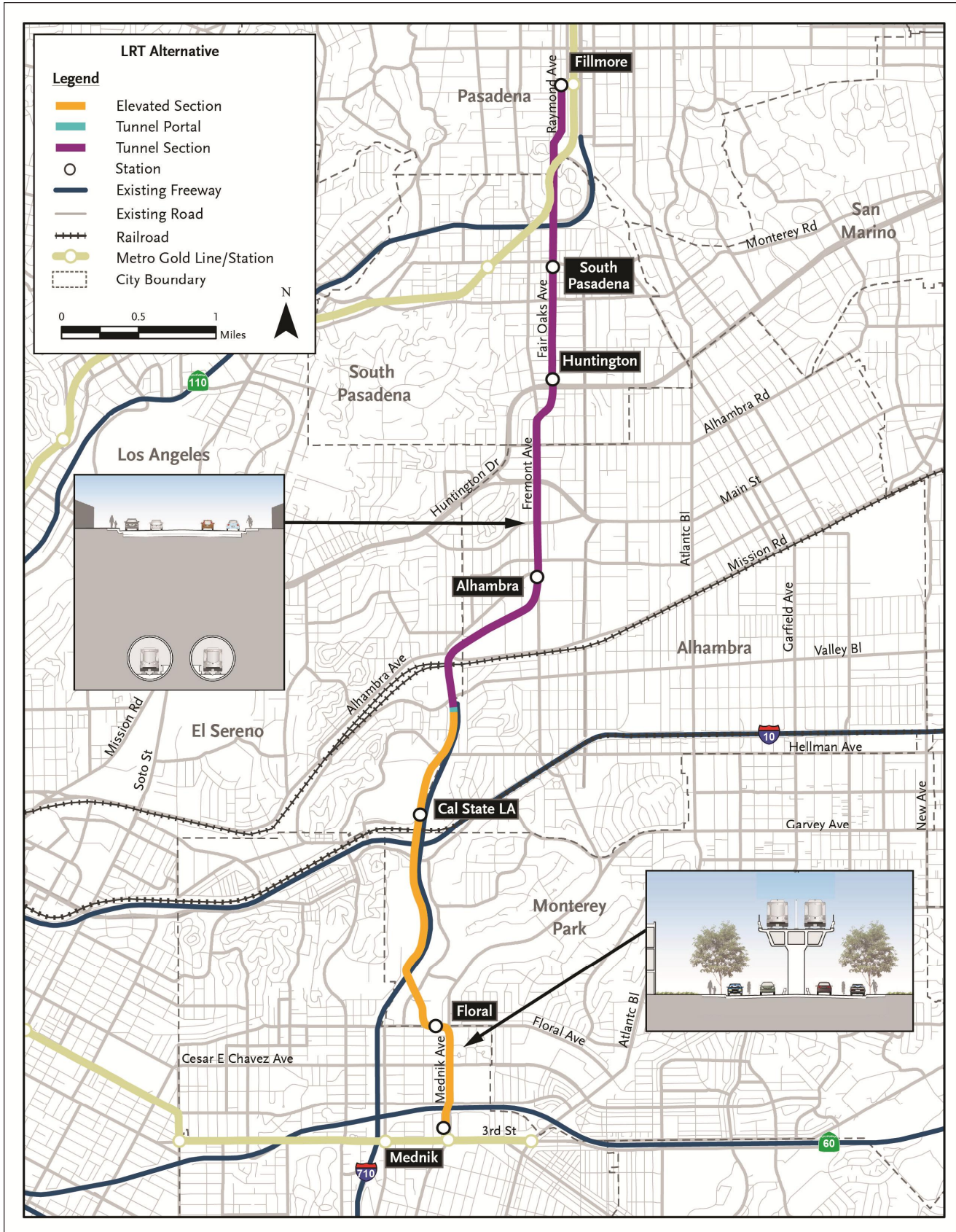

A maintenance yard to clean, maintain, and store light rail vehicles would be located on both sides of Valley Boulevard at the terminus of SR 710. A track spur from the LRT mainline to the maintenance yard would cross above Valley Boulevard.

Two bus feeder services would be provided. One would travel from the Commerce Station on the Orange County Metrolink line and the Montebello Station on the Riverside Metrolink line to the Floral Station, via East Los Angeles College. The other would travel from the El Monte Bus Station to the Fillmore Station via Rosemead and Colorado Boulevards. In addition, other existing bus services in the study area would be increased in frequency and/or span of service.

The Transportation System Management/Transportation Demand Management (TSM/TDM) Alternative improvements would also be constructed as part of the LRT Alternative. These improvements would provide the additional enhancements to maximize the efficiency of the existing transportation system by improving capacity and reducing the effects of bottlenecks and chokepoints. The only components of the TSM/TDM Alternative improvements that would not be constructed with the LRT Alternative are intersection improvements. Additional details of the TSM/TDM Alternative improvements can be found in the ACE report for the TSM/TDM Alternative.

DRAFT



# LRT Design

## 3.1 Design Criteria

All design work is based on the latest revision of Metro Baseline Design Documents – Metro Rail Design Criteria, Standard and Directive Drawings, Baseline Technical Specifications. If variances or waivers are from the criteria are necessary, they will be described here in the ACE Report.

## 3.2 Operating Plan

This section summarizes the conceptual operating plans for initial analysis of the LRT Alternative for the SR 710 Study along with an estimate of its fleet requirements. The LRT Preliminary Operating Plan is included in its entirety as Appendix B.

### 3.2.1 Operating Assumptions

Metro is assumed to be the operating agency for the proposed LRT Alternative that would provide service between East Los Angeles and Pasadena.

#### 3.2.1.1 Span of Service

The span of service for the proposed LRT alternative would provide service 24 hours per day. Table 3-1 summarizes the assumed span of service.

TABLE 3-1  
Metro LRT Span of Service

Day of Week	Time Period	Hours
Weekdays	Early AM	5:00 – 6:00 a.m.
	AM Peak Period	6:00 – 9:00 a.m.
	Midday	9:00 a.m. – 3:00 p.m.
	PM Peak Period	3:00 – 6:00 p.m.
	Evening	6:00 p.m. – 12:00 a.m.
	Owl	12:00 a.m. – 5:00 a.m.
Saturdays, Sundays and Holidays	Early AM	5:00 – 8:00 a.m.
	Midday	8:00 a.m. – 8:00 p.m.
	Evening	8:00 p.m. – 12:00 a.m.
	Owl	12:00 – 5:00 a.m.

#### 3.2.1.2 Service Frequency

The assumed service frequency of the proposed LRT alternative is presented in Table 3-2. The assumed service frequencies are based on Metro’s 2009 Long Range Transportation Plan (LRTP) criteria.

TABLE 3-2  
Metro LRT Service Frequency

Day of Week	Frequency	Hours
Weekdays	5 minutes	6:00 – 9:00 a.m., 3:00 – 6:00 p.m.
	12 minutes	9:00 a.m. – 3:00 p.m.
	10 minutes	5:00 – 6:00 a.m.
	10 minutes	6:00 p.m. – 12:00 a.m. (2:00 a.m. Friday)
	20 minutes	12:00 a.m. (2:00 a.m. Friday) – 5:00 a.m.
Saturdays, Sundays and Holidays	7.5 minutes	8:00 a.m. – 8:00 p.m.
	15 minutes	5:00 – 8:00 a.m.
	10 minutes	8:00 p.m. – 12:00 a.m. (2:00 a.m. Saturday)
	20 minutes	12:00 a.m. (2:00 a.m. Saturday) – 5:00 a.m.

### 3.2.1.3 Vehicle Performance

LRT vehicles are assumed to have a normal service maximum acceleration rate of about 2.5 miles per hour per second (mphps) between 0 and 30 mph, decreasing to an average acceleration rate of 1.0 mphps between 30 to 55 mph. Normal service braking is assumed to be a constant 2.5 mphps from 55 mph to 0 mph. LRT vehicles are assumed to have a maximum revenue operation speed of 55 mph. Operation speeds along the proposed alignments vary due to horizontal and vertical curves and station spacing, as well as speed limits on street-running alignment segments. Station-to-station LRT time estimates developed based on these criteria are presented below.

#### 3.2.1.4 Station Dwell Times and End-of-Line Layovers

The average station dwell times (i.e., time to allow passengers to board and alight the transit vehicle) for the LRT Alternative are assumed to be 20 seconds at all of the proposed stations, not including the end-of-line station.

End-of-line layovers provide sufficient time for drivers to take breaks as required by union agreement, as well as allow for schedule recovery (i.e., a late train can “catch up” to its schedule). Layovers of three minutes are assumed at each end-of-line station. Metro currently uses “drop-back” operators at most terminal stations for rail operations.

#### 3.2.1.5 Proposed Operating Plan

The LRT Alternative would begin at an aerial station on Mednik Avenue adjacent to the existing East Los Angeles Civic Center Station on the Metro Gold Line. The alignment would remain elevated as it travels north on Mednik Avenue, west on Floral Drive, north across Corporate Center Drive, and then along the west side of I-710, primarily in Caltrans ROW, to a station adjacent to the California State University, Los Angeles (Cal State LA). The alignment would descend into a tunnel south of Valley Boulevard and travel northeast to Fremont Avenue, north under Fremont Avenue, and easterly to Fair Oaks Avenue. The alignment would then cross under SR 110 and end at an underground station beneath Raymond Avenue adjacent to the existing Fillmore Station on the Metro Gold Line. The LRT Alternative station to station run times are presented in Table 3-3.

TABLE 3-3  
LRT Alternative Station-to-Station Run Times

Station	Speed (mph)	Distance (miles)		Run Time (min:sec)	Delay Time	Dwell Time	Total Time
		Increment	Total				
East LA Civic Center (Mednik Ave / Civic Center Way)	20 – 45	0.74	0.00	01:47	00:00	00:20	00:20
Floral Dr / Mednik Ave	20 – 45	1.48	0.74	02:53	00:00	00:20	02:07
Cal State LA	35 – 45	1.81	2.22	02:57	00:00	00:20	05:20
Alhambra (Fremont / Concord Aves)	45 – 55	1.37	4.03	02:00	00:00	00:20	08:37
Huntington Dr (Fair Oaks Ave / Spruce St)	55	0.77	5.40	01:16	00:00	00:20	10:57
South Pasadena (Fair Oaks Ave / Mission St)	35 – 55	1.29	6.17	02:02	00:00	00:20	12:33
Fillmore St / Fair Oaks Ave			7.39			00:00	14:55
<b>Total</b>			7.39	12:55	00:00	02:00	14:55
Average speed, station spacing	29.7	1.23					

*Note: Run times are based on one-way travel.*

### 3.2.1.6 Operating Requirements

Operating requirements were developed for the LRT Alternative based on the assumptions outlined above. Each train in service is assumed to consist of three light rail vehicles (LRVs), and fleet calculations include ready trains to support “drop back” operations and 20 percent spare capacity. Annual operation and maintenance costs are calculated based on the Fiscal Year 2012 cost per revenue service hour presented in Metro’s Fiscal Year 2013 Proposed Budget. This unit cost of \$374.48 is applied for each hour each LRV would be operated in revenue service during a one-year period, and includes transportation costs, maintenance costs, other operating costs, and support department costs.

Operating requirements for the LRT Alternative are presented in Table 3-4. A fleet of 36 LRVs would be required, and annual operation and maintenance costs would amount to \$42 million.

TABLE 3-4  
LRT Alternative Operating Requirements

Day	Headway (minutes)					Peak LRVs	Annual Revenue			Lay over Time (minutes)	Total Cycle Time	Trains			
	Peak / Wknd AM	Evening	Midday	Owl	Car-Miles		Car-Hrs	Train-Hrs	Peak / Wknd AM			Evening	Midday	Owl	
Weekdays	5	10	12	20	24	1,987,000	80,180	26,730	3	35.8	8	4	3	2	
Weekends/Holidays	15	10	7.5	20		792,400	31,970	10,660			3	4	5	2	
Estimated Totals:					24	2,779,000	112,200	37,390							
Ready Cars:					6										
Peak Revenue Total:					30										
Maintenance Spares:					6										
Total Fleet:					36										
Annual Operation and Maintenance Costs:								\$42,000,000							

### 3.3 LRT Alternative – Engineering Considerations

This section describes the engineering considerations involved for the individual segments of the LRT Alternative.

#### 3.3.1 Third Street to I-710 ROW

Starting at the southerly limits of the LRT Alternative, the Mednik Station needs to be aerial because of the requirement for stations to be on straight track, and Mednik Avenue curves as it approaches Third Street. If the station were placed at-grade north of the curve, it would block Civic Center Way, and there is not enough room between Civic Center Way and SR 60 for a station. An at-grade station cannot be south of Third Street at-grade, because the alignment cannot cross the Gold Line alignment at-grade. An aerial station over Mednik Avenue north of Third Street would require straddle bents over the streets, permanent property acquisitions for access, and temporary construction easements. Since acquisitions/easements were required in any case, it was determined that the best location for the station would be on the commercial property on the west side of Mednik Avenue (see sheet T-101). This eliminates the need for straddle bents over the street and allows for potential integration of the station into a reuse of the property. It also eliminates the need to reconstruct the Mednik Avenue bridge over SR 60.

The alignment transitions to the median of Mednik Avenue after crossing SR 60. Use of the median of Mednik Avenue avoids property acquisition on either side (see sheets T-102 through T-104). The alignment cannot return to grade because it needs to be aerial by Floral Drive again in order to make the grade over the hill to the I-710 ROW without impacting access to the corporate park on the north side of Floral Drive.

Along Floral Drive, the alignment is on the north side of the street. This allows a larger turning radius for the curve from Mednik Avenue to Floral Drive by making use of the sloped setback on the north side of the street (see sheet T-105).

#### 3.3.2 I-710 ROW

As the alignment approaches the I-710 freeway, the alignment immediately transitions to the west side of I-710 because the hillside below City Terrace provides greater width than the hillside on the east side, and it provides a direct alignment to reach the Cal State LA Station (see sheets T-107 through T-114).



The Cal State LA Station is located vertically below the level of the Cal State LA campus. It cannot be at the same level because this would make the columns as it crosses the I-10 too tall. Being below the grade of the university is acceptable because vertical circulation (e.g., elevators) will be required regardless of the platform elevation to move passengers across the tracks from the station to the university (see sheets A3-A-101 through A3-A-103). An alternative that placed the station farther west, under the university's tennis courts was investigated but determined not to be feasibly horizontally, as well as adding considerable cost and disruption to the university.

### 3.3.3 Valley Boulevard to SR 110

North of Cal State LA, the alignment remains aerial to cross Hellman Avenue and the southbound on-ramp from Valley Boulevard to SR 710. The northbound SR 710 off-ramp is relocated to be adjacent to the on-ramp, thereby creating room for the LRT mainline to descend and enter a tunnel just south of Valley Boulevard (see sheets T-116 through T-118).

The alignment of the first bored tunnel section is constrained by the 1000' turning radius requirement of the tunnel boring machine (TBM) and by the need to locate to a station near the Los Angeles County Department of Public Works building in Alhambra. These two constraints make it impossible to remain under public ROW (see sheets T-119 through T-128).

After the Alhambra station, the alignment remains under Fremont Avenue as long as possible to reduce the need for easements under residential property (see sheets T-129 through T-138). It eventually transitions under residential property to align with Fair Oaks Avenue (see sheets through T-139 through T-142), constrained again by the 1000' turning radius requirement of the TBM.

The Huntington Station is placed north of Huntington Drive as soon as the track straightens out, providing a station on a tangent alignment per Metro standards, under Fair Oaks Avenue (see sheet T-143).

### 3.3.4 SR 110/Raymond Fault Crossing

The South Pasadena Station has been located south of the center of downtown South Pasadena (see sheet T-151) to avoid potential design complexities with the Raymond fault. Once the location of the fault is better known, the location of this station could be refined in future phases of the project.

### 3.3.5 SR 110 to Fillmore Street

The alignment remains under Fair Oaks Avenue until it turns to reach an underground station near the existing Fillmore Station on the Metro Gold Line (see sheets T-143 through T-166). The angle and location of the turn were designed to avoid passing underneath the City of Pasadena power plant, and are determined by the turning radius of the TBM. The TBM could be abandoned underground past the Fillmore Station, or it could be extracted.

## 3.4 Track Design

The track alignment begins at an aerial station on Mednik Avenue adjacent to the existing East LA Civic Center Station on the Metro Gold Line. From there, the line would run north on Mednik Avenue on an elevated structure, then turn west on Floral Drive, then turn north across Corporate Center Drive and enter the I-710 ROW. After entering the I-710 ROW, the alignment would travel north, with a station at Cal State LA, providing a transfer location for El Monte Busway and Metrolink service.

Continuing north of Cal State LA, the alignment would enter a bored tunnel south of Valley Boulevard. The tunnel alignment would travel northeast to Fremont Avenue, with a station near the Los Angeles County office building in Alhambra. The alignment would then run north under Fremont Avenue, shifting slightly east to Fair Oaks Avenue, remaining in a tunnel. Stations would be placed under Fair Oaks Avenue near Huntington Drive and Mission Street. The alignment would continue in a tunnel under SR 110, and continue north to a terminus station near the existing Fillmore Station on the Metro Gold Line.

For the LRT Alternative, the design for horizontal and vertical gradients is based on the latest revision (SBNC 18 Rv. 001 05.03.95) to the Metro Design Criteria, and subsequent revisions. All segments of the alignment adhere to the Metro Design Criteria, unless otherwise noted in Section 3.4.3 (Exceptions to Design Criteria). Conceptual plan and profile drawings can be found in Appendix A.

### 3.4.1 Horizontal Alignment

The horizontal alignment of the mainline tracks consists of two geometry types: tangents and curves. Tangent track is always connected to curves by spiral transitions. The criteria for both the spiral transition and horizontal curves are governed by operational design speed. Curve lengths are to be maximized in order to increase the design speeds. Long curves are constrained by street ROW, topography and the alignments direction.

Maximum operational design speed is set at 65 miles per hour. A minimum curve radius of 1660 feet is required to achieve the maximum speed with 7 inches of superelevation. The ACE Report does not define spiral and curve superelevation; the design of the superelevation will be determined in the Preliminary Engineering (PE) Phase. Minimum curve radii are set to 300 feet for a design speed of 23 mph and absolute minimum curve radii of 200 feet are used when constrained. A curve radius of 200 feet reduces design speed to 19-21 mph depending on the super elevation. All alignment curves will be tabulated in the alignment curve data table, see sheets TD-101 to TD-103 in Appendix A.

Tangent track sections shall be a minimum of three times the length in feet of the operational design speed. All stations shall also be on tangent track section and shall extend beyond the edge of the platforms 50 feet before transitioning to spiral curves.

The minimum curve radius used in the design is 250 feet approaching the Floral Station. This reduces the speed loss that accompanies minimum curves because a train must accelerate/decelerate at the station during ingress and egress.

For below-grade segments constructed using TBMs, a minimum curve radius of 1,000 feet was used, giving a design speed of 45 mph. Curve radii over 1,200 feet are preferable to reach design speeds over 45 mph. The distance between tunnel centerlines is dictated by the station platforms with dimensions in accordance with Metro's Design Criteria. At stations that have center columns, the track centerline increases to 38 feet – 0 inches. At all transit stations, the track alignments are to be tangent at the station platforms and have a minimum 50-foot-long tangent section beyond the end of the platforms.

### 3.4.2 Vertical Alignment

The profile grade (vertical alignment) is defined by the elevation of the top of the lowest rail. Changes in profile grade are connected by parabolic vertical curves.

The maximum desired sustained grade for LRT is 4.0 percent, while the maximum short sustained grade (500 feet to 1000 feet between vertical point of intersections [VPIs]) is 5.0 percent. The maximum very-short sustained grade (less than 500 feet) is 6.0 percent.

For tunnels under private property, ten feet above the high point of the structure is the minimum required vertical distance to the surface. However, the general rule of thumb is to allow 1.5 times the diameter of the tunnel distance from the top of the structure to the surface. Except near the tunnel entry and exits points and underground stations, the tunnel designs adhere to the general rule of thumb. The LRT Alternative never falls below the minimum requirement of ten feet distance from the top of structure to the surface.

The track slopes through passenger stations are to be less than 1.0 percent. Where slopes are less than 0.3 percent, adequate track drainage must be maintained. Vertical curves must begin or end at least 50 feet beyond the station platforms. Metro Design Criteria calls for a minimum distance of 75 feet of tangent between the beginning or the end of a vertical or horizontal curve.

### 3.4.3 Storage Tracks

The storage tracks would be part of the maintenance yard that would be constructed as part of the LRT Alternative. The storage tracks and maintenance yard would be constructed at the SR 710 southern stub within the Caltrans owned ROW. The primary alignment would transfer from an aerial guideway into twin bored tunnels just south of Valley Boulevard and continue north to the Fillmore Station. The yard tracks would diverge off the primary alignment approximately 1,700 feet south of Valley Boulevard and continue on an aerial guideway to the maintenance yard, which would be constructed on top of retained fill with proposed retaining walls and above the existing Valley Boulevard at this location. The maintenance yard would provide an area for train car wash, car cleaning, paint shop, body shop, wheel truing, replacement parts and materials, and an area for heavy/hoist.

### 3.4.4 Exceptions to Design Criteria

Exceptions to design criteria will be documented and formal design waivers requested from Metro during the PE phase of the project. Potential exceptions to the design criteria and constraints and issues related to design are presented in Section 12.

## 3.5 Trackwork

### 3.5.1 Direct Fixation Track

Direct fixation track would be the primary type of track construction for the LRT Alternative. Direct fixation track would be used on the alignment's aerial and underground sections and would be composed of 115RE rail, direct fixation rail fastener pads and rail fastening assembly for holding the rail and rail fastener pads in place. The rail fastener pads would be bolted onto segmental second pour reinforced concrete plinth pads approximately 20 feet long and 27 inches wide. The plinth pads would be laid out so that a gap of approximately 6 inches is provided between plinth pads for drainage or cable runs. Holes at the bottom of the plinth pads would be provided as needed to provide for additional drainage and cable runs.

The plinth pads would in turn be connected to the existing structural concrete invert using steel stirrups that would be embedded during the pouring of the concrete invert or doweled-in by drill and grout method into concrete invert after the concrete has hardened.

### 3.5.2 Ballasted Track

Ballasted track would be used for the track construction of the maintenance yard. Ballasted track would be composed of 115RE rail, monoblock prestressed concrete ties with rail fastening assembly to hold the rail in place. Twelve inches of high quality ballast and eight inches of sub-ballast material would be installed to support the track structure.

### 3.5.3 Track Gauge

The standard track gauge would be 4 feet – 8-1/2 inches measured between the gauge side of the heads of the rails at a distance of 5/8-inch below the top of the rails. Track gauge would be widened on some curves of the alignment depending on the degree of curvature as follows:

- On curved tracks with radii of more than 500 feet, the track gauge would remain 4 feet – 8- ½ inches.
- On curved tracks with radii of 250 feet to 500 feet, the track gauge would be 4 feet – 8 -3/4 inches.
- On curved tracks with radii of 82 feet to less than 250 feet, the track gauge would be 4 feet – 9 inches.

Gauge widening would be accomplished at 1/16-inch incremental intervals in a transition distance of 31 feet starting at either the tangent to spiral point or curve to spiral point.

Track gauges in the special trackwork areas would be in accordance with the Contract Drawings and the American Railway Engineering and Maintenance-of-Way Association (AREMA) Portfolio of Trackwork Plans.

## 3.6 Special Trackwork

### 3.6.1 Crossovers

A total of five crossovers would be constructed as part of the LRT Alternative. Single crossovers, No. 10 double crossovers and No. 15 double crossovers are used throughout the alignment. The proposed locations of crossovers along are described below:

- A No. 10 double crossover north of the proposed Mednik Station on Mednik Avenue approximately 750 feet north of 1<sup>st</sup> Street (see drawing T-102);
- A No. 10 double crossover north of the proposed Cal State LA Station on an aerial guideway (see drawing T-114);
- A single crossover located approximately 400 feet south of Hellman Avenue on the aerial guideway will provide access to the maintenance yard (see drawing T-116);
- A No. 10 double crossover north of Huntington Station when the alignment is in twin bored tunnels (see drawing T-143).
- A No. 15 double crossover located on the tail tracks north of the new Fillmore Station (see drawing T-165).

Metro Rail Design Criteria require crossovers before and after terminal stations. There is insufficient room south of the proposed Mednik Station to provide a crossover. A design deviation will be required where crossovers cannot be provided per the Design Criteria.

### 3.6.2 Turnouts

Turnouts would be used in areas indicated on the LRT Alternative. Turnouts would be in accordance with the Metro Directive and Standard Drawings and the AREMA Portfolio of Trackwork Plans.

## 3.7 Track Material

### 3.7.1 Running Rail

Running rail for the LRT Alternative would be 115RE rail conforming to the latest version of the Metro Design Criteria and Standard Specifications, and the AREMA Volume 1 Track, Chapter 4 Rail, Part 1 Design of Rail, Section 1.1 Recommended Rail Sections and Part 2 Manufacture of Rail, Section 2.1 Specifications for Steel Rails.

Standard strength rail with brinell hardness of 310 HB minimum would be used on tangent tracks and curved tracks with radii of more than 500 feet. High strength rail with brinell hardness of 370 HB minimum would be used at the following locations:

- On curved tracks with radii of more than 500 feet or less. High strength rail would be extended a minimum of 35 feet beyond the point of tangencies on each end of the curves.
- On curved tracks with vertical grades greater than three percent.
- On curved tracks with repeated accelerations and/or decelerations such as passenger stations, high strength rail would be extended a minimum of 100 feet beyond each end of the platforms.
- Within the special trackwork units.
- In other areas where excessive rail wear is anticipated.

All rails to be used on curves with radii of 300 feet or less would be precurved using standard shop practices.

All running rail would be welded together into continuous welded rail (CWR) by either the flash butt or thermite welding process in accordance with AREMA standards to lengths that are practical for installation and handling except in the following locations:

- Special trackwork units.
- On curved tracks where rail handling could be a problem.
- Structural joints in the underground sections where necessary for expansion.

CWR would eventually be joined together in the field using the thermite welding process.

### 3.7.2 Direct Fixation Rail Fasteners

Direct fixation rail fasteners would be used to hold the running rail in place horizontally, vertically and longitudinally. Direct fixation rail fasteners would be composed of elastomeric rubber pad and rail fastening assembly consisting of two spring rail clips, two anchor bolts and two anchor bolt inserts.

These rail fasteners would be affixed to the concrete plinth pad by the use of anchor bolts and the anchor bolt inserts which are embedded in the plinth pad.

Rail fasteners are designed to electrically isolate the running rail from the ground in order to minimize the flow of stray currents in the surrounding areas that could be harmful to the adjacent reinforcing bars, metal parts and utility pipes.

Rail fasteners also have some properties for reducing the noise and vibration levels generated by passing trains. In areas where excessive noise and vibration are anticipated, special design of rail fasteners with increased noise and vibration reduction properties would be provided. The most commonly used rail fasteners specified for the project have top and bottom metal plates and elastomeric material in between (sandwich type).

### 3.7.3 Bonded Insulated and Bonded Standard Rail Joints

Bonded insulated and bonded standard rail joints would be used where rail welding is not practical or where required by signal track circuits.

Bonded insulated joints and bonded standard rail joints would be composed of two 36-inch six holes joint bars; six high strength bolts, nuts and washers; and epoxy glue for bonding to the web of the rail. In addition, the bonded insulated joints would have insulation on the outside face of the joint bar that is integral to the joint bars. End posts which are installed to provide separations between the ends of the two abutting rails would be approximately ¼ inch thick. Bonded insulated joints would be used in accordance with AREMA Volume 1 Track, Chapter 4 Rail, Part 3 Joining of Rail, Section 3.8 Specifications for Bonded Insulated Rail Joints.

Bonded insulated joints meeting the following requirements would be installed:

- Conforming to the AREMA specifications for 36-inch joint bars.
- Compatible with the requirements for the CWR, and able to transfer the longitudinal rail loads due to thermal expansion and contraction of the rail.
- Would not interfere with the rail fastening system or the restraining rail.

All rail ends would be beveled. If the rail is standard strength, the rail would be end hardened using standard end hardening procedure as described in Metro's Standard Specifications.

### 3.7.4 Restraining Rails

Restraining rails would be installed in areas where the radius of curvature of the horizontal alignment is less than 500 feet. Restraining rail would be installed on the gauge side of the inside running rail throughout the full length of the curve and extending at least 35 feet at each end of the curve.

Restraining rail would be bolted onto the running rail at average intervals of 10 feet. Other types of restraining rail may be used such as the U69 guardrails subject to the review and approval by Metro.

Restraining rail would consist of 115RE rail, spacer blocks, two high strength bolts per separator block and special tie plates that would hold both the running rail and the restraining rail in place. Special plates would include rail clips and anchor bolts with inserts to be embedded into the second pour plinth pads.

Restraining rail pads would have insulating properties similar to standard rail fasteners to electrically isolate the rail from the ground. Insulating pads would be installed between the separator blocks to prevent electrical leakage from the running rail to the restraining rail.

### 3.7.5 Rail Lubricators

Rail lubricators would be installed at several locations of the curved alignment to reduce excessive rail/wheel wear and noise generated due to the passing of the LRT vehicles. Rail lubricators would be either on board or wayside and would be in accordance with AREMA Volume 1 Track, Chapter 4 Rail, Part 4 Maintenance of Rail, Section 4.11 Recommended Practices for Rail/Wheel Friction Control.

For relatively short transit trains, on-board lubricators would provide a clean, compact, unobtrusive, all-weather lubrication system. Wayside lubricators allow lubricants to be controlled over short distances and/or on a curve specific basis, but would require on-track access and adjustment. Track gradient would also be considered for wayside lubricators.

The type of lubricant would be coordinated with Metro's Vehicle, Track, Systems, and Maintenance Departments during final design.

### 3.7.6 Ballasts

Where used, ballast would be placed on top of sub-ballast for providing support to the rail and ties and to distribute the track load to the subgrade. The ballast would be selected crushed and graded hard aggregate material conforming to AREMA Volume 1 Track, Chapter 1 Roadway and Ballast, Part 2 Ballast, Section 2.4 Property Requirements. Ballast material would be granite, traprock or quartzite. Carbonate materials or slag would not be accepted.

Ballast would be AREMA Size No. 5. The minimum depth of ballast would be 12 inches measured from the top of sub-ballast to the bottom of the tie directly under the low rail or the inside rail.

### 3.7.7 Sub Ballasts

Sub-ballast would be placed between the track ballast and the prepared subgrade not only to support the loads imposed by the LRT vehicles but also to act as a buffer or filter to prevent subgrade material from penetrating the sub-ballast section. Sub-ballast also performs the following functions:

- Divert most of the water falling into the track to the side ditches to prevent saturation of the subgrade which would weaken the subgrade and contribute to failure under load.
- Permit the release of the capillary water or seepage of water to prevent the accumulation of water below the sub-ballast.

Sub-ballast would be eight inches thick and composed of smaller dense or well graded granular material in accordance with AREMA Volume 1 Track, Chapter 1 Roadway and Ballast, Part 2 Ballast, Section 2.11 Sub-Ballast Specifications.

## 3.8 Civil

### 3.8.1 Utilities

Identifying the utilities for the SR 710 Study during ACE is a core consideration when designing the ACE alignments. By identifying the utilities, the engineer can design around the conflict, or coordinate with the utility's owner for relocation. After assessing each of these major utilities impacts to construction in detail, the existing

utility data and information will be incorporated into the base maps and shown in the alignment plans. The utilities identified were divided into three major categories, Municipal Wet Utilities, Private Dry/Wet Utilities, and Other Utilities. Each of these categories are described by the streets that they impact.

The locations of existing major utilities along the alternative alignments have preliminarily been identified, in addition to as-built utility information for sewers and storm drains.

### 3.8.1.1 Municipal Wet Utilities

Municipal wet utilities include the following class types of systems:

- **Water:** Existing domestic water lines are usually cast iron and weak joints are a concern for leakage. Water pipes are pressurized and are easier to relocate than gravity feed sewer systems.
- **Sanitary Sewer:** Typically these pipes are made of Vitrified Clay Pipe and are gravity systems. Because gravity drives transport they are usually deeper in the ground and are constrained to minimum slopes to effectively transport waste.
- **Storm Drain:** Storm Drain Sewer Systems are typically made of Reinforced Concrete Pipe or Cast in place Reinforced Concrete Boxes of various sizes. Because gravity drives transport they are usually deeper in the ground and are constrained to minimum slopes to effectively transport storm run-off.

**First Street to Floral Drive:** An 8 inch water line runs along Mednik Avenue underneath the proposed alignment. This water line would need to be relocated with the LRT Alternative. In addition, a 2 inch waterline runs perpendicular to the alignment at Hammel Street and another is located just north of Fisher Street. These would also need to be relocated. Lastly, an 8 inch sanitary sewer line runs along First Street that will need to be reconstructed.

**I-710 Freeway:** An 8 foot by 5 foot storm drain Reinforced Concrete Box (RCB) and a 10 foot by 11 foot double RCB owned by the Los Angeles County Flood Control District (LACFCD) will need to be protected in place. Five downdrains are located along the I-710 Freeway and directly in the path of the proposed LRT Alternative alignment to be removed. In addition, an 18 inch Corrugated Metal Pipe (CMP) will need to be removed or abandoned. A 24 inch CMP storm drain runs perpendicular to the I-710 freeway approximately 750 feet south of Ramona Boulevard that will also need to be reconstructed. After the alignment transitions from the west side of the I-710 freeway to the median via aerial structure, an 8 inch CMP storm drain begins in the median starting 200 feet south of Paseo Rancho Castilla Road. Approximately 640 feet of this CMP storm drain will need to be reconstructed.

**I-710 Freeway to Valley Boulevard:** The construction of the maintenance facility and the mining required for the TBM, would require several storm drain systems of reinforced concrete pipe (RCP) varying in sizes from 24 inches to 45 inches to be either protected or reconstructed. These storm drains connect to the local storm drain system. Some of the storm drains in this area will need to be protected in place and others will need to be removed entirely. In addition, an 8 inch sewer system will need to be protected in place as well as a 60 inch Metropolitan Water District (MWD) water line with casing will also need to be protected in place.

**Fair Oaks Avenue from Mission Street to Hope Street:** A 54 inch pipe along Mission Street and a 40 inch pipe along Fair Oaks Avenue would need to be protected in place.

No other major wet utilities would interfere with the LRT construction as the rest of the alignment is underground and too deep to interfere with utilities.

### 3.8.1.2 Private Dry/Wet Utilities

Dry utilities include communication lines (telephone fiber optic), overhead and underground electrical, and telephone and cable facilities which are located within public ROWs. It is generally preferable to relocate telephone and other communication lines. Typically a certain amount of slack is left in the utility pull-boxes for

future realignment of the conduit. Wet utilities would include any non-municipal owned utilities, which have been identified and need to be protected or relocated.

### 3.8.1.3 Other Utilities

Other utilities that will require consideration include the following:

- Power Transmission Lines and Towers: Overhead power lines impacted by construction will be identified to be relocated. The installation of new underground cables is another alternative for corridor “beautification”, provided the in-kind contributions are negotiated with the utility company.
- Gas, Petroleum, and Steam Lines: For underground structures, relocation is required. In cases where the lines cannot be relocated, approval will be required from Metro. Temporary and/or permanent relocations will follow industry standards and practices.

First Street to Floral Drive: A 4 inch gas line runs along Mednik Avenue and will need to be relocated.

## 3.8.2 Drainage

The land in the county and cities in the vicinity of the project is urbanized and largely covered with impervious surfaces associated with areas of asphalt, concrete, buildings, and other land uses which concentrate storm runoff. Along the alignments, stormwater and other surface water runoff is conveyed to municipal storm drains. Most local drainage networks are controlled by structural flood control measures.

Based on the proposed alignment and the utilities described in Section 3.8.1, a number of storm drain networks have been identified. These lines will require rerouting and require hydrologic and hydraulic analysis for the affected storm drain lines, which will be done during the PE phase.

### 3.8.2.1 Hydrology

Hydrologic and conceptual level hydrologic analysis of the drainage pattern and design flows under existing conditions for each of the storm drain pipes identified above in Section 3.8.1 will not be performed during the ACE phase. This effort will be deferred to the PE phase of the project.

### 3.8.2.2 Surface Drainage

Surface drainage will follow Metro’s Design Criteria for design in station plaza areas, parking lots, trackway areas such as yards and other open areas. All of these facilities require Metro to comply with the California Regional Water Quality Control Board, Standard Urban Run-off Mitigation Plan (SUSMP). Standard best management and design practices will be employed to minimize the surface water level, flooding and to provide a safe walking surface for pedestrians. Roadway drainage will follow the local municipal design standards that have jurisdiction over the public ROW.

### 3.8.2.3 Drainage Systems

A storm drainage system will be provided through the rail system. An underdrain will be provided along the center of track and surface run-off shall flow to it. The underdrain system shall tie into the existing storm drain system at existing or new catch basins along the alignments. New drainage structures will be designed in accordance with the Los Angeles County Flood Control District (LACFCD) Hydraulic Manual. Hydraulics and design of the new drainage system will be deferred until the PE phase of the project.

## 3.8.3 Traffic

The LRT Alternative is a major undertaking planned by Metro with a construction duration of multiple years required to build the system. The majority of the system would be built within the public ROW and would require careful planning to mitigate construction impacts to the public. The aerial portion of the LRT Alternative will be within road ROW, which will require modifications to the existing street along the alignment. The goal of the



project is to minimize traffic impacts by adopting appropriate construction methodology, conducting public outreach and developing traffic mitigations in consultation with the local agencies during the design phase and enforcing the requirements throughout the construction period.

### 3.8.3.1 Streets

Vehicle lanes will follow the standards and design guidelines of the applicable local jurisdiction with respect to lane types and lane widths. Typically lane widths would be as follows:

- Through Lanes – 12 feet
- Curb Lanes – 14 feet
- Left and Right Turn Lanes – 10 feet
- Curb lanes with parking – 20 feet
- Parking Lanes – 8 feet
- Sidewalk Widths – Vary dependent on site conditions
- These lane widths are considered optimal: all exceptions will be discussed with approval of local jurisdiction.

### 3.8.3.2 Bike Lanes and Routes

The minimum bike lane width is 4 feet, per American Association of State Highway and Transportation Officials (AASHTO) Guide For The Development of Bicycle Facilities, page 22.

Based on the Caltrans Highway Design Manual (2006), bicycle facilities are classified based on the standard typology described below:

- Class I (Bike Path) – A completely separate ROW for the exclusive use of bicycles and pedestrians, with vehicle and pedestrian cross-flows minimized.
- Class II (Bike Lane) – A restricted ROW designated for the use of bicycles, with a striped lane on a street or a highway. Vehicle parking along with vehicle and pedestrian cross-flows are permitted.
- Class III (Bike Route) – A ROW designated by signs or pavement markings for shared use with pedestrians and motor vehicles.

There are no existing bicycle facilities along the LRT alignment. Los Angeles County is considering added bicycle lanes on Mednik Avenue; this project has been included in the LRT design.

### 3.8.3.3 Roadway Signing and Striping

Roadway signing and striping will follow the standards of each applicable local jurisdiction with authority over the public roadway. Design of roadway striping during LRT operations has been determined and is shown in Appendix A, drawings SS-101 through SS-105. The only striping changes are on Mednik Avenue. Roadway signing will not be shown on drawings during ACE design. Roadway design will be deferred until after the ACE phase.

### 3.8.3.4 Maintenance of Traffic

Traffic maintenance would follow local codes and standards with respect to lane widths, number of lanes, and durations of temporary lane closures. In subsequent design phases with further design development, specific requirements would be developed with the local jurisdictions where longer term closures are required.

Maintenance of traffic during construction is significant importance. Maintenance of traffic will cover such construction activities as:

- Relocation of utilities (as required)
- Placement of piles (aerial alignment)

- Excavation of the top six to eight feet of surface materials
- Placement and removal of falsework (aerial alignments)

The degree of potential impacts on traffic flow would be dependent on the method of construction. Different types of construction methods would have varying levels of impacts.

DRAFT

# Geological Conditions

## 4.1 Exploration Program

A total of 14 borings were utilized during the geologic and geotechnical evaluation of the SR 710 North Study LRT Alternative. The explorations originated from three sources, as detailed in Tables 4-1, 4-2, and 4-3. Boring logs, associated laboratory data, and insitu test results are presented in the SR 710 North Study Preliminary Geotechnical Report [(PGR) CH2M HILL, 2014].

TABLE 4-1  
Summary of SR 710 North Study LRT Alternative Explorations

Exploration No.	Type of Exploration	Northing <sup>a</sup>	Easting <sup>a</sup>	Ground Surface Elevation <sup>b</sup> (feet)	Depth of Exploration (feet)	Purpose
A-13-001	Hollow-Stem Auger	1839403.75	6511403.50	344.1	105.4	Geotechnical
RC-13-002	Hollow-Stem/ Wireline Coring	1843137.78	6511686.47	349.24	85.1	Geotechnical
RC-13-003	Hollow-Stem/ Wireline Coring	1847540.09	6512456.89	388.78	100.5	Geotechnical
RC-13-004	Hollow-Stem / Wireline Coring	1848742.92	6512894.91	393.35	109.0	Geotechnical
RC-13-005	Hollow-Stem/ Wireline Coring	1849587.82	6512879.80	425.01	225.0	Geotechnical
R-13-006	Hollow-Stem/Rotary Wash	1855165.01	6515308.63	505.56	120.8	Geotechnical
A-13-008	Hollow-Stem Auger	1862835.52	6515983.73	615.45	96.5	Geotechnical
O-13-010	Sonic Drilling	1865277.86	6514376.75	693.46	272.0	Geotechnical/ Faulting
A-13-021	Hollow-Stem Auger	1859621.30	6515914.19	577.93	110.8	Geotechnical

<sup>a</sup> California Coordinate System, Zone 5, U.S. survey feet

<sup>b</sup> The elevations are based on NAVD 88.

TABLE 4-2  
Summary of Technical Study<sup>c</sup> Borings (CH2M HILL, 2010) Utilized in the SR 710 North Study, LRT Alternative

Exploration No.	Type of Exploration	Northing <sup>a</sup>	Easting <sup>a</sup>	Ground Surface Elevation <sup>b</sup> (feet)	Depth of Exploration (feet)
R-09-Z1B8	Rotary Wash/Wireline Coring	1850582.92	6512724.74	419.6	200
R-09-Z3B4	Rotary Wash/Wireline Coring	1870813.73	6516733.49	768.0	276
R-09-Z3B6	Rotary Wash/Wireline Coring	1868062.70	6516722.28	750	326
R-09-Z4B4	Rotary Wash/Wireline Coring	1851895.71	6514496.46	454.4	277

<sup>a</sup> California Coordinate System, Zone 5, U.S. Survey Feet

<sup>b</sup> The elevations are based on North American Vertical Datum 1988 (NAVD 88).

<sup>c</sup> SR 710 Tunnel Technical Study, Geotechnical Summary Report (CH2M HILL, 2010).

TABLE 4-3  
Previous Geotechnical Explorations Utilized in the SR 710 North Study, LRT Alternative

Exploration No.	Type of Exploration	Latitude	Longitude	Ground Surface Elevation <sup>a</sup> (feet)	Depth of Exploration (feet)
EMI-2	Rotary Wash/ Wireline Coring	N 34.115111°	E -118.166111°	650	201.1

<sup>a</sup> As noted on the boring logs presented in CH2M HILL, 2014

## 4.2 Subsurface Conditions

### 4.2.1 Regional Setting

The SR 710 North Study Area encompasses portions of the San Gabriel Valley, the southern San Rafael Hills, the Elysian Hills, and the Repetto Hills. These areas are within a transition zone between the northwest-southeast-trending Peninsular Ranges physiographic province to the south and the east-west-trending Transverse Ranges province to the north.

Regional geologic maps indicate that the SR 710 North Study Area is underlain by nonmarine Quaternary-age (approximately less than 2 million years old) alluvium, marine Tertiary-age (approximately 2 to 16 million years old) sedimentary rocks, and Cretaceous and Pre-Cretaceous (120 to 160+ million years old) crystalline basement complex of igneous and metamorphic rocks.

### 4.2.2 Geological Setting

The stratigraphy along the LRT Alternative is dominated by three principal geologic units: artificial fill soil, alluvial soils, and bedrock. Cross sectional limits of these units present along the LRT Alternative are shown in the PGR (CH2M HILL, 2014).

Artificial fill soils are present at the surface along portions of the LRT Alternative. Where encountered, the fills were generally observed to be fine-grained with some coarse-grained constituents.

Alluvial soils are present within the Los Angeles Basin and San Gabriel Valley portions of the LRT Alternative, as well as in local drainages within the Repetto Hills. The alluvial soils are either present at the surface, or concealed by artificial fill soils. The alluvial materials consist of interbedded lenses and/or discontinuous layers of fine-grained sediment (clay and silt) and coarse-grained materials (sand and gravel) that generally increase in strength with depth. Cobble-size rocks are common locally within the alluvial soils; some boulders also may be scattered throughout the unit. In general, the alluvial soils south of the Raymond Fault have a higher fines constituent and a lesser coarse-grained constituent versus the alluvial soils north of the fault.

Bedrock is present either at the surface or concealed below the artificial fill soils and/or alluvial soils along the LRT Alternative. The bedrock units consist of sedimentary rocks of the Fernando, Puente, and Topanga Formations. The Fernando Formation present along the LRT Alternative consists of the Siltstone Member (massive siltstone and claystone) and the Conglomerate Member (massive; fine to coarse grained sandstone with cobbles, to a cobble supported unit with sand matrix). The Puente Formation present along the LRT Alternative consists of the Siltstone Member (thinly-bedded to laminated siltstone with medium to thick interbeds to laminations of fine-grained sandstone) and the Sandstone Member (thickly to very thickly bedded fine-grained sandstone and silty sandstone with scattered laminations to thick interbeds of siltstone and shale). The Topanga Formation present along the LRT Alternative consists of the Siltstone Member (thinly bedded to laminated siltstones and shales, with fine- to coarse-grained sandstone interbeds) and the Sandstone Member (laminated to moderately-bedded, medium- to coarse-grained sandstone with thin interbeds and laminations of fine-grained sandstone, siltstone, and/or shale with some conglomerate beds) and the Conglomerate Member (fine gravel and cobbles in a medium- to coarse-grained friable arkosic sand matrix). All three of these units contain localized, hard to very hard, well cemented beds and concretions.

The bedrock units along the Alternative are considered non-water-bearing; however, localized seeps may be present within sandstone beds and the faults and/or fracture zones present within the bedrock formations. The Raymond fault is a known groundwater barrier; groundwater levels on the north side of this fault are significantly higher than the levels on the south side of the fault. In addition, the potentially active (Eagle Rock and San Rafael faults) and inactive faults may also act as groundwater barriers. Groundwater level data has been collected along the LRT Alternative during drilling when feasible, and from piezometers constructed in selected borings. Groundwater levels for the LRT Alternative range from approximately 10 feet bgs south of Valley Boulevard to 160 feet bgs immediately south of the Raymond fault zone.

## 4.2.3 Faulting and Seismicity

### 4.2.3.1 General Setting

Within the SR 710 North Study Area, only the Raymond fault is identified as an active fault under the Alquist-Priolo Earthquake Fault Zone (APEQFZ) Act, which implies a potential for surface rupture. Such a designation indicates the fault is known to have experienced surface offsets within the last 11,000 years and its location is well defined. Potentially active faults may not be identified as active per the APEQFZ Act simply because their locations are not well defined and/or they have not been confirmed to have surface ruptures in Holocene time. Within the SR 710 North Study Area, the San Rafael and Eagle Rock faults are considered potentially active faults. Additional detailed investigation will be required to adequately characterize the activity of the San Rafael and Eagle Rock faults. For planning purposes, the Eagle Rock and San Rafael faults are considered active.

There are very limited data concerning the slip rates or recurrence intervals of surface-rupturing earthquakes for the Raymond fault and the remaining Transverse Ranges Southern Boundary faults (Clamshell-Sawpit, Hollywood, Santa Monica, and Malibu faults). As such, there is difficulty in providing reasonable values for fault displacements. These southern boundary faults are all relatively short, and if any ruptured individually, it would generate displacements of less than 1 meter. However, there are some discussions that some of these faults could rupture together, with slip transferring from one to the other in a cascading event that would result in a larger magnitude event and resultant larger displacements on each of the faults. See the PGR for additional discussion regarding faulting within the SR 710 North Study Area.

### 4.2.3.2 Active Faults

The LRT Alternative crosses one active fault, the Raymond fault. There remains considerable inconsistency in the published data for the Raymond fault. Caltrans currently assumes a slip rate of 2.0 mm/yr and a  $M_{max}$  of 6.7 for the Raymond fault zone. Preliminary fault rupture displacement estimates have been prepared for the LRT Alternative where it crosses the Raymond fault. The estimate summarized below is from the PGR (CH2M HILL, 2014). A left-lateral fault offset of 1.0 meter and a vertical reverse offset of 0.2 meter is considered appropriate for the Raymond fault across a fault zone 25 meters in width.

### 4.2.3.3 Potentially Active Faults

The Eagle Rock/San Rafael fault is generally considered to be the southern continuation of the Verdugo fault. No paleoseismic studies have been published for the Verdugo fault. The Eagle Rock/San Rafael fault zone also has no quantitative investigations, though all three faults are considered to be potentially active. Caltrans classifies the Eagle Rock and San Rafael faults as one fault and as a continuation of the Verdugo fault. According to the Caltrans fault database, the Verdugo/Eagle Rock fault is estimated to have a slip rate of 0.6 mm/yr and an  $M_{max}$  of 6.8. Preliminary fault rupture displacement estimates have been prepared for the LRT Alternative where it crosses the San Rafael fault, also summarized from the PGR. A left-lateral offset of 0.5 meter and a reverse-vertical offset of 0.25 meter could be considered at the San Rafael fault across a fault zone 50 meters in width.

#### 4.2.3.4 Blind Thrust Fault Zones

The concealed trace of the Upper Elysian Park Blind Thrust fault (UEPBT) has been mapped just north of the I-710/I-10 interchange. The UEPBT is theorized to be bound by the Hollywood fault to the northwest and the Alhambra Wash fault (the northerly extension of the Elsinore/Whittier fault zone) to the southeast. The UEPBT has been modeled dipping to the north at angles ranging from 30 to 60 degrees from horizontal; the actual dip of the fault is unknown at this time.

The CGS models the UEPBT as a feature about 18 km long and dipping 50 degrees northeasterly with a slip rate estimate of approximately  $1.3 \pm 0.4$  mm/yr. Caltrans assumes a slip rate of 1.9 mm/yr and a  $M_{max}$  of 6.6 for the UEPBT

As discussed in the PGR (CH2M HILL, 2014), the UEPBT-generated Coyote Pass escarpment transects the LRT Alternative in the vicinity of Corporate Center Drive and Corporate Center Place, just east of I-710 in Monterey Park. Three additional UEPBT-related features (fold axes) have been mapped transecting the LRT Alternative within and north of the Montebello Hills, and south of the Coyote Hills escarpment. The potential activity of these features should be determined, in particular for coseismic deformation along the Coyote Hills Escarpment, which could affect the design of the elevated segment of the LRT Alternative.

#### 4.2.3.5 Seismic Hazards

##### Ground Shaking

The potential to experience substantial seismic ground shaking is a common hazard for every project in southern California, and the hazard cannot be avoided. As detailed in the PGR, the calculated peak ground accelerations for a return period of 2,500 years ranges from 0.90g to 1.18g (g = acceleration due to gravity) along the LRT Alternative.

##### Liquefaction

The LRT Alternative, primarily in the vicinity of I-10 and west of Corporate Place, is located within a Liquefaction Hazard Zone. Key features of this Alternative will be designed for liquefaction and its associated hazards. Where these hazards are identified outside the bored tunnel limits, various methods can be implemented to alleviate this potential hazard. Design and construction of the LRT Alternative would follow Metro Design Criteria (Revision 5, 2013) for liquefaction.

##### Settlement

Local areas along the LRT Alternative that are underlain by alluvial soils may be prone to ground settlement or collapsible soils. Where improvements are proposed on alluvial soils, the improvements would be designed in accordance with Metro Design Criteria, accounting for ground settlement and collapsible soils.

Ground settlement can also occur as a result of ground loss during deep excavations such as tunneling. Ground loss during tunneling occurs when loose, dry, or wet cohesionless soils flow into the excavation. To control this type of settlement, ground loss should be actively controlled at the tunnel face so that ground surface settlement is minimized.

##### Slope Stability

The LRT Alternative traverses hillside areas. In areas where improvements will affect existing slopes and/or developments atop existing slopes, detailed evaluations of the geologic units and geologic structure of these slopes would be conducted. These evaluations would yield the appropriate data required to conduct analyses and provide the geotechnical recommendations needed for the design and construction of the proposed hillside improvements. The portions of the LRT Alternative that are located outside the bored tunnel and are proposed on or adjacent to hillside areas would be designed in accordance with Metro Design Criteria, accounting for slope instability.

## Seiches and Tsunamis

The LRT Alternative is not located adjacent to any large bodies of water. The Alternative is located at a minimum elevation of 275 feet. As such, there is no potential for a tsunami- or seiche-related impact on the LRT Alternative.

## Flooding

The LRT Alternative is not located within a 100 year flood plain.

## 4.2.4 Mineral Resources

The SR 710 North Study Area is located within the San Gabriel Valley Production-Consumption Region [California Geological Survey (CGS), 2010]. Prior to 2010, all of the lands within the San Gabriel Valley Production-Consumption Region were classified by the State of California as containing significant aggregate resources and designated as Mineral Resource Zone -2 (MRZ-2, defined generally as an area where significant mineral deposits are or may be present. CDMG, 1982; CMR, 2007). However, due to urbanization of the region, the CGS in 2010 updated the mineral land classification for aggregate in the San Gabriel Valley Production-Consumption Region and reduced the MRZ -2 designations for the entire consumption region into smaller Sectors (CGS 2010). The project alignment is not located within a currently (2010) defined Mineral Resource Zone (or Sector) based on the CGS.

## 4.2.5 Hazardous Materials

### 4.2.5.1 Herbicide and Pesticide Use

Based on the records review conducted during the SR 710 North Study Phase I Initial Site Assessment (ISA), no specific details regarding herbicide and pesticide use were identified.

### 4.2.5.2 Asbestos-Containing Materials

The scope of work for the ISA did not include a study of asbestos-containing materials. Moreover, because owners or occupants of facilities identified for having environmental significance were not interviewed and because inspection inside these facilities were not conducted during the ISA, information regarding asbestos containing materials, if any, is not available. However, this should be investigated and identified prior to any construction activities within the SR 710 North Study Area.

### 4.2.5.3 PCB-Containing Materials

Based on the records review conducted during the ISA, no specific details regarding PCB containing materials were identified.

### 4.2.5.4 Aerially-Deposited Lead

The scope of work for the ISA did not include any sampling for aerially-deposited lead (ADL). Because of the nature and history of the study area such as freeways, potential for aerially-deposited lead impact is present. As such, ADL sampling should be conducted prior to any construction activities within the study area where potential for ADL is anticipated.

### 4.2.5.5 Lead-Based Paint

The scope of work for the ISA did not include any sampling for lead-based paint. Moreover, because owners or occupants of facilities identified for having environmental significance were not interviewed and because inspection inside these facilities were not conducted during the Phase I ISA, information regarding asbestos containing materials, if any, is not available. However, this should be investigated and identified prior to any construction activities within the study area.

## 4.3 Properties of Concern

### 4.3.1 Former Blanchard Landfill

Natural and man-made slopes are present along the LRT Alternative. On the west side of the I-710 ROW, the LRT alignment is elevated along the toe of the slope of the former Blanchard Landfill. This site is located between Blanchard Avenue and McBride Avenue at 4531 East Blanchard Street, City of Monterey Park. During the period of 1946 to 1958, the facility operated as a Class II landfill. The facility was allowed to accept liquid, solid, chemical, and industrial wastes; with the exception of hazardous waste such as acid sludge, brines, and tank bottoms. Historical documents indicate that the facility accepted several forms of liquid waste, which were mixed with soil prior to disposal. The site closed and ceased disposal activities in 1958. The property containing the former Blanchard Disposal Facility is currently owned by the County of Los Angeles.

Based on a review of environmental reports prepared by others for this site in 2010 (See CH2M HILL, 2013b), none of the reports identified hydrocarbon contaminant issues in soil; however, additional methane gas investigations are underway at this facility. A methane gas investigation conducted in 2010 indicated methane concentrations exceeding the California Code of Regulation Title 27 regulatory limit of 5 percent by volume in air for methane monitoring wells installed within the site. The Geotracker database lists the facility clean up status as Open – Verification Monitoring. See the ISA for additional information for this property.

DRAFT



# Aerial Structures

## 5.1 Design Criteria and Stations

Aerial guideway and bridge structures that carry transit loading and aerial stations shall be designed per the AASHTO Local and Resistance Factor Design (LFRD) Bridge Design Specifications, Fourth Edition with California Amendments by Caltrans, with modifications per Metro Design Criteria/Section 4 Guideway and Trackwork.

## 5.2 Bridge and Guideway Alignments

Table 5-1 shows the operational description of the LRT Alternative and length of each type of operational segment in miles. A total of four bridges would be constructed and would consist of all the aerial segments proposed under the LRT Alternative.

TABLE 5-1  
Operational Description of the LRT Alternative

Number of Stations	Number of Bridges	Operational Segments (Miles)				Total Length
		Aerial	Retained Fill	Bored Tunnel	Transition	
7	4	2.7	0.3	4.7	0.2	7.9

### 5.2.1 LRT Alternative

A total of four bridges would be constructed under the LRT Alternative. The first bridge would start at the southern terminus Mednik Station and continue until the alignment transfers to a 1,100-foot long mechanically stabilized earth (MSE) wall just south of Ramona Boulevard and the I-710/I-10 interchange. The length of this LRT bridge segment would be 1.75 miles and would vary in grade with a maximum of 2.93% occurring approximately a tenth of a mile north of the proposed Floral Station.

To traverse the I-710/I-10 interchange and El Monte Busway, the second bridge would be constructed between the northern end of the MSE wall to the proposed Cal State LA Station. The bridge would transfer from the MSE to an aerial configuration at a grade of 3.88% as it traverses the freeways before leveling out to connect into the Cal State LA Station. The length of this bridge would be approximately one quarter mile (1,350 feet).

The third LRT bridge segment would connect the proposed Cal State LA Station to the tunnel portal before the alignment transitions into twin bored tunnels at the SR 710 southern stub. This bridge would be predominately flat with a grade of -0.25% as it travels over and along the median of SR 710 before submerging into an underground tunnel configuration. North of Hellman Avenue, this bridge diverges in two directions. The mainline alignment would continue across the northbound SR 710 Freeway before transitioning underground. The other diverging bridge would continue for 1000 feet as the yard lead tracks head into the maintenance yard and storage tracks, which would be constructed on top of retained fill with proposed retaining walls for the length of maintenance yard and storage track facilities except for when the alignment is over Valley Boulevard. The fourth and shortest bridge would be constructed over Valley Boulevard for the 150-foot ROW. This bridge would span over Valley Boulevard connecting the two halves of the storage tracks and the maintenance yard that would be built on retained fill.

## 5.3 Types

### 5.3.1 Aerial Guideway

Aerial structures would typically be constructed of concrete, but steel girders might be used for long spans or in special circumstances. The rail would be fastened directly to the top slab of a cast-in-place concrete bridge, or a separately placed slab on a steel beam bridge, or a precast concrete bridge.

As part of the LRT Alternative, the proposed alignment would be constructed on an aerial guideway from its southern terminus at the proposed Mednik Station for approximately 9,300 feet as it traverses adjacent to the I-710 Freeway until it transfers onto an MSE wall for approximately 1,200 feet leading up to an aerial grade-separated crossing over the I-10 and SR 710 Freeways and the El Monte Busway. The proposed alignment would then continue on an aerial guideway until it submerges into twin bored tunnels at the SR 710 southern stub. Of the aerial grade separation section, the only locations where the alignment would not be on an aerial guideway are the MSE wall just south of I-10 and the Cal State LA Station, which would also be constructed on an MSE wall located along the hillside. The remainder of the alignment north of the SR 710 southern stub would be constructed within a bored tunnel.

#### 5.3.1.1 Construction Method of Aerial Guideway

Aerial structures (Figure 5-1 Typical Aerial Structure Cross Section) are constructed in several stages. The first stage involves sectioning off the construction area with k-rail and then installing piles that will support the weight of the structure and the loads that will be carried on it. The piles are either long steel or concrete poles (typically about 12 to 15 inches in diameter and length dependent on soil conditions) that are driven into the ground by vibratory or pile driving equipment or, alternatively, cast-in-drilled-hole (CIDH) piles. CIDH pile construction involves the drilling of shafts that are up to ten feet in diameter, inserting a rebar cage inside the shaft, and filling it with concrete. The diameter of CIDH piles can be greater depending upon the structural loads to be supported.

If driven piles are utilized, the second stage of construction involves the construction of the pile cap which joins all the piles. The pile cap is constructed of reinforced concrete and is approximately 4 to 5 feet thick. CIDH piles may or may not require a pile cap depending upon the structural loads to be supported<sup>1</sup>.

The third stage involves the construction of the columns. Columns are constructed of reinforced concrete, which is typically poured inside a reusable steel form. The shape of the column can vary; however, a circular column approximately 7 to 9 feet in diameter is generally used.

The fourth stage of construction involves the placement of the aerial girders (precast concrete) or cast-in place spans. The girders provide the horizontal support for the guideway. The precast girders are lifted into place by large cranes and secured to the columns. Erection of these girders over active roads is typically done at night to minimize traffic disruptions. Heavy cranes, generally rubber-tired, would be used for the erection of the girders. Due to their size, special staging areas close to the site would usually be needed to set up the cranes and to temporarily store the girders. Once the girders have been placed, a concrete slab would be placed and the rails affixed to it.

Cast-in-place concrete spans would require the erection of falsework (framing) to support the forms into which concrete is poured. Depending on the length of the spans, falsework can be several feet deep. If the bridge is spanning an active roadway then the bridge must be designed with sufficient clearance under the falsework to allow traffic to pass. Alternatively, clearance might be temporarily reduced during construction and trucks and

---

<sup>1</sup> Regular CIDH piles do require a pile cap just like driven piles. The purpose of the pile cap is to distribute the structural load to two or more piles. However, large diameter CIDH piles which do not require a pile cap are sometimes used. These piles can be as large as, or even larger than, the column it supports; in these situations, a single pile is designed to withstand all the forces from the column and there is no need to build a pile cap.

other vehicles may need to be detoured. The typical timeframe for construction of a cast-in-place bridge would be 12 to 18 months depending on the bridge length.

Figure 5-1: Typical Aerial Structure Cross Section

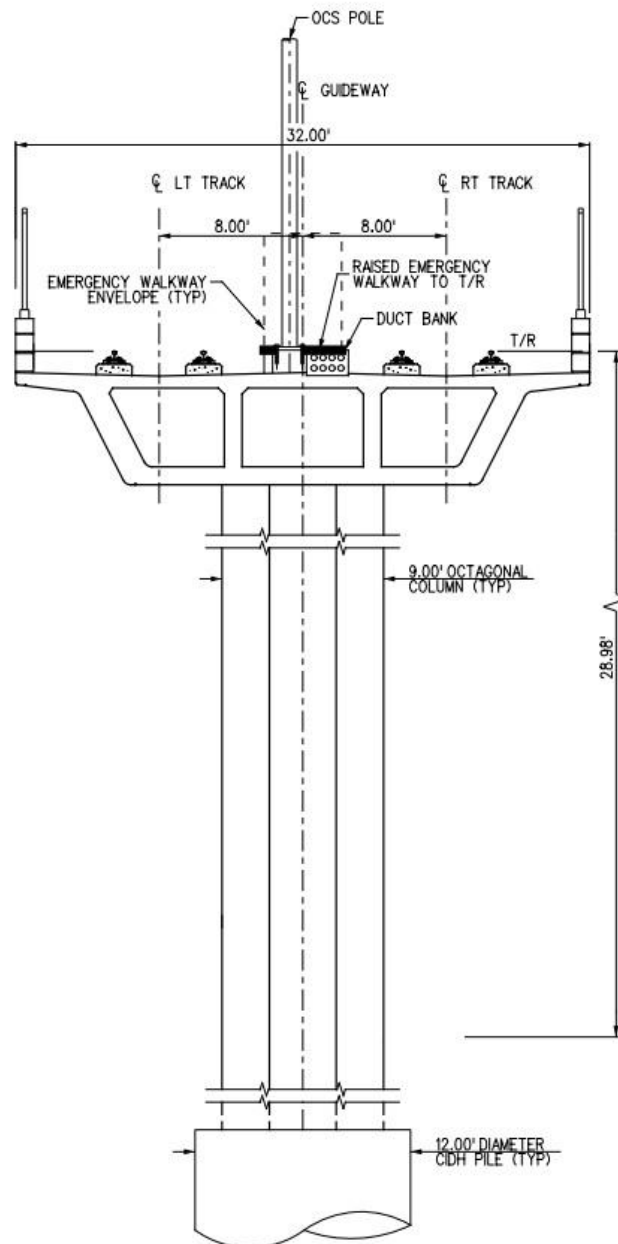

Equipment required for aerial guideway construction would include drilling rigs, possibly specialized water jet excavators, trucks to remove excavated soil, transit mix concrete trucks and concrete pumps, specialized truck trailers to deliver pre-cast concrete beams, cranes, trucks to deliver forms, reinforcing steel, pavement saws, pre-cast concrete post tensioning jacks and related equipment, and water trucks for dust control. Construction vehicles may temporarily impede traffic mobility in the areas of construction. Traffic detour and truck routes would be required during construction. To minimize any disruptions to traffic, mitigation of potential traffic adverse effects and traffic management and control measures would be implemented with coordination and involvement from the various jurisdictions within the project area before construction would occur.

### 5.3.2 Aerial Stations

The aerial stations would be between 20 to 45 feet above the existing ground. Aerial stations under the LRT Alternative would have a center platform configuration. The platforms, per Metro Design Criteria, would be approximately 300 feet long and 30 feet wide for these center platform stations. A typical aerial station cross section is shown in Figure 5-2.

Figure 5-2: Typical Aerial Station Cross Section

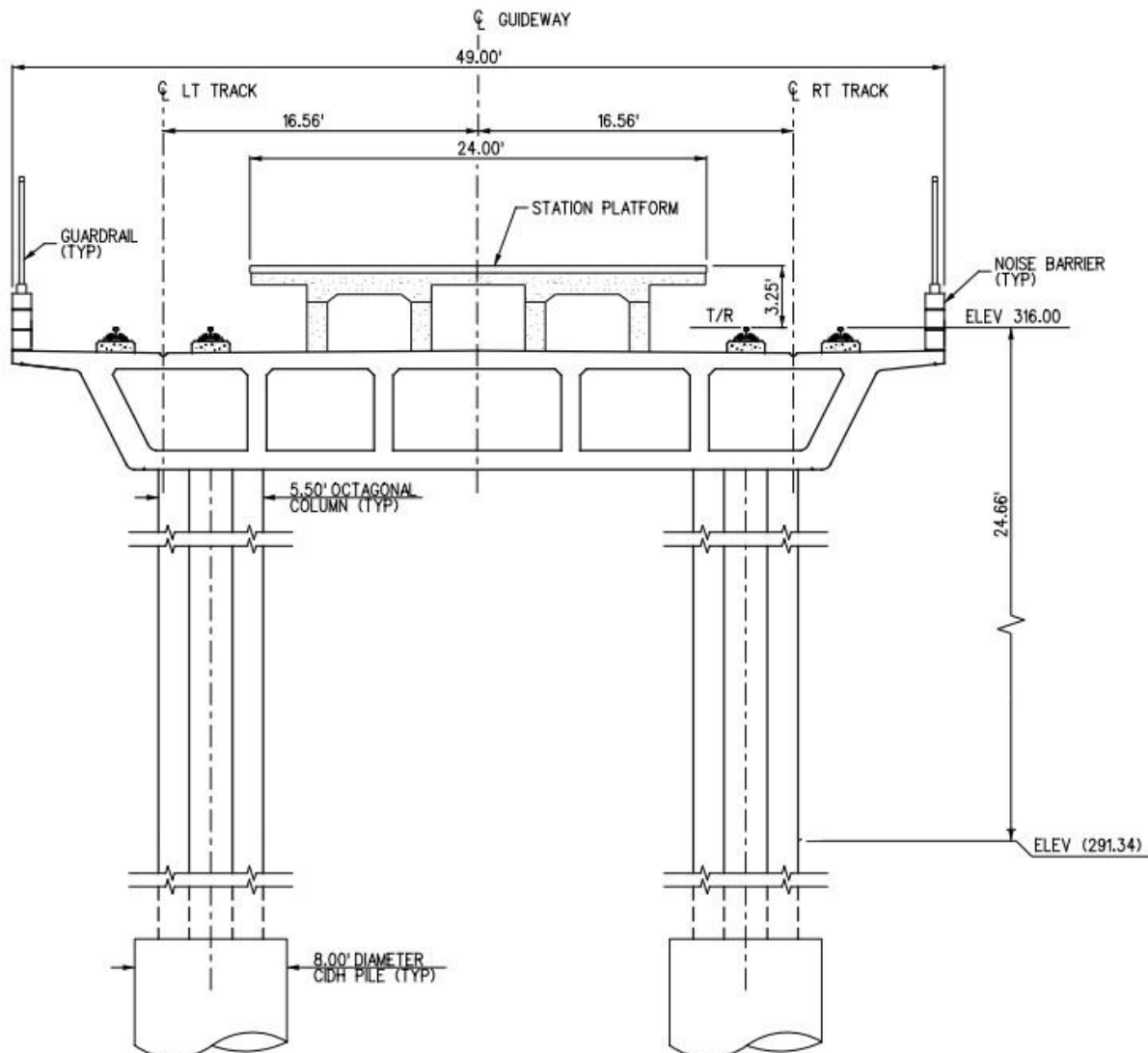

As part of the LRT Alternative, two new aerial stations (Mednik Station and Floral Station) would be constructed. The southern terminus Mednik Station would begin the alignment with an aerial station constructed 25 feet above the existing ground to top of rail. It would be constructed on three pairs of 5.5-foot octagonal support columns. This station would have a center boarding platform with a guardrail and noise barrier on the outside of the tracks adjacent to the boarding platform (see drawings T-101 and TC-101). The second aerial station to be constructed as part of the LRT Alternative would be the Floral Station. The plaza level to this station would be at street level and 45 feet below the top of rail. The concourse level would be 21 feet below the top of rail and would be at the same level as the existing adjacent office parking lot. The station would be constructed at a 0.88% grade. A retaining wall is proposed along the hillside at this location underneath the station platform to the north

between the plaza level with support columns and the existing parking lot to the north. The support columns for this station would be three pairs of 5.5-foot octagonal columns supporting a center boarding platform station with a guardrail and noise barrier on the outside of the tracks adjacent to the boarding platform (see drawing T-105 and TC-104).

The Cal State LA Station would be constructed on an MSE wall that is the length of the platform and would connect on both sides of the platform to aerial guideways; however, this station would be built on a MSE wall constructed into the hillside for additional capacity support and therefore would not be a typical aerial LRT station (see drawings T-114 and TC-114).

### 5.3.2.1 Construction Method of Aerial Stations

Construction of aerial stations would involve construction techniques similar to those for aerial guideways described in Section 5.3.1, "Aerial Guideway". Foundations and columns would be constructed to support the platform. The station platform would typically be constructed of cast-in-place concrete with falsework. Forms would be erected, reinforcing steel would be put in place, and concrete would be placed into the forms to construct the columns and the platform slab. Ancillary facilities would then be added including stairs, elevators, canopy, railings, lighting, seating, signage, and fare vending equipment.

Equipment required for aerial station construction would include drilling rigs, possibly specialized water jet excavators, trucks to remove excavated soil, transit mix concrete trucks and concrete pumps, specialized truck trailers to deliver pre-cast concrete beams (if used), cranes, trucks to deliver forms, reinforcing steel, pavement saws, precast concrete post tension jacks and related equipment.

### 5.3.3 Aerial Support Columns and Bents

A total of 93 bents would be constructed to support the aerial guideway for the LRT Alternative. Ninety of these bents and support columns would be constructed for the primary alignment, two of these ninety bents would be span to support both the primary alignment and the yard lead tracks, an additional two bents would be solely for the yard lead tracks, and one bent would be constructed as support for the storage track bridge over Valley Boulevard with the support columns in the median of Valley Boulevard.

Each bent would consist of either one or two support columns depending on the available ground space below, soil conditions, and necessary load capacity at that location. Two column bents would be located underneath aerial stations with a pair of 5.5-foot columns, after the bridge traversing over the SR-60 freeway, and north of the Cal State LA Station as the alignment transitions to above the median of I-710. The remaining 83 bents would consist of a single octagonal support column between 7 and 9 feet in diameter.

## 5.4 Limits and Clearances

According to Metro Design Criteria/Section 4 Guideway and Trackwork, vertical clearance for Rail Transit System is defined as a minimum distance, measured vertically from the top of rail to the face (bottom) of obstruction above the track. Vertical clearance shall be 15.0 feet for LRT system both at-grade and aerial guideways. The height of the overhead contact (OCS) wire for LRT system shall not be below 14.0 feet and over 22.5 feet above top of rail, and shall not be below 18 feet above top of rail at pedestrian or road vehicle grade crossings and shall be in compliance with California Public Utilities Commission (CPUC) GO 95 Rules 37 and 43.

The minimal required lateral distances from the guideway to Metro ROW lines are 5 feet and guardrails shall be provided on all aerial structures.

Aerial guideways would require relocation of utility support poles to reroute the lines around the project facilities or in some cases elimination of the poles by underground utility relocation. Street lights, poles, and conduits would require relocation along Mednik Avenue and within the parking lot northwest of the Floral Station. Additionally, existing storm drains adjacent to SR 710 would be relocated as part of this Project in order to place the aerial support columns within the hillside.



# Underground Excavation and Ground Support

## 6.1 Tunnel Design Summary

The underground tunnel preliminary design concepts for the LRT Alternative including the bored tunnels, cross passages, and fault crossings are described in the following sections.

### 6.1.1 Bored Tunnel Internal Configuration and Clearances

The bored tunnel internal configuration is dictated by the Fire/Life Safety and the Guideway and Trackwork Sections of the Metro Design Criteria and the requirements of Section 130 of the National Fire Protection Association (NFPA) code (current edition). A cross section of the bored tunnel is shown in Figure 6-1. The cross section shown has an internal diameter of 18 feet, 10 inches and an emergency egress walkway with clear width of 3 feet. The clearance envelope of the egress walkway is 30 inches wide and 80 inches high. The cross section shown in Figure 6-1 allows sufficient space for the clearance envelopes on both tangent and superelevated tracks in accordance with Section 4 of the Metro Design Criteria.

Figure 6-1: Cross Sections of Bored Tunnel

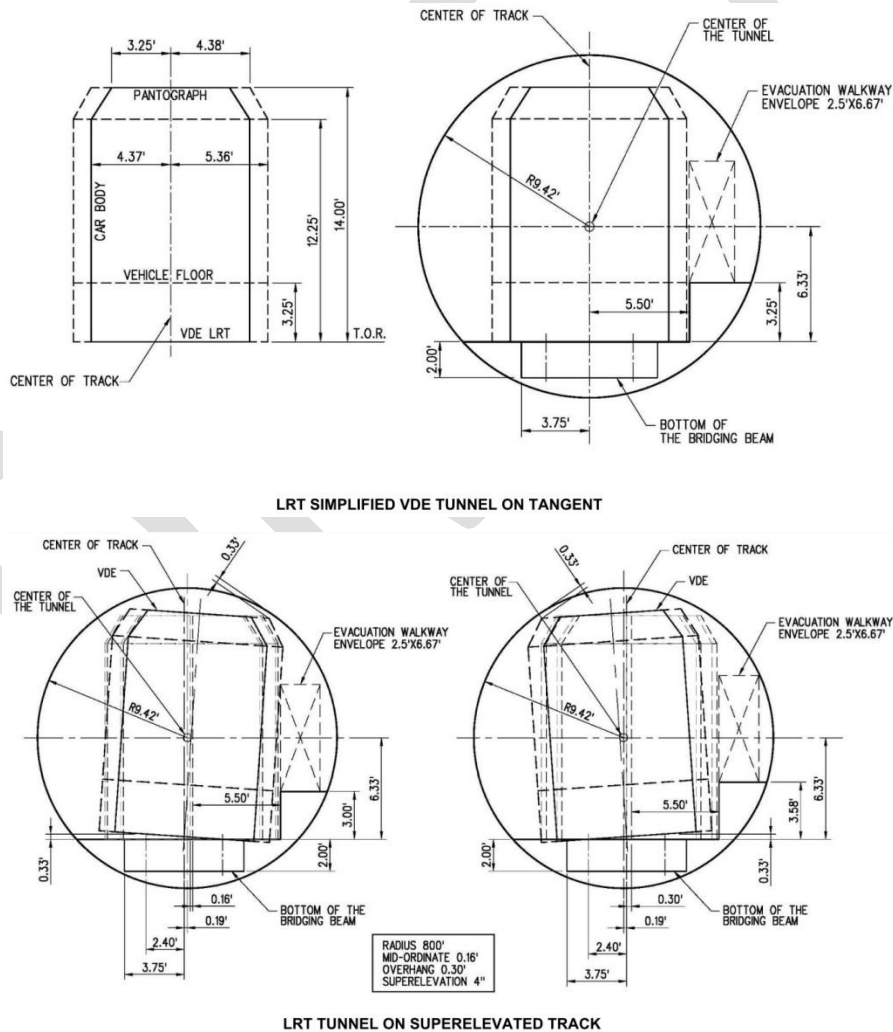

## 6.1.2 Bored Tunnel Separation

At this stage in the ACE phase, it was assumed that the bored tunnels be separated by approximately one tunnel diameter along the alignment. The separation becomes less as the tunnels approach the underground stations. The distance between the centerlines of the tracks within each tunnel varies between approximately 34 and 42 feet. The separation will be evaluated in subsequent phases of the study when more geotechnical information becomes available.

## 6.1.3 Cross Passages

Cross passages are provided throughout the bored tunnels in accordance with the Fire/Life Safety Section of the Metro Design Criteria and the requirements of Section 130 of the NFPA code (current edition). The cross passages allow for passengers to move from one tunnel bore to the other in the case of an emergency, or in any case where it is necessary.

There are twenty-six cross passages along the tunnel alignment, with a nominal spacing of 750 feet in accordance with the Metro Design Criteria. The clearance envelope for the passengers in the cross passages is 6 feet, 6 inches wide and 8 feet high. A cross section of the LRT cross passage is shown in Figure 6-2 and a plan view showing the interface of the bored LRT tunnels and one cross passage is shown in Figure 6-3.

Figure 6-2: Cross Section of Typical LRT Cross Passage

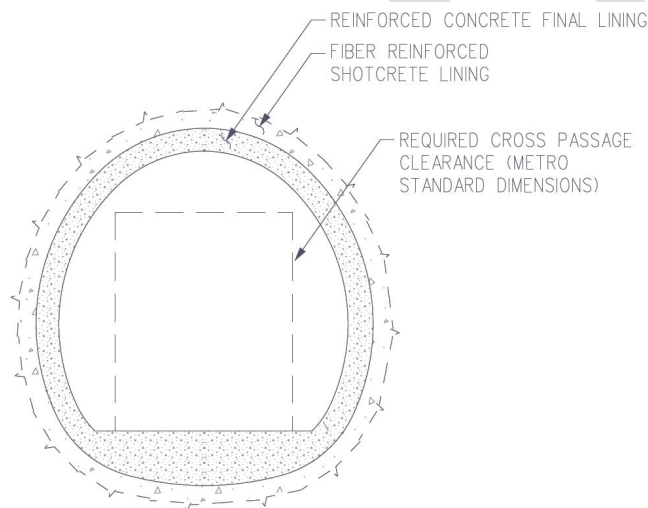
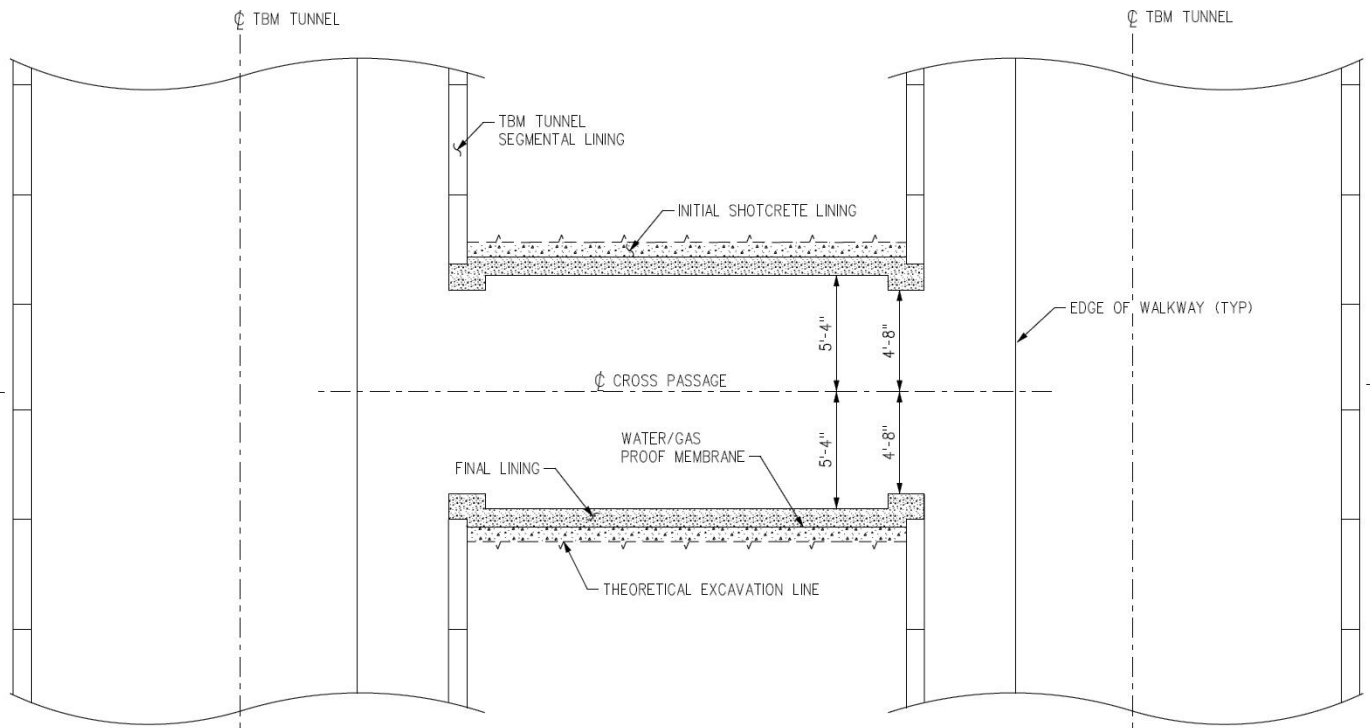



Figure 6-3: Plan of LRT Tunnels at Location of Cross Passage



## 6.1.4 Tunnel Excavation Methods

The method of excavation for tunnels is largely governed by the size and length of the tunnel and ground and groundwater conditions. Typically for long tunnels (more than about 5,000 feet or so), a TBM in conjunction with a precast concrete lining system is the most cost effective approach. Shorter tunnel excavations such as cross passages or utility chambers, are typically constructed using conventional hand-mining methods, sometimes utilizing a sequential excavation method (SEM) approach. The following sections outline the tunneling methods for both the running tunnels and the cross passages of the LRT Alternative.

### 6.1.4.1 Bored Tunnels

Where ground conditions are appropriate, TBM excavation methods are generally more attractive for long tunnel drives because of the higher advance rates, as compared to conventional methods or the SEM. Because of the length and size of the running tunnels, a TBM is considered most likely approach for these tunnels.

A pressurized-face TBM is ideally suited for this project due to the potential of high groundwater pressures combined with the varying permeability and strength of the soil units, including mixed-face conditions, along the proposed alignments. The two most common pressurized-face excavation methods are slurry and earth pressure balance (EPB) TBMs. In the EPB TBM method, a screw conveyor is connected to a cutting chamber (earth plenum), and by synchronizing the TBM advance rate and the screw conveyor extraction rate, a pressure is built up in the chamber and maintained to counterbalance the external earth and hydrostatic pressures at tunnel face. Slurry TBMs rely on a hydraulic pressure created by a recirculating bentonite slurry that applies a positive pressure to the tunnel face, counterbalancing the external earth and groundwater pressures at the tunnel face. This is achieved by a filter cake, or "impermeable" membrane, that forms on the tunnel face as excavation proceeds. A large factor that helps differentiate which type of TBM to select is the geotechnical conditions expected along the alignment.

**Applicability of TBM Based on Soil Types.** The grain size distribution of the formations along the tunnel alignment is a key factor in determining which TBM type is best suited to a given project. Applicable soil conditions for EPB and slurry TBMs have been outlined by Langmaack (2001) and Maidl (1996) and are presented in the shaded regions of Figure 6-4. The figure shows three generalized areas, as described below.

The right hand side of the figure (gray area) represents fine-grained and generally cohesive materials, which are best suited for EPB TBM technology. Within this zone are areas that will require conditioning due to adhesion or “sticky” materials, and other areas that will require only a minimum of ground conditioning. Fine-grained soils such as clayey silt and silty sand are ideally suited for EPB TBM excavation. Inadequate fines content can lead to face instability since a plug cannot be formed within the screw conveyor due to the increased permeability. When the excavated material contains few fines, bentonite, ground limestone, and/or hydrophilic polymers can be injected into to the excavation chamber to improve the consistency and lower the material permeability.

The central portion (brown area) of the figure identifies an area that is a common operating area for both technologies in terms of grain size. It should be noted that more conditioning is required for the EPB technology as the curves approach the slurry area due to the lack of fines, requiring greater volumes of ground conditioners to provide a plastic enough muck consistency to form a suitable plug that can balance the external groundwater pressure. Conversely, when using a slurry TBM close to the limit of the EPB area, the slurry will require conditioning agents such as anti-plugging dispersant agents due to the presence of fine clay and silt materials.

Finally, the area on the left hand side of the figure (tan area) would be suited for slurry TBMs. In the slurry area, polymer conditioners may be introduced to prevent the slurry migration into more permeable coarser-grained material. In practice, slurry TBMs are best suited for the excavation of cohesionless sands and gravels below the groundwater table. The slurry TBM works most effectively in these types of soils because the hydrostatic pressure is balanced by the formation of a “cake” to help form a hydraulic gradient between the hydrostatic pressure in the ground and the slurry pressure in the cutterhead chamber. Additionally, less complex separation methods can be used in the slurry separation plant, as coarse-grained soils are easily separated from the slurry using mechanical shakers, screens, and cyclones.

There are several factors that will influence the decision of what type of TBM to use for the excavation of the running tunnels. In Figure 6-4, the average grain size curves for each of the geologic units expected to be encountered in the study area have been plotted on the shaded regions. While this data is preliminary, it suggests that the majority of the grain sizes collected to date plot in the EPB TBM section of the chart due to the fines content in several of the units. Further study as to the type of TBM to be used for each of the alignments will be evaluated in future phases of this study.

Figure 6-4: Preliminary Grain Size Analysis Curves, per Geologic Unit

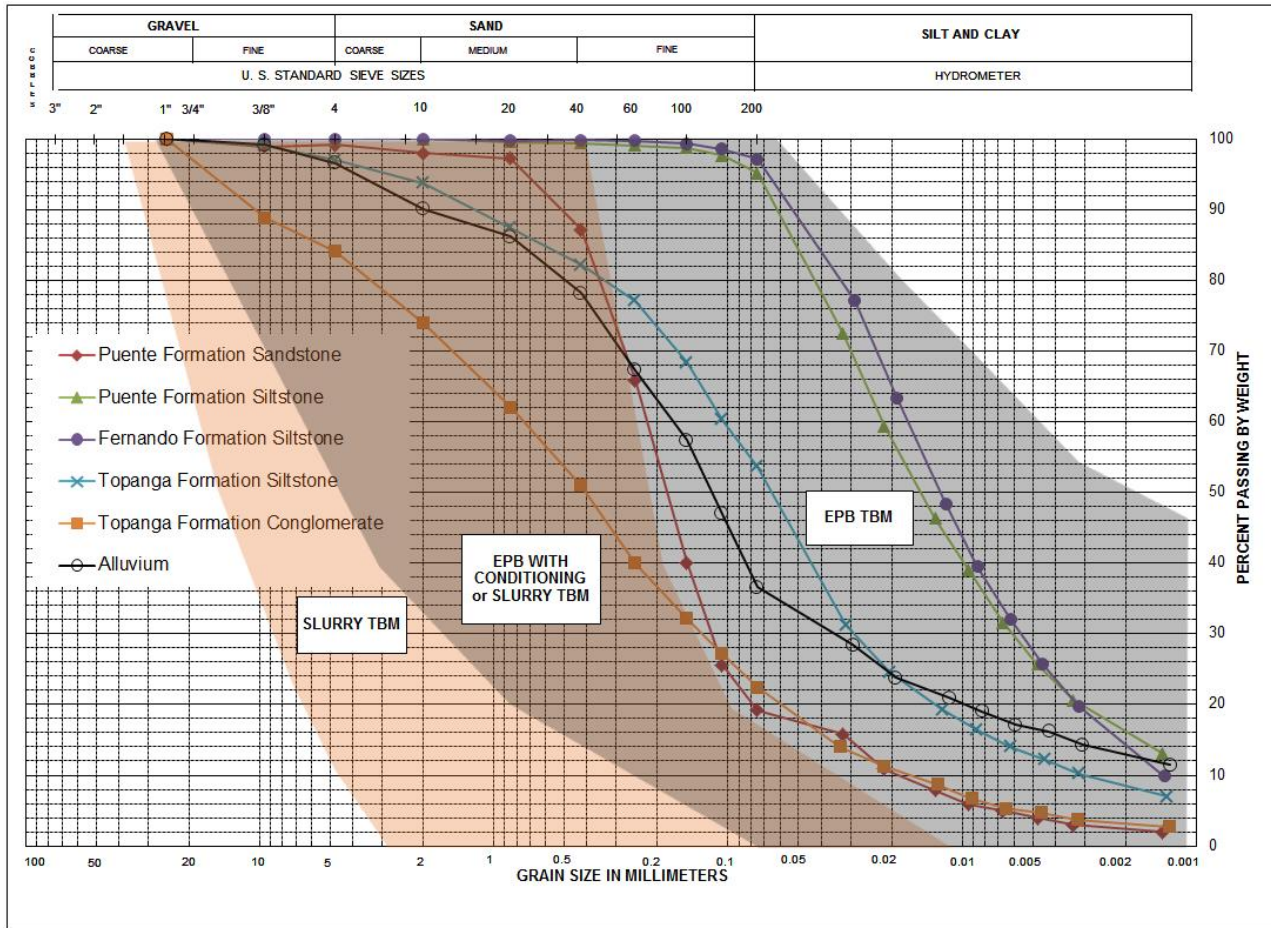

#### 6.1.4.2 Cross Passageways

Cross passages along the running tunnels will be constructed using the SEM, also known as the New Austrian Tunneling Method (NATM). With the SEM, tunnel excavation and support is typically performed in a series of drifts, depending on the anticipated ground conditions, which are sequenced to develop successively larger openings until the design profile is achieved. The SEM is flexible for tunnels in weak and variable ground conditions and considered to be the most suitable and economical method of constructing the cross passages for the LRT Alternative.

Depending on the rock strength, fracturing, and type, several tunnel excavation methods are applicable for an SEM construction approach. These methods include a hydraulic excavator, similar to a backhoe, with a digger paddle or cutterhead attachment; a roadheader; hydraulic impact hammers; and controlled drill-and-blast methods. For tunnel excavation in soil or soft ground, ground improvement prior to mining may also be required in order to ensure stability of the tunnel, minimize groundwater inflows, and control ground loss.

Based on the available geotechnical information, artificial fill and alluvial soils, and soft to moderately hard rock are the predominant ground conditions anticipated in excavation of the cross passages. Hence, it appears that conventional excavation methods using mechanical equipment will be feasible and drill-and-blast techniques do not appear to be required for cross passage excavation. Only the mechanical excavation methods, consisting of a roadheader and hydraulic excavator or backhoe in conjunction with ground improvement measures (if required) are considered for cross passage excavation.

## 6.1.5 Concepts for Tunnel and Cross Passage Lining

The permanent underground structures will be designed in accordance with Section 5 of the Metro Design Criteria. All portions of the lining need to be designed to provide the required design life of 100 years. Key portions of the design impacted by design life include required concrete cover for conventional rebar; gasket design of segmental lining; design for the effects of potential fires in the tunnels; and design for durability.

Detailed structural design of the tunnel lining should consider the anticipated ground conditions and behaviors, the various loading conditions, and the maximum allowable settlement due to excavation. The design and analysis of the tunnel lining are typically performed based on analytical methods and past experience with similar tunnels under similar ground conditions.

Analytical methods for tunnel lining design include closed-form solutions, beam-spring models, and numerical methods. One or more analytical methods can be used to evaluate the demand versus structural capacity of the lining under various loading combinations, as well as face stability, tunnel convergence and deformations, and performance of ground support elements in providing tunnel stability.

To evaluate seismic forces, closed-form solutions summarized in Federal Highway Administration (FHWA 2009) can be used to develop initial estimates of the forces and deformations induced in the tunnel lining due to seismic shear waves. In addition to closed-form solutions, the seismic effect of ovaling deformations on the tunnel lining can be evaluated using numerical modeling software program such as FLAC (Fast Lagrangian Analysis of Continua) (Itasca, 2005) and PLAXIS (PLAXIS 2D, 2010).

### 6.1.5.1 Bored Tunnels

At this stage of the design, the preliminary lining design concepts for the LRT tunnels is based primarily on relevant past experience, which includes the Regional Connector Transit Corridor and Metro Gold Line Eastside Extension projects in Los Angeles, as well as the University-Link Rail in Seattle, Washington. These light rail projects also involve twin-bore tunnels with similar diameters as the LRT tunnels, and in some of the same geologic formations and seismic settings (Regional Connector and Metro Gold Line). More detailed structural analysis following the methodology outlined above will have to be performed for subsequent stages of design.

The bored tunnels would have a one-pass lining system consisting of a concrete segmental lining with gasketed joints. Although the ring geometry is usually determined by the contractor, there are some general requirements associated with the geometry, including ring tapers to negotiate curves along the alignment, avoidance of cruciform joints between segments, and selection of tolerances for both fabrication and installation to minimize potential leakage into the tunnel.

Each of the LRT Tunnels would have an inside diameter of 18 feet 10 inches and a one-pass double-gasketed segmental concrete lining with a thickness of approximately 10 inches, similar to those on the Gold Line Eastside Extension and Regional Connector Transit Corridor. The lining is composed of six segments plus a key segment, resulting in seven radial joints per ring. Based on preliminary analysis, 6,000 psi strength concrete with approximately 1% steel rebar reinforcement of the gross concrete area is required for the segmental lining. Note the amount of steel reinforcement indicated is for hoop reinforcing of the segments. Other reinforcing details, such as the longitudinal reinforcing in the segments, segment joints, and stirrup reinforcing, should be addressed in future design phases. The continuous ethylene propylene diene monomer (EPDM) rubber gasket at each joint near the extrados and intrados of the segment provides for waterproofing and is a critical part of the gas exclusion system.

Figure 6-5 shows the erected precast concrete segmental lining University-Link LRT tunnel in Seattle, Washington.

Figure 6-5. Precast Concrete Segmental Lining, University-Link LRT Tunnel



### 6.1.5.2 Cross Passageways

Cross passages will have a two-pass lining system consisting of the initial shotcrete lining and the cast-in-place concrete final lining (refer to Figure 6-2). A water/gas proof membrane will be installed in between the initial and final linings.

For this stage of design, applicable initial support and final lining concepts for the cross passages are based primarily on relevant past experience with cross passages of similar size in similar ground conditions and seismic settings for projects such as the Regional Connector Transit Corridor and Metro Gold Line Eastside Extension projects. The Metro Gold Line Eastside Extension cross passages have been constructed, and detailed designs have been completed for the Regional Connector cross passages. As such, the cross passage designs from these two projects are specifically applicable to the cross passages of the LRT Alternative.

Cross passages would be excavated using the SEM. Hence, the design concepts for initial support for the cross passages is based on the principle of the SEM. Three support types have been developed, corresponding to the anticipated ground conditions associated with three ground classes that are expected to exhibit similar potential ground behaviors upon excavation. Each support type has a unique excavation sequence and initial support requirements to address the anticipated ground conditions. In addition, the project-specific requirements in terms of limits of surface settlements induced by tunnel excavations, the control of groundwater inflows (e.g., limits of impact to regional groundwater resources), etc., are also considered.

The key initial support and pre-support elements considered for the cross passage excavations include, but are not limited to, cement-grouted rock dowels, fiber-reinforced shotcrete lining, spiles, and fiberglass face dowels. Ground improvement measures using chemical/permeation grouting or ground freezing for cross passages located in alluvium will be required to potentially stabilize the ground and limit ground movements.

### 6.1.6 Fault Crossings

Tunnels and underground structures generally perform well in earthquakes, except for ground displacement that could occur where the tunnel crosses active faults or where there is other seismically induced ground failure such as slope failure or liquefaction. The LRT bored tunnel alignment crosses two faults that have the potential for generating ground movements (offsets) if a seismic event occurred. The active and potentially active faults include the Raymond and San Rafael faults.

The seismic design criteria for the fault offset was determined in accordance with Metro's Maximum Design Earthquake and Ordinary Design Earthquake (CH2M Hill, 2013):

- Raymond Fault: a left-lateral offset of 1.0 meter and vertical reverse offset of 0.2 meter
- San Rafael Fault: a left-lateral offset of 0.5 meter and vertical reverse offset of 0.25 meter

As part of the preliminary design concepts, a fault crossing concept was considered. The objective is to design the structure to avoid collapse in an earthquake and at the same time have a system that could be repaired without major reconstruction to restore functionality after an event.

To accommodate the expected fault offset, an enlarged tunnel vault reach for each tunnel bore is being considered. This concept is similar to what was performed for Metro's Red Line tunnels crossing the Hollywood fault (Albino et.al. 1999). The oversized vault excavation would be designed to accommodate the movement/offset from a seismic event. Construction of the tunnel vault reach at the fault zones poses a challenge not only in terms of constructability, but also because of its impact on the overall construction schedule. While there could be several ways to construct such a vault, the methods are limited by the lack of surface access to the tunnels.

Because of access limitations, one of the options could be to mine from within the TBM-excavated tunnels. This could be accomplished by stabilizing the ground in the area of the vault excavation, sequentially removing rings of segmental lining, and then excavating ground and installing an initial lining for the vault. This sequence would be repeated for the entire length of the vault. After excavation has been completed, a cast-in-place concrete final lining would be built. This operation would have an impact on the TBM trailing gear, mucking operations, and installation of the rail or other finishes, and would require specialized equipment to disassemble the segmental lining.

## 6.2 Station and Portal Excavation and Ground Support

The temporary excavation support for the TBM launch portal (referred to as portal in this section) and the four underground stations (and associated crossovers) are discussed in the following sections.

### 6.2.1 TBM Portal Excavation and Support

At the portal, the depth of excavation is approximately 40 to 50 feet. The height of the excavation at the headwall is approximately 50 feet, and the side walls will decrease in height to the south as the excavation becomes shallower. The portal will ramp down from the existing ground surface to gain enough cover to launch the TBMs; both TBMs would be launched at the headwall of this portal.

Geotechnical conditions indicate alluvial soils within the excavated height and that groundwater could potentially be encountered in the deeper portion of the excavation near the portal headwall. As one moves away from the headwall to the south, the excavation becomes shallower so that the water table will be below the excavation base. The main issue will be preventing the alluvium from sloughing into the excavation, and a secondary issue will be controlling groundwater near the portal headwall.

Several wall types can be considered for the portal excavation support system including sheetpiles, soldier piles and lagging, and soil mix walls (auger or cutter soil mix). These wall types can be installed to the depths required fairly easily. Among these, a soldier pile and timber lagging wall supported with tiebacks appears most suitable from a constructability and structural design standpoint. For the wall depth of 40 to 50 feet, this is also an economical wall type. In a soldier pile and lagging wall system, excessive sloughing is prevented by limiting the excavation lifts to no more than 4 to 5 feet and excavating the portal footprint in limited areas at a time.

A preliminary design concept for these support structures include soldier piles which are steel HP14 sections spaced laterally at 8 feet on center. Tiebacks can be installed through the soldier pile itself, eliminating the need for walers. The horizontal tieback spacing is then the same as the pile spacing, which is 8 feet. Tieback loads are expected to be in the range of 100 kips for the arrangement considered with a bond length of approximately 30

feet. These walls are not watertight; therefore, a limited dewatering effort may be necessary for groundwater control.

## 6.2.2 Underground Station and Excavation and Ground Support

All four underground stations are located predominantly within the limits of city streets, and while the footprint of each station varies based on operational needs, the basic configuration is similar for all four stations. Two of the four stations will have a crossover excavated immediately adjacent to them. The station excavations are approximately 80 to 100 feet deep and 80 feet wide, with the length of each station excavation varying from 400 feet for a standard station up to over 1,000 feet if there is a crossover adjacent to it. The stations will be excavated prior to the TBMs reaching each station, so the TBMs will need to break into and out of each station at the north and south walls (the headwalls) of each station.

The geotechnical conditions indicate that the stations will be excavated wholly in alluvial soils or in a combination of alluvial soils and weak sedimentary rock. Geotechnical conditions indicate that the Alhambra Station may have approximately 20 feet groundwater in the bottom of the excavation. All stations are excavated in an urban setting in the public ROW with buildings and structures immediately adjacent to the excavations. Four primary design considerations for the station excavation support systems include:

- Preventing caving and sloughing during excavation, which could lead to settlement-induced damage of nearby buildings, utilities, and other existing facilities.
- Installing temporary wall systems that will not deflect or move excessively to mitigate settlement-induced damage of nearby buildings, utilities, and other existing facilities.
- Dewatering where necessary if non-watertight excavation support methods are used.
- Maintaining street traffic over the excavations during excavation and construction of the permanent works.

A key design consideration for the station excavations is allowing traffic over the excavations, which a decking system and places substantial vertical loads on the walls in addition to the lateral wall loads. Wall types that are suitable for this loading are soldier pile and lagging walls, soil mix walls, and secant pile walls. Soldier piles walls have been successfully used for past Metro projects under similar loading conditions and therefore have been selected as the wall type at this conceptual design level. These walls will also satisfy the design considerations with respect to limiting settlement from soil sloughing and wall movements.

A preliminary design concept for these support structures include soldier piles which are steel W24 sections at 8 feet on center with timber lagging. Tiebacks or internal bracing (walers or struts) can be used for lateral wall support. The current design concept uses tiebacks alone; however, internal bracing may be used in case of utility conflicts and ROW issues. Tiebacks can be installed through the soldier pile itself, and therefore the horizontal tieback spacing is the same as the pile spacing, which is 8 feet. Tieback loads are expected to be in the range of 200 to 300 kips for the arrangement considered, with a bond length of approximately 40 feet. Internal bracing, if used, would consist of walers and struts.

## 6.2.3 Headwall Support and Ground Improvements

At the headwalls of the four stations and at the portal, neither steel reinforcing nor steel piles can be used over the area of the tunnel bores, nor can the headwalls be supported with tiebacks, since a TBM has to mine through this zone. Given the small span of the wall over the tunnel bores (approximately 22 feet), a variety of headwall support methods that do not have steel support elements could be feasible. To meet these requirements, a gravity wall concept could be used for the portal and station headwalls in the zones through which the TBMs will excavate. To achieve this, a substantial mass of soil at the headwall could be improved to the point that it becomes self-supporting. Several methods were considered to achieve this self-supporting improvement, including chemical grouting, jet grouting, and deep soil mixing. Soil nailing with glass-reinforced plastic (GRP) soil nails was also considered on its own and in conjunction with the above methods. A preliminary design concept for

the headwall improvement is a jet grouted zone acting as a gravity wall. The improvement is the full height of the wall and covers the zone through which the TBM will excavate.

## 6.3 Zone of Potential Settlement Disturbance

### 6.3.1 Introduction

The ground movements associated with tunnel excavation can be estimated using either semi-empirical methods or numerical modeling methods that use software programs such as PLAXIS (PLAXIS BV, 2010) or FLAC. Generally, semi-empirical methods are simpler, faster, require less-detailed understanding of the physical properties of the ground, and provide direct estimates of slope and curvature of the settlement trough. The numerical modeling methods are more sophisticated, provide more rigorous analysis for complex problems, and allow more in-depth understanding of soil-structure interaction. For these preliminary design evaluations, semi-empirical methods were used for ground movement estimates.

The focus of the evaluations in this phase of the study is on vertical ground movement and determining a zone of potential disturbance along the underground portion of the LRT Alternative to support the environmental documentation.

### 6.3.2 Ground Surface Settlement Resulting from Tunneling

The shape of the settlement trough over a single tunnel is characterized by three main parameters: depth to the tunnel springline, the ground loss, and horizontal distance from the tunnel centerline to the point of inflection of the settlement profile curve. The depth considered is the vertical distance from the building or structure's foundation bottom, or utility springline, to the proposed tunnel springline at the location of the structure under consideration. Ground loss is defined as the volume of all ground movements taking place around a tunnel and is usually characterized as a percentage of the excavated area (using external diameter,  $D$ ). Based on several case histories, a volume loss ( $V$ ) of 0.5% was adopted for the alluvium and mixed face conditions and 0.25% for the weak sedimentary rock formations for this project. The horizontal distance from the tunnel centerline to the inflection point  $i$  is characterized by a trough width factor  $K$  and the depth to the tunnel springline ( $z$ ). The trough width factor  $K$  is a function of ground and groundwater conditions. The shape of the settlement trough over twin-bore tunnels, shown in Figure 6-6, is attained by superimposing the settlement troughs from each bore.

Figure 6-6: Typical Surface Settlement above Two Tunnels

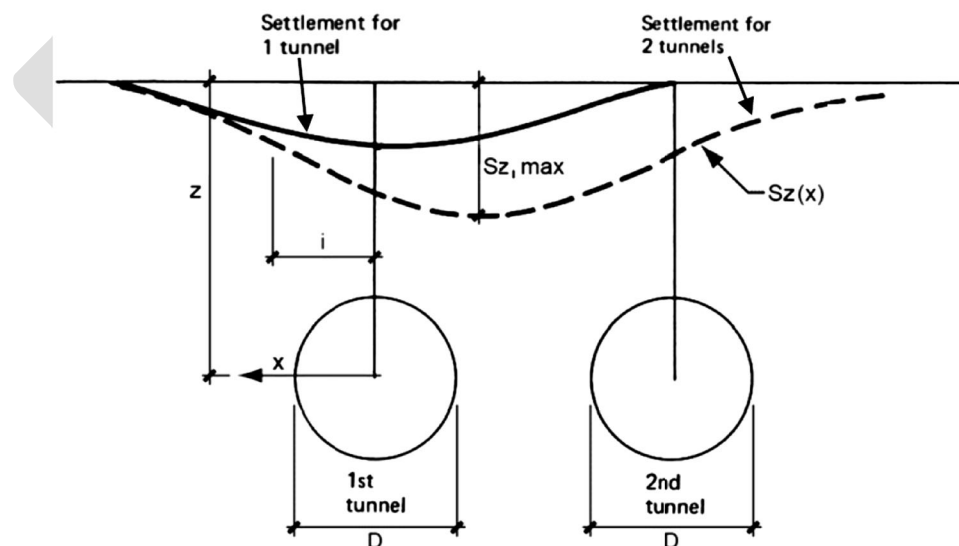



Settlement troughs were estimated at discrete locations spaced every 500 feet along each tunnel alignment. The method to establish the zones of potential disturbance is to determine the distance from the centerline to a limiting settlement value and a maximum slope of the settlement trough. The zone of potential disturbance would include the areas where settlement or a slope greater than the set criteria would occur. This method is commonly used if it is believed that damage to buildings or structures will be negligible beyond those limits. As settlement and slope do not capture the full extent of a building's response, other criteria such as angular distortion and horizontal strains will be examined in future phases of this project; however, that is not within the scope of this preliminary assessment.

Rankin (1988) refers to maximum slope limit of 1/500 accompanied by a maximum settlement of 0.4 inch as the limit for negligible damage. Wahls (1981) indicates a slope limit between 1/500 and 1/600 is the limit for potential damage (i.e., negligible damage). Several recent tunneling projects have used criteria similar to those listed above for initial screening of building subject to potential damage. The Los Angeles Eastside Gold Line Extension considered a maximum tilt of 1/600 and a maximum settlement of 1 inch as the criteria for further evaluation of structures (Choueiry et al, 2007).

A settlement trough slope value of 1/600 or 0.25 inches of settlement (whichever limit extends further from the tunnel centerline) as the criteria for determining the extent of the zones of potential disturbance from the excavation of the bored tunnels. These values were used as the screening criteria for negligible risk in the Regional Connector Transit Corridor tunnels (The Connector Partnership, 2012).

### 6.3.3 Ground Surface Settlement Resulting from Portal and Underground Station Excavations

The TBM launch portals for the bored tunnels, as well as the LRT stations, are assumed to be constructed using conventional cut-and-cover construction. The LRT stations and portals are expected to be supported using soldier piles and lagging, also with ground anchors.

Ground movements associated with these excavations can be estimated using semi-empirical methods or with numerical methods from commercially available software. In this study, simplified methods are used for the preliminary assessment of building susceptibility to ground movements.

The method used for this project estimates the movement of excavation support walls resulting from adjacent excavation and support. Data from Clough and O'Rourke (1990) combined with experience on the Los Angeles Metro Red Line Segment 2 Hollywood/Vine and Hollywood/Western Stations (Smirnoff, et al., 1997) were used to estimate the anticipated ground movements. Clough and O'Rourke (1990) compiled data on wall maximum lateral movement and maximum soil settlement for various depths of excavations and wall systems.

The Clough and O'Rourke data provide an estimate of maximum lateral wall movement for a given wall height. The data suggest that the vertical movement to wall height ratio is 0.15% for the majority of the data points. Additionally, more recent data from the soldier pile and lagging walls in the Hollywood/Vine and Hollywood/Western station excavations suggest that the maximum ground movement to depth of excavation is between 0.05% and 0.1%, which corresponds to a maximum of approximately 0.25 inches of settlement. Based on this more recent experience locally, the maximum vertical ground movement to wall height ratio is assumed to be less than 0.15%, and it's expected that total maximum vertical settlements can be controlled by the excavation support type chosen.

Using the typical portal or station depths for and the settlement ratios above, the slope of the settlement trough for these open cut excavations would be far less than 1/600, which is the criteria for damage to sensitive structures. The slope of the settlement trough is the same at any distance away from the excavation, as it's assumed to be linear in sands (alluvium). While vertical ground movements could occur at a distance two to three times the depth of the excavation depending on the soil type, the potential for impacts to structures would be limited to a distance around the open cut equal to the depth of the excavation. This can be achieved by designing an excavation support system with sufficient rigidity to limit ground movements.

Therefore, a criteria of 1H:1V is being used to determine the limits of the zones of potential disturbance from the excavation of the cut-and-cover structures to support the environmental documentation.

### 6.3.4 Preliminary Results

The zone of potential disturbance along the bored alignment was found to differ greatly for soil/mixed face conditions and rock. The average disturbance width in soil or mixed face conditions was about 90 feet, with a maximum of 130 feet. In most locations in rock, the threshold limits were not reached and the zone of potential disturbance was effectively zero. As a conservative measure, the maximum width in rock (30 feet) was considered the width of the zone of potential disturbance for all rock locations along the alignment.

For cut-and-cover excavations, the zone of potential disturbance outside the excavation footprint is equal to the excavation depth. For example, the Huntington Station excavation, which will be 80 feet deep, will have a zone of potential disturbance of approximately 80 feet on each side of the excavation.

Refer to Section 12 for discussion of further evaluation steps to be performed in subsequent studies.

DRAFT

# Station Architecture

---

## 7.1 General

Station layouts for the LRT Alternative was developed during ACE in conjunction with the work and requirements of the other disciplines; for compatibility with what is desirable for the station areas; and to provide for passenger access.

Fitting the stations among the existing developments in East Los Angeles and the western San Gabriel Valley areas has had a significant impact in determining the layout of the stations. During ACE, existing and planned site uses and structures were identified and studied. The station layouts and station access plans were developed according to the constraints posed by the alignments.

The stations would be aerial, at-grade, or underground. These stations would consist of center platforms, which are considered to allow for efficient passenger flows and equipment layouts.

Escalators, stairs, and elevators would offer access to the aerial stations. Both up and down escalators would be provided at entrances with sufficient space. At entrances with constrained space, a single up escalator would be paired with adjacent stairs. Fare gates and demarcations between fare paid and unpaid areas would be provided.

Space is designated on the adjacent acquired parcels for ancillary facilities. Development of the systems and equipment during PE will determine the space requirements and room layouts. Access to these spaces for installation and removal of large equipment will also be determined in PE.

## 7.2 Station Locations

Seven stations would be located along the LRT alignment at Mednik Avenue in East Los Angeles, Floral Drive in Monterey Park, Cal State LA, Fremont Avenue in Alhambra, Huntington Drive in South Pasadena, Mission Street in South Pasadena, and Fillmore Street in Pasadena. The Fremont Avenue Station, the Huntington Drive Station, the Mission Street Station, and the Fillmore Street Station would be underground stations. New Park-and-Ride facilities would be provided at all of the proposed stations except for the Mednik Avenue, Cal State LA, and Fillmore Street stations. The stations' elements and locations are further described below.

### 7.2.1 Mednik Station

This station will be an aerial configuration with a center platform on the west side of Mednik Avenue, just north of 3<sup>rd</sup> Street. The station includes an operator break room. Approximately 12 enclosed retail spaces will be located at plaza (ground) level, below the station. Approximately 30 surface parking spaces would be provided near the station. These spaces are intended for Americans with Disability Act (ADA) access to the station and as short-term parking for retail uses on the site. Three entrances would provide pedestrian access to this station. At the east and west ends of the platform, an escalator with adjacent staircases would be located. Elevator access would be provided by dual elevators at the center of the platform. Each of these three entrances would have its own fare collection gates, but ticket vending machines would only be located at the base of the stairs, not at the center elevators.

Primary pedestrian flow comes from the station platform, surface parking, bus stops, and existing and new retail and restaurants nearby. Enhanced walkways with special paving around this station will make for a safer pedestrian environment. Bicycle access is primarily for the local road network and the station design will incorporate bicycle racks and storage adjacent to the station entrances. Bus stops are accessed adjacent to the intersection of Mednik Avenue and 3<sup>rd</sup> Street.

## 7.2.2 Floral Station

This station would be an aerial station located on the north side of Floral Drive between Monterey Pass Road and Dangler Avenue in Monterey Park. The Floral Station will have three levels: plaza level, concourse level, and platform level. The plaza level will be at street level, while the concourse level will be at the elevation of the adjacent office park.

The boarding platform would be 270 feet long with two escalators with adjacent staircases located at the east and west ends of the platform. Two single elevator shafts would be provided in total. The aerial station would be accessible from the ground floor plaza level as well as the concourse level. One elevator will be placed at the center of the platform for access to the platform, and the other will be placed at the east end of the platform near the park and ride lot accessible from the concourse level. Each of the entrances would have its own fare collection gates, but ticket vending machines would only be located at the base of the stairs, not at the center elevators.

The park and ride lot would be located at the northwest corner of the Monterey Pass Road/Floral Drive intersection. Approximately 163 surface parking spaces would be provided at this location.

## 7.2.3 Cal State LA Station

The Cal State LA Station will be located on the southeast corner of the campus accessible from Circle Drive.

The Cal State LA Station would technically be an at-grade station but it has two levels because it will be built on an MSE wall and is located on the side of a hill. The plaza and platform level, and two single elevator shafts will provide access from the plaza level to the platform level. A new sidewalk will be constructed on the south side of Circle Drive to provide pedestrian access from the station to the existing El Monte Busway station.

Using enhanced crossings, textured pavers for speed control on Circle Drive, pedestrian signaled crossings, and a well-lit environment will all contribute to public safety. Ticket vending machines and fare collection gates will be located at the station entrance.

## 7.2.4 Alhambra Station

The Alhambra Avenue Station will be underground with pedestrian access provided at the southeast corner of the Fremont Avenue/Concord Avenue intersection in Alhambra. The site contains many residential, retail, and commercial land uses nearby including access to the Los Angeles County Department of Public Works, a major employment center in the area. Approximately 244 park and ride spaces would be provided on a lot on the northeast corner of the Fremont Avenue/Concord Avenue intersection.

The underground station will have three levels connected by four elevator shafts in total, six escalators and adjoining staircases. Ticket vending machines and centralized fare collection gates with guard rail surrounding the entrance will be located at the plaza level near the escalators and elevators. The boarding platform will be 270 feet long.

## 7.2.5 Huntington Station

The Huntington Drive Station will be underground with pedestrian access provided at the northwest corner of the Fair Oaks Avenue/Huntington Drive intersection in South Pasadena. Approximately 257 park and ride spaces would be provided on a lot on the south side of Huntington Drive. The site is highly constrained but contains many residential and commercial land uses directly surrounding the area.

The underground station will have three levels connected by four elevator shafts in total, six escalators and adjoining staircases. Ticket vending machines and centralized fare collection gates with guard rail surrounding the entrance will be located at the plaza level near the escalators and elevators. The boarding platform will be 270 feet long.

## 7.2.6 South Pasadena Station

The South Pasadena Station will be underground with pedestrian access provided at the northeast corner of the Fair Oaks Avenue/Mission Street intersection in South Pasadena. Approximately 338 park and ride spaces would be provided on a lot directly south of the station entrance. The site is highly constrained but contains many commercial and retail land uses directly surrounding the area.

The underground station will have three levels connected by four elevator shafts in total, six escalators and adjoining staircases. Ticket vending machines and centralized fare collection gates with guard rail surrounding the entrance will be located at the plaza level near the escalators and elevators. The boarding platform will be 270 feet long.

## 7.2.7 Fillmore Station

The Fillmore Station will be underground with pedestrian access provided at the northeast corner of the Raymond Avenue/Fillmore Street intersection in Pasadena. The Metro Gold Line at-grade Fillmore Station is located 200 feet away and a walkway plaza provides easy transfer from one rail line to the other. The Metro Gold Line Fillmore Station provides a 160 park and ride spaces that are well utilized. With the addition of the LRT Alternative, additional park and ride parking is not proposed. A passenger drop-off area would be provided along Raymond Avenue just north of Fillmore Street.

The underground station will have three levels connected by four elevator shafts in total, six escalators and adjoining staircases. Ticket vending machines and centralized fare collection gates with guard rail surrounding the entrance will be located at the plaza level near the escalators and elevators. The boarding platform will be 270 feet long. The station includes an operator break room.

DRAFT



# Systems Requirements

---

## 8.1 General Requirements

The LRT Alternative is proposed to be a manually operated LRT System with a combination of underground, aerial, and at-grade tracks. The systems requirements under consideration are fare collection, signals and train control, rail transit vehicles, communications, traction power and distribution, central control, security systems, and other system elements required for the project. Metro's Operation & Maintenance, Engineering, and Planning groups will participate in the determination of basis of design for each system element. Design coordination meetings will also be arranged between the design team, Metro staff, and outside agencies as appropriate to produce an integrated system design.

Technical specifications will be performance-based, but some equipment may need to be specified in detail to meet the interface requirements of the Metro rail vehicles, wayside equipment design, and the existing Control Center. Communications equipment to be added will be similar in type, function, and manufacturer to maintain consistency with the existing systems that Metro currently operates. Metro will provide a list of owner specified equipment.

Design documents shall be in accordance with the California Public Contracts Code, Section 3400 and all other local applicable codes. Sole source specifications must be avoided unless a detailed justification of requirements that limit the sources of supply is provided and accepted by Metro. Specifications will also require addressing interface issues and meeting safety and security requirements of subsystems to meet overall system safety and security goals. Communication systems will conform to the current version of the Metro Design Criteria, particularly Section 9 Systems and the Fire/Life Safety Criteria.

## 8.2 Fare Collection

The fare collection system would be designed to be compatible with Metro station design standards. The design must ensure that the layouts of the ticket vending machines and fare gates are compatible with Metro's Universal Fare System (UFS) system-wide vending machine procurement contract. Further, the placement of machines must comply with Metro security requirements for monitoring (CCTV and intrusion alarms). Infrastructure at the stations must satisfy UFS requirements for power and communications services, and protection of equipment from the elements.

CCTV surveillance of the UFS machine arrays and Supervisory Control and Data Acquisition (SCADA) intrusion alarm points would be accommodated in the station fare vending machine area designs. Fare collection system design shall be deferred until selection of a preferred alternative. Conduits and wiring for power would be provided. 56K-bit communications channels would be incorporated in the cable transmission system design, as well as additional fibers for future connection on a dedicated UFS fiber network. Refer to Section 8.5.15 Universal Fare Collection System (UFCS) for additional requirement.

The design must incorporate lessons learned from the existing Metro light rail UFS machine requirements, including physical space layouts, power, conduit, and communications requirements.

Provisions would be made in the underground stations for future barrier installation for power and communication conduits.

## 8.3 Train Control

The design of the Train Control System (including related on-board equipment) shall provide a design that is fully integrated into the civil, facilities and other subsystem designs in accordance with Metro Design Criteria Section 9/Systems, and the overall operation plan adopted for the project. Train control system design shall be deferred until selection of a preferred alternative.

## 8.4 Rail Vehicles

It is expected that the rail vehicle utilized will be the P2550 light rail vehicle (LRV), which is consistent with existing MTA rail lines. However, other LRVs such as the P2000 and P3010 could be utilized. The P2000 LRV is already being utilized in the Metro fleet and P3010 vehicles are expected to be incorporated into the Metro fleet starting in 2014.

The P2550 is a 90-foot-long articulated car, with a tare weight of 108,390 pounds (lbs). The traction power study was performed with uniform AW2 train loading, which is 134,570 lbs/car and represents 175 people (at 150 lbs/person) per car.

The initial acceleration rate of the AW2 loaded train, at nominal 750 volts direct current (VDC) voltage and flat tangent track, is 3 mph/sec. The in-service braking rate is about 3.2 mph/sec. The P2550 features regenerative braking with a maximum voltage in regenerative braking mode of 900 VDC.

Auxiliary power of 60 kW/car, used for air-conditioning and ventilation, lighting, and other auxiliary loads, was assumed for the purposes of the study.

The nominal tractive effort (TE) characteristic of the P2550 has three zones:

- Constant TW zone, where a TE of up to 19,670 lbs and as needed to achieve the 3 mph/sec initial acceleration rate is maintained up to 20 mph
- Constant power zone from 20 mph to 50 mph
- Falling power characteristic at speeds above 50 mph

The P2550 also features limited forced reduced performance (FRP) capability, where the propulsion current is progressively reduced if the line voltage falls below 650 VDC. Based on available data (where the car's output power is given at lower voltage levels), the propulsion current reduction rate below 650 VDC was determined as 1.5 A/V. These FRP parameters were incorporated in the vehicle model used in the study.

The design of the wayside train-to-wayside communication (TWC) equipment would be compatible with the vehicle on-board TWC equipment.

## 8.5 Communications

The Communications System is the collection of diverse subsystems that detect, transmit, receive, display, store, and manage information in various forms for the safe and convenient operation of the light rail system. The following subsystems and/or functions are considered part of the Communications System:

- Rail Operations Center
- Cable Transmission System
- Telephone System
- Radio System
- Transit Passenger Information System
- Closed Circuit Television System (CCTV)
- Intrusion Detection and Controlled Access System
- Fire Alarm Detection System
- Gas Detection and Alarm System
- Seismic Detection System
- Tunnel Portal Surveillance and Alarm System



- Supervisory Control and Data Acquisition System Remote Terminal Unit
- Universal Fare Collection System
- Facilities Emergency Management System
- Communications Uninterruptible Power Supply System

### 8.5.1 Rail Operations Center (ROC)

The ROC serves as the main control center for all rail lines operated by Metro, which includes operations for the Blue, Green, Red, Gold, Purple and Expo lines. All communications systems are interfaced to the ROC for monitoring and control by operations. In addition, the ROC accommodates training, conference services, and staff office space necessary for the current transit and supporting operations.

Currently, the ROC is located at Imperial Highway and Wilmington Avenue, but in the expected time frame of this project, it is expected that the ROC will be relocated to a new facility. It is envisioned that if the LRT Alternative for this project goes forward, it will be incorporated into the new ROC facility and integrated with Metro's existing rail operations.

The existing Service Control Area includes sections for the control of the various lines. Each section includes an overview display and associated work stations. Apparatus at the ROC includes console equipment to support various manned positions, recorders, printer, displays and special processing components. These include:

- ROC Consoles: The ROC consoles provide the displays, workstations, and controls for the train operations, communications, traction power, as well as the monitoring and control of the fixed facilities and emergency equipment.
- CCTV Area Console: The CCTV consoles provide camera selection and control capability to allow the operator to display the video from any camera on a large screen monitor. Each operations console shall provide access to intercom, to Systems Communications console in the operations control room, to an administrative telephone (ATEL) line and access to passenger public announcement (PA) equipment.
- Train Dispatcher and Systems Communications Consoles: These consoles perform all functions for processing control situations at each work station.
- System Status Display Console: The system status display subsystem provides a dynamical representation of the condition of the train control system and the attraction power contact rail/conductor wire to monitor the operation of trains. The display shall contain indications for track occupancy within and between stations, track occupancy within interlocking, route alignment, traffic direction, contact rail/overhead contact system segment status and other vital and non-vital alarms and indications.

### 8.5.2 Cable Transmission System (CTS)

The CTS consists of the inside and outside plant cabling infrastructure and network equipment providing SONET and Ethernet for networking in the passenger stations and tunnel areas. It also provides the non-vital network communication for the signaling system. A new SONET OC-48 sub-ring with a node at each passenger station will be incorporated into the existing OC-192 ring. The CTS will transport all network data, voice, and video traffic between the ROC and stations.

The CTS incorporates both the backbone fiber optics high-speed data transport system and the copper cable distribution system within the yard, passenger stations, maintenance shops, and administration buildings. It shall consist of the following elements:

1. The Fiber Optics Cable Transmission (FOCT) network consisting of a SONET OC-48 sub-ring connecting to the main OC-192 SONET backbone ring. The fiber cabling infrastructure shall include spurs to connect to outlying substations and signals houses back to the nearest light rail station.

2. The Outside Plant (OSP) copper cabling shall connect from the Train Control & Communications (TC&C) rooms at the stations with the traction power substation (TPSS) and signaling bungalows.
3. Inside Plant (ISP) copper cabling shall use Cat 3 wire and terminations unless otherwise specified. Serial connector interfaces in the ISP shall be RS-232/RS-485. All ISP cables shall be plenum rated.
4. For long distance runs in high EMI areas ISP/OPS may be replaced by the appropriately rated single-mode fiber optic cable. Interfaces to connecting equipment shall support optical interface I/O modules.
5. SONET Add Drop Multiplexers (ADMs) and Channel Bank: SONET ADMs and channel banks shall be supplied at each station TC&C room to interface with the existing SONET transport network.
6. Main Distribution Frames (MDF) shall be used to terminate all fiber optical and copper cables.
7. Cable Terminating Blocks shall be used to terminate all ISP OSP copper plant.
8. Protector blocks, patch panels, grounding hardware and various other ancillary devices shall be provided to complete the installation.

### 8.5.3 Telephone System

The telephone subsystem includes various types of phones in the stations and cross passages. All types of phones shall be digital using Voice over IP and communicating via the CTS.

The types of telephones are:

- Emergency Telephones (ETEL): For emergency point-to-point communications for emergency reporting and coordination. ETEs shall be provided at each passenger station, both at-grade and aerial and along the trainway. ETEs shall also be located at Emergency Management Panels, Emergency Trip Station (ETS), in elevators, and at the fire hose cabinets. Telephones in this group shall be configured with preprogrammed calling destination. .
- Passenger Assistance Telephones (PTEL): For point-to-point service from other public locations. The PTEL group shall provide priority point-to-point telephone service from designated station fare collection areas and any other designated public location to a preprogrammed destination at the ROC. PTEs shall provide provisions for individuals with Disabilities for ADA requirements.
- Maintenance Telephones (MTEL): For maintainers to call other phones within the system. The MTEL group shall provide access to the dial telephone system for maintenance personnel working in the Metro Rail system. MTEL access shall be provided at designated locations where occasional, infrequent telephone service is required (e.g., sump pumps, mechanical equipment rooms, etc.), and does not warrant permanent installation of telephone instruments. MTEL service shall be made available by installation of modular telephone jacks allowing maintenance personnel to utilize telephone installer-type handsets for placing and receiving calls.
- Administrative Telephones (ATEL): The ATEL group shall provide the administrative and operational telephone communications within the rail system. As a minimum, ATEs shall be located in any location where personnel are based.
- Gate Telephones (GTEL): Identical to PTEs and installed near gates for patron assistance.
- Elevator Telephones (LETEL): Identical to PTEs and installed in the elevators. These shall be a fully supervised and alarmed line with an automatic ring-down feature to connect directly to the ROC. LETEs shall be ADA Compliant.

Equipment and system status and failure alarms shall be monitored by the SCADA system. As part of the ETEL service group functions, the system shall provide simplified emergency reporting. This provision shall allow any designated telephone to have rapid access to the Central Control emergency reporting position by dialing the Universal Emergency Calling Code "911."

Public Telephone Service: Facilities for implementing Public Telephone service at or adjacent to station platforms shall be coordinated with the local telephone company. Such facilities may also be provided in free areas. In any case, the location shall not interfere with pedestrian flow.

#### 8.5.4 Radio System

This subsystem provides continuous radio frequency communications in the tunnels and stations for voice communications between the ROC, train operators, and Metro personnel as well as external agencies, including police, sheriff, and fire departments. It is the primary means for voice communication between the ROC, yard, maintenance facilities, wayside, and rail line passenger vehicles. All new radio systems shall be integrated with the existing radio system. Radio for Metro Operations and Maintenance will extend the existing digital radio system over Ethernet using 6.25 kHz very narrowband channels. Metro Transit Police will utilize the analog 450/460 MHz narrow band, 12.5 KHz radio system. All equipment shall be compliant with the existing equipment for alarm monitoring and event notification to the ROC.

The uplink (talk-in) and downlink (talk-out) radio coverage paths shall be equalized between all portable and rail vehicles. Worst-case talkback paths shall be considered when doing typical link budget analysis. Radio transmission system shall build upon existing two-way channels mapped to the following frequencies and service groups.

The radio system shall be designed to conform to future governmental interoperability plans and migration to narrowband and future data radio operations.

Signal quality shall be CM-4 with a 95 percent coverage probability at 95 percent of the required locations. At-grade and aerial coverage shall include the area extending 2,000 feet from each side of the track ROW as well as the main and satellite Yards and Central Control Facility external areas such as parking lots, etc.

Expansion of trunked or pooled radio channel shall be capable of expansion of up to 250 user group ROC Links to Radio Subsystem: Voting equipment shall be located at the ROC and have the capability to accommodate all radio receive equipment associated with the new build out section to include those locations in the signal strength polling voting process.

#### 8.5.5 Transit Passenger Information System (TPIS)

The TPIS provides live and prerecorded announcements on the public address (PA) system and visual message signs (VMS) in the paid and unpaid passenger station areas. The TPIS shall consist of public address message and signed announcement devices at each of the passenger station stops, with associated local controls at the stations remote controls and system status and alarm reporting at the ROC. Pre-recorded voice announcements shall be concurrent with stored, preset text messages displayed on the VMS signboards.

The TPIS shall permit operators to originate both live and prerecorded announcements to patrons and staff within stations. The ability to automatically activate dynamic train arrival destination and other selected messages shall be provided. The system's prerecorded voice announcements shall be coordinated with stored, preset text messages displayed on the VMS signboards. Prerecorded audio messages and their corresponding text messages shall be played simultaneously in accordance with ADA requirements. The PA portion of the systems shall be supervised in accordance with provisions of National Fire Protection Agency (NFPA) 72. The PA system performance shall be designed and tested to provide a level of intelligibility equal or better than STI 0.75.

A fully supervised PA subsystem shall be provided at each passenger station. The station PA equipment shall consist of preamplifiers, signal conditioning equipment, equalizers, power amplifiers, ambient noise sensing and level adjustment, cabling, loudspeakers and enclosures, local control panels, and all other required interfaces for operation and status monitoring of the equipment.

Speakers at passenger stations shall be installed and designed as to provide uniformly distributed sound pressure levels within designated coverage areas. All speakers shall be located where they are readily accessible for safety testing and maintenance replacement.

VMS displays shall be installed in each station's train boarding platforms, one for each direction. The double-sided display unit shall consist of two light-emitting diode (LED) message signboards housed in a weatherproof enclosure. Enclosure shall be both tamper proof and vandal resistant.

Station PA amplifiers, associated signal conditioning equipment and the VMS display controller shall be installed in equipment racks within the station TC&C rooms. The equipment racks cabinet shall include a local microphone position to be used for performing operation and test functions and keypads to initiate VMS messages.

ROC equipment shall include control and selection panels for originating and logging PA/VMS System announcements. There shall be a master PA/VMA system with redundant controllers. Control and selection panels shall be provided in the Dispatchers and CCTV Observers consoles at the ROC Control Center.

### 8.5.6 Closed Circuit Television (CCTV) System

The CCTV system provides visual surveillance of station areas, cross passages, and tunnel portals for safety, security, revenue protection, and anticrime and antiterrorist applications. CCTV shall be employed to enable visual monitoring at all stations with remote monitoring at the ROC with cameras monitoring selected station areas. Video signals at each station shall be recorded on a local Network Digital Video Recorder and transmitted via the CTS to the ROC.

CCTV shall be interfaced with public area emergency telephone/passenger assistance telephone (ETEL/PTEL) such that patron activation of an ETEL/PTEL unit shall cause the activation of the closest CCTV and camera image to remain fixed on the particular phone until reset.

Rack-mounted digital video recorders (DVR) shall be provided at each TC&C room to enable the recording and playback of images from all cameras associated with a particular station. DVRs shall be controllable locally through a laptop port and remotely from the ROC.

### 8.5.7 Intrusion Detection and Controlled Access System (IDCAS)

The IDCAS shall provide access control and/or intrusion detection for designated doors in the stations. It shall allow controlled access through designated doors, roll-up-grills, and hatches and detects unauthorized entries. All detected entries, intrusion alarms, and troubles shall be transmitted to and recorded at the ROC.

Intrusion detection shall be provided for the following locations:

- Train control and communications rooms
- Auxiliary power rams
- Sprinkler valve rooms
- Electrical rooms
- Cable rooms
- Station entrance to roll-up grills
- Train control shelters
- Traction power substations
- Emergency exits
- At-grade station access hatches
- Ancillary area doors
- End of platform gates (with key bypass switches)

The major components of the IDCAS are as follows:

- Local Station Intrusion Detection Monitors
- Display Terminals and Printers
- Intrusion detection rack
- Access Card Readers
- Card Reader Controllers
- Intrusion detection magnetic door contacts
- Intrusion detection limit switches
- The electric door strikes
- Exit request devices
- Audible alarm devices
- Bypass switches

Upon detection of an intrusion alarm the following sequence shall occur:

- Intrusion detection systems shall produce an alarm at the local station processing equipment
- Local station Processing Equipment shall store process and transmit the alarm to Facilities Emergency Management Systems (F&EM).
- All alarms shall be transmitted to the main intrusion detection system at the ROC and outputted to the printer.

The F&EM shall provide for storage, processing and transmission of intrusion alarms at the EMP for annunciation. The system shall maintain a record of the access/intrusion event at the ROC. Records shall include: door openings, alarms, input of cards with voided security classification numbers, attempted use of invalid identification cards, identification of valid cards used and all operator commands.

### 8.5.8 Fire Alarm Detection System

The fire detection system includes the intelligent fire alarm control panels, alarm initiating devices, alarm notification appliances, power supplies, auxiliary control devices, control panels, graphic annunciator panels and head end fire alarm consoles at the ROC. It also includes the emergency management panels (EMP).

The FACP shall be an intelligent device with network communications capability. It shall be of a modular design for the use of future system expansion. The FACP shall incorporate microprocessor-based CPU, which shall communicate and control the following types of equipment: addressable detectors, addressable modules, at-grade station Remote Annunciator Panel, EMP, Remote Emergency Management Panel (REMP), F&EM, printers and system controlled devices. Alarms, supervisory and troubles from the stations, train control shelters, and traction power substations shall be collected and formatted as individual zones. The FACP shall provide the logic and interfacing with the EMP and the ROC for automatic monitoring and control of the interconnected facility equipment.

The fire alarm system shall also include displays which shall provide all the controls and indicators required for system operation. These displays shall be used to program system parameters. The display assembly shall contain and display as required custom alphanumeric labels for all intelligent detectors, addressable modules, and software zones. The system display shall include the following operator control switches: signal silence, lamp test, reset, system test, and acknowledge.

The FACP shall transmit alarm, supervisory and trouble zones to the fire alarm console at the ROC and the EMP. Interfacing shall be provided for instigating automatic operation and control of the interconnected facility equipment. The fire detection system shall be capable of providing multiple zone detection, cross-zone detection in conjunction with fire suppression systems, and automatic ventilation controls.

The system shall monitor water flow switches and valve tamper switches for automatic sprinklers (including deluge and pre-action systems), wet standpipes, water curtains, and other suppression systems throughout the Metro system. The fire suppression monitoring system alarms and status indications shall be annunciated at central control and at the local EMP.

Fire Detection system shall comply with the California building code and with the requirements set forth by the California State Fire Marshal Office, NFPA 72 and NFPA 130.

### 8.5.9 Gas Detection and Alarm System

The gas detection and alarm system monitors for dangerous gas concentration levels in the stations and cross passages. It sends evacuation and trouble alarms to the Fire Alarm Control Panel and communicates these alarms to the ROC. Gas system alarms are reported on the FACP graphical annunciators on the emergency management panels.

It shall function as a stand-alone subsystem consisting of a control unit, detector head, transmitter, cabinet, power supply and all the accessories for proper operation. Control Units and other components shall be installed in the TC&C room shall serve the sensors for the underground passenger station and associated cross tunnel passages.

The Control Unit shall consist of a cabinet mounted programmable gas detector input output modules and controller. The control unit shall be equipped to receive and process Gas Detector signals, determined calibration information, store event information, and communicate configurable information to the SCADA RTU. The Control Units shall also provide communication links to The F&EM PLC and provide the local audible alarm when preset alarm gas levels are detected.

The system shall have an internal clock for event time and date stamping. Clock time shall be synchronized with the date and time from SCADA and F&EM system clocks. Methane gas sensors shall be configurable for three alarm levels (Minor/Major/Evacuate). Hydrogen sulfide gas sensors shall be configurable for two alarm levels (Minor/Major-Evacuate).

The system shall include a transmitter module which shall provide amplification and signal conditioning functions required to modify the signal from the sensing head element for transmission to the Control Unit. Transmitter shall use digital signal modulation for transmission to the Control Unit to minimize the effects of Radio Frequency Interference and Electro-Magnetic Interference.

### 8.5.10 Seismic Detection System

The seismic detection system detects, records, and transmits alarms of seismic events at each tunnel station.

Emergency Seismic Operation Procedures (ESOP) are activated whenever a major seismic event is detected. These are pre-programmed to trigger emergency scenarios whenever a major seismic event is detected.

The seismic event detection equipment shall be capable of detecting seismic waves that cause local ground accelerations and to record and transmit minor and major alarms of seismic events to the SCADA via the CTS and to the F&EM system. Seismic equipment functions independently at each location.

The seismic detection equipment shall be comprised of the following major components:

- Minor Alarm Seismic Switch
- Major Alarm Seismic Switch
- Event Recording System

Seismic detection equipment shall be furnished in sets. Each set shall include two seismic switches (one minor alarm and one major alarm) and one event recorder. Equipment shall be user adjustable and separated to optimize both vertical and horizontal detection. Seismic detection equipment shall be located in the TC&C Rooms of designated passenger stations and bolted to a concrete floor or pad.

Seismic switches shall be tri-axial acceleration types. Ground motion equal or above the given set point of the equipment shall actuate the equipment. Once actuated, ground motion signals shall remain actuated for a minimum of 6 seconds after the ground motion has fallen below the set point. After 6 seconds the seismic switch shall reset automatically. Set points shall be user adjustable. Seismic switches shall contain both major and minor alarm set points and two units of each shall be supplied for redundancy purposes. Seismic switches shall be designed to provide a separate signal to the seismic recorder to confirm that the recorder has been activated.

Seismic recorder shall provide a record of seismic event data including pre-event data. Prevent memory shall be set for 10 seconds. Set points shall be user adjustable. Recorders shall be actuated by the either external or internal seismic switches. Data recorded shall include event time, event duration, peak acceleration, and three channels of information: longitudinal, vertical and transverse. Recording range shall be at least 1.0 g to -1.0 g.

Recording time shall not be less than 10 minutes. Correct time shall be traceable to an accurate time source and at minimum verified and corrected once per day.

The signal interface to the F&EM PLC's shall be through a normally closed dry contact. The signals shall provide 0.1g, 0.2g event detection as well as loss of power signal to indicate the loss of output from internal power converters or transformers. Inside the equipment enclosure a terminal block shall be provided for terminating the field-routed, signal cable to the F&EM system.

Each seismic detector set shall receive 120 volts Alternating Current (AC) single phase power from the UPS. The terminal block for power shall be separate from the terminal block for signals. Seismic detection enclosures shall have a National Electrical Manufacturers Association (NEMA) Type 3R rating and a latchable cover. These enclosures shall protect the equipment in the event that a ceiling-mounted fire sprinkler is activated.

### **8.5.11 Tunnel Portal Surveillance and Alarm System**

The tunnel portal surveillance system detects persons entering the tunnels at the portals in order to warn train operators and ROC controllers of unauthorized entry. Intrusion alarm signals shall be transmitted to the ROC. The alarms signal shall identify the particular zone in alarm on the control display panels of the CCTV Observers Consoles and Train Dispatcher's Consoles. A control panel shall be provided at the ROC located on the CCTV Observers Console to alert ROC operators of an intrusion. The system shall be interfaced to the CCTV Communication Subsystem.

At each zone a transmitter/receiver pair of motion beam detectors shall be installed at a height of the 18 inches above track level and approximately three feet past the tunnel portal entrance. The second transmitter/receiver pair shall be installed directly above the first at eight feet above track level. The system shall contain logic controls such that if both beams are simultaneously interrupted, the system shall interpret this as a train passing and shall remain quiescent. In the event of only one being interrupted, the system logic shall interpret this event as an unauthorized intrusion into the tunnel and shall send an intrusion alarm signal to the ROC identifying the zone in which the alarm occurred.

Intrusion warning systems within the tunnel zone in alarm shall be activated to flash alternately on-off at one second intervals to alert train drivers of an unauthorized entry into the tunnel. This signal shall be installed at each end of every Tunnel Portal Surveillance Alarm zone. Operator warning signals shall be installed at locations approximately 100 feet ahead of tunnel portals.

## 8.5.12 Supervisory Control and Data Acquisition Remote Terminal Unit

### 8.5.13 (SCADA RTU)

The SCADA RTU provides a station-level monitoring and control interface for the LRT SCADA system at the ROC. It concentrates status, alarms, and controls for other equipment and subsystems, including the communications, fire detection, mechanical, electrical, traction power, and train control. RTUs in the stations directly interface with the graphic interfaces provided in the emergency management panels and workstations in the TC&C rooms. Communication between the RTUs and the ROC is transmitted via the CTS.

The SCADA system consists of remote terminal units (RTUs) located within the Train Control & Communications (TC&C) rooms to provide system monitoring, alarm, and control from the ROC.

RTUs and other remote I/O shall be provided at each passenger station, TPSS, and TC&C rooms as well as any additional RTUs necessary to implement all interfacing requirements.

The standard communications protocol for the SCADA RTU shall be Modbus TCP. Other communications protocols shall be determined by the requirements of the field I/O equipment interfaced with the SCADA RTU. Interface to the CTS for data transmission between each TC&C location and the ROC shall be via Ethernet.

SCADA interface to the fire alarm control panels (FACPs) shall be by discrete dedicated inputs/outputs to the various I/O devices. RTU contact input interface shall be capable of accepting isolated Form C contact inputs using 24 VDC sensing voltage from a field battery source.

Redundant interconnecting links to the CTS at each RTU site shall be provided so the SCADA system shall be able to communicate with the RTUs simultaneously on both links.

RTUs shall be capable of running full diagnostics self-test procedures. RTUs shall have a watchdog timeout function that sends an alarm to the ROC whenever the RTU detects a total loss of communication with the main SCADA server. At such times, the RTU shall be able to operate in fallback local automatic mode.

### 8.5.14 Facilities Emergency Management (FEM) System

The FEM system is the collection of user interfacing equipment in the Emergency Management Panels (EMP) and auxiliary EMPs. These EMPs are located in the stations to provide status indications, alarms, control of ventilation, seismic detection, elevators, intrusion, and the fire system. For the fire system interfacing, EMPs include a fire alarm annunciator interfaced directly to the FACP. The EMP subsystem interfaces directly or indirectly to most of the other communications subsystems, including and especially: SCADA, CCTV, Fire Detection, Gas Detection, Seismic Detection, Public Address, Visual Message Signs, Emergency Telephones and Intrusion Detection. However, certain scenario control functions are not by the FEM but are provided directly by the FACP including fan shutdown, elevator control, alarm reporting.

The FEM System provides the Programmable Logic Controller (PLC) necessary to provide logic processing, real-time data storage and communication transmission interface with the EMP, ROC and operator Work Station (OWS) systems for remote system monitoring and control. The FEM will be programmed to allow the EMPs to monitor and control the systems in other stations. This PLC shall pass on data from the following subsystems:

- Ventilation control
- Intrusion detection
- Seismic detection
- Other facilities related equipment

The F&EM Programmable Logic Controller (PLC) shall be the main element in the F&EM system that shall monitor and issue control commands to the station equipment under supervisory control actions. The F&EM PLC system



shall perform all necessary functions to enable operating personnel at the ROC or user interfaces at the EMP to carry a remote/local monitoring and supervisory control functions on station equipment.

Under normal operating conditions control shall be from the ROC. However, station control of the F&EM system device shall be available during any manual operation of the EMP.

All real-time data from switches relays transducers and all other equipment shall be collected by the PLC from remote I/O the equipment and sensors. The PLC shall be capable of responding to polls and updates of the rate of two (2) per second.

The PLC shall accept and respond to periodic on-demand requests for its specific data from the SCADA or the EMP subsystems. The PLC shall transfer and communicate the current values of the requested points, and only this specific information requested by the SCADA or the EMP shall be transmitted on demand by the F&EM PLC.

The PLC System shall perform supervisory control action on station equipment as requested by the ROC or the EMP. The PLC shall accept messages and control data from SCADA subsystem and from the EMP subsystems to store in its database and be made available for applications processing inside the PLC as necessitated by software application requirements.

The PLC shall pass the control requests received from the ROC to station equipment via the dedicated wired I/O communications network terminating outward at the PLC. This shall constitute a hardwired and supervised set of field-routed signal cables or its functional equivalent. The PLC shall be responsible for monitoring the I/O ports and equipment for the correct response.

The PLC shall respond to SCADA or the EMP after determining if the control action was successful or unsuccessful. Regardless of whether controllers exercise from the EMP or from the SCADA System indications of current status an alarm shall be transmitted to both locations from the PLC. Only one location, however, shall be in control at any given time.

#### **8.5.14.1 System Reliability**

The PLC shall be configured in a redundant mode with primary and standby hardware. Any failure in the primary PLC shall cause automatic failover to the standby PLC. A failure from primary to standby shall also cause the primary PLC's failover capability to be disabled until reset from the EMP. This is to prevent ping-ponging of the units when a failure condition exists in both.

The PLC System shall be designed such that no failure within the TLC System shall permit the equipment to be operated in an unsafe manner. The contractor shall submit for review and approval complete list of potential failure and abnormal conditions, the means of detection and reporting of each condition and suggestions for automatic control action(s) if any, to be taken to maintain safe stable operation.

#### **8.5.14.2 Operator Work Station (OWS)**

The OWS shall provide the programming terminal located in the TC&C Room that shall allow the PLC to be programmed onsite. Once the PLC is programmed, failure of the OWS shall not adversely affect systems operation. The OWS shall be a PC-compatible type computer, with Windows XP/Vista O/S and 4 GHz microprocessor, with RAM and hard drive storage to meet the database and applications needs plus a minimum of 50 percent headroom for growth.

#### **8.5.14.3 Software and Database**

All application software provided to the OWS to support supervisory control and EMP annunciation shall be capable of easy expansion to accommodate the anticipated growth of the system. Application programs shall be able obtain the size and configuration of the system from easily modified parameters contained in the database. Reassembly or recompiling of the software, or parts of the software, shall not be necessary to accommodate growth within the established size of the system database tables.

The F&EM system shall have a real time database which shall be expandable through well documented generating and editing procedures so that future functions added by the user can readily be included with a minimum of down time or system disruption.

Software shall be provided to continuously monitor hardware and communications network performance in real-time with a minimum of interference with the normal F&EM system functions. The data sampling period over which statistics are gathered shall be adjustable by the user. The accumulated statistical results shall be available for output to both computer terminal displays and to loggers after each period, and be capable of being provided in an on demand fashion anytime during the period. All statistical information shall be archived and reset at the start of each sampling period.

### 8.5.15 Universal Fare Collection System (UFCS)

Ticket vending machines and fare gates provided by Metro shall communicate via the CTS and SONET. The UFCS data shall be transmitted to the ROC and Central Data Collection System (CDCS) in the Union Station Gateway (USG) building via a dedicated Fast Ethernet network at each station. The SCADA system will include monitoring of UFCS equipment.

### 8.5.16 Communications Uninterruptable Power Supply System

The Communications UPS system provides highly reliable and clean power to all communications equipment in the TC&C rooms, throughout the stations, in the cross passages, and at the portals. This system interfaces with essential electrical power to provide AC power to all Communications subsystems, and DC power for Radio and SONET equipment.

The UPS units shall be connected to the station's vital power panels and shall rectify incoming 120V, 60 Hz Alternating Current (AC) power to DC, charge and maintain charge on the connected batteries banks, invert the DC to 120 volts 60 HZ AC which shall be connected to an associated AC Power panel for distribution to all connected subsystems requiring inverted power.

Rectifiers, Battery Banks, Inverters shall provide sufficient capacity to support their connected loads plus 50 percent to account for future loads. They are to have sufficient capacity for a power outage of not less than four (4) hours, while retaining 20 percent of full rated charge.

The battery systems shall be sealed, non-out gassing, gel types designed such that the battery shall be automatically disconnected from their associated loads should their capacity fall below 20 percent of full rated charge.

The Rectifier and Float Charge System shall be capable of powering their connected loads while simultaneously bringing depleted charge batteries from 20 percent charge to 100 percent charge within a 16 hour period. UPS supplies shall be configured for automatic switch-over to the bypass mode in the event of a UPS batteries system and or inverter failure.

Manual bypass shall also be provided for maintenance and testing purposes. The UPS System shall be connected to the SCADA System to implement the following alarms and controls:

- Loss of incoming AC Power
- Battery load shed
- Inverter failure
- Low Battery reserve
- Automatic switch to Bypass mode
- Manual set to Bypass mode
- Control switch to Bypass

- Control switch to Online

## 8.6 Ventilation System

The objective of the ventilation system design is to maintain air velocity and temperature of the underground tunnels and stations at a comfortable level for passengers and staff. For emergencies a set of environmental limits are defined in the Metro Design Criteria and NFPA 130 for allowing passengers and staff to safely evacuate from fires.

### 8.6.1 Design Conditions for Normal Operation in Stations

The ideal dry bulb temperature for normal operations inside the stations is 84°F. However, a dry bulb temperature of 89°F is the acceptable upper limit. The peak air velocity is the highest measurable air velocity, occurring for longer than five seconds. Air velocity fluctuations are caused by the piston action of moving trains and are limited in the middle segment of the station. The maximum peak air velocity in the middle segment of the station should not be higher than 1,200 fpm. The peak air velocity in the incoming and outgoing segment of the station is not limited. Humidity in the stations is not controlled and is therefore unlimited.

The average air velocity in the stations is calculated from the absolute velocities occurring in the station. Both negative and positive velocity values contribute to the average, which should not be higher than 600 fpm.

The outdoor air rate of the station should be 7.5 ft<sup>3</sup>/min per person plus 0.06 ft<sup>3</sup>/(min\*ft<sup>2</sup>) for transportation waiting areas.

### 8.6.2 Design Conditions for Normal Operation in Tunnels

Inside the tunnel a maximum average dry bulb temperature of 104°F is expected. As in the case of a station, the humidity is not controlled and is therefore unlimited. Air velocity in the tunnel is uncontrolled if the tunnel is not occupied by maintenance workers. If the tunnel is occupied, air velocity should be controlled to a minimum of 150 fpm and a maximum of 2,200 fpm.

### 8.6.3 Design Conditions for Emergency Operation in Stations

A fire in the station will increase the air temperature in the station. Close to the fire, the temperature and smoke will be greater than the normal limits. These high values are tenable as long as they do not occur in evacuation routes. The maximum tenable temperature in evacuation routes is 120°F. Smoke obscuration levels should be kept to a point at which illuminated signs are discernible at 100 ft and doors and walls are discernible at 33 ft. Therefore, the extinction level caused by smoke shall be lower than 0.08128 ft<sup>-1</sup>. The evacuation path should be clear of smoke in a height of 8.2 ft above the any point along the surface of the evacuation pathway. The tenability criteria for temperature and visibility shall not apply within 100 ft of the fire.

### 8.6.4 Emergency Ventilation System (EVS) in Stations

If a fire occurs on a train, the operator will attempt to reach the nearest station. Exhaust ducts are situated on both sides of each station above the trackways. These ducts contain exhaust dampers every 30 ft (in longitudinal direction of the station). In case of an emergency (fire in the station) the fire will be detected by sensors whereupon three exhaust dampers nearest to the fire will be opened. At the same time, the exhaust fans will be activated to extract hot smoke and gases into the exhaust duct. This exhaust action will reduce the pressure level in the station. To compensate for the pressure differential between the station and the ambient, air will flow through the tunnel openings and evacuation paths into the station. This entering fresh air entering will prevent the spread of smoke into the evacuation paths.

### 8.6.5 Design Conditions for Emergency Operation in Tunnels

In case of a fire in the tunnel, appropriate ventilation will be maintained in the paths of evacuation from the fire site to a point of safety. The maximum temperature in a path of evacuation should not exceed 120°F.

Air velocity in the path of evacuation should be controlled to a minimum of 150 fpm. A maximum of 2,200 fpm is required because people may experience difficulty in walking. The annular critical air velocity (the velocity in the train-tunnel annulus) in the path of evacuation shall not be less than that required to control the direction of spread of smoke and hot gases.

### 8.6.6 Emergency Ventilation System (EVS) in Tunnels

If a burning train is not able to reach the nearest station, it has to stop inside a tunnel. In this case the overhead trackway exhaust inside the stations cannot be used to exhaust the smoke. The emergency ventilation will be maintained in the paths of evacuation and will be designed to keep the shortest evacuation path free of smoke in a situation like this. Jet fans at the ceiling of the tunnels are used to create an airflow directed to the longer evacuation path. This way a short path is available for self-rescue and the smoke will flow into the long part of the tunnel until it reaches the exhaust dampers and drawn into the exhaust duct.

### 8.6.7 Maintenance Operation Criteria

Track and the tunnel maintenance will require the use of diesel engines vehicles. Diesel engines exhaust gases which can be harmful to workers if the tunnel is not properly ventilated. Therefore, the emergency ventilation system will be used for ventilating the tunnels during maintenance activities. The ventilation system should be able to produce a flux of 140,000 ft<sup>3</sup>/min in each ventilation zone.

## 8.7 Traction Power and Distribution

The design of the traction power supply and distribution system must meet the performance requirements and be fully integrated with all related vehicle, subsystem, civil and facilities design. The design shall adhere to the requirements listed in Metro Design Criteria Section 7/Electrical.

The development of the design of the traction power supply and distribution system will take into account the substations and vehicle characteristics. The design will contain all engineering data required to produce the plans, specifications, and estimates required. The design will integrate all traction power supply and distribution system design elements, with related system elements from other disciplines. The traction power supply and distribution system design will require coordination with design elements (signaling, communications, structures, civil, etc.), as well as with third parties (utilities, local cities, etc.). Conceptual engineering efforts on the traction power supply and distribution system are limited to identifying the location for the TPSS based on a qualitative analysis. All analysis of the traction power and OCS will be deferred until after selection of a preferred alternative.

The traction electrification system (TES) is comprised of the following major subsystems:

- TPSS
- DC power distribution system, which includes the positive DC feeders and OCS, and the negative DC return feeders and running rails

### 8.7.1 Traction Power Substations

Primary power would be three-phase AC provided by the LACDWP at 34.5 kV. The TPSS would convert the 34.5 kV AC to DC power at nominal 750V DC system voltage for distribution to trains via the OCS. Rectification would be achieved by either a diode-based or thyristor controlled 12-pulse power rectifier with one transformer-rectifier unit (TRU) per substation. The incoming utility feeders to the TPSSs must be independent; that is, supplied from different step-down utility transformers.

Based on a qualitative analysis factoring speed limits, gradients, and feasible TPSS sites, the placement of TPSSs for the LRT Alternative is as follows:

- TPSS-01 located on the northeast corner of the planned park-and-ride lot for the Floral Drive station
- TPSS-02 located on the west side of the I-710 Freeway south of the I-10 Freeway

- TPSS-03 located on the north side of Valley Boulevard at the maintenance yard
- TPSS-04 located underground at the Alhambra Station
- TPSS-05 located underground at the Huntington Station
- TPSS-06 located underground at the South Pasadena Station
- TPSS-07 located underground just south of the Fillmore Station

### 8.7.2 DC power Distribution System

The DC power distribution system is divided into positive and negative sides. The positive side would comprise an OCS, parallel feeders and positive DC feeders connecting the OCS to the TPSS. The negative side would comprise of 115 RE running rails, track impedance bonds (if necessary), cross-bonds, and negative return feeders connecting the running rails to the TPSS.

### 8.7.3 Overhead Contact System

The OCS would consist of a set of two copper wires – a contact wire and a messenger wire – supported by steel poles mounted on reinforced concrete foundations. OCS poles would be spaced along the LRT Alternative, between or adjacent to the tracks, at a typical spacing of 150 feet.

The OCS would be designed to match OCS configuration per the traction power simulation study and with the consideration of minimizing visual impact. The design of the OCS would be based on technical, economical, operational, and maintenance requirements, as well as on the local climatic conditions. The OCS design would be coordinated with the car dynamic performance characteristics to be sure that current collection is maintained.

The OCS shall also accommodate the physical characteristics of the car and the performance requirements of the propulsion system associated with the car; that is, clearance envelopes, propulsion power supply voltage, etc. Further, the OCS would be designed to provide adequate pantograph envelope, pantograph security, structure capacity for poles and foundations, and wire and components safety factors.

All analysis of the OCS will be deferred until after selection of a preferred alternative.

## 8.8 Safety/Security

### 8.8.1 Safety

Safety is a primary consideration from preliminary engineering through revenue operations. To achieve safety goals, all applicable codes and regulations, augmented by modern safety engineering technology and industry standards, are to be used to ensure and achieve a level of safety that equals or exceeds that of the rail transit industry.

Safety can be achieved by eliminating, minimizing, or controlling hazards through analysis, review, and design selection. The objectives of the safety program are the elimination or control of Category I and II hazards as defined in the Metro Guidelines for Preparation of Safety and Systems Assurance Analyses, 5-001A, and the assurance that no single point failure or no undetected failure (latent) in combination with an additional failure would result in a Category I or II hazard.

To achieve these objectives and provide a level of safety that equals or exceeds that of other rail transit systems requires a comprehensive and complete safety program. That program is described in detail in the Metro System Safety Program Plan.

The safety program would establish safety requirements and verify safety of design through analyses. It would also help assure that the Metro Rail system provides for health and safety provisions affecting maintenance and operations personnel that equal or exceed the requirements of the Occupational Safety and Health

Administration, State of California (CAL/OSHA), the Occupational Safety and Health Administration, US Department of Labor, and ADA.

Functional Hazard Analysis would be prepared which analyzes the loss or malfunction of each operational function and categorizes its effect on the equipment, personnel, patrons and general public to determine the associated hazard level (category I, II, III, IV) as defined in the MTA Guidelines for Preparation of Systems Safety Assurance Analyses 5-001A.

## 8.8.2 Security

Security refers to the prevention of acts defined as unlawful, criminal, or intended to bring harm to another person or damage property. The project alternatives, including proposed station areas, proposed park and ride facilities, proposed maintenance yards, operational parameters, and surrounding neighborhoods were evaluated to determine crime risks.

The primary objective of a security program is to ensure that the design includes features that enhance both the actual and perceived security of the using public. Of nearly equal importance is the need to protect system employees from crime and harassment, and property from loss, damage, or vandalism.

The design shall ensure a high level of security for patrons and operating personnel. Facility design and operating procedures shall promote a sense of well-being by patrons and personnel, discouraging acts of crime, violence, and abuse. Security provisions shall also discourage acts of vandalism, theft, and fraud.

The design shall include features that enhance patron and personnel security. These shall include maximum visibility from surrounding areas, with no hidden corners or alcoves; locks on doors to any rooms; landscaping; and lighting levels that support the intended means of surveillance.

A Threat and Vulnerability Analysis (TVA) will be conducted after the selection of a preferred alternative. The TVA will follow Federal Transit Administration (FTA) (FTA C 5800.1 and FTA Project Management Guidelines, Chapter 2) and Metro protocols. The TVA process will provide a more refined and detailed analysis of the security environment by identifying domestic and international security threats, potential vulnerabilities/shortcomings in the transit system, and then making recommendations to reduce those vulnerabilities to acceptable levels.

# Mechanical

---

## 9.1 Elevators

Elevators will be installed in aerial and underground stations and be located to keep the travel distance to the platform at a minimum. In stations with parking garages, parking for the handicapped will be located near the elevators. Elevator cabs will be sized for accommodating a gurney for Fire Department use. Elevator finish materials are brushed stainless steel on glazed wall surfaces, doors, frames, sill, and trim, as indicated on the Metro Design Criteria/Section 6 Architectural Standards. The hoistway doors will be safety glazed and of standard design. Elevators shall be the hydraulic type with separate or combined equipment rooms.

Four of the seven stations will be underground and will provide access to the platform via elevators. The Alhambra, Huntington, South Pasadena, and Fillmore Stations are designed as three levels, the plaza (entrance) level, the concourse (intermediate) level, and the platform level. At these stations, four elevator shafts will be provided in total, dual elevator shafts will provide access from the plaza level to the concourse level and two separate single shaft elevators will be placed on the concourse level providing access to the platform level.

The Cal State LA Station is an at-grade station, but it has two levels because it will be built on an MSE wall and located on the side of a hill. Two single elevator shafts will provide access from the plaza level to the platform level.

The two aerial stations, Mednik and Floral Station, will also provide access to the platforms via elevators. The Mednik Station will have two levels, the plaza and platform level, and a dual elevator shaft will be placed at the center of the platform. The Floral Station will have three levels: plaza level, concourse level, and platform level, and two single elevator shafts will be provided in total. One will be placed at the center of the platform for access to the platform and the other will be placed at the east end of the platform near the park and ride lot accessible from the concourse level.

## 9.2 Escalators

Several elevators would be provided at each underground station. They would be sized according to Metro standard design requirements and detailed to have transparent surfaces for the enclosure walls and elevators wherever possible in public areas.

All escalators will be 48 inches nominal width, dual direction, with 90 fpm in both directions in accordance with Metro's Design Criteria. Escalators are specified as capable of operating 24 hours non-stop. Escalators are systemwide, standard elements, as indicated in Metro's Architectural Standard and Directive Drawings. All escalators shall have stainless steel cladding.

The underground stations discussed previously, the Alhambra, Huntington, South Pasadena, and Fillmore Stations, will have three levels connected by six single escalators and adjoining staircases. The Cal State LA Station will not provide escalators, but only provide staircases and two elevators. The aerial Mednik Station will have two single escalators and adjoining staircases that give access to the station's platform at its ends. The Floral Station will have four single escalators and adjoining staircases. All stations would contain ticket vending machines and centralized fare collection gates with guard rail surrounding the entrance to the plaza level escalators and elevators. The Floral Station would have an additional fare collection gates at the concourse level where access is also provided to park and ride patrons.

## 9.3 Fire Protection Systems

The fire fighting system for the railway tunnel shall be a wet standpipe system. The system must be capable of supplying fire water demand for at least one hour. The wet standpipes shall be a Class 1 automatic-wet standpipe system installed to provide protection throughout the underground Guideway and shall conform to NFPA 14,

Uniform Building Code (UBC) Chapter 38. A Class III automatic-wet standpipe system would be provided throughout all underground/enclosed stations in accordance with NFPA 14, UBC Chapter 38 and as modified by local codes. Two independent water supply connections shall be provided in all standpipe systems.

Due to the warm weather conditions throughout the year there are no special requirements to prevent freezing in the water line. The system must be connected to a municipal or privately owned waterworks system which can provide adequate pressure and flow rate in case of fire.

The whole railway tunnel shall be divided into two sections of standby pipes. One standpipe will be supplied from the pumping station at the Filmore Station and the second standpipe will be supplied from the Huntington Station. This is necessary to fulfill NFPA 14 requirements regarding the maximum system pressures.

In both stations fire pumps are required which will deliver the required system pressure. The pumps shall operate in a duty / standby configuration. Which means that one pump shall always be available if one of the other pumps fails. All fire pumps necessary for the standpipe system shall be electrically driven and fulfill the requirements in NFPA 20.

A sprinkler system shall be provided in each tunnel railway station. Automatic sprinklers are required for stations, storage areas, trash rooms and in steel truss areas of escalators. The station sprinklers shall be supplied by pumps located in each station. To achieve an effective suppression in case of a fire the system is divided into zones. If a fire happens in one of the zones the respective valves will automatically open and the area in the emergency zone will be flooded.

An undercar deluge system in underground stations shall conform to the requirements and recommendations of NFPA 15, with devices approved by the California State Fire Marshal. It shall be hydraulically designed to provide a minimum density of 0.15 gpm per square foot for the entire length of the passenger loading platform.

A dry chemical fire suppression system shall be provided for the TC&C rooms fully supervised and electrically activated as approved by the California State Fire Marshal and conforming to NFPA 17.

Additional fire protection requirements shall include:

- Fire Hose Connection. The standpipe system shall also be provided with 2.5 inch fire hose connections. The hose connections shall be located according to the specifications in the NFPA 130 standard.
- Fire Extinguishers. Type and location of the fire extinguishers will be defined by the fire authority.



# Electrical

---

## 10.1 Power Sources

Primary power to the seven LRT stations and the maintenance yard will be three-phase AC provided by either LADWP or Pasadena Water and Power, depending on location.

A direct 480 volt power supply from the power utility company will be provided if available. A step down power transformer will be used otherwise to feed switchgear at each of the stations. The switchgear will be equipped with automatic transfer control in a main-tie-main circuit breakers concept. 480 V power will be distributed from the switchgear to low-voltage motor control centers (MCCs).

## 10.2 Temporary Construction Power

Temporary power supply will be required to launch the TBMs during construction. There will be two portal substations to support the TBMs and auxiliary loads. Also, temporary power will be required for the construction of the LRT stations.

LADWP will provide power to the south portal, and Pasadena Water and Power to the north portal. The primary power supply to the portals would be 34.5 kV.

LRT stations power will be served from LADWP, Southern California Edison or Pasadena Water and Power, depending on the stations' location.

## 10.3 Power Supply Reliability

The stations will be powered from two independent power sources. The normal power will be from the power utility company and the emergency power from diesel standby generators. Upon loss of normal power, the standby generators will provide power to lighting and ventilation equipment.

## 10.4 Power Distribution System

The power distribution system will provide power to all mechanical equipment, such as fans, lighting, elevators, escalators, sump pumps, sewage discharge systems and irrigation systems through a series of switchgear, motor control centers, local control stations and power distribution panelboards. Power will also be provided for all the systems related equipment and incorporate a power distribution design with comprehensive electrical system studies including protective device coordination, load flow and short circuit analyses.

## 10.5 Grounding

Grounding systems will include an electrical station grounding system with a buried ground grid system to ensure that all exposed electrical equipment is bonded to prevent any electrical hazards. A direct grounding system or single point ground will also be provided for the communication system.

## 10.6 Supply Voltage and Voltage Drop

Station power for the general facilities will be 480 volt, 3-phase, 4-wire, 60 Hz. Station and tunnel lighting will be 277 volt or 480 volt, motors and power outlet will be either 480 or 120 volt. Voltage drop from auxiliary power transformers to the farthest device or equipment will be no greater than 5 percent; and 3 percent for lighting and feeder circuits.

## 10.7 Lighting

Normal and emergency lighting system will be provided and independent from each other. Station lighting will consist of decorative LED luminaires for platform edge lighting and other types of luminaires per Metro's lighting standards. Lighting will use the latest energy saving lighting and lighting control technology.

DRAFT

# Right of Way

---

## 11.1 Right of Way Criteria and Limits

ROW impacts were determined by overlaying the design footprint of each alternative on top of the Los Angeles County Assessor's parcel boundary layer in the geographic information system (GIS). The system identified properties that were impacted by the designs and each impacted property's underlying ownership information and physical characteristics were subsequently exported to a database for later use in ROW cost estimation.\* At this phase of the analysis, the impact assessment was completed without site visits that would be required to verify the correctness of property ownership information. As such, the conclusions of the analysis are conceptual.

Several design alternatives evaluated in this analysis contain sections of bored tunnel that will not impact the properties on the surface that require acquisition of the property in fee. Similarly, some alternatives contain sections of overhead aerial structure that will not directly impact the underlying properties. The acquisition of subterranean and aerial easements are considered impacts for this analysis and also were considered in the ROW cost estimation process.

A number of transportation and infrastructure properties were identified by the analysis as being impacted. It was, however, agreed that the necessary relocation or reconfiguration of these properties would be handled by the agencies overseeing the design and construction of the project and would therefore not be considered impacts.

## 11.2 Right of Way Informational Requirements

Informational requirements follow Metro's Design Criteria and reflect the level of design detail developed for the current phase of work. ROW requirements are identified in the Draft Relocation Impact Report, which identifies the area, type of acquisition, usage, approximate square footage of the taking, book numbers, page and parcel number, owners and address in the County Assessor's records.

## 11.3 Affected Facilities and Right of Way

### 11.3.1 Caltrans ROW

The aerial portions of the LRT Alternative would have freeway ROW impacts. The LRT Alternative would begin at an aerial station on Mednik Avenue adjacent to the existing East Los Angeles Civic Center Station on the Metro Gold Line. The alignment would remain elevated as it travels north on Mednik Avenue, west of Floral Drive, north across Corporate Center Drive, and then along the west side of I-710, primarily in Caltrans ROW, to a station adjacent to the California State University, Los Angeles (Cal State LA). In addition, a maintenance yard to clean, maintain, and store light rail vehicles would be located in the Caltrans ROW on both sides of Valley Boulevard at the terminus of SR 710. A track spur from the LRT mainline to the maintenance yard would cross Valley Boulevard. Proposed modifications to Caltrans facilities are document in the Project Report. The final design must meet Caltrans and Federal Highway Administration (FHWA) standards, and will require the establishment of a cooperative working agreement with Caltrans and FHWA.

### 11.3.2 Cal State Los Angeles

The Cal State LA station is proposed to be located near the southeast corner of the Cal State LA campus with roadway access provided by Circle Drive. The station would be located on Cal State LA property on the east side of Circle Drive a retaining wall and sidewalk would also need to be built on the hill to connect the station with the El Monte bus station.

### 11.3.3 Flood Control Facilities

The aerial portion of LRT Alternative would require minor construction near the Laguna Regulating Basin and the Dorchester Avenue Storm Drain (Dorchester Channel). The proposed aerial system would require placement of columns and footings adjacent to the Laguna regulating Basin and the Dorchester Channel but would not impact the basins. The Dorchester Channel drains into the Laguna Regulating Basin. The Laguna Regulating Basin drains through several channel systems and eventually discharges into the Los Angeles River in the City of Vernon.

DRAFT

# Constraints and Issues to be Resolved in Next Phase

---

## 12.1 Civil, Alignment and Track Work

The aerial topographic mapping scale for ACE work was one-inch equals 100 feet with 2-foot contours. In the PE phase, one-inch equals 40 feet scale mapping is necessary and would need to be obtained.

Three issues related to the alignment remain to be resolved in the next phase, as discussed in the following sections.

### 12.1.1 Maintenance Yard Layout

Metro rail operations has suggested operational improvements and additional facilities to be incorporated into the maintenance yard. These modifications would enhance the functionality of the yard, since the proposed alignment does not have a track connection to other Metro rail facilities. Therefore, it is important to be able to provide as many service functions as possible in the yard dedicated to this alignment. Possible enhancements to the yard could include a service and inspection area with a longer track than provided by the current service bays, a longer car wash facility, and the elimination of stub end service bays to the extent possible. These improvements could be incorporated within the footprint of the yard by rearranging some existing facilities and by reducing the number of storage tracks provided, which currently exceeds the anticipated need of the LRT service. It may also be possible to eliminate one of the two heavy repair bays because of the relatively small number of vehicles that will be serviced at the proposed yard. The design of the revised yard will need to be addressed in a future phase.

Further modifications to the yard area to provide operational improvements could include a third track on the yard lead so that a train could leave the yard and travel northbound without reversing on the mainline. This third track could also include a siding to store maintenance of way equipment or problem equipment. Additional crossovers could also be provided on or near the yard leads to provide redundancy in case of switch failure.

If the layout of the maintenance yard cannot be modified to achieve a satisfactory configuration, an alternative site for the yard would need to be found. Any new site would require supplemental environmental evaluation.

### 12.1.2 Mednik Station Location

The placement of the Mednik Station on private property west of Mednik Avenue requires the acquisition of a commercial center that has strong community support. The station design provides for approximately 12 enclosed retail spaces to be located at plaza (ground) level, below the station. The station was placed in this location instead of locating directly above Mednik Avenue to eliminate the need to reconstruct the Mednik Avenue bridge over SR 60, to avoid the need for outrigger structures over Mednik Avenue, to increase the separation from the mural on the exterior of the Los Angeles County Health Department building across the street, and to allow for a platform placement closer to Third Street (because of the curvature of Mednik Avenue). Locating the station over Mednik Avenue would offer the benefit of allowing the crossover north of the station to be closer to the station, improving operations. In a future phase of the project, the location of this station should be reevaluated to determine the advantages and disadvantages of relocating it over the street.

### 12.1.3 Mednik Station Crossover

For the Mednik Station at the southern terminus, in order to be able to locate the station close to the existing Gold Line Station and not encroach on any additional properties, the crossover tracks were placed approximately 1,000 feet north of the station instead of south of the station. The Metro Design Criteria recommend crossovers beyond terminus stations. A deviation request would have to be processed in the next phase for this non-standard feature. In addition, there are station layout constraints that are further discussed in Section 12.4.

## 12.2 Geotechnical Investigations

For the design of the proposed LRT Alternative improvements, additional subsurface investigations will be required. The purpose of the investigations is to evaluate the subsurface conditions and provide geotechnical information for design and construction of structural foundations, bored tunnel, portal, stations, and remedial earthwork, if required.

Proposed explorations for the LRT Alternative are summarized below.

- **Tunnel Explorations:** The proposed field investigation for the tunnel would consist of borings, sampling, in situ testing, geophysical investigations, and laboratory testing. The borings would generally be spaced at intervals of 300 to 500 feet. The proposed borings would extend at least 1.5 tunnel diameter below the proposed tunnel invert. The borings proposed at LRT stations would extend at least 1.5 times the depth of the station for design of the shoring system. The field investigation should be carried out in phases to obtain the subsurface information necessary at each stage of the project in a cost-efficient manner.
- **Bridge Foundations:** For the bridge foundations, subsurface explorations would be conducted in accordance with Metro Design Criteria. According to Metro Design Criteria, a minimum of 50 percent of the bent locations would have been investigated for aerial guideway designs. In addition, a minimum of one exploration for each abutment support is recommended. The depth of exploration would extend below the foundation tip elevation a minimum of 20 feet, at least 3 times the pile diameter, or a minimum of 2 times the pile group dimension, whichever is deeper.
- **Retaining Walls:** For the retaining wall foundation, subsurface explorations would be conducted in accordance with Metro Design Criteria. A minimum of one exploration for each retaining wall is recommended. For retaining walls more than 100 feet in length, exploration points would be spaced every 100 to 200 feet. The depth of the exploration would extend at least 1 to 2 times the wall height. For anchored and soil-nailed walls, additional exploration points in the anchorage zone space are recommended at a distance of 1.0 to 1.5 times the height of the wall behind the wall face and spaced at 100 to 200 feet.
- **Cut Slopes:** For cut slopes, a minimum of one exploration point would be spaced every 200 to 400 feet of slope length. At critical locations, such as maximum slope heights, a minimum of three exploration points in the transverse direction are recommended to define the existing subsurface conditions for stability analyses. The exploration depth would be a minimum of 30 feet below the lowest elevation of the cut, and extend below the toe of the existing slope. In addition, the exploration depth would be advanced enough to fully penetrate through soft strata into competent material and to determine the depth of underlying pervious strata if the base of the cut is below groundwater level.
- **Active Faulting:** To further evaluate the location and activity details for the Raymond and San Rafael faults, a detailed investigation will be required. Trenching is the ideal method to evaluate a fault. However, constraints to the placement of the trenches are abundant along the Alternative, and the trenches may need to be emplaced outside the limits of the Alternative. This may be the only realistic way to gather the necessary detailed geologic and paleoseismic data needed for these faults. To better locate the Raymond and San Rafael fault crossings along the LRT Alternative, a series of continuously cored boreholes would be emplaced across the fault zones. In addition, seismic lines can be utilized to provide additional subsurface information relevant to faulting. Further evaluation of the Upper Elysian Park Blind Thrust fault generated Coyote Pass escarpment will be required as well. An investigation would be similar to that indicated for the Raymond and San Rafael faults.

## 12.3 Tunnel Excavation and Ground Support

### 12.3.1 Building Foundation Records Search Reconnaissance

Preconstruction surveys of all private and public structures and utilities within the anticipated settlements limits must be conducted to establish a baseline for assessing the actual damage from tunnel and station constructions.

Also, the reliability of predicting impacts from construction is greatly improved by obtaining knowledge of the structures' condition, sensitivity, and susceptibility to settlement. Similar factors also affect the planning and layout of instrumentation for monitoring settlement.

Structure-specific information relevant to the settlement analysis includes structure location, geometry, foundation type and depth, construction type, function, and age and current condition. The extent and degree to which condition surveys are performed depends upon the levels of risk initially estimated and on the tunnel owner's preferred approach to managing communication with third parties. However, notifying third parties and inspecting properties requires care in order to manage the public's perception of actual risk and minimize the chance of unduly elevating public concern. The surveys may include a photographic record of all preconstruction existing conditions of buildings and structures, including cracks and other pre-existing signs of distress or damage.

### 12.3.2 Settlement Estimates and Building Protection

In later phases, a study will be undertaken to evaluate the responses of structures and utilities to the ground movements and to determine which are potentially at risk of being damaged, requiring mitigation or repair. As one method to further evaluate impacts to buildings from tunneling-induced settlement, additional analysis may be performed using the method outlined in Boscardin and Cording (1989). The intent of a Boscardin and Cording Analysis is to evaluate the responses of buildings and structures to the ground movements and to determine which buildings or structures are potentially at risk of being damaged, requiring mitigation or repair.

The Boscardin and Cording method is used to estimate shear-related deformations as a function of the building angular distortion and horizontal tensile strain. The calculated maximum angular distortion and horizontal tensile strain for each building is correlated to a set of curves for constant critical tensile strain (strain in the building walls associated with a particular damage level). These curves define the limits of damage categories as shown in Figure 12-1.

Figure 12-1: Relationship of Damage to Angular Distortion & Horizontal Strain (Boscardin and Cording, 1989)

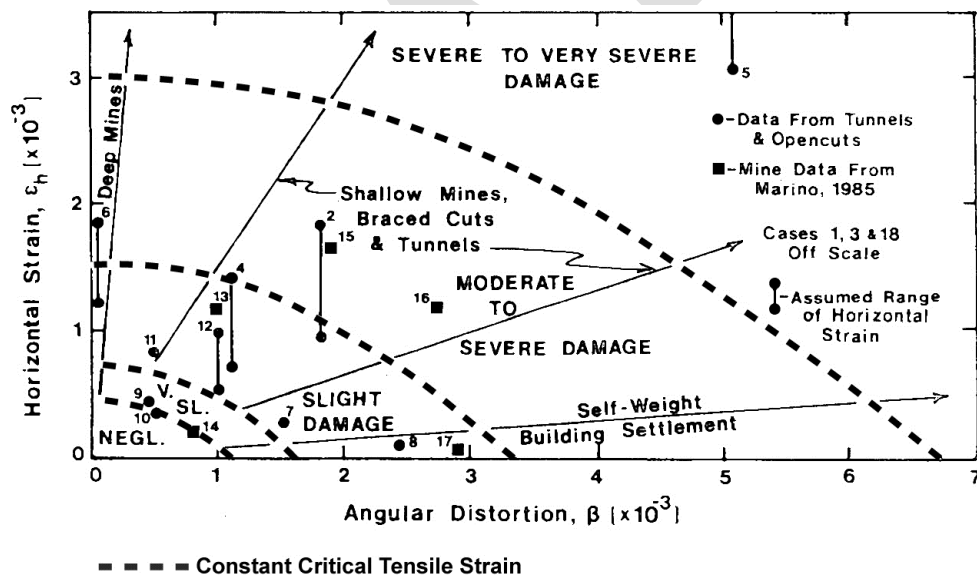

Semi-empirical methods such as O'Rourke and Trautmann (1982) will be used in subsequent phases to assess susceptibility of utilities to damage. Settlement impacts on buried pipeline utilities are typically caused by one or more of the following effects: tensile pull-apart at joints caused by relative tensile axial movements along the pipeline; opening of joints between pipe segments due to relative rotation between two pipe segments; and straining of pipe caused by flexural and lateral deformations that lead to rupture or intolerable deformation. Excessive differential settlement will lead to excessive shear forces in the utilities or contribute to joint deflection.

Where structural protection measures have been identified as necessary, mitigation methods will need to be developed in advance of the excavation to protect each structure. One anticipated methodology for structure

protection will be to use compensation grouting, which involves carefully controlled injection of grout between underground excavations and structures requiring protection from settlement. For tunnel applications, the grouting pipes are installed above the intended tunnel position in advance of tunneling. A key component in controlling compensation grouting is careful monitoring of both structure and ground movements to allow the timing and quantity of grout injected to be optimized. Grout can be injected repeatedly via sleeve port pipes (also known as tube à manchettes), with the injected volumes from each port being controlled to limit the lateral spread of the grout. Grout injection can take place before, during, and after tunneling activity by reusing the sleeve port pipes. Often a “preconditioning” phase of grouting is carried out before tunneling to consolidate the ground and produce a slight heave in structures above.

A significant advantage of compensation grouting is the wide range of soil conditions in which it can be applied, from hard clays and very dense sands to very soft clays and very loose sands. However, compensation grouting must be used carefully, particularly when implemented close to existing foundations and tunnel linings. Damage to structures due to heave and collapse of tunnel linings are potential risks.

Other examples of mitigations measures include pre-installed piles on either side of the tunnels, permeation grouting prior to tunneling, and underpinning.

### 12.3.3 Additional Geotechnical Information

The currently available geotechnical information was used for the preliminary design concepts presented herein; however, additional geotechnical data should be collected in subsequent phases of this study.

Additional field and laboratory investigations will be required to perform more advanced design of the excavation support systems, tunnel initial supports and final linings, and the seismic vault sections. Recommendations for future design evaluations include, but are not limited to, the following:

- Additional geotechnical investigations, including laboratory and in-situ testing, to better define the thickness and extents of the various formations and the ground water table along the alignment.
- Pressuremeter testing to determine soil modulus and  $K_0$  at both the station and portals. These tests can also be used to estimate bond stress values for tiebacks.
- Moisture density and grain size tests to evaluate the feasibility of various ground improvement methods at the portal and station headwalls.
- Establish seismic design parameters for the excavation support walls during construction of the tunnels.
- Further refine extent of fault zones and understanding of geology in and surrounding fault zones.

## 12.4 Station Architecture

### 12.4.1 Station Layouts

In the PE phase, the layout and size of the stations will be adjusted and finalized to ensure the following:

- Provide sufficient space and in desirable arrangements for passenger activities, movements and safety within the stations and at the station areas;
- Coordinate the station layouts in the architectural drawings with the structural design of the stations;
- Adapt the stations for desirable relationships to possible future or currently on-going non-transit developments at the station areas; and,
- Provide the facilities for electrical, mechanical and communication systems as they are developed during PE.

A few of the stations have accessibility issues due to the site constraints. The Cal State LA station is accessible via stairwell and elevators, but there was not enough room for escalators. Providing additional elevators in the PE design phase would improve the access to the station.



The Floral Station park-and-ride lot is separated from the station access by a small roadway, Kern Avenue. All Metro patrons, including the disabled, utilizing the park-and-ride lot would be required to walk across the street in order to access the station. The possibility of vacating this roadway and incorporating it into the station parking area should be investigated at the PE phase.

The Huntington Station has similar accessibility issues as the Floral Station as the park-and-ride lot is separated from the station by Huntington Drive, a 6-lane roadway. A passenger drop-off area provided in the PE design phase would improve the accessibility to this station.

## 12.4.2 Architectural Design

Also in the PE phase, the architectural and interior design approach to the stations could be determined. This would include the approach to be taken regarding the art program.

A determination could be made concerning the design of stations regarding continuity of design among them. For example, discussions with the community should address to what extent the stations would have distinct individual character as was done on the Metro Gold Line Eastside Extension or have a consistent approach as was done on the Metro Expo Line Phase I.

The art program also may be addressed in the PE. The architectural and interior design can be independent of the work of the artist – the artwork being an “overlay” – art pieces are placed at the station but do not have a major role in determining the architectural and interior design approach. Alternatively, the artist’s message can be collaboratively integrated into the architectural and interior design approach and details at the stations. Both approaches can be seen in previous Metro station design.

The development of this design and art work can include presentations and meetings to involved stakeholders in the station areas with the development of the design and approval of the work.

## 12.5 Systems

The LRT Alternative would be connected and integrated with existing light rail systems. For example, the existing CTS would be extended to incorporate this segment with a new SONET ring or extension of an existing ring. How and where it connects will depend on the current architecture of the CTS.

In the time frame of this project, it is expected that the ROC will be relocated. Presumably, the designers of the space for the new ROC will be planning for the future extensions of LRT lines, including the possibility of the SR-710 LRT Alternative.

## 12.6 Mechanical

### 12.6.1 Ventilation

Design fire scenarios and ventilation design parameters have been coordinated. In the next phase, these parameters will be applied to the detailed design of the ventilation system and calculations.

### 12.6.2 Fire Protection Requirements

In the next phase, water supply piping calculations will determine piping dimensions. These calculations will impact cost estimates for the fire protection system.

## 12.7 Electrical

If the LRT Alternative is identified as the preferred alternative, the next phase of the project will need to include:

- Coordination with utility companies to provide temporary and permanent power to the LRT stations and the light rail power system at the portals.

- Future development of the power and any other electrical requirements of the light rail system.
- Preparation the final design documents for the light rail power system, including power for LRT stations, and the lighting and ventilation in the tunnels.

## 12.8 Construction

In the PE phase, further evaluation is necessary of appropriate construction methods and required mitigation measures that will be incorporated into the designs developed during this subsequent phase.

An evaluation of contract packaging and project delivery methods would also be reviewed in the PE phase and a formal risk assessment conducted. It is important to note that FTA will require a formal risk assessment prior to granting approval for entry into the PE phase.

DRAFT

# Project Cost

---

## 13.1 General Approach

The methodology used in generating capital cost estimates has been developed in general conformance with the FTA guidelines for estimating capital costs. The FTA guidelines call for cost estimates to be prepared and reported using the latest version of the FTA's Standard Cost Categories (SCC). These cost categories form the basis of the format and structure that will be used for the capital cost detail and summary sheets. The cost estimates were converted to a Caltrans' acceptable format for consistency purposes with the Freeway Alternative.

Cost data has been developed for the LRT Alternative as part of the current Draft Environmental Impact Statement/Draft Environmental Impact Report (DEIS/DEIR) stage of the project. Costs should be further refined during the Final Environmental Impact Statement/Final Environmental Impact Report (FEIS/FEIR), in the event the LRT Alternative becomes the Locally Preferred Alternative.

Capital cost estimates have been developed with the conceptual layout plans. These layout plans form the basis of the quantity take offs and have been used to identify the various infrastructure elements used to prepare the capital cost elements.

For the DEIS/DEIR stage, where more detailed plans are available as compared to the Alternatives Analysis (AA) phase, quantity take offs have been used as appropriate to verify and update the Rough Order of Magnitude (ROM) unit costs. The updated unit costs may include items of work that did not originally appear on the ROM unit costs.

The verification of unit costs was accomplished by combining the costs for all of the individual construction elements, applicable to a given item of work identified in the SCC, and creating a representative composite unit cost.

## 13.2 Cost Estimating Assumptions

The basic assumptions and criteria used to develop the cost data were as follows:

- Estimates have been prepared using 2013 dollars
- Contingency is set at 39 percent for the tunnel portion of the estimates and 35 percent for the aerial portions
- Adequate, experienced craft labor is available
- Normal productivity rates, as historically experienced, have been utilized
- Compatible trade agreements exist in the region
- No strike impacts would be experienced by the project
- There are sufficient, experienced contractors available to perform the work
- Normal Los Angeles area weather impacts have been considered in the development of the construction schedule and costs
- Existing state-of-the-art construction technology would be available

## 13.3 Adequacy of Cost Estimates

At the DEIS/DEIR stage, capital costs as previously stated are order of magnitude cost estimates which are considered reasonable based on the level of engineering development and the historic cost information collected over the years by Metro for past completed projects in the Los Angeles region. As the project evolves into the preliminary engineering phase, a mix of detailed pricing and historical information will be utilized.

In subsequent phases of work, a more bottom-up approach will be required along with detailed development of project risks and an assessment of the probably of occurrence of the identified risks.

DRAFT

# References

---

- Albino, J.H., G. Roy, J.E. Monsees, 1999. Crossing the Hollywood Fault Using Special Seismic Section. Rapid Excavation and Tunneling Conference Proceedings.
- Boscardin, M.D., and E.J. Cording, 1989. Building response to excavation-induced settlement, *Journal of Geotechnical Engineering Division*, American Society of Civil Engineers, 115(1), 1–21.
- California Division of Mines and Geology (CDMG). 1982. *Part IV: Mineral Land Classification of the Greater Los Angeles Area: Classification of Sand and Gravel Resource Areas, San Gabriel Valley, Production-Consumption Region*: Special Report 143: Part IV.
- California Geological Survey. (CGS). 2010. *Update of Mineral Land Classification for Portland Cement Concrete-Grade Aggregate in the San Gabriel Valley Production-Consumption Region, Los Angeles County, California*: Special Report 209.
- California Office of Mine Reclamation. (CMR). 2007, *Surface Mining and Reclamation Act and Associated Regulations*: Includes SMARA, 1975.
- CH2M HILL. 2014. Draft *Preliminary Geotechnical Report, SR 710 North Study, Los Angeles County, California*. Report prepared for Los Angeles County Metropolitan Transportation Authority (Metro).
- CH2M HILL. 2013b. Draft *Phase I Initial Site Assessment, SR 710 North Study, Los Angeles County, California*. Draft Technical Report prepared for Los Angeles County Metropolitan Transportation Authority (Metro). October 31.
- CH2M HILL. 2013c. Draft *Summary Floodplain Encroachment Report, SR 710 North Study, Los Angeles County, California*. Draft Technical Report prepared for Los Angeles County Metropolitan Transportation Authority (Metro). December 4.
- CH2M HILL. 2010. *Final Geotechnical Summary Report, SR 710 Tunnel Technical Study, Los Angeles County California*. Prepared for Caltrans. EA-07-187900. April.
- CH2M HILL and Earth Consultant International, 2013. Fault Rupture Evaluation for the SR 710 North Study, Los Angeles County, California. Draft Technical Memorandum prepared for Los Angeles County Metropolitan Transportation Authority (Metro).
- Choueiry, E., A. Elioff, J. Richards, B. Robinson, 2007. "Planning and Construction of the Metro Gold Line Eastside Extension Tunnels, Los Angeles, California." *Proceedings, Rapid Excavation and Tunneling Conference 2007*. M.T. Traylor and J.W. Townsend (eds.). Society of Mining Engineers, 808-829.
- Clough, G. W., and T.D. O'Rourke, 1990. Construction induced movements of insitu walls. Design and performance of earth retaining structures (GSP 25), 439-470.
- The Connector Partnership, 2012. Building and Adjacent Structure Protection Report, Regional Connector Transportation Corridor Project.
- Federal Highway Administration (FHWA), 2009. Technical Manual for Design and Construction of Road Tunnels - Civil Elements (*FHWA-NHI-10-034*) by U.S. Department of Transportation, March 2009.
- Itasca Consulting Group, 2005. FLAC: Fast Lagrangian Analysis of Continua, version 5. Itasca Consulting Group, Inc., Minneapolis, Minnesota, USA.
- Los Angeles County Metropolitan Transportation Authority (Metro). 2013. Metro Rail Design Criteria.
- Los Angeles Metropolitan Transportation Authority, 2012. Metro Rail Design Criteria. Revised October 16, 2012
- Langmaack, L., 2001. Europe & Asia: Application of new TBM Conditioning Additives. BAUMA 2001.
- Maidl, B., M. Herrenknecht, L. Anheuser, 1996. Mechanised Shield Tunnelling. Ernst & Sohn.

- National Fire Protection Association (NFPA), 2010. NFPA 130: Standard for Fixed Guideway Transit and Passenger Rail Systems, 2010 Edition.
- O'Rourke, T.D., and C.H. Trautmann, 1982. Buried pipeline response to tunneling ground movements, Proceedings Europe '82 Conference, Switzerland, Paper 1, 9–15.
- PLAXIS 2D, 2010. A Program for the analysis of deformation, stability and groundwater flow in geotechnical engineering.
- Rankin, W.J., 1988. Ground movements resulting from urban tunnelling: Predictions and effects. Engineering Geology of Underground Movements. 5, 79-92.
- Smirnoff, T.P., A. Stirbys, and A. Elioff. 1997. Comparison of performance of soil mix wall and conventional bracing system for excavations in alluvium. In *Rapid Excavation and Tunneling Conference Proceedings 1997*, 59-71.
- Wahls, H., 1981. "Tolerable Settlement of Buildings." *Journal of the Geotechnical Engineering Division, ASCE*, Vol. 107, No. GT11. Proc. Paper 16628, November, 1981, 1489-1504.

DRAFT

DRAFT

Appendix A: Conceptual Plans and Profile Drawings

**Appendix B: LRT Preliminary Operating Plan**

---





## SR 710 North Study

### TECHNICAL MEMORANDUM

---

# LRT Preliminary Operating Plan

PREPARED FOR: Michelle Smith  
COPY TO: Caltrans  
Study Team  
PREPARED BY: CH2M HILL Team  
DATE: April 2, 2014  
PROJECT NUMBER: 428908

Since the completion of the Alternatives Analysis phase of the SR 710 North Study, the Study Team has refined the alignment of the LRT Alternative. Advanced Conceptual Engineering plans (dated August 12, 2013) have been submitted to Metro for review. This technical memorandum presents a preliminary operating plan and operating and maintenance (O&M) cost methodology for the LRT Alternative, and documents the approach used for developing the operating plan. General operating assumptions approved by Metro regarding vehicle performance and station dwell times are provided.

This technical memorandum documents the general operating assumptions for the LRT Alternative based on service levels projected for Year 2035. These assumptions include: operating agency, span of service, vehicle performance, and station dwell times. The operating plan includes a station-to-station run time estimate and operating requirements.

### Operating Assumptions

Existing transit services in the SR-710 study area are operated by Metro, Alhambra Community Transit, East Los Angeles Shuttle, Foothill Transit, Montebello Bus Lines, Monterey Park Spirit Bus, Norwalk Transit System, Pasadena Area Rapid Transit System, and South Pasadena Community Transit. Metro provides local and express bus service throughout the study area, and the other transit providers offer local bus service in the municipalities where the LRT Alternative is proposed to operate. Metro is assumed to be the operating agency for the proposed SR-710 LRT line that would connect the Metro Gold Line Eastside Extension to the Metro Gold Line in Pasadena.

**Span of Service.** The proposed LRT Alternative would provide service 24 hours per day. Table 1 summarizes the assumed span of service.

TABLE 1  
Metro LRT Span of Service

Day of Week	Time Period	Hours
Weekdays	Early AM	5:00 – 6:00 a.m.
	AM Peak Period	6:00 – 9:00 a.m.
	Midday	9:00 a.m. – 3:00 p.m.
	PM Peak Period	3:00 – 6:00 p.m.
	Evening	6:00 p.m. – 12:00 a.m.
	Owl	12:00 a.m. – 5:00 a.m.
Saturdays, Sundays and Holidays	Early AM	5:00 – 8:00 a.m.
	Midday	8:00 a.m. – 8:00 p.m.
	Evening	8:00 p.m. – 12:00 a.m.
	Owl	12:00 – 5:00 a.m.

Service Headways. The assumed service headways of the proposed LRT Alternative are presented in Table 2.

TABLE 2  
Metro LRT Service Frequency

Day of Week	Frequency	Hours
Weekdays	5 minutes	6:00 – 9:00 a.m., 3:00 – 6:00 p.m.
	12 minutes	9:00 a.m. – 3:00 p.m.
	10 minutes	5:00 – 6:00 a.m.
	10 minutes	6:00 p.m. – 12:00 a.m. (2:00 a.m. Friday)
	20 minutes	12:00 a.m. (2:00 a.m. Friday) – 5:00 a.m.
Saturdays, Sundays and Holidays	7.5 minutes	8:00 a.m. – 8:00 p.m.
	15 minutes	5:00 – 8:00 a.m.
	10 minutes	8:00 p.m. – 12:00 a.m. (2:00 a.m. Saturday)
	20 minutes	12:00 a.m. (2:00 a.m. Saturday) – 5:00 a.m.

Vehicle Performance. LRT vehicles are assumed to have a normal service maximum acceleration rate of about 2.5 miles per hour per second (mphps) between 0 and 30 miles per hour (mph), decreasing to an average acceleration rate of 1.0 mphps between 30 to 55 mph. Normal service braking is assumed to be a constant 2.5 mphps from 55 mph to 0 mph. LRT vehicles are assumed to have a maximum revenue operation speed of 55 mph. Operation speeds along the proposed alignment vary due to horizontal and vertical curves and station spacing. A summary of the station-to-station LRT travel time estimate developed based on these criteria are presented in Table 3 below; calculation details are provided in the attached spreadsheet.

Station Dwell Times and End-of-Line Layovers. The average station dwell time (i.e., time to allow passengers to board and alight the transit vehicle) for the LRT Alternative is assumed to be 20 seconds at all of the proposed stations.

End-of-line layovers provide sufficient time for drivers to take breaks as required by union agreement, as well as allow for schedule recovery (i.e., a late train can “catch up” to its schedule). Layovers of three minutes are assumed at each end-of-line station. Metro currently uses “drop-back” operators at most terminal stations for rail operations.

## Operating Plan

The LRT Alternative would have seven stations. All stations are planned to include park-and-ride facilities except the Cal State LA Station and the northern and southern termini (Fillmore and East LA Civic Center Gold Line Stations, respectively).

The LRT Alternative would originate at an aerial station on Mednik Avenue adjacent to the existing East LA Civic Center Station. From there, the line would be routed north along Mednik Avenue on an elevated structure, turn west on Floral Drive, then turn north across Corporate Center Drive and enter the Interstate 710 right-of-way. A station would be provided near the intersection of Floral Drive and Mednik Avenue. After entering the I-710 right-of-way, the alignment would be routed north, with a station at Cal State LA providing a transfer location to and from El Monte Busway and Metrolink service. Continuing north of Cal State LA, the alignment would enter a tunnel south of Valley Boulevard. The tunnel alignment would be routed northeast to Fremont Avenue, with a station near the Los Angeles County Department of Public Works building in Alhambra. The alignment would then be routed north under Fremont Avenue, shifting slightly east to Fair Oaks Avenue, remaining in tunnel. Stations would be placed at the intersections of Fair Oaks Avenue/Huntington Drive and Fair Oaks Avenue/Mission Street. The alignment would continue in a tunnel under SR 110 reaching a terminus station under Raymond Avenue adjacent to the existing Fillmore Station.

The LRT Alternative would have a total operating length of 7.4 miles and stations spaced about 1.23 miles apart, on average. The line would have a one-way run time just under 15 minutes, with trains operating at an average speed of approximately 30 mph.

TABLE 3  
LRT Alternative Station-to-Station Run Times

Station	Speed (mph)	Distance (miles)		Run Time	Dwell Time (min:sec)	Total Time
		Increment	Total			
East LA Civic Center (Mednik Ave / Civic Center Way)	20 – 45	0.74	0.00	01:47	00:00	00:00
Floral (Floral Dr / Mednik Ave)	20 – 45	1.48	0.74	02:53	00:20	02:07
Cal State LA	35 – 45	1.81	2.22	02:57	00:20	05:20
Alhambra (Fremont / Concord Aves)	45 – 55	1.37	4.03	02:00	00:20	08:37
Huntington (Fair Oaks Ave / Huntington Dr)	55	0.77	5.40	01:16	00:20	10:57
South Pasadena (Fair Oaks Ave / Mission St)	35 – 55	1.22	6.17	02:02	00:20	12:33
Fillmore (Raymond Ave / Fillmore St)			7.39		00:20	14:55
Total			7.39	12:55	02:00	14:55
Average speed, station spacing	29.7	1.23				

*Note: Run times are based on one-way travel.*

## LRT Maintenance Yard

The proposed LRT Alternative would require a maintenance yard for cleaning, maintaining, and storing light rail vehicles (LRVs). The maintenance yard would include a car wash, paint shop, and other support facilities, and would also have enough storage tracks to accommodate all of the LRVs required to operate the light rail line. A potential site has been identified for the maintenance yard near the mid-point of the alignment, located at the

north end of SR-710 between Valley Boulevard and the Union Pacific Alhambra Subdivision rail line, in the City of Los Angeles.

### Operating Requirements

Operating requirements were developed for the LRT Alternative based on the assumptions outlined above. Each train in service is assumed to consist of three LRVs, and fleet calculations include ready trains to support “drop back” operations and 20 percent spare capacity. Annual operation and maintenance costs are calculated based on the Fiscal Year 2012 cost per revenue service hour presented in Metro’s Fiscal Year 2013 Proposed Budget. This unit cost of \$374.48 is applied for each hour each LRV would be operated in revenue service during a one-year period, and includes transportation costs, maintenance costs, other operating costs, and support department costs.

Operating requirements for the LRT Alternative are presented in Table 4. A fleet of 36 LRVs would be required, and annual operation and maintenance costs would amount to \$42 million.

TABLE 4  
LRT Alternative Operating Requirements

Day	Headway (minutes)				Peak LRVs	Annual Revenue			Lay over Time (minutes)	Total Cycle Time	Trains			
	Peak / Wknd AM	Evening	Midday	Owl		Car-Miles	Car-Hrs	Train-Hrs			Peak / Wknd AM	Evening	Midday	Owl
Weekdays	5	10	12	20	24	1,987,000	80,180	26,730	3	35.8	8	4	3	2
Weekends/Holidays	15	10	7.5	20		792,400	31,970	10,660			3	4	5	2
Estimated Totals:					24	2,779,000	112,200	37,390						
Ready Cars:					6									
Peak Revenue Total:					30									
Maintenance Spares:					6									
Total Fleet:					36									
Annual Operation and Maintenance Costs:						\$42,000,000								