

LEGEND:

- BRIDGE
- CUT & COVER TUNNEL
- TUNNEL BORING MACHINE (TBM)
- PAVEMENT
- TUNNEL CROSS PASSAGES
- HISTORIC PROPERTY
- DISTURBANCE LIMIT LINE (DLL)

PLAN
SCALE: 1"=200'



CURVE TABLE

No.	R	D	T	L
(1)	2000.00'	26°07'21"	463.99'	911.85'
(2)	4000.00'	16°15'28"	571.34'	1135.00'
(3)	425.00'	138°51'34"	1075.05'	1015.17'
(4)	3000.00'	12°25'42"	326.66'	650.15'
(5)	415.00'	69°46'33"	289.38'	505.39'
(6)	3000.00'	11°01'42"	289.61'	577.44'
(7)	500.00'	40°33'10"	184.72'	353.89'
(8)	3024.00'	11°42'54"	310.23'	618.30'
(9)	401.86'	67°57'06"	270.81'	476.60'
(10)	1200.00'	6°16'16"	65.74'	131.34'
(11)	3012.00'	4°14'54"	111.72'	223.33'
(12)	400.00'	42°51'03"	156.96'	299.15'
(13)	3800.00'	16°15'28"	542.77'	1078.25'
(14)	3600.00'	27°36'15"	884.39'	1734.43'
(15)	4500.00'	2°51'45"	112.43'	224.81'
(16)	3000.00'	27°36'15"	736.99'	1445.36'
(17)	2700.00'	27°36'15"	663.29'	1300.82'
(18)	4035.00'	4°15'50"	150.21'	300.28'
(19)	3000.00'	10°13'48"	268.53'	535.64'
(20)	4051.00'	2°54'37"	103.06'	206.07'
(21)	3500.00'	27°36'15"	859.82'	1686.25'
(22)	1000.00'	16°12'32"	142.40'	282.90'
(23)	800.00'	14°53'26"	104.55'	207.91'
(24)	3024.00'	5°20'27"	141.04'	281.88'
(25)	2500.00'	19°24'34"	427.54'	846.89'
(26)	3476.00'	4°56'30"	149.99'	299.80'
(27)	1200.00'	22°12'07"	235.45'	465.00'
(28)	4350.00'	52°20'06"	2038.25'	3974.74'



PROFILE
SCALE: Horiz 1"=200'
Vert 1"=80'

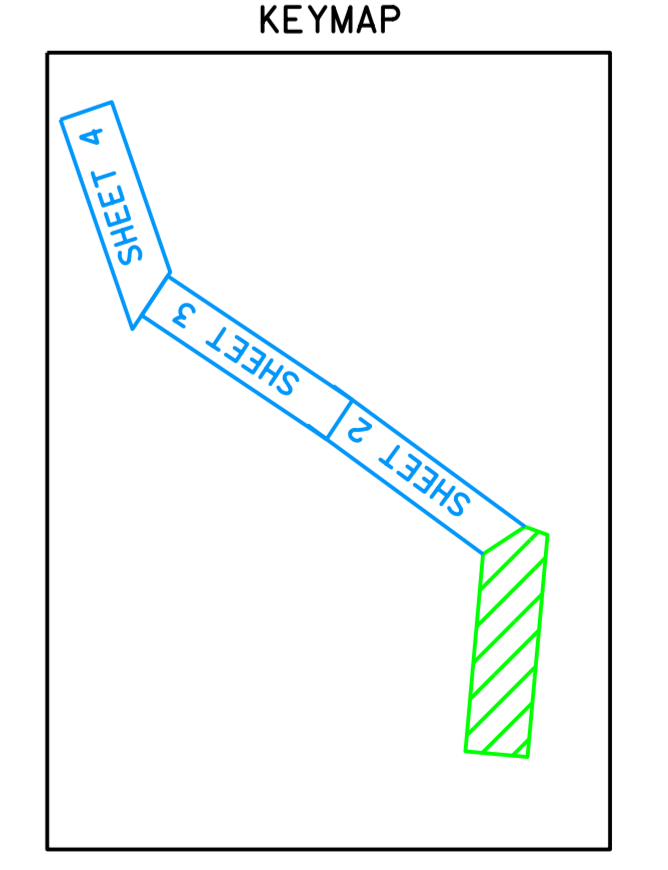

710 STUDY
 CONCEPTUAL DESIGN
 1 OF 6
 F-2
 METRO
 CH2M HILL
 GILTRON

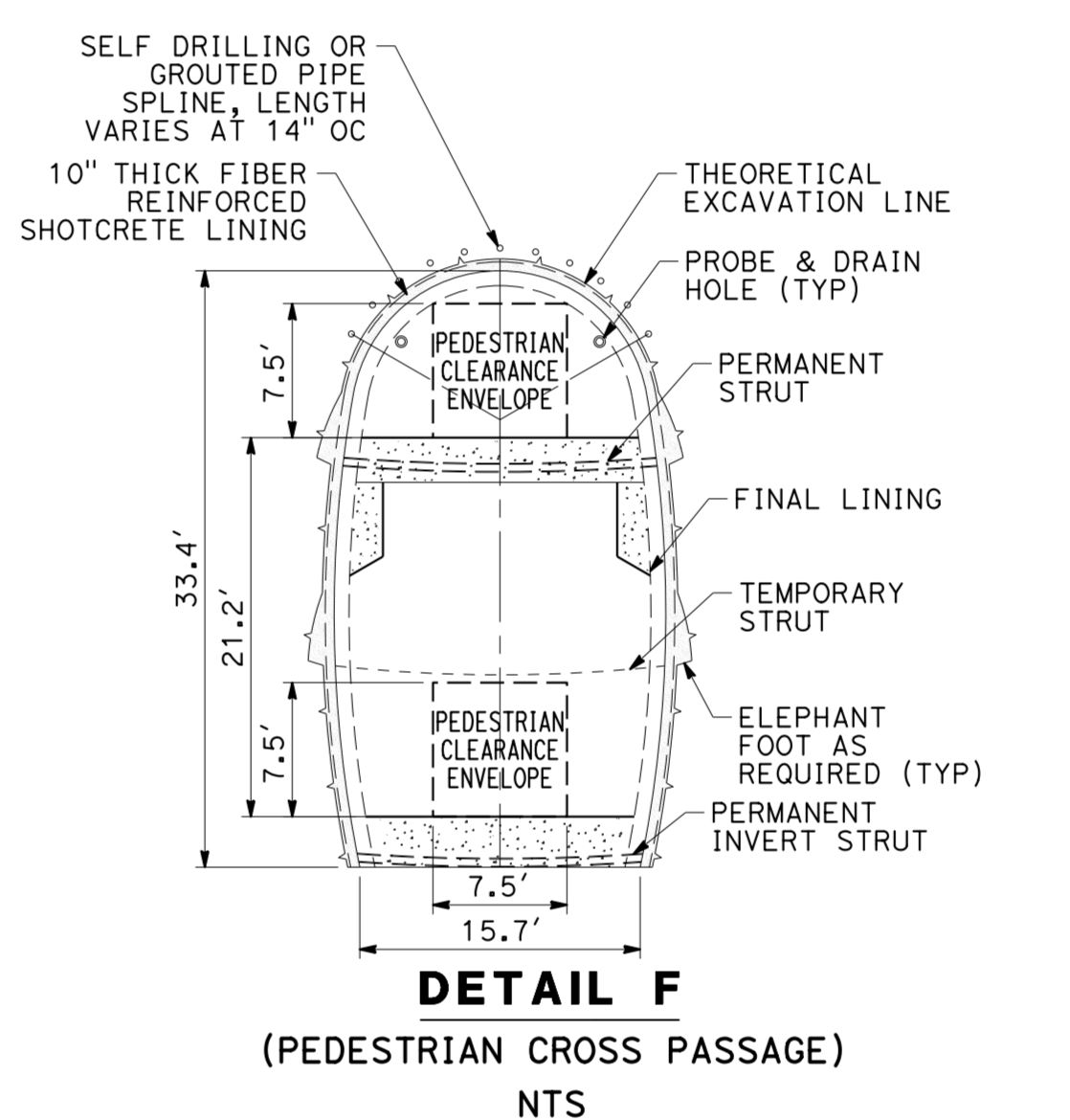
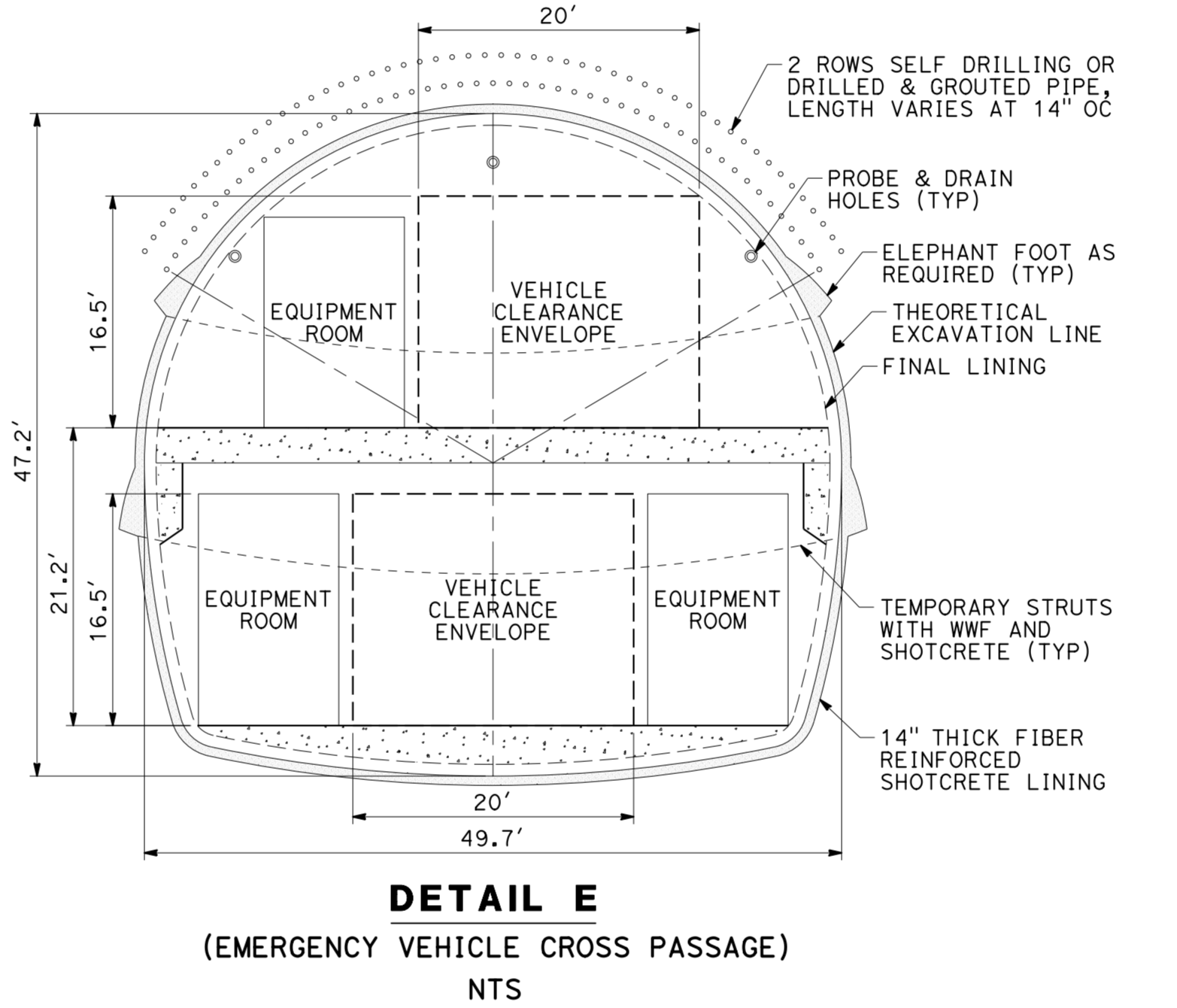
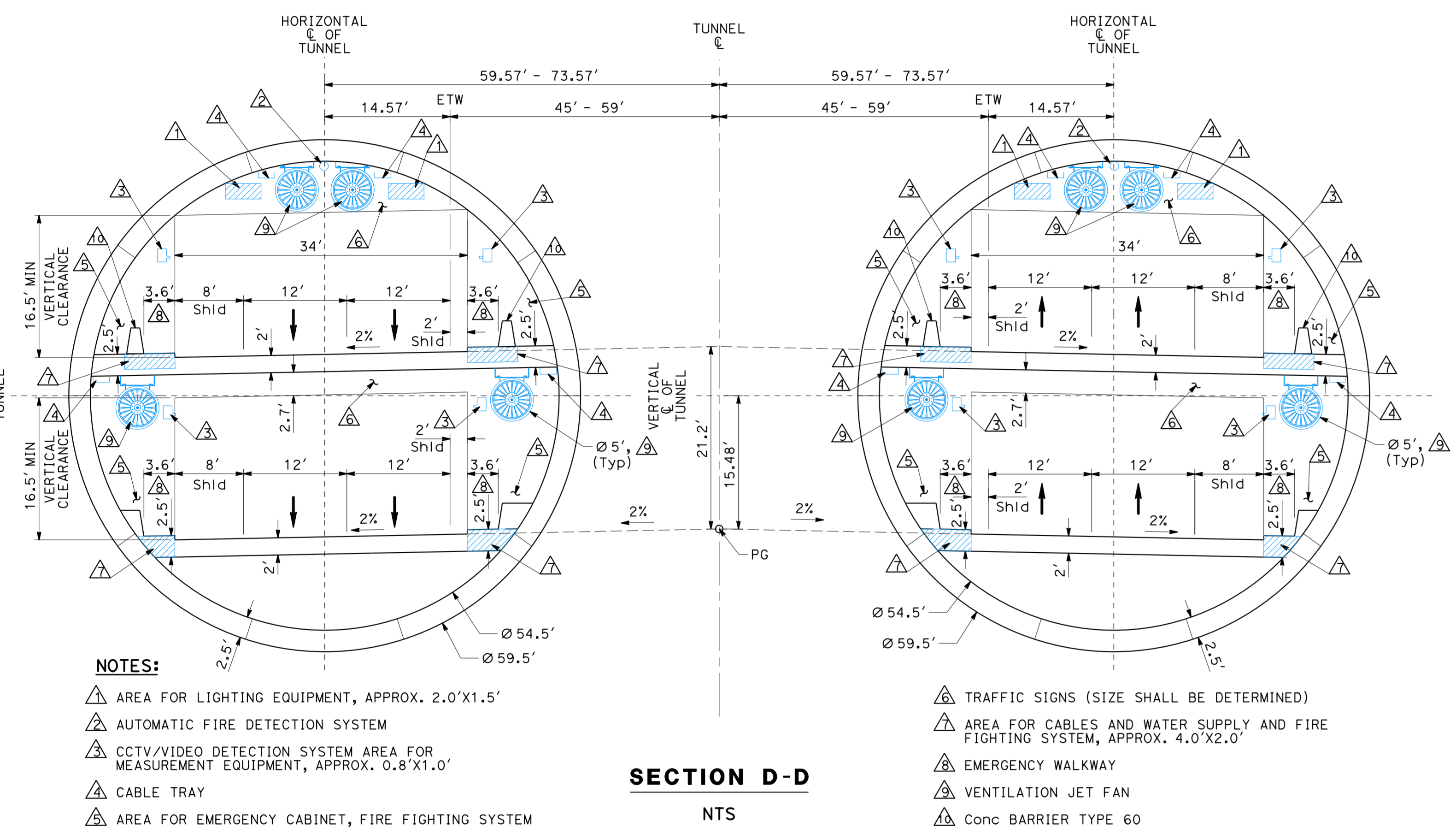
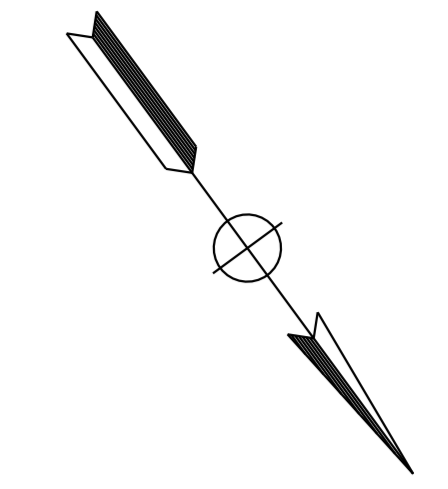

- LEGEND:**
- BRIDGE
 - CUT & COVER TUNNEL
 - TUNNEL BORING MACHINE (TBM)
 - PAVEMENT
 - TUNNEL CROSS PASSAGES
 - HISTORIC PROPERTY
 - DISTURBANCE LIMIT LINE (DLL)

CURVE DATA

No.	R	A	T	L
(1)	4950.00'	5° 21' 00"	208.25'	397.43'

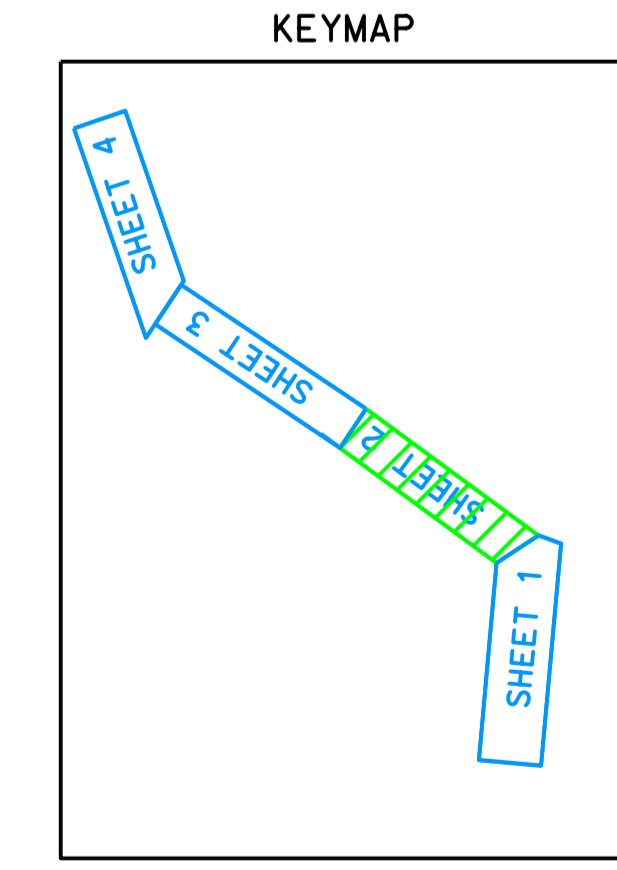
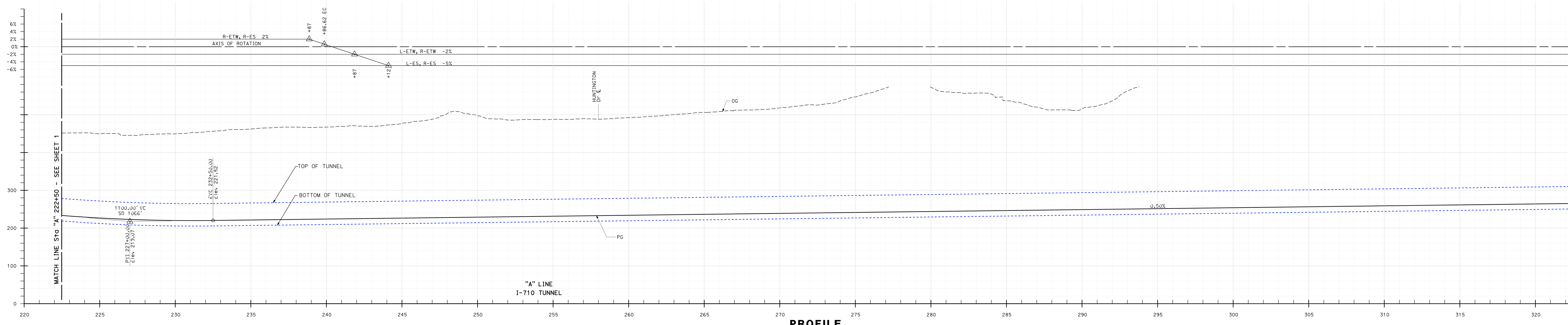

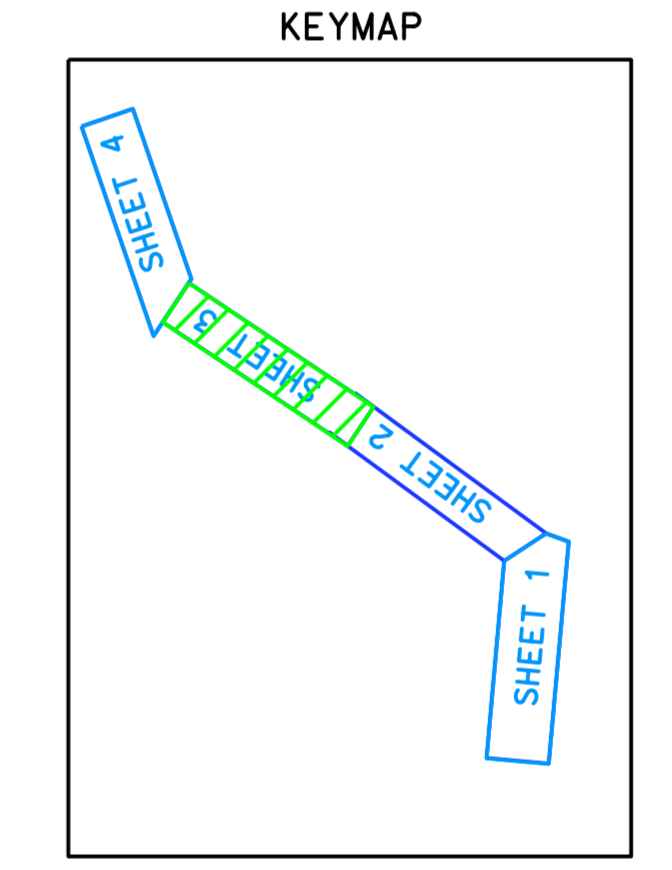
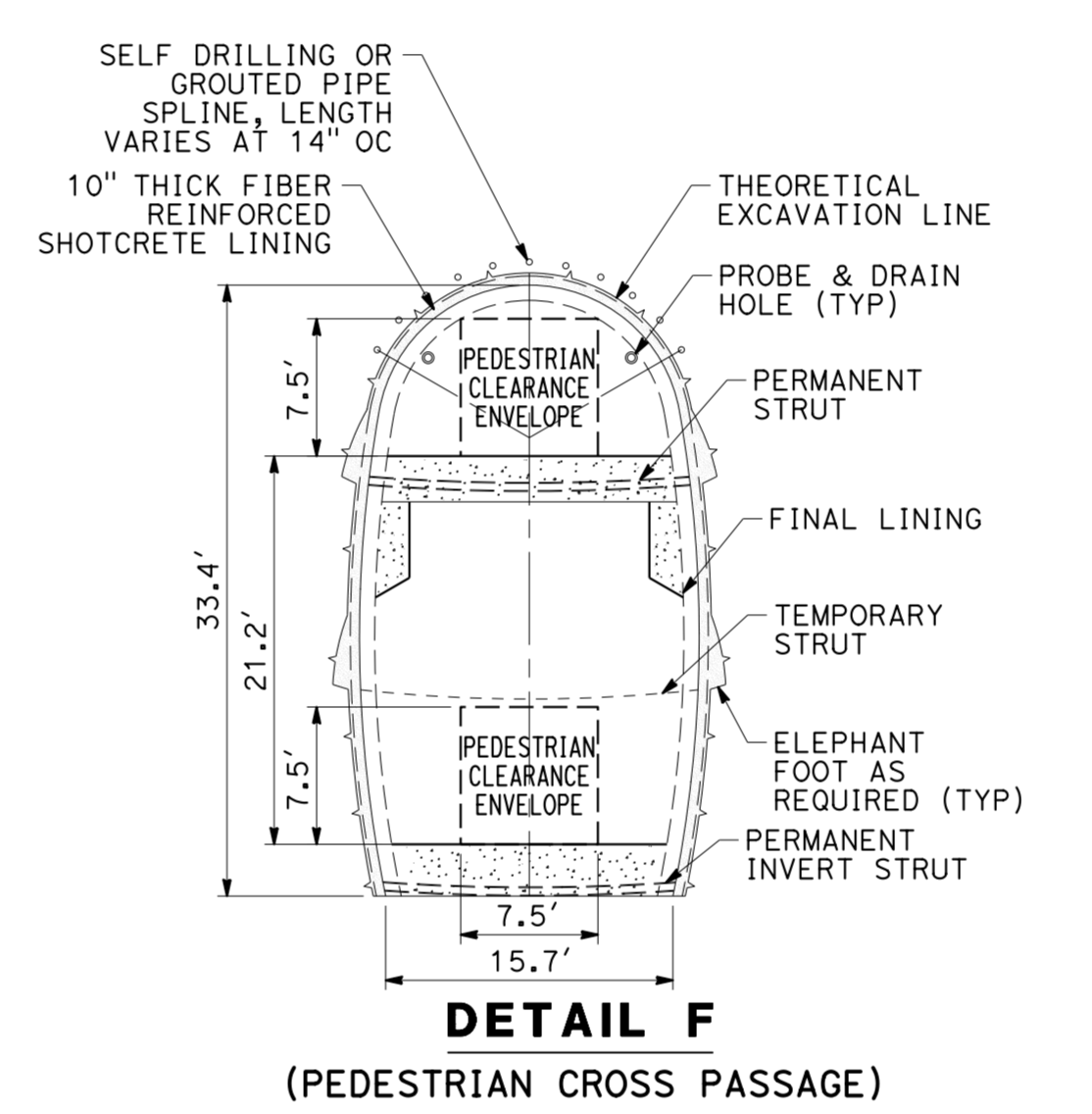
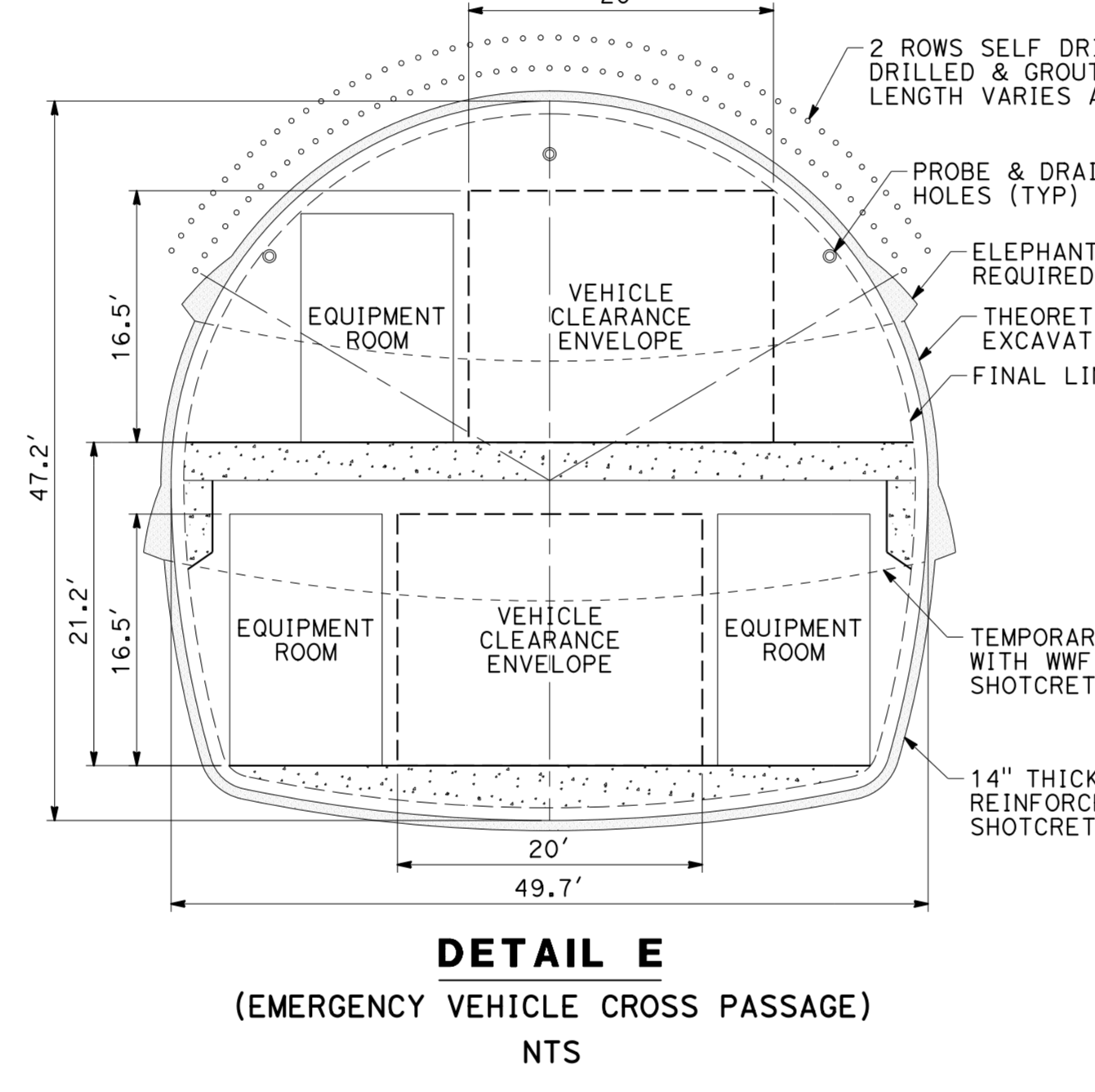
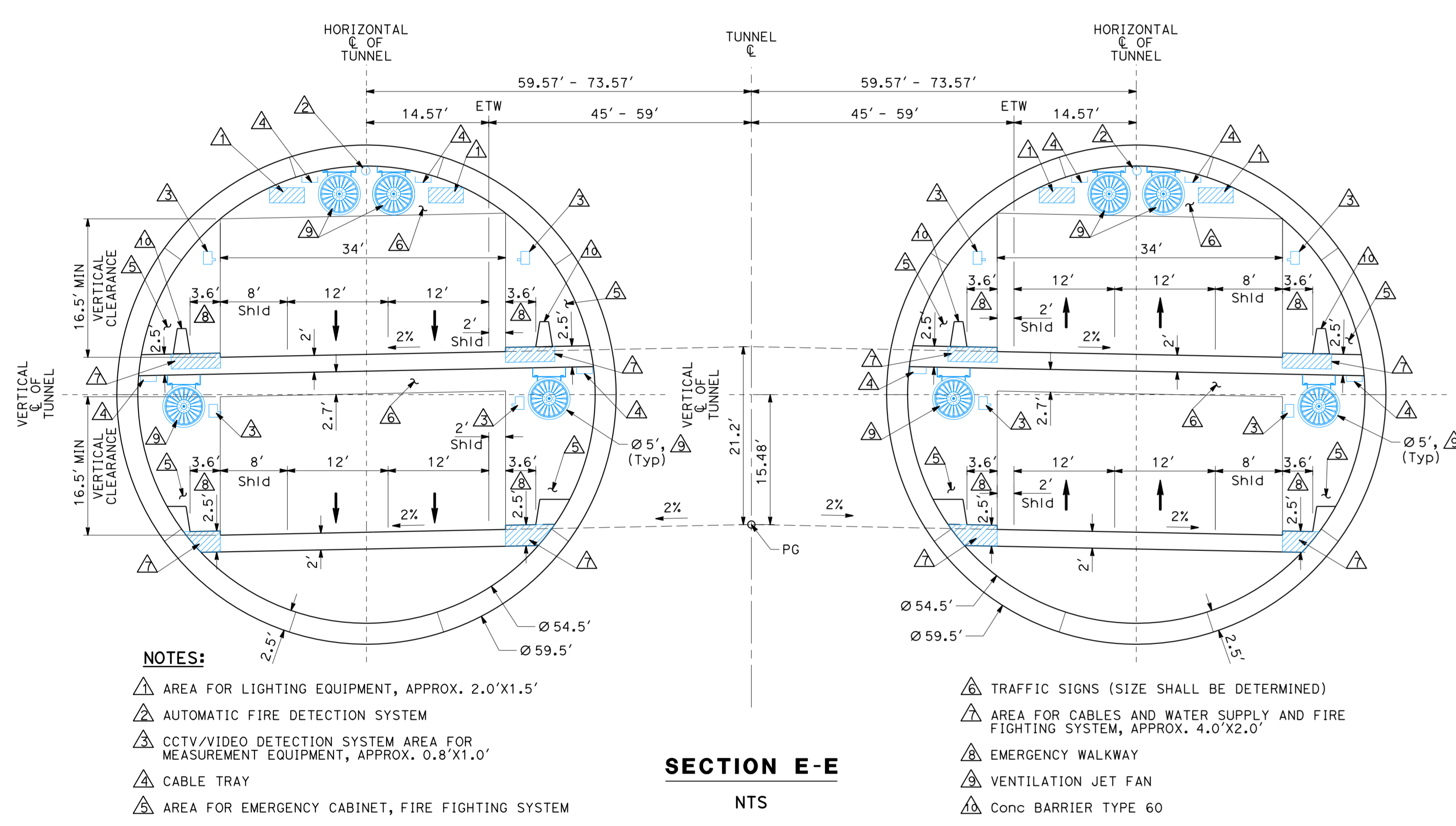


- LEGEND:
- BRIDGE
 - CUT & COVER TUNNEL
 - TUNNEL BORING MACHINE (TBM)
 - PAVEMENT
 - TUNNEL CROSS PASSAGES
 - HISTORIC PROPERTY
 - DISTURBANCE LIMIT LINE (DLL)





- LEGEND:
- BRIDGE
 - CUT & COVER TUNNEL
 - TUNNEL BORING MACHINE (TBM)
 - PAVEMENT
 - TUNNEL CROSS PASSAGES
 - HISTORIC PROPERTY
 - DISTURBANCE LIMIT LINE (DLL)

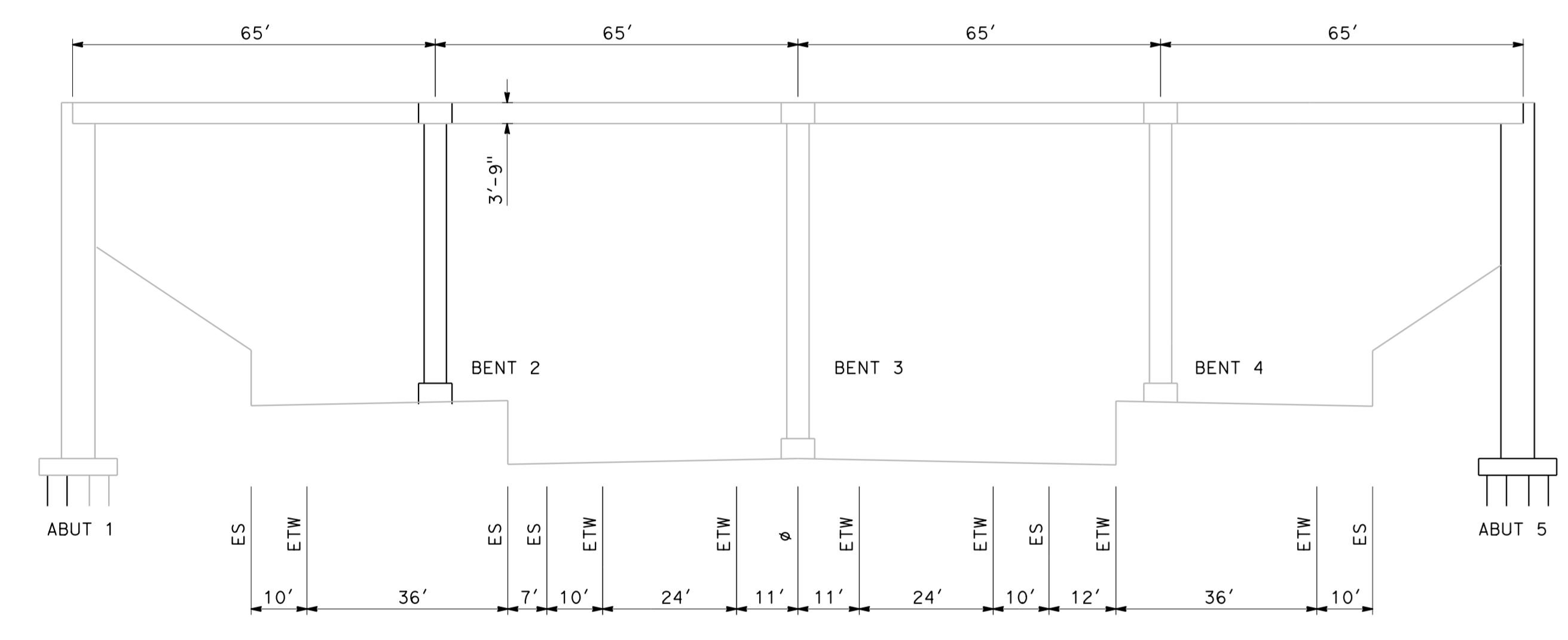

"NBBT1" ELEVATION VIEW
NTS

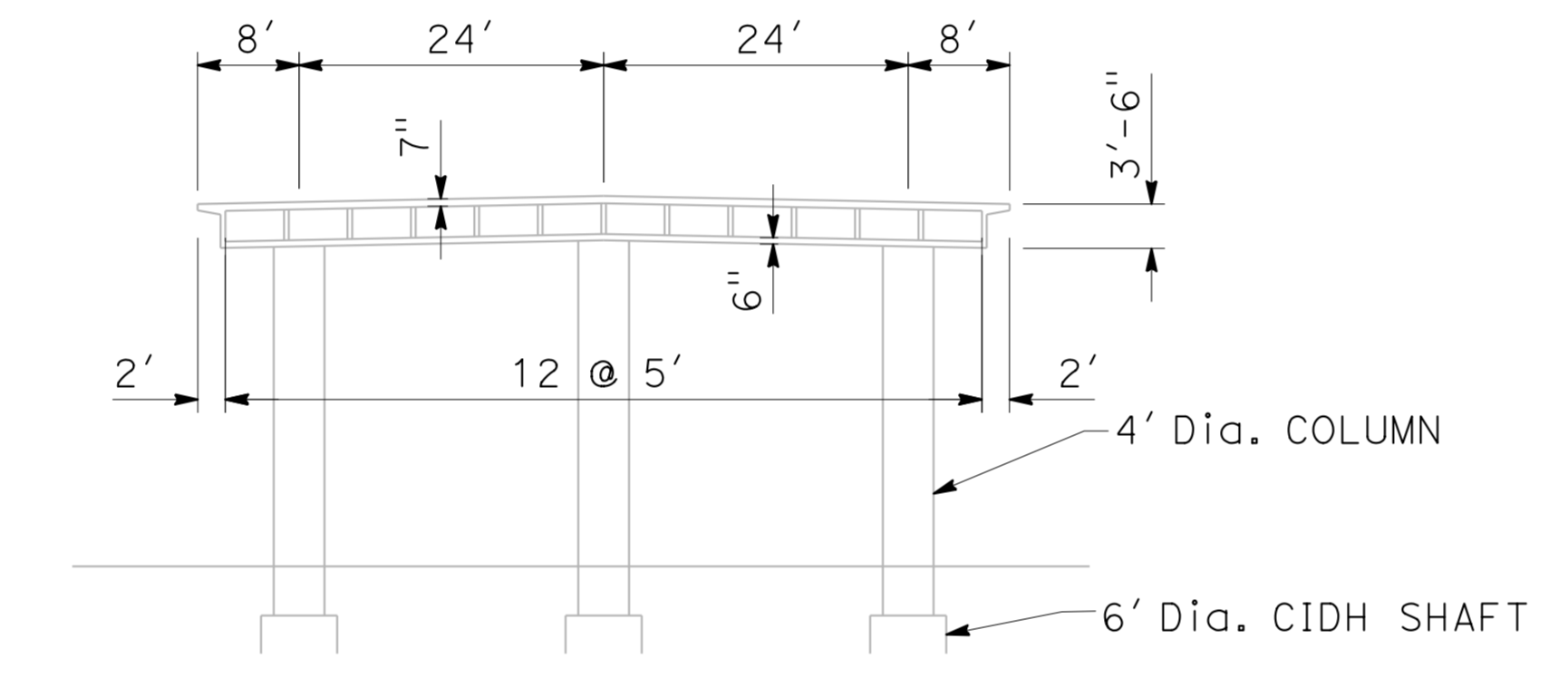

TYPICAL BRIDGE SECTION
NTS

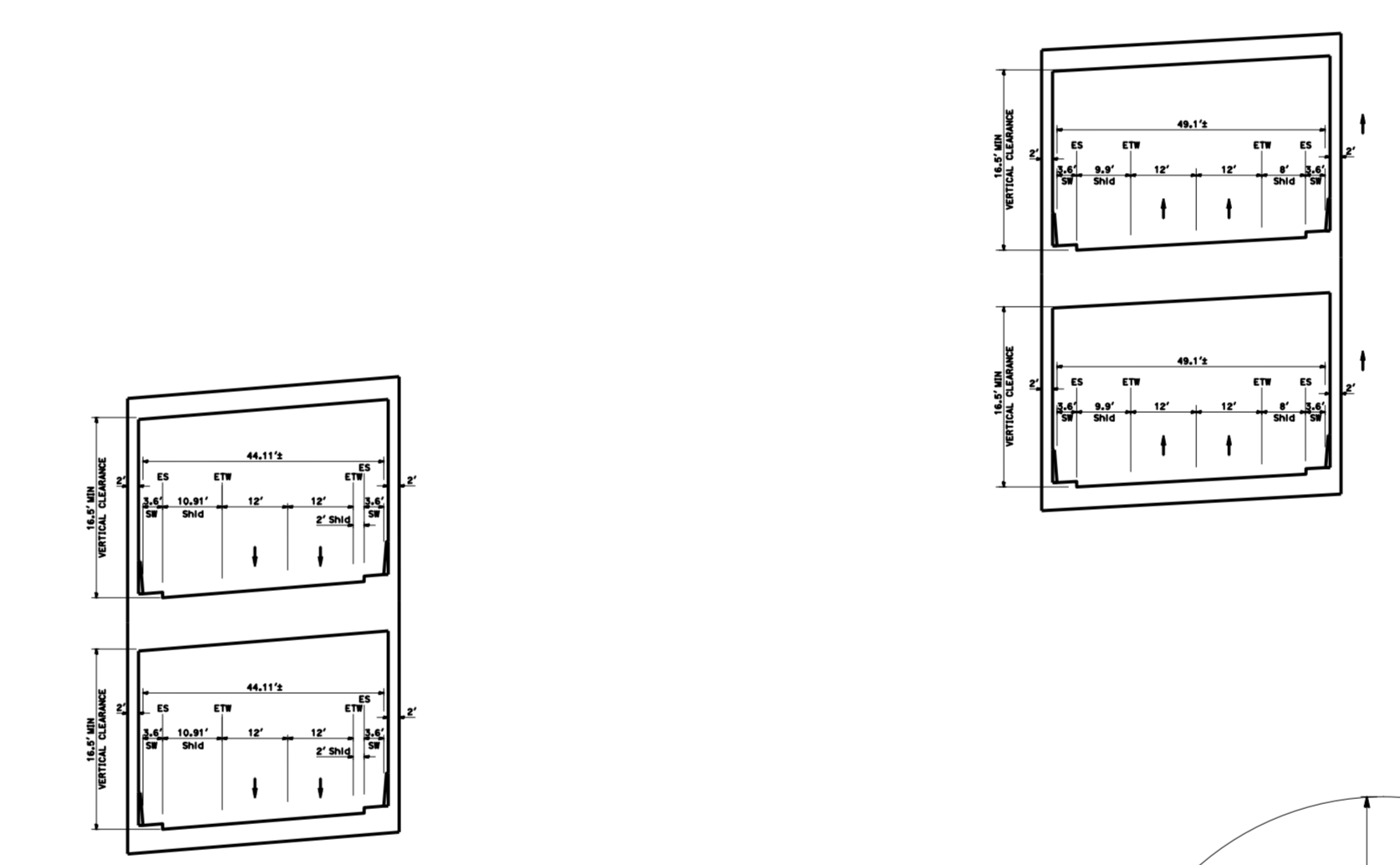

SECTION F-F
NTS

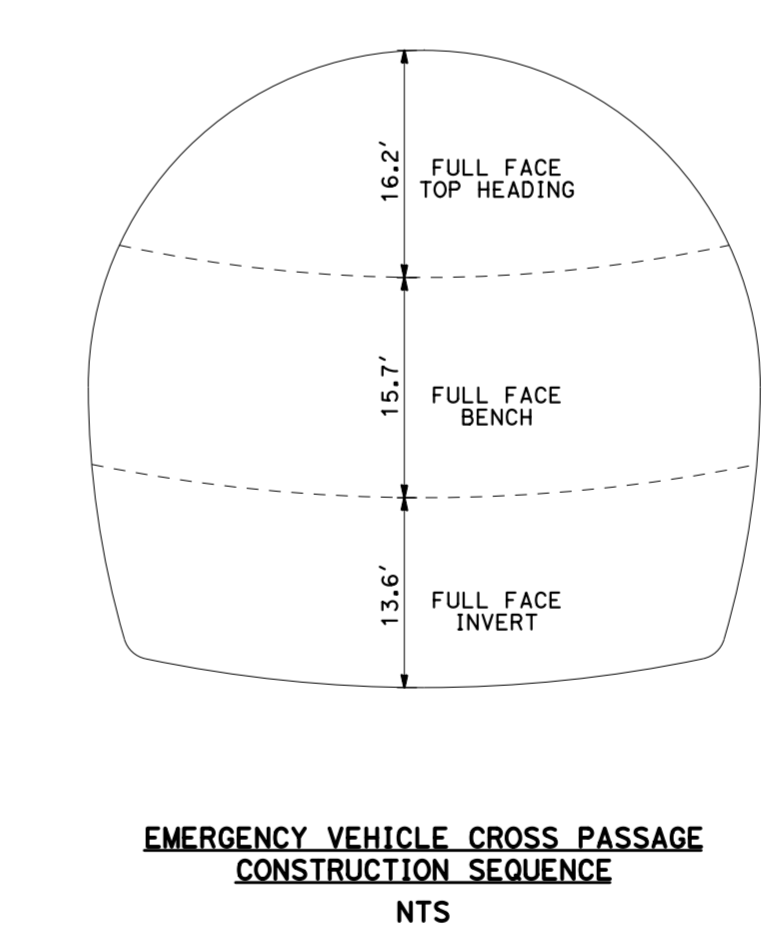

EMERGENCY VEHICLE CROSS PASSAGE CONSTRUCTION SEQUENCE
NTS

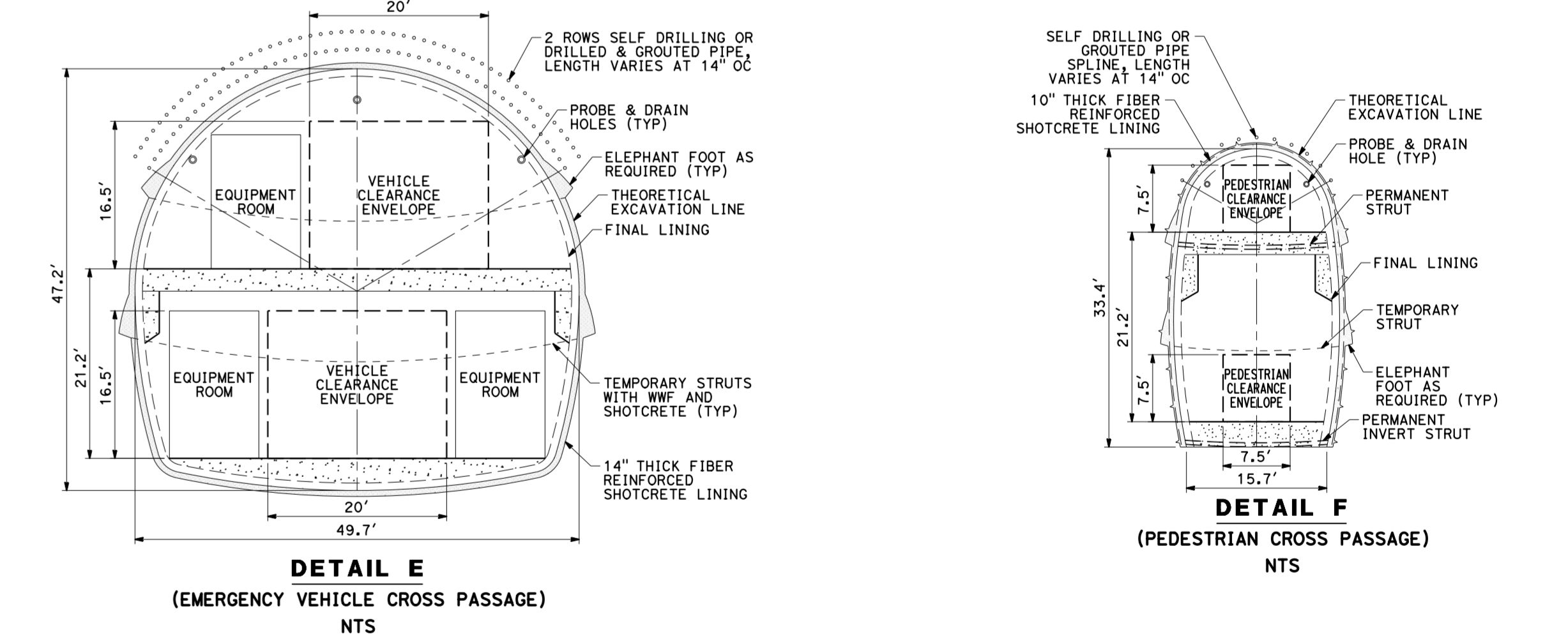

DETAIL E (EMERGENCY VEHICLE CROSS PASSAGE)
NTS

DETAIL F (PEDESTRIAN CROSS PASSAGE)
NTS

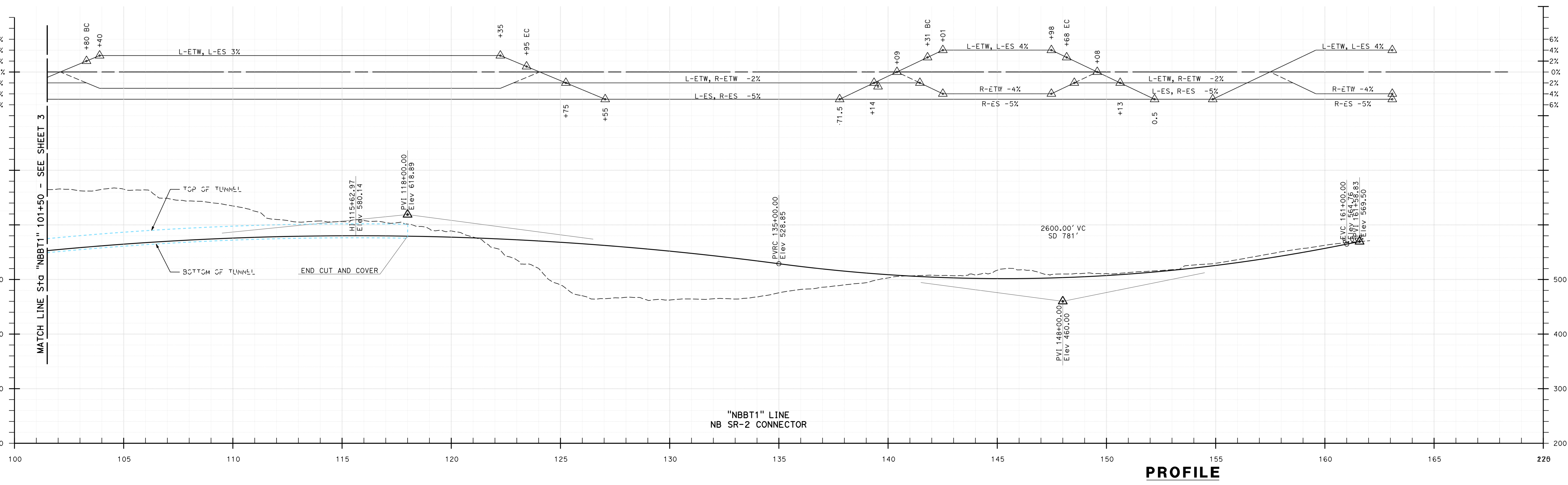

PROFILE
SCALE: Horiz 1"=200'
Vert 1"=80'

CURVE DATA

No.	R	Δ	T	L
(50)	5738.00'	52°38'58.29"	2838.98'	5272.69'
(51)	5400.00'	52°38'58.29"	2671.75'	4962.10'
(52)	3500.00'	32°04'13.46"	1005.94'	1959.07'
(53)	3600.00'	32°03'56.80"	1034.52'	2014.75'
(54)	3200.00'	11°12'44.61"	314.11'	626.22'
(55)	3000.00'	03°11'28.95"	83.57'	167.10'
(56)	3400.00'	10°43'47.88"	319.23'	636.72'
(57)	3000.00'	03°11'28.95"	83.57'	167.10'

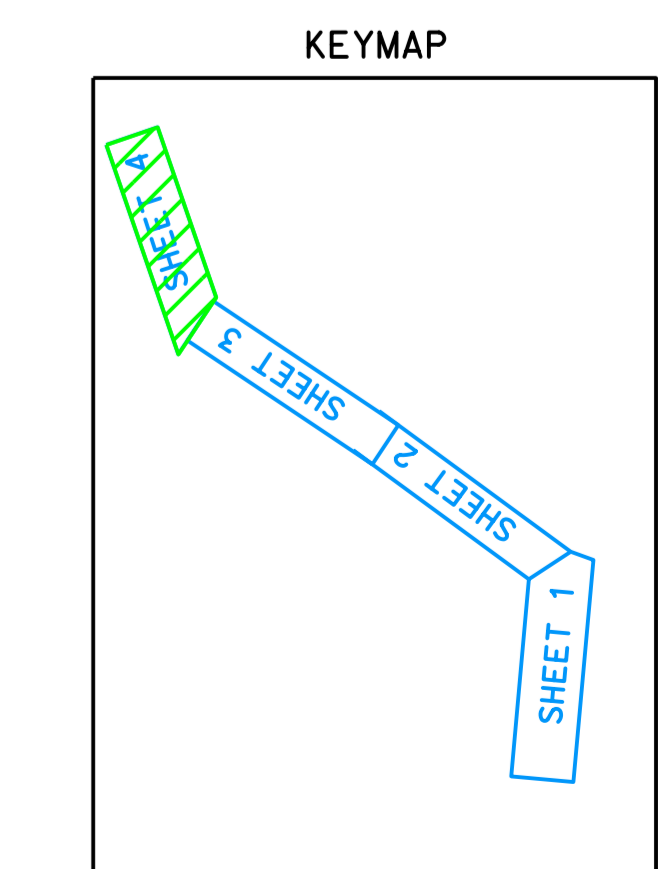

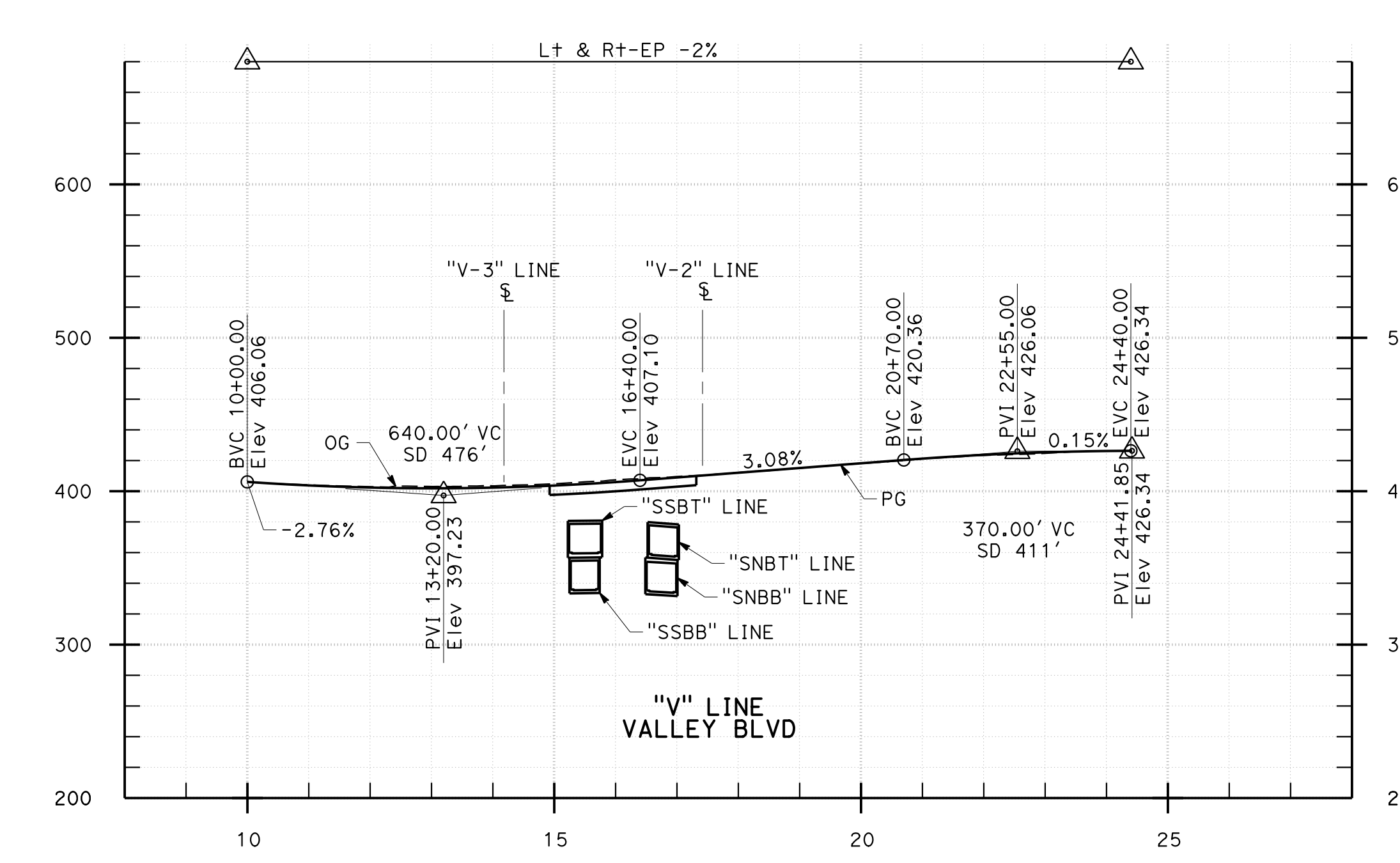
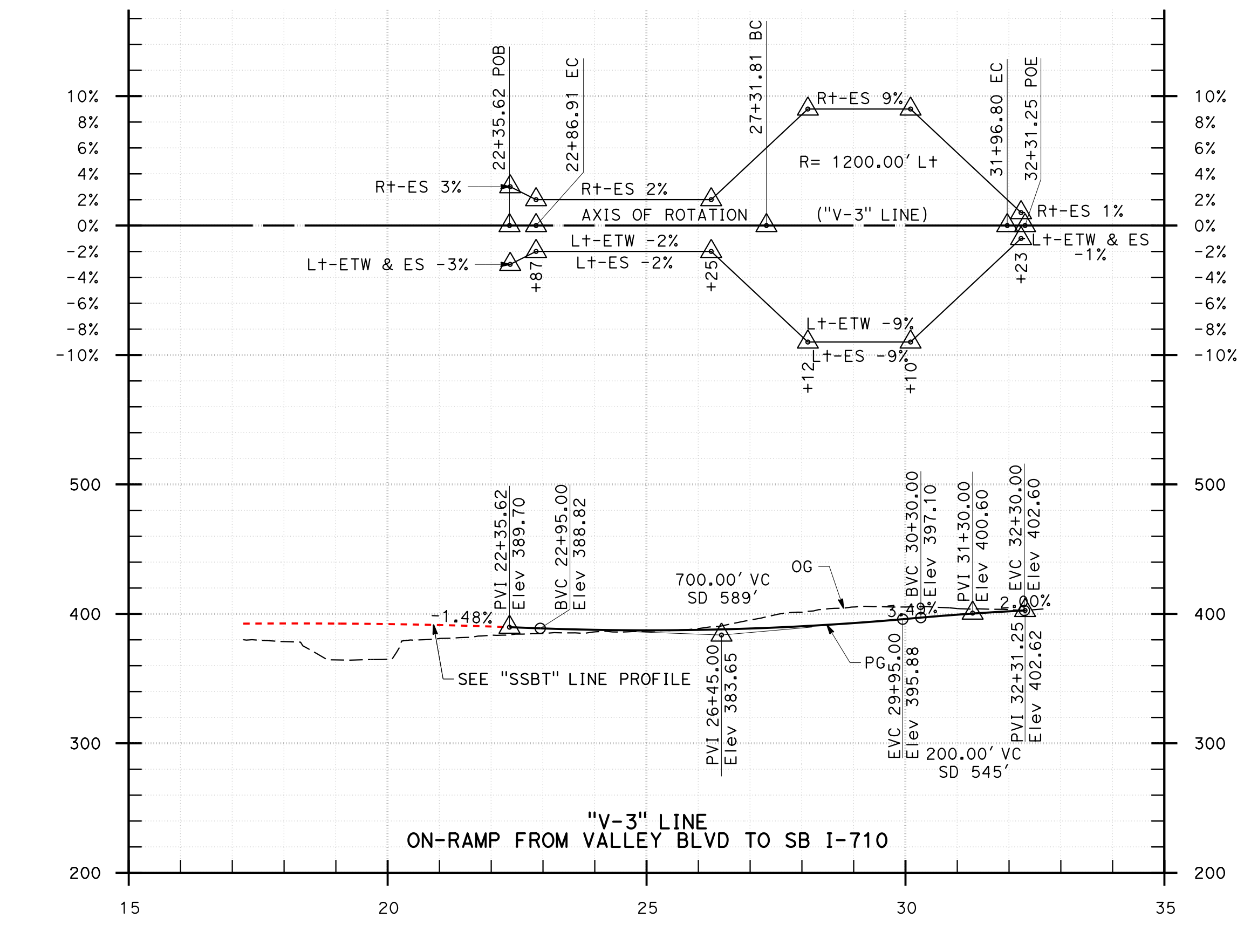
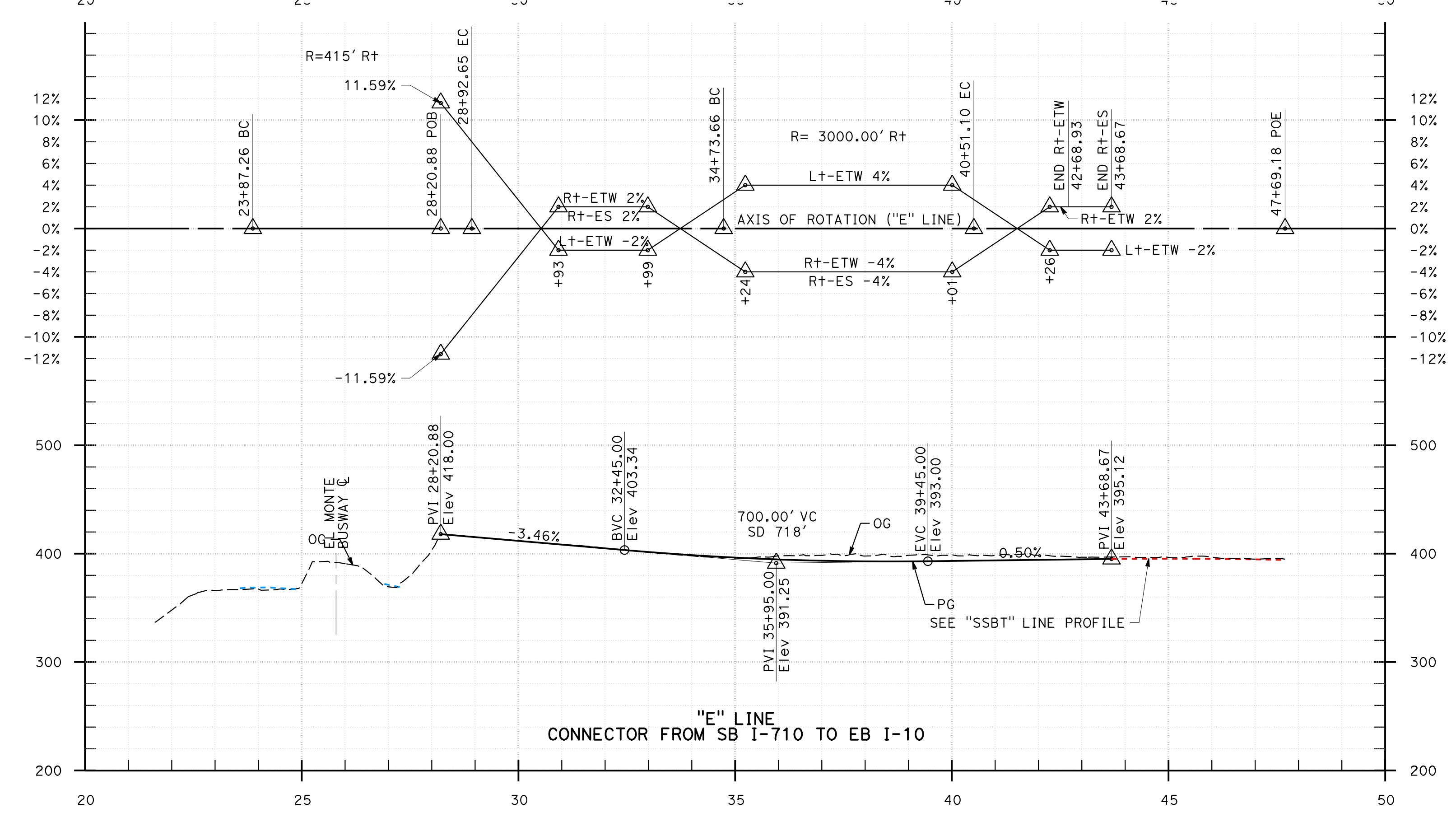
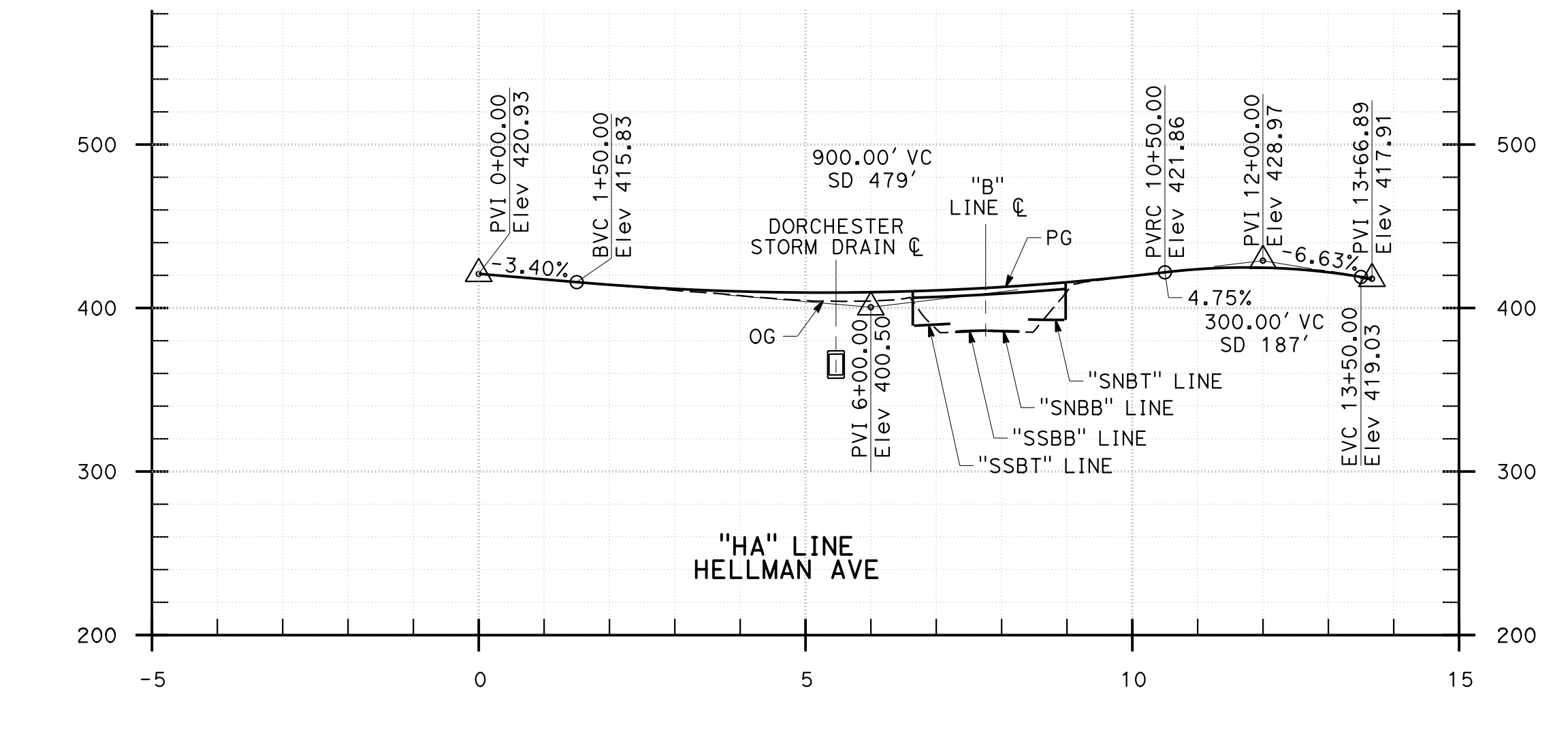
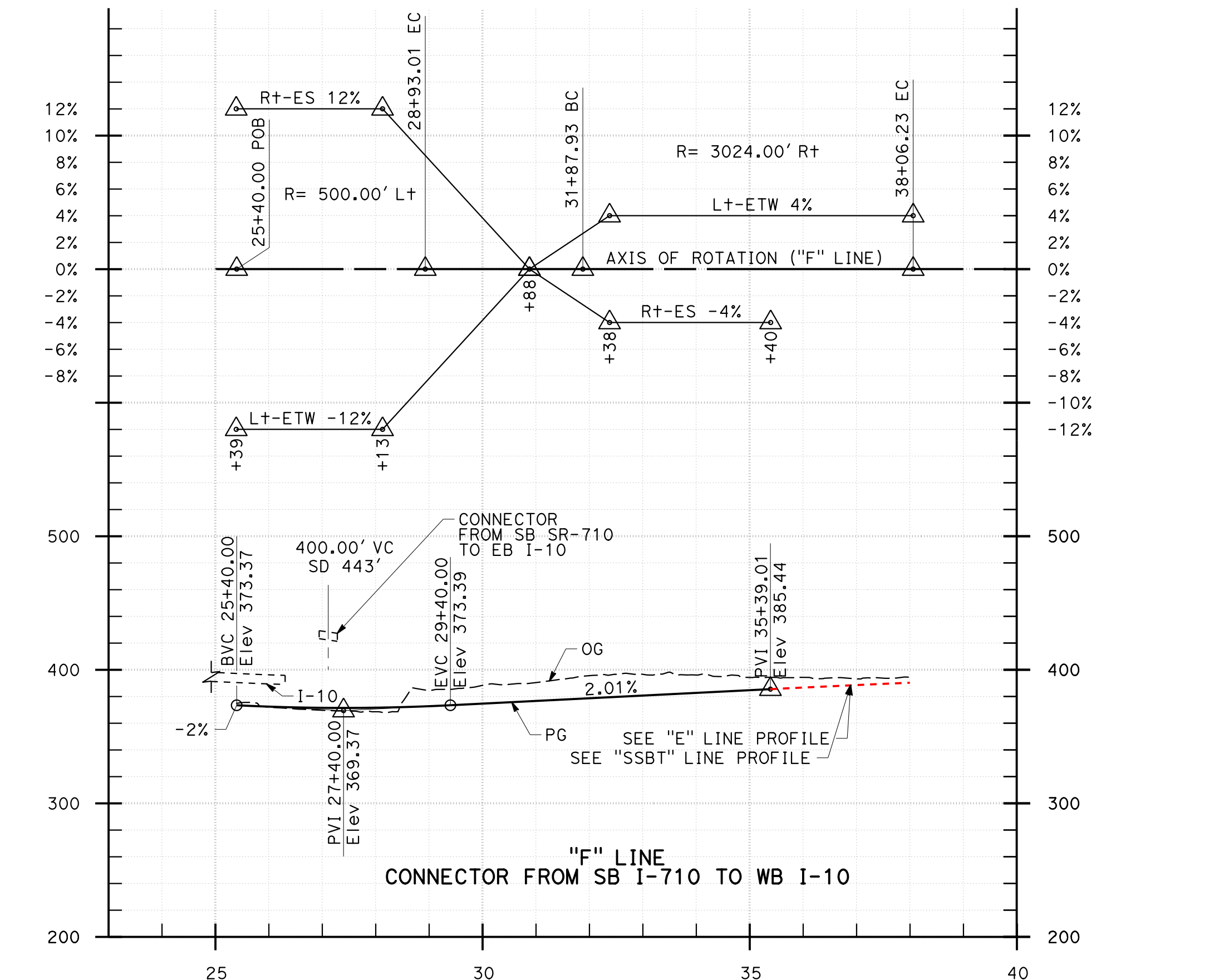
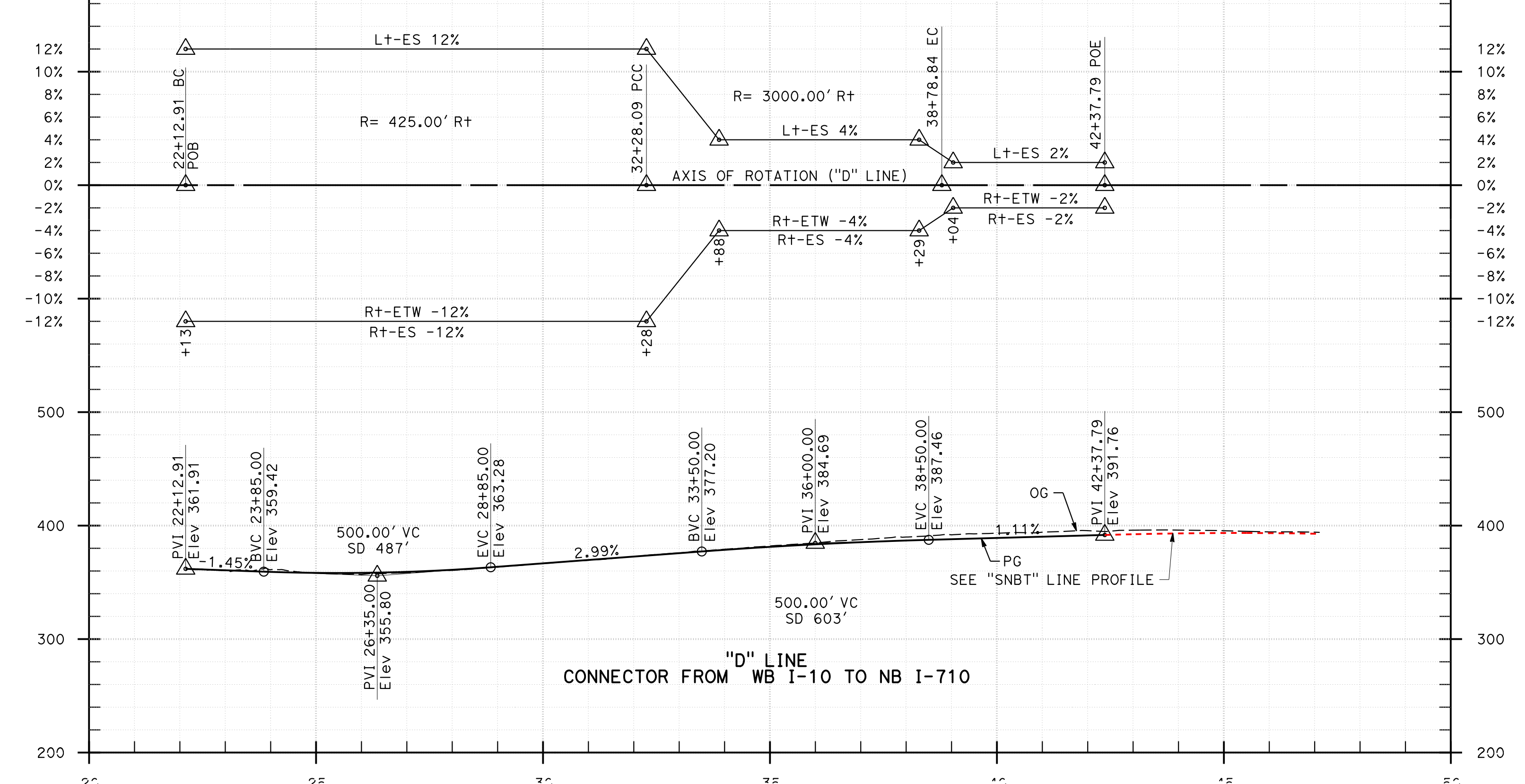
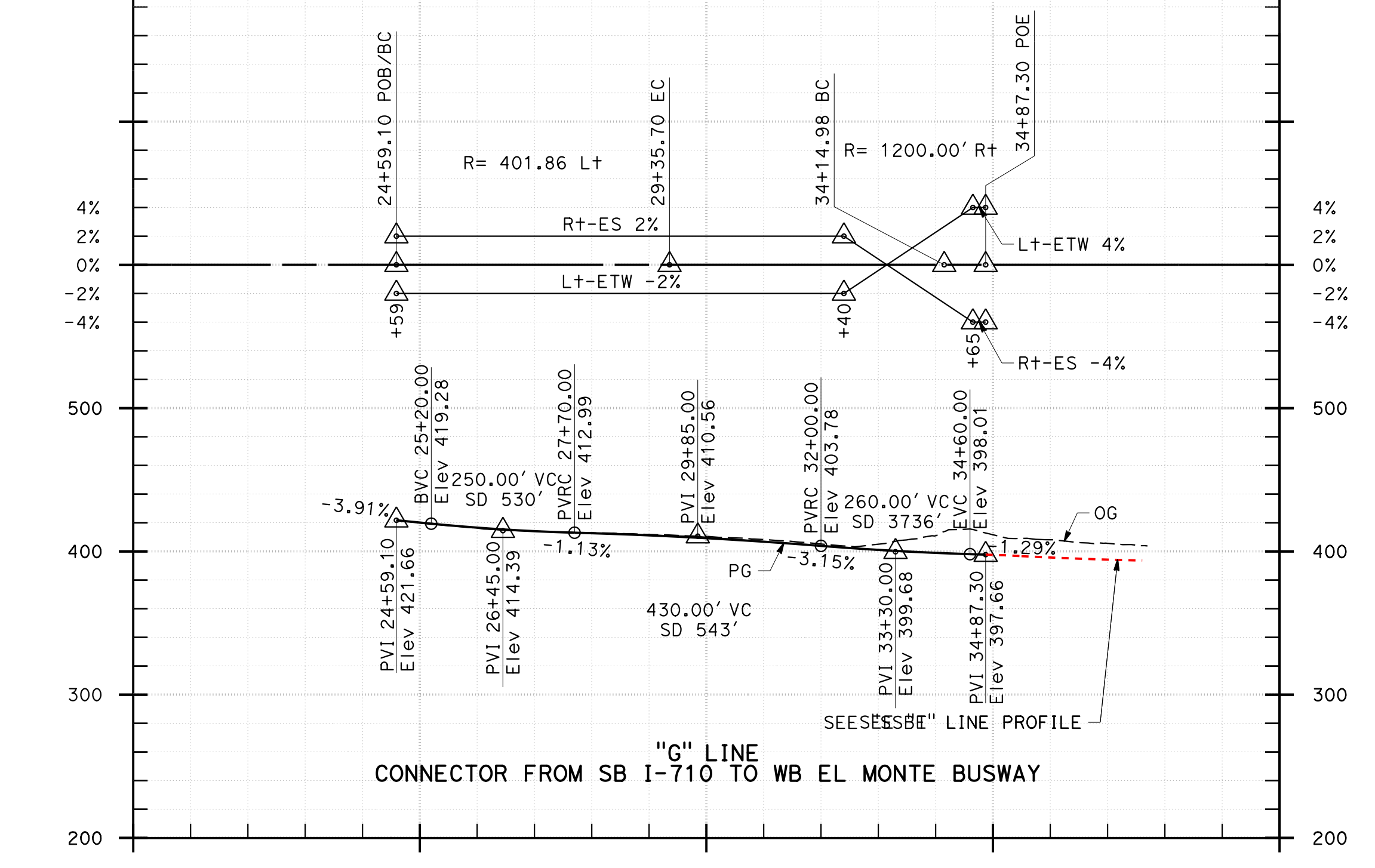
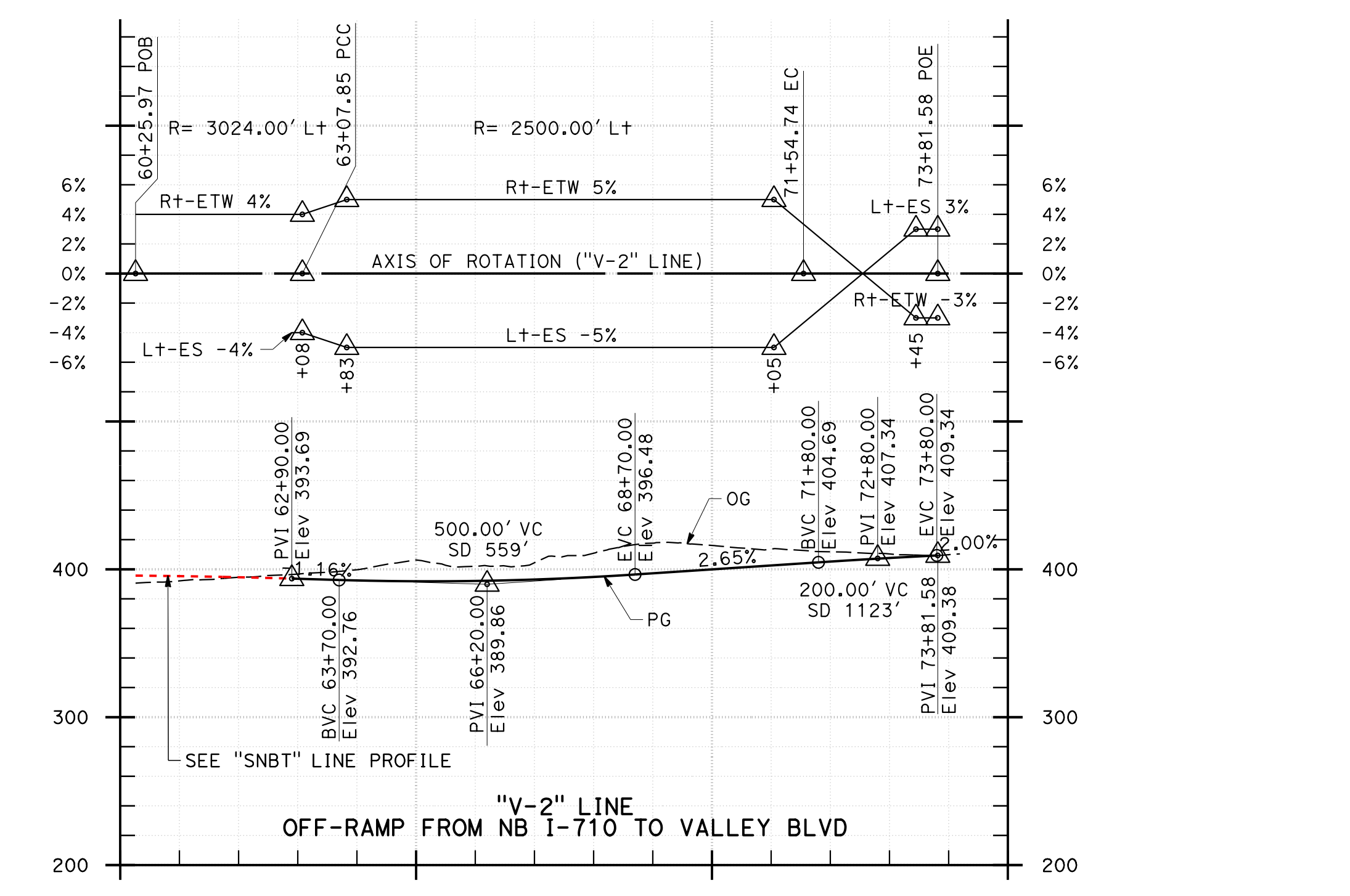
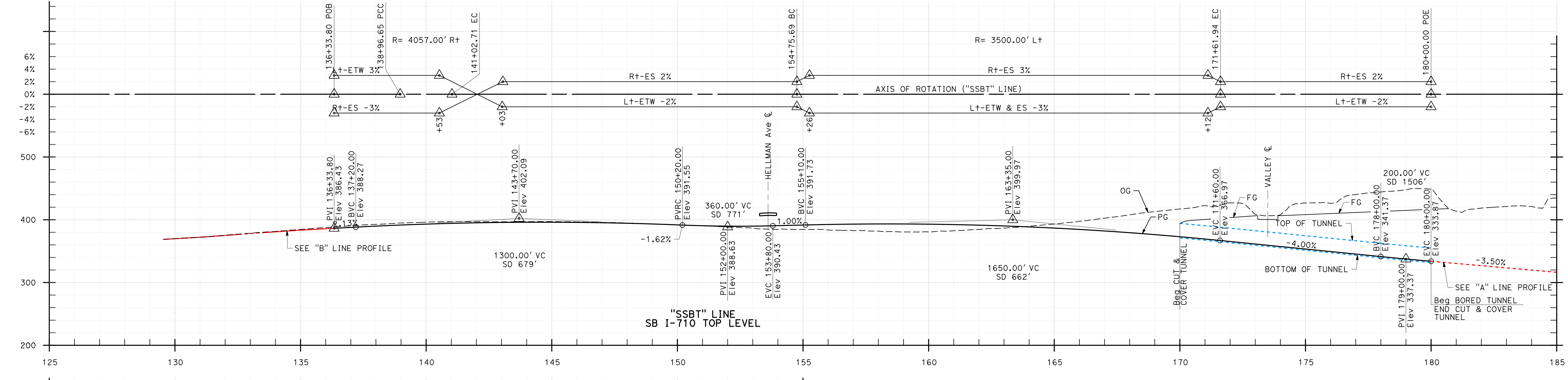
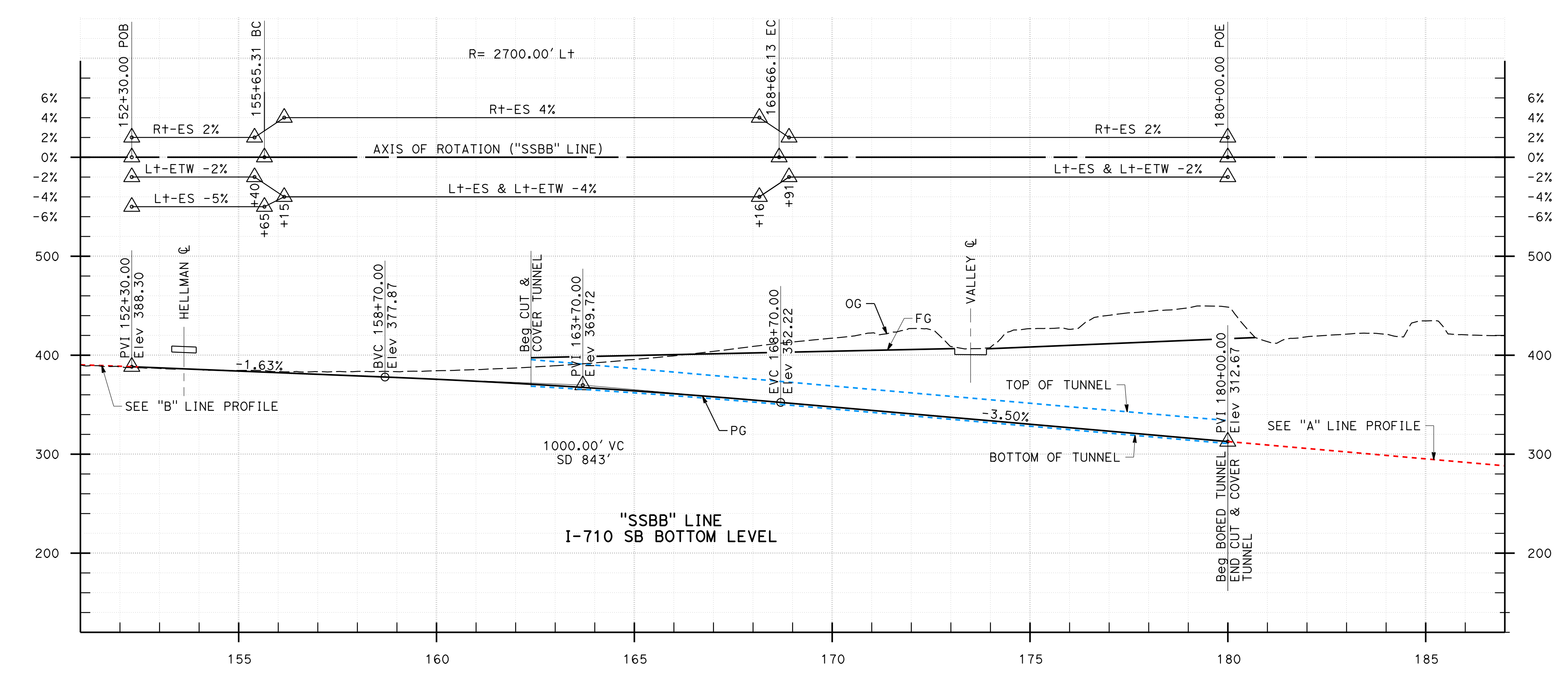
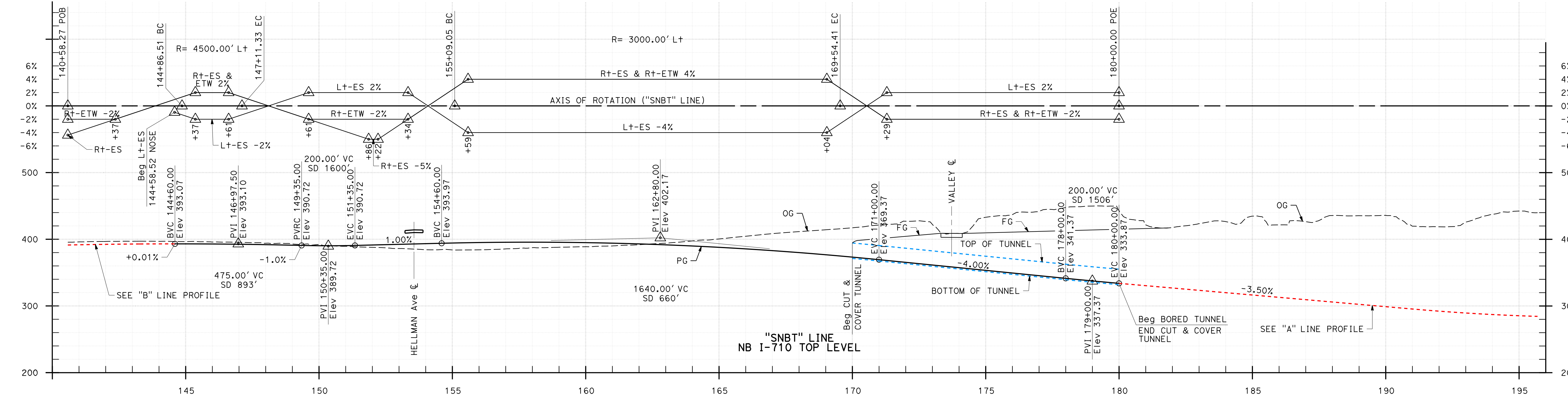

PROFILE / SUPERELEVATION DIAGRAM
SCALE: Horiz 1"=200'
Vert 1"=80'

710 STUDY
 CONCEPTUAL DESIGN
 F-2
 5 OF 6
 DATE: 10/20/2011
 PROJECT: 710

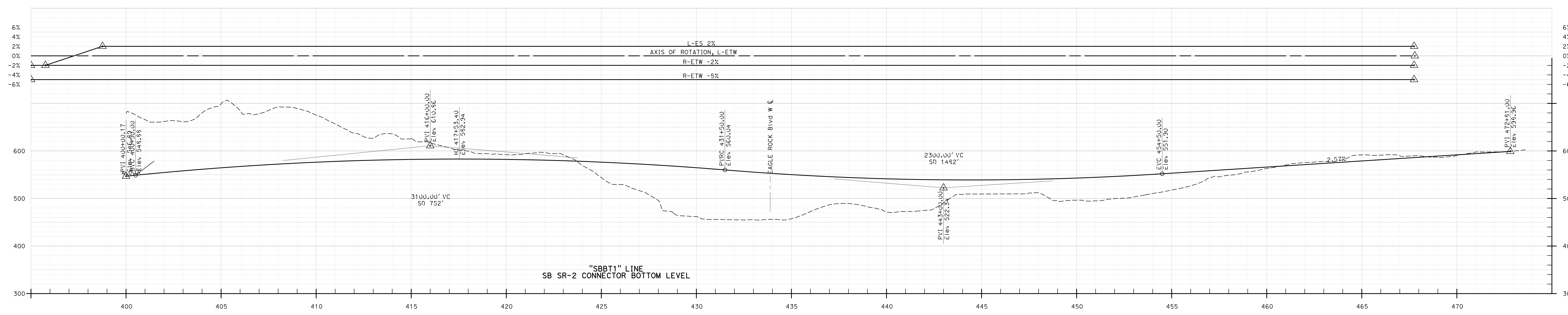
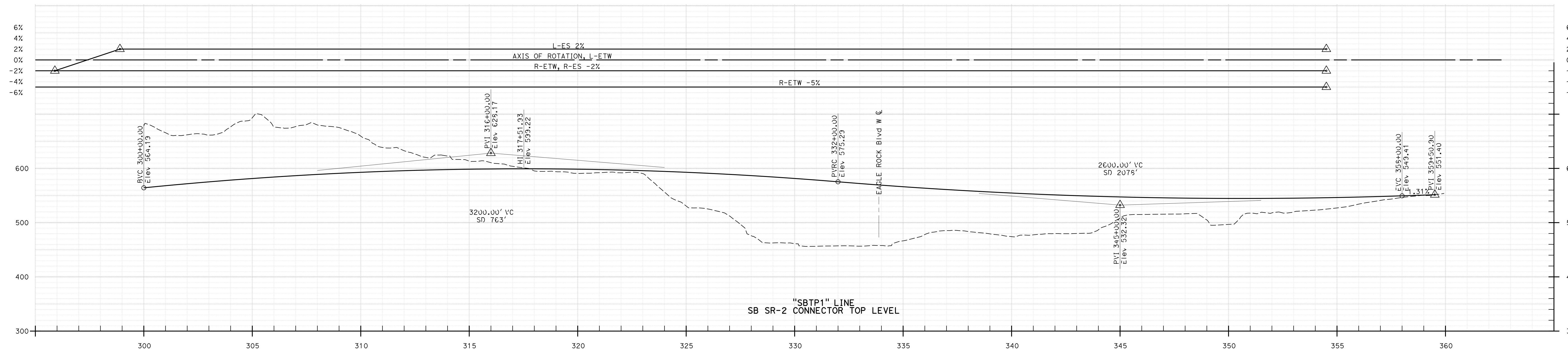
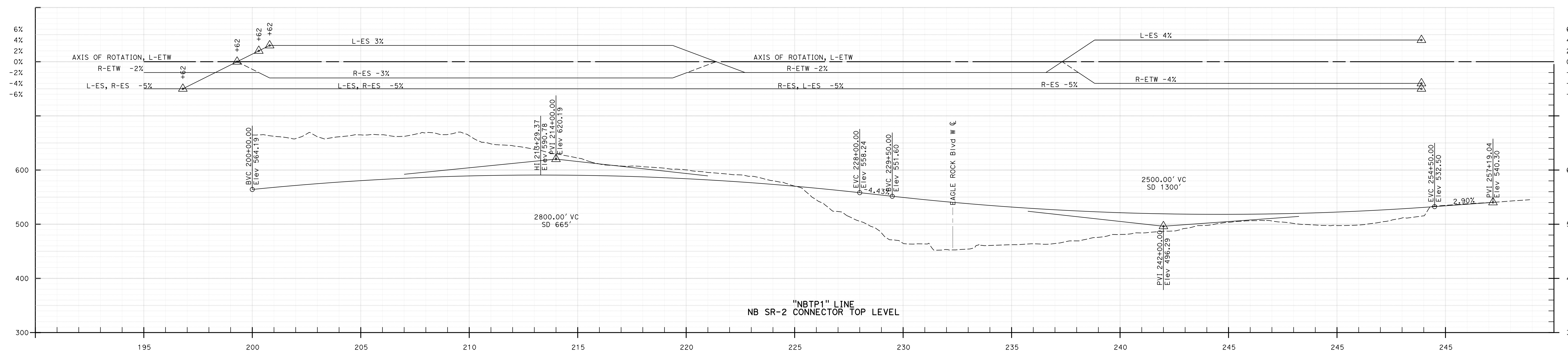

PROFILE / SUPERELEVATION DIAGRAM

SCALE: Horiz 1"=200'
Vert 1"=80'

710 STUDY CONCEPTUAL DESIGN

 F-2

 SHEET 6 OF 6