

Freight transport efficiency: a comparative study of coastal shipping, rail and road modes

October 2012

PD Cenek, RJ Kean, IA Kvatch, NJ Jamieson

Opus International Consultants, Central Laboratories, Gracefield, Lower Hutt

ISBN 978-0-478- 39486-3 (electronic)
ISSN 1173-3764 (electronic)

NZ Transport Agency
Private Bag 6995, Wellington 6141, New Zealand
Telephone 64 4 894 5400; facsimile 64 4 894 6100
research@nzta.govt.nz
www.nzta.govt.nz

Cenek, PD, RJ Kean, IA Kvatch and NJ Jamieson (2012) Freight transport efficiency: a comparative study of coastal shipping, rail and road modes. *NZ Transport Agency research report 497*. 61 pp.

This publication is copyright © NZ Transport Agency 2012. Material in it may be reproduced for personal or in-house use without formal permission or charge, provided suitable acknowledgement is made to this publication and the NZ Transport Agency as the source. Requests and enquiries about the reproduction of material in this publication for any other purpose should be made to the Research Programme Manager, Programmes, Funding and Assessment, National Office, NZ Transport Agency, Private Bag 6995, Wellington 6141.

Keywords: CO₂ emissions, coastal shipping, container tracking, goods damage, impact loads, intermodal transfers, rail, road transport

An important note for the reader

The NZ Transport Agency is a Crown entity established under the Land Transport Management Act 2003. The objective of the Agency is to undertake its functions in a way that contributes to an affordable, integrated, safe, responsive and sustainable land transport system. Each year, the NZ Transport Agency funds innovative and relevant research that contributes to this objective.

The views expressed in research reports are the outcomes of the independent research, and should not be regarded as being the opinion or responsibility of the NZ Transport Agency. The material contained in the reports should not be construed in any way as policy adopted by the NZ Transport Agency or indeed any agency of the NZ Government. The reports may, however, be used by NZ Government agencies as a reference in the development of policy.

While research reports are believed to be correct at the time of their preparation, the NZ Transport Agency and agents involved in their preparation and publication do not accept any liability for use of the research. People using the research, whether directly or indirectly, should apply and rely on their own skill and judgement. They should not rely on the contents of the research reports in isolation from other sources of advice and information. If necessary, they should seek appropriate legal or other expert advice.

Acknowledgements

The authors gratefully acknowledge contributions to this research programme by:

- the NZ Transport Agency, who funded the research described here
- Kel Sanderson (BERL), Karen Birkinshaw (EECA), Natasha Hayes (Greater Wellington Regional Council), Joanne Leung (Ministry of Transport) and Michael Dennehy (Road Transport Association NZ) for their interest in the research and helpful input
- the peer reviewers Tony Brennand (NZ Transport Agency Transport Planning Manager) and Dick Joyce (TSV Consulting Managing Director) for their constructive comments.

Abbreviations and acronyms

ABS	American Bureau of Shipping
CO	carbon monoxide
CO ₂	carbon dioxide
EPA	Environmental Protection Agency
GIS	Geographic Information System
GPS	Global Positioning System
IRI	International Roughness Index
MB	megabyte
MoT	Ministry of Transport
NCMM	Norwegian Centre for Maritime Medicine
OEM	Original Equipment Manufacturer
RAMM	Road Assessment and Maintenance Management
SCANNER	Surface Condition Assessment of the National Network of Roads
TRACS	Traffic Speed Condition Survey
USB	Universal Serial Bus

Contents

- Executive summary.....7**
- Abstract.....10**
- 1 Introduction.....11**
 - 1.1 General..... 11
 - 1.2 Report layout 11
- 2 Monitoring/tracking system.....13**
 - 2.1 Overview 13
 - 2.2 Details 13
- 3 Routes18**
 - 3.1 Overview 18
 - 3.2 Available transport routes 20
 - 3.3 Container details 26
- 4 Journey duration27**
 - 4.1 Data processing..... 27
 - 4.2 Journey duration..... 27
- 5 Impact loading.....28**
 - 5.1 Expected service conditions 28
 - 5.1.1 Coastal shipping 28
 - 5.1.2 Road 28
 - 5.1.3 Rail..... 28
 - 5.1.4 Terminal/depot handling 29
 - 5.1.5 Comparison of container design accelerations 29
 - 5.2 Measured container acceleration levels 29
- 6 CO2 emissions and fuel use.....40**
 - 6.1 Introduction..... 40
 - 6.2 Methodology..... 40
 - 6.3 Road mode (heavy truck) 41
 - 6.4 Rail mode..... 43
 - 6.4.1 CO2 emission rate for diesel locomotives..... 43
 - 6.4.2 Representative steady state speeds 44
 - 6.4.3 Representative fuel consumption for DX and DC class diesel locomotives. 44
 - 6.4.4 Estimated CO2 emission rate for monitored journeys..... 45
 - 6.5 Coastal shipping..... 46
 - 6.6 Comparative evaluation of transport modes 47
 - 6.7 Concluding remarks 48
- 7 Costs49**
- 8 Discussion51**
 - 8.1 Road-induced container vibrations..... 51
 - 8.2 In-transit damage 51
- 9 Conclusions53**
 - 9.1 Instrumentation of container..... 53

9.2	Journey duration	53
9.3	Impact loading	53
9.4	CO ₂ emissions and fuel use	54
9.5	Costs	54
10	Recommendations	56
11	Bibliography	57
	Appendix: Journey summaries	58

Executive summary

Introduction

This research consisted of a comparative study of three different transport modes (coastal shipping, rail and road) used to haul 20ft shipping containers that had been instrumented to allow real-time monitoring of time, location and impact forces.

This was in response to the findings of a 2005 Ministry of Transport (MoT) study, which had been commissioned to assist the government in making decisions on the relative competitive position of road and rail transport for freight transport. The MoT study revealed there was little New Zealand research available regarding actual resource usage – particularly regarding the relative efficiency of the modes in the use of fuel and damage to goods during transit. This paucity of information on relative resource usage was hampering the robust economic assessment of transport-related capital works projects that could provide alternatives to roading.

Methodology

Monitoring/tracking system

A stand-alone data logger that could covertly track the movement of an empty 20ft container was designed and constructed for this research. This logger measured the number, frequency, magnitude and time of any sudden movements and impacts a container experienced along its journey. The logger was built from off-the-shelf modules and consisted of a battery-powered device using a global positioning system receiver and 3-axis accelerometers to monitor movements and impacts. The data acquired from the global positioning system and accelerometer modules was stored in a 256-megabyte storage device.

Routes

Five return shipments of the 20ft instrumented container were undertaken in 2006. These five shipments encompassed the transport modes of coastal shipping, rail and road, and were from/to Seaview in Lower Hutt to/from either Christchurch or Tauranga. Christchurch was a useful destination, as all shipments from/to Seaview required the use of more than one transport mode; for example, a semi-trailer to make the journey from Seaview to CentrePort Wellington and a ferry to cross Cook Strait.

The containers were shipped empty so they would be more sensitive to in-transit disturbances and also to ensure their response to these disturbances was not influenced by a specific load type.

Conclusions

Journey duration

For a given transport mode, there was considerable variation in the time spent stationary along a route or between transfers (eg at a rail depot or port).

Impact loading

- When compared with service conditions suggested by the American Bureau of Shipping, analysis of the acceleration traces showed that under typical New Zealand service conditions, transverse accelerations were significantly greater than those expected across all transport modes, and longitudinal accelerations were significantly greater than those expected for both maritime and road modes. However, peak longitudinal accelerations measured for the rail mode were less than the expected 2.0g, suggesting sound practices are being employed in shunting operations.

- The maximum magnitude of the measured container accelerations was 2.2g, which was 10% greater than the 2g expected. This maximum acceleration level was recorded for the road transport mode, although 2g acceleration levels were measured for both the rail and maritime modes.
- For a particular acceleration level, there were generally more instances in the vertical direction than the two translational directions.

For the rail and road modes, large-magnitude vertical accelerations occurred over very short durations (ie less than a second) and not at a particular frequency. In contrast, the vertical acceleration levels for the maritime mode were considerably lower, with the peak values occurring periodically at a regular interval of about 5 seconds, corresponding to a frequency of vibration of 0.2Hz. This is likely to be associated with the motion of the ship, as swells cause random, very low-frequency vibration (less than 2Hz) of the whole ship, both longitudinally (pitching) and transversely (rolling).

- It was also shown that the likelihood of potential damage to goods from impact loading is less where the transport mode is maritime, followed by road and lastly rail. For example, the percentages of time for which the vertical acceleration levels exceeded 2m/s^2 were in the approximate ratio of 5.0 (rail): 2.0 (road):1.0 (maritime). These ratios changed to 60 (rail):4 (road):1 (ship) if the vertical acceleration levels exceeded increases to 5m/s^2 (ie half the acceleration due to gravity - 0.5g) and finally to 28 (rail):1.2 (road):1 (maritime) if the vertical acceleration levels exceeded increases to 10m/s^2 (ie 1g, where the resulting force is sufficient to lift the container off the ground). This result supports the current practice of mainly using rail to transport bulk goods, such as coal and forestry products, because high dynamic loading is less problematic for such goods. It also indicates that as the accelerations get more severe, the differences between road and maritime modes become less. When considering damage to goods, it is the severe accelerations that are of most importance.
- The high incidence of impact loading in the rail mode reflects an ageing transport network that hasn't received adequate infrastructure investment, with 200km of the 4000km network (ie 5%) approaching the end of its predicted life.

CO₂ emissions and fuel use

- To have equivalency with the road mode in terms of fuel consumption and CO₂ emissions per kilometre a container is transported, the rail mode has to transport at least 25 containers per train and the maritime mode at least 297 containers per vessel.
- When considering the maximum number of containers that can be transported by each transport mode (ie 550 for coastal shipping, 40 for rail, and 1 for road), the maritime mode is shown to be slightly more efficient in terms of fuel consumption and CO₂ emissions than the rail mode, and markedly better than the road mode. In fact, both maritime and rail modes are about twice as efficient as the road mode.

Costs

- As the journey distance increased, the cost difference between maritime, rail and road modes was shown to increase.
- For the approximately 1500km journey from Auckland to Dunedin, the ratio of costs in transporting a 20ft container was 1 (sea):1.7 (rail):2.8 (road). Although these ratios were lower than for Europe and the US, they highlighted that over long distances coastal shipping and rail are a more cost-effective way of transporting goods around New Zealand than road.
- The disproportionate cost of the road-ferry service across Cook Strait significantly impacted on the economics of transporting containers between North and South Island destinations by road. On

current (2012) prices, the road-ferry service costs between \$15.49 and \$20.57 per km (excluding GST), whereas the typical cost of freight transport is \$2.50 per km (excluding GST).

Recommendations

The key recommendations arising from the research are as follows:

- The use of an instrumented container was shown to be a low-cost and effective way of assessing the state of New Zealand's main modes of freight transport, particularly with respect to journey times and impact loading. It is therefore recommended that this exercise be performed at periodic intervals to gauge the impact of market forces and the effect of central and local government policies, especially in relation to maintenance management practices adopted on the road and rail networks.
- The highest container-impact forces often result from transfers. Accordingly, it is recommended that trials of transferring an instrumented 20ft container be carried out with a view to analysing the resulting impact forces, so that improvements can be made to the transfer technique with the aim of reducing the impact forces as much as possible.
- The measured maximum longitudinal and transverse accelerations were a factor of three and six times greater than the expected maximum acceleration levels, respectively. This result suggests that existing procedures for assessing ride quality of state highways do not take sufficient account of surface profile features that promote body roll and body pitch in the semi-trailers used to transport containers. It is therefore recommended that the NZ Transport Agency consider supplementing the quarter-car-based International Roughness Index (IRI) numeric with more freight-focused numerics.
- A worthwhile exercise would be to establish critical acceleration levels and frequency ranges for broad commodity groups. This would allow guidance to be given as to the most appropriate transport mode for a particular commodity group to minimise in-transit damage. Furthermore, if the relative damage (perhaps in dollar value) of differing acceleration levels can be determined for the dominant frequencies of each of the three transport modes, it will be possible to compare the dollar value of in-transit damage between the modes for the various commodity groups investigated.
- Of the three transport modes investigated, coastal shipping appears to be a very cost-efficient and environmentally acceptable means of transporting containerised freight between the North and South Islands. It is therefore recommended that more consideration be given to better integrating the various transport modes so that the total amount of domestic freight moved by coastal shipping is increased from the current 15%.

Abstract

Customers for long-distance goods haulage are free to decide on which transport modes to use on the basis of price and performance. However, independent up-to-date information on which to base such decisions is limited in New Zealand and so existing modes and established haulers are favoured.

In order to address this knowledge gap, a comparative study was undertaken involving the haulage of containers instrumented to allow real-time monitoring of time, location and impact forces. In analysing the results, emphasis was placed on journey duration, impact loading, fuel use/CO₂ emissions and price. The principal finding was that of the three transport modes investigated, coastal shipping appeared to be the most cost-efficient and environmentally acceptable means of transporting containerised freight between the North and South Islands. However, to have equivalency with the road mode in terms of fuel consumption and CO₂ emissions per kilometre a container is transported, the maritime mode has to transport at least 297 containers per vessel, and the rail mode at least 25 containers per train. The use of an instrumented container was shown to be a low-cost and effective way of assessing the state of New Zealand's main modes of freight transport from a consumer's perspective.

1 Introduction

1.1 General

In 2005, a Ministry of Transport (MoT) study was commissioned to assist the government in making decisions on the relative competitive position of road and rail for freight transport (MoT 2005). It found there was little available New Zealand research regarding actual resource usage, particularly regarding the relative efficiency of the modes in the use of fuel and damage to goods during transit. Brennand and Walbran (2004) believe this paucity of information on relative resource usage hampers the robust economic assessment of transport-related capital works projects that are alternatives to roading.

Customers for long-distance goods haulage are free to decide on which transport modes to use on the basis of price and performance. However, independent up-to-date information on which to base such decisions is limited in New Zealand, and so existing modes and established haulers are favoured.

The contribution to gross domestic product by the trade and transport sectors in 2007 came to \$23.5 billion (expressed in 1995/96 prices), or 18% of the total (Statistics New Zealand 2008). Not all of this contribution was directly attributable to the internal freight distribution network, but it is clear that the sector's efficiency is a major contributor to the overall performance of New Zealand's economy in terms of productivity and inflation. However, little research effort has considered how efficient the various distribution modes are and where gains could be made.

In order to help address this knowledge gap, the comparative study detailed in this research report was undertaken, involving the haulage of containers instrumented to allow real-time monitoring of time, location and impact forces. In analysing the results¹, particular emphasis was placed on:

- quantifying the effects of inter-modal operations required by coastal shipping and rail (effects could include time delays, road transport fuel use, and potential damage to goods during loading/unloading and storage)
- exposure to high-impact loading during haulage that could result in damage to goods
- fuel use/CO₂ emissions.

1.2 Report layout

- Chapter 1 outlines the need for this research.
- Chapter 2 describes the instrumentation employed in tracking the container and recording the in-transit impact forces.
- Chapters 3 and 4 detail the freight routes investigated and journey durations respectively.
- A comparison of expected and actual service conditions is provided in chapter 5.
- Chapter 6 assesses the relative efficiency of the three transport modes investigated, in terms of fuel consumption and CO₂ emission rates.
- Chapter 7 compares prices between modes and over time.

¹ The key datasets analysed were generated in 2006 and so the research findings pertain to the condition of the transportation networks at that time.

- Chapter 8 provides a discussion on two key findings of the research related to higher-than-expected maximum container acceleration levels for the road transport mode, and the need to consider vibration frequency in addition to vibration magnitude when considering in-transit damage of commodities.
- The principal findings of the research and associated recommendations are given in chapters 9 and 10 respectively.
- Key references are listed in chapter 11.
- Full journey summaries, including the minimum and maximum acceleration levels and the time spent moving or stationary, are provided in the appendix.

2 Monitoring/tracking system

2.1 Overview

A stand-alone data logger that could covertly track the movement of an empty container and measure the number, frequency, magnitude and time of any sudden movements and impacts the container experienced along its journey, was designed and constructed. The logger was built from off-the-shelf Original Equipment Manufacturer (OEM) modules and consisted of a battery-powered device using a Global Positioning System (GPS) receiver to determine the position of the container and 3-axis accelerometers to monitor movements and impacts. The data acquired from the GPS and accelerometer modules was stored in a 256-megabyte (MB) non-volatile Universal Serial Bus (USB) memory device and downloaded for processing and analysis when the logger was recovered from the container at the completion of the trip.

2.2 Details

The movement of the container, any impacts on it and its geographical position were logged on two identical, stand-alone data acquisition systems. Each system consisted of an ARM9TM-based single-board computer manufactured by Technologic Systems running Linux, an 8-channel analogue-to-digital converter, a Garmin Limited GPS16 unit, a three-axis accelerometer, a temperature sensor, a battery voltage monitor and a 12-volt battery. Five of the analogue input channels were used for the three axes of the accelerometer, battery voltage and temperature sensor, and one serial port was used to receive data from the GPS unit.

The triaxial accelerometers were interrogated 10 times per second and the resultant data, along with the container's position data obtained every second from the GPS unit, was compressed and stored in a USB memory stick every 10 minutes. In addition to storing the acceleration data, a separate log of impacts in excess of 1g was also generated. As with the acceleration data, this record was compressed and stored in the USB stick every 10 minutes. This system is shown schematically in figure 2.1 and photographs of the key components, along with their installation within the shipping container, are given in figures 2.2-2.7.

Figure 2.1 Block diagram of the ARM Log data acquisition unit

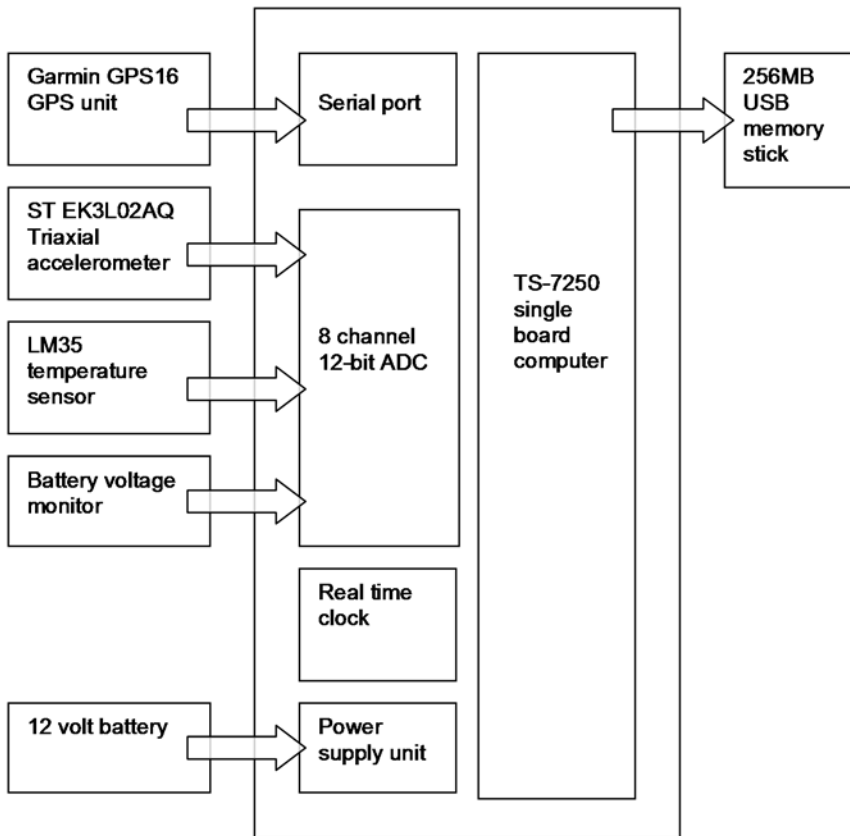

Figure 2.2 An image of the ARM log (also referred to as the Armlog) data acquisition unit



Figure 2.3 An image of the data acquisition system showing the Armlog data capture unit, the triaxial accelerometer and battery mounted inside a wooden box that was screwed to the floor of the container. The cable from the GPS antenna can be seen threading down the container wall.

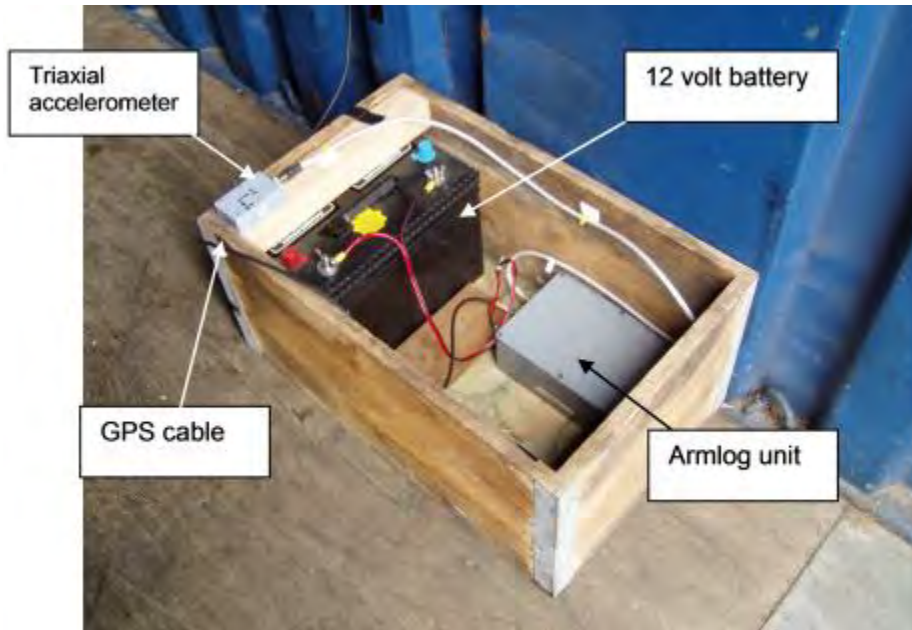

Figure 2.4 An image showing the inside of a container from the access doors. The two self-contained data acquisition systems were positioned at either end of the container.



Figure 2.5 The two GPS receivers (the black disks) were mounted on the outside of the container and disguised to look like ventilator fans.



Figure 2.6 An image of the container used in the field trials. One of the two GPS units can be seen on the side wall, just below the ridge, near the open door. The other GPS unit was positioned on the other side wall at the back of the container.



Figure 2.7 An image of an instrumented container being loaded for the first trip to Tauranga



3 Routes

3.1 Overview

The freight trips undertaken for this research are summarised in table 3.1 below. For each journey, the freighted article was a 20ft instrumented container.

Table 3.1 Journey details

Journey				Transport mode(s)	Carrier(s)	Cost (incl GST)
1	Out	24.11.06 Lower Hutt	Opus Central Laboratories, Seaview, Lower Hutt	Coastal shipping (and road from local pick-up location to Wellington Port)	Pacifica - coastal shipping (and LG Anderson - road)	\$2861
	Return	Date unspecified Christchurch	Christchurch (Lyttelton Port)			
2	Out	Date unspecified Christchurch	Christchurch (Lyttelton Port)	Coastal shipping (and road from Wellington Port to local destination)	Pacifica - coastal shipping (and LG Anderson - road)	\$2844
	Return	30.11.06 Lower Hutt	Opus Central Laboratories, Seaview, Lower Hutt			
3	Out	14.11.06 Lower Hutt	Opus Central Laboratories, Seaview, Lower Hutt	Rail (and road from local pick-up point to Wellington and ship to cross Cook Strait)	Toll Rail & Mainfreight	\$3050
	Return	Date unspecified Christchurch	RSG Service operations, CT Site, Matipo Street, Middleton, Christchurch			
4	Out	Date unspecified Christchurch	RSG Service operations, CT Site, Matipo Street, Middleton, Christchurch	Rail (and ship to cross Cook Strait and road to local destination)	Toll Rail & Mainfreight	\$5180
	Return	20.11.06 Lower Hutt	Opus Central Laboratories, Seaview, Lower Hutt			
5	Out	25.09.06 Lower Hutt	Opus Central Laboratories, Seaview, Lower Hutt	Rail (and road from local pick-up location to rail depot)	Toll Rail & Mainfreight	\$5180
	Return	Date unspecified Tauranga	Tauranga			
6	Out	Date unspecified Tauranga	Tauranga	Rail (and road from rail depot to local final destination)	Toll Rail & Mainfreight	\$5180
	Return	28.09.06 Lower Hutt	Opus Central Laboratories, Seaview, Lower Hutt			
7	Out	17.10.06 Lower Hutt	Opus Central Laboratories, Seaview, Lower Hutt	Road (and ship to cross Cook Strait)	Owens Group - John King	\$5180
	Return	Date unspecified Christchurch	31 Baigent Way, Middleton, Christchurch			
8	Out	Date unspecified Christchurch	31 Baigent Way, Middleton, Christchurch	Road (and ship to cross Cook Strait)	Owens Group - John King	\$5180
	Return	31.10.06 Lower Hutt	Opus Central Laboratories, Seaview, Lower Hutt			

Journey				Transport mode(s)	Carrier(s)	Cost (incl GST)
9	Out	11.07.06 Lower Hutt	Opus Central Laboratories, Seaview, Lower Hutt	Road	Owens Road Transport	\$2987
	Return	Date unspecified Tauranga	Tauranga			
10	Out	Date unspecified Tauranga	Tauranga	Road	JD Lyons	
	Return	14.07.06 Lower Hutt	Opus Central Laboratories, Seaview, Lower Hutt			

As shown in table 3.1, freight journeys were undertaken via coastal shipping, rail, and road transport modes. Images of representative coastal shipping, rail and road freight carriers are shown in figures 3.1- 3.3.

Figure 3.1 A Pacifica Shipping coastal freight ship (Source: www.pacship.co.nz/page125012.aspx)



Figure 3.2 A 'Toll Rail' freight train



Figure 3.3 A freight truck



3.2 Available transport routes

Schematics of the rail, road and shipping transport routes available at the time the research was undertaken are shown in figures 3.4–3.8.

Figure 3.4 Map of New Zealand rail network – North Island (Source: http://en.wikipedia.org/wiki/List_of_railway_lines_in_New_Zealand)



Figure 3.5 Map of New Zealand rail network – South Island (Source: http://en.wikipedia.org/wiki/List_of_railway_lines_in_New_Zealand)



Figure 3.6 Map of New Zealand state highway road network – North Island (Source: http://lrms.transit.govt.nz/Critchlow_Maps/Critchlow_Maps.htm)



Figure 3.7 Map of New Zealand state highway road network – South Island (Source: http://lrms.transit.govt.nz/Critchlow_Maps/Critchlow_Maps.htm)



Figure 3.8 Pacifica coastal shipping routes as in 2004 (Source: www.pacship.co.nz)

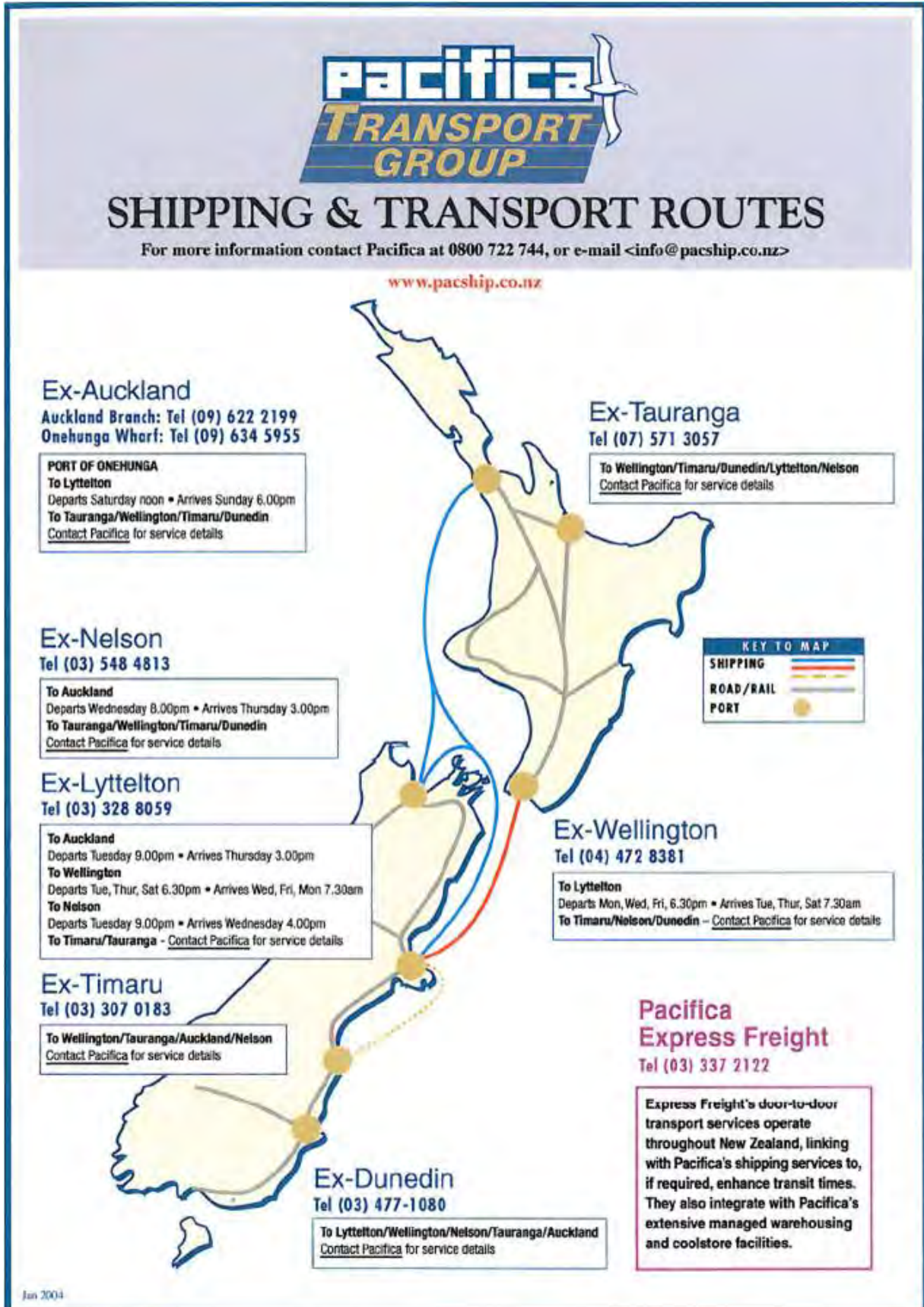

3.3 Container details

A standard 20ft container was employed. In each case it was shipped empty so the dynamic loading experienced by the container would not be influenced by carrying a load. Furthermore, having the container empty meant it would be more sensitive to any transport-related disturbances because of its lightness, and so a harder ride would result. Therefore, the measured container accelerations would be at the upper end of what would be expected.

4 Journey duration

4.1 Data processing

The data files for each 10-minute time segment were amalgamated to produce a data file combining the time, acceleration levels and Geographic Information System (GIS) location (northing and easting) for the 'out' and 'return' legs of the journey for each transport mode.

4.2 Journey duration

Each of the records was examined to determine the amount of time that the container was stationary and the amount of time it was in motion. Table 4.1 summarises the stationary and in-motion times. Note that some of the modes involved intermediate stops eg stopping for lunch or overnight. Appendix A provides a breakdown of the times when the container was in motion or stationary, for each journey.

Table 4.1 Journey duration summary

Transport mode	Journey	Stationary time during journey (hours)	Time in motion (hours)
Road	Lower Hutt ^a - Tauranga	0.9	9.2
	Tauranga - Lower Hutt	14.7	11.9
Rail	Lower Hutt - Tauranga	15.5	15.1
	Tauranga - Lower Hutt	21.9	15.4
Road	Lower Hutt - Christchurch	1.5	9.7
	Christchurch - Lower Hutt	8.6	10.1
Rail	Lower Hutt - Christchurch	24.8	7.7
	Christchurch - Lower Hutt	81.1 ^b	13.5
Maritime	Lower Hutt - Lyttelton	7.2	13.2
	Lyttelton - Lower Hutt	6.9	19.1

- a) The pick-up and drop-off location for the instrumented container was the Opus Central Laboratories compound, which has a street address of 138 Hutt Park Road, Gracefield, Lower Hutt.
- b) For this trip, Toll Rail had to be contacted as to why the container had not been delivered, whereupon it was discovered that the container had been sitting at the container terminal in Wellington for several days.

This table shows that while there was considerable variation in the time a container spent in motion for the same mode in different directions, and between the different transport modes, there was significantly more variation in the time spent stationary along the route or between transfers, such as at a rail depot or port.

With reference to table 4.1, there was no option to send from Lower Hutt to Tauranga by ship at the time the research was carried out, as Pacifica provided no coastal shipping service from Wellington to Tauranga (refer to figure 3.8).

5 Impact loading

5.1 Expected service conditions

Negative and positive accelerations are dynamic, mechanical stresses. Two main types occur during the transportation of goods:

- regular acceleration forces
- irregular acceleration forces.

Regular acceleration forces primarily occur in maritime transport. Acceleration of up to 1g ($g = 9.81 \text{ m/s}^2$) and, in extreme cases even more, may occur due to rolling and pitching in rough seas. Such regular acceleration forces have an impact on the effort involved in load securing.

Irregular acceleration forces occur during cornering or when a train passes over switches, and during braking, starting up, hoisting and lowering. Such acceleration forces are not generally repeated, but they may occur several times at varying intensities during transport. These are the typical stresses of land transport and transport, handling and storage operations.

In their *Rules for certification of cargo containers* (ABS 1998), the American Bureau of Shipping (ABS) specifies operating-load requirements for the design of containers used in multimodal transport. These requirements are expressed as accelerations in the vertical, transverse and longitudinal directions for each transport mode, and also terminal handling, and are outlined below for ready reference.

5.1.1 Coastal shipping

Containers operating in the marine mode are often stowed in vertical stacks within the cells in a ship's hold. When stowed in this manner, containers will be restrained at the end frames against longitudinal and transverse movement, by the cell structure. The reactions of the entire stack of containers are taken through the four bottom-corner fittings of the lowest containers. Containers may also be stowed on deck or in a hold restrained by lashings, deck fittings, or both. Containers are normally stowed with the longitudinal axis of the container parallel to that of the ship.

It is assumed that the combined effect of a vessel's motions and gravity results in an equivalent 1.8 times gravity for vertical acceleration, an equivalent of 0.6 times gravity for transverse acceleration, and an equivalent 0.4 times gravity for longitudinal acceleration, acting individually.

5.1.2 Road

Containers operating in the road mode are carried by container chassis, which provides support and restraint through the bottom-corner fittings, the base structure, or through a combination of the two.

It is assumed that the combined effect of a vehicle's motions resulting from road conditions, curves, braking and gravity results in an equivalent 1.7 times gravity downward for vertical acceleration, an equivalent 0.5 times gravity upward for vertical acceleration, an equivalent 0.2 times gravity for transverse acceleration, and an equivalent 0.7 times gravity for longitudinal acceleration.

5.1.3 Rail

Containers operating in the rail mode are carried by flat-deck wagons in two primary systems: container on a flat-deck wagon in which the container is supported and restrained through the bottom-corner

fittings; and trailer on a flat-deck wagon in which the container and its chassis are carried as a single unit on the wagon.

It is assumed that the combined effect of a wagon's motions, resulting from the ride characteristics of the wagon, switching operations and gravity, results in an equivalent 1.7 times gravity downward for vertical acceleration, an equivalent 0.3 times gravity for transverse acceleration, and an equivalent 2.0 times gravity for longitudinal acceleration.

5.1.4 Terminal/depot handling

A dynamic load results when handling equipment is used to lower containers onto supports. It is assumed that the combined effect of this dynamic load and gravity results in an equivalent 2.0 times gravity downward for vertical acceleration.

5.1.5 Comparison of container design accelerations

The service conditions suggested by the ABS for each transport mode are summarised in table 5.1 to facilitate ready comparisons. With reference to table 5.1, the largest-magnitude accelerations (ie 2g) imposed on a container are expected to occur during terminal/depot handling and during shunting operations performed at railyards. Of the three transport modes, acceleration levels are expected to be least for road. It is also noted that apart from rail, the largest magnitude accelerations are expected to occur in the downwards vertical direction. For rail, the largest magnitude accelerations are expected to be in the longitudinal direction.

Table 5.1 Summary of expected maximum acceleration levels for containers

Mode	Acceleration level (g)			
	Longitudinal	Transverse	Vertical	
			Upwards	Downwards
Maritime	0.4	0.6	1.8	1.8
Road	0.7	0.2	0.5	1.7
Rail	2.0	0.3	-	1.7
Terminal/depot handling	-	-	-	2.0

5.2 Measured container acceleration levels

The maximum and minimum accelerations recorded for each orthogonal axis during the Lower Hutt–Tauranga and Lower Hutt–Christchurch return journeys are provided in tables 5.2 and 5.3 respectively for each of the transport modes utilised.

Comparing the measured peak accelerations tabulated in tables 5.2 and 5.3 with the ABS's operating acceleration requirements tabulated in table 5.1, it can be seen that under the typical New Zealand service conditions that we studied, transverse accelerations were significantly greater than those expected across all transport modes, and longitudinal accelerations were significantly greater than those expected for both maritime and road modes. By comparison, peak longitudinal accelerations measured for the rail mode were less than the expected 2.0g, suggesting sound practices were being employed in shunting operations.

The maximum magnitude of the measured container accelerations was 2.2g, which was 10% greater than the 2g expected. This maximum acceleration level was recorded for the road transport mode, although 2g acceleration levels were measured for both the rail and maritime modes.

Table 5.2 Peak accelerations - Lower Hutt-Tauranga return journey

Mode	Measured peak acceleration (g)		
	Longitudinal (X)	Transverse (Y)	Vertical (Z)
Positive acceleration			
Road	1.3 ^a [0.9] ^b	1.2 [0.6]	0.7 [0.8]
Rail	1.4 [1.8]	1.1 [1.8]	1.5 [2.0]
Negative acceleration			
Road	-0.9 [-0.9]	-1.2 [-0.7]	-1.0 [-1.4]
Rail	-1.3 [-1.7]	-1.2 [-1.4]	-1.3 [-1.8]

- a) Non-bracketed value pertains to outward leg.
- b) Square-bracketed value pertains to inward leg.

Table 5.3 Peak accelerations - Lower Hutt-Christchurch return journey

Mode	Measured peak acceleration (g)		
	Longitudinal (X)	Transverse (Y)	Vertical (Z)
Positive acceleration			
Road	1.1 ^a [2.2] ^b	0.7 [0.6]	0.9 [0.9]
Rail	1.2 [1.5]	1.0 [1.5]	1.1 [1.5]
Maritime	0.7 [1.1]	1.0 [1.3]	0.9 [1.3]
Negative acceleration			
Road	-0.7 [-2.2]	-0.5 [-0.6]	-1.2 [-1.5]
Rail	-1.2 [-1.5]	-0.7 [-1.5]	-1.4 [-1.5]
Maritime	-1.2 [-2.0]	-0.7 [0.8]	-1.3 [-2.0]

- a) Non-bracketed value pertains to outward leg.
- b) Square-bracketed value pertains to inward leg.

Relative frequency distributions of the longitudinal, transverse and vertical accelerations are provided in figures 5.1 and 5.2 for the journeys between Tauranga and Lower Hutt and between Christchurch and Lower Hutt. These figures show the percentage of time that a particular acceleration level occurred throughout the journey. To enable all the data to be shown, a logarithmic y-axis has been used.

These figures show that for a particular acceleration level, accelerations in the vertical direction were generally dominant. They also show that the likelihood of potential damage to goods from impact loading was less where the transport mode was primarily maritime. Road transport was the next best, and then rail. For example, the percentages of time for which the vertical acceleration levels exceeded 2m/s² were in the approximate ratio of 5.0 (rail):2.0 (road):1.0 (maritime). These ratios changed to:

- 60 (rail):4 (road):1 (ship) if the vertical acceleration levels exceeded increased to 5m/s² (ie half the acceleration due to gravity - 0.5g)
- 28 (rail):1.2 (road):1 (maritime) if the vertical acceleration levels exceeded increased to 10m/s² (ie 1g, where the resulting force was sufficient to lift the container off the ground).

This result supports the current practice of predominantly using rail to transport bulk goods, such as coal and grains, because high dynamic loading is less problematic for such goods. It also shows that as the accelerations get more severe, the differences between road and maritime modes become less. When considering damage to goods, it is the severe accelerations that are of most importance.

Figure 5.1 Comparison of acceleration levels, Tauranga to Lower Hutt

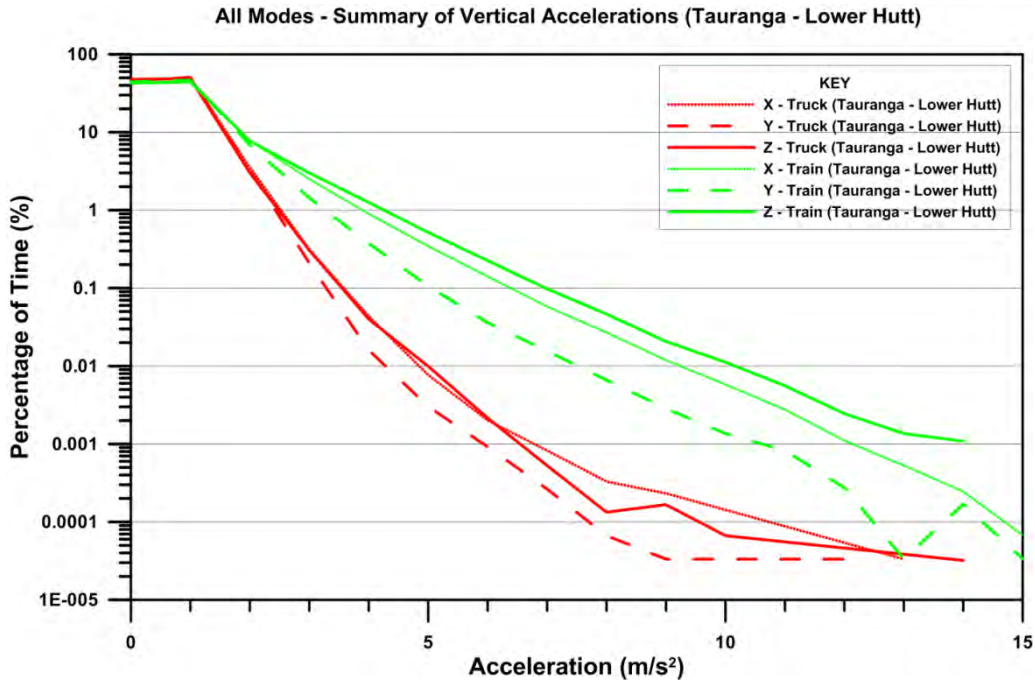
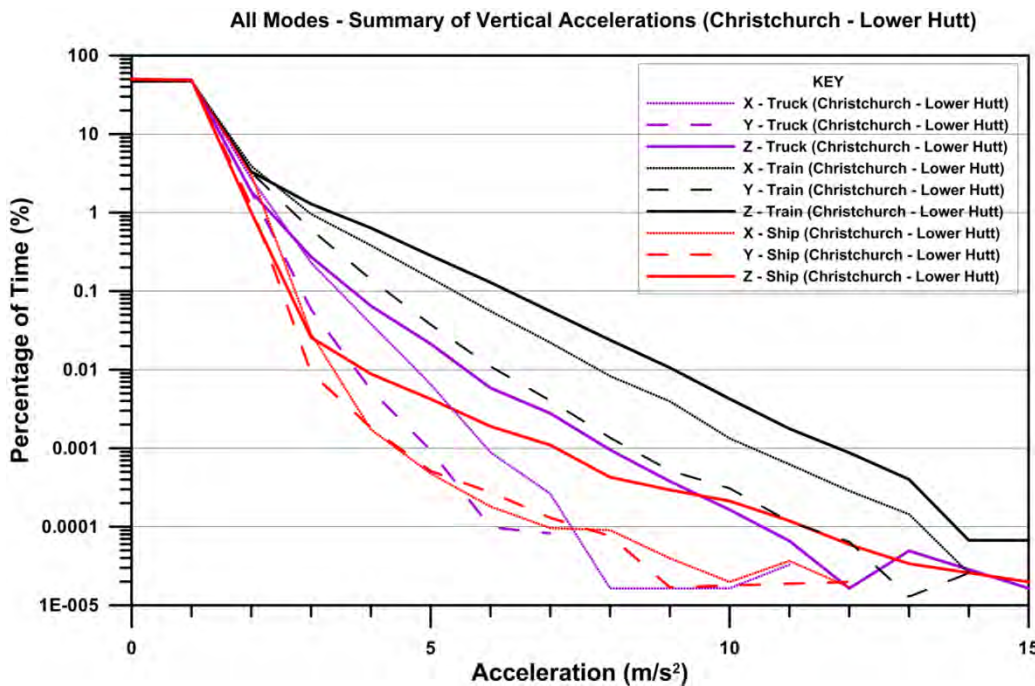

Figure 5.2 Comparison of acceleration levels, Christchurch to Lower Hutt



Given the dominance of vertical accelerations, additional time series, spectral content and spatial analyses were performed to obtain a better understanding of their characteristics for the three transport modes of interest.

Figure 5.3 shows representative 100-second time histories of vertical acceleration for each of the transport modes.

Figure 5.3 100-second vertical acceleration time histories

Road mode:

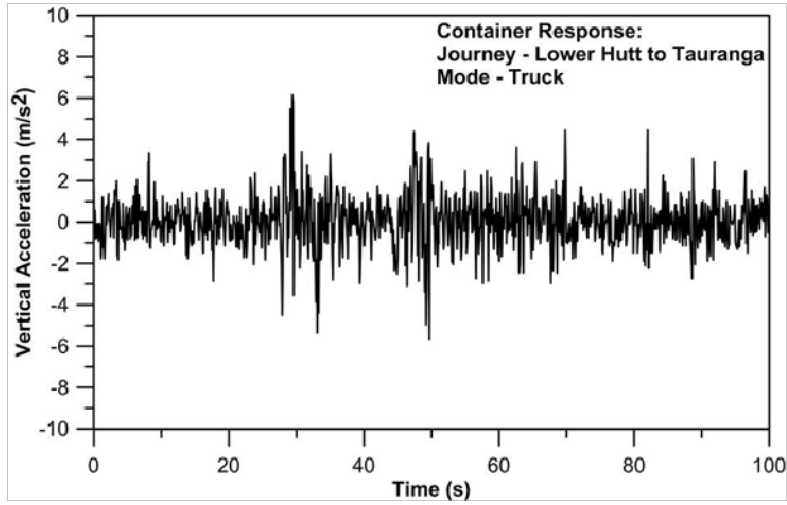

Rail mode:

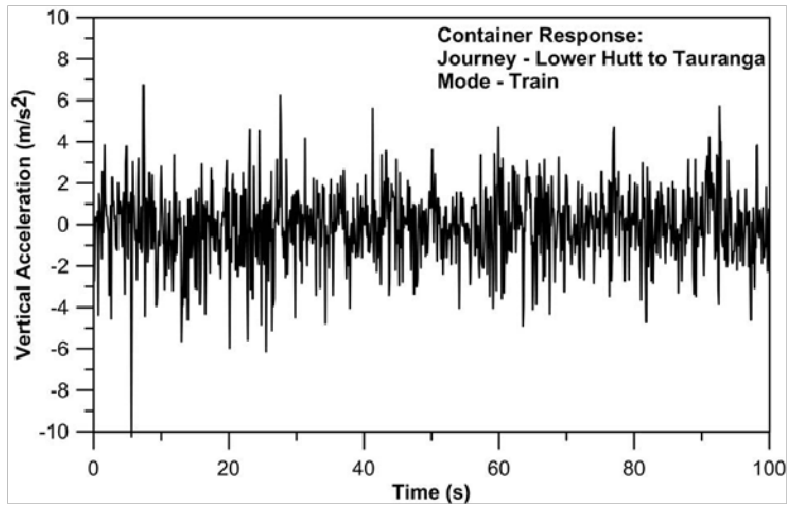

Maritime mode:

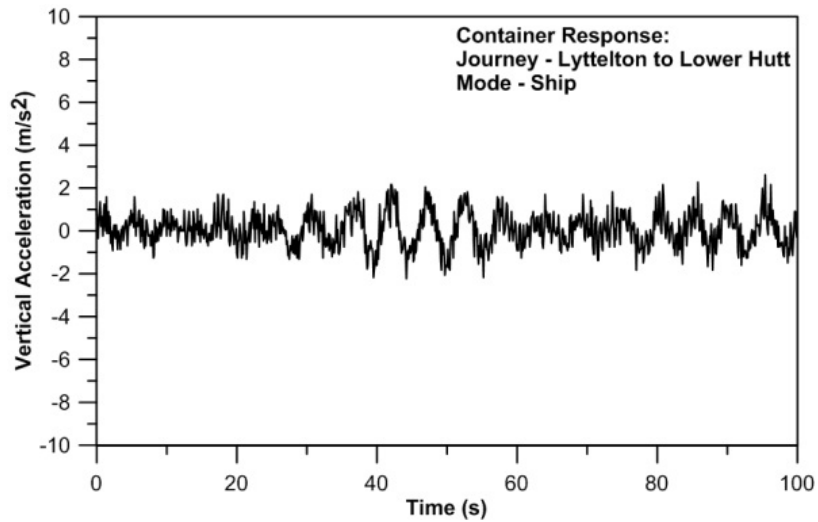

It can be seen from figure 5.3 that the vertical acceleration time histories for the road and rail modes were generally very similar, apart from there being more instances of large-magnitude vertical accelerations for the rail mode than for the road mode. In both cases, the large-magnitude vertical accelerations occurred over very short durations (ie less than a second). In both cases, the peaks occurred randomly.

By comparison, the vertical acceleration levels for the maritime mode were considerably lower, with the peak values occurring periodically at a regular interval of about 5 seconds, corresponding to a frequency of vibration of 0.2Hz. This was likely to be associated with the motion of the ship, as swells cause random, very low-frequency vibration (less than 2Hz) of the whole ship, both longitudinally (pitching) and transversely (rolling) (NCMM 2012). The frequency of this vibration is expected to be between 0.01Hz in very calm seas and 1.5Hz in bad weather. It is generally between 0.1 and 0.3Hz (ibid).

To investigate the maritime mode further, the longitudinal and transverse acceleration time histories over 50 seconds of the journey from Lyttelton to Wellington were plotted in figure 5.4, along with the vertical acceleration time history.

Figure 5.4 50-second time history for maritime mode – each orthogonal axis

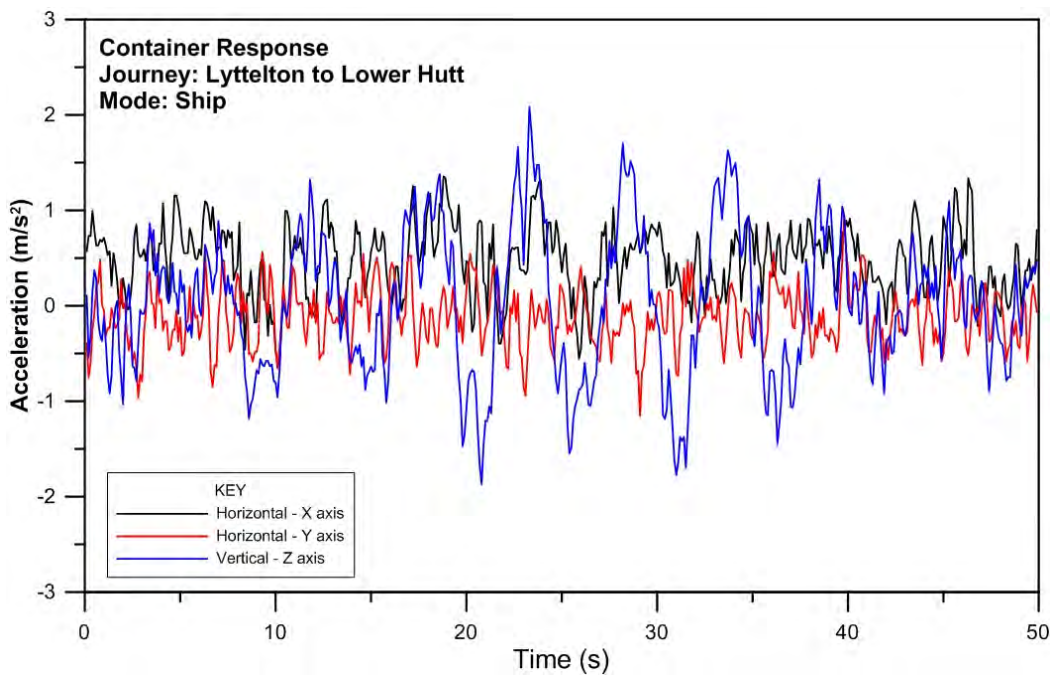

With reference to figure 5.4, the vertical (z-axis) accelerations were clearly the largest. Furthermore, no peaks at regular intervals could be observed in the y-axis acceleration trace, but sometimes peaks in the x-axis and z-axis traces coincided. The dominant frequency of the x-axis was about 0.07Hz, corresponding to a period of 14 seconds, whereas for the z-axis it was about 0.2Hz, corresponding to a period of 5 seconds. These were assumed to coincide with the roll and pitch motion of the vessel, as they fell within the range of typical roll and pitch periods for roll-on/roll-off ships, which for both motions is 6.3 to 20.9 seconds (Turnbull and Dawson 1997).

With reference to figures 5.1 and 5.2, impact/shock loading of the container occurred most often in the vertical direction for all three transport modes. Therefore, it was considered appropriate to investigate both the spectral content of the vertical acceleration signals for the different modes and the spatial distribution of high vertical acceleration levels along the two journeys monitored.

Figure 5.5 shows the resulting power spectral density (PSD) plots for each of the three transport modes. The area under the PSD plot is the square of the root-mean-square (RMS) value of the vertical acceleration time history. Therefore, the units of PSD are $(\text{m/s}^2)^2/\text{Hz}$. As can be seen, the road and rail modes were dominated by frequencies that were greater than 1 Hz, whereas for the maritime mode there was a dominant peak at around 0.2 Hz, which could be associated with the pitch or roll of the vessel.

For further comparison between the modes, mapping software was used to show the acceleration levels along the two journeys in three bands: 0–5 m/s^2 , 5–10 m/s^2 , and greater than 10 m/s^2 . This comparison was only able to be performed for the road and rail modes. Acceleration data for the maritime mode couldn't be mapped because the GPS signal was lost because of the way other containers were stacked around the container being tracked.

Figures 5.6 and 5.7 show the Lower Hutt–Tauranga journey acceleration levels for the road and rail modes respectively. Figures 5.8 and 5.9 show the Lower Hutt–Christchurch journey acceleration levels, including the Cook Strait crossing, again for the road and rail modes.

Figures 5.6–5.9 provide a visual comparison of the differences in the acceleration levels between the road and train modes, with the rail mode showing a greater proportion of higher acceleration levels than the road mode. The short length of the interisland crossing seen in figure 5.7 shows that acceleration levels of the container while on board the ferry were likely to be relatively low in light to moderate sea conditions, with most of the impact loading occurring during transfers.

With reference to figures 5.6–5.9, the locations of high ($>5 \text{m/s}^2$) vertical accelerations were much more localised for the road mode than the rail mode, typically corresponding to features such as bridge abutments and subsidence. This result was as expected, since we were comparing the performance of a modern truck on a roading network, which has had sustained investment, against an ageing rail system.

Figure 5.5 Comparison of modes - frequency power spectra

Road mode:

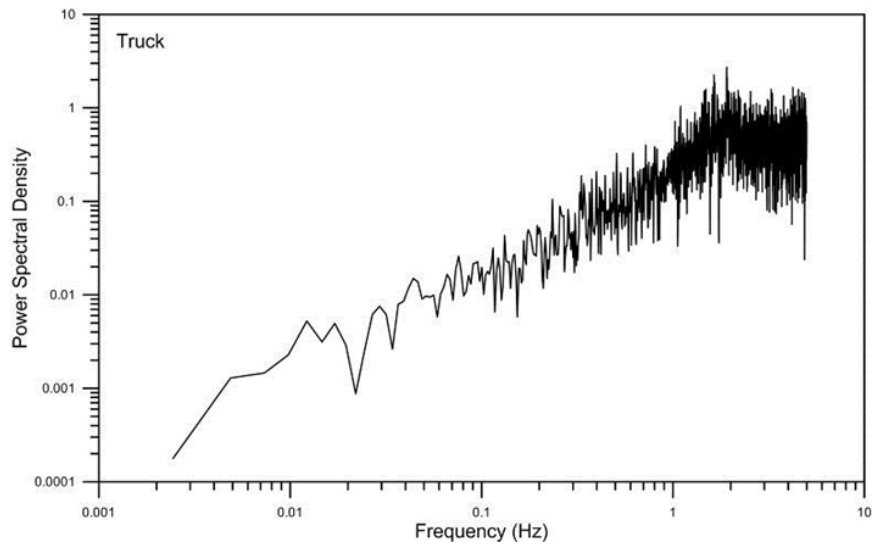

Rail mode:

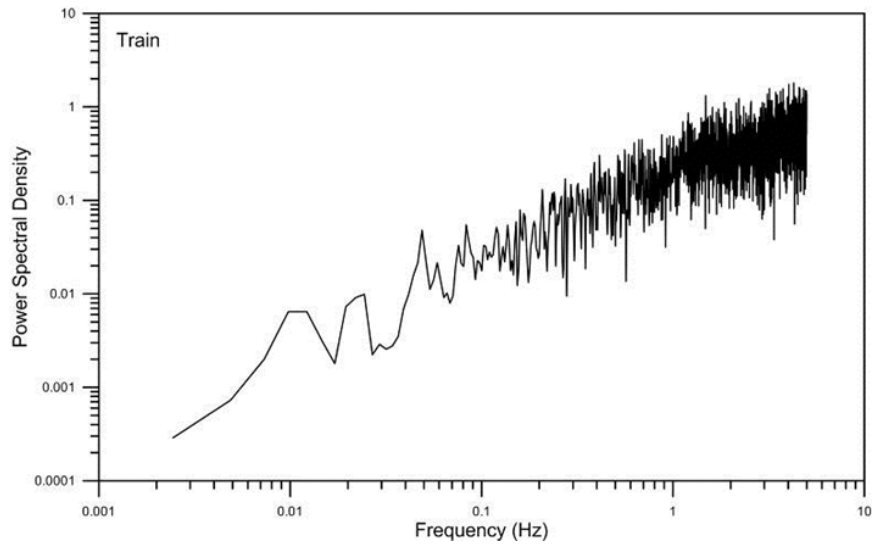

Maritime mode:

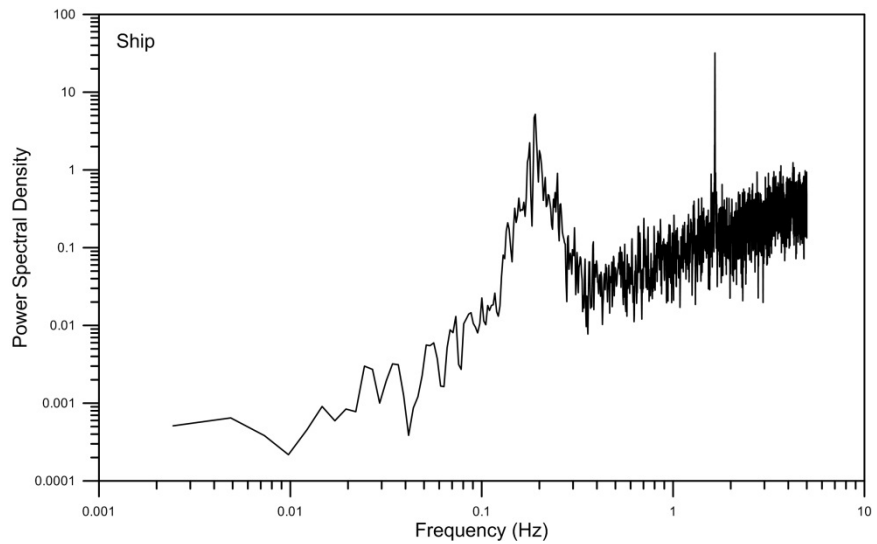

Figure 5.6 Mapping of vertical acceleration levels - road mode (Lower Hutt-Tauranga)

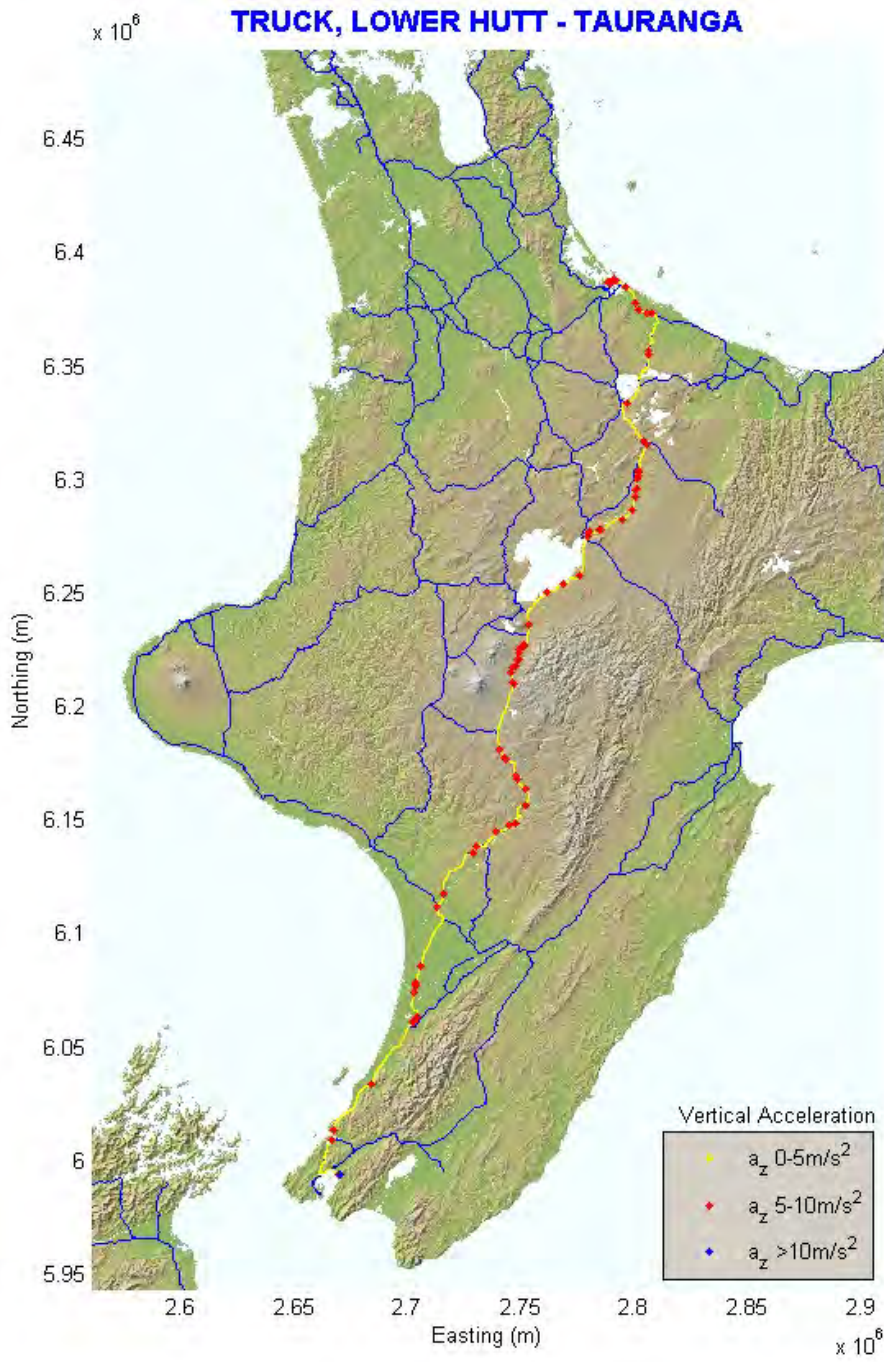

Figure 5.7 Mapping of vertical acceleration levels - rail mode (Lower Hutt-Tauranga)

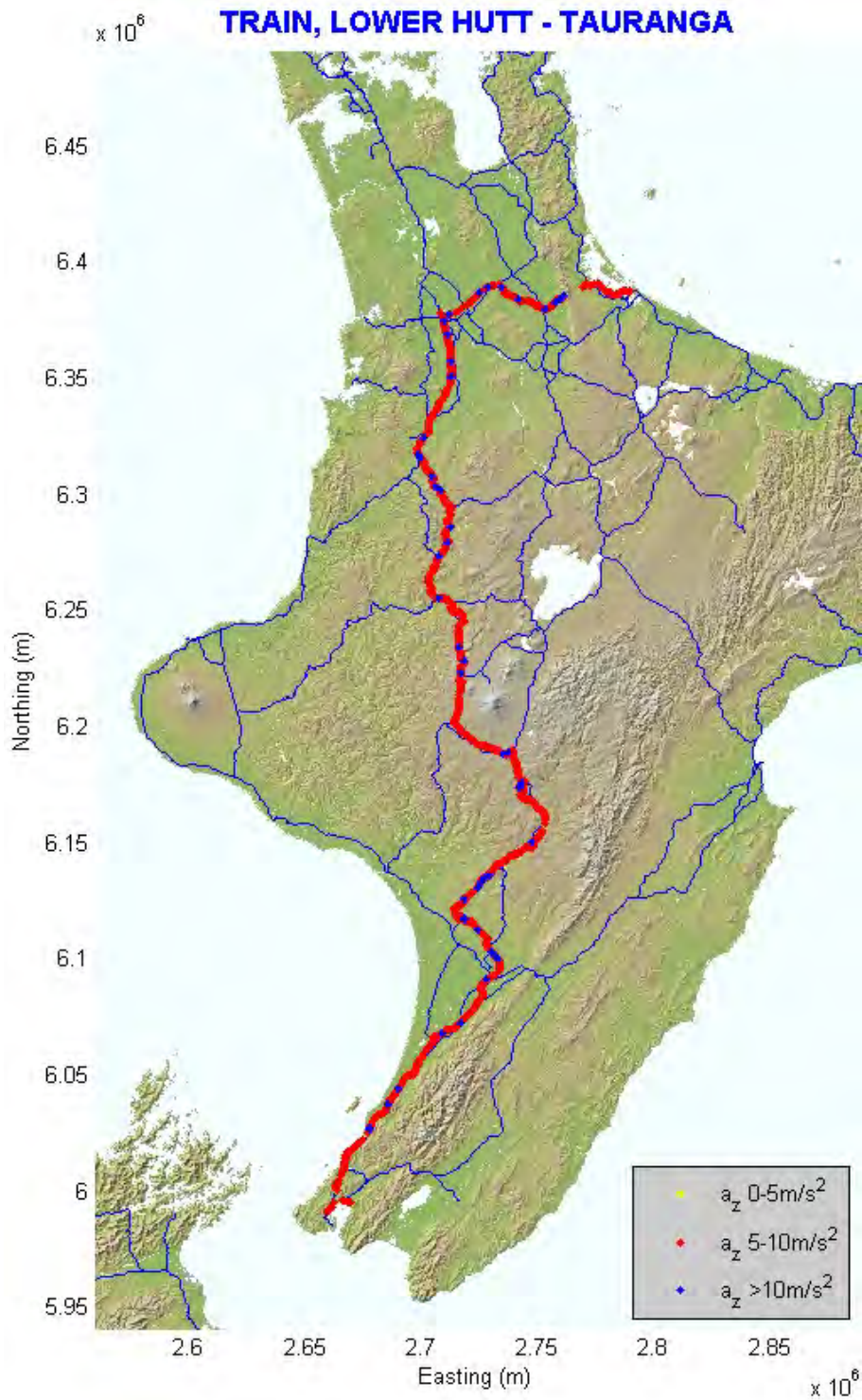

Figure 5.8 Mapping of vertical acceleration levels - road mode (Lyttelton-Lower Hutt)

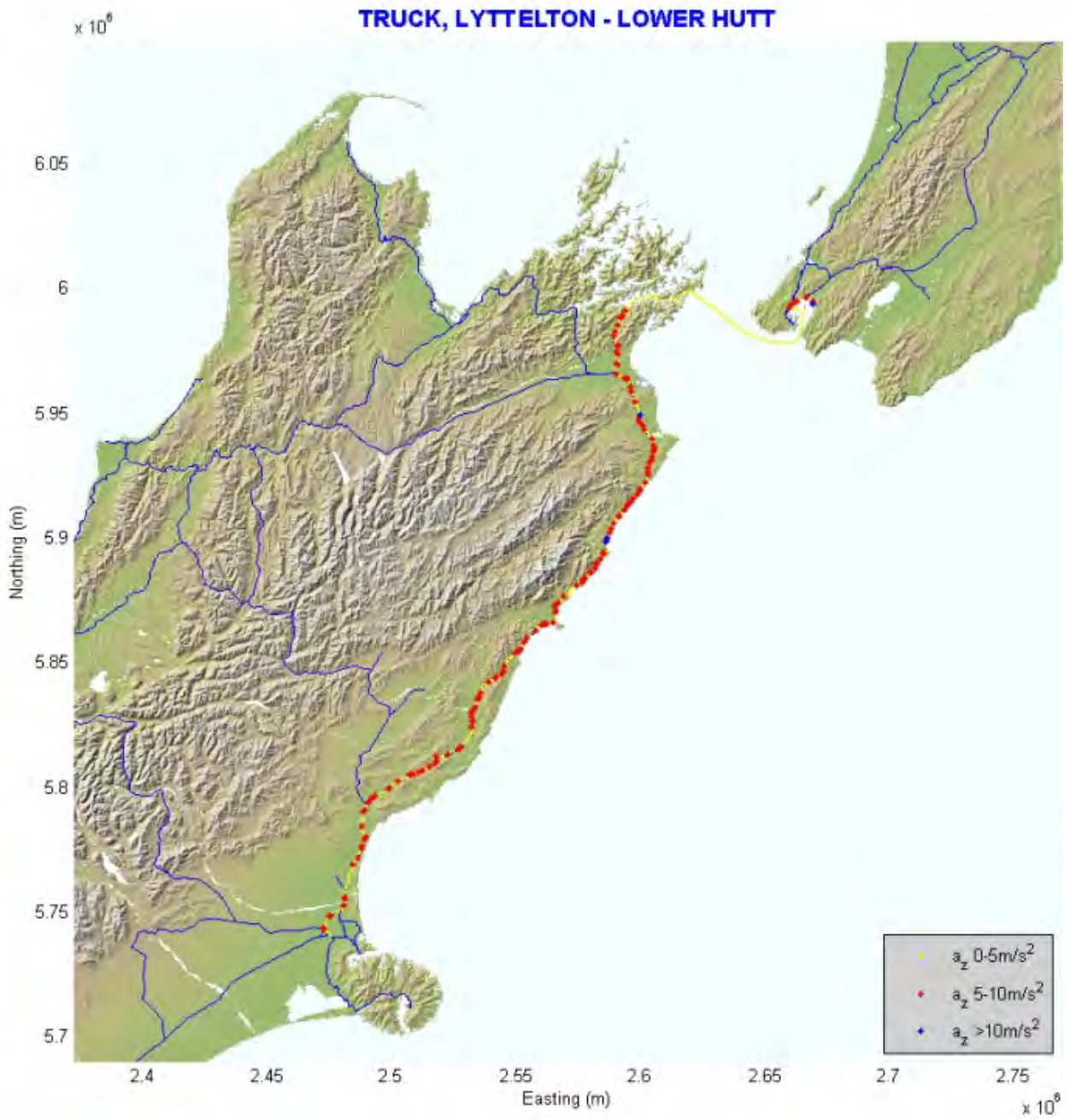
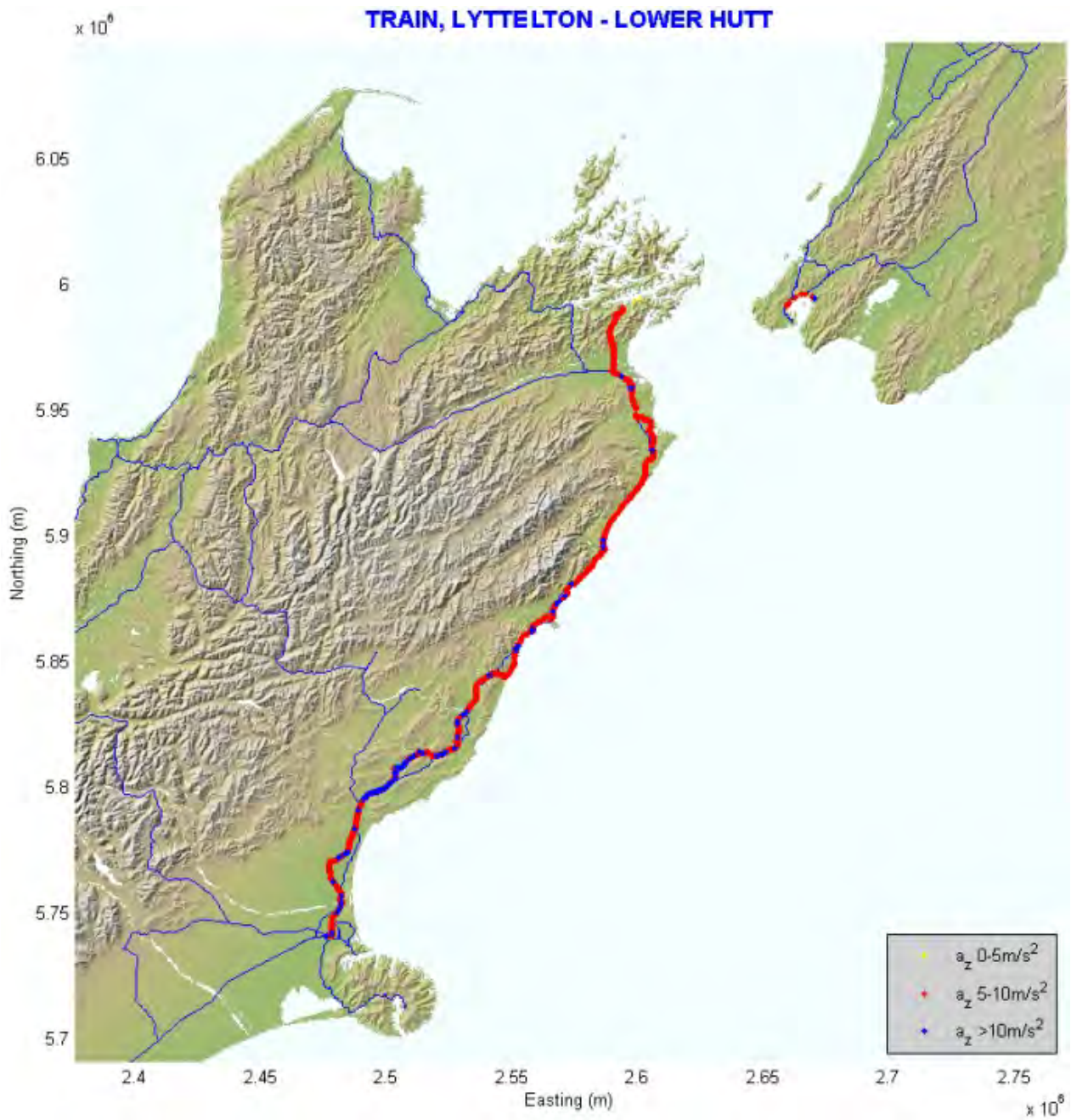

Figure 5.9 Mapping of vertical acceleration levels - rail mode (Lyttelton - Lower Hutt)



6 CO₂ emissions and fuel use

6.1 Introduction

This chapter assesses freight transport efficiency in terms of emission rates of carbon dioxide (CO₂) and fuel consumption for the three transport modes of road (section 6.3), rail (section 6.4) and coastal shipping (section 6.5). The assessment of CO₂ and fuel consumption was based on current data from the MoT, the Ministry for the Environment, the US Environmental Protection Agency (EPA) (EPA 2000) and transport companies.

6.2 Methodology

The assessment methodology for each transport mode was similar. Preference was given to New Zealand data validated by a comparison with overseas studies and the database of the environmental protection authorities.

As summarised earlier in table 3.1, return trips to two destinations were undertaken using different transport modes. In these trips, a 20ft container equipped with the measuring instruments detailed in chapter 2 was delivered from Wellington to Tauranga by truck and rail, and from Wellington to Christchurch by truck, rail and cargo vessel. Assessments were made both for:

- cumulative CO₂ emissions and cumulative fuel consumption for the entire trips
- emissions of CO₂ in kg/km per container, and fuel consumption in l/km per container.

Technology exists for measuring emissions and fuel consumption in real time. Consideration was given to utilising such technology by installing a fuel flow meter and a gas analyser on the trucks and locomotives for their trips and synchronising the output from these instruments with travelling speed. However, this instrumentation-based approach was not pursued for the following reasons:

- The road distance between Wellington and Tauranga was approximately 550km whereas the distance between Wellington and Christchurch was approximately 350km. Over short journeys, factors that could have a significant influence on fuel consumption and therefore CO₂ emissions, but were not central to the research (eg weather, road and traffic conditions), could be accounted for through performing repeat runs. For journeys over several hundred kilometres, performing repeat runs was not practical and so the effect of these external factors would increase dramatically.
- The benefits of using an instrumentation-based approach were questionable for this research project, in that a myriad of detailed data would be produced that was specific to a particular trip and therefore of limited use.
- Parts of the journeys undertaken for this project were over particularly varied topography, making it very challenging to isolate data that would be generic to a particular topographic feature.
- The transport industry players were reluctant to have their vehicles instrumented and monitored by a third party.

The methodology adopted for assessing fuel consumption and CO₂ emissions was to divide each of the two transport routes of interest into short sections of about 20–50km lengths on the basis of consistent topography, and to apply published fuel consumption and associated emission rates corresponding to that topography. The cumulative fuel consumption and emissions over the total journey distance could

therefore be calculated by summing the fuel consumption and CO₂ emission values derived for each of the short sections.

A review of literature in the public domain identified several studies had been performed in the US involving comparative measurements of emissions from road and rail modes over short journeys of up to 100km and 1–2 hours duration. Therefore, this US-based data was used to validate and supplement the available New Zealand-specific fuel consumption/CO₂ emissions data.

6.3 Road mode (heavy truck)

Emissions of CO (carbon monoxide) and CO₂ and the fuel consumption for heavy trucks vary widely depending on several factors, such as:

- vehicle type and load
- vehicle driving mode, including speed, acceleration and deceleration
- road tortuosity and gradient
- road deflection and roughness
- traffic characteristics
- wind speed and direction.

The cumulative effect of these factors on fuel consumption and CO or CO₂ emissions depends on the route used and can be taken into account by real-time measurements. The example in figure 6.1 below shows vehicle speed and concentration of CO (ie CO emissions) for an illustrative short section of road.

As discussed in the previous section, vehicle emissions can be measured in real time directly from the exhaust pipe. However, there are some issues for such emission measurements over long distances (>100km) and the more practicable solution adopted in this research was to perform calculations from models in the literature for short road sections with similar profiles, and sum these to get cumulative emissions for the whole trip. The same methodology was applied to obtain fuel consumption estimates.

Figure 6.1 Measured variation in CO emissions with vehicle speed

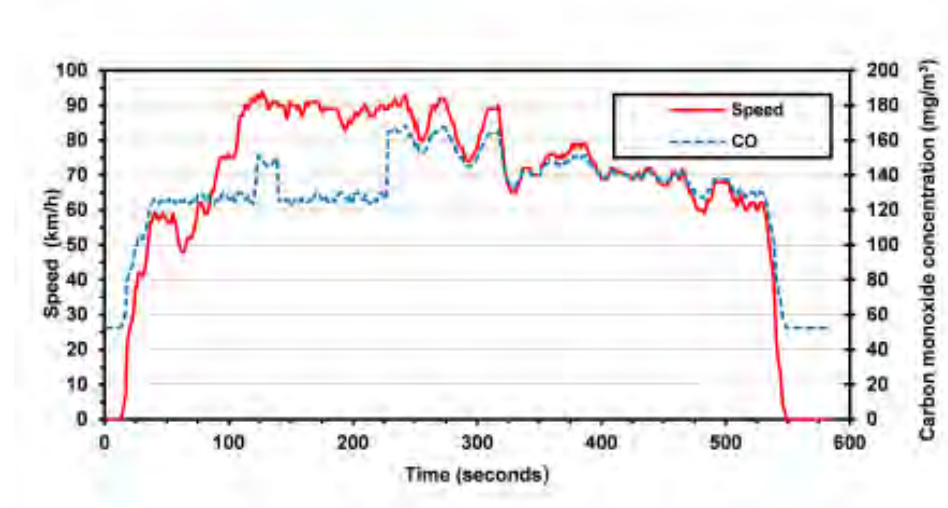

The heavy vehicles used for freighting the instrumented containers by road were ‘medium-heavy’ trucks of 7.5–12 tonnes, according to the classification in the *Vehicle fleet emissions model* (VFEM) (MoT 1998). Fuel consumption was calculated as the average value derived from the total amount of fuel consumed for the trips from Wellington to Tauranga and from Wellington to Christchurch.

Each of the trips from Wellington to Tauranga return and Wellington to Christchurch return was divided into separate sections and the prevailing driving mode assigned to each. Three driving modes were considered. For many sections, it was assumed that of these driving modes, ‘rural highway free traffic flow’ was the most appropriate. (However, in reality, fuel consumption by a truck travelling on the routes considered would vary and could be different due to variable driving conditions.) The distance and fuel consumption was calculated for each section. The results of these calculations are shown in table 6.1.

Table 6.1 Fuel consumption and travelled distance, by driving mode

Driving mode	Fuel consumption (l/100km)	Travelled distance (km)		Consumed fuel (l)	
		To Tauranga	To Christchurch	To Tauranga	To Christchurch
Free motorway	18.0	21	50	3.8	9.0
Free rural h-way	18.0	488	272	87.8	49.0
Free suburban	23.0	43	34	9.9	7.8
Free urban	23.0	18	8	4.1	1.8
Total		570	364	105.6	67.6

It should be noted that the method adopted for calculating the fuel consumed over a journey by dividing the journey by driving mode allows for topographic effects to be accounted for indirectly, as each driving mode is characterised by particular topographic features. For example rural highways are expected to have a greater proportion of hill climbing than motorways.

The fuel consumption data of table 6.1 was obtained from the VFEM (MoT 1998). These fuel consumption rates are also comparable with the European data provided in the World Bank report (1996), which presents data for medium- to heavy-duty diesel vehicles of 3.5–16.0 tonnes. (Alternatively, the actual fuel consumption data could have been provided by the freight companies involved in this research. However, the method of using a model was preferred, as it gave data that was more generally applicable, rather than data specific to a particular journey.)

Once we had the fuel consumption data, total emissions of CO₂ for the trips could be calculated, as there is a direct ratio between fuel consumption and the amount of CO₂ discharged through the exhaust pipe. To do this, some composition details of the diesel fuel were needed.

The quality of European diesel fuels is specified by the EN590:1993 standard. While specifications contained in this standard are not mandatory, they are observed by all fuel suppliers in Europe. According to EN590 specifications, standard diesel fuel contains 0.001–0.005% by weight of sulphur and has a density of 820–845 kg/m³. European-sourced references imply that one litre of EN590-specification diesel fuel will produce approximately 2.6kg of CO₂.

The New Zealand diesel fuel specifications are similar to those of EN590, and the MoT model we used assumes that 2.64kg of CO₂ emissions are produced per litre of fuel consumed, which is consistent with the values quoted in European-sourced references.

The CO₂ emission rate of 2.64kg per litre of fuel consumed was applied to the 7.5–12 tonne truck category. The emission rate was expressed as the amount of CO₂ discharged per kilometre per container,

and is tabulated in table 6.2. With reference to table 6.2, the emission rate is very similar for both trips, investigated at about 0.51kg/km/container.

By comparison, the *Inventory of greenhouse gas emissions* report (NIWA 2001), which provides vehicle fleet CO₂ emission factors, gives a CO₂ emission factor of 0.77kg/km for a broad category of heavy-duty diesel vehicles, including all trucks above 3.5 tonnes.

Table 6.2 CO₂ emissions of 7.5–12-tonne heavy vehicles

Driving mode	CO ₂ emission rate (kg/l of fuel)	CO ₂ emissions total per trip (kg)		CO ₂ emissions (kg/km per container)	
		To Tauranga	To Christchurch	To Tauranga	To Christchurch
Free motorway	2.64	10.03	23.76	-	-
Free rural h-way	2.64	231.79	129.36	-	-
Free suburban	2.64	26.14	20.59	-	-
Free urban	2.64	10.82	4.75	-	-
Total		278.78	178.46	0.507	0.510

6.4 Rail mode

All locomotives can be considered as falling into one of two main categories:

- 1 diesel shunters for local activities within railyards
- 2 mainline locomotives for long-distance operations.

Locomotives for either of these two applications are equipped with different engines and operate under different conditions which, in turn, define fuel consumption and emission rates. Only mainline locomotives were considered in the assessment following, as shunters are insignificant in terms of total fuel consumed and emissions of CO₂.

All locomotives operate in discrete power settings through a sequence of eight distinct loads (throttle settings) called notches, plus an idle-position notch. The notch position determines the fuel flow rate to the engine, which operates at the fixed load and speed condition for each notch. Emissions and the fuel consumption for any locomotive and for any travelled distance can be calculated using the time spent in each notch and the corresponding emission factor for each notch. However, this approach was not used because the fuel consumption data and the time (or distance) spent in each notch during the trip from Wellington to Tauranga and from Wellington to Christchurch were not provided by Toll Rail. Accordingly, fuel consumption and emission rates were calculated using an alternative methodology using published data for DX and DC class locomotives.

This alternative methodology, which is based on average fuel consumption values corresponding to the maximum steady state speed attained on a freight trip, is detailed in the following subsections.

6.4.1 CO₂ emission rate for diesel locomotives

The MoT provides data on the CO₂ emissions of diesel locomotives. These emissions range from 3–3.5kg per kilogram of fuel used. Taking the density of the diesel fuel as 900kg/m³ and 1 litre as 10⁻³m³ gives 1kg of diesel equivalent to 1.11 litres of diesel, allowing the CO₂ emission rates to be converted from units of fuel mass to units of fuel volume. The resulting diesel locomotive CO₂ emission rates are therefore somewhere between 2.70 and 3.15kg/l. Consequently, the average CO₂ emission rate for diesel locomotives was taken to be 2.925kg of CO₂ released per litre of burnt fuel.

6.4.2 Representative steady state speeds

Speed profiles for the Lower Hutt to Tauranga and Picton to Christchurch freight train journeys were generated from the GPS readings recorded during the journeys. From these speed profiles, it was determined that the freight train reached steady state speeds of 72–83km/h during the Lower Hutt to Tauranga journey, and 65–83km/h for the Picton to Christchurch journey. Therefore, a maximum operational speed of 80km/h was assumed.

6.4.3 Representative fuel consumption for DX and DC class diesel locomotives

No data on the fuel consumption rates of New Zealand diesel locomotives could be found. Accordingly, the following information was obtained from the US Department of Transportation – Bureau of Transportation Statistics (2006). According to this data, the average distance travelled by a train per US gallon of fuel is 0.13 miles. This number is consistent for the period 1960–2006, fluctuating within a range of between 0.11 and 0.14 miles. The average fuel consumption for a train is therefore 7.69 (1/0.13) US gallons per mile. Using the conversion 1 US gallon per mile equating to 2.352l/km resulted in a rail-mode fuel consumption figure of 18.09 litres of diesel fuel per kilometre travelled.

This US fuel consumption data included operation in the idle notch. For mainline locomotives in the US and Canada, a locomotive is typically in the idle notch for approximately 40–60% of the time. However, for this project it was considered more appropriate to investigate the fuel consumption of a loaded locomotive at close to maximum operational speed, taken to be 80km/h.

Data on fuel consumption was obtained from General Electric and General Motors locomotive engine specifications. The engines considered had a rated power in the range of 1230–2050kW. From the specifications, the fuel consumption at full load for engines of this size was estimated to be 340 litres of diesel fuel per hour. Therefore, at a speed of 80km/h, the calculated fuel consumption rate was 4.25l/km. This maximum fuel consumption rate has been utilised throughout this report.

The fuel consumption rate of 4.25l/km was independently verified by using data presented in the US Federal Railroad Administration report titled: *Final report: comparative evaluation of rail and truck fuel efficiency on competitive corridors, 19 November 2009* (ICF 2009). With reference to table 6.3, the average fuel consumption was calculated for two different diesel locomotive types (D9-C40/SD70 and C44-9) and 23 different routes ranging in length from 214km (133 miles) to 3592km (2232 miles). The measured fuel consumption rates ranged between 3.5 and 7 l/km, averaging at 4.7l/km if a 50% idle time was assumed.

The agreement with the calculated fuel consumption rate of 4.25l/km was therefore reasonable since, relative to US conditions, the loading and the number of carriages were likely to be less for New Zealand locomotives, resulting in lower fuel consumption.

Figure 6.2 Mainline container train hauled by DX locomotive



Table 6.3 Measured freight train fuel consumption from ICF (2009)

Trip no.	Travelled distance (miles)	Locomotive type	Engine HP	Locomotive number per train	Fuel consumption				
					Trip total (US gal)	US gal/mile ^a	US gal/mile/loco	l/km	l/km minus 50% idle
1	280	D9-C40/SD70	4000	2	3315	11.8	5.9	13.9	7.0
2	294	D9-C40/SD70	4000	2	2166	7.4	3.7	8.7	4.3
3	133	D9-C40/SD70	4000	2	1217	9.2	4.6	10.8	5.4
4	1083	D9-C40/SD70	4000	2	10,255	9.5	4.7	11.1	5.6
5	242	D9-C40/SD70	4000	2	2653	11.0	5.5	12.9	6.4
6	790	D9-C40/SD70	4000	2	5844	7.4	3.7	8.7	4.3
7	790	D9-C40/SD70	4000	2	7469	9.5	4.7	11.1	5.6
8	352	D9-C40/SD70	4000	2	2591	7.4	3.7	8.7	4.3
9	352	D9-C40/SD70	4000	2	3183	9.0	4.5	10.6	5.3
10	367	D9-C40/SD70	4000	1	1729	4.7	4.7	11.1	5.5
11	561	D9-C40/SD70	4000	1	2627	4.7	4.7	11.1	5.5
12	910	D9-C40/SD70	4000	2	9063	10.0	5.0	11.7	5.9
13	450	D9-C40/SD70	4000	2	3249	7.2	3.6	8.5	4.2
14	673	C44-9	4380	3	7729	11.5	3.8	9.0	4.5
15	1415	C44-9	4380	4	17,576	12.4	3.1	7.3	3.7
16	2232	C44-9	4380	4	28,675	12.8	3.2	7.6	3.8
17	445	C44-9	4380	2	3512	7.9	3.9	9.3	4.6
18	1805	C44-9	4380	3	21,000	11.6	3.9	9.1	4.6
19	2090	C44-9	4380	3	18,785	9.0	3.0	7.0	3.5
20	1034	C44-9	4380	2	6974	6.7	3.4	7.9	4.0
21	2150	C44-9	4380	3	20,977	9.8	3.3	7.6	3.8
22	1484	C44-9	4380	2	9058	6.1	3.1	7.2	3.6
23	1788	C44-9	4380	4	21,590	12.1	3.0	7.1	3.6
Average fuel consumption per locomotive (l/km):									4.7

a) 1 US gallon/mile = 2.352l/km

6.4.4 Estimated CO₂ emission rate for monitored journeys

The fuel consumption rate of 4.25l/km was used to derive various CO₂ emission rates for the whole journey from Picton to Christchurch, as this involved only diesel locomotives. With reference to table 6.4 following, the CO₂ emission rates are in terms of total train and also per container. To present the CO₂ emission data in terms of kilometres per container, the assumption was made that the freight trains typically hauled 20 wagons with two 20ft containers per wagon, ie 40 containers per train on average (refer to figure 6.2).

Table 6.4 Mainline locomotive fuel consumption and CO₂ emissions

Locomotive class	Fuel consumption (l/km)	CO ₂ emissions (kg/l)	Total train CO ₂ emissions (kg/km)	CO ₂ emissions (kg/km/container)
DX & DC	4.25	2.925	12.43	0.311

In reality, the number of wagons per train can vary along the routes from Wellington to Tauranga and from Wellington to Christchurch, and two or more locomotives instead of one can be used on sections with difficult topography.

Given the issues discussed above and associated uncertainties in calculating rail mode CO₂ emission rates, the values tabulated in table 6.4 were considered to be reasonable estimates and suitable for comparison with the corresponding CO₂ emission rates calculated for road and maritime modes presented in sections 6.3 and 6.5 respectively.

6.5 Coastal shipping

All emission data presented below was extracted from public domain reference sources and were average numbers for various coastal cargo vessel categories. Some recalculation was required to express the data in units that facilitated comparison with the emission rates obtained for the road and rail modes.

The instrumented container used in this research was delivered to the port of Lyttelton by the Roll-on-Roll-off (Ro-Ro) cargo-type vessel ‘Spirit of Competition’ operated by Pacifica Shipping (1985) Ltd, shown in figure 6.3.

Figure 6.3 The ‘Spirit of Competition’ (Source: www.pacship.co.nz)



The fuel consumption data and capacity of the ship were obtained from the vessel specification. The fuel consumption is shown in table 6.5 below. The total fuel consumption for the whole trip was 14.84 tonnes of heavy fuel oil. The vessel freight capacity is 550 containers. The running time of 13 hours from Wellington to Lyttelton was provided by the Pacifica Shipping company.

CO₂ emission rates were obtained from the US EPA publication *Analysis of commercial marine vessels emissions and fuel consumption data* (EPA 2000). This report combined four studies undertaken by the British Columbia Ferry Corporation, Environment Canada, Lloyd's and the US Coast Guard. Measurements of emission rates of several air contaminants, including CO₂, were carried out for different types of vessels, including the Ro-Ro type. Main vessel engines were tested in three different operational modes and for different engine loads. The CO₂ emission rate shown in table 6.5 is for 85% engine load.

Table 6.5 Total per trip fuel consumption and CO₂ emission rate for a coastal cargo vessel

Trip	Fuel consumption (tonne/24h)	Total fuel consumption per trip (tonne fuel)	CO ₂ emission rate (g/kW-h)	CO ₂ emission rate (kg/tonne fuel)	Total CO ₂ emissions (kg/per trip)
Wellington-Lyttelton (Ro-Ro cargo vessel)	27.4 ^a	14.84	660	3250	48,230

a) Ro-Ro cargo vessel specification data

The total CO₂ emissions value of 48,320kg for the Wellington-Lyttelton trip, a distance of 320km, was manipulated to yield emission values in terms of kilograms per kilometre, and kilograms per kilometre per container, to facilitate direct comparison with the other two transport modes. These values are tabulated in table 6.6.

Table 6.6 Maritime mode fuel consumption and CO₂ emission rates

Trip	Total CO ₂ emissions (kg/per trip)	CO ₂ emission rate (kg/km)	CO ₂ emission rate (kg/km per container)
Wellington-Lyttelton (Ro-Ro cargo vessel)	48,230	150.719	0.274

6.6 Comparative evaluation of transport modes

Fuel consumption and emission rates for each transport mode are summarised below in table 6.7. In this table the fuel consumption and the CO₂ emission rates are in terms of kilometre travelled either by the vehicle or by one container, in order to facilitate direct comparisons between the three modes.

Table 6.7 Fuel consumption and CO₂ emission rates for different transport modes

Transport mode	Fuel consumption (l/km)		CO ₂ emission rate (kg/km)	
	Per vehicle	Per container	Per vehicle	Per container
Road	0.193	0.193	0.509	0.509
Rail				
(40 containers/train)	4.250	0.106	12.431	0.311
(25 containers/train)		0.170		0.497
Maritime (ie coastal shipping)				
(550 containers/vessel)	51.476	0.094	150.719	0.274
(297 containers/vessel)		0.173		0.507

Fuel consumption and CO₂ emission rates for the rail mode were estimated for 40 and 25 containers per train. The upper value of 40 containers was selected because the current operator of New Zealand's rail network specifies that the maximum number of wagons allowed per train is 20 (ie 2x20 = 40 20ft

containers). The lower value of 25 containers was selected because this is the number of containers required to generate the same amount of CO₂ emissions per container per kilometre travelled as the road mode. This illustrates that the rail mode is estimated to be more environmentally friendly in terms of CO₂ emissions than the road mode whenever a DX/DC class locomotive transports more than 25 20ft containers.

As recorded in table 6.7, the fuel use and CO₂ emission rate for the maritime mode was estimated for two different vessel-loading regimes:

- 550 containers (the assumed maximum load for the cargo vessel delivering containers from Wellington to the Port of Lyttelton)
- 297 containers (the load required to give a CO₂ emission rate per container per kilometre travelled that is equivalent to that of the road transport mode).

6.7 Concluding remarks

The assessment of transport efficiency in terms of fuel consumption and CO₂ emissions indicated the following:

- The main factor determining the efficiency of the rail transport mode is the number of wagons/containers hauled by the train.
- A secondary factor determining the efficiency of the rail transport mode is the type of locomotive and the number of locomotives per train. (The fuel consumption and CO₂ emission rates tabulated in table 6.7 were calculated for one locomotive only. In practice, two locomotives can be used for freight trains and so fuel consumption and CO₂ emission rates can be changed significantly.)
- To have equivalency with the road mode in terms of fuel consumption and CO₂ emissions per kilometre a container is transported, the rail mode has to transport at least 25 containers per train and the maritime mode at least 297 containers per vessel.
- When considering the maximum number of containers that can be transported by each transport mode (ie 550 for coastal shipping, 40 for rail, and 1 for road), the maritime mode is shown to be slightly more efficient in terms of fuel consumption and CO₂ emissions than the rail mode, and markedly better than the road mode. In fact, both maritime and rail modes are about twice as efficient as the road mode.

Note: It must be remembered that this comparison is only applicable to the specific conditions for this research project. Factors such as topography, trip distances, cargo vessel/train capacities, freight vehicle fuel consumption and the vessel/train loading may alter the relative efficiency ranking of the various modes for other journeys.

7 Costs

In the article *Government cash revives ferry plan*, which appeared in the *Taranaki Daily News* on 6 May 2009, it was reported that the Port of Taranaki's business development manager, Jon Hacon, had said 'statistics from the United States showed that for every dollar it cost to carry a tonne of freight a kilometre by sea, it cost \$4 by rail and \$10 by road. In Europe, the equivalent ratio was \$1, \$3 and \$6'. Therefore there was an expectation that there would be a significant price difference between the three transport modes investigated, with the maritime mode costing the least, followed by rail, then followed by road.

The costs of the various 20ft instrumented container freight journeys undertaken for this research are transcribed from table 3.1 into table 7.1 for ready reference.

Table 7.1 Journey costs

Journey details	Transport mode	Date of journey	One-way journey distance (km)	Cost (excl GST)	
				Total	Per km
Lower Hutt to Lyttelton Port (near Christchurch) return	Coastal shipping	Nov 2006	400	\$2861	\$3.57
	Rail	Nov 2006	440 ^a	\$2844	\$3.23
	Road	Oct 2006	436 ^a	\$5180	\$5.94
Lower Hutt to Tauranga return	Rail	July 2006	639	\$3050	\$2.39
	Road	July 2006	532	\$2765	\$2.60

a) Distance includes crossing of Cook Strait, assumed to be 92km.

It should be remembered that the costs in table 7.1 are specific prices charged for particular dates of travel by particular freighters and so they should not be used to make generalisations on the relative costs of container freighting by the various modes. However, the following two points stand out with reference to the cost data presented in table 7.1:

- The significant cost differences between the various transport modes seen in the US and Europe were not observed in New Zealand, possibly because of the much shorter freight distances involved.
- The cost of transporting goods by road from Wellington to Christchurch was very high compared with the other two transport modes. This is attributed to the disproportionate cost of the 92km crossing of Cook Strait by roll-on roll-off ferry.

These two points were investigated further by obtaining up-to-date (2012) quotes from logistics providers for shipping a 20ft container from Auckland to Dunedin (a distance of approximately 1421km) and from Wellington to Christchurch (a distance of approximately 436km), with both journeys requiring a ferry crossing of the Cook Strait for rail and road modes.

As well as seeing what effect a three-fold increase in journey distance would have on cost differentials between the three transport modes, comparing 2006 costs with 2012 costs for the Wellington-Christchurch journey allowed us to evaluate the effects of two significant factors:

- rail returning to state ownership in 2008
- the introduction of the MV Straitsman in December 2010, giving Strait Shipping two ferries to compete with the three road-and-rail ferries operated by the Interislander (owned and operated by state-owned rail operator KiwiRail), thus allowing a more competitive ferry service across Cook Strait.

KiwiRail was formed in 2008 when the Crown purchased the rail and ferry operations from Toll NZ Ltd, and the mechanical services operations from United Group in 2009, to combine with the Crown-owned rail network ONTRACK. The outcome was a vertically integrated, state-owned rail and ferry business, similar to the one that was in place in the early 1990s.

KiwiRail has since developed a strategic plan (Turnaround Plan – TAP) with the objective to build, over 10 years, a business able to meet its long-run investment requirements, following an initial investment period from the Crown. This prioritised investment plan includes upgrading the network, rolling stock, plant, equipment, facilities and systems. The 2011 financial year was the first full year of implementing the TAP.

The 2012 costs are tabulated in table 7.2, which also provides costs provided by Interislander and Strait Shipping for shipping a 20ft container on a 16m-long semi-trailer across Cook Strait.

Table 7.2 2012 journey costs

Journey details	Transport mode	One-way journey distance (km)	Date of quote	One-way cost (excl GST)	
				Total	Per km
Auckland–Dunedin	Coastal shipping	1520	Mar 2012	\$1400.00	\$0.92
	Rail	1489 ^a	Mar 2012	\$2373.55	\$1.59
	Road	1421 ^a	Jun 2012	\$3877.00	\$2.73
Wellington–Christchurch	Rail	440 ^a	Mar 2012	\$1234.83	\$2.81
	Road	436 ^a	Jun 2012	\$1666.35	\$3.82
Wellington–Picton	Interislander	92	Jun 2012	\$1424.80 (light load) \$1892.16 (heavy load)	\$15.49 \$20.57
	Strait Shipping			\$1523.11	\$16.56

a) Distance includes crossing of Cook Strait, assumed to be 92km.

When considering the cost data presented in tables 7.1 and 7.2, it should be borne in mind that any relative cost comparison of the three freight modes considered may change with time and will depend at least on fuel price, the degree to which the particular carriers are fully laden with containers, and the relative costs imposed by authorities for use of the road network compared with the rail network and ports. Nevertheless, the following key points can be noted from table 7.2:

- As the journey distance increased, the cost difference between maritime, rail and road modes increased.
- For the approximately 1500km journey from Auckland to Dunedin, the ratio of costs in transporting a 20ft container was 1 (sea):1.7 (rail):2.8 (road). Although these ratios were lower than those for Europe and the US, they highlighted that over long distances, coastal shipping and rail are a more cost-effective way of transporting goods around New Zealand than road.
- Between 2006 and 2012, the costs of transporting a 20ft container from Wellington to Christchurch by rail and road modes dropped by 13% and 36% respectively, highlighting efficiency gains and increased competition in the freight transport sector.
- Pacifica Shipping (1985) Ltd was no longer offering a shipping service between Wellington and Lyttelton Port of Christchurch (the reason given was that it was no longer economic to do so).
- The ferry service across Cook Strait imposed a disproportionate cost to transporting a container by road – about six times more than normally paid for moving freight by road.

8 Discussion

Two findings from the research that merit further discussion are the higher-than-expected maximum container acceleration levels for the road transport mode, and the relationship between the characteristics of the transport-induced vibrations and commodity damage.

8.1 Road-induced container vibrations

The NZ Transport Agency (NZTA) uses the International Roughness Index (IRI) numeric as a measure of ride quality and to determine when road-smoothing treatment is required. It is reported over 20m and 100m intervals. However, the measured container acceleration levels presented in section 5 for the Lower Hutt-Tauranga and Lower Hutt-Christchurch return journeys suggests that the IRI numeric may not be identifying road sections that promote excessive body movement in the tractor semi-trailers used for transporting containers. This is because the quarter-car model used for calculating IRI has resonances at wavelengths of 2.3m and 16m (approximately 1.4 and 9.7Hz at 80km/h), and the latter is not typical of large trucks (Cenek et al 2000). At the legal speed limit, large trucks are excited by a road surface profile wavelength around 2.5m and 11m, with the longer wavelengths usually dominating body/tray movement.

The IRI numeric correlates primarily to vertical accelerations. However, in this study we found that the measured maximum longitudinal and transverse accelerations were a factor of three and six times greater than the expected maximum acceleration levels, respectively. This result suggests that existing procedures for assessing ride quality of state highways do not take sufficient account of surface profile features that promote body roll and body pitch. This is viewed as an important issue, particularly since 87% of land-based freight is moved by road and government studies forecast that the amount of freight being transported in New Zealand will double by 2025.

It is therefore recommended that the NZTA consider supplementing the quarter-car-based IRI numeric with more freight-focused numerics. Possible options include:

- analysing the road profile data used for generating the IRI numeric with a half-tractor semi-trailer computer model, such as the one proposed by Todd and Kulakowski (1989), so that body roll and pitch effects can be assessed
- adopting the central difference method (CDM) bump measure – as defined by Benbow et al (2006) and incorporated in traffic speed condition surveys conducted in the UK (ie TRACS surveys on the trunk road network and SCANNER surveys on local roads) to identify very localised surface corrugations, which cause high vertical body/tray accelerations.

The CDM bump measure is being collected as part of the NZTA's annual condition survey of the state highway and stored in the Road Assessment and Maintenance Management (RAMM) database for a trial period, to establish its usefulness in managing state highways. Therefore, it would be a relatively straightforward exercise to check whether the locations of high vertical accelerations as shown in figures 5.6 and 5.8 coincide with high values of CDM bump measure.

8.2 In-transit damage

US-based research has established that in-transit damage of commodities is not only dependent on the magnitude of the vibrations but also the vibrational frequencies. In particular, the majority of damage occurs in a very narrow range around the critical or resonant frequency of the commodity being shipped.

Resonance occurs when the vibrations induced from the road are at the same frequency as the natural frequency of the load. At the resonant frequency, the vibrations are magnified and the vertical movement of load also increases.

As an example, the critical frequencies for inducing the majority of damage to grapes and strawberries during shipment were found to be between 7.5Hz and 10Hz (Fischer et al 1990). This suggests that the amount of in-transit vibration damage could be greatly reduced if the transport mode selected reduces or damps out vibrations over this very narrow frequency range.

Therefore, a worthwhile exercise would be to establish critical acceleration levels and frequency ranges for broad commodity groups. This would allow guidance to be given as to the most appropriate transport mode for a particular commodity group to minimise in-transit damage. Furthermore, if the relative damage (perhaps in dollar value) of differing acceleration levels could be determined for the dominant frequencies of each of the three transport modes, it would be possible to compare the dollar value of in-transit damage between the modes for the various commodity groups investigated. For instance, the impact of a vertical acceleration of 10m/s^2 (ie acceleration due to gravity) may be insignificant for forestry products, but it could be significant for fruit.

9 Conclusions

Within the scope and limitations of the project, the following principal conclusions resulted from monitoring an instrumented 20ft container as it was transported over two different routes by three different transport modes: road, rail and coastal shipping.

9.1 Instrumentation of container

The research demonstrated that it was possible to reliably track the location of a shipping container and monitor associated accelerations in the three orthogonal directions for a period of up to 10 days using off-the-shelf componentry.

9.2 Journey duration

For a given transport mode in this study, there was considerable variation in the time spent stationary along the route or between transfers (eg at a rail depot or port).

9.3 Impact loading

- When compared with service conditions suggested by the ABS, analysis of the acceleration traces showed that under typical New Zealand service conditions, transverse accelerations were significantly greater than those expected across all transport modes, and longitudinal accelerations were significantly greater than those expected for both maritime and road modes. However, peak longitudinal accelerations measured for the rail mode were less than the expected 2.0g, suggesting sound practices are being employed in shunting operations.
- The maximum magnitude of the measured container accelerations was 2.2g, which was 10% greater than the 2g expected. This maximum acceleration level was recorded for the road transport mode, although 2g acceleration levels were measured for both the rail and maritime modes.
- For a particular acceleration level, there were generally more instances in the vertical direction than in the two translational directions.
- For the rail and road modes, large-magnitude vertical accelerations occurred over very short durations (ie less than a second) and not at a particular frequency. In contrast, the vertical acceleration levels for the maritime mode were considerably lower, with the peak values occurring periodically at a regular interval of about 5 seconds, corresponding to a frequency of vibration of 0.2Hz. This is likely to be associated with the motion of the ship, as swells cause random, very low-frequency vibration (less than 2Hz) of the whole ship, both longitudinally (pitching) and transversely (rolling).
- It was also shown that the likelihood of potential damage to goods from impact loading is less where the transport mode is maritime, followed by road and lastly rail. For example, the percentages of time for which the vertical acceleration levels exceeded 2m/s^2 were in the approximate ratio of 5.0 (rail): 2.0 (road):1.0 (maritime). These ratios changed to 60 (rail):4 (road):1 (ship) if the vertical acceleration levels exceeded increases to 5m/s^2 (ie half the acceleration due to gravity - 0.5g) and to 28 (rail): 1.2 (road):1 (maritime) if the vertical acceleration levels exceeded increases to 10m/s^2 (ie 1g, where the resulting force is sufficient to lift the container off the ground). This result supports the current practice of mainly using rail to transport bulk goods, such as coal and forestry products, because high dynamic loading is less problematic for such goods. It also indicates that as the accelerations get

more severe, the differences between road and maritime modes become less. When considering damage to goods, it is the severe accelerations that are of most importance.

- The high incidence of impact loading in the rail mode reflects an ageing transport network that hasn't received adequate infrastructure investment, with 200km of the 4000km network (ie 5%) approaching the end of its predicted life.

9.4 CO₂ emissions and fuel use

The methodology adopted for assessing fuel consumption and CO₂ emissions was to divide the transport route of interest into short sections of about 20–50km in length on the basis of consistent topography, and to apply published fuel consumption corresponding to that topography. The CO₂ emissions were calculated directly from the fuel consumption values using the following relationships:

- 2.64kg of CO₂ emissions per litre of fuel consumed for road mode
- 2.93kg of CO₂ emissions per litre of fuel consumed for rail and maritime modes

The assessment of transport mode efficiency in terms of fuel consumption and CO₂ emissions showed the following:

- The main factor determining the efficiency of the rail transport mode is the number of wagons/containers hauled by the train.
- A secondary factor determining the efficiency of the rail transport mode is the type of locomotive and the number of locomotives per train.
- To have equivalency with the road mode in terms of fuel consumption and CO₂ emissions per kilometre a container is transported, the rail mode has to transport at least 25 containers per train and the maritime mode at least 297 containers per vessel.
- When considering the maximum number of containers that can be transported by each transport mode (ie 550 for coastal shipping, 40 for rail, and 1 for road), the maritime mode is slightly more efficient in terms of fuel consumption and CO₂ emissions than the rail mode, and markedly better than the road mode. In fact, both maritime and rail modes are about twice as efficient as the road mode.

9.5 Costs

- As the journey distance increased, the cost difference between maritime, rail and road modes was shown to increase.
- For the approximately 1500km journey from Auckland to Dunedin, the ratio of costs in transporting a 20ft container was 1 (sea):1.7 (rail):2.8 (road). Although these ratios were lower than for Europe and the US, they highlighted that over long distances, coastal shipping and rail are a more cost-effective way of transporting goods around New Zealand than road.
- The disproportionate cost of the ferry service across Cook Strait significantly impacted on the economics of transporting containers between North and South Island destinations by road. On current (2012) prices, the road–ferry service costs between \$15.49 and \$20.57 per km (excluding GST), whereas the typical cost of freight transport is \$2.50 per km (excluding GST).

- Between 2006 and 2012, the costs of transporting a 20ft container from Wellington to Christchurch by rail and road modes has declined by 13% and 36% respectively, highlighting efficiency gains and increased competition in the freight transport sector.

10 Recommendations

The key recommendations arising from the research are as follows:

- The use of an instrumented container has been shown to be a low-cost and effective way of assessing the state of New Zealand's main modes of freight transport, particularly with respect to journey times and impact loading. It is therefore recommended that this exercise be performed at periodic intervals to gauge the impact of market forces and central and local government policies, especially in relation to maintenance management practices adopted on the road and rail networks.
- The highest container-impact forces often result from transfers. Accordingly, it is recommended that trials of transferring an instrumented 20ft container be carried out with a view to analysing the resulting impact forces, so that improvements can be made to the transfer technique with the aim of reducing the impact forces as much as possible. Just a handful of transfers may be required before the personnel responsible for transferring containers arrive at an improved technique that reduces impact forces. Freight journeys wouldn't be required for this study – just repeated transfers.
- The measured maximum longitudinal and transverse accelerations in this study were a factor of three and six times greater than the expected maximum acceleration levels, respectively. This result suggests that existing procedures for assessing ride quality of state highways do not take sufficient account of surface profile features that promote body roll and body pitch in the semi-trailers used to transport containers. It is therefore recommended that the NZTA consider supplementing the quarter-car-based IRI numeric with more freight-focused numerics. Possible options include:
 - analysing the road profile data used for generating the IRI numeric with a half-tractor semi-trailer computer model, so that body roll and pitch effects can be assessed
 - adopting a measure that identifies very localised surface corrugations, which cause high vertical body/tray accelerations, such as the central difference method (CDM) bump measure as incorporated in traffic speed condition surveys conducted in the UK (ie TRACS surveys on the trunk road network and SCANNER surveys on local roads).

It should be noted that, typically, a significant acceleration event occurs every 2km, and such events contribute to the fatigue of drawbars, drawbeams and chassis of heavy commercial vehicles.

- A worthwhile exercise would be to establish critical acceleration levels and frequency ranges for broad commodity groups. This would allow guidance to be given as to the most appropriate transport mode for a particular commodity group to minimise in-transit damage. Furthermore, if the relative damage (perhaps in dollar value) of differing acceleration levels can be determined for the dominant frequencies of each of the three transport modes, it will be possible to compare the dollar value of in-transit damage between the modes for the various commodity groups investigated.
- Of the three transport modes investigated, coastal shipping appears to be a very cost-efficient and environmentally acceptable means of transporting containerised freight between the North and South Islands. It is therefore recommended that more consideration be given to better integrating the various transport modes so that the total amount of domestic freight moved by coastal shipping is increased from the current 15%.

11 Bibliography

- American Bureau of Shipping (ABS) (1998) *Rules for certification of cargo containers*. New York: American Bureau of Shipping.
- Barth, MJ and R Tadi (1995) *An automobile/transit emissions evaluation of Southern California's Metrolink*. Berkley, California: University of California Transportation Center.
- Benbow, E, K Nesnas, and A Wright (2006) Shape (surface form) of local roads, version 2. *TRL Published Project Report 131*. 99pp.
- Brennand, T and W Walbran (2004) Case studies of two alternatives to roading projects. *Towards Sustainable Land Transport Conference*, 22–24 Nov 2004, Wellington.
- Cenek, PD, S Fong and MW McLarin (2000) Wavelength analysis of state highway longitudinal profiles. *Transfund New Zealand research report 153*. 47pp.
- Easton, BH and P Marks (1983) By rail or road: a case study. *New Zealand Institute of Economic Research paper 27*. 105pp.
- Swedish Standards Institute (SIS) (1993) Automotive fuels – diesel – requirements and test methods. *EN590:1993*. Stockholm: Swedish Standards Institute.
- Fischer, D, W Craig and BH Ashby (1990) Reducing transportation damage to grapes and strawberries. *Journal of Food Distribution Research* 21, no.1: 193–202. Accessed 20 June 2012.
www.personal.psu.edu/faculty/r/2/r2w/AGBM420/a-Readings/W4-7%20Spatial%20Readings-JustForFun/Example-transportdamageGrapes.pdf
- ICF International (2009) *Federal railroad administration final report: comparative evaluation of rail and truck fuel efficiency on competitive corridors*. Accessed 14 June 2012.
www.fra.dot.gov/Downloads/Comparative_Evaluation_Rail_Truck_Fuel_Efficiency.pdf
- Ministry of Transport (MoT) (1998) *Vehicle fleet emissions model (VFEM)*. Wellington: Ministry of Transport.
- Ministry of Transport (MoT) (1999) *Impacts of rail transport on local air quality*. Wellington: Ministry of Transport.
- Ministry of Transport (MoT) (2005) *Surface transport costs and charges*. Main report, p184. Prepared by Booz Allen Hamilton with Institute for Transport Studies, University of Leeds and associated consultants. Accessed 20 June 2012.
www.beehive.govt.nz/Documents/Files/STCCS%20Main%20Report.pdf
- Norwegian Centre for Maritime Medicine (NCMM) (2012) *Textbook of maritime medicine*. Accessed 12 July 2012. <http://textbook.ncmm.no/>
- Moschovou, TP and GA Giannopoulos (2010) Investigation of inland freight transport modal choice in Greece: parameters and attributes influencing freight mode choice. *Transportation Research Record: Journal* 2168: 43–52.
- NIWA (2001) *Inventory of greenhouse gas emissions*. <http://niwascience.co.nz/ncces/ghge/transport>
- Statistics New Zealand (2008) *2008 Yearbook*. Accessed 20 June 2012.
www.stats.govt.nz/yearbooks
- Todd, KB and BT Kulakoski (1989) Simple computer models for predicting ride quality and pavement loading for heavy trucks. *Transportation Research Record* 1215: 137–150.

Turnbull, SR and D Dawson (1997) The securing of rigid semi-trailers on roll-on/roll-off ships.
International Journal of Mechanical Sciences 39, no.1: 1-14.

US Department of Transportation – Bureau of Transportation Statistics (2006) *National Transportation Statistics*. www.bts.gov/publications/national_transportation_statistics/2006/

US Environmental Protection Agency (EPA) (2000) Analysis of commercial marine vessels emissions and fuel consumption data. *EPA420-R-00-002*. 158pp.

World Bank (1996) *Sustainable transport: priorities for policy reform*. Washington, DC: World Bank. 131pp.

Appendix Journey summaries

The following tables summarise some of the details of each journey, including the maximum and minimum acceleration levels and the time spent moving or stationary.

Table A.1 Journey summary – Lower Hutt to Tauranga, by road

Elapsed hours	Description	Mode	Duration	Maximum vertical acceleration (m/s ²)	Minimum vertical acceleration (m/s ²)
0.0	Stationary in Central Laboratories	Stationary	6.0	1.6	-1.3
6.0	Central Laboratories to Taupo	Truck travel	6.9	6.7	-9.4
12.9	Stationary in Taupo	Stationary	0.9	2.7	-3.1
13.8	Tauranga (local)	Truck travel	2.3	6.7	-9.4
16.1	Stationary in Tauranga	Stationary	25.6	6.0	-6.9

Table A.2 Journey summary – Tauranga to Lower Hutt, by road

Elapsed hours	Description	Mode	Duration	Maximum vertical acceleration (m/s ²)	Minimum vertical acceleration (m/s ²)
0.0	Stationary in Tauranga	Stationary	15.6	1.7	-0.1
15.6	Tauranga (local)	Truck travel	2.5	3.5	-0.4
18.1	Tauranga to Taupo	Truck travel	2.5	4.8	-5.3
20.6	Stationary in Taupo	Stationary	11.4	1.5	-1.4
31.9	Taupo to Waiouru	Truck travel	0.8	4.1	-5.6
32.8	Stationary in Waiouru	Stationary	0.7	1.5	-1.6
33.5	Waiouru to Sanson	Truck travel	2.8	7.8	-13.4
36.3	Stationary in Sanson	Stationary	0.7	2.1	-2.7
36.9	Sanson to Lower Hutt	Truck travel	2.5	4.4	-5.1
39.4	Stationary in Lower Hutt	Stationary	1.9	2.8	-4.0
41.4	Lower Hutt to Central Laboratories	Truck travel	0.8	4.2	-6.9

Table A.3 Journey summary – Lower Hutt to Tauranga, by rail

Elapsed hours	Description	Mode	Duration	Maximum vertical acceleration (m/s ²)	Minimum vertical acceleration (m/s ²)
0.0	Stationary in Central Laboratories	Stationary	3.2	1.6	-1.4
3.2	Central Laboratories to Wellington	Truck travel	0.9	5.2	-9.9
4.1	Wellington	Transfer truck to train	2.5	4.6	-5.6
6.6	Wellington to Palmerston North	Train travel	2.7	9.4	-11.9
9.3	Palmerston North (local)	Railyard shunt	2.5	5.4	-5.2
11.8	Palmerston North to Hamilton	Train travel	8.4	14.7	-12.6
20.1	Hamilton (local)	Railyard shunt	10.5	5.2	-7.1
30.6	Hamilton to Tauranga	Train travel	3.1	13.1	-12.9

Table A.4 Journey summary – Tauranga to Lower Hutt, by rail

Elapsed hours	Description	Mode	Duration	Maximum vertical acceleration (m/s ²)	Minimum vertical acceleration (m/s ²)
0.0	Stationary in Tauranga	Stationary	3.6	4.9	-8.8
3.6	Tauranga to Morrinsville	Train travel	1.8	18.0	-10.9
5.4	Stationary in Morrinsville	Stationary	0.4	1.5	-1.6
5.9	Morrinsville to Hamilton	Train travel	0.7	8.9	-11.5
6.6	Hamilton (local)	Railyard shunt	4.4	8.9	-8.8
11.0	Hamilton to Ohakune	Train travel	4.9	20.4	-13.6
15.9	Stationary in Ohakune	Stationary	0.7	1.6	-1.1
16.6	Ohakune to Marton	Train travel	2.6	20.4	-13.9
19.2	Stationary in Marton	Stationary	0.3	2.8	-3.6
19.4	Marton to Halcombe	Train travel	0.3	18.3	-13.7
19.7	Stationary in Halcombe	Stationary	0.1	1.5	-1.3
19.8	Halcombe to Palmerston North	Train travel	0.6	18.7	-11.8
20.4	Palmerston North (local)	Railyard shunt	2.5	5.2	-4.8
22.9	Palmerston North to Shannon	Train travel	0.6	18.5	-17.2
23.4	Stationary in Shannon	Stationary	0.2	1.6	-1.4
23.6	Shannon to Paraparaumu	Train travel	1.1	20.3	-13.1
24.7	Stationary in Paraparaumu	Stationary	0.3	1.6	-1.3
25.0	Paraparaumu to Paekakariki	Train travel	0.3	11.3	-9.7
25.3	Stationary in Paekakariki	Stationary	0.4	1.5	-1.3
25.8	Paekakariki to near Plimmerton	Train travel	0.8	10.0	-9.6
26.5	Near Plimmerton to Wellington	Train travel	0.6	8.5	-13.4
27.1	Wellington	Transfer train to truck	12.6	9.1	-13.6
39.7	Wellington to Central Laboratories	Truck travel	1.2	12.3	-13.6

Table A.5 Journey summary – Lower Hutt to Christchurch, by road

Elapsed hours	Description	Mode	Duration	Maximum vertical acceleration (m/s ²)	Minimum vertical acceleration (m/s ²)
0.0	Central Laboratories to Wellington	Truck travel	7.3	7.9	-11.1
7.3	Wellington to Picton	Ferry	4.6	2.3	-1.9
11.9	Picton to Blenheim	Truck travel	0.7	7.6	-7.0
12.6	Stationary in Blenheim	Stationary	1.5	3.2	-2.2
14.1	Blenheim to Christchurch	Truck travel	4.5	8.6	-12.2

Table A.6 Journey summary – Christchurch to Lower Hutt, by road

Elapsed hours	Description	Mode	Duration	Maximum vertical acceleration (m/s ²)	Minimum vertical acceleration (m/s ²)
0.0	Stationary in Christchurch	Stationary	50.0	3.8	-4.9
50.0	Christchurch to Picton	Truck travel	5.4	8.5	-12.6
55.4	Picton (local transfer)	Stationary	8.6	6.7	-6.1
64.1	Picton to Wellington	Ferry	4.0	1.9	-1.6
68.1	Wellington to Central Laboratories	Truck travel	0.6	6.2	-6.6

Table A.7 Journey summary – Lower Hutt to Christchurch, by rail

Elapsed hours	Description	Mode	Duration	Maximum vertical acceleration (m/s ²)	Minimum vertical acceleration (m/s ²)
0.0	Stationary in Central Laboratories	Stationary	2.4	1.6	-1.3
2.4	Central Laboratories to Wellington	Truck travel	0.5	8.1	-10.8
2.9	Wellington	Transfer truck to train	4.5	2.7	-2.5
6.6	Wellington	Transfer train to ferry	6.5	6.8	-8.5
13.9	Wellington to Picton	Ferry	3.3	2.3	-1.9
17.2	Picton (local transfer)	Transfer	6.9	4.5	-7.1
24.1	Picton to Blenheim	Train travel	0.6	8.5	-13.2
24.7	Blenheim to Spotswood (with stops)	Train travel	0.5	9.0	-12.9
25.2	Stationary in Spotswood	Stationary	6.8	1.6	-1.1
32.1	Spotswood to Christchurch	Train travel	2.8	11.0	-14.1
34.9	Christchurch (local)	Railyard shunt	13.7	6.3	-10.5

Table A.8 Journey summary – Christchurch to Lower Hutt, by rail

Elapsed hours	Description	Mode	Duration	Maximum vertical acceleration (m/s ²)	Minimum vertical acceleration (m/s ²)
0.0	Stationary in Christchurch	Stationary	12.2	1.5	-1.2
12.2	Christchurch to Waipara	Train travel	1.4	10.5	-16.3
13.5	Waipara to Picton (with stops)	Train travel	9.2	14.6	-15.4
22.7	Picton (local)	Transfer	9.3	5.4	-6.9
32.1	Picton to Wellington	Ferry	3.4	1.9	-1.8
35.5	Wellington	Transfer ferry to train	1.4	8.2	-7.5
36.9	Wellington	Transfer train to truck	69.1	6.6	-3.7
106.0	Wellington to Central Laboratories	Truck travel	0.9	9.0	-11.3

Table A.9 Journey summary – Lower Hutt to Lyttelton, Port of Christchurch, by sea

Elapsed hours	Description	Mode	Duration	Maximum vertical acceleration (m/s ²)	Minimum vertical acceleration (m/s ²)
0.0	Stationary in Central Laboratories	Stationary	4.4	1.5	-1.5
4.4	Central Laboratories to CentrePort	Truck travel	0.7	4.2	-4.8
5.1	CentrePort	Transfer truck to ship	7.2	4.0	-4.5
12.3	CentrePort to Lyttelton	Ship	12.4	2.5	-2.4
24.7	Stationary in Lyttelton	Stationary	3.7	9.2	-12.8

Table A.10 Journey summary – Lyttelton, Port of Christchurch to Lower Hutt, by sea

Elapsed hours	Description	Mode	Duration	Maximum vertical acceleration (m/s ²)	Minimum vertical acceleration (m/s ²)
0.0	Stationary in Lyttelton	Stationary	28.1	1.5	-1.5
28.1	Lyttelton (local transfer)	Transfer	0.4	9.5	-18.3
28.4	Lyttelton to CentrePort	Ship	17.5	2.8	-2.7
45.9	CentrePort (local transfer)	Transfer	0.3	12.7	-10.0
46.3	Stationary in CentrePort	Stationary	6.9	1.6	-1.7
53.1	CentrePort to Central Laboratories	Truck travel	0.9	10.3	-19.5