

National Cooperative Highway Research Program

**NCHRP** Synthesis 178

**Truck Escape Ramps**

A Synthesis of Highway Practice

TE  
7  
.N26  
no.  
178

Transportation Research Board  
National Research Council

## TRANSPORTATION RESEARCH BOARD EXECUTIVE COMMITTEE 1992

### *Officers*

#### Chairman

WILLIAM W. MILLAR, *Executive Director, Port Authority of Allegheny County*

#### Vice Chairman

A. RAY CHAMBERLAIN, *Executive Director, Colorado Department of Transportation*

#### Executive Director

THOMAS B. DEEN, *Transportation Research Board, National Research Council*

### *Ex Officio Members*

MIKE ACOTT, *President, National Asphalt Pavement Association*

GILBERT E. CARMICHAEL, *Administrator, Federal Railroad Administration, U.S. Department of Transportation*

BRIAN W. CLYMER, *Administrator, Federal Transit Administration, U.S. Department of Transportation*

JERRY R. CURRY, *Administrator, National Highway Traffic Safety Administration, U.S. Department of Transportation*

TRAVIS P. DUNGAN, *Administrator, Research and Special Programs Administration, U.S. Department of Transportation*

FRANCIS B. FRANCOIS, *Executive Director, American Association of State Highway and Transportation Officials*

THOMAS H. HANNA, *President and CEO, Motor Vehicle Manufacturers Association of the United States, Inc.*

BARRY L. HARRIS, *Acting Administrator, Federal Aviation Administration, U.S. Department of Transportation*

LT. GEN. HENRY J. HATCH, *Chief of Engineers and Commander, U.S. Army Corps of Engineers*

THOMAS D. LARSON, *Administrator, Federal Highway Administration, U.S. Department of Transportation*

WARREN G. LEBACK, *Administrator, Maritime Administration, U.S. Department of Transportation*

GEORGE H. WAY, JR., *Vice President, Research and Test Department, Association of American Railroads*

### *Members*

JAMES M. BEGGS, *Chairman, SPACEHAB, Inc. (former Administrator, National Aeronautics and Space Administration)*

KIRK BROWN, *Secretary, Illinois Department of Transportation*

DAVID BURWELL, *President, Rails-to-Trails Conservancy*

L.G. (GARY) BYRD, *Consultant, Alexandria, Virginia*

L. STANLEY CRANE, *former Chairman & CEO of CONRAIL*

RICHARD K. DAVIDSON, *Chairman and CEO, Union Pacific Railroad*

JAMES C. DeLONG, *Director of Aviation, Philadelphia International Airport*

JERRY L. DePOY, *Vice President, Properties and Facilities, USAir*

THOMAS J. HARRELSON, *Secretary, North Carolina Department of Transportation*

LESTER P. LAMM, *President, Highway Users Federation*

LILLIAN C. LIBURDI, *Director, Port Department, The Port Authority of New York and New Jersey*

ADOLF D. MAY, JR., *Professor and Vice Chair, Institute of Transportation Studies, University of California*

WAYNE MURI, *Chief Engineer, Missouri Highway and Transportation Department (Past Chairman, 1990)*

CHARLES P. O'LEARY, JR., *Commissioner, New Hampshire Department of Transportation*

NEIL PETERSON, *Executive Director, Los Angeles County Transportation Commission*

DELLA M. ROY, *Professor of Materials Science, Pennsylvania State University*

JOSEPH M. SUSSMAN, JR. *East Professor of Engineering, Massachusetts Institute of Technology*

JOHN R. TABB, *Director and CAO, Mississippi State Highway Department*

JAMES W. VAN LOBEN SELS, *Director, California Department of Transportation*

C. MICHAEL WALTON, *Paul D. and Betty Robertson MEEK Centennial Professor and Chairman, Civil Engineering Department,*

*University of Texas at Austin (Past Chairman, 1991)*

FRANKLIN E. WHITE, *Commissioner, New York State Department of Transportation*

JULIAN WOLPERT, *Henry G. Bryant Professor of Geography, Public Affairs and Urban Planning,*

*Woodrow Wilson School of Public and International Affairs, Princeton University*

ROBERT A. YOUNG III, *President, ABF Freight Systems, Inc.*

## NATIONAL COOPERATIVE HIGHWAY RESEARCH PROGRAM

### *Transportation Research Board Executive Committee Subcommittee for NCHRP*

WILLIAM W. MILLAR, *Port Authority of Allegheny (Chairman)*

A. RAY CHAMBERLAIN, *Colorado Department of Transportation*

FRANCIS B. FRANCOIS, *American Association of State Highway and*

*Transportation Officials*

THOMAS D. LARSON, *Federal Highway Administration*

### *Field of Special Projects*

#### *Project Committee SP 20-5*

VERDI ADAM, *Gulf Engineers & Consultants*

ROBERT N. BOTHMAN, *The HELP Program*

JACK FREIDENRICH, *The RBA Group*

JOHN J. HENRY, *Pennsylvania Transportation Institute*

BRYANT MATHER, *USAE Waterways Experiment Station*

THOMAS H. MAY, *Pennsylvania Dept. of Transportation*

EDWARD A. MUELLER, *Morales and Shumer Engineers, Inc.*

EARL SHIRLEY, *California Dept. of Transportation*

JON UNDERWOOD, *Texas Dept. of Transportation*

THOMAS WILLETT, *Federal Highway Administration*

RICHARD A. McCOMB, *Federal Highway Administration (Liaison)*

ROBERT E. SPICHER, *Transportation Research Board (Liaison)*

C. MICHAEL WALTON, *University of Texas at Austin*

THOMAS B. DEEN, *Transportation Research Board*

L. GARY BYRD, *Consulting Engineer, Alexandria, Virginia*

### *Program Staff*

ROBERT J. REILLY, *Director, Cooperative Research Programs*

LOUIS M. MACGREGOR, *Program Officer*

DANIEL W. DEARASAUGH, JR., *Senior Program Officer*

IAN M. FRIEDLAND, *Senior Program Officer*

CRAWFORD F. JENCKS, *Senior Program Officer*

KENNETH S. OPIELA, *Senior Program Officer*

DAN A. ROSEN, *Senior Program Officer*

EILEEN P. DELANEY, *Editor*

### *TRB Staff for NCHRP Project 20-5*

ROBERT E. SKINNER, JR., *Director for Special Projects*

SALLY D. LIFF, *Senior Program Officer*

SCOTT A. SABOL, *Program Officer*

LINDA S. MASON, *Editor*

CHERYL KEITH, *Secretary*

26558471

National Cooperative Highway Research Program

# Synthesis of Highway Practice 178

## Truck Escape Ramps

**DAVID K. WITHEFORD**  
Reston, Virginia

*Topic Panel*

WILEY D. CUNAGIN, *Texas Transportation Institute, College Station, TX*

WILLIAM A. PROSSER, *Federal Highway Administration, Washington, D.C.*

LARRY A. SCOFIELD, *Arizona Transportation Research Center, Phoenix, AZ*

JUSTIN G. TRUE, *Federal Highway Administration, McLean, VA*

EDWARD J. TYE, *Eugene, OR*

JAMES C. WAMBOLD, *Pennsylvania Transportation Institute, University Park, PA*

Research Sponsored by the American Association of State  
Highway and Transportation Officials in Cooperation with the  
Federal Highway Administration

**TRANSPORTATION RESEARCH BOARD**  
National Research Council  
Washington, D. C. May 1992

Systematic, well-designed research provides the most effective approach to the solution of many problems facing highway administrators and engineers. Often, highway problems are of local interest and can best be studied by highway departments individually or in cooperation with their state universities and others. However, the accelerating growth of highway transportation develops increasingly complex problems of wide interest to highway authorities. These problems are best studied through a coordinated program of cooperative research.

In recognition of these needs, the highway administrators of the American Association of State Highway and Transportation Officials initiated in 1962 an objective national highway research program employing modern scientific techniques. This program is supported on a continuing basis by funds from participating member states of the Association and it receives the full cooperation and support of the Federal Highway Administration, United States Department of Transportation.

The Transportation Research Board of the National Research Council was requested by the Association to administer the research program because of the Board's recognized objectivity and understanding of modern research practices. The Board is uniquely suited for this purpose as: it maintains an extensive committee structure from which authorities on any highway transportation subject may be drawn; it possesses avenues of communications and cooperation with federal, state, and local governmental agencies, universities, and industry; its relationship to the National Research Council is an insurance of objectivity; it maintains a full-time research correlation staff of specialists in highway transportation matters to bring the findings of research directly to those who are in a position to use them.

The program is developed on the basis of research needs identified by chief administrators of the highway and transportation departments and by committees of AASHTO. Each year, specific areas of research needs to be included in the program are proposed to the National Research Council and the Board by the American Association of State Highway and Transportation Officials. Research projects to fulfill these needs are defined by the Board, and qualified research agencies are selected from those that have submitted proposals. Administration and surveillance of research contracts are the responsibilities of the National Research Council and the Transportation Research Board.

The needs for highway research are many, and the National Cooperative Highway Research Program can make significant contributions to the solution of highway transportation problems of mutual concern to many responsible groups. The program, however, is intended to complement rather than to substitute for or duplicate other highway research programs.

---

**NOTE:** The Transportation Research Board, the National Research Council, the Federal Highway Administration, the American Association of State Highway and Transportation Officials, and the individual states participating in the National Cooperative Highway Research Program do not endorse products or manufacturers. Trade or manufacturers' names appear herein solely because they are considered essential to the object of this report.

Project 20-5 FY 1989 (Topic 21-12)

ISSN 0547-5570

ISBN 0-309-05305-6

Library of Congress Catalog Card No. 92-060469

**Price \$9.00***Subject Areas*

Highway and Facility Design  
 Safety and Human Performance

*Mode*

Highway Transportation

**NOTICE**

The project that is the subject of this report was a part of the National Cooperative Highway Research Program conducted by the Transportation Research Board with the approval of the Governing Board of the National Research Council. Such approval reflects the Governing Board's judgment that the program concerned is of national importance and appropriate with respect to both the purposes and resources of the National Research Council.

The members of the technical committee selected to monitor this project and to review this report were chosen for recognized scholarly competence and with due consideration for the balance of disciplines appropriate to the project. The opinions and conclusions expressed or implied are those of the research agency that performed the research, and, while they have been accepted as appropriate by the technical committee, they are not necessarily those of the Transportation Research Board, the National Research Council, the American Association of State Highway and Transportation Officials, or the Federal Highway Administration of the U.S. Department of Transportation.

Each report is reviewed and accepted for publication by the technical committee according to procedures established and monitored by the Transportation Research Board Executive Committee and the Governing Board of the National Research Council.

The National Research Council was established by the National Academy of Sciences in 1916 to associate the broad community of science and technology with the Academy's purposes of furthering knowledge and of advising the Federal Government. The Council has become the principal operating agency of both the National Academy of Sciences and the National Academy of Engineering in the conduct of their services to the government, the public, and the scientific and engineering communities. It is administered jointly by both Academies and the Institute of Medicine. The National Academy of Engineering and the Institute of Medicine were established in 1964 and 1970, respectively, under the charter of the National Academy of Sciences.

The Transportation Research Board evolved in 1974 from the Highway Research Board, which was established in 1920. The TRB incorporates all former HRB activities and also performs additional functions under a broader scope involving all modes of transportation and the interactions of transportation with society.

*Published reports of the***NATIONAL COOPERATIVE HIGHWAY RESEARCH PROGRAM***are available from:*

Transportation Research Board  
 National Research Council  
 2101 Constitution Avenue, N.W.  
 Washington, D.C. 20418



## **PREFACE**

A vast storehouse of information exists on nearly every subject of concern to highway administrators and engineers. Much of this information has resulted from both research and the successful application of solutions to the problems faced by practitioners in their daily work. Because previously there has been no systematic means for compiling such useful information and making it available to the entire highway community, the American Association of State Highway and Transportation Officials has, through the mechanism of the National Cooperative Highway Research Program, authorized the Transportation Research Board to undertake a continuing project to search out and synthesize useful knowledge from all available sources and to prepare documented reports on current practices in the subject areas of concern.

This synthesis series reports on various practices, making specific recommendations where appropriate but without the detailed directions usually found in handbooks or design manuals. Nonetheless, these documents can serve similar purposes, for each is a compendium of the best knowledge available on those measures found to be the most successful in resolving specific problems. The extent to which these reports are useful will be tempered by the user's knowledge and experience in the particular problem area.

## **FOREWORD**

*By Staff  
Transportation  
Research Board*

This synthesis will be of interest to highway design engineers, maintenance personnel, safety and enforcement officials, traffic engineers, and others responsible for the safe operation of large trucks on highways. Information is provided on the critical aspects of site location, design criteria, and maintenance procedures, and their relationship to truck escape ramp performance.

Administrators, engineers, and researchers are continually faced with highway problems on which much information exists, either in the form of reports or in terms of undocumented experience and practice. Unfortunately, this information often is scattered and unevaluated, and, as a consequence, in seeking solutions, full information on what has been learned about a problem frequently is not assembled. Costly research findings may go unused, valuable experience may be overlooked, and full consideration may not be given to available practices for solving or alleviating the problem. In an effort to correct this situation, a continuing NCHRP project, carried out by the Transportation Research Board as the research agency, has the objective of reporting on common highway problems and synthesizing available information. The synthesis reports from this endeavor constitute an NCHRP publication series in which various forms of relevant information are assembled into single, concise documents pertaining to specific highway problems or sets of closely related problems.

The safety of truck drivers, other road users, and occupants of roadside properties is often imperiled by the combination of heavy trucks and steep downgrades on highways. Frequently, gearing down, applying the brakes, and using the retarding power of the engine are not sufficient to control the truck, and serious crashes can result. Many states have constructed truck escape ramps to safely remove runaway trucks from the

TE  
7  
.N26  
no.  
178

13776

traffic stream. This report of the Transportation Research Board provides information on the location, design, construction materials, geometrics, and construction costs of truck escape ramps. Operational considerations, such as descriptions of advance warning signs, traffic control devices at the ramp, and vehicle removal procedures are described. Information on frequency and type of usage, maintenance of the ramps, and driver-related issues is also included.

To develop this synthesis in a comprehensive manner and to ensure inclusion of significant knowledge, the Board analyzed available information assembled from numerous sources, including a large number of state highway and transportation departments. A topic panel of experts in the subject area was established to guide the researcher in organizing and evaluating the collected data, and to review the final synthesis report.

This synthesis is an immediately useful document that records practices that were acceptable within the limitations of the knowledge available at the time of its preparation. As the processes of advancement continue, new knowledge can be expected to be added to that now at hand.

## CONTENTS

1	SUMMARY
2	CHAPTER ONE INTRODUCTION
	Background, 2
	Current Experience, 3
4	CHAPTER TWO LOCATION OF TRUCK ESCAPE RAMPS
	Types of Application, 4
	Justification for Truck Escape Ramps, 4
	Specific Location, 6
8	CHAPTER THREE DESIGN OF TRUCK ESCAPE RAMPS
	Ramp Type, 8
	Approach to Ramp, 9
	Design Entry Speed, 10
	Geometrics, 11
	Mounds, 13
	End Treatments, 13
	Vehicle Removal Provisions, 14
	Materials and Other Physical Elements, 15
	Construction Costs, 17
18	CHAPTER FOUR OPERATIONAL CONSIDERATIONS
	Advance Warning of Grades, 18
	Traffic Control Devices at the Ramp, 19
	Enforcement, 19
	Vehicle Removal Operations, 22
24	CHAPTER FIVE MAINTENANCE OF TRUCK ESCAPE RAMPS
	Routine Procedures, 24
	Winter Maintenance, 25
	Aggregate Contamination, 25
	Aggregate Upgrading, 27
	Maintenance Summary, 27
28	CHAPTER SIX SITE USE AND DRIVER-RELATED ISSUES
	Ramp Use Experience, 28
	Driver Education and Public Information, 29
	Driver-Related Issues, 30
32	CHAPTER SEVEN CONCLUSIONS AND RECOMMENDED RESEARCH
34	REFERENCES
36	BIBLIOGRAPHY
38	APPENDIX A SURVEY FORM
43	APPENDIX B ARRESTER BED STOPPING DISTANCES
46	APPENDIX C COLORADO DESIGN GUIDELINES EXCERPT
49	APPENDIX D COLORADO RAMP USAGE REPORT FORM
51	APPENDIX E IDAHO SAFETY TIPS FOR DOWNGRADES
55	APPENDIX F PENNSYLVANIA TRUCK RAMP BROCHURE

## **ACKNOWLEDGMENTS**

This synthesis was completed by the Transportation Research Board under the supervision of Robert E. Skinner, Jr., Director for Special Projects. The Principal Investigators responsible for conduct of the synthesis were Sally D. Liff, Senior Program Officer and Scott A. Sabol, Program Officer. This synthesis was edited by Linda Mason.

Special appreciation is expressed to David K. Witheford, who was responsible for collection of the data and preparation of the report.

Valuable assistance in the preparation of this synthesis was provided by the Topic Panel, consisting of Wiley D. Cunagin, Associate Research Engineer, Texas Transportation Institute; William A. Prosser, Office of Engineering, Federal Highway Administration; Larry A. Scofield, Transportation Engineering Supervisor, Arizona Transportation Research Center; Justin G. True, Office of Safety and Traffic Operations Research and Development, Federal Highway Administration; Edward J. Tye, Consultant, Eugene, Oregon; and James C. Wambold, Director, Vehicle/Surface Interaction and Safety Program, Pennsylvania Transportation Institute.

Frank R. McCullagh, Engineer of Design, Transportation Research Board, assisted the NCHRP Project 20-5 Staff and the Topic Panel.

Information on current practice was provided by many highway and transportation agencies. Their cooperation and assistance were most helpful.

# TRUCK ESCAPE RAMPS

## SUMMARY

This synthesis has been prepared from a review of literature on truck escape ramp technology and a survey of current practice by state departments of transportation. Truck escape ramps have been part of the American highway scene for more than thirty-five years. They are found in 27 states, from the mountains of the West to Appalachia and from suburban Los Angeles to small urban communities in the Northeast.

Their locations have been determined usually from a combination of accident experience and engineering judgment, but new tools are emerging that can identify needs and sites without waiting for catastrophic accidents to happen. The Grade Severity Rating System holds promise in this regard.

Design procedures for truck escape ramps continue to evolve. Gravel arrester beds are clearly the preferred choice across the country. Rounded aggregate, uniformly graded in the approximate size range of 0.5 to 0.7 in., provides the greatest rolling resistance and is the preferred material. New procedures for determining ramp length may lead to more cost-effective design. Design practice for other elements, such as widths and end treatments, are also presented.

Operational experience of the states shows that some ramps are used as frequently as once a week or more. Others may be used infrequently by truckers, serving primarily as playgrounds for four-wheel-drive vehicle operators testing their equipment. Better signing and enforcement to regulate and control casual use or abuse of ramp sites is needed in some locations. Advance signing and brake check areas at the top of grades contribute importantly to safe operations. Additional information transmitted through other public information media may also encourage truckers to use, rather than avoid, truck escape ramps in marginal situations.

Adequate maintenance is essential to the effective operation of truck escape ramps. Regrading after site use and occasional "fluffing" is necessary. Prevention of bed contamination by fines, accomplished through maintenance practices as well as design, is critical to long-term satisfactory performance.

Additional study of several issues could improve current practices. These include: benefit-cost analyses; validation of techniques for determining site locations, entry speed and ramp length requirements; aggregate performance evaluations; the need to provide for multiple entries; and effective driver information and education strategies. Because truck escape ramps perform a useful service in many locations, their design, operation, and maintenance deserve an adequate level of attention by highway agencies.

## INTRODUCTION

This synthesis compiles the considerable amount of research on and experience with truck escape ramps, and looks with special emphasis at the critical aspects of site location, design criteria, and maintenance procedures and their relationship to ramp performance. Problems and their solutions are presented, and research needs are identified. Information is presented that can be used to educate truck drivers and other motorists in the use of escape ramps.

To accomplish these objectives, two primary sources of information were used as the basis of this report. First, the body of literature compiled in recent years by researchers and practitioners on the subject of truck escape ramps was reviewed. Largely identified by a search of the Transportation Research Information Service (TRIS) database, this material has been augmented by documents obtained from states and other agencies. Second, the results of a survey sent to state transportation agencies on the current state of practice were studied. The response from 27 states that have built truck ramps (19 other states responded that they had none) provides much of the detailed information presented. The survey form is provided in Appendix A.

The synthesis is organized in chapters dealing with the following subjects: location, design, operational considerations, maintenance requirements, site usage and driver issues. A review of truck escape ramp history and the evolution of current practice is presented first to set the scene.

### BACKGROUND

#### The Scale of the Problem

The combination of heavy trucks and highway downgrades has long presented a potentially lethal safety hazard to both road users and occupants of roadside properties. On severe grades, gearing down and using brakes plus the retarding power of the engine are sometimes insufficient to hold vehicles in check. Thus, the problem of runaway trucks stems generally from brake failures, which can arise from a variety of causes. Defective or incorrectly adjusted braking systems on tractors or trailers, driver inexperience with equipment or unfamiliarity with local conditions, and the lack of or unwarranted reliance on retarder systems can all contribute to brake overheating and failure. The resulting inability of drivers to control vehicle speeds on downgrades is frequently costly.

Recent statistics in "Grade Severity Rating System—Users Manual" (1) offer some evidence of the magnitude of the problem. In one mountain state, one-sixth of truck accidents were runaway downgrade accidents. A 1981 study for the National Highway Traffic Safety Administration (NHTSA) (2), estimated that runaway truck incidents totalled 2,450 per year, incurring

costs of nearly \$37 million at that time. Of the total, 2,150 runaways were estimated to use escape ramps and incurred costs slightly over \$1 million. The remaining estimated 300 accidents, vehicles not using ramps, cost close to \$36 million. In half the runaway events involving trucks over 60,000 pounds, brake failure due to overheating was said to be the primary cause.

#### Remedial Actions

A problem that generates perhaps \$40 million or more annually in societal costs warrants some measure of attention, and it can be shown that increasing attention has been given to runaway trucks. A higher proportion of the truck fleet may be equipped with the retarder systems that augment engine braking (using lower gears) and regular service brake systems. Driver education tools are more widely available to aid less-experienced drivers. More frequent and thorough on-the-road inspection by motor carrier safety agencies is probably occurring. State highway agencies increasingly provide more information and guidance to truck operators on specific site conditions, through signing and other means. Lastly, better physical provisions are being made on highways to cope with the runaway vehicle when the situation does arise.

#### Evolution of Truck Escape Ramps

The Institute of Transportation Engineers' (ITE) Recommended Practice "Truck Escape Ramps" (3) suggests that this particular safety measure probably evolved from observation of how drivers react to runaway conditions. Obviously, truck operators experiencing these problems felt that some controlled run-off-the-road action was preferable to total loss of control. Thus, the ITE report states, "Before truck escape ramps were designed and developed, out-of-control vehicles reportedly crashed into piles of sand and gravel placed along the edge of roads for maintenance purposes. Occasionally, operators of out-of-control vehicles turned off the road into uphill slopes or logging roads to attenuate the speed of the vehicle."

The first facility designed to serve runaway trucks is reported to have been built in 1956 in California. Between that date and 1977, according to a survey by Williams (4), more than 60 ramps had been planned or placed in operation by 20 different states. Enough records on usage were accumulated during this period to indicate that this safety measure was effective.

In 1979 the Federal Highway Administration published a Technical Advisory, "Interim Guidelines for Design of Emergency Escape Ramps" (5). This publication has been the basic reference since then for use in implementing truck escape ramps on downgrades.

## Research and Development

As interest grew in the application of truck escape ramps (TER), so did the need to know how to design these facilities for effective use. Where were they needed? What physical characteristics, such as lengths, grades, and materials worked best? What maintenance procedures were necessary? Research projects were initiated in the United States by California, Colorado, New York, Oregon, and Pennsylvania to address these questions. Similar work was undertaken in Australia and the United Kingdom. Most of the formal research at this time pertained to materials, and is well summarized in Wambold's 1983 literature review (6). Some research provided data on usage, such as the characteristics and speeds of trucks entering ramps and the speed they traveled before being stopped. Formulas were derived for determining ramp lengths as a function of vehicle entry speeds, ramp grades, and the rolling resistance of ramp surfaces.

However, information obtained for this report indicates there still is not a consensus on current practice for many elements of TER design and construction. Points of commonality can be identified, directions established, and possible research needs focused on as a result of the survey made here.

## CURRENT EXPERIENCE

A benchmark may be established by recording the number of TERs in use or proposed within the United States in 1990. Based on the survey results, truck escape ramps number about 170 in the 27 states reporting them, a tripling of the 58 reported in the 1970s (4). While most are in western states, over 60 are in 12 states east of the Mississippi River. The states without escape ramps are primarily southern, midwestern or Great Plains states.

The ramps that have been constructed receive varying degrees of use. For example, one state reported that its only ramp had not yet been used, while one ramp on I-64 in West Virginia has averaged an entry per week for the last two years. A ramp on I-5 in southern California, where trucks account for 35 percent of the 35,000 average daily traffic volume, has an entry every

2½ to 3 days. But even rare usage can warrant ramp construction. The following event occurred within six months after completion of this urban ramp site (7):

A tractor-trailer loaded with metal ore lost its brakes while descending the grade during morning peak hour traffic. The driver avoided slow-moving traffic by using the shoulder. He entered the escape ramp at 40–45 mph (his estimate). The rig weighing 74,450 pounds was safely stopped 148 feet into the pile. Banksville Road and Greentree Hill traffic was virtually stopped about 100 feet below the sandpile at the time of the accident. Previous experience with accidents at this location led to an estimate that at least 10 automobiles would have been involved had it not been for the ramp.

Figure 1 shows the result of a safely controlled stop in an arrester bed. Chapter Six reports more fully on studies made of ramp usage, considering not only frequency but also ramp performance, vehicle characteristics, and driver profiles.

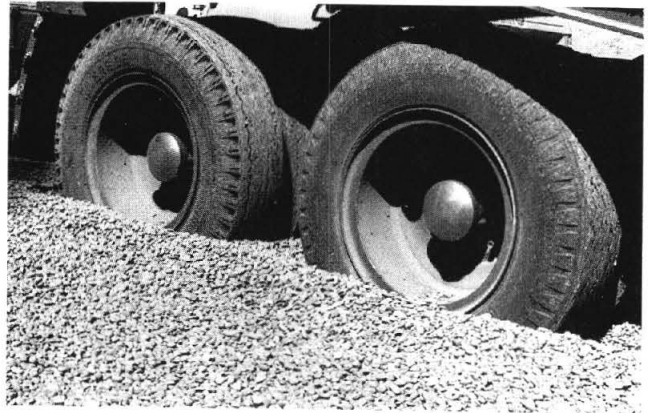

Figure 1 A gravel arrester bed results in safely controlled stops.



## LOCATION OF TRUCK ESCAPE RAMPS

This chapter describes the situations where truck escape ramps are useful, how to determine when a ramp is the solution to a particular problem, and how to select a specific location. The contents are based on a review of the literature and the survey of the states.

### TYPES OF APPLICATION

Truck escape ramps (TERs) generally are used in two sets of circumstances: on long mountain grades in rural areas, and on short, steep hills likely to be in areas of dense traffic and development. The latter are often situations where accidents involving fatalities and serious property damage have happened or are probable. They are also likely to be sites that require a stop or slow-speed turn at the bottom of the grade, such as the TER located on a short downgrade approaching a barrier toll-booth installation on I-95 in Richmond, Virginia.

Table 1 lists characteristics of grades in selected states. Some of the Pennsylvania sites are only half a mile or less in length, but have downgrades between 7 and 10 percent that have experienced several runaway truck events per year. High truck volumes are one reason, but another may be that trucks are sometimes forced to travel at low speeds in congested peakhour traffic. At the same time, longer but less severe grades on heavily traveled interstate highways also cause problems. Idaho and Oregon are

TABLE 1  
CHARACTERISTICS OF SEVERE GRADES

Location	Percent Grade	Length (miles)
Pennsylvania		
I-376	5	1.8
I-279	5.5	1.7
Stoop's Ferry Rd	10.5	0.45
Hulton Rd.	10	0.3
Idaho		
Lewiston Hill	6-7	7
Whitebird Hill	7	7
Oregon		
Siskiyou Summit	5-6.4	7
California		
I-80	5-6	40

examples of western states with downgrades as long as 7 miles, the grades ranging between 5 and 6.4 percent. Perhaps the extreme case is I-80 between Donner Pass and Sacramento. The 40-mile section has an elevation change of over 5,800 feet, and segments of varying lengths with 5 to 6 percent grades.

The survey showed that ramps on short grades were reported by 10 states, most of which were east of the Mississippi River. These ramps, however, accounted for only about 10 percent of the total. By far the greatest number of truck escape ramps are found on long downgrades in mountainous regions.

### JUSTIFICATION FOR TRUCK ESCAPE RAMPS

Determining where a TER is necessary involves several considerations that vary from state to state and that have not been formalized into routine processes or warrants. As an extreme example, one respondent noted that a good indicator of need is smoking brakes.

### Literature Review

The literature does not reveal a clear pattern for a process to determine where TERs are appropriate. In a 1979 paper, "State Practice and Experience in the Use and Location of Truck Escape Facilities" (8), Eck states: "There are still no criteria for determining the need for escape ramps, and ramp location is usually based on finding a convenient site that will minimize earthwork and construction costs." His survey results on this subject are summarized in Figure 2. The principal influence, cited twice as often as other factors, was runaway accident experience. Site conditions of grade length, percent of grade, and a combination of horizontal alignment and end-of-grade conditions, weigh about equally. Combined traffic characteristics of average daily traffic and percent trucks count about the same as site condition. Available right-of-way and topography, important in site selection, are not serious factors in determining the need for a ramp.

Current sources do not collectively provide a consensus on when TERs are needed. The most recent edition of the American Association of State Highway and Transportation Officials (AASHTO) "A Policy on Geometric Design of Highways and Streets" (9), referred to as the "Green Book," offers the following:

Where long, descending grades exist or where topographic and location controls require such grades on new alignment, the design and construction of an emergency escape ramp at an appropriate location is desirable for the purpose of slowing and stopping an out-of-control vehicle away from the main traffic stream.... Specific guidelines for the design of escape ramps are lacking at this time.... [T]he principal determinations as to the need should

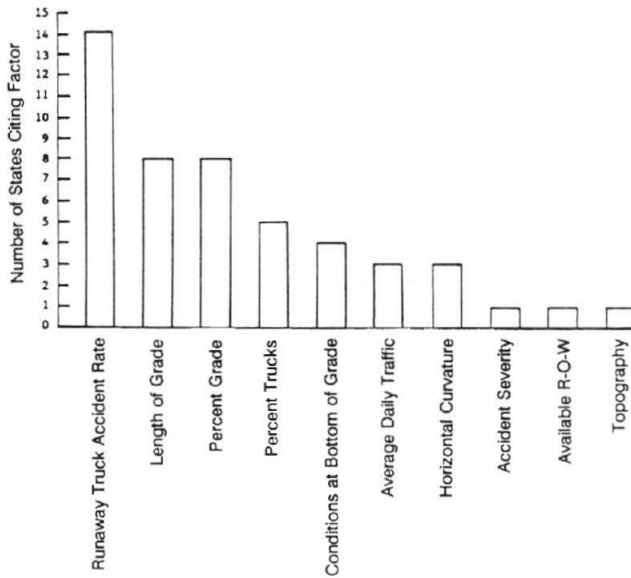

Figure 2 Factors considered in determining TER need (from 8).

be the safety of the other traffic on the roadway, the operator of the out-of-control vehicle, and the residents along or at the bottom of the grade.

It should be noted that the AASHTO text on truck escape ramps is almost a verbatim copy of the 1979 FHWA "Interim Guidelines for Design of Emergency Escape Ramps" (5).

Under "Guidelines to Determine Need," the ITE Recommended Practice (3) states:

There are, however, many interrelated and not fully understood factors to consider when determining the need to provide a truck escape ramp. A discussion of these factors follows. We suggest that engineering judgment be used when considering these factors until research can be used to establish a set of numerical warrants.

The first factor subsequently discussed is accident rates. Next is the relationship between horizontal alignment and operating speeds. Other considerations include potential for severe accidents (e.g., high volumes of school buses). A stepwise approach is also suggested. This series of progressive improvements begins with signing, adds speed control, then mandatory pull-off areas before escape ramps are built.

The progressive approach, especially one using current techniques for analyzing steep grades, has the appeal of addressing the runaway problem with increments of investment. The probability of a cost-effective solution is thereby increased.

The Grade Severity Rating System (GSRs) (1) may be a useful tool in this regard. Its objective is to calculate values for "Weight Specific Speed" (WSS) signs that instruct drivers on the maximum safe speeds on grades for vehicles of different weight. An

example is shown in Figure 3. Maximum safe speed, calculated on the basis of brake temperature estimates, is defined as "that speed from which an emergency stop at the bottom of the grade will not generate brake temperatures above a pre-selected temperature limit." (Brake temperatures can exceed 500°F on out-of-control vehicles). The GSRs has values beyond speed control applications. Besides evaluating grade severity and determining downhill truck speed limits, it can be used to establish the need and location for truck escape ramps, as its computer program has the option of calculating brake temperatures at 1/2-mile intervals along the downgrade. The calculated maximum safe descent speeds also provide a nonaccident method to substantiate traffic engineering improvements. An absence of truck accidents may indicate an absence of the need to stop rather than the capability of trucks to make safe emergency stops. Trucks using a grade at higher than recommended speeds could well have brake temperatures high enough to preclude stopping. The GSRs can thus be used to identify hazards before accidents occur, and aid in determining the appropriate level of countermeasures.

Prior to using GSRs, the author of the guidelines notes, potential sites for WSS application may be identified by observation. Police reports on speed violations, maintenance records on guard rail or other hardware repairs, fire department responses to "hot brake" problems, not to mention citizen complaints about speeding trucks, can all be related to potentially serious runaway conditions. They can also be indicative of a need for truck escape ramps.

**Survey Response on the Need for TERs**

The absence in the literature of a pattern for determining when a TER is appropriate was echoed in the responses to the survey. The survey form asked: How do the following criteria influence the decision to build a TER: accident experience, Grade Severity Rating System, engineering judgment, other (please describe)?

Accident experience was an influence in 21 states but not an exclusive one anywhere. The Grade Severity Rating System was

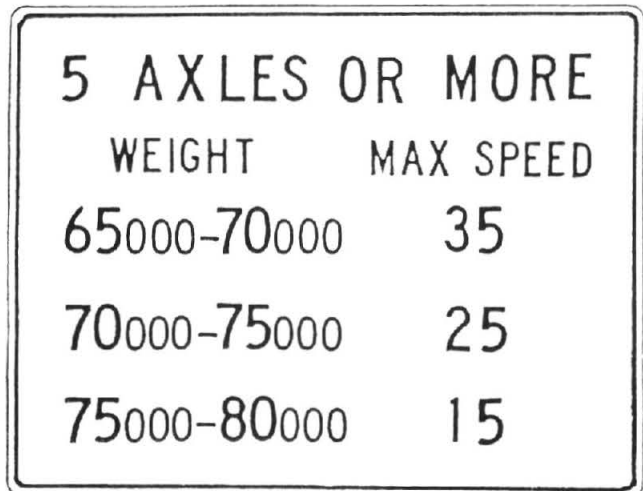

Figure 3 Example of weight specific speed (WSS) sign.

considered in 11 states, and was the sole influence in two of these. Engineering judgment was a factor in 24 states, and for two states, it was the determining factor. Other factors in various combinations were reported by 21 states. These included: ramp location (e.g., adjacent to school entrance), smoking brakes, enforcement, truck speeds, signals, inspection/scale facilities, severity resulting in public opinion pressure that may influence building a ramp, availability of right-of-way.

A number of states offered comments. "Clearly [accident experience] is the primary criterion for installing a TER, since accidents generate local concern and requests for action." Three others paralleled this thought. Regarding the GSRS as a determining factor in building a TER, states commented that it ranged in importance from a primary consideration to a minor one, with interest growing in other states. An internal report provided by Caltrans with their response (10) states:

If the maximum safe downgrade speeds for trucks along a new or realigned highway would be near or less than either 55 mph or the speeds at which the curves can be safely driven, a study should be done regarding whether one or more truck escape ramps should be constructed. Factors include total traffic volumes, truck volumes, especially of three, four and five axle trucks, the number of lanes downgrade, whether there would be so many curves that most runaway trucks would run off the road prior to one or more truck escape ramps and whether there would be a safe area such as a tangent freeway for runaway trucks to decelerate beyond the downgrade provided that the trucks did not run off the road or hit other vehicles. Posted speed limits for trucks may possibly reduce accidents but are usually not a factor regarding whether one or more truck escape ramps should be constructed along new or realigned highways. Truck escape ramps may be constructed along new or realigned conventional highways even if the probability of a runaway truck would be slight if there is a town or village nearby and if a runaway truck could get to the town or village.

### Summarizing the Need for TERs

Clearly, neither recent literature nor the survey returns point to a uniform, widely accepted procedure to determine when a truck escape ramp is appropriate. Accident experience combined with engineering judgment is the most frequently used approach. The hazard to adjacent activities and communities may be reason enough in many cases.

The fact that no clear-cut method has been found to determine the need for truck escape ramps may suggest that research is needed to fashion one. However, this was not identified as a need by any survey responses. It seems generally accepted that each situation presents enough unique variables to warrant independent means of resolving whether a ramp is necessary.

The greatest promise for an analytical tool to determine need comes from application of a grade severity rating system, a technique used with increasing frequency. Once a decision is made to build a ramp, other criteria come into play regarding its specific location.

### SPECIFIC LOCATION

The evolution of criteria for site selection for truck escape ramps can be traced in the literature. Before looking at survey

returns, therefore, this section will report on the literature review.

### Literature Review

In a 1979 description of tests at the Siskiyou Summit TER in Oregon, Young (11) states that location "was guided primarily by economics.... In addition, the selected site would experience less snow, ice, and freezing weather conditions than sections of the road located higher."

At about the same time, Eck (8) reported the factors cited by state agencies in his survey. These are summarized in Figure 4. Topography was the most frequently cited factor, followed by horizontal alignment and accident locations. This survey also recorded that locations were almost equally divided between tangents and horizontal curves, while the number located in cuts (presumably to accommodate uphill ramps) was roughly double the number in fills (which would probably require additional earthwork).

A survey in 1982 (12) concluded that:

The feasibility, type of design, and location of escape lanes are based primarily on engineering judgment.... [E]ach segment presents a unique set of design requirements, dependent in part upon the following factors:

- Nature of terrain along the segment
- Degree of slope and roadway alignment
- Availability of sites adjacent to the highway
- Environmental impact
- Logical site distance below the summit
- Maximum potential speed of runaway trucks.

A Colorado report (13) describes location criteria appropriate for long mountain grades:

To a great extent the topography determines the location of a truck escape ramp. However, the use of accident data in the design process has proven to be an excellent tool for location

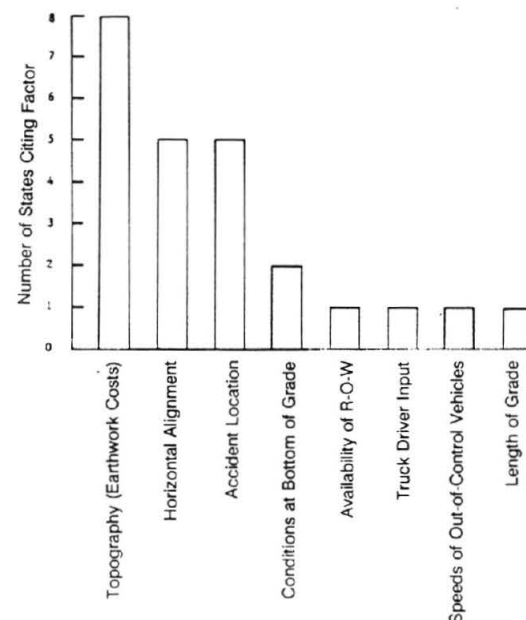

Figure 4 Factors considered in site selection (from 8).

analysis. A review of the accident data studies done for ramps constructed in Colorado has led to the following observations:

1. The ramp should be located at a position on the grade that will allow it to intercept the largest number of runaway trucks.
2. There is a probable point on a steep grade where trucks running out of control attain a speed that may create catastrophic accidents.
3. Accidents near the summit of a grade tend to be less severe.
4. Ramps should be built in advance of roadway curves that cannot be negotiated by an out-of-control vehicle.
5. Experience has shown that a ramp located between 3 to 4.5 miles from the summit of the grade will intercept 70 to 80 percent of the out-of-control vehicles.

Ballard (14) noted that states have different ideas on what site criteria are significant and goes on to show how six states treated particular situations.

California's recent Design Guide for Truck Escape Ramps (15) states the following:

The location of a truck escape ramp, whether it is an arrester bed or gravity ramp, is controlled largely by the terrain. In general, an escape ramp should only be considered on the lower half of a grade because this is where the need becomes most apparent to the operator of the runaway truck and they would then be more willing to use the ramp. An exception would be on long, sustained downgrades.

Escape ramps should not be located on curves. This adds to the problems of control that already face the driver of a runaway truck. Also, a tangent ramp off a curve can, under some conditions, appear as the through roadway. It is much better to locate an escape ramp along a tangent section of roadway.

The Caltrans Design Guide also indicates that left-side escape ramps may be used on multi-lane highways. These would only be placed in wide medians and would not require runaway vehicles to cross lanes of opposing traffic.

The recommendations above are essentially endorsed in the ITE publication (3), though it is more cautious on the subject of lefthand exits.

The AASHTO Green Book (9) states that site location is "usually based on accident experience. Analysis of accident data

pertinent to a prospective site should include evaluation of the section of highway immediately uphill." The evaluation should include determining the maximum speed obtainable at the site by a runaway vehicle. The Green Book further states that TERs should be on the right side, generally on tangent alignments, in advance of populated areas and curves that cannot be safely negotiated.

### Survey Response

The questionnaire asked respondents to describe any routine process used for site selection and to check which of these factors were considered: distance from top of grade, horizontal alignment, adjacent land use, terrain suitability, and "other." Out of 26 responses, no routine processes were reported. Eleven states combine distance, alignment, and terrain, and some of these states also included land use. Distance from the top was given as the sole factor by one state. Horizontal alignment was the sole factor in another state. Terrain suitability was the only factor listed by four states. Land use and "other" were factors in nine states, always in combination with other listed factors.

One state commented that seeing a sharp curve and the ramp at the same time helps a driver's decision making. Another noted that accident history was a factor and a third agreed, "In one case, by location of accidents. In the second case, to prevent truck runaways from going through a historic town."

### Site Selection Summary

There are no clear guidelines for fixing the specific location for truck escape ramps. Current practice continues the reliance on engineering judgment identified in previous surveys. The dominant factors are terrain, alignment, and distance from the top of grade. These reflect tradeoffs of cost to provide the facility against the safety hazards inherently related to operating speeds and alignment. Current considerations are provided in the most detail by the California Design Guide (15) and ITE Recommended Practice (3).

## DESIGN OF TRUCK ESCAPE RAMPS

The issues to be addressed in this chapter include: ramp type, approach, ramp geometrics, end treatments, vehicle retrieval, and materials. Some of these topics have been extensively researched; for example, the choice of aggregate for arrester beds has been the object of study in several countries since the 1960s. Other aspects have evolved without formal research from the growing body of field experience. This chapter incorporates findings and recommendations from the literature as well as from the responses to the survey provided by the states.

### RAMP TYPE

Since the late 1960s, technical publications typically have classified TER types as paved gravity, sandpile, and arrester bed ramps. These groups reflect two different characteristics: the materials used, and the grade of the ramp, which may be uphill (gravity), flat, or downhill.

Current practice is limited to the four combinations of grade and materials shown in Figure 5. Gravity ramps, common a few decades ago, were often logging roads or other old roadways abandoned in realignment projects. Their length and usually steep grades presented drivers with control problems not only before stopping but sometimes after, because of rollback problems. An example of a gravity ramp is shown in Figure 6.

Sandpiles, often literally a series of spaced dump truck loads, were also common in early TER experience, especially in the tight grade and alignment conditions found in eastern states. As Figure 7 suggests, these would also depend on gravity to slow vehicles. Arrester beds, on the other hand, depend primarily on the greater rolling resistance offered by larger loose aggregate (Figure 8). This makes it possible to construct ramps on flat areas, on downgrades, or to vary the grade within the ramp itself if terrain so dictates.

### Historical Review

Williams' survey (4) reported by state on the types of TERs in use or proposed. The statistics are shown in Table 2, separated into states east and west of the Mississippi River.

Eastern states accounted for most of the gravity type ramps and all but one sandpile, while western states had used arrester beds in more than two-thirds of their sites.

Ballard (14) compared the varying lengths associated with each type. Sandpiles have been the shortest, usually between 200 and 400 ft in length. Figure 7 shows one such ramp, which reflects the constraints of geometrics and terrain in the East. An example of an early design for a short gravel arrester bed built in Great Britain is shown in Figure 8. At the other extreme, gravity ramps may run to lengths of 1,200 to 1,500 ft. Arrester

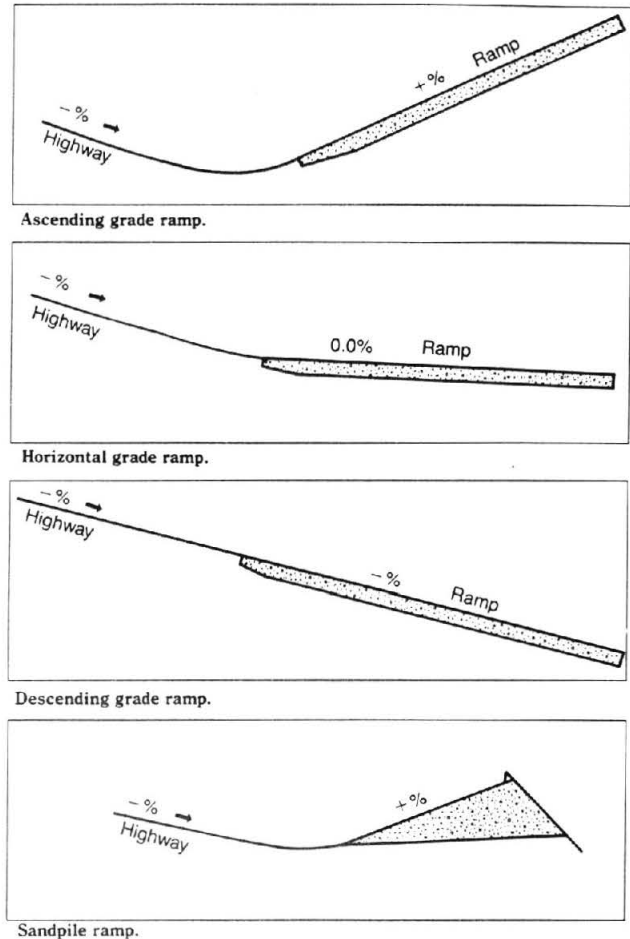

Figure 5 Basic types of truck escape ramps (from 9).

beds vary according to their grades, but would normally fall between the extremes.

### Survey Response

The 26 survey responses clearly show the growing acceptance of the arrester bed concept. Table 3 lists the types of designs and numbers of states that first used the design, what is currently the design practice, and what type of ramp will be built in the future. (Two states reported using two different types initially).

Not all states with existing ramps are planning to build additional ones, but those that have built ramps have essentially adopted the arrester bed for future designs. The following details





Figure 6 Example of a gravity ramp in British Columbia (possibly an old logging road).

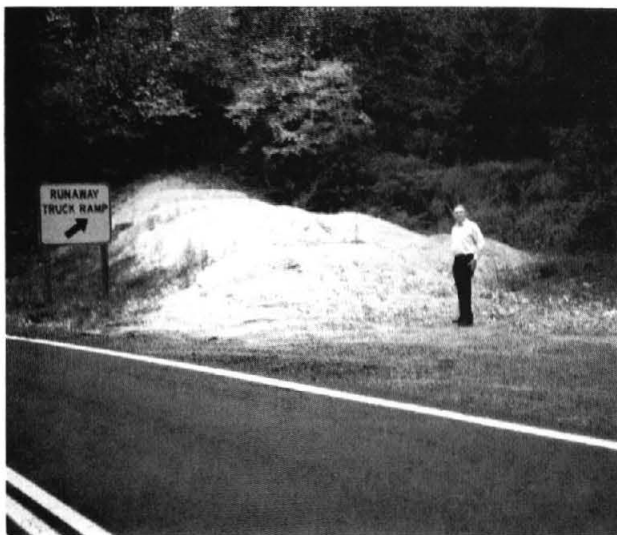

Figure 7 An early sandpile ramp.



Figure 8 An early version of a gravel arrester bed along shoulder of a British motorway.

TABLE 2  
RAMP TYPES IN USE DURING 1970s (4)

TYPE	East of Mississippi River	West of Mississippi River
Arrester bed	13 (7 sand)	11 (1 sand)
Gravity	13	8
Combination of both	4	9
Total	30	28

TABLE 3  
TYPE OF ESCAPE RAMP PROVIDED

Ramp Type	First Installed	Current Design	Proposed
Sandpile	2	2	1
Gravity	4	-	1
Arrester Bed	22	22	17

from the survey responses most likely reflect characteristics applicable to arrester beds.

#### APPROACH TO RAMP

Literature sources provide little information on approaches prior to the mid 1980s. Williams (4) suggested that apron ends

be squared off so that all wheels on an axle enter the bed simultaneously. This facilitates vehicle control during initial deceleration. More experience has produced further suggestions. Tye (15) noted that gravel beds should begin with a lateral offset from travel lanes great enough so that gravel is not sprayed back into them. These guidelines recognize the probable panic state of a runaway truck operator and also state: "For them to feel that the ramp can be negotiated safely they must be able to see as much of the ramp as possible. Grade sags or crests that obscure a portion of the ramp may influence an out-of-control driver to avoid the ramp." The guidelines further specify auxiliary lanes at least 1,000 ft long to facilitate driver access to the ramp on multilane highways. An unpublished computer program to evaluate auxiliary lane lengths, based on gaps related to volume and number of lanes, is available from the Caltrans Division of Traffic Operations.

The ITE Recommended Practice (3) additionally notes that greater lengths of apron approaching a gravel ramp give truck operators more room to maneuver the vehicle into a straight line approach to the bed.

Emphasizing the need for ramp access to be obvious through signing and sufficient sight distance in advance to allow time for drivers to react, the AASHTO Green Book states further:

The entrance to the ramp must be designed so that a vehicle traveling at a high rate of speed can enter safely. The main roadway surface should be provided to a point at or beyond the exit gore so that both front wheels of the out-of-control vehicle will enter the bed simultaneously, and the operator will have preparation time before actual deceleration begins.

Figure 9 shows such a highly visible truck escape ramp configuration.

### Survey Responses

The survey asked for information on approach sight distance, auxiliary lanes, and exit lane width.

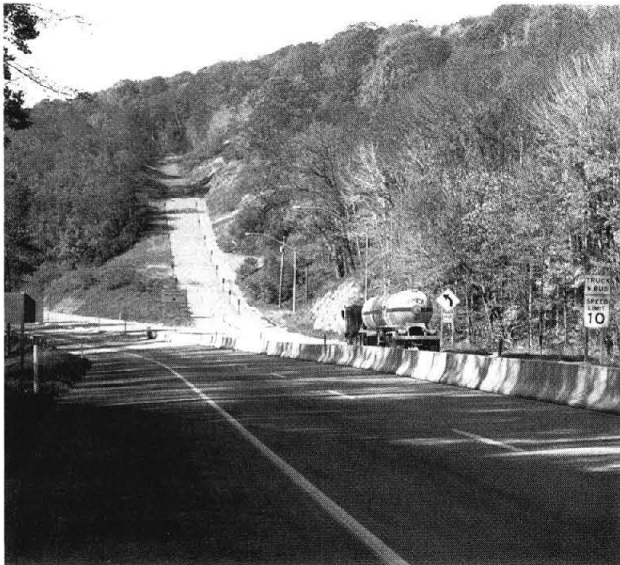

Figure 9 Highly visible gravel arrester bed.

- **Sight Distance.** Twelve responses out of 27 failed to answer or indicated that sight distance was not a factor, while four referred to use of AASHTO standards. Others referred to stopping sight distance, gave 1,000 ft as a value, or indicated that the intent was to provide the maximum visibility and thereby facilitate the driver's proper reaction regarding use of the ramp. One replied: "Meet minimum driver reaction time requirements."
- **Auxiliary Lanes.** The 23 replies on the provision of auxiliary lanes were mixed, with 10 responding positively, eight negatively, and five qualifying their replies. The last included: "if needed," "as site permits (at 4 of 14)," "sometimes," "one site only," and "Yes, short lanes for adjacent ramps."
- **Exit Lane Widths.** Of the 24 responses, several reported varying widths, presumably a taper from a narrow beginning to a wider end point. These ranged from 0–30 ft, 10–20 ft, 10–26 ft, 15–30 ft, and 20–30 ft. Most gave single values: five in the range of 12–14 ft, four from 16–18 ft, two at 20 ft, three at 24 ft, and two in the 28–30 ft range.

### DESIGN ENTRY SPEED

The design speed for vehicle entry into the ramp is critical to the determination of ramp length. The AASHTO Green Book (9) states that an escape ramp should be designed for a minimum entry speed of 80 mph, a 90 mph design being preferred. This assumes, of course, that an out-of-control vehicle can negotiate the alignment ahead of the ramp at such speeds—a requirement that is noted in both Tye (15) and the ITE Recommended Practice (3). The latter, incidentally, provides a formula for calculating speed at any point on a grade given in a manual of the Idaho Transportation Department (16). The velocity formula, based on an energy summation procedure and solved iteratively, is as follows:

$$V = 5.469[0.03343V_0^2 - H - KL - 0.000016 V_m L - (0.0012FLV_n^2/W)]^{1/2}$$

where

- $V$  = speed at distance  $L$  (mph)
- $V_0$  = speed at beginning (mph)
- $H$  = Vertical distance (ft.) corresponding to distance  $L$
- $K$  = constant incorporating surface friction and speed-independent part of mechanical loss (0.01675 for pavement, 0.26175 for gravel bed)
- $L$  = Grade distance computed from stationing (ft)
- $V_m$  = Average of  $V$  and  $V_0$
- $F$  = Frontal area of vehicle (sq ft)
- $V_n^2$  = Average of  $V^2$  and  $V_0^2$ , and
- $W$  = Vehicle weight (lbs).

A PC software program called PSU TRUCK (17) is available from the Pennsylvania Transportation Institute (PTI) to calculate the speed of a runaway truck at any point on a downgrade. The program assumes no retarding by engine or brakes and derives the speed based on initial speed and grade characteristics. Thus, the procedure can be used to determine ramp entry speeds for selected locations.



## Survey Responses

Of 23 survey replies, six states use the AASHTO values. Three use the design speed of the highway in question; six assume specific values between 60 and 80 mph; three use a formula, specified by only one; and four provided comments. These were: "It's being studied," "grade percent and length," "80 mph, often less due to terrain," and "maximum speed for prior curve." Idaho uses the formula cited above.

## GEOMETRICS

Design elements discussed in this section are: ramp alignment, grade, width, design deceleration rate, and length.

### Ramp Alignment

Recent recommendations and guidelines (3,9,15) state that ramps should be straight and that their angle to the roadway alignment should be as flat as possible (See Figure 10). The reason is that vehicles have no steering capability upon entering an arrester bed. While recognizing that terrain can prevent achieving these aims, a ramp closely paralleling the mainline also minimizes right-of-way requirements.

The 25 survey responses reflect the terrain influence. Half the states replied that ramps were tangent to the roadway and straight, but the remainder acknowledged that this was so if the terrain permitted or else that most sites were on curves. One state reported that ramps on negative grades were parallel to the roadway.

Departure angles of ramps to the roadway were generally small, however. Ten replies gave 3 degrees or less, six reported 3–5 degrees, four gave 6–10 degrees, four were greater than 10.



Figure 10 Ramps should be straight and should leave the roadway at the smallest angle possible.

### Ramp Grade

The grades of truck escape ramps show the adjustment of ramp design to local topography, such as the tradeoff of ramp length against earthwork requirements. Uphill grades reduce length requirements, while downhill grades extend length, as the grade factor is usually built into length formulas. In answering the question "Do arrester beds maintain a uniform grade?" eight states responded yes, 10 said no, and seven said usually or not always. Thus, there is no clear reason based on practice to recommend a uniform grade. One reference (14) calls for a review of vertical alignment to ensure that no part of the ramp is hidden from the view of an operator of a runaway vehicle. The full view of a ramp, as Figure 9 illustrates, is more encouraging than one that is totally or partially obscured by a grade change.

### Ramp Width

The AASHTO Green Book (9) makes this statement about ramp width:

The width of the ramp should be adequate to accommodate more than one vehicle because it is not uncommon for two or more vehicles to have need of the escape ramp within a short time. The minimum width of 26 feet may be all that is possible in some areas, though greater widths are preferred. Desirably, a width of 30 to 40 feet would more safely accommodate two or more out-of-control vehicles.

A ramp site in Arizona wide enough for simultaneous occupancy is shown in Figure 11. The ITE Recommendations and the California design guide use 26 ft for the same reason. Both organizations recognize that narrower widths, such as 14 ft, may be used on gravity ramps because their usage is usually short term, not requiring a wait for recovery vehicles.

Survey respondents were asked whether multiple vehicle use of ramps ever occurred. Seventeen of 25 replies were negative. Three said once or rarely. Five affirmative answers came from California, Colorado, Oregon, Tennessee, and Virginia, all of



Figure 11 This Arizona site facilitates entry and use by more than one vehicle at a time. Note pavement marking to minimize parking or confusion about the main travel lane direction.

which have long experience with truck escape ramps. Because ramp widths clearly affect construction costs, the question is one of obvious interest.

Despite the recommendations and experiences above, designers in many states do not accept the need to provide for simultaneous use by two vehicles. Answers to the survey on width ranged from 12 to 40 ft. Fifteen states provide widths less than 26 ft, while 10 provide 26 ft or more. Of those under 26 ft, seven were 18 ft or less, four were 20 ft, and four were 24–25 ft.

**Deceleration Rates**

A consideration in TER design is the acceptable deceleration rate to be imposed on the vehicle. Too low a value increases ramp length and cost; too high a value can cause driver injury and vehicle damage, from cargo shifting as well as external causes. Tests by Cocks and Goodram (18) showed that bed deceleration rates varied with entry speed, being the greatest at the mid-range of entry speeds. They reported that the vehicles likely to have the highest entry speed (large semi-trailers) are likely to have lower average deceleration rates in an arrester bed because of their tandem axle configurations.

A table summarizing field studies (19) on average deceleration data showed loaded tractor-trailer rates of 0.35 g in 36-in. depths of river gravel and 0.39 g in up to 96 in. of river gravel. Average rates for dump trucks in 36 in. of river gravel were about 0.5 g. The characteristic of rate variation with entry velocity is clear in Figure 12.

Whitfield et al. (20), note that care should be exercised when designing vertical curves into arrester beds, as the high g forces generated cause a potential hazard for the truck and driver.

A brochure distributed by PennDOT to truck drivers (21) offers the following comment: “The description of driving into an escape ramp given by drivers of runaway trucks and drivers of our test vehicles is that it is not as rough as an emergency panic stop.”

**Ramp Length**

An equation first published in 1945 (22) is the basis for ramp length determinations shown in the research literature, design guides, and policies published to date. As modified from the original, the distance required to stop a vehicle considering rolling resistance (R) and grade effects, is calculated by this formula:

$$L = \frac{V^2}{30(R \pm G)}$$

where

- L = distance to stop (ft)
- V = entering velocity (mph)
- G = percent grade divided by 100, and
- R = rolling resistance.

Where the grade may change within the bed, the final velocity at the end of the first grade may be calculated and used as the initial velocity (V<sub>i</sub>) for the next section, and so on. The same formula is used:

$$V^2 = V_i^2 - 30L(R \pm G)$$

Table 4 gives values for rolling resistance of different materials as listed by AASHTO and other sources.

Figure 13 shows field observations of the relationship between entry speeds of tractor-trailers and their stopping distances in a Colorado arrester bed (23). The ramp material was pea gravel (90 to 100 percent passing 3/8 in. sieve) in an 18 in. bed on asphalt pavement. This depth, shallower than current recommendations, may explain why stopping distances were greater than those calculated by the formula above.

More recent tests of arrester bed performance show that larger gravel sizes and deeper beds produce higher rolling resistance,

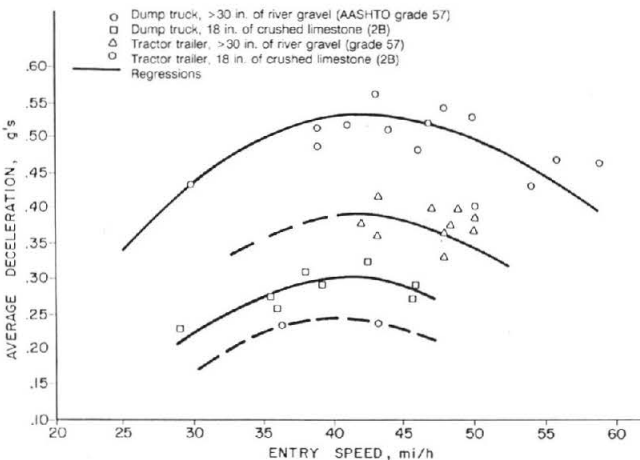

Figure 12 Relationship of entry velocity and deceleration rate (18, Fig. 56).

TABLE 4  
VALUES OF “R” FOR  
DIFFERENT MATERIALS (9)

Surfacing Material	“R” Value
Portland cement concrete	0.010
Asphalt concrete	0.012
Gravel compacted	0.015
Earth, sandy, loose	0.037
Crushed aggregate, loose	0.050
Gravel, loose	0.100
Sand	0.150
Pea gravel	0.250

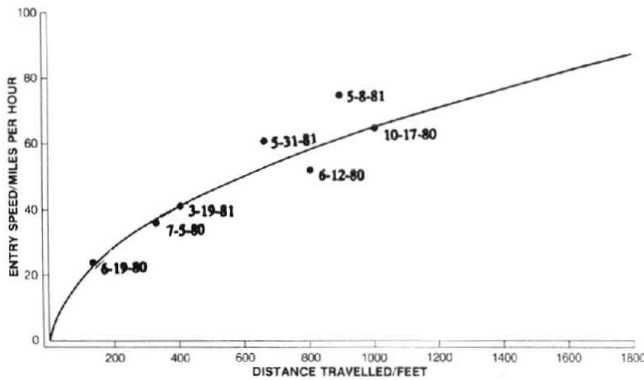

Figure 13 Entry speed vs ramp stopping distance (29, Fig. 7).

and that a third order equation can be used to predict the needed ramp lengths. As adopted in the Pennsylvania Highway Design Manual (24), the model is as follows:

$$L = AV + BV + CV^2 + DV^3$$

where L equals stopping distance or bed length (ft), V equals entry velocity (mph), and A, B, C, and D are constants derived in the research. Their values reflect the rolling resistance of material described as a rounded, uncrushed river gravel in the 0.25 to 1.5-in. range and a mean size in the 0.5 to 0.7-in. range (AASHTO Gradation 57). Appendix B provides a tabulation of calculated bed lengths related to entry speed and ramp grade.

According to the survey responses, two-thirds of the 26 responding states use the FHWA equation for determining ramp lengths, one modifying it by adding 25 ft "for safety." Four other states use unspecified procedures relating entry speeds, material type, and grades; one uses "ramp grade and experience;" three others base lengths on experiences elsewhere.

In situations where terrain or development conditions do not permit provision of desired ramp lengths, mounds and barrels can be deployed to reduce stopping distances. Their use is discussed next.

## MOUNDS

Transverse mounds or berms have been used in, or considered for, escape ramps since the first installations of sandpiles. They are still used in two states with true sandpile escape ramps. (The term "sandpile" is used in one state on signs for TERs, even for gravel arrester beds, because truckers understand the term). In the remaining 25 states, mounds are used by five, in two of these occasionally, depending on terrain. Three states use berms either alongside ramps or only at the ends. Seventeen states do not use mounds at all.

The literature in some cases acknowledges the applicability of transverse mounds at sites where topography prohibits adequate ramp length and higher deceleration rates may be necessary. Other reports cite two hazards from using mounds. First, in addition to severe horizontal deceleration, they cause abrupt

vertical accelerations that can lead to driver injury, loss of control, and greater property damage. Second, because their impacts are mainly on front axles, they impart decelerations there that are not matched at rear axles. The resulting imbalance of forces can cause load-shifting, fifth-wheel shear, and jackknifing.

It is not surprising that the most recent report (25) of field tests recommends that mound usage should be avoided, when possible. If used, they should be of the same material as the bed and placed in the bed at a point where they will be impacted at speeds less than 25 mph. The mounds in the tests were of two designs: half-mounds were 1 ft high and 5 ft across, full mounds were 2 ft high and 10 ft across. Both provided 2:1 slopes of the material.

## END TREATMENTS

"When the only feasible location for an escape ramp will not provide sufficient length and grade to completely stop an out-of-control vehicle, it should be supplemented with an acceptable attenuation device." (9, p. 279). Ballard (14) noted the frequent use of these devices, from gravel berms to specially designed sand barrels, and added a cautionary note: "care should be exercised when using such retarders to ensure that the safety of the occupants of heavy vehicles is increased, not jeopardized." Tye (15) also notes that problems may outweigh advantages. "Namely, where an articulated vehicle such as a semi-trailer encounters an abrupt speed change imposed on the front of the vehicle, load shift, fifth-wheel shear or jackknifing may result. Load shift is also a potential problem for fixed body trucks."

The hazard to others from an overrun may outweigh, in some instances, the potential harm to the driver or damage to the vehicle from attenuator-caused high g forces. For example, extreme restraints were installed at this urban Pittsburgh site (7):

Because of the proximity of the Banksville Road merge ramp, insufficient space was available to make the ramp as long as the FHWA design criteria called for. Hence, a crash barrier was placed across the end of the gravel pile. It consists of ten 14" steel H-beams driven vertically at 30" centers with a steel beam batter and bracing system. This system of "positive restraint" is designed to keep the runaway vehicle from going through all the gravel and landing on top of Banksville Road standing traffic queues.

AASHTO (9) says that a "last chance" device should be considered when an overrun could have serious consequences, recommending a mound of arrester bed material between 2 and 5 ft high and with a 1.5:1 side slope. Furthermore, at the end of a hard-surfaced gravity ramp, a gravel bed or attenuator array may sufficiently immobilize a brakeless runaway vehicle to keep it from rolling backward.

Where barrels are used, it is recommended that they be filled with the same material used in the bed, rather than with sand, which could contaminate the bed and reduce rolling resistance. As with mounds, barrel end treatments should only be employed where conditions do not permit full ramp lengths.

## Survey Responses

Among the 27 state responses, 10 reported using no end treatments, 11 reported the use of material piles (earth, sand, or

gravel), and six reported using sand barrels or tubs, or concrete barriers, sometimes in conjunction with berms. The different responses showed no discernible geographic pattern.

### VEHICLE REMOVAL PROVISIONS

The rolling resistance characteristic that makes the TER an effective safety measure becomes an impediment to vehicle removal once a ramp is used. In constructing the ramp, therefore, provisions must be made to facilitate vehicle removal by towing or other service equipment. Service lanes and anchors should be an integral part of ramp design.

Ballard (14) recorded in 1983 that this was not always the case. More recent publications endorse the use of service lanes and offer additional useful comments. For example, the ITE report (3) states: "If a service road is developed adjacent to an escape ramp, the designer should design the service road so that the operator of an out-of-control vehicle will not mistake the service road for the ramp." This distinction may be particularly important at night. AASHTO (9) suggests: "local wrecker operators can be very helpful in properly locating the anchors." The California guidelines (15) offer this:

A 12–14 foot wide service road should be provided adjacent to the gravel bed on the same side as the through highway. This service road allows tow-truck access to extricate the trapped vehicle and a hard surface clear of the through lanes to which the trapped vehicle can be pulled. Anchors for tow trucks should be spaced along the service road at about 150-foot intervals. These anchors should be offset to the side of the service road away from the gravel. In addition, an anchor should be placed about 150 feet in advance of the gravel bed on the approach. This will enable a tow truck to extricate a vehicle that has only gone a short distance into the gravel.... Where possible, it is desirable to have the service road come back to the through roadway. This will allow easier return of the tow truck and extricated vehicle to the through roadway. Also, the service road should have distance marks from the beginning of the gravel painted on it. This will allow the performance of the gravel bed to be monitored.

The consequences of not having a parallel service road and failing to use anchors have been described as follows:

A load of more than 40,000 pounds is required to extract a loaded tractor-trailer. During the tests conducted, towing service personnel who did not believe the anchor would be necessary found that the tow truck, rather than the captured vehicle, was moved during extraction attempts. In one such case, the paved approach was damaged (19).

Figure 14 shows the approach pavement condition at a site where no parallel service lane is available; while truck removal activities are not known to be the cause of the apparent pavement failure, it seems probable. Figure 15 also shows pavement damage, possibly from removal efforts not using an anchor block, on a service lane.

### Survey Responses

Twenty-two of 25 states reported using anchor blocks, while two said sometimes and one replied negatively. Pennsylvania's Design Manual (24) calls for one block in the center of the approach lane 50 to 100 ft in advance of the bed, and flush with



Figure 14 Apron pavement damage probably caused by truck retrieval.



Figure 15 Service lane pavement damage from vehicle removal activities.

the road surfaces. The typical design is a 4 x 6 x 4 ft concrete block with two loops of #12 reinforcing steel set in recessed slots covered by removable  $\frac{3}{4}$ -in. steel plates. Additional blocks may be provided in the service lane on long ramps.

The survey results showed that 24 states use service lanes and only three do not. While widths were rarely mentioned, 10 ft was reported twice, 12 ft once, and 12 to 14 ft once. Most states also use anchor blocks, and several provided design and installation details.

### Service Lane Pavement

The literature says little about pavement design for service lanes beyond using terms such as "hard-surfaced" or "paved."



Among 22 survey replies, eight showed a similar lack of specificity. Four states use gravel or granular material, while four reported "asphalt pavement," "minimum plant mix," "same as any ramp," and "pad for service truck." Showing a wide range of designs, others indicated the following alternatives:

1" Bituminous surface over 3" bit. concrete base	2" Asphalt concrete over 6" base
Double surface treatment on 18" crusher run	3" plant mix over 4" Type 1 aggregate
RC250 prime and seal over 12" aggregate base	3" A.C. on 6" A.B.
2" Hot mix on 2" stone	4" HLBC course on stone
AC Hot mix Type 2 (220 #/SY) over 6" crushed stone	6" PCC for parallel ramps, ABC class 6 on others
	6½" AC on 6–8" graded aggr.
	7½" bituminous concrete

### Median Opening

When a ramp is placed on a multilane highway with a median, consideration should be given to providing access across the median from the uphill roadway for police, emergency services, maintenance vehicles, and towing equipment.

### MATERIALS AND OTHER PHYSICAL ELEMENTS

This section briefly reviews the extensive literature on truck escape ramp materials research, reports on survey responses, and addresses the issues of drainage for arrester beds. The bibliography lists some of the reports published prior to 1980 on materials research. They are covered in detail in a 1983 literature review (6), which provides an annotated bibliography. References cited below are only the more recent publications.

#### Materials for Truck Escape Ramps

Requirements for materials in TERs are described by AASHTO (9) as follows:

The surfacing material used in the arrester bed should be clean, not easily compacted, and have a high coefficient of rolling resistance. When aggregate is used, it should be rounded, predominantly single size, and as free from fines as possible. The use of large predominantly single-size aggregate will minimize the problems due to moisture retention and freezing as well as minimizing required maintenance, which must be performed by scuffing when the material compacts.... Pea gravel is representative of the material used most frequently, although loose gravel and sand are also used. A gradation with a top size of 1.5 in. has been used with success in several states.

*Truck Escape Ramp Design Methodology* (25), gives these conclusions from extensive field testing of materials:

- Smooth, rounded, uncrushed gravel of approximately a single size is the most effective arrester bed material. The best size appears to be near 0.5 in.
- The river gravel graded to AASHTO Gradation 57 was found to be the best of those materials tested.
- An appropriate crush test, such as the Los Angeles abrasion test, should be used to evaluate the durability of stones in arrester beds.

- The use of a material with low shear strength is desirable in order to permit tire penetration.
- Rounded river gravel produces higher decelerations than the more angular crushed aggregate.

These conclusions are amplified in the full final report:

It is recommended that a rounded, uncrushed river gravel (or a synthetic equivalent) be used with stone sizes in the 0.25 to 1.5-in. size range and a mean size in the 0.5 to 0.75-in. range. Materials of the AASHTO grade 57 are effective if the fines are washed away. If it is more cost-effective to do so, these materials can be used without washing away the fines, but an additional 6 in. of depth would then be needed.

The California guidelines (15) note succinctly, "Ideally, marbles would be the answer," and go on to state: "The aggregate for an arrester bed should be washed, free-draining, uncrushed gravel of uniform shape and size." The recommended grading is shown in Table 5.

### Survey Responses

Varying detail marked replies to the questions: What aggregate types and sizes have been used, and what does experience show to be the most effective? The 27 responses ranged from the unamplified expression "pea gravel" to provision of a complete specification.

Fourteen states used the term "pea gravel," while four states reported use of crushed aggregate. Table 5 summarizes those gravel specifications that were provided.

Other states that use pea gravel gave the following comments:

- ½ in. to ¾ in. washed pit run gravel
- ¾ in. pea gravel with added specs on degradation, roundness, and percent fractured faces
- AASHTO #5 or ½ in. maximum pea gravel
- ¾ in. pea gravel (±)

Regarding comments on the most effective material, most respondents cited their own specification or referred to single-graded, rounded pea gravel. Thus, the consensus essentially is that single-graded, well-rounded gravel is the most desirable material for use in arrester beds.

### Material Depth

The AASHTO Green Book (9) states: "Arrester beds should be constructed with a minimum aggregate depth of 12 in. Successful ramps have used depths between 12 and 36 in." This was the 1979 FHWA *Guidelines* recommendation.

Research and experience since then on depths of bed material has led to recommendations for increased depths. Opened in the late 1970s, the Siskiyou Summit ramp appeared to function well with 18 in. of material (26). As Ballard (14) reported in 1983, bed depths in several states were 18 in., but some were 24 in. Whitfield (20), on the basis of scale-model and full-scale tests, recommended that beds should be configured with a maximum depth of 24 in. and noted that depths less than 18 in. act to reduce rolling resistance.

By 1986, however, California noted that the needed depth was not established with any certainty (15). Experience indicated

TABLE 5  
EXAMPLES OF GRADATIONS REPORTED FOR ARRESTER BED GRAVELS

SIZE OR SIEVE NO.	PERCENT PASSING								
	AR	CA	CO	MD	NV	NM	OR	TN	VT
2"			100						
1-1/2"		100							
1"		90-100	25		100		100		
3/4"		0-10	10		90	100	90-100	100	100
5/8"									90-100
1/2"			5		25-50	97-100	0-10		
3/8"	90-100		0-5	90-100	0-20				
#4		0-2		0		0-5		8	0-5
#8								4	
#10							0-2		

that contamination with fines could turn the bottom 12 in. almost into cement-treated base, while trucks sank 12 in. into the surfaces. They concluded, therefore, that minimum depths should be 30 in. and that 36 in. would be desirable.

Pennsylvania studies (19) concluded that even greater depths were necessary:

A minimum of 42 inches is the recommended depth for river gravel. The minimum includes 6 inches of depth required when the gravel contains many fines, especially if the bed is located where the potential for heavy use is great. Frequent use results in the significant increase in fines content, which, as discussed earlier, decreases the effectiveness of the bed.

Bed depth need not be uniform throughout. To avoid excessive deceleration at the bed entry, most of the published research advocates varying the bed depth from a few inches at the entry to full depth within 100 feet.

#### Survey Data

Twenty-two states offered information on bed depth, which is summarized in Table 6. Nine states taper depths from entry

TABLE 6  
BED DEPTHS USED BY RESPONDING  
HIGHWAY AGENCIES

Depth	Number of agencies
18 inches	5
18-30	1
24	5
36	10
42	1

points. Initial depths were as little as 3 in. in two states, 6 in. in three states and as much as 12 in. in four states. The length of taper to full depth was 100 ft in three cases, 200 ft in one, but otherwise not mentioned.

#### Drainage

Proper provision for drainage is important for two reasons. One, freezing destroys the efficacy of the bed in cold weather. Two, improper drainage can lead to accumulation of fines that fill voids, compact the aggregate and similarly reduce the performance of the bed.

Several sources testify to the importance of drainage. A Colorado study (27) that monitored the performance of aggregates for two years concluded that all ramps lacked adequate drainage and were prone to freezing four to six months during the year:

During the extreme cold weather conditions, the larger material with low contamination (of fines) developed a thin frozen crust between the aggregate. It was felt that this thin layer would be broken by trucks entering the ramp. But, the smaller aggregate with large quantities of fines were frozen solid and the degree of stiffness increased with increase in the amount of fines and moisture and decrease in temperature.

This research led to "Design Guidelines for Improvement of the Truck Escape Ramps," (27) which particularly addressed drainage issues (see Appendix C).

The Pennsylvania research (19) recommends the following:

Proper drainage so that water does not stand in the bed is important. A 6 to 12-inch layer of large (at least 3 inches in diameter) crushed limestone aggregate will effectively drain the arrester bed. The stones should be confined to the layer either by forming a gabion or covering them with fabric to separate the larger stones from the river gravel. The cross slope of the base should be to one side, with either French drains or a crown for removing any water from the arrester layer. The river gravel covering this sloping base layer should have no cross slope at the top surface; i.e., the bed should be filled such that the top surface has no cross slope.

California's guidelines suggest either paving the sides and bottom of the bed with asphaltic concrete or lining with geotextiles.

In addition to California, two other states reported paving the base, in one case in conjunction with the use of 6 in. perforated CMP underdrains. Out of 23 responses, nine states commented that drainage solutions were provided by free-draining material and the use of natural slopes or grading to drain water away from ramps. Sixteen other states described a variety of underdrain systems, some with transverse outlets every 100 ft, and some with edge drains. At least half of these are states where freezing would not be a serious problem. Their drainage provisions are presumably designed, therefore, to avoid contamination and compaction of the beds.

### CONSTRUCTION COSTS

The project developing the Prototype Grade Severity Rating System (12) compared costs of different runaway countermea-

asures and determined the following figures for truck escape ramps:

Sand piles	\$25,000-\$40,000
Arrester beds	\$31,000-\$300,000

These figures presumably were obtained from the states and represent 1970s costs. The construction cost for eight Colorado ramps opened between 1976 and 1980 totalled \$2,725,000, or slightly more than \$340,000 per ramp (13). All were ascending grade ramps, varying in length from 500 ft to 1,530 ft. Cost per foot ranged from a low of \$163 to a high of \$974 for one ramp; total costs per ramp varied between \$197,000 and \$529,000. More current data are reportedly available from at least six states, though they were not provided.

Clearly, escape ramp costs are highly site-related. Their length depends on grade characteristics, earthwork costs reflect on-site conditions, and material costs are dependent on the availability of suitable aggregate as well as the volume required.



## OPERATIONAL CONSIDERATIONS

This chapter deals with issues related to advance warning of grades, other traffic considerations at the ramp, enforcement, and vehicle removal from ramps. As before, the content is drawn from a survey of the literature and current practice.

### ADVANCE WARNING OF GRADES

Giving truck operators information about the downgrade conditions they can expect to encounter is one way of reducing the likelihood of runaway vehicle accidents. It can be done in many ways, as both the literature review and survey results revealed.

#### Literature Review

An early report on North Carolina experience (28) describes advance warning provisions for a 6 percent downgrade nearly 5 miles long on U.S. 70: "All eastbound trucks must stop at a weigh station on the summit, where the drivers are told about the sand ramp and the turnout. The weigh station was moved to the top of the mountain from Swanannoa, a town to the west, in an effort to adequately warn and protect the truck drivers on the steep descending grade." The turnout mentioned is a paved site 2 miles down the grade where drivers can stop to cool their brakes.

A research report on New York's Vickerman Hill test site (29) describes how trucks were required to stop at a specially constructed turnout before descending the grade, to ensure that transmissions were in low gear and brake failures would be minimized. A diagrammatic sign of the hill was placed in the turnout for driver information.

In "Technique for Identifying Problem Downgrades" (30), Eck reported on operation of mandatory brake check areas. They can be done on a random basis by state highway patrols at weigh stations or turnouts at summits of grades, where trucks can be required to stop. In addition to providing opportunities for informational signs, the summit sites ensure that trucks start down the grade from a stopped condition. Figure 16 shows how simply the sites can be provided, through a widened paved shoulder, and adequate advance signing. Figure 17 shows an example of advanced signing and Figure 18 shows how these and other signs for TERs can be integrated into an advanced warning system.

Weight-specific speed signs, either advisory or regulatory, are a form of advanced warning. Their use and the use of more general signing are discussed and illustrated in "The Development and Evaluation of a Prototype Grade Severity Rating System" (12).

*The Manual on Uniform Traffic Control Devices for Streets and Highways* (MUTCD) (31), covers advance warning for hills



Figure 16 A brake check area created at the top of a grade in Arizona.



Figure 17 Advance signing for turnout.

and truck escape ramps in pages 2C-13 and 2C-14, which are reproduced here as Figure 19.

#### Survey Responses

Twenty-three states responded to the question whether brake-check and driver information areas were provided at the top of grade routinely. Eleven states do routinely provide such sites, nine do not, and four reported limited use. One state reported continuous availability at truck inspection stations.

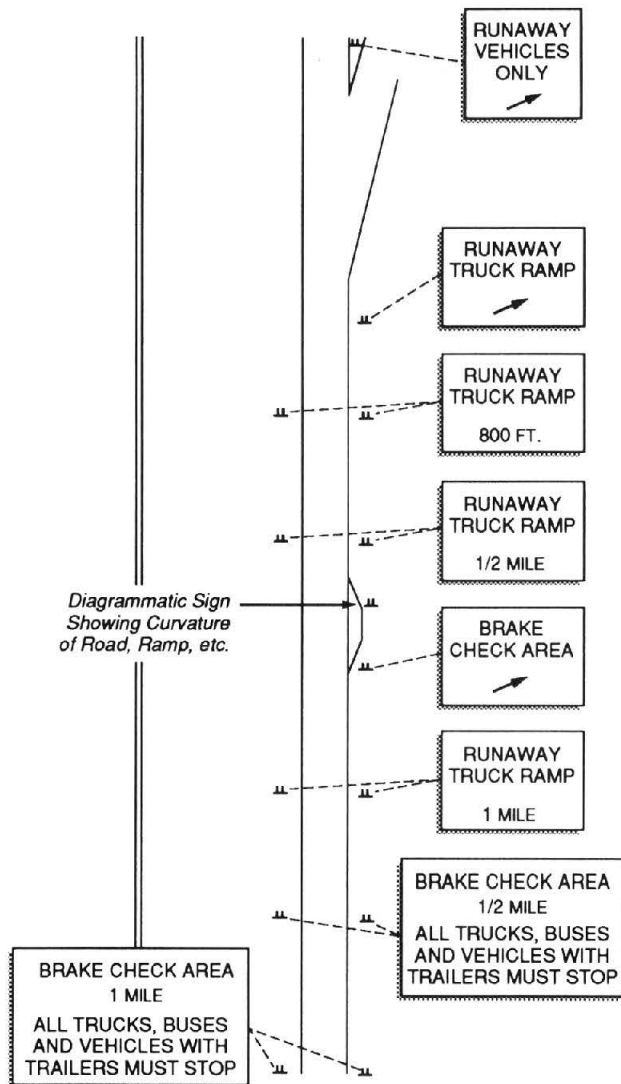

Figure 18 Advance signing for Arkansas site.

Figure 16 showed how a widened shoulder can serve for brake checks. At a site in Oregon, one 600-ft brake check lane is provided behind the shoulder and separated from it by a ditch. The lane is well-marked with red-on-white signs saying “Truck Parking Only,” “No Parking,” and “Tow Away Zone.” Figure 20 illustrates a diagrammatic information sign used at a Pennsylvania brake check area.

For the eleven states that did not offer advance warning signing plans, the listing of signs suggested that the MUTCD is exactly or closely followed. Ten states returned sign plans showing details of legend, size, and location. All were compatible with the recommendations of the MUTCD.

#### TRAFFIC CONTROL DEVICES AT THE RAMP

The literature, even the MUTCD, says little about details for traffic devices at the ramp site. The text in Figure 19 states that a regulatory “Runaway Vehicles Only” sign should be placed

near the ramp entrance, and “No Parking” signs may be placed in the same area.

Delineators define ramp edges and give nighttime direction to drivers about ramp orientation. Section 3D of the Manual (28) is more specific about the optional use of delineators:

When used, delineators shall be red in color and should normally be placed on both sides of truck escape ramps. The delineators should be spaced at 50-foot intervals for a distance sufficient to identify the ramp entrance. Delineator spacing beyond the ramp entrance should be adequate for guidance in accordance with the length and design of the escape ramp.

The use of red distinguishes these delineators from those giving guidance on the main roadway and also distinguishes the site from an ordinary exit ramp.

Figure 21 comprehensively illustrates TER signs, markings, striping, and delineation (15). Past the cantilevered overhead exit sign, ramp approach signs with arrows pointing down clearly direct the driver into the correct lane. Because the left arrow sign masks and blocks the service lane, it is not likely to be used by mistake. “No Stopping” signs are used instead of “No Parking” signs. The auxiliary lane and ramp approach are marked with “Runaway Vehicles Only” markings, and 8 in. white striping marks the gore area. Red delineators show the right edge of the auxiliary lane and both sides of the ramp.

Not shown in Figure 21 are signs giving the location of anchor blocks. These are used in some states, especially where snow may cover the anchors in winter.

#### Survey Responses

As with advance warning signs, the state responses showed general conformity with the MUTCD or some enhancement of the Manual requirements. For instance, both Arizona and California use “No Stopping” rather than “No Parking” regulatory signs. These convey more accurately the potential hazard to drivers of using TER sites for scenic viewing or rest areas. Most states use the “Runaway Vehicle Only” signs within the site, and mark the turnouts by overhead or large ground-mounted signs (See Figure 22). For extra target value or conspicuity, Oregon and Vermont use flashing beacons on signs at some ramps.

At least one state attaches an “Occupied” board to advance warning signs, as protection for personnel in the ramp on vehicle removal or maintenance tasks. At least one manufacturer offers a detector and warning system triggered by a vehicle entering the ramp, which could be used for this purpose.

Eighteen of 26 states have exercised the delineator option, but only eight specified the color red. Five use “standard delineators” or did not specify color. Three states said none were used.

Illumination of TERs is uncommon, found in only five states, and is not at all sites in those states. One state uses highway lighting and/or floodlighting, another has lighting for a parallel ramp on a busy Interstate route, two others illuminate entry points, and the fifth provides their standard area lighting. Obviously, the presence or lack of a local power supply is a factor to consider.

#### ENFORCEMENT

A number of enforcement aspects apply to downgrades and truck escape ramps. They include vehicle inspections, enforce-

2C-26 Hill Sign (W7-1 to 4)

The Hill sign (W7-1) is intended for use in advance of a downgrade where the length, percent of grade, horizontal curvature, or other physical features require special precautions on the part of drivers. When the percent grade is shown within the Hill sign (W7-1b) the message X% shall be placed below the inclined ramp/truck symbol. The word message HILL (W7-1a) may be used as an alternate legend.

11-54 (c)  
Rev. 3  
Editorial  
Change  
Rev. 4



W7-1  
30" x 30"



W7-1b  
30" x 30"

The Hill (W7-1) and Grade (W7-3) signs should be used in advance of downgrades for the following conditions:

- 5% grade and more than 3,000 feet long
- 6% grade and more than 2,000 feet long
- 7% grade and more than 1,000 feet long
- 8% grade and more than 750 feet long
- 9% grade and more than 500 feet long

These signs should also be installed for steeper grades or where accident experience and field observations indicate a need.

The supplemental plaques (W7-2 series, W7-3 series) or other appropriate legends and larger signs should be used for emphasis or where special hill characteristics exist. On longer grades, the use of the mileage plaque (W7-3a or W7-3b) at periodic intervals of approximately 1 mile spacing should be considered.



W7-2b  
24" x 18"

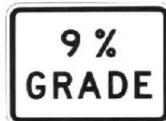

W7-3  
24" x 18"



W7-3a  
24" x 18"



W7-3b  
24" x 18"

Runaway truck ramps are desirable for the safe deceleration and stopping of runaway vehicles on long, steep downgrades where installation is practical. When such ramps are installed, the associated signing (W7-4, W7-4a) shall be black on yellow with the message "Runaway Truck Ramp." A supplemental panel may be used with the words "Sand," "Gravel," or "Paved" to describe the ramp surface. These advance warning signs should be located in advance of the gore approximately one mile, one-half mile, and then one at the gore. A regulatory sign near the entrance should be used containing the message "Runaway Vehicles Only" to discourage other motorists from entering the ramp. No Parking signs may be placed as required near the ramp entrance.



W7-4  
78" x 48"



W7-4a  
78" x 60"

Some hills have potentially hazardous conditions such as a stop condition, railroad grade crossing, sharp curvature or a community that may not be readily apparent to an unfamiliar driver. A truck turnout at the hill crest and a special trucker information diagrammatic sign may be necessary for these situations.

Figure 19 Excerpts from *Manual on Uniform Traffic Control Devices for Streets and Highways* (31).

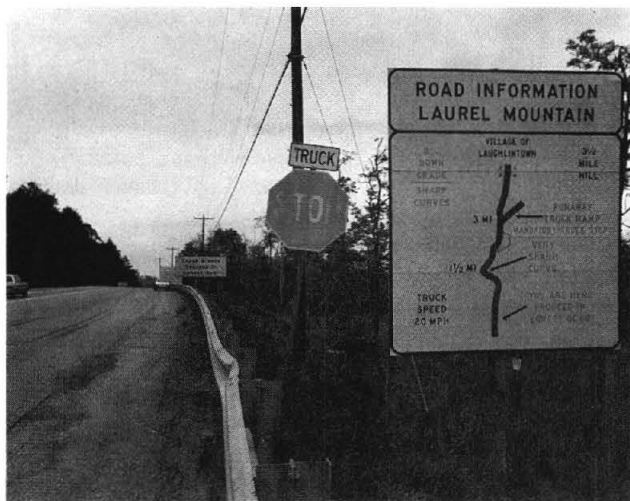

Figure 20 All trucks over 21,000 pounds are required to stop at this roadside turnout at the top of the grade. The information signs point out site characteristics, including a 20 mph speed limit and another mandatory stop partway down the grade.

ment of speed control and TER site regulations, and the recording of incidents (sometimes involving citations).

The literature search yielded little on these subjects. California's guidelines (15) note that if brake inspections at the top of the grade are made mandatory and enforced, then trucks will start down the grade from a stopped condition. Pennsylvania experience (7) highlights the value of such an action: "On November 1, 1979, Federal Highway officials and State Police stopped 26 trucks at the top of Greentree Hill. Nineteen of 26 had defective or maladjusted brakes. One having only one of eight brakes in proper adjustment was impounded and not allowed to continue."

Misuse of truck escape ramp sites was commented on in five other reports. Early experience in Colorado was described as follows:

Since the opening of the first runaway truck escape ramp in December, 1976, there have been approximately 34 reported incidents of unauthorized usage by passenger cars and pickup trucks. Twenty-two citations were issued to these motorists for disregarding traffic control devices or careless driving. These are some brief comments made by drivers for their improper use of the ramps: "Curious," "Didn't know," "Didn't see signs," "To get some rest," and "To look at map."

Writing in 1979 about Oregon's Siskiyou Summit ramp, Young (11) said:

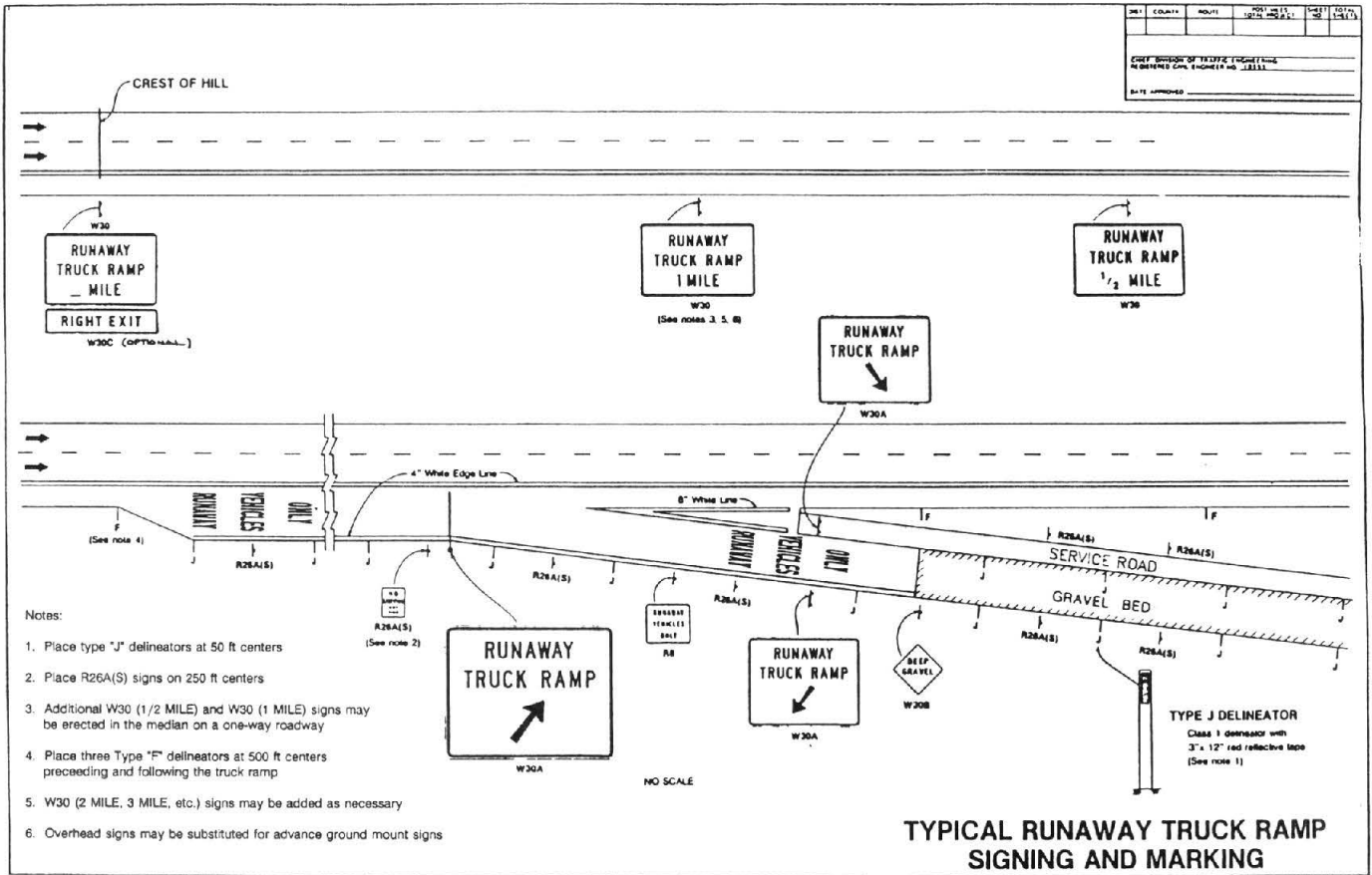

Figure 21 Recommended site signing, from California guidelines (15, Fig.3).

A few cases of misuse of the escape ramp have been reported. The problem could be the result of insufficient warning that the escape ramp is for runaway vehicles only. There may be a lack of driver understanding regarding exactly what the escape ramp provides. Also, some confusion has probably been caused by the nearness of the truck ramp signing to signing for a rest area just beyond the end of the escape ramp. In one case, a Volkswagen became stranded in the bed after being driven in for a driver change. In another case, a piggyback truck was stranded after being driven into the bed for a brake check.

A 1986 review (23) of the same ramp's performance showed that the problems continued:

Many drivers have pulled onto the ramp thinking they were entering the rest area and have become stuck. Three signing modifications have reduced the problem, but still people enter the bed thinking it to be an exit. Drivers of recreational four-wheel-drive vehicles often enter the bed to see if they can traverse it. They usually succeed, leaving the wheel tracks for the maintenance crew to smooth.

Hayden (29) also flagged the hazards created by four-wheel-drive vehicles leaving deep ruts from wheel-spinning:

The gravel rutting also posed a danger to a truck driver trying to bring his runaway vehicle back under control. This was shown on a videotape of one truck entry. The beginning of the arrester bed was badly rutted. As a result, the truck bounced rather

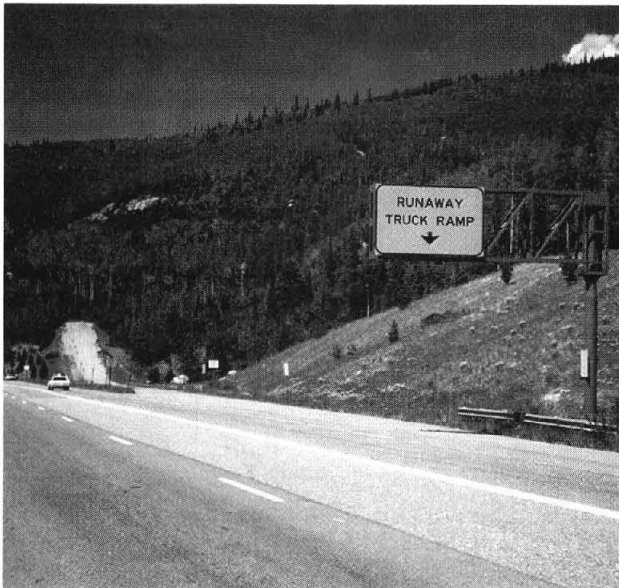

Figure 22 Overhead sign at ramp entry.



severely and was thrown to the left when it hit the ruts, but it did manage to stop safely.

Where improper use is common, a site inspection is warranted. Things to look for can include graded areas outside the escape ramp, absence of other areas for motorists to stop, inadequate signing, and an overcrowded upstream rest area. Treatment can include fencing or landscaping to screen off a graded area. In any event, remedial action should be directed at the cause of the problem and not the symptoms (15).

### Survey Responses

Perhaps because engineering office staffs responded to the survey, information on enforcement was sparse. The 27 responses are summarized below:

No response or "unknown"	9
None	4
Routine	9
Brake checks and posting maximum truck speeds	1
Two sites with special speed limits	1
Monitoring by state police and sheriff's office	1
Routine inspection and selective speed enforcement	1
PSC periodic vehicle inspection	1

Most states address the improper use of TER sites through signing. Seventeen of 25 responding to this issue use "No Stopping," "No Parking," and/or "Runaway Vehicles Only" signs. Three states indicated that on-site enforcement was carried out (i.e., non-essential users were cited), or was requested of state police. Two other states warn that violators will be cited or that vehicles will be towed away. However, five states replied that no efforts were made to keep non-users away from sites.

Figure 23 shows tire tracks most likely left by four-wheel-drive vehicle operators. Figure 24 suggests that this short ramp with both mounds and boards gets little use because of good compliance by truck operators with the 20 mph speed limit for trucks on the down grade.

Citations are sometimes given in conjunction with emergency use of ramps. Nine respondents did not know current practice in their states. Ten said citations were not given, but six states



Figure 23 Casual use of the site by four-wheel-drive vehicle operators is suggested by these shallow tire tracks.



Figure 24 Reduced speed limits for trucks are an effective safety measure when compliance is good.

said they could be. In the last group, citations could be given if some violation were proved, such as failure to observe a traffic control device, if the vehicle was not under control, or under other conditions determined by the specific case.

### Summary of Enforcement Practice

The quantity and quality of responses on enforcement issues probably do not warrant conclusions, although the results generate some impressions. First, regulatory signing of truck speed limits on downgrades is not widely practiced. Second, enforcement activities do not seem to focus on truck performance on downgrades. Third, misuse of truck escape ramp sites for non-emergency purposes seems widespread and should have more enforcement attention.

### VEHICLE REMOVAL OPERATIONS

Design provisions to aid in vehicle removal from arrester beds were addressed in the last chapter. The concern here is in the steps necessary for prompt extrication of vehicles. Only one published source shed light on this topic and that is the final report from the Pennsylvania field tests.

The PTI report's Executive Summary (25) recommends the following procedure:

Extraction should be performed with a wrecker and a winch. The front of the wrecker must be chained to a dead man anchor block, and the winch must be used with a block and tackle that has at least a two to one mechanical advantage. After the vehicle being extracted from the bed begins to move, it can be raised onto 2 x 6" boards to greatly reduce the drawbar pull...."

The report commented elsewhere that airfield expanded metal sections, fencing, conveyor belts, and sheet metal were also tried to distribute the wheel loads, but had too much flex. The 2 x 6 in. boards worked as well or better than anything else. The main report (19) gives additional details:

At least two boards per wheel set should be used so that, as a wheel rolls off one board, it will roll onto the next. As the wheel then rolls clear of the first board, that board can be placed in front of the second board.... An important note of caution must be heeded: flaps must be removed or tied such that they will not wrap around the wheel between the stones and the tire. Only a turning wheel will ride up onto the aggregate rather than dig into them, and a barrier between the stones and tire will prevent the wheel from turning.

In practice, however, tow trucks in at least one Western state apparently do not use anything under wheels. Neither do they rely on anchor blocks. Figures 25 and 26 illustrate what can happen. The tow truck front wheels are off the ground, and a wave of gravel has built up behind the truck wheels.

### Survey Responses

The survey of states asked four questions related to vehicle removal:

1. Are there communications on-site?
2. Are vehicles removed by public or private services?
3. What are usual response times?
4. What are typical removal costs?



Figure 25 Tow truck front wheels lifted off the ground during removal of embedded truck.

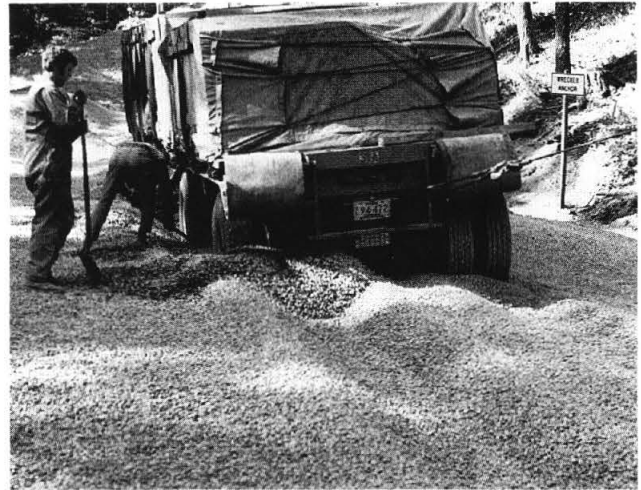

Figure 26 The use of boards during removal would eliminate the gravel wave buildup shown here.

In answer to the first question, 23 of 26 states said no communication system was provided. One state said that it was desirable, one said there were usually not communications on site, and one has a switch at the ramp that activates an "Occupied" sign at the truck inspection site up the grade. One state reported that all maintenance equipment in the vicinity of one site is equipped with CB radios to monitor calls from trucks for towing services. Regarding telephones, one guide does suggest that they be placed so that they are readily visible to someone in the bed but not to passing motorists.

Only one state replied that vehicle removal could sometimes be a publicly provided service. Twenty-four states indicated that private services handled removal.

Twenty-five replies about response times showed a broad range of results, although 12 could not provide specifics. Four states reported times of one hour or less. Adding cumulatively to that, response times would be 4 hours or less in nine states, 6 hours or less in 11 states. Two states with some clearly remote ramp sites gave values of 1 hour to 1 day and 12 hours to 32 hours maximum.

The cost of wrecker services was an unknown to most states. The only reported figures ranged from \$100–\$500, with one at \$1,200–\$1,500. The low figures are about the same order of magnitude as those reported by Williams in 1979, so the last figure may be more in line with current costs. Fancher (2) also estimated costs of ramp use to truckers at \$300 per entry counting waiting times. He concluded that the total cost of recovering trucks from ramps was \$1,200,000 per year. The question is of interest because one reason given by truck operators for "riding it out," i.e., passing up and failing to use truck escape ramps, is to avoid the costs of vehicle recovery.

## MAINTENANCE OF TRUCK ESCAPE RAMPS

Certain maintenance activities are essential to the proper functioning of truck escape ramps. The subject is well addressed in research reports and guidelines, and for the most part, drew an informative response from 27 states.

The AASHTO Green Book (9) makes a statement that can serve as a starting point:

After each use, aggregate arrester beds should be smoothed and the aggregate loosened as necessary. In addition, the bedding material should be cleaned of contaminants and loosened periodically to retain the retarding characteristics of the bedding material and maintain free drainage.

The following sections will show through the literature review why the steps recommended above are important, and, through the survey results, how they are usually carried out. The chapter is separated into sections on routine procedures, winter maintenance, aggregate contamination, and aggregate improvement.

### ROUTINE PROCEDURES

The California Guidelines (15) unequivocally state "it is essential that the aggregate bed be re-shaped as soon as possible after a vehicle has been removed from the gravel." The guidelines add the following:

Maintenance of an arrester bed escape ramp requires adequate equipment. Hand tools are not acceptable. Proper power equipment assures that the ramp will be back in service with a minimum amount of time. It also ensures that maintenance workers will be minimally exposed to the chance of a runaway truck wanting to use the ramp.

Equipment considerations may include a motor grader with an extension on its blade so the final pass in smoothing the gravel may be made from the service road. Another possibility is using a sno-cat or some other light footprint vehicle. Since escape ramps are located in mountainous terrain and their use is more frequent in warm weather, the availability of sno-cats is a possibility.

Ramps should be scarified and graded at periodic intervals even if not used, to keep them from becoming compacted. The process of scarifying recommended above has been well described as "fluffing", an apt analogy to domestic bedmaking. Tests conducted in recent research (19) showed:

Fluffing of the bed is essential to maintaining good operating conditions for successful truck capture. All of the beds tested were found to compact with time.... Beds filled with AASHTO Grade 57 river gravel must be reworked twice each year in addition to after each use.... Fluffing should be done to a minimum depth of 18 inches, and, at least once a year, to a minimum depth of 24 inches. Approximately 30 minutes is needed to pull the fluffer ... through a bed three or four times. Of course, the fluffing

procedure will take longer if mounds must be removed and reconstructed.

Figure 27 shows the device designed for and used on the Pennsylvania test sites. A sled with prongs extending down into the gravel, it is weighted with "around 200 pounds (usually one or two persons) and towed with a cable attached to a dump truck."

Cost information for TER maintenance is scarce in the literature. Ballard (14) reported an Oregon study in the 1970s that gave \$73 per use as the average restoration cost, an amount for which the vehicle operator was billed. In the same period, sand-pile restoration in North Carolina averaged \$200 per use. The ITE Recommended Practice (3) gave a figure for one state of \$150-\$200 per month for routine maintenance costs.

### Survey Results

The questionnaire asked about the frequency of maintenance checks and the equipment routinely used for TER maintenance. Several of the 27 replies used terms like "as needed" or "unknown." Most were quite specific and can be summarized as follows:

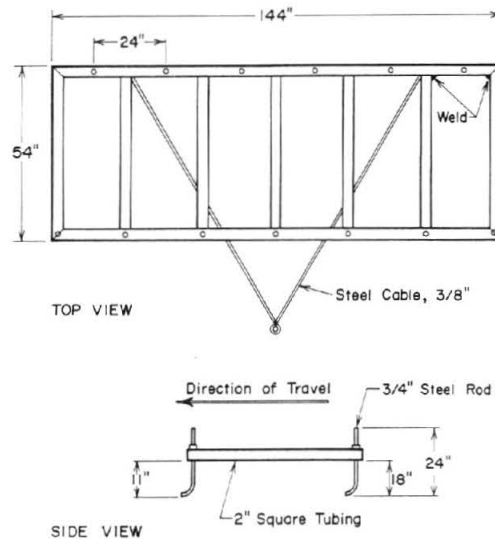

Figure 27 Device for gravel bed fluffing.



Daily or several times/week	8
Weekly	8
Monthly	2
More than once/year, "periodically"	5

One state reported making random checks, as well as after each use. It seems clear that the majority of sites are checked frequently. This is not to say, however, that the practice of regrading after each use is widely followed. The survey results did not permit correlating the frequency of checks with the frequency of use at individual sites.

Equipment used for routine site maintenance varies widely among the 27 responses, but is mostly powered as recommended above. Manual effort was noted by six replies, one of which said that most maintenance was accomplished by hand raking, while five others reported hand raking and shoveling in conjunction with backhoes, front-end loaders, or graders. Twelve states reported the use of one or more of the following: graders, backhoes, front-end loaders, Gradalls, and dozers (up to D-12). Two states use harrows as part of the equipment, another mentioned use of a hand-made drag bit, and another (not Pennsylvania) uses a fluffer drag to maintain arrester beds and eliminate unwelcome four-wheel-drive vehicle tracks. Whether heavy tracked vehicles can be used without degrading the aggregate has been questioned.

Listed below are the maintenance procedures followed by the state of Washington. It is worth noting that step 1 is to flip the "Ramp Occupied" panel on advance warning signs as a protection to maintenance personnel and as a warning to vehicle operators. In a related safety practice, another state listed equipment used for maintenance in the following sequence: lookouts—closure—shadow vehicles, snocat, two-way radios, motorgraders. No other response singled out such precautions or described these kinds of procedures.

#### Maintenance Procedures of Washington State Department of Transportation

1. Signs indicating truck ramp is occupied should be flipped as soon as possible after runaway vehicle enters ramp to inform other drivers that ramp is being used. After vehicle is removed, signs should be changed back to original position.
2. The wheel tracks must be smoothed out after a runaway truck is removed from the escape ramp. This will prevent the next vehicle from possibly overturning.
3. Gravel should be loosened to a depth of one foot.
4. Rock should be replaced whenever there is spot contamination. A visual inspection should be done in the spring after the snow has melted.
5. Ramp approaches should be plowed free of snow the same as traveled lanes. Snow should be plowed square with beginning of surfacing material. The snow berm should never be higher than two feet above surrounding snow.
6. A review of existing signs and delineation should be made as required to insure that all are in place and haven't been damaged or vandalized.

Maintenance costs were not well elicited by the survey, possibly because the question was combined with construction costs. Only one reply quoted figures for maintenance: "3-5 vehicles plus 10-20 person hours equals \$500/levelling." Twelve replies said no information was available or that costs were unknown. On the other hand, seven states implied that information would be available through maintenance management systems or other records. Four replies stated that costs were low or minor.

## WINTER MAINTENANCE

Cold weather performance of arrester beds is more dependent on design, particularly drainage provisions, than it is on maintenance practices. Nevertheless, some comments on winter maintenance are found in the literature. One Pennsylvania report (7) suggests three maintenance needs: "reshaping of the pile after each use, periodic salting to keep the pile loose during the winter, and periodic litter pickup.... Calcium chloride is hand broadcast over the surfaces periodically during the winter by tunnel employees stationed nearby."

Other Pennsylvania research (19) recommends that beds "should be inspected for a frozen crust during periods of freezing rain or extreme freezing and thawing cycles. If a frozen crust forms, salt should be used to remove it. Snow covering, however, can be ignored, as it is generally beneficial."

ITE's Recommended Practice (3), with its accustomed eye to operations, points out: "Snow accumulation can hide a truck escape ramp. During snowy periods, the ramp, or at least the approach apron, should be cleared of snow to delineate the ramp or at least indicate the presence of a ramp."

### Survey Responses

The only survey question on winter maintenance asked: What steps are taken against aggregate freezing? Of 27 responses, seven said that no steps were taken and five others said there was no problem (presumably because cold weather was not a serious issue). Ten replies simply stated drainage provisions and/or material type.

One state prevents freezing by keeping aggregate clean. Seconding this East Coast recommendation was the observation from the Southwest that they have had problems with contamination of fines from the surrounding area.

Only two states use salt, while another reply, cryptic and without further amplification, was "Winter salting was mistakenly used last year, resulting in very negative consequences."

A New England state supported the Pennsylvania comment about a snow cover being beneficial by insulating the bed. Snow can still be a problem, though, according to intra-office correspondence supplied by one Western state. This pointed out that when a snow-covered ramp is being regraded after use, it is difficult to know whether depressions and ruts have been fully removed until the snow melts. The same correspondence, incidentally, also refers to U.S. Forest Service concern about the use of chemicals that may have adverse effect on adjacent landscape.

### AGGREGATE CONTAMINATION

Figure 28 shows that the average stopping distance of trucks in the ramp increased over time, from approximately 400 to 600 ft, at the Siskiyou Summit ramp in Oregon.

The increase in stopping distance is thought to be caused by compaction of the bed through settling and contamination from the sand used to improve traction on the main highway during snow and ice conditions. Because of this, in 1982 the gravel in the first 600 feet of the arrester bed was removed, rescreened and replaced (26).

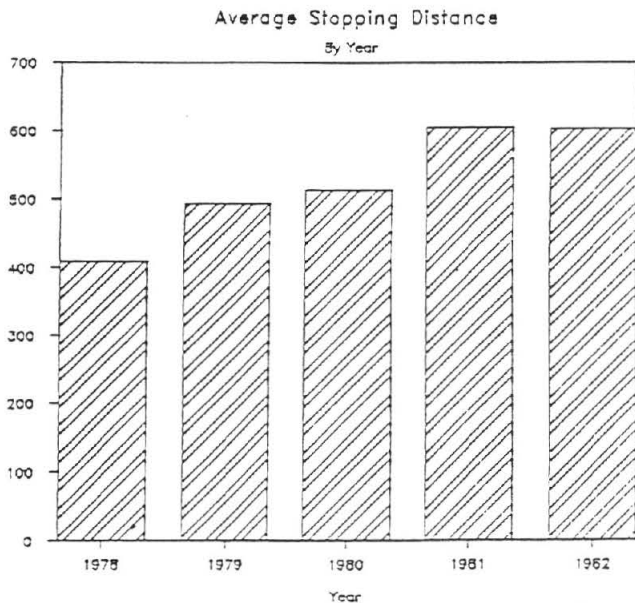

Figure 28 Average stopping distance changes over time (23, Appendix Fig.7)

A Colorado report describes how sand infiltration was blocked at the Mt. Vernon Canyon ramp (23):

The District Engineer has instructed maintenance personnel to keep a windrow of snow along the left side of the escape ramp during the winter, and this has prevented sand from migrating into the aggregate. The base beneath the gravel is also paved, which eliminated the possibility of soil particles entering the gravel.

Another Colorado report (27) indicated how infiltration of water can cause compaction and freezing of bed material:

During the Spring season the runoff water from the melted snow and rain played a key role in contaminating the arrester bed material. Water was draining out of the aggregate, and it could easily be observed at the entrance of the ascending grade truck escape ramps. The free draining water from the adjacent mountains carries the fines into the arrester bed and causes aggregate contamination.

The report further states that visual inspection in the winter revealed that large aggregate with low contamination levels developed only a thin frozen crust at the surface. In contrast, smaller aggregate with high contamination was frozen solid to the full bed depth.

A different problem was experienced in the recent Pennsylvania research (19):

At one test site, it was found that many of the stones had become quite friable and crumbled such as sandstone does. The bed was also filled with fines, creating a compacted layer just under the surface.... Such conditions might be avoided, or at least alleviated, by using the most durable of stones. Stone durability can be determined by performing a specific test. Various tests for durability and weathering exist, among them the Los Angeles abrasion test.

The California Guidelines contain a useful summary of contamination sources:

- The ground under the bed
- Fines blown or carried in from the surface
- Fuel or cargo spills from arrested vehicles
- Degradation of the bed material

An illustration of problems from a cargo spill is given in Figure 29.

Discussing measures for blocking subsurface intrusions from below, the guidelines note that asphalt paving under the bed can be attacked and destroyed by fuel leaking from vehicles. They suggest that to control the second category of contamination, surface slopes designed to direct runoff (from either the roadway or abutting terrain) away from the bed can help. Fuel leaks or cargo spills can only be treated retroactively, but the guidelines suggest that drainage systems should separate or contain contaminants before they are released into watercourses. Last, the guidelines recognize that all gravels will break down under repeated entry and reshaping impacts. They urge that the initial choice for bed material be the best available.

### Survey Responses

The survey asked what measures were taken against infiltration of fines and whether toxic materials had posed a problem. Sixteen responses, a majority, said no measures were taken against fine material, or failed to answer the question. Two states

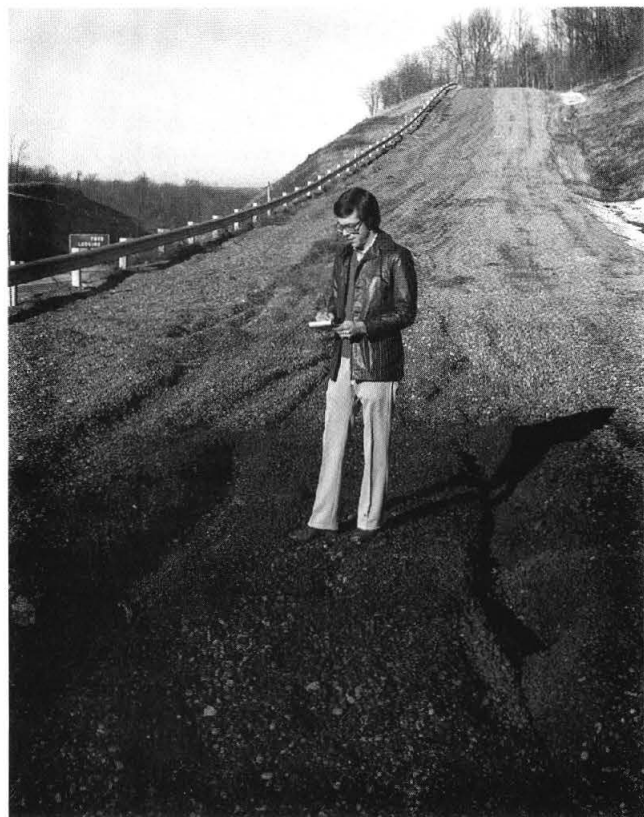

Figure 29 Contamination of West Virginia gravel arrester bed by coal fines after ramp use.

reported replacing material periodically, in one case every three years. Another said it removed, washed, and screened bed material. Three mentioned geotextiles or filter fabric under beds. Three identified surface controls, such as a grate system at the approach, earth berm alongside the bed, and intercept ditches. One reply was that the bottom 12 in. of aggregate is sacrificed and that surface drainage is collected or directed away from ramp. Last, one reply stated: "Ditching, high crown design, rock shoulders. There is positive surface drainage and high velocity subsurface drainage capable of transporting silt-size particles."

The returns regarding toxicity were minimal. Only California identified a problem, that of diesel fuel spillages. Current California design calls for paving the base with cement concrete and the provision of holding tanks to retain contaminants. Three other states replied that they had not yet had a problem, though one added that toxic contamination was a concern. While four states did not comment, nineteen responded that toxicity had not been an issue for truck escape ramps.

#### **AGGREGATE UPGRADING**

Degraded performance of arrester beds with the passage of time has been observed and the causes identified. Hayden (29)

observed that "the restoration of contaminated aggregate is expensive. It must be replaced with new material or removed, screened and reused. Either alternative is expensive and a safety hazard can be created since the escape ramp must be taken out of service while the work is being done."

A few of the survey responses above also identified the solutions. Selecting the most durable suitable aggregate initially is the surest way of deferring aggregate replacement or its treatment by removal, washing and screening.

#### **MAINTENANCE SUMMARY**

Two key practices seem essential to obtaining continuous effective performance of arrester beds. One is reshaping after the bed has been used, and the second is prevention of fine material buildup in the bed. Reshaping requires more than superficial smoothing by hand tools. The bed materials must be loosened in depth to avoid their compaction. Thus, a drag or "fluffer" is required to achieve penetration and continued looseness below the surface. Second, because infiltration of fines can destroy the effectiveness of truck escape ramps, it must be blocked. Surface runoff and subsurface infiltration must be controlled through both design and ongoing maintenance.

## SITE USE AND DRIVER-RELATED ISSUES

Previous chapters have dealt with truck escape ramp issues of concern mostly to engineering staffs of state transportation agencies: questions of location, design, operations, and maintenance. This chapter deals with issues of interest to the same groups, but also to a broader community: enforcement and public safety bodies, highway users (especially the trucking industry), and the general public.

The value of truck escape ramps is ultimately measured by comparing the costs of their use to the costs that would be incurred without them, taking into account also the costs of providing and maintaining them. Therefore, ramp usage and the factors that affect the rate of ramp usage are of interest here. Some questions are: Do truck escape ramps get used to the degree that they should be? Do some truck operators take the "ride it out" alternative rather than chance an unfamiliar device, incur delays and costs, and risk possible vehicle inspections and citations?

Some evidence of usage is presented first. The chapter then reports what is known about driver education and public information programs pertaining to runaway vehicles. Last, it presents information about driver attitudes and other driver issues related to truck escape ramps.

### RAMP USE EXPERIENCE

Colorado was among the first states to document experience at truck escape ramps (13). A report form used by state troopers to record each incident is found in Appendix D. Table 7 is a

TABLE 7  
TRUCK ESCAPE RAMP USAGE IN COLORADO (13)

Location	Date Opened	Uses to 9/81
U.S. 40 Rabbit Ears Pass	Dec 76	43
I-70 Vail Pass - Upper	Nov 78	15
I-70 Vail Pass - Lower	Nov 78	21
I-70 Mt. Vernon Canyon	Jun 79	33
I-70 W. of Tunnel - Upper	Jul 80	6
I-70 W. of Tunnel - Lower	Jul 80	41
U.S. 160 Wolf Ck. Pass - Upper	Sep 78	5
U.S. 160 Wolf Ck. Pass - Lower	Oct 80	2
S.H. 141 Slick Rock Hill	Apr 80	3
<b>TOTAL</b>		<b>169</b>

summary of the uses between the dates that each ramp was opened and September 1981. Among other findings from the collected data were the following characteristics:

- 46 percent of usages were by vehicles between 70,000 and 80,000 pounds Gross Vehicle Weight (GVW)
- 38 percent of entries occurred in summer, 24 percent each in spring and fall, and 14 percent in winter
- Vehicle defects involved 27 percent due to hot brakes and 11 percent due to loss of air pressure
- 47 percent entered the bed between 30 and 60 mph, 13 percent between 60 and 79 mph, and 17 percent at 80 mph or higher speeds (these were driver estimates)
- 72 percent of entering vehicles stopped within 600 ft

Table 8 details ramp use by year on two major grades in Idaho. Whitebird Hill is a 6 to 7 percent grade about 7 miles long with three escape ramps. Lewiston Hill is of similar length and grade with six escape ramps. The Idaho summary (33) recorded 134 usages statewide between 1978 and March 1984. Vehicles over 70,000 pounds GVW accounted for 62 percent of total entries, while those between 40,000 and 70,000 pounds were 23 percent of the total. Forty-eight percent of drivers said their brakes got hot, and 15 percent reported brakes out of adjustment. Entry speeds of between 20 and 60 mph were estimated by 77 percent of the drivers, while 15 percent were in excess of 60 mph. Eighty-five percent of all vehicles stopped in the bed within 500 feet or less, according to the report.

Ramp entry speeds estimated by drivers apparently are not accurate, according to more than one source. This conclusion was reached in California where radar monitoring of ramp sites showed that speeds claimed by drivers were 5 to 20 mph higher than those recorded by the radar unit. A Colorado study (23) that videotaped usage of one ramp produced a similar finding.

The only published data on exposure, or the rate of ramp usage related to the volume of trucks on the downgrade come from the study by Fancher et al., on the value of engine retarders (2). This study collected data from several sites and used them

TABLE 8  
RAMP USAGE AT TWO IDAHO SITES, 1978-1984 (33)

Site	1978	1979	1980	1981	1982	1983	1984*	Total
Whitebird Hill 3 ramps	2	2	1	3	0	2	1	11
Lewiston Hill 6 ramps	21	30	22	21	7	10	12	123

\* Partial data for this year



to project levels of national usage. Table 9 is derived from some of those sites, and indicates the usage, average daily traffic (ADT), and the rate of ramp use based on the number of passing trucks.

Using these figures and others, extrapolating to the number of ramps then in place, the study concluded that about 2,150 incidents of truck ramp use occurred annually.

A 1990 summary of 17 entries into one U.S. 48 ramp in West Virginia showed that all but one involved out-of-state drivers of tractor-trailers, all but one occurred on weekdays, and all occurred between May and September. No details were available on drivers, time of day, loads, or weather characteristics. The site is characterized by a 4-mile downgrade averaging a 5 percent grade, and is posted at 50 mph for vehicles weighing over 30,000 pounds.

Damage costs associated with ramp use could not be ascertained from other literature sources except for accident history in the 1970s at two North Carolina sandpiles (25). For 102 entries with damage statistics, no damage was incurred by 75, less than \$500 was estimated for 14 vehicles, between \$500 and \$5,000 for nine vehicles, and more than \$5,000 for four vehicles (one of which was demolished).

### Survey Responses

Eight states had no data available on site usage. One state reported that its only site had not yet been used, and another said one site had been used only three times in 10 years. At the other extreme were states reporting four to five uses per month at all sites, and that a ramp on I-64 was used 110 times in two years.

Records were kept by nine states, in degrees of formality varying from maintenance diaries to accident reports. None of this group provided specific information. California, Colorado, Idaho, and Pennsylvania sent tabulations summarizing usages in various ways.

The California table listed 645 entries into 11 ramps, over periods of time varying by ramp from less than six months at

one ramp to over six years at another. While one ramp had not been used at all, the Grapevine on I-5 had 306 entries, of which 64 (21 percent) were classed as "Casual" and 242 were "Needful." One California ramp with less than six months of data had 44 entries, out of which only three were needful. An indicator of maintenance needs, as well as safety values provided, the number of days per entry was calculated for each site. It ranged from 3.3 days between entries at the Grapevine to 325 days between entries at the least-used ramp. Casual entries accounted for 46 percent of usages, varying from none to the high of 93 percent noted earlier. No data on truck volumes or average daily traffic (ADT) were given in the tabulation.

Colorado data for 11 ramps gave usage by year from 1983 through 1988. For the first three years, the statewide totals were 56, 67, and 52 entries. For the last three years they were 45, 38, and 37, suggesting a significant decrease in rates. However, partial 1989 data already recorded 42 entries, so conclusions about annual trends are probably unwarranted. Usage by ramp was quite variable, from only three entries at one ramp to 114 for the ramp most frequently used. Again, no data on truck volumes or ADT were provided.

Pennsylvania statistics were for one ramp from late 1980 when the ramp opened to mid 1986. Date, time, speed, stopping distance, cargo, and truck owner location were tabulated. All but one of the 20 incidents, this involving a school bus on a Saturday trip, took place on weekdays. Thirteen occurred between 6:00 and 9:00 a.m., i.e., during the congested morning peak hours. All trucks were loaded, and, in 14 cases, were operated for out-of-state owners. Entry speeds ranged between 15 and 40 mph, and stopping distances were 200 feet or less. The figures suggest a pattern of unfamiliar drivers who encountered slow-moving commuter traffic and were unable to hold down their vehicle speeds on the grade.

### DRIVER EDUCATION AND PUBLIC INFORMATION

In the study that developed a prototype Grade Severity Rating System (12), the researchers reviewed information signing for truckers on downgrades and described a test of special signing on heavily traveled I-80 on the west side of Donner Pass, a downgrade of 40 miles which drops from an elevation over 7,200 feet at the summit to 1,355 feet near Sacramento. The project installed 27 signs with special messages "to talk truckers down the grade" so that they would have braking capability left for the steep grades in the last 10 miles. The signs obviously increased the awareness of all drivers to the problems of long downgrades. Examples of the special signs and the overall sign layout are shown in Figure 30. This study also emphasized the importance of providing graphic signs (illustrating grade length and steepness, horizontal alignment, escape ramp locations and so forth) at brake check areas, rest areas, or other turnouts and stopping points. With minor modifications, the same signs are still there.

Another study (32), based on interviews with 180 truck drivers in West Virginia, found that drivers felt that improved signing with information on grade lengths, steepness and alignment would be helpful. The researchers concluded that this kind of signing, rather than ordinary speed limit signs, would lead to better gear choices by drivers.

TABLE 9  
TRUCK RAMP USAGE RATES—SELECTED SITES (2)

Site	Ramp use per year	Downhill truck ADT	Ramp use per 100,000 trucks
U.S. 99, California	36	500 (est)	20
Willamette, Oregon	14	256	15
Siskiyou, Oregon	128	1,150	30
Vail Pass, Colorado	18	235	21
Rabbit Ears Pass, Colorado	12	65	51
Indiana, Pennsylvania	10	1,100	2
Old Fort, North Carolina	43	750	16



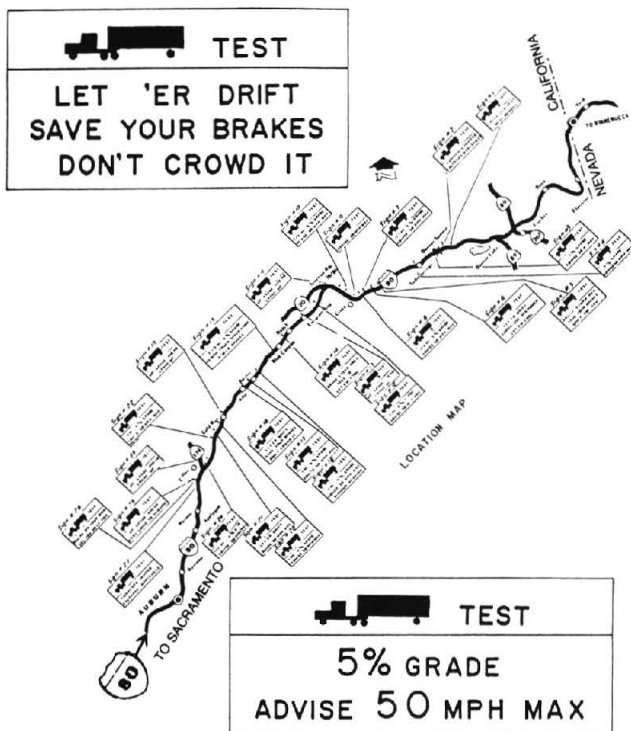

Figure 30 Special trucker signing, I-80 Donner Pass (12).

The Idaho report on ramp usage (33) contains information and maps clearly directed at truck operators. The text provides safety tips for downgrades and instructions for entering escape ramps. The pages are reproduced in Appendix E; the summary follows:

Truck escape ramps have been constructed on most major steep grades in Idaho. The ramps are clearly marked and easily accessible. They will normally stop a truck within 300–400 feet. The driver will experience total steering control of the vehicle and there should be no damage to the vehicle if the driver aims straight into the ramp. No fee is charged for ramp usage and you will not be ticketed for using the ramp.

Pennsylvania has a widely distributed brochure called “The Safe Choice.” Its text, given in Appendix F, answers these questions:

- What are truck escape ramps?
- Why should I use a truck escape ramp?
- What happens when I use a truck escape ramp?
- How do I get out?
- Where are the truck escape ramps?

The brochure footnotes the availability of a videotape with the same title upon request to the Pennsylvania Department of Transportation. The five-minute tape shows trucks entering ramps, and emphasizes the safe nature of the deceleration and stopping action. PennDOT also publishes “Trucker’s Guide to Pennsylvania,” a state highway map showing special truck routes, truck stops, and so on. The reverse side is a comprehensive collection of safety and regulatory information of use to truckers.

An additional effective public relations tool has been PennDOT’s staging of “grand openings” when a new truck escape ramp is completed. A PennDOT dump truck, usually carrying a high PennDOT official as a passenger, demonstrates a safe stop in the ramp.

More formal informational and educational materials are available. One is a slide-tape show produced by West Virginia University as a highway research project and distributed by the Federal Highway Administration. The FHWA also published, in 1985, “Model Curriculum for Training Tractor-Trailer Drivers” (34). The instructor’s manual for the course contains seven pages of outline on mountain driving, including two pages on truck escape ramps. On the other hand, contacts with three different trucking associations failed to reveal any information for drivers pertaining to truck escape ramps.

### Survey Response

In addition to the materials from Idaho, Pennsylvania, and West Virginia described above, seven other state responses indicated similar efforts. Most of these have been informational in nature, including:

- Articles in trucker magazines
- Brochures and videotape at ports of entry
- Meetings and contacts with truckers and trucking organizations
- Continuous radio broadcasts from truck inspection station
- Distribution of pamphlets to truckers
- News release on ramp installation and successful use

Oregon reported using an educational approach, covering the subject in the Commercial Drivers License Manual and the MVD Manual. Fifteen survey responses noted no informational or educational efforts.

### DRIVER-RELATED ISSUES

This section covers driver issues from two perspectives, one external to the driver community and the other from within it. The first part deals with profiles or characteristics of drivers, particularly those who have used escape ramps. The second part deals with the viewpoints of truckers themselves: insights into why they choose to use, or choose not to use, escape ramps when a runaway condition occurs.

#### Driver Characteristics

“Truck Drivers’ Perception of Mountain Driving Problems” (32) is the report on a survey of 180 drivers made in West Virginia. Individuals in the sample ranged in age from 21 to 60, the sample average being 38 years. Their professional driving experience ranged as widely, from 2 months to 41 years, averaging 14 years. About half their driving time was on mountain roads and their annual average mileage was 97,000 miles.

The researchers found that 24 percent of the sample had experienced being out of control on a downgrade, but felt that because of the survey design this proportion could not be extrapolated to

the whole truck driver population. They compared the following characteristics of this group to the 76 percent who had not experienced loss of control. There was little difference between the two:

- average age—38.8 years
- mountain driving time—51 percent of an average 98,000 miles per year
- driving experience—15.7 years

Some statistics on drivers who used Colorado truck escape ramps were reported in a study there (13):

- 67 percent were under 40 years of age
- 29 percent had less than one year of mountain driving experience
- 44 percent of drivers entering ramps applied their brakes
- 59 percent of trucks were registered in states east of Colorado (which presumably indicates driver origins in non-mountainous states.)

The Idaho report on ramp use (33), based on data collected between 1977 and 1985, showed the following driver characteristics:

- 83 percent of trucks were registered outside Idaho
- 59 percent of ramp users had never been on the grades before
- 100 percent of drivers using ramps had never used one before

The Idaho report concluded that the years of driving experience did not influence decisions regarding ramp use.

#### **Driver Concerns**

Eck's survey of drivers (32) revealed that drivers judged equipment failure to be by far the leading cause of runaway vehicle accidents, followed by driver inexperience and driver error. Several other causes were: unfamiliarity with the road, poor truck inspection, inadequate signs, poor roads. Weighing equally were the opposing factors of "too slow descent" and "too rapid descent." Least mentioned were those of overloaded vehicle and lack of engine brake.

Eck found "There were many misconceptions among truck drivers concerning what takes place when a vehicle uses an escape ramp. Some drivers feared that ramps would cause either personal injury or property damage or both."

To address those concerns, the Idaho information piece (33) stresses the safe stopping nature of the ramp:

The gravel arrester beds in Idaho will stop a vehicle smoothly and the driver will be able to maintain full control of his vehicle. The arrester beds will not damage the truck. Since the slowing action is so smooth there is no chance that the load will come over the top of the cab. Jackknifing is also eliminated. The lighter axles of the truck will float on the pea gravel and the heavier axles will sink into the arrester bed slowing the vehicle down quickly.

"The Safe Choice," from Pennsylvania, contains similar emphasis: "The description of driving into an escape ramp given by drivers of runaway trucks and drivers of our test vehicles is that it is not as rough as an emergency panic-type stop."

Further confirmation of the safe deceleration came from the study on the test site in New York. This study report (29) said: "The maximum deceleration observed over a half-second interval—0.7g—is similar to that produced by hard braking on dry pavement."

Though drivers may be aware that equipment failure is the leading cause of runaway events, that does not necessarily mean they are willing to take the time to find out about possible problems before starting down a grade. Asked in Eck's research if they felt that brake check areas should be provided at summits of grades, 76 percent of drivers said yes. But when asked if they should be mandatory, only 45 percent agreed. This survey took place at a time when brake deficiencies and maladjustments were widely reported in the literature. It is not known whether, as a result of current driver training programs and more frequent vehicle inspections, driver skills and equipment conditions are any better today.

There are other largely undocumented concerns of drivers about truck escape ramps. The survey results were provided by engineering staffs and may not adequately represent the views of enforcement personnel. Some drivers may not use ramps because they perceive a risk of attracting the attention of enforcement personnel, which could result in citations and vehicle inspections. Citations and treatment of a ramp entry as an accident rather than an incident would appear to be psychological deterrents to the use of a truck escape ramp.

## CONCLUSIONS AND RECOMMENDED RESEARCH

The survey conducted for this synthesis confirmed that truck escape ramps are well established as a feature of the nation's highway system, that many state agencies plan to build more, but suggests that some doubts and questions remain as to their worth.

The location and siting of truck escape ramps still pose problems. No universally applicable answers have been found to the question of when a ramp is needed, let alone where it should be sited. A careful benefit-cost analysis seems the best recourse to address the question; a modest research effort should be able to produce a reasonable procedure. The Grade Severity Rating System, Idaho, or Pennsylvania Transportation Institute methodologies should offer help on the siting question, through their ability to predict runaway vehicle speeds at any point on a downgrade. The site of a ramp should clearly be influenced by the relationship between attainable runaway speeds and highway design speed, as well as by adjacent terrain and construction cost considerations.

The nature or values of some ramp elements appear to be settled. Among these are the following:

- The arrester bed is the preferred technique for truck escape ramps. Rounded gravel, rather than crushed aggregate, is required in at least a 36 in. bed. Uniform grading with an approximate size range of 0.5 to 0.7 in. provides the greatest rolling resistance and thus permits the shortest ramp lengths.
- Mounds and barrels should be used only where needed ramp length cannot be provided. Vehicles should be slowed to 25 mph or less before reaching impact with them.
- Beds should be straight, at a minimal angle to the roadway, and begin at a lateral distance sufficient to keep gravel from spraying back on the main roadway.
- Regulatory signing must be adequate to discourage "casual use" of ramps and stopping by other than runaway vehicles.
- Vehicle removal must be facilitated by provision of service lanes and anchor blocks.
- Maintenance must include regrading after each use and periodic "fluffing."
- Provisions to avoid contamination of the bed are essential.

A few basic design issues are unresolved, and they bear importantly on ramp construction costs. Should entry speeds of 80–90 mph always apply? Do those values, combined with the current length formula, provide the best answers? Is a width for occupancy by two vehicles justified by the frequency of multiple usages reported? Some ramps may require double width; most may not. Research is already addressing some of these questions, but more will be necessary to support future design decisions.

The level of signing and delineation of truck escape ramps recommended in the Manual on Uniform Traffic Control De-

vices is adequate. Few, if any, states are going beyond those levels, and no evidence came from the survey to suggest that greater effort is needed. The provision of special advance signing, especially in brake check areas at grade summits, is highly desirable according to both researchers and truckers. Where state agencies are experiencing abuse of TER sites, more stringent regulatory signing and enforcement should be applied. Consideration should be given to changing the MUTCD permissive statement regarding use of "No Parking" signs to a requirement for "No Standing" signs (R7–4) at ramp entry points.

From the state agency viewpoint, current vehicle retrieval practices appear satisfactory. During periods of vehicle removal or ramp maintenance, advance signing with a "Site Occupied" message or the use of a shadow vehicle is advisable.

The literature plainly shows the absolute necessity for leveling and loosening gravel beds after they have been used. Bed compaction and contamination must be prevented, so maintenance efforts are unavoidable. The survey, however, seems to have revealed some frustration or lack of acceptance over these requirements. Perhaps the most convincing argument to encourage adequate maintenance would be demonstrated benefit-cost and safety values.

Some state officials are concerned about the driver-related matter of escape ramp underutilization. The issues, financial and psychological, can be addressed by informational and educational activities, as well as by inspection and enforcement actions. For example, Commercial Driver License manuals should provide information on truck escape ramps. The measure of response by public agencies in these respects should be tailored locally to the degree of vehicle and driver deficiency observed. "Observed" may be the key word here, inasmuch as noting the frequency of smoking brakes on a downgrade better indicates a potential problem than the infrequent catastrophic accident.

### RECOMMENDED RESEARCH

More research is needed. The list, however, is brief and the expenditure need not be great. Candidates for research include the topics below.

- Benefit-cost analysis for TER warrants. Few studies assess the benefits of truck escape ramp use relative to their costs, or to the probable cost of accidents that might otherwise have occurred. A standard methodology for such analysis could be beneficial in at least two respects: First, it might provide an economic justification for constructing a new ramp; second, it could provide a rationale that would justify the annual costs of maintaining ramps.
- Applicability of Grade Severity Rating Systems to TER design. Developed for the purpose of downgrade speed con-

trol, the technique of the GSRS has been applied by some states in conjunction with truck escape ramps. Its potential usefulness, as a warrant for TERs and as a design tool for determining their sites and estimating entry speeds, deserves further exploration.

- **Review of Ramp Length Calculation Procedures.** Field tests in Pennsylvania have demonstrated higher values of rolling resistance of certain aggregates and led to a ramp length calculation procedure different from the widely used FHWA formula. Testing in other locations would further validate the new procedure. Data collection at ramp sites instrumented to record entry speeds and distance of bed penetration relative to bed materials would be very useful.
- **Probability Analysis for Multiple Entries in TERs.** Desirable width standards for truck escape ramps allow for the possibility of simultaneous side-by-side occupancy by runaway trucks. Yet the likelihood of such events is extremely remote for little-used sites, and the need is questioned by designers concerned with site costs. It seems likely that a form of probability analysis based on truck volumes and past local runaway truck experience could determine the likely frequency for multiple occupancy and provide a basis for design decisions on widths.
- **Tests of Aggregate Suitability.** The effectiveness of arrester beds is related to the long term performance of the aggregate used. Roundness is important, but so are hardness and durability. Resistance to abrasion and crushing are essential to minimizing the contamination by fines and resultant bed consolidation. Better methods are needed to measure and evaluate the suitability of materials for arrester bed use.
- **Evaluation of Driver Information and Education Needs.** Misuse and underuse of truck escape ramps are problems in some regions, suggesting a need for more understanding of these conditions and development of measures to combat them. The consequences to operators of ramp use (removal costs, reporting as an accident or not, citations, and others), may need to be better understood and possibly modified to encourage appropriate ramp use. Public information procedures should be based on solutions to identified local problems and targeted to relevant audiences, whether drivers of recreational vehicles misusing ramps or truck operators failing to use them. Surveys of highway users, review of successful driver information programs, and dissemination of useful techniques to the proper agencies could lead to more effective use of truck escape ramps.

## REFERENCES

1. Bowman, Brian L., "Grade Severity Rating System (GSRS)—Users Manual," Federal Highway Administration, Washington, D.C. (1989) 113 pp.
2. Fancher, P., J. O'Day, H. Bunch, M. Sayers, and C. Winkler, *Retarders for Heavy Vehicles: Evaluation of Performance Characteristics and In-Service Costs*, Report No. DOT-HS-805-807, National Highway Traffic Safety Administration, U.S. Department of Transportation, Washington, D.C., February 1981, 124 pp.
3. "Truck Escape Ramps," Institute of Transportation Engineers, Washington, D.C. (1989) 17 pp.
4. Williams, E.C., Jr., "Emergency Escape Ramps for Runaway Heavy Vehicles," Final Report, Report No. FHWA-TS-79-201, Federal Highway Administration, Washington, D.C. (1979) 68 pp.
5. "Interim Guidelines for Design of Emergency Escape Ramps," FHWA Technical Advisory T5040.10, Federal Highway Administration, U.S. Department of Transportation, Washington, D.C., July 5, 1979.
6. Wambold, J.C., E.C. Yeh, J.J. Henry and M.C. Wang, "Truck Escape Ramp Design Methodology: Literature Review. Phase 1 Report." Pennsylvania Transportation Institute, Pennsylvania State University (1983) 56 pp.
7. Carrier, R.E. and J.A. Pachuta, "Runaway Trucks in Pennsylvania," Society of Automotive Engineers, Report No. SAE 811262 (1981) 12 pp.
8. Eck, R.W., "State Practice and Experience in the Use and Location of Truck Escape Facilities," *Transportation Research Record No. 736*, Transportation Research Board, National Research Council, Washington, D.C. (1979) pp. 37-43.
9. *A Policy on Geometric Design of Highways and Streets*, American Association of State Highway and Transportation Officials, Washington, D.C. (1990) pp. 272-280.
10. Rooney, F.D., "Speeds and Capacities on Grades, Climbing Lanes, Passing Lanes, and Runaway Trucks," California Department of Transportation, Sacramento, California (1985) 28 pp.
11. Young, Jonathan, "Field Testing a Truck Escape Ramp," *Highway Focus*, Vol.11, No.3 (1979) pp. 43-55.
12. Johnson, W.A., R.J. DiMarco and R.W. Allen, "The Development and Evaluation of a Prototype Grade Severity Rating System," Federal Highway Administration, Washington, D.C. (1982) 184 pp.
13. "A Report on Truck Escape Ramp Use in Colorado," Colorado Department of Highways, Denver, Colorado (1982) 48 pp.
14. Ballard, A.J., "Current State of Truck Escape-Ramp Technology," *Transportation Research Record No. 923*, Transportation Research Board, National Research Council, Washington, D.C. (1983) pp.35-42.
15. Tye, E.J., "Design Guide for Truck Escape Ramps," Traffic Bulletin No. 24, California Business, Transportation and Housing Agency, Sacramento, California (1986) 13 pp.
16. Stanley, A.F., "A Calculator Program To Estimate Truck Coasting Speeds for Designing Gravel Arrestor Beds," Idaho Transportation Department, Boise, Idaho (1978) 12 pp.
17. Wambold, J.C., "Speed of a Runaway Truck Due to Grade," Pennsylvania Transportation Institute, Pennsylvania State University (1991) (Computer program).
18. Cocks, G.C. and L.W. Goodram, "The Design of Vehicle Arrestor Beds," *Proceedings of the Australian Road Research Board*, Vol. 11, Part 3 (1982) pp. 24-34.
19. Wambold, J.C., L.A. Rivera-Ortiz and M.C. Wang, "Truck Escape Ramp Design Methodology, Volume 2: Final Report," Pennsylvania Transportation Institute, Pennsylvania State University (1988) 231 pp.
20. Whitfield, J.K., A.C. Eberhardt, J.D. Booze, and M.W. Malpass, "Runaway Truck Arresting Schemes. Final Report," North Carolina Department of Transportation, Raleigh, North Carolina (1982) 126 pp.
21. "The Safe Choice," Pennsylvania Department of Transportation, Harrisburg, Pennsylvania (1987) 2 pp.
22. Taragin, A., "Effect of Length of Grade on Speed of Motor Vehicles," *Proceedings*, Highway Research Board, Vol. 25, Washington, D.C., Highway Research Board (1945) pp. 342-353.
23. Hayden, R.L., "Mt. Vernon Canyon Runaway Truck Escape Ramp," Colorado Department of Highways, Denver, Colorado (1982) np.
24. *Design Manual, Part 2, Highway Design*, Chapter 17, "Truck Escape Ramps," Pennsylvania Department of Transportation, Harrisburg, PA (1990).
25. Wambold, J.C., "Truck Escape Ramp Design Methodology, Volume 1: Executive Summary," Pennsylvania Transportation Institute, Pennsylvania State University (1988) 52 pp.
26. Hardy, Thomas A., A. Hamilton and Gordon Beecroft, "Siskiyou Summit Negative Grade Arrestor Bed for Runaway Trucks," Oregon State Highway Division, Salem, Oregon (1986) 21 pp.
27. Derakshandeh, M., "Truck Escape Ramp Aggregate Study. Final Report," Colorado Department of Highways, Denver, Colorado (1985) 46 pp.
28. Crowe, N.C., Jr., "Photographic Surveillance of Runaway Truck Escape Ramps in North Carolina," North Carolina Department of Transportation, Raleigh, North Carolina (1977) 19 pp.
29. Allison, J.R., K.C. Hahn and J.E. Bryden, "Performance of a Gravel-Bed Truck Arrestor System," *Transportation Research Record No. 736*, Transportation Research Board, National Research Council, Washington, D.C. (1979) pp.43-47.
30. Eck, R.W., "Technique for Identifying Problem Downgrades," *Civil Engineering Practice*, (ed. by Paul M. Cheremisinoff, Nicholas P. Cheremisinoff, Su Ling Cheng), Lancaster, Pa., Technomic Publication Co. (1987-1988) Vol. 4, pp 457-471.



31. *Manual on Uniform Traffic Control Devices for Streets and Highways*, Federal Highway Administration, U.S. Department of Transportation, Washington, D.C. (1988).
32. Eck, R.W. and S.A. Lechok, "Truck Drivers' Perceptions of Mountain Driving Problems," *Transportation Research Record No. 753*, Transportation Research Board, National Research Council, Washington, D.C. (1980) pp. 14–21.
33. *Runaway Truck Ramps Save Equipment and Lives*, Idaho Transportation Department, Boise, Idaho (1984) 20 pp.
34. *Model Curriculum for Training Tractor-Trailer Drivers*, Federal Highway Administration, U.S. Department of Transportation, Washington, D.C. (1985).

## BIBLIOGRAPHY

- Allison, J.R., K.C. Hahn, and J.E. Bryden, "Performance of a Gravel-Bed Truck-Arrester System," New York State Department of Transportation, Albany, N.Y. (1978) 19 pp.
- Allison, J.R., K.C. Hahn and J.E. Bryden, "Performance of a Gravel-Bed Truck Arrester System," *Transportation Research Record No. 736*, Transportation Research Board, National Research Council, Washington, D.C. (1979) pp.43-47.
- Baldwin, G.S., "Truck Escape Lanes on Mountain Roads," *Civil Engineering*, Vol. 44. No.7 (1974) pp. 64-65.
- Ballard, A.J., "Current State of Truck Escape-Ramp Technology," *Transportation Research Record No. 923*, Transportation Research Board, National Research Council, Washington, D.C. (1983) pp. 35-42.
- Ballard, A.J. and C.E.Kimball, Jr., "Heavy Vehicle Escape Ramps—A Review of Current Knowledge, Final Report," Southwest Research Institute, San Antonio, Texas (1982) 93 pp.
- Bowman, Brian L., *Grade Severity Rating System (GSRs)—Users Manual*, Federal Highway Administration, Washington, D.C. (1989) 113 pp.
- Brown, R.G., "Report on Arrester Bed Tests Carried out by the NSW Department of Main Roads in March 1982," Australian Road Research Board, Volume 12, No.7 (1984) pp. 110-125.
- Carrier, R.E. and J.A. Pachuta, "Runaway Trucks in Pennsylvania," Society of Automotive Engineers, Report No. SAE 811262 (1981) 12 pp.
- Cocks, G.C. and L.W. Goodram, "The Design of Vehicle Arrester Beds," *Proceedings of the Australian Road Research Board*, Vol. 11, Part 3 (1982) pp. 24-34.
- Crowe, N.C., Jr., "Photographic Surveillance of Runaway Truck Escape Ramps in North Carolina," North Carolina Department of Transportation, Raleigh, North Carolina (1977) 19 pp.
- Derakshandeh, M., "Truck Escape Ramp Aggregate Study, Final Report," Colorado Department of Highways, Denver, Colorado (1985) 46 pp.
- Eck, R.W., "State Practice and Experience in the Use and Location of Truck Escape Facilities," *Transportation Research Record No. 736*, Transportation Research Board, National Research Council, Washington, D.C. (1979) pp. 37-43.
- Eck, R.W., "Technique for Identifying Problem Downgrades," *Civil Engineering Practice*, (ed. by Paul M. Cheremisinoff, Nicholas P. Cheremisinoff, Su Ling Cheng), Lancaster, Pa., Technomic Publication Co. (1987-1988) Vol. 4, pp 457-471.
- Eck, R.W. and S.A. Lechok, "Truck Drivers' Perceptions of Mountain Driving Problems," *Transportation Research Record No. 753*, Transportation Research Board, National Research Council, Washington, D.C. (1980) pp. 14-21.
- Erickson, Raymond, Jr., "A Field Test of a Grade Severity Rating System," Colorado Department of Highways, Denver, Colorado (1985) 31 pp.
- Fancher, P., J. O'Day, H. Bunch, M. Sayers, and C. Winkler, *Retarders for Heavy Vehicles: Evaluation of Performance Characteristics and In-Service Costs*, Report No. DOT-HS-805-807, National Highway Traffic Safety Administration, U.S. Department of Transportation, Washington, D.C. (February 1981) 124 pp.
- Guss, B., "Bringing Runaways Home," *Center Line*, Vol.5, No.7 (1974) pp. 1-3.
- Hardy, Thomas A., A. Hamilton and Gordon Beecroft, "Siskiyou Summit Negative Grade Arrester Bed for Runaway Trucks," Oregon State Highway Division, Salem, Oregon (1986) 21 pp.
- Hayden, R.L., "Mt. Vernon Canyon Runaway Truck Escape Ramp," Colorado Department of Highways, Denver, Colorado (1982) np.
- Hunter, William W., N.C. Crowe, Jr. and David G. Cole, "An Examination of Runaway Truck Escape Ramps," *Proceedings of American Association of Automotive Medicine Conference (22d) and International Association for Accident and Traffic Medicine Conference (7th)*, Ann Arbor, Michigan (July 1978) Vol.2.
- Indahl, George W., John J. Quinn, Kenneth C. Afferton, "Vehicle Entrapment," New Jersey Department of Transportation, Trenton, New Jersey (1976) 61 pp.
- "Interim Guidelines for Design of Emergency Escape Ramps," FHWA Technical Advisory T5040.10, Federal Highway Administration, U.S. Department of Transportation, Washington, D.C., July 5, 1979.
- Jehu, V.J., and I.B. Laker, "Vehicle Decelerations in Beds of Natural and Artificial Gravels," RRL Report LR264, Road Research Laboratory, Crowthorne, England (1969) 14 pp.
- Johnson, W.A., R.J. DiMarco and R.W. Allen, "The Development and Evaluation of a Prototype Grade Severity Rating System," Federal Highway Administration, Washington, D.C. (1982), 184 pp.
- Laker, I.B., "Tests to Determine the Design of Roadside Soft Arrester Beds," Road Research Laboratory, Crowthorne, England (1971) 23 pp.
- Manual on Uniform Traffic Control Devices for Streets and Highways*, Federal Highway Administration, U.S. Department of Transportation, Washington, D.C. (1988).
- Model Curriculum for Training Tractor-Trailer Drivers*, Federal Highway Administration, U.S. Department of Transportation, Washington, D.C. (1985).
- Overend, Robert B., "Truck Escape Ramps: Exits to Safety," *Traffic Safety*, Vol. 79, No.8 (1979) pp. 22-24.
- Pigman, J.G. and K.R. Agent, "Evaluation of Truck Escape Ramps, Interim Report," Kentucky University, Lexington, Kentucky (Jan 1985) 29 pp.
- A Policy on Geometric Design of Highways and Streets*, American Association of State Highway and Transportation Officials, Washington, D.C. (1990) pp. 272-280.
- al-Qadi, I. L. and L.A. Rivera-Ortiz, "Laboratory Testing of River Gravel Used in Arrester Beds," *Journal of Testing and Evaluation*, Vol. 19, No. 4 (July 1991) p. 280-291.
- "A Report on Truck Escape Ramp Use in Colorado," Colorado Department of Highways, Denver, Colorado (1982) 48 pp.
- Rooney, F.D., "Speeds and Capacities on Grades, Climbing Lanes, Passing Lanes, and Runaway Trucks," California De-

- partment of Transportation, Sacramento, California (1985) 28 pp.
- Runaway Truck Ramps Save Equipment and Lives*, Idaho Transportation Department, Boise, Idaho (1984) 20 pp.
- Stanley, A.F., "A Calculator Program To Estimate Truck Coasting Speeds for Designing Gravel Arrester Beds," Idaho Transportation Department, Boise, Idaho (1978) 12 pp.
- Stein, A.C. and W.A. Johnson, "Effective Signing to Reduce Truck Downgrade Runaways," *Proceedings of the Annual Conference*, American Association of Automotive Medicine (1984) pp. 77-89.
- Taragin, A., "Effect of Length of Grade on Speed of Motor Vehicles," *Proceedings*, Highway Research Board, Vol. 25, Washington, D.C., Highway Research Board (1945) pp. 342-353.
- "The Safe Choice," Pennsylvania Department of Transportation, Harrisburg, Pennsylvania (1987) 2 pp.
- "Truck Escape Ramps," Institute of Transportation Engineers, Washington, D.C. (1989) 17 pp.
- Tye, E.J., "Design Guide for Truck Escape Ramps," Traffic Bulletin No. 24, California Business, Transportation and Housing Agency, Sacramento, California (1986) 13 pp.
- Versteeg, J.H., "Truck Escape Ramps—Design and Testing," Northwest Roads and Streets Conference, Corvallis, Oregon (February 1978) 17 pp.
- Wambold, J.C., "Truck Escape Ramp Design Methodology, Volume 1: Executive Summary," Pennsylvania Transportation Institute, Pennsylvania State University (1988) 52 pp.
- Wambold, J.C., L.A. Rivera-Ortiz and M.C. Wang, "Truck Escape Ramp Design Methodology, Volume 2: Final Report," Pennsylvania Transportation Institute, Pennsylvania State University (1988) 231 pp.
- Wambold, J.C., E.C. Yeh, J.J. Henry and M.C. Wang, "Truck Escape Ramp Design Methodology: Literature Review, Phase 1 Report," Pennsylvania Transportation Institute, Pennsylvania State University (1983) 56 pp.
- Whitfield, J.K., A.C. Eberhardt, J.D. Booze, and M.W. Malpass, "Runaway Truck Arresting Schemes, Final Report," North Carolina Department of Transportation, Raleigh, North Carolina (1982) 126 pp.
- Williams, E.C., Jr., "Emergency Escape Ramps for Runaway Heavy Vehicles," Tennessee Department of Transportation, Nashville, Tennessee (1978) 68 pp. (Also available under the same title as Report No. FHWA-TS-79-201, Federal Highway Administration, Washington, D.C. (1979) 68 pp.
- Williams, Earl C. and C. Franklin Horne, "Runaway Truck Ramps are Saving Lives and Reducing Damage," *ITE Journal*, Vol.49, No.5 (1979) pp. 38-41.
- Williams, E.C., Jr., H.B. Skinner and J.N. Young, "Emergency Escape Ramps for Runaway Heavy Vehicles," *Public Roads*, Vol.42, No.4 (1979) pp. 142-147.
- Young, Jonathan, "Field Testing a Truck Escape Ramp," *Highway Focus*, Vol.11, No.3 (1979), pp. 43-55.

**APPENDIX A**  
**SURVEY FORM**

NCHRP SYNTHESIS TOPIC  
"TRUCK ESCAPE RAMPS"

S U R V E Y F O R M

The National Cooperative Highway Research Program, AASHTO's research arm, has selected the topic of Truck Escape Ramps as one of the current topics in the Synthesis Series. A compilation is being made of experience and research, emphasizing issues in site location, design criteria, operations, maintenance and their relationships to performance and safety. Problems and solutions will be identified.

Your assistance in responding to this survey will be invaluable. If space here is inadequate, please feel free to provide additional comments and documentation. Thank you.

I. APPLICATIONS AND TYPES

A) Are truck escape ramps used on highway systems in your state?

Please enter approximate number:

On state-maintained systems: \_\_\_\_\_

On Forest Service or other federal agency systems: \_\_\_\_\_

On local (County or township): \_\_\_\_\_

B) What types and roughly how many of each are employed?

Sandpile: \_\_\_\_\_

Gravity (paved surface): \_\_\_\_\_

Arrester beds: ascending \_\_\_ ; descending \_\_\_ ; horizontal \_\_\_

Other (please describe): \_\_\_\_\_

C) Is your state planning to construct more? \_\_\_\_\_

D) Of these types, which were first used, which are current, and which are proposed?

	<u>Used first</u>	<u>current</u>	<u>proposed</u>
Sandpile:	_____	_____	_____
Gravity:	_____	_____	_____
Arrester:	_____	_____	_____
Other:	_____	_____	_____

E) Do types and design standards vary by site according to highway system, truck volume or other criteria? \_\_\_\_\_

F) How do the following criteria influence the decision to build a TER?

Accident experience \_\_\_\_\_

Grade Severity Rating System \_\_\_\_\_

Engineering Judgment \_\_\_\_\_

Other (please describe) \_\_\_\_\_



II. LOCATION

- A) How many sites are on short steep hills \_\_\_\_ ;  
on long grades (several miles) \_\_\_\_ ;  
at special sites \_\_\_\_ (toll booth area)?
- B) How are specific site locations on grades determined?  
Distance from top \_\_\_\_ Horizontal alignment \_\_\_\_  
Adjacent land-use \_\_\_\_ Terrain suitability \_\_\_\_ Other? \_\_\_\_

\_\_\_\_\_

C) If a routine process is followed for site location, please describe separately.

III. DESIGN ELEMENTS (For Typical Installation)

- A) TER Approach  
What sight distance criteria affect site selection? \_\_\_\_\_  
Is an auxiliary lane provided on TER approach? \_\_\_\_\_  
What exit lane width is provided? \_\_\_\_\_
- B) Ramp Alignment and Grade  
Are ramps tangent to roadway and straight? \_\_\_\_\_  
What maximum turn or angle might have to be negotiated? \_\_\_\_\_  
Do arrester beds maintain a uniform grade? \_\_\_\_\_
- C) Ramp Width  
What minimum width is provided in stopping area? \_\_\_\_\_
- D) Ramp Length  
How is entry speed established? \_\_\_\_\_  
How is ramp length need determined? \_\_\_\_\_  
Formula? \_\_\_\_\_  
What attenuator types, if any, are used at ramp ends? \_\_\_\_\_  
\_\_\_\_\_
- E) Vehicle Removal  
Is a parallel service lane provided? \_\_\_\_\_  
Are anchors/deadmen provided? \_\_\_\_\_  
Can trucks pull out forward? \_\_\_\_\_

IV. MATERIALS

- A) What aggregate types and sizes have been used? \_\_\_\_\_
- B) What does experience show to be the most effective? \_\_\_\_\_
- C) Are transverse mounds or berms used, or only flat surface? \_\_\_\_\_
- D) What provisions are made for drainage? \_\_\_\_\_
- E) What pavement design is used for service lanes? \_\_\_\_\_
- F) What material depths are used (describe if varying along ramp) \_\_\_\_\_

V. OPERATIONS

- A) What advance signing is provided for TER's? Please describe message, size, color and locations \_\_\_\_\_
- B) What signs are used at the site? \_\_\_\_\_
- C) What delineators and/or illumination are used? \_\_\_\_\_
- D) Are communication facilities provided on site? \_\_\_\_\_
- E) What are usual response times for recoveries? \_\_\_\_\_
- F) Are brake-check and driver information areas provided at top of grade routinely? \_\_\_\_\_
- G) What enforcement activities are related to steep grades and TER's? \_\_\_\_\_
- H) What efforts are made to keep nonusers away from sites? \_\_\_\_\_
- I) Are drivers cited as a result of using TER's? \_\_\_\_\_
- J) Are vehicles removed by state or private services? \_\_\_\_\_
- K) What are typical removal charges? \_\_\_\_\_

VI. MAINTENANCE

- A) How often are TER's checked for surface condition? \_\_\_\_\_
- B) What steps are taken against aggregate freezing? \_\_\_\_\_
- C) What equipment and procedures are routinely used for TER maintenance? \_\_\_\_\_
- D) What measures are taken against infiltration of fines? \_\_\_\_\_
- E) Has toxic material removal ever been an issue? \_\_\_\_\_

VII. EXPERIENCE AND RESEARCH

- A) What data are available on site usage? \_\_\_\_\_  
 \_\_\_\_\_
- B) Has use by more than one vehicle at a time occurred? \_\_\_\_\_  
 \_\_\_\_\_
- C) What cost data on installations and maintenance are available?  
 \_\_\_\_\_
- D) What efforts in truck driver education or public information  
 have been made? (Brochures, videotapes?) \_\_\_\_\_  
 \_\_\_\_\_
- E) What aspects of TER's present the most problems? \_\_\_\_\_  
 \_\_\_\_\_
- F) Is any current research ongoing regarding TER's? \_\_\_\_\_  
 \_\_\_\_\_
- G) Has there been any litigation over use or absence of TER's? \_\_\_\_\_  
 \_\_\_\_\_

VIII. FOLLOW-UP

- A) Can reproducible drawings or photographs be provided for the  
 synthesis on current designs or successful installations? \_\_\_\_\_
- B) Suggestions for researchers or other individuals to contact  
 would be appreciated. Please give name, agency, and phone no.  
 \_\_\_\_\_  
 \_\_\_\_\_
- C) Are any design guides, unpublished reports or videotapes  
 available for review? \_\_\_\_\_  
 \_\_\_\_\_
- D) In case of a need to follow up on responses here, please give  
 the name and telephone number of the appropriate person to  
 contact \_\_\_\_\_  
 \_\_\_\_\_

THANKS FOR YOUR HELP!

Please return to : David Witheford  
 11423 Purple Beech Drive  
 Reston, VA 22091

Tel: 703-860-5017

## **APPENDIX B**

### **ARRESTER BED STOPPING DISTANCES**

STOPPING DISTANCE (FT.) FOR ENTRY SPEED (MPH) FOR SOME BED GRADES (24)

BASIC BED LENGTH							
ENTRY SPEED	PERCENT GRADE						
	-5	0	5	10	15	20	25
30	73	65	58	53	49	46	43
32	84	74	67	61	56	52	49
34	96	85	76	69	63	59	55
36	110	96	86	78	72	67	62
38	124	108	97	87	80	75	70
40	139	121	108	98	90	83	78
42	156	135	120	109	100	92	86
44	174	150	133	120	110	102	95
46	193	166	147	132	121	112	105
48	213	183	162	145	133	123	115
50	235	202	177	159	145	134	125
52	259	221	194	174	158	146	136
54	284	241	211	189	172	158	148
56	311	263	230	205	186	172	160
58	340	286	249	222	201	185	172
60	371	311	270	240	217	200	185
62	404	337	291	259	234	215	199
64	439	364	314	278	251	230	214
66	476	393	338	299	269	247	229
68	516	423	363	320	288	264	244
70	559	456	389	343	308	281	260
72	605	490	417	366	329	300	277
74	654	525	446	390	350	319	294
76	706	563	476	416	372	339	313

(CONTINUED)



## STOPPING DISTANCE (FT.) FOR ENTRY SPEED (MPH) FOR SOME BED GRADES

BASIC BED LENGTH							
ENTRY SPEED	PERCENT GRADE						
	-5	0	5	10	15	20	25
78	762	603	508	443	395	359	331
80	821	645	541	470	419	381	351
82	885	690	576	499	444	403	371
84	954	736	612	529	470	426	392
86	1027	786	650	561	497	450	413
88	1105	837	689	593	525	475	435
90	1189	892	731	627	554	500	458
92	1279	949	774	662	584	526	482
94	1375	1009	819	699	615	554	506
96	1477	1073	866	737	647	582	532
98	1586	1139	915	776	681	611	558
100	1702	1209	966	817	715	641	584
102	1824	1282	1019	859	750	672	612
104	1953	1358	1074	903	787	703	640
106	2088	1438	1131	948	825	736	669
108	2228	1521	1190	995	864	770	699
110	2372	1608	1252	1043	904	805	730
112	2521	1699	1316	1093	945	840	762
114	2671	1792	1382	1145	988	877	794
116	2824	1890	1451	1198	1032	915	828
118	2976	1990	1521	1253	1077	954	862
120	3128	2093	1595	1309	1124	994	897

## **APPENDIX C**

### **EXCERPT FROM COLORADO DESIGN GUIDELINES**

ADAPTED FROM

## DESIGN GUIDELINES FOR IMPROVEMENT OF TRUCK ESCAPE RAMPS COLORADO DEPARTMENT OF HIGHWAYS (27)

### A.1 AGGREGATE DESIGN

Theoretically, if clean, well-graded round pea gravel is placed in a truck escape ramp, the aggregate will have the potential to develop a thin frozen crust on the surface of the arrester bed during the winter months. Trucks break through this thin crust on the coarse material, but would not do so for fine-grained materials. The phenomenon was also observed for Colorado's truck escape ramps. Therefore, in cold mountains, the gradations of the aggregate should be as close as possible to the one presented in Figure 3.13 [not included here]. In addition, the round aggregate is preferred over angular aggregate for the increase of rolling resistance in the arrester bed.

### A.2 VARIOUS METHODS TO PREVENT AGGREGATE CONTAMINATION

The major reason for contamination of the aggregate is lack of a proper drainage system for run-off water due to rain or snow melting. Observations of Colorado truck escape ramps reveal that the contaminated run-off water from top and sides of the ramps is the prime source for contamination of the arrester bed aggregate. If this reasoning is accepted, the following list contains the suggested methods to reduce the degree of contamination:

1. Fabrics can be used on top of the slope to screen the contaminated run-off water on top, as shown in Figure A-1. Use of fabrics is an economical approach, because the cost of fabric is minimal compared to the total project cost.
2. A layer of fabric could be utilized on top of the subbase ground slope prior to placement of the aggregate in the arrester bed, as shown in Figure A-2. The fabric used in this figure has two functions: (1) It screens the water on top of the ramp, and (2) it prevents the transfer of fines from the natural ground in to the arrester bed. This is a natural phenomenon in cold mountains. The ground water table rises due to rain and snow fall, and seepage forces cause the fine particles to travel into the voids of the arrester bed aggregate.

FIGURE A-1 USE OF FABRIC ON TOP OF THE RAMPS TO FILTER THE RUN-OFF WATER BEFORE ENTERING THE RAMP

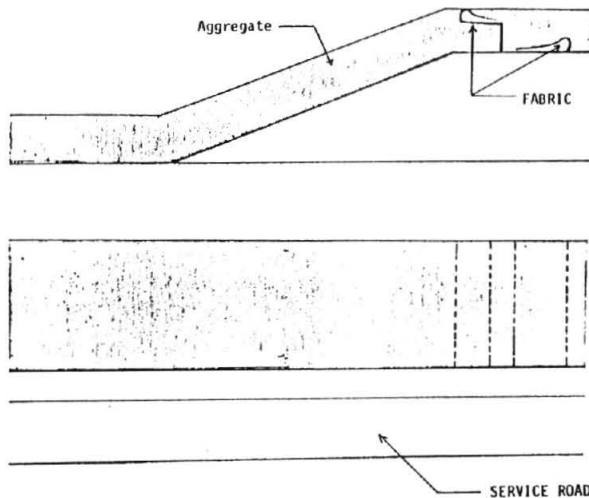
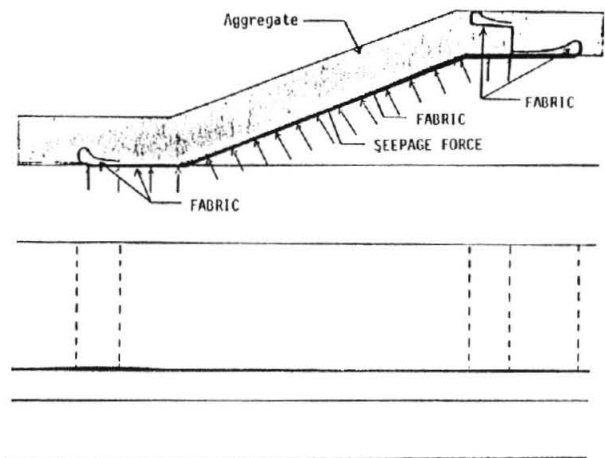
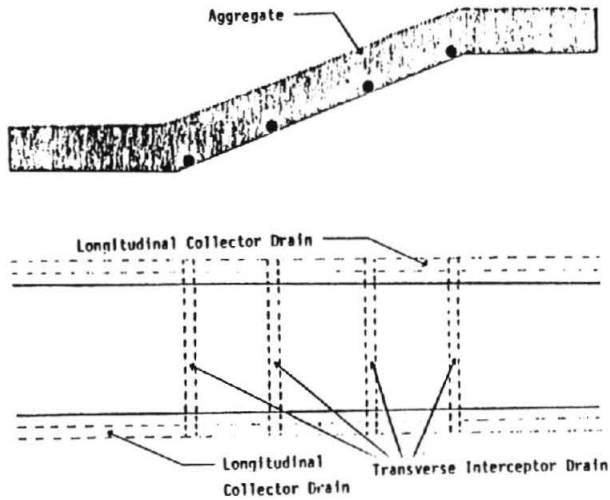

FIGURE A-2 USE OF FABRIC TO PREVENT MIGRATION OF FINE AGGREGATE INTO THE ARRESTER BED OF A TRUCK ESCAPE RAMP



3. The run-off water can be drained out by means of transverse perforated pipes and collected in longitudinal collector pipes, shown in Figure A-3.

FIGURE A-3 USE OF LONGITUDINAL AND TRANSVERSE DRAINAGE PIPES IN TRUCK ESCAPE RAMPS



The common goal of the above methods is to reduce the penetration or circulation of the contaminated run-off water into the arrester bed. Therefore, selection of appropriate aggregate combined with a good drainage system is perhaps the best solution for the freezing problem of aggregate in arrester beds of truck escape ramps.

4. Combination of fabric and perforated pipes can also be used for more assurance, as shown in Figure A-4.

FIGURE A-4 USE OF FABRIC AND DRAINAGE PIPES IN TRUCK ESCAPE RAMPS

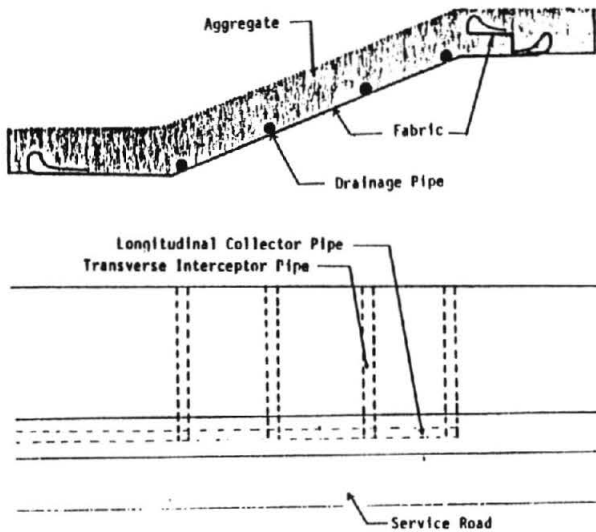

**APPENDIX D**

**COLORADO RAMP USAGE REPORT FORM**

### COLORADO STATE PATROL TRUCK ESCAPE RAMP REPORT

Sample of an actual report, with  
names & addresses deleted

Ramp Used  
 Ramp Not Used

Ramp Location I 70 (Lookout Mt.)Mt. Vernon Date 05-08-81 Time 9:00 A.M.

Truck Owner \_\_\_\_\_

Owner's Address \_\_\_\_\_

Truck, Year-Model \_\_\_\_\_ License No. \_\_\_\_\_

Driver's Name \_\_\_\_\_ D.O.B. \_\_\_\_\_

Driver's License \_\_\_\_\_ State Florida

**Mountain Driving Experience of the Vehicle Operator:**

None ( ) Over This Route 2 Trips  
Less Than 1 Year ( ) Per Month (50 Times Total)  
18 Years (x) Citation Issued X yes \_\_\_\_\_ no  
Cited for: careless Driving

**ADDITIONAL VEHICLE INFORMATION:**

Number of Axles 5 Gross Weight 74,000

Cargo Description Honey/Sandwich Bag Type of Trailer Utility

Was Vehicle Equipped with an Engine (Jacobs) Brake? Yes Was Brake Working? Yes

Was Vehicle Equipped with a "Retarder" Brake? Yes Was Brake Working? Yes

Describe any Vehicle Defects Driver States Brake Got Hot, Would Not Hold Load

Describe Vehicle Damage None

**ADDITIONAL INCIDENT INFORMATION:**

Estimated Speed of Vehicle upon Entering Ramp 70-75 MPH

Distance Traveled in Ramp before Stopping 889 Feet

Were Brakes Applied while Vehicle was in Ramp? Yes

Distance from Ramp when Driver became aware of Problem 150 Feet

Driver's Comments concerning Adequacy of Advance Signing Can't miss them, Signs are good

Describe Action of Vehicle after Entering Ramp No problems - No improvement need to be made  
States this is a lifesaver

**Condition of Ramp/Material (check those that apply):**

Gravel: Smoothed/Level (X) Ramp: Clear/Dry (X) Snow Depth \_\_\_\_\_ Inches ( )  
Rutted ( ) Wet ( ) Other \_\_\_\_\_ ( )  
Icy ( ) \_\_\_\_\_

\_\_\_\_\_  
C.S.P. OFFICER                      DISTRICT-TROOP                      REVIEWED BY:



## **APPENDIX E**

### **IDAHO SAFETY TIPS FOR DOWNGRADES**

**"How Do Truck Escape Ramps Work?"**  
 From *Runaway Truck Ramps Save Equipment and Lives*  
 Idaho Transportation Department

Currently, Idaho utilizes two types of arrester beds--the ascending grade and the descending grade types. Each bed is approximately 26 to 30 feet wide and filled to a depth of 18" to 30" with 1/4" to 3/4" pea gravel.

The ascending grade arrester ramps are built on the hillsides adjacent to the highway at about a 10 to 20 degree upward angle. The descending grade arrester is usually found at or near the bottom of long, steep grades and consists of a wide bed of pea gravel built horizontally on the righthand right-of-way adjacent to the highway. This type of arrester bed utilizes only the pea gravel to stop the truck. Because of this, this type of bed is usually much longer than the ascending grade ramps which utilize gravity and the weight of the truck to slow it down safely.

The descending grade arrester is usually the last opportunity for the trucker to slow his truck due to the fact that he did not take advantage of the ascending grade arrester ramps further up the grade.

How Do You Use the Ramps?

If you find yourself in trouble, don't panic. Aim your front wheels squarely and straight between the front guide markers of the truck escape ramp. By entering the ramp straight-on your vehicle will be slowed uniformly. Do not try to enter the ramp from the side or at an angle.

Safety

The gravel arrester beds in Idaho will stop a vehicle smoothly and the driver will be able to maintain full control of his vehicle. The arrester beds will not damage the truck. Since the slowing action is so smooth there is no chance that the load will come over the top of the cab. Jackknifing is also eliminated. The lighter axles of the truck will float on the pea gravel and the heavier axles will sink into the arrester bed slowing the vehicle down quickly.

Safety Tips

The Driver:

- Companies should begin a driver training program for those who have never traveled on steep grades. Three to four hours of driver training and sign identification should be required.
- Companies should make certain that all drivers keep accurate log books so they don't run up excess hours. Driver fatigue has been the cause of several Idaho accidents.
- When maximum rpm is reached coming down a grade, never try to downshift.
- Be cautious of the gear you choose when starting down a grade. Always select a lower gear when traveling down a 6-7 % grade. And, take your time getting down the grade.
- If you are unfamiliar with the grade, ask local truckers about the grade and the proper gear to use.
- Make absolutely certain you know the condition of your brakes before starting down a grade.

- At the first sign of brake fade pull over and let the brakes cool off.
- If you have a runaway truck, use the first truck escape ramp indicated by the roadside signing. Don't attempt to ride your truck to the bottom of the grade.

#### The Equipment:

- Always use your jake brake if you have one.
- Don't ride your brakes down the grade--they will only overheat.
- Use all retarding devices down the full length of the grade. If your air pressure is below 80 psi, don't start down the grade.
- At the top of the grade choose a gear lower than you think will be necessary. As your speed increases you probably will be able to shift up but you can't shift down.
- If you have on older truck, upgrade the brake linings with newer types of lining.
- Vehicles rarely have brake failure due to loss of air. It is usually a loss of brake adjustment.
- Don't try to maintain the same speed as local truckers. They are equipped with retarders and jake brakes and usually know the hills.
- Stop your truck at the top of the grade and use a check list. Check air lines, air pressure, brake adjustment and load ties to make sure your load will not shift.
- Always descend grades at maximum rpm to obtain maximum braking force.

#### The Route:

- Always check your route by talking to local drivers, Port of Entry personnel or contact the Idaho State Police if you are not familiar with the route.
- Look for and understand all signs posted along the route.
- Find out the exact location and number of truck escape ramps on the hill as well as the average grade percentage.

#### Usage Fee

There is no fee charged for the use of the truck escape ramps in Idaho and the State Police will not ticket you for their use. The only fee that a trucker may encounter would be that charged by a local independent towing firm to remove your vehicle from the arrester bed. This makes the use of the ramp very inexpensive compared to losing the vehicle, the load and your life.

### Ramp Entry Problems

*What do you do when you have a runaway truck and you are approaching an escape ramp but have to pass a car to keep from hitting it?*

*What do you do when there is a car in the right lane ahead of you and your runaway vehicle is in the left lane prohibiting you from using the escape ramp?*

There is no clear-cut answer to those questions, but safety experts offer these suggestions:

1. Turn on your four-way flashers so that other vehicles, hopefully, will notice that you have a problem.
2. Lay on your horn to alert drivers around you that you are in trouble.
3. When coming up on a car with your flashers flashing and your horn blasting, pull to the right and make an attempt to pass the car on the right. The majority of Idaho's highways that have truck escape ramps have fairly wide shoulders which you can drive upon.

### Unauthorized Use of Ramps:

Each of Idaho's truck escape ramps is signed--Truck Escape Ramp--and is to be used only as such. Any vehicle other than a truck in or parked on the ramp will be ticketed. Any time a car or pickup is seen parked in a ramp or blocking the entrance notify the Idaho State Police so the vehicle can be removed.

### Summary

Truck escape ramps have been constructed on most major steep grades in Idaho. The ramps are clearly marked and easily accessible. They will normally stop a truck within 300 to 400 feet. The driver will experience total steering control of the vehicle and there should be no damage to the vehicle if the driver aims straight into the ramp. No fee is charged for ramp usage and you will not be ticketed for using the ramp.

Idaho's truck escape ramps are a safety device provided for use. They offer a safe way to stop and will not damage your vehicle or cargo. To save your life the Idaho Transportation Department asks that you please use one of the ramps if you experience a runaway vehicle.

**APPENDIX F**

**PENNSYLVANIA TRUCK RAMP BROCHURE**

**WHAT ARE TRUCK ESCAPE RAMPS?**

- Escape ramps are beds of gravel or sand which are located between the bottom and the midpoint of long steep hills.
- The ramps, designed to be easily accessible and to safely stop runaway trucks, are well marked by signs like this:

**WHY SHOULD I USE A TRUCK ESCAPE RAMP?**

- There have been 30 accidents in the past five years caused by truckers ignoring existing truck escape ramps. Three people were killed and 23 people were injured as a result of these accidents.
- In the past three years there have been a total of 445 truck accidents attributed to brake failure. 492 people were injured and 23 were killed in these accidents.
- There have been over 100 incidents in which truckers have successfully stopped upon entering existing truck escape ramps in Pennsylvania, with either no injuries or minor injuries to the drivers.
- Damage to trucks using truck escape ramps is minimal compared to the damage caused if the ramps are not used.
- The average cost to extract vehicles from a truck escape ramp is approximately \$200, with the average time of removal approximately one hour.

**WHAT HAPPENS WHEN I USE A TRUCK ESCAPE RAMP?**

- In general, the truck is stopped by two forces.

If the ramp is sloped upward, gravity helps stop the truck. Drag force caused by the material in the ramp itself also helps stop the truck.

The drag force is much like running into the ocean. As the water gets deeper, your ability to move forward lessens and you slow down, the same thing happens to the truck.

The description of driving into an escape ramp given by drivers of runaway trucks and drivers of our tests vehicles is that it is not as rough as an emergency panic-type stop.

# THE SAFE CHOICE

## PENNSYLVANIA TRUCK ESCAPE RAMPS

June, 1987



Federal Highway Administration



Robert P. Casey  
Governor

Howard Yarusoff, P.E.  
Transportation Secretary

For more information please contact The Pennsylvania Department of Transportation, Harrisburg, 717-787-1739. Video available upon request.

**HOW DO I GET OUT?**

- Tow trucks should be anchored to the deadman blocks located in the ramp approach road.
- A winching mechanism with a mechanical advantage of two to four using pulleys is needed, since a fully loaded truck of 80,000 pounds requires 40,000 pounds of pull for extraction from the escape ramp because of drag resistance from the gravel.
- Always remove the mud flaps before attempting to remove the truck since they often get caught between the tire and gravel. When this happens, the wheels don't turn and become buried in the gravel. The unit then has to be dug out so the mud flaps can be removed.
- The best tow truck is one that has a high snatch wheel so that the pulling cable pulls from six to ten feet above the ground level. This type tow truck gives a small vertical pull and helps prevent digging in.
- Use two-inch by six-inch lumber approximately eight feet long placed behind the tires in the wheel path. Once the tractor and trailer is up on the lumber and supported, the pulley system should be detached. A direct one-to-one winch can be hooked up and the truck pulled out of the arrestor bed by continuously moving the two-by-six lumber behind the tires during extraction.

**WHERE ARE THE TRUCK ESCAPE RAMPS?**

1. Venango County, US 62, PA 8 approaching Franklin from southwest, 7% grade, 1.3 miles.
2. Elk County, US 219 approaching Ridgeway from South, 7½% grade, 1.5 miles. (Under construction, completion Fall, 1987)
3. Carbon County, PA 93 approaching Nesquehoning from North, 12% grade, 2.2 miles.
4. Franklin County, US 30 approaching Fort Loudon from West, 9% grade, 3.5 miles.
5. Fulton County, US 30 approaching Sideling Hill from West, 8% grade, 3.35 miles.
6. Armstrong County, US 422 Indiana Pike Hill approaching Kittanning from East, 8% grade, 1 mile.
7. Armstrong/Butler County, PA 28 approaching Freeport from North, 8% grade, 1 mile.
8. Allegheny County, I-279 Greentree Hill approaching Pittsburgh from West, 5.5% grade, 1.7 miles.
9. Fayette County, PA 40 Summit Mt. approaching Uniontown from southeast, 9% grade, 3 miles.
10. Jefferson County, US 119 Indiana Hill approaching Punxsutawney from the South, 8.5% grade, 0.8 miles.







**THE TRANSPORTATION RESEARCH BOARD** is a unit of the National Research Council, which serves the National Academy of Sciences and the National Academy of Engineering. It was established in 1974 from the Highway Research Board, which was established in 1920.

TE 7 .N26 no. 178  
 Witheford, David K.  
 Truck escape ramps

**DATE DUE**

DATE DUE	

---13776

**S.C.R.T.D. LIBRARY**

forms additional functions under the nature and performance of such produces, and to encourage program is carried out by more than 3,300 administrators, earned with transportation; they te transportation and highway of Transportation, the Association Administration, and other transportation.

f-perpetuating society of distinguished to the furtherance of upon the authority of the charter ate that requires it to advise the Frank Press is president of the

1964, under the charter of the standing engineers. It is autonomous, sharing with the National eral government. The National imed at meeting national needs, r achievements of engineers. Dr. gineering.

ational Academy of Sciences to ons in the examination of policy is under the responsibility given harter to be an adviser to the es of medical care, research, and f Medicine.

ial Academy of Sciences in 1916 with the Academy's purposes of functioning in accordance with become the principal operating onal Academy of Engineering in fic and engineering communities. Institute of Medicine. Dr. Frank an, respectively, of the National

Transportation Research Board  
National Research Council  
2101 Constitution Avenue, N.W.  
Washington, D.C. 20418

ADDRESS CORRECTION REQUESTED

NON-PROFIT ORG.  
U.S. POSTAGE  
PAID  
WASHINGTON, D.C.  
PERMIT NO. 8970



001341X  
JOEL WOODHULL  
163 SOUTH WILTON DR  
LOS ANGELES CA 90004

3