

National Cooperative Highway Research Program

**NCHRP Synthesis 198**

**Uses of Recycled Rubber Tires  
in Highways**

A Synthesis of Highway Practice

Transportation Research Board  
National Research Council

NATIONAL COOPERATIVE HIGHWAY RESEARCH PROGRAM

Systematic, well-designed research provides the most effective approach to the solution of many problems facing highway administrators and engineers. Often, highway problems are of local interest and can best be studied by highway departments individually or in cooperation with their state universities and others. However, the accelerating growth of highway transportation develops increasingly complex problems of wide interest to highway authorities. These problems are best studied through a coordinated program of cooperative research.

In recognition of these needs, the highway administrators of the American Association of State Highway and Transportation Officials initiated in 1962 an objective national highway research program employing modern scientific techniques. This program is supported on a continuing basis by funds from participating member states of the Association and it receives the full cooperation and support of the Federal Highway Administration, United States Department of Transportation.

The Transportation Research Board of the National Research Council was requested by the Association to administer the research program because of the Board's recognized objectivity and understanding of modern research practices. The Board is uniquely suited for this purpose as it maintains an extensive committee structure from which authorities on any highway transportation subject may be drawn; it possesses avenues of communications and cooperation with federal, state, and local governmental agencies, universities, and industry; its relationship to the National Research Council is an insurance of objectivity; it maintains a full-time research correlation staff of specialists in highway transportation matters to bring the findings of research directly to those who are in a position to use them.

The program is developed on the basis of research needs identified by chief administrators of the highway and transportation departments and by committees of AASHTO. Each year, specific areas of research needs to be included in the program are proposed to the National Research Council and the Board by the American Association of State Highway and Transportation Officials. Research projects to fulfill these needs are defined by the Board, and qualified research agencies are selected from those that have submitted proposals. Administration and surveillance of research contracts are the responsibilities of the National Research Council and the Transportation Research Board.

The needs for highway research are many, and the National Cooperative Highway Research Program can make significant contributions to the solution of highway transportation problems of mutual concern to many responsible groups. The program, however, is intended to complement rather than to substitute for or duplicate other highway research programs.

---

**NOTE:** The Transportation Research Board, the National Research Council, the Federal Highway Administration, the American Association of State Highway and Transportation Officials, and the individual states participating in the National Cooperative Highway Research Program do not endorse products or manufacturers. Trade or manufacturers' names appear herein solely because they are considered essential to the object of this report.

TE

7

.N26

no.

198

JUL 11 '94

18044

HESIS 198

1991 (Topic 22-02)

ISBN 0-309-05323-4

Library of Congress Catalog Card No. 94-060375

**Price \$23.00**

#### NOTICE

The project that is the subject of this report was a part of the National Cooperative Highway Research Program conducted by the Transportation Research Board with the approval of the Governing Board of the National Research Council. Such approval reflects the Governing Board's judgment that the program concerned is of national importance and appropriate with respect to both the purposes and resources of the National Research Council.

The members of the technical committee selected to monitor this project and to review this report were chosen for recognized scholarly competence and with due consideration for the balance of disciplines appropriate to the project. The opinions and conclusions expressed or implied are those of the research agency that performed the research, and, while they have been accepted as appropriate by the technical committee, they are not necessarily those of the Transportation Research Board, the National Research Council, the American Association of State Highway and Transportation Officials, or the Federal Highway Administration of the U.S. Department of Transportation.

Each report is reviewed and accepted for publication by the technical committee according to procedures established and monitored by the Transportation Research Board Executive Committee and the Governing Board of the National Research Council.

The National Research Council was established by the National Academy of Sciences in 1916 to associate the broad community of science and technology with the Academy's purposes of furthering knowledge and of advising the Federal Government. The Council has become the principal operating agency of both the National Academy of Sciences and the National Academy of Engineering in the conduct of their services to the government, the public, and the scientific and engineering communities. It is administered jointly by both Academies and the Institute of Medicine. The National Academy of Engineering and the Institute of Medicine were established in 1964 and 1970, respectively, under the charter of the National Academy of Sciences.

The Transportation Research Board evolved in 1974 from the Highway Research Board, which was established in 1920. The TRB incorporates all former HRB activities and also performs additional functions under a broader scope involving all modes of transportation and the interactions of transportation with society.

*Published reports of the*

**NATIONAL COOPERATIVE HIGHWAY RESEARCH PROGRAM**

*are available from:*

Transportation Research Board  
National Research Council  
2101 Constitution Avenue, N.W.  
Washington, D.C. 20418

Printed in the United States of America

## **PREFACE**

A vast storehouse of information exists on nearly every subject of concern to highway administrators and engineers. Much of this information has resulted from both research and the successful application of solutions to the problems faced by practitioners in their daily work. Because previously there has been no systematic means for compiling such useful information and making it available to the entire highway community, the American Association of State Highway and Transportation Officials has, through the mechanism of the National Cooperative Highway Research Program, authorized the Transportation Research Board to undertake a continuing project to search out and synthesize useful knowledge from all available sources and to prepare documented reports on current practices in the subject areas of concern.

This synthesis series reports on various practices, making specific recommendations where appropriate but without the detailed directions usually found in handbooks or design manuals. Nonetheless, these documents can serve similar purposes, for each is a compendium of the best knowledge available on those measures found to be the most successful in resolving specific problems. The extent to which these reports are useful will be tempered by the user's knowledge and experience in the particular problem area.

## **FOREWORD**

*By Staff  
Transportation  
Research Board*

This synthesis on the use of recycled rubber tires in highways will be of interest to administrators and policymakers; pavement, materials, geotechnical, environmental, and traffic operations engineers; and research engineers involved with highway design and construction issues. Information is provided on the uses of rubber tires in asphalt paving materials as well as other uses, such as on fills and embankments, for erosion control and on railroad grade crossings. Specifically, information is included which identifies the highway agencies using or implementing applications for recycled rubber tires and defines the design parameters, technical and construction limitations, performance, costs, benefits, environmental limitations, specifications, and availability.

Administrators, engineers, and researchers are continually faced with highway problems on which much information exists, either in the form of reports or in terms of undocumented experience and practice. Unfortunately, this information often is scattered and unevaluated, and, as a consequence, in seeking solutions, full information on what has been learned about a problem frequently is not assembled. Costly research findings may go unused, valuable experience may be overlooked, and full consideration may not be given to available practices for solving or alleviating the problem. In an effort to correct this situation, a continuing NCHRP project, carried out by the Transportation Research Board as the research agency, has the objective of reporting on common highway problems and synthesizing available information. The synthesis reports from this endeavor constitute an NCHRP publication series in which various forms of relevant information are assembled into single, concise documents pertaining to specific highway problems or sets of closely related problems.

This synthesis of information defines the use of recycled rubber tires in highways and

is based on a review of nearly 500 references and on information recorded from state highway agency responses to a 1991 survey of practice. Updates are included for as much of the state practice information possible through 1993. The use of scrap tires for highway applications is dynamic with regard to policy and technical issues. Therefore, the reader should keep in mind that the information presented reflects the best available data at a particular time. The synthesis also identifies current research in the topic area, critical research needs, and legislative issues that affect application and use of recycled rubber tires.

To develop this synthesis in a comprehensive manner and to ensure inclusion of significant knowledge, the Board analyzed available information assembled from numerous sources, including a large number of state highway and transportation departments. A topic panel of experts in the subject area was established to guide the researcher in organizing and evaluating the collected data, and to review the final synthesis report.

This synthesis is an immediately useful document that records practices that were acceptable within the limitations of the knowledge available at the time of its preparation. As the processes of advancement continue, new knowledge can be expected to be added to that now at hand.

## CONTENTS

1	SUMMARY
2	CHAPTER ONE INTRODUCTION Background, 2 Purpose of Synthesis, 3 Organization of the Synthesis, 4
7	CHAPTER TWO USE IN ASPHALT PAVING MATERIALS Introduction, 7 Wet Process, 7 Dry Process, 9 Recent Developments, 9 Laboratory vs. Field-Produced Binders, 10 Joint and Crack Sealers, 10 Chip Seal Coats, 19 Interlayers, 21 Hot-Mix Asphalt, 25
36	CHAPTER THREE OTHER HIGHWAY USES Fills and Embankments, 36 Environmental Considerations, 40 Other Uses, 42 Summary, 46
48	CHAPTER FOUR ENVIRONMENT, HEALTH, AND SAFETY Introduction, 48 Leachate Studies, 48 Summary, 49 Field Tests, 51
52	CHAPTER FIVE CONCLUSIONS AND RECOMMENDATIONS Crumb Rubber in Asphalt Paving Materials, 52 Other Highway Uses, 52 Environment, Health, and Safety, 53
54	REFERENCES
58	BIBLIOGRAPHY
68	APPENDIX A GLOSSARY
71	APPENDIX B SECTION 1038 OF ISTE A
74	APPENDIX C QUESTIONNAIRE ON CURRENT STATE PRACTICE
75	APPENDIX D BINDER PROPERTIES
86	APPENDIX E SELECTED PATENTS ON CRUMB RUBBER MODIFIED ASPHALT
87	APPENDIX F ASPHALT-RUBBER MEMBRANES
91	APPENDIX G CHIP SEAL DESIGN METHODS
92	APPENDIX H CHIP SEAL PERFORMANCE
100	APPENDIX I CHIP SEAL LIFE-CYCLE STUDIES
106	APPENDIX J INTERLAYER DESIGN METHODS AND CONSIDERATIONS
109	APPENDIX K INTERLAYER PERFORMANCE
124	APPENDIX L INTERLAYER LIFE-CYCLE COSTS
129	APPENDIX M CRUMB RUBBER MODIFIED HOT-MIX ASPHALT DESIGN METHODS
131	APPENDIX N PROPERTIES OF CRUMB RUBBER MODIFIED HOT-MIX ASPHALT
157	APPENDIX O CRUMB RUBBER MODIFIED HOT-MIX PERFORMANCE

## **ACKNOWLEDGMENTS**

Jon A. Epps, Ph.D., College of Engineering, University of Nevada, was responsible for collection of the data and preparation of the report.

Valuable assistance in the preparation of this synthesis was provided by the Topic Panel, consisting of Michael A. Heitzman, Federal Highway Administration; Kevin Stuart, Research Highway Engineer, Federal Highway Administration; Lawrence L. Smith, State Materials Engineer, Florida Department of Transportation; William J. Quinn, Oregon Department of Transportation; Robin L. Schroeder, Federal Highway Administration; Larry A. Scofield, Manager, Transportation Research, Arizona Department of Transportation; Wayne Brule, Director, Materials Bureau, New York State Department of Transportation; and Timothy A. Baker, Chairman, Rubber Pavements Association.

The Principal Investigators responsible for the conduct of this synthesis were Sally D. Liff, Manager, Synthesis Studies; Stephen F. Maher, Senior Program Officer; and Scott A. Sabol, Program Officer. This synthesis was edited by Linda S. Mason.

Valuable assistance also was provided by Lloyd R. Crowther, Program Officer, and Frank R. McCullagh, Senior Program Officer, National Cooperative Highway Research Program, Transportation Research Board.

Information on current practice was provided by many highway and transportation agencies. Their cooperation and assistance were most helpful.

# USES OF RECYCLED RUBBER TIRES IN HIGHWAYS

**SUMMARY** This synthesis of information defines the use of recycled rubber tires in highways and is based on the practices of state highway agencies through 1993 and a review of nearly 500 references. The synthesis addresses the use of rubber tires in asphalt paving materials as well as other applications, including geotechnical and traffic operations. The various applications of rubber tires are identified, together with their design considerations, technical strengths, construction limitations, performance, costs, environmental considerations, and specifications, as well as current research activities, critical research needs, and legislative issues. This technology is a rapidly changing field; therefore, this synthesis represents the best available information at the time of publication.

More than 242 million scrap tires, approximately 1 tire per person, are generated each year in the United States. This steady stream of scrap tires plus the 2 to 3 billion waste tires that have accumulated in stockpiles and uncontrolled tire dumps and the millions of tires scattered in deserts, forests, grasslands, and empty lots create a significant disposal problem. Currently, about 17 percent of the waste tires, which are about 2 percent of the country's solid waste, are used in 1) combustion, 2) whole tire applications, and 3) processed tire products.

The use of waste tires in highway applications has a long history. Recent legislation at the federal and state levels has renewed the highway community's interest in using larger quantities of waste tires in highway applications. At present, the largest use of waste tires in highways is as a source of rubber for asphalt. Waste tires are also used in fills and embankments, erosion control, retaining walls, membranes, revetments for slope protection, safety hardware, railroad crossings, valve box coverings, planks and posts, drainage aggregate, and culverts.

The long-term use of waste tires in highway applications will depend on the economics, performance, and environmental, health, and safety considerations associated with the various end products. This synthesis provides summaries of the information available and identifies research needs.

# INTRODUCTION

## BACKGROUND

More than 242 million scrap tires, or approximately 1 tire per person, are generated each year in the United States. More than 75 percent of these scrap tires are placed in landfills and stockpiles or dumped illegally. Some estimates indicate that illegal dumping may account for more than 70 percent of all scrap tire disposal. This steady stream of new scrap tires, plus the 2 to 3 billion waste tires that have accumulated in stockpiles and uncontrolled tire dumps or have been scattered across the landscape, create a significant disposal problem.

When tires are placed in landfills, they are difficult to handle, compact, and bury. Because of these difficulties, scrap tires are often placed in large stockpiles. Scrap tires are classified as a nonhazardous waste; their disposal is covered under Subtitle D of the Resource Conservation and Recovery Act (RCRA). The RCRA makes the operators of waste tire stockpiles responsible for taking precautions to prevent fires and to control mosquito and rodent infestations (1). However, fires in large tire stockpiles have occurred near metropolitan areas in Florida, Texas, Virginia, and Washington. These fires are hard to extinguish and typically burn for several months, producing large volumes of noxious black smoke. The pyrolysis of the tires (the application of heat to produce chemical changes resulting in new products including oil and carbon black) produces toxic oils which remain at the site after the fire is extinguished and can cause groundwater contamination and large soil cleanup costs.

About 17 percent of the yearly supply of scrap tires are used in (1) combustion, (2) whole tire applications, and (3) processed tire products. The largest use is for combustion; tires have an energy value of 15,000 BTUs/lb (coal produces about 12,000 to 16,000 BTUs/lb). Tires have been used as a fuel source in power plants, tire manufacturing facilities, cement kilns, and pulp and paper production. Whole tire burning requires a relatively sophisticated, high-temperature combustion facility to control emissions, e.g., smoke particulates and solid materials. Shredded tires (2- to 6-in. in size) are used at most facilities. Tires represent an energy source that can supply about 0.09 percent of annual U.S. energy needs. In 1990 about 26 million tires were used as a source of fuel (2).

Whole tires can be used for a number of applications, including artificial reefs, breakwaters, erosion control, playground equipment, and highway crash barriers. It is estimated that 120,000 to 150,000 tires are used annually in construction of reefs. Breakwaters and flotation devices (marina and deck floats, buoys) currently consume about 30,000 to 50,000 tires per year (2). The use of whole tires for highway crash barriers and erosion control is discussed later in this synthesis.

Tire processing includes punching, splitting, chopping, grinding, and cutting tires into shredded or "crumb" rubber, as well as chemically altering tires. Crumb rubber can be incorporated into rubber sheet and molded products such as floor mats, vehicle guards, and carpet padding. Crumb rubber can also be combined with plastics

to produce floor mats, adhesives, rubber playground surfaces, tracks and other athletic surfaces, and garbage cans. About 8.7 million tires per year are used in these products. Applications of processed tires for use in railroad crossings, asphalt-rubber binders, and roadway aggregates is discussed later in this synthesis. It is estimated that crumb rubber modified asphalt binder consumes about 2 million tires per year (2).

Crumb rubber is made by either mechanically or cryogenically (using very low temperature to change the tire material properties) reducing the size of the tires. Cryogenic size reduction is costly and does not produce an optimum rubber for use in CRM asphalt binders. Mechanical sizing, by chopping and grinding, is most often used. Tires are shredded to particles of about 3/4 in. and magnetic separators and fiber separators are used to remove steel and polyester fragments. The rubber chips are reduced further to pebble size by grinders or granulators. Additional grinding and screening operations produce crumb rubber in the desired size range. At present a significant amount of crumb rubber is obtained from buffings and peels from tire retread shops or other industrial operations that produce waste rubber. Crumb rubber and other tire-derived products can be manufactured from various tire components. Definitions of the types of rubber obtained from tires can be found in Appendix A.

Over the last 15 years, the chemical composition of tires, as viewed from the stream of scrap tires, has changed significantly. The United States has moved from predominantly bias tires to predominantly radial tires. Individual companies change their compounds for specific tires. As more uses are found for recycling this stockpile of material, older tires will be mixed into the stream. The different compounds used for radial and bias tires will change the chemical composition of the recycle stream, introducing additional variations. The physical and chemical properties of the processed scrap tires determines, to a degree, their end use.

The U.S. Environmental Protection Agency (EPA), the Department of Energy, and the Federal Highway Administration (FHWA) are active in legislative issues relative to the reuse of tires. EPA has proposed guidelines for the federal procurement of asphalt material containing ground tire rubber for construction and rehabilitation of paved surfaces (3,4). These guidelines propose to implement Section 6002 of the 1976 RCRA and state that "if a Federal, State or local procuring agency uses appropriate Federal funds to purchase certain designated items, such items must be composed of the highest percentages of recovered materials practicable." Items identified in these proposed guidelines include fly ash, paper and paper products, and asphalt rubber. These guidelines have not been issued to date.

General requirements for the use of these recovered materials state that reasonable levels of competition, cost, availability, and technical performance must be evident. In addition, specifications cannot discriminate against recovered materials, materials must be technically appropriate and economically feasible, and purchase



price must exceed \$10,000. The statement in the guidelines relative to “technically appropriate and economically feasible” implies the following:

- ASTM or AASHTO specifications must be available for a designated application.
- Materials must meet specifications.
- Materials must be reasonably available within a reasonable time period.
- Materials must be available at a reasonable price.
- A satisfactory level of competition must be maintained.

A number of bills are now before Congress as part of the reauthorization of the Solid Waste Disposal Act (5). They include proposals to stimulate alternative use technologies and recycling credits. A proposed recycling credit system may require tire manufacturers to purchase credits from scrap tire recycling companies. Legislation in S.1038, The Waste Tire Recycling Abatement and Disposal Act, mandates a market for used tires in asphalt on federally funded asphalt paving projects. Legislation in H.R. 3058 and H.R. 3059, The Tire Recycling and Recovery Act, establishes a scrap tire trust fund to assist states in developing recycling programs (5).

The Intermodal Surface Transportation Efficiency Act (ISTEA) of 1991 (6) addresses the use of scrap tires in transportation facilities. Specific reference to scrap tires is found in Section 1038, Use of Recycled Paving Materials. Subsection 1038(a) qualifies the eligibility of asphalt pavement containing scrap tire rubber on federally funded highway projects. Subsection 1038(b) requires the FHWA and the EPA to conduct a study on the human health and environmental effects, recyclability, and performance of asphalt pavement containing scrap tire rubber. The study also calls for a broad examination of using other recycled materials in highway devices, appurtenances, and projects. Subsection 1038(c) encourages the appropriate use of recycled materials in federally assisted highway projects. Subsection 1038(d) requires states to use a minimum amount of asphalt pavement containing scrap tire rubber beginning in 1994 with minimum utilization levels increasing through 1997. This subsection also addresses the use of other recycled materials, additional increases in the minimum utilization, a penalty for failure to comply, and possible waivers or reductions in the required utilization. Appendix B is a copy of Section 1038 of ISTEA.

Legislation was passed by Congress in the fall of 1993, section 325 of H.R. 2750, the Department of Transportation Appropriations Act for FY 1994 which states:

“None of the funds made available in this act may be used to implement, administer, or enforce the provisions of Section 1038(d) of Public Law 102-240.” The FHWA’s chief counsel reached the following conclusions relative to this legislation:

- Section 325 will not result in a state being assessed the Section 1038(d) FY 1994 penalty in a subsequent year; rather under the current law the first applicable penalty will be the 10 percent penalty with respect to FY 1995 provided in 1038(d).
- Section 325 does not contain any prohibitions against using funds to carry out any other subsection of Section 1038. Therefore, Section 325 does not preclude a state from using asphalt pavement containing recycled rubber on Federal-aid projects. (7)

The majority of states have laws or regulations affecting the

disposal and reuse of tires (8–10). Table One (11) provides a status report on state laws and regulations regarding scrap tires as collected by Recycling Research Institute. State laws and regulations may target all phases of scrap tire management (storing, processing, transporting, generating, and disposing), or any combination of phases. Funding sources for tire disposal vary among the states. Some states have tire disposal fees while other states use retail sales fees and vehicle title fees. These fees range from \$0.25 to \$2.00 per tire. Many states have instituted market incentives, such as tax credits, grants, loans, and price preferences to encourage recycling.

## PURPOSE OF SYNTHESIS

Federal and state legislation has been proposed or enacted that requires a reduction in the amount of solid waste that can be placed in landfills. It is estimated that about 2 percent of solid wastes in the United States are waste or used tires. Waste tire disposal is a national problem in need of a solution. An alternative disposal site for discarded tires is in the highway system. The use of tires in highway applications is not a new concept. Tires have been used for erosion control for decades and have been used in asphalt binders since the early 1960s.

Many state legislatures have recently directed state highway agencies to aggressively investigate the use of recycled tires in highway construction, rehabilitation, and maintenance activities. ISTEA, which defines the U.S. Department of Transportation (DOT) activities in this area, also has stimulated state and local public agency interest in the use of tires in highway applications (6).

This synthesis of information defines the use of recycled rubber tires in highways and is based on a review of nearly 500 references and on information recorded from state highway agency responses to a 1991 survey of current practices. The questionnaire used for this survey is shown in Appendix C. The synthesis addresses the uses of rubber tires in asphalt paving materials as well as other uses, including geotechnical and traffic operations. Information is included which identifies the agencies using many of the various applications and defines the design parameters, technical and construction limitations, performance, costs, benefits, environmental limitations, specifications, and availability, as well as current research, critical research needs, and legislative issues that agencies have encountered.

## ORGANIZATION OF THIS SYNTHESIS

Chapter Two, Use in Asphalt Paving Materials, covers crumb rubber applications in asphalt paving operations. The chapter first describes methods for incorporating crumb rubber with asphalt cement; the wet process, which blends and reacts crumb rubber with asphalt cement, and the dry process, which adds crumb rubber to aggregate in a hot-mix operation. Understanding the difference between these two processes is critical. For example, only the wet process can produce crumb rubber modified asphalt binder suitable for spray applications.

Other sections in Chapter Two discuss the use of crumb rubber modifier (CRM) for joint and crack sealers, chip seal coats, interlayers, and hot-mix asphalt.

Each section is further divided into subsections which, in most

TABLE ONE  
SCRAP TIRE LAWS AND REGULATIONS, JANUARY 1994 (11)

LEGEND: S = STORAGE P = PROCESSOR H = HAULER G = GENERATOR D = DISPOSAL PP = PRICE PREFERENCE

STATE	FUNDING	REGS	LANDFILL	MARKET INCENTIVES
AL		S P		
AR	\$1.50/tire disposal fee on retail sales \$1/tire imported into state	S P H	tires must be cut and monofilled	30% equipment tax credit; 10% PP for retreads; Grants to solid waste districts for scrap tire programs
AZ	2% fee on purchase price of new tire	S P H	bans all tires	Funding to counties for scrap tire programs; 10% equipment tax credit
CA	\$0.25/tire disposal fee	S	effective 1/93 bans whole tires	40% tax credit for manufacturers using secondary materials; Grants and loans; 5% PP for tire materials
CO	\$1/ tire recycling development fee	S P		Procurement policy for recycled products; Tax credit for recycling equipment
CT	\$2/ tire tax on new, used and retread tires [See note p. L-7]	S		10% PP
FL	\$1/tire retail sales	S P H	tires must be cut	Closed-loop purchase contracts; Grants; 10% PP Innovative technology grants and loans to cities and counties
GA	\$1/tire management fee	S P H G	bans whole tires - 1/95	State vehicles required to use retreads; Grants/loans to counties
HI			bans whole tires - 1/94	10% PP
ID	\$1/tire retail sales	S	bans all tires	Grants to cities and counties; \$20/ton end-user rebate; \$1/retread reimbursement
IL	\$1/tire retail sale and \$0.50/vehicle title transfer	S P H	bans whole tires - 7/94	Grants and loans to companies and local governments; Financial assistance for testing
IN	\$0.25/tire new tire sales transporter/storage registration fees	S H G	operators' option bans tires 1/95	10% PP and grants and loans
IA		S P H	bans whole tires	Grants and loans; Sales tax and property tax exemptions for recycling equipment
KS	\$0.50/tire retail sales	S P H	tires must be cut	Tax credits for equipment Grants
KY	\$1/tire retail sales	S	tires must be cut	Tax credits for recycling businesses; Loan guarantees; Recycled content preference
LA	permit fees \$2/tire retail sales	S P H	tires must be cut	Tax credits; 5% PP
ME	\$1/tire retail sales	S P H D	tires must be cut	State required to buy recycled; Loans and grants; tax credits
MD	\$1/tire first sale	S P H G D	effective 1/94 bans tires	5% PP; financial assistance available to firms in MES Scrap Tire Recycling System
MA		S P	bans whole tires	10% PP
MI	\$0.50/vehicle title transfer	S P H G	must use licensed facility	Grants and loans; 10% PP
MN	\$4/vehicle title transfer	S P H	bans whole and cut tires	Grants and loans; 10% PP; Grants to counties
MS	\$1/tire retail sales	S P H G D	tires must be cut	County and regional grants and loans; 10% PP
MO	\$0.50/tire retail sales	S P H	bans whole tires	10% PP; Grants

TABLE ONE  
SCRAP TIRE LAWS AND REGULATIONS, JANUARY 1994 (11) (Continued)

LEGEND: S = STORAGE P = PROCESSOR H = HAULER G = GENERATOR D = DISPOSAL PP = PRICE PREFERENCE

STATE	FUNDING	REGS	LANDFILL	MARKET INCENTIVES
MT		S		Tax credits for equipment and products; State required to buy recycled
NE	business assessment fee; \$1/tire retail sale; \$1.25/ton disposal fee		whole tires will be banned 9/1/95	Grants
NV	\$1/tire on new tire retail sales	to be written	bans tires unless no alternatives	Grants for education and highway projects; 10% PP
NH	town administered graduated vehicle registration fee	S P D	tires must be cut unless facility is exempt	State required to buy recycled
NJ		S P	must use permitted landfill transfer station	Grants; Tax credits; State required to buy recycled
NY		S P H	bans whole tires	Grants; DOT specification for crumb rubber
NC	2% sales tax on new tires	S P H	tires must be cut	Grants; Funds county tire collection
ND	\$2/new vehicle sales	S P H		
OH	\$0.50/ tire on first (wholesale) sale of tires	S P H D	tires must be cut	Grants and loans
OK	\$1/tire on new tire sales	S P		Grants; Processor credits – \$0.85/tire
OR		S P H	tires must be cut	State should buy recycled
PA		S	operator's option	5% PP on bids; Grants and low-interest loans
RI	\$0.50 and \$0.75/tire on new tire sales; \$5 deposit/ tire	S P D	bans tires	Funding for stockpile clean-up Promotes use of recycled products; grants
SC	\$2/new tire sales	S P H	bans whole tires	7.5% PP; Grants to counties and local governments; State required to buy recycled
SD	\$0.25/tire vehicle registration	S P	bans tires by 7/1/95 unless allowed by state rules	Grant fund; Tire projects have grant preference
TN	\$1/tire retail sales		bans whole tires – 1/95	50% credit for shredders purchased prior to 7/1/91; Grants to counties
TX	\$2/tire retail sales	S P H G D	bans whole tires	\$0.85/tire processor credit; Tax credits; 15% PP on asphalt rubber; Low-interest loans
UT	\$1/ tire less than 24.5 inches	S P H D	bans whole tires 1/94 disposal by transporters	\$65/ton reimbursement to end-user
VT			bans whole tires	State required to buy recycled; 5% PP; loans and grants
VA	\$0.50/tire disposal fee on new tire sales	S P	bans whole tires	10% tax credit for equipment – Sunsets 12/31/95; Funding to counties/regional districts
WA	\$1 fee on new tire sales	S P H		Grants to local governments and other government agencies
WV		S P H	bans whole tires (1988) bans all tires – 6/1/95	State required to buy recycled
WI	\$2/tire per new vehicle title transfer	S P H	bans tires – 1/1/95	\$20/ton reimbursement to end-user; Grants
WY		S		Grants; State required to buy recycled

cases, address the design methods, the construction details, the performance, and the economic considerations, and finish with a summary of performance and economic considerations. In some instances, a subsection refers to an appendix for additional information. Typically, the appendix contains a compilation of report results from different states concerning the performance or economics of a particular application. The subsections titled Summary of Performance and Economic Considerations are included in Chapter Two to give the casual reader a sense of the information available in the appendixes.

For example, the Performance subsection, under the section titled Chip Seal Coats, refers the reader to Appendix H, Chip Seal Performance. That appendix describes the experiences found in specific reports from 13 states and other governmental units. To digest information from 13 states while following the thread of the chapter would be difficult. Furthermore, these reports are not consistent in their observations, measurements, and conclusions, i.e., different agencies had different experiences, compounding the confusion. This phenomenon is common to developing technologies and the use of tires in highways is no exception.

Chapter Three, Other Highway Uses, covers other, often less well-known, uses for chopped, shredded, and whole used rubber tires in highway construction. These uses include application in fills and embankments, erosion control, side slope fill, retaining walls, membranes, safety hardware, and other uses. The research in these areas has not been as extensive as the CRM asphalt research even though the potential for disposing of large amounts of recyclable tires is substantial. Chapter Three does not reference appendixes to detail individual state experiences; they are included, where appropriate, in the main text. Fills and embankments offer the greatest potential for using large quantities of tires; consequently, they have received the most attention in both the research community and in this synthesis. However, these uses of recycled tires may have some environmental problems: the consequences of placing tires below the water table are unclear.

Chapter Four, Environment, Health, and Safety, looks more closely at the title issues. There are two major areas of concern: the environmental impact of scrap rubber tires—whether whole, ground, or shredded—buried in the infrastructure; and the emissions from the manufacture, placement, and use of crumb rubber modified binders, both in new construction and in recycling operations. Very little research has been done in these areas to date. Chapter Four includes these data within the text itself in the same format followed in Chapter Three. Both the leachate studies and the investigations of workforce exposure to emissions are too limited to

produce concrete results. Both laboratory and field leachate studies indicate the potential for environmental problems. Only a limited number of emission studies have been conducted; since limits for exposure to asphalt fumes have not been established, it is difficult to estimate any potential health hazard.

Chapter Five, Conclusions and Recommendations, discusses crumb rubber in asphalt paving materials, other highway uses, and environment, health, and safety, covering the findings of earlier chapters. These conclusions and recommendations are based on both the literature review conducted to prepare this synthesis and input received from the synthesis topic panel.

An extensive bibliography developed from the more than 500 references used in preparation of this synthesis follows the text. This list has been divided into the following subject areas:

- A. Seal Coats
- B. Interlayers
- C. Dense-Graded Hot Mixes
- D. Open-Graded Hot Mixes
- E. General
- F. Legislation
- G. Economics
- H. Noise Reduction
- I. Performance
- J. Asphalt-Rubber Binders
- K. Membrane and Slope Protection
- L. Fill Stabilizaion
- M. Rubber and Rubber Processing
- N. Specifications
- O. Other Non-Highway Uses
- P. Recycling
- Q. Environment, Health, and Safety

The Bibliography is followed by a Glossary of Terms (Appendix A) related to the use of recycled rubber tires in highways. The pertinent Section of the Intermodal Surface Transportation Act of 1991 (ISTEA) is cited in Appendix B. These are followed by the survey questionnaire for this synthesis (Appendix C) and detailed discussion of twelve subject areas (Appendices D through O).

This synthesis includes information available through 1993. The use of scrap tires for highway applications is dynamic with regard to policy and technical issues. Therefore, the reader should keep in mind that the information presented reflects data at a particular time in history and does not necessarily represent all the current practice in this field.

## USE IN ASPHALT PAVING MATERIALS

### INTRODUCTION

Scrap tire rubber has been used in asphalt mixtures for the last 30 years. Documentation is extensive but disjointed, making a summary of its historic development difficult. A definition of the several types of binders that are produced by combining waste tire rubber and asphalt is required to understand this historic development. Often the binder systems are identified by more than a single term.

A 1992 FHWA publication (5) and a 1993 FHWA/EPA publication (12) contain suitable terminology that is likely to find acceptance among binder users and producers (Figure 1). Appendix A also provides a list of these definitions.

Crumb rubber modifier (CRM) is a general type of asphalt modifier that contains scrap tire rubber. Modified asphalt paving products can be made with crumb rubber modifier by several techniques, including a wet process and a dry process. Such products may contain additional additives besides scrap tire rubber. Other types of rubbers, polymers, diluents, and aromatic oils may be used to develop asphalt-based binders, which have a wide range of properties. At present, 10 known CRM technologies are in use in the United States. (12) Table Two provides a brief description of each technology and an indication of its developmental status.

### WET PROCESS

The wet process blends and partially reacts crumb rubber with asphalt cement prior to use (1) as a prepackaged joint or crack

sealer, (2) in spray applications, or (3) as a binder in a hot-mix central plant process. Typically, asphalt cement and crumb rubber are reacted at high temperatures and diluents, aromatic oils, and polymers may be added. The resulting binder is commonly referred to as asphalt rubber or a reacted system in the literature and has been used extensively in the United States.

Charles H. McDonald (13) pioneered the U.S. development of the wet process or reacted systems. His work began in the mid 1960s, when he applied asphalt-rubber patching materials. McDonald's experimental work with Atlas Rubber, the Arizona DOT, and Sahuaro Petroleum and Asphalt Company resulted in the development of commercial binder systems. In the mid 1970s, Arizona Refining Company (ARCO) also developed an asphalt-rubber binder system. Crafcoc, Inc. purchased Sahuaro and ARCO technology in the 1980s and continued developing wet process products. Different types and sizes of rubber, polymers, diluents, aromatic oils, and base asphalt cements have been evaluated by these companies and others.

From the middle 1970s to the early 1980s, the Arizona DOT sponsored comprehensive research programs to develop an understanding of wet process or asphalt-rubber binders. Because these binders are reacted before being combined with aggregate, binder properties can be determined directly. The research indicated that the properties of asphalt-rubber mixtures vary depending on rubber type, rubber gradation, rubber concentration, asphalt type, asphalt concentration, diluent type and concentration, diluent cure time, and reaction time and temperature. The influence of these variables

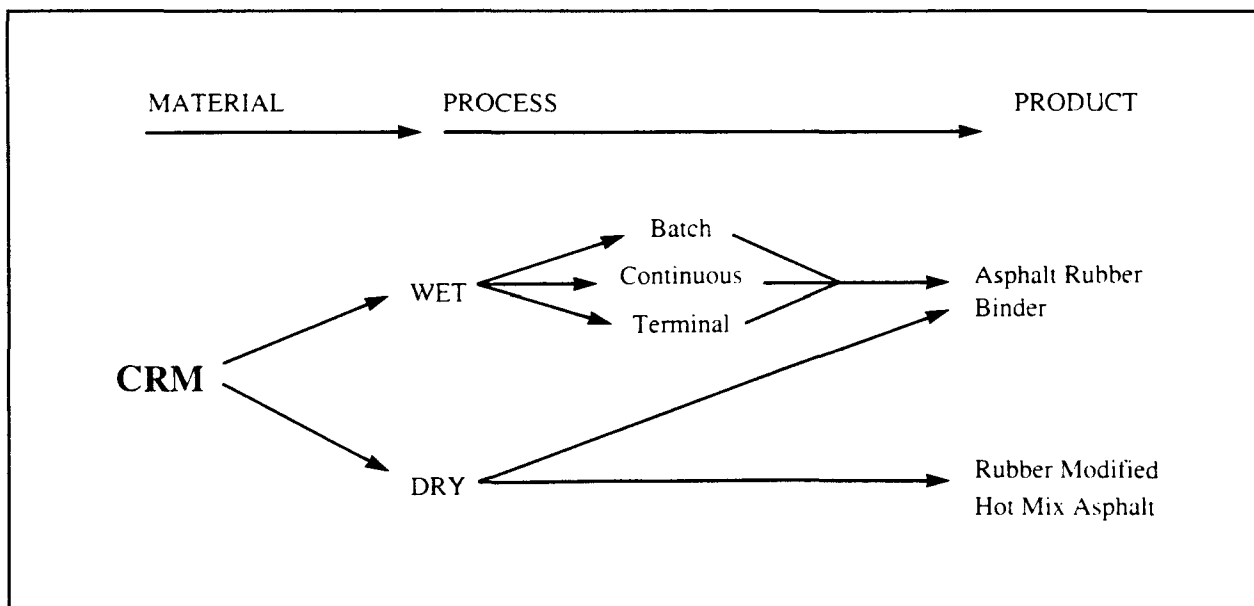

FIGURE 1 The relationship of crumb rubber modified (CRM) terminology and technology (12).

TABLE TWO  
CRUMB RUBBER MODIFIER TECHNOLOGIES (12)

Technology	Development Date and Location	Patented?	Marketing Firm
	Process/Product	Field Evaluation	
McDonald (1)	1960's - Arizona	patented (2)	(3)
	wet/batch/AR	extensive evaluation since 1970's	
pressure	1990 - Missouri	not patented	Dan Truax
	wet/batch/AR	has not been field-evaluated	
continuous blending	1989 - Florida	not patented	Rouse Rubber Industries (4)
	wet/continuous (terminal)/AR	limited evaluations since 1989	
terminal blending	1992 - Arizona - Washington	not patented	Neste U.S. Oil
	wet/terminal/AR	limited evaluations since 1992	
Ecoflex™	1992 - Canada	patented	Bitumar
	wet/terminal/AR	limited evaluations since 1992	
Flexochape™	1986 - France	patented	BAS Recycling (Beugnet)
	wet/terminal/AR	has not been field-evaluated in U.S.	
PlusRide™	1960's - Sweden	patented	EnviroTire
	dry/RUMAC-gap	extensive evaluations since 1978	
generic dry (RUMAC)	1989 - New York	not patented	TAK (4)
	dry/RUMAC-gap, dense	limited evaluations since 1989	
chunk rubber	1990 - SHRP	not patented	CRREL
	dry/RUMAC-gap	has not been field-evaluated	
generic dry (AR)	1992 - Kansas	not patented	(4)
	dry/AR-open, gap, dense	limited evaluations since 1992	

- (1) McDonald Technology includes both Overflex™ and Arm-R-Shield™ products.
- (2) There are numerous patents related to this technology. Some of the patents have expired, but others have not.
- (3) Prior to 1993, this technology was marketed through the Asphalt Rubber Producers Group and the licensed applicators. Presently, the technology is marketed by individual applicators.
- (4) Individual highway agencies are developing their own products with this technology.

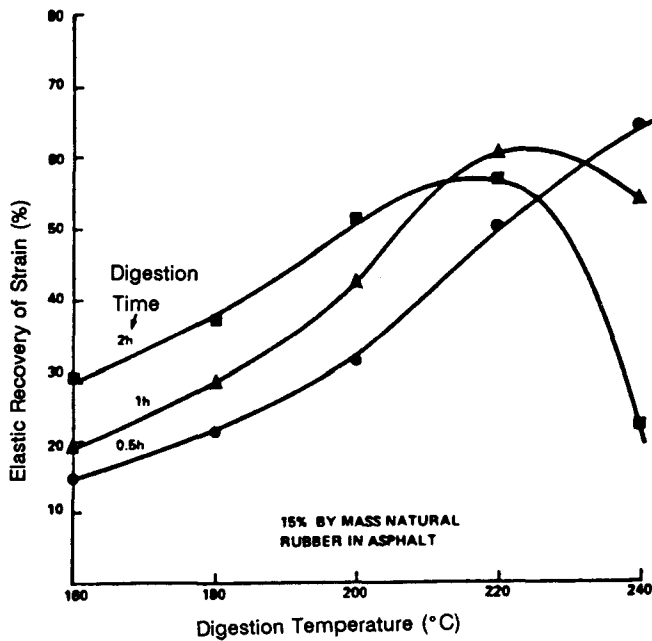

FIGURE 2 Effect of time and temperature of digestion on elastic recovery for natural-rubber tire buffings (14).

on binder properties is discussed in Appendix D. Figure 2 shows the importance of time and temperature of reaction on binder properties (14).

In addition to the batch wet processes described previously, two other methods recently have been developed: continuous blending and terminal blending. The first method describes a wet process in a continuous operation rather than a batch procedure. This continuous process was developed by Rouse Rubber Industries. (12)

Terminal blending is a wet process with the capability of combining asphalt and CRM and holding the product for extended periods of time. NESTE, U.S. Oil, Bitumarn, and BAS Recycling BEUGNET have been associated with the development and marketing of binders using terminal binding systems.

## DRY PROCESS

The dry process adds crumb rubber to the aggregate in a hot-mix central plant operation before adding the asphalt cement. The dry process is used in hot-mix asphalt dense-, open-, and gap-graded mixtures. Other names for this mixture are

- Rubber modified hot mix asphalt (RUMAC),
- Asphalt concrete, rubber-filled,
- Non-reacted system, and
- Rubber modified asphalt cement.

The dry or non-reacted process was used in the 1960s to produce mixtures for athletic field surfaces and pavements (14,15). This process was developed by U.S. Rubber Reclaiming of Vicksburg, Mississippi. Pavement projects were placed in Mississippi in 1968 (15) and in the Lake Tahoe area by the California DOT in the 1970s. The dry process used most frequently in the United States was developed in Sweden in the late 1960s. The process and

resultant product was marketed in the United States as PlusRide. Other dry process techniques include those used in New York and Kansas and developed by the Army Corps of Engineers at the Cold Regions Research and Engineering Laboratory (USA-CRREL) (12). These techniques are briefly discussed next.

The dry process mixes the crumb rubber, asphalt cement, and aggregate at the same time, making it impossible to determine the binder properties directly. Binder extraction and recovery tests alter the CRM binders. Tests performed on the mixture provide only indirect data on binder properties. Research has been conducted only on binders produced by the wet process or reacted system, but binders produced by the dry process will be affected by the same variables. Dry-processed binder systems are partially reacted.

## PATENTS

Appendix E lists some of the patents that control the CRM asphalt binders presently on the market. Several of these patents expired recently. The impact of these expirations on future use of CRM asphalt binders is not clear.

## RECENT DEVELOPMENTS

State DOT and university research efforts have been directed largely toward (1) mechanical characterization of CRM binders and the hot mixes that contain CRM, (2) techniques for using these binders, and (3) performance of pavements containing these binders. Patents on the binders, the lack of proven economic benefits, and insufficient research capital have somewhat restricted the desire to develop new and improved CRM binder systems. However, increased concern and new legislation on the use of scrap tires in asphalt binders for pavement applications has led to the development of some different concepts in the late 1980s and early 1990s. These new concepts are commonly referred to as the generic dry process, chunk-rubber asphalt concrete, and continuous blending asphalt rubber (5).

## Generic Dry Technology

This dry process is used to produce dense-graded hot mixtures. The concept requires a more detailed mix design; it uses both coarse and fine crumb rubber to match aggregate gradings and to achieve improved binder modification. The crumb rubber may need a prereaction or pretreatment with a catalyst to achieve the optimum particle swelling. In this system, rubber contents should not exceed 2 percent by total mixture weight for surface courses. Experimental pavement sections have been placed in Florida (5), New York (16), Oregon (personal communication), and Ontario (17).

## Chunk-Rubber Asphalt Concrete

The USA-CRREL investigated dry process CRM mixtures for disbonding ice on pavements. This research resulted in a recommendation to place field sections with mixtures containing crumb rubber larger than the No. 4 sieve, with a dominant size of  $\frac{3}{8}$  in.

Marshall properties, resilient modulus, and ice removal tests have been performed in the laboratory with crumb rubber concentrations of 3, 6, and 12 percent by weight of aggregate. Laboratory wheel testing indicates that the higher rubber content (percent by weight of aggregate) increases the incidence of ice cracking (14).

### Florida Wet Process

The Florida DOT has developed specifications for CRM asphalt cement to use in their dense, fine-graded, and open-graded friction course hot mixes. These specifications are based on laboratory studies and field experimental projects performed from 1989 to 1991.

Rouse Rubber Industries used the wet process approach by blending a 180-micron (No. 80) sieve crumb rubber modifier with asphalt cement using prototype equipment for continuous blending/reacting. The first experimental field application was on 4 lane-miles of open-graded friction course hot mix constructed in 1990 by the Florida DOT. The performance of continuously blended asphalt rubber binder is still being evaluated. Uniform binder properties, which indicate the efficiency of the blending equipment, are receiving particular attention. Batch equipment for blending crumb rubber modifier and asphalt cement is currently available and other types of equipment for this purpose are under development.

Florida's approach has opened the possibility of blending crumb rubber modifier with asphalt cement to make hot mix at the asphalt supply terminal, rather than at the project or plant site. Laboratory and field data using lower blending/reaction and storage temperatures indicate that the viscosity remains stable after reaction. Nor does it deteriorate with time as do typical wet-process products using high storage temperatures. It should be noted that the blend must be kept stirred or agitated to prevent stratification or separation of the crumb rubber modifier. Additional laboratory testing and field studies by others confirm these characteristics.

The engineering attributes of binder using Florida's approach may differ from McDonald asphalt rubber because of the lower percentages of crumb rubber modifier, lower temperatures, smaller CRM particle size, and shorter reaction times. It is not known if these differences will improve or reduce the performance of the modified binder. It is possible that the CRM content will differ between Florida's approach and the McDonald process to obtain the same engineering characteristics (5,19).

### LABORATORY VERSUS FIELD-PRODUCED BINDERS

Rosner and Chehovits (20) report that differences exist between field-produced binders from different suppliers. Furthermore, laboratory-produced binders designed using the Torque-Fork are significantly stiffer than field-produced mixtures. Adding diluents in the field may increase or decrease the stiffness of the binder. Careful field control based on laboratory test results is necessary to produce binder of uniform quality. Typical viscosity-time relationships observed with certain types of asphalt-rubber mixtures are shown in

Figure 3. Adding rubber to the asphalt dramatically increases the viscosity. Various quantities of kerosene or other diluents can be used to adjust viscosities to allow for spraying. Reaction temperatures will alter these relationships. Viscosity increases can occur after the addition of diluents (22).

### AGING STUDIES

Laboratory data indicate that asphalt-rubber mixtures have somewhat more resistance to aging than asphalt mixtures alone (23). Field metal pan exposure tests conducted in Phoenix were reported by Huff and Vallergera (24). Table Three shows increases in viscosity at 140°F from exposure to 15 months. The benefits of using extender oils are evident.

Aging studies performed on asphalt-rubber binders placed in northern and central Arizona pavements indicate that asphalt-rubber binders have increased resistance to hardening (Figures 4 and 5). Reduced aging or hardening may be the result of the carbon black and antioxidants present in the rubbers.

### POLYMER-MODIFIED ASPHALT RUBBERS

Industry has done research to define the properties of polymer-modified asphalt-rubber binders (22). These binders can be formulated with properties that are improvements over asphalt cement and asphalt-rubber binders. Expanded research, development, and implementation with these types of binder systems are expected in the future.

### JOINT AND CRACK SEALERS

#### Introduction

Asphalt-rubber joint and crack sealer is widely used in the United States. The questionnaire used to collect data from state highway authorities as part of this study indicates that 13 states use it routinely, 4 states use it experimentally, and 1 state is preparing to use it (Table Four). Use of asphalt rubber as a crack sealer is more widespread than its use as a joint sealer. Seventeen states use the material routinely, six experimentally, and one state has use pending (Table Four A).

A number of joint and crack sealant experimental field projects have been performed in the United States, but only a few have used asphalt rubber in formal comparison studies. Because of the wide acceptance of asphalt rubber as a crack sealer, most public agencies feel that a life-cycle cost advantage exists when they use asphalt-rubber products.

#### Requirements

Requirements for joint and crack sealing materials can be stated in general terms. Specific tests to define these desirable properties have been developed over the years; however, most of these tests do not measure fundamental properties or, in some cases, properties that can be easily related to performance.

Joint and crack sealants must meet the following general requirements:



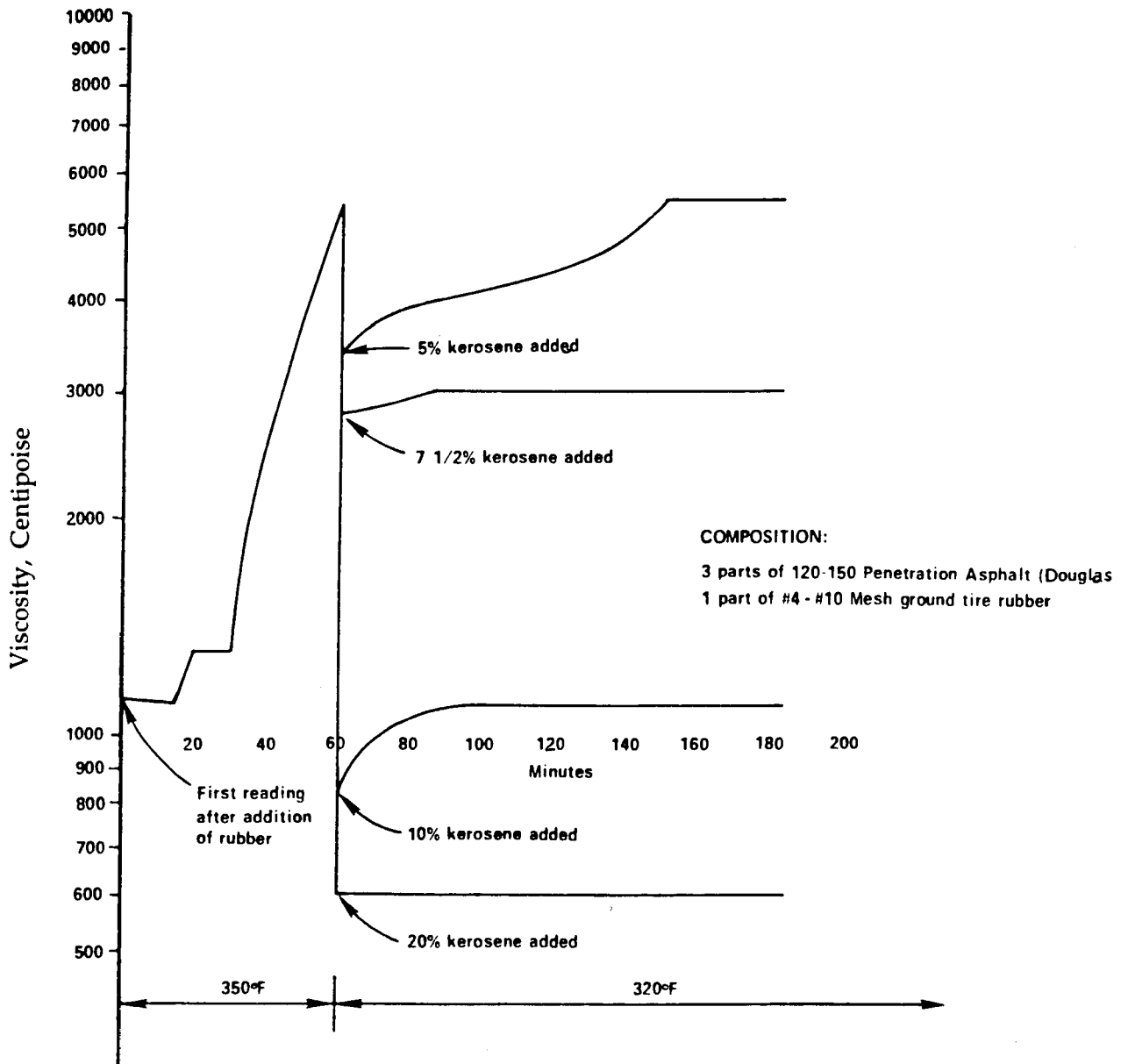

FIGURE 3 Solvent dilution phenomenon (21).

- Ability to be handled, installed, and stored,
- Adhesion to surfaces of cracks or joints,
- Resistance to softening to prevent flow,
- Resistance to tracking by traffic,
- Resistance to intrusion,
- Elasticity and elongation at cold temperatures to resist cracking,
- Resistance to the effects of the environment (air, water, temperature),
- Resistance to the effects of chemicals,
- Compatibility with pavement material, and
- Ability to cure rapidly, to allow traffic to use the facility within a short time.

#### Typical Products

A wide range of products are used for joint and crack sealants. Typical joint sealant products are silicone rubbers, polyvinyl chlo-

ride (PVC) coal tars, polyurethane, polymer asphalt, and various types of asphalt rubbers. Products can be hot poured or cold poured. Products typically used to seal cracks in asphalt concrete pavements can be grouped into three fundamental classifications based on their physical characteristics and degree of temperature susceptibility modification: unmodified asphalts, asphalt rubber, and polymer-modified asphalt (25).

#### Construction

To achieve long-lasting performance from asphalt-rubber sealants, good installation practices must be followed. Cracks must be free of moisture, dust, and loose aggregate or other contaminants before the sealants are applied. Heating and application equipment must be capable of heating and maintaining the sealant at the desired temperature without localized overheating. Application can

TABLE THREE  
RESULTS OF DURABILITY STUDY OF ASPHALT-RUBBER BLENDS (23)

Test No.	Composition of Blend (%)			Time (months)	Exposure 140° (poises)		Viscosity at Viscosity Ratio
	Asphalt	Extender Oil <sup>a</sup>	Ground Rubber <sup>b</sup>		Before	After	
1	80 <sup>c</sup>	-	20	15	5704	18 034	3.16
2	78.4 <sup>c</sup>	1.6	20	15	5204	12 341	2.37
3	72.6 <sup>d</sup>	7.4	20	15	5978	15 759	2.64

<sup>a</sup>Shell Dutrex 739.

<sup>b</sup>U.S. Rubber Reclaiming Company G-274, consisting of 40 percent powdered reclaim (i.e., devulcanized) rubber and 60 percent crumb (i.e., ground scrap) rubber high in natural rubber content.

<sup>c</sup>AR-4000.

<sup>d</sup>AR-5000.

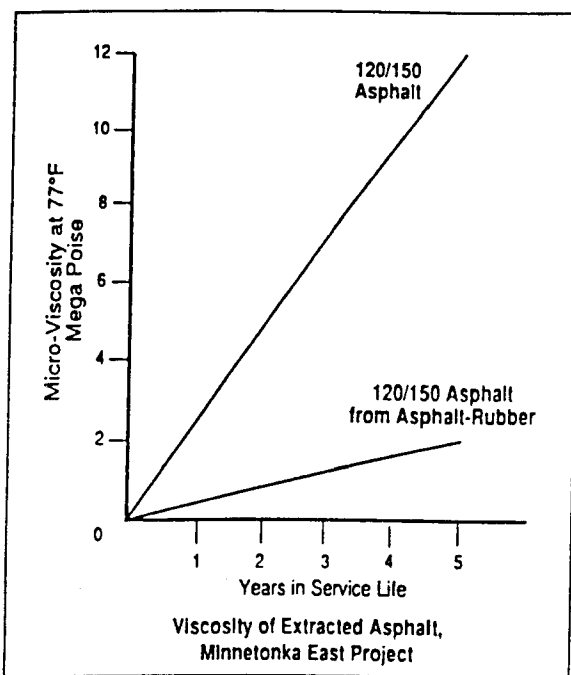

FIGURE 4 Aging resistance (22).

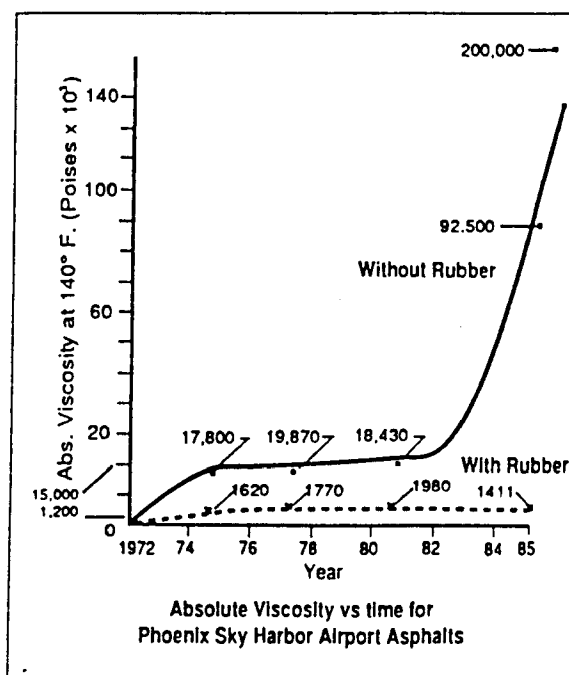

FIGURE 5 Absolute viscosity vs. time for Phoenix Sky Harbor Airport asphalts (22).

be performed by using one of three methods: (1) band-aid, (2) routed reservoir, and (3) inverted band-aid (26). The band-aid method involves spreading a 2- to 4-in. wide strip of sealant over the crack and wiping or squeegeeing the surface to about a  $\frac{1}{8}$ -in. thickness.

A router is used to prepare the crack to receive the sealant in the routed reservoir method. Typical routed dimensions are  $\frac{1}{2}$ -in. wide by  $\frac{1}{2}$ -in. deep to 2-in. wide by  $1\frac{3}{8}$ -in. deep. The rectangular-shaped cut is filled to the surface. This method is recommended for thermal cracks with movements less than about  $\frac{1}{2}$ -in. The inverted band-aid method uses a wider and shallower routed reservoir. Typical configurations are  $1\frac{1}{2}$ - to 2-in. wide by  $\frac{1}{4}$ - to  $\frac{1}{2}$ -

in. deep. The inverted band-aid approach is suggested for thermal cracks when movements of  $\frac{1}{2}$ -in. or greater are expected.

Installing sealants for portland cement concrete pavements also requires good construction practices. Cleaning and shaping joints are important steps. Backer rods may have to be used to obtain a proper shape. The asphalt rubber must be heated and held at the application temperature during the sealing process. However, holding the heated sealant overnight may adversely affect the flexibility, resilience, and softening point of some asphalt-rubber binders (26).

TABLE FOUR  
RECYCLED RUBBER TIRES IN BINDERS FOR HIGHWAY PAVEMENTS

State	Chip Seal			Interlayer			Hot-Mix Asphalt Concrete			Open-Graded Hot-Mix Asphalt			Comments
	Use	Rubber, tons	Lane miles	Use	Rubber, tons	Lane miles	Use	Rubber, tons	Lane miles	Use	Rubber, tons	Lane miles	
Alabama	E		25										
Alaska				E		0.2	E		0.2				
Arizona	R			R			R			R			
Arkansas	E	450	32	E	1915	138	E	478	6				
California	E			E			E			E			
Colorado	E		30	E		36							
Connecticut	E	3	1	E	2	0.5	E	27	3.6				
Delaware	E	40	8	E	160	5							
Florida	E	3	<1	E*	4.5	<1	E*	2.5	~2	E*	10	~6	*Specs for routine use in review process
Georgia	E			E			P						
Hawaii	-			-			-			-			
Idaho		250	25		50	5		-	-		-	-	
Illinois							E						
Indiana							E		1.5				
Iowa							E	217					
Kansas	E	89	19	E	360	77	E	220	27				
Kentucky	R*	0	0										*Rubber permitted but contractors don't use
Louisiana							E						



TABLE FOUR  
 RECYCLED RUBBER TIRES IN BINDERS FOR HIGHWAY PAVEMENTS (Continued)

	Chip Seal		Interlayer		Hot-Mix Asphalt Concrete		Open-Graded Hot-Mix Asphalt	
South Carolina	E	4						
South Dakota								No report
Tennessee	E*		E*					*Not used in last 10 years
Texas	E		E		P,E	8		
Utah	E		E		E			
Vermont								
Virginia	P,E	20	4.2		E	26	3.8	
Washington	E		88	E	106	E	3	E 17
West Virginia								No report
Wisconsin	E	10	10	E	20	10	E	40 10
Wyoming	P			—		—		E 150 10
Washington, DC						E	0 0	

P=PENDING  
 E=EXPERIMENTAL  
 R=ROUTINE



TABLE FOUR A  
 RECYCLED RUBBER TIRES IN SEALANTS AND OTHER HIGHWAY APPLICATIONS (Continued)

State	Joint Sealant			Crack Sealant			Other Applications			Comments
	Use	Rubber, tons	Lane miles	Use	Rubber, tons	Lane miles	Use	Rubber, tons	Lane miles	
Louisiana	R	O								
Maine										
Maryland										
Massachusetts	—			—			E			PlusRide
Michigan										
Minnesota	R									
Mississippi										
Missouri	P			P						
Montana										No report
Nebraska										
Nevada										No report
New Hampshire										No report
New Jersey	R			—			E	18	1/4	Rubber-filled
New Mexico										
New York										
North Carolina				R	100					
North Dakota										
Ohio				R	60*					*In 1990
Oklahoma	E	<1		E	<1	2				
Oregon	R			R			P,E	33	1	Rubber-filled asphalt concrete

TABLE FOUR A  
 RECYCLED RUBBER TIRES IN SEALANTS AND OTHER HIGHWAY APPLICATIONS (Continued)

State	Joint Sealant			Crack Sealant			Other Applications			Comments
	Use	Rubber, tons	Lane miles	Use	Rubber, tons	Lane miles	Use	Rubber, tons	Lane miles	
Pennsylvania	R	*		R	*					*20 total tons
Rhode Island							E	20	1.3	PlusRide
South Carolina										
South Dakota										No report
Tennessee				E						
Texas	E			R						
Utah				R						
Vermont							E	100	0.06	Town highway base
Virginia	R			R						
Washington				R						
West Virginia										No report
Wisconsin	E	2		E	1					
Wyoming	—			—						
Washington, DC										

P=PENDING  
 E=EXPERIMENTAL  
 R=ROUTINE



## Performance

The Arizona DOT installed different types of joint sealants using asphalt rubbers on one project. The sealants tested on this project included silicone rubber, PVC-coal tar, and rubberized asphalt. Three rubberized asphalts were used. Asphalt rubber 1 was a pre-packaged block of asphalt and rubber and was heated to 375°F. Asphalt rubber 2 was a project blend of 75 percent AC-20 asphalt cement and 25 percent ground rubber. Asphalt rubber 3 was a blend of 75 percent cutback asphalt and 25 percent ground rubber reacted at 250°F.

The joint sealants were evaluated carefully for appearance, hardness, incompressibility, bond, pullout, and percent of joint sealed. Performance of the various products after 5 years of service are summarized below:

Silicone rubber	Excellent
PVC-coal tar	Fair
Asphalt rubber 1	Fair
Asphalt rubber 2	Poor
Asphalt rubber 3	Fair

The study concluded that the asphalt-rubber sealants did not perform as well as the silicone rubber or the PVC-coal tar products (27).

*NCHRP Synthesis 98, Resealing Joints and Cracks in Rigid and Flexible Pavements (28)* identified sealant types used by public agencies and provided a summary of reported performance. Tables Five and Six are based on responses to a survey of public agencies for that synthesis. Hot-applied rubberized asphalt was used by 31 public agencies, which reported performance that ranged from very poor to very good (Table Five). The average effectiveness rating of hot-applied rubberized asphalt was 4.40, which is higher than all other commonly used products (28). Table Six indicates very poor to very good performance associated with hot-asphalt rubberized asphalt joint sealants as used by 36 public agencies. The average effectiveness rating of 4.12 was second highest to silicones (28). Tables Five and Six indicate widespread use of hot-asphalt rubberized asphalt joint sealants.

## Summary

Limited data are available on the performance or cost of asphalt-rubber joint and crack sealers. Studies report varied performance. The average effectiveness appears to be relatively high and substantial quantities of asphalt rubber are used for this purpose.

## CHIP SEAL COATS

### History

McDonald's band-aids, placed on the streets in Phoenix, were the first use of chip seals. These seals were placed by hand over a limited pavement area (13). A major problem arose when asphalt-rubber binder was applied through an asphalt distributor rather than with hand equipment. The first large spray application in 1968 produced poor results. Beginning in 1969, slurry seal equipment was used on a limited basis to apply the binder. Unsatisfactory binder application led to modification of the binder, by reducing crumb rubber content and adjusting the viscosity with diluents,

to allow the use of a specially designed asphalt distributor. In 1970 the first project using a diluent (kerosene) was placed (13).

These chip seal coat applications became known as stress-absorbing membranes (SAM). This terminology is used throughout the literature. For the purposes of this synthesis, however, reference will be made to this use as a chip seal constructed with a special binder—*asphalt rubber produced by the wet process*.

## Design Methods

The majority of chip seals using asphalt-rubber binders have been placed without predetermining the binder or aggregate application rate. The most common approach has been to specify a fixed rate of asphalt-rubber binder (produced by the wet process) and then vary the aggregate application to achieve the desired product. In general, aggregate application is judged satisfactory when it provides for one and one-half aggregate depth embedment. Typical asphalt-rubber spray quantities are 0.55 to 0.70 gal/yd<sup>2</sup> yard (at the elevated spray temperature) and typical aggregate quantities are 30 to 40 lbs/yd<sup>2</sup>. Conventional chip seals spray asphalt cement in quantities of 0.35 gal/yd<sup>2</sup> and apply a single aggregate layer in quantities of between 20 and 25 lbs/yd<sup>2</sup>. These design practices have resulted in poor performance on a large number of projects. Both aggregate loss and flushing have occurred. Appendix G describes chip seal design methods when asphalt-rubber binders are used.

## Construction

A major supplier of asphalt-rubber chip seals (and interlayers) indicates that the construction is nearly identical to the construction of conventional chip seals. The major differences include the preparation of the asphalt-rubber binder and the use of specialized spray equipment.

Crumb rubber is most often shipped in 50-lb bags or 2,000-lb reusable shipping containers. The bags can be moved by hand, but the shipping containers require specialized equipment. Specialized blending units are available to ensure that the crumb rubber and asphalt are uniformly proportioned before entering the reaction vessel. Dumping bags of crumb rubber directly into a reaction vessel already charged with asphalt is an alternate blending method.

Reaction vessels are often either specialized tanks or specialized binder distributors (Figures 6 and 7). They must be capable of heating the base asphalt cement, mixing the crumb rubber and base asphalt cement, and keeping the crumb rubber in suspension to avoid separation. When the crumb rubber is introduced into the asphalt cement, it swells and physical-chemical reactions occur which alter the properties of the base asphalt. Diluents of various types may also be introduced to adjust viscosity for spraying purposes. The reaction vessels must be able to accommodate these operations without health or safety problems.

Binder distribution equipment should be capable of maintaining the temperature of the binder at the desired level, circulating the binder to avoid separation of the crumb rubber and base asphalt, and discharging the binder in a uniform manner (Figure 8). Special pumps and nozzles are required to handle some asphalt-rubber binders. The viscosity of the asphalt-rubber binder changes when

TABLE FIVE  
MATERIALS USED TO SEAL AND RESEAL CRACKS IN FLEXIBLE PAVEMENTS (28)

Material Type	Number Listings by Agencies	Effectiveness Rating Range	Average Effectiveness Rating <sup>a</sup>	Comments
Asphalt Cement	10	Fair-Very Good	3.50	
Cutback Asphalt	20	Poor-Good	2.90	Generally requires blotter, relatively short life.
Emulsion	20	Very Poor-Very Good	3.02	Relatively short life, tends to bleed.
Asphalt General Class or Type Specified	5	Poor-Good	3.10	
Rubberized Asphalt, Hot Applied	31	Very Poor-Very Good	4.40	Relatively long life.
Cutback Asphalt with Rubber	2	Good-Very Good	4.50	Limited data. Good performance.
Asphalt Emulsion with Rubber	5	Poor-Very Good	3.40	
Rubberized Asphalt; materials not fully identified	7	Fair-Very Good	4.14	Good performance.
Material Class not identified	11	Very Poor-Very Good	2.61	
Mixture	3	Good-Very Good	4.33	Mixtures of asphalt and sand or aggregate. Used in wide cracks.
Other (Arm-R-Shield, Vulken)	4	Very Poor-Good	3.25	Vulken rates very poor.
Tar	3	Very Poor-Poor	1.33	Too rigid, short life.
Catalytically Blown Asphalt	1	Good	4.00	

<sup>a</sup>Rating Scale

Very Good	- 5.00
Good	- 4.00
Fair	- 3.00
Poor	- 2.00
Very Poor	- 1.00

the reaction time or temperature is altered. A field rotational viscometer (Figure 9) is used to maintain field control of the reactions.

As with all seal coat construction, application of the cover stone or chip should immediately follow application of the binder to ensure proper adhesion (Figure 10). This requires good construction coordination between the asphalt distributor and the chip spreader. Rolling and brooming can be performed in a conventional manner.

### Performance

A number of reports describe the performance of chip seals (SAMs) constructed with asphalt-rubber binders. Selected references are reviewed in Appendix H.

### Economic Considerations

Because of the experimental nature and inherent small size of projects using new paving products, economic evaluations are of-

ten difficult. Once the use of a new product becomes common, project size increases and costs are normally reduced. Several economic studies have been performed to determine the cost effectiveness of asphalt-rubber chip seals. Information from these studies can be found in several references (27-41). A summary of first-cost information presented in these references is given in Table Seven. Typical cost increases for asphalt-rubber chip seals relative to conventional chip seals are 1.5 to 2.0. Life-cycle cost comparisons have been made by several agencies and groups. These studies are reviewed in Appendix I.

### Summary of Performance and Economic Considerations

Asphalt-rubber chip seal performance has ranged from poor to good relative to chip seals made with conventional binders. This variation in performance can be attributed partially to design and construction quality control problems. Improvements in asphalt-

TABLE SIX  
MATERIALS USED TO SEAL AND RESEAL CRACKS AND JOINTS IN RIGID PAVEMENTS (28)

Material Type	Number Listings by Agencies	Effectiveness Rating Range	Average Effectiveness Rating <sup>a</sup>	Comments
Asphalt Cement	11	Poor-Good	3.15	Does not penetrate; must be resealed often.
Cutback Asphalt	17	Very Poor-Good	2.29	Generally requires blotter; relatively short life.
Emulsion	10	Very Poor-Good	3.22	Seasonal. Generally must be resealed often.
Rubberized Asphalt, Cold Applied	1	Good	4.00	Labor intensive.
Rubberized Asphalt, Hot Applied	36	Very Poor-Very Good	4.12	Relatively long life.
Cutback Asphalt with Rubber	2	Good-Very Good	4.75	Limited data; good performance.
Asphalt Emulsion with Rubber	1	Good-Very Good	4.50	Limited data; good performance.
Preformed Filler	2	Fair-Good	3.50	
Silicone Dow 888	7	Good-Very Good	4.60	Relatively limited data but good performance to date.
Preformed Joint Seal	5	Poor-Very Good	3.60	Costly.
Other (PVC, Polyurethane, Vulken)	6	Very Poor-Good	3.25	Vulken rates very poor.
Tar	2	Very Poor	1.00	Short life; too rigid.
Catalytically Blown Asphalt	1	Good	4.00	

<sup>a</sup>Rating Scale  
 Very Good - 5.00  
 Good - 4.00  
 Fair - 3.00  
 Poor - 2.00  
 Very Poor - 1.00

rubber binder properties and quality control will provide better performance.

Reflection cracking is not substantially reduced with asphalt-rubber binder systems. Some projects have noted improved performance while others show no improvement.

Typical first-cost increases for asphalt-rubber chip seals relative to conventional chip seals are 1.5 to 2.0 (Table Seven). Life cycles for chip seals made with asphalt-rubber binders, therefore, must be nearly double those for conventional chip seals if their life-cycle costs are to equal those of conventional chip seals. Costs of asphalt-rubber binders are expected to decrease in the future as a result of increased competition, expiration of patents, supply and demand, and increased project volume. (12)

## INTERLAYERS

### History

Asphalt-rubber chip seals overlaid with hot-mix asphalt are known as stress-absorbing membrane interlayers (SAMIs). The Arizona DOT placed its first SAMI in 1972 as part of a project

to evaluate techniques to reduce reflection cracking. Historically, SAMI development followed SAM development (Figure 11) (42). Several states, including Arizona, have placed asphalt-rubber interlayers over the years.

### Design Methods

The majority of asphalt-rubber membrane interlayers have been placed without predetermining the binder or aggregate application rate. The most common approach, as with seal coats, has been to specify a fixed rate of asphalt-rubber binder and then vary the rate of aggregate application to achieve the desired interlayer. The quantity of binder has been greater than that used for asphalt-rubber chip seals, typically in the range of 0.60 to 0.80 gal/yd<sup>2</sup>. Sufficient aggregate is used to ensure that the overlay can be placed on the interlayer surface without construction difficulty. Aggregate has been used in quantities as small as 15 to 25 lbs/yd<sup>2</sup>. A SAMI's constructed thickness of 0.35 to 0.50 in. is thin enough so that the binder properties, not the aggregate, influence its mechanical behavior. This design practice has frequently resulted in satisfactory performance because the chip seal is overlaid. However, ex-

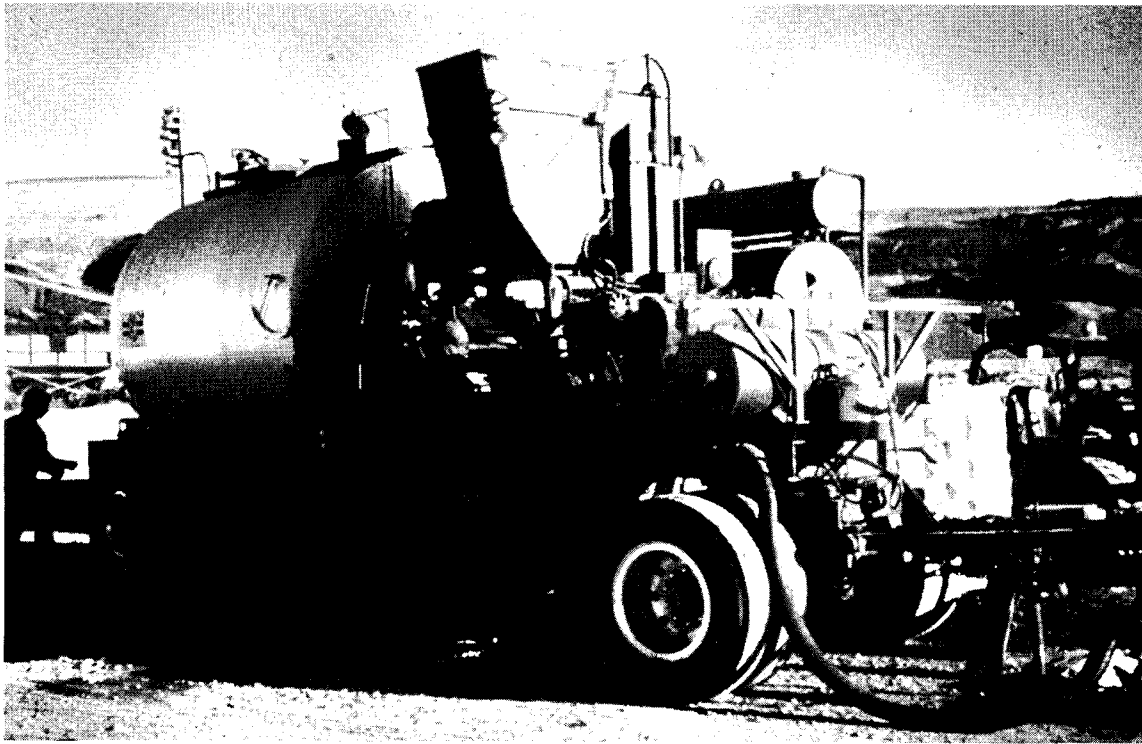

FIGURE 6 Reaction vessel.

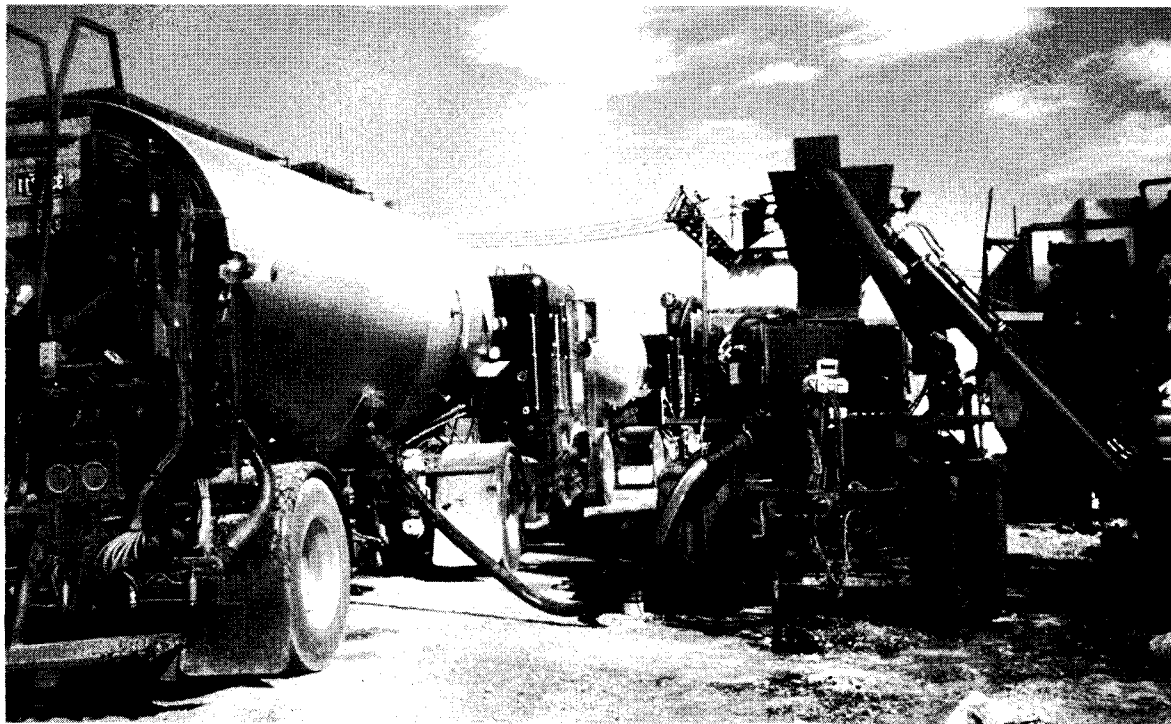

FIGURE 7 Specialized binder distributor for reaction vessel.

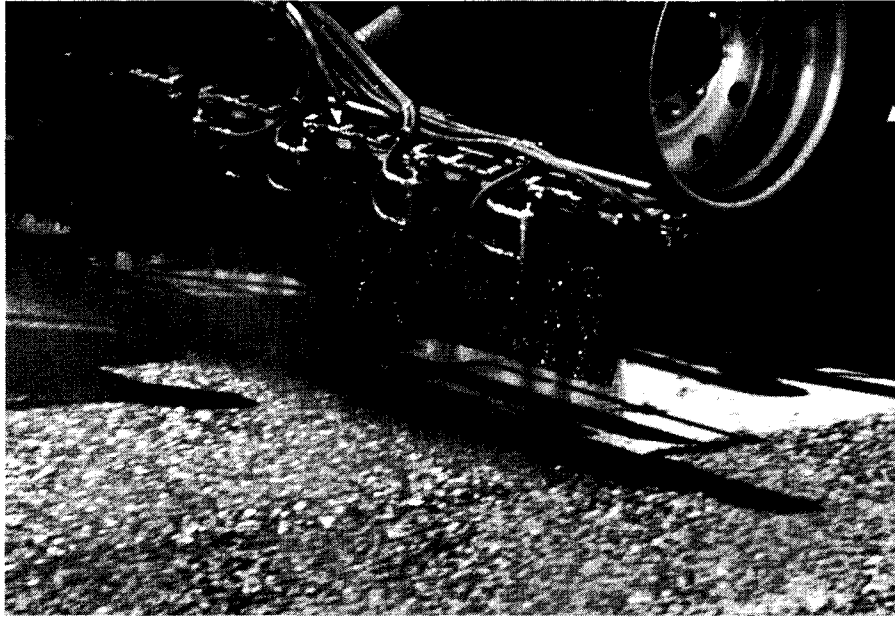

FIGURE 8 Binder distributor.



FIGURE 9 Field rotational viscometer.

cess binder or diluents trapped in the interlayer when the overlay is placed may cause bleeding in a dense- or open-graded hot-mix asphalt overlay.

Design methods have been developed by Texas (43) and ARCO (44). These methods are similar to those used for chip seals. Nei-

ther method has been field verified. Appendix J contains additional details on these methods.

Reducing or preventing reflection cracking is an important attribute for any interlayer that should be considered as a part of any SAMI design method. Theoretical reflection cracking studies have been performed by research teams at the University of Arizona (45), the Arizona DOT (46), and the University of California (47,48). These studies show that interlayers constructed with asphalt-rubber perform better than interlayers constructed with conventional asphalt. Additional findings suggest that (1) interlayers without chips perform better than interlayers with chips, (2) thicker interlayers help prevent reflection cracking, and (3) interlayers should be placed on top of a leveling course rather than on top of the old pavement. Appendix J contains additional information on these studies.

Asphalt-rubber binders are not specifically designed for interlayer applications. The binders used for interlayers are produced by the wet process and have properties that depend on those factors identified previously. Binder properties of particular importance to interlayer applications are also discussed in Appendix J.

#### Construction

Asphalt-rubber interlayer and chip seal construction are nearly identical to conventional chip seal construction. Details can be found in the preceding section on chip seals.

#### Performance

A number of reports describe the performance of interlayers constructed with asphalt-rubber binder (SAMI). Selected references are reviewed in Appendix K.

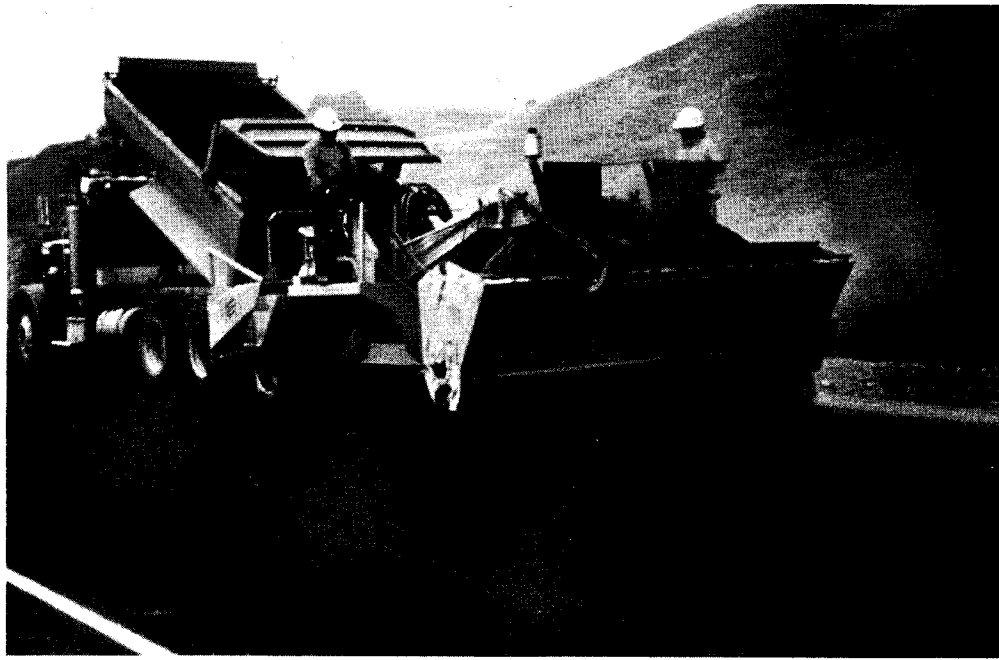

FIGURE 10 Chip distributor.

TABLE 7  
MISCELLANEOUS COST INFORMATION ON ASPHALT-RUBBER CHIP SEALS

Reference	Asphalt rubber chip seal, \$/yd	Conventional chip seal, \$/yd	Year	Comments
Arizona (35)	1.12		1978	
Arizona (37)	1.84	1.07	1988	
Florida (33)			1980	SAM is 2.5 times cost of conventional chip seal
Minnesota (36)	1.48	1.07	1978	
Oklahoma (34,38)	1.64	0.73	1982	
Oregon (31,32)	0.95		1982	
Texas (30)	1.14	0.48	1990	
Australia (42)			1991	SAM is 44 % higher cost
Epps (40)	1.25	0.85	1981	
FHWA (29)	0.60		1973	
Jacobson (41)	1.64	0.92	1989	
Schnormeir (39)	1.40	0.72	1981	

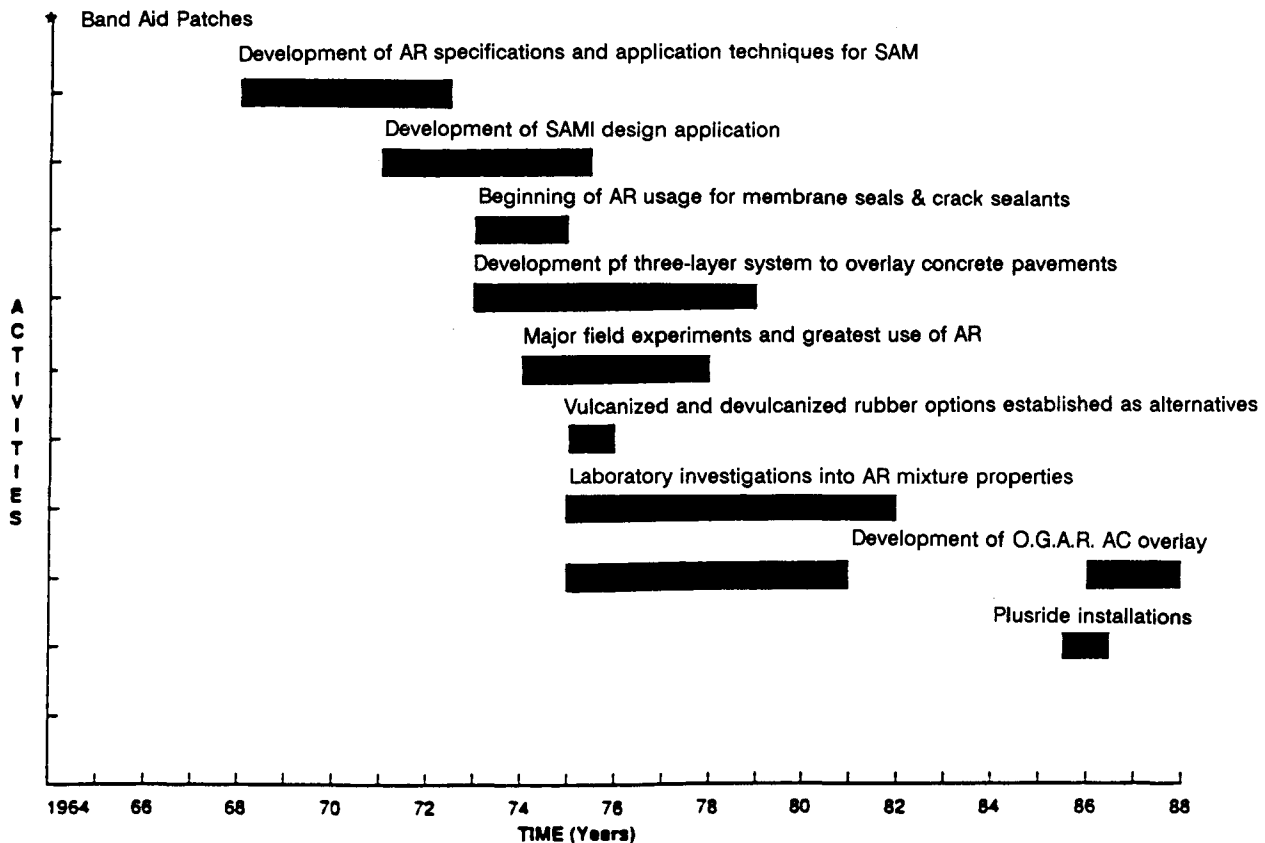

FIGURE 11 Chronology of asphalt-rubber development in the Arizona DOT (43).

### Economic Considerations

Several economic studies have been performed to determine the cost effectiveness of asphalt-rubber interlayers. Information from these studies can be found in several references (28,34,36,49-54). A summary of first-cost information presented in these references is given in Table Eight. Additional first-cost information obtained from several states (55) is shown in Table Nine. Performance of these projects is shown in Table Ten. The costs of interlayers and chip seals made with asphalt-rubber binders are similar. Typical costs for asphalt-rubber interlayers are 1.5 to 2.5 times the cost of interlayers made with asphalt cement and about the same as fabric interlayers.

Life-cycle cost comparisons have been made by several agencies and groups. These studies are reviewed in Appendix L.

### Summary of Performance and Economic Considerations

The performance of asphalt-rubber interlayers is highly variable and ranges from poor to good when compared with various types of control sections. Asphalt-rubber interlayers placed with overlays on portland cement concrete pavements are not very effective in reducing reflection cracking. Neither are asphalt-rubber interlayers placed on hot-mix asphalt pavements containing transverse cracks. Data indicate that the reflection cracks on pavement sections containing asphalt-rubber interlayers are not as severe and do not need

maintenance as frequently as their control sections. Alligator crack reflection has been reduced when asphalt-rubber interlayers were used.

Typical costs for pavement sections containing asphalt rubber are 1.5 to 2.5 times the costs of conventional sections. Life cycles of pavements containing asphalt-rubber interlayers must be twice as long as those without SAMIs to justify the additional SAMI cost, i.e., for equal life-cycle costs. Costs of asphalt-rubber binders are expected to decrease in the future.

### HOT-MIX ASPHALT

#### History

CRM hot mixes have been used since the 1960s. They have contained binders prepared from both the wet process (asphalt rubber) and the dry process (rubber modified). Sahuaro, ARCO, Crafcro, International Surfacing, and others have supplied asphalt-rubber binder for hot-mix applications. The dry process or rubber-modified hot mixes have been supplied by PlusRide or manufactured under the control of public agencies. Dense-, open-, and gap-graded hot-mix asphalts have been made using crumb rubber. This section is concerned primarily with dense- and gap-graded mixtures. Use of CRM in hot mix asphalt has increased substantially in the last few years. A survey of state highway administrations conducted by AASHTO in January of 1993 indicated that 21 states used CRM in hot mixes in 1992 and 34 states were expected to

TABLE EIGHT  
MISCELLANEOUS COST INFORMATION ON ASPHALT-RUBBER INTERLAYERS

State	Reference	Asphalt Rubber Interlayer \$/yd <sup>2</sup>	Conventional treatment &/yd <sup>2</sup>	Year	Comments
Arizona	(35)	1.12		1978	Interlayer only
Arizona	(37)	4.16	2.46	1988	2-in. overlay with & without interlay
Delaware	(50)	1.97		1980	Interlayer only
Florida	(53)			1980	Interlayer cost equal to 375 in. asphalt concrete—2.5 times cost of standard chip seal
Minnesota	(52)	2.30		1978	Fabric interlayers 2.03 & 1.97
New York	(55)	5.66	4.50	1986	Interlayer plus 2 in. asphalt concrete vs. 2 in. asphalt concrete
Texas	(30)	4.25	3.20	1990	Interlayer plus 2 in. asphalt concrete vs. 2 in. asphalt concrete
Washington	(54)			1992	3.7 times cost of standard chip seal
Wyoming	Harvey, 1979	1.48	0.56		Interlayer plus 2 in. asphalt concrete vs. 2 in. asphalt concrete

use CRM in 1993. During this same period, the tonnage of CRM increased 273 percent to expected levels of 1,123,000 tons in 1993 (Table Eleven) (56).

#### Design Methods

Variations of the standard Hveem and Marshall procedures have been used to design dense-graded hot mixes using crumb rubber

modifiers. Crafc0 (57), the University of Nevada (58), the Texas Transportation Institute (59,60), the Federal Highway Administration (5) and the National Center for Asphalt Technology (61) have developed laboratory design methods for CRM asphalt dense mixtures. Marshall and Hveem stability tests and weight-volume parameters are the basis for these designs. The design criteria recognize that lower Marshall flow values and Hveem stabilities are obtained using CRM asphalt mixtures.



TABLE NINE  
DEMONSTRATION PROJECT UNIT COSTS, QUANTITIES, AND PLACEMENT DATES (55)

State	Cost, vd <sup>2</sup>	Quantity, vd <sup>2</sup>	Month Built
<b>ASPHALT-RUBBER CHIP SEALS (SAMs)</b>			
Oklahoma	\$1.65 <sup>a</sup>	65,732	October 1978
Pennsylvania	1.66	138,763	August 1979
Texas	0.80 <sup>b, c</sup>	28,000 <sup>b</sup>	July 1976
Texas	0.80 <sup>b, c</sup>	22,711 <sup>b</sup>	July 1976
Texas	0.80 <sup>b, c</sup>	28,128 <sup>b</sup>	July 1976
Vermont	1.91	129,998	July 1979
Virginia	1.18	31,621 <sup>b</sup>	August 1978
Virginia	1.18	25,813 <sup>b</sup>	August 1978
<b>ASPHALT-RUBBER INTERLAYERS (SAMIs)</b>			
Colorado	0.96 <sup>d</sup>	7,600	August 1977
Delaware	2.02	22,806	October 1980
Idaho	1.11	348,668	August 1977
Idaho	1.15	321,771	August 1977
Mississippi	1.53 <sup>b</sup>	159,024	August 1980
New York	2.00	80,000	June 1980
Texas	0.86	295,680	April 1977
Vermont	1.91	15,294	July 1979

<sup>a</sup>Includes cost of tack coat.

<sup>b</sup>Estimated.

<sup>c</sup>Includes cost of asphalt-rubber binder in place only.

<sup>d</sup>Does not include cost of cover aggregate.

Mixing and compaction temperatures for CRM mixtures are higher than those for conventional mixes. Design air voids and aggregate gradation depend on the CRM content and the type (wet or dry process). Low CRM content in the wet process has little or no effect on the mix design, whereas nearly all CRM content in the dry process affects design air voids and aggregate gradation. CRM binder contents are typically 10 to 20 percent higher than conventional mixes. As a rule of thumb, if 20 percent crumb rubber is used in the binder, the CRM binder will be 20 percent greater than a conventional binder, i.e., 6 percent versus 5 percent by dry weight of aggregate.

The FHWA (5) and Crafcoc (57) have also published methods for the design of open-graded friction courses. An increase in CRM asphalt binder is necessary to account for thicker binder film and the presence of the crumb rubber. More detailed descriptions of these design methods can be found in Appendix M.

#### Mixture Properties

Mixtures containing binders produced by both the wet and the dry process have been tested in the laboratory. The results of this research are summarized in Appendix N and discussed briefly below. Stability, resilient modulus, permanent deformation, fatigue, water susceptibility, low temperature cracking, reflection

cracking, and surface abrasion properties are available for typical CRM mixtures.

#### Stability

Marshall stability can be reduced, Marshall flow increased, air voids and the voids in the mineral aggregate (VMA) increased, and Hveem stability reduced when asphalt-rubber or wet process binders are used. Properties of rubber asphalt (dry process) are largely dependent on crumb rubber concentration and aggregate gradation, as well as other factors. In general, both Marshall and Hveem stability will be reduced in mixtures produced by the dry process.

#### Resilient Modulus

Resilient modulus values for CRM mixtures may be greater or less than for conventional mixes depending on a number of factors. Typically, lower values are obtained in mixtures containing crumb rubber. Reports of experience in Oregon (62) and California (63) indicate that mixtures produced by the dry process will have a larger resilient modulus than mixtures produced by the wet process.

TABLE TEN  
OVERALL EVALUATIONS OF DEMONSTRATION PROJECT SAMs AND SAMIs (55)

State	Relative Performance With Respect to Control		
	Same	Better	Worse
<b>ASPHALT-RUBBER CHIP SEALS (SAMs)</b>			
Florida	X		
Georgia		X	
Pennsylvania	X		
South Dakota		X	
Texas	X		
Texas	X		
Texas		X	
Texas		X	
Vermont			X
Virginia <sup>a</sup>		X	
Virginia <sup>a</sup>		X	
<b>ASPHALT-RUBBER INTERLAYERS (SAMIs)</b>			
Colorado		X	
Delaware	X		
Florida	X		
Georgia		X	
Idaho	X		
Idaho	X		
New York	X		
Pennsylvania	X		
Pennsylvania	X		
Vermont			X

<sup>a</sup>No control sections, relative performance inferred.

#### *Permanent Deformation*

Studies conducted in Texas (59) and Nevada (64) suggest that mixtures containing crumb rubber and conventional mixes have similar resistance to permanent deformation. A Virginia study (65) indicates that mixes with asphalt-rubber binders have less resistance to permanent deformation. Dry process and wet process mixtures have similar behavior (66).

#### *Fatigue*

Fatigue life is improved when crumb rubber is added to hot mix asphalt by either the wet or the dry process.

#### *Tensile Strength*

Tensile strengths may either increase or decrease when crumb rubber is added to a mixture.

#### *Water Susceptibility*

Water sensitivity may be a problem when crumb rubber is used in mixtures. Testing should be performed to determine water sensitivity.

#### *Thermal Cracking*

Improved resistance to thermal cracking has been reported (67). The base asphalt and degree of reaction, among other factors, control low temperature properties and resistance to thermal cracking.

#### *Surface Abrasion*

Improved resistance to abrasion is reported based on results from laboratory tests in California (63). Other data indicate no improvement in abrasion resistance (63).

TABLE ELEVEN  
AASHTO MEMBER DEPARTMENT CRUMB RUBBER MODIFIED (CRM) HOT MIX ASPHALT (HMA) PROJECTS AND TONNAGES FOR 1992 AND 1993, INCLUDING PATENTED CRM AND WET AND DRY PROCESSES (56)

	Number <sup>a</sup> Of States		% Increase	Estimated # of Projects		% Increase	Est. Tons in 1000's <sup>b</sup>		% Increase
	1992	1993		1992	1993		1992	1993	
TOTALS	21	34	62	52	119	129	301	1,123	273
Patent	17	12	-47	41	34		229	566	
No Patent	7	18	158	11	55		72	125	
Both	3	3	0		13			279	
Unknown		7			15			153	
Wet	19	30	58	50	61		263	218 <sup>c</sup>	
Dry	6	17	183	17	19		38	52 <sup>d</sup>	
Both	4	13	225	15	39			853 <sup>e</sup>	

<sup>a</sup>Adding these columns will result in a number higher than the TOTAL # of states because some states are using either both the patented and non-patented processes or both the wet and dry processes.

<sup>b</sup>Seven member departments reported unknown quantities for a total of 30 projects; no additions were made to any tonnage totals to account for these projects. Additionally, no allocation of the tonnages or project #'s accounted for under the "Both" or "Unknown" headings was made to other headings. For example, 13 projects using 279,000 tons were identified by member departments using both patented and non-patented processes. No adjustment was made to the "Patent" or "No patent" heading to account for this.

<sup>c</sup>17 projects of unknown quantities not included in estimates.

<sup>d</sup>7 projects of unknown quantities not included in estimates.

<sup>e</sup>6 projects of unknown quantities not included in estimates.

#### Friction

In general, the presence of rubber lowers friction numbers.

#### Construction

The construction process normally used for hot-mix asphalt pavements must be modified in order to produce a quality CRM hot mix. These modifications do not have a substantial impact on existing contracting equipment.

#### Asphalt-Rubber Binders (Wet Process)

When using asphalt-rubber binders in hot mix (dense, open or gap), several changes in the construction process will have to be considered (5):

- A blending and reacting unit should be added to ensure proper proportioning of the crumb rubber, base asphalt cement, and other modifiers. The blended material should be stored in a reaction vessel where temperature and time can be controlled to produce a binder with the desired properties.
- An interlocking control system should be used to provide accurate binder quantities.
- The target temperature for mixing, laydown, and compaction

should be higher to allow for the binders' greater viscosity at construction temperatures. Typical mixing temperatures are 300 to 350°F and laydown temperatures are at least 250°F. Compaction must be completed as soon as possible.

- Release agents used for the construction equipment (e.g., truck beds, steel wheel rollers) must not be petroleum based. Detergents are recommended.
- Pneumatic tire rollers cannot be used, because asphalt rubber will build up on the roller tires.
- Blotter sand may be necessary if traffic will be allowed on a new pavement. Spread rates of 2 to 3 lbs/yd<sup>2</sup> are typically used. Blotter sand should not be applied to open-graded friction courses.
- Joint raking is generally not possible.

#### Rubber-Modified Asphalt Binders (Dry Process)

When using rubber-modified asphalt mixtures, the following changes in conventional methods warrant consideration: (5)

- A separate crumb rubber feed system is needed for either batch or drum plants. Manual bag feeding is common at batch plants. Some drum plants have used recycled asphalt concrete hoppers to feed the crumb rubber. The hopper or belt should be tied electronically to the plant proportioning control system.

- Batch plants require a dry mix cycle to ensure that the heated aggregate is mixed with the crumb rubber before the asphalt cement application.
- Mixtures should be produced at 300 to 350°F with a laydown temperature of at least 250°F. Compaction must be completed as soon as possible.
- Pneumatic rollers should be avoided.
- Detergent release agents should be used on the construction equipment.
- The finish roller must continue to compact the mixture until it cools below 140°F. Otherwise, the continuing reaction of the asphalt and crumb rubber at elevated temperatures will cause the mixture to swell.

As the technology changes, some of these recommendations may change.

### Three-Layer System

The three-layer system was developed by the Arizona DOT and is used to restore badly cracked or warped sections of rigid or flexible pavements. The three layers consist of a layer normally used as a hot-mix asphalt friction course over the existing pavement, an asphalt-rubber interlayer, and a final hot-mix asphalt friction course. Typical thicknesses of these three layers are  $\frac{5}{8}$ -,  $\frac{3}{8}$ -, and  $\frac{5}{8}$ -in., respectively (68). Without the first layer or leveling course, the asphalt-rubber used to construct the interlayer could flow into the joints or large cracks, making a continuous stress-absorbing layer impossible. Finite element analysis with this three-layer system also suggests that stress concentrations are reduced at the interlayer when the first or leveling course is applied.

The interlayer chip application helps transmit vertical traffic-associated stresses and helps prevent slippage failures. A low-modulus binder is preferred as the interlayer material to help prevent reflection cracking. The application of the top layer helps prevent chip loss and other problems associated with the use of chip seals. The three-layer system thus becomes a rehabilitation alternative for facilities subject to high traffic volumes.

### Recycling

Any pavement material selection process should include an assessment of the possibility of recycling both the material and its associated pavement layer. Asphalt-rubber binders, when used in pavement materials, should be capable of being recycled. This subject is a major concern of public agencies at present.

The literature indicated that seven field projects have recycled old CRM pavements. These projects were performed in the 1990s and very little detailed information was available when this synthesis was prepared. Table Twelve summarizes information on these projects.

The projects in Michigan (70), New Jersey (71), Texas (72), and Ontario (72,78) will supply not only information on mixture properties and pavement performance, but also environmental, health, and safety data. Florida, California, and the City of Los Angeles are expected to perform recycling projects in 1994. (72) Little information is available on projects performed in the District of Columbia (75), the Netherlands (76), and France (77).

### Traffic Noise

Comparisons have been made of traffic noise level studies on pavement surfaces made with asphalt-rubber binders. Noise reduction attributed to asphalt-rubber open-graded mixtures was first quantified in Belgium in 1991. Several measurements made since 1991 are summarized in Table Thirteen. Several comparative studies indicate that a noise reduction of up to 10 dB, or 90 percent, is possible when asphalt-rubber open-graded mixtures are used in place of portland cement concrete surfaces. Other comparative studies indicate a 3-dB, or 50 percent, reduction in the noise from asphalt and portland cement-bound surfaces when asphalt-rubber open-graded mixes are used. Carefully designed surfaces without rubber can also provide a 3-dB improvement.

### Extraction of Asphalt-Rubber Binders from Aggregate

Many public agencies require that binders be extracted from the hot-mix aggregates to determine binder content and aggregate gradation for quality control and quality assurance purposes. Florida (80) and California (81,82) have conducted limited research programs to investigate the feasibility of using solvent extraction and nuclear gauges to determine binder contents in asphalt-rubber aggregate mixtures.

The results of solvent extraction tests from Florida (80) indicate that such tests cannot be used to accurately determine asphalt cement, rubber, or total binder content in mixes. The extraction test can, however, be used to recover aggregates for sieve analysis. A California study completed in 1983 (81) indicated that California's hot extraction method is not suitable for determining binder content in rubberized-asphalt concrete mixtures. Extraction apparatus clogging was a major problem. The same study concluded that nuclear gauges should not be used to determine total binder content. Suitable quality control methods for accurately determining binder contents remain a problem.

### Performance

A number of reports describe the performance of mixtures containing crumb rubber modifiers. Table Fourteen shows a summary of state experience with CRM hot mixes by technology associated with preparation of the binder (12). Selected references are reviewed in Appendix O.

### Economic Considerations

A number of agencies have first-cost information on CRM hot mixes. Table Fifteen presents a summary of these data. In-place cost increases of 1.5 to 2.0 are typical for either dense- or open-graded mixtures containing CRM binders. An AASHTO survey conducted in January 1993 and summarized in Table Sixteen also indicates typical cost increases of 1.5 to 2.0 (54). Differences in first costs are associated with the cost of the crumb rubber, changes in the construction operation, use of special aggregate, and increased uncertainty.

Life-cycle cost estimates have been made at Texas A & M University (30,44,83). Table Seventeen indicates that, if the two

TABLE TWELVE  
CRUMB RUBBER MODIFIED RAP RECYCLING PROJECTS

Location	Date	Process	Comments	Reference
Michigan	Sept. 1993	Dry	- 20-25 % CRM - Stack and worker exposure tests, results not available at this time	(70,72)
New Jersey	Aug. 1992	Dry	- 20 % 4-year-old dry process CRM RAP used - Air quality tests at plant and paving operation showed insignificant amounts of particulates, carbon monoxide and total hydrocarbons - No problems noted during construction operations	(71)
Texas	1993	Wet	- 20-25 % - Stack test results not available at this time - Large variability in air quality test results	(72)
Florida	1994	Wet	- I-95 project scheduled for 1990 - Dry process RAP - Air quality testing will be performed	(72)
District of Columbia	Sept. 1992		- Open-graded recycled mix with CRM RAP	(73)
City of Los Angeles	1994		- 10-year-old asphalt rubber pavement to be recycled in 1994 - Air quality and worker exposure tests to be performed	(72)
Ontario	1991	Dry	- 30 % 1-year-old dry process CRM RAP used - No problems were noted during mixture production and placement engineering	(72,78)
Netherlands	Unknown	Unknown	- 200-ton pilot project performed - 25 % rubber asphalt RAP used - No mix production problems - Good quality pavement produced	(76)
France	Sept. 1990	Wet	- Hot in-place recycling	(77)

rehabilitation alternatives are to have equal annual costs, a CRM hot mix would have to last 22 years if a conventional hot mix lasts 10 years. The Texas Transportation Institute (30) found favorable uniform annual costs for asphalt-rubber hot mix based on a laboratory performance analysis (Table Eighteen).

First costs of CRM hot mixes are expected to decrease as the quantity sold increases and as competition increases. Florida and New York's experimentation with wet- and dry-processed mixtures at reduced crumb rubber content may also result in more favorable economics.

#### Summary of Performance and Economic Considerations

The performance of CRM hot mixes has varied greatly. Mixtures made with asphalt-rubber binders (wet process) generally have better overall performance than those made with rubber asphalt

(dry process). California indicated a reduced occurrence of reflection cracking and good performance with a reduced thickness of CRM asphalt mixes on selected projects.

Typical cost increases (without a reduction in thickness) for mixtures containing crumb rubber modifiers are 1.5 to 2.0 times the cost of conventional mixtures. Life cycles of pavement containing asphalt-rubber modified hot mixes must be approximately twice as long as those of normal pavement for equal life-cycle costs. Costs of CRM asphalt are expected to decrease in the future as the result of increased competition, expiration of patents, supply and demand, and increased project volume.

TABLE THIRTEEN  
NOISE REDUCTION WITH ASPHALT-RUBBER MIXTURES (79)

Noise Reduction with Asphalt Rubber Mixtures			
Project Location	Noise Reduction, decibels (dB)	Percent Noise Reduction	Comments
Phoenix, AZ	10	88	One inch gap graded
Arizona	6.7 relative to PCC	78	PCC pavement 80.4 dB Asphalt rubber open-graded 73.7 dB
Paris, France	3-5 w/no trucks 2-3 w/trucks	50-75	Asphalt rubber open-graded
Belgium	8-10	75	Asphalt rubber open-graded
West Germany	3	50	Asphalt rubber open-graded
Europe	3-10	50-90	Asphalt rubber open-graded
Austria	3 relative to stone city streets	50	Asphalt rubber open-graded
Europe	6	75	Asphalt rubber open-graded
Austria	4.1 to 5.5	60-70	Asphalt rubber open-graded

TABLE FOURTEEN  
SUMMARY OF STATE EXPERIENCE WITH MODIFIED HOT MIX

Technology	Extensive	Limited	Comment
McDonald	AZ, CA	AL, AR, CO CT, DE FL, GA, ID, IA, KS, ME, MD, MA, MI, MS, MO, NC, NE, OH, OK, OR, PA, TN, TX, VA, WA, WI, WY	Most of the 1970s and early 1980s experience was with SAM and SAMI applications. Most of the research in the last 10 years has focused on HMA applications. Some routine use in the Southwest.
pressure react.			Has not been field-evaluated.
cont. blending		FL, IA, KS, MS, NJ, PA, VA, WA	Projects with low CRM contents are not expected to exhibit improved performance.
terminal blend		AZ, FL, OR, WA	Designed to meet local binder specifications.
Ecoflex		NC	Very limited experience.
Flexochape			Has not been field-evaluated in U.S.
PlusRide™	AZ	AZ, CA, IA, MN, MT, NJ, NM, NY, NV, OK, OR, SC, UT, WA	Projects constructed prior to 1985 do not represent existing PlusRide™ design guidelines.
generic dry-RUMAC		CA, IA, IN, IL, NY, OR	Projects represent early technology development.
chunk rubber generic dry-AR		FL, KS	Has not been field-evaluated. Very limited experience.

TABLE FIFTEEN  
COMPARISON OF FIRST COSTS FOR CRM HOT MIXES

State	Reference	Wet Process		Dry Process		Conventional	
		Dense-Graded	Dense-Graded	Dense-Graded	Open-Graded	Dense-Graded	Open-Graded
Arizona	(37)				1.56-1.84		1.00*
California	Van Kirk (1989)			1.40-1.50		1.00*	
Florida	(19)			1.10		1.00*	
Maine	Maine DOT (1990)	1.60		1.45-2.14		1.00*	
Minnesota	(36)	56.58				23.27	
Minnesota	(36)			41.60		19.95	
Minnesota	(36)			52.60		25.18	
New Jersey	Deringer, Smith (1985)			56.00		15.90	
New York	Shook (1990)			1.28-1.67		1.00*	
Rhode Island	Rhode Island DOT	52.00		1.80		1.00*	
Texas	(30)	48.00				32.00	
Virginia		1.1-3.7				26.30	
Washington	(54)						1.0*
Washington	(54)			2.0		1.0	
NCAT	(61)	59.15		45.00-51.00		33.58	
Texas A&M	(44)					32.50	

\* relative cost

TABLE SIXTEEN  
COST OF HOT MIX ASPHALT (HMA) AND HMA WITH CRUMB RUBBER MODIFIER  
(CRM) (54)

	Average \$/Ton		# of Responses	
	Mix	Liquid	Mix	Liquid
Hot Mix Asphalt	\$27-29	\$110	39	14
w/CRM no patent	\$40-44	\$346-394	22	5
Increase over HMA	\$13-15	\$236-284		
% Increase	50%	236%		
w/patented CRM	\$53-58	\$416-458	25	12
Increase over HMA	\$26-29	\$306-348		
% Increase	98%	297%		

TABLE SEVENTEEN  
COMPARISONS OF DENSE-GRADED ASPHALT CONCRETE  
REHABILITATION ALTERNATIVES (43)

Rehabilitation Alternative	First Cost \$/yd <sup>2</sup>	Life for Equal Annual Cost				
		3.0	6.0	8.0	10.0	12.0
2 in AC Hot Mix	3.30	6.0	8.0	10.0	12.0	
2 in AR Hot Mix	5.92	12.0	16.8	22.2	28.1	

\* Assumes 4 percent rate of return and no maintenance costs.

TABLE EIGHTEEN  
EQUIVALENT UNIFORM ANNUAL COSTS FOR AC-10 AND ASPHALT-RUBBER CONCRETE MIXTURES (30)

Material	Approximate In-Place Cost (\$/yd <sup>2</sup> )	Predicted Service Life (years)		Equivalent Uniform Annual Cost (\$/yd <sup>2</sup> )	
		Fatigue <sup>a</sup>	Rutting <sup>b</sup>	Fatigue	Rutting
AC-10 Control Mix	10.87	3	13	3.92	1.09
Asphalt- Rubber	16.97	14	13	1.61	1.70

<sup>a</sup>Service life prior to 600 ft<sup>2</sup>/100 ft<sup>2</sup> of cracking.

<sup>b</sup>Service life prior to 0.5-inch rutting.



## OTHER HIGHWAY USES

Chopped, shredded, and whole tires have been used for a number of other transportation related uses:

- Fills and embankments,
- Erosion control,
- Retaining walls,
- Membranes,
- Revetments for slope protection,
- Safety hardware,
- Railroad crossings,
- Valve box coverings,
- Planks and posts,
- Drainage aggregate, and
- Culverts.

Table Nineteen summarizes the results of a survey conducted in 1991 which identifies states that have used tires in these applications. The results of some of the documented projects are presented in this chapter.

### FILLS AND EMBANKMENTS

Chopped, shredded, and whole tires have been considered for use as fill and embankment materials since the mid 1980s. The major advantages identified for this use of waste tires include the following:

- Landfill disposal replacement,
- Aggregate replacement,
- Lightweight material,
- Improved drainage characteristics (permeability),
- Good thermal characteristics related to frost penetration,
- Resistance to ultraviolet radiation,
- Non-biodegradable, and
- Economy.

The survey of state highway agencies in 1991 indicated that 10 states (California, Colorado, Indiana, Maine, Minnesota, North Carolina, Oregon, Vermont, Washington, Wisconsin) have used tires for fills or embankments and 3 states (New Jersey, Ohio, Pennsylvania) have pending projects. An embankment fill using 2.2 million tires was placed in Virginia in 1993 (84). Only one state, Minnesota, considers the use of tires for this application as routine (Table Twenty).

Colorado (85) and North Carolina have pending projects where tires will be used as embankment materials. Field projects have been placed in Minnesota (87–88), Oregon (89–91) and Vermont (92). California's laboratory study (93), reported in 1986, indicates that chopped and shredded tires can be used as a permeable pavement layer. Results from several projects are summarized below.

### Minnesota Experience (86-88)

In 1985, a tire recycling firm and logging contractor presented a proposal for using waste tires in forest road construction to the Minnesota Pollution Control Agency. The contractor proposed replacing the commonly used wooden corduroy system with a type of geogrid. The Department of Natural Resources, Division of Forestry, was asked to comment on the proposal because it appeared to offer an economical method for crossing peat and other soft soil. Reported advantages for the project included the following:

- Unaffected by ultraviolet radiation,
- Not biodegradable above or below the water line,
- Lightweight characteristics,
- Low placement costs,
- Improved drainage, and
- Increased load-carrying capacity.

These reported advantages have stimulated the construction of several projects in Minnesota.

Near Floodwood, Minnesota, nine experimental test sections were placed on a roadway upgrading project across a peat swamp on Hedbom Forest Road in 1986. Tire mats were placed on top of the peat and over the existing road bed. Borrow was placed on top of the tire mats, and a gravel wearing surface completed the structural section. The tires were tied together with a nylon toggle strap to form the mats. The nylon strap was inserted into pre-punched holes in the tires. The following mat types were formed:

- A single layer of whole tires,
- A double layer of whole tires,
- A single layer of whole tires with 8 in. of shredded tires,
- A single layer of half tires with 8 in. of shredded tires,
- A single layer of half tires with cups up,
- A single layer of half tires with cups down,
- A double layer of half tires,
- A single layer of half tires with geotextiles, and
- A layer of tire chips 3 ft deep.

Each test section was 40 ft long. Standard geotextile sections were placed at each end of the test sections.

Test observations after 2 years of service on the tire sections showed measured settlements of 12 to 18 in., about 12 to 24 in. less than that expected on conventional road sections placed on these types of soils. Overall performance on the test sections has been good. No holes have developed in the test sections although a few soft spots have appeared in other sections of the road.

Near Eden Prairie, a natural fill embankment that failed during construction was removed and replaced with shredded tire material. The project used about 30,000 yd<sup>3</sup> of tires (more than 600,000

TABLE NINETEEN  
USES OF TIRES IN TRANSPORTATION FACILITIES

Type of Use	State	Reference	Description of Use	Advantages	Concerns
Erosion use	California	(94-96) (97,100)	Shoulder reinforcement Channel slope protection	Disposal Low cost Erosion Control	Visual acceptance by public Labor intensive Cost
		(94)	Windbreaks	Availability of tires	
	Louisiana	(99)	Slope reinforcement	Disposal	Pull out values
	Pennsylvania		Pending project		
	Vermont	(98)	Side slope fill	Disposal Flatten side slope	Unloading Leachate Cost
Retaining wall	Wisconsin		Experimental project		
	California	(100)	Anchored timber walls		
	North Carolina		Experimental retaining wall		
Membrane	Rhode Island		Experimental retaining wall		
	Arizona	(101-103)	Membrane to control expansive subgrade soils Shoulder membrane Ditch membrane	Less moisture fluctuations Seal out moisture Prevent cracking Ride quality Lower maintenance cost	
	California		Routine use		
	Oregon		Routine use		
	Washington		Routine use on bridge decks		
Safety hardware	Wisconsin		Experimental use		
	Colorado	FHWA (1990)	Experimental project		Tires become projectiles
	Connecticut	(106,107) Marquis (1975)	Tire-sand inertial barrier	Disposal Low cost Maintenance	Debris Deceleration of vehicle
	Oregon		Bases for tubular markers		
	Pennsylvania		Pending projects		
Railroad crossings	Texas	(104)	Bases for vertical panel supports		
	Oregon	(108,74)	Routine use	Ease of installation Smooth Reduced maintenance Potential reuse	
Valve box coverings	Pennsylvania		Experimental only		
	Oregon	(108,109)		Ease of installation Reduced maintenance Easy to adjust Durability	
Planks and posts	California	(111, 100)	Laminated tires for planks and posts	Strength Durability Lightweight Sound loss	Burning Smoke
	Ontario	Carsonite (O)	Sound barrier walls		
Drainage material	Pennsylvania	(112)	Aggregate drain rock replacement	Water-draining Stable roadway	Leachate
Culvert	Vermont	(113)	Whole tires bound together to form culvert	Cost	
Interlocking block	Minnesota	(114)	Erosion control, safety barriers, retaining walls, dikes, levees	Ease of installation Shock absorbing Resist chemical damage Durability	

TABLE TWENTY  
RECYCLED RUBBER TIRES IN HIGHWAYS

State	Fill or Embankment		Erosion Control		Crash Attenuators		Other Safety Hardware		Membrane		Other		Comments
	Use	Rubber, tons	Lane miles	Use	Rubber, tons	Use	Rubber, tons	Use	Rubber, tons	Use	Rubber, tons		
Arizona									R				
California	E			R				P		R	E,R		Windbreak—blowing sand
Colorado	E	*						E					*10,000yd <sup>3</sup>
Connecticut						E	<1						
Hawaii		0			0		0		0				
Indiana	E												
Maine	P,E	540											
Minnesota	E,R		~5										
New Jersey	P			—		—		—		—			
North Carolina	E	709	0.5								E	163	Tire retaining wall
Ohio	P												
Oregon	E	5800						R*		R	R		Railroad crossing, valve box cushions *Bases for tubular markers (candles)
Pennsylvania	P			P							E		Railroad crossing pads Aggregate substitute in drains
Rhode Island											P,E		Retaining walls
Texas								E*					*Bases for vertical panel supports
Vermont	E	1369	0.06										
Washington	P,E			—		—		—		R			
Wisconsin	E	50	5	E	20					E	10		

P=PENDING  
E=EXPERIMENTAL  
R=ROUTINE

tires). A geotextile fabric was placed on top of the shredded tires and capped with 4 ft of soil.

Other projects in Minnesota include installation of a whole-tire mat under 18 in. of borrow in Carlton county, a whole-tire mat covered with 12 in. of shredded tires, and a section of roadway with 24 in. of shredded tires.

Based on observations of the Minnesota field projects, the following roadway sections are suggested (86):

- Use half tires with cups down for geogrid type applications.
- Use separation fabrics with shredded tires.

Using shredded tires as lightweight fill appears to be a promising method for crossing soft soil.

The half-tire and whole-tire geogrid systems are labor intensive. A mechanized tire insertion method for formatting mats needs to be developed.

#### **Oregon Experience (89–91)**

Shredded tires were used as lightweight fill to correct a landslide that occurred on US Route 42 in Oregon. The existing soil embankment was removed and replaced with shredded tires capped with 3 ft of soil. More than 600,000 tires were used in this project.

Shredded tire chips were transported 150 to 250 mi. The chips were placed and compacted in three lifts using a D-8 dozer. The densities of the tire chips were as follows:

- 30 lbs/ft<sup>3</sup> loose in the haul vehicles,
- 45 lbs/ft<sup>3</sup> compacted in place, and
- 52 lbs/ft<sup>3</sup> when compressed under the soil cap.

The 12-ft-thick section of shredded tires was compressed 20 in., or 13 percent, by the capping load of 3 ft of soil, 2 ft of aggregate base, and 6 in. of asphalt concrete. This compression is about twice that expected in an earth embankment.

Four vendors supplied tires for this project. Shredded chip quality control was a problem. Specification violations included the following:

- Excessive exposed wire,
- Exceeding maximum size (24 in.) of chip, and
- Presence of miscellaneous debris, including wheel rims and whole tires.

The exposed wire punctured tires on the haul vehicles when they backed over previously placed material.

Post-construction observations and measurements indicated that 2 in. of settlement occurred during the first 4 weeks of traffic on a temporary pavement surface. In addition, perceptible vibration is evident when a heavy truck travels over the shredded tire embankment. Falling weight deflection testing on the fill section indicates a maximum deflection about twice that expected for a conventional pavement. Because the deflection basin has a longer radius, the stresses in the pavement may not be as large as those in conventional pavements with high deflections.

Shredded tires delivered to a stockpile near the project cost \$30/ton. The Oregon Department of Environmental Quality reimbursed the Oregon Highway Division \$20/ton for using the waste tires. The net cost of \$10/ton is equivalent to \$7.02/yd<sup>3</sup> in place.

An additional cost of \$8.33/ton or \$5.85/yd<sup>3</sup> was required for placement and compaction. Net costs were less than for comparable lightweight fill materials.

#### **Vermont Experience (92)**

Shredded tires were used as a drainage layer and barrier against gravel base contamination from a wet silty sand subgrade on a town highway in Vermont. On this reconstruction project, 24 in. of existing base material and 6 in. of subgrade were removed. Rubber chips were placed in a 9- to 12-in. layer. Gravel was placed over the layer of rubber chips.

The experimental shredded tire section performed very well through the first winter/spring season as compared with the adjacent roadway. The experimental section did not freeze until several days after the control section. During the spring period, the tire chips prevented the capillary rise of the ground water and aided in the drainage of the surface moisture from the gravel.

#### **California Laboratory Study (93)**

California completed a laboratory study in 1984 that investigated the use of tires as a permeable aggregate. Chopped tires and shredded tires were used in the study. The measured physical properties of these two types of processed tires are available (77). Permeability values were equivalent to those of typical conventional aggregate permeable base materials.

Deformation measurements made during density testing indicated that a 12 to 25 percent deformation is possible under static loading. The larger deformations occurred on shredded tires. This high deformation may limit the use of these materials to non-load-bearing applications such as behind structures, deep cut-off trenches, and stabilization trenches.

The estimated cost of producing 2-in. shredded tires is between \$25/ton and \$35/ton (\$14 to \$19/yd<sup>3</sup>). Transportation and placing costs will add to these processing costs. Transportation costs can approach \$6.25/ton-mi. In-place costs for conventional permeable material range from \$15 to \$33/yd<sup>3</sup>.

#### **Wisconsin Experience (94)**

A test embankment containing shredded waste tires as soil replacement was constructed at the Dane County Landfill No. 2 near Madison, Wisconsin. The embankment contained eight experimental sections 20 ft long to evaluate tire chip size and type, soil type and chip-to-soil ratio, and placement conditions. Normal construction machinery was used. Vibratory and static compaction did not significantly induce compaction in the tire chips. The compacted unit weight of the tire chip sections was 35 to 37 lbs/ft<sup>3</sup>. Mixtures of tire chips and sand had unit weights in the range of 70 lbs/ft<sup>3</sup>.

The overall performance of the gravel road placed on tire chip embankments appears similar to that of most gravel roads. Thicker layers of soil cover (3 ft) on top of the tire chip embankment performed better than sections with 1 ft of soil cover. Tire chip sections and tire chip/soil sections settled relatively rapid for the first 60 days under traffic. Settlements ranged from 1/4 in. to nearly 1/2 in. during this period for those sections containing chips. The control section settled about 0.1 in.

## ENVIRONMENTAL CONSIDERATIONS

The environmental impacts of using waste tires as subbase and fill materials is a concern identified by the states. Four leachate studies have been conducted and are reported in the literature. These studies are discussed in Chapter Four.

### Erosion Control

California has performed field research and prepared implementation packages for using tires for shoulder reinforcement and channel slope protection (95-97).

### Shoulder Stabilization

California's installation specifications for shoulder stabilization using whole tires are shown in Figure 12. A sketch of a finished project is shown in Figure 13. A summary of the construction procedures for installing the tires, as presented by Caltrans (96) is given below.

At the eroded shoulder, a bench should be cut and sloped slightly towards the traveled way. The width of the cut should be the width of the truck tire mat plus a minimum of 6 in. Engineering fabric should be placed behind, under, and over the tires to prevent soil from eroding. The tires should be placed in parallel rows and back-filled with imported permeable material. The tires should be connected using clips which are fabricated from 1/2-in. steel reinforcing bar. A 12-in. layer of permeable material should be placed on top of the first layer of tires. Then the second layer of tires should be placed and backfilled. Salvaged metal posts, if available, should be driven through the hole a minimum of every other tire in the inside row. The top of the post should be driven flush with the top of the last layer of tires. To provide an unpaved shoulder, an 18-in. layer of native soil should be placed on top of the tires and compacted. Woody plants could then be planted on the slope below the tire installations to accelerate the reestablishment of vegetation. Alternative recommended method of placement of engineering fabric and soil containment between mats is also shown on the drawing sheet.

A typical cost for waste tire shoulder reinforcement is \$80 per lineal foot for a 5-ft high wall. Cost comparisons with gabion, concrete crib, and reinforced concrete walls are shown in Table Twenty-One (96).

### Channel Slope Protection

California's installation specifications for channel slope protection using whole tires are shown in Figure 14. A sketch of a finished project is shown in Figure 15. California DOT notes (96) about materials selection and installation are given below:

- Scrap tires will be in such condition that they will retain original manufactured shape when stacked.
- The steel tire clip is to be made of "cold rolled" 1/2-in. diameter steel. All measurements, except bend radius, are to be center of bar; bend radius is inside diameter.
- All posts shall be recycled metal posts in good condition.
- Posts shall be secured tightly against bend on the inner row of tires, placed at a minimum of every other tire and at ends of tire mats.
- Excavated material may be accepted for backfill provided it

can be readily consolidated with the use of hand-held vibratory compactors.

- Ponding and jetting may be permitted if it will not damage foundation material, if it will not develop hydrostatic pressure on the tire unit, and if the backfill material is free-draining.
- Sidewalls of tires should be spread during backfilling operations to facilitate adequate compaction.
- Salvaged materials shall be state furnished, if available.
- Ends of mesh shall be lapped 6 in. and secured with hog rings or 14-gauge wire.
- Tires shall be used on lower slopes and in locations not visible to motorists.
- Painting the tires to blend with the surrounding terrain will improve the aesthetics of the installations.

Typical costs for channel slope protection are \$50 to \$80 per lineal foot for a 5-ft high wall. Cost comparisons with rock slope protection, broken slope protection, gabion wall, and reinforced concrete are shown in Table Twenty-Two (96).

### Windbreak (95)

California investigated the use of tires to reduce blowing sand damage to newly planted trees in desert areas. Trees are often planted as wind and blowing-sand breaks for the highways in the southern California deserts in order to reduce visibility problems and vehicle damage problems. Blowing sand will destroy young seedling trees if they are not protected properly.

Woven tire walls and mats of tires were constructed at one site and compared with other treatments including installation of salvaged signs, recycled glare screens, snow fences, and polyethylene fences. The discarded tire barrier prevented the buildup of sand on the roadway and used a large number of discarded auto tires. Installation was labor intensive and the cost is greater than alternative treatments.

### Side Slope Fill (98)

Vermont used tire chips to help flatten a highway side slope. A photograph of the construction operation is shown in Figure 16. Problems associated with unloading chips are illustrated in Figure 17. Chips were placed on the excavated soil and compacted. A filter fabric was placed on the chips followed by 2 in. of earth fill. Lift thicknesses were limited to 18 in. because greater thicknesses would not compact satisfactorily. Measured physical properties of the rubber chip material are given below:

In-place density	47 to 56 lbs/ft <sup>3</sup>
Specific gravity	1.21
Void ratio (compacted)	0.45

Cost estimates and actual expenditures for the project are inconclusive when used to determine the cost benefits relative to earth fills. The costs of chips delivered to the site appear to be the single most expensive item.

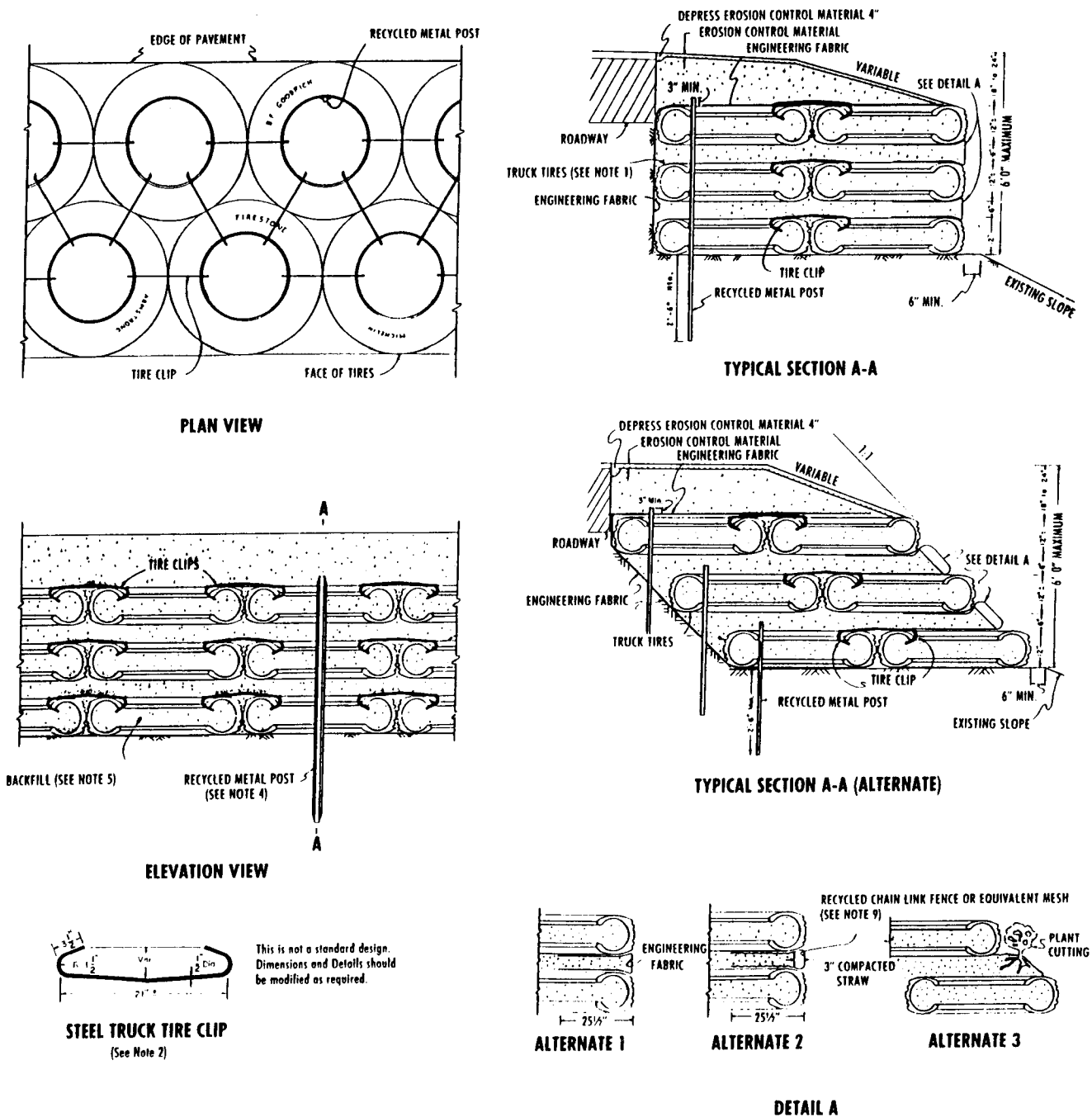

FIGURE 12 Specifications for shoulder stabilization with recycled tires (95).

**Slope Reinforcement (99)**

Louisiana is conducting a research project that will determine the pull-out forces associated with the use of tire sidewalls as reinforcement for roadway embankment slope stability.

**Retaining Wall**

California, North Carolina, and Rhode Island report using tires for retaining walls. The North Carolina and Rhode Island uses

were identified as experimental in the 1991 state survey reported in Table Twenty.

California has a specification for a tire-anchored timber wall (100), which is excerpted in the following paragraphs.

Before beginning a tire-anchored timber wall, the foundation or natural soil is compacted to 90 percent relative density to the planned grade. The backfill material can be imported or obtained from excavation and should be free from (1) stones or lumps exceeding 6 in. in size, (2) organic material and (3) other unsuitable material. The backfill material is to be placed in uniform layers not to exceed 8 in. in thickness and compacted to not less than 95

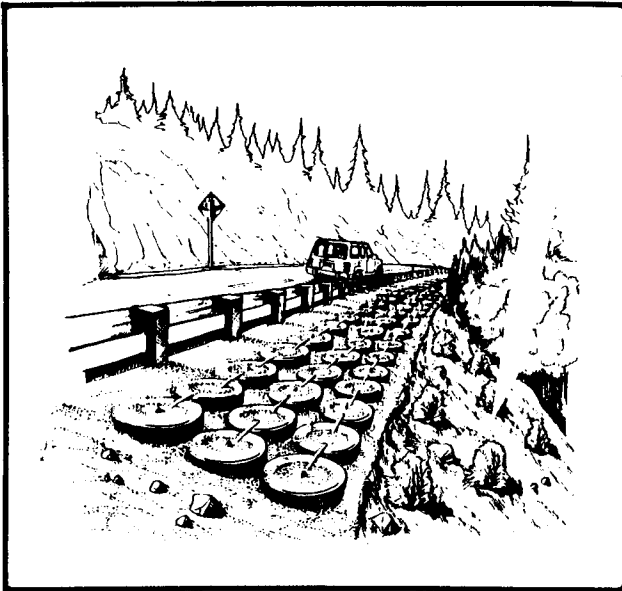

FIGURE 13 Shoulder stabilization with recycled tires (95).

TABLE TWENTY-ONE  
REPRESENTATIVE COSTS FOR SHOULDER  
REINFORCEMENT (96)

In 1988 Dollars Per Lineal Foot For a 5' High Wall

Discarded tire wall*	80.00
Gabion wall	165.00
Concrete crib wall	230.00
Reinforced concrete wall	325.00

\*Suitable excavated material is assumed as backfill.

percent relative density. The tie-bar anchor assemblies are shop fabricated and welded and galvanized.

Tire sidewalls consist of discarded passenger vehicle or pickup truck tires only of wheel sizes of 14 or 15 in. The tires are separated into three sections: two sidewall sections and the tread section. The tire is cut circumferentially at each shoulder or the point where the tread and sidewall meet. The cut tires are placed either side down. Timber is used for the cross members and vertical posts.

Plan and cross-section views of a typical tire-anchored timber wall are shown in Figures 18 and 19 (97). Typical tire assembly embedment depths and bar sizes are shown in Table Twenty-Three. Figure 20 shows a typical tire sidewall, anchor assembly detail. Typical spacing between tire assemblies is 2 ft vertically and 3 ft horizontally. Two feet of fill is required over the top of most tire assemblies (99).

### Membranes

Arizona, Oregon, and Washington report routine use of membranes made with asphalt-rubber binders (Table Nineteen). Reports

are available which describe the use of membranes in Arizona (101-103). Arizona has used asphalt-rubber membranes for pond liners and to control moisture content in swelling clay soil subgrades. Results from these projects indicate that asphalt-rubber membranes are cost-effective solutions for reducing the effects of swelling clay subgrades.

### Safety Hardware

Colorado, Connecticut, Oregon, Pennsylvania, and Texas report using recycled tires for highway safety devices (Table Nineteen). Oregon and Texas use recycled tires as bases for tubular traffic control markers and bases for vertical panel supports (104). Colorado and Pennsylvania report the experimental use of recycled tires in safety hardware.

Recycled rubber blockouts have been proposed as replacements for wood or steel blockouts on guardrails. Prototype recycled rubber blockouts have been made with 75 percent shredded rubber and 25 percent fine rubber grindings. Proprietary crash tests have shown that rubber blockouts are not stiff enough, permitting the W-beam rail to rotate and cause vaulting or sagging problems (105).

### Tire-Sand Inertial Barrier (106,107)

The Connecticut DOT installed a tire-sand inertial barrier system at the junction of Routes 2 and 17 in 1975. Design modules for this vehicle impact attenuator are shown in Figure 21. A plan view for the installation is shown in Figure 22 (106). First, or installation, costs are relatively low for the sand-tire system; replacement costs are higher than other systems (106,107). Conclusions for this field study indicated satisfactory performance in terms of vehicle deceleration, installation replacement costs, and maintenance costs. Results are not conclusive concerning the reduction of secondary hazards caused by debris on the roadway after a collision with the system.

### OTHER USES

#### Railroad Grade Crossing (108,72)

A manufacturer in Oregon uses recycled tires to manufacture planks that are used in railroad grade crossings (72). The Oregon DOT reports that this product is used routinely.

#### Valve Box (108,109)

Rubber valve box cushions are 2 ft square and 8 in. thick. They are designed to support the cover, spread vehicle loads, provide better compaction of the asphalt concrete around the cushion, and eliminate infiltration (108).

#### Drainable Mat

U.S. Patent 4,850,738 (110) describes a water drainage stable mat constructed with vehicle tires and cut pieces of tires or chips. Vehicle tires, or parts of tires, are bound together and placed on

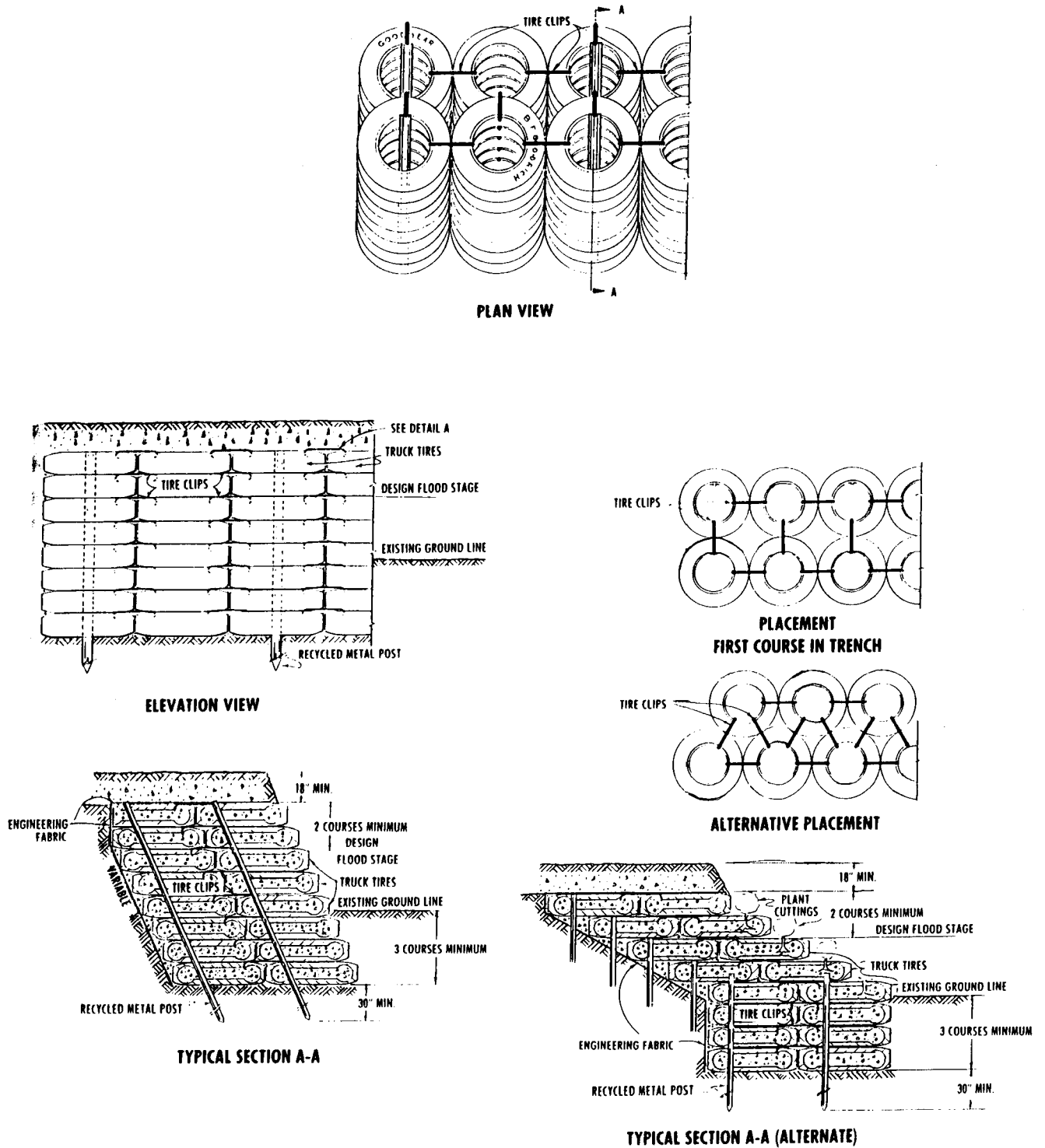

FIGURE 14 Specifications for channel slope protection with recycled tires (95).

the subgrade. A second layer is constructed with tire chips. The surfacing is constructed with unstabilized surfacing materials.

**Planks and Posts**

The California DOT (111) reports the development of laminated rubber planks and posts.

Field use of these devices was not reported in the survey of states; however, data gathered for an NCHRP synthesis titled *Recycling and Use of Waste Materials and By-Products in Highway Construction* (112) states that Ontario has been contacted by several companies about the possibility of using recycled tires as a base material for noise barriers. Binders are used to bond chopped



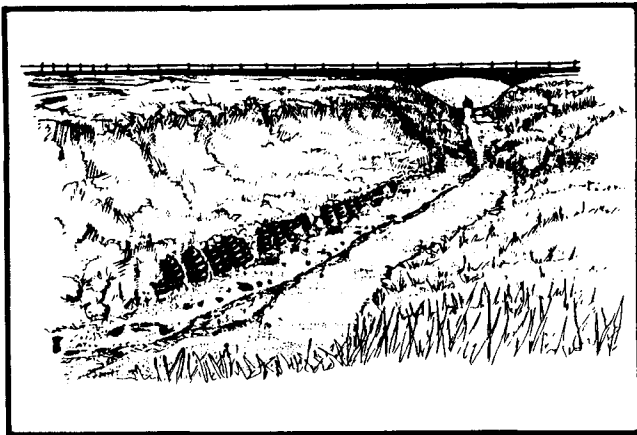

FIGURE 15 Channel slope protection with recycled tires (95).



FIGURE 16 Tire chips when the embankment was about 12 ft deep (96).

tires ( $\frac{1}{4}$  in. to  $\frac{1}{16}$  in.) into panels for the noise barriers. Ontario has been conducting tests on these panels for a variety of properties. Key concerns include flammability and smoke. Flammability does not appear critical based on comparison tests with pine wood. Smoke output is high when the panels are burned. Smoke retardants are being investigated by one company. Product durability appears excellent. No leachate problems were found using standard tests. However, costs are expected to be higher than the costs of current systems. Other concerns identified include toxicity when the panels burn and insufficient panel stiffness or rigidity (112).

#### Culvert

Vermont (113) reported the development of a culvert made from whole truck tires. The tires are bound together with black steel reinforcing bars. These culverts have been used in the town of Georgia, Vermont and have performed at an acceptable level. Figure Twenty-Three shows a culvert section made from 15 to 20 tires.



FIGURE 17 Unloading became a problem when packed chips would not fall out and had to be pushed with hydraulic rams integral to the truck (96).

TABLE TWENTY-TWO  
REPRESENTATIVE COSTS FOR CHANNEL SLOPE  
PROTECTION (100)

In 1988 Dollars Per Lineal Foot For a 5' High Wall

Discarded tire*	50.00-80.00
Rock slope protection	125.00
Broken concrete slope protection	150.00
Gabion wall	165.00
Reinforced concrete	325.00

\*Suitable excavated material is assumed as backfill.

#### Interlocking Blocks (114)

A Minnesota company has developed a non-heated, cost-effective method for molding scrap tire rubber into interlocking blocks. These blocks can be used for parking lot curbs, highway barriers, riverbank stabilization, and soil erosion control on slopes. The blocks can be produced in various sizes, densities, and colors depending on the type of application.

#### SUMMARY

Chopped, shredded, and whole tires have been used in several fills and embankments. Results to date have been encouraging. This application has the potential to use large quantities of waste tires. However, this use of recycled tires may have some effect on the environment. Studies completed to date have given mixed results for tires placed below the water table.

The use of recycled tires for erosion control is fairly well established in a number of states. California's design guides are useful

for this application. Concerns about visual acceptance by the public and cost need to be addressed.

A wide variety of other uses and potential uses have been identified in the literature. Promising ones include the following: retaining walls, membranes, revetments, safety hardware, railroad crossings, valve box coverings, planks, posts, drainage aggregate, and culverts.

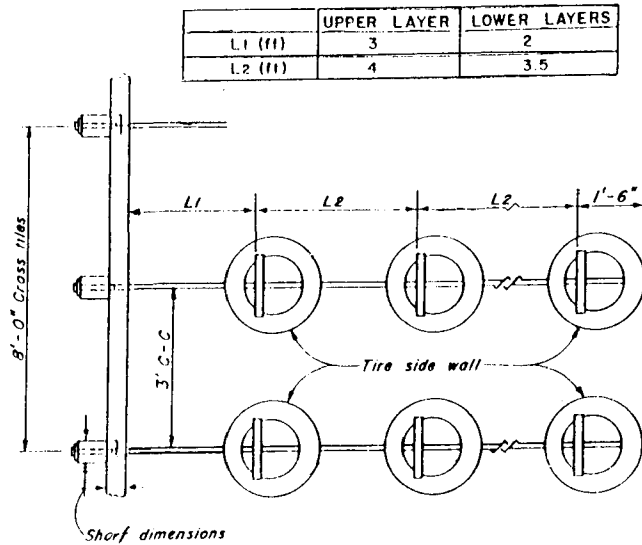

FIGURE 18 Top view of tire and tie bar anchor (97).

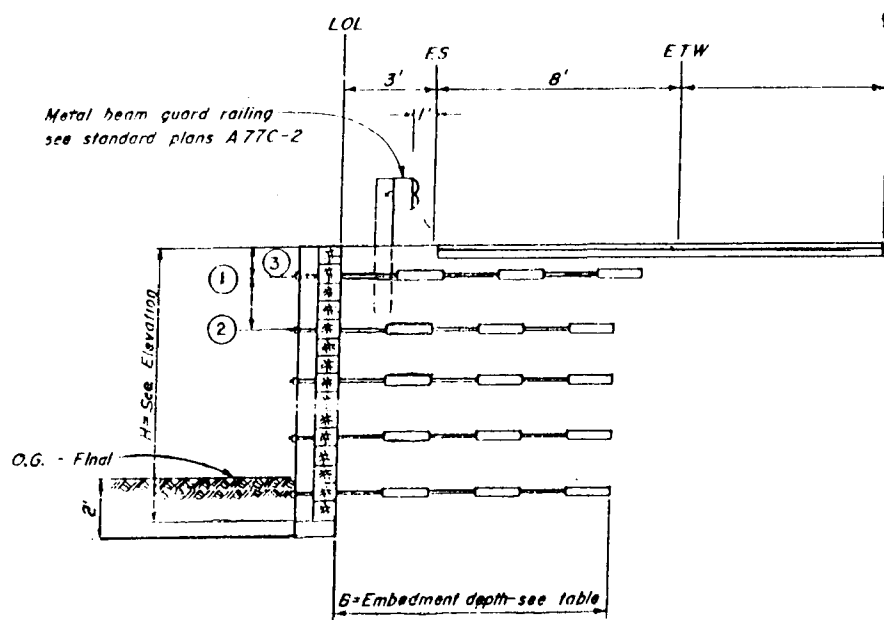

FIGURE 19 Typical cross section of tire and tie bar anchor (99).

TABLE TWENTY-THREE  
EMBEDMENT DEPTH AND BAR SIZE (99)

Wall Height Ht. (Ft.)	Embedment Depth 8 (ft)		Bar No.	Bar Size (in.)
	Upper Layer	Lower Layers		
4 < H < 8	12.5	7.0	6	3/4
8 < H < 12	12.5	10.5	6	3/4

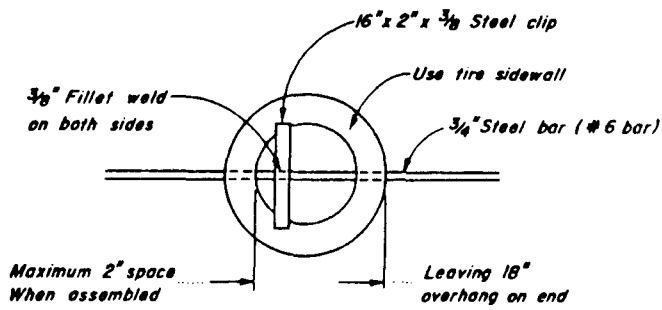

FIGURE 20 Tire sidewall anchor assembly detail (99).

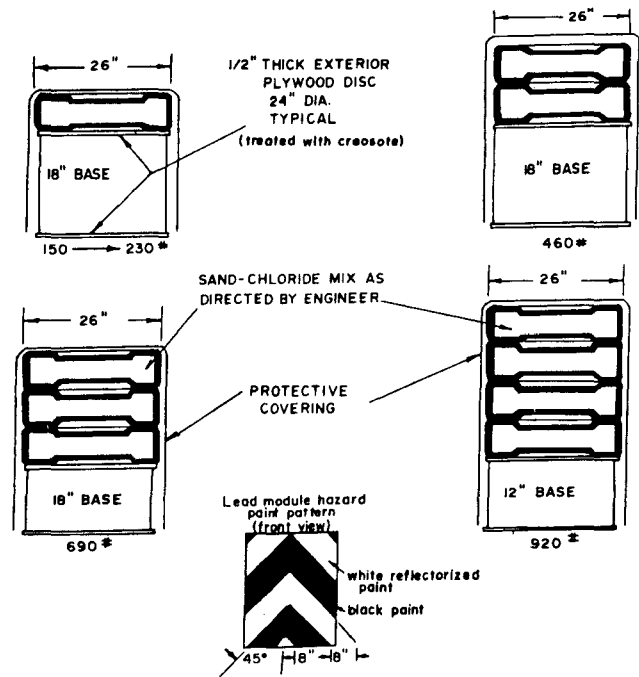
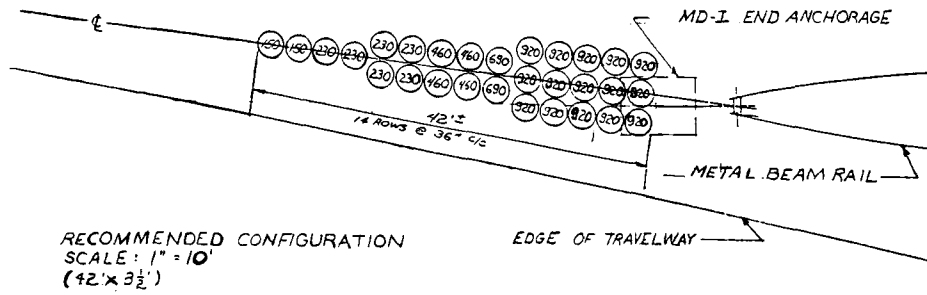

FIGURE 21 Various sand-tire modules for inertia barrier (105).



RECOMMENDED CONFIGURATION  
 SCALE: 1" = 10'  
 (42' x 3 1/2')

- |              |                         |                |
|--------------|-------------------------|----------------|
| 2 - 150 LB.  | - 1 TIRE EA - 18" BASE  | } EA. TIRE . . |
| 6 - 230 LB.  | - 1 TIRE EA - 18" BASE  |                |
| 4 - 460 LB.  | - 2 TIRES EA - 18" BASE |                |
| 2 - 690 LB.  | - 3 TIRES EA - 18" BASE |                |
| 15 - 920 LB. | - 4 TIRES EA - 12" BASE |                |

FIGURE 22 Plan view of 1975 Connecticut barrier system (106).

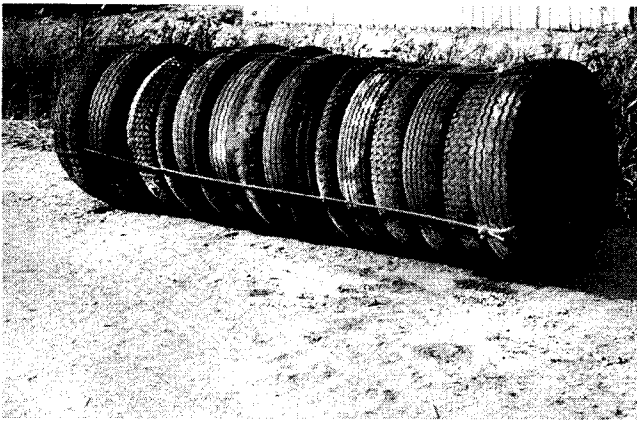

FIGURE 23 Truck-tire culvert from Vermont (113).

## ENVIRONMENT, HEALTH, AND SAFETY

### INTRODUCTION

Several states have raised the question of environmental impacts and health risks associated with using waste tires in highway construction, rehabilitation, and maintenance. California, Colorado, Minnesota, Vermont, and Wisconsin have expressed concerns about using waste tires as subbase fill materials, erosion barriers, retaining walls, etc. Many states and other individuals are troubled by the emissions from the manufacture, placement, and use of crumb rubber modified asphalt binders in new construction and in recycling operations. Selected studies are reviewed briefly in this chapter.

### LEACHATE STUDIES

Three states have conducted and reported leachate studies in the literature. A Minnesota laboratory and field study appears to be the most detailed of the available studies. This investigation and the limited work conducted in Vermont and Wisconsin are summarized in the following sections.

#### Minnesota Study (87)

The laboratory test program consisted of four leach tests designed to simulate a range of pH conditions. Leachates were prepared using U.S. EPA SLO-846 Method 1310. Two fluids, at pH 3.5 and 5.0, used acetic acid for pH adjustment. A third fluid used a 0.9 percent sodium chloride solution, and the extraction fluid mixture used ammonium hydroxide and ammonium acetate to obtain a pH 8.0 solution. Both new and old tires and an asphalt concrete mixture were subjected to these fluids. A band saw was used to cut rubber tire specimens into 2 to 4 in. chunks. For the purposes of the Minnesota report, new tires were defined as recently discarded scrap tires. Old tires were scrap tires in the same stockpile, having been discarded 15 to 20 years previously.

#### *Inorganic Analysis*

Fourteen metal concentrations were measured in these laboratory leachate studies. These laboratory procedures represent "worst-case" conditions when compared with actual conditions where waste tires might be used (87). Although not directly comparable, the Minnesota report measured the results against current state standards for drinking water. The Recommended Allowable Limits (RALs) were exceeded under the following conditions:

- Arsenic in new tire samples at pH 5.0,
- Cadmium for new and old tire samples at pH 3.5,
- Cadmium in new tire samples at pH 5.0,

- Chromium in new tire, old tire, and asphalt concrete samples at pH 3.5,
- Lead in new tire samples at pH 3.5,
- Selenium in new tire, old tire, and asphalt concrete samples at pH 3.5,
- Zinc in new tire and old tire samples at pH 3.5 and 5.0, and
- Zinc in old tire samples with sodium chloride leachate solution.

Laboratory leachate sample results were also compared with aquatic life criteria, denoted as chronic toxicity, for surface waters. Chronic toxicity criteria were exceeded under the following conditions:

- Barium in new tire samples at pH 3.5 and pH 8.0 and in asphalt concrete samples at pH 3.5, 5.0, and 8.0,
- Cadmium in new tire samples at pH 3.5 and 5.0 and in old tire and asphalt concrete samples at pH 3.5,
- Chromium in new tire, old tire, and asphalt concrete samples at pH 3.5,
- Iron in all samples, except new tires, at pH 8.0,
- Zinc in new tire and old tire samples at pH 3.5 and 5.0, and in old tire samples in sodium chloride leachate solution.

The authors of the Minnesota study note that the laboratory leachate tests represent "worst-case" conditions and that surface waters generally provide a large dilution factor.

Results from this laboratory study were also compared with co-disposal criteria established for acceptability of wastes for disposal in landfills. The laboratory leachate studies are considered to be more aggressive than those used for co-disposal studies and their respective limits. Results exceeded the co-disposal limits as follows:

- Barium for asphalt concrete samples at pH 3.5,
- Cadmium in new tire and old tire samples at pH 3.5,
- Chromium in old tire samples at pH 3.5,
- Lead in new tire samples at pH 3.5, and
- Selenium in new tire, old tire, and asphalt concrete samples at pH 3.5.

None of the laboratory leachate samples exceeded the EPA's extraction procedure toxicity criteria (EP-TOX) or the toxicity characteristic leaching procedure (TCLP) criteria.

#### *Organic Analysis*

Total petroleum hydrocarbons and polynuclear aromatic hydrocarbons (PAHs) were determined on the extraction fluids. Recommended allowable limits and chronic toxicity criteria for List 1

carcinogenic PAHs and List 2 non-carcinogenic PAHs were generally exceeded under all test conditions. Highest concentrations were observed under pH 8.0 leaching conditions in both new and old tires. New tires contain slightly higher concentrations of leachable PAH compounds than older tires. Asphalt concrete samples exhibited similar or higher concentrations under all conditions when compared with the tire samples.

#### Field Sampling Program

Field sampling programs were conducted at two sites where waste tires had been used to build roads through wetlands. Both soil and groundwater samples were collected at these sites. At one site, aluminum, iron, magnesium, and zinc exhibited higher concentrations in background soil samples than in the areas where the tires were located. The following inorganics were present in higher concentrations in the tire areas than in background soil samples—arsenic, barium, calcium, and selenium.

Soil sample inorganic concentrations at the second sampling site were similar to those at the first site. Metals in soil samples obtained from tire stockpile areas were similar to those in soil samples obtained from roadway sites where tires were used. These results indicate that no difference exists between the roadway tire stockpile sites and the background soil samples.

Total petroleum hydrocarbons for soil samples collected at the tire stockpile sites were similar in type and more highly concentrated than samples taken from the roadway sites. These high values constitute a potential concern at the tire stockpile sites.

Water samples collected at one of the roadway sites exceeded the recommended allowable limits for barium, cadmium, chromium, and lead, while background samples at the site did not exceed these limits. Water samples from the second site exceeded the recommended allowable limits for List 1 carcinogenic and List 2 non-carcinogenic PAHs. The study suggests that using waste tires may affect ground-water quality.

A biological survey conducted on two sites found no major differences in vegetation composition between waste tire and non-waste tire areas.

The results from the Minnesota study (87) were compared with data obtained from two other leachate studies (114,115). Metal analyses in all three studies were similar for neutral pH conditions. PAH compounds were non-detectable in the other studies which used less aggressive leachate environments.

The Minnesota study suggests that potential environmental impacts from using waste tires can be minimized by placing tire materials only in unsaturated zones of the subgrade or fill areas. In March 1990, the Minnesota Pollution Control Agency indicated that it will not allow waste tires and tire-derived products to be used in surface waters or below the water table (117).

#### Vermont Study (98)

A limited Vermont study recorded water and soil pH near an area where tires were used to flatten a highway slope. The results indicated that surface water flowing through tire chips will probably not leach metals.

#### Wisconsin Study (94,115,118)

Professors Edil and Park have prepared an interpretation of leach test results reported by the Wisconsin State Laboratory on Hygiene

(118). Tire chips in this study were shredded to increase the wire exposure in the tire chips. Their interpretation of these test results is presented below:

- Sampling, bulk analysis, toxicity tests, and batch leaching tests appear to be appropriate for evaluating the environmental effect of shredded tires.
- The EP-TOX results show that shredded tires are not hazardous.
- Styrene-butadiene rubber (SBR) is the most important synthetic rubber used by the tire industry. SBR is made by copolymerizing 75% butadiene and 25% styrene. Park et al. (1989) found that SBR, which is commonly used in the water industry to joint pipes together, behaves like a sponge, absorbing extremely large amounts of hazardous organic chemicals from the surrounding environment. This can actually help alleviate the environmental impact from chemical contamination.
- The results of inorganic chemistry analyses show that shredded tires do not release any significant amounts of metals. Metals are not ingredients for tires except for the wire bead, which is designed to reinforce the tire. Thus, the only possible source of metals (if some appear in the analysis of the leaching test samples) may be when the tires are contaminated with hazardous materials during driving. Wire bead may release some metals if it is oxidized and corroded, but not a significant amount.
- BOD<sub>5</sub> (biochemical oxygen demand), COD (chemical oxygen demand), and concentrations of NO<sub>3</sub>-N and NO<sub>2</sub>-N for leaching test samples are lower than those for top soils, but may be higher than those for B or C horizon soils.
- The results of organic chemical analyses show that shredded tires do not release any significant amounts of priority organic pollutants.
- There is concern that some microorganisms may attack shredded tires. Further information is needed to determine whether or not this will cause a problem in highway applications.

Professors Edil and Park do not expect any significant impact on groundwater quality from using tire chips in buried applications (118).

Water samples obtained from a lysimeter placed under a tire chip embankment indicate that most of the determined parameters were within acceptable limits. The elevated magnesium concentration may be due to the geological formations in the area (114).

#### SUMMARY

A report prepared for Congress by the U.S. Department of Transportation and the Environmental Protection Agency (12,75) provides a summary of environmental, health, and safety issues relative to the use of crumb rubber modifiers in asphalt binders. Environmental risk assessment is an integration of four processes: hazard identification, dose-response assessment, exposure assessment, and risk characterization. The basic questions in regard to this process are:

1. Does the chemical produce adverse effects?
2. What is the relationship between dose and adverse effect?
3. What exposures occur or are anticipated?

TABLE TWENTY-FOUR  
ENVIRONMENTAL, HEALTH, AND SAFETY TESTING ASSOCIATED WITH ASPHALT-RUBBER BINDERS

Location	Date	Process	Plant Type	Comments	References
Florida	1993	Wet	Batch	Compared conventional and CRM HMA; some statistical differences between the two; Florida will continue to place CRM mixes	(119)
Michigan	1993	Dry		Test results not available	(70,72)
New Jersey	1992	Dry	Drum	CRM RAP used; Dry process CRM can be reduced within current air quality standards	(12),(75), (120),(71), (121)
Texas, Parmer Co.	1992	Wet	Drum	Large test variability; Little difference between conventional and CRM HMA	(12), (122)
Texas, San Antonio	1992	Wet	Drum	Large test result variability; some differences noted	(12),(123), (22)
California (NAPA)	1992	Wet	Batch	Few conclusions from pilot study	(12), (75), (124)
California (ARPG)	1988-90	Wet		Emission exposures in asphalt rubber operations did not differ from those of conventional operations	(125), (12), (75)
Ontario (Thamesville)	1991	Dry	Drum	Analysis not completed	(75)
Ontario (Haldimand-Norfolk)			Batch	Large test result variability; some differences noted	(12),(75), (126)
Netherlands				Site concentrations of fumes and PAH during production and hardline are below maximum acceptable concentrations	(76)

4. What is the estimated incidence of adverse effect at a given exposure?

These questions have not been answered in detail because of the limited number of studies that have been performed to date relative to the complexity of the issues involved in making the assessment. The complexity of the issues results from a number of factors, including those briefly discussed next (12).

**Complex Issues**

Asphalt cement is not a material with a known chemical composition. Asphalt is obtained by refining a wide variety of crude oils with a variety of processes. These differences in crude oil refinery processes produce asphalt with different chemical compositions.

Crumb rubber modifiers have been produced from a variety of waste and by-product rubbers and are not necessarily from whole tires. In addition, tires are manufactured from a number of rubbers

and chemicals depending on the tire use. This chemistry, while not as complex as that for asphalt, is variable and includes numerous chemical species.

Hot mix production facilities differ as to the type of plant including dryers, screening, blending, handling, weighing, transferring, storage, temperature, and air quality or emission control systems. These differing systems create and capture different chemical compounds at a variety of concentrations.

Differences between the various wet and dry processes for adding CRM to hot-mix asphalt can also be expected to contribute to the chemical compound variation at the production plant and lay down operation.

The FHWA/EPA report (12,75) states that “determining definite quantitative risks from asphalt or modified asphalts will be extremely difficult or impossible at this time. But, determining the relative comparative threats/risks of conventional asphalt pavements with those of CRM asphalt pavements can be done in a qualitative sense and primarily on a comparative risk basis.”

#### **FIELD TESTS**

Table 24 identifies 10 studies conducted to obtain environmental, health, and safety related data. Most of these studies were

conducted in the 1990s. The FHWA/EPA reviewed the results of most of these field tests and drew the following conclusions:

Intra-study differences in emission rates between conventional and modified asphalt paving mixtures were generally smaller than inter-study differences by factors of 10 to 100. This suggests that variables other than CRM may be more important determinants of emission rates for most chemicals. Risks associated with the release of most chemicals from conventional and modified asphalt pavements may not be significantly different. The one exception is methyl isobutyl ketone, which was consistently observed to be emitted during mixing of asphalt pavement modified with CRM, but not during mixing of conventional asphalt. These conclusions must be highly caveated with assumptions regarding the relationship between emission rates observed in these studies, and human health and environmental risks. (75)

Based on limited data, leachate studies conducted in both the laboratory and the field indicate the potential for environmental problems. Soil samples taken at waste tire stockpiles indicate that the stockpiles do not raise the soil's non-organic chemical contents. Tire stockpile areas may contain higher petroleum hydrocarbon concentrations than background soils. A limited number of emission studies have been conducted. Since exposure limits for fumes have not been established, health effects are difficult to estimate.



## CONCLUSIONS AND RECOMMENDATIONS

The conclusions and recommendations contained in this chapter are based on a literature review, a survey of state highway agency practice (1991), and on input received from the synthesis topic panel. Conclusions and recommendations are provided for the use of crumb rubber in asphalt paving materials; for other highway uses; and for environmental, health, and safety considerations.

### CRUMB RUBBER IN ASPHALT PAVING MATERIALS

Crumb rubber has been used in asphalt paving materials since the 1960s. Its use in joint and crack sealers, chip seals, interlayers, and hot-mix asphalt has been relatively slow to develop because of (1) high first costs, (2) the lack of conclusive engineering data with which to predict the performance of these binder systems, and (3) the lack of substantial field performance information to support claims of life-cycle cost advantages.

Formulations of CRM and asphalt have changed over the last 30 years. Thus, performance information has been reported for binder systems that are no longer used. Reported first costs for CRM binders are higher than anticipated future costs because of high mobilization costs, small project size, and contractor inexperience. First costs should be lower in the future as quantities increase, and as more cost-effective methods are developed to incorporate rubber in asphalt binders.

#### Conclusions

- CRM asphalt binders can be produced by either the wet or the dry process.
- CRM asphalt binders have been successfully used for joint and crack sealers, and in chip seals, interlayers, and hot mixes.
- The properties of CRM asphalt binders depend on the rubber type, size, and concentration; asphalt type and concentration; diluent types and concentration; and reaction temperature and time.
- Field performance of CRM asphalt binders used for joint and crack sealers and in chip seals, interlayers, and hot mixes has been mixed. This performance variability is due in part to poor design, project selection, and field quality control.
- Chip seal and interlayer applications have not been successful in reducing transverse and longitudinal reflection crack occurrence in asphalt pavements.
- Chip seals and interlayers have not been successful in stopping reflection cracks in portland cement concrete pavement overlays.
- Existing quality control and quality assurance methods have not been developed enough to ensure that the desired binder properties are obtained in the field.
- The cost effectiveness of CRM asphalt binders appears to be

marginal at current prices for a number of applications in a variety of climates.

#### Recommendations

- Desirable binder properties for joint and crack sealers, chip seals, interlayers, and hot mixes need to be better defined using existing or new tests. CRM asphalt binders that meet these properties need to be developed.
- Improved mixture design methods are needed for hot-mix applications. Hot mixes containing wet- and dry-processed binders need to be investigated using the Strategic Highway Research Program mixture tests.
- Better field quality control and quality assurance are needed to ensure that desirable binder and mixture properties are achieved.
- Carefully controlled experimental field sections need to be placed in different climatic regions in the United States to obtain performance data. Binder and mixture properties in these different regions need to be determined, and section performance monitored over a 5- to 30-year period.
- Detailed life-cycle cost analyses based on available information are needed. These should be compared with analyses of control sections and sections built with polymer-modified binders.
- CRM binders are used routinely in several states for specific rehabilitation activities. These applications need to be defined carefully and the information presented to other public agencies.
- Additional studies are needed to determine the recyclability of pavements containing CRM asphalt binders.
- Additional research is needed to define the properties of binders produced by both wet and dry processes.

#### OTHER HIGHWAY USES

Waste tires have been used successfully for a number of non-pavement highway applications, some of which used large quantities of tires.

#### Conclusions

- Chopped, shredded, and whole tires have been used successfully for a limited number of highway related applications including fills, embankments, erosion control devices, slope protection, safety hardware, and membranes.
- The quantity of tires used for these applications is small. Large quantities of scrap tires potentially can be used in fills and embankments.

- The performance of these uses is not well documented.
- The cost of these uses is not well documented.
- Environmental, health, and safety issues related to the use of waste tires for these applications need further research.

### Recommendations

- Design guides and manuals are needed to define nonpavement highway applications and to provide guide specifications.
- Performance and cost information on these uses needs to be documented.
- Lower-cost construction techniques need to be developed.

### ENVIRONMENT, HEALTH, AND SAFETY

Leachate studies conducted in the laboratory and in the field suggest the potential for environmental problems. The number of emission studies available is small and the findings inadequate to provide a satisfactory data base for environmental, health, and safety assessment. Exposure limits need to be established before the available emission studies can be properly evaluated.

### Conclusions

- Leachate studies conducted with tires in low and high pH water environments indicate that organic material and a number of metals can be leached. The concentrates of these organ-

ics and metals exceed certain health standards. The authors of these studies note that these laboratory leachate tests represent "worst case" conditions. Surface waters generally provide a large dilution factor.

- Field leachate studies have provided mixed results. Some studies have indicated higher metal and organic concentrations than exist in control sections.
- A Minnesota study suggests that potential environmental impacts from using waste tires in fills and embankments can be minimized by placing the tire materials only in unsaturated zones (above ground-water table).

An FHWA/EPA study (12) summarizes available environmental, health, and safety assessment information as follows:

Using the currently available information, we find there is no compelling evidence that the use of asphalt pavement containing recycled rubber substantially increases the threat to human health or the environment as compared to the threats associated with conventional asphalt pavements.

### Recommendations

- Additional laboratory and field leachate studies need to be conducted.
- Additional field studies to define environmental, health, and safety issues need to be conducted.
- Health and safety training courses need to be developed and delivered to the work force.

## REFERENCES

1. Hershey, R.L., M.D. Waugh, and E.T. Hanny, *Waste Tire Utilization*, Science Management Corporation; U.S. Department of Energy, April 1987.
2. *Markets for Scrap Tires*, U.S. Environmental Protection Agency, Office of Solid Wastes, Oct. 1991.
3. *Development of Governmental Procurement Guidelines for Construction Products Containing Recovered Materials—Section 11, Use of Waste Rubber in Highway Construction*, U.S. Environmental Protection Agency, Office of Solid Waste, Oct. 1979.
4. Pavlovich, R.D., Environmental Protection Agency Procurement Guidelines, presented at Scrap Tire Recycling and Vendor's Workshop, Fayetteville, North Carolina, Sept. 19, 1986.
5. Heitzman, M.A., *State of the Practice for the Design and Construction of Asphalt Paving Materials with Crumb Rubber Additive*, Report No. FHWA-SA-92-022, Office of Engineering, Pavement Division, Federal Highway Administration, May 1992.
6. Intermodal Surface Transportation Efficiency Act of 1991, Public Law 102-240, Dec. 18, 1991.
7. "ISTEA Section 1038 and Section 325 of HR 2750" Memorandum from Executive Director, Federal Highway Administration, November 2, 1993.
8. *Scrap Tire News*, Vol. 3, No. 5, Recycling Research Institute, Suffolk, Conn., Sept./Oct. 1989.
9. *Scrap Tire News*, Vol. 4, No. 4, Recycling Research Institute, Suffolk, Conn., July/Aug. 1990.
10. *Scrap Tire News*, Vol. 5, No. 1, Recycling Research Institute, Suffolk, Conn., Jan. 1991.
11. *Scrap Tire News, Special Report*, Recycling Research Institute, Suffolk, Conn., Jan. 1994.
12. *A Study of the Use of Recycled Paving Materials—Report to Congress*, Report No. FHWA-RD-93-147, Federal Highway Administration, June 1993.
13. McDonald, C.H., Recollections of Early Asphalt-Rubber History, presented at the National Seminar on Asphalt-Rubber, Oct. 1981.
14. Oliver, J.W.H., Modification of Paving Asphalts By Digestion with Scrap Rubber, in *Transportation Research Record 821*, Transportation Research Board, National Research Council, Washington, D.C. (1981).
15. Coley, J.O., *A Study of Flexible Pavement with Ramflex Rubber Additives*, Report No. 1, Mississippi State Highway Department, Dec. 1, 1970.
16. Shook, J.F., H.B. Takallou, and E. Oshinski, *Evaluation of Use of Rubber-Modified Asphalt Mixtures for Asphalt Pavements in New York State*, New York State Department of Transportation, Dec. 1989.
17. Takallou, H.B., and A. Sainton, Advances in Technology of Asphalt Paving Materials Containing Used Tire Rubber, in *Transportation Research Record 1339*, Transportation Research Board, National Research Council, Washington, D.C. (1992).
18. Eaton, R.A., R.J. Roberts, and R.R. Blackburn, Use of Scrap Rubber in Asphalt Pavement Surfaces, presented at ARA International Tire Recycling Conference, San Jose, Calif., Jan. 1991.
19. Ruth, B.E., *Evaluation of Ground Tire Rubber in Asphalt Concrete, Final Report*, Florida Department of Transportation, Jan. 1992.
20. Rosner, J.C., and J.G. Chehovits, *Chemical and Physical Properties of Asphalt-Rubber Mixtures—Phase III, Volume 4—Physical Properties of Field-Mixed Asphalt-Rubber Mixtures and Comparisons of Lab and Field-Mixed Asphalt Rubbers*, Report No. FHWA/AZ-82/159/4, Arizona Department of Transportation, June 1982.
21. Morris, G.R., Asphalt-Rubber Membranes: Development, Use, Potential, presented at Conference of the Rubber Reclaimers Association, Cleveland, 1975.
22. Schnormeier, R.H., Waste Tire Utilization for Improvement of Asphalt Pavements, presented at International Road and Bridge Maintenance/Rehabilitation Conference and Exposition, Atlanta, 1988.
23. *Asphalt-Rubber Aging Study*, Reports I-89-286, I-89-287, and I-90-34, Crafcoc Inc., Nov. 1989 and Feb. 1990.
24. Huff, B.J., and B.A. Vallergera, Characteristics and Performance of Asphalt-Rubber Material Containing A Blend of Reclaim and Crumb Rubber, in *Transportation Research Record 821*, TRB, National Research Council, Washington, D.C. (1981).
25. Chehovits, J., and M. Manning, Materials and Methods for Sealing Cracks in Asphalt Concrete Pavements, presented at the 63d Annual Meeting of TRB, Washington, D.C. 1984.
26. Thompson, V., The Use of Asphalt Rubber for Crack Sealing in Asphalt Concrete Pavements and Joint Sealing in Portland Cement Concrete Pavements, presented at the National Seminar on Asphalt Rubber, Oct. 1989.
27. McCullagh, F.R., and M. D'Souza, *ADOT's Joint Sealant Study*, Arizona Department of Transportation, ADOT A50001, 1985.
28. Peterson, D.E., *NCHRP Synthesis of Highway Practice 98: Resealing Joints and Cracks in Rigid Pavements*, TRB, National Research Council, Washington, D.C., 1982.
29. Olsen, R.E., *Rubber-Asphalt Binder for Seal Coat Construction*, Implementation Package 73-1, Federal Highway Administration, Feb. 1973.
30. Estakhri, C.K., E.G. Fernando, J.W. Button, and G.R. Teetes, *Use, Availability, and Cost-Effectiveness of Asphalt-Rubber in Texas*, Research Report No. 1902-1S, Texas Transportation Institute, 1991.
31. *Evaluation of Rubber-Asphalt Chip Seals in Oregon*, Interim Report, Oregon Department of Transportation, May 1977.
32. Beecraft, G., T.A. Hardy, and R.J. Steyskal, *Evaluation of Rubber-Asphalt Chip Seals in Oregon*, Final Report, Oregon Department of Transportation, Sept. 1982.
33. Murphy, K.H., and C.F. Potts, *Evaluation of Asphalt-Rubber as a Stress Absorbing Interlayer*, Report No. FHWA-DP-37-14, Florida Department of Transportation, Aug. 1980.
34. Brewer, W., *Discarded Tires in Highways using Precoated Aggregate, Kingfisher, Oklahoma*, Report No. FHWA/OK 82.4, Oklahoma Department of Transportation, Nov. 1982.

35. Way, G.B., *Prevention of Reflective Cracking, Minnetonka—East (1979 Addendum Report)*, Report No. 1979-GW1, Arizona Department of Transportation, Aug. 1979.
36. Turgeon, C.M., The Use of Asphalt-Rubber Products in Minnesota, presented at the National Seminar on Asphalt-Rubber, Oct. 1989.
37. Zaniewski, J.P., *Summary of Arizona Department of Transportation Experience with Asphalt-Rubber—State of the Art*, Report No. FHWA-AZ88-818, Arizona Department of Transportation, Aug. 1988.
38. Brewer, W.B., *Dense Graded Rubber Mixtures and Chemkrete*, Oklahoma Department of Transportation, Jan. 1984.
39. Schnormeier, R.H., Time Proves Asphalt-Rubber Seals Cost Effective, presented at the National Seminar on Asphalt-Rubber, Oct. 1981.
40. Epps, J.A., and B.M. Gallaway, Cost and Energy Associated with Asphalt-Rubber Binders, presented at the National Seminar on Asphalt-Rubber, Oct. 1981.
41. Jacobsen, C.C., and R.H. Schnormeier, Cost Effectiveness of Asphalt-Rubber, presented at the National Seminar on Asphalt-Rubber, Oct. 1989.
42. Allen, R.G., Bitumen Scrap Rubber Seals—Recent Developments, presented at 37th Conference of Municipal Engineers, Local Government Engineers Association of Victoria, Australia, March 1981.
43. Schofield, L., The History, Development, and Performance of Asphalt Rubber at ADOT, presented at the National Seminar on Asphalt-Rubber, Oct. 1989.
44. Shuler, T.S., R.D. Pavlovich, J.A. Epps, and C.K. Adams, *Investigation of Materials and Structural Properties of Asphalt-Rubber Paving Mixtures, Volume I—Technical Report*, Report No. FHWA/RD-86/027, Texas Transportation Institute, Sept. 1986.
45. Vallerga, B.A., and J.R. Bagley, *Design of Asphalt-Rubber Single Surface Treatments with Multi-Layered Aggregate Structure*, ASTM STP 724, Dec. 1979.
46. Jimenez, R.A., and W.P. Meier, Laboratory Evaluation of an Asphalt-Rubber SAL, in *Transportation Research Record 1034*, Transportation Research Board, National Research Council, Washington, D.C. (1985).
47. Morris, G.R., N.J. Chen, and J.A. DiVito, Application of Asphalt-Rubber on New Highway Pavement Construction, in *Transportation Research Record 888*, Transportation Research Board, National Research Council, Washington, D.C. (1982).
48. Coetzie, N.F., and C.L. Monismith, *An Analytical Study of the Applicability of a Rubber Asphalt Membrane to Minimize Reflection Cracking in Asphalt Concrete Overlay Pavements*, Department of Civil Engineering, University of California, Berkeley, June 1978.
49. Coetzie, N.F., and C.L. Monismith, Analytical Study of Minimization of Reflection Cracking in Asphalt Concrete Overlays by Use of a Rubber-Asphalt Interlayer, in *Transportation Research Record 700*, Transportation Research Board, National Research Council, Washington, D.C. (1979).
50. Mills, D.R., A.D. Donofrio, and T.J. Keller, *Discarded Tires in Highway Construction—Bethany Beach, Delaware*, Report No. FHWA-DP-37-16, Delaware Division of Highways, Feb. 1981.
51. Schnormeier, R.H., Use of Asphalt-Rubber on Low-Cost, Low-Volume Streets: A Review After 13 Years, in *Transportation Research Record 898*, Transportation Research Board, National Research Council, Washington, D.C. (1983).
52. Ravn, T., R. Cassellius, and R. Olson, *Methods and Materials for Reducing Crack Reflectance*, Report No. 1, Investigation No. 202, Minnesota Department of Transportation, 1987.
53. Murphy, K.H., and C.F. Potts, *Evaluation of Asphalt-Rubber as a Stress Absorbing Interlayer and a Binder for Seal Coat Construction (SR 60, Hillsborough County)*, Florida Department of Transportation, June 1980.
54. Anderson, K.W., and N.C. Jackson, *Rubber-Asphalt Pavements in the State of Washington*, Report No. WA-RD-2681, Washington State Department of Transportation, March 1992.
55. Gupta, P.K., *Asphalt-Rubber Surface Treatments and Interlayers*, Report No. FHWA/NY/RR-86/131, New York Department of Transportation, March 1986.
56. Steiner, A., 1993 Crumb Rubber Modifier (CRM) AASHTO Survey Result Summarization, memo to Standing Committee on Highways, AASHTO, April 1, 1993.
57. Chehovits, J.G., Design Methods for Hot-Mixed Asphalt-Rubber Concrete Paving Materials, presented at the National Seminar on Asphalt-Rubber, Oct. 1989.
58. Stroup-Gardiner, M., N. Krutz, and J.A. Epps, Comparison of Mix Design Methods for Rubberized Asphalt Concrete Mixtures, presented at the National Seminar on Asphalt-Rubber, Oct. 1989.
59. Roberts, F.L., R.L. Lytton, and D.M. Hoyt, *Criteria for Asphalt-Rubber Concrete in Civil Airport Pavements: Mixture Design*, Report No. DOT/FAA/PM-88/39, Texas Transportation Institute, July 1986.
60. Roberts, F.L., and R.L. Lytton, FAA Mixture Design Procedure for Asphalt-Rubber Concrete, presented at the 66th Annual Meeting of TRB, Washington, D.C. 1987.
61. Roberts, F.L., P.S. Kandhal, E.R. Brown, and R.L. Dunning, *Investigation and Evaluation of Ground Tire Rubber in Hot Mix Asphalt*, National Center for Asphalt Technology, Aug. 1989.
62. Hicks, R.G., K. Martin, and J.E. Wilson, *Evaluation of Asphalt Additives: Lava Butte Road—Fremont Highway Junction*, Report No. FHWA-OR-OD-87-03, Oregon State Highway Division, June 1987.
63. Van Kirk, J.L., *The Effect of Fibers and Rubber on the Physical Properties of Asphalt Concrete*, Report No. CA/TL-85/18, California Department of Transportation, June 1986.
64. Krutz, N.C. and M. Stroup-Gardiner, *Permanent deformation Characteristics of Recycled Tire Rubber Modified and Unmodified Asphalt Concrete Mixtures*, Asphalt Rubber Producers Group, University of Nevada, Aug. 1991.
65. Maupin, G.W., Virginia's experimentation w/Asphalt Rubber Concrete, in TRR 1339 '92.
66. LaGrone, B.D., Rubber Used in Asphalt-Rubber Applications, presented at National Seminar on Asphalt-Rubber, Oct. 1981.
67. *Open-Graded and Dense-Graded Mixes with Asphalt Rubber*, ESSO Belgium, 1984.
68. Krutz, N.C., and M. Stroup-Gardiner, *Low Temperature Cracking Characteristics of Ground Tire Rubber and Unmodified Asphalt Concrete Mixtures*, University of Nevada; Asphalt Rubber Producers Group, Sept. 1991.
69. Sarsam, J.B., and G.R. Morris, The Three Layer System on

- Arizona Highways—Development and Analysis, presented at 21st Idaho Asphalt Conference, Nov. 1982.
70. "Michigan DOT Evaluates Rubber Asphalt," *Asphalt*, The Asphalt Institute, Vol. 7, No. 3, Winter 1993-1994.
  71. Connolly, E. and A. Sutton, *Rubberized RAP Recycling—Ferry Street, Newark, New Jersey*, New Jersey Department of Transportation, August 1992.
  72. Flynn, L., "Asphalt Rubber Recycling? State Tests will Shed Light," *Roads and Bridges*, Jan. 1994.
  73. Aurilo, V., Recycling Crumb Rubber Modified Mixtures, presented at the 72d Annual Meeting of TRB, Washington, D.C. 1993.
  74. *Rubber Grade Crossing Application Guide*, Omni Rubber Grade Crossing Systems, Portland, Oregon.
  75. Bloomquist, D., G. Diamond, M. Odin, B. Ruth and M. Tia, *Engineering and Environmental Aspects of Recycled Materials for Highway Construction*, Report No. FHWA-RD-93-088, Federal Highway Administration, June 1993.
  76. Heerkens, J. and C. Jonker, The Application of Rubber-Bitumen in the Netherlands, EAM, March 19, 1993.
  77. Sainton, A., Hot In-Place Recycling of Silted Porous Asphalt-Rubber Concrete Implemented in the North of France, *The Rebounder*, Vol. 7, No. 1, Winter 1991.
  78. Kennepohl, G.J., *Scrap Tire Applications in Ontario's Transportation Industry*, Ontario Ministry of Transportation, PAV-92-08, Dec. 1992.
  79. Noise Reduction with Asphalt-Rubber, *The Rebounder*, Vol. 6, No. 3, Summer 1990.
  80. West, R.C., and J.A. Musselman, *Extraction Testing of Asphalt Concrete Mixtures Containing Ground Tire Rubber, Bituminous Materials Study 89-4*, Florida Department of Transportation, June 16, 1989.
  81. Investigate Extraction Test Method for Rubberized AC, Memo to R.A. Forsyth from T. Fellenz, California Department of Transportation, June 10, 1988.
  82. Effect of Rubber on Tests for Binder Content Using the Troxler Nuclear Gage Model 3241, Memo to R.W. Dotz, California Department of Transportation, Dec. 2, 1988.
  83. Estakhri, C.K., J.W. Button, and E.G. Fernando, Use Availability and Cost-Effectiveness of Asphalt Rubber in Texas, in *Transportation Research Record 1339*, Transportation Research Board, National Research Council, Washington, D.C. (1992).
  84. "Virginia Embankment: Where the Rubber Really Meets the Road," *Engineering News Record*, Sept. 20, 1993.
  85. Discarded Tires Find New Life in an Embankment Along I-76, *Research Newsletter*, Colorado Department of Highways, Feb. 1991.
  86. Geisler, E., W.K. Cody, and M.K. Niemi, Tires for Subgrade Support, presented at the Annual Conference on Forest Engineering Meeting, Coeur D'Alene, Idaho, Aug. 1989.
  87. Use of Tire-Derived Products as Lightweight Subgrade Fill Materials in the CSAH Project, letter to D.C. Carlson from D.B. Thompson of Minnesota Pollution Control Agency, Oct. 5, 1989.
  88. Twin City Testing Corporation, *Waste Tires in Sub-grade Road Beds*, Minnesota Pollution Control Agency, Feb. 19, 1990.
  89. Coos Bay Highway has Tires on Both Sides of the Pavement, *The Oregon Civil Engineer*.
  90. New Life for Old Tires, *AASHTO Quarterly*, Jan. 1991.
  91. Read, J., T. Dodson, and J. Thomas, *Experimental Project use of Shredded Tires for Lightweight Fill, Post Construction Report*, Oregon Department of Transportation, Feb. 1991.
  92. Frascoia, R.I., *Use of Tire Chips in a Georgia Vermont Town Highway Base*, Research Update U91-06, Vermont Agency of Transportation, April 17, 1991.
  93. Bressette, T., *Used Tire Material as an Alternate Permeable Aggregate*, Report No. FHWA/CA/TL-84/07, California Department of Transportation, June 1984.
  94. Bosscher, P.J., T.B. Edil, and N.N. Eldin, Construction and Performance of a Shredded Waste Tire Test Embankment, in *Transportation Research Record 1345*, Transportation Research Board, National Research Council, Washington, D.C. (1992).
  95. Williams, J., and D. Weaver, *Guidelines for Using Recycling Tire Carcasses in Highway Maintenance*, Report No. FHWA/CA/TL-87/07, California Department of Transportation, May 1987.
  96. Nguyen, M.X., and J.A. Williams, *Implementation Package for Using Discarded Tires in Highway Maintenance*, Report No. CA/TL-89/10, California Department of Transportation, June 1989.
  97. *Use of Discarded Tires in Highway Maintenance*, Translab Design Information Brochure No. TL/REC/1/88, California Department of Transportation.
  98. Winters, P., *Use of Tire Chips in a Highway Embankment*, Research Update U91-5, Vermont Agency of Transportation, April 8, 1991.
  99. *Use of Tire Sidewalls as Slope Reinforcement*, Louisiana Department of Transportation.
  100. *Special Provisions for Construction on State Highway in Contra Costa County, District 04, Route 24*, California Department of Transportation, April 30, 1990.
  101. Way, G.B., *Dewey-Yarber Wash, Membrane Encapsulated Subgrade Experimental Project*, FHWA Contract DOT-FH-15-186, Arizona Department of Transportation, Aug. 1982.
  102. Frobel, R.K., R.A. Jimenez, and C.B. Cluff, *Laboratory and Field Development of Asphalt-Rubber for Use as a Waterproof Membrane*, Report No. ADOT-RS-14 (167), Arizona Department of Transportation, July 1977.
  103. Forstie, D., H. Walsh, and G. Way, Membrane Technique for Control of Expansive Clays, in *Transportation Research Record 705*, Transportation Research Board, National Research Council, Washington, D.C. (1979).
  104. New Products, *Signal*, American Traffic Safety Services Association, Inc., March 1991.
  105. *Workshop on Composite Materials and Recycled Materials for Roadside Safety Hardware, Final Report*, Federal Highway Administration, Oct. 31, 1991.
  106. Lane, K.R., *Installation of a Sand-Tire Inertial Barrier System in Connecticut*, Connecticut Department of Transportation, Aug. 1975.
  107. Button, E.F., *Performance of a Tire-Sand Inertial Barrier System in Connecticut—Final Report*, Report No. FHWA-CT-RD-343-F-77-6, Connecticut Department of Transportation, May 1977.
  108. A Cure for Valvebox Depression, *APWA Reporter*, Sept. 1989.
  109. *OMNI Valve Box Cushion*, Omni Rubber Products Inc., Portland, Oregon.

110. Roadway Mat and Methods for Its Construction, Patent No. 4,850,738, U.S. Patent Office, July 25, 1989.
111. Coffin, J.H., Laminated Rubber Planks, information supplied by California Department of Transportation.
112. Collins, R.J., *Recycling and Use of Waste Materials and By-Products in Highway Construction*, NCHRP Synthesis of Highway Practice, Project 20-5, Topic 22-10, National Cooperative Highway Research Program, Transportation Research Board, National Research Council, Washington, D.C., Dec. 1992.
113. Memo from S.A. Sabol of NCHRP on Whole Truck Tires Used as Culvert, based on meeting with C. Bocash of Town of Georgia, Vermont, Oct. 2, 1992.
114. Tirelessly Cleaning the Environment, *Minnesota Technology*, Vol. II, No. II, Second Quarter, 1992.
115. Memo from Robert Grefe, State of Wisconsin DNR to Tuncer Edel, University of Wisconsin, titled Waste Characterization Recommendations for Waste Tires, Jan. 31, 1989.
116. Shredded Tires for Landfills as Flow-Zone Material, by JACA Corporation to Domino Salvage, Inc., April 11, 1988.
117. General Letter from Minnesota Pollution Control Agency, March 16, 1990.
118. Waste Characterization of Tire Chips, letter to M. Niemi from T.B. Edil, Geotechnical Consultant, Madison, Wisconsin, Oct. 13, 1989.
119. Hicks, J., K. Work, and N. Drew, "Occupational Exposure Assessment of Asphalt, Ground Tire Rubber, Blending, Mixing and Paving Operations," Vol.1, Florida Department of Transportation, May 28, 1993.
120. Smith, R.J., "Recycling PlusRide Paving Mixtures—Ferry Street, Newark, New Jersey," New Jersey Department of Transportation, September 1992.
121. Brown, T.P., *Stack Sampling Report for the Asphalt Plant Stack Outlet at Mount Hope Rock Products*, Project 6219, Air Recon., Wharton, New Jersey, Sept. 1992.
122. Stack Emissions Survey, Parmer County, Texas, Duinick Brothers, Inc., Western Environmental Services, Inc., September 1992.
123. Air Pollutant Emissions Testing at Asphalt Plant Baghouse Stack—San Antonio, Texas Facility, Southwestern Laboratories, July 1992.
124. Asphalt Rubber Fume Pilot Study, National Asphalt Producers Association, March 1993.
125. Chapman, Q.R., Environmental Impact of Rubberized Asphalt, letter to Susan Mayer, Congressional Research Services, Library of Congress, March 17, 1993.
126. Rinck, G., and D. Napier, *Exposure of Pairing Workers to Asphalt Emissions (When Using Asphalt-Rubber Mixes)*, Asphalt-Rubber Producers Group, 1991.

## BIBLIOGRAPHY

### A: SEAL COATS

- Bergh, A.O., Uses and Field Control, presented at the Annual Transportation Conference, South Africa, Aug. 1984.
- Dlamini, M.A.V., and R.H. Renshaw, A Case Study: The Cost Effective Use of Bitumen-Rubber on Municipal Roads in Mbabane, Swaziland, presented at 5th Conference on Asphalt Pavements for Southern Africa, Swaziland, June 1989.
- Meier, W.R., M. Post, and E. Elnicky, *Laboratory Testing for Aggregate Chip Precoating and Chip Retention for Asphalt-Rubber Chip Seals*, Western Technologies, Inc., Sept. 1985.
- Rust, F.C., V.P. Servas, and N. van der Walt, Performance of Various Modified Binders in Road Trials and Under Simulated Crack Movement in the Laboratory, presented at 5th Conference on Asphalt Pavements for Southern Africa, Swaziland, June 1989.
- Semmelink, C.J., Rational Design of Bitumen-Rubber Seals According to the NTIR Method Using the Modified Tray Test, presented at 5th Conference on Asphalt Pavements for Southern Africa, Swaziland, June 1989.
- Watson, M.J., and L.K. Davidson, Roadmix Experience in Bitumen-Rubber, presented at the Annual Transportation Conference, South Africa, Aug. 1984.

### B: INTERLAYERS

- Allison, R.E., *Rubber Asphalt Binder Stress Absorbing Membrane Interlayers*, Report No. WA-RD-185.1, Washington Department of Transportation, March, 1989.
- Anderson, K.W., *Rubber-Asphalt Binder Stress Absorbing Membrane Interlayer*, Materials Office Report No. 187, Washington Department of Transportation, Dec. 1983.
- Anderson, K.W., *SAMI and Heavy Duty Bituthene Reflection Crack Prevention Study*, Materials Office Report No. 186, Washington Department of Transportation, Dec. 1983.
- Galloway, B.M., and B.D. LaGrone, Use of Rubber Aggregate in a Strain Relieving Interlayer for Arresting Reflection Cracks in Pavements, presented at International Symposium on Use of Rubber in Asphalt Pavements, Salt Lake City, Utah, May 1971.
- Hardy, T.A., L.G. Bruck, and G. Beecroft, *Stress Absorbing Membrane Interlayer, Final Report*, Oregon Department of Transportation, April 1985.
- Jimenez, R.A., and W.R. Meier, *Laboratory Evaluation of Anti-Reflection Cracking Material*, Report No. FHWA/AZ-83/186, Arizona Department of Transportation, Dec. 1983.
- Jimenez, R.A., G.R. Morris, and D.A. DaDeppo, *Tests for a Strain-Attenuating Asphaltic Material*, Association of Asphalt Paving Technologists, 1979.
- Kekwick, S.V., HVS Evaluation of Proposed Rehabilitation Measures for the Warden-Villius Section on National Route N3, presented at the Annual Transportation Conference, Southern Africa, Aug. 1984.
- Molenaar, A.A.A., J.C.P. Heerkens, and J.H.M. Verhoeven, *Effects of Stress Absorbing Membrane Interlayers*, Association of Asphalt Paving Technologists, 1986.

- Newcomb, D.E., and R.G. McKeen, *Development of Criteria for the Use of Asphalt-Rubber as a Stress-absorbing Membrane Interlayer*, Report ESL-TR-83-50, Air Force Engineering and Services Center, Tyndall Air Force Base, Dec. 1983.
- Peters, A.J., and R.L. Schultz, *Asphalt-Rubber Binder Stress Absorbing Membrane Interlayers*, Report No. WA-RD-128.1, Washington Department of Transportation, July 1987.
- Sherman, G., *Minimizing Reflection Cracking of Pavement Overlays*, NCHRP Synthesis No. 92, National Cooperative Highway Research Program, Transportation Research Board, National Research Council, Washington, D.C., Sept. 1982.
- Strauss, P.J., and N. van der Walt, Stress Absorbing Membranes and Flexible Asphalt Overlays to Prevent Reflection Cracking at Joints or Cracks in Stiff Pavements, presented at 5th Conference on Asphalt Pavements for Southern Africa, Swaziland, June 1989.
- Thin Three-Layer Highway Overlay Resists Abuse, *Engineering News Record*, Feb. 20, 1986.
- Vallerga, B.A., G.R. Morris, J.E. Huffman, and B.J. Huff, *Applicability of Asphalt-Rubber Membranes in Reducing Reflection Cracking*, Association of Asphalt Paving Technologists, 1980.

### C: DENSE-GRADED HOT MIXES

- Adams, J.F., *Laboratory Evaluation of Asphalt-Rubber in Asphalt Paving Mixtures*, Report No. MLR-89-15, Iowa Department of Transportation, April 1990.
- Allison, R.E., *Plusride Asphalt Concrete Pavement*, Report No. WA-RD 130.2, Washington Department of Transportation, Jan. 1990.
- Anderson, J.L., *Plusride and BoniFibers Pavement Evaluation: SR-530, Stanwood Vic.*, Report No. 147.1, Washington Department of Transportation, Sept. 1987.
- Asphalt-Rubber is Compared with Standard Asphalt, *The Rebounder*, Vol. 6, No. 4, Fall 1990.
- Asphalt Rubber Hot Mix-Gap Graded Thickness Determination Guide*, California Department of Transportation, Feb. 28, 1992.
- Bergh, A.O., H.C. Thompson, and A. Nel, Bitumen Rubber Asphalt (Dry Process), presented at 5th Conference on Asphalt Pavements for Southern Africa, Swaziland, June 1989.
- Bardet, J.G., The Use of Rubber Bitumen in Road Construction, presented at the National Seminar on Asphalt-Rubber, Oct. 1989.
- Cano, J.O., and E. Charania, Gap-Graded Asphalt-Rubber Hot Mix Used in the City of Phoenix, Arizona, presented at International Rubber Works Congress, Boston, Mass., Sept. 1992.
- Cano, J.V., E. Charania, and D.C. Wong, Gap-Graded Asphalt-Rubber Mix in the City of Phoenix, presented at 4th Annual Conference and Road Show, San Antonio, Texas, Dec. 1990.
- Carey, D.E., *A Laboratory Evaluation of Rubber-Asphalt Paving Mixtures*, Report No. 79, Louisiana Department of Highways, June 1974.
- Eaton, R.A., R.J. Roberts, and R.R. Blackburn, *Use of Scrap Rubber in Asphalt Pavement Surfaces*, Special Report 91-27, U.S. Army Corps of Engineers, Dec. 1991.

- Esch, D.C., *Asphalt Pavements Modified with Coarse Rubber Particles—Design, Construction and Ice Control Observations*, Report No. FHWA-AK-RD-85-07, Alaska Department of Transportation, Aug. 1984.
- Fager, G.A., *Asphalt-Rubber Hot Mix Overlay*, FHWA Experimental Project No. 3, Kansas Department of Transportation, Dec. 1990.
- Hoyt, D.M., R.L. Lytton, and F.L. Roberts, *Criteria for Asphalt-Rubber Concrete in Civil Airport Pavements; Vol. II-Evaluation of Asphalt-Rubber Concrete*, Report No. DOT/FAA/PM-86/39, II, Federal Aviation Administration, March 1987.
- Hoyt, D.M., R.L. Lytton, and F.L. Roberts, Performance Prediction and Cost-Effectiveness of Asphalt-Rubber Concrete in Airport Pavements, TRB 1988.
- Hoyt, D.M., and R.L. Lytton, Laboratory Behavior, Performance Prediction and Cost-Effectiveness of Asphalt-Rubber Concrete in Airport Pavements, presented at the National Seminar on Asphalt-Rubber, Oct. 1989.
- Hugo, F., and R. Nichenius, Some Methods of Evaluating Bitumen Rubber Asphalt and Binders, presented at 5th Conference on Asphalt Pavements for Southern Africa, Swaziland, June 1989.
- Hugo, F., and R. Nachenius, *Some Properties of Bitumen-Rubber Asphalt and Binders*, Association of Asphalt Paving Technologists, 1989.
- Jimenez, R.A., Laboratory Measurements of Asphalt-Rubber Concrete Mixtures, in *Transportation Research Record 843*, TRB, National Research Council, Washington, D.C., 1982.
- Jimenez, R.A., *Testing of Asphalt-Rubber and Aggregate Mixtures*, Report No. FHWA/AZ-79/111, Arizona Department of Transportation, Oct. 1979.
- Jimenez, R.A., *Testing Methods for Asphalt-Rubber*, Report No. ADOT-RS-15(164)-Final Report-Phase 1, Arizona Department of Transportation, Jan. 1978.
- Kirk, T., Asphalt-Rubber Hot Mix Investigation by Test Section for Reflection of Fatigue Cracks, presented at the National Seminar on Asphalt-Rubber, Oct. 1989.
- Krutz, N.C., *Executive Summary of Research Conducted at the University of Nevada for the Asphalt Rubber Producers Group*, University of Nevada, Reno, 1992.
- Krutz, N.C., and M. Stroup-Gardiner, Permanent Deformation Characteristics of Recycled Tire Rubber-Modified and Unmodified Asphalt Concrete Mixtures, in *Transportation Research Record 1339*, Transportation Research Board, National Research Council, Washington, D.C. (1992).
- Krutz, N.C., and M. Stroup-Gardiner, *Permanent Deformation Characteristics of Recycled Tire Rubber Modified and Unmodified Asphalt Concrete Mixtures*, University of Nevada; Asphalt Rubber Producers Group, Aug. 1991.
- Laboratory Evaluation of Verglimit and Plusride*, Publication No. FHWA-RD-91-013, Federal Highway Administration, Feb. 1991
- LaRorce, R.F., *Rubber Modified Asphalt Concrete*, Report No. ODOH-SMB-R-87-15, Colorado Department of Highways, Dec. 1987.
- Lundy, J.R., and R.G. Hicks, *Evaluation of Rubber-Modified Asphalt Pavement Performance—Mt. St. Helens Project*, Association of Asphalt Paving Technologists, Vol. 56, 1987.
- Maupin, G.W., Virginia's Experimentation with Asphalt Rubber Concrete, in *Transportation Research Record 1339*, Transportation Research Board, National Research Council, Washington, D.C. (1992).
- McRae, J.L., and B.D. LaGrone, Effect of Modified Reclaimed Rubber and Ground Vulcanized Rubber on the Physical Properties of Bitumen Pavements as Evaluated by the Gyrotory Testing Machines, in *Transportation Research Record 361*, Transportation Research Board, National Research Council, Washington, D.C. (1971).
- Page, G.C., Florida's Initial Experience Utilizing Ground Tire Rubber in Asphalt Concrete Mixes, presented at the National Seminar on Asphalt-Rubber, Oct. 1989.
- Page, G.C., B.E. Ruth, and R.C. West, Florida's Approach Using Ground Tire Rubber in Asphalt Concrete Mixtures, in *Transportation Research Record 1339*, Transportation Research Board, National Research Council, Washington, D.C. (1992).
- Peters, A.J., and R.L. Schultz, *PlusRide Asphalt Pavement, SR-82*, Report No. WA-RD-127.1, Washington Department of Transportation, Sept. 1987.
- Piggott, M.R., and R.T. Woodhams, *Recycling of Rubber Tires in Asphalt Paving Materials*, University of Toronto; Environmental Canada, March 1979.
- Roberts, F.L., P.S. Kandhal, E.R. Brown, and R.L. Dunning, *Investigation and Evaluation of Ground Tire Rubber in Hot Mix Asphalt*, National Center for Asphalt Technology, Auburn University; Florida Department of Transportation, Aug. 1989. (Also F36)
- Shook, J.F., *Experimental Construction of Rubber-Modified Asphalt Mixtures for Asphalt Pavements in New York State*, ARE, Inc.; New York State Department of Transportation, May 16, 1990.
- Solberg, C.E., and D.L. Lyford, Recycling with Asphalt-Rubber, presented at the National Seminar on Asphalt-Rubber, Oct. 1989.
- Stephens, J.E., and S.A. Mokrezewshi, *The Effect of Reclaimed Rubber on Bituminous Paving Mixtures*, Report No. CE 74-75, University of Connecticut, March 1974.
- Stuart, E., *Effects of Rubber Additives in Asphalt Concrete*, U.S. Forest Service, Region 5, Dec. 1965.
- Stuart, K.D., and W.S. Mogawer, *Laboratory Evaluation of Verglimit and Plusride*, Report No. FHWA-RD-91-013, Federal Highway Administration, March 1991.
- Stuart, K.D., and W.S. Mogawer, Laboratory Evaluation of Verglimit and PlusRide, *Public Roads*, Vol. 55, No. 3, Dec. 1991.
- Takallou, H.B., and R.G. Hicks, Development of Improved Mix and Construction Guidelines for Rubber Modified Asphalt Pavements, presented at 73rd Annual Meeting of TRB, Washington, D.C. 1988.
- Takallou, H.B., R.G. Hicks, and D.C. Esch, Effect of Mix Ingredients on the Behavior of Rubber-Modified Asphalt Mixtures, *Transportation Research Record 1096*, Transportation Research Board, National Research Council, Washington, D.C. (1986).
- Takallou, H.B., R.G. Hicks, and D.C. Esch, Use of Rubber Modified Asphalt Pavements in Cold Regions, presented at Workshop on Paving in Cold Areas, Ottawa, Ontario, Canada, July 1987.
- Takallou, M.B., R.D. Layton, R.G. Hicks, and J. Lund, An Overview of Alternative Surfacing for Forest Roads, in *Transportation Research Record 1106*, Transportation Research Board, National Research Council, Washington, D.C. (1987).

#### D: OPEN-GRADED HOT MIXES

- Anderson, K.W., *Asphalt-Rubber Open-Graded Friction Course, I-5, Vancouver Vicinity*, Report No. WA-RD—131.1, Washington Department of Transportation, Sept. 1987.



Potgieter, C.J., P. Botha, R.H. Renshaw, and O. Lieckerman, Bitumen-Rubber Asphalts and Seals—A Report on Full Scale Applications, presented at 5th Conference on Asphalt Pavements for Southern Africa, Swaziland, June 1989.

## E: GENERAL

- A.D. Little Inc., *Marketing Development Strategies for Recyclable Materials—Batteries, Waste Paper, Plastics, Ferrous Auto Scrap, Tires*, New Jersey Department of Environmental Protection, July 1989.
- A.D. Little Inc., *Recycling Handbook for Selected Materials—Batteries, Waste Paper, Plastics, Ferrous Auto Scrap, Tires*, New Jersey Department of Environmental Protection, March 1989.
- Ahmed, I., *Use of Waste Materials in Highway Construction*, Report No. FHWA/IN/JHRP-91/3, Joint Highway Research Program, Purdue University, Jan. 21, 1991.
- Amirkhanian, S.N., *A Feasibility Study of the Use of Waste Tires in Asphaltic Concrete Mixtures*, Report FHWA-SC-92,04, Clemson University, May 1992.
- Asphalt Rubber: Potential for Tougher Road, *Construction Engineer*, Feb. 1991.
- Asphalt-Rubber: State-of-the-Art, *Highway & Heavy Construction*, May 1989.
- Asphalt-Rubber Fact Sheet*, Manhole Adjusting Inc.
- Asphalt-Rubber, The Product and Its Uses, presented at Tri-Regional Pavement Rehabilitation Workshop, Federal Highway Administration, Oklahoma City, May 1984.
- Asphalt Rubber System, marketing information.
- Bitumen-Rubber: Review of Development in South Africa, symposium presented by the National Institute for Transport and Road Research and by the Road Industry, South Africa, Aug. 1984.
- Chamberlin, W.P., and P.K. Gupta, *Use of Scrap Automobile Tire Rubber in Highway Construction*, Special Report 85, N.Y. Department of Transportation, May 1986.
- Clemmer, H.F., N.G. Smith, and L.E. Gregg, Rubber in Bituminous Pavements, *Technical Bulletin No. 194*, America Road Builders Association, 1953.
- Collins, R.J., *Waste Materials and By-Products*, NCHRP Synthesis Topic 22-10, draft, National Cooperative Highway Research Program, Transportation Research Board, National Research Council, Washington, D.C., 1992.
- Collins, R.J., Availability and Uses of Wastes and By-Products in Highway Construction, presented at Transportation Research Board, Jan. 1992.
- Comprehensive Review of Feasible Alternatives of Utilizing Recyclable Materials in Construction*, Report to 115th Legislature, Maine Department of Transportation, Jan. 1991.
- Diringer, K.T., *The Use of Discarded Tires and Reclaimed Rubber in Highway Construction and Maintenance*, Report No. FHWA/NJ 86-003, New Jersey Department of Transportation, Sept. 1985.
- Epps, J.A., and B.M. Gallaway, Workshop Summary, presented at 1st Asphalt-Rubber User-Producer Workshop, May 1980.
- An Evaluation of Asphalt-Rubber Mixtures for Use in Pavement Systems*, Air Force Engineering and Services Center, Tyndall Air Force Base, April 1979.
- Goddard, H.C., Incentives for Solving the Scrap Tire Problem Through Existing Markets, *Journal of Hazardous Materials*, No. 29, 1992.
- Heitzman, M., Design and Construction of Asphalt Paving Materials with Crumb Rubber Additive, in *Transportation Research Record 1339*, Transportation Research Board, National Research Council, Washington, D.C. (1992).
- How to Turn 41 Million Problems into a 60,000 Mile Solution*, Manhole Adjusting Contractors Inc.
- Huffman, J.E., *The Use of Ground Vulcanized Rubber in Asphalt*, ASTM STP 724, 1979.
- International Surfacing Inc., markets information.
- Jury Remains Out on Asphalt-Rubber Use, *Roads and Bridges*, Dec. 1992.
- McDonald, C.H., Rubberized Asphalt Pavements, presented at the 58th Annual Meeting of American Association of State Highway Officials, Phoenix, Dec. 1972.
- Morgan, R.D., and J. Rugg, *Asphalt Rubber-Update*, Special Report, National Asphalt Pavement Association, May 1992.
- Morris, G., Asphalt-Rubber Development, Field Experience, and Research in Arizona, presented at 1st Asphalt-Rubber User-Producer Workshop, May 1980.
- Morris, G., Asphalt Rubber Overlay Systems, presented at International Road and Bridge Maintenance/Rehabilitation Conference and Exposition, Atlanta, 1988.
- Nielsen, D.L., Bitumen-Rubber in the United States—Its Origin, Cost Effectiveness, Durability, and New Uses, presented at Pyhrn Autobahn AG International Conference, Graz, Austria, 1988.
- Oliver, J.W.H., *A Critical Review of the Use of Rubbers and Polymers in Bitumen Bound Paving Materials*, Project No. AIR 1037-1, Australian Road Research Board Internal Report, March 1977.
- Pennoni Associates Inc., *Implementation of Mandatory Recycling for Use in Pennsylvania Transportation System, Final Report*, Pennsylvania Department of Transportation, Oct. 15, 1989.
- Polson, R., Old Tires Bounce Back in New Roads, *The Rebounder*, Vol. 6, No. 3, Summer 1990.
- Proceedings of the 1st Asphalt-Rubber User-Producer Group*, Scottsdale, Ariz., May 7-8, 1980.
- Proceedings of the National Seminar on Asphalt-Rubber*, Kansas City, Mo., Oct. 30-31, 1989.
- Renshaw, R.H., Bitumen-Rubber: Its Introduction and Development in South Africa, presented at the Annual Transportation Conference, South Africa, Aug. 1984.
- The Road to Less Waste: Recycling New York State's Scrap Tires into Asphalt Paving Material*, Legislative Commission on Solid Waste Management, New York, Jan. 1991.
- Ruth, B.E., *Executive Summary of Information Compiled for Investigations and Demonstration Projects Pertaining to the Use of Ground Tire Rubber in Highway Construction*, Florida Department of Transportation, Jan. 1991.
- "A Report on the Problems and Possible Solutions to Disposing of or Recycling Used Tires as Required by House Resolution #37 in the 1973 Session of the Legislature," Caltrans Transportation Laboratory, Jan. 1975.
- Scofield, L.A., *The History, Development, and Performance of Asphalt Rubber at ADOT*, Report No. AZ-SP-8902, Arizona Department of Transportation, Dec. 1989.
- Scrap Tire Use/Disposal Study*, Scrap Tire Management Council, Sept. 11, 1990.
- SCS Engineers, *Illinois Scrap Tire Management Study*, Report No. ILENR/RR-89/04, Illinois Department of Energy and Natural Resources, Oct. 1989.

- Study of Asphalt Cement Additives and Extenders*, Roads and Transportation Association of Canada, Jan. 1983.
- Summary of Markets for Scrap Tires*, Report No. EPA/530-SW-90-074B, U.S. Environmental Protection Agency, Oct. 1991.
- The Use of Discarded Rubber in Highway Construction—A Transportation Perspective*, Georgia Department of Transportation, Oct. 24, 1990.
- The Use of Rubber Bitumen in Road Construction—Draining Mixes*, ESSO Belgium, 1989.
- The Use of Tire Rubber in Pavements, Preliminary Report*, Technical Services Division, Maine Department of Transportation, March 1990.
- Use of Waste Materials and By-Products in Road Construction*, Organization for Economic Cooperation and Development, Sept. 1977.
- Uses of Asphalt Rubber*, Asphalt-Rubber User Producer Group.
- Takallou, M.B., and H.B. Takallou, *Benefits of Recycling Waste Tires*, presented at the 70th Annual Meeting of TRB, Washington, D.C. 1991.
- Waste Tires in New York State: Alternatives to Disposal, *Conference Proceedings*, Nov. 1987.
- Westerman, R.R., *Tires: Decreasing Solid Wastes and Manufacturing Throughput*, Report No. EPA-600/5-78-009, U.S. Environmental Protection Agency, Cincinnati, Ohio, July 1978.
- Winters, R.E., *The Conception and Development of Asphalt-Rubber*, presented at the National Seminar on Asphalt-Rubber, Oct. 1989.
- Witzak, M.W., *State of the Art Synthesis Report—Use of Ground Rubber in Hot Mix Asphalt*, Maryland Department of Transportation, June 1, 1991.

## F: LEGISLATION

- An Act to Promote Reduction, Recycling, and Integrated Management of Solid Waste and Sound Environmental Regulation, First Regular Session, Maine, 1989.
- Assembly Bill No. 320, an Act relating to solid waste, etc., Nevada, Feb. 8, 1991.
- Assembly Bill 939, California.
- A Bill for an Act Concerning Recycling, First Regular Session, 107th General Assembly, State of Indiana, 1991.
- Caltrans Response to AB 1306, memorandum to J. Reeves, J. Allison, and E. Shirley from Chun, L., R. Doty, E. Delano, and D. Mayer.
- Crumb Rubber Additive (CRA) for Asphalt Products*, Position Paper, Federal Highway Administration.
- Experimental Classification of Crumb Rubber Additive (CRA), Minute-Memo to G. Strout for M. Heitzman, U.S. Department of Transportation, Feb. 7, 1991.
- Governor Acts to Expand State Recycling Efforts, *News*, Office of the Governor, Illinois, Feb. 15, 1991.
- House Floor Amendment to SB 1340, State of Texas, 1991.
- LEGI-SLATE Report for the 102d Congress through Feb. 14, 1991, Bill Text Report for S.396, introduced Feb. 7, 1991.
- Paving Materials, an Act to add Division 12.6 to Public Resources Code, Assembly Bill No. 1306, Chapter 1092, State of California, Sept. 1989.
- Program Plan for the Virginia Used Tire Management Program and Waste Tire Trust Fund*, Virginia Used Tire Management Program, Feb. 1992.
- Proposed Louisiana Solid Waste Rules and Regulations, Subpart II, Chapter 103—Recycling Regulations, Title 33—Environmental Quality, Part VII—Solid Waste, Subpart II—Recycling, Louisiana Department of Environmental Quality, Oct. 16, 1990.
- Rives, H., letter to the Honorable Q.N. Burdich on use of tires, American Association of State Highway and Transportation Officials, June 24, 1991.
- Scrap Tires, Title 8, 1991–1992 Regular Sessions, State of New York, March 26, 1991.
- Second Substitute Senate Bill 5143, 52nd Legislature, Regular Session, State of Washington, 1991.
- Senate Bill No. 53, 85th General Assembly, State of Missouri.
- Senate Bill No. 287, Virginia 1990 Session.
- Senate Bill S.2923, U.S. Senate, 101st Congress, 2nd Session, July 10, 1990.
- The Solid Waste Dilemma: Solutions for the 90's, Preliminary Draft for Focus Group Comment*, U.S. Environmental Protection Agency, Office of Solid Waste, Municipal Solid Waste Program, Aug. 1990.
- Solid Waste Recycling and Reduction Law, Act No. 185, Chapter 18, Louisiana 1989 Regular Session, 1989.
- Special Provision and/or Specification Change Memorandum 13-89, Texas Department of Transportation, Aug. 1, 1989.
- Tempe, Barker, and Sloane Inc., *Preliminary Review of H.R. 4147/S.2462, The Tire Recycling Incentives Act of 1990*, The Rubber Manufacturers Association, Sept. 28, 1990.
- Testimony of the Honorable Sonny Bono, Mayor of Palm Springs, California, Hearing on Legislation to Promote Energy Efficiency Through the Use of Waste and Recoverable Materials, before the Senate Committee on Energy and Natural Resources, Subcommittee on Energy Regulation and Conservation, Aug. 2, 1990.
- Tire Recycling, Recommendations to the Governor and Legislature*, New Jersey Department of Environmental Protection, 1989.
- Use of Scrap Tire Rubber in Asphalt Pavement, A Report to the Governor and Legislators in Compliance with Chapter 599 of the Laws of 1987*, New York State Department of Transportation, Sept. 1990.
- Washington Alert, *Rubber Manufacturers Association Newsletter*, Vol. XI, No. 2, July-Aug. 1991.
- Waste Tire Advisory Committee, *Report to Legislature*, State of Washington, Jan. 1989.
- Waste Tires, Division 30, Chapter 16, Public Resources Code, State of California.

## G: ECONOMICS

- Asphalt-Rubber*, Asphalt Rubber Producers Group.
- Deese, P.L., J.F. Hudson, R.C. Innes, and D. Funkhouser, *Options for Resource Recovery and Disposal of Scrap Tires—Volume 1*, Report No. EPA-600/2-81-193, Urban Systems Research and Engineering, Inc.; U.S. Environmental Protection Agency, Sept. 1981.
- Environmental Law Institute, *The Scrap Tire Problem: A Preliminary Economic Study*, Grant No. CR-811897-01, U.S. Environmental Protection Agency, Oct. 1985.
- Goddard, H.C., *An Economic Evaluation of Technical Systems for Scrap Tire Recycling*, Municipal Environmental Research

- Laboratory, U.S. Environmental Protection Agency, Cincinnati, Ohio.
- Humpstonek, C.H., E. Ayres, S.G. Keahey, and T. Schell, *Incentives for Tire Recycling and Reuse*, International Research and Technology Corporation; U.S. Environmental Protection Agency, 1974.
- Masters, M., Cost Comparisons Using Conventional Methods of Rehabilitation Versus Methods Using Asphalt-Rubber Systems, presented at the National Seminar on Asphalt-Rubber, Oct. 1989.
- McQuillen, J.L., H.B. Takallou, R.G. Hicks, and D. Esch, Economic Analysis of Rubber-Modified Asphalt Mixes, *Journal of Transportation Engineering*, Vol. 11, No. 3, May 1988.
- NAPA Scrap Tire Bulletin, National Asphalt Pavement Association, June 15, 1992.
- The Role of Markets for Recycling, Summary of Markets for Scrap Tires*, Report No. EPA 530 SW-90-0748, U.S. Environmental Protection Agency, Oct. 1991.
- SCS Engineering, *Financial Analysis of Selected Facilities for Producing Tire-Derived Products, Technical Appendix*, Washington Department of Trade and Economic Development, Dec. 29, 1988.
- Shook, J.F., H.B. Takallou, and E. Oshinski, *Evaluation of the Use of Rubber-Modified Asphalt Mixtures for Asphalt Pavements in New York State*, ARE, Inc.; New York State Department of Transportation, Dec. 1989.
- Takallou, H.B., Benefits of Recycling Used Tires in Rubber Asphalt Paving, Small Business Subcommittee on Environment and Labor, April 1990.
- The Tough, Resilient, Waterproof Solution to Highway Surface Problems, ARM-R-Shield*, Arizona Refining Company.
- H: NOISE REDUCTION**
- Gruner, J.R., and A.J. Assaf, *Sound Level Survey, Phoenix, Ariz.*, letter report to J. Cano, Western Technologies, April 5, 1990.
- Gruner, J.R., and A.J. Assaf, *Sound Level Survey, Tucson, Ariz.*, letter report to G. Morris, Western Technologies, April 19, 1990.
- Heerkens, J.C.P., and I.A. Von Meier, Open Graded Rubberized Asphalt for Traffic Noise Reduction in Urban Areas, presented at the National Seminar on Asphalt-Rubber, Oct. 1989.
- McManigle, K.A., *Interim Corrective Skid Resistance Treatments on I-83*, Pennsylvania Department of Transportation, May 1989.
- Nievelt, G., G. Stehno, H. Stickler, J. Ertl, *Noise Level Reduction Through Silent Asphalt*, ARGE, ESSO Spezialbitumen.
- Noise Reduction with Asphalt-Rubber*, Asphalt Rubber Producers Group.
- I: PERFORMANCE**
- Adams, C.K., and J. Gonzales, *Asphalt-Rubber Interlayer Field Performance*, Report No. FHWA/TX-87/449-1F, Texas Transportation Institute, June 1987.
- Ahlich, R.C., *Evaluation of Asphalt Rubber and Engineering Fabrics as Pavement Interlayers*, Miscellaneous Paper GL-86-34, U.S. Army WES, Nov. 1986.
- Allen, H.S., *Evaluation of Plus Ride (Rubber Modified Plant Mixed Bituminous Surface Mixture)*, Special Study 387, Minnesota Department of Transportation, March 1986.
- Allen, H.S., *Methods and Materials for Reducing Crack Reflections*, Report No. FHWA/MN/RD-84/09, Minnesota Department of Transportation, Jan. 1985.
- Allen, H.S., and K.P. Keel, *Evaluation of an Asphalt-Rubber Interlayer*, Special Study No. 383, Minnesota Department of Transportation, Aug. 1985.
- Anderson, C., *Evaluation of Recycled Rubber in Asphalt Concrete, Construction Report*, Iowa Department of Transportation, Dec. 1991.
- Asphalt-Rubber Concrete Test Section*, Missouri Department of Transportation.
- Atkinson, T., *Evaluation of Rubber-Asphalt Membrane in Wyoming*, Contract No. DOT-FH-15-216, Wyoming State Highway Department, Oct. 1980.
- Bernard, D.A., Federal Highway Administration Programs, presented at 1st Asphalt-Rubber User-Producer Workshop, May 1980.
- Bethune, J.D., *Report on Overseas Mission to Study Bituminous Surfacing Developments*, County Roads Board, Victoria, Australia, May-July 1977.
- Blasienz, J.A., and A.A. Geick, *Evaluation of Rubber-Asphalt Mixture Used as a Stress Relieving Inner Layer*, Report No. FHWA-DP-37-13, Texas State Department of Highways and Public Transportation, Aug. 1980.
- Blas, D.J., *Asphalt-Rubber Used as an Interlayer*, North Dakota State Highway Department, Sept. 1982.
- Brewer, W.B., *Dense Graded Rubber Mixtures and Chemcrete*, Oklahoma Department of Transportation, 1984.
- Brewer, W.B., *Discarded Tires in Highway Construction*, Report No. FHWA/OK 82(4), Oklahoma Department of Transportation, Nov. 1982.
- Brown, D.J., Involvement of the FHWA's Demonstration Projects Division in the Development of Asphalt-Rubber Paving Materials, presented at the National Seminar on Asphalt-Rubber, Oct. 1981.
- Brownie, R.B., *Evaluation of Rubber-Asphalt Binder for Seal Coating Asphaltic Concrete*, Report No. TM-M-S3-76-5, Western Division, Naval Facilities Engineering Command, U.S. Department of the Navy, Aug. 1976.
- Cano, J.O., and E. Charania, The Phoenix Experience Using Asphalt-Rubber, presented at the National Seminar on Asphalt-Rubber, Oct. 1989.
- Charania, E., J.O. Cano, and R.H. Schnormeier, Twenty-Year Study of Asphalt Rubber Pavements in Phoenix, AZ, in *Transportation Research Record 1307*, Transportation Research Board, National Research Council, Washington, D.C. (1991).
- Clarke, W.H., Restorative Highway Maintenance Techniques, paper presented to 19th presented at the Annual Asphalt Paving Conference, March 1979.
- Constantino, P., M.P. Abraham, and D. Murry, *Evaluation of Asphalt-Rubber Overlay of Old Concrete, Sterling, Massachusetts*, Asphalt Rubber Producers Group.
- Cooper, J.A., D.F. Lynch, and R.C. Aquin, *Stress Absorbing Membrane Interlayer—Construction Report*, Report No. 50, Ontario Ministry of Transportation and Communications, April 1983.
- Craner, C., G. Wiley, and J. Keyes, *Plus-Ride, Experimental Project UT-83-04*, Utah Department of Transportation, March 1987.
- Crisman, R.E., S.J. Gage, and R.F. Nichol森, *Experimental Use of an Asphalt Rubber Surface Treatment*, Report No. FHWA-DP-37-9, Vermont Agency of Transportation, March 1990.
- A Current Assessment of Caltrans RAC Experience, memorandum

- to E. Shirley from R. Doty, California Department of Transportation, Dec. 13, 1990.
- DeFoe, J.H., *Evaluation of Ground and Reclaimed Tire Rubber in Bituminous Resurfacing Mixtures*, Research Report No. R-1266, Michigan Department of Transportation, Oct. 1985.
- Delano, E.B., Performance of Asphalt-Rubber Stress Absorbing Membranes and Stress Absorbing Membrane Interlayers in California, presented at the National Seminar on Asphalt Rubber, Oct. 1989.
- deLaubenfels, L., *Effectiveness of Rubberized Asphalt in Stopping Reflection Cracking of Asphalt Concrete (Interim Report)*, Report No. FHWA/CA/TL-85/09, California Department of Transportation, Jan. 1985.
- Dense Graded Rubber Mixtures and Chemcrete at Speiling, Oklahoma—Second Year Evaluation*, Oklahoma Department of Highways, Dec. 1985.
- Depuyot, M., *Summary Report on Asphalt-Rubber Usages*, Minnesota Department of Transportation, Sept. 1987.
- Deringer, K.T., and J. Smith, *Asphalt Additives Study, Construction Report*, Report No. FHWA/NJ-85-007-7713, New Jersey Department of Transportation, Feb. 1985.
- Discarded Tires in Highway Construction, Jamestown, North Dakota*, Report No. FHWA-DP-37-5, North Dakota State Highway Department, Oct. 1979.
- Donnelly, D.E., *Reflection Cracking, Crumb Rubber Demonstration—Kannah Creek, Colorado*, Report No. FHWA-DP-37-2, Colorado Department of Highways, Feb. 1979.
- Doty, R.N., Flexible Pavement Rehabilitation Using Asphalt-Rubber Combinations—A Progress Report, presented at Transportation Research Board, Jan. 1988.
- Doty, R.N., Flexible Pavement Rehabilitation Using Asphalt-Rubber Combinations—A Progress Report, presented at Transportation Research Board, 1989.
- Doty, R.N., Solid Waste Utilization in Highway Construction, Caltrans, presented at Triaxial Institute, April 1991.
- Dudley, S.W., *Investigation of an Asphalt-Rubber Interlayer For Reducing or Preventing Reflection Cracking in Bituminous Overlays*, Ohio Department of Transportation, July 1980.
- Esch, D.C., *Construction and Benefits of Rubber-Modified Asphalt Pavements*, Report No. AK-RD-82-17, Alaska Department of Transportation, Jan. 1982.
- Estakhri, C.K., Performance of Asphalt-Rubber in Texas, presented at 4R Conference, San Antonio, Texas, Dec. 1990.
- Evaluation of Asphalt Additives: Lava Butte to Fremont Highway Junction—Final Report*, Oregon State Highway Division.
- Evaluation of Asphalt-Rubber as a Stress Absorbing Interlayer and a Binder for Seal Coat Construction, A Thirty-Six Month Survey*, Florida Department of Transportation.
- Experimental Utilization of a Stress Absorbent Membrane in Peru and a Stress Absorbent Membrane Interlayer in Kennebunk, Maine*, State Study No., 89-12, Maine Department of Transportation, Nov. 1988.
- Fager, G.A., *Asphalt-Rubber Hot Mix PCCP Overlay*, Project 75-70 K3845-01, Kansas Department of Transportation, Oct. 5, 1990.
- Fager, G.A., Test Sections/Asphalt-Rubber, US-24/Jefferson County, memo to R. Maag, Kansas Department of Transportation, June 10, 1991.
- Fager, G.A., R.G. Maag, and W.H. Parcels, *Heater Scarification and Asphalt-Rubber—Sami*, Marion County Project 77-57-F 055-2(6), Kansas Department of Transportation.
- Gilbertson, D.A., and W.R. Meier, Airport Pavement Maintenance and Rehabilitation at Arizona Airports with Asphalt-Rubber, presented at the National Seminar on Asphalt-Rubber, Oct. 1989.
- Giles, K.E., and W.H. Clark, Asphalt-Rubber Interlayers on Rigid Pavements in New York State, presented at the National Seminar on Asphalt-Rubber, Oct. 1981.
- Gonsalves, G.F.D., *Evaluation of Road Surfaces Utilizing Asphalt-Rubber—1978*, Report No. 1979-GG3, Arizona Department of Transportation, Nov. 1979.
- Gulden, W., *Evaluation of Asphalt-Rubber Seal Coats and Interlayers for Rehabilitation of Flexible Pavements*, Report No. FHWA/GA-82/004, Georgia Department of Transportation, Sept. 1982.
- Hankins, K.D., and J.F. Nixon, *Experimental Seal Coat Construction Including Overflex—Two Year Analysis*, Report No. FHWA-DP-37-1, Texas State Department of Highways and Public Transportation, March 1979.
- Harvey, F.M., *Reduction of Reflective Cracking in Asphaltic Overlays*, Interim Report, Wyoming State Highway Department, 1979.
- Heiman, G.H., Rubber Asphalt Binders Used in Saskatchewan, Canada, presented at 1st Asphalt-Rubber User-Producer Workshop, May 1980.
- Henderson, H., *Rubberized Asphalt on Minnesota Drive Extension*, Alaska Department of Transportation, Sept. 1988.
- Herendeen, H., *Evaluation of Stress Absorbing Membrane Interlayer in Idaho*, Report No. FHWA-DP-37-6, Idaho Transportation Department, Aug. 1980.
- Jackson, N.C., *Post-Construction Report on Rubber-Asphalt Binder Stress-Absorbing Membrane Interlayer*, Report No. FHWA-DP-37-7, Washington State Department of Transportation, Nov. 1979.
- Kemp, P., *The Use of Rubberized Asphalt Concrete on Lemon Road*, Alaska Dept of Transportation, Feb. 1984.
- Kidd, S.Q., *Asphalt Rubber Stress Absorbing Membrane Interlayers*, Report No. FHWA-DP-37-17, Mississippi State Highway Department, Aug. 1981.
- Klesges, R.C., *The Alternative: Asphalt-Rubber*, Manhole Adjusting Company, 1990.
- Lansdon, H.G., Construction Techniques of Placement of Asphalt-Rubber Membranes, presented at 13th Paving Conference, University of New Mexico, Jan. 1976.
- Larsen, D.A., *Eight-Year Performance Evaluation of an Asphalt-Rubber Hot Mix Pavement*, Report No. 116-3-89-8, Connecticut Department of Transportation, 1989.
- Larsen, D.A., Eight Year Performance Evaluation of an Asphalt-Rubber Hot Mix Pavement, presented at the National Seminar on Asphalt-Rubber, Oct. 1989.
- Larsen, D.A., and D.G. Bowers, *Six-Year Evaluation of an Asphalt-Rubber Hot Mix Asphalt*, Report No. 116-2-86-13, Connecticut Division of Highways, Sept. 1986.
- Lundy, J.R., *Rubberized Asphalt Mix Performance Report*, Oregon State University.
- Maag, R.G., KDOT's 1977, 1978, and 1979 3R Experimental Projects, presented at Recycling and Reclaiming Association Annual Meeting, March 1980.
- Maag, R.G., *Prevention of Reflective Cracking in Flexible Pavements, Asphalt-Rubber SAMI, NEPT KS-7701B, 1982 Annual and Final Report*, Kansas Department of Transportation, 1982.
- Mahone, D.C., *Use of Discarded Tires in Highway Construction*,

- Virginia, Report No. FHWA-DP-37-15, Virginia Highway and Transportation Research Council, Dec. 1980.
- Mample, S.J., and L.E. Van Over, *Evaluation of Stress Absorbing Membrane Interlayer*, Idaho Department of Transportation, May 1980.
- The Manhole Messenger*, Vol. 1, No. 3, Fall 1990.
- Maree, J.H., V.C. Francis, and N.J. van der Walt, The Uses of Bitumen-Rubber Binders in Interim Rehabilitation Measures Aimed at Prolonging the Life of Distressed Pavement Structures, presented at the Annual Transportation Conference, South Africa, Aug. 1984.
- Maupin, G.W., *Installation and Early Performance of a Field Test Section of Asphalt Rubber Concrete*, Report No. VTRC-92-1R1, Virginia Transportation Research Council, Oct. 1991.
- McCullagh, F.R., *A Five Year Evaluation of Arizona's Three Layer System on the Durango Curve in Phoenix*, Association of Asphalt Paving Technologists, 1985.
- McManigle, K.A., and D.B. Mellot, *Interim Corrective Skid Resistance Treatments on I-83*, Report No. FHWA-PA-86-038-76-10, Pennsylvania Department of Transportation, May 1989.
- Mellott, D.B., *Discarded Tires in Highway Construction*, Research Report No. 79-02, Pennsylvania Department of Transportation, April 1989.
- Mellott, D.B., *Discarded Tires in Highway Construction, Construction Report*, Research Project No. 79-2, Pennsylvania Department of Transportation, May 1981.
- Meadors, A., *Experimental Projects Using Rubber Asphalt Membrane to Retard Reflective Cracking*, Report No. FHWA/AR-86/002, Arkansas State Highway and Transportation Department, July 1986.
- Meadors, A., and H. Snow, *Experimental Projects Using Rubber Asphalt Membrane to Retard Reflection Cracking, Final Report*, Arkansas State Highway and Transportation Department, April 1988.
- Miller, B., and L.G. Scholl, *Evaluation of Asphalt Additives: Lava Butte to Fremont Highway Junction*, Oregon Department of Transportation, Oct. 1990.
- Morris, G., Asphalt Rubber Overlay Systems, presented at International Road and Bridge Maintenance/Rehabilitation Conference and Exposition, Atlanta, 1988.
- Morris, G.R., and C.H. McDonald, Asphalt-Rubber Stress Absorbing Membranes: Field Performance and State of the Art, in *Transportation Research Record 595*, Transportation Research Board, National Research Council, Washington, D.C. (1976).
- Ormsby, W.C. and D.G. Fohs, Use of Waste and By-Products in Highway Construction, presented at Transportation Research Board, Jan. 1990.
- Page, G.C., *Florida's Initial Experience Utilizing Ground Tire Rubber in Asphalt Concrete Mixes*, Research Report FL/DOT/MO 89-366, Florida Department of Transportation, Sept. 1989.
- Parcells, W.H., *Asphalt-Rubber for Stress Absorbing Membrane to Retard Reflective Cracking, Final Report*, Kansas Department of Transportation, June 1989.
- Payne, C.D., et al., *Discarded Tires in Highway Construction on IH-10, Hudspeth County, Texas*, FHWA Contract DOT-FH-15-185.
- Reduction of Reflective Cracking in Asphaltic Overlays*, Interim Report, Wyoming State Highway Department, April 1982.
- Renshaw, R.H., A Review of the Road Performance of Bitumen-Rubber in South and Southern Africa, presented at the National Seminar on Asphalt Rubber, Oct. 1989.
- Renshaw, R.H., P.J. Strauss, and E.G. Kleyn, Review of the Performance of a Bitumen-Rubber Over a Six-Year Period, presented at 5th Conference on Asphalt Pavements for Southern Africa, Swaziland, June 1989.
- Report on Plus Ride Pavement, Route 2, South County Trail, East Greenwich, Rhode Island*, Rhode Island Department of Transportation.
- Rubberized Asphalt Road Surface Demonstration*, South Dakota Department of Transportation, July 1984.
- Texas Asphalt-Rubber Survey*, Asphalt-Rubber Producers Group.
- Ruth, B.E., *Documentation of Open-Graded Asphalt-Rubber Friction Course Demonstration Project on Interstate 95, St. Johns County*, Department of Civil Engineering, University of Florida, Dec. 1990.
- Ruth, B.E., *Evaluation of Experimental Asphalt-Rubber, Open Graded, Friction Course Mixtures: Materials and Construction of Test Pavements on State Road 16*, Department of Civil Engineering, University of Florida; Florida Department of Transportation, Nov. 1989.
- Ruth, B.E., S. Sigurjonsson, and C.L. Wu, *Evaluation of Experimental Asphalt-Rubber, Dense Graded, Friction Course Mixtures: Materials and Construction of Test Pavements on N.E. 23rd Avenue, Gainesville, Florida*, Department of Civil Engineering, University of Florida; Florida Department of Transportation, May 1989.
- Schnormeier, R.H., *Cold Climate Condition Survey of Asphalt-Rubber Membranes*, Asphalt Rubber Producers Group.
- Schnormeier, R.H., Eleven Year Pavement Condition History of Asphalt-Rubber Seals in Phoenix, Arizona, ASTM STP 724, 1979.
- Shnormeier, R.H., *Evaluation of Asphalt-Rubber Concrete*, Asphalt Rubber Producers Group, Jan. 1989.
- Shnormeier, R.H., *Fifteen Year Pavement Condition History of Asphalt Rubber Membranes, City of Phoenix*.
- Shook, J.F., *Experimental Construction of Rubber-Modified Asphalt Pavements in New York State*, New York State Department of Transportation, May 16, 1990.
- Shook, J.F., H.B. Takallou, and E. Oshinski, *Evaluation of the Use of Rubber-Modified Asphalt Mixtures for Asphalt Pavements in New York State*, New York State Department of Transportation, Dec. 1989.
- Shuler, S., B.M. Gallaway, and J.A. Epps, *Evaluation of Asphalt-Rubber Membrane Field Performance*, Report No. FHWA/TX-82/51+287-2, Texas Transportation Institute, May 1982.
- Shuler, T.S., B.M. Gallaway, and J.A. Epps, *Evaluation of Asphalt Rubber Membrane Field Performance*, Research Report No. 287-2, Texas Transportation Institute, May 1982.
- Shuler, T.S., R.D. Pavlovich, and J.A. Epps, Field Performance of Rubber Modified Asphalt Paving Materials, in *Transportation Research Record 034*, Transportation Research Board, National Research Council, Washington, D.C. (1985).
- Skog, J.B., J.A. Matthews, G.H. Mann, and D.V. Roberts, *State-wide Flexible Pavement Performance and Deflection Study*, Report No. FHWA-CA-TL-78-28, California Department of Transportation, Dec. 1978.
- Snyder, R.R., *Discarded Tires in Highway Construction*, Report No. FHWA-DP-37-12, Pennsylvania Department of Transportation, Aug. 1990.
- Stephens, J.E., Field Evaluation of Rubber-Modified Bituminous

- Concrete, in *Transportation Research Record 843*, Transportation Research Board, National Research Council, Washington, D.C. (1982).
- Stephens, J.E., *Nine Year Condition Survey of Connecticut Department of Transportation Experimental Rubber/Asphalt Application*.
- Stephens, J.E., *Nine Year Evaluation of Recycled Rubber in Roads, Final Report*, Project 86-8, University of Connecticut, May 1989.
- Stewart, J., *Seal Coat Construction at Rocky, Oklahoma, Using Asphalt Rubber as the Binder*, Report No. FHWA-DP-37-3, Oklahoma Department of Transportation, Sept. 1979.
- Strong, M.P., *The Evaluation of Rubber Asphalt Surface Treatment in Preventing Fatigue Crack Reflection in Bituminous Overlay Construction*, Interim Report, Report No. FHWA-DP-3-10, North Carolina Division of Highways, Nov. 1979.
- Strong, M.P., *The Evaluation of Rubber Asphalt Surface Treatment in Preventing Fatigue Crack Reflection in Bituminous Overlay Construction*, Interim Report, Report No. FHWA-DP-3-10, North Carolina Division of Highways, Jan. 1982.
- Summary of Asphalt-Rubber Performance in Washington*, Washington Department of Transportation (response to NCHRP questionnaire), June 1991.
- Turgeon, C.M., *Waste Tire and Shingle Scrap Bituminous Paving Test Section on the Meinger Recreational Trail Gateway Segment*, Report No. NE MN/RD-91/06, Minnesota Department of Transportation, Feb. 1991.
- Use of Granulated Rubber from Discarded Tires in Seal Coat Construction*, Report No. FHWA-DP-37-4, South Dakota Department of Transportation, Sept. 1979.
- Van Kirk, J.L., Caltrans Experience with Asphalt-Rubber Concrete—An Overview and Future Direction, presented at the National Seminar on Asphalt-Rubber, Oct. 1989.
- Van Kirk, J.L., Caltrans Experience with Rubberized Asphalt Concrete, presented at Technology Transfer Seminar, Topeka, Kansas, Jan. 23, 1991.
- Vedros, P.J., *Evaluation of the Effectiveness of Membranes for Prevention of Crack Reflection in Thin Overlays*, Miscellaneous Paper GL-79-4, U.S. Army Engineer Waterways Experiment Station, March 1979.
- Vedros, P. J., Evaluation of the Effectiveness of Membranes for Prevention of Crack Reflection in Thin Overlays, presented at 1st Asphalt-Rubber User-Producer Workshop, May 1980.
- Way, G.B., Prevention of Reflective Cracking in Arizona, presented at 18th New Mexico Paving Conference, Albuquerque, Jan. 1981.
- Way, G.B., *Prevention of Reflective Cracking, Minnetonka—East (1979 Addendum Report)*, Report No. 1979-GW1, Arizona Department of Transportation, Aug. 1979.
- Way, G.B., *Prevention of Relective Cracking in Arizona*, Association of Asphalt Paving Technologists, Vol. 49, 1980.
- Weiss, L.L., Asphalt Rubber Chip Seals in South Dakota, presented at the National Seminar on Asphalt-Rubber, Oct. 1981.
- Chehovits, J., *Preliminary Report, Creep Testing of Asphalt Rubber and Poymer Modified Asphalt Rubber*, Project I-006, Crafcoc Inc., Aug. 1, 1989.
- Dickinson, E.J., Assessment of the Deformation and Flow Properties of Polymer Modified Paving Bitumens, *Australian Road Research*, Vol. II, No. 3, Sept. 1981.
- Evaluation of McDonald Compression-Recovery Test for Field Quality Control of Asphalt-Rubber, Phase IV*, Job No. 2154J011, Western Technologies, Inc., Jan. 1986.
- Green, E.L., and W.J. Tolonen, *The Chemical and Physical Properties of Asphalt-Rubber Mixtures*, Report No. ADOT-RS-14 (162), Arizona Department of Transportation, July 1977.
- Huff, B., and B.A. Vallerga, Characteristics and Performance of Asphalt-Rubber Material Containing A Blend of Reclaim and Crumb Rubber, presented at Transportation Research Board, 1979.
- Huffman, J.E., Sahuaro Concept of Asphalt-Rubber Binders, presented at 1st Asphalt-Rubber User-Producer Workshop, May 1990.
- Huff, B., Arizona Refining Concept of Asphalt-Rubber Binders, presented at 1st Asphalt-Rubber User-Producer Workshop, May 1990.
- Jimenez, R.A., Viscosity Measurements of Asphalt-Rubber Binders, presented at the National Seminar on Asphalt-Rubber, Oct. 1989.
- Lourens, T., and G. Jordaan, The Prevention of Stripping in Bitumen-Rubber Asphalt, presented at 5th Conference on Asphalt Pavements for Southern Africa, Swaziland, June 1989.
- Oliver, J.W.H., Modification of Paving Asphalts By Digestion with Scrap Rubber, in *Transportation Research Record 821*, Transportation Research Board, National Research Council, Washington, D.C. (1981).
- Oliver, J.W.H., Research on Asphalt-Rubber at the Australian Road Research Board, presented at the National Seminar on Asphalt-Rubber, Oct. 1981.
- Palmgren, H., Unique Swedish Process for Rubber Recycling Presents New Interesting Possibilities for Rubber Compounder, presented at the Scandinavian Rubber Conference, May 1980.
- Pavlovich, R.D., T.S. Shuler, and J.C. Rosner, *Chemical and Physical Properties of Asphalt-Rubber—Phase II—Product Specifications and Test Procedures*, Report No. FHWA/AZ-79/121, Arizona Department of Transportation, Nov. 1979.
- Piggott, M.R., J.D. George, and R.T. Woodhams, Toronto Experience with Rubber-Asphalts, presented at 1st Asphalt-Rubber User-Producer Workshop, May 1990.
- Rosner, J.C., and J.G. Chehovits, *Chemical and Physical Properties of Asphalt-Rubber Mixtures—Phase III, Volume 1—Effects of Rubber Type, Concentration and Asphalt*, Report No. FHWA/AZ-82/159/1, Arizona Department of Transportation, June 1982.
- Rosner, J.C., and J.G. Chehovits, *Chemical and Physical Properties of Asphalt-Rubber Mixture—Phase III, Volume 2—Effects of Asphalt*, Report No. FHWA/AZ-82/159/2, Arizona Department of Transportation, June 1982.
- Rosner, J.C., and J.G. Chehovits, *Chemical and Physical Properties of Asphalt-Rubber Mixtures—Phase III, Volume 3—Effects of Diluent*, Report No. FHWA/AZ-82/159/3, Arizona Department of Transportation, June 1982.
- Rosner, J.C., and J.G. Chehovits, *Chemical and Physical Properties of Asphalt-Rubber Mixtures—Phase III, Volume 5—Effects*

## J: ASPHALT-RUBBER BINDERS

- Asphalt-Rubber—A Viable Candidate for the SHRP's Program*, Asphalt Rubber Producer Group, Phoenix.
- Chehovits, J., *Creep Test Results at Low Temperature, Project I-113*, Crafcoc Inc., Jan. 31, 1990.

of Temperature, Report No. FHWA/AZ-82/159/5, Arizona Department of Transportation, June 1982.

Rosner, J.C., and J.G. Chehovits, *Chemical and Physical Properties of Asphalt-Rubber Mixtures—Phase III, Volume—Summary*, Report No. FHWA/AZ-82/159/Summary, Arizona Department of Transportation, June 1982.

Rostler, F.S., *Rubber in Asphalt Pavements*, presented at International Symposium on the Use of Rubber in Asphalt Pavements, Salt Lake City, May 1971.

Sainton, A., *A Revolution in Asphalt-Rubber Binders: Flexochape Storage Binder*, presented at the National Seminar on Asphalt-Rubber, Oct. 1989.

Shuler, T.S., S. Adams, and A. Lamborn, *Asphalt-Rubber Binder Laboratory Performance*, Report No. TTI-2-9-83-347-1F, Texas Transportation Institute.

Shuler, T.S., and D.J. Hamberg, *A Rational Investigation, Asphalt-Rubber Properties*, University of New Mexico Engineering Research Institute, Aug. 1981.

Strauss, P.J., *Field Testing and Control of Bitumen-Rubber*, presented at the Annual Transportation Conference, South Africa, Aug. 1984.

Stroup-Gardiner, M., D.E. Newcomb, and B. Tanquist, *Asphalt-Rubber Interactions*, Paper prepared for TRB presented at the Transportation Research Board Annual Meeting, 1993.

Van Assen, E.J., M.M. Hattingh, and C. Maccarron, *Monitoring of Bitumen-Rubber Applications*, presented at the Annual Transportation Conference, South Africa, Aug. 1984.

#### K: MEMBRANE AND SLOPE PROTECTION

Frobel, R.K., R.A. Jimenez, C.B. Cluff, and G.R. Morris, *Asphalt-Crumb Rubber Waterproofing Membrane*, American Society of Civil Engineers.

Schlossel, R.H., *Selecting Asphalt-Rubber to Seal a Landfill*, presented at the National Seminar on Asphalt-Rubber, Oct. 1989.

Sergeant, Hauskins and Beckwith, *Pond Lining Test Program Report—Arizona Nuclear Power Project*, proposal for Arizona Refining Company, April 1981.

Vallerga, B.A., C.L. Monismith, and R. Yuce, *Asphalt Revetments for Slope Protection in the Arctic*, presented at ASCE.

*Waste Tires in Sub-grade Road Beds*, Waste Tire Management Unit, Minnesota Pollution Control Agency, prepared by Twin City Testing Corporation, Feb. 1990.

#### L: FILL STABILIZATION

Humphrey, D.N., *Tire Chips as Lightweight Backfill for Retaining Walls*, New England Transportation Consortium, information supplied by Rhode Island, Dec. 1990.

*Use of Discarded Tires in Roadway Maintenance*, slide show developed by California Department of Transportation.

Yee, W.S., *Fill Stabilization Using Non-Biodegradable Waste Products—Phase II*, Report No. FHWA-DP-37-11, California Department of Transportation, May 1980.

#### M: RUBBER AND RUBBER PROCESSING

LaGrone, B.D., *Rubber Used in Asphalt-Rubber Applications*, presented at the National Seminar on Asphalt-Rubber, Oct. 1981.

LaGrone, B.D., *What is Reclaimed Rubber*, presented at 1st Asphalt-Rubber User-Producer Workshop, May 1980.

Smith, M.A., *Tire Rubber Chemical Corporation—Historic Survey 1976 to 1991*, Baker Rubber, Inc., Jan. 10, 1992.

Winters, R.E., *Ambient Grand Rubber Crumb*, presented at American Chemical Society, Rubber Division, Atlanta, Oct. 1986.

#### N: SPECIFICATIONS

*Asphalt Concrete, Type HMR*, Project No. F-4-5(1001), Nebraska Department of Roads, June 21, 1990.

*Asphalt-Rubber Binder Specifications*, Memo to Fred Graebe from R.N. Doty, California Department of Transportation, Nov. 1, 1990.

*Asphalt-Rubber Bituminous Mixtures, Special Provision*, Michigan Department of Transportation, Feb. 23, 1990.

*Asphalt-Rubber Cement and Plant Mix Wearing Course, Special Provision to 1987 Standard Specifications*, Wyoming Highway Department.

*Asphalt Rubber Concrete*, Job 4P 994-71, Missouri Department of Transportation.

*Asphalt-Rubber Joint and Crack Seal, Supplemental Specification*, Georgia Department of Transportation, Sept. 1977.

*Asphalt Rubber (Reacted), Special Provision to the Standard Specifications*, Kansas Department of Transportation, 1990.

*Bituminous Concrete Asphalt-Rubber Binder*, Maryland Department of Transportation.

*Bituminous Crack Relief Layer, Item 312, Standard Specifications for Road and Bridge Construction*, Florida Department of Transportation, 1991.

*Crack Sealing-Rubberized Asphalt, Section 9-04.10*, Washington Department of Transportation.

*General Information for the Specification for Dense-Graded Asphalt-Rubber Hot Mix*, Asphalt Rubber Systems, Riverside, Rhode Island.

*Granulated Reclaimed Rubber Additives, Special Provision to Item 300*, Texas Department of Transportation, Feb. 1991.

*Guide Specification for Hot Asphalt-Rubber Membrane*, Asphalt Rubber Producer Group.

*Guide Specifications for Open and Dense-Graded Asphalt Concrete Pavements with Asphalt-Rubber Binder*, International Surfacing.

*Hot Asphalt-Rubber Seal Coat, Special Specification Item 3600*, Texas Department of Transportation, July 1989.

*Hot Bituminous Pavement (Asphalt-Rubber Mixtures), Special Provision, Section 403*, Maine Department of Transportation, Dec. 24, 1990.

*Joint Sealants, Hot-Poured for Concrete and Asphalt Pavements*, New Jersey Department of Transportation.

*The Manhole Messenger*, Vol. 1, No. 1, Spring 1990.

*Materials for Joints, Section 1057*, Missouri Department of Transportation.

*Membrane Waterproofing (Deck Seal), General Special Provision Division 6*, Washington Department of Transportation, Dec. 26, 1989.

Myburgh, P.A., *Specifications for Bitumen-Rubber: Recent Developments in the RSA*, presented at the Annual Transportation Conference, South Africa, Aug. 1984.

*Rubber-Asphalt Crack Sealing Compound*, Texas Department of Transportation, Dec. 1990.

*Rubber Modified Asphalt Concrete Pavement, SR 530*, Washington Department of Transportation.

*Rubber Modified Asphalt Concrete, Special Provision*, Indiana Department of Transportation.

*Rubber Modified Asphalt Concrete, Specification EXD 142*, New York State Department of Transportation, 1992.

*Rubberized Asphalt Concrete Pavement Class D, SR 195*, Washington Department of Transportation.

Sealant, Crafcoc Inc.

Shuler, S., Specification Requirements for Asphalt-Rubber, in *Transportation Research Record 843*, Transportation Research Board, National Research Council, Washington, D.C. (1982).

*Special Provision for ARHM-GG*, California Department of Transportation, March 1992.

Specifications for Asphalt-Rubber Concrete Mix, source unknown.

*Specifications for Asphalt-Rubber Concrete Mix*, Virginia Department of Transportation.

*Stress Absorbing Membrane Interlayer, Special Provision No. 79 A(88)*, Kentucky Department of Highways, 1989.

*Stress Absorbing Membranes, Specifications for SR 12*, Washington Department of Transportation, Dec. 27, 1977.

*Test Methods for Bitumen-Rubber*, Southern African Bitumen and Tar Association, 1989.

#### **O: OTHER NON-HIGHWAY USES**

Bauman, B.D., Scrap Tire Utilization Via Surface Modification, presented at The Tire Industry Conference, Clemson University, Oct. 1990.

*dB Minus Sound Barrier Wall*, Carsonite International, Carson City, Nevada.

Gaines, L.L., and A.M. Wolsky, *Discarded Tires: Energy Conser-*

*vation Through Alternative Uses*, Report No. ANL/CNSV-5, Argonne National Lab, U.S. Department of Energy, Dec. 1979.

Kearney, A.T., *Scrap Tire Use/Disposal Study*, Scrap Tire Management Council, Sept. 11, 1990.

Letter to R.W. Stregge from M. Moncada, Federal Highway Administration, June 29, 1990.

Marquis, E.L., and T.J. Hirsch, *Full-Scale Crash Test of a Two-Sand Interstitial Barrier*, Texas Transportation Institute, March 1975.

Reclaimed/Reprocessed Tires for Traffic Control Purposes, Memorandum, Federal Highway Administration, Office of Highway Safety, Dec. 14, 1990.

Scrap Tire Recycling and Vendor's Workshop, North Carolina Board of Science and Technology, Fayetteville, North Carolina, Nov. 13, 1986.

*The Solid Waste Dilemma: Solutions for the 90's, Preliminary Draft for Focus Group Comment*, U.S. Environmental Protection Agency, Office of Solid Waste, Municipal Solid Waste Program, Aug. 1990.

Wallace, J., All Tired Out, *Across the Board*, Nov. 1990.

Waste Tires as Highway and Erosion Barriers, reference unknown.

#### **P: RECYCLING**

Sainton, A., *Great Innovation with a Process of Hot In-Place Recycling With Silted Porous Asphalt Concrete*, The Beugnet Group, 1991.

#### **Q: ENVIRONMENT, HEALTH, AND SAFETY**

*Analysis of Asphalt-Rubber Emissions*, Asphalt-Rubber Producers Group.



## APPENDIX A

### GLOSSARY

Terms associated with waste tires and crumb rubber modifier have been defined by the Federal Highway Administration (FHWA) (1), ASTM, LaGrone (2) and Witczak (3). These terms as defined by these authors are given below.

#### FEDERAL HIGHWAY ADMINISTRATION (1)

**Asphalt rubber**—asphalt cement modified with crumb rubber modifier.

**Buffing waste**—high quality scrap tire rubber which is a by-product from the conditioning of tire carcasses in preparation for retreading.

**Crackermill**—process that tears apart scrap tire rubber by passing the material between rotating corrugated steel drums, reducing the size of the rubber to a crumb particle (generally 4.75-mm to 425-micron [No. 4 to No. 40] sieve).

**Crumb rubber modifier**—a general term for scrap tire rubber that is reduced in size and is used as a modifier in asphalt paving materials.

**Cryogenic**—process that freezes the scrap tire rubber and crushes the rubber to the particle size desired.

**Diluent**—a lighter petroleum product (typically kerosene) added to asphalt-rubber binder just before the binder is sprayed on the pavement surface.

**Dry process**—any method that mixes the crumb rubber modifier with the aggregate before the mixture is charged with asphalt binder. This method applies only to hot-mix asphalt production.

**Extender oil**—an aromatic oil used to supplement the reaction of the asphalt and the crumb rubber modifier.

**Granulated crumb rubber modifier**—cubical, uniformly shaped, cut crumb rubber particle with a low surface area, which are generally produced by a granulator.

**Granulator**—process that shears apart the scrap tire rubber, cutting the rubber with revolving steel plates that pass at close tolerance, reducing the rubber to particles generally 9.5-mm to 2.0-mm [ $\frac{3}{8}$  in. to No. 10] sieve) in size.

**Ground crumb rubber modifier**—irregularly shaped, torn crumb rubber particles with a large surface area, generally produced by a crackermill.

**Micro-mill**—process that further reduces a crumb rubber to a very fine ground particle, reducing the size of the crumb rubber below a 425-micron (No. 40) sieve.

**Reaction**—the interaction between asphalt cement and crumb rubber modifier when blended together. The reaction, more appropriately defined as polymer swell, is not a chemical reaction. It is the absorption of aromatic oils from the asphalt cement into the polymer chains of the crumb rubber.

**Rubber aggregate**—crumb rubber modifier added to hot-mix asphalt mixture using the dry process, which retains its physical shape and rigidity.

**Rubber-modified hot-mix asphalt**—hot-mix asphalt mixtures which incorporate crumb rubber modifier primarily as rubber aggregate.

**Shredding**—process that reduces scrap tires to pieces 0.15 m (6 in.) square and smaller.

**Stress-absorbing membrane (SAM)**—a surface treatment using an asphalt-rubber spray application and cover aggregate.

**Stress-absorbing membrane interlayer (SAMI)**—a membrane beneath an overlay designed to resist the stress and strain of reflective cracks and delay the propagation of the cracks through the new overlay. The membrane is often a spray application of asphalt-rubber binder and cover aggregate.

**Wet process**—any method that blends crumb rubber modifier with the asphalt cement before incorporating the binder in the asphalt paving project

#### ASTM

**Asphalt rubber**—a blend of asphalt cement, reclaimed tire rubber, and certain additives in which the rubber component is at least 15 percent by weight of the total blend and has reacted in the hot asphalt cement sufficiently to cause swelling of the rubber particles (ASTM D8).

#### LaGRONE (2)

**Ambient ground rubber**—rubber that is ground or processed at or above ordinary room temperature.

**Automobile tires**—tires with an outside diameter less than 26 in. (66 cm) used on automobiles, pickups, and light trucks.

**Cryogenically ground rubber**—rubber that is ground or processed at or below the embrittlement temperature of the rubber.

**Devulcanized rubber**—rubber that has been subjected to treatment by heat, pressure, or the addition of softening agents after grinding to alter properties of the recycled material.

**Recycled tire rubber**—rubber obtained by processing used automobile, truck, or bus tires (note: solid tires; tires from fork lifts, aircraft, and earthmoving equipment; other non-automotive tires; and non-tire rubber sources are excluded).

**Tread rubber**—rubber that consists primarily of tread rubber with less than approximately 5 percent sidewall rubber.

**Truck tires**—tires with an outside diameter greater than 26 in. (66 cm) and less than 60 in. (152 cm) used on commercial trucks and buses.

**Vulcanized rubber**—rubber that has not been subjected to treatment by heat, pressure, or the addition of softening agents after grinding to alter properties of the recycled material.

**Whole tire rubber**—rubber that includes tread and sidewalls in proportions that approximate the respective weights in an average tire.

### WITCZAK (3)

#### Pavement Layers

**Asphalt-rubber friction course**—implies the use of an asphalt-rubber blend (binder) with open-graded aggregates in a hot-mix application.

**Asphalt-rubber concrete**—implies the use of an asphalt-rubber blend (binder) with dense-graded aggregates in a hot-mix application.

**PlusRide**—a patented form of a rubber-modified asphaltic mix. The product was developed in 1960 in Sweden and patented under the name **PlusRide** in the United States and **Rubit** in Sweden. It uses coarse rubber particles ( $\frac{1}{4}$ – $\frac{1}{16}$  in.) as rubber-filled aggregates, generally about 3 percent weight of mix. The rubber is added directly to a gap-graded aggregate so that a relatively dense grading between the aggregate and rubber is obtained.

**Rubber-filled asphalt concrete**—same meaning as rubber-modified asphalt concrete.

**Rubber-filled friction course**—same meaning as rubber-modified friction course.

**Rubber-modified asphalt concrete**—a hot-mix asphalt-concrete mixture with dense-graded aggregates using a rubber-modified asphalt.

**Rubber-modified friction course**—a hot-mix asphalt mixture with open-graded aggregates using a rubber-modified asphalt.

**SAL**—the abbreviation for a strain-attenuating layer and has the same meaning as the SAM.

**SAM**—the abbreviation for a stress-absorbing membrane. A SAM is used primarily to mitigate reflective cracking of an existing distressed asphaltic or rigid pavement. It comprises an **asphalt-rubber blend** sprayed on the existing pavement surface followed immediately by an application of a uniform aggregate which is then rolled and embedded into the binder layer. Its nominal thickness generally ranges between  $\frac{1}{4}$  and  $\frac{3}{8}$  in.

**SAMI**—the abbreviation for a stress-absorbing membrane interlayer. The **interlayer** may be an asphalt-rubber chip seal, fabric, fine unbound aggregate, or an open-graded asphalt layer. A SAMI is a SAM that is applied beneath an asphalt overlay (which may or may not contain rubber in the mix).

**TLS**—the abbreviation for three-layer system. It was developed by Arizona as a means of restoring the rideability of a badly cracked, warped, or faulted PCC pavement. The principle is equally valid for asphalt-concrete pavements. As currently used, the TLS consists of two thin ( $\frac{1}{2}$ – $\frac{3}{4}$  in.) conventional open-graded friction course layers placed between a low modulus SAMI (approximately  $\frac{3}{8}$  in. thick). The bottom open-graded friction course layer is placed directly on the existing pavement and functions, in part, as a leveling course. Early in the development of this system, other asphaltic mixes (e.g., dense-graded asphaltic concrete) were used in lieu of the open-graded course.

#### Processes

**Asphalt-rubber blend**—a blend of ground tire rubber (generally finely ground No. 16 to No. 25 crumb rubber) and asphalt cement which is used as the “binder” in various types of pavement construction. It generally consists of 18 to 26 percent ground tire rubber by total weight of the blend. The blend is formulated at elevated temperatures to promote the chemical and physical bonding of the two constituents. Various petroleum distillates or extender oils may be added to the blend to reduce viscosity, increase sprayability and promote workability. The “blend” can be used as the binder in chip seals, seal-slurry coats, and dense or open-graded asphalt hot-mix construction. When used in this manner, the aggregate gradation can generally conform to typical gradings used with conventional asphaltic concrete mixes. Asphalt-rubber blends can be produced directly at the plant site by adding ground rubber (18 to 26 percent), to the appropriate asphalt cement, and applying heat (375 to 425°F) for 1 to 2 hours. Special equipment in the form of mixing chambers, reactor and blending tanks, and oversized pumps are needed. Two types of commercially available asphalt-rubber blends are used frequently: McDonald-Sahuaró (Crafco) process, and ARCO-ARM-R-SHIELD (Arizona refining process).

**ARCO-ARM-R-SHIELD (Arizona refining process)**—an asphalt-rubber blend process which was developed in 1975. The blend is composed of approximately 20 percent rubber (of which 40 percent is devulcanized and 60 percent ground ambient vulcanized) and 80 percent AR-4000/8000 with 2 to 4 percent Witco

extender oil. The granulated rubber has gradings in which 98 percent pass the No. 16 mesh and 8 percent pass the No. 100 mesh. Diluents are not used routinely.

**Dry process**—the process by which dry ground tire is added as part of the aggregate component. The rubber is not blended with asphalt cement before mixing with the asphalt cement. Unlike the **asphalt-rubber blend**, physical and chemical bonding does not occur between the asphalt and rubber. In fact, portions of the rubber actually serve as “elastic mineral aggregate” in the mix. This term applies only to hot-mix asphaltic mixes. This process can be accomplished either by the plant operator or through the use of the patented **PlusRide** mix.

**Rubber-filled**—same meaning as **dry process**.

**Rubber-modified asphalt**—same meaning as **rubber-filled**.

**Rubberized asphalt**—same meaning as **asphalt-rubber blend**.

**Wet process**—same meaning as **asphalt-rubber blend**.

#### Types of Rubber

**Ambient ground rubber**—tire rubber that is ground or processed at ordinary room temperature.

**Automobile tires**—arbitrarily selected as tires having an outside diameter less than 26 in. that are used by automobiles or light trucks.

**Cryogenically ground rubber**—tire rubber that has been subjected to temperature below the embrittlement temperature of the rubber during the grinding process.

**Devulcanized rubber**—tire rubber that has been subjected to treatment by heat, pressure, or the addition of softening agents to alter properties of the recycled material.

**Reclaimed tire rubber**—rubber obtained by processing and recycling used automobile, truck, and bus tires. Solid tires; tires from fork lifts, aircraft, and earthmoving equipment; other non-automobile (truck) tires; and non-tire rubber sources are excluded.

**Tread rubber**—tire rubber that consists primarily of tread rubber or peel with less than 5 percent sidewall rubber.

#### REFERENCES

1. Heitzman, M.A., *State of the Practice for the Design and Construction of Asphalt Paving Materials with Crumb Rubber Additive*, Report No. FHWA-SA-92-022, Office of Engineering, Pavement Division, Federal Highway Administration, May 1992.
2. LaGrone, B.D., Rubber Used in Asphalt-Rubber Applications, presented at the National Seminar on Asphalt-Rubber, Oct. 1981.
3. Witzzak, M.W., *State of the Art Synthesis Report-Use of Ground Rubber in Hot Mix Asphalt*, Maryland Department of Transportation, June 1, 1991.

## APPENDIX B

### Section 1038 of Intermodal Surface Transportation Efficiency Act

105 STAT. 1988

PUBLIC LAW 102-240—DEC. 18, 1991

#### SEC. 1038. USE OF RECYCLED PAVING MATERIAL.

Environmental  
protection.  
23 USC 109 note.

(a) **ASPHALT PAVEMENT CONTAINING RECYCLED RUBBER DEMONSTRATION PROGRAM.**—Notwithstanding any other provision of title 23, United States Code, or regulation or policy of the Department of Transportation, the Secretary (or a State acting as the Department's agent) may not disapprove a highway project under chapter 1 of title 23, United States Code, on the ground that the project includes the use of asphalt pavement containing recycled rubber. Under this subsection, a patented application process for recycled rubber shall be eligible for approval under the same conditions that an unpatented process is eligible for approval.

#### (b) STUDIES.—

(1) **IN GENERAL.**—The Secretary and the Administrator of the Environmental Protection Agency shall coordinate and conduct, in cooperation with the States, a study to determine—

(A) the threat to human health and the environment associated with the production and use of asphalt pavement containing recycled rubber;

(B) the degree to which asphalt pavement containing recycled rubber can be recycled; and

(C) the performance of the asphalt pavement containing recycled rubber under various climate and use conditions.

(2) **DIVISION OF RESPONSIBILITIES.**—The Administrator shall conduct the part of the study relating to paragraph (1)(A) and the Secretary shall conduct the part of the study relating to paragraph (1)(C). The Administrator and the Secretary shall jointly conduct the study relating to paragraph (1)(B).

(3) **ADDITIONAL STUDY.**—The Secretary and the Administrator, in cooperation with the States, shall jointly conduct a study to determine the economic savings, technical performance qualities, threats to human health and the environment, and environmental benefits of using recycled materials in highway devices and appurtenances and highway projects, including asphalt containing over 80 percent reclaimed asphalt, asphalt containing recycled glass, and asphalt containing recycled plastic.

(4) **ADDITIONAL ELEMENTS.**—In conducting the study under paragraph (3), the Secretary and the Administrator shall examine utilization of various technologies by States and shall examine the current practices of all States relating to the reuse and disposal of materials used in federally assisted highway projects.

(5) **REPORT.**—Not later than 18 months after the date of the enactment of this Act, the Secretary and the Administrator shall transmit to Congress a report on the results of the studies conducted under this subsection, including a detailed analysis of the economic savings and technical performance qualities of using such recycled materials in federally assisted highway projects and the environmental benefits of using such recycled materials in such highway projects in terms of reducing air emissions, conserving natural resources, and reducing disposal of the materials in landfills.

#### (c) DOT GUIDANCE.—

(1) **INFORMATION GATHERING AND DISTRIBUTION.**—The Secretary shall gather information and recommendations concerning the use of asphalt containing recycled rubber in highway projects from those States that have extensively evaluated and experimented with the use of such asphalt and implemented such projects and shall make available such information and

recommendations on the use of such asphalt to those States which indicate an interest in the use of such asphalt.

(2) **ENCOURAGEMENT OF USE.**—The Secretary should encourage the use of recycled materials determined to be appropriate by the studies pursuant to subsection (b) in federally assisted highway projects. Procuring agencies shall comply with all applicable guidelines or regulations issued by the Administrator of the Environmental Protection Agency.

(d) **USE OF ASPHALT PAVEMENT CONTAINING RECYCLED RUBBER.**—

(1) **STATE CERTIFICATION.**—Beginning on January 1, 1995, and annually thereafter, each State shall certify to the Secretary that such State has satisfied the minimum utilization requirement for asphalt pavement containing recycled rubber established by this section. The minimum utilization requirement for asphalt pavement containing recycled rubber as a percentage of the total tons of asphalt laid in such State and financed in whole or part by any assistance pursuant to title 23, United States Code, shall be—

- (A) 5 percent for the year 1994;
- (B) 10 percent for the year 1995;
- (C) 15 percent for the year 1996; and
- (D) 20 percent for the year 1997 and each year thereafter.

(2) **OTHER MATERIALS.**—Any recycled material or materials determined to be appropriate by the studies under subsection (b) may be substituted for recycled rubber under the minimum utilization requirement of paragraph (1) up to 5 percent.

(3) **INCREASE.**—The Secretary may increase the minimum utilization requirement of paragraph (1) for asphalt pavement containing recycled rubber to be used in federally assisted highway projects to the extent it is technologically and economically feasible to do so and if an increase is appropriate to assure markets for the reuse and recycling of scrap tires. The minimum utilization requirement for asphalt pavement containing recycled rubber may not be met by any use or technique found to be unsuitable for use in highway projects by the studies under subsection (b).

(4) **PENALTY.**—The Secretary shall withhold from any State that fails to make a certification under paragraph (1) for any fiscal year, a percentage of the apportionments under section 104 (other than subsection (b)(5)(A)) of title 23, United States Code, that would otherwise be apportioned to such State for such fiscal year under such section equal to the percentage utilization requirement established by paragraph (1) for such fiscal year.

(5) **SECRETARIAL WAIVER.**—The Secretary may set aside the provisions of this subsection for any 3-year period on a determination, made in concurrence with the Administrator of the Environmental Protection Agency with respect to subparagraphs (A) and (B) of this paragraph, that there is reliable evidence indicating—

(A) that manufacture, application, or use of asphalt pavement containing recycled rubber substantially increases the threat to human health or the environment as compared to the threats associated with conventional pavement;

(B) that asphalt pavement containing recycled rubber cannot be recycled to substantially the same degree as conventional pavement; or

(C) that asphalt pavement containing recycled rubber does not perform adequately as a material for the construction or surfacing of highways and roads.

The Secretary shall consider the results of the study under subsection (b)(1) in determining whether a 3-year set-aside is appropriate.

(6) **RENEWAL OF WAIVER.**—Any determination made to set aside the requirements of this section may be renewed for an additional 3-year period by the Secretary, with the concurrence of the Administrator with respect to the determinations made under paragraphs (5)(A) and (5)(B). Any determination made with respect to paragraph (5)(C) may be made for specific States or regions considering climate, geography, and other factors that may be unique to the State or region and that would prevent the adequate performance of asphalt pavement containing recycled rubber.

(7) **INDIVIDUAL STATE REDUCTION.**—The Secretary shall establish a minimum utilization requirement for asphalt pavement containing recycled rubber less than the minimum utilization requirement otherwise required by paragraph (1) in a particular State, upon the request of such State and if the Secretary, with the concurrence of the Administrator of the Environmental Protection Agency, determines that there is not a sufficient quantity of scrap tires available in the State prior to disposal to meet the minimum utilization requirement established under paragraph (1) as the result of recycling and processing uses (in that State or another State), including retreading or energy recovery.

(e) **DEFINITIONS.**—For purpose of this section—

(1) the term “asphalt pavement containing recycled rubber” means any hot mix or spray applied binder in asphalt paving mixture that contains rubber from whole scrap tires which is used for asphalt pavement base, surface course or interlayer, or other road and highway related uses and—

(A) is a mixture of not less than 20 pounds of recycled rubber per ton of hot mix or 300 pounds of recycled rubber per ton of spray applied binder; or

(B) is any mixture of asphalt pavement and recycled rubber that is certified by a State and is approved by the Secretary, provided that the total amount of recycled rubber from whole scrap tires utilized in any year in such State shall be not less than the amount that would be utilized if all asphalt pavement containing recycled rubber laid in such State met the specifications of subparagraph (A) and subsection (d)(1); and

(2) the term “recycled rubber” is any crumb rubber derived from processing whole scrap tires or shredded tire material taken from automobiles, trucks, or other equipment owned and operated in the United States.

**QUESTIONNAIRE**  
for  
**NCHRP SYNTHESIS TOPIC 22-02**  
on  
**USES OF RECYCLED RUBBER TIRES IN HIGHWAYS**

**APPENDIX C**  
**QUESTIONNAIRE ON CURRENT STATE PRACTICES**

USE	USE CONSIDERED			QUANTITY TO DATE	
	Pending	Experimental	Routine or Conventional	Rubber, Tons	Lane Miles of Pavement
Fill or Embankment					
Erosion Control					-----
Crash Attenuators					-----
Other Safety Hardware					-----
Membrane					-----
Joint Sealant					-----
Crack Sealant					
Binder for Chip Seal (SAM)					
Binder for Interlayer (SAMI)					
Binder for Dense Graded Hot Mix Asphalt					
Binder for Open Graded Hot Mix Asphalt					
Other (Please Specify)					

Also Include in Your Response

1. Significant literature associated with the use of used tires in your State (Pavements, fuel source, other forms of recycling or innovative disposal)
2. Current specifications for the various uses of tires in your transportation department.
3. Description of research underway relative to the use of tires in highways.
4. Information on existing or pending legislation issues relative to the use of tires in your transportation system.

Please Respond To:  
Jon A. Epps  
College of Engineering/256  
University of Nevada  
Reno, Nevada 89557

Respondent  
Name \_\_\_\_\_  
Address \_\_\_\_\_  
\_\_\_\_\_  
Phone \_\_\_\_\_

## APPENDIX D

### BINDER PROPERTIES

#### INTRODUCTION

Today's asphalt-rubber binders evolved largely from original concepts developed by McDonald in the 1960s and further developed by Sahuaro, Arizona Refining Company (ARCO), Crafcro, and International Surfacing Inc. The state of Arizona has been heavily involved in asphalt-rubber binder research. New Mexico and Texas have also contributed to this knowledge base. Much of the early research on binders was performed by Western Technology, Inc., of Phoenix, Arizona. International contributions have been made by Australia, Canada, South Africa, and Sweden. A review of this work indicates that a number of binder blends have been prepared and tested. Various test results indicate that dramatic property changes can occur depending upon the binder blends being evaluated.

#### HISTORY OF BINDER DEVELOPMENT

Early asphalt-rubber materials contained approximately 25 percent ground rubber and 75 percent asphalt cement by weight. Other early products contained reclaimed rubber. Different types of rubber, rubber sizes, rubber quantities, and reaction times were used to produce binders of varying properties. Sahuaro further developed asphalt-rubber binders by selecting types of rubber, matching different rubber types with different asphalts, controlling reaction times, and blending with kerosene to control spray application viscosities. Sahuaro was successful in developing and marketing binders for joint and crack sealers, chip seals, interlayers, and hot-mix applications. Arizona Refining Company (ARCO) developed similar asphalt-rubber binder systems, blended with aromatic oils, which were successful for the same uses.

In an attempt to improve binder properties and constructability, Sahuaro and ARCO reduced the rubber quantities in the blends and became more selective in the type of rubber used. Both recognized the need for field quality control by establishing reaction temperatures and times. Crafcro further developed these binder systems when Sahuaro and ARCO divested their asphalt-rubber business. Crafcro investigated other blends of different types of rubber, sizes of rubber, quantities of rubber, aromatic oils, diluents, and other polymers. They also conducted more research with reaction temperatures and times. Laboratory and field studies conducted by these groups and others are reviewed in the following sections.

#### ARIZONA DEPARTMENT OF TRANSPORTATION

From the middle 1970s to the early 1980s, the Arizona Department of Transportation (DOT) sponsored comprehensive research programs to develop an understanding of asphalt-rubber binders.

The studies concluded that the properties of asphalt-rubber mixtures vary depending on

- Rubber type and gradation,
- Rubber concentration,
- Asphalt type and concentration,
- Diluent type and concentration,
- Diluent cure time, and
- Reaction temperature and time.

The studies also indicated the asphalt-rubber binders produced in the laboratory were stiffer than field-produced binders. The force-ductility and sliding plate microviscometer tests were found to yield variation acceptable enough to permit their use for specification purposes. The influence of these variables on binder properties is summarized below. A description of the rubber types and gradations used in the study can be found in Rosner and Chehovits (1982, Volume 1) (1).

#### Rubber Type and Gradation

Research performed by Rosner and Chehovits for the Arizona DOT (1) evaluated the effects of rubber type and concentration on the properties of asphalt-rubber binders. Tests performed on 48 different asphalt-rubber mixtures included absolute viscosity at 140°F, Schweyer Rheometer at 39.2°F, force ductility at 39.2°F, sliding plate microviscometer at 32°F, and viscosity by the Torque-Fork and Haake viscometer at 375°F. Figures D-1, D-2, and D-3 indicate that rubber type will affect the viscosity at 140°F and the force ductility properties at 39.2°F. Rubber type and gradation are two of the important variables that must be considered when formulating asphalt-rubber binders.

#### Rubber Concentration

The Rosner and Chehovits study also evaluated the influence of rubber concentration on binder properties. Viscosity at 140°F, force ductility at 39.2°F, and viscosity at 375°F data are shown in Figures D-4 to D-7. These figures indicate that a viscosity increase will often accompany an increase in rubber concentration. Data from the force ductility test at 39.2°F indicate that the load at failure increases, and the elongation at failure decreases, as rubber concentration increases (Figures D-5 and D-6).

#### Asphalt Type and Concentration

A second report for the Arizona DOT by Rosner and Chehovits (2) evaluated the effects of asphalt cement and extender oils on the



physical properties of asphalt-rubber mixtures. Sixteen different asphalt-rubber mixtures were formulated and tested for viscosity at 39.2°F, 140°F, and 374°F and for force ductility at 39.2°F. Figures D-8 to D-11 indicate that viscosity and force ductility results are affected by the type of base asphalt cement and extender oil used in the asphalt-rubber blend. These figures and data indicate that asphalt cement and extender oil characteristics significantly influence the physical properties of asphalt-rubber binders. Generally, low-viscosity base asphalts produce lower viscosities, lower failure stresses, and higher failure strain properties in asphalt-rubber binders.

#### Diluent Type, Concentration, and Cure Time

A third study by Rosner and Chehovits (3) for the Arizona DOT evaluated the effects of diluent additions and curing times on the properties of asphalt-rubber mixtures. This study used AR 1000 asphalt cement and 25 percent TPO 44 rubber with four different percentages of a kerosene diluent. The mixtures were cured at 140°F, and measurements were made at five different curing times. The tests performed were the Ring and Ball softening point, viscosity at 39.2°F and 375°F, and the force ductility test. Figures D-12 to D-16 indicate that the softening point and ductility properties are altered by the concentration of kerosene and the cure time. Softening points, force ductility load at failure, and viscosity decrease with increasing diluent concentrations. Increased cure time increases the softening point. Diluent concentrations and cure time did not significantly alter force ductility elongation at failure.

#### Reaction Temperature and Time

Rosner and Chehovits' Arizona DOT studies (1-5) were mostly performed with reaction times of 1 hour and at temperatures of 375°F. Data obtained from two reaction times were reported in the second study (2). Figure D-11 shows the influence of reaction time on viscosity at 375°F.

Oliver's research (6) more clearly defined the influence of time and temperature on the properties of asphalt rubber. Figures D-17

and D-18 illustrate property changes due to the reaction or digestion of synthetic rubber tire buffings and natural rubber tire buffings. The parameter elastic recovery of strain is obtained from a sliding plate rheometer. It is defined as the percentage of load applied strain recovered when the load is removed, using a recovery period of 10 times the load period. The test temperature was 60°C. Figures D-17 and D-18 show that the properties of the asphalt-rubber binder are a function of the type of rubber and the time and temperature of reaction or digestion. Figure D-17 indicates that reactions at high temperatures for long periods of time may produce undesirable binders.

#### REFERENCES

1. Rosner, J.C., and J.G. Chehovits, *Chemical and Physical Properties of Asphalt-Rubber Mixtures—Phase III, Volume 1—Effects of Rubber Type, Concentration and Asphalt*, Report No. FHWA/AZ-82/159/1, Arizona Department of Transportation, June 1982.
2. Rosner, J.C., and J.G. Chehovits, *Chemical and Physical Properties of Asphalt-Rubber Mixture—Phase III, Volume 2—Effects of Asphalt*, Report No. FHWA/AZ-82/159/2, Arizona Department of Transportation, June 1982.
3. Rosner, J.C., and J.G. Chehovits, *Chemical and Physical Properties of Asphalt-Rubber Mixtures—Phase III, Volume 3—Effects of Diluent*, Report No. FHWA/AZ-82/159/3, Arizona Department of Transportation, June 1982.
4. Rosner, J.C., and J.G. Chehovits, *Chemical and Physical Properties of Asphalt-Rubber Mixtures—Phase III, Volume 4—Physical Properties of Field-Mixed Asphalt-Rubber Mixtures and Comparisons of Lab and Field-Mixed Asphalt Rubbers*, Report No. FHWA/AZ-82/159/4, Arizona Department of Transportation, June 1982.
5. Rosner, J.C., and J.G. Chehovits, *Chemical and Physical Properties of Asphalt-Rubber Mixtures—Phase III, Volume 5—Effects of Temperature*, Report No. FHWA/AZ-82/159/5, Arizona Department of Transportation, June 1982.
6. Oliver, J.W.H., Modification of Paving Asphalts By Digestion with Scrap Rubber, in *Transportation Research Record 821*, TRB, National Research Council, Washington, D.C. (1981).

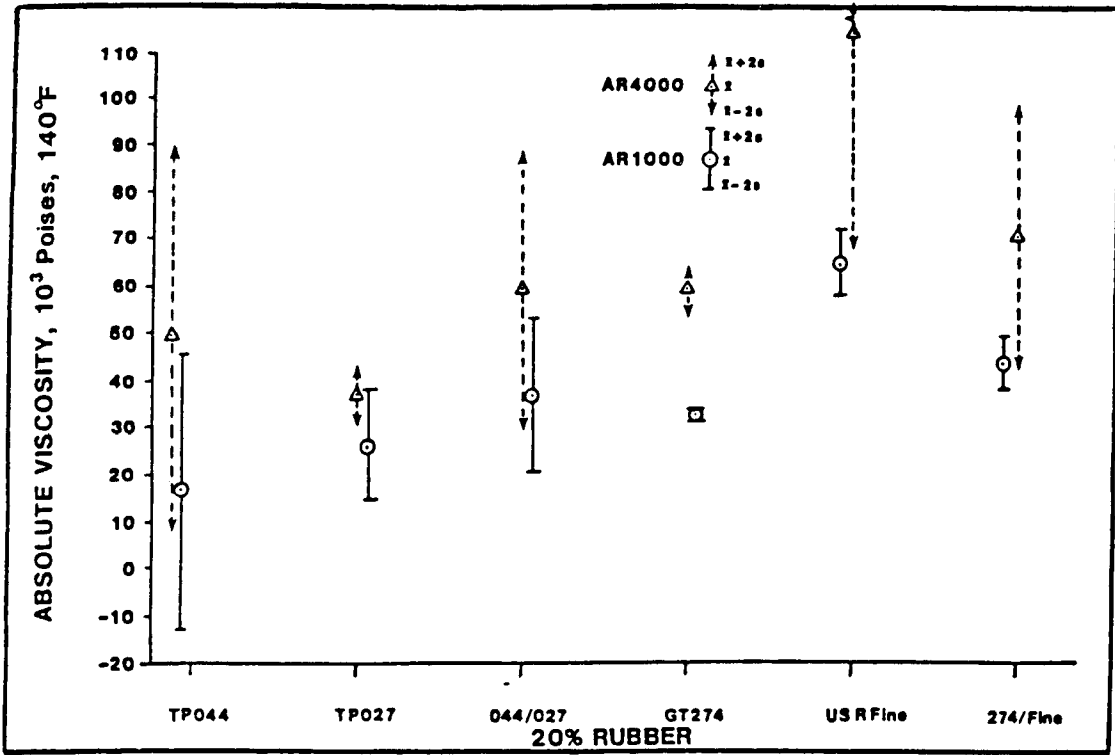

FIGURE D-1 Influence of rubber type on viscosity at 140°F. (D1)

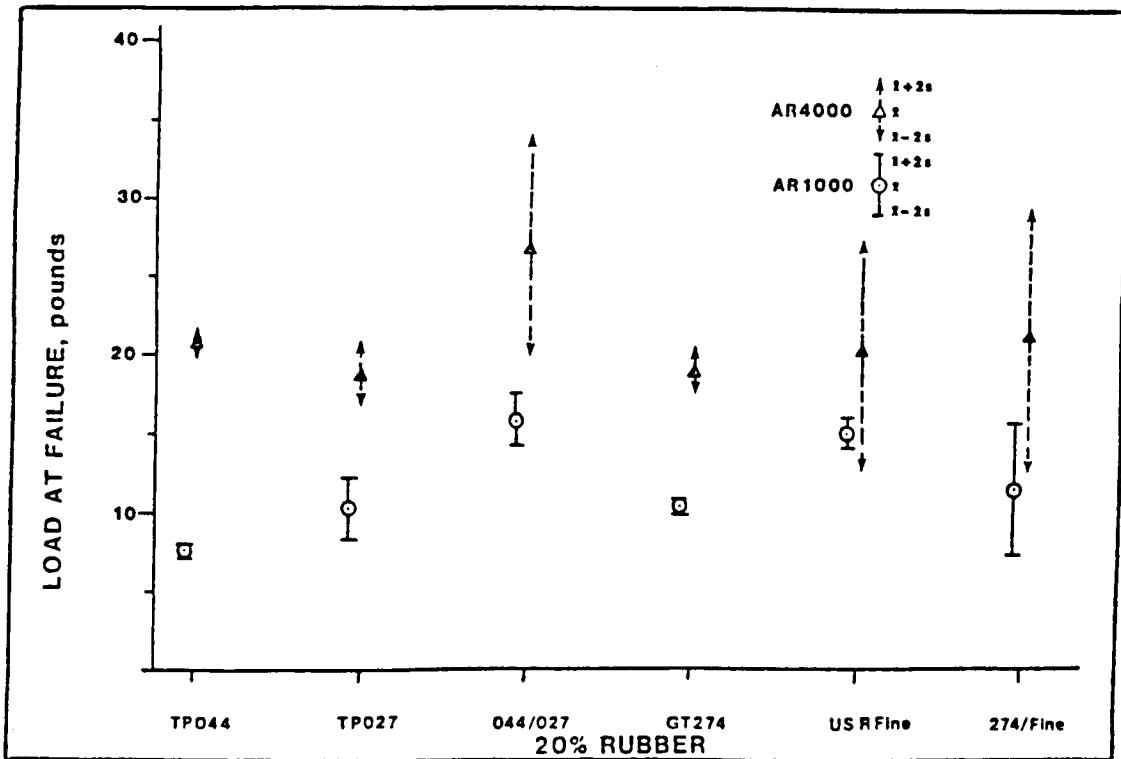

FIGURE D-2 Influence of rubber type on force ductility load at failure at 39.2°F. (D1)

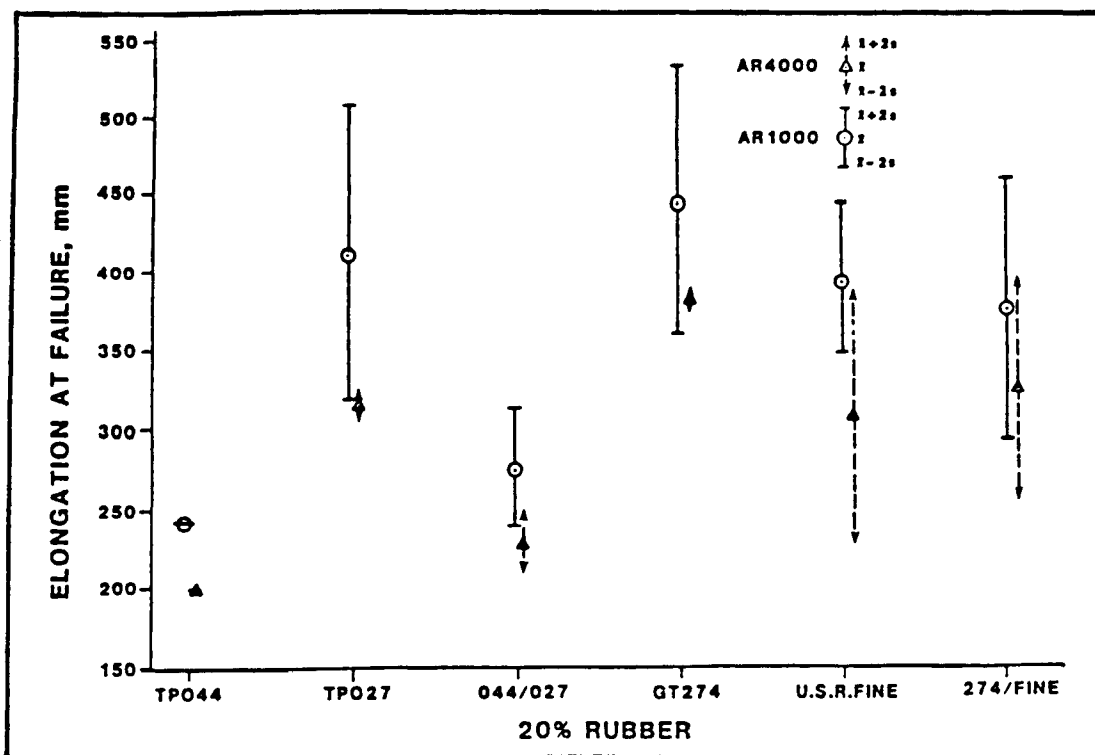

FIGURE D-3 Influence of rubber type on force ductility elongation at failure at 39.2°F. (D1)

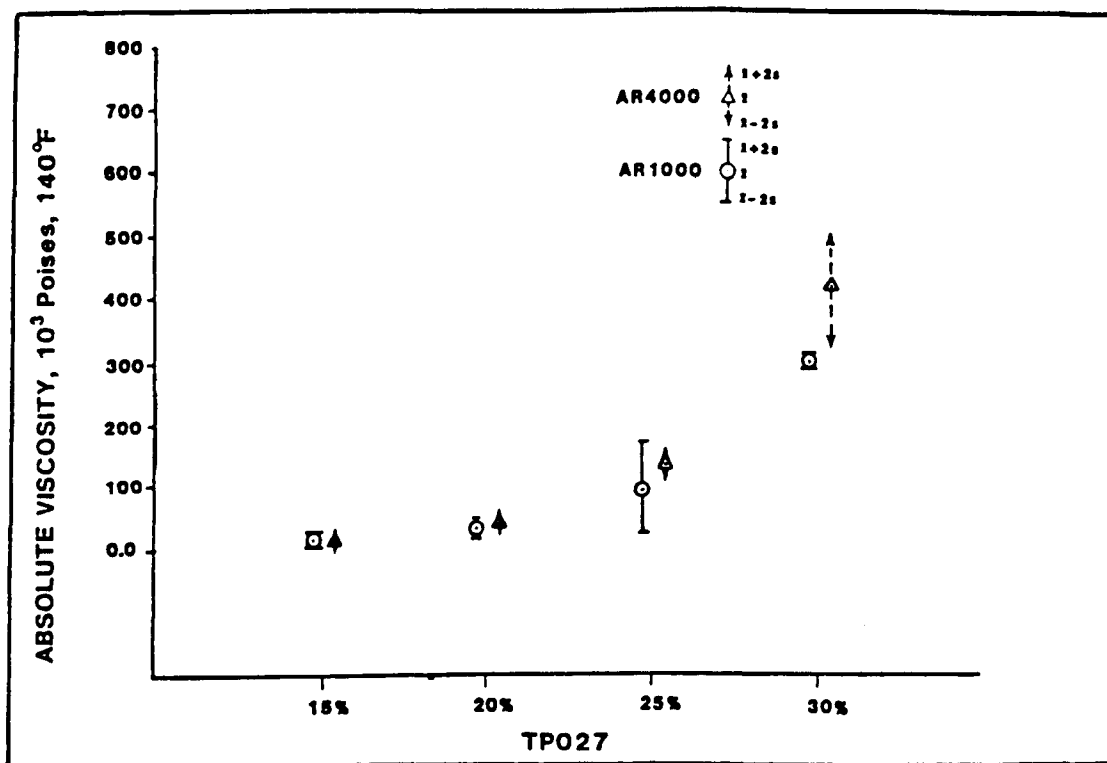

FIGURE D-4 Influence of rubber concentration on viscosity at 140°F. (D1)

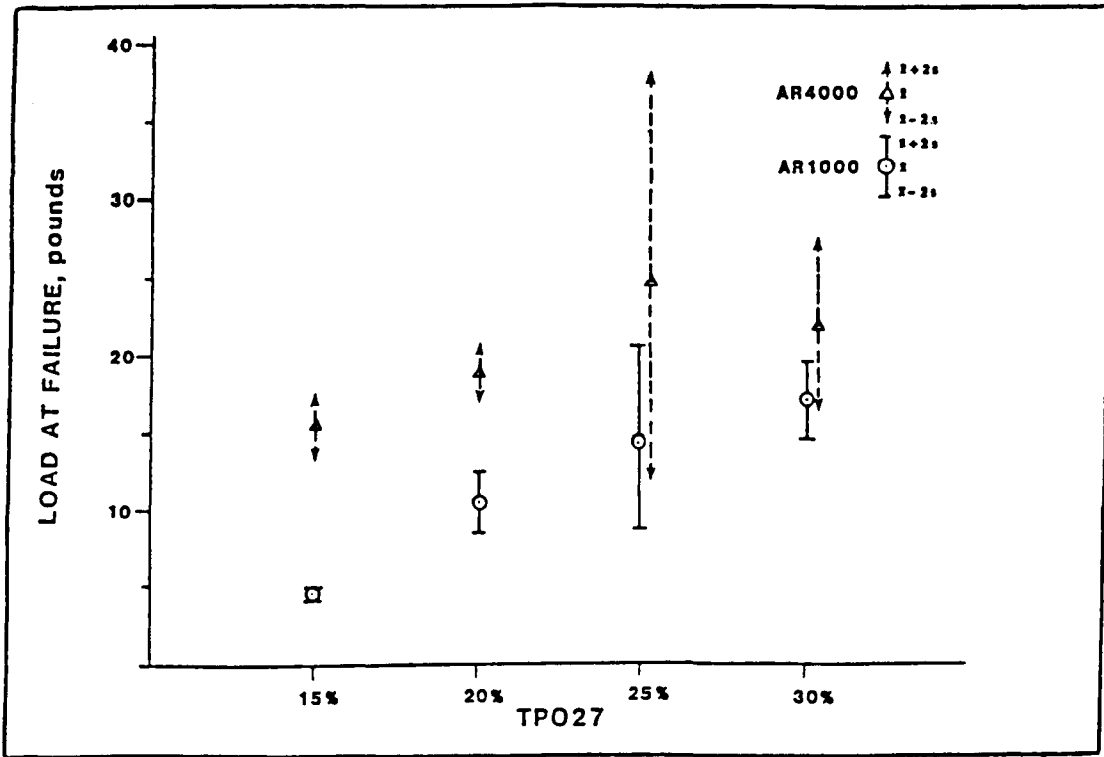

FIGURE D-5 Influence of rubber concentration on force ductility load at failure at 39.2°F. (D1)

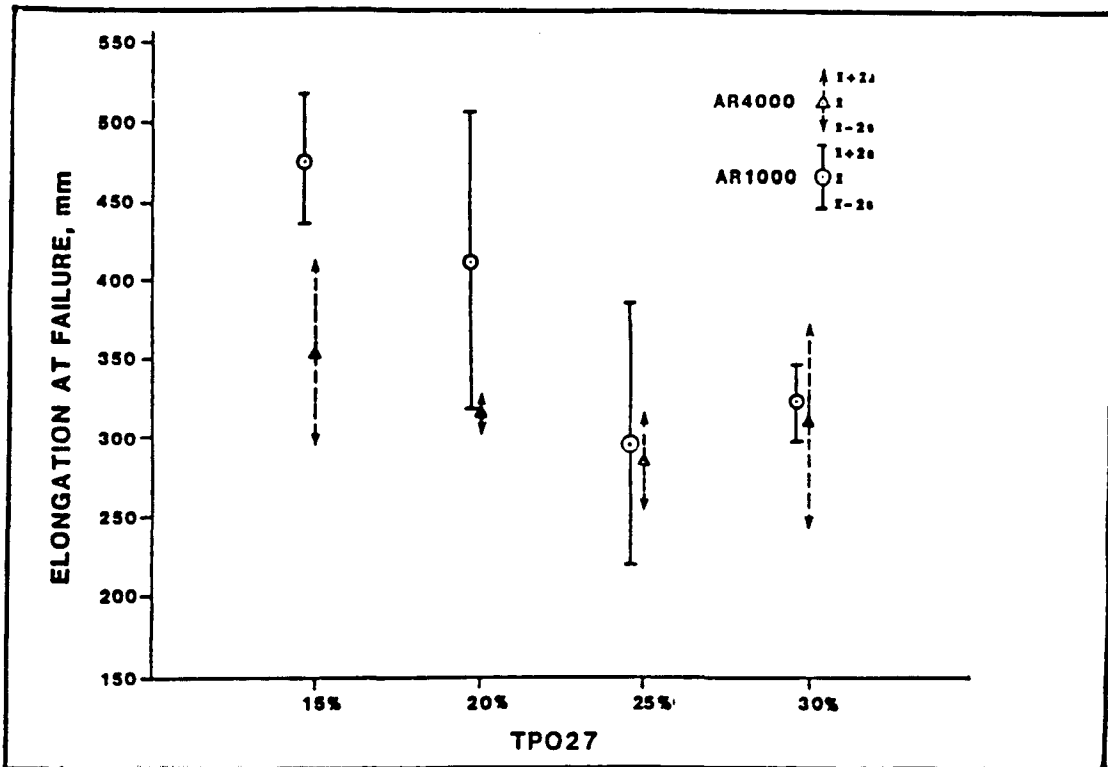

FIGURE D-6 Influence of rubber concentration on force ductility elongation at failure at 39.2°F. (D1)

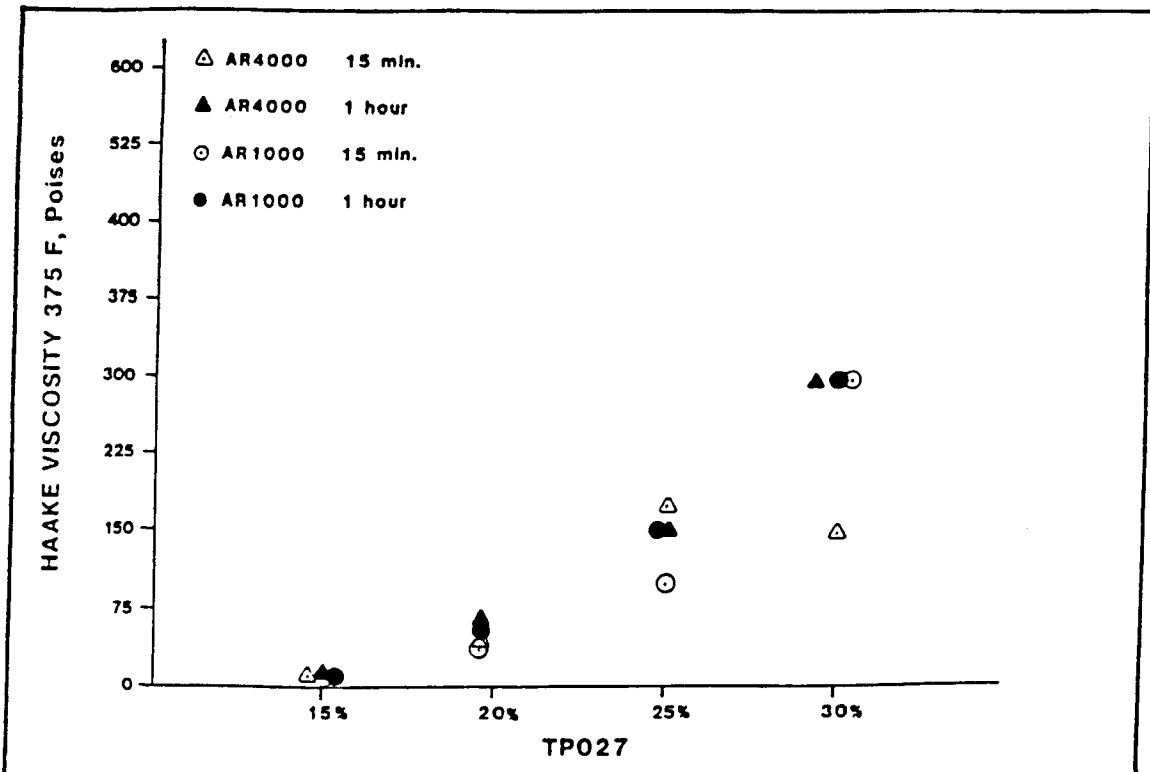

FIGURE D-7 Influence of rubber concentration on viscosity at 375°F. (D1)

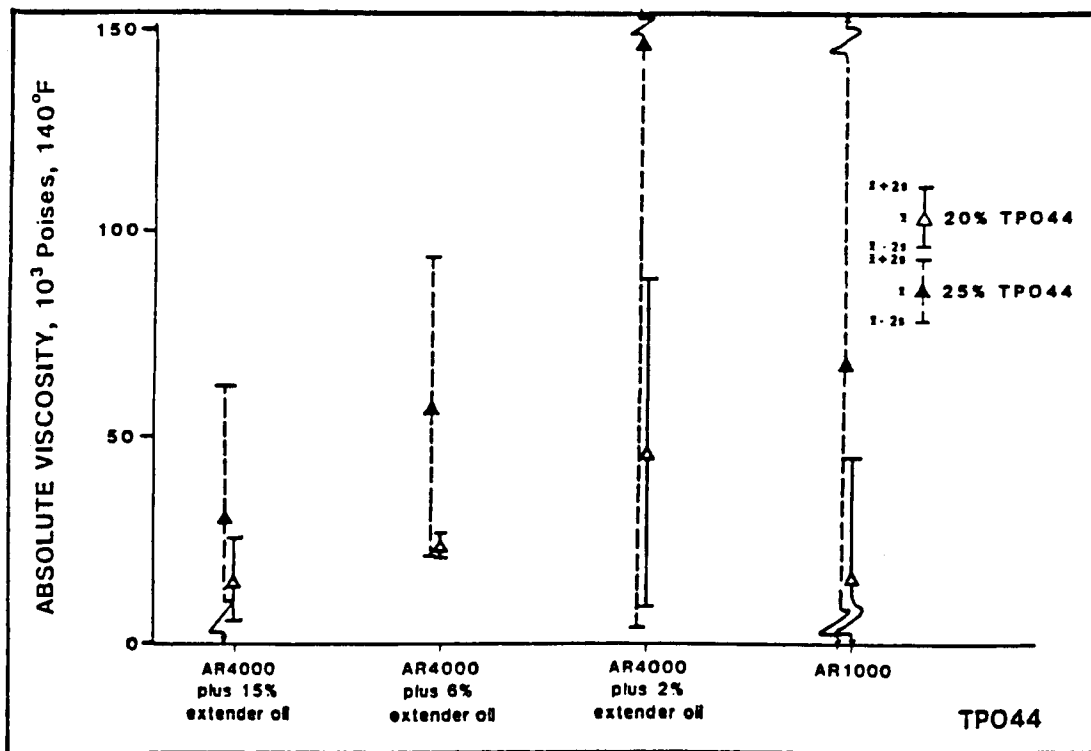

FIGURE D-8 Influence of asphalt cement and oil extender on viscosity at 140°F. (D2)

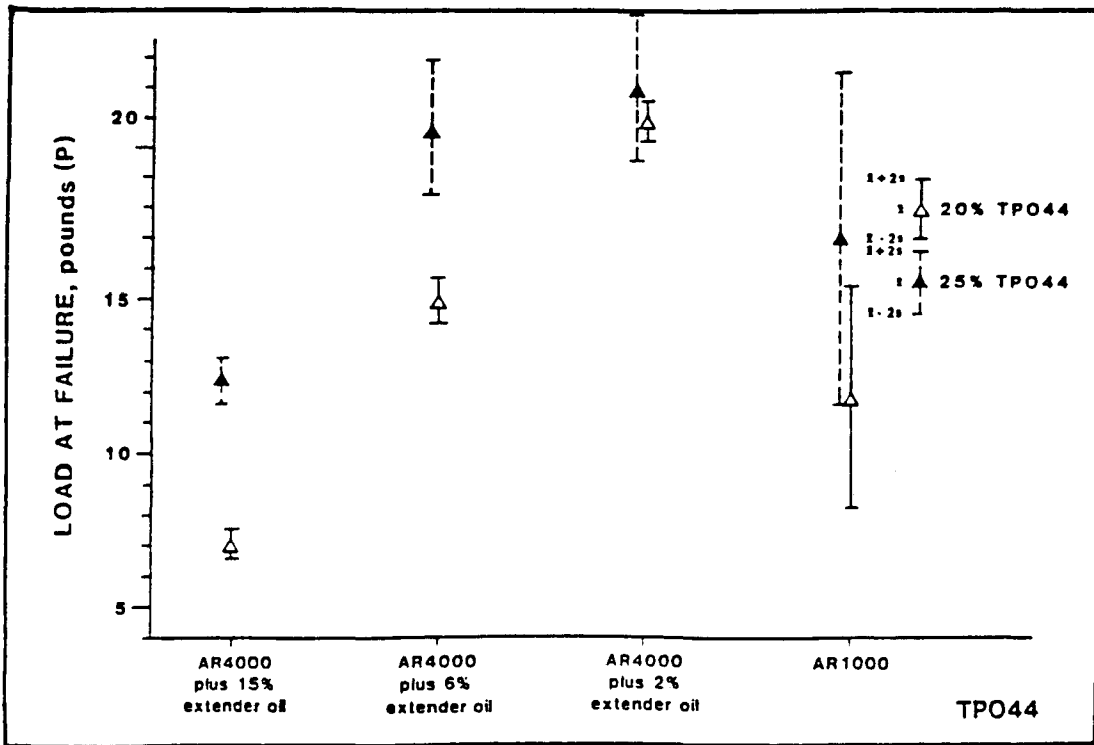

FIGURE D-9 Influence of asphalt cement and oil extender on force ductility load at failure at 39.2°F. (D2)

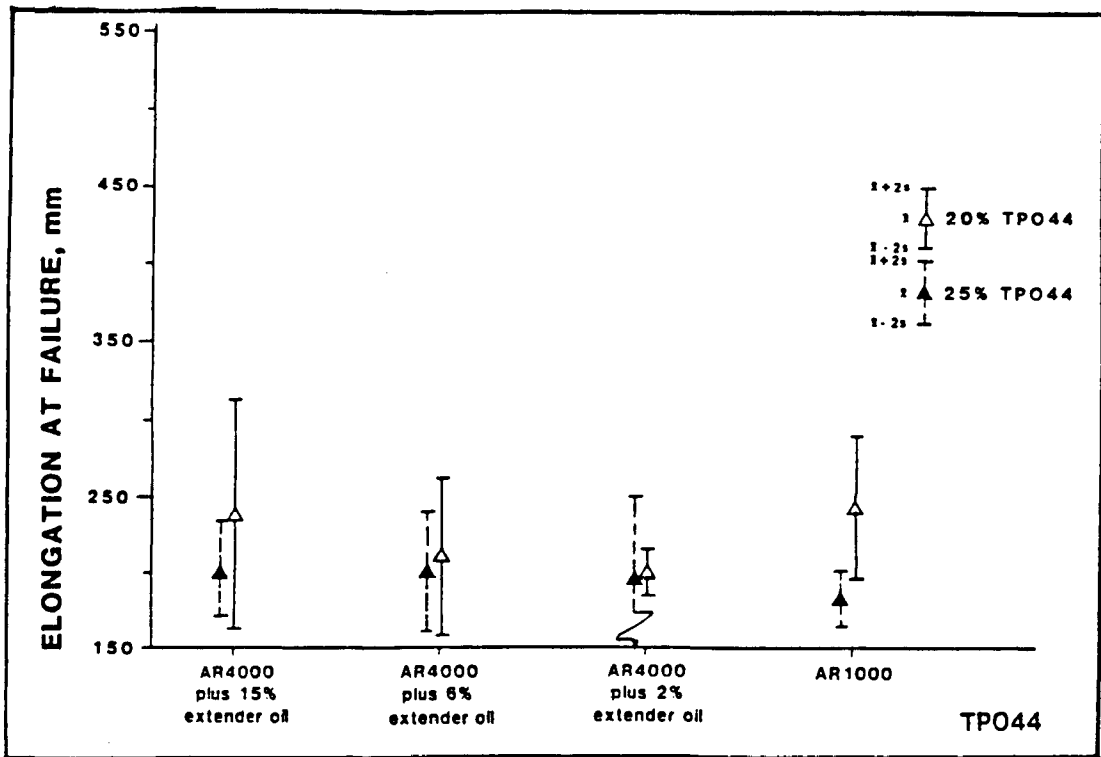

FIGURE D-10 Influence of asphalt cement and oil extender on force ductility elongation at failure at 39.2°F. (D2)

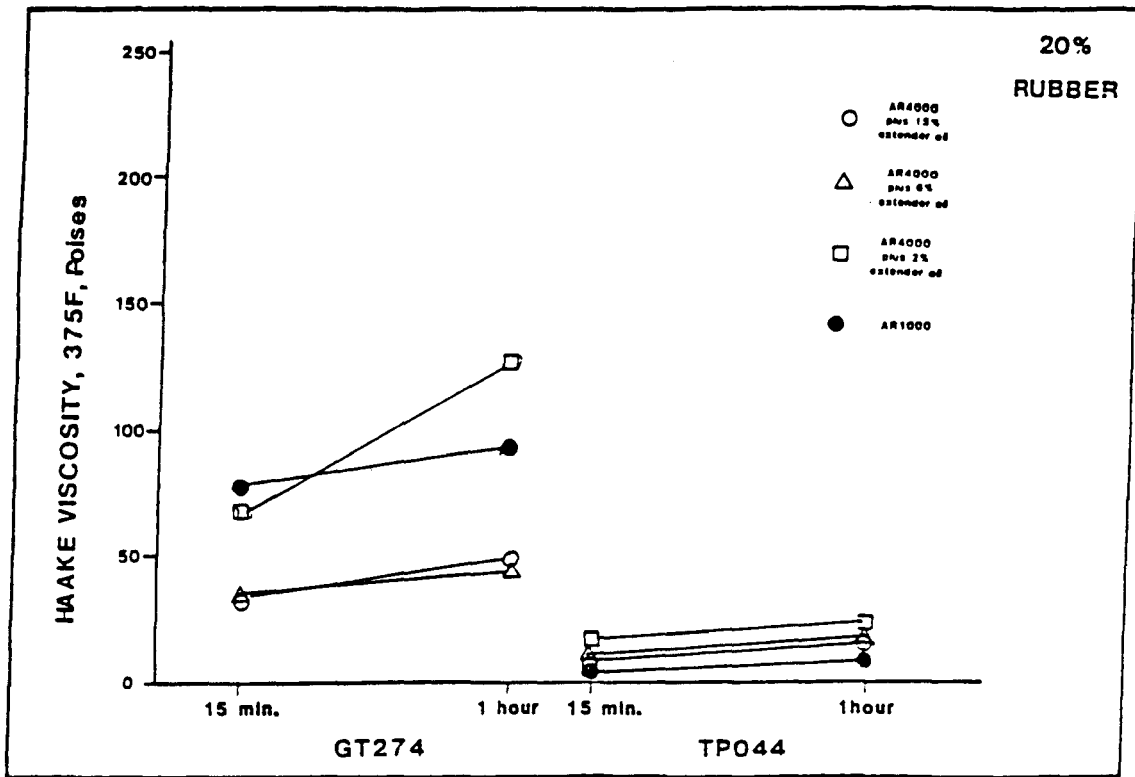

FIGURE D-11 Influence of asphalt cement and oil extender on viscosity at 375°F. (D2)

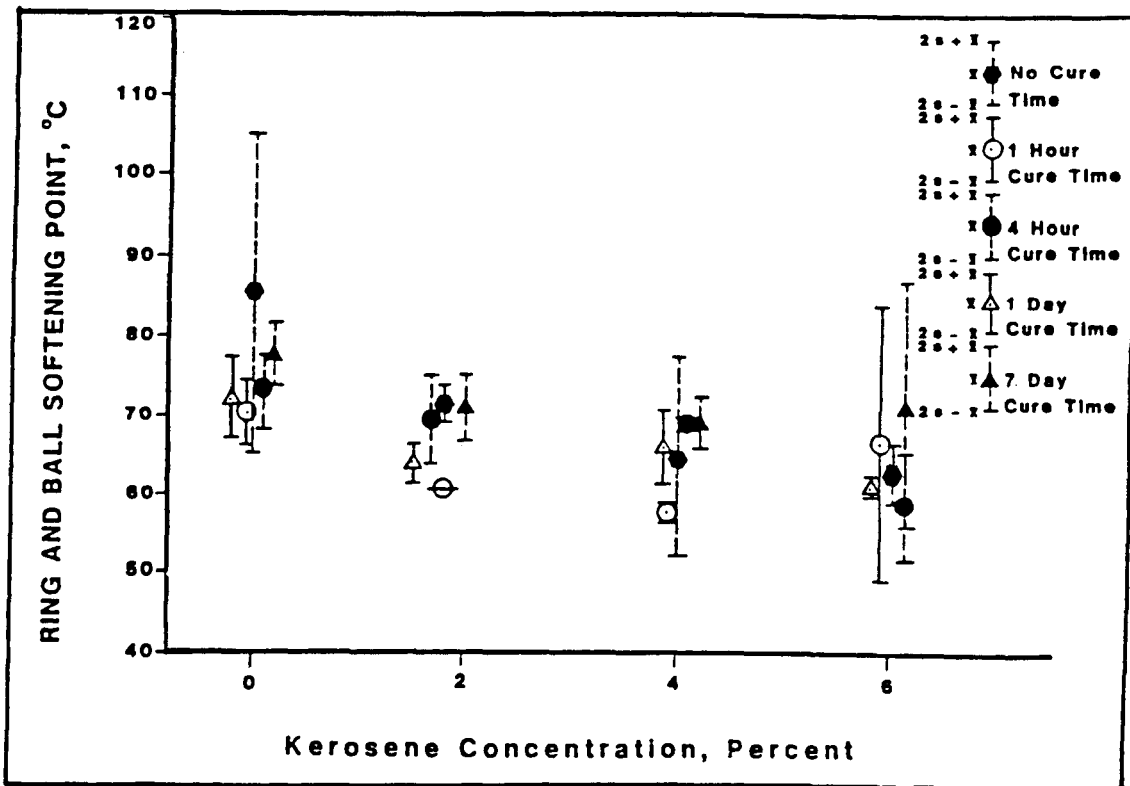

FIGURE D-12 Influence of kerosene concentration on ring and ball softening point. (D3)

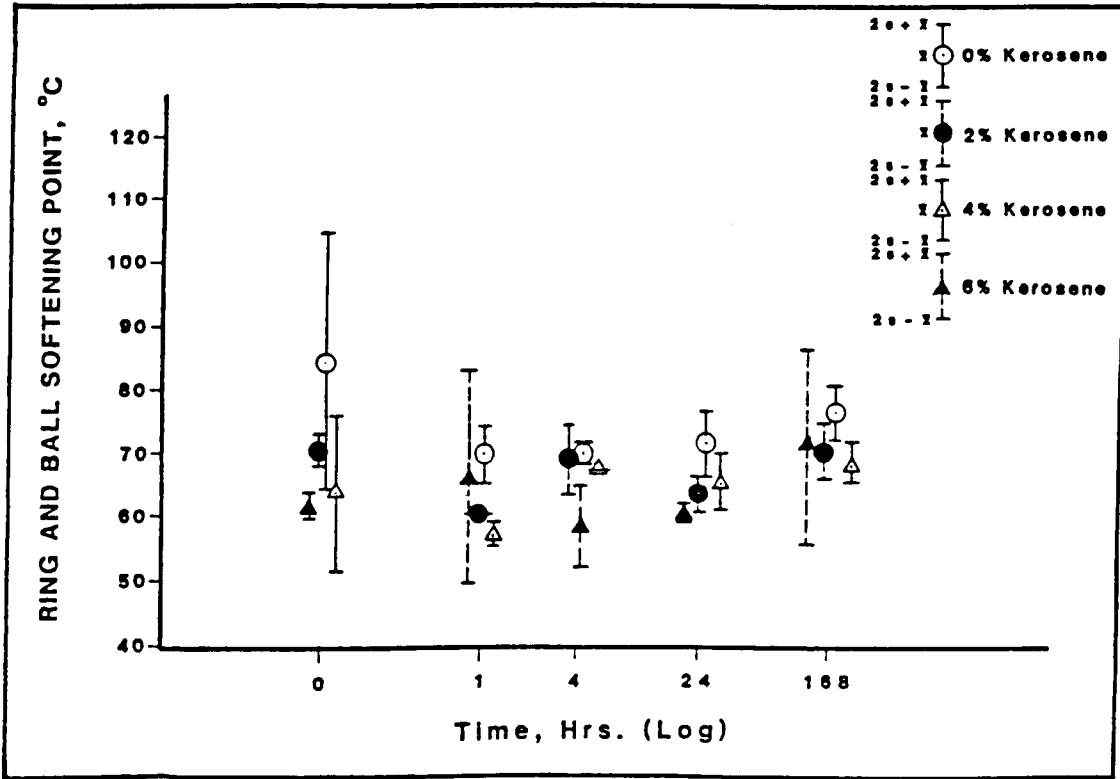

FIGURE D-13 Influence of cure time on ring and ball softening point. (D3)

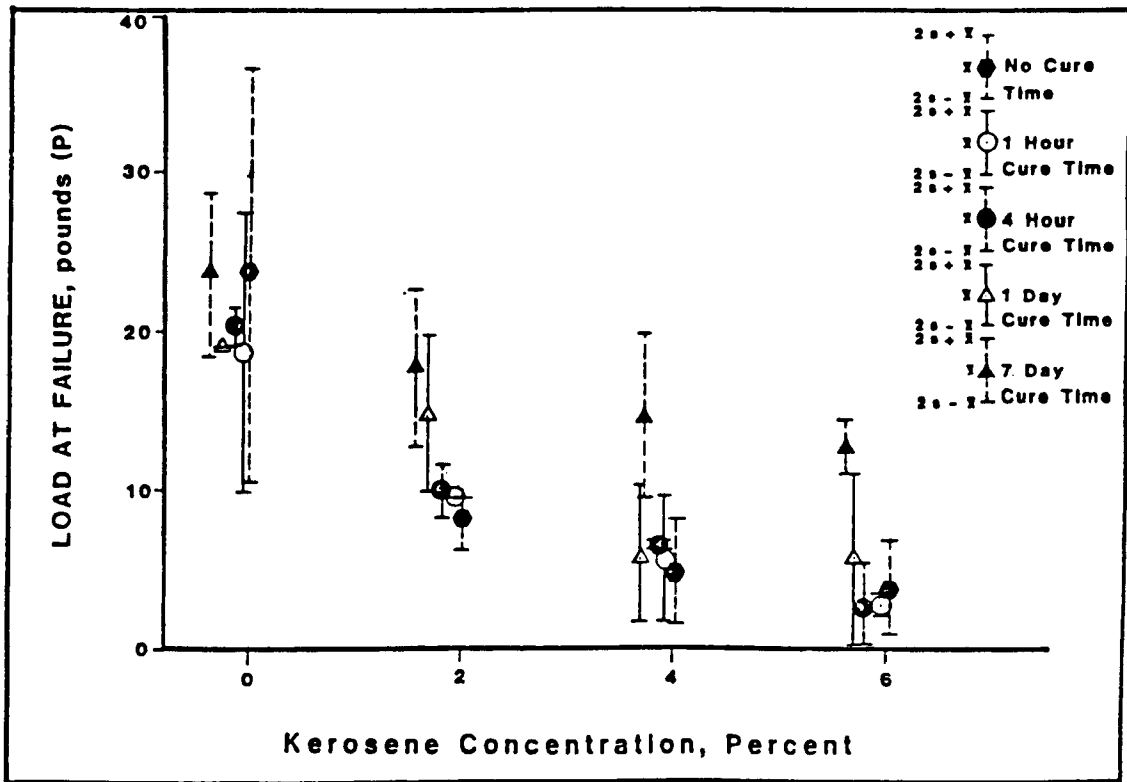

FIGURE D-14 Influence of kerosene concentration on force ductility load at failure at 39.2°F. (D3)



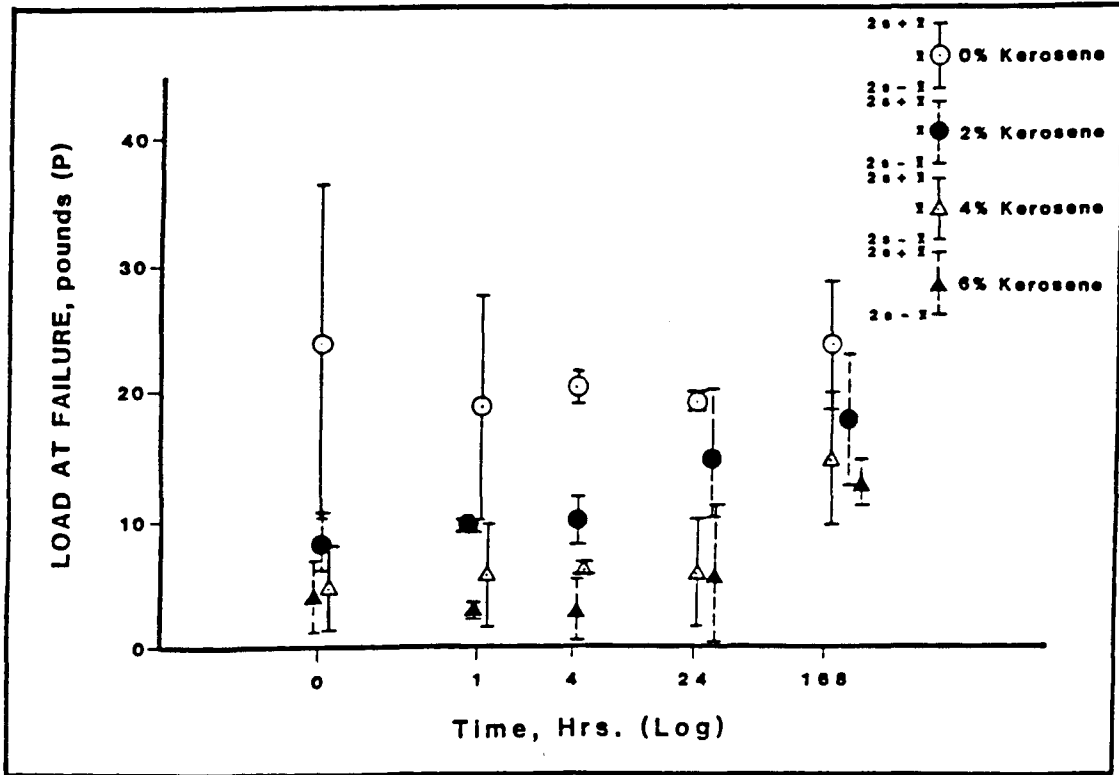

FIGURE D-15 Influence of cure time on force ductility load at failure at 39.2°F. (D3)

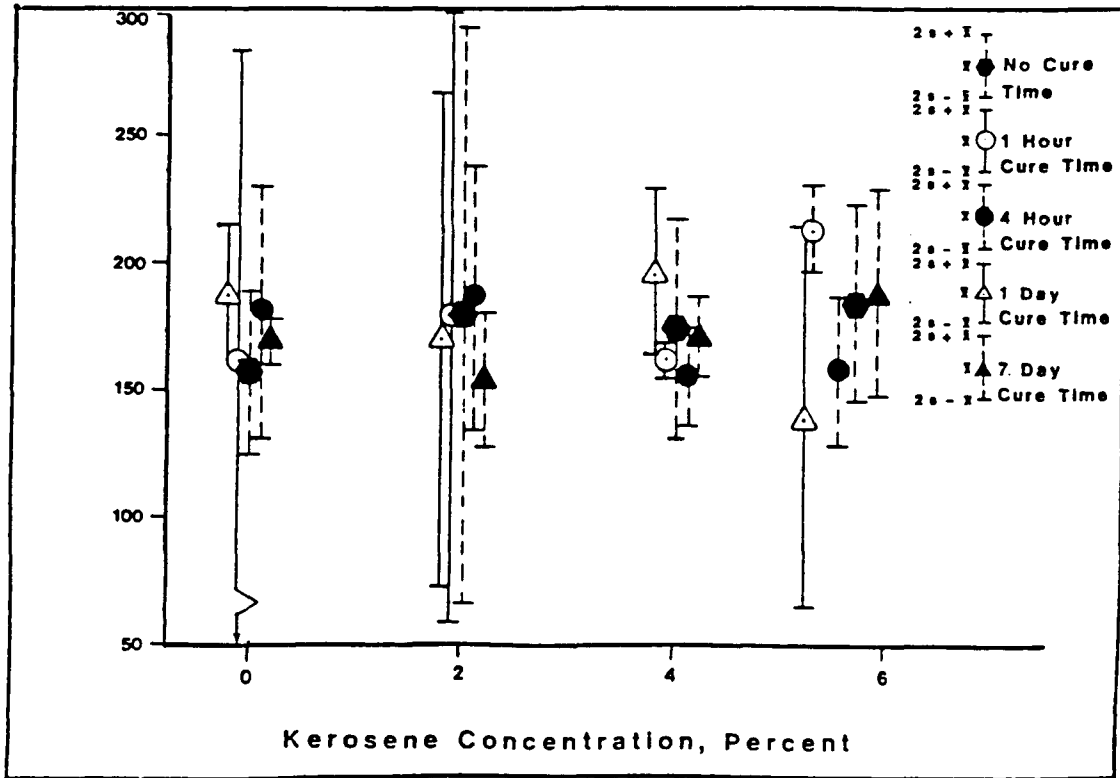

FIGURE D-16 Influence of kerosene concentration and cure time on force ductility elongation at failure at 39.2°F. (D3)

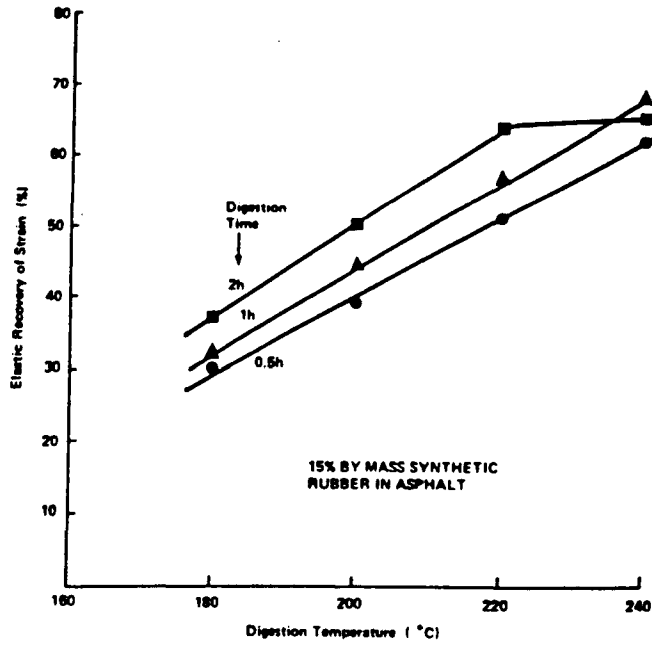

FIGURE D-17 Effect of time and temperature of digestion on elastic recovery for synthetic-rubber tire buffings. (D6)

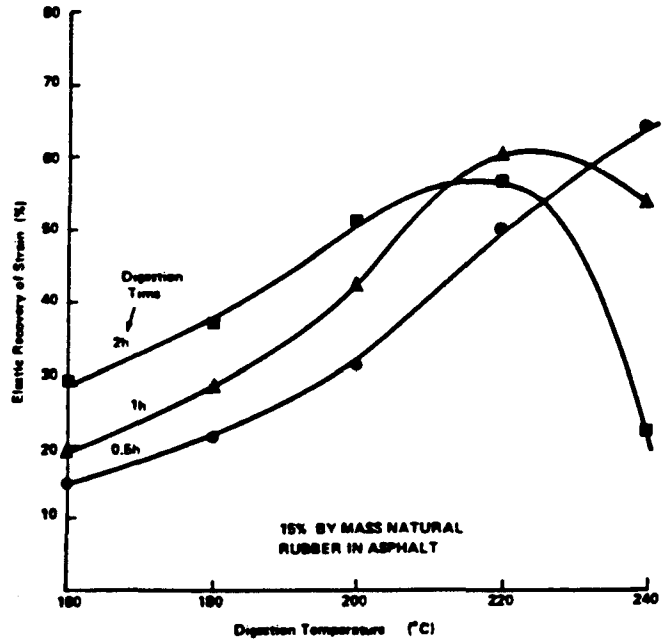

FIGURE D-18 Effect of time and temperature of digestion on elastic recovery for natural-rubber tire buffings. (D6)

## APPENDIX E

### SELECTED PATENTS ON CRUMB RUBBER MODIFIED ASPHALT

1. Taylor, N.H., Incorporating of Rubber with Bitumen in Asphalt Paving Mixtures, U.S. Patent 2,686,166, Aug. 10, 1954.
2. Endres, H.A., J.W. Shaw, and H.B. Pullar, Rubber Compositions, U.S. Patent 2,700,655, Jan. 25, 1955.
3. Pullar, H.B., Paving Composition, U.S. Patent 2,089,351, April 4, 1961.
4. Gzemeski, F.C., and R.C. Taylor, Process for Preparing Synthetic Rubber-Asphalt Compositions and Composition Prepared Thereby, U.S. Patent 3,041,200, June 26, 1962.
5. McDonald, C.H., Elastomeric Pavement Repair Composition for Pavement Failure and a Method of Making the Same, U.S. Patent 3,891,585, June 24, 1975.
6. Winters, R.E., Pavement Composition, U.S. Patent 3,919,148, Nov. 11, 1975.
7. Nielsen, D.L., and J.R. Bagley, Rubberized Asphalt Paving Composition and Use Thereof, U.S. Patent 4,069,023, Jan. 10, 1978.
8. McDonald, C.H., Elastomeric Pavement Repair Composition, U.S. Patent 4,069,182, Jan. 17, 1978.
9. McDonald, C.H., Low Viscosity Asphalt-Rubber Paving Material, U.S. Patent 4,085,078, April 18, 1978.
10. Huff, B.J., Process of Producing a Rubberized Asphalt Composition Suitable for Use in Road and Highway Construction and Repair of Product, U.S. Patent 4,166,049, Aug. 28, 1979.
11. Oliver, J.W.H., Pavement Binder Composition, U.S. Patent 4,430,464, Feb. 7, 1984.
12. Lindmark, G., Rubberized Asphaltic Concrete Composition, U.S. Patent 4,548,962, Oct. 22, 1985.
13. Wilkes, E., Rubberized Asphalt Emulsion, U.S. Patent 4,609,696, Sept. 2, 1986.

## APPENDIX F

### ASPHALT-RUBBER MEMBRANES

#### MEMBRANES

Arizona, California, Oregon, and Washington report routine use of membranes made with asphalt-rubber binders (Table 19). Wisconsin reported experimental use of membranes. Reports are available which describe the uses of membranes in Arizona (1-4). These projects are summarized below.

#### LABORATORY STUDY (2)

Arizona has conducted an extensive study of the physical properties of asphalt-rubber binders used as waterproofing membranes. Three asphalt-rubber binders, containing one part rubber and three parts asphalt cement, were compared with a control asphalt-cement membrane system. The three asphalt-rubber binders were prepared with different rubber particle sizes. The binders were prepared by blending the asphalt cement and rubber without the addition of kerosene or aromatic oils. A number of laboratory tests were conducted; the results are discussed below.

#### Water Absorption

Water absorption tests determined the amount of water absorbed by the asphalt-rubber membrane while submerged. Typical values of water absorption after 28 days are 0.6 to 0.8 percent by dry weight of asphalt rubber.

#### Water Vapor Transmission

Water vapor transmission, as measured by weight loss, was determined. Typical weight loss/time relationships are shown in Figure F-1. These data indicate that water vapor transmission is inversely proportional to membrane thickness. The size of the rubber particles used to manufacture this reacted system did not significantly affect water vapor transmission (Figure F-2).

#### Permeability

These tests experienced problems with the interface sealing and the results were unreliable. The results imply, however, that asphalt-rubber binders provide increased flow resistance or lower permeability than conventional asphalt-cement membranes.

#### Ductility

Ductility values decreased as rubber particles were added to the asphalt. Binders containing smaller rubber particles had higher

ductility values (Figure F-3). Ductility values are higher than those typically specified for asphalts used in hydraulic structures.

#### Toughness/Tensile Pull-Out

Test results for a typical asphalt cement and asphalt rubber are available. The coarser the binder rubber gradation, the greater the toughness (Figure F-4).

#### Slide

A modified Barrett Slide Test, used by the Bureau of Reclamation, was used to determine the relative flow/slope stability characteristics of the asphalt-rubber binders. Results of these tests indicate that larger rubber particles cause more base asphalt to separate from the rubber, resulting in increased flow. Binders with the finest rubber particles had the greatest resistance to flow. Adding rubber to the asphalt reduces flow or downslope movement.

#### Viscosity

The asphalt's viscosity increases with the addition of crumb rubber; the larger the particle size, the higher the viscosity. Adding rubber also reduced temperature susceptibility (Figure F-5).

#### FIELD STUDY

Several asphalt-rubber membranes have been installed in Arizona. Small field plots placed in the middle 1970s indicated that outstanding waterproofing characteristics were obtained after 1 year of exposure; the asphalt-rubber membrane experienced no deterioration. A small plot placed over expansive clay deteriorated because of soil movement. These cracks healed on hot days as the membrane was uncovered and exposed to surface environmental conditions. Some atmospheric degradation was also evident without a soil cover (2).

#### Reservoir Application

An asphalt-rubber membrane installed on a reservoir exhibited minimal downslope movement and good sealing characteristics. White paint was applied to the membrane surface to reduce its temperature (2).

**1977 Field Project**

In 1977, a field project was installed in the Dewey-Yarber wash area in Arizona over expansive clay soils. Five types of treatments were used:

- A. Compacted subgrade, 2 in. of asphalt concrete,
- B. 6 in. of lime-fly ash stabilized subgrade, asphalt-rubber membrane, 1 in. of open-graded friction course,
- C. 6 in. of cement stabilized subgrade, asphalt-rubber membrane, one in. of open-graded friction course,
- D. Compacted subgrade with moisture control, asphalt-rubber membrane, 1 in. of open-graded friction course, and
- E. Enzymatic compaction aid in subgrade, asphalt-rubber membrane, one in. of open-graded friction course.

Section A was the control section. The asphalt-rubber membrane covered the entire roadway width, shoulders, and cut ditches (2).

Field performance data, collected over a 4-year period, and engineering analysis were used to determine the life-cycle costs shown in Table F-1. Costs do not include maintenance or user costs. Stabilization with a membrane and 1 in. of open-graded asphalt concrete appear to be cost effective on low-volume roads with expansive clays.

**IH-40 and US-89 Projects**

Forstie et al. (3) present data about asphalt-rubber membrane sections placed on overlay projects on IH-40 and US-89 in Arizona. A leveling course was applied to the existing pavement, followed by blading and compacting of the shoulder slopes. An emulsion prime (0.08 gal/yd<sup>2</sup>) was shot on the soil slopes before

placing the asphalt-rubber membrane. Typically 0.60 to 0.70 gal/yd<sup>2</sup> of asphalt-rubber binder was used on the pavements and 0.70 to 0.75 gal/yd<sup>2</sup> on the earthen shoulder. Twenty-five percent ground rubber was reacted with an AR-1000 asphalt cement and kerosene. The membrane on the traveled roadway and shoulders was overlaid with asphalt concrete, and 6 in. of soil was used to cover the membrane on earth shoulders (3). An evaluation of the projects indicates that new construction without membranes will have a life of 10 to 12 years before unacceptable levels of roughness and maintenance occur. Overlays of these sections without membranes will have an expected life of about 16 years. Overlays with membranes have an expected life of 33 years. Field performance data also indicate that reflection cracking and maintenance costs are reduced when asphalt-rubber membranes are used (3).

**REFERENCES**

1. Way, G.B., *Dewey-Yarber Wash, Membrane Encapsulated Subgrade Experimental Project*, FHWA Contract DOT-FH-15-186, Arizona Department of Transportation, Aug. 1982.
2. Frobels, R.K., R.A. Jimenez, and C.B. Cluff, *Laboratory and Field Development of Asphalt-Rubber for Use as a Waterproof Membrane*, Report No. ADOT-RS-14 (167), Arizona Department of Transportation, July 1977.
3. Forstie, D., H. Walsh, and G. Way, Membrane Technique for Control of Expansive Clays, in *Transportation Research Record 705*, TRB, National Research Council, Washington, D.C. (1979).
4. Morris, G.R., Asphalt-Rubber Membranes, Development, Use, Potential, presented at Conference of the Rubber Reclaimers Association, Cleveland, 1975.

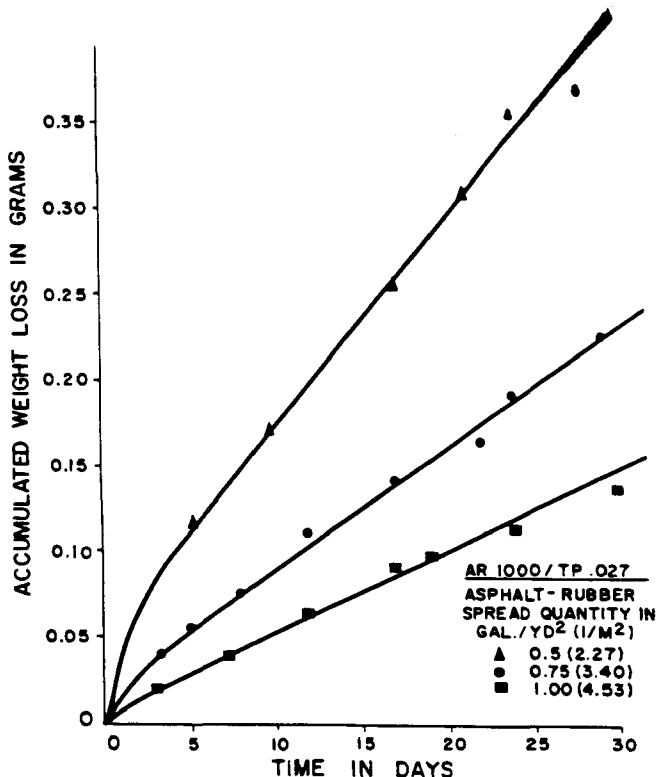

FIGURE F-1 Water vapor transmission accumulated weight loss vs. time for AR 1000/TP.027. (F2)

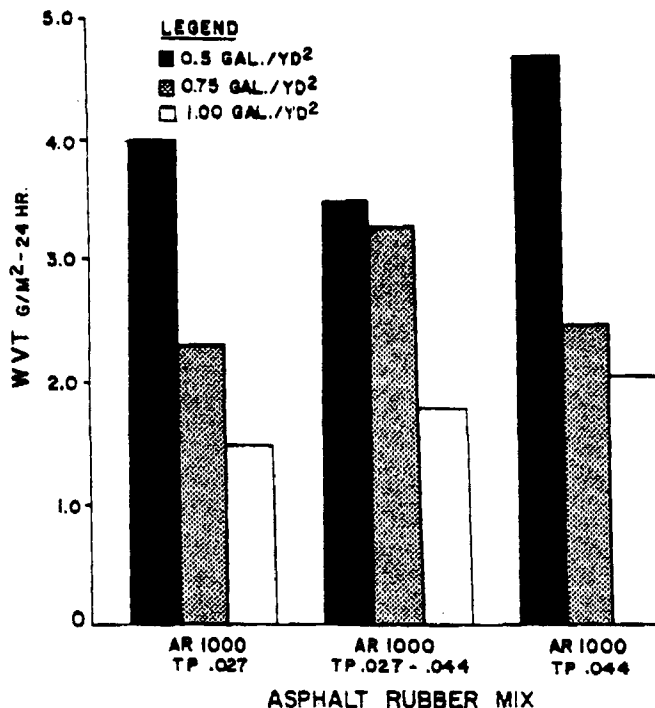

FIGURE F-2 Water vapor transmission rate for various A-R combinations. (F2)

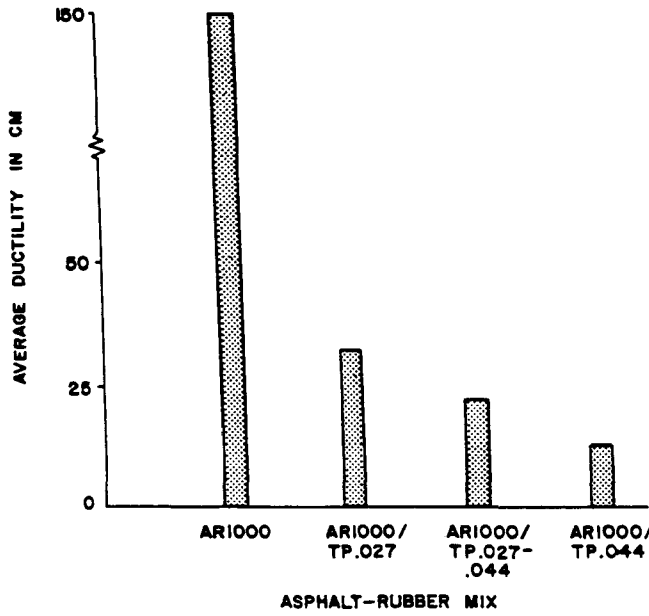

FIGURE F-3 Average ductility for various A-R mixes. (F2)

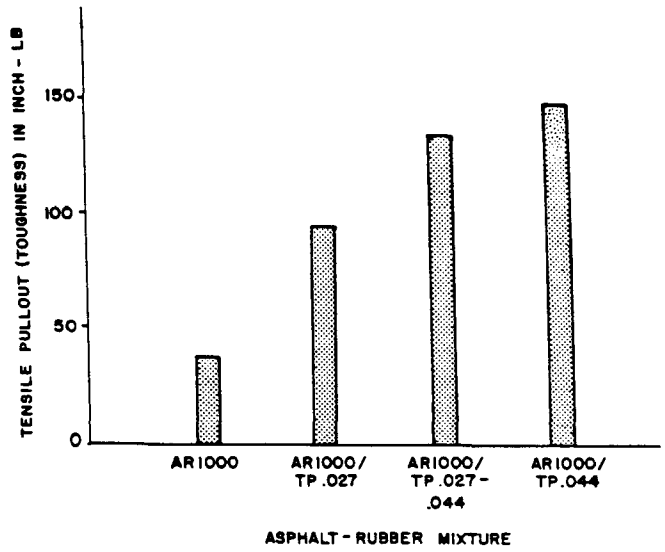

FIGURE F-4 Toughness values for various A-R mixes tested at 77°F. (F2)

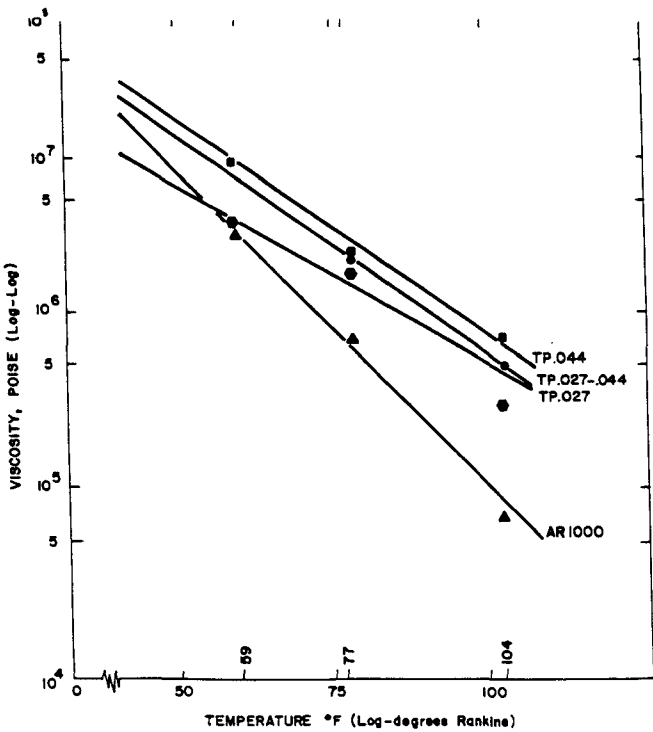

FIGURE F-5 Viscosity-Temperature relationship for asphalt and asphalt-rubber mixes. (F2)

TABLE F-1 LIFE-CYCLE COSTS OF MEMBRANES (F1)

Section	First Cost Dollars/yd.	Expected Life, Yrs.	Cost Per Year, \$/yd.
A Control	3.00	7	0.43
B Lime-Fly Ash, Membrane	3.25	10	0.33
C Cement & Membrane	3.25	10	0.33
D Membrane	2.50	4	0.63

## APPENDIX G

### CHIP SEAL DESIGN METHODS

#### CHIP SEAL DESIGN

##### Texas Method (1)

Asphalt-rubber chip seals or SAMs should be designed in the laboratory and then field adjusted. Debate as to the use of a single thickness aggregate or approximately one and one-half aggregate depth embedment for seal coats continues. Shuler et al. (1) suggest that single aggregate thickness chip seals with asphalt-rubber binders will produce the best performance. This reference contains a design method for asphalt-rubber chip seals of one stone thickness. The method is based on the field-validated Texas Method and with a "board test" to determine the aggregate application rate. The binder application rate depends on the aggregate size and size distribution. The amount of asphalt-rubber binders suggested for use in chip seals is about 15 to 20 percent higher than that required for typical asphalt cement binder without a temperature correction. The amount of asphalt-rubber binder suggested for use in interlayers made with asphalt rubber is about 45 percent higher than that typically used for asphalt-cement binder without a temperature correction. Additional field verification of this method and others presented in this appendix is needed.

##### ARCO Method (2)

Research conducted by ARCO resulted in a chip seal design method based on the use of multilayers of chip. It can be used to determine the rates of application of asphalt rubber and aggregate to obtain a desired thickness or to determine the aggregate application quantity and thickness of chip seal for a specific rate of asphalt rubber. The method is based on experimental field installations of multi-aggregate layered chip seals.

##### Australian Method (3)

Development work on asphalt-rubber binders was initiated in Australia in 1975. Based on field and laboratory experience a design method has been developed. This method uses the standard procedure used for conventional asphalt chip seals to determine the "base rate" of application of binder. The base rate quantity is adjusted by an asphalt-rubber binder factor based on the percentage of crumb rubber contained in the base asphalt and the traffic volume. The correction factors are given in Table G-1. These are larger adjustment factors than used in the Texas Method and were established to allow for multiple aggregate layer embedment.

##### South Africa (4)

A revision of the standard chip seal design method is used in South Africa for asphalt-rubber binders. The design method

considers the embedment of the aggregate into the underlying layer, the wear of the aggregate due to traffic, the voids in the aggregate, the surface texture required for skid resistance, and the fact that the initial contact between the chip and binder is firm and the stone may not flatten under the action of rolling and traffic. The method uses a modified tray test which determines the effective aggregate layer thickness and void content. Binder and aggregate contents can be calculated from these parameters.

#### REFERENCES

1. Shuler, T.S., R.D. Pavlovich, J.A. Epps, and C.K. Adams, *Investigation of Materials and Structural Properties of Asphalt-Rubber Paving Mixtures, Volume I—Technical Report*, Report No. FHWA/RD-86/027, Texas Transportation Institute, Sept. 1986.
2. Vallerga, B.A., and J.R. Bagley, *Design of Asphalt-Rubber Single Surface Treatments with Multi-Layered Aggregate Structure*, ASTM STP 724, Dec. 1979.
3. Allen, R.G., *Bitumen Scrap Rubber Seals—Recent Developments*, presented at 37th Conference of Municipal Engineers, Local Government Engineers Association of Victoria, Australia, March 1981.
4. Semmelink, C.J., *Rational Design of Bitumen-Rubber Seals According to the NTIR Method Using the Modified Tray Test*, presented at 5th Conference on Asphalt Pavements for Southern Africa, Swaziland, June 1989.

TABLE G-1  
ADJUSTMENT FACTORS FOR AUSTRALIAN CHIP SEAL  
DESIGN METHOD USING ASPHALT-RUBBER BINDERS (G3)

Crumb Rubber Content Percent by wt. of asphalt	Traffic Volume (7:00a.m. to 7:00p.m.)	Factor
5	All Traffic	1.0-1.1
15-25	15,000 plus	1.5
	5,000-15,000	1.50-1.75
	1,000-5,000	1.75-2.00
25-30	Less than 1,000	Special Considerations
	15,000 plus	1.75
	5,000-15,000	2.00
	Less than 5,000	2.25

## APPENDIX H

### CHIP SEAL PERFORMANCE

#### Arizona DOT (1,2)

Several chip seal or stress-absorbing membrane (SAM) projects have been placed and evaluated by the Arizona DOT. Results of these studies are shown in Table H-1 and Figures H-1 and H-2.

Pavement survival cores generated by Arizona DOT from their pavement management system are shown in Figure H-1 for Interstate, U.S., and State highways. Survival was defined as the time at which the next major rehabilitation occurred. Table H-1 shows the statistics revealed by these curves, together with the age of the pavement at the time of the chip seal placement and the average traffic on the type of highway studied. The average life of asphalt-rubber chip seals for the various categories of highways is given below:

Interstate	5 years
U.S. routes	8 years
State routes	10 years

The amount of reflection cracking in these chip seals is shown in Figure H-2. Arizona has used the asphalt-rubber binder chip seal on a large number of cracked pavements. Asphalt-rubber chip seals will not prevent reflection cracking. The frequency distribution of the performance of these chip seals for other types of distress can be found in Gonsalves (1).

#### Arkansas (3)

Arkansas has placed a number of asphalt-rubber chip seals and interlayers over concrete pavements. Performance of these sections is shown in Table H-2. After 8 years of service all sections experienced 100 percent reflection cracking. Reflection cracking in control sections and sections containing asphalt-rubber chip seals occurred at approximately the same time after construction.

#### California (4)

An experimental project placed in the southern California desert consisted of an overlay over a fabric interlayer, 0.2-ft and 0.35-ft overlay control sections, and an asphalt-rubber chip seal. The condition of the pavement before rehabilitation was defined as badly alligator cracked, dry, and brittle. After 4 years of service, no reflection cracking was evident in the control sections or the overlay sections containing a fabric interlayer. Intermittent to continuous alligator cracks were observed through the asphalt-rubber chip seal sections.

#### Connecticut (5)

A Connecticut performance study indicated that, after 3 to 4 years of performance, the asphalt-rubber seals were better than the

control sections. After 9 years of performance, many of the asphalt-rubber chip seals were resurfaced. Asphalt-rubber chip seals placed on new surface of HMA appear to be aiding the performance of the pavements.

#### Florida (6,7)

Three years of performance information are available for a Florida experimental section. The asphalt-rubber chip seal embedded in the leveling course caused bleeding on one section. The asphalt-rubber chip seal placed on the existing pavement exhibited more reflection cracking than a chip seal control section.

#### Georgia (8)

Asphalt-rubber experimental chip seals were placed in Georgia in 1976. Single, double, and triple chip seals were placed and evaluated for fatigue (alligator cracking), longitudinal, and transverse cracking over a 6-year period. Table H-3 shows the development of these forms of cracking. The triple surface treatment constructed with a conventional asphalt cement had excellent performance. The asphalt-rubber single chip seal sections performed better than the control sections.

#### Oregon (9)

Oregon has evaluated the performance of asphalt-rubber chip seals and conventional chip seals. A summary of performance after 3 years of service is shown in Table H-4. The asphalt-rubber chip seal sections had superior performance: the cracks took longer to reflect, the cracking was less extensive, and all but the larger cracks remained sealed.

#### Texas (10-12)

A larger number of asphalt-rubber chip seals have been placed in Texas since 1976. Conclusions provided as a result of a survey conducted by the Asphalt-Rubber Producers Group (10) are given below:

- Asphalt-rubber chip seals have proven to be very successful on farm-to-market and suburban roads and streets.
- Asphalt rubber reduces maintenance costs by its resiliency, its flexibility, and its ability to seal the surface.
- Asphalt rubber extended the life cycle of Texas roads while utilizing a waste product.
- Asphalt rubber has stopped all alligator cracking.



Studies conducted by the Texas Transportation Institute on 45 asphalt-rubber projects in 13 highway districts were compared with a data base of 148 conventional chip seal projects. Conclusions from this study are given below:

- Flushing occurred on 99 percent of all asphalt-rubber seals and 74 percent of conventional seal coat projects.
- Shrinkage cracking appears in about 50 percent of all asphalt-rubber chip seals and conventional chip seals.
- Alligator cracking appears at approximately twice the frequency in conventional chip seals as asphalt-rubber chip seals.
- Chip or stone loss occurs on 44 percent of conventional chip seal projects and 17 percent of asphalt-rubber chip seal projects.
- Improved design methods for asphalt-rubber chip seals may alleviate these performance problems.

A more recent study in Texas (12) had the following conclusions:

- Asphalt-rubber chip seals typically exhibit more distress than conventional chip seals; however, this distress is attributed to design, construction practices, and the fact that this type of chip seal is used on the more difficult projects.
- Five of 24 districts as of 1990 use asphalt-rubber chip seals on a somewhat regular basis. More than half of the districts have no plans for constructing asphalt-rubber chip seals. The reason cited for not using asphalt-rubber chip seals is the cost. Some districts, however, believe this to be a cost-effective treatment.

#### **Washington (13)**

Four asphalt-rubber chip seal projects were placed in the state of Washington. The two projects placed in 1978 experienced nearly immediate problems as the aggregate chips became embedded and friction became a problem. Two projects built in 1980 experienced no early problems and performed until a standard seal was placed over the section. The service life of these sections ranged from 3 to 7 years with an average of 5.8 years. Conventional chip seals in eastern Washington have an average life of 6.5 years. Since the asphalt-rubber chip seals cost 2.5 to 3 times as much as conventional seals, it was concluded that this performance did not justify the added expense.

#### **City of Phoenix (14)**

The City of Phoenix performed a condition survey on asphalt-rubber chip seals 11 years after placement. Conclusions from this study are summarized below:

- Asphalt-rubber chip seals are doing a "good job" of preventing reflections of fatigue cracking and shrinkage cracking results from soil cement treatment. Cracks that have reflected in the asphalt-rubber chip seals have no raveling, spalling, or potholing.
- Loss of cover stone is evident on some projects. Embedment depths of 50 percent or greater are needed for cool weather.
- Bleeding was evident on a few projects.

- Asphalt-rubber chip seals have performed well for 11 years over severely cracked pavements, whereas conventional chip seals normally last about 1 or 2 years over badly cracked pavements and 6 to 8 years over reasonably sound pavements.
- Maintenance costs were greatly reduced on pavements with asphalt-rubber chip seals.

#### **National Studies**

Two studies have reported the performance of asphalt-rubber chip seals in several states (5,15,16). The state pooled final study (15,16) used an improvement rating scale to quantify the difference between pavement sections containing asphalt rubber and control sections (Figure H-3). Positive numbers indicate improved performance was obtained with the use of asphalt-rubber binders. Figure H-4 shows the relative performance of asphalt-rubber chip seals placed since 1979 and evaluated after about 5 or 6 years of performance.

These performance data indicate an approximate normal distribution but with a negative skew. Flushing was the primary cause for negative performance. When flushed sections are removed from the data base, a positive performance relationship is noted. The negative performance of asphalt-rubber seal coats does not appear to be a fundamental material property but one of design and construction (16).

Based on the pooled fund study, asphalt-rubber seals appear to be most effective in the following situations:

- Maintenance of pavements containing alligator cracking or random transverse or longitudinal cracks at less than 8-ft intervals,
- Maintenance of low traffic volume facilities in conditions where conventional seals would oxidize and crack due to lack of use, and
- Facilities where high traffic would not permit the use of conventional seals.

#### **U.S. Navy (17)**

A study conducted by the U.S. Navy (17) evaluated the performance of asphalt-rubber seals at several military facilities. Based on these evaluations, the asphalt-rubber seals are stated to be as effective as 2 in. of hot-mix asphalt overlay in preventing reflection cracks over pavements which contain fatigue distress. Other findings are given below:

- Shrinkage cracks will reflect almost completely within 1 year after sealing.
- The loss of aggregate is not solved by the use of asphalt-rubber binder.
- Narrow reflection fatigue cracks are self-healing in hot weather.

#### **Australia (18)**

A paper published in Australia identified several advantages and disadvantages associated with the use of asphalt-rubber chip seals. The following advantages were identified:

- Reduced reflection cracking,
- If reflection cracks occur, they are finer and have less chance of spalling,
- Reflection cracks tend to heal in summer,
- Binder is less susceptible to temperature,
- High binder contents can be used,
- Provides a surface that will delay rehabilitation, and
- Can be used in difficult traffic situations.

The disadvantages identified in the report are summarized below:

- Higher cost,
- Darker color,
- Requires greater construction care,
- Need better weather conditions for applications,
- Needs stricter safety precautions,
- Cannot store binder at elevated temperature, and
- More difficult to obtain initial adhesion.

## REFERENCES

1. Gonsalves, G.F.D., *Evaluation of Road Surfaces Utilizing Asphalt-Rubber—1978*, Report No. 1979-GG3, Arizona Department of Transportation, Nov. 1979.
2. Schofield, L., The History, Development, and Performance of Asphalt Rubber at ADOT, presented at the National Seminar on Asphalt-Rubber, Oct. 1989.
3. Meadors, A., and H. Snow, *Experimental Projects Using Rubber Asphalt Membrane to Retard Reflection Cracking, Final Report*, Arkansas State Highway and Transportation Department, April 1988.
4. Skog, J.B., J.A. Matthews, G.H. Mann, and D.V. Roberts, *Statewide Flexible Pavement Performance and Deflection Study*, Report No. FHWA-CA-TL-78-28, California Department of Transportation, Dec. 1978.
5. Stephens, J.E., *Nine Year Condition Survey of Connecticut Department of Transportation Experimental Rubber/Asphalt Application*.
6. Murphy, K.H., and C.F. Potts, *Evaluation of Asphalt-Rubber as a Stress Absorbing Interlayer*, Report No. FHWA-DP-37-14, Florida Department of Transportation, Aug. 1980.
7. Coley, J.O., *A Study of Flexible Pavement with Ramflex Rubber Additives*, Report No. 1, Mississippi State Highway Department, Dec. 1, 1970.
8. Deringer, K.T., and J. Smith, *Asphalt Additives Study, Construction Report*, Report No. FHWA/NJ-85-007-7713, New Jersey Department of Transportation, Feb. 1985.
9. Beecraft, G., T.A. Hardy, and R.J. Steyskal, *Evaluation of Rubber-Asphalt Chip Seals in Oregon*, Final Report, Oregon Department of Transportation, Sept. 1982.
10. *Texas Asphalt-Rubber Survey*, Asphalt-Rubber Producers Group.
11. Shuler, T.S., B.M. Gallaway, and J.A. Epps, *Evaluation of Asphalt Rubber Membrane Field Performance*, Research Report No. 287-2, Texas Transportation Institute, May 1982.
12. Estakhri, C.K., E.G. Fernando, J.W. Button, and G.R. Teetes, *Use, Availability, and Cost-Effectiveness of Asphalt-Rubber in Texas*, Research Report No. 1902-1S, Texas Transportation Institute, 1991.
13. Anderson, K.W., and N.C. Jackson, *Rubber-Asphalt Pavements in the State of Washington*, Report No. WA-RD-2681, Washington State Department of Transportation, March 1992.
14. Schnormeier, R.H., *Eleven Year Pavement Condition History of Asphalt-Rubber Seals in Phoenix, Arizona*, ASTM STP 724, 1979.
15. Shuler, T.S., R.D. Pavlovich, J.A. Epps, and C.K. Adams, *Investigation of Materials and Structural Properties of Asphalt-Rubber Paving Mixtures, Volume I—Technical Report*, Report No. FHWA/RD-86/027, Texas Transportation Institute, Sept. 1986.
16. Shuler, T.S., R.D. Pavlovich, and J.A. Epps, *Field Performance of Rubber Modified Asphalt Paving Materials*, in *Transportation Research Record 034*, TRB, National Research Council, Washington, D.C. (1985).
17. Brownie, R.B., *Evaluation of Rubber-Asphalt Binder for Seal Coating Asphaltic Concrete*, Report No. TM-M-S3-76-5, Western Division, Naval Facilities Engineering Command, Department of Navy, Aug. 1976.
18. Allen, R.G., *Bitumen Scrap Rubber Seals-Recent Developments*, presented at 37th Conference of Municipal Engineers, Local Government Engineers Association of Victoria, Australia, March 1981.

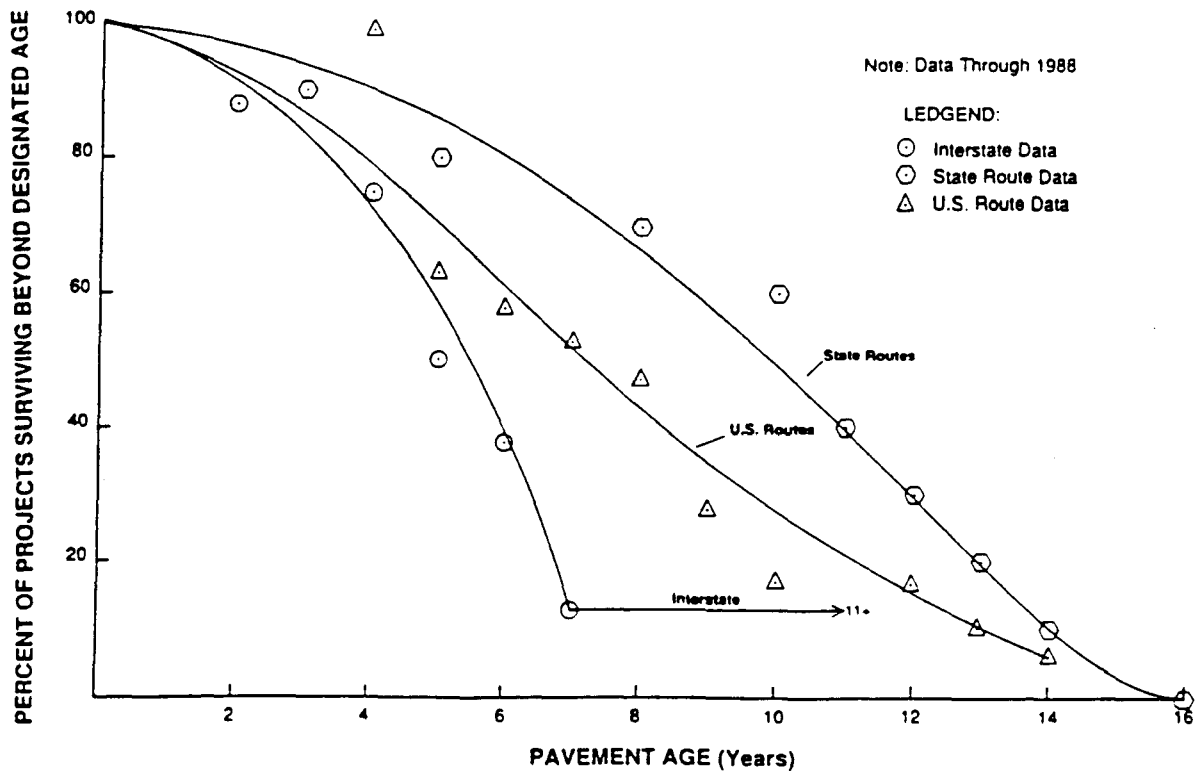

FIGURE H-1 Pavement survival curves for SAM surface treatments. (H2)

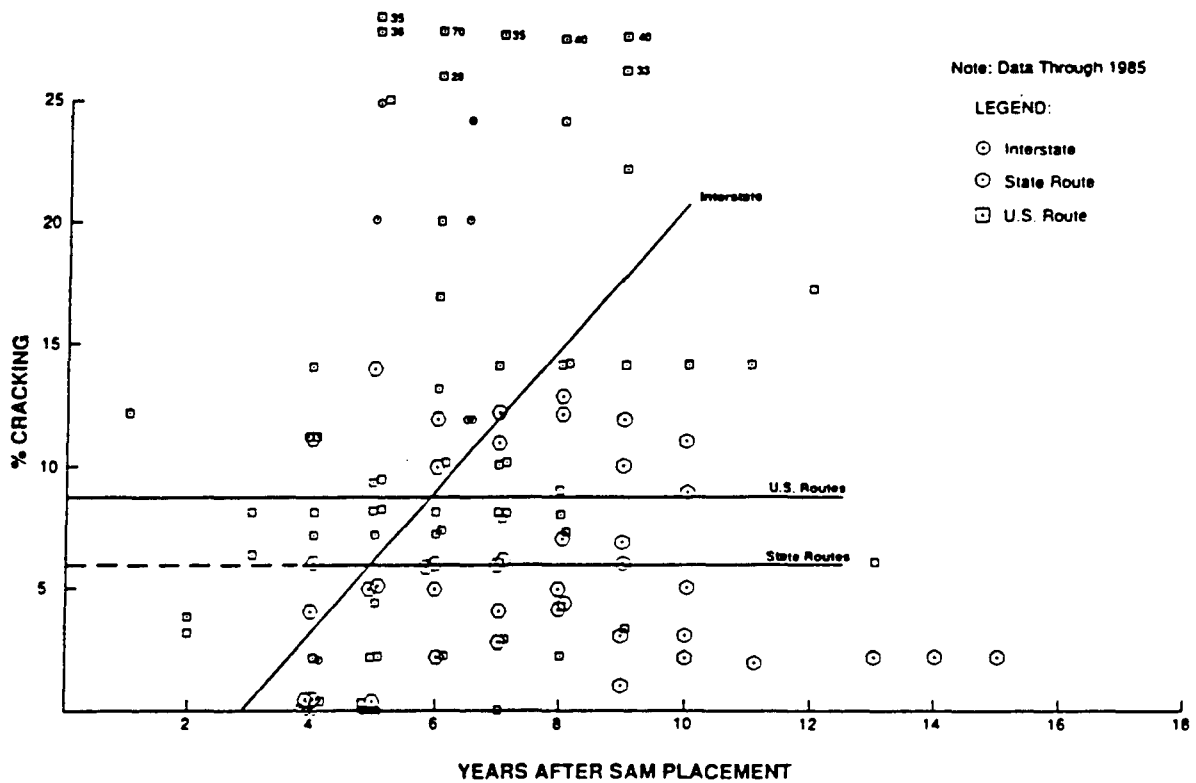

FIGURE H-2 Pavement crack development in SAMs. (H2)

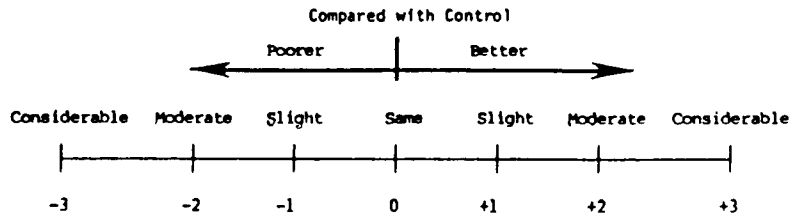

FIGURE H-3 Improved rating scale. This scale was developed to quantify performance differences between pavement sections containing rubber and control sections. Positive numbers indicate that sections containing rubber provide improved performance compared to control sections. Negative numbers indicate that sections containing rubber provide poor performance relative to control sections. (H16)

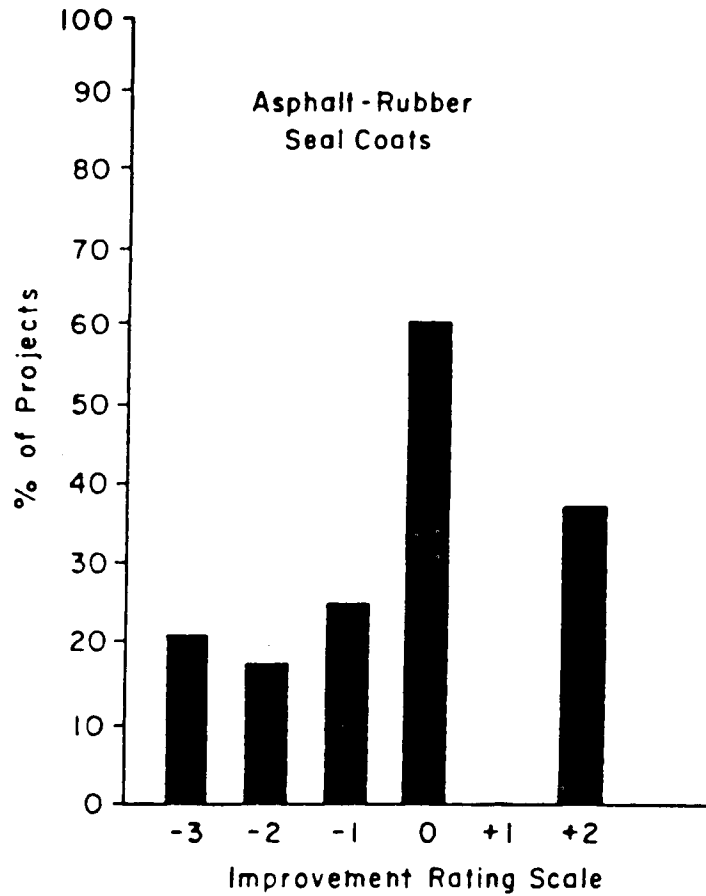

FIGURE H-4 Performance projects constructed after 1979. (H15)

TABLE H-1 PERFORMANCE DATA FOR SAM (H2)

Route	SAM LIFE (Years)				Pavement Age @ SAM Placement (Years)				Mean 18K ESALS* Since SAM Placement
	$\bar{X}$	$\sigma$	C.V.	R	$\bar{X}$	$\sigma$	C.V.	R	
Interstate	5.3	1.7	31%	2-7	11.6	2.7	23%	8-17	3944
State Route	10.0	3.8	38%	3-15	17.9	8.0	45%	2-29	401
U.S. Route	8.2	3.2	38%	4-13	23.4	9.7	41%	16-48	496

TABLE H-2  
EVALUATION OF ASPHALT-RUBBER PROJECTS (H3)

State Job Number	Location	Route-Sec	Log Mile from to	Date of Construction	Supplier	Overlay Thickness	Use	PERCENT FAILURE
11950	West Memphis	70-20	7.00- 9.00	07/79	Sahuaro	1½"-2½"	SAM/SAMI	100
11917	Louise	147-01	5.34-11.02	06/80	Sahuaro	4"	SAM	100
3854	Hope	30-12	22.30-36.80	04/81	Sahuaro	5"	SAMI	100
60137	Little Rock	30-23	137.2-138.5	10/82	Sahuaro	1½"-3½"	SAM/SAMI	100
60180	Little Rock	30-23	138.5-140.3	11/83	Sahuaro	5½"	SAM	100
4702	Fayetteville	471-3	0.30- 2.23	06/82	Sahuaro	3½"	SAMI	100
4-606	Fort Smith	22-01	17.00-20.13	10/80	Sahuaro	--	Seal	100
7842	Arkadelphia	67-05	2.00-15.00	11/80	Sahuaro	--	Seal	100
3858	Ashdown	71-04	7.69-12.39	01/84	Sahuaro	1½"	SAMI	100
100006	Jonesboro	63-07	5.01-12.37	07/83	Sahuaro	1½"-3½"	SAM	100

TABLE H-3  
 PERFORMANCE HISTORY, SR-37, CALHOUN  
 COUNTY (H8)

DISTRESS AS PERCENT OF ORIGINAL CONDITION

DATE OF EVALUATION	RUBBER ASPHALT SECTIONS 2-10			TRIPLE SURFACE TREATMENT SECTIONS 11-13			DOUBLE SURFACE TREATMENT SECTIONS 14-17			RUBBER ASPHALT SECTIONS 18-17		
	FATIGUE CRACKS	LONGITUDINAL CRACKS	TRANSVERSE CRACKS	FATIGUE CRACKS	LONGITUDINAL CRACKS	TRANSVERSE CRACKS	FATIGUE CRACKS	LONGITUDINAL CRACKS	TRANSVERSE CRACKS	FATIGUE CRACKS	LONGITUDINAL CRACKS	TRANSVERSE CRACKS
April 1977	0	0	0	0	0	0	0	0	34	0	0	1
Feb. 1978	0	60	25	0	0	4	0	0	91	0	0	45
Aug. 1979	0	50	35	0	0	1	22	134	97	0	3	24
Sept. 1980	66	35	21	0	0	0	469	23	17	23	17	29
Aug. 1981	102	30	16	0	0	0	572	23	9	46	47	40
May 1982	129	50	20	0	0	0	662	0	0	126	70	50

TABLE H-4  
SUMMARY OF PERFORMANCE (H9)

	<u>Years Since Sealing</u>	Percentage of Sections in Each Category of Defect		
		<u>None</u>	<u>Minor</u>	<u>Major</u>
Rubber- Asphalt	1	76	24	0
	3	43	52	5
O-31 Oil Mat	1	27	73	0
	3	0	73	27

---

None - no defects.

Minor - few defects, minor in nature.

Major - extent of cracking equal or worse than before seal applied.

## APPENDIX I

### CHIP SEAL LIFE-CYCLE STUDIES

#### Arizona DOT (1-3)

Three economic studies have been performed in Arizona which deal with life-cycle costs. The study reported by Way (1) indicates that an asphalt-rubber seal coat placed on an asphalt-concrete overlay is an effective method for reducing reflection cracking and is cost effective.

Gonsalves (2) shows the cost increases in asphalt-rubber binder from 1971 to 1977 rising from about \$220/ton to \$350 to \$400/ton. Typical prices in the early 1990s are in the range of \$450 to \$500/ton.

Zaniewski's (3) report to the Arizona DOT contains life-cycle cost comparisons. First costs of alternative treatments and maintenance costs based on historical records were used. An estimate of user costs and salvage values was included in the analysis. The results of the life-cycle costs in terms of present worth for different sizes of projects, types of highways, traffic volumes, and life of rehabilitation alternatives are shown in Table I-1. The analysis indicates that if a conventional chip seal lasts 5 years, an asphalt-rubber chip seal would need to last 10 years for the same life-cycle cost.

#### Texas (4)

A report prepared by the Texas Transportation Institute provides costs of chip seals made with different types of binders (Figure I-1). Asphalt-rubber chip seal costs are more than twice as much as the first costs of chip seals made with asphalt cement, asphalt cement with latex, asphalt emulsion, and asphalt emulsion with polymer.

#### New York (5)

Gupta performed an economic analysis of asphalt-rubber chip seals using life-cycle costing techniques with the costs for pavement rehabilitation alternatives shown in Table I-2. Comparisons were developed between alternatives to have certain life cycles for equal annual costs (Table I-3). If a conventional chip seal has a life of 6 years, an asphalt-rubber chip seal must have a life of 13 years for both to have an equal annual cost.

#### Industry Data (6-8)

First cost and life-cycle cost information has been published by the suppliers of asphalt-rubber binders. These estimates of first costs and service life are shown in Tables I-4 and I-5. These figures illustrate the economic benefits of the asphalt-rubber chip seal.

Schnormeier (6) shows the cost increases of asphalt-rubber and conventional chip seals from 1971 to 1982. The cost of conven-

tional chip seals escalated to a larger degree than the asphalt-rubber chip seal.

#### Other Studies (9,10)

Life-cycle cost analysis were performed in a state pooled-fund study (9). This report is a revision and extension of that reported in Epps and Gallaway (10). Results indicated that if a conventional chip seal will last 6 years, an asphalt-rubber chip seal must last 15 to 16 years for equal annual life-cycle costs (Table I-6). A comparison of alternatives considering rehabilitation and maintenance costs and salvage value indicate the potential economic benefits of using asphalt-rubber chip seals (Table I-7).

#### REFERENCES

- Way, G.B., *Prevention of Reflective Cracking, Minnetonka—East (1979 Addendum Report)*, Report No. 1979-GW1, Arizona Department of Transportation, Aug. 1979.
- Gonsalves, G.F.D., *Evaluation of Road Surfaces Utilizing Asphalt-Rubber—1978*, Report No. 1979-GG3, Arizona Department of Transportation, Nov. 1979.
- Zaniewski, J.P., *Summary of Arizona Department of Transportation Experience with Asphalt-Rubber—State of the Art*, Report No. FHWA-AZ88-818, Arizona Department of Transportation, Aug. 1988.
- Estakhri, C.K., E.G. Fernando, J.W. Button, and G.R. Teetes, *Use, Availability, and Cost-Effectiveness of Asphalt-Rubber in Texas*, Research Report No. 1902-1S, Texas Transportation Institute, 1991.
- Gupta, P.K., *Asphalt-Rubber Surface Treatments and Interlayers*, Report No. FHWA/NY/RR-86/131, New York Department of Transportation, March 1986.
- Schnormeier, R.H., *Use of Asphalt-Rubber on Low-Cost, Low-Volume Streets: A Review After 13 Years*, in *Transportation Research Record 898*, TRB, National Research Council, Washington, D.C. ( ).
- Jacobsen, C.C., and R.H. Schnormeier, *Cost Effectiveness of Asphalt-Rubber*, presented at the National Seminar on Asphalt-Rubber, Oct. 1989.
- Masters, M., *Cost Comparisons Using Conventional Methods of Rehabilitation Versus Methods Using Asphalt-Rubber Systems*, presented at the National Seminar on Asphalt-Rubber, Oct. 1989.
- Shuler, T.S., R.D. Pavlovich, J.A. Epps, and C.K. Adams, *Investigation of Materials and Structural Properties of Asphalt-Rubber Paving Mixtures, Volume I—Technical Report*,



Report No. FHWA/RD-86/027, Texas Transportation Institute, Sept. 1986.

with Asphalt-Rubber Binders, presented at the National Seminar on Asphalt-Rubber, Oct. 1981.

10. Epps, J.A., and B.M. Gallaway, Cost and Energy Associated

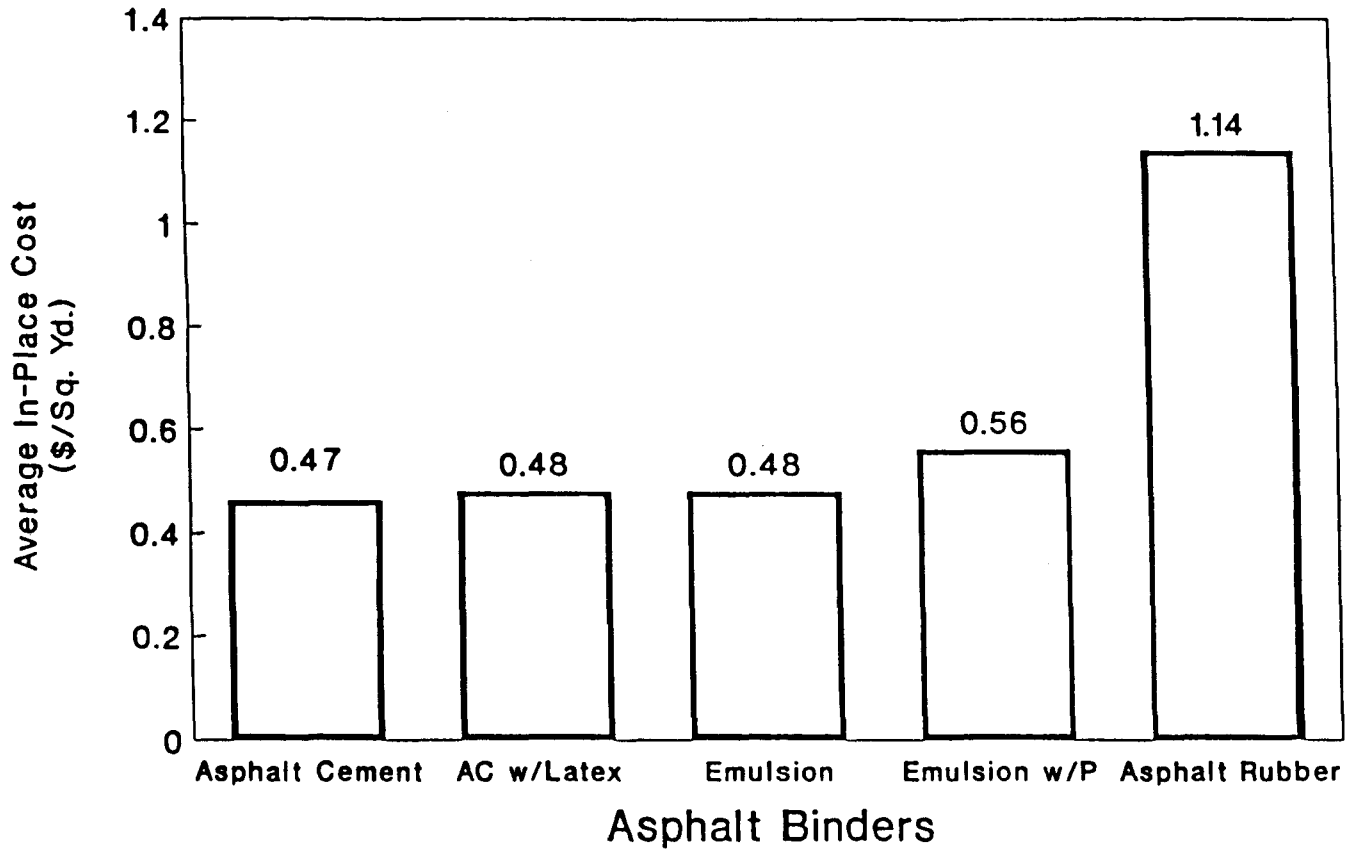

FIGURE I-1 Typical in-place costs for chip seals constructed with different binders in 1989. (14)

TABLE I-1  
ECONOMIC ANALYSIS OF ALTERNATIVE TREATMENTS (NET PRESENT VALUE, \$/YD2) (13)

PROJECT LENGTH	TREATMENT	ROUTE TYPE	1,000 ADT			10,000 ADT			
			5 YRS	10 YRS	25 YRS	5 YRS	10 YRS	25 YRS	
2 MILE	SAM	I	6.75	4.66	3.06	7.12	4.82	3.06	
		S	6.37	4.23	2.60	6.74	4.39	2.60	
		U	6.63	4.52	2.91	7.00	4.68	2.91	
	SAMI 1"	I	11.60	7.48	4.34	11.98	7.65	4.34	
		S	12.01	7.94	4.84	12.39	8.10	4.84	
		U	11.76	7.66	4.53	12.14	7.82	4.53	
	SAMI 2"	I	16.37	10.42	5.88	16.75	10.58	5.88	
		S	16.79	10.88	6.37	17.16	11.04	6.37	
		U	16.53	10.60	6.07	16.91	10.76	6.07	
	SEALCOAT	I	4.46	3.16	2.17	4.84	3.32	2.17	
		S	4.68	3.40	2.43	5.05	3.56	2.43	
		U	3.98	2.62	1.59	4.35	2.79	1.59	
	OL 1"	I	6.30	4.20	2.60	6.68	4.36	2.60	
		S	6.90	4.87	3.32	7.28	5.03	3.32	
		U	6.45	4.37	2.77	6.82	4.53	2.77	
	OL 2"	I	11.07	7.14	4.13	11.45	7.30	4.13	
		S	11.68	7.81	4.86	12.05	7.97	4.86	
		U	11.22	7.30	4.31	11.60	7.46	4.31	
	OL 4"	I	20.62	13.01	7.21	20.99	13.17	7.21	
		S	21.22	13.68	7.93	21.59	13.84	7.93	
		U	20.77	13.18	7.38	21.14	13.34	7.38	
	10 MILE	SAM	I	6.41	4.43	2.92	7.53	4.91	2.92
			S	6.02	4.00	2.46	7.14	4.49	2.46
			U	6.28	4.29	2.77	7.40	4.78	2.77
SAMI 1		I	10.63	6.87	4.00	11.75	7.35	4.00	
		S	11.04	7.33	4.49	12.16	7.81	4.49	
		U	10.79	7.05	4.19	11.91	7.53	4.19	
SAMI 2		I	12.71	8.15	4.67	13.83	8.64	4.67	
		S	13.13	8.61	5.17	14.25	9.10	5.17	
		U	12.87	8.33	4.86	13.99	8.82	4.86	
SEALCOAT		I	4.03	2.88	2.01	5.15	3.37	2.01	
		S	4.25	3.12	2.26	5.37	3.61	2.26	
		U	3.55	2.34	1.42	4.67	2.83	1.42	
OL 1"		I	5.73	3.83	2.38	6.85	4.32	2.38	
		S	6.33	4.50	3.11	7.45	4.99	3.11	
		U	5.88	4.00	2.56	7.00	4.48	2.56	
OL 2"		I	7.81	5.12	3.06	8.93	5.60	3.06	
		S	8.42	5.79	3.78	9.54	6.27	3.78	
		U	7.96	5.28	3.23	9.08	5.77	3.23	
OL 4"		I	11.99	7.68	4.40	13.11	8.17	4.40	
		S	12.59	8.35	5.12	13.71	8.84	5.12	
		U	12.13	7.85	4.58	13.25	8.33	4.58	

I - INTERSTATE  
S - STATE HIGHWAYS  
U - US HIGHWAYS  
OL - OVERLAY OF HOT MIX ASPHALT

TABLE I-2  
ESTIMATED COSTS OF PAVEMENT-REHABILITATION ALTERNATIVES (15)

Treatment	Cost/yd. <sup>2</sup>
<b>EXPERIMENTAL</b>	
Asphalt-rubber surface treatment or "chip seal" (SAM)	52.00
Asphalt-rubber interlayer with 2-in. asphalt-concrete overlay (SAMI)	5.66
<b>CONVENTIONAL</b>	
Single-course bituminous surface treatment	1.05
1-in. armor coat	1.81
2½-in. asphalt-concrete overlay	4.50

TABLE I-3  
COMPARISONS OF SERVICE LIVES (IN YEARS) EQUAL ANNUAL COSTS (15)

**EXPERIMENTAL TREATMENTS**

1. Asphalt-rubber surface treatment or "chip seal" (SAM)
2. Asphalt-rubber interlayer with 2-in. asphalt-concrete overlay (SAMI)

**CONVENTIONAL TREATMENTS**

3. Single-course bituminous surface treatment
4. 1-in. armor coat top course
5. 2½-in. asphalt-concrete overlay (1½-in. binder and 1-in. surface course)

4-percent Interest		8-percent Interest		14-percent Interest	
1* vs 3**		1* vs 3**		1* vs 3**	
3.9	2.0	4.1	2.0	4.5	2.0
8.3	4.0	9.1	4.0	11.5	4.0
13.0	6.0	15.9	6.0	Infinite	6.0
1* vs 4**		1* vs 4**		1* vs 4**	
2.2	2.0	2.2	2.0	2.2	2.0
4.5	4.0	4.5	4.0	4.6	4.0
6.7	6.0	6.8	6.0	7.0	6.0
2* vs 5**		2* vs 5**		2* vs 5**	
10.6	8.0	11.2	8.0	12.9	8.0
13.4	10.0	14.6	10.0	19.1	10.0
16.3	12.0	18.5	12.0	44.4	12.0

\*Service lives (years) computed for equal annual cost  
(Annual Cost = Present Cost x Capital Recovery Factor).  
\*\*Service lives (years) assumed.

TABLE I-4  
MANUFACTURER'S ESTIMATED COSTS FOR VARIOUS  
REHABILITATION ALTERNATIVES (15)

Treatment	Cost/yd <sup>2</sup>
ARIZONA REFINING COMPANY	
Asphalt-rubber interlayer with 3/4-in. OGFC* containing 6% asphalt cement	\$2.59
Asphalt-rubber interlayer with 3/4-in. OGFC* containing 7% asphalt-rubber binder	3.10
4-in. asphalt-concrete overlay	5.75
2-in. asphalt-concrete overlay	2.88
SAHUARO PETROLEUM AND ASPHALT COMPANY	
HS&R** with asphalt-cement surface treatment	1.83
HS&R** with 1 1/4-in. asphalt-concrete overlay	2.92
Fabric with 1 1/4-in. asphalt-concrete overlay	2.90
1-in. asphalt-concrete overlay	1.16
1 1/4-in. asphalt-concrete overlay	1.80
2-in. asphalt-concrete overlay	2.37
3-in. asphalt-concrete overlay	3.59
Single-course asphalt-cement chip seal	0.83
Double-course asphalt-cement chip seal	1.65
Triple-course asphalt-cement chip seal	2.50
1 1/4-in. asphalt-concrete overlay and asphalt-rubber interlayer	3.33

\*OGFC = open-graded friction course.  
\*\*HS&R = heater scarification and rejuvenation.

TABLE I-5  
MANUFACTURER'S ESTIMATED SERVICE LIVES AND ANNUAL COSTS FOR  
REHABILITATION ALTERNATIVES (15)

Treatment	Service Life, years		Annual Cost/yd <sup>2</sup>
	Range	Mean	
HS&R* with 1 1/4-in. asphalt-concrete overlay	3-6	4.5	\$0.65
Fabric with 1 1/4-in. asphalt-concrete overlay	4-7	5.5	0.53
1-in. asphalt-concrete overlay	1-3	2.5	0.52
1 1/4-in. asphalt-concrete overlay	2-4	3.0	0.60
2-in. asphalt-concrete overlay	3-6	4.5	0.53
3-in. asphalt-concrete overlay	5-8	6.5	0.55
Single-course asphalt-cement chip seal	2-3	2.5	0.33
Double-course asphalt-cement chip seal	3-6	4.5	0.37
Triple-course asphalt-cement chip seal	4-8	6.0	0.42
Asphalt-rubber chip seal	4-8	6.0	0.26
1 1/4-in. asphalt-concrete overlay and asphalt-rubber interlayer	6-10	8.0	0.42

\*HS&R = heater scarification and rejuvenation.  
\*\*For annual interest rate of 4.0%.

TABLE I-6  
COMPARISON OF CHIP SEAL REHABILITATION ALTERNATIVES (19)

Rehabilitation Alternative	First Cost \$/yd <sup>2</sup>	Life for Equal Annual Cost				
		2.0	4.0	6.0	8.0	10.0
AC Chip Seal	0.85	2.0	4.0	6.0	8.0	10.0
A-R Chip Seal	1.85	4.6	9.7	15.6	22.5	31.2

\*Assumes 4 percent rate of return and no maintenance costs.

TABLE I-7  
LIFE-CYCLE COST EXAMPLE (19)

Rehabilitation Alternatives	First Cost	Life Cycle Cost	First Energy	Life Cycle Energy
	\$/yd <sup>2</sup>	\$/yd <sup>2</sup>	Btu, yd <sup>2</sup>	Btu, yd <sup>2</sup>
1. Asphalt rubber chip seal to delay overlay	1.25	7.31	6,200	139,300
2. 3 in asphalt concrete overlay	4.95	9.88	83,400	199,800
3. Heater-scarification + 2 in overlay	4.20	7.32	76,600	156,100
4. Asphalt-rubber interlays +.2 in overlay	5.15	7.36	61,800	115,500
5. Fabric interlays + 2 in overlay	4.50	7.62	58,100	137,600

## APPENDIX J

### INTERLAYER DESIGN METHODS AND CONSIDERATIONS

#### INTERLAYER DESIGN

##### Texas Method (1)

Asphalt-rubber interlayers should be designed in the laboratory and then field adjusted. This design method encourages the use of multiple stone thicknesses and determines binder application rates which are 45 percent higher than those typically used for asphalt-cement binders without a temperature correction. Additional field verification is needed of this method and others presented in this section.

##### ARCO Method (2)

This design method is intended for use on chip seal applications but it can be used as a starting point for interlayer applications. It can be used to determine the rates of application of asphalt rubber and aggregate to obtain a desired thickness or to determine the aggregate application quantity and thickness of chip seal for a specific rate of asphalt-rubber membrane. The method is based on experimental field installations of multi-aggregate layered chip seals.

#### REFLECTION CRACKING-THEORETICAL STUDIES

Groups at the University of Arizona (3), the Arizona DOT (4) and the University of California (5,6) have performed laboratory tests and used computer models to characterize the performance of asphalt-rubber interlayers. At the University of Arizona, Jimenez and Meir performed repeated vertical shear, static horizontal shear, repeated horizontal shear, and flexural fatigue tests on asphalt-rubber membrane systems. Test results indicate that asphalt-rubber binders give improved performance over conventional asphalts and that membranes without chips perform better than membranes with chips. Calculations on pavement structural elements suggested that in interlayers asphalt-rubber application rates should be limited to about  $\frac{1}{8}$  in. or 0.70 gal/yd<sup>2</sup>.

Finite element work performed at the Arizona DOT and the University of California indicate that a low modulus interlayer such as an asphalt-rubber binder can reduce both load- and temperature-related thermal stress in cracked pavements. Crack width, interlayer modulus, and overlay thickness appear to have significant effects on crack tip stress. The benefit of placing the interlayer on top of a leveling course rather than directly on old pavement can be quantified by these analyses.

#### PROPERTIES OF BINDERS

Binders used for interlayer applications are produced by the wet process and referred to as asphalt-rubber. Typical properties of

these binders are described in the section on binder properties. Specialized properties of these types of binders have been determined by research groups at the University of Arizona, the University of California, and the U.S. Air Force.

##### University of Arizona (3,7)

The horizontal and vertical shear test properties of asphalt-rubber and RC-250 materials are shown in Figures J-1 and J-2. These figures illustrate the benefit of using thicker asphalt-rubber interlayers (higher tack coat quantities) for overlayers subjected to increasing amounts of horizontal shear.

##### University of California (6)

Creep compliance data on asphalt-rubber binders at different strain ratios were obtained by the University of California. These data were used to model the effect of interlayers on crack tip stresses in a finite element model whose mesh is shown in Figure J-3.

##### U.S. Air Force (8)

Creep compliance information was also performed by the New Mexico Engineering Research Institute for the U.S. Air Force. A sampling of these data are shown in Figure J-4. The properties of the binder depend on mixing and reaction times. This study also established a correlation between compliance and modified softening points for a group of binders (Figure J-5).

A comparison of laboratory- and field-produced mixtures indicated that 1 hour of laboratory mixing always produced a stiffer mixture than 1 hour of field mixing. After 26 weeks of field curing, the properties of the laboratory mixtures remained stiffer than the field-produced binders.

#### REFERENCES

1. Shuler, T.S., R.D. Pavlovich, J.A. Epps, and C.K. Adams, *Investigation of Materials and Structural Properties of Asphalt-Rubber Paving Mixtures, Volume I—Technical Report*, Report No. FHWA/RD-86/027, Texas Transportation Institute, Sept. 1986.
2. Vallerga, B.A., and J.R. Bagley, Design of Asphalt-Rubber Single Surface Treatments with Multi-Layered Aggregate Structure, ASTM STP 724, Dec. 1979.
3. Jimenez, R.A., and W.P. Meier, Laboratory Evaluation of an Asphalt-Rubber SAL, in *Transportation Research Record*

1034, Transportation Research Board, National Research Council, Washington, D.C. (1985).

4. Morris, G.R., N.J. Chen, and J.A. DiVito, Application of Asphalt-Rubber on New Highway Pavement Construction, in *Transportation Research Record 888*, Transportation Research Board, National Research Council, Washington, D.C. (1982).
5. Coetzee, N.F., and C.L. Monismith, *An Analytical Study of the Applicability of a Rubber Asphalt Membrane to Minimize Reflection Cracking in Asphalt Concrete Overlay Pavements*, Department of Civil Engineering, University of California, Berkeley, June 1978.
6. Coetzee, N.F., and C.L. Monismith, Analytical Study of Minimization of Reflection Cracking in Asphalt Concrete Overlays by Use of a Rubber-Asphalt Interlayer, in *Transportation Research Record 700*, Transportation Research Board, National Research Council, Washington, D.C. (1979).
7. Jimenez, R.A., G.R. Morris, and D.A. DaDeppo, *Tests for a Strain-Attenuating Asphaltic Material*, Association of Asphalt Paving Technologists, 1979.
8. Newcomb, D.E., and R.G. McKeen, *Development of Criteria for the Use of Asphalt-Rubber as a Stress-Absorbing Membrane Interlayer*, Report No. ESL-TR-83-50, Air Force Engineering and Services Center, Tyndall Air Force Base, Dec. 1983.

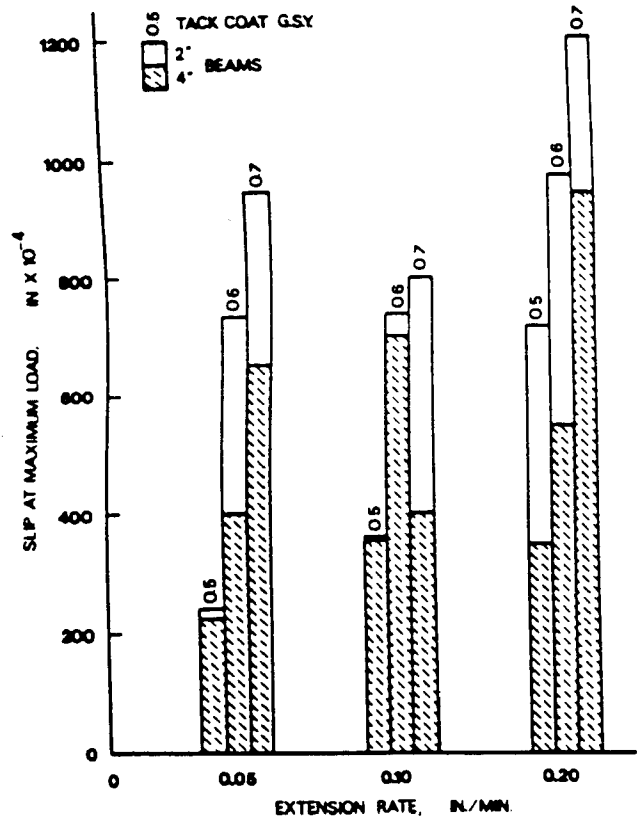

FIGURE J-1 Effects of beam thickness and amount of A-R on slip in the horizontal shear test. (J7)

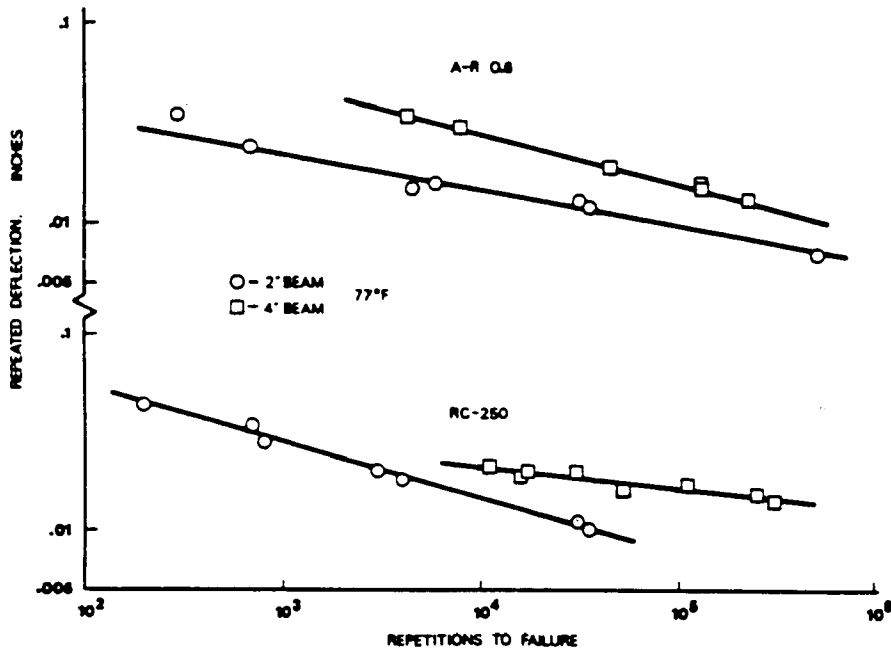

FIGURE J-2 Relationship between repeated deflection and number of repetitions to cause failure in the vertical shear test. (J7)

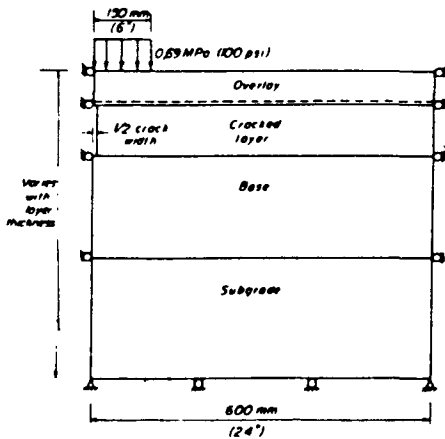

FIGURE J-3 Schematic finite-element representation of pavement structure. (J5)

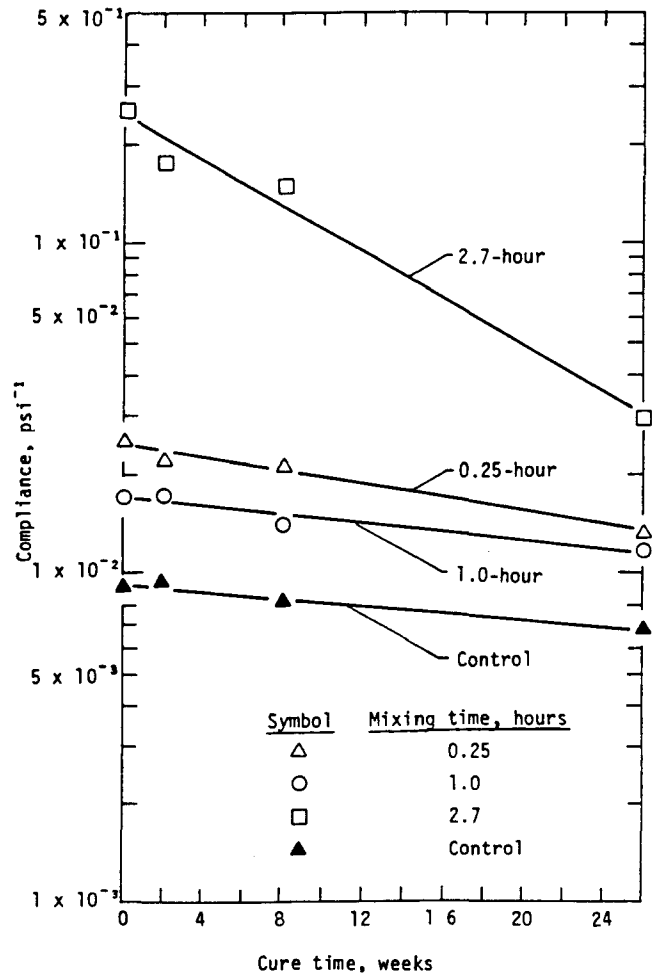

FIGURE J-4 Compliance vs. cure time for TP044. (J8)

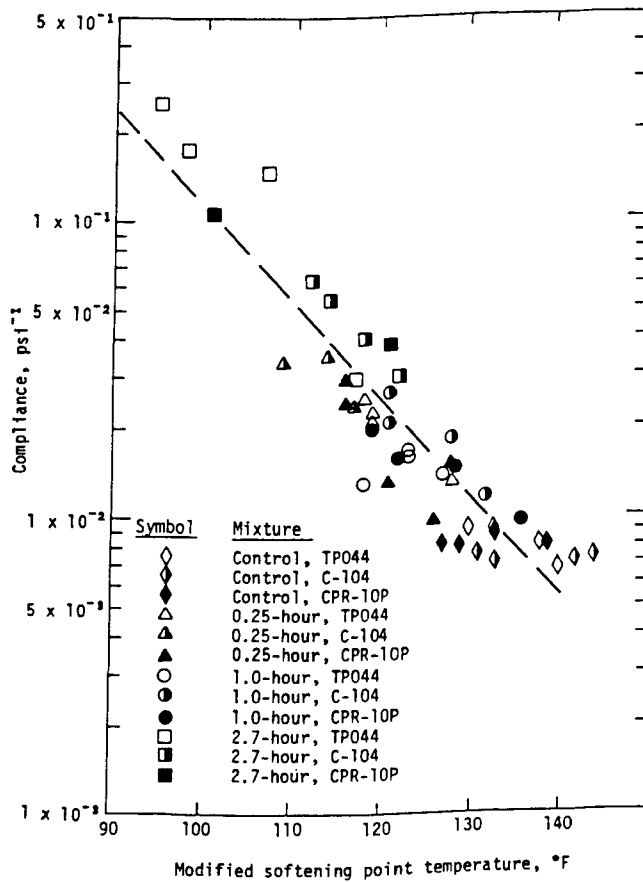

FIGURE J-5 Compliance vs. modified softening point temperature. (J8)



## APPENDIX K

### INTERLAYER PERFORMANCE

#### Arizona DOT (1-4)

Pavement survival curves for asphalt-rubber interlayers have been developed from the Arizona DOT's pavement management system data base. These curves, shown in Figure K-1, represent the pavement life from construction of the interlayer to the next major treatment. Statistical data for the interlayer treatments are shown in Table K-1 for the three general classifications of highways. Figure K-2 indicates the extent of cracking for each highway classification as a function of time. Zaniowski's report (4) indicates that only 3 of 57 sections have developed significant amounts of cracking. The mean amount of cracking was 1 percent cracking or less after 10 years of service.

Three pavement projects contained both interlayer and non-interlayer sections (Table K-2). On the US-666 section, after 10 years of service, the interlayer section has performed equally as well as the control overlay, which is almost twice as thick. On US-60, after 8 years of traffic, the asphalt-rubber interlayer is performing slightly better than the overlay section of equal thickness. The US-89 pavement was in place for 3 years before the performance evaluation. Both the control and the interlayer sections are performing at a high level.

Performance studies conducted on a major study to solve the reflection cracking problem indicated that an asphalt-rubber membrane is one of five acceptable treatments (1).

#### Arkansas (5)

Arkansas has evaluated eight stress-relieving membrane projects and two seal coat projects. These treatments, when placed over distressed portland cement concrete, do not show a reduction in the amount and degree of reflection cracking. Reflection cracks in control sections and those in asphalt-rubber interlayer sections occurred in approximately the same length of time following construction.

#### California (6-8)

California has placed several asphalt-rubber interlayers with mixed performance. Those sections in northeastern California's high desert areas did not perform well (6,7), while others performed at an acceptable level (8).

#### Florida (9,10)

Information on performance at 6 and 36 months indicates that open-graded friction courses should not be placed directly over asphalt-rubber interlayers. Test sections constructed in this manner

flushed and experienced rutting due to the migration of asphalt binder into the open-graded friction course.

Pavement sections constructed with asphalt-rubber interlayers between the existing pavement surface and the hot-mix asphalt overlay have performed well to date. Control sections have also performed well to date.

#### Georgia (11)

Table K-3 shows the amount of fatigue cracking in test sections for different types of interlayers. The asphalt-rubber interlayer was successful. Because none of the treatments used in these sections can "bridge over" weak areas, standard overlay thicknesses should be used.

#### Kansas (12-14)

The Kansas DOT constructed five projects using asphalt-rubber interlayers. The US-77 Marion County project results indicated that the asphalt-rubber interlayers had retarded longitudinal and transverse cracks but had not prevented the reflection cracks. Transverse cracking occurred in both the interlayer and control section after 6 months of service. On this project, the asphalt-rubber interlayer could not be justified economically.

The US-77 project in Marion County used hot in-place recycling and overlay as the control section and hot in-place recycling plus an interlayer and overlay as the test section. The results of the crack surveys indicate that the control section performed better than the section with the interlayer. The interlayer system was judged to be not cost effective.

A project constructed in Allen County contained a 3-in. overlay control section and a section with an interlayer and a 3-in. overlay. Reflection cracking results indicate only a marginal difference in the rate of reflection cracking. The increased cost of the asphalt-rubber interlayer does not justify its use.

The project constructed in Woodson County on US-54 also contained a 3-in. overlay control section and a section with an asphalt-rubber interlayer and a 3-in. overlay. The test sections with the overlay cracked more than the control section. The added cost of the interlayer was not justified.

The US-83 project in Thomas County contained a 2-in. overlay as a control section and several types of asphalt-rubber blends as interlayers. Some reduction in the amount of transverse cracking was noted with the use of the interlayers.

#### Massachusetts (15)

Seven rehabilitation alternatives were used to overlay a portland cement concrete pavement in Massachusetts. After 8 years of ser-

vice, both the 3-in. hot-mix asphalt overlay control section and the full-depth section experienced major cracking; the section containing an asphalt-rubber interlayer and fabric strips had the least amount of cracking and has performed very well.

#### **Minnesota (16–19)**

Turgeon (16) presents a summary of Minnesota's experience with asphalt-rubber materials. The asphalt-rubber interlayers did not eliminate reflective cracking. On two of the three interlayer projects a reduction in cracking was evident. The third project showed little benefit from using the interlayer. Reflection crack counts per mile for one of the projects are shown in Table K-4.

#### **New York (20)**

The New York State Thruway Authority has placed asphalt-rubber interlayers over portland cement concrete pavements. In general, reflection cracks developed later, did not open as wide, and developed less frequently at the pavement edge/shoulder interface in the interlayer sections than they did in the control sections.

#### **North Carolina (21)**

After 2 years of service, both the asphalt-rubber interlayer section and the control section withstood the early reflection of fatigue cracks (Table K-5).

#### **North Dakota (22)**

North Dakota investigated the use of asphalt-rubber interlayers on portland cement concrete pavements. After 4 years of service, the interlayer did not appear to reduce reflection cracking from the joints, nor did this treatment appear to have an effect on the rate at which the cracks were reflected.

#### **Oregon (23)**

Oregon placed an asphalt-rubber interlayer on I-84 and evaluated its performance. Transverse temperature cracks appeared in the section within 2 years of placement. After 5 years of service, reflection cracks and alligator cracks were present in the double-interlayer section. Upon coring, it was noted that, in a significant number of cores, no bonding was present between the overlay and interlayer.

#### **Pennsylvania (24,25)**

Pennsylvania's experience has been summarized in Mellott (24). This report states that the interlayers should be used only on asphalt pavements. Based on economics, however, the report discourages their continued use.

#### **Texas (26–28)**

Three full-scale test sections containing asphalt-rubber interlayers have been placed in Texas. One test section contained a thick overlay and does not contain distress. A second interlayer test section was constructed with excess binder and all sections are flushing. Nine different types of asphalt-rubber interlayers were placed in a third test section. All of the interlayer sections are performing better, in terms of delaying reflection cracking, than the control section. Cracks reflected through the interlayer sections by the second winter, but they were "hairline" cracks and tended to heal the following summer. Much of the research in Texas has been inconclusive to date (26).

The Asphalt-Rubber Producers Group (28) indicates that SAMIs have "eliminated" reflection cracking for the last 15 years on interstate, primary, and secondary routes. Mixed success is reported.

#### **Washington (29–33)**

Washington has constructed six projects which contain asphalt-rubber as an interlayer. These interlayers were largely successful in retarding alligator crack reflection, but were not successful in retarding longitudinal and transverse crack reflection. One trial project compared control sections with asphalt-rubber and conventional asphalt-cement interlayers. The control section experienced reflection of all underlying cracks early in its life. The asphalt-rubber and asphalt-cement interlayers retarded the reflection of alligator cracking but did not retard the reflection of longitudinal and transverse cracks.

Interlayers constructed with normal asphalt cements are only slightly less effective than interlayers constructed with asphalt-rubber (Figure K-3). The asphalt-rubber interlayers cost about 3.7 times the cost of asphalt-cement interlayers. The state routinely uses asphalt-cement interlayers. The average service life of overlays with asphalt-rubber interlayers is 12.3 years; with 2- to 3-in. conventional overlays the average life is 12.5 years (33).

#### **Wyoming (34,35)**

Performance data are available on a project in Wyoming constructed with different types of interlayers. The interlayers contained 2-in. overlays except for one section, which had a 3-in. overlay. Most of the reflection cracking occurred during the first winter after construction. In reducing reflection cracking, the slurry seal system appears to be performing as well as or better than the other interlayer treatments (Figure K-4).

#### **Corps of Engineers (36–38)**

The Corps of Engineers placed interlayers at five Army installations in the United States. Performance of these materials after a 6-month period has been reported (36). A follow-up report contains performance over a longer period of time. Data from a number of states are reported and shown in Figures K-5 through K-22. The success of these interlayers has varied from state to state and job to job. Significant variables influencing performance are the overlay thickness, the amount of crack sealing, and the geographic location

of the pavement. The interlayers that have performed favorably are often located in warm climates.

Recommendations from this study are shown in Figure K-22. Interlayers should not be used in the colder climates. Overlays of 2 in. on interlayers are recommended in the warmer climates to achieve improved performance. Asphalt-rubber interlayers are not recommended for use on portland cement concrete pavements.

### Pooled-Fund Study (39)

The overall performance of asphalt-rubber interlayer contained in this data base, and constructed after 1979, is shown in Figure K-23. Mixed performance has been noted. These interlayers are ineffective at reducing reflection cracks in asphalt-concrete overlays over jointed portland cement concrete pavements or where transverse cracks in asphalt concrete exceed 15-ft intervals.

### REFERENCES

- Way, G.B., *Prevention of Reflective Cracking, Minnetonka—East (1979 Addendum Report)*, Report No. 1979-GW1, Arizona Department of Transportation, Aug. 1979.
- Gonsalves, G.F.D., *Evaluation of Road Surfaces Utilizing Asphalt-Rubber—1978*, Report No. 1979-GG3, Arizona Department of Transportation, Nov. 1979.
- Schofield, L., *The History, Development, and Performance of Asphalt Rubber at ADOT*, presented at the National Seminar on Asphalt-Rubber, Oct. 1989.
- Zaniewski, J.P., *Summary of Arizona Department of Transportation Experience with Asphalt-Rubber—State of the Art*, Report No. FHWA-AZ88-818, Arizona Department of Transportation, Aug. 1988.
- Meadors, A., and H. Snow, *Experimental Projects Using Rubber Asphalt Membrane to Retard Reflection Cracking, Final Report*, Arkansas State Highway and Transportation Department, April 1988.
- Skog, J.B., J.A. Matthews, G.H. Mann, and D.V. Roberts, *Statewide Flexible Pavement Performance and Deflection Study*, Report No. FHWA-CA-TL-78-28, California Department of Transportation, Dec. 1978.
- deLaubenfels, L., *Effectiveness of Rubberized Asphalt in Stopping Reflection Cracking of Asphalt Concrete (Interim Report)*, Report No. FHWA/CA/TL-85/09, California Department of Transportation, Jan. 1985.
- Delano, E.B., *Performance of Asphalt-Rubber Stress Absorbing Membranes and Stress Absorbing Membrane Interlayers in California*, presented at the National Seminar on Asphalt Rubber, Oct. 1989.
- Murphy, K.H., and C.F. Potts, *Evaluation of Asphalt-Rubber as a Stress Absorbing Interlayer*, Report No. FHWA-DP-37-14, Florida Department of Transportation, Aug. 1980.
- Evaluation of Asphalt-Rubber as a Stress Absorbing Interlayer and A Binder for Seal Coat Construction, A Thirty-Six Month Survey*, Florida Department of Transportation.
- Gulden W. *Evaluation of Asphalt-Rubber Seal Coats and Interlayers for Rehabilitation of Flexible Pavements*, Report No. FHWA/GA-82/004, Georgia Department of Transportation, Sept. 1982.
- Fager, G.A., R.G. Maag, and W.H. Parcels, *Heater Scarification and Asphalt-Rubber—Sami, Marion County Project 77-57-F 055-2(6)*, Kansas Department of Transportation.
- Parcels, W.H., *Asphalt-Rubber for Stress Absorbing Membrane to Retard Reflective Cracking, Final Report*, Kansas Department of Transportation, June 1989.
- Maag, R.G., *Prevention of Reflective Cracking in Flexible Pavements, Asphalt-Rubber SAMI, NEPT KS-7701B, 1982 Annual and Final Report*, Kansas Department of Transportation, 1982.
- Constantino, P., M.P. Abraham, and D. Murry, *Evaluation of Asphalt-Rubber Overlay of Old Concrete, Sterling, Massachusetts*, Asphalt Rubber Producers Group.
- Turgeon, C.M., *The Use of Asphalt-Rubber Products in Minnesota*, presented at the National Seminar on Asphalt-Rubber, Oct. 1989.
- Allen, H.S., and K.P. Keel, *Evaluation of an Asphalt-Rubber Interlayer*, Special Study No. 383, Minnesota Department of Transportation, Aug. 1985.
- Allen, H.S., *Methods and Materials for Reducing Crack Reflections*, Report No. FHWA/MN/RD-84/09, Minnesota Department of Transportation, Jan. 1985.
- Ravn, T., R. Cassellius, and R. Olson, *Methods and Materials for Reducing Crack Reflectance*, Report No. 1, Investigation No. 202, Minnesota Department of Transportation, 1987.
- Giles, K.E., and W.H. Clark, *Asphalt-Rubber Interlayers on Rigid Pavements in New York State*, presented at the National Seminar on Asphalt-Rubber, Oct. 1981.
- Strong, M.P., *The Evaluation of Rubber Asphalt Surface Treatment in Preventing Fatigue Crack Reflection in Bituminous Overlay Construction*, Interim Report, Report No. FHWA-DP-3-10, North Carolina Division of Highways, Jan. 1982.
- Blasl, D.J., *Asphalt-Rubber Used as an Interlayer*, North Dakota State Highway Department, Sept. 1982.
- Hardy, T.A., L.G. Bruck, and G. Beecroft, *Stress Absorbing Membrane Interlayer, Final Report*, Oregon Department of Transportation, April 1985.
- Mellott, D.B., *Discarded Tires in Highway Construction*, Research Report No. 79-02, Pennsylvania Department of Transportation, April 1989.
- Mellott, D.B., *Discarded Tires in Highway Construction, Construction Report*, Research Project No. 79-2, Pennsylvania Department of Transportation, May 1981.
- Estakhri, C.K., E.G. Fernando, J.W. Button, and G.R. Teetes, *Use, Availability, and Cost-Effectiveness of Asphalt-Rubber in Texas*, Research Report No. 1902-1S, Texas Transportation Institute, 1991.
- Shuler, S., B.M. Gallaway, and J.A. Epps, *Evaluation of Asphalt-Rubber Membrane Field Performance*, Report No. FHWA/TX-82/51+287-2, Texas Transportation Institute, May 1982.
- Texas Asphalt-Rubber Survey*, Asphalt-Rubber Producers Group.
- Peters, A.J., and R.L. Schultz, *Asphalt-Rubber Binder Stress Absorbing Membrane Interlayers*, Report No. WA-RD-128.1, Washington Department of Transportation, July 1987.
- Allison, R.E., *Rubber Asphalt Binder Stress Absorbing Membrane Interlayers*, Report No. WA-RD-185.1, Washington Department of Transportation, March 1989.
- Anderson, K.W., *Rubber-Asphalt Binder Stress Absorbing*

- Membrane Interlayer*, Materials Office Report No. 187, Washington Department of Transportation, Dec. 1983.
32. Anderson, K.W., *SAMI and Heavy Duty Bituthene Reflection Crack Prevention Study*, Materials Office Report No. 186, Washington Department of Transportation, Dec. 1983.
  33. Anderson, K.W., and N.C. Jackson, *Rubber-Asphalt Pavements in the State of Washington*, Report No. WA-RD-2681, Washington State Department of Transportation, March 1992.
  34. *Reduction of Reflective Cracking in Asphaltic Overlays*, Interim Report, Wyoming State Highway Department, April 1982.
  35. Harvey, F.M., *Reduction of Reflective Cracking in Asphaltic Overlays*, Interim Report, Wyoming State Highway Department, 1979.
  36. Vedros, P.J., *Evaluation of the Effectiveness of Membranes for Prevention of Crack Reflection in Thin Overlays*, Miscellaneous Paper GL-79-4, U.S. Army Engineer Waterways Experiment Station, March 1979.
  37. Vedros, P., *Evaluation of the Effectiveness of Membranes for Prevention of Crack Reflection in Thin Overlays*, presented at 1st Asphalt-Rubber User-Producer Workshop, May 1980.
  38. Ahlrich, R.C., *Evaluation of Asphalt Rubber and Engineering Fabrics as Pavement Interlayers*, Miscellaneous Paper GL-86-34, U.S. Army WES, Nov. 1986.
  39. Shuler, T.S., R.D. Pavlovich, J.A. Epps, and C.K. Adams, *Investigation of Materials and Structural Properties of Asphalt-Rubber Paving Mixtures, Volume I—Technical Report*, Report No. FHWA/RD-86/027, Texas Transportation Institute, Sept. 1986.

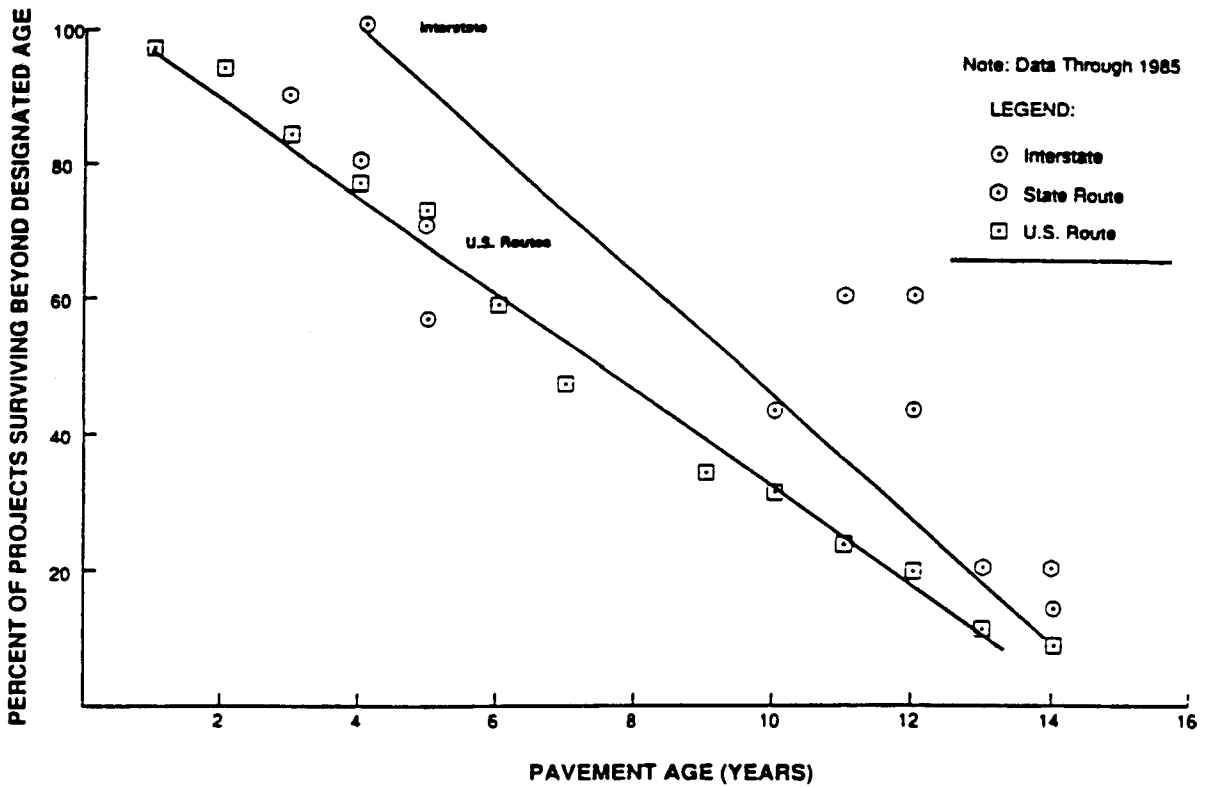

FIGURE K-1 Pavement survival curves after SAMI applications. (K3)

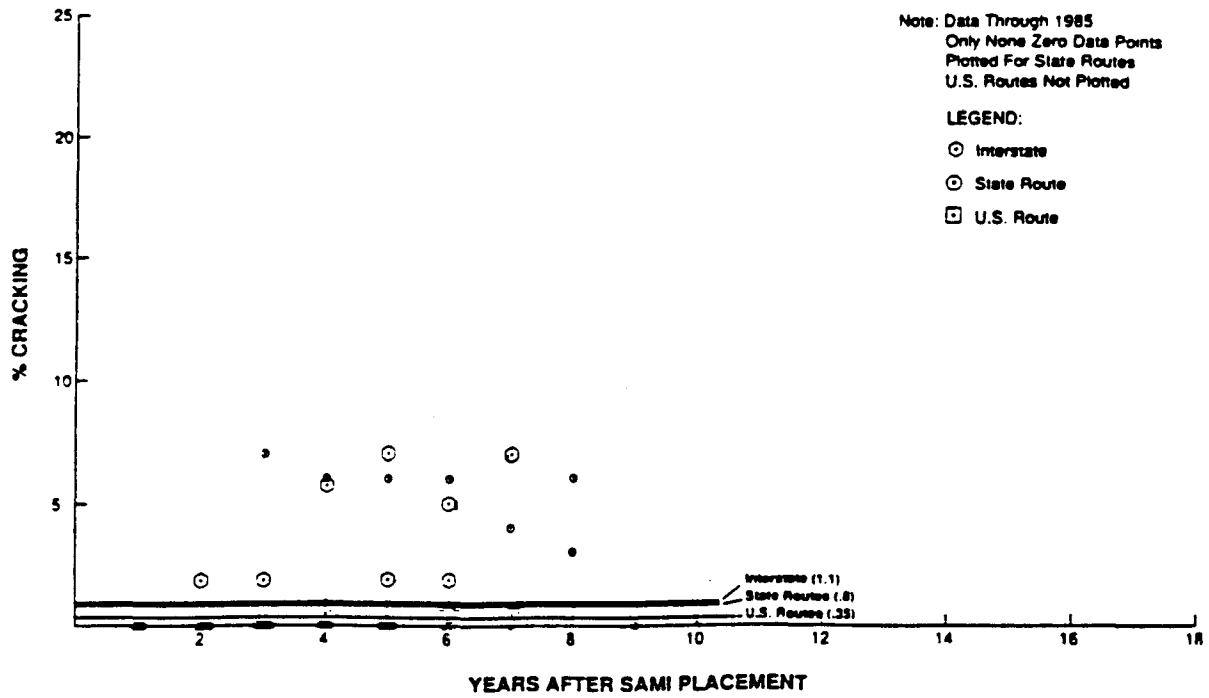

FIGURE K-2 Pavement crack development in SAMIs. (K3)

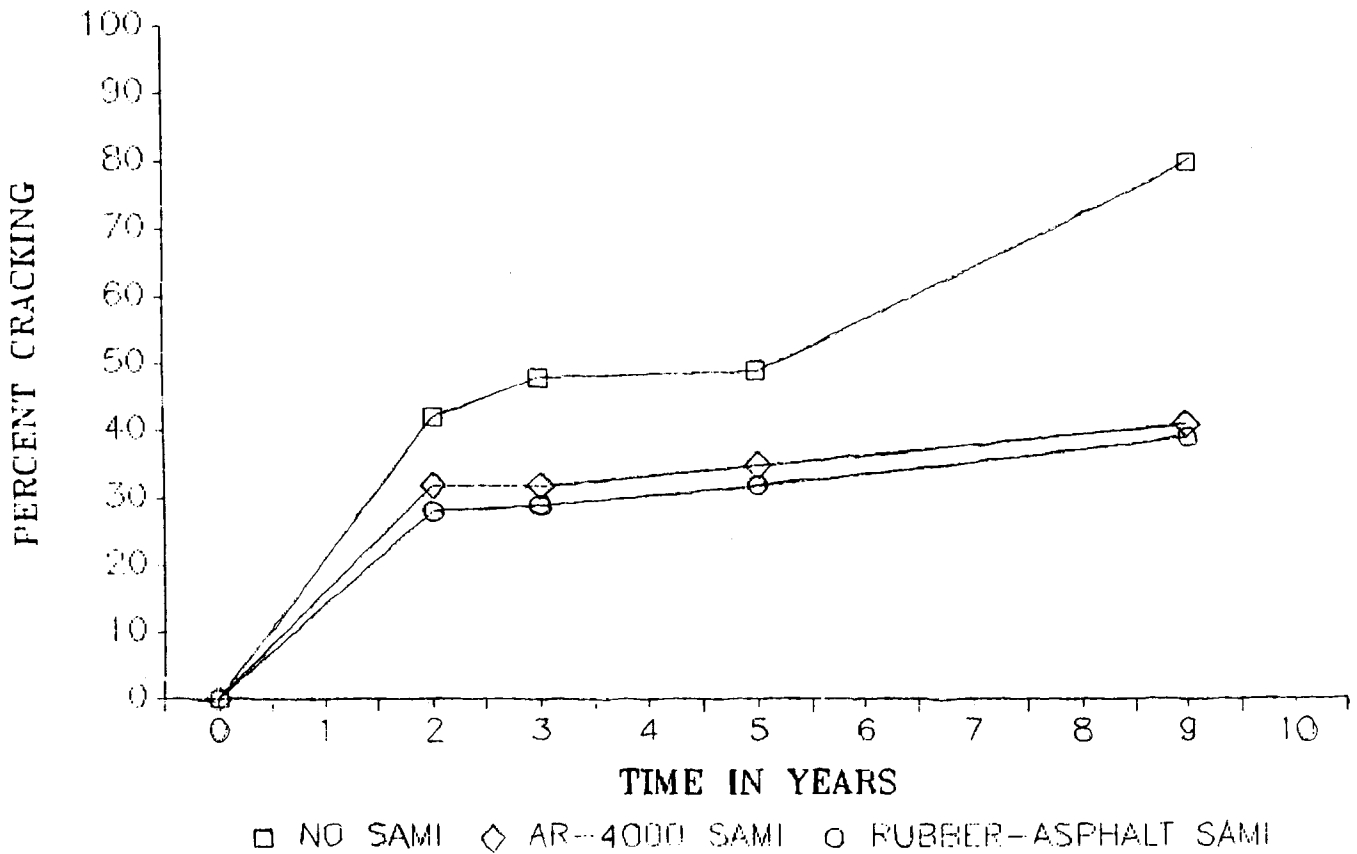

FIGURE K-3 Percentage of crack reflection vs. time. (K29)

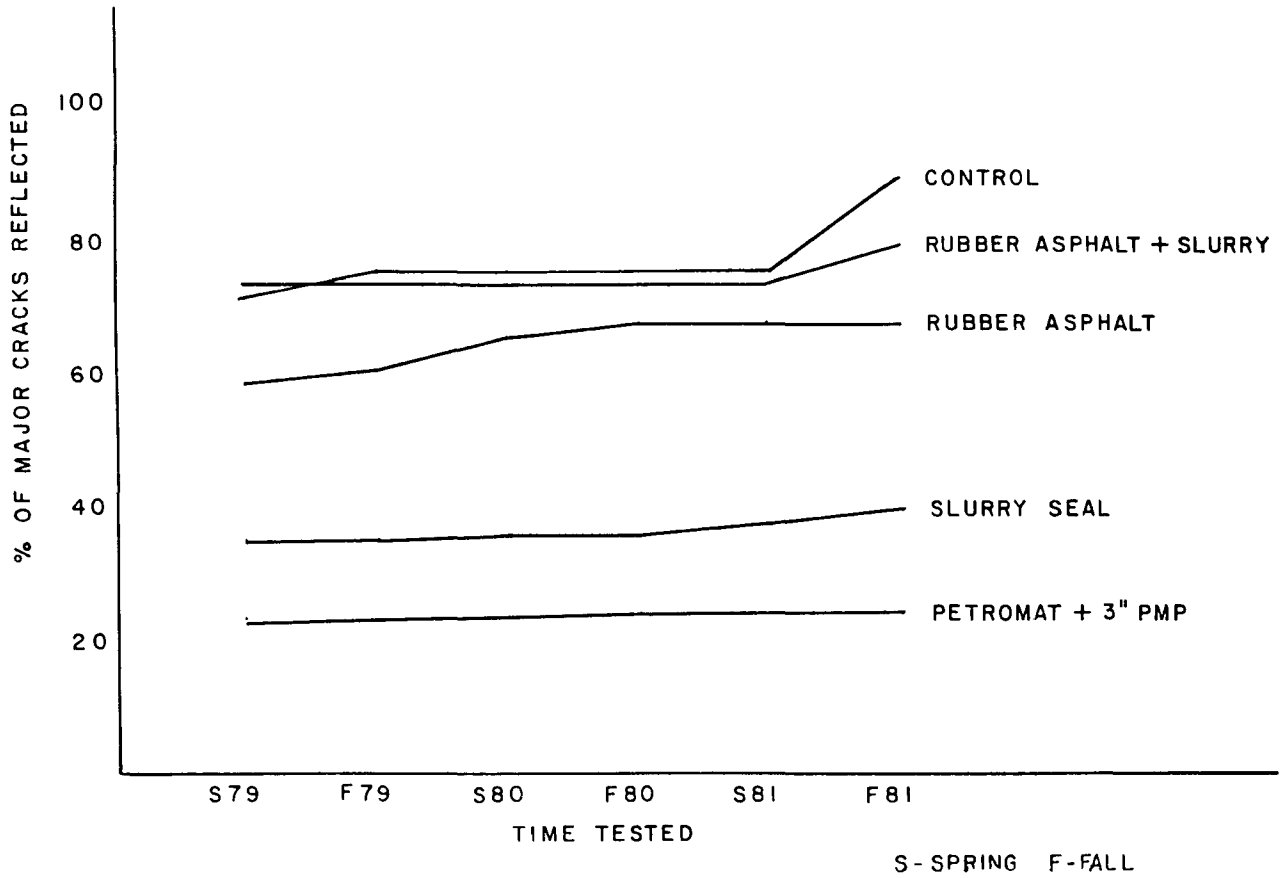

FIGURE K-4 Percent major cracks reflected vs. time. (K34)

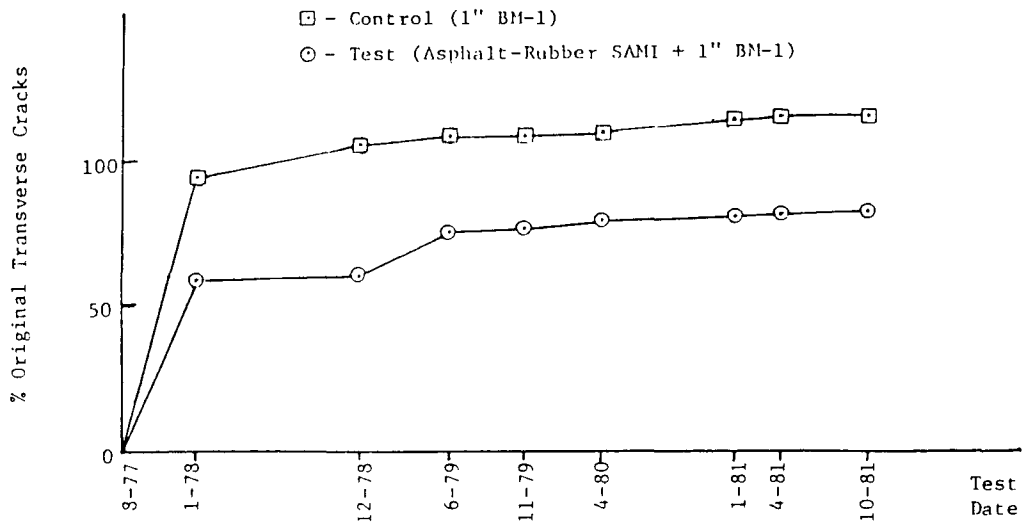

FIGURE K-5 Percent transverse cracks vs. time, Osage County. (K14)

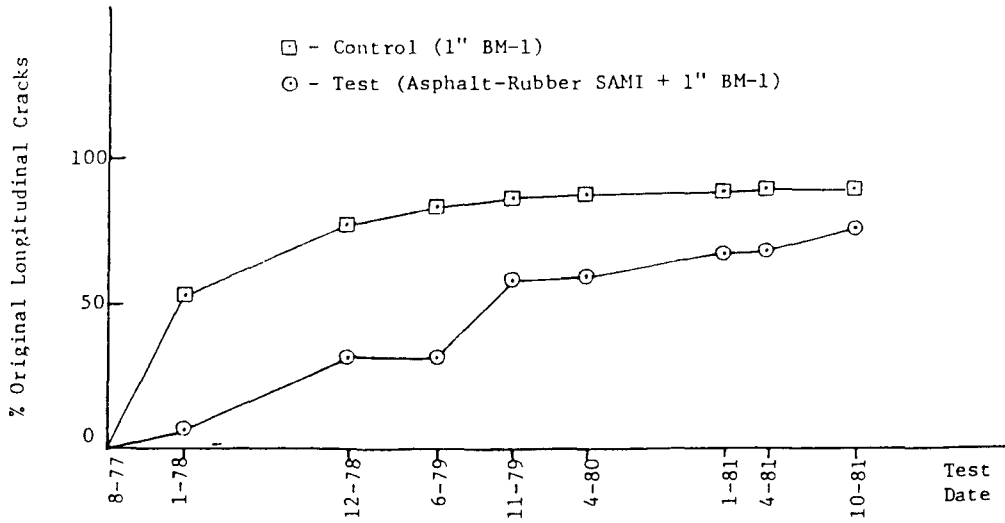

FIGURE K-6 Percent longitudinal cracks vs. time. (K14)

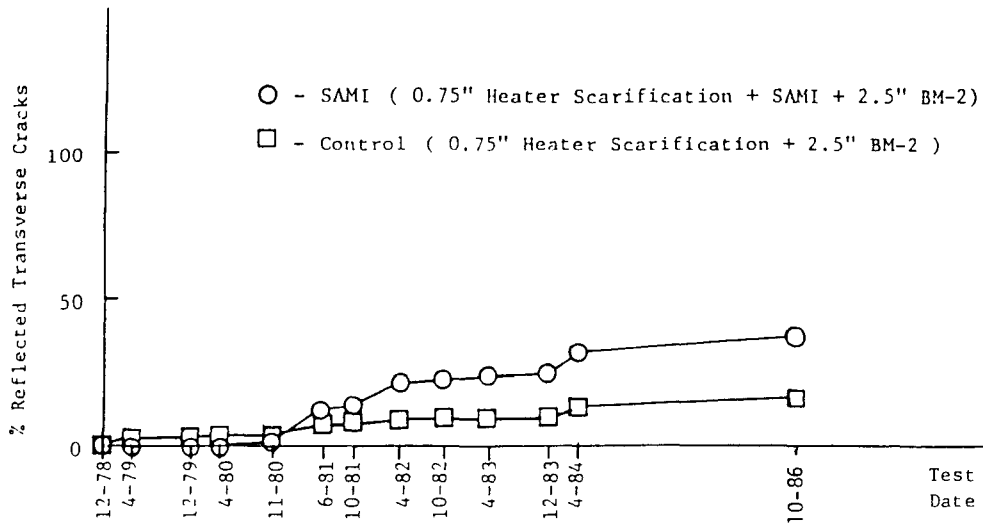

FIGURE K-7 Percent transverse cracks vs. time, Marion County. (K13)

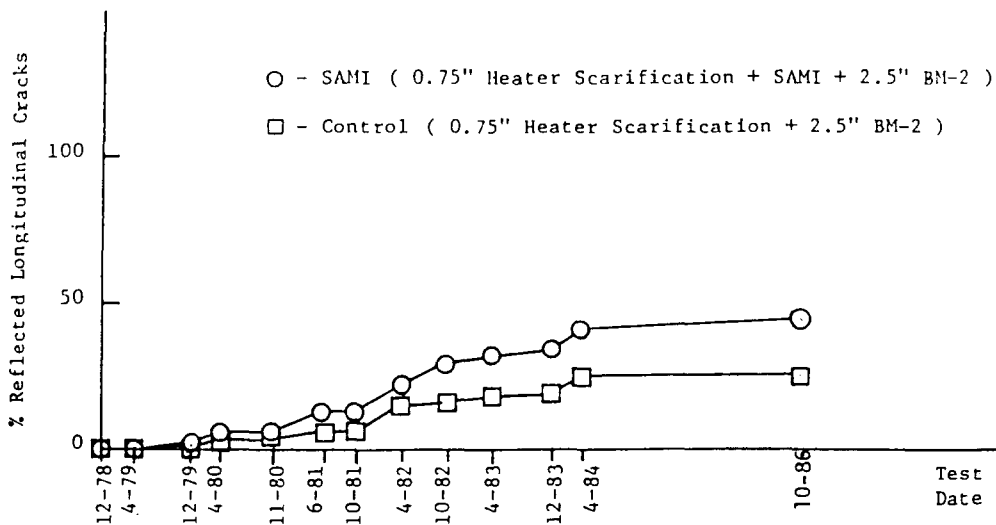

FIGURE K-8 Percent longitudinal cracks vs. time. (K13)

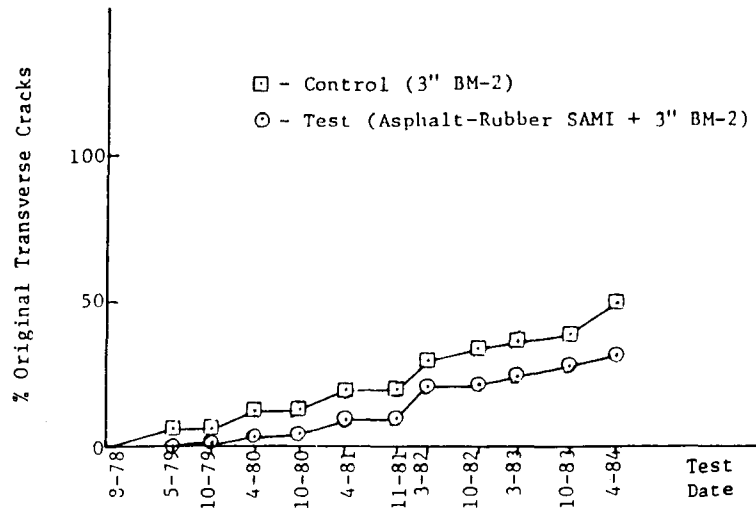

FIGURE K-9 Percent transverse cracking vs. time, Allen County. (K13)

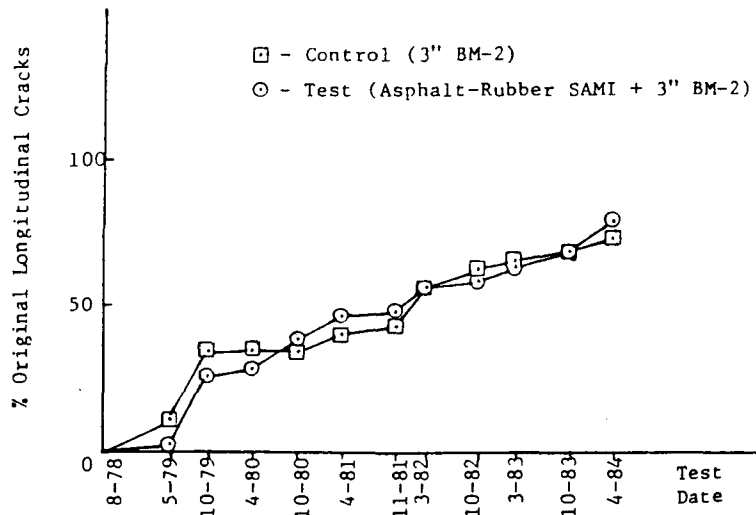

FIGURE K-10 Percent longitudinal cracking vs. time. (K13)

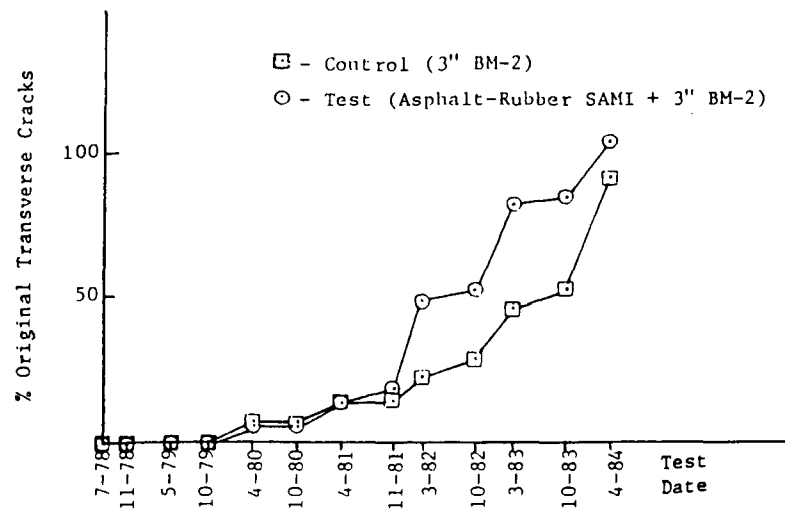

FIGURE K-11 Percent transverse cracking vs. time, Woodson County. (K13)



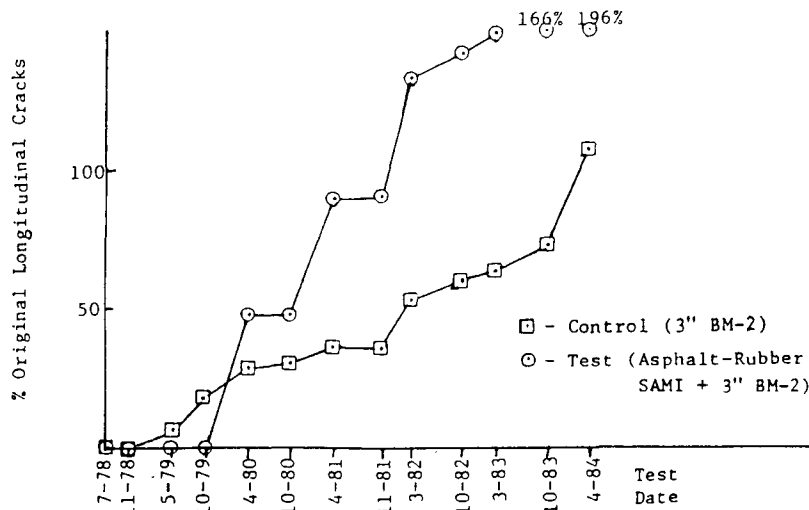

FIGURE K-12 Percent longitudinal cracks vs. time. (K13)

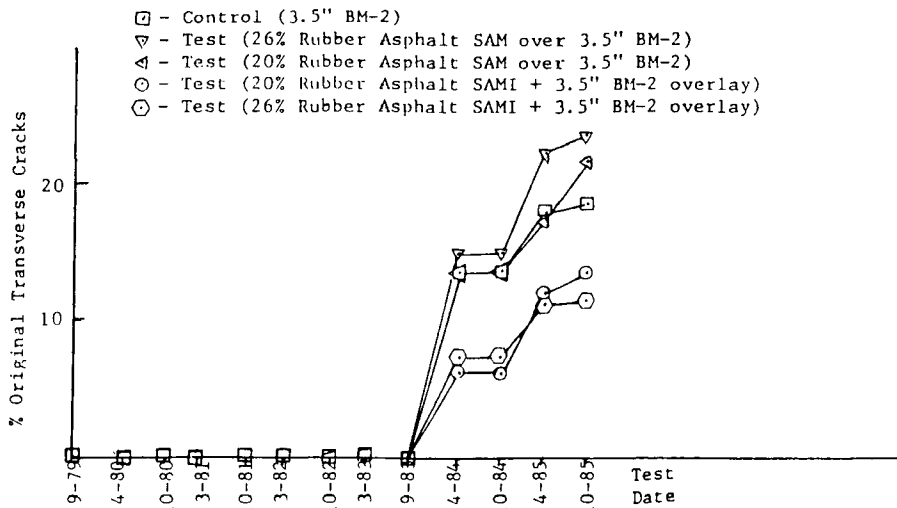

FIGURE K-13 Percent transverse cracking vs. time, Thomas County. (K13)

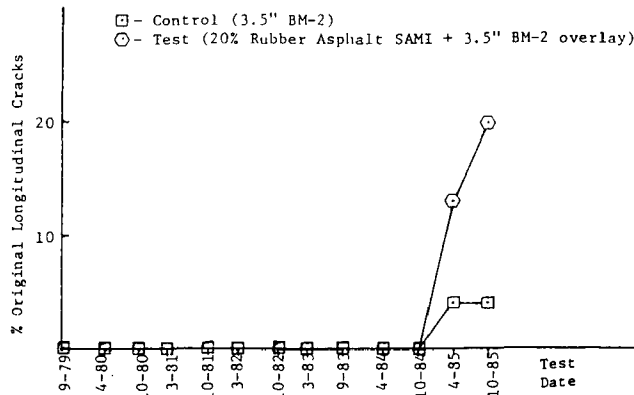

FIGURE K-14 Percent longitudinal cracks vs. time. (K13)

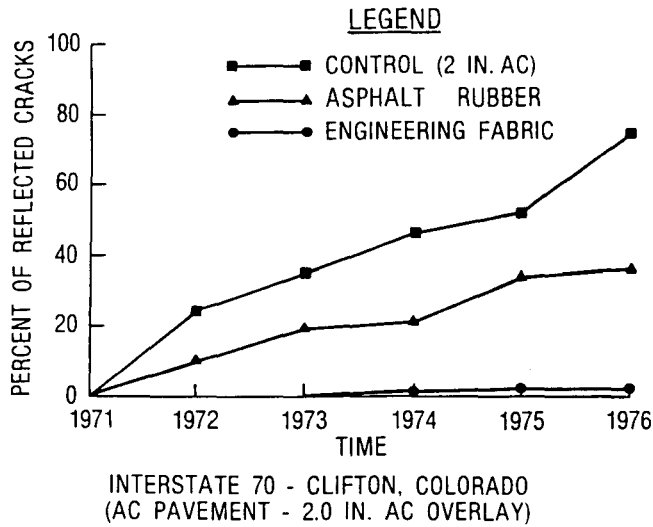

FIGURE K-15 Percent of reflected cracks vs. time, Interstate 70. (K38)

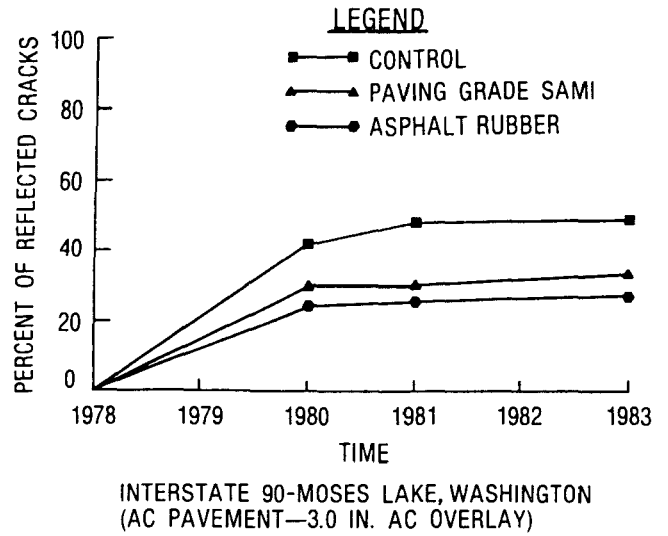

FIGURE K-17 Percent of reflected cracks vs. time, Interstate 90. (K38)

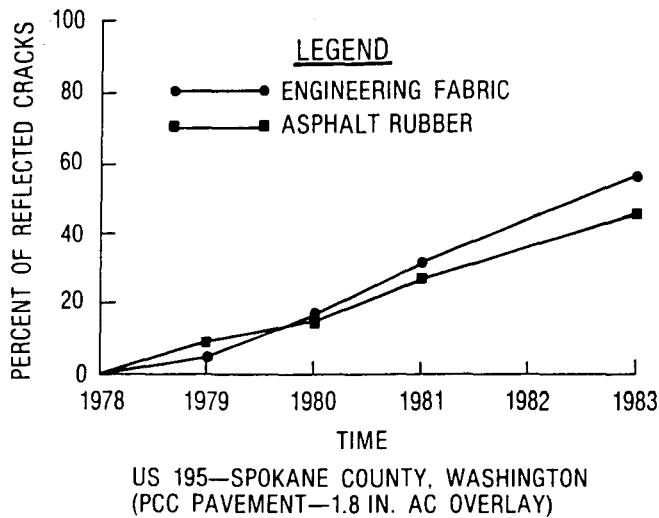

FIGURE K-16 Percent of reflected cracks vs. time, US 195. (K38)

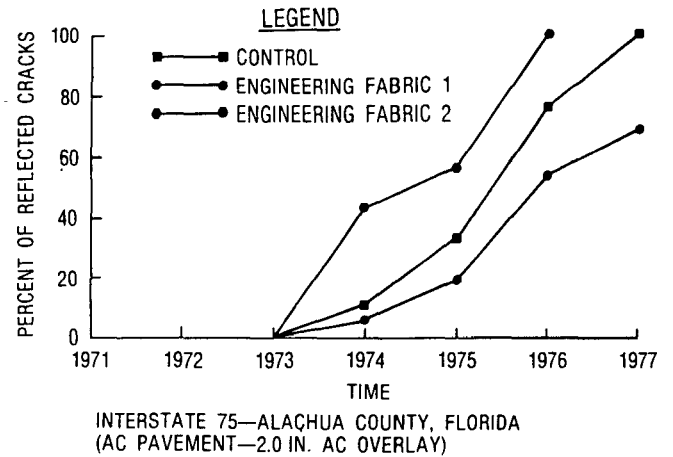
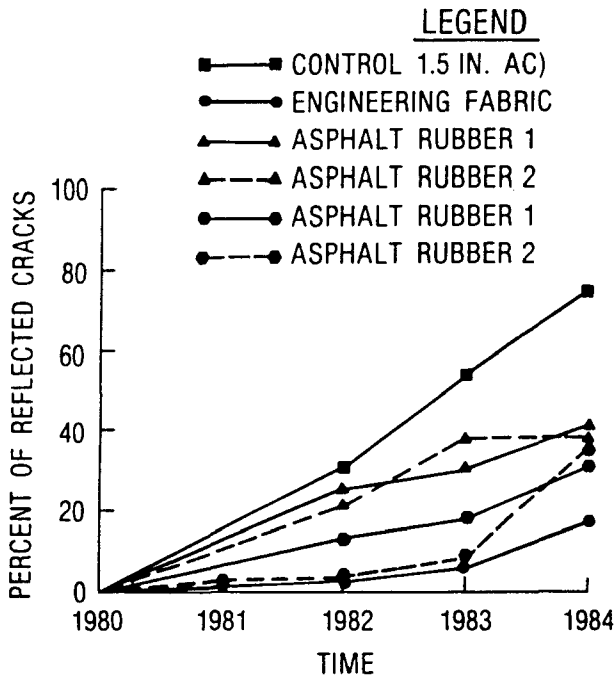
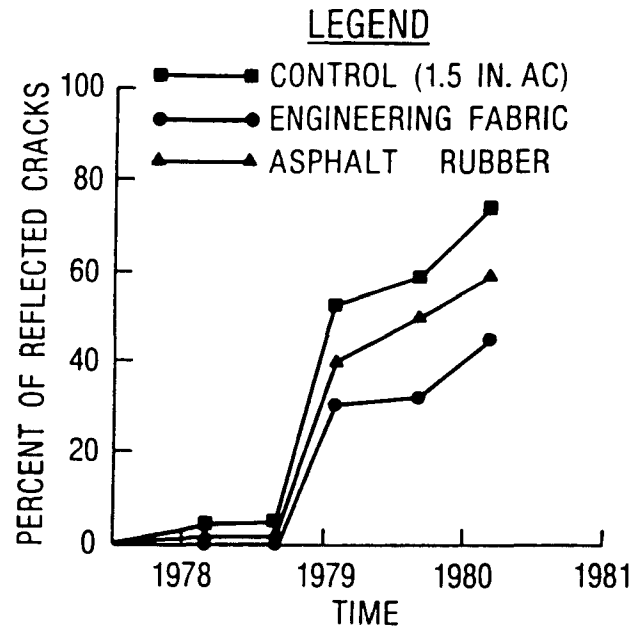

FIGURE K-18 Percent of reflected cracks vs. time, Interstate 75. (K38)



U. S. 98 - McCOMB, MISSISSIPPI  
(AC PAVEMENT - 1.5 IN. AC OVERLAY)

FIGURE K-19 Percent of reflected cracks vs. time, US 98. (K38)



ALAMEDA AVENUE - DENVER, COLORADO  
(AC PAVEMENT - 1.5 IN. AC OVERLAY)

FIGURE K-21 Percent of reflected cracks vs. time, Alameda Avenue. (K38)

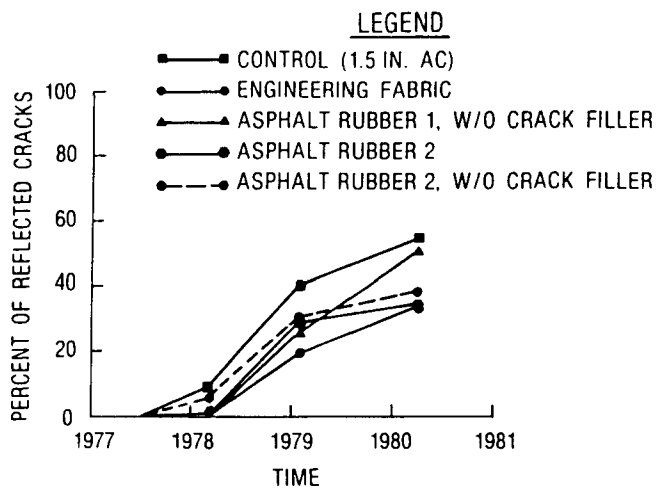

KANNAH CREEK - GRAND JUNCTION, COLORADO  
(AC PAVEMENT - 1.5 IN. AC OVERLAY)

FIGURE K-20 Percent of reflected cracks vs. time, Kannah Creek. (K38)

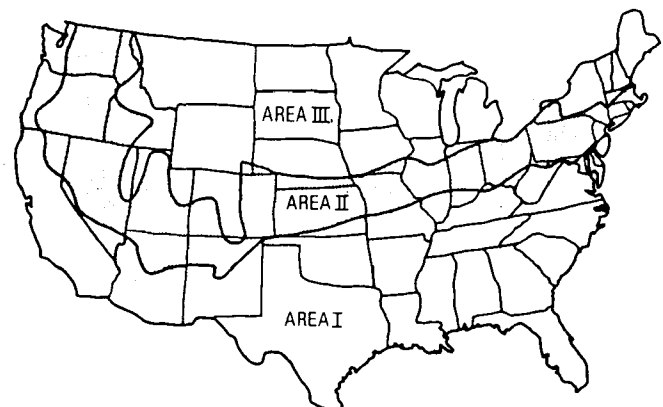

- AREA I - INTERLAYERS ARE RECOMMENDED WITH MINIMUM OVERLAY THICKNESS OF 2 IN.
- AREA II - INTERLAYERS ARE RECOMMENDED WITH OVERLAY THICKNESS OF 3-4 IN.
- AREA III - INTERLAYERS ARE NOT RECOMMENDED.

FIGURE K-22 Location guide for overlaying AC pavements to minimize reflective cracking. (K38)

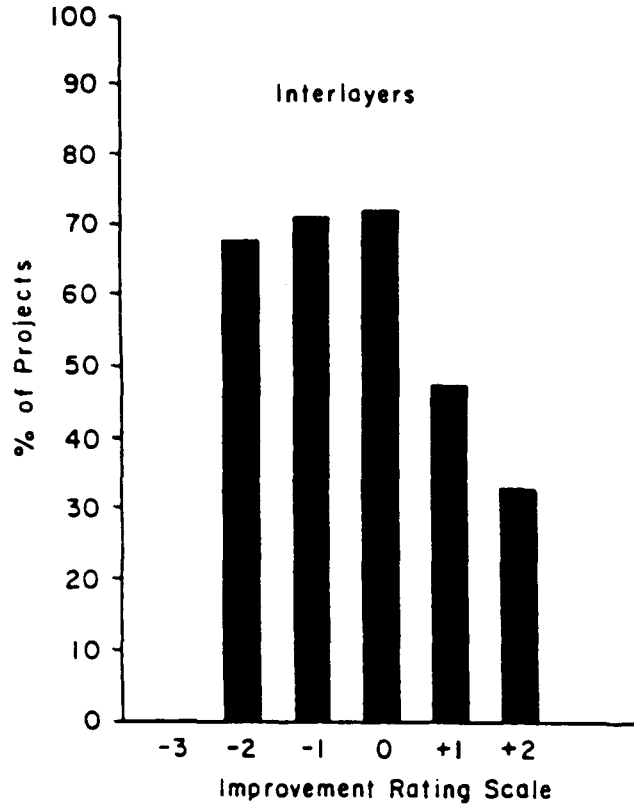

FIGURE K-23 Performance of projects constructed after 1979. (K39)

TABLE K-1  
PERFORMANCE DATA FOR SAMI (K3)

Route	Mean SAMI Life (Years)				Mean Overlay Thickness @ SAMI (inches)	Pavement Age @ SAMI (years)		Mean 18K ESALS* Since SAMI Application
	$\sigma$	C.V.	$\bar{X}$	R		$\bar{X}$	R	
Interstate	3.9	44	9	5-15	4.0	14	8-29	2676
State Route	3.9	41	9.5	3-13	2.0	19	9-32	241
U.S. Route	3.6	45	7.8	6-12	2.5	28	10-44	227

TABLE K-2  
1987 DISTRESS SURVEY RESULTS (K3)

Route U.S. 666		Route U.S. 60		Route U.S. 89	
SAMI	CONTROL	SAMI	CONTROL	SAMI	CONTROL
2.5 inch overlay	4.5 inch overlay	1.5 inch overlay	1.5 inch overlay	1.5 inch overlay	4.0 inch overlay
$\bar{X}$ $\sigma$	$\bar{X}$ $\sigma$	$\bar{X}$ $\sigma$	$\bar{X}$ $\sigma$	$\bar{X}$ $\sigma$	$\bar{X}$ $\sigma$
75.1   9.5	75.2   8.7	80.7   4.6	75.3   5.1	100   0	100   0

\* A 2 inch leveling course was placed prior to the SAMI.

TABLE K-3  
FATIGUE CRACKING AS PERCENT OF ORIGINAL CONDITION SR-20, CHEROKEE COUNTY, GEORGIA (K11)

Type Treatment	Evaluation Date				
	Dec. 1976	June 1977	Feb. 1978	Sept. 1980	June 1982
Asphalt-Rubber Sections 1-10	0	0	2	9	35
Petromat	0	0	0	12	12
Mirafi 140	0	1	8	**	**
Bidim C-22	0	0	0	45	104
Bidim C-28	0	0	0	0	4
Asphalt-Rubber Sections 27-31	0	0	0	5	12
Control	0	0	10	***	***
Asphalt-Rubber West of River	-	-	-	0	13

\*\* Entire section resurfaced due to slippage problems and fatigue failure.  
\*\*\* Resurfaced when topping was placed over asphalt-rubber interlayer west of Etowah River

TABLE K-4  
MINNESOTA DEPARTMENT OF TRANSPORTATION OVERLAY PROJECT (K3)

<u>TYPES OF CONSTRUCTION</u>	<u>NUMBER OF CRACKS/MILE</u>
SAMI over 1" bituminous overlay	90
SAMI over existing PCC	91
5 saw cuts/panel	123
Control section--No saw cuts	125
SAMI over 3" of bituminous	126
Petromat over 3" of bituminous overlay	130
Control section--2 saw cuts/panel	132
Petromat over 1" of bituminous overlay	133
Strip fabric over existing PCC pavement	171

---

CRACK COUNT DATA, 1984 (Four years after construction)

TABLE K-5  
 ANNUAL CRACK SURVEY NORTH CAROLINA 194, JAMESTOWN WEST (SOUTH ROADWAY)  
 ASPHALT-RUBBER INTERLAYER (K21)

<u>Section</u>	<u>Type of Section</u>	<u>Station</u>	<u>Number of Joints</u>	<u>Number of Joints Reflected</u>			
				<u>6-79</u>	<u>4-80</u>	<u>5-81</u>	<u>7-82</u>
1	Interlayer Omitted Joints Sealed	124+00 - 126+00	10	6	7	10	10
2	Typical Section	151+00 - 153+00	10	4	7	7	8
3	Control-Interlayer Omitted Joint Sealer Omitted	158+00 - 160+00	10	6	6	6	10
4	Typical Section	169+00 - 171+00	10	6	6	6	10
5	Typical Section	184+00 - 186+00	10	3	5	5	10
6	Typical Section	224+00 - 226+00	10	4	5	6	10
7	Typical Section	229+00 - 231+00	10	4	5	5	10
8	Typical Section	242+00 - 244+00	10	3	4	4	10
9	Typical Section	292+00 - 294+00	11	*	8	9	11
10	Joint Sealing Omitted	304+00 - 306+00	10	5	5	6	10

\* Cracks not counted as section had received flush coat with sand blotter.

## APPENDIX L

### INTERLAYER LIFE-CYCLE COSTS

#### Arizona DOT (1,2)

Two economic studies have been performed in Arizona. The study reported by Way (1) indicates that pavement sections containing an asphalt-rubber interlayer are effective in reducing reflection cracking and is cost effective.

Zaniewski's (2) report to the Arizona DOT contains life-cycle cost comparisons. First costs of alternative treatments and maintenance costs based on historical records were used. An estimate of user costs and salvage value was also used in the analysis. Results of this study are shown in Table L-1. The analyses indicate that if a conventional overlay lasts 10 years, an overlay of equal thickness with an asphalt-rubber interlayer would need to last more than 20 years for the same life-cycle cost.

#### New York (3)

This study performed economic analysis of asphalt-rubber interlayers using the cost information shown in Table L-2. Comparisons were developed between alternatives to have certain life cycles for equal annual costs (Table L-3). If a 2.5-in. overlay lasts 10 years, a 2-in. asphalt-concrete overlay with an asphalt-rubber interlayer would need to last 13.5 years for both to have an equal annual cost.

#### Industry Data (3,4)

First cost and life-cycle cost information has been published by the suppliers of asphalt-rubber binders. These estimates of first cost and service life are shown in Table L-4 and L-5. These tables illustrate the economic benefits of asphalt-rubber interlayers.

#### Other Studies (5)

Life-cycle costs analysis were performed in the state pooled-fund study. Results are presented in Table L-6 which indicate that if a 1.5-in. overlay were placed without an interlayer and had a life of 6 years, a 1.5-in. overlay with an asphalt-rubber overlay would have to last 11.6 years. A comparison of alternatives considering maintenance costs, rehabilitation, and salvage value indicates the potential economic benefits of using asphalt-rubber interlayers (Table L-7).

#### REFERENCES

1. Way, G.B., *Prevention of Reflective Cracking, Minnetonka—East (1979 Addendum Report)*, Report No. 1979-GW1, Arizona Department of Transportation, Aug. 1979.
2. Zaniewski, J.P., *Summary of Arizona Department of Transportation Experience with Asphalt-Rubber—State of the Art*, Report No. FHWA-AZ88-818, Arizona Department of Transportation, Aug. 1988.
3. Gupta, P.K., *Asphalt-Rubber Surface Treatments and Interlayers*, Report No. FHWA/NY/RR-86/131, New York Department of Transportation, March 1986.
4. Schnormeier, R.H., Use of Asphalt-Rubber on Low-Cost, Low-Volume Streets: A Review After 13 Years, in *Transportation Research Record 898*, TRB, National Research Council, Washington, D.C. ( ).
5. Shuler, T.S., R.D. Pavlovich, J.A. Epps, and C.K. Adams, *Investigation of Materials and Structural Properties of Asphalt-Rubber Paving Mixtures, Volume I—Technical Report*, Report No. FHWA/RD-86/027, Texas Transportation Institute, Sept. 1986.



TABLE L-1  
ECONOMIC ANALYSIS OF ALTERNATIVE TREATMENTS (L2)

PROJECT LENGTH	TREATMENT	ROUTE TYPE	1,000 ADT			10,000 ADT			
			5 YRS	10 YRS	25 YRS	5 YRS	10 YRS	25 YRS	
2 MILE	SAM	I	6.75	4.66	3.06	7.12	4.82	3.06	
		S	6.37	4.23	2.60	6.74	4.39	2.60	
		U	6.63	4.52	2.91	7.00	4.68	2.91	
	SAMI 1"	I	11.60	7.48	4.34	11.98	7.65	4.34	
		S	12.01	7.94	4.84	12.39	8.10	4.84	
		U	11.76	7.66	4.53	12.14	7.82	4.53	
	SAMI 2"	I	16.37	10.42	5.88	16.75	10.58	5.88	
		S	16.79	10.88	6.37	17.16	11.04	6.37	
		U	16.53	10.60	6.07	16.91	10.76	6.07	
	SEALCOAT	I	4.46	3.16	2.17	4.84	3.32	2.17	
		S	4.68	3.40	2.43	5.05	3.56	2.43	
		U	3.98	2.62	1.59	4.35	2.79	1.59	
	OL 1"	I	6.30	4.20	2.60	6.68	4.36	2.60	
		S	6.90	4.87	3.32	7.28	5.03	3.32	
		U	6.45	4.37	2.77	6.82	4.53	2.77	
	OL 2"	I	11.07	7.14	4.13	11.45	7.30	4.13	
		S	11.68	7.81	4.86	12.05	7.97	4.86	
		U	11.22	7.30	4.31	11.60	7.46	4.31	
	OL 4"	I	20.62	13.01	7.21	20.99	13.17	7.21	
		S	21.22	13.68	7.93	21.59	13.84	7.93	
		U	20.77	13.18	7.38	21.14	13.34	7.38	
	10 MILE	SAM	I	6.41	4.43	2.92	7.53	4.91	2.92
			S	6.02	4.00	2.46	7.14	4.49	2.46
			U	6.28	4.29	2.77	7.40	4.78	2.77
SAMI 1		I	10.63	6.87	4.00	11.75	7.35	4.00	
		S	11.04	7.33	4.49	12.16	7.81	4.49	
		U	10.79	7.05	4.19	11.91	7.53	4.19	
SAMI 2		I	12.71	8.15	4.67	13.83	8.64	4.67	
		S	13.13	8.61	5.17	14.25	9.10	5.17	
		U	12.87	8.33	4.86	13.99	8.82	4.86	
SEALCOAT		I	4.03	2.88	2.01	5.15	3.37	2.01	
		S	4.25	3.12	2.26	5.37	3.61	2.26	
		U	3.55	2.34	1.42	4.67	2.83	1.42	
OL 1"		I	5.73	3.83	2.38	6.85	4.32	2.38	
		S	6.33	4.50	3.11	7.45	4.99	3.11	
		U	5.88	4.00	2.56	7.00	4.48	2.56	
OL 2"		I	7.81	5.12	3.06	8.93	5.60	3.06	
		S	8.42	5.79	3.78	9.54	6.27	3.78	
		U	7.96	5.28	3.23	9.08	5.77	3.23	
OL 4"		I	11.99	7.68	4.40	13.11	8.17	4.40	
		S	12.59	8.35	5.12	13.71	8.84	5.12	
		U	12.13	7.85	4.58	13.25	8.33	4.58	

I - INTERSTATE  
S - STATE HIGHWAYS  
U - US HIGHWAYS  
OL- OVERLAY OF HOT MIX ASPHALT

TABLE L-2  
ESTIMATED COSTS OF PAVEMENT REHABILITATION ALTERNATIVES (L3)

Treatment	Cost/yd <sup>2</sup>
<b>EXPERIMENTAL</b>	
Asphalt-rubber surface treatment or "chip seal" (SAM)	52.00
Asphalt-rubber interlayer with 2-in. asphalt-concrete overlay (SAMI)	5.66
<b>CONVENTIONAL</b>	
Single-course bituminous surface treatment	1.05
1-in. armor coat	1.81
2½-in. asphalt-concrete overlay	4.50

TABLE L-3  
COMPARISONS OF SERVICE LIVES (YEARS) EQUAL ANNUAL COSTS (L3)

**EXPERIMENTAL TREATMENTS**

1. Asphalt-rubber surface treatment or "chip seal" (SAM)
2. Asphalt-rubber interlayer with 2-in. asphalt-concrete overlay (SAMI)

**CONVENTIONAL TREATMENTS**

3. Single-course bituminous surface treatment
4. 1-in. armor coat top course
5. 2½-in. asphalt-concrete overlay (1½-in. binder and 1-in. surface course)

4-percent Interest		8-percent Interest		14-percent Interest	
1* vs 3**		1* vs 3**		1* vs 3**	
3.9	2.0	4.1	2.0	4.5	2.0
8.3	4.0	9.1	4.0	11.5	4.0
13.0	6.0	15.9	6.0	Infinite	6.0
1* vs 4**		1* vs 4**		1* vs 4**	
2.2	2.0	2.2	2.0	2.2	2.0
4.5	4.0	4.5	4.0	4.6	4.0
6.7	6.0	6.8	6.0	7.0	6.0
2* vs 5**		2* vs 5**		2* vs 5**	
10.6	8.0	11.2	8.0	12.9	8.0
13.4	10.0	14.6	10.0	19.1	10.0
16.3	12.0	18.5	12.0	44.4	12.0

\*Service lives (years) computed for equal annual cost  
(Annual Cost = Present Cost x Capital Recovery Factor).

\*\*Service lives (years) assumed.

TABLE L-4  
MANUFACTURER'S ESTIMATED COSTS FOR VARIOUS  
REHABILITATION ALTERNATIVES (L3.4)

Treatment	Cost/yd <sup>2</sup>
<b>ARIZONA REFINING COMPANY</b>	
Asphalt-rubber interlayer with 3/4-in. OGFC* containing 6% asphalt cement	\$2.59
Asphalt-rubber interlayer with 3/4-in. OGFC* containing 7% asphalt-rubber binder	3.10
4-in. asphalt-concrete overlay	5.75
2-in. asphalt-concrete overlay	2.88
<b>SAHUARO PETROLEUM AND ASPHALT COMPANY</b>	
HS&R** with asphalt-cement surface treatment	1.83
HS&R** with 1 1/4-in. asphalt-concrete overlay	2.92
Fabric with 1 1/4-in. asphalt-concrete overlay	2.90
1-in. asphalt-concrete overlay	1.16
1 1/4-in. asphalt-concrete overlay	1.80
2-in. asphalt-concrete overlay	2.37
3-in. asphalt-concrete overlay	3.59
Single-course asphalt-cement chip seal	0.83
Double-course asphalt-cement chip seal	1.65
Triple-course asphalt-cement chip seal	2.50
1 1/4-in. asphalt-concrete overlay and asphalt-rubber interlayer	3.33

\*OGFC = open-graded friction course.  
\*\*HS&R = heater scarification and rejuvenation.

TABLE L-5  
MANUFACTURER'S ESTIMATED SERVICE LIVES AND ANNUAL COSTS FOR  
REHABILITATION ALTERNATIVES (L4)

Treatment	Service Life, years		Annual Cost/yd <sup>2</sup>
	Range	Mean	
HS&R* with 1 1/4-in. asphalt-concrete overlay	3-6	4.5	\$0.65
Fabric with 1 1/4-in. asphalt-concrete overlay	4-7	5.5	0.53
1-in. asphalt-concrete overlay	1-3	2.5	0.52
1 1/4-in. asphalt-concrete overlay	2-4	3.0	0.60
2-in. asphalt-concrete overlay	3-6	4.5	0.53
3-in. asphalt-concrete overlay	5-8	6.5	0.55
Single-course asphalt-cement chip seal	2-3	2.5	0.33
Double-course asphalt-cement chip seal	3-6	4.5	0.37
Triple-course asphalt-cement chip seal	4-8	6.0	0.42
Asphalt-rubber chip seal	4-8	6.0	0.26
1 1/4-in. asphalt-concrete overlay and asphalt-rubber interlayer	6-10	8.0	0.42

\*HS&R = heater scarification and rejuvenation.  
\*\*For annual interest rate of 4.0%.

TABLE L-6  
COMPARISON OF INTERLAYER REHABILITATION ALTERNATIVES (L5)

Rehabilitation Alternative	First Cost \$/yd <sup>2</sup>	Life for Equal Annual Cost			
		4.0	6.0	8.0	10.0
None	2.48	4.0	6.0	8.0	10.0
AC Chip Seal	3.33	5.5	8.4	11.4	14.6
A-R Chip Seal	4.33	7.4	11.6	16.1	21.3
Fabric	3.48	5.8	8.9	12.0	15.2
Heater-Scarification	3.38	5.7	8.6	11.6	14.9

\*Assumes 1.5 inch Asphalt Concrete Overlay, 4 percent rate of return, and no maintenance costs.

TABLE L-7  
LIFE-CYCLE COST EXAMPLE (L5)

Rehabilitation Alternatives	First Cost	Life Cycle Cost	First Energy	Life Cycle Energy
	\$/yd <sup>2</sup>	\$/yd <sup>2</sup>	Btu. yd <sup>2</sup>	Btu. yd <sup>2</sup>
1. Asphalt rubber chip seal to delay overlay	1.25	7.31	6,200	139,300
2. 3 in asphalt concrete overlay	4.95	9.88	83,400	189,800
3. Heater-scarification + 2 in overlay	4.20	7.32	76,600	156,100
4. Asphalt-rubber interlays + 2 in overlay	5.15	7.36	61,800	115,500
5. Fabric interlays + 2 in overlay	4.50	7.62	58,100	137,600

## APPENDIX M

### CRUMB RUBBER MODIFIED HOT-MIX ASPHALT DESIGN METHODS

#### Crafco (1)

A paper presented by Chehovits discusses a design method for dense-graded hot-mix asphalts made with asphalt-rubber binders. Trial asphalt-rubber binder contents are typically 15 to 25 percent higher than those typically used for conventional mixes since the binder contains 15 to 20 percent crumb rubber. The paper recommends that, before mixing, the asphalt-rubber be heated to 350°F and the aggregate to 300°F. Certain precautions should be used when heating the asphalt-rubber binder, including stirring and preventing conditions where localized binder overheating can take place.

Standard mixes and mixing procedures can be used. Total mix time should not exceed 2 minutes. Marshall compaction should be performed at 280°F. After compaction, the samples should be allowed to cool for 4 hours before extrusion. Mixes with rubber particle sizes that are not compatible with aggregate gradation will appear spongy and will have to be adjusted.

The design binder content should be selected based on stability, flow, VMA, air voids, and density, as with conventional mixes. Air void design criteria should be in the 3 to 4 percent range since CRM mixes do not densify as much under traffic. Flow values can also be increased to 24 for light traffic, 22 for medium traffic, and 20 for heavy traffic, due to the higher binder contents typically required. When using the Hveem procedure, stability values of 20 are acceptable when asphalt-rubber binders are being used, provided the same mixture containing asphalt cement has a stability of 35 to 37. Air void target values should be 3 to 4 as well. Water sensitivity should be evaluated on the mixture at the design binder content.

#### University of Nevada (2)

A testing program was conducted at the University of Nevada to investigate problems associated with the use of the Marshall and Hveem procedures for the design of dense-graded mixtures containing asphalt-rubber binder. In the Marshall mix design method, asphalt-rubber binders reduce the stability and unit weight while increasing the flow and VMA values. Similar values of air voids are obtained.

Hveem samples were prepared in this study at 230°F and 300°F. The higher compaction temperatures produce samples with reduced stability and air voids. Mixtures containing asphalt-rubber have lower Hveem stability. The unit weight, VMA, and air voids either increase or decrease depending on the type of binder. The samples' volumetric expansion after extrusion was not a problem in this study.

#### Texas Transportation Institute (3,4)

The Texas Transportation Institute developed a mixture design method for asphalt-rubber dense-graded mixture. This method rec-

ognizes potential problems with mixing, compaction, and swelling upon removal from the compaction mold. Modifications to the Marshall mix design procedure as suggested by the Institute are given below:

1. Adjust the aggregate gradation to permit space for the rubber particles. The unreacted rubber was treated as aggregate relative to nesting the aggregate gradation specifications.
2. Mix and compact the materials at 375°F.
3. Seventy-five blow Marshall compaction is suggested.
4. Use high-energy mechanized mixers.
5. Allow the compacted specimen to cool in the mold to room temperature before extrusion.

The Institute suggests that satisfactory mix designs will result using these techniques.

#### Federal Highway Administration (5)

The FHWA reports that conventional Marshall and Hveem mix design procedures have been used successfully for designing dense-graded mixtures using asphalt-rubber or wet process binders. When using the Marshall procedure, mixing and compaction temperatures should be higher than for conventional mixtures. Marshall stability can be lower, and the flow, VMA, and binder contents are higher than with conventional mixes.

Hveem stability is typically lower, and VMA and binder contents higher, when using asphalt-rubber binders. Typical binder contents for asphalt-rubber mixtures are higher and proportional to the amount of crumb rubber in the mixture. A binder which contains 20 percent crumb rubber will typically require a 20 percent increase in binder content. Compacted samples should remain in the molds until they are cool before they are extracted.

When using the partially reacted asphalt-rubber binder, consideration should be given to the match between the aggregate gradation and rubber gradation. Although the crumb rubber is "reacted" with the asphalt; spongy, swollen rubber is present and occupies space which is typically occupied by aggregate. Aggregate gradations with small nominal maximum sizes may need finer rubber particles (passing the No. 40 sieve). The crumb rubber volume should fit into the available VMA. Adjustments in aggregate gradations below the maximum density gradation line (0.45 power line) may be required.

Mixtures produced using dry process binders do not follow normal Marshall or Hveem mixture design procedures. PlusRide uses conventional preparation equipment and procedures, with some modification. The property used for design is the air voids' percentage. Stability is not normally used. The aggregate gradation, and crumb rubber content and gradation, are specified by the

PlusRide patent. Target air voids are between 2 and 4 percent. The aggregate gradation follows a narrow, gap-graded band with relatively high minus No. 200 content. Crumb rubber content is 3 percent by weight of total mix. The crumb rubber typically passes the 1/4-in. sieve with some of the material passing the No. 10 sieve supplement with bufferings. Binder contents in the range of 7.5 to 9 percent are typical. The asphalt cement used is that used typically for the area and pavement.

During the laboratory mixing process, the crumb rubber is dry mixed with the aggregate before adding the asphaltic cement. The mixture is cooled for 1 hour after mixing. After compaction, the sample is confined and cooled to room temperature. Air void content is determined after extrusion.

A generic dry process has been used in New York and Florida. This process uses available aggregate. The aggregate's typical gradations determines how fine the rubber particles will be. The rubber content is lower than that used in the PlusRide concept. At the time this synthesis was written, it was not clear if this concept infringes on the existing patents.

CRREL's "chunk" rubber asphalt-concrete concept (5) used a dense-graded aggregate and a relatively large maximum size crumb rubber which was nearly two sized. High crumb rubber contents require some adjustments in the aggregate gradation. Selection of the optimum asphalt content is based primarily on air void content.

#### National Center for Asphalt Technology (6)

The National Center for Asphalt Technology at Auburn University performed a study for the Florida DOT in which mixture design issues were addressed. Suggestions from this study are summarized below.

- Aggregate gradations should be opened to allow for the use of the thicker binder and the unreacted rubber that are present.
- The quantity of rubber should be limited to 3 to 5 percent of total binder weight until performance information is available.
- Finer rubber particles (passing the No. 80 sieve) should be used with the finer aggregate gradations.
- Conventional mix design procedures should be used; however lower stabilities at higher flow should be expected.
- Higher binder contents should be used.

These suggestions are based on reacted binder systems, although the Florida DOT has placed dry processed materials.

#### Open-graded Hot Mix

The discussion so far has been directed toward the design of dense- and gap-graded mixtures. This section will discuss design techniques for open-graded mixtures.

The FHWA (5) suggests that two revisions be made in their published method for the design of open-graded friction courses. The first is to increase the asphalt-rubber binder to account for the thicker binder film and the presence of the crumb rubber. A revision in the design formula could be used, or the binder content could be increased in proportion to the amount of crumb rubber present in the asphalt-rubber binder. The second revision is to increase the mixing temperature to account for the increase in binder viscosity associated with asphalt-rubber binders.

Chehovits (7) lists three steps for determining asphalt-rubber content:

1. Determine the surface content for the aggregate by the Kerosene equivalent procedure ( $K_c$ ).
2. Calculate the required asphalt-cement content as follows:  
percent asphalt content =  $2.0 K_c + 4.0$
3. Determine the asphalt-rubber content by dividing the binder content obtained in step 2 by the asphalt-cement or base asphalt content in the asphalt-rubber binder.

#### REFERENCES

1. Chehovits, J.G., Design Methods for Hot-Mixed Asphalt-Rubber Concrete Paving Materials, presented at the National Seminar on Asphalt-Rubber, Oct. 1989.
2. Stroup-Gardiner, M., N. Krutz, and J.A. Epps, Comparison of Mix Design Methods for Rubberized Asphalt Concrete Mixtures, presented at the National Seminar on Asphalt-Rubber, Oct. 1989.
3. Roberts, F.L., R.L. Lytton, and D.M. Hoyt, *Criteria for Asphalt-Rubber Concrete in Civil Airport Pavements: Mixture Design*, Report No. DOT/FAA/PM-88/39, Texas Transportation Institute, July 1986.
4. Roberts, F.L., and R.L. Lytton, FAA Mixture Design Procedure for Asphalt-Rubber Concrete, TRB 1987.
5. Heitzman, M.A., *State of the Practice for the Design and Construction of Asphalt Paving Materials with Crumb Rubber Additive*, Report No. FHWA-SA-92-022, Office of Engineering, Pavement Division, Federal Highway Administration, May 1992.
6. Roberts, F.L., P.S. Kandhal, E.R. Brown, and R.L. Dunning, *Investigation and Evaluation of Ground Tire Rubber in Hot Mix Asphalt*, National Center for Asphalt Technology, Aug. 1989.
7. Chehovits, J.G., Design Methods for Hot-Mixed Asphalt-Rubber Concrete Paving Materials, presented at the National Seminar on Asphalt-Rubber, Oct. 1989.

## APPENDIX N

### PROPERTIES OF CRUMB RUBBER MODIFIED HOT-MIX ASPHALT

#### HOT-MIX ASPHALT PROPERTIES

##### Marshall Stability

Marshall test results on mixtures prepared with asphalt-rubber binders are shown in Figure N-1. That figure indicates that Marshall stability can be reduced, Marshall flow increased, air voids increased, and the maximum unit weight unchanged, when asphalt-rubber binders are used rather than typical asphalt cements (1,2).

Tests performed on mixtures prepared by the dry process indicate that stability, flow, and air voids are dependent upon aggregate gradation and rubber content, among other factors (3) (Figures N-2, N-3, N-4, N-5). Data reported by New Jersey (4) on dry process binders indicate a slight reduction in stability and a large increase in flow values when compared with control mixtures (Figure N-6).

##### Hveem Stability

Hveem stability data indicate that the asphalt-rubber binder may produce mixtures with an increase in stability (5). Results from Oregon indicate that mixes containing asphalt-rubber binders have comparable Hveem stabilities, while mixtures produced by the dry process may have considerably lower stability values than control mixtures (Figures N-7 and N-8) (6). Data from a Colorado study also indicate that considerably lower stability values will be obtained for mixtures produced by the dry process (7) when compared with control mixtures.

##### Resilient Modulus

Resilient modulus data are reported in many references. Representative data obtained on mixtures containing binders produced by the wet and the dry process are presented here.

Resilient modulus values for mixtures containing asphalt-rubber binders are shown in Figures N-9 and N-10. Resilient modulus values for a mixture containing a gravel aggregate and asphalt-rubber binder are higher at 77°F than for a mixture containing a conventional asphalt cement (Figure N-9). Resilient modulus data over a temperature range for a mixture containing limestone aggregate is shown in Figure N-10. The mixture containing the asphalt-rubber has a lower resilient modulus at all temperatures (5).

Resilient modulus data (8,9) obtained on mixtures containing binders produced by the dry process are shown in Figures N-11 to N-16. These data indicate that aggregate gradation, crumb rubber gradation, crumb rubber type, crumb rubber amount, and mixing temperature influence the resilient modulus. In general, lower resilient modulus values were obtained than for conventional mixes. Higher resilient modulus results when mixing temperature and cure time increase and fine crumb rubber is used at lower concentrations. Data for both dense- and gap-graded mixes are shown.

Oregon and California data provide a comparison between mixtures containing binder produced by the wet and the dry processes. Resilient modulus values for the wet-produced asphalt-rubber binder are lower than those from the dry-produced rubber modified binder (Figure N-17) (6). Data from California indicate a similar trend. The asphalt-rubber binder section (AR5) with a resilient modulus of 95,000 psi is considerably lower than the mixtures produced by the dry process (PlusRide, 250,000 psi and Ramflex, 334,000 psi) (Table N-1) (10).

##### Permanent Deformation

A limited amount of permanent deformation test results appear in the literature. These data are summarized here.

Research at Texas A&M University and the University of Nevada on asphalt-rubber binders indicate that permanent deformation properties of asphalt-rubber dense mixtures are within the range of properties normally associated with conventional hot-mix asphalt. Figure N-18 and N-19 show permanent deformation data for both static and dynamic compressive loading conditions (11). Data developed in Virginia suggests that asphalt-rubber mixtures may be less resistant to permanent deformation (2).

Static and repeated load permanent deformation test results on rubber modified binders are shown in Tables N-2 and N-3 (9). These data show a higher potential for permanent deformation when the rubber-modified binder is used than when the control mixture is used. These data are supported by that contained in Roberts et al. (12). Additional repeated load data are needed to clarify these limited data.

ESSO Belgium (13) provides data which allow for a comparison among conventional mixes and wet and dry process binders (Figure N-20). The dry process material (pugmill blended) and wet process material (bitumen blended) have similar properties.

##### Fatigue

Data describing the fatigue properties of CRM mixtures indicate that when crumb rubber is added to hot-mix asphalt, by either the wet or the dry process, the fatigue life is improved. Fatigue behavior is affected by aggregate type and gradation, crumb rubber type and gradation, concentration of crumb rubber, reaction temperature, and air voids, among other variables.

Results of controlled stress fatigue tests performed on asphalt-rubber hot mix is shown in Figure N-21 and compared with those performed on a conventional mix in Figure N-22. The asphalt-rubber field mixes have greater fatigue lines regardless of the age of the samples. Fatigue curves for rubber-modified mixtures are shown in Figure N-23 and N-24. The rubber-modified mixture exhibits improved fatigue performance (14).

Figures N-25 and N-26 compare fatigue behavior of mixtures

containing binders produced by the wet and the dry processes (6,13). The controlled strain tests shown in Figure N-25 indicate that improved performance was obtained with the dry-processed binder mix (site 1). The reverse is indicated in Figure N-26. The wet asphalt-rubber mixture has improved performance relative to the control and the dry-processed mixture. The dry-processed mixture has a reduced fatigue life as compared with the control mixture.

### Tensile Strength

Results from a Virginia field project (15) and a laboratory study in Texas (5) indicate that asphalt-rubber hot-mix asphalts may have higher or lower tensile strengths than control mixtures (Table N-4 and Figure N-27). Indirect tensile strengths were lower for a rubber-modified mixture compared with a control mix test in New Jersey (4) (Figure N-28).

### Water Sensitivity

Some references contain laboratory test results which imply water sensitivity. Test results obtained on asphalt-rubber hot-mix asphalt are shown in Table N-5 and Figure N-29. Virginia results indicate little damage due to water (14). These test were performed without a freeze-thaw cycle. Figure N-29 indicates no damage with a freeze-thaw cycle in a mixture that contains an aggregate that is not water sensitive. Test results obtained on mixtures containing a binder produced by the dry process show a decrease in strength on the presence of water versus control samples (Figure N-30) (9). Substantial strength losses are also evident in Figure N-31 for mixtures produced by both the wet and dry process. Strength losses in the presence of moisture are about the same as the control. Note that the tensile strength of the control mixture is greater than the CRM mixtures.

### Thermal Cracking

Reports from Stuart and Mogawer (9) and Krutz and Stroup-Gardiner (16) contain information about thermal or low temperature cracking. The study they report, conducted with asphalt-rubber binder, reports indirect and direct tensile test results at three low temperatures along with the results for the SHRP restrained thermal shrinkage test. Fracture temperatures for mixtures prepared with and without asphalt-rubber binders are shown in Table N-6 (16). The mixture prepared with crumb rubber reacted with an AC5 had a colder fracture temperature than the other mixtures. Indirect tensile-strength results from this same set of mixtures are shown in Figure N-32 for the other temperatures. The asphalt-rubber mixtures prepared with the AC5 base asphalt had low tensile strengths compared with control mixtures. Cold temperature, direct tensile-strength test results at  $-20^{\circ}\text{F}$  are shown in Figure N-33. At this low temperature the tensile strength of all mixtures appears to be nearly the same. Relatively good agreement was obtained when comparing results from direct and indirect tensile tests (Figure N-33).

Stuart and Mogawer (9) utilize resilient modulus and tensile strength at low temperatures to infer that rubber-modified hot-mix

asphalt is more resistant to thermal cracking. Additional testing needs to be performed.

### Reflection Cracking

A crack reflection test apparatus was used to determine the number of crack openings required to reflect a crack through an asphalt-rubber hot mix. These results are shown in Table N-7 (20). At a test temperature of  $34^{\circ}\text{F}$  the asphalt-rubber medium and high binder content mixtures performed better than the control mixture.

### Surface Abrasion

California has developed a surface abrasion test to evaluate a mixture's ability to resist tire chain wear (10). Results on California mixtures are shown in Tables N-1, N-8, and N-10. Table N-8 contains results obtained on laboratory mixed and compacted mixtures. The AR5 material is an asphalt-rubber hot mix, and the Ramflex and crumb rubber materials are produced by the dry process. The AR5 product shows improved behavior when compared with the controls and other modifiers. Data obtained with the AR5 binder on a different aggregate (Table N-1) show improved surface abrasion resistance relative to the control and other mixtures evaluated.

The PlusRide product produced by the dry process also shows improved performance (Table N-1) (10). Other California data show no benefit or limited benefit when dry processed rubber modified binders are used (Table N-9 and N-10).

### Friction

Several reports (3,4,15,18) contain friction data on crumb-rubber modified mixtures. In general, friction numbers were decreased by the presence of rubber (Table N-11). A study conducted in Alaska, however, shows that stopping distance is reduced when dry-processed binder mixtures are used in icy conditions. Table N-12 contains the supporting data.

### REFERENCES

1. Asphalt-Rubber is Compared with Standard Asphalt, *The Rebounder*, Vol. 6, No. 4, Fall 1990.
2. Maupin, G.W., Virginia's Experimentation with Asphalt Rubber Concrete, in *Transportation Research Record 1339*, Transportation Research Board, National Research Council, Washington, D.C. (1992).
3. Esch, D.C., *Asphalt Pavements Modified with Coarse Rubber Particles—Design, Construction and Ice Control Observations*, Report No. FHWA-AK-RD-85-07, Alaska Department of Transportation, Aug. 1984.
4. Miller, B., and L.G. Scholl, *Evaluation of Asphalt Additives: Lava Butte to Fremont Highway Junction*, Oregon Department of Transportation, Oct. 1990.
5. Shuler, T.S., R.D. Pavlovich, J.A. Epps, and C.K. Adams, *Investigation of Materials and Structural Properties of Asphalt-Rubber Paving Mixtures, Volume I—Technical Report*,



- Report No. FHWA/RD-86/027, Texas Transportation Institute, Sept. 1986.
6. Report on PlusRide Pavement, Route 2, South County Trail, East Greenwich, Rhode Island, Rhode Island Department of Transportation.
  7. LaRorce, R.F., *Rubber Modified Asphalt Concrete*, Report No. ODOH-SMB-R-87-15, Colorado Department of Highways, Dec. 1987.
  8. Takallou, H.B., R.G. Hicks, and D.C. Esch, Effect of Mix Ingredients on the Behavior of Rubber-Modified Asphalt Mixtures, *Transportation Research Record 1096*, TRB, National Research Council, Washington, D.C. ( ).
  9. Stuart, K.D., and W.S. Mogawer, Laboratory Evaluation of Verglimit and PlusRide, *Public Roads*, Vol. 55, No. 3, Dec. 1991.
  10. Van Kirk, J.L., *The Effect of Fibers and Rubber on the Physical Properties of Asphalt Concrete*, Report No. CA/TL-85/18, California Department of Transportation, June 1986.
  11. Krutz, N.C., and M. Stroup-Gardiner, *Permanent Deformation Characteristics of Recycled Tire Rubber Modified and Unmodified Asphalt Concrete Mixtures*, University of Nevada; Asphalt Rubber Producers Group, Aug. 1991.
  12. Roberts, F.L., P.S. Kandhal, E.R. Brown, and R.L. Dunning, *Investigation and Evaluation of Ground Tire Rubber in Hot Mix Asphalt*, National Center for Asphalt Technology, Aug. 1989.
  13. *Open-Graded and Dense-Graded Mixes with Asphalt Rubber*, ESSO Belgium, 1984.
  14. Jimenez, R.A., *Testing of Asphalt-Rubber and Aggregate Mixtures*, Report No. FHWA/AZ-79/111, Arizona Department of Transportation, Oct. 1979.
  15. "Virginia Embankment: Where the Rubber Really Meets the Road" *Engineering News Report*, Sept. 20, 1993.
  16. Blasl, D.J., *Asphalt-Rubber Used as an Interlayer*, North Dakota State Highway Department, Sept. 1982.
  17. Krutz, N.C., and M. Stroup-Gardiner, *Low Temperature Cracking Characteristics of Ground Tire Rubber and Unmodified Asphalt Concrete Mixtures*, University of Nevada; Asphalt Rubber Producers Group, Sept. 1991.
  18. Hoyt, D.M., R.L. Lytton, and F.L. Roberts, *Criteria for Asphalt-Rubber Concrete in Civil Airport Pavements; Vol. II-Evaluation of Asphalt-Rubber Concrete*, Report No. DOT/FAA/PM-86/39, II, Federal Aviation Administration, March 1987.
  19. McManigle, K.A., and D.B. Mellot, *Interim Corrective Skid Resistance Treatments on I-83*, Report No. FHWA-PA-86-038 + 76-10, Pennsylvania Department of Transportation, May 1989.

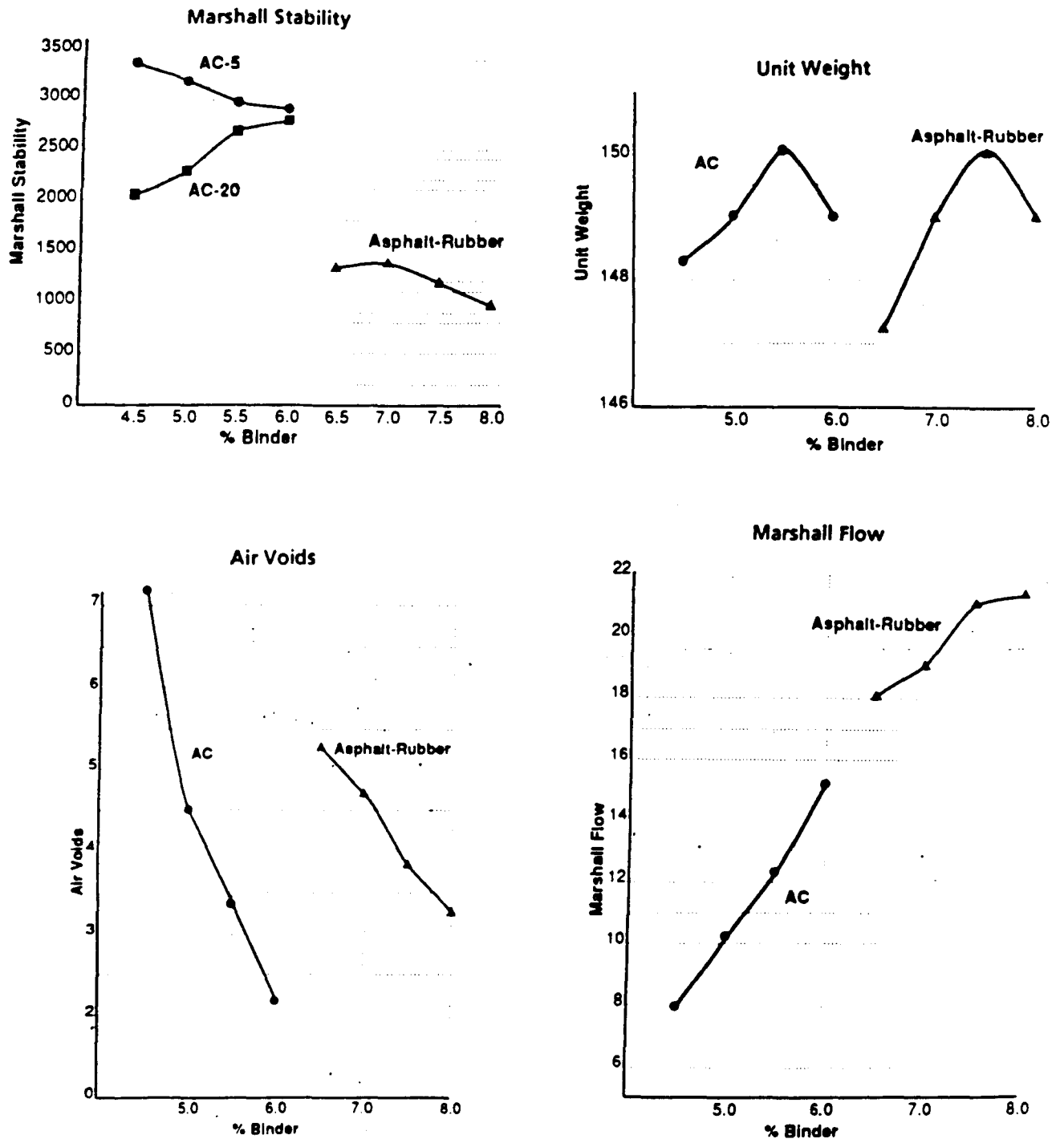

FIGURE N-1 Typical Marshall stability data. (NI)

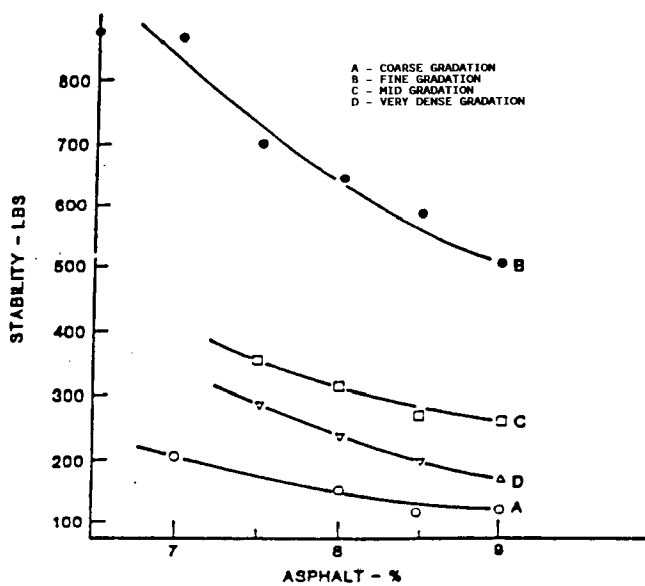

FIGURE N-2 Differences in Marshall stability for different aggregate gradations within a single specification band. (N3)

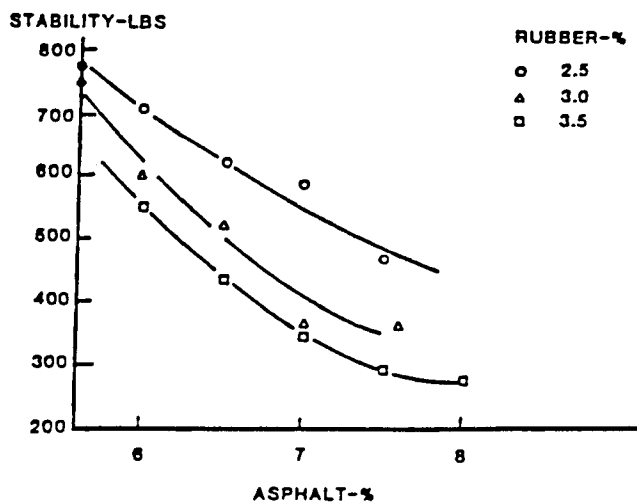

FIGURE N-4 Effects of rubber-content variations on mix stability by Marshall test procedure. (N3)

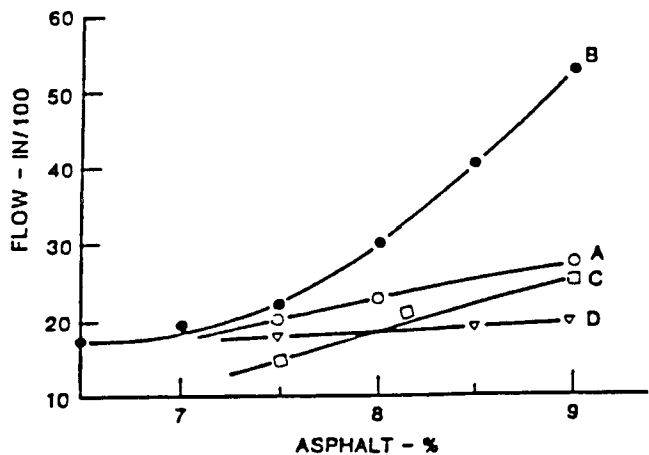

FIGURE N-3 Differences in Marshall flow for different aggregate gradations within a single specification band. (N3)

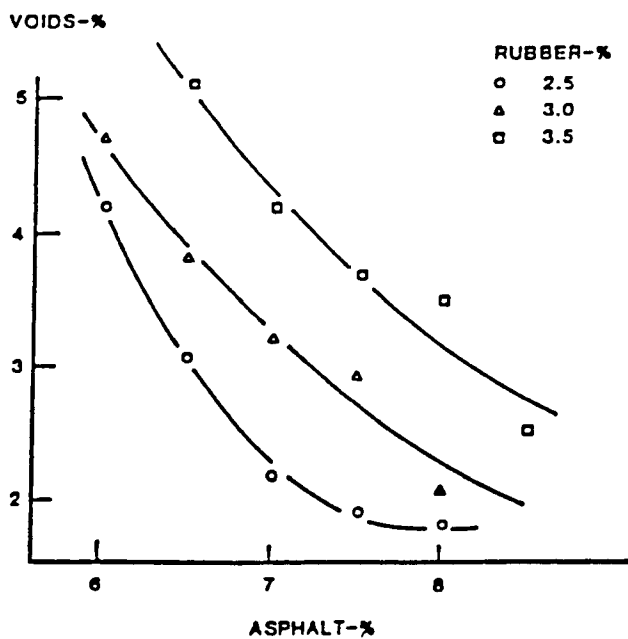

FIGURE N-5 Effects of rubber-content variations on percent voids in mix. (N3)

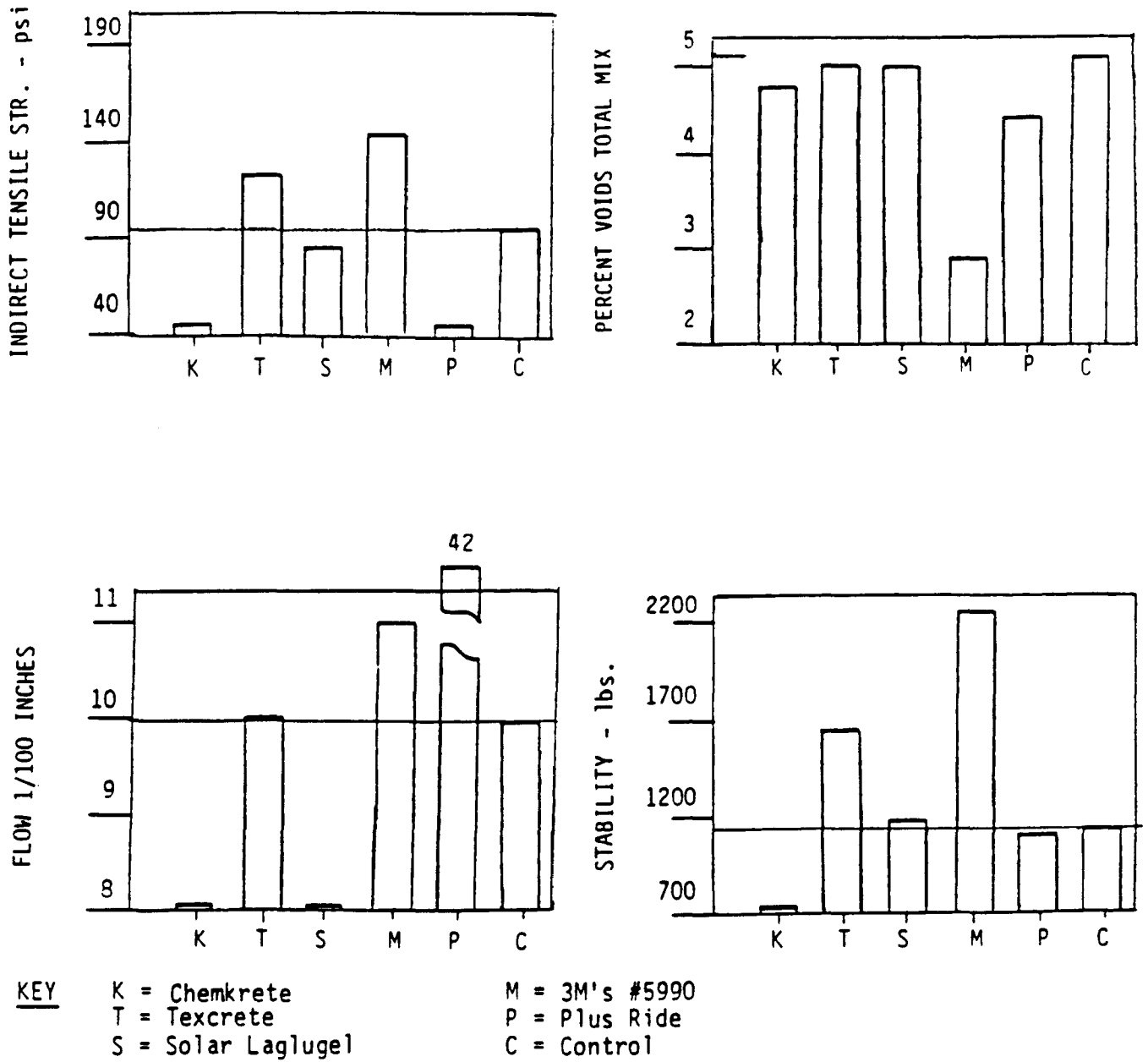
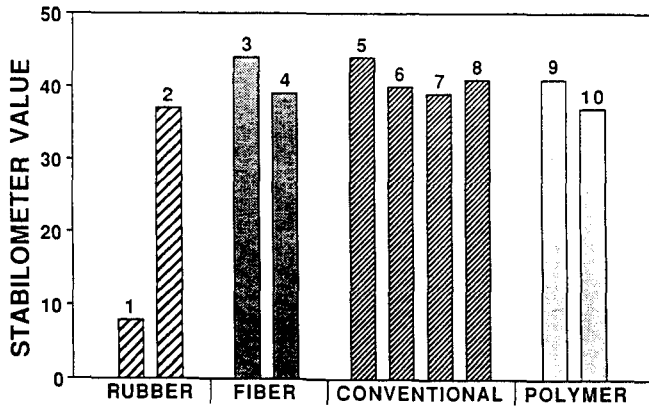

FIGURE N-6 Comparative laboratory test results. (N4)



NOTE: NUMBERS INDICATE DIFFERENT TYPES OF MIXTURES NOT SPECIFICALLY IDENTIFIED IN REPORT.

FIGURE N-7 Hveem stability, field mixed-laboratory compacted at 140°F, August 1985 mix sample. (N6)

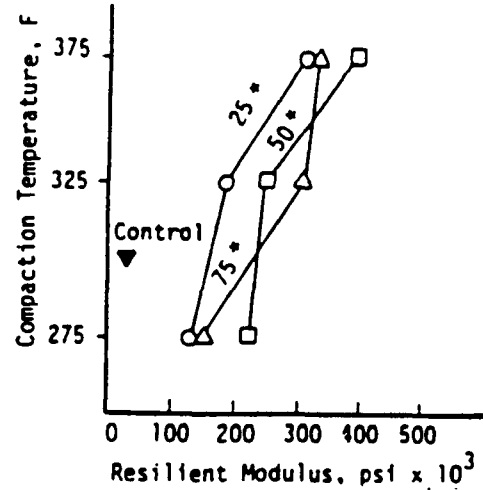

FIGURE N-9 Effect of compaction temperatures on resilient modulus. (N5)

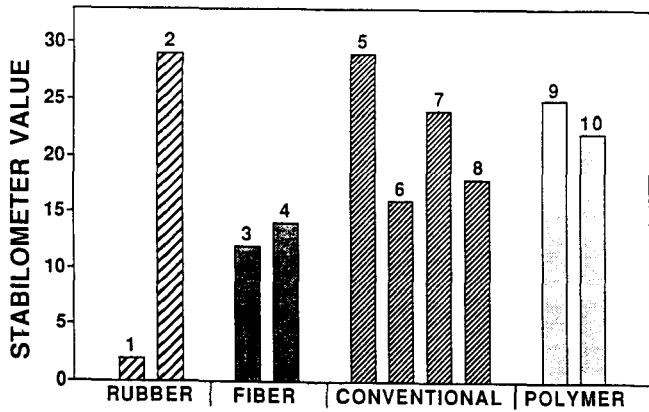

FIGURE N-8 Hveem stability, field mixed-field compacted in-place at 140°F, September 1985 cores. (N6)

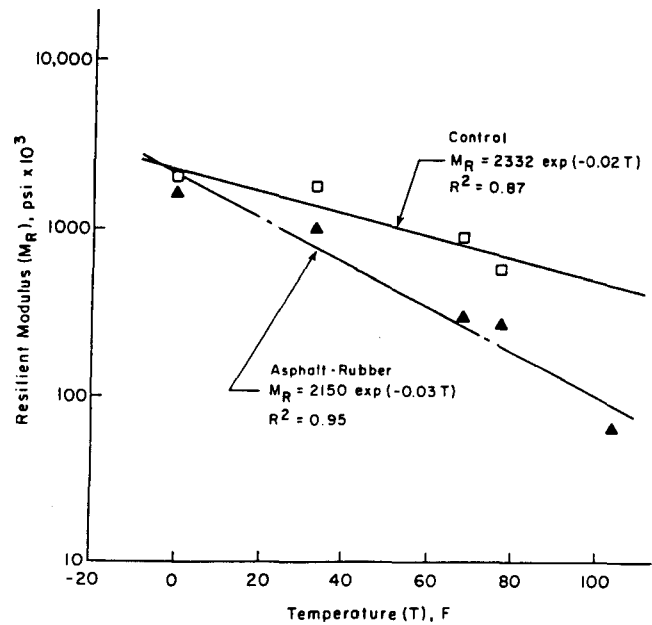

FIGURE N-10 "Adequate" limestone mix performance. (N5)

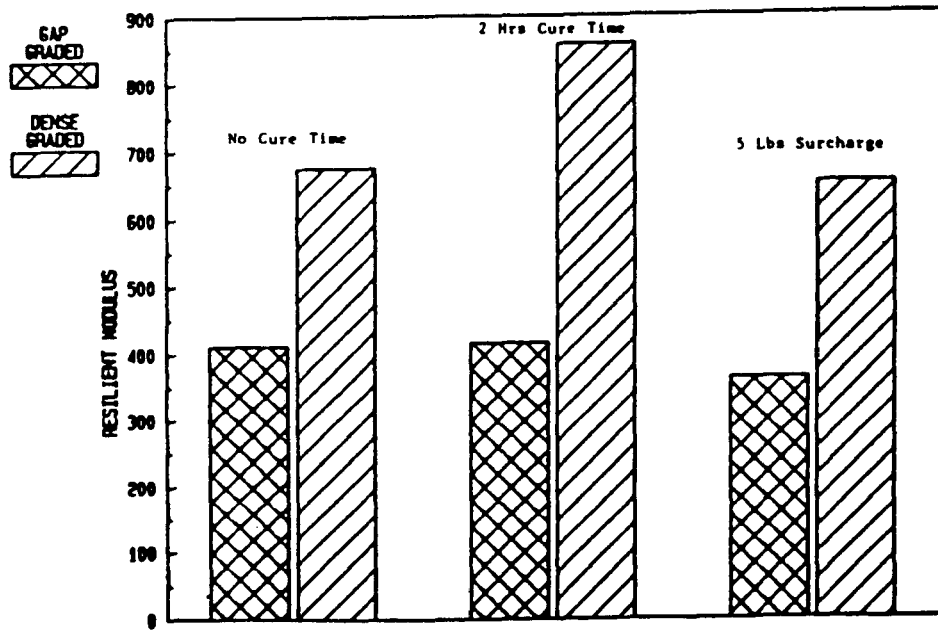

FIGURE N-11 Effect of aggregate gradation, cure time, and surcharge on resilient modulus at +10°C (3% rubber, 80/20 blend). (N8)

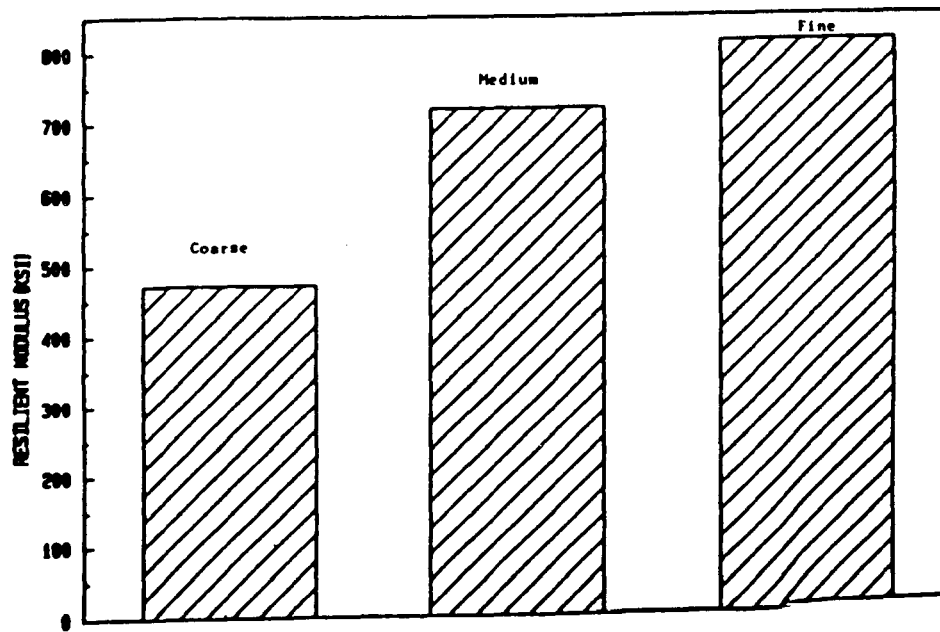

FIGURE N-12 Effect of rubber gradations on resilient modulus at +10°C (gap-graded aggregate). (N8)

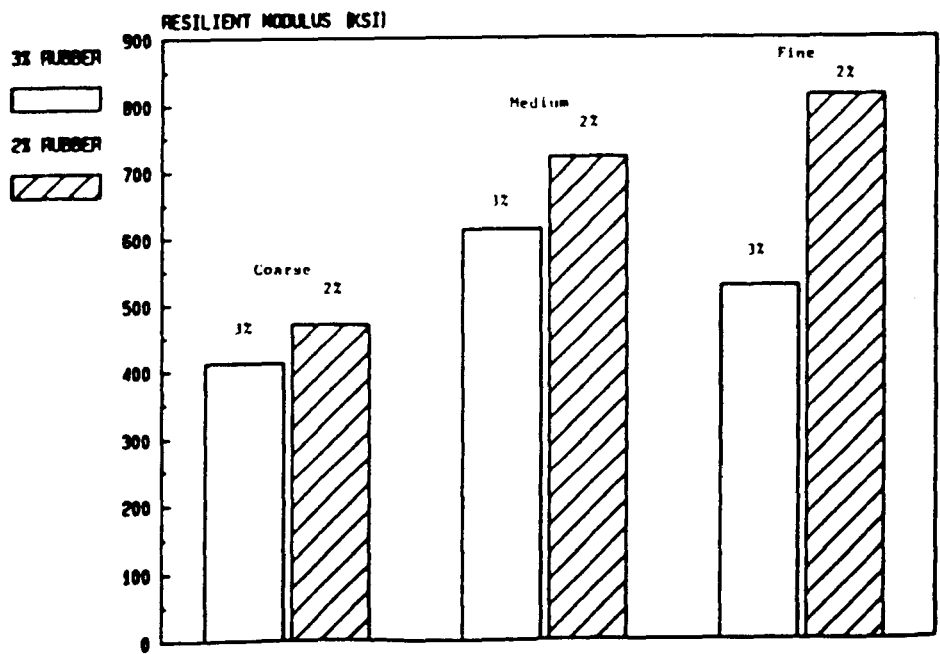

FIGURE N-13 Effect of rubber content on resilient modulus at +10°C (gap-graded aggregate). (N8)

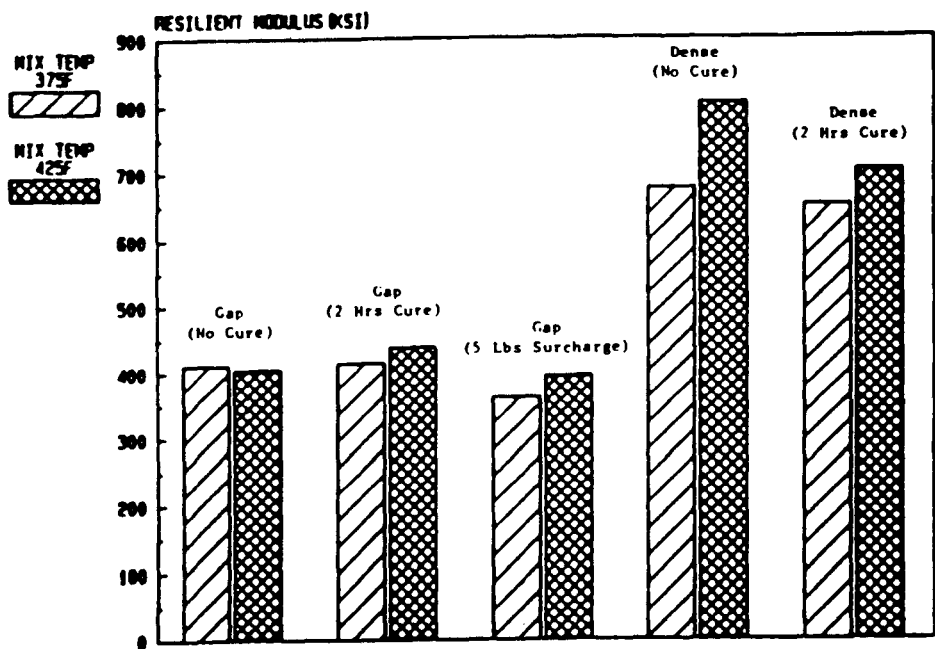

FIGURE N-14 Effect of mixing temperature on resilient modulus at +10°C (3% rubber, 80/20 blend). (N8)

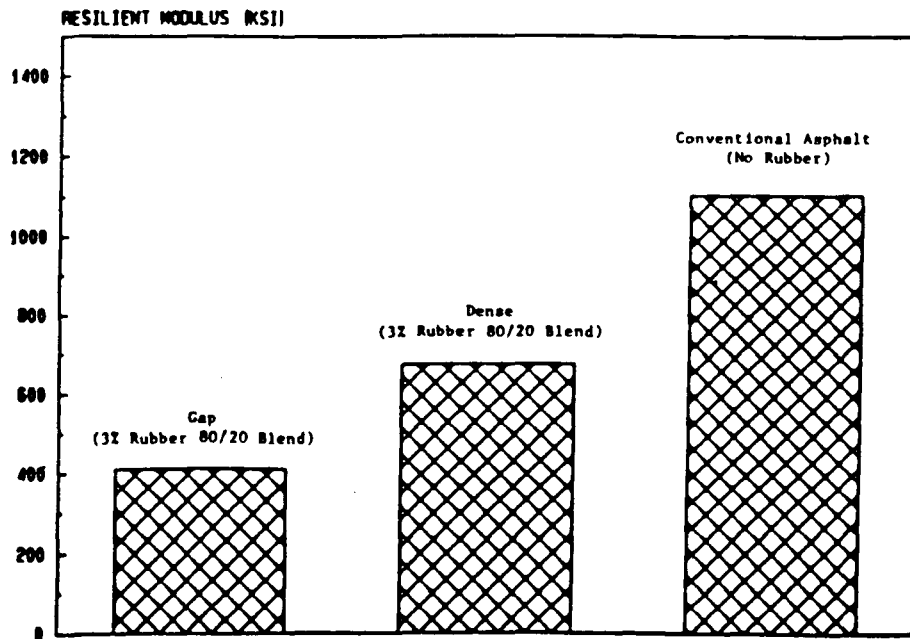

FIGURE N-15 Effect of rubber content and aggregate gradation on resilient modulus at +10°C. (N8)

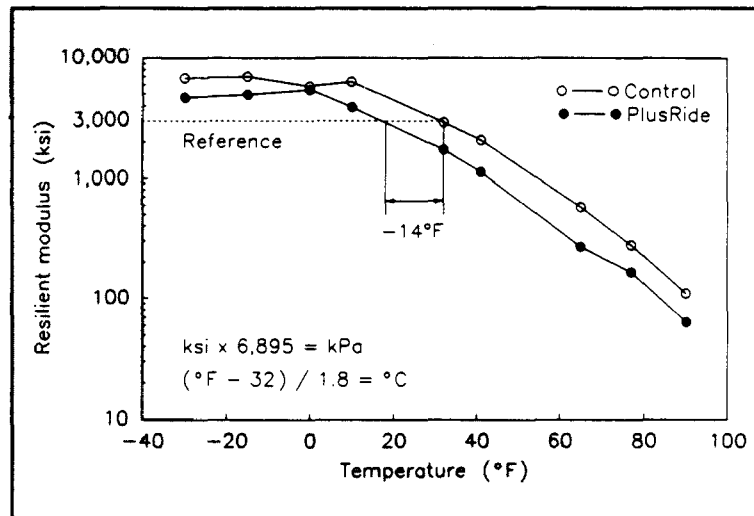

FIGURE N-16 PlusRide: Resilient modulus vs. temperature for evaluating low temperature cracking. (N9)



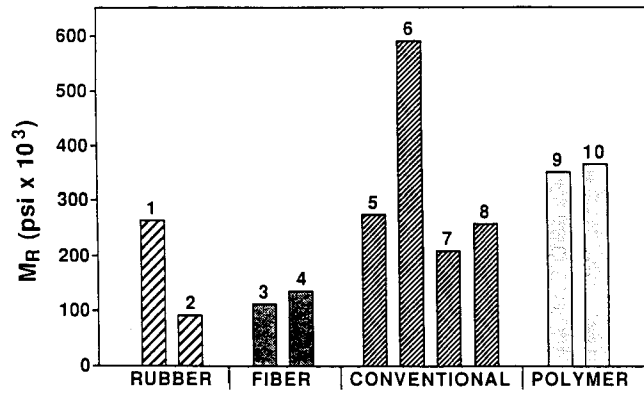

FIGURE N-17 Pavement modulus at construction at 77°F, September 1985, cores. (N6)

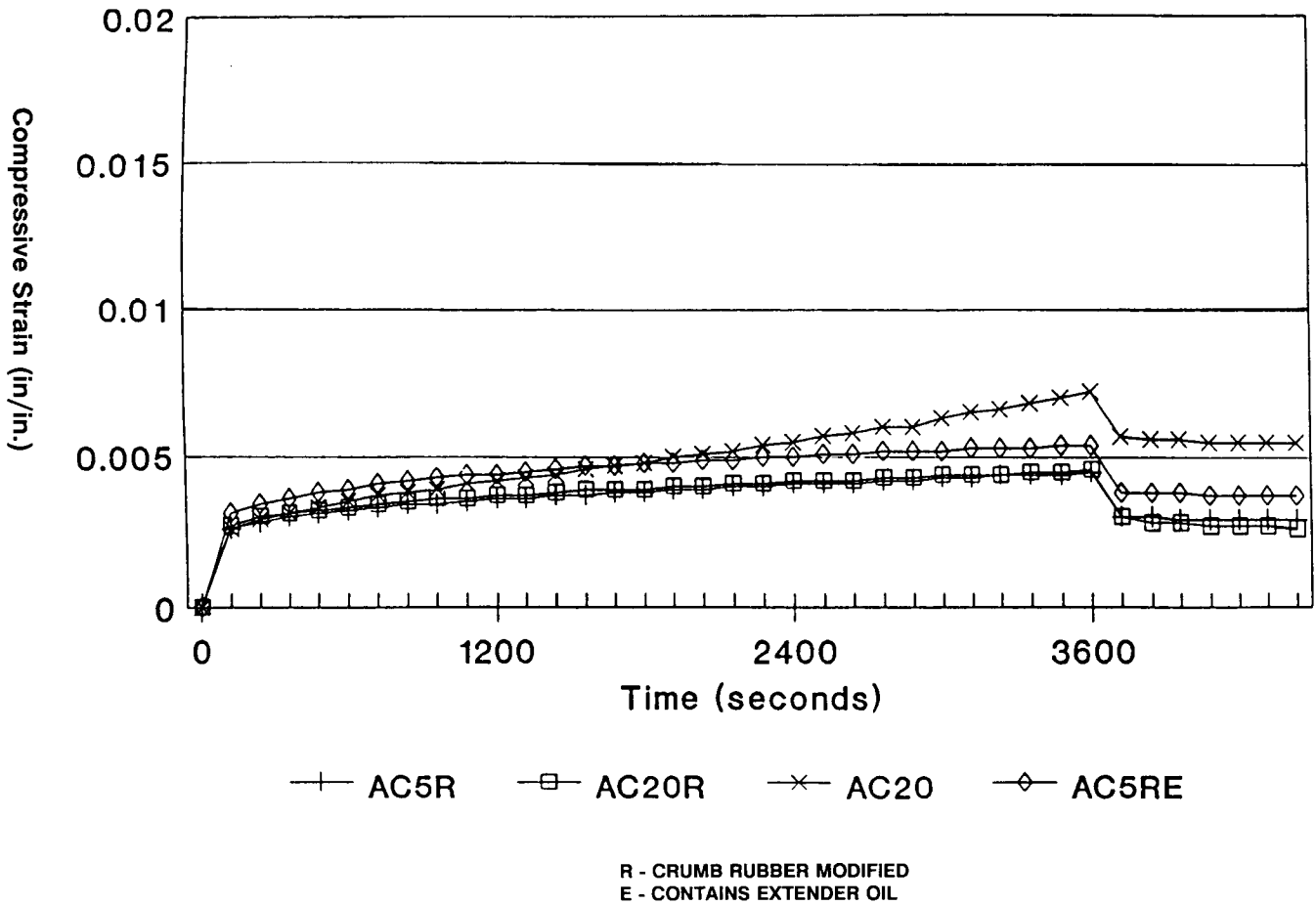

FIGURE N-18 Compressive strain vs. time for static loading conducted at 104°F. (N11)

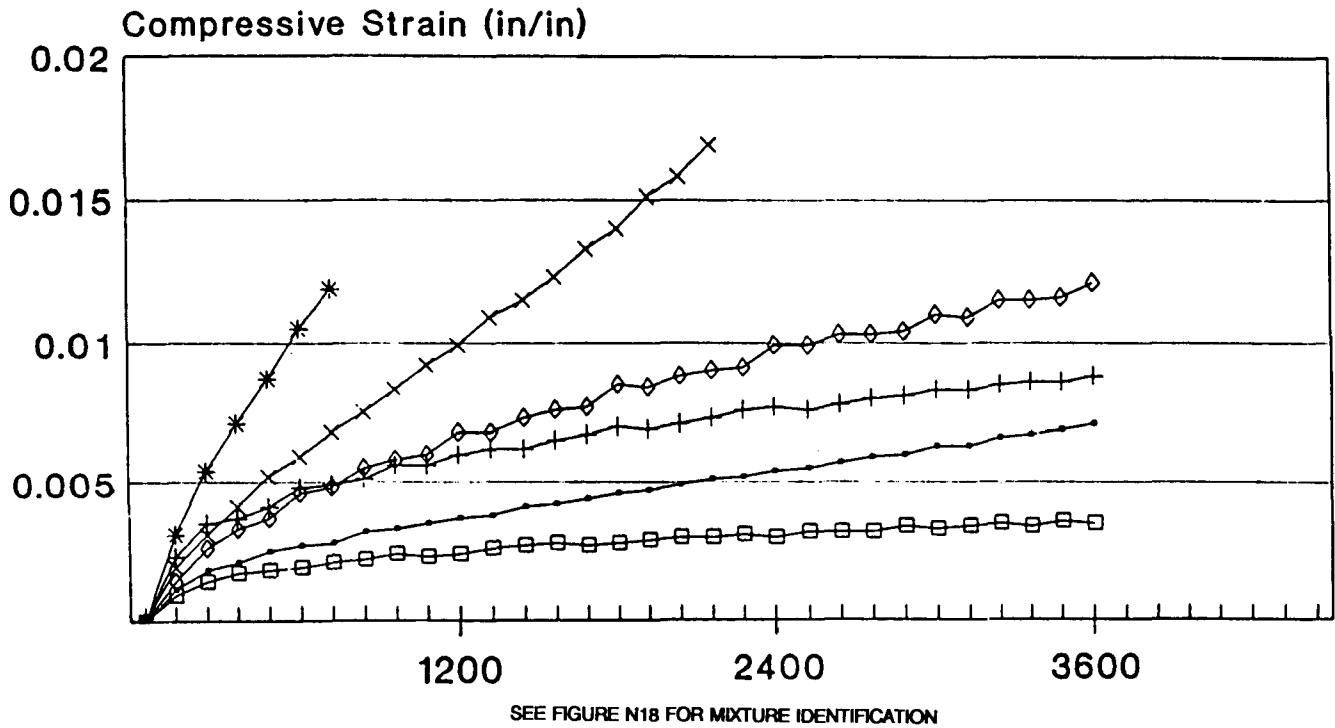

FIGURE N-19 Compressive strain vs. time for repeated loading conducted at 104°F. (N11)

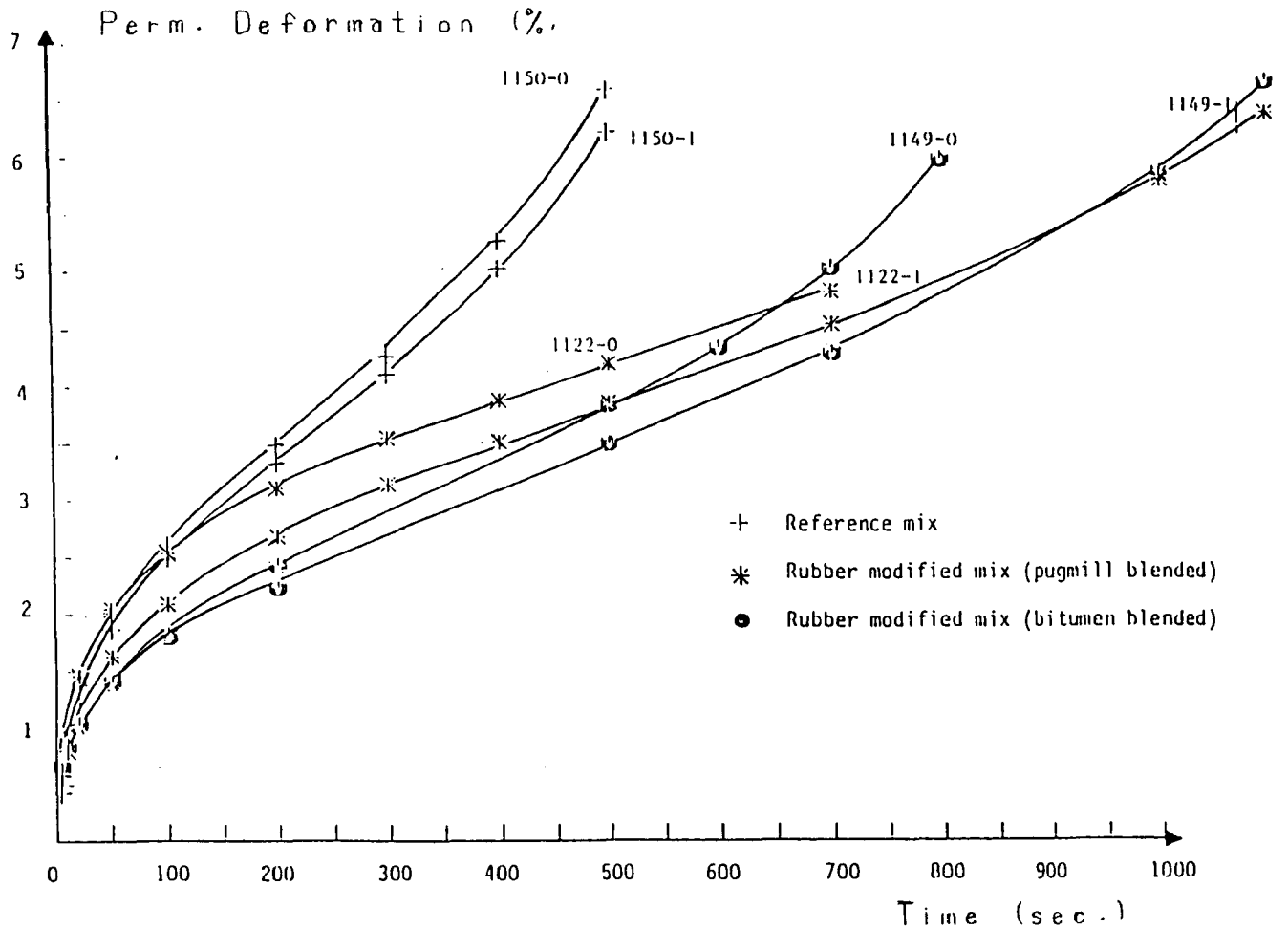

FIGURE N-20 Dynamic creep curves. (N13)

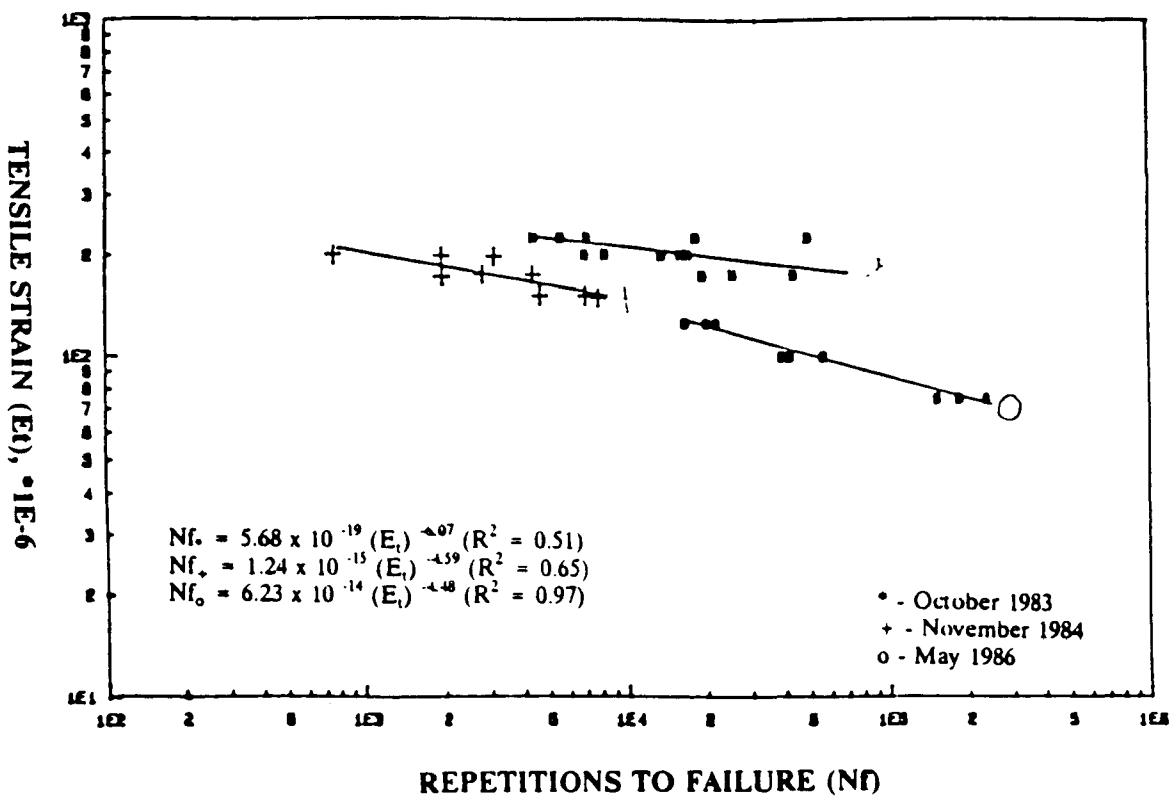

FIGURE N-21 Tensile strain vs. fatigue life, rubber samples. (N14)

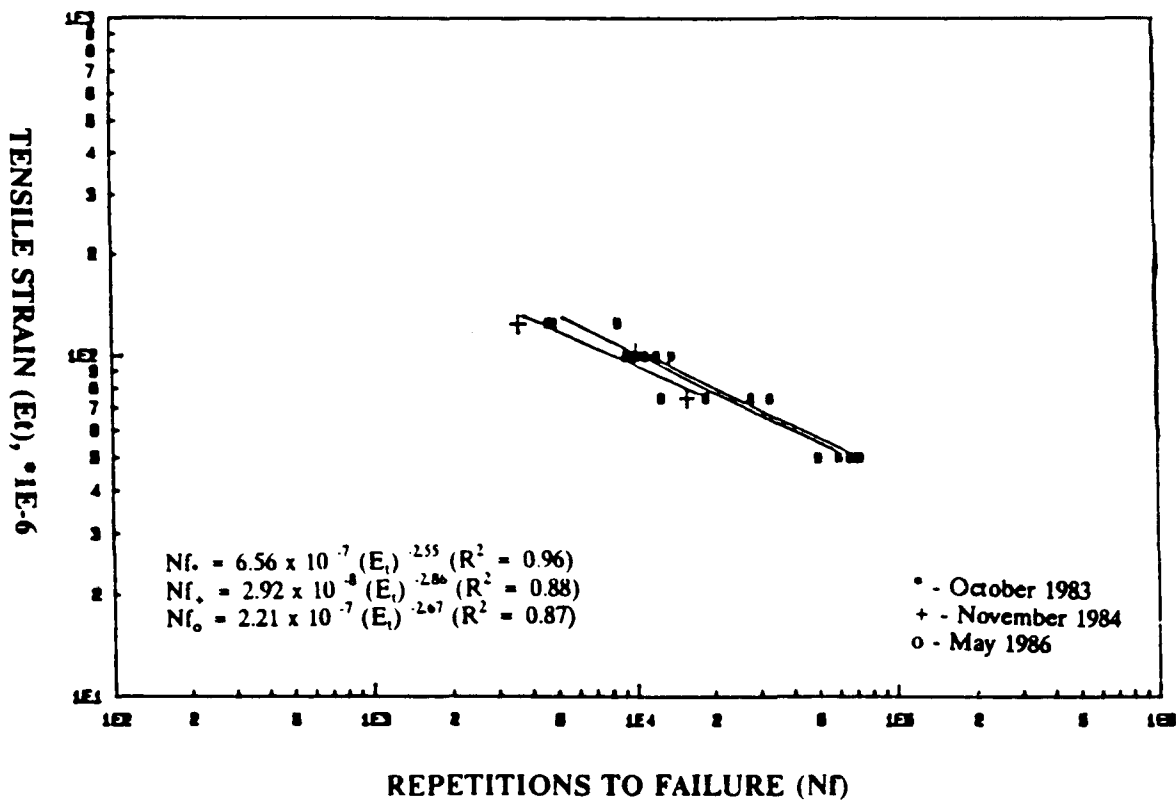

FIGURE N-22 Tensile strain vs. fatigue life, control samples. (N14)

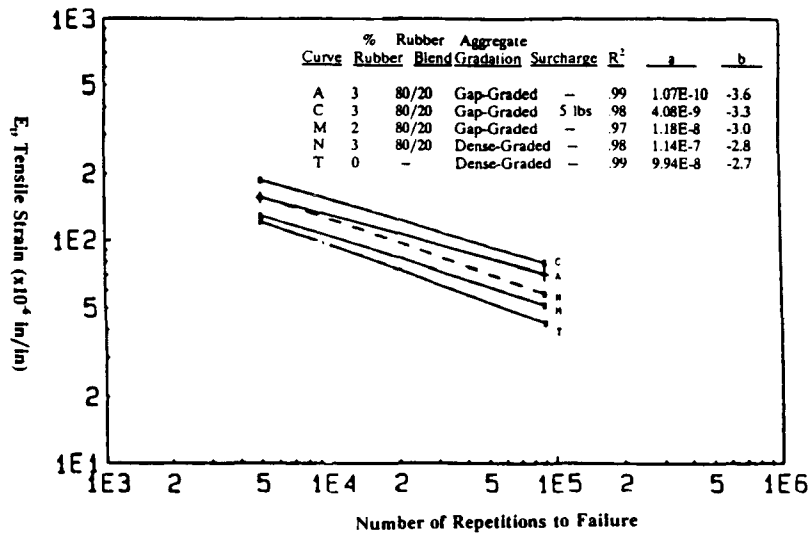

FIGURE N-23 Laboratory fatigue curves at 50°F. (N15)

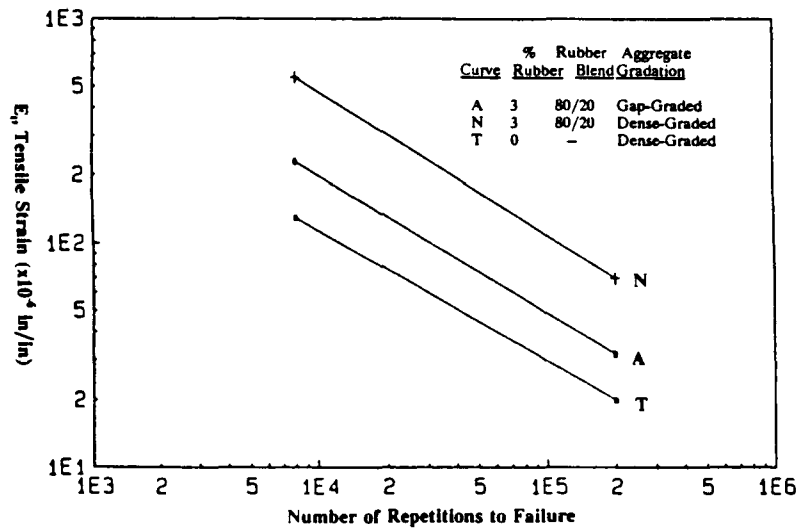

FIGURE N-24 Laboratory fatigue curves at 21°F. (N15)

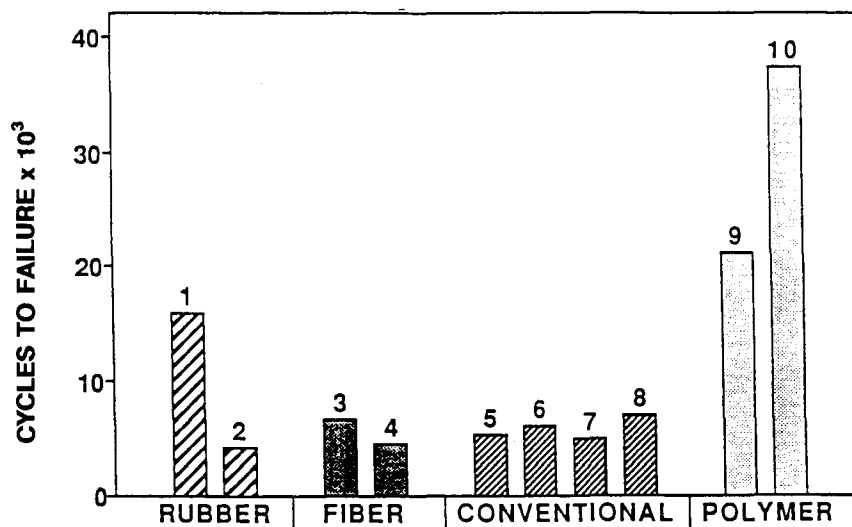

FIGURE N-25 Fatigue test at 73°F and 200 microstrain, March 1986, cores. (N6)

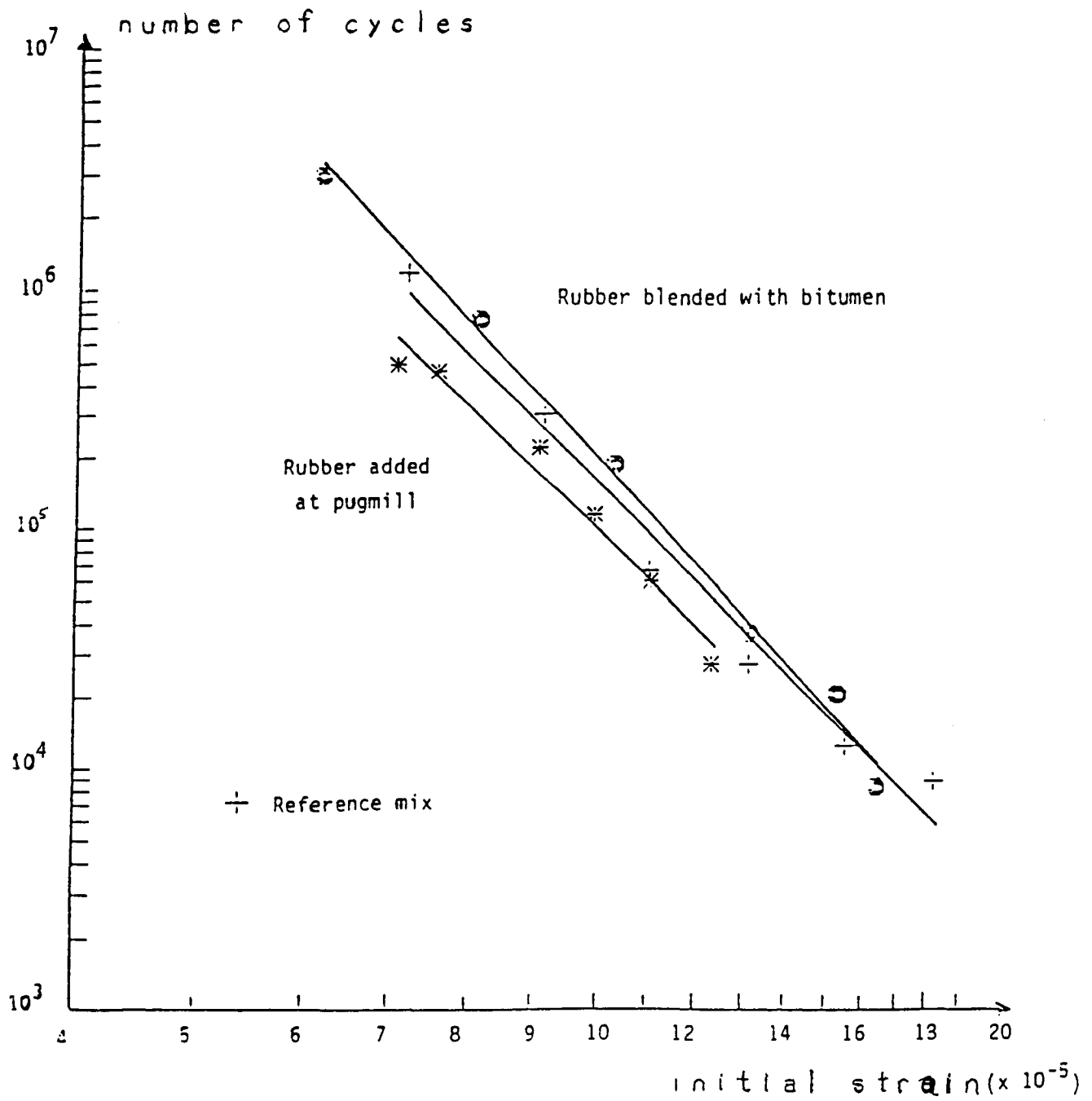

FIGURE N-26 Fatigue curves. (N13)

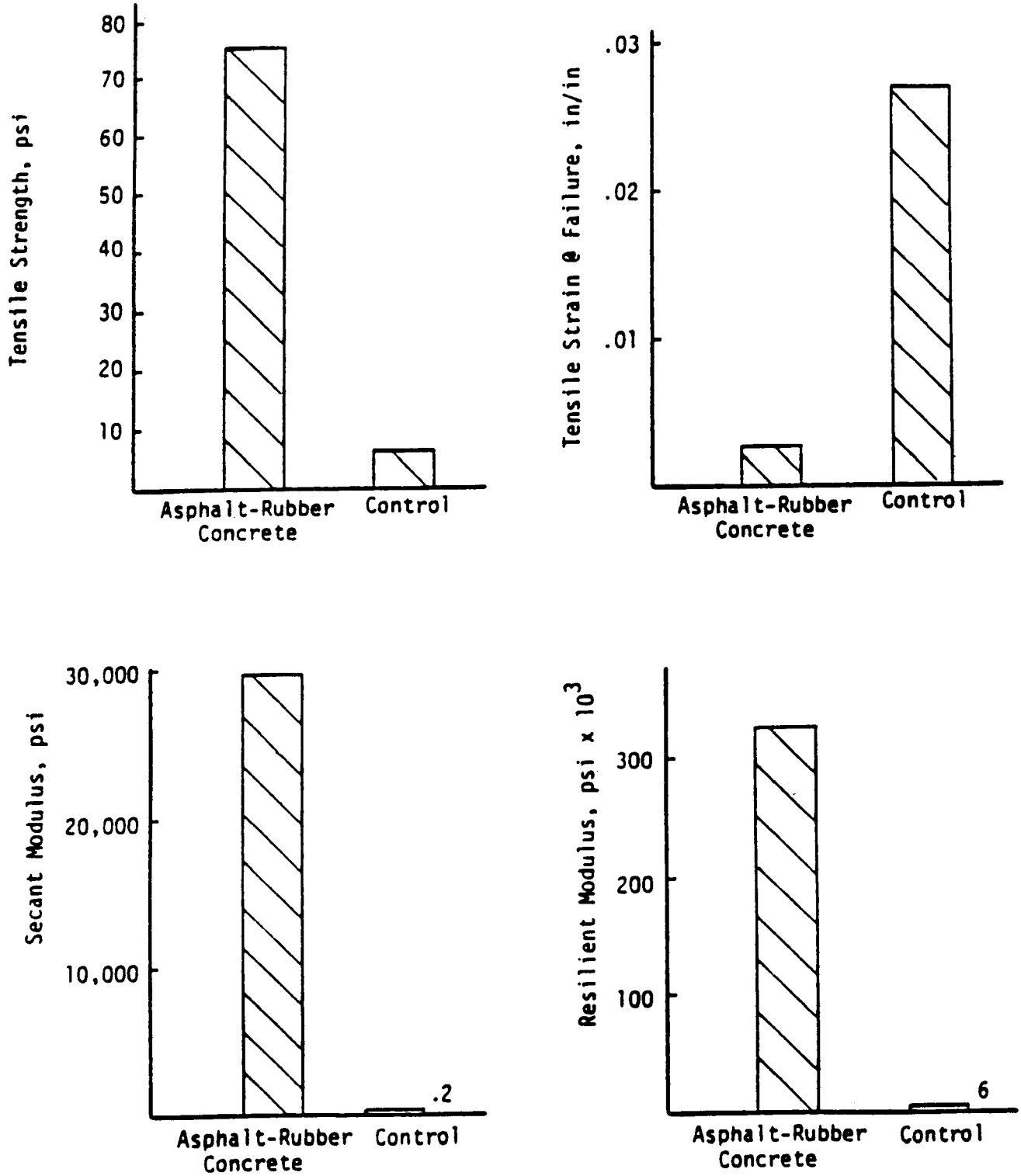

FIGURE N-27 Type A asphalt-rubber concrete vs. control "marginal" limestone mixes. (N5)

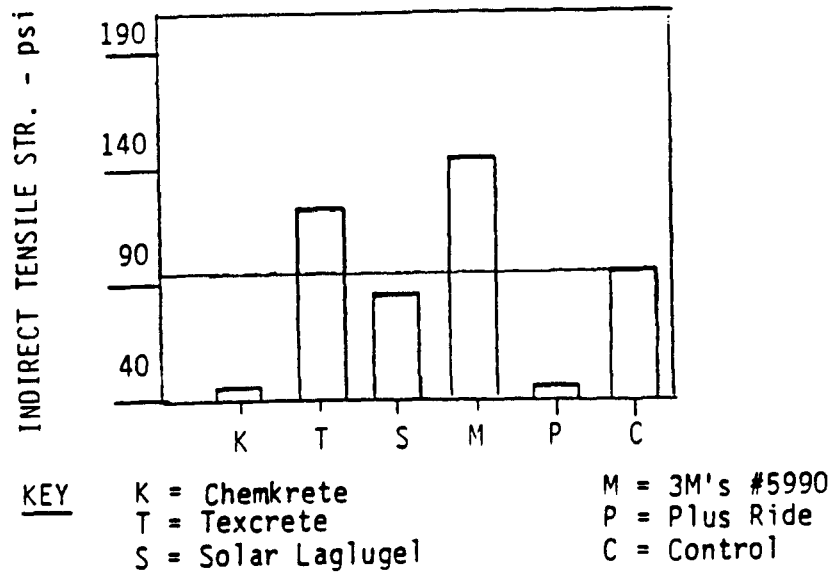

FIGURE N-28 Comparative laboratory test results. (N4)

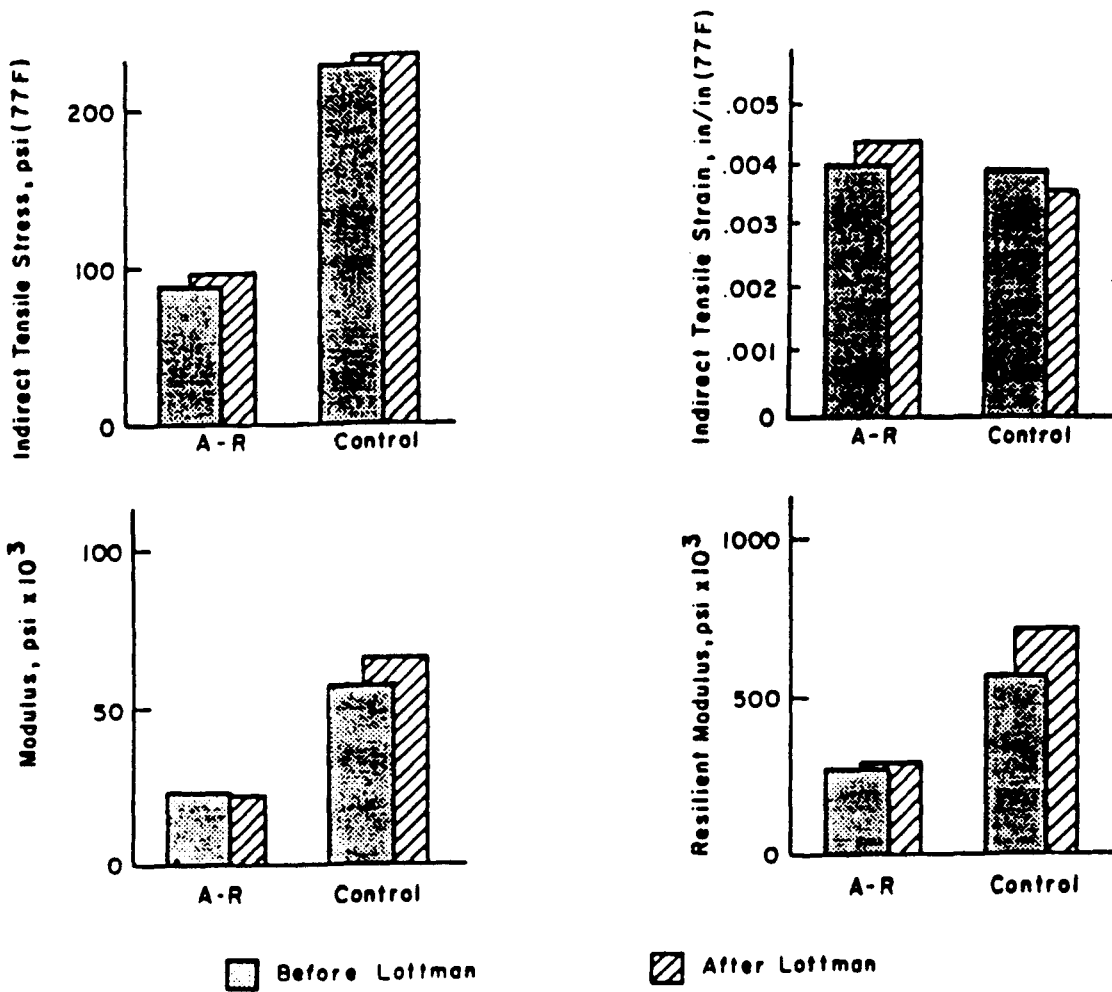

FIGURE N-29 Asphalt-rubber concrete vs. control "adequate" limestone mixes. (N5)

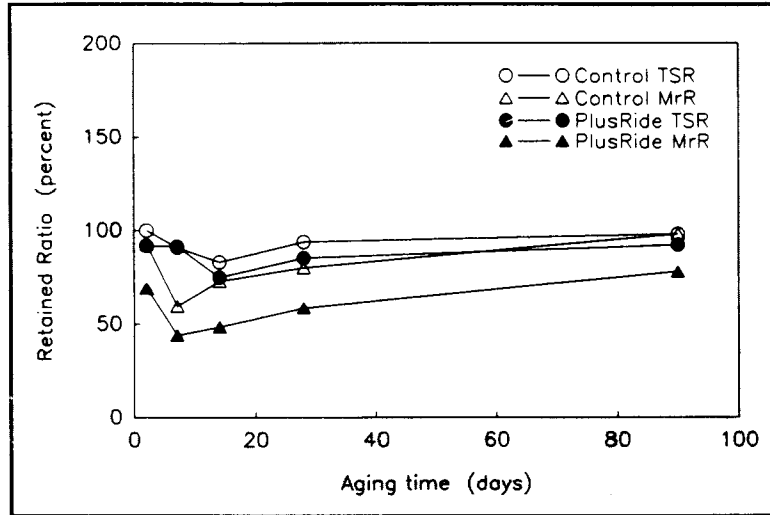

FIGURE N-30 PlusRide: MrR and TSR vs. aging time. (N9)



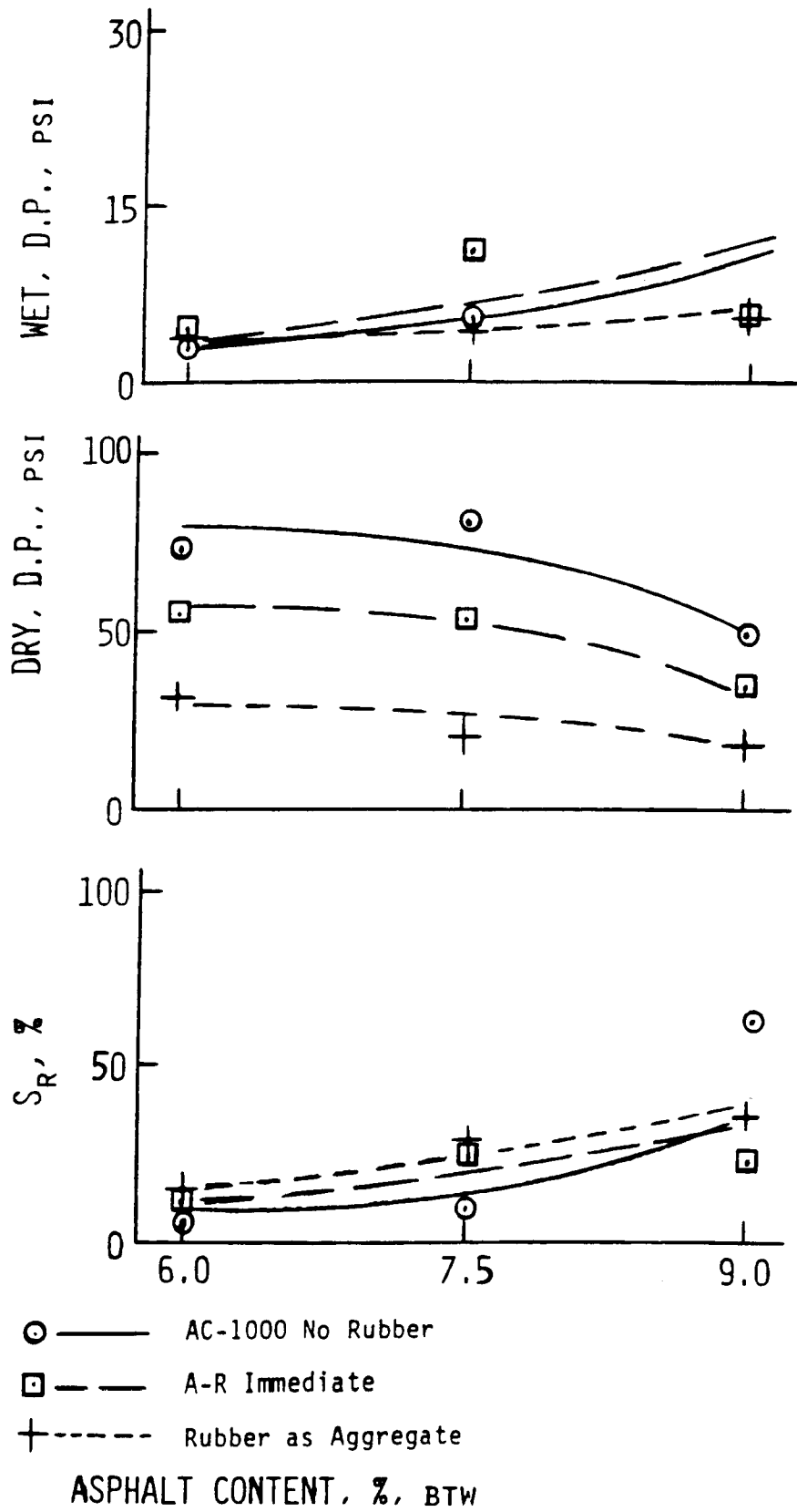

FIGURE N-31 Effects of asphalt content and rubber on debonding test on specimen using vibratory compaction on  $\frac{3}{8}$ -in. dense gradation. (N14)

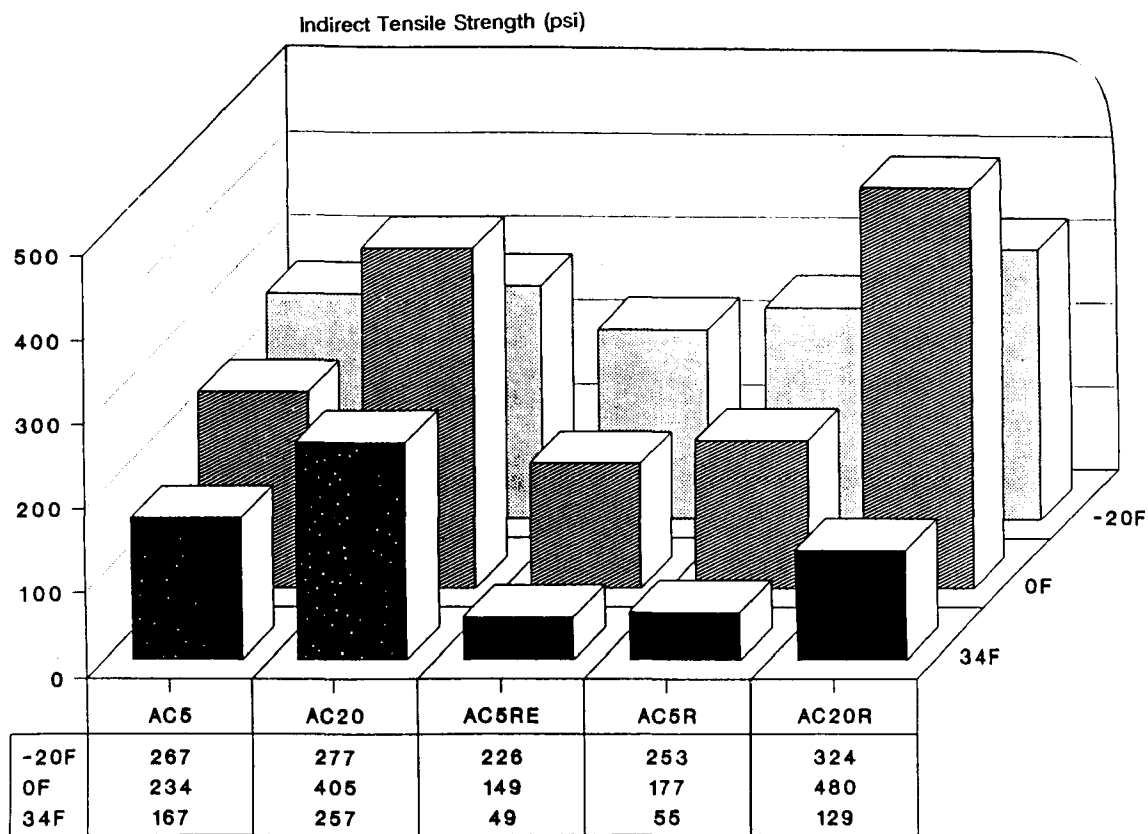

FIGURE N-32 Comparison of average indirect tensile strengths at all temperatures for all mixtures. (NII)

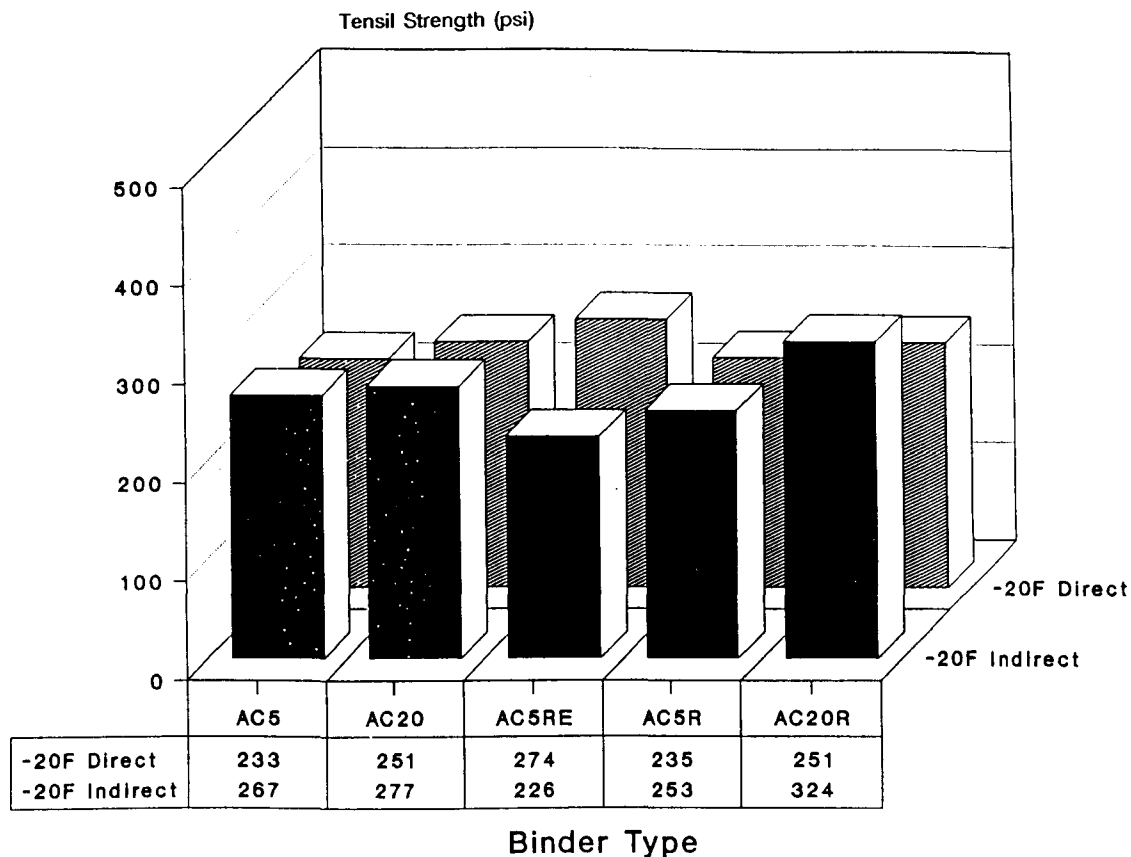

FIGURE N-33 Comparison of average direct tensile strength and indirect tensile strength at -20°F (-29°C) for all mixtures. (NII)

TABLE N-1  
 PRODUCT EVALUATION TEST DATA SUMMARY (AGGREGATE B1) (N10)

ADDITIVE	OPTIMUM BITUMEN CONTENT (%)	$M_r$ (psi x 105)	STABILITY	SPECIFIC GRAVITY	VOIDS (%)	COHESION	SURFACE ABRASION LOSS (gm)
Control (Conv. Mix)	7.4	4.91	37	2.25	6.8	130	33.5
Ramflex (1.0%) <sup>2</sup> Crumb Rubber	8.2	3.34	23	2.28	4.6	335	27.5
BoniFibers (0.25%)	7.9	1.10	39	2.27	5.5	275	29.2
FiberPave 3010 (0.3%)	7.9	0.94	34	2.23	7.0	235	27.6
Marvess Olefin (0.4%) (60 Den)	7.9	6.50	35	2.25	6.3	230	23.8
Marvess Olefin (0.4%) (16 Den)	7.9	3.50	39	2.20	8.3	142	25.0
G-274 (1.0%) Crumb Rubber	8.2	2.91	23	2.24	6.2	212	34.5
ARS (Arm-R-Shield)	8.2 <sup>3</sup>	0.95	30	2.18	8.7	141	8.1
PlusRide	8.5	2.57	2	2.22	3.1	56	12.5

- Notes: 1. 1/2" maximum medium Type B.  
 2. All percentages are by dry weight of aggregate.  
 3. This mix used a binder which contained 76% asphalt, 20% rubber, and 4% extender oil. Considering asphalt only, it was 6.2% by dry weight of aggregate.

TABLE N-2  
RESISTANCE TO RUTTING--CREEP TEST RESULTS: PLUS  
RIDE (N9)

Creep Time (sec)	Control			PlusRide		
	Temperature 65 °F	Temperature 77 °F	Temperature 104 °F	Temperature 65 °F	Temperature 77 °F	Temperature 104 °F
	Creep Modulus (ksi)			Creep Modulus (ksi)		
0.10	667	297	67	286	100	26
0.30	395	168	51	148	52	14
1.0	203	97	46	73	28	9
3.0	116	66	48	36	20	7
10.0	82	51	45	19	20	7
30.0	53	46	—	14	—	—
100.0	44	42	—	—	—	—
1,000.0	34	37	—	—	—	—
	Permanent Strain (microinches)			Permanent Strain (microinches)		
0.10	19	124	535	65	167	386
0.30	56	223	733	109	540	1,561
1.0	145	429	1,002	414	1,141	3,362
3.0	283	626	1,042	968	1,879	6,592
10.0	506	870	999	2,168	2,601	12,503
30.0	628	981	—	3,040	—	—
100.0	920	1,163	—	—	—	—
1,000.0	1,619	1,765	—	—	—	—

(ksi)(6895) = (KPa)      (in)(2.54) = (cm)      (°F - 32)/1.8 = °C

TABLE N-3  
RESISTANCE TO RUTTING--REPEATED LOAD TEST RESULTS:  
PLUSRIDE (N9)

Temperature	Control			PlusRide		
	65 °F	77 °F	104 °F	65 °F	77 °F	104 °F
Number of Cycles	Permanent Strain (microinches)			Permanent Strain (microinches)		
1	18	68	291	66	177	1,644
3	36	138	496	134	376	3,885
10	73	253	885	322	835	8,343
30	115	379	1,630	630	1,562	10,670
100	154	543	3,244	1,128	2,620	14,453
200	177	667	4,628	1,487	3,524	17,765
300	185	754	5,455	1,617	4,084	22,239
400	194	835	6,204	1,692	4,426	24,769
500	198	910	6,722	1,760	4,908	26,627
600	201	976	6,998	1,826	5,112	28,857
1,000	209	1,197	—	2,079	6,219	—
3,000	235	2,080	—	2,681	8,000	—
7,000	285	3,804	—	2,994	10,511	—
10,000	300	—	—	3,143	—	—
20,000	373	—	—	4,055	—	—
30,000	415	—	—	4,451	—	—
40,000	657	—	—	4,881	—	—
50,000	692	—	—	5,552	—	—

(in)(2.54) = (cm)      (°F - 32)/1.8 = °C

TABLE N-4  
INDIRECT TENSILE STRENGTH (N16)

Test Section	Average	Std. Dev.
South control	102	4.9
North control	100	7.5
South and north control	101	6.2
South rubber	58	3.2
North rubber	68	4.6
South and north rubber	63	6.6

TABLE N-5  
STRIPPING TEST RESULTS (N16)

Test	Southern		Northern	
	Rubber	Control	Rubber	Control
TSR	0.95	0.71	0.85	0.84
Visual rating (0-5)*	0	3	0	2
Boiling	Pass	Pass	Pass	Pass

\* 0 = no stripping; 5 = severe stripping.

TABLE N-6  
RESTRAINED THERMAL SHRINKAGE TEST CONDUCTED ON ASPHALT RUBBER MIXTURE (N11)

Mixture Identification <sup>a</sup>	Fracture Temperature, °F	Peak Load, psi
AC-5	-25.7	287
AC-20	-25.4	278
AC-5R	-33.7	237
AC-20R	-25.1	157

a. Designates binder used in mixture, R=crumb rubber.

TABLE N-7  
RESULTS OF FRACTURE TESTS (N18)

Material	Sample No.	Temp. °F (°C)	Crack Opening, in.	Load Cycle Time, sec.	No. of Cycles to Failure	Fracture Properties	
						A	n
AC-10 (4.73% Binder)	T1C	34 (1°)	0.02	20	4	$0.160 \times 10^1$	-0.075
	T4C	34 (1°)	0.02	20	30	$0.363 \times 10^{-3}$	0.875
	T2C	77 (25°)	0.07	10	9	$0.292 \times 10^{-4}$	1.61
	T3C	77 (25°)	0.05	10	142	$0.300 \times 10^{-10}$	3.34
ARC-Low (4.23% Binder)	T1L	34 (1°)	0.02	20	400	$0.123 \times 10^4$	-1.47
	T3L	34 (1°)	0.02	20	834	$0.281 \times 10^6$	-2.12
	T4L	77 (25°)	0.05	10	50	$0.681 \times 10^{-9}$	3.16
	T2L	77 (25°)	0.05	10	7	$0.312 \times 10^{-4}$	1.56
ARC-Medium (4.73% Binder)	T2M	34 (1°)	0.02	20	1253	$0.756 \times 10^{-8}$	2.34
	T4M	34 (1°)	0.01	20	1084	$0.367 \times 10^3$	-1.26
	T3M	77 (25°)	0.07	10	4	$0.595 \times 10^{-2}$	0.836
	T1M	77 (25°)	0.06	10	2	$0.677 \times 10^0$	0.079
ARC-High (5.23% Binder)	T2H	34 (1°)	0.02	20	241	$0.977 \times 10^{-8}$	1.82
	T4H	34 (1°)	0.02	20	470	$0.304 \times 10^6$	-2.11
	T5H	77 (25°)	0.05	10	410	$0.178 \times 10^{-13}$	6.67

TABLE N-8  
SURFACE ABRASION LOSS DATA (AGGREGATE A1) (N10)

ADDITIVE	OPTIMUM BITUMEN CONTENT (OBC) <sup>3</sup> (%)	SURFACE ABRASION LOSS <sup>4</sup> (gm)
Control (Conv. mix)	6.7	33.0
Ramflex (1.0%) <sup>2</sup> Crumb Rubber	7.0	30.4
Bonifibers (0.25%)	7.0	26.2
Fiber Pave 3010 (0.3%)	7.0	26.7
Marvess Olefin (0.4%) (16 Den)	7.0	25.7
G-274 (1.0%) Crumb Rubber	7.0	27.6
ARS (Arm-R-Shield)	8.0 <sup>5</sup>	13.2

- Notes:
- 1/2" maximum medium Type A.
  - All percentages are by dry weight of aggregate.
  - California Test 367.
  - California Test 360, Method B.
  - This is a binder which contains 76% asphalt, 20% rubber and 4% extender oil. Considering asphalt only, it was 6.1%, by dry weight of aggregate.

TABLE N-9  
MIX DESIGN TEST DATA FOR 03-NEV-80 TEST SECTIONS (N10)

ADDITIVE	% USED	OPTIMUM BITUMEN* CONTENT (%)	STABILITY	SPECIFIC GRAVITY	VOIDS (%)	SURFACE ABRASION LOSS (gm)	TEMP. (°F) MIX/COMPACT
Control (Conv.Mix)	-	7.1	38	2.26	3.3	28.9	**
Ramflex	1.0	7.6	37	2.23	3.9	28.8	350/300
Ramflex	1.0	7.6	35	2.21	4.7	50.3	350/230
Ramflex	1.0	7.6	33	2.22	4.3	59.2	**
Bonifibers	0.3	7.3	40	2.19	6.0	35.8	**
Fiber Pave 3010	0.3	7.3	34	2.18	6.4	40.4	**
Marvess Olefin	0.3	7.3	34	2.22	5.6	41.8	**

- Notes: \* TransLab recommended O.B.C. (California Test 367) using AR-4000. (The O.B.C. for the control sample, although exhibiting less than 4.0% voids, was selected due to the high void content (6.4%) at 6.8% asphalt content. The possibility of high permeability and the freeze/thaw action anticipated in the placement area justified compromising a design criterion to obtain a "tighter" mixture).

- \*\* Normal mixing (300°F) and compacting (230°F) temperature (California Test 304 & 360, Method B).

TABLE N-10  
STREET SAMPLE TEST DATA (N10)

ADDITIVE		SAMPLE NO.	ASPHALT CONTENT (%) <sup>3,4</sup>	STABILITY	SPECIFIC GRAVITY	VOIDS (%)	COHESION	SURFACE ABRASION LOSS (gm)
First Lift	Control (Conv.Mix)	842-192	6.6	40	2.26	4.6	534	28.3
	Ramflex	842-190	7.4 <sup>1</sup>	14	2.25	3.0	331	23.1 <sup>2</sup>
	BoniFibers	842-193	7.3	38	2.19	6.8	342	26.8
	FiberPave 3010 <sup>5</sup>	842-195	7.3 <sup>5</sup>	30	2.22	5.5	463	24.1
	Marvess Olefin <sup>5</sup>	842-194	7.7 <sup>5</sup>	30	2.23	4.7	450	20.5
Final Lift	Control (Conv.Mix)	842-204	7.4	13	2.30	1.7	440	24.9
	Ramflex	842-208	8.2	10	2.25	2.2	287	21.4
	BoniFibers	842-207	7.3	34	2.21	6.0	389	31.8
	Fiber Pave 3010	842-206	7.1	28	2.23	5.1	400	32.6
	Marvess Olefin	842-205	7.0	30	2.24	5.1	495	24.0

- Notes:
1. Difficulty flushing out after extraction.
  2. Fabricated @ 300°F.
  3. Hot extractor (California Test 310) was used for all first lift mixes.
  4. Vacuum extractor (California Test 362) was used for all final lift mixes.
  5. No fibers visible in mix (in all other modified mixes the rubber or fibers were visible after extraction).
  6. All numbers represent an average of two samples except for the surface abrasion (three samples).
  7. California test methods were used for all tests.

TABLE N-11  
FRICTION DATA FOR CRM MIXTURES

State	Reference	Section	Skid number, SN 40	Type of mixture
New Jersey	4	Control	45	Dense-graded
		Rubber-modified	39	Dense-graded
Pennsylvania	18	Control	53	Open-graded friction course
		Asphalt rubber	43	Open-graded friction course
		Control	55	Dense-graded
Virginia	15	Control - S	31	Dense-graded
		Asphalt rubber - S	26	Dense-graded
		Control - N	34	Dense-graded
		Asphalt rubber - N	36	Dense-graded

TABLE N-12  
STOPPING DISTANCE TEST COMPARISONS (N3)

Date	Pavement Temperature (°F)	Site	Stopping Distance ft @ 25 mph		Percent Reduction with Rubber
			PlusRide	Normal	
01/22/81	-13	Carnation	91	114	20
01/22/81	-13	Fairhill	64	129	50
01/30/81	+27	Fairhill	75	113	34
02/02/81	+27	Carnation	98	101	3
02/05/81	+27	Carnation	53	91	42
02/06/81	+21	Carnation	52	64	19
12/10/81	+13	Peger Road	61	66	7
12/11/81	+ 6	Peger Road	43	49	12
12/16/81	+ 6	Peger Road	58	90	36
12/18/81	+18	Peger Road	63	77	18
01/11/82	- 9	Peger Road	82	97	15
01/14/82	-11	Peger Road	82	100	18
01/29/82	0	Peger Road	55	109	50
02/02/82	10	Peger Road	80	93	14
02/03/82	17	Peger Road	48	55	13
02/04/82	25	Peger Road	65	80	19
02/09/82	21	Peger Road	70	87	20
12/10/82	14	Peger Road	94	123	24
12/11/82	6	Peger Road	62	124	50
11/29/83	+24	Peger Road	62	87	29
12/2/83	+12	Peger Road	45	53	15
Avg. Values			67	91	25



## APPENDIX O

### CRUMB RUBBER MODIFIED HOT-MIX PERFORMANCE

#### Alaska (1–3)

Alaska placed a number of pavement sections utilizing the dry binder concept between 1979 and 1983. These SECTIONS were placed to improve friction under snow and ice conditions and improvements were noted (Table O-1). The dry-processed mixtures appear to be more sensitive to variations in aggregate gradation than the normal mixes, and good quality control practices are needed to ensure good performance. These mixtures had superior fatigue resistance but were not as good as conventional mixes in resisting ravelling and pothole formation.

#### Arizona (4)

Arizona has researched and field-tested hot mixes produced from both the wet and the dry process binders. Based on experimental test road results, Arizona now uses both dense- and open-graded mixtures made with asphalt-rubber binders for overlays on rigid and flexible pavements. Typically, thicknesses are 1.5 in. for the open-graded mixes and 2 in. for the dense-graded mixes.

#### California (5–8)

California has been using CRM mix for more than 20 years. More than 21 rehabilitation projects have been placed. Based on data collected in these studies, California offers the following recommendations:

- Asphalt-rubber open-graded friction courses should be removed from the experimental category and their use allowed where justified economically.
- Asphalt-rubber dense-graded, rubber-modified dense-graded, asphalt-rubber gap-graded, and the three-layer systems containing asphalt rubber should be used on an experimental basis.
- Dry process mixes using devulcanized rubber should not be used on future projects.

#### Connecticut (9–11)

A 9-year performance study of Connecticut pavements (9) offers the following conclusions relative to mixtures containing dry-processed binders.

- On thick overlays, 1 percent crumb rubber additives reduced the amount of longitudinal cracking on low- to medium-distressed pavements. Over badly distressed pavements, the rubber-modified mixtures did not significantly reduce longitudinal reflection cracking. No clear pattern was apparent when

comparing transverse crack reflection at the 1 percent crumb rubber addition level.

- On thick overlays, 2 percent crumb rubber additives increased the amount of longitudinal and transverse reflection cracking as compared with control sections.
- On thin overlays, the addition of 1 percent crumb rubber reduced the amount of reflection cracking by two-thirds. Increased crumb rubber contents resulted in more cracking.

#### Florida (12–14)

Florida constructed dense- and open-graded asphalt-rubber hot-mix sections in 1989 and 1990. Field construction operations with the asphalt-rubber mixtures were essentially the same as those with conventional friction course mixtures. All test sections are performing well (12).

The optimum crumb rubber content for dense-graded friction course mixtures has been identified by the Florida DOT as 5 percent by weight of asphalt cement using a maximum nominal 80-mesh ground tire rubber. The optimum crumb rubber content for open-graded friction course mixtures has been identified as 12 percent by weight of asphalt cement using a maximum nominal 40-mesh ground tire rubber. Typical crumb rubber contents are 20 percent by weight of asphalt cement for wet process binders.

In the open-graded mixtures, higher binder contents can be used. This should result in improved durability. Ground tire rubber is used in friction courses as a standard practice (12).

#### Kansas (15)

Kansas placed two experimental asphalt-rubber dense-graded sections in 1990. The results of two crack surveys to date are shown in Figure O-1. More cracks were reflected through the asphalt-rubber hot-mix sections. One of the sections was placed as an overlay on portland cement concrete pavement.

#### Michigan (16)

Eight experimental test sections contained rubber-modified and asphalt-rubber binders were placed in Michigan in 1978 and 1979. Field performance was based on reflective cracking for the portland cement concrete pavement, rut depth, and friction levels. Results are shown in Figures O-2 and O-3. The mixtures in these figures identified as “reclaimed” were asphalt rubber; “ground” identifies rubber-modified mixtures. The rubber-modified hot mixes which contained 1.5 percent crumb rubber performed poorly in terms of reflection cracking and surface disintegration cracking. No overall reduction in reflection cracking was achieved with any of the CRM hot mixes. Some reduction in rutting was obtained

with all crumb rubber mixtures. Based on these results Michigan does not recommend the use of CRM hot-mix asphalt.

#### Minnesota (17-19)

Minnesota has placed three sections containing CRM hot mix. An asphalt-rubber test section was placed in 1984. A crack survey conducted in 1989 indicated no difference in cracking between the asphalt-rubber section and the control section. One of the other two sections ravelled shortly after placement and was removed. The third section has not revealed enhanced frictional resistance or other attributes. These pavements have not shown benefits which offset costs (20). No future sections of dense-graded asphalt rubber are planned until more specific benefits are identified.

#### Mississippi (21)

During the summer of 1968, the Mississippi State Highway Department placed a test section with a dry process, rubber-modified asphalt concrete. The devulcanized rubber was obtained from the U.S. Rubber Reclaiming Company. The rubber additive was approximately 6 percent of the asphalt cement. After 2 years of service, little significant difference in crack pattern, skid resistance, and rutting existed between the rubber-modified and control sections.

#### Oregon (22)

Five-year performance data from an Oregon experimental section are shown in Table O-2. The rubber-modified asphalt-concrete section has better resistance to cracking than all other sections; however, ravelling in the section is of concern. The asphalt-rubber (ARM-R-Shield) sections had the best overall performance, but the cost is considered too high at present.

#### South Dakota (23)

A dry process, rubber-modified asphalt concrete overlay was placed in South Dakota in 1982. During 1983 the section containing rubber developed some potholes and break-up; subsequently, it developed large areas of delamination and peeling. The overlay was 1.5 in. in thickness. The ability of the CRM asphalt concrete to facilitate the removal of packed snow and ice was not readily apparent. Higher binder contents were suggested for improved performance.

#### Texas (24)

Two asphalt-rubber hot-mix experimental sections have been placed in Texas. One project raveled shortly after construction and was chip sealed. The second pavement has performed satisfactorily.

#### Utah (25)

Utah placed an overlay with a dry process, rubber-modified asphalt concrete in 1982. Three years after construction, rut depths

in the rubber-modified section were 0.3 to 0.6 in. The control section had ruts that averaged 0.2 in. After a prolonged rain storm (during the third year of service), the rubber-modified section showed marked deterioration in the form of raveling. The experimental section was removed after 3 years of service because of the severe distress. Reflection cracking had not occurred during the 3 years of service. The control sections were performing adequately.

#### Washington (26-29)

Five open-graded friction course projects which contain asphalt-rubber binders have been placed in Washington. All projects are showing good to very good performance with the exception of a bridge deck treatment. Longer evaluation periods are needed to establish cost effectiveness.

The performance of pavements constructed with binder produced by the dry process has ranged from poor to average. Construction problems and design problems account for a portion of these problems.

#### National Study (30)

A FHWA pooled-fund study evaluated the performance of several types of CRM hot mixes. The results of this study, which are shown in Figure O-4, indicate mixed performance compared with conventional mixtures. The notations in the figure are given below.

ACRF—dry process, dense-graded  
FCRF—dry process, open-graded  
ARC—wet process, dense-graded  
ARFC—wet process, open-graded

The mixed performance can in part be attributed to problems in design and construction.

#### REFERENCES

1. Esch, D.C., *Asphalt Pavements Modified with Coarse Rubber Particles—Design, Construction and Ice Control Observations*, Report No. FHWA-AK-RD-85-07, Alaska Department of Transportation, Aug. 1984.
2. Henderson, H., *Rubberized Asphalt on Minnesota Drive Extension*, Alaska Department of Transportation, Sept. 1988.
3. Kemp, P., *The Use of Rubberized Asphalt Concrete on Lemon Road*, Alaska Dept of Transportation, Feb. 1984.
4. Jimenez, R.A., *Testing of Asphalt Rubber and Aggregate Mixtures*, Report No. FHWA/AZ-79/111, Arizona Department of Transportation, Oct. 1979.
5. Doty, R.N., *Flexible Pavement Rehabilitation Using Asphalt-Rubber Combinations—A Progress Report*, presented at Transportation Research Board, 1989.
6. deLaubenfels, L., *Effectiveness of Rubberized Asphalt in Stopping Reflection Cracking of Asphalt Concrete (Interim Report)*, Report No. FHWA/CA/TL-85/09, California Department of Transportation, Jan. 1985.
7. Van Kirk, J.L., *Caltrans Experience with Rubberized Asphalt*

- Concrete, presented at Technology Transfer Seminar, Topeka, Kansas, Jan. 23, 1991.
8. A Current Assessment of Caltrans RAC Experience, memorandum to E. Shirley from R. Doty, California Department of Transportation, Dec. 13, 1990.
  9. Larsen, D.A., *Eight-Year Performance Evaluation of an Asphalt-Rubber Hot Mix Pavement*, Report No. 116-3-89-8, Connecticut Department of Transportation, 1989.
  10. Stephens, J.E., *Nine Year Condition Survey of Connecticut Department of Transportation Experimental Rubber/Asphalt Application*.
  11. DeFoe, J.H., *Evaluation of Ground and Reclaimed Tire Rubber in Bituminous Resurfacing Mixtures*, Research Report No. R-1266, Michigan Department of Transportation, Oct. 1985.
  12. Page, G.C., B.E. Ruth, and R.C. West, Florida's Approach Using Ground Tire Rubber in Asphalt Concrete Mixtures, in *Transportation Research Record 1339*, Transportation Research Board, National Research Council, Washington, D.C. (1992).
  13. Page, G.C., Florida's Initial Experience Utilizing Ground Tire Rubber in Asphalt Concrete Mixes, presented at the National Seminar on Asphalt-Rubber, Oct. 1989.
  14. Ruth, B.E., S. Sigurjonsson, C.L. Wu, *Evaluation of Experimental Asphalt-Rubber, Dense Graded, Friction Course Mixtures: Materials and Construction of Test Pavements on N.E. 23rd Avenue, Gainesville, Florida*, Department of Civil Engineering, University of Florida, May 1989.
  15. Fager, G.A., *Asphalt-Rubber Hot Mix Overlay*, FHWA Experimental Project No. 3, Kansas Department of Transportation, Dec. 1990.
  16. *Experimental Utilization of a Stress Absorbent Membrane in Peru and a Stress Absorbent Membrane Interlayer in Kennebunk, Maine*, State Study No., 89-12, Maine Department of Transportation, Nov. 1988.
  17. Turgeon, C.M., The Use of Asphalt-Rubber Products in Minnesota, presented at the National Seminar on Asphalt-Rubber, Oct. 1989.
  18. Allen, H.S., *Evaluation of Plus Ride (Rubber Modified Plant Mixed Bituminous Surface Mixture)*, Special Study 387, Minnesota Department of Transportation, March 1986.
  19. Allen, H.S., *Methods and Materials for Reducing Crack Reflections*, Report No. FHWA/MN/RD-84/09, Minnesota Department of Transportation, Jan. 1985.
  20. Heiman, G.H., Rubber Asphalt Binders Used in Saskatchewan, Canada, presented at 1st Asphalt-Rubber User-Producer Workshop, May 1980.
  21. Coley, J.O., *A Study of Flexible Pavement with Ramflex Rubber Additives*, Report No. 1, Mississippi State Highway Department, Dec. 1, 1970.
  22. Hicks, R.G., K. Martin, and J.E. Wilson, *Evaluation of Asphalt Additives: Lava Butte Road—Fremont Highway Junction*, Report No. FHWA-OR-OD-87-03, Oregon State Highway Division, June 1987.
  23. *Rubberized Asphalt Road Surface Demonstration*, South Dakota Department of Transportation, July 1984.
  24. Hankins, K.D., and J.F. Nixon, *Experimental Seal Coat Construction Including Overflex—Two Year Analysis*, Report No. FHWA-DP-37-1, Texas State Department of Highways and Public Transportation, March 1979.
  25. Craner, C., G. Wiley, and J. Keyes, *Plus-Ride, Experimental Project UT-83-04*, Utah Department of Transportation, March 1987.
  26. Allison, R.E., *Plusride Asphalt Concrete Pavement*, Report No. WA-RD 130.2, Washington Department of Transportation, Jan. 1990.
  27. Anderson, J.L., *Plusride and BoniFibers Pavement Evaluation: SR-530, Stanwood Vic.*, Report No. 147.1, Washington Department of Transportation, Sept. 1987.
  28. Peters, A.J., and R.L. Schultz, *PlusRide Asphalt Pavement, SR-82*, Report No. WA-RD-127.1, Washington Department of Transportation, Sept. 1987.
  29. Anderson, K.W., and N.C. Jackson, *Rubber-Asphalt Pavements in the State of Washington*, Report No. WA-RD-2681, Washington State Department of Transportation, March 1992.
  30. Shuler, T.S., R.D. Pavlovich, J.A. Epps, and C.K. Adams, *Investigation of Materials and Structural Properties of Asphalt-Rubber Paving Mixtures, Volume I—Technical Report*, Report No. FHWA/RD-86/027, Texas Transportation Institute, Sept. 1986.

# ASPHALT-RUBBER OVERLAY (US-75)

TOTAL CRACKING

A-R #1    
  A-R #2    
  A #3    
  A #4

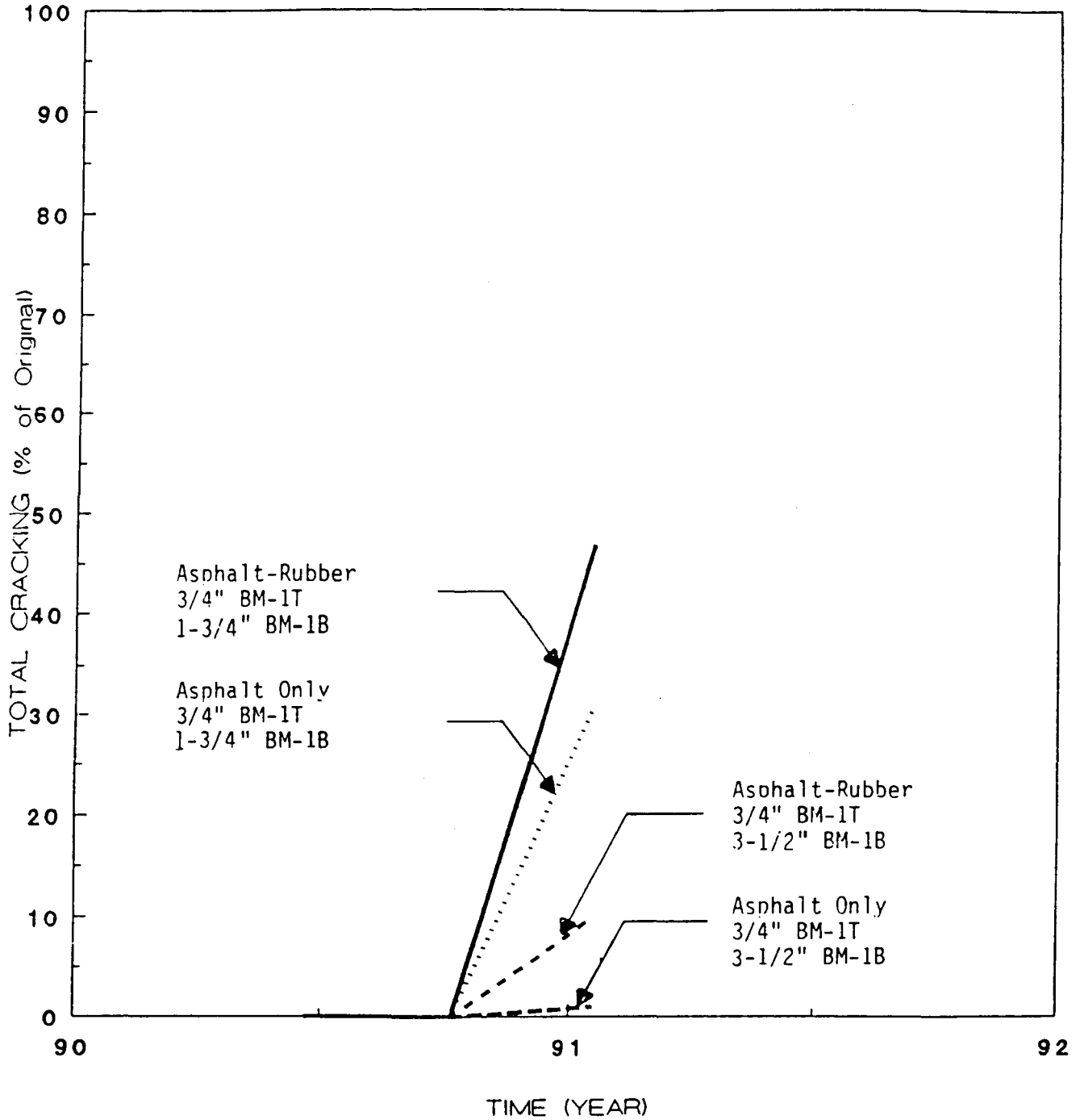

FIGURE O-1 Test and control sections/total cracking, US 75. (O15)

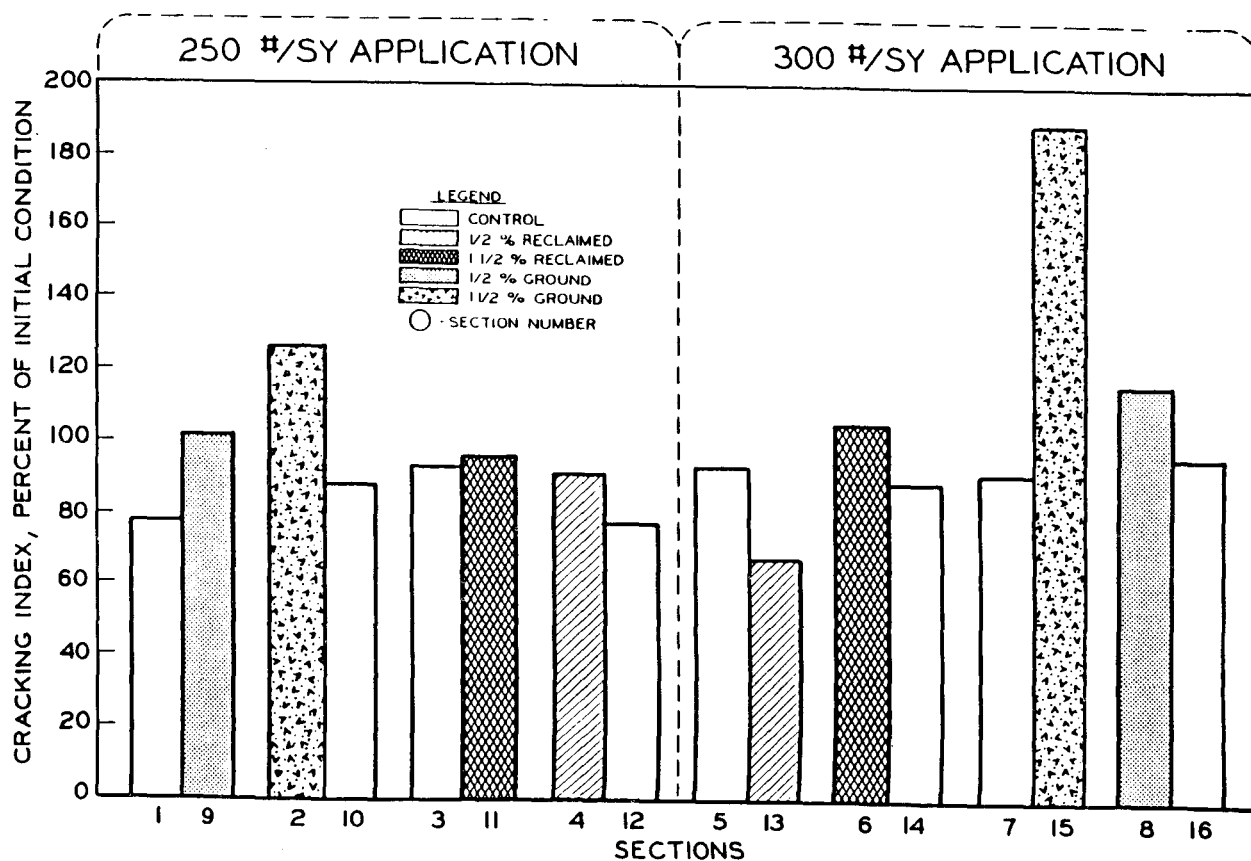

FIGURE O-2 Cracking index ratios for test sections and comparable control sections of conventional mixture. (O11)

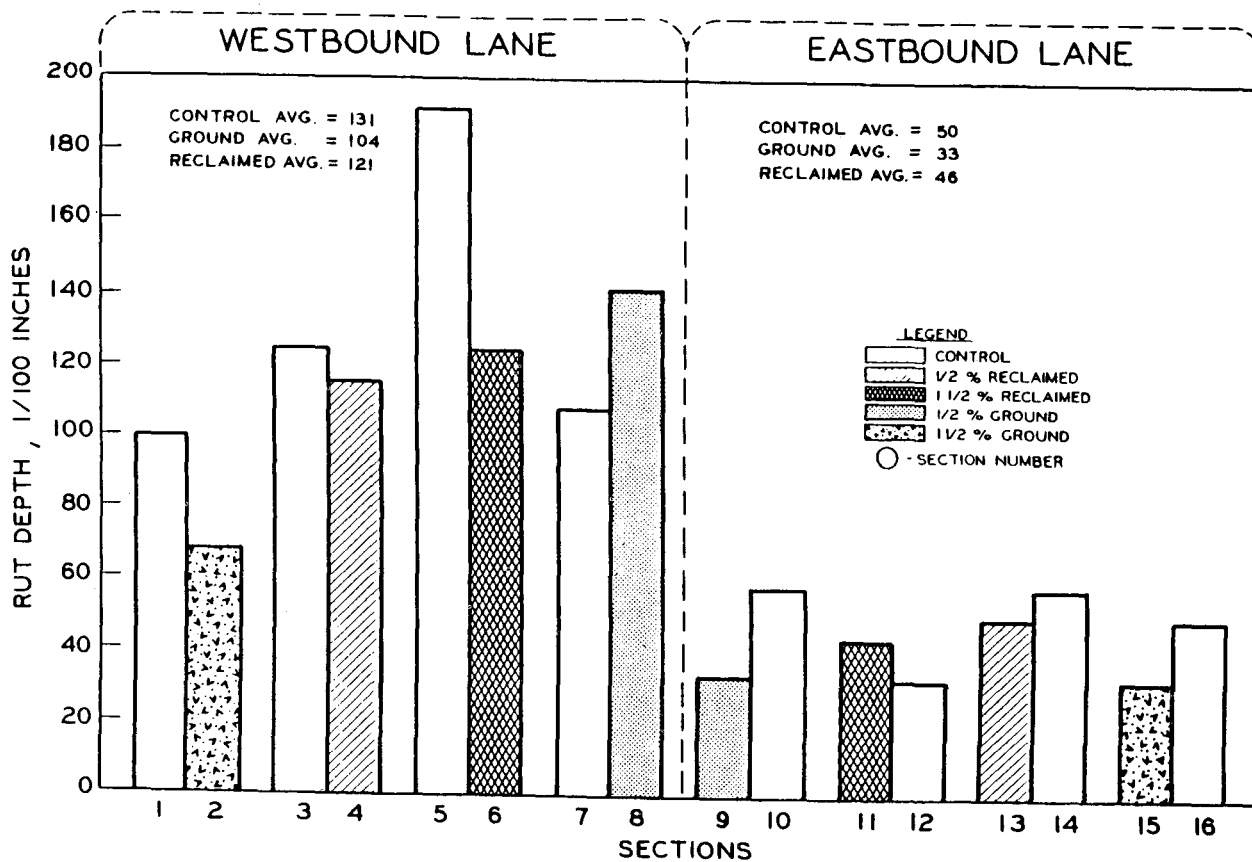

FIGURE O-3 Final rut-depth measurements for test sections and comparable control sections. (O11)

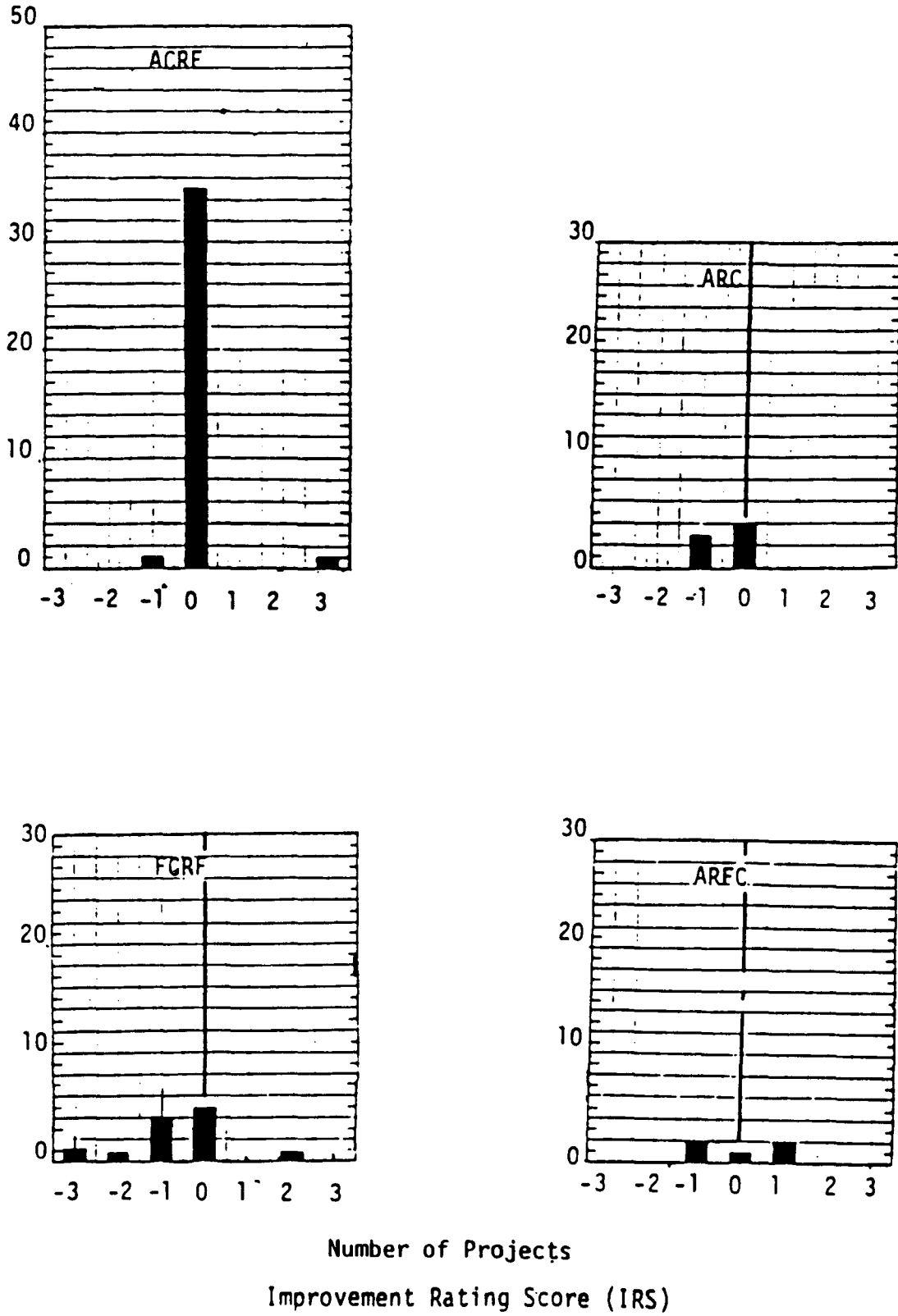

FIGURE O-4 Performance of projects by application type. (O30)

TABLE O-1  
STOPPING DISTANCE TEST COMPARISONS (01)

Date	Pavement Temperature (°F)	Site	Stopping Distance ft @ 25 mph		Percent Reduction with Rubber
			PlusRide	Normal	
01/22/81	-13	Carnation	91	114	20
01/22/81	-13	Fairhill	64	129	50
01/30/81	+27	Fairhill	75	113	34
02/02/81	+27	Carnation	98	101	3
02/05/81	+27	Carnation	53	91	42
02/06/81	+21	Carnation	52	64	19
12/10/81	+13	Peger Road	61	66	7
12/11/81	+ 6	Peger Road	43	49	12
12/16/81	+ 6	Peger Road	58	90	36
12/18/81	+18	Peger Road	63	77	18
01/11/82	- 9	Peger Road	82	97	15
01/14/82	-11	Peger Road	82	100	18
01/29/82	0	Peger Road	55	109	50
02/02/82	10	Peger Road	80	93	14
02/03/82	17	Peger Road	48	55	13
02/04/82	25	Peger Road	65	80	19
02/09/82	21	Peger Road	70	87	20
12/10/82	14	Peger Road	94	123	24
12/11/82	6	Peger Road	62	124	50
11/29/83	+24	Peger Road	62	87	29
12/2/83	+12	Peger Road	45	53	15
Avg. Values			67	91	25

TABLE O-2  
FIELD PERFORMANCE OF OREGON EXPERIMENTAL SECTION (O22)

Section Number	Section Name	Resistance to Transverse Thermal Cracking	Resistance to Longitudinal Fatigue Cracking in Wheeltrack	Resistance to Shrinkage Cracking	to Loss of Fines and Binder from Surface (Weathering)	to Loss of Large Aggregate From Surface (Ravelling)	Overall Performance Compared to Control
1	Plus Ride w/Pave Bond (Southbound Lane)	Much Better	Much Better	Better	Worse	Worse	Better
1	Plus Ride w/Pave Bond (Northbound Lane)	Much Better	Same	Better	Worse	Much Worse	Same
2	Arm-R-Shield	Better	Much Better	Much Better	Better	Same	Better
3	Fiber Pave	Same	Much Better	Better	Same	Same	Better
4	Boni Fibers	Better	Much Better	Much Better	Same	Same	Better
5	Class "C" w/ Pave Bond	Better	Much Better	Same	Same	Same	Better
6	Class "C" w/ Lime and Pave Bond	Same	Much Better	Better	Same	Same	Better
7	Class "C" w/Lime	Better	Same	Same	Same	Same	Same
8	Class "C"	Control	Control	Control	Control	Control	Control
9	CA(P)-1	Much Worse	Worse	Better	Same	Same	Same
10	CA(P)-1 w/Lime	Much Worse	Worse	Better	Same	Same	Same





Transportation Research Board  
National Research Council  
2101 Constitution Avenue, N.W.  
Washington, D.C. 20418

ADDRESS CORRECTION REQUESTED

NON-PROFIT ORG.  
U.S. POSTAGE  
PAID  
WASHINGTON, D.C.  
PERMIT NO. 8970

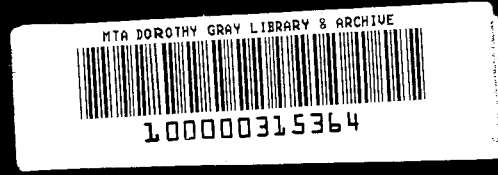

002523-00 \*  
Patricia V. McLaughlin  
Deputy Executive Officer  
Metropolitan Transit Authority  
P O Box 194  
Los Angeles CA 90053