

National Cooperative Highway Research Program

NCHRP Synthesis 211

Design, Construction, and Maintenance of PCC Pavement Joints

A Synthesis of Highway Practice

Transportation Research Board
National Research Council

TRANSPORTATION RESEARCH BOARD EXECUTIVE COMMITTEE 1995

Officers

Chair

LILLIAN C. LIBURDI, *Director, Port Department, The Port Authority of New York and New Jersey*

Vice Chair

JAMES W. VAN LOBEN SELS, *Director, California Department of Transportation*

Executive Director

ROBERT E. SKINNER, JR., *Transportation Research Board, National Research Council*

Members

EDWARD H. ARNOLD, *Chairman & President, Arnold Industries*

SHARON D. BANKS, *General Manager, Alameda-Contra Costa Transit District, Oakland, California*

BRIAN J. L. BERRY, *Lloyd Viel Berkner Regental Professor & Chair, Bruton Center for Development Studies, University of Texas at Dallas*

DWIGHT M. BOWER, *Director, Idaho Transportation Department*

JOHN E. BREEN, *The Nasser I. Al-Rashid Chair in Civil Engineering, The University of Texas at Austin*

DAVID BURWELL, *President, Rails-to-Trails Conservancy*

A. RAY CHAMBERLAIN, *Vice President, Freight Policy, American Trucking Associations, Inc. (Past Chair, 1993)*

RAY W. CLOUGH, *Nishkian Professor of Structural Engineering, Emeritus, University of California, Berkeley*

JAMES N. DENN, *Commissioner, Minnesota Department of Transportation*

JAMES C. DeLONG, *Director of Aviation, Denver International Airport*

DENNIS J. FITZGERALD, *Executive Director, Capital District Transportation Authority*

JAMES A. HAGEN, *Chairman & CEO, CONRAIL*

DELON HAMPTON, *Chairman & CEO, Delon Hampton & Associates*

LESTER A. HOEL, *Hamilton Professor, University of Virginia, Department of Civil Engineering*

DON C. KELLY, *Secretary and Commissioner of Highways, Transportation Cabinet, Kentucky*

ROBERT KOCHANOWSKI, *Executive Director, Southwestern Pennsylvania Regional Planning Commission*

JAMES L. LAMMIE, *President & CEO, Parsons Brinckerhoff, Inc.*

CHARLES P. O'LEARY, JR., *Commissioner, New Hampshire Department of Transportation*

JUDE W. P. PATIN, *Secretary, Louisiana Department of Transportation and Development*

CRAIG E. PHILIP, *President, Ingram Barge Company*

DARREL RENSINK, *Director, Iowa Department of Transportation*

JOSEPH M. SUSSMAN, JR. *East Professor and Professor of Civil and Environmental Engineering, Massachusetts Institute of Technology*

MARTIN WACHS, *Director, Institute of Transportation Studies, Department of Urban Planning, University of California, Los Angeles*

DAVID N. WORMLEY, *Dean of Engineering, Pennsylvania State University*

HOWARD YERUSALIM, *Secretary of Transportation, Pennsylvania Department of Transportation*

MIKE ACOTT, *President, National Asphalt Pavement Association (ex officio)*

ROY A. ALLEN, *Vice President, Research and Test Department, Association of American Railroads (ex officio)*

ANDREW H. CARD, JR., *President & CEO, American Automobile Manufacturers Association (ex officio)*

THOMAS J. DONOHUE, *President and CEO, American Trucking Associations, Inc. (ex officio)*

FRANCIS B. FRANCOIS, *Executive Director, American Association of State Highway and Transportation Officials (ex officio)*

JACK R. GILSTRAP, *Executive Vice President, American Public Transit Association (ex officio)*

ALBERT J. HERBERGER, *Maritime Administrator, U.S. Department of Transportation (ex officio)*

DAVID R. HINSON, *Federal Aviation Administrator, U.S. Department of Transportation (ex officio)*

GORDON J. LINTON, *Federal Transit Administrator, U.S. Department of Transportation (ex officio)*

RICARDO MARTINEZ, *Administrator, National Highway Traffic Safety Administration (ex officio)*

JOLENE M. MOLITORIS, *Federal Railroad Administrator, U.S. Department of Transportation (ex officio)*

DAVE SHARMA, *Administrator, Research & Special Programs Administration, U.S. Department of Transportation (ex officio)*

RODNEY E. SLATER, *Federal Highway Administrator, U.S. Department of Transportation (ex officio)*

ARTHUR E. WILLIAMS, *Chief of Engineers and Commander, U.S. Army Corps of Engineers (ex officio)*

NATIONAL COOPERATIVE HIGHWAY RESEARCH PROGRAM

Transportation Research Board Executive Committee Subcommittee for NCHRP

LILLIAN C. LIBURDI, *Port Authority of New York and New Jersey (Chair)*

FRANCIS B. FRANCOIS, *American Association of State Highway and Transportation Officials*

LESTER A. HOEL, *University of Virginia*

Field of Special Projects

Project Committee SP 20-5

KENNETH C. AFFERTON, *New Jersey Department of Transportation*

JOHN J. HENRY, *Pennsylvania Transportation Institute*

GLORIA J. JEFF, *Federal Highway Administration*

EARL SHIRLEY, *Consulting Engineer*

JON UNDERWOOD, *Texas Dept. of Transportation (Chair)*

WILLIAM A. WESEMAN, *Federal Highway Administration*

J. RICHARD YOUNG, JR., *Mississippi Department of Transportation*

RICHARD A. McCOMB, *Federal Highway Administration (Liaison)*

ROBERT E. SPICHER, *Transportation Research Board (Liaison)*

ROBERT E. SKINNER, JR., *Transportation Research Board*

RODNEY E. SLATER, *Federal Highway Administration*

JOSEPH M. SUSSMAN, *Massachusetts Institute of Technology*

JAMES W. VAN LOBEN SELS, *California Department of Transportation*

Program Staff

ROBERT J. REILLY, *Director, Cooperative Research Programs*

CRAWFORD F. JENCKS, *Manager, NCHRP*

LOUIS M. MacGREGOR, *Administrative Officer*

LLOYD R. CROWTHER, *Senior Program Officer*

B. RAY DERR, *Senior Program Officer*

AMIR N. HANNA, *Senior Program Officer*

FRANK R. McCULLAGH, *Senior Program Officer*

KENNETH S. OPIELA, *Senior Program Officer*

SCOTT A. SABOL, *Senior Program Officer*

EILEEN P. DELANEY, *Editor*

TRB Staff for NCHRP Project 20-5

STEPHEN R. GODWIN, *Director for Studies and Information Services*

SALLY D. LIFF, *Manager, Synthesis Studies*

STEPHEN F. MAHER, *Senior Program Officer*

LINDA S. MASON, *Editor*

TRB
7
1526
NO.
211
- - - 34215
FEB 16 2007

National Cooperative Highway Research Program

Synthesis of Highway Practice 211

Design, Construction, and Maintenance of PCC Pavement Joints

KENNETH H. MCGHEE, P.E.

**Consulting Civil Engineer
Madison, Virginia**

Topic Panel

JOHN W. BUGLER, *New York State Department of Transportation*

RICK W. DEEVER, *Georgia Department of Transportation*

PETER A. KOPAC, *Federal Highway Administration*

ROGER M. LARSON, *Federal Highway Administration*

FRANK N. LISLE, *Transportation Research Board*

CHARLES V. SLAVIS, *Wilbur Smith Associates*

EGONS TONS, *University of Michigan*

Transportation Research Board

National Research Council

Research Sponsored by the American Association of State
Highway and Transportation Officials in Cooperation with the
Federal Highway Administration

NATIONAL ACADEMY PRESS
Washington, D.C. 1995

Subject Areas
Pavement Design, Management, and Performance;
Materials and Construction; and Maintenance

NATIONAL COOPERATIVE HIGHWAY RESEARCH PROGRAM

Systematic, well-designed research provides the most effective approach to the solution of many problems facing highway administrators and engineers. Often, highway problems are of local interest and can best be studied by highway departments individually or in cooperation with their state universities and others. However, the accelerating growth of highway transportation develops increasingly complex problems of wide interest to highway authorities. These problems are best studied through a coordinated program of cooperative research.

In recognition of these needs, the highway administrators of the American Association of State Highway and Transportation Officials (AASHTO) initiated in 1962 an objective national highway research program employing modern scientific techniques. This program is supported on a continuing basis by funds from participating member states of the Association and it receives the full cooperation and support of the Federal Highway Administration, United States Department of Transportation.

The Transportation Research Board of the National Research Council was requested by the Association to administer the research program because of the Board's recognized objectivity and understanding of modern research practices. The Board is uniquely suited for this purpose as it maintains an extensive committee structure from which authorities on any highway transportation subject may be drawn; it possesses avenues of communication and cooperation with federal, state, and local governmental agencies, universities, and industry; its relationship to the National Research Council is an insurance of objectivity; it maintains a full-time research correlation staff of specialists in highway transportation matters to bring the findings of research directly to those who are in a position to use them.

The program is developed on the basis of research needs identified by chief administrators of the highway and transportation departments and by committees of AASHTO. Each year, specific areas of research need to be included in the program are proposed to the National Research Council and the Board by AASHTO. Research projects to fulfill these needs are defined by the Board, and qualified research agencies are selected from those that have submitted proposals. Administration and surveillance of research contracts are the responsibilities of the National Research Council and the Transportation Research Board.

The needs for highway research are many, and the National Cooperative Highway Research Program can make significant contributions to the solution of highway transportation problems of mutual concern to many responsible groups. The program, however, is intended to complement rather than to substitute for or duplicate other highway research programs.

NOTE: The Transportation Research Board, the National Research Council, the Federal Highway Administration, the American Association of State Highway and Transportation Officials, and the individual states participating in the National Cooperative Highway Research Program do not endorse products or manufacturers. Trade or manufacturers' names appear herein solely because they are considered essential to the objective of this report.

NCHRP SYNTHESIS 211

Project 20-5 FY 1985 (Topic 17-05)
ISSN 0547-5570
ISBN 0-309-05671-3
Library of Congress Card Catalog No. 95-60497

Price: \$12.00

NOTICE

The project that is the subject of this report was a part of the National Cooperative Highway Research Program conducted by the Transportation Research Board with the approval of the Governing Board of the National Research Council. Such approval reflects the Governing Board's judgment that the program concerned is of national importance and appropriate with respect to both the purposes and resources of the National Research Council.

The members of the technical committee selected to monitor this project and to review this report were chosen for recognized scholarly competence and with due consideration for the balance of disciplines appropriate to the project. The opinions and conclusions expressed or implied are those of the research agency that performed the research, and, while they have been accepted as appropriate by the technical committee, they are not necessarily those of the Transportation Research Board, the National Research Council, the American Association of State Highway and Transportation Officials, or the Federal Highway Administration of the U.S. Department of Transportation.

Each report is reviewed and accepted for publication by the technical committee according to procedures established and monitored by the Transportation Research Board Executive Committee and the Governing Board of the National Research Council.

The National Research Council was established by the National Academy of Sciences in 1916 to associate the broad community of science and technology with the Academy's purposes of furthering knowledge and of advising the Federal Government. The Council has become the principal operating agency of both the National Academy of Sciences and the National Academy of Engineering in the conduct of their services to the government, the public, and the scientific and engineering communities. It is administered jointly by both Academies and the Institute of Medicine. The National Academy of Engineering and the Institute of Medicine were established in 1964 and 1970, respectively, under the charter of the National Academy of Sciences.

The Transportation Research Board evolved in 1974 from the Highway Research Board, which was established in 1920. The TRB incorporates all former HRB activities and also performs additional functions under a broader scope involving all modes of transportation and the interactions of transportation with society.

Published reports of the

NATIONAL COOPERATIVE HIGHWAY RESEARCH PROGRAM

are available from:

Transportation Research Board
National Research Council
2101 Constitution Avenue, N.W.
Washington, D.C. 20418

Printed in the United States of America

PREFACE

A vast storehouse of information exists on nearly every subject of concern to highway administrators and engineers. Much of this information has resulted from both research and the successful application of solutions to the problems faced by practitioners in their daily work. Because previously there has been no systematic means for compiling such useful information and making it available to the entire community, the American Association of State Highway and Transportation Officials has, through the mechanism of the National Cooperative Highway Research Program, authorized the Transportation Research Board to undertake a continuing project to search out and to prepare documented reports on current practices in the subject areas of concern.

This synthesis series reports on various practices, making specific recommendations where appropriate but without the detailed directions usually found in handbooks or design manuals. Nonetheless, these documents can serve similar purposes, for each is a compendium of the best knowledge available on those measures found to be the most successful in resolving specific problems. The extent to which these reports are useful will be tempered by the user's knowledge and experience in the particular problem area.

FOREWORD

*By Staff
Transportation
Research Board*

This synthesis report should be of special interest to pavement engineers and pavement construction and maintenance personnel responsible for portland cement concrete (PCC) pavement joints. Still pertinent information from *NCHRP Synthesis 19* (1973) as well as new or updated information in the areas of joint design, construction, and maintenance are included.

Administrators, engineers, and researchers are continually faced with highway problems on which much information exists, either in the form of reports or in terms of undocumented experience and practice. Unfortunately, this information often is scattered and unevaluated and, as a consequence, in seeking solutions, full information on what has been learned about a problem frequently is not assembled. Costly research findings may go unused, valuable experience may be overlooked, and full consideration may not be given to available practices for solving or alleviating the problem. In an effort to correct this situation, a continuing NCHRP project, carried out by the Transportation Research Board as the research agency, has the objective of reporting on common highway problems and synthesizing available information. The synthesis reports from this endeavor constitute an NCHRP publication series in which various forms of relevant information are assembled into single, concise documents pertaining to specific highway problems or sets of closely related problems.

This report of the Transportation Research Board records the state of the practice with respect to the design, construction, and maintenance of PCC pavement joints. In addition, information on joint materials and sealing, the control of water on and in pavements, and the evaluation of pavement joint performance is provided.

To develop this synthesis in a comprehensive manner and to ensure inclusion of significant knowledge, the Board analyzed available information assembled from numerous sources, including a large number of state highway and transportation departments. A topic panel of experts in the subject area was established to guide the research in organizing and evaluating the collected data, and to review the final synthesis report.

This synthesis is an immediately useful document that records practices that were acceptable within the limitations of the knowledge available at the time of its preparation. As the processes of advancement continue, new knowledge can be expected to be added to that now at hand.

CONTENTS

- 1 SUMMARY
- 3 CHAPTER ONE OVERVIEW OF CONCRETE PAVEMENT JOINTING
 - Problem Statement, 3
 - Pavement Dynamics, 3
 - Pavement Jointing Background, 6
 - Types and Uses of Pavement Joints, 7
 - Summary of Current Practices, 8
- 12 CHAPTER TWO JOINT DESIGN CONSIDERATIONS
 - General, 12
 - Transverse Joints, 14
 - Longitudinal Joints, 16
 - Bridge Approach Joints, 16
 - Drainage and Joint Sealants, 17
- 21 CHAPTER THREE JOINT CONSTRUCTION PRACTICES AND QUALITY CONTROL
 - Transverse Joints, 21
 - Longitudinal Joints, 23
 - Joint Sealing, 24
- 26 CHAPTER FOUR JOINT PROBLEMS: MAINTENANCE AND REHABILITATION
 - Joint Problems: Causes and Repairs, 26
 - Preventive Maintenance of Pavement Joints, 32
- 34 CHAPTER FIVE EVALUATION OF JOINT PERFORMANCE
 - Evaluation Methods, 34
 - Benefits of Performance Evaluation, 34
- 36 CHAPTER SIX RESEARCH
 - Research Under Way, 36
 - Research Needs, 36
- 38 GLOSSARY
- 40 REFERENCES
- 44 APPENDIX A QUESTIONNAIRE
- 47 APPENDIX B SUMMARY OF AGENCY PRACTICES FOR JOINTED PAVEMENT DESIGN

ACKNOWLEDGMENTS

Kenneth H. McGhee, P.E., Consulting Civil Engineer, Madison, Virginia, was responsible for collection of the data and preparation of the report.

Valuable assistance in the preparation of this synthesis was provided by the Topic Panel, consisting of John W. Bugler, Civil Engineer, New York State Department of Transportation; Rick W. Deaver, Special Projects Engineer, Georgia Department of Transportation; Peter A. Kopac, Research Highway Engineer, Federal Highway Administration; Roger M. Larson, Development Team Leader, Federal Highway Administration; Frank N. Lisle, Engineer of Maintenance, Transportation Research Board; Charles V. Slavis, Senior Associate, Wilbur Smith Associates, Albany, New York; and Egons Tons, Ph.D., Professor Emeritus, Department of Civil Engineering, University of Michigan.

The Principal Investigators responsible for the conduct of this synthesis were Sally D. Liff, Manager, Synthesis Studies, and Stephen F. Maher, Senior Program Officer. This synthesis was edited by Linda S. Mason, assisted by Rebecca B. Heaton.

Scott A. Sabol, Senior Program Officer, National Cooperative Highway Research Program, assisted the NCHRP 20-5 staff and the topic panel.

Information on current practice was provided by many highway and transportation agencies. Their cooperation and assistance were most helpful.

DESIGN, CONSTRUCTION, AND MAINTENANCE OF PCC PAVEMENT JOINTS

SUMMARY

Portland cement concrete (PCC) pavements require joints to control the natural cracking associated with shrinkage caused by drying and with movements caused by changes in temperature and moisture conditions. Joints also facilitate the construction of PCC pavements. A significant part of the initial cost of a PCC pavement is associated with joint construction and many of the required maintenance expenditures are joint related.

Joint technology includes an evolving set of practices spelled out in guidelines and specifications that are generally provided by the concrete paving industry and by the various transportation departments. Many changes have taken place in the two decades since publication of the previous synthesis on pavement joints and it is the purpose of this synthesis to provide an up-to-date summary of current practice. However, this document is not intended to serve as a design, construction, or maintenance manual, but to provide an overview of those areas. It is hoped that the practitioner can use the material provided here as a guide and as a reference in determining sources of more detailed information. Responses to a 1992 questionnaire, which was circulated to all state highway departments and the Canadian provinces, were a major source of information for this synthesis. Other resources included the body of PCC pavement joint literature available through the Transportation Research Board (TRB), the Federal Highway Administration (FHWA), the various state highway departments, and the paving industry.

The design of PCC pavement joints involves many elements, beginning with the pavement foundation, they include the projected traffic as well as pavement movements resulting from temperature and moisture changes. Among the many other design elements to be considered are pavement thickness, slab length, load transfer, and joint sealants. Questionnaire responses and the literature show a growing preference for thicker pavements and shorter slab lengths over the past two decades. This change has been accompanied by a heightened concern for positive pavement drainage and by improvements in the joint sealants available.

Construction issues addressed for each type of transverse and longitudinal joint include the location and installation of load transfer devices, suggested means of joint formation or sawing, and the provision of effective joint sealants. It was determined that dowel inserters are a feasible alternative to basket assemblies, although some agencies have reported that the use of inserters may be detrimental to ride quality. Further, performance problems with formed joints have led most agencies to require joint sawing for both transverse and longitudinal contraction joints. The installation of joint sealants has been enhanced by the development and use of new self-leveling materials.

A chapter on maintenance of PCC pavement joints summarizes the major types of joint distresses and briefly discusses the causes of those distresses. Suggested repair procedures are outlined with the appropriate references provided. Major improvements in repair materials and methods that have occurred over the past 20 years, such as high early strength concretes and proprietary materials, and greater use of doweled repairs are discussed. The programming of joint rehabilitation has benefitted from greater use of economic analysis to select repair alternatives having the lowest life-cycle cost.

All aspects of joint design, construction, and maintenance technology have benefitted greatly from published guidelines provided by the American Association of State Highway and Transportation Officials (AASHTO), the FHWA, the American Concrete Pavement Association (ACPA), and the Portland Cement Association (PCA).

OVERVIEW OF CONCRETE PAVEMENT JOINTING

PROBLEM STATEMENT

Historically, joints have been of major concern to designers, builders, and owners of portland cement concrete (PCC) pavements. Much of the cost of a concrete pavement is associated with joint construction. Similarly, many of the maintenance expenditures incurred are joint related. As a consequence, designers have tried numerous approaches to improve jointing practices or to eliminate jointing altogether. Pavement engineers now have nearly 100 years of experience in dealing with joint related issues.

There have been several efforts to summarize that experience. Published in 1973, NCHRP Synthesis 19 (1) was one of the first major documents on the practice. In the same year, the British Transport and Road Research Laboratory (TRRL) published a report summarizing the practice in that country (2). Since that time, the technical publications in the areas of joint design, construction, and maintenance have been innumerable. However, many recent developments, including much of the new technology, have not been documented in a single source. The present effort was undertaken to provide the needed single source with information updated to the early 1990s.

Scope of Synthesis

The scope of this synthesis is to include the still pertinent information from NCHRP Synthesis 19 as well as new or updated information in the general areas of joint design, construction, and maintenance. Information on joint materials and sealing, the control of water on and in pavements, and the evaluation of pavement joint performance is also included.

PAVEMENT DYNAMICS

General

Concrete pavements would require little jointing if they were not dynamic systems subject to movements resulting from loads, changes in moisture content and temperature, and variations in support conditions. Most joints permit movements without destroying pavements. Some joints are used to facilitate construction. In this chapter, the types and general magnitudes of various joint movements are discussed, while the application of those movements to joint design is reserved for later chapters.

One of the early joint design and construction research studies to provide data on joint movements took place in the 1940s. Six states constructed experimental jointed concrete pavement projects in 1940 and 1941 in cooperation with the U.S. Bureau of Public Roads (BPR) (3). Each project contained basic pavement sections that had been built in all six states while several agencies incorporated sections of their own specific interest. The result was a large

information database on pavement joint design and performance. The majority of the sections constructed were plain pavements with contraction joints spaced from 3 to 9 m (10 to 30 ft). Each state also constructed some sections of reinforced pavement with 18.3 m (60 ft) slab lengths. Expansion joints were spaced from 37 m (120 ft) to 1.6 km (1 mi) in the plain sections and at 37 m (120 ft.) in the reinforced.

In discussing the BPR experiment, Sutherland (3) noted:

As the temperature of the pavement drops seasonally, the slab units will not be shifted over the subgrade, but will expand and contract about their own centers. After the first year there should be little or no progressive closure of the expansion joints resulting purely from temperature changes, but if foreign material infiltrates the contraction joints, closure of the expansion joints will continue.

Typical annual and progressive changes in both expansion and contraction joint widths are illustrated in Figures 1 and 2. The scenario outlined by Sutherland is clearly evidenced by the progressive opening of expansion joints and closing of contraction joints over time. Other more recent studies of joint movements, including those at the American Association of State Highway Officials (AASHTO) road test (4) and by Cook et al. in Ohio (5), complement the early cooperative work to provide an excellent database for joint design and construction. Some work on undoweled PCC pavements in Chile showed that "at low temperatures, the pavement behaves as a set of relatively isolated slabs, whereas on very hot days, the pavement behaves as a continuous strip, with complete locking of joints" (6).

Longitudinal Thermal Movement

Numerous studies have shown that the relationship between temperature change and volume change applicable to most solids also is applicable to PCC. However, for a typical PCC pavement, that volume change is resisted by friction between the pavement and the underlying subbase layer. The general equation for change in slab length (ΔL) with change in temperature (ΔT) is given by Smith et al. (7) as:

$$\Delta L = CL(\alpha\Delta T + \epsilon) \quad \text{Eq. (1)}$$

where:

ΔL = the expected change in slab length (cm or in.),

C = the subbase/slab frictional restraint factor (0.65 for stabilized material and 0.80 for granular material),

L = the slab length (cm or in.),

α = the PCC coefficient of thermal expansion (contraction),

ΔT = the maximum temperature range, and

ϵ = the shrinkage coefficient of the concrete (this factor can be ignored for concrete past the early curing and hydration stage).

Recent work by Bodocsi et al. shows that for older pavements (up to 20 years) Eq. (1) may be simplified to $\Delta L = \alpha L \Delta T$ and used to calculate horizontal movements caused by temperature changes

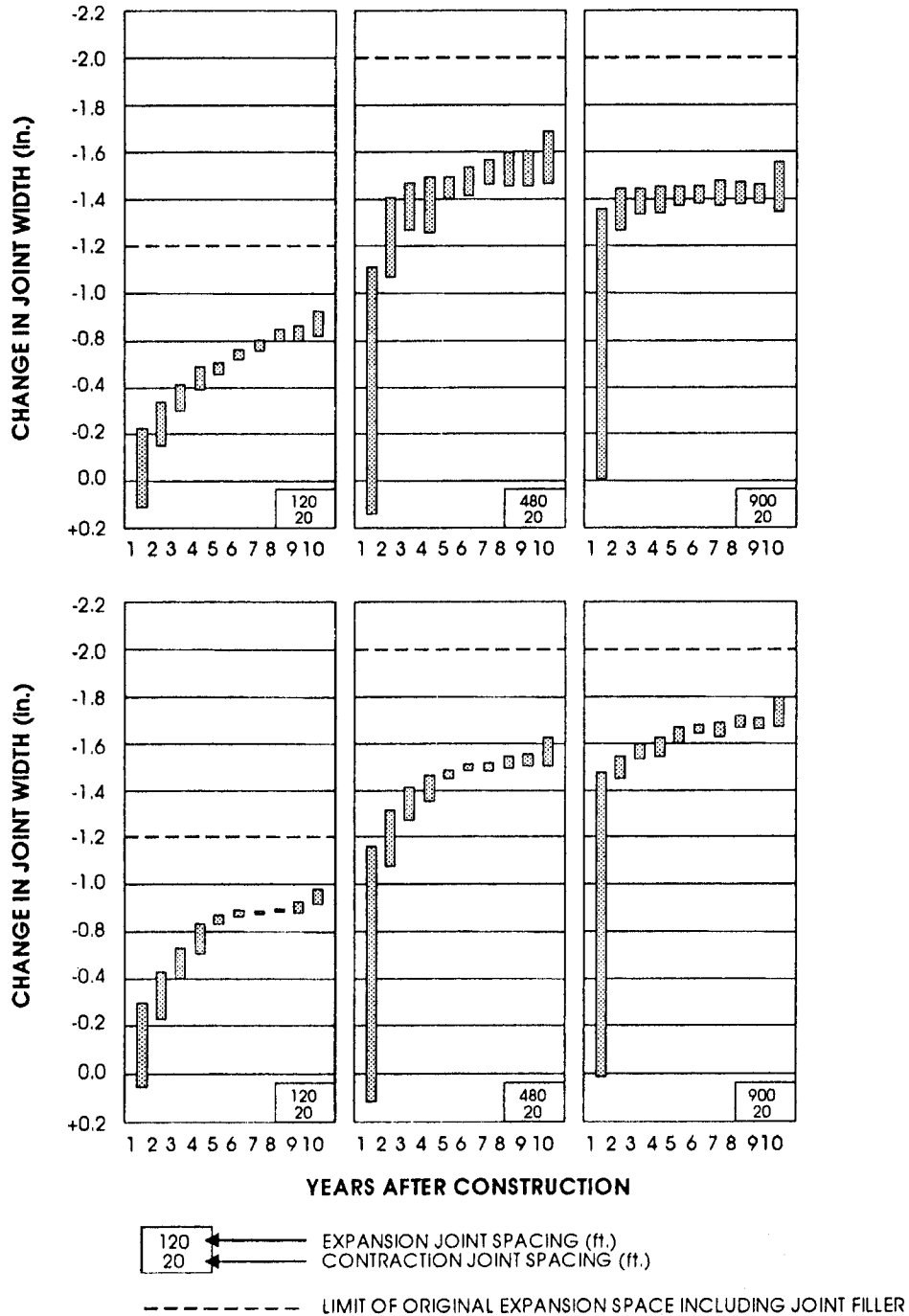

FIGURE 1 Typical annual and progressive changes in expansion joint widths non-reinforced sections (after 3).

(8). The American Concrete Pavement Association (ACPA) lists typical values for α and ϵ as determined by the FHWA (9,10). The thermal coefficient is highly sensitive to the type of coarse aggregate used in the concrete. For example, concrete containing a quartz aggregate will be nearly twice as thermally active as a concrete containing a limestone aggregate. Typical values of the thermal coefficient are given in Table 1 (9). Assuming a granite coarse aggregate with a thermal coefficient of $9.5 \times 10^{-6}/^{\circ}\text{C}$ ($5.3 \times 10^{-6}/^{\circ}\text{F}$) (10) and 56°C (100°F) temperature change, Eq. (1) results in ap-

proximately 0.13 cm (0.05 in.) of slab length change for each 3 m (10 ft) of slab length for mature concrete. Some researchers have calculated the maximum seasonal temperature difference to exceed 80°C (150°F) for much of the United States (1). While this exercise provides some idea of the slab length changes to be encountered, field studies show that slab movements are not uniform and that actual movements depend on numerous variables (5,9). Wimsatt et al. have thoroughly examined the factors influencing frictional resistance of subbases (11).

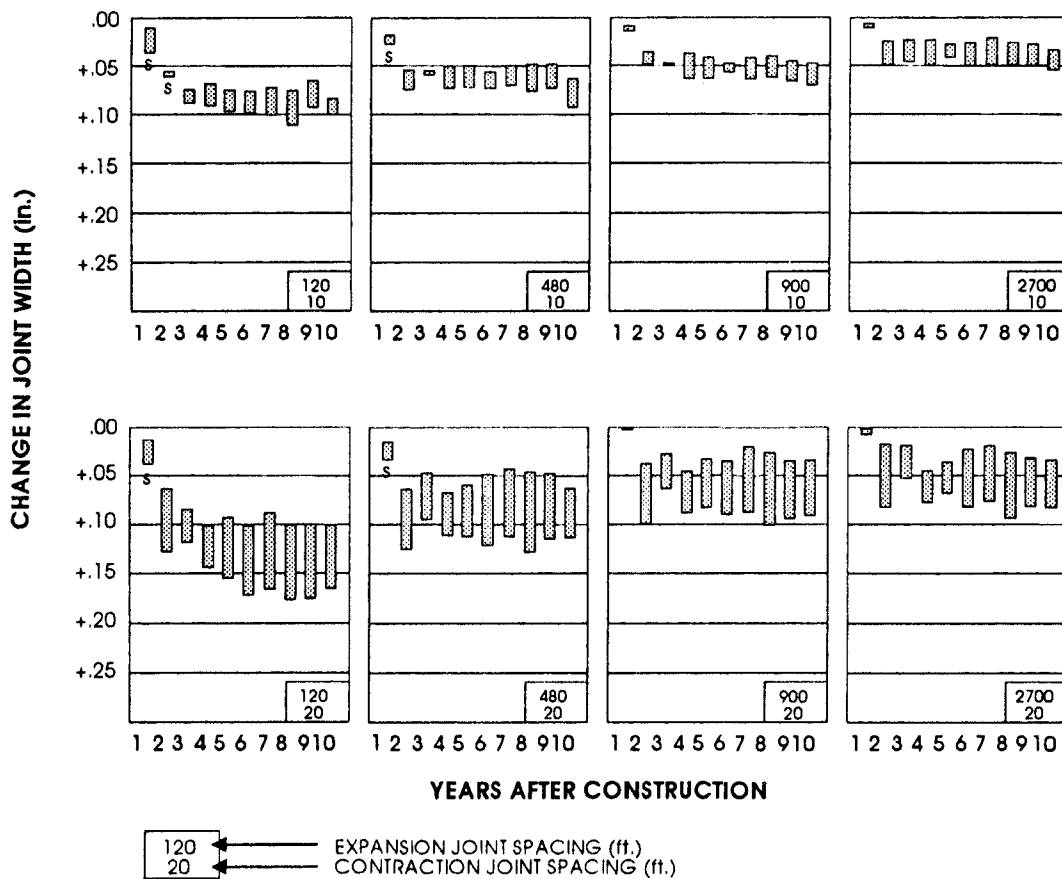

FIGURE 2 Typical annual and progressive changes in contraction joint widths non-reinforced sections (after 3).

Movement Caused by Variations in Moisture Content

PCC slabs may undergo significant volume changes because of variations in the amount of moisture absorbed by the concrete. The magnitudes of this volume change and of the associated joint movement are difficult to measure. However, one study indicated that, in wet environments, moisture-induced expansion and contraction may be similar to that caused by temperature changes (12). While it is often assumed that moisture-induced volume change is not a

major consideration in dry environments, research in Chile (13) and in California (14) showed that the condensation of water vapor as the temperature drops can significantly increase the PCC slab moisture content. Therefore, it is important to consider the combined effects of temperature and moisture changes on concrete volume.

Slab Curling and Warping

Studies have shown that pavement slabs tend to curl and warp because of temperature and moisture gradients from one surface of the slab to the other. The temperature at the slab-subbase interface varies little as a result of changes in ambient air temperature (1). However, the pavement surface may be much warmer than the interface in summer and much colder in winter. Similar but smaller gradients exist daily as the slab tends to warm during daylight hours and cool at night.

When the lower surface of the slab is warmer than the top, the slab curls upward at its edges and ends (Figure 3). Conversely, when the top is warmer than the bottom, the slab curls downward at its edges and ends. Theoretical analyses of the movements and stresses induced by curling and warping are given in pavement design textbooks (15) and are integral to the design process. The direct relationship with joint design is discussed later.

TABLE 1
TYPICAL VALUES FOR PCC THERMAL COEFFICIENT
(A) (9)

Type of Coarse Aggregate	PCC Thermal Coeff. $10^{-6}/^{\circ}\text{C}$
Quartz	11.8
Sandstone	11.6
Gravel	10.7
Granite	9.5
Basalt	8.6
Limestone	6.8

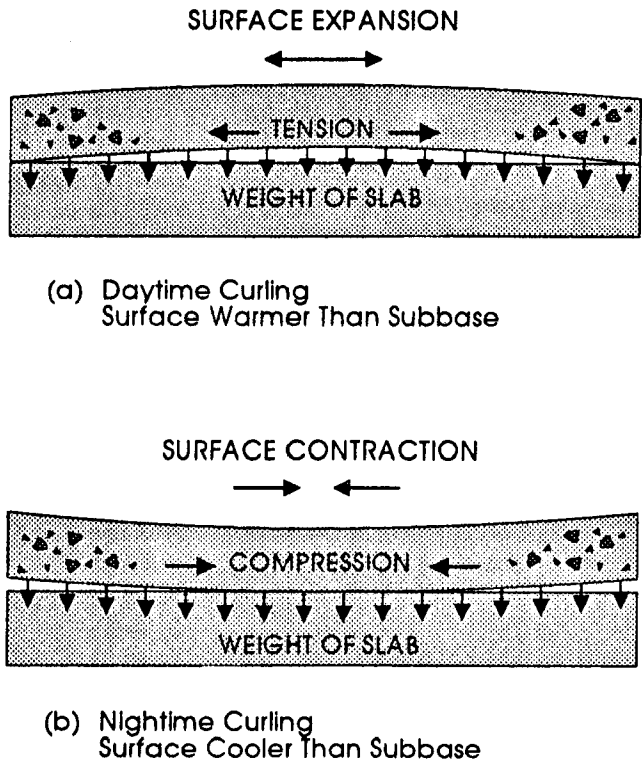

FIGURE 3 Pavement curling (after 9).

Joint Deflections

The deflection of pavement joints under load is an important type of movement that greatly affects the design and performance of those joints. Deflections depend on the pavement foundation, slab thickness, effectiveness of load transfer, magnitude of applied loads, and, to some extent, slab length. The slab length affects the warping and curling components of deflections up to a point. For example, a joint may be warped upward such that it is already out of contact with the subbase prior to the application of a load. An increased total net deflection results when a load application depresses the joint to the subbase elevation.

Joint deflections may increase substantially with pavement deterioration, especially as load transfer diminishes or as voids develop under the pavement.

PAVEMENT JOINTING BACKGROUND

Brief History

Synthesis 99 reports that the earliest PCC pavement in the United States was built in 1891 in Belafontaine, Ohio (1,19). Records of that and other very early projects suggest that jointing was a matter of construction expediency rather than the accommodation of slab movements. In the early 1900s, the thinking was that concrete continued to expand with age so that some space to accommodate that expansion should be provided (1). In about 1914, it was recognized that the first slab length changes are contraction associated with drying of the new concrete. From then on, fewer expansion and more contraction joints were used.

With increased traffic and the evolution of wider pavements, wider slabs tended to develop meandering longitudinal cracks in the central area (1). In response, longitudinal center joints were introduced in about 1920 in pavements 6.1 m (20 ft) or more in width. Soon thereafter, tiebars were introduced between lanes to prevent separation. Later, Westergaard (16) theorized that warping stresses were sufficient to cause longitudinal cracking of wide slabs.

At about the same time that center joints were introduced, some agencies began to experiment with load transfer devices at transverse joints. The first reported use of dowels was in 1918 on a pavement near Newport News, Virginia (1). In 1947, Illinois reported tests of numerous load transfer devices, including dowels (17). While various studies of dowel use were conducted over the years, major progress in their design awaited the publication of a paper by Teller and Cashell in 1958 that showed the need for dowels to have a minimum diameter of 1/8 the slab thickness (18).

Major variations have taken place over the past several decades in typical slab lengths, load transfer devices, joint forming techniques, and joint sealing approach. By the 1930s, most PCC pavements contained mesh reinforcement and a combination of contraction and expansion joints. In many cases, expansion joints were spaced at 28 m (90 ft) and contraction joints at 9 m (30 ft) (19). However, these did not perform particularly well as the expansion joints closed while the contraction joints opened and became filled with incompressibles. The result was serious spalling and blowups (19).

During World War II, steel shortages developed and a new generation of plain pavements evolved. Many were undoweled and had expansion joints at 32 to 38 m (105 to 120 ft) and contraction joints at 4.5 to 6 m (15 to 20 ft). Again, expansion joints closed and contraction joints opened and performance was poor because of loss of load transfer (19).

Subsequent to World War II, PCC pavement design went in two general directions: (1) plain, undoweled pavements with short slabs separated by contraction joints, but with no expansion joints; and (2) mesh-doweled pavement with either expansion or contraction joints spaced at 15 to 30 m (50 to 100 ft) (19). Spalling and blowups were problems for the mesh-dowel design and by 1981, many states and foreign countries had adopted a design employing plain pavement with dowels and contraction joints at 4.5 to 6 m (15 to 20 ft) (19). Because failures have been related to dowel or mesh corrosion, some agencies now specify corrosion-resistant (coated) dowels.

The Portland Cement Association (PCA) has reported on 100 years of concrete pavement design and construction evolution, much of which is associated with jointing issues (20). The state of the practice has now evolved to the use of plain pavements with doweled joints at a 3.5 to 6 m (12 to 20 ft) spacing, depending on slab thickness, or mesh-doweled with joints at no more than 9 m (30 ft) apart (9). Michigan has reported an evolution since 1989 in reinforced slab lengths from 30 m (99 ft) prior to 1964 to 8.2 m (27 ft) for pavements designed for more than 3,000 daily commercial vehicles (21). Much of the research supporting those changes in joint spacing and in dowel design has been conducted by Snyder (22,23) and by others working in cooperation with him (24,26). A summary of agency practice, provided in Appendix B, shows that most agencies have adopted the plain pavement design, usually with dowels. In addition, some agencies reported using skewed and randomly spaced joints. Others considered skewed and randomly spaced joints difficult to construct, therefore making little use of those features. Recent research suggests a need for changes in both skewed and randomly spaced joint designs, as will be discussed in Chapter 3 (27-30).

TYPES AND USES OF PAVEMENT JOINTS

The two general classifications of pavement joints are transverse (joints approximately perpendicular to the direction of travel) and longitudinal (joints approximately parallel to the direction of travel). There are numerous variations of these types depending on particular geometric as well as other considerations. These are discussed briefly below and in more detail in later chapters on design and construction considerations.

Transverse Contraction Joints

Transverse contraction joints are used to accommodate the early shrinkage stresses associated with hardening and curing of fresh portland cement concrete. To a lesser extent, these joints help allay warping and curling stresses. Contraction joints are typically formed or sawed to a minimum depth $1/3$ of the slab thickness, which controls the location of shrinkage cracks that extend the full depth of the pavement. Contraction joints may be sealed with a variety of sealing materials. The slab length and required joint shape factor (discussed under joint sealing) will normally determine the width (typically 1 to 2 cm ($3/8$ to $3/4$ in.)) of the final sawcut. A major cause of pavement joint distress is random cracking associated with late sawing of contraction joints.

Expansion Joints

Expansion joints, usually transverse, were used in many earlier pavements to provide space for temperature and moisture related volume changes. These joints were almost always formed so that a compressible insert could be placed in the opening to fill the space and prohibit the intrusion of foreign materials. Where expansion joints were used intermittently, it was in conjunction with contraction joints. Expansion joints, intended to accommodate more movement than contraction joints, were typically somewhat wider, ranging from 15 to 25 mm ($5/8$ to 1 in.), and were sealed with either poured or preformed materials. Deen et al. (26) state that jointed PCC pavement performance, especially pavements subject to "D" cracking, would be enhanced by the use of small expansion joints maintained in a condition of constant compression or near compression.

With the exception of several agencies, including New Jersey, modern pavements have few expansion joints, which are usually reserved for situations where unaccommodated longitudinal movements cannot be tolerated (e.g., on grade structures that might be damaged by pavement thrust). Experience showed that the use of expansion joints provided in earlier pavements to overcome compressive stresses and prevent blowups were not very successful. While somewhat helpful in reducing blowup incidence, the expansion joints permitted adjoining contraction joints to open too wide, resulting in a loss of aggregate interlock and sealant damage (9). New Jersey state highway agency personnel, however, report that their agency continues to use expansion joints successfully and has employed slipform pavement construction on several recently completed projects. Large expansion or "pressure relief" joints are discussed later.

Construction Joints

As the name suggests, construction joints are used to expedite construction and usually are established at the point where work is

stopped for the day or where paving continuity must be interrupted for other reasons. While construction joints may be treated as contraction or expansion joints, in many cases they are formed as simple doweled butt joints. When paving resumes, the paving train merely begins at the previously established joint and moves ahead without any special attention to the joint with the exception of careful vibration of concrete at the joint.

Pressure Relief Joints

Pressure relief joints typically are transverse joints located at 150 to 300 m (500 to 1000 ft) spacing to accommodate excessive pavement movements often associated with pavement growth. Such growth may be real growth caused by reactive aggregates or other volume unstable materials. The growth may also be "pseudo", caused by the infiltration of incompressibles into transverse joints that become progressively wider. Most relief joints have been installed 4 or more inches apart and are filled with a compressible material such as a styrofoam or rubber compound. The theory is that the joints provide room for continued growth and protect the surrounding pavement from damage resulting from excessive compression.

Unfortunately, the joints often are installed in a plain sawcut with no provision for restoration of load transfer. While pressure relief joints have been shown to be helpful in extreme situations of pavement growth, they lead to extremely wide surrounding joints while the "free" ends created can be subject to pumping and erosion of the subbase (31). In many cases, the disadvantages have outweighed the advantages (32). The FHWA makes provision for the use of such pressure relief joints only "where excessive compressive stress exists" (10).

Longitudinal Contraction Joints

Longitudinal contraction joints used for lane separation purposes are needed because of the limitations on lane widths, which are imposed by the pavement warping concerns discussed earlier. Most pavements are therefore constructed with lanes about 3.7 m (12 ft) wide and separated by a formed or sawed joint. As discussed later, many agencies now use a widened lane design to keep wheelloads from bearing directly on the pavement edge.

If two or more lanes are placed monolithically, the interior longitudinal joints may be sawed or formed. Sawing is accomplished as soon as the pavement can sustain the weight of the sawing operation without damage. Typically, a thin (approximately 3 mm ($1/8$ in.) wide) sawcut is made at least $1/3$ the slab depth. Many longitudinal contraction joints are not sealed because of the relatively small movement expected. They also are not doweled, but typically employ tiebars to hold the aggregate interlock load transfer capabilities intact (9). Some agencies employ keyways to further enhance load transfer. Certain limitations on the use of keyways are discussed in Chapter 3.

Lane-Shoulder Joints

Lane-shoulder joints are longitudinal joints separating the mainline pavement from the shoulder pavement. The type and construction of the joint depends on the shoulder type. Flexible shoulders

normally are constructed after the mainline and a simple butt joint is used with the flexible paving material compacted at the edge of the concrete pavement. In such instances, the joint will usually be approximately 25 mm (1 in.) wide and filled with a hot- or cold-poured sealing material.

If the shoulder is PCC, it may or may not be placed concurrent with the mainline paving operation. If shoulder paving is concurrent, the joint may be treated much as in the case of the longitudinal contraction joint between lanes. In other instances, load transfer may be enhanced by the use of a keyway (Figure 4) with or without tiebars (9). Again, there are some limitations on the use of a keyway and some agencies do not permit bending of tiebars as a construction expedient. Both of these features are discussed further in later chapters.

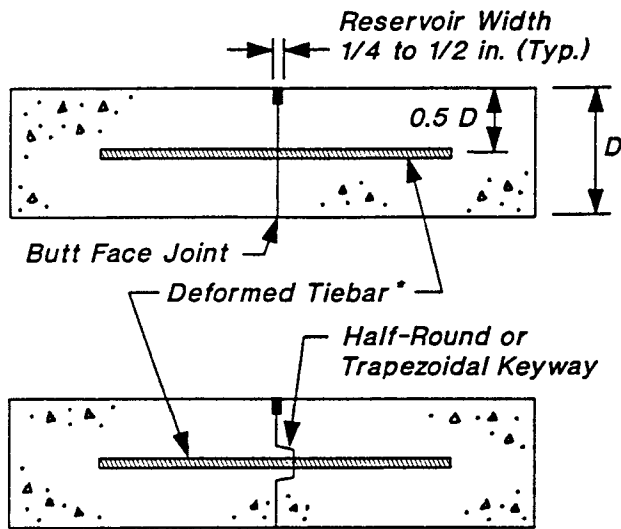

* Tiebars are bent, drilled & inserted or threaded into place.

FIGURE 4 Longitudinal construction joint with keyway (9).

Regardless of shoulder type, a widened outside concrete pavement lane may be used to reduce the number of wheelloads applied to the pavement edge. Performance of the concrete pavement can be significantly enhanced by this widening, which typically ranges from 300 to 600 mm (1 to 2 ft).

Bridge Protection Joints

Bridge protection joints, often called bridge protection expansion joints, have been used by many agencies to protect on-grade bridges from the damaging effects of pavement growth. These transverse joints range from ordinary expansion joints a few millimeters wide, to some over a meter in width. While the larger joints afford excellent protection to structures, they are subject to their own peculiar set of problems. One such joint is underlain by a sleeper slab and is very expensive to construct (Figure 5). The same joint is 1.2 m (4 ft) wide and filled with asphalt concrete, which tends to upheave and cause a loss in pavement ride quality. These large joints are being replaced by conventional expansion

joints in most modern design standards, both in the United States (Appendix B) and in Europe (33).

Joints Associated with Pavement Repairs

Joints used in conjunction with pavement repairs may be either longitudinal or transverse and may be of the construction, contraction, expansion, or lane separation types. Details of these joints are dictated by the sizes and other characteristics of the associated repairs. Special joint considerations for repair work are discussed later.

SUMMARY OF CURRENT PRACTICES

A questionnaire concerning current concrete pavement practices was sent to 50 state highway or transportation agencies and to the Canadian provinces. The questionnaire included a request that the responding agency update concrete pavement joint design information tabulated in Synthesis 19 (1). Forty-five states and four provinces responded. The questionnaire is reproduced in Appendix A, the results of the responses are discussed below, and the updated joint design information is given in Appendix B.

Joint Construction Problems and Solutions

In this portion of the questionnaire, agencies were asked to identify and discuss major joint construction problems and the solutions they had applied to those problems. Most agencies either declined to respond to this question or attached reports concerning the use of pavement management data in the rehabilitation planning process. Such management issues are discussed later in this synthesis.

Drainage Philosophy

This portion of the questionnaire addressed agency attitude toward pavement drainage. Agency response to this question was excellent as seen in the following discussion of the specific questions (statements). Some agencies embraced more than one type of drainage philosophy depending on local conditions and the class of highway considered.

Stated Philosophy	Number of Agencies
Our agency attempts to seal pavement joints as well as possible and is not too concerned with subsurface drainage	9
Our agency takes the position that water will enter the pavement and attempts to control the water through the use of	
(a) a drainage layer	4
(b) other subsurface drainage	5
(c) both	2
Our agency attempts to seal pavement joints as well as possible and to control the water through the use of	
(a) a drainage layer	7
(b) other subsurface drainage	3
(c) both	20

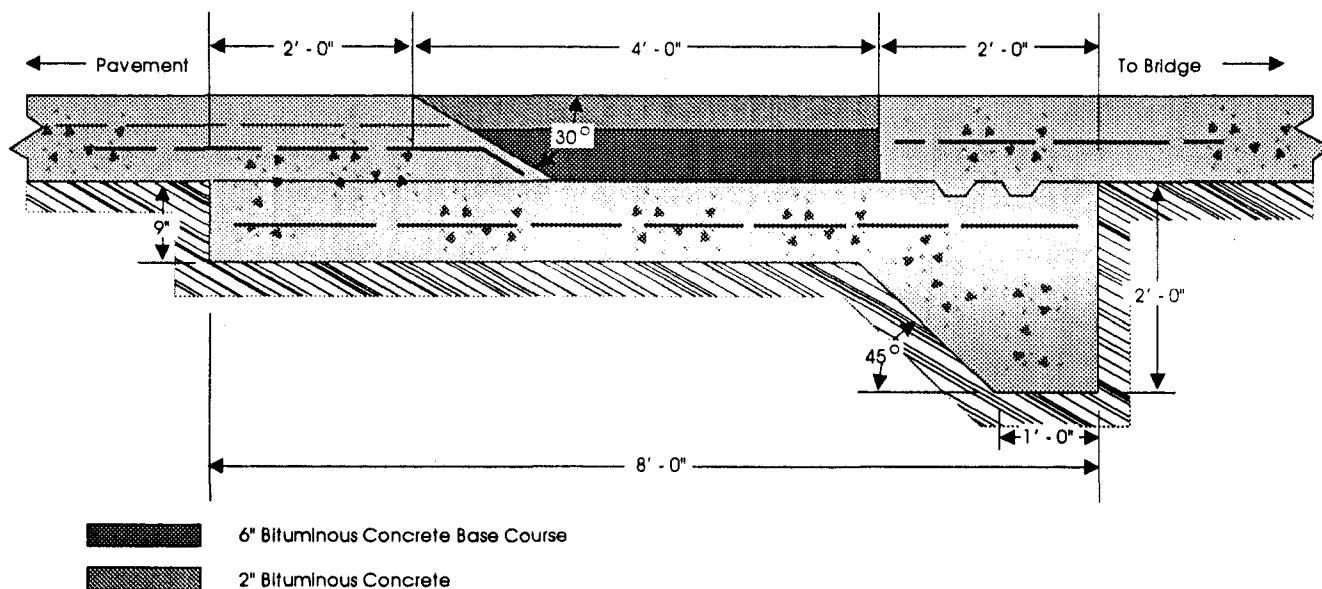

FIGURE 5 Bridge approach expansion joint (after 31).

It is of interest that some 2/3 (30 of 45) of the agencies responding take the third position, i.e., they both seal joints and make provision to remove water through the use of some kind of drainage system. Of the nine agencies taking the first position (little concern with subsurface drainage), only two were unqualified. That is, the other seven use some type of drainage system on certain classes of roads or in certain climatic zones. It is evident that highway agencies are very much aware of pavement drainage issues and that the

majority make some effort to accommodate those issues in the design process.

Joint Sealing Practices

The portion of the questionnaire dealing with joint sealing practices is reproduced in Table 2 where the number of agencies responding to each item is listed in the corresponding box.

TABLE 2
JOINT SEALING PRACTICES

Joint Type	Predominant Sealant Used (Check)			
	Hot-poured	Cold-poured	Pre-formed	None
TRANSVERSE				
Construction	12	18	3	8
Contraction	21	22	7	3
Expansion	10	14	16	3
Bridge Protection	5	6	26	1
Pavement Rehab.	20	21	2	4
Other	1	3	0	0
LONGITUDINAL				
Lane Separation				
Concrete to concrete	23	18	2	4
Concrete to asphalt	17	4	0	20
Lane Shoulder				
Concrete to concrete	21	17	2	4
Concrete to asphalt	21	6	0	3
Pavement Rehab.				
Concrete to concrete	25	16	0	3
Concrete to asphalt	20	6	0	18

The purpose of this section was to determine the predominant types of sealants used for various types of joints and under what conditions sealants were used. The major observations from the tabulation are:

- Highway agencies use hot- and cold-poured joint sealing materials almost equally on all types of joints.
- Preformed seals are used by a few agencies for a variety of purposes but are most widely used to seal expansion and bridge protection joints.
- While most agencies seal all joints between PCC slabs, many do not seal joints between PCC and asphalt concrete.
- Approximately 25 AASHTO, American Society for Testing and Materials (ASTM), and military specifications for joint sealing materials were referenced. Yet, the strongest consensus was on cold-poured sealants where 18 agencies simply gave "silicone" with no specification listed.

Joint Performance Evaluation

This section of the questionnaire was included in an effort to determine the state of practice in evaluating joint performance. To clarify the intent of the question, the pavement-concrete index (PCI) (34) and the concrete pavement evaluation system (COPES) (35) methods of condition evaluation were given as examples while the agencies were asked to cite other methods they use. The results are summarized in Table 3.

TABLE 3
METHODS OF JOINT PERFORMANCE
EVALUATION IN USE

Method	No. of Agencies
None	17
PCI (34)	1
COPES (35)	1
SHRP (36)	1
Other	14

Several agencies failed to answer this question; one-half (17 of 34) of those who did respond noted that no formal method of evaluation was in use. Only three agencies showed the use of nationally recognized procedures. These were one each for the PCI, the COPES, and the SHRP methods. Fourteen agencies listed "other" methods. "Other" refers almost exclusively to an agency specific method, usually relating to methods used in the agency's pavement management system. Two observations appear warranted from this tabulation: (1) many agencies use no formal joint performance evaluation procedure; and (2) the "nationally recognized" pavement evaluation procedures are used very little in the highway agencies for joint performance evaluation. The fact that agencies generally use their own procedures suggests that there is little standardization and that the nationally recognized methods are used principally for research rather than for operational purposes.

Changes in Practice

Based on the updated design details summarized in Appendix B, it is helpful to consider several changes that have occurred in practice in the nearly 20 years since the earlier synthesis was completed. These are:

- There is a strong move by highway agencies to use much thicker PCC pavements now than in 1973 (see Figure 6).
- Fewer agencies are using jointed reinforced concrete (JRC) pavements, which are now constructed with much shorter slabs than in 1973.
 - At least six agencies now specify permeable subbase courses for PCC pavements, while none did in 1973.
 - A few more agencies are using skewed, randomly spaced joints for plain PCC pavements (11 and 15 agencies for 1973 and 1992, respectively). As will be discussed later, skewed and randomly spaced joints are not considered necessary for adequate load transfer and pavement performance when other design parameters have been appropriately addressed.
 - As opposed to widespread use earlier, very few agencies now permit formed contraction joints or inserts to create a weakened plane. While all allow sawing, most permit only that method.
 - There was a significant movement toward the use of higher quality joint sealants in 1992. Some of those now available were not marketed in 1973.
 - There is a trend toward the use of larger dowels and to more corrosion-resistant dowels.

The first two of the above findings lend themselves to graphical display. For the first, the data show that for the agencies providing a 1992 response, the average maximum thickness specified for higher traffic corridors was 236 mm (9.30 in.) and 297 mm (11.71 in.) for 1973 and 1992, respectively. Both plain and reinforced pavements are included in those averages. The change of more than 60 mm (2.4 in.) in the average is reflected in the pavement thickness distribution given in Figure 6. Note that in 1973, no

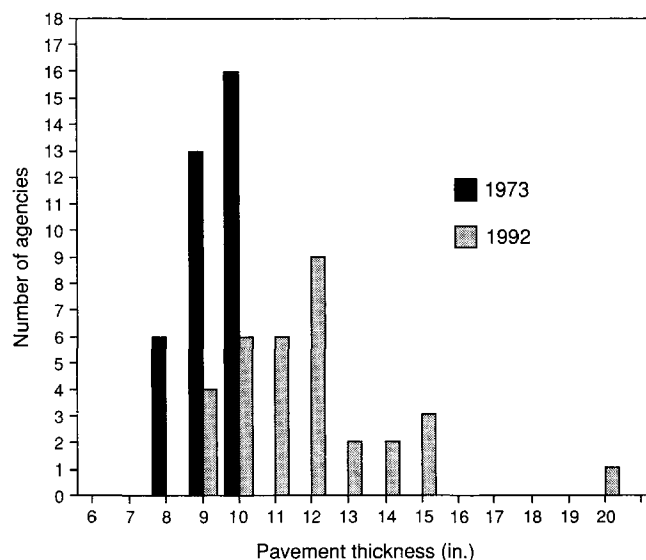

FIGURE 6 Distribution of maximum specified pavement thicknesses.

agency called for more than a 250 mm (10 in.) thick pavement while by 1992, only four states specified a maximum of less than 250 mm (10 in.). At the same time, several agencies have gone as high as 380 to 510 mm (15 to 20 in.) while others reportedly are revising design standards to call for thicker pavements. Some engineers, however, doubt the need for pavements thicker than about 330 mm (13 in.) for highways.

In the second instance, the data yield the distributions of maximum design slab lengths for JRC pavements, which are given in Figure 7. Note that in 1973, several agencies used lengths in excess of 18 m (60 ft). Presently, no slabs exceed that length and most are under 12 m (40 ft).

Some design items have changed little since the earlier synthesis. The dozen agencies using expansion joints still use them mostly to protect structures, and almost all longitudinal joints are sawed and have tiebars between lanes. Joints at lane edges, such as for PCC shoulders, are almost all keyed rather than butted.

Information from the United States and Canada has been supplemented throughout this document by a report of European practice recently issued by the FHWA (33).

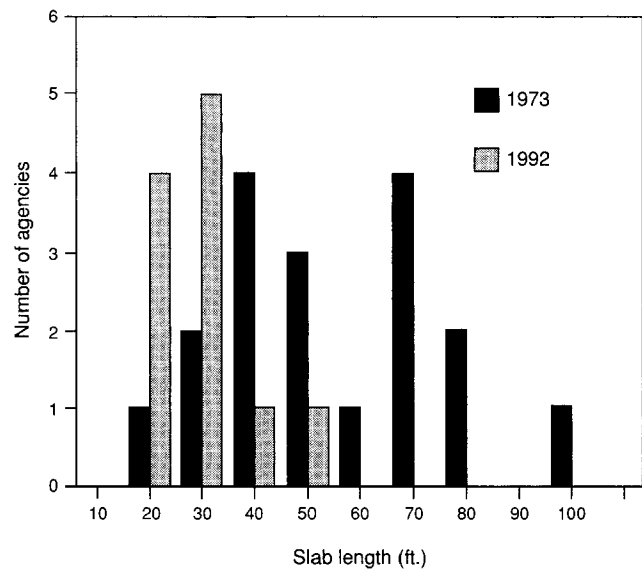

FIGURE 7 Distribution of maximum slab lengths, JRC pavements.

JOINT DESIGN CONSIDERATIONS

The design of rigid pavement joints is thoroughly covered in the 1986 *AASHTO Design Guide for Pavement Structures* (37) to which joint designers should refer for detailed procedures. This chapter provides an overview. Construction and maintenance issues will be covered in later chapters.

GENERAL

Numerous factors must be considered in the proper design of joints in concrete pavements. However, most of the concerns can be traced to the need to address three fundamental design issues:

- (1) Concrete volume changes brought about by changes in thermal and moisture conditions,
- (2) The prevailing and projected traffic stream, and
- (3) Pavement deflections relating to that traffic and the underlying support conditions.

To accommodate these issues, the FHWA (38) notes the following minimum joint design considerations:

- (1) The provision of adequate load transfer,
- (2) The allowance for slab end movements, and
- (3) The selection of a proper joint sealant.

While many of the other factors have been mentioned in earlier chapters, those identified in the literature as most important are further addressed here.

Traffic

Traffic volume and weights impact joint design in many ways. Perhaps the most important of these is the relationship between traffic and the need for and effectiveness of load transfer devices (discussed later). Pavements in low-traffic corridors (fewer than about 120 trucks per day) and built without load transfer devices can last for many years without significant joint distress. Those in high-traffic corridors are subject to joint faulting and pumping, which can be alleviated only with proper attention to load transfer. The relationships between traffic and the design of load transfer devices can be found in textbooks (15), in the *AASHTO Design Guide for Pavement Structures* (37), and in other recent work (39,40).

Foundation/Subbase Conditions

Because of the need for adequate support under PCC pavements the foundation (subgrade and subbase combined) is an important consideration in joint design. The magnitude of joint deflections and therefore of stresses on the aggregate interlock interface or on embedded load transfer devices is directly related to the type and strength of the foundation.

Current design procedures provide for the use of an effective modulus of subgrade reaction (k) made up of a combination of the subgrade and subbase elastic moduli. In addition, modern design procedures provide for the consideration of how effectively the subbase material removes water from beneath the pavement (37). The composite k value as well as the drainage factor provide direct inputs to pavement thickness determination and indirect inputs to joint design. In progress, NCHRP Project 1-30 "Support Under Portland Cement Concrete Pavements" will address the selection of k values and the loss-of-support values for use in the design of rigid pavements and overlays.

Finally, studies have shown that adequately designed stabilized subbases provide greater strength and lead to better long-term joint load transfer for both doweled and undoweled pavements (9,41). The emphasis on adequate design is important as some impervious stabilized bases still have eroded and led to pavement damage because of pumping (7). As a guideline, a minimum of 7 to 8 percent by weight of portland cement will provide a highly non-erodible subbase (42). While the details of subbase design are beyond the scope of this synthesis, additional information has been provided by Hansen and Johannesen (43), DeBeer (44), and Christory (45).

Pavement Thickness

The thickness of the pavement is an important parameter in joint design and is determined through a weighting of traffic parameters, foundation strength, and other factors discussed above. Joint spacing is in large part a function of pavement thickness. For example, the maximum recommended transverse joint spacing is 21 times the slab thickness with ceilings of 6 and 9 m (20 and 30 ft) for plain and reinforced pavements, respectively (9). In addition, for plain, undoweled pavements, load transfer through aggregate interlock increases directly with the increased cross-sectional area associated with increased pavement thickness. Finally, for doweled pavements, the numbers and sizes of dowel bars are directly related to the pavement thickness, with larger dowels typically specified for thicker pavements (9).

Accommodating Slab Movements

The major function of joints in PCC pavements is to accommodate the movements undergone by the individual pavement slabs. Joint spacing and dimensions are functions of slab dimensions and of the shrinkage and expansion characteristics of the concrete in those slabs. As discussed in Chapter 2, those movements are primarily related to temperature and moisture changes within the concrete and to how much the concrete is restrained by subbase friction. Warping and curling of the slabs also must be considered in joint design.

The combination of volume change and subbase friction at the

interface between the PCC slab and the subbase materials is an important consideration in the design of slab thickness and other dimensions. Studies have shown that if a slab's largest dimension is greater than about 21 times the slab thickness, random cracking tends to increase. Design guidelines often limit the greatest slab dimension in feet to twice its thickness in inches (37). For pavements constructed on stabilized bases, a greatest dimension in feet of 1.75 times the thickness in inches is recommended (9).

Load Transfer

The ability of a pavement joint to transfer loads from one side to the other is referred to as the joint's load transfer capability (9). Conceptually, load transfer is related to joint deflections and is measured by the relative deflections on either side of the joint as a load passes across. When the load is fully transferred from one side of the joint to the other (deflections on both sides of the joint are equal), the load transfer is considered to be 100 percent effective. Load transfer situations of 0 and 100 percent are depicted in Figure 8. The equation used to rate joint effectiveness is (9):

$$E = \frac{2d_U}{d_L + d_U} 100$$

where

E = joint effectiveness,

d_L = deflection of the loaded side, and

d_U = deflection of the unloaded side.

A joint effectiveness of 75 percent or more is considered necessary for the joint to perform satisfactorily under medium and heavy truck loadings (18,40).

There are three mechanisms of load transfer across a joint (1), two of which are direct load transfer by the use of aggregate interlock or through imbedded mechanical devices. The third is through the use of very strong foundations provided by cement treated non-erodible (39) subbases, as specified by the California DOT and others (42,46,47).

In the case of aggregate interlock, the loads are transferred through shear on the faces of coarse aggregate particles at the joint/

crack interface. Clearly in this case, load transfer is related to how closely the joint faces are engaged so that the degree of transfer provided is a function of joint opening and closing. Load transfer through aggregate interlock is not an alternative for expansion joints and should not be used where there is any appreciable truck traffic.

The second means of achieving joint load transfer is through mechanical devices, the most common of which are steel dowel bars spanning the joint. The FHWA (38) lists the following requirements for mechanical load transfer devices, which should:

- Provide adequate load transfer across the joint,
- Be simple in design to allow proper installation or placement without difficulty,
- Offer little resistance to joint opening, and
- Be corrosion resistant.

Mechanical load transfer devices are more important when slab lengths exceed about 4.5 m (15 ft), because at greater lengths joint movements are such that aggregate interlock begins to become ineffective. Nor is aggregate interlock considered capable of long-term performance under heavy truck traffic, even when slab lengths are very short. The industry recommends the use of dowel bars wherever the design pavement loadings will exceed 4 to 5 million 80 kN (18,000 lb) equivalent single axle loads (ESALs) (9). The AASHTO design guide provides a thorough analysis of the load transfer efficiencies of various joint types and configurations, both with and without dowel bars (37). The designer may address the load transfer issue through life-cycle cost analysis of dowelled versus non-dowelled pavements (37). However, given the uncertainties of projecting pavement performance under dowelled versus non-dowelled conditions, Kelleher and Larson take the position that dowel bars are good insurance for nearly all pavements:

As dowels cannot be economically retrofitted on short slab pavements they should be installed initially to prevent undesirable pavement faulting or differential slab elevations due to foundation settlements, consolidation of base or subbase under traffic, frost heave, or swelling soils. Until an improved design procedure for undowelled pavements is available that can reliably predict performance on an individual project, the use of dowels and short slab lengths should be considered for most pavements with other than light truck traffic (39).

Similarly, the British specified dowels 20 years ago for moving joints on pavements thicker than 150 mm (6 in.) (2).

When dowels are used, the guideline is that dowel diameter should equal the slab thickness times 1/8 (37). For example, a 250 mm- (10 in.-) thick slab would have a dowel diameter of 250/8 or 31 mm (1-1/4 in.). Appendix B shows that most agencies use at least 32 mm (1-1/4 in.) diameter dowels with spacing and length of 300 mm (12 in.) and 450 mm (18 in.), respectively. In addition, the literature shows that the FHWA and the paving industry presently support a minimum dowel diameter of 32 mm (1-1/4 in.) (40).

Dowels must be smooth and free to move as the joint opens and closes. Movement is ensured by the use of a lubricant on the dowels prior to placing the concrete. In addition, dowels must be installed in the pavement parallel to the centerline and to the pavement surface, otherwise joint performance may be adversely affected. Acceptable alignment tolerances, in both the horizontal and vertical directions, are ± 6 mm (1/4 in.) per 300 mm (12 in.) of dowel length (9).

In most modern work, epoxy coating of dowels is specified as a means of protection against corrosion thereby ensuring greater du-

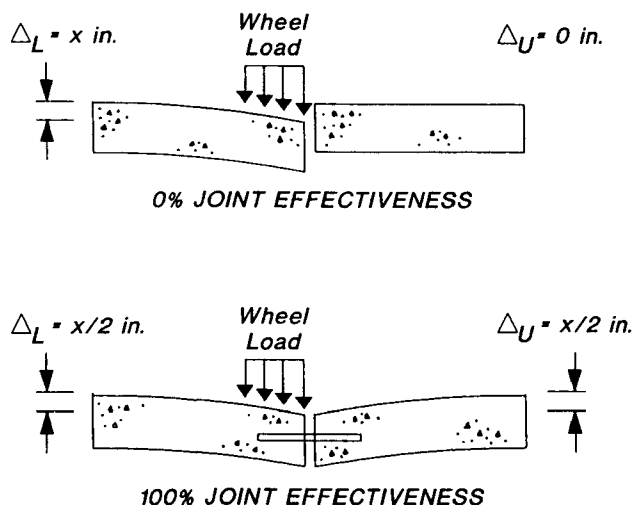

FIGURE 8 Effectiveness of load transfer (9).

rability (38). While many coatings have been applied in the past and stainless steel bars have been used, the most cost-effective approach seems to be the epoxy coatings. The FHWA (38) lists the factors to consider in the evaluation of dowel coatings as the effectiveness of coatings to reduce corrosion, the ability of the dowel to retain free movement, and the effect of coating thickness on load transfer across the joint.

Another means of providing load transfer at longitudinal construction joints is the keyway, mentioned earlier. The keyway is formed and cast when the concrete is placed and while the deformed tiebars hold the male and female portions of the keyway in contact so that load transfer is maintained. While the majority of agencies that use a keyway use 13 or 16 mm (No. 4 or 5) bars 750 mm (30 in.) long and spaced at 750 mm (30 in.), the FHWA (40) finds considerable evidence that those sizes are too light for heavy truck traffic and recommends at least a 19 mm (No. 6) bar. Germany uses five 20 mm (No. 6) tie bars per 5 m- (16-1/2 ft-) long slab and Spain uses six bars for a similar slab where shoulders are added after the mainline has been constructed (48).

Some agencies have eliminated use of keyways when pavements are less than 250 mm (10 in.) thick because of poor keyway performance in thin slabs (shear failure of the male portion or of the slab above the keyway). In those cases, larger tiebars are recommended to ensure that adequate load transfer is provided (40).

Skewed and Randomly Spaced Joints

A means of enhancing load transfer, especially for undoweled joints, is to use joints skewed transversely so that wheels on the same axle strike the joints at different times. A typical skew arrangement of 0.6 m (2 ft) in 3.7 m (12 ft) is depicted in Figure 9.

A few states in the United States as well as New South Wales, Australia have switched to a lesser skew of 1 in 10 (28,29,49). This change is justified in Australia by the occasional incidence of corner cracking as predicted by finite element analysis (49). If a skew is to be used at all, the FHWA suggests the latter (1 in 10) configuration (30).

Skewed joints typically do not have dowels, although in some cases they are provided on heavily travelled roads. The AASHTO design guide advises that skewed joints are helpful in plain and

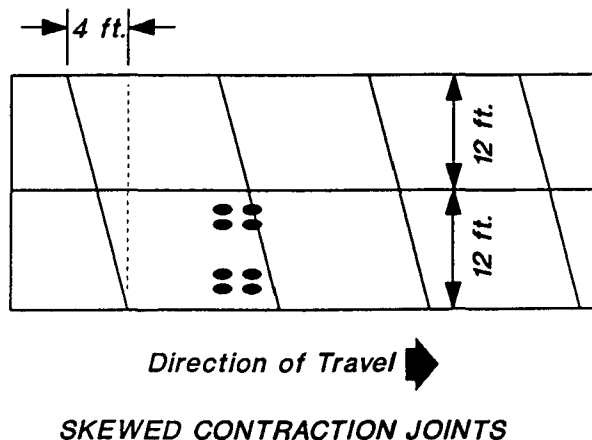

FIGURE 9 Typical skewed transverse joints (9).

reinforced pavements and with or without dowels (37). The guide continues that skewed joints have the following advantages: (1) reduced deflection and stress at joints, thereby increasing the load-carrying capacity of the slab and extending pavement life; and (2) less impact reaction in vehicles as they cross the joints, hence a smoother ride if the joints have some roughness.

The American Concrete Pavement Association (ACPA) (9), on the other hand, suggests that when dowels are used, skewing should be a contractor option in the interest of construction expediency. Further, some engineers suggest that transverse joints built at 90° to the centerline are easier to construct properly and their performance may equal that of skewed joints.

Random joint spacing is used to avoid the sometimes objectionable resonant frequency phenomenon that can occur with jointed PCC pavements when the combination of vehicle speed, axle spacing, and joint spacing trigger near natural frequency vehicle response. On the other hand, Packard (27) reports random joint spacing to be a product of outdated (1950s) automotive engineering. He goes on to suggest that agencies still specifying random joint spacing reconsider those specifications in light of modern high-performance tires and suspension systems. AASHTO suggests that joint spacing multiples of 2.3 m (7.5 ft) should be avoided (37). An example set of random joint spacings from Appendix B is 3.7, 4.0, 4.6, and 4.3 m (12, 13, 15, and 14 ft). This pattern has been used in California (38) for several years and is now being adopted by several other states.

Approximately one-half of the agencies responding to the questionnaire for this synthesis use skewed and randomly spaced joints under some circumstances. Conversely, the FHWA takes the position that performance data do not support the need for skewed joints or random joint spacing on adequately doweled concrete pavements (28).

TRANSVERSE JOINTS

While many of the issues relating to joint design have been discussed above as general subjects, specific concerns regarding joint type are addressed briefly below.

Transverse Contraction Joints

Transverse contraction joints are used to control the natural shrinkage cracking a pavement would experience if no relief was provided. As noted earlier, such cracking is more likely whenever the slab length in feet exceeds about twice the thickness in inches. Figure 10 demonstrates graphically how transverse shrinkage cracking increases with slab length. The literature shows that plain pavements often have been built with contraction joint spacings of up to 9 m (30 ft) while reinforced slabs up to 30 m (100 ft) long are not uncommon. However, performance of pavements with such long slabs has been questionable (50). Current recommendations are that plain slabs be no more than 4.5 m (15 ft) long and that reinforced slabs not exceed 9 m (30 ft) in length (50). Appendix B shows that few agencies exceed the 4.5 m (15 ft) recommendation for plain pavements while most that build reinforced pavements tend toward 12 to 15 m- (40 to 50 ft-) long slabs. Recall from the earlier discussion that there has been a dramatic decrease in reinforced pavement slab length over the past 20 years.

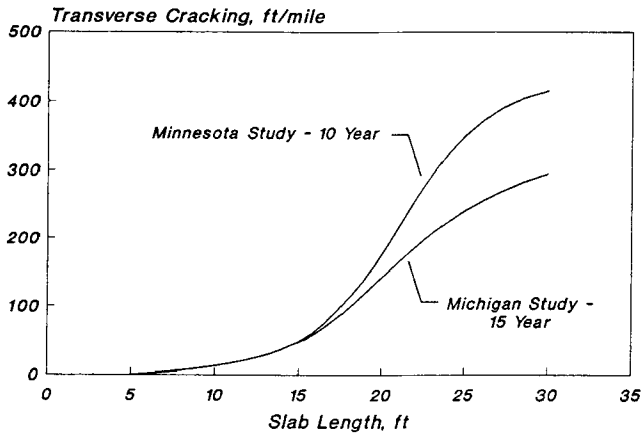
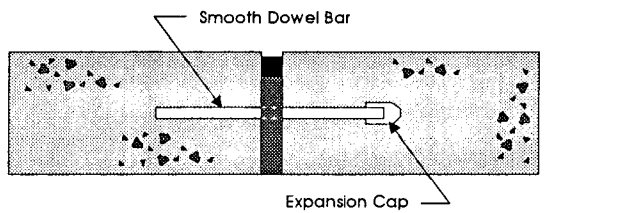

FIGURE 10 Sensitivity of transverse cracking to slab length, Minnesota and Michigan studies (9).

Transverse Expansion Joints

For modern pavements, most transverse expansion joints are used to protect on-grade structures from damage caused by horizontal pavement movements. Because the joint is formed full-depth, there is no possibility of aggregate interlock, and dowels are required to provide load transfer. The ACPA also provides for an undoweled expansion joint used at ramps and in other situations where it is desirable to permit differential movements without damage to the abutting pavement (9). Both types of expansion joint are illustrated in Figure 11. It is important to note here that the tapered slab used in the undoweled joint could be subject to nonuniform frost heave in susceptible areas.

For doweled expansion joints, the dowel assemblies typically



(a) Doweled

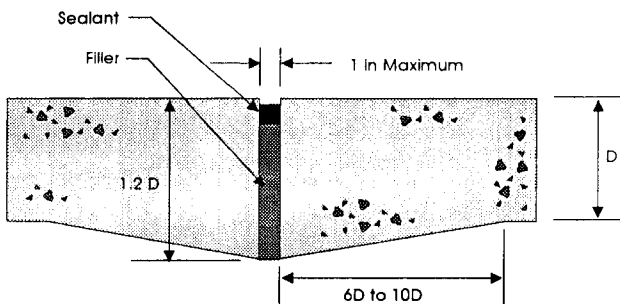

(b) Undoweled - Thickened Edge (Isolation)

FIGURE 11 Typical expansion joints (after 9).

incorporate a 19 to 25 mm- (3/4 to 1 in.-) thick compressible fiberboard installed vertically to occupy the design expansion space. The fiberboard occupies the center portion of the assembly, is supported by the dowels (Figure 12), and reaches from the subbase to about 25 mm (1 in.) below the pavement surface. In most cases, the board is capped with a removable metal or plastic strip that can be paved over. For expansion joint use, one end of each dowel is equipped with an expansion cap designed to permit free joint movement as the pavement expands and contracts. The capped and uncapped ends alternate (Figure 12). The entire dowel is lubricated to prevent bond and to ensure free movement inside the cap, which must be sufficient to accommodate the total design movement of the joint, otherwise the dowel “freezes” and major distresses can occur. Bugler (personal communication, John W. Bugler, New York DOT, March 1993) reports that the New York DOT uses a translucent dowel cap that permits ready examination of the posi-

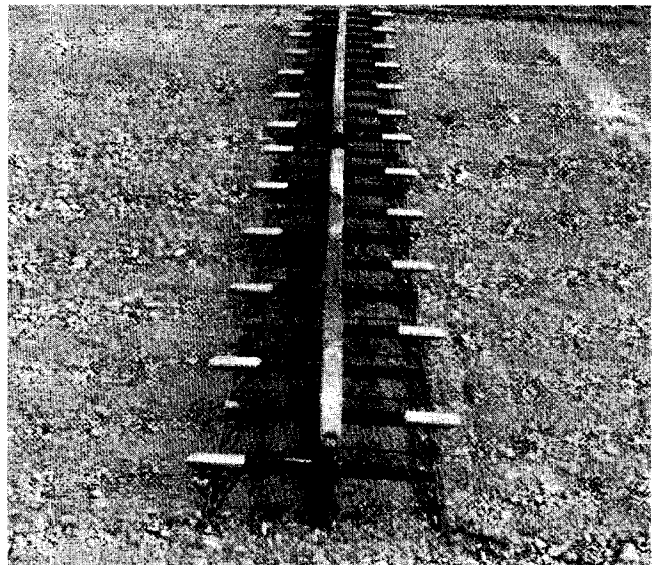

FIGURE 12 Typical dowel assembly (9).

tions of the dowel and of a compressible material contained in the cap.

Dowel size and spacing requirements applicable to contraction joints also apply to expansion joints. Alignment requirements are similar as are placement and consolidation concerns. Again, epoxy coated dowels are used by many agencies.

In all cases of expansion joint use, it is important to note that the presence of such joints relieves pressures from adjacent contraction joints and can lead to nonuniform action of those joints resulting in joint sealant and performance problems (39). It is particularly important for maintenance personnel to be aware of the associated maintenance requirements.

Transverse Construction Joints

Transverse construction joints are provided at the end of a day’s paving or at designed “leave outs” in the pavement. The joints are built to conform with the designed joint locations except in the

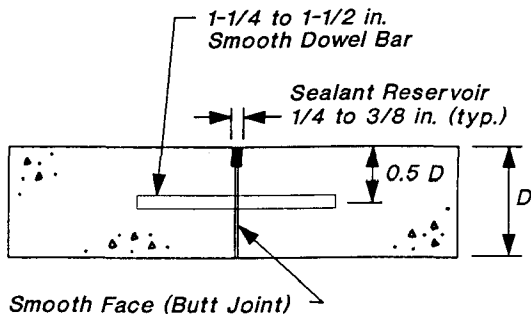

FIGURE 13 Typical transverse construction joint (9).

event of equipment failure or other emergencies. Transverse construction joints are butt joints, which are not capable of load transfer through aggregate interlock. A dowel arrangement as given in Figure 13 is required. Even on projects where contraction joints are skewed, transverse construction joints are always placed perpendicular to the pavement centerline (9). If justified by proximity to an on-grade structure, a transverse construction joint can be constructed as an expansion joint through the use of a compressible fiberboard installed when the header is removed.

Dowel sizing, spacing, and alignment requirements discussed earlier for contraction and construction joints also apply to transverse construction joints.

In instances where no planned joint corresponds approximately to the construction joint location, provision must be made for continuity of reinforcement in JRC pavements.

LONGITUDINAL JOINTS

Longitudinal Contraction Joints

A major design consideration for longitudinal lane separation joints, often called longitudinal contraction joints, is the resulting width of pavement once the joints are in place. The criteria given earlier on maximum slab dimension apply if random cracking is to be avoided. One guideline provides for lane widening or combined lane and shoulder widths of up to 4.6 m (15 ft) without a contraction joint (51).

Most pavements up to two lanes wide with shoulders are constructed with one pass of the paving machine so that a popular way of constructing the longitudinal joint is to provide a sawed weakened plane to control the drying shrinkage associated with curing of the concrete. In this type of construction, load transfer is provided by aggregate interlock while the lanes are tied together with deformed bars. Thirteen to 16 mm diameter (No. 4 or 5) bars are used for lightly traveled roads with 19 to 25 mm diameter (No. 6, 7, or 8) bars used for truck climbing lanes and for other lanes carrying appreciable truck traffic.

Longitudinal Construction Joints

In cases where pavement lanes are constructed separately, longitudinal construction joints are provided between the first lane placed and those placed subsequently. Load transfer typically is through the use of a keyed joint, as illustrated in Figure 4. This keyway provides for either inserted bars or threaded inserts as a means to tie lanes together. As an alternative to the keyway, a

simple butt joint is constructed. In fact, for pavements less than about 250 mm (10 in.) thick, the butt joint is preferred because the upper portion of the keyway contains insufficient material to sustain loads and environmentally imposed stresses (40). Whichever type of joint is used, much the same configuration of tiebars is provided as described above for weakened plane construction.

Edge Joints

Edge joints are a special class of longitudinal construction joint. The nature of this joint depends totally on what type of shoulder will be provided.

If PCC shoulders are to be tied to the pavement edge, the type of edge joint depends on the construction methodology. If the shoulders are placed with the mainline pavement, the joint will be of the weakened plane type. If shoulders are placed later, either a keyed or butt joint may be used. In both cases, tiebars typically are spaced and sized similar to those used between traffic lanes. Again, FHWA recommends five or six 20 mm tiebars per 5 m (16 ft) of slab (48).

Where a flexible shoulder is to be provided, the edge joint is left plain with no tiebars or keyways. In this case, the widened lane approach often is employed to reduce the incidence of wheelloads on the pavement edge (37).

BRIDGE APPROACH JOINTS

Bridge approach joints are expansion joints conceived as a means of providing protection to on-grade structures from the encroachment of growing or expanding PCC pavements. The design and use of such joints covers a wide spectrum of practice (Appendix B). Some agencies use a simple expansion joint between the pavement and a bridge approach slab, while others go as far as providing segments of flexible pavement between structures and the PCC pavement. Between those extremes are multiple slab and expansion joint configurations and large asphalt concrete filled expansion joints with sleeper slabs. In some instances anchor systems are used to restrain the end movement of mainline pavements, especially continuously reinforced concrete pavement (CRCP) (52).

While the asphalt concrete filled expansion joint and flexible pavement gap are recognized as sure ways to protect structures, there are some performance tradeoffs that have led to their declining popularity. In both situations, movement of the PCC pavement causes some upward movement of the asphalt concrete, which results in a bump that will contribute to a rough ride and must be maintained. In addition, joints near the end of the PCC pavement may open excessively with the resultant failure of load transfer and of joint sealants (1).

The tendency in bridge approach joint design seems to be away from the more unusual types and toward more simple designs. The use of several conventional expansion joints on each side of the structure seems to be the consensus now as they provide adequate protection and are not overly rough riding. When this approach is used, however, it is necessary to be aware that the presence of the expansion joints will impact the behavior of adjacent contraction and other joints such that their movements may be increased.

Interestingly, both Belgium and France design some bridges for the extra load of the pavement that is placed directly over the deck (33). Clearly, end movement concerns are eliminated by this approach.

DRAINAGE AND JOINT SEALANTS

Drainage

One of the survey questions for this synthesis concerned the drainage philosophy adopted by each highway agency. The responses show that some agencies take the position that subsurface drainage is not a major issue if all joints are kept well sealed. Others make little provision for joint sealants, but provide drainage layers or other positive drainage systems to remove the water entering through unsealed joints. Still others emphasize both good sealing practices and positive subsurface drainage.

The latter view probably is most defensible from an experience and performance review standpoint. Ideally, sealants would both protect the pavement against the ingress of surface water and prevent the intrusion of incompressible materials into the joints. In reality, the first role of joint sealing often is fully served for a very short time compared to pavement design lives of 20 to 30 years. Then, either adhesive or cohesive failures occur although the sealant may remain in place for years. At that point, the sealant ceases to prevent water ingress, but may block incompressibles from entering (53). Although Iowa has reported success in identifying leaking joint seals with a vacuum test (54), this common situation usually is detected only through close inspection and therefore may prevail for years. Only an effective subsurface drainage system will protect the pavement from joint pumping, undermining, faulting, and other water related distresses.

Joint Sealants

Joint sealants serve two main purposes: (1) to prevent or minimize the access of surface water to the underlying pavement elements, and (2) to prevent the intrusion of incompressible materials into joints. In the first case, lower pavement layers can become saturated and cease to provide the design support. Further, joint pumping can develop with the resulting expulsion of subbase and other materials creating a void under the pavement. The loss of support again contributes to shorter than expected pavement performance.

The intrusion of incompressible materials into joints leads to a different set of problems. First, as joints open and close, the infiltrated materials can accumulate to the point where joints can no longer fully close. The result is pavement "growth" and an increase in longitudinal compressive stresses and in pressures on structures adjoining the pavement. Second, in advanced cases and especially in hot, wet weather, joint crushing and serious pavement damage, including blowups, can occur.

Concerns with Sealant Design

Following is a brief discussion of the design concerns associated with the two major types of joint sealants, poured and preformed. The American Concrete Institute (ACI) provides a full discussion of this topic, including the various materials available, in the 1990 report of Committee 504 (55). This work has been supplemented for highway work by the ACPA in a 1993 technical bulletin (56). The latter document includes a comprehensive discussion of various sealant types; the applicable ASTM, AASHTO, or other specifications; and the physical properties of the materials. Some of the major issues are discussed below.

Poured (Field-Molded) Sealants

While a few agencies still use plastic or other joint forming devices that are left in place and replace the usual sealants, most are sealed with materials intended specifically for that purpose. A designer must take care to specify sealants and reservoirs that are compatible with the expected joint function in the conditions prevailing at the job site. Even the lane-shoulder joint between concrete pavement and an asphalt concrete shoulder can be a candidate for resealing with guidelines provided by Carpenter and Tirado (57).

Poured sealants fall into three general classes (55), two of which are used in highway works. These two are (1) thermoplastics: asphalts, rubber asphalts, and coal tar materials that become soft on heating and stiff or hard on cooling, and (2) thermosetting: one- or two-component materials that cure by chemical reaction from an original liquid state to a nonreversible solid state. The two types are often generically referred to as "hot-poured" and "cold-poured," respectively.

The factors to consider in the design and selection of poured sealants, which were identified in the earlier synthesis (1), are repeated here.

- Adhesion to the joint faces,
- Cohesion throughout the range of temperatures to be experienced,
- Preservation of ductility at low temperatures,
- Resistance to infiltration at high temperatures,
- The range of extension through which the material will retain the desired properties,
- Durability under both weather and traffic,
- Potential health hazards to workers,
- Pot life during installation, and
- Operation latitudes (e.g., how sensitive or forgiving is the material to variations in construction conditions, limitations on heating, mixing, etc.).

Further, a major field-molded sealant design parameter called the shape factor was defined by Tons (58), who showed that an elastically deformed rectangular sealant plug assumes a parabolic shape (Figure 14) during extension and compression. Tons concluded that total sealant extensibility increases directly with joint width and inversely with the depth of sealant in the joint. The shape factor was defined as the depth-to-width ratio as given in Figure 14. In theory, the ideal shape factor, based on minimized

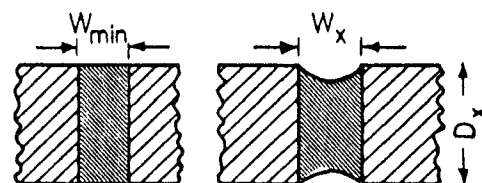

W_{min} = Minimum Width
 W_x = In Service Width
 D_x = Depth of Sealant
 Shape Factor = D_x/W_x

FIGURE 14 Joint sealant shape factor (after 58).

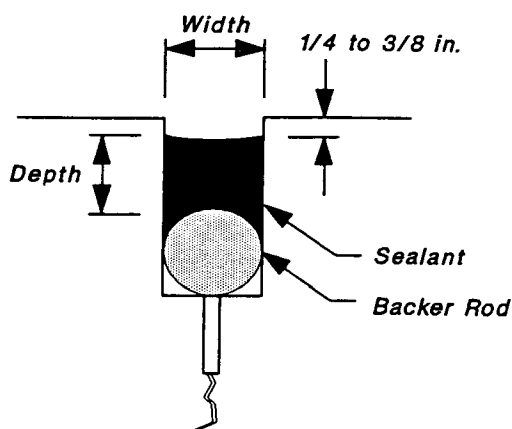

FIGURE 15 Typical poured joint sealant installation (9).

cohesive strains, would be as low as possible (58). However, in practice it is also necessary to provide sufficient bond area to accommodate adhesive stresses at the sealant-joint interface. In view of the interaction of strain and bond area factors and of the difficulty of placing seals with very low shape factors, a practical shape factor design for concrete pavement joints is about 3:2 (37,55). In general, the sealant manufacturer's recommended shape factor should apply.

To control the depth of sealant in the joint sealant reservoir, a backer rod as indicated in Figure 15 is often used. The rod also prevents seal adhesion to the bottom of the reservoir, which means it must consist of a material that will not adhere to the sealant. Typically, rods are made from a polyethylene or polyurethane foam and should have a nominal diameter of approximately 25 percent greater than the joint width (40). In conjunction with the shape factor, joint movements, as discussed earlier under Pavement Dynamics, play an important role in the selection of field-molded joint sealants. Given that a sealant is originally installed at a fixed width (Figure 14), the material is extended and compressed as the joint opens and closes, respectively. Each class of sealant has limiting

values of material extension-compression. If the limiting value is exceeded, the sealant will fail. Clearly, where effective slab lengths are short, both the movement and the demands on a sealant are minimized. Even then, maintenance personnel should be aware that the failure of contraction joints to occur (i.e., the expected cracking does not occur) at a few joints can lead to inordinately large movements of various magnitudes at other working joints. For longer slab lengths, movement is always important and must be seriously considered.

Typical extension-compression limits for field-molded joint sealing materials are tabulated in Table 4. Clearly, from the standpoint of permissible extension-compression, the thermosetting materials are superior. Of this class of materials, the silicones suggest far better performance than the other materials listed. Many agencies have adopted silicone seals for their "high type" sealing purposes (Appendix B). South Dakota recently reported an excellent service record for one brand of silicone used in PCC pavement joints since 1979 (59). The state's tests of several other brands of silicones were conducted in an effort to provide a competitive climate for silicone sealant sales. However, these tests have not been in place long enough to provide conclusive results. Bugler (personal communication, John W. Bugler, New York DOT, May 1993) reports that several states have been dissatisfied with silicone sealant performance to the point where they are no longer used by those agencies.

FHWA recommendations on the use of silicones provide for a shape factor of 1:2 to 1:1 with a minimum sealant width of 3/8 in. (10 mm) (40). AASHTO provides guide specifications for the use of poured joint sealants (60) while SHRP (61) has provided recent information on silicone selection and use.

Not found in published guidelines are problems at least two states have had with incompatibility between silicone seals and certain types of aggregates. In Virginia, Long (62) reported that unsatisfactory adhesion of a silicone seal had been traced by the manufacturer to a lack of compatibility between the silicone and dolomitic aggregates. In studying a similar earlier problem in Wisconsin involving the same silicone, Shober and Johnson (63) found that the silicone could not develop a chemical bond with dolomitic aggregates and that adhesion depended entirely on mechanical

TABLE 4
EXTENSION-COMPRESSION LIMITS FOR FIELD-MOLDED JOINT SEALANTS (55)

Sealant Class	Example Material	Compression Limit (%)	Extension ⁽¹⁾ Limit (%)
Thermoplastic (Hot-poured)	Asphalt rubber	--	5
	Polyvinylchloride	--	25
Thermoplastic (Cold-poured)	Asphalt rubber	--	7
Thermosetting	Silicones	-50	100
	Polyurethanes	--	25
	Polysulfides	--	25
	Epoxy based	--	<25

⁽¹⁾ Shape factor of approximately 3:2.

bond. With Virginia, the situation was found to be compounded by the presence of aggregate surface moisture at the time of sealing. In both cases, the use of a joint primer provided by the silicone manufacturer reduced, but did not eliminate, the adhesive failures.

Preformed Seals

Preformed pavement joint seals come in several types (50). The important characteristics of materials used for preformed seals include durability, resiliency, and compressibility, as well as the ability of the material to sustain a long-term compressible state without developing “compression set,” a condition permitting the seal to either drop into the joint or come out under traffic. Most preformed seals are extruded neoprene rubber and have “webbed” cross sections such as indicated in Figure 16. The web configuration allows the seal to maintain a constant compressive state in service. Specifications should provide for a maximum 2 percent stretch of preformed seals during the installation process while the ends should be turned down at the edge of slabs (40).

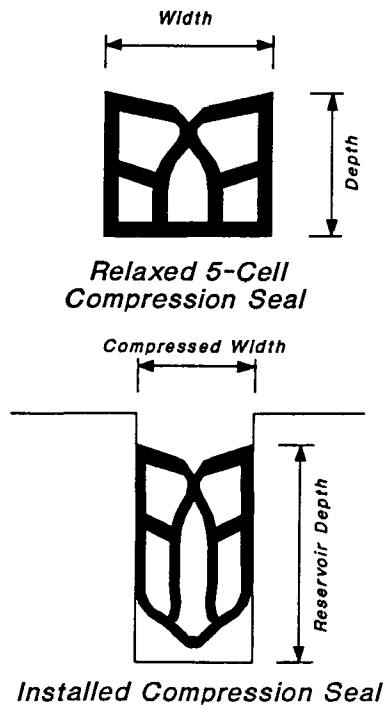

FIGURE 16 Cross section of typical 5-cell preformed seal (9).

The selection of a preformed seal is dependent on the joint size, slab length, and expected movement of the joint. The time of the year and the expected ambient temperatures at that time also are important considerations. Design criteria provide for the seal to function at 20 to 50 percent compression (32,39). Thus, the selected seal should have an uncompressed width of about twice the minimum expected width of the joint reservoir. Special consideration must be given to joints adjacent to expansion joints as non-uniform joint openings can be expected in those situations. It is also necessary to be mindful of situations where designed contraction joints have not formed and where excessive joint movement is transferred to adjacent joints. Again, such nonuniform movements

are to be expected when expansion or pressure relief joints have been added to in-service pavements (31).

The reservoir depth must exceed the uncompressed seal depth to provide room for downward deformation of the seal in service. AASHTO provides guide specifications on the use of preformed joint seals (60). Recall from the earlier discussion that most agencies using preformed seals now use them almost exclusively on wide joints such as expansion or bridge protection joints.

Cost of Joint Sealants

The sealing materials with the lowest initial cost are the hot-poured rubberized asphalts. These are followed by the cold-poured two component elastomeric materials and then by the silicones and the preformed materials. Often, the latter two are very close in first cost.

In practice, the relative costs of sealing materials can be extremely misleading to a designer. For example, the much lower cost hot-poured materials also have a much lower life expectancy. Thus, the pavement sealed with hot-poured material will need re-sealing at short time intervals. Each time the pavement is resealed, it can be expected that traffic control and increased user costs (delays) will be incurred. Such considerations lead a design engineer to an economic (life-cycle cost) analysis (64) as a part of the sealant selection process. The analysis that considers initial as well as recurring costs may find that the sealant with the highest initial cost may turn out to have the lowest life-cycle cost. Generally, unless a designer is constrained by agency policy or budget limitations, the material with the lowest life-cycle cost should be chosen.

In Wisconsin an interesting variation in joint sealing approach has taken place over the past few years. A 10-year study of the performance of pavements with sealed and unsealed joints, where sealed joints seemed to perform only slightly better than unsealed, led the Department of Transportation to conclude that “there may be conditions and circumstances that do not justify the cost of sealing PCC pavement joints” (65). While that conclusion is general enough that it certainly could be true, it is necessary to carefully examine all aspects of the sealant issue, including specific design features and economic analysis, before a designer chooses not to seal joints. However, it is of interest to note that joint sealing is not universal in Europe. For example, in Austria certain narrow (3 mm (0.1 in.)) joints are sawcut and left unsealed; in Spain, transverse joints are sealed in “wet” areas, but left unsealed in “dry” areas (33). In France, joints left unsealed for 10 years led to clogging of permeable base materials. Taking the other side of the issue, the British require all joints, however formed, to have a groove to accommodate a sealant material (2).

Cook et al. at the University of Cincinnati have conducted a comprehensive study of joint sealants including interviews, field evaluations, measurements of joint movements, and laboratory testing. Their report provides three sets of guidelines relating to joint sealants (5). In summary, these guidelines address predicting the potential of materials for use as sealants, selecting sealant materials and configurations, and evaluating sealants in place.

Considering all the above factors, the FHWA (40) promotes high-type sealants such as silicones and preformed sealants for all contraction, longitudinal, and construction joints. Iowa, on the other hand, has reported good preliminary results with some of the newer hot-poured sealants, placed with appropriate shape factors and used

in 6 mm (1/4 in.) to 10 mm (3/8 in.) wide-skewed joints spaced at 4.5 m (15 ft) (66). These materials were reported to cost 30 to 50 percent less to furnish and install than a popular brand of silicone sealant. Because the materials tested are identified by brand name rather than generically, the reader is referred to the authors (66) for additional information.

Peterson (53), who summarized the performance of a wide spectrum of joint sealants, reported mixed results from all types. He did show both silicones and preformed seals as providing very good performance in some cases, and it is worth noting that joint sealants comprise an evolving technology such that a design engineer must be constantly aware of new materials and techniques.

JOINT CONSTRUCTION PRACTICES AND QUALITY CONTROL

Joints in PCC pavements are unforgiving from the standpoint of construction quality. Many PCC pavement failures have been traced to poor construction practices and lack of attention to quality of workmanship or materials. Many of the major joint construction issues identified in the literature are discussed in this chapter under joint type. In this discussion, it is assumed that the design concerns brought out earlier have been adequately addressed.

TRANSVERSE JOINTS

Transverse Contraction Joints

Placement

Proper attention to placement of the concrete is important to good performance of the joint. Unless the concrete is of good quality and adequately consolidated, it may be weak and unable to sustain load transfer capability of either aggregate interlock or mechanical devices. Further, overworking of the surface will weaken the mixture and contribute to joint spalling.

Load Transfer

Dowels may be installed by an inserter in the paving train or by the use of dowel assemblies or "baskets."

A number of dowel assemblies are available for contraction joints. An example is given in Figure 17. In most specifications, the assemblies are required to have the dowels configured with alternating fixed and movable ends. In most early paving, only the free end was coated with a bond breaker (1), whereas in most modern work the entire dowel is coated (9).

Baskets must be located properly to conform with weakened plane joint locations and to be compatible with any reinforcement used. In addition, they must be secured to the subbase with stakes

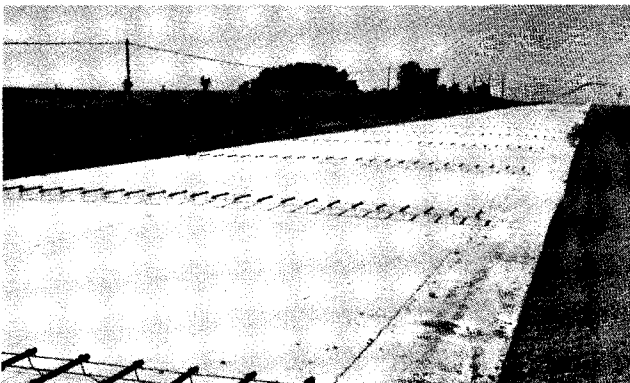

FIGURE 17 Dowel assemblies in place prior to paving (9).

or pins to ensure against movement by elements of the paving train. Where lean concrete subbase is used, the assemblies may be seated in the plastic subbase material if positioning requirements can be met (9). The alignment tolerances discussed earlier must be observed.

Some agencies permit the insertion of dowels with a mechanical placing device attached to the paver (Figure 18). The inserter places the dowels by a process of simultaneous insertion and vibration. FHWA guidelines on the use of inserters suggest that alignment tolerances of 40 mm per m (1/2 in. per ft) are realistic (67). These guidelines are based on the results of a Wisconsin compar-

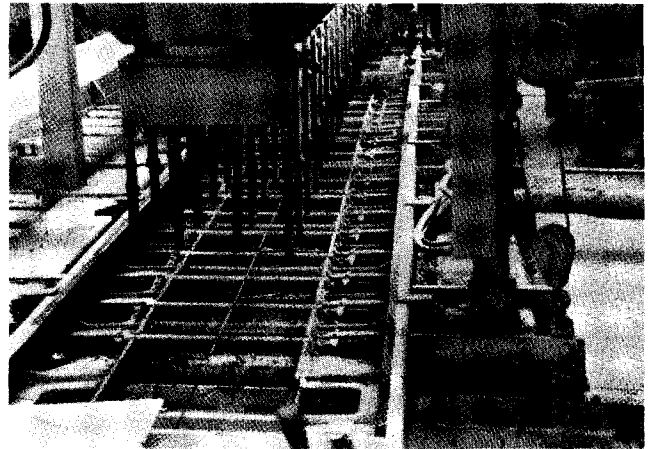

FIGURE 18 Dowel bar inserter in operation (9).

tive study of dowel bar placement through the use of inserters and dowel basket assemblies (68) and on earlier published British work (2). The Wisconsin study was conducted on pavements having short randomly spaced slabs and the state has not experienced pavement distress suggesting dowel alignment problems. Wisconsin advises:

The initial setup of the dowel bar inserter with respect to depth of dowel placement is critical at the start of each project, and dowel depths should be verified by probing through the fresh concrete.

Kelleher and Larson concur with the Wisconsin recommendation that a test section be required to verify that a proposed dowel inserter can meet placement tolerances (39).

The FHWA goes on to suggest that the location of dowels placed by either inserters or with baskets be verified with metal detectors, radar, or cores (67). The FHWA continues to evaluate the specification tolerances for dowel alignment. Some engineers suggest that the use of dowel basket assemblies is advisable if dowel location is considered to be a critical design issue. However, several European countries have successfully made use of inserters for more than 20 years (33).

Joint Creation

Contraction joints are nearly always created by reducing the cross-section of the pavement to result in a "weakened plane". The stresses and strains associated with early shrinkage of the concrete are then carried on a lessened cross-section so early cracking is restricted to that zone. Weakened planes are created by early sawing of the concrete or by the use of an insert. An older practice of providing a groove in the fresh concrete (1) seems to have fallen into disuse in recent years.

Location of the weakened plane is important, especially in doweled pavements where the plane must be centered on the dowel assembly if the dowels are to function properly. For this reason, most contractors will mark predetermined joint locations at the time of paving. The FHWA notes that a minimum of 150 mm (6 in.) of dowel embedment is considered necessary if 100 percent load transfer is to be assumed (38). If embedment is less than 75 mm (3 in.), the load transfer is considered to be zero.

Early Sawing Weakened planes created by early sawing are highly effective, but very sensitive to the degree of set of the concrete. The concrete must be capable of sustaining the weight of personnel and sawing equipment and of being sawed without aggregate pullout or excessive spalling of the sawcut. At the same time, if sawing is delayed too long, early cracking will develop outside of the desired zone. An anticipated average sawing time is difficult to define, however, because of the sensitivity of concrete to drying conditions. But depending on conditions, times between 4 and 12 hours after placement are not unusual. Mixtures with soft coarse aggregates (e.g., limestone) do not require as much strength development prior to sawing as mixtures with hard coarse aggregates (9). Experienced personnel as well as a good knowledge of the mixture being used are important in determining the proper sawing time.

Okamoto et al. have developed guidelines for timing contraction joint sawing that address a "window of opportunity" for control joint sawing (69). Early sawing guidelines relate to a permissible level of surface raveling and address aggregate hardness, geometry, and cement content. Late sawing guidelines relate to the prevention of random cracking and address keeping axial restraint stresses below the tensile strength of the concrete. Such stresses depend on both average slab temperature drop and the temperature gradient through the slab.

Some agencies are beginning to use an early sawcut, referred to as the Soff-cut approach, which provides greater probability of control on early cracking (70). In this method, a special light weight "dry cut" saw slides across the pavement on a special skid plate. The time interval between the completion of finishing operations and sawcutting ranges from 1 to 4 hours depending on curing conditions. Typically, sawing can be accomplished in 2 hours or less without raveling if proper procedures and equipment are used (71). Procedures and results of the Soff-cut approach have not been well documented, however, so information is rather limited.

Early sawcuts are almost always made with a single narrow blade (approximately 3mm^{or} 1/8 in.). While diamond-studded steel blades often are used, composite blades of carborundum or similar materials may be less costly and generally are adequate for the early work. Early cuts typically are 1/3 of the pavement depth. Cuts made during rising temperature usually are of no particular concern and may be made to the full design sawcut depth in one pass (1). Early cuts made during falling temperatures, however,

require special attention as concrete shrinkage will be accelerated at that time. Cuts to the full design sawcut depth may reduce the cross-section so much that full pavement depth random cracking may occur ahead of the saw. It is sometimes possible to avoid this problem, however, by the use of two sawcuts, the first of which is one-half the design sawcut depth (1).

Experience has shown that special care is needed in sawcutting when the pavement is underlain by a cement treated subbase (39). In such cases, the friction at the interface is enhanced by bonding so that restraint cracking can occur earlier and more frequently. Further, it is recommended that both longitudinal and transverse joints be sawed at the same time when the treated subbase is used.

Early sawcuts made to control random cracking generally are not wide enough to accommodate the joint sealing material (i.e., the shape factor is not adequate). For this reason, it is usually necessary to make a second cut with a wider or "gang" blade to the depth required for such things as the sealant and backing material. As it is not sensitive to concrete curing requirements, this cut may be made shortly before the sealing operation.

Inserts For many earlier pavements, the weakened plane was created by the insertion of a thin polyethylene strip or by the use of metal or other rigid inserts. Performance problems with both cases have led to a reduction in the use of the insert approach and to more use of early sawing. These problems typically relate to breakage of the plastic strip or to nonvertical installation of the strip and to corrosion or other failure of inserts. In comparison with the 21 agencies given in the earlier synthesis (3), eight states and provinces now provide for the use of inserts. The performance issues are discussed in greater detail in Chapter 6.

Transverse Expansion Joints

As discussed earlier, most expansion joints are formed by a vertical fiberboard held in position by the dowel assembly. In most cases the board is capped with a removable metal or plastic strip that can be paved over. Before the concrete sets, the strip is removed to form the upper portion of the joint. The final finishing around the joint is done by hand with a final floating to remove blemishes. Because of the need for hand work in these situations, more agencies are using sawing methods over the top of the fiberboard.

Other dowel alignment and placement requirements applicable to contraction joints also apply to expansion joints.

Transverse Construction Joints

In instances where no planned joint corresponds approximately to the construction joint location, provision must be made for continuity of reinforcement in JRC pavements. In such cases, the header typically is configured so that reinforcing bars can protrude far enough for tying or welding. The ACPA (9) notes that when paving is adjacent to an existing lane, tiebars are helpful in preventing sympathy cracking of the existing lane. In dowelled work, dowels are inserted through the header at pre-drilled locations prior to finishing for the day. The ACPA offers an alternative to forming transverse construction joints:

Although transverse construction joints (headers) are generally formed against a header board, they can also be sawed. To con-

struct a sawed header, the slipform paver operator runs the machine past the desired construction joint location. Generally the last two concrete batches approaching a sawed header are altered for high-early strength gain. No forms are used. Excess material is removed after sawing at the desired location. The contractor drills holes and grouts dowel bars into the sawed header face. Sawed headers are advantageous because they provide very smooth transitions between paving sections (9).

In the case of drilled-in dowels, cleanliness of the hole is imperative and good engineering practice suggests that load transfer efficiency occasionally be checked to verify that design assumptions are being met.

The Delaware DOT employs a special construction joint procedure (personal communication, Roger Larson, FHWA, March 3, 1993). In this procedure, a dowel "basket" is placed at the desired construction joint location. However, rather than dowels, the basket holds rigid plastic pipe with an inside diameter equal to the dowel diameter at the future dowel locations. End-of-day paving with appropriate attention to consolidation and other construction details continues slightly past the plastic pipe. When paving is to continue, a full-depth sawcut is made through the pavement at the plastic pipe, and the concrete on the leave end of the joint is wasted. The result is a receptacle ready for the insertion of dowels. The Delaware DOT reports that there is no standard specification for the procedure but that it is used on nearly all PCC paving projects (personal communication, Jim Pappas, Delaware DOT, September 10, 1993).

Transverse construction joints have been a source of frequent performance problems for two major reasons. The first is that consolidation of the concrete is too often inadequately stressed at construction joints, resulting in open, pervious concrete that becomes subject to freeze-thaw damage and to the ingress of deicing chemicals. This concrete is often inadequately vibrated so that some specifications require supplementary vibration with hand-held vibrators. The second problem relates to the quality of the concrete placed at the joint, especially at the "second" side to be constructed. There is the potential that the first concrete received in the morning may become too wet because of residual wash water in mixers or trucks if careful construction quality control inspection procedures are not followed.

LONGITUDINAL JOINTS

Longitudinal Warping Joints

Longitudinal warping joints, also known as longitudinal weakened plane joints, depend on aggregate interlock for load transfer and are constructed with deformed tiebars to hold the two crack faces in contact (Figure 19). For many years the weakened plane was provided by making a properly located early sawcut approximately $1/3$ of the pavement thickness deep. In about the 1960s, the use of a polyethylene strip about 10 mils (0.25 mm) wide and $1/3$ of the pavement thickness high became very popular. This strip was mechanically inserted in a vertical plane by a device mounted on the rear of the paving machine. While used frequently for about 20 years, occasional performance problems have related to breaking of the strip during construction or to failure to insert the strip vertically. As a result of these problems, the method is no longer recommended (40) and has been dropped by most agencies. Now, almost all specifications again provide for longitudinal warping joints to be sawcut.

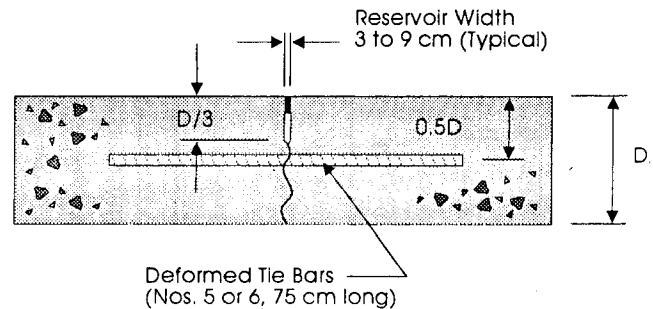

FIGURE 19 Typical longitudinal construction joint (after 9).

In most construction of this type, tiebars used to hold the lanes together are inserted in the fresh concrete by a tiebar placer on the rear of the paver or as a separate unit following the paver. Technically, tiebar spacing is a function of the pavement thickness and the distance from the joint to the nearest free edge. While the FHWA provides tiebar size and spacing recommendations (10), most agencies use 750 mm (30 in.) long bars spaced at 750 mm (30 in.) center to center (Appendix B). Almost all agencies use No. 4 or 5 bars, although the FHWA is encouraging the use of 3 to 5 No. 6 bars per each 4.6 m (15 ft) of slab length (33). Even larger bars at closer spacing often are recommended in areas frequently crossed by truck traffic (e.g., acceleration/deceleration lanes, truck climbing lanes, and high-volume merge areas) (39).

In cases where longitudinal joints are sawed, timing is again critical as uncontrolled cracking can develop if sawing is delayed too long. Such cracking is especially likely to develop in cold weather paving, particularly over stabilized subbases where rapid overnight temperature drop can cause shrinkage stresses exceeding the tensile strength of the "green" (partially cured) concrete. Only the initial sawcut of 3 to 10 mm ($1/8$ to $3/8$ in.) is used for most longitudinal warping joints. Typical longitudinal joint movements are so small that many agencies consider a designed sealant reservoir to be unnecessary and that less expensive hot-poured joint sealants are adequate. The FHWA, however, recommends high-type sealants in longitudinal joints (39). Further, it is important to keep in mind that multi-lane, full-width pavements may develop movements similar to transverse contraction joints. In such cases, a designer should provide for the proper shape factor and sealing material.

Longitudinal Construction Joints

Longitudinal construction joints may be designed as either butt or keyed joints. When the keyway is provided, it is fashioned by providing a deformed plate in the sideform or by using a forming device on slipform pavers.

On keyed joints where forms are used, tiebars are installed as indicated in Figure 20. In some cases, the bars are bent then supported between the forms so that the longitudinal portion is in the keyway. After the forms are removed, the bars are straightened in preparation for paving of the next lane. Some designers are beginning to prohibit bending and straightening as being detrimental to the steel and any corrosion inhibiting coatings (72). In such cases, alternative construction methods are required. One alternative to bending the bars is to use two-piece threaded devices, the female portion of which is installed perpendicular to the keyway (Figure

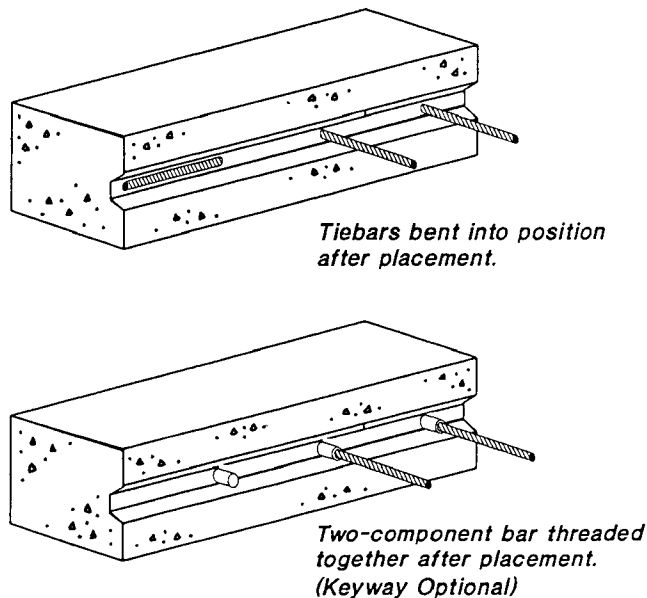

FIGURE 20 Typical placement of tiebars in fresh concrete (9).

20). The male portion can be readily installed after the forms are removed. A third alternative is to drill holes in the pavement edge and grout tiebars into place with an approved cement grout or proprietary grouting material.

The installation of tiebars in the edge of slipformed pavements is a still developing technology. While some agencies insert the bars in the “green” concrete shortly behind the paving machine, most are using drilled-in bars installed sometime after paving. In the latter, the bars are grouted into place as mentioned above. In any case, minimum pullout resistance is needed if tiebars are to function properly. Pullout resistance criteria are provided by the FHWA (40). Some engineers caution that the Grade 40 steel typically furnished for tiebars may in fact be “rejected” Grade 60 steel, which breaks easily when bent and restraightened (72).

Based on tests of “very heavy” (not defined, but generally aircraft) loads, The Corps of Engineers no longer permits keyed longitudinal joints on “heavy-duty” (also not defined, but generally air-field) pavements (73).

JOINT SEALING

Reservoir Preparation

One of the most important elements of proper joint sealing is the preparation of the reservoir designed in accordance with criteria outlined in Chapter 3. While some agencies recognize differences in preparation techniques depending on the quality of sealant to be installed, the state of the art suggests that to achieve maximum sealant performance certain precautions apply in all cases. SHRP published new guidelines on the materials and procedures used in joint sealing and resealing in 1993 (61).

Although some agencies permit the use of forming inserts, the FHWA recommends that all joints be sawed (40). After the reservoir has been sawed or the forming device has been removed, the first major step is to remove all debris, laitance, and oils from the groove. Most agencies employ sandblasting, water blasting, wire

brushing, or some combination thereof followed by air blasting just prior to sealing. Belangie (74) noted that the lack of repeatable cleaning measures has resulted in highly variable preparation and may be a major factor in some cases of adhesion failure. While sandblasting is necessary, it must be applied with care because of safety concerns and, the possibility of infiltration of the lower portion of joints with sand particles leading to restriction of joint movement in service. To overcome this problem, the industry recommends that sandblasting be applied only to the top portion of the joint face where the sealant will adhere (56). It is recommended that the sandblasting nozzle should be held at an angle in this process to prevent deep penetration of sand particles. In any event, other cleaning operations must be followed by air blasting just prior to resealing (56). To overcome problems with the infiltration of incompressibles during construction, both Germany and the Netherlands use a long elastic band to plug the first sawcut (33).

After cleaning, if preparation is for a poured sealant, the backer rod is placed in the reservoir at the design depth as discussed earlier. Again, it is necessary to provide the proper shape factor if satisfactory sealant performance is to be realized. For preformed seals, no backer rod is used.

Depending on project and sealing material characteristics, it may be necessary to apply a primer to the reservoir walls prior to installation of the sealant. Sealant manufacturer recommendations should be followed as discussed below.

New Construction Sealing Practices

Hot-Poured Sealants

Hot-poured sealants conform to the materials properties and specifications outlined in Chapter 3 and usually consist of some combination of asphalt and rubber. Overheating must be avoided to preserve elasticity of the material. If underheated, however, the materials are not workable and cannot be properly placed in the reservoir. Most manufacturers call for slow heating and rigorous control of the temperature within relatively narrow limits.

Hot-poured sealants are injected into pavement joints using wands especially designed to penetrate and fill the reservoir. To avoid tracking of the material by vehicle tires, most agencies provide for the sealant surface to be 3 to 6 mm (1/8 to 1/4 in.) below the pavement surface (40). Bugler (75) reports on the development of a special applicator wand that prevents overfilling. Some specifications provide for a protective tape to be applied over sealants if traffic will use the pavement soon after sealing.

Cold-Poured Sealants

Cold-poured sealants consist of polymeric materials delivered at the job site ready to use or generated by two components mixed at the site. As discussed earlier, some of those used are polysulfides, polyurethanes, and silicones. In some cases, the basic material is provided in one container with a hardener in another. Depending on the material and the manufacturers recommendations, cold-poured sealants may be mixed in volume in a paddle wheel or other mixer, mixed in small quantities by hand, or fed from separate containers to a mixing nozzle, which also serves as the means for injection of the material into the joint reservoir.

The cold-poured materials usually possess greater extensibility and higher cohesive and adhesive strengths than the hot-poured

types (55). As discussed earlier, cold-poured sealants also tend to have a significantly higher first cost (by approximately a factor of two) than hot-poured sealants and some cold-poured sealants have provided the apparently better performance of the two poured types. The advantages gained in performance tend to be slightly offset by handling difficulties, hazards to workers, and the quality of workers required. Most of the cold-poured materials are sensitive to how they are mixed, have short pot lives, and are difficult to remove from tools. In addition, the solvents needed for cleaning are generally toxic and expensive. For these reasons, most cold-poured sealants are installed by specialty contractors rather than by routine construction workers. Again, it is necessary to conduct life-cycle cost analyses to determine the most cost-effective sealant.

The reservoir preparation steps discussed earlier are adequate for cold-poured sealants with the precaution that cold-poured materials are generally more sensitive to moisture in the reservoir. Therefore, construction personnel must be especially careful to assure that the reservoir is dry. Finally, cold-poured materials may need a protective tape until curing proceeds to where the tackiness disappears.

The installation of cold-poured sealants has been somewhat enhanced over the last few years with the introduction of "self-leveling" sealers by some manufacturers. Those generally available are composed of silicones, nitrile rubbers, and polysulfides (9). These sealants are installed by placing the material in the reservoir with an applicator as with any poured sealant. However, they have flow characteristic such that no tooling is required to achieve a level sealant. These materials, however, are too new to have long-term performance records.

All of the above direct and indirect costs associated with handling should be considered in a life-cycle-cost analysis of joint sealing materials.

Preformed Seals

Design requirements for preformed seals were discussed earlier, but the need for proper sizing cannot be overemphasized. If too small for the joint opening, seals will become loose and either fall to the bottom of the joint or come out under the action of traffic. If too large, compression set will take place and the seal will not function properly with joint movements. Bryden (76) has reported difficulty in getting 21 mm (13/16 in.) preformed seals to perform well in 10 mm (3/8 in.) wide joints between 19 m (60 ft, 10 in.) long slabs. In that situation, excessive joint movement led to conditions outside the minimum and maximum compression limits. Performance was greatly improved by adjusting the joint width to 16 mm (5/8 in.) with a 32 mm (1-1/4 in.) uncompressed seal. But even after 7 years of service, 65 percent of the preformed seals were found to have taken compression set (77). Clearly the move to shorter slab lengths will result in better performance.

In most cases of preformed seal installation, a primer is required and is applied to the joint vertical faces just prior to insertion of the seal. The primer serves principally as a lubricant to facilitate installation. While it may also enhance sealing properties, it is not considered to function as an adhesive because preformed seals are designed to perform in constant compression. Seals are installed by a machine especially designed for the purpose. Hand installation is discouraged because of tendencies to produce seal twisting in the joint and because it is difficult to avoid overextension of seals. Overextension results in a reduction in seal cross section through elongation rather than through compression. The maximum allowable elongation is typically about 5 percent, although some agencies specify a 2 percent limit.

JOINT PROBLEMS: MAINTENANCE AND REHABILITATION

JOINT PROBLEMS: CAUSES AND REPAIRS

Numerous distresses occur in connection with PCC pavement joints. Those presently identified are discussed by the Transportation Research Board (TRB) (78), by the National Cooperative Highway Research Program (NCHRP) in the COPEs program (35) and in an earlier synthesis (79), by the Corps of Engineers (34), and by the Strategic Highway Research Program (SHRP) (36). In addition, Michigan has recently published its method of conducting concrete pavement condition surveys (80), while the New York DOT has developed a comprehensive rehabilitation manual addressing both condition surveys (81) and rehabilitation techniques (82). The various distresses addressed in these documents are discussed next in the order they are likely to occur as a pavement deteriorates.

The repair techniques discussed are documented in several references in addition to those cited throughout the text. Some of these are publications by Snyder (22-25), the ACPA (83,84), the FHWA (9,85-87), SHRP (61,88), and others (89-91). In addition, the former SHRP (now FHWA) long-term pavement performance (LTPP) program has a long-range research study dealing with preventive maintenance effectiveness of rigid pavements (92). Results of this program should provide assistance to pavement maintenance personnel for many years.

Joint Sealant Failure

Distress

Poured sealants fail in either adhesion (failure to maintain contact with the joint walls) or cohesion (internal failure or tearing) of the material (7).

Preformed joint seals may fail early if not properly sized for joints. Seals may be either expelled from joints under traffic or drop deep into joints where they are equally ineffective. Later failures generally relate to aging of the material and may be manifested in "compression set," a condition wherein the webs adhere to each other and the seal is no longer elastic (7).

Joint sealant failures can be traced to several major causes:

- The geometrics of the joint are incompatible with the sealant material selected. Typically, the joint is too narrow for the expected movement, the shape factor is incorrect, or the material does not have the necessary extensibility to accommodate the movement. Recall that contraction joints in the proximity of expansion joints are especially subject to large movements.
- The joint was not properly cleaned and prepared for installation of the seal. In some cases, debris is not prevented from entering the joint (33) or fully removed from the joint prior to pouring or installing the seal. In others, the joint walls are wet, therefore causing failure of the sealant to adhere. A primer is needed with a few sealants and adequate adhesion will not occur if it is omitted.

- The sealant has aged or oxidized and no longer retains its original extensibility or its adhesive and cohesive characteristics. Either adhesive or cohesive failure can occur.

- Sealants sometimes fail as the result of excessive joint movements associated with various types of pavement or joint failure. For example, as mentioned earlier, blowups release pent-up pressures and permit excessive opening of joints in nearby slabs. Poured sealants can then be torn from the joint faces while preformed seals lose the necessary compression to hold them in place. Other possible causes of excessive movement are deflections under load and large horizontal movement due to wide variations in pavement temperature. Finally, for curled or warped slabs, frequent axle loadings may force water upward in joints causing seals that are "blown" out.

Repair

Clearly, the role maintenance can play in enhancing sealant performance is to make sure that periodic inspections of sealant condition are performed, and that any failures are repaired as soon as discovered and before infiltration and further damage can occur. For preformed sealants, one important maintenance operation is the repair of small spalls that destroy the contact between the concrete and the sealant wall.

Some engineers consider it significant that in the early stages of failure, joint sealants may prevent the intrusion of incompressible materials even though the joints are no longer sealed against water.

Joint Raveling

Distress

Joint raveling is a fairly minor distress generally caused by tearing along early sawcuts or where joint-forming inserts are removed early in the pavement's life. The distress is of little consequence, except in cases where preformed seals are to be installed and the raveling may prevent full contact of the seal with the upper portions of joint walls and result in a leaking joint.

Raveling usually can be prevented by waiting until the sawcut goes through coarse aggregate particles rather than tearing them from the surface. Some agencies have found the use of higher strength concretes of 62 to 76 Mpa (9,000 to 11,000 psi) to be helpful in eliminating raveling. One special case of joint raveling relates to tearing of concrete along skewed joints during tining operations. To prevent this type of distress, some agencies employ a blanking band over the joint area.

Repair

If raveling is to be repaired at all, the best approach seems to be through the use of a sand-epoxy mortar mixture applied to the clean raveled face.

Joint Spalling

Distress

Spalling is general deterioration of joints caused by excessive compressive stresses, which may be related to joint infiltration or to pavement growth caused by reactive aggregates (35). Other causes of spalling may be related to poor quality of concrete or poor construction practices. Spalls range from very small edge spalls (Figure 21) to large spalls reaching several inches back into the slab or down into the joint.

While spalling may be an advanced stage of raveling, it is more often a manifestation of compressive failure of concrete in the upper regions of the joint. Other causes of spalling have been related to the use of various inserts or joint-forming devices and to overworking of the concrete during joint forming. In the latter case, high quality concrete with an appropriate air content will help eliminate the problem.

Most compressive failures relate to the infiltration of incompressible materials such as sand, grit, and metal particles into joints under the action of traffic and opening and closing of joints because

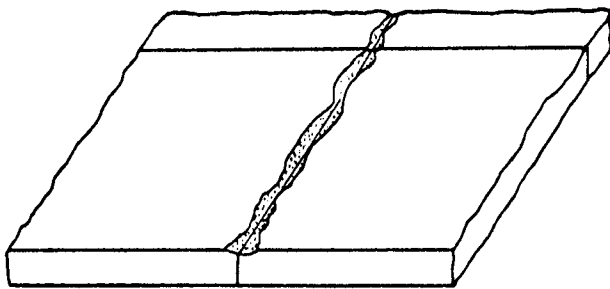
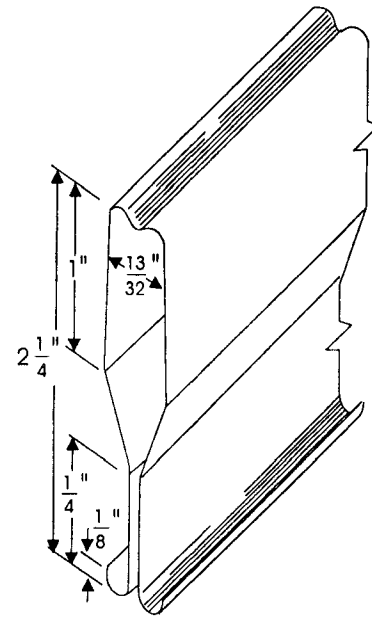

FIGURE 21 Joint spalling (after 79).

of changes in thermal and moisture gradients. Infiltration is much more severe when joint seals have failed or are missing because infiltrated materials accumulate in the joint and resist normal joint closure. The resulting horizontal shear stresses eventually reach the point where the concrete is ruptured. The problem occurs more frequently and is generally more severe for pavements with longer slabs and, therefore, greater joint movement.

Spalling resulting from inserts was reported as early as the 1943 TRB annual meeting (93) when a metal insert was shown to entrap incompressibles leading to the typical shear failures. Unfortunately, that lesson had to be relearned in the mid 1960s when many pavements were built with a new generation of metal inserts (Figure 22) (94). In this latter case, the inserts were made of a corrodible metal that soon allowed the joint seal and residual metal to fall deep into joints and aggravate infiltration tendencies. The problem was further aggravated by the corrosion of the metal "ear" embedded in the concrete at a depth of about 50 mm (2 in.). The resulting plane of weakness was the origin of many spall-type failures that led to expensive repairs.

Joint spalls can be prevented by the use of high quality concrete and other materials, the use of good construction practices, and by keeping joints well sealed. From a construction standpoint, one of the most effective ways to prevent spalling is to use sawed rather than formed joints. In that way, many problems associated with workmanship and with the use of various inserts are avoided com-



(a) Tubular Metal Insert

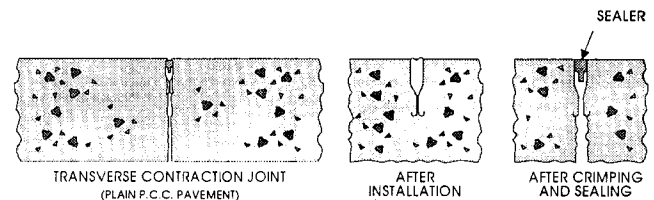

(b) Tubular Metal Insert Installed

FIGURE 22 Typical joint forming metal insert (no longer used) (after 94).

pletely. If inserts must be used, they should be noncorrodible and designed so as not to entrap incompressibles.

Repair

Joint spalls often are temporarily repaired by filling the spalled areas with asphalt concrete to restore ride quality and reduce user complaints. However, permanent repairs need to be made with concrete, epoxies, or other compatible materials. The details of permanent repair depend to a great extent on the mechanism of spalling. If spalling is caused by joint infiltration, careful study of the problem through coring is necessary to determine the extent and depth of infiltration. If the infiltration is confined to the sealant reservoir, it may be possible to clean the joints, provide partial-depth repairs, and reseal the joints. If infiltration goes into the lower portions of the joint, it is likely that it cannot be removed and would continue to cause performance problems. In such cases, full-depth repairs are required if additional compressive failures are to be avoided. If spalling is related to the use of joint-forming inserts, the distress may be confined to the upper regions of the joint and removal of the insert, partial-depth repairs, and joint re-sealing may be adequate repairs.

Excellent guidelines for both partial- and full-depth repairs of

PCC pavements have been provided by the FHWA (10). Additional guidelines are provided by the ACPA (83,84) while NCHRP Report 281 documents the state of the art on all aspects of PCC joint repairs in 1985 (89). Finally, SHRP has provided detailed guidelines for partial-depth repairs (88). These publications also provide helpful guidelines on making the decision between partial and full repairs.

Key elements of a major partial-depth repair geometric consideration are given schematically in Figures 23 and 24. Figure 23 is an example of poor practice where repair concrete is placed in direct contact with the existing pavement on both sides of the joint. Pavement expansion in warm or humid weather results in thrust forces exceeding the strength of the concrete and thrust failure occurs. Figure 24 is the recommended proper practice where a compressible insert is used to separate the repair and existing concretes. Note that the insert extends below the depth of the repair so that there is no contact between the repair and the existing pavement.

While the details of pavement repair methods are beyond the scope of this synthesis, establishing load transfer for full-depth repairs deserves some discussion. Recently, many designs have provided for one of three methods of establishing load transfer between the full-depth repair and the existing pavement. These methods were aggregate interlock, undercutting (sometimes called the inverted "T"), and the use of drilled-in dowels (89). However, poor performance of both the aggregate interlock and the undercut methods has led to a revision of guidelines and now only the drilled-in dowels as illustrated in Figure 25 are recommended (10). Dowels 30 mm (1-1/4 in.) in diameter are recommended. After drilling the hole, a cement grout or epoxy resin is placed in the back of the hole, the dowel is inserted with a twisting motion to force the grout out and around the bar, and a thin plastic disk is placed tightly over the dowel and forced into contact with the slab face (85). The disk is considered to be an important step in ensuring that the dowels are anchored when low-viscosity epoxies are used (10). The disks may be omitted with high-viscosity epoxies.

While most of the literature addresses the repair of transverse joints, Texas has published studies of longitudinal joint and crack repairs (90). In this work, polymer concretes have been used successfully on the longitudinal cracks while a system of cross-stitch-

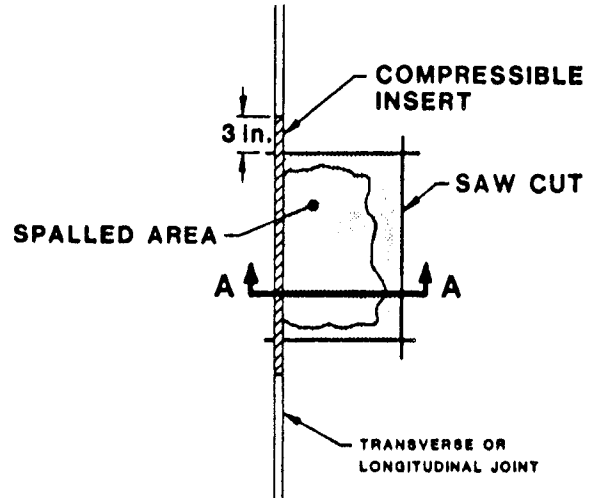

TOP VIEW

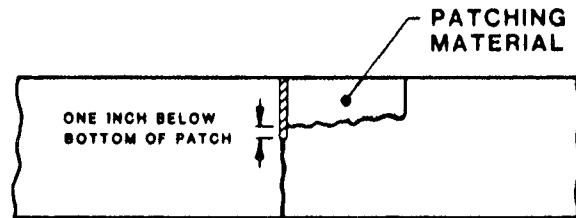

SECTION A-A

NOT TO SCALE

FIGURE 24 Recommended placement of the compressible joint insert (83).

ing is used to restore structural integrity to longitudinal joints. The latter resulted in significant reduction in joint deflections. Figure 26 shows an example of cross-stitching.

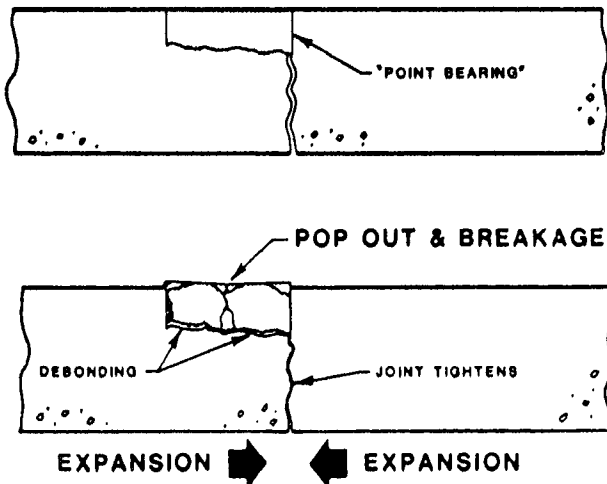

FIGURE 23 Pop-out of the patch due to a "point bearing" situation (83).

Joint Faulting

Distress

Faulting is differential vertical displacement of joints caused by repetitive axle loads. The generally accepted mechanism is indicated in Figure 27. Approaching traffic gradually depresses the approach side of the joint and forces water and suspended solids under the leave side. When the wheel crosses the joint, there is a sudden rebound of the approach side followed quickly by sudden depression of the leave slab. This action forces the water and suspended solids back under the approach slab at high velocity, and some of the solids are deposited under the approach slab causing it to gradually rise as repetitive wheelloads continue. After numerous cycles the deposited materials lead to permanent elevation of the approach slab. Thus, what appears to be depression of the leave slab is, in fact, the opposite. Clearly, full load transfer would inhibit faulting. Unfortunately, the faulting mechanism described puts tremendous stress on load transfer resulting in gradual erosion

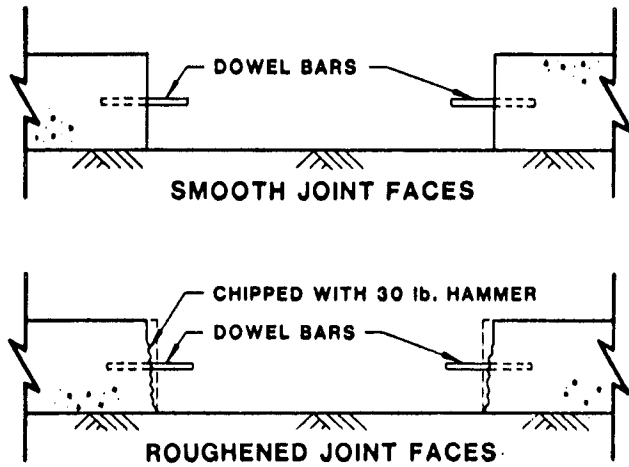

FIGURE 25 Drilled in dowels used in smooth or roughened joint faces (after 84).

of aggregate interlock or elongation of dowel sockets, depending on the design load transfer mechanism.

Other incidental causes of faulting include foundation weakness, overloading of the pavement, inadequate pavement thickness, and poor subsurface drainage. Avoiding these deficiencies generally will make the pavement more resistant to joint pumping. Other important preventive measures include proper joint seal and reservoir as well as load transfer design and construction. The California DOT has published comprehensive studies of the causes of pavement faulting and of the numerous mitigation techniques that can be applied (99). Further work has been published by the University of Florida (43), Purdue University (41), TRB (42), and the Permanent International Association of Road Conferences (PIARC) (45).

Repair

The repair of joint faulting has undergone a major transition in philosophy over the past two decades. Twenty years ago, almost all corrective effort was through attempted slab jacking and, in the worst cases, total removal and replacement. Almost all agencies

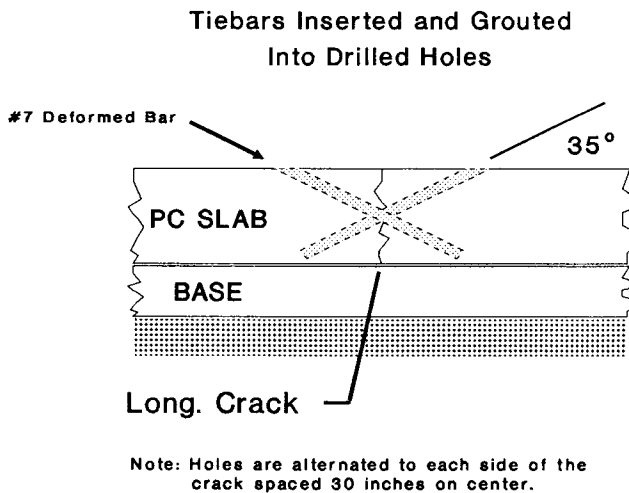

FIGURE 26 Profile of cross stitching. (Source: ACPA)

now use selective grinding of joint areas to restore ride quality and delay the progress of faulting. In some cases, grinding is accompanied by undersealing to fill any voids under the pavement and further delay future faulting. Joints that have been ground typically perform well for several years before the faulting again gradually develops to where further corrective action is necessary (85).

Generally, grinding is considered to be feasible when joints are faulted no more than about 6 mm (1/4 in.) and if the pavement has not been previously ground to reduce the slab thickness excessively. Where grinding is not feasible, one alternative is full-depth removal and replacement of the pavement at which point economic analysis of various overlay and rehabilitation alternatives is advisable (64).

In cases where joints are faulted and effective load transfer is less than about 50 percent, methods for restoration of load transfer may apply (10). Two retrofit load transfer approaches that have been used successfully are drilled-in shear devices and dowels implanted from the pavement surface. Such devices have been found to reduce deflections from 50 to 75 percent and to increase load transfer to as much as 100 percent (9,95). An example of the implanted dowel approach, used successfully in Georgia (96) for many years, is illustrated in Figure 28.

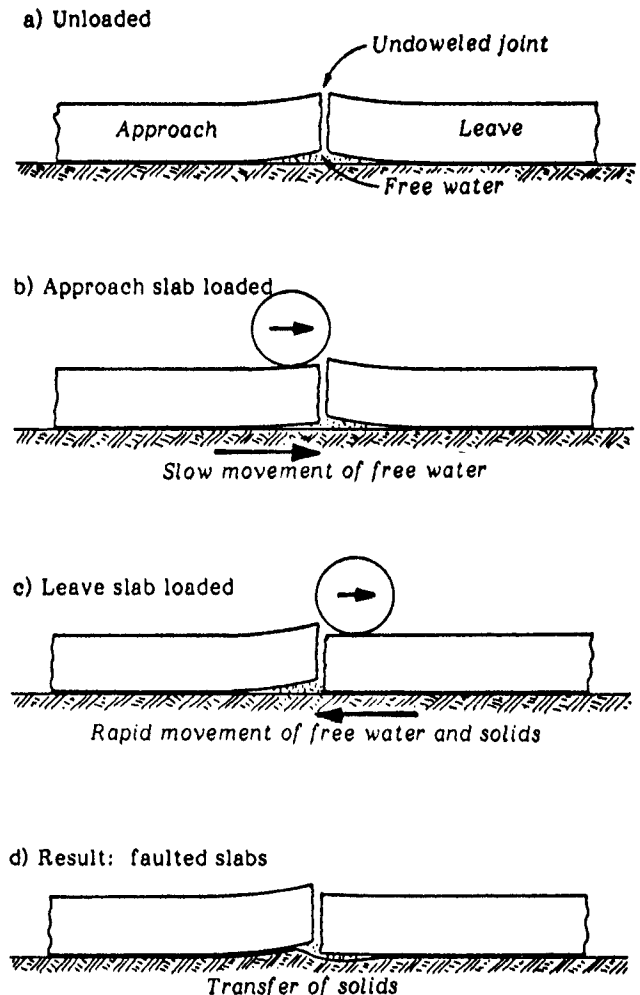

FIGURE 27 Faulting caused by pumping of solids from beneath leave slab to beneath approach slab (79).

In promoting additional experimentation with implanted dowels through Special Project No. SP-204 (97), the FHWA (98) has noted that equipment is now available to economically construct retrofit load transfer at joints or cracks in existing concrete pavements. Recent projects in Washington state, Indiana, and Puerto Rico where dowels were successfully implanted through milling processes are cited. However, the FHWA (98) cautions that for retrofitting to be cost effective, it must be performed before serious joint deterioration occurs. Project SP-204 has the objective of demonstrating cost-effective methods of cutting multiple slots for retrofit load transfer. Retrofit demonstration projects will be built in a number of states through 1996.

When installing dowels per the schematic given in Figure 28, it is important to note that the old joint or crack left in place after the milling is completed must be sealed to prevent the downward infiltration of new concrete used to implant the dowels. Otherwise, the joint will cease to function and compressive stresses will develop in the repair.

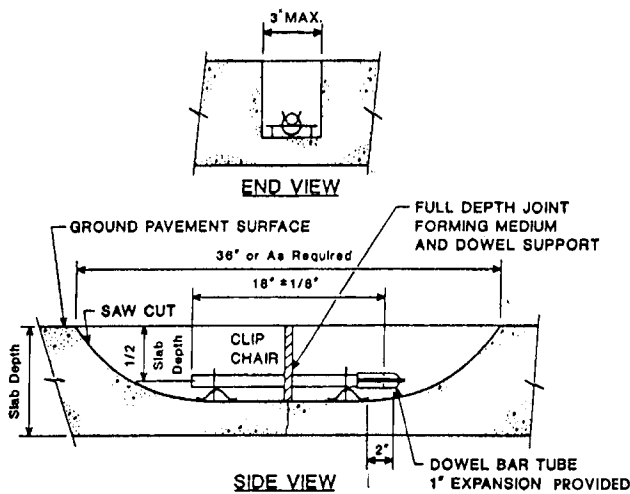

FIGURE 28 Typical implanted dowels (after 89).

Pumping

Distress

Closely related to joint faulting is the phenomenon known as pavement pumping. Pumping is the expulsion of water from under a pavement because of the action of repetitive wheelloads. Unfortunately, fine materials from the subbase or subgrade often go into suspension and are expelled along with the water. Cyclical pavement deflections gradually produce small voids under the pavement and water and suspended solids in those voids may be ejected upward through transverse or longitudinal joints. The result is a progressively larger void under the pavement, the aggravation of joint faulting, and the possibility of corner breaks (discussed later) where support has been destroyed. Pumping is evidenced by stains on the pavement or shoulder surface where ejected solids have been deposited.

Pumping is best avoided by providing for adequate load transfer, by preventing the accumulation of water at the pavement-subbase interface, by reducing deflections to a minimum, and by the provision of strong, well-constructed, subbases. Those subbases

should have drainage characteristics sufficient to remove infiltrated water in a short time to avoid saturation of the underlying pavement layers. Modern designs make provision for special drainage layers to accomplish similar objectives (100). As mentioned earlier, erosion-resistant subbases constructed of cement stabilized aggregates are an alternative design approach. Clearly, the maintenance of well-sealed joints is an added preventive measure for pumping.

Repair

The problem of pumping is difficult to correct short of pavement reconstruction. Slabjacking and undersealing are partially successful but expensive short-term solutions as the problem usually recurs with time. More permanent solutions may be achieved by the restoration of load transfer and by the provision of positive drainage systems. Retrofit edgedrains, however, are an unproven alternative as some agencies have experienced poor performance, even to the extent that the added drains appeared to accelerate the loss of support. Others have had success with properly designed and installed edgedrains (101). As with most joint performance problems, the maintenance of well-sealed joints will help reduce pumping.

Corner Breaks

Distress

Corner breaks, such as depicted in Figure 29, are the result of excessive pumping. The breaks occur after pumping has removed support from under the slabs so that wheelloads can no longer be carried and the concrete is overstressed.

Repair

Either slab replacement or full-depth repair techniques as discussed earlier are needed to correct corner breaks.

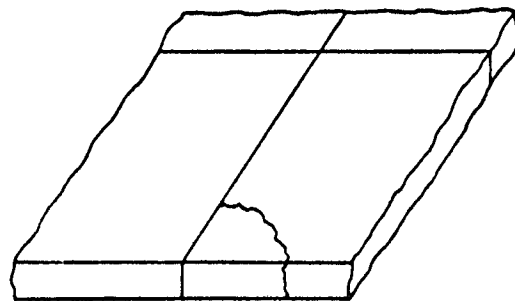

FIGURE 29 Typical corner break (after 79).

Blowups

Distress

Blowups are compressive joint failures (Figure 30) brought about by excessive expansion related to high temperatures, high moisture contents, or a combination of the two. Blowups may

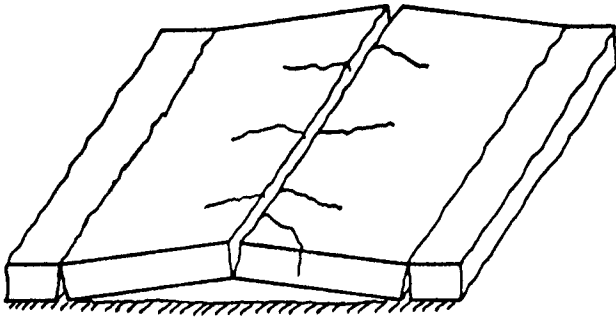

FIGURE 30 Blowup schematic (79).

occur gradually or may be sudden and dramatic. Failures are full-depth and full-lane width and can present serious hazards to traffic.

Blowups become likely when normal joint movement is restricted by infiltration. Increases in concrete volume brought about by elevated temperatures and moisture contents create longitudinal thrust that may overcome the compressive strength of the weakest joint in the section. Blowup tendency is more pronounced on pavements with long slabs where individual joint movements are greatest. The mechanism of joint upheaval at many blowups is illustrated in Figure 31. Note that joints typically fail in the lower portions first. This failure provides an inclined plane for the slab to slide upward when further expansion occurs. A sudden and dramatic blowup can occur when the upper portion shears off with little or no warning (31,32).

Several generalizations concerning blowups have been identified earlier (1) and are repeated below:

- Most blowups occur during the spring or early summer after a significant hot spell combined with recent rain, and usually occur late in the afternoon.
- Although blowups do occur in growing concrete caused by chemical reactions (such as alkali-aggregate reaction), the extent of such growth is not very prevalent across the United States. Most blowups occur in chemically stable concrete where physical lengthening is caused by debris infiltrations at the cracks and joints.
- A pavement incorporating all expansion joints does not suffer blowups. Pavements containing intermixed expansion and contraction joints are very susceptible to blowups. Blowups seldom occur where joint spacings are less than 20 ft (6 m) (with no intermediate expansion joints), even where joints are not sealed. (The New York DOT reports frequent blowups of 20-year-old short slab pavements exposed to wind-blown fines or sanding operations

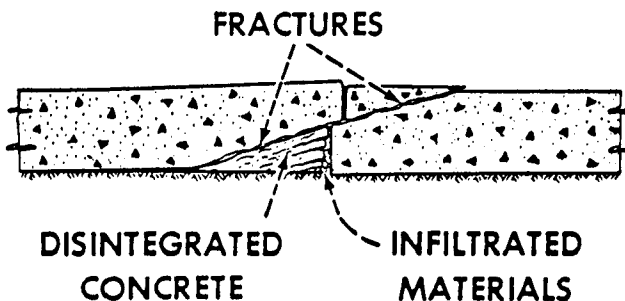

FIGURE 31 Blowup mechanism (after 93).

(personal communication, John W. Bugler, New York DOT, May 1993)).

- Blowups almost never occur in new pavements. If the pavement is susceptible to blowups, they begin to occur after 3 to 5 years of age.
- Blowups occur at various frequencies; the maximum observed is about one blowup per mile per year (0.6 per km per year).
- Blowups usually occur at joints or cracks in the pavement and the concrete at the blowup appears to be weak or deteriorated at that point.

Repair

Because of the nature of blowup failure, the repair is necessarily a major undertaking. The whole joint assembly must be removed out to the limits of observed pavement damage. Then, full-depth repair techniques discussed earlier are employed to restore the joint. In some cases of larger blowups, it may be necessary to replace one or more full slabs.

At least one state has found that the repair of a blowup in one lane of a multiple lane pavement can lead to subsequent blowups in adjoining lanes (31). The observation was that the removal and repair of the blowup in the first lane removes the horizontal thrust from that lane, but may shift an inordinate load to the remaining lanes. For this reason, some specifications provide for full-pavement width blowup repair even if only one lane has been damaged. Sometimes, it is also advisable to place time limitations on the replacement of the damaged concrete (31,32).

Foundation Movements

Pavement joints sometimes suffer distortions or damage caused by movements taking place in the foundation of the roadway. Generally, these movements are related to either swelling clays or to frost action (102). Other causes may relate to densification under traffic of granular or other layers insufficiently compacted during construction. While the distortions may be somewhat lessened by the provision of edge or other drains, permanent repair involves total reconstruction of the distressed area.

Locked Joints

Distress

Transverse joints sometimes suffer damage resulting from malfunction of dowels that are locked or "frozen" in place. The locking may be caused by corrosion of the dowels because corrosion products, which occupy more volume than the clean steel, prevent proper movement. Locking is more often caused by dowel misalignment during construction. In these cases, some dowels are not placed in the proper horizontal or vertical plane and the assembly cannot function as a unit.

The damage caused by locked joints may be relatively minor, especially if adjoining joints are functioning properly. At times, however, a failure plane develops just outside the dowel assembly. Then, a full-depth, full-width crack begins to function as the joint. Because there is no load transfer faulting, pumping and general joint failure soon follow.

In modern construction, dowel locking is largely avoided by the use of epoxy-coated dowels with effective bond breakers and by the use of new installation technologies, which make misalignment less likely. Further, concern about dowel locking has been lessened by the national trend to short-slab JRC pavements.

Repair

The repair of a joint where the dowels are misaligned or frozen is almost always a major undertaking and involves the removal and replacement of the joint area and the dowel assembly (10,84,86,87). Typically, such repairs are full depth, full-lane width, and 1.2 to 2.4 m (4 to 8 ft) long. The length is necessary to accommodate the new dowel assembly.

Problem Aggregates

Other joint problems not mentioned above can lead to costly repairs and even require reconstruction of pavements. While it is not possible to discuss all of these, some of the most serious and often found are those relating to problem aggregates. Two general types of aggregate problems can lead to serious deterioration of joints: (1) aggregates subject to "D" cracking, and (2) those that react adversely with other components of concrete mixtures. In both cases, the joint distresses observed often appear first as a fine pattern of interconnected random cracks called "map" (Figure 32) cracks by some observers. In later stages of deterioration, joint spalling and general joint failure may occur.

Aggregates subject to "D" cracking are those tending to be highly unstable in freezing and thawing environments. The mechanism of distress involves the expansion of coarse aggregate particles that exert disruptive forces on the cement mortar matrix. Aggregates having the pore structure subject to excessive freeze-thaw damage often occur in areas previously subject to glaciation and are found most frequently in the upper midwestern United States. While it is possible to minimize the effects of these aggregates by using high-quality, very dense concrete, the best course of action is to avoid their use because the only known permanent repair is total reconstruction of the pavement.

Joint distress related to reactive aggregates also is caused by expansion of coarse aggregate particles that exert disruptive forces in the matrix. In this case, the aggregate expands because the reaction products occupy greater volume than the original aggregate structure. The most common reactive aggregates are those having certain types of siliceous crystalline structure, and certain types of limestones. Figure 33 is an example of a well developed pattern of cracking associated with alkali-silica reactivity (ASR), as viewed transversely across jointed pavement. Both types are reactive with the alkalis in the concrete and can be somewhat controlled by placing limitations on the alkali content of the cement (103). Reactive aggregates may be found in almost every part of North America. Again, however, the only permanent repair is total reconstruction of the pavement.

PREVENTIVE MAINTENANCE OF PAVEMENT JOINTS

Pavement joints, like many infrastructure elements, benefit greatly from preventive maintenance. Unfortunately, for too long,

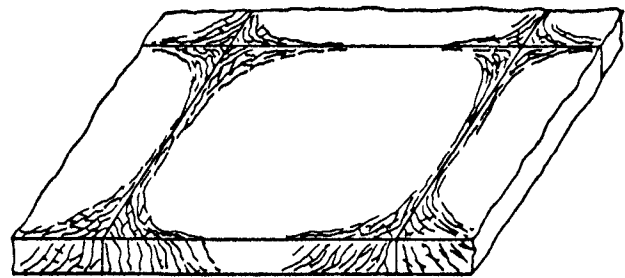

(a)

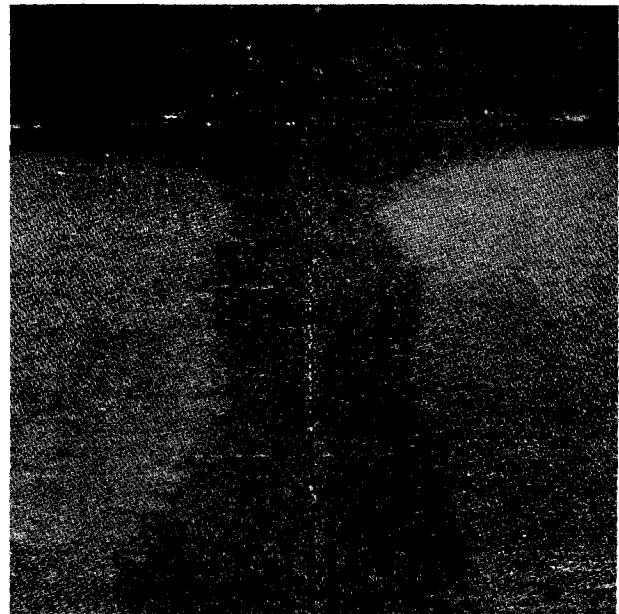

(b)

FIGURE 32 (a) "D" cracking (79); (b) "D" cracking due to freeze-thaw deterioration of coarse aggregate along transverse joint. (Source: SHRP)

many agencies have ignored the need for that preventive work. In many of those cases, joint rehabilitation rather than routine maintenance is needed before any corrective action is taken.

Perhaps the two most cost-effective preventive maintenance activities are cleaning and other maintenance of drainage features and the resealing of joints. Both of these actions aid in preventing pavement damage caused by subsurface water that is not readily removed. While both are also subjects of separate syntheses (53,104), resealing is discussed here briefly.

Joint Resealing

The resealing of in-service joints takes place in a totally different environment from sealing on newly constructed pavements. Guidelines for joint resealing have been provided by the FHWA (10), the ACPA (56), and SHRP (61).

Most resealing work must be done under traffic. Wear and tear has changed the character of the joints; they are no longer of uniform width, and many have small spalls and other irregularities not present on new joints. Clearly, what worked on new pavement may



FIGURE 33 A well-defined crack pattern associated with the development of ASR in highway pavement. (Source: SHRP)

not work at all on in-service pavement. For example, irregularities in joint width and the presence of spalls are very difficult and expensive to deal with through preformed seals. To do so requires that seals of various sizes be on hand and that spalls and other irregularities be repaired before the seals are installed. On the otherhand, poured sealants can accommodate variations in both joint width and conditions. Thus, pavements originally sealed with preformed seals often will be resealed with one of the poured types. Rarely is it practical or economical to reseat with preformed seals.

The ACPA provides guidelines on the evaluation of existing sealants noting that the most important considerations are the “bonding conditions, the presence of incompressibles, and the condition of the adjacent concrete” (56). The details of such surveys are given in the ACPA’s document as well as in several other references (35,53,56,110).

Guidelines from the ACPA give the following five-step process applicable to successful resealing projects (56):

- (1) Old sealant removal.
- (2) Shaping the reservoir.
- (3) Cleaning the reservoir.
- (4) Installing the backer rod.
- (5) Installing the sealant.

As with new construction, one of the most important resealing elements is proper cleaning of joint vertical faces prior to applica-

tion of the sealing material. Because conditions are harsh, in-service joints tend to be extremely dirty and usually infiltrated with incompressible materials. Thus, very aggressive cleaning actions are required. A typical joint cleaning sequence for resealing work involves removal of old seal remnants with a pointed “plow” type tool mounted behind a tractor. This is often followed by a wire brush cleaning or sand blasting and by air blowing. In some cases, resawing of joints and sealing as in new construction is advisable particularly where joints have small surface spalls. The use of solvents generally is not recommended as residues can prevent or inhibit bonding of the sealant to the joint face (10).

Once the joint reservoir is clean, resealing can be accomplished as described earlier for new construction. Again, it is necessary that the selection of sealants be based on expected joint movements to prevent overextension. Bugler (75) provides a good discussion of the consequences of failure to clean joint faces and of failure to maintain the proper shape factor, a part of which can include resawing of joints that were built too narrow or that have become too narrow in service. Bugler concluded that, “It would appear that rigorous inspection with regard to field application is the key to successful performance.”

Backer rods must be of material that is compatible with the sealant to be used and should be about 25 percent wider than the reservoir (56). Rollers designed to insert the rod at the proper uniform depth make installation relatively easy. The insertion tool must not stretch or tear the backer rod material, and guidelines suggest two passes of the insertion wheel over the backer rod (56).

Generally, sealants are so varied in their properties that manufacturers recommendations must be followed during installation. However, certain requirements may be considered as standard, such as the following:

- The joint walls must be clean and dry.
- Sealants must be installed at the proper installation temperature (75). In addition, the first few liters of sealant through the equipment should be wasted as they will be contaminated with old sealant and cleaning solvents (56).
- The design shape factor must be maintained.
- The sealant must not be installed too close to the surface as tracking by vehicles will occur.
- A sealing tool or wand (discussed earlier) should be used to maintain the proper sealant depth and to provide a proper sealant “bead” (75).
- Non-self-leveling sealants may require additional tooling to provide the proper finish. Tooling forces the sealant into contact with the joint walls and assists in securing the proper shape factor. Tooling of non-self-leveling silicone sealants is required before the material begins to cure and form a “skin” (56).

EVALUATION OF JOINT PERFORMANCE

EVALUATION METHODS

FHWA initiatives to promote more formal pavement management processes in the state departments of transportation have led to rapid change in pavement evaluation (105,106). The National Research Council recently published a synthesis on various practices in use (110), which supplements a previous synthesis on the collection and use of pavement condition data (108). The FHWA has another excellent reference in *Field Inspection Guide for Restoration of Jointed Concrete Pavements* (87) and SHRP has published guidelines for the repair of joint seals (61) and for partial-depth joint repairs (88). While the latter documents provide excellent resource materials for pavement evaluation, some of the major points on evaluation are discussed below.

The evaluation of existing pavement condition consists of three major elements: serviceability (functional condition), structural testing, and distress surveys (36). Any of the three separately or in combination with either of the others can contribute to a pavement rehabilitation decision. While all three elements have general pavement evaluation applicability, they also can be focused specifically on joints and cracks.

Functional Adequacy

In general, serviceability refers to user perception of pavement condition, which is usually reflected in ride quality. While panel ratings may be used for this evaluation, most agencies use objective measures of ride quality such as response-type road roughness measurements (109). The correction of joint and crack faulting through pavement grinding might be an appropriate response to a loss of functional adequacy because of poor ride quality. Grinding may or may not be accompanied by the restoration of load transfer. Generally, such actions would be taken when the pavement no longer meets one or more levels of service established as agency policy.

Structural Adequacy

The preferred approach to determining the structural adequacy of an existing pavement by far is through non-destructive testing (NDT) to assess the pavement's response to applied loads. In the case of joints, NDT methods are used to evaluate load transfer effectiveness and to assess the possibility of undermining resulting from pumping. Texas has developed procedures and evaluation criteria applicable to both uses (107), while the AASHTO pavement design guide (37) offers structural evaluation procedures consistent with other rehabilitation design issues.

Joint and crack rehabilitation actions that might be triggered by the NDT evaluation include load transfer and drainage retrofitting and undersealing.

Distress Surveys

Distress surveys are used to determine the extent and nature of deterioration of a pavement. Such data are extremely important in the case of joint distress as the nature of the rehabilitation will depend to a great extent on the nature of the distress.

While several procedures have been established to evaluate such distresses, there seems to be little consensus on their use, although the FHWA is attempting to standardize the procedures (36). Some of the most frequently used procedures were mentioned in Chapter 4 under the discussion of joint problems (34-36,78,111). In addition, a digital joint fault measuring device has recently been developed by the Georgia DOT (112) and adopted by SHRP (36). This device should provide easy and accurate measurement of joint faulting for pavement rehabilitation and other purposes.

The details of distress evaluation procedures and the uses of the data are beyond the scope of the present synthesis. However, the joint distresses addressed in a variety of methods are summarized in Table 5, which also includes an indication of the probable distress cause and of the usual maintenance or rehabilitation action.

While the above procedures employ subjective evaluation methods, many new efforts use automated equipment capable of collecting more objective data (110). Some methods collect permanent photographic records that can be used to track pavement deterioration and better plan rehabilitation strategies. A few are capable of detecting the faulting of joints and cracks at normal traffic speeds, providing valuable information for the selection of rehabilitation strategies (113).

BENEFITS OF PERFORMANCE EVALUATION

Formal evaluation procedures for concrete pavements and joints are relatively new, most having been developed since about the mid 1970s. Again, much of the impetus for formal evaluation procedures has resulted from a generally greater interest in objective management of pavements (114), all of which relates to heightened accountability for public resources.

While joint distress typically is only a part of the overall concrete pavement evaluation procedure, it is probably the most important as the majority of pavement distress is joint related. The procedures in use were developed principally to provide pavement engineers with objective, structured, and repetitive procedures by which they could evaluate the overall condition of concrete pavements.

A series of evaluations conducted over time provides a record of pavement performance as reflected in the familiar pavement performance curve. Such performance records, when aggregated over a highway network, permit the establishment of project priorities for remedial action. As suggested in Table 5, the information gathered on a project basis provides a basis for rehabilitation decisions including cost estimates and the establishment of repair contract quantities. AASHTO provides some guidance on rehabilitation management in a 1993 report by its Committee on Design (37).

TABLE 5
TYPICAL JOINT DISTRESSES

Distress	Probable Cause	Usual Repair
Long. Cracking	Infiltration, locked joints, late sawing	Full-depth, cross-stitch
Corner Breaks	Pumping	Full-depth
"D" Cracking	Unsound or reactive aggregate	Reconstruct, overlay
Sealant Damage	Sealing practices, excess movement materials deficiency	Clean and reseal
Trans. Spalls	Sawing, unsound concrete	Spall repair
Long. Spalls	Sawing, unsound concrete	Spall repair
Trans. Faulting	Loads, load transfer	Grind, underseal, slabjack, reconstruct, retrofit
Long. Faulting	Loads, load transfer	Grind, underseal, slabjack, reconstruct, retrofit
Blowups	Infiltration, unsound concrete	Full-depth repair
AC Patching	Spalling, cracking	Partial or full-depth
PC Patching	Spalling, cracking	Partial or full-depth

RESEARCH

RESEARCH UNDER WAY

A recent search of the Transportation Research Information Service (TRIS) database shows that a number of agencies have under way research studies directly related to PCC pavement joints. Many are related to joint sealing materials, especially the newer class of self-leveling sealants.

The FHWA also identifies numerous ongoing jointed pavement research activities in its publication *Nationally Coordinated Program of Highway Research, Development and Technology* (115). Major efforts identified by both the FHWA and TRB are discussed briefly below.

In 1990, Kentucky began a study of installation procedures and short-term performance on four types of sealant (116). This study supplements a study begun in 1985 of the long-term performance of various seals, the objective of which was to determine the most cost-effective material for future use.

Iowa, Michigan, North Dakota, and Wisconsin continue with active research programs concerning jointed pavements. While most of the effort is directed at the evaluation of sealant materials, one North Dakota study has as its objective the evaluation of partial- and full-depth repair procedures (117). The Utah DOT supports an ongoing evaluation of a number of joint sealant materials and recently released an 8-year status report (118).

One FHWA research project (Contract DTFH61-91-C-0053) addresses the data collection and analysis aspects of experimental rigid pavement performance evaluation. Included in the study, which is expected to be completed by June 1995, are some 300 U.S. pavement sections and about 100 from European countries and Chile. Still others under way include the development of performance related specifications for rigid pavements and the development of a standard test method for determining the thermal coefficient of PCC (115).

Another contributor to advancements in PCC joint technologies will be SHRP (119). In this 20-year program, plain and reinforced jointed concrete pavements throughout North America will be studied in controlled experiments capable of yielding statistically defensible results. Among the joint related elements to be studied are slab length and thickness, load transfer assemblies, and joint sealing materials.

RESEARCH NEEDS

Clearly, the technologies associated with the design, construction, and maintenance of PCC pavement joints have advanced greatly over the past two decades. Yet, many of the issues identified as needing research 20 years ago still command a great deal of attention today.

One evolving technology involves the early sawcutting of joints in PCC pavements. While a number of agencies seem to be experimenting with the Soff-cut equipment and early sawing approach,

there is little well-documented research in the area. The subject deserves full examination in light of the potential benefits to pavement performance, which might derive from better control of early cracking.

As noted above, numerous studies continue on the types, cost, application, and performance of joint sealing materials. Although the materials in use now are at a much higher level, there is still great room for improvement and great need for formal documentation of performance. Unfortunately, many of the studies of sealant performance reported in the literature are of very limited scope, take place in limited environments, and the results are confounded by uncontrolled variables (including constant changes in materials by manufacturers). It is hoped that the SHRP effort will provide clearly defined, defensible results.

In a recent research needs workshop, the Utah DOT identified the life-cycle cost analysis of joint sealing and other joint maintenance issues as among top priority research needs (120). Historically, constructibility rather than maintainability may have been the driving force behind changes in PCC pavement joint designs. The application of life-cycle cost analyses to the total design-construction-maintenance package might lead to some dramatic policy changes.

Skewed joints are something of an issue with design engineers. The literature reveals some differences of opinion concerning the use of skewed joints with dowels and vice versa. While some take the position that doweled joints do not benefit from being skewed, others feel that both features used together will enhance pavement performance. Generally, construction interests would prefer that doweled joints not be skewed because of construction difficulty. A formal research study of the whole question of skewed joints may be appropriate. Utah also identified skewed joints and other load transfer issues as among top priority research needs (120).

Although required in Germany for many years (33), the preponderance of literature suggests that the use of dowel inserters may merit further study. When inserters are used, horizontal and vertical alignment tolerances after concrete placement are approximately twice those for fixed dowel assemblies measured prior to concrete placement. It is not clear that those more lenient tolerances will not be detrimental to the performance of pavements with longer slabs. The FHWA is monitoring additional dowel placement installations of both the inserter and basket types.

Reports by the state of Wisconsin over the past few years that unsealed joints, in certain situations, may perform better than those with seals have important implications. Because the Wisconsin work involved pavements with short slabs and with randomly spaced joints, a study of sealed versus unsealed joints for longer slabs may be in order. Some agencies still build reinforced pavements with 12 to 15 m (40 to 50 ft) long slabs where unsealed joints may create serious problems.

The introduction of life-cycle cost concepts to the joint sealing issue may produce surprising results depending on joint spacing, materials used, and many indirect factors such as volume of traffic

and type of traffic control. The joint sealing process, including the question "to seal or not to seal," is in need of careful economic analysis. To further this effort, a synthesis of practice on pavement joint sealing could be undertaken, as the most current NCHRP work on the subject (53) is more than 10 years old and the technology has changed dramatically in that time.

The general area of load transfer restoration is in need of formal

research. While there have been occasional studies of various restoration techniques and appliances, it is unclear whether one approach is better than another. Some of the appliances in need of further evaluation are drilled-in shear devices, implanted dowels, and implanted miniature I beams. Both the devices and the means of installation need to be examined as do the materials used to backfill implanted volumes.

GLOSSARY

- adhesion**—The state in which two surfaces are held together by interfacial forces (55).
- aggregate interlock**—A load transfer mechanism whereby the shear is carried by the aggregate-cement paste interface.
- backer rod**—A compressible material used in the bottom of sealant reservoirs to control the depth of the sealant thus keeping its shape factor constant. Also serves to support the sealant against sag or indentation (55).
- blowup**—An upward eruption of a concrete pavement slab near a crack or joint (78).
- bond breaker**—Material used to prevent a sealant bonding undesirably to the bottom of a joint; or to facilitate independent movement between two units (such as a smooth dowel bar and the surrounding concrete) that would otherwise behave monolithically (55).
- bridge protection expansion joints**—PCC pavement expansion joints designed to protect on-grade bridges from forces exerted by growth or movement of the pavement toward the structure.
- butt joint**—A joint in which the structural units being joined abut each other (i.e., the joint faces are in intimate contact with zero designed clearance).
- cohesion**—The form of attraction by which the body of an adhesive or sealant is held together. The internal strength of an adhesive or sealant (55).
- cold-poured sealant**—A construction joint or crack sealant applied at ambient temperature.
- construction joint**—A joint made necessary by a prolonged interruption in the placing of concrete (37).
- continuously reinforced concrete**—PCC pavements with no transverse joints and with relatively heavy amounts of longitudinal steel to ensure holding the cracks tightly closed (15).
- contraction joint**—A joint normally placed at recurrent intervals in a rigid slab to control transverse cracking (37).
- curling**—Deformation of a pavement slab caused by a temperature gradient between the two surfaces of the slab.
- deflections**—Vertical deformation of a pavement under an applied load.
- dowel**—A load transfer device in a rigid slab, usually consisting of a plain round steel bar (37). Many new specifications require epoxy coating for corrosion protection.
- elastomer**—Macromolecular material that returns rapidly to approximately the initial dimensions and shape after substantial deformation by a weak stress and relief of the stress (55).
- expansion joint**—A joint located to provide for expansion of a rigid slab, without damage to itself, adjacent slabs, or structures (37).
- extensibility**—The capacity of a sealant to be stretched in tension (55).
- faulting**—Elevation or depression of a slab in relation to an adjoining slab (78).
- hot-poured sealant**—A construction sealant applied at an elevated temperature.
- incompressibles**—Solids incapable of deformation under pressure as in PCC pavement joints.
- infiltration**—The act of gaining access as with water or incompressibles to PCC pavement joints.
- load transfer device**—A mechanical means designed to carry loads across a joint in a rigid slab (37).
- mastic**—A sealant with putty-like properties (55).
- plain concrete**—PCC without reinforcing steel.
- pot life**—The time duration after a sealant batch has been prepared (e.g., by heating or mixing its constituent parts) during which it retains its workability and capability to achieve strength and adhesion in place.
- preformed sealant**—Sealant functionally preshaped by the manufacturer so that only a minimum of field fabrication is required prior to installation (55).
- pressure relief joints**—A transverse joint installed to relieve compressive stress for the purpose of reducing deterioration of existing joints, preventing blowups, and protecting abutments (31,32).
- pumping**—The ejection of foundation material, either wet or dry, through cracks or joints, or along edges of rigid slabs resulting from vertical movements of the slab under traffic (37).
- random cracking**—Unrestrained, uncontrolled, irregular break of a slab (78).
- raveling**—A PCC pavement distress where tearing of the concrete at joint edges is caused by improper sawing or joint-forming practice (38).
- reactive aggregates**—PCC aggregates having the property of reacting chemically with components of the cement.
- reservoir**—The portion of a PCC pavement joint serving as the receptacle for joint sealing material.
- shape factor**—The ratio between depth and width of a field-molded sealant (55).
- silicone**—One of the class of thermosetting, chemically curing joint sealing materials (55).
- skewed joints**—A variation of transverse contraction joint often used in plain undoweled pavements and placed at an angle such that no two wheels of a vehicle traverse the joint simultaneously.
- spalling**—The cracking, breaking, or chipping of the slab edges within 2 ft (0.6 m) of a crack or joint (35).
- subbase**—The layer or layers of specified or selected material of designed thickness placed on a subgrade to support a base course (or in the case of rigid pavements, the PCC slab) (37).
- subbase friction**—The property of the pavement-subbase interface that resists movement of the pavement over the subbase.
- thermoplastic**—Mobile, softening with heat (55).
- thermosetting**—Becoming rigid by chemical reaction and not remeltable (55).
- tiebar**—A deformed steel bar or connector embedded across a joint in a rigid slab to prevent separation of abutting joints (37).
- warping**—Deformation of a pavement slab caused by a moisture

gradient between the two surfaces of the slab. Usually only seasonal variations are of significant magnitude.

weakened plane joint—A PCC pavement joint configured such that the cross-section of the pavement is reduced to control natural shrinkage cracking.

REFERENCES

1. *NCHRP Synthesis of Highway Practice 19: Design, Construction, and Maintenance of PCC Pavement Joints*, Transportation Research Board, National Research Council, Washington, D.C., 1973.
2. Parmenter, B.S., *The Design and Construction of Joints in Concrete Pavements, TRRL Report LR512*, Crowthorne, Berkshire, 1973.
3. *Joint Spacing in Concrete Pavements*, Research Report 17-B, Highway Research Board, National Research Council, Washington, D.C., 1956.
4. *HRB Special Report No. 61E: The AASHTO Road Test - Report 5, Pavement Research*, Highway Research Board, National Research Council, Washington, D.C., 1962.
5. Cook, J.P., F.E. Weisgerber, and I.A. Minkarah, *Final Report, Development of a Rational Approach to the Evaluation of Pavement Joint and Crack Sealing Materials*, University of Cincinnati, Ohio, 1991.
6. Poblete, M., R. Valenzuela, and R. Salsilli, "Load Transfer in Undoweled Transverse Joints of PCC Pavements," in *Transportation Research Record 1207*, Transportation Research Board, National Research Council, Washington, D.C., 1988.
7. Smith, K.D., D.G. Peshkin, M.I. Darter, A.L. Mueller, and S.H. Carpenter, *Performance of Jointed Pavements, Vol. IV, Appendix A*, FHWA-RD-89-139, Federal Highway Administration, Washington, D.C., 1990.
8. Bodocsi, A., I.A. Minkarah, and R.S. Arudi, *Analysis of Horizontal Movements of Joints and Crack in PCC Pavements*, Paper No. 931010, Transportation Research Board Annual Meeting, Washington, D.C., January 1993.
9. *Design and Construction of Joints For Concrete Highways, Technical Bulletin-010.0 D*, American Concrete Pavement Association, Portland Cement Association, 1991.
10. "FHWA Pavement Rehabilitation Manual," FHWA-ED-88-025, Federal Highway Administration, Washington, D.C., October 1990.
11. Wimsatt, A.W., and B.F. McCullough, "Subbase Friction Effects on Concrete Pavements," *Proceedings, 4th International Conference on Concrete Pavement Design and Rehabilitation*, Purdue University, West Lafayette, Indiana, 1989.
12. Friberg, B.F., *Highway Research Board Bulletin 332: Investigations of Prestressed Concrete for Pavements*, Highway Research Board, National Research Council, Washington, D.C., 1962.
13. Poblete, M., R. Salsilli, R. Valenzuela, A. Bull, and P. Spratz, "Field Evaluation of Thermal Deformations in Undoweled PCC Pavement Slabs," in *Transportation Research Record 1207*, Transportation Research Board, National Research Council, Washington, D.C., 1988.
14. Hveem, F.N., "Slab Warping Affects Pavement Performance," *Proceedings*, American Concrete Institute, Volume 47, 1951.
15. Yoder, E., and M. Witczak, *Principles of Pavement Design, Second Edition*, John Wiley and Sons, Inc., New York, New York, 1975.
16. Westergaard, H.M., "Analysis of Stresses in Concrete Pavements Due to Variations in Temperature," *Proceedings*, Highway Research Board, Volume 6, Washington, D.C., 1926.
17. *Experience in Illinois With Joints in Concrete Pavements*, Bulletin No. 23, University of Illinois, Engineering Experiment Station, Urbana, 1947.
18. Teller, L.W., and H.D. Cashell, *Highway Research Board Bulletin 217: Performance of Dowelled Joints Under Repetitive Loading*, Highway Research Board, National Research Council, Washington, D.C., 1959.
19. Ray, G.K., "35 Years of Pavement Design and Performance," *Proceedings*, 2nd International Conference on Concrete Pavement Design, Purdue University, West Lafayette, Indiana, 1981.
20. "Concrete Paving—100 Years of Progress Through Innovation," *Concrete in Highway Transportation*, No. 10, Portland Cement Association, Skokie, Illinois, November 1991.
21. Arnold, C., "Jointed Portland Cement Concrete Pavements: Michigan's Experience," *Mates*, Issue No. 57, Michigan Department of Transportation, Lansing, 1991.
22. Snyder, M.B., *Dowel Load Transfer Systems for Full-Depth Repairs of Jointed Portland Cement Concrete Pavements*, Ph.D. dissertation, Department of Civil Engineering, University of Illinois, Urbana, 1988.
23. Snyder, M.B., "Cyclic Shear Load Testing of Dowels in PCC Pavement Repairs," in *Transportation Research Record 1215*, Transportation Research Board, National Research Council, Washington, D.C., 1989.
24. Snyder, M.B., M.J. Reiter, K.T. Hall, and M.I. Darter, *Rehabilitation of Concrete Pavements, Volume I: Repair Rehabilitation Techniques*, Report FHWA-RD-88-071, Federal Highway Administration, U.S. Department of Transportation, Washington, D.C., 1989.
25. Snyder, M.B., and M.I. Darter, "Design Procedures for Dowel Load-Transfer Systems for Full-Depth Repair Joints," in *Transportation Research Record 1272*, Transportation Research Board, National Research Council, Washington, D.C., 1990.
26. Deen, R.C., J.H. Havens, and A.S. Rahal, "Cracking in Concrete Pavements," *American Society of Civil Engineers, ASCE Journal of Transportation Engineering*, Vol. 106, No. 2, March 1980.
27. Packard, R.G., "Concrete Solutions," *Roads and Bridges Magazine*, April 1990.
28. Wells, G.K., "Recommendations to Improve JPCP Performance," Memorandum to Mr. Joseph B. Hannon, California Department of Transportation, October 26, 1993.

29. Armaghani, J.M., "Factors Affecting Performance of Concrete Pavements," *Proceedings, 5th International Conference on Concrete Pavement Design*, Purdue University, 1993.
30. Larson, R.M., *Comments on Caltrans Recommendations to Improve JPCP Performance*, Federal Highway Administration, Washington, D.C., December 8, 1993.
31. McGhee, K.H., "Effectiveness of Pressure Relief Joints in Reinforced Concrete Pavements," in *Transportation Research Record 632*, Transportation Research Board, National Research Council, Washington, D.C., 1977.
32. Smith, K.D., M.B. Snyder, M.I. Darter, M.J. Reiter, and K.T. Hall, *Pressure Relief and Other Joint Rehabilitation Techniques*, Federal Highway Administration, Washington, D.C., 1987.
33. *Report on the 1992 U.S. Tour of European Concrete Highways*, Publication No. FHWA-SA-93-012, Federal Highway Administration, Washington, D.C., 1992.
34. Shahin, M.Y., M.I. Darter, and S.D. Kohn, "Evaluation of Airfield Pavement Condition and Determination of Rehabilitation Needs", in *Transportation Research Record 700*, Transportation Research Board, National Research Council, Washington, D.C., 1979.
35. Darter, M.I., J.M. Becker, M.B. Snyder, and R.E. Smith, *NCHRP Report 277: Portland Cement Concrete Pavement Evaluation System*, Transportation Research Board, National Research Council, Washington, D.C., 1985.
36. *Distress Identification Manual For the Long-Term Pavement Performance Studies Sites*, Report No. SHRP-P-338, Strategic Highway Research Program, National Research Council, Washington, D.C., 1993.
37. *AASHTO Guide for the Design of Pavement Structures*, AASHTO Committee on Design, Washington, D.C., 1993.
38. *Improved Rigid Pavement Joints*, Publication No. FHWA/RD-86/040, Federal Highway Administration, U.S. Department of Transportation, McLean, Virginia, 1986.
39. Kelleher, K., and R.M. Larson, "The Design of Plain Doweled Jointed Concrete Pavement," *Proceedings, 4th International Conference on Concrete Pavement Design and Rehabilitation*, Purdue University, West Lafayette, Indiana, 1989.
40. *Technical Advisory 5040.30, Concrete Pavement Joints*, Federal Highway Administration, Washington, D.C., 1990.
41. Ray, M., and J.P. Christory, "Combating Concrete Slab Pumping: State of the Art and Recommendations," *Proceedings, 4th International Conference on Concrete Pavement Design and Rehabilitation*, Purdue University, West Lafayette, Indiana, 1989.
42. Van Wijk, A.J., and C.W. Lovell, "Prediction of Subbase Erosion Caused by Pavement Pumping," in *Transportation Research Record 1099*, Transportation Research Board, National Research Council, Washington, D.C., 1986.
43. Hansen, E.C., and R. Johannesen, *Field and Laboratory Study of the Effects of Water Pumping Beneath Pavement Slabs*, University of Florida, Gainesville, August 1989.
44. DeBeer, M., *Erodibility of Cementitious Subbase Layers in Flexible and Rigid Pavements*, International Workshop on the Theoretical Design of Concrete Pavements, Sigüenza, Spain, October 1990.
45. Christory, J.P., "Assessment of the PIARC Recommendation on the Combatting of Pumping in Concrete Pavements," *Proceedings, 6th International Symposium on Concrete Roads*, Madrid, Spain, October 1990.
46. Woodstrom, J.H. "Improved Base Design for Portland Cement Concrete Pavements," *Proceedings, International Conference on Concrete Pavement Design*, Purdue University, West Lafayette, Indiana, 1977.
47. Ames, W.H., "Concrete Pavement Design and Rehabilitation in California," *Proceedings, International Conference on Concrete Pavement Design*, Purdue University, West Lafayette, Indiana, 1985.
48. *Summary Report, U.S. Tour of European Concrete Highways (US Tech), Follow-up Tour of Germany and Austria*, Publication No. FHWA-SA-93-080, Federal Highway Administration, Washington, D.C., 1993.
49. Ayton, G.P., "Concrete Highway Pavements in Australia," *Proceedings, 5th International Conference on Concrete Pavement Design*, Purdue University, West Lafayette, Indiana, 1993.
50. Smith, K.D., D.G. Peshkin, M.I. Darter, A.L. Mueller, and S.H. Carpenter, *Performance of Jointed Pavements, Vol. 1, Evaluation of Concrete Pavement Performance and Design Features*, FHWA-RD-89-136, Federal Highway Administration, Washington, D.C., 1990.
51. *Technical Advisory 5040.29, Paved Shoulders*, Federal Highway Administration, Washington, D.C., 1990.
52. *Technical Advisory 5080.14, Continuously Reinforced Concrete Pavement*, Federal Highway Administration, Washington, D.C., 1990.
53. Peterson, D.E., *NCHRP Synthesis of Highway Practice 98: Resealing Joints and Cracks in Rigid and Flexible Pavements*, Transportation Research Board, National Research Council, Washington, D.C., 1982.
54. Steffes, R.F., *Innovative Leak Test for Pavement Joint Seals*, Paper No. 930422, Transportation Research Board Annual Meeting, Washington, D.C., January 1993.
55. *Guide to Sealing Joints in Concrete Structures, Reported by ACI Committee 504*, American Concrete Institute, Detroit, Michigan, 1990.
56. *Joint and Crack Sealing and Repair for Concrete Pavements TB-012.0*, American Concrete Pavement Association, Skokie, Illinois, 1993.
57. Carpenter, S.H., and M.R. Tirado, *Methods for Shoulder Joint Sealing*, FHWA DTFH 61-85-C00050, Federal Highway Administration, Washington, D.C., 1987.
58. Tons, E., "A Theoretical Approach to Design of a Road-Joint Seal," in *Highway Research Board Bulletin 229*, Highway Research Board, National Research Council, Washington, D.C., 1959.
59. Marks, K.E., D.P. Johnston, and D.L. Huft, *Evaluation of PCC Joint Sealants: Interim Report and Recommendations*, South Dakota Department of Transportation, Pierre, 1992.
60. *Guide Specifications for Highway Construction*, American Association of State Highway and Transportation Officials, Washington, D.C., 1988.
61. "Materials and Procedures for the Repair of Joint Seals in Concrete Pavements," in *Concrete Pavement Repair Manuals of Practice, SHRP-H-349*, Strategic Highway Research Program, National Research Council, Washington, D.C., 1993.
62. Long, R.R., Jr., "Dow Corning 888 Silicone Joint Sealant," Memorandum to Mr. B.W. Sumpter, VDOT District Engi-

- neer, Virginia Department of Transportation, File 4-3-14, July 8, 1987.
63. Shober, S., and K. Johnson, *Experimental Rehabilitation of Jointed PCC Pavement*, Wisconsin Department of Transportation, February 1983.
 64. Peterson, D.E., *NCHRP Synthesis of Highway Practice 122: Life-Cycle Cost Analysis of Pavements*, Transportation Research Board, National Research Council, Washington, D.C., 1985.
 65. Shober, S.F., "Portland Cement Concrete Pavement Performance as Influenced by Sealed and Unsealed Contraction Joints," in *Transportation Research Record 1083*, Transportation Research Board, National Research Council, Washington, D.C., 1986.
 66. Harris, G., *Final Report, Transverse Joint Sealing With Improved Sealants*, Iowa Department of Transportation, Ames, 1991.
 67. *Dowel Bar Inserters, Memorandum from Chief, Pavement Division to Regional Pavement Engineers*, Federal Highway Administration, Washington D.C., March 6, 1990.
 68. Sharma, A.K., and J.M. Parry, *Final Report, Dowel Bar Placement: Mechanical Insertion Versus Basket Assemblies*, Wisconsin Department of Transportation, 1989.
 69. Okamoto, P.A., P.J. Nussbaum, and K.D. Smith, "Guideline Recommendations for Timing Contraction Joint Sawing of PCC Highway Pavements," *Proceedings, 5th International Conference on Concrete Pavement Design*, Purdue University, West Lafayette, Indiana, 1993.
 70. *On the Job Report No. 34, City of Santa Ana Selects Concrete Pavement to Support Increasing Civic Center Traffic*, Southern California Ready Mix Concrete Association, Pasadena, 1990.
 71. Phelan, W.S., "Discussion of Soff-cut[®] Saw and Its Proper Usage," unpublished position letter for ACI Committee 302, The Euclid Chemical Company, Cleveland, Ohio, May 1990.
 72. Wimsatt, A.J., "Concrete Pavement Design and Construction Practices by the Texas DOT," *Proceedings, 5th International Conference on Concrete Pavement Design*, Purdue University, West Lafayette, Indiana, 1993.
 73. Ahlvin, R.G., *Origin of Developments for Structural Design of Pavements, Technical Report GL-91-26*, Department of the Army, Waterways Experiment Station, Vicksburg, Mississippi, 1991.
 74. Belangie, M.C., "Factors Affecting Joint System Performance," in *Transportation Research Record 1268*, Transportation Research Board, National Research Council, Washington, D.C., 1990.
 75. Bugler, J.W., "Rigid Pavement Joint Sealing: Field Applications, State of the Art," in *Transportation Research Record 990*, Transportation Research Board, National Research Council, Washington, D.C., 1984.
 76. Bryden, J.E., W.M. McCarty, and L.J. Cocozzo, *Maintenance Resealing of Rigid Pavement Joints, Research Report No. 49*, Engineering Research and Development Bureau, New York Department of Transportation, Albany, 1977.
 77. Bryden, J.E., and R.A. Lorini, *Performance of Preformed Compression Sealers in Transverse Pavement Joints, Research Report No. 76*, New York Department of Transportation, Albany, 1980.
 78. *Highway Research Board Special Report 113: Standard Nomenclature and Definitions for Pavement Components and Deficiencies*, Highway Research Board, National Research Council, Washington, D.C., 1970.
 79. *NCHRP Synthesis of Highway Practice 56: Joint Related Distress in PCC Pavement*, Transportation Research Board, National Research Council, Washington, D.C., 1979.
 80. *Concrete Pavement Condition Survey Manual*, Michigan Department of Transportation, Lansing, 1991.
 81. *Pavement Rehabilitation Manual, Volume I, Pavement Evaluation*, New York State Department of Transportation, Albany, 1992.
 82. *Pavement Rehabilitation Manual, Volume II, Treatment Selection*, New York State Department of Transportation, Albany, 1992.
 83. *Guidelines For Partial Depth Repair, Technical Bulletin 003.0 CPR*, American Concrete Pavement Association, 1989.
 84. *Guidelines For Full Depth Repair, Technical Bulletin 002.0 CPR*, American Concrete Pavement Association, 1989.
 85. Darter, M.I., S.H. Carpenter, M. Herrin, E.J. Barenburg, B.J. Dempsey, M.R. Thompson, R.E. Smith, and M.B. Snyder, *Participant's Notebook, Techniques for Pavement Rehabilitation*, National Highway Institute, Federal Highway Administration, Washington, D.C., 1993.
 86. *Construction Handbook on PCC Pavement Rehabilitation*, Federal Highway Administration, Washington, D.C., January 1984.
 87. *Field Inspection Guide for Restoration of Jointed Concrete Pavements*, Federal Highway Administration, Washington, D.C., December 1987.
 88. "Materials and Procedures for Rapid Repair of Partial Depth Spalls in Concrete Pavements," *Concrete Pavement Repair Manuals of Practice, SHRP-H-349*, Strategic Highway Research Program, National Research Council, 1993.
 89. Darter, M.I., E.J. Barenburg, and W.A. Yrjanson, *NCHRP Report 281: Joint Repair Methods for Portland Cement Concrete Pavements*, Transportation Research Board, National Research Council, Washington, D.C., 1985.
 90. Hoskins, B.E., D.W. Fowler, and B.F. McCullough, *An Evaluation of Repair Techniques Used for Uncontrolled Longitudinal Cracking and Failed Longitudinal Joints, Research Report 920-4*, The University of Texas, Austin, 1991.
 91. Ortiz, D., E.J. Barenburg, M.I. Darter, and J. Darling, *Final Report, Effectiveness of Existing Rehabilitation Techniques for Jointed Concrete Pavements*, University of Illinois, Urbana, 1986.
 92. *The Long Term Pavement Performance Program Guide*, Federal Highway Administration, Washington, D.C., December 1993.
 93. Giffin, H.W., "Transverse Joints in the Design of Heavy Duty Concrete Pavements," *Proceedings*, Highway Research Board, Washington, D.C., 1943.
 94. McGhee, K.H., *A Review of Pavement Performance on Virginia's Interstate System*, Virginia Transportation Research Council, Charlottesville, 1976.
 95. *Evaluation of Load Transfer Restoration Techniques and Undersealing Practices*, Report No. FHWA/RD-86/043, Federal Highway Administration, Washington, D.C., 1986.
 96. Gulden, W., and D. Brown, "Establishing Load Transfer in Existing Jointed Concrete Pavements," in *Transportation Research Record 1043*, Transportation Research Board, National Research Council, Washington, D.C., 1985.
 97. *Project Proposal, Special Project No. SP-204, "Retrofit*

- Load Transfer*", Federal Highway Administration, Washington, D.C., January 1993.
98. *Information Memorandum, SP204-Retrofit Load Transfer*, Pavement Division, Federal Highway Administration, Washington, D.C., February 10, 1994.
 99. Neal, B.F., *California PCC Pavement Faulting Studies: A Summary*, California Department of Transportation, Sacramento, 1985.
 100. *Demonstration Project No. 87, Drainable Pavements Systems Workbook*, Federal Highway Administration, Washington, D.C., March 1992.
 101. "Geocomposite Pavement Drain Systems," in *Transportation Research Record 1329*, Transportation Research Board, National Research Council, Washington, D.C., 1991.
 102. *State-of-The-Art Report No. 8, Guide to Earthwork Construction*, Transportation Research Board, National Research Council, Washington, D.C., 1990.
 103. *Handbook For the Identification of Alkali-Silica Reactivity in Highway Structures*, Strategic Highway Research Program, National Research Council, Washington, D.C., 1991.
 104. Ridgeway, H.H., *NCHRP Synthesis of Highway Practice 96: Pavement Subsurface Drainage Systems*, Transportation Research Board, National Research Council, Washington, D.C., 1982.
 105. *Federal-Aid Policy Guide 23-CFR-626, Pavement Design Policy*, Federal Highway Administration, U.S. Department of Transportation, Washington, D.C., 1992.
 106. *Federal Register 23 CFR Parts 500 and 626 MANAGEMENT AND MONITORING SYSTEMS*, Federal Highway Administration, Washington, D.C., December 1993.
 107. Ricci, E.A., A.H. Meyer, W.R. Hudson, and K.H. Stokoe II, *The Falling Weight Deflectometer for Nondestructive Evaluation of Rigid Pavements, Research Report 387-3f*, Center For Transportation Research, The University of Texas, Austin, 1985.
 108. *NCHRP Synthesis of Highway Practice 76: Collection and Use of Pavement Condition Data*, Transportation Research Board, National Research Council, Washington, D.C., 1981.
 109. Janoff, M.S., *NCHRP Report 308: Pavement Roughness and Rideability, Field Evaluation*, Transportation Research Board, National Research Council, Washington, D.C., 1988.
 110. Gramling, W.L., *NCHRP Synthesis of Highway Practice 203: Current Practices in Determining Pavement Condition*, Transportation Research Board, National Research Council, Washington, D.C., 1994.
 111. Zaniewski, J.P., S.W. Hudson, and W.R. Hudson, *Pavement Condition Rating Guide*, Federal Highway Administration, U.S. Department of Transportation, Washington D.C., May 1985.
 112. Stone, J., *Implementation Package for the Georgia Digital Faultmeter; Design, Operation, and Maintenance Manual*, Georgia Department of Transportation, Forest Park, 1991.
 113. Hegmon, R.R., "A Close Look at Road Surfaces," *Public Roads*, Summer 1993.
 114. *Guidelines for Pavement Management Systems*, American Association of State Highway and Transportation Officials, Washington, D.C., 1990.
 115. *Nationally Coordinated Program of Highway Research, Development, and Technology*, Publication No. FHWA-RD-92-094, Federal Highway Administration, Washington, D.C., 1992.
 116. Hunsucker, D.Q., *Portland Cement Concrete Pavement Joint Seals*, University of Kentucky, Kentucky Transportation Center, Lexington, April 1990.
 117. Marquart, M., *Evaluation of PCC Pavement Repair and Joint Restoration*, North Dakota State Highway Department, Bismarck, 1982.
 118. Voigt, G.F., and W.A. Yrjanson, *Concrete Joint Sealant Performance Evaluation*, Utah Department of Transportation, Salt Lake City, 1992.
 119. *Final Report, Research Plans*, Strategic Highway Research Program, National Research Council, Washington, D.C., 1986.
 120. *Workshop on Transportation Research Needs, UDOT Report UT-93.07*, Utah Department of Transportation, Salt Lake City, 1993.

APPENDIX A

QUESTIONNAIRE

QUESTIONNAIRE
National Cooperative Highway Research Program
NCHRP PROJECT 20-5
TOPIC 17-05

DESIGN, CONSTRUCTION, AND MAINTENANCE OF PCC PAVEMENT JOINTS

Date: _____

AGENCY RESPONDING : _____

Person: _____

Title: _____

Address: _____

PERSON TO WHOM QUESTIONS ABOUT THE RESPONSE SHOULD BE DIRECTED:

Name: _____

Title: _____

Phone: _____

PLEASE RETURN COMPLETED QUESTIONNAIRE AND ANY SUPPORTING DOCUMENTS TO:

(Mail) Kenneth H. McGhee, PE
HCR 05, Box 100
Madison, VA 22727

(Fax) (804) 293-1990

CALL KEN AT (703)948-4754 IF YOU WISH TO DISCUSS THE QUESTIONNAIRE.

NCHRP Synthesis Topic 17-05
Questionnaire

Agency
Reporting: _____

PART 1 JOINT DESIGN STANDARDS FOR NEW CONSTRUCTION AND FOR REHABILITATION PROJECTS

Please provide copies of current joint design standards for both new construction and for rehabilitation projects. It is recognized that variable standards may be used in a given agency at any one time. For that reason, please provide the predominant standards used at present.

Please check the following that apply:

Joint Construction Design Standards Attached----- []

Joint Rehabilitation Design Standards Attached----- []

No joint design standards are available ----- []

PART 2 JOINT CONSTRUCTION PROBLEMS AND SOLUTIONS FOR NEW CONSTRUCTION AND REHABILITATION PROJECTS

Describe specific joint construction problems for both new construction and for rehabilitation projects. Provide brief descriptions of major problems encountered and the solutions employed, if any. Discuss any quality control/quality assurance procedures that may apply. Please attach additional sheets as necessary. Any relevant reports you can furnish will be appreciated.

Check those applicable:

No joint construction problems have been identified-----[]

Supporting reports are attached-----[]

NCHRP Synthesis Topic 17-05
Questionnaire

Agency Reporting: _____

PART 3 DRAINAGE PHILOSOPHY

Check those that apply:

Our agency attempts to seal pavement joints as well as possible and is not too concerned with subsurface drainage----- []

Our agency takes the position that water will enter the pavement and attempts to control the water through the use of (a) a drainage layer ----- []
(b) other subsurface drainage----- []
(c) both----- []

Our agency attempts to seal pavement joints as well as possible and to control the water through the use of (a) a drainage layer ----- []
(b) other subsurface drainage----- []
(c) both----- []

Other comments on drainage considerations: (Attach supporting documents if available.)

Supporting documents are attached----- []

NCHRP Synthesis Topic 17-05
Questionnaire

Agency Reporting: _____

PART 4 JOINT SEALING PRACTICES

Again, it is recognized that a variety of sealing practices may apply to a variety of conditions. However, please respond to the following in view of the predominant current usage:

Joint Type	Predominant Sealant Used (Check)			
	Hot Poured	Cold Poured	Pre- Formed	None
TRANSVERSE Construction	[]	[]	[]	[]
Contraction	[]	[]	[]	[]
Expansion	[]	[]	[]	[]
Bridge Protection	[]	[]	[]	[]
Pavement Rehab.	[]	[]	[]	[]
Other _____	[]	[]	[]	[]

LONGITUDINAL

<u>Lane Separation</u>				
Concrete to Concrete	[]	[]	[]	[]
Concrete to Asphalt	[]	[]	[]	[]
<u>Lane-Shoulder</u>				
Concrete to Concrete	[]	[]	[]	[]
Concrete to Asphalt	[]	[]	[]	[]
<u>Pavement Rehab.</u>				
Concrete to Concrete	[]	[]	[]	[]
Concrete to Asphalt	[]	[]	[]	[]

Please give AASHTO or ASTM Specs. No.* _____

* If standard specifications are not used please enclose copies of any local specs. available.

NCHRP Synthesis Topic 17-05
Questionnaire

Agency
Reporting: _____

PART 5 JOINT PERFORMANCE EVALUATION

Please indicate the joint performance evaluation procedure(s) used by your agency:

- None [] None are used.
- PCI [] Pavement condition index, as used in the "PAVER" package. ⁽¹⁾
- COPEs [] The procedures developed and published in NCHRP Project 1-19. ⁽²⁾
- Other [] Other procedures, please describe briefly and provide supporting documents or references if available.

⁽¹⁾ U. S. Army Corps of Engineers, Construction Engineering Research Laboratory. 1988. "Micro Paver Users Guide, Version 2.0."

⁽²⁾ Transportation Research Board, NCHRP Report No. 277. 1985. "Portland Cement Concrete Pavement Evaluation System (COPEs)."

PART 6 UPDATE OF MATERIALS REPORTED IN NCHRP SYNTHESIS 19.

Attached is a reproduction of Appendix B from NCHRP Synthesis No 19, "Design, Construction, and Maintenance of PCC Pavement Joints" published in 1973. Please review this attachment and use marginal or other notes to make any desired changes. Indicate the joint practices currently used by your agency. Note that the printed material is 20 or more years old so your careful attention to changes is very important to the new synthesis.

The attachment has been updated -----[]

No updating was required -----[]

APPENDIX B

SUMMARY OF AGENCY PRACTICES FOR JOINTED PAVEMENT DESIGN

SURVEY OF CONCRETE PAVEMENT JOINT PRACTICES IN THE UNITED STATES AND CANADA

Data for this tabulation were obtained in the summer of 1992 through a questionnaire distributed to all states and Canadian provinces. As a part of that questionnaire, respondents were asked to review a similar tabulation given as Appendix B of the 1973 Synthesis and to update that tabulation to reflect current practices of their respective agencies. The present tabulation reproduces all columns from the 1973 Synthesis with the exception of those relating to roadway geometrics. Most of the respondents did not consider such data as relevant to the present synthesis and did not provide updated information. Therefore, the columns entitled "Crown" have been eliminated from this Appendix.

It is realized that agencies may use a variety of standards depending upon the conditions prevailing at a given time and site. For that reason, it is assumed that the standards given are those most frequently applied. When several numbers separated by commas occur in a cell those discrete values were reported by the agency. A range of numbers indicates that the agency reported a range rather than discrete values.

In cases where a number was not definitive, letters or reference digits enclosed in parentheses were placed in the relevant cell. In other cases, descriptive words or abbreviations indicate an exclusive area of use or an applicable specification. The abbreviations used are:

P	plain concrete pavement
R/C	conventionally reinforced concrete
CRC	continuously reinforced concrete
mod.	a modification
Exp't'l	experimental
rpt	repeat
Var	variable

Other symbols are as follows:

A	as shown on plans
E	as directed by engineer
ac	asphalt treated or bituminous base
ct	cement treated or stabilized
d	concrete depth or thickness
lt	lime treated
lcb	lean concrete base
m	mils (0.001 in)
o	untied
og	open graded
pb	permeable base
pl	plastic strip
rc	in rock cut
s	secondary road
st	stabilized
ua	untreated aggregate

The notes indicated by numbers enclosed in parentheses are:

- (1) Width uniform except as indicated.
- (2) Untreated aggregate or stabilized base.
- (3) Excluding plastic strip inserts.
- (4) Same as mainline pavement.
- (5) Insert sawed to provide reservoir or to remove.
- (6) Metal plate or preformed plank or fiber.
- (7) No subbase.
- (8) Untreated aggregate on 6-in. stabilized subgrade.
- (9) Option, 16-ga. metal, 5/8 in. top clearance, no seal.
- (10) ac used over ct or lt soil.
- (11) Keyed for two or more paving operations.
- (12) Only with gravel aggregate concrete.
- (13) 2 in. for cold-applied seal, 1 in. for preformed.
- (14) R/C = $d/4 + 1/4$, P = $d/4$ except 9in. @ 2-1/2 in. depth.
- (15) R/C @ 33 ft., P > 8 @ 32 ft., P ≤ 8 @ 48 ft.
- (16) Normally ac.
- (17) Rural 15 ft., urban 19 ft.
- (18) 18-ga. deformed metal.
- (19) Tie bars 5/8 x 30 @ 30 in. used infrequently.
- (20) Actual thickness based on support.
- (21) Interstate repeats 15-13-17.
- (22) Either 4 in. wide on base or 2 in. on sleeper and lugs.
- (23) Repeat pattern 13-19-18-12.
- (24) Wide ac pressure relief provided.
- (25) Top 3/4 in. widened to 1/2 in.
- (26) Used only in adjacent three slabs each side of bridge.
- (27) 4 lugs, 2 ft. wide x 3 ft. deep @ 15 ft., CRC only.
- (28) Repeat pattern 13-18-17-12.
- (29) Used only as alternate.
- (30) Not used in P.
- (31) Only CRC: 2 in. doweled expansion joint and 3 lugs, 2 ft. wide x 4 ft. deep @ 20 ft.
- (32) Expansion Joints used rather than contraction.
- (33) First joint 20 ft. from bridge.
- (34) 4 lugs, 2 ft. wide x 3 ft. deep @ 17 ft.
- (35) 1 in. for 8 R/C, 1-1/4 in. for 9 and 10 R/C.
- (36) 10 ga. x 5-1/2 sheet metal, or 1/2 in. x 2-1/2 to 2-3/4 in. wood strip.
- (37) In CRC: 3/4 in. joints @ 0,20,60; 4 lugs, 2 ft. x 4 ft. @ 40 ft.
- (38) P: 2 joints @ 25 ft.; CRC: 3 joints @ 50 ft.
- (39) Hot-poured sealant only for maintenance.
- (40) P: 4 ft. joint on sleeper and 5 joints 3/4 in. wide @ 20 ft. CRC: 3 joints 1 in. wide @ 40 ft. and 6 lugs 2 ft. x 3 ft. 2 15 ft.
- (41) Varies with distance from edge of slab.

SI equivalents:	1 in. = 25.4 mm
	1 ft = 0.3048 m
	1 lb. = 0.4536 kg
	1 ft ² = 0.0929 m ²

State (Prov.)	FREEWAYS, EXPRESSWAYS, INTERSTATE									2-LANE PRIMARY				SECONDARY ROADS				
	Concrete Pavement			Pavement Base materials & depth, in.				Shoulder Base		PAVEMENT	Base (Subbase)			PAVEMENT	Base (Subbase)			
	Mainline	Ramps		ct/lcb	Other Stab.	ua	Depth ft. in.	ct	Flex. (2)	Depth in.	ct	Other stab.	ua (in.)	Depth in.	ct/lcb	Other stab.	ua (in.)	None
	Depth in.	Depth in.	Width ft. (1)															
Ala*	8,9,10	(4)	Var	y	y	y	6	y	y	8,9 6-8	y	y	y					
Ariz*	10-15	9-11	Var		y	y	4	y	y	9								
Ark*	10,11,12	(4)	15	y	AC	y	6	y	y	9 - 10,2	4.8	3 - 4.2	6	8.4	4.2	pb		
Cal*	8,9,10,2			4.8-6.0	3-4.2(pb)	y	6		y									
Colo*	8 - 12	8 - 10	25		y		8			8		y	y					
Conn*	9 - 10	9	24			y	6-10,18 rc		y	8			y					
Del*	9-10	8-10	Var	4		y	8	y	u	8,9	y		y	8		y	y	
DC*	10	9,10	Var			y	Var		y	10			y	8		y		
Fla*	10-13	10-13	Var		ac or pb		12-48		y	8,10		y						
Ga*	9,10,11	9,10	16-20	5	1 ac	8	14	y	y	9	y	y	y	9	y	y	y	
HI*																		
Ida*	8			y			4		y	8	y							
Ill*	8-10	8-10	16	y	y		4		y	8-10	y						d<8	
Ind*	10-15	10-14	16			y	7		p	10-12			y					
Iowa*	8-12	8-12	16, Var			y	6		y	6-11			(7)				y	
Kan*	10-5	10-5	18	4	(8)	y	4	4	y	9	4	(8)	9			lt	y	
Ky*	10-14	10-14	15	y	lt	y	8	y	y	8-12	y	lt	8	y		lt	y	
La*	8,10	9	15	y	ac(10)	y	6	y		8,9	y		8	y			y	
Me*	A					y	A		y	8			8				y	
Man*	8,10	8,10	Var		(8)	y	5		y	8,10		(8)	6-8				y	
Md*	10-12	10-12	Var	y	ac	y	6	y	y	9			9				y	
Mass*	9	9	Var			y	12		y									
Mich*	10-11	9	16	y	ac,pb	y	4-12		y	9			8,9				y	
Minn*	9-13	8,9	16			y	3-6		y	8-11			7-10				y	
Miss*	8,9	8,9	16, Var	y	4 ac		6	y	ac	8,9	y	ac						
Mo*	8-14	8,9	18, Var		o.g.	y	Var	y	p	8-12		o.g.	8,10			o.g.	y	
Mont*	8,9	8	Var	y	ac	y	Var		y	8,9,10	y		8	y			y	
Neb*	10 - 14	10 - 14	16	y		y	4		y	9 - 10	y		8 - 9					
Nev*	10,11	10	12-24	y			4-6	y										
NJ*	8-10	8-10 (16)	Var			y	Var		y	8-10			8,9				y	
NM*	10-15	9-13	Var		o.g.ac		4-6		y	8,9		o.g. ac						
NY*	9	9 (16)	Var			y	12		y	9			9			y	y	
NC*	9,10	9	Var			y	4		y	8,9			A				y	
ND*	8 - 11	8 - 10	14, Var		ac,db		4 - 8		y	8,9		lt	8					
NS*										8								
Ohio*	10 - 15	9 - 12	16, Var (17)	4	4* ac	6		y	y	8 - 10 8,9	4*	4* ac	6	8 - 10	4*	4* ac	6*	
Okla*																		
Ont*	225-250 mm	225-250 mm	4.5 m		ac, db	y	100-150 m	y	y	225 mm			y	250 mm		y	y	
Ore*	12	10-12	Var	y	ac,pb	y	6-14		y	8 - 10								
Pa*	9 - 20	9 - 20	15 min	y	ac	y	Var		y	6 - 20		y	y	6 - 20			y	
Que*	9	9	12	y	y	y	Var	y	y	9	y	y	y					
Ri*	8					y	12		y	8							y	
SC*	11, 12	11, 12	Var. A		y		6		y				8					
SD*	10-11	8,9	18			y	5 - 6		y	8 - 10			y					
Tenn*	10 Rural, 11 Urb	9 Rural, 10 Urb.	Var	y	y	y	6		y	9	y	y	y	10 urb	y	y	y	
Tex*	8 - 15	8 - 15	Var	y	ac		4-8		y	8 - 15	y	ac		8 - 15	y	ac		
Utah*	9,10	9,10	A	4		4	8		y	9,10	4		(16)					
Vt*	8	A	A			y	A		y	8			8				y	
Va*	9 +	9P	16, Var	y			6	y	y	8P	y						y	
Wash*	10 - 12	A	14		y	y	6 min.		y	8 - 10			7.8				y	
W. VA.*	8 - 12	8-10	18	y	y	y	4, 6		y	9	y	ac,pb	9	y	ac,pb		y	
Wis*	9 - 12	9	15				6-9		y	9 - 12			8 - 10				y	
Wyo#	8-9 (20)	8	16	y			4 & 6		y	7.5, 8	y		7.5				y	

*Either has no rigid pavement, is not presently constructing rigid pavement, or did not respond to 1992 questionnaire.

#Revised in 1992 synthesis.

#Appendix not addressed in response to 1992 questionnaire.

State (Prov.)	TRANSVERSE JOINTS											TRANSVERSE JOINTS										
	Construction Joints				Spacing Ft.		Contraction Joints					Perm. Insert	Contraction Joints			Expansion Joint Spacing ft.	Hot Poured Elastic	Sealants Specified				
	Type				Plain	R/C	Type						Dimensions		Dowels			Cold Applied	Preformed Elastic			
	Keyed	Butt	Tied	Dowels			Skew	Saw	Form	Insert	Width in. (3)	Depth in.	Dia. in.	Length in.	Spacing in.							
Ala*	y			y	20	57.5		y				y (5)	1/4,3/8	d/4	d/8	18	12					
Alta*		y		y	20		y	y	y				1/4 max	d/4 - d/5	A	A	A	A	A	M-173		
Ariz*		y	y		15 (21)		y	y					1/8	d/4	1-1/4	18	12			Silicone		
Ark*		y		y	15	45	y	y					3/8 - 1/2	d/3	1-1/4	18	15			Silicone		
Cal*	y		y		12-13-14-15		y	y					1/4 max	d/3								
Colo*			y					y					1/8	d/4	1-1/4 - d/8	18	(41)					
Conn*		y		y	20	40			y			fiber	3/8	d/3	1-1/8 - 1-1/4	18	12	A	M-173			
Del#		y		y	45			y					3/16	3/16	1-1/4	18	12			Colo. AASHTO T40		
DC*			y		15	A						(6)	1/4	d/3	A	A	12	30		SS-S-164	M-220	
Fla*		y		y	15-20			y					3/8	1-1/4	1-1/4	=>18	=>12		M-173, Im			
Ga*		y		y	20		y	y					3/16 (25)	2-1/4	1-1/4 (26)	18	12		SS-S-1401A	silicone		
HI*																						
Ia*	y		y	s	(28)		y	y				20 m,pl	1/4 (3)	2	1-1/4, 1-1/2 (30)	18	12		D-3405	D-1850	(28)	
Ill*	y	y	y	y	s	20-40	y	y					1/8 min	2-3/4, 1/4 s	1-1/4	18	12			Approved List	M-153, M213	
Ind*	y		y		20		y	y					1/8	d/4	1-1/4	18	12					
Iowa*		y		y	20, 15 S		y	y					3/8 min	d/3 min	1-1/4, 1-1/2	18	12		M-173			
Kan*	y			y	12,13,17,18	15		y	y				3/8	2-3	1-1/4	18	12		kan	Kan		
Ky*		y	y		20	58.5		y					1/8 - 1/4	2	d/8	18	12		D-3405		D-2628	
La*		y	y	y	A	A			y				7/16	2 - 3	1	24	12			A	Neoprene	
Me*					(28)	15,20	y	y					A	A	A	A	A	@ Structures	A	A	Neoprene	
Man*		y		y									1/4	2-1/2	A	A	A					
Md*	(11)	y	y	y	30			y	(12)				1/4+1/16	(13)	1-1/4, 1-1/2	18	12	600	D-1190	D-1850, D-3405	Md	
Mass*		y	y	y	40			y					3/8	2-1/4	1-1/8	16	12		SS-S-164			
Mich*		y	y	y	A			y					9/16	2-1/2	1-1/4, 1-5/16	17,18	12	1*/328'			Mich	
Minn*	y		y		15	27							3/8	1-1/4, D/4	1 - 1-3/4	15	12		M-173 mod	Silicone		
Miss*		y		y	16,20	(32)	y	y					3/8	1-1/4, d/3	d/8	18	12	63-3/4	M-173	Silicone		
Mo*	y		y		30	61.5		y					3/8 min.	d/4	1 - 1-1/2	18	12		M-173 mod.			
Mont*	y		y		12,13,14,15		y	y					1/8 - 3/8	d/2	1-1/4 - 1-1/2	18	12		D-3405			
Neb*		y			16.5		y	y					1/8 - 3/16	d/4	(35)	18	12		D-3405			
Nev*	y	y	y	8 - 14	15,13,14,12		y	y					1/8 - 3/8	d/4		18	12			silicone		
NU*			y		15-20	(32)			y			(36)	(36)	(36)				78.17		NJ		
NM*		y		y	12-15		y	y					1/8-1/4	d/4	1-1/4	16	12		M-173	Silicone		
NY*		y		y		20		y					3/8+1/16	d/3	1-1/8	18	12			Silicone, NY	NY	
NC*		y		y	30			y					3/8+1/16	d/4 + 1/4	d/8	2d - 2	12		M-173		M-220	
ND*	y		y	y	12-15		p	y	y				5/16 max	d/4	1-1/4	18	12		D-1190 mod		A	
NS*		y		y		56		y					1/4	1-1/2	1-1/2	12	12				Ont	
Ohio*		y		y	17	21		y					5/8+1/16	d/4, d/3	1, 1-1/4, 1-1/2	18	12		D-3405	Ohio	M-220	
Okla*		y		y	15			y					13 mm	0.25d	32 mm	450 mm	300 mm	A	OPSS-1212			
Ont*	y			y	(23)			y					1/4 - 1/8	d/4	1-1/4	18	12		M-173		M-220, M-213	
Ore*		y	y	y	Var, 15 max.			y					1/2-1-1/4	d/4	1-1/4 - 1-1/2	18	30	15 - 40	D-3405, D-1190	Silicone	M-220	
Pa*		y		y	15 - 20	30		y	y													
Que*		y		y		60		y					1/4	2-1/4	1-1/4	18	12		D-1190		Que	
Ri*		y		y	20	40		y	y				1/4	2	1	18	12		Ri			
SC*		y		y				y					1/4	d/3	d/8	18	12		M-173	SL Silicone		
SD*		y	y		20			y					3/8	d/4	1-1/4	18	12		D-3405	SD-870		
Tenn*		y		y	18 - 20		y	y					3/8	2 - 3	1-1/4-1-1/2	18	12		A	A	A	
Tex*												redwd	1/2 - 3/4	d/3-d/4	1 - 1-7/8	18	12		Tex	Tex	Tex	
Utah*	y			CRC	(28)	15	y	y					1/8 - 1/4	2-1/4	5/8	30	48	A	SS-S-164		A	
Vt*		y		y	A	A		y	y				1/4 min	d/5	A	A	A		M-173, SS-S-164	SS-S-159b		
Va*		y		y	15			y	y				1/4 min.	d/4	1-1/4	18	12		D-3406 (39)	MIS-8802	D-1058	
Wash*		y		y	10,14,13,9		y	y					1/8 - 1/4	d/4					M-173		M-220	
W. VA.*		y		CRC	R/C	15		y	y				3/8	d/4 + 1/4	1-1/4	18	12					
Wis*		y		y	13,19,18,12		y	y					1/4 max	d/4	1-1/4 - 1-1/2	18	12					
Wyof*	y		y		(23)		y	y	y				1/8 - 3/16	2					M-173		A	

*Either has no rigid pavement, is not presently constructing rigid pavement, or did not respond to 1992 questionnaire.
 *Revised in 1992 synthesis.

#Appendix not addressed in response to 1992 questionnaire.

State (Prov.)	LONGITUDINAL JOINTS											SPECIAL ITEMS								
	Construction				Control			Dimensions		Tie Bars		Reinforcement Steel		Bridge Approach						
	Keyed	Butt	Tied	Sawed	Formed	Insert	Perm. Insert	Width in. (3)	Depth in.	Dia. in.	Length in.	Spacing in.	RC lb/100 sq. ft.	CRC Long. % of section	No.	Width in.	Spacing ft.	Dowels	Sleeper	Anchor Lugs
Ala*	y		y	y		y	1/4	d/4	1/2, 5/8	30	18 - 26	54	0.6	3	1	80	y	y	A	
Ala*	y		y	y			1/4	d/4	A	A	A	A	A	A	A	A	A	A	A	A
Ariz*		y	y	y			1/8	d/4	5/8	24	30	30		1	(22)			y	y	A
Ark*			y	y			3/8	d/3	5/8	30	30	59	0.6	3	1-1/2	15	As needed	As needed	As needed	As needed
Cal*			y	y			1/4	d/3	5/8	30	30			1	As needed	As needed	As needed	As needed		
Colo*	y		y	y	y		3/8	d/3	1/2 - 3/4	30	30			3	3/4	20		y		
Conn*	y		y	y		y	1/4	d/3	1/2 - 5/8	30	30	67.3	0.6	1	3/4 (24)	40		y		
Del#		y	y	y			3/16	d/4 + 1/4	5/8	48	40	54	0.6	1	3/4	20		y		
DC*	y					y	1/4	d/3	1/2	36	A	50 - 61		var	Var	Var		y	Var	
Fla*	y	y	y	y			3/8	1-1/4	1/2-5/8	24-30	Varies			2	2-1/4	40+/-		y		
Ga*			y	y			1/4 - 5/16	2-3/4	5/8	30	18		0.6	3	3/4	30				(22)
HI*																				
Ila*				y		y	10 m, pl													
Ill*	y		y	y			1/4	2 - 2-1/4						1	1-3/8				y	(31)
Ind*	y		y	y			1/8	2-3/4, 1/3 s	5/8, 1/2 s	30	30		0.6	1	3			(31)		
Iowa*	y		y	y			1/8	d/4	5/8	36	36			1	48 (24)	20.5		y	y	
	y		y	y			3/8	d/4 min	5/8	36	30		0.6 - 0.65	2	3 - 4	50	y	CRC		
Kan*	y		y	y	y		10m, pl (9)	3/8	2-3	5/8	24	24		2	2-3	33		y		
Ky*	y		y	y			1/8 - 1/4	d/3	1/2	30	30			3	1	48-78-108		y		
La*			y	y	y	y	pl	7/16	2 - 3	1/2	24	24	74	0.6	1	3/4	20		y	
Me*							A	A	A	A	A	A	A	A	A	A	A	A	A	A
Man*		y	y	y			1/4	d/4	3/4	36	30	89		A	A	A	A	A	A	A
Md*	(11)		y	y	(12)		1/4+/-1/16	(13)	A	A	A	A	A		(24)				CRC	
Mass*	y		y	y			1/4	2-1/2	5/8	30	48	45, 65		3	(24)					
Mich*		y	y	y			1/8 - 1/4	1 - 3	5/8	30	VAR	76, 83		1	1-3/4	29.5, 15.5		y		
Minn*	y	y	y	y			1/8	d/3	1/2, 5/8	30	36	30		1	4			y		
Miss*			y	y		y	8 m, pl	1/4	2	1/2	30	30	78	0.585	4	1	40 (33)	y		(34)
Mo*	y		y	y			1/8 min	d/4	1/2-5/8	30-40	30	61		2	2	Var			Or agg.	
Mont*	y		y	y			1/8 - 3/8	d/3 min.	1/2, 5/8	var,A	var,A			1	A	A	A	A	A	
Neb*	y		y	y		y	1/8 - 3/16	(14)	5/8	30	(15)			1	@ 4, 1 @ 2	25		y		
Nev*		y	y	y			1/4	d/3	1/2	24	30			1	4			y		
NU*	y		y	y			1/4	2-1/4 - 2-3/4	5/8	36	48	80		5	1	23.58	y			
NM*	y	y	y	y			1/8-1/4	d/3	5/8	30	30			2	3/4	15, 18	y			
NY*			y	y			3/8+/-1/16	d/3	5/8	15	40			4	1 (24)			y		
NC*		y	y	y			3/8+/-1/16	d/4 + 1/4	1/2, 5/8	30	30	A	0.6	2	1	A		y		
ND*	y		y	y	y	E	pl	1/4-3/8	d/3 + 1/4	1/2, 5/8	30	45 - 90	0.6	A	A	A	A	A	A	
NS*			y	y			1/4	1-1/2	5/8	30	30	74		2	A	A	A	A	A	
Ohio*		y	y	y	y		1/8	d/3 min.	5/8	30	30	80	0.61	1	1	A		y		
Okla*	y	y	A	y	y		(18)		1/2	30	30		0.612	2	1-1/2	A		y		
Ont*	y		y	y			10 mm	0.33 d	15 mm	760 mm	600 mm			2	32 mm	A		y		
Ore*		y	y	y			1/8 - 1/4	d/3	(19)			61	0.6-0.7	1	3/4	20		y		
Pa*	y		y	y			1/4	1, d/3	9/16 bolt	30	30	A	A	1				y	(37)	
Que*	y		y	y			1/4	2-1/4	9/16	24	30	89		2	3/4	100	y			
Ri*		y	y	y			1/4	2	1/2	20	30	65		1	3/4			y		
SC*	y		y	y		y	20m, pl	1/4	d/4 + 1/4	1/2	30	30		(38)	1	(38)		y		
SD*			y	y			1/8	d/4	5/8	30	30		0.7	1	4	20		y		
Tenn*	y		y	y	y		3/8	d/3	1/2	24	30			1	1-3/4					
Tex*			y	y			1/8 - 1/4	d/3 - d/4	1/2, 3/4	36	10 - 36	66 - 91	0.47 - 0.70	1	1-1/2				y	y
Utah*	y		A	y			1/8 - 1/4	2-1/4	5/8	30	30			1	3/4	10.5 min		A	A	
Vt*	A	A	A	y	y		1/8 min	d/4	A	A	A	A		A	A	A	A	A	A	
Va*		y	y	y	y		3/8	d/3	5/8	30	40	61	0.6	3, 6	(40)	20, 40		y	(40)	
Wash*		y	y	y		(5)	pl	1/8 - 1/4	d/4 + 1/2	5/8	30	18		1	1/2			y		
W. VA.*	y		y	y	y		y	1/4	1 +/- 1/4	5/8	30	30		1	18	A		y	y	
Wis*	y	y	y	y	y		pl	1/4 max	d/4	1/2	24	21 - 48		2	1,2	20		y		
Wyo#	y		y	y	y		8m, pl	1/8 - 3/16	2	1/2	24	30		2	3/4	15		y		

*Either has no rigid pavement, is not presently constructing rigid pavement, or did not respond to 1992 questionnaire.

#Revised in 1992 synthesis.

#Appendix not addressed in response to 1992 questionnaire.

THE TRANSPORTATION RESEARCH BOARD is a unit of the National Research Council, which serves the National Academy of Sciences and the National Academy of Engineering. It evolved in 1974 from the Highway Research Board, which was established in 1920. The TRB incorporates all former HRB activities and also performs additional functions under a broader scope involving all modes of transportation and the interactions of transportation with society. The Board's purpose is to stimulate research concerning the nature and performance of transportation systems, to disseminate information that the research produces, and to encourage the application of appropriate research findings. The Board's program is carried out by more than 270 committees, task forces, and panels composed of more than 3,300 administrators, engineers, social scientists, attorneys, educators, and others concerned with transportation; they serve without compensation. The program is supported by state transportation and highway departments, the modal administrations of the U.S. Department of Transportation, the Association of American Railroads, the National Highway Traffic Safety Administration, and other organizations and individuals interested in the development of transportation.

TE 7 N26 no. 211 ---34215

McGhee, Kenneth H.

Design, construction, and
maintenance of PCC pavement

ivate, nonprofit, self-perpetuating society of distin-
ineering research, dedicated to the furtherance of
general welfare. Upon the authority of the charter
demy has a mandate that requires it to advise the
atters. Dr. Bruce Alberts is president of the National

established in 1964, under the charter of the National
n of outstanding engineers. It is autonomous in its
rs, sharing with the National Academy of Sciences
nment. The National Academy of Engineering also
; national needs, encourages education and research,
ngineers. Dr. Robert M. White is president of the

in 1970 by the National Academy of Sciences to
propriate professions in the examination of policy
ie Institute acts under the responsibility given to the
onal charter to be an adviser to the federal govern-
issues of medical care, research, and education.
s of Medicine.

ed by the National Academy of Sciences in 1916 to
chnology with the Academy's purposes of furthering
it. Functioning in accordance with general policies
become the principal operating agency of both the
l Academy of Engineering in providing services to
c and engineering communities. The Council is
e Institute of Medicine. Dr. Bruce Alberts and Dr.
in, respectively, of the National Research Council.

MTA LIBRARY
ONE GATEWAY PLAZA, 15th Floor
LOS ANGELES, CA 90012

NON-PROFIT ORG.
U.S. POSTAGE
PAID
WASHINGTON, D.C.
PERMIT NO. 8970



Transportation Research Board
National Research Council
2101 Constitution Avenue, N.W.
Washington, D.C. 20418

ADDRESS CORRECTION REQUESTED