

National Cooperative Highway Research Program

NCHRP Synthesis 250

**Highway-Rail Grade Crossing
Surfaces**

A Synthesis of Highway Practice

Transportation Research Board
National Research Council

TE
7
.N26
no.
250

TRANSPORTATION RESEARCH BOARD EXECUTIVE COMMITTEE 1998

Officers

Chairwoman

SHARON D. BANKS, *General Manager, AC Transit, Oakland, California*

Vice Chairman

WAYNE SHACKELFORD, *Commissioner, Georgia Department of Transportation*

Executive Director

ROBERT E. SKINNER, JR., *Transportation Research Board, National Research Council, Washington, D.C.*

Members

BRIAN J. L. BERRY, *Lloyd Viel Berkner Regental Professor, Bruton Center for Development Studies, University of Texas at Dallas*

SARAH C. CAMPBELL, *President, TransManagement Inc., Washington, D.C.*

E. DEAN CARLSON, *Secretary, Kansas Department of Transportation*

JOANNE F. CASEY, *President, Intermodal Association of North America, Greenbelt, Maryland*

JOHN W. FISHER, *Director, ATLSS Engineering Research Center, Lehigh University*

GORMAN GILBERT, *Director, Institute for Transportation Research and Education, North Carolina State University*

DELON HAMPTON, *Chairman & CEO, Delon Hampton & Associates, Washington, D.C.*

LESTER A. HOEL, *Hamilton Professor, University of Virginia, Department of Civil Engineering (Past Chair, 1986)*

JAMES L. LAMMIE, *Director, Parsons Brinckerhoff, Inc., New York*

THOMAS F. LARWIN, *San Diego Metropolitan Transit Development Board*

BRADLEY L. MALLORY, *Secretary of Transportation, Commonwealth of Pennsylvania*

JEFFREY J. MCCAIG, *President and CEO, Trimac Corporation, Calgary, Canada*

JOSEPH A. MICKES, *Chief Engineer, Missouri Department of Transportation*

MARSHALL W. MOORE, *Director, North Dakota Department of Transportation*

ANDREA RINIKER, *Executive Director, Port of Tacoma, Washington*

JOHN M. SAMUELS, *Vice President-Operations Planning & Budget, Norfolk Southern Corporation, Virginia*

LES STERMAN, *Executive Director of East-West Gateway Coordinating Council, St. Louis, Missouri*

JAMES W. VAN LOBEN SELS, *Director, California Department of Transportation (Past Chair, 1996)*

MARTIN WACHS, *Director, University of California Transportation Center, University of California, Berkeley*

DAVID L. WINSTEAD, *Secretary, Maryland Department of Transportation*

DAVID N. WORMLEY, *Dean of Engineering, Pennsylvania State University, (Past Chair, 1997)*

(Ex Officio)

MIKE ACOTT, *President, National Asphalt Pavement Association, Lanham, Maryland*

JOE N. BALLARD, *Chief of Engineers and Commander, U.S. Army Corps of Engineers, Washington, D.C.*

ANDREW H. CARD, JR., *President & CEO, American Automobile Manufacturers Association, Washington, D.C.*

KELLEY S. COYNER, *Acting Administrator, Research & Special Programs Administration, U.S. Department of Transportation, Washington, D.C.*

MORTIMER L. DOWNEY, *Deputy Secretary, Office of the Secretary, U.S. Department of Transportation, Washington, D.C.*

FRANCIS B. FRANCOIS, *Executive Director, American Association of State Highway and Transportation Officials, Washington, D.C.*

DAVID GARDINER, *Assistant Administrator, Office of Policy, Planning, and Evaluation, U.S. Environmental Protection Agency, Washington, D.C.*

JANE F. GARVEY, *Administrator, Federal Aviation Administration, U.S. Department of Transportation, Washington, D.C.*

JOHN E. GRAYKOWSKI, *Acting Administrator, Maritime Administration, U.S. Department of Transportation, Washington, D.C.*

ROBERT A. KNISELY, *Deputy Director, Bureau of Transportation Statistics, U.S. Department of Transportation, Washington, D.C.*

GORDON J. LINTON, *Administrator, Federal Transit Administration, U.S. Department of Transportation, Washington, D.C.*

RICARDO MARTINEZ, *Administrator, National Highway Traffic Safety Administration, Washington, D.C.*

WALTER B. McCORMICK, *President and CEO, American Trucking Associations, Inc., Alexandria, Virginia*

WILLIAM W. MILLAR, *President, American Public Transit Association, Washington, D.C.*

JOLENE M. MOLITORIS, *Administrator, Federal Railroad Administration, U.S. Department of Transportation, Washington, D.C.*

KAREN BORLAUG PHILLIPS, *Senior Vice President, Policy, Legislation, and Economics, Association of American Railroads, Washington, D.C.*

GEORGE D. WARRINGTON, *Acting President and CEO, National Railroad Passenger Corporation, Washington, D.C.*

KENNETH R. WYKLE, *Administrator, Federal Highway Administration, U.S. Department of Transportation, Washington, D.C.*

NATIONAL COOPERATIVE HIGHWAY RESEARCH PROGRAM

Transportation Research Board Executive Committee Subcommittee for NCHRP

SHARON D. BANKS, *AC Transit (Chairwoman)*

FRANCIS B. FRANCOIS, *American Association of State Highway and*

Transportation Officials

LESTER A. HOEL, *University of Virginia*

ROBERT E. SKINNER, JR., *Transportation Research Board*

RODNEY E. SLATER, *Federal Highway Administration*

JAMES W. VAN LOBEN SELS, *California Department of Transportation*

Field of Special Projects

Project Committee SP 20-5

JON P. UNDERWOOD, *Texas Department of Transportation (Chair)*

KENNETH C. AFFERTON, *New Jersey Department of Transportation (Retired)*

GERALD L. ELLER, *Federal Highway Administration (Retired)*

JOHN J. HENRY, *Pennsylvania Transportation Institute*

C. IAN MacGILLIVRAY, *Iowa Department of Transportation*

GENE E. OFSTEAD, *Minnesota Department of Transportation*

EARL C. SHIRLEY, *Consulting Engineer*

J. RICHARD YOUNG, JR., *Mississippi Department of Transportation*

RICHARD A. McCOMB, *Federal Highway Administration (Liaison)*

ROBERT E. SPICHER, *Transportation Research Board (Liaison)*

KENNETH R. WYKLE, *Administrator, Federal Highway Administration*

Program Staff

ROBERT J. REILLY, *Director, Cooperative Research Programs*

CRAWFORD F. JENCKS, *Manager, NCHRP*

DAVID B. BEAL, *Senior Program Officer*

LLOYD R. CROWTHER, *Senior Program Officer*

B. RAY DERR, *Senior Program Officer*

AMIR N. HANNA, *Senior Program Officer*

EDWARD T. HARRIGAN, *Senior Program Officer*

RONALD D. McCREADY, *Senior Program Officer*

KENNETH S. OPIELA, *Senior Program Officer*

EILEEN P. DELANEY, *Editor*

TRB Staff for NCHRP Project 20-5

STEPHEN R. GODWIN, *Director for Studies and Information Services*

SALLY D. LIFF, *Senior Program Officer*

STEPHEN F. MAHER, *Senior Program Officer*

LINDA S. MASON, *Editor*

National Cooperative Highway Research Program

Synthesis of Highway Practice 250

Highway-Rail Grade Crossing Surfaces

HOY A. RICHARDS

Principal,
Richards & Associates
College Station, Texas

Topic Panel

HOWARD H. BISSELL, *Federal Highway Administration*
LOUIS T. CERNY, *Association of American Railroads*
RICHARD A. CUNARD, *Transportation Research Board*
CHARLES RAYMOND LEWIS, II, *West Virginia Department of Transportation*
CRAIG J. REILEY, *Oregon Public Utility Commission*
CLIFF SHOEMAKER, *Union Pacific Railroad*
THOMAS D. SIMPSON, *Railway Progress Institute*
ROBERT C. WINANS, *Federal Highway Administration*
THOMAS P. WOLL, *Federal Railroad Administration*
MARK D. ZACHER, *Missouri Highway and Transportation Department*

Transportation Research Board
National Research Council

Research Sponsored by the American Association of State
Highway and Transportation Officials in Cooperation with the
Federal Highway Administration

NATIONAL ACADEMY PRESS
Washington, D.C. 1998

Subject Areas
Highway and Facility Design; Pavement
Design, Management and Performance;
and Materials and Construction

MTA LIBRARY

Systematic, well-designed research provides the most effective approach to the solution of many problems facing highway administrators and engineers. Often, highway problems are of local interest and can best be studied by highway departments individually or in cooperation with their state universities and others. However, the accelerating growth of highway transportation develops increasingly complex problems of wide interest to highway authorities. These problems are best studied through a coordinated program of cooperative research.

In recognition of these needs, the highway administrators of the American Association of State Highway and Transportation Officials initiated in 1962 an objective national highway research program employing modern scientific techniques. This program is supported on a continuing basis by funds from participating member states of the Association and it receives the full cooperation and support of the Federal Highway Administration, United States Department of Transportation.

The Transportation Research Board of the National Research Council was requested by the Association to administer the research program because of the Board's recognized objectivity and understanding of modern research practices. The Board is uniquely suited for this purpose as it maintains an extensive committee structure from which authorities on any highway transportation subject may be drawn; it possesses avenues of communication and cooperation with federal, state, and local governmental agencies, universities, and industry; its relationship to the National Research Council is an insurance of objectivity; it maintains a full-time research correlation staff of specialists in highway transportation matters to bring the findings of research directly to those who are in a position to use them.

The program is developed on the basis of research needs identified by chief administrators of the highway and transportation departments and by committees of AASHTO. Each year, specific areas of research needs to be included in the program are proposed to the National Research Council and the Board by the American Association of State Highway and Transportation Officials. Research projects to fulfill these needs are defined by the Board, and qualified research agencies are selected from those that have submitted proposals. Administration and surveillance of research contracts are the responsibilities of the National Research Council and the Transportation Research Board.

The needs for highway research are many, and the National Cooperative Highway Research Program can make significant contributions to the solution of highway transportation problems of mutual concern to many responsible groups. The program, however, is intended to complement rather than to substitute for or duplicate other highway research programs.

NOTE: The Transportation Research Board, the National Research Council, the Federal Highway Administration, the American Association of State Highway and Transportation Officials, and the individual states participating in the National Cooperative Highway Research Program do not endorse products or manufacturers. Trade or manufacturers' names appear herein solely because they are considered essential to the object of this report.

Project 20-5 FY 1994 (Topic 26-04)
ISSN 0547-5570
ISBN 0-309-06106-7
Library of Congress Catalog Card No. 97-69824
© 1998 Transportation Research Board

Price \$20.00

NOTICE

The project that is the subject of this report was a part of the National Cooperative Highway Research Program conducted by the Transportation Research Board with the approval of the Governing Board of the National Research Council. Such approval reflects the Governing Board's judgment that the program concerned is of national importance and appropriate with respect to both the purposes and resources of the National Research Council.

The members of the technical committee selected to monitor this project and to review this report were chosen for recognized scholarly competence and with due consideration for the balance of disciplines appropriate to the project. The opinions and conclusions expressed or implied are those of the research agency that performed the research, and, while they have been accepted as appropriate by the technical committee, they are not necessarily those of the Transportation Research Board, the National Research Council, the American Association of State Highway and Transportation Officials, or the Federal Highway Administration of the U.S. Department of Transportation.

Each report is reviewed and accepted for publication by the technical committee according to procedures established and monitored by the Transportation Research Board Executive Committee and the Governing Board of the National Research Council.

The National Research Council was established by the National Academy of Sciences in 1916 to associate the broad community of science and technology with the Academy's purposes of furthering knowledge and of advising the Federal Government. The Council has become the principal operating agency of both the National Academy of Sciences and the National Academy of Engineering in the conduct of their services to the government, the public, and the scientific and engineering communities. It is administered jointly by both Academies and the Institute of Medicine. The National Academy of Engineering and the Institute of Medicine were established in 1964 and 1970, respectively, under the charter of the National Academy of Sciences.

The Transportation Research Board evolved in 1974 from the Highway Research Board, which was established in 1920. The TRB incorporates all former HRB activities and also performs additional functions under a broader scope involving all modes of transportation and the interactions of transportation with society.

Published reports of the

NATIONAL COOPERATIVE HIGHWAY RESEARCH PROGRAM

are available from:

Transportation Research Board
National Research Council
2101 Constitution Avenue, N.W.
Washington, D.C. 20418

and can be ordered through the Internet at:

<http://www.nas.edu/trb/index.html>

Printed in the United States of America

APR 14 1999

PREFACE

A vast storehouse of information exists on nearly every subject of concern to highway administrators and engineers. Much of this information has resulted from both research and the successful application of solutions to the problems faced by practitioners in their daily work. Because previously there has been no systematic means for compiling such useful information and making it available to the entire community, the American Association of State Highway and Transportation Officials has, through the mechanism of the National Cooperative Highway Research Program, authorized the Transportation Research Board to undertake a continuing project to search out and synthesize useful knowledge from all available sources and to prepare documented reports on current practices in the subject areas of concern.

This synthesis series reports on various practices, making specific recommendations where appropriate but without the detailed directions usually found in handbooks or design manuals. Nonetheless, these documents can serve similar purposes, for each is a compendium of the best knowledge available on those measures found to be the most successful in resolving specific problems. The extent to which these reports are useful will be tempered by the user's knowledge and experience in the particular problem area.

FOREWORD

*By Staff
Transportation
Research Board*

This synthesis will be of interest to state and local highway personnel who are responsible for the design, construction, and maintenance of road surfaces and to railroad personnel with similar responsibilities associated with highway-rail grade crossings. It will also be of interest to manufacturers and suppliers of pavement and track materials for crossings. It presents information on the current practices related to highway-rail grade crossing surfaces, including the design and selection of crossing surface materials.

Administrators, engineers, and researchers are continually faced with highway problems on which much information exists, either in the form of reports or in terms of undocumented experience and practice. Unfortunately, this information often is scattered and unevaluated and, as a consequence, in seeking solutions, full information on what has been learned about a problem frequently is not assembled. Costly research findings may go unused, valuable experience may be overlooked, and full consideration may not be given to available practices for solving or alleviating the problem. In an effort to correct this situation, a continuing NCHRP project, carried out by the Transportation Research Board as the research agency, has the objective of reporting on common highway problems and synthesizing available information. The synthesis reports from this endeavor constitute an NCHRP publication series in which various forms of relevant information are assembled into single, concise documents pertaining to specific highway problems or sets of closely related problems.

This report of the Transportation Research Board describes the various types of highway-rail crossing surfaces, and the issues related to design, operation, and maintenance. Design elements include intersection geometry; drainage; special users, such as bicyclists; and descriptions of failures and their causes. Information is presented on crossing material selection factors, including life-cycle costs and on state practices in selection. Funding issues are also discussed.

To develop this synthesis in a comprehensive manner and to ensure inclusion of significant knowledge, the Board analyzed available information assembled from numerous sources, including a large number of state highway and transportation departments. A topic panel of experts in the subject area was established to guide the research in organizing and evaluating the collected data, and to review the final synthesis report.

This synthesis is an immediately useful document that records the practices that were acceptable within the limitations of the knowledge available at the time of its preparation. As the processes of advancement continue, new knowledge can be expected to be added to that now at hand.

CONTENTS

- 1 SUMMARY

- 3 CHAPTER ONE INTRODUCTION
 - The Synthesis Study, 3
 - Historic Context, 3
 - Organization of the Report, 4

- 6 CHAPTER TWO U.S. GRADE CROSSINGS AND THEIR SURFACES
 - Characteristics of the Crossing, 7
 - Crossing Surface Types, 7
 - Surface Selection Factors, 11
 - Characteristics of Grade Crossing Surfaces in the United States, 11

- 13 CHAPTER THREE GRADE CROSSING SURFACE DESIGN
 - Grade Crossing Intersection Design Geometry, 13
 - The Crossing Surface, 14
 - Crossing Drainage, 15
 - Surface Design Considerations Associated with Special Users, 16
 - Newer Crossing Design Concepts, 17
 - Failures of Crossings and Their Surfaces, 18

- 20 CHAPTER FOUR GRADE CROSSING SURFACE SELECTION
 - Principal Factors Affecting Crossing Surface Life, 20
 - Life-Cycle Economic Approach to Surface Selection, 21
 - State Practices in Crossing Surface Improvement, 24

- 25 CHAPTER FIVE GRADE CROSSING SURFACE MANAGEMENT
 - Installing Crossing Surfaces, 25
 - Crossing Surface Repair and Replacement, 26
 - Routine Crossing Maintenance and Its Costs, 26
 - Procedures for Selecting Crossings for Improvement, 26

- 30 CHAPTER SIX PROGRAMS AND FUNDING FOR GRADE CROSSING SURFACE MANAGEMENT
 - Funds for Crossing Surface Improvements, 30
 - An Example of State-Funded Crossing Surface Improvement Programs, 31

- 34 CHAPTER SIX CONCLUSIONS

- 37 REFERENCES

37	APPENDIX A	QUESTIONNAIRE
39	APPENDIX B	NATIONAL INVENTORY OF PUBLIC AT-GRADE HIGHWAY-RAIL CROSSINGS
40	APPENDIX C	EXTRACTS FROM THE AREA <i>MANUAL FOR RAILWAY ENGINEERING</i> AND EXTRACTS FROM THE AASHTO POLICY ON GEOMETRIC DESIGN OF HIGHWAY AND STREETS
43	APPENDIX D	ILLUSTRATIONS OF CROSSING SURFACE FAILURE MODES
45	APPENDIX E	SELECTED DESCRIPTIONS OF CROSSING SURFACE PRODUCTS
51	APPENDIX F	SELECTIONS FROM THE FEDERAL-AID GUIDE FOR CROSSINGS
53	APPENDIX G	DETAILS OF STATE RESPONSES TO SURVEY QUESTIONNAIRE REGARDING CROSSING SURFACE IMPROVEMENT PRACTICES, STATES WITHOUT FORMAL GUIDELINES
55	APPENDIX H	MINNESOTA CROSSING SURFACE POLICY

ACKNOWLEDGMENTS

Hoy A. Richards, Principal, Richards & Associates, College Station, Texas, was responsible for collection of the data and preparation of the report. Andrew C. Lemer, Ph.D., of the Matrix Group, Inc., assisted in the research and preparation of the report.

Valuable assistance in the preparation of this synthesis was provided by the Topic Panel, consisting of Howard H. Bissell, Highway Research Engineer, Federal Highway Administration; Louis T. Cerny, Executive Director, Engineering Section, Association of American Railroads; Richard A. Cunard, Engineer of Traffic and Operations, Transportation Research Board; Charles Raymond Lewis, II, Planning and Research Engineer, Traffic Engineering Division, West Virginia Department of Transportation; Craig J. Reiley, Technical Coordinator for Crossing Safety Section, Oregon Public Utility Commission; Cliff Shoemaker, Director, Industry & Public Projects, Union Pacific Railroad; Thomas D. Simpson, Vice President, Railway Progress Institute;

Robert C. Winans, Highway Engineer, Federal Highway Administration; Thomas P. Woll, Rail Crossing Engineer, Federal Railroad Administration; and Mark D. Zacher, Railroad Liaison Engineer, Missouri Highway and Transportation Department.

This study was managed by Sally D. Liff, Senior Program Officer, who worked with the consultant, the Topic Panel, and the Project 20-5 Committee in the development and review of the report. Assistance in Topic Panel selection and project scope development was provided by Stephen F. Maher, P.E., Senior Program Officer. Linda S. Mason was responsible for editing and production.

Crawford F. Jencks, Manager, National Cooperative Highway Research Program, assisted the NCHRP 20-5 staff and the Topic Panel.

Information on current practice was provided by many highway and transportation agencies. Their cooperation and assistance are appreciated.

HIGHWAY-RAIL GRADE CROSSING SURFACES

SUMMARY

An at-grade highway-rail crossing is the physical intersection of two very different vehicle-carrying surfaces and areas approaching the physical intersection. Within the crossing area, physical design characteristics of each structure, i.e., rail and highway, may have to be specifically adjusted to accommodate the other transportation mode. Every crossing establishes a discontinuity in both the normal track structure and the normal highway or street pavement. The grade-crossing surface, the subject of this synthesis study, consists of pavement or other highway and rail surface materials on the approaches and crossover points with the railroad track. This surface must carry the train or highway vehicle and transmit their wheel loads to the foundation structure.

There are more than 164,000 public at-grade crossings in the United States. More than half of these crossings serve very low road-traffic volumes, with average daily traffic (ADT) of less than 400 vehicles. Railroad operating companies, in aggregate, each year spend some \$34 million to maintain these crossing surfaces. Public transportation agencies spend additional millions for reconstruction and improvement of the surfaces at public crossings.

The Federal Highway Administration (FHWA), American Railway Engineering Association (AREA), and American Association of State Highway and Transportation Officials (AASHTO) provide guidance on the design for traffic management and safety of grade crossings. Few regulations and little guidance address the specific requirements for the design, material specifications, construction, installation, and maintenance of grade-crossing surfaces. Railroads generally have the responsibility for maintaining the crossing surface between the tracks and a few inches from the ends of the ties supporting the crossing surface, while the highway agency has jurisdiction and responsibilities for construction and maintenance of roadway approaches to the crossing.

Crossing surfaces in use today fall into two general categories: monolithic and sectional. Monolithic crossings are those that are formed at the crossing and cannot be removed without destroying the surface. Typical monolithic crossings are made of asphalt, poured-in-place concrete, and cast-in-place rubber-and-elastomeric compounds. Sectional crossings are those manufactured in sections or panels that are placed at the crossing and can be removed and reinstalled. These crossing surfaces facilitate the maintenance of track through the crossing. Typical sectional crossing surfaces include treated timbers, reinforced concrete, steel, rubber, and high-density polyethylene. The commercial market offers a wide selection of sectional crossing-surface products.

The crossing surface must contend with design requirements for the road and rail that are in a sense incompatible. The steel rails, wood or concrete cross-ties, and crushed stone ballast of the typical rail track structure are designed to accommodate small routine vertical deflections, i.e., they are designed to flex slightly under the heavy weight of trains. The highway surface, in contrast, is designed to remain rigidly in place under the load of highway vehicles.

The rail line is designed to allow water to filter freely through the base to drainage structures or a free-draining and impervious subbase or foundation layer, while the highway pavement is designed to be absolutely impervious. A highway pavement surface is typically

either crowned or slanted to facilitate rapid drainage to drainage structures along the pavement's edges, while the rail slope is essentially constant (e.g., flat) over the short distance that a grade crossing represents.

Effective drainage is widely recognized as the most important element in ensuring that a crossing provides long-term good ride quality and economical maintenance. If good drainage is maintained, then inability of the surface to withstand the impact loads imposed by highway vehicles passing over the irregularities of the crossing (e.g., at the rails and flangeways, sharp grade transitions) is the next most important source of crossing-surface failures. In addition, surface abrasion, splitting and compaction of shims, and displacement of rail and surface-material fasteners can create irregularities that increase impact loads and lead to larger-scale cracking of pavement and crossing materials. Wood-plank and timber-panel crossings are also subject to rot and splitting. Wood, rubber, and other relatively elastic materials may be damaged by scraping of low-clearance vehicles or other heavy equipment.

For most properly maintained crossings, regardless of the characteristics of the road traffic using that crossing, the loads that road traffic impose are the primary determinants of the crossing surface's life. Heavier and multi-axle vehicles (e.g., trucks) impose more severe loads on the crossing surface than automobiles. A variety of other factors also can affect the life of a grade-crossing surface, including railroad traffic, train speed, and crossing geometry (e.g., number of traffic lanes, angle of crossing to road, and number of tracks).

There are no widely accepted specifications defining the onset of crossing-surface failure, nor are there widely accepted procedures for determining likely service life of a particular surface material exposed to particular highway traffic, rail traffic, and environmental conditions. A rough riding surface, large deflections in rail or road surfaces, and substantial deterioration of structural integrity in the road pavement or track-and-tie assembly are indicators of crossing-surface failure. Highway agencies that give particular attention to crossings under their jurisdiction typically include ride-quality assessments among the factors motivating crossing-surface improvement priorities.

Surveys indicate that only about one-third of state transportation agencies use some more-or-less formal procedure to judge their own priorities for grade crossings warranting surface improvement. Most states rely substantially on the railroads for management of the crossing surface, at least within the immediate vicinity of the track. Federal highway programs make funds available that may be used for crossing-surface improvements and states may use their own highway funds as well, but only a small fraction of the funds spent for crossing improvements is devoted to crossing surfaces. Railroads are the primary source of funds for crossing-surface maintenance and reconstruction.

INTRODUCTION

At-grade intersections of highways and rail lines present potential obstructions to both highway and rail traffic. One aspect of this obstruction is the conflict of highway and rail traffic trying to occupy the intersection at the same time, causing safety hazards and time delays. A second aspect of the obstruction is the mismatch of surface materials and grade levels between the highway pavement and the railroad track structures. This latter aspect, while generally less obvious to users of either transportation mode, can cause safety hazards and costly operating and maintenance problems that warrant careful attention.

At-grade crossings include crossings of roads and streets with railroad and rail transit lines. These crossings may occur on public road right-of-way, i.e., public crossings or within the boundaries of private property, e.g., private crossings on the grounds of factory compounds or rail yards. Railroad operations, rather than transit, account by far for the majority of public crossings; the Federal Rail Administration (FRA) reports there are more than 164,000 such public at-grade rail-highway crossings in the United States (Table 1).

An at-grade crossing establishes a discontinuity in both the normal track structure and in the normal highway or street pavement. The crossing includes not only the actual intersection of the two vehicle-carrying surfaces, but also the approach areas where physical design characteristics of one structure may have to be specifically adjusted to accommodate the other transportation mode. The *grade crossing surface*, the subject of this synthesis report, consists of pavement or other highway and rail surface materials on the approaches and crossover points with the railroad track. This surface must carry the train or highway vehicle and transmit their wheel loads to the foundation structure. Within the boundaries of the crossing surface area, the track structure typically carries both highway and railroad loads to the subgrade.

THE SYNTHESIS STUDY

This synthesis reviews the current state of practice regarding highway-railroad crossing surface management. Safety, traffic control, and related signing and signaling concerns raised by the potential conflict between highway and rail vehicles are not addressed here. The term “management” here encompasses design, construction, and maintenance of individual crossings and the allocation of resources among multiple crossings in an agency’s highway or rail system. The study includes practices applied by railroads and highway agencies.

As a part of this study, a questionnaire was developed and sent to the “Rail Crossing Engineering Coordinator” for highway-rail safety improvements in each state department of transportation (DOT) of the United States. Appendix A is a copy of the questionnaire. Thirty-seven states responded to this questionnaire with specific information regarding the state’s

program for selection, funding, and monitoring grade crossing surface improvements. As Table 1 summarizes, the responding states represent approximately 78 percent of all U.S. highway-rail grade crossings. Appendix B lists highway-rail crossings by state and crossing surface, collected by the USDOT and the Association of American Railroads. As will be discussed in some detail in chapter 2, asphalt is the predominant material used for crossing surfaces in the United States; more than one-half of all public crossings are asphalt-surfaced. Wood surfaces (sectional timber and wood plank) account for nearly one-third of all crossings. The distribution is changing, however, as newer materials are introduced with improved characteristics of durability, ease of maintenance, and life-cycle cost.

HISTORIC CONTEXT

At-grade crossings for the most part are the result of conflict between two major transportation modes that developed at different times in the nation’s history. The railroads were born and experienced their great age of expansion in the 19th century. Their physical and economic scale dominated the areas through which they passed and made the companies a sizeable target in discussions of who was responsible for safety and maintenance-of-way at railroad intersections. Dramatic increases in the number of railroad accidents and numbers of fatalities in those accidents in the early years of the 20th century provided a rich subject for the popular press, and placed railroad safety high on the agenda of for legislative and regulatory control. As the responsible federal government agency, the Interstate Commerce Commission (ICC), provided a central focus for the gathering of statistics and establishment of management principles; roads, however, were almost entirely a local matter. (The Department of Agriculture led the first federal forays into highways by establishing the Office of Road Inquiry in the mid 1890s; the office was renamed the Office of Public Roads Improvement in 1905.)

Under the ICC’s direction, the “Senior-Junior” principle established that the railroad held both authority and responsibility for grade-crossings, by virtue of its initial occupancy and primary use of the space to be shared by the two modes; the railroad’s “senior” rights took precedence. However, both road-building activity and highway traffic increased rapidly in the early part of this century, and by the 1930s the railroads were clearly experiencing the early stages of a dramatic decline in usage as they lost ground to the automobile. By 1935, the Supreme Court was moved to comment (in the case of *C. and St. L. Ry. v. Walters*, 294 U.S. 405, 1935) that “The railroad has ceased to be the prime instrument of danger and the main cause of accidents. It is the railroad which now requires protection from dangers incident to motor transportation.”

TABLE 1
NUMBER OF PUBLIC RAIL-HIGHWAY GRADE CROSSINGS, BY STATE, WITH TOTALS

State	Number of Crossings, by Surface Type										Total
	Sectional Timber	Wood Plank	Asphalt	Concrete Slab	Concrete Pavement	Rubber	Metal Section	Other Metal	Gravel	Other	
<i>Total, All States (Appendix B)</i>											
Number	27,461	25,490	84,889	1,652	795	6,246	161	181	17,123	839	164,837
Percent	16.7	15.5	51.5	1.0	0.5	3.8	0.1	0.1	10.4	0.5	100
<i>Survey Respondents (37 States)</i>											
Number	23,811	17,060	66,059	1,249	702	5,107	155	170	14,549	676	129,583
Percent	18.4	13.2	51.0	1.0	0.5	3.9	0.1	0.1	11.2	0.5	100
<i>Survey Sample As A Percentage of Reported National Inventory</i>											
Percent	86.7	66.9	77.8	75.6	88.3	81.8	96.3	93.9	85.0	80.6	78.6

Source: Federal Railroad Administration, as of June 30, 1995.

Federal funds became generally available for road building in 1916 when Congress established a formula for distributing funds among the states, but it was the Federal Highway Act of 1921 that ushered in what one historian has termed the "Golden Age" of highway building, from 1921 to 1936 (1). While the railroads continued to invest in crossing improvements, public highway funds increasingly were used as well and the principle of "joint responsibility" became firmly established. The Federal-Aid Highway Act of 1944 limited the railroad's required contribution to crossing improvement projects constructed with federal-aid funding to no more than 10 percent of total project costs. Maintenance even of federal-aid roads was still a state or local responsibility, shared on a case-by-case basis between the railroad and government highway agency.

In the early 1960s, the ICC conducted an investigation of highway-rail safety needs and issued a report and regulatory order setting aside entirely the idea of joint responsibility (2). Reasserting the Supreme Court's earlier declaration that it was the motor vehicle, not the train, that created the hazard, the ICC stated that the public should bear full responsibility for the cost of crossing safety. The ICC's "sole responsibility" philosophy understandably failed to gain immediate and enthusiastic acceptance by highway agencies.

In 1967, the U.S. Department of Transportation (USDOT) was created. The FRA, along with the Federal Highway Administration (FHWA), a unit of the USDOT, assumed the ICC's responsibilities. A similar consolidation of public agency interests has occurred at the state level as most states have followed the federal lead and formed state departments of transportation. These agencies have assumed the responsibilities for rail regulation previously held by Public Service or Public Utilities Commissions. While these consolidations have tended to bring rail and highway regulatory activities under one roof, the responsibilities for highway-rail intersection improvements have remained divided between public agencies and the railroads.

The 1973 Federal Highway Safety Act established programs aimed specifically at grade separations, crossing protection devices, and improved crossing surfaces, which continued with the Federal Highway Act of 1976. These programs spurred research and the development of engineering guidance

materials on crossing surfaces, but a search of the literature indicates that relatively little has been produced since the 1970s.

As will be discussed in subsequent chapters, there is little federal guidance and few state regulations address requirements for the design, material specifications, construction, installation, and maintenance of grade-crossing surfaces. In general, railroads have responsibility for the crossing surface between the tracks and a few inches from the ends of the ties supporting the crossing surface, while the highway agency has jurisdiction and responsibilities for construction and maintenance of roadway approaches to the crossing to the point where railroad responsibility begins.

ORGANIZATION OF THE REPORT

This synthesis report is intended to be a resource for those who are responsible for the management of highway-rail intersections, particularly with regard to the selection of the appropriate surface materials, maintenance of surfaces, and the administration of surface improvement programs. This initial chapter provides a background for subsequent discussion of the specific factors that influence crossing management decisions in practice.

Chapter 2 describes the basic characteristics of grade crossings that influence crossing surface management and the principal types of surfaces found at U. S. highway-rail grade crossings. Chapter 3 then reviews current U.S. practices for designing, constructing, and maintaining crossing surfaces. This review includes both general guidance provided by federal agencies and industry groups and the specific practices reported by states responding to the survey.

Chapter 4 discusses what is known about the factors that influence crossing surface performance and durability, and what surface types are preferred under particular operating conditions. Chapter 5 addresses the problems of managing the crossing surface, crossing-by-crossing and of overseeing the inventory of many grade crossings that are under the jurisdiction of a railroad or highway agency. Chapter 6 reviews programs for funding crossing-surface improvements.

Chapter 7 presents conclusions regarding this summary assessment of the current state of practice in crossing surface management. The author also proposes areas that warrant research or other action to improve current practice.

In addition to the survey questionnaire included in Appendix A, excerpts and summaries of selected reference materials are included in a series of other appendices. This

information is likely to be useful to decision makers faced with crossing surface management problems. In particular, these appendices include data and guidance materials prepared by the American Railway Engineering Association and the Federal Highway Administration, and brief descriptions of selected proprietary products currently available for crossing surfaces.

U.S. GRADE CROSSINGS AND THEIR SURFACES

The grade crossing includes not only the actual intersection of the two vehicle-carrying surfaces, i.e., track and pavement, but also the approach areas where physical design characteristics may have to be specifically adjusted to accommodate one or the other transportation mode (see Figure 1). The grade-crossing surface occupies a relatively small area at the intersection. This surface consists of pavement or other highway and rail surface materials on the approaches and crossover points with the railroad track. The crossing surface must carry the train or highway vehicle and transmit their wheel loads to

the subbase or foundation, which is typically uncompacted soil or rock. Within the boundaries of the crossing surface area, the track structure, i.e., the ties and rail base material, typically carries both highway and railroad loads to the subgrade.

The railroad and highway agency share an interest in obtaining a safe, smooth-riding, and low-maintenance crossing, but there is an inherent potential for conflict in the crossing's physical design and in the subsequent allocation of costs for crossing construction and maintenance. Highway agencies typically pay a substantial portion of crossing construction

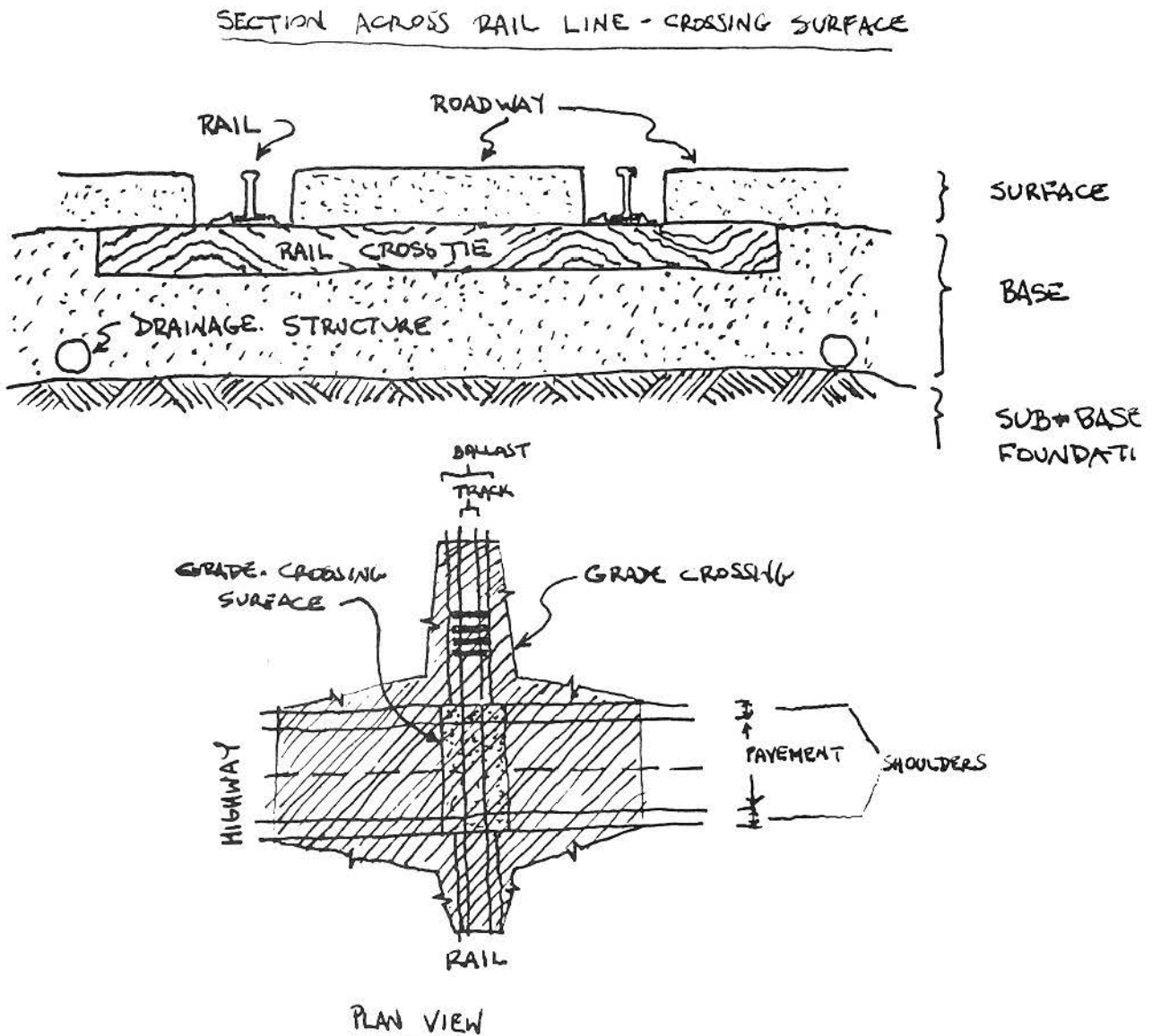

FIGURE 1 Schematic of highway-rail grade crossing.

costs, often using federal highway funds to do so (see chapter 4), but railroads typically take responsibility for crossing surface maintenance. A major railroad (e.g., a Class I railroad) operating in several states may have to work with and accommodate the differing requirements of dozens of local road agencies. Local and state agencies may similarly have to work with several rail companies, each with its own operating policies and design standards, in the application of public road funds to crossing design and construction. Smaller railroads (e.g., shortline roads) and smaller local government road agencies often lack expertise and financial resources to deal effectively with crossing problems.

Early crossing surfaces were made by filling the area between the rails with sand and gravel, probably from the railroad ballast. Later, planks, heavier timbers, or bituminous material began to be used. Treated timber panels and prefabricated metal sections followed, and in 1954, the first proprietary rubber-panel crossing surface was put on the market. Proprietary surface treatments, usually patented, now are fabricated from concrete, rubber, steel, synthetics, wood, and various combinations of these materials.

Crossing surfaces available today can be divided into two general categories: monolithic and sectional. Monolithic crossings are those that are formed at the crossing and cannot be removed without destroying the surface. Typical monolithic crossings are made of asphalt, poured-in-place concrete, and cast-in-place rubber (elastomeric) compounds. Sectional crossings are those manufactured in sections (panels) that are placed at the crossing and can be removed and reinstalled. These crossing surfaces facilitate the maintenance of track through the crossing. Typical sectional crossing surfaces include treated timbers, reinforced concrete, steel, high-density polyethylene, and rubber.

CHARACTERISTICS OF THE CROSSING

The railroad's operating requirements almost always determine the topography, i.e., the grade, in the design of the highway-rail intersections. In many instances, the roadway alignment is such that the roadway surface must be brought to the level (grade) of the railroad track structure.

If the railroad track is an embankment, then efforts to reduce highway cost can establish rather severe slopes on the roadway's approaches (i.e., vertical curve) to the intersection, thereby creating a "hump" crossing. Similarly, if the railroad track is in a cut or is otherwise depressed relative to the roadway alignment, the vertical curve of the roadway's approaches to the intersection can involve severe downgrades. Additional concerns arise over "skewed angle" crossings, the result of an intersection occurring on a horizontal curve of one of the modes, typically of the rail line. The track structure will, in such cases, be canted to accommodate the horizontal forces of vehicles passing through the curve, with the outer edge of the track higher than the inner edge. Steep slopes, sudden slope changes, and skewed angles present safety hazards for highway vehicles; bicycles and, in urban areas especially, pedestrians and other types of vehicles may require special consideration in

crossing design. In most situations, the cost of bringing the two systems to an even grade with gradual approaches is considered by responsible officials to be prohibitive, typically involving several thousand feet of cut or fill along the rail approaches and substantial additional right-of-way acquisition along the roadway.

Regardless of approach geometry, the basic requirements that underlie rail and road pavement designs are simply incompatible. The steel rails, wood cross-ties (they may also be made of concrete), and crushed stone ballast of the typical rail track structure are designed to accommodate routine vertical deflections, i.e., to flex under the heavy weight of trains. The highway surface, in contrast, is designed to remain rigidly in place under the load of highway vehicles (although over long periods of time, the repeated loadings these vehicles impose may cause permanent deformations in the road surface). In addition, the rail line is designed to allow water to filter freely through the base to drainage structures or a free-draining and impervious subbase or foundation layer. The highway pavement is designed to be absolutely impervious, and water entering the base and subbase beneath the pavement can cause structural failure of the pavement. A highway pavement surface is typically either crowned or slanted to facilitate rapid drainage to drainage structures along the pavement's edges, while the rail slope is essentially constant (e.g., flat) over the short distance that a grade crossing represents.

Roadway drainage typically carries sand, grease, and other impurities that can foul both ballast and drainage structures beneath the rail line. While the flow of water through the ballast is intended to cleanse the coarse stone and maintain its free movement, these impurities can act as a binder when drying occurs. The resulting "hard-spot" of cemented aggregate increases stresses that can cause structural failure of the rail line.

The crossing surface must accommodate both the flexing of the rails and the rigidity of the highway pavement, the previous rail condition and the requirement that water be kept out of the pavement structure. Transmission of the flexing from rail to pavement can cause high stresses, cracking, and structural failure in the pavement. Debris from the pavement can clog the track structure and cause structural failure. Because the tracks and the crossing surface must be level with one another across the entire pavement-rail intersection, the crossing surface must also accommodate. Routine loosening of rail fasteners (e.g., spikes), misalignment of segments of the crossing surface, road pavement potholes, and other irregularities can set up unusually high stresses (e.g., the impact of vehicle tires) that can damage the crossing surface and structure. In general, crossing surface design and maintenance are troublesome responsibilities for all concerned.

CROSSING SURFACE TYPES

The FHWA's *Railroad-Highway Grade Crossing Handbook* (3) describes 10 categories of surface materials widely used at U. S. grade crossings: sectional timber, wood plank, asphalt, concrete slab, concrete pavement, rubber, metal section,



ILLUSTRATIVE CROSS SECTION THRU
SECTIONAL TREATED TIMBER CROSSING

FIGURE 2 Typical prefabricated timber panel crossing.

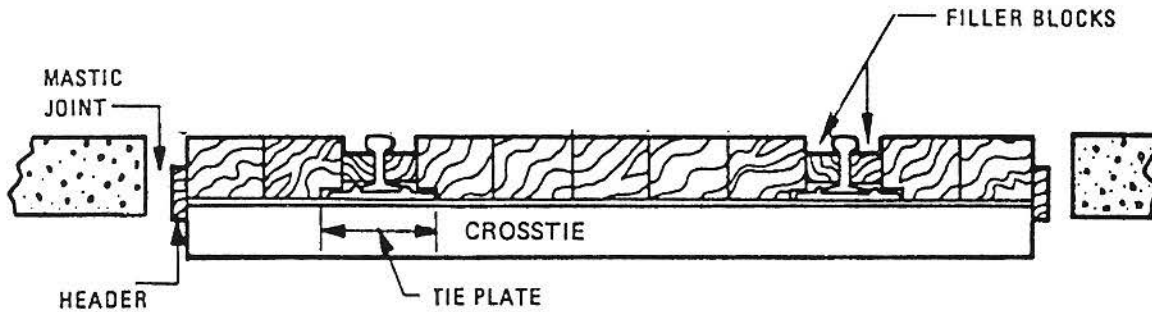

FIGURE 3 Typical wood plank crossing.

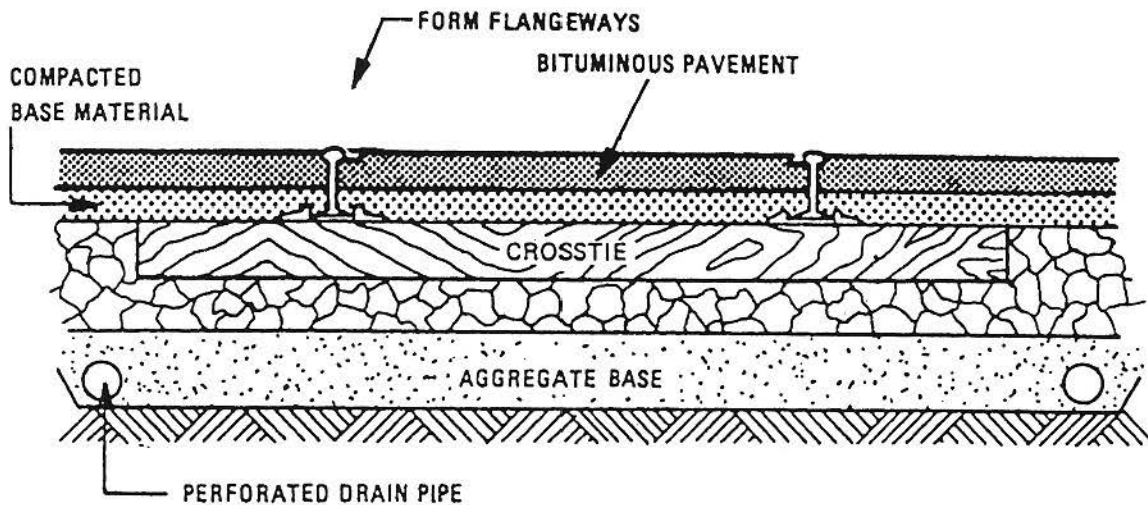

FIGURE 4 Typical asphalt crossing.

other metal, gravel, and other materials. The following descriptions are adapted from the *Handbook* and supplemented with schematic diagrams of typical cross sections showing the construction of each type of crossing. Appendix E includes brief descriptions of many of the commercial products available for crossing construction.

Not included in these descriptions is the placement of stabilization fabric, a heavy-duty synthetic-fiber material typically placed between soil layers within the base or between the base and foundation, it distributes load and retards infiltration of fine particles (e.g., soil) into base materials. Such fabrics may be used, if warranted by the specific physical and operational characteristics of the individual highway-rail intersection, with any of these crossing surface materials.

Sectional Timber crossings consist of an assembly of prefabricated, treated timber panels, installed between rails and to the ends of the ties (Figure 2). The panels can be removed and

replaced for maintenance purposes. The panels are fabricated from mixed timbers that are thick enough to reach from the top of the rail to the top of the tie without requiring shims. Thinner timbers, however, can be used with shims on top of the ties. Some manufacturers provide rubber cushions that are placed under the timber panels to reduce vibration and keep pressure on fasteners. Other manufacturers provide a nonskid safety plate or a thin, high-density polyethylene material on top of the surface panels.

Wood Plank crossings are formed by installing planks or timbers as individual pieces over the entire crossing area (Figure 3). In contrast to sectional timber crossings, where timbers are joined into panels, this crossing surface can be continuously maintained by the replacement of individual deteriorated or worn planks.

Asphalt crossings are formed essentially by applying a monolithic paving across the surface area (Figures 4 and 5). A

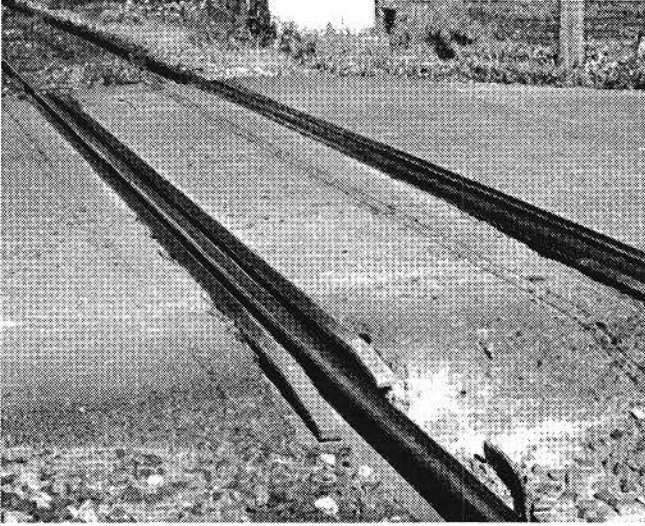

FIGURE 5 Formed-in-place asphalt.

pavement-type mixture of nonmetallic aggregate and bituminous binder (usually hot mix) is either poured over the entire crossing area or poured only in the area between flangeway protectors. Flangeway protectors may be planks, flange rails, or other devices that form flangeway openings on the inside of the running rails. A line of timbers or flangeway rails is sometimes placed on the outside of the running rails. While track maintenance may require extensive surface damage and reconstruction, the ease of reconstruction with bituminous asphalt and the accompanying smooth riding surface make this a popular choice for crossings. As Table 1 showed, this type is

by far predominant, accounting for approximately 51 percent of all U.S. public crossing surfaces.

Concrete Slab crossings use precast reinforced concrete panels that may be removed and reinstalled for maintenance and replacement purposes (Figure 6). Most precast concrete slab crossings use at least two slabs for the center section with treated guard timbers adjacent to the running rail on both the inside and outside slabs. Some precast concrete slabs are full depth from top of rail to top of tie, while others use shims on the ties to bring the top surface of the slab up to the top of the rail. Some concrete slabs have edges that are protected with steel armor that requires special provisions for electrical insulation when located in the vicinity of track circuitry. Some manufacturers include rubber pads placed on the ties while others provide a continuous polyurethane strip placed underneath the rails. Precast concrete slabs are held in place by fasteners, their own weight, or are bonded together with a weld and anchored on each end of the total surface. While the national inventory (Table 1) indicates that concrete slab surfaces account for only one percent of all crossings, interviews with railroad and public works engineers suggest this type of surface may be more widely used.

Concrete Pavement crossings are continuous-in-place continuous portland cement concrete that covers the entire crossing area for the width of the ties (Figure 7). As in the case of asphalt crossings, track maintenance entails extensive damage of the surface, making this surface type unpopular in most applications.

Rubber crossing surfaces typically consist of molded rubber panels, usually steel-reinforced, and fabricated with a patterned riding surface to enhance traction in wet conditions

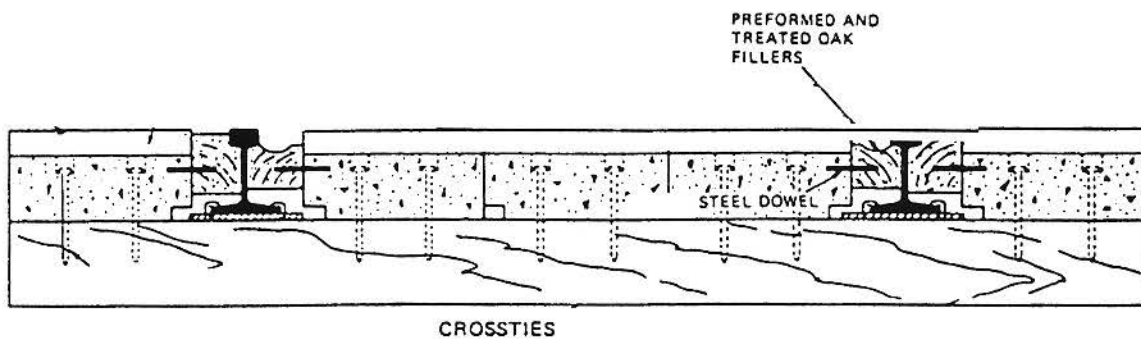

FIGURE 6 Precast reinforced concrete panels.

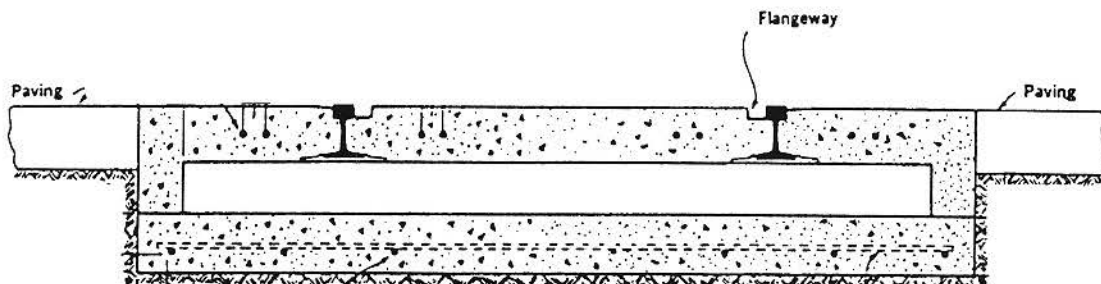

FIGURE 7 Concrete surface cast-in-place.

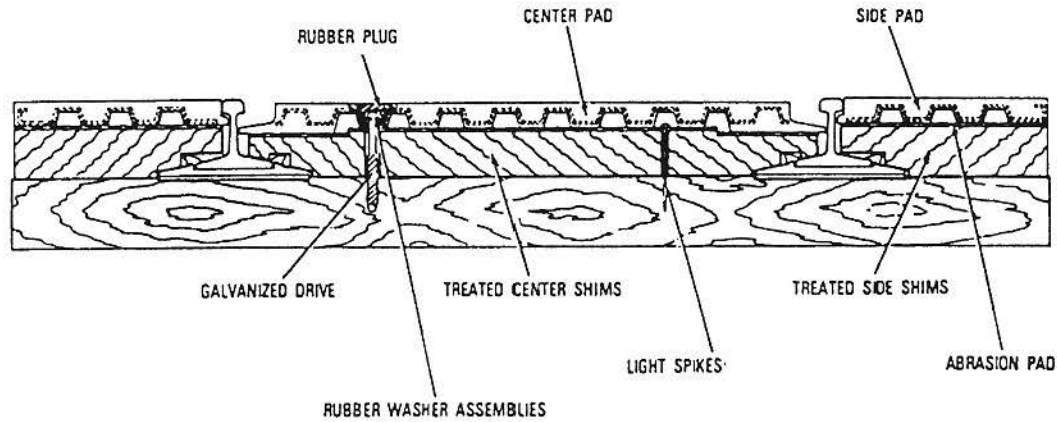

FIGURE 8 Typical molded rubber panels crossing.

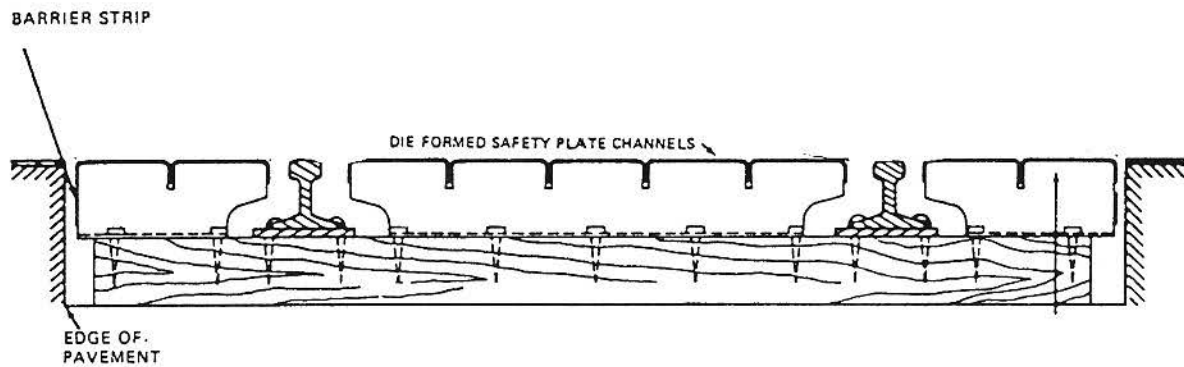

FIGURE 9 Typical prefabricated steel section crossing.

(Figure 8). Some rubber crossing surfaces require shims while others do not. Most of these commercial products are made with an antiskid tread design that also improves wear resistance and drainage. Some manufacturers provide rubber header boards while others provide wood header boards. Like the concrete slabs and sectional timber, the rubber panels can be removed and replaced for track maintenance.

Metal Section refers to prefabricated open-grating panels, typically steel, that may be installed and removed individually for maintenance and replacement purposes (Figure 9). *Other metal* includes steel and other plate laid across ties, typically with shims, to create a riding surface. These plates will typically be cast metal with a patterned surface to facilitate traction and drainage (Figure 10). Taken together, all metal crossings account for 0.2 percent of the nation's public crossings.

Gravel or other unconsolidated materials (e.g., sand) may be placed between and outside the rails to construct a crossing for unpaved roads with low traffic volumes that intersect rail lines serving a low-density train operation. For example, FRA data indicate that about one-fifth of public at-grade crossings have an annual average daily traffic (AADT) of 250 vehicles or less and a train volume of no more than two trains per day.

Other surfaces include molded high-density polyethylene panels and hybrid constructions. Polyethylene panels are typically fabricated with recessed openings for fasteners. Most of

these panels are full-depth (a few require shims). Interlocking and interchangeable modules are fastened directly to ties. The authors of this study estimate that fewer than 800 public at-grade crossings have polyethylene crossing surfaces, which still accounts for most of the nation's crossings reported in this category.

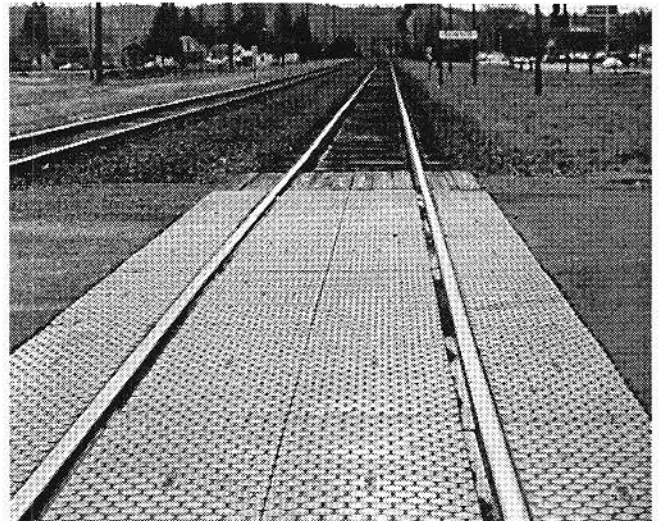

FIGURE 10 Removable panels.

SURFACE SELECTION FACTORS

There are no national guidelines for selecting the appropriate surface for a specified crossing. Although several states have guidelines for selecting the type of crossing surface, many states require that the railroad select, construct, and maintain crossing surfaces. The Railway Progress Institute (RPI) has published "guidelines" listing factors that should be considered in selecting an appropriate surface type (4).

- a) The surface material withstands the environment.
- b) No full rigidity in the crossing structure when completed.
- c) Simple adaptation for all rail sizes, for both tangent and curved trackage.
- d) Independent or specified tie spacing, adaptable to any type of tie spacing.
- e) Simple flangeway maintenance.
- f) No-skid and anti-hydroplaning surface.
- g) Adaptation to existing roadway profile.
- h) Simple and fast installation procedures; interchangeable and easy to relocate sections of panels.
- i) Insulating qualities in signal and communication territory.
- j) Adaptability to skewed crossings.

- k) Provisions for flangeway filler material for small-wheeled vehicles.
- l) Provisions for safety end ramps.

CHARACTERISTICS OF GRADE CROSSING SURFACES IN THE UNITED STATES

Data from the USDOT and Association of American Railroads (AAR) National Rail Highway Crossing Inventory show that in 1994 there were more than 164,000 public at-grade crossings in the United States. Appendix C includes the state-by-state listing of these FRA-reported data, by surface type. Texas, Illinois, California, and Iowa lead the nation in number of highway-rail intersections.

Tables 2 and 3 present summary information on other characteristics of the national crossing inventory. More than half of the nation's crossings serve very low road-traffic volumes, with AADT less than 400 vehicles. The safety hazard and traffic disruptions associated with more heavily used intersections often warrant grade separation of road and rail lines, so very few crossings serve an AADT of more than 20,000 vehicles.

The numbers and types of crossings in the nation's inventory have changed substantially in recent years. Table 4 shows that between 1978 (the first year the FRA published its

TABLE 2
TOTAL PUBLIC AT-GRADE CROSSINGS BY AVERAGE ANNUAL DAILY TRAFFIC (AADT), 1994

AADT	Crossings	Percent	AADT	Crossings	Percent
1-100	52,812	31.5	1,001-2,000	16,080	9.4
101-200	15,593	9.4	2,001-3,000	8,789	5.3
201-300	12,156	7.3	3,001-4,000	5,519	3.3
301-400	7,458	4.4	4,001-5,000	4,818	3.0
401-500	7,210	4.4	5,001-6,000	3,058	1.8
501-600	4,757	2.8	6,001-7,000	2,330	1.5
601-700	3,537	2.2	7,001-8,000	2,211	1.3
701-800	4,058	2.4	8,001-9,000	1,601	1.0
801-900	2,666	1.6	9,001-20,000	7,913	4.0
901-1000	3,618	2.3	>20,000	1,931	1.1
Totals	113,865			168,115	100.0

Source: Highway-Rail Crossing Accident/Incident and Inventory Bulletin No. 16, July 1994, for calendar year 1993 (Table 57) Federal Railroad Administration.

TABLE 3
TOTAL PUBLIC AT-GRADE CROSSINGS BY NUMBER OF TRACKS AND TRAFFIC LANES, 1994

Traffic Lanes	Number of Tracks						Total
	1	2	3	4	5	>5	
1	20,228	4,292	742	170	38	43	25,513
2	88,070	28,882	9,280	3,032	1,036	869	131,169
3	734	336	100	35	9	13	1,227
4	5,615	2,136	764	268	99	91	8,973
5	405	121	35	8	3	4	576
>5	471	133	37	9	3	4	657
Total	115,526	35,900	10,958	3,522	1,188	1,024	168,115

Source: Highway-Rail Crossing Accident/Incident and Inventory Bulletin No. 16, July 1994, for calendar year 1993 (Table 38) Federal Railroad Administration.

TABLE 4
TOTAL PUBLIC AT-GRADE CROSSINGS BY TYPE OF CROSSINGS FOR CALENDAR YEARS
1978 AND 1994

Type of Crossing Surface	Total 1978	Total 1994	Percent Change
Section Timber	30,269	27,622	(8.7)
Full Wood Plank	34,607	25,902	(25.2)
Asphalt	117,699	85,382	(27.5)
Concrete Slab	825	1,564	89.6
Concrete Pavement	957	792	(17.2)
Rubber	425	6,151	1,347.3
Metal Sections	256	162	(36.7)
Other Metal	200	182	(9.0)
Unconsolidated	31,591	17,474	(44.7)
Other	239	804	42.3
Total	217,068	166,035	(23.5)

() = Decrease

Source: FRA 1994 data is current with Inventory update information supplied by December 31, 1994. FRA 1978 data from Rail-Highway Crossing Accident/Incident and Inventory Bulletin No. 1 for calendar year 1978.

Rail-Highway Crossing Accident/Incident and Inventory Bulletin) and 1994, the total number of highway-rail intersections declined by 23.5 percent as rail lines were retired and some of the remaining crossings reconstructed with separated grades. In addition, there has been a conversion of crossings to more durable and easily maintained surface materials, as reflected in the actual increase in numbers of concrete slab, rubber, and "other" categories and the relatively modest decreases in section timber and "other metal" crossings.

The AADT at highway-rail intersections is a significant factor in the selection of crossing surface materials. Intersections

with very low volume—an AADT of 100 or less, almost one-third of all crossings—are likely to have timber, wood, or gravel surfaces because these have low initial cost and relatively low wear and tear. At the other extreme, crossings with an AADT of more than 10,000 vehicles are more likely to have high-durability, easier-maintenance surfaces such as rubber or concrete. Low traffic volumes are correlated with fewer traffic lanes: fewer than 7 percent of crossings have more than two lanes crossing the rails. Nearly 69 percent of the nation's crossings involve only a single railroad track.

GRADE CROSSING SURFACE DESIGN

The FHWA's *Railroad-Highway Grade Crossing Handbook* states that "a railroad-highway grade crossing may be viewed as simply a special type of highway intersection" (3), guidance that applies primarily, at best, to the control of traffic conflicts at the intersection. This *Handbook* is the principal source of guidance for highway engineers. The FHWA's *Handbook of Highway Safety Design and Operating Practices* (6) contains limited information on crossing design, including brief reference to characteristics of the pavement section and crossing surface. The FHWA's *Manual on Uniform Traffic Control Devices* (MUTCD) offers guidance that includes grade-crossing approach warning and protection (7).

The American Railway Engineering Association's (AREA) *Manual for Railway Engineering* (8) includes more extensive discussion of recommended practices that railroads may follow in the construction or reconstruction of highway-rail grade crossings. Similarly, the American Association of State Highway and Transportation Officials' (AASHTO) *Policy on Geometric Design of Highways and Streets* (popularly known as the "AASHTO Green Book") contains discussion of at-grade highway-rail intersections (9). Much of the guidance in these sources concerns crossing geometry and structural profiles that are determined, for the most part, without regard for the surface material that will later be applied. (Appendix B provides relevant sections from both documents.)

GRADE CROSSING INTERSECTION GEOMETRY DESIGN GUIDANCE

Chapter 5 of the AREA's *Manual* contains recommended practices related to engineering aspects of highway-rail grade crossings. Two of the AREA's technical committees develop and maintain this guidance: Committee 1 is responsible for Foundations for Highway-Railway Grade Crossings (D-1-87), and Committee 5 deals with Approaches to Highway-Railway Grade Crossings (D-2-87) and Grade Crossing Surfaces (C-1-87) (8).

The AREA recommends that, at crossings involving two or more tracks, the top of the rails for all tracks as well as the highway surface should be brought to the same plane. The surface of the highway should be at this plane with the top of the rails for a distance of 2 ft outside of rails, regardless of the number of crossings. The vertical curves connecting the top of the rail plane to the highway approaches should provide riding conditions and sight distances normally applied to the highway under consideration.

The surface of the highway should not be more than 3 in. higher or 6 in. lower than the top of nearest rail at a point 30 ft from the rail, measured at a right angle to the rail alignment, unless track superelevation dictates otherwise. If practical, the

highway alignment should intersect the railroad track at or nearly at right angles.

The FHWA's *Rail-Highway Grade Crossing Handbook* suggests that the crossing length, measured along the track, should be sufficient to extend at least 1 ft beyond the edge of the highway pavement, including any paved shoulders on the highway approaches to the crossing. Median strips, shoulder escape routes, and sidewalks normally should have the same surface material installed to provide one continuous crossing surface.

The width of the crossing should meet requirements set by local or state law, but the AREA recommends that width should not be less than 2 ft wider than the width of the highway (excluding shoulders). The width of roadway at the crossing should be no narrower than the approaching roadway. Traffic lanes on all paved approaches to the crossing should be distinctly marked in accordance with MUTCD recommendations.

As might be expected, the AREA is more explicit regarding the rail structure profile, e.g., specifying that treated No. 5 hardwood or concrete ties should be used through the crossing and beyond the crossing for a minimum of 20 ft. Rails through the crossing should be laid to eliminate joints within the crossing and, preferably, with the nearest joint no closer than 20 ft from the end of the crossing. Either long rails or welding of rail ends to form continuous rail through the crossing may be used. Rails should be firmly attached to the ties and protected with an approved rust inhibitor.

Chapter IX of AASHTO's *Policy on Geometric Design of Highways and Streets*, "At-Grade Intersections," contains general guidelines pertaining to the horizontal and vertical alignment of the approaching roadways and the intersection at a highway-rail crossing. AASHTO recommends the highway should intersect the tracks at a right angle, as does the AREA, and that there should be no nearby road intersections or driveways. This layout enhances the driver's view of the crossing and tracks, reduces conflicting vehicular movements from crossing roads and driveways, and enhances safety for bicyclists using the road. To the extent practical, crossings should not be located on either highway or railroad curves, because roadway curvature inhibits a driver's view of a crossing ahead and a driver's attention may be directed toward negotiating the curve rather than looking for a train. Railroad curvature may inhibit a driver's view down the tracks from both a stopped position at the crossing and on the approach to the crossings.

Sometimes complicated crossing geometries are unavoidable, e.g., when a railroad-railroad intersection is located in the same area with a highway-rail intersection or when routes intersect at severely skewed angles (see Figure 11). In such cases, a poured-in-place crossing surface (e.g., PC concrete, cast rubber, or polymer) may be the only technically feasible

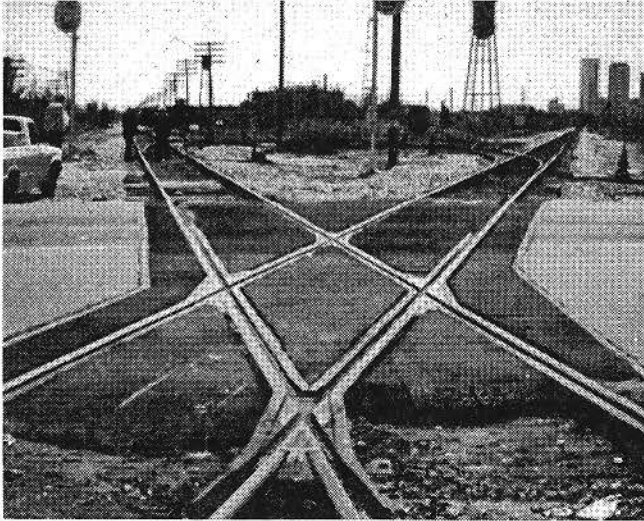

FIGURE 11 Complicated rail-rail-road intersection.

solution, although custom-designed sectional panels may also be fabricated to suit the situation.

Where highways that are parallel with main tracks intersect highways that cross the main tracks, there should be sufficient distance between the tracks and the highway intersections to enable highway traffic in all directions to move expeditiously and safely. Where physically restricted areas make it impossible to obtain adequate stopped-traffic storage distance between the main track and a highway intersection, interconnection of highway traffic signals with the grade crossing signals should enable vehicles to clear the grade crossing when a train approaches; placement of "Do Not Stop on Track" signs on the roadway approaches to the grade crossing may be warranted.

AASHTO suggests it is desirable to have the intersection of highway and railroad as level as possible to enhance sight distances and rideability and to provide maximum braking and acceleration distances. Vertical curves should be of sufficient length to ensure an adequate view of the crossing.

To prevent low-clearance vehicles from becoming caught on the tracks, the crossing surface should be at the same plane as the top of the rails for a distance of at least 0.6 m outside the rails. The surface of the highway should also not be more than 75 mm higher or lower than the top of nearest rail at a point 9 m from the rail unless track superelevation dictates

otherwise (see Figure 12). Vertical curves should be used to traverse from the highway grade to the level plane of the rails.

THE CROSSING SURFACE

As already remarked, there are no national guidelines for selecting the appropriate surface for a specified crossing. The AASHTO Green Book offers no guidance on crossing surface materials and design. Several respondents to this Synthesis study's questionnaire indicated that they refer to FHWA's *Handbook of Highway Safety Design and Operating Practices* (6) for information regarding highway-rail intersections, but the 1978 version of this document contains less than one page devoted to railroad grade crossings, with only brief references to crossing surfaces.

The AREA *Manual* (4) recommends that the operating railroad should have discretion to choose and determine how to use any crossing surface material. Specifications and plans concerning the crossing surface material's use should, however, abide with the manufacturer's recommendations and, where applicable, to the standards of the public agency having jurisdictional authority at the specific location.

As with crossing geometry, the AREA *Manual* is more explicit about the rail structure in the crossing. Flangeways, for example, should be not less than 2.5 in. or more than 3 in. in width, and generally at least 2 in. deep. The track surface should be machined or mechanically tamped and surfaced to grade and alignment. As many train movements as time permits should be allowed across the crossing before final surfacing and alignment, to help achieve the optimum ballast compaction through the crossing area. The ballast and subballast should be dug out on an existing structure, to a minimum of 10 in. below the bottoms of the ties, 1.0 ft beyond the ends of the ties, and 20 ft beyond the end of the crossing, and rebalasted to conform with AREA specifications.

In situations where the grade of the highway approach descends toward the crossing, provisions should be made to intercept surface and subsurface drainage and discharge it laterally so that it will not reach the track area. Surface ditches shall be installed and, if necessary, subdrainage with suitable inlets and provisions for clean-out. The drainage should be connected to a storm water sewer system, if available, or to suitable piping, geotextile fabrics or French drains. Where

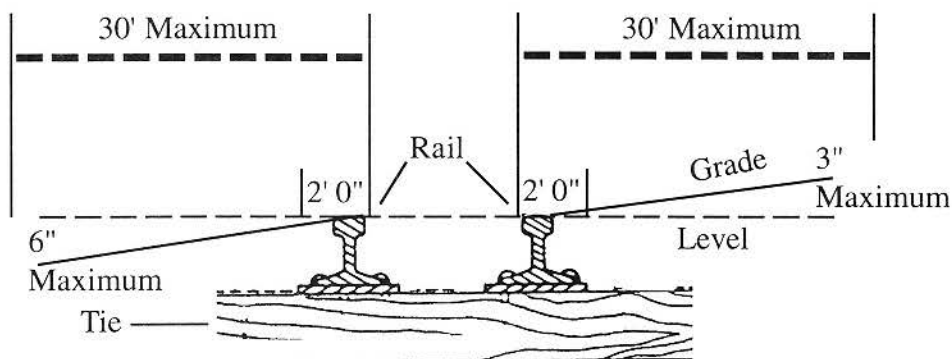

FIGURE 12 AASHTO design policy for elevation at highway-rail crossings.

gravity drainage is not possible, a sump may be provided or the crossing may be sealed and the track roadbed stabilized by using asphalt ballast or its equivalent (Figure 13).

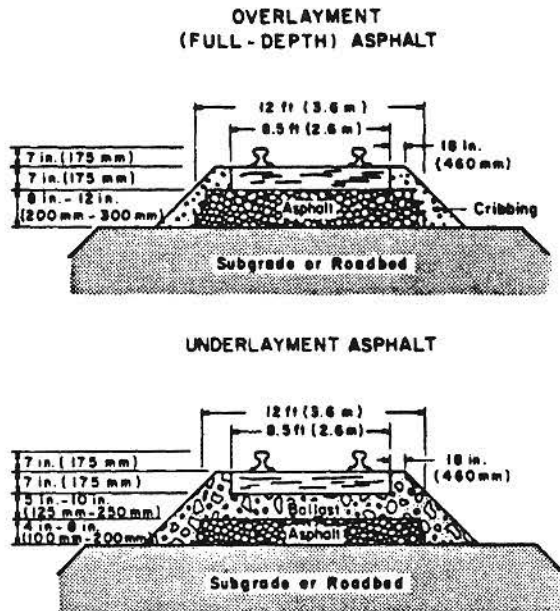

FIGURE 13 Use of hot-mix asphalt in overlayment and underlayment application.

The *Manual* recommends that geotextiles, also termed filter fabrics, be used between the ballast section and the subgrade under the crossing and at least 20 ft beyond each end of the crossing. If a rail joint falls within these limits, the fabric should be further extended at least 5 ft beyond the rail joint. If practical, the geotextile fabric should extend under the roadway approach surface as well, 15 ft each way from the center line of the track.

CROSSING DRAINAGE

Effective drainage (Figure 14a) is widely recognized as the most important element in ensuring the long-term good ride quality and economical maintenance of a crossing. In cases where train weights and frequencies have increased in the years since the track structure was constructed, drainage is often the key to a stable track structure (10). Increased train weight increases compressive forces on the subgrade forcing water from high moisture-content subgrade soils upward into the foundation. The bearing capacity of susceptible soils (e.g., compressible clays and silts) can lose half of their compressive strength when saturated. Ditching to lower the water table beneath the track structure is a common method for reducing the moisture content of the subgrade. Care must be taken in crossing design and maintenance not only to avoid blocking such drainage, but also to ensure that the roadway structure neither acts as a dam blocking the free-draining track-ballast section nor channels water directly from the road surface into the track structure. Figure 14b illustrates damage that can be caused by poor crossing drainage.

The *Railroad-Highway Grade Crossing Handbook* recognizes the importance of crossing drainage, asserting that good



FIGURE 14a A properly drained crossing surface.

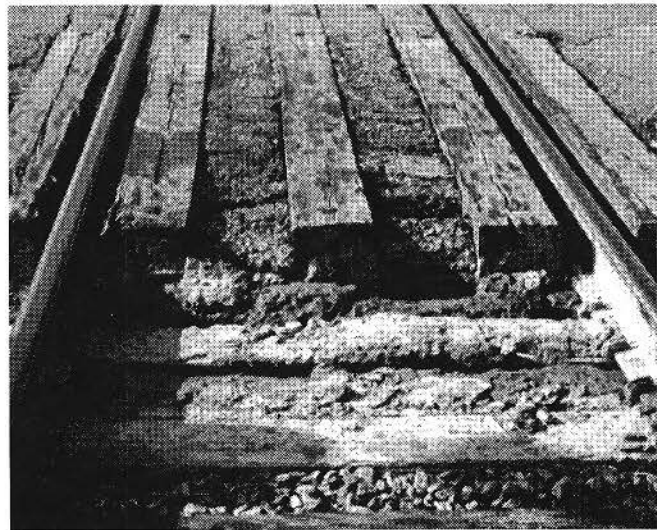

FIGURE 14b A poorly drained crossing surface.

drainage of the subgrade is essential to good performance from any type of crossing surface. The *Handbook* recommends that surface and subsurface drainage should be intercepted and discharged away from the crossing. The highway profile at all crossings should be such that water drains away from the crossing (11).

A recent report by the Association of American Railroads (AAR), *Track Substructure Drainage* (12) gives a detailed technical discussion of drainage requirements. The report suggests that both "external" and "internal" track drainage must be functioning well to ensure that water entering the track structure exits rapidly. External drainage refers to ditches along the track that carry water away from the structure. Internal drainage refers to the geometry and permeability of track structure itself, i.e., the several layers of material beneath the rails. Both blocked or poorly graded ditches and fouled and clogged ballast can severely damage the structural performance of the track structure and crossing.

SURFACE DESIGN CONSIDERATIONS ASSOCIATED WITH SPECIAL USERS

Automobiles and standard trucks represent the principal types of highway vehicles for which crossing surfaces must be designed. The practices and guidance cited previously are aimed at accommodating this traffic. Special design considerations arise when other types of users must also be accommodated.

As already noted, *low-clearance vehicles* are one such type of user and include double-drop lowbed equipment trailers, boat transporters, auto transporters, and double-drop livestock trailers. A survey of traffic on interstate and federal-aid primary highways in West Virginia in May 1990 found that 13 percent of the traffic stream was trucks and that low-clearance trucks were only 0.8 percent of all traffic (or about 5.7 percent of all trucks).

Based on several National Transportation Safety Board (NTSB) accident investigations, conversations with highway and trucking officials, and the issuance (by the FHWA Office of Motor Carriers) of an "On Guard" advisory to truck drivers, researchers concluded that hang-up accidents are a serious problem. These researchers asserted that "low-ground-clearance vehicle hang-up accidents on railroad-highway grade crossings underscore the lack of readily available geometric standards for designing and maintaining roadway profiles at grade crossings . . . ;" although some highway agencies have developed such standards they are not commonly used by highway engineers (13). The researchers developed a computer program that incorporates graphics and animation to simulate the movement of trucks over grade crossings, predicting where hangups will occur, caused when vehicles with low ground clearance "hump" grade crossings. The HANGUP program, intended to run on the IBM-PC or compatible personal computers, was programmed using the Microsoft Quick BASIC compiler Version 4.5 under MS DOS Version 3.3. The program is not widely in use.

Most highway-rail crossing surfaces in principle accommodate *pedestrian traffic* as well as motor vehicles. However, where a dedicated public sidewalk crosses the tracks (i.e., primarily in urbanized areas), the crossing should be constructed and maintained to provide the same degree of safety for pedestrians as for vehicles. This provision is not always routinely made (see Figure 15a). Sidewalk users (pedestrians with or without child carriages, bicyclists, and wheelchair users) may find it difficult to negotiate a crossing that does not offer a smooth surface and relatively flat grade (Figure 15b).

The Americans with Disabilities Act (ADA) requires that public buildings provide barrier-free access to mobility impaired individuals and may apply to grade crossings in areas where such individuals are likely to require access. The Architectural and Transportation Compliance Board has proposed standards (Section 14.2.1), not yet officially adopted, setting out minimum requirements for new construction of public sidewalks over railroad tracks. Among other things, the standards specify that the public sidewalk surface must be level and flush with the rail top at the outer edge and between the rails, with a horizontal gap on the inner edge of each rail (necessary to allow passage of rail-vehicle wheel flanges) not

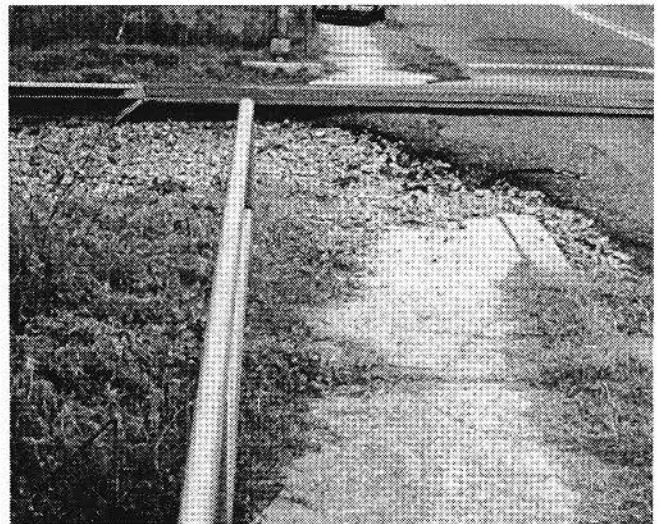

FIGURE 15a Provision not made for sidewalk through track structure.

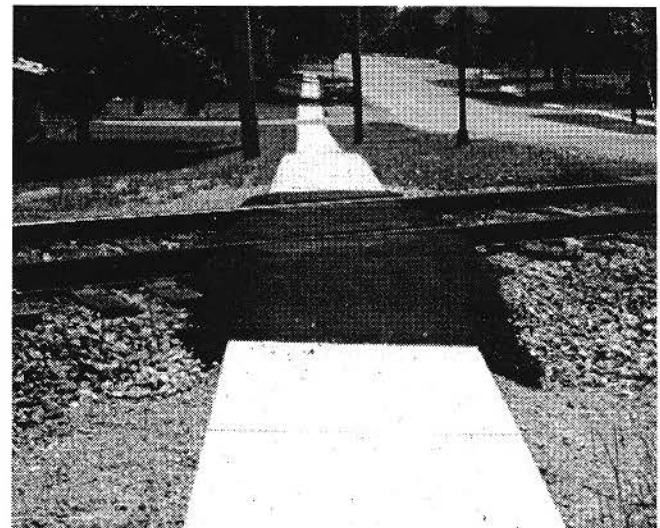

FIGURE 15b Appropriate sidewalk design through track structure.

exceeding 2.5 in. (64 mm). Figure 15c shows the design of an accessible crossing surface at the Opryland theme park in Nashville, Tennessee, which includes an insert in the flangeway of sufficient length to accommodate wheelchairs and motorized carts. The passage area is clearly marked for safe use. More than one-third of the respondents to this synthesis questionnaire reported that ADA requirements are not considered in the construction and maintenance of grade crossings.

The MUTCD and the *Railroad-Highway Grade Crossing Handbook* say little about the design or signing for bicycle paths or for motorcycles crossing railroad tracks. The *Handbook* states that surface materials and the flangeway width and depth should be evaluated for safety, noting that the more the crossing deviates from the ideal 90-degree crossing, the greater the potential is for a cycle wheel to be trapped in the flangeway. If the crossing angle is less than 45 degrees, consideration should be given to widening the bikeway to

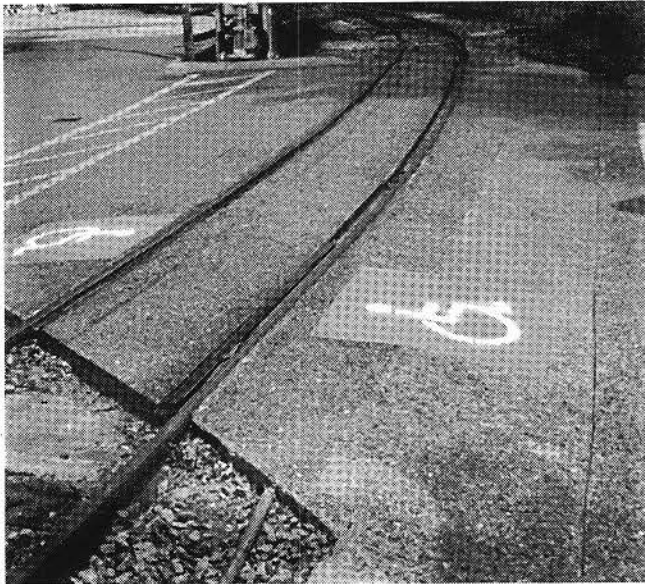

FIGURE 15c Example of accessible crossing surface.

allow sufficient width to cross the tracks at a safer angle. The bicyclist should be warned with suitable markings and signs that the trail is approaching a grade crossing. Figure 16 illustrates an example of how a “bad-angle” crossing may be designed to provide for improved bikeway safety. Not only was the bikeway removed from the adjacent grade crossing and relocated to a point where a 90-degree bikeway-track crossing could be constructed, but unique signing also was installed at the intersection. While motorcyclists use the regular roadway, there are similar concerns for skidding and tire width.



FIGURE 16 Relocated bike path to elevate bad-angle crossing.

NEWER CROSSING DESIGN CONCEPTS

As already noted, current crossing designs create relatively abrupt changes in stiffness for both highway and railroad as they enter the crossing. This discontinuity, combined with the problems of drainage, account for many of the structural failures of at-grade crossings. Researchers at the Texas Transportation Institute have sought to devise a new conceptual crossing design that would deal more effectively with both problems. A key element of the concept is provision of a gradual increase in stiffness on the approaches. For the highway, pavement depth would increase over a distance of 100 to 150 ft from the track edge, maintain a constant depth through the crossing, and then decrease gradually to its original design thickness over a distance of 100 to 150 ft on the other side of the crossing. The researchers suggest that this tapering will drastically reduce stress concentration and, with adequate drainage, should eliminate the problem of pavement raveling at the edge adjacent to the track.

Similar tapering of railroad trackbed stiffness would be much more difficult to accomplish; researchers, however, suggest that anything that spreads the effect of the crossing out over a larger area will reduce the potential deterioration of the trackbed. Hot-mix asphalt concrete (HMA) and geotextile underlayers below the normal ballast section and continuation of the asphalt concrete section below the ties throughout the crossing might be employed.

Figure 17 illustrates the difference between typical current (a) and new-concept (b) designs. Note that the depth of the pavement and the total height of improved subgrade are increased in the new design, while the normal 6- to 8-inch ballast section remains unchanged. The researchers suggest that

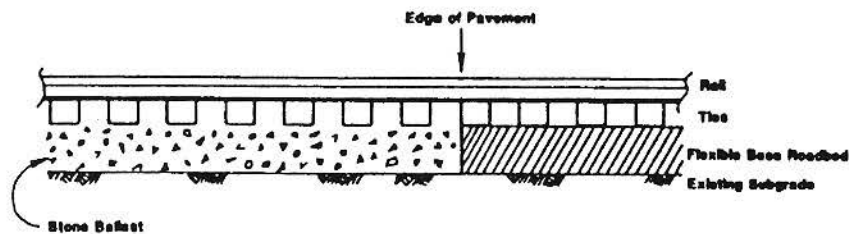

FIGURE 17a Cross section of crossing surface prior to hot-mix asphalt application.

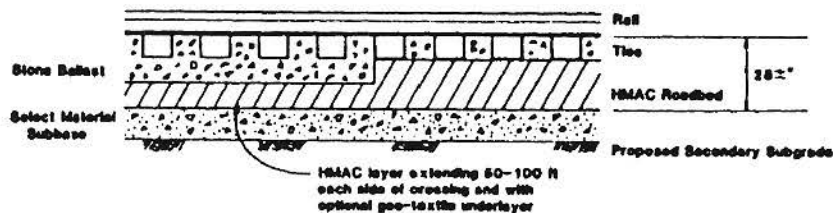

FIGURE 17b Cross section crossing surface following hot-mix asphalt application.

any of the available crossing surface materials, e.g., timber or concrete, could be used with this new concept. The design has not been widely tested.

HMA is also used as a subballast underlayment or overlayment, to solve specific instability problems (15). An HMA mat is placed directly on either subgrade or old roadbed and covered with a layer of ballast on which the ties are placed. With the overlayment or "full-depth" method, there is no intervening ballast used between the HMA mat and the ties. The placement of ties directly on top of the HMA mat requires a very smooth, plane HMA surface. Cribbing aggregate is placed between and at the end of the ties to restrain track movement. Such a use of HMA improves the load distribution to the subgrade, waterproofing of the subgrade, and confinement of both subgrade and ballast, thus providing more consistent load-carrying capability for the trackbed, even on subgrades of marginal quality. In addition, the HMA mat provides a positive separation of ballast from the subgrade, thereby eliminating subgrade pumping.

FAILURES OF CROSSINGS AND THEIR SURFACES

Crossing surface failure occurs when the crossing ceases to provide a safe, smooth ride at reasonable speeds for highway vehicles or trains. The failure may occur in the riding surface or, most frequently, within the load-bearing structure of the crossing.

The literature on crossing surface evaluation studies suggests no definitive way of predicting general crossing surface failure. Experimental installations and research sponsored by FHWA and several states indicate that surface failure is highly dependent on the type of crossing surface, site preparation, and the installation methods used for the surface material. Appendix D presents a brief cataloging, with illustrations, of examples of typical modes for crossing surface failure.

In general, inability to withstand the impact loads imposed by highway vehicles passing over the irregularities of the crossing (e.g., at the rails and flangeways, sharp grade transitions) is a primary cause of surface failures. Asphalt surfaces, for example, are particularly prone to edge raveling, alligator cracking, and longitudinal deterioration. Surface abrasion, splitting and compaction of shims, and displacement of rail and surface-material fasteners can create irregularities that increase impact loads and lead to larger-scale cracking of pavement and crossing materials. Wood-plank and timber-panel crossings are also subject to rot and splitting. Wood, rubber, and other relatively plastic materials may be damaged by scraping of low-clearance vehicles or other heavy equipment.

Improper seating of crossing materials and loosening of fastenings can allow motion of the surface material and create stresses and wear in areas other than those exposed to wheel impact. Damage occurring below the surface may not be detected until it is serious enough to be visible on the surface level. Stress concentrations around holes drilled in the surface material to accommodate fasteners are another source of weakness and early damage.

Despite these difficulties, studies conducted by participants in that FHWA Office of Highway Operations' Experimental Projects Program confirm that most problems associated with crossing surfaces relate to site preparation or the installation of the surface materials. The principal causes of crossing failures, as summarized by a Pennsylvania Department of Transportation study, are shown in Figure 18 (16).

Particular attention was mandated by law in such studies to the performance of proprietary "high-type" crossing surfaces (see Appendix E), for crossings constructed or improved using federal funds. The PennDOT study highlighted several problems with proprietary surfaces, including abrasion and structural failure of the surface-material member (e.g., metal panel); loose or broken wood support-shims; loose or broken mechanism securing the surface material to the track structure, due to over-stressing or to corrosion caused by poor drainage of the

Cracks and settlement of approach pavement and crossing-surface joint due to
 Inadequate compaction of subgrade, ballast, and pavement material in the area from the end of the tie to the existing pavement.
 Failure to install header board.
 Misaligned and damaged header boards.
 Failure to seal or maintain pavement/crossing joint with rubberized asphalt sealant.
 Inadequate existing pavement removed for crossing installation, creating a space too narrow to compact replacement materials properly.
 Improper crosstie length creating voids and misalignment between header boards.

Crossing settlement causing poor transition and premature loss of riding comfort, due to
 Inadequate ballast depth and/or compaction under rails.
 Unstable subgrade (e.g., due to inadequate preliminary investigation by soils engineer).
 Inadequate or improperly installed drainage system.
 Improper establishment of highway crossing elevation.

Poor drainage of crossing area, due to
 Improper size of coarse aggregate for pipe backfill.
 Damaged pipe used and improperly installed.
 Improperly sloped pipe.
 Heatbonded geotextiles often chosen to wrap trenches, thus trapping water and not providing planar flow.
 Excess flow into crossing area when excessive debris and "road dirt" accumulate along the flange way.

Lightweight and heatbonded fabrics or otherwise inadequate geotextiles used for trackbed stabilization, typically due to inadequate specification.

Damage to high-type crossing surface material, due to
 Dragging railroad equipment where end drag protection plates are missing.
 Digging by blades of highway snowplows.

FIGURE 18 Principal causes of crossing failure cited in PennDOT studies (16).

track structure; loss of numerous panel spike plugs or rubber caps; and minor cracking in surface material.

Similar studies by the Louisiana Department of Transportation and Development (LADOTD) concluded that "problems which have been noted are generally limited to individual design or poor construction techniques rather than the durability of the materials (17). However, the evaluation report concluded also that the general overall performance of rubber panels was considered satisfactory while installations of high-density polyethyl or structural foam rubber products were classed as unsuitable for LADOTD use. The study included review of a novel poured-in-place rubber-type crossing con-

sisting of ground rubber tires blended onsite into a two-component epoxy. This product, generally used in proximity to switches or with odd track configurations, was rated well by evaluators.

Emphasizing the importance of site preparation, the FHWA's *Grade Crossing Handbook* states that "proper preparation of subgrade cannot be overemphasized. Several states have experienced problems with crossing surfaces that can be directly related to inadequate subgrade preparation" (11). Typical subgrade preparation problems noted are inadequate compaction, frost heaving of pavement on highway approaches, and improper placement of filter cloth.

GRADE CROSSING SURFACE SELECTION

While the railroad industry and public agencies annually spend millions of dollars on crossing surfaces, little research has been conducted on selecting the most cost-effective surfaces. The Florida Department of Transportation sponsored development of a Highway-Railroad *Grade Crossing Material Selection Handbook* (18) that judges crossing-surface life-expectancy in three broad categories of crossing surfaces (high-, medium-, and low-type, referring to degree of strength and finish, based primarily on direct observations of crossing conditions). Asphalt and panelized timber are included in the same category, a judgment that some users find questionable.

A 1993 survey of states' practices for improving highway-rail intersection safety found that 57 percent of the states surveyed did not have written guidelines for the selection of appropriate crossing surfaces (19). Those guidelines that were established referred generally to conditions warranting the selection of high-type crossing surface materials. ADT was mentioned almost exclusively as the determining factor in material selection; e.g., some states required crossings to have ADT counts in excess of 20,000 to qualify for rubber, while others required as little as 5,000 ADT to qualify for this surface. Concrete panels generally were considered appropriate for crossings with ADT in the range of 1,000 to 5,000 vehicles. Some states reported using an index to make crossing surface improvement decisions. In almost all cases, research and practice have primarily considered the highway related aspects of the crossing, with little regard for the joint costs of both the railroad and highway (20).

PRINCIPAL FACTORS AFFECTING CROSSING SURFACE LIFE

Regardless of the characteristics of the road traffic using the crossing, and with the possible exception of wood-surfaced crossings (which are more subject to environmental degradation than other surface types), the loads that traffic imposes are the primary determinants of the crossing surface's life and of

the preferred surface type. The volume of this traffic, typically expressed as ADT is measured in passenger-car units, but heavier and multi-axle vehicles (e.g., trucks) can impose loads on the crossing surface that are heavier or more frequent or both. Hence, ADT levels are generally supplemented, at a minimum, with an estimate of the percentage of trucks in the traffic stream. Taken together, ADT and percentage of truck are the two key parameters in selection of crossing surfaces. Some engineers have developed design formulas that also take into consideration highway speed and rail traffic.

There are several aspects of trucks that could account for a particular role in crossing surface wear. Heavy trucks, for example, typically have six to 18 wheels, so that a truck can impose two to four times the number of impacts that an automobile imposes on the crossing. However, the weight carried on a truck tire is up to 2.2 tons, compared to a car's 0.375 tons, so the load-equivalency would be approximately 5.9 car tires for each truck tire. In addition, the contact pressure of a truck tire on the pavement surface is 50 to 100 percent higher than that of a car, and tire pressures are four to five times higher than a car's. Further, the mass of the truck's wheels and axle is nearly six times greater than that of a car. Considering all these factors, the impact damage a truck tire imposes on the crossing surface is estimated to be some 20 to 30 times higher than that for a car tire, and a truck with three times more wheels on average than a car, is probably equivalent to 50 to 100 cars in terms of structural loading. Considering surface abrasion, a truck has about 50 times the wheel contact area of a car.

Despite these theoretical arguments, a review of the data available on the influence of trucks on crossing life shows no consistent equivalency relationships between cars and trucks. One study (20) presents estimates of crossing-surface life (for crossings with little train traffic) as a function of a Car-Equivalent Count (CEC), defined as the sum of the number of cars plus 100 times the number of trucks in the ADT. Table 5 and Figure 19 show the estimated life of crossings as a function of highway traffic measured with this indicator.

TABLE 5

LIFE OF GRADE-CROSSING SURFACES FOR VARIOUS HIGHWAY TRAFFIC LEVELS—NEGLIGIBLE RAILROAD TRAFFIC

CEC/Lane	Asphalt	Asphalt & Timber (1)	Asphalt & Rail (1, 2)	Timber Panels	Rubber & Timber	Rubber Long. Shim	Rubber Lat. Shim	Rubber Full Depth	Concrete (3)
1,000	15.0	25.0	30.0	28.0	30.0	28.0	28.0	30.0	30.0
5,000	6.5	12.5	18.1	13.0	18.1	18.5	18.5	18.6	24.0
10,000	4.8	10.4	15.4	10.9	15.4	16.4	16.4	16.7	20.2
25,000	2.5	7.6	10.8	8.1	11.3	13.5	13.5	14.7	16.4
50,000	1.3	6.2	7.4	6.6	8.9	11.6	11.6	13.5	14.1
75,000	1.1	5.7	5.8	5.8	7.7	10.7	10.7	12.5	12.5
100,000	1.0	5.0	5.0	5.0	7.0	10.0	10.0	12.0	11.0

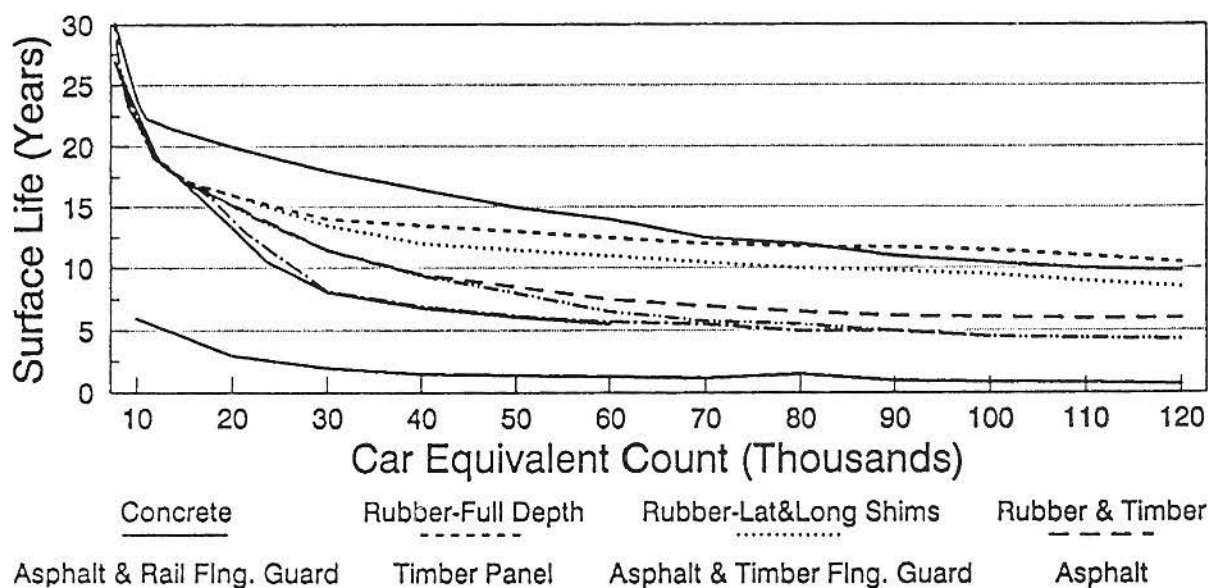

FIGURE 19 Service life of grade crossing surfaces—years versus highway traffic with limited railroad traffic.

In general, many factors besides rail and highway traffic influence crossing-surface durability. When there are parallel railroad tracks within the crossing, for example, increased dynamic loading from road traffic occurs on the second track and can reduce crossing-surface life by up to 10 percent for typical track spacings. If the crossing is in a curve (unless train speeds are very low), track superelevation places one rail higher than the other, also resulting in higher road-traffic impact loads. A function of the amount of superelevation and highway speed, this effect can shorten the surface life by up to 15 percent. Crossing angle and high highway-vehicle speeds (e.g., 40 to 50 mph) can cause similar reductions in crossing-surface life.

Track maintenance neglect, e.g., track through the crossing not surfaced on a regular basis, can cause uneven tie settlement and more rapid crossing failure, particularly with surfaces consisting of longitudinal beams or asphalt. Crossings with large numbers of hold-down screws will fail more quickly if not maintained, and in those situations where water can drain into localized areas of the crossing, e.g., through fastener holes or cracks in asphalt, more rapid tie settlement will occur.

Crossings with higher levels of road traffic are likely to generate feedback from the public. Greater numbers of people complain when the crossing surface becomes rough. The crossing then may have a shorter effective life because of the extra incentive for replacement that public scrutiny generates.

Railroad traffic can influence grade-crossing settlement and deterioration of the track structure under the road surface. Uneven settlement causes more rapid failure of certain types of crossing surfaces and the need to periodically remove road surface for releveling of the ties (referred to as “surfacing” or “tamping”). Also, rail uplift ahead of the rail wheels can cause failure of the road surface closest to the rail, especially if surfaces have asphalt flangeway fillers. Rail traffic is generally measured in terms of its annual load density (e.g., in million gross tons, MGT), train speed, and type of trains. Figure 20

shows an estimate of the relationship of crossing surface life and rail traffic, based primarily on the tamping cycle in rail-line maintenance.

A variety of other factors can affect the life of a grade crossing surface. For example, the mismatch between durability of grade crossing surface and track components (e.g., rail, tie, ballast, and subgrade) is such that the crossing surface may be replaced several times during the life of the track components. However, the need to temporarily remove the surface to align and level the railroad track, particularly on heavily used rail lines, may reduce the surface material’s life. Crossing geometry such as highway width (number of traffic lines), angle of crossing to road, drainage, number of tracks, rail size, and superelevation.

LIFE-CYCLE ECONOMIC APPROACH TO SURFACE SELECTION

Most observers would agree when the surface provides a noticeably uncomfortable ride and becomes a potential safety hazard, it has failed. However, there are no widely accepted specifications defining the onset of crossing surface failure. Hence, there are no widely accepted procedures for determining likely service life of a particular surface material exposed to particular highway traffic, rail traffic, and environmental conditions. The previously mentioned work by Burns (20) specifies distinct failure modes for the principal types of crossing surfaces, as shown in Table 6. Burns also provides guidelines on how crossing-surface life will be influenced by highway speeds, crossing angle, track spacing and superelevation, and other factors. Generally these guidelines involve adjustments of the CEC estimate at the crossing.

By conducting a life-cycle economic analysis of alternative crossing surfaces under various traffic conditions, Burns develops a graphical display that indicates a likely-least-cost surface as a function of highway and rail traffic at the crossing, as

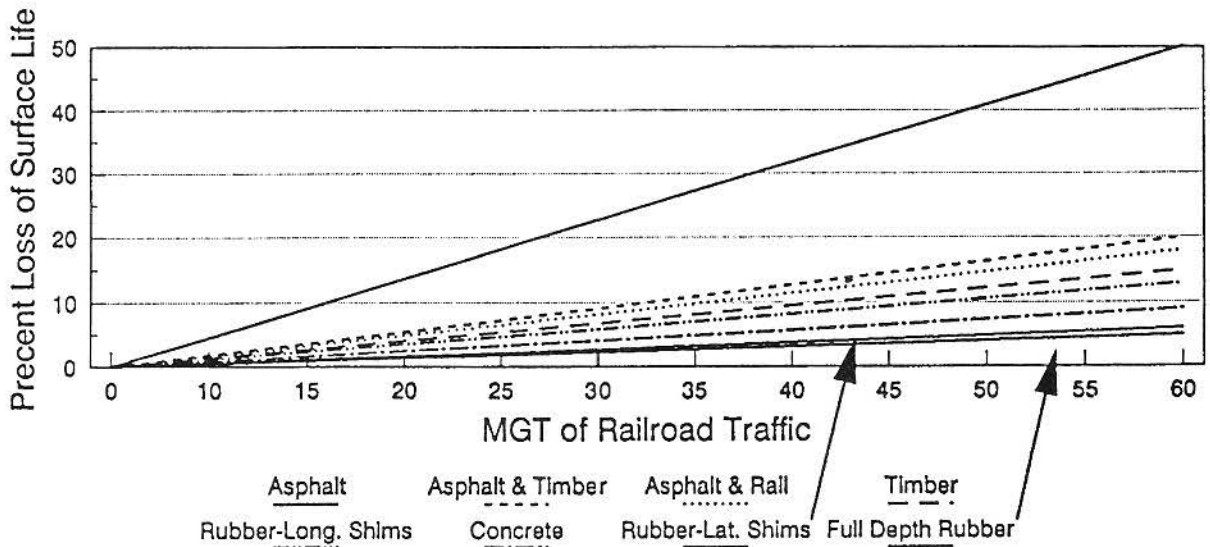

FIGURE 20 Percentage loss of road surface as a result of rail traffic (slope of graph is the rail traffic adjustment factor).

TABLE 6
PRIMARY MODES OF CROSSING SURFACE FAILURE

Surface Type	Failure Mode	Low Rail Traffic	High Rail Traffic
Asphalt	Inability to withstand impact loads	Failure at flangeway	Failure at flangeway plus the asphalt failure above ties as ties settle under the traffic
Asphalt and wood	Wood abrasion and rot and asphalt inability to withstand impact	Wood abrasion and rot	Wood abrasion and rot plus the asphalt failure above ties as ties settle under traffic
Asphalt and rail	Asphalt inability to withstand impact	Failure of asphalt along running rail. Guard rails become loose	Failure of asphalt above ties as ties settle under traffic, guard rails become loose
Timber panels	Abrasion, rot and impact damage resulting from loose fastenings	Abrasion, rot loosening of fastenings	Uneven settlement of ties causing uneven loading on panels, and loosening of fastenings
Rubber-timber panels	Failure of timber panels	Rot and loosening of fastenings	Uneven settlement of ties causing uneven loading on panels and fastenings and loosening of fastenings
Rubber-longitudinal shims	Failure of timber panels	Rot and loosening of fastenings. Since the panels are thinner, and grain parallel to rail, splitting.	Uneven settlement of ties causing uneven loading on panels and fastenings and loosening of fastenings
Rubber-lateral shims	Loosening of fastenings and splitting of shims	Loose fastenings and splitting of shims. Header board failure.	Loose fastenings, splitting of shims, also uneven settlement. Header board failure
Rubber-full depth	Abrasion, rubber separation	Abrasion	Uneven tie settlement will cause distortion resulting in rubber separation
Concrete panels-shimmed	Abrasion of surface, cracking of panels	Abrasion of surface	Abrasion of surface and lack of panel support from tie settlement will result in cracking and panel abrasion.
Concrete panels-full depth	Abrasion of surface, cracking of panels	Abrasion of surface	Abrasion of surface and lack of panel support will result in cracking and panel abrasion. Failure of asphalt flangeway filler resulting drainage problem will reduce substructure support.

shown in Figure 21. An important part of the analysis is the expectation that less durable surfaces subjected to higher-than-anticipated traffic wear out, fail, and must be replaced. There is then a tradeoff among construction and maintenance costs and crossing ride-quality and safety that is the basis for defining an optimum surface material in any particular situation.

The analysis and the results reflected in Figure 21 are primarily theoretical, however, and have not yet been verified through extensive testing and in-service observation.

The selection chart is designed to be used by first determining the ADT and the percentage of trucks, the number of highway traffic lanes, and the railroad traffic (MGT) to be

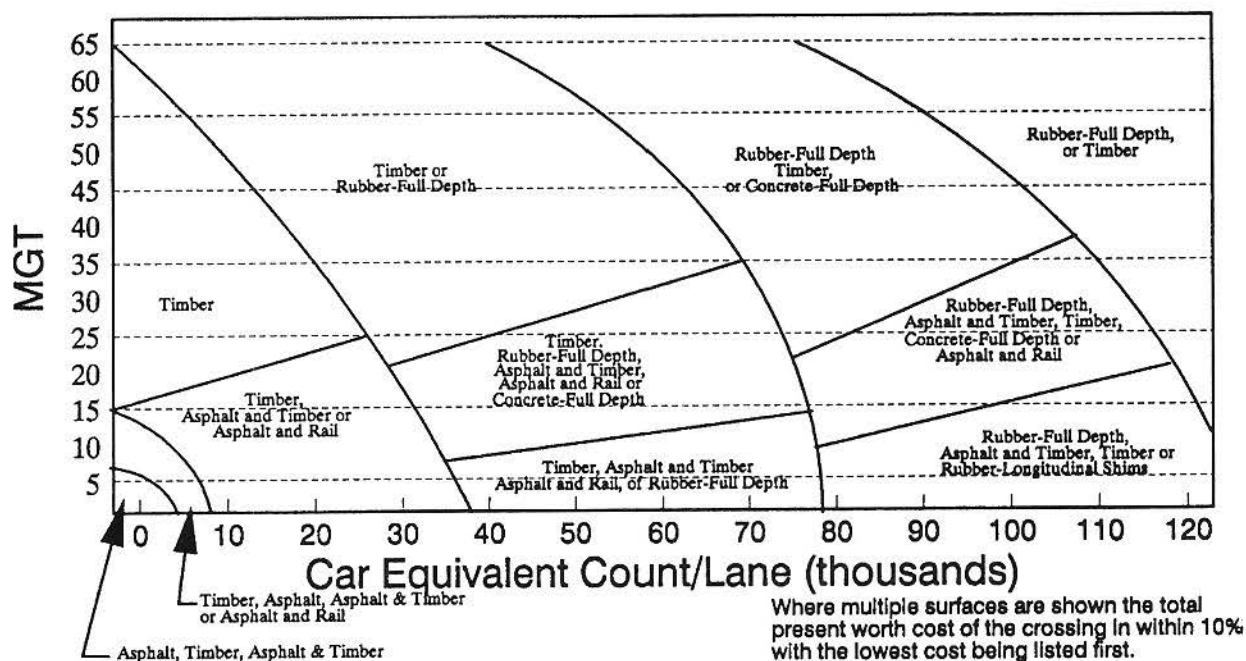

FIGURE 21 Selection chart for grade crossing surfaces.

FACTOR	OVERALL RANK
The importance of good ride quality	1
Volume and type of highway traffic	2
Functional class of roadway	3
Type of roadway surface on the roadway approach	4
Motor vehicle speed	5
Drainage conditions	6*
Type and volume of railroad traffic	6*
Initial construction cost including both rail and road	8
General classification of the railroad; main line branch, industrial, yard	9
Nature of subgrade of the roadway and track	10*
Replacement cost, including estimated life of materials	10*
Maintenance cost, including both roadway and railroad	12
Climatic conditions	13
*Tie for rank	
Source: State Survey Response	

FIGURE 22 Factors judged by state agencies to be important in selection of crossing for improvement, in order of priority.

accommodated at the crossing. Truck traffic is multiplied by 100 and added to the car traffic to determine the basic CEC for the design lane; on a multilane highway, the outside lanes will typically carry a relatively higher proportion of the traffic than the inside lanes. Secondary factors that can reduce crossing life are considered by increasing the CEC count, e.g., if there is more than one railroad track and the tracks are less than 20 ft apart on centerlines, the CEC is increased by 10 percent.

Where several surfaces are found to be equally suited to the traffic conditions, Burns recommends that secondary factors such as the following are an appropriate basis for surface selection:

- Road characteristics that force changes in traffic speed or direction warrant the use of a surface that does not so easily abrade, e.g., PC concrete.
- If adjacent track is likely to be poorly maintained, then preference should be given to surfaces that can better withstand poor maintenance, e.g., full-depth rubber or concrete.
- If the crossing is located in an urban environment or is used by a large number of cars, preference should be given to a high-type crossing, e.g., concrete or rubber rather than timber-panels, with better long-term ride characteristics.

STATE PRACTICES IN CROSSING SURFACE IMPROVEMENT

The selection of crossing surfaces is typically made in the context of improving existing crossings. The survey conducted as part of this synthesis study included a question asking those states without written improvement policies to judge the importance placed on a variety of physical and operational characteristics of the crossing that might be considered in selecting a highway-rail intersection for crossing surface improvement. Figure 22 lists these characteristics in order of the importance accorded them by agencies responding to the questionnaire.

While 62 percent of the respondents reported that they have specific programs for highway-rail grade crossing improvement, most states reported that they rely on railroads to make crossing surface selections and that agency staff had received no special instructions or training in how to select, construct, or maintain grade-crossing surfaces. Most respondents identified the AREA recommended practices or the AASHTO Green Book as their principal sources of guidance. Appendix G gives details of agency responses.

Some states have developed crossing-design criteria to meet special purposes in their states. For example, Alaska requires that the grade of approaches to all crossings be level with top of rail (± 1 in.) for at least 100 ft to prevent long, low trailers from hitting the crossing; short-radius curves and skew-angle approaches below 75 degrees are not permitted.

The state of Arkansas uses diagnostic teams to conduct crossing inspections and rate the need for improvements. A formal inspection report on the "Highway-Railroad Crossing Surface" is the basis for selecting grade crossings for surface improvements. The crossing surface is assigned a numerical score by using the following parameters:

- Visual Inspection (rated excellent to poor),
- Rideability (rated excellent to poor),
- Average Daily Traffic (ADT),
- Average Daily Trains (number of trains),
- Posted highway speed limit (MPH),
- Percent Truck Traffic, and
- Drainage quality (rated excellent to poor).

GRADE CROSSING SURFACE MANAGEMENT

Management of the crossing surface must begin when the crossing is constructed and continues with maintenance (or its neglect) throughout the crossing's existence. Both railroads and highway agencies face the problem of ensuring that each crossing under their jurisdiction gives safe and operationally acceptable service and that the total cost of managing their entire crossing inventory is financially in balance with the demands imposed by rail and highway traffic.

INSTALLING CROSSING SURFACES

As described in chapter 3, the FHWA's *Rail-Highway Grade Crossing Handbook* includes extensive discussion of the specific requirements for effective construction of crossings and installation of crossing surfaces. Installation may involve construction of a new crossing, reconstruction to expand the size or otherwise alter the crossing geometry at the location of an existing crossing, or replacement and possibly upgrading of the surface materials at an existing crossing.

In all cases, proper preparation of the track structure and ensuring good drainage of the subgrade are essential. Surface and subsurface drainage should be intercepted and discharged away from the crossing. A suitable filter fabric spread over the entire subgrade area under the crossing and for a sufficient distance beyond can significantly improve the crossing's structural characteristics. Numerous fabrics made of polymeric materials, woven or nonwoven (e.g., produced by spunbonding or felting) are available. Such "engineering fabrics" or "plastic filter fabrics" have various applications in below-grade drainage structures and, together with ballast or other granular material, can be used to construct nonclogging French drains, combined with perforated pipe, where greater flow capacity is needed.

When used, the fabric should be rolled beyond each end of the crossing for at least 20 ft. If a rail joint falls within this 20-ft distance, the fabric should extend at least 5 ft beyond the rail joint. If practical, the fabric should extend under the highway surface 15 ft each way from the center line of the track. One manufacturer suggests extending the fabric up the sides of the crossing to prevent soil fines from migrating horizontally into the clean ballast. This technique is called encapsulating or building a fabric envelope.

Ties and rail also warrant special attention within the crossing. Ties should be well-seated in clean ballast and fully tie-plated and box anchored within the crossing area and for at least 20 ft beyond. The rails through the crossing should be laid or welded to eliminate joints within the crossing and this extended area of 20 ft from the end of the crossing. The use of heavier rail through the crossing area may be warranted at crossings with high traffic volumes. Rails should be spiked to line and the track mechanically surfaced to appropriate grade and alignment so that the crossing surface is in the same plane

as or slightly above the top of the rails for a distance of 2 ft outside the rails, to minimize rail jarring and overturning from the movement of heavily loaded highway vehicles. The details of flangeway geometry and crossing-surface grading immediately adjacent to the rails must be adjusted to prevent damage to either the rail vehicle or the crossing surface when trains pass through. Flangeway openings are formed by using removable spacers (e.g., wood strips) adjacent to the head of the rail and removing them after the surface has been placed or by using permanently fastened timbers or scrap rails to provide a more durable flangeway.

Following completion of initial tamping, arrangements should be made for rail traffic to move over the track to compact the track structure (e.g., ballast settlement). The track should then be retamped to assure track stability.

When the crossing occurs on signalized track, the rails must be kept insulated one from the other. Metal contact and possibly standing water between the rails will shunt the track circuit and cause signal failures. It may be necessary in highway resurfacing projects to raise the crossing surface, to avoid creating a pocket or depression that will attract surface drainage into the crossing area.

When either track or highway resurfacing projects include a crossing, care is required to avoid detrimental effects to the crossing surface. In track surfacing projects, the general track raise should be tapered off in the area approaching the crossing, to avoid disturbing the elevation of the crossing, or the level of the entire crossing should be raised and gradual adjustments made in the grade-line of the highway approaches (consistent with the profile-design criteria for the class of highway). If more than one track is involved, the adjusted surface of the entire crossing should be kept in one plane and all tracks should be raised to correspond with the new elevation (Figure 23).



FIGURE 23 Multiple tracks in a crossing with different elevations.

Cooperation between railroad and highway authorities, in planning and scheduling such work, will help to avoid adverse effects on grade lines of either rail or highway. Avoiding grade conflicts is particularly important in snow removal; a trough at the track line (e.g., caused by incomplete snow removal on the crossing and approaches) may cause vehicle stalling. The snow plow operation must not cause damage to the rails nor should it create windrows across the track or the highway.

CROSSING SURFACE REPAIR AND REPLACEMENT

In most cases, there is no exact definition of crossing surface failure, so replacement will usually coincide with a surfacing (tamping) cycle or crossing rebuilding. Railroads typically will rebuild a grade crossing in conjunction with a larger rail maintenance project, e. g., rail surfacing or tie repair and surfacing. Rebuilding the crossing will usually be adjusted to the surfacing (i.e., tamping) cycle. (This adjustment is reflected in the crossing surface life shown in Figure 19.)

Prolonging a crossing surface's life is possible at the cost of a significant increase in maintenance expenditures. For example, the experience of some professionals is that extending the life of a crossing with a panelized surface by one year would probably require at least two maintenance visits, removal of several panels, and filling the area of the removed panels with asphalt (20). Frequently, the crossing surface will receive no maintenance or repair, resulting in damage to highway vehicles, repair costs, and, possibly, accidents.

The railroads schedule track maintenance, including the repair and replacement of crossing surfaces. Some railroad companies have written policies that recommend coordination with the road agency having jurisdiction during reconstruction or maintenance of highway-rail grade crossings. These policies usually suggest that in the performance of ordinary track maintenance, the operating railroad notify all roadway jurisdictions along the track at least six months prior to the track work. At least 60 days prior to the actual track work at the grade crossing, the local roadway jurisdiction should be reminded of the scheduled work and requested to meet with the track work supervisor to plan reconstruction and work zone safety activity. A week before the work is scheduled, the local news media should be informed of the scheduled work and the public notified of modifications in traffic that will be required during the reconstruction of the highway-rail grade crossing.

The FHWA's *Work Zone Traffic Control: Standards and Guidelines* (21) offers guidance on appropriate traffic controls during crossing maintenance or construction. However, state and local practices may vary from these general guidelines.

ROUTINE CROSSING MAINTENANCE AND ITS COSTS

Regular maintenance of a grade crossing is critical for both obtaining the full service life from the crossing surface and

ensuring smooth railroad track. There are three primary elements of maintenance at a grade crossing:

- The *surface* itself must be kept sound and solidly in place by tightening screws, bolts, or other fasteners; replacing panels; and cleaning flangeways.
- *Drainage* elements need inspection and possibly cleaning.
- *Track*, particularly at the transition between open track and the crossing, requires regular tamping and periodic realignment through a crossing; this requires removal of the crossing surface and tamping ties.

Switches and signals within the crossing area and nearby may require additional regular maintenance.

The AREA 1979 guidance on maintenance requirements for track and related components such as switches and grade crossings suggests that the costs of maintaining a crossing are equivalent to about 0.039 to 0.14 mi of track for railroad tracks with traffic ranging from light branch line to heavy main line tonnage (e.g., 35 MGT or more) (8). The AREA's analysis neglected highway traffic, however, so this equivalency must be presumed valid for low-road-traffic crossings, e.g., with traffic in the range of 200 to 300 ADT. Higher traffic levels will increase maintenance requirements and/or reduce crossing-surface life.

PROCEDURES FOR SELECTING CROSSINGS FOR IMPROVEMENT

A 1989 survey conducted by the California Department of Transportation and the survey conducted for this synthesis both found that about one-third of state transportation agencies use some more-or-less formal procedure to prioritize grade crossings warranting surface improvement with state highway funding. These prioritization procedures fall generally into two categories: ride-quality assessments for individual crossings and systemwide assessment, e.g., pavement management systems.

Ride-quality assessments or rideability evaluations typically assign a single-number rating to a crossing, reflecting a composite of several factors judged to contribute to that crossing's safety, rider quality for highway vehicles, and structural condition implied by ride quality or other observations. Crossings with poorer ratings are then presumed to warrant earlier or greater attention for maintenance or improvement, and a minimum acceptable rating level may be set by policy as a basis for scheduling remedial action. Ride-quality assessments may be based on the field observations of agency staff, observations of traffic behavior at the crossing, or measurements made at the crossing, using standard devices (e.g., grade-change measurements, accelerometer readings). The state of Florida has established such a rating system, for example, described in its *Highway-Railroad Grade Crossing Material Selection Handbook* (18).

Figure 24 illustrates a procedure used by California that involves both staff raters and observations of vehicle and driver behavior. For the former, raters determine (by judgment) the

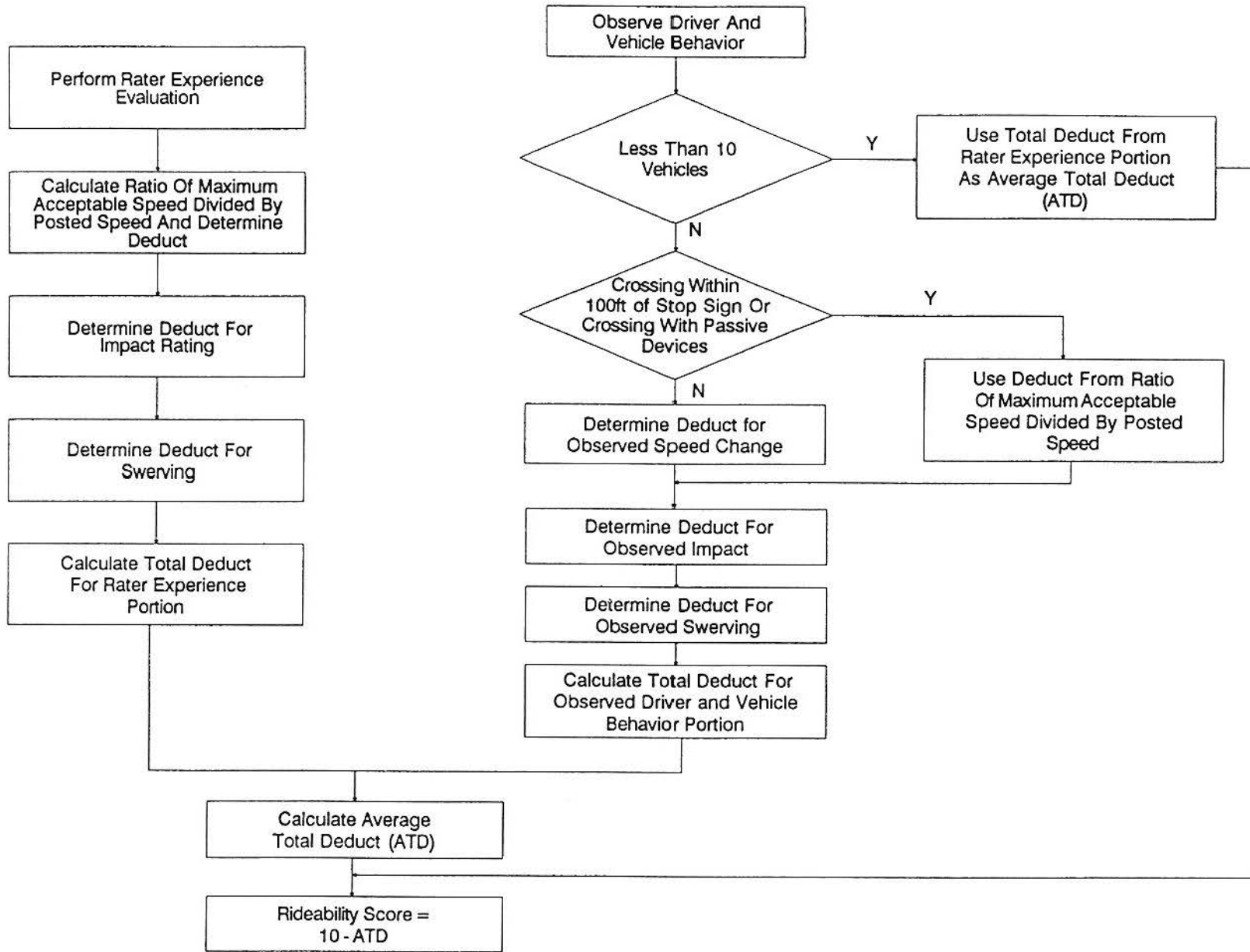

FIGURE 24 Example computation of rideability assessment.

<u>INVENTORY DATA</u>			
U.S. DOT/AAR INVENTORY NO: _____		PUC NO: _____	
LOCATIONAL DATA			
STREET/ROAD NAME: _____		COUNTY: _____	
RAILROAD OPERATOR: _____		CITY (IN OR NEAR): _____	
JURISDICTION: _____			
VEHICLE DATA		TRAIN DATA	
AADT: _____		NO. OF TRAINS: _____	
NO. LANES: _____		NO. OF TRACKS: _____	
		TRAIN SPEED: _____	
<u>RATER EXPERIENCE</u>			
<small>(MUST BE DETERMINED IN ACCORDANCE WITH INSTRUCTIONS)</small>			
APPROACH ROADWAY WITHIN 500' OF CROSSING			
POSTED SPEED: _____			
CROSSING TRAVERSE			
TRIAL SPEED 1: _____		MAX. ACCEPTABLE SPEED: _____	
TRIAL SPEED 2: _____		VEHICLE IMPACT (Check One)	
TRIAL SPEED 3: _____		LOW <input type="checkbox"/> MEDIUM <input type="checkbox"/> HIGH <input type="checkbox"/>	
WAS WEAVING PERFORMED ON ANY OF THE TRIALS TO AVOID A PORTION OF CROSSING BECAUSE OF APPEARANCE OF UNACCEPTABLE RIDE? (Y or N) _____			
<u>OBSERVED DRIVER AND VEHICLE BEHAVIOR</u>			
<small>(SEE INSTRUCTIONS FOR OBSERVATION PROCEDURES)</small>			
SPEED CHANGE	NO.	MAJORITY (CHECK ONE)	
NONE:	_____	<input type="checkbox"/>	
OFF ACC./LT. BRK:	_____	<input type="checkbox"/>	
HEAVY BRAKING:	_____	<input type="checkbox"/>	
		WEAVING	NO.
		YES	_____
		NO	_____
		PERCENT (Y/Y+N)	_____
VEHICLE IMPACT/PITCHING			
LOW:	_____	<input type="checkbox"/>	
MEDIUM:	_____	<input type="checkbox"/>	
HIGH:	_____	<input type="checkbox"/>	

FIGURE 25 Caltrans railroad grade crossing PMS rideability evaluation form.

speed reduction necessary to negotiate the crossing at an acceptable comfort level (i.e., “acceptable speed”), the severity of the impact felt by both the driver and the passengers as the crossing is negotiated at the “acceptable speed,” and whether swerving action was taken to avoid a rough or damaged portion of the crossing. Observations of traffic behavior determine essentially the same three response characteristics. In this case, observations are taken at two locations: at or near the advance warning sign and within the crossing zone.

Ride-quality assessments may be made for an individual crossing and the minimum acceptable rating determined

without regard for either the overall condition of an agency’s inventory of crossings or the agency’s available budget for crossing maintenance. In contrast, a pavement management system (PMS) is used to make consistent and defensible decisions related to the preservation of pavement in a highway network. PMSs vary in type and level of sophistication, but generally include an inventory of the network and the observed condition of its pavements (e.g., from visual inspection and photo-logging), a prediction module that forecasts pavement deterioration as a function of traffic, and a rating module that indicates which pavement sections or highway links are most

in need of attention. More sophisticated systems may include a set of standard maintenance actions (e.g., crack-sealing, overlay) and algorithms to match strategies to pavement sections in a cost-effective manner. A few PMSs have included provisions to apply the full management analysis to highway-rail grade crossings.

One such system was developed by consultants under contract with the California Department of Transportation. In this PMS, a network prioritization is made through the use of a crossing-priority index that combines a rideability score with an inventory index calculated from function and usage data obtained from the USDOT/AAR National Inventory. Figure 25 shows a typical condition checklist developed for diagnostic team use. Inventory information used to calculate the inventory index includes ADT, number of trucks, number of trains, number of lanes, and train speed. The inventory information is combined into a formula and an inventory index is computed for each crossing, as follows:

$$\text{Inventory Index} = \left[\frac{\text{CEC}}{\text{number of lanes}} \right] \left[\frac{\text{number of trains}}{\text{train speed}} \right]$$

where

$$\begin{aligned} \text{CEC} &= \text{Car-Equivalent Count} = \text{ADT} \\ &\quad [1 + 99 (\text{percent of trucks})] \\ \text{Priority Index} &= (\text{Inventory Index}) / (\text{Rideability Score})^2 \end{aligned}$$

For these formulas, “number of lanes” equals the number of highway traffic lanes crossing the track. “Number of trains” is the total number of trains (including through trains and switching trains) using the crossing in a 24-hour period. “Train speed” is the maximum timetable speed. For the CEC calculation, the

“percent trucks” should be expressed as a decimal value. A larger inventory index indicates greater usage of the crossing. In addition, lower train speed is presumed to be a surrogate for maintenance level; i. e., the lower the speed, the greater the chance that the crossing surface will deteriorate prior to track resurfacing.

The rideability score is assigned based on an assessment such as that described previously. A key distinction between this PMS-based prioritization and a simple ride-quality assessment is the use of the inventory index that in effect predicts that more heavily used crossings will deteriorate faster and warrant greater attention. All crossings within a state can be listed by priority index and those with the highest priority can be evaluated on the project level by a diagnostic team to determine repair strategies. The output from the network level analysis is then a list of crossings that merit more detailed analysis on the project level.

The project-level evaluation of the California PMS was performed on only a small portion of the total number of crossings. The actual number scheduled for diagnostic assessment can be based on generalized cost estimates for work at each crossing. Starting with the highest-priority crossing and moving down the list, estimated costs accumulate until the total repair budget likely to be available is exceeded; an allowance may be made for cost uncertainties and construction sequencing by accumulating costs to a level of as much as 150 percent of the likely budget. The resulting “short list” is then scheduled for visits by diagnostic teams made up of representatives from the responsible roadway jurisdiction and railroad. Based on the recommendations from the team evaluations (along with other considerations such as safety issues, project packaging, and public complaints), projects are programmed for repair.

PROGRAMS AND FUNDING FOR GRADE CROSSING SURFACE MANAGEMENT

Funding sources for highway-rail safety improvements include federal, state and local government programs. In addition, railroads and other private industries provide a significant amount of funding for this purpose. In general, public agencies account for the predominant share of funding public crossing safety-improvement construction projects, while railroads and private industry fund such projects at private crossings. However, railroads assume most of the cost of maintaining both public and private crossings.

The 1989 Report to Congress indicated that annual average public-sector spending for the period 1985–1987 was \$465 million for all crossing improvements; less than \$71 million (i.e., “other” improvements) or 15 percent of this spending would have been devoted to crossing-surfaces (Table 7). Railroads, generally responsible for maintaining crossing surfaces, spent approximately \$34 million annually on crossing surfaces in the same period (Table 8). Most of the “reimbursement” railroads received offset the costs of maintaining active-warning devices (e.g., crossbars, flashing lights).

FUNDS FOR CROSSING SURFACE IMPROVEMENTS

As prescribed by the Intermodal Surface Transportation Efficiency Act (ISTEA) of 1991, several sources of federal-aid highway funds can be used for highway-rail safety improvements, including crossing surfaces. For example, each state must set aside 10 percent of their Surface Transportation Program (STP) funds for eligible safety projects, which may include Highway-Rail Crossings (23 U.S.C. 130) and Hazard Elimination (23 U.S.C. 152) Programs. From the 10 percent set aside for safety, each state must reserve the same amount for Section 130 and 152 projects as they had apportioned in FY 1991. If the 10 percent is not adequate to meet the 1991 levels, then the 10 percent funds are proportionately split between rail-highway and hazard elimination projects. The federal share payable when using STP funds set aside for safety is 90 percent. STP funds not set aside for safety can also be used for highway-rail grade crossing safety improvements. However,

TABLE 7
PUBLIC AGENCY EXPENDITURES AT HIGHWAY-RAIL CROSSINGS 1985–1987 ANNUAL AVERAGE
(Thousands of Dollars)

Type of Improvement	Primary Funding Source				Total
	Sec. 130 ¹	Other Federal ¹	State ²	Other	
Passive Devices	3,110	1,460	500	120	5,190
Active Devices	110,460	8,570	17,280	1,070	137,380
Other (Alignment, surfaces, etc.)	39,780	18,650	9,960	2,290	70,680
Structures	<u>20,230</u>	<u>147,600</u>	<u>71,400</u>	<u>12,770</u>	<u>252,060</u>
Total	173,580	176,340	99,140	16,250	465,310

¹Includes State/Local Matching

²Solely State Funded

TABLE 8
RAILROAD EXPENDITURES FOR MAINTENANCE
(Thousands of Dollars)

	1985	1986	1987
Active Devices	93,266	98,505	98,895
Crossbucks	382	388	390
Crossing Surfaces	34,742	34,113	34,022
Structures	5,192	5,666	6,111
Other Projects	1,500	1,500	1,500
Private Crossings	<u>2,730</u>	<u>2,861</u>	<u>2,763</u>
Total	137,812	143,033	143,681
Less:			
Reimbursement	<u>5,484</u>	<u>5,536</u>	<u>5,913</u>
Balance	<u>132,328</u>	<u>137,497</u>	<u>137,768</u>

the federal share is 80 to 100 percent, depending on conditions that are documented by a state.

Until Congressional approval of the National Highway System (NHS), highways classified as principal arterials were eligible for the use of NHS funds. Highway safety projects are included in the NHS program, with the basic federal share for NHS projects set at 80 percent. However, as with STP funds, certain safety improvements funded with NHS funds have a 100 percent federal share. Federal funds are available for crossing surface improvements at the discretion of the individual states.

Some 80 percent of the survey respondents reported using state funds for "on-state-system" projects involving crossing-surface improvements, while for "off-state-system" projects the amount was 35 percent. Approximately 70 percent reported using federal funds for "off-state-system" projects. Almost all (90 percent) reported that federal funds were used for "on-state-system" projects. STP set-aside funds specifically are used by approximately 60 percent of respondents for "on-state-system" projects, while just more than half use this source of funds for "off-state-system" projects.

Local agencies often participate in the identification of crossing surface improvement needs, selection of the appropriate surface materials, and construction and maintenance of crossing approaches for highway-rail intersections that are "off-state-system." Some local governments actually provide part or all of the matching funds for federal-aid projects. A few local governments have established programs to fund crossing improvements, and to finance crossing maintenance costs.

Railroads usually fund routine repairs, minor patching, and replacement of small portions of an individual crossing from the railroad's operating expense account. In most cases, however, because of the industry's depreciation accounting system, surface maintenance requires a work order, and any work performed by railroad crews under such a work order requires advance capital-budget planning. Unless the railroad maintenance-of-way department has advance notice of a failed or about to fail crossing surface, the specific project will not be included in the capital budget planning process.

General funds for crossing surface improvements may be budgeted within a railroad company, and in general, railroads have two approaches to assigning these funds. The first approach is to establish an explicitly identified crossing rehabilitation program for replacing crossing surfaces not eligible for funding through other programs. The second approach is to rehabilitate or replace crossing surfaces in conjunction with track related projects, e.g., surfacing and lining, sledding, tie renewal, and ballast cleaning. Since such track related projects usually require the removal and replacement of the crossing surface, rehabilitation and upgrading of the replacement surface may be "piggy-backed" onto the other budget category. This budgeting mechanism has the effect of making it desirable to replace the surfaces at many crossings where the existing surface may have additional years of life, because doing so avoids the costs and effort of obtaining a work order for a separate crossing project.

AN EXAMPLE STATE-FUNDED CROSSING SURFACE IMPROVEMENT PROGRAM

The state of Texas uses dedicated state highway maintenance funds to maintain the railroad crossings located on the state highway system. The Texas Railroad Grade Crossing Replanking Program was originally authorized by the Texas Legislature in 1979 to replace worn-out grade crossing surfaces on the state highway system. The program was established to respond to complaints from the traveling public and the railroad companies' apparent inability to maintain and replank crossing surfaces in a timely manner. Since 1979, this program has provided for the replacement of approximately 2,280 railroad grade crossings. Annual funding for this program, reauthorized by the Texas Legislature each legislative session, was \$3,500,000 in 1994. The Texas Department of Transportation (TxDOT) schedules approximately 138 projects each year, managing the state's inventory on a 16-year replacement cycle.

Contracts are negotiated with each responsible railroad to perform required work on crossings on that company's track. These contracts, termed Railroad Grade Crossing Master Agreements, are updated each program year by the addition of a list of current projects. If a railroad does not complete the project within the one-year program period, it is responsible for performing the installation at no cost to the state. To encourage faster completion of the work, railroads are not permitted to submit partial invoices for payment, but only the final invoice for completion of the year's project list.

Initially, these master agreements specified that the state would reimburse the railroad for actual costs for all labor and materials for the installation of the crossing surface; the railroad company was responsible for all costs for track materials and labor. Subsequent master agreements have been negotiated to pay the railroad a lump sum based on a negotiated fixed fee per track-foot, for each type of surface material (e.g., timber, concrete, and rubber). This approach reduces administrative costs by eliminating individual project-cost estimates and any need for final project audits.

Projects are proposed for inclusion in the master agreement on the basis of a condition assessment submitted by highway district offices using a standard "Railroad Crossing Submission Form" (Figure 26). Priorities are established on the basis of a unit cost per vehicle using the crossing, using the negotiated cost per track-foot, in principle maximizing the benefits to highway users within the constraints of a fixed budget. Each district is guaranteed their two top-priority crossings will be included in the master agreements, regardless of the crossings' estimated costs per vehicle. Over the last 10 program years, the district offices have submitted an average of 207 candidate project requests, but the state funds an average of only 134 projects per program year.

Surface materials selected for each project are recommended by the district offices. The district recommendation is reviewed by the program administrator and recommended in turn to the railroad. The railroad company is nevertheless responsible for making the final material selection and ordering what it judges to be the most economical and durable brand of

RAILROAD GRADE CROSSING SUBMISSION FORM

(Form must be completed and furnished to D-5RR for each Crossing submitted for replacement on the 19__ Railroad Grade Crossing Replanking Program)
 DATE: _____

DISTRICT No.: ____ Dist. Priority number: _____

DOT No.: _____ Name of Railroad: _____

COUNTY: _____ No. of trains per day: _____

CONT-SEC: _____ No. of tracks thru crossing: _____

HIGHWAY: _____ No. of tracks proposed for replanking: _____

LOCATION: _____ Type of surfacing material **existing**:
 (city or nearest city or town)

No. OF TRAVEL LANES: _____ Type of surfacing material **proposed**: _____

ADT: _____ *Length of each crossing proposed for replanking: _____

CONDITION OF CROSSING

Visually Rate Each Factor:

0 1 2 3 4 5

Excellent Condition

Poor Condition

VISUAL RATING SCALE

Each factor should be considered in assigning an overall rating for each category below. Please check or make notes next to all problem factors in and around crossing.

HIGHWAY:

1. Condition of Pavement
 - a. Potholes
 - b. Edge Ravelling
 - c. Profile (high/low)
 - d. Cross Section
2. Crossing Surface
 - a. Roughness
 - b. Deterioration
 - c. Headerboards
 - d. Hardware (missing/loose)
3. Traffic Behavior
 - a. Speed Reduction
 - b. Braking
 - c. % of trucks to Cars (Est.)

RAILROAD:

1. Condition of Rail
 - a. Superelevation (between tracks and/or highway)
 - b. Flangeway (open/fouled)
 - c. Rail height to xing (high/low)
2. Condition of Track
 - a. Anchors, plates, spikes (loose/missing)
 - b. Ties (rotten/loose/broken)
 - c. Ballast (clean/fouled)
 - d. Rail movement under loads (tracks pumping)
 - e. Subgrade Stabilization

DRAINAGE:

1. Crossing Condition
 - a. Fouled ballast - No. of feet out from xing?
 - b. Standing water - No. of feet out from xing?
2. Crossing Area
 - a. Grading Contour (into\away from xing)
 - b. Culverts (existing, open\fouled)
 - c. Subdrains (exposed, damaged, blocked, etc.)
 - d. Adjacent Vegetation (blocking drainage)

FIGURE 26 Railroad grade crossing submission form.

Type of Material	No. of Projects	No. of Track Ft.
Timber	30	1,432
Concrete	109	6,928
Rubber	7	888
Total	146	9,248

FIGURE 27 1994 Texas replanking program.

crossing material. In the early 1980s, timber was considered the standard crossing surface material on all but the most heavily used crossings (e.g., ADT in excess of 8,000 vehicles per day). Throughout the decade, timber crossing material was used in approximately 55 to 65 percent of the projects installed under this program. Over the last 10 years, however, TxDOT has observed a decline in the overall serviceability of timber materials and premature deterioration of more heavily used timber crossings.

To meet the 16-year replacement cycle mandated by the program, "high-type" surface materials are now being used, primarily rubber, concrete, or steel. Rubber or concrete materials are now considered on all replanking projects with ADT less than 2,000 vehicles per day, except on farm and ranch-to-market roads. Figure 27 shows the distribution of surface materials for the 146 projects on the 1994 replanking program; concrete crossing surfaces account for three-quarters of the projects.

CONCLUSIONS

An at-grade highway-rail crossing includes not only the actual intersection of the two vehicle-carrying surfaces, but also the approach areas where physical design characteristics of one structure may have to be specifically adjusted to accommodate the other transportation mode. There are more than 164,000 public at-grade crossings in the United States. More than half of these crossings serve very low road-traffic volumes, with average daily traffic (ADT) less than 400 vehicles.

Every crossing establishes a discontinuity in both the normal track structure and in the normal highway or street pavement. The *grade crossing surface* consists of pavement or other highway and rail surface materials on the approaches and crossover points with the railroad track. This surface must carry the train or highway vehicle and transmit their wheel loads to the foundation structure. Railroad operating companies, in aggregate, each year spend some \$34 million to maintain these crossing surfaces. Public transportation agencies spend additional millions for reconstruction and improvement of the surfaces at public crossings.

Despite the substantial numbers of at-grade crossings in the United States and the substantial expenditures their care entails, the guidance for crossing-surface engineering and management is surprisingly limited. The Federal Highway Administration (FHWA), American Railway Engineering Association (AREA), and American Association of State Highway and Transportation Officials (AASHTO) provide guidance on the design for traffic management and safety of grade crossings, but there is little guidance and few regulations that address the specific requirements for the design, material specifications, construction, installation, and maintenance of grade-crossing surfaces. Railroads generally have the responsibility for the crossing surface between the tracks and a few inches from the ends of the ties supporting the crossing surface, while the highway agency has jurisdiction and responsibilities for construction and maintenance of roadway approaches to the crossing, to the point where railroad responsibility begins. In most cases the railroad undertakes crossing-surface maintenance and replacement, often as a part of its track-maintenance programs.

Early crossing surfaces were made simply by filling the area between the rails with sand and gravel, probably from the railroad ballast. Later, planks, heavier timbers, bituminous and other materials began to be used. The evolutionary development of crossing-surface treatments is reflected in the current practices of crossing-surface engineering and management, which are more on experience and professional consensus rather than theory and experimental analyses. The literature on crossing surfaces is not extensive, nor has it grown much in recent years.

Crossing surfaces in use today fall into two general categories: monolithic and sectional. Monolithic crossings are

those that are formed at the crossing and cannot be removed without destroying the surface. Typical monolithic crossings are made of asphalt, poured-in-place concrete, and cast-in-place rubber-and-elastomeric compounds (e.g., using chopped scrap vehicle tires). Sectional crossings are those manufactured in sections or panels that are placed at the crossing and can be removed and reinstalled. These crossing surfaces facilitate the maintenance of track through the crossing. Typical sectional crossing surfaces include treated timbers, reinforced concrete, steel, rubber, and high-density polyethylene. The commercial market offers a wide selection of sectional crossing-surface products.

The crossing surface must contend with design requirements for the road and rail that are incompatible. The steel rails, wood or concrete crossties, and crushed stone ballast of the typical rail track structure are designed to accommodate routine vertical deflections, i.e., to flex under the heavy weight of trains. The highway surface, in contrast, is designed to remain rigidly in place under the load of highway vehicles. The rail line is designed to allow water to filter freely through the base to drainage structures or a free-draining and impervious subbase or foundation layer, while the highway pavement is designed to be absolutely impervious. A highway pavement surface is typically either crowned or slanted to facilitate rapid drainage to drainage structures along the pavement's edges, while the rail slope is essentially constant (e.g., flat) over the short distance that a grade crossing represents. Discontinuities in materials and surface irregularities create stress concentrations that can quickly damage surface materials, creating a rough ride, safety hazards, and failures in the road or rail structure. In general, crossing surface design and maintenance are troublesome responsibilities for all concerned.

Effective drainage is widely recognized as the most important element in ensuring that a crossing provides long-term good ride quality and economical maintenance. If good drainage is maintained, the primary source of crossing surface failure is inability to withstand the impact loads imposed by highway vehicles passing over the irregularities of the crossing (e.g., at the rails and flangeways, and at sharp grade transitions). Asphalt surfaces, for example, are particularly prone to edge raveling, alligator cracking, and longitudinal deterioration under such loads.

In addition, surface abrasion, splitting and compaction of shims, and displacement of rail and surface-material fasteners can create irregularities that increase impact loads and lead to larger-scale cracking of pavement and crossing materials. Wood-plank and timber-panel crossings are also subject to rot and splitting. Wood, rubber, and other relatively plastic materials may be damaged by scraping of low-clearance vehicles or other heavy equipment.

For most properly maintained crossings, regardless of the characteristics of the road traffic using that crossing, the loads

that road traffic imposes are the primary determinants of the crossing surface's life. Heavier and multi-axle vehicles (e.g., trucks) impose more severe loads on the crossing surface than automobiles. The traffic loading on a crossing surface is then typically estimated in terms of "car-equivalent crossings" (CEC). CEC is computed as the sum of the number of passenger vehicles and an adjusted value of the number of trucks in an average day's traffic. There is little experimental basis for the adjustment factors used to express the equivalency of cars and trucks.

A variety of other factors can affect the life of a grade-crossing surface, including railroad traffic (generally measured in terms of its annual load density, e.g., in million gross tons MGT), train speed, and crossing geometry (e.g., number of traffic lanes, angle of crossing to road, number of tracks, and rail superelevation). However, failure to establish and maintain effective drainage of the crossing area and its subgrade foundation is a primary cause of premature surface failure and crossing-structure damage.

There are no widely accepted specifications defining the onset of crossing surface failure, nor are there widely accepted procedures for determining likely service life of a particular surface material exposed to particular highway traffic, rail traffic, and environmental conditions. A rough riding surface, large deflections in rail or road surfaces, and substantial deterioration of structural integrity in the road pavement or track-and-tie assembly are indicators of crossing-surface failure.

The railroads schedule track maintenance, including the repair and replacement of crossing surfaces. Professionals in the field agree that effective communication between rail companies and state or local government agencies is an important element of effective crossing management, but there are no generally applicable regulations that require such communication. Surveys indicated that only about one-third of state transportation agencies use some more-or-less formal procedure to judge their own priorities for grade crossings warranting surface improvement. These prioritization procedures

involve ride-quality assessments for individual crossings and, in a few states, systemwide assessments that consider overall budgets and benefits to the highway user. Ride-quality assessments typically assign a single-number rating to crossings, reflecting a composite of highway agency and railroad personnel judgment regarding a crossing's need for improvement.

Federal highway programs make funds available that may be used for crossing surface improvements and states may use their own highway funds as well. Only a small fraction of the funds spent for crossing improvements is devoted to crossing surfaces. Railroads are the primary source of funds for crossing surface maintenance and reconstruction. Railroad accounting practices that treat crossing reconstructions as capital budget items may encourage replacement of crossing surfaces before wear and aging have progressed to a level at which failure is likely.

The numbers of crossings and level of spending for their management would seem to warrant research to develop more scientifically based engineering and management guidance for crossing surfaces; an analysis of the aggregate benefits achievable through this research would consider both public and private costs and benefits. The research literature presents some research in this area, but the range of analyses and data used has limited the profession's adoption of the results presented to date. All 50 states have public at-grade crossings, but only about one-third report giving any particular attention to crossing-surface management issues.

Railroad operating companies bear the principal responsibility for crossing-surface management. Current management practices seem to encourage premature replacement of crossing surfaces, as a part of routine maintenance-of-way activities, before normal wear and aging have degraded the crossing surface to a degree at which failure is likely. Improved engineering and management practices might then yield significant savings in railroads' operating and capital budgets.

REFERENCES

1. Seely, B.E., *Building the American Highway System: Engineers as Policy Makers*, Temple University Press, Philadelphia, Pennsylvania (1987).
2. *Prevention of Rail-Highway Grade Crossing Accidents Involving Railway Trains and Motor Vehicles*. Docket No. 33440, Interstate Commerce Commission, Washington, D.C. (1964).
3. *Railroad-Highway Grade Crossing Handbook*. FHWA-TS-86-215, 2nd ed., Federal Highway Administration, Washington, D.C. (1986).
4. The Railway Progress Institute, "Rail/Highway Grade Crossing Warning Systems and Surfaces: Equipment, Materials, and Their Application" (1983).
5. *Rail-Highway Crossing Accident/Incident and Inventory Bulletin*. No. 17, Federal Railroad Administration, Washington, D.C., for the year 1994, (1995).
6. *Handbook of Highway Safety Design and Operating Practices*. Federal Highway Administration, Washington, D.C. (1978).
7. *Manual of Uniform Traffic Control Devices*. Part IV, 1988 ed., Revision 3, Federal Highway Administration, Washington, D.C. (1993).
8. *Manual for Railway Engineering*. American Railway Engineering Association, Washington, D.C. (1995).
9. *Policy on Geometric Design of Highways and Streets*. Chapter IX, At-Grade Intersections, American Association of State Highway and Transportation Officials, Washington, D.C. (1994).
10. Matthews, R., "Adequate Drainage Provides the Key to a Stable Roadbed." *Railway Track & Structures*, Simmons-Boardman Publishing Corp., New York, NY (1990).
11. Olsen, R.M., *Railroad-Highway Grade Crossing Handbook*. FHWA-TS-78-214, Federal Highway Administration, Texas Transportation Institute, College Station (1978).
12. Association of American Railroads, *Track Substructure Drainage*. AAR Report No. R-850 (1993).
13. Eck, R.W., and S.K. Kang, "Roadway Design Standards to Accommodate Low-Clearance Vehicles." Presented at the 71st Annual of the Transportation Research Board, Washington, D.C. (1992).
14. Morgan, J.R., and R.M. Olson, *Development of a Stable Foundation for Highway-Railroad Grade Crossing Substructures*. Report No. FHWA/TX-87/49-483-1F, Texas Transportation Institute, College Station (1987).
15. Rose, J.D., "Construction, Performance, and Economic Analysis of Hot-Mix Asphalt Subballast Highway-Railroad Crossing." *Proceedings of the 1989 National Conference on Highway-Rail Safety*, Richards & Associates, College Station, Texas (1989).
16. Maurer, D.A., "High-Type Railroad Crossing Surface Monitoring and Evaluation." Project 77-21, Pennsylvania Department of Transportation (1985).
17. Louisiana Department of Transportation and Development Railroad-Highway Grade-Crossing Policy (1979).
18. Florida Department of Transportation, *Highway Railroad Grade Crossing Material Selection Handbook*, Department of Civil Engineering, University of Florida, Gainesville (1984).
19. Bowman, B.L. and C. Colson, *Current State Practices and Recommendations for Improving the Rail-Highway Grade Crossing Program*, Auburn University, Alabama (1993).
20. Burns, D.R., "Selecting the Most Cost-Effective Grade Crossing Surface." *Proceedings of the 1989 National Conference on Rail-Highway Safety*.
21. *Work Zone Traffic Control: Standards and Guidelines*, Federal Highway Administration, USDOT, Washington, D.C. Report No. FHWA.

APPENDIX A

Questionnaire

NATIONAL COOPERATIVE HIGHWAY RESEARCH PROGRAM
Project 20-5, Topic 26-04

Highway-Rail Crossing Surfaces

QUESTIONNAIRE

The completion of this questionnaire is being requested to provide information for the development of a synthesis of highway-railroad practice for the selection, installation and maintenance of crossing surface materials. A number of states, local jurisdictions, and railroads have developed methodologies for selection, installation and performance measurements of highway-rail crossing surface materials. The information requested by this questionnaire will provide valuable input to the synthesis.

Date: _____

Agency Responding: _____

Person: _____
 Title: _____
 Address: _____
 Telephone: _____
 FAX: _____

1. Does your state have a program for rail-highway crossing surface improvements?
 Yes No

2. For crossings **ON** the state system, are state funds used for the purchase of crossing surface materials?
 Yes No

3. For crossings **OFF** the state system, are state funds used for the purchase of crossing surface materials?
 Yes No

4. Are federal funds used for the purchase of crossing surface materials?
 On state system:
 Yes No

 Off state system:
 Yes No

5. Are Surface Transportation safety set-aside funds used for the purchase of crossing surface materials?
 On state system:

Yes No

Off state system:

Yes No

6. Does your state have written procedures, policies or criteria for the identification and selection of highway-rail crossings programmed for surface improvements?

Yes No

Note: If yes, please provide a copy of the procedure (policy) with the returned questionnaire.

7. If your state does not have a written procedure (policy) for the selection of crossings to be improved, which of the following factors are considered in your selection decision?

Factor:	Significant	Important	Little Importance
Functional class of roadway	<input type="checkbox"/>	<input type="checkbox"/>	<input type="checkbox"/>
Motor vehicle speed	<input type="checkbox"/>	<input type="checkbox"/>	<input type="checkbox"/>
Volume and type of highway traffic	<input type="checkbox"/>	<input type="checkbox"/>	<input type="checkbox"/>
Type of roadway surface on the roadway approach	<input type="checkbox"/>	<input type="checkbox"/>	<input type="checkbox"/>
General classification of the railroad; main line branch, industrial, yard	<input type="checkbox"/>	<input type="checkbox"/>	<input type="checkbox"/>
Type and volume of railroad traffic	<input type="checkbox"/>	<input type="checkbox"/>	<input type="checkbox"/>
Nature of subgrade of the roadway and track	<input type="checkbox"/>	<input type="checkbox"/>	<input type="checkbox"/>
Climatic conditions	<input type="checkbox"/>	<input type="checkbox"/>	<input type="checkbox"/>
Drainage conditions	<input type="checkbox"/>	<input type="checkbox"/>	<input type="checkbox"/>

Initial construction cost, including both rail and road	<input type="checkbox"/>	<input type="checkbox"/>	<input type="checkbox"/>
Replacement cost, including estimated life of materials	<input type="checkbox"/>	<input type="checkbox"/>	<input type="checkbox"/>
Maintenance cost, including both roadway and railroad	<input type="checkbox"/>	<input type="checkbox"/>	<input type="checkbox"/>
The importance of good ride quality	<input type="checkbox"/>	<input type="checkbox"/>	<input type="checkbox"/>
Other (list)	<input type="checkbox"/>	<input type="checkbox"/>	<input type="checkbox"/>
_____	<input type="checkbox"/>	<input type="checkbox"/>	<input type="checkbox"/>
_____	<input type="checkbox"/>	<input type="checkbox"/>	<input type="checkbox"/>
_____	<input type="checkbox"/>	<input type="checkbox"/>	<input type="checkbox"/>

8. If your state participates, in any way, in the selection of crossing surface materials what type of crossings are involved?

- Asphalt
- Asphalt with header
- Full width plank
- Sectional timber
- Rubber (with shims)
- Full depth rubber
- Concrete slab (panels)
- Other (please list) _____
- _____
- _____

9. Has your state conducted, or participated, in crossing surface product evaluation studies?

- Yes No

10. Has your state participated in FHWA "experimental" crossing surface installation projects?

- Yes No

Note: If you answered yes to either question 9 or 10 please provide the name and telephone number of the person having information on the projects. A telephone or personal interview will be scheduled.

_____ Name _____ Phone

11. What manuals, recommended practices, handbooks, guides or other published material does your state use in crossing surface selection, installation and maintenance?

Please List:

12. Does your state follow ADA guidelines for construction and maintenance of highway-rail crossing surfaces?

- Yes No

13. What procedures does your state use for motor vehicle traffic control during construction, reconstruction or maintenance of crossing surfaces?

14. Has your staff received special instructions, training (e.g. NHI or T2) for the selection, construction or maintenance of crossing surfaces?

- Yes No

Note: If yes please describe: _____

15. Is the state notified, by the railroad, when track maintenance is to take place through a crossing?

- Yes No

Note: If the answer is yes how is the state notified and how far in advance is the notification made?

16. Please provide the name title and telephone number of local (city, county) government transportation department staff, in your state, that should be contacted regarding this survey.

Name _____

Telephone _____

Name _____

Telephone _____

Name _____

Telephone _____

APPENDIX B

National Inventory of Public At-Grade Highway-Rail Crossings

DOT-AAR NATIONAL INVENTORY
PUBLIC-AT-GRADE RAIL-HIGHWAY CROSSINGS
BY STATE AND TYPE OF CROSSING SURFACE

PAGE 1
10/12/95

STATE	SECTION TIMBER	WOOD PLANK	ASPHALT	CONCRETE SLAB	PAVEMENT	RUBBER	METAL SECTION	OTHER METAL	GRAVEL	OTHER	STATE TOTAL
ALABAMA	125	171	3057	7	1	49	1	1	245	1	3658
ALASKA	11	97	57	10	0	40	0	0	1	11	227
ARIZONA	179	180	383	3	1	130	0	0	62	2	940
ARKANSAS	798	248	1579	50	8	12	2	2	597	4	3300
CALIFORNIA	820	1277	5517	83	30	102	0	0	129	28	7986
COLORADO	702	415	608	31	4	131	7	23	144	11	2076
CONNECTICUT	109	0	115	2	0	142	2	0	0	0	370
DELAWARE	3	0	206	14	1	47	0	0	1	0	272
DIST OF COLUMBIA	6	1	25	0	5	0	0	0	0	0	37
FLORIDA	1216	50	2089	301	32	236	7	1	108	39	4079
GEORGIA	120	124	5377	15	18	16	1	1	487	2	6161
HAWAII	0	0	6	0	0	0	0	0	0	0	6
IDAHO	232	742	437	19	2	30	0	0	81	11	1554
ILLINOIS	1882	1474	4817	39	38	866	7	7	1090	25	10245
INDIANA	821	97	5060	22	14	388	9	0	205	6	6622
IOWA	120	1198	2188	11	10	312	1	2	1319	103	5264
KANSAS	2245	2348	1130	84	35	128	7	1	1917	13	7908
KENTUCKY	305	312	1458	1	4	77	1	3	476	0	2637
LOUISIANA	714	575	1403	107	7	458	1	4	396	1	3666
MAINE	53	215	598	0	0	9	0	0	7	0	882
MARYLAND	206	72	325	1	6	62	0	0	16	3	691
MASSACHUSETTS	64	29	992	8	0	84	0	0	15	0	1192
MICHIGAN	1390	423	3037	11	10	435	90	1	369	18	5784
MINNESOTA	265	2575	1779	17	10	257	0	1	289	14	5207
MISSISSIPPI	160	369	1568	10	4	136	1	1	756	2	3007
MISSOURI	1511	750	1602	18	3	80	2	1	883	18	4868
MONTANA	28	1145	285	17	2	11	0	8	20	17	1533
NEBRASKA	861	732	642	120	40	56	2	2	1585	15	4055
NEVADA	46	55	90	24	1	21	1	2	40	8	288
NEW HAMPSHIRE	12	57	419	1	0	7	0	0	6	1	503
NEW JERSEY	153	8	1429	13	16	83	0	58	67	35	1862
NEW MEXICO	444	183	49	1	2	33	0	0	96	0	808
NEW YORK	417	157	2286	8	15	285	0	2	92	16	3278
NORTH CAROLINA	22	47	4448	6	12	32	1	1	300	6	4875
NORTH DAKOTA	126	3546	476	19	2	39	0	2	410	4	4624
OHIO	1876	173	4275	14	15	145	0	2	179	19	6698
OKLAHOMA	1661	542	1110	68	15	45	1	6	1169	10	4627
OREGON	483	119	1335	14	23	60	0	0	44	262	2340
PENNSYLVANIA	964	77	3781	59	243	99	1	16	355	4	5599
RHODE ISLAND	1	1	79	0	10	36	0	1	0	0	128
SOUTH CAROLINA	34	3	2899	28	7	7	0	1	100	7	3086
SOUTH DAKOTA	13	1424	444	1	1	118	0	0	86	50	2137
TENNESSEE	105	239	2690	5	5	106	3	0	212	6	3371
TEXAS	4607	1201	4262	251	104	297	5	18	1762	32	12539
UTAH	219	232	384	47	5	29	3	2	84	4	1009
VERMONT	34	43	331	0	1	11	0	0	75	1	496
VIRGINIA	230	54	1695	5	2	15	4	9	122	18	2154
WASHINGTON	126	1138	1300	76	7	173	0	0	30	3	2853
WEST VIRGINIA	838	11	756	2	3	10	0	1	344	2	1967
WISCONSIN	60	362	3851	7	20	279	1	1	232	1	4814
WYOMING	44	199	138	2	1	22	0	0	118	6	530
PUERTO-RICO	0	0	22	0	0	0	0	0	2	0	24
TOTAL FOR INVENTORY	27461	25490	84889	1652	795	6246	161	181	17123	839	164837

* THIS DATA WAS PRODUCED BY THE FEDERAL RAILROAD ADMINISTRATION
* DATA IS CURRENT WITH INVENTORY UPDATE INFORMATION SUPPLIED BY JUNE 30, 1995

APPENDIX C

Extracts from the AREA Manual for Railway Engineering and Extracts from the AASHTO Policy on Geometric Design of Highways and Streets

The American Railway Engineering Association's (AREA) *Manual for Railway Engineering* offers guidance on crossing design and surface selection. The *Manual* states in general

The material in this and other chapters in the AREA Manual for Railway Engineering is published as recommended practice to railroads and others concerned with the engineering, design and construction of railroad fixed properties (except signals and communications), and allied services and facilities. For the purpose of this Manual, **Recommended Practice** is defined as a material, device, design, plan, specification, principle or practice recommended to the railways for use as required, either exactly as presented or with such modifications as may be necessary or desirable to meet the needs of individual railways, but in either event, with a view to promoting efficiency and economy in the location, construction, operation or maintenance of railways. **It is not intended to imply that other practices may not be equally acceptable.**

Chapter 5 presents "Guidelines for the Construction or Reconstruction of Highway-Railway Crossings." The following paragraphs are quoted from that chapter.

Crossing Surface Materials

Any crossing surface material may be used on any crossing at the discretion of the operating railroad or as may be recommended by a diagnostic evaluation of the crossing. Specifications and plans concerning the crossing surface material and use should abide with the manufacturer's recommendations, and/or the operating railroad's specifications and plans and, where applicable, to the standards of the public agency having jurisdictional authority at the specific location.

Width of Crossing

The crossing shall be of such width as prescribed by law, but in no case shall the width be less than that of the adjacent traveled way plus two feet.

Profile and Alignment of Crossings and Approaches

Where crossings involve two or more tracks, the top of the rails for all tracks shall be brought to the same plane where practicable. The surface of the highway shall be in the same plane as the top of the rails for a distance of two feet outside of rails for either multiple or single-track crossings. The top of the rail plane shall be connected with the grade line of the highway each way by vertical curves of such length as is required to provide riding conditions and sight distances normally applied to the highway under consideration. It is desirable that

the surface of the highway be not more than three inches higher nor six inches lower than the top of nearest rail at a point 30 feet from the rail, measured at right angle, thereto, unless track super-elevation dictates otherwise. If practical, the highway alignment should be such as to intersect the railroad track at or nearly at right angles.

Width and Marking of Approaches

Width of roadway at a highway-rail grade crossing should correspond to that of the adjoining highway and have the same number and width of traffic lanes as adjoining highway without extra lanes and with center turn lanes at the crossing being delineated. At all paved approaches to the highway-rail grade crossing, the highway traffic lanes in the vicinity of the crossing should be distinctly marked in accordance with the recommendations of the Manual on Uniform Traffic Control Devices (MUTCD).

Drainage

In situations where the grade of the highway approach descends toward the crossing, provisions shall be made to intercept surface and subsurface drainage and discharge it laterally so that it will not be discharged on the track area. Surface ditches shall be installed. If required, sub-drainage with suitable inlets and the necessary provisions for clean-out shall be made to drain the sub-grade thoroughly and prevent the formation of water pockets. The drainage shall be connected to a storm water sewer system, if available; if not, suitable piping, geotextile fabrics and/or french drains shall be installed to carry water a sufficient distance from the roadbed. Where gravity drainage is not available, a nearby sump may provide an economical outlet, or the crossing may be sealed and the roadbed stabilized by using asphalt ballast or its equivalent.

Ballast

The ballast and sub-ballast shall be dug out a minimum of 10 in. below the bottoms of the ties, 1.0 ft. minimum beyond the ends of the ties and beyond the end of the crossing a minimum of 20 ft., and re-ballasted with ballast to conform with AREA specifications.

Ties

Treated No. 5 hardwood or concrete ties shall be used through the limits of the crossing and beyond the crossing a minimum of 20 feet.

Rail

The rails throughout the crossing shall be so laid to eliminate joints within the crossing. Preferably, the nearest joint should be not less than 20 feet from the end of the crossing. Where necessary, long rails shall be used or rail ends shall be welded to form continuous rail through the crossing. Rails shall be spiked to line, and the track shall be thoroughly and solidly tamped to uniform surface. Rails should be protected with an approved rust inhibitor.

Flangeway Widths

Flangeways not less than 2 1/2 inches or more than 3 inches in width should be provided. Flangeways shall be at least 2 inches deep unless approved by operating railroad.

Profile

An agreed upon profile, railroad and highway, should be established between the operating railroad and the road authority.

Sub-grade

Sub-grade should be cleaned of all old contaminated ballast and bladed to a level surface at a minimum of 10 inches below bottom of tie and at least 20 feet beyond each end of the crossing.

Geotextile Fabrics

When practical, a geotextile fabric should be used between the sub-grade and the ballast section and at least 20 feet beyond each end of the crossing and if a rail joint falls within these limits at least 5 feet beyond the rail joint. If practical, the geotextile fabric should extend under the roadway surface traveled way, 15 feet each way from the center line of the track.

Tie Plate, Spikes, Anchors

All ties through the crossing area and at least 20 feet beyond each end of the crossing should be fully tie plate with four spikes per tie plate and fully box anchored. Optional placement of the tie pads is acceptable.

Lining and Surfacing Track

Rails should be spiked to line and the track machined or mechanically tamped and surfaced to grade and alignment of the existing track and roadway. As many train movements as

time permits should be allowed across the crossing before final surface and alignment. This will help achieve the optimum ballast compaction through the crossing area.

AASHTO's *Policy on Geometric Design of Highways and Streets* offers guidance on highway-rail intersection design. The following guidance is taken directly from the "Green Book:"

Railroad Grade Crossings

A railroad-highway crossing, like any highway-highway intersection, involves either a separation of grades or a crossing at-grade. The geometrics of a highway structure that entails the over-crossing or under-crossing of a railroad are substantially the same as those for a highway grade separation without ramps. The horizontal and vertical geometrics of a highway approaching an at-grade railroad should be constructed in a manner that does not divert attention to roadway conditions.

Horizontal Alignment—If possible, the highway should intersect the tracks at a right angle with no nearby intersections or driveways. This layout enhances the driver's view of the crossing and tracks, reduces conflicting vehicular movements from crossing roads and driveways, and is preferred for bicyclists. To the extent practical, crossings should not be located on either highway or railroad curves. Roadway curvature inhibits a driver's view of a crossing ahead and a driver's attention may be directed toward negotiating the curve rather than looking for a train. Railroad curvature may inhibit a driver's view down the tracks from both a stopped position at the crossing and on the approach to the crossings. Those crossings that are located on both highway and railroad curves present maintenance problems and poor rideability for highway traffic due to conflicting super elevations.

Where highways that are parallel with main tracks intersect highways that cross the main tracks, there should be sufficient distance between the tracks and the highway intersections to enable highway traffic in all directions to move expeditiously and safely. Where physically restricted areas make it impossible to obtain adequate storage distance between the main track and a highway intersection, the following should be considered:

1. Interconnection of the highway traffic signals with the grade crossing signals to enable vehicles to clear the grade crossing when a train approaches.
2. Placement of a "Do Not Stop on Track" sign on the roadway approach to the grade crossing.

Vertical Alignment—It is desirable that the intersection of highway and railroad be made as level as possible from the standpoint of sight distances, rideability, braking and acceleration distances. Vertical curves should be of sufficient length to insure an adequate view of the crossing. In some instances, the roadway vertical alignment may not meet acceptable geometrics for a given design speed because of restrictive topography or limitations of right-of-way. Acceptable geometrics necessary to prevent drivers

of low-clearance vehicles from becoming caught on the tracks would provide the crossing surface at the same plane as the top of the rails for a distance of 0.6 m outside the rails. The surface of the highway should also not be more than 75 mm higher or 75 mm lower than the top of nearest rail at a point 9 m from the rail unless track super elevation dictates otherwise as shown on Figure 4. Vertical curves should be used to traverse from the highway grade to the level plane of the rails.

APPENDIX D

Illustrations of Crossing Surface Failure Modes

Asphalt

Figure D-1 shows the failure of an asphalt only crossing surface. The inability of the material to withstand impact loads is the major reason for surface failure. Edge raveling, alligator cracking, and longitudinal deterioration are all symptoms of surface failure.

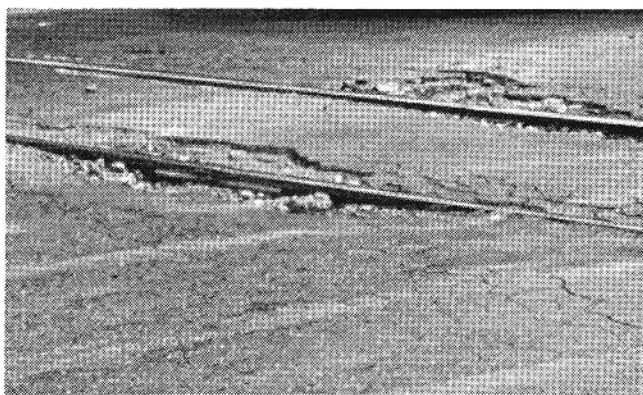

FIGURE D-1

Asphalt and Wood

Wood abrasion and rot, along with asphalt's inability to withstand impact, has contributed to the failure of this crossing surface (Figure D-2).

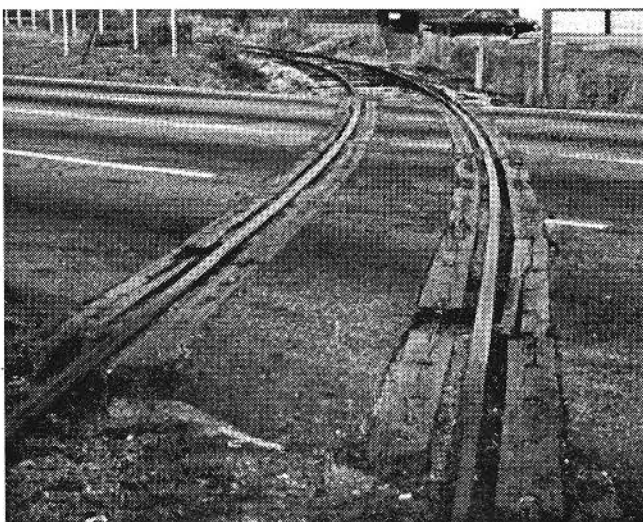

FIGURE D-2

Timber Panels

Figure D-3 illustrates how surface failure is accelerated by loose fastenings. Wood abrasion, rot, and impact damages contribute to the backing off of fasteners and therefore contribute to future deterioration of the crossing surface structure.

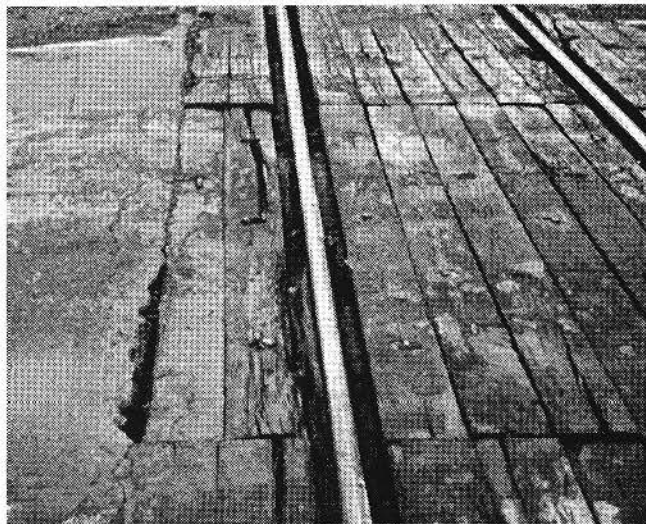

FIGURE D-3

Rubber-Timber Panels

The timber in this combination material crossing surface frequently is the cause of the surface failure.

Rubber-Longitudinal Shims

The angle of the intersection contributes to the wear of the shims. An uneven surface resulting from shim wear places stress on the surface pad and frequently contributes to a cracked surface near fastener drill holes.

Rubber-Lateral Shims

Lateral shims are subject to the same failure described in the application of longitudinal shims. Figure D-4 is an illustration of this surface type. In addition to being subject to loosening of fastenings, splitting shims also contribute to the failure of this crossing surface structure.

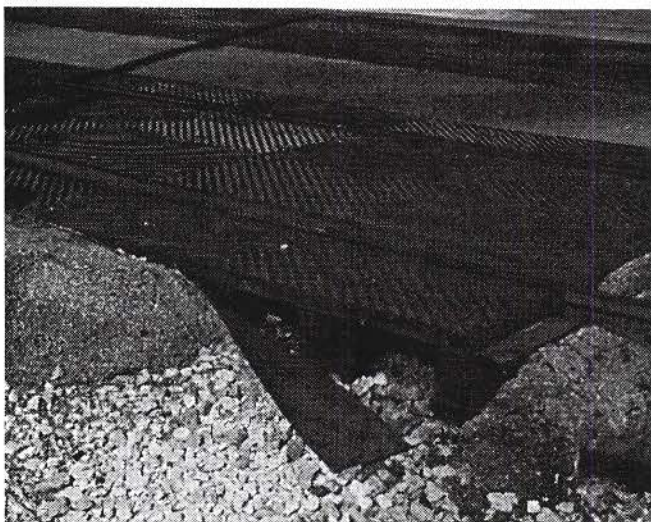

FIGURE D-4

Rubber-Full Depth

Damage from dragging equipment (both rail and motor vehicle), abrasion, and rubber separation are the major cause of failure for this surface type. Figure D-5 is a photograph of an intersection entering a port area. Large trucks and materials handling equipment have contributed to the failure of these rubber panels. Both full-depth and shimmed rubber panels are subject to snow plow gouging.

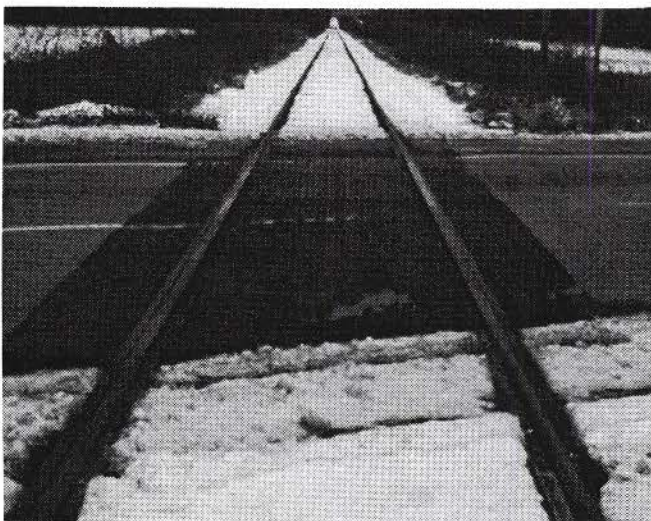

FIGURE D-5

Concrete Panels-Shimmed

Concrete panels are exposed to surface abrasion (Figure D-6) similar to that of rubber panels. Due to the wear of shims

and the resulting misalignment of the crossing surface, concrete panels are subject to cracking. When fasteners loosen, these panels frequently are subject to a “rocking” motion. Stress resulting from movement on the less-than-full-depth panels can cause their failure.

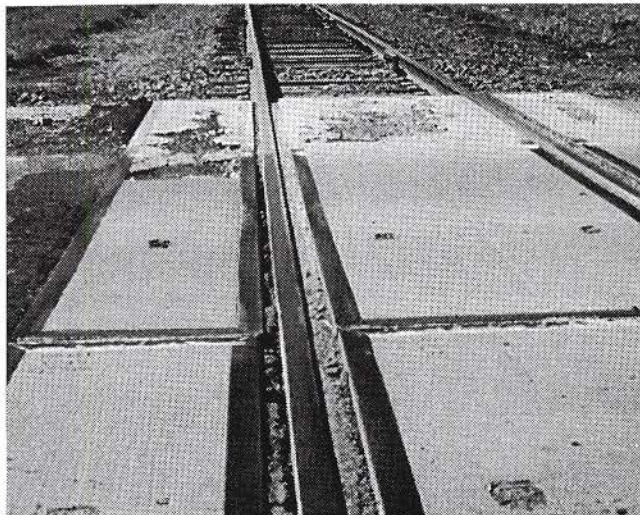

FIGURE D-6

Concrete Panels-Full Depth

Figure D-7 illustrates the impact of surface abrasion on this crossing surface structure. Full-depth concrete panels can withstand stress from heavy loading better than the shimmed installation. However, damage to the surface of the concrete panel will contribute to cracking and deterioration of the full-depth panel.



FIGURE D-7

APPENDIX E

Selected Descriptions of Crossing Surface Products

Grade Crossing Surfaces

Note: The products described below do not represent a standard specification or endorsement. They are product descriptions that were made available to the author at the time of synthesis preparation.

The following is a brief description of the crossing surfaces that were available in the beginning of the year 1994. The descriptions are taken directly from advertisements in the RT&S magazine. Some of the pictures and illustrations accompanying the description were also taken from the advertisement. However, where available, pictures and illustrations are from materials submitted to the study team following an RPI-sponsored meeting with suppliers.

Airtek

The Cobra-X-Module concept utilizes an injection-molded, high-density polyethylene material with a rugged honeycomb base. It is said to be highly resistant to abrasion, moisture, solvents, road shock and wear. The interlocking design facilitates installation, and the full-depth modules eliminate the need for wood shims and better boards. For pedestrian-crossing surfaces, a unique abrasive-type solvent was developed to provide better traction (Figure E-1).

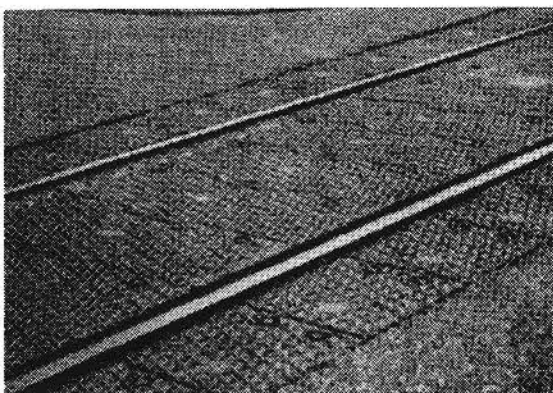

FIGURE E-1

Burke-Parsons-Bowlby Corp.

Durable oak timbers are used in the construction of the Solid Timber Panel Crossing. The field panels are 20 in. wide, consisting of two 10-in. timbers with a flange-way clearance notch, which prevents crushing of the edge of the filed panel. The gauge panels are 25-1/2 in. wide, consisting of three 8-1/2 in. timbers. All panels are doweled together and pre-bored with countersink holes for drive spikes or lag screws. Panels

can be shipped with pre-attached filler blocks and beveled ends (Figure E-2).



FIGURE E-2

Century Precast

Full depth concrete panels distribute weight over a large number of ties and are said to eliminate the need for grout bags or shim boards. The panels are said to be easily handled with a rubber-tire backhoe. They are manufactured of reinforced high strength concrete, are said to be quick to install and meet or exceed HS20-44 loading standards. Panels for curves are manufactured for the degree needed, and panels are available for turnouts. No wedges are required during installation, and panels are manufactured in lag-type and lagless style. Tapered-end panels are standard and eliminate the need for deflector shields (Figure E-3).

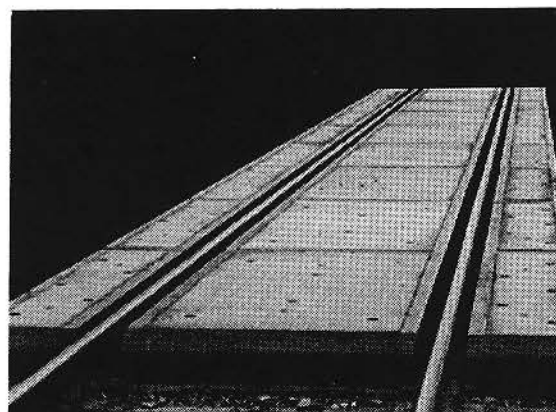

FIGURE E-3

CXT Inc.

Concrete grade crossing slabs can be used on either wood or concrete ties, with all types of rail fastenings. The crossing slabs can be removed for track maintenance and are said to provide a durable, trouble-free surface with excellent ride quality. The slabs can be varied for track curvature, rail size and tie spacing to fit particular requirements (Figure E-4).

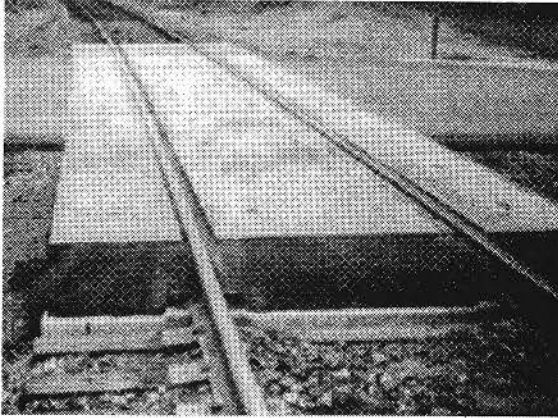

FIGURE E-4

Fab-Ra-Cast, A Division of Orgo-Thermit, Inc.

This grade crossing systems consists of 6,000 psi precast concrete panels and Fab-Ra-Filler flangeway filler. The company says the system is the only crossing that allows for leveling each crossing panel with the top of the running rail, the result of a patented leveling and support system. Long-life crossings from custom panels fit specific configurations, including turnouts, diamonds, bridge decks, or devil strips (Figure E-5).

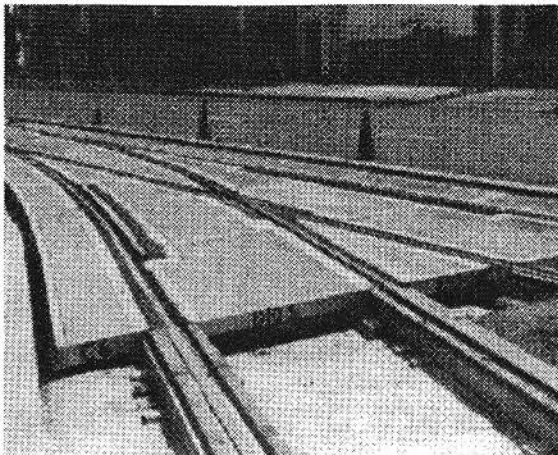

FIGURE E-5

Goodyear Tire and Rubber Co.

Full-depth crossing pads are all rubber and designed for the toughest highway crossing applications. Lag bolts, wood

shims and header boards are not required, which is said to result in faster and easier installations and removals. The pads have tongue-and-groove interlocking joints for water-tight fit and are furnished in 3-ft lengths for straight, as well as most curved, tracks.

Goodyear Tire and Rubber Co.

Hi-Miller crossing pads are molded from a tough ASTM-D2000 minimum-specification rubber and are reinforced with corrugated steel inserts. Pads are capable of handling all highway pneumatic tire loading without surface breakup or deterioration. They have excellent abrasion, weathering and shock-absorption properties for maximum service life, the manufacturer says. Pads are fastened to the sub-structure and ties with galvanized spikes for an integrated structure, and can be molded to fit curved track up to 30 degrees.

Goodyear Tire and Rubber Co.

Super Cushion "MLT" rubber crossing pads are made of the same heavy-duty corrugated steel and ASTM-D2000 rubber as the standard Super Cushion for the heaviest traffic-loading and impact conditions. They are said to have excellent abrasion, weathering and shock absorption properties. Pads are fastened with timber screws, with fewer pieces to handle, which allows for quicker installation and removal as required on main-line track applications.

Goodyear Tire and Rubber Co.

Super Cushion rubber crossing pads have been used in crossings since 1954. Pads are heavy-duty corrugated steel completely encased in rubber, and are capable of handling the heaviest traffic loading and impact conditions. The rubber elastomer meets the ASTM-D2000 minimum specification and has excellent abrasion, weathering and shock-absorption properties for maximum service life. Pads are fastened to the substructure and ties with galvanized spikes for an integrated structure. Pads can be molded to fit curved track up to 30 degrees (Figure E-6).

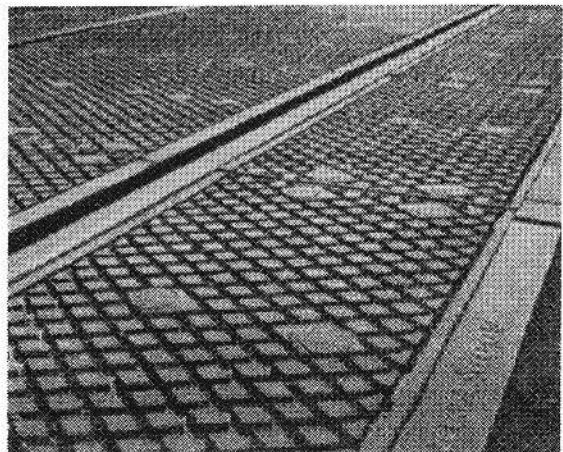

FIGURE E-6

Hi-Rail Corp.

The Hi-Rail rubber grade crossing system is a full-depth, no-lag-bolt, heavy-duty system that eliminates the need for wooden shims and header boards. Each pad locks under the head of each rail and into the adjacent pad with a tongue and groove, resulting in a monolithic, water-tight construction throughout the crossing. The company reports that, since 1993, Hi-Rail systems have been manufactured at Kraiburg of America's new Iowa plant, which facilitates market delivery (Figure E-7).

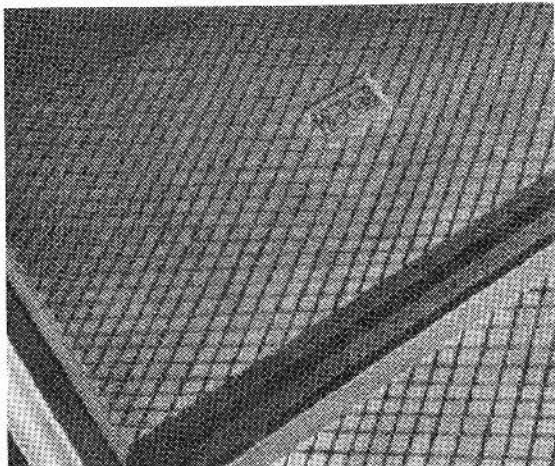

FIGURE E-7

Kerr-McGee Chemical Corp.

Pressure-treated hardwood grade crossing panels are custom-manufactured to exact specifications to assure quick installation at job sites. Kerr-McGee wood crossing panels and crossing timbers are designed to be an economical answer for road crossing needs. The company reports that recent renovation and expansion of its crossing-manufacturing facilities have resulted in reduced lead times and greater flexibility in consistently meeting customer needs in terms of quality, dependability and service (Figure E-8).

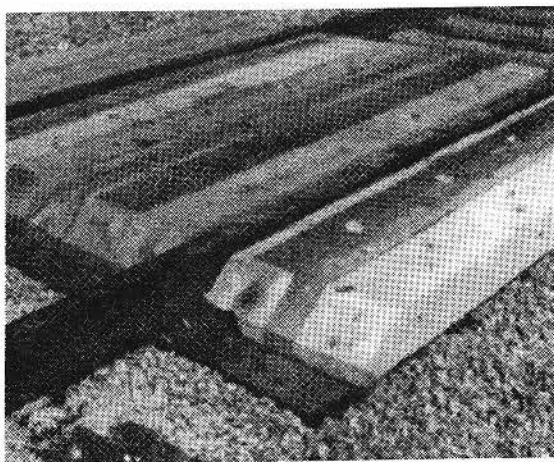

FIGURE E-8

Magnum Manufacturing Corp.

Concrete grade crossings are manufactured to fit any rail from 115 lb. to 136 lb and accommodate any length of tie or tie spacing (Figure E-9).

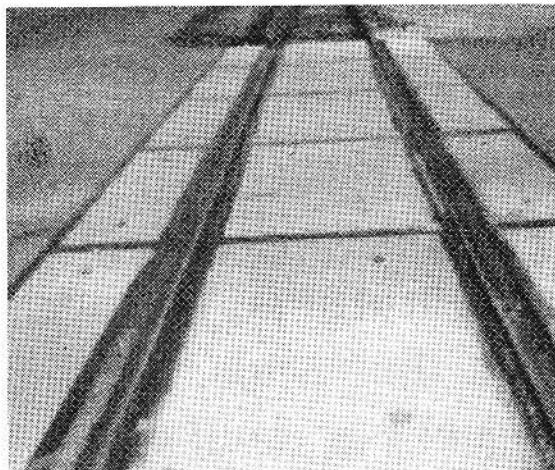

FIGURE E-9

OMNI Products, Inc.

Full-depth panels made of recycled rubber, OMNI Rail-Guard is a low-cost crossing system that takes advantage of rubber around the rail with timber and asphalt or poured-in-place concrete to finish the grade. Rail-Guard provides a positive rubber flangeway that increased safety for pedestrians and bicycles (Figure E-10).

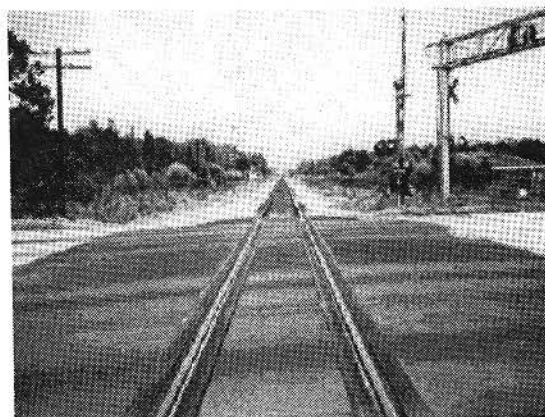

FIGURE E-10

OMNI Products, Inc.

OMNI Standard full-depth panels are an economical design made of recycled rubber and backed by more than 10 years of successful applications. Ideal for city streets with medium ADT, OMNI Standard comes in a unitized version that eliminated timber screws.

OMNI Products, Inc.

Full-depth panels made of durable virgin rubber, OMNI Heavy Duty is ideal for fast, heavy-truck traffic and high ADT roads. OMNI Heavy Duty is available in a panelized option that connects the panels together and reduces installation time.

OMNI Products, Inc.

Steel Reinforced virgin rubber is a 20-yr, time-proven design. The 1/4 in. corrugated steel plate is molded in 3 in. of virgin rubber. Said to be ideal for heavy concentrated loads found with lift-truck traffic or ports using container handlers, OMNI Steel Reinforced stays smooth and level under heavy loads.

OMNI Products, Inc.

Steel-reinforced, 5,000-psi concrete with molded rubber rail interface, makes OMNI Improved-Concrete one of the most complete concrete designs, according to the manufacturer. Panels come in 9 ft or 12 ft lengths with built-in lifting hooks. The system incorporates rubber RailGuard, which provides a positive rubber flangeway, eliminating the need to pack asphalt between the rail and the concrete panels. Improved-Concrete can be lagged-down or free-floating (Figure E-11).

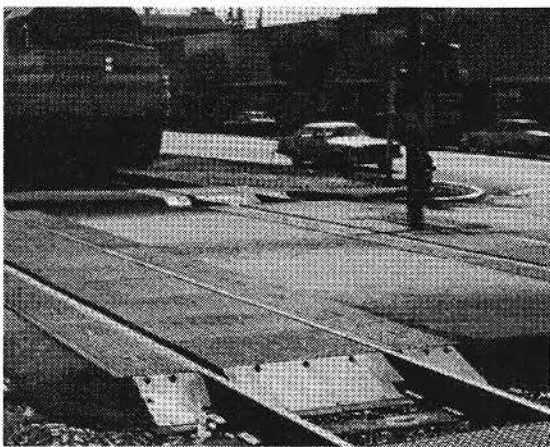

FIGURE E-11

Pace

The Pittenger and Cook Engineering system is full-depth, all-rubber and lag-less. The design accommodates curves of any degree, as well as tangent, using the company's standard stock. Built-in rail anchor reliefs permit the use of any type of anchor. Every module is stabilized to prevent longitudinal, lateral or vertical movement. The patented hinge kerf in the gauge pad allows fast and easy installation without the need for special tools and equipment. The PACE system is available for 8 ft, 6 in., or 9 ft wood ties, or any concrete tie shape, for all standard AREA rail from 90 lb to 136 lbs (Figure E-12).

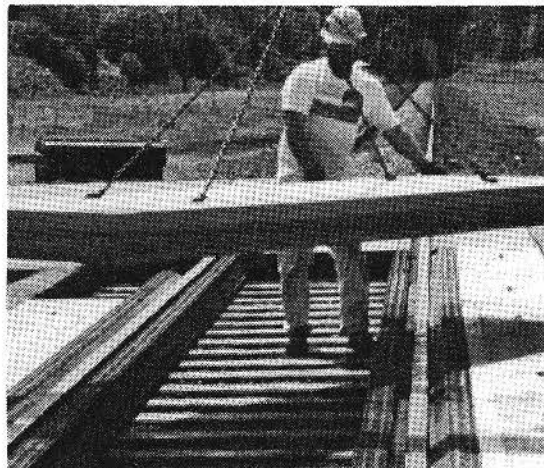

FIGURE E-12

Permacrete Products Corp.

Precast concrete sectional crossing slabs are 16 ft long and 16-3/4 in. wide and from 5 to 8 in. thick, in multiples of 1/4 in. One bottom edge of each slab is rabbeted to clear tie plates and track spikes. Holes are provided for attaching timber filler and flangeway sections. A 2-in. steel armor channel with a 1/2-in. wide flange is anchored to the slab with countersunk head-bent spikes to prevent chipping of meeting edges. Intermediate and end slabs with filler and flangeway pieces are a complete package installation (Figure E-13).

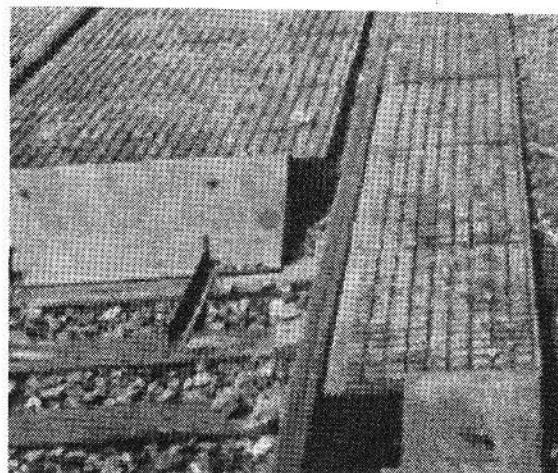

FIGURE E-13

Premier

Premier's concrete module grade crossing system eliminates the need for crossties or rail fasteners, and is said to provide maintenance-free performance. The system offers permanent support for heavy-traffic loadings when installed on a properly prepared subgrade. Easy access to the rail is provided via pre-formed and removable center panels, which hold the rail to gauge. Modules come in 4 ft and 8 ft lengths and can fit up to a 33-degree curve.

StarTrack Railroad Crossings

The modular precast-concrete grade crossing system uses no ties and is set on a prepared subgrade to form a self-supporting slab system free of vertical or lateral movement. Rail lays on UHMW polyethylene strips, which cushion impact loadings and protect the underlying concrete surface from abrasion, that attach with a bolted-down clip. Rail joints are fixed on a continuous stable base so they cannot flex. Bolted joints are said to be sufficient except for high-speed track, which eliminates grinding and welding costs. The newest design incorporates Pandrol fasteners for ease of installation and easy access to rail after installation. Each panel is cast of 6,000 psi reinforced concrete and measures 4 ft along the track and 8 ft in width; shoulder thickness is 7 in. StarTrack panels are precast at regional concrete plants, which results in prompt delivery and professional supervision, according to the company.

Steel Crossings, Inc.

SCI manufactures heavy-duty, diamond-plate, custom-designed steel railroad crossings for heavy-crossing areas. Steel crossings are easily installed, easy to maintain, and ideal for severe weather conditions with no tearing, chipping, splintering, cracking or disintegration, the manufacturer says.

Tie Collar Ltd.

The Tie Collar is a 330 lb iron casing, shaped like a flattened bell, that attaches near each end of a wooden tie. The design disperses train loads over a large bearing area to reduce the pressures on the roadbed, and provides a firm foundation, according to the company, translating into reduced maintenance costs and longer track life. The assemblies work on highway grade crossings, curves, spirals, turnouts and diamond intersections, and are said to be especially beneficial on heavy-tonnage mainlines, high-speed corridors and areas with weak soil characteristics (Figure E-14).



FIGURE E-14

Fillers and Fasteners

Century Precast

Preformed rubber flangeway filler prevents debris from lodging in flangeway and is said to help reduce intrusion of water, salt and sand into ballast. The filler is said to be economical, durable, fast to install and compatible with all anchor systems.

Crown Steel Rail Company

The Flangemaster is said to provide a proper flangeway and assure a smooth crossing. It is adaptable to paved and industrial areas where tracks are installed. A rigid steel guard bar provides a smooth surface between tracks, so that rubber-tired or steel-wheeled vehicles can cross without jolting or unnecessary bumping. It is suitable for use with concrete, asphalt or plank crossings. The system is simple in design, easy to install and reduces job and maintenance costs, the manufacturer says. Installation requires only blocks and flat steel guard bar.

Epton Industries Inc.

Epton Railseal is manufactured from a high-quality EPDM rubber compound that is specifically designed to absorb the shocks of both vehicle and train traffic. Railseal is available in numerous profile sizes, allowing a tight fit for all rail sizes and fastener systems. The interface provides a seal between the track and surface materials, minimizing surface-water infiltration to the ballast, which is said to extend the performance life of the crossing.

Extrud-A-Rail Inc.

The company's patented flange-way fillers are manufactured of 100 percent recycled rubber and are easily installed over cut-spike or elasticized fasteners and interface with poured-in-place concrete or asphalt or modular panels. Full-depth rubber panels with non-skid surfaces are also manufactured by Extrud-A-Rail for a complete crossing package. The flangeway fillers are also used for embedded track construction by light-rail transit, forming a continuous flangeway for girder or T-rail applications with a wide variety of fasteners.

Fab-Ra-Cast, A Division of Orgo-Thermit, Inc.

Fab-Ra-Filler is a mixed-on-site and poured-in-place flangeway filler, which consists of cryogenically-processed rubber and moisture-cured polyurethane. It is said to contour to the shape of the flangeway, adhere to any surface and act as a moisture barrier to help protect track structure and subgrade. Because it

insulates the flange area, it can be used in signal territory, the company says, and it complies with ADA regulations.

International Track Systems, Inc.

Flangeway rubber inserts eliminate the flangeway gap on industrial crossings. Manufactured from 70-durometer EPDM synthetic rubber, the inserts provide a smooth crossing surface that compresses under the wheels of railway traffic. The inserts have excellent weathering properties and are available for wood, concrete, asphalt or rubber crossings.

International Track Systems, Inc.

Full-length, 3/16 × 8 in. × 8 ft, 6 in., rubber tie pads improve ride quality and reduce grade-crossing maintenance when used on each tie in the crossing, the manufacturer says.

Lewis Bolt & Nut Co.

Sealtite Dome Head Drive Spikes have a thin dome-shaped head that eliminates counter-boring, thus preventing excessive timber decay and rust, and reduces maintenance. Low profile adds to worker safety. The large-diameter head seals moisture away from spike shank and prevents rust, and the extra large bearing surface holds tight. Easily installed with a pneumatic air tool or with a maul, the spikes are used to fasten highway crossing planks, bridge timber guard rail, bridge decking, dock timbers, bridge fender timbers, retaining walls and other timber structures.

Lewis Bolt & Nut Co.

Specially-coated 5/8 in. diameter recessed-head timber screws allow quick installation with standard tools. Preboring is recommended, but is not necessary, and the screws are available in various lengths with either round or square heads. Forged one-piece washer-head eliminates the need for separate washer, and seals out moisture, preventing rust and wood decay. Used to fasten highway crossing planks, bridge decking and other timber structures.

Lewis Bolt & Nut Co.

Washerhead timber drive spikes are single-forged, which eliminates both the need for a separate washer and the corrosion that occurs between washer and head. The spikes can be driven with a maul or pneumatic spike driver, and can be removed with hand or power tools. The threads have excellent holding power, and the spikes can be easily and quickly installed and

removed. They are used in highway crossing planks, bridge timber guard rails, motorcar set-offs and other timber structures.

Magnum Manufacturing Corp.

Rubber flange filler is a durable material that is to be placed in the flangeways of concrete grade crossings. The filler is reusable and can be installed during a concrete grade crossing installation. The filler is contoured to adhere to the web of each side of the rail and is available in 10 ft lengths, which can be trimmed to any necessary size.

Phoenix

The Phoenix track filler profile has been designed for sealing around railroad tracks in order to allow pedestrian and vehicular traffic to cross over the rail safely, to provide easy access to the rail and rail fasteners and to allow rail car wheel movement without damage. Different sizes and shapes are available, and Phoenix can custom-make profiles.

Rails Co.

Grade crossing rail anchors protect rails at grade crossings, industrial sidings and other areas requiring moderate longitudinal rail restraint. They minimize spike pull, tie wear and unstable subgrade, which can result from vertical motion caused by train and highway traffic. A Rails Compression Rail Anchor acts as a spring, absorbing the vertical movement of the rails; two torque timber screws provide secure hold-down. The fasteners fit all rail sizes and are said to install quickly with no pre-drilling required.

RFR Industries, Inc.

The RFR flange insert system, featuring the proprietary "pop-down" gauge insert, is usable with standard full-depth concrete panels or timber planks for highway grade crossings. The RFR system seals the rail from dirt, mud, and roadway debris, and is said to enhance crossing safety by eliminating the field-side gap. RFR inserts fit 90 lb to 140 lb rail, are anchor-adaptable, accommodate concrete or timber-tie rail fasteners, require no special tools or equipment for installation, no specific tie spacing for support and are connected at each joint to ensure a consistent and precise seal between the rail and crossing panels. RFR inserts can be produced in custom lengths up to a maximum of 45 ft, will accommodate any degree of track curvature, and are said to be maintenance-free and completely reusable. RFR inserts are designed for either new installations or to retrofit existing open flangeways without removing the crossing panels.

APPENDIX F

Selections from the Federal-Aid Policy Guide for Crossings

FEDERAL-AID POLICY GUIDE September 8, 1992

The following is a "selection" of FHWA regulations regarding the eligibility of crossing improvement projects for Federal funds.

1. DEFINITIONS (23 CFR 646.204)

a. The diagnostic team will generally include a representative of the railroad(s) operating the tracks at the crossing(s), the Federal Highway Administration (FHWA), the State highway agency, and other State agency or political subdivision exercising jurisdiction over the crossing(s) involved.

2. TYPES OF PROJECTS (23 CFR 646.206)

a. Grade crossing elimination projects include:

- (1) new grade separations
- (2) relocation of highways
- (3) relocation of railroads
- (4) crossing closure without other construction

b. Grade crossing improvement projects include:

- (1) installation of standard signs and pavement markings
- (2) installation of replacement of active warning devices
- (3) upgrading of active warning devices, including track circuit improvements and interconnection with highway traffic signals
- (4) crossing illumination
- (5) crossing surface improvements
- (6) general site improvements

4. FEDERAL SHARE (23 CFR 646.212)

a. Use of Federal Funds for Local Match

(1) Title 23 U.S.C. Section 130 sets the Federal share for the categorical rail-highway crossing program at 90 percent. Title 23 U.S.C. 130(h), however, allows the use of Section 130 funds to provide a local government with funds to be used on a matching basis when State funds are available which may only be spent when the local government produces matching funds.

(2) Many states are prohibited by law from spending State funds on local roads. As a result, because many local governments have been unable to provide the necessary 10 percent matching funds in the Section 130 program, many needed projects are not being done on the local system.

(3) If a State has a law to allow State funds to be used for a certain percentage of the 10 percent match, the entire local government share could come from Federal funds in accordance with the language of Section 130(h). Federal funds may provide the local government share regardless of its percentage of the 10 percent on match. Such a funding arrangement may be used only for Section 130 projects on those highways where State law requires that a local government contribution is required to supplement the expenditure of State funds.

5. DESIGN (23 CFR 646.214)

a. When initiating a project to eliminate a grade crossing of a highway and a low traffic volume railroad line, the State highway agency should determine if abandonment of the railroad line is probably within a reasonable time.

6. GENERAL PROCEDURES (23 CFR 646.216)

c. State-Railroad Agreements

(1) No special form of written agreement is prescribed for State-railroad agreements. Such agreement usually consists of a formal document signed by officers who are authorized to bind the parties thereto, but in appropriate cases, it may consist of an exchange of correspondence which fully sets forth all the essential terms and conditions and bears the endorsement of both parties.

d. Construction

(1) The railroad should notify the State in writing (a) when construction will commence, and (b) when construction is completed.

(2) Costs of stage or extended construction should generally be limited to the first 24-month period of operation of the company's revenue trains on the relocated tracks and to those costs in excess of the cost of normal maintenance which would have been incurred had the old permanent track remained in service.

(3) Participation in costs of grade corrections and slope stabilization should not exceed the amount set up for the items

in the estimate portion of the State/railroad agreement without approval by FHWA.

FEDERAL-AID POLICY GUIDE

December 9, 1991

STATE-RAILROAD AGREEMENTS

(1) Where construction of a Federal-aid project requires use of railroad properties or adjustments to railroad facilities, there shall be an agreement in writing between the State highway agency and the railroad company.

(2) The written agreement between the State and the railroad shall, as a minimum include the following, where applicable:

- (i) The provisions of this subpart and of 23 CFR, Part 140, Subpart I, incorporated by reference,
- (ii) A detailed statement of the work to be performed by each party,
- (iii) Method of payment (either actual cost or lump sum),
- (iv) For projects which are not for the elimination of hazards of railroad-highway crossings, the extent to which the railroad is obligated to move or adjust its facilities at its own expense,
- (v) The railroad's share of the project cost,
- (vi) An itemized estimate of the cost of the work to be performed by the railroad,
- (vii) Method to be used for performing the work, either by railroad forces or by contract,
- (viii) Maintenance responsibility,
- (ix) Form, duration, and amounts of any needed insurance,
- (x) Appropriate reference to or identification of plans and specifications,
- (xi) Statements defining the conditions under which the railroad will provide or require protective services during performance of the work, the type of protective services and the method of reimbursement to the railroad, and
- (xii) Provisions regarding inspection of any recovered materials.

3. On work to be performed by the railroad with its own forces and where the State highway agency and railroad agree, subject to approval by FHWA, an agreement providing for a lump sum payment in lieu of later determination of actual costs may be used for any of the following:

- (i) Installation or improvement of grade crossing warning devices and/or grade crossing surfaces, regardless of cost, or
- (ii) Any other eligible work where the estimated cost to the State of the proposed railroad work does not exceed \$25,000 or
- (iii) Where FHWA finds that the circumstances are such that this method of developing costs would be in the best interest of the public.

4. Where the lump sum method of payment is used, periodic reviews and analyses of the railroad's methods and cost data used to develop lump sum estimates will be made.

5. Master agreements between a State and a railroad on an areawide or statewide basis may be used. These agreements would contain the specifications, regulations, and provisions required in conjunction with work performed on all projects. Supporting data for each project or group of projects must, when combined with the master agreement by reference, satisfy the provisions of Sec. 646.216(d) (2).

6. Official orders issued by regulatory agencies will be accepted in lieu of State-railroad agreements only where, together with supplementary written understandings between the State and the railroad, they include the items required by Sec. 646.216(d)(2).

7. In extraordinary cases where FHWA finds that the circumstances are such that requiring such agreement or order would not be in the best interest of the public, projects may be approved for construction with the aid of Federal funds, provided satisfactory commitments have been made with respect to construction, maintenance and the railroad share of project costs.

APPENDIX G

Details of State Responses to Survey Questionnaire Regarding Crossing Surface Improvement Practices, States Without Formal Guidelines

Alaska

"Sight distances, track profile, drainage, and train operation will all be factors considered in the design and improvement of crossings. The Railroad-Highway Grade Crossing Handbook, Federal Highway Administration Publication TS-86-215 (or revision), and current State of Alaska design standards thereof will be consulted in the design of crossings." Under the Section on New Crossings, Alaska policy states that: 1) The grade of approaches to all crossings should be level with top of rail (\pm 1 in.) for at least 100 ft to prevent long low trailers from hitting the crossing; and 2) Roadway approaches to the crossing should be at or near 90 degrees. Short radius curves or skew angle approaches below 75 degrees will not be permitted.

Arizona

The Arizona policy on railroad/highway grade crossing surfaces is to establish criteria for upgrading at-grade railroad crossing surface materials. According to the policy statement the surface material is to be improved in keeping with the following guidelines:

- Railroad/highway crossing improvements must move up the following list to be eligible for Federal-aid funding:

1. Concrete or Rubber
2. Timber
3. Asphalt
4. Gravel or Ballast
5. Dirt.

- The schedule of improvements for railroad "crossing surface only" improvement projects will be prioritized as follows:

Improvement projects will be selected from the upper third of a prioritized list of crossings in the order of highest ADT and roadway speed.

State Highways

For any ADT, asphaltic concrete or Portland Cement pavement highways warrant Rubber or Concrete crossing surface.

All Other Roads and Streets

- 3,000 ADT and above warrants Rubber or Concrete crossing.

- For any ADT, asphalt concrete or Portland Cement roadways warrants Timber crossing surface.

- Engineering judgement will be used to determine the crossing surface material considering unique conditions at each crossing, i.e. turning movements, heavy vehicle (truck) traffic, roadway geometrics, etc.

Arkansas

Arkansas uses the results of a diagnostic team inspection report, "Highway-Railroad Crossing Surface," as the basis for selecting grade crossings for surface improvements. The crossing surface is evaluated by using the following criteria:

<i>Visual Inspection</i>		<i>Average Daily Trains</i>	
Excellent	(1)	1-5	(1)
Good	(3)	6-10	(3)
Fair	(4)	Over 10	(5)
Poor	(5)	<i>Posted Highway Speed (mph)</i>	
<i>Rideability</i>		5-20	(1)
Excellent	(1)	21-40	(5)
Good	(2)	Over 40	(10)
Fair	(3)	<i>Percent Truck Traffic</i>	
Poor	(4)	1-5	(1)
<i>Average Daily Traffic</i>		6-10	(5)
0-750	(1)	Over 10	(10)
750-2000	(3)	<i>Drainage</i>	
2001-5000	(4)	Excellent	(1)
5001-8000	(7)	Good	(3)
Over 8000	(10)	Fair	(4)
		Poor	(5)

The total score, given by the Diagnostic Team, for the criteria evaluated becomes the crossing surface improvement rating factor.

Colorado

No reference listed: In Colorado the railroads are responsible for maintenance of the rail crossing surface. The state and local governments have participated in surface upgrades when they have felt that they were in the public interest. Normally that would be based on ride quality.

Connecticut

Railroad-Highway Grade Crossing Handbook: under the Rail-Highway crossing program in Connecticut, we do not initiate surface only projects. When a safety project is undertaken, it is for a total improvement, including welded rail through the crossing to maintain track circuit integrity.

Georgia

Georgia law requires the railroads whose tracks cross a public road at-grade to maintain the grade crossing in a condition to permit safe and convenient passage of public traffic. Most all grade crossings in Georgia are maintained as asphalt timber crossings where the railroad pays for the maintenance or their own adjustments. On State highway improvement projects the GaDOT, or the local government pay for the track adjustment. GaDOT receives requests from shortline railroads for high type crossings when they do not have to pay for the improvement. Local governments request funding for high type crossings, but their requests are normally rejected since Section 130 funds are used only for the railroad signal program. GaDOT has no policy or other basis to determine the need for a high type crossing.

Illinois

Although the department has no documentation, it is our perception that a more productive approach to crossing surface maintenance would be welcomed.

Indiana

Manufacturer's specs, InDOT special provisions, Indiana law, AREA manual and FHWA handbook.

Iowa

The railroad company is responsible for engineering, installation, and maintenance. The railroads contribute 20% of the cost of the project. Iowa DOT relies on the railroad's use of good engineering, installation and maintenance practices. Iowa DOT requires continuous welded rail, at least 12–15 feet beyond the edge of the panel, new ties, new ballast and filter cloth.

Kansas

In Kansas crossing surface improvements are the part of another project that requires the crossing surface to be repaired, modified or replaced. They are either highway improvement projects or rail-highway signalization projects.

Louisiana

Although Louisiana does not have a separate surface railroad grade crossing improvement program, efforts are made to replace or enhance railroad surfaces in other highway construction and maintenance programs.

Mississippi

We recommend from surveys over past 20 years and the railroad selects the crossing materials.

Nebraska

Railroad does work.

North Carolina

All crossings at grade are usually rebuilt under paving projects or active highway projects. Highway project funds, both federal and state funds are used. No funds are available for crossing rehabilitation only.

Oregon

Mostly railroads responsibility.

Utah

Local railroad representatives work well with UDOT, but railroad field crews do not communicate as well with the Department.

Wyoming

FHWA handbook, manufacturer brochures, and field observation of performance. The agency works with railroads to follow MUTCD or other guidelines, but feels more cooperative efforts would be beneficial.

APPENDIX H

Minnesota Crossing Surface Policy

Minnesota Crossing Surface Policy: An Example

The Railroad Administration of the Minnesota Department of Transportation has established a policy regarding grade crossing surfaces. Published in July 1988, the Policy states that the first priority of the Minn DOT Federal Rail Grade Crossing Program is safety enhancement with at least 50 percent of the available funds designated to active warning systems. Further, the Policy states that “among other acceptable uses of the funds is the installation of crossing surfaces.”

The guidelines for installation of crossing surfaces are spelled out in the Minn DOT policy as follows:

High Cost Durable Crossing Surface

Eligibility—A crossing surface must meet the following criteria to be eligible for consideration:

- a) The road traffic exceeds 2,500 average annual daily traffic (AADT) or 250 heavy commercial vehicles per day;
- b) There are at least two trains per day; and
- c) The crossing surface is in poor condition per Minn DOT Guidelines (see Minn DOT Guidelines at the end of this article), even after a demonstrated record by the railroad of responsible maintenance;

A crossing that contains tracks that have low train volumes (less than two trains per day) may qualify for a high cost durable crossing surface if it has significantly higher AADT counts than established in (a) above. Minn DOT will determine the need for high cost durable surfaces on these tracks on a crossing-by-crossing basis.

Financial Responsibility—The Federal share will be 70 percent of the total project cost. The road authority share will be 15 percent of the total project cost. In addition, the road authority will contribute, at its expense, the following items to the project:

- a) *Site Plan*—A plan and profile drawn to scale showing all important features and all work to be completed or contributed by the road authority.
- b) *Traffic Control*—Provide detours and construction signing as needed.
- c) *Utilities*—Move, or have moved by their owners at local authority expense, any gas, electric, water, sewer, telephone, etc., that may be in the way.
- d) *Approaches*—Construct, or cause to be constructed, satisfactory approaches to the crossing. This shall include the necessary curb and gutter work.

- e) *Parking*—Restrict parking in the vicinity of the crossing in such a way as to eliminate sight problems that are caused by parked vehicles.
- f) *Material Storage*—Restrict storage of material in the vicinity of the crossing in such a way to eliminate sight problems.
- g) *Barricades, signs and markings*—Install, or cause to be installed, all necessary barricades, signs and markings in accordance with MUTCD.
- h) *Trees*—Trim all trees and brush on road authority right-of-way up to the track with sight visibility at the crossing.
- i) *Sidewalks*—Construct or extend sidewalks, when appropriate, up to the track area from both sides.

The railroad share will be 15 percent of total project costs. In addition, the railroad shall contribute, at its expense, the following items to the project:

- a) *Betterments*—Any upgrades which are more than necessary for the proposed project. (For example, placing 132 pound rail through a crossing where the adjoining rail line is only 112 pound rail.)
- b) *Site clearances*—The railroad shall clear its right-of-way of any vegetation that creates a sight obstruction.

Crossing Surface Safety Enhancement

The Minnesota DOT crossing surface policy provides for surface improvement funding under certain criteria. Eligibility for funding is based upon a “significant safety concern.” Although the program is not restricted by AADT or train traffic, these two factors determine the type of surface that is to be installed at the crossing.

Examples of significant safety concerns are:

- A crossing with an accident history that is related to surface condition.
- A crossing that needs to be reconstructed because it is a part of a larger project.
- A crossing with special geometric problems.

For eligible projects, the Federal share of costs will be 90 percent of the total project cost. The road authority share will be 10 percent. The road authority and the railroad will contribute the same items as listed above. If the railroad chooses, it may contribute toward the road authority share.

General Comments

The Minnesota DOT policy states further that:

1. No Federal grade crossing safety improvement funds will be used where the crossing does not meet the criteria of the programs.
2. The railroad will continue to maintain the crossing, at its expense, and in accordance with Minn DOT requirements.
3. Minnesota DOT permits any party to voluntarily contribute funds for the installation of materials that will provide a betterment in excess of what is called for in the guidelines outlined above.
4. The railroad and the road authority have the joint responsibility to agree upon the elevation and super-elevation of both the roadway and the tracks, before construction begins. Each party will be responsible, at its own expense, to correct deviations from the agreed upon construction plan.
5. If Federal funds are accepted for a high cost durable crossing surface, the railroad must agree to maintain the crossing with the same type of surface material for the expected life of the surface material installed. To change the type of material, the railroad must receive approval from all participating parties. The railroad must repair all damage done to the crossing. The party responsible for the damage will pay for the repair.
6. Replacement of the crossing surface, at the end of the expected service life, will be according to agreements with the involved parties.
7. If a crossing is abandoned, Minn DOT will be reimbursed for any usable material that was initially funded by state or Federal programs. With Minn DOT approval, the railroad may use the materials at another crossing.

Crossings Within Highway Construction Projects

The following is taken directly from the Minn DOT policy on grade crossing surfaces:

Trunk Highways—If the trunk highway construction project requires a reconstruction of the crossing due to road realignment, grade change, etc., the State will pay 100 percent of the cost.

If an existing road is to be resurfaced in such a manner as not to require a change in the crossing but the crossing should be reconstructed because of its condition, the State and the railroad shall negotiate a cost-sharing agreement.

If there is no State project and the rail-highway crossing needs reconstruction, the State and/or railroad shall pay the costs, depending on whose facility caused the problem (e.g., the rail line sinking under rail traffic or the road approaches heaving).

Non-Trunk Highways—By state statute, no State-Aid funds may be used on non-trunk highway crossing surface projects. Only Federal funds are available for projects in this highway class. The eligibility criteria for Federal funds will be the same as set forth in the previous sections of the Minn DOT

policy statement. Any feature of a highway construction project at a railroad crossing which is the result of a highway project improvement, and does not stem from rail-highway safety concerns at the crossing, shall be the financial responsibility of the road authority.

Minnesota DOT Guidelines for Surfaces

1. Good—Smooth, does not produce an uncomfortable bounce when the vehicle is driven over the crossing at the design speed or speed limit.
2. Fair—No holes, slight speed reduction is necessary to avoid an uncomfortable bounce, some unevenness and some pavement deterioration.
3. Poor—Rough, holes, uneven tracks, broken rails, pavement broken, drastic speed reduction necessary. Also, multiple tracks with differences in elevation between track centerlines.

Crossing surfaces in the “Poor” class will be considered for improvement with any qualifying funds available to the Department.

High cost “Durable” crossing surface material (*) is recommended on crossings where the ADT exceeds 2,500 and there are at least 2 trains per day. High cost “Durable” crossing surface material may also be considered on a roadway with less than the 2,500 ADT if it has substantial truck traffic (Heavy Commercial). Substantial truck traffic is regarded as exceeding 10% Heavy Commercial.

High Cost “Durable” crossing surface materials consist of the following:

1. Rubber
2. Concrete
3. High Density Polyethylene
4. Steel.

Other materials that are in common usage consist of:

1. Full Depth Treated Timber
2. Timber with asphalt
3. Flange Rail with asphalt.

High density polyethylene may be used on high volume roads where the speeds do not exceed 30 mph. Full depth treated timber and flange rail or timber with asphalt are recommended for crossings not meeting the guidelines for a High Cost “Durable” material.

(*) High Cost “Durable” Crossing Surface Material

These are manufactured products normally made of rubber, concrete, or other special materials having distinctive performance characteristics, but costing more than other materials designed for use as grade crossing surfaces.

THE TRANSPORTATION RESEARCH BOARD is a unit of the National Research Council, a private, nonprofit institution that provides independent advice on scientific and technical issues under a congressional charter. The Research Council is the principal operating arm of the National Academy of Sciences and the National Academy of Engineering.

The mission of the Transportation Research Board is to promote innovation and progress in transportation by stimulating and conducting research, facilitating the dissemination of information, and encouraging the implementation of research findings. The Board's varied activities annually draw on approximately 4,000 engineers, scientists, and other transportation researchers and practitioners from the public and private sectors and academia, all of whom contribute their expertise in the public interest. The program is supported by state transportation departments, federal agencies including the component administrations of the U.S. Department of Transportation, and other organizations and individuals interested in the development of transportation.

The National Academy of Sciences is a nonprofit, self-perpetuating society of distinguished scholars engaged in scientific and engineering research, dedicated to the furtherance of science and technology and to their use for the general welfare. Upon the authority of the charter granted to it by the Congress in 1863, the Academy has a mandate that requires it to advise the federal government on scientific and technical matters. Dr. Bruce Alberts is president of the National Academy of Sciences.

The National Academy of Engineering was established in 1964, under the charter of the National Academy of Sciences, as a parallel organization of outstanding engineers. It is autonomous in its administration and in the selection of its members, sharing with the National Academy of Sciences the responsibility for advising the federal government. The National Academy of Engineering also sponsors engineering programs aimed at meeting national needs, encouraging education and research, and recognizes the superior achievements of engineers. Dr. William A. Wulf is president of the National Academy of Engineering.

The Institute of Medicine was established in 1970 by the National Academy of Sciences to secure the services of eminent members of appropriate professions in the examination of policy matters pertaining to the health of the public. The Institute acts under the responsibility given to the National Academy of Sciences, by its congressional charter to be an adviser to the federal government and, upon its own initiative, to identify issues of medical care, research, and education. Dr. Kenneth I. Shine is president of the Institute of Medicine.

The National Research Council was organized by the National Academy of Sciences in 1916 to associate the broad community of science and technology with the Academy's purposes of furthering knowledge and advising the federal government. Functioning in accordance with general policies determined by the Academy, the Council has become the principal operating agency of both the National Academy of Sciences and the National Academy of Engineering in providing services to the government, the public, and the scientific and engineering communities. The Council is administered jointly by both Academies and the Institute of Medicine. Dr. Bruce Alberts and Dr. William A. Wulf are chairman and vice chairman, respectively, of the National Research Council.

Transportation Research Board
National Research Council
2101 Constitution Avenue, N.W.
Washington, D.C. 20418

NON-PROFIT ORG.
U.S. POSTAGE
PAID
WASHINGTON, D.C.
PERMIT NO. 8970

ADDRESS CORRECTION REQUESTED

MTA DOROTHY GRAY LIBRARY & ARCHIVE
Highway-rail grade crossing surfaces
TE7 .N26 no. 250



100000194298

007168-00
Keith L. Killough
421 South Van Ness Avenue #22
Los Angeles CA 90020-4630