

National Cooperative Highway Research Program

NCHRP Synthesis 218

Mitigation of Nighttime Construction Noise, Vibrations, and Other Nuisances

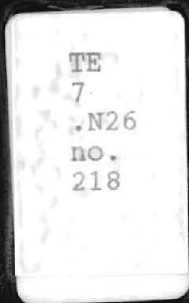

A Synthesis of Highway Practice

Transportation Research Board
National Research Council

TRANSPORTATION RESEARCH BOARD EXECUTIVE COMMITTEE 1999

Officers

Chair: WAYNE SHACKELFORD, *Commissioner, Georgia DOT*

Vice Chairman: MARTIN WACHS, *Director, University of California Transportation Center, University of California at Berkeley*

Executive Director: ROBERT E. SKINNER, JR., *Transportation Research Board*

Members

SHARON D. BANKS, *General Manager, AC Transit (Past Chairwoman, 1998)*
THOMAS F. BARRY, JR., *Secretary of Transportation, Florida DOT*
BRIAN J. L. BERRY, *Lloyd Viel Berkner Regental Professor, University of Texas at Dallas*
SARAH C. CAMPBELL, *President, TransManagement Inc., Washington, D.C.*
ANNE P. CANBY, *Secretary of Transportation, Delaware DOT*
E. DEAN CARLSON, *Secretary, Kansas DOT*
JOANNE F. CASEY, *President, Intermodal Association of North America, Greenbelt, Maryland*
JOHN W. FISHER, *Joseph T. Stuart Professor of Civil Engineering and Director, ATLSS Engineering Research Center, Lehigh University*
GORMAN GILBERT, *Director, Institute for Transportation Research and Education, North Carolina State University*
DELON HAMPTON, *Chairman & CEO, Delon Hampton & Associates, Washington, D.C.*
LESTER A. HOEL, *Hamilton Professor, Civil Engineering, University of Virginia*
JAMES L. LAMMIE, *Director, Parsons Brinckerhoff, Inc., New York, New York*
THOMAS F. LARWIN, *General Manager, San Diego Metropolitan Transit Development Board*
BRADLEY L. MALLORY, *Secretary of Transportation, Pennsylvania DOT*
JEFFREY J. MCCAIG, *President and CEO, Trimac Corporation, Calgary, Alberta, Canada*
JOSEPH A. MICKES, *Director, Missouri DOT*
MARSHALL W. MOORE, *Director, North Dakota DOT*
JEFFREY R. MORELAND, *Senior VP, Burlington Northern Santa Fe Corporation*
SID MORRISON, *Secretary of Transportation, Washington State DOT*
JOHN P. POORMAN, *Staff Director, Capitol District Transportation Committee*
ANDREA RINKER, *Executive Director, Port of Tacoma, Washington*
JOHN M. SAMUELS, *VP-Operations Planning & Budget, Norfolk Southern Corporation, Norfolk, Virginia*
CHARLES THOMPSON, *Secretary, Wisconsin DOT*
JAMES A. WILDING, *President and CEO, Metropolitan Washington Airports Authority*
DAVID N. WORMLEY, *Dean of Engineering, Pennsylvania State University, (Past Chair, 1997)*

MIKE ACOTT, *President, National Asphalt Pavement Association (ex officio)*
JOE N. BALLARD, *Chief of Engineers and Commander, U.S. Army Corps of Engineers (ex officio)*
KELLEY S. COYNER, *Administrator, Research and Special Programs, U.S. DOT (ex officio)*
MORTIMER L. DOWNEY, *Deputy Secretary, Office of the Secretary, U.S. DOT (ex officio)*
DAVID GARDINER, *Assistant Administrator, U.S. DOT (ex officio)*
JANE F. GARVEY, *Federal Aviation Administrator, U.S. DOT (ex officio)*
EDWARD R. HAMBERGER, *President and CEO, Association of American Railroads (ex officio)*
CLYDE J. HART, JR., *Maritime Administrator, U.S. DOT (ex officio)*
JOHN C. HORSLEY, *Executive Director, American Association of State Highway and Transportation Officials (ex officio)*
GORDON J. LINTON, *Federal Transit Administrator, U.S. DOT (ex officio)*
RICARDO MARTINEZ, *National Highway Traffic Safety Administrator, U.S. DOT (ex officio)*
WILLIAM W. MILLAR, *President, American Public Transit Association (ex officio)*
JOLENE M. MOLITORIS, *Federal Railroad Administrator, U.S. DOT (ex officio)*
ASHISH K. SEN, *Director, Bureau of Transportation Statistics, U.S. DOT (ex officio)*
GEORGE D. WARRINGTON, *President and CEO, National Railroad Passenger Corporation (ex officio)*
KENNETH R. WYKLE, *Federal Highway Administrator, U.S. DOT (ex officio)*

NATIONAL COOPERATIVE HIGHWAY RESEARCH PROGRAM

Transportation Research Board Executive Committee Subcommittee for NCHRP

WAYNE SHACKELFORD, *Georgia DOT (Chair)*
SHARON D. BANKS, *AC Transit*
LESTER A. HOEL, *University of Virginia*
JOHN C. HORSLEY, *American Association of State Highway and Transportation Officials*

*Field of Special Projects
Project Committee SP 20-5*

C. IAN MACGILLIVRAY, *Iowa Department of Transportation (Chair)*
KENNETH C. AFFERTON, *New Jersey Department of Transportation*
THOMAS R. BOHUSLAV, *Texas Department of Transportation*
NICHOLAS J. GARBER, *University of Virginia*
GLORIA J. JEFF, *Federal Highway Administration*
YSELA LLORT, *Florida Department of Transportation*
WESLEY S. C. LUM, *California Department of Transportation*
HENRY H. RENTZ, *Federal Highway Administration*
GARY TAYLOR, *Michigan Department of Transportation*
J. RICHARD YOUNG, JR., *Post Buckley Schuh & Jernigan, Inc.*
JOSEPH S. TOOLE, *Federal Highway Administration (Liaison)*
ROBERT E. SPICHER, *Transportation Research Board (Liaison)*

TRB Staff for NCHRP Project 20-5

STEPHEN R. GODWIN, *Director for Studies and Information Services*

TE 7
N26
no FEB 16 2007
218

ROBERT E. SKINNER, JR., *Transportation Research Board*
MARTIN WACHS, *University of California Transportation Center,
California at Berkeley*
KENNETH R. WYKLE, *Federal Highway Administration*

Program Staff

ROBERT J. REILLY, *Director, Cooperative Research Programs*
CRAWFORD F. JENCKS, *Manager, NCHRP*
DAVID B. BEAL, *Senior Program Officer*
B. RAY DERR, *Senior Program Officer*
AMIR N. HANNA, *Senior Program Officer*
EDWARD T. HARRIGAN, *Senior Program Officer*
TIMOTHY G. HESS, *Senior Program Officer*
RONALD D. MCCREADY, *Senior Program Officer*
KENNETH S. OPIELA, *Senior Program Officer*
EILEEN P. DELANEY, *Editor*
JAMIE FEAR, *Associate Editor*
HILARY FREER, *Associate Editor*

STEPHEN F. MAHER, *Senior Program Officer*

LINDA S. MASON, *Editor*

National Cooperative Highway Research Program

Synthesis of Highway Practice 218
**Mitigation of Nighttime Construction
Noise, Vibrations, and
Other Nuisances**

CLIFF J. SCHEXNAYDER, Ph.D., P.E.

Eminent Scholar,
Arizona State University

and

JAMES ERNZEN, Ph.D., P.E.

Associate Professor
Arizona State University

Topic Panel

STEVEN D. DEWITT (Chair), *North Carolina Department of Transportation*
DOMENICK J. BILLERA, *New Jersey Department of Transportation*
JOHN F. CONRAD, P.E., *Washington State Department of Transportation*
ARTHUR GRUHN, *Connecticut Department of Transportation*
FREDERICK D. HEJL, *Transportation Research Board*
CRAWFORD F. JENCKS, *Transportation Research Board*
JOHN M. SMYTHE, *Iowa Department of Transportation*
ERICH S. THALHEIMER, *Central Artery/Tunnel Project, Boston*
DONALD R. TUGGLE, *Federal Highway Administration*
RON WILLIAMS, *Arizona Department of Transportation*

Transportation Research Board
National Research Council

Research Sponsored by the American Association of State
Highway and Transportation Officials in Cooperation with the
Federal Highway Administration

NATIONAL ACADEMY PRESS
Washington, D.C. 1999

Subject Areas
Energy and Environment, Highway
and Facility Design, and Materials
and Construction

Systematic, well-designed research provides the most effective approach to the solution of many problems facing highway administrators and engineers. Often, highway problems are of local interest and can best be studied by highway departments individually or in cooperation with their state universities and others. However, the accelerating growth of highway transportation develops increasingly complex problems of wide interest to highway authorities. These problems are best studied through a coordinated program of cooperative research.

In recognition of these needs, the highway administrators of the American Association of State Highway and Transportation Officials initiated in 1962 an objective national highway research program employing modern scientific techniques. This program is supported on a continuing basis by funds from participating member states of the Association and it receives the full cooperation and support of the Federal Highway Administration, United States Department of Transportation.

The Transportation Research Board of the National Research Council was requested by the Association to administer the research program because of the Board's recognized objectivity and understanding of modern research practices. The Board is uniquely suited for this purpose as it maintains an extensive committee structure from which authorities on any highway transportation subject may be drawn; it possesses avenues of communication and cooperation with federal, state, and local governmental agencies, universities, and industry; its relationship to the National Research Council is an insurance of objectivity; it maintains a full-time research correlation staff of specialists in highway transportation matters to bring the findings of research directly to those who are in a position to use them.

The program is developed on the basis of research needs identified by chief administrators of the highway and transportation departments and by committees of AASHTO. Each year, specific areas of research needs to be included in the program are proposed to the National Research Council and the Board by the American Association of State Highway and Transportation Officials. Research projects to fulfill these needs are defined by the Board, and qualified research agencies are selected from those that have submitted proposals. Administration and surveillance of research contracts are the responsibilities of the National Research Council and the Transportation Research Board.

The needs for highway research are many, and the National Cooperative Highway Research Program can make significant contributions to the solution of highway transportation problems of mutual concern to many responsible groups. The program, however, is intended to complement rather than to substitute for or duplicate other highway research programs.

NOTE: The Transportation Research Board, the National Research Council, the Federal Highway Administration, the American Association of State Highway and Transportation Officials, and the individual states participating in the National Cooperative Highway Research Program do not endorse products or manufacturers. Trade or manufacturers' names appear herein solely because they are considered essential to the object of this report.

Project 20-5 FY 1996 (Topic 20-07)
ISSN 0547-5570
ISBN 0-309-06855-X
Library of Congress Catalog Card No.99-74398
© 1999 Transportation Research Board

Price \$30.00

NOTICE

The project that is the subject of this report was a part of the National Cooperative Highway Research Program conducted by the Transportation Research Board with the approval of the Governing Board of the National Research Council. Such approval reflects the Governing Board's judgment that the program concerned is of national importance and appropriate with respect to both the purposes and resources of the National Research Council.

The members of the technical committee selected to monitor this project and to review this report were chosen for recognized scholarly competence and with due consideration for the balance of disciplines appropriate to the project. The opinions and conclusions expressed or implied are those of the research agency that performed the research, and, while they have been accepted as appropriate by the technical committee, they are not necessarily those of the Transportation Research Board, the National Research Council, the American Association of State Highway and Transportation Officials, or the Federal Highway Administration of the U.S. Department of Transportation.

Each report is reviewed and accepted for publication by the technical committee according to procedures established and monitored by the Transportation Research Board Executive Committee and the Governing Board of the National Research Council.

The National Research Council was established by the National Academy of Sciences in 1916 to associate the broad community of science and technology with the Academy's purposes of furthering knowledge and of advising the Federal Government. The Council has become the principal operating agency of both the National Academy of Sciences and the National Academy of Engineering in the conduct of their services to the government, the public, and the scientific and engineering communities. It is administered jointly by both Academies and the Institute of Medicine. The National Academy of Engineering and the Institute of Medicine were established in 1964 and 1970, respectively, under the charter of the National Academy of Sciences.

The Transportation Research Board evolved in 1974 from the Highway Research Board, which was established in 1920. The TRB incorporates all former HRB activities and also performs additional functions under a broader scope involving all modes of transportation and the interactions of transportation with society.

Published reports of the

NATIONAL COOPERATIVE HIGHWAY RESEARCH PROGRAM

are available from:

Transportation Research Board
National Research Council
2101 Constitution Avenue, N.W.
Washington, D.C. 20418

and can be ordered through the Internet at:

<http://www.nas.edu/trb/index.html>

Printed in the United States of America

PREFACE

A vast storehouse of information exists on nearly every subject of concern to highway administrators and engineers. Much of this information has resulted from both research and the successful application of solutions to the problems faced by practitioners in their daily work. Because previously there has been no systematic means for compiling such useful information and making it available to the entire community, the American Association of State Highway and Transportation Officials has, through the mechanism of the National Cooperative Highway Research Program, authorized the Transportation Research Board to undertake a continuing project to search out and synthesize useful knowledge from all available sources and to prepare documented reports on current practices in the subject areas of concern.

This synthesis series reports on various practices, making specific recommendations where appropriate but without the detailed directions usually found in handbooks or design manuals. Nonetheless, these documents can serve similar purposes, for each is a compendium of the best knowledge available on those measures found to be the most successful in resolving specific problems. The extent to which these reports are useful will be tempered by the user's knowledge and experience in the particular problem area.

FOREWORD

*By Staff
Transportation
Research Board*

This synthesis report describes current practice in mitigating nighttime construction nuisances such as noise, vibration, light, and dust. Roadway construction work is increasingly done at night to mediate traffic congestion; however, this trend also increases the potential for disturbing adjacent property owners. This report will be of interest to DOT construction, design, and project engineers, and to those responsible for community relations.

Administrators, engineers, and researchers are continually faced with highway problems on which much information exists, either in the form of reports or in terms of undocumented experience and practice. Unfortunately, this information often is scattered and unevaluated and, as a consequence, in seeking solutions, full information on what has been learned about a problem frequently is not assembled. Costly research findings may go unused, valuable experience may be overlooked, and full consideration may not be given to available practices for solving or alleviating the problem. In an effort to correct this situation, a continuing NCHRP project, carried out by the Transportation Research Board as the research agency, has the objective of reporting on common highway problems and synthesizing available information. The synthesis reports from this endeavor constitute an NCHRP publication series in which various forms of relevant information are assembled into single, concise documents pertaining to specific highway problems or sets of closely related problems.

This report of the Transportation Research Board stresses the importance of informing project neighbors and establishing cooperative relations with the community as a first measure of successful mitigation. Examples show how project design can address construction nuisances by locating and sequencing construction operations to minimize their impact. Current practices used in source control, path control, and receptor control are described and documented in examples from the Boston Central Artery/Tunnel

(CA/T) project and projects in Arizona and Salt Lake City, Utah. Appending materials provide sample specifications for mitigation of noise and dust control.

To develop this synthesis in a comprehensive manner and to ensure inclusion of significant knowledge, the Board analyzed available information assembled from numerous sources, including a large number of state highway and transportation departments. A topic panel of experts in the subject area was established to guide the research in organizing and evaluating the collected data, and to review the final synthesis report.

This synthesis is an immediately useful document that records the practices that were acceptable within the limitations of the knowledge available at the time of its preparation. As the processes of advancement continue, new knowledge can be expected to be added to that now at hand.

CONTENTS

- 1 SUMMARY

- 3 CHAPTER ONE INTRODUCTION
 - Background, 3
 - Sources of Information, 3
 - Review of Problems, 4

- 6 CHAPTER TWO SOUND
 - Equipment Noise, 7
 - Noise from Blasting, 11
 - Noise Impact Assessment, 11
 - Criteria, 12
 - Noise Regulation, 12

- 16 CHAPTER THREE NOISE MITIGATION
 - Design Considerations, 16
 - Source Controls, 17
 - Path Controls, 19
 - Receptor Controls, 28
 - Contract Specifications for Addressing Noise Control, 30
 - Noise Abatement: A Case Study, 32

- 33 CHAPTER FOUR LIGHTING
 - Glare, 33
 - Required Illumination and Glare Control, 33
 - Highway Construction Lighting Design, 34

- 36 CHAPTER FIVE DUST
 - Watering or Dust Suppressants, 36
 - Barriers, Screens, and Covers, 36
 - Public Roadway Dust Control, 37
 - Demolition, 38

- 39 CHAPTER SIX VIBRATION
 - Vibration Sources and Strength Levels, 39
 - Construction Vibration Mitigation, 40
 - Pile Driving Vibration Effects, 41

- 42 CHAPTER SEVEN COMMUNITY AWARENESS
 - During the Planning Process, 42
 - Successful Implementation, 43

44	CHAPTER EIGHT	CONCLUSIONS
		Community Awareness, 44
		Nuisance Mitigation, 44
46	REFERENCES	
48	APPENDIX A	TELEPHONE SURVEY OF THE FIFTY STATE DEPARTMENTS OF TRANSPORTATION
49	APPENDIX B	FAX QUESTIONNAIRE OF NIGHTTIME CONSTRUCTION NUISANCES
50	APPENDIX C	MITIGATION TECHNIQUES ON THE CENTRAL ARTERY (I-93)/TUNNEL (I-90) PROJECT IN BOSTON, MASSACHUSETTS HIGHWAY DEPARTMENT
53	APPENDIX D	MITIGATION TECHNIQUES ON THE I-15 PROJECT IN SALT LAKE CITY, UTAH
59	APPENDIX E	MITIGATION TECHNIQUES USED BY THE ARIZONA DEPARTMENT OF TRANSPORTATION
67	APPENDIX F	CENTRAL ARTERY/TUNNEL PROJECT, NOISE CONTROL SPECIFICATION 721.560
89	APPENDIX G	CENTRAL ARTERY/TUNNEL PROJECT, CONSTRUCTION DUST CONTROL SPECIFICATION 721.561



ACKNOWLEDGMENTS

Cliff J. Schexnayder, Ph.D., P.E., Eminent Scholar, Arizona State University and James Ernzen, Ph.D., P.E., Associate Professor, Arizona State University collected the data and prepared the report.

Valuable assistance in the preparation of this synthesis was provided by the Topic Panel of NCHRP Project 20-07/Task 94, consisting of Steven D. DeWitt (Chair), State Roadway Construction Engineer, North Carolina Department of Transportation; Domenick J. Billera, Project Engineer, New Jersey Department of Transportation; John F. Conrad, P.E., Assistant Secretary for Field Operations Support, Washington State Department of Transportation; Frederick J. Hejl, Engineer of Materials and Construction, Transportation Research Board; John M. Smythe, Director, Office of Construction, Iowa

Department of Transportation; Erich S. Thalheimer, Noise Control Technical Lead, Central/Artery Tunnel Project, Boston; Donald R. Tuggle, Highway Engineer, Federal Highway Administration; and Ron Williams, Assistant State Engineer, Arizona Department of Transportation Construction Group.

This study was managed by Crawford F. Jencks, Manager, National Cooperative Highway Research Program, who worked with the consultant, the Topic Panel, and the Project 20-7/Task 94 Committee in the development and review of the report. Linda S. Mason was responsible for editing and production.

Information on current practice was provided by many highway and transportation agencies. Their cooperation and assistance are appreciated.

MITIGATION OF NIGHTTIME CONSTRUCTION NOISE, VIBRATIONS, AND OTHER NUISANCES

SUMMARY

Because of high traffic volumes during the normal workday on major urban transportation corridors, many construction operations are now conducted during the nighttime. Nighttime work requirements have in turn precipitated an increase in disturbances to adjacent property owners. This synthesis presents the current practice in mitigation of nighttime construction nuisances.

Community relations is the key to the mitigation of nighttime construction nuisance problems. Early communication with the general public is indispensable in creating a bond of trust and cooperation. Inform the public of any potential construction noise impacts and the measures that will be employed to reduce the impacts. Establish and publicize a responsive complaint mechanism. The establishment of good rapport with the community can provide immense benefits at low cost.

Design has a major impact on the generation of construction nuisances. Early coordination and communication with project designers can aid in locating and sequencing construction operations to minimize potential construction impacts at sensitive receptors. The use of any existing natural or artificial features that can shield the construction noise should be accounted for in the project design. Permanent project noise barriers should be constructed as early as possible to reduce potential visual and noise impacts of construction.

Source control is the most effective method of eliminating nighttime construction nuisances. Source controls, which limit noise, vibration, and dust emissions, are the easiest to oversee on a construction project.

Mitigation at the source reduces the problems everywhere, not just along a single path or for one receiver. Construction equipment is a major noise and nuisance generator on nearly all nighttime construction projects. Specifying noise emission limits for equipment promotes the use of modern equipment with better engine insulation and mufflers.

Path control of nuisances should be implemented when source controls prove insufficient to adequately minimize impacts on abutting sensitive receptors. This situation can result from close proximity or from the very nature of the construction work. Thus, having exhausted all possible mitigation methods of controlling a nuisance at the source, the second line of attack is controlling noise, light, vibration, or dust radiation along their transmission paths. When barriers are used, they should provide a substantial reduction in noise levels, be cost-effective, and be implementable in a practical manner without limiting accessibility.

Receptor control of a nuisance must be undertaken when all other approaches to mitigation have failed. It should be remembered that the critical receiver might not be human. Certain precision equipment is sensitive to very low levels of ambient noise and vibration. Additionally, the response of human beings, either singularly or as a group, can be problematic

because no one individual is likely to exhibit the same reaction to a noise stimulus on two successive days. There is also the reality that some people are simply hypersensitive. The receptor problems usually involve individuals very close to the nuisance generating activity, in which case it may be easier and more effective to improve the individual's environment than to control all emitted noise, vibration, or dust.

Documentation of mitigation practices used on projects in Arizona, the Boston CA/T project, and the Salt Lake City I-15 project is provided in appendixes C, D, and E. Examples of noise and dust specifications for nuisance mitigation are presented in appendixes F and G. The specifications are presented to aid agencies in the development of their own specifications. Any specification should be tailored to the conditions of the particular project and work location.

INTRODUCTION

BACKGROUND

In recent years there have been fundamental changes in the types of projects that Departments of Transportation (DOTs) are constructing. Today a significant number of projects are urban widening and rehabilitation work where daylight construction closures of the routes cause unacceptable congestion problems. Therefore, because of the high traffic volumes during the normal workday on these major urban transportation corridors, it is usually only possible to perform construction operations during the nighttime. In 1990 Hinze reported in his *An Evaluation of the Important Variables in Nighttime Construction* that, "Because of age and condition of this nation's metropolitan roadways, coupled with traffic levels approaching or exceeding roadway capacities it is expected that nighttime construction will become more prevalent as a means of accomplishing pavement rehabilitation or maintenance activities" (1).

Departments of transportation are writing into the specifications for these projects severe restrictions on when a contractor can execute the work. Typically the work must be performed at night. In turn, these nighttime work requirements precipitated disturbances to adjacent property owners' (2). When residents complain, the path of their complaints is often through their local government. Additionally, the resulting complaints are coming during a climate of national concern about the adverse effects of environmental noise (3). Therefore, because urban projects have such strict work time restrictions in the contracts, contractors find themselves in situations that violate local ordinances.

An objective assessment of the magnitude of nighttime construction nuisances and a compilation of methods and techniques for mitigating such nuisances are critical requirements for serving the traveling public, for conducting DOT business in a locally responsible manner, and for preparing valid contract documents. Agencies realize that in the conduct of their construction and rehabilitation programs they must struggle with three interested and impacted parties who must be satisfied:

- The driving public, both commercial and private,
- The community through which the transportation corridor traverses, and
- The construction contractors.

This synthesis exposes the magnitude of the nighttime construction nuisance issue, identifies the major nuisance generators, qualifies the impact of these nuisances, and recommends mitigation techniques that can be used by transportation agencies within the context of their contracting processes.

SOURCES OF INFORMATION

At the outset of the exploratory work for this synthesis, each of the 50 states was contacted by phone and queried (Appendix A) about problems with nighttime construction nuisances. States reporting a problem with nighttime construction nuisances received a faxed questionnaire (Appendix B) followed the initial phone contact. The responses to the questionnaire provided practical information concerning specific problems and mitigation strategies.

A review of literature revealed a large number of published papers and other documents addressing noise, light, vibration and other construction nuisances. These sources of information are used extensively in this synthesis and are documented as references. The intent of the synthesis is to inform state DOT highway and roadway design and project engineers, and contractors about nighttime construction nuisances and in particular about noise nuisances. It contains an outline of sound and vibration physics only to the depth necessary for understanding and addressing the problems. It describes specific mitigation methods with the purpose of helping those involved determine appropriate mitigate actions. It is not intended to make anyone a "sound" or "lighting" engineer. However, if more technical information is needed about noise or vibration effects, one very good source is *Transit Noise and Vibration Impact Assessment* (4), by Harris Miller Miller & Hanson Inc. This U.S. Department of Transportation (U.S. DOT) document describes how to perform mathematical modeling in order to determine noise or vibration effects.

Additionally several ongoing highway projects located in metropolitan areas were visited by the authors. All of these projects were working nightshifts and had formal nuisance mitigation programs (appendixes C, D, and E). Substantial parts of this synthesis are extracted from the contractual experiences of those programs.

REVIEW OF PROBLEMS

The major nuisances associated with the nighttime construction are noise, vibration and illumination. Noise problems are normally caused by the operation of heavy equipment and specifically by vehicle and machine backup-alarms. Vibration problems are primarily a result of pile driving, blasting operations, or the use of vibratory rollers. While good illumination is necessary for the work to proceed at night and for the safety of the traveling public, proper work zone illumination can be very intrusive to project neighbors. There is also some concern by DOTs about exposure to possible contractor claims if noise objectives are not properly presented in the contract documents.

Phone Survey

A telephone survey of the state DOTs was conducted to determine the magnitude of the nighttime construction nuisance problem and to quantify problem specifics. As would be expected, the DOTs that have problems with nighttime construction nuisances are those with a significant portion of their work in highly urbanized environments. This results from the fact that problems of nighttime construction in densely populated commercial areas are magnified. Twenty-seven states reported serious nighttime construction nuisance problems often described as site-specific. From the survey it was clear that DOTs either experience a problem or they are involved in only a limited amount of nighttime work and have not had any problems.

There were a few surprises as some highly urbanized states reported only minor problems with nighttime construction nuisances. This appeared to be a function of the nature of the nighttime work performed and the location of that work. Those states reported that only paving, patching, or resurfacing operations on interstate highways were taking place at night. Therefore, the operations were taking place where the background noise from the traffic remained and the operations were constantly moving. It was reported that these types of operations generated few complaints.

When queried regarding the generators of the nuisances, many of the responses were very similar. Back-up alarms and slamming tailgates were the most frequent answers. Demolition equipment used in pavement breaking and bridge deck removal was another frequent response. Many states recognizing the problems caused by these types of equipment limit their use to daytime hours only. Therefore, they were not identified as many times as a problem due to these use restrictions. Pile driving was a problem in certain areas of some states. However, pile driving at night seems to take place very infrequently and again many states do not allow such operations at night.

Tables 1 and 2 summarize the problem in terms of critical noise generators and activities. The tables represent the opinions of construction personnel in all 50 states.

TABLE 1
CRITICAL NIGHTTIME CONSTRUCTION NOISE
GENERATORS

Noise Generator	Percent Identifying Activity as Cause of Problems*
Back-up Alarms	41
Slamming Tailgates	27
Hoe Rams	24
Milling/Grinding Machines	16
Earthmoving Equipment	14
Crushers	6

*As rated by the 50 State DOTs

TABLE 2
TYPE OF ACTIVITIES THAT CAUSE NIGHTTIME
CONSTRUCTION NOISE PROBLEMS

Activity Type	Percent Identifying Activity as Cause of Problems*
Pavement Breaking	27
Paving/Resurfacing	25
Pile Driving	24
Bridge Deck Removal	24
Rehab	20
Patching	12
Earthmoving	2
Crushing	2

*As rated by the 50 State DOTs

A number of DOTs require adherence to certain noise (decibel) limits during nighttime construction. In many cases, these limits are the consequence of specific local ordinances. Some Departments indicated that they could receive local ordinance waivers rather easily. Others have jurisdiction over the local municipalities in these matters, but try to abide by the local ordinances.

Fax Survey

A fax survey was developed from information gathered in the phone survey. The purpose of this survey was to specifically identify equipment and project types according to their impact in creating nighttime construction nuisances. This survey was sent only to those DOTs whose response to the phone survey indicated a significant problem with nighttime construction nuisances.

Equipment

A list of nuisance generating equipment was compiled from the phone survey. This list was included in the fax survey and the responding Departments were asked to

rank each equipment type on a scale of 1 to 5, based on severity of noise nuisance created.

Pneumatic equipment such as jackhammers ranked highest in nuisance creation with back-up alarms a close second. Milling and grinding equipment also posed significant problems, as well as slamming tailgates and hoe rams. After ranking the equipment listed on the survey, there was space for writing in additional equipment types. Write-ins included catch basin cleaners (vacuums), hydro demolition equipment, saws, pavers, and rollers. These additional write-in items were not ranked by all of the Departments, so their overall rankings are low relative to the equipment pieces listed on the survey.

Projects, Type and Location

A list of project types or activities that had caused nuisance complaints was compiled from the phone survey. These included pile driving, earthmoving, and crushing activities; bridge deck removal and pavement breaking work; and paving or resurfacing projects. In the fax survey the responding Departments were asked to rank each activity as to the magnitude of the nuisance created. The Departments were also asked to annotate the location of problem projects according to four location categories: residential, commercial, industrial, or rural.

Pavement breaking and bridge deck removal operations create the majority of problems while paving and resurfacing projects and pile driving operations cause significant nuisances. As in the phone survey the pile driving did not create as many nuisances simply because many Departments do not allow pile driving at night and the requirement for pile foundations is location specific.

The problems associated with nighttime construction are location dependent. All Departments reported that their problems involved work in residential areas. A few Departments reported problems with work in commercial and rural areas. No problems were reported for work in industrial locations.

Mitigation Techniques

The Departments were asked to identify mitigation techniques they had used to deal with issues such as backup alarms, banging tailgates, and demolition equipment. The response included a variety of similar mitigation techniques, including:

- Keep the public informed; door-to-door project fact sheets.
- Operate 24-hour complaint/notification phone lines.
- Use back-up alarms of the least intrusive ambient-sensitive type or allow the contractor to use a back-up observer.
 - Line haul truck beds with rubber to reduce impact noise. In some states, the DOT specifies the use of rubber bed liners to mitigate the impact noise of debris being dumped into trucks. These liners are 4 to 5 inches thick and are constructed of a rubber having a stiffness very similar to that of a vehicle tire. The liners are steel backed for installation and the average cost is about \$12,000. The liners last 3 to 4 years depending upon usage. As well as limiting impact noise the liners greatly reduce the wear on the bed of the truck so there is a maintenance advantage to the contractor.
 - Establish truck clean-out staging areas for mitigation of banging tailgates.
 - Limit certain activities to specific time periods; pile driving can only be conducted between 6 a.m. and 10 p.m.
 - Shield residential areas from stationary equipment such as light plants, generators and pumps.
 - Require that excavation decking plates (steel) be secured to reduce rattling when vehicles pass over; use thicker plates; use stiffer beams beneath the plates, with rubber gaskets between the beam and plate; if possible, detour traffic around the plates.
 - Specify the order of work; permanent sound walls must be constructed before other work items can begin.

Claims

Only 10 states gave positive responses to the claims questions on the phone and Fax surveys. One of the 10 actually had experienced no claims but simply expressed concern at the possibility. Likewise, three others had not experienced actual claims, but reported occurrences where they had handled problems with change orders and extra compensation. A fifth DOT reported that a claims commission had handled the claims. Arizona, California, Delaware, New York, and North Carolina reported definite claim experiences. The causal situations involved resident engineers ordering the contractor to stop work or changing the contractor's work hours because of noise complaints. As a result there were delay claims and requests for additional time. Therefore, it is clear that the specifications must address the noise issue and specify definite limits (see appendix E paragraph 1.04) and clearly state that the contractor is responsible for alleviating nuisance conditions (see appendix E, paragraph 3.06, D).

SOUND

The human ear does not judge sound in absolute terms, but instead senses the intensity of how many times greater one sound is than another. A decibel is the basic unit of sound level; it denotes a ratio of intensity to a reference sound. Most sounds that humans are capable of hearing have a decibel (dB) range of 0 to 140. A whisper is about 30 dB, conversational speech 60 dB, and 130 dB is the threshold of physical pain. Figure 1 provides further examples.

To facilitate the measurement of sound to human receptors, a weighted decibel scale is used to accentuate the frequencies heard by man, from 2020 Hz up to 20 kHz. Most people do not hear high and low frequencies as well as they hear mid-range frequencies. The A-weighted decibel scale (dBA) is a single number descriptor that accounts for human ear frequency response but weighs the frequencies by the ear's sensitivity. A 3-dBA change in noise level is a barely noticeable difference while a 10-dBA is subjectively perceived as a doubling or halving in loudness. A 5-dBA change is required before most people realize there is a perceptible sound difference.

Environmental noise fluctuates from moment to moment, so some means of temporal (time) averaging is necessary. Consequently it is common practice to amalgamate all sound information into a single number called the "equivalent" or "energy-average" (L_{eq}) sound level (5). The L_{eq} indicator is the average acoustic intensity over time and is the equivalent noise energy level of a steady, unvarying tone. Environmental sound can also be presented on a statistical basis using percentile sound levels,

L_n , which refer to the sound level exceeded "n" percent of the time. An L_{10} nomenclature would mean an A-weighted sound level exceeded 10 percent of the time. In the case of construction noise, the L_{10} has often been found to be about 3 dBA greater than the L_{eq} and correlates well with construction activity.

In the early 1970s, the Environmental Protection Agency developed a community noise exposure measurement to represent an average energy sound level for a 24-hr period. This is the day-night sound level (DNL or L_{dn}) adjusted by adding 10 dB to nighttime noise events that occur between 10 p.m. and 7 a.m. Many federal agencies have adopted a L_{dn} value of 65 dB as a threshold above which land is considered incompatible for residential use (6).

Sound and noise are not the same thing, but sound becomes noise when:

- It is too loud,
- It is unexpected,
- It is uncontrollable,
- It occurs unexpectedly, and
- It has pure tone components.

Noise is any sound that has the potential to annoy or disturb humans, or cause an adverse psychological or physiological effect on humans.

The noise levels generated during the construction process vary depending on the type of equipment and the

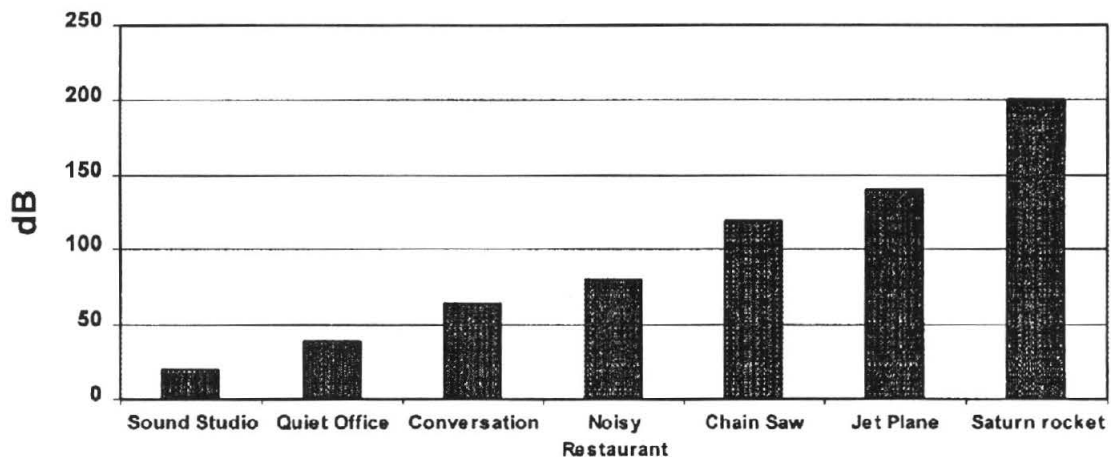

FIGURE 1 Representative noise levels.

nature of the work being performed. It should be recognized that noise impacts can be severe, especially during nighttime activities, and that in many cases simple noise mitigation strategies will not suffice.

Noise generation on most construction projects is the result of equipment operation, with diesel engines being the primary generators. Equipment components that generate noise include: the engine, cooling fan, air intake, exhaust, transmission, and tires (4,7,8). Other noise generators include pile driving, pavement demolition, earth material processing, and safety equipment. In assessing noise generation, construction equipment can be grouped into two categories—stationary and mobile. Equipment noise can also be categorized as being either continuous or impulse in nature. Stationary equipment is considered to operate in one location for one or more days at a time; pumps, generators, compressors, screens, are typical examples of stationary equipment. In addition, pile drivers and pavement breakers are sometimes categorized as stationary equipment. Mobile equipment includes machinery that performs cyclic processes such as: bulldozers, scrapers, loaders, and haul trucks.

The current Federal Highway Administration (FHWA) regulations concerning construction noise and its mitigation is included in 23 CFR Part 772—*Procedures for Abatement of Highway Traffic Noise and Construction Noise*. The abatement requirements are very broadly stated. Basically, control of construction noise should include the following steps:

- *Assessment*—Identify “receptors” in the community that are sensitive to construction noise and adjudge appropriate noise criteria limits.
- *Construction specifications*—Determine measures that are needed to minimize nuisances. Mitigation measures can be incorporated into the construction documents where necessary as identified by the impact assessment.

EQUIPMENT NOISE

Construction equipment is a major noise generator on nearly all nighttime construction projects. The equipment type, specific model, equipment condition, and the operation performed influence equipment noise. Equipment manufacturers began attacking machine noise problems in the late 1960s and today because of design improvements and technological advances, new machines have been quieted to an acceptable level for almost every situation (9). Newer equipment is noticeably quieter than older models due primarily to better engine mufflers, refinements in fan design and improved hydraulic systems.

How equipment noise will be perceived is also a function of use duration. On a monitored project in New Jersey the highest noise levels resulted from pile driving; but, because the driving was completed in a short period of time, the activity did not draw any complaints (10). The Society of Automotive Engineers (SAE) has published practice-standards for the measurement of construction equipment exterior noise (11,12). Noise levels as generated by typical equipment are shown in Table 3.

One of the conclusions from the U.S. DOT’s 1979 construction equipment noise study was that 88 dBA is a reasonable noise level to expect for *used* equipment with an engine horsepower of 400 or less (13). These tests were per the SAE J88a (10) modified to use fast response for the idle-max rpm-idle (IMI) test procedure. It should be noted that these tests were made in the field under actual operating conditions at road construction sites, mines, and quarries.

Additionally, it should be noted that the 1994 and 1995 studies were performed by the same consultant, Harris Miller Miller & Hanson Inc. However, one study was a year earlier and sought to quantify an *average* noise level while the second defined a *typical* noise level. It would seem that a typical value is better to use in developing specifications or project restrictions, as it delineates the most commonly occurring level.

Looking at all three data sets, it appears that these noise levels are very conservative when compared to manufacturers’ data. The Central Artery/Tunnel Project (CA/T) specification requires that the equipment be tested at high idle, maximum governed rpm, under full-load condition (HI). The 1979 test used the IMI test procedure. Manufacturers usually test their equipment under several different conditions, high idle (HI), rated rpm (RTD), IMI, hydraulic cycle (machine stationary, at full-throttle) (HYD) and machine-moving full-throttle mid-gear speed (MGM).

How a test is conducted will affect the results. In the case of mobile equipment such as scrapers and dozers, one manufacturer’s data for the MGM test gives a 1 to 5 dBA higher result than the HI test. But no matter which test was employed, all of the manufacturer’s tests gave results below the Table 3 levels by 2 to 3 dBA. Again in the case of loaders, the manufacturer’s data was below the Table 3 levels by 3 to 5 dBA for all tests. One point for consideration is that manufacturers test their machines when they are new (in good condition), so the importance of good maintenance is clear from the differences between Table 3 data and manufacturers’ new machine noise data. Table 4 lists the major sources of equipment noise that cause complaints and specific methods for controlling the identified noise problem.

TABLE 3
CONSTRUCTION EQUIPMENT NOISE EMISSION LEVELS

Equipment	Typical Noise Level (dBA) 50 ft., U. S. Dept. of Trans. study 1979 (14)	Average Noise Level (dBA) 50 ft., CA/T Project study 1994 (15)	Typical Noise Level (dBA) 50 ft., U. S. Dept. of Trans. study 1995 (4)	Lmax Noise (dBA) 50 ft., CA/T Project Spec. 721.560 (16)
Air Compressor		85	81	80
Backhoe	84	83	80	80
Chain Saw				85
Compactor	82		82	80
Compressor	90	85		80
Concrete Truck		81		85
Concrete Mixer			85	85
Concrete Pump			82	82
Concrete Vibrator			76	80
Crane, Derrick	86	87	88	85
Crane, Mobile		87	83	85
Dozer	88	84	85	85
Drill Rig		88		85
Dump Truck		84		84
Excavator				85
Generator	84	78	81	82
Gradall		86		85
Grader	83		85	85
Hoe-Ram		85		90
Impact Wrench			85	85
Jackhammer*		89	88	85
Loader	87	86	85	80
Paver	80		89	85
Pile Driver, Impact		101	101	95
Pile Driver, Sonic			96	95
Pump	80		85	77
Rock Drill			98	85
Roller			74	80
Scraper	89		89	85
Slurry Machine		91		82
Slurry Plant				78
Truck	89	85	88	84
Vacuum Excavator				85

* There are 82 dBA @ 7 meter rated jackhammers (90 lb. class) available. This would be equivalent to 74 dBA @ 50 ft. These are silenced with molded intricate muffler tools.

TABLE 4
CONSTRUCTION EQUIPMENT NOISE CONTROL OPTIONS

Noise Source	Control
• Backup alarms	Use manually-adjustable alarms Use self adjusting alarms Use an observer
• Slamming tailgates	Configure traffic pattern to minimize backing movement Establish truck cleanout staging areas Use rubber gaskets Decrease speed of closure Use bottom dump trucks
• Pavement breakers (jackhammers)	Fit with manufacturer approved exhaust muffler Prohibit within 200 ft. of a noise sensitive location during nighttime hours Enclose with a noise tent
• Prolonged idling of equipment	Reduce idling Locate equipment away from noise sensitive areas

Backup Alarms

Departments should realize that there can be a conflict between Occupational Safety and Health Standards

(OSHA) and environmental concerns. The Occupational Safety and Health Standards for the Construction Industry (29CFR Part 1926) state in 1926.601 (b) (4) that, "No employer shall use any motor vehicle equipment having

TABLE 5
 AMBIENT-SENSITIVE TYPE AND MANUALLY ADJUSTABLE BACKUP-ALARM TESTED
 IN THE CA/T STUDY

Alarm Type	Preco	Ecco	Grote
Manually adjustable	Model 45AA	Model 820	
Self-adjusting	Model 1048	Model SA907 Model SA901	Model 73100

an obstructed view to the rear unless: (i) The vehicle has a reverse signal alarm *audible above the surrounding noise level*; or (ii) The vehicle is backed up only when an observer signals that it is safe to do so.” The critical OSHA requirement “*audible above the surrounding noise level*” causes backup alarms to be a primary source of public complaints regarding construction noise. Backup alarms emit a distinct attention-drawing sound for safety reasons; however, that sound can cause considerable irritation, even to neighbors inside buildings.

Standard backup alarms emit a consistently loud noise regardless of background noise levels. At night a standard backup alarm seems excessively noisy against the quieter background sound levels. There have been studies seeking to identify alternate systems that would be effective in reducing the nighttime noise nuisance caused by this essential safety device. Two studies on the Central Artery/Tunnel Project in 1995 and 1996 tested audible devices, discriminating devices, such as the radar systems used on some school buses, and visual warning devices (Table 5). As a result of those tests two types of adjustable sound backup alarms were recommended for use on that project during nighttime activities. The advocated alternatives are either an ambient-sensitive type or a manually adjustable (set to a lower level during nighttime operation.) type. One warbler type audible alarm tested was very good for warning but correspondingly very bad as a sound nuisance.

The ambient-sensitive, self-adjusting backup alarms increase or decrease their volume based on background noise levels. These alarms work best on smaller equipment such as backhoes and trucks. The alarm self-adjusts to produce a tone that is readily noticeable over ambient noise levels (a minimum increment of 5 decibels is typically considered readily noticeable), but not so loud as to be a constant annoyance to neighbors. The typical alarm adjustment is 82 or 107 dBA at 4 ft. Close attention must be given to the alarm’s mounting location on the machine in order to minimize engine noise interference, which can be sensed as the ambient noise level. These alarms should be mounted as far to the rear of the machine as possible. An alarm mounted directly behind a machine’s radiator will sense the cooling fan’s noise and adjust accordingly, Figure 2. Such a mounting will negate the purpose of the device. Most backup alarm manufacturers sell self-adjusting backup alarms ranging in price from \$50 to \$100.

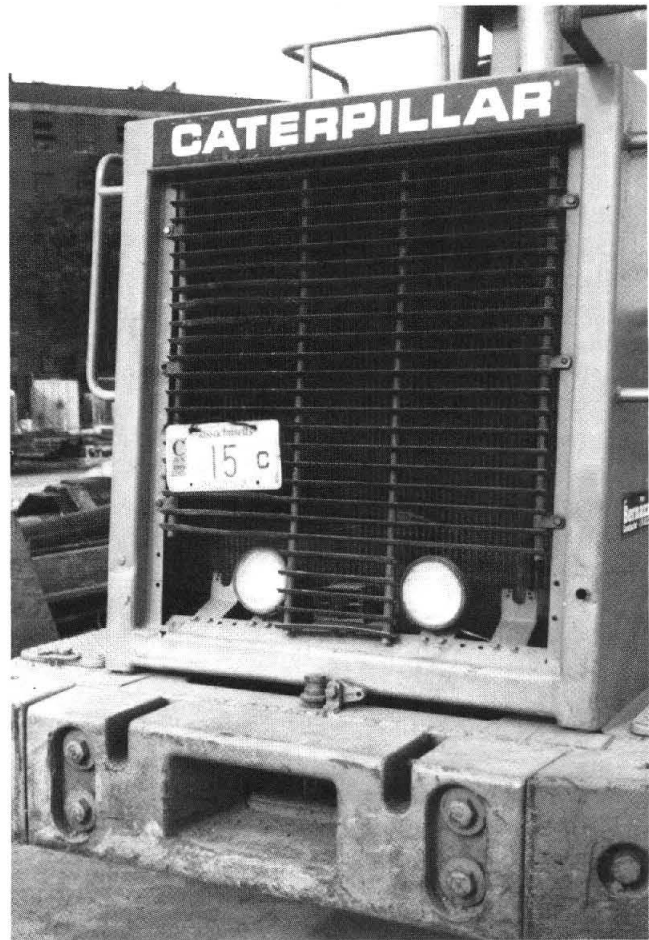

FIGURE 2 A self-adjusting backup alarm mounted.

Manually adjustable alarms are effective in reducing backup alarm noise nuisance but their use requires that each alarm be set at the beginning of each day and night shift. The manual setting feature eliminates the machine mounting location problem of the ambient-sensitive self-adjusting backup alarms. The manually adjustable alarms typically have an 87- and 107-dBA setting at 4 ft., with the 87-dBA setting used for nighttime operations.

Pavement Breakers

There are integral or bolt-on type non-metallic muffler coverings for pavement breakers. Most manufacturers

have muffler attachments to retrofit existing impact equipment. Some manufacturers sell longer “European” style mufflers that cover the exhaust port and the lower portion of the breaker.

Prolonged Idling of Equipment

There is also the issue of engine fumes being a nuisance in residential areas. Include in the specifications a requirement that if equipment is parked for more than five minutes the engine must be shut down.

Blue Angel Certification

Due to the strict environmental requirements common in Europe, manufacturers have developed machines for that market that are significantly quieter than similar models sold in the United States. The German government gives a “Blue Angel” certification to machines that meet strict “environmentally friendly” requirements (<http://www.blauer-engel.de/Englisch/index.htm>). To date, 38 manufacturers have participated in this program and 163 machine models have been certified. Although these machines are available in Europe, it would be extremely difficult to purchase a “Blue Angel” machine in the United States. But these machines definitely demonstrate that the technology is currently available to decrease the noise levels of some construction equipment as much as 15 dBA.

Pile Driving Equipment

There is no standard method for rating sound levels for pile driving equipment. The hammer and pile can make a variety of different types of noise including impact noise as well as vibration noises of metal piles, especially in the case of sheet piling. The test pile used by one hammer manufacturer is a 36-in. steel pipe pile with 1-in. walls and that is filled with reinforced concrete. The data from the manufacturer’s sound measurements is shown in Figure 3. The tests were taken at the manufacturer’s yard, which is surrounded by metal buildings. A major factor that can affect the noise ratings of the equipment is the surrounding environment and how the noise is absorbed. This makes the lack of a standard testing procedure even more significant.

It should be noted that for all the different hammers tested, the sound level at 100 feet from the driving location was over 95 dBA. The fact that pile-driving operations are a nighttime noise nuisance is obvious from these tests.

With the vibratory pile equipment, the diesel motors make most of the noise (except in the case of driving sheet

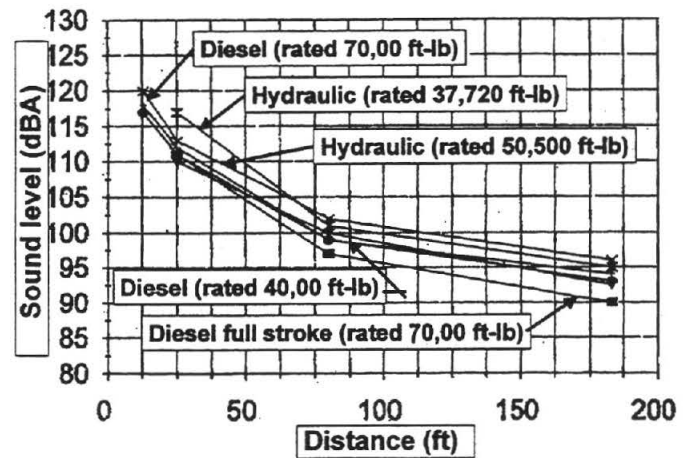

FIGURE 3 Manufacturer’s test stand pile hammer sound measurements.

piles), whereas with a single acting hammer, the contact with the pile and the hammer makes the majority of the noise. In the late 1970s, one manufacturer marketed a muffler specifically designed for air and steam pile hammers. In a study sponsored by the Corps of Engineers, this equipment was tested on a project where an extensive amount of pile driving was required (16). The study reported that the muffler did reduce off-site noise by about 10 dB. However, industry representatives state that the muffler took away too much of the hammer’s power, and there were mounting problems. Therefore, very few were actually sold.

In general, vibratory drivers are less “annoying” than impact hammers. Other noise mitigation measures can include pre-trenching the piles, hanging noise curtains on the pile and rig, and forewarning the affected neighbors.

Asphalt Plants

Virtually all asphalt plants in the United States emit noise (17). The principal asphalt plant noise sources are the burner, dryer drum, turbo-blower, pugmill, and screens.

- *Burner*—The burner and its associated equipment is the most significant noise source on an asphalt plant. Burners may be either opened fired, semi-sealed, or sealed. In the case of opened fired and semi-sealed burners, combustion noise generated within the burner is transmitted to the outside as airborne noise through openings around the burner. With a sealed burner, airborne noise is carried back through the burner and blower and emitted from the blower intake. One manufacturer by using burner enclosures has been able to reduce burner noise at 50 feet to the 75- to 80-dBA range.

- *Dryer drum*—Dryer drum noise will vary considerably from plant to plant. The intensity of drum noise is a function of the type of material being processed. The sounds are primarily caused by impact of coarse aggregate

on the drum and by sliding material within the drum. Both sources of noise are intensified as the weight of the individual aggregate particles increases. When very coarse aggregate is used there will a 10 to 15 dBA increase in the medium to medium-high frequency ranges.

- *Turbo-blower*—Noise from the turbo-blower is frequently a problem around asphalt plants. Many blowers generate a whining high-pitched intake noise. Intake silencers are available.

- *Pugmill*—Generally pugmill noise is not an issue. Often, however, when a plant is in poor mechanical condition, the pugmill will generate intense noise. Proper repair and maintenance are the solution.

- *Screens*—Screens have the potential to be significant noise generators if not properly isolated. They are capable, when processing large size aggregate, of inducing severe vibration into the hot-mix plant tower. This will literally turn the tower into a large loud speaker transmitting high-intensity, low-frequency noise.

NOISE FROM BLASTING

Because of its frequency content, noise generated by construction blasting differs from other construction noise. Blasting noise originates from air pressure waves generated by the explosions. A non-audible lower frequency portion that excites structures (1 to 30 Hz) and in turn can cause a secondary and audible rattle within a structure accompanies the audible high-frequency portion (18). Because blasting is not a continuous source, its effects on humans cannot be easily extrapolated from studies of constant type sources.

Human concerns about blasting noise are in most cases the result of sound caused by loose objects rattling during building movement. These resulting sounds, while not very loud, have a startling affect on occupants.

A venting (blowout) of the explosive gas from a blasthole will cause high blast noise. By following good blasting practice and using good stemming material, this noise can be controlled. Wind or temperature inversions can cause air blasts to focus, at higher than expected pressures, in localized areas.

- *Wind*—For windy conditions, downwind air-blast pressures 10 to 15 dB higher, compared to a no wind condition, have been reported by Kamperman (19).

- *Temperature*—A temperature inversion occurs when the upper air layers are warmer than those below; the normal decrease in temperature with altitude is reversed. An upper warm layer will cause the sound pressure wave to be refracted back to the ground. These inversions can cause average sound level intensification of up to 3 times (20).

The issue of limiting blasting operations when wind or temperature conditions can cause problems should be addressed in the specifications.

Blast noise criteria limits of 0.01 psi overpressures (130 dB) have been promulgated by the U.S. Bureau of Mines (BOM) to avoid structural damage to buildings. The CA/T Project adopted a blast noise criteria limit of 120 dB (unweighted) peak measured at the external facade of a building. But this was done to avoid structural damage to adjoining building and not as a noise control measure.

NOISE IMPACT ASSESSMENT

Several mathematical formulas have been developed for predicting the effect of machine noise. Harris Miller Miller & Hanson in their work for the U. S. Department of Transportation offer the following equation (4):

$$L_{eq}(equip) = E.L. + 10 \log(U.F.) - 20 \log\left(\frac{D}{50}\right) - 10G \log\left(\frac{D}{50}\right)$$

where

- $L_{eq}(equip)$ = L_{eq} at the receiver resulting from the operation of a single piece of equipment over a specified time. It reflects in a single number the sound energy experienced.
- $E.L.$ = noise emission level of the particular piece of equipment at the reference distance of 50 feet.
- $U.F.$ = usage factor that accounts for the fraction of time that the equipment is in use over the specified time period. In the case of nighttime U.F. should be increased by a factor of 10 to account for noise sensitivity.
- D = distance from the receiver to the piece of equipment, and
- G = constant that accounts for topography and ground effects.

The importance of distance as a mitigating factor is clearly evident by this equation. An adequate general assessment can be made assuming:

- Full power operation for a time period of one hour. $U.F. = 1$, and $10 \log(U.F.) = 0$.
- Free field conditions are assumed and ground effects are ignored. $G = 0$.
- Emission levels (E. L.) at 50 feet, (some data is given in Table 3).

- All pieces of equipment are assumed to operate at the center of the project, or centerline.
- The predictions include only the two noisiest pieces of equipment expected to be used in each construction phase.

(On the CA/T project the above construction noise equation is used to calculate the L_{eq} . But the L_{10} is derived by simply adding 3 dBA to the L_{eq} value; $L_{10} = L_{eq} + 3$ dBA.)

CRITERIA

23 CFR part 772 sets no specific criteria for construction noise. As a result, criteria are typically developed on a project-specific basis, usually as required by local ordinances. The local ordinances tend to limit the hours of operation and, in some instances, limit the maximum levels of noise generated. Local ordinances, while sometimes stipulating limits, provide no means for reasonable assessment. Table 6 presents two sets of suggested criteria, the first is a simple night criteria and the second is a 30-day average criteria, both are from Harris Miller Miller & Hanson's work for the U.S. DOT (4). The military established in the late 70s a day-night criteria (21) that included a penalty for night sounds but those criteria are seldom used.

TABLE 6
CRITERIA FOR ASSESSING NOISE IMPACT (4)

Location	8-hour L_{eq} (dBA) Night	30 day Avg. dBA
Residential	70	75 L_{dn}
Commercial	85	80 L_{eq} 24 hr
Industrial	90	85 L_{eq} 24 hr

The Arizona Department of Transportation's Construction Manual (22) states that the maximum allowable noise level is generally considered to be 67 dBA for areas where noise may be an issue. This conforms to the FHWA's 67-dBA loudest-hour L_{eq} . Andrew S. Harris of Harris Miller Miller & Hanson Inc. has stated that "an L_{dn} (L_{dn} is the day-night average sound level) value of 65 is generally regarded as the threshold of unacceptable community noise; above this level, residential land use is inappropriate (23)."

Albeit for hearing conservation rather than community acceptability, the Department of Housing and Urban development has published site acceptability standards. "It is a HUD goal that exterior noise levels do not exceed a day-night average sound level of 55 decibels (24)." However, HUD makes it clear that this is an Environmental Protection Agency recommendation that does not take into account cost or feasibility. Therefore, the section goes on to

state that for regulation purposes a day-night average sound level of 65 decibels and below is acceptable and allowable (24 CFR subtitle A(4-1-97)).

The National Institute for Occupational Safety and Health (NIOSH) has recommended that the workplace noise limit be reduced to 85 decibels (24). The current NIOSH exposure limit is 90 decibels. That standard was adopted in 1972. The Occupational Safety and Health Administration, which enforces such rules, is studying the recommendation.

Several large public works projects have developed their own project-specific noise criteria. In many cases this is done in cooperation with local government agencies. The CA/T Project's noise criteria are included in Appendix F.

NOISE REGULATION

Since the disturbances generated by the nighttime construction noise can be a major problem, many jurisdictions have established noise ordinances, which limit the level of noise activity that can occur during certain hours. Today many municipalities are putting these restrictions on the World Wide Web (Figure 4), making it very easy for agencies to track the regulations. It also makes it very easy for irritated citizens to know the regulations and demand compliance.

States and local municipalities specified maximum daytime construction noise levels range from 50 to 90 dBA in residential areas with about 75 dBA as an average. Construction nighttime noise limits range from 45 to 75 dBA with an average of about 55 dBA. A sampling of regulatory restrictions across the country is provided in Table 7. Most of these data are from a report prepared for Bechtel/Parsons Brinckerhoff on the Boston Central Artery/Tunnel project (14).

Alaska, Anchorage

The maximum noise level for construction equipment is limited to 80 dBA at a distance of 100 ft. (86 dBA at 50 ft.).

California, San Francisco

The maximum noise level for construction equipment is limited to 80 dBA at a distance of 100 ft. (86 dBA at 50 ft.). Impact devices are exempt but such equipment must be equipped with mufflers and shields. Construction work is restricted to the period between 7 a.m. and 8 p.m. if it causes more than a 5 dBA increase in noise at the nearest property line, unless a permit is granted.

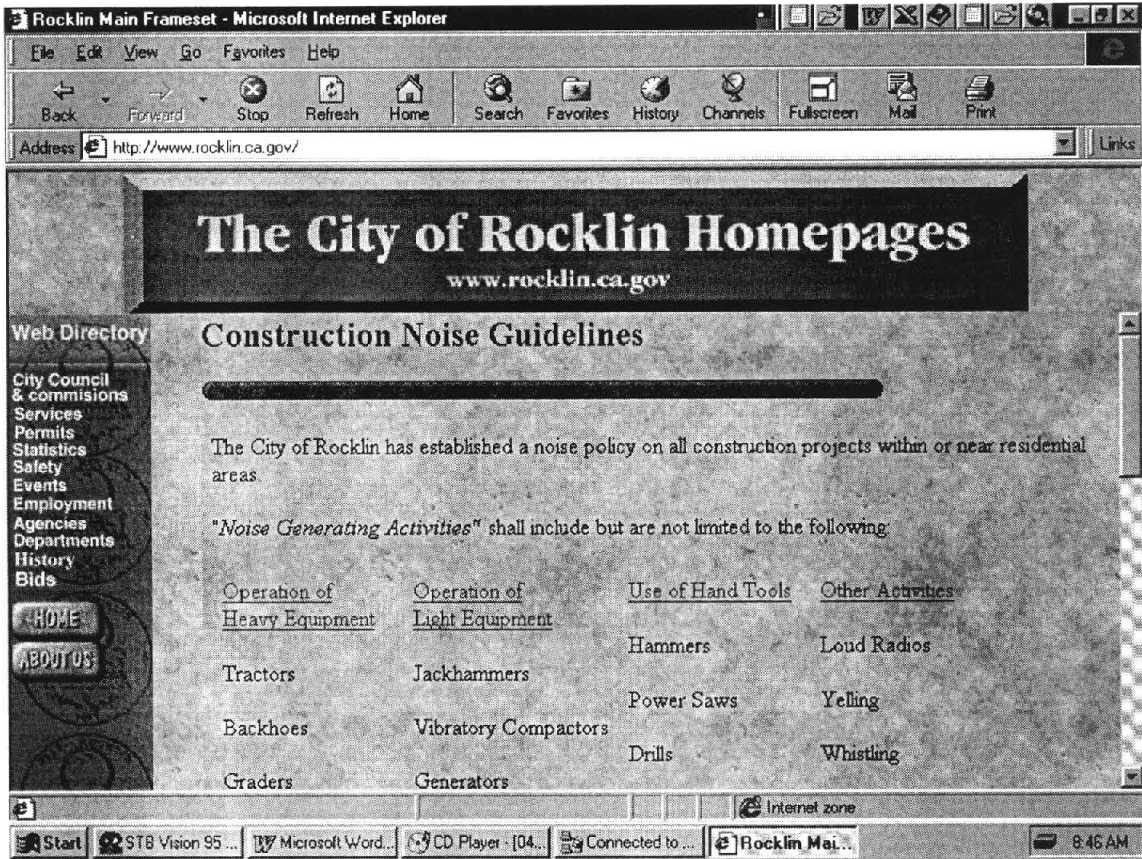

FIGURE 4 Construction noise guidelines on the World Wide Web.

TABLE 7
NIGHTTIME CONSTRUCTION NOISE LIMIT REGULATIONS

Location	dBA at 25 ft.	dBA at 50 ft.	dBA	Time
Anchorage, Alaska			80 at 100 ft	
San Francisco, California			80 at 100 ft	
Colorado	75			7 p.m.-7 a.m.
District of Columbia	55 (residential) 60 (commercial)			7 p.m.-7 a.m.
Hawaii	45 to 70 depending on land use			10 p.m.-7 a.m.
Chicago, Illinois		70 to 80 depending on land use		
Maryland	55 to 75 depending on land use			10 p.m.-7 a.m.
Billings, Montana		75		8 p.m.-8 a.m.
New Jersey	50 (residential) 65 (commercial)			10 p.m.-7 a.m.
New York			64 to 74 at 400 ft depending on land use	
Houston, Texas	58 (residential)			10 p.m.-7 a.m.
Alexandria, Virginia		85		
Washington	45 or 50 (residential)			10 p.m.-7 a.m.

Colorado

By state regulation, the sound level at 25 ft. or more from a construction site boundary must not exceed 75 dBA between 7 p.m. and 7 a.m.

District of Columbia

Between 7 p.m. and 7 a.m. maximum construction noise levels at 25 ft. from the project limits are 55 dBA for residential areas, 60 dBA for commercial areas and 65 dBA for industrial areas.

Hawaii

The Hawaii Department of Health has established community noise control regulations for Oahu that limit construction noise as measured at the property line. The limits depend on land use and range between 45 dBA and 70 dBA for the 10 p.m. to 7 a.m. time period.

Illinois, Chicago

Maximum noise levels from construction are limited to between 70 and 80 dBA depending on land use. Except for pile drivers, construction equipment manufactured after January 1, 1980 is limited to a noise level of 80 dBA at 50 ft.

Maryland

Construction noise between the hours of 10 p.m. and 7 a.m. is limited to a range of 55 to 75 dBA depending on land use.

Massachusetts

Construction noise can be limited to no more than 10 dBA above the quietest background L_{90} levels and there are restrictions on pure tone emissions.

Montana, Billings

Maximum noise level from construction equipment at a distance of 50 ft. is limited to 75 dBA between the hours of 8 p.m. and 8 a.m.

New Jersey

Construction noise at residential property is limited to 50 dBA between the hours of 10 p.m. and 7 a.m. A limit of

65 dBA applies at all times at commercial or industrial property.

New York

The state has guidelines limiting construction noise to a 64 to 74 dBA range at a distance of 400 ft. from the construction site depending on the land use. New York City limits construction activities to weekdays between 7 a.m. and 6 p.m. with variances issued only in urgent cases.

Texas, Houston

General noise limits for residential property is set at 58 dBA between 10 p.m. and 7 a.m.

Virginia, Alexandria

Equipment manufactured after July 1, 1977 must meet an 85 dBA noise limit at 50 ft.

Washington

Between 10 p.m. and 7 a.m. the construction noise limit at residences is set at either 45 or 50 dBA. However, the limit may be exceeded by 5 dBA for up to 15 minutes per hour, by 10 dBA for up to 5 minutes per hour, and by 15 dBA for up to 1.5 minutes per hour.

Germany

In Germany there are two laws that allow an abutter to seek monetary compensation when noise abatement features do not control sound levels (25).

The Federal Roads Act: In the planning decision on the construction or major alteration of a federal road, noise abatement measures (for example sound insulation walls or embankments) are required to be taken by the party responsible for the construction. A claim for compensation can be made if the noise abatement measures are not compatible with the project, or if their costs are disproportionate to the intended noise reduction. This provision applies also to federal testing facilities for lane-led traffic; similar possibilities exist in some state road laws.

The Civil Code: The federal court has approved monetary compensation for necessary sound insulation on land affected by unreasonable noise levels; it accepted the justification of compensation for loss of value of the land (for expropriation) only in the case of sound barriers being impracticable or disproportionately expensive, and where the permitted use of the road area results in a long-term alteration in the situation on the land and thereby affects the neighboring housing severely and unreasonable.

In many cases highway departments can receive variances to local noise regulations and ordinances. Some variances can be easily obtained but in some areas the process is difficult and the variance may have very strict and specific requirements. One state submitted a copy of an approved variance that had the stipulation that after two substantiated complaints the state would have to undertake sound testing in the bedrooms of the affected residents. If the tests proved that the construction noise is above the specified limits the Department is required to

take further mitigation action such as, but not limited to, using portable noise shields, insulating the windows, or providing motel accommodations.

A typical requirement was the posting of a 24-hour notification phone number for residents to call in complaints. Another variance requirement described, and one that should be considered as standard procedure, was that contractor personnel attend a training session covering the requirements of the variance.

NOISE MITIGATION

Of interest in terms of community noise impact is the overall noise resulting from a construction site. The noise of each individual piece of equipment and sometimes the highest noise source is not always the number one priority. Noise control is directed toward modification of a perceived sound field. It strives to change the impact at the receiver so that the sounds conform to a desired level. Mitigation of undesired sounds should consider source control, path control, and receptor control (Figure 5).

DESIGN CONSIDERATIONS

There must be a willingness to form area-specific noise mitigation strategies tailored to community needs and sensitivities. Early coordination and communication with project designers can greatly aid in locating and sequencing construction operations to minimize potential construction noise impacts at sensitive receptors. Abatement measures need to be incorporated into the plans and specifications of the project (26). Permanent noise barriers included in a project should be constructed as early as possible to reduce potential construction noise impacts. Alternate construction methods and equipment can also be suggested or specified to lessen potential construction

noise impacts (i.e., cast-in-place piles rather than driven piles, top-down rather than open cut- and-cover construction, rubber-tired equipment rather than steel-tracked equipment, etc.).

Things to Remember

- Sources that may contribute minimally to the overall noise environment may be very significant because their sound is so identifiable that people find it objectionable.
- Wind direction and speed can greatly affect noise levels, particularly at more distant receptor locations (27).
- When an elevated structure passes over a project site or lies adjacent to it, noise can reflect from the underside of the structure.
- A wet pavement greatly increases tire noise.
- As a rule-of-thumb in evaluating the ease of mitigating noise problems, achievement of (28):

5 dBA reduction—simple
 10 dBA reduction—attainable
 15 dBA reduction—very difficult
 20 dBA reduction—nearly impossible.

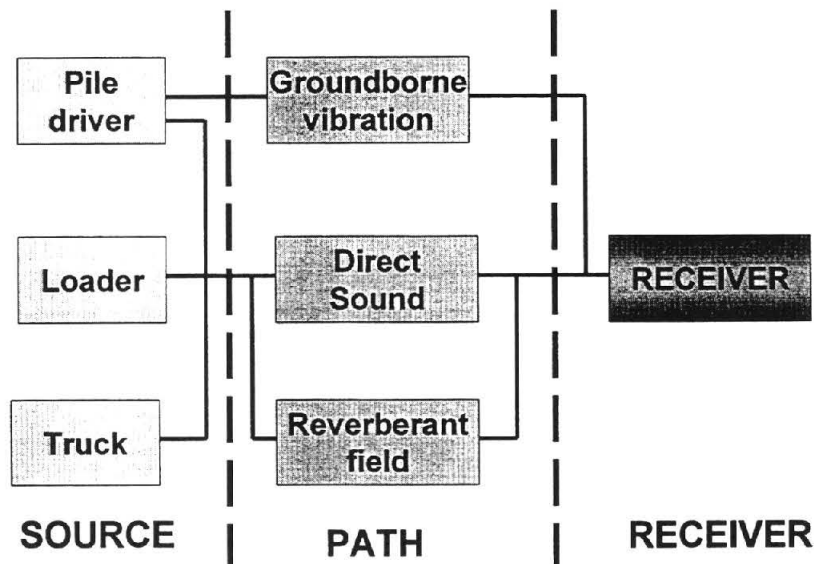

FIGURE 5 Noise transfer situation.

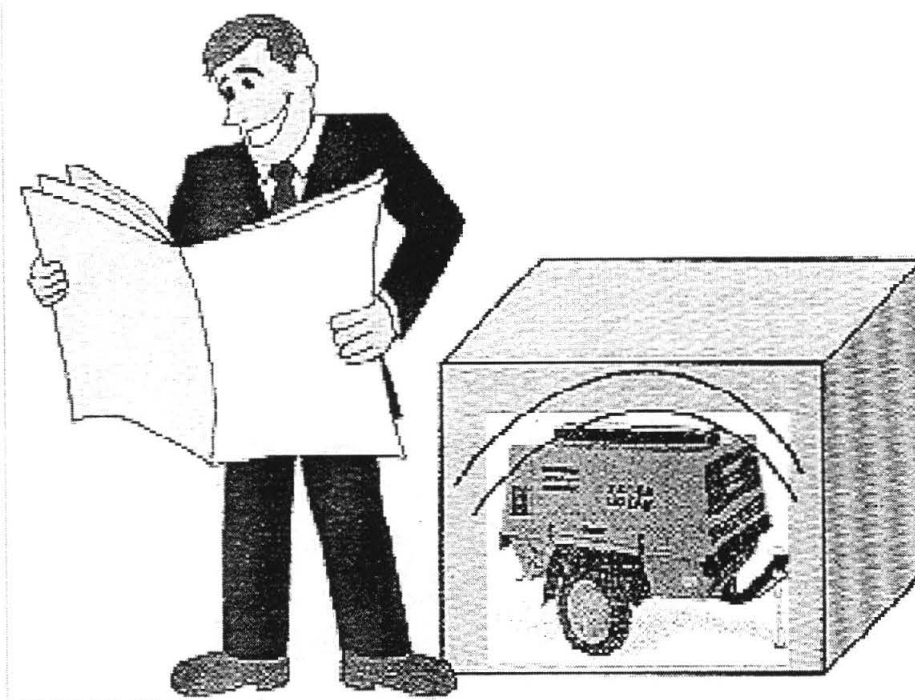

FIGURE 6 Control the noise at the source.

SOURCE CONTROLS

Source controls, which limit noise emissions, are the most effective method of eliminating noise problems and the easiest to oversee on a construction project. Wherever possible, noise control should occur at the source (Figure 6) (29).

Source Mitigation Techniques

Source mitigation reduces the noise problem everywhere, not just along a single path or for one receiver. Consequently, a project's noise mitigation strategy should emphasize noise control at the source.

Require Construction Operations Planning

Restrict the movement of equipment into and through the construction site. Long-term impacts are generated along haul routes when there are large quantities of materials to be moved. Reroute truck traffic away from residential streets. Impose seasonal limitations on construction noise; the spring and fall are critical times in residential areas because windows are usually open at night.

Example Specifications: Where practical and feasible, construction sites shall be configured to minimize back-up alarm noise. For example, construction site access should be designed such that delivery trucks move through the site in a circular manner without the need to back up.

Require Modern Equipment

Unions recognize construction noise as a hazard to workers and the first of five things suggested to workers to address the problem is that they "Ask contractors to buy quieter equipment when they buy new equipment (30)." The specification of equipment noise emission limits forces the use of modern equipment having better engine insulation and mufflers. The emission levels specified should reflect levels that can reasonably be achieved with well-maintained equipment, see Table 3.

Ensure Proper Maintenance

Recertification on a semiannual basis calls attention to the need for good maintenance. Manufacturers can incorporate noise reduction packages into their machines, but they cannot prevent those packages from being compromised. The end user must ensure that the machine is maintained in such a way that it will continue to run quietly. Adequate lubrication and non-leaking mufflers are two important maintenance items.

Equipment Restrictions

Requiring the use of equipment modified to reduce noise or restricting the use of certain equipment types to particular locations or times of day are enforceable source controls.

Example Specifications: The use of impact pile drivers shall be prohibited during evening and nighttime hours.

All jackhammers and pavement breakers used on the construction site shall be fitted with manufacturer's approved exhaust mufflers.

The use of pneumatic impact equipment (i.e. pavement breakers, jackhammers) shall be prohibited within 200 feet of a noise-sensitive location during nighttime hours.

The local power grid shall be used wherever feasible to limit generator noise. No generators larger than 25 kVA shall be used and, where a generator is necessary, it shall have a maximum noise muffling capacity.

Call the contractor's attention to the back-up alarm noise problem and require measures to address the issue.

Example Specifications: The Contractor shall minimize noise from the use of back-up alarms using measures that meet OSHA regulations. This includes use of self-adjusting back-up alarms, manual alarms on low setting, use of observers, and scheduling of activities so that alarm noise is minimized.

or

All equipment with back-up alarms operated by the contractor, vendors, suppliers, and subcontractors on the construction site shall be equipped with either audible self-adjusting backup alarms or manual adjustable alarms. The self-adjusting backup alarms shall automatically adjust to 5 dBA over the surrounding background noise levels. The manually adjustable alarms shall be set at the lowest setting required to be audible above the surrounding noise. Installation and use of the alarms shall be consistent with the performance requirements of the current revisions of the Society of Automotive Engineering (SAE) J994, J446, and OSHA requirements.

By specification, direct the use of only power grid connected or solar powered traffic control devices, Figure 7.

Example Specifications: All variable message/sign boards shall be solar powered or connected to the local power grid.

Operate At Minimum Power

Noise emission levels tend to increase with equipment operating power. This is a critical issue with older street sweepers, demolition work using a hoe-ram, and equipment

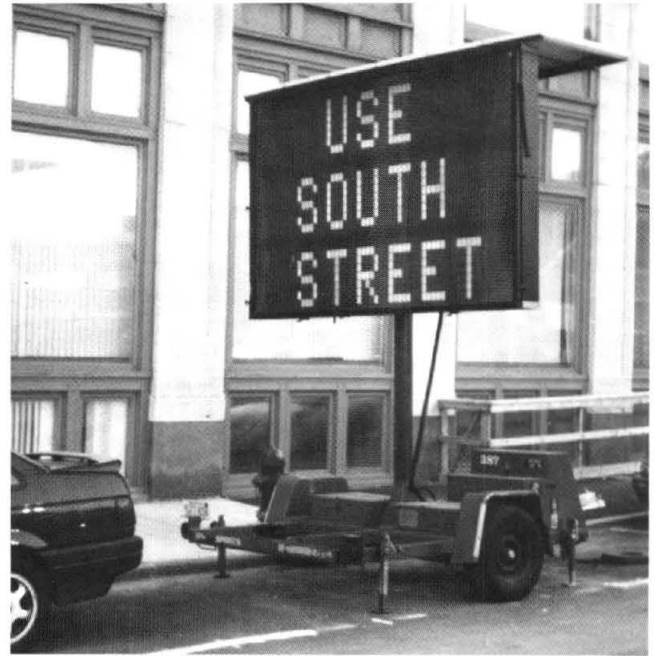

FIGURE 7 Solar-powered traffic control devices.

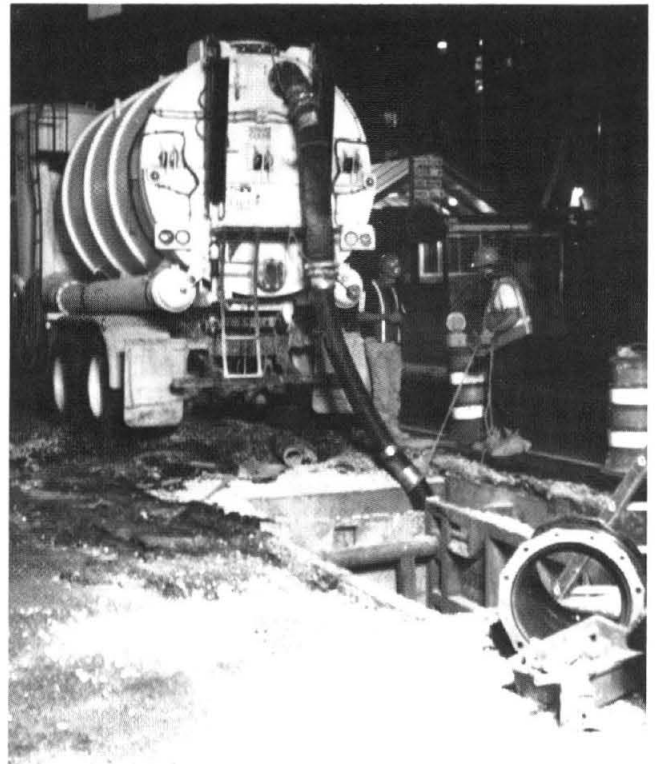

FIGURE 8 Vacuum truck working at night.

such as vacuum trucks, Figure 8. Require that such equipment operate at the lowest possible power levels.

Operational or Time Constraints

Combine noisy operations to occur in the same time period. The total noise level produced will not be significantly

greater than the level produced if the operations were performed separately.

Prohibit work during sensitive times (night) in certain areas. Care should be given to the definition of working hours. Contractor personnel routinely start equipment early to allow for warm-up or for maintenance service. Because the equipment is not working (engaged in construction activities) contractors do not believe this is non-compliance with working hour restrictions. It may be necessary to have designated warm-up areas that are removed from noise-sensitive areas.

Specified sequence of operations activities (order of pile driving, bents close to abutments only during the daytime other bents at any time).

Example Specifications: Material storage areas will be restricted from areas near residences.

Construction activity will be limited to between the hours of 6:00 a.m. and 11:00 p.m.

Any process which requires the use of any kind of impact or vibratory device will only be allowed between the hours of 7:00 a.m. and 7:00 p.m. Such devices include but are not limited to jackhammers, hoe-rams, pile drivers, and scarifiers.

Contractors shall use DOT approved haul routes to minimize noise at residential and other sensitive noise receptor sites.

Control Non-Construction Traffic

Limit non-construction heavy truck movements on side or residential streets to weekday daytime hours.

Use Quieter Alternate Methods

Encourage the use of quieter methods when possible. Use top-down or tunneling rather than cut-and-cover construction techniques. The selection of detour routes should consider traffic noise effects.

Impact pile driving is one of the noisiest construction operations. Alternates to consider include: Use hydraulic impact hammers in place of diesel hammers; Use pre-cast concrete piles in place of steel piles; Construct bored piles by augering; Use vibratory drivers in place of impact hammers; Use hydraulic loading to push rather than drive piles; and Substitute slurry wall construction for impact pile driving.

The conventional method for *removing concrete* is to crush it in place with percussion breakers. Alternatives to consider include: Use hydraulic, electric, or gasoline-powered tools instead of pneumatic equipment; Use a whip-action impact hammer in place of excavator-mounted

hoe-rams; Use a thermal lance to burn holes in the concrete; Use diamond drills and saws to cut the concrete; Use hydraulic jaws to bust the concrete; and Use non-explosive chemical agents that expand to crack the concrete.

Use Quieter Alternate Equipment

Electric or hydraulic powered equipment is usually quieter than a diesel powered machine. Encourage contractors to use alternate equipment, for example tower cranes as shown in Figure 9 instead of mobile cranes.

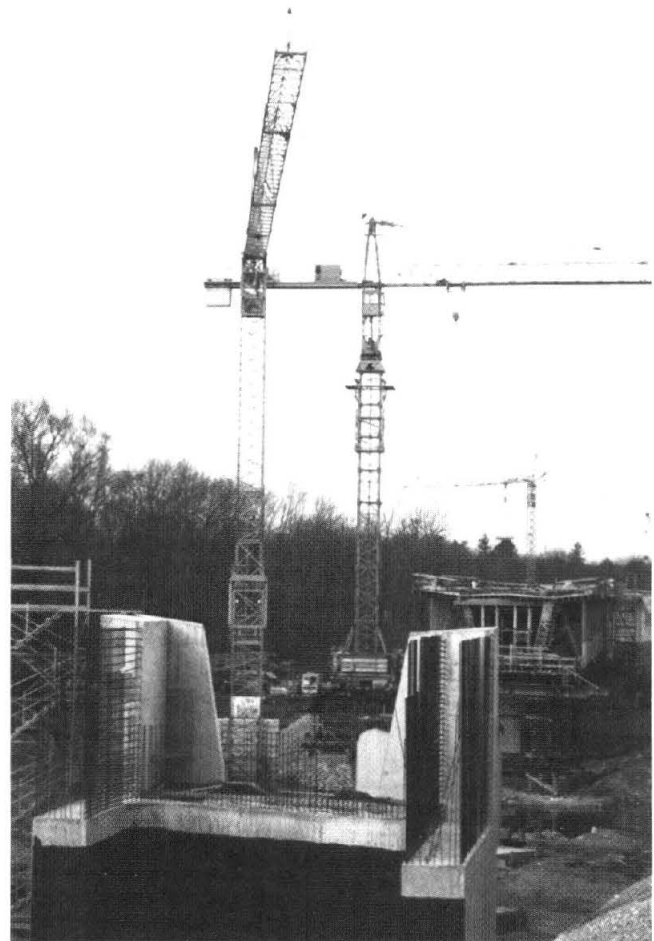

FIGURE 9 Electric tower cranes used for bridge construction.

PATH CONTROLS

Alone, source noise controls are frequently inadequate to minimize noise impacts on abutting sensitive receptors because of the close proximity to residences and businesses in urban areas and because of the very nature of the construction work. Thus, having exhausted all possible mitigation methods of controlling noise at the source, the second line of attack is controlling noise radiation along its transmission path (Figure 10). Noise path barriers should provide a substantial reduction in noise levels, be cost-

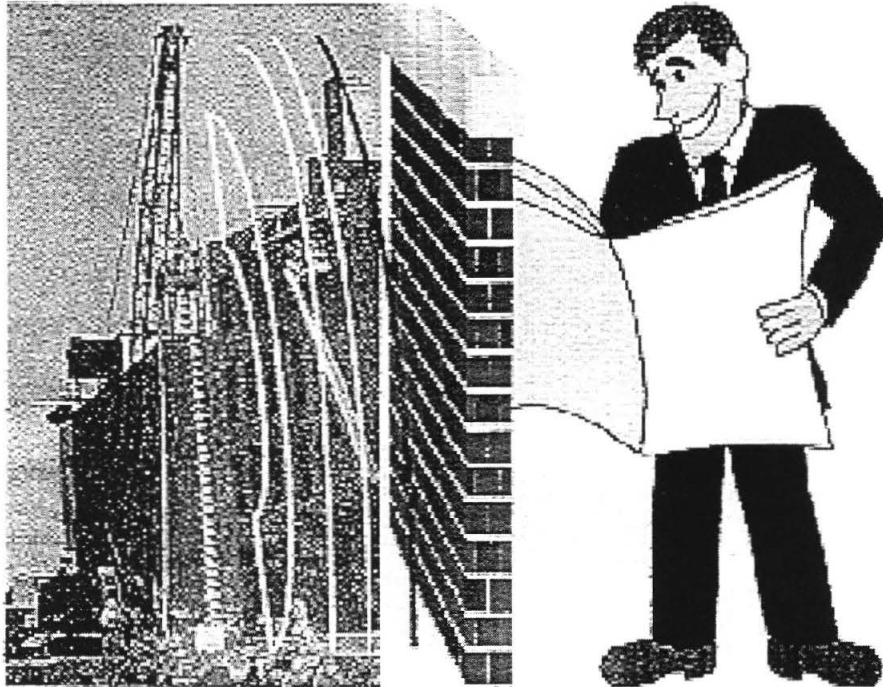

FIGURE 10 Control the noise path.

effective, and be implemented in a practical manner without limiting accessibility. Barriers can increase a project's visual impact. This visual change can have either a positive or negative impact. Therefore, aesthetic effects must be considered when designing barrier systems (31).

Path Mitigation Techniques

Once established, only reflection, diffraction, insulation, or dissipation can modify an airborne sound field. In other words, it is necessary to increase the distance from the source or to use some form of solid object to either destroy part of the sound energy by absorption, or to redirect part of the energy by wave deflection. The three techniques for path mitigation are distance, reflection, and absorption. Specific practical techniques are described below.

Move Equipment Farther Away from the Receiver

By doubling the distance between the source and the receiver, a 3- to 6-dBA reduction can be achieved. It is important to recognize that a 6-dBA reduction of sound pressure represents a noticeable change in noise level.

Enclose Especially Noisy Activities or Stationary Equipment

Enclosures can provide a 10- to 20-dBA sound reduction. Additionally, the visual impact of roadwork activities affects how construction sounds are perceived (32). An important



FIGURE 11 Slurry plant enclosure for audio-visual and dust control.

noise mitigation issue, therefore, is the audio-visual sensing factor. Enclosures address both the absolute audio and the visual perception issues (Figures 11 and 12).

Example Specifications: All jackhammers and pavement breakers used at the construction site shall be enclosed with shields, acoustical barrier enclosures, or noise barriers.

Erect Noise Barriers or Curtains

Barriers can provide a 5- to 20-dBA sound reduction. These may be very temporary systems mounted on jersey

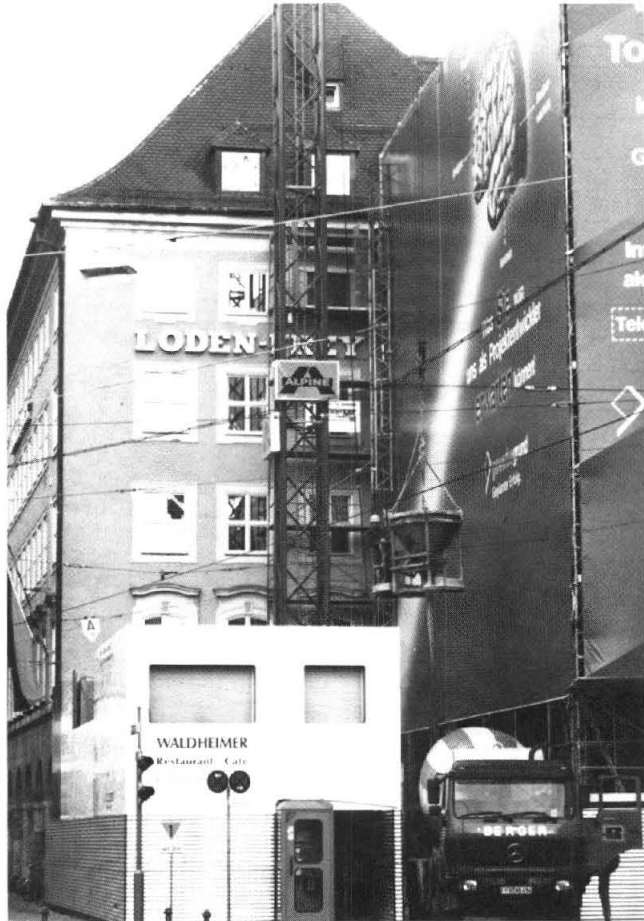

FIGURE 12 Enclosure constructed around concreting activities.

bases for easy relocation (Figure 13) or semi-permanent walls designed to last several years on projects of long duration (Figure 14). The design of a noise barrier should involve a structural and wind load analysis. In the case of a semi-permanent wall, it is good practice to consult with the abutter on the reasonableness of the wall design.

Barrier design and construction must incorporate consideration of aesthetics and public safety. A tall barrier placed close to a building front can create a tunnel effect. The creation of such dark spaces can be dangerous to the public, which must use the adjoining sidewalk. Barriers constructed of transparent materials are appropriate in such locations (Figures 15). Special facings may be appropriate when the wall abuts upscale commercial establishments (Figures 16).

Use Landscaping

Landscaping with trees, shrubs, and berms can be effective in visually shielding large open areas, such as parks or pedestrian areas. Thickly grown bushes and trees can be effective in reducing sound reflection from walls, but should not be relied on as a noise barrier.

Active Noise Control

An emerging and potentially viable means of source control involves “active” noise control technologies. With



FIGURE 13 Movable noise barrier mounted on jersey bases.



FIGURE 14 Semi-permanent noise barrier wall.

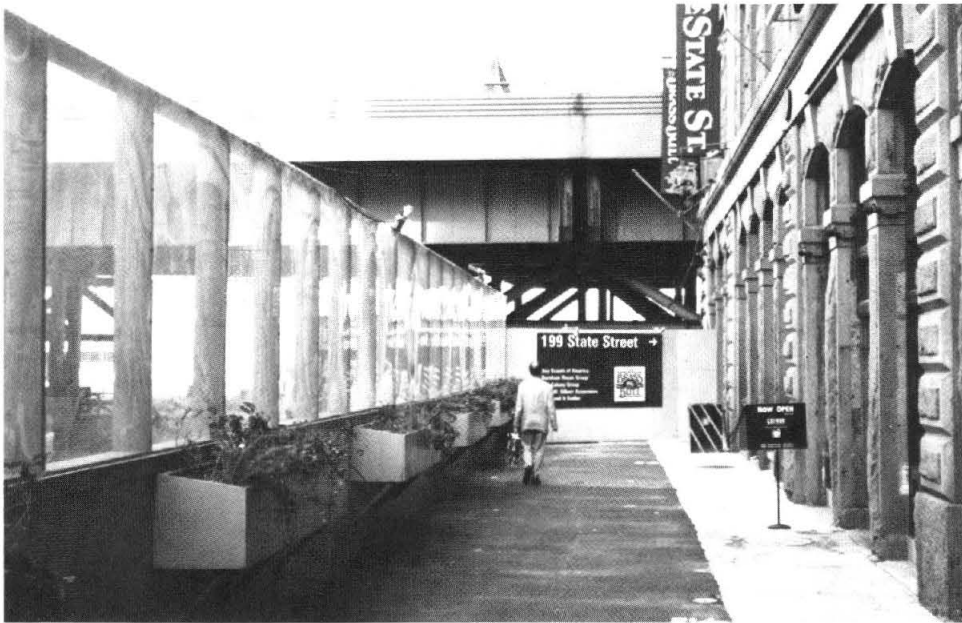

FIGURE 15 Transparent sound barrier for aesthetic and safety reasons.

active noise control, an equal but opposite noise wave is artificially created and mixed 180° out of phase with the subject noise, thus canceling the sound. While this technique offers much promise, particularly in confined pathways like mufflers, there are too many reflective paths on an open construction site to consider it a viable control method given today's technology.

Acoustic Barrier Design

When a sound wave encounters a barrier, three interactions take place: some of the sound energy is transmitted

through the barrier, some is absorbed within the material of the barrier, and the majority of the sound energy is reflected back toward the source, Figure 17. The ability of a barrier to resist the flow of sound energy is largely determined by its mass. Heavy, dense materials are good barriers; while soft, porous materials are poor barriers. Therefore, it should be noted that there is no such thing as an ultra-lightweight high-efficiency acoustic barrier. A second important characteristic of a good barrier is stiffness. A barrier constructed from a rigid material can transmit vibration and reradiate noise on the backside of the barrier.



FIGURE 16 Special facing for aesthetics on sound barrier abutting a commercial establishment.

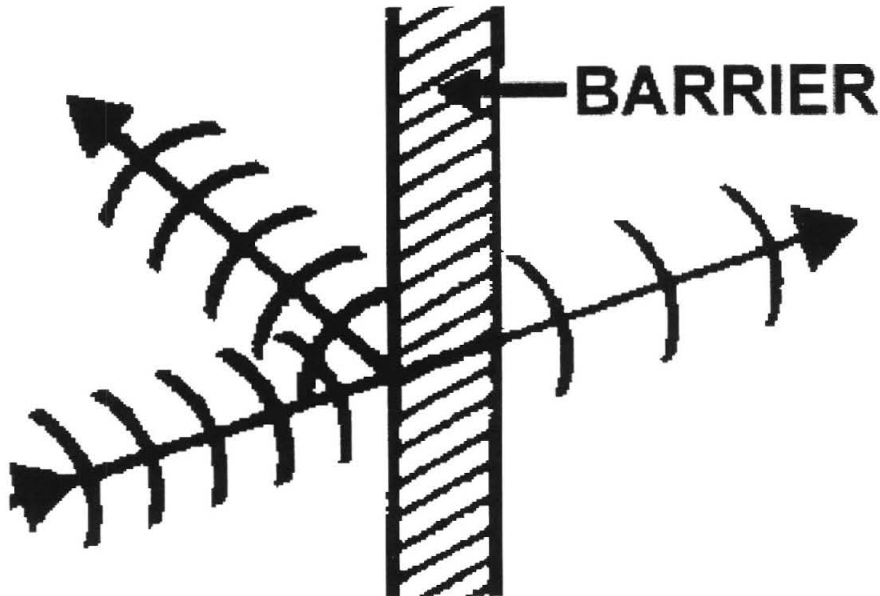

FIGURE 17 Acoustical barrier.

The noise reduction occurs on the side of the barrier opposite the source in the acoustic shadow zone, in much the same manner as a shadow created by a light source, Figure 18. The effectiveness of a barrier is also dependent on the wavelength of the sound. Low frequencies have long wavelengths and tend to roll over the barrier. High frequencies have shorter wavelengths and the barrier is much more effective. There can be situations where temperature and wind gradients must be considered. While it

is only a minor effect an increase in temperature tends to bend the sound waves upward, while a decrease in temperature causes sound waves to move horizontally. Furthermore, sound at more remote receptor locations can be louder on the downwind side of a source than on the upwind side (33).

Sound barriers can be temporary walls or piles of excavated material. The ratio of the distance between two

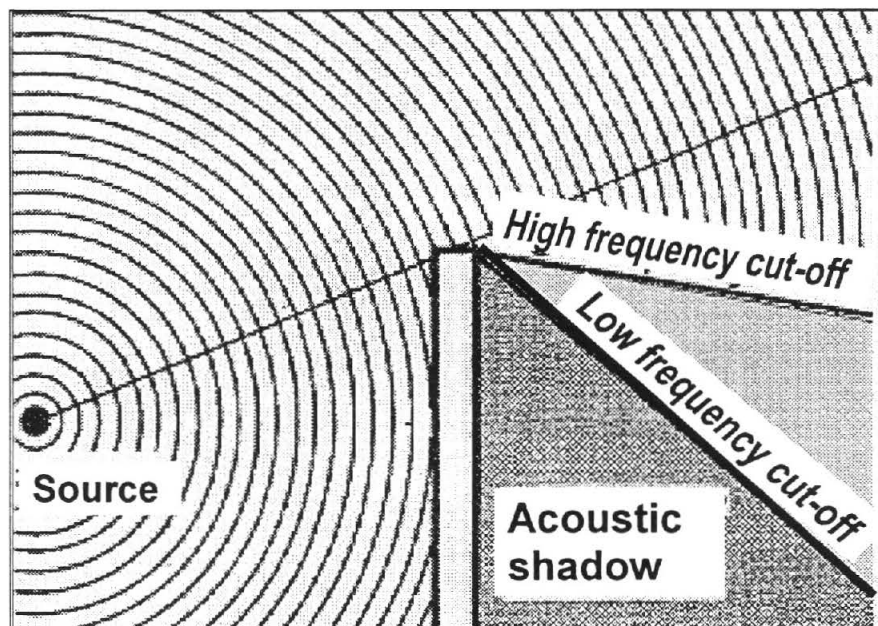

FIGURE 18 Acoustic screening of a barrier wall.

parallel barriers to the height of the barriers should be on the order of 15:1 (e.g. two 10-ft. barriers 150 ft. apart). As the ratio decreases, the potential effectiveness of the barrier decreases due to increased sound reverberation between the barriers (34).

If the barriers must be constructed such that the ratio is less than 15:1 they should be tilted away from the noise generating activity at an angle of 10° to the vertical in order to eliminate the majority of reflections between the barriers (35). This approach has been successfully used on permanent traffic noise barriers in New Jersey and Nevada.

Another approach to the reverberation problem is to provide noise-absorptive surfaces on the walls. Several manufacturers produce noise barrier materials with durable and effective absorptive surfaces for permanent concrete, metal, or wood barriers. However, providing durable, weather-resistant cost-effective treatment for temporary barriers is a challenge.

When working in urban areas with multi-story buildings it may be advantageous to place a baffle on top of the barrier, facing inward at a 45° angle. This will help to break the line of sight to noise receptors on upper floors.

Performance Requirement

In general, noise barriers or curtains are cost-effective when they provide perceptible noise reduction benefits to a relatively large number of receptors. To do this the barrier must physically fit in the space available and completely

break the line-of-sight between the noise source and the receptors. Further, it must not be degraded by nearby reflective surfaces. These requirements can be difficult to satisfy when challenged by urban multi-story receptor building situations.

- A minimum performance requirement to justify barriers is a 10 dBA noise reduction at receptor locations.

Such a reduction will be perceived by the affected receptors as a halving of the original noise level. It is, however, not uncommon to see performance design goals in the 7- to 10-dBA range.

Barrier Specifications

Solid barriers should be constructed of a material having a surface density of at least 2 lb./sq. ft. to ensure adequate sound transmission loss. When acoustical curtains are used or when it has been necessary to provide a barrier that would permit unimpeded vision (transparent vinyl barriers), a surface density of at least 1 lb./sq. ft. should be required.

The most commonly used reference to quantify a material's ability to reduce transmitted noise is its Sound Transmission Class (STC) rating. A material's STC is determined by measuring the noise energy reduction through the material as a function of frequency and then evaluating the results against a standard curve with the resulting rating taken at 500 Hz. Noise barriers should have STC ratings of at least 25, with 30 being a more desirable value. Table 8 lists STC ratings for common materials.

TABLE 8
ACOUSTIC INSULATION PERFORMANCE OF
COMMON MATERIALS (36)

Material	Sound Transmission Class (STC)
Quilted blanket	27
Clear vinyl barrier	20
Vinyl acoustic curtain	22
PVC acoustic curtain	21
Felt, cotton	3
Glass, 1/8 in.	26
Plexiglas	
1/4 in.	27
1/2 in.	30
1 in.	32
Laminated glass	
1/2 in.	40
3/4 in.	43
Two panes	
1/8-in. glass, 2 1/4-in air space	37
Gypsum board	
1/2 in.	28
5/8 in.	29

Example Specifications: Temporary barriers shall be constructed 3/4-inch Medium Density Overlay (MDO) plywood sheeting, or other acceptable material having a surface weight of 2 pounds per square foot or greater, and a demonstrated STC rating of 30 or greater as defined by ASTM Test Method E90.

The acoustical barrier enclosure shall consist of durable, flexible composite material featuring a noise barrier layer bonded to sound-absorptive

material on one side. The noise barrier layer shall consist of rugged, impervious material with a surface weight of at least one pound per foot.

To avoid objectionable noise reflections, the source side of the barrier must be lined with an acoustic absorption material, Figure 19. This is especially important in the design of a full or partial enclosure. The lack of sound absorbing materials causes a high reverberant condition inside the enclosure. Absorption depends on the sound wave entering the material and being converted to heat on the porous material surface and cells.

The absorption material should have a Noise Reduction Coefficient (NRC) rating of 0.70 or greater in accordance with ASTM Test Method C423. The NRC is a measure of the acoustical absorption performance of a material. It is calculated by averaging the material's sound absorption coefficients at 250, 500, 1,000 and 2,000 Hz, expressed in the nearest integral multiple of 0.05. Absorption coefficients indicate the percentage of incident sound that is absorbed by the material. The coefficient varies with material thickness and the frequency of the incident sound. Sound absorption coefficients of common materials are given in Table 9.

When barrier units are joined together they should be flush with one another. Gaps through or under noise barriers have far more effect than would seem reasonable. The sound energy that passes through a gap can substantially compromise a barrier's performance (27). Any gaps should be sealed with material that will completely close the openings and attenuate sound, Figure 20. Often there

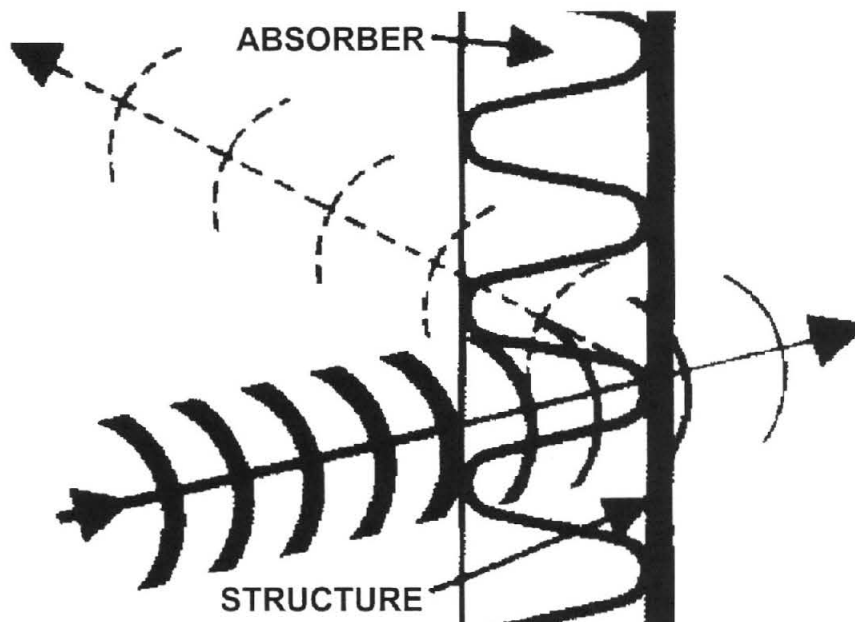

FIGURE 19 Acoustical absorbers.

TABLE 9
SOUND ABSORPTION COEFFICIENTS OF COMMON MATERIALS

Material	Frequency Hz					
	125	250	500	1,000	2,000	4,000
Fibrous glass 1-in. thick	0.07	0.23	0.48	0.83	0.88	0.80
Polyurethane foam ½-in. thick	0.05	0.12	0.25	0.57	0.89	0.98
1-in. thick	0.14	0.30	0.63	0.91	0.98	0.91
Gypsum board	0.29	0.10	0.05	0.04	0.07	0.09
Plywood	0.28	0.22	0.17	0.09	0.10	0.11
Wood	0.15	0.11	0.10	0.07	0.06	0.07

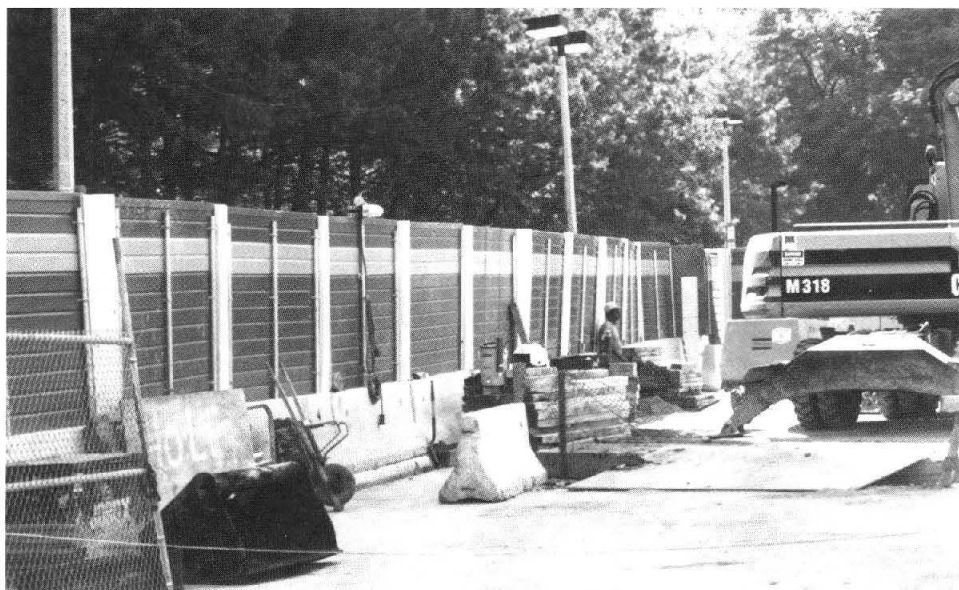

FIGURE 20 Noise barrier wall with sealed gaps.

is a requirement for access gaps in barriers. At such locations two barrier segments should be overlapped to provide access. The overlap causes the sound to “bend” several times before heading toward the neighbors. A 15- to 20-foot overlap is generally sufficient (27).

Example Specifications: When barrier units are joined together, the mating surfaces of the barrier sides shall be flush with each other. Gaps between barrier units, and between the bottom edge of the barrier panels and the ground, shall be closed with material that will completely close the gaps, and be dense enough to attenuate noise.

Noise Barrier Products

Depending on the project and its location, sound barriers are usually temporary construction or constructed in such a manner as to be movable about the site. Sometimes, however, the barriers are incorporated in a project as

permanent construction. There are many ways to construct sound barriers using different materials from different manufacturers.

The use of timber barriers is the most common and effective approach because of the material’s relatively high sound transmission blocking characteristics, its low initial cost, and the advantage of construction ease. At a minimum, the barrier should be constructed of 3/4-in. medium density overlay (MDO) plywood sheeting lined on the transmission side with sound-absorbing material (glass fiber, mineral wool, foam, or noise curtain).

One manufacturer has developed a sight and sound screen system specifically for highway construction. The system can be used as either a permanent barrier or as an aesthetically pleasing wall during long-term construction projects. The product, which has been tested by the Highway Innovative Technology Evaluation Center (HITEC), is a post and panel wall system (37). The system’s 4 ft. × 12-ft. panels are approximately 6¾-in. thick and consist of

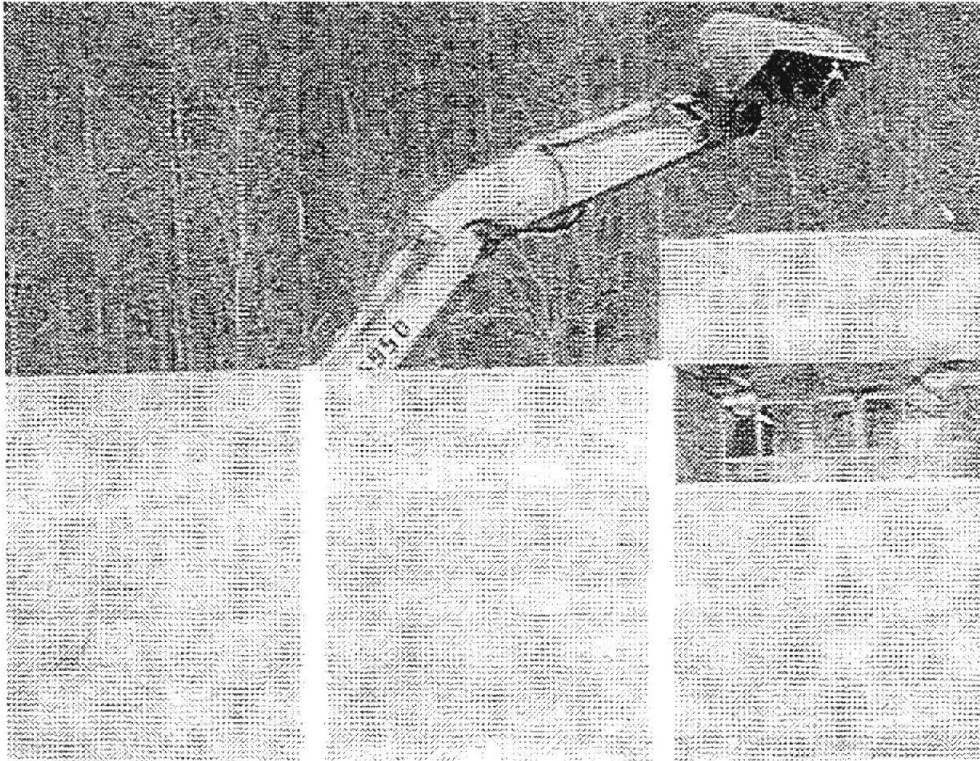

FIGURE 21 Prefab panel noise barrier.

three laminated layers reinforced with steel to provide some flexural strength. The three laminated layers consist of: 1) ½-in. cement board, 2) rigid polystyrene, and 3) ½-in. cement board. To build a wall the panels are set between wide flange steel or precast concrete columns. A wall 20-ft. high can be constructed by staking panels, Figure 21.

These panels come pre-finished and cost approximately \$12 to \$14 per square foot depending on location and project. This price includes all necessary labor and materials to construct foundations, set columns, and install the panels. For permanent applications, the columns are set in concrete, but for temporary ones they can be bolted for ease of relocation.

Acoustical Curtains

Another temporary noise barrier option is acoustical curtains, Figure 22. Depending on the application, these quilts can reduce sound levels about 10 dBA. Curtains are typically installed in vertical segments. These products are available in a wide range of modular “off-the-shelf” panel sizes. All seams and joints should have a minimum overlap of 2 inches and be tightly sealed. This is typically accomplished with Velcro edges.

One company manufactures curtains that are a “combination of a 2-in. thick vinyl-based quilted fiberglass

sound absorber and a reinforced loaded vinyl noise barrier.” The quilts come with grommets for attaching multiple quilts together. They can be suspended from either the structure being worked on or a tubular framework. Cost for these quilts is in the \$7–\$9 per square foot range depending on whether they are pre-cut with grommets or if they come in a roll to be cut and sized by the user. This price is for the curtain material only and does not include the labor to install or any labor, material, or equipment to fabricate a supporting framework. In Boston the CA/T Project estimated prices for installing several hundred feet of 22-ft. long curtains from an existing expressway superstructure ranged from \$13 to \$21 per sq. ft.

Example Specifications: The acoustical material shall be weather and abuse resistance, and exhibit superior hanging and tear strength during construction. The material shall have a minimum breaking strength of 120 lb/in. per FTMS 191 A-M5102 and minimum tear strength of 30 lb/in. per ASTM D117. Based on the same test procedures, the absorptive material facing shall have a minimum breaking strength of 100 lb/in. and minimum tear strength of 7 lb/in.

The acoustical material shall have a Sound Transmission Class of STC-25 or greater, based on certified sound transmission loss data taken according to ASTM Test Method E90. It shall also have a Noise Reduction Coefficient rating of NRC-0.70 or

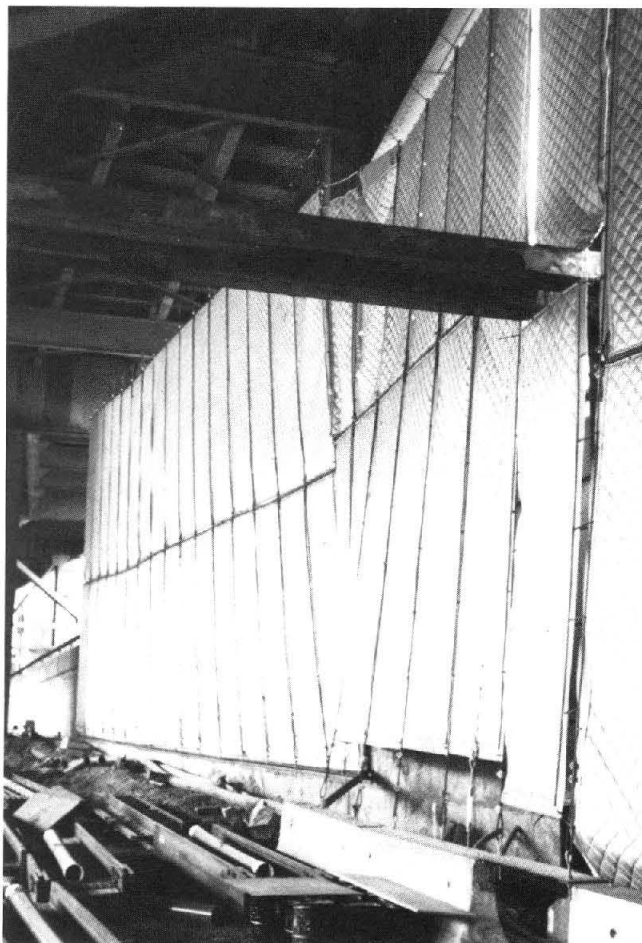

FIGURE 22 Acoustical curtains.

greater, based on certified sound absorption coefficient data taken according to ASTM Test Method C423.

Note that the above specification refers to two test criteria. The *Sound Transmission Class* has to do with the noise shielding (transmission loss) efficiency of the material and the *Noise Reduction Coefficient* rates absorption quality.

Quilts can also be used to form movable three sided tents to be used as barriers for specific work operations such as over jackhammer pavement breaking or over generators. The tents can be built and then moved around the site.

Each system has its specific advantages (38). The quilt curtains are much more portable and can be handled by hand, whereas other barriers typically require lifting equipment. The quilts can be hung from existing structures, saving the cost of framework to support the barrier. On the other hand, the prefabricated noise barrier systems are more permanent for long-duration projects. Also, if these types of barriers are ordered with a finish, they are much more pleasing visually than other barriers.

Barrier Effectiveness

The limiting factor controlling noise barrier effectiveness is the physical placement of the barrier. To be effective, the barrier should be placed as close to the noise source or as close to the receptor as possible. The barrier must intervene and break the line of sight between the noise source and the receptor. Consequently it can become difficult to mitigate noise affecting the upper stories of tall buildings because the practical height to which temporary barriers can be built is limited to about 25 feet (Figure 23).

RECEPTOR CONTROLS

When all other approaches to noise control have failed, then a program of control at the receiver should be undertaken (Figure 24). It should be remembered that the critical receiver might not be human. Certain precision equipment can require very low levels of ambient noise and vibration.

Receptor Mitigation Techniques

The response of human beings, either singularly or as a group, is a problem because people are all different. Additionally no one individual is likely to exhibit the same reaction to a noise stimulus on two successive days, and there are those who are hypersensitive.

Community Relations

Early communication with the general public is vital. Inform the public of any potential construction noise impacts and the measures that will be employed to reduce these impacts. Establish and publicize a responsive complaint mechanism for the duration of the project. The establishment of good rapport with the community can provide high benefits at low cost. Instill an awareness of public attitudes and reactions in the minds of the construction equipment operators so that unnecessary annoyances will be avoided.

Community Participation

Honest disclosure will increase tolerance. It is helpful to empower people to aid in developing the solutions to their particular problem.

Window Treatment Program (15)

In general, window openings are the weak link in a structure's external façade allowing noise infiltration into a



FIGURE 23 Augmented height for noise wall in front of tall building.

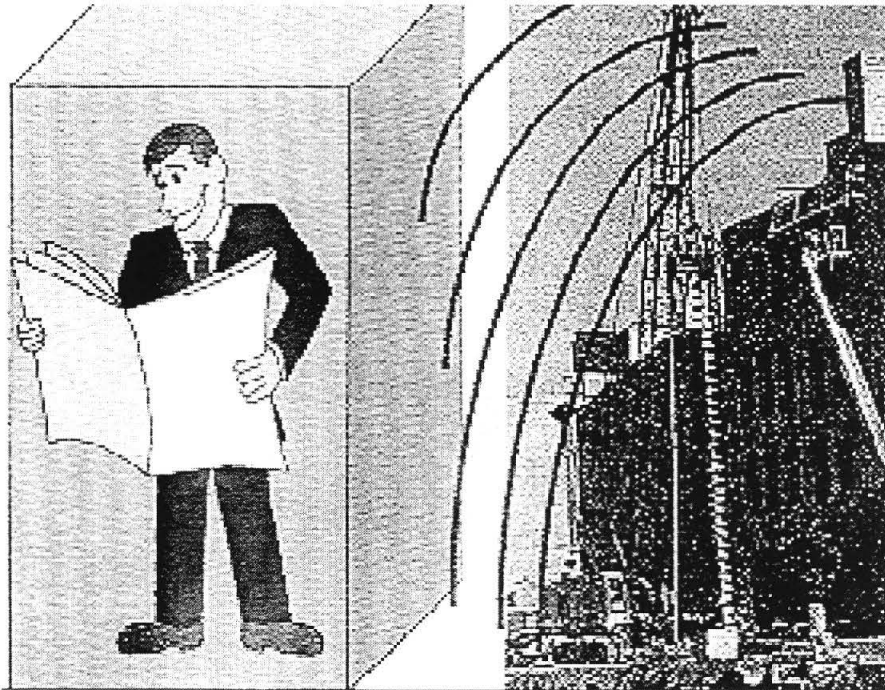

FIGURE 24 Receptor control.

building. A good window treatment can provide an incremental 10 dBA sound reduction in a building. Such a reduction can be achieved with a treated window system capable of meeting a Sound Transmission Class (STC) of 39 or greater.

The receptor problems usually involve individuals located very close to the noise generating activity, in which case it may be easier and more effective to improve the individual’s acoustic environment instead of controlling all emitted noise. Window treatments are cost effective when a relatively few or a widely scattered number of receptors require noise mitigation. Treatment can involve

only interior storm sashes or a full replacement of the window.

If the existing windows and frames are in decent condition the most cost-effective treatment involves insertion of interior storm sashes. If the existing window or frame is in decrepit condition, then a full replacement acoustic window is warranted. Critical issues to be considered are eligibility policy, legal concerns, and historic preservation issues.

Eligibility policy—The window treatment policy on the CA/T project states that the following standard be used to determine eligibility:

- The resident must be subjected to nighttime (10 p.m. to 7 a.m.) construction noise.
- Other control methods (source and path) must not adequately mitigate the noise.
- The resident must be in close proximity to the construction work. This is defined by a calculated noise impact zone.
- The applicant must be a legal resident.
- Construction noise levels at the residence must be exceeding the Project's noise limit criteria.
- Elevated noise levels are forecasted to exist consistently for a period in excess of two consecutive months.
- Situations must involve health condition, hardship, or severe impact (NOT financial means).
- Mitigation is limited to bedroom windows, unless a relevant health condition is documented.
- There must be a written right-of-entry to authorize the work.
- The CA/T Noise Panel must approve the treatment and associated cost.

CA/T limits the treatment to affected bedroom windows only. If a treatment is approved CA/T issues a task order to a window contractor. After the work is performed, a second noise assessment is conducted. The contractor is paid by CA/T after the resident signs off on the completed work.

Temporary Relocation

In very special cases, temporary relocation may be necessary. Relocation has been used in California during 24-hour work to repair earthquake damaged highways; on one occasion in Utah on the I-15 project, because of an individual's medical problem; and in Massachusetts involving four apartments very close to the CA/T project.

CONTRACT SPECIFICATIONS FOR ADDRESSING NOISE CONTROL

A good construction noise control specification is an effective tool in mitigating the effect of nighttime construction on abutting communities. The goal is to minimize the impact of construction noise. The mechanisms to achieve that goal will vary from contract to contract because of area-specific conditions, the type of construction, the inherent noise reduction qualities of affected receptor structures, and the desires of the affected abutters. The construction noise control specification being used for the CA/T projects is presented in Appendix F. Supplemental standard provisions can specify mitigation measures on a contract-by-contract basis to address special local condition noise. In addition it may be necessary to have specific noise mitigation measures specified for certain work items. In the case of the viaduct demolition for the Westway project

in New York City, a specific noise control curtain and barrier system was specified. The existence and importance of noise control specifications should be emphasized at pre-bid and pre-construction conferences.

Specification Content

Effective specifications or supplemental standard provisions require that there be a construction noise analysis performed during the final design stage of a project. This analysis should review any special construction equipment, material haul routes (job access), locally imposed noise regulations, and all commitments made to abutters. The approach to selecting noise and vibration-sensitive sites should be described in detail. Sensitive sites and site descriptions should be clearly stated. When the requirement to comply with all restrictions and commitments is included in the contract documents, contractors can be expected to allow for compliance in the bid price. Such an approach allows contractors to effectively plan their operations and to seek innovative solutions to the clearly identified problem. This approach will minimize potential complaints, and serve to control construction cost and delays.

Items to be considered for inclusion in the contract documents include:

- Contract-specific nuisance evaluation measures.
- Identification of noise-sensitive receptors.
- Criteria for lot-line and/or emission noise limits. Lot-line criteria should be established based on the preconstruction baseline level. The acoustical industry generally accepts that an increase of 5 dBA is noticeable but does not represent an unacceptable noise hardship condition (16). Therefore, a lot-line specification might allow L_{10} noise levels 5 dBA above the preconstruction baseline, see Figure 20. These limits will vary with the time of day—daytime, evening, and night.
- Prohibit specific types of construction activities. Certain types of activities can generate noise complaints even though their sound level does not exceed emission limits. This is especially true for rattling, banging, tonal, and repetitive sounds. In residential areas during nighttime hours, it may be necessary to restrict activities generating such sounds.
- Include equipment noise emission limits (see Table 3 for typical emission levels). These should be conservatively set as low as possible in order to force good equipment maintenance practices. Equipment must be certified before it is allowed to work on-site. A good noise-emission certification distance is 50 ft. as there are problems with trying to acquire reliable measurements at closer distances and at distances greater than 50 ft. other noise sources may contribute instrument readings.
- Establish operational (working hour) constraints.

- Provide noise abatement incentives for contractors. It may be effective to pay bonuses for staying below noise standards over certain contract periods.

- Include provisions for temporary variances.
- Detail required submittals of mitigation measures.

Several rail transit projects have used absolute noise level restrictions. But Harris Miller Miller & Hanson Inc. reports that “Typically, the Contractors do not pay serious attention to noise limits and do not plan for extensive noise mitigation measures that would be required to achieve these limits (14).” The Harris’ report further states “This often leads to serious community complaints as well as delays or added costs for the project.” Consequently, specifications should force noise identification and control planning, and provide the Department with a means of ensuring that mitigation efforts are implemented. The specifications for the CA/T project require contractor noise control planning and contain both relative noise criteria limits for identified sensitive receptor locations and absolute limits for on-site equipment.

Required Submittals

Requiring contractors to prepare detailed noise control plans is an effective first step in addressing construction noise nuisances. Submittals in support of noise mitigation planning include:

- Baseline noise levels—contractor measurements made prior to the start of construction at specific locations noted in the monitoring plan. These should be for both daytime and nighttime ambient conditions. These data are critical so that reasonable (relative) noise criteria limits can be set, and noise mitigation planning and control efforts can be targeted effectively.

- Noise control plans—should predict the construction noise at the receptors based on the contractor’s construction methods and proposed equipment. An experienced acoustical engineer should prepare this plan. If the analysis identifies situations where the specification’s noise criteria will be exceeded the plan must set forth the proactive mitigation measures that will be utilized to correct the situation and demonstrate quantitatively the expected noise reductions resulting from the mitigation methods proposed. The specification should also clearly present the procedures for taking noise measurements. Noise measurement procedures and responsibility can be assigned by specification to the contractor. An example of such a specification is provided in Appendix F, specifically sections 2.02 and 3.01.

Because it is difficult to anticipate construction equipment locations and methods far in advance, it is good to require quarterly or semi-annual plans on projects of long

duration. These plans will help to identify potential noise problems that are not anticipated early in the work or that result from changes in methods or equipment.

- Noise monitoring plan—only monitoring can demonstrate compliance with noise restrictions (selected locations should be at least 6 feet from buildings and other sound-reflecting objects). Monitoring can be done over short- and/or long-term time periods. This can be accomplished with hand-held noise meters or automated noise monitors deployed at key receptor locations. Noise monitoring should be conducted during the period of highest noise generation, be it daytime or nighttime in the case of residences. To ensure adequate accuracy, noise monitors should meet accuracy requirements for Type 2 instruments or better as defined in ANSI S1.4.

Example Specifications: The Contractor shall prepare a noise and vibration-monitoring plan, which shall be submitted to the Engineer for review. The Monitoring plans shall at a minimum, identify historic structures and other sensitive locations in the immediate vicinity of construction operations. The Plans shall designate locations in the vicinity of the Work at which levels will be measured and the Contractor shall install measuring equipment at those locations. Data shall be furnished to the Engineer on a weekly basis. In the event that levels exceed allowable limits, the Engineer shall be notified immediately and corrective measures implemented. Development and implementation of the noise and vibration monitoring program is considered incidental to the Work and shall not be measured for payment.

- Noise monitoring data—this data proves compliance with noise restrictions and factual information for investigating the legitimacy of noise complaints, Figure 25. No operation will be perfect but the monitoring data provides a good method for evaluating the quality of the noise control effort. It should be remembered that spikes could be caused by noise sources other than the construction operations.

- Equipment noise certification tests (biannually)—certification provides the means to enforce equipment noise emission limits, and to encourage good maintenance practice and the employment of equipment having effective mufflers.

Example Specifications: Construction equipment to be certified includes any equipment of the types listed in Table xx brought on-site.

This equipment shall be re-tested every 6 months while in use on-site. Any equipment used during construction may be subject to confirmatory noise level testing by the contractor at the request of the Engineer.

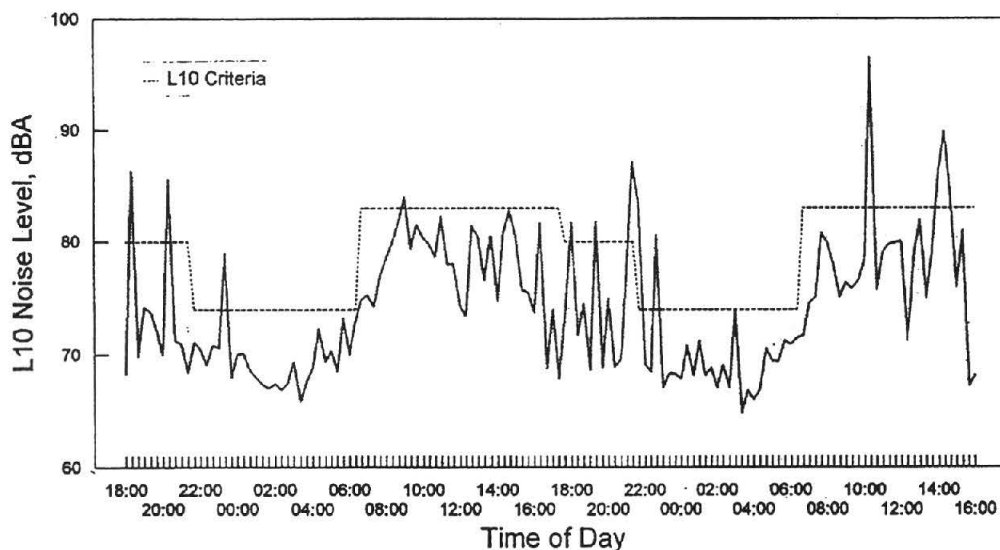

FIGURE 25 Noise monitoring record.

All engine-powered equipment shall be operated at high idle (maximum governed rpm) under full-load condition during the test.

- Noise complaint investigation and resolution procedures—the objective is to ensure that public and agency complaints are addressed and resolved consistently and expeditiously. A quick response is important because the conditions that cause a complaint may quickly change. When a complaint occurs, use the information gathered to establish a preventive strategy, this will avoid a repeating cycle of complaint/response.

- Certification—shop drawings of mitigation measures such as noise barriers or curtain systems should be stamped by a Professional Engineer.

- Qualifications of the acoustical engineer—a listing of acoustical engineers can be obtained from either the National Council of Acoustical Consultants, 66 Morris Avenue, Suite 1B, Springfield, NJ 07081-1409, (201) 564-5859 or the Acoustical Society of America, 335 East 45th Street, New York, NY 10017-3483, (516) 576-2360.

Example Specifications: Bachelor of Science or higher degree from a qualified program in engineering, physics, or architecture offered by an accredited university or college, and five years experience in noise control engineering and construction noise analysis.

NOISE ABATEMENT: A CASE STUDY

An Arizona project completed in the early 1980s illustrates a very practical approach to mitigation of nighttime

construction noise (39). On a previous urban-interstate rehab project neighbors had taken their complaints ultimately to the Governor's office. In fact the neighboring residents were so incensed that the Arizona Department of Transportation (ADOT) continued to receive inquiries from the complainants after project completion. As a result, ADOT sought to incorporate more stringent noise-level limits in the specifications of subsequent projects involving urban nighttime work.

The tightened specification caused contractors to threaten a boycott of the work. In the process of reconciling the concerns of the contractors and still allowing ADOT to be responsive to the public's concerns, a monetary noise reduction incentive was offered in later contracts. These contracts offered a sliding scale of incentives based on noise reductions between an upper limit of 86 and a minimum of 75-dBA. All sound measurements being at a distance of 50 ft. The incentive payments were made for each pay period of the work based on the sound measurements during the period. The specifications stated that any equipment producing noise at levels exceeding the 86 dB limit would be shut down until repaired or modified. ADOT, however, was careful not to use the specifications to suggest abatement measures.

ADOT considered these projects a success because the noise level was reduced to 82 dBA and the contractor reported that the incentive payments covered the cost of retrofitting the equipment with modified exhaust mufflers and better shrouding. The same equipment had been used on a previous job in Georgia where the noise was measured at 95 dBA and greater.

LIGHTING

Lighting of the work area is important for both quality and safety. Yet temporary lighting and flashing safety lights associated with nighttime highway work can create nuisance problems. The central issue is adequate illumination of the work area without simultaneously creating intolerable glare. Excessive light glare can be hazardous for motorists and annoying to nearby residences. Very little research has been done on the proper lighting of construction sites (40) and decisions pertaining to work zone lighting are usually left to the discretion of the site engineer or contractor. In the late 1960s and early 1970s there was some research proposing the use of polarized light for vehicle headlamps to reduce glare but the literature review found no references addressing construction lighting glare.

The primary requirement for highway construction lighting is that it facilitates the performance of construction related visual tasks in the work zone. Twenty-three of the state transportation departments surveyed said construction lighting was a problem. But in most cases the issue was not lighting as a nuisance but how to provide sufficient lighting. Specific comments included such statements as: “It is hard to get sufficient lighting.” or “In paving artificial light is not conducive to good quality work.” Correct lighting should enable a crew to observe and effectively control various equipment and processes.

While sufficient contrast is necessary to achieve prominence, excessive contrast or brightness within the immediate surroundings can be glaring and uncomfortable, and even hazardous to the driving public. Six Departments specifically called attention to the issue of construction lighting “blinding” or “distracting” passing motorists. High brightness, such as from head-on views of lamps can be annoying or temporarily “blinding.” Additionally four Departments reported experiencing complaints from project neighbors about lights shining into residences.

GLARE

The technical literature defines glare as the presence within the human visual field of very brightly illuminated areas that degrade visual performance. There are two forms of disabling glare—veiling glare and spot glare. Veiling glare is a decline in target detection as a result of light extraneous to the light emanating from the target entering the visual system and reducing the contrast ratio between

target and the surrounding environment. Spot glare is a different phenomenon. Spot glare occurs when illumination sources reduce the sensitivity of a specific portion of the retina causing a temporary inability to sense a target should one appear at that spot.

Veiling glare is the sum of all illumination within view—streetlights, specular reflections, construction lighting, etc. All of the illumination sources can cumulate to create a very bright background against which or “through” which an observer must peer to distinguish targets. When the observer is a motor vehicle operator traversing a roadway lane adjacent to the illuminated construction site the degraded visual performance results in diminished driving performance. The effect of bright illumination glare is influenced by the age of the observer. Therefore “allowable levels” must consider the percentage of elderly drivers that will be using the roadway.

Spot glare is the experience of looking directly at an intense illumination source and then being unable to see a dark target even when looking directly at it. The amount of visual degradation produced by a glare source increases rapidly as the angle between the light and the line of sight decreases. That fact is the critical element to remember when designing construction site illumination.

REQUIRED ILLUMINATION AND GLARE CONTROL

Standard highway lighting or illumination from abutters is generally inadequate to properly light the area where the work will be performed. Therefore, it is good practice to require a lighting plan for all operation that will be performed during non-daylight hours. The plan should cover achievement of necessary illumination levels and nuisance control. In some circumstances the department might want to require by contract the number, position and intensity of project lights. Achieving necessary illumination levels was mentioned in the surveys as being as much of a problem as mitigating the nuisances of glare and generator noise. New Jersey has proposed minimum illumination requirements tied to the type of construction operation. The specification set a minimum illumination level of 5 foot-candles for operations such as earthwork and asphalt paving, and 10 foot-candles for structural work and concrete paving. With paving operations, artificial light is not as conducive to quality work as natural light, therefore it



FIGURE 26 Aim construction lighting fixtures down when possible.

is very important that minimum illumination levels are maintained. Price suggested a 30- to 40-foot-candles level as necessary for tasks such as crack filling (43). These foot-candle levels are in line with the NCHRP Project 5-13 recommendations except for Prices' 30- to 40 foot-candle level which is much higher than the report's 20 foot-candle recommendation for such work. Things that should be addressed in the plan and checked when operations begin in the field include:

- Are lights mounted properly on construction equipment?
- Are lights mounted to allow for aiming and positioning to reduce glare?
- Can light towers be easily moved to keep pace with operations?
- Is the lighting illumination free from shadows or glare?

Example Specifications: Glare Control—All lighting provided under this item shall be designed, installed, and operated to avoid glare that interferes with traffic on the roadway or that causes annoyance or discomfort for residences adjoining the roadway. The contractor shall locate, aim, and adjust the lighting fixtures to provide the required level of illumination and uniformity in the work area without the creation of objectionable glare. The engineer shall be the sole judge of when glare is unacceptable, either for traffic or for adjoining residences. The contractor shall provide screening such as shields, visors or louvers on lights as necessary to reduce objectionable levels of glare.

It should be remembered that portable systems are often provided on a rental basis and they often provide more

lighting than is desired, creating a glare hazard. Additionally, equipment-mounted lighting systems generally are not engineered to provide predetermined task-specific lighting levels (44).

Simply ensuring that field personnel had an awareness of the problem can eliminate many lighting nuisances. Project personnel must pay close attention to where lights are located and the direction of aim. In open areas, position luminaries at the highest practical locations to minimize glare. High lights solve many problems. Aim fixtures down, when possible (Figure 26). The required use of hydraulic generators on equipment will minimize noise pollution. Good awareness training of the contractor's work force and the inspectors is important. This is particularly important for projects in residential areas because both the extra lighting and the extra traffic can cause problems.

HIGHWAY CONSTRUCTION LIGHTING DESIGN

Illumination guidelines for nighttime highway construction work were developed under NCHRP Project 5-13. Those guidelines address visibility requirements, lighting equipment, lighting design, lighting configuration and arrangement, and lighting system economic considerations. In the study, three illumination categories are proposed:

- Category I is recommended for general illumination in the work zone and for areas where crew movement takes place, minimum illumination is 54 lux (5 foot-candles).
- Category II is recommended for illumination on and around construction equipment, minimum illumination is 108 lux (10 foot-candles).

TABLE 10
LAMP CHARACTERISTICS AND APPLICATIONS (42)

Light Source	Lumen Output per Lamp	Efficiency (Lumens per watt)	Color Adaptability	Degree of Light Control	Recommended Application
Incandescent Tungsten Halogen	Fair	Low (24)	High (Daylight White)	High	Task oriented lighting Equipment mounted lights Small areas Low mounting heights Not recommended
Mercury Vapor	Good	Fair (63)	Fair to Good (Medium White)	Fair	
Metal Halide	High	Good (110)	Good (Bright White)	Good	Medium sized areas Good color rendition required Varied mounting heights
High Pressure Sodium	High	High (140)	Fair (Soft Orange)	Good	Large areas Color rendition not important Varied mounting heights
Fluorescent	Low	Fair to good (85)	Fair to High (Daylight White)	Fair	Not recommended

- Category III is recommended for tasks that require increased attention, minimum illumination is 216 lux (20 foot-candles).

The study's lighting design procedure relies on the amount of light flux reaching the work surfaces and light uniformity on that surface. The procedure includes the following steps (44):

1. Assess the work zone to be illuminated.

2. Select the type of light source. Table 10, which is taken from the study, provides information about specific lighting lamp characteristics and applications.
3. Determine recommended lighting levels.
4. Select lighting fixture locations.
5. Determine luminaire wattage.
6. Select luminaire and aiming points.
7. Check design for adequacy and glare.

This process is discussed in detail with an illustrative example in the project's final report (45).

DUST

During the night many households leave their windows open to take advantage of the cool night air. With urban nighttime construction projects being very close to people's living space, dust can be a problem. The problem is accentuated by the nighttime construction lighting, which makes the particulate matter very visible. If it is believed that fugitive dust will be generated by construction operations, the contract specifications should require that the contractor prepare a dust control plan. In many cases this is not a problem limited to nighttime activities, therefore air quality/dust control plans must be for all hours of the day or night. Specific subjects that the plan should address include:

- Earthwork—watering, prewet sites.
- Disturbed surface areas—watering, chemical stabilizers, wind fences, wind screens, berms, stabilization with vegetation or gravel.
- Open storage stockpiles—watering, chemical stabilizers, wind fences, wind screens, berms, coverings, enclosures.
- Unpaved roads—watering, chemical stabilizers, stabilization with gravel, restrict vehicle speed.
- Paved road trackout—limit or restrict access, stabilized, gravel or paved construction entrance pad; wheel wash station; vacuum/wet-broom public roadway.
- Hauling—maintain minimum freeboard, tarp.
- Demolition—watering, prewetting.
- Work limits during high winds—cease work temporarily on hot dry nights or for certain wind directions.

WATERING OR DUST SUPPRESSANTS

Watering is usually the easiest and most common method of controlling work site dust. In the case of a constantly changing ground contour, as during grading operations, watering is the most practical dust control method however, it does require a constant effort. In arid and semi-arid areas it can sometimes be very difficult to supply sufficient water, therefore, dust suppressants should be considered for use in areas that are not subject to constant grading changes.

Spray-on dust suppressants are available for all types of applications. There are fiber-reinforced, cement-based products that are sprayed over the ground and form a protective shell that reduces the dust nuisance. A machine

similar to a hydroseeder is used to apply these suppressants. The product costs from \$0.02–\$0.07 per square foot depending on site location and conditions. Application costs are about \$0.01 per square foot.

These shell-forming products are longer lasting in a hot dry climate. In a cold moist environment the shell's effective life will be reduced. Suppressants are not designed to be driven on but they can be walked on without any destruction of the shell. The shell can last up to 2 years if it is not driven over and the conditions are favorable. When these products disintegrate they simply turn to dirt and become part of the soil.

Example Specifications: Wet suppression shall be used to provide temporary control of dust.

Calcium chloride shall be used to control dust instead of wet suppression when freezing conditions exist.

Dust suppression wetting agents shall be water soluble, non-toxic, non-reactive, non-volatile, and non-foaming.

BARRIERS, SCREENS, AND COVERS

In the case of stockpiles, water is not usually a practical solution for controlling dust because of the need to constantly keep wetting. Suppressants usually work well if the stockpile is not being worked. If the stockpile is being constructed or excavated then barriers, screens and/or covers can provide good dust control. Stockpiles protected by plastic tarp covers that are secured with sandbags or other equivalent methods to prevent the cover from being dislodged by the wind is another good technique in some cases.

Example Specifications: Windscreens shall be durable fabric mesh of 50 percent porosity, attached to construction fence.

Wind barriers shall be solid wood fences, solid durable fabric attached to construction fence, or other solid barriers intended to block the passage of wind.



FIGURE 27 Urban project egress point wheel wash station.



FIGURE 28 Dump site wheel wash station.

PUBLIC ROADWAY DUST CONTROL

Control of dirt on public roadways usually requires a multiple attack strategy. The first point of attack is attention to overloading of trucks. No material should be allowed above the free board space of the cargo body. This will prevent part of the load from falling onto the roadway.

The second step is limited and well-constructed egress points. These points should either be paved or constructed of 1½-in. diameter crushed stone 4 to 6 in. deep. In the case of operations through mud, the egress point may have

to include a wash station (Figure 27). Egress control and wash stations are needed at both the loading point location and at the stockpile or dump points (Figure 28).

The third step is constant attention to cleaning the roadway. This will require as a minimum a laborer and in the case of major hauling operations, a street sweeper (Figure 29). The street sweeper should be the vacuum/wet-broom type. These are more effective in getting small particles off the roadway. There was a noise issue with older models but the new models meet noise standards or have noise mitigation packages available.



FIGURE 29 Vacuum/wet-broom street sweeper.

Example Specifications: Vehicles leaving the construction site shall have no mud and dirt on the vehicle body or wheels. Temporary wheel-wash stations shall be provided and water from the wheel-wash stations shall be controlled.

Haul truck cargo areas shall be securely covered during material transport on public roadways.

The Contractor is responsible for daily clean up of public roadways and walkways affected by work of this Contract. A wet power vacuum street sweeper shall be used on paved roadways. Dry power sweeping is prohibited.

DEMOLITION

In the case of building demolition, spraying the work area with water from hoses is the most common approach. Hoe-rams equipped with water jets provide a fine mist directly at the point of assault. Windscreens can also provide some control. Roadway structure demolition is similar to building work, thus water hose spraying and water jet hoe-rams are very beneficial. In the case of bridge structures having large surface areas, control of work times is important. The resident engineer should be able to stop the work if meteorological conditions are conducive to the spreading of airborne dust emissions. Particular potential problems are hot and dry weather, high winds, and winds from certain directions.

VIBRATION

Construction activities can cause varying degrees of vibration that spread through the ground. Though the vibrations diminish in strength with distance from the source, they can be heard and felt in buildings very close to the work site. Rarely do these vibrations reach levels that cause damage to structures but the issue of vibration problems is very controversial. The case of old, fragile, or historical buildings is a possible exception where special care must be exercised in controlling vibrations because there is a danger of significant structural damage. Therefore, the issue of vibration can cause restraints on the construction method and lead to additional project cost and time (44). Determining "acceptable" vibration levels is often problematic because of its subjective nature with regard to being a nuisance. Humans and animals are very sensitive to vibration, especially in the low frequency range (1–100 Hz).

It is the unpredictability and unusual nature of a vibration source, rather than the level itself that is likely to result in complaints. The effect of intrusion tends to be psychological rather than physiological, and is more of a problem at night, when occupants of buildings expect no unusual disturbance from external sources (45).

VIBRATION SOURCES AND STRENGTH LEVELS

Vibrations from construction work are normally the result of blasting, impact pile driving, demolition, drilling or the use of vibratory rollers. Construction vibrations are generally assessed in terms of peak particle velocity (PPV). Peak particle-velocity vibration information, based on measured data (44, 46–48) for construction equipment and operations has been published, Table 11 (4). The information in Table 11 is average source levels under a wide variety of construction activities. Resulting PPV can provide a measure of the damage potential of the vibrations.

Barry New reports that when vibration levels from an "unusual source" exceed the human threshold of perception (PPV, 0.008–0.012 inches/sec) complaints may occur. In an urban situation, serious complaints are probable when PPV exceeds 0.12 inches/sec (45) even though these levels are much less than what would result from slamming a door in a modern masonry building. He goes on to state that people's tolerance will be improved provided that the origin of the vibrations is known in advance and

no damage results. It is also important to provide people with a good motivation to accept some temporary disturbance (49).

TABLE 11
VIBRATION LEVELS FOR CONSTRUCTION EQUIPMENT AND OPERATIONS (4)

Equipment		PPV at 25 ft (in./sec)
Pile Driver (impact)	upper range	1.518
	typical	0.644
Pile Driver (sonic)	upper range	0.734
	typical	0.170
Clam shovel drop (slurry wall)		0.202
Hydromill (slurry wall)	in soil	0.008
	in rock	0.017
Large bulldozer		0.089
Caisson drilling		0.089
Loaded trucks		0.076
Jackhammer		0.035
Small bulldozer		0.003

TABLE 12
HUMAN RESPONSE TO MOTION (50)

Response of Humans	Earthquakes (in./sec)	Blasting (in./sec)
Barely perceptible	0.26–0.80	0.01–0.10
Distinctly perceptible	0.46–1.40	0.05–0.50
Strongly perceptible	1.50–5.70	0.50–5.00

Oriard (50) has published similar information and for comparison purposes created a matrix of human response in relation to both blasting and earthquake motion, Table 12. It is interesting to note that humans are more sensitive to blasting motion than that of earthquakes.

Oriard has also published the results of studies comparing the stresses impose on structures by typical environmental changes and equivalent particle velocities (50). Some of that information is presented in Figure 30. A 19 percent change in inside humidity imposes a stress equivalent to about a 2.8 in/sec particle velocity. A 35 percent change in outside humidity imposes a stress equivalent to almost a 5.0 in/sec particle velocity. A 12° F change in inside temperature imposes a stress equivalent to about a 3.3 in/sec particle velocity. A 27° F change in inside temperature imposes a stress equivalent to almost an 8

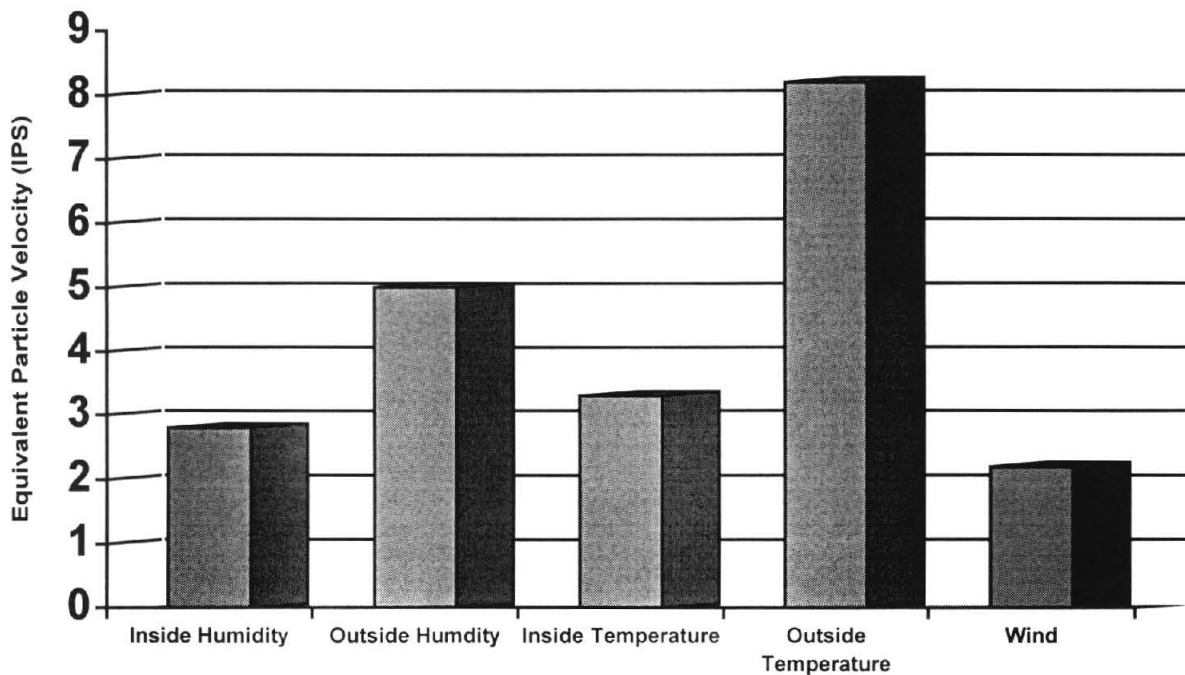

FIGURE 30 Typical environmental stresses compared to equivalent ground vibrations (52,53).

in/sec particle velocity and a 23 mph wind differential imposes a stress equivalent to about a 2.2 in/sec particle velocity. Typical construction blasting creates particle velocities of less than 0.5 in/sec and upper range pile driving caused velocities are about 1.5 in/sec.

It must be remembered that people can perceive very low levels of vibration, and that they are unaware of the silent environmental forces acting on and causing damage to their properties. So even though construction activities actually cause movements significantly less than those created by common natural occurrences, the perceived impact by humans can cause public concern.

CONSTRUCTION VIBRATION MITIGATION

The mitigation techniques for reducing vibration impacts are similar to those used to reduce noise nuisances. The series of questions that should be addressed concerning vibration effects are:

1. Will vibrations be caused?
2. Are sensitive people or structures in the vicinity?
3. Is damage/intrusion possible?
4. Can site specific trials be conducted to assess possible damage/intrusion?
5. Modify design and/or construction method if the answer is yes to number three.

Answering these questions requires a clear understanding of construction equipment location and construction processes in relation to critical receptors.

Contract specifications to control vibration typically impose a limiting value for vibration. This is usually in terms of a resultant PPV at a specified distance or a critical structure. It should be recognized that specifying such a criterion results in shared risk by the transportation department and the contractor.

Establishing limitations on blasting and pile driving is another solution employed. Specific actions that have been employed to limit vibration disturbances are outlined below.

Project Layout and Access

- Route heavily loaded trucks away from residential streets. Establish designated haul routes so that the fewest possible homes are affected.
- Place operating equipment on the construction site as far as possible from vibration-sensitive receptors.

Sequence of Operations

- Phase demolition, earthmoving and ground-impacting operations so as not to occur in the same time period. Unlike noise, the total vibration level produced can be significantly less when each vibration source operates separately.

- Avoid vibration-causing activities at night. People are more aware of vibration in their homes during nighttime hours.

Alternative Construction Methods

- Avoid impact pile driving where possible in vibration-sensitive areas. Drilled piles or the use of a sonic or vibratory pile driver causes lower vibration levels where the geological conditions permit their use. Cautionary note:

Sonic pile drivers may provide substantial reduction of vibration levels. However, there are some additional vibration effects of sonic pile drivers that may limit their use in sensitive locations. A sonic pile driver operates by continuously shaking the pile at a fixed frequency, literally vibrating it into the ground. Vibratory pile drivers operate on the same principle, but at a different frequency. However, continuous operation at a fixed frequency may be more noticeable to nearby residents, even at lower vibration levels. Furthermore, the steady-state excitation of the ground may increase resonance response of building components. Resonant response may be unacceptable in cases of fragile historical buildings or vibration-sensitive manufacturing processes. Impact pile drivers, on the other hand, produce a high vibration level for a short time (0.2 seconds) with sufficient time between impacts to allow any resonant response to decay (4).

- Select demolition methods not involving impact (saw bridge decks into sections for removal).
- Avoid using vibratory rollers and tampers near sensitive areas.

PILE DRIVING VIBRATION EFFECTS

With careful planning and execution of pile driving operations, actual physical damage from vibrations can be avoided. However, it is also necessary to accommodate the

most sensitive neighbor if damage *claims* are to be avoided. Vibrations present a two-pronged hazard; first, the potential for real damage due to the activity, and second, potential for litigation based on human perception. Experience has shown that direct damage to structures is not likely to occur at a distance from the driven pile of (a) more than 50 ft. for piles 50 feet or less in length, or (b) one pile length for piles longer than 50 feet (52). Vibration-generated settlement can be a problem at much greater distances. Extreme cases may demand caution out as far as 1,300 feet.

A zone of influence distance has typically been developed based on distance to attenuate the ground motion to a level of 2 inches/sec. But this criterion considered only structural damage effects. If the goal is to mitigate complaints even from simply noticeable vibrations the zone of concern may need to be expanded out as far as 1,300 feet. Neighbors within this radius should be surveyed and warned. Vibration amplitudes as small as 1×10^{-6} inches can cause damage to very sensitive equipment such as electron microscopes and the Florida DOT reported having to move a doctor who was performing laser surgery. Sites must therefore be screened to determine the existence of sensitive functions including research laboratories, clinics, and hospitals.

The principal means of mitigating vibration problems, as reported by state DOTs, pile driving contractors, and engineering consultants in the NCHRP Synthesis 253, *Dynamic Effects of Pile Installations on Adjacent Structures* (52) were:

- Changing the pile driving equipment,
- Switching to drilled shaft piles,
- Jetting or partial jetting of piles into place,
- Switching to vibratory driving, and
- Scheduling pile driving to specially selected hours for the specific site to minimize the disturbance to the neighborhood.

All pile driving should be performed under a vibration specification. An example specification containing many appropriate provisions is included in Synthesis 253 or can be found in Dowding's *Construction Vibrations* (53).

COMMUNITY AWARENESS

The public does not always understand or appreciate the need for nighttime construction work; therefore, community awareness is a vital part of the total nuisance mitigation endeavor. It is important to maintain positive community relations in unison with actual construction nuisance abatement measures. Public involvement creates a bond of trust and helps to eliminate potential problems before they become major issues. To be successful community awareness efforts must be championed by top management, be integrated into the project development process and continue during the construction phase.

A variety of methods are available to agencies to disseminate information about project duration, type of work, and the benefits of the work. Table 13 delineates commonly used methods and an associated ranking of effectiveness from a study by Shepard and Cottrell (54). Their rankings are based on a survey of 211 state, city and county agencies. They found that the most common medium of communication was the newspaper, followed by the radio and television. However, special signs and door-to-door contacts were ranked as the most effective means of communicating the information.

TABLE 13
COMMUNITY AWARENESS TECHNIQUES AND
REPORTED EFFECTIVENESS (49)

Technique	Effectiveness (1 = most effective)
Special signs	1
Personal Contact	
Door-to-door	2
Special gathering	5
Special mailings	
Personalized letter	3
Occupant form letter/memo	7
Registered notice	9
Press Releases	
Radio	4
Newspaper	6
Television	8

DURING THE PLANNING PROCESS

Possible nuisances should be identified and addressed when working with local governments and neighbors. Additionally, the public should be given the opportunity to provide timely input. It may even be good business to conduct public hearings. These can be important to ensure that the public is informed, to receive feedback and to

provide early identification of controversial issues. The objective is to notify local governments, and affected businesses and residents. It is imperative that the details of the proposed construction phasing and methods, and the resulting noise, vibrations, and other nuisances be explained. Steps to minimize impacts should likewise be clearly stated.

Examples

The DOT is planning to improve the culvert on Highway 67. This project will be advertised with alternative methods of construction. One method will be open-cut construction. The open-cut method will require a number of noise variance nights. The second method of construction will be pipe ramming. Pipe ramming is a trenchless technology method that does not disturb traffic movements but will require a number of noise variance nights. The time of completion and number of noise variance nights required will depend on the contractor's method. The selection of the method of construction and subsequently the noise variance required will be based on the Contractor with the lowest bid.

The DOT is proposing to rehabilitate the bridges on Highway 95 within the City of Good Friends. During the rehabilitation work, each bridge will be closed. In order to reduce the traffic impacts, the contractor will work double shifts for all work but the cleaning and painting. The contractor will be required to work 24 hours a day 7 days a week during the bridge cleaning and painting. Equipment to be used may include, but is not limited to:

Diesel air compressor

Diesel generators

Hydraulic cranes

Vacuum recovery systems for cleaning and painting.

While noise is usually the primary cause of nuisance complaints, visual impacts draw attention to the construction process. Big trucks using residential streets for project access create noise, but they also draw attention to the work. It is important to consider such impacts and to include appropriate restrictions in contract documents. When working close to businesses and specifying sound barriers it may be necessary to include requirements concerning exterior appearance. Such project-specific specifications will reduce

nuisance complaints and help to avoid costly change orders that severe complaints can occasion.

SUCCESSFUL IMPLEMENTATION

The key to successful implementation is good communication. Educate the public about:

- Positive impacts of the completed project (highlight improvements),
- Exactly what to expect; work hours, type of work, type of equipment and the expected nuisance duration,
- Where to get more information,
- How to voice complaints.

It is important to provide accurate and easily accessible information. Depending on the size and scope of the project, any or all of the following methods can be used to inform the public or to ensure that adjacent impacted neighbors are informed:

- Door-to-door visits
- Neighborhood letters or fact sheets
- Local media, newspaper notices, press releases, news conferences
- Public informational workshops
- Information kiosks in public areas (shopping malls)
- Speakers bureau
- Brochures/newsletters.

The second part of successful implementation is listening and sensitivity to concerns. A significant portion of the listening and response effort will be simply to answer questions. It will not result in any changes in the project's design or construction operations. Listening and sensitivity create and strengthen a bond of trust with affected individuals.

There will, however, always be some individuals with complaints. There should be an established procedure for receiving, tracking, and ensuring a timely response to all complaints. Procedures that help in handling complaints include:

- Having a knowledgeable individual to field all questions,
- Establish a hotline to handle queries,
- Develop a system to ensure all queries are answered in a timely manner,
- Anticipating potential impacts.

Department inspectors are required in some areas to have a portable telephone on the job site at all times during nighttime construction activities. This ensures quick response to citizen inquiries and complaints. In the case of a major project inquiries can be processed through a central control center, which then notifies the correct inspector. But for small jobs, the inspector's number should be posted and circulated in the abutting neighborhood.

CONCLUSIONS

Widening and rehabilitation work will constitute a significant number of the projects departments of transportation build in the future and many of these projects will be in urban locations where daylight highway construction closures cause unacceptable congestion problems. Consequently, the construction of a significant number of these future projects will take place at night. Therefore, it is important that before contracts are advertised and bid, an objective assessment is made of the magnitude of nighttime construction nuisances. The major nuisances associated with the nighttime construction are noise, vibrations, and lights. Noise problems are normally caused by the operation of heavy equipment and specifically by machine backup-alarms. Identifying methods and techniques for mitigating such nuisances is a critical requirement for serving the traveling public, for conducting DOT business in a responsible manner, and for preparing valid contract documents.

Twenty-seven state DOTs reported that they are already experiencing serious nighttime construction nuisance problems. They usually qualified their problems with a statement that the problems are “site specific.” For that reason it is obvious that the first step in a pro-active approach to mitigation of nighttime construction nuisances is an assessment of the critical receptors that will be impacted. The level of detail of the assessment depends on the scale and type of project. In the case of a major project where the construction duration will be more than a few months and the work will take place near sensitive receptors, the assessment must be conducted in considerable detail.

When queried regarding the generators of the nuisances, many of the responses were very similar. Back-up alarms and slamming tailgates were the most frequent answers. Demolition equipment used in pavement breaking and bridge deck removal was another frequent problem generator. Therefore, it is obvious that particular attention should be paid to projects that will require a large fleet of haul trucks operating at night. In the case of such projects, back-up alarms should be the least intrusive ambient-sensitive type or the contractor should use a back-up observer and it may be necessary to establish truck clean-out staging areas for mitigation of banging tailgates.

COMMUNITY AWARENESS

Community awareness is a vital part of the total nuisance mitigation endeavor. It is important to maintain positive

community relations in unison with actual construction nuisance mitigation measures. Public involvement helps to eliminate potential problems before they become major issues. Personal contact is the best first step in a community awareness program. The next step should be a personal letter to all affected neighbors. All modes of disseminating information should clearly present the following particulars:

- Identify the work activity and location.
- Identify the crew work hours, and the duration of the activity.
- Explain what to expect—sounds, lights and equipment and include a statement of concern about the nuisances, making it clear that every effort is being made to reduce impacts.
- Provide a point of contact for obtaining more information.

NUISANCE MITIGATION

The community is concerned about the overall impact resulting from the construction site. It is important to assess the background conditions of a project site and to realize the differences in background conditions that exist at night. The project design must allow the contractor a means to accomplish the work while conforming to a desired impact level at the receiver. Mitigation of nuisances should consider source, path, and receptor controls, in that order.

Source Controls

Source control is the most effective method of eliminating nuisances. Source controls, which limit noise, vibration, light and dust emissions are the easiest to oversee on a construction project. Source mitigation reduces the problem everywhere, not just along a single path or for one receiver. Consequently, a project’s mitigation strategy should emphasize control at the source. The techniques for source control are:

- Require construction operations planning,
- Require modern equipment,
- Ensure proper maintenance,
- Equipment restrictions,
- Operate equipment at minimum power,
- Operational or time constraints,
- Control traffic patterns,

- Use quieter alternate methods, and
- Use quieter alternate equipment.

Path Controls

Source controls may be insufficient in adequately minimizing impacts on sensitive abutters. Thus, having exhausted all possible mitigation methods of controlling nuisances at the source, the second line of attack is controlling its radiation—path control. Barriers can provide a substantial reduction in the nuisance effect in some cases. The use of barriers should be examined against other possible measures to prove that they are cost effective. Further, aesthetic effects must be considered when designing barrier systems. Path control measures include:

- Move equipment farther away from the receiver,
- Enclose especially noisy activities or stationary equipment,
- Erect noise barriers or curtains, and
- Use landscaping as a shield and dissipater.

Receptor Controls

When all other approaches to nuisance control fail, then a program of control at the receiver should be undertaken and it should be remembered that the critical receiver may not be a human. Nuisances are a perception problem in many cases and communications can reduce negative perceptions. Often the best method to address receptor controls is not a physical system but simply communication. There may be a need for physical solutions but these are usually a solution of last resort. Receptor controls include:

- Community relations,
- Community participation,
- Window treatment program, and
- Temporary relocation.

Specifications

Highway agencies can influence the construction environment through the use of controlling specifications. A good construction specification is an effective tool in mitigating the effect of nighttime construction nuisances. The mechanisms to achieve that goal will vary from contract to contract because of area-specific conditions, the type of construction, the inherent noise reduction qualities of affected receptor structures, and the desires of the affected abutters. Supplemental standard provisions can specify mitigation measures on a contract-by-contract basis to address special local condition noise. The criteria for allowable maximum noise levels and working hours should reflect the noise sensitivity of adjacent neighbors. It might be necessary to have specific noise mitigation measures specified for certain work items. The existence and importance of nuisance control specifications should be emphasized at pre-bid and pre-construction conferences.

When the requirement to comply with all restrictions and commitments is included in the contract documents, contractors can be expected to allow for compliance in the bid price. Such an approach allows contractors to effectively plan their operations and to seek innovative solutions to the clearly identified problem. This approach will minimize potential complaints, and serve to control construction cost and delays.

REFERENCES

1. Hinze, J. W. and D. Carlisle. *An Evaluation of the Important Variables in Nighttime Construction*, Final Report TNW90-07, Transportation Northwest (TransNow), Department of Civil Engineering, University of Washington, Seattle (February 1990).
2. *Mitigation of Nighttime Construction Noise, Vibrations, and other Nuisances*, Request for Proposals, NCHRP Project 20-7, Task 94, FY'98, Transportation Research Board, Washington, D.C. (1998).
3. Miller, R.K. *Noise Control Solutions for the Construction Industry*, The Fairmont Press, Inc., Atlanta, Georgia (1980).
4. *Transit Noise and Vibration Impact Assessment*, DOT-T-95-16, by Harris Miller Miller & Hanson Inc., for U.S. Department of Transportation, Washington, D.C. (April 1995).
5. Haling, D. and H. Cohen. "Residential Noise Damage Costs Caused by Motor Vehicles," in *Transportation Research Record 1559*, Transportation Research Board, National Research Council, Washington, D.C. (1996).
6. *Transportation Noise: Federal Control and Abatement Responsibilities May Need to be Revised*, General Accounting Office, Resources, Community and Economic Development Division, Washington, D.C. (Oct. 1989).
7. *Noise Mitigation Strategies*, WA-RD 327.2, Final Technical Report, Washington State Department of Transportation (September 1993).
8. Bolt, Beranek and Newman. *NCHRP Report 173: Highway Noise Generation and Control*, Transportation Research Board, National Research Council, Washington, D.C. (1976).
9. Landberg, L. "Quiet Machines Become a Reality," *Construction Equipment*, Vol. 91, No. 1 (January 1995).
10. Diehl, D.A. "Construction Noise: I-78 Through the Watchung Reservation," in *Transportation Research Record 1176*, Transportation Research Board, National Research Council, Washington, D.C. (1988).
11. *Exterior Sound Level Measurement Procedure for Powered Mobile Construction Equipment*, SAE Recommended Practice J88a, Society of Automotive Engineers (1976).
12. *Sound Levels for Engine Powered Equipment*, SAE Standard J952b, Society of Automotive Engineers (1976).
13. Toth, W.J. *Noise Abatement Techniques for Construction Equipment*, DOT-TSC-NHTSA-79-45, for U.S. Department of Transportation, Washington, D.C. (August 1979).
14. *Central Artery/Tunnel Project Noise Control Review*, Harris Miller Miller & Hanson Inc., for Bechtel/Parsons Brinckerhoff, Boston, Massachusetts (April 1994).
15. Thalheimer, E.S. *Central Artery (I-93) / Tunnel (I-90) Project, Construction Noise Control Program and Mitigation Strategy Overview*, Bechtel/Parsons Brinckerhoff, Boston, Massachusetts (November 1997).
16. Kessler, F.M. "Cost Assessment of Construction Noise Control," *Noise and Vibration Measurement: Prediction and Mitigation*, ASCE, Proceedings of a Symposium, Denver, Colorado (1985) pp. 33-47.
17. *Noise in and Around Asphalt Plants*, Information Series #75, National Asphalt Pavement Association (NAPA), Lanham, Maryland.
18. Dowding, C.H. "Noise and Air Blast from Construction Blasting," *Noise and Vibration Measurement: Prediction and Mitigation*, ASCE, Proceedings of a Symposium, Denver, Colorado (1985) pp. 17-31.
19. Kamperman, G. *Quarry Blast Noise Study for the Institute of Environmental Quality*, Illinois Institute of Environmental Quality, Springfield, Illinois (1975).
20. Schomer, P.D. *Predicting Community Response to Blast Noise*, Technical Report E-17, U. S. Army Corps of Engineers Civil Engineering Research Laboratory, Champaign-Urbana, Illinois (1973).
21. *Environmental Protection: Planning in the Noise Environment*, TM 5-803-2, Department of the Air Force, the Army and the Navy, Washington, D.C. (June 1978).
22. *Construction Manual*, Arizona Department of Transportation, Intermodal Transportation Division Construction Group, Phoenix, Arizona (October 1997).
23. Harris, A.S. "The Noise Mitigation Plan for Stapleton Airport," *Noise and Vibration Measurement: Prediction and Mitigation*, ASCE, Proceedings of a Symposium Denver, Colorado (1985) pp. 68-75.
24. "Keep IT Down!" *The Wall Street Journal*, Vol. CXXXIX, No. 53 (15 September 1998), p. A1.
25. <http://www.umweltbundesamt.de/uba-info-daten-e/daten-e/compensation-for-road-traffic-noise.htm>, (July 1998).
26. Bowlby, W. and L.F. Cohn. "Prediction of Highway Construction Noise Levels," *Noise and Vibration Measurement: Prediction and Mitigation*, ASCE, Proceedings of a Symposium, Denver, Colorado (1985) pp. 1-16.
27. Anderson, G.S. "Highway Noise: FHWA Requirements and Barrier Design," *Noise and Vibration Measurement: Prediction and Mitigation*, ASCE, Proceedings of a Symposium, Denver, Colorado (1985).
28. *Guide on Evaluation and Abatement of Traffic Noise 1993*, prepared by the AASHTO Highway Subcommittee on Design, Task Force for Environmental Design, American Association of State Highway and Transportation Officials, Washington, D.C. (1993).

29. Webb, J.D. editor. *Noise Control in Industry*, Sound Research Laboratories Limited, Holbrook Hall Sudbury Suffolk, Great Britain (1976).
30. <http://www.cpwr.com/haznoise.html> (September 1998).
31. Farnham, J. and E. Beimborn. "Techniques for Aesthetic Design of Freeway Noise Barriers," in *Transportation Research Record 1312*, Transportation Research Board, National Research Council, Washington, D.C. (1991).
32. Watkins, L.H. *Environmental Impacts of Roads and Traffic*, Applied Science Publishers, London, Great Britain (1981).
33. Pelton, H.K. *Noise Control Management*, Van Nostrand Reinhold, New York, New York (1993).
34. Barrett, D.E. "Traffic-Noise Impact Study for Least Bell's Vireo Habitat Along California State Route 83," in *Transportation Research Record 1559*, Transportation Research Board, National Research Council, Washington, D.C. (1996).
35. Menge, C.W. "Highway Noise Barriers: Sloped Barriers as an Alternative to Absorptive Barriers," *Noise Control Engineering*, Vol. 14, No. 74, March–April (1980).
36. Cowan, J.P. *Handbook of Environmental Acoustics*, Van Nostrand Reinhold, New York, New York (1994).
37. *An Evaluation of Laboratory Test Results for the U. S. Gypsum Sight and Sound Screen System*, CERF Report: 40200, prepared by the Highway Innovative Technology Evaluation Center, Civil Engineering Research Foundation, Washington, D.C. (July 1997).
38. Bowlby, W. *NCHRP Synthesis 181: In-Service Experience with Traffic Noise Barriers*, Transportation Research Board, National Research Council, Washington, D.C. (1992).
39. Kay, G.B. "Arizona's Experience with a Construction Noise-Abatement Incentive," in *Transportation Research Record 937*, Transportation Research Board, National Research Council, Washington, D.C. (1983).
40. Ellis, R. and S. Amos. "Development of Work Zone Lighting Standards for Nighttime Highway Work," in *Transportation Research Record 1529*, Transportation Research Board, National Research Council, Washington, D.C. (1993).
41. Price, D.A. *Nighttime Paving*, Colorado Dept. of Transportation, for the Federal Highway Administration, Washington, D.C. (1985).
42. *Illumination Guidelines for Nighttime Highway Work*, NCHRP Research Results Digest 216, Transportation Research Board, National Research Council, Washington, D.C. (December 1996).
43. Ellis, R.D. and Z. Herbsman. *Illumination Guidelines for Nighttime Highway Work, NCHRP Project 5-13, Draft Report*. Transportation Research Board, National Research Council, Washington, D.C. (1999).
44. Wiss, J.F. "Damage Effects of Pile Driving Vibrations," *Highway Research Record 155*, Highway Research Board, Washington, D.C. (1967).
45. New, B.M. "Ground Vibration Caused by Construction Work," *Tunneling and Underground Space Technology*, Vol. 5, No. 3, Great Britain (1990).
46. Martin, D.J. "Ground Vibrations from Impact Pile Driving During Road Construction," Supplementary Report 544, United Kingdom Department of the Environment, Department of Transport, Transport and Road Research Laboratory (1980).
47. Wiss, J.F. "Vibrations During Construction Operations," *Journal of Construction Division*, Proceedings, American Society of Civil Engineers, Vol. 100, No. CO3, New York, New York (Sept. 1974).
48. Towers, D. A. and Y. Kimura. "Central Artery/Tunnel Project: Hydromill Vibration Testing," report prepared for Massachusetts Highway Department, Boston, Massachusetts (Feb. 1995).
49. Franzen, T. "Noise and Vibration—An Obstacle for Underground Construction?" *Tunneling and Underground Space Technology*, Vol. 5, No. 3, Great Britain (1990).
50. Oriard, L.L. "The Scale of Effects in Evaluating Vibration Damage Potential," 15th Conference on Explosives and Blasting Technique, Society of Explosive Engineers, Cleveland, Ohio (1989).
51. Siskind, D.E., Stagg, M.E., Kopp, J.W., and Dowding, C.H. "Structure Response and Damage Produced by Ground Vibration from Surface Mine Blasting," *U.S. Bureau of Mines Report of Investigation 8507*, U.S. Bureau of Mines, Washington, D.C. (1980).
52. Woods, R.D. *NCHRP Synthesis 253: Dynamic Effects of Pile Installations on Adjacent Structures*, Transportation Research Board, National Research Council, Washington, D.C. (1997).
53. Dowding, C.H., *Construction Vibrations*, Prentice-Hall, Upper Saddle River, New Jersey (1996).
54. Shepard, F.D. and B.H. Cottrell, Jr. *Benefits and Safety Impact of Night Work Zone Activities*, Virginia Highway and Transportation Research Council, for the Federal Highway Administration, Washington, D.C. (1985).
55. Doebler, J.C. and T. Brown, "Boston's Central Artery/Tunnel Project: Challenging Problems, Innovative Solutions," *Managing Engineered Construction in Expanding Global Markets, Proceeding of Construction Congress V*, ASCE (1997) pp.251–259.
56. Zuk, P. M., *EOEA #4325, Central Artery/Tunnel Project Amendment to the Project Section 61 Findings Construction-Period Noise Control Program*, letter to Trudy Cox, Secretary Environmental Affairs, Boston, Massachusetts, 15 October, 1997.

APPENDIX A

Telephone Survey of the Fifty State Departments of Transportation

State:		Date:	
Name:		Phone Number:	
Organization:		Title:	

Is noise, vibration, other nuisances a problem?	Large	Medium
	Small	Not an issue

	What are the key generators?
Noise	
Vibration	
Lighting	
Others	

	What is the impact of these nuisances on the agency?
Delays	
Claims	
Lost production	
Others	

	What are the mitigation techniques used to deal with these issues?
Noise:	
Vibration:	
Lighting:	
Dust:	
Other:	

Additional points of contact:	
Name:	Phone number:

Would you participate in a one-page fax survey?	
Yes	No

Comments
Respondents interest level:

APPENDIX B

FAX Questionnaire of Nighttime Construction Nuisances

Return Fax to: (602) 965-1769

A. This survey is for an AASHTO research project being performed by the Del E. Webb School of Construction at Arizona State University. The information will aid ASU in the development of a synthesis on the mitigation of nighttime construction nuisances for AASHTO. Thank you for your participation.

During **nighttime** construction have you had problems with:? (check all that apply)

<input type="checkbox"/>	Noise	<input type="checkbox"/>	Lighting
<input type="checkbox"/>	Vibration	<input type="checkbox"/>	Other _____

What type of Equipment generates most of the noise problems during **nighttime** construction?

(1 to 5, 1=most 5=fewest)

<input type="checkbox"/>	Earthmoving Equip	<input type="checkbox"/>	Slamming tailgates	<input type="checkbox"/>	Hoe Rams
<input type="checkbox"/>	Grinding/ Milling equip	<input type="checkbox"/>	Crushers	<input type="checkbox"/>	Other _____
<input type="checkbox"/>	Pneumatic tools (jack hammers, etc)	<input type="checkbox"/>	Back-up alarms	<input type="checkbox"/>	Other _____

What types of projects generate most of the **nighttime** nuisances? (number 1-5, 1=most 5=fewest)

<input type="checkbox"/>	Bridge deck removal	<input type="checkbox"/>	Pile driving	<input type="checkbox"/>	Other _____
<input type="checkbox"/>	Paving operations/ resurfacing	<input type="checkbox"/>	Earthmoving	<input type="checkbox"/>	Other _____
<input type="checkbox"/>	Pavement Breaking	<input type="checkbox"/>	Crushing	<input type="checkbox"/>	Other _____

What is the location of most of the problem projects?

<input type="checkbox"/>	Residential Area	<input type="checkbox"/>	Industrial Area
<input type="checkbox"/>	Commercial Area (stores, hotels)	<input type="checkbox"/>	Rural Location

Do you mitigate **nighttime** construction noise by limiting certain operations to specific time periods?

Yes No

Does your agency require that specific operations be completed at certain times in the schedule?

(ex. Permanent sound barrier walls must be completed first.) Yes No

If yes, please explain: _____

What other strategies do you use to mitigate **nighttime** construction nuisances? What provisions are written into **nighttime** construction contracts to limit the nuisances?

Back-up Alarms:
Banging tailgates:
Hoe Rams/ Other demolition equip.:
Others:

Have you received claims from contractors due to delays, lost production, etc. that are a direct result of **nighttime** construction nuisances? Yes No

If so, please list contact that could give specifics on the claim.

Name: _____ Phone Number: _____

Are your **nighttime** construction contracts affected by noise limiting ordinances enforced by local jurisdictions?

Yes No

If yes, please describe: _____

APPENDIX C

Mitigation Techniques on the Central Artery (I-93)/Tunnel (I-90) Project in Boston, Massachusetts Highway Department

Boston's Central Artery/Tunnel Project (CA/T) is the largest, most complex highway project ever undertaken in the United States. Construction in and around downtown Boston began in 1991 and is scheduled to be completed in 2004. The project alignment passes through residential and commercial sections of downtown Boston, and in some cases is as close as three feet from residential buildings. It involves an eight-to-ten lane underground expressway built directly beneath the existing six-lane elevated highway. The project is being built by the Massachusetts Highway Department, with design and construction management services provided by a joint venture of Bechtel Corp. and Parsons Brinckerhoff Quade & Douglas (B/PB). The construction contractors are working 24 hours/day on the mainline construction that comprises movement of more than 13,000,000 cu. yd. of excavation and placement of 4,000,000 cu. yd. of concrete. Key elements of the project's nuisance mitigation program include (55):

- A computer tracking system and reporting structure to ensure that all mitigation commitments made to the city are monitored and met.
- A distinctive sign and construction barrier system that helps route drivers and pedestrians through construction areas.
- A staff of community liaisons who field and help resolve resident, community, and business concerns about construction.
- A 24-hour monitoring center that maintains video surveillance of traffic and construction, and provides around-the-clock telephone access for complaints.
- An extensive proactive noise control program, coupled with specific limitations on construction operations.

NOISE CONTROL EFFORT

CA/T believes that noise accounts for 50 percent of all complaints. Because this is a design-bid-build project, the owner is taking the lead in the mitigation efforts and using the bid documents to compel contractor performance. The total project's noise program was formulated in coordination with the City of Boston and the elements are designed to be consistent with the intent of the City's noise regulations and ordinances. There are three important focus areas of the Massachusetts Highway Department's CA/T project noise control program (56):

- Documenting noise baseline conditions so that appropriate specification criteria can be developed. As an important point of note, it was found that the background noise levels at night exceeded the City's specified maximum.
- Controlling construction noise at the source.
- Developing a process to respond to and remediate noise problems as quickly as possible to reduce community impacts and to keep construction proceeding on schedule.

The project's noise control program is continually being modified and improved based on experience with the ongoing construction. An example of this is the back-up alarm requirement. New contracts being bid require the use of either manually adjustable or self-adjusting back-up alarms, both of which are quieter alarm types.

Training

An important step supporting the noise mitigation effort has been the Department's institution of noise control training for Resident Engineers and Field Engineers. The objectives of this training are:

- Knowledge of noise level limits
- Knowledge of pertinent contract specifications and submittal requirements
- Ability to identify types of equipment for which noise control measures are appropriate
- General knowledge of methods and techniques for noise control
- Ability to identify improper or missing noise control methods and knowledge to direct proper corrective methods.

Noise Limits

Generally, contractors are allowed to proceed with construction activities 24 hours per day, provided the noise impacts from construction activities do not exceed the applicable noise limits. Noise level restrictions are specified for daytime (7 a.m.–6 p.m.), evening (6 p.m.–10 p.m.) and nighttime (10 p.m.–7 a.m.). The noise specification time periods do not necessarily correspond to construction work shifts. Limits for work performed on Sundays and federal holidays are similar to the nighttime noise limits.



FIGURE C-1 Sound measurements for monitoring noise during construction.

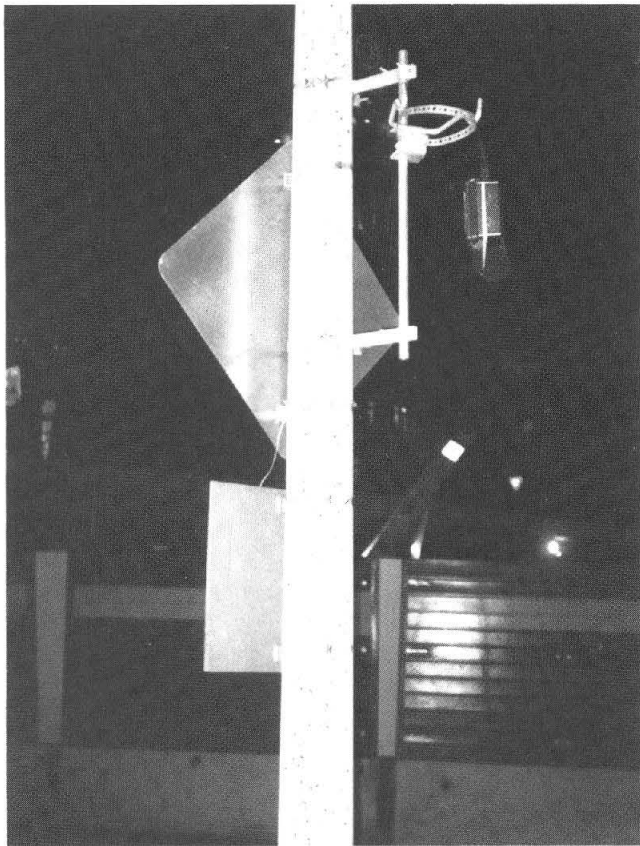

FIGURE C-2 Long-term sound recording station.

Night Noise Patrol Program

The project has established a night noise patrol program. Department personnel are provided on weeknights to patrol construction areas and assess noise control operational

performance. These patrols focus on identifying and monitoring construction activities that have the greatest potential to disturb abutters, Figure C-1.

Environmental Operations Office

The Massachusetts Highway Department (the owner), using B/PB as its agent, has established a CA/T Environmental Operations Office. The office is charged with developing the noise specification sections for the construction contracts and providing technical and field support to the project's Resident Engineers. A sample of the basic noise specification is presented in Appendix F.

In compliance with the project's environmental commitments, personnel of this office perform both short- and long-term noise monitoring for quality assurance purposes, Figure C-2. There is a 24-hour-a-day Interim Operations Control Center for the project, which receives complaints (CAT-HELP is the phone number), Figure C-3. On any given night, the center receives from zero to 12 noise complaints. The environmental office, through its B/PB field staff, investigates the legitimacy of noise complaints and recommends noise mitigation measures.

Construction Contractors

The individual construction contractors are obligated under the noise specification to have both a Noise Control Plan and a Noise Monitoring Plan. Under these plans the contractor must monitor noise prior to and during construction, must respond to community complaints, and



FIGURE C-3 Interim operations control center.

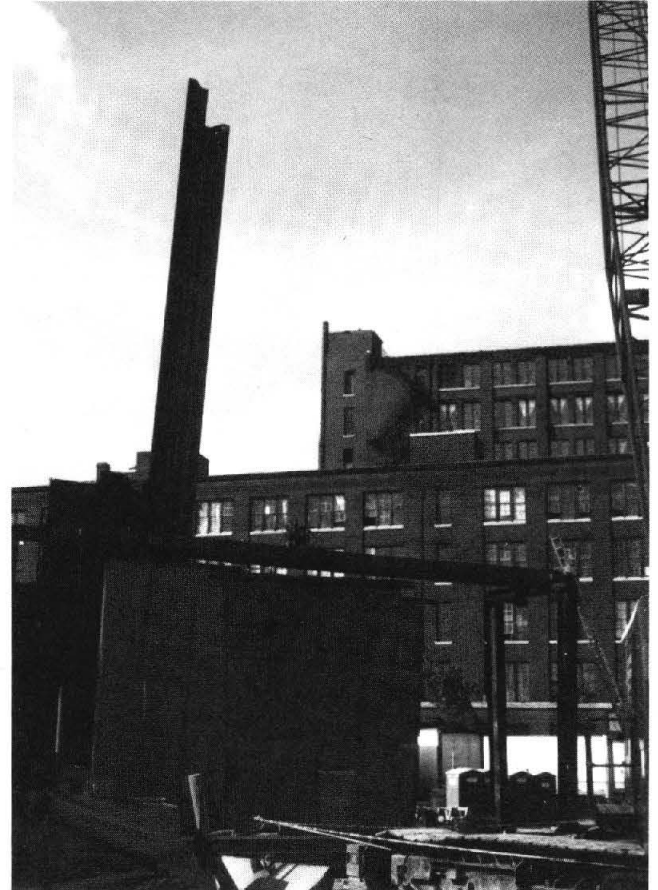

FIGURE C-4 Pile driving noise mitigation curtains.

TABLE C-1
CA/T NOISE PROGRAM COST ESTIMATE

Cost Category	Past Expense (1987–1997) (\$)	Future Cost (1998–2004) (\$)	Total Cost (\$)
Direct expenses ¹	2,522,520	2,803,840	5,326,360
Indirect expenses ²	44,500	57,500	102,000
Mitigation costs ³	2,189,650	2,539,950	4,729,600
Contractor costs ⁴	<u>1,503,179</u>	<u>3,918,771</u>	<u>5,420,660</u>
Total	6,259,849	9,318,77	15,578,620

¹Direct expenses include fully burdened cost of staff and task orders to sub-consultants.

²Indirect expenses include equipment and noise measurement instrumentation monitors.

³Mitigation costs include window treatments and prorated noise-related legal settlements.

⁴Contractor costs to fulfill requirements of the Noise Specification, 721.560.

must have on-site equipment certified. Contractually required submittals include:

- Noise control plan
- Noise monitoring plan
- Qualifications of acoustical engineer
- Baseline noise levels
- Equipment noise certification tests
- Shop drawings of mitigation measure structures (see Figure C-4, pile driving noise mitigation structure).
 - Construction noise compliance result reports
 - Investigation and resolution of noise complaint reports.

CA/T NOISE CONTROL COST

It is estimated that the overall CA/T noise control program will cost about \$15.6 million, Table C-1. This number includes: owner direct, indirect, and mitigation expenses and the contractor added construction cost. Assuming a final project cost of \$10.4 billion, the noise program represents approximately 0.15 percent of project cost. The use of detailed noise specifications, noise control technologies, mitigation measures based on location-specific need and alternative analysis, and strong communications are the program's foundation (4).

APPENDIX D

Mitigation Techniques on the I-15 Project, Utah DOT, Salt Lake City, Utah

The Interstate-15 reconstruction project in Salt Lake City encompasses work on 17 miles of metropolitan freeway to include reconstruction of 144 bridges and movement of five million cubic yards of material. Design/build contracting is being used for this project to meet the desired reconstruction schedule. The project must be completed before the 2002 Winter Olympics. To meet this schedule the contractor is working two 10-hour shifts per day.

Understanding the impact of the project on the community, the contractor, Wasatch Constructors, created a public information plan designed to provide important information to all interested parties. Information is available through

- I-15 Information hotline (phone): 1-888-INFO-I-15,
- Noise and Vibration hotline (phone),
- Environmental hotline (phone),
- Mass media,

- Printed materials,
- I-15 project Web site, and
- Highway advisory radio.

Over the course of the first year of the project the highway advisory radio has been used only to a very limited extent. In contrast, the Internet web page received over 1,000,000 hits during the first 13 months of the project, <http://www.I-15.com/>, Figure D-1.

PHONE HOTLINES

The contractor maintains three phone hotlines. The I-15 Information Hotline 1-888-INFO-I-15 was established when construction began. This phone line provides construction road closure information broken down by geographical area. It is basically a recording that provides information. However, there is an option that allows the

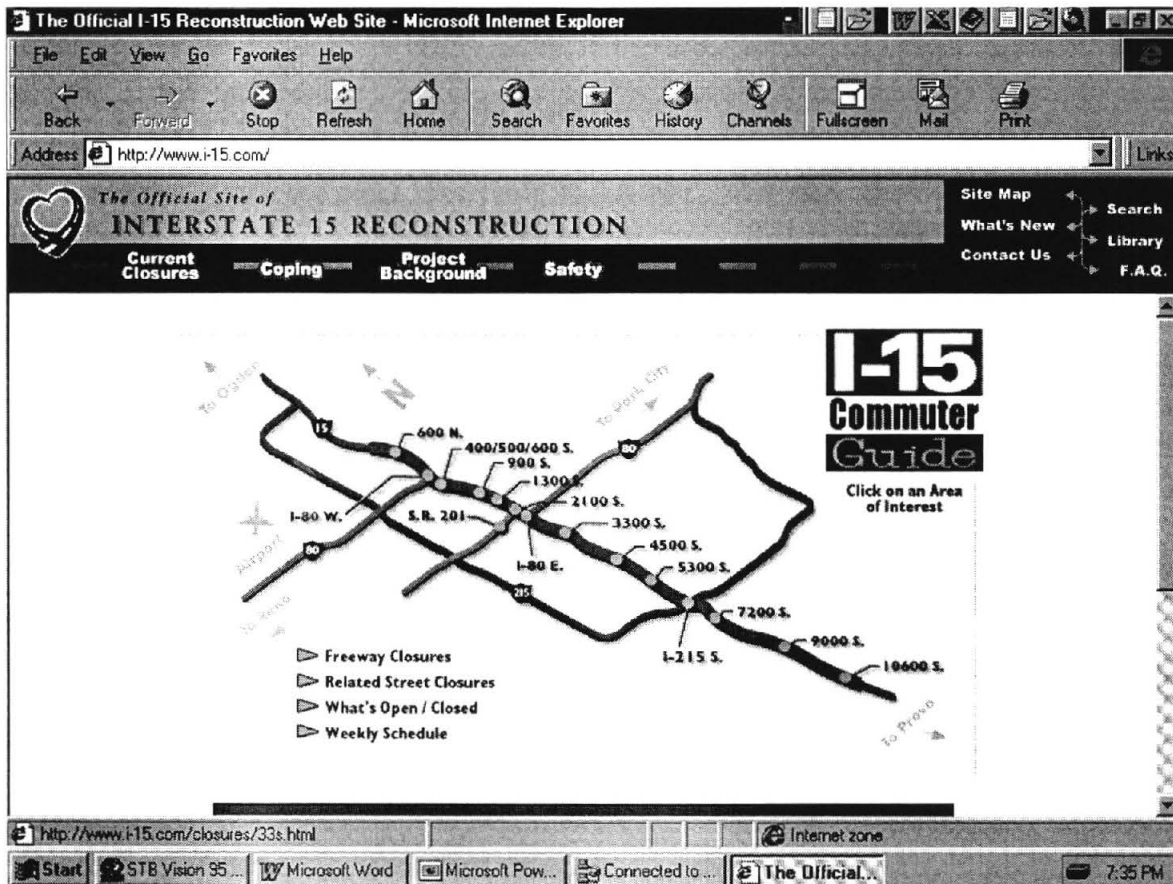

FIGURE D-1 Interstate 15 Internet web site.

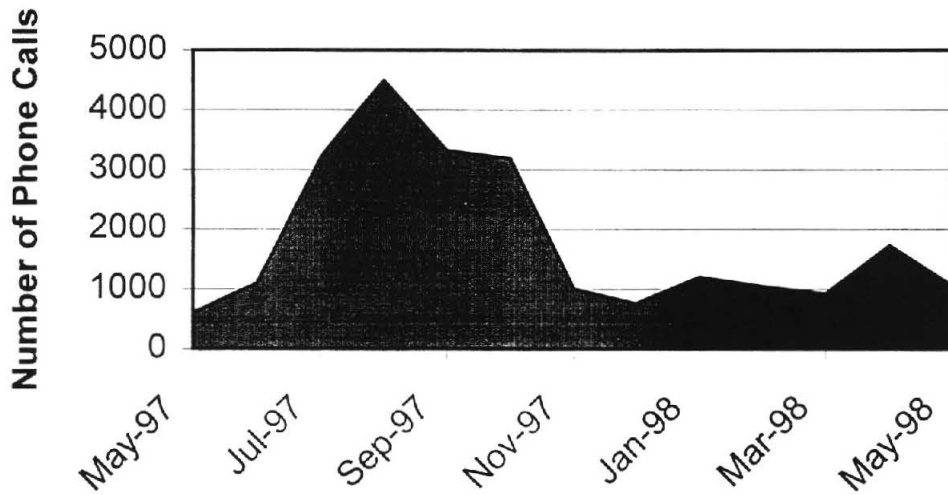

FIGURE D-2 Number of I-888-line calls versus project months.

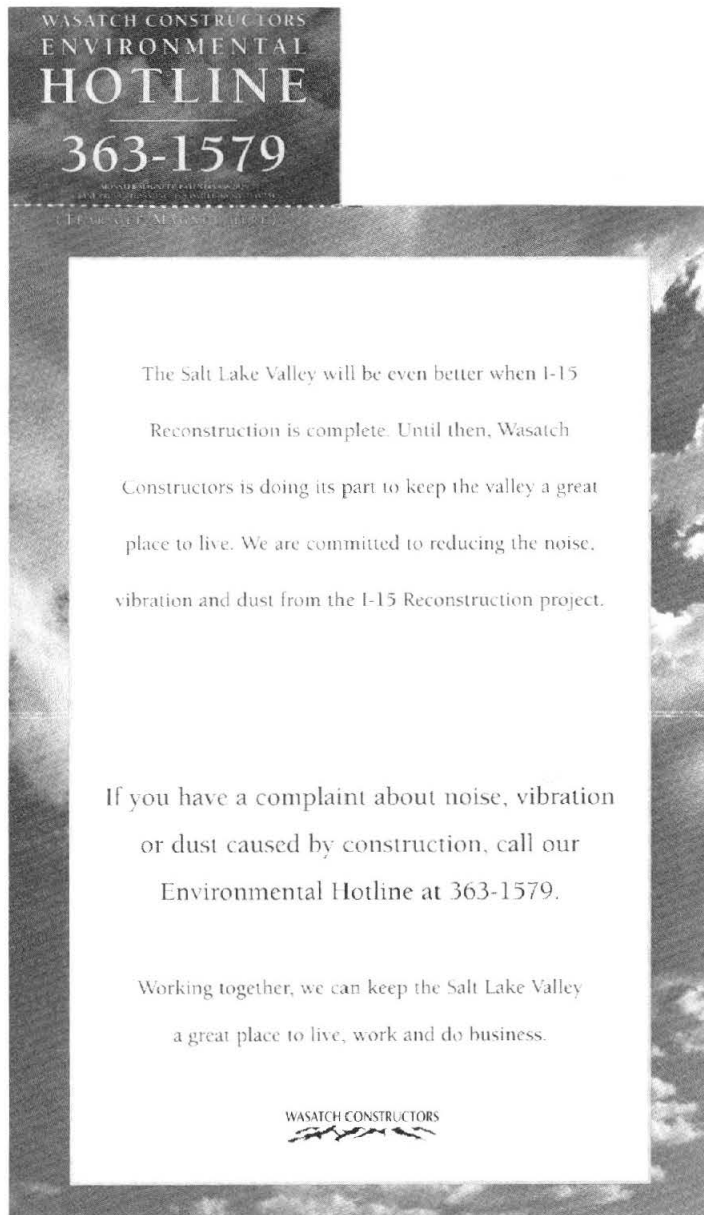

FIGURE D-3 Contractor's public relations mail-out with magnetic "environmental hotline" phone number card.

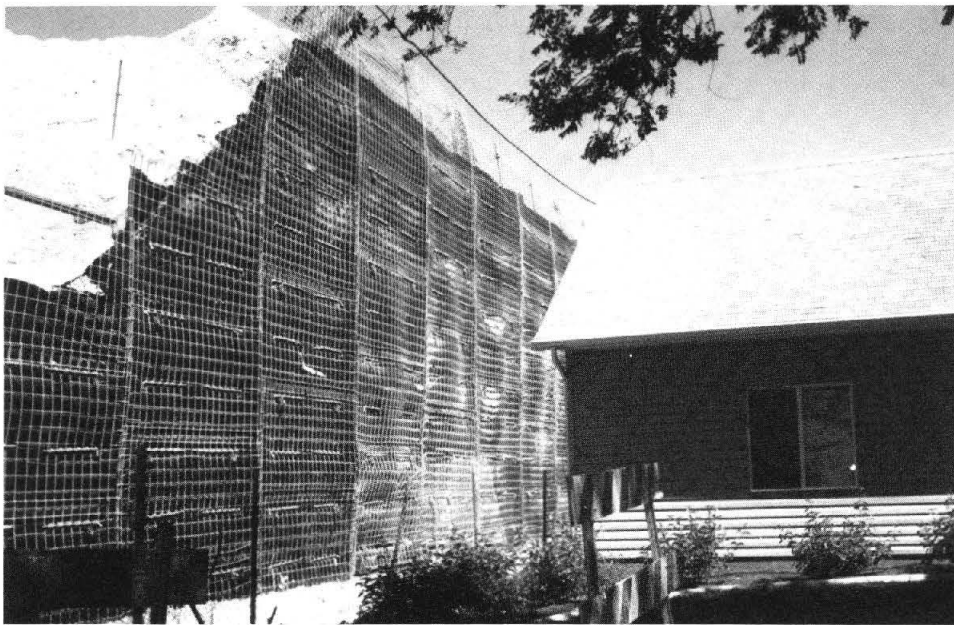

FIGURE D-4 I-15 Project impacted neighbors.

caller to speak with an operator. This phone line also has a fax-on-demand option whereby the caller can receive a hard copy of requested information. The two hotlines that were established specifically for mitigation of construction nuisances are known as the “Noise and Vibration” line and the “Environmental” hotline.

Noise and Vibration Phone Line

The Noise and Vibration line has been in operation since the beginning of the project. This was before any construction operations actually began in the field. The number was distributed to impacted project neighbors by means of flyers. The calls to this number are routed through the 1-888-information phone system. This system received all inquiry calls to the project, including those concerning issues other than noise or environmental complaints. Because of this routing arrangement it is not possible to establish the number of calls received concerning strictly noise and environmental issues. Still, the call history of the 1-888- system is very interesting and provides some insight as to the value of a hotline as a public relations tool, Figure D-2. Neglecting the first month the line was available, the average number of calls for the subsequent five months was slightly over 3,000. After that initial surge the average number of calls has settled down to about 1,100 per month.

This phone line was purposely established to handle noise and vibration complaints; but, because it later received general dissemination, it has been found that the majority of the callers want to know how to get from point A to point

B. Many of the calls are from other western states but a few have been from as far away as Florida.

Environmental Hotline

Although the contractor did not say so, but maybe because the original hotline had degenerated into a general information line, a third phone line was established strictly for “Environmental” problems. In April 1998 the contractor mailed to 32,000 residents and businesses a post card notice that included a magnet with the new environmental hotline phone number, Figure D-3. This new number was also published on subsequent neighborhood flyers instead of the “Noise and Vibration” number, though it is still maintained in operation. This “Environmental” line has been receiving about nine calls per week. The most common complaints are noise and dust.

INFORMATION HOTSHEETS

The contractor is using information hotsheets (flyers) targeted to specific audiences. These are usually hand-delivered to affected neighbors, Figure D-4. Potential impacts from a particular construction operation are identified and then an impacted region is determined. Based on those two analyses, a distribution zone is established. Typical activities announced by hotsheets would include bridge demolition and pile driving.

All sheets follow a standard format, as shown in Figure D-5.



INTERSTATE 15

PLAN ON IT!

December 11, 1997

I-215 Detour on 6600/6400 South - 1 Night Only

On December 15, 1997, the I-15 Reconstruction Team will close the south loop of I-215 eastbound between Union Park Ave. and Fashion Blvd. while they construct a new overhead electronic message sign at about 900 East. Due to this closure, freeway traffic will be diverted from I-215 onto the Union Park exit and to 6600/6400 South. Traffic will then be directed back to I-215 via the Fashion Blvd. entrance.

Installation of an overhead sign bridge such as the one mentioned above is not possible without a full freeway closure.

The closure will only occur the night of the 15th from 10 p.m. to 6 a.m. During this closure, area residents should expect heavy traffic on 6600/6400 South. The I-15 Team encourages residents to stay off the road, if possible.

Some residents may experience noise disturbances due to the closure and detour. Those with specific concerns should call the Construction Noise Hotline at 322-2378.

Road to the Future

With the installation of overhead electronic message signs in the coming two weeks,

Salt Lake County transportation will enter a new era where timely roadway messages can be relayed to motorists in an instant. Additional electronic message signs will be placed on I-215 southbound at 5400 South, I-80 eastbound at 3200 West and I-80 westbound at 1700 East.

Keeping Up With Construction

The I-15 Reconstruction project will reduce congestion and provide residents and businesses with a state-of-the-art freeway.

To learn more about this project, call our toll-free information line at 1-888-INFO-I-15 (1-888-463-6415). You can also look for traffic reports in the local media or access our Web site at www.I-15.com. One way that you can work through this project is to try reducing the total number of daily car trips your family takes.

Questions?

Wasatch Constructors	594-6400
UDOT I-15 Team	594-6145
Construction Noise	322-2378

- Call UTA at BUS-INFO for information on bus service in your area.
- Construction Noise Hotline - 322-2378

FIGURE D-5 Contractor's neighborhood public relations flyer.

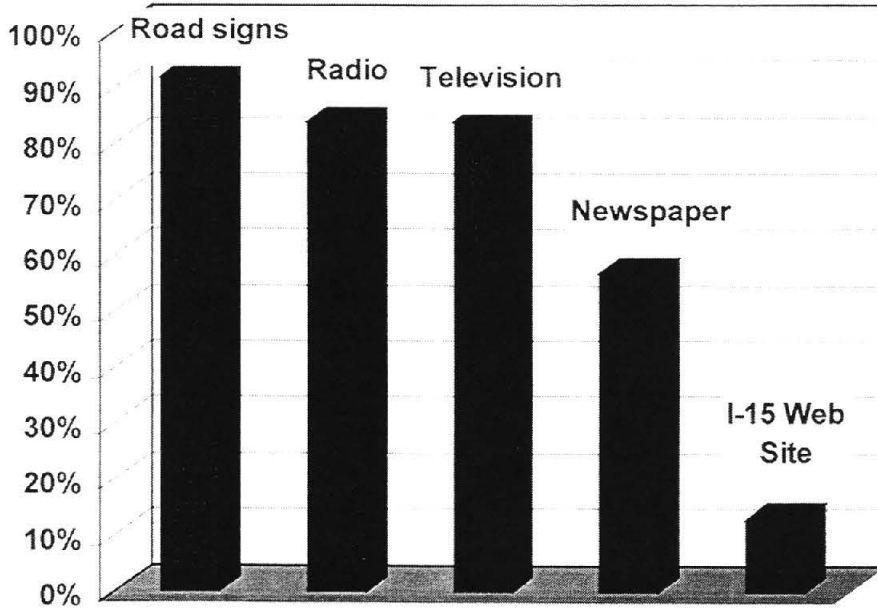

FIGURE D-6 Source of information for general public.

- Identify the work activity and location.
- Identify the crew work hours, and the duration of the activity.
 - Explain what neighbors can expect—sounds, lights, and equipment. A statement of concern about the nuisances and that every effort is being made to reduce impacts is important. “Whenever possible, crews will point lights away from homes and will also try to move heavy equipment so that back-up alarms are angled away from homes.”
 - Where to get more information.
 - Noise complaint hotline number.

- Erecting temporary sound control devices, i.e. temporary sound walls, berms, etc.
- Careful control of construction vehicle traffic routes.
- Relocation of the neighbor to an alternate site during the offending period of time. This is a special case solution, but it has been appropriate on an individual basis for high impact situations.

All of these control techniques have been used on the project.

NOISE COMPLAINT POLICY

The contractor does have a noise complaint policy in place, which includes the following principle procedures:

- Pre-activity notification
- Aggressive education campaign
- Response to complaint. Common courtesy solves many complaints. Try to solve problems before they get to regulatory agencies.
- Noise monitoring
- Investigation of methods to reduce impacts.

Controls that are to be evaluated include:

- Shifting of operations and operational times. In the case of pile driving either change the hours of operation or the order of work. Drive those piles that are closest to the neighbors during the day.

EFFECTIVENESS OF OUTREACH EFFORTS

Although the contractor constantly evaluates the effectiveness of its public information efforts, UDOT, through a professional public opinion research firm, formally surveys the public’s perception of the project and the effectiveness of the informational outreach efforts. The Figures D-6 and D-7 are from UDOT’s June 24, 1998 report.

These two figures show how the motoring public gets information, particularly information pertinent to daily route choices. But because of the effort made in this regard, a generally favorable impression is created and a favorable impression helps to mitigate many minor problems. The research found that 60 percent of the commuters and 55 percent of drivers in general had a favorable impression of UDOT. The contractor scored even higher with a 67 percent favorable rating from commuters,

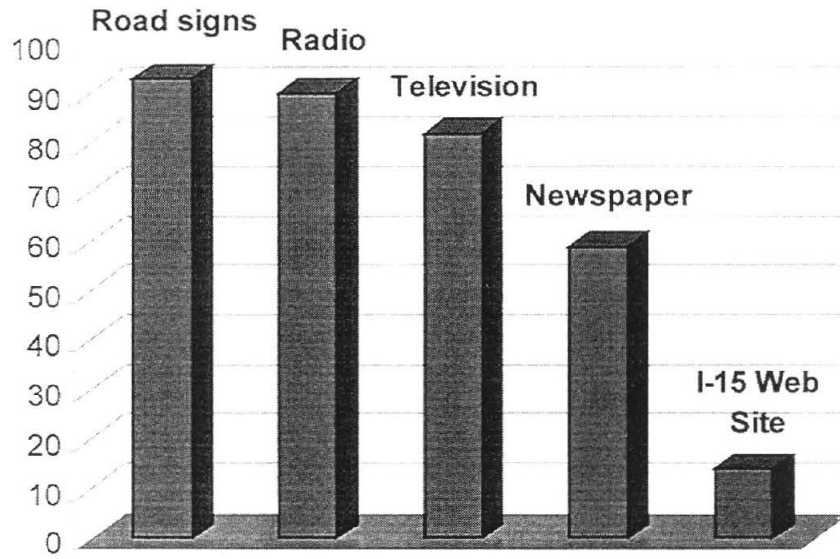

FIGURE D-7 Source of information for commuters.

56 percent from general drivers and 65 percent from business people. The aggressive communications effort has

resulted in more calls but at the same time it has mitigated complaints.

APPENDIX E

Mitigation Techniques Used by the Arizona Department of Transportation

Maricopa County, Arizona, which encompasses the Phoenix metropolitan area, is one of the fastest growing counties in the United States. The Arizona Department of Transportation (ADOT) is currently constructing over \$150M per year of mostly urban freeways as it tries to keep up with its explosive growth. To verify the information obtained through the phone and fax surveys described earlier, the authors interviewed project engineers from several urban freeway projects in the Phoenix metropolitan area regarding nighttime noise issues that occurred on the jobs and how they were handled. The persons interviewed were all ADOT project engineers and resident engineers primarily responsible for high-profile additions to the Phoenix metropolitan freeway system.

COMMUNITY AWARENESS

ADOT operates an effective community relations program to actively partner with the community it seeks to serve with its transportation facilities. The program involves an active plan for holding town meetings to announce plans for road construction in an area, describe the project to the residents, and solicit their input as to decisions that will be made regarding design and appearance of the structures. These gatherings are then followed with more meetings as needed and flyers explaining progress made, updating the schedule, and or explaining a change in traffic pattern necessitated by the construction sequence. On each of the three projects visited, it was evident that the local engineers and project managers for each project appeared at each meeting held with the community and took the project "out to the people" in order to obtain their "buy-in." Each field office designated a principal person on the project with the authority to make decisions to handle complaint calls. This attitude of customer service among ADOT's field personnel was key to minimizing the construction impact on the population. Figures E-1 and E-2 are copies of letters written and signed by the local project engineers and contractor's project managers that are used to keep the public informed and give them an avenue to voice their opinions. Figures E-3 and E-3A show an ADOT brochure printed to publicize the progress made on the freeway system. The brochures, distributed at the motor vehicle registration, provide an easily read snapshot of the project, a description of the progress to date, and most importantly, the names and phone numbers of people to call if the public has questions.

PROJECT 1

This project consisted of a \$36M, 2-mile stretch of six-lane freeway that extended an existing portion of freeway in the north central portion of the city. The freeway was alternately depressed and elevated throughout the 2-mile stretch with several street crossings. The public sentiment on this particular job was somewhat negative due to the fact the contract required the displacement of 640 homes that fell within the right-of-way. Starting out the project by forcibly displacing so many residents and essentially splitting a neighborhood in half created an atmosphere of tension from the outset of the project. The resident engineer reports that, as a result, every time the remaining residents were disturbed by the construction, they were quick to voice their opinion.

The major complaints from residents centered on noise and dust, and to a much lesser degree, lighting. The job required a large amount of soil removal and ADOT had mandated that this soil be transported to another project site several miles away that was in need of fill. The city located between the two project sites restricts the time period that haul trucks can be on the city streets to between 8:30 a.m. and 4:00 p.m. and between 8:00 p.m. and 5:00 a.m. These restrictions placed the contractor in the position of needing to work at night in order to obtain an economical day's work. The nighttime work resulted in many complaints to ADOT regarding noise and dust.

Dust Control

In an effort to control dust from cutting and filling operations ADOT mandates the use of a pre-wetting operation. Prior to the disturbance of the soil, the contractor is required to wet the soil to within 2 percent of the optimum moisture content at a depth of 18 inches below grade. This is usually done by employing several golf course style sprinklers on the area to be excavated for a period of several days or weeks. This operation has been found to significantly reduce the amount of available dust generated during excavation and subsequent fill operations. During this particular contract, the specification language for the pre-wetting operations was not clear and the contractor resisted the effort to meet the requirement, which resulted in an increased number of complaints received. Despite this lack of cooperation, ADOT reported that, when used, the pre-wetting did an excellent job of reducing the airborne dust particles. In addition to pre-wetting, the contractor

February 14, 1996

Dear Neighbor:

Work has begun on an 18 month project to complete the second phase of the Loop 101 /U.S. 60 traffic interchange. A \$13.4 million contract for construction was awarded to Kiewit Western Company, Phoenix, by the State Transportation Board in December. The first phase of the traffic interchange project, freeway to freeway ramp connections between the U.S. 60 Superstition Freeway and the Loop 101 Price Freeway, was completed in December 1993. The third, and final phase for interchange completion could enter construction before the end of this year. All construction associated with the interchange will be completed by 1999.

There are four key elements to the Phase II project. A new bridge will be built which will carry Baseline Road traffic over the future Price Freeway corridor; the existing interim Price Road (the future frontage roads for the Price Freeway) will be reconstructed in permanent configuration from U.S. 60 to a quarter-mile south of Baseline Road; nearly two miles of 84-inch diameter reinforced concrete pipe will be placed, up to 35-foot deep, between Baseline Road and the Western Canal to finalize the Carriage Lane drainage system, and other utility relocations will be completed; and, finally, new sound walls will be erected at select locations between U.S. 60 and the neighborhoods on the east and west sides of the Price Freeway corridor.

Our contractor will be staging this complex work to maintain the highest degree of safety and a minimum of disruption to traffic and to nearby businesses and residences. Access to the construction zone will be limited, however we must advise that caution must be exercised by everyone, especially during trenching operations, to ensure complete safety as our work advances.

For construction of the new Baseline Road bridge and traffic interchange (which will provide an exit from the future Price Freeway's northbound lanes, and an entrance to its southbound lanes) traffic restrictions will be imposed on Baseline Road. To maintain traffic flow, the bridge will be built in halves, with the south half entering construction first. To complete this stage of bridge construction, traffic will be shifted to the north-half of Baseline Road. Two lanes of traffic in each direction on Baseline will be maintained through a majority of this work. The new frontage roads will be constructed at the outside edges of the freeway corridor, and this work is scheduled to be completed during the first 190 working days of the project, or within the first 10 months of work. The new frontage roads will connect with the existing interim Price Road system south of Baseline Road. Slump block sound wall construction will occur in the early stages of the project. The rerouting of existing utilities within the corridor will also occur during the early stages of the project.

It is our goal to complete this project as rapidly as possible without forsaking any commitments to quality. We recognize that there will be inconvenience to you and your neighbors and we thank you for your patience and perseverance as our work progresses. If problems arise, I will address your construction related concerns as quickly as possible. You can contact me at 255-8114, at our ADOT field office at 48th Street and Broadway Road. Mr. Terry Cole will serve as Project Manager for Kiewit Western. His office telephone number is 820-2490 Or, you can contact Mark Bonan, at ADOT's Phoenix Construction District Community Relations Office, by calling 255-7176.

We look forward to keeping you informed as our work continues to modernize the Valley's freeway system by completing a new Price Freeway project that will provide many benefits to everyone for years into the future.

Sincerely,

Michael Harrington
Senior Resident Engineer
AZ. Dept. Of Transportation

Terry Cole
Project Manager
Kiewit Western

FIGURE E-1 Sample ADOT letter to the public.

provided personnel with hoses at the location where the trucks left the construction site and entered the hard pavement. The contractor also used tarps to cover the beds of all haul vehicles on the site. ADOT provided the water for this job at no cost to the contractor to the tune of \$517,000 or approximately 1.4 percent of the contract cost.

Noise Control

The close proximity of many of the homes to the project coupled with the contractor's decision to work at night resulted in many complaints concerning noise. ADOT took sound measurements at the job site locations and determined that the levels were not in violation of the contract



	<p>ARIZONA DEPARTMENT OF TRANSPORTATION</p> <p>INTERMODAL TRANSPORTATION DIVISION</p> <p>Phoenix Construction District 1309 North 22nd Avenue - Phoenix, Arizona 85009 (602) 255-8965</p>	
<p>Jane Dee Hull Governor</p> <p>Mary Peters Director</p>	<p>March 30, 1998</p>	<p>Thomas G. Schmitt State Engineer</p> <p>Dan Lance District Engineer</p>
<p>Dear Neighbor:</p> <p>Over the next month, several complicated construction elements must be completed on our \$17.1 million project to complete the Loop 101 Price Freeway between Baseline and Guadalupe roads. To keep the project on schedule, the intersection of Guadalupe and Price roads must be closed over three weekends in April. Full closures will begin on Friday evenings and end early on the following Monday, clearing the intersection for the morning commute. The closures are scheduled for April 3~6, April 17~20, and April 24~27.</p> <p>When the work is done, traffic will be placed on the new Guadalupe bridge which spans the future Loop 101 Price Freeway. During the first weekend closure our contractor (Pulice Construction, Phoenix) will replace existing paving on both the east and west ends of the bridge. Over the second weekend, Price Freeway frontage roads will be paved at the bridge, completing initial construction on the new Guadalupe/Price Freeway traffic interchange. The last weekend closure will finish preparations for the placement of traffic across the new Guadalupe bridge. Future bridge work will occur in the median where raised islands will be constructed.</p> <p>Price Road will be closed at Elliot and Baseline roads, however local traffic may proceed to Curry from the south and to Watson Drive from the north. Guadalupe Road will be closed between McClintock Drive and Dobson Road, with local traffic access to River Drive from the west and to Carriage Lane from the east.</p> <p>The closures will be in effect from Friday night at 7:00 p.m. to Monday morning at 5:00 a.m. each weekend. We thank you for your patience during this period of construction on the Price Freeway between Baseline and Guadalupe roads. Our work is nearly half done, and project completion is now anticipated late this fall. If you have any construction related concerns please call me at 255-8114, or contact Mark Heisler of Pulice Construction at 456-6476.</p> <p>Sincerely,</p> <p>Michael J. Harrington, P.E. ADOT Senior Resident Engineer</p>		
	<p>HIGHWAY S • AERONAUTICS • MOTOR VEHICLE • PUBLIC TRANSIT PLANNING • ADMINISTRATIVE SERVICES • TRANSPORTATION</p>	

FIGURE E-2 Sample ADOT letter to the public.

ARIZONA DEPARTMENT OF TRANSPORTATION



CONSTRUCTION ALERT



PRICE FREEWAY TRAFFIC INTERCHANGE • JANUARY 1998

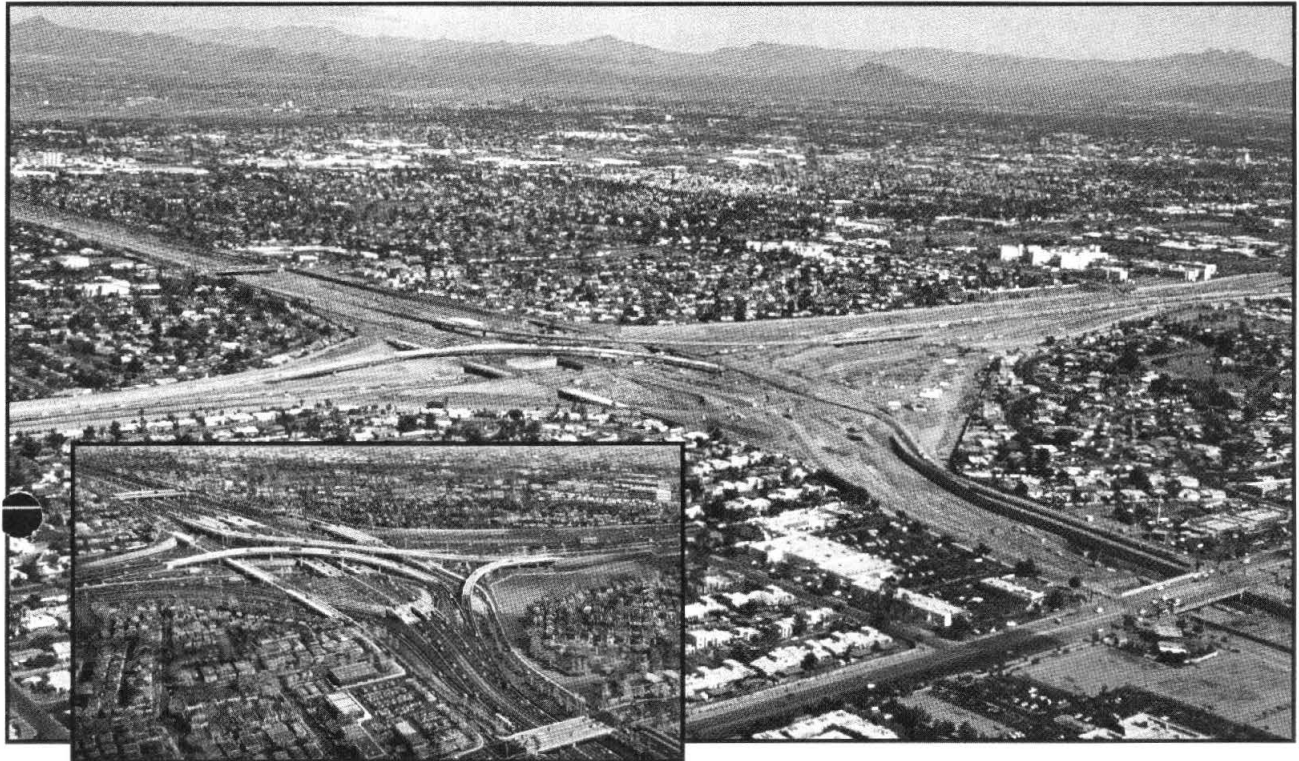

Dear Neighbor,

The massive project to link the Superstition (U.S. 60) and Price (Loop 101) freeways has passed the halfway point and many of our construction activities continue to be completed ahead of schedule. In February, all westbound U.S. 60 traffic will be shifted onto new lanes between Dobson Road and McClintock Drive and the westbound U.S. 60 exit to McClintock Drive will reopen. Reconstruction for new eastbound lanes will begin after the traffic shift and continue through summer.

During this period, the McClintock entrance to eastbound U.S. 60, and the eastbound U.S. 60 exit to Dobson will be closed.

Southbound Price Road traffic will soon be shifted onto the newly constructed Loop 101 frontage road, allowing construction to proceed on the new freeway's through lanes.

Major construction items already completed include:

- Reconstruction of westbound U.S. 60
- New westbound exit to McClintock
- Two southbound frontage road bridges
- Two 101L freeway bridges north of U.S. 60
- North half of 101L bridge over westbound U.S. 60

- Many retaining walls and noise walls on U.S. 60
 - Underground drainage improvements on U.S. 60.
- Major earthwork activities for the project are also progressing with almost two-thirds of the excavation finished. This work will continue through early summer.

Other traffic changes will occur this spring prior to project completion. A temporary detour for the southbound 101L ramp to eastbound U.S. 60 will also be implemented soon. And, a temporary detour of northbound Price Road will be installed between Baseline and the Superstition during construction of a new ramp bridge for northbound 101L to eastbound U.S. 60.

We realize the potential impacts a project of this magnitude can have on neighborhoods and motorists, and we appreciate your patience and perseverance.

Sincerely,

William P. Sloan, P.E.
Senior Resident Engineer

FIGURE E-3 ADOT community awareness brochure.

Dobson Road

PRICE TRAFFIC INTERCHANGE

PROJECT PARTICULARS

- Project Award: October '96
- Project Cost: \$42.2 million
- Contractor: Sundt Corporation, Tucson
- Project Time: 535 Working Days, beginning January 13, '97
- Project Length: 1-mile on 101L and 2-miles on U.S. 60
- Project Target Completion: December '98

FOR MORE INFORMATION

Mary Viparina, ADOT Project Manager 255-7545
 Bill Sloan, ADOT Sr. Resident Engineer 255-7054
 Mark Bonan, ADOT Valley Project Information 255-7176
 Greg Bode, Sundt Project Manager 413-9493

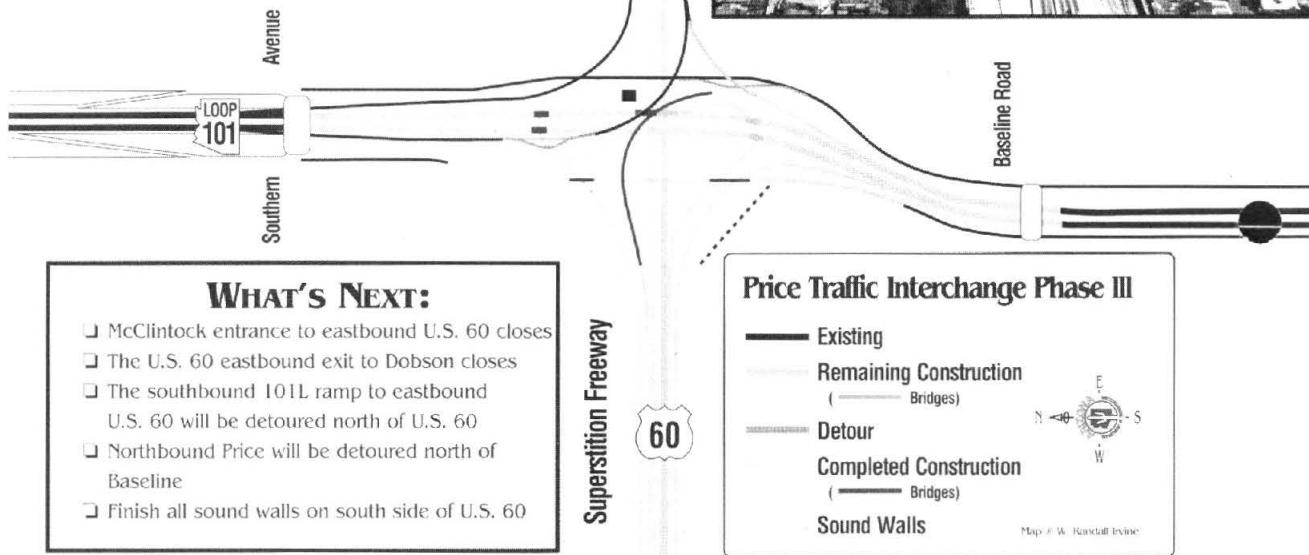
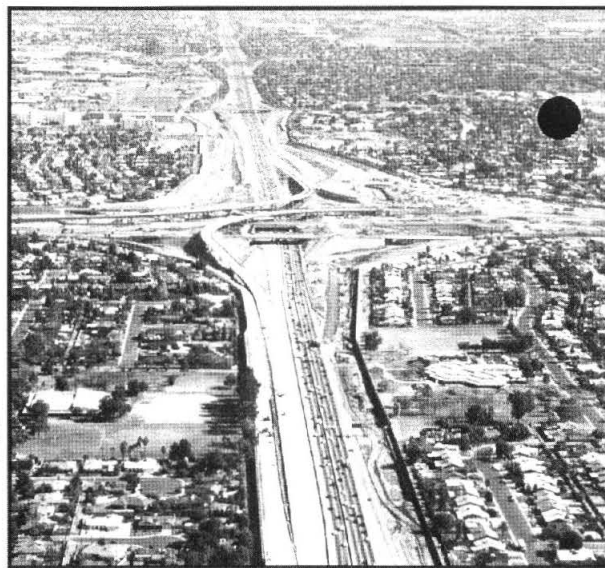

WHAT'S NEXT:

- McClintock entrance to eastbound U.S. 60 closes
- The U.S. 60 eastbound exit to Dobson closes
- The southbound 101L ramp to eastbound U.S. 60 will be detoured north of U.S. 60
- Northbound Price will be detoured north of Baseline
- Finish all sound walls on south side of U.S. 60

Price Traffic Interchange Phase III

- Existing
- Remaining Construction (Bridges)
- Detour
- Completed Construction (Bridges)
- Sound Walls

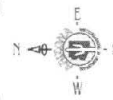

Map © W. Randall Irvine

PRICE FREEWAY: BASELINE TO GUADALUPE

CONSTRUCTION UPDATE

The majority of excavation for the 1.2 mile depressed freeway segment is complete, as is the first portion of the new bridge at Guadalupe Road. The construction bypass around the new bridge should be removed, and traffic shifted onto the new roadway, by August. A significant portion of the drainage system for the freeway is complete and footings for all the sound walls on the east side of the corridor are finished. Actual wall erection began this month. This \$17.1 million project which began in June '97 remains on schedule for completion by the end of '98.

FOR MORE INFORMATION:

ARIZONA DEPARTMENT OF TRANSPORTATION
 Mike Harrington, Senior Resident Engineer • 255-8114
 Mark Bonan, Valley Project Information • 255-7176

PULICE CONSTRUCTION INC.
 Mark Heisler, Project Manager • 456-6476

CITY OF TEMPE
 Ed VanderGinst, Freeway Liaison 350-8206

CITY OF MESA
 Anthony Araza, Freeway Liaison • 644-3556

FIGURE E-3A ADOT community awareness brochure.

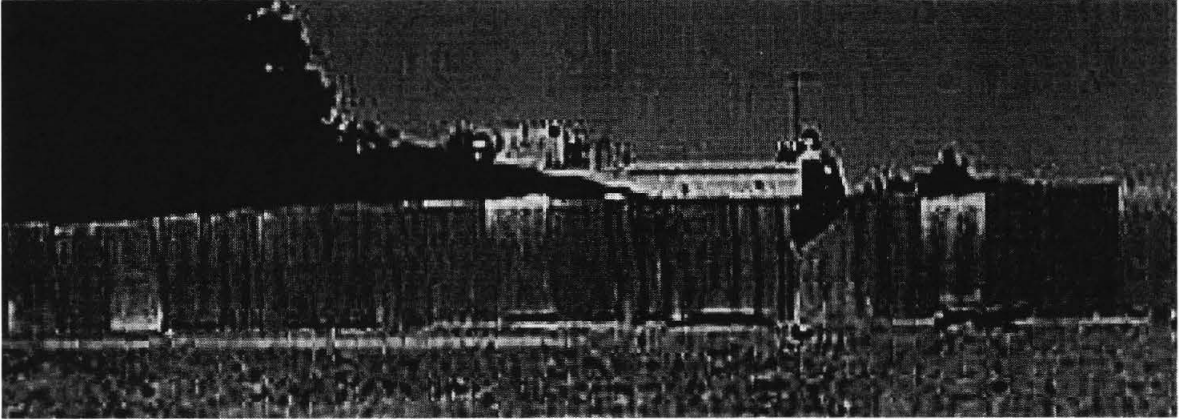

FIGURE E-4 Temporary sound wall.

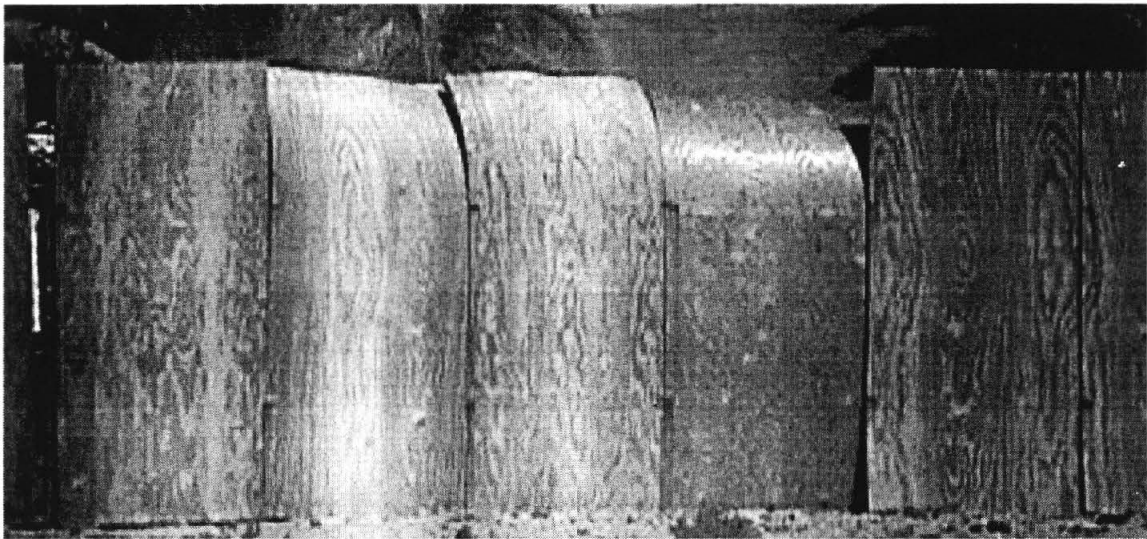

FIGURE E-5 Temporary sound wall.

terms that limited nighttime noise to 75 dBA. The agency first requested that the contractor perform some of this stockpiling work during the day and leave only the loading operations for the night. This was accomplished, however the residents continued to complain, mostly about the backup alarm on the bucket loader. When the complaints continued, ADOT responded with two innovative ideas. The first was the use of temporary sound barrier made from plywood. Since the contractor was required to place a security fence around the property site, ADOT authorized the contractor to attach sheets of plywood to the chain link fence to help attenuate the sound, Figure E-4. Erected in a vertical fashion and attached by drilling holes and using electrical wire the plywood made an effective 8-foot high wall that substantially reduced the view neighbors had of the construction, Figure E-5. ADOT subsequently made additional measurements, which revealed that the addition of the plywood resulted in very little sound attenuation. Despite the lack of attenuation, the number of complaints was substantially reduced. The Agency's second idea was

to offer any homeowners bothered by nighttime noise free sheets of Styrofoam, which they could cut to fit inside their window frames to reduce the sound transmission at night. Flyers were distributed door-to-door though the neighborhoods that informed them where to pick up the free Styrofoam.

Upon the completion of these two actions, the number of complaints about noise and dust virtually disappeared. The project resident engineer believed that many of the complaints were due to the unhappiness the people felt over losing their neighborhood. ADOT's actions, though relatively simple, showed the agency's concern for the residents and the 'good faith effort' alone was instrumental in reducing complaints. The efforts resulted in approximately one mile of temporary sound wall that cost the agency about \$21,000 and was paid by force account. The cost of the Styrofoam was only a few hundred dollars as the actual usage by the residents was fairly light.

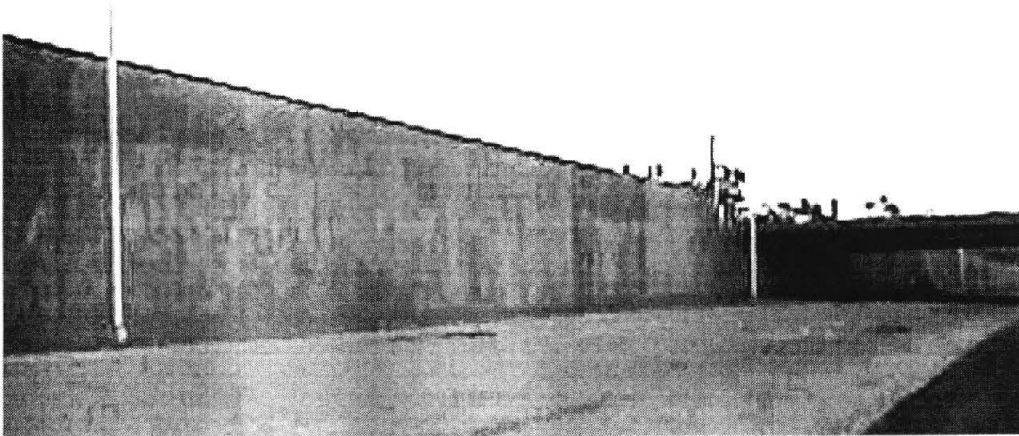

FIGURE E-6 Early construction of sound wall.

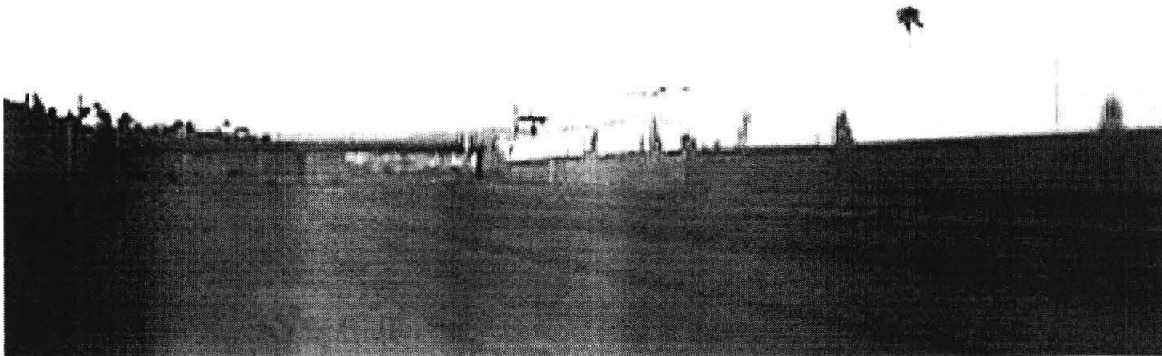

FIGURE E-7 Early construction of sound wall.

PROJECT 2

This project consisted of a \$42 million, two-mile segment of eight-lane freeway with a major freeway interchange in the middle of it. The ADOT project engineer on this project had served on Project 1 so he was familiar with the problems encountered there. This project did not have nearly the number of complaints because this right-of-way followed a major arterial road so that the neighborhoods were already divided to some degree. Furthermore, this freeway route had been planned for a long time so public acceptance of this project was simply much higher. Nevertheless there were complaints about noise emissions from generators used to power lightsets. The contractor solved this problem by digging the generators down into the ground and placing either a wall of sandbags around it or a sheet of plywood to reflect the sound back into the construction site. The contractor used a sheet of plywood in this fashion whenever he had a stationary piece of equipment producing noise at night and this was very successful. Another significant complaint arose from the backup alarms and equipment horns that the contractor was using to signal the dump trucks to move when their load was full. Requesting the loader driver flash his lights at the truck driver to signal the movement easily solved this

problem. The contractor had a substantial fill and compaction operation at night and he voluntarily devised a method of roundtrip passes for his rollers, which eliminated them from making every other pass in reverse with the backup alarm sounding.

This contract also used the pre-wetting specification along with mandatory tarps on all trucks and hose stations wherever the trucks left the site and entered paved roads. A sample from the specification requiring the contractor to provide pre-wetting of material prior to excavation is shown below:

Example Specification on Pre-wetting

Material to be excavated shall be pre-wetted prior to removal. The Engineer will specify the areas to be pre-wetted. The contractor shall rip or scarify these areas prior to the application of water and provide a method to verify penetration of moisture for the full depth of the excavation. The contractor shall provide a sprinkler system for distribution, and apply water at a rate to allow sufficient penetration without excess runoff.

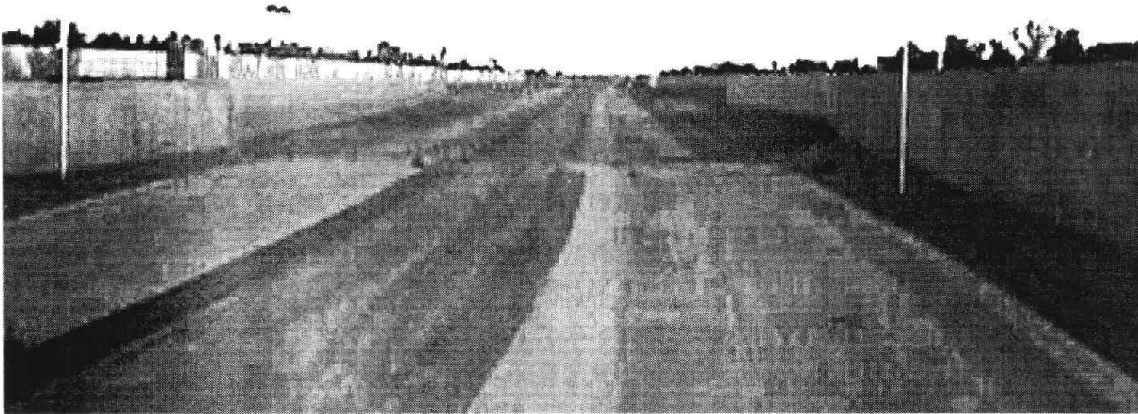

FIGURE E-8 Early construction of sound wall.

PROJECT 3

This project is a \$17M 2-mile segment of eight-lane freeway that connects to Project 2 discussed above. This project involved a unique issue in that the freeway straddles the border between two cities, one of which does not allow nighttime construction. It became necessary during the reconstruction of a major bridge over the proposed mainline that several operations be accomplished at night to reduce congestion on the road that had to be kept open. Alternatives were developed, ADOT wrote letters, hand delivered them to neighbors in the area, and then held open meetings to give the affected residents input on the decision. The neighborhood people overwhelmingly voted for doing the work at night to preserve traffic flow during the day. Armed with this information, ADOT approached the city and then obtained permission to allow the contractor to perform work at night.

A significant advantage in this contract stemmed from efficient use of the specifications. During preliminary design meetings with the public there was significant concern over the impact that construction of one particular section of the freeway would have on a nearby school. As a result of this concern, ADOT wrote into the specification

that one section of sound wall must be erected within 60 days of Notice to Proceed. The specification further stated that all noise barrier walls “must be installed at the first opportunity as determined by the engineer.” The full text of the specification is shown below:

Example Specification Noise Barrier Wall and Fence Construction

The contractor shall construct wall RN3 within the first 60 days of Contract Time. Noise Barrier walls shall be installed at the first opportunity as determined by the engineer. The maintenance and care of the walls shall be the full and complete responsibility of the contractor until project acceptance.

The contractor took this section of the specification to heart and in fact installed nearly all of the noise barrier walls very early in the project. These walls, some of which are more than 25 feet high, have served their purpose during construction very well, as there have been virtually no complaints about sound or dust on this project. Figures E-6 through E-8 show samples of this project prepared for paving with the noise walls completed on both sides of the project.

APPENDIX F

Central Artery/Tunnel Project, Noise Control Specification 721.560

In general, construction noise on the CA/T project is limited to 5 decibels above baseline conditions.

SECTION 721.560 CONSTRUCTION NOISE CONTROL DESCRIPTION

The following replaces CA/T Supplemental Specifications Section 721.560 dated 4/5/96.

1.01 GENERAL

- A. The intent of this Section is to minimize construction noise within construction areas, lay-down areas, and communities adjacent to the construction site. To this end, the Contractor and all subcontractors, suppliers, and vendors, are required to comply with all applicable noise regulations, specification requirements, and the noise level limits specified herein. This Section supplements the requirements of Division I, Subsection 7.01E. Refer also to Division I, Subsection 8.06, Limitation of Operations, Subsection 7.27, Safety, and Exhibit I-J, Mitigation Requirements.
- B. This Section specifies requirements for Noise Control Plans, a Noise Monitoring Plan, noise monitoring prior to and during construction, response to community complaints, and equipment certification. All requirements of this Section shall be overseen by an approved Acoustical Engineer employed by the Contractor.
- C. The Contractor shall use equipment with efficient noise-suppression devices and employ other noise abatement measures such as enclosures and barriers necessary for the protection of the public. In addition, the Contractor shall schedule and conduct operations in a manner that will minimize, to the greatest extent feasible, the disturbance to the public in areas adjacent to the Work and to occupants of buildings in the vicinity of the Work.
- D. In no case shall the restrictions identified in this Section limit the Contractor's responsibility for compliance with all Federal, state, and local safety ordinances and regulations.
- E. Related Work specified elsewhere: Section 850.001 Traffic Control for Construction and Maintenance Operations.

1.02 TERMS USED

- A. Noise is any audible sound, which has the potential to annoy or disturb humans, or to cause an adverse psychological or physiological effect on humans.
- B. Daytime refers to the period from 7 AM to 6 PM local time daily, except Sundays and Federal holidays.
- C. Evening refers to the period from 6 PM to 10 PM local time daily, except Sundays and Federal holidays.
- D. Nighttime refers to the period from 10 PM to 7 AM local time daily, as well as all day Sunday and Federal holidays.
- E. Noise-Sensitive Locations shall mean locations where particular sensitivities to noise exist, such as residential areas, institutions, hospitals, and parks.
- F. Nuisance Noise refers to sound levels that annoy or disturb a reasonable person of normal sensitivities, but do not exceed the noise limits specified herein.
- G. Lot-line refers to the line separating a parcel of land from another parcel or from the street.
- H. Background Noise shall be defined as the measured ambient noise level associated with all existing environmental, transportation, and community noise sources in the absence of any audible construction activity.
- I. dBA shall be defined as the sound level (in decibels referenced to 20 micro-pascals) as measured using the A-weighting network on a sound level meter, in accordance with ANSI S1.4 Standards.
- J. L_{max} shall be defined as the maximum measured sound level at any instant in time.
- K. L_{eq} shall be defined as the equivalent sound level, or the continuous sound level that represents the same sound energy as the varying sound levels, over a specified monitoring period.
- L. L10 shall be defined as the sound level exceeded 10 percent of the time for a specified monitoring period.
- M. Slow specifies a time constant or 1 second for the root-mean-square (RMS) detector used by a sound level meter, in accordance with ANSI S1.4 Standards.

N. Impact noise is noise produced from impact or devices with discernible separation in sound pressure maxima. Examples for impact equipment include, but are not limited to; blasting, clam shovel or chisel drops, pavement breakers, jackhammers, hoe rams, mounted impact hammers, and impact pile drivers (but not vibratory pile drivers). Table 2 specifies types of equipment which are considered to emit impact or continuous noise.

1.03 SUBMITTALS

- A. Submit the name, address, and qualifications of the Acoustical Engineer, as specified in Article 1.05 of this Section, for review and acceptance as required by Division I, Subsection 5.02. This submittal is required prior to preparing the Noise Monitoring and Noise Control Plans, performing any noise monitoring, or initiating any construction activity.
- B. Submit the Noise Monitoring Plan prior to construction, as specified in Article 1.06 of this Section, for review and acceptance as required by Division I, Subsection 5.02.
- C. Submit a current laboratory calibration conformance certificate for the noise monitoring equipment, as specified in Article 2.02 of this Section, prior to performing any noise level monitoring. Submit updated certificates following subsequent yearly calibrations, or upon completion of repairs to the instrument, for the duration of this Contract.
- D. Submit a Noise Control Plan every 6 months as specified in Article 1.07 of this Section, for review and acceptance as required by Division I, Subsection 5.02. The first of these submittals shall reference the background noise measurements as furnished by the Engineer, and is required prior to construction and no later than 60 Days after Notice -to-Proceed. An updated Noise Control Plan submittal is required every 6 months after the date that the initial Noise Control Plan was due, or more frequently as work conditions or work hours change substantively from the conditions described in a previously approved Noise Control Plan.
- E. Submit Noise Measurement Reports weekly during construction as specified in Article 3.01 and 3.02 of this Section. The weekly reports shall include all noise level measurements taken during the previous week, including construction, complaint response, and equipment certification measurements.
- F. Submit shop and working drawings, computations, material data, and other descriptions for abatement measures identified in the Noise Control Plan or used as Temporary Noise Barriers, Acoustical Barrier Enclosures, or Noise Control Curtains as specified in Articles 2.04, 2.05, 2.06 of this Section. Drawings and computations shall be stamped by a Registered Professional Engineer of the Commonwealth of Massachusetts as required by Division I, Subsection 5.02.

1.04 CONSTRUCTION LIMITATIONS

A. Noise Levels

1. Daytime, evening, and nighttime construction noise levels at noise-sensitive locations and other noise monitoring locations, as specified in paragraph 1.06.B.1, shall not exceed the lot-line noise limits specified in Table 1. The lot-line criteria shall apply to all points on a given lot-line of an affected receptor.
2. Equipment and associated equipment operating under full load that meets the requirements as specified in Article 1.08 of this Section shall not exceed the Lmax noise limits specified in Table 2. The 50-foot noise emission limits specified in Table 2 shall apply to the entire operation in which the equipment is engaged. Table 2 also provides distinction as to which equipment is considered to emit impact or continuous noise.
3. Work shall be performed in a manner to prevent nuisance conditions such as noise which exhibits a specific audible frequency or tone (e.g., back-up alarms, unmaintained equipment, brake squeal) or impact noise (e.g., jackhammers, hoe rams). The Engineer will make any final interpretation concerning whether or not nuisance noise conditions exist. The Engineer has the authority to stop the Work until nuisance noise conditions are resolved, without additional time or compensation for the Contractor.

B. Equipment Operations

1. The use of impact pile-drivers shall be prohibited during evening and nighttime hours (i.e. 6 PM to 7 AM as defined in Article 1.02).
2. Vibratory sheet pile driving shall be prohibited during the nighttime period (i.e. 10 PM to 7 AM as defined in Article 1.02).

3. All jackhammers, chainsaws, and pavement breakers used on the construction site shall be enclosed with shields, acoustical barrier enclosures, or noise barriers as described in an Exhibit at the end of Division II Special Provisions.
4. Use of all impact devices, including hoe rams, jackhammers, chiseling devices, and pavement breakers, shall be prohibited during the nighttime hours (i.e. 10 PM to 7 AM). Any necessary use of impact devices between 10 PM and 7 AM shall be reviewed by the Engineer in advance and allowed as an exception only upon sufficient justification.
5. Contractors shall use approved CA/T haul routes to minimize noise at residential and other sensitive noise receptor sites.
6. All equipment with back-up alarms operated by the Contractor, vendors, suppliers, and subcontractors on the construction site shall be equipped with either audible self-adjusting ambient-sensitive back-up alarms or manually-adjustable alarms. The ambient-sensitive alarms shall automatically adjust to a maximum of 5 dBA over the surrounding background noise levels. The manually-adjustable alarms shall be set at the lowest setting required to be audible above the surrounding noise. Installation and use of the alarms shall be consistent with the performance requirements of the current revisions of Society of Automotive Engineering (SAE) J994, J1446, and OSHA regulations, and as described in an Exhibit at the end of Division II Special Provisions.
7. Per State regulations, engine idling for trucks is limited to 5 minutes maximum.

1.05 ACOUSTICAL ENGINEER

- A. The Acoustical Engineer identified in this Article shall oversee all requirements of this Section. These include the preparation and implementation of the Noise Monitoring Plan and Noise Control Plans, the equipment noise certifications, and the construction and complaint response noise monitoring.
- B. The Acoustical Engineer shall have the following minimal qualifications:
 1. Bachelor of Science or higher degree from a qualified program in engineering, physics, or architecture offered by an accredited university or college, and five years experience in noise control engineering and construction noise analysis; or current enrollment as a full Member or Board-certified Member in the Institute of Noise Control Engineering (INCE).
 2. Demonstrated substantial and responsible experience in preparing and implementing construction noise controls and monitoring plans on construction projects conducted in an urban setting, calculating construction noise levels, and designing and overseeing the implementation of construction noise abatement measures.
- C. If at any point, in the judgement of the Engineer, the quality of the Acoustical Engineer's submittals proves to be repeatedly unacceptable, then the Engineer can require the submittal and selection of an alternative Acoustical Engineer meeting the requirements in this Article.

1.06 NOISE MONITORING PLAN

- A. The Noise Monitoring Plan describes the noise monitoring and reporting procedure to be used during construction. The Plan shall be prepared by and bear the signature of the Acoustical Engineer and shall be submitted to the Engineer as specified in paragraph 1.03.B. Noise generating equipment shall not be operated prior to acceptance of the Noise Monitoring Plan.
- B. The Noise Monitoring Plan shall identify and describe the following in detail:
 1. The receptor locations where noise monitoring will be performed. Include locations identified in Table 3 and shown in Figure 1 and others as appropriate to effectively monitor noise conditions during construction. Include sketches of all locations.
 2. The type of noise level measurement device that will be used, as specified in Article 2.02 of this Section.
 3. The noise monitoring methods and procedures that will be used, as specified in Article 3.01 of this Section.
 4. The data reporting method that will be used, as specified in Article 3.02 of this Section.
 5. The response procedure and actions to be taken for any lot-line or equipment noise level that exceeds the noise limits specified in Article 1.04 of this Section. The response procedure may include, but not be limited to, use of noise reduction materials and equipment listed in Article 2.03 and methods listed in Article 3.03.
 6. The complaint response and resolution procedures, as specified in Article 3.06 of this Section.
 7. Documentation from noise monitor manufacturer warranting that the specific equipment is "Y2K Compliant".

1.07 NOISE CONTROL PLAN

- A. The Noise Control Plan describes the procedure for predicting construction noise levels prior to performing construction activities and describes the noise reduction measures required to meet the noise level limitations and minimize nuisance noise conditions. The Plan shall be prepared by and bear the signature of the Acoustical Engineer and shall be submitted to the Engineer as specified in paragraph 1.03.D. Noise generating equipment shall not be operated prior to acceptance of the first Noise Control Plan. The initial Noise Control Plan is required no later than 60 Days after Notice-to-Proceed. Updated Noise Control Plans shall be resubmitted every six months thereafter, or whenever the Construction activities or the construction work hours have changed, as specified in paragraph 1.03.D.
- B. The Plan shall include:
1. Contract-specific noise control commitments made previously by the Project as referenced in this Section.
 2. A description of the anticipated construction activities.
 3. An inventory of construction equipment and associated noise levels using Part A of the Noise Control Plan Form in Figure 2. The following information is required:
 - a. Column (a): Code to identify equipment for sketches and equipment certification procedures.
 - b. Column (b): Appropriate equipment category from Table 2.
 - c. Column (c): Equipment manufacturer and model.
 - d. Column (d): Unique identifier (ID), such as registration number.
 - e. Column (e): Horsepower rating of the equipment.
 - f. Column (f): Equipment noise emission limit from Table 2.
 - g. Column (g): Estimated noise level at 50 feet. If greater than the limit specified in Table 3, noise reduction measures will need to be included.
 - h. Column (h): Estimated date of first use on site.
 - i. Column (I): Estimated date of last use on site.
 - j. Column (j): Expected use; circle D for daytime, E for evening, N for nighttime use.

4. Noise Level Calculations

Perform calculations to predict lot-line construction noise during applicable daytime, evening, and nighttime periods. The calculations shall be made for noise monitoring locations as specified in paragraph 1.06.B.1 where noise emitted by all applicable equipment will cause the greatest noise level for each type of land use for a given time period. The Contractor shall provide the results on Part B of the Noise Control Plan Form in Figure 3 with calculations included below the results, and with the locations for the calculations indicated on the site sketch. The noise level calculation procedure shall be as follows:

a. Calculate Lmax:

1. Calculate the maximum equipment noise level at the closest point on the lot-line for each item of equipment using the following equation:

$$L_{\max}(\text{equipment}) = E.L. - 20 \log (D/50)$$

where:

E.L. is the estimated equipment noise emission level at 50 feet (Figure 2, column g or from Table 2 of this Section) in dBA.

D is the distance from the equipment to the closest point on the lot-line in feet, but shall not be less than 50 feet.

2. Whereas the maximum noise level produced by each piece of equipment may not occur simultaneously, obtain the overall maximum construction noise level at the lot-line from the loudest single piece of equipment as follows:

$$L_{\max}(\text{overall}) = \text{MAX} [L_{\max}(\text{equipment})]$$

b. Calculate Leq:

1. Calculate Leq at the closest point on the lot-line for each item of equipment using the following equation:

$$Leq(\text{equipment}) = E.L. - 20 \log (D/50) + 10 \log (U.F.)$$

where:

E.L. and D are as defined above in Article 1.07.B.4.a.1.

U.F. is the "usage factor", and is used to time-average the noise levels associated with an operating piece of equipment. The U.F. is expressed as the fraction of time that the equipment is operated at full power while on site. This factor shall be estimated by the Contractor or the Acoustical Engineer. Guidelines for the selection of usage factors are provided by the U.S. Environmental Protection Agency ("Noise From Construction Equipment and Operations, Building Equipment, and Home Appliances", U.S. Environmental Protection Agency Report NTID 300.1, December 31, 1971), or are also available upon request from the Engineer.

2. Combine the individual contributions of each piece of equipment to obtain the overall construction Leq at the lot-line as follows:

$$Leq(\text{overall}) = 10 \log \Sigma 10^{[Leq(\text{equipment})/10]}$$

- c. Calculate L10:

Finally, as supported by previous construction noise studies, calculate the estimated overall L10 by simply adding 3 dBA to the overall Leq as follows:

$$L10(\text{overall}) = Leq(\text{overall}) + 3 \text{ dBA}$$

5. Noise Level Limit Calculations

Perform calculations to determine L10 lot-line noise level limits during applicable daytime, evening, and nighttime periods based on the background noise level data as specified in Article 3.01 of this Section. The calculations shall be made for noise monitoring locations as specified in paragraph 1.06.B.1.

- a. Determine the L10 noise level limits for Monday through Saturday daytime, evening, and nighttime time periods from Table 1 based on the background L10 noise levels (as furnished by the Engineer) for each time period.
 - b. Determine the L10 noise level limits for Sunday by adding 5 dBA to the Sunday background data (as furnished by the Engineer) for three time periods: 12 midnight to 7 AM, 7 AM to 6 PM, and 6 PM to 12 midnight.
 - c. The L_{max} noise level limits are absolute limits from Table 1 and do not rely on background conditions.
6. A sketch of the construction site indicating the following:
 - a. Contract name and number, Contractor's name, date, scale, legend of symbols, and direction of North.
 - b. Construction equipment locations, designated by codes used in Column (a) in Figure 2.
 - c. All noise receptor locations near the construction site, as specified in paragraph 1.06.B.1.
 - d. Locations and types of noise reduction measures that may be required to demonstrate compliance with noise limits as specified in Article 1.04 of this Section.
 7. A summary table listing the anticipated unmitigated and, if warranted, mitigated construction noise levels shall be provided for all the noise receptor locations (per Article 1.06.B.1.). Each receptor's appropriate lot-line criteria limits (from Table 1) shall also be referenced in the table.
 8. A description of noise reduction measures, if necessary, to meet the lot-line and equipment noise level limitations as specified in Tables 1 and 2. The noise reduction measures may include, but not be limited to, the noise reduction materials and equipment listed in Article 2.03 and noise reduction methods listed in Article 3.03 of this Section. If noise reduction measures are required, re-calculate the noise levels at the lot-line of the noise monitoring location using the anticipated noise reduction measures and submit the results in Figure 3.
 9. Where excessive noise levels are anticipated, noise mitigation measures must be proposed. The beneficial noise reducing effects of the mitigation measures must be quantitatively predicted, and compliance with the specified noise limits in Table 1 must be demonstrated in the resulting predicted mitigated noise levels. Calculations for noise barrier performance design predictions shall use the "path-length-difference" method involving fresnel numbers.
 10. Any drawings, sketches and suitable calculations which demonstrate anticipated noise reduction benefits. Submit shop and working drawings, computations, materials data, and other descriptions as specified in paragraph 1.03.F.

1.08 EQUIPMENT NOISE CERTIFICATION

- A. The construction equipment to be certified includes any equipment of the types listed in Table 2 brought on-site. Noise emission limits in Table 2 shall apply to Contractor and subcontractor equipment.
- B. All construction equipment that meets the requirements described above shall be tested using the procedures specified in Article 3.05 of this Section to ensure compliance with equipment L_{max} noise limits in Table 2. The equipment noise certification shall be overseen by the Acoustical Engineer and certificates shall be submitted to the Engineer as specified in paragraph 1.03.E.
- C. Equipment shall be tested every 6 months while in use and shall also be subject to periodic compliance testing whenever evidence of non-compliance is apparent. Testing shall be performed as described in Article 3.05 of this Section.
- D. Equipment without a currently valid noise certification on file with the Engineer, or equipment that fails its random noise compliance test (i.e. exceeds the 50 ft emission limits in Table 2) shall be required to cease operation until adequate mitigation measures can be implemented.

MATERIALS

2.01 GENERAL

- A. All equipment and materials specified in this part will remain the property of the Contractor or Contractor's subcontractors, vendors, and suppliers, as applicable.

2.02 NOISE MONITORING EQUIPMENT

- A. All noise measurements shall be performed with an instrument that is in compliance with the criteria for a Type 1 (Precision) or Type 2 (General Purpose) Sound Level Meter as defined in the current revision of ANSI Standard S1.4.
- B. The sound level meter shall be capable of measuring dBA noise levels and operating on the SLOW response setting.
- C. Sound level meters shall be capable of measuring L_{max} and L₁₀ over 20 minute intervals in the field without the need for post-processing of data.
- D. All sound level meters, microphones, and calibrators shall undergo certified laboratory calibration conformance testing at least once a year. The calibration certificate shall be submitted to the Engineer as specified in paragraph 1.03.C.
- E. The sound level meter shall be on-site and readily accessible at all times.
- F. All noise monitoring equipment must be documented as being "Y2K Compliant" to avoid any problems associated with the year 2000 programing issues.

2.03 NOISE REDUCTION MATERIALS AND EQUIPMENT

- A. Noise reduction materials may be new or used. Used materials shall be of a quality and condition to perform their designed function.
- B. Noise reduction equipment and materials may include, but not be limited to:
 1. Shields, shrouds, or intake and exhaust mufflers.
 2. Noise-deadening material to line hoppers, conveyor transfer points, storage bins, or chutes.
 3. Noise barriers using materials consistent with the Temporary Noise Barrier materials specified in Article 2.04 of this Section.
 4. Noise curtains using materials consistent with the Noise Control Curtains materials specified in Article 2.06 of this Section.
- C. All equipment with back-up alarms operated by the Contractor, vendors, suppliers, and subcontractors on the construction site shall be equipped with either audible self-adjusting ambient-sensitive back-up alarms or manually-adjustable alarms. The ambient-sensitive alarms shall automatically adjust to a maximum of 5 dBA over the surrounding background noise levels. The manually-adjustable alarms shall be set at the lowest setting required to be audible above the surrounding noise. Installation and use of the alarms shall be consistent with the performance

requirements of the current revisions of Society of Automotive Engineering (SAE) J994, J1446, and OSHA regulations, and as described in an Exhibit at the end of Division II Special Provisions.

- D. All equipment used on the construction site, including jackhammers and pavement breakers, shall have exhaust systems and mufflers that have been recommended by the manufacturer as having the lowest associated noise.
- E. The local power grid shall be used wherever feasible to limit generator noise. No generators larger than 25 KVA shall be used and, where a generator is necessary, it shall have maximum noise muffling capability and meet the noise emission limits specified in Table 2.

2.04 TEMPORARY NOISE BARRIERS

- A. Temporary barriers shall be constructed of 3/4-inch Medium Density Overlay (MDO) plywood sheeting, or other material of equivalent utility and appearance having a surface weight of 2 pounds per square foot or greater. The temporary noise barriers shall have a Sound Transmission Class of STC-30, or greater, based on certified sound transmission loss data taken according to ASTM Test Method E90.
- B. The temporary barriers shall be lined on one side with glass fiber, mineral wool, or other similar noise curtain type noise-absorbing material at least 2-inches thick and have a Noise Reduction Coefficient rating of NRC-0.85, or greater, based on certified sound absorption coefficient data taken according to ASTM Test Method C423.
- C. The materials used for temporary barriers shall be sufficient to last through the duration of construction for this Contract, and shall be maintained in good repair.
- D. Construction Details
 - 1. Barrier panels shall be attached to support frames constructed in sections to provide a moveable barrier utilizing the standard "Temporary Precast Concrete Median Barrier" for the Project, as shown on Standard Drawing SD-H-401 and SD-H-403 for Construction Barricade, or other supports designed to withstand 80 mph wind loads plus a 30 percent gust factor.
 - 2. When barrier units are joined together, the mating surfaces of the barrier sides shall be flush with each other. Gaps between barrier units, and between the bottom edge of the barrier panels and the ground, shall be closed with material that will completely fill the gaps, and be dense enough to attenuate noise.
 - 3. The barrier height shall be designed to break the line-of-sight and provide at least a 5 dBA insertion loss between the noise producing equipment and the upper-most story of the receptor(s) requiring noise mitigation. If for practicality or feasibility reasons, which are subject to the review and approval of the Engineer, a barrier can not be built to provide noise relief to all stories, then it must be built to the tallest achievable height.
- E. Prefabricated acoustic barriers are available from various vendors. An equivalent barrier design can be submitted as specified in Paragraph 1.03.F. in lieu of the plywood barrier described above.

2.05 ACOUSTICAL BARRIER ENCLOSURE

- A. Materials
 - 1. The acoustical barrier enclosure shall consist of durable, flexible composite material featuring a noise barrier layer bonded to sound-absorptive material on one side.
 - 2. The noise barrier layer shall consist of rugged, impervious material with a surface weight of at least one pound per square foot. The sound absorptive material shall include a protective face and be securely attached to one side of the flexible barrier over the entire face.
 - 3. The acoustical material used shall be weather and abuse resistant, and exhibit superior hanging and tear strength during construction. The material shall have a minimum breaking strength of 120 lb/in. per FTMS 191 A-M5102 and minimum tear strength of 30 lb/in. per ASTM D117. Based on the same test procedures, the absorptive material facing shall have a minimum breaking strength of 100 lb/in. and a minimum tear strength of 7 lb/in.
 - 4. The acoustical material shall be corrosion resistant to most acids, mild alkalies, road salts, oils, and grease.
 - 5. The acoustical material shall be fire retardant and be approved by the City of Boston Fire Department prior to procurement. It shall also be mildew resistant, vermin proof, and non-hygroscopic.
 - 6. The acoustical material shall have a Sound Transmission Class of STC-25 or greater, based on certified sound transmission loss data taken according to ASTM Test Method E90. It shall also have a Noise Reduction Coefficient rating of NRC-0.70 or greater, based on certified sound absorption coefficient data taken according to ASTM Test Method C423.

7. The Contractor shall submit the name of the manufacturer, properties of the material to be furnished, and two one-foot square samples to the Engineer for review prior to submittal of design and detailed engineering as specified in Paragraph 1.03.F.

B. Construction Details

1. The acoustical barrier enclosure shall be designed similar to the example shown in Exhibit II-C, "Construction Noise Control Specification and Guidelines".
2. The acoustical material shall be installed in vertical and horizontal segments with the vertical segments extending the full enclosure height. All seams and joints shall have a minimum overlap of 2 inches and be sealed using double grommets. Construction details shall be performed according to the manufacturer's recommendations.
3. The Contractor shall be responsible for the design, detailing, and adequacy of the framework and supports, ties, attachment methods, and other appurtenances required for the proper construction of the acoustical barrier enclosure.
4. The design and details for the acoustical noise barrier enclosure framework and supports shall be prepared and stamped by a Professional Engineer licensed in the Commonwealth of Massachusetts. The Contractor shall submit the design and detailed engineering drawings to the Engineer as specified in Paragraph 1.03.F.

2.06 NOISE CONTROL CURTAINS

A. Materials

1. The noise control curtain shall consist of durable, flexible composite material featuring a noise barrier layer bonded to sound-absorptive material on one side. The noise barrier layer shall consist of a rugged, impervious material with a surface weight of at least one pound per square foot. The sound absorptive material shall include a protective face and be securely attached to one side of the flexible barrier over the entire face.
2. The noise curtain material used shall be weather and abuse resistant, and exhibit superior hanging and tear strength during construction. The curtain's noise barrier layer material shall have a minimum breaking strength of 120 lb/in. per FTMS 191 A-M5102 and minimum tear strength of 30 lb/in. per ASTM D117. Based on the same test procedures, the noise curtain absorptive material facing shall have a minimum breaking strength of 100 lb/in. and a minimum tear strength of 7 lb/in.
3. The noise curtain material shall be corrosion resistant to most acids, mild alkalies, road salts, oils, and grease. It also shall be mildew resistant, vermin proof, and non-hygroscopic.
4. The noise curtain material shall be fire retardant and be approved by the City of Boston Fire Department prior to procurement.
5. The noise control curtain shall have a Sound Transmission Class of STC-30 or greater, based on certified sound transmission loss data taken according to ASTM Test Method E90. It shall also have a Noise Reduction Coefficient rating of NRC-0.85 or greater, based on certified sound absorption coefficient data taken according to ASTM Test Method C423.
6. The Contractor shall submit the name of the manufacturer, properties of the material to be furnished, and two one-foot square samples to the Engineer for review prior to submittal of the design and detailed engineering drawings as specified in Paragraph 1.03.F.

B. Construction Details

1. The noise control curtains shall be designed such as described in an Exhibit at the end of Division II Special Provisions, "Construction Noise Control Specification and Guidelines." The curtains shall be secured above, at the ground, and at intermediate points by framework and supports designed to withstand 80 mph wind loads plus a 30 percent gust factor.
2. The curtains shall be installed in vertical and horizontal segments with the vertical segments extending the full curtain height to the ground. All seams and joints shall have a minimum overlap of 2 inches and be sealed using Velcro or double grommets spaced 12 inches on center. Curtains shall be fastened to framework and guardrails with wire cable 12 inches on center. Construction details shall be performed according to the manufacturer's recommendations.
3. The curtain height shall be designed to break the line-of-sight and provide at least a 5 dBA insertion loss between the noise producing equipment and the upper-most story of the receptor(s) requiring noise mitigation. If for practicality or feasibility reasons, which are subject to the review and approval of the Engineer, a curtain system can not be built to provide noise relief to all stories, then it must be built to the tallest achievable height.
4. The Contractor shall be responsible for the design, detailing, and adequacy of the framework and supports, ties, attachment methods, and other appurtenances required for the proper installation of the noise control curtains.

5. The design and details for the noise control curtains framework and supports shall be prepared and stamped by a Professional Engineer licensed in the Commonwealth of Massachusetts. The Contractor shall submit the design and detailed engineering drawings to the Engineer as specified in Paragraph 1.03.F.

CONSTRUCTION METHODS

3.01 NOISE MONITORING METHODS

A. General

1. The sound level meter and the acoustic calibrator shall be calibrated and certified annually by the manufacturer or other independent certified acoustical laboratory. The sound level meter shall be field calibrated using an acoustic calibrator, according to the manufacturer's specifications, prior to and after each measurement.
2. All measurements shall be performed using the A-weighting network and the SLOW response of the sound level meter.
3. The measurement microphone shall be fitted with an appropriate windscreen, shall be located 5 feet above the ground, and shall be at least 5 feet away from the nearest acoustically-reflective surface.
4. Noise monitoring shall not be performed during precipitation or when wind speeds are greater than 15 mph, unless the microphone is protected in such a manner as to negate the acoustic effects of rain and high winds.

B. Background Noise Monitoring

1. Background noise measurements have been taken for at least 24 hours over two non-consecutive days Monday through Saturday and one Sunday at noise monitoring receptor locations as specified in paragraph 1.06.B.1 prior to the start of construction. Consequently, background noise measurements for each of the noise monitoring receptor locations identified in Table 3 and Figure 1 will be furnished by the Engineer.

C. Construction Noise Monitoring

1. Noise level measurements shall be taken at each noise-sensitive location during ongoing construction activities at least once each week during the applicable daytime, evening, and nighttime period. All other noise monitoring locations as specified in paragraph 1.06.B.1 shall be measured at least once each week during the daytime period.
2. The time period for each noise measurement shall be 20 minutes.
3. Construction noise measurements shall coincide with daytime, evening, and nighttime periods of maximum noise-generating construction activity, and shall be performed during the construction phase or activity that has the greatest potential to exceed noise level limitations as specified in Article 1.04 of this Section. Compliance noise measurements for the noise limits in Table 1 shall be performed at a point on a given lot-line which is the closest to the construction activity.
4. If, in the estimation of the person performing the measurements, outside sources contribute significantly to the measured noise level, the measurements shall be repeated with the same outside source contributions when construction is inactive to determine the background noise level contribution.
5. All measurements shall be taken at the affected lot-line. In situations where the work site is within 50 feet of a lot-line, the measurement shall be taken from a point along the lot-line such that a 50 foot distance is maintained between the sound level meter and the construction activity being monitored.
6. Two 24-hour noise monitors shall be maintained at the lot-line of noise receptor locations and shifted among locations corresponding to construction activity as directed by the Engineer. These monitors shall be capable of recording the Lmax and L10 values in 20-minute intervals over 24-hour periods. These monitors shall be durable and enclosed in weather resistant cases, and located in a manner that will prevent vandalism. The data shall be downloaded and submitted as specified by Paragraph 1.03.E.

3.02 REPORTING

- A. Background, construction, and complaint response noise data shall be recorded on the Noise Measurements Report Form provided in Figure 4. The type of measurement shall be noted on the form.
- B. Twenty-four hour noise measurements shall be plotted graphically showing L10 and Lmax noise levels vs time along with appropriate lot-line criteria limits (from Table 1) for daytime, evening, and nighttime periods.
- C. Provide a sketch or diagram for the exact location of the noise measurement on the back of Figure 4. Include the location and distance of the noise measurement in relationship to the noise monitoring location specified in paragraph 1.06.B.1.

- D. During construction and complaint response monitoring, all construction equipment operating during the monitoring period shall be identified and the location sketched on the back of Figure 4. The sketch shall include the distance between the noise measurement location and the construction equipment.
- E. All activities occurring while performing noise measurements shall be noted in the "Field Notes" area of Figure 4. For example, "auger banging on ground to clean soil from threads" or "heavy traffic passing near the sound level meter." In addition, any noise level of 85 dBA or greater requires an explanation.

3.03 NOISE REDUCTION METHODS

- A. The Contractor shall use all reasonable efforts to implement noise reduction methods listed below to minimize construction noise emission levels and as described or specified under Limiting Unnecessary Construction Noise in an Exhibit at the end of Division II Special Provisions. Noise reduction methods shall include, but not be limited to:
 1. Use of: 1) concrete crushers or pavement saws for concrete deck removal, demolitions, or similar construction activity; 2) pre-auguring equipment to reduce the duration of impact or vibratory pile driving; 3) local power grid to reduce the use of generators.
 2. Attaching: 1) intake and exhaust mufflers, shields, or shrouds; 2) noise-deadening material to inside of hoppers, conveyor transfer points, or chutes.
 3. Maintaining: 1) equipment mufflers and lubrication; 2) precast decking or plates; 3) surface irregularities on construction sites to prevent unnecessary noise.
 4. Limiting: 1) the number and duration of equipment idling on the site; 2) the use of annunciators or public address systems; 3) the use of air or gasoline-driven hand tools.
 5. Configuring, to the extent feasible: 1) the construction site in a manner that keeps loud equipment and activities as far as possible from noise-sensitive locations; 2) barrels or signage to detour traffic away from plated trenches.
 6. Scheduling of construction events and limiting usage times to minimize noise, especially during nighttime hours and near sensitive abutters.
 7. Constructing noise barriers and/or noise curtain systems.
 8. Minimizing noise from the use of back-up alarms using measures that meet OSHA regulations. This includes use of self-adjusting ambient-sensitive backup alarms, manually-adjustable alarms on low setting, use of observers, and scheduling of activities so that alarm noise is minimized.
 9. Where practical and feasible, configuring construction sites to minimize back-up alarm noise. For example, construction site access should be designed such that delivery and dump trucks move through the site in a forward manner without the need to back up.
 10. Preventing nuisance noise conditions using methods such as those described under Limiting Unnecessary Construction Noise in an Exhibit at the end of Division II Special Provisions.
 11. Using only variable message and sign boards that are solar powered or connected to the local power grid.

3.04 TEMPORARY NOISE BARRIERS

- A. General
 1. The Contractor shall erect temporary noise barriers to mitigate construction noise at locations specified in the Noise Control Plan or as directed by the Engineer.
 2. The temporary noise barriers shall be readily moveable so that they may be re-positioned, as necessary, to provide noise abatement for non-stationary, as well as stationary, processes.
- B. Installation, Maintenance, and Removal
 1. The barriers shall be installed such that the noise-absorptive surfaces face the construction noise source.
 2. The Contractor shall maintain the temporary noise barriers and repair all damage that occurs, including, but not limited to, keeping barriers clean and free from graffiti and maintaining structural integrity. Gaps, holes, and weaknesses in the barriers, and openings between or under the units, shall be repaired promptly or replaced by the Contractor with new material.
 3. The Contractor shall remove and dispose of the temporary noise barriers at the end of the Contract or sooner at the direction of the Engineer.

3.05 EQUIPMENT NOISE CERTIFICATION

A. General

1. For each piece of equipment meeting the requirements of paragraph 1.08.A of this Section, complete an Application for Certificate of Equipment Noise Compliance (Figure 5), which shall be signed by the Acoustical Engineer.
2. The equipment identification number used for certification shall be consistent with the identification number used in the Noise Control Plan (Figure 2).

B. Test Procedures for Construction Equipment

1. All engine-powered equipment shall be operated at high idle (maximum governed rpm) under full-load condition during the test.
2. Portable and mounted impact devices, such as hoe-rams and jackhammers, shall be tested during the first day of actual operation at the construction site under maximum load conditions as rated by the equipment manufacturer.
3. Pile-driving equipment shall be tested under maximum load conditions as rated by the manufacturer.
4. All noise monitoring equipment specified in Article 2.02 of this Section shall have a current certificate of calibration sticker affixed to it.
5. An acoustic calibrator of the type recommended by the sound level meter manufacturer shall be used prior to and after all measurements.
6. The noise level measurements shall be for a minimum period of 1 minute.
7. If possible, measurements shall be made at 50 feet \pm 2 feet from the front, rear, and right and left sides of the equipment, at a height of 5 feet above ground level.
8. Measurements made at less than 50 feet, due to space limitations at the test site, shall be reduced by the values given in Table 4 to estimate the 50 foot noise level.
9. When confirmatory noise level testing is requested by the Engineer, the Contractor shall locate and operate the equipment as directed by the Engineer at the designated site so as to facilitate recording of the noise level by the Contractor.

C. Compliance

1. If the Lmax noise levels expressed in dBA, slow, obtained during the tests exceed those specified in Table 2, the Contractor shall promptly modify or alter such equipment, or substitute other equipment, and retest the equipment to show compliance with the noise level requirements.
2. Upon compliance, the Contractor shall submit the noise certificates to the Engineer for validation as specified in paragraph 1.03.E.
3. The Certificate of Noise Compliance will remain valid for a period of 6 months only. Delays caused by the certification rejection, and time lost in mitigating the rejected equipment or finding alternate acceptable equipment, shall not be a basis for any monetary or time delay claims, or for avoidance of late completion penalties.

3.06 COMPLAINT PROCEDURE

A. General

1. The objective of the complaint procedure is to ensure that public and agency complaints are addressed and resolved consistently and expeditiously.

B. If the Contractor receives a complaint regarding construction noise, the Contractor shall immediately notify the Engineer and the Interim Operations Center (IOC) or successor to the IOC.

C. Upon receipt or notification of a noise complaint from the Engineer, the Contractor shall promptly perform noise measurements at the complainant's location during activities representative of the offending operation. The noise measurements shall be performed using equipment and methods as specified in Articles 2.02 and 3.01 and reported as specified in Article 3.02 of this Section. The complaint response noise measurements shall be immediately submitted to the Engineer as specified in paragraph 1.03.E of this Section.

D. In the event that the measured noise level exceeds allowable limits as specified in Article 1.04 of this Section, or is resulting in nuisance conditions, the Contractor shall immediately use noise reduction materials and methods such as, but not limited to, those described in Article 3.03 to reduce noise levels or to alleviate the nuisance conditions.

3.07 ACOUSTICAL BARRIER ENCLOSURE

A. General

1. The Contractor shall erect acoustical barrier enclosures to mitigate construction noise at locations specified in the Noise Control Plan as required in Article 1.07, construction drawings, or as directed by the Engineer.
2. The acoustical barrier enclosures shall be readily moveable so that they may be repositioned, as necessary, to provide noise abatement for non-stationary equipment (e.g., jackhammers, chain saws, compressors).

B. Installation, Maintenance, and Removal

1. The acoustical enclosure shall be installed such that the noise-absorptive surfaces face the construction noise source.
2. The Contractor shall maintain the acoustical barrier enclosures and repair all damage that occurs, including, but not limited to, keeping barriers clean and free from graffiti and maintaining structural integrity. Gaps, holes, and weaknesses in the acoustical enclosure, and openings between or under the panels, shall be repaired promptly or replaced by the Contractor with new material. Construction work shall not proceed until such repairs are made.
3. The Contractor shall remove and dispose of the acoustical enclosure at the end of the Contract or sooner at the direction of the Engineer.

3.08 NOISE CONTROL CURTAINS

A. General

1. The Contractor shall erect noise control curtains to mitigate construction noise at locations specified in the Noise Control Plan as required in Article 1.07, construction drawings, or as directed by the Engineer.
2. Noise control curtains shall particularly be used for short-term operations (e.g., less than 3 months), or where vehicular or pedestrian access is required during the day, or as directed by the Engineer.

B. Installation, Maintenance, and Removal

1. The noise control curtains shall be installed without any gaps such that the sound-absorptive side faces the construction activity to be shielded. The curtains shall be supported by the existing elevated Expressway, ramps, or other methods identified in the Noise Control Plan.
2. The Contractor shall maintain the noise control curtains and repair all damage that occurs, including, but not limited to, keeping barriers clean and free from graffiti and maintaining structural integrity. Gaps, holes, and weaknesses in the noise control curtains, and openings between or under the panels, shall be repaired promptly or replaced by the Contractor with new material. Construction work shall not proceed until such repairs are made.
3. The Contractor shall remove and dispose of the noise control curtains at the end of the Contract or sooner at the direction of the Engineer.

COMPENSATION

4.01 METHOD OF MEASUREMENT

- A. The Noise Monitoring Plan and first Noise Control Plan will be considered incidental to Mobilization (Section 748.001).
- B. The 6 month Noise Control Plans, equipment certifications, and complaint response and weekly construction noise monitoring reports will be considered incidental to the construction.
- C. Temporary noise barriers installed per Article 3.04 of this Section will be measured by surface area of one face of the noise barrier wall with no additions for bracing, supports, and other such projections.
- D. Acoustical barrier enclosures constructed per Article 3.07 of this Section will be measured by surface area of one face of the acoustical enclosure with no additions for bracing, supports, and other such projections.
- E. Noise control curtains installed per Article 3.08 of this Section will be measured by surface area of one face of the noise control curtains with no additions for bracing, supports, and other such projections.

4.02 BASIS OF PAYMENT

- A. Payment for the Noise Monitoring Plan and first Noise Control Plan will be considered part of the payment for Mobilization.
- B. Payment for the 6 month Noise Control Plans, equipment certifications, and complaint response and weekly construction noise monitoring reports will be considered part of the payment for related construction.

- C. Payment for temporary noise barriers installed per Article 3.04 of this Section will be at the Contract unit price per square foot, which shall be full compensation for constructing, providing, placing, maintaining, moving, and disposing of temporary noise barrier walls.
- D. Payment for the acoustical barrier enclosures constructed per Article 3.07 of this Section will be at the Contract unit price per square foot, which shall be full compensation for constructing, providing, placing, maintaining, moving, relocating, and disposing of temporary acoustical barrier enclosure.
- E. Payment for the noise control curtains installed per Article 3.08 of this Section will be at the Contract unit price per square foot, which shall be full compensation for constructing, providing, placing, maintaining, moving, relocating, and disposing of the noise control curtains.

4.03 PAYMENT ITEM

- 721.565 Temporary Noise Barrier Square Foot
- 700.721 Acoustical Barrier Enclosure Square Foot
- 700.722 Noise Control Curtains Square Foot

TABLE 1. CONSTRUCTION NOISE LOT-LINE LIMITS^c

<u>Noise Monitoring Location Land Use</u>	<u>L10 Level (dBA)^b (whichever is greater)</u>	<u>Lmax Level (dBA)^b</u>
DAYTIME (7 AM to 6 PM)		
Noise-Sensitive Locations	75 <u>or</u> Background + 5 (a)	85 (b); 90 (impact equipment)
Commercial Areas	80 <u>or</u> Background + 5 (a)	None
Industrial Areas	85 <u>or</u> Background + 5 (a)	None
EVENING (6 PM to 10 PM)		
Noise-Sensitive Location	Background +5	85
Commercial Areas	None	None
Industrial Areas	None	None
NIGHTTIME (10 PM to 7 AM)		
Noise-Sensitive Locations		
If Background < 70 dBA	Background +5	80
If Background ≥ 70 dBA	Background +3	80
Commercial Areas	None	None
Industrial Areas	None	None

NOTES

(a) Noise from impact equipment is exempt from this requirement.

(b) All measurements shall be taken at the affected lot-line. In situations where the work site is within 50 feet of a lot-line, the measurement shall be taken from a point along the lot-line such that a 50 foot distance is maintained between the sound level meter and the construction activity being monitored.

(c) Lot-line noise limits shall apply to all points along the receptor's lot-line.

TABLE 2
CONSTRUCTION EQUIPMENT 50 FOOT NOISE EMISSION LIMITS

<u>Equipment Category</u>	<u>Lmax Level (dBA)^{1,2}</u>	<u>Impact/Continuous</u>
Arc Welder	73	Continuous
Auger Drill Rig	85	Continuous
Backhoe	80	Continuous
Bar Bender	80	Continuous
Boring Jack Power Unit	80	Continuous
Chain Saw	85	Continuous
Compressor ³	70	Continuous
Compressor (other)	80	Continuous
Concrete Mixer	85	Continuous
Concrete Pump	82	Continuous
Concrete Saw	90	Continuous
Concrete Vibrator	80	Continuous
Crane	85	Continuous
Dozer	85	Continuous
Excavator	85	Continuous
Front End Loader	80	Continuous
Generator	82	Continuous
Generator (25 KVA or less)	70	Continuous
Gradall	85	Continuous
Grader	85	Continuous
Grinder Saw	85	Continuous
Horizontal Boring Hydro Jack	80	Continuous
Hydra Break Ram	90	Impact
Impact Pile Driver	95	Impact
Insitu Soil Sampling Rig	84	Continuous
Jackhammer	85	Impact
Mounted Impact Hammer (hoe ram)	90	Impact
Paver	85	Continuous
Pneumatic Tools	85	Continuous
Pumps	77	Continuous
Rock Drill	85	Continuous
Scraper	85	Continuous
Slurry Trenching Machine	82	Continuous
Soil Mix Drill Rig	80	Continuous
Street Sweeper	80	Continuous
Tractor	84	Continuous
Truck (dump, delivery)	84	Continuous
Vacuum Excavator Truck (vac-truck)	85	Continuous
Vibratory Compactor	80	Continuous
Vibratory Pile Driver	95	Continuous
All other equipment with engines larger than 5 HP	85	Continuous

NOTES:

¹ Measured at 50 feet from the construction equipment, with a “slow” (1 sec.) time constant.

² Noise limits apply to total noise emitted from equipment and associated components operating at full power while engaged in its intended operation.

³ Portable Air Compressor rated at 75 cfm or greater and that operates at greater than 50 psi.

**TABLE 3
NOISE MONITORING LOCATIONS (SEE FIGURE 1)**

CA/T LOCATION	<u>LOCATION/ADDRESS</u>	<u>LAND USE NUMBER</u>
----------------------	--------------------------------	-------------------------------

CONTRACT SPECIFIC NOISE MONITORING LOCATIONS

TABLE 4
ADJUSTMENTS FOR EQUIPMENT NOISE MEASUREMENTS AT LESS THAN 50 FEET

<u>Measurement</u> <u>Distance (Feet)</u>	<u>Values to be Subtracted from Measured Noise</u> <u>Level to Estimate Noise Level at 50 Feet (dBA)</u>
19-218	
22-237	
24-266	
27-295	
30-334	
34-373	
38-422	
43-471	
48-500	

INSERT CONTRACT- SPECIFIC MAP

FIGURE 1. NOISE MONITORING LOCATIONS

NOISE CONTROL PLAN (DUPLICATE AS NEEDED)

PART A: EQUIPMENT INVENTORY

Contract No.: _____ Contract Name: _____ Contractor: _____

Site: _____ Date: _____

Resubmit every 6 months
(ATTACH SITE SKETCH)

Code (a)	Equipment				Noise Limit (dBA) (f)	Estimated Noise at 50' (dBA) (g)	Date Begin (h)	Date End (i)	Daily Use (j)
	Category (b)	Model (c)	ID# (d)	HP (e)					
									D/E/N
									D/E/N
									D/E/N
									D/E/N
									D/E/N
									D/E/N
									D/E/N

FIGURE 2. NOISE CONTROL PLAN FORM - PART A

NOISE CONTROL PLAN (DUPLICATE AS NEEDED)

PART B: PREDICTED NOISE LEVELS

Contract No.: _____
 Contractor: _____
 Date: _____

Contract Name: _____
 Site: _____
 Land Use: _____

Resubmit every 6 months

Time Period	Calculated Noise Levels (dBA)		Noise Level Limit (dBA)	
	Calculated L ₁₀ (dBA)	Calculated L _{max} (dBA)	L ₁₀ Limit (dBA)	L _{max} Limit (dBA)
Daytime				
Evening				
Nighttime				

NOISE ABATEMENT MEASURES

ANTICIPATED EFFECTS

CALCULATIONS - attach additional sheet(s) as needed

FIGURE 3. NOISE CONTROL PLAN FORM - PART B

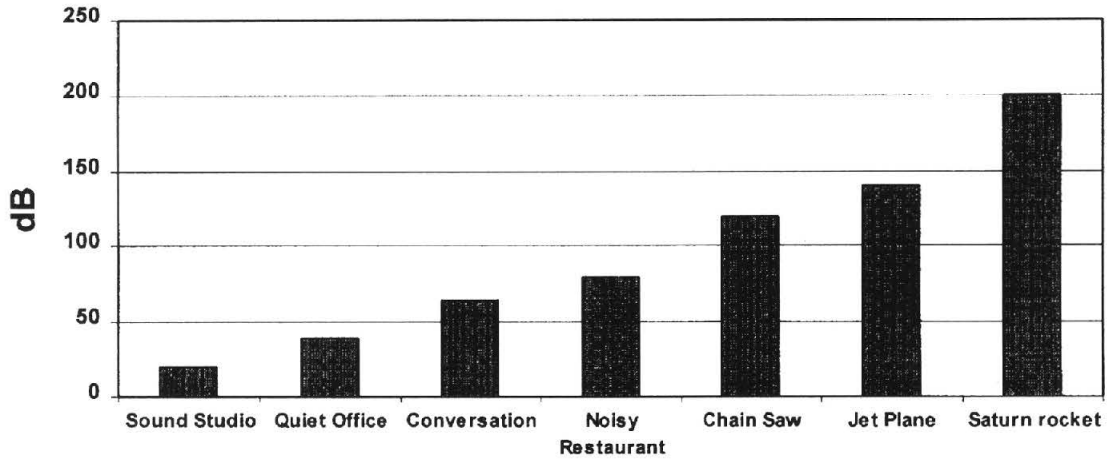



CENTRAL ARTERY/TUNNEL

CONTRACT NO(S)

DATE:

TIME: _____ H

(0000 H-2539 H)

NOISE MEASUREMENTS REPORT FORM

MEASURED BY: _____ OF: _____
(COMPANY)

MONITORING ADDRESS: _____
(PROVIDE SKETCH ON BACK)

LOCATION NO: N - _____ WIND SPEED: _____ MPH DIRECTION: _____

LOCATION OF SOUND LEVEL METER: (NO CLOSER THAN 50 FEET FROM EQUIPMENT AND 5 FEET FROM REFLECTIVE SURFACE)

MONITORING WAS CONDUCTED: _____ FEET FROM EQUIPMENT (_____)
(TYPE(S); LEAVE BLANK FOR BASELINE)

LAND USE: RESIDENTIAL/INSTITUTIONAL BUSINESS/RECREATIONAL INDUSTRIAL

SOUND LEVEL METER: MAKE AND MODEL: _____

DURATION OF MEASUREMENT:

CALIBRATION LEVEL: _____

FIELD NOTES

(e.g., 2200-2205 H, AIRPLANE, 90dBA)

	Noise Level	Noise Limit
	(dBA)	(dBA)
L _{max} *		
L ₁₀ *		
L ₅₀		
L ₉₀		
L _{eq}		

- CHECK ONE OF THE FOLLOWING
- ONGOING CONSTRUCTION
- POST-CONSTRUCTION:
- BASELINE CONDITIONS
(CONTRACT)

(COMPLETE ALL THAT APPLY BELOW)

ACTIVE CONTRACT(S): _____ (LIST ALL CONTRACTS THAT CONTRIBUTE TO MEASURED NOISE)

COMPLAINT RESPONSE: _____ (DESCRIBE; INCLUDE LOG-IN NUMBER)

ABATEMENT FOLLOW UP: _____ (DESCRIBE)

FIGURE 4. NOISE MEASUREMENTS REPORT FORM

APPLICATION FOR CERTIFICATE OF EQUIPMENT NOISE COMPLIANCE

Contractor Name:

Contract Name & Number:

Equipment Type:

Manufacturer & Model NO:

Identification Number:

Rated Power & Capacity:

Operating Cond. During Test:

Measured Lmax Noise Levels and Distance:

Right Side: _____ dBA(SLOW), at _____ feet

Left Side: _____ dBA(SLOW), at _____ feet

Adjusted Lmax Noise Levels at 50 Feet:

Right Side: _____ dBA(SLOW).

Left Side: _____ dBA(SLOW).

Equipment Noise Emission Limit (Table 2): _____ dBA(SLOW)

If equipment noise level exceeds maximum value allowed, indicate action taken to achieve compliance:

ACOUSTICAL ENGINEER

Name, Address & Phone No.

ACOUSTICAL ENGINEER

Authorized Signature: _____ Date:

CONTRACTOR'S CONCURRENCE:

Authorized Signature: _____ Date:

ENGINEER'S CONCURRENCE:

Authorized Signature: _____ Date:

FIGURE 5. EQUIPMENT NOISE LEVEL DATA REPORTING FORM

APPENDIX G

Central Artery/Tunnel Project, Construction Dust Control Specification 721.561

SECTION 721.561	
CONSTRUCTION DUST CONTROL	
DESCRIPTION	
1.01	GENERAL
A.	This Section specifies requirements for controlling dust generated during Work of this Contract. It supplements the air pollution control requirements of Division I, Subsection 7.01B.
B.	The Contractor is responsible for control of dust at all times during Work of this Contract, 24 hours per day, 7 days per week, including nonworking hours, weekends, and holidays.
1.02	REGULATORY REQUIREMENTS
A.	The Contractor shall perform all Work specified under this Section in compliance with the Massachusetts Department of Environmental Protection, Code of Massachusetts Regulations (CMR) 310 CMR 7.00, "Air Pollution Control Regulations", specifically 310 CMR 7.09, "Dust, Odor, Construction and Demolition".
B.	Work of this Contract shall be conducted in a manner that will not result in excessive particulate matter emissions, nuisance dust conditions, or PM ₁₀ (particulate matter with an aerodynamic diameter less than or equal to 10 microns) concentrations exceeding the Massachusetts and National Ambient Air Quality Standard of 150 µg/m ³ on 24-hour average basis.
1.03	SUBMITTALS
A.	Make submittals as required by Division I Subsection 5.02 and 6.01.
B.	Submit product literature and Material Safety Data Sheets for dust suppression wetting agents and stabilizers.
C.	Submit a dust control plan that outlines in detail the measures to be implemented by the Contractor to comply with this Section, including suppression, wind screens and barriers, prevention, cleanup, and other measures.
D.	Submit a plan for seeding to control dust. The plan shall include University of Massachusetts (Amherst MA, Soil Test Lab) soil test results (including soluble salts and organic content) and recommendations, seed species, and quantity of each seed species to be used.
MATERIALS	
2.01	DUST SUPPRESSION AGENTS
A.	Dust suppression wetting agents shall be water soluble, non-toxic, non-reactive, non-volatile, and non-foaming.
CONSTRUCTION DUST CONTROL	
721.561	
CA/T Suppl. Spec. 9/03/96 Page 1 of 5	

- B. Soil stabilizer shall be a sprayable organic or inorganic tackifier.

2.02 BARRIERS, SCREENS, AND COVERS

- A. Wind screens shall be a durable fabric mesh of 50 percent porosity, attached to construction fence.
- B. Wind barriers shall be solid wood fences, solid durable fabric attached to construction fence, or other solid barriers intended to block the passage of wind.
- C. The construction fence itself (chain link or solid) is not part of the Work of this Section.
- D. Covers for stockpiles shall be plastic tarps. Contaminated soil covers shall comply with Section 120.080.

2.03 SEEDING

- A. Seeding for dust control shall conform to Section 765 and the additional requirements of this Section. The Contractor shall conduct soil tests to determine the materials and methods necessary for the Contractor to satisfactorily produce a stand of grass that will effectively control dust. The Contractor shall submit a plan as specified under Submittals.

CONSTRUCTION METHODS

3.01 CONSTRUCTION SITE DUST CONTROL - GENERAL

- A. Wet suppression shall be used to provide temporary control of dust. Several applications per day may be necessary to control dust depending upon meteorological conditions and work activity. The Contractor shall apply wet suppression on a routine basis as necessary or directed by the Engineer, to control dust.
 1. Wet suppression consists of the application of water or a wetting agent in solution with water. Ensure wetting agent is not used on plantable soils.
 2. Wet suppression equipment shall consist of sprinkler pipelines, tanks, tank trucks, or other devices capable of providing regulated flow, uniform spray, and positive shut-off.
- B. Calcium chloride shall be used to control dust instead of wet suppression when freezing conditions exist. Calcium chloride shall be uniformly applied by a mechanical spreader at 1 1/2 pounds per square yard, unless otherwise directed by the Engineer. Ensure vegetation, or soil to be used for vegetation, is not treated.
- C. The use of petroleum products for dust suppression is prohibited in this Contract.
- D. Provide wind screens and wind barriers in locations where they would be effective in minimizing wind erosion and spread of dust. Locations shall be submitted as part of the

Contractor's dust control plan. The Contractor shall keep wind screens and barriers in good repair for the life of the Contract.

- E. Seeding used to prevent wind erosion shall be in accordance with Section 765 and the additional requirements of this Section. During seeding, furnish to the Engineer all container labels, or empty containers, from all materials used. Do not seed without direction of the Engineer.

3.02 PUBLIC ROADWAY DUST CONTROL

- A. Vehicles leaving the construction site shall have no mud and dirt on the vehicle body or wheels. Temporary wheel-wash stations shall be provided and water from wheel-wash stations shall be controlled per Section 140.141.
- B. Haul truck cargo areas shall be securely covered during material transport on public roadways.
- C. Vehicle mud and dirt carryout, material spills, and soil wash-out onto public roadways and walkways and other paved areas shall be cleaned up immediately.
- D. The Contractor is responsible for daily clean-up of public roadways and walkways affected by Work of this Contract. A wet spray power vacuum street sweeper shall be used on paved roadways. Dry power sweeping is prohibited.

3.03 CONTROL OF EARTHWORK DUST

- A. During batch drop operations (i.e., earthwork with front-end loader, clamshell bucket, or backhoe) the free drop height of excavated or aggregate material shall be reduced as practical to minimize the generation of dust.
- B. To prevent spills during transport, freeboard space shall be maintained between the material load and the top of the truck cargo bed rail.

3.04 CONTROL OF STOCKPILE DUST

- A. The Contractor shall use the following methods to control dust and wind erosion of active and inactive stockpiles:
 1. Wet suppression without wetting agent during active stockpile load-in, load-out, and maintenance activities. Salty or brackish water shall not be used on soils to be planted.
 2. Soil stabilizers applied to the surface of inactive stockpiles.
 3. Plastic tarps ^{that are not stabilized} on stockpiles, secured with sandbags or an equivalent method to prevent the cover from being dislodged by the wind. The Contractor shall repair or replace covers whenever damaged or dislodged, at no additional cost to the Department.
 4. Seeding of inactive stockpiles.

- B. The methods to be used shall be submitted to the Engineer as part of the dust control plan and plan for seeding specified under Submittals.

3.05 DEMOLITION DUST CONTROL MEASURES

- A. Closed chutes shall be used for the handling of debris as provided by Section 112. Dropping or throwing of debris is prohibited.
- B. Debris shall not be stockpiled. Debris shall be removed promptly from the site.
- C. During transport of debris, the truck cargo area shall be securely covered.
- D. Removal of asbestos-containing material shall be in accordance with Section 722.810.

COMPENSATION

4.01 METHOD OF MEASUREMENT

- A. Calcium chloride and soil stabilizer will be measured by the respective weight of each material applied.
- B. Water will be measured by the volume applied, determined by use of tanks of known capacity or by satisfactorily installed meters. All measuring devices shall be furnished by the Contractor.
- C. Wetting agents will be measured by weight of wetting agent added to the water to form a solution in accordance with the manufacturer's recommendations.
- D. Street sweeping by wet spray power vacuum street sweeper will be measured by time spent sweeping.
- E. Wind screens, barriers, and covers will be measured by area of material installed.
- F. Seeding will be measured as specified in Section 765.
- G. All other dust control measures specified in this Section will be considered incidental to the Work and will not be measured or paid for separately.

4.02 BASIS OF PAYMENT

- A. Calcium chloride and soil stabilizer will be paid for at the respective Contract unit price per pound.
- B. Water will be paid for at the Contract unit price per M gallons (1000 gallons). (Item 443 will apply to water for stockpile as well as roadway dust control.)
- C. Wetting agents will be paid for at the respective Contract unit prices per pound.

- D. Street sweeping by wet spray power vacuum street sweeper will be paid for at the Contract unit price per hour.
- E. Wind screens, barriers, and covers will be paid for at the respective Contract unit prices per square yard.
 - 1. Construction fences will not be paid for under this Section, but are part of the Work of Section 644.010, 850.005, or other Section as applicable.
 - 2. Covers for contaminated stockpiles will not be paid for under this Section but are part of the Work of Section 120.080.
- F. Seeding will be paid for as specified in Section 765. Seeding includes all necessary related soil testing, seeds, application water, hydrofiber, tackifier, lime, fertilizer, erosion blankets or netting and hay mulch, irrigation, and mowing.

4.03 PAYMENT ITEMS

440.-	Calcium Chloride for Dust Control	Pound
442.-	Street Sweeping	Hour
443.-	Water for Roadway Dust Control	M Gallons
440.101	Wetting Agents for Dust Control	Pound
440.103	Soil Stabilizer for Dust Control	Pound
444.101 ✓	Wind Screen	Square Yard
444.102 ✓	Wind Barrier	Square Yard
444.111 ✓	Temporary Stockpile Cover	Square Yard
765.44	Seeding for Dust Control	Square Yard

TE 7 .N26 no.-218 **34219**

Schexnayder, Cliff J.

Mitigation of nighttime
construction noise,

DATE DUE

DATE DUE	

MTA LIBRARY
ONE GATEWAY PLAZA, 15th Floor
LOS ANGELES, CA 90012

~~ConnDOT Library & Information Center
2800 Berlin Turnpike
Newington, CT 06111-4116~~

DEMCO

THE TRANSPORTATION RESEARCH BOARD is a unit of the National Research Council, a private, nonprofit institution that provides independent advice on scientific and technical issues under a congressional charter. The Research Council is the principal operating arm of the National Academy of Sciences and the National Academy of Engineering.

The mission of the Transportation Research Board is to promote innovation and progress in transportation by stimulating and conducting research, facilitating the dissemination of information, and encouraging the implementation of research findings. The Board's varied activities annually draw on approximately 4,000 engineers, scientists, and other transportation researchers and practitioners from the public and private sectors and academia, all of whom contribute their expertise in the public interest. The program is supported by state transportation departments, federal agencies including the component administrations of the U.S. Department of Transportation, and other organizations and individuals interested in the development of transportation.

The National Academy of Sciences is a nonprofit, self-perpetuating society of distinguished scholars engaged in scientific and engineering research, dedicated to the furtherance of science and technology and to their use for the general welfare. Upon the authority of the charter granted to it by the Congress in 1863, the Academy has a mandate that requires it to advise the federal government on scientific and technical matters. Dr. Bruce Alberts is president of the National Academy of Sciences.

The National Academy of Engineering was established in 1964, under the charter of the National Academy of Sciences, as a parallel organization of outstanding engineers. It is autonomous in its administration and in the selection of its members, sharing with the National Academy of Sciences the responsibility for advising the federal government. The National Academy of Engineering also sponsors engineering programs aimed at meeting national needs, encouraging education and research, and recognizes the superior achievements of engineers. Dr. William A. Wulf is president of the National Academy of Engineering.

The Institute of Medicine was established in 1970 by the National Academy of Sciences to secure the services of eminent members of appropriate professions in the examination of policy matters pertaining to the health of the public. The Institute acts under the responsibility given to the National Academy of Sciences, by its congressional charter to be an adviser to the federal government and, upon its own initiative, to identify issues of medical care, research, and education. Dr. Kenneth I. Shine is president of the Institute of Medicine.

The National Research Council was organized by the National Academy of Sciences in 1916 to associate the broad community of science and technology with the Academy's purposes of furthering knowledge and advising the federal government. Functioning in accordance with general policies determined by the Academy, the Council has become the principal operating agency of both the National Academy of Sciences and the National Academy of Engineering in providing services to the government, the public, and the scientific and engineering communities. The Council is administered jointly by both Academies and the Institute of Medicine. Dr. Bruce Alberts and Dr. William A. Wulf are chairman and vice chairman, respectively, of the National Research Council.

Transportation Research Board
National Research Council
2101 Constitution Avenue, N.W.
Washington, D.C. 20418

ADDRESS CORRECTION REQUESTED

MTA DOROTHY GRAY LIBRARY & ARCHIVE



100000409316