

TRANSIT

MTA LIBRARY
ONE GATEWAY PLAZA, 15th Floor
LOS ANGELES, CA 90012

NOV 16

OPERATING

MANUAL

HE
308
.V83
c.2



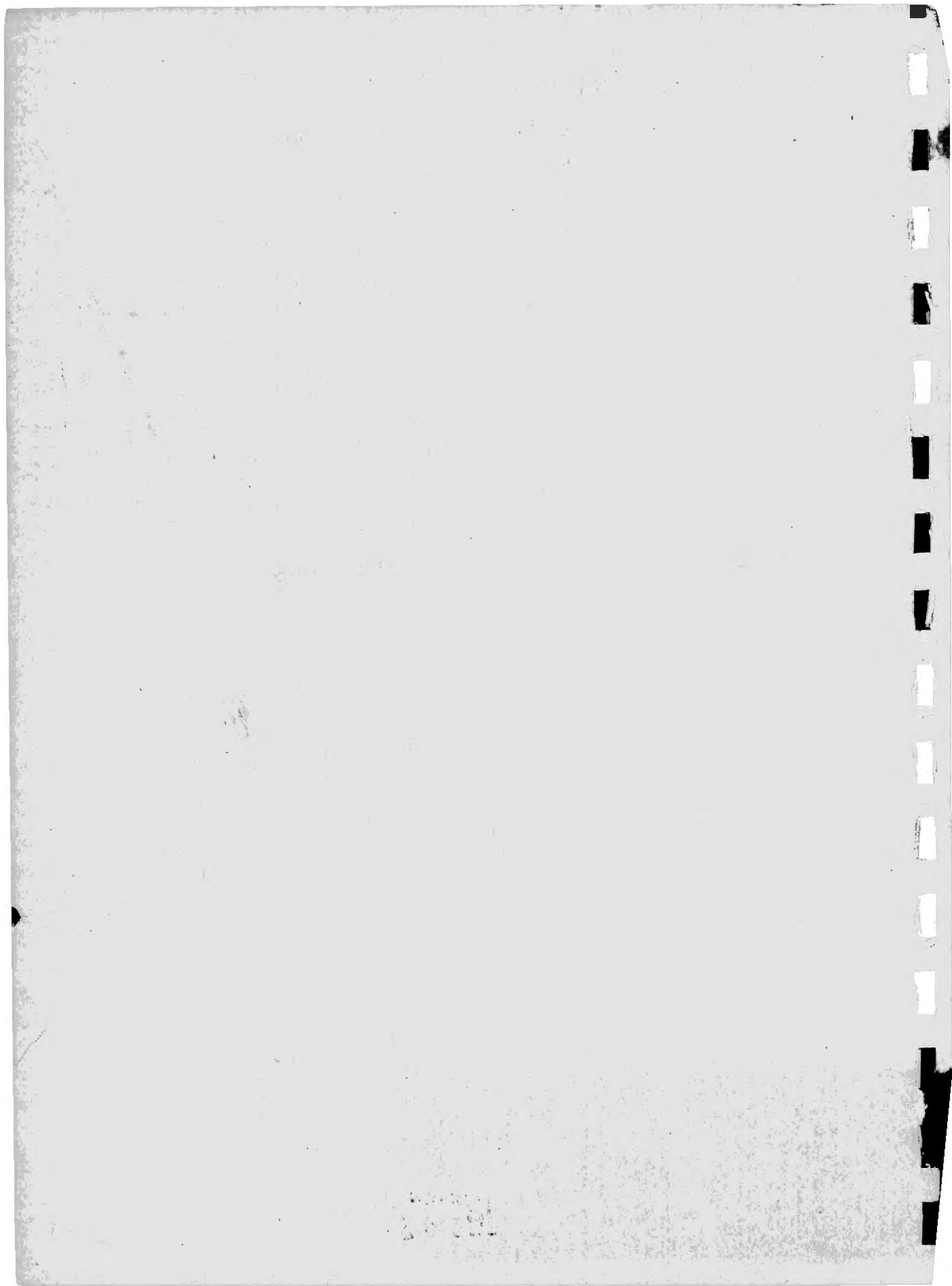

TRANSIT OPERATING MANUAL

Professor Vukan R. Vuchic

with Research Fellows:

F. Brian Day

Shinya Kikuchi

George N. Dorshimer

David J. Rudinger

This Manual has been prepared by the Department of Civil and Urban Engineering, University of Pennsylvania, under a research grant through the Mass Transportation Assistance Program, administered by the Bureau of Mass Transit Systems, Pennsylvania Department of Transportation, Harrisburg.

MILTON J. SHAPP

Governor

Commonwealth of Pennsylvania

WILLIAM H. SHERLOCK, P.E.

Secretary

Department of Transportation

1976

LACTC/RCC
LIBRARY

MTA LIBRARY

ACKNOWLEDGEMENTS

The authors wish to gratefully acknowledge the valuable support for preparation of this Manual from the Bureau of Mass Transit Systems and continuous cooperation of its Director, Mr. William C. Underwood. Constructive comments on the text were also received from Mr. Edson L. Tennyson, Deputy Secretary for Local and Area Transportation, and Mr. Robert Doughty, Director of the Bureau of Traffic Engineering, Pennsylvania Department of Transportation. Responsibility for accuracy of the presented materials rests with the authors.

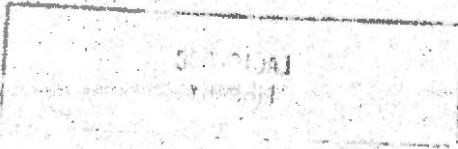

TABLE OF CONTENTS

	<u>Page</u>
LIST OF ILLUSTRATIONS	vii
LIST OF TABLES	ix
CHAPTER 1: INTRODUCTION	1- 1
1.1 Purpose of the Manual	1- 2
1.2 Potential Users of the Manual	1- 2
CHAPTER 2. POLICY, LEGISLATION, AND FINANCING	2- 1
2.1 Rationale for Mass Transit Public Assistance	2- 1
2.2 Pennsylvania's Legislative Policy on Mass Transportation Assistance	2- 2
2.2.1 Mass Transportation Assistance Program Goals and Objectives	2- 2
2.2.2 Financing Mass Transit Operating Deficits	2- 3
2.2.3 Financing Mass Transit Capital Improvement Projects	2- 4
2.2.4 Other Funding Programs	2- 5
CHAPTER 3: TRANSIT PLANNING	3- 1
3.1 Definition of a Transit Plan	3- 1
3.2 Long-Range Transit Planning	3- 1
3.2.1 Examples of Long-Range Planning Projects	3- 2
3.2.2 Steps in the Planning Process	3- 3
3.3 Short-Range Transit Planning	3- 7
3.3.1 Examples of Short-Range Planning Projects	3- 7
3.3.2 Coordination of the Plan	3- 8
3.4 Legislative and Regulatory Aspects of Transit Planning	3- 9
3.5 References and Bibliography	3-10
CHAPTER 4: DESIGN OF TRANSIT NETWORKS, ROUTES AND FIXED FACILITIES	4- 1
4.1 Transit Network and Routes	4- 1
4.1.1 General Network Requirements	4- 1
4.1.2 Types of Routes	4- 3

4.1.3	Types of Networks	4- 4
4.1.4	Transfers between Routes	4- 5
4.1.5	Directness of Routes	4- 8
4.1.6	Spacing between Routes	4-12
4.2	Street and Highway Design	4-12
4.2.1	Transit Priority at Intersections	4-12
4.2.2	Transit Stop Locations	4-17
4.2.3	Parking on Transit Streets	4-22
4.2.4	Criteria for Establishment of Reserved Transit Lanes	4-25
4.2.5	Design of Reserved Transit Lanes	4-27
4.2.6	Transit at Intersections	4-29
4.2.7	Design of Transit Stops	4-31
4.2.8	Pavement Markings	4-34
4.3	References and Bibliography	4-36
CHAPTER 5: OPERATIONS		5- 1
5.1	Definition of Basic Elements	5- 1
5.2	Data Required for Scheduling and Analysis of Operations	5- 6
5.2.1	Vehicle Operating Conditions Analysis	5- 6
5.2.2	Passenger Demand Analysis	5- 7
5.2.3	Scheduling Data	5- 9
5.3	Passenger and Traffic Surveys	5- 9
5.3.1	Organization of Surveys	5- 9
5.3.2	Passenger Load Count	5-10
5.3.3	Passenger Boarding and Alighting Count	5-11
5.3.4	Transit Speed and Delay Survey	5-17
5.4	Criteria for Determining the Basic Operating Elements	5-18
5.4.1	Headway (h)	5-18
5.4.2	Load Factor (α)	5-23
5.4.3	Fleet Size and Vehicle Capacity	5-23
5.5	Transit Line Schedules	5-24
5.5.1	Types of Scheduling	5-24
5.5.2	Scheduling of Branch Routes	5-26
5.5.3	Run Cutting	5-27

5.5.4	Scheduling a Transit Line: Example Computation	5-28
5.5.5	Use of Computers in Scheduling and Run-Cutting	5-30
5.6	Increase of Transit Speed	5-31
5.7	Possible Measures for Speed Increase	5-32
5.7.1	Vehicle Design and Performance Characteristics	5-32
5.7.2	Intersection and Street Design and Operation	5-34
5.7.3	Transit Stops	5-35
5.7.4	Transit Operations	5-37
5.8	Evaluation of Measures for Speed Increases	5-38
5.8.1	Example 1: Fare Collection Improvement	5-40
5.8.2	Example 2: Transit Lane Introduction	5-42
5.9	References and Bibliography	5-48
CHAPTER 6:	FARES	6- 1
6.1	Introduction	6- 1
6.2	Fare Structures	6- 2
6.2.1	Flat Fare	6- 4
6.2.2	Zonal Fare	6- 4
6.2.3	Sectional Fare	6- 5
6.2.4	Comparison of the Three Basic Fare Structures	6- 5
6.3	Reduced and Special Fares	6- 7
6.3.1	Commuter Fares	6- 7
6.3.2	Peak Hour Fares	6- 7
6.3.3	Children and Student Fares	6-10
6.3.4	Fares for the Underprivileged, Senior Citizens, and Handicapped	6-10
6.3.5	Shopper Fares	6-10
6.3.6	Owl Fares	6-11
6.3.7	Other Special Fares	6-11
6.4	Fare Level	6-11
6.4.1	Major Factors	6-11
6.4.2	The Desirable Fare Level	6-11
6.4.3	Free Transit	6-13
6.4.4	Low and Moderate Fares	6-14

MTA LIBRARY

6.5. Fare Collection Methods	6-15
6.5.1 Definition of a Fare Collection System	6-15
6.5.2 Evaluation of a Fare Collection System	6-16
6.5.3 Cash Fares	6-16
6.5.4 Prepaid Fares	6-17
6.5.5 Automated Collection	6-19
6.5.6 Honor Fare System	6-19
6.6 References and Bibliography	6-21
CHAPTER 7: TRANSIT INFORMATION FOR THE PUBLIC	7- 1
7.1 Planning of a Transit Service Information System	7- 2
7.1.1 Users of the System	7- 2
7.1.2 Items of Information, Methods and Locations of Distribution	7- 3
7.2 Coordination of the Information System	7- 3
7.2.1 Transit Stops	7- 3
7.2.2 Transit Terminals	7-13
7.2.3 Transit Vehicles	7-23
7.2.4 Public Places	7-27
7.2.5 Media	7-27
7.2.6 Telephone Information	7-27
7.3 Implementation of the Information System	7-29
7.4 Maintenance of the System	7-29
7.5 References and Bibliography	7-31
CHAPTER 8: PUBLIC TRANSIT MARKETING	8- 1
8.1 Marketing: Definition and Purpose	8- 1
8.2 Format of a Marketing Program	8- 1
8.2.1 Marketing Strategy	8- 1
8.2.2 Marketing Activities	8- 4
8.3 Conclusions	8-13
8.4 References and Bibliography	8-14
CHAPTER 9: MANAGEMENT DATA	9- 1
9.1 Introduction	9- 1
9.2 The Data File	9- 1
9.2.1 Urban Area Data	9- 1

9.2.2 Transit Service Data	9- 4
9.2.3 Transit Usage Data	9-10
9.2.4 Transit Agency Data	9-12
9.3 References and Bibliography	9-22

LIST OF ILLUSTRATIONS

<u>Figure No.</u>	<u>Title</u>	<u>Page</u>
3. 1	Steps in the long-range planning process.	3- 4
4. 1	Per cent of potential transit passengers using transit as a function of walking access time.	4- 2
4. 2	Types of transit routes shown on a predominantly radial-circumferential network.	4- 6
4. 3	Radial network with branch lines.	4- 7
4. 4	Examples of circuitous routing in bus operations.	4- 9
4. 5	Relationship between line spacing and frequency of service for a given fleet size.	4-11
4. 6	Priority for streets carrying transit: un-signalized intersection.	4-13
4. 7	Priority for more heavily traveled transit route: unsignalized intersection.	4-15
4. 8	Transit vehicle travel time for all-NS, all-FS and alternate stop locations.	4-19
4. 9	Impact of bus stop locations on convenience of passenger transfers.	4-23
4.10	Turning characteristics of transit buses.	4-30
4.11	Design of double mid-block bus stop.	4-32
5. 1	Graphical representation of terms related to passenger demand distribution and capacity.	5- 2
5. 2	Graphical representation of terms related to travel and scheduling.	5- 3
5. 3	Passenger trip length distribution diagram.	5- 8
5. 4	Suggested passenger load count field sheet.	5-12
5. 5	An example of summary sheet of transit load count.	5-13
5. 6	Passenger boarding and alighting count sheet.	5-15
5. 7	Transit load profile for different time periods.	5-16
5. 8	Transit speed and delay survey field sheet.	5-19
5. 9	Transit speed and delay survey summary sheet.	5-20
5.10	Relationship between demand and required headway.	5-22
5.11	Graphical schedule for a transit route.	5-25
5.12	Relationship between commercial speed and fleet size.	5-33

5.13	Illustration of different types of stopping schedules.	5-39
5.14	Evaluation of introducing multiple-ride or other fare collection improvements.	5-43
5.15	Evaluation of transit lane introduction.	5-46
6. 1	"Vicious Circle" caused by fare increases.	6- 3
6. 2	Summary of the characteristics of the three types of fare structures.	6- 6
6. 3	Fare variation with trip length for the three fare structures.	6- 8
6. 4	Schematic presentation of the three types of fare structure.	6- 9
6. 5	Relationships between fare, ridership and revenue.	6-12
6. 6	Review of various fare system characteristics.	6-20
7. 1	Example transit stop markers.	7-5, 7-6
7. 2	Examples of transit system logos for selected cities.	7- 7
7. 3	Variations in curb design at bus stops.	7- 9
7. 4	Bus stop pavement markings for parking lane and peak hour through lane locations.	7-10
7. 5	Example timetable (SEPTA--Philadelphia).	7-12
7. 6	Example timetable (modeled on Rhode Island Public Transit Authority, Providence).	7-14
7. 7	Example bus route map to accompany timetable (SEPTA--Philadelphia).	7-15
7. 8	Importance of direction arrows on route maps.	7-17
7. 9	Example of a city map with transit line designation (MBTA--Boston).	7-18
7.10	Schematic transit system map (London).	7-19
7.11	Schematic transit system map (Hamburg).	7-20
7.12	Schematic transit system map (Boston).	7-21
7.13	Schematic transit system map (Philadelphia).	7-21
7.14	Condensed route and service frequency information for transit networks.	7-22
7.15	Information and signing priorities at transit stations.	7-24
7.16	Examples of informational signing employed in Boston MBTA.	7-25
7.17	Exterior informational signing on bus vehicles (WMATA, Washington, D.C.).	7-26
8. 1	Example newspaper advertisement (Nashville, MTA).	8-10

MTA LIBRARY

LIST OF TABLES

<u>Table No.</u>	<u>Title</u>	<u>Page</u>
4. 1	Minimum desirable bus curb/freeway loading zone lengths.	4-21
5. 1	Summary of passenger counts and computation of person-kilometers.	5-17
5. 2	Benefits and costs from fare collection improvements.	5-44
7. 1	Summary of transit information distribution system.	7-30
8. 1	Influence of different factors upon choice of marking strategy.	8- 3
8. 2	Characteristics commonly used in market segmentation.	8- 6

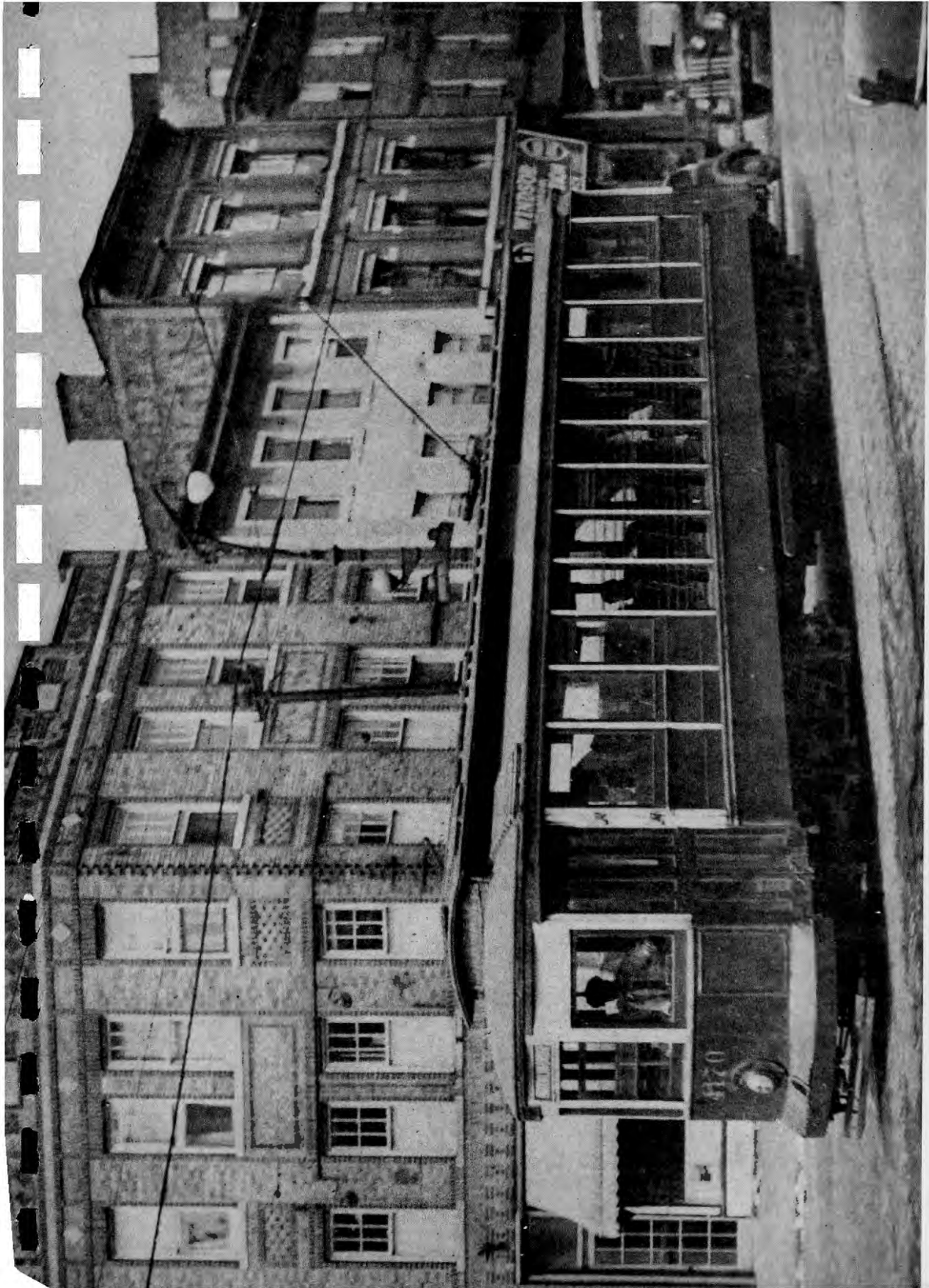

14987

HE
308
.V83
c.2

JUN 11 '93

MTA LIBRARY
ONE GATEWAY PLAZA, 15th Floor
LOS ANGELES, CA 90012

Chapter 1

INTRODUCTION

Significant changes have taken place in our society and economy in recent years. The former belief that natural resources are inexhaustible and that our use of them would continue to increase indefinitely has been proved incorrect by two major developments. First, continuous increase in consumption of disposable materials has caused damage to the environment which is much more harmful than had been expected. And second, it has been realized that reserves of the basic resources, primarily energy, are exhaustible in the foreseeable future.

Our cities are feeling this change very strongly. The trend of increasing reliance on the automobile for more and longer trips, typical for the 1950s and 1960s, requiring the continuous construction of more highways and parking, and resulting in deteriorating public transportation, obviously must be stopped and drastically revised. Although the automobile will undoubtedly remain an indispensable component in our lives and an important, often dominant mode of urban travel, it cannot be the only mode which is receiving attention and which is being improved. A substantial portion of urban travel can and should be served by public transportation. Both auto and transit must be better incorporated in the urban environment to permit revitalization of our cities. Instead of construction of additional urban freeways, improved traffic engineering measures should be applied; instead of increasing subsidized parking, use of transit should be encouraged; instead of unattractive, slow and expensive transit which is provided by most citizens who have cars, fast, attractive and reasonably priced services should be introduced.

The task of reversing trends in transit and creating modern, attractive systems is not an easy one, and it requires two major factors. First is to provide adequate financing to remove transit from the struggle for survival in which it was for several decades. The second factor is related to the first and it is at least as important: to increase expertise in transit - including all aspects, from planning to

MTA LIBRARY

daily operations. Decades of neglect of transit have created serious voids in the professional knowledge of transit in both planning authorities and transit agencies.

1.1. Purpose of the Manual

This manual is intended to present the basic principles, methods and techniques for transit planning, management and operations. The material is presented through general definitions and mathematical relationships with simple explanations of their use. A number of actual examples from transit system operations are given. Procedure of scheduling is illustrated by numerical examples.

The Manual incorporates the latest developments and standards in transit system operations and planning, governmental procedures, etc. It also examines such areas as design, scheduling, fares, information systems, marketing, as well as legal, procedural and planning issues. Much of this material has not been available in recent literature in a form convenient for application.

1.2 Potential Users of the Manual

Since professional expertise in smaller agencies is particularly in need of improvement, this Manual is primarily oriented for agencies in small-to-medium cities operating buses only. Design and regulation therefore refer more to bus than rail systems, although the latter are by no means excluded. Such areas as scheduling, information and marketing are, of course, independent of modes and they should be equally useful to large and small transit agencies.

The Manual may prove useful for the following groups and applications:

- Transit agency personnel in their regular work;
- City, county, and state officials involved in urban transportation planning, financing, operation, etc.;
- Decision makers who are involved in urban transportation issues; these include board members of transit agencies, local and state public officials and others;
- For instruction at colleges and in various continuing educa-

tion courses. However, since the practical use of the Manual was to be emphasized, relatively little emphasis has been given to academic or theoretical aspects of the discussed topics.

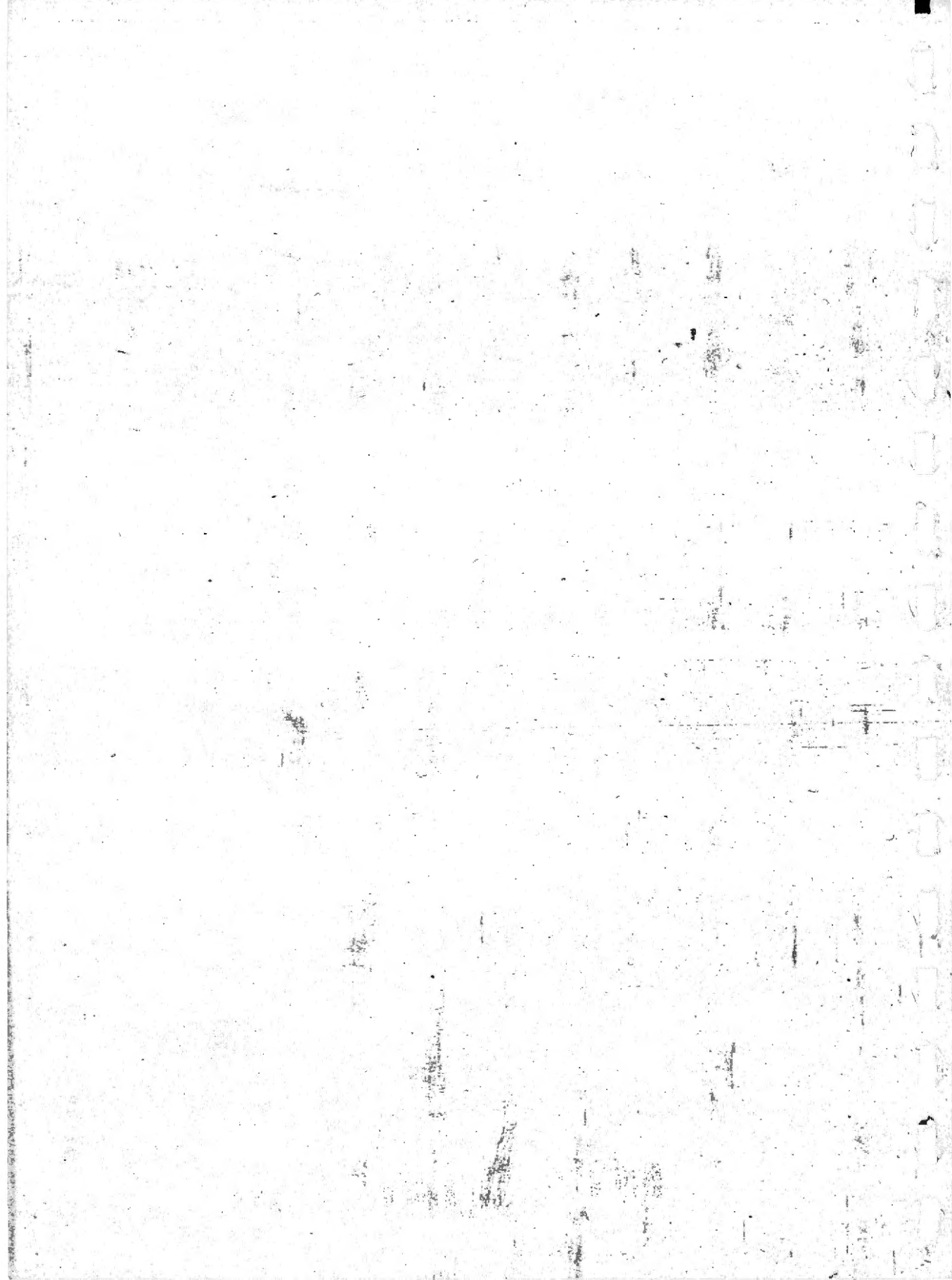

Chapter 2

POLICY, LEGISLATION, AND FINANCING

An extensive program of assistance to urban mass transit has been in existence since 1967. Main features of these programs and of the related federal assistance programs are briefly summarized in this Chapter.

2.1 Rationale for Mass Transit Public Assistance

It is a generally accepted fact that in many cities it is neither desirable nor possible to cover the total cost of transit services by fare box revenues only, since the fares required for total coverage would cause excessive diversion of passengers to other modes of travel and impose hardship on the remaining passengers; therefore, transit must be viewed as an essential public service. Some of the reasons why transit is often no longer self-supporting are as follows:

- Public transport provides many services (e.g. evening hours, lightly traveled lines, etc.) which are not economically justifiable but are socially desirable and necessary. The "standby" feature is essential, although not directly remunerative.
- Transit carries passengers predominantly during peak hours, which is uneconomical because of the poor utilization of facilities during off-peaks. Peak hour travel on any mode is "uneconomical" and its cost is usually cross-subsidized by travel at other times.
- In choosing their mode of travel, most urban travelers are faced with the choice between the marginal cost of using an automobile (since they own it for other purposes anyway) and the out-of-pocket cost of transit (fare).
- Transit causes much lower negative side-effects per traveler (congestion, aesthetic damage, noise, air pollution, etc.) than the automobile. These effects are not reflected in prices urban travelers pay for each mode. Potential advantage of

MTA LIBRARY

transit is thus not utilized.

Therefore the welfare of the urban population and the economic and environmental vitality of cities depend heavily on the effectiveness of the transportation system, of which transit is a major component. In order that transit fulfill such a role, the vicious circle of decline in quality of services and decreasing patronage must be stopped and reversed.

2.2 Pennsylvania's Legislative Policy on Mass Transportation Assistance

In accordance with Act 8 of 1968, the Pennsylvania Urban Mass Transportation Assistance Law of 1967, the State's legislative policy in relation to mass transportation assistance is as follows:

- The social and economic development in urban areas is dependent upon efficient and coordinated urban mass transportation systems, facilities, and services.
- Mass transportation is essential to the solution of urban problems.
- Mass transportation will promote the health, safety, convenience, and welfare of the citizens of the Commonwealth.

Based on these policies, Act 120 of 1970 specifies the powers and duties given to the Pennsylvania Department of Transportation, including the following ones relating to public transportation systems:

- development of programs designed to foster efficient and economical public transportation services in the State;
- preparation of plans for the preservation and improvement of the commuter railroad systems;
- development of plans for more efficient public transportation service by motor bus operation; and
- preparation and development of plans and programs for all modes of urban transportation including motor bus, trolleybus, light rail, rapid transit, commuter rail, and other modes of urban transportation.

2.2.1 Mass Transportation Assistance Program Goals and Objectives.

The goals of the Pennsylvania Mass Transportation Assistance Program

are as follows:

- to assist in the development of public transportation services which will contribute to more unified and balanced transportation systems throughout urban areas in Pennsylvania (implicit in this goal is the reduction of traffic congestion);
- to encourage the development of desirable land uses and environments in urban areas; and
- to assist in the provision of public transportation facilities and services to those persons who do not have access to other modes of transportation.

In large metropolitan areas (population over 500,000), the first goal is the most important one, followed by the second. If these goals are met, the third one will in most cases also be reached.

In medium-size cities (100,000 - 500,000), the relative importance of all three goals varies from case to case, while in small cities (population less than 100,000), the third goal is likely to be the dominant one, since traffic congestion is a less serious problem.

In order to achieve these goals, the program has several immediate objectives. The program should:

- maintain existing transit services;
- increase the network coverage, capacity, and frequency of transit services;
- improve the quality of service (reliability, speed, comfort, information, etc.);
- stabilize or reduce transit fares;
- stimulate the use of transit services and facilities;
- modernize operating practices and reduce operating costs; and
- encourage the development of working relationships between transit agencies and other transportation authorities, such as:
 - local and regional planning agencies,
 - city traffic engineering departments,
 - parking authorities, and
 - airport authorities, etc.

2.2.2 Financing Mass Transit Operating Deficits. Act 8 of 1968, "The Pennsylvania Urban Mass Transportation Assistance Law of 1967", January 22, P. L. 42 (66 P. S. Section 1951 et seq.) of the General Assembly of the Commonwealth of Pennsylvania established a

program designed to assist in financing mass transit services where fare box revenues are insufficient to meet the actual cost of providing such services.

According to this law, the amount of Commonwealth funds for a particular project shall not exceed two-thirds of the deficit. The deficit eligible for financial support shall be in accordance with the Department's definition of allowable costs and revenues. In cases when the applicant is eligible to receive Section 5 Federal Operating Assistance Grants, Commonwealth funds will be limited to two-thirds of the deficit (net project cost) that is not funded by the Federal grant. The remaining portion of the deficit is funded through local sources.

The National Mass Transportation Assistance Act of 1974 created a new program of Federal financial assistance for urban mass transportation systems. Grants distributed on a formula basis through this program may be used by the recipients either for capital or operating assistance projects.

This Federal operating assistance program is limited to urbanized areas, having a population of 50,000 or more. Under this program, transit agencies may be eligible to receive Federal operating assistance grants covering no more than 50 percent of net project costs (operating deficits) as defined by the Urban Mass Transportation Administration of U. S. DOT.

2.2.3 Financing Mass Transit Capital Improvement Projects. The capital grant program was established by Acts 7 and 8 of 1968, January 22, P. L. 27, 42 (66 P. S. Section 1901, 1951 et seq.) of the General Assembly of the Commonwealth of Pennsylvania. This legislation was enacted to promote the health, safety, convenience and welfare of the State's inhabitants by means of State financial assistance for the development of efficient and coordinated urban common carrier mass transportation systems, facilities and services.

Commonwealth financial support must be matched with locally provided funds and, if eligible, Federal funds. In no instance may the Commonwealth provide 100% funding for Capital Grant projects. The Act states "Capital grants may be made for the acquisition, con-

struction, reconstruction, and improvement of facilities and equipment, including land (but not public highways), buses and other rolling stock, and other real or personal property needed for an efficient and coordinated mass transportation system".

The State participation in a capital project is limited to one-half (1/2) of the non-Federal share when funding is available from the U. S. Department of Transportation. (Federal funding is up to 80 percent of net project cost for approved projects). The remaining 10% is provided by local governments.

2.2.4 Other Funding Programs. In addition to operating and capital assistance programs, the Pennsylvania Department of Transportation provides grants for other transit related functions and activities, including:

- (a) Promotion and advertising programs
- (b) Research and demonstration projects
- (c) Technical studies
- (d) Free Transit Program for Senior Citizens
- (e) Intercity and rural public transportation projects.

MTA LIBRARY



Chapter 3

TRANSIT PLANNING

This chapter highlights the basic principles and methodology of transit planning. The information presented here is partially a review of material described in [1]* and in other references cited therein. In actual transit planning the agency should refer to these sources in order to obtain more complete guidance in specific planning tasks, clarification of concepts, detailed technical analyses and definition of some technical planning terms.

3.1 Definition of a Transit Plan

The purpose of transit planning is to develop a sequenced program of activities or tasks which are coordinated to achieve specific objectives over a defined period of time. The objectives may be quite diversified: they may be rather limited, such as improvement of existing service or introduction of an information system, or they may be more comprehensive in scope, such as in the case of the purchase of new rolling stock or the development of a master plan for an expanded rapid transit system.

The basic classification of planning is made on the basis of the time span for which they are developed. Usually, short-range planning covers a period 1-5 years into the future, while long-range planning refers to planning for actions which are to be undertaken or completed 5-20 years from the present. While some planning activities are easily classified under either short- or long-range planning, many types of improvements can be classified under either or both time-range groups.

3.2 Long-Range Transit Planning

The purposes of long-range transit planning are to foresee or influence future changes in the city and its population's travel needs, and to prepare the actions necessary to adequately meet the projected demand for transit service. Planning is therefore also done to obtain a basis for the estimation of capital needs, particularly for projects

* Numbers in brackets [] refer to references listed at the end of chapter.

which usually require considerable lead time for planning, design, financing and implementation. Projects included in long-range plans often require large amounts of land acquisition and long construction periods. Long-range planning is therefore appropriate for large cities where the scale of improvements or new facilities is large and the potential consequences of poor planning most severe. Small and medium-sized cities, however, may also find it either necessary or desirable to give some attention to long-range planning in view of changing community characteristics and goals.

3.2.1 Examples of Long-Range Planning Projects. The following are examples of projects typically classified under long-range planning:

1. Introduction of new transit rights-of-way requiring large land acquisition or major construction, as for light rail, rapid transit and specially constructed busway facilities.
2. Separation of transit modes from street and highway traffic and priority treatment of transit, which may not require extensive land acquisition or construction, but which may necessitate long lead time for community and regulatory agency approval, ordering and installation of traffic control devices, education of the population with regard to new traffic policies, etc. Such improvements may include the designation of existing expressway lanes for transit, contra-flow bus lanes, bus priority treatment in the CBD, transit actuated street signal systems and the like.
3. Improved coordination between transit modes and services, including the construction of multi-mode terminals, agreement on common stations and transfer points, schedule coordination, integration of fare structure, fare collection methods, etc.
4. Introduction of new or experimental services which require marketing analyses and manpower and equipment planning. Examples include charter services, feeder bus, dial-a-bus, etc.
5. Anticipated changes and replacement of rolling stock and other operating equipment such as fare collection hardware, station security equipment (monitoring devices, vandal proofing), etc.
6. Major transit way refurbishing, such as new roadbed, track replacement or alignment, and station platform reconstruction from low- to

high level.

Of course, there are numerous other types of improvements which must be planned well in advance of the date they are needed. In classifying them under either short- or long-range plans, the agency should always anticipate time for project approval and clearance by local, state and federal authorities, and the communities affected as well as for actual construction and implementation time. The former is often underestimated.

3.2.2 Steps in the Planning Process. Figure 3.1 shows the steps followed in the traditional long-range transportation planning process. Briefly, they are described as follows:

1. Establish:

- Goals
- Objectives
- Standards
- Constraints.

Relevant to the planned project these factors guide the agency in coordinating transit improvement projects with the need of the community. The items considered can relate to orientation of urban growth, land use plans, transit service standards and guidelines, and topographical, financial and social constraints.

2. Collect data on:

- Population
- Land use
- Social and economic characteristics
- Travel patterns
- Other modes of transportation and their facilities.

These data allow the agency to determine the characteristics of the community, the existing transportation system and deficiencies in that system. Traditional methods and techniques used in the highway planning process are employed.

3. Collect information and data related to the transit service, transit usage and managerial data. A description of specific data items is given in Chapter 9.

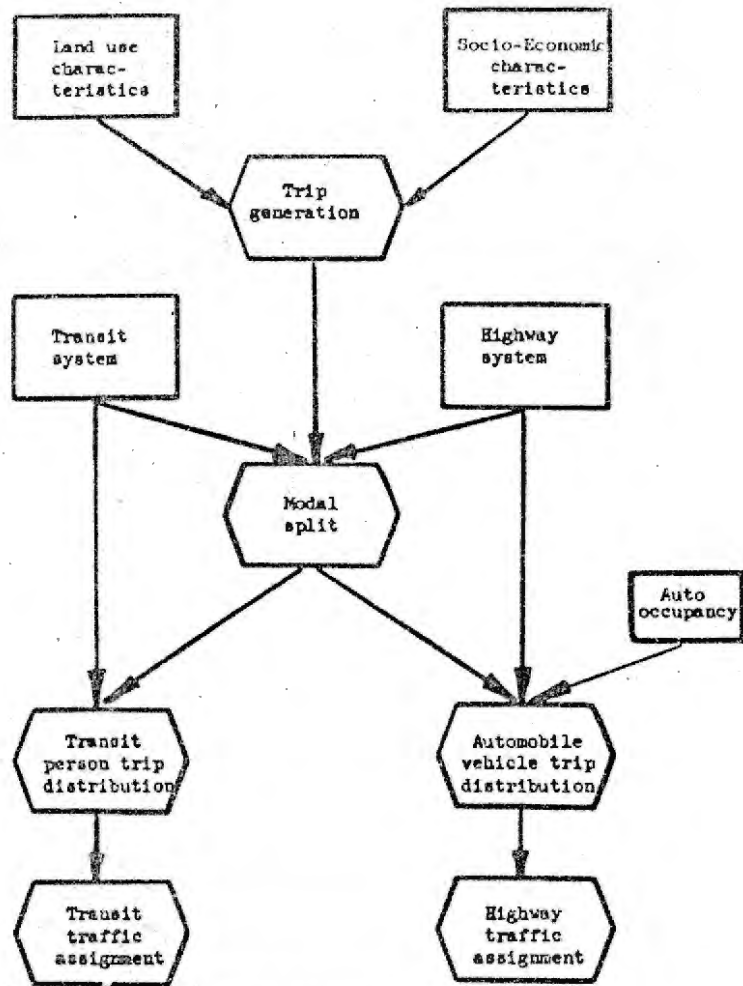

a. Trip-end modal-split model.

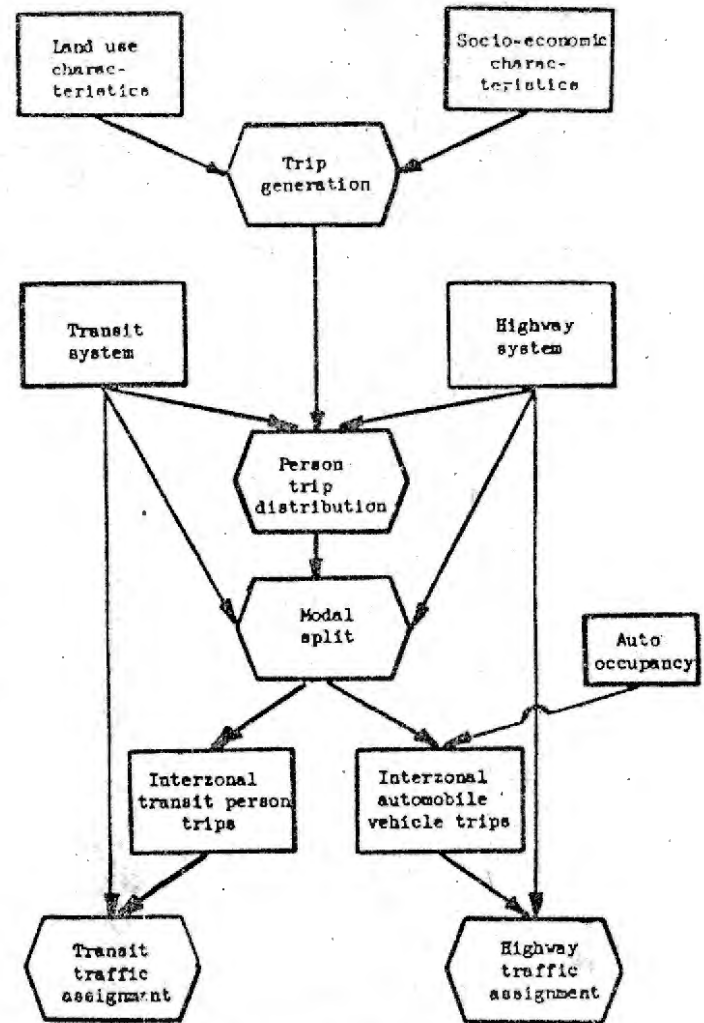

b. Trip-interchange modal-split model.

Figure 3.1 -- Steps in the long-range planning process.

4. Based on the collected data, project future travel demand for transit.

5. Develop plans for one or several alternative transit network services which can satisfy the projected transit travel demand.

6. Evaluate alternative plans with respect to Step 1 and select the best plan.

The following more detailed description of the specific technical steps in the planning procedure has been adopted, with minor modifications, from [1].

1. Code the study-year transit network, assign the on-board ridership survey transit trip table (for transit survey techniques description see Chapter 5) and calibrate the network such that peak loads on selected key routes are acceptably reproduced.

2. Develop a study-year transit trip distribution model and demonstrate by assignment to the calibrated network that it will also acceptably reproduce peak loads on selected key routes.

3. Review future modal split prepared for the comprehensive highway study and revise as necessary. Modal split models must be sensitive to the different variables that affect the usage of rapid transit, commuter rail, and local bus services in different ways. In addition to time and cost, such service characteristics as reliability and qualitative aspects such as comfort, convenience and safety, should be considered.

4. Develop transit plans to be tested. In some instances, only one plan should be tested initially, and then revisions to the plan to improve it should be tested incrementally to reach a recommended plan. More often, however, initially it may be desirable to test alternatives based on differing policies with regard to (1) growth and settlement patterns as between center city and the suburbs, (2) relative emphasis to be placed on the transportation modes to serve such patterns, and (3) relative emphasis to be placed on capital-intensive or labor-intensive systems.

In all networks considered, particular emphasis should be given to the prediction of central city tripmaking. This will involve projecting those public policies which may most shape the demand for transit ridership, such as central business district parking fees, renewal and redevelopment policies regarding planned densities of development, the

number of parking spaces provided for housing and commercial development, general land use plans and zoning ordinances, street closures, relative travel times and so forth.

5. Assign the trip matrix based upon revised modal split to each of the plans developed.

6. Determine desired transit routes and major improvements.

7. Consider modifying area goals, objectives or policies, as appropriate to avoid or reduce unwarranted or infeasible transportation effects such as excessive travel, right-of-way needs, or costs. Modification of land use plans in corridors served by an existing rail right-of-way might, for example, be sufficient to make a proposed commuter rail facility warranted where it otherwise would not be.

8. Revise the test plan in accordance with constraints, priorities and warrants; recalculate the future modal split, and reassign trips to the revised network.

9. Repeat steps 6, 7, and 8 as necessary to reach a final recommendation.

In the testing process certain long-range proposals may be found unnecessary due to the diversion of travelers from automobile to transit. Should that occur, long-range highway plans should be modified accordingly, and the appropriate modal split recalculated as necessary for transit planning and highway network evaluation purposes.

The recommendations resulting from the long-range planning procedure should be documented thoroughly. These recommendations should include a summary of long-range transit system requirements in terms of individual line capacities and schedules, manpower and equipment needs, other major capital cost items, projected system revenues and expenses, etc. With respect to these requirements, a program should be developed listing priorities, sources of funds and anticipated support activities such as marketing analyses and technical studies (planning, design and engineering) which are necessary before implementation. Particularly important is a well-defined set of recommended policy changes necessary at all levels of government, including legal and administrative ramifications.

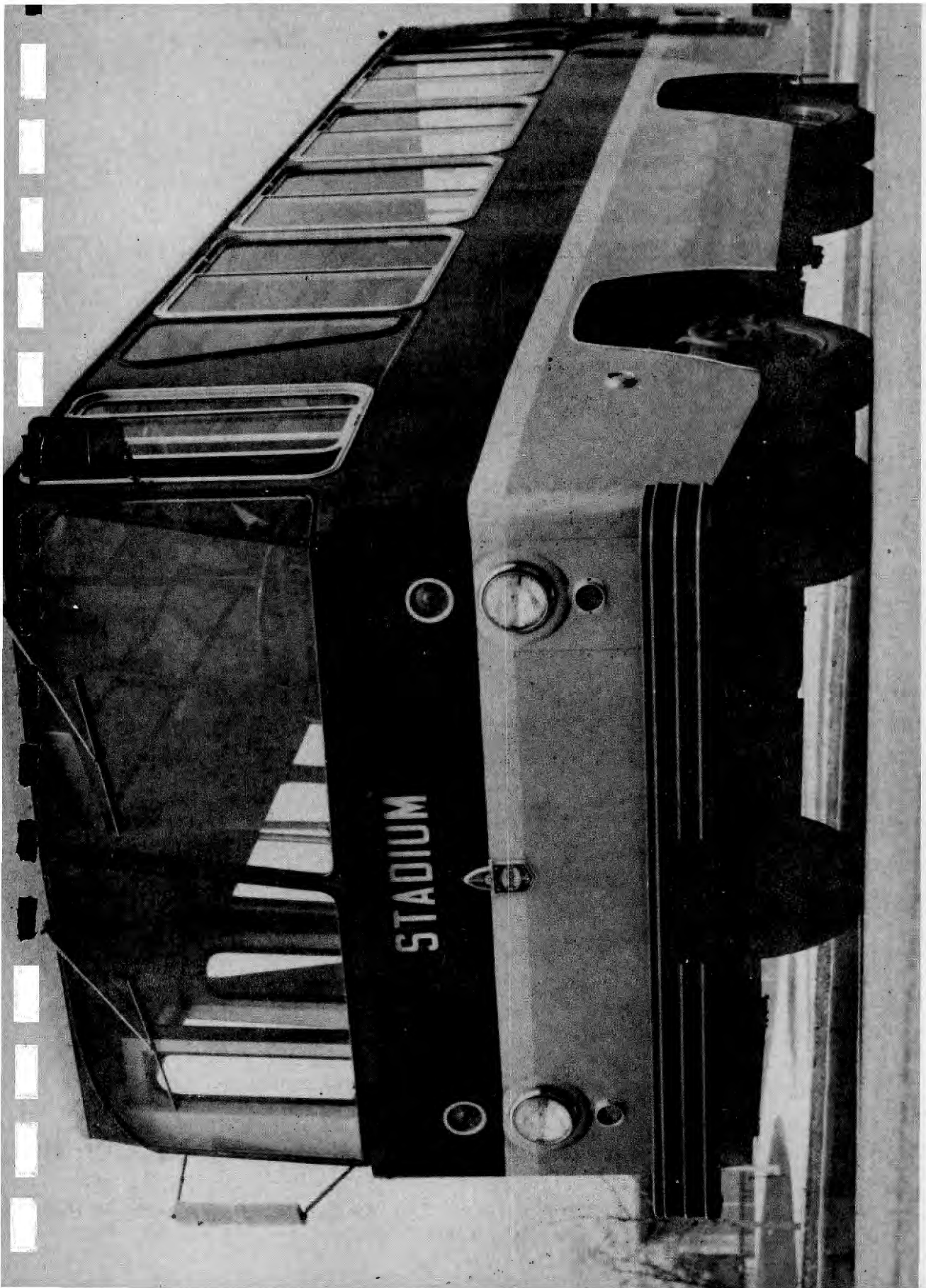



3.3 Short-Range Transit Planning

Short-range planning is usually undertaken to produce either Immediate Action Programs or Transit Development Programs; both of these can be planned and implemented within a 5-year period. Whereas long-range plans usually treat improvement programs of a large scale, short-range plans ordinarily treat isolated problems which can be alleviated or remedied with minor improvements and only moderate investment. Cities of all sizes undertake programs which can be classified as short-range planning.

3.3.1 Examples of Short-Range Planning Projects. Some examples of short-range planning for improvements are listed below. Of course, on a very large scale (i.e. in a large city) many of these programs must be classified under long-range planning because of the overall high capital cost and increased complexity of implementation. Likewise, some previously listed long-range improvements may, when they apply to a very small system, be incorporated under short-range plans. Typical short-range improvement programs may include:

1. Transit priority treatment measures which may not be cost-intensive include:
 - transit-actuated signal equipment at selected street and arterial intersections
 - modifications to existing street network and traffic controls to favor transit and increase operating speed (e.g. changes in one-way street patterns, closing of streets, auto-free zones or malls, turn restrictions)
 - limitation of on-street parking in the CBD.
2. Service adjustments, including:
 - rerouting to eliminate indirectness or duplication of service
 - condensation of close, parallel routes to increase frequency of service and simplify network
 - provision of night and weekend service.
3. Implementation of new scheduling and run cutting techniques. Such effort can achieve reductions in equipment, manpower and operating costs, as well as improvements in operating speed and service frequency.
4. Adjustments to transit stop locations, including elimination of selected stops on lines with close stop spacings and high demand, and

MTA LIBRARY

the introduction of alternating near- and far-side stops, both of which can increase operating speed and reduce operating costs (see Chapter 5).

5. Improved coordination of all modes, through:

- improved pedestrian access to stops and terminals
- provision of park-and-ride and kiss-and-ride facilities at outlying stations and major stops
- coordination of common stop locations, schedules and fare structure between separate operating agencies or different modes.

6. Improvements to the transit information system such as through printed media, redesign of stops and associated markings, signs, etc. (see Chapter 7).

7. Adjustments to fare system, including fare level, fare collection methods, and fare structure (see Chapter 6).

8. Redesign of intersections and stop sites to permit priority treatment of transit at critical locations (see Chapters 4 and 7).

9. Development of routing maintenance programs for vehicles, stations and way.

10. Program improvements for passenger safety and security.

11. Conduct of routing studies regarding analysis of demand and ridership characteristics (see Chapter 5).

3.3.2 Coordination of the Plan. Similar to the long range plan, several types of improvements in the short-range plan should be given individual priorities. Ultimately the components of the long-range plan staged for different time periods become part of the short-range plan. The two sets of planned improvements must therefore be closely coordinated and developed together.

In each case, also, there must be continuous coordination and evaluation of plans by authorities outside the transit agency: the local planning and zoning commission, traffic engineering office, Chamber of Commerce, and other influential organizations should be kept apprised of developments and changes in both the long- and short-range plans. This coordination is extremely important not only because it avoids unnecessary last-minute delays brought about by unanticipated community opposition, but it also ensures that the transit service will be efficiently designed to meet the need and constraints within the city. It

is therefore often desirable to designate a liaison officer as a person who disseminates information to such groups and receives their comments and opinions.

3.4 Legislative and Regulatory Aspects of Transit Planning

To qualify for operating and/or capital assistance grants from the Pennsylvania and U. S. Departments of Transportation, a mass transit authority or agency must meet certain transportation planning requirements.

The Pennsylvania Department of Transportation (PennDOT) is responsible for planning (or for coordinating the planning) for all modes of moving people and goods within the Commonwealth. Within PennDOT, transit planning for urbanized areas is the primary responsibility of the Bureau of Advance Planning in cooperation with the Bureau of Mass Transit Systems and the Bureau of Economic Research and Programming. In non-urbanized areas the Bureau of Mass Transit Systems assumes primary responsibility for transit planning. In addition, PennDOT is authorized to participate in all technical study and planning programs of the Urban Mass Transportation Administration (UMTA), U. S. Department of Transportation. For further information concerning these programs, refer to Chapter II, Section E, of UMTA's External Operating Manual [9]* and PennDOT's Mass Transit Procedural Guide for Applicants [7].

The U. S. Department of Transportation requires that a transportation plan exist for each urbanized area and that the plan be developed from an approved transportation planning process. The transportation plan includes two elements: the transportation system management (TSM) element, and the long-range element. The TSM element is a plan for operating the existing system and making improvements required for improved efficiency and effectiveness. It is multi-modal and oriented toward short-range planning.

*Numbers in brackets [] refer to corresponding items in References and Bibliography for respective chapters.

The metropolitan planning organizations (MPOs) designated by the Governor are required to prepare a Transportation Improvement Program (TIP) and to update the program annually. Projects are selected from the TSM and long-range elements of the transportation plan and encompass a period of not less than three years and up to five years.

Projects are initiated by submitting the Annual Element of the TIP to the Governor and the Urban Mass Transportation Administrator for transit projects, and through the State to the Federal Highway Administrator for highway projects. Projects selected for funding by the Federal Government are based on both the proposal made by the MPO in the Annual Element of the TIP and from State-initiated projects. Rules and regulations regarding the Transportation Improvement Project are available in the Federal Register, Vol. 40, No. 181, September, 1975.

Transit planning studies are eligible for Federal and State funding provided there is local participation. The cost-sharing formula is 80 percent Federal and 20 percent State/local. PennDOT assistance is generally one-half the non-Federal share. The local share may be in cash or specified staff services and may be provided by municipalities, counties, or other local sources in any combination.

3.5 REFERENCES AND BIBLIOGRAPHY

1. Bureau of Public Roads, Estimating Transit Usage -- Modal Split, 1967.
2. FHWA, Urban Mass Transportation Travel Surveys, U. S. DOT, August 1972.
3. Hillegass, T., Transit Travel Analysis for Smaller Urbanized Area, Federal Highway Administration, U. S. DOT, March 1973.
4. Homburger, W. (ed.), Urban Mass Transit Planning, University of California, Berkeley, 1967.
5. Manual of Traffic Engineering Studies (Fourth Edition), Institute of Transportation Engineers, Washington, 1976.
- 6.* Pennsylvania Department of Transportation, Operating Guidelines and Standards, prepared for PennDOT by the University of Pennsylvania, 1973.

*This document is also included in [7] as Section III.

7. Pennsylvania Department of Transportation, Procedural Guide for Applicants; Bureau of Mass Transit Systems Pub. #132, November 1975.
8. Pennsylvania Department of Transportation, Urban Transit Planning Guidelines, Harrisburg, June 1974.
9. UMTA, External Operating Manual, U. S. DOT, August 1972.
10. UMTA, Short-Range Transit Planning Manual, U. S. DOT, 1972.
11. Weiner, E., "Outline for Transit Planning", Urban Transportation Planning Course, Federal Highway Administration, U. S. DOT, March 1968.

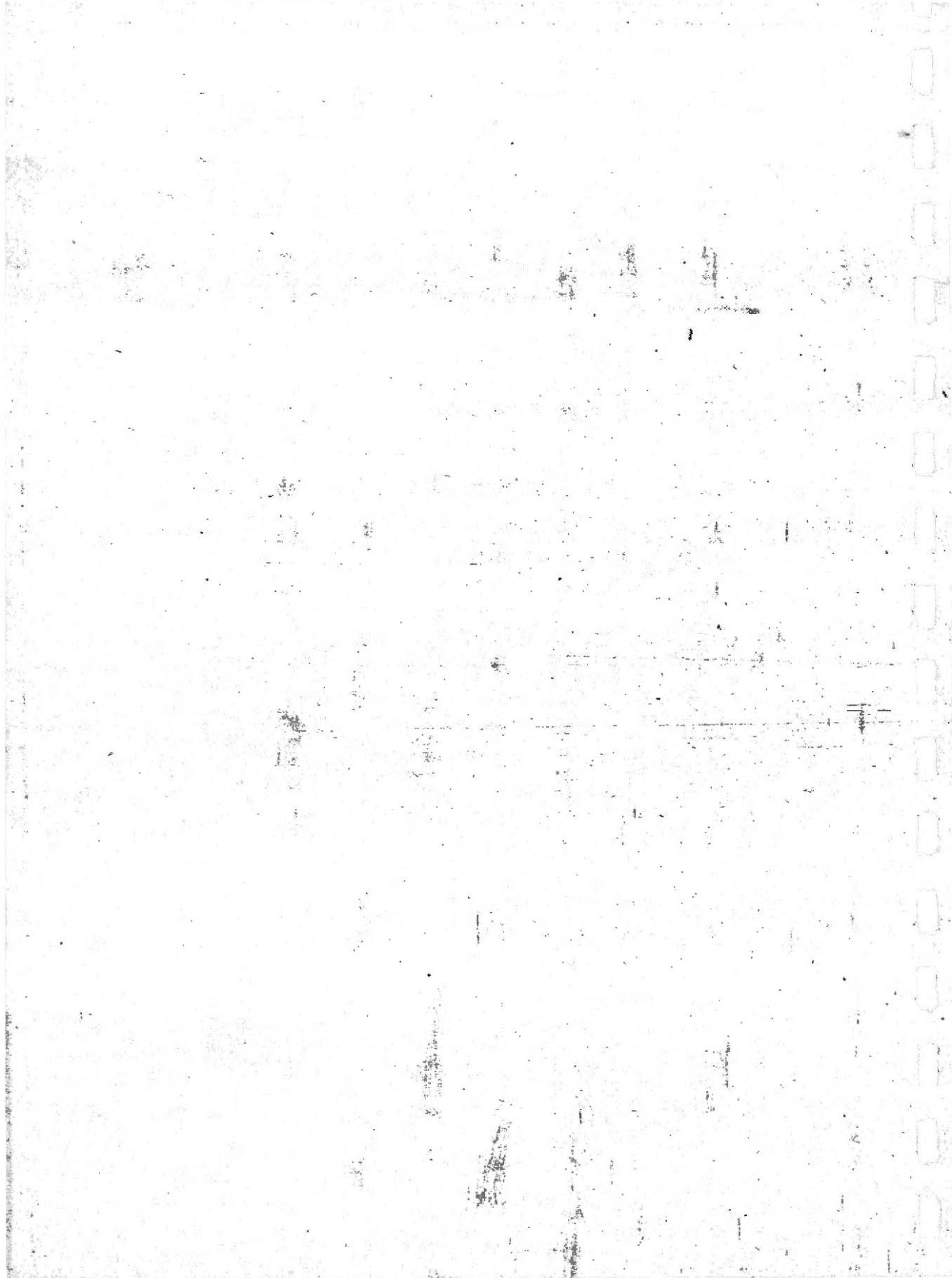

DESIGN OF TRANSIT NETWORKS, ROUTES AND FIXED FACILITIES

Efficient design of the transit network, individual routes and facilities is an important prerequisite of good transit service and economical operation. This Chapter contains a review of the basic design features of a transit network and related facilities.

4.1 Transit Network and Routes

In addition to planning individual transit lines, the operator must also analyze the total network and ensure that it provides satisfactory service for the entire city.

4.1.1 General Network Requirements. Design of a transit network, or layout of routes in a city must be based on consideration of the following basic requirements.

Area coverage expresses the extent or spread of a network in the area it serves; it is defined as the area served by the transit system. The area within a five-minute walking distance (about $\frac{1}{4}$ mile) from all transit stations is considered as the primary served area. Points between 5- and 10-min. walking distance represent the secondary served area. But for outlying stations where many passengers use automobiles for access to transit, the served area is much greater; its approximate boundaries can be found only through surveys of passenger origins.

Most of the potential passengers within a five-minute walk of a transit stop can be expected to use the available service provided it is of satisfactory quality. Beyond the five-minute radius, the percentage choosing transit drops off rather rapidly, as illustrated in Fig. 4.1 due to unwillingness of people to walk so far. The curve plotted in Fig. 4.1 is hypothetical; its actual shape depends on the type and quality of transit service offered as well as on various other local factors.

In determining how far out the transit service should extend, ideally the entire urbanized area should be served. A publicly owned

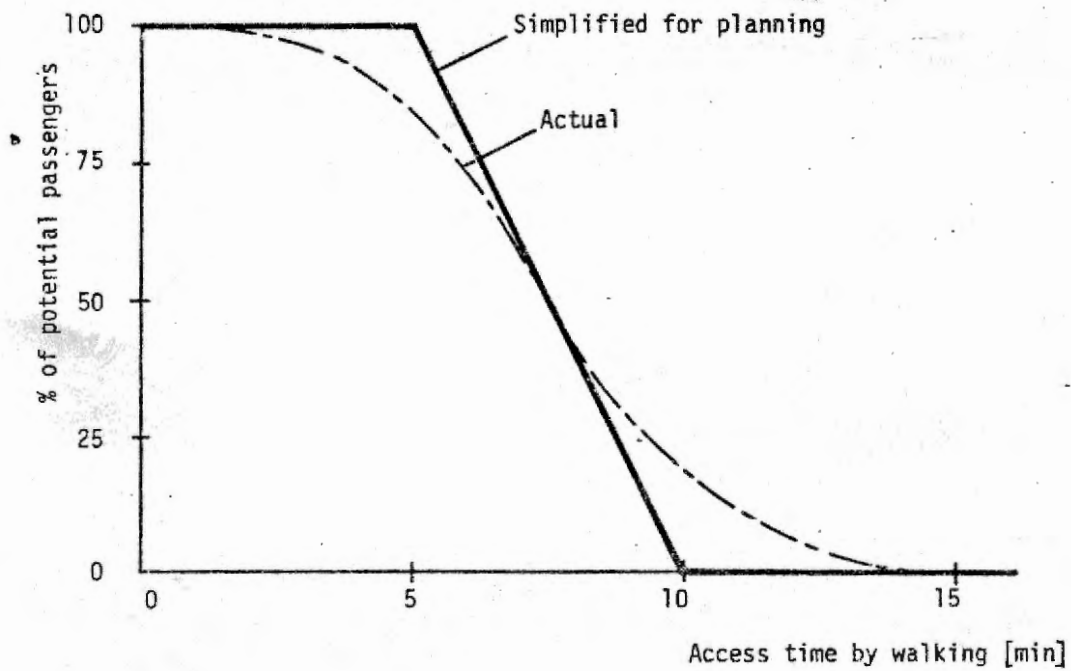

Figure 4.1 -- Per cent of potential transit passengers using transit as a function of walking access time.

transit agency should attempt to extend its network to cover as extensive an area as is economically reasonable and socially desirable, so that it provides a public service to the entire community. Private companies, on the other hand, often find it unprofitable to service the lower density outlying regions and can only be expected to provide transit service in areas for which external financial assistance is available.

Number of trips served should be maximized by proper network design. Travel desire lines may be determined from various origin-destination studies; transit lines should be made to follow these desire lines to the greatest possible extent.

Directness of travel should also be provided as much as possible. This concept is discussed in section 4.1.4.

Transfers of passengers among lines should be minimized by designing long routes along the heaviest concentrations of desire lines.

Cost of various system configurations must be weighed against the other characteristics of each, particularly the service quality.

Topography and existing street network always represent constraints on the type of transit networks that are feasible.

Optimum density of the network should be determined through a trade-off analysis between density of lines and frequency of service. This point is discussed further later in this section.

4.1.2 Types of Routes. By their form and direction transit routes can be classified into several categories or types.

Radial routes lead from a central area (usually the central business district) in radial directions to different suburbs or other major trip generators. These routes usually coincide with the location of the corridors of heaviest transit travel, but they often do not provide adequate distribution in the central area.

Through routes are obtained by connecting two radial routes so that suburbs on opposite sides of the central area are directly connected. This type of route provides better distribution within the central area; also, terminal facilities in the CBD, where land is particularly valuable, are not needed. Attention must be given that both sections (radial segments) of a through route have similar passenger volumes to avoid uneven utilization of provided capacity.

Circumferential routes follow a circumferential direction with respect to city center. They connect radial routes and serve for better distribution of their trips. They also serve medium and high density points in the area immediately surrounding the CBD. These lines are often well-utilized since they serve a relatively even density of travel throughout their entire lengths and thus, are not subject to the problems associated with a high demand on one part of the line. A problem with circumferential lines is that if they are located at a distance away from the CBD they often do not have sufficient demand to make frequent service feasible.

Crosstown routes have perpendicular direction on radial routes and usually have the same functions as circumferential routes.

Irregular routes include all routes which do not belong into any of the above categories.

4.1.3 Types of Networks. Although most transit networks are irregular, some have forms which can be classified into the following categories.

Radial-circumferential networks consist predominantly of radial, through, and circumferential routes. Radial routes often have branches toward their outlying sections. In planning branches of radial lines problems of regularity of service on the sections after convergence of branches must be carefully analyzed to prevent "pairing" of vehicles, wherein an overloaded vehicle is followed at a short headway by a lightly loaded vehicle. This problem may be particularly acute during the peak hours.

Rectangular networks are typical for cities with rectangular street patterns. They do not have the problem of overconcentration of routes on a few arterials sometimes characteristic for radial networks; on the other side, rectangular (or grid) networks do not follow travel desire lines as closely as radial networks do, so that they may require more transfers. Rectangular networks are usually poorly suited for non-axial trips.

Combination networks consist of both radial and crosstown routes, often minimizing disadvantages of both radial-circumferential and rectangular networks.

Irregular networks are created due to irregular street networks, topographic limitations or other factors. In designing such networks all requirements for transit networks discussed above should be carefully considered.

Shown in Figs. 4.2 and 4.3 are schematic networks and route configurations demonstrating selected types of each.

4.1.4 Transfers between Routes. Passengers always prefer a direct ride in one vehicle to travel which requires a transfer. However, objections to transferring depend greatly on the conditions under which the transfer takes place. Due to serious neglect of transfer facilities during the last 2-3 decades, there is an exaggerated belief that a transfer is one of the greatest obstacles to use of transit. Experience of cities which have developed excellent transfer facilities between routes and among different modes (Toronto, Lindenwold Line in Philadelphia, Cleveland, Edmonton, Munich) clearly shows that:

1. A network of routes can operate much more economically and offer higher frequency of service with transfers than if attempts are made to avoid them at all costs.
2. Transfer stations can be very efficiently integrated with such facilities as long-distance terminals, shopping centers, administrative complexes, etc.
3. When transfers are well-designed and operated, passenger objections to transferring are diminished.

The basic elements which must be provided for transferring are:

- Convenience: short walking, escalators, full weather protection, etc.
- Cleanliness, comfort and safety
- Excellent information about directions, routes and schedules
- Short waiting time
- Availability of amenities such as telephones, minor food shops, drug store, etc.

Transfers between lines with short headways never present problems with waiting time; transfers from lines with short headways to lines with long ones do involve waiting. Transfers among suburban routes with long headways can be organized through the "time transfer focal point" system. This system utilizes selected points at key locations

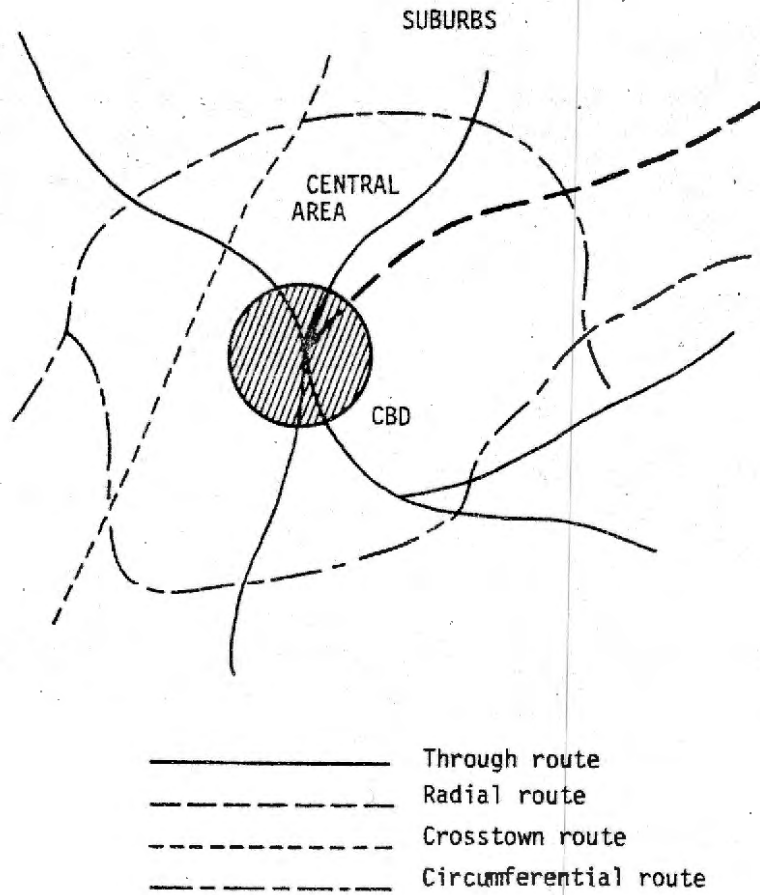

Figure 4.2 -- Types of transit routes shown on a predominantly radial - circumferential network.

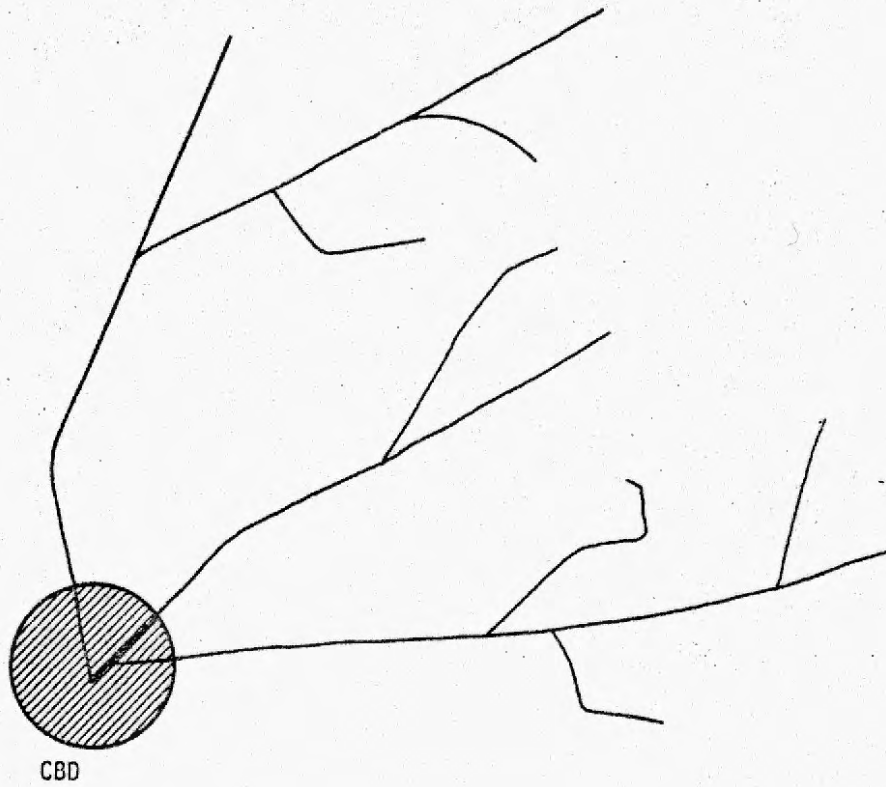

Figure 4.3 -- Radial network with branch lines.

such as suburban towns, shopping centers, etc. for transfers. Vehicles from all routes are scheduled to arrive simultaneously and spend at least a 5-minute terminal time there before returning to their routes. This time insures some overlap in standing times among routes, thus allowing two-way passenger exchange among all routes.

Transfer among different modes, particularly park-and-ride and kiss-and-ride, are becoming increasingly important. The basic principles of design of outlying rapid transit stations, including treatment of pedestrians, buses and private automobiles, are presented in [14].

4.1.5 Directness of Routes is defined as the ratio of the actual physical travel distance between two points via the transit system to the straight line distance between these two points. It is desirable to minimize this ratio; however, route layouts are often constrained by street patterns and topography. Directness of routes for the entire system can best be minimized by connecting large traffic generators and placing routes along the most concentrated travel desire lines, while serving populated areas between them as much as possible.

While directness of route is a desirable goal, it often conflicts with area coverage which should be maximized. Area coverage can often be increased by the use of more circuitous routes. Where demand for transit is high, it is feasible to have direct routes that provide good area coverage; however, in areas of low demand, service would be too infrequent if only direct routes were used. When circuitous routes are necessary, it is desirable that their greatest circuitry occur on outlying sections of the route so that the least number of riders are delayed. This is illustrated in Fig. 4.4 by examples of a good circuitous route -- offering a good area coverage in the suburb -- and an example of a poor circuitous route that would be justifiable only under special circumstances.

4.1.6 Spacing between Routes. The distance between parallel routes should be determined from the density of travel demand along the parallel corridors, keeping in mind that a person is considered to be well-served by transit if he resides within a $\frac{1}{4}$ -mile (five minute

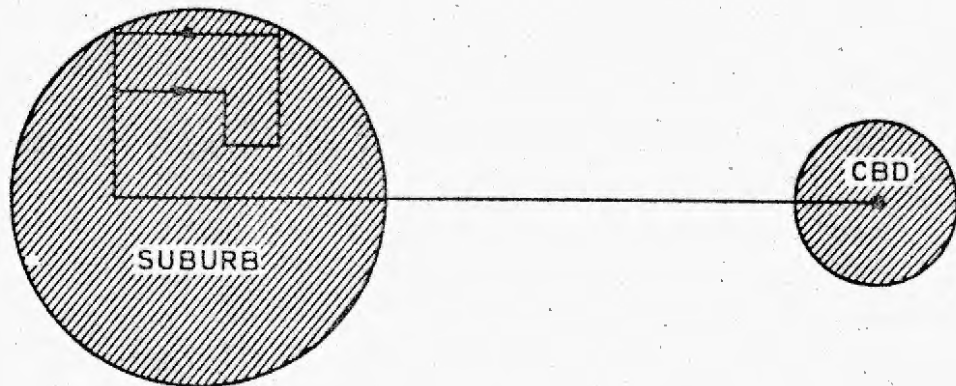

a. Circuitous routing at end of route: acceptable.

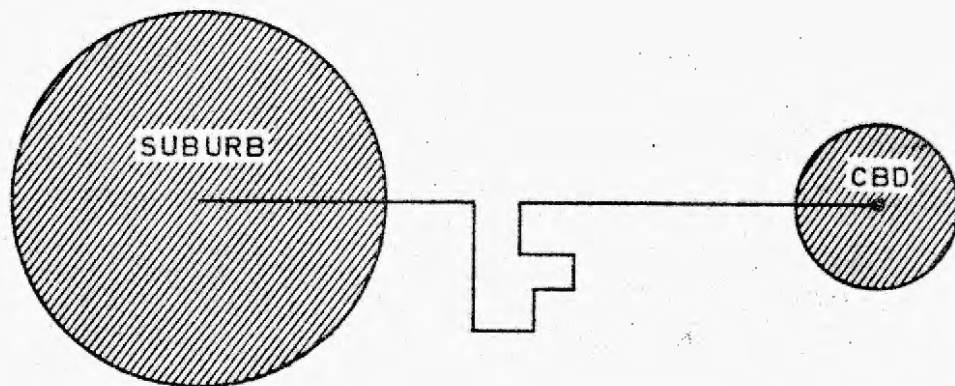

b. Circuitous routing at mid-route: undesirable.

Figure 4.4--Examples of circuitous routing in bus operations.

walk) of a transit line. For a given demand for transit in one direction, there is a choice between offering a few routes with frequent service and many routes with infrequent service. A simple theoretical exercise illustrates this trade-off very clearly.

Suppose that in a corridor shown in Fig. 4.5 with a width W there is a total demand for F transit vehicles/hour. Service can be provided in several different ways. In the first case (a) 3 parallel lines are provided; the maximum walking distance to a line from any point within the corridor is $W/6$, while the average walking distance is $W/12$, assuming a uniform population density across the corridor. Frequency of service is $F/3$ on each line. In the second case (b), frequency has been increased to $F/2$ by eliminating one line. Here, the maximum walking distance is $W/4$, and the average is $W/8$. Finally, if all lines are consolidated into one central line (case c), a frequency of F vehicles per hour can be offered, while the maximum walking distance is increased to $W/2$, and the average to $W/4$.

In general, it is preferable to have fewer lines with very frequent service than many lines with infrequent service. Operation of similar types of lines parallel to each other at short distances (less than $\frac{1}{2}$ -mile) represents a duplication of service and results in a lower overall quality of service than could otherwise be provided.

If there is sufficient demand, line spacing every $\frac{1}{2}$ -mile (requiring a maximum walking distance of only $\frac{1}{4}$ mile) is desirable. In areas where demand is not sufficient to support frequent service on lines spaced so closely, it may be desirable to increase spacing somewhat (up to a maximum of about 1 mile) in order to maintain reasonably frequent service. At line separations of one mile, half of the served area is within $\frac{1}{2}$ -mile of the line and nobody has to walk farther than $\frac{1}{2}$ -mile (about a ten minute walk) to reach a transit route. In areas of very low demand, it is preferable to reduce the frequency of service rather than increase separation of lines farther than one mile because service will be infrequent enough to require users to rely on the schedule while a further separation of routes will result in very poor area coverage.

The characteristics of the potential users can also be a factor in deciding on line separation. The above discussion assumed that

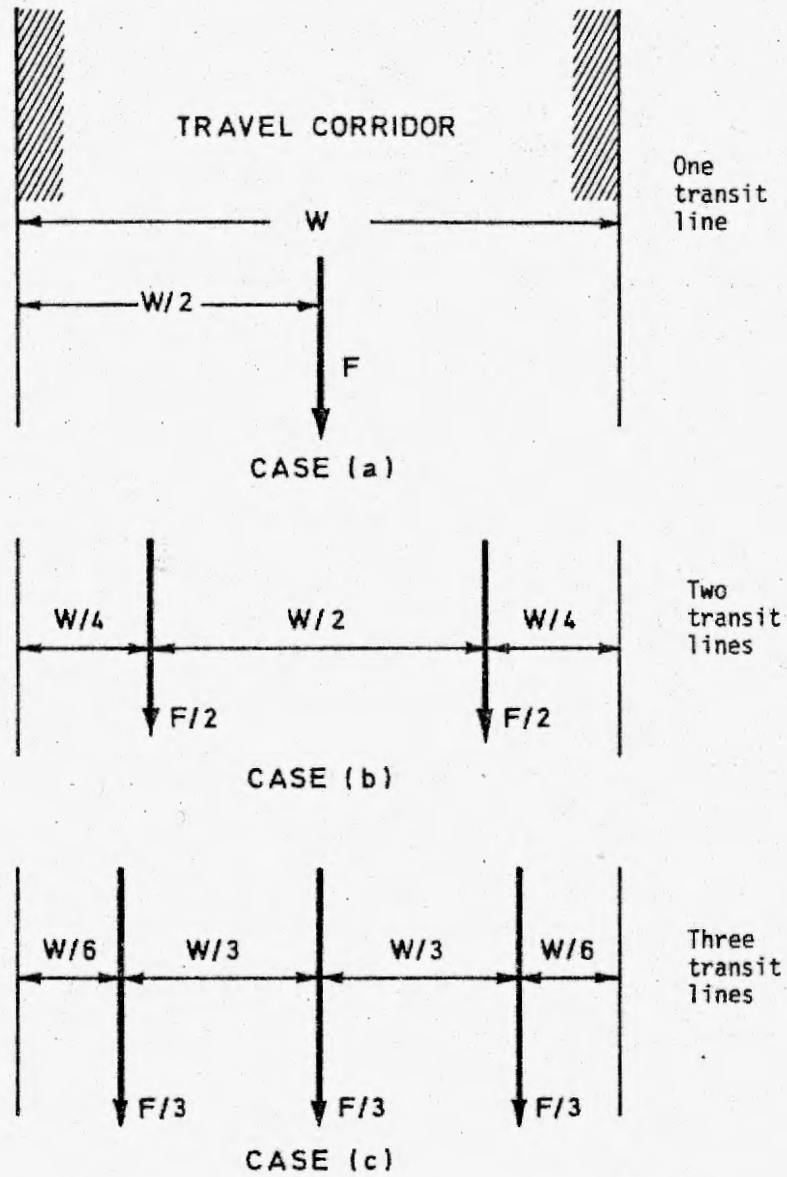

Figure 4.5 -- Relationship between line spacing and frequency of service for a given fleet size.

the primary access mode to the transit line is walking. Where there is a possibility for kiss-and-ride or park-and-ride access to transit, such as for rapid transit or express bus service to the CBD from the suburbs, line spacings may be greater than 1 mile. On the other hand, in cases for which many riders are captive riders and there is a large number of young children and elderly persons who are riders, it is desirable to keep transit lines separated by not much more than 1/2-mile so that walking distance to the transit stops remains short.

4.2 Street and Highway Design

Speed, reliability and safety of transit operations depend considerably on physical facilities and the operational measures which are provided for transit along its routes. By far the best results are achieved through full separation of transit from other traffic, i.e. through provision of private rights-of-way. However, even on existing streets it is possible to introduce a number of measures which can significantly improve transit operation. These measures are described in this section.

All traffic engineering measures should comply with the practices and standards recommended in the Manual on Uniform Traffic Control Devices (MUTCD) ^{*}. The only exceptions may be special transit regulatory devices which are not covered in the MUTCD. Another helpful technical document is the Regulations, listed as reference [12] in this chapter. For the introduction of exclusive transit lanes, one-way streets or parking prohibitions a city ordinance is usually required.

4.2.1 Transit Priority at Intersections. Treatment of transit at intersections is of particular importance since most delays and accidents occur at those locations.

Unsignalized intersections are the most common type of at-grade intersections. For the purposes of this Manual, unsignalized intersections are classified as either (1) those in which one cross-street carries a transit route, and (2) those in which two or more of the intersecting streets carry transit routes.

In the first case the street carrying transit should be given

^{*}This document, [13], can be obtained from the U. S. Government Printing Office, Washington, D. C. 20402; price \$3.50.

priority. This may be accomplished by installing stop signs for vehicles on the other intersecting streets. Four-way stop signs are not recommended at intersections of arterials with transit routes: They cause delay, decrease riding comfort and increase exhaust emissions by buses.

The rationale for installing stop signs on cross streets, as illustrated in Fig. 4.6, is the much greater occupancy of transit vehicles compared with other vehicles and the general principle of favoring transit to increase its competitiveness with the private automobile.

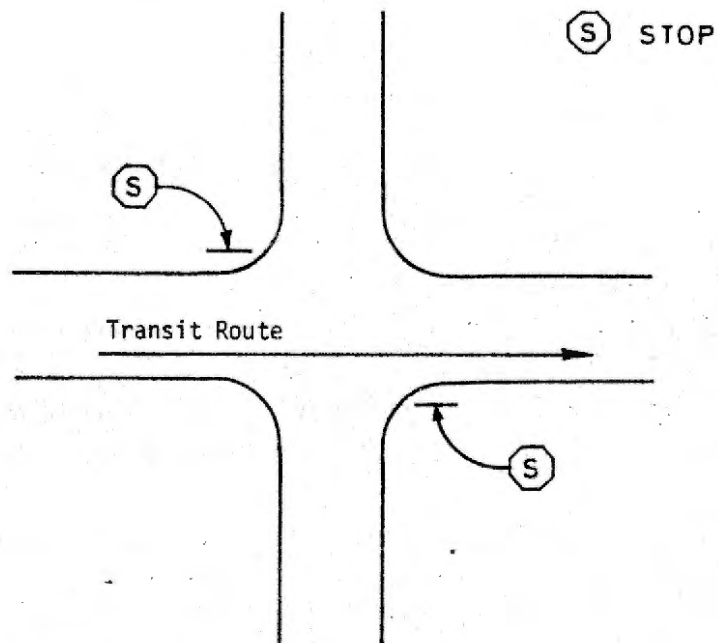

Figure 4.6 -- Priority for streets carrying transit: unsignalized intersection.

In the second case, when two or more intersecting streets carry transit vehicles, priority should be given to the street which carries the greatest volume of persons including both transit and auto traffic, as Fig. 4.7 shows. Again, four-way stop signs are not appropriate for such intersections.

Signalized intersections offer some excellent opportunities to increase both the speed and reliability of transit service.

The same general principles used at unsignalized intersections can be used for signalized ones. Using the number of persons moved through the intersection as the basic design criterion results in allocation of longer green phase for the street with a transit line. Although this measure may result in increased delay to vehicles on streets without transit, the total person delay in all vehicles is minimized; in addition, attractiveness of transit service is increased.

Where it is possible to examine and revise the signal network for an entire area or section of the city, signals on streets with transit service should be coordinated for progression (a through-band should be provided for vehicles travelling at a constant speed). Afterward, timing for the remainder of the network is done.

With other types of signal control, such as area-wide volume responsive or computerized programs, the same principle of favoring movement of transit vehicles can be introduced.

While the transit agency has no jurisdiction over changes in these areas, it must actively seek the support and cooperation of the city's traffic engineering department, the State Bureau of Traffic Engineering and Bureau of Mass Transit Systems by demonstrating the benefits that would result from the types of improvements discussed here. As shown in Section 5.7, the great significance of time saving to be realized from small investments should not be overlooked.

Signal actuation by transit vehicles is an even better solution than signal adjustment (although one which requires higher investment). This is accomplished by actuation of signals by transit vehicles, either electrically through a continuous wire or electronically via a radio transmitter. Using this type of system, the driver of a transit vehicle can send a signal ahead to a receiver attached to the traffic

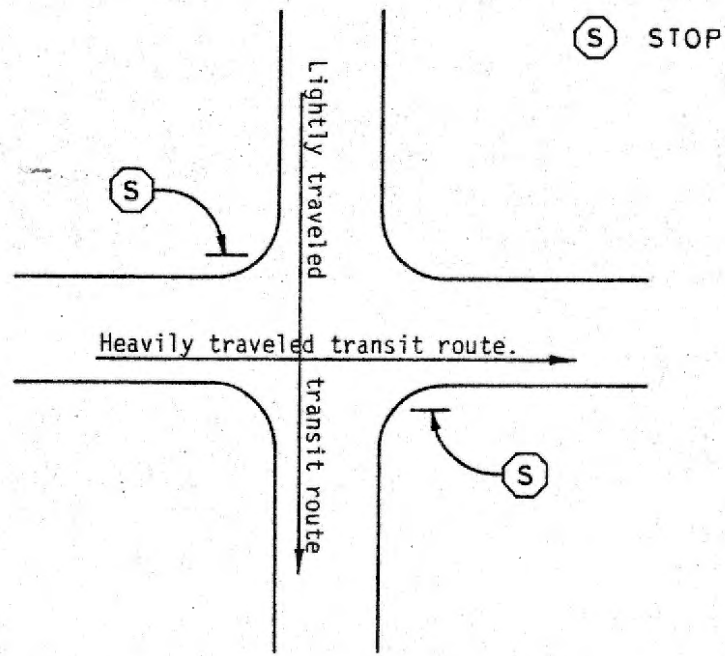

Figure 4.7 -- Priority for more heavily traveled transit route: unsignalized intersection.

signal controller at the intersection which he is approaching. A phase selector then interrupts the normal signal pattern to give the transit vehicle a green signal, either by holding the green light in the direction of the transit vehicle or by accelerating the normal cycle (shortening the red phase) to provide a green interval by the time the vehicle reaches the intersection.

Extension of the green time can occur at the beginning or at the end of the normal green time, but not at both. This insures that a minimum cross street green interval is always provided.

As an example, suppose that a major street has a "through band" of 34 seconds, leaving a normal green phase for the cross of 26 seconds on a 60 second cycle. Suppose also that the minimum required green for the cross street is only 16 seconds, allowing a possible extension of green on the major street to 44 seconds. These extra 10 seconds could be taken either before or after the "through band", giving a total of 54 seconds out of the 60-second cycle in which the transit vehicle could pass. The main limitation of signal actuation by transit vehicles is that it can be effectively applied only where transit vehicles are separated from other traffic, i.e. on transit streets or on streets with exclusive transit lanes.

The advantages of introducing such a signal actuation system over a large network can be particularly significant for increasing transit speed.

Transit vehicle turning movements are an important consideration, both in the geometric design of intersections and in traffic signal operation.

In the case of a right turn, a special lane can sometimes be provided allowing free turn of transit vehicles separated by a channelization island.

Left turns are somewhat more difficult to accommodate due to the conflict between traffic flows they cause. The best means of giving priority to transit is to provide a special left turn signal phase, preferably before the through traffic phase (advanced green); in some cases a phase following that for through traffic (lagging green) can also be successfully applied.

4.2.2 Transit Stop Locations. In planning transit stops two decisions must be made. First, the approximate spacings between stops should be decided (this problem is discussed in section 5.7); and second, the locations of stops along streets should be selected; this problem is discussed here.

There are three types of locations for transit stops along streets: near-side (NS), or at the intersection, prior to crossing the cross street; far-side (FS), or at the intersection, passed the cross-street; and midblock (MB), or away from intersections. There is a practice in many cities to adopt one type of stop location and to use it throughout the city. Most commonly, a NS stop policy is used, sometime FS, while MB stops are found in special cases only. However, uniformity of stop location is seldom justified. The only significant advantage of it is that passengers become accustomed to a standard location and there is less opportunity for confusion; but if stops are properly marked, this problem is largely resolved, regardless of whether there is a uniform stop location policy or a combination policy. On the other hand, various factors influence choice of location and there are considerable advantages to using different types, particularly NS and FS, at different locations along the same route.

Major factors influencing the choice of stop locations are:

- Timing of traffic signals;
- Geometry of turning and stopping;
- Vehicular and pedestrian traffic conditions; and
- Passenger access.

Each of these factors are reviewed here.

Signal timing can be an important factor in choosing stop locations. The main reason that transit vehicles do not travel as quickly as automobiles on city streets, is that they must stop not only for traffic signals, but also to pick up and discharge passengers. Thus, their operating speed can be increased if the need to stop for a red light can be combined with a transit stop. Where the transit vehicle encounters a green light, the transit stop should be located beyond the signal, i.e. FS, so that the vehicle can take advantage of the green phase. Since, at a given intersection, the transit stop

remains at a fixed location, the proper placement of the stop depends upon whether a green or a red phase is expected (i.e. is "probable") as the transit vehicle reaches the intersection. In the case for which traffic signals are not synchronized (i.e., they are not timed so that a vehicle moving at a constant speed will reach each traffic signal during the green phase) and where the traffic is moderate to heavy, there is not likely to be a significant time saving by using either NS or FS stops. In this case the proper placement of the transit stops should be determined by examining other factors which are discussed later in this section. Where traffic is light, or where a separate bus lane exists, it may be possible to predict in each signal cycle when the transit vehicle will most probably reach the intersection; thus, transit stops can be planned so that delays caused by signals are minimized.

In the case where traffic signals are fully synchronized there is a "through band" at a given speed, the transit vehicle will periodically drop out of one band and wait for the next one. The time the vehicle loses should be utilized for stopping at one or two passenger stops. This is best achieved by use of alternating NS and FS stops. This method can result in time savings as high as 10 to 15% over operating on streets with all-NS or all-FS stops.

Figure 4.8 illustrates the concept of alternating NS and FS stops. The figure shows the path of one transit vehicle stopping at NS stops and another vehicle using FS stops. Time lost at stops for passenger boarding/alighting is assumed to be the same for both runs. The diagram shows that both runs have equal travel times over the plotted section, although the all-FS policy requires the vehicle to stop more times. If, however, the NS and FS locations are alternated, the transit vehicle delay will be considerably shortened, as the third line on the diagram shows.

In some situations, there may be a sequence of NS and FS stops which yields an even higher operating speed than simply alternating them, since vehicle delays depend on the frequency and duration of stopping for passengers and the signal synchronization pattern. However, two basic rules are always valid:

1. When a NS stop is followed by two or more progressively coordina-

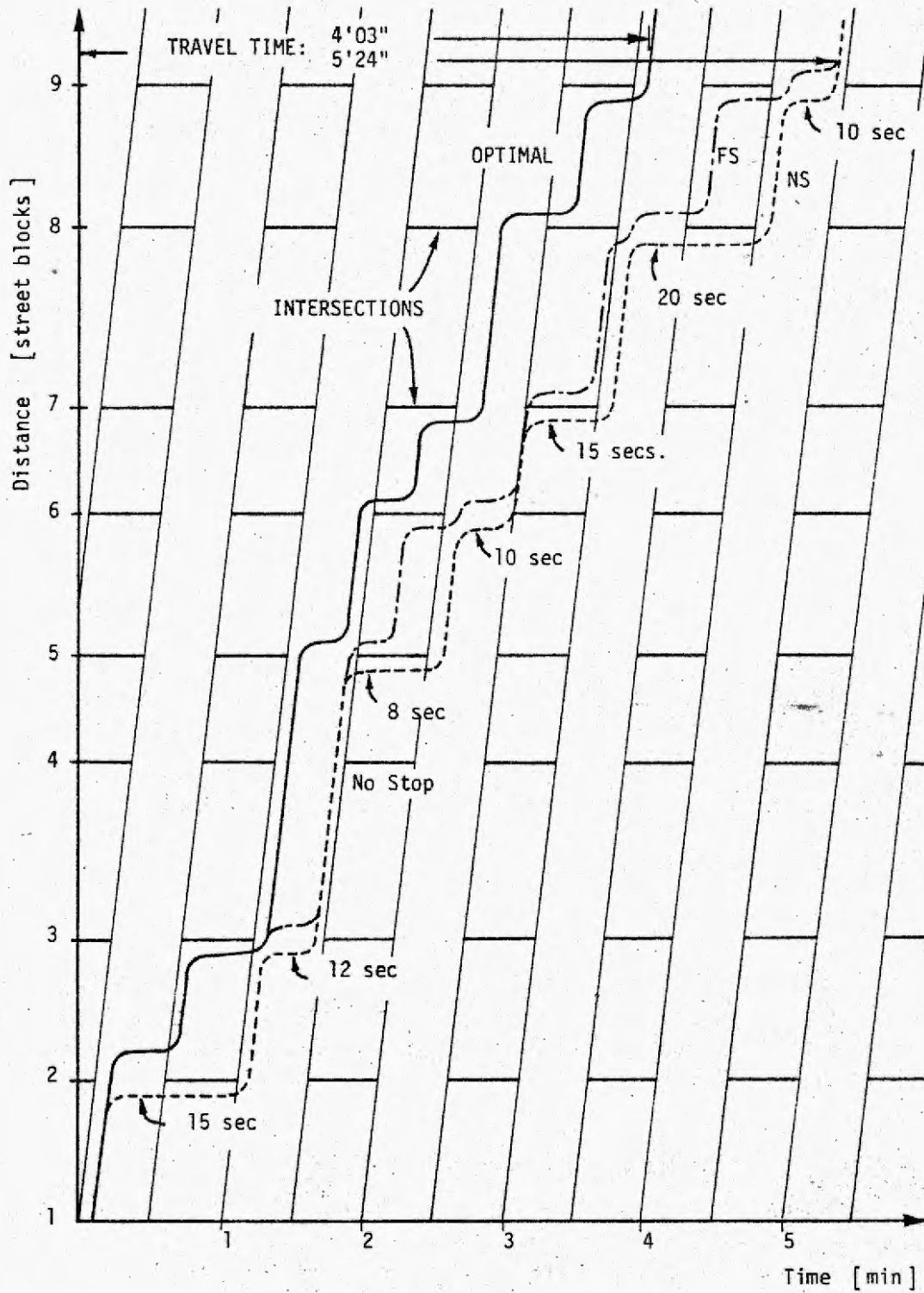

Figure 4.8 -- Transit vehicle travel time for all-NS, all-FS and alternate stop locations.

ted signals, the following stop should be FS.

2. For any length of signal phases and length of delays at stops, alternating NS and FS stops are at least equal to, and usually considerably better than all-NS and all-FS stop policies.

The method of alternating NS and FS stops on streets with synchronized signals usually cannot yield as significant speed increases as can signal actuation by transit vehicles; however, signal actuation requires a considerably greater capital cost and a reserved transit lane. By contrast, obstacles to introduction of alternating NS and FS stops are minimal.

Geometry of bus turning and stopping bays may influence stop locations. Where a bus must turn right it cannot often do so from the curb lane because its turning radius is larger than the curb radius. In this case a FS stop is preferable to a NS stop. Where a left turn must be made and there is more than one lane of traffic in the same direction the turn is made from the left lane, so that FS stop is preferable.

Where a bus must pull out of a traffic lane into a no-parking zone along the curb lane, or into a special bay for a stop, the length of stop required for bus maneuvering must be considered. Since the approach to the curb requires a greater length than that needed for departure, a far-side location is preferable where it is desirable to minimize the curb space preempted for bus stops. Table 4.1 gives the curb lengths needed for typical bus stops.

Traffic conditions must also be considered in stop location. It is desirable to locate bus stops so as to minimize interference with other vehicular and pedestrian traffic. Interference with turning movements of other vehicles, ability of the bus to merge into traffic, and visibility at pedestrian crossings are the most important items and they should be studied at each bus stop location. In general, the NS location causes the least amount of interference when the following conditions are present:

- Approaching traffic is lighter than the exit traffic on the transit street;
- Cross street is a one-way street with traffic flowing

Table 4.1 - Minimum desirable bus curb/freeway loading zone lengths.

Approx. bus seating cap.	Approx. bus length	One-bus stop			Two-bus stop:		
		NS	FS	MB	NS	FS	MB
30 and less	25	90	65	125	120	90	150
35	30	95	70	130	130	100	160
40-45	35	100	75	135	140	110	170
51-53	40	105	80	140	150	120	180

Note: The length of stops is measured from the extension of a building line or established stop line, whichever is appropriate. It is based on the side of the bus being positioned one foot from the curb; for the bus to be as close as 6 inches, 20 feet should be added to NS stops, 15 feet to FS stops, and 35 feet to MB stops. NS stops should be increased 15 feet where buses are required to make a right turn. If there is a heavy right-turn movement of other vehicles, the increase should be 30 feet. The FS lengths are based on roadways 40 feet wide, which enables buses to leave the loading zone without passing over the centerline. The length should be increased by 15 feet for a 36 foot wide street and 30 feet for a 32 foot width.

from right to left;

- Number of vehicles that turn right from the transit street is small.

For the opposite conditions, a FS stop causes less disruption.

Passenger access should also be carefully considered. Stops should be located where waiting passengers are well-protected from traffic, have sufficient space for circulation and comfort and do not impede the pedestrian flow on the sidewalk. Where there is a major pedestrian generator, e.g. a major store or office building, it is preferable that the stop be located on the same side of the street, particularly at busy intersections where there are no special pedestrian crossings or signal systems.

At intersecting points of two or more bus lines, the stops should be located to minimize the walking distance required for transfer between buses, as shown in Fig. 4.9.

Mid-block stops (MB) are, in general, undesirable for the following reasons:

- they require longer walking to cross streets and transfer points;
- they occupy more curb space;
- passenger jay walking is encouraged.

However, in certain cases mid-block stops are desirable. Factors that can lead to a choice of mid-block location include the following:

- location of a major traffic generator at mid-block;
- heavy pedestrian traffic at an intersection which would result in interference among waiting passengers and pedestrians;
- unusual traffic or geometric conditions at an intersection which make stopping there undesirable;
- bus is turning left and FS stop is not possible.

In conclusion, no simple rule can be given that states categorically whether NS, FS or MB locations are best for transit stops. Each transit stop location should be selected on the basis of the discussed factors.

4.2.3 Parking on Transit Streets. The operation of bus service in mixed traffic can be improved by prohibition of curb parking on streets with transit routes. The benefits from such a policy include

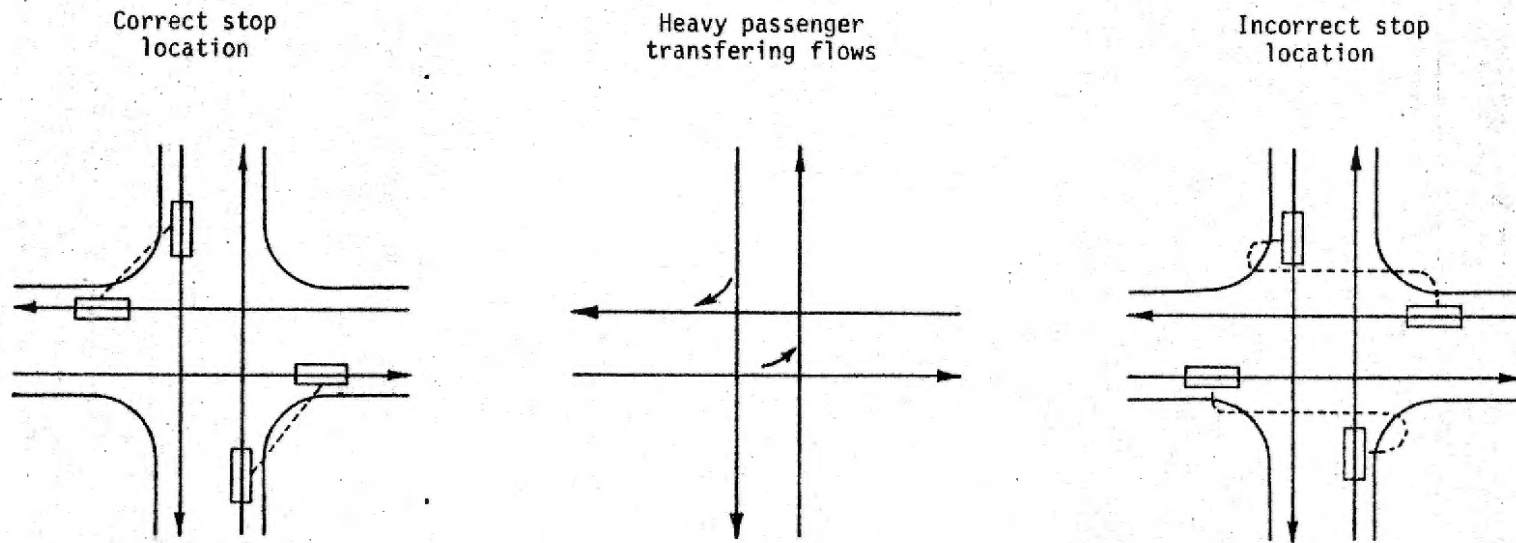

Figure 4.9 -- Impact of bus stop locations on convenience of passenger transfers.

faster bus operation and reduced friction between automobile traffic and buses. The faster bus operation results in increased ridership and cost savings to the transit agency.

Since, a transit agency typically does not have authority over parking regulations, cooperation is required from the appropriate city agencies to introduce effective parking regulations. While elimination of parking along transit streets is almost always desirable from the standpoint of speeding up transit operation; there are other factors important in considering a ban on parking. The problem is essentially a trade-off between improved transit operation on one side and the convenience of on-street parking for auto drivers on the other side. The following factors should be examined:

Number of existing lanes for moving traffic. Where there is only one lane of traffic and one lane for parking in each direction on a street, traffic flow is often interrupted since any car that slows to park forces the following vehicles to stop. In addition, every time that a bus stops, it interferes with the traffic flow. In this situation, a significant increase in operating speed and reliability can be achieved by parking prohibition. In the case where two lanes of traffic flow are increased to three, the benefits are usually less dramatic, although not insignificant.

Traffic volume. On streets where traffic flow is very light, the benefits derived from an added lane are obviously not as significant as the case where traffic flow is very heavy. Thus, on some streets, a ban on parking would be appropriate only during the peak hours.

Frequency of transit service. The more frequent transit service is, the more transit riders will benefit from the improvement. Thus, the inconvenience caused by a ban on parking may not be justified on a very low-frequency transit route, but justified on a similar street where transit frequency is higher.

Type of neighborhood. In the older residential areas of many cities on-street parking is a necessity because of the lack of driveways. Here, it is clearly undesirable to try to prevent on-street parking even if the existing traffic flow is slow and congested. If it is desired to obtain an extra lane of traffic for faster and more reliable transit operation, consideration should be given to making a pair of one-way streets. In newer residential areas, the

the problem of needed parking spaces on the street usually does not exist; yet, residents may object to giving up the convenience of on-street parking. This resistance should be overcome by showing the potential benefits from such a measure.

In CBD commercial areas a good case can usually be made for prohibition of on-street parking along transit routes. Generally, municipal and private parking lots are available, and the merchants do not have to depend solely upon the few parking spaces which front their establishments in order to attract business. In addition, increasing the operating speed and reliability of transit into the CBD is likely to attract more customers who usually shop in the suburbs to patronize stores in that area. Unfortunately, most store owners greatly overestimate the importance of curb parking spaces for their businesses and oppose parking elimination and plans for transit lanes, streets or pedestrian malls prior to their introduction; later results in most cases change their attitudes.

In neighborhoods without off-street parking facilities prohibition of on-street parking may be difficult or impossible unless sufficient parking is available on cross streets. This is often the case in older areas around the CBD. Farther out, in newer suburban areas, off-street parking is usually provided and a no-parking policy on transit streets is often feasible.

Loading zones. Where reserved loading zones exist in sections of the parking lanes, a substitute arrangement for deliveries must be made. Provision of loading zones around the corner on cross streets is often a satisfactory solution. Another possibility is allowing loading in the evening and morning hours when buses can easily use other lanes.

4.2.4 Criteria for Establishment of Reserved Transit Lanes. Where transit vehicles and private automobiles must share the same traffic lanes, the result is a mutual interference of the two types of vehicles. Automobile drivers are annoyed by having to slow down as a transit vehicle stops for passengers during a green light. Similarly, buses are impeded in pulling out from stops by a heavy traffic flow, which results not only in a slower operating speed, but also, as importantly, in a less reliable transit service. This problem occurs in the downtown area, and on major arterials leading into almost every city. The most

effective means of resolving the conflict is to introduce lanes reserved exclusively for transit vehicles.

A reserved transit lane has several benefits. By separating transit vehicles from automobiles, both speed and reliability of transit operations are greatly increased. The separation also facilitates preferential treatment of transit vehicles at intersections, further increasing their operating speed. In addition, while a reserved transit lane may have been previously one of the automobile lanes, the automobile traffic flow is not necessarily impaired. First, the increased homogeneity of traffic helps to speed up the automobile traffic. Secondly, if the reserved transit lane is planned properly with high service quality, a substantial number of automobile drivers should be diverted to the transit system. If diversion is very high both transit and automobile traffic speeds are increased. Thus, a reserved transit lane may result in faster, more reliable, and more frequent transit service, as well as a faster flow of automobile traffic.

Criteria for introduction of transit lanes vary among cities. In some cities a reserved transit lane is considered justified only if there are a large number of transit vehicles per hour, i.e. where there are sufficient transit vehicles to consume a large fraction of a lane's capacity. This criterion neglects the fact that it is not the number of vehicles which is important, but the number of passengers carried by transit which should be the main consideration. Consequently, the number of passengers carried by buses versus the number carried by automobiles on the same street should be the criterion: when buses carry as many persons per hour as private automobiles carry on the average per remaining lane, reserving the lane for buses is justified. Bus headways are thus not directly relevant.

However, even this criterion may be too conservative and biased against transit in some cases. If the introduction of a reserved lane is expected to improve transit so much that a substantial number of auto drivers are diverted to transit, a reserved bus lane should be introduced even if it carries somewhat fewer passengers than private automobiles in other lanes.

Cities which are trying to reduce air pollution or automobile

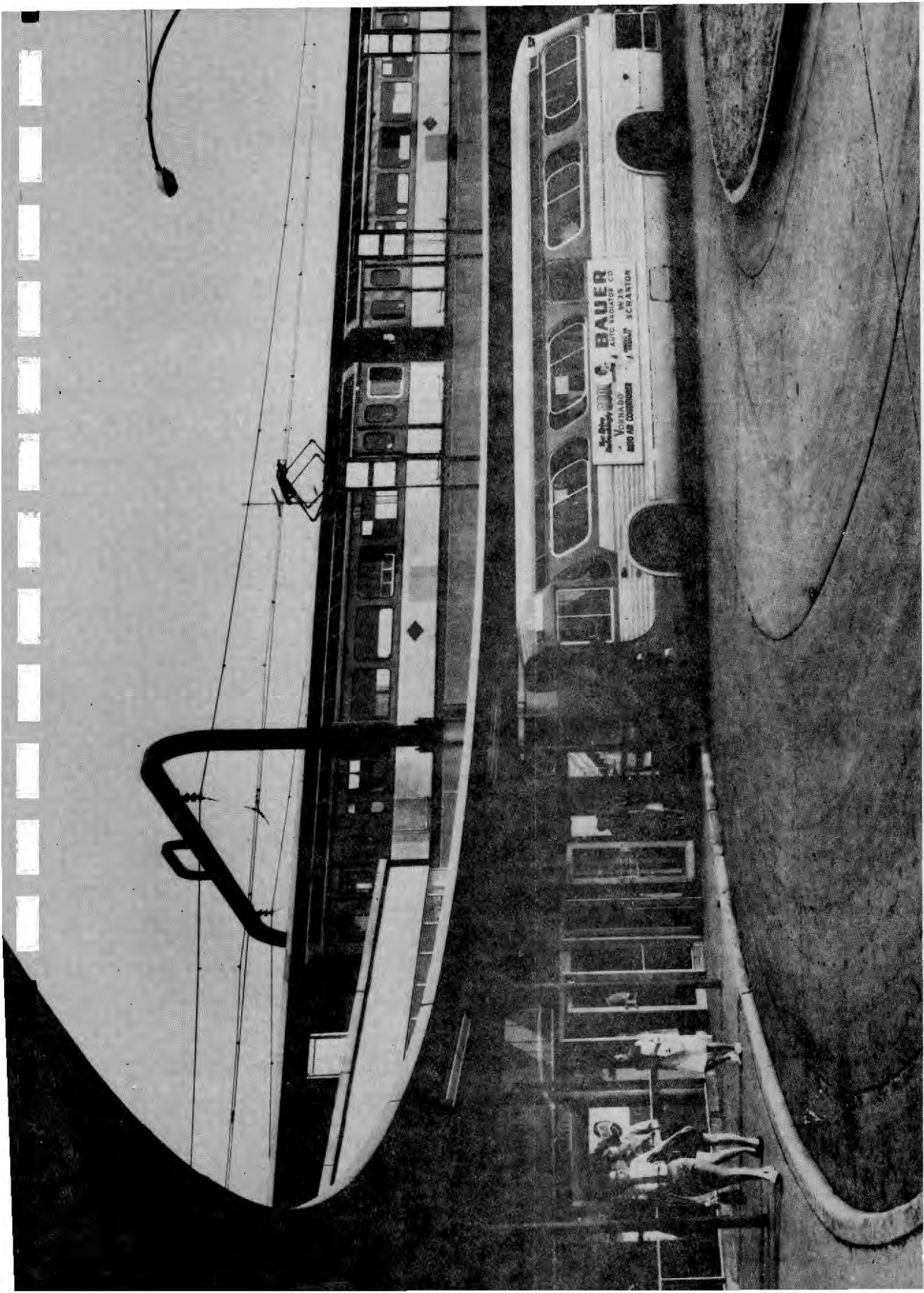



congestion might embark on setting up reserved transit lanes where there exists a large number of potential transit users. Such a policy encourages transit use and discourages private automobile use in a given area.

In order to establish a reserved lane for a transit vehicle, there must be sufficient roadway width to provide both transit and automobile lanes; thus there should be a minimum of one lane of traffic and one transit lane in each direction. In cases of breakdowns in either of the two lanes vehicles can utilize the other one. In general, the wider a street, the more suitable it is for introduction of a reserved transit lane.

One important point that should be remembered about reserved bus lanes is that enforcement is very important. Many reserve bus lanes are only separated from other traffic by pavement markings, and when the automobile traffic lanes are congested, they provide a tempting additional lane for motorists. Unless there is a strict enforcement policy, especially when the reserve lanes are new, frequent violations may occur, defeating their advantages. When frequency of transit vehicles is very high, transit lanes are practically self-enforcing.

If reserved transit lanes exist only during the peak hours and at other times are available for on-street parking, it is important that all parked cars be removed from that lane when the peak hours begin. This type of operation must have particularly good signing, strict penalties, and a tow-away program.

4.2.5 Design of Reserved Transit Lanes. There are three types of transit lanes on city streets:

- Curb lanes
- Contraflow curb lanes
- Central median lanes.

Main characteristics of each type are described here.

Curb lanes are the most common type since they are the easiest to introduce. Their position allows buses easy passenger boarding/alighting. The problem exists with right turning vehicles where this movement cannot be eliminated. If the turn is made from the lane adjacent to (to the left of) the transit lane, the turning movement must be separated from bus movement by signals; if turning autos

are permitted into the transit lane, buses may be slowed considerably at locations of heavy turns or heavy pedestrian crossings at which autos must yield right-of-way.

Enforcement may also be a problem. Construction of a raised curb can solve it; but on the other hand, it prevents movements of vehicles between lanes in case of breakdowns. The curb also may represent a hazard if it is not carefully designed; it also requires considerably higher investment cost.

Contraflow curb lanes are usually extreme left lanes on one-way streets, again allowing the bus to stop along the curb for passengers. The number of existing contraflow lanes is rather small, but it is increasing.

Compared to a normal-flow curb lane, a contraflow lane has the following advantages:

- + It is "self-enforcing": automobile use of the lane is minimized even when no physical barriers exist.
- + The problem of right turning vehicles does not exist. At the same time, left-turning vehicles have less difficulty than they would on an ordinary two-way street.

The disadvantages of contraflow lanes are:

- There are two safety hazards associated with them. One is the obvious potential for head-on collisions with an automobile getting into the lane - a problem which can be satisfactorily solved by a liberal application of pavement markings plus the use of overhead signs or lane signals. Ideally, the pavement for the lane should be of different color and texture.

The other safety problem relates to pedestrians walking across the reserved lane. Since at first glance all traffic appears to be moving one-way, pedestrians may not look in the direction from which the transit vehicles are traveling. A low barrier or fence at the edge of the sidewalk (except at stops) can reduce this danger.

- On a one-way street, traffic lights are often synchronized. The movement of a transit vehicle operating in a contraflow lane may thus be slow, since its direction of travel is opposed to the progression of the traffic signals.

Central median lanes are placed in the center or median of wide streets. Two lanes are usually reserved for transit--one in each direction. Median transit lanes have the following important characteristics:

- + The problem of automobiles penetration of reserved lanes does not exist since the center lanes are usually separated from the automobile lanes by curbs.
- + The problems associated with turning vehicles or of oncoming vehicles illegally using the lanes do not exist as they do for normal flow and contraflow reserved lanes.
- + If cross traffic and left turns can be limited to only a few intersections, a very high operating speed can be achieved.

Disadvantages of central-median reserved lanes include:

- Wide streets are required in order to obtain a center median.
- The cost of implementation can be significant since reconstruction of a center median is often required.
- Since passengers must board and alight in the center of the street, adequate transit stop areas must be provided.
- Left turns must be given special signal phases or eliminated.

4.2.6 Transit at Intersections. Although transit agencies are not directly responsible for the design of street intersections, whenever existing intersections are modified or where new intersections are being designed which may be used by transit vehicles, the transit agency should be consulted to check adequacy of design for its vehicles--to allow easy movement of buses, trolleybuses or rail vehicles.

The main problem of transit vehicles at intersections are associated with turning movements. For buses, the inside rear wheel follows an arc close to the curb, while the outside of the front fender follows an arc farthest from the curb. Figure 4.10 illustrates a bus turning movement with the important turning radius data for several different bus models. It can be seen that the more a curb is cut back at the corner, the less the bus must pull out of its lane to avoid running over the curb. However, in the downtown area of many cities, extensive curb flaring may cut down on sidewalk area needed for pedestrians at the intersections. Thus, curb flaring should be limited so as not to seriously interfere with pedestrian movement and safety.

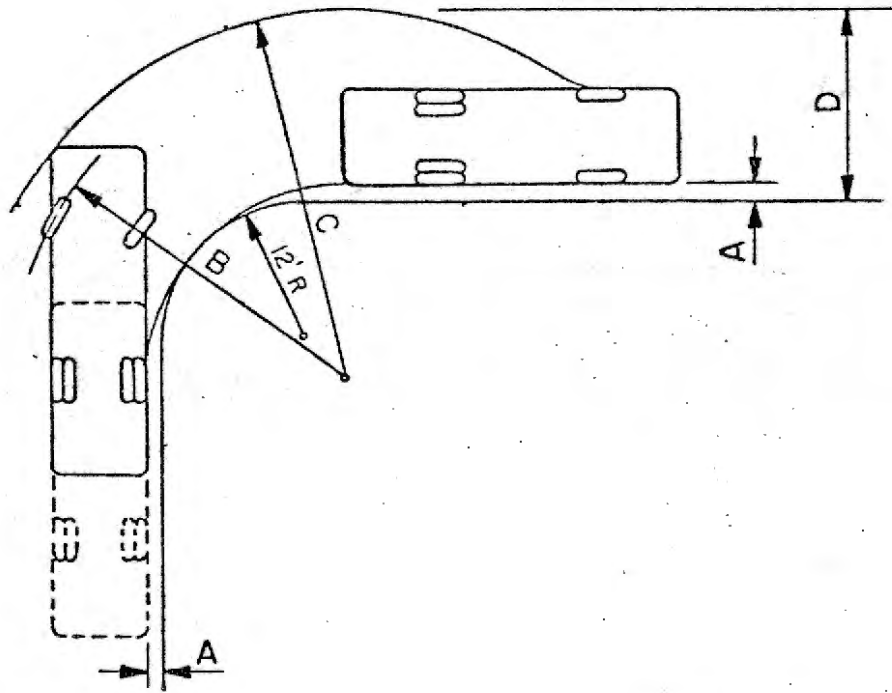

CHARACTERISTICS OF BUS					TURNING RADIUS DATA			
GMC MODEL	No. of Seats	Body		Length Wheel Base	A	B	C	D
		Width	Length					
TDH3301A	35	8'0"	29'3"	15'7"	1'8"	29'2"	33'0"	17'5"
TDH4521 SDH4501 SDH4503	45	8'0"	35'0"	19'7"	0'10"	31'2"	36'1"	22'2"
TDH4520	45	8'6"	35'0"	19'7"	0'10"	31'4"	36'3"	22'4"
TDH5306 S8M5303A	53	8'0"	39'11"	23'9"	1'9"	37'1"	42'1"	26'3"
TDH5305	53	8'6"	39'11"	23'9"	1'9"	37'3"	42'3"	26'5"
PD4107 PD4108	41	8'0"	35'1"	21'7"	4'0"	39'6"	43'6"	22'3"
PD4903 PD4905	49	8'0"	40'0"	26'6"	4'9"	45'0"	48'6"	25'0"

SOURCE: General Motors Truck and Coach Division

Figure 4.10 -- Turning characteristics of transit buses

4.2.7 Design of Transit Stops. There are three basic types of bus stops:

- Stops along a straight curb;
- Stops in "No Parking" zones of parking lanes; and
- Bus bays.

Choice among these types depends on several factors including:

- Whether there is a reserved transit lane;
- Intensity and speed of automobile traffic;
- How strongly transit is favored over other traffic;
- Duration of bus standing at stops.

A common practice in many cities, particularly where excessively frequent stops exist, is that the bus does not pull into the bus stop area but remains in its travel lane. Drivers often do this to avoid the problem of getting back into the travel lane when traffic is heavy, or just because it is easier for them not to make the maneuver. This practice has serious disadvantages: it is less safe and less convenient for passengers to board buses from roadway than from curb; in addition, a travel lane is paralyzed during the bus stoppings. Stops in a travel lane may be used when other traffic is light, or where stop durations are usually short. In such cases the sidewalk may be widened to reach the travel lane allowing boarding from a curb and making the parking lane a long bay with easy enforcement.

The pulling of buses from stop areas into travel lane should be facilitated where traffic flow is heavy either by the introduction of an advanced bus signal at NS stops, or by their change into FS stops.

Recessing bus stops into the curb parking lane or bus bays have the advantage of eliminated impedance to other traffic, but they involve a slightly long maneuver and some time loss in pulling back into the traveled lane. The most common stops are in parking lanes in which "No Parking - Bus Stop" zones are designated. These stops require very low cost to introduce and they can be combined with use of the same lane for moving traffic (unrestricted or bus lane) during the peak hour. A serious drawback of this type of stop is that illegal parking or stopping in them is frequent unless enforcement is extremely stringent. Any obstacle in the bus stop zones causes buses not to use them or to pull into them only partially blocking the second lane during the stop. It is therefore always desirable that bus stops

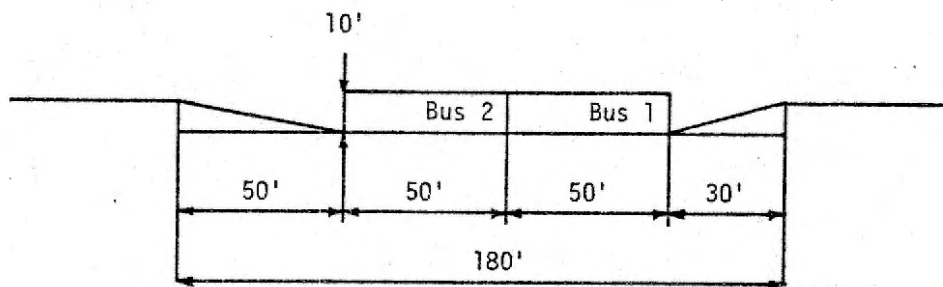

Figure.4.11 -- Design of double mid-block bus stop.

be separated from the parking lane by curb design, such as shown in Fig. 7.3. This design cannot be applied in lanes which are used for moving traffic at any other time.

Bus bays, shown with dimensions in Fig. 4.11, have excellent operational and safety features when their introduction is warranted, as for the following cases:

- Where there is only one traffic lane in each direction and traffic is not heavy enough to seriously impede the reentry of the bus into the traffic lane;
- Where there are a large number of passengers boarding or alighting, necessitating a prolonged stop;
- Where the curb lane is reserved for transit, bays are needed only if there is an extremely heavy volume of buses and their mutual overtaking is desired. This is a rather exceptional situation.

Where bus frequency is high enough to require bus stops for two vehicles, the lengths of the stops should be increased by one bus length plus 5 feet.

Pedestrian loading islands should be provided where transit vehicles, bus or rail, operate in a center lane and, in some cases, where a transit stop is located directly before a left turn so that straight-through traffic passes on the right of it. Pedestrian loading islands should have the following characteristics:

Protection: They must provide protection for the pedestrians who are waiting on the island. To accomplish this, a strong physical barrier, such as pipe posts with vehicle attenuators, should be placed at the end of the island. Breakaway structures are not applicable here because pedestrian protection is more important than protection of vehicles which lose control. In addition, visibility devices such as reflectors, reflectorized paint, and illumination, must be used to warn and divert oncoming automobiles. Some physical protection for the side should also be afforded by the use of pipe posts, 3 feet high, spaced 8 feet apart, and connected by chains, rails or wire-mesh fencing.

Size: Ideally, the length of the pedestrian area should be equal to that of the longest transit vehicle that uses the island stop, plus 5 feet. As a minimum it should be equal to the length between the front of the vehicle and the back of the rear door. For multiple vehicle loadings, the

length should allow for at least 3 feet between stopped vehicles. The width should be at least 4 feet but preferably 6 feet.

Bus shelters are an important element of passenger comfort, particularly in cities that have severe weather conditions. Since it is often prohibitively expensive to provide a shelter at each stop, the following factors can be used in determining where they should be.

- the number of passengers that use the stops;
- the average passenger waiting time;
- stops that are transfer points;
- the availability of alternative shelters;
- exposure to the wind and weather elements.

Bus stop markings are discussed in the following section. Proper design for bus stop signs is described in Chapter 7.

4.2.8 Pavement markings. Most pavement markings that affect transit operations fall into one of three categories: parking prohibitions, markings of bus stops, and designation of reserved transit lanes.

Parking prohibitions are particularly needed for reliable operation of the transit service. Effectiveness of prohibition depends mostly on enforcement, but also on the type of signing.

Posted "No Parking" signs are sometimes overlooked especially if they become twisted and are spaced far apart. To increase the effectiveness of the signs, curb markings should be added. The most common type of marking is to paint a yellow stripe on the curb in the section. This type of marking is becoming more widely recognized as indicating a parking ban. In addition, painting "No Parking" about every 100' on the pavement can further increase the effectiveness of the parking ban.

Designation of bus stops can also be accomplished with pavement markings; it is often desirable to paint "Bus Stop" directly on the pavement, in addition to providing a bus stop sign. The benefits to be gained are (1) motorists who are less likely to park illegally at a bus stop that is well marked; (2) motorists who use the street frequently will be made aware of where transit vehicles stop and thus are more likely to drive in the correct lane when following a transit vehicle; (3) the size of the lettering makes the stop more visible to transit patrons who are unaware of the exact stop

location; and (4) bus drivers are less likely to overlook a stop.

Designation of transit lanes must often be accomplished with pavement markings. Since some lanes are reserved only during peak hours or allow right turning vehicles to share exclusive right-of-way, it is often not feasible to physically separate such lanes from the adjacent traffic lanes. When such is the case, pavement marking, rather than barriers, must be used to prevent automobiles from using the reserved lane. The standard sign for reserved transit lanes is a diamond, defined by change M 26 to the MUTCD. Where the lane is reserved at all times, pavement markings must also include a double solid line to separate the reserved lane from automobile lanes. Where the reserved lane is a center lane, two sets of double lines are required. When the transit lane is reserved only at certain hours, it should be designated by a single solid line. In addition to the lines, "Buses only 4-6 P.M.", or a similar message may be painted on the pavement of the reserved lane at evenly-spaced distances.

For further emphasis, in the case of the full-time reserved lane, widely spaced diagonal stripes are sometimes painted across the lane. When a street that has a reserved transit lane is being repaved the installation of a different type of pavement for the reserved lane is a good way to enhance the image of separation.

The following characteristics of pavement marking should be kept in mind:

1. Pavement markings enable a driver to receive information without looking away from the roadway.
2. They are easily obliterated by ice and snow.
3. In areas of heavy traffic, they wear quickly.
4. They are obscured to a driver's vision by vehicles directly ahead.

In using pavement markings, the following practices should be followed:

1. Markings should be uniform throughout the state.
2. White paint, hot or cold thermoplastic should be used for lane lines and word messages. On light colored pavement, the markings can be accented by the use of black paint as contrasting background.
3. Yellow paint should be used for double lines separating lanes for opposing directions. Other applications should also be as recommended by MUTCD.

4. High quality paint with glass beads should be used since labor costs are the major cost in pavement markings.
5. Standard thickness of paint is 15 mills which should provide about 100 square feet of markings per gallon.
6. For messages, letters should be elongated in the direction of traffic movement. The message should read up with the first word nearest the driver. Letter sizes, spacing between lines and exact designs are specified in the MUTCD.

4.3 REFERENCES AND BIBLIOGRAPHY

1. American Association of State Highway Officials, A Policy on Design of Urban Highways and Arterial Streets, Washington, 1973.
2. Baerwald, J. E., Ed. (ITE), Transportation and Traffic Engineering Handbook (Fourth Edition), Prentice-Hall, 1976.
3. De Leuw, Cather & Company, Light Rail Transit, UMTA-DOT report DOT UT 50009, USGPO, Washington, 1976.
4. Highway Research Board, "Highway Capacity Manual 1965", HRB Special Report 87, Washington, 1965.
5. Highway Research Board, "Improved Street Utilization Through Traffic Engineering", Special Report 93, Washington, 1967.
6. Pontier, W. E. et. al., "Optimising Flow on Existing Street Networks", NCHRP Report 113, HRB, National Research Council, Washington, 1971.
7. Homburger, W. S., Notes on Transit System Characteristics, ITTE, University of California, Berkeley, 1975.
8. Kraft, W. H. and Boardman, T. J., "Location of Bus Stops", Transportation Engineering Journal of ASCE, Proceedings of the American Society of Civil Engineers, Vol. 98, No. 1, TEI, February 1972, pp. 103-116.
9. Leonard, H. J., "Benefits from TOPICS -- type improvements", Civil Engineering, New York, Vol. 41, No. 2, February 1971.
10. Levinson, H., Adams, L., and Hoey, F., "Bus Use of Highways, Planning and Design Guidelines", NCHRP Report 155, TRB, National Research Council, Washington, 1975.
11. Levinson, H. S. et. al., "Bus Use of Highways, State of the Art", NCHRP Report 143, HRB, National Research Council, Washington, 1973.
12. Pennsylvania Department of Transportation, Regulations Governing the Design ..., Pub. #68, 0350-4500-0680, Harrisburg, June 1975.

13. U. S. DOT, Manual on Uniform Traffic Control Devices, U. S. Government Printing Office, 1971.
14. Vuchic, V. R., and Kikuchi, S., "Design of Outlying Rapid Transit Stations", TRB Record 505, 1974, pp. 1-12.
15. Vuchic, V. R. and Weston, M. J., "Urban Transportation Improvements Through Low Cost Traffic Engineering Measures", H. R. Record 461, 1973, pp. 30-34.

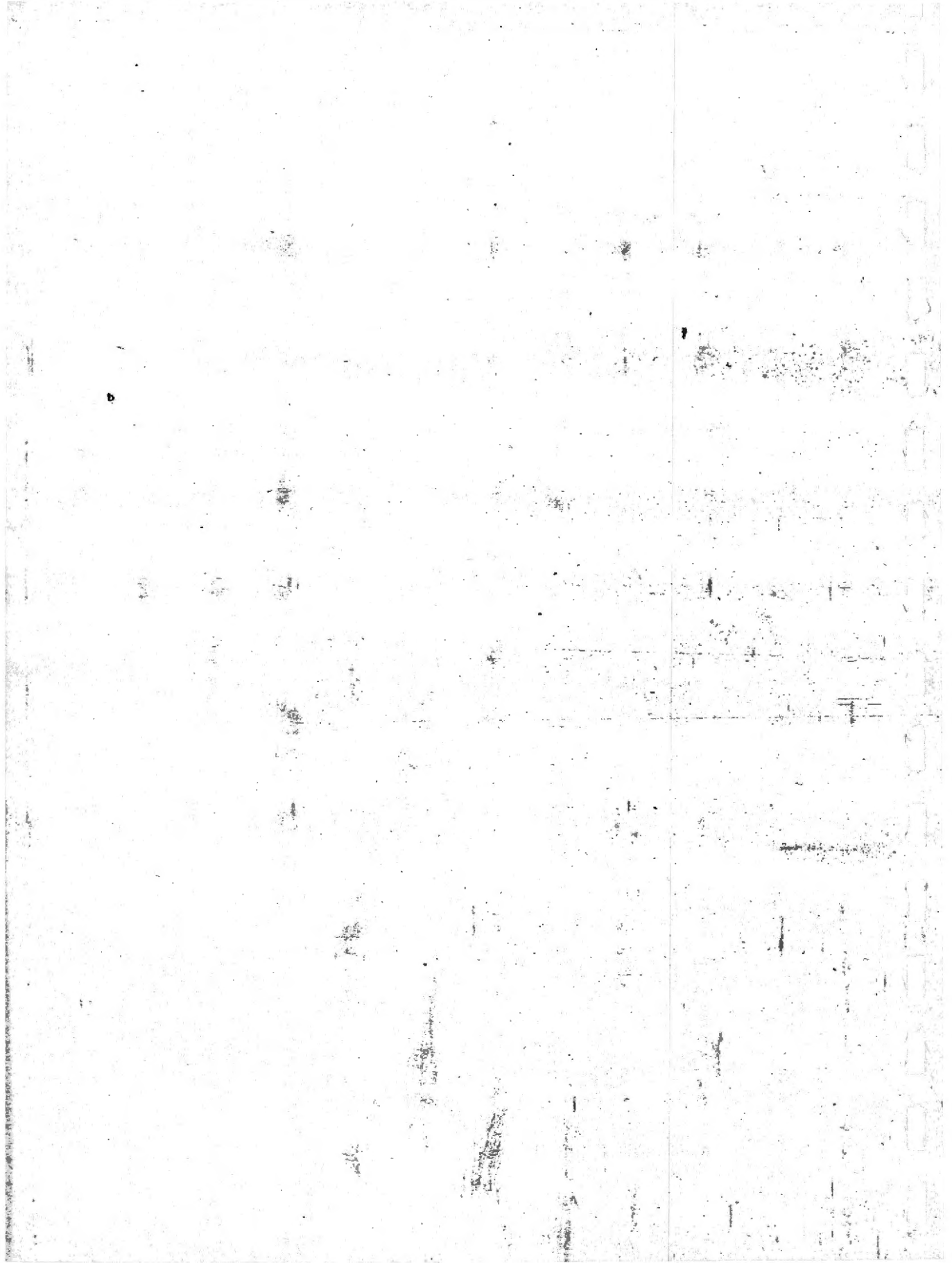

Chapter 5

OPERATIONS

This chapter examines aspects of transit system operations. The basic elements and concepts of operation are defined and methods for data collection are explained. A scheduling method for individual transit routes is presented with an overall description, step-by-step procedure, and numerical examples. Various practical measures for increase of transit speed in urban areas are described and a method for evaluation of their feasibility is presented.

5.1 Definition of Basic Elements

Figures 5.1 and 5.2 show commonly used graphical representations of transit line operation. These figures are of assistance in understanding the basic elements defined here.

Headway (h) is the time interval in minutes between two successive departures of transit vehicles on a line. Transit users are interested in having service with short headways to minimize waiting time. However, since for any given volume of passengers per hour it is cheaper to operate a smaller number of large vehicles than a greater number of small vehicles, the operator is interested in operating with larger vehicles at longer headways. Consequently, headways are usually determined as a compromise between passenger convenience and operating cost.

The point along a transit line at which minimum possible headways between successive vehicles are the longest determines the minimum headway for the whole line. Consequently, to find the shortest possible headway on a line (h_{min}), the minimum headway should be determined for stops with heavy passenger boarding/alighting; the longest of these headways is then the minimum possible headway on the line.

Frequency of Service (f) is the number of transit trips passing a point on the line during one hour (or any given period of time). Thus, short headways mean high frequency, long headways represent low frequency.

The two are related by the formula:

$$f = \frac{60}{h}$$

(1) •

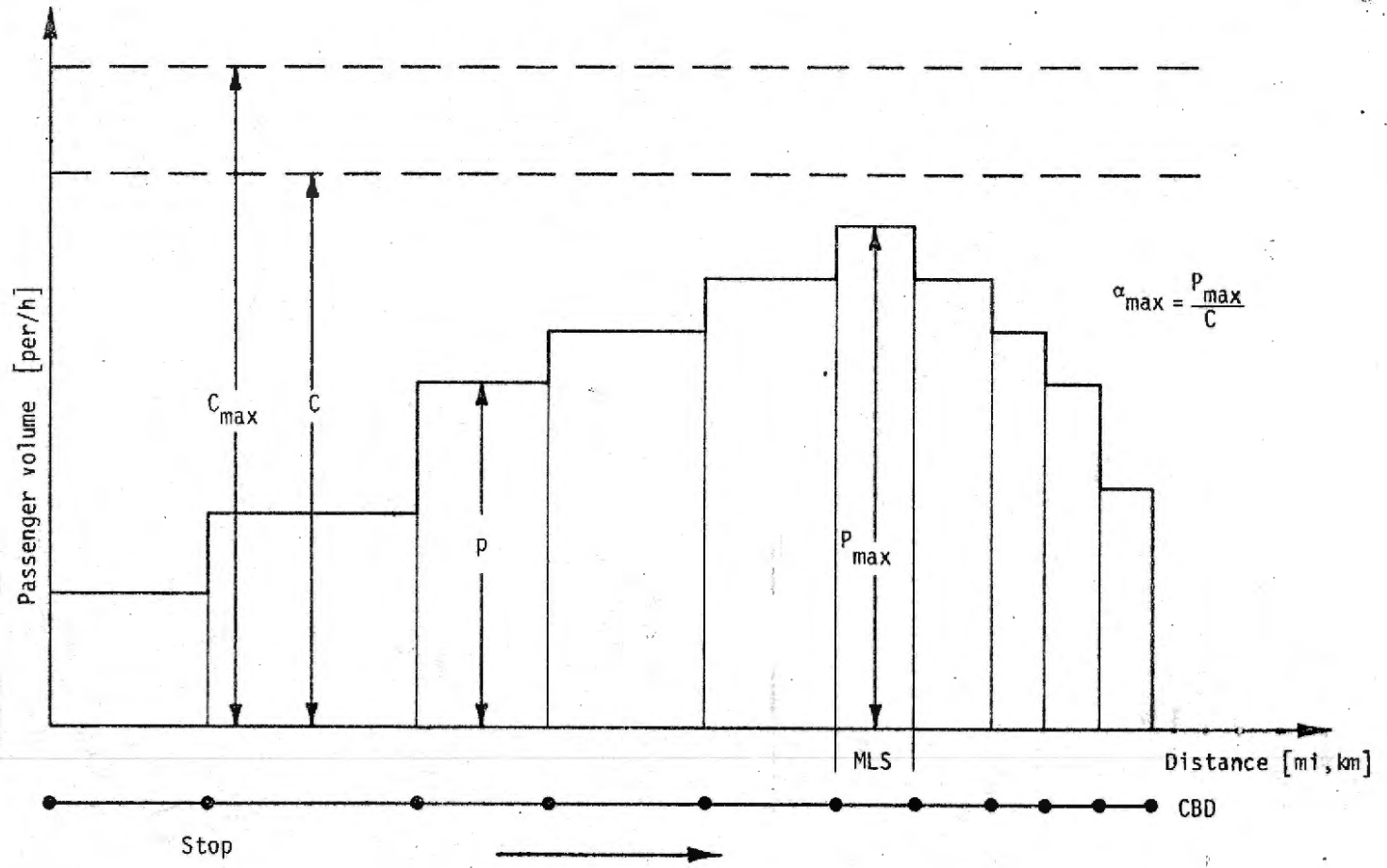

Figure 5.1 -- Graphical representation of terms related to passenger demand distribution and capacity.

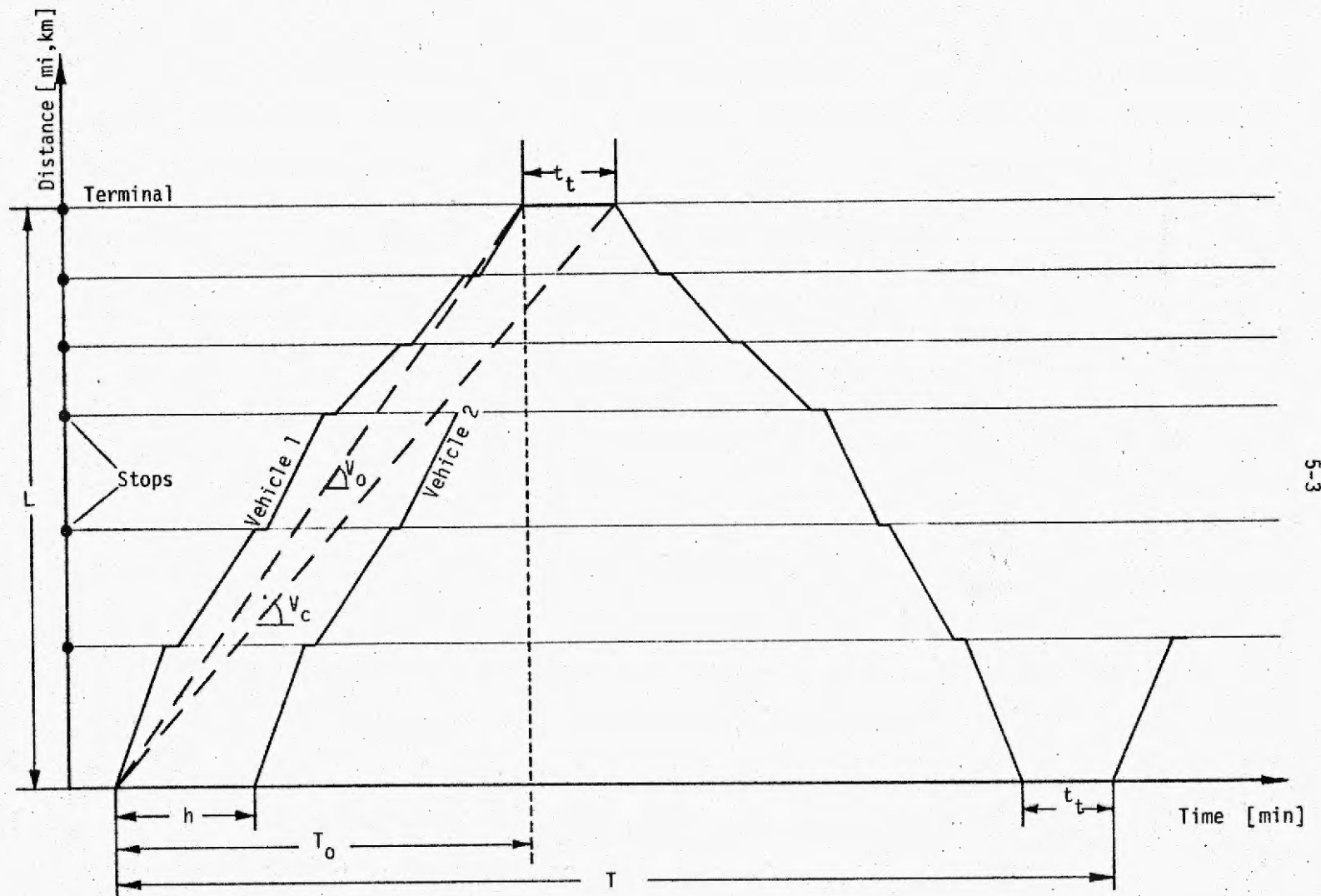

Figure 5.2 -- Graphical representation of terms related to vehicle travel and scheduling.

where f is in vehicles per hour and h is in minutes.

The maximum frequency of vehicle arrivals (f_{\max}) is determined by the minimum headway as:

$$f_{\max} = \frac{60}{h_{\min}} \quad (2)$$

Vehicle Capacity (C_v) is the total number of passenger spaces on the vehicle. It is calculated by adding the number of seats plus the standing capacity. This definition applies to intraurban rapid transit, local bus and trolley lines. For suburban railroads and for bus and trolley lines with medium or long average trip lengths, seating capacity alone is commonly used as C_v .

Passenger Volume (p) is the number of passengers traveling on a line past a fixed point during one hour, or during some other specified period of time. Passenger volume varies along the line with time of the day, day of the week and season of the year.

Maximum Load Section (MLS) is the line section between two stations on which the maximum passenger load occurs. The MLS is shown in Fig. 5.1.

Design Hour Volume (P) is the highest passenger volume for all sections along the line, as shown in Fig. 5.1. This volume is the basic factor in determining the line capacity which should be offered.

Line Capacity Offered (C) is the total number of passenger spaces offered at a fixed point of a transit line during one hour. Line capacity is basic to transit system planning and design. Each facility must provide the capacity equal to or greater than P . The line capacity is derived from the product of frequency and vehicle capacity:

$$C = f \cdot C_v \quad (3)$$

Dimension of capacity is persons/hour.

The Maximum Line Capacity (C_{\max}) is the maximum number of passengers per hour a line can carry with minimum operationally feasible headways.

C_{\max} is given as the product of maximum frequency and vehicle capacity:

$$C_{\max} = f_{\max} \cdot C_v = \frac{60}{h_{\min}} \cdot C_v \quad (4)$$

Operating time (T_o) is the scheduled time interval between departure

of a vehicle from one terminal (end-of-line stop or station) and its arrival at another terminal on a route; T_0 is usually expressed in minutes.

Operating Speed (V_0) is the average speed of a transit vehicle, including stopping time at stations or stops and expected delays for traffic reasons (as on surface lines, such as bus and trolley). It is computed as the one-way line length (L) in miles divided by the operating time in minutes:

$$V_0 = \frac{60L}{T_0} \quad (5)$$

Speed computed by this equation is in mph. If L is in kilometers, V_0 is in km/h.

Terminal Time (t_t) is the time a vehicle spends at a terminal or end-of-line stop in excess of the interval required for the boarding and alighting of passengers. Its purpose is to allow time for vehicle turning or change of driver's cabin, rest of the driver (or crew), and adjustment in schedule (e.g. to maintain uniform headway, or to recover delays incurred in travel).

The crew rest and the delay recovery usually govern the terminal time for bus and trolley lines. The minimum rest time is often determined by labor union contract. Since the rest and delay recovery times depend on durations of operating time, terminal time for surface systems is often expressed through a ratio (γ) of terminal and operating times: $\gamma = t_t/T_0$. The value of γ may range between 0.12 and 0.18, depending on labor work rules, traffic conditions, variation in passenger volume and other local factors.

On lines and during time periods for which traffic congestion is serious, travel time varies considerably. For such cases, long terminal times should be allowed so that departure time for the return trip can be kept and schedules maintained despite moderate delays. For rapid transit or other systems with high schedule reliability the terminal time is independent of operating time and line length, and it can be much shorter than for lines running in mixed traffic. A common value for terminal time of rapid transit is 5 to 8 minutes.

Cycle Time (T) is the total round trip time for a vehicle, i.e., the

time interval between two consecutive times the same vehicle passes a fixed point traveling in the same direction. This time can be expressed as:

$$T = 2(T_o + t_t) , \quad (6)$$

if the line has equal T_o for each direction and equal t_t for each terminal. All these time intervals are usually expressed in minutes.

Commercial Speed (V_c) is the average speed of transit vehicle for a complete round trip:

$$V_c = \frac{120 L}{T} , \quad (7)$$

V_c being in mph., T in minutes and L in miles. Commercial speed is the most important type of speed for the operator since it directly determines (along with headway) the required fleet size and cost of operation.

Fleet Size (N_f) is the total number of vehicles which a transit agency owns. The fleet size consists of the vehicles required for regular peak hour service on all lines (N), vehicles in reserve (N_r), plus vehicles which are in maintenance and repair (N_m):

$$N_f = N + N_r + N_m . \quad (8)$$

Load Factor (α) is the ratio of the number of passengers in a vehicle to the vehicle capacity. A higher value of α means that a vehicle is crowded and that it is more likely that some vehicles will not have sufficient capacity to collect all waiting passengers.

5.2. Data Required for Scheduling and Analysis of Operations

A transit agency should maintain a current inventory of data on operating conditions and demand. Such an inventory is necessary for preparation of schedules for different periods of each day and for analysis of existing and planned operations.

5.2.1 Vehicle Operating Conditions Analysis. The operator should know precisely the condition of the way on which transit vehicles operate.

This is basic information for the determination of operating time, terminal time and evaluation of service quality. The information includes:

Physical conditions along the route:

- Number of lanes on streets
- Gradients of streets
- Number of turns along the route
- Number of traffic lights
- Number of stops
- Design of stops (special bays, stops in driving lanes)
- Spacing between stops

Traffic conditions along the route:

- Traffic volume (automobiles and transit vehicles)
- Level of congestion
- On-street parking conditions
- Other factors (loading zones, pedestrian crossing areas, etc.)

Vehicle running times:

- For peak period (range and average value)
- For off-peak period (range and average value).

Methods of collecting these data and the areas of application of the results for analytical purposes are discussed in section 5.3.

5.2.2 Passenger Demand Analysis. For analysis of the existing operations and the planning of future operations, detailed data on passenger demand characteristics are needed. They include the following items:

Passenger demand distribution along the route:

- Boarding distribution along the route (number of persons boarding at each station)
- Alighting distribution along the route
- Locations of maximum load section (MLS)
- Maximum load (P)

Trip length distribution:

- Classification of passengers by length of ride (Fig. 5.3)

Other information related to demand:

- Per cent of users classified as elderly citizens
- Dates of local or special events
- Opening and closing times of stores, offices and factories located along each route

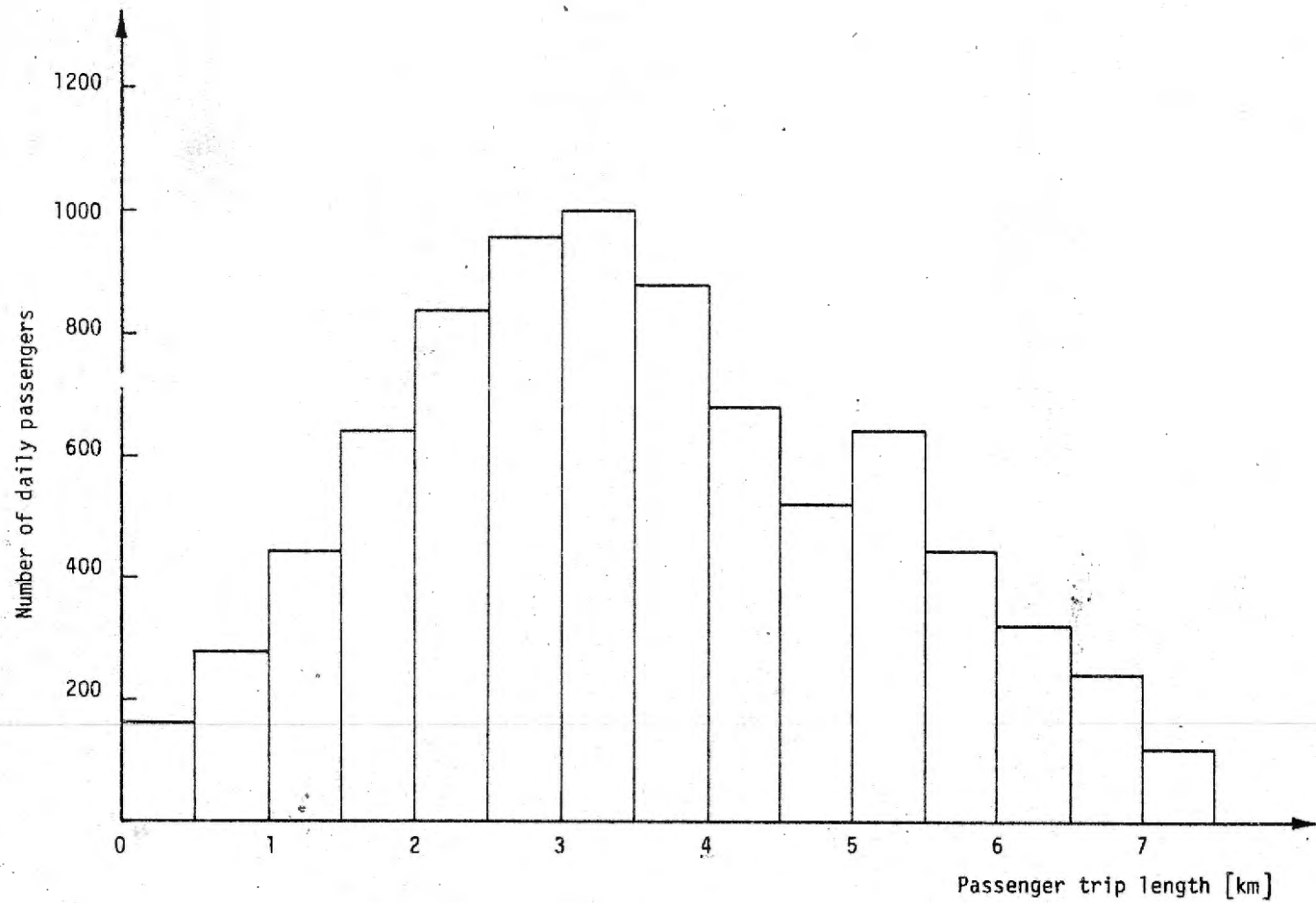

Figure 5.3 -- Passenger trip length distribution diagram.

- Volume of transferring passengers.

5.2.3 Scheduling Data. For transit scheduling the operator should have the following basic information:

Information on route:

- Route length (L)
- Vehicle operating time (T_0)

Information on vehicles:

- Vehicle capacity (C_v)

Information on demand:

- Maximum load (P)
- Fluctuations of demand for each day for which a different schedule is made: quarter-hourly for peaks, hourly for other times

Information on personnel:

- Labor rules and requirements with respect to hours of work, shifts, terminal times, etc.

The operator should collect these data at regular intervals.

5.3 Passenger and Traffic Surveys

For scheduling of vehicles, analyses of operations and planning, the transit operator must have data about the existing system. Some of these data are obtained through field surveys and can be divided into two groups. The first group relates to demand: counts of passenger boarding and alighting and vehicle load. The second group relates to supply: travel conditions along the routes, vehicle running, reliability, etc.

5.3.1 Organization of Surveys. Good planning and continuity in data collection are necessary to obtain and maintain a current data file which is the basis for efficient scheduling, effective marketing and intelligent planning decisions. Frequency and comprehensiveness of field surveys must be determined as a compromise between accuracy of information and cost of surveys. The best compromise is achieved by organizing major, detailed surveys at longer intervals, and supplementing them by minor ones, often on a sampling basis, within these intervals.

For example, every five years, the operator may organize passenger counts on all routes on one weekday, and on several routes for a whole week. Selected routes are counted every month of that year to determine seasonal variations of travel. This count provides data on passenger demand by route, its distri-

bution along the route and its hourly variations. Then, every year several routes selected as typical of the whole system are counted along their whole lengths or on their maximum load sections. This may be done during all hours, or during peaks only--depending on the variations which may have occurred and desired accuracy of data.

Surveys of transit operations focus on vehicle running conditions: operating speeds must be measured regularly since they must be known for the purpose of scheduling. Analysis of traffic conditions, reasons for delays, etc., are usually done on an ad hoc basis, with notation of external conditions which affect transit operations.

5.3.2 Passenger Load Count. The purpose of this count is to find the number of passengers riding transit vehicles at selected points along a route. This information is needed for finding the maximum passenger volume on vehicles over any one section of line, the location of that section, analysis of service quality, and scheduling of operations. A passenger load count survey must be undertaken for all these purposes.

A detailed survey should include passenger load counts at several points along each route, including those where passenger volumes are the highest. Minor annual surveys may be limited to the maximum load section (MLS) and one or more additional locations for verification of changes which may be recorded on the MLS.

Personnel for the load count consist of observers at each counting location. For single surface vehicles one observer can do the job at each location. If the route is heavily loaded or has simultaneous loading of several vehicles, two observers may be needed. Larger teams are needed only at rapid transit stations when long trains are operated.

The observer must be given at least brief training on the techniques of counting. Very often, exact counts cannot be made because of short standing time of the vehicle, so the observer must know how to make a fast estimate of number of people in each group, or seating section. The observer should be trained in this through fast estimates at locations where exact counts can be made to check the estimates, making efforts to correct any tendency to over- or undercount. In addition, the observer must know the exact seating and total capacity of vehicles, so that he can accurately estimate the number of passengers in a full vehicle; or, when there are some

standees, he can add these to the seating capacity of the vehicle.

It is often possible that the observer counts the load on the arriving vehicle as well as alighting and boarding passengers. These data then provide counts for the sections before and after that station.

Each observer must have a specially designed field sheet, clip board, pen and a watch. The sheet should have the general information needed for all field surveys:

- Route and location
- Vehicle capacity
- Date and day
- Survey time period (from-to)
- Weather
- Name of observer
- Remarks.

The columns should provide for the following items:

- Run number
- Time: scheduled, actual
- Number of passengers:
 - on arriving vehicle
 - alighting, boarding
 - on departing vehicle.

Columns for passenger numbers should have totals at the bottom. If both directions are counted, the same set of columns should be provided for the other direction. Figure 5.4 shows a suggested passenger load count field sheet.

Counts are summarized after the field survey on a single sheet for 15- or 20-minute peak, 30- or 60-minute off-peak periods, and average vehicle loads for each period are computed. These numbers are then ready for use for route scheduling and various analyses. Figure 5.5 is an example of a summary sheet of a transit load count.

5.3.3 Passenger Boarding and Alighting Count. The most detailed information on passenger volumes on a transit route is obtained through the counts of boarding and alighting passengers at each stop along its entire length. This count not only provides the data on the number of passengers using each station, but also vehicle loads at all points along the route.

PASSENGER LOAD COUNT (Field Sheet)		Time: From _____ to _____											
Date _____	Day _____	Route _____	Location _____										
Weather _____	Vehicle capacity _____	Prepared by _____											
(North) Bound													
(South) Bound													
Run No.	Time		No. of Passengers				Run No.	Time		No. of Passengers			
	Scheduled	Actual	On arriv. veh.	Alight.	Board.	On * depart. veh.		Scheduled	Actual	On arriv. veh.	Alight.	Board.	On * depart. veh.
Total							Total						
Remarks						Remarks							

* May be computed after the survey.

Figure 5.4--Suggested passenger load count field sheet.

STREET CAR BUS ✓ T. T.
 SCHEDULED SEATING CAPACITY 44
 DIRECTION WEST

LINE FAIRFIELD ROUTE NO. 74
 SCHEDULE NO. 2274 SAT., SUN.
 MONTH APRIL YEAR 1947

TIME APPLIES AT	OBSERVED AT <u>W. 24-LORAIN (1927-APRIL)</u>																MONTHLY AVERAGES				COMMENTS
	DAY <u>WEDNESDAY</u> DATE <u>4/23</u>				DAY <u>FRIDAY</u> DATE <u>4/25</u>				DAY <u>SAT.</u> DATE <u>4/27</u>				DAY <u>SUN.</u> DATE <u>4/28</u>								
	WEATHER <u>CLDY</u>				WEATHER <u>RAIN</u>				WEATHER <u>CLDY</u>				WEATHER <u>CLDY</u>								
	OBSERVED BY <u>MURPHY-ROBER</u>								OBSERVED BY <u>VEFANSKIE-BALAZS</u>												
PERIOD BEG. AT	UNITS SCH	SEATS SCH	PASS	OPER	AVER PER UNIT	UNITS SCH	SEATS SCH	PASS	OPER	AVER PER UNIT	UNITS SCH	SEATS SCH	PASS	OPER	AVER PER UNIT	UNITS SCH	SEATS SCH	PASS	OPER	AVER PER UNIT	
5:00																					
5:15																					
5:30																					
5:45																					
6:00	2	88	25	2	13	2	88	41	2	11						2	88	23	2	12	
6:15	3	132	36	3	12	3	132	34	3	11						3	132	35	3	12	
6:30	3	132	6	1	6	3	132	11	2	6						3	132	9	1.5	6	
6:45	3	132	64	4	16	3	132	62	4	16						3	132	63	4	16	
7:00	3	132	36	3	12	3	132	39	2	20						3	132	38	2.5	15	
7:15	3	132	89	3	14	3	132	87	4	22						3	132	68	3.5	19	
7:30	5	220	53	4	13	5	220	87	4	22						5	220	70	4	18	
7:45	4	176	42	4	11	4	176	65	4	16						4	176	54	4	14	
8:00	3	132	64	3	21	3	132	56	3	18						3	132	60	3	20	
8:15	2	88	35	3	12	2	88	23	3	8						2	88	29	3	10	
8:30	2	88	16	1	16	2	88	37	1	27						2	88	22	1	22	
8:45	2	88	31	2	16	2	88	40	2	20						2	88	36	2	18	
9:00	2	88	20	2	10	2	88	42	2	21						2	88	31	2	16	
9:15	2	88	12	2	6	2	88	20	2	10						2	88	16	2	8	
TOTAL	39	1716	689	37	13	39	1716	614	38	16						39	1716	552	37.5	15	
9:30	RELIEF										RELIEF										
10:00	3	132	37	4	9	3	132	35	2	18						3	132	36	3	12	
10:15	4	176	46	3	15	4	176	28	4	32						4	176	87	3.5	25	
10:30	3	132	45	3	15	3	132	107	3	36						3	132	76	3	25	
10:45	3	132	67	3	22	3	132	123	4	31						3	132	95	3.5	27	
11:00	4	176	77	4	19	4	176	84	3	28						4	176	87	3.5	23	
11:15	4	176	80	4	20	4	176	120	3	40						4	176	100	3.5	29	
11:30	4	176	69	4	17	4	176	160	5	32						4	176	115	4.5	26	
11:45	4	176	129	4	32	4	176	153	4	38						4	176	191	4	48	
12:00	5	220	131	5	26	5	220	127	4	34						5	220	134	4.5	30	
12:15	5	220	150	5	30	5	220	166	6	38						5	220	158	4.5	29	
TOTAL	39	1716	831	39	21	39	1716	1213	38	32						39	1716	1022	38.5	27	
3:00	3	132	63	2	32	3	132	63	2	32						3	132	63	2	32	
3:15	2	88	127	3	42	2	88	107	3	36						2	88	117	3	39	
3:30	3	132	83	2	47	3	132	52	2	30						3	132	76	2	38	
3:45	3	132	237	4	59	3	132	171	4	43						3	132	204	4	51	
4:00	3	132	123	3	41	3	132	111	3	37						3	132	117	3	39	
4:15	4	176	177	4	44	4	176	154	4	39						4	176	169	4	42	
4:30	4	176	149	3	50	4	176	155	4	39						4	176	152	3.5	43	
4:45	4	176	199	4	50	4	176	136	3	45						4	176	168	3.5	48	
5:00	3	132	197	4	49	3	132	251	4	63						3	132	234	4	56	
5:15	4	176	216	4	54	4	176	185	4	49						4	176	206	4	52	
5:30	4	176	215	4	54	4	176	242	4	61						4	176	214	4	54	
5:45	3	132	140	3	47	3	132	225	4	54						3	132	157	3.5	52	
6:00	2	88	81	2	41	2	88	182	3	34						2	88	92	2.5	37	
6:15	3	132	96	3	32	3	132	101	2	51						3	132	99	2.5	40	
TOTAL	45	1980	2113	45	47	45	1980	2074	46	45						45	1980	2014	46.5	46	
GRAND TOTAL	140	6160	3777	138	28	143	6732	4736	152	52						141.5	6166	4418	145	30	
TAB. BY	LENTZAS DATE 4/3				TAB. BY	H. WEBBER DATE 4/5				TAB. BY	DATE				TAB. BY	SCHWARTZ DATE 4/5					

Figure 5.5 -- An example of summary sheet of transit load count.
 Source: Ref. [6]

Thus, one can compute the total work of the route in passenger-miles per hour and, with some modifications, the distribution of trip lengths. This represents virtually all the information needed for scheduling, analyses of operations, extending or shortening of the route, abandonment of some stops, etc.

The decision when to make this survey is again dependent on the cost and the need for accurate data. Whenever the operator can afford its higher cost, a boarding/alighting survey should be undertaken instead of a passenger load count, since it provides much more detailed information.

Personnel are best utilized on surface transit if one observer travels on each vehicle. With the exceptions of very heavy stops where another observer may be placed to assist, the person riding the vehicle can count all boarding and alighting movements. For high frequency service, particularly on rapid transit lines, it is more efficient to place one or more observers at each station.

Personnel must be given similar training to that for load counts. Boarding/alighting is usually simpler to count than vehicle occupancy, provided the observer can be positioned inside or outside the vehicle so that all doors can be easily observed.

The equipment required again consists of a special field sheet, clip board, pen and watch. A typical sheet design for this survey is shown in Fig. 5.6. It is convenient to use one sheet for each one-way or round-trip run. After the survey, sheets from all vehicles (or stations) are summarized by time periods, usually 15-min. for peak and 60-min. for off-peak hours. An example of a summary sheet is given in Table 5.1. These data are used for development of various passenger volume diagrams, such as shown in Fig. 5.7.

Average trip length on the route can be obtained from these counts by dividing total passenger-kilometers by the number of passengers who used the line (total of boarding or of alighting). These and other average data for the route are shown in Table 5.1. Distribution of trip lengths (such as Fig. 5.3 shows), precise origins/destinations of passengers, their trip purposes and similar data can be obtained only by questioning passengers--either directly by observers, or by a post-card survey questionnaire.

TRANSIT BOARDING AND ALIGHTING COUNT
(Field Sheet)

Line _____ Direction _____
 Vehicle number _____ Weather _____

Time		Location of stop	Passengers			Remarks
Arrive	Depart		Boarding	Alighting	On board	

Date _____ Recorder _____

Figure 5.6--Passenger boarding and alighting count sheet.

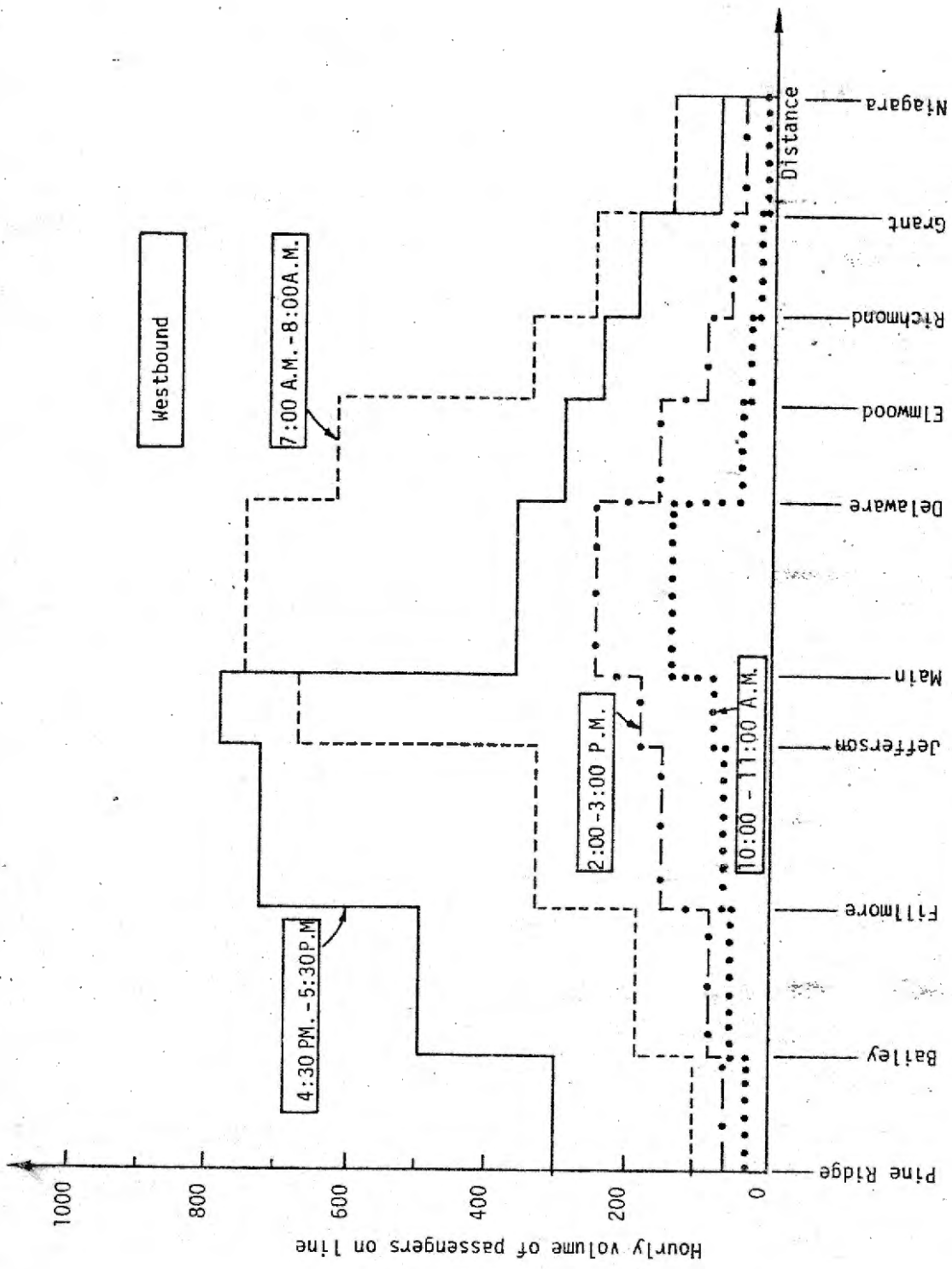

Figure 5.7 -- Transit load profile for different time periods.

Table 5.1--Summary of passenger counts and computation of person-kilometers.

Route no. <u>84</u>	Direction <u>N8</u>			Time period <u>16:30-17:30</u>	Person-kilometers
	Number of passengers				
Transit stop	Boarded	Alight.	On veh.	Km. betw. stops	
1 (S. termin.)	48	-	48	2.2	105.6
2	35	12	71	2.8	198.8
3	54	30	95	3.2	304.1
4	29	13	111	3.4	377.4
5	16	46	81	2.0	162.0
6 (N. termin.)	-	81			
Totals	182	182	-	13.6	1147.9

Average trip length: $1147.9 \div 182 = 6.3$ km.

Average boardings/km: $182 \div 13.6 = 13.4$

Average passenger volume/km: $1147.9 \div 13.6 = 8.4$.

5.3.4 Transit Speed and Delay Survey. The purpose of this survey is to record the locations, durations and causes of delays experienced by transit vehicles operating on a route. From the route length, measured travel times and delays at different periods of the day, the operating speed and reliability of service are computed which are needed for scheduling. In addition, the obtained information is used for finding the major causes and locations of delays and planning for their elimination.

Unlike passenger demand surveys, speed and delay surveys are usually not made at regular, seasonal or annual intervals. They are undertaken on routes where new service is planned, or on existing routes when an increase in irregularities is noticed or improvements of transit operations are contemplated.

These surveys are made mostly for congested traffic conditions, such as peak hours on radial routes and midday period in downtown areas. To obtain representative results, several runs should be made on one day and repeated on other workdays.

A speed and delay survey is usually performed by one observer riding

the transit vehicle, usually in a front seat so as to observe reasons for slowdowns. Careful instructions should be given to the observers on how to define stopped times, how to classify causes of delays and what codes to use.

Observer's equipment consists of the field sheet, clip board, pen, watch, and a stop watch for measuring delays (in seconds). The field sheet, shown in Fig. 5.8 has columns for locations, duration and causes of delays and slowdowns. Causes are marked by codes, such as: P-passenger boarding/alighting; SS-stop sign; PK-parked cars; PD-pedestrians; LR-left turning vehicles; T-traffic congestion; etc.

Several different summary sheets may be used for speed and delay studies, depending on the intended use of results. An example is shown in Fig. 5.9. Average speed is always computed; sometimes variations in travel times are computed to find reliability, which influences length of terminal times. For analyses of possible improvements delays are classified by individual causes and their percentages are computed. For plotting of time-distance diagrams of vehicle travel (Fig. 5.2), travel times are summarized by route sections.

Speed and delay studies are not made on rapid transit systems since they do not have such delays; however, similar surveys may be undertaken to measure station standing times and travel regimes between rapid transit stations with much greater precision than for surface transit.

In addition to schedule adjustments and planning of operational improvements which are described in the following text, results of delay surveys can be used to monitor the performance of individual drivers, as well as for measuring effects of changes, such as new routing, one-way street regulation, elimination of parking, etc. For this purpose "before and after studies" are performed.

5.4 Criteria for Determining the Basic Operating Elements

Prior to scheduling operations for individual lines, the operator must make certain decisions on some basic elements of service. Specifically, the decisions must be made on the headways which will be used during different hours, spacing of stops along lines, load factors, fleet size and vehicle capacity.

5.4.1 Headway (h). Two basic requirements determine headways:

- (1) Adequate capacity must be provided to meet passenger demand;

TRANSIT SPEED AND DELAY
(Summary Sheet)

Line _____ Date _____

Length (one-way) _____ Time _____ to _____

Direction _____ Weather _____

Dep. time	Veh. no.	One-way trip no.	Name of operator	Trip time min.	Average trip speed*	Total time stopped	Number of			
							stops	slow starts	slow stops	slow-downs
Average										

* Average trip speed = $\frac{\text{Line length (mi)} \times 60}{\text{Overall trip time (min)}} =$ mph
 Date _____ Compiled by _____

Figure 5.9 --Transit speed and delay survey summary sheet.

(2) Service must have a certain minimum frequency.

The first requirement is the basis for scheduling on heavily traveled lines or during the peak hours. In such cases, the operator must provide adequate capacity which results in shorter headways than the second requirement would give.

The frequency of service which will provide needed capacity to meet the demand is obtained by dividing passenger volume on the maximum load section (P) by the average number of passengers assigned to each vehicle through selection of the value for load factor (α). Thus the required frequency is:

$$f = \frac{P}{\alpha \cdot C_v} \quad (9)$$

From Eqs. (1) and (9) the headway is computed as:

$$h = \frac{60}{f} = \frac{60 \cdot \alpha \cdot C_v}{P} \quad (10)$$

Since all schedules with headways greater than 6 minutes (min) should be such that passengers can easily memorize them, the departure times should repeat themselves every hour. Therefore, the headways must be numbers divisible as whole numbers into 60, i.e. they should have the following values:

7.5, 10, 12, 15, 20 and 30.

When headways longer than 30 min. are appropriate, values of 40, 45, and 60 min. should be used. Consequently, the value of headway obtained by Eq. (10) should be rounded down to the nearest of these values. Headways shorter than 6 min may have any value since passengers do not use schedules for lines with high frequency.

An example of headways determined by passenger volume, based on vehicle capacity $C_v = 50$ and load factor $\alpha = 0.9$, is plotted graphically in Fig. 5.10.

For off-peak hours, weekends, or lightly traveled lines, the minimum frequency requirement usually governs. That is, headway should not be greater than the one which is determined by the service policy and revenue, i.e. the operator's policy with respect to the minimum service frequency. This is the so-called policy headway (h_p), which should also be one of the above numbers. This headway should never be longer than one hour and desirably not longer than 30 minutes.

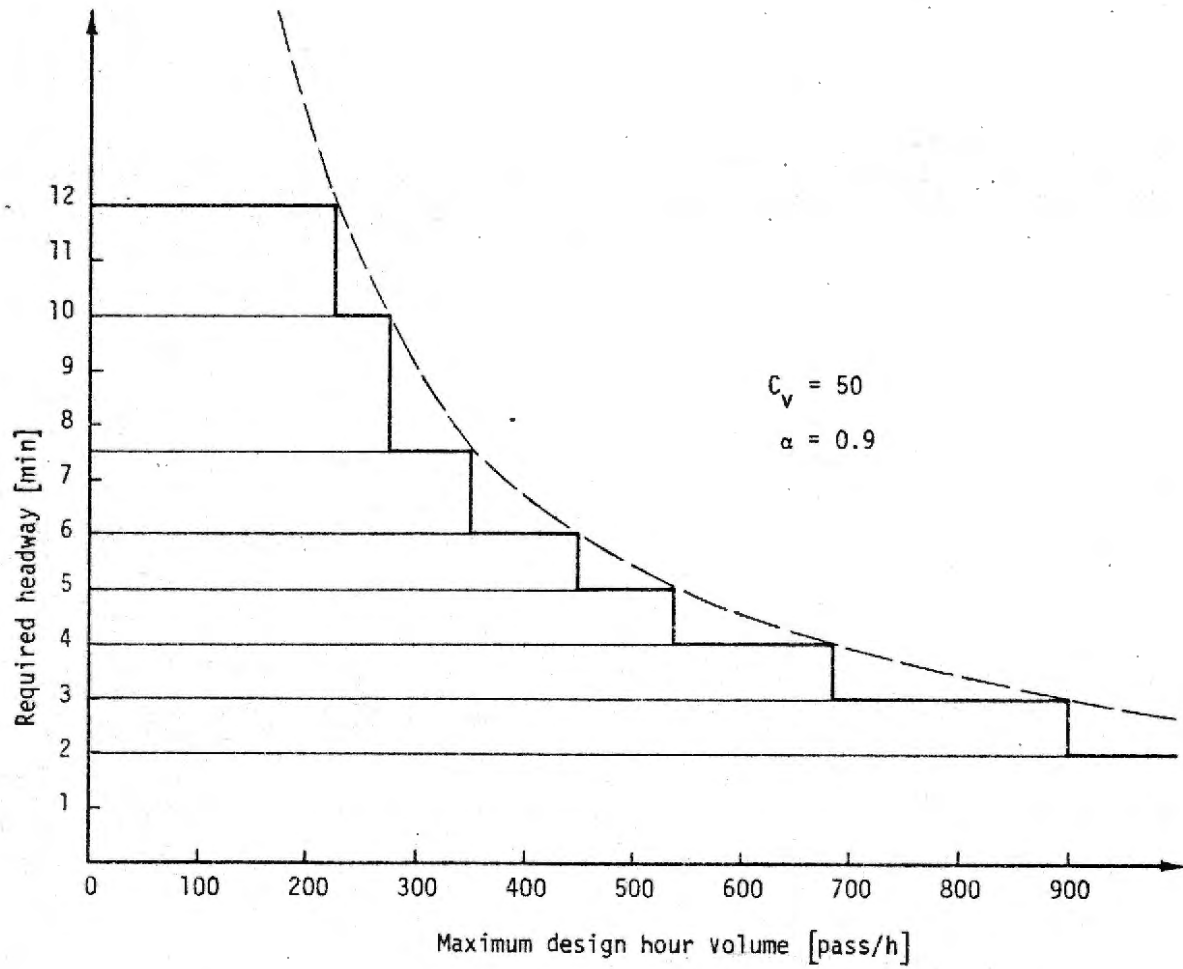

Figure 5.10--Relationship between demand and required headway.

Operators should refer to standards S-3, S-4, and S-5 of PennDOT's Operating Guidelines [7] in scheduling the transit lines.

5.4.2. Load Factor (α). The value of this factor influences the following characteristics of transit operations:

- Level of passenger comfort: high values of α result in a considerable number of standees and in occurrences of vehicle overcrowding.
- Cost of operation: if a higher value of α is adopted, a smaller number of vehicles is required to transport a given number of passengers than for a low value of α . On the other hand, a smaller number of vehicles provides lower frequency of service. Also a higher value of α results in longer boarding/alighting times, thus lowering travel speed.

The choice of value for α should therefore be made such that a compromise among these factors is achieved. In determining the value of α for this compromise the operator should also consider the following factors which influence passenger comfort and cost of operation:

Conditions requiring lower value of α :

- Greater variations in passenger volume
- Higher seated/standing passenger ratio desired
- High average trip length (e.g. express bus, commuter train)
- High percentage of senior citizens

Conditions requiring higher value of α :

- Fairly constant passenger volume
- Lower seated/standing passenger ratio desired
- Low average trip length (e.g. CBD shuttle bus)
- High percentage of school children.

Specifically, the operator can determine the value of α for a given scheduling period (higher for peaks, lower for off-peak periods) by first computing the ratio of seats and total vehicle capacity: C_s/C_v . Then he may use the following guidelines:

- The minimum value of α should be slightly lower than the ratio C_s/C_v . This value guarantees seats to all passengers except for some short periods.
- The maximum value of α can be as high as 0.9 but its value should only be used for peak hours if the maximum load section is short and the passenger volume does not vary significantly from day to day.

5.4.3 Fleet Size and Vehicle Capacity. For a given passenger volume on a line, service can be provided by a small number of large capacity

vehicles or a greater number of smaller capacity vehicles. The second combination results in a higher frequency of service, but requires higher investment and operating cost than the first combination.

Before ordering buses, every agency should make an analysis of all costs, operating conditions and service quality (headways, speed, etc.) that would result from using each type of equipment. Selection of vehicle type should be based on the results of that analysis.

In planning the purchase of new vehicles transit agency should examine the trade-offs between large and small vehicles. Compared with large vehicles, smaller ones have the following advantages (+) and disadvantages (-):

- + Their cost of operation per bus-mile is lower; thus for the same total operating cost a transit agency can operate shorter headways with smaller buses and thereby attract more passengers;
- + Their travel through congested streets is faster and easier;
- Total purchase and operating cost of a fleet of smaller buses is greater since more of them must be purchased and operated to handle a given peak hour passenger volume.

5.5 Transit Line Schedules

5.5.1 Types of Scheduling. The computed headways, speeds, terminal times and other elements are used to develop schedules which may be presented in two different forms: graphical schedule, which is actually a time-distance diagram of vehicle travel, and the numerical schedule (commonly known as a timetable).

The graphical schedule is usually developed first, since timetables can easily be derived from it. The time-distance schedule (Fig. 5.11) shows the actual travel of each vehicle along the route. The diagram allows derivation of exact times for the position of each vehicle at different check points along the route. Bus and streetcar lines have control points every 1 - 3 miles while for fully controlled systems, such as rapid transit, each station has scheduled times.

The graphical schedule is made for all hours of daily operation, usually on a single long sheet of paper. Each vehicle in operation, designated by a sequence number, is represented by a "zig-zag" line on the diagram going between the two terminals, having the operating speed as its slope on each section. If operating speeds vary from one section to another, the slope changes on the vehicle's path from one terminal to the other. Station stop times are not included, but terminal times are plotted exactly.

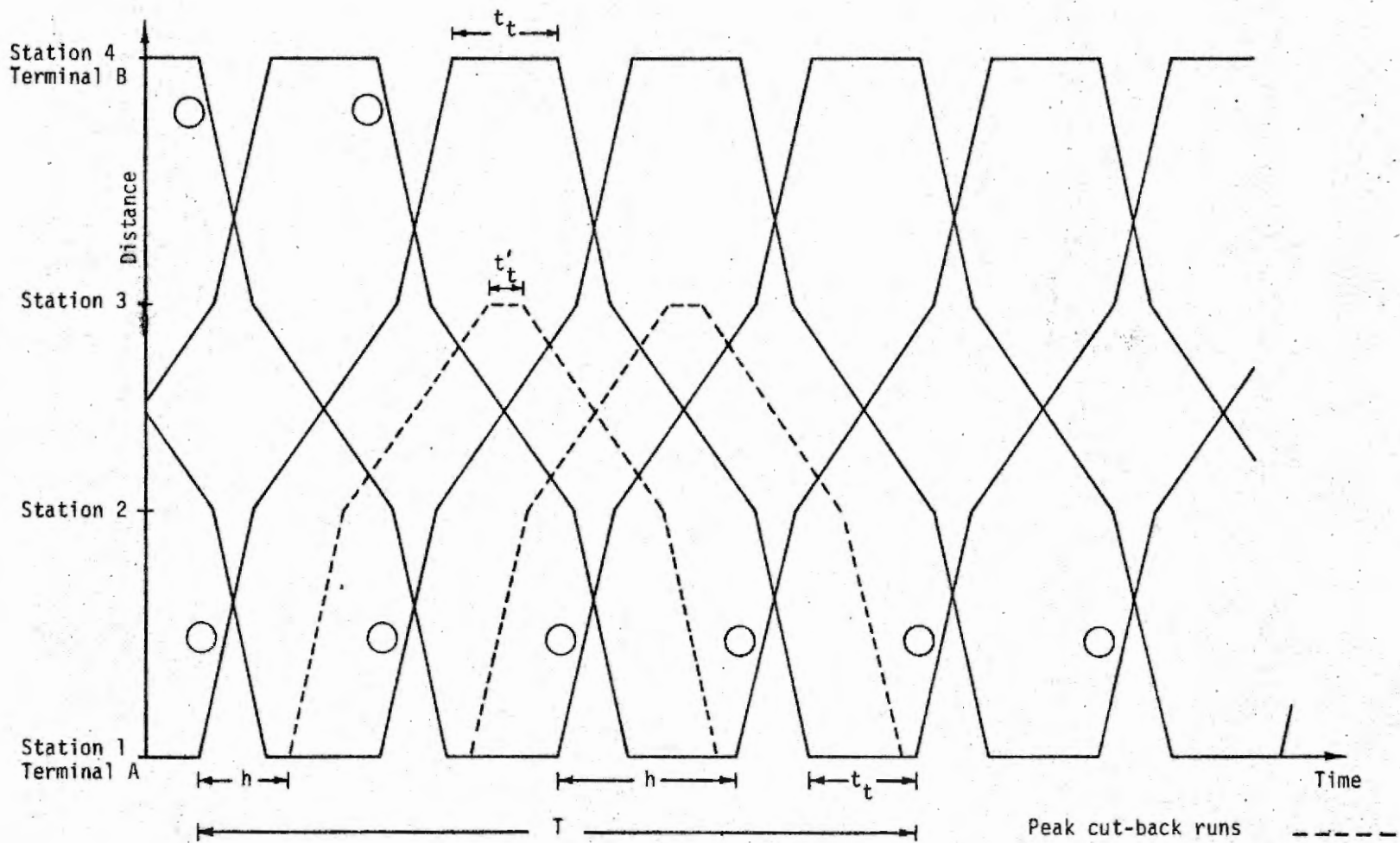

Figure 5.11 -- Graphical schedule for a transit route (regular and peak cut-back runs are shown).

After the first vehicle's path is plotted, the next one's is plotted at a horizontal distance of one headway following the first vehicle. This procedure is repeated for all vehicles in service. Since the cycle time is an integer multiple of the headway, there must be exactly one headway between the departure time of the last vehicle used and the time the first vehicle departs for a second round trip.

The introduction of additional vehicles running between regular vehicles during the peak hours, changes in headways, cut-back runs, and other variations can all be presented on the graphical schedule (see Fig. 5.11).

A separate numerical schedule is made for each individual vehicle based on the computations or on the graphical schedule. Since each driver is responsible only for the time performance of his own vehicle, schedules for individual vehicles consist of departure and arrival times at each terminus as well as at all control points along the route for all trips during the day.

Numerical schedules for the public, usually referred to as timetables, contain all departure times from all stations or check-point stops throughout the day. The exceptions to this are the routes which have short headways for which no public timetables need to be published. The complexity of the timetables is greatly reduced when headways divisible into an hour are used since long periods of time can be presented by a single set of figures and the designation of the constant headway during that period. An example of such a timetable is given in Chapter 7.

Careful and detailed scheduling computations and precise presentation of the schedules are extremely important aspects of transit system operation, since they affect the efficiency and economy of operation, the regularity and reliability of service, and the facility with which the public can use the system.

5.5.2 Scheduling of Branch Routes. Merging of two or more branch routes into a common trunk section creates the problem of maintaining uniform headways and equal vehicle loadings. If n branches have approximately the same passenger volumes, they are scheduled with the same headway (h). Vehicles from different lines alternate on the trunk line, running at headways h/n . If individual branches have different passenger volumes, it is not possible to achieve operation with uniform headways and uniform vehicle loads on the trunk line. In such cases either non-uniform headways or different vehicle loads are operated on the trunk line.

Average headway on the trunk line (h_t) is computed using:

$$h_t [\text{min}] = \frac{60}{f_t} = \frac{60}{f_1 + f_2 + f_3 + \dots + f_n} \quad (11)$$

f_t being the frequency on the trunk and f_1, f_2, \dots, f_n the frequencies on the n individual lines. Trunk line frequency is very important to examine since it is critical for capacity of all converging lines.

5.5.3 Run Cutting. Assigning drivers or crews to transit vehicles is commonly known in the transit industry as run-cutting. The task in run cutting is to assign personnel to a given schedule of vehicle operations which will require minimum total wages and meet various constraints which often exist in the agreements between the operator and employees or their labor union.

Transit is a service which usually must be offered every day of the year for 16, 20 or even 24 hours per day. Since the quantity of service offered varies greatly for different days and hours of the day, transit operating personnel must work during irregular hours for periods of varying length, sometimes during the nights, on weekends and on holidays.

The very sharp peaking of demand which usually occurs on transit in the morning and afternoon hours of each working day creates particular problems. Since many more drivers are needed during peak than during off-peak periods, many drivers must be scheduled to work during the two peaks with several unpaid hours between. Such a work schedule is called a "split run" as distinguished from a "straight run" which consists of a continuous working period, usually of 8 hours. The time interval between beginning work in the morning and its termination in the afternoon is referred to as "spread time".

Labor rules, usually established by the management/labor union agreement, specify wage rates for work under different schedules. Typically, regular pay is given for eight hours of work which are either continuous or within a certain length of spread time interval. Higher wage rates are usually paid for some or all of the following conditions:

- Longer spread time than prescribed
- Night shift
- Work on holidays
- Overtime.

Additionally, the contract may stipulate the frequency with which shifts involving night, holiday or overtime work can be given to any one

employee, after which a higher-than-regular wage rate must be paid. For example, the maximum percent of split runs, or ratio of split to straight runs, is often stipulated.

These requirements, together with many local conditions in each agency, make the task of achieving the minimum-cost driver assignments a very complicated one. No general mathematical formulae or exact procedures for finding the optimal solution exist. One basic method suggests the following sequence in run-cutting:

- a. Develop as many straight runs as possible;
- b. Formulate split runs within spread time;
- c. Divide some straight runs into two or three segments and combine these segments with the pieces left over from step b to form additional split runs.

5.5.4. Scheduling a Transit Line: Example Computation. The procedure to be followed in scheduling a transit line is presented in the following sequence of steps. Sample data are given to demonstrate the computations.

Step 1: Collection of required data. The basic data which are necessary to schedule a line must be obtained. Defined earlier in section 5.2.1, those data are:

One-way line length:	L	=	10 miles
Operating time:	T_o	=	45 minutes for peak period
	T_o'	=	40 minutes for off-peak period
Maximum load :	P_{max}	=	375 persons per hour for peak period
Vehicle capacity:	C_v	=	45 seats + 25 standees = 70

Step 2: Determination of Some Operating Factors. Based on the definitions and description of terms in sections 5.1 and 5.4, determine or compute:

Operating speed:	V_o	=	$\frac{60L}{T_o}$
		=	13.3 mph for peak period
		=	15.0 mph for off-peak period
Policy headway:	h_p	=	15 minutes
Load factor	α	=	0.7
Minimum terminal time:	t_t	=	6 minutes .

(The initially assumed values for the load factor α and the terminal time t_t are often adjusted later in the calculation procedure).

Step 3: Determination of headway. First, calculate headway h by Eq. (10):

$$h = 60 \frac{\alpha \cdot C_v}{p} = 60 \frac{0.7 \cdot 70}{375} = 7.84 \text{ minutes.}$$

The value of h computed in this way must be rounded down to the nearest practical value for headway. If the obtained value is longer than 6 min., only the following numbers should be used: 7.5, 10, 12, 15, 20, 30, 40, 45 and 60; thus vehicle departure times repeat themselves every hour except for headways of 40 and 45 minutes.

Second, the headway computed above must be compared with h_p , the policy headway for the particular period of the day being scheduled. The smaller of the two is adopted. Since in this case the computed value for headway is $h = 7.84$ and that is shorter than $h_p = 15$, the value of 7.5 minutes is adopted as the headway during the peak period 15 minutes during the off-peak period.

Step 4: Computation of Cycle Time. Cycle time is computed by Eq. (6):

$$\begin{aligned} T &= 2(T_0 + t_t) \\ &= 2(45 + 6) = 102 \text{ minutes for peak period} \\ &= 2(40 + 6) = 92 \text{ minutes for off-peak period.} \end{aligned}$$

Step 5: Determination of Fleet Size and Adjustments of Previously Determined Factors.

The required fleet size (N) is obtained from the following equation:

$$N = \frac{T}{h} \quad (12)$$

Since N must be an integer, the computed value is rounded up to the next whole number. For the case at hand, Eq. (12) is applied:

$$\begin{aligned} N &= \frac{102}{7.5} = 13.6 = 14 \text{ vehicles for peak period} \\ &= \frac{92}{15} = 6.3 = 7 \text{ vehicles for off-peak period.} \end{aligned}$$

A new cycle time T' is then computed for each period using the calculated fleet size values:

$$\begin{aligned} T' &= N \cdot h \\ &= (14)(7.5) = 105 \text{ minutes for peak period} \\ &= (7)(15) = 105 \text{ minutes for off-peak period.} \end{aligned}$$

Cycle times for the two cases are usually not equal, as happened in this case.

A new terminal time t_t is then computed based on Eq. (6) using:

$$\begin{aligned}
 t_t' &= \frac{T' - 2 T_0}{2} \\
 &= \frac{105 - 2(45)}{2} = 7.5 \text{ minutes for peak period} \\
 &= \frac{105 - 2(40)}{2} = 12.5 \text{ minutes for off-peak period.}
 \end{aligned}$$

If the difference between peak and off-peak values is small, adopt the computed fleet size N , T' as cycle time and t_t' as terminal time.

Finally, we can compute the commercial speed V_c by Eq. (7):

$$\begin{aligned}
 V_c &= \frac{120L}{T} \\
 &= \frac{120(10)}{105} = 11.4 \text{ mph for peak period} \\
 &= \frac{120(10)}{105} = 11.4 \text{ mph for off-peak period.}
 \end{aligned}$$

A summary of the scheduling results is as follows:

<u>Item</u>	<u>Peak Period</u>	<u>Off-peak period</u>
Headway (h)	7.5 minutes	15 minutes
Cycle time (T)	105 minutes	105 minutes
Terminal time (t_t)	7.5 minutes	12.5 minutes
Fleet size (N)	14 vehicles	7 vehicles
Commercial speed (V_c)	11.4 mph	11.4 mph

5.5.5 Use of Computers in Scheduling and Run-Cutting. While the basic procedure of vehicle scheduling is rather simple, preparation and analysis of data for it obtained through passenger counts is a time-consuming process. Scheduling by computers can under certain conditions result in considerable savings to the operator. When voluminous data are collected frequently and the system has a great number of routes, use of computers becomes very efficient. While an analysis of passenger counts and scheduling for one route takes many man-hours, it can be done by computer in several minutes. This permits a rapid evaluation of service, fast reaction to demand change, etc. The limitation is, however, that computers can be efficiently applied only to rather standard cases, i.e. for the routes which do not have many irregularities such as different vehicles, special crew assignment requirements, etc., since these often can be taken into account only by manual scheduling.

Built with strength for dependability and safety.

In our HD-31 mid-size bus, you get the traditional strength and safety that is offered in Fixible's 35' and 40' big buses. All three have exterior fluted side panels made of special, high-strength .063" thick aluminum. For even more general strength these body panels are riveted to high-tensile, low-carbon steel carline posts and other body structure.

And, just like our 35' and 40' buses, Fixible's 31' coach has an underframe anchored by a special 12-gauge steel front-to-rear main frame girder that extends about 1" outside the body panels. When welded to form our integral unitized body frame, this Fixible-only feature provides a crush-resistant rub rail, the toughest in the business. It protects the coach sides, wheel housings — and passengers.

General dimensions for Fixible's model HD-31 heavy-duty 31-35 passenger transit coach with transverse, rear-mounted diesel engine and automatic hydraulic transmission.

Length overall	30' 10 1/4"
Width	98"
Height overall	125"
Seating capacity	31-35
Step height from ground—front	13 1/2"
Step height from ground—rear	18"
Turning radius (front body corner)	33'

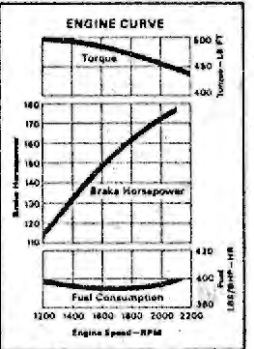
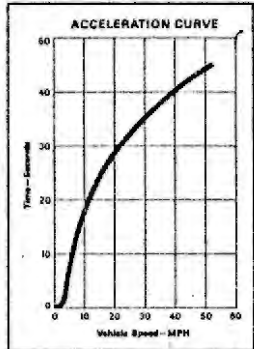
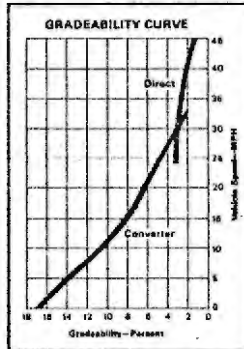

Model — HD-31 • Engine — Detroit Diesel 6V-71N (2 valve) transverse mounted with 71C6 fuel injectors • Transmission — Allison VH • Transmission ratio — 1.0435:1 • Axle ratio — 6-1/8 (5.167):1 • Tire Size — 10.00 x 20 • Air conditioning — On • Curb weight — 19,800 lbs. • 35 passengers plus driver (@150) — 6,400 lbs. • Gross vehicle weight — 25,200 lbs.

Model — HD-31 • Engine — Detroit Diesel 6V-71N (2 valve) with 71C6 fuel injectors • Rated power output — Guaranteed within 8% of SAE standard ambient conditions: 85°F/Elevation 500 FT/Barometer 29.00 IN HG (dry)

Trane or Halstead Mitchell air conditioning evaporator and condenser, and Trane compressor.

New-look window sash.

Detroit Diesel 6V-71 engine with gear-driven accessories Allison VH transmission

Rockwell D8822 axle and brake assembly (460 sq. in.)

Rockwell 16930 axle and brake assembly (290 sq. in.)

31 / 31 35 Passengers

WARRANTY:
35,000 miles or 3 year,
full parts and labor. (En-
gine warranty is standard
DDA warranty.)

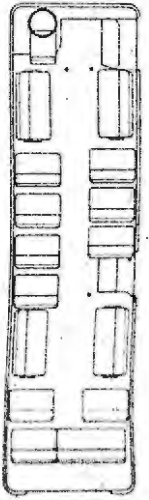

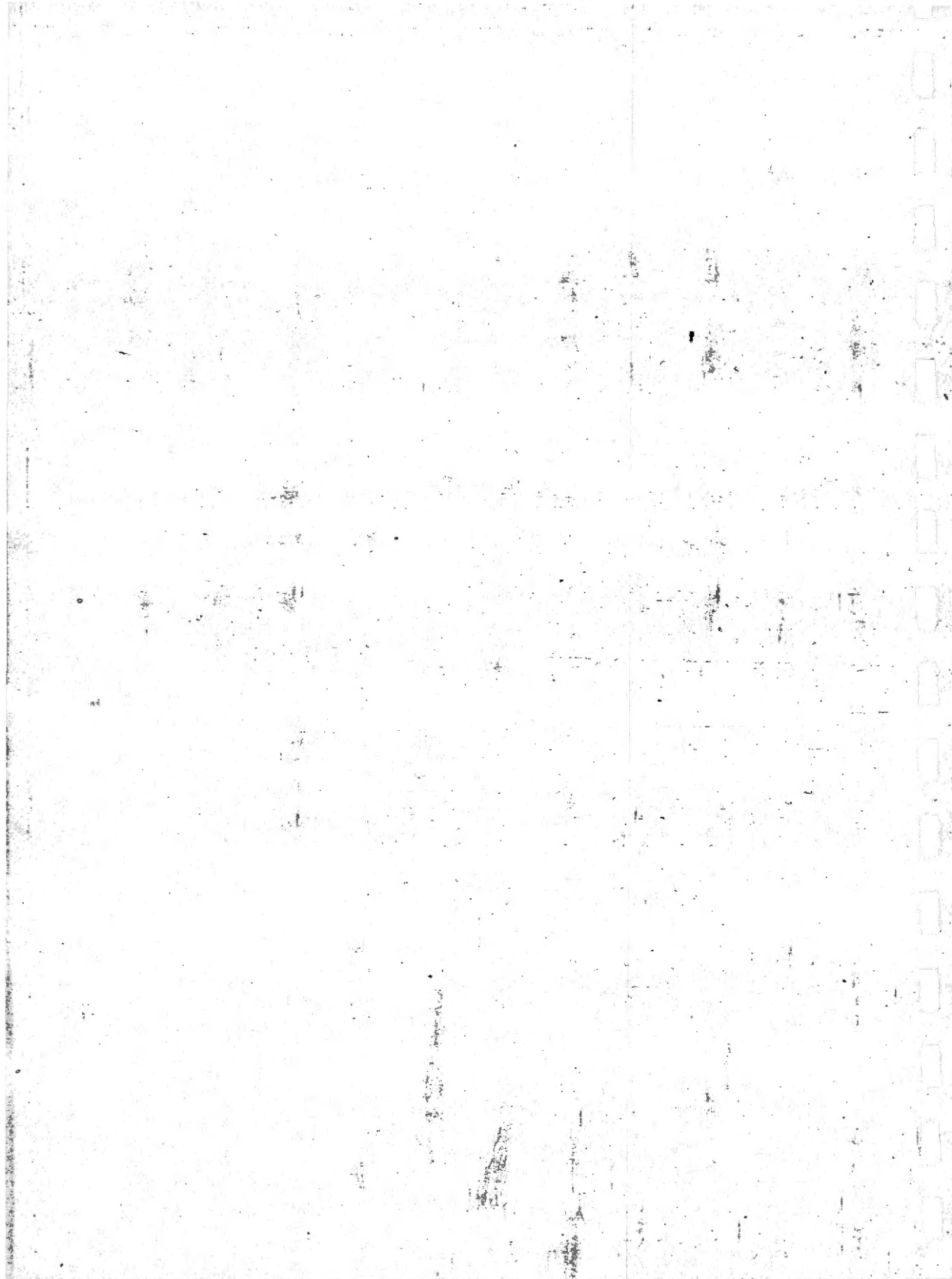

Whenever computers are used for scheduling, however, a valuable side-product is also obtained: statistical data on transit operations. Such data as passengers transported, seat-miles offered, as well as various coefficients, are easily programmed and their precise values are obtained with minimum additional computer time.

Attempts to optimize schedules and run-cutting by application of operations research and computers have had only a limited success so far. A rather complete review of recent progress in these areas and their evaluation are given in [3].

5.6 Increase of Transit Speed

An increase in average transit operating speed is desirable for both the passengers and the operator. Higher speed results in shorter passenger travel time and sometimes in reduction of the required fleet size, lowering the capital and operating cost for the agency. Even more significant in some cases is that since the speed is a strong factor in passenger attraction, its increase results in the generation of new transit passengers. Therefore the importance of speed of transit service should not be underestimated. The operator should make every effort to achieve as high a speed as operational and economic conditions allow.

There has been a considerable difference of opinion among transit operators in U.S. cities with respect to transit speed. Many agencies which operate surface routes have made little effort to improve the speed of their vehicles; for example, the obsolete policy of stopping for passengers at every corner still practiced in many cities results in such low speed that few persons who have other modes of travel available can be attracted to transit. Another group, the operators who plan and operate rapid transit and regional rail systems, has often opted for very high speed by planning rail lines with extremely long interstation spacings and very high maximum speeds (up to 80 m/h) at the expense of area coverage and energy consumption. While high speed is always an asset, the sharply increasing cost of energy will force transit planners and operators to modify their design approach. Instead of the presently common operation of vehicles without any regard to energy consumption, they should make a careful analysis of the trade-off between speed and

energy consumption, and adopt designs which result in the best possible compromise.

5.7 Possible Measures for Speed Increase

Passengers are interested in the high operating speed, while the operator's costs are directly related to the commercial speed, since this influences the fleet size as shown in Fig. 5.12. Usually, an increase in the operating speed leads to an increase in the commercial speed, so that the focus of efforts to increase speed should be on measures affecting vehicle running; however, terminal times should not be neglected either.

A great number of physical and operational changes may result in increased transit speed. The operator should consider which ones may be applicable to his system. Such potential changes on surface transit are presented here, classified into several major categories. The sequence of items is not necessarily related to their significance since applicability of individual measures and their effects depend heavily on local conditions.

5.7.1 Vehicle Design and Performance Characteristics. Several changes in vehicle design may lead to increased travel speed. Most of them should be planned for new vehicles since only limited modifications can be made on the existing ones.

- Interior circulation may cause delays at stops if the aisle is narrow and passenger interchange is heavy. In such cases elimination of one row of seats between the front and center door should be considered.

- Double-channel doors and low floors substantially decrease boarding-alighting times: they should be considered for all urban services. On longer suburban routes with low passenger interchanges their advantages are outweighed by the requirement for maximum seating capacity.

- Dynamic characteristics of vehicles must be carefully determined in connection with route layout and type of operation. Steep streets require special gearing to provide reasonably high speed. Freeway operation requires high maximum speed, while street operation benefits more from high acceleration/deceleration than from high maximum

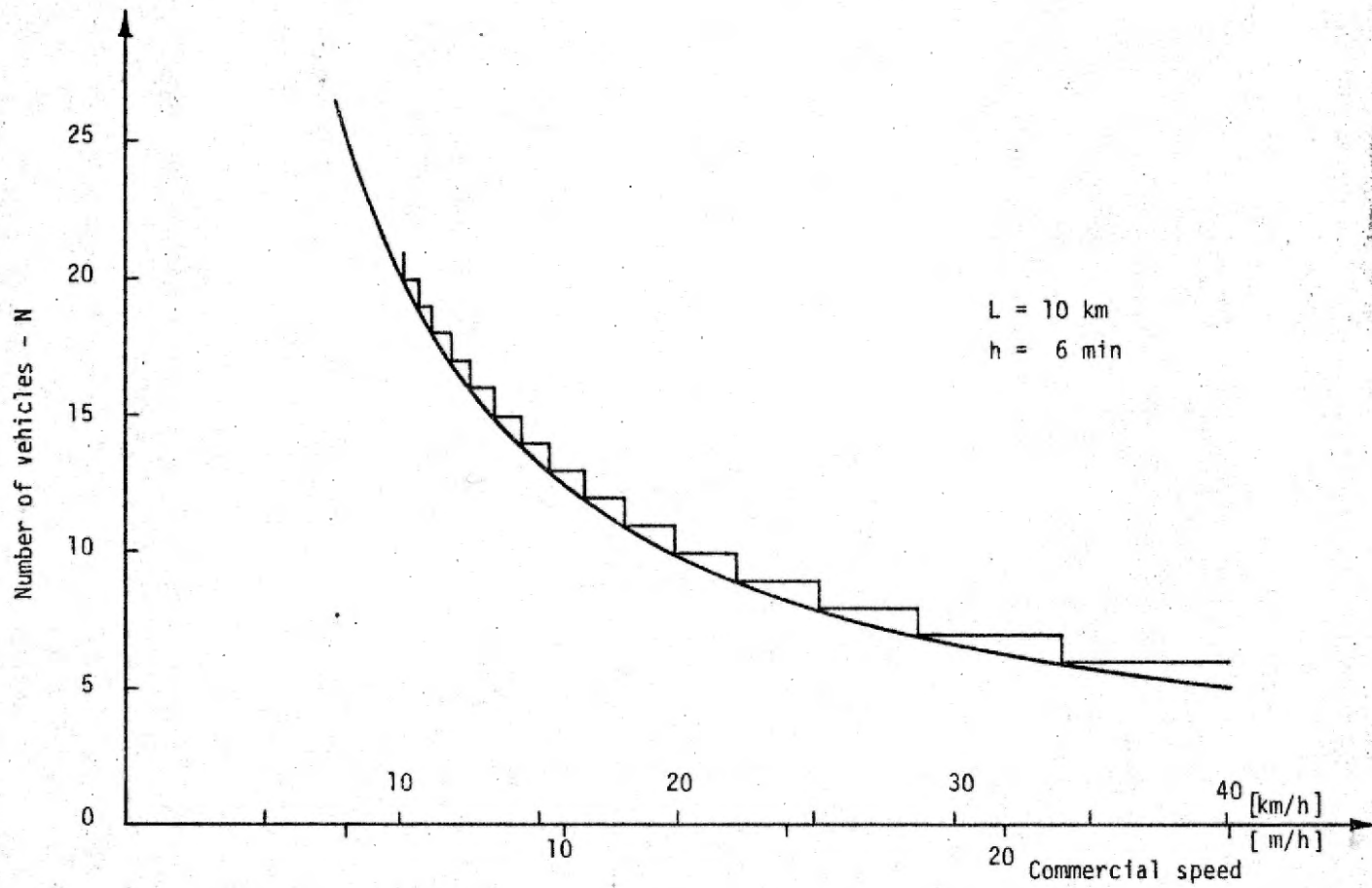

Figure 5.12 -- Relationship between commercial speed and fleet size.

speed.

5.7.2 Intersection and Street Design and Operation. In most cities street design and traffic regulations have been developed without much attention given to transit vehicles. For example, in determining design capacities or signal timing, buses are included with other vehicles without any special considerations. Since the basic objects of passenger transportation are not vehicles but persons, the attention given to different vehicle classes should be proportional to the number of persons they carry. Thus a bus or light rail vehicle should be given many times greater preference than a single private car. If in addition, the vital role transit plays in the city is also taken into account, one can easily see that numerous changes in intersection and street design and operation for increasing transit speed are justified in most cities. The most important such improvements are given here.

- Extention of green phases for streets with transit routes.
- Police officer's intervention to favor transit vehicles.
- Introduction of transit-actuated signals which can be of several types. Via a contact on an overhead wire, radio impulse or magnetic loop in the pavement a transit vehicle activates the signal to extend the green phase, to provide a special phase (e.g. a left turn with designation "Buses only") or makes a complete override of regular timing and provides green phase following only a clearance interval. The last type represents the highest order of preferential treatment. Signal actuation can be fully utilized, however, only where an exclusive transit lane is provided.

- Improvement of intersection design and control through modern channelization, provision of bus bays, special transit turning lanes, pedestrian control and protection, etc.

- Elimination of curb parking on transit streets, with proper enforcement can greatly enhance transit operation by providing for more efficient use of the full width of street for moving vehicles and at the same time, allow faster travel speed for transit vehicles due to decreases in street congestion and vehicular friction. This action also simplifies or eliminates the bus maneuver to approach the curb and then return into the traffic lane, and increases passenger safety by allowing boarding at the curb.

Elimination of curb parking and loading zones often creates objections from merchant associations and residents. Several actions can alleviate this problem. The eliminated parking may often be compensated for by providing these facilities on close-by off-street areas, vacant lots, etc., or additional parking on adjacent streets (see section 4.2.3). Also, various transit improvements may be helpful to attract some of the affected auto users to transit. For example, increased frequency of service is often possible, since vehicle travel time is decreased by the elimination of parking. If this is coupled with other traffic improvements, a substantially more frequent and faster transit service may become feasible without any fleet size increase. Another possible improvement is introduction of shopper-special service with discount fares, or a transit validation system (reimbursement of fares in cooperation with merchants).

- Introduction of transit lanes or exclusive transit rights-of-way represents the most significant measure in increasing transit speed and reliability. An exclusive transit lane may be obtained by:

- Converting an existing traffic lane by prohibiting all other vehicles from it;
- Elimination of curb parking and use of that lane for transit; or use of that lane for other traffic and construction of physically separated lanes in the center of the street;
- Placing transit lanes or track in wide unused medians;
- Building transit rights-of-way independent of street alignments.

For this, one can use many different horizontal and vertical positions. Various design options for exclusive bus and light rail rights-of-way, as well as methods of their implementation, are described in Chapter 4.

5.7.3 Transit Stops. Improvements in the design and location of stops may have a major impact on transit speed. Most common are two potential improvements:

1. Increased spacings between stops can be introduced in many cities. Generally, transit vehicles should not stop more often than every 750 feet (7 times per mile), as standard S-2 of PennDOT's Operating Guidelines [7] specifies. In low density suburban areas or on other lightly

traveled routes particular during off-peak hours, spacings shorter than 750 ft. may be used; due to the small number of passengers transit vehicles bypass most stops, stopping on the average at distances greater than the 750 ft minimum. On well patronized routes, however, close stops are highly unproductive.

Some cities still have the obsolete practice of stopping at every corner. Although this type of operation minimizes walking to stops, it decreases operating speed of transit vehicles so drastically that many potential passengers are lost to the much faster automobile.

Superiority of operation with longer spacings between stops over operation with frequent stopping can be clearly shown by an example. Transit line with stops at every other intersection, e.g., at spacings of 1000 ft. compared with the same line operating with stops at every intersection (500 ft.) has the following advantages and disadvantages:

<u>Party Affected</u>	<u>Advantage</u>	<u>Disadvantage</u>
Passengers	<ul style="list-style-type: none"> • Higher travel speed • Saved time • Higher comfort (reduced frequency of accel.-decel.). 	<ul style="list-style-type: none"> • Walking to and from stops increased by an average of $\frac{1}{4}$ block each or a total of $2 \times 0.25 \times 500 = 250$ ft. This walk takes approx. 1 minute.
Operator	<ul style="list-style-type: none"> • Fewer vehicles required for a given schedule • Less energy consumption • Less vehicle wear and tear • Number of stops requiring signs, markings, benches reduced to half • Improved stopping bays or parking prohibition possible. 	
Streets and Police Departments, other Public	<ul style="list-style-type: none"> • Less curb space taken by stops • Easier enforcement of no parking at stops • Reduced impedance of traffic by bus stopping in travel lane • Less air pollution and noise. 	

The amounts and significance of all these items can be estimated

in detail for each specific case; but even without that, it is quite clear that the advantages heavily outweigh the disadvantages.

2. Alternating near-side and far-side locations along a street with synchronized signalization. The details of this procedure are explained in Sec. 4.2.

5.7.4 Transit Operations. Several operational elements which are largely under the operator's control can often be modified to increase transit operating speed.

- Faster fare collection through introduction of tokens, multiple-ride tickets, weekly or monthly passes, honor system or pre-sale of tickets prior to boarding are all useful in reducing processing time per passenger. For more details on fares see Chapter 6.

- Changes in route layout for elimination of excessive turns or indirect routings. It is a common practice, particularly in smaller cities, to operate very complicated transit routes to cover as much area as possible by a few routes. Many turning movements on a route not only increase vehicle travel time, but also decrease reliability of service and passenger comfort. Also, complicated route layouts decrease the simplicity and image of the system and create passenger confusion, resulting in low patronage. A partial solution to this problem may be to divide routes which have many turns into fewer more direct routes. Since the vehicle speed on each route is then increased, it may be possible to operate more direct routes without changing the fleet size.

- Different vehicle stopping policies should be considered, particularly when the demand for a route is high or the demand is heavily CBD-oriented. The three types of vehicle stopping policies are explained. They are:

1. Express operation;
2. Zonal operation;
3. Skip-stop operation.

1. Express operation. Under this operation, the vehicle stops at a few specially designated stops, usually at major traffic generators, such as schools, factories, department stores, etc. The spacing of stops is several times greater than spacing for local service. This operation becomes efficient when used with local operation, especially

along the city corridor route at peak periods. Greater spacing between stops increases the speed of vehicles, enabling them to circulate more frequently. Schematic diagram of this operation is shown in Fig. 5.13.

2. Zonal operation. Heavily traveled long radial lines can be divided into zones. A vehicle or train stops at all stations in one zone and then travels non-stop into the center city. The next vehicle serves the next zone; etc. Fig. 5.13 shows the zonal operation graphically. This type of operation may, under certain conditions, result in a high occupancy level and shorter cycle times than regular local stop operation.

3. Skip-stop operation. Under this operation, all stops are designated either A, B, or AB. Vehicles designated as "A" stop at A and AB stops. Vehicles designated "B" stop at B and AB stops. Thus at AB stops all vehicles stop and at A and B stops, "A" vehicles and "B" vehicles stop respectively. Passengers wishing to travel from an A stop to a B stop transfer at an AB stop. This type of operation can increase vehicle operating speed considerably and yet can maintain the same area coverage. For bus operation where stop spacings are rather short, the skip-stop operation can be designed such that the two groups of vehicles make stops alternately. In other words, all stops are designated either A or B (no AB stops). The skip-stop operation is suited for routes where travel demand is rather evenly distributed. This operation is also shown in Fig. 5.13.

5.8 Evaluation of Measures for Speed Increases

To decide whether introduction of a measure for speed increase is justified, the operator must make an analysis of all its benefits and costs in the broad sense, i.e., not only through monetary aspects. In some cases, particularly with respect to changes which the operator can introduce alone (e.g., a new fare collection method, faster vehicles, etc.), this analysis is rather simple; in others, particularly those involving introduction of transit lanes, signal actuation or reconstruction of streets, which are under jurisdiction of other bodies and affect not only transit users, but also auto drivers and other parties, it is necessary to make a very comprehensive analysis. A systematically organized analysis is very helpful in justifying the effort and determining who should participate in it and to what extent.

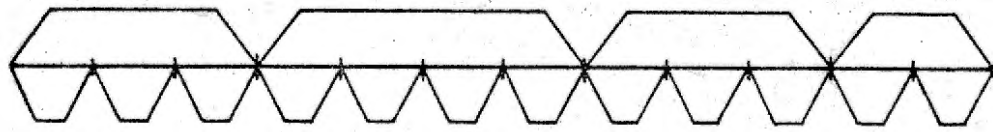

a. Express/Local Operation

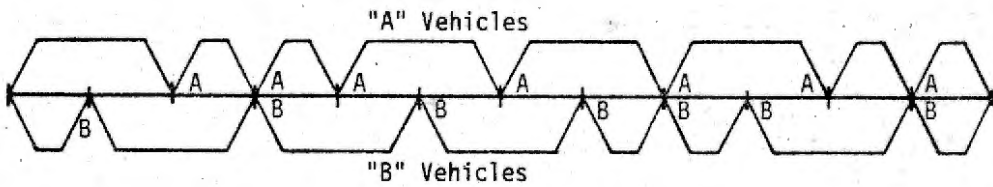

b. Skip-Stop Operation

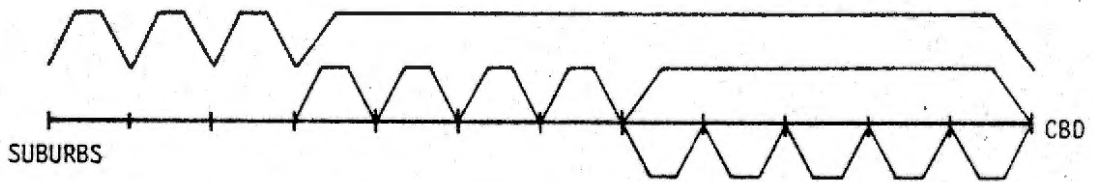

c. Zonal Operation

Figure 5.13--Illustration of different types of stopping schedules.

Due to the great number of direct and indirect consequences of any significant speed change, it is useful to have a graphical presentation of the whole process. Two examples of such diagrams and computations based on them are presented here. One analyzes the consequences of a measure which increases speed of fare collection, such as introduction of the honor fare collection with prepaid (multiple ride or monthly) tickets. The second example, defines the steps in evaluating the benefits and costs of introducing an exclusive lane for transit operation.

5.8.1 Example 1: Fare Collection Improvement. Suppose that a transit agency is considering an improvement in fare collection which will result in a significant reduction of vehicle delays for passenger boarding. The framework for examination of the feasibility of this improvement is presented here. All major items for analysis are shown in Fig. 5.14 and explained here in detail both qualitatively and quantitatively, using the following assumed numerical values prior to the improvement:

$$L = 6 \text{ miles} \quad T_o = 36 \text{ min} \quad l_a = 3 \text{ miles}$$

$$t_t = 6 \text{ min} \quad h = 6 \text{ min}$$

Actions required for introduction of the new fare collection method, given in the Figure, are self-explanatory. Individual benefits and costs are given here by reference numbers from Fig. 5.14.

1. Increased vehicle operating speed. By introducing the honor fare collection method with substantial percentage of prepaid tickets, vehicle standing times at stops are reduced. This reduction in time lost at stops will result in reduced vehicle operating time. If a 3-minute vehicle operating time saving per one-way trip is expected by this improvement, the vehicle operating speeds before and after the improvement respectively, are computed by Eq. (5):

$$V_o = \frac{60L}{T_o} = \frac{60 \times 6}{36} = 10.0 \text{ mph}$$

and

$$V_o' = \frac{60L}{T_o} = \frac{60 \times 6}{36-3} = 10.9 \text{ mph.}$$

Therefore, a 0.9 mph vehicle operating speed increase is achieved.

2. Reduced user travel time. An immediate effect of vehicle operating

speed increase is the saving in user travel time. For an average user trip length (l_a) of 3 miles, average user travel time changes from:

$$t_o = \frac{60l_a}{V_o} = \frac{60 \times 3}{10.0} = 18.0 \text{ min}$$

to:

$$t_o' = \frac{60l_a}{V_o'} = \frac{60 \times 3}{10.9} = 16.6 \text{ min}$$

Thus an average saving of 1.4 minutes per passenger is achieved.

3. Reduced fleet size. With the increase in vehicle operating speed, the operator will have two options:

- to decrease fleet size while maintaining the existing headway;
- to decrease headway while maintaining existing fleet size.

The first option reduces the operating costs (depreciation, driver, fuel, and maintenance costs). This option, however, can only be taken when the difference between the cycle times before and after the improvement ($T - T'$) is greater than or equal to the headway, so that the same service frequency can be maintained if one vehicle is withdrawn. In this case, the cycle time, commercial speed and fleet size requirements before and after the improvements are:

Equation	Eq. no.	Before	After	Change
$T \text{ [min]} = 2(T_o + t_t)$	(6)	$2(36 + 6) = 84$	$2(36 - 3 + 6) = 78$	-6
$V_c \text{ [mph]} = \frac{120L}{T}$	(7)	$\frac{120 \times 6}{84} = 8.6$	$\frac{120 \times 6}{78} = 9.2$	+0.6
$N \text{ [vehicles]} = \frac{T}{h}$	(12)	$\frac{84}{6} = 14$	$\frac{78}{6} = 13$	-1

Therefore, one vehicle is saved under the assumed numerical values.

4. Higher service frequency. If the same fleet size is maintained, the operator can try to reduce headway as a result of commercial speed increase. The headway of 6 min. could become after the improvement:

$$h' = \frac{T'}{N} = \frac{78}{14} = 5.5 \text{ min.}, \text{ rounded value: } 6 \text{ min.}$$

Thus, in this case, a shortening of headway would not be operationally practical.

5. Interest on revenue. Another advantage for the operator from

introduction of prepaid tickets or passes is the receipt of revenue in advance. This enables the operator to make advanced planning or investment on other projects and to earn additional interest by depositing the revenue at the beginning of each month.

6. User convenience. The introduction of the honor system with prepaid tickets greatly increases user convenience since users do not have to prepare cash for each ride. Also, these types of tickets are often sold with some discount per ride.

Due to this increase in user convenience coupled with reduced travel time, some demand shift from automobile to transit use can be expected. The increase in patronage may require some fleet size increase to provide necessary capacity. Although this requires investment, this trend is desirable since it increases the size of the operation and generates more revenue, while it decreases dependence on automobile travel with its attendant congestion, parking problems and air pollution in urban areas.

7. Simplified monitoring of payment and accounting. The simpler fare collection procedure resulting from the improvement eases the driver's supervision of fare payment. It largely simplifies daily accounting procedures at the office since less cash is collected.

The cost items defined in Fig. 5.14 which are self-explanatory should be computed and presented in a convenient summary form, such as Table 5.2.

5.8.2 Example 2: Transit Lane Introduction. This measure for speed increase is much more complex than fare collection changes since it concerns not only the transit operator and passengers, but also other traffic, residents along the streets, etc. Preparation for its introduction must therefore include cooperation with the Traffic Engineering Department, citizens' groups and other concerned parties. However, all these organizational and often political actions should be based on a comprehensive analysis of the technical/economic factors involved in such a change, which are outlined here. The better the analysis is, the weaker will be the influence of unjustified individual interests, pressures, and emotional arguments.

The analysis of benefits and costs of introducing a reserved transit

Example 1

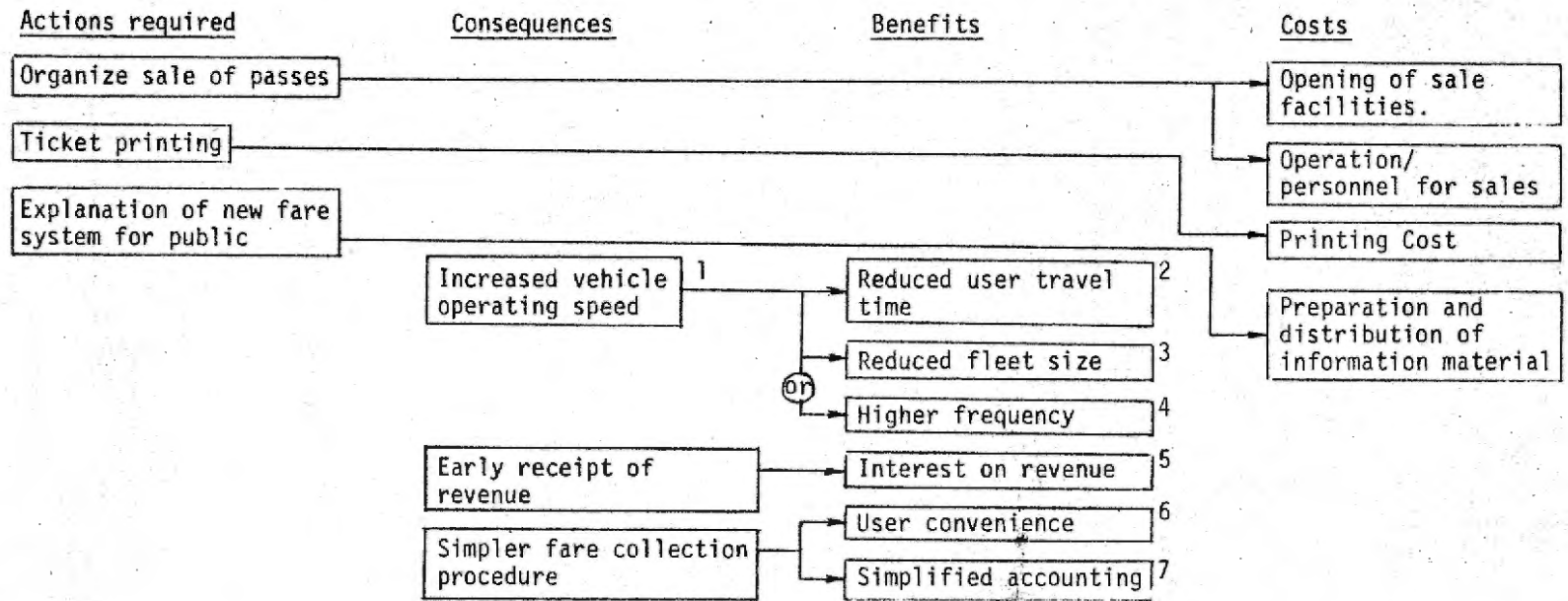

Figure 5.14 -- Evaluation of introducing multiple-ride or other fare collection improvements.

Table 5.2 -- Benefits and costs from fare collection improvements.

Benefits

- Fleet reduction: 1 bus;
Annual amount \$ _____
- Increase in interest on
revenue: \$ _____/month
Annual amount \$ _____
- Total annual savings \$ _____

- User time saved
_____/min/pass
Annual pass. hrs. _____
- Increased passenger
convenience
- Newly attracted passengers
- Simplified driver's duty
- Other benefits

Costs

- Opening sale facilities:
Annual depreciation \$ _____
- Annual salaries for sales
personnel \$ _____
- Annual printing cost \$ _____
- Distribution of infor-
mation materials: no
expense
- Other costs \$ _____
- Total annual costs \$ _____

lane on an arterial street follows a procedure similar to the one in the preceding example, as Fig. 5.15 shows. Its description is presented in sequence of the numbered boxes in the figure.

1. Actions required. The extent of investment cost, time of implementation and disruption incurred by the introduction of an exclusive transit lane must be specified. They depend on the location and design of the facility to be provided. The lowest-cost alternative would be conversion of an existing parking or driving lane into a transit lane. With this option, some sort of visual control or physical restraint devices (such as stanchions along lane lines) which either prohibit or discourage entry of non-transit vehicles into the lane, must also be provided. In addition, visual controls (such as signs and signals) and special minor construction may be required at certain intersections and stop areas to ensure safety of operation and to eliminate potential conflicts with other vehicular traffic. Other, more expensive measures for transit lane introduction are possible, including the construction of lanes or rail tracks in freeway medians (when these have sufficient width) or on available railroad rights-of-way. The magnitude of benefits and costs for each alternative investment vary with the investment cost, but each has the same kind of effects which must be analyzed.

2. Increased speed and reliability. Provision of a reserved lane or a fully separated right-of-way for transit significantly improves the average speed of vehicles since interference from other traffic is substantially reduced or eliminated. Likewise, there is an improved reliability of service. These improvements provide added benefits which are described below.

3. Reduced user travel time. Calculated as in Example 1, the travel time savings for present transit users can be significant. Auto drivers who switch to transit will also experience reduced travel times or increased convenience (otherwise they would not have switched). Finally, auto drivers who continue to drive their cars, may also save time in some cases, as explained under item 8 below.

4. Increased schedule adherence. Because of their greater independence from street traffic, transit vehicles traveling on their exclusive lane have higher reliability and can therefore meet schedules more easily and

Example 2

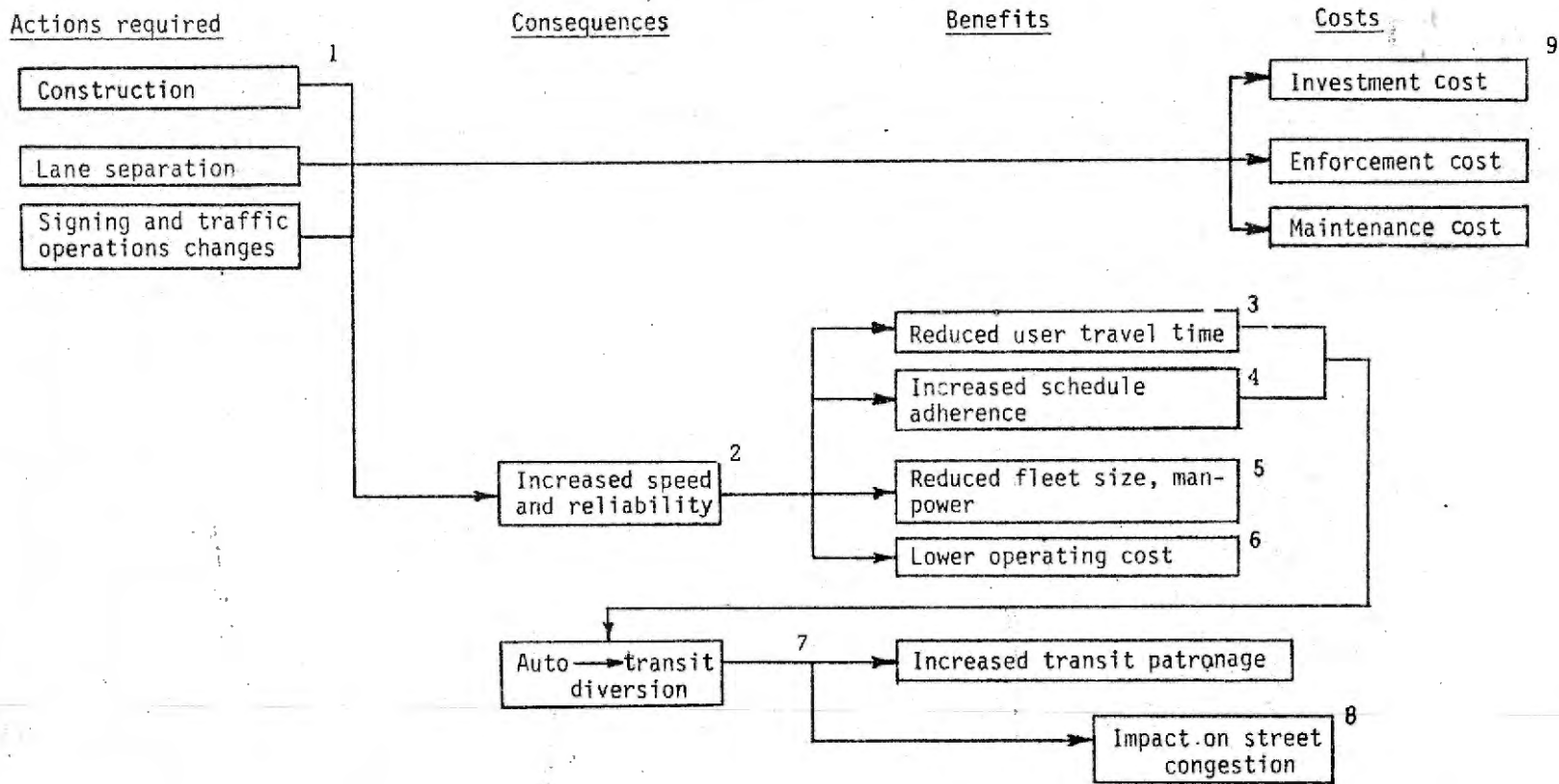

Figure 5.15 -- Evaluation of transit lane introduction.

consistently. The improved schedule adherence can be measured by observing the per cent of late arrivals before and after the lane installation.

5. Reduced fleet size and manpower. The savings in fleet size and manpower resulting from the speed increase should be calculated in the same way as in Example 1.

6. Lower operating costs. With the fewer delays in traffic and fewer stops and starts, the operation and maintenance costs per vehicle are reduced. Such savings are reflected in lower fuel consumption, maintenance and replacement of vehicle parts, as well as in driver time requirements.

7. Auto-to-transit diversion and increased transit patronage. The combined improvements of transit service resulting from the introduction of exclusive transit lane usually result in some diversion of travel from auto to transit. The amount of diversion depends heavily on whether critical conditions on the streets exist prior to operation of the transit lane and whether auto drivers are adversely affected by the lane introduction. For example, diversion from auto to transit would be higher where a lane on a heavily congested expressway is removed from use by auto traffic and assigned for exclusive use by transit vehicles than it would be if the transit lane were built in the median. This is because highway travel may be substantially hurt by removal of one lane in the first alternative, whereas it would be improved by the second. This leads to the next point.

8. Impact on street congestion. The nature of the impact of a transit lane on street congestion varies with the right-of-way used (existing and presently used, or new construction) and the amount of diversion to transit. Obviously, if an entirely new facility is provided, present highway users will benefit by having transit vehicles removed from traffic. On the other hand, if a presently used street lane is taken for transit, auto drivers may be adversely affected to the point where so many of them switch to transit that original traffic conditions are again achieved or even improved. There have been cases in which conversion of an existing traffic lane to exclusive transit lane has resulted in increased speed of both due to lower "friction" between the two different types of vehicles.

Since the impact of a transit lane on congestion may be positive

or negative depending on conditions, its box in Fig. 5.15 is placed between benefits and costs.

9. Costs. Investment costs and disruption from construction vary with the type of facility used or constructed. There is always a trade-off between the level of investment cost and required enforcement cost. For example, on a physically separated exclusive transit rights-of-way, particularly rail tracks, there is little or no opportunity for violators (non-transit vehicles) to enter the right-of-way; enforcement costs of patrolling or monitoring, therefore, are virtually nil. An expressway or urban street lane which is easily accessible from other lanes by autos, on the other hand, must be monitored closely for potential abusers. The maintenance costs incurred by the transit lane introduction, such as the up-keep of signs, markings, and other traffic control devices, exist at any level of investment, although they are also somewhat lower for high-investment, high-quality options.

Fully controlled rights-of-way generally require the highest investment, but offer the highest service quality and lowest operating costs as compared with other alternatives.

Results of this analysis, which should be presented in a summarized form for each review, thus contain all significant monetary, other quantitative (e.g. travel times), as well as a number of qualitative aspects of the analyzed proposal for transit lane introduction.

5.9 REFERENCES AND BIBLIOGRAPHY

1. Alan M. Voorhees and Associates, "Urban Mass Transit Planning Project", Technical Reports 1-6, prepared for UMTA-HUD, Washington, 1966-68.
2. Baerwald, J. E., Ed. (ITE), Transportation and Traffic Engineering Handbook (Fourth Edition), Prentice-Hall, 1976.
3. Bergmann, D., "Issues in Urban Bus System Schedule Optimization", Report to the Michigan Dept. of Commerce, 1972, NTIS, PB 214 473.
4. Eisele, D., "Application of Zone Theory to a Suburban Rail Transit Network", Traffic Quarterly, Vol. 22, January 1968, pp. 49-67.
5. Manual of Traffic Engineering Studies (Fourth Edition), Institute of Transportation Engineers, Washington, 1976.

6. Mossman, F., ed., Principles of Urban Transportation, The Press of Western Reserve University, 1951.
7. Pennsylvania Department of Transportation, Operating Guidelines and Standards, prepared for PennDOT by University of Pennsylvania, 1973.
8. Roberts, K. R., "Vehicle Scheduling and Driver Run-Cutting: RUCUS Package Overview", MITRE Corp. Report #M71-58, McLean, Va., 1971.
9. Smerk, G. M. et. al., Mass Transit Management: A Handbook for Small Cities, Institute for Urban Transportation, Indiana University, DOT Project No. IND-MTD-1, February 1971.
10. Vuchic, V. R., "Skip-Stop Operation as a Method for Transit Speed Increase", Traffic Quarterly, Vol. 27, April 1973, pp. 307-327.
11. Vuchic, V. R., et. al., Value of Speed in Public Transit Services, Transportation Studies Center, University of Pennsylvania, Philadelphia, 1970.
12. Wren, A., Computers in Transport Planning and Operation, Ian Allen Ltd., London, 1971.

Chapter 6

FARES

6.1 Introduction

Fares represent the main source of revenue for transit agencies. They also affect the present and potential ridership of every transit system and often strongly influence attitudes toward transit services. In the long run, fares have a significant impact on the form and development of cities. It is therefore necessary to plan fares for every transit system with great care and consideration of a number of related factors.

To provide a basis for the analysis of transit fare level and structure, it is helpful to examine objectives in setting up a fare system. The most important objectives and requirements which a fare system should achieve are:

1. To attract the maximum number of passengers;
2. To generate the maximum revenue to the transit agency;
3. To achieve specific social goals, such as to facilitate travel of children and students, to increase mobility of labor force, etc.;
4. To be convenient for passengers as well as for the operator of the agency in terms of the fare structure, facility and supervision of payment, collection of revenue, obtaining statistical data, etc.

It is apparent that all of these objectives cannot be satisfied in their extremes, since some of them are mutually conflicting. This is most obvious for objectives number 1 and 2: attraction of the maximum number of passengers will in most cases require a moderate level of fares and therefore usually result in generation of lower level of revenue than higher fares would achieve. Therefore, a compromise must be found between the two objectives; similar compromises must be found among other objectives also.

In order to determine the appropriate fare structure and level, the transit agency which designs the fare system and the public body which approves it must decide on the relative importance of each objective.

It is in this respect that mistakes are commonly made. For example, maximization of revenue has sometimes been given absolute preference over other objectives. This policy was critical for private transit companies when their actual survival depended on obtaining adequate revenue from fares. When the revenue is adequate for both covering the expenses as well as creating profits, well-managed companies tend to give due consideration to other objectives also. However when the company experiences financial strain, revenue must cover expenses; it becomes a question of survival, and the operator is forced to focus on that objective alone. This requirement for maximization of revenue then leads to the introduction of very high fares, causing serious losses of patronage. This in turn leads to reduction of service, making it even less attractive to passengers and inducing them to switch to private automobile. It is this "vicious circle", shown in Fig. 6.1, that necessitates assistance by public bodies to maintain transit service at certain levels rather than allow it to continue to deteriorate and eventually be discontinued.

Another example of excessive emphasis placed on one objective is reflected in the widespread use of flat fare, which is superior to others only because it is convenient to the riders and the operator (objective 3). Although flat fare does have this advantage, it is in some cases highly detrimental to the more important objectives 1 and 2, as will be shown later.

As will be discussed below, it is presently considered that in most cases the objective of attracting riders (and thereby increasing the mobility of population, decreasing automobile congestion, parking space requirements, air pollution, etc.) is far more important than maximization of revenue. Therefore, maximizing patronage (objective 1) should be given considerably greater weight than the achievement of certain levels of revenue (objective 2).

6.2 Fare Structures

Fare structures are classified on the basis of how the fare relates to distance traveled. Using this criterion, there are three main fare structure categories: flat fare, zone fares, and graduated fares. For the first one, fare is constant and independent of the trip length,

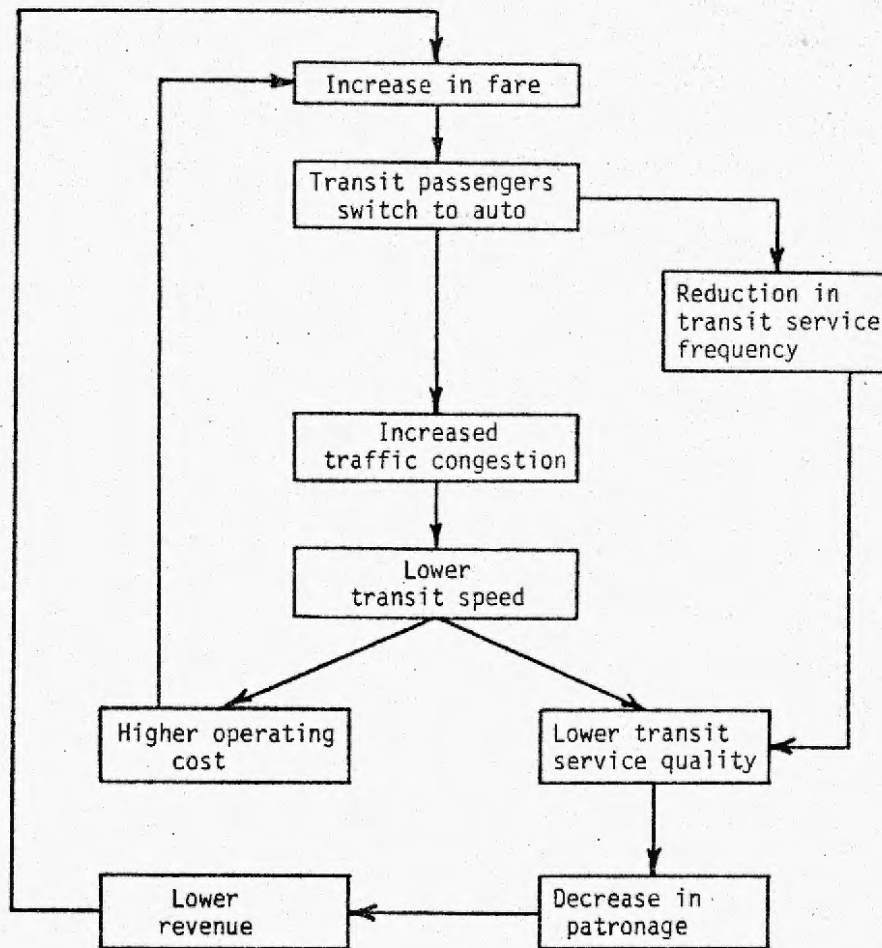

Figure 6.1 -- "Vicious Circle" caused by fare increases.

while for the other two categories fares increase with distance traveled on a transit system.

6.2.1 Flat Fare. This fare is constant regardless of the distance passengers travel on a transit line or network. The flat fare is the simplest possible fare since it is easy for passengers to memorize; it is used for all trips throughout the system, and it is usually collected at the entrance of the station or vehicle. Thus, supervision of payment is also very easy, simplifying the work of fare collectors or drivers and allowing a fast boarding process.

The basic disadvantage of the flat fare is that it does not in any way reflect the quantity of service the rider receives; a passenger traveling three blocks pays the same amount as one traveling eight or ten miles. In cities with limited geographic size, travel distances are relatively uniform so that the conveniences of the flat fare far outweigh the inequities related to its lack of correlation with trip length. In large cities, however, while the convenience of flat fare (simple collection) is at least as important as in smaller cities, its disadvantages often become very serious. For example, if the level of the flat fare is such that it reasonably corresponds to trip lengths of 2 to 5 miles, such a fare will be excessive for persons traveling several blocks in center city, while it will be so low for riders traveling 6-10 miles, that undercharging will result in loss of considerable potential revenue.

6.2.2 Zonal Fare. The simplest method for charging different fares for different trip lengths is achieved by dividing the city into zones, sometimes two (central and outlying), sometimes more, and charging one fare for trips within a zone, a higher fare for trips crossing from one zone into another, an even higher fare for crossing two boundaries, etc.

The main advantage of this fare structure is that it is possible to provide low cost transportation for certain types of trips (such as within the CBD) while collecting correspondingly higher revenue for longer trips.

A zonal fare system must be carefully planned. As much as practically possible, individual zones should be basically self-contained

areas delineated by natural boundaries such as rivers, major parks, avenues, etc. It is especially important not to have a great number of short trips crossing the zone boundaries since these trips are charged a much higher amount per mile than long trips. Fare increments between zones should be in convenient amounts, such as 5, 10 or 25 cents.

In comparison with flat fare, zonal fare has the advantage that different amounts are charged for different trip lengths; zonal fare is therefore more equitable and results in the attraction of higher patronage and collection of higher revenue. On the side of disadvantages, this fare structure has greater complexity of computing and collecting fares and control of payment. Also, certain riders traveling short distances across the zone boundaries may be charged unjustifiably high amounts.

6.2.3 Sectional Fare. This fare structure is obtained by dividing transit lines into sections and determining fares on the basis of the number of sections the passenger travels. Since sections are usually shorter than size of zones for zonal fares, fare level with sectional fares is even more closely related to distance than is the case with zonal. On the other hand, sectional fare is correspondingly more complicated to compute, collect and control than zonal. Consequently, sectional fare often requires more personnel, allows increased opportunity for avoidance of full fare payment, and results in longer fare collection time. This fare can therefore be readily used on routes with light-to-moderate passenger volumes; on heavily traveled routes it is necessary to have an efficient fare collection system to avoid undue delays.

6.2.4 Comparison of the Three Basic Fare Structures. In the immediately preceding sections, the three basic fare structures (flat, zonal and sectional) were defined. Each structure has distinctive features, advantages and disadvantages. A summary of these features is presented in Fig. 6.2.

The fare for a trip between any two points on a transit line for all three cases can be expressed by:

$$F = C + i \cdot n$$

CHARACTERISTICS		T Y P E O F F A R E		
		Flat	Zonal	Graduated
Important Characteristics	Equity	Poor	Good	Excellent
	Passenger attraction	Poor	Good	Excellent
	Revenue collected	Variable	Good	Excellent
	Simplicity of collection	Excellent	Fair-Good	Poor
	Simplicity of control	Excellent	Fair	Poor
	Simplicity for passengers	Excellent	Fair-Good	Poor
Desired Conditions	Route length	Short (< 3 mi)	Medium	Long
	Travel distance	Short	Variable	Variable

Figure 6.2 -- Summary of the characteristics of the three types of fare structures.

where

F = fare to be paid

C = base fare

i = increment in price to be paid for crossing a zone or section; and

n = the number of zone or section boundaries crossed.

Obviously, for a flat fare $i=0$, so that $F=C$ for all trips.

Figures 6.3 and 6.4 show diagrams of fare as a function of distance for the three fare structures. The first diagram gives the total amount of fare and shows the amount of fare per mile traveled. The relationship of fare paid to distance traveled is thus clearly shown in the second part of Fig. 6.3. Superiority of the zonal and sectional fares in this respect is obvious.

Figure 6.4 also shows how the three types of fare structure are superimposed on an urban area and the variations in equity between them.

6.3 Reduced and Special Fares

A number of variations on the basic types of fare structure is possible and it is frequently used in conjunction with the conventional fare systems. Such fares are used for one or more of the following reasons:

- To stimulate the use of transportation facilities and increase revenue during hours of low transit system utilization
- To favor a segment of the population
- To achieve specified social goals (e.g. provide a minimum level of mobility for the public).

In the following sections some special fares are described.

6.3.1 Commuter Fares. Commuter fares generally provide reduced travel cost to those who use the transit service on a regular daily basis, usually workers traveling to their jobs. In addition to rewarding the regular customer, the lower commuter fares encourage steady utilization and stability of demand. By attracting commuters with reduced fares, a large segment of the population is familiarized with the use of the transit system, thus increasing the likelihood of use of the system for other trip purposes (recreation, medical, social, etc.) at other times of the day and days of the week.

6.3.2 Peak Hour Fares. Many transit systems use higher fares for

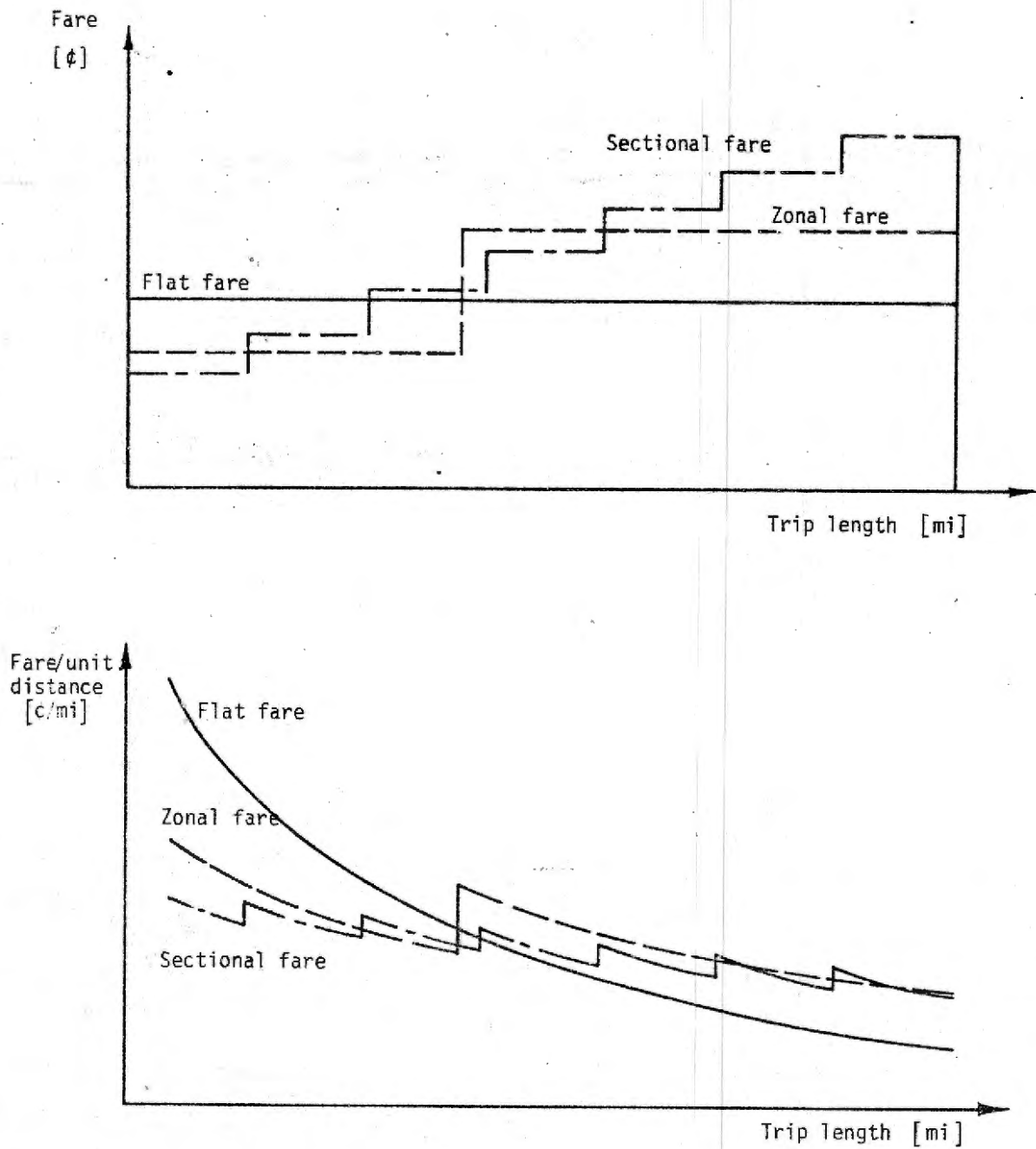
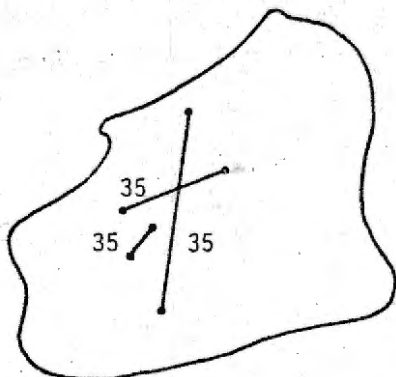
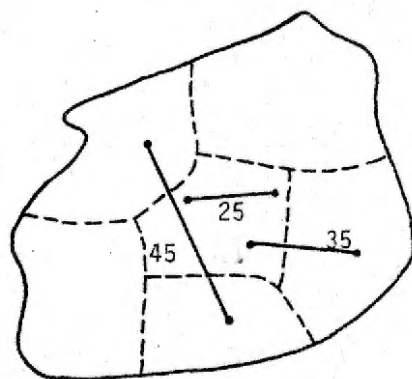

Figure 6.3 -- Fare variation with trip length for the three fare structures.



a. flat fare



$c = 25¢$
 $i = 10¢$

b. zonal fare

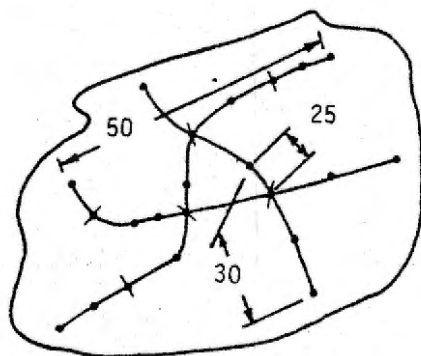

—●— station/stop
 —+— station with section limit

c. sectional fare

Figure 6.4 -- Schematic presentation of the three types of fare structure.

peak hour users in an effort to evenly distribute demand over a longer segment of the day. Since peak hour users dictate the capacity to be offered and thus the required fleet size and manpower costs, the higher cost per ride for those riders is justified. Although this policy appears contradictory to the preceding one (reduced fares for commuters), both of them may be partially reconciled and applied simultaneously. A fare structure can incorporate a fare reduction to regular users and off-peak users and still charge higher rates for infrequent and peak users. This can be done by making different fare levels in the following descending order:

- Infrequent peak-hour user
- Regular peak-hour user
- Infrequent off-peak user
- Regular off-peak user.

6.3.3 Children and Student Fares. It is a common practice to charge considerably reduced fares for children and students for social and equity reasons: both classes of citizens have low or no income, and often no other means of travel. The transit agency also benefits in the long run from such a policy, since it encourages the habit of using public transit early in life, a habit that often continues beyond the "low fare" years. Most transit systems allow free rides for children up to the age of 6 (or a specified height), and a low fare (not more than half of the regular fare) for ages 6-12 and for school children and students with special I.D. cards.

6.3.4 Fares for the Underprivileged, Senior Citizens and Handicapped. These three groups also warrant reduced or free fares for social reasons. While the underprivileged should usually pay a reduced fare (perhaps through a program comparable to food stamps), senior citizens and handicapped persons are often given free rides, although in most cases during off-peak hours only. During peak-hours either a nominal or regular fare may be applied. Since the reduction of fares in this and the preceding category is made for social reasons, the transit agency should be compensated for this difference in revenue from general taxation or some other revenue sources (school budget, lottery, etc.).

6.3.5 Shopper Fares. Shopper fares are reduced fares usually offered on routes or in directions of shopper travel after the morning peak until mid-afternoon (e.g. 10:00 AM till 3:00 PM) and possibly

after the evening peak (e.g. after 6:30 PM) to discourage unnecessary peak-hour travel and to distribute demand more evenly throughout the day. Sometimes weekdays with consistently lower ridership than other days are selected for days with reduced shopper fares.

6.3.6 Owl Fares. Owl fares are fares charged for travel during the night hours, such as 11:00 PM - 6:00 AM. They should be considerably higher than (often double) conventional daytime fares. The higher fare reflects the high cost per passenger of providing this service (overtime pay, extra safety, etc.), primarily due to the very low demand during those hours.

6.3.7 Other Special Fares. A wide variety of special fares are available which can attract riders during periods of otherwise low riding, such as on weekends and during off-peak hours. Family fares, which can be reduced rates to whole families traveling together, weekend fares, and special event fares are just a few of the possibilities that can improve revenues for the agency, give transit good exposure, and increase public interest in using transit.

6.4 Fare Level

The fare level refers to the amount of money charged for riding transit. There are a number of considerations which should be reviewed in establishing the fare levels. This section discusses the most important ones.

6.4.1 Major Factors. Every transit agency has several objectives which heavily influence selection of the most desirable fare level. Among those are the four objectives cited in the introduction to this chapter. All these objectives are affected by the fare level so that selection of the fare level must be done with regard to the relative importance attached to each of the objectives. The transit agency must therefore be aware of the trade-off among individual objectives. Figure 6.5 schematically shows a typical trade-off between revenues and patronage with increasing fares.

6.4.2 The Desirable Fare Level. It is seen in Fig. 6.5 that when fares are low, revenue increases with the fare. However, as fares become higher, there is a decreasing gain in revenue due to an accelerated loss of ridership. At a certain point* (B in the Figure)

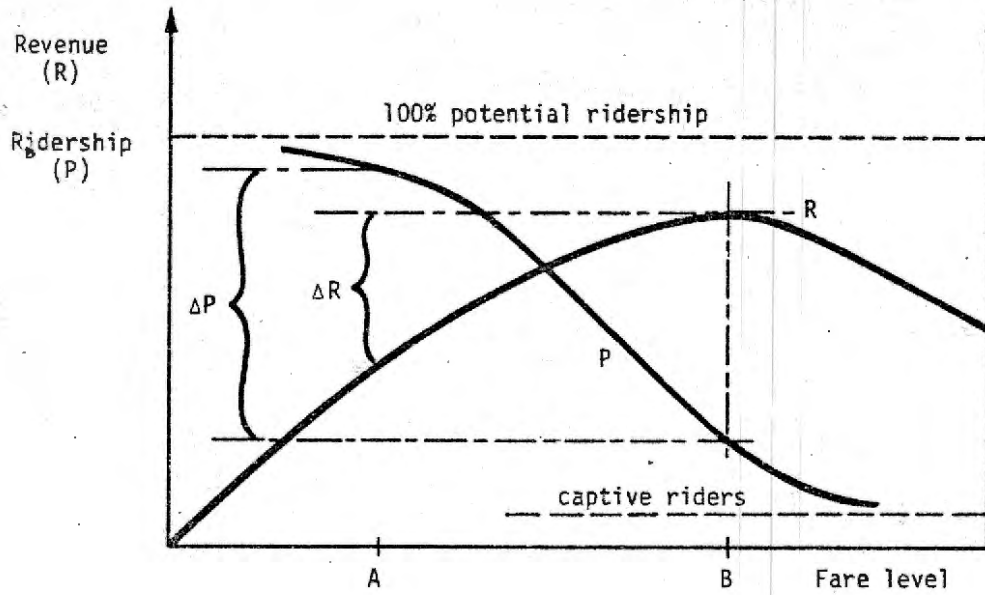

Figure 6.5 -- Relationships between fare, ridership (P) and revenue (R).

Note: This is a conceptual diagram. Scales of revenue and ridership are independent.

the maximum revenue is achieved. Beyond this point an increase in fare would result in a decrease of both gross revenue and ridership. Thus, B represents the absolute maximum fare that should ever be used.

A lower bound for fares (A) is established by either the minimum fare considered desirable, or a minimum amount of revenue required to be collected, e.g. for coverage of direct operating expenses or the like.

As can be seen in the figure, in shifting from an A to B fare level, ΔP passengers are lost while ΔR dollars in revenue are gained. Numerous data about elasticity of demand, or passenger loss due to fare increase, exist; see for example Curtin [2]. However, many of these data are from a time period with conditions quite different from those prevailing today and cannot be directly used in predicting passenger response to fare increases.

It is desirable that fare level correspond to (1) the quality and quantity of service provided, and (2) the cost of providing the service. Therefore it is justifiable to place higher fare charges on express service and other high quality cost-intensive services. Correspondingly, low quality service should not be overcharged. A particularly undesirable policy is to raise fares and cut back service simultaneously. This should always be avoided since the inevitable consequence is a loss of patronage, leading to another service cut-back and higher fares: the "vicious circle" of deteriorating transit service and decreasing ridership is created.

6.4.3 Free Transit. There have recently been a number of proposals to eliminate fares entirely and to finance transit service through general funds. While this proposition appears initially attractive from the viewpoint of maximization of ridership, there are some compelling reasons why free fare represents an unsound policy under most conditions:

- It is equitable that a transit user pay at least a portion of the cost of service he is using; the general public accepts that view.
- Most users are attracted to transit more by higher service quality than by lower fares. Therefore additional funds should be used for improved service rather than elimination of fares.
- Free fare would lead to some abuses: unnecessary rides, possible increase in vandalism.

- Free fare could result in lower control of costs which, when funds are tight, would lead to reduced quality of service.

For the above reasons a fare of some moderate amount is more desirable from both a social and an economic viewpoint than no fare whatsoever. If the funds needed for free fare were readily available, it would still be more desirable to charge moderate fares and use the collected additional funds for improvements of service, facilities, etc.

6.4.4 Low and Moderate Fares. Transit statistics show that the highest number of annual rides per capita exist in New York City, San Francisco and New Orleans--cities which have traditionally had low or moderate fares. Although the extensive networks and high frequency of service in these cities are partly to be credited for this fact, low fares have certainly been an important contributing factor.

In recent years several cities (e.g. Atlanta, Cincinnati, Los Angeles, Salt Lake City) have introduced temporary or permanent fare reductions, some quite drastic ones (Atlanta from 40 to 15¢). Increase in ridership has been quite significant (20 to 30 per cent or more), considerably higher than some theoretical studies had previously predicted. These fare reductions did not "break even", i.e., the increased ridership was not sufficient to compensate for lower fares, so that the total revenue was reduced. Additional funds were allocated from other sources (often additional sales or property tax). Yet, the experiments have been overwhelmingly evaluated as very successful: additional ridership, i.e., improved mobility and decreased traffic congestion, have been considered well worth the extra funds.

An important fact is that a moderate fare which is easily afforded by everyone and which is charged for a service of high quality attracts only slightly fewer passengers than a free transit would attract. Yet it provides a large amount of continuous revenue that would not be available from a no-fare policy.

It is emphasized that, while experiences and experiments from different cities give extremely useful insight into many aspects of fare policy, each agency must carefully study the conditions in its city in deciding on the best fare for its transit services. In experimentation with fares the agency should obtain cooperation of the city and regulatory agencies.

6.5 Fare Collection Methods

Fare collection method is a very important element of transit operations. This is because station standing time at a stop is often a prime factor in determining quality of service for the user and operating cost for the operator. Moreover, different fare collection methods may facilitate or prevent use of some fare structures. To summarize, the collection method affects:

- Average speed on a line;
- Capacity offered by a line;
- Required fleet size and manpower; and
- Fare structure applied.

These influences are especially true for surface transit operations, for which it is particularly important that the process of fare collection be speeded up as much as possible.

6.5.1 Definition of a Fare Collection System. There are two basic components which define a fare collection system. They are:

1. Time and location of payment; and
2. Form of payment.

Time and location of payment classifies fares into two types:

1. Prior to boarding the vehicle, i.e., off-vehicle. This includes payment at the station ticket booth or barrier, purchase of monthly ticket, etc.;
2. After boarding, i.e., on-vehicle. This may be:
 - upon boarding ("pay enter")
 - prior to alighting ("pay leave").

Payment of fare prior to the time of boarding is desirable since this policy reduces interference with vehicle operation. Time savings in such cases can reduce fleet size and manpower requirements, and thus require lower operating cost.

When a fare is paid on the vehicle, a "pay-enter" method is best applied on a line for which there is a rather even distribution of boarding passengers. In general, a "pay-leave" method is most effectively used on a line for which there is a heavy concentration of boarding passengers, while alighting passengers are evenly distributed along the line. A "pay-leave" method is commonly used during evening

peak hours, i.e., for outbound heavy passenger loads. This method minimizes departure headways from major center-city terminals.

Form of payment refers to the way the fare is paid. There are four forms of payment which are possible (individually or in combination) on a transit system:

1. Cash fares
2. Pre-paid fares
3. Automated collection
4. Honor fares.

• These are discussed individually below.

6.5.2 Evaluation of a Fare Collection System. There are a number of factors which should be considered in establishing a fare collection system. The major ones are:

- User convenience
- Minimum vehicle delay
- Ease of monitoring payment
- Security of fare deposits (possibility of crime)
- Attraction of passengers
- Cost of operation.

Each form of collection has certain positive and negative characteristics with respect to these factors.

6.5.3 Cash Fares. Cash is the most common form of fare payment since it requires the least amount of planning and it is simple to implement. However, unless an exact fare requirement is imposed, certain delays at stops can be expected. On the other hand, it is most convenient from the users' viewpoint and most encouraging to potential users that change be available at the time of payment.

As a compromise between these two conflicting requirements, it is desirable to charge higher fares if change is given at the time of payment. An extra 5 or 10 cents is enough to encourage use of exact fare to a considerable degree but will not discourage (or prohibit) riders who desire to ride but do not have exact change. Larger fares should have proportionally higher penalties than smaller ones.

The primary benefit of an exact fare requirement is the security it affords, particularly in large cities with a high incidence of crime. The locked fare box which is used in exact fare collection

THE SPIRIT OF 1776



THE SPIRIT OF 1776

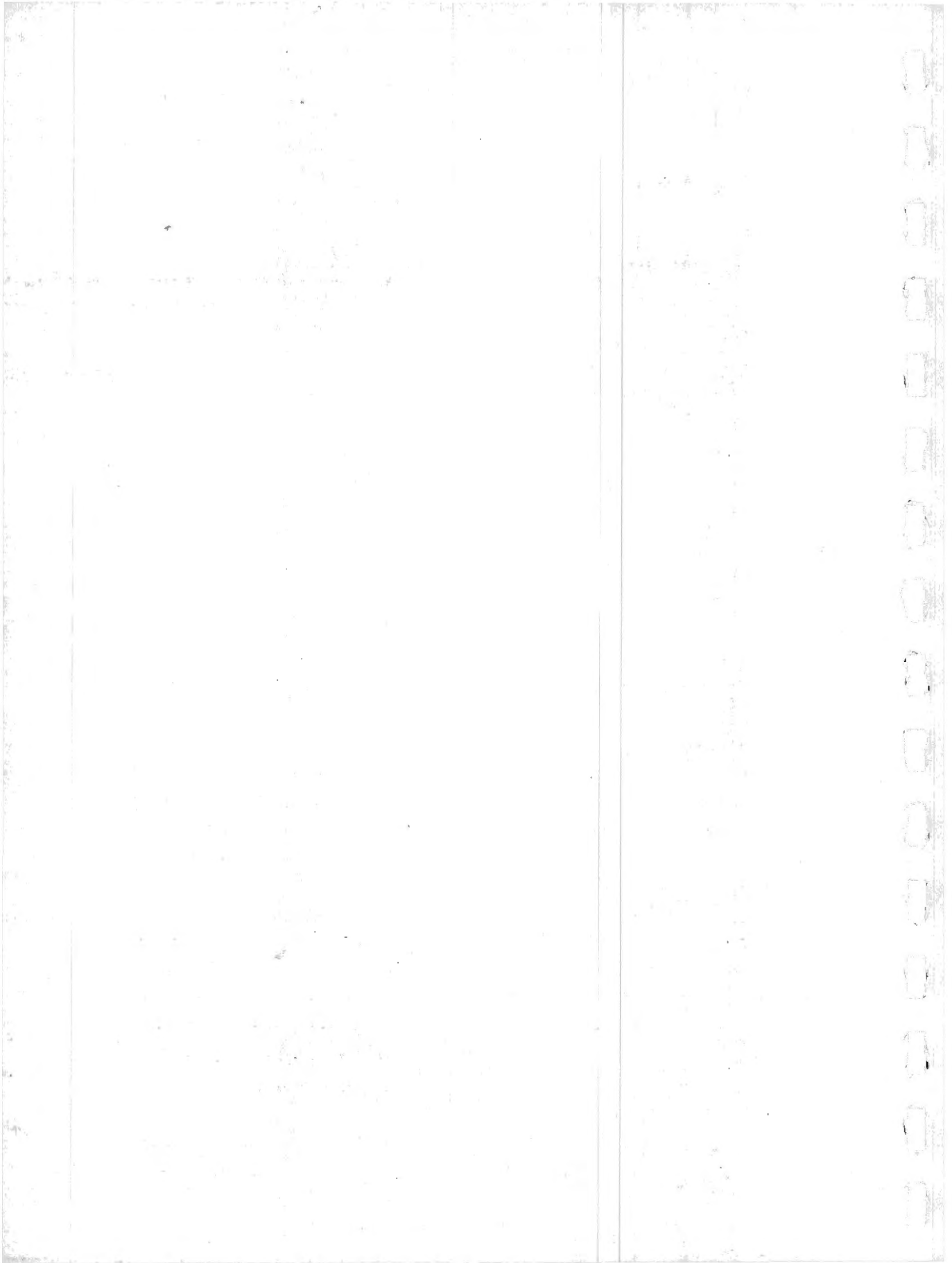

systems makes it impossible for even drivers of vehicles to open the box and thus discourages robbery attempts.

6.5.4 Prepaid Fares. Many of the problems associated with cash fare collection can be reduced through presale of tickets. A number of alternative types of fares can be used for such presale, including:

1. Tokens
2. Multiple-ride tickets
3. Weekly, monthly or annual passes
4. Permits.

These tickets and passes may be sold at major stops and public places or at stores located near such stops. Presale of fares increases passenger convenience over a strict exact fare requirement and encourages long-term use of the system on a regular basis. It also allows earlier investment of revenue by the agency than is possible with payment of fares at the time of riding. Tokens, multiple-ride tickets and passes are usually sold with some discount to induce passengers to purchase them. This discount is economically justified because of the savings the operator has through reduced accounting and faster vehicle travel resulting from such presale.

Tokens are coined with the transit agency's symbol prominently shown on them.

Multiple-ride tickets can take the form of a sheet of several detachable stubs which can be removed one at a time for each ride; or they can take the form of a single card which is punched for each ride taken, up to the total number of rides for which the card is valid. Generally, this type of ticket has a time limit. The problem that arises in using such a ticket is that it increases station stop time because of the punching operation by the driver.

Passes are cards sold by the agency at a flat rate but permitting an unlimited number of rides by the buyer during a limited time period, usually one week or month. Since passes only have to be shown to the driver on boarding or alighting the vehicle, station stop time is not increased; identification of the bearer of the pass is desirable since passes should not be transferrable. Several types of passes are possible:

Unconditional pass: good for unlimited system use during a given time (usually one month, but sometimes as long as one year); this

is the highest priced pass.

Point-to-point pass: good only for use on one route or between a fixed pair of stations on the system, but at any time of day or week for the life of the pass; it has a lower price than the unconditional pass; particularly useful for zonal or graduated fare structure since they require otherwise complicated fare collection.

Off-peak passes: usually offered at considerably reduced cost from standard fare for use during off-peak periods and on weekends; with respect to routing, these passes may be either unconditional or point-to-point.

A variety of other types of passes is also possible that may be tailored to specific community needs: weekend family passes, sporting event passes, and shopping passes for days that otherwise experience below-average system use. Expenses incurred for the printing of passes can be minimized by offering advertising privileges (on reverse side of pass, on vehicles) for sharing financial support by various companies and businesses.

Permits are similar to passes in that they entitle their owner to an unlimited number of rides for a given time period, but differ in that they require a small payment (such as 10¢) for each ride. The concept behind the permit (as opposed to the pass) is that although they can be priced at a rate which allows 10-ride-per-week users (commuters) to save money, they continue to generate money for the transit agency if they are used more frequently. Also the nominal charge per ride tends to discourage abuse, i.e., excessive useless travel. Pittsburgh uses such a permit system.

Another type of ticket is the transfer. Ideally, there should be no charge for transfers between different routes of the same mode since the passenger is not to "blame" for transit routes which do not serve his trip directly. In addition, passengers forced to transfer undergo an inconvenience. However, free transfers often lead to abuses such as their sale to other riders. Therefore, it is often necessary to charge a nominal fare (such as 5 or 10¢) for transfers.

It is also highly desirable to provide for low-cost transfers between different modes (e.g. bus to light rail or rapid transit).

While such a policy can be difficult to arrange and implement when there is a separate ownership and jurisdiction of each individual mode, the benefits in improved passenger convenience, increased attractiveness of the total transit system and greater patronage are often overriding considerations. Low-cost transfers between modes should therefore be planned and implemented wherever feasible.

6.5.5 Automated Collection. With present technology it is possible to provide for automated (unmanned) off-vehicle fare collection. However, because of the high cost of installing such a system, it should be considered only on the most heavily traveled lines and at the busiest stations. Surface transit lines usually cannot utilize such equipment.

6.5.6 Honor Fare System. This system provides that passengers may enter a station area, board a transit vehicle and leave it freely on the presumption that a ticket has been purchased. It is left to each person to be honest and to buy such a ticket, although spot checks are performed on vehicles to deter abuse. Passengers caught without a valid ticket pay a penalty of 10-20 times the value of the ticket they should have had.

While the concept of honor fare is untested in U.S. cities, there has been wide success with this method in many European cities. Major advantages of the method are that station standing time is minimized, speed of transit is increased and the need for station personnel is reduced or eliminated. The honor fare system continues to spread in Europe and it is receiving increased attention in this country.

A summary of fare system characteristics and options is shown in Fig. 6.6.

Time of Payment
<ul style="list-style-type: none"> ·Prior to boarding ·On-vehicle Pay enter Pay leave

Location of Payment
<ul style="list-style-type: none"> ·Ticket sales office, stations ·At stops, prior to boarding ·On-vehicle farebox

Payment Control
<ul style="list-style-type: none"> ·Turnstile ·Driver ·Honor fare

Form of Payment		
Cash	Prepaid	Automated
<ul style="list-style-type: none"> ·Exact fare ·Change given Same amount Extra charge 	<ul style="list-style-type: none"> ·Passes ·Permits ·Multiple-ride ·Tokens (·Transfers) 	<ul style="list-style-type: none"> ·Cash ·Credit Card

Figure 6.6 -- Review of various fare system characteristics.

6.6 REFERENCES AND BIBLIOGRAPHY

1. Charles River Associates, Free Transit, D. C. Heath and Company, Lexington, Mass., 1970.
2. Highway Research Board, "Passenger Transportation--5 Reports", H. R. Record 213, 1968, esp. J. Curtin, "Effects of Fares on Transit Riding", pp. 9-20.
3. Kemp, M. A., "Reduced Fare and Free-Fare Urban Transit Services--Some Case Studies", Urban Institute Paper 1212-3, Washington, 1974.
4. Kemp, M. A., "Transit Improvements in Atlanta--the Effects of Fare and Service Changes", Urban Institute Paper 1212-2, Washington, 1973.
5. Mossman, F., Principles of Urban Transportation, The Press of Western Reserve University, 1951.
6. Robbins, R. M. and Postgate, R., "Passenger fares: a consideration of the economic aspects of alternative fare structures", Report IV, 34th Annual Congress of the UITP in Copenhagen, UITP, Brussels, 1961.
7. Smerk, G. M., et. al., Mass Transit Management: A Handbook for Small Cities, Institute for Urban Transportation, Indiana University, DOT Project No. IND-MTD-1, February 1971.

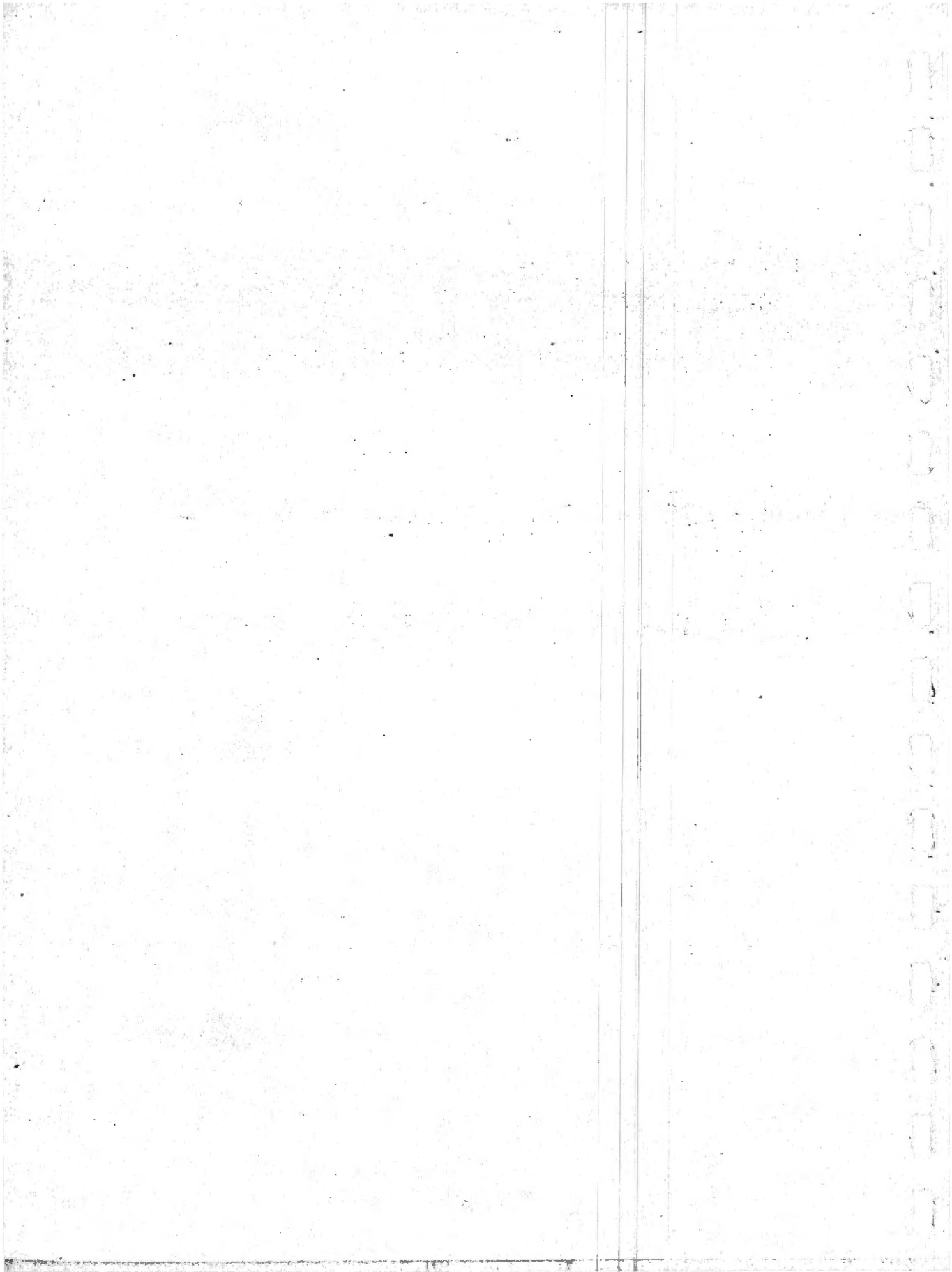

Chapter 7

TRANSIT INFORMATION FOR THE PUBLIC

For a transit system to be used, the public must know when and where the service is provided. An information system is therefore an essential element of every transit service. The failure of many systems to recognize the importance of a transit information system as an integral part of the transit service has often been a major contributing factor in patronage loss and financial ruin of transit agencies.

Underestimating the importance of available information to the traveling public is caused by a lack of understanding of public attitudes and needs. A common error made by many transit agencies is to undertake a survey of passengers to examine the importance of information about services provided for the entire public. This type of survey serves only to assess the attitudes and needs of existing users of the system. It does not consider the needs of the infrequent or potential rider who may be discouraged from using the system because of lack of information about it; in other words, this method of evaluating the adequacy of the information system by definition eliminates the possibility of discovering its faults. Therefore such a survey can be considered only as a partial means of evaluating the adequacy of the transit information system and it should not be interpreted as representative for all existing and potential passengers.

Although the impact of an improved information system cannot usually be noticed immediately, many agencies have found that the maintenance of a high-quality information system has yielded long-term benefits in terms of high ridership and good public image.

The term "information system" implies that there are several components which complement each other in supplying the public with information about the transit system. These individual components must be coordinated in their content and places of distribution. Only if the system is planned and designed in this way can it provide the information which is necessary for each segment of the public.

7.1 Planning of a Transit Service Information System

In the planning of a transit service information system, three questions must be addressed:

1. What types of people are going to use the system?
2. What information do they need when they want to use the system?
3. How can that information best be distributed to them?

These three considerations in planning the distribution of information are discussed below.

7.1.1 Users of the System. There are four major classes of transit users, grouped according to their needs for information about transit service:

1. Regular user on his regular route. Typically these are the work commuters, school children and some shoppers.
2. Regular user making an irregular or unscheduled trip. Passengers traveling to an unfamiliar part of the city are in this group.
3. Incidental users. This class comprises residents familiar with the city, but who use the transit system infrequently.
4. Visitor to the city. Visitors to the city, i.e., those totally unfamiliar with the transit system infrequently.

Generally, it can be said that the four classes are listed in order of increasing need for information. The regular user needs the least amount of information--only to be kept informed of any changes in schedule, routing or stop locations. The regular user making an irregular trip needs slightly more information: while he is familiar with how the system operates (amount of fare, fare collection method, etc.), he may need schedule, route and stop information for his trip to an unfamiliar part of the city. Much the same type of information is needed for the third class of user (incidental user). He may have to be reminded, however, of fare structure, exact fare requirement, and the like. Finally, the city visitor requires the most complete information about the city and transit service since he is totally unfamiliar with the local conditions.

Each one of these groups must be considered in determining the type of information needed, means through which it can best be distributed,

and the locations for its distribution.

7.1.2 Items of Information, Methods and Locations of Distribution. Information generally needed by users can be classified as follows:

- Transit system network routes and stop locations
- Schedule of service
- Fare information
- Methods of transfer between routes and between different modes.

The means by which these items of information are conveyed to the user of the system include:

- Signs, markings and special transit symbols
- Pamphlets
- Displays
- Telephone
- News media.

Finally, the locations of information distribution include:

- Transit stops
- Transit vehicles
- Transit terminals
- Banks, stores, administrative buildings
- Other public places.

7.2 Coordination of the Information System

It is necessary to carefully plan the transit information system by coordinating the type of information with the medium through which and the location at which it is distributed. Below, locations of information distribution are discussed with the types of information and media appropriate for those locations.

7.2.1 Transit Stops. In designing stops, several means should be used to convey information to the public. Clear stop designation is the first priority item of transit information since the people must know where the service is provided before they can use it. Therefore, all stops must be clearly and prominently designated, preferably with a uniform set of design elements for all stops for easy recognition throughout the city. This objective is achieved through careful selection of

signs, pavement markings and other stop design features.

Signing at each stop should clearly display the following information on a permanent support pole:

- The system logo (ensignia or symbol)
- Route designation (by street, route number or letter)
- Transit agency name
- Transit information telephone number
- Direction of vehicles ("Northbound", "To City", etc.): optional
- Stop designation (by street, number or name): optional.

Special attention should be given to the size, shape, color combination, physical orientation and visibility of the sign and information items. Users should be able to find transit stops without effort; sketches, symbols, and text on the sign should be easy to read and comprehend.

Sign colors should draw attention and contrast with the immediate vicinity; distinctive shapes (such as triangular, oval and round) facilitate user recognition and attract non-user attention more quickly than the more common rectangular signs.

The orientation and placement of signs should be such that they are highly visible to pedestrians in the vicinity, but also such that visibility of other vehicular and pedestrian traffic is not impeded, especially at corner stop locations.

An example of a transit stop marker which would be adequate for most stops is shown in Fig. 7.1a. At important stops and at transfer points, it is desirable to display a map indicating the transit routes, route transfer points and a timetable. Fig. 7.1b shows the format that such a display could take.

The system logo at each transit stop should be a distinctive design and color combination. Also, it should be easily distinguished from other traffic regulation signs to avoid confusion of passengers in finding transit stops. Figure 7.2 shows selected examples of system logos presently used in several world cities. It is interesting to note that the U-Bahn and S-Bahn symbols shown, as well as another sign not shown for light rail and bus stops, are standardized throughout West Germany.

Pavement markings on the street (or also on the sidewalk) can assist

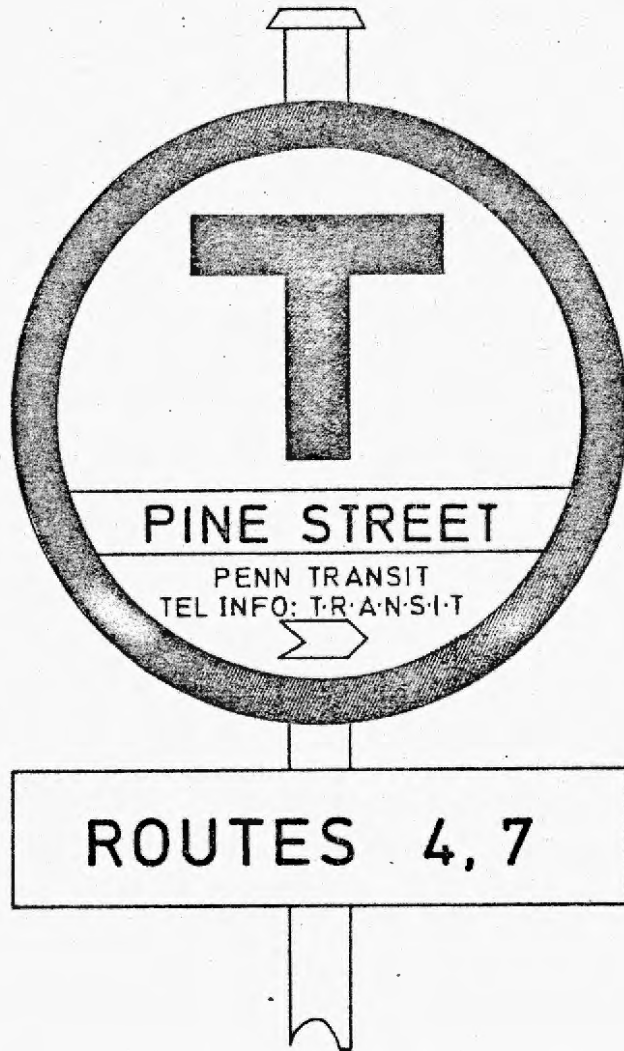

Figure 7.1a -- Transit stop marker with minimum information.

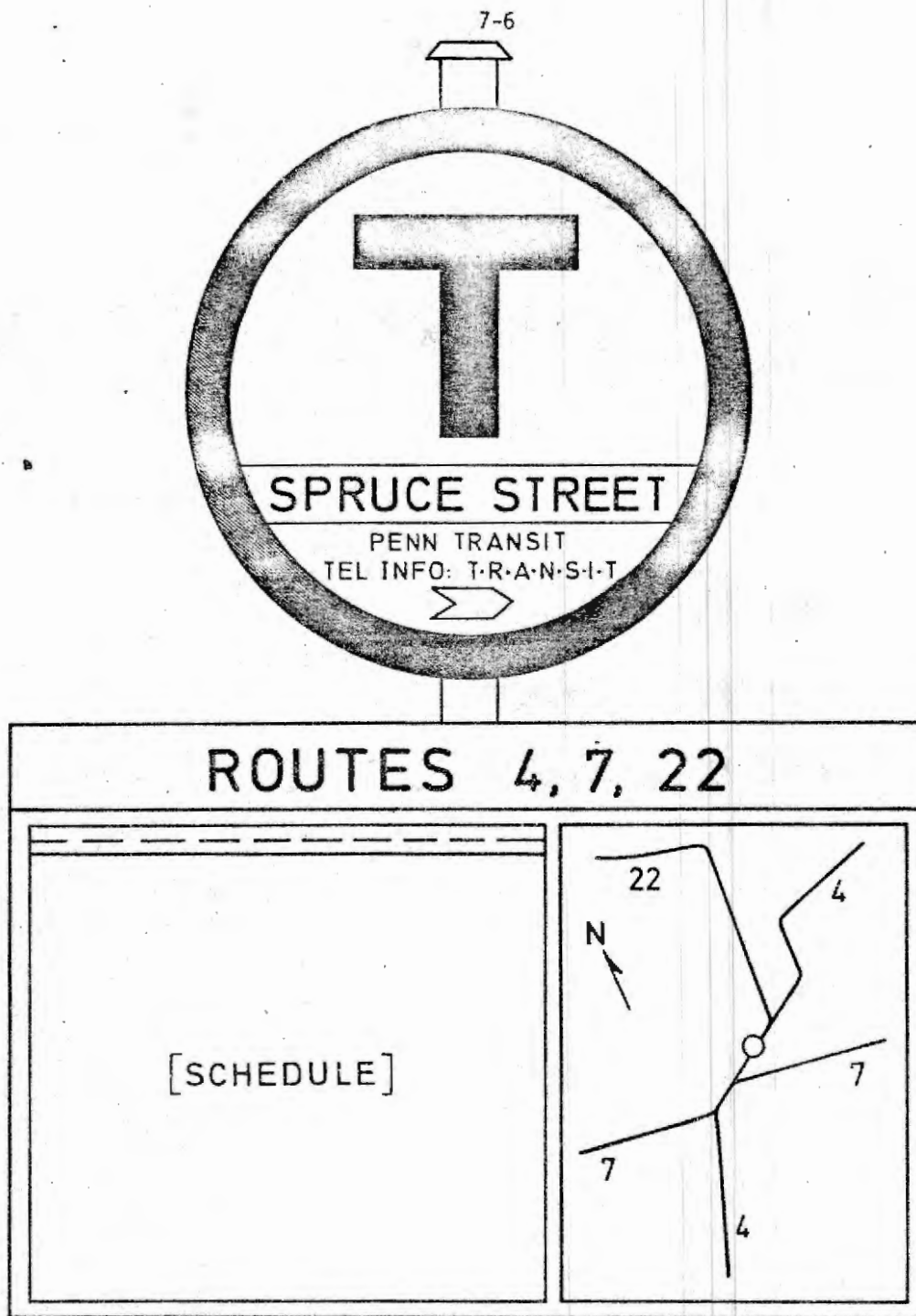
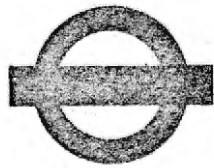
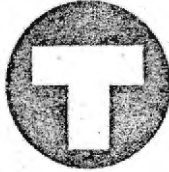

Figure 7.1b -- Transit stop marker with information desirable at major stops.



LONDON



STOCKHOLM

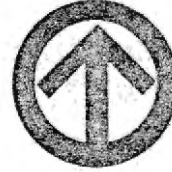

MONTREAL



S-BAHN



U-BAHN

WEST GERMANY



HARRISBURG



SAO PAULO

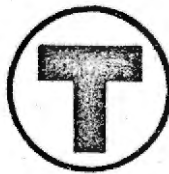

BOSTON

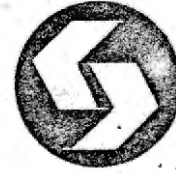

PHILADELPHIA

Figure 7.2--Examples of transit system logos for selected cities.

in accenting the stop location for passengers and for car drivers who might otherwise violate parking restrictions in the stop area. Application of painted stripes and/or solid coloring of the on-street stop area and adjacent sidewalk waiting area are most commonly used.

Figures 7.3 and 7.4 show selected pavement marking designs for near-side and mid-block stops. Similar designs would apply to far-side stop locations.

Construction of bus bays may assist in bus operations and maneuvers of buses and other vehicles as well as in passenger recognition of stops. Figure 7.3 shows common types of bus bay designs which should be considered in constructing or reconstructing streets or street intersections. Since the provision of bays primarily benefits automobile traffic through the elimination of bus interruption of the driving lane, their construction should be financed from regular street construction funds.

The curb contouring in Fig. 7.3b is another design technique which can assist bus operations. The design shown effectively prohibits moving traffic from using one lane. In such a case, curb parking space can be provided in front of and behind the stop location. If only pavement markings are used and there is no curb contouring in designating stops, it is possible to allow peak hour use of the curb lane by automobile traffic. Two examples are shown in Fig. 7.4.

After clearly defining and drawing attention to stop locations, map and schedule information should be provided. At each major stop location a permanent display should be posted showing a map of the route(s) on which the stop is located and the scheduled passing times of vehicles for that stop.

Route maps should show at least the following information:

- All routes serving the stop
- Major stops on all shown routes, labeled by name
- A "YOU ARE HERE" designation
- A north arrow.

At major stops a map of the entire transit system should be posted which shows the following:

- All routes on the transit system
- All stops and terminals

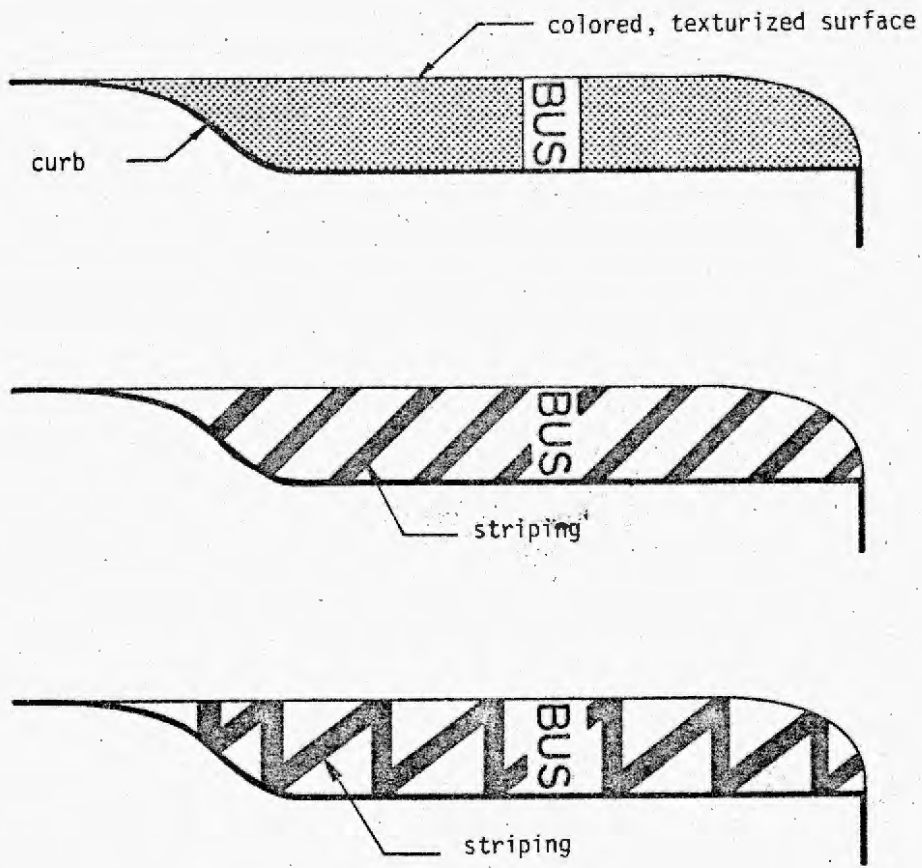

(a) use of texture and striping for bus bays at corners

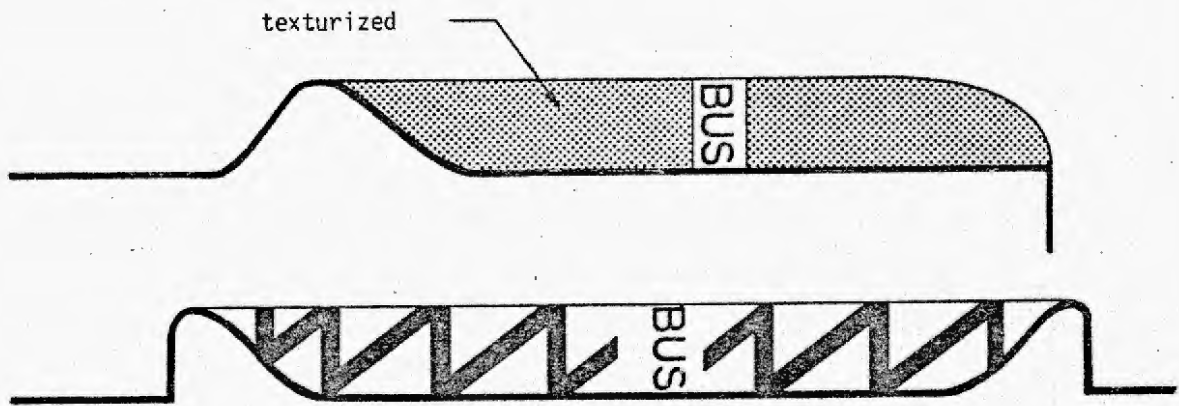

(b) curb contouring at transit stops

Fig. 7.3 -- Variations in curb design at bus stops.

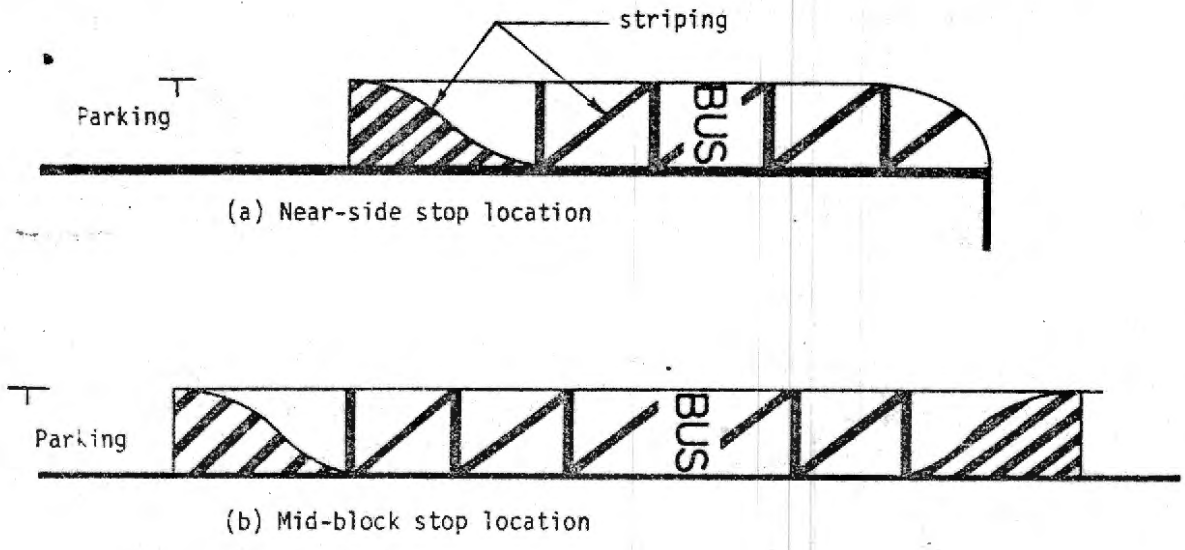

Figure 7.4 -- Bus stop pavement markings for parking lane and peak hour through lane locations.

- The major streets in the served area
- Transfer points to other modes
- Park-and-Ride and Kiss-and-Ride facilities
- Miscellaneous points of interest and landmarks
- A north arrow and scale of the map.

Preparation and design of the route map should be coordinated with other agencies and groups who are also interested in its distribution; these may include the Chamber of Commerce, Tourist Bureau, Park Commission, as well as with any other transit agencies in the area.

A timetable should accompany route displays at all major stops. The timetable should provide complete schedule information for the stop, and preferably for major stops on the route(s) on which it lies. The following information should be shown on the timetable:

- Name and number of route
- Direction of travel
- Effective date of schedule
- Schedule for selected route stops by day of week (weekdays, Saturdays, Sundays)
- Designation of important stops, (e.g. Civic Center)
- Designation of points of transfer to other routes and transit modes
- Key for symbols and abbreviations.

Since many routes have too many stops to be conveniently listed in a timetable, only the major stops can be shown. The stops listed in the timetable should be selected so that they are relatively evenly distributed along the route; generally, stops appearing in the schedule should not be more than 2 miles distance or 10 minutes travel time apart. Each stop should be identified by street name or nearby landmark. The layout of the timetable should be such that:

- The direction of the route is clearly shown by designation of terminal points: CITY HALL → CIVIC CENTER
- Effective days of the week are indicated
- AM or PM is indicated by letter type of physical separation.

A well designed timetable is shown in Fig. 7.5.

It is very important that the timetable be simple, easy to read and, if headways are long, easy to memorize. For this reason, timetables

MONDAYS THRU FRIDAYS

4370

SOUTHBOUND							NORTHBOUND						
Bus Rt. 52 Leaves 54th & City Line Ave. (Loop)	52nd & Girard Ave.	52nd & Market Sts.	Market-Frd. Trains Leave 52nd St. E.B. for Center City	Market-Frd. Trains Arrive 52nd St. E.B. for Center City Leave 12th & Min. Earlier	52nd & Baltimore Ave.	Bus Rt. 52 Arrives 50th & Woodland Ave.	Bus Rt. 52 Leaves 50th & Woodland Ave.	52nd & Baltimore Ave.	52nd & Market Sts.	Market-Frd. Trains Leave 52nd St. E.B. for Center City	Market-Frd. Trains Arrive 52nd St. E.B. for Center City with Rt. 52 N.B. Leave 12th St. 8 Min. Earlier	52nd & Girard Ave.	Bus Rt. 52 Arrives 54th & City Line Ave. (Loop)
AM	AM	AM	AM	AM	AM	AM	AM	AM	AM	AM	AM	AM	AM
6.10	6.27	6.33	6.41	6.27	6.38	6.45	6.35	6.43	6.50	6.57	6.45	6.56	7.07
6.24	6.34	6.40	6.46	6.37	6.46	6.55	6.43	6.51	6.57	7.01	6.54	7.03	7.14
6.31	6.41	6.47	6.52	6.37	6.53	7.00	6.47	6.57	7.04	7.09	7.01	7.10	7.21
6.37	6.48	6.54	6.57	6.43	6.59	7.07	6.53	7.02	7.09	7.14	7.01	7.13	7.26
6.44	6.54	7.00	7.04	6.54	7.07	7.17	7.01	7.10	7.17	7.22	7.01	7.13	7.26
6.50	7.00	7.07	7.11	7.01	7.13	7.20	7.07	7.16	7.23	7.28	7.01	7.13	7.26
6.56	7.06	7.13	7.17	7.07	7.19	7.29	7.13	7.22	7.29	7.34	7.01	7.13	7.26
7.01	7.12	7.18	7.21	7.13	7.25	7.32	7.19	7.28	7.35	7.40	7.01	7.13	7.26
Then Every 10 Min. or Less From 50th & Woodland Until 8.39 AM													
7.05	7.15	7.22			7.28	A7.38							
7.13	7.23	7.30			7.37	A7.48							
7.21	7.32	7.39			7.46	A7.57							
7.29	7.40	7.47			7.54	A8.07							
7.35	7.47	7.54			8.01	A8.12							
7.44	7.56	8.03			8.10	A8.21							
7.54	8.06	8.12			8.19	A8.30							
8.04	8.16	8.22			8.29	A8.40							
8.24	8.36	8.42			8.49	A9.01							
8.39	8.50	8.56			9.03	9.21							
8.45	8.56	9.02			9.09	A9.19							
8.52	9.03	9.10			9.17	9.25							
Then Every 10 Min. or Less From 50th & Woodland Until													
PM	PM	PM			PM	PM							
1.37	1.48	1.54			2.01	2.09							
1.45	1.56	2.01			2.09	A2.19							
1.52	2.03	2.09			2.16	2.24							
2.00	2.10	2.16			2.24	A2.34							
2.07	2.18	2.24			2.31	2.39							
2.15	2.25	2.31			2.40	A2.50							
2.22	2.33	2.39			2.48	2.56							
2.29	2.40	2.47			2.55	3.03							
2.35	2.46	2.53			3.01	A3.11							
2.41	2.52	2.59			3.07	3.15							
2.47	2.58	3.05			3.13	A3.23							
2.53	3.04	3.11			3.19	3.27							
3.04	3.15	3.17			3.25	A3.35							
	3.15	3.22			3.30	3.38							
	83.18	3.28			3.34	3.42							
			Every 8 to 6 Min.	Every 3 to 8 Min.									
Then Every 10 Min. or Less From 50th & Woodland Until 8.36 AM													
							6.55	6.43	6.50	6.57	6.45	6.56	7.07
							6.43	6.51	6.57	7.01	6.54	7.03	7.14
							A6.47	6.57	7.04	7.09	7.01	7.10	7.21
							6.53	7.02	7.09	7.14	7.01	7.13	7.26
							Then Every 10 Min. or Less From 50th & Woodland Until 8.36 AM						
							A6.55	7.07	7.14			7.20	7.31
							A7.10	7.13	7.22			7.29	7.40
							A7.20	7.32	7.40			7.46	7.58
							A7.31	7.43	7.51			7.57	8.10
							A7.40	7.52	8.00			8.06	8.19
							A8.11	8.23	8.31			8.37	8.49
							A8.17	8.31	8.39			8.45	8.57
							A8.36	8.46	8.54			9.00	9.11
							A8.42	8.53	9.01			9.07	9.18
							8.50	9.00	9.07			9.13	9.24
							Then Every 10 Min. or Less Until						
							PM	PM	PM			PM	PM
							2.03	2.12	2.19			2.26	2.38
							A2.08	2.19	2.27			2.33	2.45
							2.18	2.27	2.35			2.42	2.54
							2.25	2.33	2.42			2.48	3.00
							A2.29	2.40	2.48			2.55	3.07
							2.38	2.46	2.55			3.01	3.13
							A2.42	2.53	3.01			3.09	3.20
							2.51	2.59	3.08			3.14	3.26
							A2.54	3.05	3.14			3.20	3.32
							3.03	3.11	3.20			3.26	3.38
							A3.12	3.23	3.32			3.38	3.50
							3.21	3.29	3.39			3.44	3.56
							A3.23	3.34	3.43			3.49	4.01
							3.31	3.39	3.48			3.54	4.07
							Then Every 10 Min. or Less From 50th & Woodland Until 8.46 PM						
							A3.33	3.44	3.53			3.59	4.12
							3.43	3.54	4.03			4.09	4.22
							A3.58	4.09	4.17			4.24	4.36
							4.08	4.19	4.27			4.33	4.46

7-12

Figure 7.5 -- Example timetable (SEPTA -- Philadelphia).

for services with long headways have several departure times and then the phrase "Then every 'x' minutes until". When headways are 10 min, or less, they do not have to be listed; the phrase "Every 10 min. or less" can be used.

Figure 7.6 shows another design for a timetable. The time of each vehicle departure is listed and, on a separate map, travel times to intermediate points are given. From this information, a passenger can determine the times of arrival of transit vehicles at his stop. The advantage of this design is that it makes possible a more compact format for providing all the needed timetable information. Its main drawback is its complexity which makes it difficult to decipher the needed information.

A small route map should appear on each pocket timetable. The map should show the route with all street names, all its transfer points, and direction of travel on each one-way route section. It should also show the location of the route with respect to the rest of the city. Figure 7.7 shows an example of such a route map on a SEPTA (Philadelphia) timetable.

7.2.2 Transit Terminals. Major transfer points for different transit routes or transit station on railroad lines, long distance bus stations or major shopping centers represent the focal points of the transit system. For this reason, such locations must be supplied with a complete set of transit information: complete schedules, stop locations, fare information, etc. for all lines of each mode. An information booth may also be necessary at selected, heavily used terminals such as airports and railroad terminals, in order to provide specific detailed information. System maps showing major points of interest and schedules for all modes should be posted. In addition to such a display, information pamphlets and schedules should be available.

It is desirable that two types of transit system maps be made available to the public. They are (1) a standard street map of the city showing all transit routes and (2) a schematic map.

The standard map shows all major streets and important landmarks. Superimposed on the street network in darker type should be lines repre-

30 OLENY-TUNNEL

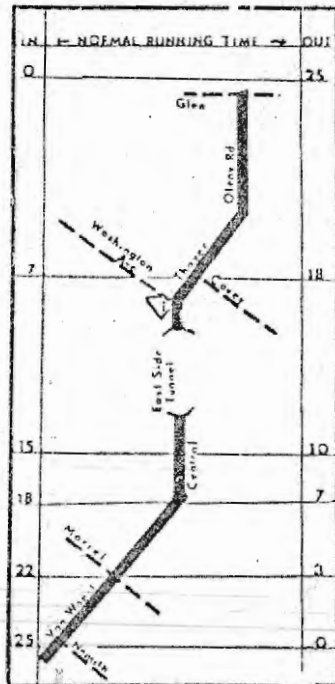

▽-Transfer Point

Inbound Lv. Oleny & Glen

MONDAYS THRU FRIDAYS			
Inbound		Outbound	
AM	PM	AM	PM
552	1233	604	1254
612	1253	624	114
632	113	644	134
652	133	704	154
711	153	725	214
731	213	745	234
751	233	805	254
811	256	825	314
831	313	850	334
853	334	914	354
913	400	934	414
933	420	954	434
953	440	1014	454
1013	500	1034	514
1033	520	1054	534
1053	540	1114	554
1113	602	1134	614
1133	622	1154	634
1153	642		654
	708		710

SATURDAYS			
Inbound		Outbound	
AM	PM	AM	PM
554	1234	613	1253
614	1254	633	113
636	114	653	133
656	134	713	153
714	154	733	213
734	214	753	233
754	234	813	253
814	254	833	313
834	314	853	333
854	334	913	353
906	354	933	413
926	414	953	433
954	434	1013	453
1014	454	1033	513
1034	514	1053	533
1054	534	1113	553
1114	554	1133	615
1134	616	1153	648
1154	636		715
	706		

SERVICE ON
WEEKDAYS & SATURDAYS ONLY

30 OLENY-TUNNEL

Effective Sept-Dec 1970

OUTBOUND

FROM VAN WOERTH AND NEMITH
via Van Woert, Central Ave.,
East Side Tunnel, Thayer,
Oleny Rd., to Glen St.

INBOUND

FROM OLENY AND GLEN
via Oleny Rd., Thayer, East Side
Tunnel, Central Ave., Van Woert
to Nemith

TRANSFER to line 20
at Washington Ave., and Thayer St

Exact Change Fare \$.30

FOR ADDITIONAL INFORMATION
ON SCHEDULES OR ROUTES
CALL 487-7433

IDEAL TRANSIT SYSTEM INC

Figure 7.6 -- Example timetable (modeled on Rhode Island Public Transit Authority, Providence).

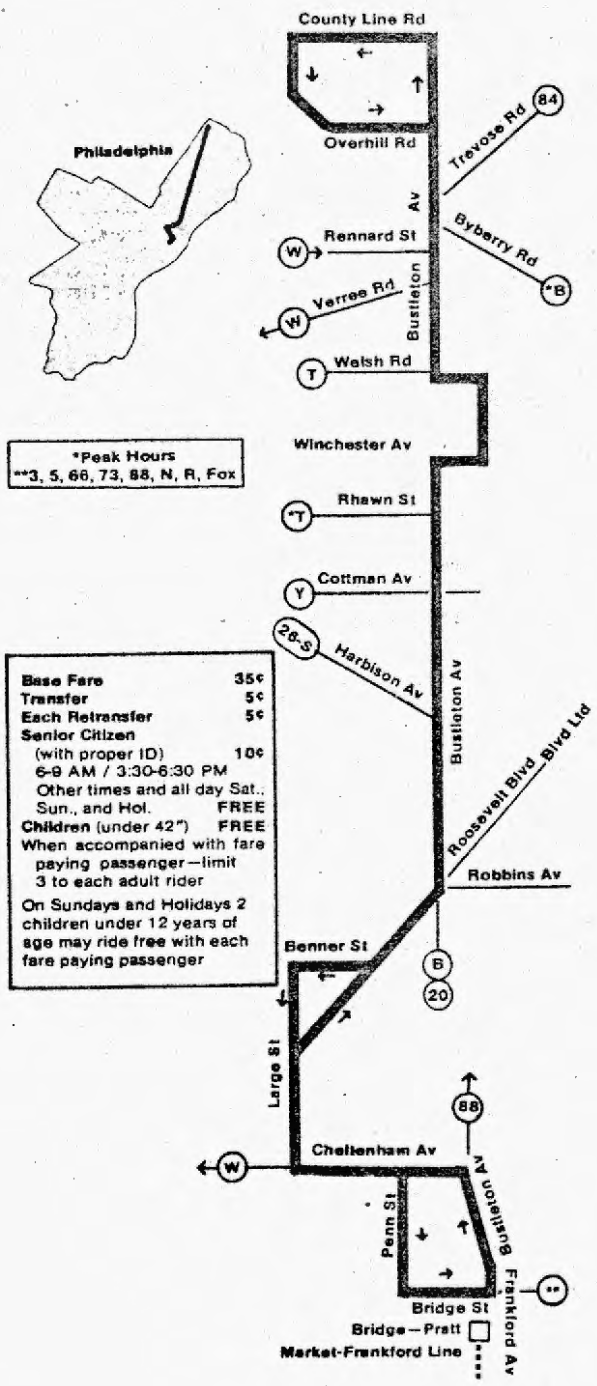

Figure 7.7 -- Example bus route map to accompany timetable (SEPTA--Philadelphia).

senting transit routes. In designing these maps, it is important that:

- Transit route lines do not obscure street names
- Transit route numbers are marked next to each line at frequent intervals to prevent confusion
- Turning of routes and separation of routes is marked clearly by the use of arrows. (Fig. 7.8 shows how the use of directional arrows on lines can reduce ambiguity.)
- For large cities, where many routes converge in the CBD, an enlarged CBD map is also included.

Figure 7.9 is an example of a good design of this type of system map, taken from the MBTA (Boston).

The other type of map is schematic, i.e., only transit routes are shown, usually not drawn to scale. They can take the form of small, pocket-sized cards so that they are handy for regular users of the system who only need to check routes, transfers and stations. Figures 7.10, 7.11, 7.12, and 7.13 show schematic pocket maps for the London, Hamburg, Boston, and Philadelphia transit systems. These schematic maps are usually made for networks of high quality transit services such as rapid transit and light rail. For some cities with relatively simple bus networks, the same type of map can also be used.

Both types of maps should indicate all Park-and-Ride lots. Knowing the locations of these lots facilitates use of the transit system by visitors who are unfamiliar with the system.

Since most passengers usually do not have any timetables other than for routes they frequently use, it is desirable to provide a capsule summary of timetable information on all routes on the back of the system map. In that way, a passenger can have some idea of how long he must wait to use any route and whether he needs a more specific timetable.

Figure 7.14 shows a suggested form for summarizing this information. Pamphlets with the same information could also be made available separately for the system maps. The fact that such a large system as the MBTA is able to provide a capsule summary of its routes demonstrates that this can be done even for extensive network and complicated routes.

In addition to general transportation information, passengers in a transportation terminal must be assisted in their orientation and movement

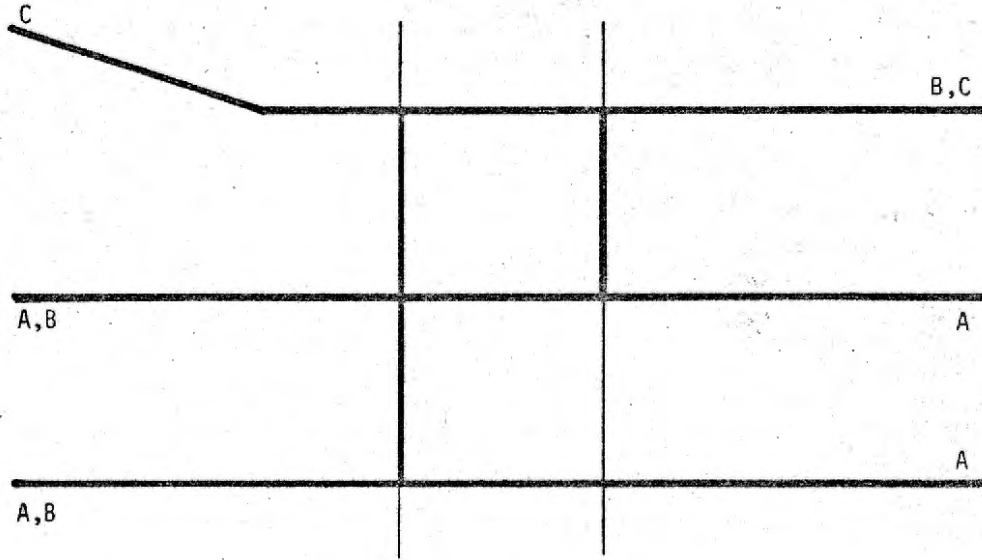

(a) confusing

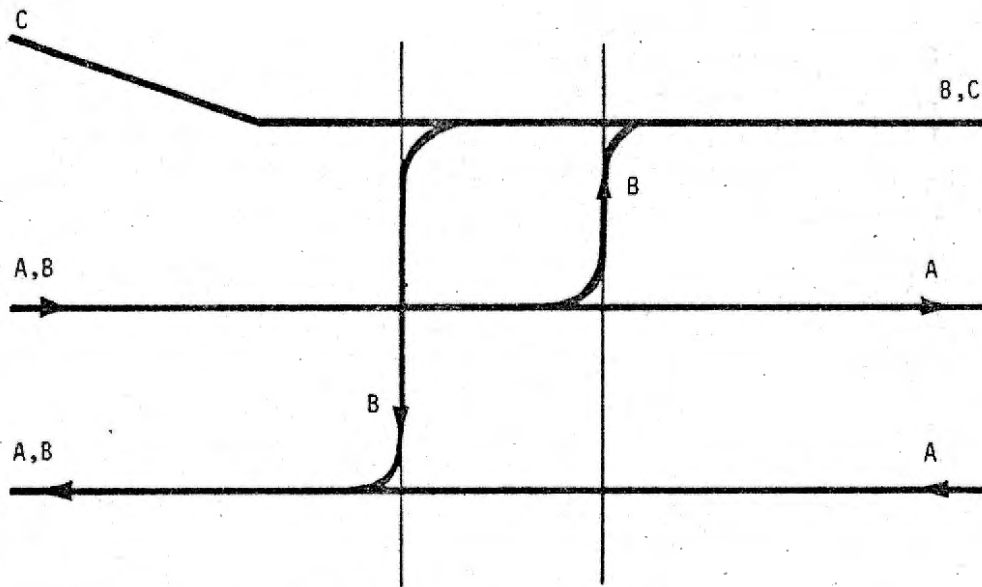

(b) unambiguous

Figure 7.8 -- Importance of directional arrows on route maps.

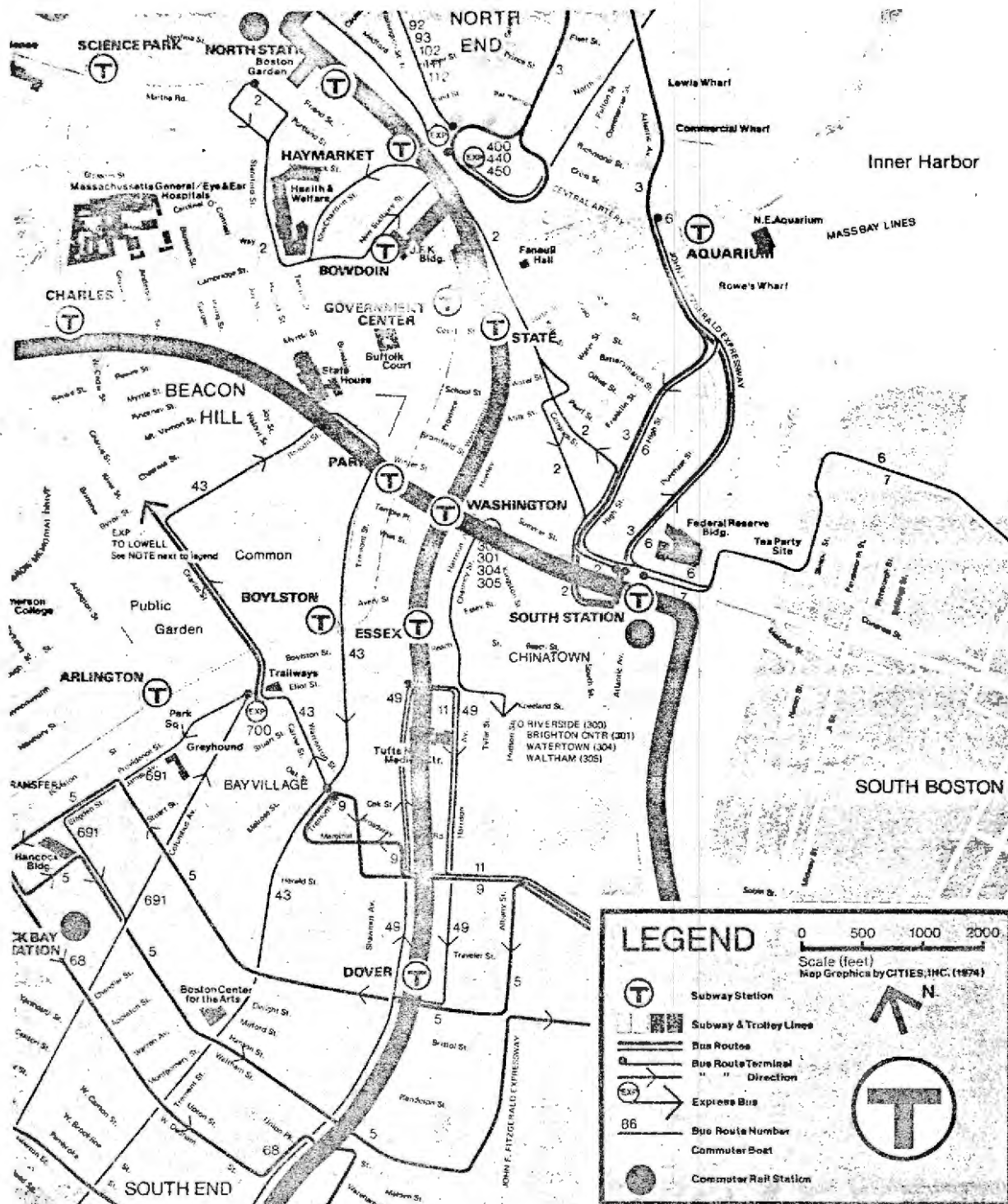

Figure 7.9 -- Example of a city map with transit line designation (MBTA - Boston).

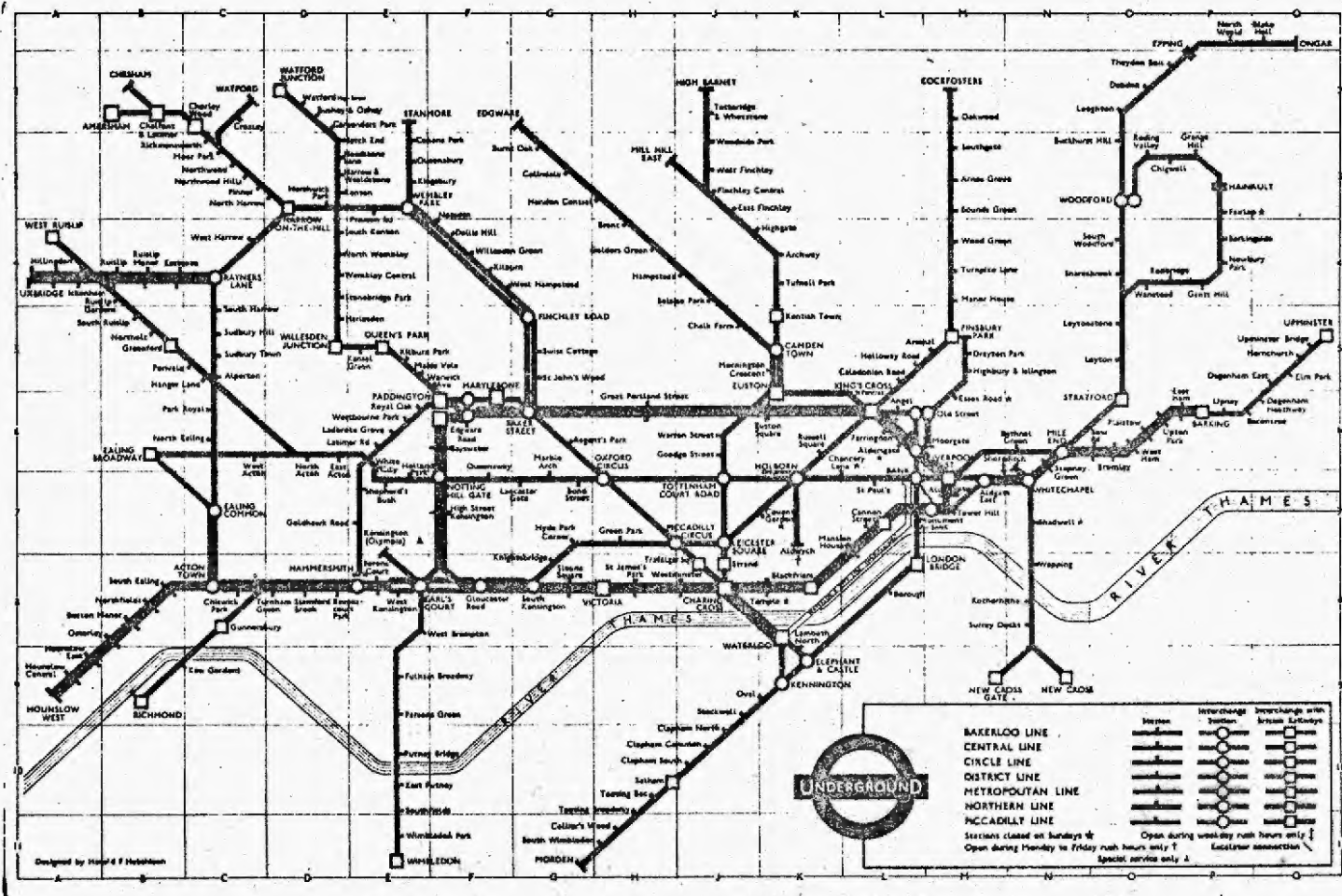

Figure 7.10 -- Schematic transit system map (London).



Figure 7.11 -- Schematic transit system map (Hamburg).

Effective from _____ to _____

ROUTE NO.	ROUTING DESCRIPTION	DAY	MAXIMUM TIME BETWEEN VEHICLE DEPARTURES IN MINUTES					
			A-M			P-M		
			12-6	6-9	9-4	4-6	6-9	9-12
		M-F						
		Sa						
		Su						
		M-F						
		Sa						
		Su						
		M-F						
		Sa						
		Su						
		M-F						
		Sa						
		Su						
		M-F						
		Sa						
		Su						
		M-F						
		Sa						
		Su						

Figure 7.14 -- Condensed route and service frequency information for transit networks.

through and within the terminal facility. This is important since many passengers at those locations are not familiar with the system and how to use it. For this purpose the direction to loading platforms must be clearly designated. A grouping of signs should be placed at key points in the terminal area giving information on the direction to platforms for the various modes (taxi, bus, subway, etc.) to the information booth, to comfort facilities, and the like. Signing should be continuous along the path of passenger circulation. Such groupings of signs should appear on all platforms and at all entrances to the terminal, since both arriving and departing passengers should be considered in planning the signing layout at the terminal. Exits from the terminal should be marked by the street to which they lead, facilitating orientation of first-time users and visitors.

Figure 7.15 shows a transit terminal and the appropriate locations for different items of information. Figure 7.16 shows a few examples of information signs that are used by the MBTA in Boston.

7.2.3 Transit Vehicles. In addition to providing travel, the transit vehicle should also be used to inform riding passengers, waiting passengers and potential users about the service.

The exterior of the transit vehicle should prominently show the following information:

- The route number and destination of the vehicle in large, bold numbers and letters on the front and right hand side, and desirably rear side of the vehicle.
- The transit agency logo and name on all sides of the vehicle.
- The transit information telephone number on each side of the vehicle.

It is important that the route and destination appear prominently on all sides of the vehicle since such information displayed only in the front and rear is blocked when vehicles are in queues or if passengers approach from the side of the vehicle. A practical way of having accurate signing, even when vehicles change routes, is to use interchangeable metal plates that extend from the side of the vehicles. Figure 7.17 shows such devices. These signs are particularly helpful where there is a long queue of buses, since they allow a passenger to locate his bus more easily.

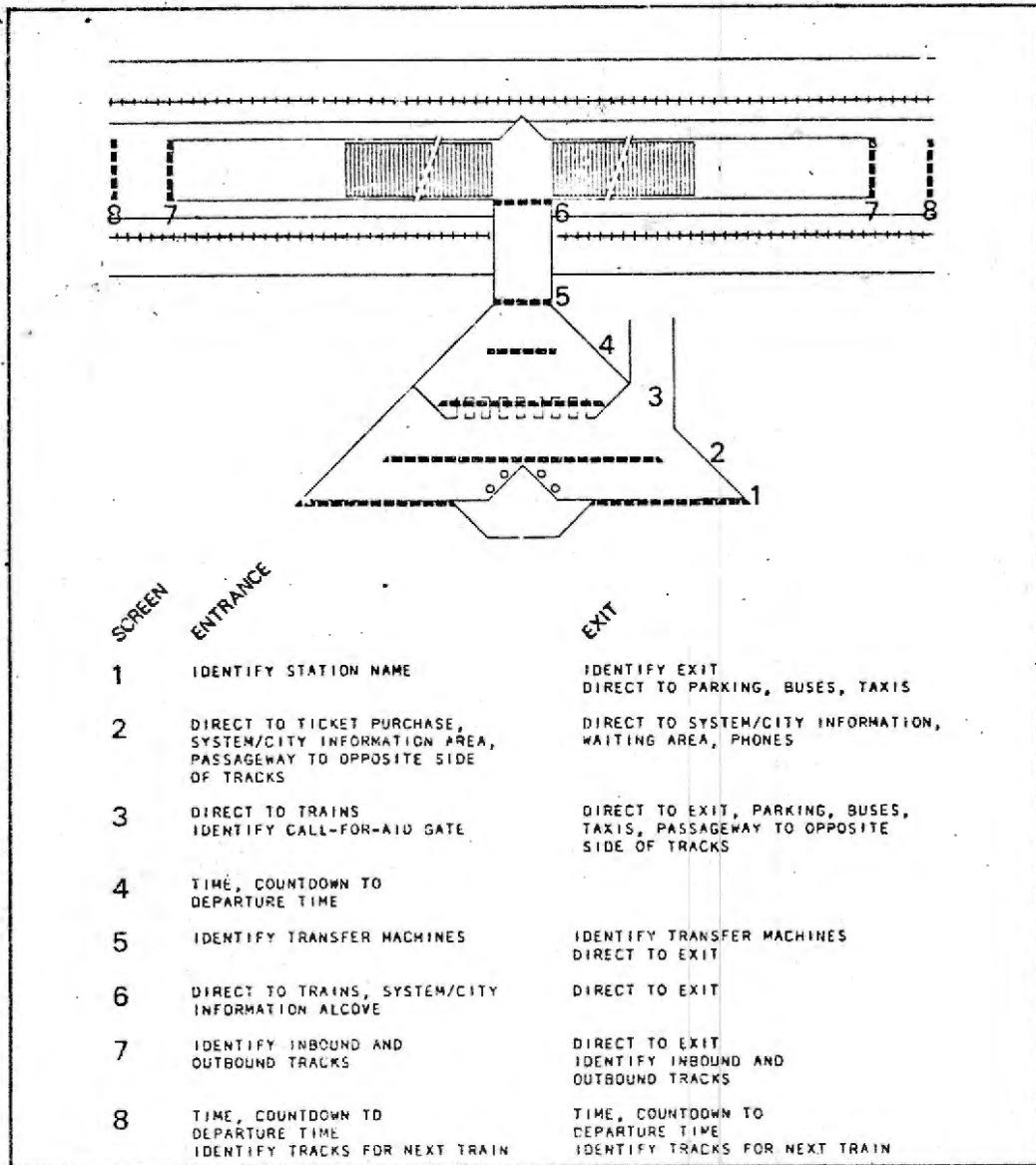

Source: Reference 3

Figure 7.15 -- Information and signing priorities at transit stations.
Source: (2)

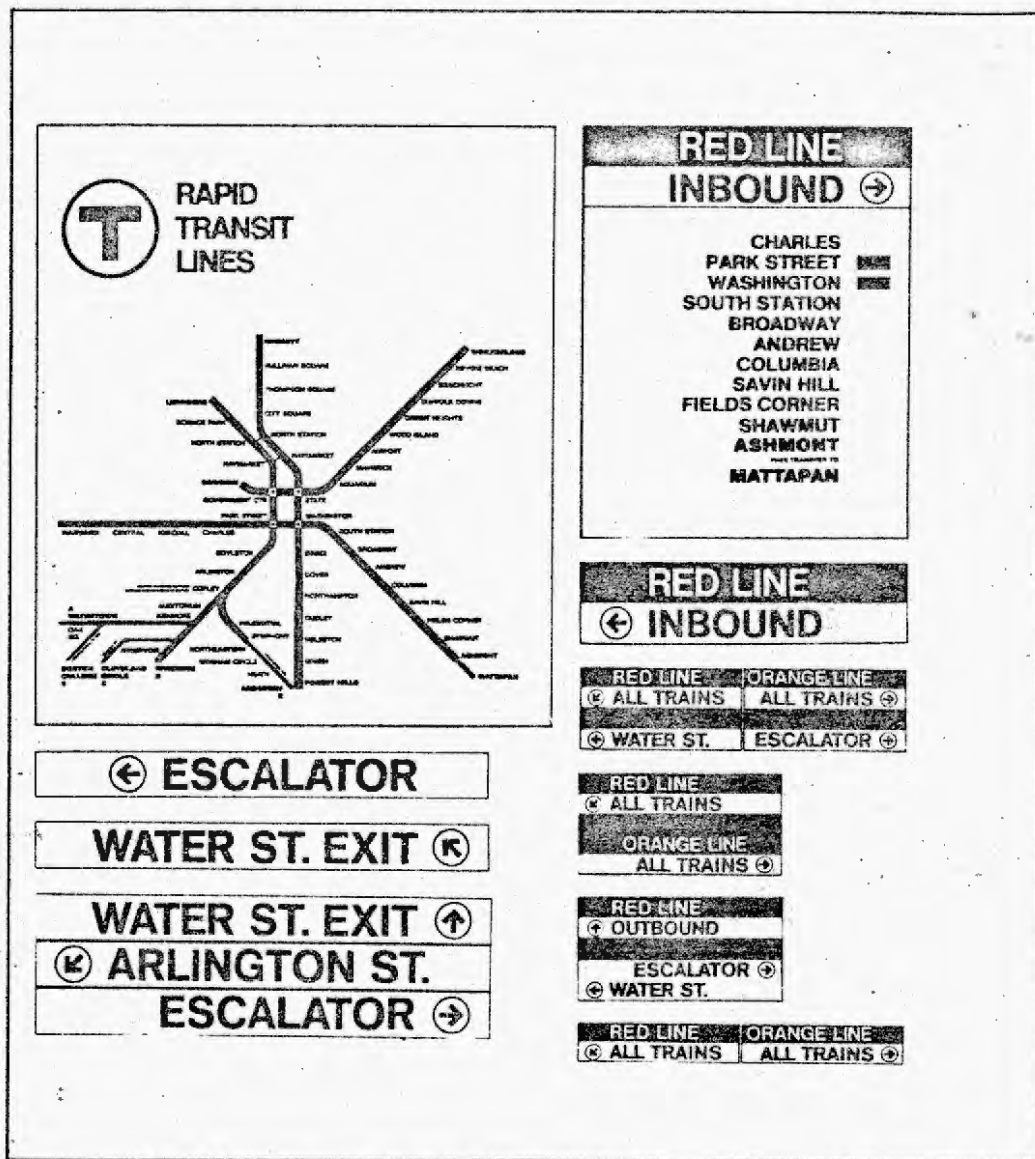
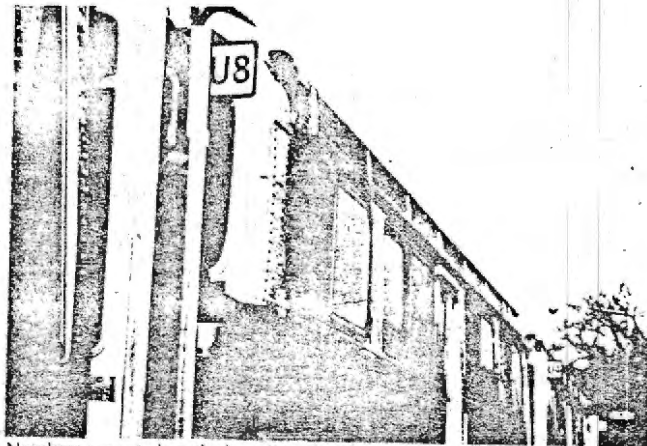

Figure 7.16--Examples of informational signing employed in Boston by MBTA.



Numbers mounted on the boarding doors were recommended to eliminate running up and down the sidewalk trying to determine which was the desired bus. It also permitted closer parking at terminal stops.

Figure 7.17 -- Exterior informational signing on bus vehicles.
(WMATA--Washington, D.C.)

Reprinted from: Transit Information Aids--Mass Transportation Demonstration Project INT-MTD-10, p.23.

The vehicle interior should provide the following:

- A displayed route map with labeled stops.
- Pocket maps and schedules of the route and of these routes intersecting it.

Signs for on-vehicle regulation (e.g. NO SMOKING) should also be displayed clearly to all passengers stipulating respective penalties under the law.

7.2.4 Public Places. Tourist centers, hotels, recreational and cultural centers, major agencies and newstands are examples of places that could conveniently distribute transit information via pamphlets for routes and schedules. Since the wide availability of such information both assists and encourages travel, the cost of this action to those who distribute the information is usually easily recovered and exceeded by the revenues resulting from increased ridership.

7.2.5 Media. The printed media--especially newspapers--should be used for conveying information, and for promotion in two different ways. One is to announce through regular advertisements, significant changes or innovations in transit service, such as:

- Changes in schedule
- Changes of routes
- Changes in stop locations
- New routes added, with schedules.

This information particularly assists the occasional transit user who may otherwise rely on an obsolete schedule kept at home and incur unnecessary inconvenience in not knowing the correct service. For new routes such information is, naturally, a basic part of implementation.

The other way of utilizing the media is to keep the press informed about transit service and operations and to ask for assistance in such steps as introduction of new service, fare changes or any other changes which bring benefits to most passengers, but may affect negatively a few.

7.2.6 Telephone Information. All transit agencies should provide a telephone information service operating during the times of day during which transit service is provided. Many would-be transit passengers do not have readily available the information needed for planning a trip. Unless they can easily obtain the route number and timetable information by phone, these potential riders will be lost. Since almost all transit agencies now provide some such service, the following suggestions are designed to lead to improvements.

1. Telephone information personnel should be thoroughly knowledgeable about the city, transit service, fares and other relevant items.

2. Telephone information personnel should be provided with information aids to assist in answering questions. They should have maps that show streets, house numbering system, as well as major objects such as hotels, theaters, terminals, etc. In addition, these maps should show the location of every transit stop in the system.

3. It is very important that telephone personnel be courteous and patient in dealing with callers. A caller should not be made to feel that he is imposing on the transit agency in order to find out some timetable information.

4. The telephone personnel on duty should be sufficient to make it easy for caller to "get through".

5. It is preferable when all operators are busy, to play a recorded message for callers, than to merely allow the telephone to continuously ring -- a policy which leaves the caller uncertain as to whether the service is in their operation; however, the number of callers which are accepted by the answering machine should not be so large as to result in callers having to wait for a long period of time for an operator. If a waiting time of more than about 5 minutes is likely, the caller should receive a busy signal.

6. The telephone information number should be displayed prominently on timetables, route maps, at stops and on vehicles.

7. The hours of telephone information service should be at least from one hour before the beginning to the end of regular transit operations (standard S-12 in the Operating Guidelines [4]). At all other times, the service should provide a recorded message which informs callers as to the hours of service.

Telephone information, while extremely important, should never be considered as the basic information system. The reason is the high cost relative to other means of providing information. (In Pittsburgh the cost of providing telephone information have been estimated at 25¢ per call.). Full use of these additional methods, as discussed previously, will reduce the number of potential passengers who must use the phone service. As a result, the number of operators required for a large system can be reduced. In smaller cities, where there is

only one operator on duty at a time, better written information will improve telephone information since the chance of the phone being busy is decreased. The above comments should not be taken as encouragement to reduce telephone information availability; on the contrary, the service should be strongly promoted. At the same time, it should not have to give out information continually which could be provided by other means at a lower cost.

7.3 Implementation of the Information System

In implementing the information system, all items listed above cannot be introduced into service immediately. Because limited funds are a very real constraint, a list of priorities should be established which reflects the most effective use of the available funds.

To do this, a general rule may be applied: Allocate money on the basis of its ability to inform the maximum number of people about the system. A recommended grouping of priorities is shown in Table 7.1 which summarizes the elements of the information system described so far: the locations of distribution, the types of users, the type of information, and the means of distribution.

7.4 Maintenance of the System

The importance of maintaining an attractive and accurate information system can hardly be over-emphasized, for a poorly designed or misleading system can be a greater deterrent to ridership than no information system at all. With this in mind, the agency has the responsibility to:

- Protect displayed information at stops from weather and vandalism to the greatest possible extent.
- Promptly replace damaged or missing signs and displays
- Update schedules and route maps as changes are implemented
- Inform the public through the printed media of stop , route or schedule changes
- Maintain pavement markings.

Table 7.1 Summary of transit information distribution system.

LOCATION	PRIMARY GROUP SERVED				TYPE OF INFORMATION		
	Regular User, Regular Route	Regular User, Irregular Route	Incidental and Potential User	Visitors to City, New User	A	B	C
Transit Stops /Terminals							
All Stops	X	X	X	X	1,2	3	5
Major Stops	X	X	X	X	1-3	4,5	
All Mode Terminal	X	X	X	X	1-6		
Mode Transfer Points (K+R, P+R)	X	X	X	X	1-5	6	
Transit Vehicles							
Exterior	X	X	X	X	1,2	5	
Interior		X	X	X	1-3,5	4	6
Public Places							
Hotels			X	X		2-5	6
Entertainment Centers		X	X	X		2-5	6
Arenas, stadium		X	X	X	2,4	1,3,5	6
Schools, univers.	X	X	X	X	3-5	1,2	
Employment Places	X	X	X			2-5	
Newstands		X	X	X	4		6
Tourist Bureau			X	X	2,4,5,6		3

1. System name and symbol
2. Transit information telephone number
3. Route map and schedule
4. Transit network map
5. Fare information
6. Information on all transport services (other lines, long distance, taxi)

7.5 REFERENCES AND BIBLIOGRAPHY

1. Mossman, F. H., ed., Principles of Urban Transportation, Press of Western Reserve University, 1951.
2. Murphy, Levy, Wurman, Station Design Criteria, Part 3.3 for Delaware River Port Authority, Philadelphia, February 1972.
3. New York State Department of Transportation, Guidelines for Developing Transit Information Systems, August 1972.
4. Pennsylvania Department of Transportation, Operating Guidelines and Standards, prepared for PennDOT by the University of Pennsylvania, 1973.
5. Smerk, G. M. et. al., Mass Transit Management: A Handbook for Small Cities, Institute for Urban Transportation, Indiana University, DOT Project No. IND-MTD-1, February 1971.

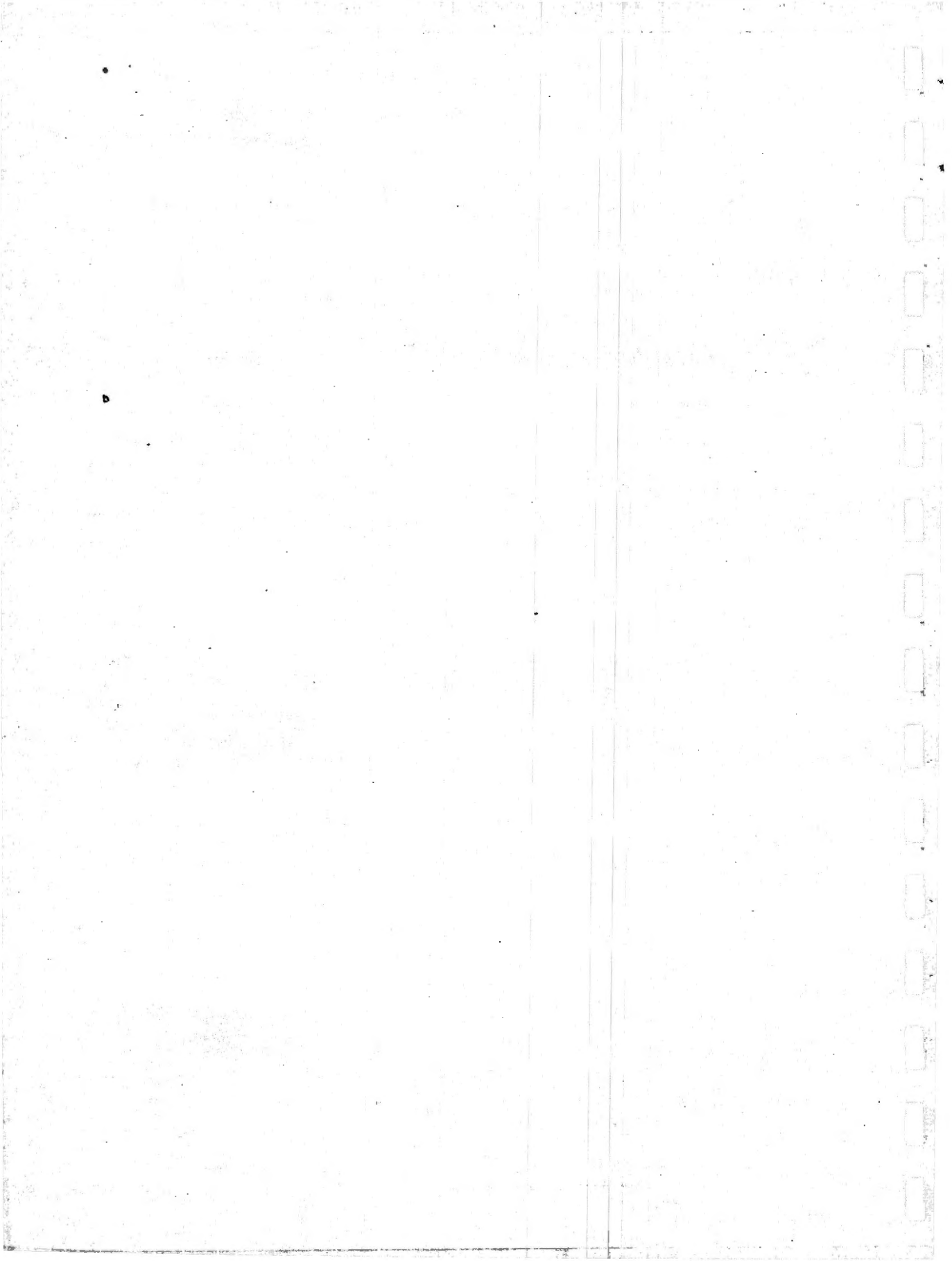

PUBLIC TRANSIT MARKETING

8.1 Marketing: Definition and Purpose

Marketing of transit is an organized program undertaken by the transit agency in order to achieve the following basic goals:

1. To promote transit services and inform the public of them.
2. To assure that the maximum number of potential riders is attracted to the transit mode.
3. To assure that transit service is provided where it has maximum overall benefit, not only from the operator's viewpoint (efficient operation), but from the community and passenger viewpoints as well.

Because many transit operators have had financial difficulties over the past few decades, concern for short-term financial solvency has been often considered the dominant criterion in successful transit operation. Although financial assistance from external sources is likely to grow in the future, there is still a great need to attract to the transit system the greatest ridership possible in order to maintain a high service quality.

Good marketing is essential to high passenger attraction and system utilization which increases revenue and reduces deficit. Inefficient marketing (or no marketing program whatsoever) has the long-term effect of discouraging auto drivers and other potential users from using the transit system and increasing the operating ratio. These facts are often overlooked by operators.

8.2 Format of a Marketing Program

A marketing program has two basic components:

1. A marketing strategy
2. A set of marketing activities.

8.2.1 Marketing Strategy. A marketing strategy coordinates the various marketing activities into a plan that has defined objectives with regard to passenger attraction and provision of service. The plan should be designed with programs for achieving the objectives. Three types of marketing

strategies can be used, singularly or in combination.

Undifferentiated marketing is a strategy in which a single product (transportation) is provided and promoted in a way designed to appeal to the public-at-large, i.e. the entire population of a defined service area (town, city or metropolitan area). In this strategy, the "typical" or "average" consumer is appealed to and served; an attempt is made to attract the most passengers with a single service/promotion package.

For most cases, undifferentiated marketing is the simplest and cheapest of the marketing strategies to implement. However, its effectiveness as a sole strategy for marketing generally depends on a population with fairly uniform characteristics and on an assumed limited role for transit. In most cases, therefore, undifferentiated marketing is the base on which to build a more sophisticated and effective marketing program.

Differentiated marketing, in contrast to undifferentiated marketing, appeals to each segment of the population to ride transit based on their differing needs. For example, a campaign to attract more off-peak riders may highlight the benefits of riding transit during those hours for shoppers, housewives, the elderly and others who would be potential candidates for such a program.

Differentiated marketing is typically more expensive than undifferentiated marketing because of the need for diversity and specialization in the planning and presentation of the program. The higher investment level in differentiated marketing, however, is often offset by increased patronage level and larger revenues than the first type of program could achieve

Concentrated marketing is a program which has as its goal the promotion of a single component of transit service or the attraction of selected segments of the ridership market. This type of marketing is most effective for agencies which offer specialized services.

The choice or combination of the three transit marketing strategies depend on four basic factors:

I. Role of transit: If transit is to play a dominant role in the community or if there is a community decision to attract as many passengers as possible to transit, it is desirable to invest heavily in a marketing program. Differentiated and concentrated marketing are usually more effective in these cases.

Conversely, when transit is used primarily to supplement auto travel in a city, it is not necessary to have a highly specialized marketing program. An undifferentiated marketing strategy is then acceptable.

2. Available Resources: The financial resources available often limit the initial marketing effort to undifferentiated or concentrated marketing, depending on community characteristics.

3. Community Characteristics: Each economic and social group in a city has different transit needs. In determining the type of marketing program best suited for a city, the analyst must determine how diverse transit needs of the population are. A "one-industry" city with fairly uniform population characteristics, for example, may find that an undifferentiated transit marketing program is both cheaper and more desirable than a more sophisticated program. Cities which have more variety in social and economic groups, often will find a differentiated marketing program essential.

4. Type of Transit Service: Transit services can be differentiated by a number of features including time of service (peak, off-peak), area coverage (CBD-oriented, dispersed), function (commuting, shopping, recreational), etc. The more diversified a transit service is, the greater the need is for a differentiated marketing program.

Table 8.1 presents a summary of influences of these major factors on the choice of a marketing strategy. The Table should be viewed not as a set of inflexible rules, but rather as an aid when considering alternative strategies. After determining the best marketing strategy for the defined objectives and conditions, the strategy should be reviewed periodically for its effectiveness, possible expansion, and possible improvement.

Table 8.1 -- Influence of different factors upon choice of marketing strategy.

Type of Marketing Strategy	Undifferentiated	Differentiated	Concentrated	Combination
<u>Basic Factor</u>				
<u>Role of Transit</u> dominant supplemented	• •	•	• •	•
<u>Resources (cost)</u> limited adequate	• •	•	• •	•
<u>Community Type</u> diverse uniform	•	•	•	•
<u>Transit Services</u> several types single type	•	•	•	•

8.2.2 Marketing Activities. There are several marketing activities which comprise the marketing program. Transit marketing activities can be classified into:

1. Market research
2. Market segmentation
3. Service adjustments
4. Information distribution
5. Advertising
6. Public relations.

Market Research: Market research collects the type of information necessary for an effective marketing program. In general, it defines present and projected (or planned) characteristics of the community, its population and transportation patterns and demand features. Included in this type of information are:

- demographic characteristics (population densities, etc.)
- physical features of the city (topography, etc.)
- sociological factors (average income, etc.)
- origin-destination data
- auto ownership data
- peaking characteristics, and so on.

Other types of information may be included to suit analysis of specific needs in a given situation; the amount and kind of data gathered and the frequency with which it is updated will depend to a large extent on the availability of funds, the stability of the community and other factors.

It is also important to remember that for a balanced marketing program data must be collected on the attitudes and preferences of transit riders already using the system, as well as the potential ridership which may exist in the community. With this information the analyst can determine the service which may be deficient in the view of the riding public.

There are many ways to gather information for market research. An easy way to start is with information that has already been gathered by others. Government agencies such as the Department of Motor Vehicles, Regional Planning Offices and the Census Bureau are good sources. The Motor Vehicle Department can provide information on automobile ownership by area and population group. In addition, it can provide drivers' addresses corresponding to license plate numbers for any survey of automobile driver origins. The Census Bureau has the information for each census tract of

a city on such factors as population, age, income, job distribution, and automobile ownership. For large cities the Bureau also provides trip origin-to-destination information. The local county or regional planning office has data on zoning and land use. District office of the Department of Transportation has data on highway network and traffic volumes.

It is often useful to contact the transit agency's own complaint department, as well as its telephone information service for useful information on public needs, attitudes and values. More specifically, it is possible to find out passengers' most common complaints about deficiencies in service and their suggestions for improvements. However, for much of the information that the transit agency needs, it is necessary to conduct a market survey. The main techniques for conducting a market survey consist of questionnaires and interviews.

Questionnaires which are lengthy or complex should be avoided if individuals are expected to complete them alone. Questionnaires should generally be kept brief and simple. If more detailed information is required, an interviewer should assist in filling out the form.

Questions to be answered should be unambiguous and brief. It is also generally preferable to provide answer choices which can be checked off by each respondent. This also avoids possible misinterpretation of questions. Questions for which the respondent must compose an answer may reveal more precise or unexpected information, but they require more time and are more costly to read and to analyze.

Finally, care must be taken in phrasing questions so as not to influence answers. Easier questions should be placed first in the questionnaire; more complex questions should appear last.

The major problem with mailed questionnaires is that the percentage of returns is usually very low, often resulting in a biased survey. It is possible to ensure a higher response rate by a "follow-up" campaign of letters stressing the importance of the questionnaire. Another technique which can be used to increase the response rate is to offer inducements (chances for prizes on drawings, free passes on transit, etc.). Surveys taken on board transit vehicles can elicit a high response rate, but do not provide in-depth information about potential riders.

Interviews are another mechanism through which marketing data may be collected. They may take the form of telephone interviews, which are relatively inexpensive, or house interviews, which are very costly and re-

quire a large staff.

The low cost and convenience advantages of the telephone interview are off-set somewhat by inherent biases which are often not known. Many poor people, for example, do not have telephones. Other complications with phone interviews arise in reaching commuters at home at a convenient time of day, multiple phone listings for a single family, unlisted phone numbers, etc.

When there is sufficient need for detailed and highly accurate information, personal interviews are the best method to use. Such interviews are conducted at less frequent intervals than phone surveys since they are more expensive.

Market Segmentation: The market segmentation activity divides the users and potential users of transit into classes or groups, based on social, economic, geographic or other characteristics which differentiate between the transit needs of individuals. It is after market segmentation that the differentiated marketing strategy or the concentrated marketing strategy is applied.

The degree of market segmentation attainable depends on the kind and amount of data gathered during the market research phase.

Table 8.2 shows selected characteristics convenient for market segmentation. A market group may be formed on the basis of one, or a combination of any number of the factors listed. However, in deciding how to segment the market, the following criteria should be adhered to:

1. Each segment should have a sufficient number of people to justify the cost of advertising to that group individually.
2. Each segment should be distinct in its needs for and attitudes toward transit.

Table 8.2 -- Characteristics commonly used in market segmentation

Type of Characteristic			
Social/Economic	Trip	Time of Trip	Geographic
Age	Work	Peak	Trip length
Education	Shopping	Off-peak	Trip ends
Sex	Recreational	Weekday	CBD-internal
Family size	Medical	Weekend	CBD-suburb
Occupation	Educational		Suburb-CBD
Income			
Auto ownership			
Driver/non-driver			

An excellent example of applied market segmentation followed by concentrated marketing has been applied in Pittsburgh. To counter a detected low patronage level on Tuesdays, the transit agency offered reduced shoppers' fares on that day, promoting through advertising the use of the "Tuesday Special". A follow-up study showed that Tuesday patronage had increased substantially, with no loss of patronage from other days of the week: an indication that the increase was due to newly generated trips.

Service Adjustments: On the basis of data collected during market research and market segmentation, it may become apparent that certain modifications to service are required. Such modifications include:

Route modifications

- Rerouting
- Elimination or addition of route segments
- Elimination of duplicating routes
- Additional routes
- Improved transfer locations and facilities

Fare adjustments

- Change in fare structure (zonal, sectional, etc)
- Special fares (weekend fares, passes, etc)

Schedule changes

- Adjustments to peak hour service
- Adjustments to off-peak service

Operational modifications

- Express, Skip-Stop, etc.
- Type of right-of-way (exclusive, semi-exclusive, mixed)
- Special services (shoppers special, special events, etc.).

Principles to be used in route planning, fare structure, scheduling and operations are given in Chapters 4, 5 and 6.

Special services can be a particularly effective means of service innovation. A special service is initiated usually in response to an expressed or observed need and the potential market is often easily determined (e.g. airport - center city shuttles, special event service, etc.); this service is often an excellent means of achieving exposure of potential users to transit services.

Information Distribution: Another essential marketing activity is a program for dissemination of the information necessary for the utilization of the transit service by the public. Such a program is discussed in Chapter 7.

Adjustments and improvements to the information system based on marketing

studies may affect any component of the information system: available on-vehicle information, station signing, schedule designs and so on. An efficient and comprehensive information distribution program is essential to the success of a marketing program; therefore particular care should be given to this activity.

Advertising: The activity most commonly associated with marketing is advertising, which has three related purposes:

1. To draw public attention to the transit service;
2. To inform the public of the qualities or advantages of the transit service; and
3. To create a positive image for transit in the eyes of the public.

Public attention can be drawn to the transit service in a number of ways, some of which were already discussed in Chapter 7. Among these ways are distribution of printed media (brochures, pamphlets, newspaper advertisements, posters, billboards, yellow page advertising, direct mailing, etc.), radio and television commercials, the design of stations and stop designations and the selection of system color theme (for signing, vehicles, schedules, etc.).

In informing the public of the qualities and advantages of the transit service, practical appeals should be emphasized:

- Money savings (e.g. the annual savings of an actual transit rider over what otherwise would be spent on an automobile).
- Time savings (where applicable).
- Comfort and convenience (e.g. ability to read on transit, avoidance of aggravation in traffic jams).
- Increased safety and reliability (e.g. comparing accident rates, per cent of on-time arrivals by transit).

At times, practical appeals are not sufficient to overcome the negative image transit has acquired in many cities. Therefore, it is desirable to convince the public that it is not only "socially acceptable" but even "fashionable" to ride transit. This can be accomplished if a certain status image can be developed for the transit service. Such an image is developed in advertising:

1. By appealing to the public spirit: using transit saves fuel, helps reduce air pollution, etc.
2. By implying that transit users are "smarter" than auto drivers.
3. By using celebrities and prominent community leaders to endorse transit, where in fact they do use it.

Figure 8.1 is an example of an advertisement of this nature for the Nashville MTA.

Coordination of the advertising message with the various media is necessary for a successful advertising program. Each medium is best-suited to a different advertising objective or message. Visual media are often best utilized to change or project a desirable image of transit or the transit agency; this advantage is particularly true for television. Radio and posters can be used effectively for "spot" promotional advertisements which make the public continually aware of the presence of the transit system. Radio, however, is generally not easily used to convey details of service which normally appear in promotional brochures, pamphlets and schedules.

The type of medium must also be coordinated with the market segment at which the marketing effort is directed. Each medium is experienced by each segment to varying degrees. Therefore, how and at what time a given market segment will be appealed to will depend on that segment's characteristics. For example, potential riders from a high-income category would best be reached via newspapers, radio stations with a news or classical music orientation, or during evening hours by either radio or television. Direct contact by mail is one of the few ways to reach all of the potential riders in a market segment, but it is expensive.

The expenditure devoted to advertising depends on the objectives to be achieved and on costs of advertising or other marketing activities. Experience has shown that in most cases an expenditure of approximately 1.5 per cent of gross revenues, although still very low compared with 4 to 5 per cent spent for this purpose by the beverage, tobacco, chemical and movie industries, is usually adequate for successful marketing by transit agencies.

There are various ways by which some advertising expenses can be reduced. One way is for the transit agency to share expenses with another organization: e.g. the promotion of a sporting event (or series of games) with the transit service that may be used for access. With this approach to advertising, both parties benefit since advertising costs are reduced for each party. The transit agency also benefits from an explicit, well-publicized example of how its service may be utilized.

Another way to keep advertising expenses low is to sell a product which promotes transit usage as a secondary function. Examples include

THINGS YOU ALWAYS WANTED TO KNOW ABOUT THE MTA*

*(but were too busy fighting traffic to ask)

Q. WHAT KIND OF MAN RIDES THE MTA?

A. He's suave, intelligent, witty, debonair, and usually has a little extra cash. (MTA fare is just 35c.)

Q. What will I do with my car?

A. Cars are still great to hang onto for vacation trips. One imaginative soul in Hillsboro is at present, renting his to six college students as a sleeping room.

Q. HOW RELIABLE IS THE SERVICE?

A. Many people set their watch by the MTA. We admit this statement is bold, but then again, taking the MTA is a bold step in the right direction.

Q. Are the MTA coaches comfortable?

A. So comfortable many people have to be coaxed off at the end of the line. A lot of people prefer the comforts of the new MTA coaches to their own living room. The only thing missing is a TV, but maybe we'll work on that next.

Q. How much can I save by riding the MTA to and from work?

A. Anywhere from six hundred dollars to thirty thousand dollars, depending upon how expensive your present form of transportation is. The thirty thousand dollar figure is based on renting a chauffeur-driven limousine every day. The average person will save eight or nine hundred dollars a year riding the MTA. (Actually, MTA riders enjoy pretty much the same treatment as the guy who rents a limousine . . . they have a chauffeur who opens the door for them, takes them right to their stop . . . and it's not so lonely.)

RIDE THE 
Metropolitan Transit Authority
It's a better way to go.
For information: 242-4433

Figure 8.1 -- Example newspaper advertisement (Nashville MTA).

distribution of beer coasters or jig-saw puzzles with transit maps, printing of transit system name and/or logo on all city maps, tourist literature, memorabilia such as T-shirts, etc. In addition, free advertising is sometimes available in neighborhood and college newspapers, professional circulars and publications, and the like.

Public Relations: The marketing activities whose purpose is to project a positive, progressive image of the transit agency are broadly classified as "public relations". The basis for good public relations is quality of service provided by the transit agency: a positive public image cannot be established without reasonably good service. Assuming that this basic requirement is satisfied, there are other techniques which can improve the image of the agency and the transit service.

Public relations is based on the transit agency's contact and exposure to three parties:

1. The general public
2. The press
3. Governmental agencies and representatives.

The general public's perception of the transit service can be enhanced by the following measures:

1. Frequent cleaning of vehicles; repair of damage due to vandalism as soon as it occurs. This method of maintenance is often less expensive than it first appears: a vehicle already damaged by vandalism attracts more vandalism. Thus, in the long run, it may cost no more to keep vehicles well-maintained than it would to make infrequent repair of much greater damage.
2. Design transit stops, shelters, and stations so that their maintenance is easy.
3. Encourage an attitude of helpfulness and courtesy on the part of all employees (bus drivers, station employees, and telephone information personnel) who come in contact with the public. This condition is most easily attained in agencies in which the top management reflects a concern for the public welfare, and where good employer-employee relations exist.
4. Ensure that the telephone information service has sufficient operators so that transit users are not frustrated in obtaining assistance. A continuous busy signal on the telephone information service leaves the impression that the agency is not very

- interested in providing that service.
5. Provide a complaint department that actually seeks to eliminate the causes of complaints.
 6. Provide a lost-and-found service.
 7. When breakdowns in service occur, provide a prompt explanation as to what the problem is and how soon it will be corrected. Apologies are also in order, especially to passengers aboard a vehicle that breaks down. Printed explanations should be available the next day. These explanations can then be used by commuters who may have arrived late to work because of the breakdown. Poor public relations occur when officials of a transit agency appear indifferent to service breakdowns and the delays suffered by the public.

While the previous suggestions are primarily directed toward improving public relations with the users of the transit system, the transit agency should also maintain a good image in the community-at-large by becoming involved in civic affairs. Some of the activities in which a transit agency could participate would include:

1. Help with charity drives by free on-vehicle advertising space and other assistance.
2. Support progressive transportation improvement programs, such as staggered work hours.
3. Assist in local job training programs.
4. Assist local agencies in community planning.
5. Actively participate in special events: holiday parades, civic and sports events, commercial activities, etc.

The press is another important party in public relations. Favorable news stories about a transit agency not only bolster its image, but also reduce the amount of money required for advertising. For these reasons, maintaining good relations with the press is very important. The following guidelines are suggestions for successful relations with the press.

1. Make sure that top management representatives are available to the press.
2. Provide access to all information requested by the press to the maximum possible extent. A policy of openness prevents unfounded speculation and provides for community feedback on anticipated or planned projects.

3. Be honest with the press and avoid misleading or ambiguous statements.
4. Notify the news media well-in-advance about important stories
5. Provide "press kits" with relevant information, brochures, etc., when the agency is issuing an important news release.
6. Keep in mind considerations of press deadlines when scheduling news conferences and news releases.
7. Do not favor one publication over another in the dissemination of information.
8. Do not threaten favoritism due to erroneous or poorly presented publicity unfavorable to the agency. Attempt to have the mistake corrected instead.
9. Advise the press of extenuating circumstances when service breakdowns occur.

Government agencies are important to good public relations, since public transit is a regulated industry, and since most transit agencies at various times need assistance from different governmental agencies. The following guidelines suggest some ways of developing and maintaining these good relationships.

1. Maintain an up-to-date list of the key personnel of all relevant agencies, legislative representatives, etc.
2. Forward all press releases, new brochures, etc. to these people.
3. Forward an annual report of the agency to these same persons.
4. On important occasions, such as the introduction of new vehicles, some or all of the people on the list should be invited.
5. Keep key officials informed about developing problems before they become public issues.
6. Be aware of the constraints under which these agencies operate and consider these in your dealings with them.

8.3 Conclusions

This chapter has described the basic components of an effective marketing program and the various marketing strategies and activities. It is important to remember that the primary prerequisite for good marketing is a good product, i.e. good transit service. Without good service, the difficulty in attracting passengers through segmentation analysis, advertising and other techniques is very difficult and investment in these activities is not as effective as it otherwise would be.

Finally, marketing must be organized as a continuing process which must be given constant attention since attitudes and values of the public are constantly changing. The marketing program must be continually reviewed and adjusted to adapt to the changing needs and values of the community and its residents.

8.4 REFERENCES AND BIBLIOGRAPHY

1. Smerk, George M. et al., Mass Transit Management: A Handbook for Small Cities, Institute for Urban Transportation, Graduate School of Business, Indiana University, Bloomington, Indiana, February, 1971.
2. Schneider, Lewis, M., Marketing Urban Mass Transit, A Comparative Study of Management, Division of Research, Graduate School of Business Administration, Harvard University, Boston, 1965.
3. Mossman, Frank H. (ed.), Principles of Urban Transportation, The Press of Western Reserve University.
4. SEPACT III Final Report: Operation Reading, Final Report to the U.S. D.O.T on Mass Transportation Demonstration Project No. PA-MTD-5, April, 1965--October, 1966.
5. "Center City Transportation", Nation's Cities, vol. 8, #2 (February, 1970).
6. Garver, Robert I., "Marketing Can Mean A Transit Turnaround", Metropolitan, September/October, 1972.
7. A Transit Development Program for the Lehigh Valley, prepared for the Joint Planning Commission Lehigh-Northampton Counties, Pennsylvania. Consultant: Barton-Aschmann Associates, Inc. Associated Consultant: Robert I. Garver & Associates. March, 1973.
8. Beier, Frederick J., "Marketing Programs for Mass Transit", Traffic Quarterly, vol. 26, p.533. (October, 1972).
9. Kotler, Philip, "The Major Tasks of Marketing Management", Journal of Marketing, vol. 37, #4.
10. Millward, C., Coleman, A. H., and Dunford, J.E., "Passenger Transport Interchanges--Theory and Practice on Merseyside", Traffic Engineering and Control, vol. 14 #11. (March, 1973).
11. "Railroads and the Press: A View from the Newsroom", Railway Age, February 11, 1974.

Chapter 9

MANAGEMENT DATA

9.1 Introduction

This Chapter outlines the basic economic and managerial aspects of transit operation and administration. Data required for managerial functions are listed and defined; basic service and efficiency measures for system evaluation are given and their use is explained. Transit agencies must collect these data and derive the various operating and economic indicators and measures for the following reasons:

1. To be able to compare their indicators with those of other transit agencies. These comparisons allow detection of ineffective or inefficient operations or components of transit service.
2. To provide basis for analysis of trends in certain measures of performance and efficiency over a period of time (several years).
3. To ensure the most cost-effective allocation of funds and the establishment of a rational ordering of priorities in scheduled improvements.

9.2 The Data File

Essential to good transit management is the maintenance of a well-organized and maintained set of data. Such data are necessary for the determination of evaluative measures of service, performance and efficiency.

The data which should be collected by the transit agency can be classified into four categories:

1. Urban area data
2. Transit service data
3. Transit usage data
4. Transit agency data.

The items of data under each of these classifications are given below.

9.2.1 Urban Area Data. The transit agency should collect and maintain up-to-date information on the characteristics of the community it serves. Data on the urban area should include social, population, economic and topographical characteristics which provide a basis for planning of transit service and for evaluation of services in meeting community transportation

needs. Data on the urban area assist the agency in determining the proper role of transit, the types of population and neighborhoods to be served, the existing and potential transit ridership.

The following data should be obtained and updated annually:

The City

1. Population

- a. city proper
- b. urbanized area

2. Area (square miles or square kilometers)

- a. city proper
- b. urbanized area

3. Population density (persons per square mile or per sq. km.).

- a. city proper
- b. urbanized area

4. Employment (number by group: industry, service, administrative, etc.).

- a. city proper
- b. urbanized area

5. Auto ownership (persons per passenger car)

- a. city proper
- b. urbanized area

6. Work trips(trips per day)

7. Major types of economic activities

8. City topography (hilly, flat, rivers, etc.) and form (linear, centralized, nucleated, dispersed)

9. Social/economic characteristics

- a. median income, average income
- b. income per capita
- c. social and ethnic facts (e.g. special or religious holidays).

CBD Characteristics

10. Area (square miles or sq. km.).

11. Population

- a. day time (max. accumulation)
- b. night time (residential)

12. Employment (number by group)

CBD Characteristics - Continued

13. Floor Area (square feet or sq. meters)
 - a. offices
 - b. retail
14. Traffic conditions description (bottleneck locations, overloaded sections, etc.)
15. Per cent of peak hour CBD trips by transit

$$\frac{\text{Peak hour trips to CBD by transit}}{\text{Total peak hour trips to CBD by all modes}}$$

Comment: Indicates the role of transit in the city and particularly for the activities and vitality of the CBD.

16. Parking spaces
 - a. off-street
 - b. on-street
17. Parking rates
 - a. off-street
 - b. on-street
18. Control of parking rates (are they determined by individuals or regulated by an authority)
19. Availability of off-street parking

Transit Agencies

20. Names of agencies providing transit in the city and modes operated by each
21. Agency characteristics
 - a. ownership and control (public, private, combination)
 - b. service area (square miles or sq. km.).
 - c. annual passengers
 - d. number of routes
 - e. length of routes (miles or km.)
 - f. number of vehicles operating during peak
22. Coordination of services among agencies (schedule coordination, common stops and terminals, information distribution, etc.)
23. Agencies responsible for planning transit

9.2.2 Transit Service Data. The physical and operational characteristics of the transit system have several descriptors which indicate the quality and amount of service offered by the agency. While many descriptors can be used, the following ones are the most basic for transit service.

1. Number of routes
 - a. for each mode
 - b. for system
2. Length of routes (mi or km): Route length represents round trip length, regardless of the number of times a given section is shared by two or more routes.
 - a. for each mode
 - b. for system
3. Length of lines (mi or km): Line length represents the length of street, track, or other types of right-of-way on which regular service is operated without double-counting overlapping route sections. A section of line served by more than one route is counted only once; a length of line served in both directions is also counted only once.
 - a. for each mode
 - b. for system
4. Number of stops/stations: The total number of passenger stops along each route but only in one direction is counted, regardless of whether both directions are served. Both terminals for each route are also counted:
 - a. for each mode
 - b. for system
 - c. for CBD

Comment: Data pertaining to the number of stops are necessary for the derivation of other service measures and for the operator in assessing some fixed station facility needs (personnel, shelters, change machines, etc.)

5. Average stop spacing (ft or m): Stop spacing represents the average density of stops along the line and is derived by the

following ratio:

$$\frac{\text{One-way route length}}{\text{No. of one-way stops incl. terminals} - 1}$$

Spacings are computed for each route sometimes also for the whole network.

Comment: Average stop spacing is important for two reasons

1. It influences transit operating speed: longer stop spacing increases speed.
 2. It is a rough measure of spatial accessibility of the transit service to the public: longer stop spacing increases walking distance to the stop and thus increases access time.
6. Average stop density (stop/mi² or /km²): Stop density is the number of transit access points per unit area and is derived by the following ratio:

$$\frac{\text{Number of stops}}{\text{Total area considered}}$$

It may be computed for:

- a. each mode
- b. total system network
- c. CBD
- d. urbanized area.

Comment: Average stop density is an indicator of the area coverage and overall spatial accessibility of the transit service.

7. Total number of park-and-ride spaces: The number of formally designated park-and-ride parking spaces at urban and suburban transit stations should be inventoried:
- a. by location (urban, suburban)
 - b. for each mode
 - c. for system

Parking spaces should be classified into two categories: free and paid.

Comment: The number of park-and-ride spaces is an indicator of the potential attraction of auto drivers who do not

have walking access to transit. A large number of park-and-ride spaces encourages diversion of drivers to transit and increases transit utilization by persons from suburban and low-density areas.

8. Area Coverage (%): Area coverage is the percentage of the urban area served by transit. It is computed by the ratio of the area within 5-min walk from stations and the total urbanized area:

$$\frac{\text{Area with 1250 ft around all transit stops}}{\text{Area considered}}$$

This indicator may be computed for:

- a. CBD
- b. Central city
- c. Total service area of the transit agency

If stops are very close on all lines, such as on some surface transit lines, the following formula may be used for approximation of the area coverage:

$$AC [\%] = \frac{0.475 \times (\text{Line length})}{\text{Area considered}} \times 100\%$$

Comment: The percent area coverage is another measure of spatial accessibility. A 100% area coverage indicates that all combinations of origins and destinations in the urban area are served by transit.

9. Percent of population served (%): This indicator represents the proportion of residents having access to a transit stop, and is derived from the following ratio:

$$\frac{\text{Population within served area}}{\text{Area considered}}$$

Percent of population served may be computed for the same areas in the urban coverage (above).

Comment: The percent of population served is generally a good indicator of transit availability. However, caution must be exercised in using it as a single measure, since it only accounts for availability at the home end of a trip.

Whether the destination is reasonably accessible by transit is not indicated by this measure. The preceding measure (area coverage) is a better indicator of the latter.

10. Daily vehicle-miles (or veh-km): The total number of miles traveled by all vehicles during one day of operation. This should be computed for:
- each mode
 - weekday
 - Saturday
 - Sunday

Comment: The number of daily vehicle-miles of travel is obtained as the product of route length and the number of round trips performed per day for each route. Vehicle miles for different modes are usually not summed into a total because of significant differences among modes in capacities, speeds, costs, etc.

11. Daily seat-miles (or seat-km): The total number of seat-miles offered (or space-miles if standees are included in vehicle capacity) during one day. It is computed by the following product:

$$(\text{Total daily vehicle-miles}) \times (\text{Average vehicle capacity})$$

It may be derived for:

- each mode
- whole system

Comment: Daily seat-miles represent a basic productivity measure of the transit service, i.e. the quantity of service offered during one day.

12. Annual seat-miles (or seat-km): The quantity of service provided during one year is calculated by:

$$(\text{Total annual vehicle-miles}) \times (\text{Average vehicle capacity})$$

and it may be examined for:

- each mode
- the whole system

Comment: Annual seat-miles is the most commonly used indicator of the total volume of offered transit service.

13. Headways (min): Defined in Chapter 5, headway should be computed for:
- each mode
 - peak hour
 - mid-day
 - evening
 - weekend

Comment: Headway is a basic measure of service quality and temporal availability of transit.

14. Travel operating speed (mph or km/h): Also defined in Chapter 5, average operating speed should be computed for:
- each route
 - each mode
15. Hours of service: Total hours of regular operation during which service is offered should be examined for:
- weekday
 - weekend
 - week
 - each mode

Comment: Total hours of service is an indicator of system use from the operator's viewpoint and a measure of temporal availability of service from the passenger's viewpoint.

16. Vehicle utilization: There are two measures of vehicle utilization:

The number of vehicles in service for:

- each mode
- system
- peak
- mid-day
- evening

Vehicle employment peak-to-base ratio, this is calculated as:

$$\frac{\text{Number of vehicles operating during peak}}{\text{Number of vehicles operating during mid-day}}$$

This ratio is computed for:

- each mode
- entire system

Comment: High value peak-to-base ratios are an indication of unbalanced system use and uneconomic operation.

17. Schedule reliability (%): The per cent of on-time arrivals, known as schedule reliability, is computed for a given time period as:

$$\frac{\text{Number of arrivals 0-5 min late}}{\text{Total number of arrivals during period}}$$

It is computed separately for:

- a. each mode
- b. system
- c. specific route (for selected comparison)

Comment: Schedule reliability is a measure of system punctuality and is an important service quality component. Examining each route individually for schedule adherence helps in finding troublesome sections and in re-routing for more efficient operation.

18. Fare level and fare structure: As defined in Chapter 6, fare level and structure should be outlined for each mode.
19. Amenities: Components of the transit system which assist the passenger in using the service are defined in Chapter 7. Among the most important are:
- a. availability of transit network and route information to passengers
 - b. availability of schedules
 - c. transit stop designations
 - d. location of service information on vehicle exteriors
 - e. percentage or number of stops having shelters.
20. Fleet characteristics: For each mode and type of vehicle, the following data should be maintained:
- a. number of vehicles
 - b. gross floor area per vehicle
 - c. number of seats
 - d. total capacity: seats plus standing spaces
 - e. number or percent of air-conditioned vehicles
 - f. age(s) of vehicles
 - g. motor power (HP)

9.2.3 Transit Usage Data. The preceding section defined data which describe the transit service offered to the public, i.e. the "supply" side of the transit service. If the "demand" side is examined simultaneously, it can be determined how effective the service was in attracting passengers and in matching supply to demand, or the degree of utilization of the service.

The following are the data used to evaluate system usage and efficiency.

1. Annual revenue passengers: The number of fare-paying passengers per year should be calculated for
 - a. each mode
 - b. system

Comment: Each ride of an individual passenger counts separately. Transfer rides are not, however, counted as separate trips. The number of revenue passengers indicates the revenue producing capability of the system.

2. Annual total passengers: The total number of passengers per year should be derived for:
 - a. each mode
 - b. system

Comment: Each ride of an individual passenger is counted separately; transfer rides are not counted as separate trips. The total number of passengers represents the actual use of the mode or system.

3. Riding habit: The average number of transit trips per capita per year is obtained by the following ratio:

$$\frac{\text{Total annual passengers}}{\text{Urban area population}}$$

The riding habit is computed for:

- a. each mode
- b. system

Comment: Riding habit is the main indicator of citizens behavior with respect to transit. As an indicator that is independent of urban area population size, riding habit is a more meaningful indicator of community dependence

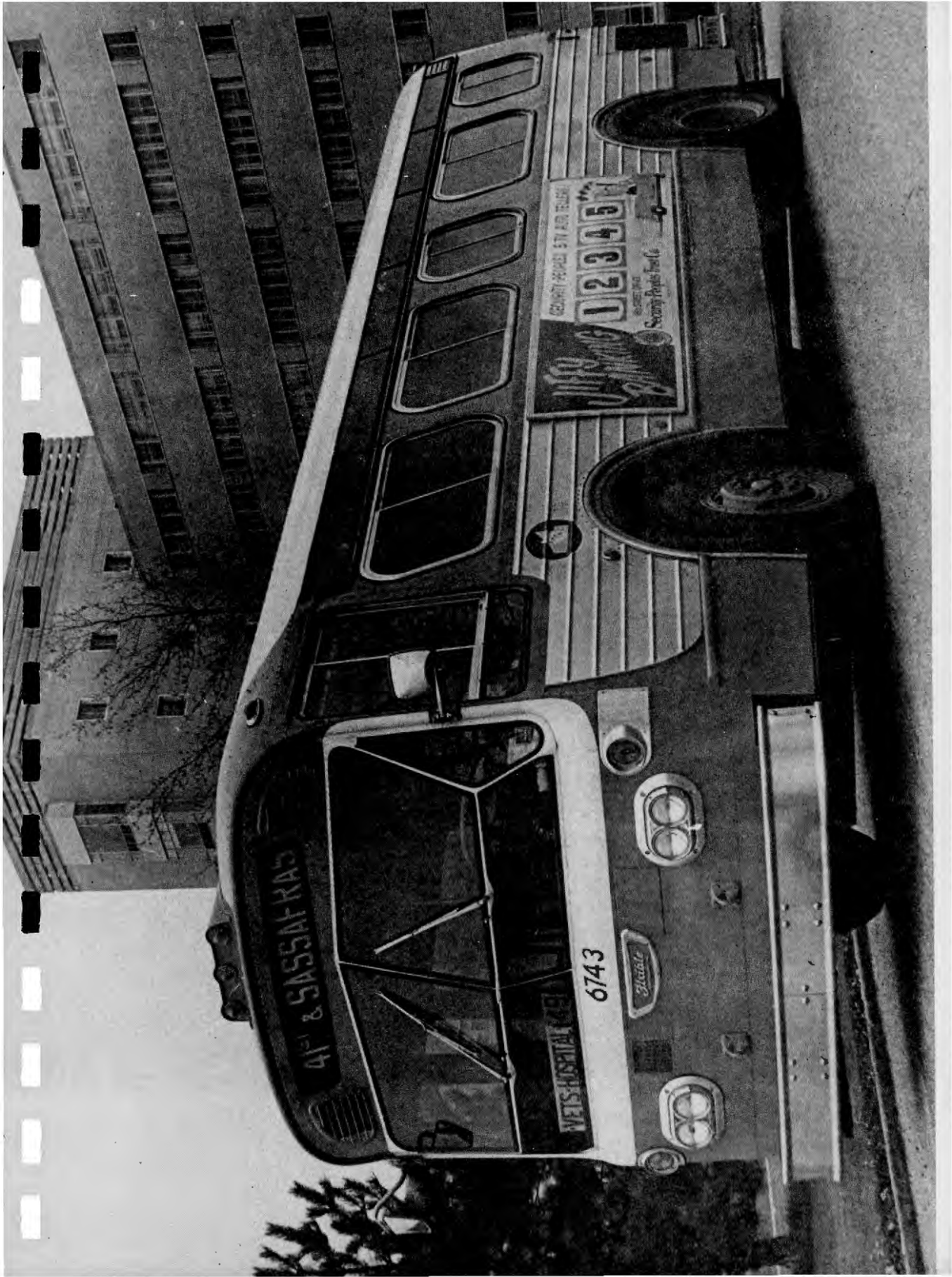



on transit than are the absolute figures of revenue passengers and total annual passengers.

4. Average daily revenue passengers: This data are kept for:
- each mode
 - system

and each one of these for weekday, Saturday and Sunday.

Comment: Relative numbers of transit passengers on the various days of the week are a partial indication of system utilization. Low weekend travel results in poor fleet utilization and possible low labor efficiency (personnel utilization).

5. Annual passenger-miles: The total number of miles travelled by all passengers during one year should be computed for:
- each mode
 - system

Comment: The annual passenger-miles is the actual amount of transportation work (vehicle capacity miles) utilized by the public.

6. Average trip length: Average distance traveled by passengers along a route per one-way trip is computed for:
- each mode
 - system

Comment: Average trip length gives insight into the nature of transit demand: longer trips dictate longer station spacing and vice versa. Modes with short average trip length therefore have a greater frequency of stops - and consequently lower speeds - than modes with longer average trip length.

7. Density of usage: Average number of passengers per mile of line per year is defined as density of usage. It is calculated by the following ratio:

$$\frac{\text{Total annual passengers}}{\text{Total length of lines}}$$

This is computed for:

- individual routes

- b. each mode
- c. system

Comment: Density of usage is an indicator of density of travel demand. Higher density of usage justifies higher service quality and more capital-intensive modes and services than does lower density usage. The average value for bus lines is in the vicinity of 20,000 passengers per mile per year, but this value depends heavily on local conditions and can vary greatly. Larger operations in concentrated areas may have densities of usage as high as 40,000 passengers per mile per year, while small suburban operations may have densities of usage as low as 5,000 passengers per mile per year.

8. Utilization ratio: Per cent utilization of transporting capacity offered per year is calculated from the following ratio:

$$\frac{\text{Total annual passenger-miles}}{\text{Total annual vehicle capacity miles offered}}$$

This is computed for:

- a. each mode
- b. system
- c. each route

Comment: A high utilization ratio for the system, or any component of the system, is desirable since the unit cost of offering the services is reduced. While it is desirable to have a high utilization ratio on all routes for all modes, it is unrealistic to expect all components to achieve equally good utilization rates. Even though some routes may have lower utilization ratios, they may be crucial to other system operations and should not be eliminated solely on the basis of a low ratio. Service to the community and indirect benefits from the transit service as a whole must be examined during such an evaluation.

9.2.4 Transit Agency Data. The final category of data focuses on the information required to evaluate the overall efficiency of the

transit operation and its administration. The data which are basic to such an evaluation are as follows:

1. Type of agency (public, private, combination, other)
2. Agency executives (including names, titles)
3. Number of employees by categories.
 - a. Management and administration
 - b. Clerical
 - c. Planning and marketing
 - d. Engineering
 - e. Dispatching, station personnel
 - f. Operators
 - g. Maintenance
 - h. Other

Comment: This classification of employees should not be considered as necessarily uniform for all agencies. The employees may be grouped or sub-divided depending on the needs and organization of the agency.

4. Number of garages and shops:

Comment: The number and location of maintenance and storage areas should be inventoried together with the capacity of each facility (number of maintenance berths, personnel assignments, etc.)

5. Number of vehicles: The total number of vehicles (all types) owned by the company, regardless of their operating condition or frequency of use.
6. Per cent of vehicles operating at peak
 - a. for each mode
 - b. for system

Comment: A high per cent of vehicles operating during peaks indicates efficient utilization of transit facilities and equipment and good technical condition of the rolling stock.

7. Average hours of operation per vehicle per day: This is obtained by the following ratio:

$$\frac{\text{Total vehicle-hours operated per weekday}}{\text{Total number of vehicles}}$$

This is computed for:

- a. each mode
- b. system

Comment: The average vehicle hours of operation per day is an indicator of vehicle utilization. The values of this measure depend largely on the peak-to-base ratio.

8. Average hours of operation per vehicle per year: This measure is derived by the following ratio:

$$\frac{\text{Total vehicle-hours operated per year}}{\text{Total number of vehicles}}$$

This is computed for:

- a. each mode
- b. system

Comment: This indicator reflects the total vehicle utilization throughout the year. Generally, values for this measure fall between 2000 and 3000 for buses, typical being about 2500. The measure is also used in scheduling maintenance and capital investment in rolling stock.

9. Average miles per vehicle per day: This measure is obtained from the ratio:

$$\frac{\text{Total vehicle-miles operated per weekday}}{\text{Total number of vehicles}}$$

This is computed for:

- a. each mode
- c. system

Comment: Daily mileage per vehicle indicates the total amount of transportation work produced, i.e. system productivity. This measure is also strongly correlated with operating costs.

10. Average miles per vehicle per year: Obtained from the ratio:

$$\frac{\text{Total annual vehicle-miles}}{\text{Total number of vehicles}}$$

This is computed for:

- a. each mode
- b. system

Comment: Average annual vehicle mileage is an indicator of the intensity of vehicle utilization and is related to operating costs. The measure is important in estimating vehicle life. The average value for bus systems is about 28,00 miles per vehicle per year with values typically ranging from 21,000 to 35,000 miles.

11. Average commercial speed: Average vehicle speed based on total time in service (including terminal time) is obtained by the

ratio:
$$\frac{\text{Average miles per vehicle per day}}{\text{Average hours of operation per vehicle per day}}$$

This is computed for:

- a. each route
- b. each mode
- c. system

Comment: Commercial speed is the basic indicator of efficiency of operations. This speed directly determines the number of vehicles required for service at a given service frequency, and is therefore important to the transit agency. Values for commercial speed for bus operations average about 11 mph, although congested streets and long layover time may reduce this value to 6 to 9 mph; on the other hand, in open areas with short layovers, speeds may be as high as 13 mph for surface transit. Rapid transit generally averages 15 to 25 mph.

12. Average passengers carried per vehicle-mile: This measure is obtained from the ratio:

$$\frac{\text{Total annual passengers}}{\text{Total annual vehicle miles}}$$

This is computed for:

- a. each mode
- b. system

Comment: Average number of passengers per vehicle-mile represents the average passenger volume related to the quantity of offered service. Higher values mean better vehicle utilization and economy of operation, but may also

signify inadequate service frequency and vehicle overloading. Values average 2.25, but range from 1.25 to 3.25, depending on the nature of the service.

13. Average weekday passengers per operating employee: This is obtained from the ratio:

$$\frac{\text{Average weekday revenue passengers}}{\text{Total number of operating employees}}$$

and it is computed for:

- a. each mode
- b. system

Comment: Average weekday passengers per operating employee is a basic labor efficiency measure which correlates with the revenue/cost ratio.

14. Total number of employees per million annual vehicle-miles: This is obtained from the ratio:

$$\frac{(\text{Total number of employees}) \times 10^6}{\text{Annual vehicle miles}}$$

This is computed for:

- a. each mode
- b. system

Comment: Number of employees per million vehicle-miles indicates the degree of automation and overall production efficiency of an agency's operation. However, this indicator must be observed together with service quality offered. Values of 65 are typical, the normal range being between 53 and 77.

15. Total number of operating employees per million vehicle-miles: Defined as the ratio:

$$\frac{\text{Total number of operating employees} \times 10^6}{\text{Annual vehicle-miles}}$$

This is computed for:

- a. each mode
- b. system

Comment: Similar to the immediately preceding measure, this indicator reflects purely operating efficiency (not administrative efficiency) of the agency. Services with

slow operation, such as surface buses, have high values, while high speed rail systems with one-man train operation have the lowest values.

16. Annual revenue: usually computed separately:

- a. for each mode
- b. for system

Revenues are classified in the following categories:

- i. passenger fares
- ii. advertising and other privileges
- iii. charter service
- iv. school bus contract
- v. other - tariffs, interest, rents, leases, etc.

17. Annual expenses:

- a. for each mode
- b. for system

are classified as:

- i. operating expenses:
 - wages and salaries
 - fringe benefits
 - taxes
 - supervision and scheduling of operations
 - ticketing and fare collection expenses
 - vehicle licensing and registration
- ii. Fuel and power expenses
- iii. Maintenance and repair:
 - rolling stock
 - fixed facilities
 - miscellaneous equipment
- iv. Information - advertising - promotion
- v. Depreciation
- vi. Injuries and damages:
 - insurance premiums
 - supervision and clerical support for injury and damage claims
 - settlement of liability cases

vii. Administration:

- system executives
- legal fees
- accounting costs
- data processing
- office management and services

viii. Miscellaneous:

- equipment leases
- space rental
- taxes
- etc.

18. Operating ratio: This ratio is:

$$\frac{\text{Total annual expenses}}{\text{Total annual revenue}}$$

Comment: The operating ratio is the basic indicator of the agency's financial profitability. The indicator may also be computed for individual modes or routes but some expenses are often difficult to determine precisely enough for this purpose.

19. Revenue per vehicle-mile: This measure is obtained from:

$$\frac{\text{Total annual revenue}}{\text{Total annual vehicle-miles offered}}$$

This is computed for:

- a. each mode
- b. system

Comment: Revenue per vehicle-mile is an indicator of the earning ability of the transit system. It reflects demand density, volume and quality of service as well as fare level and structure utilized. Average values are about 51 cents per vehicle-mile on bus systems, but values typically range from 35 to 60 cents per vehicle-mile. This indicator is very sensitive to the commercial speed of the system.

20. Fare and charter revenues per vehicle-mile: This measure is obtained from:

$$\frac{\text{Annual revenues from fares and charter service}}{\text{Total annual vehicle-miles offered}}$$

This is computed for:

- a. each mode
- b. system

Comment: Fares and charter revenue per vehicle mile indicate earning ability of the different modes and the system. It is similar in purpose and meaning to the preceding measure.

21. Revenue per vehicle-hour: This measure is obtained from:

$$\frac{\text{Total annual revenue}}{\text{Total number of vehicle-hours operated per year}}$$

This is computed for:

- a. each mode
- b. system

Comment: Revenue per vehicle-hour is a time efficiency indicator of earning ability.

22. Fares and charter revenue per vehicle-hour: The ratio:

$$\frac{\text{Annual revenues from fares and charter service}}{\text{Total annual vehicle-hours operated}}$$

This is computed for:

- a. each mode
- b. system

Comment: This indicator is also a time-efficiency measure of earning ability.

23. Total annual revenues per vehicle: The ratio:

$$\frac{\text{Total annual revenue}}{\text{Total number of vehicles}}$$

This is computed for:

- a. each mode
- b. system

Comment: This is an indicator of the equipment efficiency in generation of revenue.

24. Fares and charter revenues per vehicle: The ratio

$$\frac{\text{Annual revenues from fares and charter service}}{\text{Total number of vehicles}}$$

This is computed for:

- a. each mode
- b. system

25. Total annual revenue per passenger: The ratio:

$$\frac{\text{Total annual revenue}}{\text{Total annual passengers}}$$

This is computed for:

- a. each mode
- b. system

Comment: Indicates average earning per unit of "product" (passenger trip).

26. Fares and charter revenue per passenger. The ratio:

$$\frac{\text{Annual revenues from fares and charter service}}{\text{Total annual passengers}}$$

This is computed for:

- a. each mode
- b. system

27. Total cost per vehicle-miles: The ratio:

$$\frac{\text{Total annual expenses}}{\text{Total annual vehicle-miles}}$$

This is computed for:

- a. each mode
- b. system

Comment: Average values for buses are about 70 cents per vehicle mile, with typical values ranging from 55 to 80 cents per vehicle-mile.

28. Operating cost per vehicle-mile: The ratio:

$$\frac{\text{Annual expenses for operation, maintenance and fuel}}{\text{Total annual vehicle-miles}}$$

This is computed for:

- a. each mode
- b. system

Comment: Average value is 48 cents with normal range between 40 and 55 cents per vehicle-mile.

29. Total cost per vehicle-hour: The ratio:

$$\frac{\text{Total annual expenses}}{\text{Total annual vehicle-hours of operation}}$$

This is computed for:

- a. each mode
- b. system

30. Operating cost per vehicle-hour: The ratio:

$$\frac{\text{Annual expenses for operation, maintenance and fuel}}{\text{Total annual vehicle hours of operation}}$$

This is computed for:

- a. each mode
- b. system

31. Total annual cost per vehicle: The ratio:

$$\frac{\text{Total annual cost}}{\text{Total number of vehicles}}$$

This is computed for:

- a. each mode
- b. system

32. Annual operating cost per vehicle: The ratio:

$$\frac{\text{Annual expenses for operation, maintenance and fuel}}{\text{Total number of vehicles}}$$

This is computed for:

- a. each mode
- b. system

Comment: Annual operating cost per vehicle gives an indication of operating efficiency of the system and the marginal cost of operating additional vehicles.

33. Total annual cost per passenger: The ratio:

$$\frac{\text{Total annual cost}}{\text{Total annual passengers}}$$

This is computed for:

- a. each mode
- b. system

Comment: Annual operating cost per passenger is an indicator of the unit cost of providing service. It can be compared with revenue per passenger per year for a measure of profitability.

34. Operating cost per passenger: The ratio:

$$\frac{\text{Annual expenses for operation, maintenance and fuel}}{\text{Total annual passengers}}$$

This is computed for:

- a. each mode
- b. system

As mentioned, not all agencies need (nor are they able to) collect all of the above data and compute all the indicators: for some data may not be available, or some may be considered redundant. However, agency managements will find most of these data and indicators useful for analyses of their operations, planning of improvements and checking of effects of changes in operating practices. Pennsylvania DOT and UMTA require most of these data to be reported annually for the purpose of efficiency analyses of each agency as well as their mutual comparisons.

9.3 REFERENCES AND BIBLIOGRAPHY

1. Mossman, F. (ed.), Principles of Urban Transportation, The Press of Western Reserve University, 1951.
2. Smerk, G.M., et al., Indiana University--Graduate School of Business, Mass Transit Management: A Handbook for Small Cities, Institute for Urban Transportation, DOT Project No. IND-MTD-1, February 1971.
3. Pennsylvania Department of Transportation, Operating Guidelines and Standards, prepared for PennDOT by the University of Pennsylvania, 1973.