

1. Report No. FHWA/TX-01/1792-3		2. Government Accession No.		3. Recipient's Catalog No.	
4. Title and Subtitle TESTING AND EVALUATION OF A PEDESTAL BASE SIGN SUPPORT				5. Report Date January 2001	
				6. Performing Organization Code	
7. Author(s) D. Lance Bullard, Jr., Roger P. Bligh, Wanda L. Menges, and Sandra K. Schoeneman				8. Performing Organization Report No. Report 1792-3	
9. Performing Organization Name and Address Texas Transportation Institute The Texas A&M University System College Station, Texas 77843-3135				10. Work Unit No. (TRAIS)	
				11. Contract or Grant No. Project No. 0-1792	
12. Sponsoring Agency Name and Address Texas Department of Transportation Construction Division Research and Technology Transfer Section P. O. Box 5080 Austin, Texas 78763-5080				13. Type of Report and Period Covered Research: September 1998-August 2000	
				14. Sponsoring Agency Code	
15. Supplementary Notes Research performed in cooperation with the Texas Department of Transportation and the U.S. Department of Transportation, Federal Highway Administration. Research Project Title: Roadside Safety Hardware for Traffic Control Devices					
16. Abstract <p>The purpose of this series of tests is to verify the performance of the pedestal base sign installation when attached to the ground with a helical type screw-in foundation anchor assembly.</p> <p>A square base pedestal sign installation attached to the ground with a helical type screw-in foundation anchor assembly successfully met the evaluation criteria set forth in National Cooperative Highway Research Program (<i>NCHRP Report 350</i>). The installation was fabricated using a Pelco (model SP 1014 TX) square cast aluminum traffic signal base with a 114 mm (4.5 in) O.D. × 3.96 m (13 ft) long spun aluminum pole. Attached to the pole was a 16 mm × 1.2 m × 1.2 m (0.625 inch × 48 inch × 48 inch) plywood warning sign with the bottom of the sign height 2.26 m (7.4 ft). In addition, a 305 mm (12.0 inch), LED lamp, flashing yellow signal beacon was mounted directly above and below the sign panel. The helical type screw-in foundation anchor assembly (model PB5306) was placed in <i>NCHRP Report 350</i> standard soil.</p> <p>Under this project, the safety performance of selected work zone traffic control devices were evaluated through full-scale crash testing in accordance with <i>NCHRP Report 350</i> guidelines. The pedestal base sign support installation installed atop a screw-in helical type ground anchor was found to be in compliance with <i>NCHRP Report 350</i> guidelines and is considered suitable for implementation. Installations that deviate in construction significantly from the details presented herein may require additional engineering evaluation and/or testing.</p>					
17. Key Words Signs, Sign Support, Pedestal Base, Traffic Signal, Beacon Light, Crash Testing, Roadside Safety			18. Distribution Statement No restrictions. This document is available to the public through NTIS: National Technical Information Service, 5285 Port Royal Road, Springfield, Virginia 22161		
19. Security Classif. (of this report) Unclassified		20. Security Classif. (of this page) Unclassified		21. No. of Pages 84	22. Price



# **TESTING AND EVALUATION OF A PEDESTAL BASE SIGN SUPPORT**

by

D. Lance Bullard, Jr., P.E.  
Associate Research Engineer  
Texas Transportation Institute

Roger P. Bligh, P.E.  
Assistant Research Engineer  
Texas Transportation Institute

Wanda L. Menges  
Associate Research Specialist  
Texas Transportation Institute

and

Sandra K. Schoeneman  
Research Associate  
Texas Transportation Institute

Report 1792-3  
Project Number 0-1792  
Research Project Title: Roadside Safety Hardware  
for Traffic Control Devices

Sponsored by the  
Texas Department of Transportation  
In Cooperation with the  
U.S. Department of Transportation  
Federal Highway Administration

January 2001

TEXAS TRANSPORTATION INSTITUTE  
The Texas A&M University System  
College Station, Texas 77843-3135



## **DISCLAIMER**

The contents of this report reflect the views of the authors, who are solely responsible for the facts and accuracy of the data, and the opinions, findings, and conclusions presented herein. The contents do not necessarily reflect the official views or policies of the Texas Department of Transportation (TxDOT), Federal Highway Administration (FHWA), The Texas A&M University System, or the Texas Transportation Institute. This report does not constitute a standard, specification, or regulation, and its contents are not intended for construction, bidding, or permit purposes. In addition, the above listed agencies assume no liability for its contents or use thereof. The use of names of specific products or manufacturers listed herein does not imply endorsement of those products or manufacturers. The engineer in charge of the project was Mr. Roger P. Bligh, P.E. #74550.

## ACKNOWLEDGMENTS

This research project was conducted under a cooperative program between the Texas Transportation Institute, the Texas Department of Transportation and the U.S. Department of Transportation, Federal Highway Administration. The TxDOT project director for this research was Mr. Greg Brinkmeyer. His assistance is acknowledged and appreciated.

Special thanks go to the project panel:

- Greg Brinkmeyer, Traffic Operations Division-TE
- Dan Maupin, Traffic Operations-TE
- Paul Frerich, Yoakum District
- Larry Colclasure, Waco District
- Manny Aguilera, El Paso District
- David Mitchell, Traffic Operations Division-TM
- Billy Wehring, Highway Safety Service Company, Inc.
- Bill Yates, Safety Lights Company
- Garry Silagi, City of Austin

The Lubbock District and David Mitchell (TxDOT Traffic Operations Division) provided components for test installations and assistance with erecting the installations. This assistance helped the study by saving money and time.

# TABLE OF CONTENTS

	Page
LIST OF FIGURES .....	ix
LIST OF TABLES .....	x
<b>I. INTRODUCTION .....</b>	<b>1</b>
<b>PROBLEM/BACKGROUND .....</b>	<b>1</b>
<b>OBJECTIVES/SCOPE OF RESEARCH .....</b>	<b>1</b>
<b>II. STUDY APPROACH .....</b>	<b>3</b>
<b>CRASH TEST FACILITY .....</b>	<b>3</b>
<b>CRASH TEST CONDITIONS .....</b>	<b>3</b>
<b>EVALUATION CRITERIA .....</b>	<b>4</b>
<b>III. TEST ARTICLES .....</b>	<b>7</b>
<b>TEST INSTALLATION FOR TESTS 417920-1 and 2 .....</b>	<b>7</b>
<b>IV. CRASH TEST RESULTS .....</b>	<b>13</b>
<b>TEST NO. 417920-1 (NCHRP Report 350 TEST NO. 3-60) .....</b>	<b>13</b>
Test Vehicle .....	13
Soil and Weather Conditions .....	13
Test Description .....	13
Damage to Test Installation .....	16
Vehicle Damage .....	16
Occupant Risk Factors .....	16
<b>TEST NO. 417920-2 (NCHRP Report 350 TEST NO. 3-61) .....</b>	<b>22</b>
Test Vehicle .....	22
Soil and Weather Conditions .....	22
Test Description .....	22
Damage to Test Installation .....	25
Vehicle Damage .....	25
Occupant Risk Factors .....	25
<b>V. FINDINGS AND CONCLUSIONS .....</b>	<b>31</b>
<b>SUMMARY OF FINDINGS .....</b>	<b>31</b>
Low-Speed Test 417920-1 (NCHRP Report 350 Test 3-60) .....	31
High-Speed Test 417920-2 (NCHRP Report 350 Test 3-61) .....	34
<b>CONCLUSIONS .....</b>	<b>37</b>
<b>IMPLEMENTATION STATEMENT .....</b>	<b>37</b>

## TABLE OF CONTENTS (continued)

<b>REFERENCES</b> .....	41
<b>APPENDIX A. CRASH TEST PROCEDURES AND DATA ANALYSIS</b> .....	43
<b>ELECTRONIC INSTRUMENTATION AND DATA PROCESSING</b> .....	45
<b>ANTHROPOMORPHIC DUMMY INSTRUMENTATION</b> .....	46
<b>PHOTOGRAPHIC INSTRUMENTATION AND DATA PROCESSING</b> .....	46
<b>TEST VEHICLE PROPULSION AND GUIDANCE</b> .....	47
<b>APPENDIX B. TEST VEHICLE PROPERTIES AND INFORMATION</b> .....	49
<b>APPENDIX C. SEQUENTIAL PHOTOGRAPHS</b> .....	57
<b>APPENDIX D. VEHICLE ANGULAR DISPLACEMENTS</b> .....	63
<b>APPENDIX E. VEHICLE ACCELERATIONS</b> .....	67



## LIST OF FIGURES

Figure		Page
1	Pedestal Base Sign Support as Used in Tests 417920-1 and 417920-2 .....	8
2	Installation of Anchor Used in Tests 417920-1 and 417920-2 .....	10
3	Pedestal Base Sign Support before Test 417920-1 .....	11
4	Pedestal Base Sign Support before Test 417920-2 .....	12
5	Vehicle/Installation Geometrics for Test 417920-1 .....	14
6	Vehicle before Test 417920-1 .....	15
7	After Impact Trajectory for Test 417920-1 .....	17
8	Installation after Test 417920-1 .....	18
9	Vehicle after Test 417920-1 .....	19
10	Interior of Vehicle for Test 417920-1 .....	20
11	Summary of Results for Test 417920-1, <i>NCHRP Report 350 Test 3-60</i> .....	21
12	Vehicle/Installation Geometrics for Test 417920-2 .....	23
13	Vehicle before Test 417920-2 .....	24
14	After Impact Trajectory for Test 417920-2 .....	26
15	Installation after Test 417920-2 .....	27
16	Vehicle after Test 417920-2 .....	28
17	Interior of Vehicle for Test 417920-2 .....	29
18	Summary of Results for Test 417920-2, <i>NCHRP Report 350 Test 3-61</i> .....	30
19	Vehicle Properties for Test 417920-1 .....	51
20	Vehicle Properties for Test 417920-2 .....	54
21	Sequential Photographs for Test 417920-1 (Perpendicular and Oblique Views) .....	59
22	Sequential Photographs for Test 417920-2 (Perpendicular and Oblique Views) .....	61
23	Vehicular Angular Displacements for Test 417920-1 .....	65
24	Vehicular Angular Displacements for Test 417920-2 .....	66
25	Vehicle Longitudinal Accelerometer Trace for Test 417920-1 .....	69
26	Vehicle Lateral Accelerometer Trace for Test 417920-1 .....	70
27	Vehicle Vertical Accelerometer Trace for Test 417920-1 .....	71
28	Vehicle Longitudinal Accelerometer Trace for Test 417920-2 .....	72
29	Vehicle Lateral Accelerometer Trace for Test 417920-2 .....	73
30	Vehicle Vertical Accelerometer Trace for Test 417920-2 .....	74

## LIST OF TABLES

Table		Page
1	Performance Evaluation Summary for Test 417920-1, <i>NCHRP Report 350</i> Test 3-60 .....	38
2	Performance Evaluation Summary for Test 417920-2, <i>NCHRP Report 350</i> Test 3-61 .....	39
3	Exterior Crush Measurements for Test 417920-1 .....	52
4	Occupant Compartment Measurements for Test 417920-1 .....	53
5	Exterior Crush Measurements for Test 417920-2 .....	55
6	Occupant Compartment Measurements for Test 417920-2 .....	56

# I. INTRODUCTION

## PROBLEM/BACKGROUND

FHWA has formally adopted the performance evaluation guidelines for highway safety features set forth in National Cooperative Highway Research Program (*NCHRP Report 350*) as a “Guide or Reference” document in Federal Register, Volume 58, Number 135, dated July 16, 1993, which added paragraph (a) (13) to 23 CFR, Part 625.5.<sup>(1)</sup> FHWA has mandated, starting in October 1998, only support structures that have successfully met the performance evaluation guidelines set forth in *NCHRP Report 350* may be used on the National Highway System (NHS) for new installations.

Previous full-scale crash tests have demonstrated the activation and crashworthiness of pedestal-style cast aluminum base support structures when attached to a traditional concrete base (Hayes E. Ross, Jr. and D. Lance Bullard, Jr., March 1989, unpublished). Several districts within TxDOT expressed interest in using helical, screw-in foundation anchors for these supports. Screw-in foundation anchors can significantly reduce installation cost and time. A sign crew using a screw-in anchor assembly can complete an installation in a single trip rather than having to wait for a conventional concrete footing to cure. However, before this system can be used, the crashworthiness of the support attached to a screw-in anchor foundation must be demonstrated through full-scale testing. Specifically, the screw-in foundation should provide sufficient anchorage capacity to prevent excessive ground motion and permit proper activation of the cast aluminum pedestal base during a vehicular collision.

## OBJECTIVES/SCOPE OF RESEARCH

The objective of this study is to evaluate additional sign support structures and their anchor systems to determine the structures which perform satisfactorily when impacted by errant vehicles. The performance of these sign support structures would be evaluated in accordance with national safety performance guidelines set forth in *NCHRP Report 350* and the 1994 American Association of State Highway and Transportation Officials (AASHTO) *Standard Specifications for Structural Supports for Highway Signs, Luminaires and Traffic Signals*.<sup>(2)</sup>

Researchers performed two full-scale crash tests on a pedestal base sign installation attached to the ground with a helical type screw-in foundation anchor assembly.

This report presents the details of the tests. [Chapter II](#) outlines the research approach of the study, including the crash test matrix, and the evaluation criteria. Descriptions of the sign support structures tested are presented in [Chapter III](#). Results of the crash tests are presented in [Chapter IV](#). A summary of findings, conclusions, and recommendations are presented in [Chapter V](#).



## II. STUDY APPROACH

### CRASH TEST FACILITY

The test facilities at the Texas Transportation Institute's Proving Ground consist of an 809 hectare (2000 acre) complex of research and training facilities situated 16 km (10 mi) northwest of the main campus of Texas A&M University. The site, formerly an Air Force Base, has large expanses of concrete runways and parking aprons well suited for experimental research and testing in the areas of vehicle performance and handling, vehicle-roadway interaction, durability and efficacy of highway pavements, and safety evaluation of roadside safety hardware. The site selected for placement of the TxDOT sign installations was just off the edge of a wide expanse of concrete aprons that were originally used as parking aprons for military aircraft. These aprons consist of unreinforced jointed concrete pavement in 3.8 m by 4.6 m (12.5 ft by 15.0 ft) blocks nominally 152-203 mm (6-8 inch) deep. The aprons and runways are about 50 years old, and the joints have some displacement but are otherwise flat and level. The sign supports were installed in *NCHRP Report 350* standard soil. [Chapter III](#) presents further details of each of the installations.

### CRASH TEST CONDITIONS

*NCHRP Report 350* requires two tests for test level 3 evaluation of breakaway support structures:

***NCHRP Report 350 test designation 3-60:*** This test involves an 820 kg (1806 lb) passenger vehicle (820C) impacting the support structure at a nominal speed and angle of 35 km/h (21.7 mi/h) and 0–20 degrees. The purpose of this test is to evaluate the breakaway, fracture, or yielding mechanism of the support and occupant risk.

***NCHRP Report 350 test designation 3-61:*** The test involves an 820 kg (1806 lb) passenger car (820C) impacting the support structure at a nominal speed and angle of 100 km/h (62.1 mi/h) and 0–20 degrees. The test is intended to evaluate vehicle and test article trajectory and occupant risk.

Researchers performed both of these tests on the pedestal base support installation attached to a screw-in anchor assembly. The crash test and data analysis procedures were in accordance with guidelines presented in *NCHRP Report 350*. Brief descriptions of these procedures are presented in [Appendix A](#).

## EVALUATION CRITERIA

The crash tests performed were evaluated in accordance with *NCHRP Report 350*. As stated in *NCHRP Report 350*, “Safety performance of a highway appurtenance cannot be measured directly but can be judged on the basis of three factors: structural adequacy, occupant risk, and vehicle trajectory after collision.” Accordingly, the following safety evaluation criteria from table 5.1 of *NCHRP Report 350* were used to evaluate the crash tests reported herein:

- **Structural Adequacy**

B. *The test article should readily activate in a predictable manner by breaking away, fracturing, or yielding.*

- **Occupant Risk**

D. *Detached elements, fragments or other debris from the test article should not penetrate or show potential for penetrating the occupant compartment, or present an undue hazard to other traffic, pedestrians, or personnel in a work zone. Deformation of, or intrusions into, the occupant compartment that could cause serious injuries should not be permitted.*

F. *The vehicle should remain upright during and after collision although moderate roll, pitching and yawing are acceptable.*

H. *Occupant impact velocities should satisfy the following:*

<u>Longitudinal Occupant Impact Velocity - m/s</u>	
<u>Preferred</u>	<u>Maximum</u>
3 (9.8 ft/s)	5 (16.4 ft/s)

I. *Occupant ridedown accelerations should satisfy the following:*

<u>Longitudinal Occupant Ridedown Accelerations - g's</u>	
<u>Preferred</u>	<u>Maximum</u>
15	20

- **Vehicle Trajectory**

K. *After collision it is preferable that the vehicle's trajectory not intrude into adjacent traffic lanes.*

N. *Vehicle trajectory behind the test article is acceptable.*

In addition, the 1994 AASHTO Specification states:

*Satisfactory dynamic performance is indicated when the maximum change in velocity for a standard 1800 pound [817 kg] vehicle, or its equivalent, striking a breakaway support at speeds of 20 mi/h to 60 mi/h [32 km/h to 97 km/h] does not exceed 16 ft/s [4.87 m/s], but preferably does not exceed 10 ft/s [3.05 m/s] or less.*





### III. TEST ARTICLES

#### TEST INSTALLATION FOR TESTS 417920-1 AND 2

A pedestal base sign installation attached to the ground with a helical type screw-in foundation anchor assembly was constructed for crash testing and evaluation. The installation was fabricated using a Pelco (model SP 1014 TX) square cast aluminum traffic signal base with a 114 mm (4.5 in) O.D.  $\times$  3.96 m (13 ft) long spun aluminum pole. Attached to the pole was a 16 mm  $\times$  1.2 m  $\times$  1.2 m (0.625 in  $\times$  48 in  $\times$  48 in) plywood warning sign with the bottom of the sign mounted at a height of 2.26 m (7.4 ft). In addition, a 305 mm (12.0 in), LED lamp, flashing yellow signal beacon was mounted directly above and below the sign panel. The helical type screw-in foundation anchor assembly (model PB5306) was placed in *NCHRP Report 350* standard soil. [Figure 1](#) shows the details of the support structure and screw-in anchor. The system was constructed identically for each test. The screw-in anchors were installed using an auger truck, as shown in [Figure 2](#). Photographs of the completed installation for the low-speed (35 km/h) and high-speed (100 km/h) tests are shown in [Figures 3](#) and [4](#).

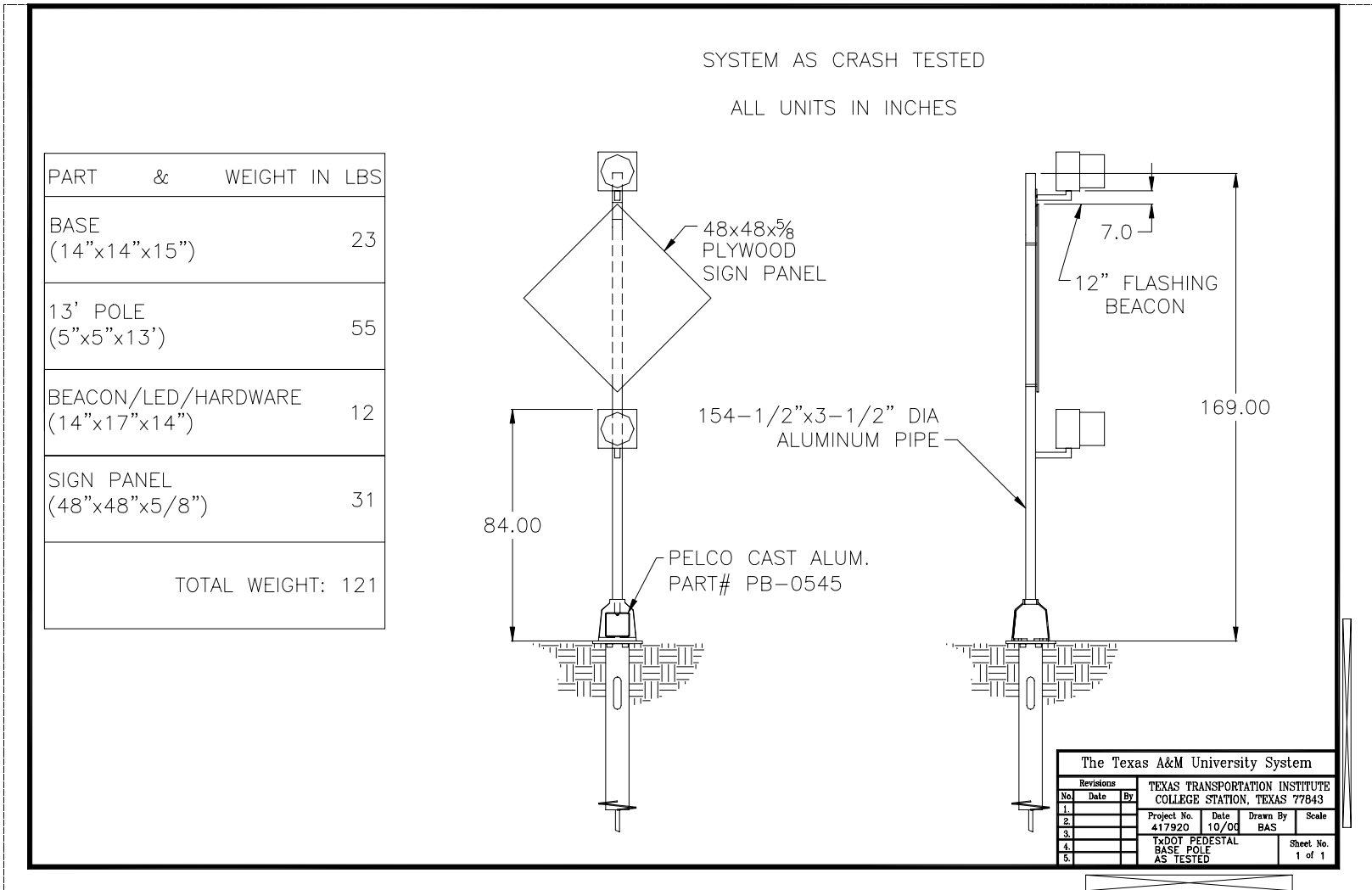

**Figure 1. Pedestal Base Sign Support as Used in Tests 417920-1 and 417920-2.**

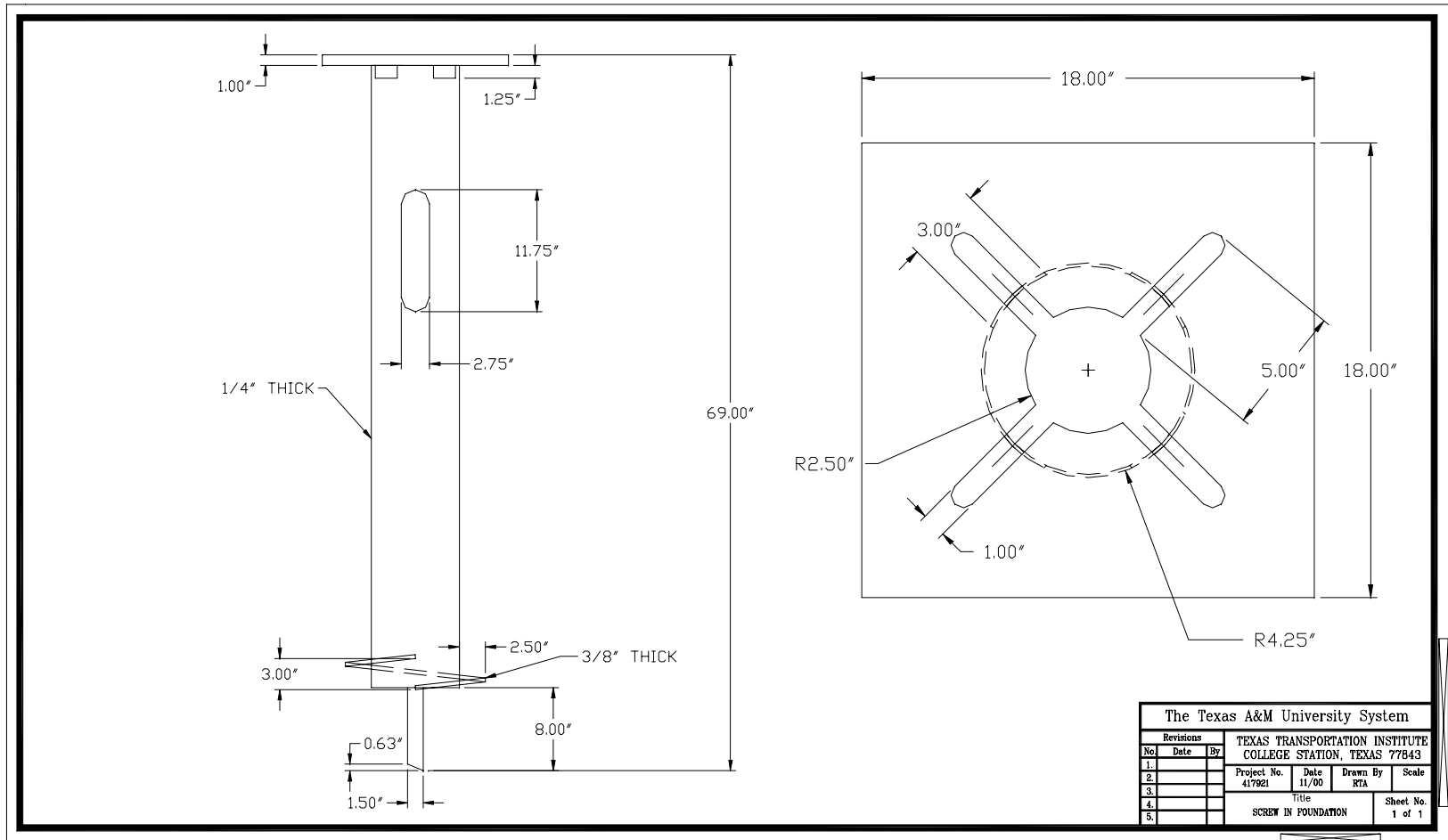

Figure 1. Pedestal Base Sign Support as Used in Tests 417920-1 and 417920-2 (continued).



**Figure 2. Installation of Anchor Used in Tests 417920-1 and 417920-2.**



**Figure 3. Pedestal Base Sign Support before Test 417920-1.**



**Figure 4. Pedestal Base Sign Support before Test 417920-2.**

## IV. CRASH TEST RESULTS

### TEST NO. 417920-1 (*NCHRP Report 350* TEST NO. 3-60)

A pedestal base sign support attached to a screw-in foundation, shown in [Figure 1](#) and [Figure 2](#), was evaluated in this crash test.

#### Test Vehicle

A 1994 Geo Metro, shown in [Figures 5](#) and [6](#), was used for the crash test. Test inertia weight of the vehicle was 820 kg (1806 lb), and its gross static weight was 894 kg (1969 lb). The height to the lower edge of the vehicle bumper was 370 mm (14.6 inch), and it was 455 mm (18.0 inch) to the upper edge of the bumper. Additional dimensions and information on the vehicle are given in [Appendix B, Figure 19](#). The vehicle was directed into the installation using the cable reverse tow and guidance system, and was released to be free-wheeling and unrestrained just prior to impact.

#### Soil and Weather Conditions

The test was performed the morning of December 16, 1999. Seven days before the test, 10 mm (0.4 inch) of rain fell; five days before, 3 mm (0.1 inch); and four days before, 20 mm (0.8 inch). No other rainfall occurred for the remaining 10 days prior to the test. The *NCHRP Report 350* standard soil in which the sign supports were placed was moistened slightly just prior to the test in order to settle the dust to ensure an unimpaired view for the high-speed cameras. Weather conditions at the time of testing were as follows: temperature: 9 °C (49 °F); relative humidity: 37 percent.

#### Test Description

The vehicle impacted the sign support head-on at a speed of 35.2 km/h (21.9 mi/h). At 0.002 s, the underside of the bumper of the vehicle contacted the pedestal base, and at 0.015 s, the pedestal base and pole moved. A crack on the field side of the pedestal base formed at 0.041 s. By 0.049 s, the pedestal base had fractured, and by 0.056 s, the pole bounced off the bumper of the vehicle. The vehicle lost contact with the pole at 0.126 s as the vehicle was traveling at a speed of 27.0 km/h (16.8 mi/h). At 0.481 s, the lower signal light contacted the vehicle at the top of the windshield near the roof, and at 0.507 s, the pole was parallel with the ground above the hood. The sign panel contacted the rear right corner of the roof of the vehicle at 0.569 s, and at 0.692 s, the pole lost contact with the rear window. By 0.719 s, the lower signal light lost contact with the roof of the vehicle as the vehicle was traveling at a speed of 26.6 km/h



**Figure 5. Vehicle/Installation Geometrics for Test 417920-1.**





**Figure 6. Vehicle before Test 417920-1.**

(16.5 mi/h). By 0.811 s, the upper warning beacon contacted the ground surface. Brakes on the vehicle were applied as the vehicle exited the test site and the vehicle came to rest 32.0 m (105.0 ft) from the impact point. Sequential photographs of the test can be found in [Appendix C, Figure 21](#).

### **Damage to Test Installation**

The pedestal base fractured into several pieces, as shown in [Figures 7 and 8](#). The base of the pedestal moved 15 mm (0.6 inch) on the right front side and 10 mm (0.4 inch) on the left rear side. The sign panel detached from the top bracket. The top beacon detached, and the bottom beacon was cracked but remained attached to the pole. The debris extended 9.0 m (30.0 ft) downstream from the impact point.

### **Vehicle Damage**

As shown in [Figure 9](#), the vehicle sustained minimal damage to the bumper, hood, fan, radiator, and radiator support. Maximum exterior crush to the vehicle was 140 mm (5.5 inch) to the right front inner bumper at bumper height. Maximum deformation of the occupant compartment was 30 mm (1.2 inch) to the center of the roof. The interior of the vehicle is shown in [Figure 10](#). Exterior vehicle crush and occupant compartment measurements are shown in [Appendix B, Tables 3 and 4](#).

### **Occupant Risk Factors**

Data from the accelerometer located at the vehicle center of gravity were digitized for evaluation of occupant risk and were computed as follows. In the longitudinal direction, the occupant impact velocity was 1.6 m/s (5.2 ft/s) at 0.397 s, the highest 0.010-s occupant ridedown acceleration was 0.4 g's from 0.653 to 0.663 s, and the maximum 0.050-s average acceleration was -3.9 g's between 0.013 and 0.063 s. In the lateral direction, the occupant impact velocity was 0.3 m/s (1.0 ft/s) at 0.397 s, the highest 0.010-s occupant ridedown acceleration was -0.4 g's from 0.585 to 0.595 s, and the maximum 0.050-s average was 0.4 g's between 0.075 and 0.125 s. These data and other pertinent information from the test are summarized in [Figure 11](#). Vehicle angular displacements are shown in [Appendix D, Figure 23](#), and vehicle accelerations versus time traces are presented in [Appendix E, Figures 25 through 27](#).



**Figure 7. After Impact Trajectory for Test 417920-1.**

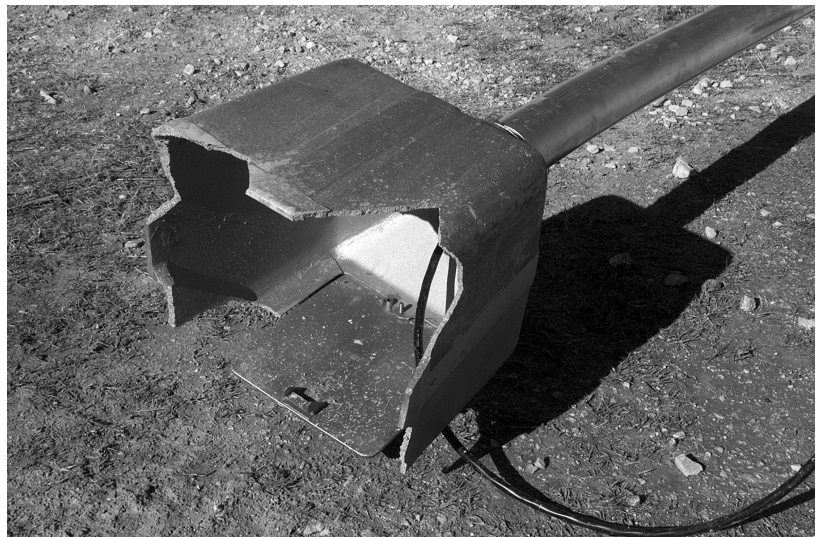
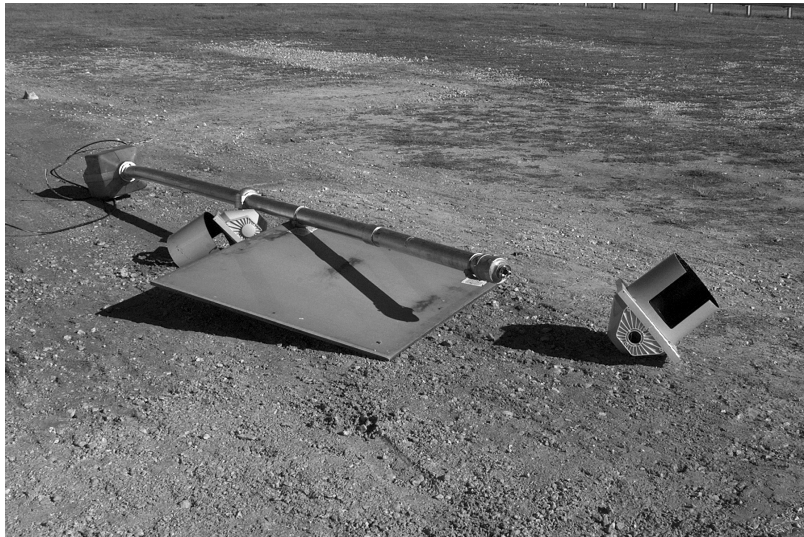
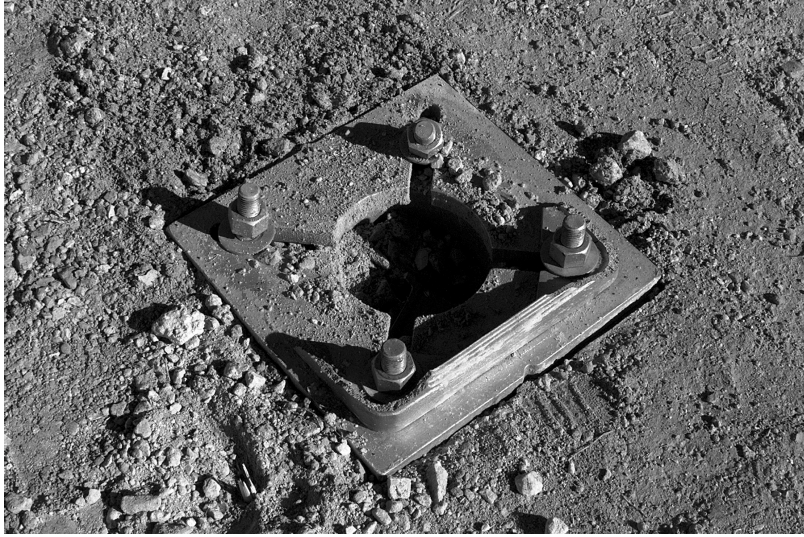

**Figure 8. Installation after Test 417920-1.**



**Figure 9. Vehicle after Test 417920-1.**



Before test



After test

**Figure 10. Interior of Vehicle for Test 417920-1.**

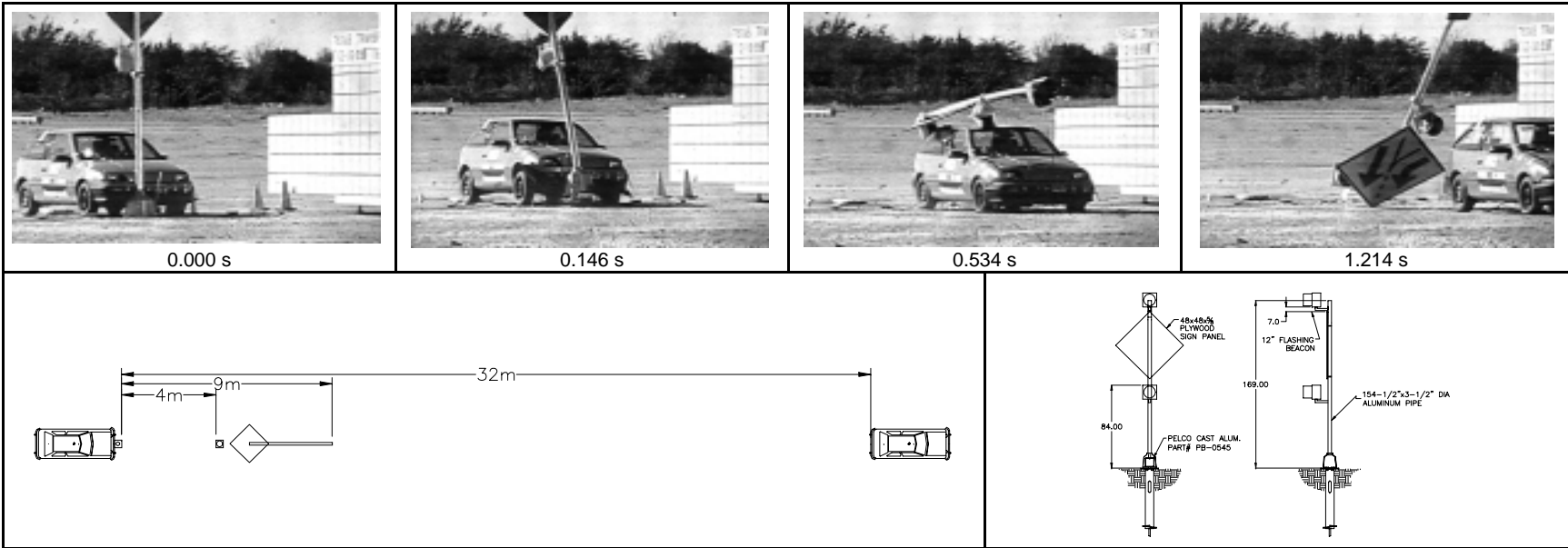

21

<p><b>General Information</b></p> <p>Test Agency ..... Texas Transportation Institute</p> <p>Test No. .... 417920-1</p> <p>Date ..... 12/16/99</p> <p><b>Test Article</b></p> <p>Type ..... Sign Support</p> <p>Name ..... Pedestal Base Sign Support</p> <p>Installation Height (m) ..... 2.1 (7.0 ft)</p> <p>Material or Key Elements ... Single Steel Post w/ 1.2 m x 1.2 m x 16 mm (4 ft x 4 ft x 0.625 in) Sign Panel, Mounted at 2.1 m (7.0 ft)</p> <p><b>Soil Type and Condition</b> .... Standard Soil, Dry</p> <p><b>Test Vehicle</b></p> <p>Type ..... Production</p> <p>Designation ..... 820C</p> <p>Model ..... 1994 Geo Metro</p> <p>Mass (kg)</p> <p>  Curb ..... 743 (1638 lb)</p> <p>  Test Inertial ..... 820 (1806 lb)</p> <p>  Dummy ..... 74 (163 lb)</p> <p>  Gross Static ..... 894 (1969 lb)</p>	<p><b>Impact Conditions</b></p> <p>Speed (km/h) ..... 35.2 (21.9 mi/h)</p> <p>Angle (deg) ..... 0</p> <p><b>Exit Conditions</b></p> <p>Speed (km/h) ..... 27.0 (16.8 mi/h)</p> <p>Angle (deg) ..... 0</p> <p><b>Occupant Risk Values</b></p> <p>Impact Velocity (m/s)</p> <p>  x-direction ..... 1.6 (5.2 ft/s)</p> <p>  y-direction ..... 0.3 (1.0 ft/s)</p> <p>THIV (km/h) ..... 5.9 (3.7 mi/h)</p> <p>Ridedown Accelerations (g's)</p> <p>  x-direction ..... 0.4</p> <p>  y-direction ..... -0.4</p> <p>PHD (g's) ..... 0.8</p> <p>ASI ..... 0.39</p> <p>Max. 0.050-s Average (g's)</p> <p>  x-direction ..... -3.9</p> <p>  y-direction ..... 0.4</p> <p>  z-direction ..... -2.4</p>	<p><b>Test Article Debris Scatter (m)</b></p> <p>Longitudinal ..... 9 (30.0 ft)</p> <p>Lateral ..... nil</p> <p><b>Vehicle Damage</b></p> <p>Exterior</p> <p>  VDS ..... 12FR1</p> <p>  CDC ..... 12FREW1</p> <p>Maximum Exterior</p> <p>  Vehicle Crush (mm) ..... 140 (5.5 inch)</p> <p>Interior</p> <p>  OCDI ..... FR01000000</p> <p>Max. Occ. Compart.</p> <p>  Deformation (mm) ..... 30 (1.2 inch)</p> <p><b>Post-Impact Behavior</b> (during 1.0 s after impact)</p> <p>Max. Yaw Angle (deg) ..... 3</p> <p>Max. Pitch Angle (deg) ..... 3</p> <p>Max. Roll Angle (deg) ..... -3</p>
--	--	--

**Figure 11. Summary of Results for Test 417920-1, NCHRP Report 350 Test 3-60.**

## TEST NO. 417920-2 (NCHRP Report 350 TEST NO. 3-61)

A pedestal base sign support attached to a screw-in anchor foundation, shown in [Figure 1](#) and [Figure 3](#), was evaluated in this crash test.

### Test Vehicle

A 1994 Geo Metro, shown in [Figures 12](#) and [13](#), was used for the crash test. Test inertia weight of the vehicle was 820 kg (1806 lb), and its gross static weight was 896 kg (1974 lb). The height to the lower edge of the vehicle bumper was 370 mm (14.6 inch) and it was 455 mm (18.0 inch) to the upper edge of the bumper. Additional dimensions and information on the vehicle are given in [Appendix B, Figure 20](#). The vehicle was directed into the installation using the cable reverse tow and guidance system, and was released to be free-wheeling and unrestrained just prior to impact.

### Soil and Weather Conditions

The test was performed the afternoon of December 16, 1999. Seven days before the test, 10 mm (0.4 inch) of rain fell; five days before, 3 mm (0.1 inch); and four days before, 20 mm (0.8 inch). No other rainfall occurred for the remaining 10 days prior to the test. The *NCHRP Report 350* standard soil in which the sign supports were placed was moistened slightly just prior to the test in order to settle the dust to ensure an unimpaired view for the high-speed cameras. Weather conditions at the time of testing were as follows: wind speed: 13 km/h (8 mi/h); wind direction: 180 degrees with respect to the vehicle (vehicle was traveling in a northerly direction); temperature: 19 °C (66 °F); relative humidity: 15 percent.

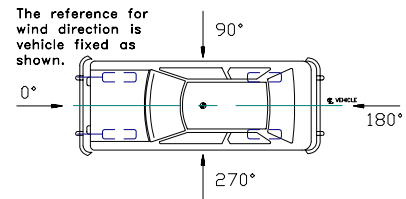

### Test Description

The vehicle impacted the sign support head-on at a speed of 99.9 km/h (62.1 mi/h). At 0.002 s, the underside of the bumper of the vehicle contacted the pedestal base, and at 0.007 s the pedestal base and pole moved. By 0.019 s, the pedestal base had fractured, and by 0.026 s, a crack on the field side of the pedestal base formed. The post bounced off the bumper of the vehicle at 0.049 s, and at 0.100 s the vehicle lost contact with the pole. The vehicle lost contact with the pedestal base at 0.119 s as the vehicle was traveling at a speed of 94.2 km/h (58.5 mi/h). At 0.146 s, the lower beacon signal light contacted the vehicle at the middle of the roof, and at 0.175 s, the pole was parallel with the ground. The lower light lost contact with the roof of the vehicle, and the upper beacon signal light contacted the ground surface at 0.248 s as the vehicle





**Figure 12. Vehicle/Installation Geometrics for Test 417920-2.**



**Figure 13. Vehicle before Test 417920-2.**

was traveling at a speed of 94.2 km/h (58.5 mi/h). The sign panel detached from the pole at 0.277 s. Brakes on the vehicle were applied as it exited the test site, and the vehicle came to rest 86.9 m (285.1 ft) downstream from impact point and 3.0 m (9.8 ft) toward traffic lanes. Sequential photographs of the test can be found in [Appendix C, Figure 22](#).

### **Damage to Test Installation**

The pedestal base fractured into several pieces, as shown in [Figures 14 and 15](#). The base of the pedestal sign moved 8 mm (0.3 in) on the right front side and 15 mm (0.6 in) on the left rear side. The sign panel detached from the pole. The top beacon signal detached, and the bottom beacon broke but stayed attached to the pole. The debris extended 30.0 m (98.4 ft) downstream, 1.5 m (5.0 ft) to the right, and 5.3 m (17.4 ft) to the left of the impact point.

### **Vehicle Damage**

As shown in [Figure 16](#), the vehicle sustained minimal damage to the bumper, hood, fan, radiator and radiator support. Maximum exterior crush to the vehicle was 200 mm (7.9 inch) to the left front inner bumper at bumper height. The interior of the vehicle is shown in [Figure 17](#). Exterior vehicle crush and occupant compartment measurements are shown in [Appendix B, Tables 5 and 6](#).

### **Occupant Risk Factors**

Data from the accelerometer located at the vehicle center of gravity were digitized for evaluation of occupant risk and were computed as follows. In the longitudinal direction, the occupant impact velocity was 1.2 m/s (3.9 ft/s) at 0.521 s, the highest 0.010-s occupant ridedown acceleration was -0.3 g's from 0.959 to 0.969 s, and the maximum 0.050-s average acceleration was -2.8 g's between 0.001 and 0.051 s. In the lateral direction, the occupant impact velocity was 0.4 m/s (1.3 ft/s) at 0.521 s, the highest 0.010-s occupant ridedown acceleration was 0.2 g's from 0.538 to 0.548 s, and the maximum 0.050-s average was -0.3 g's between 0.059 and 0.109 s. These data and other pertinent information from the test are summarized in [Figure 18](#). Vehicle angular displacements are shown in [Appendix D, Figure 24](#), and vehicle accelerations versus time traces are presented in [Appendix E, Figures 28 through 30](#).



**Figure 14. After Impact Trajectory for Test 417920-2.**

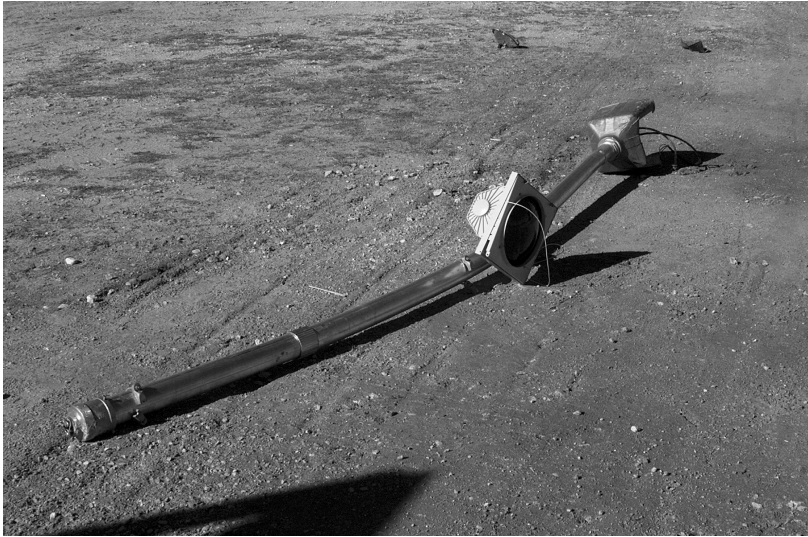

**Figure 15. Installation after Test 417920-2.**



**Figure 16. Vehicle after Test 417920-2.**



Before test



After test

**Figure 17. Interior of Vehicle for Test 417920-2.**

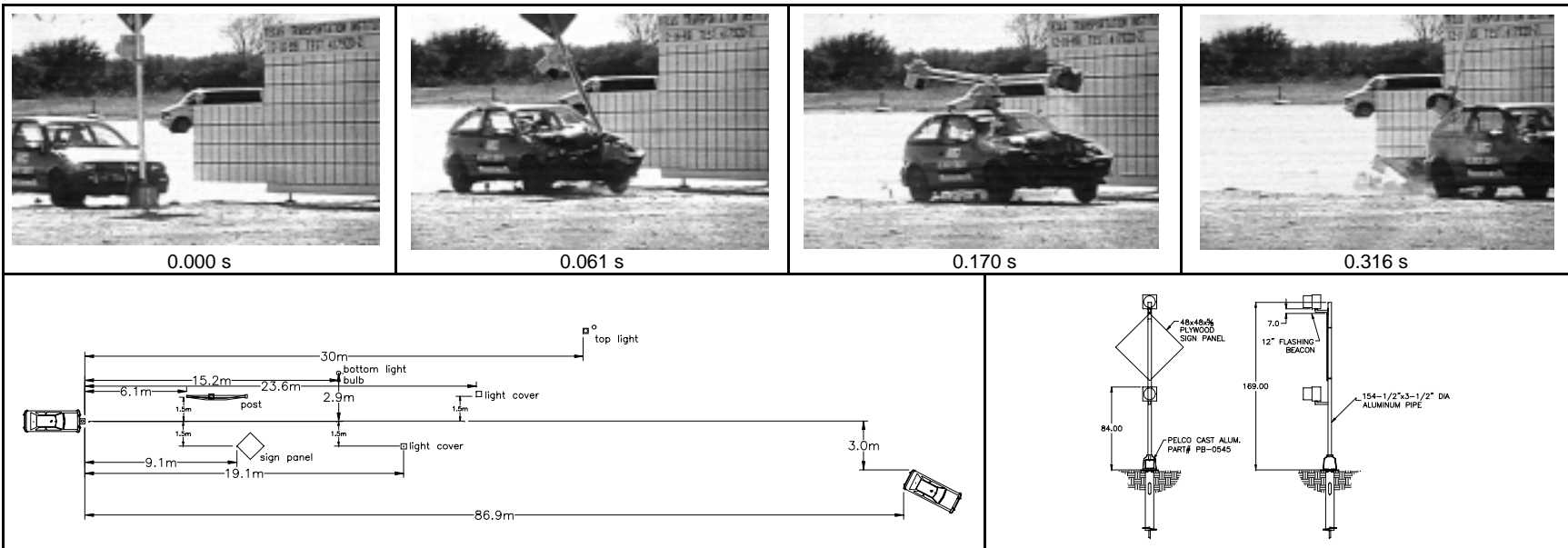

30

**General Information**

Test Agency ..... Texas Transportation Institute  
 Test No. .... 417920-2  
 Date ..... 12/16/99

**Test Article**

Type ..... Sign Support  
 Name ..... Pedestal Base Sign Support  
 Installation Height (m) ..... 2.1 (7.0 ft)  
 Material or Key Elements ... Single Steel Post w/ 1.2 m x 1.2 m x 16 mm (4 ft x 4 ft x 0.625 in) Sign Panel, Mounted at 2.1 m (7.0 ft)

**Soil Type and Condition** .... Standard Soil, Dry

**Test Vehicle**

Type ..... Production  
 Designation ..... 820C  
 Model ..... 1994 Geo Metro  
 Mass (kg)  
 Curb ..... 764 (1684 lb)  
 Test Inertial ..... 820 (1806 lb)  
 Dummy ..... 76 (168 lb)  
 Gross Static ..... 896 (1974 lb)

**Impact Conditions**

Speed (km/h) ..... 99.9 (62.1 mi/h)  
 Angle (deg) ..... 0

**Exit Conditions**

Speed (km/h) ..... 94.2 (58.5 mi/h)  
 Angle (deg) ..... 0

**Occupant Risk Values**

Impact Velocity (m/s)  
 x-direction ..... 1.2 (3.9 ft/s)  
 y-direction ..... 0.4 (1.3 ft/s)  
 THIV (km/h) ..... 4.6 (2.9 mi/h)  
 Ridedown Accelerations (g's)  
 x-direction ..... -0.3  
 y-direction ..... 0.2  
 PHD (g's) ..... 0.5  
 ASI ..... 0.28  
 Max. 0.050-s Average (g's)  
 x-direction ..... -2.8  
 y-direction ..... -0.3  
 z-direction ..... -1.6

**Test Article Debris Scatter (m)**

Longitudinal ..... 30.0 (98.4 ft)  
 Lateral ..... 5.3 (17.4 ft)

**Vehicle Damage**

Exterior  
 VDS ..... 12FC2  
 CDC ..... 12FCEW2  
 Maximum Exterior  
 Vehicle Crush (mm) ..... 200 (7.9 inch)  
 Interior  
 ODCI ..... FS0000000  
 Max. Occ. Compart.  
 Deformation (mm) ..... nil

**Post-Impact Behavior**

(during 1.0 s after impact)  
 Max. Yaw Angle (deg) ..... -2  
 Max. Pitch Angle (deg) ..... 7  
 Max. Roll Angle (deg) ..... 7

**Figure 18. Summary of Results for Test 417920-2, NCHRP Report 350 Test 3-61.**



## V. FINDINGS AND CONCLUSIONS

### SUMMARY OF FINDINGS

An assessment of each test base on the applicable *NCHRP Report 350* safety evaluation criteria is provided below.

#### Low-Speed Test 417920-1 (*NCHRP Report 350 Test 3-60*)

- **Structural Adequacy**

- B. *The test article should readily activate in a predictable manner by breaking away, fracturing, or yielding.*

Result: The cast aluminum pedestal base met the requirements for structural adequacy by fracturing and yielding to the vehicle.

- **Occupant Risk**

- D. *Detached elements, fragments or other debris from the test article should not penetrate or show potential for penetrating the occupant compartment, or present an undue hazard to other traffic, pedestrians, or personnel in a work zone. Deformation of, or intrusions into, the occupant compartment that could cause serious injuries should not be permitted.*

Result: The detached elements did not penetrate or show potential to penetrate the occupant compartment, or otherwise present undue hazard to others in the area. Maximum deformation of the occupant compartment was 30 mm (1.2 inch) (3 percent reduction of space) to the center of the roof.

- F. *The vehicle should remain upright during and after collision although moderate roll, pitching and yawing are acceptable.*

Result: The vehicle remained upright during and after the collision period.

H. *Occupant impact velocities should satisfy the following:*

*Longitudinal Occupant Impact Velocity - m/s*

<u><i>Preferred</i></u>	<u><i>Maximum</i></u>
<i>3 (9.8 ft/s)</i>	<i>5 (16.4 ft/s)</i>

Result: Longitudinal occupant impact velocity was 1.6 m/s (5.2 ft/s).

I. *Occupant ridedown accelerations should satisfy the following:*

*Longitudinal Occupant Ridedown Accelerations - g's*

<u><i>Preferred</i></u>	<u><i>Maximum</i></u>
<i>15</i>	<i>20</i>

Result: Longitudinal ridedown acceleration was 0.4 g's and in the lateral ridedown acceleration was -0.4 g's.

● **Vehicle Trajectory**

K. *After collision it is preferable that the vehicle's trajectory not intrude into adjacent traffic lanes.*

Result: The vehicle did not intrude into adjacent traffic lanes.

N. *Vehicle trajectory behind the test article is acceptable.*

Result: The vehicle trajectory behind the test article is acceptable.

The following supplemental evaluation factors and terminology, as presented in the FHWA memo entitled "Action: Identifying Acceptable Highway Safety Features," were used for visual assessment of test results:

◆ **PASSENGER COMPARTMENT INTRUSION**

**1. Windshield Intrusion**

- |  |  |
|--|--|
| a. <u>No windshield contact</u>                            | e. Complete intrusion into passenger compartment |
| b. Windshield contact, no damage                           | f. Partial intrusion into passenger compartment  |
| c. Windshield contact, no intrusion                        |  |
| d. Device embedded in windshield, no significant intrusion |  |

**2. Body Panel Intrusion**                      yes          or          no

◆ **LOSS OF VEHICLE CONTROL**

1. Physical loss of control
2. Loss of windshield visibility
3. Perceived threat to other vehicles
4. Debris on pavement

◆ **PHYSICAL THREAT TO WORKERS OR OTHER VEHICLES**

1. Harmful debris that could injure workers or others in the area
2. Harmful debris that could injure occupants in other vehicles

The debris was not dispersed in a pattern that could injure occupants in other vehicles or others in the area.

◆ **VEHICLE AND DEVICE CONDITION**

1. Vehicle Damage

- a. None
- b. Minor scrapes, scratches or dents
- c. Significant cosmetic dents
- d. Major dents to grill and body panels
- e. Major structural damage

2. Windshield Damage

- a. None
- b. Minor chip or crack
- c. Broken, no interference with visibility
- d. Broken and shattered, visibility restricted but remained intact
- e. Shattered, remained intact but partially dislodged
- f. Large portion removed
- g. Completely removed

3. Device Damage

- a. None
- b. Superficial
- c. Substantial, but can be straightened
- d. Substantial, replacement parts needed for repair
- e. Cannot be repaired

In addition, the 1994 AASHTO Specification states:

*Satisfactory dynamic performance is indicated when the maximum change in velocity for a standard 1800 pound [817 kg] vehicle, or its equivalent, striking a breakaway support at speeds of 20 mi/h to 60 mi/h [32 km/h to 97 km/h] does not exceed 16 ft/s [ 4.87 m/s], but preferably does not exceed 10 ft/s [3.05 m/s] or less.*

Result: Maximum change in velocity for this test was 2.3 m/s (7.5 ft/s).

**High-Speed Test 417920-2 (NCHRP Report 350 Test 3-61)**

- **Structural Adequacy**

- B. *The test article should readily activate in a predictable manner by breaking away, fracturing, or yielding.*

Result: The cast aluminum pedestal base met the requirements for structural adequacy by fracturing and yielding to the vehicle.

- **Occupant Risk**

- D. *Detached elements, fragments or other debris from the test article should not penetrate or show potential for penetrating the occupant compartment, or present an undue hazard to other traffic, pedestrians, or personnel in a work zone. Deformation of, or intrusions into, the occupant compartment that could cause serious injuries should not be permitted.*

Result: The detached elements did not penetrate or show potential to penetrate the occupant compartment, or otherwise present undue hazard to others in the area. No deformation or intrusion of the occupant compartment occurred.

- F. *The vehicle should remain upright during and after collision although moderate roll, pitching and yawing are acceptable.*

Result: The vehicle remained upright during and after the collision period.

- H. *Occupant impact velocities should satisfy the following:*

<u>Longitudinal Occupant Impact Velocity - m/s</u>	
<u>Preferred</u>	<u>Maximum</u>
3	5

Result: Longitudinal occupant impact velocity was 1.2 m/s (3.9 ft/s).

I. *Occupant ridedown accelerations should satisfy the following:*

<u>Longitudinal Occupant Ridedown Accelerations - g's</u>	
<u>Preferred</u>	<u>Maximum</u>
15	20

Result: Longitudinal ridedown acceleration was -0.3 g's and in the lateral ridedown acceleration was 0.2 g's.

- **Vehicle Trajectory**

K. *After collision it is preferable that the vehicle's trajectory not intrude into adjacent traffic lanes.*

Result: The vehicle traveled in a straightforward manner and came to rest 86.9 m (9.8 ft) behind the sign support and 3.0 m (9.8 ft) toward traffic lanes.

N. *Vehicle trajectory behind the test article is acceptable.*

Result: The vehicle trajectory behind the test article is acceptable.

The following supplemental evaluation factors and terminology, as presented in the FHWA memo entitled "Action: Identifying Acceptable Highway Safety Features," were used for visual assessment of test results:

- ◆ **PASSENGER COMPARTMENT INTRUSION**

**1. Windshield Intrusion**

- |  |  |
|--|--|
| a. <u>No windshield contact</u>                            | e. Complete intrusion into passenger compartment |
| b. Windshield contact, no damage                           | f. Partial intrusion into passenger compartment  |
| c. Windshield contact, no intrusion                        |  |
| d. Device embedded in windshield, no significant intrusion |  |

**2. Body Panel Intrusion**                                  yes                  or                  no

- ◆ **LOSS OF VEHICLE CONTROL**

- |   |  |
|---|--|
| <b>1. Physical loss of control</b>      | <b>3. Perceived threat to other vehicles</b> |
| <b>2. Loss of windshield visibility</b> | <b>4. <u>Debris on pavement</u></b>          |

◆ **PHYSICAL THREAT TO WORKERS OR OTHER VEHICLES**

**1. Harmful debris that could injure workers or others in the area**

**2. Harmful debris that could injure occupants in other vehicles**

The debris was not dispersed in a pattern that could injure occupants in other vehicles or others in the area.

◆ **VEHICLE AND DEVICE CONDITION**

**1. Vehicle Damage**

- |                                      |  |
|--------------------------------------|--|
| a. None                              | d. <u>Major dents to grill and body panels</u> |
| b. Minor scrapes, scratches or dents | e. Major structural damage                     |
| c. Significant cosmetic dents        |  |

**2. Windshield Damage**

- |  |   |
|--|---|
| a. <u>None</u>   | e. Shattered, remained intact but partially dislodged |
| b. Minor chip or crack   | f. Large portion removed                              |
| c. Broken, no interference with visibility                         | g. Completely removed                                 |
| d. Broken and shattered, visibility restricted but remained intact |   |

**3. Device Damage**

- |   |  |
|---|--|
| a. None                                 | d. <u>Substantial, replacement parts needed for repair</u> |
| b. Superficial                          | e. Cannot be repaired                                      |
| c. Substantial, but can be straightened |  |

In addition, the 1994 AASHTO Specification states:

*Satisfactory dynamic performance is indicated when the maximum change in velocity for a standard 1800 pound [817 kg] vehicle, or its equivalent, striking a breakaway support at speeds of 20 mi/h to 60 mi/h [32 km/h to 97 km/h] does not exceed 16 ft/s [ 4.87 m/s], but preferably does not exceed 10 ft/s [3.05 m/s] or less.*

Result: Maximum change in velocity for this test was 1.6 m/s (5.2 ft/s).

## CONCLUSIONS

A square base pedestal sign installation attached to the ground with a helical type screw-in foundation anchor assembly successfully met the evaluation criteria set forth in *NCHRP Report 350*. A summary of the evaluation is provided in [Tables 1](#) and [2](#). The installation was fabricated using a Pelco (model SP 1014 TX) square cast aluminum traffic signal base with a 114 mm (4.5 inch) O.D. × 3.96 m (13 ft) long spun aluminum pole. Attached to the pole was a 16 mm × 1.2 m × 1.2 m (0.625 inch × 48 inch × 48 inch) plywood warning sign with the bottom of the sign height 2.26 m (7.4 ft). In addition, a 305 mm (12.0 inch), LED lamp, flashing yellow signal beacon was mounted directly above and below the sign panel. The helical type screw-in foundation anchor assembly (model PB5306) was placed in *NCHRP Report 350* standard soil using an auger truck provided by TxDOT.

## IMPLEMENTATION STATEMENT

A pedestal base sign support installation installed atop a screw-in helical type ground anchor was evaluated through full-scale crash testing. The system met *NCHRP Report 350* guidelines and is considered suitable for implementation.

This report presents details of the pedestal base sign installation as tested. Installations that deviate in construction significantly from the details presented herein may require additional engineering evaluation and/or testing.

**Table 1. Performance Evaluation Summary for Test 417920-1, NCHRP Report 350 Test 3-60.**

Test Agency: Texas Transportation Institute

Test No.: 417920-1

Test Date: 12/16/99

<b>NCHRP Report 350 Evaluation Criteria</b>				<b>Test Results</b>		<b>Assessment</b>									
<u>Structural Adequacy</u>															
B. The test article should readily activate in a predictable manner by breaking away, fracturing, or yielding.				The cast aluminum pedestal base fractured and yielded to the vehicle.		Pass									
<u>Occupant Risk</u>															
D. Detached elements, fragments or other debris from the test article should not penetrate or show potential for penetrating the occupant compartment, or present an undue hazard to other traffic, pedestrians, or personnel in a work zone. Deformations of, or intrusions into, the occupant compartment that could cause serious injuries should not be permitted.				The detached elements did not penetrate or show potential to penetrate the occupant compartment, or otherwise present undue hazard to others in the area. Maximum deformation of the occupant compartment was 30 mm (1.2 in) to the center of the roof.		Pass									
F. The vehicle should remain upright during and after collision although moderate roll, pitching and yawing are acceptable.				The vehicle remained upright during and after the collision period.		Pass									
H. Occupant impact velocities should satisfy the following:															
<table border="1" style="width: 100%; border-collapse: collapse;"> <thead> <tr> <th colspan="3">Occupant Velocity Limits (m/s)</th> </tr> <tr> <th>Component</th> <th>Preferred</th> <th>Maximum</th> </tr> </thead> <tbody> <tr> <td>Longitudinal</td> <td>3</td> <td>5</td> </tr> </tbody> </table>				Occupant Velocity Limits (m/s)			Component	Preferred	Maximum	Longitudinal	3	5	Longitudinal occupant impact velocity was 1.6 m/s (5.2 ft/s).		Pass
Occupant Velocity Limits (m/s)															
Component	Preferred	Maximum													
Longitudinal	3	5													
I. Occupant ridedown accelerations should satisfy the following:															
<table border="1" style="width: 100%; border-collapse: collapse;"> <thead> <tr> <th colspan="3">Occupant Ridedown Acceleration Limits (G's)</th> </tr> <tr> <th>Component</th> <th>Preferred</th> <th>Maximum</th> </tr> </thead> <tbody> <tr> <td>Longitudinal</td> <td>15</td> <td>20</td> </tr> </tbody> </table>				Occupant Ridedown Acceleration Limits (G's)			Component	Preferred	Maximum	Longitudinal	15	20	Longitudinal ridedown acceleration was 0.4 g's.		Pass
Occupant Ridedown Acceleration Limits (G's)															
Component	Preferred	Maximum													
Longitudinal	15	20													
<u>Vehicle Trajectory</u>															
K. After collision it is preferable that the vehicle's trajectory not intrude into adjacent traffic lanes.				The vehicle traveled in a straightforward manner and came to rest 32.0 m (105.0 ft) directly behind the sign support.		Pass									
N. Vehicle trajectory behind the test article is acceptable.				The vehicle trajectory behind the test article is acceptable.		Pass									



**Table 2. Performance Evaluation Summary for Test 417920-2, NCHRP Report 350 Test 3-61.**

Test Agency: Texas Transportation Institute

Test No.: 417920-2

Test Date: 12/16/99

<b>NCHRP Report 350 Evaluation Criteria</b>		<b>Test Results</b>	<b>Assessment</b>									
<u>Structural Adequacy</u>												
B.	The test article should readily activate in a predictable manner by breaking away, fracturing, or yielding.	The cast aluminum pedestal base fractured and yielded to the vehicle.	Pass									
<u>Occupant Risk</u>												
D.	Detached elements, fragments or other debris from the test article should not penetrate or show potential for penetrating the occupant compartment, or present an undue hazard to other traffic, pedestrians, or personnel in a work zone. Deformations of, or intrusions into, the occupant compartment that could cause serious injuries should not be permitted.	The detached elements did not penetrate or show potential to penetrate the occupant compartment, or otherwise present undue hazard to others in the area. No deformation or intrusion of the occupant compartment occurred.	Pass									
F.	The vehicle should remain upright during and after collision although moderate roll, pitching and yawing are acceptable.	The vehicle remained upright during and after the collision period.	Pass									
H.	Occupant impact velocities should satisfy the following:											
<table border="1"> <thead> <tr> <th colspan="3">Occupant Velocity Limits (m/s)</th> </tr> <tr> <th>Component</th> <th>Preferred</th> <th>Maximum</th> </tr> </thead> <tbody> <tr> <td>Longitudinal</td> <td>3</td> <td>5</td> </tr> </tbody> </table>		Occupant Velocity Limits (m/s)			Component	Preferred	Maximum	Longitudinal	3	5	Longitudinal occupant impact velocity was 0.8 m/s (2.6 ft/s).	Pass
Occupant Velocity Limits (m/s)												
Component	Preferred	Maximum										
Longitudinal	3	5										
I.	Occupant ridedown accelerations should satisfy the following:											
<table border="1"> <thead> <tr> <th colspan="3">Occupant Ridedown Acceleration Limits (G's)</th> </tr> <tr> <th>Component</th> <th>Preferred</th> <th>Maximum</th> </tr> </thead> <tbody> <tr> <td>Longitudinal</td> <td>15</td> <td>20</td> </tr> </tbody> </table>		Occupant Ridedown Acceleration Limits (G's)			Component	Preferred	Maximum	Longitudinal	15	20	Longitudinal ridedown acceleration was 0.1 g's.	Pass
Occupant Ridedown Acceleration Limits (G's)												
Component	Preferred	Maximum										
Longitudinal	15	20										
<u>Vehicle Trajectory</u>												
K.	After collision it is preferable that the vehicle's trajectory not intrude into adjacent traffic lanes.	The vehicle traveled in a straightforward manner and came to rest 86.9 m (285.1 ft) behind the sign support and 3.0 m (9.8 ft) toward traffic lanes.	Pass									
N.	Vehicle trajectory behind the test article is acceptable.	The vehicle trajectory behind the test article is acceptable.	Pass									

## REFERENCES

1. H. E. Ross, Jr., D. L. Sicking, R. A. Zimmer and J. D. Michie, *Recommended Procedures for the Safety Performance Evaluation of Highway Features*, National Cooperative Highway Research Program Report 350, Transportation Research Board, National Research Council, Washington, D.C., 1993.
2. *Standard Specifications for Structural Supports for Highway Signs, Luminaires, and Traffic Signals*, American Association of State Highway and Transportation Officials (AASHTO), Washington, D.C., 1994.



## **APPENDIX A. CRASH TEST PROCEDURES AND DATA ANALYSIS**



## **APPENDIX A. CRASH TEST PROCEDURES AND DATA ANALYSIS**

The crash test and data analysis procedures were in accordance with guidelines presented in *NCHRP Report 350*. Brief descriptions of these procedures are presented as follows.

### **ELECTRONIC INSTRUMENTATION AND DATA PROCESSING**

The test vehicle was instrumented with three solid-state angular rate transducers to measure roll, pitch, and yaw rates; a triaxial accelerometer near the vehicle center of gravity (c.g.) to measure longitudinal, lateral, and vertical acceleration levels; and a back-up biaxial accelerometer in the rear of the vehicle to measure longitudinal and lateral acceleration levels. These accelerometers were ENDEVCO Model 2262CA, piezoresistive accelerometers with a  $\pm 100$  g range.

The accelerometers are strain gage type with a linear millivolt output proportional to acceleration. Angular rate transducers are solid state, gas flow units designed for high-“g” service. Signal conditioners and amplifiers in the test vehicle increase the low level signals to a  $\pm 2.5$  volt maximum level. The signal conditioners also provide the capability of an R-Cal or shunt calibration for the accelerometers and a precision voltage calibration for the rate transducers. The electronic signals from the accelerometers and rate transducers are transmitted to a base station by means of a 15 channel, constant bandwidth, Inter-Range Instrumentation Group (I.R.I.G.), FM/FM telemetry link for recording on magnetic tape and for display on a real-time strip chart. Calibration signals, from the test vehicle, are recorded before the test and immediately afterwards. A crystal controlled time reference signal is simultaneously recorded with the data. Pressure-sensitive switches on the bumper of the impacting vehicle are actuated prior to impact by wooden dowels to indicate the elapsed time over a known distance to provide a measurement of impact velocity. The initial contact also produces an “event” mark on the data record to establish the instant of contact with the installation.

The multiplex of data channels, transmitted on one radio frequency, is received and demultiplexed onto separate tracks of a 28 track (I.R.I.G.) tape recorder. After the test, the data are played back from the tape machine, filtered with Society of Automotive Engineers (SAE J211) filters, and digitized using a microcomputer, at 2000 samples per second per channel, for analysis and evaluation of impact performance.

All accelerometers are calibrated annually according to SAE J211 4.6.1 by means of an ENDEVCO 2901, precision primary vibration standard. This device, and its support instruments, is returned to the factory annually for a National Institute of Standards Technology (NIST) traceable calibration. The subsystems of each data channel are also evaluated annually, using instruments with current NIST traceability, and the results factored into the accuracy of the total data channel, per SAE J211. Calibrations and evaluations are made any time data are suspect.

The digitized data are then processed using two computer programs: DIGITIZE and PLOTANGLE. Brief descriptions on the functions of these two computer programs are provided as follows.

The DIGITIZE program uses digitized data from vehicle-mounted linear accelerometers to compute occupant/compartments impact velocities, time of occupant/compartments impact after vehicle impact, and the highest 10-ms average ridedown acceleration. The DIGITIZE program also calculates a vehicle impact velocity and the change in vehicle velocity at the end of a given impulse period. In addition, maximum average accelerations over 50-ms intervals in each of the three directions are computed. For reporting purposes, the data from the vehicle-mounted accelerometers are then filtered with a 60 Hz digital filter and acceleration versus time curves for the longitudinal, lateral, and vertical directions are plotted using a commercially available software package (Excel).

The PLOTANGLE program uses the digitized data from the yaw, pitch, and roll rate transducers to compute angular displacement in degrees at 0.0002-s intervals and then instructs a plotter to draw a reproducible plot: yaw, pitch, and roll versus time. These displacements are in reference to the vehicle-fixed coordinate system, with the initial position and orientation of the vehicle-fixed coordinate system being that which existed at initial impact.

## **ANTHROPOMORPHIC DUMMY INSTRUMENTATION**

An Alderson Research Laboratories Hybrid II, 50th percentile male anthropomorphic dummy, restrained with lap and shoulder belts, was placed in the driver's position of the 820C vehicle. The dummy was un-instrumented.

## **PHOTOGRAPHIC INSTRUMENTATION AND DATA PROCESSING**

Photographic coverage of the test included two high-speed cameras: one placed behind the installation at an angle; and a second placed to have a field of view perpendicular to and aligned with the installation. A flash bulb activated by pressure sensitive tape switches was positioned on the impacting vehicle to indicate the instant of contact with the installation and was visible from each camera. The films from these high-speed cameras were analyzed on a computer-linked Motion Analyzer to observe phenomena occurring during the collision and to obtain time-event, displacement, and angular data. A BetaCam, a VHS-format video camera and recorder, and still cameras were used to record and document conditions of the test vehicle and installation before and after the test.

## **TEST VEHICLE PROPULSION AND GUIDANCE**

The test vehicle was towed into the test installation using a steel cable guidance and reverse tow system. A steel cable for guiding the test vehicle was tensioned along the path, anchored at each end, and threaded through an attachment to the front wheel of the test vehicle. An additional steel cable was connected to the test vehicle, passed around a pulley near the impact point, through a pulley on the tow vehicle, and then anchored to the ground such that the tow vehicle moved away from the test site. A two to one speed ratio between the test and tow vehicle existed with this system. Just prior to impact with the installation, the test vehicle was released to be free-wheeling and unrestrained. The vehicle remained free-wheeling, i.e., no steering or braking inputs, until the vehicle cleared the immediate area of the test site, at which time brakes on the vehicle were activated to bring it to a safe and controlled stop.





## **APPENDIX B. TEST VEHICLE PROPERTIES AND INFORMATION**



## APPENDIX B. TEST VEHICLE PROPERTIES AND INFORMATION

DATE: <u>12/16/99</u>	TEST NO.: <u>417920-1</u>	VIN NO.: <u>2C1MR2469R6764108</u>
YEAR: <u>1994</u>	MAKE: <u>GEO</u>	MODEL: <u>METRO</u>
TIRE INFLATION PRESSURE: <u>35 QSI</u>	ODOMETER: <u>79715</u>	TIRE SIZE: <u>155R12765</u>

1st Use:  2nd or More Use:  Minor Damage Charged to Project:

MASS DISTRIBUTION (kg) LF 259 RF 238 LR 172 RR 151

DESCRIBE ANY DAMAGE TO VEHICLE PRIOR TO TEST:

---

ACCELEROMETERS  
note: \_\_\_\_\_

TEST INERTIAL C.M.

ENGINE TYPE: 3 CYL.

ENGINE CID: 1.0L

TRANSMISSION TYPE:

AUTO

MANUAL

OPTIONAL EQUIPMENT:

\_\_\_\_\_

\_\_\_\_\_

DUMMY DATA:

TYPE: 50th percentile male

MASS: 74 kg

SEAT POSITION: Driver

GEOMETRY - (mm)					
A	<u>1460</u>	E	<u>620</u>	J	<u>675</u>
B	<u>745</u>	F	<u>3625</u>	K	<u>455</u>
C	<u>2270</u>	G	<u>889.2</u>	L	<u>95</u>
D	<u>1325</u>	H	_____	M	<u>370</u>
		I	_____	N	<u>1365</u>
		J	_____	O	<u>1340</u>
		K	_____	P	<u>530</u>
		L	_____	Q	<u>330</u>
		M	_____	R	<u>380</u>
		N	_____	S	<u>520</u>
		O	_____	T	<u>930</u>
		P	_____	U	<u>2440</u>
		Q	_____		
		R	_____		
		S	_____		
		T	_____		
		U	_____		

MASS - (kg)	CURB	TEST INERTIAL	GROSS STATIC
M <sub>1</sub>	<u>472</u>	<u>497</u>	<u>532</u>
M <sub>2</sub>	<u>271</u>	<u>323</u>	<u>362</u>
M <sub>T</sub>	<u>743</u>	<u>820</u>	<u>894</u>

**Figure 19. Vehicle Properties for Test 417920-1.**

**Table 3. Exterior Crush Measurements for Test 417920-1.**

**VEHICLE CRUSH MEASUREMENT SHEET<sup>1</sup>**

Complete When Applicable	
End Damage	Side Damage
Undeformed end width _____  Corner shift: A1 _____ A2 _____  End shift at frame (CDC) (check one) < 4 inches _____ ≥ 4 inches _____	Bowing: B1 ____ X1 ____  B2 ____ X2 ____   Bowing constant $\frac{X1 + X2}{2} = \underline{\hspace{2cm}}$

Note: Measure C1 to C6 from Driver to Passenger side in Front or Rear impacts-  
Rear to Front in Side impacts.

Specific Impact Number	Plane* of C-Measurements	Direct Damage		Field L**	C <sub>1</sub>	C <sub>2</sub>	C <sub>3</sub>	C <sub>4</sub>	C <sub>5</sub>	C <sub>6</sub>	±D
		Width ** (CDC)	Max*** Crush								
1	Front inner bumper	600	140	820	0	60	90	110	40	0	+200

<sup>1</sup>Table taken from National Accident Sampling System (NASS).

\*Identify the plane at which the C-measurements are taken (e.g., at bumper, above bumper, at sill, above sill, at beltline, etc.) or label adjustments (e.g., free space).

Free space value is defined as the distance between the baseline and the original body contour taken at the individual C locations. This may include the following: bumper lead, bumper taper, side protrusion, side taper, etc. Record the value for each C-measurement and maximum crush.

\*\*Measure and document on the vehicle diagram the beginning or end of the direct damage width and field L (e.g., side damage with respect to undamaged axle).

\*\*\*Measure and document on the vehicle diagram the location of the maximum crush.

Note: Use as many lines/columns as necessary to describe each damage profile.

**Table 4. Occupant Compartment Measurements for Test 417920-1.**

## Small Car

### Occupant Compartment Deformation

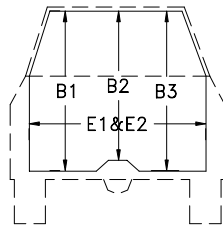
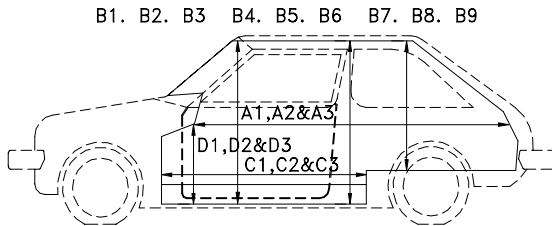
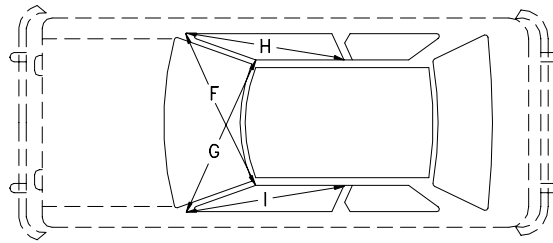

	BEFORE	AFTER
A1	2020	2020
A2	2065	2065
A3	2025	2025
B1	970	970
B2	906	876
B3	975	975
B4	948	938
B5	870	870
B6	955	955
B7	774	774
B8	760	760
B9	780	780
C1	581	581
C2	705	705
C3	585	585
D1	290	290
D2	100	100
D3	280	280
E1	1230	1230
E2	1230	1230
F	1215	1215
G	1215	1215
H	1000	1000
I	1000	1000

DATE: 12/16/99 TEST NO.: 417920-2 VIN NO.: 2C1MR246XR6767583  
 YEAR: 1994 MAKE: GEO MODEL: METRO  
 TIRE INFLATION PRESSURE: \_\_\_\_\_ ODOMETER: 80039 TIRE SIZE: 155R12

1st Use:  2nd or More Use: \_\_\_\_\_ Minor Damage Charged to Project: \_\_\_\_\_

MASS DISTRIBUTION (kg) LF 253 RF 248 LR 168 RR 151

DESCRIBE ANY DAMAGE TO VEHICLE PRIOR TO TEST:  
 \_\_\_\_\_  
 \_\_\_\_\_

ACCELEROMETERS  
note: \_\_\_\_\_

ENGINE TYPE: 3 CYL.  
 ENGINE CID: 1.0L  
 TRANSMISSION TYPE:  
 AUTO  
 MANUAL  
 OPTIONAL EQUIPMENT:  
 \_\_\_\_\_  
 \_\_\_\_\_  
 \_\_\_\_\_

DUMMY DATA:  
 TYPE: 50th percentile male  
 MASS: 76 kg  
 SEAT POSITION: Driver

GEOMETRY - (mm)

A	<u>1470</u>	E	<u>615</u>	J	<u>675</u>	N	<u>1365</u>	R	<u>380</u>
B	<u>750</u>	F	<u>3635</u>	K	<u>455</u>	O	<u>1340</u>	S	<u>525</u>
C	<u>2270</u>	G	<u>883.1</u>	L	<u>90</u>	P	<u>530</u>	T	<u>940</u>
D	<u>1325</u>	H	_____	M	<u>370</u>	Q	<u>330</u>	U	<u>2450</u>

MASS - (kg)	CURB	TEST INERTIAL	GROSS STATIC
M <sub>1</sub>	<u>481</u>	<u>501</u>	<u>535</u>
M <sub>2</sub>	<u>283</u>	<u>319</u>	<u>361</u>
M <sub>T</sub>	<u>764</u>	<u>820</u>	<u>896</u>

Figure 20. Vehicle Properties for Test 417920-2.

**Table 5. Exterior Crush Measurements for Test 417920-2.**

**VEHICLE CRUSH MEASUREMENT SHEET<sup>1</sup>**

Complete When Applicable	
End Damage	Side Damage
Undeformed end width _____  Corner shift: A1 _____ A2 _____  End shift at frame (CDC) (check one) < 4 inches _____ ≥ 4 inches _____	Bowing: B1 ____ X1 ____  B2 ____ X2 ____   Bowing constant $\frac{X1 + X2}{2} = \underline{\hspace{2cm}}$

Note: Measure C1 to C6 from Driver to Passenger side in Front or Rear impacts-  
Rear to Front in Side impacts.

Specific Impact Number	Plane* of C-Measurements	Direct Damage		Field L**	C <sub>1</sub>	C <sub>2</sub>	C <sub>3</sub>	C <sub>4</sub>	C <sub>5</sub>	C <sub>6</sub>	±D
		Width ** (CDC)	Max*** Crush								
1	Front inner bumper	800	200	1000	+60	-40	-200	-100	-60	0	-60

<sup>1</sup>Table taken from National Accident Sampling System (NASS).

\*Identify the plane at which the C-measurements are taken (e.g., at bumper, above bumper, at sill, above sill, at beltline, etc.) or label adjustments (e.g., free space).

Free space value is defined as the distance between the baseline and the original body contour taken at the individual C locations. This may include the following: bumper lead, bumper taper, side protrusion, side taper, etc. Record the value for each C-measurement and maximum crush.

\*\*Measure and document on the vehicle diagram the beginning or end of the direct damage width and field L (e.g., side damage with respect to undamaged axle).

\*\*\*Measure and document on the vehicle diagram the location of the maximum crush.

Note: Use as many lines/columns as necessary to describe each damage profile.



**Table 6. Occupant Compartment Measurements for Test 417920-2.**

## Small Car

### Occupant Compartment Deformation

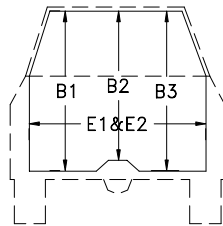
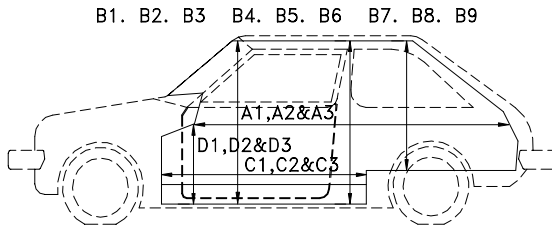
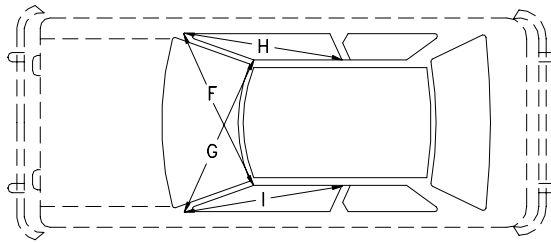

	BEFORE	AFTER
A1	1440	1440
A2	267	267
A3	1448	1448
B1	980	980
B2	925	925
B3	980	980
B4	951	951
B5	875	875
B6	955	955
B7	780	780
B8	791	791
B9	779	779
C1	705	705
C2	705	705
C3	570	570
D1	285	285
D2	100	100
D3	275	275
E1	1225	1225
E2	1226	1226
F	1210	1210
G	1210	1210
H	1100	1000
I	1100	1100

## **APPENDIX C. SEQUENTIAL PHOTOGRAPHS**



## APPENDIX C. SEQUENTIAL PHOTOGRAPHS

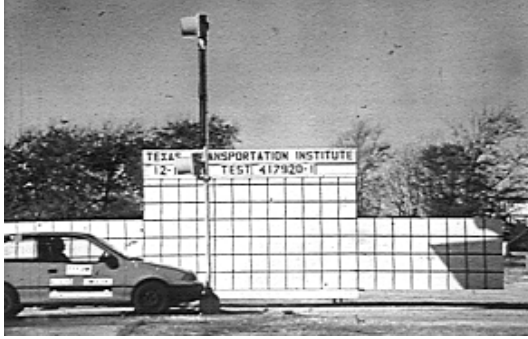

0.000 s

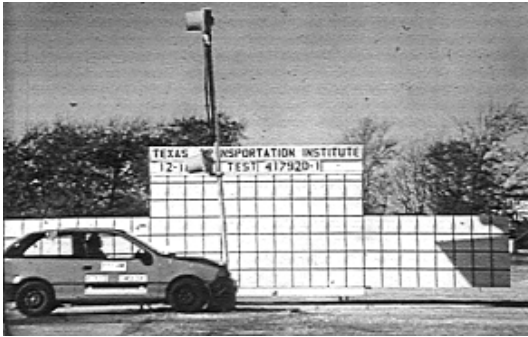

0.049 s



0.146 s



0.291 s



**Figure 21. Sequential Photographs for Test 417920-1 (Perpendicular and Oblique Views).**



0.534 s

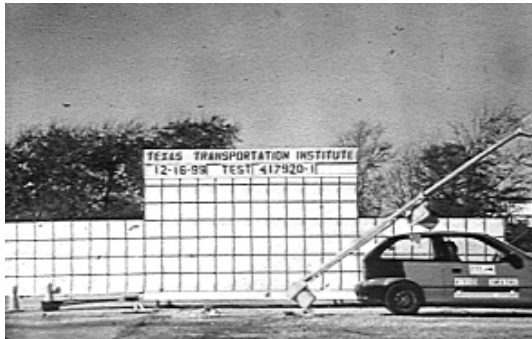

0.777 s

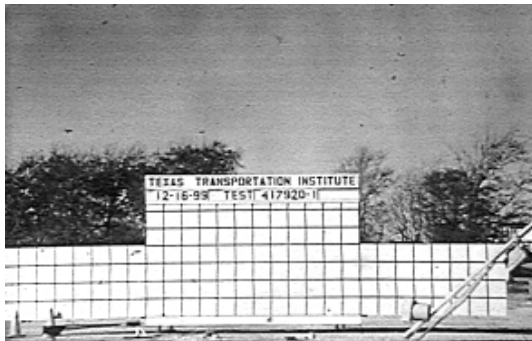

1.214 s

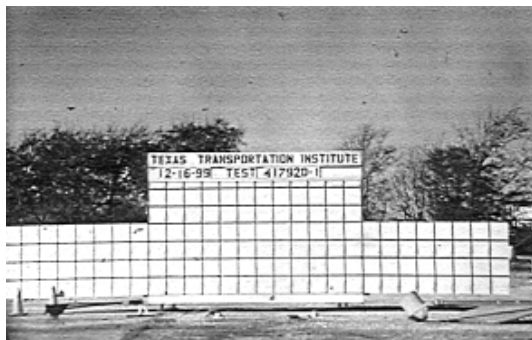

2.306 s

**Figure 21. Sequential Photographs for Test 417920-1 (Perpendicular and Oblique Views) (continued).**

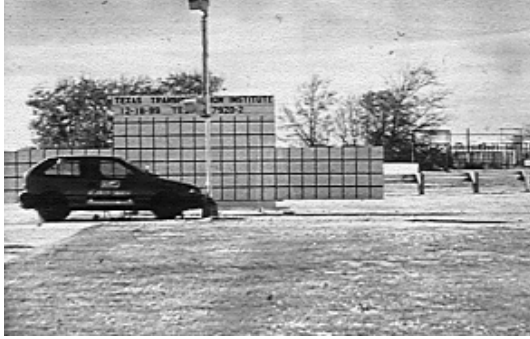

0.000 s

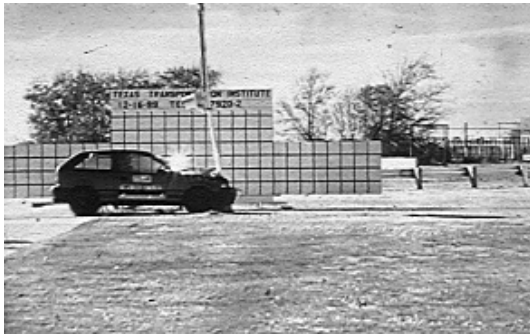

0.024 s

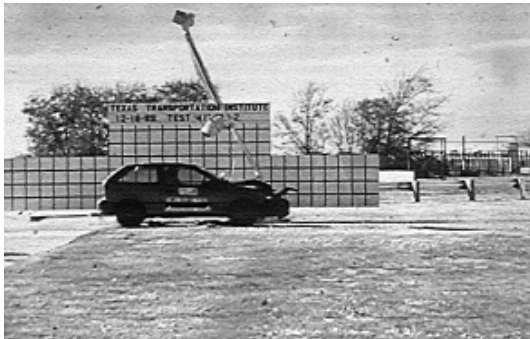

0.061 s



0.097 s

**Figure 22. Sequential Photographs for Test 417920-2  
(Perpendicular and Oblique Views).**



0.170 s



0.243 s

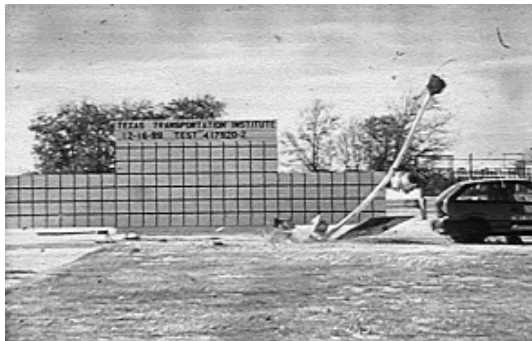

0.316 s

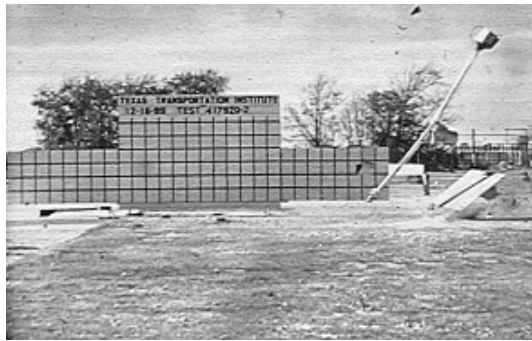

0.535 s



**Figure 22. Sequential Photographs for Test 417920-2 (Perpendicular and Oblique Views) (continued).**

## **APPENDIX D. VEHICLE ANGULAR DISPLACEMENTS**





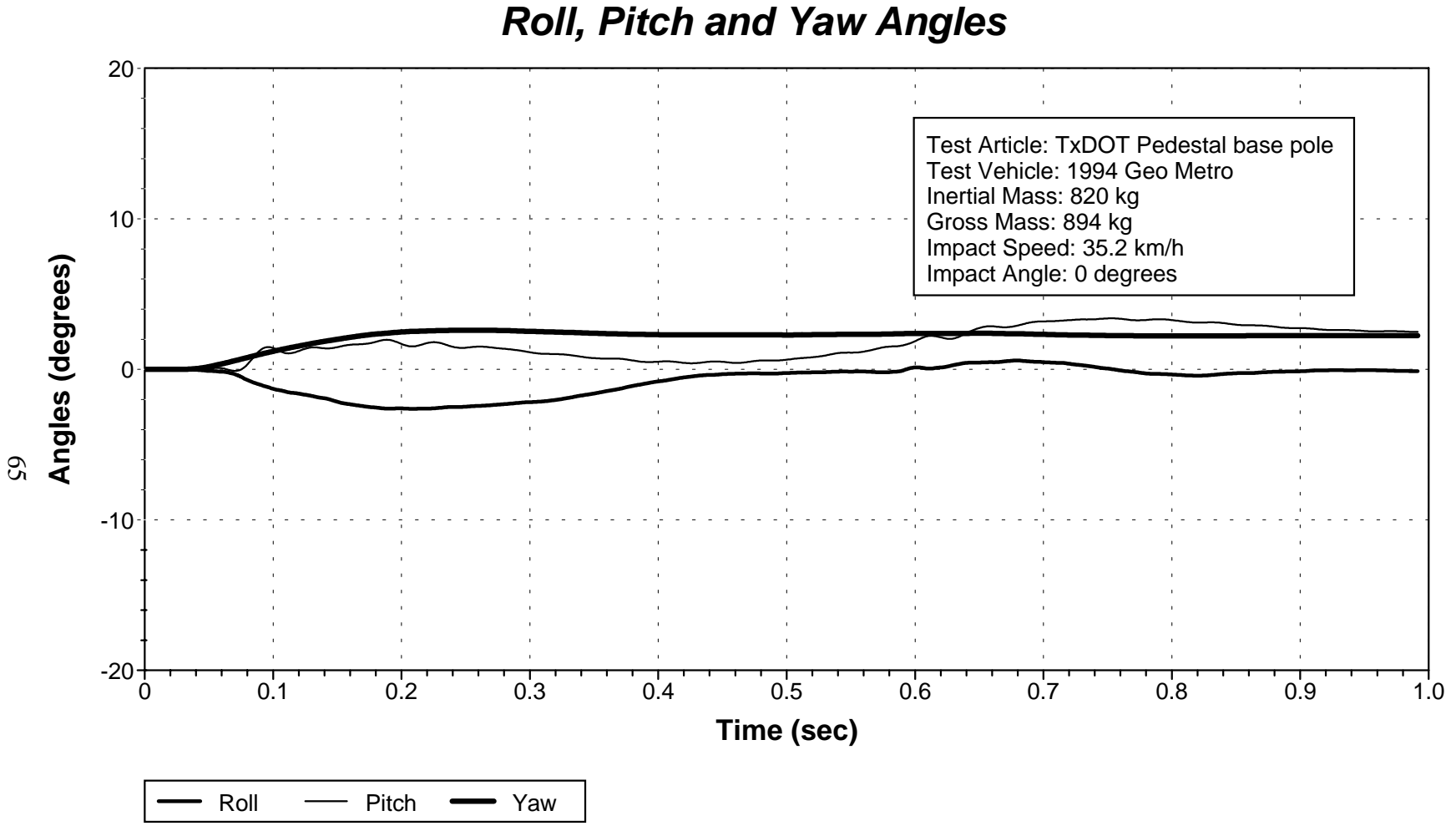
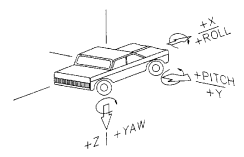

Figure 23. Vehicular Angular Displacements for Test 417920-1.



## Roll, Pitch and Yaw Angles

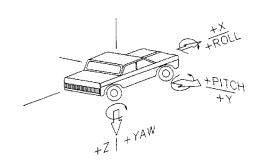
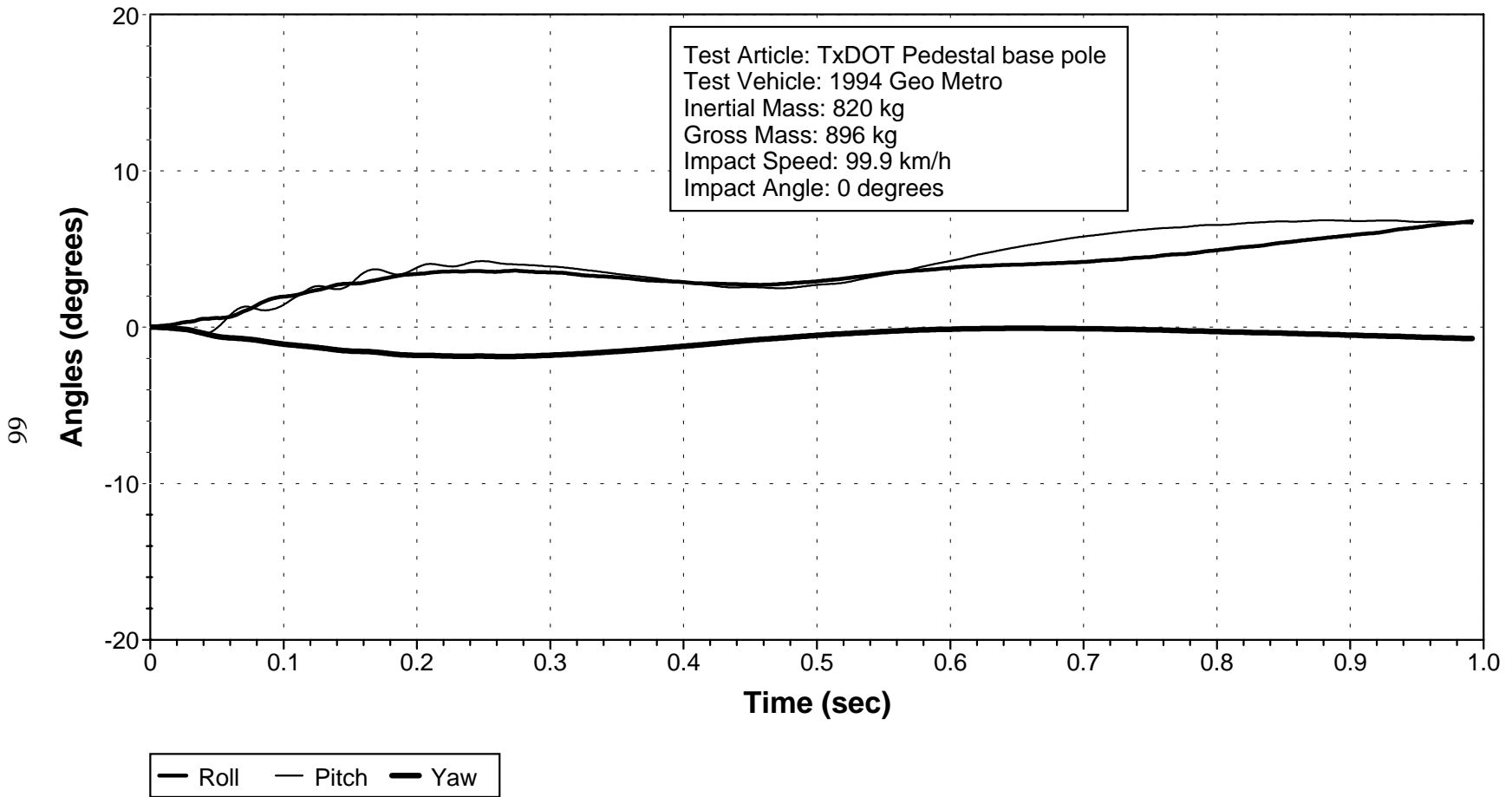

Figure 24. Vehicular Angular Displacements for Test 417920-2.

## **APPENDIX E. VEHICLE ACCELERATIONS**



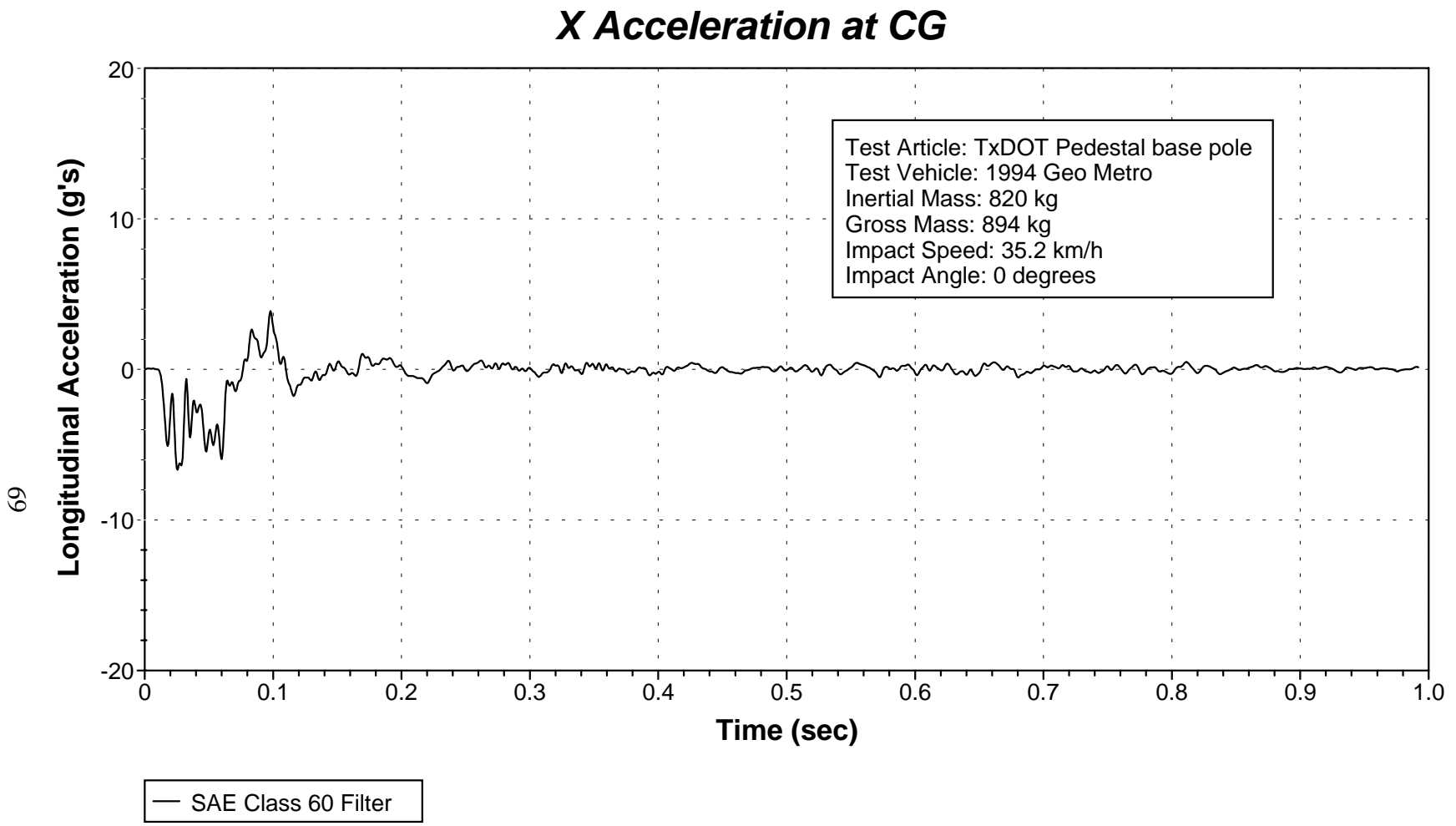

Figure 25. Vehicle Longitudinal Accelerometer Trace for Test 417920-1.

## Y Acceleration at CG

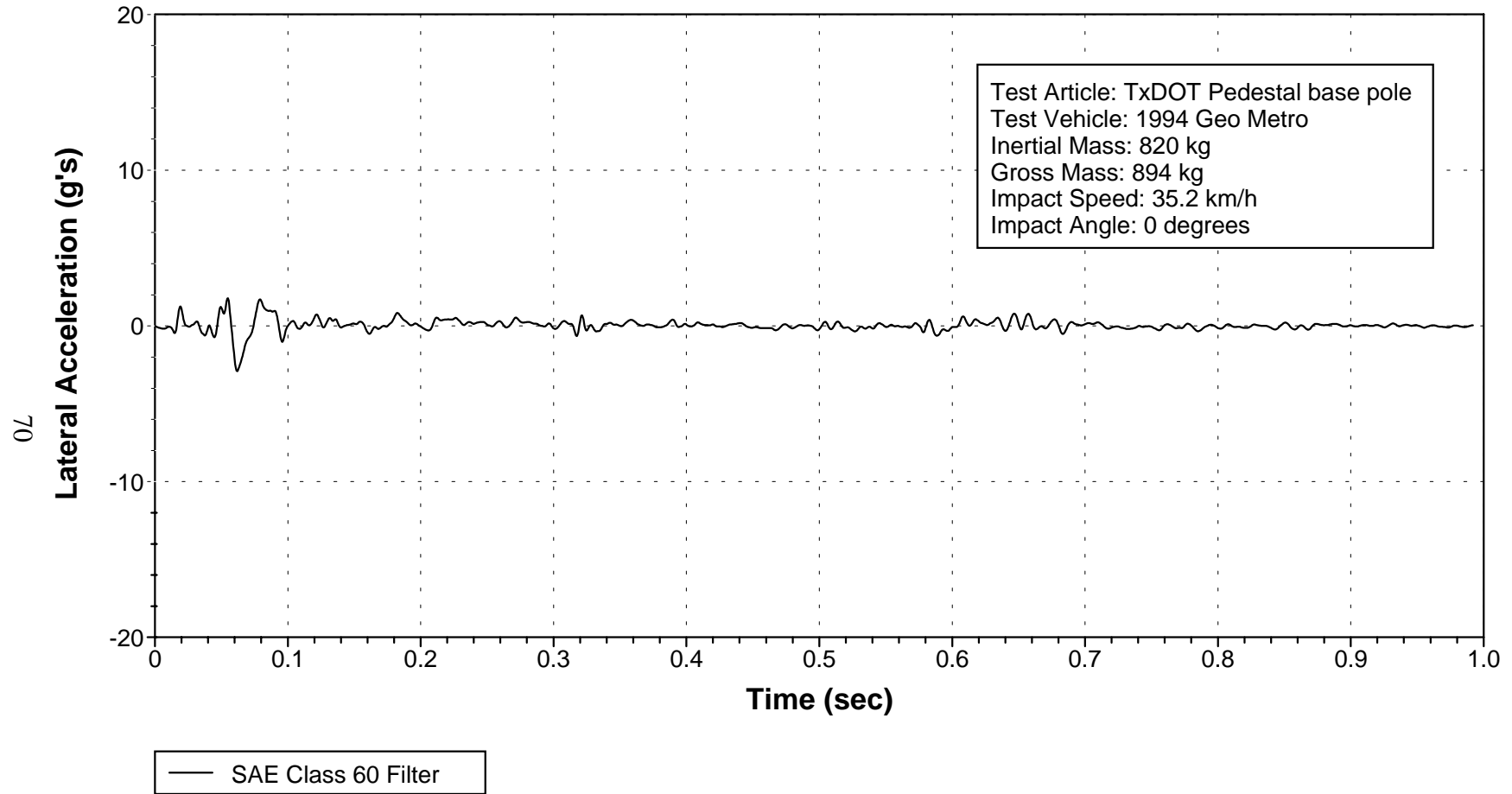

Figure 26. Vehicle Lateral Accelerometer Trace for Test 417920-1.

## Z Acceleration at CG

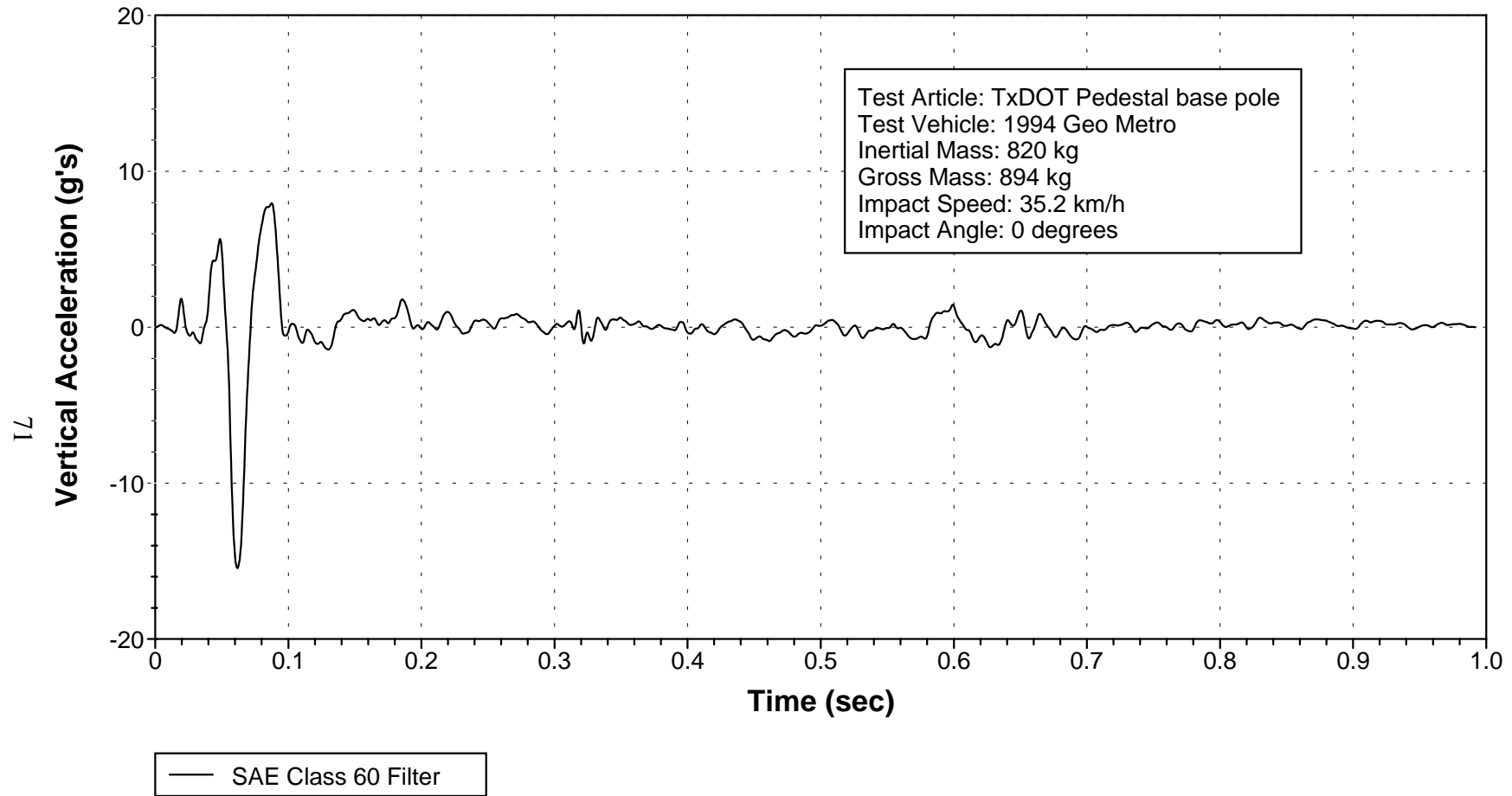

Figure 27. Vehicle Vertical Accelerometer Trace for Test 417920-1.



## X Acceleration at CG

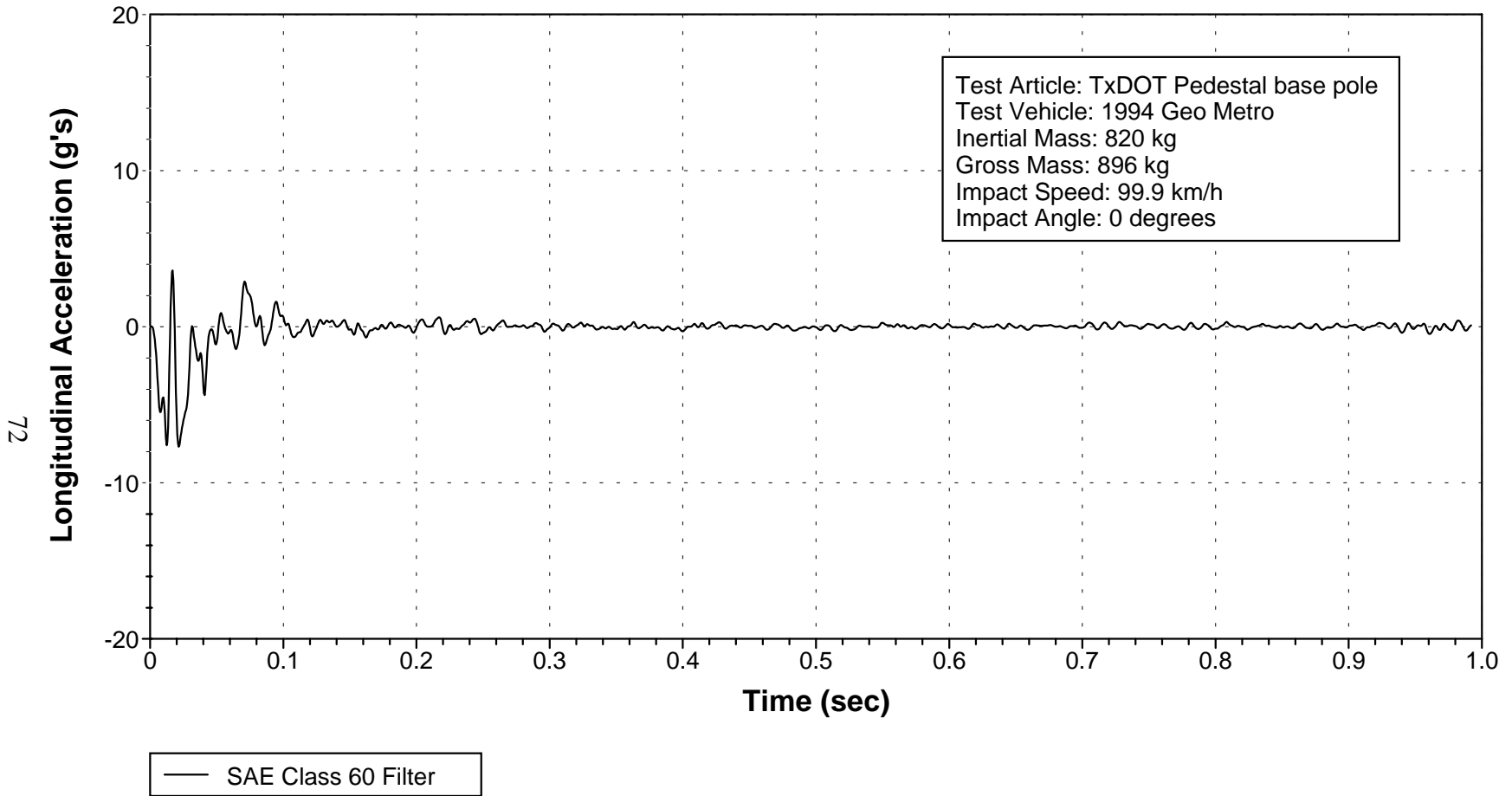

Figure 28. Vehicle Longitudinal Accelerometer Trace for Test 417920-2.

## Y Acceleration at CG

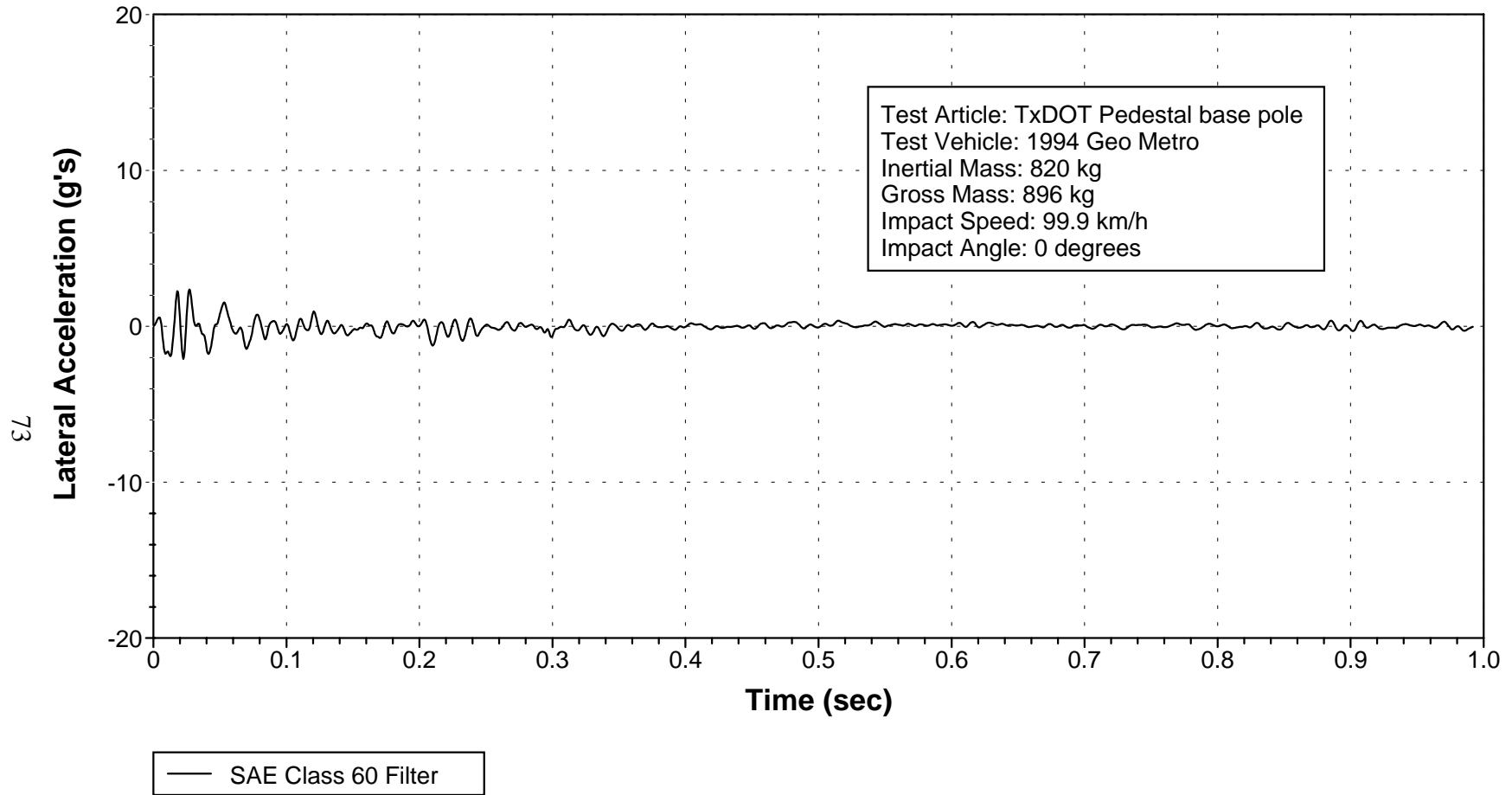

Figure 29. Vehicle Lateral Accelerometer Trace for Test 417920-2.

## Z Acceleration at CG

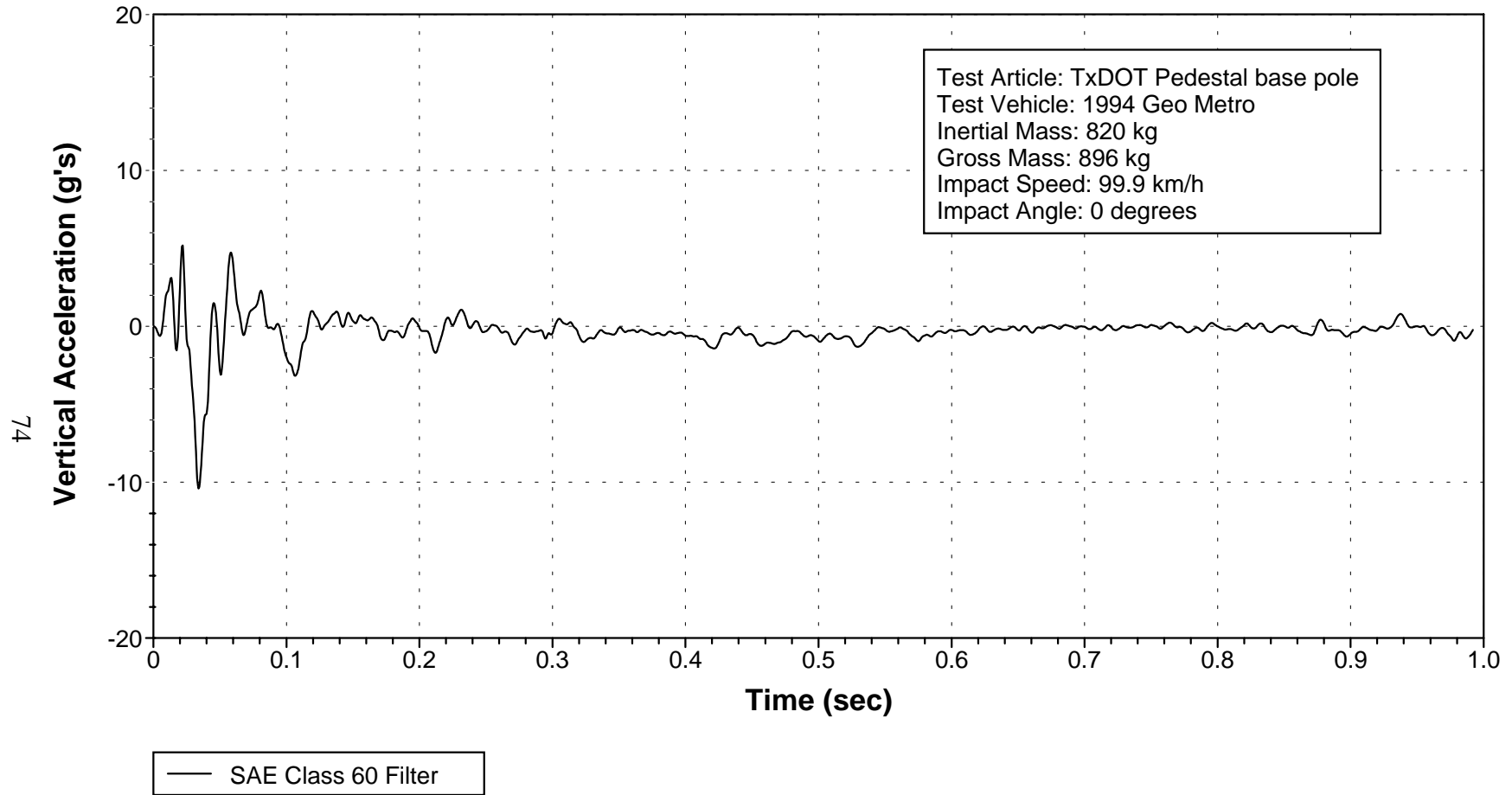

Figure 30. Vehicle Vertical Accelerometer Trace for Test 417920-2.