

# *Advanced Technology Transit Bus*

## Final Test Report for ATTB Prototypes

April 1999



Prepared for:

Los Angeles County  
Metropolitan Transportation Authority

In Response to:

Contract No. 5842

***NORTHROP GRUMMAN***

Integrated Systems and Aerostructures

# *Advanced Technology Transit Bus*

## Final Test Report for ATTB Prototypes

April 1999

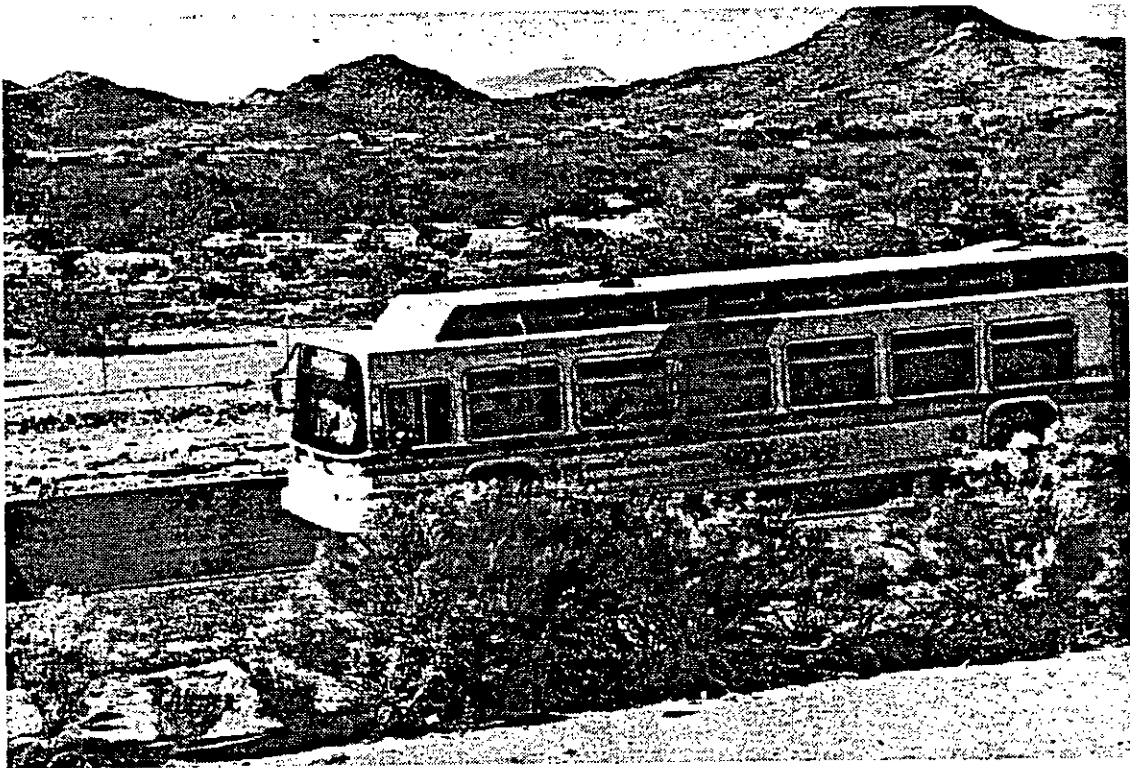

Prepared for:

Los Angeles County  
Metropolitan Transportation Authority

In Response to:

Contract No. 5842

***NORTHROP GRUMMAN***

Integrated Systems and Aerostructures

**THIS PAGE INTENTIONALLY LEFT BLANK**

Written By:

  
H. L. Reutter Jr.

Approved By:

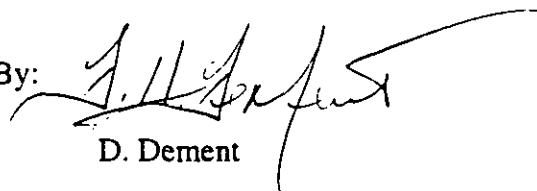
  
D. Dement

  
A. Arieli

**THIS PAGE INTENTIONALLY LEFT BLANK**

<b>TABLE OF CONTENTS</b>		<b>Page</b>
LIST OF FIGURES .....		vi
LIST OF TABLES .....		vi
EXECUTIVE SUMMARY .....		ix
1.0 INTRODUCTION .....		1
2.0 TEST ITEM DESCRIPTION .....		5
3.0 FUNCTIONAL TESTING RESULTS .....		13
4.0 PERFORMANCE TESTING RESULTS .....		17
5.0 BRAKE TESTING RESULTS .....		25
6.0 VEHICLE HANDLING TEST RESULTS .....		35
7.0 ENVIRONMENTAL TESTING RESULTS .....		39
8.0 STRUCTURAL AND DURABILITY TESTING RESULTS .....		47
9.0 OPERATIONAL AND ROAD TESTING RESULTS .....		53
10.0 RELIABILITY SUMMARY .....		59
11.0 MAINTAINABILITY EVALUATION .....		63
12.0 RECOMMENDATIONS .....		67
APPENDICES .....		69
Appendix A: References .....		71
Appendix B: Definitions .....		72
Appendix C: Facilities .....		73
Appendix D: Instrumentation Description .....		76
Appendix E: Instrumentation Measurand List .....		78
Appendix F: Phoenix Testing Synopsis .....		80

## LIST OF FIGURES

1.4	Final Test Schedule for ATTB Prototypes.....	3
1.6	ATTB-1 Rollout.....	4
2.0	ATTB Pictorial View.....	5
2.1	ATTB Interior.....	6
2.3	Rear View of ATTB Showing GENSET and Power Systems.....	7
2.4	ATTB Power Schematic.....	8
2.5	Rear Suspension With Wheelmotors.....	9
3.2	Vehicle Maneuverability.....	14
3.4	ATTB Testing I Rain at Phoenix.....	15
4.5	ATTB-1 at Speed on the FaAA Test Track.....	20
5.0	ATTB-1 Braking on Phoenix Skid Pad.....	25
5.6-1	Partial Service Brake System Failure.....	29
5.6-2	Rear Brake System Disabled.....	30
5.8	ATTB on Grade for Parking Brake Test in Phoenix.....	32
5.9	Inoperative Primary Brake Power Assist Unit Results.....	33
6.4	Double Lane Change Layout.....	36
6.5-1	U-Turn Course Layout.....	37
6.5-2	ATTB-1 Performing U-Turn.....	37
7.5	ATTB-3 in Test at Thermo King.....	43
8.2.1	ATTB-1 on Phoenix Random Pothole Course.....	51
9.1	ATTB-3 Conducting Boston Road Tests.....	54

## LIST OF TABLES

E.1	ATTB Test Mileage.....	xi
E.2	Test Summary.....	xii
E.3	Test Summary.....	xiii
1.4	Final Test Schedule for ATTB Prototypes.....	3
1.5	Test Matrix.....	4
3.1	Steering Wheel Authority Results.....	13
3.2	Vehicle Maneuverability Results.....	13
3.3	Rain Gutter Results.....	14
3.4	Windshield Wipers Results.....	15
4.1	GENSET Power Results.....	17
4.2-1	Phoenix Acceleration Results.....	17
4.2-2	Los Angeles Acceleration Results.....	18
4.2-3	Altoona Acceleration Results.....	18
4.3	Grade Acceleration Results.....	19
4.4-1	Acceleration At Speed Results.....	19
4.4-2	Straight Course Acceleration Results.....	19
4.5-1	Top Speed Results.....	20
4.5-2	LA Top Speed Results.....	21
4.6-1	Climb Speed And Grade Repeatability Results.....	21

## LIST OF TABLES (continued)

4.6-2	Unlimited Time Results.....	21
4.6-3	Restart Results.....	22
4.6-4	Grade Repeatability Results .....	22
4.7	Emissions Testing Results.....	23
4.8-1	ABRTC Fuel Economy Results.....	23
4.8-2	LACMTA Fuel Economy Results .....	23
4.9	Altitude Results .....	24
5.1-1	Regenerative/Service Braking Results .....	26
5.1-2	Regenerative Braking Off Results .....	26
5.1-3	Regenerative Braking Comparison Results .....	27
5.2	Maximum Braking (Non-Skid, Dry) Results .....	27
5.3	Maximum Braking (Non-Skid, Wet) Results .....	28
5.4	Maximum Braking (Skid, Wet) Results .....	28
5.5	Panic Braking (Wet) Results .....	28
5.6-1	Regenerative/Service Braking Circuit Failure Results .....	29
5.6-2	Rear Brake System Disabled Results .....	30
5.7	Braking Under Complete Power Failure Results .....	31
5.8-1	Emergency Braking Results .....	31
5.8-2	Secondary Braking Results.....	32
5.8-3	Parking Brake Results .....	32
5.9	Inoperative Primary Brake Power Assist Unit Results.....	33
6.1	Steering Control Results.....	35
6.2	Ride Quality Results.....	35
6.3	200-Foot-Diameter Circle Results.....	36
6.5	U-Turn Results .....	37
6.6	Hydroplaning - J Turn Results.....	38
6.8	Acceleration (Wet) Results.....	38
7.1	HVAC Capacity And Performance Results.....	40
7.2-1	High Temperature Operation Results .....	40
7.2-2	Tat HVAC Pull-Down Results .....	41
7.3	Low Temperature Operation Results.....	41
7.4	Defroster Performance Results.....	42
7.6	Humidity Results.....	42
7.7	Rain Intrusion Results .....	43
7.9	Internal And External Noise Results .....	45
7.10	Sound Insulation Test Results .....	45
8.1.1	Structural Shakedown Results.....	47
8.1.4	Jacking Results .....	48
8.1.5	Hoisting Results .....	48
8.1.6	Structural Durability Results .....	49
8.2.1	FaAA Track Test Conditions.....	50
10.1	LACMTA Reliability Results.....	59



**LIST OF TABLES (continued)**

10.2-1	ABRTC Service Delays .....	60
10.2-2	ABRTC System Reliability .....	60
11.1	ABRTC Maintainability Summary .....	63
11.2-1	Windshield Wiper Test Results .....	64
11.2-2	Component Replacement Times .....	64
12.0-1	Recommended ATTB Improvements .....	67
12.0-2	Recommended ATTB Improvements .....	68
C.1	Facility Utilization .....	73
D.1	Instrumentation Utilization .....	76

**EXECUTIVE SUMMARY**

This Final Test Report contains the results of the test program for the Advanced Technology Transit Bus (ATTB) program, as directed by Contract No. 5842, Addendum 9, and therefore includes all testing conducted on the six ATTB prototypes by Northrop Grumman Corporation (NGC).

This report provides data that verifies ATTB prototype capability to meet federal, local, state and county regulations in addition to requirements set forth by the Los Angeles County Metropolitan Transit Authority (LACMTA) and the ATTB Program.

**TEST RESULTS SUMMARY**

The test program documented System performance and identified no "Show Stoppers". We identified shortcomings and implemented many solutions during the course of the test program.

Overall bringing this design to the next step represents low technical risk. The test results demonstrated the soundness of the structural concept. No removals for maintenance highlighted our excellent wheel-motor reliability. We showed the soundness of our Vehicle Management Computer (VMC) concept and demonstrated the ease with which updates are implemented. The electrical inverter issues are understood and well documented. We validated the "GENSET" concept as an effective means in reducing downtime for engine replacement. Our Thermo King HVAC (re-procured after original unit failed to perform) performed very well.

*In summary, the test program did exactly what it was supposed to do; proved the basic design concepts while discovering the strengths and weaknesses of the detail designs!*

**Functional Testing**

We completed all Functional tests successfully and the data collected documents functional test requirements were met or exceeded. These tests demonstrated that ATTB specification functional characteristics were properly implemented in the hardware and software designs, and worked as intended.

**Performance Testing**

The performance tests demonstrated that our design meets "White Book" requirements. Some shortcomings were identified, relative to our goals, in the area of acceleration which are correctable. The primary causes are inadequate engine power and unforeseen inefficiencies in the electrical power system. We knew the Detroit Diesel Series 30 engine was at the low end of our power needs (based on our simulation) and that power inefficiencies (beyond our assumptions) could adversely impact performance. Development of a new power management scheme (Limiting Speed Governor) wrung significant improvements from the hardware as evidenced in improved acceleration and top speed performance.

**Brake Testing**

The Brake tests were all completed successfully. Data collected documents braking performance that exceeded our requirements. These tests demonstrated superior braking characteristics that result in a safe transit vehicle devoid of any braking idiosyncrasies. While anti-lock brakes are required by law in the future, the current ATTB design brakes hard and true with wheel lock-up (skid) only on the front tires during severe stops. Wet pavement tests again demonstrated the ATTB prototype's ability to stay firmly gripped to the pavement while stopping straight and true. Hydraulic boost failures led to braking difficulties at Altoona.

**Vehicle Handling Test**

All functional tests were completed successfully. The data collected documents vehicle handling performance requirements were met or exceeded. The bus behaves in a consistent and reliable manner during hard maneuvers including panic stops. Altoona testing revealed that when power steering failed (hydraulic boost failure), our steering wheel size (smaller than typical transit buses) made the bus harder to steer.

**Environmental Testing**

Most environmental tests were completed successfully and demonstrated that all desired ATTB environmental characteristics are achievable. The data collected documents critical environmental requirements tested were met or exceeded except for shortcomings in the operator's area (electric heater and defroster as well as inadequate air flow). The prototype composite structure provides outstanding insulating performance.

**Structural and Durability Testing**

All Structural and Durability tests were completed successfully, except the testing at Altoona Bus Research and Testing Center (ABRTC) was concluded after completing the Gross Vehicle Weight Rating (GVWR) which amounted to 5,250 miles. The data collected documents structural and durability requirements were met or exceeded.

The composite structure problems at the ABRTC were not fundamental to the design. Rather, human errors during initial fabrication and subsequently during the repair of these faults led to delays at ABRTC. We believe the positive results from the Altoona testing and our collective test experience, as a whole, speaks well of our structural concept and detail design.

## Operational and Road Testing

We completed all Operational and Road tests and ATTB road testing performance demonstrated readiness of the overall design concept for revenue service. Data collected documents road test requirements were met or exceeded. Testing identified the strengths and weaknesses of the detail design. As a result we believe the weaknesses require relatively low risk changes to improve robustness and reliability.

Operator and maintenance technician reaction to the ATTB at LACMTA and other city transit agencies was very positive and demonstrated that the basic design concepts are sound and in the right direction. Detailed comments were collected and offer significant insight into improving the detail design. These are discussed in Section 9 of this report.

As listed in Table E.1, we accumulated 14,230 miles on the streets of Los Angeles as well as 1,993 miles on streets in Boston, Washington, DC, New York City, and Minneapolis, MN that demonstrated the suitability of this design for rapid transit service.

		Total Miles
<b>Bus 1 - Total Mileage</b>		2,368
	Factory Test:	2,368
	LACMTA Service:	0
<b>Bus 2 - Total Mileage</b>		8,632
	Factory Test:	879
	LACMTA Service:	0
	Altoona Durability Track:	5,250
	Altoona Other:	2,503
	Altoona Total:	7,753
<b>Bus 3 - Total Mileage</b>		2,785
	Factory Test:	792
	City Service:	1,993
<b>Bus 4 - Total Mileage</b>		9,588
	Factory Test:	1,675
	LACMTA Service:	7,813
<b>Bus 5 - Total Mileage</b>		4,400
	Factory Test:	3,269
	LACMTA Service:	1,131
<b>Bus 6 - Total Mileage</b>		7,864
	Factory Test:	2,578
	LACMTA Service:	5,286
<b>ATTB Program Total</b>		35,637

TABLE E.1. ATTB TEST MILEAGE

## Reliability Summary

System reliability was substantially less than desired and resulted in our ability to usually keep only one bus available for service at any one time. After some improvements were incorporated, this improved. ATTB-5 spent considerable time and miles (see Table E.1) supporting the VMC software development process. We sacrificed gaining service miles since this activity was very important to improving bus reliability and system performance.

## Maintainability Evaluation

Maintenance data primarily gathered from ABRTC testing and our own experience indicates replacement times for commonly replaced component were good. The ability to replace the GENSET in two man hours demonstrated the superiority of this design innovation.

## Test Summary

Tables E-2 and E-3 summarize the Test Program content and the locations where we obtained the data.

Test	Phoenix	LA	ABRTC	Other*
<b>3.0 Functional</b>				
3.1 Steering Wheel Authority	Passed			
3.2 Vehicle Maneuverability	Passed			
3.3 Rain Gutter		Passed	Passed	Passed
3.4 Windshield Wipers		Passed	Passed	Passed
3.5 Wheel Motor Hi-Pot		Passed		
<b>4.0 Performance</b>				
4.1 GENSET Power		Passed		
4.2 Acceleration	Passed	Passed		
4.3 Grade Acceleration		Passed		
4.4 Acceleration At Speed	Passed			
4.5 Top Speed	Failed	Passed		
4.6 Climb Speed and Grade Repeatability		Failed	Passed	
4.7 Emissions		Passed		
4.8 Fuel Economy		Passed	Passed	
4.9 Altitude				Failed
<b>5.0 Brake</b>				
5.1 Regenerative/Service Braking	Passed			
5.2 Maximum Braking (Non-Skid, Dry)	Passed			
5.3 Maximum Braking (Non-Skid, Wet)	Passed			
5.4 Maximum Braking (Skid, Wet)	Passed			
5.5 Panic Braking (Wet)	Passed			
5.6 REGEN/Service Braking Circuit Failure	Passed			
5.7 Braking Under Complete Power Failure	Passed			
5.8 Secondary / Parking System	Passed			
5.9 Inoperative Primary Brake Power Assist	Passed			

\* Boston, MA; Washington, DC; New York, NY; Minneapolis, MN; Denver, CO

TABLE E.2. TEST SUMMARY

Test	Phoenix	LA	ABRTC	Other*
<b>6.0 Vehicle Handling</b>				
6.1 Steering Control	Failed			
6.2 Ride Quality	Passed			
6.3 200-Foot-Diameter Circle	Passed			
6.4 Double Lane Change	Passed			
6.5 U-Turn	Passed			
6.6 Hydroplaning - J Turn	Passed			
6.7 Adverse Weather			Passed	Passed
6.8 Acceleration (Wet)	Passed			
<b>7.0 Environmental</b>				
7.1 HVAC Capacity and Performance				Passed
7.2 High Temperature Operation				Passed
7.3 Low Temperature Operation				Passed
7.4 Defroster Performance				Failed
7.5 U-Factor Testing				Passed
7.6 Humidity				Passed
7.7 Rain Intrusion			Passed	Passed
7.8 Sand and Dust	Passed			
7.9 Acoustic Measurements		Passed		
7.10 Internal Noise and Vibration			Passed	
<b>8.0 Structural and Durability</b>				
8.1.1 Structural Shakedown			Passed	
8.1.2 Structural Distortion			Passed	
8.1.3 Static and Dynamic Towing			Passed	
8.1.4 Jacking			Passed	
8.1.5 Hoisting			Passed	
8.1.6 Structural Durability			Passed	
8.2.1 High Energy Impact	Passed			
8.2.2 Dynamic Road Testing	Passed	Passed	Passed	Passed
<b>9.0 Operational and Road</b>				
9.1 City Participation Testing				Completed
9.2 LACMTA Operational Testing		Completed		
9.3 Survey Results		Completed	Completed	Completed
<b>10.0 Reliability Evaluation</b>				
10.1 LACMTA Test Results		Completed		
10.2 ABRTC Test Results			Completed	
<b>11.0 Maintainability Evaluation</b>				
11.1 ABRTC Maintainability Evaluation			Completed	
11.2 ABRTC Component Replacement Times			Completed	

\* Boston, MA; Washington, DC; New York, NY; Minneapolis, MN; Denver, CO

TABLE E.3. TEST SUMMARY

**Recommendations**

Since the ATTB test program succeeded in proving the basic design concepts while discovering the strengths and weaknesses of the detail designs, bringing the ATTB design to the next step represents low technical risk. With no "Show Stoppers", the reliability and performance issues are well understood and documented. Therefore, we recommend the LACMTA consider further development of the ATTB design by upgrading the detail designs to improve reliability and performance.

Subsequent operational testing on LACMTA routes would serve to verify the improvements and gain additional service experience we were unable to gain previously. This additional service experience coupled with testing some new technologies (a "clean diesel" engine with ultra capacitor energy storage) can put the ATTB design on a firm footing to attract a viable production entity to build this advanced bus design.

## **1.0 INTRODUCTION**

This Final Test Report contains the results of the test program for the Advanced Technology Transit Bus (ATTB) program, as directed by Contract No. 5842, Addendum 9, and therefore includes all testing conducted on the six ATTB prototypes.

This report by Northrop Grumman Corporation (NGC) provides data that verifies that the prototype ATTB is capable of meeting federal, local, state and county regulations in addition to requirements set forth by the Los Angeles County Metropolitan Transit Authority (LACMTA) and the ATTB Program.

### **1.1 ATTB PROGRAM OBJECTIVES**

To develop a lightweight, low floor, low-emission transit bus using proven advanced technologies developed by the aerospace and other industries. Northrop Grumman designed the ATTB to meet federal, state and local axle weight and clean air requirements and meet or exceed American with Disabilities Act (ADA) requirements through the use of a low, flat floor and a simple ramp system that is more reliable than current wheelchair lift technology. NGC developed the ATTB to meet the following program objectives:

- Curb weight 10,000 lb. below 1992 (equivalently configured) buses in use in the USA
- Meet or exceed current mobility standards and ADA requirements
- Low to zero tailpipe emissions
- Reduced vehicle operation costs
- User-friendly for both operators and passengers
- Full-sized 40-foot bus that accommodates 43 seated and 29 standee passengers (Figure 1.6)
- Maximum unit cost of \$300,000 (1992 \$ at production rate)

### **1.2 TEST PROGRAM OBJECTIVES**

NGC designed the ATTB test program to thoroughly evaluate the prototypes and document their performance. This testing verified and demonstrated critical ATTB characteristics as well as providing simulated\* revenue service experience to validate the ATTB design and provide customer defined improvements.

\* Simulated in that no fares were charged when carrying passengers.

Specific Test Program objectives were as follows:

1. Verify ATTB compliance with Federal and California motor vehicle codes.

Proof of ATTB compliance with the FMVSS and California local and state codes involved testing the ATTB prototype using specific pass/fail criteria set out in the ATTB System Specification (SS300-001000) and other applicable documents.



**2. Demonstrate ATTB Specification Compliance.**

Due to the unique nature of the ATTB design, testing to provide additional safety and performance data was required. Additional performance testing includes tests that are not specified or required by the FMVSS and California local and state codes.

**3. Demonstrate ATTB Structural Integrity and Durability Characteristics.**

This testing involved structural and durability testing at the Altoona Bus Research and Testing Center (ABRTC), run by the Pennsylvania Transportation Institute of Penn State University for the Federal Transportation Authority of the Department of Transportation..

**4. Demonstrate ATTB functionality and serviceability in simulated revenue service.**

The main objective of this testing demonstrated the overall vehicle design meets and/or exceeds all operational durability requirements in each city. This testing provided revenue service qualitative and quantitative data at selected transit Authority cities. NGC solicited passenger, operator and transit Authority comments and advice (surveys) during actual road tests in various climates and on regular city transit routes. Service and maintenance records were kept to add this service experience into our logistics data base.

In addition, the ABRTC test program yielded data on ATTB performance based on their standardized test program for heavy-duty transit bus category vehicles. This includes maintainability, reliability, safety, performance, fuel economy and noise data in addition to the already mentioned structural and durability data.

**1.3 TEST REPORT SCOPE AND OVERVIEW**

The test report provides results to verify and demonstrate the prototype Advanced Technology Transit Bus (ATTB) as capable of meeting federal, local, state and county regulations in addition to requirements set forth by the Los Angeles County Metropolitan Transit Authority (LACMTA) and ATTB Systems Engineering.

The attitude of the test team was similar to that of software beta testers: *push the limits and identify all weaknesses*. Although achieving vehicle breakdown was not an objective of the test program, it was the intention of the ATTB test program to expose any weaknesses in the vehicle design and to be completely forthcoming in the presentation of all test results.

Test results on the ATTB prototypes is divided into the following areas:

Section 3.0 -- FUNCTIONAL  
Section 4.0 -- PERFORMANCE  
Section 5.0 -- BRAKING  
Section 6.0 -- VEHICLE HANDLING  
Section 7.0 -- ENVIRONMENTAL  
Section 8.0 -- STRUCTURAL AND  
DURABILITY

Section 9.0 -- OPERATIONAL AND ROAD  
Section 10.0 -- RELIABILITY SUMMARY  
Section 11.0 -- MAINTAINABILITY  
EVALUATION  
Section 12.0 -- RECOMMENDATIONS

1.4 MASTER TEST SCHEDULE

The testing of the ATTB prototypes was dynamic and ever changing as we strove to meet changing customer requirements. The schedule in Figure 1.4 represents the test programs schedule as conducted.

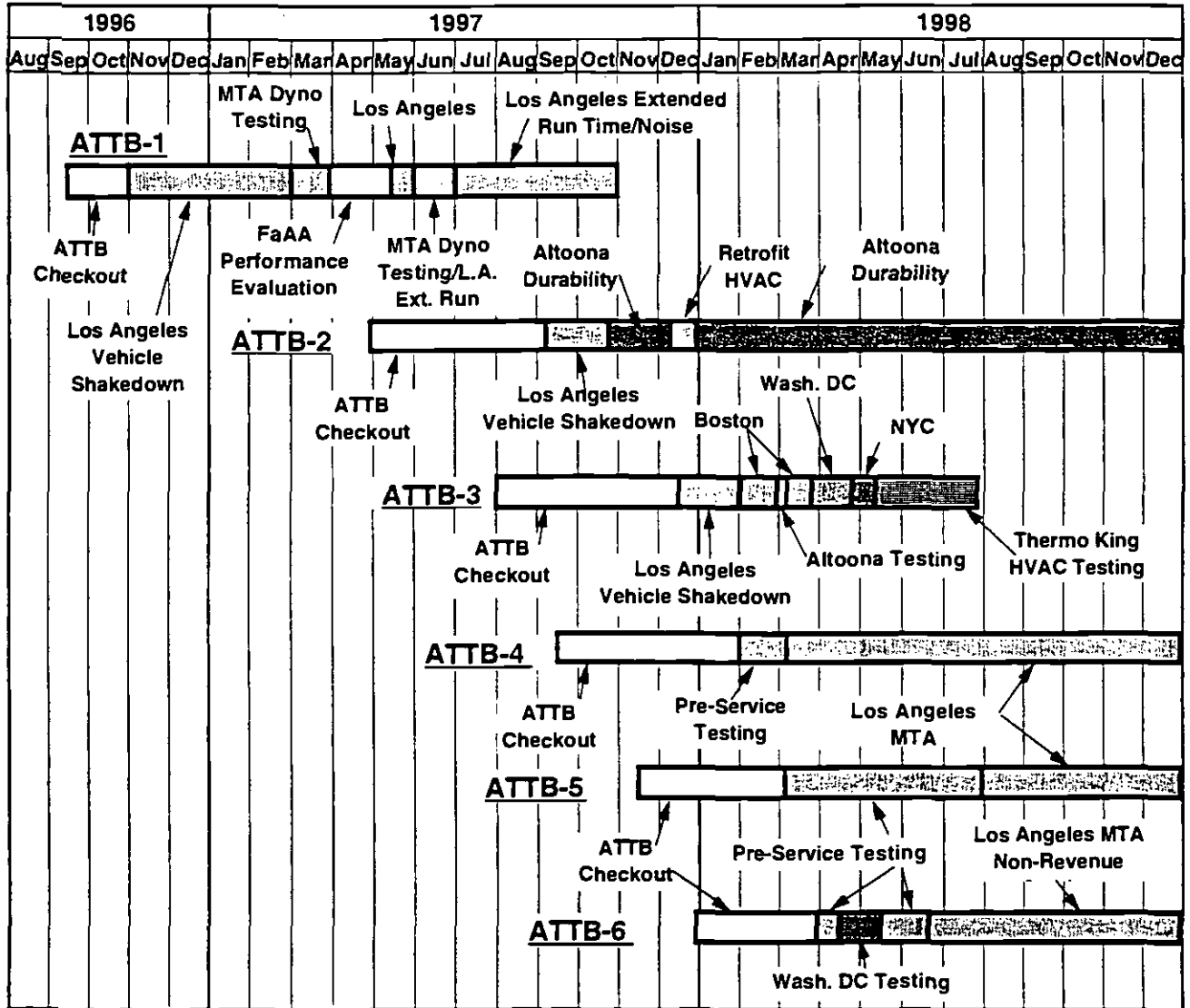

FIGURE 1.4. FINAL TEST SCHEDULE FOR ATTB PROTOTYPES

1.5 TEST SERIES ASSIGNMENTS

Support and participation in the ATTB test program varied depending on the testing required. Appendix C (Facilities) contains a description of each test site. Table 1.5 shows the types of testing done on each prototype and the test sites utilized:

Test Activity	ATTB Prototypes						Test Sites					
	1	2	3	4	5	6	NG	LACMTA	FaAA	ABRTC	Cities & Other	
3.0 Functional	X	X	X	X	X	X	X				X	
4.0 Performance	X	X	X				X	X	X	X		
5.0 Brake	X								X	X		
6.0 Vehicle Handling	X								X	X		
7.0 Environmental	X	X	X						X	X		X
8.0 Structural & Durability	X	X	X						X	X		X
9.0 Operational and Road			X	X	X	X	X	X	X	X		X

TABLE 1.5. TEST MATRIX

In those cases where support from outside agencies was required, NGC personnel were in attendance to help conduct the test or on-call to aid the supporting test agency as required. Also note that in some cases Altoona (ABRTC) collected duplicate data as a part of their standard bus test program.



FIGURE 1.6. ATTB-1 ROLLOUT

## 2.0 TEST ITEM DESCRIPTION

The ATTB is a user-friendly American with Disabilities Act (ADA) compliant, low emissions, 12.2 meters (40 feet) long, 2.6 meters (102 inches) wide transit vehicle capable of accommodating 43 seated passengers (or 34 seated and two wheel chair passengers) and 29 standing passengers. The ATTB also has provisions for conversion to a Zero Emission Vehicle (ZEV). Figure 2.0 presents a pictorial view of the ATTB configuration.

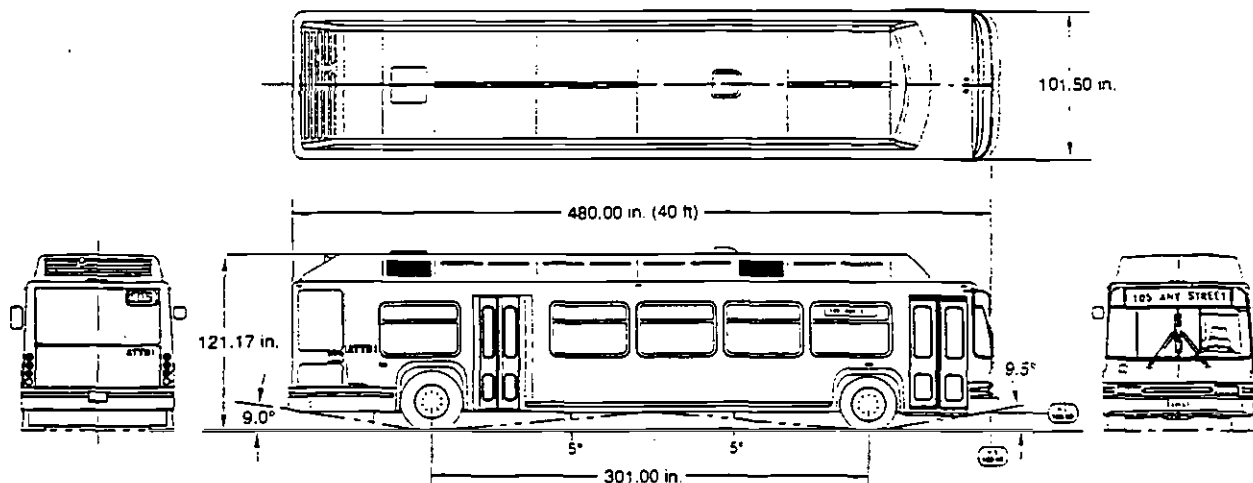

FIGURE 2.0. ATTB PICTORIAL VIEW

## 2.1 INTERIOR

The ATTB low flat floor design (Figure 2.1) incorporates cantilevered seat structure supports to provide an unobstructed, slip resistant surface to aid passenger egress and transit authority cleaning. Three seats are mounted over the left front wheel well facing curb side behind the driver. The opposite right wheel well cover is designed to carry bulky passenger parcels. The plastic seat covers and interior panels are graffiti resistant and easily replaced. The doors and wheel chair ramp meet all ADA requirements. Restraint belts and fold-up seats provide space and a secure area for 2 wheel chair customers.

The operator position is ergonomically designed for comfort and ease of use. The Recaro seat is fully adjustable for comfort and control access. The steering wheel has tilt control and telescopes for proper placement. Controls are placed in easy reach and are simple to operate. The color CRT operator display provides pertinent vehicle operating parameters and warnings.

## 2.2 STRUCTURE

The ATTB is composed of four major structural components that are of a fiberglass and structural foam composite design that draws upon Northrop Grumman's considerable expertise in this structural medium. The components are independently fabricated using a proprietary process and then bonded together to form a tough, strong, lightweight structure to which the doors, windows, suspension, power train, electrical, fuel, air and interior components are attached. The composite design allows tailoring the ply and foam makeup to the stresses and

loads encountered which along with our process technology is a significant contributor to achieving the low weight goals for the program.

As an aside, Prototype 1 weighs more than the other 5 buses. About 1000 pounds of structural weight was removed from the ATTB design through structural design refinements after the construction of ATTB 1.

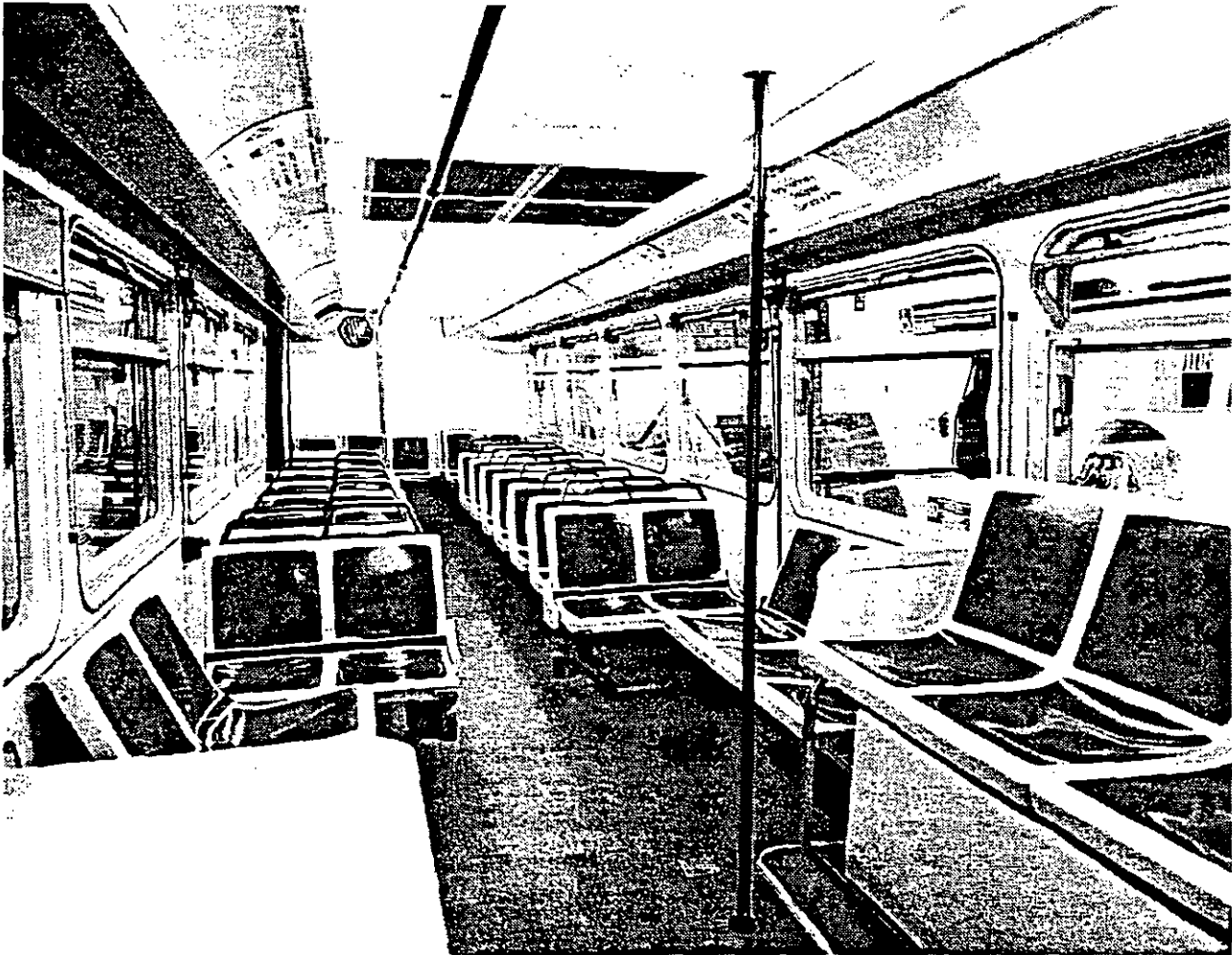
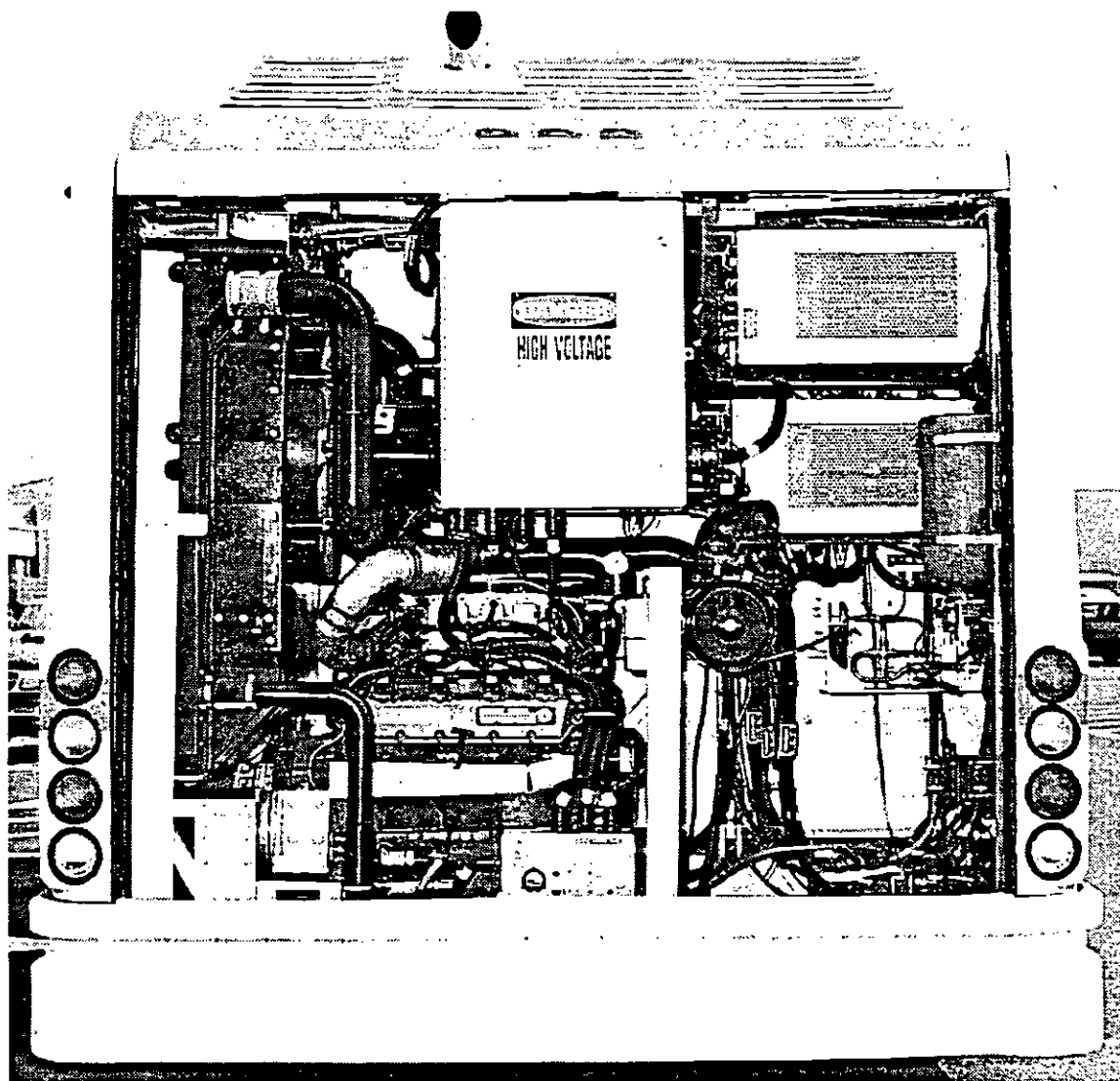

**FIGURE 2.1. ATTB INTERIOR**

### **2.3 POWER TRAIN**

The ATTB is designed to meet urban mass transit need with a non-conventional power train. The ATTB uses a compressed natural gas (CNG) fueled engine to drive an electrical generator which in turn supplies energy to operate the rear wheel electrical motors.

The turbo-charged engine with attached generator are housed in an easily removable GENSET skid package that allows rapid replacement for ease of maintenance and reduced vehicle downtime. The radiators, inter-cooler and other cooling system components are also attached to the GENSET skid. Figure 2.3 shows the GENSET and other power system components.



**FIGURE 2.3. REAR VIEW OF ATTB SHOWING GENSET AND POWER SYSTEMS**

Each rear wheel is powered by a Kaman Electromagnetics Corporation (KEC) wheel motor assembly containing their advanced three-phase, AC motor design, a planetary reduction gear train, and drum brake hub. The wheel motor is attached to the bus swing arm rear suspension system.

## **2.4 ELECTRICAL POWER CONTROL**

Operation of ATTB systems is controlled by a Vehicle Management Computer (VMC). Operator commands for bus movement and system activation are processed by the VMC and then transmitted to the proper systems for action.

The control of the wheel motors and generator is provided by individual KEC inverters (Generator and Wheel motor units). These ethylene glycol and air cooled units convert AC to DC, DC to AC and manage the power output of the generator and wheel motors. The VMC interfaces directly with the inverters to perform its' power management functions. The Heating

and Ventilation Air Conditioner (HVAC) system receives power from three separate inverters directly tied to the 360 volt bus. Figure 2.4 shows an overall schematic of the electrical power system.

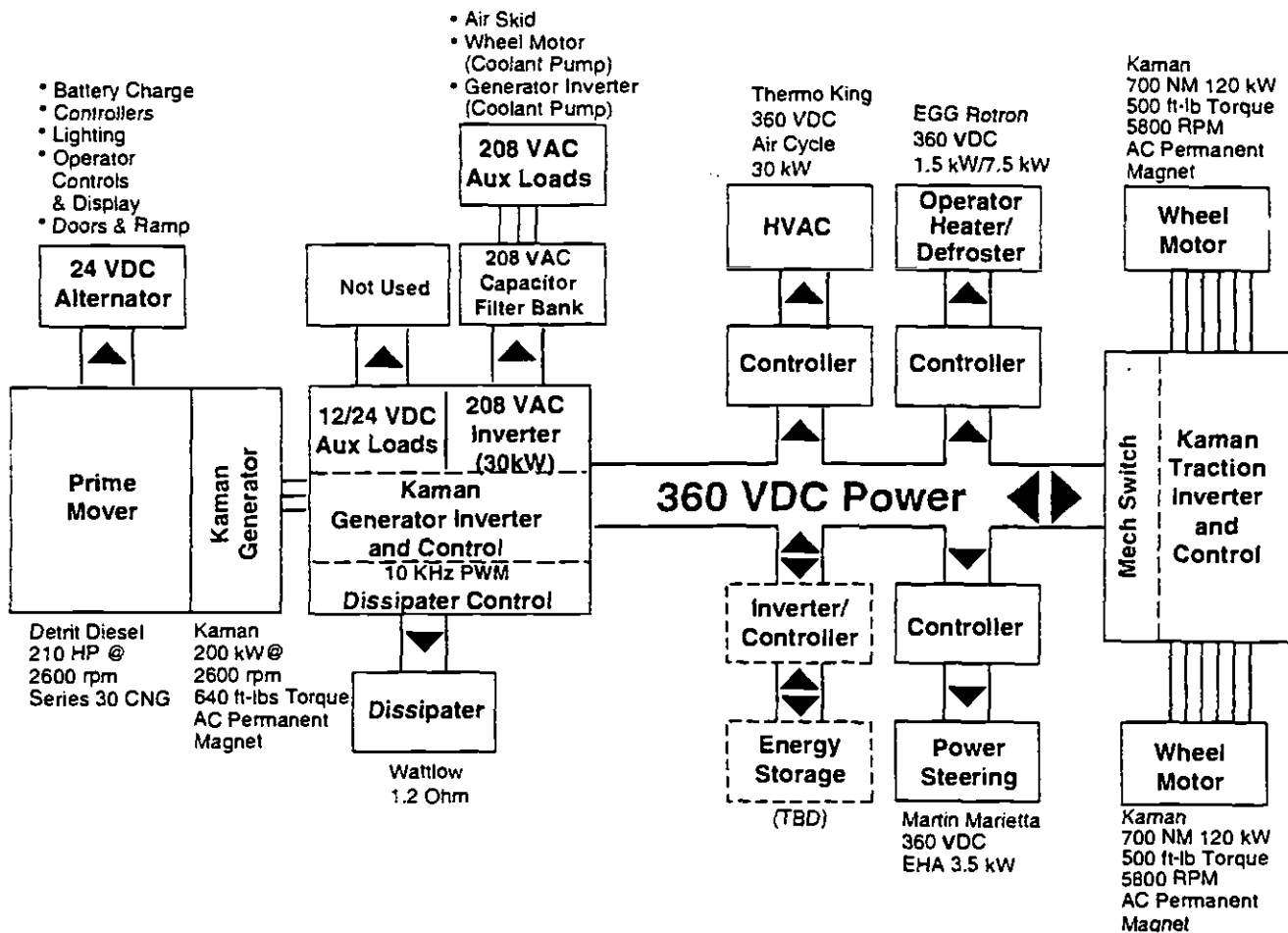

FIGURE 2.4. ATTB POWER SCHEMATIC

The 24 volt DC electrical system includes an engine belt-driven 50-amp alternator tied to a battery package at the right rear of the engine bay. This bus provides power for the engine starter, door actuation, lighting systems and the VMC. This is different from the original design concept where all 24 volt DC power was provided by the KEC auxiliary inverter. We were unable to get that system to operate reliably, so we added the alternator to the engine.

The Generator inverter also provides a 208 volt AC output that powers the inverter coolant pumps and the air skid compressor which were originally powered on the 24 volt DC system. During the development phase we converted them to 208 volt AC motors to off-load the 24 volt DC system.

In the case of bus movement, the selection of drive or reverse causes current to flow to the drive wheel motors in response to accelerator pedal travel. The acceleration of the bus and the response of the engine to operator commands are all controlled by the VMC, which tries to provide what the operator desires in the most efficient manner possible. This power management technology is

part of the reason the ATTB promises to be one of the most fuel efficient transit buses ever produced.

## **2.5 SUSPENSION SYSTEM**

The front suspension system utilizes a ZF Industries Macpherson strut design that incorporates dual air suspension bags and hydraulic disc brakes on oil lubricated front hubs. The struts are attached to the top of the front wheel well structure. The lower control arms are secured to a steel breast plate that is anchored to the bus structure between the wheel wells. This design concept allows build-up of the front suspension as a unit on the bench simplifying assembly and installation. The two front wheels are Alcoa units with a Goodyear 275/70R22.5 G159 radial tire mounted on each.

The rear suspension is a NGC swing-arm design that utilizes dual air bags and single shock absorbers on each side to absorb and control rear wheel movement. The wheel motors bolt directly to the swing arms whose pivot trunnions are rigidly bolted to the structure between the rear wheel wells. Figure 2.5 shows the suspension with wheelmotors ready for installation. Like the front, this design concept allows build-up of the rear suspension as a unit, including wheel motors, on the bench simplifying assembly and installation. The two rear wheels are Alcoa units with a Goodyear 385/65R22.5 G286 radial tire mounted on each.

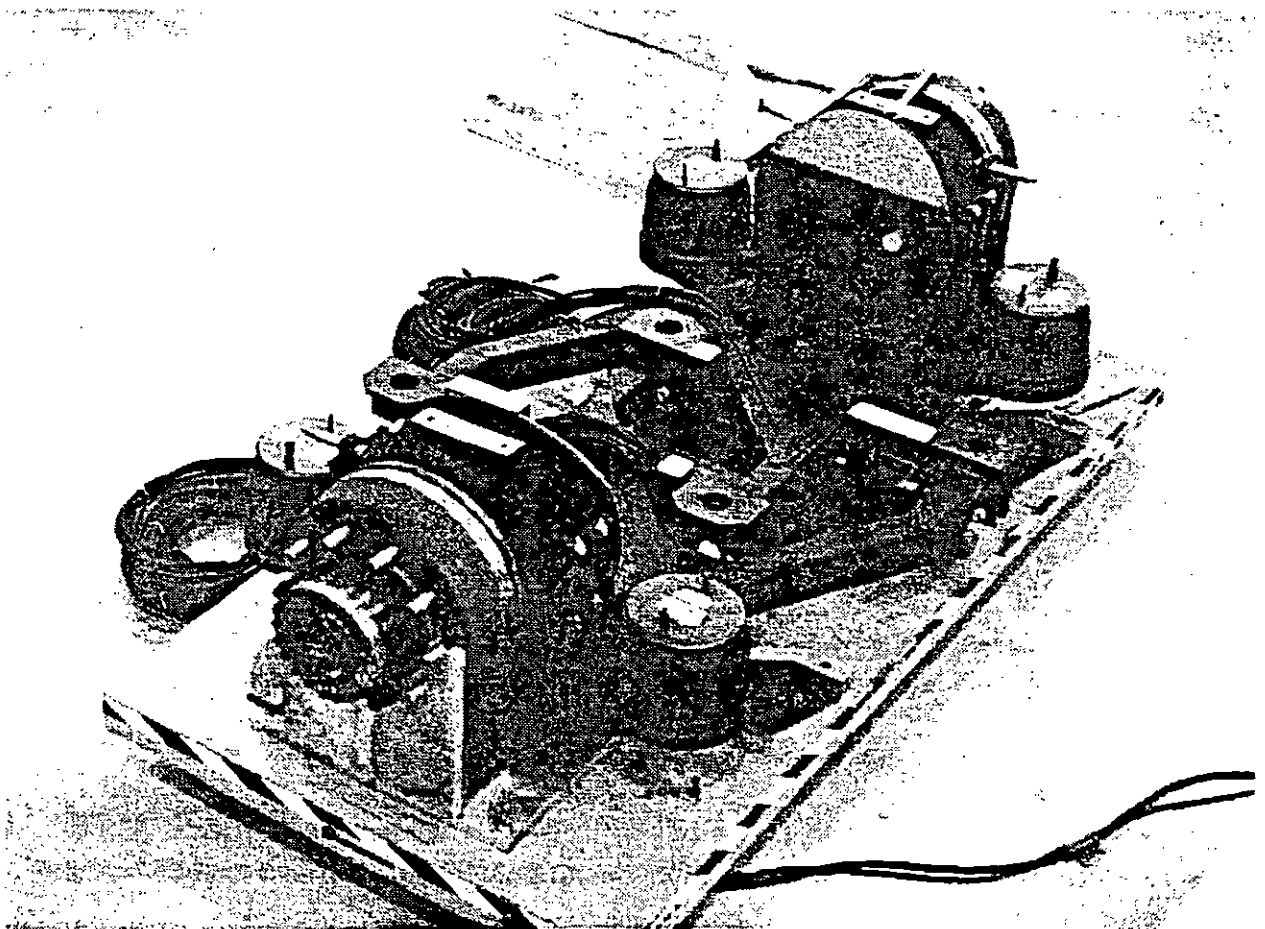

**FIGURE 2.5. REAR SUSPENSION WITH WHEELMOTORS**



The air bag suspension system incorporates an on-board compressor unit (mounted curb side forward on the roof), wheel position indicators and the VMC to control ATTB ride height. Depressing the "Drive" button at any time instructs the VMC to level the bus, which is then done automatically. In addition, the operator can command the bus to "kneel" (front air suspension bags deflate) to aid passenger and wheelchair egress at stops where there is no curb.

Steering is provided via a telescoping and tilt adjustable steering wheel assembly connected to a Lockheed Martin power steering pump and the ZF steering drive gear. Standard control arms and ball joints connect to the front strut axles.

The front axle is rated to 13,220 lb. and the rear axle rating is 18,740 lb. which yields an ATTB Gross Vehicle Weight Rating (GVWR) of 31,960 lb. ATTB weight distribution differs slightly on each prototype due to structure manufacturing process changes.

## **2.6 BRAKE SYSTEM**

The brake system incorporates hydraulically actuated front disc brake calipers and integral rear drum brakes, and regenerative braking. This system provides outstanding brake capability for safely stopping the ATTB.

Regenerative braking (REGEN) is commanded by the VMC via a brake pedal sensor, which causes the wheel motor polarity to be reversed. The motors become generators pulling energy out of the drive system by producing electricity thereby slowing the bus down. This energy is sent to a dissipater that is mounted behind the engine radiator where the electricity is turned into heat.

Hydraulic boost power is provided by the steering pump for the front and rear brake system circuits. The brake system includes a backup power brake pump powered by 12 Vdc in the event the primary unit should fail. The hydraulic operated parking brake that actuates the front and rear brakes can also be used as an emergency brake system by the operator from the front control panel. An accumulator in the system ensures adequate hydraulic pressure remains even with the steering pump inoperative. In the event of total power brake failure, the system can still apply brake force manually, albeit requires higher operator pedal effort to apply.

## **2.7 AUXILIARY SYSTEMS**

### **2.7.1 Radio System**

A watertight enclosure is provided to house any Transit Authority radio and telephone equipment that is required. This box is located on the roof just aft of the operators position.

### **2.7.2 Heating and Ventilation Air Conditioner (HVAC)**

The HVAC is mounted on the bus aft of the radio box and air compressor pallet. ATTB-1 had a TAT Industries HVAC. Thermo King Corporation, in 1997 supplied five custom-designed units for buses 2, 3, 4, 5 and 6.

**2.7.3 CNG Tank System**

The CNG fuel storage units for the ATTB consist of three Lincoln composite fuel tanks mounted to the roof with a combined capacity of 9,069 cubic feet. Two 12 foot tanks are mounted on the right half of the roof aft of the HVAC and one 4 foot tank is on the left side. A methane detection system is also incorporated in the tank storage area and the engine bay.

**2.7.4 Cooling Systems**

The inverter and wheelmotor cooling systems are housed on the rear roof of the bus behind the CNG tanks. The ethylene glycol units for the inverters and the oil cooler for the wheel motors incorporate electric pumps and fans with shrouded radiators to provide coolant for heat dissipation.

An oil cooler and electric motor driven pump are built onto the GENSET skid for the KEC generator. The generator cooler radiator is integral to the engine radiator, inter-cooler and dissipater cooler package which is cooled by an electric fan unit.

**2.7.5 Fire Extinguishing System**

A fire detection and suppression system is provided in the engine bay compartment. An infrared detection sensor monitors the bay for fire and upon detection will discharge the fire bottle contents into the bay via an overhead pipe system to extinguish the fire.

**2.8 ATTB CONFIGURATION CHANGES**

During the test program numerous changes were made to the prototype bus configuration. The changes listed were implemented during the test program to improve operability and reliability of the ATTB system.

**2.8.1 Generator Rewind**

The generators were "rewound" by Kaman Electromagnetics to match generator maximum output to maximum engine RPM. This modification reduced inverter current 50%, improving design margins and reliability.

**2.8.2 Engine Driven Alternator**

The 24 volt DC system of the generator inverter never worked correctly and would not keep the 24 volt DC batteries charged sufficiently. These batteries supplied the engine starter and provided power to the VMC prior to engine starting. Engine mounted alternators (one per bus) were added to bypass the generator inverter 24 volt DC system entirely, thus providing reliable 24 volt DC power.

### **2.8.3 360 Volt Bus Management**

Load bank step response testing at Northrop Grumman revealed the system to have no proportional gain. We sent data to Kaman Electromagnetic, who in turn revised the regulation constraints until a step response was obtained in further testing at Northrop Grumman. The software required a times 100 multiplier in line with the normal gain constant. Power bus (360 volts) regulation is now +/- 5 volts as opposed to + 40 / -150 volts previously. This change permits all accessories to operate, even after regenerative braking.

### **2.8.4 VMC Software Improvements**

The previous semi-open loop "tuned" engine/wheelmotor scheme (Variable Speed Governor) was discarded in favor of a closed-loop system (Limited Speed Governor). The wheelmotors load the engine to obtain the required RPM corresponding to a throttle input (accelerator pedal). Maximum power is thus obtained from the engine independent of how much power the engine may put out on a given day or operating condition. The engine responds instantly to throttle command without the need for "headroom" that was used in the old control scheme. ATTB-2 made White Book acceleration numbers at seated load weight during Altoona testing with this new control scheme.

### **2.8.5 208 Volt Bus Changes**

To reduce the 24 Volt DC system load, motors for the air compressor, inverter cooling and wheelmotor cooling pumps were replaced with 208 Volt three-phase AC motors. Replacement with more efficient motors has also improved system reliability.

### **2.8.6 External 208 Volt Capacitors**

After numerous internal capacitor failures in the 208 volt AC side of the generator failed, a new scheme was devised to have Kaman Electromagnetics eliminate the internal capacitors from their design and have Northrop Grumman install an external capacitor bank instead. This system modification has improved inverter reliability.

### 3.0 FUNCTIONAL TESTING RESULTS

This section covers the test results gathered to demonstrate the ATTB meets certain functional requirements as defined in the specification that can only be determined by demonstration or test.

#### 3.1 STEERING WHEEL AUTHORITY

The operator steering wheel was turned from left-stop to right-stop. ATTB results exceeded the requirement in Table 3.1.

Requirement	Test Results Left to Right
The maximum allowable number of steering wheel revolutions is seven.	4.75 turns

TABLE 3.1. STEERING WHEEL AUTHORITY RESULTS

#### 3.2 VEHICLE MANEUVERABILITY

Table 3.2 and Figure 3.2 define the maneuver requirements and list our results. We measured ATTB maneuverability to the left only due to time constraints in Phoenix. The measurement method employed was to drive the bus in a circle with the wheels locked to the left. After a couple of revolutions the test engineer leaned out the front door and, using a chalk spray can, scribed a circle using the right front corner of the bus as the compass point. We used the same method for the other corner measurements. Wheel positions and bus nose position were also marked with chalk. Then the bus was driven off the circle and measurements taken. The bus meets or exceeds all requirements except for the overall turning radius (dimension A). We did not have time to adjust the steering travel to bring this into compliance. It is not considered a significant technical issue.

Requirement	Test Results Left
Referring to Figure 3-1, the ATTB must have a turn radius of no more than 44 feet, as indicated by radius dimension A (Figure 3.2).	44'-10"
The front end swing-over must be no greater than 58 inches (4 ft-10 in), as shown by dimension B (Figure 3.2).	4'-6"
The turn out clearance at maximum wheel lock angle must be no greater than 85 inches (7 ft-1 in), as indicated by dimension C (Figure 3.2).	7'-0"
The rear end swing-out at maximum wheel lock must be no greater than 30 inches (2 ft-6 in), as indicated by dimension D(Figure 3.2).	1'-0"
The sweep path must be no greater than 24 feet as indicated by dimension E (Figure 3.2).	20'-10"

TABLE 3.2. VEHICLE MANEUVERABILITY RESULTS

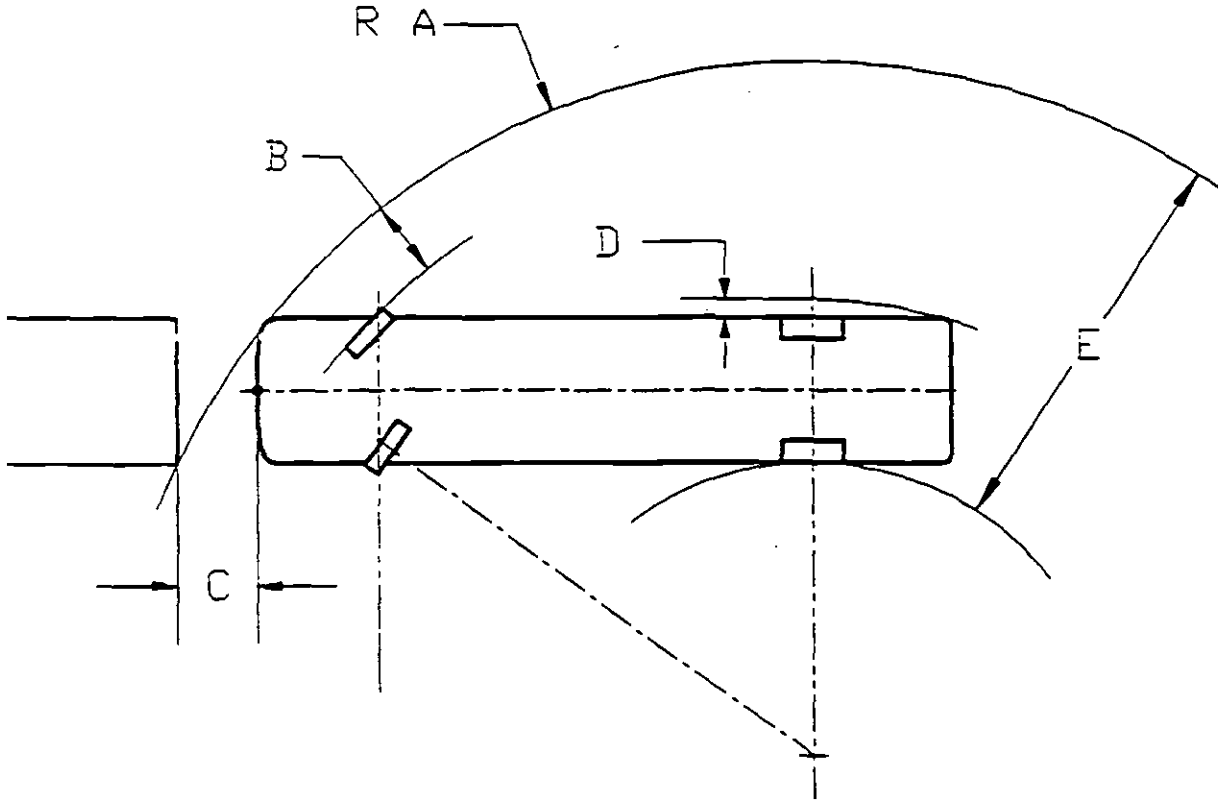

FIGURE 3.2. VEHICLE MANEUVERABILITY

**3.3 RAIN GUTTER**

Inclement weather conditions (rain and snow) were encountered during testing at Altoona and during the Operational and Road testing (reported on later) to support this test. Operator comments and our test personnel observations documented that the rain gutters worked properly to meet the requirements of Table 3.3.

Requirement	Test Results
When the bus is decelerated, the gutter shall not drain onto the windshield, operators roadside window, into the boarding area or the operators mirrors.	Passed

TABLE 3.3. RAIN GUTTER RESULTS

**3.4 WINDSHIELD WIPERS**

Inclement weather conditions were encountered during testing at Phoenix (see Figure 3.4) and Altoona, and during the Operational and Road testing (reported on later). Windshield wiper operation during rain and snow conditions was deemed satisfactory. Operator comments, observations and reliability data collected documented compliance with the requirements of Table 3.4.

Requirement	Test Results
No part of the windshield wiper mechanism shall be damaged by manual manipulation of the arms.	Passed
At 60 mph, no more than 10% of the wiped area shall be lost due to wiper lift.	Passed

**TABLE 3.4. WINDSHIELD WIPERS RESULTS**

Although not measured, windshield wiper performance was judged satisfactory throughout the test program. No complaints or squawks were written relative to the performance of this system at ABRTC or during operational testing.

Over the course of the test program, we did observe that the articulating arm on the curb side wiper rubbed on the top of the wiper blade during blade movement. This is due to wiper mechanism geometry on the curb side. A modification to the design for production will correct this light rubbing condition.



**FIGURE 3.4. ATTB TESTING IN RAIN AT PHOENIX**

**3.5 WHEEL MOTOR HI-POT TEST**

A hi-pot (voltage break-down) test was run on each wheel motor per the Hi-Pot Test Plan (Appendix A, Reference 5) on the first four prototypes produced (ATTB-1 through ATTB-4) and they all passed. The hi-pot test is designed to measure any leakage currents on high voltage systems and determine that any detected leakage is within acceptable limits and therefore present no shock hazard to personnel. This test also detects shorts and flash-over between cabling and/or equipment.

**THIS PAGE INTENTIONALLY LEFT BLANK**

**4.0 PERFORMANCE TESTING RESULTS**

**4.1 GENSET POWER**

Performance test data was analyzed to verify the GENSET requirements of Table 4.1. While it was determined that the GENSET provided enough power, the ATTB was only able to meet the requirements after a long development period. During development, a new software control scheme was developed and integrated in concert with Kaman Electromagnetics, to wring maximum power from the GENSET. This testing determined that the ATTB could use another 15 to 20 hp of power to provide some performance margin that would improve acceleration and allow for engine degradation over time.

Requirement	Test Result
The GENSET shall provide adequate power to enable the bus to meet minimum acceleration, top speed and gradeability requirements as defined in spec. par. 3.2.1.	Passed
SUFFICIENT EXCESS power shall be available to operate all accessories.	Passed

**TABLE 4.1. GENSET POWER RESULTS**

**4.2 ACCELERATION**

The ATTB was tested on a straight, level and dry roadway at SLW with all accessories except the HVAC compressor operating. Starting from a complete stop, the ATTB was run at maximum acceleration to meet the requirements listed in Table 4.2-1.

Phoenix test results are summarized in Table 4.2-1 using two methods of acceleration testing. Power blocking is where the bus is restrained from moving with the brake whilst the accelerator pedal is depressed. This reduces the spool-up time of the engine and allows quicker accelerations. The second method is the normal driving technique of removing the foot from brake to accelerator pedal to initiate bus movement. While quicker, power block starts are not representative of normal bus operation.

While at Phoenix we also accomplished some power block and non-power block accelerations on wet pavement from 0 to 10 mph and 0 to 20 mph. At CW and SLW no degradation in ATTB handling or traction characteristics were observed by the operator or on-board test team.

Phoenix Test Data (ATTB-1)		Test Results	
Requirement (ATTB Goal)	White Book	Power Block	No Power Block
0 to 10 mph in 4.0 seconds	5.6 sec.	2.86* sec.	4.73 sec.
0 to 20 mph in 8.1 seconds	10.1 sec.	10.01* sec.	14.10 sec.
0 to 30 mph in 14.0 seconds	20 sec.	21.32 sec.	24.63 sec.
0 to 40 mph in 23.0 seconds	34 sec.	34.64 sec.	No Data**
0 to 50 mph in 40.0 seconds	60 sec.	> 99.0 sec.	No Data**

\* Average of opposite direction runs

\*\* Did not run these conditions

**TABLE 4.2-1. PHOENIX ACCELERATION RESULTS**



At this point in the development of the ATTB it took quite a while to accelerate to 50 mph and we knew some of this was due to ATTB-1 having a different wheel motor gear-set (10-1 ratio) than the other 5 prototypes (7-1), so these results were not indicative of final ATTB performance.

We repeated acceleration testing, once we completed power system development, on another prototype. Table 4.2-2 summarizes our Los Angeles testing with ATTB-5 using the old software scheme (Variable Speed Governor or VSG) and the new scheme (Limiting Speed Governor or LSG). These tests were conducted using the Hawthorne Airport runway at CW.

Los Angeles Test Data (ATTB-5)		Test Results		
Requirement (ATTB Goal)	White Book	VSG S/W	LSG S/W	Improvement
0 to 10 mph in 4.0 seconds	5.6 sec.	4.40 sec.	4.04 sec.	8.2 %
0 to 20 mph in 8.1 seconds	10.1 sec.	9.29 sec.	8.10 sec.	12.8 %
0 to 30 mph in 14.0 seconds	20 sec.	18.71 sec.	15.83 sec.	15.4 %
0 to 40 mph in 23.0 seconds	34 sec.	32.75 sec.	26.72 sec.	18.4 %
0 to 50 mph in 40.0 seconds	60 sec.	58.54 sec.	44.45 sec.	24.1 %
0 to 55 mph		N/A*	58.52 sec.	-

\* Vmax was 52.8 mph as we were constrained by test course length used

**TABLE 4.2-2. LOS ANGELES ACCELERATION RESULTS**

Table 4.2-2 represents the final acceleration characteristics of the ATTB with improved power management VMC software (LSG) developed by Northrop Grumman in collaboration with Kaman Electromagnetics. These results are an average of two test runs in opposite directions to normalize grade variations and any wind aiding. VSG software is the latest VMC version before development of LSG.

Table 4.2-3 summarizes the acceleration data taken by ABRTC during the test program they conducted on ATTB-2 at SLW. They conducted three tests counter-clockwise (CCW) and three tests clockwise (CW) for each speed point condition to gather the data.

Altoona Test Data (ATTB-2)		Test Results		
Requirement (ATTB Goal)	White Book	CCW	CW	Average
0 to 10 mph in 4.0 seconds	5.6 sec.	5.03	4.85	4.94
0 to 20 mph in 8.1 seconds	10.1 sec.	9.96	9.48	9.72
0 to 30 mph in 14.0 seconds	20 sec.	20.78	18.11	19.45
0 to 40 mph in 23.0 seconds	34 sec.	37.75	30.40	34.08
0 to 50 mph in 40.0 seconds	60 sec.	66.20	50.16	58.18

**TABLE 4.2-3. ALTOONA ACCELERATION RESULTS**

**4.3 GRADE ACCELERATION**

The results of Table 4.3 are mathematically derived from ATTB-2 acceleration testing at Altoona.

Altoona Test Data (ATTB-2) Vehicle Speed (MPH)	Test Results		
	Time (SEC)	Acceleration (FT/SEC <sup>2</sup> )	Max Grade (%)
1.0	.41	3.5	11.0
5.0	2.16	3.2	10.0
10.0	4.61	2.8	8.7
15.0	7.43	2.4	7.5
20.0	10.73	2.0	6.4
25.0	14.66	1.7	5.3
30.0	19.44	1.4	4.3
35.0	25.40	1.1	3.4
40.0	33.11	.8	2.6
45.0	43.56	.6	1.8
50.0	58.70	.4	1.2

**TABLE 4.3. GRADE ACCELERATION RESULTS**

**4.4 ACCELERATION AT SPEED**

On a level, dry roadway, we ran the ATTB (at SLW) at maximum acceleration and measured the time to reach a target speed while starting from a specified speed. Table 4.4-1 lists the results without LSG S/W or rewind generator.

Phoenix Test Data (ATTB-1) Requirement	Test Results (sec)
	SLW
5 mph to 15 mph	6.5
10 mph to 20 mph	8.8
15 mph to 25 mph	11.45
20 mph to 30 mph	13.01
20 mph to 40 mph	44.20
20 mph to 50 mph	71.45
30 mph to 50 mph	59.43

**TABLE 4.4-1. ACCELERATION AT SPEED RESULTS**

While testing at Phoenix, ATTB Engineering requested an acceleration test to help them understand the performance shortcomings we were encountering. At GVWR, on a level, dry roadway, we ran the ATTB at maximum acceleration and measured the time to travel 1000 feet and the speed attained, the results of which are listed in Table 4.4-2 without LSG S/W or rewind generator.

Phoenix Test Data (ATTB-1) Requirement	Test Results	
	SPEED (mph)	TIME (seconds)
Acceleration to the East (up slope)	30.3	34.21
Acceleration to the West (down slope)	34.5	29.61

**TABLE 4.4-2. STRAIGHT COURSE ACCELERATION RESULTS**

4.5 TOP SPEED

On a straight, level roadway, the ATTB was run to its maximum speed at SLW, with all accessories running at a nominal duty cycle. Table 4.5-1 lists the requirements and results.

Phoenix Test Data (ATTB-1) Requirement	Test	Results	(mph)
	CW	SLW	GVWR
The ATTB must be capable of no less than 62 mph.	57*	53	53.5
Supplemental testing with HVAC on.		-	49.9

\*Possible wind aided reading

TABLE 4.5-1. TOP SPEED RESULTS

Unfortunately, the FaAA Phoenix test track layout affected our ability to acquire accurate and complete data. The test track size (only 1.9 miles around) caused us to lose speed during the turns due to tire scrub so we were not able to reach maximum speed on both straightaways (thus canceling wind effects). In addition, the test track tilts up towards the East such that the North straightaway had a measured 0.78 % grade and the South straightaway measured at 0.67 %. This caused us to gain speed on the North straight-a-way and lose it on the South straight away while going in a counter clockwise direction. As stated earlier ATTB-1 has a different wheel motor gear set than the other 5 prototypes, so these results are also not indicative of ATTB fleet performance. These factors made testing at a later date a requirement to complete this data set. Figure 4.5 shows ATTB-1 performance testing on the FaAA Phoenix test track.

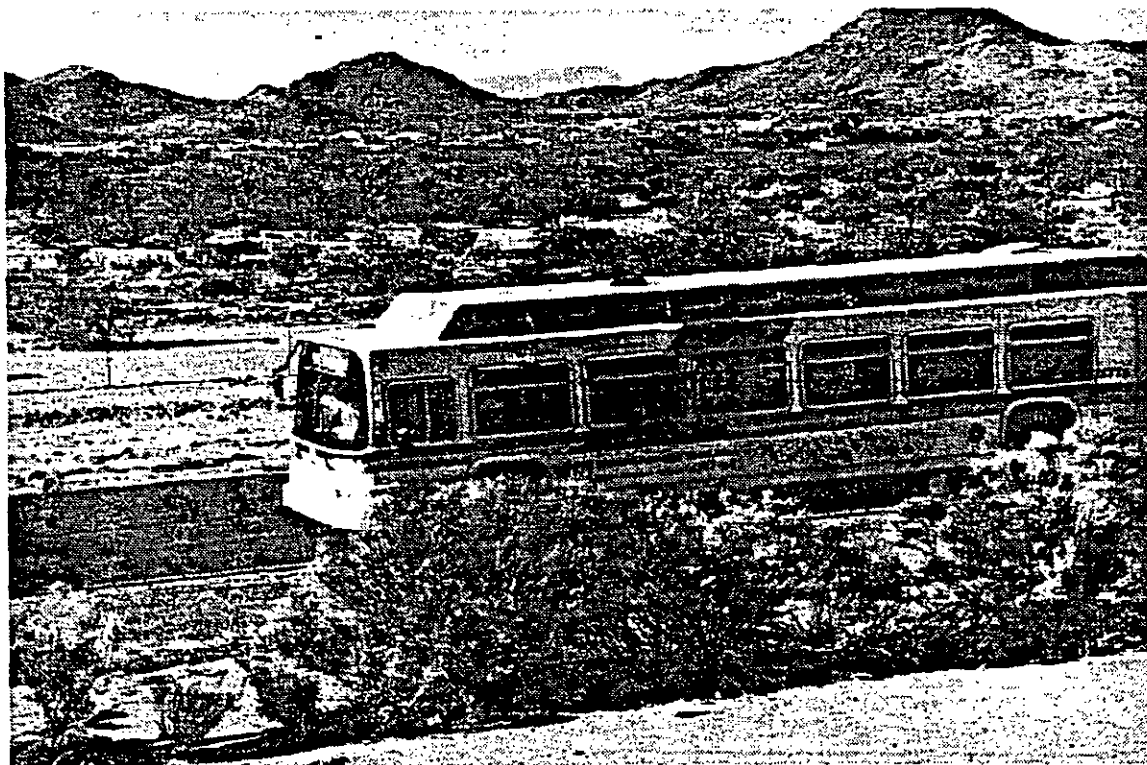

FIGURE 4.5. ATTB-1 AT SPEED ON THE FaAA TEST TRACK

We repeated top speed testing once we completed power system development and another prototype was available; and achieved the results listed in Table 4.5-2.

Los Angeles Test Data (ATTB-3)		Test	Results	(mph)
Requirement		CW	SLW	GVWR
The ATTB must be capable of no less than 62 mph.		67		

TABLE 4.5-2. LA TOP SPEED RESULTS

4.6 CLIMB SPEED AND GRADE REPEATABILITY

A suitable roadway was not available, therefore we accomplished these tests using a dynamometer facility. Engineering provided the test engineer with dynamometer horsepower settings for the speeds, grade and weight required (ATTB physically at curb weight).

Limited Time

No roadway was available in Phoenix to do these tests nor was the FaAA dynamometer capable of providing the load required (excessive load fluctuation at speed). Therefore, these tests were accomplished at the LACMTA Regional Repair Facility Dynamometer as listed in Table 4.6-1 without LSG S/W or rewound generator.

Los Angeles Test Data (ATTB-1)		Test	Results
Requirement		SLW	GVWR
The ATTB must be able to sustain for 2 minutes these climbs with no degradation in performance:			
7 mph at 16 % grade		14%	*
44 mph at 2.5 % grade		3%	1%

\* Not tested since we missed the requirement at SLW

TABLE 4.6-1. CLIMB SPEED AND GRADE REPEATABILITY RESULTS

At 7 mph the ATTB could only sustain a 14% grade at SLW. At any grades steeper than this the ATTB would overheat the propulsion system causing an automatic shutdown (thermal protection). The ATTB was able to exceed the 44 mph requirement, but at GVWR (supplemental test) the ATTB was only able to sustain 44 mph at 1% grade.

Unlimited Time

We did not accomplish the test of Table 4.6-2 since we could only sustain 44 mph in the previous (limited time) test without LSG S/W or rewound generator.

Requirement	Test Results
	GVWR
The ATTB must be able to sustain the climb at 45 mph with no degradation in performance on a 1 % grade until a defined fuel source is exhausted.	Failed (44 mph)

TABLE 4.6-2. UNLIMITED TIME RESULTS

**Restart**

We did not accomplish this test series (Table 4.6-3) since suitable roads and dynamometer facilities capable of performing this test were not available. The FaAA dynamometer could not hold load consistently and the MTA dynamometer (Division 10), using manual load entries, could not alter load fast enough to allow the start and stopping required for these tests. A new software program was needed to run the test with the driver following test program cues.

Requirement	Test Results SLW
The ATTB must be able to sustain the climb at 7 mph on a 16 % grade for one minute, followed by a two minute stop interval for a total of 12 times (restarts) with no degradation in performance.	Not Tested
The ATTB must be able to sustain the climb at 44 mph on a 2.5 % grade for one minute, followed by a two minute stop interval for a total of 12 times (restarts) with no degradation in performance	Not Tested

**TABLE 4.6-3. RESTART RESULTS**

**Grade Repeatability**

We did not accomplish this test series (Table 4.6-4) since suitable roads and dynamometer facilities capable of performing this test were not available. In this case simulating the downhill grade was not possible with any of the dynamometers available to us.

Requirement	Test Results GVWR
The ATTB must be able to sustain two consecutive 6% uphill grades, each approximately three miles long with each grade separated by a minimum 6%, 2.5-mile downhill grade with no degradation in performance.	Not Tested

**TABLE 4.6-4. GRADE REPEATABILITY RESULTS**

We believe we met Table 4.6-4 requirements based on the many trips to and from Altoona and the test track at Penn State University (PSU) conducted by ABRTC. There are two long climb segments going from Altoona on Route 220 to PSU (at State College, PA), that although not measured, clearly taxed the bus.

**4.7 EMISSIONS**

Table 4.7 summarizes the not installed emissions data from Detroit Diesel used to gain California Air Resources Board (CARB) certification for the Detroit Diesel Series 30 CNG engine that powers the ATTB. The levels were significantly below the requirements.

Requirement		Test Results With Catalytic Converter gm/bhp-hr
The emissions must not exceed the CARB optional Low Emissions Bus (LEB) standards when tested in accordance with the Federal Heavy-Duty Engine Transit Cycle*	gm/bhp-hr	
Carbon Monoxide	≤ 15.5	2.8
Oxides of Nitrogen	≤ 2.5	1.7
Non-methane Hydrocarbon	≤ 1.2	0.6

TABLE 4.7. CARB CERTIFICATION EMISSION RESULTS

4.8 FUEL ECONOMY TESTING

There are no minimum requirements to meet for fuel economy, but this parameter is extremely important to potential operators since it is a major factor in their operating cost structure. As such the ATTB was designed to have an endurance of the lessor of 22 hours or 400 miles range in revenue service at SLW.

LACMTA Fuel Economy

As a part of Operational and Road testing, the three buses used by LACMTA were monitored for fuel consumption during their non-revenue service. The results are tabulated in Table 4.8-1 with MPG expressed in miles per equivalent diesel gallon.

Result	Test Results			
	ATTB-4	ATTB-5	ATTB-6	Fleet Average
MPG (Equivalent Diesel)	3.52	3.74	4.38	3.95

TABLE 4.8-1. LACMTA FUEL ECONOMY RESULTS

ABRTC Fuel Economy

As a part of ABRTC testing, the ATTB was driven over a measured course to gather fuel mileage data on the Transit Coach Operating Duty Cycle at SLW. Includes in this testing is driving a City Business District (CBD), Arterial and Commuter cycles plus idle consumption per the ABRTC test plan (Appendix A, Reference 6). The ABRTC reported mileage and our conversion of their data to equivalent diesel miles per gallon is listed in Table 4.8-2.

Altoona Test Data (ATTB-2)		Test	Results
Requirement	ABRTC Report	Equiv. Diesel	
ABRTC Transit Coach - CBD Cycle	.5 mile/lb.	2.66 mile/gal	
ABRTC Transit Coach - Arterial Cycle	.59 mile/lb.	3.13 mile/gal	
ABRTC Transit Coach - Commuter Cycle	1.02 mile/lb.	5.43 mile/gal	
ABRTC Transit Coach - Idle Consumption	10.84 lb./hr		

TABLE 4.8-2. ABRTC FUEL ECONOMY RESULTS

4.9 ALTITUDE

Unfortunately, we discovered on a short promotional visit to Denver, Colorado (6/20/97 to 6/22/97) with ATTB-3, that the ATTB engine (Detroit Diesel, Series 30-CNG) can not maintain full-power in high altitude operation. The DDEC (electronic engine control system) does not have altitude compensation capability (sensors or software). Therefore the engine performed poorly (substantially reduced power) in Denver so no further testing per Table 4.9 was scheduled.

Requirement	Test Results
The ATTB shall operate from sea level to 6,000 ft without degrading performance unless otherwise specified.	Failed

TABLE 4.9. ALTITUDE RESULTS

## 5.0 BRAKE TESTING RESULTS

All brake performance tests were performed on a hard macadam surface that was substantially level, dry (wet where specified), smooth and free of loose material. A 12-foot lane was set up on the roadway or skid pad with one side marked-off in 25-foot increments using traffic lane cones. The bus was accelerated to speed and braking applied, per the applicable test paragraph conditions, when the first cone of the brake lane was adjacent to the test drivers position (just forward of the front wheels). The stop distance was measured from the point at which movement of the service brake pedal begins (at the first cone) and ended where the vehicle came to a complete stop. The test engineer examined the roadway for skid marks and deviation from the brake lane and noted deviations from desired conditions in his test log as appropriate. Figure 5.0 shows ATTB-1 performing a brake test in Phoenix.



FIGURE 5.0. ATTB-1 BRAKING ON PHOENIX SKID PAD

Wet roadway tests were accomplished utilizing either natural weather or by applying water to the roadway with a water truck. The roadway was judged sufficiently wet when puddles formed on the surface or water was observed running-off the road surface. The test engineer had the water truck re-wet the roadway as needed to maintain the desired conditions for each test run.

The ATTB started in the center of a 12-foot-wide lane at the beginning of the tests and did not deviate from that lane during all brake tests including the wet pavement series. In summary, the front disk, rear drum hydraulic brake system coupled with REGEN in the rear has yielded a very effective stopping bus that behaves in a straightforward and safe manner.



**5.1 REGENERATIVE/SERVICE BRAKING**

Under unloaded (CW) and maximum (GVWR) conditions, the ATTB was accelerated to 20 mph and decelerated with maximum non-skid brake application. Table 5.1-1 shows the ATTB met or exceeded all requirements tested.

Requirements	Test	Results
	CW*	GVWR
The ATTB must develop a braking force at least equal to <b>43.5%</b> of the GVWR		80%
Additionally, the brake system must develop a <b>0.6 g</b> or greater vehicle deceleration (at 20 mph to 0) with maximum braking command (no tire skid)	0.65 g	0.8 g
The ATTB must decelerate to a stop from 20 mph at a rate of no less than <b>14 ft/sec<sup>2</sup></b>	20.8 ft/sec <sup>2</sup>	25.6 ft/sec <sup>2</sup>
The ATTB must stop from 20 mph in a distance of no more than <b>35 feet</b> . The distance will be measured from the point at which movement of the service brake pedal begins and will end where the vehicle comes to a complete stop	27 ft-5 in	23 ft-6 in
The roadway will be watered down, and the previous test rerun. The ATTB must come to a complete stop in <b>60 feet</b> or less	No Data**	26 ft-3 in
The braking system will be tested on a 7% downhill grade during a 90°F or hotter day. The brakes should be capable of continuous operation without any brake fading (Note: Only if 7% grade is available)	No Grade Available	No Grade Available
The ATTB will be run at 20 mph on a minimum 20% grade. The vehicle will be at GVWR and the braking system must be capable of bringing the vehicle safely to a complete stop (Note: Only if 20% grade is available)	No Grade Available	No Grade Available

\* "Normal" brake application (less than maximum) used.

\*\* Test not run at this weight.

**TABLE 5.1-1. REGENERATIVE/SERVICE BRAKING RESULTS**

**Regenerative Braking Off**

Supplemental tests were conducted to determine the braking performance at GVWR with Regenerative (REGEN) braking disabled. Table 5.1-2 tabulates the results.

Phoenix	Requirement	Test Results GVWR
	10 mph to 0 mph	11'-9"
	20 mph to 0 mph	31'-0"
	Repeat	31'-0"
	30 mph to 0 mph	60'-2"
	40 mph to 0 mph	104'-10"
	50 mph to 0 mph	189'-4'

**TABLE 5.1-2. REGENERATIVE BRAKING OFF RESULTS**

When compared to similar tests with REGEN braking enabled it appears REGEN braking provided an overall average 16 % improvement in braking performance (Table 5.1-3). For these tests at Phoenix, REGEN was programmed for 30 kW of braking energy. Later in the development program we were able to increase REGEN to 60 kW, but we did not repeat these tests. It is unclear why the tests from 30 mph yielded negative improvement. If this disparity had been noticed at the time of testing, repeating the test point may have resolved this issue.

Otherwise it would seem that REGEN is most effective braking from 20 mph or less, which would be very helpful on CBD type bus routes.

Requirement	Test	Results	@ GVWR
	REGEN Off	REGEN On	Improvement
10 mph to 0 mph	11'-9"	8'-0"	31.5%
20 mph to 0 mph	31'-0"	23'-6"	24.2%
30 mph to 0 mph	60'-2"	62'-4"	-3.5%
40 mph to 0 mph	104'-10"	93'-8"	11.9%
50 mph to 0 mph	189'-4"	157'-0"	17.1%
Average Improvement			16.2 %

TABLE 5.1-3. REGEN BRAKING COMPARISON RESULTS

5.2 MAXIMUM BRAKING (NON-SKID, DRY)

The ATTB was accelerated to speed on a dry, straight roadway. The ATTB brakes were applied to provide maximum braking without skidding and the distance measured for a complete stop from the point at which maximum braking was applied. Table 5.2 lists the results at SLW and GVWR.

Requirement	Test Results		
	CW	SLW	GVWR
10 mph to 0 mph	*	9'-0"	8'-0"
20 mph to 0 mph	*	21'-4"	23'-6"
Repeat		26'-6"	
Repeat		35'-8"	
30 mph to 0 mph	*	73'-6"	62'-4"
40 mph to 0 mph	*	94'-8"	93'-8"
50 mph to 0 mph	*	168'-0"	157'-0"
60 mph to 0 mph	**	**	**

\* Not Tested

\*\* At time of test, 60 mph was not achievable

TABLE 5.2. MAXIMUM BRAKING (NON-SKID, DRY) RESULTS

5.3 MAXIMUM BRAKING (NON-SKID, WET)

The ATTB was accelerated to speed on a straight roadway that has been watered down. The ATTB brakes were applied in such a manner to achieve maximum braking without skidding. At Seated Load Weight (SLW), from 40 and 50 mph, the front tires did lock up as noted in Table 5.3. The distance for a complete stop is measured from the point at which maximum braking is applied. Curb Weight (CW) was not tested due to time constraints.

Phoenix Requirement	Test	Results	(ft-in)	Comments
	CW	SLW	GVWR	
10 mph to 0 mph	-	10-9	8-7	
20 mph to 0 mph	-	28-4	26-3	
30 mph to 0 mph	-	76-8	62-3	
40 mph to 0 mph	-	138-6*	135-2	* Locked front tires at end of stop **
Repeat		123-8**		Both front tires locked up
50 mph to 0 mph	-	186-4#	196-6	# Locked front tires at end
Repeat		198-3##		## Sliding right front tire
60 mph to 0 mph	*	*	*	Not Tested

\* At the time of this test the ATTB was not able to achieve this speed

TABLE 5.3. MAXIMUM BRAKING (NON-SKID, WET) RESULTS

5.4 MAXIMUM BRAKING (SKID, WET)

The ATTB was accelerated to speed on a wet, straight roadway. Maximum braking was applied in such a manner as to cause the vehicle to lock up all four tires. At GVWR we tested at 40 and 50 mph with results (Table 5.4), very similar to our non-skid distances. Therefore, the other speeds and weights were not tested. The bus did not swerve or break loose and stopped in a straight line. We were unable to lock the rear wheels and cause them to skid.

Requirement	Test Results		
	CW	SLW	GVWR
10 mph to 0 mph	*	*	*
20 mph to 0 mph	*	*	*
30 mph to 0 mph	*	*	*
40 mph to 0 mph	*	*	111'-0"
50 mph to 0 mph	*	*	197'-8'
60 mph to 0 mph	*	*	*

\* Not tested

TABLE 5.4. MAXIMUM BRAKING (SKID, WET) RESULTS

5.5 PANIC BRAKING (WET)

The ATTB was driven down a wet roadway at speeds of 40 and 50 mph. The ATTB brakes is applied so that all four wheels of the vehicle will be locked in a panic braking situation. Vehicle performance and handling is noted in Table 5.5, although we were unable to get the rear brakes to lock.

Requirement	Test Results		
	Handling	Tire Skid	GVWR
40 mph to 0 mph	Stopped straight within 12 ft lane	Front wheels only locked	111'-0"
50 mph to 0 mph	Stopped straight within 12 ft lane	Front wheels only locked	197'-8"

TABLE 5.5. PANIC BRAKING (WET) RESULTS

5.6 REGENERATIVE/SERVICE BRAKING CIRCUIT FAILURE

The requirements for this test were to disable the front brake system by completely emptying the hydraulic fluid from the front brake circuit. In the interest of saving time, we instead disabled the circuit by capping off the front brake lines. With the ATTB at GVWR we accelerated to speed and then made a normal deceleration to a complete stop. Table 5.6-1 documents the results obtained.

Requirements			Test Results GVWR (ft - in)
Front Brake System Disabled:	Speed (mph)	Stopping Distance (ft)	
Supplemental data taken.	10	-	7-4
Supplemental data taken.	20	-	39-0
Supplemental data taken, REGEN braking off.	20	-	38-0
ATTB (at GVWR) must be capable of stopping in less than the specified distances from the specified speeds:	30	170	128-2
	35	225	No Data*
	40	288	292-10
	45	358	No Data*
	50	435	707-0
	55	530	N/A
	60	613	N/A

\* Test not run at this speed. N/A=Not Achievable - Speed could not be reached at this time

TABLE 5.6-1. REGENERATIVE/SERVICE BRAKING CIRCUIT FAILURE RESULTS

It is believed that the method used to disable the front brakes adversely effected the outcome of the tests. The method employed (capping the front lines and not draining the brake fluid) trapped fluid in the lines which was compressed during brake application. This may have prevented maximum braking force development by the rear drum brakes.

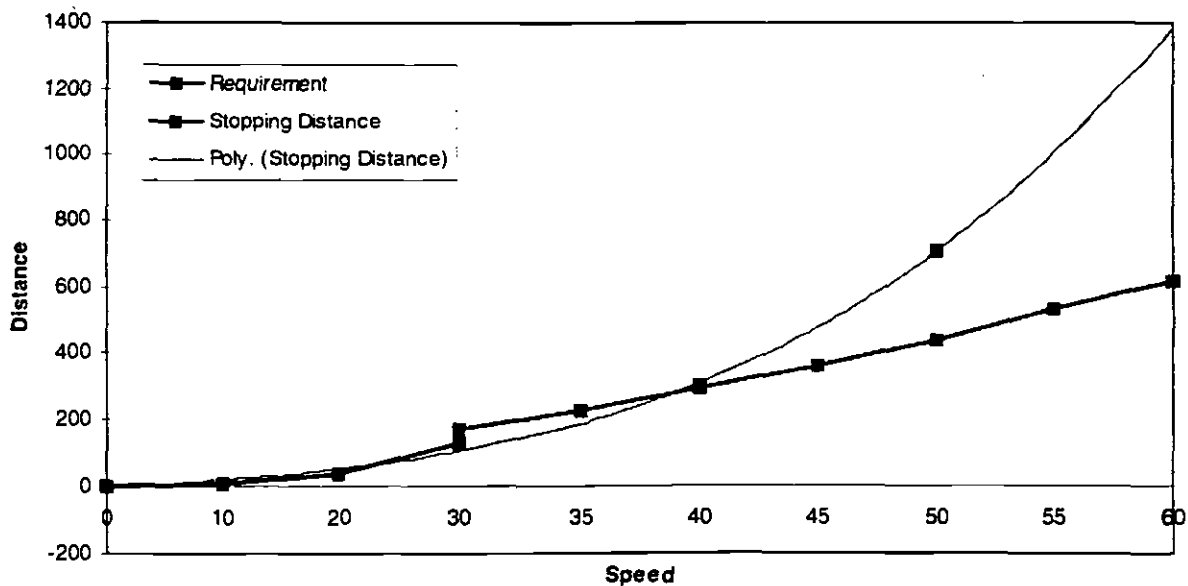

FIGURE 5.6-1. PARTIAL SERVICE BRAKE SYSTEM FAILURE

Using the existing data, a polynomial fit (Figure 5.6-1 above) shows that at speeds above 40 mph, the ATTB fails the requirement.

The front brake system was reconnected, reservoir filled and the lines bled. The rear brake system was then completely disconnected at the brake drums and capped off and the test rerun.

Requirements			Test Results GVWR (ft - in)
	Speed (mph)	Stopping Distance (ft)	
Supplemental data taken.	10	-	12-9
Supplemental data taken.	20	-	38-3
Supplemental data taken, REGEN braking off.	40	-	172-6
ATTB (at GVWR) must be capable of stopping in less than the specified distances from the specified speeds:	30	170	84-0
	35	225	126-4
	40	288	167-2
	45	358	204-0
	50	435	249-0
	55	530	N/A
	60	613	N/A

TABLE 5.6-2. REAR BRAKE SYSTEM DISABLED RESULTS

Table 5.6-2 lists the data collected which is graphically shown in Figure 5.6-2, with rear brake disabled, the ATTB comfortably meets the requirements at the speeds tested. With the old S/W (VSG) and no rewind generator in Phoenix 50 mph was the maximum speed tested. The polynomial trend line shows the ATTB will meet the higher speed requirement as well. At the end of these tests, the rear brake system was returned to normal operation.

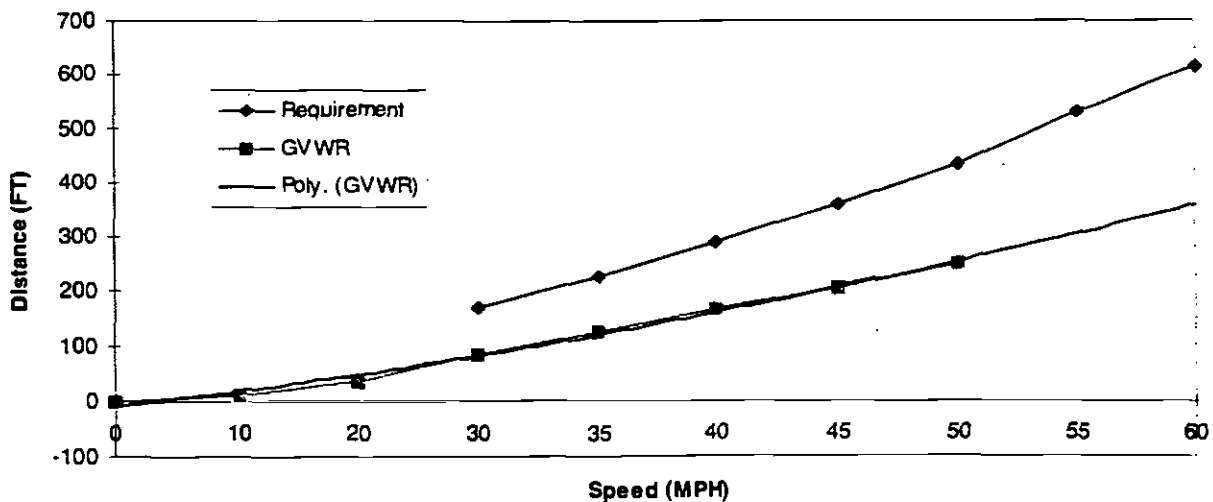

FIGURE 5.6-2. REAR BRAKE SYSTEM DISABLED

## 5.7 BRAKING UNDER COMPLETE POWER FAILURE

By removing power to both the power steering pump and the backup power assist unit a simulated failure of both the primary and secondary brake power assist units was tested. The ATTB was accelerated to 20 mph and stopped by engaging the Emergency Parking Brake to meet the requirements of Table 5.7, where the results are also listed.

Requirement	Test Results GVWR
The distance required to come to a complete stop from the point at which braking was applied will be measured (20 mph to 0 mph).	93'-8"
Repeat	85'-3"
Additional data, without REGEN braking	143'-0"
Repeat	155'-0"

TABLE 5.7. BRAKING UNDER COMPLETE POWER FAILURE RESULTS

The test driver was "standing on the brake pedal" for these tests. Without brake pedal force instrumentation (Phoenix test) it is not possible to quantify the load, but it was significantly higher than "normal" brake pedal forces.

## 5.8 SECONDARY / PARKING BRAKE SYSTEM

This system was tested as described in the following sections.

### Emergency Braking

At GVWR, the ATTB was accelerated to 20 mph and the parking brake only activated. The ATTB met or exceeded all requirements as shown in Table 5.8-1.

Requirements	Test Results GVWR
Supplemental Data, 10 mph to 0 mph	18'-10"
The ATTB must come to a complete stop in a distance no greater than 85 feet.	61'-11"
The vehicle must not deviate from the 12-foot-wide lane that it started in.	No Deviation

TABLE 5.8-1. EMERGENCY BRAKING RESULTS

### Secondary Braking

There was no 7% grade available at Phoenix to do this test. We did verify that a deceleration force in excess of .25g could be generated with normal brake pedal pressure as shown in Table 5.8-2.

Requirement	Speed (mph)	Test Results
		GVWR
Safely bring ATTB to a stop on a downhill grade of 7%.	62	N/A
Supplemental data, Capable of generating a 0.25 g force or greater, deceleration with an operator force of less than 15.7 lb. (ATTB goal)	37	211'-0"

TABLE 5.8-2. SECONDARY BRAKING RESULTS

**Parking Brake**

With the ATTB at CW and GVWR, the parking brake was tested on the steepest ramp available at Phoenix with the results listed in Table 5.8-3. The wheels were marked with spray chalk and the engine shutdown. Figure 5.8 shows the ATTB on the grade used.

Requirement	Test Results	
	CW	GVWR
The parking brakes must be adequate to hold the vehicle indefinitely under all loading and grade conditions.	Held for 45 min. @ 17 deg.*	Held for 1 hour @ 17 deg.*

\* This equates to 30.57 % slope.

TABLE 5.8-3. PARKING BRAKE RESULTS



FIGURE 5.8. ATTB ON GRADE FOR PARKING BRAKE TEST IN PHOENIX

**5.9 INOPERATIVE PRIMARY BRAKE POWER ASSIST UNIT**

The primary brake power assist unit was made inoperative by removing power to the power steering pump. The backup brake power assist subsystem was operational. Upon completion of this test, all brake systems were restored to a fully operational state. The ATTB, as illustrated in Table 5.9 and Figure 5.9, exceeded the requirement by a substantial amount (35%):

Requirement	Test Results GVWR
Supplemental data taken at 10 mph.	14'-0"
Supplemental data taken at 20 mph.	34'-8"
Supplemental data taken at 30 mph.	82'-3"
Supplemental data taken at 30 mph, REGEN braking off.	77'-10"
Supplemental data taken at 40 mph.	140'-4"
Supplemental data taken at 50 mph.	213'-4"
Supplemental data taken at 50 mph, REGEN braking off	251'-9"
The ATTB (at GVWR) will be accelerated to 60 mph and must stop in a distance no greater than 613 feet.	310' *

\* At the time of this test the ATTB was not able to achieve the required speed, however from Figure 5.9 this is the projected number from a 3rd order polynomial fit curve using data from this table

**TABLE 5.9. INOPERATIVE PRIMARY BRAKE POWER ASSIST UNIT RESULTS**

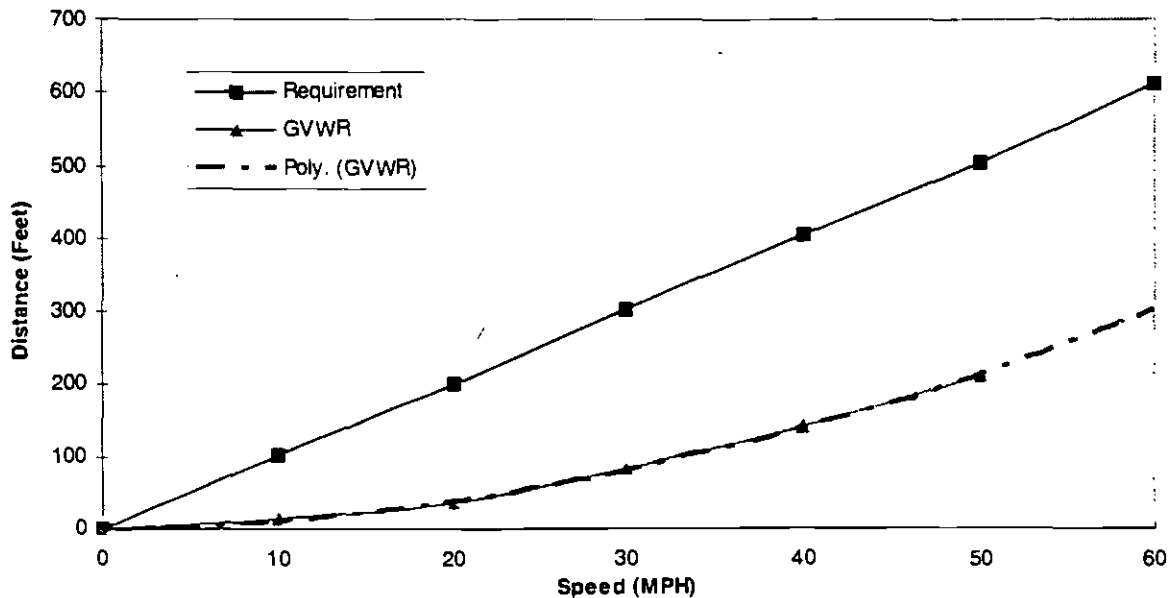

**FIGURE 5.9. INOPERATIVE PRIMARY BRAKE POWER ASSIST UNIT RESULTS**



**THIS PAGE INTENTIONALLY LEFT BLANK**

**6.0 VEHICLE HANDLING TEST RESULTS**

**6.1 STEERING CONTROL**

The ATTB was driven in a straight line at 10 mph. The steering wheel was turned one-eighth turn to the right and then released. This test was repeated for a one-eighth turn to the left. The ATTB failed the requirements in Table 6.1 (bus would not return to a straight line). Video was used to further document the results.

To meet this current requirement the front strut geometry needs to be adjusted (out of ZF recommended specs.) to add caster and/or toe-in to the front suspension. This was considered outside the scope of this effort, and not necessary given the otherwise favorable steering characteristics of the ATTB

Requirement	Test Results	
	Left	Right
The ATTB should return to a straight line with no operator assistance.	No	No
Supplemental data at 20 mph	No	No
Supplemental data at 30 mph	No	No

**TABLE 6.1. STEERING CONTROL RESULTS**

**6.2 RIDE QUALITY**

For this test, the ATTB operator performed several maximum acceleration runs (zero to 10 mph, 5 to 15 mph, 10 to 20 mph, 15 to 25 mph, 20 to 30 mph, 25 to 35 mph, 30 to 40 mph, 35 to 45 mph and 40 to 50 mph). Table 6.2 lists the requirements and results.

Requirement	Test Results	
	CW	SLW
The maximum allowable rate of change of acceleration should be no greater than 0.3 g's per second.	< 0.25g	< 0.2g

**TABLE 6.2. RIDE QUALITY RESULTS**

**6.3 200-FOOT-DIAMETER CIRCLE**

A 200-foot-diameter circle was marked on a flat, dry surface with a surface coefficient of friction of 0.7 or greater. At GVWR the ATTB was driven at speeds of 15, 20 and 25 mph in a clockwise and counterclockwise direction around the circle. After completion of each maneuver, at least two minutes was spent with the bus at idle to allow the suspension system to re-level the ATTB. Table 6.3 lists the results of this test and video was recorded to further document this test.

Requirement	Test Results			
	CW Roll (degrees)	CW Lat. Force (g's)	CCW Roll (degrees)	CCW Lat. Force (g's)
10 mph	3	< 0.2	= 3.5	< 0.2
20 mph	= 5.2	= 0.3	= 5.5	= 0.3
25 mph	5.8	0.5	7.0	0.45
30 mph	6.8	0.5	7.1	0.5

TABLE 6.3. 200-FOOT-DIAMETER CIRCLE RESULTS

6.4 DOUBLE LANE CHANGE

6.4.1 Phoenix Test Results

A course was laid out as shown in Figure 6.4 on the North straight-away of the FaAA test track just West of the East turn. With the ATTB at GVWR the ATTB approached the right lane and made a lane change to the left adjacent lane between the pylons. and after 100 feet, made a lane change right to the original starting lane between the pylons. The ATTB was driven at ever increasing speeds (10, 20, 30, 40) until a maximum of 45 mph was accomplished without tipping over any pylons.

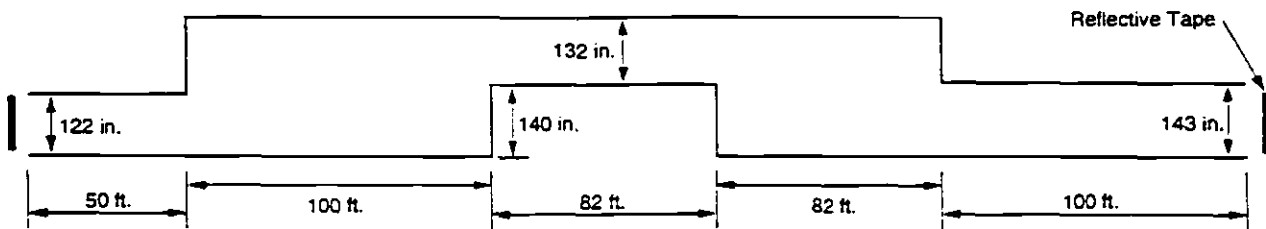

FIGURE 6.4. DOUBLE LANE CHANGE LAYOUT

6.4.2 ABRTC Test Results

Altoona also conducted a double lane change test (Safety) per their test procedure (Appendix A, Reference 6) that is nearly identical to the our test. Their double lane change results duplicated our results. They were able to achieve 45 mph making the change to the left and right directions. Their results indicated that handling and stability were maintained at a safe level and that the ATTB maintained tire contact with the road at all times.

6.5 U-TURN

A course was laid out as shown in Figure 6.5-1 on the 10-acre FaAA skid pad. At GVWR the ATTB was driven in both directions into the course performing a U-Turn maneuver at speeds of 10, 20 and 30 mph. Table 6.5 lists the results of this test and video was recorded to further document this test. Figure 6.5-2 shows ATTB-1 on one of U-Turn test runs.

Requirement	Test Results			
	CW Roll (degrees)	CW Lat. Force (g's)	CCW Roll (degrees)	CCW Lat. Force (g's)
10 mph	1.6	< 0.2	2.8	< 0.2
20 mph	≈ 4.9	≈ 0.3	≈ 4.1	≈ 0.3
30 mph	≈ 4.5	0.5	≈ 5.5	≈ 0.4*

\* Vehicle speed dropped to 23 mph as turn was completed

TABLE 6.5. U-TURN RESULTS

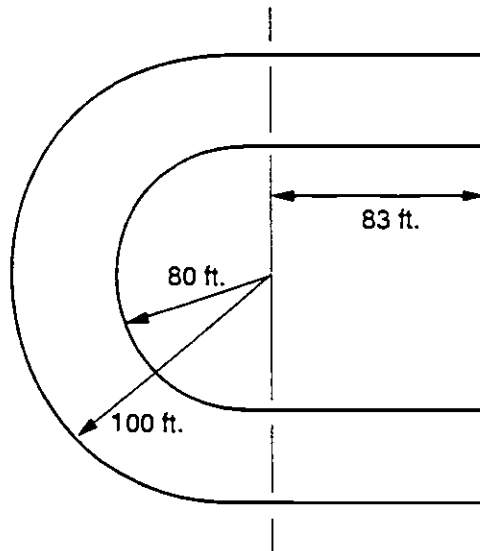

FIGURE 6.5-1. U-TURN COURSE LAYOUT



FIGURE 6.5-2. ATTB-1 PERFORMING U-TURN

**6.6 HYDROPLANING - J TURN**

We determined that we would not be able to perform the hydroplaning test as originally envisioned. There was not enough space on the FaAA dynamic skid pad to do the straight line test with adequate safety margin to stop the bus even though the bus was not exhibiting hydroplaning tendencies. Therefore, we changed the test and performed a series of "J" turns on a watered down portion of the skid pad. Using the 200-foot diameter circle course layout described by Figure 6.5, the ATTB was driven into the watered down course circle on a tangent, then turned for 90 degrees of turn and then steered to exit the course on a straight line. The maneuver was performed at increasing speeds while measuring vehicle roll and lateral force and recording the tests on video. We decided we needed to collect data in only one direction which is listed in Table 6.6. Our test driver reported no tendency of the bus to lose traction either at the front or rear end during the maneuvers.

Requirement	Test Results			
	CW Roll (degrees)	CW Lat. Force (g's)	CCW Roll (degrees)	CCW Lat. Force (g's)
20 mph	3.5	0.45	*	*
25 mph	4.1	0.48	*	*
30 mph	4.9	0.50	*	*
40 mph **	5.1	0.53	*	*

\* Not tested. \*\* Actual speed was 38 mph

TABLE 6.6. HYDROPLANING - J TURN RESULTS

**6.7 ADVERSE WEATHER**

In severe weather conditions (rain, snow and ice) ATTB directional control was observed and noted. Altoona and Boston operator comments (or absence) yielded favorable results of driving experiences with ATTB-2 and ATTB-3 respectively in these conditions. Therefore, the requirement that "the operator shall be capable of maintaining ATTB control at greatly reduced speeds" was passed.

**6.8 ACCELERATION (WET)**

Starting from a complete stop on a level, wet roadway, the ATTB (at SLW) underwent maximum acceleration to verify the requirements listed in Table 6.8. The test was also accomplished at Curb Weight (CW) conditions with no change in vehicle handling or traction noted. The ATTB electric wheel motors provide strong but not excessive acceleration torque to the rear wheels, so the tires do not slip.

Requirement	Test	Results
	CW	SLW
The vehicle handling and traction characteristics noted at 0-10 mph.	Passed*	Passed*
The vehicle handling and traction characteristics noted at 0-20 mph.	Passed*	Passed*

\* No skidding / slipping was observed during power block and non-power block accelerations

TABLE 6.8. ACCELERATION (WET) RESULTS

## 7.0 ENVIRONMENTAL TESTING RESULTS

The environmental test series is designed to evaluate the performance of the HVAC system and ATTB under severe environmental conditions, and determine the ATTB environment created by the operation of its various systems. Most of this testing is under controlled environmental conditions and some test results will be gleaned from the operational and road testing described later in this plan. We recognize that, while laboratory testing provides needed quantitative data, it can not replace operational performance data that is primarily qualitative, but just as valuable in judging overall system performance.

The following tests involve testing the ATTB under specific environmental conditions. If no passenger loading requirements are specified, assume that the ATTB is tested in an unloaded (Curb Weight) condition.

### 7.1 HVAC CAPACITY AND PERFORMANCE

We tested the HVAC in a Thermo King bus test cell in Minneapolis, MN. Their HVAC design performed very well and performed one of the fastest Houston Pull-down test times seen on a 40-foot bus! They attributed this to several factors different from conventional transit buses they've tested:

- Very Low U-Factor of 655 BTU/Degree (measured)
- Insulated Floor from Foam used in the Composite Structure
- HVAC System Capacity Not Dependent on Engine RPM - Full Capacity Available at Initial Pull-down (where it is needed most)
- Large, Unobstructed Passenger Air Ducts
- Lots of Airflow
- Efficient HVAC Unit (14 HP for 95,000 BTU/HR Capacity)
  - No Belt Drives
  - Large Efficient Coils
  - Reserve Capacity (2nd Compressor Cycles on as Needed)

Table 7.1 lists the results of HVAC capacity and performance tests. This testing and the U-factor test (section 7.5) revealed that leakage around the front door, especially in cold weather would be detrimental to passenger comfort of near the front door and the operator. The heating performance test showed the engine to be a more than adequate heat source for the HVAC, but the air temperature distribution data for cold climates (heater test) would need baseboard level heat registers to provide a comfortable passenger environment.

Requirement				Test Results
The cooling mode shall be capable of reducing the passenger compartment temperature from 110F to 90F in less than 20 minutes after engine start-up with the bus parked in direct sunlight with the ambient temperature at 100F and humidity less than 20% (no passengers and doors shall be closed).				7 Minutes
The cooling mode shall be capable of reducing the passenger compartment temperature from 110F to 70F in less than 30 minutes after engine start-up with the bus parked in direct sunlight with the ambient temperature at 100F and humidity less than 20% (no passengers and doors shall be closed). <i>Houston Pull-down</i>				
The HVAC shall maintain an average passenger compartment temperature as follows:				
Ambient Temp. Range	Relative Humidity	Interior Bus Temp. Range	Passenger Load	
95°F to 115°F	Less Than 50%	15°F Below Ambient	Full Standee (72) Plus Driver	73°F
10°F to 95 °F	5% to 50%	65°F to 80°F	Full Standee (72) Plus Driver	73°F 65°F*
-10°F to 10°F	Not Applicable	No Less Than 55°F	Driver Only (No Passengers)	Not Tested**

\* At 32°F.

\*\* With engine running we were limited to testing no lower than 32°F.

TABLE 7.1. HVAC CAPACITY AND PERFORMANCE RESULTS

7.2 HIGH TEMPERATURE OPERATION

We partially ran this test to determine if the ATTB system meets the requirements of Table 7.2-1. Unfortunately, the FaAA environmental chamber was not capable of meeting the test criteria. Our experience during LACMTA operation would indicate failure to meet these requirements in our current design configuration.

Requirement	Test Results
ATTB meets specification requirements while operating continuously at temperature up to 115°F.	Partial*
ATTB capable of operation up to 125°F without damage (HVAC On).	Not Tested
Exposure to 140°F in a non-operational mode shall not damage the ATTB (HVAC Off).	Not Tested

\* FaAA test chamber was not capable of reaching this temperature, however we did operate successfully at 106 °F during the test of Section 7.2.1

TABLE 7.2-1. HIGH TEMPERATURE OPERATION RESULTS

TAT HVAC Testing

Limited testing was conducted at Failure Analysis Associates (FaAA) in Phoenix, Arizona. No passenger loading requirements were specified, therefore the ATTB was tested in an unloaded condition. The vehicle was parked in direct sunlight, the ambient temperature was 106 °F at a (minimum required = 100°F) and a humidity of 17 % with the results listed in Table 7.2-2.

Test Results

Requirement	Start Temp	End Temp
The cooling mode shall be capable of reducing the passenger compartment temperature from 110F to 90F in less than 20 minutes after engine start-up with the bus parked in direct sunlight with the ambient temperature at 100F and humidity less than 20% (no passengers and doors shall be closed).	104°F	91°F
Supplemental data: after 30 minutes.	104°F	89°F

TABLE 7.2-2. TAT HVAC PULL-DOWN RESULTS

This test showed the TAT HVAC system to be inadequate for a variety of reasons. Qualitatively the noise is excessive from the exterior and the interior noise seems high for the amount of air being delivered. Our test driver commented that the flow of air to the front is poor. Our measurements were taken at the rear of the bus with the thermocouple over the right wheel well (out of the direct sun). Opening the rear door actuator access panel significantly increased the amount of air coming to the back. Although not measured, the temperature of the air coming from the overhead ducts seemed warmer than one would expect for an operating air conditioning system.

**7.3 LOW TEMPERATURE OPERATION**

We ran this test concurrently with the HVAC tests of Section 7.1 to determine if the ATTB meets the requirements of Table 7.3. During our testing at Thermo King, our lowest cold temperature test was at 32 °F.

Requirement	Test Results
ATTB meets specification requirements while operating continuously at temperature up to -10°F.	Failed*
ATTB capable of operation up to -40°F without damage, but not necessarily meet specification requirements.	-20°F Failed*
Exposure to -65°F in a non-operational mode shall not damage the ATTB.	Not Tested

\* During our testing at FaAA, the ATTB would not run (engine start) below 25°F. During our testing at Thermo King, our lowest cold temperature test was at 32 °F.

TABLE 7.3. LOW TEMPERATURE OPERATION RESULTS

**7.4 DEFROSTER PERFORMANCE**

We evaluated defroster performance based on performance during the testing of Section 7.5.1, during the course of Operational and Road testing (Section 9.0) and that testing accomplished at Altoona. Operator comments on defroster performance were also gathered to determine if the requirements of Table 7.4 were met.



Requirement	Test Results
The windshield defroster shall meet the requirements of SAE Recommended Practice J382, Windshield Defroster Systems Performance Requirements, and shall have the capability of diverting heated air to the operator's feet and legs.	Failed
The interior climate control system shall maintain visibility throughout the operator's side window.	Failed

**TABLE 7.4. DEFROSTER PERFORMANCE RESULTS**

The fully-electric defroster and operator heater designs did not work properly. They suffered from problems that we could not fix to ensure reliable and effective operation. When the defroster did work it put out too much heat. The defroster blower did consistently work and provided a measure of defrost capability blowing interior air on the windshield. However, in Boston we discovered that the defroster vents did not direct the air properly on the windshield. The test crew rigged stiff paperboard deflectors to improve the situation so the windshield would stay clear during the Boston cold weather we experienced.

**7.5 U-FACTOR TESTING**

During their testing on the ATTB Thermo King also did tests to determine the insulation value or factor of the ATTB. The determined that the U-factor was 655 BTU/Degree, which is the lowest they've ever measured on a 40-foot transit bus design. Two factors helped us to reach this low level. One was the overall insulation value the structural foam adds to the design as a side benefit of the fiberglass and foam sandwich construction we employed. Secondly, the low-floor design and this structure provides insulation in the floor which is not usually found on a conventional plywood-floored transit bus. Figure 7.5 shows ATTB-3 in the Thermo King Test Cell undergoing environmental tests.

**7.6 HUMIDITY**

During ATTB testing at Altoona and at various cities in the Northeast the bus encountered humidity conditions higher than that usually encountered in Southern California. This was especially true at Washington, DC, where ATTB-3 was exposed to high humidity for about a week. No systems damage or degradation was apparent upon completion of the conditions. This experience verifies compliance with Table 7.6 requirements.

Requirement	Test Results
The ATTB shall withstand humidity is up to 100%, including conditions wherein condensation takes place in and on the ATTB and its subsystems. The ATTB shall withstand these conditions during operation and non-operation.	Passed

**TABLE 7.6. HUMIDITY RESULTS**

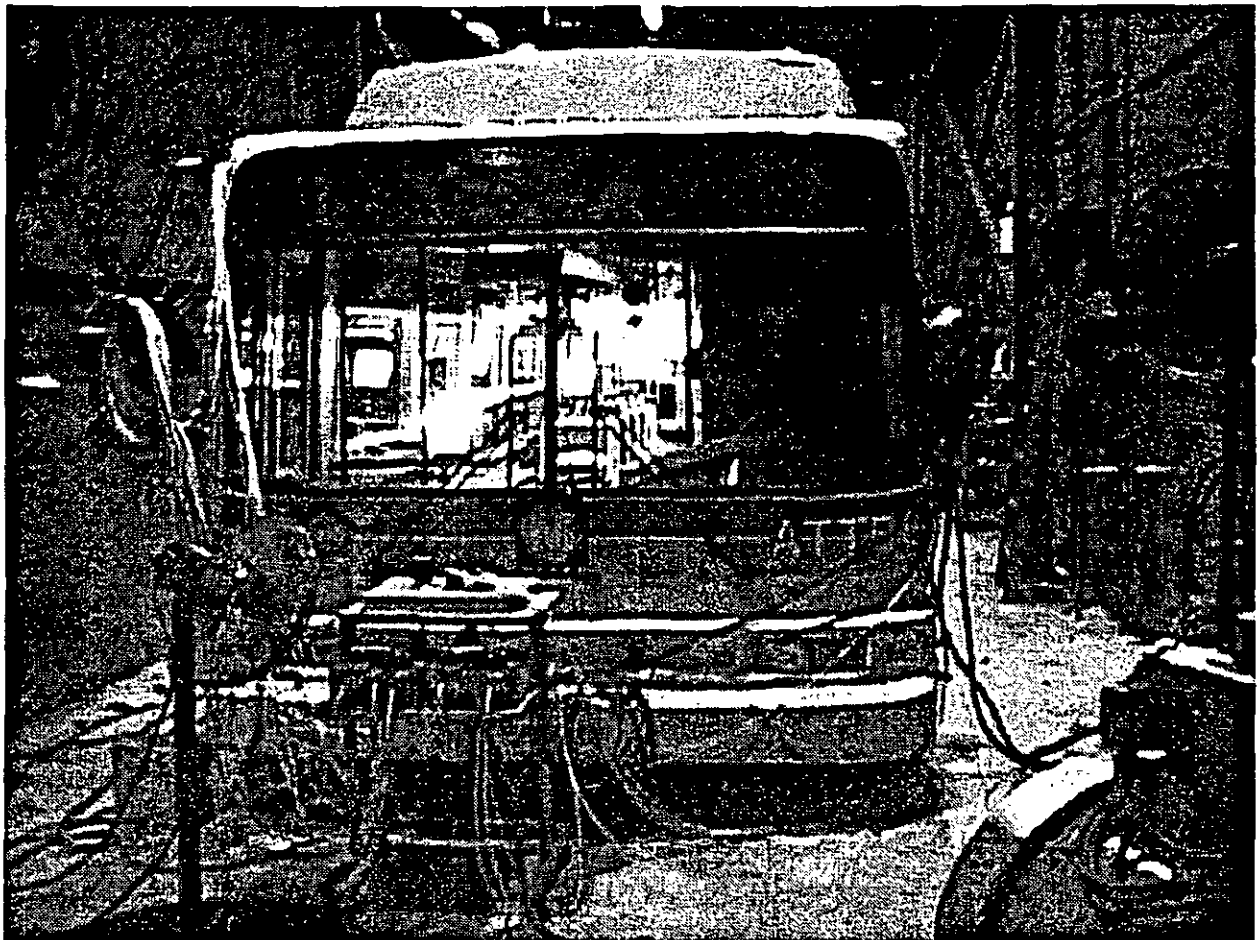

FIGURE 7.5. ATTB-3 IN TEST AT THERMO KING

**7.7 RAIN INTRUSION**

During ATTB testing at Altoona and at various cities we exposed our prototypes to rain conditions whenever possible to demonstrate compliance with the requirements of Table 7.7.

Requirement	Test Results
The roof, windows, windshields and all doors of the ATTB shall withstand a minimum of 30 continuous minutes sustained driving rain.	Passed (Final Results)
ATTB must maintain watertight integrity of all electrical and mechanical systems as demonstrated by successfully starting and operating immediately after completion of the rain exposure.	Passed (Final Results)

**TABLE 7.7. RAIN INTRUSION RESULTS**

During initial testing of ATTB-2 and ATTB-3 at Altoona and Boston respectively water intrusion was a problem. Both buses failed this test due when rain water collecting in the interior of the buses and into the Rear Power Panel (RPP) box in the engine bay.

The interior water problem was traced to the radio box where flexure of the bus roof caused the radio box to de-bond from the roof and let water enter via the electrical cable routing hole (protected by the radio box). On buses 4, 5 and 6 the radio box mounting method was changed to fasteners and a silicone flexible sealant which solved the problem. Buses 2 and 3 were likewise modified in the field.

We also discovered that the RPP connectors on the top were not all sealed properly where they entered the box and therefore leaked. These too were sealed on all buses which solved the problem.

Once these two water intrusion problems were solved the ATTB passed requirements of this test as the windows and windshield on all buses were watertight. During Durability testing the windshield on ATTB-2 was starting to come loose at the upper street side. If rain had been encountered this would have let water intrude (to expedite testing, we had instructed Altoona to not fix the windshield).

## **7.8 SAND AND DUST**

This test was to prove the ATTB capable of withstanding the effects of two weeks exposure to sand and dust particles (as seen in the desert areas of the United States) in both an operating and non-operating condition with no system damage or degradation apparent upon completion of the test.

The hot, desert environment of Phoenix Arizona exposed the bus to significant amounts of sand and dust. The bus was housed outdoors on a concrete pad next to the dynamometer building which provided a wind break from the East only. After seven weeks of outdoor exposure at the FaAA test track, while the floor and interior were often covered with dust and sand, no failures could be attributed to this environment.

## **7.9 ACOUSTIC MEASUREMENTS**

This testing quantified ATTB noise characteristics so that noise abatement techniques could be used to reduce any "hot spots".

We completed our first test (Phase 1) at our NGC Mojave, CA site in June, 1997 per the Acoustic test procedure (Appendix A, Reference 9) by department 9H11 using ATTB-1. The data from this test, summarized in Table 7.8 (from Acoustic Test Report; Appendix A, Reference 10), determined that external generated noise from the engine compartment required sound abatement to reduce interior levels to acceptable levels. The data in Table 7.8 is from the rear most seat location on the back wall of the bus which is the worst case location for the ATTB.

After the sound abatement material was applied, subsequent tests (Phase 2) at El Segundo culminating on November 4, 1997 using ATTB-1 revealed these materials were successful in reducing our interior noise to acceptable levels. Table 7.9 lists the requirements and the results from both tests.

Requirement	Test	
	Phase 1	Phase 2
Static	84.0 dBA, A-Weight	77.2 dBA, A-Weight
Acceleration	94.4 dBA, A-Weight	91.1 dBA, A-Weight

TABLE 7.9. INTERNAL AND EXTERNAL NOISE RESULTS

7.10 INTERIOR NOISE AND VIBRATION

In addition to the tests of section 7.9, ABRTC conducted independent acoustic tests as defined in their test plan (Appendix F, Reference 6) using ATTB-2. Table 7.10 lists the requirements and the results.

ABRTC (ATTB-2) Requirement	Test Results
The combination of inner and outer panels and any material used between them shall provide sufficient sound insulation so that a sound source with a level of 80 dBA measured at the outside of the bus shall have a sound level of <b>65 dBA</b> or less at any point inside the bus. These conditions shall prevail with all openings, including doors and windows, closed and with the engine and accessories switched off.	52.7 dBA
Bus accelerating from 0 to 35 mph, measure interior noise.	82.4 dBA
Bus operating at speeds from 0 to 55 mph, document audible rattles or vibration	None noted

TABLE 7.10. INTERIOR NOISE AND VIBRATION TEST RESULTS

**THIS PAGE INTENTIONALLY LEFT BLANK**

## 8.0 STRUCTURAL AND DURABILITY TESTING RESULTS

### 8.1 STRUCTURAL INTEGRITY AND DURABILITY

This portion of the test program involves over 70% of the overall testing period at Altoona. ABRTC breaks the testing sequence down into seven different procedures: structural shakedown, structural distortion, static and dynamic towing, jacking, hoisting, and structural durability. The following subsections discuss the results of performing these procedures with data extracted from the ABRTC test report (STURAA Test, 12 Year, 500,000 Mile, NG Model ATTB).

#### 8.1.1 Structural Shakedown

ABRTC isolates the bus structure from the suspension system to prevent the frame from moving prior to loading. They then load ballast equal to 2.5 times the maximum passenger capacity onto the bus. With the bus loaded, they measure deflection at strategic positions under the bus to determine settling or movement of the structure. Table 8.1.1 lists the ABRTC measured results.

Requirement	Test Results
Maximum deflection under load	.611 "
Permanent deflection measured	-.003" to .006"

TABLE 8.1.1. STRUCTURAL SHAKEDOWN RESULTS

#### 8.1.2 Structural Distortion

In the structural distortion test, ABRTC twisted the ATTB (at GVWR) longitudinally by using a set of ramps to alternately raise and lower each wheel by 6 inches (simulates operation over a curb). While the vehicle is stressed, various sections of the bus and suspension components are observed. In addition, they spray water over the vehicle doors and windows to check for leaks.

All systems revealed no discrepancies as a result of this test. Altoona did observe water leakage at the bottom center and top left corner of the windshield, leakage through a hole for wiring to the operators outside mirror adjustment motor; and under some test cases a small leak at the drivers sliding glass window.

#### 8.1.3 Static and Dynamic Towing

Due to our termination of the test program after completing the GVWR portion these tests were not completed by ABRTC. We are confident that we would have passed given the number of times we used our front tow hooks at the test track both at State College, Phoenix and Los Angeles, when it was necessary to tow the bus.

#### 8.1.4 Jacking

ABRTC observed test program data demonstrated the ATTB met Table 8.1.4 requirements at CW. With the ATTB at curb weight, they replaced tires at one corner of the vehicle with deflated tires of the same type. A portable hydraulic floor jack (minimum height of 8.75 inches) raised the

ATTB and they replaced the deflated tire with an inflated tire. During this test the jacking point clearances ranged from 2.10 to 13.60 inches. No deformation or damage was observed during this testing.

Requirement	Test Results
Possible to safely jack the bus with a common 10-inch hand jack or 10-ton floor jack when a tire is completely flat with the bus on a level hard surface without crawling under any portion of the bus.	Demonstrated
Jacking from a single point shall permit raising the bus sufficiently to replace any wheel and tire assembly.	Demonstrated
Jacking pads on the structure or suspension shall permit easy and safe jacking with the tire flat on a 6-inch run-up block not wider than a single tire.	Demonstrated
The bus shall withstand jacking at any one or combination of wheel locations without permanent deformation or damage	Demonstrated
Frame Point Clearance - Front Axle - One tire flat	9.5 in.
Frame Point Clearance - Rear Axle - One tire flat	7.2 in.
Frame Point Clearance - Rear Axle - Two tires flat	Not Applicable

**TABLE 8.1.4. JACKING RESULTS**

**8.1.5 Hoisting**

Hoisting tests involved raising the front of the ATTB to a height sufficient to allow placement of jack stands under axles or jacking pads according to NGC specified requirements. The vehicle was checked for stability on the jack stands and for any damage to the jacking pads or bulkheads. This test was repeated for the rear of the bus and then for the front and rear simultaneously. ABRTC observed test program data demonstrated the ATTB met Table 8.1.5 requirements at Curb Weight.

Requirement	Test Results
The bus axles or jacking pads shall accommodate the lifting pads of a 2-post hoist system.	Demonstrated
Jacking plates, if used as hoist pads, shall be approximately 5-in and with a turned down flange (1-in) to prevent the bus from falling off the hoist.	Demonstrated
Other pads or the bus structure shall support the bus independent of the hoist.	Demonstrated

**TABLE 8.1.5. HOISTING RESULTS**

**8.1.6 Structural Durability**

ABRTC conducted structural durability tests at their special vehicle durability test track located on PSU property next to the State College, PA airport. The test track simulates the types of pavement conditions that the bus would experience during routine driving operations. The use obstacles such as high crown intersections, railroad crossings, chatter bumps and frame twisting to provide a 10:1 accelerated durability test that is intended to approximate 25% of the service life of a heavy-duty transit bus. Test vehicles are normally tested at three different loading conditions; gross vehicle weight, seated load weight and curb weight (Table 8.1.6). During this testing, they use all bus subsystems (i.e., doors, lights, wheel chair ramp, etc.) in their normal operating modes.

We removed the ATTB-2 prototype from this test after completing the GVWR portion as a joint decision by Northrop Grumman and our customers (FTA and LACMTA). We decided that no more useful information could be gained from continuing the testing given the known and continuing reliability problems with the Auxiliary and Traction inverter systems which were the primary culprits in extending the test schedule.

Requirement	Test Results
5250 miles at GVWR	Demonstrated
2600 miles at SLW	Not Tested
5250 miles at CW	Not Tested

**TABLE 8.1.6. STRUCTURAL DURABILITY RESULTS**

**8.1.7 ABRTC Structural Test Experience Discussion**

**Test Incidents**

During the test program at the durability test track ATTB-2 was involved in two incidents that did minor damage to the bus, but serve to highlight the unique damage resistance of our composite structure. The first event occurred when the bus was accidentally driven too close to a parked trailer which caused a gouge in the ATTB structure, curb-side below the crash beam. Two plastic trim pieces were also pulled off by the incident and were not replaced. The gouge penetrated approximately two plies of fiberglass for about 4 feet in length, approximately two feet forward of the rear wheel well.

The second incident occurred when the bus was leaving the garage area going back to the test track. In making a hard left turn, the curb side rear axle left the pavement and slid off into the soft grass area. The bus hit the ground hard enough to flex the area under the rear door (forward of the rear wheel well). The structure did not suffer permanent deformation, but the rear door did. Due to the deformation the rear door mechanism interlock to prevent the bus from moving. Once the door was straightened enough to get the interlock fixed, the bus was able to drive back to the track.

These two minor incidents illustrate the resilience of the ATTB structure to accidents that would have seriously damaged conventional bus structures. We experienced a similar incident during LACMTA service testing (see Section 9.0).

**Structure Durability**

The ABRTC test report documents the broken seat brackets (made by American Seating) for the rear seats that attach to the wheel wells. These attachments did not withstand the vibration rigors of the durability track and will need redesign for a production configuration. The front windshield attachment seal came loose during the GVWR test at the upper right corner and then later at the upper left corner. The upper left corner is where the windshield leaked during distortion tests, so for a production bus this area must be improved.



The cracked rear suspension control arms were caused by inferior quality welds as evidenced by the poor penetration discovered upon disassembly and documented with photographs. After re-welding these suspension arms gave us no more trouble.

The aluminum structure weld cracks on the GENSET skid and air compressor skid were due to poor weld penetrations and design details. A production design would need to improve these structures.

ATTB-2 experienced a structural delamination problem in the area between the rear wheel wells where the suspension control arms attach. The composite structure problems at the ABRTC were not fundamental to the design. Rather, human errors during initial fabrication and subsequently during the repair of these faults led to delays at ABRTC. We reported the details on these structure problems, unique to ATTB-2 and ATTB-3, at the two most recent RTRB meetings in Washington, DC (6/98) and Los Angeles (3/99).

**8.2 DYNAMIC TESTING**

**8.2.1 High Energy Impact Testing**

We designed these tests to gather dynamic structural data on the ATTB design at CW and GVWR over obstacles similar to those at Altoona and those likely to occur during Operational and Road testing. This early look at loads and dynamic characteristics provided an opportunity to modify bus components that, based on data analysis, have lower than desired strength margins, and to alter our instrumentation package if a data improvement can be made by moving sensors to new locations. The results of this test (Appendix A, Reference 8) required no changes to the bus or the instrumentation system.

We used the FaAA test track, with a number of obstacles (Figure 8.2.1) and road hazards and two Los Angeles City Business District (CBD) routes, listed in Table 8.2-1, to excite and load the ATTB suspension and composite structure. We describe these in detail in the Test Plan (Reference 1 of Appendix A).

Test Obstacle	Direction/Passes	Speed (MPH)	Axle
5-Inch Drop	CCW - Once	5, 10, 15 and 20	Curb Side Only
Three-Inch Speed Bumps	CCW - Once	5, 10, 15 and 20	Both
Belgian Block	CCW - Once	5, 10, 15 and 20	Both
Railroad Crossing Impact	CCW - Two Passes	5, 10, 15 and 20	Both
Pothole Impact-3"	Once	5, 10, 15, 20, 25 and 30	Curb Side Only
Pothole Impact-3"	Once	5, 10, 15, 20, 25 and 30	Both
Single Pothole Impact	Twice	20, 25 and 30	Curb Side Only
Curb Impact-4"	Twice at 10, 30, 60, 90 degrees	3, 5 and 10	Curb Side
Frame Twist	Twice	5, 10, 15 and 20	Both
Staggered Bump	Twice	5, 10, 15 and 20	Both
CBD Route # 1	Once	Various	Both
LA Downtown CBD Route	Once	Various	Both

**TABLE 8.2.1. FaAA TRACK TEST CONDITIONS**



FIGURE 8.2.1. ATTB-1 ON PHOENIX RANDOM POTHOLE COURSE

## 8.2.2 Dynamic Road Testing

We gathered structural data similar in content to that collected at the FaAA test track and on local Los Angeles roads. We conducted this testing at various weights (CW, SLW and GVWR) including operator and instrumentation engineer on-board. At ABRTC we gathered data on multiple passes over each test section.

In addition we gathered dynamic data on the harshest roads available in Boston, Massachusetts, Washington, DC and New York City, New York when ATTB-3 visited these cities for Operational and Road Testing (Section 9). This data provide our structural engineers valuable insight into the loads imposed by actual, worst-case road conditions that are typical for these cities. The following results are extracted directly from the reference 8 report (Appendix A):

1. "For all road and track tests, the measured Power Spectral Density levels are consistently lower than analytically derived test levels, except the FaAA track. Therefore, the qualification test levels specified for the ATTB are conservative."
2. "The dynamic response of all sprung masses, such as the chassis floor, passenger seat or roof mounted HVAC are much lower than the unsprung mass. This indicates the shock absorbers are efficient to attenuate undesirable vibration from the road to the composite structure. The right lower control arm peak PSD is  $0.51 \text{ g}^2/\text{Hz}$  whereas the response of the center floor and passenger seat are  $0.035 \text{ g}^2/\text{Hz}$  and  $0.05 \text{ g}^2/\text{Hz}$  respectively. This amounts to more than 90% vibration reduction."

3. "Transfer function analysis indicates the ABRTC test track created the highest dynamic response at the GENSET skid (aluminum engine and radiator support structure). At GVWR, the GENSET skid dynamic response is almost 200% of the rear swing axle."
4. "Results from the probability density plots indicated the travel range is 2.6" in jounce, 3.4" in rebound for the front suspension height sensors. For the rear height sensors the results were 2.1" in jounce and 2.7" in rebound. These ranges are within the design limits of the suspension air bags."
5. "The test results from each accelerometer and suspension height sensor followed roughly a normal distribution pattern."

The following recommendations are extracted directly from the reference 8 report (Appendix A).

1. "The GENSET skid/hanger structure appears on the flexible side. The structure needs to be shock-mounted or redesigned for Production."
2. "The ATTB specified qualification test levels of the chassis-mounted components appear on the conservative side. Both functional and endurance test levels may be adjusted downward during the production design phase."

## 9.0 OPERATIONAL AND ROAD TESTING RESULTS

“Real life” conditions can be handily summarized in one word: *diversity*. As a result, this test series focused on subjecting the ATTB Prototypes to as many different and extreme conditions as possible. To accomplish this goal, several cities were visited to provide conditions such as severe road conditions, high precipitation levels, and hot and cold climates. Three of the ATTB prototypes were also “delivered” to LACMTA for evaluation and non-revenue passenger service.

Testing in each city focused on vehicle performance and “user friendliness” (as pertaining to vehicle operators, passengers and maintenance personnel) under actual city driving conditions. Instrumentation data was collected on vehicle structural dynamics over a variety of loading conditions (discussed in Section 8.2). The magnitude of data collection in each city varied based on the unique aspects of each city.

### 9.1 CITY PARTICIPATION TESTING

The primary goal was to evaluate how well the ATTB has achieved its “user friendly” and other design goals by visiting three transit authorities. Evaluations were performed with surveys involving passenger groups and local Transit Authority operators and maintenance personnel. Specific system evaluations for various weather and road conditions were also performed as reported in Sections 3, 6 and 7 of this report.

ATTB-3 accomplished this testing and overall the experience was positive for us. We visited Boston, MA, Washington, DC and NYC and gained valuable operating experience in each city. We collected dynamic road data at these cities, as well as at the Altoona test track, and this data is reported on in Section 8.2 of this report. In addition, we also visited Minneapolis, MN to accomplish environmental testing (Section 7) at Thermo King (HVAC supplier) facilities.

While these visits were not without their problems and frustrations, the operational experience and perspective gained was invaluable to understanding the demands of weather and transit operator operations on transit buses. In addition, our Product Support department gained valuable experience training operators and maintainers at each city. The CD-ROM driven, PC-based training curriculum was well received by operators at Altoona and each city visited.

#### **Boston, MA**

We visited Boston twice from 1/31/99 to 2/19/99 and 3/9/99 to 3/25/99 and stayed at the MBTA Charleston Facility on Arlington Avenue as guests of John Englert. Our visit was interrupted when we discovered a delamination of the rear suspension mount doubler which we discuss in Section 8.1. Since we had no indoor facilities readily available to us that would accommodate a CNG propelled vehicle, we elected to take ATTB-3 back to Altoona for the repair.

From our viewpoint, the Boston visit was very successful. We were able to carry passengers on some arterial/commuter routes and took some visiting FTA dignitaries on a tour around the metro construction downtown. The MBTA got good exposure to the bus and we got exposed to the uniqueness each transit agency brings to the table. Unfortunately, their expectations were higher than ATTB-3 was able to deliver. As we discovered in Phoenix (cold chamber tests), the

membrane switch panels gave us some fits in Boston during their brisk winter temperatures. In this time period we were still struggling with power shutdowns due to 24 volt DC system and inverter 208 volt section problems.

In order to carry passengers we had to meet a daily braking test and also make a small modification to add a cover over the rear door emergency lever. The test team had trouble consistently passing the MBTA 20 mph braking test which required us to stop in 60 feet by initiating the parking brake (spring brake). When we did miss the mark (64-68 feet stop lengths), we then adjusted the rear brake cables to remove slack, and then we would pass. While cable slack was a factor, the real culprit in the spring brake is the delay we have from button push until engagement caused by the time it takes the hydraulic fluid to exit the spring cylinder.

The parking brake was never intended as an emergency braking device and in fact this requirement imposed by the MBTA is not required by the FMVSS. It is a requirement for air brakes but, not for hydraulic brakes. Hydraulic brakes require a redundant braking system which air brakes do not have.

The test team came away very impressed with the professionalism of the MBTA training staff and operators who worked with us. They are very committed to the safety and comfort of their riding public. Figure 9.1 shows ATTB-3 road testing in Boston.



**FIGURE 9.1. ATTB-3 CONDUCTING BOSTON ROAD TESTS**

**Washington, DC**

The next stop was Washington, DC where we stayed as the guests of WMATA and Ted Woods at their Bladensburg Division (NE of the capital) from 3/26/99 to 5/1/99. Like Boston this was not a CNG equipped facility, so we parked outdoors. While we were able to do operator and maintenance training and our dynamic road data collection, we did not carry any passengers or do as much route driving as originally envisioned. The test team also participated in a "roll-out" ceremony at the capital with our customer and the FTA.

The weather was much warmer than Boston (70's-80's) and humid. ATTB-3 started to experience sluggish engine performance after 8-15 miles that was not helped by replacing numerous CNG fuel and engine components. This problem manifested itself as a severe reduction in engine power available that often resulted in engine shutdown from excessive generator load. Before heading for New York we replaced the GENSET which solved the problem. This problem prevented us from doing any more with WMATA than we did.

**New York City, NY**

For this visit ATTB-3 was based at the NYCTA Jackie Gleason Depot in Brooklyn which is a CNG bus facility. Our two week stay here (5/2/99 to 5/16/99) went very well primarily due to the efforts of Bill Parsley who orchestrated a full two-weeks of events which is very well documented in their report (Appendix A, Reference 11). His efforts yielded a comprehensive, objective report that accurately represents comments received at Boston and Washington. The test team also completed our dynamic road data gathering on two routes used by NYCTA previously for gathering road data. From NYC we went to the Minneapolis Thermo King facilities to conduct our HVAC tests.

**9.2 LACMTA OPERATIONAL TESTING**

LACMTA tested three ATTB prototypes in an actual operating service on the nations' heaviest traveled routes. These prototypes were absorbed into the bus fleet at Divisions 10 and were dispatched from that division. The schedule in Figure 1.4 shows the test period for each bus.

**9.2.1 Check-in**

Before LACMTA put the three ATTB prototype buses into service their Quality Assurance and Safety Departments inspected the buses. This was in addition to the normal checks performed by NGC to ensure the prototypes meet all applicable requirements necessary for safe and efficient operation on MTA routes. All three buses passed these check-in inspections.

**9.2.2 Testing**

The LACMTA assigned the three ATTB prototypes to designated routes on a rotating basis designed to ensure thorough exposure to the rigors of each route and maximize public exposure to the future of Transit Bus technology embodied in the ATTB.

### 9.2.3 Structural Incident

During the test period one of the buses (ATTB-5) had a minor run-in with another MTA bus in the Division 10 bus yard. During the morning safety walk-around the operator discovered that ATTB-5 had been sideswiped by another bus while the ATTB was parked. There was no deformation of the structure (just below the street side window just forward of the rear wheel well. The aluminum window frame was deformed and the Lexan window was slightly bent (seen as an optical blemish). Under normal bus operations this would not be fixed unless the window leaked. In our case the operator knew we would be interested in documenting the incident. Since we had a spare window frame we elected to replace it. It took less than 2 hours to replace the window, and repair the trim decal. Other than this accident, these three prototypes encountered no structural problems during LACMTA service testing.

### 9.3 SURVEY RESULTS

Development of the surveys was a joint effort between the transit authorities (LACMTA, Boston, NYC) and Northrop Grumman. Since the ATTB has some unique systems not usually found on a transit bus, we wanted to document any ideas to improve the ATTB design without identifying the individual or city. Unfortunately our reliability on the visits (except for NYC) prevented the kind of in-depth experience we wanted each transit authority to experience. WMATA, in particular, did not get nearly the drive time desired. The MBTA in Boston did collect survey data but considers their report confidential. As a result we believe the NYCTA report presents the best and most complete summary of survey experience gathered. What follows are extracted from the report that illustrate the type of comments received.

*Bus operators are generally quite positive about the ATTB prototype provided that certain modifications are made to the bus. They like the simplicity of the wheel chair ramp, the ease of the one-step entrance, the more comfortable ride and smoother acceleration and braking. The operator's seat, controls and visibility are very favorably received. The seating configuration, however, needs to be changed to allow more space for standees and flow through the bus. Seats over the front wheel pocket are unsafe and likely to block flow into the bus.*

*All Operators in the research commend the ATTB bus for providing a smooth ride without "jumps, jerkiness or rough shifting". The bus handles well. The braking is smooth and feels more comfortable than on current buses. The brakes did not lock up during a hard stop on the test runs."*

*Opinion on the steering wheel is mixed. Some participants felt uncomfortable with the steering wheel.*

*Operators generally praised the visibility of the ATTB.*

*Operators raved about the low floor's one-step boarding for the convenience to passengers and improved safety.*

*Nearly all Operators favor replacing current bus lifts with ramps as on the ATTB.*

*Bus maintenance supervisors were generally positive about having "high tech" features on the ATTB, viewing technology as "the future" and "what's coming". They welcome the lower emissions, wheel chair ramp, and use of fewer parts on the ATTB.*

*On the ATTB prototype, wheels must be removed to check the brake linings. This is a routine task that would be impracticably time-consuming if it involved "pulling the wheels" each time.*

*Access to the engine needs to be improved so that all routine maintenance can be performed without removing the engine.*

*Maintenance supervisors point out that the electric motor cables are too close to the rear wheels for road hazards, snow and ice. Supervisors recommend that the cables be moved so they are not exposed.*

*The 300-volt power creates little concern among Supervisors, however. They feel that with proper insulation of wiring and proper training of maintenance staff, the buses can be worked on safely.*

*The ATTB prototype has a composite floor coated with textured paint. They expect to repaint the floor "every year" because of wear, which was already evident near the front door. Supervisors recommend continuing with the current rubber flooring, which can be easily replaced.*

*The challenge of maintaining the ATTB is two-fold: (1) training in the new equipment; and (2) reorienting maintainers to troubleshoot electronics.*



**THIS PAGE INTENTIONALLY LEFT BLANK**

**10.0 RELIABILITY SUMMARY**

Data collected from Altoona testing as well as all other testing allowed assessment of this vital ATTB characteristic. The reliability of the ATTB prototypes was not stellar, but typical for prototypes with limited spares and limited resources to effect corrective action for chronic problems. Going into the test program our engineers knew the reliability of some electronic components would be poor based on the compromises (functional vibration and operating temperature waivers, etc.) necessary to meet ATTB program schedule and cost constraints.

Unlike a program slated for production, limited funds were available to effect major design changes to improve reliability. Some very effective changes were made to our design as time and budget permitted, but not all problems could be addressed. Some changes improved reliability, but they were "Band-Aids" rather than fixes for the root cause of failure.

**10.1 LACMTA TEST RESULTS**

NGC documented all breakdowns or malfunctions which are tabulated in Table 10.1.

Bus	ATTB-4		ATTB-5		ATTB-6		ATTB Total	
Miles	7,813		1,131		5,286		14,230	
System	Failures	MMBF	Failures	MMBF	Failures	MMBF	Failures	MMBF
Doors	2	3,907					2	7,115
Powertrain	8	977	3	377	10	529	21	678
Braking System	4	1,953			2	2,643	6	2,372
Suspension			1	1,131			1	14,230
Fuel System			2	566			2	7,115
HVAC			1	1,131			1	14,230
Wheel Chair Lift								
Onboard Diagnostics								
Methane Detection/Fire Suppression					1	5,286	1	14,230
Miscellaneous	1	7,813	1	1,131	2	2,643	4	3,558
Total	15	521	8	141	15	352	38	374

**TABLE 10.1. LACMTA RELIABILITY RESULTS**

Excessive heat build-up in the engine bay was suspected to be causing both engine and inverter problems. The test team conducted a temperature survey to quantify the problem and modifications were made to the engine bay by adding heat shields, baffles and extra overhead exhaust area. We added a cooling fan to provide forced-air cooling to the inverter electronics (auxiliary and traction). Initially this appeared to solve the problem, but when the heat of the LA summer arrived in 1998, our LACMTA buses (4,5 & 6) still encountered problems that appeared to be heat related. Additional testing with differential pressure instrumentation and thermocouples on the inverter air supply concluded that the engine bay was over pressurized with hot air which was being sucked into the air cooling circuit for the inverters (Auxiliary and Traction). Additional cooling exhaust openings were added to the upper rear bay door to relieve this pressure.

10.2 ABRTC TEST RESULTS

While operating the ATTB in the structural integrity and durability phase, technicians collected maintenance data about servicing, preventive maintenance and repair. Reliability information was compiled weekly, and pertinent data (including photographs) were collected and recorded. Any unscheduled breakdowns or malfunctions were noted, along with the person-hours required to make the repair. The full details are contained in the ABRTC Test Report (Appendix A, Reference 7). Tables 10.2-1 and 10.2-2 summarize the data collected.

Type of Service Delays	Service Delays	MMBF*	EMMBF**
Class 1 (Physical Safety)	1	7,753	55,003
Class 2 (Road Call)	3	2,584	18,334
Class 3 (Coach Change)	52	149	1,058
Class 4 (Bad Order)	2	3,877	27,502
<b>Total</b>	<b>58</b>	<b>135</b>	<b>948</b>

\* Based on Altoona actual mileage of 7,753

\*\* Based on Equivalent miles of 55,003

TABLE 10.2-1. ABRTC SERVICE DELAYS

The service delays were determined from ABRTC data using the worst class failure as the delay cause and counting the rest of the failures taken care of at that time as secondary failures discovered. Based on the actual miles driven the mean miles between service delays is 135 miles. However, if you consider the 10:1 acceleration factor on the durability track miles and add in the other miles accumulated at ABRTC the equivalent miles is 55,003 for a mean miles between service delay of 948. Not stellar by any means, but not unreasonable for a prototype bus.

Subsystems	Class 1	Class 2	Class 3	Class 4	Total
Electrical System	0	2	41	1	44
Engine and Framework (Skid)	0	1	26	0	27
Suspension	0	0	21	0	21
Wheel Motors	0	0	12	0	12
Brake System	0	0	10	0	10
Air System	0	0	6	0	6
Body	0	0	0	6	6
Tires	0	0	0	2	2
Fuel System	0	0	0	1	1
Steering	1	0	0	0	1
<b>Total</b>	<b>1</b>	<b>3</b>	<b>116</b>	<b>10</b>	<b>130</b>
<b>MMBF</b>	<b>7,753</b>	<b>2,584</b>	<b>67</b>	<b>775</b>	<b>60</b>
<b>EMMBF</b>	<b>55,003</b>	<b>18,334</b>	<b>474</b>	<b>5,500</b>	<b>423</b>

Class 1 - Physical Safety

Class 2 - Road Call - Service stopped until fixed or spare coach arrives

Class 3 - Coach Change - Able to meet replacement coach location

Class 4 - Bad Order - Degrades operation

TABLE 10.2-2. ABRTC SYSTEM RELIABILITY

As shown in Table 10.2-2 we had one Class 1 failure. The steering arm "broke" because two of the four bolts, that secure the arm to the suspension breastplate, fell out causing the arm to not operate properly.

Also, brake system wear was adversely affected by the lack of REGEN braking on ATTB-2. Before implementation of LSG VMS software we would have power shutdowns due to REGEN braking which we first discovered in our Phoenix testing. For Altoona we decided to remove REGEN from the VMC software to reduce the number of power shutdowns they would experience due to the frequent braking encountered on their durability test course.

REGEN was not installed on ATTB-4, -5 and -6, during LACMTA service testing, as in Altoona, to reduce the number of power shutdowns. When LSG software was installed in ATTB-5, the REGEN power shutdown problem was fixed.

**THIS PAGE INTENTIONALLY LEFT BLANK**

**11.0 MAINTAINABILITY EVALUATION**

We based this evaluation on the data gathered during the Altoona STURAA/ISTEA Bus Test Procedure - Heavy-Duty Large Buses (Appendix A, Reference 6), reported in the ABRTC Test Report (Appendix A, Reference 7) and from maintenance surveys gathered at Altoona, Boston, NYC and Washington, DC (WMATA).

Two unique ATTB concepts were soundly demonstrated in the field. The GENSET and the composite structure experienced problems that on conventional transit buses would have incurred considerable delays in returning the bus to service.

NGC accomplished a GENSET change-out several times at ABRTC and even once in Washington, DC. The ability to replace the prime mover (engine, generator and associated cooling radiators and pumps in one package quickly was demonstrated easily at WMATA secured facilities using a forklift to replace the temperamental GENSET on ATTB-3.

ATTB-2 and ATTB-3 experienced some structural delamination problems in the area between the rear wheel wells where the suspension control arms attach. The composite structure problems were not fundamental to the design. Rather, human errors during initial fabrication and subsequently during the repair of these faults led to the delays at ABRTC on ATTB-2. NGC reported the details on these structure problems, unique to these two buses, at the two most recent RTRB meetings in Washington, DC (6/98) and Los Angeles (3/99). What is important to this discussion, is that with minimal tooling, both buses were easily and promptly repaired. Once properly repaired neither ATTB-2 or ATTB-3 suffered additional problems in this area.

**11.1 ABRTC MAINTAINABILITY EVALUATION**

The recommended ATTB servicing schedule was followed during all testing at Altoona. Replacement or repair times for various subsystems (i.e., GENSET, batteries, windshield wiper motor, etc.) were established under this testing category. Table 11.1 summarizes ATTB maintenance experience during our testing at ABRTC.

Service Delays	Maintenance Actions	Cumulative Repair Time	Maintenance Time per Maintenance Action (MT/MA)
58	130	465 Hours	3.58 Hours

**TABLE 11.1. ABRTC MAINTAINABILITY SUMMARY**

Of particular note is front tire wear experienced during the one year of testing and the 7,753 total Altoona miles (8,632 total) accumulated on ATTB-2, the front tires were replaced twice for an average of 3,810 Altoona miles per set. The rear tires were never replaced. Therefore this high wear rate must be attributed to the constant tight 180 turns done to traverse the durability test track.

The rear brakes were replaced after only 2,996 Altoona miles. This also must be attributed to the high number of stops done during each trip around the durability test track.

**11.2 ABRTC COMPONENT REPLACEMENT TIMES**

As part of their test program ABRTC conducts replacement of certain standard transit bus components by removing and reinstalling these items as a minimum part of their maintenance evaluation test. The ABRTC test report (Appendix A, Reference 7) provided the data to determine we met the ATTB requirement listed in Table 11.2-1. Table 11.2-2 lists the replacement times for these standard items (first 5 listed) as well as for other items removed during the course of testing. In the case of the engine-generator assembly, it took two men one-hour to remove and replace the assembly.

Requirement	Test Results
Windshields wiper motors shall be easily accessible for repairs or service from inside or outside the bus and shall be removable as complete units.	Passed 0.50 Man Hours

**TABLE 11.2-1. WINDSHIELD WIPER TEST RESULTS**

Subsystem or Component	Test Results (Man-hours)
Engine - Generator Assembly	2.00
Wiper Motor	0.50
Starter	1.00
Generator	1.00
Batteries	1.00
Air Compressor Head Gasket	1.00
24 volt Pioneer Inverter	2.00
Suspension Air Bag	0.50
Throttle body and Fuel Regulator	5.50
Left Rear Leveling Valve Arm	0.50
Driver Monitor	2.00
Engine DDEC	1.00
Wheel Motor Inverter	7.00
Ride Height Sensor	2.00
Steering Arm	3.00
Brake Kits for Both Rear Wheels and Right Brake Cable	3.00
New Fan for Radiator Fan	1.00
Mounting Brackets for Upper Inverter	0.50
Cooling System Circulating Pump	2.00
Both Front Tires	2.00
Rear Suspension Pivot Bushings	5.00
Power Inverter	6.00
Power Steering Inverter	4.00
Generator/Aux Inverter	4.00
HVAC Inverter	2.00
Output Command Module	2.00

**TABLE 11.2-2. COMPONENT REPLACEMENT TIMES**

**11.3 MAINTENANCE COMMENTS**

The maintenance effort on the ATTB at ABRTC was a joint effort between ABRTC and NGC. NGC supplied technicians and engineers initially as needed to assist in troubleshooting and for the more involved repairs. It became apparent to us in 1998 we would need an on-site representative present at all times to make progress on the durability track. This is no reflection on the ABRTC staff. After one year at ABRTC, we left impressed with and grateful for the professional staff the Pennsylvania Transportation Institute has in place at both the State College test track and at Altoona. They did as much as they could given the level of training we provided. Their dedication, perseverance and assistance at all hours were especially appreciated. The types of ATTB problems were beyond what we envisioned when planning the training program and in many cases could only be solved by engineers familiar with the design.



**THIS PAGE INTENTIONALLY LEFT BLANK**

## 12.0 RECOMMENDATIONS

The test program identified ATTB components and design elements that performed at less than desired levels of reliability and performance. These prototype items need re-engineering to address their shortcomings and subsequent testing to verify the validity of the redesign.

NGC recommends the LACMTA consider the benefit of making the improvements outlined in the sections that follow on a number of ATTB prototypes and then testing these improvements in LACMTA operational service. Tables 12.0-1 and 12.0-2 lists these items which are categorized into two areas, Reliability and Performance.

During the 6 years that have passed since the start of the ATTB program considerable progress has been made advancing engine and energy storage technology. We believe the time is right to test two new technologies, a "clean diesel" engine and ultra capacitor energy storage. These items are the last two recommendations in Table 12.0-2.

### 12.1 RELIABILITY IMPROVEMENTS

Less than desired reliability reduced the level of mileage accumulated in Service Testing and at the ABRTC. As discussed earlier, the program did not have the funding or schedule allowance to permit us to fix these issues.

### 12.2 PERFORMANCE IMPROVEMENTS

While meeting White Book acceleration and braking requirements, the ATTB fell short of our performance expectations in certain areas like fuel economy and acceleration. This reduced our ability to exploit the full potential of the ATTB design. It should be noted that some of the items listed under "performance" improve the serviceability or troubleshooting of the ATTB.

Recommended Improvement	Reliability	Performance
1. Upgrade all Auxiliary Inverters to newest configuration, with 208 Vac capacitors mounted externally in a separate enclosure.	X	
2. Upgrade inverters to Kaman proposed configuration.	X	
3. Modify all inverter systems software including VMC to optimize overall bus performance.		X
4. Add appropriate advisory messages to operators display for inverter troubleshooting		X
5. Move the Auxiliary inverter and Wheel Motor inverter to a roof mounted location out of the heat and vibration environment of the engine bay.	X	
6. Re-manufacture the power harnesses by upgrading harness material to improve reliability or EMI characteristics then reinstall to prevent damage during operational service.	X	
7. Relocate W/M cooler assembly and inverter cooler assembly to facilitate the moving of the inverters to a roof mounted location. Also install temperature switch to Inverter cooling system to turn cooling fan on/off.		X
8. Relocate engine cooling fan inverter to bus roof out of the heat and vibration environment of the engine bay.	X	

Table 12.0-1. Recommended ATTB Improvements

Recommended Improvement	Reliability	Performance
9. Remotely locate pressure and temperature sensors on the generator and each of the wheel motors.	X	
10. Add external air intake plumbing to engine.		X
11. Increase engine cooling system overflow capacity and relocate engine cooling system fill point location.		X
12. Add an advisory message that appears on the driver's display when the engine cooling fan is not operating.		X
13. Relocate 208 Vac circuit breaker panel to wall of bus structure		X
14. Improve serviceability of ramp and door mechanisms		X
15. Replace power steering inverter (Lockheed Martin no longer supports power steering inverter) with commercial Off The Shelf (COTS) inverter	X	
16. Replace Kaman single 208 inverter power with individual controllable Micro Drives for remaining pumps and fans. Also add an RS-485 communication card to the VMC to control and status the micro drives	X	X
17. Read fault codes from Labview port using the second channel of the card used for micro drive control		X
18. Redesign ride height sensors for reliability and environmental durability	X	
19. Replace worn driver switch panel		X
20. Upgrade rear suspension structural doubler (same as that done on ATTB-2 and ATTB-3)	X	
21. Improve CNG system by installing roof top vent system		X
22. Improve engine Idle speed control during and after regenerative braking	X	X
23. Inspect and upgrade the welded air skid, rear suspension, system cooler packages, and engine skid (Incorporate ATTB-2 Altoona modifications) assemblies	X	
24. Increase regenerative braking from 30 kW to 100 kW to reduce brake wear. (currently ATTB 6 @ 60 kW)	X	X
25. Replace operator heater and defroster unit.	X	X
26. Investigate and develop solution(s) for rear hub gears noise		X
27. Install an ultra capacitor energy storage system		X
28. Install an alternate "clean diesel" engine and associated systems		X

Table 12.0-2. Recommended ATTB Improvements

APPENDICES

**THIS PAGE INTENTIONALLY LEFT BLANK**

## APPENDIX A - REFERENCES

<u>Reference # (If Applicable)</u>	<u>Nomenclature</u>	<u>Date</u>
1. ATTB-96-03-132	Test Plan for Prototypes 1 and 2	Nov. 21, 1996
2. ATTB-96-03-133	Test Plan for Prototypes 3 - 6	Nov. 21, 1996
3. SS300-001000	System Specification for ATTB System (Rev. B)	Feb. 28, 1997
4. ATTB-95-02-115	Structural Test Bed Crash Test	Apr. 13, 1995
5. ATTB-97-03-148	Hi-Pot Test Plan: System Level 1	Sept. 11, 1997
6. None	STURAA/ISTEA Bus Test Procedure - Heavy-Duty Large Buses	September 1992
7. PTI-BT-R9713-04-99	STURAA Test, 12 Year, 500,000 Mile NG Model ATTB	February 1999
8. Memo 9B55-98-015	ATTB Vehicle #1 and #3 Road and Track Tests Dynamic Response	Jun. 11, 1998
9. None	ATTB Internal / External Characterization Test Plan	
10. Memo 9B20-97-268	Acoustic Test Report	Jul. 14, 1997
11. None	Bus Operator and Maintenance Supervisor Evaluation - NYC Transit	June 1998
12. Memo 9N10-98-34	ATTB-1 Road & Track Correlation	Sept. 11, 1998
13. Memo 9N10-98-35	ATTB-3 Road & Track Correlation	Sept. 11, 1998

**APPENDIX B - DEFINITIONS**

**Normal Acceleration (Non-Power Block)** - The operator selects drive and removes their right foot from the brake pedal to depress the accelerator pedal to the floor.

**Maximum Acceleration (Power Block)** - The operator selects drive and depresses the accelerator pedal with the right foot (until maximum engine rpm (currently 2700) is noted) while holding the brake pedal down with the left foot. Once maximum rpm is reached ( $\approx 4$  sec.) the brake is released and bus acceleration begins.

It should be noted that if the brake is held too long the ATTB may experience a wheel motor and/or inverter malfunction which will prevent bus movement. Shutdown of the bus and subsequent restart should clear the fault. Repeated shutdowns doing "power blocks" could seriously damage propulsion system components needlessly.

**Wet Roadway** - For the purposes of our tests we met this requirement either by a water truck or inclement weather. The road should be sufficiently wet so that puddles on the surface remain. We applied additional water if the surface started to dry out.

**Curb Weight (CW)** - The weight of the ATTB fully fueled with only a driver and no passengers on-board. For the ATTB prototypes CW is 21,240 lb.

**Seated Load Weight (SLW)** - The weight of the ATTB fully fueled with only a driver and 43 seated passengers on-board. For the ATTB prototypes SLW is 27,770 lb.

**Gross Vehicle Weight Rating (GVWR)** - The weight of the ATTB fully fueled with only a driver and 43 seated passengers on-board. For the ATTB prototypes GVWR is 31,960 lb.

**APPENDIX C - FACILITIES**

The test program utilized various facilities around the country including those of city transit authorities (T/A's) to test the prototype vehicles. A basic description of each facility and the capabilities provided is included in this section. Table C.1 shows the facility utilization for conducting the test program:

Test	NGC	LACMTA	FaAA	ABRTC	Thermo King	City TA's
Functional	X					
Performance	X	X	X	X		
Braking	X		X	X		
Vehicle Handling			X	X		
Environmental				X	X	X
Structural Durability			X	X		X
Operational and Road	X	X				X

**TABLE C.1. FACILITY UTILIZATION**

**NGC Integrated Systems and Aerostructures Sector - Air Combat Systems (ACS)  
West Complex  
El Segundo, California**

The ATTB program headquarters is in the North end of the 905 Building at the West Complex of ACS located at One Hornet Way, El Segundo, California. All design, development and manufacturing operations for the program are carried out at this site. The adjacent employee parking lot and streets were used to perform functional, and some performance testing on the ATTB prototypes.

**NGC Integrated Systems and Aerostructures Sector - Air Combat Systems (ACS)  
Advanced Development Flight Test  
Mojave, California**

The Advanced Development Flight Test Facility was located at the Kern County Airport in Mojave, California. This prototype test facility was primarily devoted to airborne vehicle tests, however the airport and location offered an ideal area for ground tests where low ambient noise is required.

**LOS ANGELES COUNTY METROPOLITAN TRANSIT AUTHORITY (LACMTA)  
Los Angeles, California**

The LACMTA was the host agency for the ATTB test program when the ATTB prototypes were service tested on the streets of LA County. The agency provided maintenance space, hoists, jacks and other maintenance support as needed to NGC during the ATTB tests. Two operators were also provide to the program to drive the buses from our El Segundo facility and accumulate road mileage prior to delivery to LACMTA. In addition the LACMTA provided NGC support and the use of their dynamometer equipment at the Regional Repair Facility and the Division 10 Maintenance Facility.



**APPENDIX C - FACILITIES (continued)****LACMTA****Regional Repair Facility**

The Regional Repair Facility is located at the corner of Caesar Chevez and Lyon in downtown LA. Their facility includes a single roller, electric dynamometer coupled to a certified emissions test unit from Horiba Instruments, Inc. This facility permits measurement of bus emissions on either CBD or Arterial bus cycles. This facility also is responsible for all overhaul maintenance for the MTA fleet, and therefore has extensive machine shop, paint and repair facilities.

**LACMTA****Division 10 Maintenance Facility**

The Division 10 Maintenance Facility is off Mission Street just north of Caesar Chevez in Downtown LA. The facility has a dual roller, water brake dynamometer system by Superflow Corporation. While the system is designed to test existing bus platforms for troubleshooting and diagnosis, this dynamometer also allows dynamic and steady state load testing. This facility also is responsible for all routine service and maintenance for the Division 10 MTA fleet.

**FAILURE ANALYSIS ASSOCIATES (FaAA), Inc.**

Phoenix, Arizona

FaAA is an automotive testing facility located just north of Phoenix, Arizona, East of Interstate 17. The facility includes a ride quality/endurance course, environmental chamber/dynamometer facility, vehicle dynamics pad, parking brake ramps, water troughs, and a crash test course and related equipment. The capabilities of the facility, the privacy offered and schedule flexibility were key factors in selecting their support.

The ride quality/endurance course consists of a two-mile oval test track with "Altoona-style" road obstacles including random chuckholes, rail road crossings, high crown-to-crown intersections and cobblestones. The vehicle dynamics pad is adjacent to the south straight away which is conducive to performing braking tests. Any part of the course can be watered down (construction type water truck) when wet conditions are required.

**APPENDIX C - FACILITIES (continued)****ALTOONA BUS RESEARCH AND TESTING CENTER (ABRTC)**

Altoona, Pennsylvania

The ABRTC is located on 6th Avenue in Altoona, Pennsylvania and operated by the Pennsylvania Transportation Institute (PTI), which is part of the State University of Pennsylvania (Penn State), under contract to the Federal Department of Transportation. PTI operates this facility and the test track at State College, Pennsylvania to support federally mandated transit bus tests. Maintainability, reliability, safety, performance, structural integrity and durability and fuel economy tests are conducted by ABRTC and a report published documenting the results.

Testing at this facility is required of all bus manufacturers planning on selling their vehicles to customers that are being funded by the Federal Transit Administration (FTA). Each bus test is 80% funded by the FTA and 20% funded by the respective bus manufacturer.

**THERMO KING CORPORATION (TKC)**

Minneapolis, Minnesota

ATTB-3 completed environmental tests at TKC facilities including operational performance of the TKC built HVAC. TKC provided all instrumentation and support to conduct these tests with minimal NGC on-site support.

**MASSACHUSETTS BAY TRANSIT AUTHORITY (MBTA)**

Boston, Massachusetts

The MBTA was the host agency for the test program when our ATTB-3 prototype tested on the streets of NYC. The agency provided maintenance space, hoists, jacks and other maintenance support as needed to NGC during the ATTB tests.

**NYC TRANSIT AUTHORITY (NYCTA)**

New York City, New York

The NYCTA was the host agency for the test program when our ATTB-3 prototype tested on the streets of NYC. The agency provided maintenance space, hoists, jacks and other maintenance support as needed to NGC during the ATTB tests.

**WASHINGTON METROPOLITAN AREA TRANSIT AUTHORITY (WMATA)**

Washington, District of Columbia

WMATA was the host agency for the test program when ATTB-3 and ATTB-6 prototypes tested on the streets of the nations capital. The agency provided maintenance space, hoists, jacks and other maintenance support as needed to NGC during the ATTB tests.

## APPENDIX D - INSTRUMENTATION DESCRIPTION

### INTRODUCTION

On-board instrumentation was used to gather most of the pertinent data on ATTB system and subsystem operational performance. Other methods to collect data were utilized, when appropriate, to measure the ATTB characteristic when instrumentation was not cost and or time efficient. Table D.1 lists instrumentation utilization for each test series.

Test	Instrumentation Package				
	None	VMS	IO Tech	Micro Motion	Acoustic
Functional		X			
Performance		X	X	X	
Brake			X		
Vehicle Handling			X		
Environmental			X		X
Structural and Durability			X		
Operational and Road	X				

TABLE D.1. INSTRUMENTATION UTILIZATION

### INSTRUMENTATION MEASURAND LIST

Appendix E defines the list of data parameters acquired.

### VEHICLE MANAGEMENT SYSTEM (VMS)

Vehicle propulsion system data (360 parameters) can be acquired at a 160 Hz sampling rate from the Vehicle Management Computer. Propulsion data includes parameters such as commanded wheel motor torque, generator current and voltage, regeneration commands, suspension heights, accelerator and brake pedal angles and cooling system temperatures and pressures. NGC recorded this data using a separate Unix-based mobile system to acquire and process real-time data.

### IO TECH DATA SYSTEM

A full instrumentation package was installed on Prototypes #1 and #3 that allowed for both short term and limited long term data collection (high resolution).

The system capability included displaying short term (one hour or less) multi-channel analog data that can be digitized at rates up to 800 samples/second. In addition, data analysis could be performed either real-time or recorded for later evaluation.

Each prototype (#1 and #3) was installed with an instrumentation package consisting of 51 strain gages and 23 accelerometers. A two axis gyroscope (pitch and roll) was installed on Bus 1 only. In addition, suspension height, brake and accelerator pedal angles and vehicle speed were available. The IO Tech system uses an Intel Pentium-based computing platform to process, display and record the data (we will use an AMS Tech portable PC). Once recorded on the

**APPENDIX D - INSTRUMENTATION DESCRIPTION (continued)**

internal hard drive, the data was replayed and analyzed, and then archived on Iomega Zip drive disks (100 mb capacity).

Data was both observed and recorded in real-time using the IO Tech system. Data sampling rates could be varied from 100 samples per second to up to 15,000 samples per second depending on the amount of active channels. Various digital filtering values were utilized and the data acquisition system custom modified to meet varying needs.

Strain gages were mounted on both metal suspension systems and also on the vehicle composite structure as listed in Appendix E. Accelerometers were located on the interior of the vehicle and also on suspension components (i.e., rear swing arm, front control arm, wheel motors).

**MICRO MOTION**

The Micro Motion Coriolis Mass Flow sensor allows for long term calculation of compressed natural gas (CNG) usage by the test vehicle. CNG flow rates, density and total flow (in kilograms) are displayed on a LCD display panel on the front of the unit. Data is recorded by the test conductor as needed.

**ACOUSTIC MEASUREMENT SYSTEM**

The system to acquire acoustic data is described in section 2.2, "Instrumentation and Equipment" of the "ATTB Internal / External Characterization Test Plan", by D.B. Schein and J.S. Hausmann, of ACS department 9H11/GK (Appendix A, Reference 9).

## APPENDIX E - INSTRUMENTATION MEASURAND LIST

IO Tech		
No.	Nomenclature - Strain Gage	Type
1	Front Suspension, Drag Link - Horiz.	Axial
2	Front Suspension, Relay Link - Horiz.	"
3	Front Suspension, Left Tie Rod - Horiz.	"
4	Rear Suspension, Bent-Arm Down	"
5	Front Suspension, Right Tie Rod - Horiz.	"
6	6" Outboard of SG16 (on doubler plate)	"
7	Front Suspension, Right A-Frame-Aft Link, Up In	"
8	Front Suspension, Right A-Frame-Aft Link, Down In	"
9	Front Suspension, Right A-Frame-Aft Link, Up Out	"
10	Front Suspension, Right A-Frame-Aft Link, Down Out	"
11	Front Breastplate-Left Rear	"
12	Front Breastplate-Centerline Rear	"
13	Front Breastplate-Left Center	"
14	Front Breastplate-Centerline Center	"
15	Front Breastplate-Left Front	"
16	Right Rear Suspension-Right Front Beam Arm Up	"
17	Right Rear Suspension-Right Front Straight Arm Up	"
18	Right Rear Suspension-Right Front Straight Arm Down	"
19	Right Rear Suspension-Right Front Straight Arm Fwd	"
20	Right Rear Suspension-Right Front Straight Arm Aft	"
21	Right Rear Suspension-Rt Front Straight Arm Web Up	"
22	Rt Rear Suspension-Rt Frt Straight Web Bottom Side	"
23	Rt Rear Suspension-Rt Frt Straight Web Bottom Side	"
24	Genset Skid, Rear Vertical	"
25	Left Truss Bottom Diagonal-Right Rear, Right Frt, Top	"
26	Left Truss Left Front Vertical Front	"
27	Left Truss Left Front Vertical Outside	"
28	Left Truss Left Front Diagonal Outside	"
29	Left Truss Left Front Diagonal Back	"
30	Wheel Well-Right Frt Pylon Hoop RID, Inside Bus	"
31	Wheel Well-Right Frt Pylon Hoop RID, Inside Bus	"
32	Wheel Well-Right Frt Pylon Hoop RID, Inside Bus	"
33	Whl Well-Rt Frt Pylon Hoop RID, 90 deg Aft, Inside Bus	"
34	Wheel Well-Left Right Rear Frt Bottom, Inside Bus	"
35	Wheel Well-Left Rear Frt Top, Inside Bus	Rosette (1A)
36	Wheel Well-Left Rear Frt Top, Inside Bus	Rosette (1B)
37	Wheel Well-Left Rear Frt Top, Inside Bus	Rosette (1C)
38	Wheel Well-Left Rear Frt Top, Inside Bus	Axial
39	Door-Rear Up In Aft Top RAD, Inside Bus	Rosette (2A)
40	Door-Rear Up In Aft Top RAD, Inside Bus	Rosette (2B)
41	Door-Rear Up In Aft Top RAD, Inside Bus	Rosette (2C)
42	Door-Rear Up In Aft Center RAD, Inside Bus	Rosette (3A)
43	Door-Rear Up In Aft Center RAD, Inside Bus	Rosette (3B)
44	Door-Rear Up In Aft Center RAD, Inside Bus	Rosette (3C)
45	Door, Right Rear Upper Aft Corner On RAD	Axial
46	Sill, Wheel Well Rear Right Frt Fwd Inside Bus	"
47	Sill, Wheel Well Rear Left Frt Aft Outside Bus	"
48	Rear Carry Through, Aft-Left Outside Bus	Rosette (4A)

## APPENDIX E - INSTRUMENTATION MEASURAND LIST (continued)

IO Tech			
No.	Nomenclature - Strain Gage	Type	
49	Rear Carry Through, Aft-Left Outside Bus	Rosette (4B)	
50	Rear Carry Through, Aft-Left Outside Bus	Rosette (4C)	
51	Forward Door, Ceiling-Rear Inside Bus	Axial	
No.	Nomenclature - Accelerometer	Accel Type	Max G's
1	Top Surface of Right Lower Control Arm	Z Axis	100
2	Top Surface of Right Rear Swing Arm	Z Axis	100
3	Top Surface of Right Wheel Motor	X Axis	100
4	Top Surface of Right Wheel Motor	Y Axis	100
5	Top Surface of Right Wheel Motor	Z Axis	100
6	Bottom Center Floor of Bus @ F.S. 334.8	Z Axis	30
7	Bottom Right Metal Surface of Operators Seat	Y Axis	30
8	Bottom Right Metal Surface of Operators Seat	Z Axis	30
9	Bottom Surface of Passenger Seat @ Metal Beam Attach	X Axis	30
10	Bottom Surface of Passenger Seat @ Metal Beam Attach	Y Axis	30
11	Bottom Surface of Passenger Seat @ Metal Beam Attach	Z Axis	30
12	Lower Inside Surface of Rt Carline Located Aft Rear Door	X Axis	30
13	Lower Inside Surface of Rt Carline Located Aft Rear Door	Y Axis	30
14	Lower Inside Surface of Rt Carline Located Aft Rear Door	Z Axis	30
15	Curb Side Front Wheel at Connection to Tie Rod	X Axis	100
16	Curb Side Front Wheel at Connection to Tie Rod	Y Axis	100
17	Curb Side Front Wheel at Connection to Tie Rod	Z Axis	100
18	HVAC Center Mounting Beam at Bus Centerline	X Axis	30
19	HVAC Center Mounting Beam at Bus Centerline	Y Axis	30
20	HVAC Center Mounting Beam at Bus Centerline	Z Axis	30
21	Genset Skid Vertical Beam Right Surface	X Axis	30
22	Genset Skid Vertical Beam Right Surface	Y Axis	30
23	Genset Skid Vertical Beam Right Surface	Z Axis	30
No.	Nomenclature - Other	Model	
1	Accelerator Pedal Position	Williams WM540	
2	Brake Pedal Position	Contelec GL-60	
3	3 Axis Roll Gyro*	Humphrey	
4	Micro Motion Coriolis Mass Flow Sensor*	RFT9712	
5	Vehicle Speed Sensor (A-DAT Radar Speed Sensor)	DRS-6	

\* Deleted on Bus 3

**APPENDIX F - PHOENIX TESTING SYNOPSIS**

Significant delays were experienced, due to ATTB problems, that impeded our progress completing the planned test program (Appendix A, Reference 1) at the Failure Analysis Associates, Inc. (FaAA) test track in Phoenix, AZ. From a test operations standpoint these problems made planning tests a real-time process that often evolved over breakfast each morning. The testing took one more week than originally planned. This is typical for a prototype test program.

**TEST SCHEDULE** -- The test program at FaAA was conducted from 31 March to 15 May 1997 on a 5-day work week schedule. A synopsis of the test activities for each week follows:

**Week 1** -- Plan was to deliver and unload the bus, set-up maintenance area, run full vehicle check list, practice drive the test track and make our first run for fuel.

*3/31 -- Monday:* ATTB-1 left for Phoenix in morning and arrived at track early next day by way of company truck and trailer. One member of the test team accompanied the bus.

*4/1 -- Tuesday:* Test team arrived and checked in with FaAA to sign non-disclosure statements and driver rules. They then unloaded the bus and support container and set-up the maintenance area. They prepped bus for running by completing the full vehicle check list. Took bus out for familiarization runs around test track.

*4/2 -- Wednesday:* Took unloaded performance data (accels, braking and top speed) since ballast had not yet arrived. Weather was overcast with drizzly rain and cool (low 40's).

*4/3 -- Thursday:* The drove into Phoenix to get CNG fuel at the Southwest Gas facility. Encountered numerous engine and generator "shutdowns" on this first extended city driving trip.

*4/4 -- Friday:* Unloaded braking tests conducted including parking brake test. Trial loaded bus on dynamometer.

**Week 2** -- Plan was to repair the bus and then set-up and conduct the planned dynamometer testing with Kaman Electromagnetics personnel. The test was designed to measure electrical power output while running at constant speeds on the dynamometer.

*4/7 -- Monday:* Replaced melted and severed starter cable due to pulling bus off the dynamometer rollers. We uploaded updated REGEN braking S/W from Kaman. Improvement in the REGEN decel was noted. Dynamometer support team arrived and instrumentation set-up began. Distinguished visitor from potential partner arrived late afternoon.

*4/8 -- Tuesday:* Dynamometer test team continued their set-up work. Test data reviewed with visitor. Ballast arrived.

*4/9 -- Wednesday:* Gas card picked up from Southwest Gas. Dynamometer testing continued all day.

*4/10 -- Thursday:* Dynamometer testing continued all day. We also started weighing ballast and putting it into a second outer bag to prevent breakage.

*4/11 -- Friday:* Dynamometer testing continued all day. VMS and Kaman S/W changes made on-site by Pierre Wong and Matt Falcone (Kaman). Test set-up was torn down and equipment (including alternator) returned to LA with test team.

**APPENDIX F - PHOENIX TESTING SYNOPSIS (continued)**

**Week 3** -- Plan was to replace bus tires, conduct driver training, get fuel and then continue planned test program in dynamometer environmental chamber. Testing was to check ATTB operation at low temperatures (near 0 °F).

*4/14 -- Monday:* No testing. Replaced both rear tires (tread separated during previous week's dynamometer testing). We completed weighing ballast bags. Track running confined to new driver training.

*4/15 -- Tuesday:* No testing. After getting some CNG from FaAA and our spare tank, trip to get CNG at Peoria School District was started. Bus "stalled" after 4.4 miles and would not excite the generator after restart. We had the bus towed back to FaAA using commercial tow service. Bus was lifted from rear using rear frame.

*4/16 -- Wednesday:* No testing accomplished. Generator excitation problem solved, but wheel motor contactor problem discovered. Replacement relays ordered from NGC Product Support.

*4/17 -- Thursday:* No testing accomplished. Attempt to get fuel again stymied by continuing contactor problem. Bus quit just before hitting public roads. We used the FaAA truck to pull us back to parking spot.

*4/18 -- Friday:* No testing accomplished. Greg Epke flew out to help troubleshoot contactor problem. We discovered a pin pushed back in a cable that caused intermittent contact. Left in afternoon for fuel and were successful in getting CNG at the school district.

**Week 4** -- The plan was to acquire additional economy and acceleration data, given the changes made to VMC and Kaman inverter software the previous weeks (resulting from the dynamometer tests), and then continue the planned test program in dynamometer environmental chamber. Testing was to check ATTB operation at low temperatures (near 0 °F).

*4/21 -- Monday:* We spent the day acquiring fuel economy and acceleration data (empty). Experienced numerous system shutdowns that appear to heat related. We then loaded the bus onto dynamometer in preparation for cold temperature testing and fired up coolers to cold soak overnight.

*4/22 -- Tuesday:* Day spent troubleshooting bus start and generator excitation problems due to cold temperatures. Able to determine 25 °F as lowest operational temperature for current bus systems.

*4/23 -- Wednesday:* A repeat of Tuesday activities and we experienced the same problems.

*4/24 -- Thursday:* No testing accomplished. John Gongola and Pierre Wong arrived to help work cold weather problems.

*4/25 -- Friday:* We continued development work with Pierre trying to improve VMS S/W and John working on our nagging hardware problems. We completed a fuel run to Peoria School District with only minor shutdown problems on the trip return leg.



**APPENDIX F - PHOENIX TESTING SYNOPSIS (continued)**

**Week 5 --** The plan was to finish performance testing at SLW and then go on to GVWR testing.

*4/28 -- Monday:* We replaced the generator cooling pump motor and instrumented the motor and other components with portable thermocouples. Mr. Art Crabtree (LACMTA) arrived for a visit. Spent rest of day doing SLW accels and brake tests.

*4/29 -- Tuesday:* We continued bus test program. SLW top speed, braking (wet & dry), accels, fuel consumption, and coast-downs. We also made an uneventful fuel run to school district.

*4/30 -- Wednesday:* We added ballast to achieve GVWR. We checked front and rear axle loading on FaAA scale and adjusted ballast to meet axle limits. We then repeated Tuesday test series at this weight. Testing cut short by hard generator inverter failure that we removed for replacement.

*5/1 -- Thursday:* No testing accomplished. The replacement inverter (shipped overnight from LA) picked up at airport and installed. We could not get bus to move due to a GFI fault that we could not clear.

*5/2 -- Friday:* No testing accomplished. Kaman directed a partial disassembly of replacement inverter that to determine if we could find a cause. We discovered a disconnected internal cable that when connected, cleared the GFI problem. The bus would move, but not very well, as the electrical load characteristics with this inverter cause frequent bus stalls (engine shutdowns).

**Week 6 --** The plan was to gather structural dynamic data, handling tests and remaining testing as time permitted after curing the excessive load problem.

*5/5 -- Monday:* No testing accomplished as we troubleshot excessive load problem.

*5/6 -- Tuesday:* Continued work to improve loading and got the bus working properly. Was able to run 200-ft circle test at GVWR.

*5/7 -- Wednesday:* We completed wet braking at GVWR. We accomplished structural dynamic testing per engineering on-site direction. The full rough road course was used including rail road crossings, 3" and 4" potholes, Belgian block and a single axle drops. We completed HVAC pull-down test. Bart Mancini (FTA) arrived for a two day visit.

*5/8 -- Thursday:* Set-up lane change and U-Turn courses. Testing completed with video data also taken. We completed parking brake test at GVWR on 17 deg. slope.

*5/9 -- Friday:* CCW accels, wet road J-turns and dry road steering control (self centering) tests completed. We also completed accels with and without the capacitor bank connected, steering wheel authority and bus maneuverability tests.

**APPENDIX F - PHOENIX TESTING SYNOPSIS (continued)**

**Week 7 --** The plan was to complete disabled braking tests, restore braking system, video tape suspension components going over dynamic obstacles, and do endurance running before shipping bus back to Los Angeles on Thursday.

*5/12 -- Monday:* We completed a fuel run to school district. Reinstalled GVWR ballast (removed down to SLW for fuel run) and did REGEN off braking tests. Completed brake tests under complete power failure.

*5/13 -- Tuesday:* Completed front brake disabled testing. We then disabled the rear brakes and reconnected the front brakes. Upon resuming testing, the bus acceleration was sluggish. Found rear brakes dragging (almost locked), from disabled front brake testing, and spent afternoon fixing the problem.

*5/14 -- Wednesday:* We restored rear brake system to operational status and prepped bus for video of undercarriage suspension components. Took video of suspension going over all dynamic obstacles we had previously used.

*5/15 -- Thursday:* We started in the early morning to complete undercarriage suspension video and final data collection (endurance run). Afternoon spent loading bus and support container on trailer. Our plan to ship ballast on trailer was modified when trailer and tractor axle weight limits were exceeded. We left two pallets of ballast for later shipment back to plant.

**THIS PAGE INTENTIONALLY LEFT BLANK**