

REPLACES 8/06/85 ISSUE

CONTRACT SPECIFICATIONS

TRACKWORK INSTALLATION

CONTRACT NUMBER CA 610

RECEIVED
SCRTD - TSD
TRANSIT FACILITIES

AUG - 9 1985

ITEM # 7851

FILE # _____

SCRTD
1985
.C66
T726

Pre-100% Review
August 1985

29902210

SOUTHERN CALIFORNIA
RAPID TRANSIT DISTRICT

CONTRACT
for
TRACKWORK INSTALLATION
CONTRACT CA610

TABLE OF CONTENTS

Title of Document	Number of Pages
TABLE OF CONTENTS	4
X BIDDING REQUIREMENTS	
INVITATION TO BID	2
INSTRUCTIONS TO BIDDERS	9
INFORMATION AVAILABLE TO BIDDERS	3
X FORMS FOR SUBMITTAL OF BIDS	
+ Proposal Letter	4
+ Bid Form	((12))
+ List of Proposed Subcontractors	2
+ Buy America Certificate	1
+ Bid Bond	1
X CONTRACT DOCUMENTS	
Construction Agreement	2
Performance Bond	2
Payment Bond	2
Bidders Qualification and Business References	8
General Conditions	91
Exhibit 1 - DBE/WBE Schedule A	10
Exhibit 2 - DBE/WBE Schedule B	5
Exhibit 3 - DBE/WBE Unavailability Certificate	1
Exhibit 4 - Summary Subcontracts Award and Paid Report	2
Exhibit 5 - Letter of Intent (DBE/WBE)	2
Exhibit 6 - Continuation of Work Agreement	33
Exhibit 7 - Minimum Wage Rates	2
Special Conditions	2
* Insurance Specifications	x
* Construction Safety and Security Manual	x
* Contract Drawings	x
* Forms for Submittal of Bids	15

+ Included in Forms Package

* Under separate cover.

x = Not Included In This Submittal

14562

APR 10 1985

SCRTD

1985

.C66

T726

Specifications

<u>Section Number</u>	<u>Section Title</u>	<u>Number of Pages</u>
DIVISION 1 - GENERAL REQUIREMENTS		
01010	Summary of the Work	6
01018	District Furnished Equipment Interface	3
01050	Grades, Lines, and Levels	3
01200	Contract Meetings	4
01300	Submittals	4
01310	Network Analysis System	13
01311	Bar Chart Schedule	6
01321	Notices and Requests	2
01322	Certificates and Reports	3
01340	Shop Drawings, Product Data and Samples	4
01342	Working Drawings	2
01370	Schedule of Values	2
01410	Testing Laboratory Services	3
01500	Temporary Facilities	6
01505	Mobilization	2
01518	Temporary Ventilation	3
01540	Security	2
01545	Worksite Safety Requirements	2
01546	First Aid Facilities	2
01566	Pollution Controls	8
01580	Temporary Signs	5
01620	Storage and Protection	2
01630	Substitutions	3

<u>Section Number</u>	<u>Section Title</u>	<u>Number of Pages</u>
01710	Cleaning	3
01720	Contract Record Documents	2
01730	Operation and Maintenance Data	4
01740	Warranties and Bonds	1
DIVISION 2 - SITE WORK		
02232	Crushed Aggregate Base	1
02450	General Track Construction	24
02451	Direct Fixation Track Construction	9
02452	Ballasted Track Construction	5
02453	Special Trackwork Construction - Direct Fixation	15
02454	Special Trackwork Construction - Ballasted	5
02455	Running Rail	8
02456	Direct Fixation Rail Fasteners	30
02457	Timber Ties	9
02458	Ballast	4
02459	Track Appurtenances and Other Track Material	15
02460	Contact Rail System	9
02461	Coverboard	3
02462	Jumper Cable Assemblies	5
02466	Special Trackwork	12
02467	Rail Welding	7
02512	Asphalt Concrete Pavement	4
02601	Maintenance of Utilities	6
DIVISION 3 - CONCRETE		
03100	Concrete Formwork	12

MTA LIBRARY

<u>Section Number</u>	<u>Section Title</u>	<u>Number of Pages</u>
03200	Concrete Reinforcement	9
03300	Cast-in-Place Concrete	27
03301	Portland Cement Concrete	12
03410	Non-tensioned Precast Concrete	12

DIVISION 4 - MASONRY (Not Used)

DIVISION 5 - METALS (Not Used)

DIVISION 6 - WOOD AND PLASTIC (Not Used)

DIVISION 7 - THERMAL AND MOISTURE (Not Used)

DIVISION 8 - DOORS AND WINDOWS (Not Used)

DIVISION 9 - FINISHES (Not Used)

DIVISION 10 - SPECIALTIES (Not Used)

DIVISION 11 - EQUIPMENT (Not Used)

DIVISION 12 - FURNISHINGS (Not Used)

DIVISION 13 - SPECIAL CONSTRUCTION (Not Used)

DIVISION 14 - CONVEYING SYSTEMS (Not Used)

DIVISION 15 - MECHANICAL (Not Used)

DIVISION 16 - ELECTRICAL (Not Used)

END OF TABLE OF CONTENTS

SECTION 01010

SUMMARY OF THE WORK

PART 1 - GENERAL

1.1 DESCRIPTION

A. The Work specified in this Contract consists of constructing tracks for MOS-1 in accordance with this specification including furnishing track materials except as specified.

B. Coordinate the Work of this Contract with adjacent Contracts and other contractors on this construction site.

1.2 MEASUREMENT - The Work of this Contract will be measured for payment as indicated in the included Sections of this Specification.

1.3 PAYMENT - The Work will be paid for under the payment clauses of the included various Specification Sections.

PART 2 PRODUCTS

2.1 PRODUCTS furnished by the Contractor shall be as described in the various Specification Sections, and shall be new except as indicated.

PART 3 - EXECUTION

3.1 CONTRACTOR'S DUTIES

A. Except as otherwise specified, furnish the following and pay the cost thereof:

1. Labor, superintendence, and products.
2. Construction supplies, equipment, tools, machinery and materials.
3. Utilities required for construction.
4. Other facilities and services necessary to properly execute and complete the Work.

B. Pay costs of legally required sales, consumer, and use taxes, and governmental fees and permits.

C. After the City of Los Angeles has approved the Worksite Traffic Control Plan, that body will issue the construc-

tion permit for the Work. The District will coordinate the necessary actions to obtain the permit.

- D. Provide off-site grading agreements, utility hook-up permits, licenses necessary to prosecute the Work, and pay charges and fees related thereto.
- E. Notify fire and police departments, utility owners and U.S. Postal Service, giving adequate advance notice, but not less than 30 days prior to starting Work. Deliver a copy of the notice to the District or its designee. Notify the District or its designee 72 hours before beginning Work.
- F. Perform Work in accordance with codes, ordinances, rules, regulations, orders, and other legal requirements of governmental bodies and public agencies, including the District, which bear on performance of the Work.
- G. Promptly submit written notice of variances in the Contract Drawings and Specifications from the legal requirements stipulated in Paragraph 3.1F above. Necessary changes will be made by appropriate modifications to Contract Drawings and Specifications.
- H. Maintain order, safe practices, and proper conduct, among Contractor's and subcontractors employees. The District or its designee may require that disciplinary action be taken against an employee for disorderly, improper, or unsafe conduct. Should an employee of the Contractor be dismissed from his duties, as a result of that employee's misconduct, incompetence, or unsafe practices, or combinations thereof, do not rehire that employee for the Contract.
- I. Coordinate prosecution of the Work with those public utilities, governmental bodies, private utilities, and other contractors, performing Work on, and adjacent to, the worksite; either eliminate or minimize, delays in the Work and conflicts with those utilities, bodies, and contractors. Schedule that governmental, private utility, and public utility Work, which relies upon survey points, lines, and grades established by the Contractor, to occur immediately after those points, lines, and grades have been established. Confirm coordination measures for each individual case, with the District or its designee, by memorandum.
- J. Prosecute the Work as specified and in a timely manner. Submit schedule of that Work which will be performed at times other than during the normal eight-hour working day, daylight hours, and five-day working week, to the District or its designee, for review and acceptance, not less than 48 hours in advance of those times. Construction operations will normally be confined to those hours

between dawn and dusk. Approval to Work at night may be obtained after Contractor presents a written program outlining special precautions to be taken to control the extraordinary hazards presented by night Work. That program shall include, but not be limited to, supplementary lighting of Work areas, availability of medical facilities, security precautions and noise limitations.

3.2 WORK BY OTHERS - Utility owners will remove and restore pavements, sidewalks, curbs, and gutters affected by their Work except as specified otherwise.

- A. U.S. Postal Service will remove postal facilities from worksite before Work begins, at no expense to Contractor.
- B. Los Angeles Department of Water and Power, Water System will disconnect its water lines, sanitary lines and services from those to be abandoned and to be removed from service, and will cap its lines before Contractor removes those lines, at no expense to the Contractor. Removal and restoration of impacted pavement, sidewalks, curbs, and gutters are a part of this contract. The Department will relocate its mains and construct its temporary mains and service connections, at no expense to the Contractor.
- C. The Los Angeles Department of Water and Power, Power System will disconnect its electric lines and services from street lights and Traffic Control Facilities from those facilities to be abandoned and to be removed from service before Contractor removes those lines, at no expense to Contractor. The Los Angeles Department of Water and Power will relocate power lines, construct its duct banks, and connect services to buildings, all at no expense to the Contractor.
- D. Los Angeles Department of Transportation will deactivate Traffic Control Facilities, (light heads, and controllers) and remove Parking Meters.
- E. The Southern California Gas Company will disconnect its lines and services from those to be abandoned and to be removed from service, and will cap its mains before Contractor removes those lines, at no expense to Contractor. The Southern California Gas Company will relocate its mains and construct its temporary mains and service connections, at no expense to the Contractor.
- F. Pacific Bell will disconnect its lines and services from those to be abandoned and to be removed from service before Contractor removes those lines, and will relocate its lines, construct its duct banks, and connect services to buildings at no expense to the Contractor.
- G. Western Union will disconnect its lines and services from those to be abandoned, and to be removed from service,

before the Contractor removes those lines, at no expense to the Contractor. Western Union will relocate its lines construct its duct banks, and reconnect service to buildings at no expense to the Contractor.

- H. Communicom Cable TV will disconnect its lines and services from those to be abandoned, and to be removed from service, before the Contractor removes those lines, and will relocate its lines and reconnect service. Work by Communicom Cable TV will be at no expense to the Contractor.
- I. Maintain access to and visibility of fire hydrants, police call boxes, fire alarm boxes, standpipe connections and traffic control devices.

3.3 WORK BY OTHERS

- A. The following Contracts are scheduled to begin Work within the limits of this Contract at the times indicated below. These times are based on the most current schedule and are provided for information only and without guarantee against variance from actual commencements.
 - 1. Elevators Installation, Contract (()) - Installation of elevators is expected to occur for a (()) week period during the interval between the (()) and (()) day of this station Contract.
 - 2. Escalators Installation, Contract (()) - Installation of the escalator truss is expected to occur for a (()) month period during the interval between the (()) and (()) month of this station Contract.
 - 3. Traction Power Equipment Installation, Contract (()) - Installation of the AC switchgear in the traction power substation is expected to occur for a (()) month period and during the interval between the (()) day and (()) day of this station Contract. The specific period of installation will be identified after the receipt of the installation schedule of Contract (()) whose Notice to Proceed has been awarded in (()). The remaining traction power equipment installation work will be performed after the (()) day and will also be specifically identified after receipt of the Contract schedule.
 - 4. Train Control Equipment Installation, Contract (()) - Installation of this equipment is expected in (()).
 - 5. Communications Equipment Installation, Contract (()) - Installation of this equipment is expected in (()).

6. Fire and Intrusion System Installation, Contract (())
- Installation of this equipment is expected to occur for a (()) month period during the interval between the (()) and (()) day of this station Contract. The specific period of installation will be identified after the receipt of the installation schedule of Contract No. (()) whose Notice to Proceed is expected in (())).
- B. The Contractor shall coordinate his work with the work to be performed under other Contracts and shall not interfere with the orderly progress of such Contracts. The Contractor shall limit his work in certain areas and give priority to work in other areas, to provide proper interface between Contract No. and the interfacing Contracts. Some limitations in the performance of Contract No. (()) are as follows:
 1. The Contractor shall not construct elevator hoistway enclosures, finish floor surrounding enclosures at upper and lower landings and skylight section directly above elevator hoistway prior to coordination with awarded elevator contractor, and shall perform only such elevator interface work as is compatible with Work performed by elevator contractor prior to complete elevator installation. Upon complete elevator installation, the Contractor shall perform remaining finish Work.
 2. The Unit Substation shall be installed prior to the start of the Elevator and Escalator Work.
- C. In the coordination effort with work by others, the Contractor shall obtain and refer to equipment locations and other layouts, as available, to avoid interface problems.
- D. The District reserves the right to afford such access to the site of the Work for the performance of work by other Contractors and persons at such times the District deems proper. The exercise of such reserved right shall in no way nor to any extent relieve the Contractor from liability for all loss and damage to the Work due to or resulting from his operations, or from his responsibility for complete execution of the Contract. The Contractor shall cooperate with other Contractors and persons in all matters requiring common effort.
- E. The Contractor shall advise the District or its designee in writing of all agreements pertaining to coordinating his Work with work by other Contractors and utility companies, engaged upon the project.

3.4 ORDER OF WORK. Construct Work in stages as follows:

- A. (())).

B. (()).

3.5 CONTRACTOR USE OF WORKSITE

- A. Confine worksite operations to areas permitted by law, ordinances, permits, and the Contract Documents.
- B. Consider the safety of the Work, and that of people and property on, and adjacent to, worksite when determining amount, location, movement, and use of materials and equipment on worksite.
- C. Do not load site with equipment and products which would endanger integrity of the Work.
- D. Protect products stored on worksite.
- E. Relocate stored products which interfere with operations of the District, governmental bodies, public and private utilities, and other contractors at no additional expense to the District.
- F. Secure additional storage and Work areas needed for operations at no additional expense to the District.
- G. Coordinate scheduling of Work to be performed on private property with property owner and property tenant which will minimize inconvenience to the property owner and property tenant.
- H. Protect the general public and residents within limits of construction from construction-related activities; do not unduly inconvenience those persons by construction activities. Work conducted in and on streets and highways shall conform to the Worksite Traffic Control Plan (WTCP) as approved by the City of Los Angeles, Department of Transportation.
- I. If Contractor wishes to have utilities temporarily relocated for his own convenience arrange with the utility owners and reimburse them, at no additional expense to the District, for the cost of that Work.
- J. Restrict construction operations to areas within Right-of-Way Lines, Temporary Construction Easement Line, Permanent Drainage Easement Line, Temporary Slope Easement Line, and Construction Staging Area as indicated. If no additional easements are indicated, restrict construction operations for permanent drainage facilities to Permanent Drainage Easement. Do not use temporary easement areas for purposes other than those for which originally acquired. Use areas bearing notation, Temporary Construction Easement, Construction Staging or Storage, only for active prosecution of the Work. Use of worksite will be exclusive and complete, except as indicated.

END OF SECTION

SECTION 01018

DISTRICT-FURNISHED EQUIPMENT INTERFACE

PART 1 - GENERAL

1.1 DESCRIPTION

- A. The Work specified in this Section consists of providing the labor, materials, for obtaining installing, and testing of District-Furnished Equipment necessary for a complete operational systems.
- B. The Work shall include but not be limited to the following:
 - 1. Obtaining and inspecting the equipment.
 - 2. Rigging and setting the equipment in place.
 - 3. Make piping, ductwork, and electrical connections.
 - 4. Starting and testing the equipment in accordance with manufacturer's recommendations, applicable standards, and codes.
 - 5. Maintaining the equipment until such time as the final acceptance of the Contract by the District.

1.2 REFERENCE STANDARDS AND CODES - Workmanship, materials, and installation shall comply with, but not be limited to the following standards and specifications in effect at the time of the bid except as otherwise shown or specified.

- A. American National Standard Institute (ANSI)
- B. American Society of Mechanical Engineers (ASME)
- C. American Society of Testing and Material (ASTM)
- D. American Welding Society (AWS)
- E. Sheet Metal and Air Conditioning Contractors National Association (SMACNA)
- F. National Electrical Code (NEC)

1.3 MEASUREMENT - The Work of the Section will be measured as a unit acceptably performed.

1.4 PAYMENT will be made under:

Item No. 01000.01 - General Requirements - per lump sum.

PART 2 - PRODUCTS

2.1 DISTRICT FURNISHED EQUIPMENT - Items furnished by the District are described in the various Specification Sections, and will be available to the Contractor as required by the construction schedule. The District will provide installation Drawings and instructions. The following equipment will be furnished by the District:

A. Contract A740

1. Axial Fan-Motor Units
2. Motor-Operated Dampers
3. Sound Attenuators

B. Contract A745

1. Automatic Roll-Type Filters
2. Station Air-Handling Units
3. Traction Power Substation Supply Fans

C. Contract CA(()) - Signage.

D. Contract CA795 - Uninterruptible Power Supply System.

1. UPS assembly
2. Storage battery and racks.

E. The above documents will be available for the Contractor for review. The Contractor shall review these documents to ascertain that he has included the labor and materials to install these District Furnished equipment and complete the system it serves.

2.2 MATERIALS - Pipes, fittings, ductwork, conduits, wiring, mechanical and electrical hardware shall be as specified in these Specifications.

PART 3 - EXECUTION

3.1 SEQUENCING AND SCHEDULING

A. Refer to the above Contract Documents for the District Furnished Equipment delivery schedules.

B. Inspect those District-furnished items, which are available at the District's Storage Facility, and report damaged and defective items which are unacceptable for the Work. Pick up acceptable products and transport those

items to worksite; unload, uncrate, and store items at worksite; and protect items from exposure to elements and from damage. Repair to District's satisfaction or replace items damaged; and install, connect, and finish items as indicated.

- C. Refer to Section 16610 for the special requirement on equipment delivery and installation of Contract A795, uninterruptible power supply system.
- C. The Contractor shall be responsible for coordination of the equipment delivery for delivered equipment or obtaining non-delivered equipment and installation, performance testing, inspection and system operational testing, and shall make arrangements with the District or its designee, the equipment manufacturers and subcontractors with respect to the installation, start-up, and testing.

3.2 INSTALLATION

- A. Install District-furnished equipment strictly in accordance with the manufacturer's instructions and installation manuals. The services of a field representative, upon the request by the District or its designee, will be provided during the installation of the unit and connection of interfacing components, pipes, fittings, and electrical hardware to assure the installation and interfacing components are in compliance with the manufacturer's specifications.
- B. Supply labor, equipment, and materials to unload the equipment, installation, and interfacing components (not supplied with the equipment), necessary for a complete operational systems.

- 3.3 START-UP - After the equipment is installed and ready for start-up, notify the District or its designee that the equipment and the system components it serves are ready for initial operation. Start-up procedures shall be strictly in accordance with the manufacturer's instructions.

Refer to Section 16610 for the special requirement on Field Test and Specific Test of Contract CA795, Uninterruptible Power Supply System.

- 3.4 FIELD QUALITY CONTROL - Perform testing in accordance with the manufacturer's instructions and applicable codes and standards. Submit test reports to the District or its designee.

Refer to Section 16610 for the special requirement on Field Quality Control of Contract CA795, Uninterruptible power supply system.

END OF SECTION

SECTION 01050

GRADES, LINES AND LEVELS

PART 1 - GENERAL

1.1 DESCRIPTION - The Work of this Section consists of establishing grades, lines and levels excepting primary control monuments and bench marks.

1.2 SUBMITTALS

A. Make submittals in accordance with Section 01300, Submittals.

B. Submit Shop Drawings of movement detection markers, before movement detection markers are installed.

1.3 MEASUREMENT - Grades, lines and levels will be measured as a unit acceptably performed.

1.4 PAYMENT will be made under:

A. Item No. 01000.01 - General Requirements - per lump sum.

B. Cost of replacing the District's established primary control monuments, and bench marks damaged or destroyed by the construction operations will be deducted from monies due and from those becoming due the Contractor. Additional compensation or extension of time will not be granted for suspending the Work to enable the District to reestablish primary controls.

PART 2 - PRODUCTS

No Products are required in this Section.

PART 3 - EXECUTION

3.1 CONSTRUCTION LINES AND GRADES

A. The District will establish the primary controls for the Work, both horizontal and vertical. The District will provide the Project baseline, bench marks and basic tie-in points on and near the construction site that in its judgement are necessary for the proper control of the work. The Contractor shall carefully preserve such marks and points and shall be held responsible therefor. If it becomes necessary for the Contractor to remove or disturb

a primary control or tie-in point he shall notify the District or its designee before removing or disturbing said control or tie-in point. If in the opinion of the District or its designee, stakes, monuments, marks or points are carelessly or willfully disturbed by the Contractor, the cost to the District of replacing such stakes, monuments, marks or points shall be charged against him and shall be deducted from payment for the Work.

- B. The Contractor shall proceed from the controls established by the District to make surveys and layouts as may be necessary to conform to the requirements of the Contract Documents and shall provide qualified surveying and other personnel for the purpose. The Contractor shall make the surveys for the proper performance of the Work. As a part of such surveys, the Contractor shall furnish, establish and maintain in good order survey control points which may be required for the completion of the Work, subject to the approval of the District or its designee as to their location, sufficiency and adequacy. However such approval by the District or its designee shall not relieve the Contractor of his responsibility for the accuracy of his survey work.
- C. The District or its designee will check surveys and layouts made by the Contractor prior to approving any of the work as ready for placing. The Contractor shall give advance notice to the District to enable such checking prior to placing any Work. The Contractor shall furnish assistance as may be required for checking purposes when so requested by the District or its designee.
- D. The Contractor shall furnish skilled labor, instrument platforms, ladders and such other temporary structures, special lights or groups of lights as may be necessary for making and maintaining points and lines in connection with the surveys required. The Contractor shall furnish the necessary electric current.
- E. The Contractor shall notify the District a reasonable time in advance of the Contractor's needs and of the time and place at which the Contractor plans to perform Work, and the District will furnish the Contractor with such primary lines, grades and elevations as he deems necessary by such time as not to delay the Contractor's operations. The District, however, shall not be held responsible for any delay resulting from lack of such information if the Contractor fails to notify the District sufficiently in advance of his needs.
- F. The District or its designee may draw the Contractor's attention to errors or omissions in lines or grades but an omission on the part of the District to point out such errors or omissions shall not give the Contractor any

right or claim nor shall in any way relieve the Contractor of his obligations according to the terms of this Contract.

END OF SECTION

SECTION 01200

CONTRACT MEETINGS

PART 1 - GENERAL

1.1 DESCRIPTION

A. The Work specified in this Section requires the Contractor, along with his Superintendent and Safety Engineer, to attend meetings scheduled by the District for the collection and dissemination of information related to the subject Contract.

B. The District or its designee will prepare the minutes of each meeting and distribute them to each of the participants.

1.2 DISTRICT MEETINGS - The Contractor will be advised of times, dates, and places of District Contract meetings.

1.3 MEASUREMENT - The Work of this Section will be measured as a unit, acceptably performed.

1.4 PAYMENT will be made under:

Item No. 01000.01 - General Requirements - per lump sum.

PART 2 - PRODUCTS

Products are not required for this Section.

PART 3 - EXECUTION

3.1 A PRE-CONSTRUCTION MEETING will be scheduled by the District after receipt of the required signed Contract Documents, prior to issuing the Notice To Proceed. The purpose of this meeting is to introduce the District's Representatives for Safety and Quality Assurance and Construction Management to their counterparts in the Contractor's organization and to establish lines of communication between these representatives.

3.2 SPECIAL MEETINGS between the District and the Contractor will be scheduled by the District throughout the course of construction as it deems necessary.

3.3 INITIAL CONSTRUCTION MEETING not more than seven working days after the effective date of the Notice To Proceed.

- A. The District will distribute a notice of this meeting, along with an agenda of the subjects to be addressed, not less than four working days prior to such meeting.
- B. The District will explain and discuss the responsibilities and authorities of the District, the General Consultant, and the Construction Manager's Organization.
- C. The Contractor, the Contractor's Superintendent, trade foremen, Safety Engineer, EEO Officer, subcontractor representations and Community Relations Representatives shall attend this meeting.
- D. The District or the Contractor will provide the following information for this meeting:
 1. The District will discuss Equal Employment Opportunity (EEO) and affirmative action requirements along with the Community Relations functions.
 2. The District will explain the requirements of labor provisions stipulated by U.S. Department of Transportation (DOT).
 3. The District will explain and discuss insurance, laws, codes, traffic regulations, permit requirements of public agencies and their regulations.
 4. The District will discuss procedures for processing change orders, Shop Drawings, product data, and samples.
 5. The District will discuss monthly estimate cut-off dates.
 6. The District will discuss partial and final payments.
 7. Introduce Contractor's representatives, and briefly describe each person's responsibilities.
 8. The Contractor will distribute and discuss a list of major subcontractors, sequence of critical Work, and tentative schedule of construction.
 9. The Contractor will discuss use of office, storage areas, construction areas, and temporary easements.
 10. The Contractor will define arrangements for safety, first-aid, emergency actions, and security.
 11. The Contractor will define housekeeping procedures.
 12. The Contractor will discuss construction methods, quality control, and inspection and coordination of Work with the District's system as a whole.

13. The Contractor will describe construction sequencing of entire Contract, general worksite layout, erosion and sedimentation control plans, haul routes, noise, air and water pollution control, temporary street closing, and street restoration.
 14. The Contractor will discuss coordination and notification for utility Work.
 15. The Contractor will discuss deliveries and priorities of major equipment.
 16. The Contractor will discuss breakdown of lump sum items.
 17. The Contractor will discuss Construction Progress Schedule.
- 3.4 CONSTRUCTION PROGRESS MEETINGS will be scheduled on the first working day of each month and more often as necessary for the competent and timely execution of the Contract.
- A. The Contractor will distribute notices of these meetings prior to such meeting, to subcontractors engaged in the construction, all those expected to be engaged in the Work prior to the next scheduled meeting, and to the District or its designee.
 - B. The Contractors personnel as listed in Article 3.3C, shall attend.
 - C. The following is agenda for construction progress meetings:
 1. Introduce attendees and area of responsibility.
 2. Review minutes of previous meetings, amend minutes if necessary, and accept minutes.
 3. Analyze Work accomplished since previous meeting, offsite fabrication problems, product delivery problems, submitted schedule slippages, problems arising from proposed changes, and other circumstances which might affect progress of Work.
 4. Discuss sequence of critical Work, and schedule of construction using the Construction Progress Schedule.
 5. Discuss observations, problems, work quality control program, and employee work standards.
 6. Discuss coordination of utility Work.
 7. Discuss changed conditions and time extensions.

8. Discuss corrective measures to maintain construction schedule when necessary.
 9. Discuss upcoming month's Work.
- D. Each of the inquiries, requests for information or request for solution of problems presented during such meetings shall be answered, when possible, during the meeting; those not answered during the meeting shall be resolved, the resolution documented and delivered in person or mailed to the person requesting the information within 72 hours of the close of the meeting.
- 3.5 TOOL BOX MEETINGS as indicated in the Construction Safety and Security Manual.

END OF SECTION

SECTION 01300

SUBMITTALS

PART 1 - GENERAL

- 1.1 DESCRIPTION - The Work specified in this Section summarizes the requirements for the submittal of documents to the District or its designee, which are defined in these Specifications. It also describes the procedures for "Supplemental" submittals.
- 1.2 MEASUREMENT - The Work of this Section will be measured as a unit, acceptably performed.
- 1.3 PAYMENT will be made under:
- Item No. 01000.01 - General Requirements - per lump sum.

PART 2 - PRODUCTS

2.1 INITIAL SUBMITTALS

- A. Identify the submittals which will be required and determine the date on which each submittal will be required in conformance with the Construction Progress Network Diagram, or ((Construction Progress Bar Chart.))
- B. Action Block - Include a blank space, three inches by four inches, in the lower right corner, just above the title block, in which the District or its designee may indicate the action taken. Show the following information:
1. Date and revision dates.
 2. Contract title and number.
 3. The names Contractor, subcontractor, supplier, manufacturer, and, when applicable, the seal and signature of an Engineer, registered in the State of California, for the involved discipline.
 4. Identification of product by either description, model number, style number, serial number, or lot number.
 5. Subject identification by Contract Drawing or Specified reference.
- C. Make submissions sufficiently in advance so that the District or its designee can review and accept them not less than 30 days before Work represented by those

submittals is scheduled to be performed. Unless otherwise specified submit four copies of each certificate and report.

- D. Allow a maximum of 30 days for review by the District or its designee.
- E. Ship submittals prepaid.
- F. Accompany submittals with a Contractor Transmittal Form containing the following information:
 - 1. Contractor's name, address, and telephone number
 - 2. Submittal number and date
 - 3. Contract title and number
 - 4. Supplier's, manufacturer's or subcontractor's name, address, and telephone number
 - 5. Subject identification including Contract Drawing and Specification reference
 - 6. Identification of deviations from Contract Documents.
 - 7. Contractor's stamp and signature certifying his review.
- G. Changes in accepted submittals will not be permitted unless those changes have been accepted, in writing, by the District or its designee.

2.2 SUPPLEMENTAL SUBMITTALS - Supplemental submittals initiated by the Contractor for consideration of corrective procedures shall contain sufficient data for review. Make supplemental submittals in the same manner as initial submittals.

PART 3 - EXECUTION

3.1 CONTRACTOR REVIEW - The Contractor shall review submittals, stamp and sign as reviewed and approved, prior to submission to the District.

3.2 DISTRICT REVIEW

- A. Submittals will be reviewed for conformance to requirements of the Contract Drawings and Specifications. Review of a separate item will not constitute review of an assembly in which item functions. Review will not relieve Contractor from his responsibility for accuracy of submittals, for conformity of submittals to requirements of Contract Drawings and Specifications, for compatibility of described product with contiguous products and the

rest of the system, or for prosecution and completion of the Contract in accordance with the Contract Drawings and Specifications.

- B. Review stamp will be affixed, action block will be marked, and stamp will be signed and dated.
- C. The District or its designee will review the submittals for general conformance with the Contract Documents and mark, sign, and date the review stamp.
- D. The marks have the following meanings:
 - 1. The mark NO EXCEPTIONS TAKEN is an acceptance, and means that every illustration and description appears to conform to the respective requirements of the Contract Documents; that fabrication, assembly, manufacture, installation, application, and erection of the illustrated and described product may proceed; and that the submittal need not be resubmitted.
 - 2. The mark EXCEPTION AS NOTED is an acceptance, and means that every illustration and description appears to conform to the respective requirements of the Contract Documents upon incorporation of the reviewer's corrections, and that fabrication, assembly, manufacture, installation, application, and erection of the illustrated and described product may proceed. Submittals so marked need not be resubmitted immediately unless the Contractor challenges the reviewer's exception, but correct and resubmit the submittal for record before Final Acceptance of the Contract.
 - 3. The mark SUBMIT SPECIFIED ITEMS is an acceptance conditioned upon submission and acceptance of noted products, and means that the submittal is correct except for products noted as incomplete, and that the reviewer listed submittals, taken from the respective Specifications sections, are yet to be submitted and accepted.
 - 4. The mark REVISE AND RESUBMIT is a rejection, and means that the submittal is deficient to the degree that the reviewer cannot correct the submittal with a reasonable degree of effort, that the submittal needs revision and is to be resubmitted.
 - 5. The mark REJECTED is a rejection, and means that the submittal is deficient to the degree that the reviewer has not made a thorough review of the submittal, that the submittal needs revision and is to be corrected and resubmitted.

3.3 CONTRACTOR RESPONSIBILITIES .

- A. Coordinate each submittal with the requirements of the Work; place particular emphasis upon ensuring that each submittal of one trade is compatible with other submittals of that trade and submittals of other trades.
- B. Contractor's responsibility for errors and omissions in submittals and associated calculations is not relieved by the District or its designee's review and acceptance of submittals.
- C. Contractor's liability to the District in case of deviations in the submittals from the requirements of the Contract Documents is not relieved by the District or its designee's review and acceptance of submittals containing deviation unless the District expressly approves the deviation through the issuance of a change notice.
- D. Distribution of Submittals After Review - Distribute accepted submittals, bearing District or its designee's stamp and signature, to Contractor's field office and the District or its designee's field office; to concerned subcontractors, suppliers, and fabricators; and to concerned members of Contractor's workforce.

END OF SECTION

SECTION 01310

NETWORK ANALYSIS SYSTEM

PART 1 - GENERAL

1.1 DESCRIPTION - The Work specified in this Section includes submitting a Critical Path Method (CPM) network schedule and analysis in two parts as described herein. The two-part network submittal, along with "Monthly Progress Status Reports" (Monthly Report) and revisions to the network and analysis are collectively referred to as the Network Analysis System (NAS). The planning, scheduling, management, and execution of construction in accordance with the Contract Drawings and Specifications is the responsibility of the Contractor. The NAS requirement is established to ensure adequate planning, scheduling, management, and execution of the work by the Contractor and to enable the District or its designee to evaluate work progress and recommend progress payments.

1.2 MEASUREMENT - The Work of this Section will be measured as a unit, acceptably performed.

1.3 PAYMENT will be made under:

Item No. 01000.01 - General Requirements - per lump sum.

PART 2 - PRODUCTS

Products are not required for this Section.

PART 3 - EXECUTION

3.1 NAS COMPONENTS - The NAS component documents consist of three distinct submittal sets:

A. Part One Submittal - A CPM network schedule developed in precedence diagram method (PDM) format and a narrative.

B. Part Two Submittal - A CPM network schedule developed in PDM format, computer printout reports of the network, a written narrative of the schedule and an operation manual. Revisions to the schedule are a special category of the Part Two submittal.

C. Monthly Report Submittal - An updated computer printout reports of the network schedule and a written narrative addressing progress.

3.2 PART ONE SUBMITTAL

- A. The Part One submittal shall include a time-scaled precedence diagram in a work item format for Contract activities to be worked on during the first 120 days of the Contract and a supporting narrative. The Part One submittal shall be delivered within 20 days after award of the Contract and shall use the NTP date as the data date. In the absence of an actual NTP and unless otherwise approved, assume a Monday start.
- B. The Contractor's general approach for meeting the interim and final completion dates will also be indicated in narrative form. Work items expected to be completed before delivery and approval of the Part Two submittal will be shown. The submittal will not be approved unless it is complete, as specified, and represents a realistic and logical approach to the Work.
- C. The District or its designee will have 14 days after receipt of the submittal to respond. Upon receipt of these comments, the Contractor shall make necessary changes and deliver the corrected Part One submittal within ten days. No progress payments will be made until the Part One submittal is approved.
- D. CPM Network Schedule shall include the following:
 1. Work Item Identification, i.e., work item numbers. Not more than one work item shall contain the same work item number.
 2. Work items
 - a. Work Item descriptions shall be brief but shall convey the scope of Work indicated. Work items shall be discrete items of Work that inherently must be accomplished under the Contract and that, when complete, produce definable, recognizable entities or stages within the project. Work items, including work associated with Contract deliverables, shall be shown.
 - b. Work items shall include the submittal and approval of samples or materials and shop drawings, the procurement of critical material and equipment, fabrication of special materials and equipment and their installation and testing, and delivery of District-furnished items. Work items of the District that may affect progress shall be reflected, as well as those of affected utilities and other similarly involved third parties.

3. Lag factors shall show logical and necessary relationships between work items and shall be shown as dotted lines.
4. The estimated work item duration (D) shall be listed with the work item description and shall be in whole working days (See Appendix 1).

Work items shall have durations of 30 working days or less. Should an item of work require more than 30 working days, it shall be subdivided to define appropriate work items. The District or its designee may approve using longer durations on such nonconstruction activities as the procurement and fabrication of materials and equipment.

5. The precedence diagram shall be time-scaled (by week, ending Friday) and grouped (banded) by work areas. Where float time exists, the work items shall be shown at the time they are scheduled to be accomplished. The format of the precedence diagram shall be in accordance with Appendix 1.
 6. The precedence diagram shall be clear, neat, and legible and shall be submitted on sheets 24 inches by 36 inches on a medium suitable for reproduction. Each sheet shall contain a title block and a revision block.
- E. The narrative shall describe the Contractor's approach for meeting the interim and final completion dates as specified by the Contract. The narrative shall be shown on separate 8 1/2 inch by 11 inch sheets.
- F. The Part One submittals shall include the precedence diagram on a medium suitable for reproduction and six copies. The submittal includes six copies of the narrative.
- G. The Contractor, at the end of each month following NTP and continuing through the first 120 days, shall submit a narrative detailing progress, problems, proposed corrective actions, and a tabulation of selected data (in the format detailed below).
1. During the initial 120-day period of the Contract, a given Monthly Progress Payment will be processed only after the District or its designee has received a satisfactory narrative and tabulation of data for the period to which that Monthly Progress Payment corresponds. The tabulation of data shall be arranged and detailed as follows:
 2. Monthly narrative - In addition to sections devoted to the statement of general progress during the period

and to a discussion of problems and their proposed solutions, another section shall be devoted to tabular data arranged as follows:

- a. Completed work items - Work items shall be listed in ascending order and, for each work item, the following data shall be shown: work item identification, description, date started, date completed, and work-days ahead or behind schedule at the time the work item was completed.
 - b. In-progress work items - Work items shall be listed in order and, for each work item, the following data shall be shown: work item identification, description, date started, scheduled forecast completion date, estimated remaining work-days required to complete, and estimated work-days ahead of or behind schedule as of the end of the reporting period.
 - c. Scheduled - Work items scheduled to start in the next 30-day period shall be listed in ascending order and, for each work item, the following data shall be shown: work item identification, description, scheduled start date, estimated start date (based on progress to-date on work for which the work item start date is dependent), scheduled finish date and estimated finish date (based on progress to-date on work for which the activity start date is dependent).
- H. Revisions - If it becomes apparent that minor logic changes and/or work item additions to the approved Part One submittal could be advantageous to one or both parties, the Contractor may propose, in writing, such changes and/or additions. If the District or its designee approves, the Contractor shall submit a revised precedence diagram and narrative. Payments will continue to be made from the approved Part One submittal until the District or its designee approves the revised submittal.

3.3 PART TWO SUBMITTAL

- A. The Part Two submittal shall include a time-scaled precedence diagram in a work item format showing Contract work items, computer printout reports of the mathematical analysis of the diagram, and a narrative describing the Contractor's approach for meeting the required interim and final completion dates. The initial Part Two submittal shall be submitted within 75 days after the date of receipt of NTP and shall use the NTP date as the data date. The District or its designee will have 30 days after receipt of the submittal to respond. Upon receipt of the District or its designees comments, the Contractor shall confer with the District or its designee in the

appraisal and evaluation of the proposed schedule. Necessary revisions resulting from this review shall be made by the Contractor, and the schedule shall be resubmitted within 15 days after the conference.

- B. The approved schedule, unless subsequently changed with the approval or at the direction of the District or its designee, is the schedule to be used by the Contractor for planning, scheduling, managing, and executing the work to be accomplished. No progress payments will be made for work performed after the first 120 days of the Contract until the initial Part Two submittal is approved and the first Monthly Report (based on the approved Part Two submittal) is delivered to the District or its designee. Part Two submittals shall be prepared in accordance with the following procedure.
- C. Schedule Preparation- The precedence diagram shall be prepared in accordance with the technical specifications in Paragraph 1.1,C. The diagram shall include Contract work items, including Part One work items. The Part One work items and data as originally approved shall be included in the Part Two submittal without modification. The critical path activities shall be identified, including critical paths for interim completion dates, as applicable. Scheduled start or completion dates imposed on the schedule by the Contractor shall be consistent with Contract milestone dates. Milestone events shall be defined as the scheduled dates specified in the Special Conditions and shall be prominently identified (flagged) and connected to the appropriate work item, denoting its start or completion, as applicable. Each start milestone event shall restrain the start of dependent work items. Work items included in the scope of work associated with a completion milestone event must be finished before that milestone event can occur. Failure to include any element of work required for performance of this Contract shall not excuse the Contractor from completing work required to achieve applicable completion milestone event, notwithstanding the approval of the Part Two submittal.
- D. Schedule Reports - In addition to the precedence diagram described above, various reports shall be prepared using data processing equipment. Reports shall contain the following data for each work item: identification, description, estimated total duration, estimated remaining durations, computed or specified early start date, computed early finish date, computed late start date, computed or specified late finish date, and total float. Completion milestone dates in the Special Conditions shall be plugged as late finish dates. Access dates establishing earliest feasible start dates shall be reflected as constraints, and required not-later-than start dates shall be reflected as constraints. The Part

Two submittal requires four separate computer printout reports, each sorted as follows:

1. Work Item Report - This report shall contain work items as shown on the precedence diagram listed in order of ascending work item number.
2. Float Report - This report shall contain work items as shown on the precedence diagram listed in the order of the ascending total float values.
3. Early Start Report - This report shall contain work items as shown on the precedence diagram listed in chronological order by early start date.
4. Late Finish Report - This report shall contain work items and restraints as shown on the precedence diagram listed in chronological order by late finish date.

E. Written Narrative

1. Part Two submittals shall include a written narrative sufficient to explain the basis of the Contractor's determination of durations and shall describe the Contractor's approach for meeting the required interim milestone and final completion dates, as specified by the Contract. Such explanation shall include estimated quantities and production rates, hours per shift that are proposed, the work days per week, and a listing of the major items of construction equipment planned for use on the project. The equipment listing shall include type, number of units, unit capacities, and a schedule showing the proposed time each piece of equipment will be on the job. Should the District or its designee require similar information on other work items, this information shall be supplied by the Contractor.
2. Work items that may be expedited by use of overtime or additional shifts shall be identified. Sequencing and other restraints such as manpower, material, and equipment shall be identified and explained. The Contractor shall include a listing of the holidays and any special non-work days being used for the computer reports.

F. The Initial Part Two Submittal shall include a copy of the Operation (User's) Manual for the computer program being used.

G. The Part Two submittal shall include the precedence diagram on a medium suitable for reproduction and six copies, six sets each of the four required computer printout reports, and six copies of the written narra-

tive. Documents in one submittal shall have the same data date irrespective of the date(s) that the individual documents are prepared.

3.4 MONTHLY PROGRESS STATUS REPORT

- A. Not later than 150 days after NTP and monthly thereafter, the Contractor shall submit to the District or its designee a draft Monthly Progress Status Report with data as of the last day of the pay period.
- B. The Contractor shall participate with the District or its designee in monthly meetings on dates and at a location as directed by the District or its designee. The purpose of the meetings is the joint review and agreement on job progress. Job progress shall specifically include:
 - 1. Actual completion dates for work items completed during the report period.
 - 2. Actual start dates for work items started during the report period.
 - 3. Estimated remaining durations for work items in progress.
 - 4. Estimated start dates for work items scheduled to start during the month following the report period.
 - 5. Changes in the duration(s) of any work item and/or minor logic changes.
 - 6. Identification of current and most critical path(s) to required interim/project completion dates.
 - 7. Work items not included in the Part Two submittal.
- C. After Discussion and Inclusion of this Data, the Contractor shall submit to the District or its designee final copies of the Monthly Progress Status Report within 7 days after the last day of the pay period. No progress payment will be made for pay periods for which the Contractor fails to submit an approved Monthly Progress Status Report. Upon receipt of the Monthly Progress Status Report, the District or its designee will expedite the preparation of the Monthly Progress Payment. The Monthly Progress Status Report shall consist of:
 - 1. Six sets of each computer printout report as specified under Paragraph 1.1,D,4 to include data specified therein but expanded and updated as follows:
 - a. Additional general reporting requirements - Reports shall show work items, including completed work items and work items in the latest approved Part

Two submittal. The latter work items are discussed in Paragraph 1.1,F. The requirement to report on activities applies for the duration of the project.

b. Additional time-data reporting requirements:

- 1) Completed work items - Include actual start and finish dates and estimated remaining duration (equal to zero). The latter item and the data date are needed for computerized data computations, including computations for work items performed out of the sequence originally planned.
 - 2) Started-but-incomplete work items - Include actual start dates and estimated remaining durations, i.e., number of days required to complete the respective work items. The latter item and the data date are needed for computerized data computations, including computations for work items performed out of the sequence originally planned.
 - 3) Not-started work items - No change in reporting requirements from the data specified in Paragraph 1.1,D,4; however, the data date and the respective estimated remaining durations of started-but-incomplete work items are to be used in arriving at the updated computed data for work items not yet started.
2. Six copies of a narrative that shall state the work actually completed and reflect the progress along the critical path in terms of days ahead of or behind the allowable dates. Specific requirements of the narrative are as follows:
- a. If the Monthly Progress Status Reports indicates an actual or potential delay to the Contract completion date or interim milestone dates as specified under the Special Conditions, the delay(s) shall be treated in the narrative in one of the following ways:
 - 1) If the delay is within the Contractor's scheduling control, e.g., normal weather conditions, crew inefficiency, or underestimated duration, the Contractor shall identify the problem, the cause, and the work item(s) affected and shall provide an explanation of the proposed corrective action to meet the milestone dates involved or to mitigate further delays.
 - 2) If the delay is not within the Contractor's scheduling control, the Contractor shall identi-

fy the problem, cause, duration, specific work item(s) affected, and logic restraints of each work item.

- b. The narrative shall identify, by work item number and description, work items to be started during the month following the report period. The Contractor's forecast start date and forecast finish date, as well as the late start date and late finish date from the current report, shall be shown.
 - c. The narrative shall discuss added change order work items that were included in the part two submittal.
 - d. Added work items will be treated in the narrative as more specifically provided in Paragraph 1.1,F.
3. Subject To Approval, work items that were not included in the initial approved part two submittal will be added to the computer reports and narrative submitted with the Monthly Progress Status Report under the following circumstances: When change order work items are introduced or when there is an actual or potential delay to the Contract completion date or interim milestone date(s) as specified under the Special Conditions. The original Contract milestone dates shall not be changed except by an Approved Change Order. A revision, as specified in Paragraph 1.1,H, need not be submitted when the foregoing situations arise unless required by the District or its designee. Acceptance of a Monthly Progress Status Report containing added work items will not be construed to be approval of the duration or constraints for such added work items; instead, the corresponding data as ultimately incorporated into the applicable Approved Change Order shall govern.
- a. For Approved Change Orders granting time extensions, the sum of the calendar-day durations of work items, which are both included in the Change Order and fall on the appropriate, currently existing critical path, shall equal the calendar-day total time extension specified for the applicable change work in the Approved Change Order. For any path governing the computation of the time extension that is to be granted and that has become critical as a result of the added work, the time extension is adjusted downward from such sum.
 - b. Data on each added work item, except as further provided in items c and d below, shall include the following:
 - 1) Work item identification.

- 2) Work item description.
 - 3) Original estimated work item duration and estimated remaining duration.
 - 4) Actual start and actual finish, computed or specified early start and early finish, or late start and late finish dates and total float, as applicable. The data date and remaining durations will be used, as appropriate, in making the computations specified in this paragraph.
- c. For actual delays, add a work item prior to each delayed work item on the appropriate critical path(s). Data on the added work items of this type shall include the following:
- 1) Work item identification.
 - 2) Work item description indicating cause of the delay.
 - 3) Work item duration consistent with whichever set of dates in item d below applies.
 - 4) The actual start and finish dates of the delay or, if the delay is not finished, the actual start date and the data date of the Monthly Progress Status Report.
- d. For potential delays, add a work item prior to each potentially delayed work item on the appropriate critical path(s). Data for added work items of this type shall include the following:
- 1) Work item identification.
 - 2) Work item description indicating cause of the potential delay.
 - 3) Work item duration equal to zero work days.
 - 4) Computed early start, late start, early finish, and late finish dates.
- e. As a part of the Monthly Progress Status Report narrative and to the extent hereinafter required, the Contractor shall discuss the progress of any work item not shown in the approved Part Two submittal. The discussion shall be in the same format as that required for work items that are included in the approved initial Part Two submittal (see Paragraph 1.1,E,3,b).

g. Newly introduced change order work items and the CPM path(s) that they affect must be identified specifically. Change order work items shown in the network are considered to be the Contractor's proposal until a change order incorporating the change work into the Contract is approved. Acceptance of a CPM diagram containing change order work items will not be construed to be approval of the durations or constraints concerning those work items. Applicable Approved Change Orders shall govern in those regards.

4. The Mutually Agreed-To Monthly Progress Status Report shall be the basis for evaluating the Contractor's progress. If the Contractor fails to provide acceptable updated reports that, in the sole judgement of the District or its designee, accurately reflect the work completed to date and are in accordance with the Contract requirements, the Contractor will be deemed not to have provided a basis upon which progress may be evaluated, and no payment will be made. Furthermore, no Monthly Progress Status Report will be accepted as a basis for evaluating progress unless it is based on an approved Part Two submittal. Documents in a single Monthly Progress Status Report shall have the same data date irrespective of the date(s) that the individual documents are prepared.

3.5 REVISIONS

A. Revised Part Two submittals shall be made in the same format and detailed as the original submittal and shall be accompanied by an explanation of the reasons for such revisions, all of which shall be subject to approval. Minor changes to the approved Part Two submittals may be approved at monthly meetings; a minor change is not considered a revision in the context of this paragraph. However, a revision shall incorporate previously made changes, both major and minor, to reflect current as-built and as-planned conditions. The work items of the revised portions shall be properly connected to, and constrained by, previously existing predecessor and successor work items, as applicable. The value of work items in a revised portion of the schedule, which in aggregate corresponds to work contained in the initial approved Part Two submittal, shall be identical, in aggregate value, to the value of the work as reflected in the initial approved Part Two submittal.

B. A Revised Part Two Submittal shall be submitted for approval, when required by the District or its designee, for one of the following reasons:

1. The District or the District's designee directs a change that affects the milestone date(s) specified

under the Special Conditions or alters the length of a critical path.

2. When a change order significantly affects the Contract completion date or the sequence of work items.
 3. The Contractor elects to change any sequence of work items which may affect a critical path of the currently approved NAS documents, or any other path which may affect his interface with other Contractors.
 4. The Contractor's progress on any critical work item falls significantly behind the approved progress schedule.
- C. The Contractor shall submit one copy of the revised schedule using the original Contract NTP as the data date and originally approved as-planned durations for those work items that are not a part of work reflected in the revised portions of the schedule. The Contractor shall submit a copy of the revised schedule using the revision date as the data date and reflecting as-built data through that date. It is this latter version of the revised schedule that, when approved and when updated in the Monthly Progress Status Report process, will be the basis for subsequent progress payments.
- D. Except as specifically provided in Paragraph 1.1,F, until the District or its designee approves the revised Part Two submittal, the Contractor shall continue to submit Monthly Progress Status Reports based on the currently approved Part Two submittal.
- E. If, prior to agreement on an equitable adjustment to the Contract duration, the District or its designee requires revisions to the Part Two submittal in order to evaluate planned progress, the Contractor shall provide an interim revised Part Two submittal for approval with change effect(s) incorporated as directed. Approved interim revisions to Part Two NAS documents will be incorporated during the first subsequent Monthly Progress Status Report.
- 3.6 CONTRACT EXTENSIONS - Float time is not time for the exclusive use or benefit of either the District or the Contractor. Extensions of time for Contract performance as specified in the Contract will be granted only to the extent that equitable time adjustments to the affected work item(s) exceed the total float time along the affected paths of the approved computer printout report in effect at that time. Slippage of work items shall not be the basis for a time extension to this Contract unless, and until, such slipped work items are resolved as set forth in Article 32, (Extension of Time) of the Contract General Conditions.

- 3.7 Documentation - After Contract work items are complete, the Contractor shall submit an as-built computer printout report and a time-scaled as-built precedence diagram. The documents shall reflect Project as-built critical paths. The diagram shall be prepared in accordance with the requirements for Contract record drawings in the General Conditions and in Paragraph 1.1,D above, except the following:
- A. Contract work items, including added work items, shall be shown.
 - B. Work item durations shall be the actual number of separate work days during which work was performed on the work item.
 - C. Work item start/finish dates shall reflect the actual dates the work started and finished as agreed to between the Contractor and the District or its designee.
 - D. Contract milestone completions shall be plotted on the date of the Substantial Completion Reports.
- 3.8 LEGAL STATUS - The currently approved NAS documents shall be used by the Contractor for planning, organizing, and directing his work for reporting progress, and for determining delay(s) in achieving milestone dates specified under the Special Conditions.
- 3.9 SUSPENSION OF PAYMENTS - Should the Contractor's NAS document submittals not be approved, the District may suspend progress payment. When Part One and Part Two construction schedules, or revisions to either as appropriate, satisfy the Contract Specifications and present a realistic approach to the work required to meet the Contract completion date/ interim milestone dates and form the basis for a reasonable cost distribution, the District or its designee will approve the Contractor's progress schedule submittals and, in the case of a Part Two submittal (on the Contractor's providing a satisfactory Monthly Progress Status Report based thereon), the District will resume making progress payments. The determination as to whether the foregoing conditions have been met will be based on information furnished by the Contractor as to the Contractor's equipment, resources, crew sizes, crafts, overall manpower allocation, planned unit rates, reasonableness of procurement times, costs, and other pertinent factors. However, in the final analysis, the determination is solely that of the District or its designee.

END OF SECTION

SECTION 01311

BAR CHART SCHEDULE

PART 1 - GENERAL

1.1 DESCRIPTION - The Work specified in this Section includes submitting a bar graph in sufficient detail to show the sequence in which the Contractor proposes to carry out the work required under this contract. The planning, scheduling, management, and execution of construction in accordance with the Contract Drawings and Specifications are the responsibility of the Contractor.

1.2 SUBMITTALS

A. Refer to Section 01300, Submittals for submittal procedures

B. Initial Bar Chart Submittal - The initial Bar Chart Schedule and a narrative describing the Contractor's approach for meeting the required interim milestone and final completion dates shall be submitted within ten days after the date of receipt of NTP and shall use the NTP date as the data date. The Contractor shall submit six copies to the District or its designee. The District or its designee will have 14 days after receipt of the submittal to respond. Upon receipt of these comments, the Contractor shall confer with the District or its designee in the appraisal and evaluation of the proposed schedule. Necessary revisions resulting from this review shall be made by the Contractor, and the schedule shall be resubmitted within ten days after the conference. The approved schedule, unless subsequently changed with the approval by, or at the direction of, the District or its designee, is the schedule to be used by the Contractor for planning, scheduling, managing, and executing the work to be accomplished. No progress payments will be made until the initial Bar Chart Schedule submittal is approved.

1.2 MEASUREMENT - The Work of this Section will be measured as a unit, acceptably performed.

1.3 PAYMENT will be made under:

Item No. 01000.01 - General Requirements - per lump sum.

PART 2 - PRODUCTS

Products are not used in this Section.

PART 3 - EXECUTION

3.1. BAR CHART SCHEDULE - Submit in the following format:

- A. Identify salient work items required to complete the Work. Work items descriptions shall be brief but shall convey the scope of Work indicated. Work items shall be discrete items of work that inherently must be accomplished under the Contract and that, when complete, produce definable, recognizable entities or stages within the project. Work items including work associated with Contract deliverables shall be shown.
- B. Work items shall include the submittal and approval of samples or materials and shop drawings, the procurement of critical material and equipment, fabrication of special materials and equipment and their installation and testing, and delivery of District-furnished items. Work items of the District that may affect progress shall be reflected, as well as those of affected utilities and other similarly involved third parties.
- C. Identify the NTP date, interim milestones (as specified in the Special Conditions) and the Project Completion Date.
- D. Include a time-scaled schedule (by week, ending Friday).
- E. Include a data dateline.
- F. Include title block, revision block, Contract number and legend.
- G. Identify the order and interdependence of work items and the sequence in which the work is to be accomplished.
 1. Identify how the start of a given work item depends on the completion of preceding work items, and how its completion is necessary for the start of following work items.
 2. Scheduled start or completion dates imposed on the schedule by the Contractor shall be consistent with Contract milestone dates. Milestone events shall be defined as the scheduled dates specified in the Special Conditions and shall be prominently identified (flagged) and connected to the appropriate activity, denoting its start or completion, as applicable. Each start milestone event shall constrain the start of dependent work items. Furthermore, work items included in the scope of work associated with a completion milestone event must be finished before that milestone event can occur. Failure to include any element of work required for performance of this Contract shall not excuse the Contractor from completing Work

required to achieve applicable completion milestone event, notwithstanding the approval of the Bar Chart Schedule submittal.

- H. The Bar Chart Schedule shall be clear, neat, and legible, and shall be submitted on sheets not to exceed 24 inches by 36 inches on a medium suitable for reproduction.

3.2 WRITTEN NARRATIVE

- A. The initial Bar Chart Schedule submittal shall include a written narrative sufficient to explain the basis of the Contractor's determination of durations and shall describe the Contractor's approach for meeting the required interim milestone and final completion dates, as specified by the Contract. Such explanation shall include estimated quantities and production rates, hours per shift that are proposed, the work days per week, and a listing of the major items of construction equipment planned for use on the project. The equipment listing shall include type, number of units, unit capacities, and a schedule showing the proposed time each piece of equipment will be on the job. Should the District or its Designee require similar information on other work items, this information shall be supplied by the Contractor.
- B. Work items that may be expedited by use of overtime or additional shifts shall be identified. Sequencing and other constraints such as manpower, material, and equipment shall be identified and explained. The Contractor shall include a listing of the holidays and special non-work days.

3.3 MONTHLY PROGRESS STATUS REPORT - At the end of each month following NTP, the Contractor shall submit to the District or its designee six copies of the updated Bar Chart with data as of the last day of the pay period. The Contractor shall participate with the District or its designee in monthly meetings on dates and at locations as directed by the District or its designee. The purpose of the meetings is the joint review and agreement on job progress. Job progress shall specifically include:

- A. Actual completion dates for work items completed during the report period.
- B. Actual start dates for work items started during the report period.
- C. Estimated remaining durations for work items in progress.
- D. Estimated start dates for work items scheduled to start during the month following the report period.

- E. Changes in the duration(s) of work items and/or minor logic changes.
 - F. Work items not included in the Bar Chart submittal.
- 3.4 BAR CHART UPDATING - The Contractor shall update the Bar Chart in the following manner:
- A. Initial schedule, solid bar, shall remain the same for each update.
 - B. Actual progress shall be shown in a different pattern directly under the work item with the percentage complete indicated as of the data date.
 - C. Date of data shall be shown for each update.
 - D. Actual start/finish dates shall be shown for work items in progress.
 - E. Identify the current sequence to the interim milestones or project completion.
- 3.5 STATUS REPORT DELAYS - If the Monthly Progress Status Report indicates an actual or potential delay to the Contract completion date or interim milestone completion dates as specified under the Special Conditions, delay(s) shall be treated in a narrative in one of the following ways:
- A. If the delay is within the Contractor's scheduling control, e.g., normal weather conditions, crew inefficiency, or underestimated duration, the Contractor shall identify the problem, the cause, and the work item(s) affected and shall provide an explanation of the proposed corrective action to meet the milestone dates involved or to mitigate further delays.
 - B. If the delay is not within the Contractor's scheduling control, the Contractor shall identify the problem, cause, duration, specific work item(s) affected, and logic constraints of each work item.
- 3.6 REVISIONS - Revised Bar Chart submittals shall be made in the same format and detail as the original submittal and shall be accomplished by an explanation of the reasons for such revisions. Revisions shall be subject to approval. Minor changes to the approved Bar Chart submittal may be approved at monthly meetings; a minor change is not considered a revision in the context of this paragraph. A revision shall incorporate previously made changes, both major and minor, to reflect current as-built and as-planned conditions. A revised Bar Chart shall be submitted for approval, when required by the District or its designee, for one of the following reasons:

- A. The District or its designee directs a change that affects the milestone date(s) specified under the Special Conditions.
- B. When a change order significantly affects the Contract completion date or the sequence of work items.
- C. The Contractor elects to change any sequence of work items which may affect the planned sequence of work in the currently approved Bar Chart Schedule, or which may affect his interface with other Contractors.
- D. The Contractor's progress on critical work item falls significantly behind the approved progress schedule.

The Contractor shall submit six copies of the revised schedule using the revision date as the data date and reflecting as-built data through that date.

- 3.7 CONTRACT EXTENSIONS - Extensions of time for Contract performance as specified in the Contract will be granted only to the extent required for equitable time adjustments to the affected work item(s). Slippage of work items shall not be the basis for a time extension to this Contract unless, and until, such slipped work items are resolved as set forth in Article 32, (Extension of Time) of the Contract General Conditions.
- 3.8 DOCUMENTATION - After Contract activities are complete, the Contractor shall submit six copies of an as-built Bar Chart Schedule. The documents shall reflect project as-built work. The Bar Chart shall be prepared in accordance with the requirements for Contract record drawings in the General Conditions and in Paragraph 1.2A, except the following:
 - A. Contract work items, including added work items, shall be shown.
 - B. Work item durations shall be the actual number of separate work days during which work was performed on the work item.
 - C. Work item start/finish dates shall reflect the actual dates the work started and finished as agreed to between the Contractor and the District or its designee.
 - D. Contract milestone completions shall be plotted on the date of the Substantial Completion Reports.
- 3.9 LEGAL STATUS - The currently approved Bar Chart Schedule shall be used by the Contractor for planning, organizing, and directing his work, for reporting progress, and for determining delay(s) in achieving milestone dates specified under the Special Conditions.

3.10 SUSPENSION OF PAYMENTS - Should the Contractor's revised Bar Chart schedule submittal not be approved, the District may, on determination by the District or its designee, suspend progress payment. When the revised Bar Chart schedule submittal satisfies the Contract Specifications and presents a realistic approach to the Work required to meet the Contract completion date/interim milestone dates and forms the basis for a reasonable cost distribution, the District or its designee will approve the Contractor's revised progress schedule submittal and the District will resume making progress payments. The Determination as to whether the foregoing conditions have been met will be based on information furnished by the Contractor as to the Contractor's equipment, resources, crew sizes, crafts, overall manpower allocation, planned unit rates, reasonableness of procurement times, costs, and other pertinent factors. However, the final determination is solely that of the District or its designees.

END OF SECTION

SECTION 01321

NOTICES AND REQUESTS

PART 1 - GENERAL

1.1 DESCRIPTION

- A. The Work specified in this Section consists of preparing and submitting notices and requests required by the several Specification Sections.
- B. Notices - Information transmitted by the contractor of impending contractor activity, required by a specification or necessary for prosecution of the Work.
- C. Requests - A submittal by the Contractor asking for District's or its designee's action or inspection of Work of this Contract.

1.2 SUBMITTALS - Refer to Section 01300, Submittals for submittal procedures.

1.3 MEASUREMENT - The Work of this Section will be measured as a unit, acceptably performed.

1.4 PAYMENT will be made under:

Item No. 01000.01 - General Requirements - per lump sum.

PART 2 - PRODUCTS

Products are not used in this Section.

PART 3 - EXECUTION

3.1 IDENTIFY NOTICES AND REQUESTS by reference to Specification Section numbers by whose authority notices and requests are being submitted, place on 8 1/2 by 11 inch white, bond paper bearing Contractor's letterhead, prepare and sign by a duly authorized representative of the Contractor; state the essence of the notice or request.

3.2 PROVIDE ten days notice on all witness and assembly hold points for fabrication off site.

3.3 SUBMISSION REQUIREMENTS

- A. Submit notices and requests within those times specified in the several Specification sections.

1. Address notices and requests to those owners at the addresses furnished by the District or its designee.
 2. Address notices and requests to the District or its designee, at the address furnished by the District.
- B. Accompany requests and notices to District or its designee and copies to owners, with a Contractor Transmittal Form.
- C. Include a blank space, three inches by four inches, in lower right corner, in which District or its designee may indicate action taken.

END OF SECTION

SECTION 01322

CERTIFICATES AND REPORTS

PART 1 - GENERAL

1.1 DESCRIPTION

- A. The Work specified in this Section consists of preparing and submitting certificates and reports required by the several Specification Sections. Designate dates for submission in the Progress Schedule and in the Submittal Register.
- B. Certificates of Compliance may be submitted in lieu of sampling and testing those products for which sampling and testing is specified but only if the certificates:
1. State that the product complies with the respective Contract Specification and Contract Drawing requirements.
 2. Are accompanied by a certified copy of test results pertaining to the product.
 3. Show the submittal date, Contractor's name and address, Contract Title and Number, product represented and its location in the Contract, producer's name, product trade name and catalog number, place of product origin, test date, testing organization's name and address, quantity of the product to be furnished, and Contract Drawing and Specification Section numbers.
 4. Are signed by an officer or another authorized representative of the producer and are notarized.
 5. Six copies are submitted.
 6. Are received by the District or its designee not later than 30 days before the products are to be installed.
- C. If the Contractor elects to submit Certificates of Compliance, the submitting of those certificates do not relieve the Contractor from his responsibility for furnishing and installing products which conform to the requirements of the Contract Documents. Products, which have been delivered to the worksite and for which Certificates of Compliance have been submitted, are subject to being sampled and tested, and either accepted or rejected, by the District or its designee.

D. Definitions

1. Certificates consist of written releases, permits, warranties, bonds and specimens of bonds, and other documents which contain certified statements.
2. Reports consist of written accounts of damaged materials received at the jobsite; written results of field and shop tests including drilling, driving, load-bearing, uplift, noise reduction, stone, soils, and other quality assurance tests and written statements of manufacturing procedures, concrete and grout mix designs, welders' qualifications, and welding procedures. Unless otherwise specified in the several Specification Sections or required by law, reports need not be notarized.

1.2 SUBMITTALS

- A. Refer to Section 01300, Submittals for submittal procedures.
- B. Include number and title of each certificate and report.
- C. Identify certificates and reports by reference to the respective Specification Sections.
- D. If the Contractor elects to submit Certificates of Compliance, each shipment of products described by a Certificate of Compliance shall be accompanied by a Certificate.
- E. Changes in products, for which Certificates and Reports have been accepted, will not be permitted unless those changes have been accepted, in writing, by the District or its designee.

1.3 MEASUREMENT - The Work of this Section will be measured as a unit, acceptably performed.

1.4 PAYMENT will be made under:

Item No. 01000.01 - General Requirements - per lump sum.

PART 2 - PRODUCTS

Products are not required for this Section.

PART 3 - EXECUTION

3.1 REVIEW BY DISTRICT - One copy of each certificate and report will be returned to the Contractor, either within 30 days. After the submittals have been received.

3.2 CONTRACTOR RESPONSIBILITIES - Certificates and reports shall be reviewed, stamped, and signed as reviewed, approved, and accepted by the Contractor's designated representative prior to certificates and reports being submitted to the District or its designee.

END OF SECTION

SECTION 01340

SHOP DRAWINGS, PRODUCT DATA, AND SAMPLES

PART 1 - GENERAL

1.1 DESCRIPTION - The Work specified in this Section consists of preparing and submitting Shop Drawings, product data, and samples required by individual specification Sections.

1.2 SUBMITTALS

A. Refer to Section 01300, Submittals for submittal procedures.

B. Quantities

1. One reproducible sepia and five prints of each Shop Drawing.
2. Six copies of manufacturers' standard schematic drawings.
3. Four copies of manufacturers' calculations, and six copies of manufacturer's standard data.
4. Six copies of manufacturers' printed installation, erection, application, and placing instructions.
5. Three samples of each item specified in the various Specification Sections, unless otherwise specified.
6. Six copies of inspection, test reports, and certificates of compliance.

1.3 MEASUREMENT - The Work of this Section will be measured as a unit, acceptably performed.

1.4 PAYMENT will be made under:

Item No. 01000.01 - General Requirements - per lump sum.

PART 2 - PRODUCTS

2.1 SHOP DRAWINGS

A. Prepare Shop Drawings on a maximum mylar sheet size of 22 inch by 34 inch to a scale large enough to easily depict and annotate each of the various items.

- B. Include the following as they apply to the subject.
1. Contract title and number.
 2. Respective Contract Drawing numbers.
 3. Applicable Contract Specification Section numbers.
 4. Relation to adjacent structure or materials.
 5. Field dimensions, clearly identified as such.
 6. Applicable standards, such as ASTM or Federal Specification number.
 7. Identification of deviations from the Contract Drawings and Specifications.
 8. Contractor's stamp, initialed or signed, certifying:
 - a. Verification of field measurements.
 - b. Review of submittals for compliance with Contract requirements.
 - c. Compatibility of the Work shown thereon with that of affected trades.

2.2 PRODUCT DATA

- A. Modify manufacturers' standard schematic drawings to delete information which is not applicable to the Contract. Supplement standard information with additional information applicable to this Contract.
- B. Modify Manufacturers' standard catalog cuts, brochures, diagrams, schedules, performance charts, illustrations, calculations, and other descriptive data to delete information which is not applicable to the Contract. Indicate dimensions, clearances, performance characteristics, capacities, wiring and piping diagrams, and controls.
- C. Modify manufacturer's printed installation, erection, application, and placing instructions to delete information which is not applicable to the Contract.
- D. Include the following:
 1. Contract title and number.
 2. Respective Contract Drawing numbers.
 3. Applicable Contract Specification Section numbers.

4. Applicable standards, such as ASTM or Federal Specification number.
5. Identification of deviations from the Contract Drawings and Specifications.
6. Contractor's stamp, initialed or signed, certifying:
 - a. Dimensional compatibility of the product with the space in which it is intended to be used.
 - b. Review of submittals for compliance with Contract requirements.
 - c. Compatibility of the product with other products with which it is to perform or with which it is to be placed in juxtaposition.

2.3 SAMPLES

- A. Use office samples of sizes and quantities to clearly illustrate full color range and functional characteristics of products and materials, including attachment devices.
- B. Erect field samples and mock-ups at the worksite as specified in the several Specifications Sections and as may be necessitated by Contractor submitting value engineering proposals, and at locations acceptable to the District or its designee.
- C. Show the following information:
 1. Contract title and number.
 2. Respective Contract Drawing numbers.
 3. Applicable Contract Specifications Section numbers.
 4. Applicable standards, such as ASTM or Federal Specification number.
 5. Identification of deviations from the Contract Drawings and Specifications.
 6. Contractor's stamp, initialed or signed, certifying:
 - a. Dimensional compatibility of the product with the space in which it is intended to be used,
 - b. Review of submittals for compliance with Contract requirements.

- c. Compatibility of the product with other products with which it is to perform or which will be next to it.

2.4 RECORD DOCUMENTS:

- A. Maintain one record copy of all Contract Documents, Shop Drawings, Change Orders and one set of full-size reproducible Contract Drawings at the site. Annotate the reproducible Contract Drawings to indicate the following:
 - 1. Horizontal and vertical location of underground utilities.
 - 2. Location of internal utilities and appurtenances concealed in construction referenced to visible and accessible features of the structure.
 - 3. Field changes of dimension and detail, as changes occur.
 - 4. Details not on original Contract Drawings.
- B. Stamp all such documents "RECORD DOCUMENTS" and keep available for examination by the District or its designee. Maintain record documents in a clean, dry and legible condition.

PART 3 - EXECUTION

3.1 CONTRACTOR RESPONSIBILITIES

- A. Verify field measurements, catalog numbers, and similar data.
- B. Do not start Work for which submittals are required until submittals bearing the stamp of the District or its designee and signature indicating review and acceptance have been received.
- C. Before making submittals, ensure that products will be available in the quantities required by the Contract.
- D. Submit a final, corrected, reproducible sepia of each Shop Drawing and show the Work as actually installed, placed, erected, and applied.

- 3.2 REVIEW BY THE DISTRICT OR ITS DESIGNEE - A reproducible Shop Drawings, one copy of marked-up Shop Drawings, one copy of product data, and one sample will be returned to Contractor within 30 days after submittals have been received.

END OF SECTION

SECTION 01342

WORKING DRAWINGS

PART 1 - GENERAL

1.1 DESCRIPTION - The Work specified in this Section consists of preparing and submitting Working Drawings and associated calculations required by the several Specification Sections.

1.2 SUBMITTALS

A. Refer to Section 01300, Submittals for submittal procedures.

B. Submit one reproducible and five prints of Working Drawings and associated calculations.

1.3 MEASUREMENT - The Work of this Section will be measured as a unit, acceptably performed.

1.4 PAYMENT will be made under:

Item No. 01000.01 - General Requirements - per lump sum.

PART 2 - PRODUCTS

2.1 DRAWING IDENTIFICATION - Identify Working Drawings by reference to Contract Drawing numbers and Specification Section numbers. Use a Working Drawing sheet with a maximum size of 22 inches by 34 inches. Prepare, stamp, and countersign Working Drawings by an Engineer, of the involved discipline, registered as an Engineer in the State of California. Working Drawings shall show:

A. Contract title and number.

B. Relation to adjacent structure or materials.

C. Field dimensions, clearly identified as such.

D. Applicable standards, such as ASTM or Federal Specification number.

E. Identification of acceptable deviations from Contract Documents.

2.2 SIGNATURES - Prepare, stamp, and countersign associated calculations by an Engineer, of the involved discipline, registered as an Engineer in the State of California. Identify calculations by reference to Contract Drawing numbers and Specification Section numbers.

PART 3 - EXECUTION

3.1 CONTRACTOR RESPONSIBILITIES - Review Working Drawings and associated calculations before submitting to the District or its designee.

A. Verify field measurements.

B. Do not begin Work, for which Working Drawings and associated calculations are required, until the drawings and calculations have been reviewed by the District or its designee, the District's or its designee's exceptions, if any, have been addressed, and submittal has been returned to Contractor with the required approval stamp and signature.

C. Distribute copies of Working Drawings and calculations after the District or its designee's review and acceptance.

3.2 REVIEW BY THE DISTRICT OR ITS DESIGNEE

A. Review Working Drawings and associated calculations and mark with comments, if any.

B. Reproducible Working Drawings and associated calculations, reviewed by District or its designee, will be returned to Contractor within 30 days after those drawings and calculations have been received.

END OF SECTION

SECTION 01370

SCHEDULE OF VALUES

PART 1 - GENERAL

1.1 DESCRIPTION

- A. The Work specified in this Section consists of preparing and submitting a Schedule of Values and a Schedule of on site Material Allowances and, if the schedules are affected by Change Orders, of preparing and submitting updated copies of the schedules.
- B. Schedule of on site Material Allowances - A detailed cost breakdown for Materials which will be temporarily stored prior to their being installed, and for which the Contractor seeks partial payments.

1.2 SUBMITTAL

- A. Refer to Section 01300, Submittals for submittal procedure.
- B. Submit a Schedule of Values as indicated in the General Conditions.
- C. Identify items in the Schedule of Value and Material Allowances with the Specification Section numbers, Specification Section title, and Bid Item number.
- D. Upon request by the District or its designee, support values given with data which will substantiate the correctness of the values.
- E. Schedules will be used only as a basis for Contractor's Application for Progress Payment.

1.3. REVIEW AND RESUBMITTAL - If review by the District or its designee indicates that changes to the schedules are required, revise and resubmit schedules in the same manner as the original schedules were prepared and submitted.

1.4 MEASUREMENT - The Work of this Section will be measured as a unit, acceptably performed.

1.5 PAYMENT will be made under:

Item No. 01000.01 - General Requirements - per lump sum.

PART 2 - PRODUCTS

Products are not required for this Section.

PART 3 - EXECUTION

3.1 PREPARING SCHEDULE OF VALUES

- A. Upon approval by District or its designee, break down Bid Item costs as follows:
 - 1. Delivered cost of product, with taxes paid.
 - 2. Total installation cost, with overhead and profit.
- B. Break down costs of each lump sum and, in accepted circumstances, unit price Bid Item to list major products and major operations for which Contractor seeks to receive progress payments to Recover his costs for that Bid Item.
- C. Upon application from the Contractor, the District, or its designee may waive requirements of Paragraphs 3.1A, and B.

3.2 PREPARING SCHEDULE OF ON SITE MATERIAL ALLOWANCES

- A. Separate schedules of unit prices, indicate whether products will be stored on the worksite, or off the worksite in accordance with article 22.G of the General Conditions. Schedules shall show quantities and types of products which will be stored.
- B. Allowances consist of only the net cost of the product, the cost of delivery and unloading at the storage site, and the cost of sales taxes.

END OF SECTION

SECTION 01410

TESTING LABORATORY SERVICES

PART 1 - GENERAL

1.1 DESCRIPTION - The Work specified in this Section consists of employing, and paying for the services of, an independent testing laboratory.

1.2 QUALIFICATION OF LABORATORY

A. Select a laboratory that will satisfy the requirements of the American Council of Independent Laboratories' "Recommended Requirements for Independent Laboratory Qualification," and ASTM E329. The Laboratory need not be a member of the American Council of Independent Laboratories.

B. Calibrate testing equipment, using an accredited calibration agency, at not more than six months, or such other intervals as are set forth in the various Sections of the Specifications, using devices of accuracy traceable to the National Bureau of Standards or accepted values of material physical constants.

1.3 SUBMITTALS

A. Refer to Section 01300 for submittal procedures.

B. Testing equipment calibration report.

C. Laboratory's notices of inspections, tests, and sampling at a time which will permit the District or its designee to witness those activities.

D. Laboratory's reports of observance of Work irregularities and deficiencies.

E. Laboratory's reports of inspection, test, and sampling.

F. Laboratory's Quality Assurance/Quality Control Manual.

1.4 MEASUREMENT - The Work of this Section will be measured as a unit, acceptably performed.

1.5 PAYMENT - The Work of this Section will be paid for as part of the Contract lump sum price for General Requirements.

PART 2 - PRODUCTS

Products are not required for this Section.

PART 3 - EXECUTION

3.1 LABORATORY'S DUTIES

- A. Furnish qualified testing personnel promptly upon notice of readiness for inspection or testing. cooperate with the Contractor and the District or its designee.
- B. Perform specified inspection, sampling, and testing of materials and methods of construction in conformance with the referenced standards, and to compare results of inspections, sampling, and testing with requirements of these Specifications.
- C. Promptly report work irregularities and deficiencies which are observed during testing, inspecting, and sampling.
- D. Promptly submit copies of each inspection, sampling, and testing report through the Contractor to the District or its designee. Include in reports the following:
 - 1. A detailed report of the inspection, sampling, or testing delineating what materials or systems were inspected, sampled, or tested, the grid location on the Contract Drawing along with the Specification Section and paragraph number requiring such process; the methods utilized to perform the process and an enumeration, item by item, indicating conformance or nonconformance with the Contract Documents.
 - 2. Date of inspection, sampling, or testing.
 - 3. Date of report.
 - 4. Project title.
 - 5. Contract title and number.
 - 6. Testing laboratory name and address.
 - 7. Name and signature of testing laboratory's inspector and Contractor's representative present when sample is taken and/or test is performed.

3.2 CONTRACTOR'S RESPONSIBILITY WITH RESPECT TO TESTING - The District or its designee may chose to appoint an independent testing laboratory to verify the quality of product and workmanship. Contractor to assist and provide:

- A. Cooperate with laboratory personnel and provide access to the Work for those personnel.

- B. Furnish the laboratory with representative samples of materials to be tested, along with copies of supplier's or manufacturer's test reports.
- C. Furnish casual labor and facilities to:
 - 1. Provide access to the Work to be tested.
 - 2. Obtain and handle samples at the work site.
 - 3. Facilitate inspections and tests.
 - 4. Assist laboratory personnel in storing and curing test samples.
- D. Notify the laboratory sufficiently in advance of operations to allow laboratory personnel to be assigned and to allow scheduling of tests.
- E. Notify the District sufficiently in advance of operations to allow the District's personnel to witness the tests.

END OF SECTION

SECTION 01500

TEMPORARY FACILITIES

PART 1 - GENERAL

1.1 DESCRIPTION - The Work specified in this Section consists of furnishing, installing, operating, maintaining and removing temporary facilities including electrical power, telephone, water, fire protection and sanitary service.

A. Electrical Service:

1. Provide lighting and power and costs thereof for field offices, storage facilities, and other construction facilities and areas.
2. Provide street lighting, in areas where the existing street lighting system is disturbed by construction operations, to the levels established by the City of Los Angeles Bureau of Street Lighting. Temporary Street Lighting is to be on a dedicated street lighting circuit and shall not be connected to other street lighting circuits in the area.
3. Provide power centers for electrically operated and controlled construction facilities including tools; equipment; testing equipment; interior construction lighting; heating, cooling, and ventilation equipment.
4. Provide night security lighting at secured areas within construction limits at offices, storage facilities, and excavated areas.
5. Provide battery operated or equivalent emergency lighting facilities at construction areas where normal light failures would cause employees to be subjected to hazardous conditions. Test such facilities monthly.
6. Bear costs of temporary electric service permits, fees, and deposits required by the governing authorities; connection charges and temporary easements, including installation, maintenance, and removal of equipment.

B. Telephone Service:

1. Furnish, install and maintain three telephones in the Districts or its designee's field office. All telephones shall be connected on three lines in rotary with one intercom line. Initiate telephone service at the worksite before beginning construction.

2. Furnish, install and maintain telephone service or other communication system between the tunnel work face and tunnel portal independent of tunnel power supply. Ensure communication is manned and working while persons are in the tunnel.

C. Water Service:

1. Furnish, install and maintain a temporary water system throughout the construction period needed for drinking, construction, sanitation, first aid, fire protection and cleaning.
2. Obtain permits and approvals from regulating authorities. Pay fees deposits and connection costs associated with temporary water system.

D. Fire Protection:

1. Furnish, install and maintain a temporary fire protection system throughout the construction period.
2. Furnish, install and maintain temporary portable fire protection equipment throughout the construction period.

E. Sanitary Service:

1. Furnish, install and maintain temporary sanitary facilities and services throughout the construction period.
2. Ensure that separate or single user toilets shall be provided to assure privacy between the sexes.
3. Furnish and maintain the number of enclosed toilet facilities as follows:
 - a. Fewer than 20 employees, one toilet.
 - b. For 20 to 199 employees, one toilet and one urinal per 40 employees.
 - c. For 200 or more employees, one toilet and one urinal per 50 employees.
4. Provide general washing facilities adequate for the number of employees.
5. Provide special washing facilities adequate for the number of employees engaged in the application of paints, coating and other volatile or hazardous materials.

1.2 QUALITY ASSURANCE - Provide products for, and the execution of, the Work of this Section that will satisfy requirements of the NEC, CAL-OSHA, and local codes. Provide products that satisfy requirements of NEMA and are UL-listed.

1.3 SUBMITTALS

A. Refer to Section 01300, Submittals for submittal procedures.

B. Submit Shop Drawings and manufacturer's literature. Show and describe temporary facilities equipment and materials.

C. Submit Shop Drawings with details and layout of temporary installations.

D. Submit a detailed street lighting plan showing the temporary lighting facilities, electrical service location and circuit diagram.

1.4 MEASUREMENT - The Work of this Section will be measured as a unit, acceptably performed.

1.5 PAYMENT will be made under:

Item No. 01000.01 - General Requirements - per lump sum.

PART 2 - PRODUCTS

2.1 ELECTRICAL SERVICE:

A. PROVIDE temporary power and lighting equipment consisting of fixtures, transformers, panelboards, groundings, lamps, switches, poles, conduits, and wiring sized and capable of continuous service and having the capacity adequate to ensure a complete operating system. Comply with NEMA.

B. PROVIDE TEMPORARY EXTENSION CORDS, to supply tools, not longer than 200 feet, except that additional length may be used if equipment will be grounded within 200 feet of tool or power.

C. PORTABLE POWER GENERATORS - Grounded.

2.2 TELEPHONE SERVICE - Provide equipment that is compatible with that of Pacific Bell. Provide weatherproof enclosures for instruments and directories at exterior locations. Telephones may be coinoperated except those at the District or its designee's field office.

2.3 WATER SERVICE - Provide materials and equipment, sanitary and adequate for purposes intended, and satisfying the

requirements of codes and regulations pertaining to temporary water systems. Bottled products may be used if those products comply with codes. Clearly label portable containers having a dispensing tap and used only for drinking water. Provide single service disposable cups and sanitary container for dispensing cups.

2.4 FIRE PROTECTION

- A. Standpipe system and water supply with fire hose of sufficient capacities and pressures required by the local fire jurisdictions.
- B. Twenty-pound, dry chemical type extinguisher having a UL rating as required by Los Angeles City and Los Angeles County codes.
- C. Ten-pound, all-purpose (ABC) dry chemical type extinguishers having a UL rating as required by Los Angeles City and Los Angeles County codes.

2.5 SANITARY SERVICE

- A. Provide Materials and Equipment adequate for the intended purposes, and neither create unsanitary conditions nor violate the codes applicable to temporary sanitary facilities. Enclosures for toilet and washing facilities shall be weatherproof, sightproof, ventilated, and sturdy.
- B. Provide Portable Type Toilet Facilities satisfying the requirements of CAL-OSHA.
- C. Provide Washing Facilities of either temporary lavatories or sheet metal basins having faucets. Furnish soap, single-service paper towels, towel dispenser, and towel receptacle. If paints, coatings, and other volatile or hazardous materials injurious to humans will be applied as part of the Contract, provide washing facilities with warm water of approximately 120°F.

PART 3 - EXECUTION

3.1 ELECTRICAL SERVICE

- A. Installation - Locate products where they will not interfere with material-handling equipment, storage spaces, traffic, and prosecution of the Work. Install products to present a neat and orderly appearance, and be structurally sound. Maintain products in a manner which will ensure continuous electrical service and safe working conditions.

1. Install temporary lighting facilities in station sections, concourses, service rooms, passageways, tunnels, and Work areas in conformance with CAL-OSHA.
 - a. Illuminate each flight of stairs. Provide stairway lighting on circuits separate from other temporary lighting circuits.
 2. Install temporary power facilities framework and mount in space served.
 - a. Provide distribution stations on an average of one for each 20,000 square feet of station or building floor area, nor more than 300 feet maximum distance between any two distribution stations.
 - b. Provide power centers on an average of one for each 10,000 square feet of building area or station floor; locate centers where electricity may be secured with an extension cord not longer than 100 feet.
 - c. Provide power centers on an average of one for each 100 linear feet of subway line.
- 3.2 TELEPHONE SERVICE - Install temporary telephone service in a neat and orderly manner, make structurally and electrically sound, ensure continuous service, and modify, relocate, and extend as Work progress requires. Place conduit and cable where those products will not interfere with traffic, work areas, materials, handling equipment, storage areas, and Work of other District contractors. Service lines may be aerial. Post telephone numbers and locations of emergency facilities including, but not limited to, emergency hospitals, physicians, ambulance service, and police and fire departments in conspicuous locations at the worksite, and at telephone locations.
- 3.3 WATER SERVICE
- A. Install the systems in a neat and orderly manner. Make them structurally and mechanically sound. Provide continuous service. Modify, relocate, and extend the systems as Work progresses.
 - B. Locate systems where they will be convenient to Work stations, sanitary facilities, and first-aid station but will not interfere with traffic, Work areas, materials handling equipment, storage areas, or the Work of other contractors.
 - C. Provide sanitary bubbler drinking fountains, if portable water service is available. Disinfect water piping before using for the potable water service.

- D. Install vacuum breakers, backflow preventers, and similar devices in a manner and location which will prevent temporary water from returning to the water mains.
- E. Do not incorporate any part of temporary water distribution system into the permanent water distribution system.

3.4 FIRE SERVICE

- A. Install products in conformance with CAL-OSHA requirements.
 - 1. Provide fire extinguishers and fire water supply accessible, functional, and clearly identified during period of construction, remaining until permanent fire protection systems are functional.
 - 2. Furnish not less than one ten-pound, all-purpose (ABC) dry chemical fire extinguisher within ten feet of cutting and welding operations.
 - 3. Provide portable 20-pound, dry chemical type fire extinguishers, excepting those to be kept within ten feet of cutting and welding operations.
- B. Instruct construction personnel as to location and use of temporary fire protection equipment.

3.5 SANITARY SERVICE

- A. Installation - Place temporary sanitary and washing facilities in a neat and orderly manner within the limits of the Work and convenient to the Work stations. Make these facilities structurally and mechanically sound. Anchor them to prevent dislocation and conceal them from public observation. Modify, relocate, and extend the facilities as required by progress of the Work.
- B. Service toilets at hose time intervals which will minimize the accumulation of wastes and prevent creation of unsanitary conditions but not less than once a week.
- C. Connect washing facilities to public sanitary sewer.

END OF SECTION

SECTION 01505

MOBILIZATION

PART 1 - GENERAL

- 1.1 DESCRIPTION - The Work specified in this Section consist of preparatory work and operations, including, but not limited to, those necessary for the movement of personnel, equipment, supplies, and incidentals to the project site; for the establishment of all offices, buildings and other facilities necessary for work on the project; and for all other work and operations which must be performed or costs incurred prior to beginning work on the various contract items on the project site.
- 1.2 QUALITY ASSURANCE - The District or its designee will have the right to reject construction tools, equipment, materials, and supplies which are, in its opinion, unsafe, improper, or inadequate. Bring rejected construction tools, equipment, materials, and supplies to acceptable condition or remove from jobsite.
- 1.3 SUBMITTALS
 - A. Refer to Section 01300 for submittal procedures.
 - B. In accordance with Section 01342, Working Drawings submit within seven days after effective date of Notice to Proceed, a layout of the construction site including fences, roads parking, buildings and storage areas.
- 1.4 DELIVERY to the jobsite of construction tools, equipment, materials, and supplies shall be accomplished in conformance with local governing regulations.
- 1.5 MEASUREMENT - The Work of this Section will be measured as a unit, acceptably performed and will include accumulating tools, apparatus, equipment, materials, and personnel, and manning the Contract.
- 1.6 PAYMENT will be made under Item 01505.01 Mobilization, as follows:
 - A. When the monthly partial payment estimate of the amount earned, not including the amount earned for mobilization, is five percent or more of the original contract amount, 50 percent of the contract item price for mobilization or five percent of the original contract amount whichever is the lesser, will be included in said estimate for payment.

- B. When the monthly partial payment estimate of the amount earned, not including the amount earned for mobilization, is 10 percent or more of the original contract amount, the total amount earned for mobilization shall be 75 percent of the contract item price for mobilization or 7.5 percent of the original contract amount, whichever is the lesser, and said amount will be included in said estimate for payment.
- C. When the monthly partial payment estimate of the amount earned, not including the amount earned for mobilization, is 20 percent or more of the original contract amount, the total amount earned for mobilization shall be 95 percent of the contract item price for mobilization or 9.5 percent of the original contract amount, whichever is the lesser, and said amount will be included in said estimate for payment.
- D. When the monthly partial payment estimate of the amount earned, not including the amount earned for mobilization, is 50 percent or more of the original contract amount, the total amount earned for mobilization shall be 100 percent of the contract item price for mobilization or 10 percent of the original contract amount, whichever is the lesser, and said amount will be included in said estimate for payment.
- E. The contract lump sum price paid for mobilization shall include full compensation for furnishing all labor, materials, tools, equipment, and incidentals, and for doing all the Work involved in mobilization as specified herein.

PART 2 - PRODUCTS

- 2.1 PROVIDE CONSTRUCTION TOOLS, equipment, materials, and supplies of the type and quantities which will facilitate the timely execution of the Work and conform to the requirements of the California Administrative Code and the Los Angeles City Code.

PART 3 - EXECUTION

- 3.1 PROVIDE PERSONNEL, products, construction materials, equipment, tools, and supplies at the jobsite at the time they are scheduled to be installed or utilized.
- 3.2 PLANT LOCATION - Locate, plant or plants, appropriately close to the portion of the Work for which it will be used.
- 3.3 DEMOBILIZATION - Upon completion of the Work, remove construction tools, apparatus, equipment, unused materials and supplies, plant, and personnel from the jobsite.

END OF SECTION

SECTION 01518

TEMPORARY VENTILATION

PART 1 - GENERAL

1.1 DESCRIPTION - The Work specified in this Section consists of providing, operating, and maintaining temporary ventilation systems in open or enclosed areas through the construction period, in accordance with CAL-OSHA requirements and of removing those systems at the completion of the construction period.

A. Modify temporary ventilation systems as the Work progresses to ensure adequate ventilation to satisfy health regulations for safe working environment, and allow beneficial occupancy of the Contract, or portions thereof, until completion of the Work.

B. Prevent hazardous accumulations of dusts, fumes, mists, vapors, and gases in spaces or, open areas occupied during construction by positive ventilation. Ventilate adequately for the curing of installed materials, regulating humidity, and ventilating of temporary sanitary facilities.

1. Prevent ventilation exhaust from dispersing hazardous substances into occupied spaces.

2. Dispose of exhaust materials in a manner which will not be detrimental to persons or the environment.

3. Ventilate storage spaces containing hazardous and volatile materials.

4. Ventilate:

a. When personnel occupy a space that is subject to hazardous accumulations of harmful elements.

b. After personnel have vacated the space, and until offensive odors, foul air, and toxic gases have been removed.

c. When installed products are curing and drying.

1.2 SUBMITTALS - Refer to Section 01300, Submittals for submittal procedures. Submit working drawing with layout and details of temporary ventilation system.

1.3 JOB CONDITIONS

A. Permits for right-of-entry into structures, and for right-to-support, will be obtained from property owner and paid for by the District.

B. Underground easements required to install tie-backs will be secured by the District.

1.4 MEASUREMENT - The Work of this Section will be measured as a unit, acceptably performed, including installing, operating, maintaining, and removing system.

1.5 PAYMENT will be made under:

Item No. 01000.01 - General Requirements - per lump sum.

PART 2 - PRODUCTS

2.1 MATERIALS - Provide materials, new or used, adequate for purposes intended and satisfying requirements of codes and regulations pertaining to temporary ventilation. Patented specialty products may be used if those products comply with codes applicable to temporary heat and ventilation.

2.2 FACILITIES - Provide facilities, including wiring, controls, and ducting satisfying requirements of codes and regulations pertaining to temporary ventilation.

PART 3 - EXECUTION

3.1 REQUIREMENTS OF REGULATORY AGENCIES - Satisfy utility company regulations, and federal, state, and Local codes, pertaining to temporary ventilation systems. Conform to the requirements of the California Administrative Code (CAC), Title 8, Sections 8400 through 8500.

3.2 TEMPORARY VENTILATION SYSTEMS - Install temporary ventilation systems in a neat and orderly manner; make structurally, mechanically, and electrically sound; ensure safe, continuous service at required times; and modify and extend as Work progresses, ensuring air movement. Install system where it will not interfere with, and will not be a hazard to, the Work, movement of personnel, traffic, materials handling, storage areas, finishes, or the Work of other District contractors.

3.3 PERMANENT VENTILATION SYSTEMS - Do not use permanent ventilation system for temporary ventilation, unless otherwise permitted by the District or its designee.

3.4 GAS MONITORING

- A. Perform air sample analyses in the detail, and the frequencies required by CAL-OSHA.
- B. Operate, and maintain the gas monitoring system and the ventilation system required by CAL-OSHA if hazardous gas levels are found.
- C. Maintain a leased telephone line for the gas monitoring system to report to the Los Angeles Fire Department.
- D. If a warning or alarm level annunciation is received, be prepared to provide additional ventilation. Provide for installation and use of standby fans that can be run in parallel with the main fans.
- E. Retain the services of a qualified person, certified by the California Division of Industrial Safety as a Gas Tester to monitor the air for dangerous and explosive conditions by test means acceptable to the Division and the District or its designee.

END OF SECTION

SECTION 01540

SECURITY

PART 1 - GENERAL

- 1.1 DESCRIPTION - The Work specified in this Section consists of furnishing security for the worksite.
- 1.2 QUALITY ASSURANCE - Provide full-time, trained, and bondable guards who are employees of an insured, and state-licensed guard and patrol service.
- 1.3 SUBMITTALS
 - A. Refer to Section 01300, Submittals for submittal procedures.
 - B. Submit the staffing program of the security patrol and the plan for patrol deployment.
 - C. Submit guard certifications in accordance with Section 01322, Certifications and Reports.
- 1.4 MEASUREMENT - The Work of this Section will be measured as a unit, acceptably performed.
- 1.5 PAYMENT will be made under:

Item No. 01000.01 - General Requirements - per lump sum.

PART 2 - PRODUCTS

- 2.1 GUARDS - Trained, licensed, armed, uniformed, and equipped with a portable, two-way radio.
- 2.2 RADIOS - Provide units having the same frequency band range as security headquarters' radio.

PART 3 - EXECUTION

- 3.1 SECURITY PATROL - Provide the surveillance required to prevent unauthorized persons from entering worksite or storage areas during nonworking hours, holidays and weekends. Protect the Work from trespass and the products stored from theft and vandalism. Notify the District and local police of actual and attempted thefts, vandalism, and trespass.
- 3.2 SECURITY SURVEILLANCE - Terminate security surveillance upon the District's written acceptance of the Contract. Suspension of Work, for any cause, will not relieve the Contractor

from his responsibility for security of the Work, materials,
and equipment.

END OF SECTION

SECTION 01545

WORKSITE SAFETY REQUIREMENTS

PART 1 - GENERAL

1.1 DESCRIPTION - The Work specified in this Section consists of furnishing and utilizing trained personnel and safety equipment, furnishing, operating, and maintaining safety aids on the construction equipment, as indicated. Compliance with the requirements of this Section shall not relieve the Contractor from other obligations imposed elsewhere in the Contract, by law and by regulation.

1.2 QUALITY ASSURANCE

A. Construction Equipment and Tools - Selection and operation parameters for construction equipment and tool shall meet CAL-OSHA requirements and the requirements of the SCRTD Safety and Security Manual.

B. Train personnel and provide equipment for an emergency response team, to be available on site, during all periods of active tunneling where gas is suspected to be present.

1.3 SUBMITTALS

A. Refer to Section 01300 for submittal procedures.

B. Submit training procedures and equipment list for emergency response team.

1.4 MEASUREMENT - The Work of this Section will be measured as a unit, acceptably performed.

1.5 PAYMENT will be made under:

Item No. 01000.01 - General Requirements - per lump sum.

PART 2 - PRODUCTS

2.1 CONSTRUCTION AND SAFETY EQUIPMENT - Selected by the Contractor and acceptable to the District or its designee.

2.2 TESTING EQUIPMENT - Conform testing equipment to the requirements for the California Administrative Code (CAC), Title 8, Division of Industrial Safety, unless indicated otherwise.

PART 3 - EXECUTION

- 3.1 SHORING - Excavate using shoring under the immediate supervision of a person having authority to modify the shoring system and the Work methods to provide greater safety. Frequently examine materials being excavated and cause shoring system and Work methods to be improved to the extent that workmen will be protected from moving material.
- A. Do not remove parts of shoring system until steps have been taken to avoid hazard to workmen. If a newly-installed masonry or concrete wall will be relied upon for that protection, wall must have attained a strength which will restrain resulting earth pressures.
 - B. Do not extend adjustment screws on cross braces and trench jacks beyond limits stipulated in cross-brace and trench jack manufacturers' printed recommendations or two-thirds of threaded length.
 - C. Do not allow persons to climb upon or Work from crossbracing.
- 3.2 PERSONAL SAFETY EQUIPMENT - Meet CAL-OSHA and the SCRTD Safety and Security Manual requirements.
- 3.3 BLASTING - Meet CAL-OSHA and the SCRTD Safety and Security Manual requirements.
- 3.4 GAS MONITORING - Meet CAL-OSHA and the SCRTD Safety and Security Manual requirements.
- 3.5 EMERGENCY RESPONSE TEAMS - Meet CAL-OSHA and the SCRTD Safety and Security Manual requirements.

END OF SECTION

SECTION 01546

FIRST AID FACILITIES

PART 1 - GENERAL

- 1.1 DESCRIPTION - The Work specified in this Section consists of furnishing, installing, and maintaining, throughout the construction period, first aid facilities, and services.
- 1.2 SUBMITTALS
- A. Refer to Section 01300, Submittals for submittal procedures.
- B. Submit location, layout and list of first aid equipment for first aid facility.
- 1.3 MEASUREMENT - The Work of this Section will be measured as a unit, acceptably performed.
- 1.4 PAYMENT will be made under:
- Item No. 01000.01 - General Requirements - per lump sum.

PART 2 - PRODUCTS

- 2.1 FIRST AID STATION - A heated and ventilated enclosure of approximately 100 square feet identified by an emblem and letters not less than six inches high, maintained between 68°F and 72°F with general illumination of 50 foot candles at three feet above the floor. Area to be used to provide minor medical and surgical services during construction period.
- 2.2 FIRST AID KITS - Conforming to CAL-OSHA requirements.
- 2.3 HARD HATS - Painted white with a red cross and red letters "FIRST AID" on the front and back.
- 2.4 STRETCHERS - One for every 25 persons on the site but not less than two.
- 2.5 TELEPHONE - A minimum of one instrument posted with the numbers of local emergency units and hospitals.

PART 3 - EXECUTION

- 3.1 INSTALLATION - Install the First Aid Station adjacent to a public thoroughfare.

- 3.2 SIGNAGE - Erect "FIRST AID" sign so that it is visible from all parts of the work site.
- 3.3 FIRST AID KITS - Provide one First Aid Kit, as described above, for each 25 persons on the site.
- 3.4 STRETCHERS - Provide stretchers where they are easily accessible.
- 3.5 FIRST AID PERSON - Provide one First Aid person trained and certified by the U.S. Bureau of Mines or the American Red Cross for each 25 persons on the site.

END OF SECTION

SECTION 01566

POLLUTION CONTROLS

PART 1 - GENERAL

- 1.1 DESCRIPTION - The Work specified in this Section consists of either minimizing or eliminating noise, air pollution, and water pollution caused by the construction activities.
- 1.2 MEASUREMENT - The Work of this Section will be measured as a unit, acceptably performed.
- 1.3 PAYMENT will be made under:
Item No. 01000.01 - General Requirements - per lump sum.

PART 2 - PRODUCTS

- 2.1 WATER - Potable or non-potable
- 2.2 CHEMICAL palliatives
- 2.3 ASPHALT palliatives

PART 3 - EXECUTION

3.1 NOISE CONTROL

- A. Conduct construction activities in such a manner that the noise levels 200 feet from the construction limits or at the nearest affected building, whichever is closer, conform to the following conditions:
 1. Stationary/Continuous Noise - Prevent noise intrusion from stationary sources, and/or parked mobile sources which produce repetitive or long-term noise lasting more than a few hours from exceeding the limits shown on Table 1.
 2. Mobile/Intermittent Noise - Prevent noises from non-stationary mobile equipment operated by a driver or from any source of non-scheduled, intermittent, non-repetitive, short-term noises not lasting more than a few hours from exceeding the limits shown on Table 2.
- B. Special Zone or Special Construction Site
 1. In areas outside of Construction Limits but for which the Contractor has obtained designation as a Special

Zone or Special Construction Site from the agency having jurisdiction, the noise limitations for buildings in industrial areas apply.

2. In zones designated by the local agency having jurisdiction as a special zone or special premise or special facilities, such as hospital zones, the noise level and working time restrictions imposed by the agency shall apply. These zones and work hour restrictions shall be obtained by the Contractor from the local agency.
- C. Use only equipment meeting the noise emission limits listed in Table 3, as measured at a distance of 50 feet from the equipment in substantial conformity with the provisions of the latest revisions of SAE J366b, (Society of Automotive Engineers (SAE) 1973, "Exterior Sound Level for Heavy Trucks and Buses".) SAE J88, (SAE, 1979, "Exterior Sound Level Measurement Procedure for Earthmoving Machinery".) and SAE J952b (SAE, 1973, "Sound Levels for Engine Powered Equipment".) (SAE, 1973a,b,1979) or in accordance with the measurement procedures specified herein.
 - D. In no case expose the public to construction noise levels exceeding 90dB(A) (slow) or to impulsive noise levels with a peak sound pressure level exceeding 140 dB as measured on an impulse sound level meter or 125 dB(C) maximum transient level as measured on a general purpose sound level meter on "fast" meter responses.
 - E. Notwithstanding the specific noise level limitations specified herein, utilize the noise mitigation measures listed below in order to minimize, to the greatest extent feasible, the noise levels in the following areas:
 1. Inside Construction Limits:
 - a. Use of alternative procedures of construction and selection of the proper combination of techniques that would generate the least overall noise and vibration. Such alternative procedures include, but are not limited to, the following:
 - 1) Using a Tunnel Boring Machine in place of conventional blasting techniques as a method of excavation.
 - 2) Using welding instead of riveting.
 - 3) Mixing concrete offsite instead of onsite.
 - 4) Employing prefabricated structures instead of assembling them onsite.

- b. Use of construction equipment modified to dampen noise and/or vibration emissions, such as:
 - 1) Using electric instead of diesel-powered equipment.
 - 2) Using hydraulic tools instead of pneumatic impact tools.
 - 3) Using drilled piles or vibratory pile drivers instead of impact pile drivers.
 - 4) Utilizing "time-delay" charges instead of "instantaneous" charges, where drill and blast techniques must be used and the TBM is impractical.
- c. Maximize the physical separation, to the extent feasible, between noise generators and noise receptors. Such separation includes, but is not limited to, the following measures:
 - 1) Selection of truck routes for muck disposal so that the noise from heavy duty trucks will have minimal impact on sensitive land uses (e.g., residential). Specific routes and measures for accomplishing this objective have been developed and specified in Disposal of Tunnel and Station Excavation Material (Sedway/Cooke, 1983).
 - 2) Providing enclosures for stationary items of equipment and barriers around particularly noisy areas on the site or around the entire site.
- d. Minimize noise-intrusive impacts during the most noise sensitive hours. Some of the key techniques used for this purpose could be as follows:
 - 1) Plan noisier operations during times of highest ambient levels.
 - 2) Keep noise levels at relatively uniform levels; avoid peaks and impulse noises.
 - 3) Turn off idling equipment.

2. Outside Construction Limits:

- a. Utilize shields, impervious fences or other physical sound barriers to inhibit transmission of noise.
- b. Utilize sound-retardant housings or enclosures around noise-producing equipment.

- c. Utilize effective intake and exhaust mufflers on internal combustion engines and compressors.
- d. Line or cover hoppers, storage bins and chutes with sound-deadening material.
- e. Do not use air- or gasoline-driven saws.
- f. Conduct truck loading, unloading and hauling operations so that noise and vibration are kept to a minimum.
- g. Route construction equipment and vehicles carrying spoil, concrete or other materials over streets and routes that will cause the least disturbance to residents in the vicinity of the Work.
- h. Site stationary equipment to minimize noise and vibration impact on the community, subject to approval of the District or its designee.
- i. Use vibratory pile drivers or augering for setting piles in lieu of impact pile drivers. If impact pile drivers must be used, their use is restricted to the hours from 8:00 a.m. to 5:00 p.m. weekdays in residential and semi-residential/commercial areas.

3.2 AIR POLLUTION CONTROLS

- A. Burning of wastes is prohibited. Remove scrap and waste material and dispose of in accordance with laws, codes, regulations and ordinances.
- B. Establish and maintain records of the routine maintenance program for all internal combustion engine powered vehicles and equipment used on the project.
- C. Establish regular cycles and locations for washing trucks which haul tunnel spoil from site.
- D. Cover loads of debris (and tunnel spoil).
- E. Water down and sweep streets which have heavy volumes of construction vehicles carrying debris and excavated materials at least daily.
- F. Water down construction sites as needed to suppress dust, especially during handling of excavation spoil or debris or during demolition.
- G. Use construction equipment which has been designed and equipped to prevent or control air pollution in conformance with the most restrictive regulations of the EPA, state and local authorities.

3.3 WATER POLLUTION CONTROLS

- A. Treat wastewater from the construction operation to remove suspended particles and hydrocarbons through settling basins or hydrocarbon separators.
- B. Obtain a National Pollution Discharge Elimination System permit for water discharge where required.
- C. Monitor wastewater discharge to insure it meets standards set by appropriate laws, codes, regulations and ordinances.
- D. Do not discharge pollutants such as chemicals, fuels, lubricants, bitumens, raw sewage, or other harmful wastes into or alongside rivers, streams, and impoundments, nor into channels leading thereto.

TABLE 1

ALLOWABLE SOUND LEVELS OF STATIONARY CONSTRUCTION EQUIPMENT

<u>Affected Structure or Area</u>	<u>Maximum Allowable Intermittent Noise Level, dB(A)</u>	
	<u>Day/time</u> 7:00 AM to 8:00 PM 8:00 PM	<u>Nighttime</u> All other periods including all day Sunday and Legal holidays.
Residential		
single family residence	60	50
along an arterial or in multifamily residential areas, including hospitals	65	55
in semi-residential/com- mercial areas, including hotels	70	60
Commercial	<u>At All Times</u>	
in semi-residential/com- mercial areas, including schools	70	
in commercial areas with no nighttime residency	75	
Industrial		
all locations	80	

TABLE 2

ALLOWABLE SOUND LEVELS OF STATIONARY CONSTRUCTION EQUIPMENT

<u>Affected Structure or Area</u>	<u>Maximum Allowable Intermittent Noise Level, dB(A)</u>	
	<u>Day/time</u> 7:00 AM to 8:00 PM 8:00 PM	<u>Nighttime</u> All other periods including all day Sunday and Legal holidays.
Residential		
single family residence	75	60
along an arterial or in multifamily residential areas, including hospitals	80	65
in semi-residential/com- mercial areas, including hotels	85	70
Commercial	<u>At All Times</u>	
in semi-residential/com- mercial areas, including schools	85	
in commercial areas with no nighttime residency	85	
Industrial		
all locations	90	

TABLE 3

NOISE EMISSION LIMITS ON CONSTRUCTION NOISE

<u>TYPE OF EQUIPMENT</u>	<u>MAXIMUM NOISE LIMIT</u>	
	<u>Date Equipment Acquired</u> Before <u>Jan. 1, '83</u>	<u>On or After</u> <u>Jan. 1, '83</u>
Equipment other than highway trucks; including hand tools and heavy equipment	90 dB(A)	85 dB(A)
Highway trucks in any operating mode or location	83 dB(A)	80 dB(A)

NOTE: California Motor Vehicle Law has been relaxed. Highway trucks purchased on or after January 1, 1986 must meet 80 dB(A) maximum noise level.

END OF SECTION

SECTION 01580

TEMPORARY SIGNS

PART 1 - GENERAL

- 1.1 DESCRIPTION - The Work specified in this Section consists of furnishing, installing, maintaining, and removing one general construction sign, one United States DOT construction sign, one District field office sign, and one safety sign as delineated.
- 1.2 QUALITY ASSURANCE - Signs shall be painted by a professional sign painter.
- 1.3 MEASUREMENT - The Work of this Section will be measured as a unit, acceptably performed.
- 1.4 PAYMENT will be made under:
- Item No. 01000.01 - General Requirements - per lump sum.

PART 2 - PRODUCTS

2.1 SIGNS

- A. Panel - New 3/4 inch, five-ply, exterior type, APA plywood with inset hardwood edges with mitered corners.
- B. Frame and cleats - New, construction grade lumber.
- C. Posts - Pressure preservative treated, new, construction grade lumber.
- 2.2 HARDWARE - Brass, aluminum, or galvanized steel, of sizes and types which will enable sign assemblies to resist a wind velocity of 50 mph.
- 2.3 SAFETY SIGN NUMBER TAGS - Removable aluminum or galvanized steel, with four inch high, blue numerals and steel tag hooks.
- 2.4 PAINT - Primer and exterior, semi-gloss, alkyd enamel; GWS.
- 2.5 LETTERING - Typeface size and spacing as indicated on attachments in this section.

PART 3 - EXECUTION

- 3.1 INSTALLATION OF POSTS - Set posts in the ground, fill the annular space with soil, and tamp to compact the soils

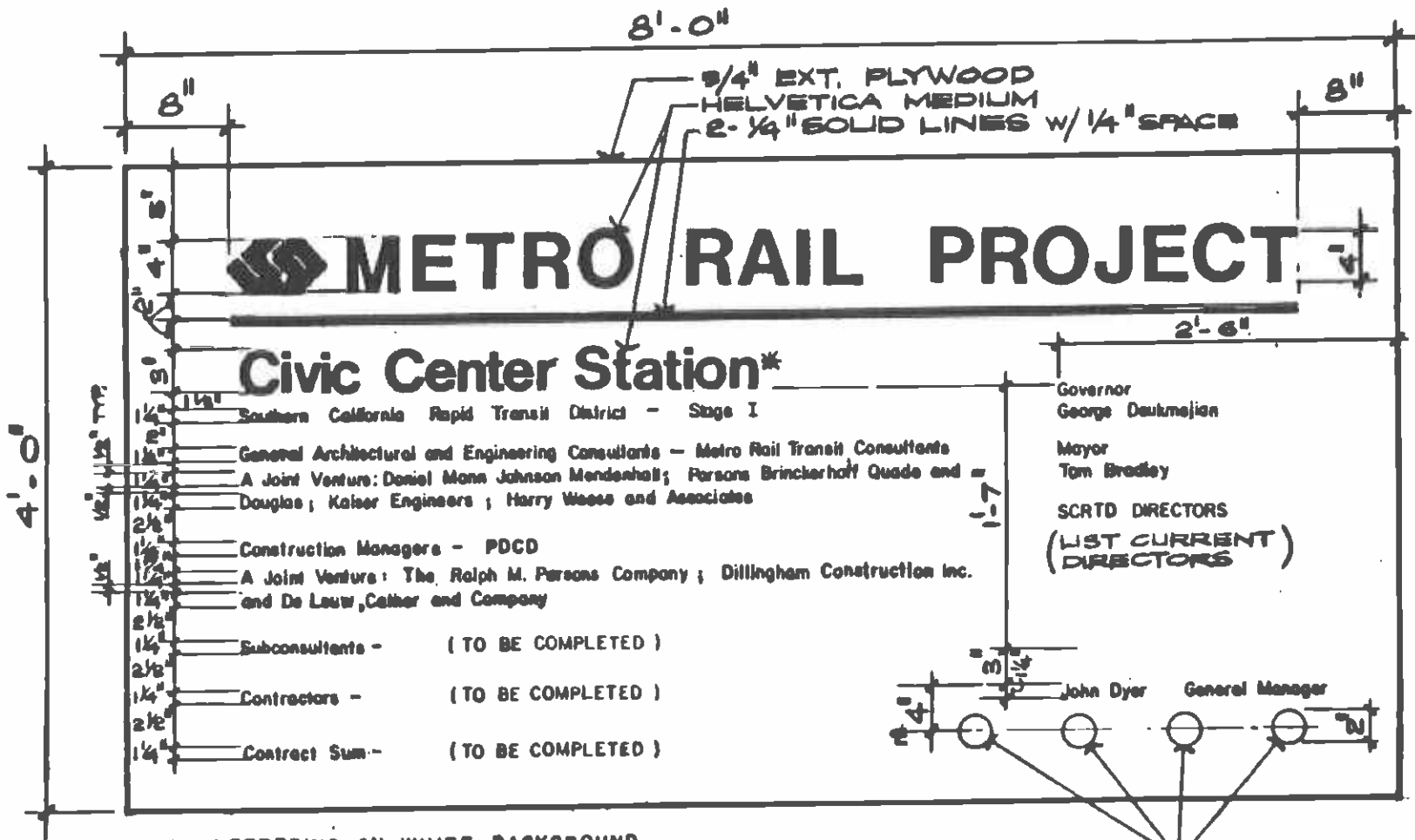

BLACK LETTERING ON WHITE BACKGROUND.
 RTD LOGO SHALL BE RED, THE L.A. CITY, L.A. COUNTY TRANSPORTATION
 COMMISSION, STATE OF CALIFORNIA AND U.S. DEPARTMENT OF TRANSPORTATION
 SEALS ARE IN COLOR.
 THE DISTRICT SHALL PROVIDE COLOR SAMPLES OF LOGO AND SEALS.

* TO BE COMPLETED ON A SITE SPECIFIC BASIS

GENERAL CONSTRUCTION SIGN

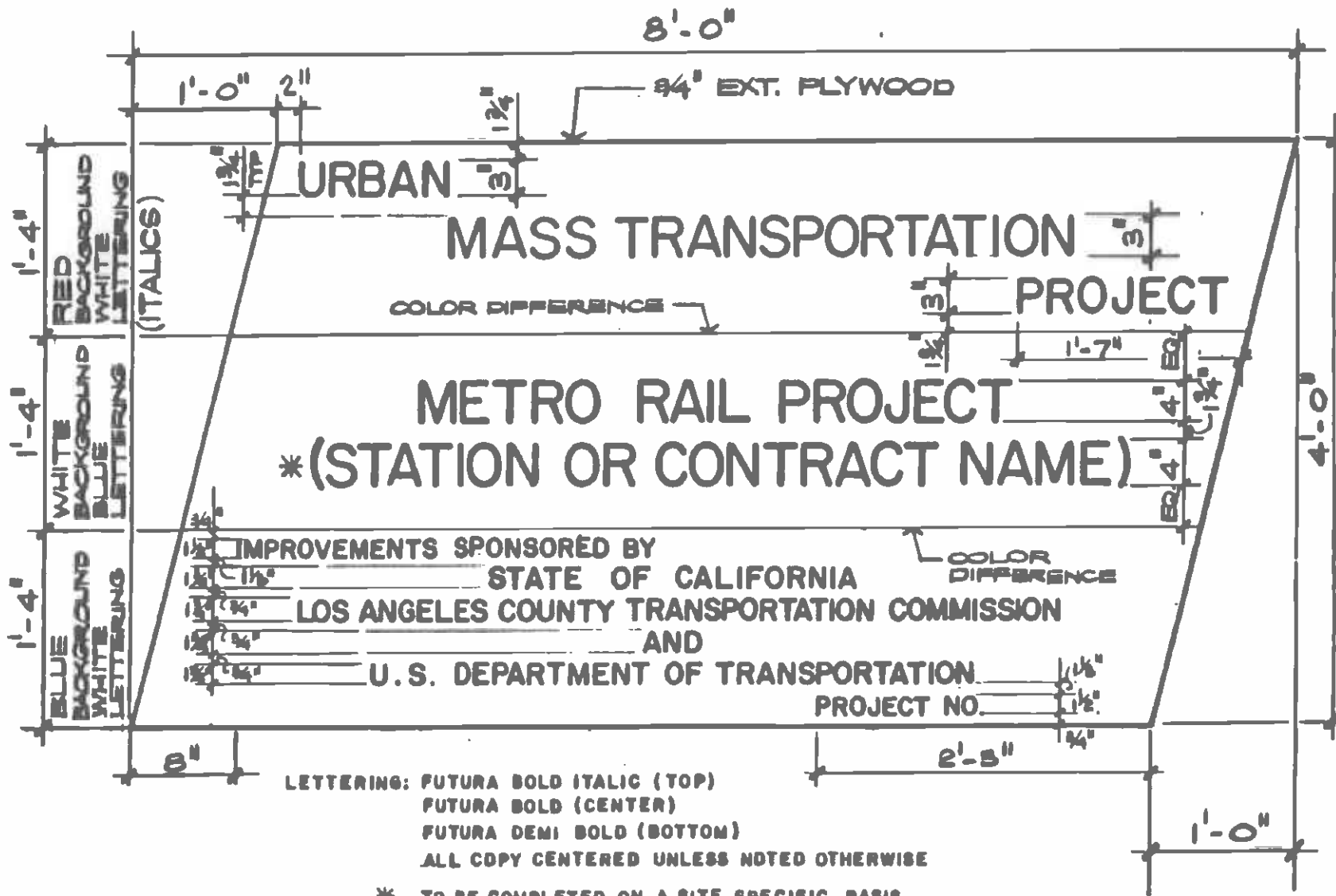

U. S. D. O. T. C O N S T R U C T I O N S I G N

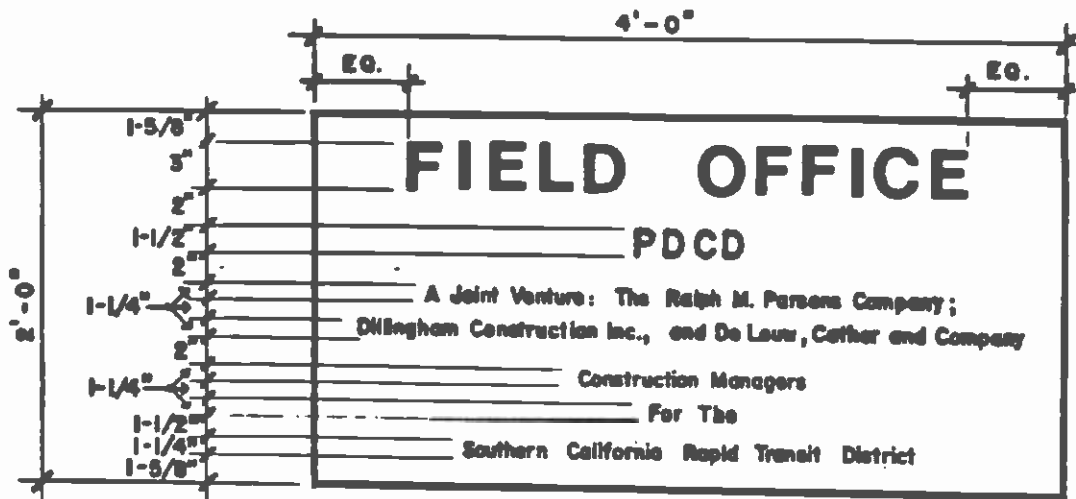

LETTERS SHALL BE HELVETICA MEDIUM, AND SHALL BE PANTONE - PROCESS BLUE. BACKGROUND SHALL BE WHITE. ALL COPY SHALL BE CENTERED

DISTRICT FIELD OFFICE SIGN

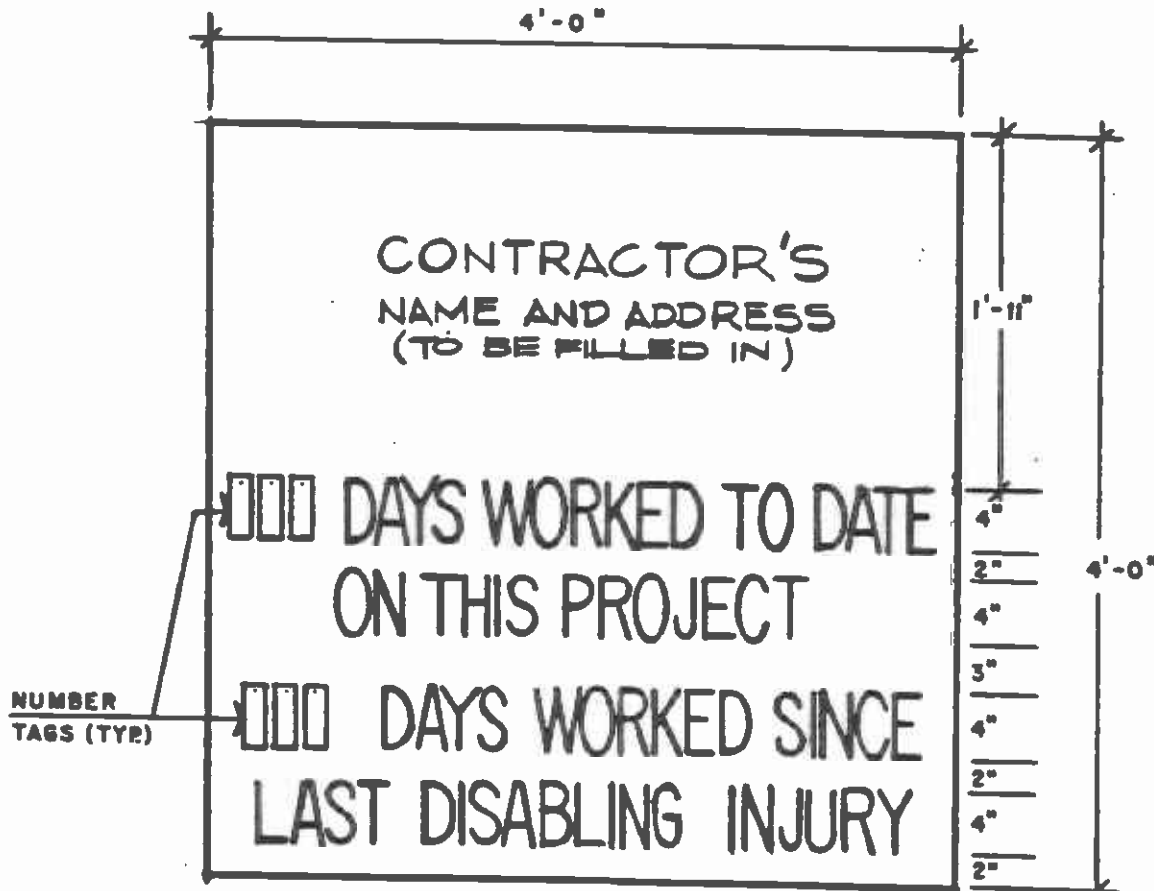

LETTERS SHALL BE NEWS GOTHIC, AND SHALL BE PANTONE - PROCESS BLUE. BACKGROUND SHALL BE WHITE. ALL COPY SHALL BE CENTERED

SAFETY SIGN

END OF SECTION

SECTION 01620

STORAGE AND PROTECTION

PART 1 - GENERAL

1.1 DESCRIPTION - The Work specified in this Section consists of providing storage and protection of the materials, products, and supplies which are to be incorporated into the construction; providing storage for the Contractor's construction tools, supplies, and equipment; and indicating such storage areas on a Shop Drawing; and the locations and dates when such areas will be available for each purpose.

1.2 SUBMITTALS

A. Refer to Section 01300, Submittals for submittal procedures.

B. Shop Drawings showing locations of storage areas not indicated on the Contract Drawings. Do not locate storage areas in dedicated streets, within the drip line of shrubs and trees indicated to remain, in pedestrian ways, or on private property without approval by the property owner.

C. Submit descriptions of proposed methods for storing and protecting products.

1.3 MEASUREMENT - The Work of this Section will be measured as a unit, acceptably performed.

1.4 PAYMENT will be made under:

Item No. 01000.01 - General Requirements - per lump sum.

PART 2 - PRODUCTS

2.1 MATERIALS required for the storage and protection of the items specified shall be durable, weatherproof, and either factory finished or painted to present an acceptable appearance.

PART 3 - EXECUTION

3.1 PALLETIZE materials, products, and supplies which are to be incorporated into the construction, and store off the ground, only in those areas which are shown as storage areas on the Contract Drawings and on the reviewed and accepted Shop Drawings. Store these items in a manner which will prevent damage and which will facilitate inspection. Leave

seals, tags, and labels intact and legible. Maintain access to products to allow inspection. Protect products which would be affected by adverse environmental conditions.

A. Do not stack lumber higher than eight feet in unsecured areas. Conform to CAL-OSHA requirements. Periodically inspect stored products to ensure that products are being stored as stipulated and that they are free from damage and deterioration.

B. Do not remove items from storage until they are to be incorporated into the Work.

3.2 STORAGE - Store the Contractor's construction tools, supplies, and equipment which are not to become a part of the owner's property only in areas indicated on the Contract Drawings and on the reviewed and accepted Shop Drawings. Store said items in a manner which will prevent damage to the Owner's property. Do not store hydraulic fluids, gasoline, liquid petroleum, gases, explosives, diesel fuel, and other flammables in excavations, except one day's supply of diesel fuel may be stored in open excavations.

3.3 LABELS - Storage Cabinets and Sheds which will contain flammable substances and explosive substances FLAMMABLE---KEEP FIRE AWAY and NO SMOKING with conspicuous lettering and conforming to CAL-OSHA requirements.

END OF SECTION

SECTION 01630

SUBSTITUTIONS

PART 1 - GENERAL

1.1 DESCRIPTION - The Work specified in this Section consists of preparing, submitting, amending, and updating lists of products or methods of construction which the Contractor proposes to furnish and install in lieu of those shown or specified.

1.2 SUBMITTALS

A. Refer to Section 01300, Submittals for submittal procedures.

B. Submit documentation on materials, products, and supplies which are proposed for substitution of the items shown on the Contract Drawings or in the Contract Specifications.

C. Submit documentation on the methods of construction which are proposed for substitution of the methods indicated or implied on the Contract Drawings or in the Contract Specifications.

D. Submit redesign, when required, for acceptance of substitution.

1.3 MEASUREMENT - The Work of this Section will be measured as a unit, acceptably performed.

1.4 PAYMENT will be made under:

Item No. 01000.01 - General Requirements - per lump sum.

PART 2 - PRODUCTS

2.1 Proposals for substitutions.

PART 3 - EXECUTION

3.1 REQUEST FOR SUBSTITUTION - The list of materials, products, and supplies and the list of methods of construction for substitution of those shown or specified will be considered only if those requests have been submitted as set forth in Section 01300, Submittals. Acceptance of substitute items or methods will be only for characteristics and the use named in the acceptance. This acceptance will not be interpreted as a modification of Contract Specifications or Contract Drawings, nor to establish acceptance of products and

methods for other portions of the District's System. Acceptance of a substitution does not relieve the Contractor of the responsibility of fulfilling the requirements of the Contract Documents. The District or its designee will be the sole judge of quality and suitability of substitute items or methods and its decision is final. If the use of substitute products or methods involves redesign of other parts of the Work, the cost required to effect that redesign will be charged to Contractor. Perform the redesign and submit for acceptance by the District or its designee. The direct cost of evaluating substitutions by the District or its designee will be borne by the Contractor.

A. Include with the documentation for materials, products, and supplies the following information:

1. Complete data substantiating compliance of proposed substitution with requirements of the Contract Drawings and Specifications.
2. Identification of materials, products, or supplies including manufacturer's name, catalog name and number, and the manufacturer's address.
3. Installation characteristics, installation drawings, and manufacturer's literature including product description, performance and test data, and reference standards if pertinent.
4. Name and address of projects on which product was used under similar circumstances, and date of installation.
5. Itemized comparison of proposed substitution with the item specified. Include differences in materials, size, finish, estimated life, estimated maintenance, availability of spare parts and repair services, energy consumption, performance capacity, salvageability, and manufacturer's warranties.
6. Effect of change on Construction Schedule.
7. Accurate cost data for proposed substitution in comparison with product specified.
8. Equitable adjustment and credit Contractor proposes to offer the District.
9. When applicable or requested by the District or its designee, provide off-the-shelf samples of the specified item and the proposed substitution.

B. Certify the following when making request for substitution:

1. The Contractor has personally investigated the proposed item and believes it to be equivalent, or superior, to that shown or specified; and that he will update information as new or different data becomes known to him.
2. The Contractor will furnish the same guarantee for the substitution as he would for product specified.
3. The Contractor will coordinate installation of accepted substitution into the Work, and will make those changes required for the Work to be complete in all respects.
4. The Contractor waives all claims for additional costs, related to the substitution.
5. Cost data are complete, including related costs, except the costs of the District or its designee's redesign.

C. Substitutions indicated, or implied, on Shop Drawings or product data submittal will not be considered unless a request for substitution has been submitted in conformance with this Section.

D. Include in the documentation for construction methods the following information:

1. Detailed description of proposed method.
2. Working drawings illustrating methods.
3. Itemized comparison of proposed substitute methods with the methods shown, with product implied or specified. Include differences in estimated time for execution, labor, materials, revisions to construction process, and cost.

END OF SECTION

SECTION 01710

CLEANING

PART 1 - GENERAL

- 1.1 DESCRIPTION - The Work specified in this Section consists of maintaining a clean, orderly, hazard-free worksite and final cleaning for District's occupancy.
- 1.2 QUALITY ASSURANCE - Accomplish final cleaning by workmen experienced in cleaning operations.
- 1.3 JOB CONDITIONS - Safety Requirements
 - A. Maintain the worksite neat, orderly, and hazard-free until final acceptance of the Work in conformance with the local governmental requirements. Keep catwalks, underground structures, worksite walks, public sidewalks, roadways, and streets, along with public and private walkways adjacent to worksite, free from hazards caused by construction activities. Inspect those facilities regularly for hazardous conditions caused by construction activities.
 - B. Hazards Control
 1. Store volatile wastes in covered metal containers, and remove those wastes from worksite daily.
 2. Do not accumulate wastes which create hazardous conditions.
 3. If volatile and noxious substances are being used in spaces which are not naturally ventilated, provide artificial ventilation.
- 1.4 MEASUREMENT - The Work of this Section will be measured as a unit, acceptably performed.
- 1.5 PAYMENT will be made under:

Item No. 01000.01 - General Requirements - per lump sum.

PART 2 - PRODUCTS

- 2.1 CLEANING MATERIALS - Utilize the type of cleaning materials recommended by the manufacturer of the surfaces to be cleaned.

PART 3 - EXECUTION

3.1 INTERIM CLEANING

- A. Clean the worksite every workday during the construction of the Contract. Maintain structures, grounds, and other areas of worksite, including public and private properties immediately adjacent to worksite, free from accumulations of waste materials caused by construction operations. Place waste materials in metal containers.
- B. Remove or secure loose material on open decks and on other exposed surfaces at the end of each workday, or more often, in a manner which will maintain the worksite hazard-free. Secure material in a manner which will prevent dislodgement by wind and other forces.
- C. Sprinkle waste materials with water or acceptable chemical palliative, to prevent blowing of dust.
- D. Promptly empty waste containers when they become full and legally dispose of the contents at dumping areas off the District's property.
- E. Vacuum clean interior building surfaces to be painted. Vacuum clean on an as-needed basis, as determined by the District or its designee, until structure is ready for the District's occupancy.
- F. Control the handling of waste materials. Do not permit materials to be dropped or thrown from structures.
- G. Immediately remove spillages of construction-related material from haul routes.
- H. Clean only when dust and other contaminants will not precipitate upon newly painted surfaces.

3.2 FINAL CLEANING

- A. Inspect interior and exterior surfaces, including concealed spaces, in preparation for substantial completion and occupancy.
 - 1. Remove dirt, dust, litter, corrosion, solvents, discursive paint, stains, and extraneous markings.
 - 2. Wash and polish glass, metal, ceramic, and plastic surfaces.
 - 3. Remove surplus materials, except those materials intended for maintenance.
 - 4. Remove tools and equipment used in the construction but not the property of the District or its designee.

5. Remove detachable labels and tags. File them with the manufacturer's specifications for that specific material for the District's records.
6. Repair damaged materials to the specified finish or remove and replace.

END OF SECTION

SECTION 01720

CONTRACT RECORD DOCUMENTS

PART 1 - GENERAL

1.1 DESCRIPTION - The Work specified in this Section consists of annotating and delivering one record copy of full-size Contract Drawings and one Contract Specification Book.

1.2 SUBMITTAL

A. Refer to Section 01300, Submittals for submittal procedures.

B. Submit one copy of full-size Contract Drawings and one copy of the Contract Specification Book which have been marked to indicate the "as-built" conditions of the Contract. Deliver same with a Contractor Transmittal Form indicating the date of transmittal, the Contract title and number, Contractor's name and address, title of each Contract Record Document, and the signature of Contractor (or his authorized representative) attesting that said Documents are a true and complete record of the ramifications of the Contract.

1.3 MEASUREMENT - The Work of this Section will be measured as a unit, acceptably performed.

1.4 PAYMENT will be made under:

Item No. 01000.01 - General Requirements - per lump sum.

PART 2 - PRODUCTS

2.1 DOCUMENTS

A. One full-size set of Contract Drawings.

B. One Contract Specification Book.

PART 3 - EXECUTION

3.1 MARKINGS

A. Mark each page or sheet of the Contract Drawings and Contract Specification Book with "CONTRACT RECORD DOCUMENT."

B. Mark the Contract Drawings and Contract Specification Book to show the "as-built" conditions which deviate from the Contract issue of those documents.

1. Mark the Contract Drawings to show the horizontal location, elevation, and dimensions of each underground or otherwise concealed structure, utility, abandoned cutoff pile, abandoned tieback, subsurface obstruction, and appurtenance not shown on the Contract Drawings or the elevations and dimensions which vary from those indicated. Reference locations and elevations to permanent surface features.
2. Mark the Contract Specification Book to show names of manufacturers, trade names, model number, and style numbers of the installed products.
3. Legibly record the information concurrent with the construction progress. Do not conceal the Work until this information has been recorded.
4. Use felt-tip pens for record marking devices. Mark changes accepted by the District or its designee in green. Mark deviations necessitated by field adjustments in red.
5. Store the Contract Record Documents, during construction, in a fire-resistant lockable cabinet in the Contractor's field office, apart from other documents.

3.2 RECORD DOCUMENTS

- A. Maintain one record copy of all Contract Documents, Shop Drawings, Change Orders and one set of full-size reproducible Contract Drawings at the site. Annotate the reproducible Contract Drawings to indicate the following:
 1. Horizontal and vertical location of underground utilities.
 2. Location of internal utilities and appurtenances concealed in construction referenced to visible and accessible features of the structure.
 3. Field changes of dimension and detail, as changes occur.
 4. Details not on original Contract Drawings.
- B. Stamp all such documents "RECORD DOCUMENTS" and keep available for examination by the District or its designee. Maintain record documents in a clean, dry and legible condition.
- C. Submit a final, corrected, reproducible transparency of each Working Drawing and show the Work as actually installed, placed, erected, and applied.

END OF SECTION

SECTION 01730

OPERATION AND MAINTENANCE DATA

PART 1 - GENERAL

1.1 DESCRIPTION - The Work specified in this Section consists of preparing and submitting operation and maintenance data for mechanical, electrical, and other specified equipment.

1.2 SUBMITTALS

A. Refer to Section 01300, Submittals for submittal procedures.

B. Proposed Operation and Maintenance Data format including a table of contents not less than 90 days prior to acceptance tests and final inspection.

C. Completed Operation and Maintenance Data Manual in final form 30 days prior to acceptance tests and final inspection.

D. Six copies of Operation and Maintenance manual within ten days after acceptance tests and final inspection.

1.3 CONTINUOUS UPDATING PROGRAM - Furnish one copy of letter indicating that suppliers have been notified to provide updated operation and maintenance data, service bulletins, and other information pertinent to the equipment, as it becomes available.

1.4 MEASUREMENT - The Work of this Section will be measured as a unit, acceptably performed.

1.5 PAYMENT will be made under:

Item No. 01000.01 - General Requirements - per lump sum.

PART 2 - PRODUCTS

Products are not required for this Section.

PART 3 - EXECUTION

3.1 GENERAL - Assemble operation and maintenance manual using manufacturer's latest standard commercial data.

3.2 FORMAT

A. Size - 8-1/2 inches by 11 inches

- B. Paper - White bond, at least 20 pound weight
 - C. Text - Printed or typewritten
 - D. Printed Data - Manufacturer's catalog cuts, brochures, operation and maintenance data. Clear reproductions thereof will be acceptable.
 - E. Drawings - 8 1/2 inches by 11 inches, preferably bound in with text. Larger drawings are acceptable, provided they are folded to fit into a pocket inside the rear cover of the manual. Reinforce edges of large drawings.
 - F. Prints of drawings - black on white, sharp in detail and suitable for making reproductions.
 - G. Flysheets - Separate each portion of the manual with colored, neatly prepared flysheets briefly describing contents of the ensuing portion.
 - H. Covers - Provide 40 to 50 mil, clear plastic, front and back covers for each manual.
 - I. Bindings - Conceal the binding mechanism inside the manual; 3-ring binders will be acceptable. Binding is subject to the District or its designee's approval.
- 3.2 CLEARLY IDENTIFY the manual, on or through the front cover, with at least the following information:

OPERATION AND MAINTENANCE INSTRUCTIONS

(TITLE OF STRUCTURE OR FACILITY)

(TITLE AND NUMBER OF CONTRACT)

(ADDRESS)

(City, State)

(General subjects of this Manual)

(Space for signature of the District or its Designee
acceptance date)

3.3 CONTENTS OF THE MANUAL

- A. An index of all volumes, in each volume of multiple volume systems.
- B. An index, in and for each volume. List and combine the literature, for each system, in the sequence of operation.

- C. Name, address, and telephone numbers of Contractor, suppliers, and installers.
- D. Name, address, and telephone numbers of manufacturers' nearest service representatives.
- E. Name, address and telephone number of nearest parts vendor and service agency.
- F. Copy of guarantees and warranties issued to, and executed in the name of, the District.
- G. Anticipated date District assumes responsibility for maintenance.
- H. Description of system and component parts.
- I. Pre-operation check or inspection list.
- J. Procedures for starting, operating, and stopping equipment.
- K. Post operation check or shut down list.
- L. Inspection and adjustment procedures.
- M. Emergency operating instructions.
- N. Accepted test data.
- O. Maintenance schedules and procedures.
- P. One copy of each wiring diagram.
- Q. One copy of each piping diagram.
- R. One copy of each duct diagram.
- S. One copy of each accepted Shop Drawing.
- T. Manufacturer's parts list with catalog names, numbers and illustrations.
- U. An exploded view of each piece of the equipment with part designations.
- V. List of manufacturer's recommended spare parts, price and quantities for two years of operation.
- W. List of special tools and test equipment required for the operation, maintenance, adjustment, testings, and repair of the equipment, instruments, and components.
- X. Scale and corrosion control procedures.

- Y. Dismantling and reassembly instructions.
- Z. Trouble shooting, repair instructions.
- AA. Calibration procedures.
- BB. Ordering information.

END OF SECTION

SECTION 01740

WARRANTIES AND BONDS

PART 1 - GENERAL

- 1.1 DESCRIPTION - The Work specified in this Section consists of preparing and submitting warranties and bonds required by these Specifications.
- 1.2 SUBMITTALS - Refer to Section 01300, Submittals for submittal procedures.
 - A. Blank warranties and bonds for acceptance of form.
 - B. Executed warranties and bonds.
- 1.3 MEASUREMENT - The Work of this Section will be measured as a unit, acceptably performed.
- 1.4 PAYMENT will be made under:
 - Item No. 01000.01 - General Requirements - per lump sum.

PART 2 - PRODUCTS

Products are not required for this Section.

PART 3 - EXECUTION

- 3.1 EXECUTE THE WARRANTIES AND BONDS required by these Specifications in the form accepted by the District or its designee.
- 3.2 PROVIDE WARRANTIES OR BONDS for the materials, labor and time period set forth in the Sections of these Specifications requiring such documents.

END OF SECTION

SECTION 02232

CRUSHED AGGREGATE BASE

PART 1 - GENERAL

1.1 DESCRIPTION - The Work specified in this Section includes furnishing, spreading, and compacting crushed aggregate base to the lines, grades, and dimensions indicated.

1.3 PAYMENT will be made under:

Item No. 02232.01 - Aggregate Base - per cubic yard

The work of this section will be paid for at the Contract unit price per cubic yard of crushed aggregate base placed within the horizontal and vertical limits shown on the Contract Drawings. The price paid for aggregate base will be considered complete compensation for furnishing labor, materials, tools, equipment and incidentals involved in constructing crushed aggregate base, complete as indicated on the Contract Drawings acceptably installed.

PART 2 - PRODUCTS

2.1 PROVIDE, at the time of depositing, Crushed Aggregate Base conforming to the requirements of Sections 200-2.2 of the Standard Specifications for Public Works Construction, 1982 Edition.

PART 3 - EXECUTION

3.1 SPREADING AND COMPACTING - Spread and compact crushed aggregate base in conformance with the requirements of Section 301.2.2 and 301.2.3 of the Standard Specifications for Public Works Construction, 1982 Edition.

3.2 COMPACT each layer of base material to not less than 98 percent relative density, in lieu of 95 percent as stated in Subsection 301.2.3 of the Standard Specifications. Determine relative density by California Tests 216 or 231. Rework aggregate base, not conforming to this requirement, to achieve compliance with the specified requirements.

END OF SECTION

SECTION 02450

GENERAL TRACK CONSTRUCTION

PART 1 - GENERAL

1.1 DESCRIPTION

- A. The Work specified in this Section consists of track construction procedures and requirements that are common to both standard direct fixation and ballasted track, and to direct fixation and ballasted special trackwork, including laying and fastening continuous welded rail, joining rail, anchoring rail, rail grinding, final alignment, inspection, and cleanliness of the site.
- B. All materials required for track construction, unless specified as District Furnished Materials, will be furnished by the Contractor.
- C. The Contractor may propose, in writing to the District or its designee, alternatives for performing the Work specified herein. These alternatives may be used in lieu of the procedures specified herein only if written acceptance of these alternatives has been received from the District or its designee.
- D. Trackwork Definitions - The following abbreviations and terms, with their coinciding definitions, represent the standard glossary of trackwork terms for the District and supplement the definitions contained elsewhere in the Specifications and in the AREA Manual for Railway Engineering. In the event of a conflict between the AREA definition and a definition contained herein, the definition contained herein will apply.
 - 1. Adzed - To cut into the top surface of a tie to provide proper bearing for a tie plate.
 - 2. Anchor:
 - a. Rail Anchor - A track device in ballasted track designed to resist longitudinal rail movement due to traffic and temperature variations.
 - b. Back-Up Anchor - A rail anchor applied to control rail movement during anchoring procedures.
 - c. Box Anchor - To install four rail anchors on the running rails at one tie with two anchors on each rail, one on each side of the tie.

3. Approach Slab - A concrete slab located at interface of ballasted track with direct fixation track to provide a transition from direct fixation track to ballasted track.
4. Ballast - An integral part of the ballasted track structure, composed of crushed stone, in which timber ties are embedded.
5. Bonded Joint - A rail joint that uses high-strength adhesives in addition to bolts to hold rail together. The bonded joint may be insulated or non-insulated.
6. Bumping Post - A device attached to the rail, designed to stop a rail vehicle at the end of a track.
7. Cant - Inward inclination of the running rails, nominally 1:40.
8. Cross Level - The vertical relationship of the top of one running rail to that of the opposite running rail at any point in the track.
9. Crossover:
 - a. Double - Two single crossovers which intersect each other between the two adjacent and generally parallel tracks forming a connection between them. Sometimes referred to as a "diamond" crossover.
 - b. Crossover, Single - Two turnouts, with track located between the frogs and arranged to form a continuous passage between two adjacent and generally parallel tracks.
 - c. Crossing Diamond - A special trackwork assembly consisting of two end frogs and two center frogs that together comprise the central portion of a double crossover.
10. Curve:
 - a. Circular Curve - A horizontal curve defined by the arc definition and specified by a radius.
 - b. Spiral Curve - A transition curve connecting a tangent to a circular curve and defined by the Barnett Spiral.
 - c. Vertical Curve - A parabolic curve connecting different profile grades.
11. Dap - A recess cut into a switch tie to depress the switch machine below the collector shoes of the passenger vehicle.

12. Derail - A device that protects main track by derailing rolling stock, thereby preventing rolling stock from entering or obstructing the track.
13. Direct Fixation Rail Fastener - A resilient device for securing running rail to a concrete trackbed in direct fixation track.
 - a. Rail Clip Assemblies - One or more components of the direct fixation rail fastener used to attach the running rail to the body of the direct fixation rail fastener.
 - b. Anchorage Assemblies - One or more components of the direct fixation rail fastener used to attach the body of the direct fixation rail fastener to a concrete trackbed.
 - c. Anchorage Insert - A component of the Anchorage Assemblies which is embedded in the concrete and is threaded to hold the anchor assembly bolts.
14. Dutchman - A short piece of running rail temporarily placed between the ends of CWR to reduce the damage which would occur to the rail ends as a result of rail mounted track equipment passing over those ends.
15. Electrical Isolation - The electrical resistance required between the running rail and the ground to prevent harmful levels of stray current from the D.C. Traction Power circuit.
16. Floating Slab - A concrete slab supported by a resilient foundation designed to support direct fixation track and special trackwork units in a manner which will dampen noise and vibrations.
17. Grade Crossing - The crossing of a railway track and a vehicular roadway at the same elevation. Conventionally constructed of timber, asphalt, rubber, or concrete.
18. Heartwood Face - The side of a timber tie about which the growth rings are concave.
19. OTM - Other track material. Miscellaneous materials required to complete track construction, other than rail, special trackwork, ties, and ballast.
20. Plate:
 - a. Gauge Plate - A steel plate installed at the switch or the frog to maintain the gauge.

- b. Riser Plate - A steel plate welded to a special switch plate for the purpose of raising the switch rail slightly above the stock rail.
 - c. Special Plate - A steel plate for use in special trackwork designed to replace the AREA standard gauge, switch, heel and hook twin tie plates commonly used under switches and frogs.
21. Pocket Track - A track located between the two main tracks on which a train may lay over or reverse direction.
22. Profile Grade Line (PGL) - The datum line which defines the vertical alignment of the track, applied at the top of the low rail.
23. Rail:
- a. Contact Rail - An electrical conductor, located alongside the track, designed to carry energy for the propulsion of trains.
 - b. Continuous Welded Rail (CWR) - A number of standard length rails welded together into a single length.
 - c. Jointed Rail - Rails with a nominal length of 78 feet or less joined together by means of joint bars and bolts.
 - d. Running Rail - Rail which supports and guides the flanged wheels of the rail vehicle.
 - e. Special Trackwork Rail - Rails in the special trackwork area to be manufactured in a shop rather than fabricated in the field.
 - f. Inside Rail - On curved track, the rail closest to the curve center; the rail with the shorter radius. Sometimes referred to as the "low rail".
 - g. Outside Rail - On curved track, the rail farthest from the curve center; the rail with the longer radius. Sometimes referred to as the "high rail".
24. Rail Brace - A device which provides lateral support on the field side of stock rails to maintain the track gauge.
25. Rail Clamp Assembly:
- a. Rail Clamp - The portion of the rail clamp assembly which secures rails and frog to special plates.

- b. Rail Clamp Block - The portion of the rail clamp assembly which is welded to the special plate.
 - c. Rail Clamp Spring Clip - The portion of the rail clamp assembly which holds the rail or frog to the special plate and which is bolted to the rail clamp block.
26. Rail Field Side - The side of the rail farthest from the center of track.
27. Rail Gauge Side - The side of the rail nearest the center of the track.
28. Rail Stop - A steel plate welded to a special plate to provide lateral restraint to the rail.
29. Roadbed - The earth bed or foundation which supports the ballast, ties and rail of a track structure.
30. Rod:
- a. Front Rod - A rod connecting the switch rails to the lock (detector) rod. (NIC)
 - b. Switch Rod - A rod which connects two switch rails together.
 - c. Operating Rod - A rod connecting the switch rod to the switch operating mechanism.
 - d. Lock Rod - A rod connecting the front rod to the lock mechanism.
31. Sub-Ballast - A material superior in composition to the roadbed material which provides a layer between the track ballast and the roadbed.
32. Superelevation - The design vertical distance that the outer rail is set above the inner rail on a curve.
33. Switch machine - A device for remote controlled mechanical operation of a switch or derail. (NIC)
34. Switch Rail (Switch Point) - A tapered rail which diverts the wheel flanges to the desired track.
35. Tie:
- a. Cross Tie - The transverse member of the ballasted track structure which is centered on the track and holds the rails in position and distributes the rail loads to the roadbed.

- b. Contact Rail Tie - A transverse member of track structure which functions as a cross tie, but also supports the contact rail.
- c. Switch Tie - A transverse member of the track structure which functions as a cross tie, but is longer and supports a crossover or turnout.

36. Track:

- a. Ballasted Track - Track constructed of rail, ties, OTM, and ballast.
- b. Direct Fixation (DF) Track - Track constructed of rail and direct fixation rail fasteners attached to a concrete surface.

37. Zero Thermal Stress Temperature - The temperature at which a string of continuous welded rail will have no stress in it due to thermal expansion or contraction.

E. Traction Power Definitions - The following abbreviations and terms with their coinciding definitions represent the standard glossary of traction power terms for the District.

- 1. Contact Rail System - The positive electrical distribution system for transmission of traction power to the transit vehicles.
- 2. Contact Rail Anchor Assembly - An insulated attachment which retains the contact rail in the longitudinal direction and prevents transmission of longitudinal forces to the insulators.
- 3. Connector Plate - A plate attached to the field side of the contact rail to accommodate connecting of feeder or jumper cables.
- 4. Composite Contact Rail - A steel rail section with an aluminum extrusion secured to each side of the rail web to increase the current carrying capacity of the rail.
- 5. End Approach - Special ramp sections of contact rail used at the ends of contact rail sections to lift the collector shoe to the top of the contact rail or to lower the collector shoe off the contact rail.
- 6. Expansion Joint - An assembly placed in the contact rail to accommodate thermal expansion and contraction of the rail.
- 7. Insulator Mounting Bracket - A bracket used for mounting insulators on concrete ties and at grade slabs.

8. Insulator - A non-conducting body that supports the contact rail.
9. Coverboard - A cover of insulating material secured on top and side of the support bracket to guard against contact by persons or objects.
10. Side Approach - A metal plate attached to the track side of the contact rail to guide the collector shoe to the top of the contact rail or to lower the collector shoe of the contact rail at crossover locations.
11. Support Bracket - An assembly that supports coverboard.

1.2 QUALITY ASSURANCE

A. Quality Assurance Program

1. The Contractor shall establish, implement and maintain a quality assurance program to provide verification of compliance with contract requirements through generation of inspection and test records and related objective evidence. The quality assurance program shall consist of detailed procedures and instructions for monitoring and controlling those activities related to quality during design, fabrication, delivery, handling, storage, assembly, inspection and testing. The areas which the quality assurance program shall address include the following:
 - a. Establishment, review and control of quality procedures and instructions.
 - b. Calibration/certification of measuring and testing of construction equipment.
 - c. Qualification and certification of personnel.
 - d. Control of special processes.
 - e. Inspection (receiving, first article and in-process).
 - f. Test.
 - g. Procurement quality assurance.
 - h. Quality assurance records.
 - i. Identification of inspection status.
 - j. Identification and control of items.
 - k. Handling, delivery and storage.

2. Adequate records shall be maintained by the Contractor in accordance with the requirements of his quality assurance program. These records will provide the objective evidence of compliance with the requirements of the Contract, and shall include the following:
 - a. Evaluation of subcontractors' and suppliers' qualifications and past performance.
 - b. Results of inspections and tests.
 - c. Certificates of compliance.
 - d. Qualified procedures for special processes.
 - e. Personnel certifications.
 - f. Measuring and test equipment calibration certificates.
 - g. Transmittals of contract related information.
3. The appropriate requirements of the Contractor's quality assurance program shall be imposed upon subcontractors and suppliers.
4. The quality assurance activities of the Contractor/subcontractors and suppliers will be subject to District verification at any time. Verification methods include: surveillance of the operations to determine that practices, methods and procedures of the quality assurance program are being properly applied; inspection to measure quality of items awaiting release for shipment; and audits to ensure compliance with Contract requirements.

B. General Requirements

1. Conform to AREA Portfolio of Trackwork Plans and Manual for Railway Engineering except as modified herein.
2. Employ personnel qualified by experience in conventional and special trackwork installation as foremen or leadmen for trackwork installation.
3. Use proper tools and techniques. Any practice liable to damage the track material or existing installations will not be permitted.
4. Use qualified surveyor registered in the State of California to establish and maintain alignment and elevation.
5. Use a creosote treatment for treating field bored holes, cuts and adzes in timber ties.

6. Electrical isolation of the running rail from the concrete invert is essential to contain the returning traction power current within the running rails. Such stray current results in cumulative damage to metallic components of fasteners, transit structures, and facilities outside the transit structures leading to considerable reduction in their service life. Experience indicates that many failures of track to meet required electrical isolation levels are directly related to moisture, dirt, and debris which are present on and around the fastener during track assembly. The site shall be cleaned of miscellaneous materials and contaminants with particular attention given to metallic wires and banding used in component packaging. Materials such as dirt and sand will conduct sufficient electrical current to cause accelerated corrosion of adjacent steel reinforcing and conduits. An unkempt trackway will be indicated by the field quality control tests performed by the District and the Contractor shall correct all deficient trackways.
 7. Do not use electrical conducting lubricants or sealants.
 8. Lubricate with approved lubricants and maintain special trackwork installations until final acceptance by the District.
- C. Equipment - construction equipment to comply with the following:
1. Loading and clearance requirements indicated on Figures 02450-1 and 02450-2, respectively, of this Section.
 2. Use wheel contour and gauge for trackwork equipment which meet the standards of the AAR Mechanical Division.
- D. Tolerances - Allowable deviation from indicated geometric design for trackwork installation is shown on Figure 02450-3.
- E. Reference Standards
1. American Railway Engineering Association (AREA) "Portfolio of Trackwork Plans" and "Manual for Railway Engineering".
 2. West Coast Lumber Inspection Bureau (WCLB) "Standard Grading Rules No. 16".
 3. American Wood-Preservers' Association (AWPA) "Book of Standards".

4. American Society of Testing and Materials (ASTM).
5. American Society for Nondestructive Testing (NSNT).
6. U.S. Army Corps of Engineer.

1.3 WORK PERFORMED BY THE DISTRICT

A. Benchmarks and Horizontal Control Points

1. Bench marks and horizontal control points will be provided by the District or its designee to establish the centerline of the track.
2. The District or its designee will furnish the Contractor with identifications and elevations of bench marks and horizontal control points. Bench marks and horizontal control points damaged by the Contractor will be replaced by the District or its designee at the expense of the Contractor.
3. The use of controls for survey other than those described above is at the Contractor's risk.

B. Electrical Testing

1. Tests of electrical resistance and continuity will be performed by the District or its designee at no cost to the Contractor.
2. The following items will be electrically tested:
 - a. Insulated joints (bonded) - Minimum resistance, 10^7 ohms each.
 - b. Running rail continuity - Maximum resistance, .010 ohms per 1000 feet at 20°C.
 - c. Contact rail continuity - Maximum resistance, for mainline .002 ohms per 1000 feet, for yard .004 ohms per 1000 feet at 20°C.
 - d. Track to ground resistance - Minimum resistance, for direct fixation track 500 ohms per 1000 feet, for ballasted track 60 ohms per 1000 feet.
 - e. Contact rail to ground resistance - Minimum resistance, 10^7 ohms per 1000 feet.
 - f. Running rail to running rail resistance - Minimum resistance, direct fixation track 500 ohms per 1000 feet, ballasted track 50 ohms per 1000 feet.
3. Contractor installations which fail the electrical tests will be retested, after corrective measures have

been executed by the Contractor, at the expense of the Contractor.

4. The following will be inspected visually:
 - a. Steel reinforcement continuity
 - b. Propulsion bonds for negative return.

1.4 SUBMITTALS

- A. Refer to Section 01300, Submittals and submit the following:
 1. The Quality Assurance Program in compliance with this Section.
 2. Construction equipment data showing compliance with wheel contour, gauge, loads, and clearances for on-track equipment.
- B. Refer to Section 01340, Shop Drawings, Product Data, and Samples, and submit the following:
 1. Procedures for unloading and stocking materials.
 2. Procedures for artificially adjusting rail for anchoring including data on mechanical vibrators for relieving internal rail stresses prior to anchoring.
 3. Procedures on handling and anchoring CWR.
 4. Procedures on rail grinding and subsequent cleanup.
 5. Procedures for end hardening standard strength rail.
 6. Product data - Manufacturer's printed information and recommendations for adhesive for bonding metal tags to concrete.
- C. Refer to Section 01322, Certificates and Reports, and submit the following:
 1. Certification of calibration of specified torque wrench by independent testing laboratory accepted by District or its designee.
 2. Rail laying records.
 3. Complete and current record of bonded joints and locations of short rails in accordance with information as specified in Figure 02450-4.
 4. Rail end-hardening test results.

5. Daily rail grinding log indicating grinding date, locations, number of passes of grinder, manufacturer and model number of grinder, and name of operator.
6. Pre-Construction inspection reports.
7. Qualifications of registered Surveyor.
8. Ultrasonic test reports on shop welds prior to installation.
9. Ultrasonic test reports on shop welds after installation.

1.5 QUALIFICATION TESTS

A. General Requirements

1. Prepare two samples of field end hardened standard strength rails in accordance with the approved procedure.
2. The test samples are to be prepared by the crew which will perform the field end hardening required by this contract.
3. The tests are to be performed by a testing laboratory in conformance with Section 01410, Testing and Laboratory Services.
4. Do not perform rail end hardening on contract work until procedures, crews, and qualification tests are approved by the District or its designee.

B. End Hardening Test Procedure - Test two samples for Rockwell hardness in accordance with ASTM E18, "Rockwell Hardness and Rockwell Superficial Hardness of Metallic Materials," using a 150 kgf diamond sphero-conical penetrator in a grid pattern of 1/8 inch increments for a distance of six inches from the end of the rail. After the hardness test is performed, one sample shall be sectioned for one foot along the centerline of rail and the other sample shall be sectioned transversely 1/2 inch from the end of rail. These cross sections shall be etched to enable the observation of the hardness pattern.

C. Acceptance Criteria - The Rockwell hardness number shall not be less than C29.5 nor more than C37.0 when measured at a point on the centerline of rail 1/2 inch from the rail end. The hardness shall decrease uniformly from the end of the rail to the hardness of the untreated rail in a distance not less than two inches. The hardness pattern shall be uniform across the top surface of the rail head. The etched cross sections of the rail shall be

examined and shall exhibit a uniformly distributed hardness pattern.

1.6 HANDLING AND STORAGE

- A. Load, transport, unload, store, and handle of trackwork materials in a manner which will prevent damage to the trackwork materials. Items which are included in the AREA "Manual of Railway Engineering" will be handled as described therein.
- B. Move all material on site including ballast in a manner which prevents damage to existing above and below ground installations.
- C. Refer to Section 02460 and 02461 for additional requirements for materials furnished by the District.
- D. Damage to existing installation or District owned materials, caused by the Contractor shall be repaired, corrected, or replaced by the Contractor at no cost to the District.

1.7 MEASUREMENT - The Work of this Section will not be measured for payment.

1.8 PAYMENT - The Work of this Section will be paid for at the Contract unit price for each type of track construction shown on the Bid Form.

PART 2 - PRODUCTS

- 2.1 METAL TAGS - Brass or anodized aluminum; 1 1/4-inches wide by two-inches long by 0.050-inch thick; and stamped with numerals 1/2-inch high. Tags to be stamped in 1/4-inch increments from zero superelevation to maximum superelevation. Adhesive for bonding tags to concrete shall be TACA Corp.'s "Temprage," PRECO's "Rockweld," or W.R. Grace Co.'s "Expoxite" or approved equal.
- 2.2 CREOSOTE TREATMENT - Creosote used to treat field bored holes - conform with AWWA Standard P7 "Standard for Creosote for Brush or Spray Treatment for Field Cuts".

PART 3 - EXECUTION

3.1 INSPECTION

- A. Inspect the construction area prior to installation of trackwork for any discrepancies with proposed installation plans.

- B. Inspect existing installations for damage prior to construction.
- C. Examine exposed conduit, conduit stub-ups, and drainage fittings for conformance to vertical and horizontal positioning and required interface with surface-mounted appurtenances.
- D. Examine alignment and elevation of existing work for interface with Work of this Section. Use bench marks and horizontal control points established by the District or its designee. Adjustments at interfaces with existing work, to produce alignment and elevations indicated for Work of this Section, must be authorized by the District or its designee before Work of this Section is started.
- E. Prepare and submit a pre-construction report detailing discrepancies in existing installations.
- F. Correct deficiencies in existing installations found during the pre-construction inspection, as authorized by the District or its designee. Authorized corrections will be paid for by the District or its designee.

3.2 PREPARATION

- A. Establish track alignment based on the Contract Drawings and monuments established by the District or its designee and the following:
 - 1. Track Gauge is four feet 8 1/2 inches between rails measured 5/8 inch below top of rail.
 - 2. Alignment of tangent track is based on the centerline of track, equidistant between the gauge sides of the running rails.
 - 3. Alignment of curved track is the centerline of track with the low rail located 28 1/4 inches measured from the Profile Grade Line in the plane of the rails.
 - 4. Alignment of track utilizes station equations which must be adhered to.
 - 5. Rail Cant:
 - a. Incline rails inwardly at a 1-in-40 ratio. Do not incline rails within limits of special trackwork, except for that provided by the AREA tie plates within the ballasted special trackwork area.
 - b. Accomplish transition of inclined rail to special trackwork rail in direct fixation track within the ten feet of track immediately preceding special track rail fasteners, and at a uniform rate.

B. Set top of rail and superelevation based on the Contract Drawings and the following:

1. Obtain superelevation by maintaining the inner rail at the required profile grade line indicated on the Contract Drawings and raising the outer rail above the inner rail.
2. Start superelevation at the point of tangency and increase uniformly to full superelevation of the outer rail at the junction of the spiral with the circular curve.
3. Obtain superelevation on curves without spiral over equal lengths on the tangent and curve by increasing linearly throughout the length.
4. Use metal tags to mark the beginning and ending points of superelevation and locate at 1/4 inch increments between the beginning and ending points for curved track. Attach metal tags stamped with the superelevation in 1/4 inch increments from zero superelevation to maximum superelevation for each end of the curve at points approximately one foot inside the outer rail. Face metal tags to read in ascending order.

C. The basic geometric data is shown on the Contract Drawings. Any additional geometric data required by the Contractor will be the Contractor's responsibility.

3.3 LAYING CONTINUOUS WELDED RAIL

A. General

1. Unload and lay continuous welded rail in a manner which will prevent damage to the ties, rails, and structures.
2. Prepare and submit rail laying records which provide weight, mill-brand, rolling year, and heat number of end rails in rail string; date and time of placing rail string; length of rail string; air and rail temperature; stationing of both ends of rail string; weather conditions; and rail end gap to nearest 1/16 inch.
3. Place CWR string on ties or direct fixation rail fasteners. Arrange ends of opposite rails to be more than ten feet apart when measured along centerline and track.
4. Install rail with rail stamping on the field side of the track.

5. The type of rail required from the portal to Wilshire/Alvarado station is shown on the track charts. Use standard rail in the yard except in the special trackwork areas. In special trackwork areas refer to Section 02454, "Special Trackwork Construction - Ballasted".

B. Cutting and Drilling of Rails

1. Cut rails square and clean by means of either rail saws or abrasive cutting disks. Flame cutting will not be permitted. Do not cut rails for installation of standard or bonded joints within 30 inches of a shop weld. Sawcut rail end, in which pulling hole has been drilled, one inch from hole, away from rail end and perpendicular to rail; discard portion containing hole.
2. For joining rails with standard joints, drill and space bolts holes in rail in accordance with AREA Manual for Railway Engineering Volume 1, Chapter 4.
3. For joining rails with bonded standard joints, drill and space bolt holes in rail to provide no gap between rail ends.
4. For joining rails with bonded insulated joints, drill and drill all bolts holes in rail to provide gap for insulated end post between rail ends.
5. Drill holes perpendicular to rail web using template as drilling guide. Do not use the joint bar as a drilling guide. Drill to be used must be approved by the District or it's designee.
6. Collect and remove from site all drilling particles.

- #### C. Beveling of Rail Ends - Bevel Rail ends at standard bolted joint locations in accordance with current AREA Standard Plan No. 1005-40. Bevel Rail ends in bonded joints in accordance with the manufacturer's written specifications.

D. Hardening of Rail Ends

1. At bolted and bonded joints, harden rail ends of standard strength rail. Joint bars and associated insulating materials shall be removed from rail ends during the end-hardening process.
2. Use approved end-hardening procedure and the qualified personnel to perform the end-hardening on the rails.

E. Determining Rail Gap

1. Calculate rail gap, by the formula:
 $G = 0.000078 * L * (t - T) + Q$. (* = multiplication)

Where G = gap, in inches

t = Optimum anchoring temperature in °F; 63°F if rail will be anchored at-grade; and 60°F if rail will be anchored in subway.

T = temperature of rail at the time of laying in °F.

L = Length of rail in feet (one-half the sum of the length of the two rail strings adjacent to the joint).

Q = Zero inch if joint will be bonded standard type, end-post thickness if joint will be bonded insulated type, and 1/8 inch if bolted standard joints.

2. Negative values indicate that the rail length is too long and the rail must be cooled to zero stress level.
3. Determine rail temperature by placing thermometer on shaded side of rail base next to web and allowing thermometer to remain there until no change in temperature is detected, but for not less than five minutes. Use standard AREA standard rail thermometer as specified in AREA Manual of Railway Engineering, Volume 1.
4. If rail gap is wider than 1 1/2 inches, insert a dutchman equal to rail gap G minus 1/2 inch after rail has been aligned with abutting rail to prevent damage to rail ends during laying, ballasting and other operations requiring passage of on-track equipment over rail joints. Remove dutchman before anchoring rail. and if rail temperature would cause rail gap to close.

F. Initial Fastening of Rail - Prior to using on-track equipment, temporarily anchor rail to gauge on every fifth fastener or tie if rail is either on tangent or on curves with a radius larger than 1,900 feet and on every third rail fastener or tie if rail is on curves with a radius of 1,900 feet or less.

G. Anchoring CWR

1. Install rail anchoring devices when the rail is within the permissible anchoring temperature range of 55°F to 65°F in subway or 58°F to 68°F in at grade track. Anchor opposite rail only when its temperature is within five degrees F of the previously anchored rail's temperature at the time of its anchoring.
2. Prior to joining CWR strings, adjust the CWR strings for the zero thermal stress temperature, vibrate to relieve internal rail stresses, and fully anchor. Join CWR strings when the rail gap is at the specified

gap. If the rail gap is not within the recommended tolerances for joining CWR strings, the Contractor will unanchor the CWR strings for 300 feet on each side of the rail gap, and readjust each CWR string to within the specified zero thermal stress range. Re-anchor the CWR strings before installing the rail joint. If the recommended rail gap cannot be obtained in this manner, sawcut a section of rail from the end of one of the CWR strings and insert a rail not less than 14 feet long to ensure the recommended rail gap. If the Contractor elects to use an artificial means of adjusting the rail for anchoring, the method and equipment proposed must first be reviewed and accepted by the District or its designee.

3. Zero thermal stress in CWR may be achieved by heating, cooling, or pulling the rails, or a combination thereof. When zero thermal stress is obtained, anchoring shall begin immediately. The stress within the rail shall remain with the specified zero thermal stress range until the rail is fully anchored. Once zero thermal stress has been obtained, maintain the correct rail gap during installation of joint bars. Vibrators used for relieving internal rail stresses shall be of a type acceptable to the District or its designee and shall not damage the CWR.
4. Record the rail temperature and the information listed below at the time of rail anchoring.
 - a. location by station, track designation, and rail;
 - b. date and time;
 - c. air temperature, rail temperature, and approximate weather conditions;
 - d. rail gap at time of anchoring to nearest 1/16 inch; and
 - e. adjustment applied (type and end movement).

Record the rail temperature every 30 minutes during the anchoring process. If the rail temperature deviates from the specified zero thermal stress range, cease anchoring until the rail temperature returns to within the specified range.

H. Joining Continuous Welded Rail

1. Remove dutchman if one has been inserted in rail gap.
2. Join CWR in the yard area with standard joints.

3. Join CWR in the subway area with bonded standard joints.
4. Join rail ends together by either pulling rail ends together, vibrating rails, or heating rails, or a combination thereof.
5. Do not locate the center of standard joints or bonded standard joints within the following locations:
 - a. Not closer than ten feet from bonded standard joint in opposite rail.
 - b. Not closer than 14 feet from the center of shop welds, bonded standard joints, or standard joints in the same rail.

I. Final Alignment

1. The District or its designee will make a survey of the track prior to acceptance. The final horizontal and vertical alignment, gauge, cross level, and superelevation shall be within the specified tolerances.
2. Track deviations, as disclosed by the survey, which exceed specified tolerances shall be corrected by the Contractor at no additional cost to the District.

J. Rail Grinding

1. After the completion of trackwork to its final alignment and elevation, grind CWR in a continuous operation. Inform the District or its designee, before starting to grind rail, and obtain from the District written approval to operate rail-grinding equipment over the completed track.
2. Grind top and gauge side of running rail head with a high-speed rail mounted grinder capable of removing a minimum of 0.001 inch and a maximum of 0.002 inch per pass. Make a minimum of three separate passes. Remove not less than 95 percent of rust, mill scale, and surface irregularities from top of rail head with successive passes of rail grinder. Use rail grinder with grinding wheels not smaller than ten inches in diameter and control downward pressure to permit grinding more metal per pass at high spots and bridging at low spots less than ten inches in length.

3.4 FIELD QUALITY CONTROL

- A. After completing installation, test all shop welds ultrasonically in accordance with Section 02467, Rail Welding.

- B. Welds which fail the ultrasonic test shall be replaced by removing not less than 14 feet of rail centered about the faulty weld, but not within 30 inches of an existing weld. Replace with a rail at least 14 feet in length and two bonded standard joints.
- C. Testing of all shop welds and replacement of faulty welds are the contractor's responsibility and will be performed at no additional cost to the District.
- D. The Contractor shall cooperate with the District or its designee during the Field Quality Control testing.
- E. Operate work trains over trackwork and turnouts only after approval by the District or its designee.

3.5 CLEAN UP

- A. Remove loose debris, track materials, clusters of rail grinding particles and spilled concrete. Cut exposed stirrups and tie wires flush with the concrete surfaces. Remove from the site at no additional cost to the District.
- B. Sweep clean any concrete trackway and wash down with water.
- C. Examine all drainage inverts, pipes, sumps and other conduits for spilled concrete, rail grindings, ballast material, and other debris. Remove all such obstruction at no additional cost to the District.

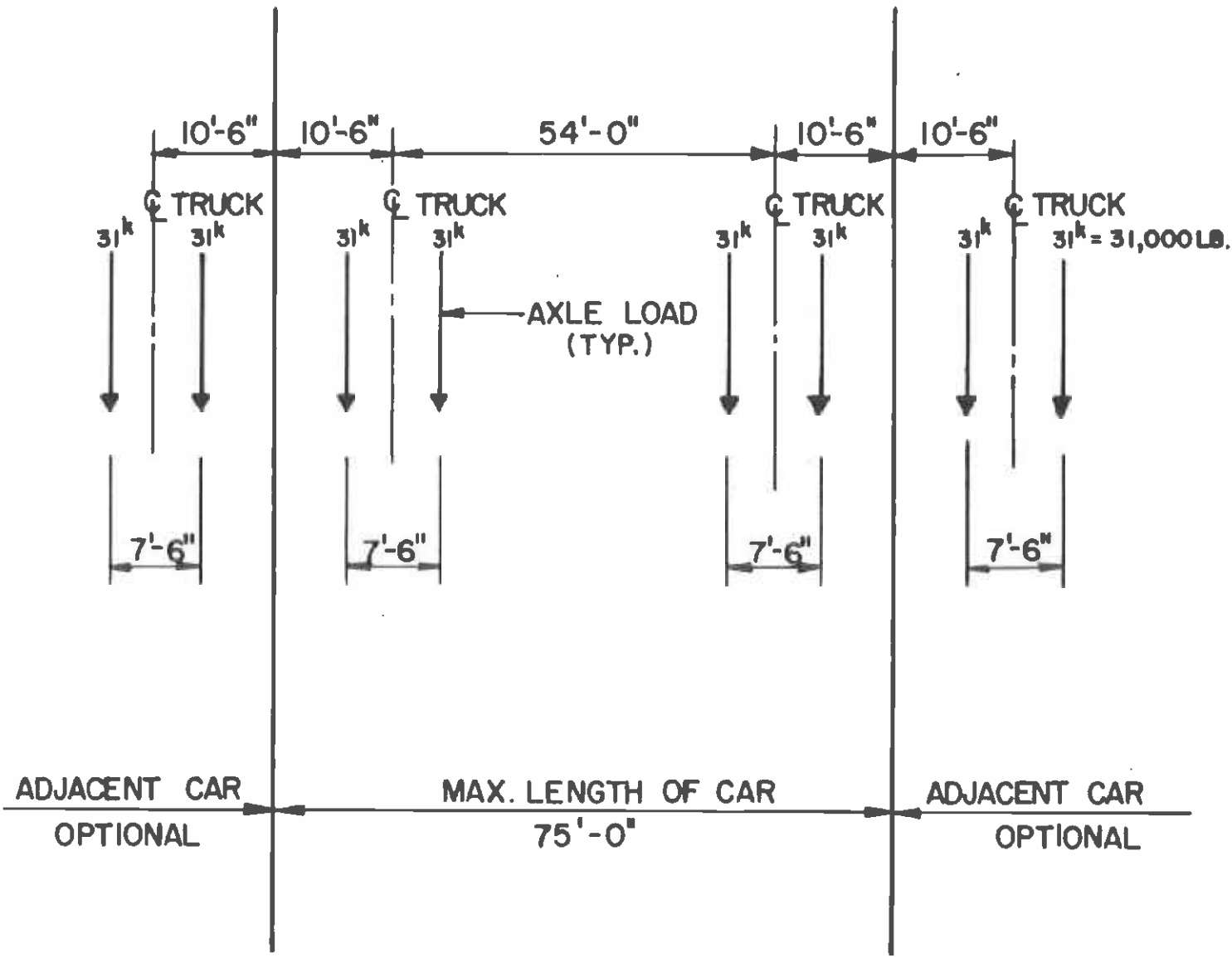

SOUTHERN CALIFORNIA RAPID TRANSIT DISTRICT

METRO RAIL TRANSIT CONSULTANTS

STANDARD LOADING

DMJM/PBQD/KE/HWA

SCALE: NONE	DATE: 28 JUN 85	SPEC SECTION: 02450	FIGURE: 02450-1
-------------	-----------------	---------------------	-----------------

COORDINATES		
POINT	Y	X
A	10.5	149.625
B	30.0	147.25
C	40.0	145.5
D	50.0	141.0
E	60.0	135.35
F	65.25	131.5
G	68.0	125.0
H	68.5	63.5
J	66.75	51.0
K	65.0	47.5
L	65.0	38.0
M	59.75	18.875
N	57.25	13.0
O	48.5	13.0

ALL DIMENSIONS IN INCHES

Y = DISTANCE FROM
VEHICLE CENTERLINE

X = DISTANCE FROM TOP
OF RUNNING RAIL

NOTE:

THE ABOVE OFFSETS
("Y" VALUES) APPLY TO
TANGENT TRACK. NO
PORTION OF CONSTRUCTION
EQUIPMENT SHALL EXCEED
THE OFFSET VALUES BY
MORE THAN $7\frac{1}{4}$ " (.6 FT)
WHEN THE EQUIPMENT
IS NEGOTIATING A CURVE
WITH A 600 FOOT RADIUS

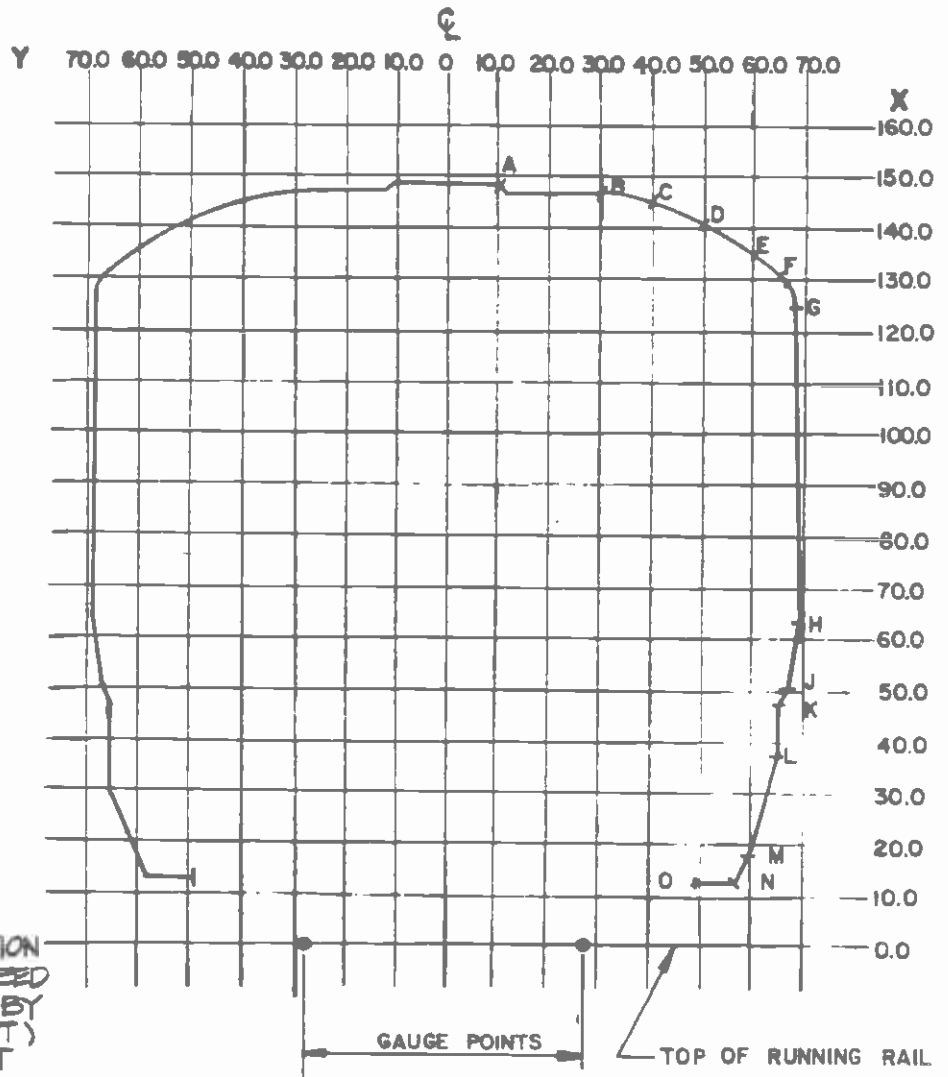

SOUTHERN CALIFORNIA RAPID TRANSIT DISTRICT

METRO RAIL TRANSIT CONSULTANTS

DMJM/PBQD/KE/HWA

MAXIMUM DYNAMIC OUTLINE
FOR CONSTRUCTION EQUIPMENT

SCALE: NONE

DATE: 28 JUN 85

SPEC SECTION: 02450

FIGURE: 02450-2

SOUTHERN CALIFORNIA RAPID TRANSIT DISTRICT

METRO RAIL TRANSIT CONSULTANTS

DMJM/PBQD/KE/HWA

TRACK CONSTRUCTION TOLERANCES

TYPE OF TRACK	GAUGE VARIATION INCH	CROSS LEVEL AND SUPERELEVATION VARIATION INCH	VERTICAL TRACK ALIGN		HORIZONTAL TRACK ALIGN	
			TOTAL DEVIATION INCH	MIDDLE ORDINATE IN 62" CHORD INCH	TOTAL DEVIATION INCH	MIDDLE ORDINATE IN 62" CHORD INCH
DIRECT FIXATION	± 1/8	± 1/8	± 1/8	± 1/8	± 1/8	± 1/8
BALLASTED	± 1/8	± 1/8	± 1/4	± 1/8	± 1/4	± 1/8

NOTES:

1. TOTAL DEVIATIONS IN VERTICAL AND HORIZONTAL TRACK ALIGNMENTS ARE MEASURED BETWEEN THEORETICAL AND ACTUAL ALIGNMENTS AT ANY POINT IN TRACK.
2. VARIATIONS FROM THEORETICAL GAUGE, CROSS LEVEL, AND SUPERELEVATION ARE NOT TO EXCEED 1/8 INCH PER 31 FEET TRACK.
3. TOTAL DEVIATION IN HORIZONTAL TRACK ALIGNMENT IN PASSENGER PLATFORM AREAS SHALL BE ZERO INCHES TOWARD THE PLATFORM AND 1/8 INCH AWAY FROM PLATFORM.

SCALE: NONE

DATE: 28 JUN 85

SPEC SECTION: 02450

FIGURE: 02450-3

TIME: _____

TRACK DESIGNATION: _____

LOCATION: STA. _____ TO STA. _____ (LT.-RT.) _____

RAIL SECTION: _____

MILL BRAND: _____

YEAR ROLLED: _____ (AHEAD) _____ (BACK)

HEAT NUMBER: _____ (AHEAD) _____ (BACK)

TYPE OF RAIL: HIGH STRENGTH STANDARD (CIRCLE)

RAIL CUT REQUIRED: _____ (YES) _____ (NO)

MANUFACTURER OF BONDED JOINT: _____

AIR TEMPERATURE: _____ INSULATED _____ (YES) _____ (NO)

RAIL TEMPERATURE: _____

WEATHER CONDITIONS: _____

RAIL GAP (NEAREST 1/16 INCH): _____

TRACK ALIGNMENT AND CONSTRUCTION: _____
(CURVE, TANGENT, GRADE, ETC.)

NAME OF ENGINEER OR REPRESENTATIVE PRESENT: _____

NAME OF CONTRACTOR'S FOREMAN PRESENT: _____

NAME OF MANUFACTURER'S REPRESENTATIVE PRESENT: _____
(INITIALED BY THOSE PRESENT)

RECORDER: _____

SOUTHERN CALIFORNIA RAPID TRANSIT DISTRICT

METRO RAIL TRANSIT CONSULTANTS
DMJM/PBQD/KE/HWA

RECORD OF BONDED JOINTS

SCALE: NONE

DATE: 28 JUN 85

SPEC SECTION: 02450

FIGURE: 02450-4

SECTION 02451

DIRECT FIXATION TRACK CONSTRUCTION

PART 1 - GENERAL

1.1 DESCRIPTION - The Work specified in this Section consists of the following:

A. Furnish materials including:

1. Second pour concrete.
2. Expansion anchors and anchorage inserts for contact rail insulator mounting.
3. Direct fixation rail fasteners with anchorage assemblies.
4. Running rail.
5. Support bracket with hardware for installing contact rail insulators.
6. Elastomeric filler material for bridging beam support.
7. Track appurtenances and other track material as required to complete construction.

B. Construct direct fixation track including:

1. Preparation of existing concrete invert and placement of elastomeric filler material for second pour concrete.
2. Place reinforcement, embedded inserts and direct fixation fastener anchorage inserts.
3. Place second pour concrete for direct fixation track and support pedestals for contact rail.
4. Install direct fixation rail fasteners.
5. Install support bracket for contact rail insulators.
6. Install continuous welded rail, anchor, align and join rail to indicated grades, lines and elevations.

C. Construct demonstration section installation.

D. Assist in electrical testing.

E. Perform final adjustments and clean up of site area.

1.2 QUALITY ASSURANCE

A. Quality Assurance Program - Refer to Section 02450, General Track Construction, and conform to the requirements of the Quality Assurance Program.

B. Reference Standards

1. American Society for Testing and Materials (ASTM).
 - a. C109 - Compressive strength of Hydraulic Cement Mortars (using two-inch or 50-mm cube specimens).
 - b. C191 - Time of Setting of Hydraulic Cement by Vicat Needle.
 - c. C309 - Liquid Membrane-forming Compounds for Curing Concrete.
2. U.S. Army Corps of Engineers CRD-C621, "Non-shrink Grout."

C. Tolerances

1. The allowable deviations for second pour concrete are:
 - a. Horizontal - 0.04 foot.
 - b. Vertical - 0.01 foot.
 - c. Transverse cant 40:1 inward slope from rail plane toward centerline of track - 0.002 foot per foot.
 - d. Uniformity of slope, deviation from a 10 foot straight-edge placed in all directions - 0.01 foot.
2. The allowable deviations for placement of anchorage assembly positioning templates are:
 - a. Horizontal - 0.02 foot with respect to centerline of track.
 - b. Vertical elevation at centerline of inserts - 0.01 foot.
 - c. Difference in deviation from vertical between adjacent plates - 0.01 foot.
 - d. Uniformity of slope, concrete bearing surface of insert positioning template - free of voids greater than 1/2 inch in size and less than 10 percent of area occupied by voids. Maximum 0.01 inch gap between straight-edge and concrete surface all around.

3. Deviation from gauge, cross level, superelevation, horizontal alignment and vertical alignment - Section 02450, General Track Construction.

1.3 SUBMITTALS

- A. Refer to Section 01300, Submittals.
- B. Refer to Section 01340, Shop Drawings, Product Data and Samples, and submit the following:
 1. Samples - Insert positioning template.
 2. Shop Drawings - Method and procedure for computing and establishing cant and cross level of track in the formwork.
- C. Refer to Section 01342, Working Drawings, and submit detailed drawings of formwork for second pour concrete. Illustrate manner of adjusting the top elevation of form to equal the indicated elevation of the abutting edge of the second pour concrete as required in Section 03300, Cast-in-Place Concrete.
- D. Refer to Section 01322, Certificates and Reports, and submit a Certificate of Compliance with ASTM and CRD Standards for each product submittal.

1.4 DEMONSTRATION SECTION INSTALLATION

- A. The Contractor shall demonstrate the ability to correctly install the direct fixation track in conformance with Contract requirements by constructing a demonstration section having a length of at least one construction cycle but not less than 300 feet.
- B. The demonstration section installation location will be designated by the District or its designee and will be a portion of the permanent direct fixation trackwork construction.
- C. The remaining direct fixation track construction shall not proceed until the demonstration installation has been constructed by the Contractor, inspected and accepted by the District or its designee.

- 1.5 MEASUREMENT - The Work of this Section will be measured for payment by the track foot, measured horizontally, along the centerline of direct fixation track and excluding track footage within special trackwork Work limits, as shown on the Contract Drawings, complete with specified and miscellaneous items in place.

- 1.6 PAYMENT - The Work of this Section will be paid for at the Contract unit price per track foot complete in-place as shown on the Bid Form.

PART 2 - PRODUCTS

- 2.1 CONCRETE REINFORCEMENT - Section 03200, Concrete Reinforcement.

- 2.2 CONCRETE - Class 4000; Section 03301, Portland Cement Concrete.

- 2.3 GROUT

A. General Requirements

1. Grout for repairing voids in second-pour concrete - 0.0 percent shrinkage in plastic state and not more than 0.1 percent expansion in hardened state when tested in accordance with CRD-C621, Sections 10.1 and 10.2.
2. Provide a grout which does not initially set sooner than 60 minutes as determined by ASTM C191.
3. Provide a grout which develops a compressive strength of 5000 psi at the end of 28 days as determined by ASTM C109.

- ### B. Materials - Pre-measured, pre-packaged, cement-based, non-metallic (aluminum powder or iron filings), non-shrink type; grout conforming to CRD C621.

C. Manufacture

1. Supply technical services of grout manufacturer's representative when producing grout for installation.
2. Retemper grout in accordance with manufacturer's printed instructions.
3. Water utilized in making grout will be potable.

- 2.4 INSERT POSITIONING TEMPLATE - One inch larger than rail fastener on all sides, and have air relief holes drilled in plate.

- 2.5 DIRECT FIXATION RAIL FASTENERS AND ANCHORAGE ASSEMBLIES - Section 02456, Direct Fixation Rail Fasteners.

- 2.6 CURING COMPOUND - White pigmented, non-wax, liquid type conforming to ASTM C309, Type 2; Feb America, Inc.'s "Febcure" or approved equal.

- 2.7 THREAD SEALANT - Low melting point wax; Sanchem, Inc.'s "NO-OX-ID 'A' Special" or approved equal.
- 2.8 RUNNING RAILS - Section 02455, Running Rail.
- 2.9 JOINT BARS - Section 02459, Track Appurtenances and Other Track Materials.
- 2.10 CONTACT RAIL SUPPORT INSULATOR MOUNTING PLATES - Section 02460, Contact Rail System.
- 2.11 ELASTOMERIC FILLER MATERIAL
 - A. General Requirements - Filler material for support of bridging beam to be a plain, non-laminated sheet, 1/4 of an inch thick.
 - B. Materials
 - 1. Elastomer shall comply with CR Grade 2 as per ASTM D4041.
 - 2. Elastomer shall have a durometer of 70 +/-5 points.

PART 3 - EXECUTION

3.1 INSPECTION

- A. Refer to Section 02450, General Track Construction, and prepare a pre-construction inspection report.
- B. Inspect first pour concrete invert for defects or installation variances which would affect the subsequent work.

3.2 PREPARATION

- A. Establish alignment and elevation points as per Section 02450, General Track Construction.
- B. Sweep clean the existing concrete invert surface and wash with water.
- C. Straighten bent stirrups embedded in concrete invert to provide a proper connection to the second pour concrete.
- D. Drill and grout steel reinforcing where necessary to maintain a proper contact rail support. The end approach shall be supported 24 inches from its end. The maximum spacing between supports is 10 feet.
- E. Place elastomeric filler material without sheet overlap and apply sealer on joints.

3.3 INSTALLATION

A. Second Pour Concrete

1. Establish bench marks for formwork by referencing to control points established by the District.
2. Set tops of forms for direct fixation track and contact rail support pedestals to indicated line and grade of finished edges for second pour concrete in accordance with the accepted working drawings and Section 03100, Concrete Formwork.
3. Install reinforcing steel in accordance with Section 03200, Concrete Reinforcement.
4. Weld the reinforcing steel to steel lugs attached to existing No. 2/0 or AWG No. 6 bare copper conductors spaced at approximately 500 feet intervals as shown on the Contract Drawings.
5. Weld the reinforcing bars of the bridging beam to the existing reinforcing bars of the concrete invert as shown on the Contract Drawings.
6. Secure insert positioning templates to the top of the forms as follows:
 - a. In tangent track set templates in pairs directly opposite each other and perpendicular to the centerline of track.
 - b. In curved track, set templates in pairs opposite each other and radial to the centerline of track.
 - c. Set the template pairs 30 inches apart maximum, on centers, as measured along the centerline of track.
 - d. Set each template at a 40:1 cant with respect to the plane of the running rails.
 - e. Set each template with a 1/4 inch offset between the centroid of the anchorage inserts and the centerline of the running rails, and so that at least 3/8 inch of rail adjustment on the gauge side will remain in each direct fixation rail fastener after final rail adjustment has been performed. At least 1/8 inch of rail adjustment must be available in the field side after final rail adjustment has been performed.
7. Position anchorage inserts on template and set top of insert flush with the finished surface of the second pour concrete.

8. Provide 1 1/2 inches of clearance between anchorage inserts and reinforcing steel. Reinforcement may be bent, but not cut to achieve insert clearance.
9. Place blockouts for drainage chases and sleeves for cross bonding cables as indicated on the Contract Drawings.
10. Do not place concrete until the District or its designee has tested and approved the steel reinforcement continuity.
11. Place second pour concrete and trowel concrete surfaces, in accordance with Section 03300, Cast-In-Place Concrete.
12. Do not remove forms until concrete has been in place for not less than 24 hours or has attained a compressive strength of not less than 1000 psi.
13. Grout shall not be used to correct second pour concrete which is not within required tolerances.
14. Concrete, which is not within required tolerances and cannot be corrected without disturbing anchorage inserts, shall be removed and replaced.
15. Insert nylon or plastic pull-away plug into anchorage inserts immediately after removing the insert positioning template and before repair of any voids.
16. Repair any unacceptable voids in the direct fixation rail fastener area with approved grout.
17. Cure concrete with either the curing compound specified in this section or by one of the moist curing methods specified in Section 03300, Cast-in-Place Concrete.
18. Cut exposed stirrups and tie wires flush with second pour concrete.

B. Direct Fixation Rail Fasteners

1. Prior to positioning the direct fixation rail fasteners, sweep, wash clean, and dry the second pour concrete.
2. Install fasteners after second pour concrete has attained the specified 28-day compressive strength, but not sooner than ten days after concrete has been placed.
3. Remove pull-away plug from anchorage insert, set a rubber base shim on the concrete and position the

direct fixation rail fastener with anchor bolts engaged in inserts. Coat threads of anchor bolts with thread sealant specified in this Section before engaging bolts in inserts.

C. Laying, Joining and Anchoring CWR.

1. Refer to Section 02450, General Track Construction.
2. Adjust rail, if required, to final vertical alignment with an additional polyethylene shim placed between the rail fastener and the rubber base shim. No more than one polyethylene shim is to be used under each direct rail fastener.
3. Fully anchor rail fasteners to second pour concrete with anchor bolts tensioned to torque as recommended by rail fastener manufacturer. Tighten anchor bolts on both sides of rail simultaneously. Before and during installation of rail fasteners, the equipment to be used for torquing anchor bolts shall be checked daily and shall be within two foot-pounds of the calibrated and certified torque wrench specified.
4. Final track alignment - After final aligning and surfacing of track, not less than 3/8 inches of lateral rail adjustment in each fastener shall remain for tightening gauge to compensate for rail wear and alignment adjustment.

D. Contact Rail Support Insulator Mounting Plates and Insulators

1. Refer to Section 02460, Contact Rail System.
2. After concrete has cured for at least 10 days and after the final adjustment of the direct fixation track has been completed, drill and install the expansion anchors for the contact rail support insulator mounting plates or contact rail support insulators.
3. Install contact rail support insulator mounting plate to ensure that the contact rail will be properly positioned with respect to the gauge line of the nearest running rail and in the same top of running rail plane.

3.4 FIELD QUALITY CONTROL

- A. The District or its designee will perform the electrical tests as listed in Section 02450, General Track Construction.
- B. The Contractor must cooperate with the District or its designee during the Field Quality Control Tests by:

1. Not placing any second pour concrete until inspection of steel reinforcement continuity is completed.
 2. Providing advance notice of at least 5 working days that a section will be ready for testing or that a section previously scheduled for testing will not be ready.
 3. Ceasing operations which would interfere with the Field Quality Control Tests.
 4. Provide a test section which is cleaned of debris.
 5. Provide supervisory personnel to observe the tests and assist the District or its designee.
- C. Running rail and contact rail which exhibits high electrical resistance or non-conductance will be corrected by the Contractor at no cost to the District.
- D. Track and contact rail installations which exhibit low resistance to ground will be corrected by the Contractor at no cost to the District.
- 3.5 ADJUSTMENT AND CLEANING .- Refer to Section 02450, General Track Construction.

END OF SECTION

SECTION 02452

BALLASTED TRACK CONSTRUCTION

PART 1 - GENERAL

1.1 DESCRIPTION - The Work specified in this Section consists of the following:

A. Furnish materials including:

1. Ballast
2. Timber ties
3. Running rails
4. Track appurtenances and Other Track Material

B. Construct ballasted track including:

1. Preparing of existing subballast
2. Placing and compacting ballast
3. Installing timber ties
4. Installing continuous welded rail, anchoring, aligning, joining rail, raising and surfacing track to the indicated lines, grades, and elevations.

C. Perform final adjustment and cleanup at site area

1.2 QUALITY ASSURANCE

A. Quality Assurance Program - Refer to Section 02450, General Track Construction and conform to the requirements of the Quality Assurance Program.

B. Source Quality Control - If the Contractor requests approval for a change in the source of ballast, test the proposed ballast as per Section 02458, Ballast.

C. Tolerances - Deviation from gauge, cross level, superelevation, horizontal alignment, and vertical alignment - Section 02450, General Track Construction.

1.3 SUBMITTALS

A. Refer to Section 01300, Submittals for submittal procedures.

B. Refer to Section 01322, Certificates and Reports and, if change in a ballast source is requested, submit test reports as required in Section 02458 Ballast.

1.4 MEASUREMENT - Excepting ballast, the Work in the track area will be measured for payment by the track foot, measured horizontally, along the centerline of ballasted track and excluding track footage within special trackwork Work limits, as shown on the Contract Drawings, complete with specified and miscellaneous items in-place. The Work on the ballast pad area will be measured for payment by the cubic yard, in place. Ballast will be measured in accordance with Section 02458, Ballast.

1.5 PAYMENT - Excepting ballast, the Work on the track area will be paid for at the Contract unit price per track foot complete in-place, as shown on the Bid Form. The Work on the ballast pad area will be paid for at the Contract unit price per cubic yard, in place, as shown on the Bid Form. Ballast will be paid for in accordance with section 02458, Ballast.

PART 2 - PRODUCTS

2.1 BALLAST - Section 02458, Ballast

2.2 TIMBER TIES - Section 02457, Timber Ties.

2.3 RUNNING RAIL - Section 02455, Running Rail.

2.4 RAIL ANCHOR, SPIKES, JOINT BARS, TIE PLATES - Section 02459, Track Appurtenances and Other Track Material.

PART 3 - EXECUTION

3.1 INSPECTION

A. Refer to Section 02450, General Track Construction and prepare a pre-construction inspection report.

B. Examine surface of subballast for defects or installation variances which would affect subsequent Work.

3.2 PREPARATION

A. Establish alignment and elevation points as per Section 02450, General Track Construction.

B. If authorized, correct subballast which does not conform to indicated smoothness sections and deviations.

3.3 INSTALLATION

A. Placement of Initial Ballast

1. Uniformly distribute and firmly compact an initial layer of ballast over the subballast before distributing ties. Distribute and compact ballast over the entire section indicated in the Contract Drawings including the area where ballast pad is required.
2. Uniformly spread and compact each lift of ballast within the initial layer, with not less than four passes of either a roller or compactor. Limit the depth of each compacted lift within the initial layer to four inches. Make top of initial layer not less than four inches below the final elevation for the bottom of the timber ties.

B. Placement of Cross Ties and Contact Rail Ties

1. Place ties on 24 inch centers with every fifth tie being a contact rail tie unless otherwise specified herein or shown on the Contract Drawing.
2. Place ties in a manner which will ensure that bottom of each tie will bear fully on initial layer of ballast and be normal to track centerline.
3. Position ties in a manner which will result in the proper installation of the contact rail as shown on the Contract Drawings.
4. Place ties with the heartwood face down.

C. Laying, Joining, and Anchoring CWR

1. Refer to Section 02450, General Track Construction.
2. Remove ballast and debris from the top of ties before placement of tie plates and CWR. Do not drag CWR over tie plates.
3. Place CWR on the tie plate in accordance with accepted working drawings. Do not use on-track equipment until CWR has been fastened to ties.
4. Field bore contact rail ties with 9/16 inch diameter hole to a depth not less than 5 1/2 inches or greater than six inches. Immediately treat holes with creosote treatment.
5. Proceed with final rail anchoring in ballasted track only after track has been ballasted to a degree which will prevent tie movements caused by thermal expansion

or contraction and until track has been initially raised, tamped, and aligned.

6. Fully spike all tie plates within the ballast track construction work limits using two cut spikes in rail holding positions and two lock spikes in plate holding positions for both tangent and curved track construction.

D. Surfacing and Aligning

1. After track has been installed, place ballast in cribs and shoulders of track structures, and in quantities which will fill tie cribs and be sufficient for initial track raise and to hold track after initial track raise.
2. Surface track by methods which will neither bend rail, strain joints, nor damage rail fastenings. Limit track lift to not more than four inches. Each track raise shall be a lift of four inches or less, and the final raise bringing the track to proper surface shall be three inches or less.
3. After track has been initially raised and aligned, join and anchor rails within specified zero thermal stress range. Suspend surfacing when rail temperature is hotter than 68°F.
4. Simultaneously tamp ballast with a squeeze-vibratory type power tamper approved by the District or its Designees on both sides of tie, from points 15 inches inside both rail centers for a distance of 30 inches or to ends of cross tie.
5. Compact shoulders and cribs with a vibrator compactor acceptable to the District or its designee.

- E. Contact Rail Support Insulators - Refer to Section 02460, Contact Rail System.

3.4 FIELD QUALITY CONTROL

- A. At no additional expense to the District, remove at random, a maximum of one percent of ties so that the District may inspect compaction of ballast beneath ties to determine tamping variables of each piece of tamping equipment, and for spot checking of production work. Reinstall ties immediately after compacted ballast has been accepted.
- B. Inspect timber ties prior to installation and reject timber ties with defects or handling damage.

- C. Remove and replace any ties which exhibit end or side splits, unplanned rail fastener protrusions, improper field boring or other damage from the installation process.
- 3.5 ADJUSTMENT AND CLEANUP - Complete final surfacing and aligning of track. Reslope fouled and disturbed subballast outside toe of slope of ballast. Dress ballast in cribs one inch below top of timber ties.

END OF SECTION

SECTION 02453

SPECIAL TRACKWORK CONSTRUCTION - DIRECT FIXATION

PART 1 GENERAL

1.1 DESCRIPTION - The work specified in this Section consists of the following.

A. Furnish materials including:

1. Second pour concrete.
2. Expansion anchors and anchorage insert for contact rail insulator.
3. Special trackwork components.
4. Running rail.
5. Timber switch ties with rubber boots and insulating pads.
6. Direct fixation rail fasteners with anchorage assemblies.
7. Contact rail support insulator mounting plate with hardware.
8. Track appurtenances and other track material as required to complete construction.

B. Construct special trackwork including:

1. Preparing of existing concrete invert for second pour concrete.
2. Placing reinforcement, embedded inserts and direct fixation fastener anchorage inserts.
3. Placing second pour concrete for direct fixation track and support pedestals for contact rail.
4. Installing direct fixation rail fasteners.
5. Installing contact rail support insulator mounting plate.
6. Installing special trackwork components, rubber boots, timber ties, and continuous welded rail, anchoring, aligning, and joining rail to indicated grades, lines, and elevations.

- C. Perform qualifications testing.
- D. Construct demonstration section installation as required.
- E. Assist in electrical testing.
- F. Perform final adjustments and clean up of site area.

1.2 QUALITY ASSURANCE

A. General Requirements - Refer to Section 02450, General Track Construction, and Section 02451, Direct Fixation Track Construction, and conform to the Quality Assurance requirements including the Quality Assurance Program.

B. Tolerances

1. The variance from the designed distance for the turnout lead - less than 3/16 inch.
2. The variance from the designed location for the point of intersection of a turnout (PITO) - less than 1/8 inch as determined by the frog position.
3. The variance from the designed distances between the points of intersection (PI) and/or points of intersection of a turnout (PITO) within a specific turnout unit - less than 1/4 inch as determined by the frog position.
4. The variance from the designed distance of the frog guard rail offset - less than 1/4 inch.
5. The variance from the designed distances of the turnout offsets to the curved closure rail - less than 1/8 inch.
6. The gap between the switch rail and the stock rail from the point of switch to the No. 2 switch rod - less than 1/32 inch.
7. With the switch points in normal position, they shall be square within one half inch.

1.3 SUBMITTALS

- A. Refer to Section 01300, Submittals.
- B. Refer to Section 01340, Shop Drawing, Product Data, and Samples, and submit the following:
 1. Product Data - Manufacturer's printed installation instructions for lubricants, sealants, and adhesives.

2. Tie distribution, application of boot, leveling, and concreting.
- C. Refer to Section 01322, Certificates and Reports, and submit the following:
1. Qualification test reports on rubber boot resiliency and special trackwork assembly behavior. Each test shall be reported on a separate form. In addition, test results of each test section shall be summarized separately. Conformance or deviations shall be highlighted in a report summary.
 2. Progress Photographs - Accompanying the written test reports shall be a Photograph Record of the tests. The Photograph Record shall contain photographs of sufficient clarity to distinguish relevant details as described or referenced in the respective written report.
 3. Submit a certified copy of reports on the analyses and tests required by referenced ASTM specifications.

1.4 QUALIFICATION TESTS

A. General

1. The Contractor shall perform the required qualification tests for rubber boot resiliency. The Contractor is responsible for the testing program; furnishing instruments, labor, tools, and procedures for testing.
2. Tests and chemical analyses shall be performed by either an independent testing laboratory or a District approved manufacturer's laboratory. In either case, qualified personnel and proper equipment are mandatory and District approval of the testing facility is required prior to qualification testing.

B. Test Procedures

1. Vertical load resiliency test
 - a. Support a four foot long bottom section of the rubber boot (with resilient support pad if supplied) and test by uniformly loading the section with a total vertical load varying from 2000 to 16,000 pounds in 200 pound increments, then subject the test section to a load cycling from 200 to 10,400 pounds for 10,000 cycles between one and two Hertz. Immediately repeat the static load test from 2000 to 16,000 pounds.
 - b. Plot the load versus deflection curves for the bottom section of the rubber boot during both

static tests. The bottom section of the rubber boot shall conform to the resiliency requirements shown in Figure 02453-1.

2. Lateral load resiliency test

- a. Support a four foot long side section of the rubber boot and test by uniformly loading the section with a total lateral load varying from 600 to 8000 pounds in 200 pound increments, then subject the test section to a load cycling from 200 to 5200 pounds for 10,000 cycles between one and two Hertz. Immediately repeat the static load test from 600 to 8000 pounds.
- b. Plot the load versus deflection curves for the side section of the rubber boot during both static load tests. The side section of the rubber boot is to conform to the resiliency requirements shown in Figure 02453-2.

3. Vertical repeated load - special trackwork assembly test.

- a. Prepare two test sections each 4 foot long consisting of a 7" deep by 10" wide and four feet long timber tie, as per Section 02457, with rubber boot and end pieces, one special plate 10-SP-1, two lag screws with insulator bushings, one insulating pad, two rail clamp assemblies, and one 115 RE rail 12 inches in length. Center the rail and completely assemble all components on the timber tie as shown on the Contract Drawings using approved sealants and adhesives. Embed test sections in sufficient concrete to simulate field installation and add steel reinforcement as required to preclude a concrete failure during the testing period. Provide relief access to prevent entrapping air.
- b. Position test section and repeat the static and dynamic loads as stated in the vertical load resiliency tests, but increase the test cycles to 250,000 between one and two Hertz. All loads are to be applied to the center of the rail head.
- c. Plot the load versus deflection curves for top of rail and top of timber tie. Visually examine all components for wear, cracks, slippage, or other indications of premature failure.
- d. Repeat test on the second test section.

4. Vertical and lateral repeated load - special trackwork assembly test.

- a. Prepare two test sections as per the vertical load special trackwork assembly test.
- b. Position the test section and apply a vertical load to the center of the rail head so as to produce a vertical downward load of 10,400 pounds. Apply lateral loads of 4000 pounds to the gauge side and 2,500 pounds to the field side of the rail head 0.625 inches below the top of the rail and along the center line of the opposing rail clamp block and normal to the rail. Lateral loads shall be applied alternating in the gauge and field side direction and combined with the application and release of the vertical load. Application of the lateral load in the gauge direction together with the vertical load, release of loads, and then the application of the lateral load in the field direction together with the vertical load and loads release will constitute one cycle. Execute 250,000 cycles between one and two Hertz. Without disassembly, examine all components for signs of wear, cracks, slippage, or other indications of premature failure.
- c. Remove the rail and apply the vertical load of 10,400 pounds directly to the 10-SP-1 special plate. Through the rail clamp blocks apply a lateral load, in 200 pound increments, up to 15,600 pounds or 1/2 inch of lateral displacement. Plot lateral deflection versus lateral load and L/V ratio. Examine all components for signs of failure.
- d. Repeat test on the second test section.

1.5 DEMONSTRATION SECTION INSTALLATION

- A. The Contractor shall demonstrate the ability to correctly install the special trackwork in conformance with the Contract requirements by constructing one of the No. 10 turnouts.
- B. The demonstration section installation shall be a portion of the permanent special trackwork construction.
- C. The remaining special trackwork construction shall not proceed until the demonstration installation is constructed and accepted by the District or its designee.

1.6 MEASUREMENT - The Work of this Section will be measured for payment by each unit as shown by the work limits on the Contract Drawings, complete with specified and miscellaneous items in place.

- 1.7 PAYMENT - The Work of this Section will be paid for at the Contract unit price for each type of special trackwork unit complete and in place as shown on the Bid Form.

PART 2 - PRODUCTS

- 2.1 TIMBER SWITCH TIES - Section 02457, Timber Ties.
- 2.2 RUNNING RAIL - Section 02455, Running Rail.
- 2.3 SPECIAL TRACKWORK - Section 02466, Special Trackwork.
- 2.4 JOINT BARS, LAG SCREWS, SPIKES, BOLTS, NUTS AND WASHERS - Section 02459, Track Appurtenances and Other Track Material.
- 2.5 CONCRETE - Class 4000; Section 03301, Portland Cement Concrete.
- 2.6 DIRECT FIXATION RAIL FASTENER - Section 02456, Direct Fixation Rail Fasteners
- 2.7 RUBBER BOOTS

A. General Requirements

1. Provide either a one-piece or two-piece rubber boot to resiliently support timber ties embedded in concrete.
 - a. A one-piece rubber boot must provide for both vertical and lateral resiliency (parallel to running rails).
 - b. A two-piece rubber boot must provide for lateral resiliency with the use of an outer rubber covering and vertical resiliency with the use of an additional elastomeric support pad placed under the timber tie and between the timber tie and the outer rubber covering.
2. Provide continuous rubber boot without splices for each embedded segment of a timber tie.
3. Coordinate the rubber boot design with the construction and installation procedures to avoid localized deformations from support blocks, bonding, and concrete placement.
4. Provide horizontal ribs on all vertical surfaces of the rubber boot. Design ribs so that ribs will not exhibit wear and damage from a vertical timber tie movement of 1/8 inch.

5. Provide continuous elastomeric support pad (if used) without splices for the entire embedded length of the tie at least nine inches in width.
6. Design the horizontal surface of the rubber boot supporting the timber tie for use with both a nine-inch or ten-inch wide tie.
7. The shape factor for the one-piece rubber boot must be uniform in the direction parallel to the timber tie.
8. Each linear foot of the horizontal surface of the bottom section supporting the timber tie in the vertical direction must provide the following:
 - a. Deflect 1/8 inch under loading between 1900 pounds and 2600 pounds per linear foot.
 - b. Maintain a spring rate between 18,000 and 34,000 pounds per inch after deflecting 1/8 inch, when the loading is increased to 4000 pounds per linear foot.
9. Each linear foot of vertical surface of the side section of rubber boot restraining the timber tie in the lateral direction parallel to the running rails must provide the following:
 - a. Deflect 1/16 inch under loading between 900 pounds and 1300 pounds per linear foot.
 - b. Maintain a spring rate between 15,000 and 35,000 pounds per inch after deflecting 1/16 inch when the loading is increased to 2000 pounds per linear foot.
10. The rubber boot design must be free draining longitudinally.
11. The elastomer of the rubber boot shall not have compressive strains greater than 25% or shear strains greater than 50% based on 1/8 inch timber tie deflection in the vertical direction and a 1/16 inch deflection in the transverse direction with respect to the timber tie.
12. The rubber boot shall comply with the basic configuration shown on the Contract Drawings.
13. The rubber boot design shall use elastomer end pieces at the ends of the timber ties with the same resiliency characteristics as the vertical sides of the rubber boots. The end pieces shall have at least one inch overlap with the rubber boot on the sides and the bottom. The overlap shall be designed to seal the end

piece and rubber boot connection either mechanically or with an adhesive.

B. Material Requirements

1. The elastomer used for the rubber boot is to comply with and be tested according to Section 02456, Direct Fixation Rail Fasteners, for the following characteristics:
 - a. Hardness
 - b. Tensile strength
 - c. Ultimate elongation
 - d. High temperature compression set
 - e. Compression set at minus 10° C
 - f. Accelerated aging
 - g. Resistance to ozone cracking
 - h. Oil absorption
 - i. Flame spread and smoke generation
2. The elastomer used for the rubber boot and the resilient support pad (if supplied) is to exhibit no degradation of performance due to exposure to Grade 1 creosote.
3. The elastomer used for support pads (if supplied) shall meet or exceed the requirements of ASTM D1056 for SBE-45-B1-E2 and shall have a minimum thickness of 1/2 inch.

2.8 INSULATING PADS AND BUSHINGS

A. General Requirements - Conform to the details shown on the Contract Drawings.

B. Material

1. Insulating Pad - Ultra high molecular weight polyethylene (UHMW) with the following properties.
 - a. Modulus of elasticity, 80,000 to 100,000 psi
 - b. Tensile strength, 4000 to 5500 psi
 - c. Nominal weight average molecular weight of three million or greater.

- d. Minimum resistivity of 10^{16} ohm-centimeter as per ASTM D257.
 - e. Flamability UL rated at 94V-0 as per UL 94.
 - f. Rockwell hardness R60.
- 2. Insulating bushing and washer - In accordance with NEMA Standard LI-1-1971 Industrial Laminated Thermo-setting Products Grade G-10 with a minimum resistivity of 10^{14} ohm-centimeters measured in accordance with ASTM D257.
 - 3. Bushing Sealant - silicone compound, GE-RTV 112 or approval equal.
 - 4. Steel flat washer - pre-coated with epoxy material in the fabrication shop. Washer coating - 100 percent dry power epoxy resin; 3m Corp's "Scotch Kote No. 213" or approved equal.

C. Fabrication

- 1. Fabricate the bushing and washer components as a pre-assembled unit using suitable adhesive to secure the components.
 - 2. Chamfer insulating pad as indicated on the Contract Drawings.
- 2.9 LUBRICANT Provide a dry film lubricant for application to special plates. The lubricant shall have low electrical conducting properties as approved by the District or its designee.
- 2.10 ADHESIVE
- A. Provide an adhesive specifically formulated to bond steel to the insulating pad material.
 - B. Provide an adhesive specifically formulated to bond the insulating pad to a creosote-treated timber tie.
- 2.12 FIRE RETARDANT - Provide a surface-applied fire retardant meeting ASTM E108 Class B rating. NONFLAM by Ocean Coatings Ltd. or approved equal.
- 2.13 TIMBER TIE END SEALANT - Liquid polyurethane or approved equal.

MTA LIBRARY

PART 3 - EXECUTION

3.1 INSPECTION

- A. Refer to Section 02450, General Track Construction, and prepare a pre-construction report.
- B. Inspect first pour concrete invert for defects or installation variances which would affect the subsequent work.

3.2 PREPARATION

- A. Establish alignment and elevation points as per Section 02450, General Track Construction.
- B. Sweep clean the existing concrete invert surface and wash with water to remove all laitance and deleterious material.
- C. Drill and grout stirrups in existing concrete invert in areas shown on the Contract Drawings.

3.3 INSTALLATION

- A. Second Pour Concrete - Refer to Section 02451, Direct Fixation Track Construction.
- B. Direct Fixation Fasteners - Refer to Section 02451, Direct Fixation Track Construction.
- C. Embedded Timber Ties
 - 1. Using liquid polyurethane sealant, seal ends of the ties before securing the rubber boots.
 - 2. Attach rubber boots to the tie as shown on the Contract Drawings by the use of non-metallic bands or other methods approved by the District or its designee. Install rubber boots on each embedded portion of the tie. No splicing of rubber boots will be permitted except at ends of the tie where the rubber boots will be securely fastened and sealed to the end piece to prevent concrete from coming in contact with the tie.
 - 3. Distribute, space, and line timber switch ties as shown on the Contract Drawings.
- D. Insulating Pads and Special Plates
 - 1. Cut insulating pad to the necessary length to comply with requirements shown on the Contract Drawings and lay square and parallel to the tie.

2. Using template, drill 3/4 inch diameter holes in the insulating pad at the locations indicated for anchorage assembly. Do not use the holes of the special plate as the template.
3. Assemble the special plates, special plate anchorage assembly, insulating pad and insulating bushings and washers. Examine the interfacing surfaces for burrs or localized deformations which would inhibit proper adhesion and correct all deficiencies. Assemble the components using the approved adhesives.
4. Place the assembled special plates with special plate anchorage assembly and insulating pad on the top of the timber tie, making sure that the special plates are on the right location and mark the location of the holes for the lag screws on the timber tie.
5. Using template, field bore the tie with a 9/16 inch diameter hole for the lag screws to a depth of not less than 4 1/2 inches and not greater than 5 inches. Do not use the holes of the special plate and insulating pad as a template.
6. Coat bottom of insulator pad with approved adhesive and position on timber tie.
7. Fasten special plate to timber tie with lag screws coated with approved sealant.

E. Special Trackwork

1. Assemble rails, switches, and frogs and attach to the timber ties as shown on the Contract Drawings. Use indicated tangent offset tables to establish line for turnout rails.
2. Raise the ties by lifting uniformly making sure that the tie spacings or the rubber boots are not disturbed.
3. Install wooden wedges or concrete blocks under the tie when correct elevation is attained. Do not place wedges or blocks directly under the rail seat. Install a minimum of two wedges under each tie at two locations for ties less than 12 feet long. Install a minimum of three wedges under each tie at three locations for ties 12 feet or longer.
4. Make adjustment in elevation by adjusting the height of wedges or blocks. Do not allow the tie plate and tie to be suspended from the rail.
5. Install bonded joints as specified in Section 02459, Track Appurtenances and Other Track Materials.

6. Join special trackwork to adjacent section of track after adjustment has been made.

F. Placement of Concrete

1. Clean the area around and under the ties for inspection and approval by the District or its designee prior to the placement of concrete.
2. Place portland cement concrete in accordance with Section 03300, Cast-in-Place Concrete. Finish concrete so that surface water flows away from timber tie and into drains.
3. Finish half round drainage invert avoiding low spots or irregularities which would impede or retain water.
4. Do not place any load on the ties until the concrete has reached its 28 day compressive strength.

G. Application of fire retardant.

1. Apply fire retardant in accordance with manufacturer recommendations to all exposed surfaces of embedded timber ties.
2. Apply carefully and avoid any material overspray and intrusions on concrete or special plates.

H. Second pour concrete and direct fixation rail fasteners - Refer to Section 02451, Direct Fixation Track Construction.

I. Laying, Joining, and Anchoring CWR - Refer to Section 02450, General Track Construction.

J. Contact Rail Insulators - Refer to Section 02460, Contact Rail System and Section 02451, Direct Fixation Track Construction.

3.4 FIELD QUALITY CONTROL

- A. Refer to Section 02451, Direct Fixation Track Construction.
- B. Demonstrate to the District or its designee that switch points move freely without binding or excessive force in each completed special trackwork switch section.

3.5 ADJUSTMENT AND CLEANING

- A. Refer to Section 02450, General Track Construction.
- B. Clean special plates before applying a uniform coat of approved lubricant over the entire sliding surface.

C. Final adjustment of switch to be performed in cooperation with the Train Control Contractor and as scheduled by the District or its designee.

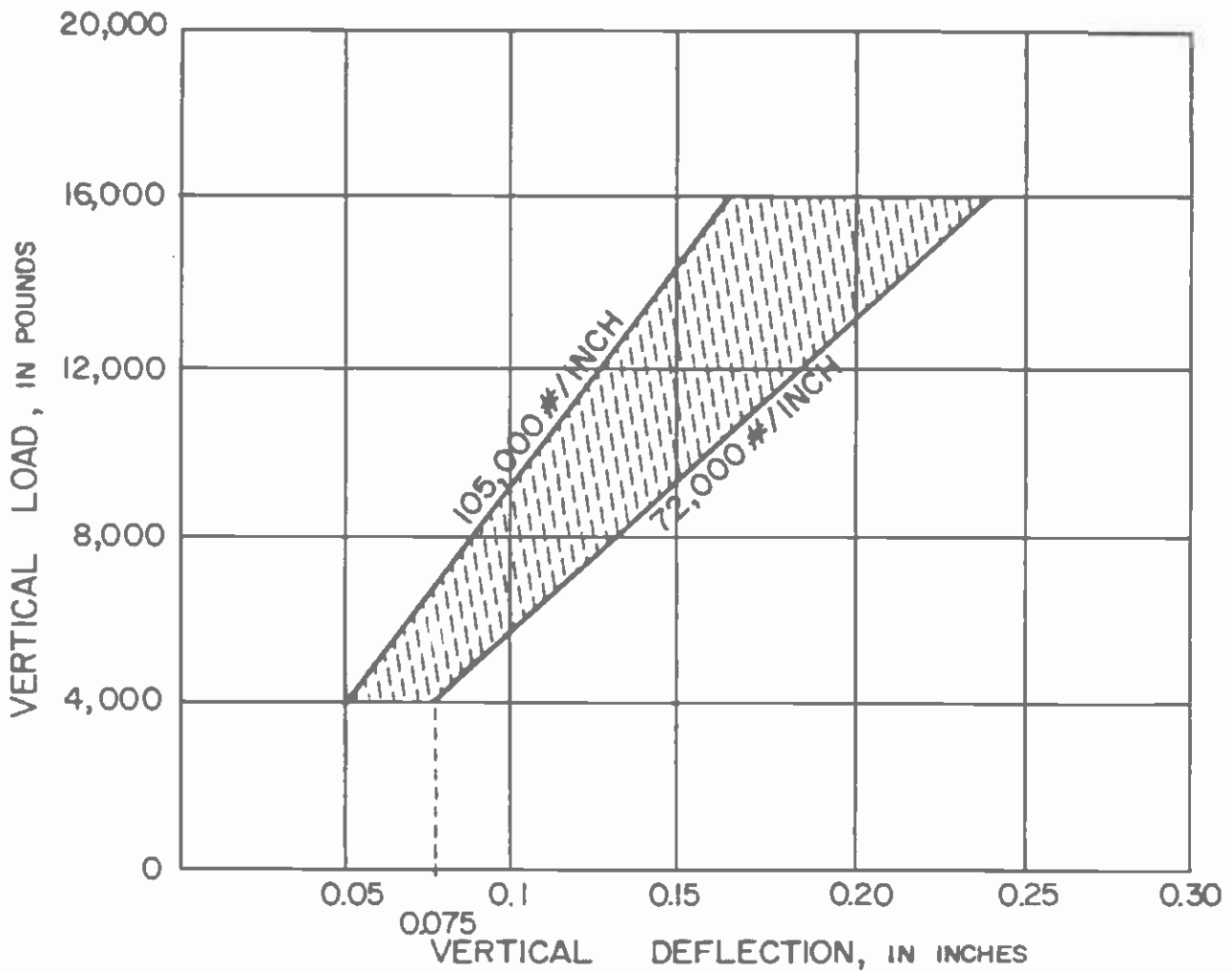

THE VERTICAL LOAD VERSUS DEFLECTION CURVE FOR A 4 FOOT LONG BOTTOM SECTION OF THE RUBBER BOOT TO BE WITHIN THE INDICATED ENVELOPE. INDICATED SPRING RATES ARE ONLY FOR DEFINING ENVELOPE OUTLINE.

SOUTHERN CALIFORNIA RAPID TRANSIT DISTRICT

METRO RAIL TRANSIT CONSULTANTS
DMJM/PBQD/KE/HWA

VERTICAL RESILIENCY
ACCEPTANCE CRITERIA

SCALE: AS NOTED

DATE: 28 JUN 85

SPEC SECTION: 02453

FIGURE: 02453-1

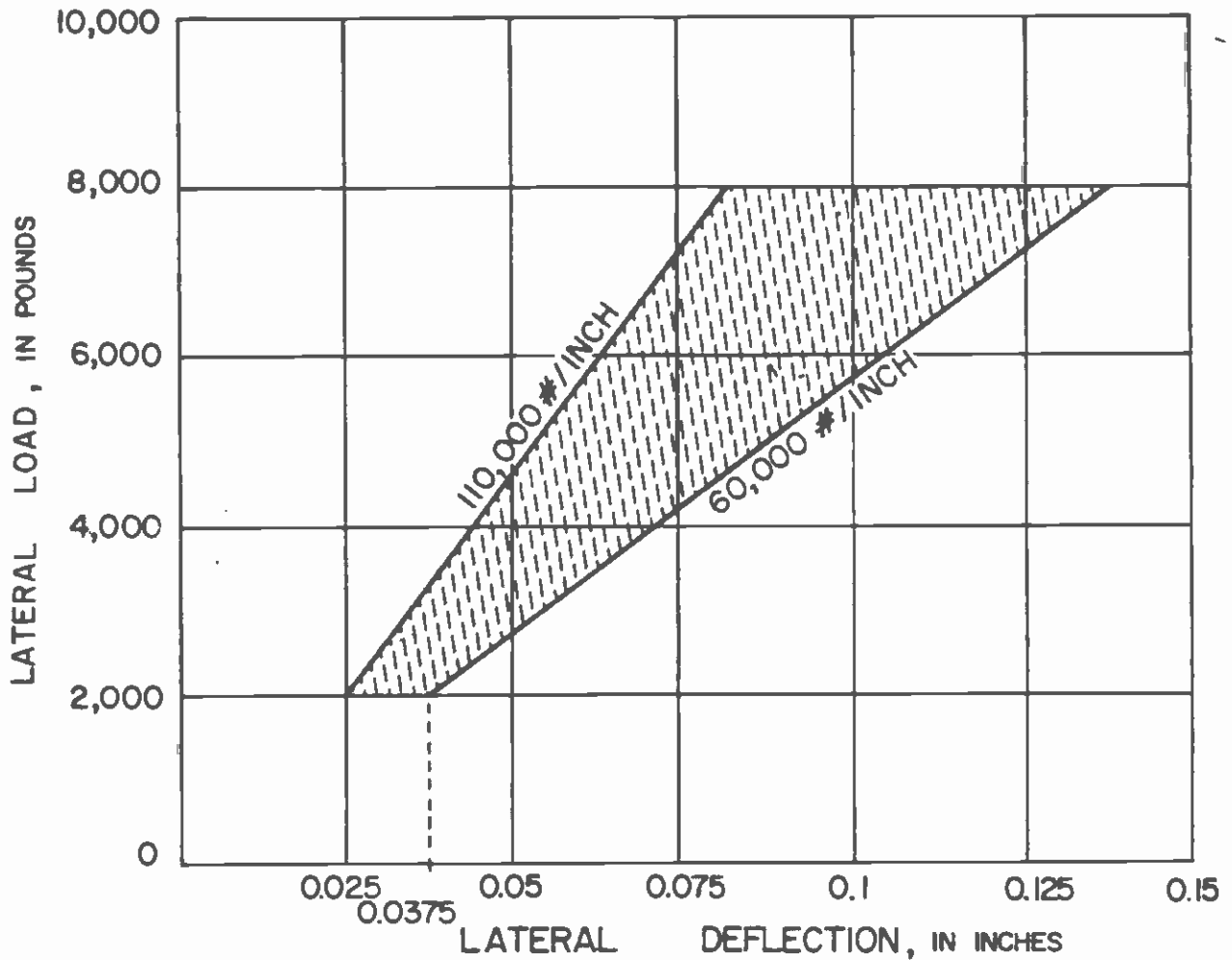

THE LATERAL LOAD VERSUS DEFLECTION CURVE FOR A 4 FOOT LONG SIDE SECTION OF THE RUBBER BOOT TO BE WITHIN THE INDICATED ENVELOPE. INDICATED SPRING RATES ARE ONLY FOR DEFINING ENVELOPE OUTLINE.

SOUTHERN CALIFORNIA RAPID TRANSIT DISTRICT

METRO RAIL TRANSIT CONSULTANTS

DMJM/PBQD/KE/HWA

LATERAL RESILIENCY
ACCEPTANCE CRITERIA

SCALE: AS NOTED

DATE: 28 JUN 85

SPEC SECTION: 02453

FIGURE: 02453-2

SECTION 02454

SPECIAL TRACKWORK CONSTRUCTION - BALLASTED

PART 1 - GENERAL

1.1 DESCRIPTION - The Work specified in this Section consists of the following:

A. Furnish Materials in including:

1. Ballast
2. Special trackwork components
3. Running rail
4. Timber ties
5. Track appurtenances and other track material as required to complete construction

B. Construct Special Trackwork including:

1. Place and compact initial ballast layers
2. Install special trackwork components, continuous welded rail, anchor, align, and join rail to indicated grades, lines, and elevations.
3. Place, compact, tamp, and dress ballast materials.

C. Assist in electrical tests

D. Perform final adjustments and clean up of site area.

1.2 QUALITY ASSURANCE

A. General Requirements - Refer to Section 02450, General Track Construction, and Section 02452, Ballasted Track Construction, and conform to the Quality Assurance requirements including the Quality Assurance Program.

B. Tolerances

1. The variance from the designed distance for the turnout lead - less than 3/16 inch.
2. The variance from the designed location for the point of intersection of a turnout (PITO) - less than 1/4 inch as determined by the frog position.

3. The variance from the designed distances between points of intersection (PI) and/or points of intersection of a turnout (PITO) within a specific turnout unit - less than 1/4 inch as determined by the frog position.
4. The variance from the designed distance of the frog guard rail offset - less than 1/4 inch.
5. The variance from the designed distances of the turnout offsets to the curved closure rail - less than 1/8 inch.
6. The gap between the switch rail and the stock rail from the point of switch to the No. 2 switch rod - less than 1/32 inch.
7. With the switch points in normal position, they shall be square within one half inch.

1.3 SUBMITTALS

- A. Refer to Section 01300, Submittals.
- B. Refer to Section 01340, Shop Drawings, Product Data, and Samples, and submit manufacturer's printed installation instruction for lubricants.

1.4 MEASUREMENT - Excepting ballast the Work of this Section will be measured for payment by the unit each, complete with all specified items and miscellaneous track appurtenances in-place. Variations in similar special trackwork units due to slight geometry alterations or various contact rail configurations will not be measured separately.

1.5 PAYMENT - The Work of this Section will be paid for at the Contract unit price for each type of special trackwork unit shown on the Bid Form.

PART 2 - PRODUCTS

- 2.1 BALLAST - Section 02458, Ballast.
- 2.2 TIMBER TIES - Section 02457, Timber Ties.
- 2.3 RUNNING RAIL - Section 02455, Running Rail.
- 2.4 SPECIAL TRACKWORK - Section 02466, Special Trackwork.
- 2.5 JOINT BARS, SPIKES, PLATES, BOLTS, NUTS AND WASHERS, RAIL ANCHORS - Section 02459, Track Appurtenances and Other Track Material.

- 2.6 CREOSOTE TREATMENT - Conform with A.W.P.A. standard P7 "Standard for Creosote for Brush or Spray Treatment for Field Cuts.
- 2.7 LUBRICANTS - Provide a dry film lubricant for application to special plates. The lubricant shall have low electrical conducting properties as approved by the District or its designee.

PART 3 - EXECUTION

3.1 INSPECTION

- A. Refer to Section 02450, General Track Construction, and Section 02452, Ballasted Track Construction, and prepare a pre-construction report.
- B. Inspect sub-ballast surface for ruts or other defects which impede its function as a drainage surface.

3.2 PREPARATION

- A. Place and compact an initial layer of ballast as specified in Section 02452, Ballasted Track.
- B. Stake-out centerline of special trackwork units and locate points of switches, points of frogs, and points of intersection.
- C. Set top of rail elevation markers.
- D. Distribute, space, and align timber ties normal to centerline of track, at spacings indicated, and with tie ends on line side of track equidistant from rail and with wider heartwood face down.

3.3 INSTALLATION

- A. Assemble special trackwork units complete on the initial ballast layer within two inches of final alignment.
- B. Field bore timber ties with a 9/16 inch diameter hole for all spikes to a depth not less than 5 inches or greater than 5 1/2 inches. Immediately treat holes with creosote treatment.
- C. Fully spike all plates within the special trackwork unit, using cut spikes in rail holding positions and lock spikes in plate holding positions as follows:
 - 1. Slide plates with braces - 4 lock spikes
 - 2. Slide plates without braces - 2 lock & 2 cut spikes

3. Gauge plates with risers - 8 lock spikes
 4. Gauge plates without risers - 8 lock spikes
 5. Heel plate - 8 lock & 4 cut spikes
 6. Hook twin plates - per pair, 4 lock & 2 cut spikes
 7. Guard Rail Plates - 4 lock and 4 cut spikes
 8. Standard AREA Tie Plates - 2 lock & 3 cut spikes -
Install 2 cut spikes on gauge side of rail and 1 cut
spikes on field side of rail.
 9. Install additional spikes as required in modified
plates of split switch derail.
- D. Use indicated tangent offsets tables to establish line
for turnout rails.
 - E. Raise, surface, align, and anchor trackwork as specified
herein and in Section 02452, Ballasted Track
Construction.
 - F. Uniformly tamp ballast along both sides of each tie for
15 inches on both sides of running rail.
 - G. Make top of ballast section 1 inch below top of tie
throughout special trackwork units, except make ballast
level three inches below the base of the rail in the
cribs between point and heel of switch rails to provide
additional ballast clearance at operating and vertical
switch rods.
 - H. Install bonded insulated joints and standard joints as
specified in Section 02459, Track Appurtenances and Other
Track Material.
 - I. Contact rail insulators - Refer to Section 02460, Contact
Rail System.

3.4 FIELD QUALITY CONTROL

- A. Refer to Section 02452, Ballasted Track Construction and
to Section 02459, Track Appurtenances and Other Track
Materials.
- B. Demonstrate to the District or its designee that switch
points move freely without binding or excessive force in
each completed special trackwork switch section.

3.5 ADJUSTMENT AND CLEANING

- A. Refer to Section 02450, General Track Construction
- B. Clean riser plates before applying a uniform coat of lubricant over entire sliding surface.
- C. Final adjustment of switch to be performed in cooperation with the Train Control Contractor and as scheduled by the District or its designee.

END OF SECTION .

SECTION 02455

RUNNING RAIL

PART 1 - GENERAL

1.1 DESCRIPTION - The Work specified in this Section consists of manufacturing, and testing, of running rail.

1.2 QUALITY ASSURANCE

A. Quality Assurance Program - Refer to Section 02450, General Track Construction, and conform to the requirements of the Quality Assurance Program.

B. Except for modifications, amplifications, and additions indicated herein, perform Work in accordance with the requirements of the American Railway Engineering Association (AREA), 1984-85 Manual for Railway Engineering (Fixed Properties), Volume 1, Chapter 4, "Rail".

C. Tolerances

1. Dimensions to conform with AREA "Specifications for Steel Rails, Article 5, Section."

2. Workmanship to conform with AREA "Specifications for Steel Rails, Article 13, Workmanship."

D. Source Quality Control

1. Brinell Hardness Test. Perform in accordance with AREA "Specifications for Steel Rails, Article 4, Hardness Properties", and as specified herein, for the following rail types.

a. Fully Heat-Treated Rails - In accordance with AREA "Specifications for Fully Heat-Treated Carbon Steel Tee Rails as produced by Bethlehem Steel Corporation" with the following modifications:

1) Perform Brinell hardness determinations on a minimum of ten percent of the rails or equivalent samples in each tempering charge.

2) Test equivalent samples which are full rail sections and at least ten inches in length from the same heat as the rails being treated.

3) Obtain Brinell hardness readings at the midpoint of the hardness test specimens, with regard to both length and width, on the top of the rail head after removing the decarburized metal.

- 4) If a rail sample tested fails to meet the specified Brinell hardness values, recheck it by making additional hardness measurements, one on each side of the point first measured and approximately one inch from that point. If both of these check measurements meet the required hardness, the hardness of the rails represented will be considered acceptable. If any of the rail samples tested fail in the check test to meet the required hardness, test each rail in the charge and retain only those showing a hardness meeting the specifications.
 - 5) Rails failing to meet the required hardness may be retreated only one additional time. Retest rails for hardness which have been retreated in accordance with these specifications.
- b. Surface Heat-Treated Rails - In accordance with AREA "Specification for Heat-Treated Carbon Steel Tee Rails (USS Curvemaster) As Produced By The United States Steel Corporation", with the following modifications:
- 1) After removing decarburized metal, conduct two Brinell hardness tests on the top head surface of each heat-treated rail, within two feet from each end. Such hardness measurements shall be in the range of 321-388 HB.
 - 2) In addition, conduct at least one hardness pattern test per 1600 feet of heat-treated rail or one per day of treatment. Perform the test on a cross-section sample cut from within two feet of the end of the tested rail. After etching the sample, determine the extent of the heat-treated zone and ensure that it has a cross-section as shown in Figure O2455-1. Determine the Brinell hardness through the heat treated zone along traverses 1 and 2, shown in Figure O2455-1, in 1/16 inch intervals from the hardened surface toward the unhardened base metal. Each traverse must show a pattern of hardness gradually decreasing toward the unhardened base metal from the head surface. Hardness measurements within the heat treated zone must be in the range of 321-388 HB.
 - 3) Rails failing to meet the required hardness may be retreated only one additional time. Retest rails for hardness which have been retreated in accordance with these specifications.

2. Ultrasonic Testing - Determine the internal condition of the rails by nondestructive testing in accordance

with AREA "Specifications for Steel Rails, Supplementary Requirements, Articles S2 and S3, Ultrasonic Testing and Calibration and Operation of Instruments", with the following modifications:

a. Test the full length of each rail's head, web and base after completion of rail straightening operations. Personnel operating ultrasonic equipment shall be certified for testing in accordance with ASNT specification No. SNT-TC-1a, NDT Level 1. The testing may be performed with automatic in-line or manual equipment.

b. Automatic In-Line Testing:

1) Use standard dual element transducers from 2.25 to 5 MHz. Place a sufficient number of transducers to scan vertically down through the centerline of rail from the top of the head, horizontally through the head from the side, horizontally through the web from the side, and across the rail base.

2) For calibration of the testing equipment, use a full section 115 RE test rail of sufficient length to accurately calibrate the testing equipment at production testing speed. The test rail must contain at least one calibration reference for each transducer. Run the test rail through the testing equipment before the beginning of operation and at least once every eight hour testing period. Adjust the sensitivity level of the testing equipment to detect the calibration references.

3) At a minimum, the testing equipment must be capable of detecting a 1/8-inch by 1/4-inch deep by 12-inch long discontinuity in the head; a 1/4-inch by 5/16-inch deep discontinuity the full height of the web; and a 1/4-inch by 1/2-inch deep by 1/2-inch long vertical discontinuity in the base at rail centerline. Any rail with discontinuities greater than the above shall be cut back to sound metal in accordance with the minimum rail length requirements or it will not be accepted.

c. Manual Testing:

1) Use a standard dual element transducer from 2.25 to 5 MHz. Produce the test reference block from a material similar to the rail steels being tested. It shall have a thickness of approximately 5/8 inch and contain a 3/64-inch diameter flat bottom hole drilled to 5/16-inch depth.

- 2) Calibrate the equipment before start of testing and every 30 minutes thereafter. When the search unit is coupled to the calibration test block, the indication height from the calibration reference shall serve as a reference level for the test. The reference level should appear from 40 percent to 80 percent of the maximum height on the cathode ray tube graticule.
 - 3) Any rail giving an indication greater than the reference level shall be cut back to sound metal in accordance with the minimum rail length requirements or it will not be accepted.
3. Magnetic Particle Inspection - A Powder or dye penetrant test, in accordance with ASTM E709 or ASTM E165 is acceptable as a complimentary method when it may provide a better indication of shallow defects and cracks, but it will not be accepted as a substitute for ultrasonic testing.
 4. Resistance to Impact Test - In accordance with AREA "Specifications for Steel Rails, Article 8, Resistance to Impact".
- D. Testing Laboratory Services - Refer to Section 01410, Testing Laboratory Services.

1.3 SUBMITTALS

- A. Refer to Section 01300, Submittals.
- B. Refer to Section 01340, Shop Drawings, Product Data, and Samples, and submit the following.
 1. Process for casting the steel
 2. Process for hydrogen elimination
 3. Process for heat treatment if applicable.
 4. Chemical composition of the proposed alloy rail, if to be supplied, including the average Brinell Hardness that will be attained.
 5. Proof of alloy rail's ability to consistently meet rail welding requirements in accordance with Section 02467, Rail Welding, when flash butt welding alloy rail to alloy rail, and alloy rail to standard rail.
- C. Refer to Section 01322, Certificates and Reports, and submit the following.
 1. Description of the ultrasonic testing equipment, procedure, and certification for the testing personnel.

2. Completed AREA Report Forms 401-A, 401-B, and 401-D or equivalent forms.
 3. Brinell hardness testing records.
 4. Ultrasonic testing records, including equipment calibration results, a listing of all rails tested and hardcopy readouts from the ultrasonic testing equipment for all rails with rejectable discontinuities.
 5. The control cooling, vacuum-treating and heat treating records.
- 1.4 MEASUREMENT - The Work specified in this Section will not be measured for payment.
- 1.5 PAYMENT - The Work in this Section will be paid for as part of the contract unit price for the particular type of track construction to which it pertains.

PART 2 - PRODUCTS

2.1 RUNNING RAIL

A. General Requirements

1. Rail Section and Weight - New 115 RE rail section conforming with the dimensional requirements shown in AREA "Recommended Rail Sections, 115 RE Rail Section."
2. Rail Types
 - a. Standard Rail - Standard strength carbon steel rail.
 - b. High Strength Rail - Either fully heat-treated, surface heat-treated, or alloy high-strength rail.
3. Hardness Properties - In accordance with AREA "Specifications for Steel Rails, Article 4, Hardness Properties". For alloy high strength rail, the Brinell hardness shall conform with the AREA requirements for high-strength rail.
4. Interior Condition - In accordance with AREA "Specifications for Steel Rails, Article 9, Interior Condition". The AREA required macro-etched rail sample shall reveal a clean steel which is devoid of harmful segregation, nonmetallic inclusions, pipes, and cracks. Rail steel shall have fully pearlitic microstructure.

5. Surface Classifications - In accordance with AREA "Specifications for Steel Rails, Article 10, Surface Classification".
6. Rail Length - In accordance with AREA "Specifications for Steel Rails, Article 11, Length".
7. Rail Ends - Furnish rails with blank ends.

B. Material Requirements

1. Chemical Composition

- a. Standard Rail - In accordance with AREA "Specifications for Steel Rails, Article 3, Chemical Composition," for "Standard Rail."
 - b. High Strength Rail - Fully heat-treated or surface heat-treated rail in accordance with the chemical composition requirements for "Standard Rail". The chemical composition for high-strength alloy rail to meet with manufacturer's requirements provided that it also is in accordance with all applicable articles in these specifications.
2. Use only rails which are free from surface imperfections and flaws of all kinds for heat-treated high strength rail.

C. Manufacturing

1. Conform with AREA "Specifications for Steel Rails, Article 2, Manufacture."
2. Conform with AREA "Specifications for Steel Rails, Article 7, Hydrogen Elimination."
3. Cut rails square and clean by rail saw, shear or abrasive cutting wheel. Torch cutting is prohibited.

D. Identification

1. Stamp and brand rails in accordance with AREA "Specifications for Steel Rail, Article G, Branding and Stamping." Include the rail type in the web of the rail following the method of hydrogen elimination.
2. Mark rails in accordance with AREA "Specifications for Steel Rails, Article 15, Markings". Rail, which is less than the standard length, mark green.

PART 3 - EXECUTION

3.1 INSTALLATION - Installation of rail and rail welding is not part of the work specified in this Section. For installation and rail welding requirements, refer to the applicable track installation and rail welding specification Sections.

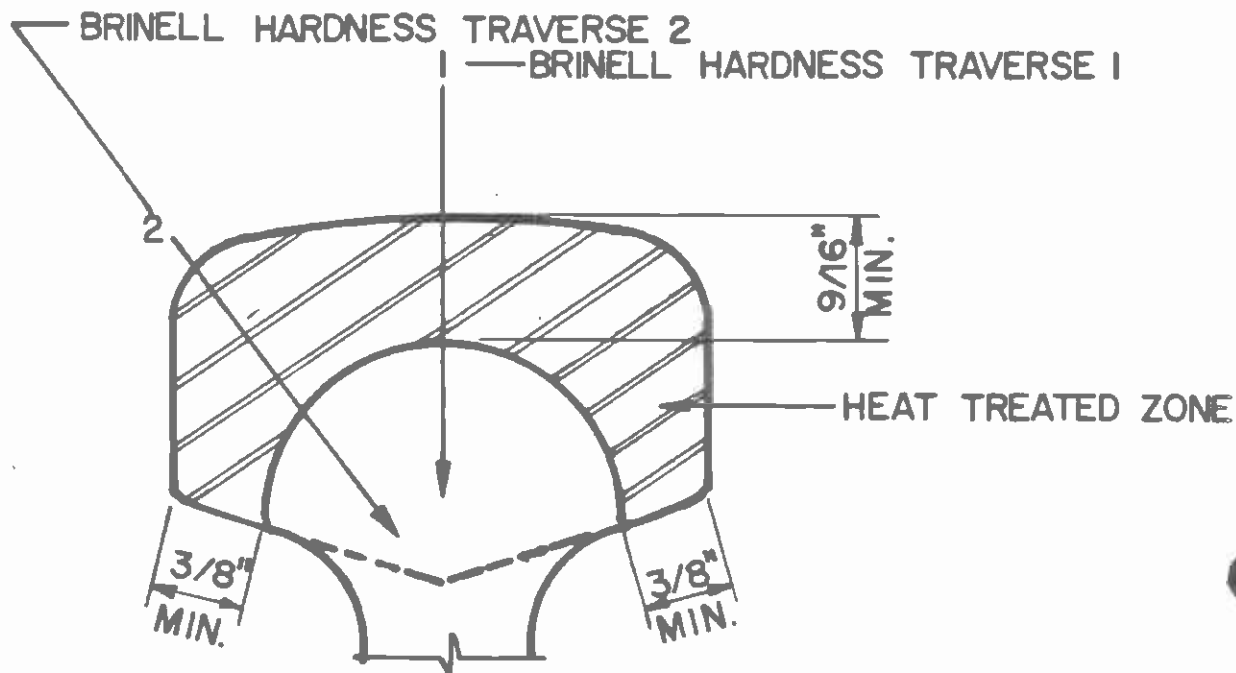

SOUTHERN CALIFORNIA RAPID TRANSIT DISTRICT

METRO RAIL TRANSIT CONSULTANTS

DMJM/PBQD/KE/HWA

CROSS SECTION OF SURFACE HEAT-TREATED

115 RE RAIL SAMPLE PREPARED FOR TESTING

SCALE: NONE

DATE: 28 JUN 85

SPEC SECTION: 02455

FIGURE: 02455-1

SECTION 02456

DIRECT FIXATION RAIL FASTENERS

PART 1 - GENERAL

1.1 DESCRIPTION

A. The Work specified in this Section consists of designing, qualification testing, manufacturing, and production testing of direct fixation rail fasteners.

B. Function of Rail Fastener

1. Secure running rail to concrete trackbed in direct fixation track and floating slab track;
2. Provide vertical, lateral, and rotational stability to the rail;
3. Restrain rail from movement in longitudinal direction;
4. Dampen noise vibrations generated by moving wheels on the rail; and
5. Electrically isolates rail from trackbed.

1.2 QUALITY ASSURANCE

A. Quality Assurance Program - Refer to Section 02450, General Track Construction and conform to the requirements of the Quality Assurance Program.

B. Reference Standards

1. American National Standards Institute (ANSI):

B18.21.1, Lock Washers

B18.22.1, Plain Washers

2. American Society of Testing and Materials (ASTM):

A165, Electrodeposited Coatings of Cadmium on Steel.

A167, Stainless and Heat-Resisting Chromium-Nickel Steel Plate Sheet, and Strip.

A325, High Strength Bolts for Structural Steel Joints Including Suitable Nuts and Plain Hardened Washers.

B117, Salt Spray (Fog) Testing.

- B633, Electrodeposited Coatings of Zinc on Iron and Steel.
 - B395, Rubber property - Compression Set.
 - C39, Compressive Strength of Cylindrical Concrete Specimens.
 - D25/, D-C Resistance or Conductance of Insulating Materials.
 - D412, Rubber Properties in Tension.
 - D429, Adhesion of Vulcanized Rubber to Metal.
 - D471, Rubber Property - Effect of Liquids.
 - D518, Rubber Deterioration - Surface Cracking.
 - D570, Water Absorption of Plastics.
 - L573, Rubber Deterioration in an Air Oven.
 - D1125, Electrical Conductivity and Resistivity of Water.
 - D1149, Rubber Deterioration - Surface Ozone Cracking in a Chamber (Flat Specimen).
 - D1229, Rubber Property - Compression Set at Low Temperatures.
 - D2000, Standard Classification System for Rubber Products in Automotive Applications.
 - D2240, Rubber property - Durometer Hardness.
 - E162, Surface Flammability of Materials Using a Radiant Heat Energy Source.
 - G8, Cathodic Disbonding of Pipeline Coatings.
 - G12, Non-destructive Measurement of Film Thickness of Pipeline Coating on Steel.
3. National Fire Protection Association (NFPA): No. 258, Determining Smoke Generated by Solid Materials.
 4. Rubber Manufacturers Association - Rubbers Handbook.
 5. UL 94, Tests for Flammability of Plastic Materials.

C. Tolerances

1. Dimensions affecting the shape factor of the elastomer shall be determined by the Contractor so that the complete rail fastener conforms to the physical requirements and acceptance criteria for fastener tests.
2. Manufacturing tolerances for fastener shall be:
 - a. Length and widths - plus or minus 1/16 inch;
 - b. Thickness - plus or minus 1/32 inch;
 - c. Squareness - plus or minus one degree;
 - d. Centering of holes - plus or minus 1/32 inch;
 - e. Diameter of holes - plus or minus 1/32 inch;
 - f. Durometer Shore A - plus or minus five.
 - g. Serration depth - plus .013 inches and minus .002 inches.

D. Source Quality Control

1. Production tests shall be performed on two direct fixation rail fasteners from the initial production lot of 50 rail fasteners and on two direct fixation rail fasteners from each lot of 5,000 rail fasteners or portion thereof.
2. The rail fasteners selected for production tests shall be subjected to the entire test series required for "Fastener A" in Figure 02456-1 except that the number of cycles for the Vertical and Lateral repeated load test shall be 500,000.
3. The production lot will not be accepted until the production tests have been successfully completed. Should any fastener fail to meet the test requirements, two additional fasteners from the same production lot shall be subjected to the production tests.
4. Fasteners used for production testing and meeting all test requirements shall be permanently marked as a production test fastener and be included in the final delivery quantity.
5. The Contractor shall provide certification on each batch of elastomer used in the manufacture of direct fixation rail fasteners, verifying compliance of each batch of elastomer seven days prior to shipment of fasteners.

6. Facilities for production testing shall be approved by the District or its designee.

1.3 SUBMITTALS

- A. Refer to Section 01300, Submittals.
- B. Refer to Section 01340, Shop Drawings, Product Data, and Samples, and submit the following:
 1. Submit Shop Drawings of the fastener, including information for fabrication and the ASTM D2000 designation for the elastomer. Show tolerances, dimensions, details, materials, welds, and finishes. Describe the procedures for installation and replacement of the fastener components. Describe the procedures for lateral adjustment.
 2. If the rail clips furnished are not suitable for use at bonded joints, submit drawings of rail clips for bonded joints. The rail clips shall hold the rail firmly to the body of the rail fastener and shall be made of the same type of spring steel used for the standard rail clips.
 3. Epoxy coating for inserts - Submit material specifications, and application procedure.
 4. Testing facility - Submit descriptions of test equipment.
- C. Refer to Section 01322, Certificates and Reports, and submit the following:
 1. Test Reports - Test reports of fastener prototype testing shall be furnished by the testing facility to the Contractor and to the District or its designee. Each test shall be reported on a separate form or forms. In addition, test results of each fastener shall be summarized separately. Conformance or deviations shall be highlighted in a Report Summary.
 2. Progress Photographs - Accompanying the written test reports shall be a Photographic Record of the tests. The photographic record shall contain photographs of sufficient clarity to distinguish relevant details as described or referenced in the respective written report.
 3. Welding Records and Data
 - a. Prior to commencing work requiring welding, submit the procedure which will be used for prequalifying welders and welding procedures. For procedures other than those set forth in Paragraph 5.1 of

AWS D1.1, submit a copy of procedure qualification test records.

b. Submit certified copy of qualification test record for each welder, welding operator, and tacker who will be employed in the work.

4. Submit certified copy of reports for analyses and tests required by referenced ASTM specifications, including test reports for filler metals for welding and mechanical tests for high strength bolts.

5. Submit certifications on elastomer batches.

1.4 QUALIFICATION TESTS

A. General

1. The Contractor shall perform the required Qualification Tests consisting of testing samples of elastomer, anchorage assemblies, and assembled fasteners as indicated. The Contractor is responsible for the testing program; furnishing instruments, labor, tools, and procedures for testing.

2. Qualification test procedures and acceptance criteria for elastomer compounds with a natural rubber base shall be used only if the elastomer compound contains 50 percent or more natural rubber.

3. Tests and chemical analyses shall be performed by either an independent testing laboratory in conformance with Section 01410, Testing and Laboratory Services, or a district approved manufacturer's laboratory. In either case, qualified personnel and proper equipment are mandatory and District approval (of the testing facility) is required prior to qualification testing.

4. Test equipment shall be in calibration with standards, which are certified and traceable to the National Bureau of Standards, within one year immediately preceding the test date.

5. All qualification tests on elastomer, anchorage assemblies, and assembled rail fasteners shall be successfully completed to the approval of the District or its designee before commencing the production of rail fasteners and fastener components.

B. Direct Fixation Rail Fastener Test Assembly.

1. Following review of the shop drawings by the District or its designee, prototype fasteners and shims shall be manufactured for testing. From a lot of not less

than thirty fasteners, fifteen fasteners, meeting the design requirements outlined in these specifications, shall be furnished to the laboratory for testing. Of the 15 fasteners, seven shall be retained for the District or its designee and eight delivered to the testing facility. Four (or four pair if required) standard direct fixation fasteners designated as A, B, C, and D shall be assembled and mounted as specified. Each shall be subjected to the designated tests and in the indicated sequence as shown in Figure 02456-1.

2. Except as otherwise specified herein, each test shall be performed on a completely assembled direct fixation fastener with a section of 115 RE Rail not less than one foot in length mounted thereon. Before assembly, metal parts and elastomer shall be wiped clean and dry. The fastener shall be assembled as shown on the Contractor's drawing and approved by the District or its designee and as outlined in the installation description. Threaded elements shall be tensioned as specified.
3. The fastener, with 1/8 inch base shim and 3/8 inch polyethylene shim, and the anchorage assemblies shall be mounted on a concrete block. The test block shall be of concrete with a compressive strength of not greater than 4,000 pounds as determined by ASTM C39. The tests may be performed in a multiple fastener configuration in which case, two complete fasteners shall be mounted on 30 inch centers with a section of rail not less than 3 1/2 feet long. With this assembly, the specified loading shall be applied to the rail at two locations corresponding to the centers of the fasteners. The test report shall clearly indicate the performance of each of the fasteners separately. Failure of either one of the fasteners will be sufficient cause for the rejection of the fastener design. Shims are to be removed when performing the static vertical load test procedure.
4. Before commencing tests, the fasteners and concrete test blocks shall be stabilized at a temperature of 23°C, +/- 4°C, for at least four hours. Testing shall be performed within the same temperature range except as otherwise noted.

C. Static Load Tests:

1. Vertical Load Test - A vertical load increasing in increments of 1,000 pounds to a maximum load of 16,000 pounds at a rate not less than 100 pounds per minute and not more than 1000 pounds per minute, shall be applied downward at the centerline of the rail head at the centerline of the fastener and normal to the rail. For each increment of load at 4,000 pounds and above,

measure and record the vertical deflection of the rail head to the nearest 0.001 inch. The load shall be removed and the final position of the rail head measured and recorded. No shims are to be used during this test procedure.

2. Acceptance Criteria

- a. The vertical load versus deflection curve shall lie within the envelope shown in Figure 02456-2. The slope of the load-deflection curve (the fastener spring rate) shall be within 15 percent of a constant slope as determined by a line fitted to points at each 1,000 pound increment from 4,000 to 8,000 pounds.
 - b. The total compressive deflection of the elastomer at the 10,400 pound load shall not exceed 25 percent of the uncompressed thickness. After removal of the maximum load of 16,000 pounds, the fastener shall return to within 0.005 inch of its original position within one minute. At no time during the tests shall a fastener component exhibit a sign of failure by slippage, yielding or fracture. Slippage is defined herein to mean movement of any fastener component relative to its initial position not attributable to deflection of the elastomer.
 - c. The values obtained when this test is repeated, after performance of other tests, on a fastener shall be within 15 percent of the initial test values.
3. Vertical Uplift Test - Apply a vertical load to the center of the rail head at the centerline of the fastener normal to the rail, alternating continuously from a downward load to an upward load. The upper and lower peaks per cycle shall be increased in increments of 200 pounds each cycle up to a maximum load of 2,400 pounds. The loads and deflections shall be continuously measured to the nearest 0.001 inch and immediately recorded on a load-versus-time graph and deflection-versus-time graph, respectively. Remove the load and measure and record the final position of the rail head. The reaction force to the uplift load shall be applied to the test block on which the fastener is mounted.
4. Acceptance Criteria - The vertical deflection of the fastener for an upward load of 2,000 pounds shall be within plus 5 percent to plus 135 percent for the 2000 pound downward vertical load as determined from the vertical load tests. When the vertical load is continuously varied from vertical downwards to vertical uplift loads, there shall be no indication of backlash

or freeplay at times when the load or the deflection changes direction. After removal of the maximum load, the rail shall, within two minutes, return to within 0.005 inch of its original position. At no time during the test shall a fastener component, including the anchorage to the test block, exhibit a sign of failure by slippage, yielding, or fracture.

5. Lateral Load Test - While applying a constant vertical load of 10,400 pounds downward at the center of the rail head, a lateral load, increasing in increments of 1,000 pounds to a maximum load of 7,000 pounds at a rate not less than 100 pounds per minute and not more than 1000 pounds per minute, shall be applied horizontally to the gauge side of rail head at the point of vertical load. The horizontal force shall be applied 0.625 inch below the top of the rail. For each load increment the lateral deflection of the rail head at a point 0.625 inch below the top of the rail shall be measured to the nearest 0.001 inch and recorded. Remove the lateral load and measure and record the final position of the rail head.
6. Acceptance Criteria - The lateral load versus deflection curve shall lie within the envelope shown in Figure O2456-3. The difference between the original and final positions of the gauge line shall not exceed 0.062 inches. At no time during the test shall a fastener component exhibit a sign of failure by slippage, yielding or fracture.
7. Lateral Restraint Test - Two equal lateral loads increasing simultaneously in increments of 500 pounds up to a maximum load of 3,000 pounds shall be applied normal to the rail in the same direction and at the base of the rail. Loads shall be symmetrical on each side of the fastener centerline. The lateral deflection shall be measured to the nearest 0.001 inch at the intersection of the centerline of the fastener and the gauge line of the rail. Measurements shall be recorded after each increment of loading.
8. Acceptance Criteria - The difference between the original and final positions of the gauge line shall not exceed 0.062 inch. The lateral deflection of the rail when fully loaded shall not exceed 0.125 inch from the original gauge line of the rail. At no time during the test shall a component show signs of slippage, yielding or fracture.
9. Longitudinal Restraint Test - Support the rail end on a roller or other frictionless support properly elevated to prevent the longitudinal load from binding the rail in the fastener. Apply a load longitudinally to the rail at its centroid increasing in increments

of 200 pounds up to a total load of 4,000 pounds or until the rail deflects 0.6 inches from the initial position. Maintain each load increment constant until the longitudinal deflection of the rail ceases before increasing the load by the next increment. For each load measure and record the longitudinal deflection of the rail to the nearest 0.001 inch. Then remove the longitudinal load and measure and record the final position of the rail. Plot the recorded values for longitudinal load versus deflection on a graph as shown on Figure 02456-4.

10. Acceptance Criteria - The difference between the original and final positions of the rail shall not exceed 0.125 inch plus the slippage distance of the rail. The longitudinal load versus deflection curve when plotted on a graph similar to Figure 02456-4 shall lie entirely within the limits shown shaded. At no time during the test shall a fastener component exhibit a sign of failure by slippage, yielding, or fracture except for the slippage which occurs between the rail hold-down clips and the rail.
11. Voltage Withstand Test - Prepare a fully assembled fastener and thoroughly spray it with distilled water to make the fastener and rail completely wet. Within 15 minutes after spraying, apply a DC potential of 15,000 volts between the rail head and the bottom plate of the direct fixation rail fastener for one minute.
12. Acceptance Criteria - The elastomer shall withstand this test with no visible damage such as splits, cracks, pinholes or fractures. There shall be no evidence of arcing, arc tracking, or other voltage breakdown.
13. Electrical Resistance and Impedance Test - Following the Voltage Withstand Test apply 500 volts DC to the rail head for three minutes with all anchor bolts and the bottom plate grounded. Measure the resistance with an accuracy of plus or minus two percent and record. Next remove the fastener from the test block and immerse it in deionized water for 70 hours at 100°C for neoprene based elastomers or for 336 hours at 70°C for natural rubber based elastomers. After removal from the water immersion, without drying and with no portion of the fastener at a temperature less than 35°C, install the fastener on the test block and test for electrical resistance and impedance. With all anchor bolts and the bottom plate grounded, apply 500 volts DC to the rail head for three minutes. Measure the resistance with an accuracy of plus or minus two percent and record. Apply a potential of 50 volts AC to the rail head for three minutes for each

increment of measurement for frequencies from 20 Hertz to 12 kilohertz; in increments of 10 hertz up to 100 hertz, 200 hertz up to 1,000 hertz and 2,000 hertz up to 10 kilohertz. The impedance after three minutes shall be measured with an accuracy of plus or minus two percent and recorded for each frequency.

14. Acceptance Criteria - The minimum resistance for 500 volts DC shall be 10 megohms when dry and one megohm when wet. The minimum impedance for frequencies between 20 hertz and 10 kilohertz with 50 volts AC shall be 10,000 ohms.

15. Surface Leakage Electrical Test Procedure -

a. On the assembled direct fixation rail fastener, check electrical continuity between the rail head and the top plate, and between each anchor bolt and the bottom plate. Correct any occurrence of electrical resistance.

b. Precondition the test assembly between 60°F and 80°F with a relative humidity at 50 to 70 percent.

c. Immerse the assembled direct fixation rail fastener in potable water with a resistivity raised with sodium chloride of 1000 to 1500 ohm-centimeter in accordance with ASTM D1125.

d. Drain the water from the container to a level $\frac{1}{2}$ -inch below the ground plate and without drying, or otherwise disturbing the fasteners, or creating a condition that causes the fastener surfaces to dry, measure the resistance within fifteen (15) seconds after draining as follows:

1. Apply 100 volts between the rail head and the bottom plate for a period of fifteen (15) seconds.

2. Measure the applied voltage and resulting current flow, with an accuracy of plus or minus two percent and calculate the DC wet resistance.

3. Dry the fastener through use of heat lamps, but do not disturb any surface films which may develop during the drying period. Apply the heat for a time period sufficient to remove any visible evidence of moisture from the top and sides of the fastener.

e. Repeat the immersion, draining, and testing for 5 cycles.

16. Acceptance Criteria - The desired electrical resistance at 100 volts is 400,000 ohms. If the anchor bolts are normally isolated from the bottom plate, check each anchor bolt's resistance in addition to the bottom plate's resistance. This test is for informational purposes only.
17. Corrosion Test Procedure - The direct fixation rail fastener, without loose components, shall be exposed to a five percent chloride solution in accordance with ASTM B117-73, Salt Spray Fog Testing, for 744 hours.
18. Acceptance Criteria - There shall be no evidence of pitting by rust or stress corrosion on metal surfaces. There shall be no evidence of adhesion loss or blistering of adhesive coating. In areas where prior testing has removed the protective coatings, light surface rust is acceptable.

D. Repeated Load Tests:

1. Vertical and Lateral Repeated Load Test - Apply load on the rail head center so as to produce a vertical downward load of 10,400 pounds. Apply lateral loads to the gauge side of the rail head 0.625 inches below the rail head. Lateral loads shall be applied at the centerline of the fastener and normal to the rail. Lateral loads from the field side shall be 2,500 pounds and from the gauge side 4,000 pounds. Application of the lateral loads shall be alternate, each combined with the application and release of the vertical load. Application of the field side load together with the vertical load, loads release and then the gauge side load together with the vertical load and loads release shall constitute one cycle. The test shall be conducted for three million cycles. The loading frequency shall be regulated to prevent the temperature of components exceeding 50°C. The rail clips shall not be repositioned nor threaded elements retorqued without written approval of the District or its designee.
2. Acceptance Criteria - The fastener shall withstand the three million cycles of load application with no evidence of failure. Upon visual inspection, no component of the fastener shall exhibit evidence of failure by slippage, yielding, abrasion or fracture at any time during the test. The rail shall exhibit no evidence of wear or grooving that could contribute to failure of a rail.
3. Repeated Load Test With One Anchor Bolt - After completion of the vertical and lateral repeated load test, reassemble the fastener using only the original components previously tested. Then, with the gauge

side anchor bolt removed, repeat the vertical and lateral repeated load test for 15,000 cycles.

4. Acceptance Criteria - The fastener shall withstand the 15,000 cycles of loading with the gauge side anchor bolt removed with no evidence of failure by slippage, yielding, or fracture. The rail shall exhibit no evidence wear or grooving that could contribute to failure of a rail.

5. Uplift Repeated Load Test

a. A fully assembled fastener shall have loads applied to the rail head so as to produce alternately a vertical downward load of 10,400 pounds and a vertical upward load of 2,400 pounds at the centerline of the fastener normal to the rail. Apply the loads alternately for a total of 1.5 million complete cycles. The frequency shall be regulated to prevent component temperature reaching 50°C. Do not reposition rail clips nor retorqued threaded elements without written approval of the District or its designee.

b. During the final 500,000 cycles, a longitudinal load shall be applied to the rail at its centroid. Increase the load in increments of 100 pounds up to 600 pounds at intervals of at least one increment per 100 cycles of vertical loading. For each load increment, measure and record the longitudinal deflection of the rail to the nearest 0.001 inch. Then remove the longitudinal load and measure and record the longitudinal position of the rail. Plot the recorded values for the longitudinal load versus deflection on a graph.

6. Acceptance Criteria - The fastener shall withstand 1.5 million cycles of load application with no evidence of failure. Upon visual inspection no component of the fastener shall exhibit evidence of failure by yielding, abrasion, slippage or fracture. The rail shall exhibit no evidence of wear or grooving that could contribute to its failure. The plot of the load versus deflection curve shall indicate the elastic deformation and the residual deflection. The residual deflection shall not exceed 0.003 inch.

7. Push Pull Test

a. The rail end shall be supported on a roller or other frictionless support properly elevated to prevent the longitudinal load from binding the rail in the fasteners. Apply a cyclic longitudinal load at the centroid of the rail to slip the rail approximately 1/2 inch back and forth about its

initial position for a total of 10,000 cycles without repositioning rail clip or retorquing bolts. The 1/2 inch slip shall be measured with respect to a fixed point on the testing machine. Following this, components shall be checked against the acceptance criteria. Next, a cyclic longitudinal load at the rail centroid shall be applied to slip the rail approximately 1/8 inch back and forth about its initial position for a total of one million cycles.

b. Repositioning of rail hold down assembly will not be allowed during the second phase of the test. Loading frequency shall be regulated to prevent the temperature of components exceeding 50°C. Clean water may be applied occasionally as a spray in order to keep the temperature below 50°C.

8. Acceptance Criteria - The fastener shall withstand the 10,000 cycles and the one million cycles of load application with no evidence of failure. Upon visual inspection, no component shall exhibit evidence of failure by slippage, yielding, heavy abrasion, or fracture at any time during the test nor shall a spring clip show evidence of sliding out or backing out of its hold down housing. The rail shall exhibit no evidence of wear that could contribute to failure of a rail.

9. Dynamic to Static Stiffness Ratio Test

An oscillating downward load shall be applied at the centerline of the rail head at the centerline of the fastener so as to produce a sinusoidal load alternating between 4,000 and 8,000 pounds at a rate of between 10 and 20 Hertz. The load and deflection versus time shall be continuously recorded on a high speed oscillograph. After a minimum of 1,000 cycles, the dynamic stiffness shall be determined from the ratio of peak-to-peak force to peak-to-peak deflection from the recorded information. The deflection shall be measured to an accuracy of 0.001 inch or better.

Between 5 and 10 minutes after completion of the dynamic stiffness measurement, a vertical load increasing in 1,000 pound increments to a maximum load of 8,000 pounds at a rate not less than 100 pounds per minute and not more than 1,000 pounds per minute shall be applied at the centerline of the rail head at the centerline of the fastener. For each increment of load between 4,000 and 8,000 pounds record the vertical deflection of the rail head to the nearest 0.001 inch. The static stiffness of the fastener shall be the difference in load divided by the difference in deflection between 4,000 and 8,000 pounds.

10. Acceptance Criteria - The dynamic stiffness shall not exceed 1.5 times the static stiffness.
11. Heat Aging Test - Age test rail fastener, without rail, concrete test block, rail clip assembly, and anchorage assembly in an air oven. Neoprene based elastomers will be aged for 70 hours at 100°C and natural rubber based elastomer will be aged for 336 hours at 70°C as per ASTM D573.
12. Acceptance Criteria - This is a conditioning process and there is no acceptance criteria.

E. Testing Elastomer:

1. Specimens - Perform the following tests on each of two specimens that are identical in all respects to the elastomer proposed for use in fasteners. Use a separate pair of specimens for each test. Use specimens taken from a batch of compound used for making the elastomeric component of the fastener and having a cure equivalent to the cure of the elastomeric component. Prior to testing, condition specimens for at least seven days at 23°C and 50 percent relative humidity.
2. Hardness, measured by ASTM D2240 - At least 40 and not more than 75 Durometer, Shore A.
3. Tensile strength, measured by ASTM D412 - 1500 psi, minimum.
4. Ultimate elongation, measured by ASTM D412 - 350 percent, minimum.
5. High temperature compression set - Test for 22 hours in accordance with ASTM D395, Method B. For neoprene base elastomers, the test shall be conducted at 100°C and the set shall not exceed 35 percent. For natural rubber base elastomers, the test shall be conducted at 70°C and the set shall not exceed 25 percent.
6. Compression set at minus 10°C - Using ASTM D1229, test for 70 hours at minus 10°C. The compression set at 30 minutes after release (t_{30} reading) shall not exceed 65 percent.
7. Accelerated aging - Using ASTM D573, age the elastomer for 70 hours at 100°C. Measure and record the change in hardness and the percentage change of properties from the original tensile strength and ultimate elongation. For neoprene base elastomers, the percentage of decrease in tensile strength shall not exceed 15 percent; the percentage of decrease of ultimate elongation shall not exceed 40 percent; and the change in

hardness, measured on the Durometer A scale, shall not exceed ten points. For natural rubber base elastomers, the percentage of decrease of tensile strength shall not exceed 25 percent; the percentage of decrease of ultimate elongation shall not exceed 25 percent; and the change in hardness, measured on the Durometer A scale, shall not exceed 10 points.

8. Resistance to ozone cracking - Prepare test specimens in accordance with Procedure A of ASTM D518. Test the specimens in accordance with ASTM D1149 at a temperature of 40°C and ozone concentration of 50 pphm. The elastomer shall not exhibit cracking when examined in accordance with ASTM D1149 at the end of a 100 hour exposure.
9. Oil absorption - Using ASTM D471, conduct one test with ASTM No. 3 oil at 100°C for 70 hours and conduct another test using a different sample with ASTM No. 1 oil at 100°C for 70 hours to determine the volume change of the elastomer. The volume change for the No. 1 oil shall not exceed minus 10 or plus 20 percent; and for the No. 3 oil, the volume change shall not exceed 100 percent.
10. Adhesion to metal - Test the elastomer's adhesion to the metal components as per ASTM D429 Method B. Use the same metal, metal preparation, elastomer, and adhesives in preparing the test specimen as used in the production of the direct fixation rail fasteners.
11. Flame spread and smoke generation - Test the elastomer in accordance with ASTM E162 to determine the flame propagation index. Test the elastomer in accordance with NFPA 258 in both the flaming and non-flaming modes to determine the smoke generation specific optical index. The elastomer shall not exhibit flaming drippings when tested. No acceptance criteria are specified for the flame propagation index and the smoke generation specific optical index. Report these indices to the District or its designee for information only.
12. Electrical Resistivity - Test the specimens in accordance with ASTM D257. The elastomer shall have a minimum volume resistivity of 10^{12} ohm-centimeters.
13. Water Absorption - Test the specimens in accordance with ASTM D570. The elastomer shall have a maximum increase in weight of 0.1 percent after 24 hours immersion.

F. Testing Anchor Assemblies:

1. A minimum of three sets of anchor assemblies shall be subjected to the following tests. For the acceptance of anchorage design, each anchorage assembly shall satisfy the test requirements and the tests results shall not be averaged.
2. Restrained Pull-out Test - A steel plate with a hole in the center 1/2 inch larger than the anchor bolt shall be placed on the concrete test block. An anchor bolt shall be installed to the recommended installation torque and a vertical load of 30,000 pounds is applied to the bolt; held for a minimum of one minute and then released.
3. Acceptance Criteria - There shall be no evidence of slippage or cracking of concrete or failure of bond between the bolt or insert, and concrete.
4. Unrestrained Pull-out Test - Apply a vertical pullout load of 16,000 pounds on the anchor bolt, in such a manner that no restraining load is applied to the concrete within a radius of six inches from the center of the bolt.
5. Acceptance Criteria - There shall be no evidence of concrete cracking or failure of bond between the bolt or insert, and concrete.
6. Torsion Test - The anchor bolt shall be subjected to a torque at least 100 percent greater than the recommended installation torque; the load held for three minutes and gradually released.
7. Acceptance Criteria - There shall be no evidence of failure of the bond between the bolt or insert and concrete.

G. Anchor Insert Coating Tests:

1. Test two sample anchorage inserts. If either sample fails, change either coating or coating procedure. Continue alternately testing and changing coating or coating procedure until two equally treated inserts pass both tests.
2. Disbondment, in equivalent circle diameter, shall not exceed 1/2 inch when tested in accordance with ASTM G8.
3. Insert coating thickness shall be within specified limits as determined by ASTM G12.

4. Insert coating hardness shall be within specified limits as determined by ASTM D2240 shore D.
5. Remove coating from a small portion of insert. Attach wire to bare portion of insert and immerse coated portion in a three-percent sodium chloride electrolyte. Measure resistance between a stainless steel electrode and insert; repeat test with reverse polarity. Average of two readings shall be not less than one megohm.

1.5 MEASUREMENT - The Work specified in this Section will not be measured for payment.

1.6 PAYMENT - The Work in this Section will be paid for as part of the contract unit price for the particular type of track construction to which it pertains.

PART 2 - PRODUCTS

2.1 DIRECT FIXATION RAIL FASTENER ASSEMBLY

A. General Requirements

1. The assembled direct fixation rail fastener assembly shall be within the fastener envelope shown in Figure O2456-5.
2. The overall vertical distance, excluding shims, between base of rail fastener and base of rail shall be neither less than 1 3/8 inches nor more than 1 1/2 inches. No part of rail fastener shall project more than 4 1/8 inches above rail base.
3. Overall dimensions of rail fasteners including elastomer, shall be neither narrower than seven inches nor wider than ten inches measured parallel to rail, and neither shorter than 14 inches nor longer than 18 inches measured normal to rail. No portion of an assembled rail fastener shall extend beyond the top plate.
4. Rail fastener shall be symmetrical about its centerlines and with no designated field or gauge sides.
5. Longitudinal and lateral rail restraint properties of the fastener assembly shall be identical in both directions in all positions of the rail on the fastener.
6. Rail fastener design shall provide for two anchor bolts, 7/8 inch in diameter, for securing to fastener inserts embedded in concrete trackbed. The anchor bolt holes shall be symmetrically located with respect to fastener centerlines. One inch of clearance from

second pour reinforcing is required in determining anchor bolt hole location.

7. Rail fastener design shall provide an electrical leakage distance path of not less than 3/4 inch under all load and adjustment conditions, measured from and grounded portion of the fastener to any metallic portion of the fastener in direct contact with rail by the most direct path that does not pass through insulating material. The leakage distance path will exclude recesses and other geometric configurations which could collect and hold moisture, dust, and other materials which could create a conductive path to ground.
8. The normal, regardless of the position of the contact rail, installation and removal procedures of the fastener body or other component shall be accomplished without violating the envelope shown in Figure 02456-6.
9. Rail fastener shall permit installation and replacement of the entire fastener assembly, or its components, by one man using hand tools, and so that the rail may be removed by raising the rail vertically until it is completely free of rail fastener without disturbing the horizontal alignment of the track.
10. Rail fastener design shall provide a means of adjusting the rail laterally within a range of plus or minus 1/2 inch in increments of 1/8 inch or less. Lateral or longitudinal stability of the rail shall not be reduced in adjusted position. Friction alone shall not be used as a means of adjustment. Lateral adjustment shall be by a method that does not require permanent removal, substitution, or addition of a component and does not require the movement of an anchor bolt.
11. Lateral rail adjustments shall have not less than three interlocking serrations in each required increment of lateral adjustment.
12. Neither the rail clip assembly nor the means of preventing lateral movement of rail shall make point contact against rail. Contact area shall be not shorter than one inch measured along the rail and not smaller than 0.15 square inch in area.
13. The anchorage assembly shall not precompress the elastomer of the direct fixation rail fastener body when installed at proper torque.
14. Steel bearing surfaces for use in anchoring the fastener to the invert shall be an integral part of the fastener and shall be encased in elastomer on all

sides except on the top, which shall remain uncovered to the extent required to allow for washer installation.

15. An electrically insulating anchor bolt sleeve, if utilized in the direction fixation rail fastener, shall be included as an integral part of the fastener body and not a separate component requiring field installation.

B. Components

1. Design the direct fixation rail fastener to have as few components as economically and technically feasible to facilitate assembling, disassembling, and maintaining in the field by means of standard hand tools.
2. The following components are to be designed in accordance to this specification.
 - a. direction fixation rail fastener body
 - b. rail clips
 - c. anchorage assembly
 - d. base shims (rubber)
 - e. vertical adjustment shims (polyethylene)

- C. Identification - Manufacturer's name or trade name shall be marked on each rail fastener in a permanent manner. Sequential lot number and fastener number to identify each fastener shall be permanently stamped on top of each fastener in such a manner as to enable viewing when installed.

2.2 DIRECT FIXATION RAIL FASTENER BODY

A. General Requirements

1. Rail fastener body consists of an elastomer pad bonded to either a steel or ductile iron rail base plate on one side and to a steel bottom plate on the other side.
2. The rail base plate or top plate shall have a thickness not less than 1/2 inch.
3. The bottom plate shall have a thickness not less than 1/8 inch.
4. The elastomer pad shall have a thickness not less than 3/4 inch.
5. The top plate shall be flat, continuous, and impart no cant to rail.

6. The bottom plate shall be flat and parallel to plane of rail seat with no projections into the concrete pad.
7. The stability of the rail fastener in any direction shall not be dependent solely upon the strength of the bond of the elastomer to metal.
8. The load deflection of the elastomer shall not exceed 25 percent of its uncompressed thickness for a load of 10,400 pounds applied vertically to the rail in a fully assembled rail fastener.
9. The rail fastener shall have full bearing on the elastomer in all positions of lateral adjustment.
10. The outside vertical metallic surfaces of the rail fastener body shall be fully covered by the elastomer for a thickness of at least 1/32 inch.
11. Recesses or notches which penetrate the top plate and expose the elastomer shall be free draining with at least a 2% slope over the 1:40 cant of the direct fixation rail fastener. The maximum depth of elastomer which can be removed for recesses or notches is 1/2 inch. The top surface of the bottom plate shall have at least 1/4 inch of elastomer cover.
12. Exposed metallic surfaces of the rail fastener body to be coated with the primer and material used to form the bond. This coating shall protect the exposed surfaces of the metal parts from corrosion and shall protect the elastomer-to-metal bond.
13. Elastomer surfaces which separate grounded and non-grounded portions of the direction fixation rail fastener shall be smooth with a finish and appearance equal to or better than an F-3 designation as per the Rubbers Handbook. Non-vertical elastomer surfaces shall also be free of stamping or raised markings.

B. Materials

1. The rail base or top plate may be rolled, forged or cast plate of steel or ductile iron.
 - a. Rolled steel plate shall be minimally of ASTM A36 steel and the fabrication procedure shall insure that the grain structure of the plate shall be perpendicular to the base of the rail.
 - b. Ductile iron castings for top plate shall be produced in conformance with ASTM A536 specification for ductile iron castings Grade 65-45-12. The castings shall be heat treated by full annealing,

normalizing, quenching, tempering, or combinations of these procedures at the Contractor's option, in accordance with ASTM A148.

2. The bottom plate shall be minimally of ASTM A36 steel and the fabrication procedure shall insure that the grain structure of the plate will be perpendicular to the base of the rail.
3. The elastomer shall be fabricated and compounded of polychloroprene (neoprene), natural rubber, or blends of natural rubber and synthetics.

2.3 RAIL CLIP ASSEMBLIES

A. General Requirements

1. Each direct fixation rail fastener assembly shall have two rail clip assemblies, one on each side of the rail base.
2. Each rail clip assembly shall consist of a resilient-type rail clip and either a fixed or adjustable rail clip holder.
3. The rail clip shall be neither a spring-wedge type nor a type requiring other than standard hand tools for its installation, assembly, or removal.
4. Rail fasteners which employ threaded elements in the rail clip assembly shall not permit more than 1/8 inch total lateral movement of the rail base relative to the fastener when the threaded elements are finger tight.
5. The rail clip assembly shall be designed to enable installation and removal without damage to rail fastener, holder, clip, or running rail.
6. Rail clips shall not be dependent on elastomeric components in torsion.
7. The rail clip shall bear directly on the rail and the contact area between the rail clip and the rail shall be at least 5/32 square inches.
8. The rail clip design shall be the same as that commonly produced by the rail clip manufacturer. Underbent or overbent rail clips will not be accepted.

- B. Materials - Spring steel. The bars used for rail clips shall be free of injurious defects and shall have a workmanlike finish consistent with good hot-rolling practices for bars intended for use in springs. Do not use merchant quality steel bars.

2.4 ANCHORAGE ASSEMBLIES

A. General Requirements

1. Each direct fixation rail fastener shall provide for two anchorage assemblies, each consisting of an anchor bolt, coated insert, and miscellaneous hardware.
2. Anchor bolts which penetrate the top plate are not to be used for lateral adjustment purposes. The anchor bolt shall be on a raised surface at least 1/4 inch above the top surface of the top plate and designed to increase electrical isolation of the anchor bolt.
3. Anchor bolts which do not penetrate the top plate may be designed as the site of lateral adjustment.
4. Anchor Bolt - 7/8 inch diameter, 9 UNC Class 2A threads electroplated with zinc in accordance with ASTM B633, Type III, SC2, and length sufficient to provide 1 1/4 inch thread engagement in insert when installed at the maximum vertical adjustment.
5. Washers - 7/8 inch, steel, and zinc-electroplated in accordance with ASTM B633, Type III, SC2.
 - a. Lock - ANSI B18.21.1, Type 302, Extra Duty
 - b. Circular - ANSI B18.22.1, Type B, Regular
6. Insert - 7/8 inch diameter, 9 UNC Class 2B internal threads, female type, not longer than 5 1/2 inches, and have non-welded collar and rotation-prevention device and 1 3/4 inches of thread engagement for anchor bolt, with nylon or plastic pull-away type plug.
7. Insert to have at least ten but not more than twenty mils of epoxy coating on exterior surfaces with a hardness not less than 85 or greater than 90 as per ASTM D2240 shore D. The coating shall not have runs, sags, chips, pinholes, or breaks.

B. Materials

1. The anchor bolt - SAE J429, Grade 5
2. The insert - SAE J429, Grade 5
3. The insert coating - 100 percent dry power epoxy resin; 3M Corp's "Scotch Kote No. 213" or approved equal.

C. Fabrication

1. Apply insert coating in accordance with manufacturer's printed instructions and as follows:

- a. Remove oil, grease, and other foreign matter by solvent cleaning in accordance with SSPC SP1, caustic degreasing, or steam cleaning.
- b. Preheat inserts to a uniform temperature not cooler than 325°F. Measure and record insert temperature every hour.
- c. Immerse inserts in a fluidized bed of epoxy powder and move inserts in a pattern predetermined to completely and uniformly coat inserts.
- d. After inserts have been coated, cure inserts at a temperature between 400 and 425°F. until epoxy has cured. Record temperature every hour.

2.5 SHIMS

A. General Requirements

1. The base shim shall be provided in thicknesses of 1/8 inch and 3/16 inch.
2. The vertical adjustment shim shall be provided in thicknesses of 1/8, 1/4, and 3/8 inches.
3. The base shim and the vertical adjustment shim shall be the same width and length as the Direct Fixation Rail Fastener Bottom Plate.
4. The base shim shall have a shape factor which provides a spring rate greater than 1 million pounds per inch.
5. The base shim is not to be a slip in - slip out design. Each anchor bolt hole punched in the base shim must be larger than the top at the anchor bolt insert and elongated if the anchor bolt is the site of lateral adjustment.
6. The vertical adjustment shim may be a slip in - slip out design permitting installation and removal without removal at anchor bolts.

B. Material:

1. The base shim shall be made of an elastomer which conforms to and passes all tests required of the elastomer used for the direct fixation rail fastener body.
2. The vertical adjustment shim shall be made of ultra high molecular weight polyethylene (UHMW) with the following properties:
 - a. Modulus of elasticity 80,000 to 100,000 psi.

- b. Tensile strength 4000 to 5500 psi.
- c. Nominal weight average molecular weight of 3 million or greater.
- d. Minimum resistivity of 10^{16} ohm-centimeter as per ASTM D257.
- e. Flamability UL rated at 94V-0 as per UL 94.
- f. Rockwell hardness R60.

PART 3 - EXECUTION - Installation of direct fixation rail fasteners is not part of the work specified in this Section. For installation requirements, refer to the applicable track construction specification Section.

SOUTHERN CALIFORNIA RAPID TRANSIT DISTRICT

METRO RAIL TRANSIT CONSULTANTS

DMJM/PBDD/KE/HWA

FASTENER TESTS

FURNISHED BY CONTRACTOR
 3D FASTENERS
 2D 1/8" RUBBER BASE SHIMS
 20 3/8" POLYETHYLENE SHIMS

RETAINED BY DISTRICT
 7 FASTENERS
 2 1/8" RUBBER BASE SHIM
 2 3/8" POLYETHYLENE SHIM

FORWARDED FOR TESTINGS
 8 FASTENERS
 16 1/8" RUBBER BASE SHIM
 16 3/8" POLYETHYLENE SHIM

STATIC TESTS
 FASTENERS A, B, C, & D
 (OR 1-2, 3-4, 5-6, 7-8)

1. VERTICAL LOAD	5. LONGITUDINAL RESTRAINT
2. VERTICAL UPLIFT	6. VOLTAGE WITHSTAND
3. LATERAL LOAD	7. ELECTRICAL RESISTANCE AND IMPEDANCE
4. LATERAL RESTRAINT	

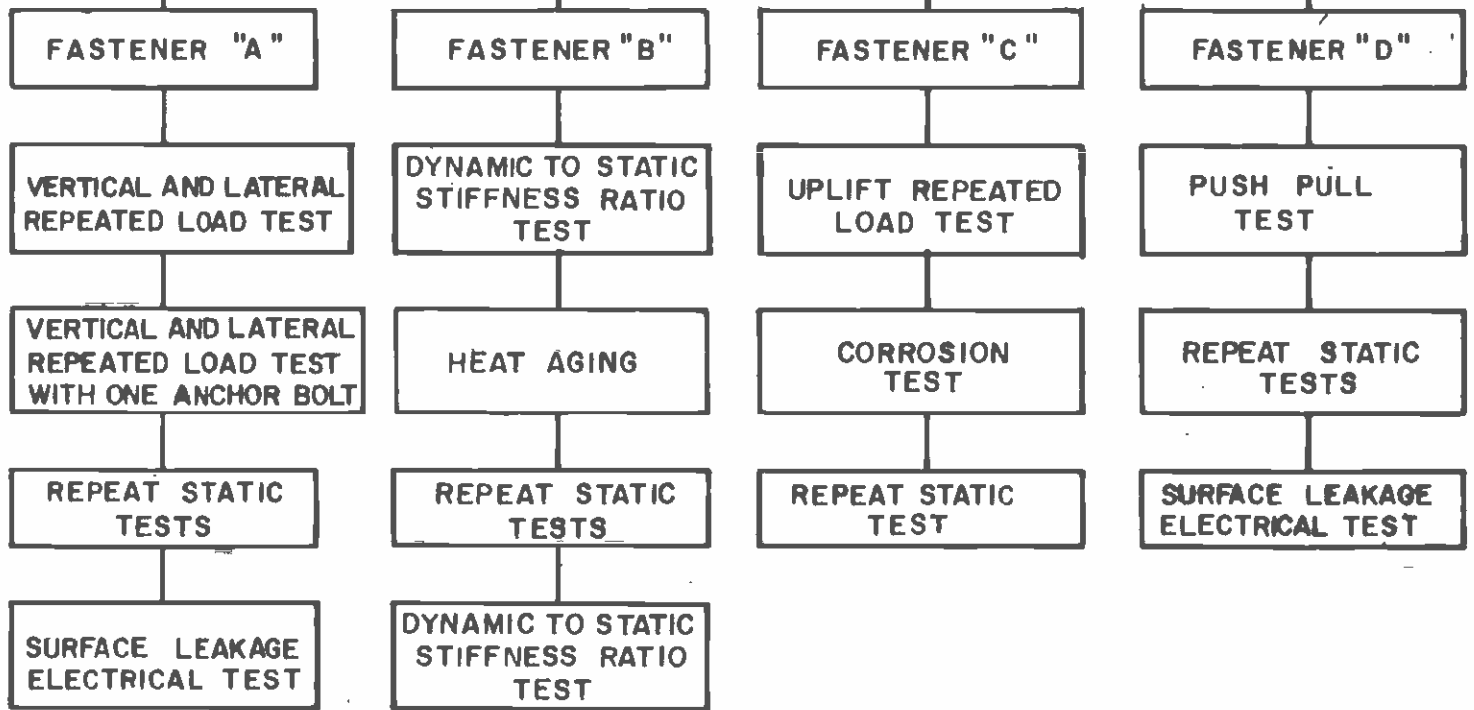

SALE: NONE DATE: 28 JUN 85 SPEC SECTION: 02456 FIGURE: 02456-1

SCRTD CA610

02456-25

07/30/85

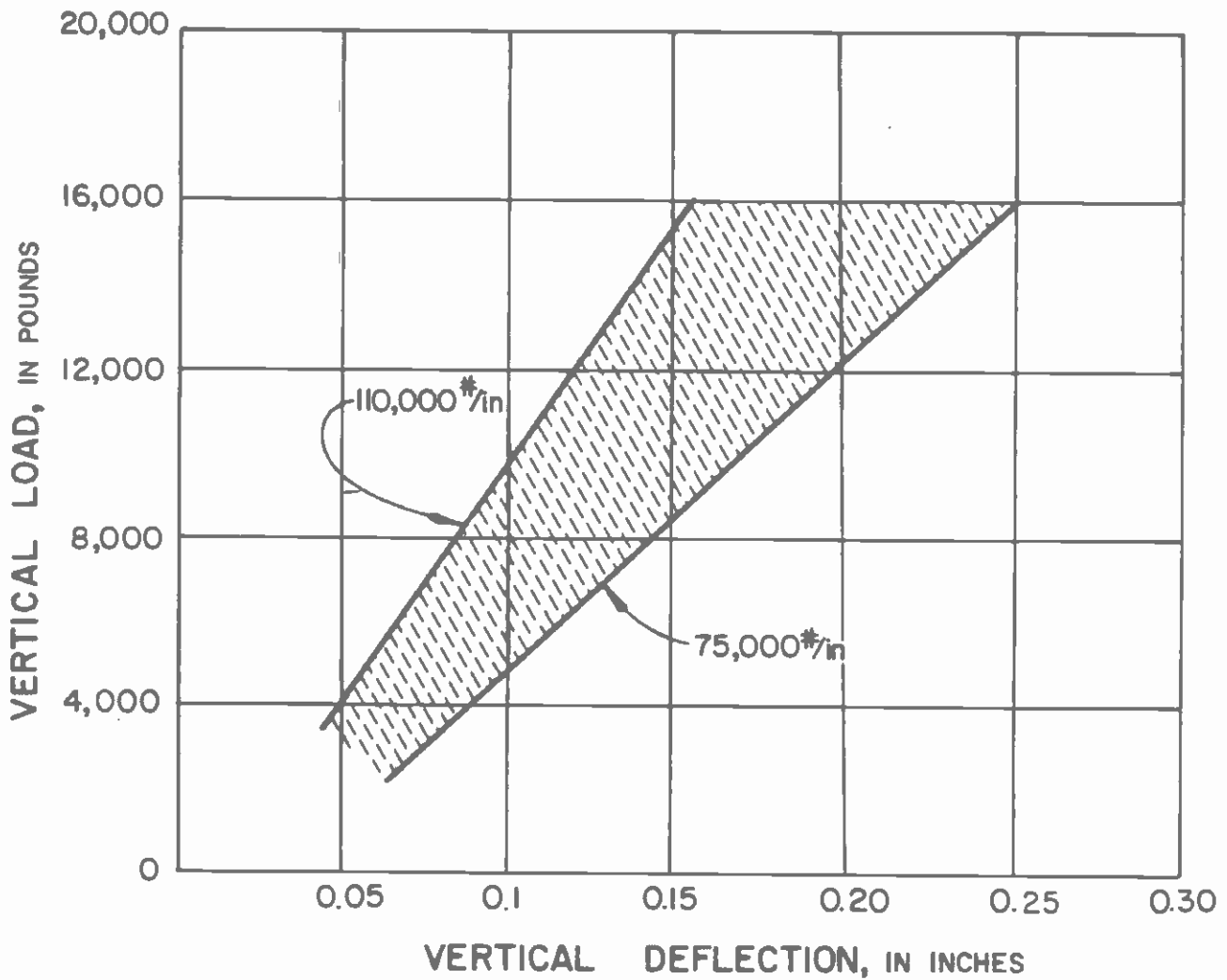

ACCEPTANCE LOAD vs DEFLECTION ENVELOPE.
INDICATED SPRING RATES ARE ONLY FOR DEFINING ENVELOPE OUTLINE

SOUTHERN CALIFORNIA RAPID TRANSIT DISTRICT

METRO RAIL TRANSIT CONSULTANTS
DMJM/PBQD/KE/HWA

VERTICAL LOAD TEST
ACCEPTANCE CRITERIA

SCALE: AS NOTED

DATE: 28 JUN 85

SPEC SECTION: 02456

FIGURE: 02456-2

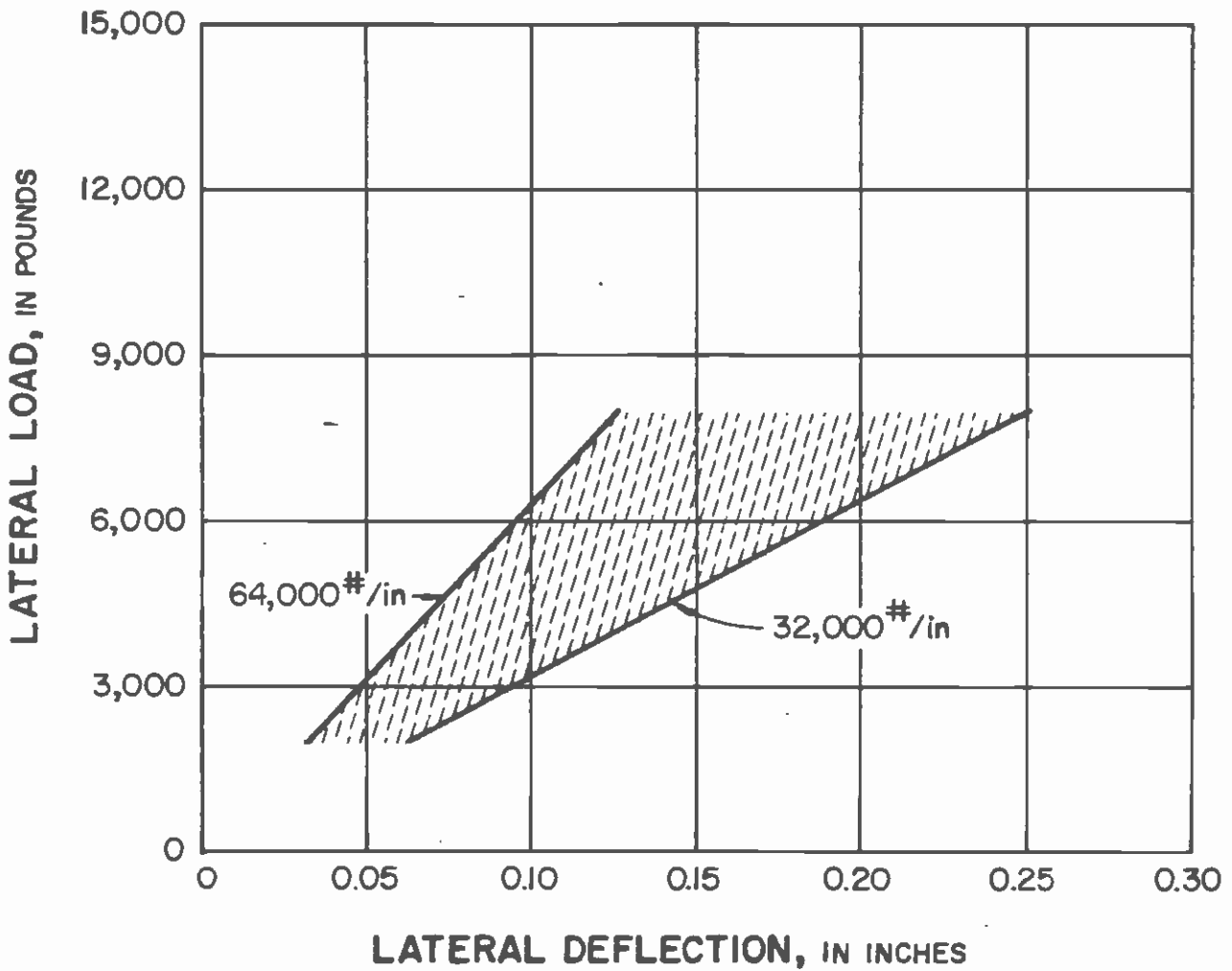

ACCEPTANCE; LOAD vs DEFLECTION ENVELOPE
INDICATED SPRING RATES ARE ONLY FOR
DEFINING ENVELOPE OUTLINE

SOUTHERN CALIFORNIA RAPID TRANSIT DISTRICT

METRO RAIL TRANSIT CONSULTANTS
DMJM/PBQD/KE/HWA

**LATERAL LOAD TEST
ACCEPTANCE CRITERIA**

SCALE: AS NOTED

DATE: 28 JUN 85

SPEC SECTION: 02456

FIGURE: 02456-3

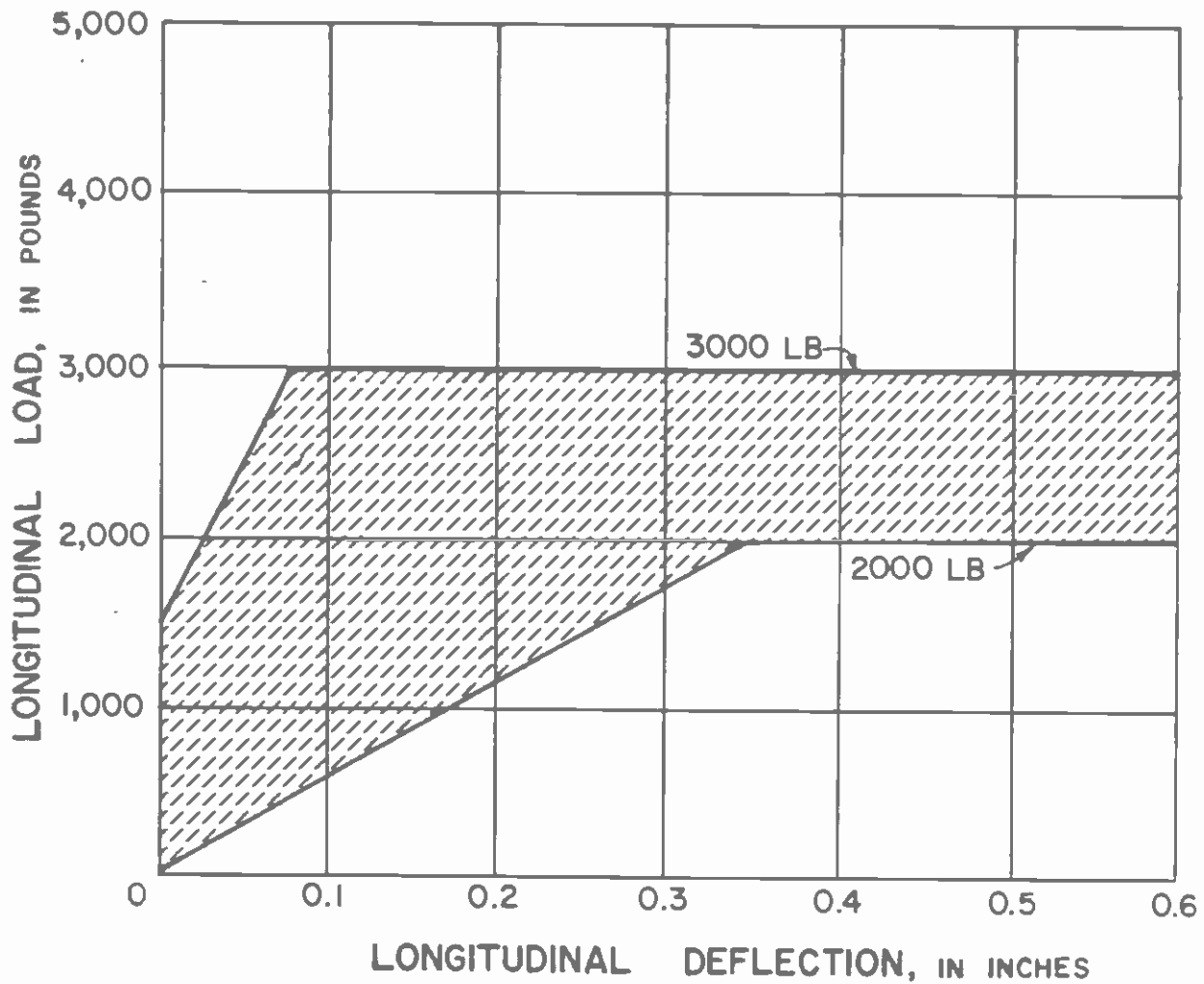

SOUTHERN CALIFORNIA RAPID TRANSIT DISTRICT

METRO RAIL TRANSIT CONSULTANTS

DMJM/PBQD/KE/HWA

**LONGITUDINAL RESTRAINT TEST
ACCEPTANCE CRITERIA**

SCALE: AS NOTED

DATE: 28JUN85

SPEC SECTION: 02456

FIGURE: 02456-4

- ① 115 RE RAIL
- ② FASTENER BODY
- ③ ANCHOR BOLT
- ④ FASTENER ENVELOPE
- ⑤ ANCHORAGE ENVELOPE
- ⑥ ϕ ANCHOR BOLT
- ⑦ SHIM - VARIABLE THICKNESS VARIES

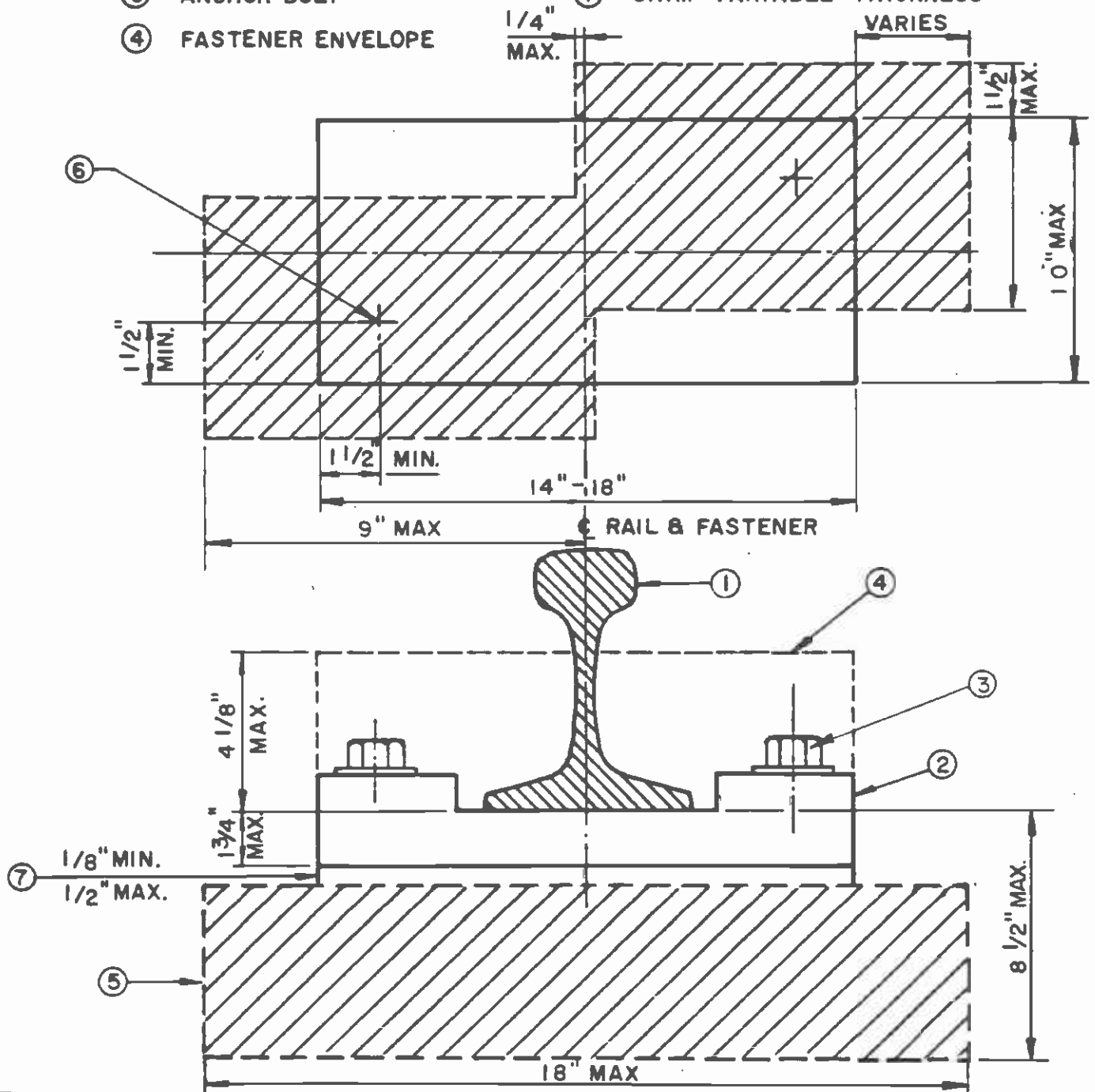

SOUTHERN CALIFORNIA RAPID TRANSIT DISTRICT

METRO RAIL TRANSIT CONSULTANTS

DIRECT FIXATION RAIL FASTENER
CLEARANCE ENVELOPE

DMJM/PBQD/KE/HWA

SCALE: NONE

DATE: 28 JUN 85

SPEC SECTION: 02456

FIGURE: 02456-5

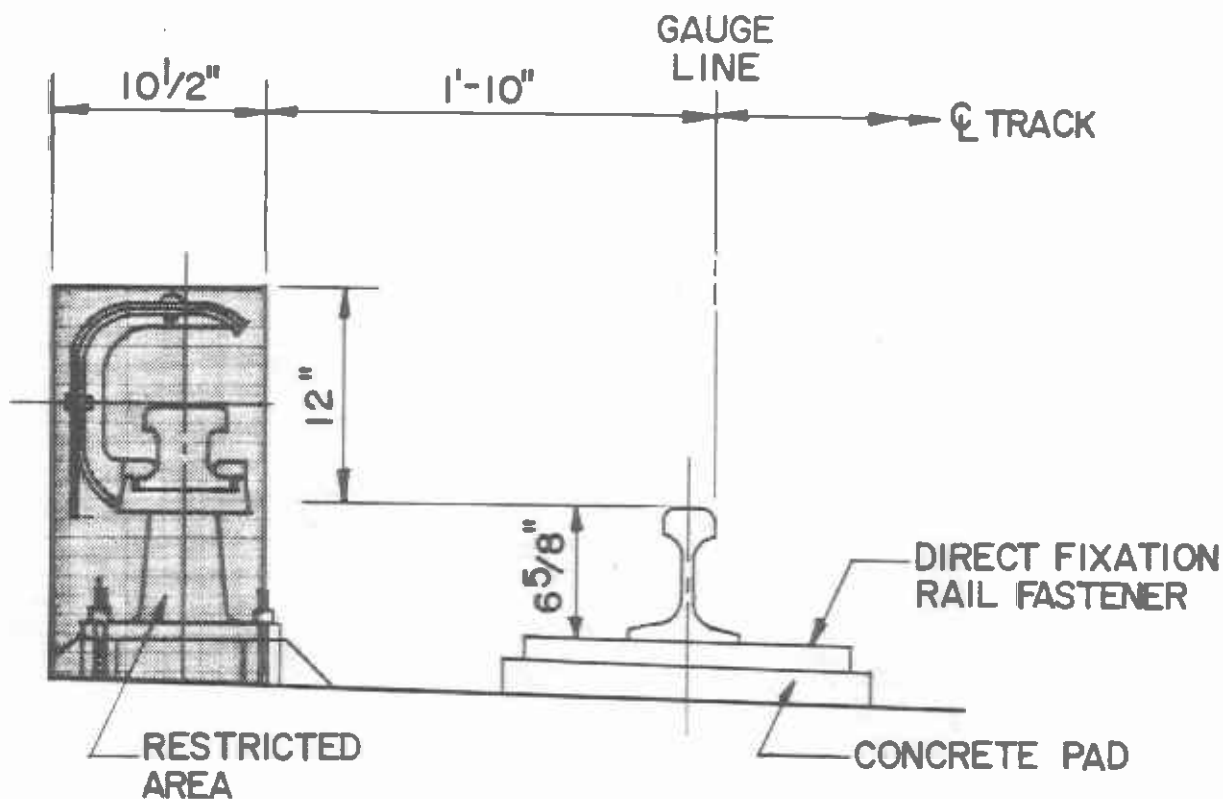

SOUTHERN CALIFORNIA RAPID TRANSIT DISTRICT

METRO RAIL TRANSIT CONSULTANTS

DMJM/PBQD/KE/HWA

RESTRICTED AREA DURING
INSTALLATION AND MAINTENANCE

SCALE: NONE

DATE: 28 JUN 85

SPEC SECTION: 02456

FIGURE: 02456-6

SECTION 02457

TIMBER TIES

PART 1 - GENERAL

1.1 DESCRIPTION - The Work specified in this Section consists of manufacturing, treating, testing, and handling of timber cross ties, contact rail ties, and switch ties.

1.2 QUALITY ASSURANCE

A. Quality Assurance Program - Refer to Section 02450, General Track Construction and conform to the requirements of the Quality Assurance Program.

B. Preservatives, Conditioning, and Treatment Processes - Conform to AWPA Standard C6 with the following modifications.

1. Incise all ties.

2. Provide results of treatment for Pacific Coast Douglas Fir and Western Hemlock as follows:

8 pound minimum retention

3/4 inch average penetration

90 percent of sapwood penetrated

3. Provide empty cell process treatment utilizing an expansion bath with final vacuum.

C. Provide ties free of excess preservative. Tie exhibiting exudation of preservative will be rejected.

D. Reference Standards

1. The requirements, terminology, and standards for preservatives, conditioning, inspection, and treatment processes are those specified and recommended by American Wood-Preservers' Association (AWPA) except as modified herein.

2. The requirements, terminology, and standards for timber grading, inspection, and manufacture are those specified and recommended by West Coast Lumber Inspection Bureau (WCLB) except as modified herein.

3. The requirements, terminology, and standards for handling and machining timber are those specified and

recommended by American Railway Engineering Association (AREA) except as modified herein.

E. Tolerances

1. Timber cross ties and contact rail ties dimensions:
 - a. Length - plus one inch minus zero inch
 - b. Depth - plus one inch minus zero inch
 - c. Width - plus one inch minus zero inch.
2. Timber switch ties dimensions:
 - a. Length - plus one inch minus zero inch
 - b. Depth - plus 1/4 inch minus zero inch
 - c. Width - plus 1/4 inch minus zero inch.

F. Source Quality Control

1. Provide ties that are free from defects which may impair their strength or durability, such as decay, large splits, large shakes, slope of grain, large holes or large knots.
2. Provide ties that have a rate of growth classification of either close grain or dense material.
3. Provide ties containing no decay. Although blue stain is not decay, ties will be inspected for the presence of decay in heavily stained areas.
4. A hole is not acceptable in critical areas if it exceeds 1/2 inch in diameter and three inches deep. A hole is not acceptable in non-critical areas if its diameter exceeds 1/4 of the surface's width, on which it appears, and is three inches deep. The critical and non-critical areas for timber cross ties, contact rail ties, and switch ties are shown in Figure 02457-1.
5. A knot is not acceptable in critical areas, if its average diameter exceeds 1/4 the surface's width on which it appears. A knot is not acceptable in non-critical areas if its average diameter exceeds 1/3 the surface's width on which it appears. Numerous small knots are not acceptable if equalling a large knot in damaging effect.
6. Provide well-manufactured ties with surfaces that are even and not scored to a depth in excess of 1/4 inch in critical areas or 1/2 inch in non-critical areas.

Ties shall be double end-trimmed with both ends cut square, free of bark, and shall have parallel sides. Ties are parallel if any difference in thickness at the sides or ends does not exceed 1/2 inch.

7. Season checks are acceptable on all faces provided the depth of the check in a seasoned tie is less than 1 1/4 inches and the check length is shorter than 1/2 of the tie's length.
8. Shakes are acceptable, provided that they do not exceed 1/3 the width of the tie and appear only on the ends of the timber tie.
9. Splits are acceptable if the separation of the wood, after treatment, extending from one surface to an opposite or adjacent surface is less than five inches long.
10. Provide ties in which the slope of the grain does not exceed one inch in 15 inches.
11. Provide ties adhering to the following WCLB warp designations.

CROSS TIES

<u>TYPE OF WARP</u>	<u>DESCRIPTION</u>
Bow	1/2 inch
Crook	1 inch
Cup	1/32 inch
Twist	1/2 inch

CONTACT RAIL TIES AND SWITCH TIMBER

<u>TYPE OF WARP</u>	<u>TOLERANCE</u>	
	<u>LESS THAN 18 FEET</u>	<u>GREATER THAN 18 FEET</u>
Bow	1/4 inch	1/2 inch
Crook	1 inch	1 inch
Cup	1/32 inch	1/32 inch
Twist	1/4 inch	1/2 inch

12. Perform preservative quality analysis in conformance with AWPA-A1-Standard Methods for Analysis of Creosote and Oil Type Preservatives.
13. Perform preservative retention analysis in conformance with AWPA-A6, Method for the Determination of Oil-Type Preservatives and Water in Wood.

14. Provide inspection branding confirming timber grading using a hammer brand in accordance with WCLB requirements.
15. Provide inspection branding confirming a properly executed treatment using a hammer brand.
16. Tie machining - Conform to the AREA manual, Chapter 3, Part 1, Section 1.5: "Specifications for Machining Cross Ties".

1.3 SUBMITTAL

- A. Refer to Section 01300 - Submittals
- B. Refer to Section 01322 - Certificates and Reports.
 1. Submit to the District or its designee the official WCLB certificates of inspection in conformance with WCLB procedures at least ten days prior to commencement of Work.
 2. Submit to the District or its designee the executed inspector's report form as described by AWPA M2 - Standard for Inspection of Treated Timber Products, including step by step work sheets of preservative analyses and retention assays, at least ten days prior to site delivery.
- C. Provide two copies of the current AWPA standards and WCLB standard grading rules for District use.

1.4 PRODUCT DELIVERY, STORAGE, AND HANDLING

- A. Product delivery, storage, and handling shall conform to AREA, Chapter 3, Part 5.
- B. Treated ties to be segregated by tie type (cross, contact, or switch) and tie length; and properly stockpiled at the plant for at least two months before final inspection by the District or its designee is conducted.
- C. Bundle ties for shipment by type and length in groups weighing four tons or less. All the identification brands to be on one side and ties to be protected from the metal bands.

1.5 MEASUREMENT - The Work of this Section will not be measured for payment.

1.6 PAYMENT - The Work in this Section will be paid for as part of the contract unit price for the particular type of track construction to which it pertains.

PART 2 - PRODUCTS

2.1 TIMBER TIES

A. General Requirements

1. Cross ties - Seven inches deep by nine inches wide and eight feet six inches long.
2. Contact rail ties - Seven inches deep by nine inches wide and ten feet long.
3. Switch ties for ballasted track - Seven inches deep by nine inches wide. Length requirements are shown on Contract Drawings.
4. Switch ties with rubber boots embedded in concrete for direct fixation - Seven inches deep by ten inches wide. Length requirements are shown on Contract Drawings.
5. Switch ties with rubber boots embedded in asphalt over cable trench - six inches deep by ten inches wide. Length requirements are shown on the Contract Drawings.

B. Materials

1. Switch ties - Pacific Coast Douglas Fir.
2. Cross ties and contact rail ties - Pacific Coast Douglas Fir or Western Hemlock.
3. Preservative.
 - a. Preservatives to conform to AWPA standards.
 - b. Treat switch ties with P1 preservative.
 - c. Treat timber ties which are embedded in concrete or asphalt with rubber boots (10 inches wide ties) with P1 preservative.
 - d. Treat cross ties and contact rail ties with either P1, P2, or P3 maintaining a minimum of 50 percent creosote in the preservative.

C. Fabrication and Manufacture

1. Prebore cross ties as shown on Figure 02457-2.
2. Dap switch ties, for switch machine installation, as shown on Figure 02457-3.
3. Tie machining to be performed prior to treatment.

4. Selected doweling of splits is acceptable. Dowels are to be installed as per AREA specification at no extra cost to the District.
5. Identification branding to conform to AWPA M6 - Brands Used on Forest Products.

PART 3 - EXECUTION

3.1 INSPECTION

- A. Obtain post treatment inspection and acceptance by the District or its designee before shipping to the site.
- B. Handling of ties for inspection purposes shall be performed by the Contractor at no cost to the District.
- C. The District or its designee may exercise the right to observe all facets of the timber tie production process, without advance notice, to verify compliance.

- 3.2 INSTALLATION - Installation of timber ties is not part of the Work specified in this Section. For installation requirements, refer to the applicable track construction specification section.

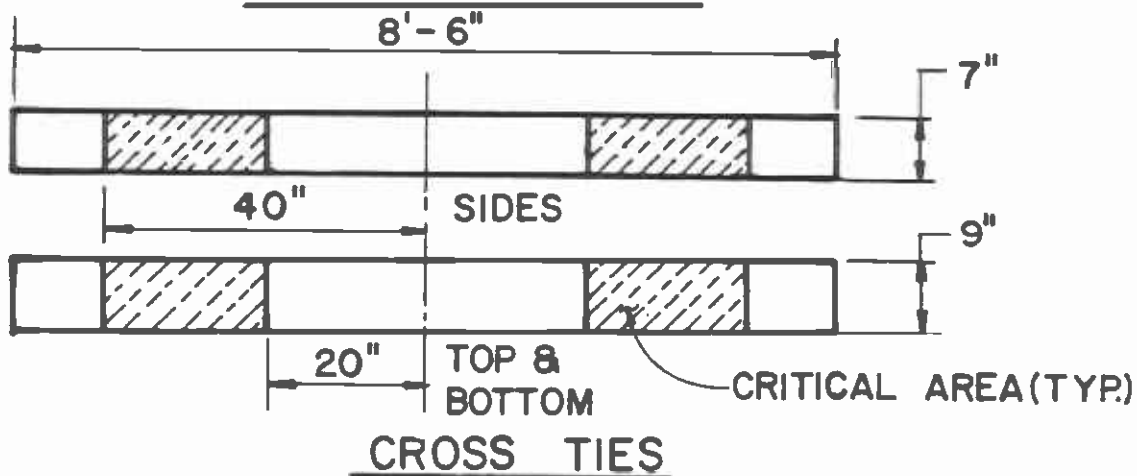
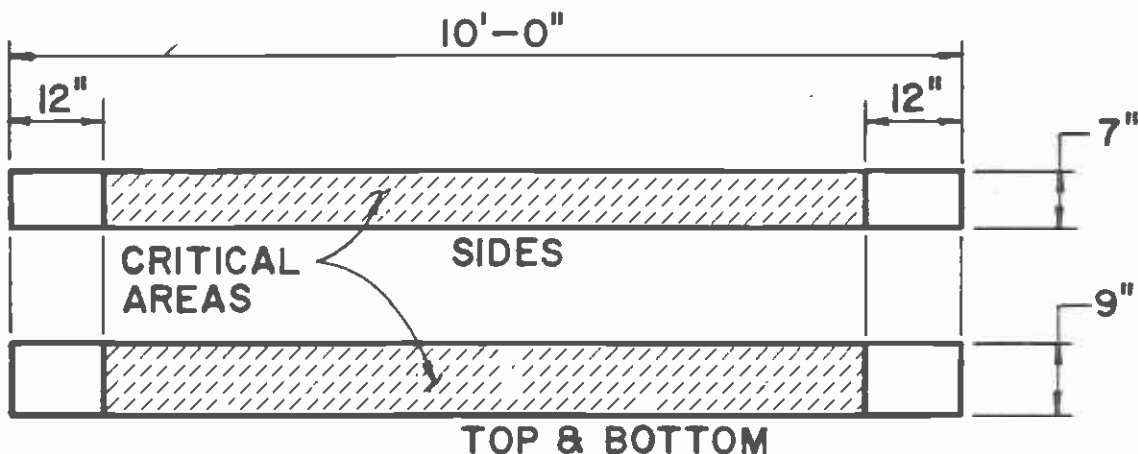
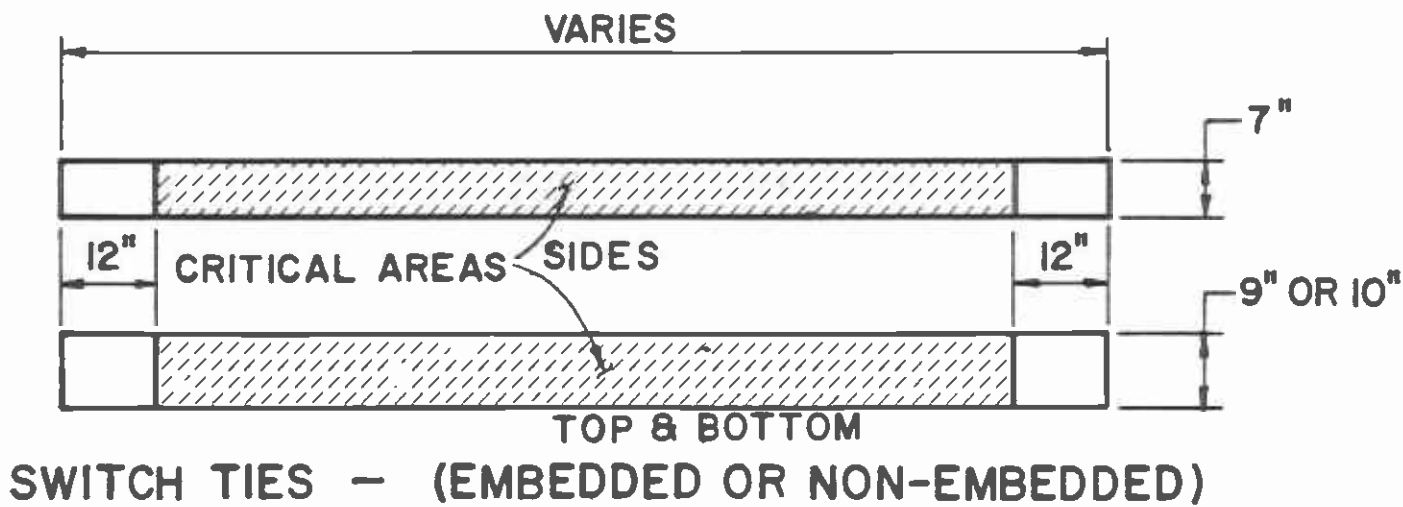

SOUTHERN CALIFORNIA RAPID TRANSIT DISTRICT

METRO RAIL TRANSIT CONSULTANTS

DMJM/PBQD/KE/HWA

CRITICAL TIMBER TIE AREAS

SCALE: NONE

DATE: 28 JUN 85

SPEC SECTION: 02457

FIGURE: 02457-1

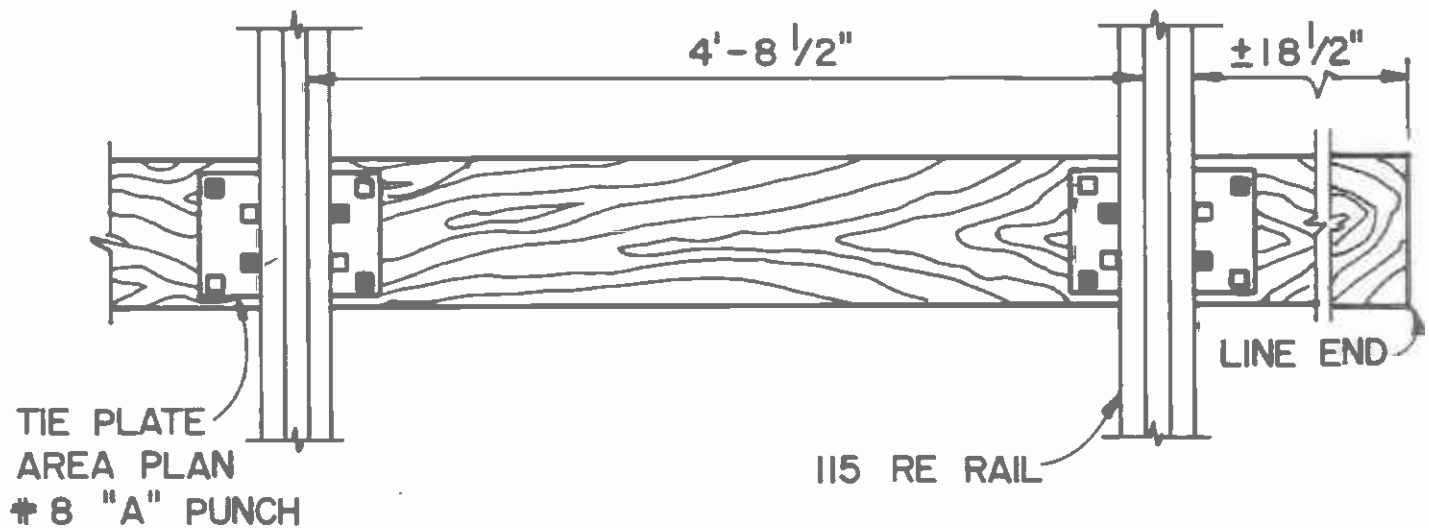

■ INDICATES LOCATION OF HOLE

NOTES:

1. PREBORED HOLES SHALL BE $\frac{9}{16}$ " IN DIAMETER AND DRILLED TO A DEPTH OF $5" \pm \frac{1}{4}"$
2. THE SPACING OF THE PREBORED HOLES SHALL ACHIEVE STANDARD GAGE ($+0", -\frac{1}{8}"$) WHEN SPIKES ARE PROPERLY INSTALLED.

SOUTHERN CALIFORNIA RAPID TRANSIT DISTRICT

METRO RAIL TRANSIT CONSULTANTS

DMJM/PBQD/KE/HWA

BORING PATTERN
FOR 8'-6" CROSS TIES

SCALE: NONE

DATE: 28JUN85

SPEC SECTION: 02457

FIGURE: 02457-2

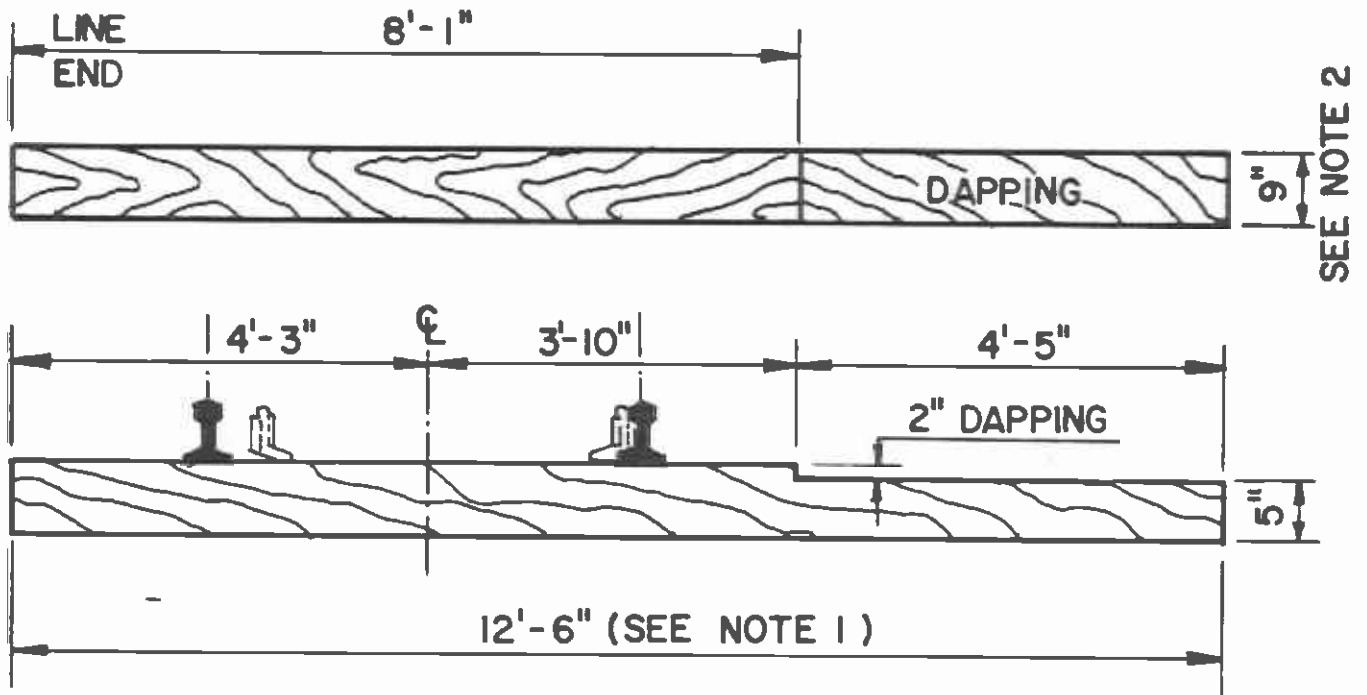

SEE NOTE 2

NOTES:

- 1. SEE SWITCH TIMBER LIST ON CONTRACT DRAWINGS FOR OTHER LENGTHS WHICH REQUIRE DAPPING.
- 2. SWITCH TIMBER FOR INSTALLATION OF DIRECT FIXATION SPECIAL TRACKWORK IS 10 INCHES IN WIDTH.

SOUTHERN CALIFORNIA RAPID TRANSIT DISTRICT

METRO RAIL TRANSIT CONSULTANTS DMJM/PBQD/KE/HWA		DAPPING FOR SWITCH TIES	
SCALE: NONE	DATE: 28 JUN 85	SPEC SECTION: 02457	FIGURE: 02457-3

SECTION 02458

BALLAST

Part 1 - GENERAL

1.1 DESCRIPTION - The Work of this Section consists of quality acceptance testing, production testing, and furnishing crushed rock for use as ballast for ballasted track and ballast pad construction in the locations required by the Contract Drawings.

1.2 QUALITY ASSURANCE

A. Quality Assurance Program - Refer to Section 02450, General Track Construction, and conform to the requirements of the Quality Assurance Program.

B. General Requirements

1. Deleterious substances present in prepared ballast - not to exceed the following amounts as determined by the specified current method of test.

<u>MATERIAL</u>	<u>PERCENT BY WEIGHT</u>	<u>METHOD OF TEST</u>
Soft Pieces	5.0	ASTM C235
Fines less than No. 200 sieve	1.0	ASTM C117
Clay Lumps and Friable Particles	0.5	ASTM C142

2. Percentage of wear, after testing in a Los Angeles abrasion testing machine - in accordance with ASTM C131, grading A, not to exceed 40 percent.

3. The percentage of flat and elongated particles - not to exceed a weighted average of 25 percent by weight, as determined by the United States Army Corps of Engineers specification CRD-C 119.

4. The weighted average loss - not to exceed 10 percent as determined in the sodium sulfate soundness test in accordance with ASTM C88.

5. Determination of weight per cubic yard - in accordance with the ASTM C29.

C. Testing Laboratory Services - Refer to Section 01410, Testing Laboratory Services. The supplier's laboratory, if acceptable to the District, may be utilized for bal-

last production testing, but not for initial product acceptance tests.

D. Source Quality Control

1. From each 4000 tons of ballast, a test sample of not less than 150 pounds is to be subjected to the following tests:
 - a. Deleterious substances
 - b. Los Angeles abrasion
 - c. The percentage of flat and elongated particles
 - d. Sodium sulfate soundness
 - e. Weight per cubic yard
 - f. Sieve analysis
2. Provide certification that ballast delivered to the job site is typical of ballast which passed acceptance and production tests.

E. Acceptance Tests

1. Prior to initial shipment, ballast source shall be approved by the District.
2. The following tests will be performed by an independent laboratory:
 - a. deleterious substance
 - b. Los Angeles abrasion
 - c. The percentage of flat and elongated particles
 - d. Sodium sulfate soundness
 - e. Weight per cubic yard
 - f. Sieve analysis

1.3 SUBMITTALS

- A. Refer to Section 01300 Submittals
- B. Refer to Section 01322, Certificates and Reports, and submit the following:
 1. Acceptance tests
 2. Production tests

3. Ballast certifications

1.4 MEASUREMENT

- A. The Work in this Section will be measured for payment by the net volume in cubic yards based on the neat line of the ballast sections indicated on the Contract Drawings. The quantity shown on the Bid Form is a fixed quantity and is the final quantity on which payment will be made unless the dimensions shown on the Contract Drawing are revised by the District or its designee.
- B. Changes to the fixed quantity will be measured by the net volume in cubic yards based on the change in neat lines. Responsibility for running cross section and calculating the change in volume is as follows:
1. Prior to tracklaying, the District or its designee will check cross sections. Discrepancies discovered at this time may be corrected at the District or its designee's direction by placing additional ballast or placing subballast.
 2. During tracklaying, the Contractor shall provide all cross section data, compute volumes, and submit the requested changes to the District or its designee. The District or its designee will verify all surveys and calculation.

- 1.5 PAYMENT - The Work in this Section will be paid for at the Contract unit price per cubic yard shown on the Bid Form or as determined above. Payment for placing, compacting, and finishing ballast will be paid for under Section 02452. Ballasted Track Construction.

PART 2 - PRODUCTS

- 2.1 BALLAST - Provide prepared ballast that is of crushed rock and hard, strong, angular, durable particles, free from injurious amounts of deleterious substances and conforming to the following gradation.

<u>Size of Sieve Opening</u>	<u>Percent Passing by Weight</u>
1 1/2 inches	100
1 inch	90-100
3/4 inch	30-60
1/2 inch	0-20
No. 4	0-5

PART 3 - EXECUTION

- 3.1 INSPECTION - If material loaded or being loaded does not conform to these Specifications, the Contractor shall stop further loading until the fault has been corrected. Defective material shall be promptly removed and replaced. The District or its designee will reject ballast arriving at the site for unloading that does not conform to the specifications.
- 3.2 INSTALLATION - Installation of ballast is not part of the Work specified in this Section. For installation requirements, refer to Section 02452, Ballasted Track Construction.

END OF SECTION

SECTION 02459

TRACK APPURTENANCES AND OTHER TRACK MATERIAL

PART 1 - GENERAL

1.1 DESCRIPTION - The Work specified in this Section consists of furnishing and installing standard joints, bonded standard joints, bonded insulated joints, bumping posts, grade crossing, crosswalk, hinged derail, hinged wheel stops, and other track materials required for track construction.

1.2 QUALITY ASSURANCE

A. Quality Assurance Program - Refer to Section 02450, General Track Construction, and conform to the requirements of the Quality Assurance Program.

B. General Requirements

1. Before permanently installing either bonded insulated joints or bonded standard joints, each crew installing bonded joints of either type must be prequalified.
2. Prequalify each crew and its foreman by testing two samples of each type of bonded joint in accordance with the longitudinal compression test specified herein. Prepare the test samples in track. The bonded insulated joints tests shall be performed with one sample using high strength rail and the other sample using standard rail. Both bonded standard joint samples shall use high strength rail.
3. Failure of any test sample disqualifies the responsible foreman for permanent installation work. Assign a new foreman and repeat procedure and test.

C. Testing Laboratory Services - Refer to Section 01410, Testing Laboratory Services.

D. Reference Standards

1. American Railway Engineering Association (AREA) - Manual of Railway Engineering and Portfolio of Trackwork Plans.
2. American Society for Testing and Materials (ASTM) - A325, High-strength Bolts for Structural Steel Joints.
3. Association of American Railways (AAR) - Signal Specifications.

4. National Electrical Manufacturers Association (NEMA) -
LI-1 Industrial Laminated Thermosetting Products.
- E. Equipment - Equipment used to fasten proprietary bolts in bonded joint installation to be specifically designed for that purpose. The same equipment used in field installation of bonded joints shall be used in assembling all test samples.
- F. Tolerances
 1. Other track material to conform to tolerances as per AREA.
 2. Bonded insulated joint bar and bonded standard joint bar to conform to:
 - a. Fishing height: +/- 1/64 inch
 - b. Length: +/- 1/8 inch
 - c. Straightness, as determined by a 36-inch straight-edge: +/- 1/32 inch
 - d. End post thickness: +/- 1/64 inch
 - e. Projection below base of rail - 1/16 inch
 - f. Bolt hole location - as specified in AREA Manual for Railway Engineering, Chapter 4 for 36-inch joint bar modified to receive 1 1/8-inch bolt.

1.3 SUBMITTALS

- A. Refer to Section 01300, Submittals.
- B. Refer to Section 01340, Shop Drawings, Product Data, and Samples, and submit the following.
 1. Shop drawings on:
 - a. Bonded insulated joints
 - b. Bonded standard joints
 - c. Standard joints
 - d. Proprietary bolts and fasteners
 - e. Bumping posts, wheel stops, and derail
 - f. Grade crossing materials
 - g. Cross walk timbers

2. Product data on:

- a. Bonded insulated joints and adhesives
- b. Bonded standard joints and adhesives
- c. Proprietary bolts and fasteners
- d. Bumping posts
- e. Coal tar for Epoxy coatings
- f. Mastic coating and fillers.

C. Submit the following in accordance with Section 01322, Certificates and Reports.

- 1. Qualification tests for bonded insulated joint and bonded standard joints.
- 2. Crew qualification tests for bonded joint installation.
- 3. Descriptions of dynamically testing bonded insulated and standard joints by methods other than those specified in Section 1.4 Bonded Joint Qualification Test.
- 4. Certificates of product conformance.

1.4 BONDED JOINT QUALIFICATION TESTS

A. General Requirements

- 1. Prior Qualification Tests - In lieu of qualification testing, Contractor may submit certification by an independent testing laboratory that the bonded joints have passed the tests specified in this Section or equivalent tests.
- 2. The test specimens:
 - a. Bonded insulated joint fully assembled with high strength 115 RE rail.
 - b. Bonded insulated joint fully assembled with standard 115 RE rail.
 - c. Bonded standard joint fully assembled with high strength 115 RE rail.
 - d. Bonded standard joint fully assembled with standard 115 RE rail.
- 3. Test sequences:

- a. For test specimens using bonded insulated joints, first perform the electrical resistance test followed by the stroke rolling load test, then repeat the electrical resistance test concluding by removing the end post and subjecting the test specimens to the longitudinal compression test.
 - b. For both test specimens using bonded standard joints, perform the stroke rolling load test followed by the longitudinal compression test.
4. Do not begin testing until shop drawings and installation procedures have been accepted.

B. Electrical Resistance Test

1. Test preparation

- a. Assemble two each of bonded insulated joint test specimens complete, in accordance with manufacturer's instructions using two pieces of 115-pound RE rail, one piece 24 inches long, the other 42 inches long.
- b. Support both rails on electrically nonconductive material.

2. Test procedure:

- a. Apply 500 volts DC to the rail on either side of the bonded insulated joint for three minutes. Measure and record current flow through joint, during that period, to nearest 0.1 microampere.
- b. Apply 50 volts AC to the rail in either side of the joint for three minutes for each increment of measurement for frequencies from 20 hertz to 10 kilohertz in increments of 20 hertz to 100 hertz; 200 hertz to 1,000 hertz, and 2,000 hertz to 10 kilohertz. After three minutes, measure and record impedance within accuracy of plus or minus two percent.

3. Test acceptance criteria:

- a. Resistance for 500 volts DC - not less than 10 megohms.
- b. Impedance for all frequencies between 20 hertz and 10 kilohertz with 50 volts AC - not less than 10,000 ohms.

C. Rolling Load Test

1. Test Preparation - After being tested for electrical resistance test, mount the test specimen on a 33-inch stroke rolling load test machine and support on 36-inch centers with joint centered as indicated in Figure 02459-1.
2. Test procedure - Apply 44,000 pounds load on rail for 2,000,000 cycles. Measure and record deflection at rail centerline to nearest 0.001 inch when wheel load is over points A and B for every 500,000 cycles.
3. Stroke rolling load test acceptance criteria:
 - a. After 2,000,000 cycles - exhibit no evidence of failure by bending of the bonded joint.
 - b. Deflection exhibited by bonded joint - not further than 0.065 inch.
4. Stroke rolling load test alternative procedure - Other methods of testing the bonded joint may be submitted for review. The proposed alternative shall generate a moment diagram equivalent to or greater than the moment diagram in Figure 02459-2.

D. Longitudinal Compression Tests

1. Test Preparation:
 - a. After completing the electrical resistance test and the stroke rolling load test, saw joint assembly in half where rails are butted together perpendicular to the centerline of the rail.
 - b. Ensure that sawing does not overheat and damage the bonding adhesive.
 - c. Affix a device which shall confine the reaction at the sawn end to the face of the joint bar when a load is applied at the centroid of the rail at the opposite end.
2. Test Procedure:
 - a. Apply test load longitudinally in increments of 25,000 pounds maintaining each increment until longitudinal deflection of rail ceases before increasing load to next increment.
 - b. Increase load in those increments until either a total load of 650,000 pounds is attained or failure occurs.

c. At each increment of loading, record the load and differential movement of rail and joint bars, to nearest 0.001 inch.

3. Test acceptance criteria:

a. Stability - No indication of slippage of rail joint before total test load reaches 650,000 pounds.

b. Differential movement in all directions - Not more than 1/8 inch.

c. Difference between original position of joint bar and rail and final position thereof after final test load has been released - not more than 1/32 inch.

d. Basis of rejection - Failure of joint to satisfy above requirements.

1.5 MEASUREMENT - The Work of this Section will not be measured for payment except for the following which will be measured by each unit in place complete with all items specified.

A. Bumping Posts

1. Hydraulic Bumping Post with anti-climber device.

2. Standard Bumping Post with shock-free head and anti-climber device.

3. Standard Bumping Post with standard head and smooth face.

B. Asphalt Grade Crossings complete with asphalt and flange-way guard coated with coal tar epoxy.

C. Type 1 Track Crosswalk

D. Type 2 Track Crosswalk

E. Type 3 Track Crosswalk complete with asphalt and flange-way guard coated with coal tar epoxy.

F. Hinged Derail

G. Hinged wheel stop

1.6 PAYMENT - The Work of this Section will be paid for as part of the Contract unit price for each type of track construction to which it pertains except for the following which will be paid for at the quantities determined at the Contract unit price shown on the Bid Form with all hardware and incidentals required for complete installations.

A. Bumping Post

1. Hydraulic Bumping Post with anti-climber device - Each, complete in place.
2. Standard Bumping Post with shock-free head and anti-climber device - Each, complete in place.
3. Standard Bumping Post with standard head and smooth face - Each, complete in place.

B. Asphalt Grade Crossings - Lump Sum, complete in place.

C. Type 1 Track Crosswalk - Lump Sum, complete in place.

D. Type 2 Track Crosswalk - Lump Sum, complete in place.

E. Type 3 Track Crosswalk - Lump Sum, complete in place.

F. Hinged Derail - Each, completed in place.

G. Hinged Wheel Stops - Each pair, complete in place.

PART 2 - PRODUCTS

2.1 BONDED JOINTS (INSULATED AND STANDARD)

A. General Requirements

1. The joint bars shall be 36 inches in length.
2. The joint bars shall have six, 1 1/8 inch diameter bolt holes.
3. The joint bars shall provide full web contact, such as a "RIB" bar or "D" bar as manufactured by Allegheny Drop Forge Company, Portec, Inc., conforming to the configuration of 115 RE rail and shall have no markings on contact surfaces.
4. Inside face shall have the insulating material pre-bonded and shall be smooth with no stamping or branding.
5. Insulated end post shall be 3/16 thickness and project at least 1/4-inch below the base of the rail.
6. Flat washers shall be 2 1/4 inches O.D., 1 3/16 inches I.D., and 1/8 inch minimum thickness.

B. Materials

1. Joint bars shall be quenched and tempered carbon steel in accordance with AREA Specifications.

2. Insulating material shall be high pressure, laminated design, impervious to oil, grease, and water, and having electrical characteristics equal to or greater than fiber insulation meeting requirements of the AAR Manual, Part 116, and electrical resistance test specified herein.
 3. Bonded joint adhesive - Allegheny Drop Forge Co.'s "Temprange" or equal.
 4. High strength bolts, either threaded or pin type, ASTM A325.
 5. Washers - ASTM A325.
- 2.2 STANDARD JOINTS - Head-free, heat-treated carbon steel six-hole joint bars, 36 inches long, quenched carbon steel in accordance with AREA specifications for use with 115 RE rail. Standard joints shall be complete with bolts, nuts, and washers in accordance with AREA specifications for heat treated carbon steel track bolts and spring washers.
 - 2.3 STANDARD JOINT LUBRICANT - Electrically non-conductive grease or oil-type lubricant.
 - 2.4 NEGATIVE RETURN JOINT BOND - Refer to the Contract Drawings.
 - 2.5 LOCK SPIKES - Six inches in length as manufactured by Bethlehem style 6220, or approved equal.
 - 2.6 LAG SCREWS - One piece washer head bolts 3/4 inch in diameter and 8 inches long with gimlet point in accordance with ANSI B.18.2.1. The bottom surface of the washer head and the unthreaded body shank shall be smooth and de-burred.
 - 2.7 CUT TRACK SPIKES - Six inches by 5/8 inch with reinforced throat in accordance with AREA specifications for soft steel track spikes and design of cut track spikes.
 - 2.8 TIE PLATES - Double shoulder tie plates with no ribs in accordance with AREA Plan No. 8 and specifications for low carbon steel tie plates.
 - 2.9 TIE PLUGS - Treated tie plugs five inches in length in accordance with AREA specifications for tie plugs for 5/8 inch spikes.
 - 2.10 COAL TAR EPOXY COATING - Koppers "Bitumastic No. 300-M" or equal.
 - 2.11 RAIL ANCHORS - Heavy duty one-piece design with a single tie/tie plate-bearing face for use with 115 RE rail requiring no special tool for installation, such as the "Standard Channeloc" rail anchor manufactured by True Temper Corpora-

tion, "Hi-Guard" as manufactured by CF&I Corporation or an approved equal.

2.12 ASPHALT GRADE CROSSING - Provide full depth asphalt in accordance with Section 02512, Asphalt Concrete Paving, the Contract Drawings, and flangeway guard as per L. B. Foster "flangemaster" as modified by the Contract Documents.

2.13 TYPE 1 TRACK CROSSWALK

A. General Requirements

1. Provide cast-in-place concrete with treated timber flangeway in conformance with details and configuration requirements shown on the Contract Drawings.
2. The surface of the crosswalk shall be even without unfilled holes or discontinuities greater than 1/8 inch.

B. Materials

1. Concrete - Refer to Section 03300, Cast-in-Place Concrete.
2. Treated Timber Flangeways - Refer to Section 02457, Timber Ties, and conform to the requirements for switch ties.

2.14 TYPE 2 TRACK CROSSWALK

A. General Requirements

1. Provide pre-cast concrete with treated timber flangeway in conformance with details and configuration requirements shown on the Contract Drawings.
2. The surface of the crosswalk is to be even without unfilled hole or discontinuities greater than 1/8 inch.

B. Materials

1. Pre-cast concrete - Refer to Section 03410, Non-tensioned Precast Concrete.
2. Treated Timber Flangeway - Refer to Section 02457, Timber Ties, and conform to the requirements for switch ties.
3. Timber Drive Spikes - Plan 2M-63 AREA washer-head drive spikes in accordance with AREA specifications for steel drive spikes.

4. Rubber Washer - Vibra Pad as manufactured by Lewis Bolt and Nut Company or approved equal.

2.15 TYPE 3 TRACK CROSSWALK - Provide full depth asphalt in accordance with Section 02512, Asphalt Concrete Paving, the Contract Drawings, and flangeway guard as per L.B. Foster "Flangemaster".

2.16 BUMPING POSTS

A. General Requirements

1. The hydraulic bumping post shall be an energy absorbing and automatic resetting bumping post capable of withstanding a 6 mph impact from trains weighing 385 tons such as the Hydro Bumper, manufactured by Holley Engineering, or equal.
2. The standard bumping post with shockfree head shall consist of a steel bumping post equipped with a shock-absorbent head of multiple-spring and shock bed design. The bumping post will be a modified Type WA bumping post as manufactured by the Hayes Track Appliance Company or an approved equal. The shock-absorbent head shall be a Hayco Shock-free head as manufactured by the Hayes Track Appliance Company or approved equal.
3. The standard bumping post with standard head and smooth surface shall be a Type WA as manufactured by the Hayes Track Appliance Company or approved equal.
4. All bumping posts shall be designed to be bolted to the running rails and will not require anchoring to cross ties or concrete track bed. No part of the bumping post assembly shall extend more than 2 inches below the rail base.
5. The hydraulic bumping post and the standard bumping post shock-free head shall be designed for use with transit vehicles. The striking face shall engage the transit vehicle's anti-climber. The bumping post components shall clear the transit vehicle coupler regardless of its position. Clearances shall be based on the coupler swing radius, swing angle, and size of coupler.

B. Material - Tension Bars and Compression Beams to be ASTM A 36 steel.

2.17 HINGED-TYPE DERAIL - Hand throw hinged derail as manufactured by L. B. Foster, Type 113-N, or approved equal. No portion of the derail will be one-half inch above top of rail when in clear position.

2.18 HINGED WHEEL STOPS - Hand throw hinged wheel stops as manufactured by L.B. Foster, Type SH, or approved equal. No portion of the wheel stops will be one-half inch above top of rail when in clear position.

PART 3 - EXECUTION

3.1 PREPARATION

A. Bonded joint and standard joint installation:

1. End-harden rail ends of standard rail as specified in Section 02450, General Track Construction.
2. Remove rail brands which are located in joint bar rail contact areas.
3. Drill rail holes in conformance with AREA specifications or manufacturer's printed instructions using a template as the drilling guide. De-burr all field drilled holes.
4. Calibrate bolt-tightening equipment by testing three typical bolts in a device capable of indicating actual bolt tension.

B. Type 1 and Type 2 Track Crosswalks.

1. Lay out crosswalk and pre-bore timberties or drill concrete to install track crosswalk fastenings.
2. Apply two coats of the coal tar-epoxy coating on all metallic surfaces of the running rail and track fastenings within the track crosswalk area.

C. Asphalt Grade Crossings

1. Tamp ballast under all timber ties in the grade crossing area for the full length of each tie.

3.2 INSTALLATION

A. Bonded Joints

1. Install bonded joints in accordance with manufacturer's printed recommendations with the same equipment and materials used in the qualification tests.
2. Bonded joints shall be installed by a qualified installation crew supervised by a qualified foreman.
3. Ensure that there is no contact between joint assemblies and rail fasteners for use with insulated joints.

4. Ensure that center of insulated joints are no closer than four inches to edge of joint support.
 5. Bonded joints shall be fully bolted in all six holes.
- B. Standard Joint
1. Apply approved lubricant on joint bars and rail.
 2. Install bolts with nuts and lock washers in all six holes and tension bolts between 20,000 and 30,000 pounds.
- C. Negative Return Joint Bonds - All non-insulated bonded joints and all standard joints shall be installed with power bonds. Refer to Contract Drawings for installation procedure.
- D. Type 1 and Type 2 Track Crosswalk
1. Install as shown on the Contract Drawings without damage to the coal tar-epoxy coating.
 2. Fill in any holes with an asphalt base mastic filler.
- E. Asphalt Grade Crossing and Type 3 Crosswalk
1. Install flangeway guard as shown on Contract Drawings. Chip off weld slag and wire brush welds.
 2. Apply two coats of coal tar epoxy to running rails, rail fastenings, and flangeway guard covering all metallic surfaces.
 3. Install asphalt in layers not exceeding 3 inches. Compact each layer with a powered roller.
 4. Fill in any holes or low spots in the flangeway with an asphalt base mastic filler.
- F. Bumping Posts - Install bumping post in accordance with the Contract Drawings and the manufacturer's instructions.
- G. Hinged Derail - Install hinge-type derail in accordance with the Contract Drawings and the manufacturer's instructions.
- H. Hinged Wheel Stops - Install hinged wheel stops in accordance with the Contract Drawings and the manufacturer's instructions.

3.3 FIELD QUALITY CONTROL

- A. The District or its designee will perform the following electrical tests as listed in Section 02450, General Track Construction.
 - 1. Electrical resistance of each bonded insulated joint
 - 2. The continuity of each bonded standard joint and non-bonded standard joint as determined by a visual inspection of the negative return joint bond.
- B. Bonded insulated joints which exhibit unacceptable electrical resistance shall be corrected by the Contractor at no cost to the District.
- C. Poor electrical continuity at noninsulated bonded joints and standard joints shall be corrected by the Contractor at no cost to the District.

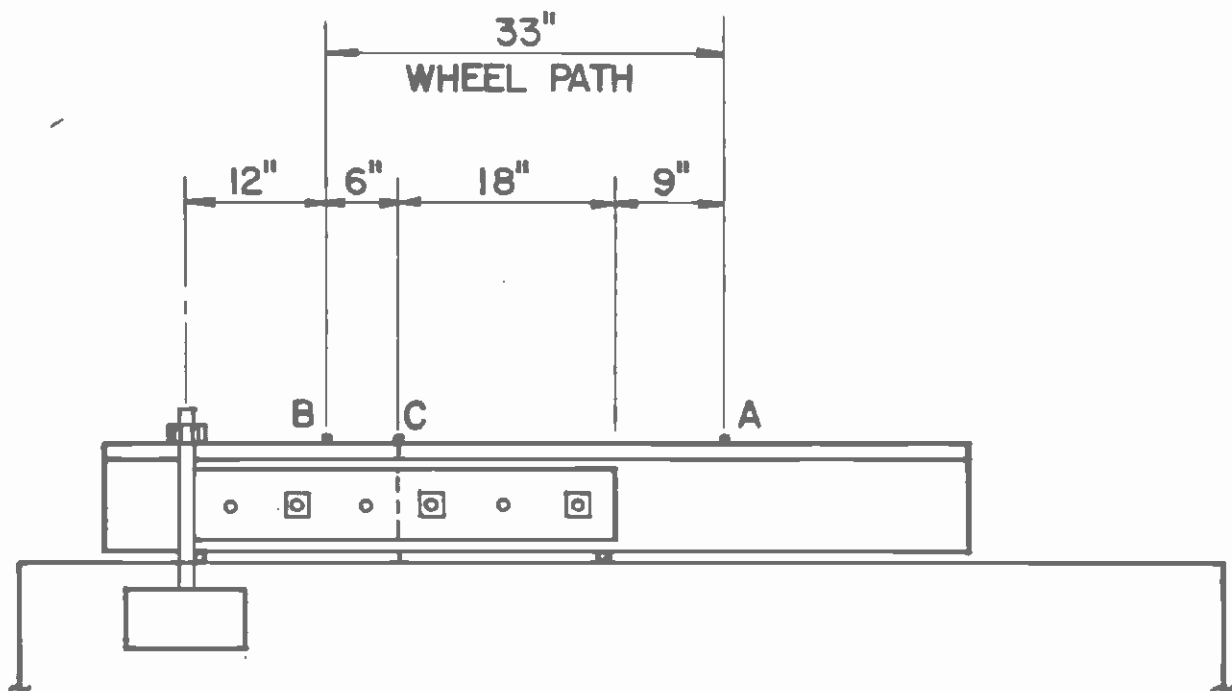

WHEEL LOAD = 44,000 LBS

SOUTHERN CALIFORNIA RAPID TRANSIT DISTRICT

METRO RAIL TRANSIT CONSULTANTS

ROLLING LOAD TEST

DMJM/PBQD/KE/HWA

SCALE: NONE

DATE: 28 JUN 85

SPEC SECTION: 02459

FIGURE: 02459-1

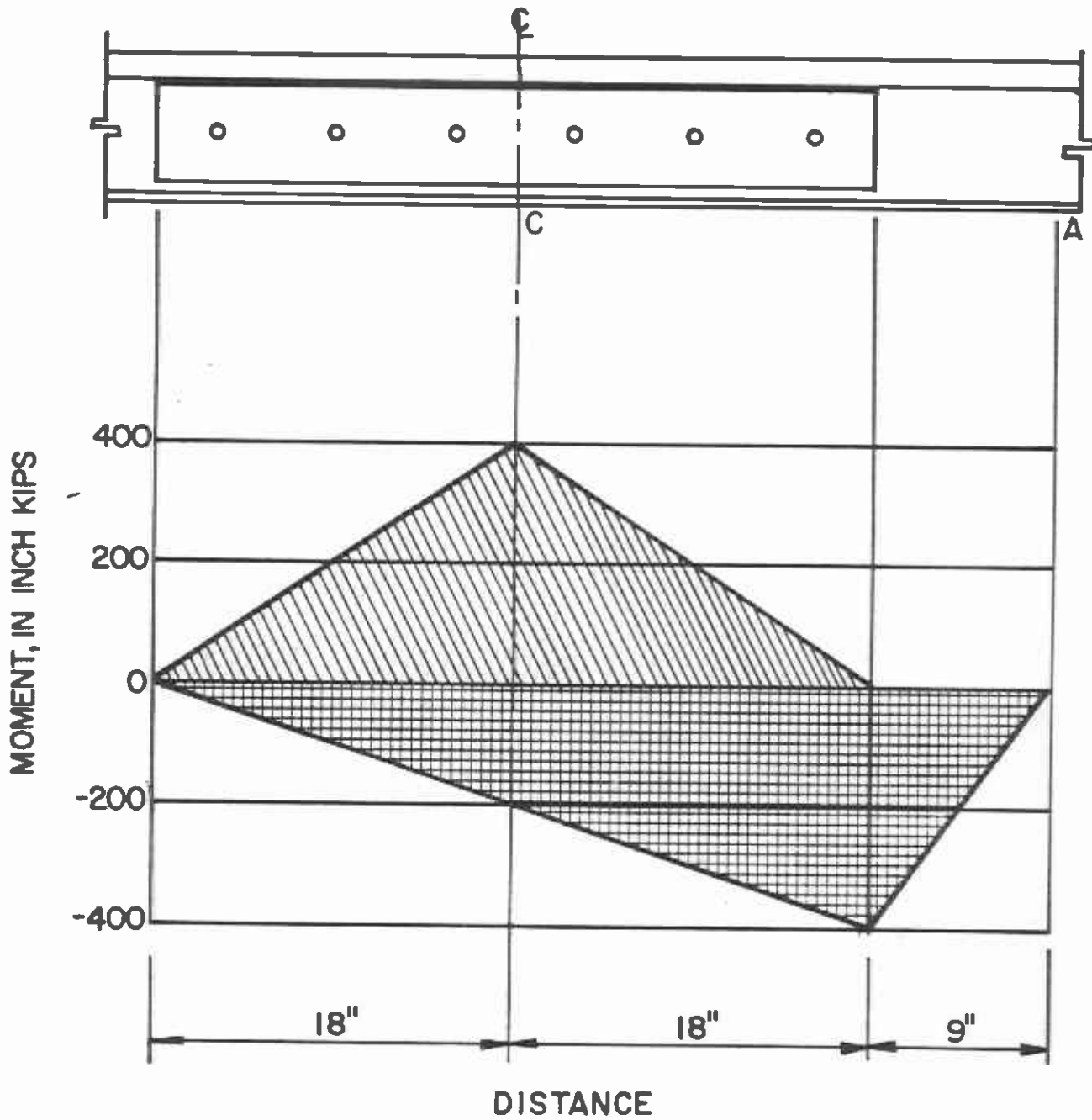

MOMENT DIAGRAM FOR
44,400 POUND LOAD
OVER POINT C



MOMENT DIAGRAM FOR
44,400 POUND LOAD
OVER POINT A

SOUTHERN CALIFORNIA RAPID TRANSIT DISTRICT

METRO RAIL TRANSIT CONSULTANTS

MOMENT-DIAGRAM ROLLING-LOAD TEST

DMJM/PBQD/KE/HWA

SCALE: NONE

DATE: 28 JUN 85

SPEC SECTION: 02459

FIGURE: 02459-2

SECTION 02460

CONTACT RAIL SYSTEM

PART 1 - GENERAL

1.1 DESCRIPTION - The Work specified in this Section includes:

A. Installation of contact rail system components furnished by the District, including:

1. Contact rail sections
2. Splice-joint assemblies
3. Expansion-joint assemblies
4. Dip-section assemblies
5. End-approach assemblies
6. Anchor assemblies
7. Side-approach assemblies
8. Support insulators

B. Furnishing and installation of fasteners, shims, and lubricants.

C. Loading, transporting to the installation site, unloading, and storing at the installation site of the District furnished materials.

1.2 QUALITY ASSURANCE - Quality Assurance Program - Refer to Section 02450, General Track Construction, and conform to the requirement of the Quality Assurance Program.

1.3 SUBMITTALS

A. Refer to Sections 01300, Submittals and 01340, Shop Drawings, Product Data, and Samples.

B. Submit manufacturer's literature indicating product specifications, installation instructions, and procedures.

C. Submit products utilization schedule.

1.4 PRODUCT DELIVERY, STORAGE, AND HANDLING

A. Handle and store materials so as to prevent being damaged.

- B. District furnished materials will be available to the Contractor at a location in Metropolitan Los Angeles. Load materials at this location, transport to the Work site, unload and store them.
- C. Upon installation of a contact rail string, return unused materials to the District at a District designated location.
- D. Before final site clean-up, submit to the District or its designee a list of District furnished left-over materials. The District or its designee will inspect the materials and identify the ones to be saved. Classify, pack, tag and deliver tagged materials to a location within Los Angeles County that will be identified by the District or its designee.

1.5 MEASUREMENT

- A. Installation of contact rail will be measured by the linear foot of contact rail to the nearest half foot complete in place and accepted.
- B. Installation of expansion-joint assemblies, dip-section assemblies, end-approach assemblies, anchor assemblies, side-approach assemblies, support insulators, jumper cable assemblies, and appurtenances, will not be separately measured but will be considered as included in the measurement of contact rail.

1.6 PAYMENT

- A. The installation of contact rail will be paid at the Contract unit price per linear foot as measured above.
- B. Payment for loading, transporting, unloading and storage will be considered as included in the Contract unit price.

PART 2 - PRODUCTS

2.1 PRODUCTS FURNISHED BY THE DISTRICT

A. (I).Contact Rail Sections

- 1. Each contact rail section consists of a 39-foot long, (when measured at 60°F with a tolerance of +/-7/16 inch) aluminum rail with the same height and base dimensions and base configuration as the ASCE 85 pound steel rail, with extruded aluminum bars fastened on both sides of the rail web. Ends of each section will have holes for attachment of splice bars.

2. Each contact rail section will be provided with the identifying markings either "mainline" or "yard". Mainline contact rail will be capable of carrying 4000A dc current and will have a maximum electrical resistance [calculated at 20°C(68°F)] of 0.002 ohms per 1,000 feet. Yard contact rail will be capable of carrying 2000A dc current and will have a maximum electrical resistance [calculated at 20°C(68°F)] of 0.004 ohms per 1,000 feet.

A. (II).Contact Rail Sections

1. Each contact rail section consists of a 39-foot long (when measured at 60°F, with a tolerance of +/-7/16 inch) aluminum rail with the same height and base dimensions and base configuration as the ASCE 85-pound steel rail. Ends of each section will have holes for attachment of splice bars.
2. Each contact rail section will be provided with the identifying markings either "mainline" or "yard". Mainline contact rail will be capable of carrying 4000A dc current and will have a maximum electrical resistance [calculated at 20°C(68°F)] of 0.002 ohms per 1,000 feet. Yard contact rail will be capable of carrying 2000A dc current and will have a maximum electrical resistance [calculated at 20°C(68°F)] of 0.004 ohms per 1,000 feet.

(Paragraph A(I) or A(II) and number in parentheses will be deleted when the contact rail type proposed by the contact rail procurement contractor is known.)

- B. Splice Joint Assemblies - Each splice joint assembly consists of two extruded aluminum bars with holes and lock bolts for attachment to contact rail sections.
- C. Expansion Joint Assemblies - Each expansion joint is furnished preassembled and consists of three specially cut contact rail sections interconnected by two bolted expansion joint plates.
- D. Dip-Section Assemblies - Each dip-section assembly is furnished disassembled and consists of three rail sections, eight bent splice plates and bolt locks.
- E. End-Approach Assemblies - Each end-approach assembly consists of a section of partially sloped contact rail with holes at one end for attachment to contact rail section. End-approach assemblies are furnished in two lengths, one with a five foot ramp and another with a nine foot ramp.
- F. Anchor Assemblies - Each anchor assembly is furnished disassembled and consists of a steel anchor bracket, two

fiberglass rods with clevises attached to each end, two anchor clamps, one anchor clamp eye bolt, two clevis pins and two cotter pins.

G. Side-Approach Assemblies - Each side-approach assembly is furnished disassembled and consists of two 1/2 inch thick steel plates, one splice plate, clamps, and bolts.

H(I) Support Insulators - Each support insulator is a complete assembly consisting of a porcelain insulator, rail clip with bolt, rail clip cushion, base, and base o-ring.

H(II). Support Insulators - Each support insulator is made of fiberglass reinforced polyester resin.

(Paragraph H(I) or H(II) and number in parentheses will be deleted when the insulator type proposed by the contact rail procurement contractor is known.)

2.2 PRODUCTS FURNISHED BY THE CONTRACTOR

A. Oxide-Inhibiting Paste - NO-OX-ID "A" SPECIAL" by Sanchem Inc, 1600 South Canal Street, Chicago, IL 60616, or an approved equal.

B. Bolts and Washers - High-strength steel ASTM A325, hot-dip galvanized in accordance with ASTM A153.

C. Nuts - ASTM A 563, hot-dip galvanized in accordance with ASTM A153.

D. Lubricant - DOW-CORNING 33, or an approved equal.

E. Concrete Expansion Anchors

1. Anchor - FS FF-S-325, Interim Amendment 3, Group VIII, Type 1.

2. Material - Steel, ASTM A108.

3. Finish - Electrodeposited zinc coating, ASTM B633, Class Fe/Zn 5, Type III.

F. Washers - Neoprene, 1/8 inch thick

G. Rail Thermometer - As specified in AREA manual for Railway Engineering Chapter 5, Plan 34-71.

H. Lag Screws - ASTM A563, hot-dip galvanized in accordance with ASTM A153.

I. Shims - Steel, ASTM A36, hot-dip galvanized in accordance with ASTM A123.

- J. Contact Rail Support Insulator Mounting Plate - Steel, ASTM A36, hot-dip galvanized in accordance with ASTM A123.
- K. Jumper Cable Assemblies - As specified in Section 02462, Jumper Cable Assemblies.
- L. Insulating Coating - Bitumastic No. 300-M by Koppers, or an approved equal.

PART 3 - EXECUTION

3.1 INSPECTION

- A. Inspect Materials prior to their installation to assure that they are free of manufacture's defects and shipping and handling damage.
- B. Examine existing Work for conditions that will adversely affect the installation.
- C. Do not proceed with the installation until all unsatisfactory conditions have been corrected.

3.2 GENERAL - Install products as indicated and in accordance with manufacturer's instructions furnished by the District.

3.3 SUPPORT INSULATORS

- A. Install insulators at maximum intervals of ten feet unless otherwise indicated.
- B. Install insulators at the indicated distances to the running rail.
- C. Secure insulators to concrete base using expansion anchors and bolts.
- D. Adjust insulator height installing shims under the insulator.
- E. Install insulators at 24 inches typically, and at no less than 12 inches and no more than 36 inches from the end of end-approaches as indicated.
- F. Install outside connector of expansion joint jumper cable assemblies at no less than seven inches from insulator.
- G. Install the center of each expansion joint on a support insulator.
- H. Install retainer clip with a gap between clip and contact rail to allow free movement of the contact rail. (This

paragraph will be deleted if Type I contact rail is used.)

3.4 CONTACT RAIL

- A. Install contact rail marked "yard" at yard tracks except where contact rail strings are shown on the Contract Drawings with a designation starting with "TT".
- B. Install contact rail marked "mainline" at tracks north from portal and at yard tracks where contact rail strings are shown on the Contract Drawings with a designation starting with "TT".
- C. Install contact rail to rest evenly and uniformly on the top bearing surface of support insulators.
- D. Cut and drill, where required, contact rail sections to match splice joint assemblies. Make cuts only to ensure that the end of contact rail falls at the indicated location.
- E. Cut contact rail sections so as to minimize waste. Use left over fractions of 39-foot sections whenever possible.
- F. Cut contact rail as necessary to displace splice plates and eliminate interference with a support insulator.
- G. Field curve contact rail sections as required.
- H. Lightly sand mating surfaces of ends and holes with 180 grit paper and immediately coat with oxide-inhibiting paste.
- I. Provide horizontal and vertical mounting tolerances of contact rail within 1/8 inch from the indicated dimensions.
- J. Do not make attachment to the contact rail within seven inches of a support insulator.
- K. Locate contact rail gaps where indicated within a tolerance of plus or minus six inches.

3.5 SPLICE-JOINT ASSEMBLIES

- A. Lightly sand mating surfaces of ends and holes with 180 grit paper and immediately coat with oxide-inhibiting paste.
- B. Place splice bars in position to join adjoining contact rail sections and install lock bolts.

- C. Align joints so that on the contact surface there shall be a maximum of 1/64 inch difference in the elevation of the joined rails.

3.6 EXPANSION-JOINT ASSEMBLIES

- A. Install expansion joint assemblies as specified for contact rail sections and splice-joint assemblies.
- B. Set expansion joint gap in accordance with the temperatures indicated on the Contract Drawings.
- C. Use a rail thermometer to measure the temperature of the rail. Place the thermometer on the contact rail base on the side away from the sun.
- D. Unless otherwise indicated, install expansion-joint assemblies at maximum intervals of 1,000 feet for Type I and 600 feet for Type II contact rail, within a tolerance of plus or minus ten feet from the indicated location.

- 3.7 END-APPROACH ASSEMBLIES - Install end-approach assemblies as specified for contact rail sections and splice joint assemblies, as indicated.

- 3.8 SIDE-APPROACH ASSEMBLIES - Install as indicated. Align joints so that there is a maximum difference of 1/64 inch in elevation between the top surfaces.

3.9 ANCHOR ASSEMBLIES

- A. Install anchor assemblies as indicated on the Contract Drawings.
- B. Install anchor assemblies within 10 feet of the following locations as applicable:
 - 1. Mid-point of contact rail string.
 - 2. Mid-point between expansion joints.
 - 3. Mid-point between expansion joints and end-approach assemblies.
- C. Install anchor assemblies so that center of anchor assembly is at the center of a support insulator.
- D. Torque bolts to 140 foot pounds.

3.10 OXIDE-INHIBITING PASTE

- A. Apply oxide-inhibiting paste in accordance with the paste manufacturer's instructions and procedures.

- B. Apply oxide-inhibiting paste in sufficient quantity so that when splice plates are fastened to the contact rails, excess of oxide-inhibiting paste will come out between the contact rail and the splice plates.
- 3.11 LUBRICANT - Apply lubricant to the bottom of the contact rail on the area of contact with the support insulator and extend application one foot in each direction from the support insulator.
 - 3.12 WOOD TIE BORING FOR LAG SCREWS - Bore wood ties as required. After drilling, brush the drill chips from the top surface of the tie and apply creosote to the holes.
 - 3.13 SHIMS - Install shims to provide leveling and the indicated height of the contact rail.
 - 3.14 EXPANSION ANCHORS - Install expansion anchors in accordance with the expansion anchor manufacturer's written instructions.
 - 3.15 INSULATING COATING - Apply two coats, in accordance with the manufacturer's instructions, to cover completely contact rail support insulator mounting plate.
 - 3.16 PRODUCTS UTILIZATION SCHEDULE
 - A. Develop, and submit not less than 60 days prior to starting installation, a product utilization schedule of products furnished by the District. Schedule forms will be furnished by the District.
 - B. The schedule shall identify each string of contact rail, including coverboard (specified in Section 02461, Coverboard), using the designation number indicated on the Contract Drawings and shall reference the Contract Drawing where the string of contact rail is shown.
 - C. Each string of contact rail shall consist of uninterrupted contact rail from end-approach to end-approach and shall include quantities of the following, as applicable:
 - 1. 39-foot contact rail sections
 - 2. Length of fraction of contact rail section
 - 3. Splice-joint assemblies
 - 4. Expansion-joint assemblies
 - 5. Dip-section assemblies
 - 6. End-approach assemblies

7. Anchor assemblies
 8. Side-approach assemblies
 9. Support insulators
 10. Top coverboard sections
 11. Length of fraction of top coverboard sections
 12. Side coverboard sections
 13. Length of fraction of side coverboard sections
 14. Coverboard expansion joints
 15. Coverboard support brackets.
- D. Forms shall include the date Contractor plans to start installation of products listed in the schedule.

END OF SECTION

SECTION 02461

COVERBOARD

PART 1 - GENERAL

1.1 DESCRIPTION - The Work specified in this Section includes:

- A. Installation of coverboards, support brackets and fasteners furnished by the District.
- B. Furnishing and installation of warning signs.
- C. Loading, transporting to the installation site, unloading and storage at the installation site of the District furnished materials.

1.2 QUALITY ASSURANCE - Quality Assurance Program - Refer to Section 02450, General Track Construction, and conform to the requirement of the Quality Assurance Program.

1.3 SUBMITTALS

- A. Refer to Sections 01300, Submittals, and 01340, Shop Drawings, Product Data, and Samples.
- B. Submit manufacturer's literature indicating product specifications, installation instructions, and procedures.
- C. Submit full size camera-ready artwork of the warning sign.
- D. Submit products utilization schedule.

1.4 PRODUCT DELIVERY, STORAGE AND HANDLING

- A. Handle and store materials so as to prevent being damaged.
- B. District furnished materials will be available to the Contractor at a location in Metropolitan Los Angeles. Load materials at this location, transport to the Work site, unload and store them.
- C. Before final site clean-up, submit to the District or its designee a list of District furnished leftover materials. The District or its designee will inspect the materials and identify the ones to be saved. Classify, pack, tag and deliver tagged materials to a location within Los Angeles County that will be identified by the District or its designee.

1.5 MEASUREMENT

- A. Installation of Coverboards will be measured by the linear foot of coverboard, to the nearest half foot complete in place and accepted.
- B. Installation of support brackets, expansion joints and warning signs will not be separately measured but will be considered as included in the measurement of coverboard.

1.6 PAYMENT

- A. The installation of coverboard will be paid at the contract unit price per linear foot as measured above.
- B. Payment for loading, transporting, unloading and storage will be considered as included in the Contract unit price.

PART 2 - PRODUCTS

2.1 PRODUCTS FURNISHED BY THE DISTRICT

- A. Coverboards and expansion joints will be manufactured of fiberglass reinforced resin in ten-foot sections complete with mounting holes. Two shapes will be furnished: curved, top coverboards, and flat, side coverboards.
- B. Support brackets will be manufactured of fiberglass reinforced resin.
- C. Fasteners will be furnished as required to install brackets and protective coverboard.

2.2 PRODUCTS FURNISHED BY THE CONTRACTOR

A. Warning Signs

- 1. Sheeting: Scotchlite series 680-10 by 3M, or an approved equal.
- 2. Typeface: Helvetica medium by Haas.
- 3. Reflective markings: Screen printing inks Scotchlite Series 4400 red, and clear coating Scotchlite 4430 by 3M or an approved equal.
- 4. Fabrication: In accordance with sign manufacturer's instructions.

PART 3 - EXECUTION

3.1 INSPECTION

- A. Inspect materials prior to their installation to assure that they are free of manufacturer's defects and shipping and handling damage.
- B. Examine existing Work for conditions that will adversely affect the installation.
- C. Do not proceed with the installation until all unsatisfactory conditions have been corrected.

3.2 COVERBOARD AND APPURTENANCES

- A. Install coverboards and brackets as indicated on the Contract Drawings.
- B. Cut and drill coverboard sections as required to ensure that the ends of coverboard falls at the indicated location.
- C. Coat drillings and cuts with ultraviolet inhibitor coating.

3.3 WARNING SIGNS

- A. Clean coverboard immediately before applying sign.
- B. Apply sign in accordance with sign fabricator instructions.

3.4 PRODUCTS UTILIZATION SCHEDULE - As specified in Section 02460, Contact Rail System.

END OF SECTION

SECTION 02462

JUMPER CABLE ASSEMBLIES

PART 1 - GENERAL

1.1 DESCRIPTION - The Work specified in this Section consists of furnishing and installing jumper cable assemblies for bonding around contact rail expansion joints.

1.2 QUALITY ASSURANCE

A. Quality Assurance Program - Refer to Section 02450, General Track Construction, and conform to the requirement of the Quality Assurance Program.

B. Reference standards applicable to this section.

1. Association of Edison Illuminating Companies (AIEC)

6: Specifications for Ethylene Propylene Rubber Insulated Shielded Power Cables

2. American Society for Testing and Materials (ASTM)

B3: Specification for Soft or Annealed Copper.

B173: Specification for Rope-Lay-Stranded Copper Conductors having bunch-stranded members for electrical conductors.

E662: Test for specific optical density of smoke generated by solid materials.

3. Institute of Electrical and Electronics Engineers (IEEE)

383: Standard for type test of Class 1E Electric Cables; Field Splices and Connections for Nuclear Power Generating Stations.

4. National Electrical Manufacturers Association (NEMA)

5. Insulated Cable Engineers Association (ICEA)

NEMA WC8/ICEA S-68-165 - Ethylenepropylene-rubber-insulated wire and cable for the transmission and distribution of electrical energy.

1.3 SUBMITTALS

A. Refer to Sections 01300, Submittals and 01340, Shop Drawings, Product Data and Samples.

- B. Submit manufacturer's literature indicating product specifications, installation instructions and procedures.
 - C. Submit certification of compliance with these specifications.
- 1.4 PRODUCT DELIVERY, STORAGE AND HANDLING - Handle and store materials so as to prevent them being damaged.
 - 1.5 MEASUREMENT - Jumper cable assemblies will not be measured separately but will be considered as included in the measurement of contact rail as specified in Section 02460, Contact Rail System.
 - 1.6 PAYMENT - Jumper cable assemblies will be paid for as part of the Contract unit price for Contact Rail.

PART 2 - PRODUCTS

- 2.1 GENERAL - Each jumper cable assembly shall consist of 15 feet of dc power cable and two contact rail cable connector attached to the cable, one at each end.
- 2.2 DC POWER CABLES
 - A. DC Power Cables Shall:
 - 1. Comply with the requirements of NEMA WC8/ICEA S-68-516.
 - 2. Pass IEEE 383 flame tests.
 - 3. Be low-smoke.
 - 4. Be 2000V single conductor, unshielded, for use on nominal 750V dc distribution system.
 - 5. Be rated for a maximum conductor temperature of 90°C for normal operation, 130°C for emergency overload, and 250°C for short-circuit operation as defined in AEIC 6.
 - B. Cable conductors shall be 1000MCM ASTM B3 soft or annealed copper, ASTM B173, Class G stranding.
 - C. Cable insulation shall be NEMA WC8/ICEA S-68-516, Type II, low-smoke flame retardant, thermosetting ethylene-propylene-rubber, 110 mils thick minimum. Cable insulation shall also be tested in accordance with ASTM E662 and shall have the following maximum specific optical densities Ds and Dm:

<u>SPECIMEN THICKNESS</u>		<u>Ds (uncorrected) 4 MINUTES</u>		<u>Dm (corrected)</u>
<u>mils</u>	<u>Flaming</u>	<u>Nonflaming</u>	<u>Flaming</u>	<u>Nonflaming</u>
100	100	100	200	350

D. The cable jacket shall be 110 mils thick minimum, made of a low-smoke, flame retardant, non-halogen polyolefin thermoset compound complying with the following requirements when tested in accordance with NEMA WC8/ICEA S-68-516, except as otherwise specified.

1. Physical Requirements Before Aging:

- a. Tensile strength, minimum, psi 1800
- b. Elongation at rupture, minimum, percent 150

2. Physical Requirements After Aging:

a. After air oven test at 121°C for 168 hours:

- 1) Tensile strength, minimum, % of unaged value 95
- 2) Elongation, minimum, % of unaged value 70

b. After air oven test at 150°C for 168 hours:

- 1) Tensile strength, minimum, % of unaged value 80
- 2) Elongation, minimum, % of unaged value 50

3. After Oil Immersion Test at 121°C for 18 Hours (ASTM #2 oil):

- a. Tensile strength, minimum, % of unaged value 60
- b. Elongation, minimum, % of unaged value 60

4. Ozone Resistance (ASTM D470) - After 24 hours exposed to an ozone concentration of 0.015%

No Cracks

5. Oxygen Index - % minimum when tested in accordance with ASTM D2863

28

6. Cold Bend at -30°C

No Cracks

7. Halogen Content

0

8. Specific Optical Density: - The jacket material shall be tested in accordance with ASTM E662 and shall have maximum specific optical density as follows:

<u>SPECIMEN THICKNESS</u>		<u>Ds (uncorrected) 4 MINUTES</u>		<u>Dm (corrected)</u>
<u>mils</u>	<u>Flaming</u>	<u>Nonflaming</u>	<u>Flaming</u>	<u>Nonflaming</u>
50	50	150	100	300
100	100	80	200	350

E. Cable Identification - The following information shall be printed on the jacket, in contrasting color, at approximately two-foot intervals:

1. Manufacturer's name
2. Year of manufacture
3. Conductor size
4. Voltage rating
5. Insulation type and thickness
6. Jacket type and thickness

2.3 CONTACT RAIL CABLE CONNECTORS

A. Cable connectors shall be as indicated and shall be rated for conducting 1100 amperes continuously by without exceeding a temperature rise of 40°C above 30°C average ambient temperature in still air.

B. Cable connectors shall be:

1. Catalog 85-100-1 for contact rail type I
2. Catalog 85-1000-2 for contact rail type II.
3. by Connector Products Inc. P.O. Box 534, Pennsauken, New Jersey 08110. (609) 541-9638, or an approved equal.

2.4 ANTIOXIDANT-Aluma-shield by Thomas and Bett or an approved equal.

PART 3 - EXECUTION

3.1 INSPECTION

A. Inspect materials prior to their installation to assure that they are free of manufacturer's defects and shipping and handling damage.

B. Examine existing work for conditions that will adversely affect the installation.

- C. Do not proceed with the installation until all unsatisfactory conditions have been corrected.

3.2 CABLE INSTALLATION

- A. Cut cable to the indicated length to provide free movement of the expansion joint.
- B. Cut back insulation to expose cable conductor to a maximum of one inch beyond the connector.
- C. Clean thoroughly and remove rust on contact soil area where connector is going to be installed.
- D. Apply antioxidant on the contact rail immediately after cleaning.
- E. Install connector and cable as indicated and in accordance with the manufacturer's written instructions using a torque wrench to tighten-up bolt.

END OF SECTION

SECTION 02466

SPECIAL TRACKWORK

PART 1 - GENERAL

1.1 DESCRIPTION

A. The Work specified in this Section consists of manufacturing, testing, and shop assembly of special trackwork.

B. Definitions

1. Buffer Rails - Running rails which are adjacent to stock rails in order to facilitate insulated joint installation, and track maintenance.
2. Closure Rails - The lead rails connecting the heels of the switch points to the toe of the frog in a turnout.
3. Crossover connecting rails - The additional running rails forming the connecting track in either single or double crossover units.

1.2 QUALITY ASSURANCE

A. Quality Assurance Program - Refer to Section 02450, General Track Construction, and conform to the requirement of the Quality Assurance Program.

B. Special trackwork - Conform with AREA "Specifications for Special Trackwork" in all aspects unless modified by the Contract Documents and this Specification.

C. Rail - Conform with Section 02455, Running Rail.

D. Reference Standards

1. American National Standards Institute (ANSI):
B18.22.1, Plain Washers.
2. American Society for Testing and Materials (ASTM):
A36, Structural Steel
A148, High-Strength Steel Castings for Structural Purposes
A307, Carbon Steel Externally Threaded Standard Fasteners
A325, High-Strength Bolts for Structural Steel Joints

3. American Railway Engineering Association (AREA):

Manual for Railway Engineering Volume I.

Portfolio of Trackwork Plans.

Specifications for Special Trackwork.

4. National Electrical Manufacturer's Association (NEMA)
- LI-1, Industrial Laminated Thermosetting Products.

C. Tolerances - Conform with the AREA "Portfolio of Trackwork Plan Nos. 1010 and 1011, permissible variations in completed Frogs and Switches" respectively.

D. Source Quality Control - Test insulated gauge plates and switch rods in accordance with AAR Manual, Part 116, Signal Section, "Assembly and Test of Insulated Track Fittings".

E. Preassembly

1. Shop assemble, test, and operate the following for inspection by the District or its designee prior to site delivery.

a. At least one No. 8 lateral turnout, complete-right hand.

b. At least one No. 8 lateral turnout, complete - left hand.

c. At least one No. 10 lateral turnout, complete - right hand.

d. At least one No. 10 lateral turnout, complete - left hand.

e. At least one Wilshire/Alvarado lateral turnout, complete - right hand.

f. At least one Wilshire/Alvarado lateral turnout, complete - left hand.

g. Diamond Crossing - 23 degrees, 40 minutes, 00 seconds, complete.

h. Diamond Crossing - 19 degrees 11 minutes 00 seconds, complete.

2. Use specified joint bars to connect rail joints. Install 3/16 inch end post shim where insulated joint bars are shown on the Contract Drawings. Do not apply adhesives during this process.

3. No bracing will be permitted to hold components to proper gauge.

1.3 SUBMITTALS

- A. Refer to Section 01300, Submittals.
- B. Refer to Section 01340, Shop Drawings, Product Data, and Samples, and submit the following:
 1. Shop drawings showing:
 - a. Insulated curved split switch section including stock rails for both right and left hand switches
 - b. Insulated straight split switch section including stock rails for both right and left hand switches
 - c. Railbound manganese steel frogs
 - d. Closure rails
 - e. Buffer rails
 - f. Crossover connecting rails
 - g. Frog guard rail
 - h. All special plates, rail clamp assemblies, and miscellaneous parts
 - i. Complete layouts and details for all types of right hand turnouts, left hand turnouts, single crossovers, and double crossovers.
 2. Product data - Submit the procedure to be used in the depth hardening of frog castings.
- C. Refer to Section 01322, Certificates and Reports, and submit the following:
 1. Certificates of material compliance required by AREA and this specification.
 2. Test reports of chemical analyses, Brinell hardness, electrical insulation, and other tests required by AREA and this specification.
 3. Frog depth hardening results

1.4 RAIL CLAMP ASSEMBLY QUALIFICATION TEST

A. General Requirements

1. Submit shop drawings of the proposed rail clamp assembly to the District or its designee for approval. Prior to approval, submit two samples of the rail clamp assembly for testing to an independent test laboratory approved by the District or its designee.
2. Test specimen - Two fully assembled rail clamp assemblies welded on any of the special plates shown on the Contract Drawings.
3. Vertical Uplift Test - Apply a load to the rail clamp spring clip sufficient to deflect the clip upwards 0.10 inch above its normal installed position and then released. Record the load and permanent deflection in the clip. A one-foot length of 115 RE rail shall then be attached to the special plate. Apply a load varying cyclically from zero to two thousand pounds to the rail head in an upward direction at the centerline of the clamp assembly. This load shall be repeated one million times. Record the normal force of the rail clamp spring clip both before and after the cyclic test.
4. Acceptance Criteria - After the static loading of the rail clamp spring clip, the permanent deflection shall not exceed 0.015 inch. At the end of the cyclic loading, the rail clamp, rail clamp spring clip, and the special plate shall show no signs of cracking or fatigue. The normal force of the rail clamp spring clip as recorded both before and after the cyclic loading test shall be 2500 pounds plus or minus 500 pounds.

1.5 MEASUREMENT - The Work of this Section will not be measured for payment.

1.6 PAYMENT - The Work of this Section will be paid for as part of the contract unit price for the particular type of track construction to which it pertains.

PART 2 - PRODUCTS

2.1 SWITCH AND STOCK RAILS

A. General Requirements

1. Straight split switches - 16 feet, six inches long, double reinforced, in accordance with AREA Plan Nos. 112 and 221 using point detail 5100 and the Contract Drawings.

2. Curved split switches - 19 feet, six inches long, double reinforced, in accordance with AREA Plan Nos. 124 and 221 using point detail 5100 and the Contract Drawings.
3. Curved split switches - 21 feet long, double reinforced, in accordance with AREA point detail 5100 and the Contract Drawings.
4. Stock rails - 39 feet long, undercut according to type of switch rail and turnout hand in accordance with the contract drawings and AREA Plan No. 221.

B. Materials - Switch and stock rails to conform to 115 RE high strength rail as per Section 02455 Running Rails.

C. Manufacture

1. Switch and stock rails may be machined initially and subsequently heat treated to achieve the requirements of high strength rail as per Section 02455, Running Rails.
2. Drill switch and stock rails for reinforcing bars, heel block assembly, switch rods, standard joints and insulated joints in accordance with the Contract Drawings and AREA Specifications for "Rail Drilling, Bar Punching, and Track Bolts". Perform all drilling of switch and stock rails in the shop. Field drilling of these products is not acceptable.
3. Bevel all switch and stock rail ends in accordance with AREA Plan No. 1005.
4. Remove rail brands in reinforcing bar area and within one-foot eight inches of the rail end.

D. Identification

1. Stencil paint mark each component prior to shipment. Use white lead-based paint on a background of permanent black paint suitable for steel.
2. Place markings in an area that will not subsequently be covered by joint bars.
3. Identification markings for switch and stock rails to provide:
 - a. Component location
 - b. Component part name

- c. Turnout number or turnout radius
- d. Turnout hand.

2.2 TURNOUT AND DIAMOND FROGS

A. General Requirements

1. Turnout, center, and end frogs shall be heavy wall railbound manganese steel frogs in accordance with the Contract Drawings and AREA Plan Nos. 600A-79, 600B-79, 621-82, 622-82, 623-82, 700-68, 750-81, and 761-83.
2. All castings shall be designed for 115 RE rail section.
3. Drill frogs for standard or bonded joints in accordance with the Contract Drawings, and AREA, Specifications for "Rail Drilling, Bar Punching, and Track Bolts."

B. Materials

1. Rail used in the manufacture of frog components shall conform to 115RE high strength rail as per Section 02455 Running Rail.
2. The castings for the frog inserts shall be manganese steel.

C. Manufacture

1. Depth harden the impact areas of the manganese steel castings for turnout and diamond frogs by explosive, press, or hammer hardening procedure in accordance with AREA "Specifications for Special trackwork, Manganese steel castings, Section M2.7, Depth Hardening".
2. Drill frog rails for standard joints in accordance with the Contract Drawings and AREA Specifications for "Rail Drilling, Bar Punching, and Track Bolts." Perform all drilling in the shop. Field drilling is not acceptable.
3. Bevel all rail ends in accordance with AREA Plan No. 1005.
4. Remove rail brands in reinforcing bar area and within one foot eight inches of rail end.

D. Identification

1. Stencil paint mark each frog prior to shipment. Use white lead-based paint on a background of permanent black paint suitable for steel.

2. Place markings in an area that will not subsequently be covered by joint bars.
3. Identification marking for frogs to provide:
 - a. frog location,
 - b. either frog number or frog type with angle or radius
 - c. frog hand, if applicable.
4. Stamp location of 1/2 inch point of frog on casting.

2.3 SPECIAL TRACKWORK RAILS

A. General Requirements

1. Provide special trackwork rails, such as the closure, buffer and crossover connecting rails, at the lengths specified in the Contract Drawings.
2. Drill special trackwork rails for standard joint, bonded joint or frog guard rail installation as shown in the Contract Drawings and in accordance with AREA.

- #### B. Materials - Closure, buffer, and crossover connecting rails to be high strength rail as per section 02455, "Running Rail".

C. Manufacture

1. Drill and cut special trackwork rails which are not shown as continuous welded rail in the shop. Field cutting and drilling of these products is not acceptable.
2. Bevel special trackwork rail ends in accordance with AREA Plan No. 1005.
3. Remove rail brands within one-foot eight inches of the rail end.
4. Supply rails to lengths shown on Contract Drawing without additional joints.

D. Identification

1. Stencil paint mark each component prior to shipment. Use white lead-based paint on a background of permanent black paint suitable for steel.
2. Place markings in an area that will not subsequently be covered by joint bars.

3. Identification markings for special trackwork rails to provide:

- a. component location,
- b. component part name.

2.4 ADJUSTABLE RAIL BRACES

A. General Requirements

1. Adjustable rail brace shall be in accordance with AREA Plan No. 224, Type Fit A.
2. In accordance with Design 811 as manufactured by Bethlehem Steel Corporation or "Top Notcher" as manufactured by Pettibone Corporation, or accepted equal.

B. Materials - Adjustable rail braces shall be made of copper bearing mild steel, malleable iron or cast steel.

2.5 ADJUSTABLE FROG GUARD RAILS

A. General Requirements

1. Frog guard rails shall be planed tee rail design in accordance with the Contract Drawings and AREA Plan No. 504, complete with filler blocks, bolts, nuts, etc.
2. Frog guard rails shall be twelve feet in length.
3. Cast fillers to match the 115 RE and 132 RE rail section as detailed in the Contract Drawings.

B. Materials - Frog guard rails shall be manufactured from 132 RE high strength rail.

C. Manufacture - Frog guard rails may be machined initially and subsequently heat treated to achieve the requirements of high strength rail as per Section 02455, "Running Rail".

D. Identification

1. Stencil paint mark each component prior to shipment. Use white lead-based paint on a background of permanent black paint suitable for steel.
2. Identification markings for frog guard rails to provide:
 - a. component part name
 - b. centerline of guard rail.

2.6 SWITCH HEEL BLOCK ASSEMBLY AND SEPARATOR BLOCK

A. General Requirements

1. Switch heel block assembly shall be in accordance with AREA Plan NO. 221 and the Contract Drawings.
2. Switch heel block shall be a five bolt design complete with bars, bolts, nuts and washers.
3. Separator block for Number 10 and Wilshire/Alvarado switch section shall be five inches long with a single 1 3/8 inch diameter bolt.

B. Materials - Switch heel block and separator block shall be carbon steel casting as per AREA specification, Article M3.1.1.

C. Identification - Switch heel block shall be stamped with the following information:

- a. switch rail length
- b. switch rail hand
- c. rail section (115 RE).

2.7 SWITCH ROD ASSEMBLY

A. General Requirements

1. Switch rod assemblies shall be a vertical rod design, insulated, and in accordance with the Contract Drawings.
2. Switch rod assemblies shall be in accordance with RACOR Type "MJ" and "MF" as manufactured by ABEX Corporation or approved equal.
3. Switch rod assembly shall include adjustable basket.

B. Materials

1. Switch rod assemblies to conform to AREA "Specifications for Special Trackwork, Rolled Mild Steel".
2. Fiberglass insulation shall be in accordance with AAR Signal Manual, Part 116, Signal Section Specification 216, "Assembly and Test of Insulated Track Fittings". Fiber angles, plates and channels shall be fabricated of 3/16 inch thick fiberglass mat reinforced polyester, GPO-1 Sheet Stock NEMA Class B. Fiber bushing shall be fabricated of NEMA Grade 10 epoxy glass fabric.

- C. Manufacture - Seal cut edges of fiberglass with Sherman Williams Polane, two part coatings or accepted equal. Before assembly, paint contact metal surfaces with General Electric insulating enamel Red Glyptol No. 1201 or accepted equal. During assembly, fill areas between outside edge of bolts and inside edge of holes with clear silicon rubber paste, Devon Silite 100, General Electric RTV 108 or accepted equal.
- D. Identification - Assemble switch rods shall be stamped No. 1 and No. 2 as required.

2.8 SPECIAL TRACKWORK PLATES

A. General Requirements

1. Shoulder Slide Plates - In accordance with AREA "Portfolio of Trackwork Plan No. 223, Details 7021 and 4130".
2. Solid Base Slide Plates - In accordance with AREA "Portfolio of Trackwork Plan No. 224, Details 7020 and 7022.
3. Hook Twin Plates - In accordance with AREA "Portfolio of Trackwork Plan No. 241".
4. Frog Guard Rail Plates - In accordance with the Contract Drawing and AREA "Portfolio of Trackwork Plan No. 504".
5. Heel Plates - In accordance with the Contract Drawings.
6. Switch Gauge Plates - In accordance with the Contract Drawings and AREA "Portfolio of Trackwork Plans No. 223 and No. 224, Details 4103 and 7026. Gauge Plates shall not be bent to suit switch angle. Rail brace will be affixed to account for switch angle. Gauge Plates will have the ends upturned to allow splice extension for switch machine extension plate. Switch machine extension plate is not in contract.
7. Frog Gauge Plates - In accordance with the Contract Drawings and AREA "Portfolio of Trackwork Plan No. 223, Detail 4103.
8. Special plates for embedded trackwork - In accordance with the Contract Drawings.
9. Special trackwork plate thickness - In accordance with the Contract Drawings.

B. Materials

1. All plates shall be in accordance with AREA "Specifications for Special Trackwork, Rolled Mild Steel".
2. Fiberglass Insulation - In accordance with AAR Signal Manual, Part 116, Signal Section Specification 216, "Assembly and Test of Insulated Track Fittings". Fiber angles, plates and channels shall be fabricated of 3/16 inch thick fiberglass mat reinforced polyester, GPO-1 Sheet Stock NEMA Class B. Fiber bushing shall be fabricated of NEMA Grade 10 epoxy glass fabric.

C. Manufacture - Gauge Plates shall be fully assembled and may be welded or milled. During assembly, place at the seat of angle bends between gauge plate, insulation and steel angles a bead of silicon rubber paste, Devon Silite 100, General Electric RTV 102 or accepted equal.

D. Identification

1. Stamp plates with suitable letters and figures not less than 1/2 inch in height, located on the top surface of the plates, plainly visible when assembled and not subject to wear.
2. Stamp plates with the following information:
 - a. Manufacturer's initials.
 - b. Identification numbers and letters shown on the Contract Drawings.

2.9 RAIL CLAMP ASSEMBLY

A. General Requirements

1. Rail clamp assembly for use with special plates to be designed in accordance with the Contract Drawings.
2. Rail clamp assembly to be composed of rail clamp, rail clamp block, rail clamp spring, bolts, nuts and washers.
3. Rail clamp spring to be designed to provide a normal force on the rail of 2500 pounds plus or minus 500 pounds and to provide a one square inch area in contact with the rail.
4. Weld rail clamp block to special plate in the shop.
5. A positive means for maintaining the tension during in-service vibration to be provided by a prevailing

torque lock nut complying with the Industrial Standards 1F1-100 and 1F1-101, Grade C.

B. Materials

1. Fabricated rail clamp and rail clamp block of cast steel in accordance with ASTM A27, Grade 65-35.
2. Nuts, bolts and washers to conform with the chemical and mechanical requirements of SAE J429f, Grade 5. Nuts to conform with SAE J995b and shall be furnished with suitable plain hardened washers.

C. Manufacture - Serrations shall be clean and sharp. The depth of serrations shall be within limits shown on the Contract Drawings.

2.10 SPLIT SWITCH POINT DERAIL

A. General Requirements

1. Provide straight split switch, stock rail, guard rail, adjustable rail braces, switch heel block assembly, switch rod assemblies special trackwork plates, and miscellaneous hardware in accordance with Contract Documents.
2. Modify special trackwork plates for additional spikes and lag screws for running rail and rod guide.
3. Lag screws - 3/4 inch diameter, six inches in length. and with gimlet point in accordance with ANSI B.18.2.1.

B. Identification - All modified special trackwork components shall be permanently marked as "modified" in addition to the standard identification requirements.

PART 3 - EXECUTION - Installation is not part of the Work specified in this Section. For installation requirements refer to the applicable special trackwork construction specification section.

END OF SECTION

SECTION 02467

RAIL WELDING

1.1 DESCRIPTION - The Work specified in this Section consists of fabricating continuous welded rail (CWR) by electric flash butt welding process. The Work includes handling, welding, grinding, testing, inspecting, and all incidental work necessary to provide CWR.

1.2 QUALITY ASSURANCE

A. Refer to Section 02450, General Track Construction and conform to Quality Assurance Program requirements.

B. General Requirements

1. Shop weld rail in accordance with AREA Specifications for Fabrication of Continuous Welded Rail as modified herein. Make all shop welds by the electric flash butt welding process.
2. Do not commence production of CWR until the District or its designee approves the results of the qualification tests.
3. All inspection personnel shall be technicians qualified in accordance with AWS QC1.
4. All NDE personnel shall be certified in accordance with ASNT-TC1A.

C. Refer to Section 01410, Testing Laboratory Services for requirements in radiographic testing.

D. EQUIPMENT

1. Ultrasonic test equipment shall be capable of detecting a 3/64 inch discontinuity, 6-1/2 inch below the top of rail. The sensitivity and resolution of the proposed equipment shall be demonstrated using appropriate area amplitude and distance amplitude reference blocks made of material similar to the rail steels being tested. All equipment shall be equipped with a distance amplitude correction feature. The equipment shall be calibrated before start of testing and every 30 minutes thereafter using equipment and calibration methods meeting the approval of the District or its designee.
2. Welding machine performance and operation shall adhere to the recommendations of the welding machine manufacturer. The welding machine shall be equipped with a

reorder to record platen movement and current impulses.

E. Source Quality Control

1. Inspect all shop welds by the dry powder magnetic particle method in accordance with ASTM E709.
2. Inspect all shop welds prior to installation ultrasonically in accordance with ASTM E164.
3. Record the welding machine's platen movement and current impulses for each weld.
4. Prepare production records on each CWR string as follows;
 - a) heat numbers of first and last pieces of rail in each string.
 - b) number of welds in each string.
 - c) heat numbers of rail on each side of any weld performed during a reweld procedure.
 - d) rail type.

F. Tolerances - Adhere to AREA's "Specifications for Fabrication of Continuous Welded Rail".

1.3 SUBMITTALS

- A. Refer to Section 01300; Submittals and submit the following.
1. Welding plant site requirements if performing onsite rail welding.
 2. Welding plant location, methods of transporting and location if performing off-site rail welding.
 3. Rail welding schedule.
- B. Refer to Section 01340, Shop Drawings, Product Data and Samples, and submit the following;
1. Welding machine standards of performance as determined by the manufacturer.
 2. Welding procedure, equipment description, calibration methods, and rail straightening method.
 3. Ultrasonic inspection procedure, equipment description and calibration methods.

4. Method of dry powder magnetic particle inspection.
 5. Procedure for defective weld cut-out and re-welding.
- C. Refer to Section 01322; Certificates and Reports, and submit the following;
1. Radiographic test results.
 2. Platen movement and current impulses for each weld.
 3. Magnetic particle inspection records for each weld.
 4. Ultrasonic inspection records of each weld for inspections conducted prior to installation.
 5. Inspection records of each weld for straightness as per AREA requirements.
 6. Production CWR string records.
 7. Daily calibration of ultrasonic inspection equipment.
 8. Certification of welding operators, ultrasonic, magnetic particle, and radiographic test personnel.

1.4 QUALIFICATION TESTS

A. General Requirements

1. Nuclear by-product materials for radiographic testing shall be in accordance with United States Nuclear Regulatory Commission Rules and Regulations, Title 10, Atomic Energy, Part 20, "Standard for Protection Against Radiation."
2. Transportation, handling, and storage of hazardous materials used in radiographic inspection of welds shall be performed only by or under the supervision of a person of proven experience and ability operating under a proper license. The laboratory and procedure to be utilized in radiographic testing shall be submitted to the District or its designee for approval.
3. All test welds shall be made in the presence of the District or its designee, using the same method and procedure proposed for production welding, including methods and procedures for cut-out and rewelding of rejected welds. Rail for test welds shall be furnished by the Contractor.
4. The radiographic tests shall provide sufficient detail to establish the ability of the welding machine to meet the requirements specified herein.

B. Radiographic Test Samples

1. Prepare twelve test samples by producing two samples of each rail weld conforming to the following:
 - a. Two standard rails welded together at average rail alignment.
 - b. Two standard rails welded together at the maximum allowable alignment deviations.
 - c. Two high strength rails welded together at average rail alignment.
 - d. Two high strength rails welded together at the maximum allowable alignment deviations.
 - e. A standard rail and a high strength rail welded together at average rail alignment.
 - f. A standard rail and a high strength rail welded together at the maximum allowable alignment deviations.
2. Prepare twelve additional test samples as originally specified except use the cut-out and reweld procedure.

C. Radiographic Test Procedures

1. Perform radiographic tests on each of the radiographic test samples. At least four areas at each weld will be radiographed: the head, the web, and each side of the rail base.
2. The radiographic tests shall conform to ASTM E142, "Controlling Quality of Radiographic Testing".
3. A weld is defective if it does not exhibit full penetration, complete fusion, and freedom from flaws when subjected to the specified testing and inspection. If a defective weld is detected in the test series, the welding procedure shall be modified and the test series repeated on new sample rails until all test samples are acceptable.
4. Upon conclusion of the qualification tests, prepare a report describing all radiographic tests depicting the information given on the film and whether the weld was acceptable or defective. The report shall include what remedial measures were required to prevent recurrence of any defective welds.

- D. Identification - Each radiographic film shall be identified, through the use of lead numbers and letters, to

show the contract number, rail identity, date, inspection agency and the view.

- 1.5 MEASUREMENT - The Work in this Section will not be measured for payment.
- 1.6 PAYMENT - The Work in this Section will be paid for as part of the contract unit price for the particular type of track construction to which it pertains.

PART 2 - PRODUCTS

2.1 Continuous Welded Rail

A. General Requirements

1. Produce CWR in lengths conforming to the rail schedule approved by the District or its designee.
2. Position rails for each string so that the rail stamping is on the field side of the CWR string when installed in track.
3. Do not weld rails shorter than 19 feet for CWR production.
4. Produce welds which have full penetration, complete fusion and freedom from flaws.

B. Materials - Refer to Section 02455, Running Rails for rail requirements in production of CWR.

C. Manufacture

1. Cut rail ends square and clean by means of either rail saws or abrasive cutting disk. Flame cutting of rail ends is not permitted.
2. Remove mill scale on the head and base of the rail down to bare metal for a length of six inches from the rail end.
3. Remove all burrs from the area where the welding current electrodes contact the head and base of the rail.
4. Align vertically contiguous rail ends to match the top of the rail heads with the vertical rail variances assigned to the rail base.
5. Align horizontally contiguous rail ends to match the gauge side of the rail heads with the horizontal rail variance assigned to the field side of the CWR string.

6. Forge the electric-flash butt weld to the point of refusal to further plastic deformation. The upset weld shall be 5/8 inch minimum with 3/4 inch as standard. The upset cylinder shall not bottom out during the upset portion of the weld cycle.
7. Shear off the upset weld metal while the weld is still hot.
8. Post weld straightening may be permitted if the surface of the weld is above 500 degrees F.
9. Quenching of the weld metal is not permitted.
10. Cut out and reweld all rails giving weld fault indication in either magnetic particle or ultrasonic inspection.

D. Identification

1. After welding but prior to installation mark the CWR strings with a paint that is suitable for application to steel and is weather resistant for a period of two years.
2. Each end of each string shall be marked with the approximate station of the string end.
3. The gauge side of the CWR string shall be marked at least once every 200 feet.
4. Location of planned field cuts in CWR shall be marked.
5. Welds performed on contiguous rail of different strength shall be marked indicating that dissimilar rails were welded at that point.

PART 3 - EXECUTION

3.1 PREPARATION

- A. Develop a material schedule for the production of CWR by reviewing plans for CWR interruptions resulting from special trackwork, train control, traction power rail joints, and rail types.
- B. The CWR schedule shall identify each string with a unique designation which references; track designation, stationing of CWR ends, and right or lefthand position as determined by the direction of increasing stationing.
- C. Each section of CWR over 1000 feet in length may be scheduled for two or more strings with a minimum CWR string length of 500 feet. Each Section of CWR under 1000 feet

in length shall be scheduled for only one string of CWR providing the required length.

D. CWR strings positioned entirely within a special track-work unit shall be scheduled with no additional rail joints beyond those indicated on the Contract Drawings.

3.2 INSTALLATION - Installation of CWR is not part of the Work specified in this Section. For installation requirements refer to Section 02450, General Track Construction.

3.3 ADJUSTMENT AND CLEANUP - The Contractor shall correct and clean up the site area from any damage or debris resulting from the production, storage, and handling of CWR.

END OF SECTION

SECTION 02512

ASPHALT CONCRETE PAVEMENT

PART 1 - GENERAL

1.1 DESCRIPTION - The Work specified in this Section consists of furnishing and placing asphalt concrete pavement to the thicknesses, line, and grades indicated and in accordance with the requirements of the Standard Specifications for Public Works Construction, 1982 Edition.

1.2 QUALITY ASSURANCE

- A. Utilize asphalt concrete producer who is regularly engaged in production of hot-mix, hot-laid asphalt concrete pavement.
- B. Utilize asphalt concrete pavement construction supervisor who has acceptable evidence of successful experience in supervising the Work specified.
- C. Referenced Standards - Standard Specifications for Public Works Construction, 1982 Edition, Section 203 and Sub-section 302-5.
- D. Asphalt Tolerance - Concrete pavement will be measured by the square yard for each indicated thickness, except that when a deficiency in thickness is detected, the measured area between joints or core location per lane width in which the deficiency occurs, will be reduced as follows:

<u>DEFICIENCY IN THICKNESS DETERMINED BY CORES, IN INCHES</u>	<u>PROPORTIONAL PART OF MEASURED AREA ALLOWED FOR PAYMENT</u>
0.00 to 0.20	100
0.21 to 0.30	80
0.31 to 0.40	72
0.41 to 0.50	68
0.51 to 0.75	57
0.76 to 1.00	50

1.3 SUBMITTALS

- A. Refer to Section 01300 Submittals for submittal procedures.
- B. Test reports and certification in accordance with the requirements of Section 01322, Certificates and Reports and Article 203-1.3, Standard Specification for Public Work Construction, 1982 Edition.

1.4 MEASUREMENT - The Work of this Section will be measured by the ton of Asphalt Concrete Pavement, as indicated in Article 302-5.8 of the Standard Specification for Public Work Construction, 1982 Edition.

1.5 PAYMENT will be made under:

Item No. 02512.01 - Asphalt Concrete Paving 1" Thick - per square yard

Item No. 02512.02 - Asphalt Concrete Paving 1 1/2" Thick - per square yard

Item No. 02512.03 - Asphalt Concrete Paving 2" Thick - square yard

Item No. 02512.04 - Asphalt Concrete Paving 2 1/2" Thick - square yard

Item No. 02512.05 - Asphalt Concrete Paving 3" Thick - square yard

Item No. 02512.06 - Asphalt Concrete Curbs - linear foot

Concrete wheel stops will be paid for as part of the Contract unit price for Asphalt Concrete Paving. No separate payment will be made for concrete wheel stops.

PART 2 - PRODUCTS

2.1 ASPHALT MATERIALS

A. Asphalt Concrete, Standard Specifications for Public Works Construction Section 203-6 Type I-B-AR-8000.

B. Liquid Asphalts, Standard Specifications for Public Works Construction Section 203-2.

C. Asphalt Emulsions, Standard Specifications for Public Works Construction Section 203-3 SS1h.

D. Prime Coat, provide cut-back asphalt type prime coat complying with the requirements for liquid asphalts.

E. Tack Coat, provide asphalt base tack coat uniformly emulsified with water and an emulsifying or stabilizing agent complying with the requirements for asphalt emulsion as specified. Dilute 1:1 with water.

2.2 BASE MATERIAL - As specified in Section 02232, Crushed Aggregate Base.

- 2.3 WHEEL STOPS - Precast Portland cement concrete, as specified for concrete curbs and sidewalks in Standard Specifications for Public Works Construction, 1982 Edition, Section 303-5.

PART 3 - EXECUTION

- 3.1 JOB CONDITIONS - Examine the area and conditions under which Work will be performed. Correct conditions detrimental to the proper and timely completion of the Work. Do not proceed until unsatisfactory conditions have been corrected to the satisfaction of the District or its designee.
- 3.2 APPLICATION OF PRIME COAT - Apply in conformance with Standard Specifications for Public Works Construction, Section 302-5.2.
- 3.3 APPLICATION OF TACK COAT shall be applied in conformance with Standard Specifications for Public Works Construction Section 302-5.3.
- 3.4 APPLICATION OF ASPHALT PAVEMENT - Apply and place in accordance with Standard Specifications for Public Works Construction Section 302-5.
- 3.5 RECONDITIONING OF BASE COURSE
- A. Condition the previously constructed base course as specified below; and in all cases, immediately before applying the prime coat remove debris or other objectional substance from the surface by means of a power broom or blower supplemented with handbrooms. After the cleaning operation and prior to the application of the prime coat, an inspection of the areas to be primed will be made by the District or its designee to determine the fitness of the area to receive the bituminous priming material. Immediately before the application and as directed by the District or its designee, assure a uniform spread of the bituminous material by lightly sprinkling with water excessively dry portions of the base course prepared for treatment.
- B. Base Course - The surface of the base course will be inspected and tested for adequate compaction and surface tolerances by the District or its designee. Correct ruts or soft yielding spots that may appear in the base course, areas having inadequate compaction, and any deviations of the surface from the requirements specified for the underlying course by loosening the affected areas, removing unsatisfactory material and adding approved material where required, reshaping and recompacting to line and grade and to the specified density requirements to the satisfaction of the District or its designee.

- 3.6 JOINING PAVEMENT - Carefully lay joints between existing and new pavements or between successive days Work in such a manner as to ensure a continuous bond between existing and new sections. Expose, clean, and cut edges to straight, vertical surfaces. Paint joints with a uniform coat of tack coat before the fresh mixture is placed.
- 3.7 DEFECTIVE MATERIALS - Materials not complying with the specified requirements are not acceptable. Remove and replace defective materials as directed by the District or its designee.
- 3.8 FLOOD TEST - Flood asphalt pavement with water to check for positive drainage. Provide materials and equipment for flood testing. Test with the District or its designee present.
- 3.9 TESTING
- A. Perform testing of pavement at the District's or its designee's request on the following:
1. Thickness
 2. Compaction
 3. Grade Control
 4. Other as directed.
- B. Areas not accepted shall be removed and replaced to the satisfaction of the District or its designee.
- 3.10 WHEEL STOPS
- A. Install precast concrete wheel stops at indicated parking stalls.
- B. Apply with epoxy cement to paved surface, after the pavement has cured, as specified in Caltrans, Section 85-1.06 for pavement markers.
- 3.11 OFF-SITE AREAS - Construct Work within a public right-of-way or easement in accordance with the requirements of the agency having jurisdiction over such right-of-way or easement.

END OF SECTION

SECTION 02601

MAINTENANCE OF UTILITIES

PART 1 - GENERAL

1.1 DESCRIPTION - The Work specified in this Section consists of the protection, support, removal of supports, and maintenance of utilities within, adjacent to, or affected by the Work under this Contract. Maintain and protect utilities shown on the Contract Drawings or encountered in the Work, in their locations, unless otherwise provided.

1.2 UTILITY LOCATIONS

A. The Contract Drawings indicate the known existing public and private utilities in their approximate locations and the rearrangement of these utilities to the extent known, within the limits of the Contract, which are expected to affect the Work. However, these locations are not guaranteed nor is there any guarantee that all existing utility facilities, within the limits of the Contract, have been shown on the Contract Drawings. The location of utilities rearranged for this, or in other contracts, have been shown in their proposed locations but it is the Contractor's responsibility to coordinate with the utility owners to determine the actual locations of their facilities. The location of utility facilities, as indicated, does not relieve the Contractor of his obligation of coordinating Work affecting the facilities, with the utility owners involved.

B. Notify the affected utility owner, and the District or its designee, of damage to utilities facilities and assume financial liability for repairs made by the utility owner's forces for damage caused by the Contractor's acts of carelessness or neglect, or otherwise caused by the Contractor's operations. Adjust existing pull, junction and valve boxes, curb cock and meter boxes for restoration of sidewalks and street pavement.

1.3 REARRANGEMENT OF UTILITY FACILITIES - The rearrangement of existing water, electrical, communications, and gas will be performed by the owners of the respective utilities in close coordination with the Work specified in this Contract.

A. Where utilities or their appurtenances interface with permanent construction, the Work involved in permanently relocating, or otherwise altering such utilities and their appurtenances, will not be a part of this Contract, but will be done, as indicated, by the utility owners at no cost to the Contractor. If the Contractor wishes to have utilities temporarily relocated for his own

convenience, he shall make the necessary arrangements with the owners and reimburse them, at his own expense, for the cost of the Work.

- B. Notify the owners a minimum of two weeks in advance of the time proposed to perform Work which would endanger their facilities or property and cooperate with the owners in relocating and protecting their facilities and property during construction operations.
 - C. Permit the utility owners and personnel engaged by them, access to the site of the Work in order to maintain, relocate or inspect their facilities, and cooperate with them in performing this Work.
 - D. Be responsible for the continuity of service and maintain, in a safe and satisfactory operating condition, overhead, surface, or subsurface utilities or pipe lines within the area of operations. The provisions of this paragraph apply equally to, and refer to facilities owned by the District, public utilities, or private owners.
- 1.4 EXISTING SERVICE CONNECTIONS - Existing service connections to buildings are not necessarily shown on the Contract Drawings but the Contractor shall protect, support, and maintain them to ensure continuous service.
- 1.5 PRESERVATION OF PROPERTY - Protect existing utilities not indicated as "Abandoned", or "To Be Abandoned" and rearranged facilities. When a facility rearrangement has been placed in service, verify that facilities to be abandoned have been out-of-service before starting other Work in the area. Abandoned facilities shall be removed by the Contractor as necessary to complete other Work.
- 1.6 WORKSITE CONDITIONS - Do not start work until the District or its designee and the utility owners have given their acceptance, in writing, of the plan for performing the work.
- 1.7 MEASUREMENT - The Work of this Section will be measured as a unit, acceptably performed.
- 1.8 PAYMENT will be made under:

Item No. 02601.01 - Maintenance of Utilities - per lump sum.

PART 2 - PRODUCTS - Provide materials conforming to the requirements of the respective Sections of the Specifications for each system for which they are required or, if not specified, conform to the requirements of the respective utility owner.

PART 3 - EXECUTION

- 3.1 LOCATE SUBSURFACE STRUCTURES before the Work in the vicinity of those structures begins. Perform Work in the vicinity of subsurface structures in a manner which will not damage subsurface structures.
- 3.2 PERFORM EXCAVATION AND BACKFILLING as specified in Section 02200, Earthwork.
- 3.3 REMOVE PAVEMENTS, SIDEWALKS, CURBS, AND GUTTERS as required to perform utility excavation Work. Each utility owner will perform removal and restoration Work as required for its portion of the work. Salvage materials in accordance with Section 01045, Cutting and Patching.
- 3.4 UNSAFE AND UNSUITABLE FACILITY STRUCTURES - If, upon exposure, a condition or location of a facility, to be supported in place, is unsafe for maintenance and support, and when the unsafe or unsuitable condition is part of Work scheduled to be performed by the Utility's forces, including temporary pavement patch over ductbank and manhole excavations, notify the District or its designee and the utility owner of the conditions requiring remedial action. Maintenance and restoration of temporary ductbank and manhole enclosures shall be the responsibility of the Contractor.
- 3.5 DRAINAGE FACILITIES AND SANITARY SEWERS
 - A. Maintain service for active storm drains, sewers, house connections and laterals in an operating condition and in a closed system at all times. Take adequate precautions and safety measures to avoid flooding during storms and to avert dangers from sudden increase in flows, for any reason, that might clog, damage, or interfere with normal operations. Do not permit discharge of storm water and construction generated sediment into the sanitary sewer system nor flow of sewage across surfaces of streets, property, into open excavations.
 - B. Where abandonment of pipe is scheduled and cutoffs of service are directed, construct bulkheads of brick masonry or Class 2500 concrete, minimum of one pipe diameter thick, at the manholes and catch basins and at cut ends. Fill pipe to be abandoned with sand before the bulkheads are constructed. Salvage manhole and catch basin frames and covers in conformance with Section 01045, Cutting and Patching.
 - C. Provide temporary drainage facilities and sewer lines and supports necessitated by the construction, where indicated or required. Provide these temporary drains and sewers and supports and construct in accordance with Working Drawings accepted by the District or its designee. Refer to the requirements of Section 01342, Working Drawings.

Furnish, install, maintain and ultimately remove temporary drainage and sewer facilities. Furnish and install new storm drain and sewer lines and manholes at the lines and grades indicated or required.

- D. Backfill exposed existing facilities to the same minimum requirements as those required for new installations in conformance with Section 02720, Storm Drainage Systems, and 02730, Sanitary Sewer Systems.
- E. Demolish manholes, catch basins, and other drainage structures to be abandoned, within three feet of the final grade. Fill remaining portions of these structures with wet sand break base slabs for drainage.

3.6 WATER MAINS

- A. Where indicated, maintain the continuity of existing water mains and provide temporary support and protection for the City of Los Angeles, Department of Water and Power water mains during operations.
- B. The Los Angeles Department of Water and Power will perform the Work in connection with the relocation, removal, replacement, and construction of new permanent water mains and service connections at no cost to the contractor, unless otherwise indicated. Where water lines are to be abandoned or taken out of service, Los Angeles Department of Water and Power will disconnect the lines and services, therefore, prior to removal Work by the Contractor. Los Angeles Department of Water and Power will supervise removal of temporary supports from its line and also supervise placing of backfill around and over its lines.
- C. Conform utility Work to the Standard Specifications of the Los Angeles Department of Water and Power.

3.7 ELECTRIC DISTRIBUTION AND SERVICES

- A. Maintain the continuity of the existing facilities and provide the temporary support and protection of Los Angeles Department of Water and Power power facilities during operations.
- B. Los Angeles Department of Water and Power will perform Work in connection with the relocation, removal, replacement, and construction of new permanent service connections and duct banks, at no cost to the Contractor, unless otherwise indicated. Where electric lines are to be abandoned, or taken out of service, Los Angeles Department of Water and Power will disconnect the lines and services therefrom, prior to removal Work by the Contractor. Los Angeles Department of Water and Power will supervise removal of temporary supports from its lines

and also supervise placing of backfill around and over its ductbanks and conduits.

3.8 GAS MAINS AND SERVICES

- A. Maintain the continuity of the existing facilities and protect the Southern California Gas Company facilities during Contractor operations.
- B. The Southern California Gas Company will perform Work in connection with the relocation, removal, replacement and construction of temporary gas mains and service connections at no cost to the Contractor. Where gas mains are to be taken out of service or abandoned, Southern California Gas Company will disconnect the mains and services therefrom and cap the mains to remain, prior to removal work by the Contractor.

3.9 TELEPHONE FACILITIES

- A. Maintain the continuity of the existing telephone facilities and support and protect these facilities during operations.
- B. Pacific Bell will perform the Work, except as indicated on the Contract Drawings, in connection with the relocation, removal, replacement and construction of new permanent telephone service connection and duct banks at no cost to the Contractor. Where telephone lines are to be abandoned or taken out of service, Pacific Bell will disconnect the lines and services therefrom, prior to removal Work by the Contractor.

3.10 TRAFFIC SIGNALS - Maintain the continuity of the existing and rearranged facilities and provide for the temporary support and protection of these facilities during Contractor operations. Contact the Automated Traffic Surveillance and Control (ATSAC) Section of LADOT at (213) 485-4271 three working days prior to any excavation work in the vicinity of the fiber optics cable.

3.11 STREET LIGHTS - Refer to Section 02790.

3.12 POLICE COMMUNICATIONS - Maintain the continuity of the existing and rearranged facilities and provide for the temporary support and protection of the facilities during operation.

3.13 POSTAL BOXES will be relocated out of the Work area by their owner, at no cost to the Contractor, prior to the start of Work in the area. Notify the U.S. Postal Service 30 days prior to beginning Work in the area.

3.14 TELEGRAPH FACILITIES

- A. Maintain the continuity of the existing and rearranged facilities and provide for the temporary support and protection of the facilities during Contractor operations.
- B. Western Union Telegraph Company will perform work, except as indicated on the Contract Drawings in connection with the relocation, removal, replacement, and construction of new permanent telegraph service connection and ductbanks at no cost to the Contractor. Where telegraph lines are to be abandoned or taken out of service, Western Union will disconnect the lines and services therefrom, prior to removal work by the Contractor.

3.15 TELEVISION FACILITIES

- A. Maintain the continuity of the existing and rearranged facilities and provide for the temporary support and protection of the facilities during Contractor operations.
- B. A new ductbank shall be constructed by the Contractor during the restoration of the street.

END OF SECTION

SECTION 03100

CONCRETE FORMWORK

PART 1 - GENERAL

1.1 DESCRIPTION -

- A. The Work specified in this Section consists of designing, furnishing materials for, fabricating, erecting, and removing formwork as indicated.
- B. Related Work - Documents affecting Work of this Section include, but are not necessarily limited to, General Conditions, Supplementary Conditions and various specification Sections in Division Three.

1.2 QUALITY ASSURANCE

A. Criteria for Design of Formwork

- 1. Unless otherwise indicated design, construct, erect, maintain, and remove forms and related structures for concrete work in accordance with ACI manual of concrete practice. Forms shall be lined when necessary to provide for specific finishes.
 - 2. Formwork surface materials - Use material which will produce surfaces within the allowable tolerances specified in Section 03300, Cast-In-Place Concrete, and which will conform to the following:
 - a. Concrete exposed to view - Use material which will produce smooth, uniform, blemish-free concrete surfaces.
 - b. Concrete concealed from view - Use material which will produce concrete surfaces free of fins and honeycomb.
 - 3. Special sections - Provide openings, offsets, sinkages, keyways, recesses, moldings, rustication strips, chamfers, blocking, screeds, bulkheads, door frames, anchorages, and other features. Select materials which will ensure indicated finishes.
 - 4. Removal features - Design formwork to be readily removable without impact, shock, and damage to concrete surfaces and adjacent materials.
- B. Formwork Tolerances - ACI 301 Chapter 4, except as indicated in Section 03300, Cast-in-Place Concrete.

1.3 SUBMITTALS

- A. Refer to Section 01300, Submittals for submittal procedures.
 - 1. Manufacturer's literature describing products specified and indicated.
 - 2. Detailed shop drawings describing shop fabricated forms and support members.
- B. Submit working drawings in accordance with Section 01342, WORKING DRAWINGS that indicate following.
 - 1. Falsework, centering, accompanied by design calculations.
 - 2. Locations of construction, contraction, and expansion joints in plan and elevation views.
 - 3. Locations and sizes of conduits, door frames, openings, recesses, and other attached products.
 - 4. Forming system and method of erection with associated details.
 - 5. Beam intersection and other conditions where concrete casting by vertical drop may be restricted.
 - 6. Method and schedule for removing forms, falsework, and centering.
 - 7. Reshoring procedure.
 - 8. Schedule for removing shoring and reshoring.
 - 9. Manufacturers' certifications of conformance of materials to specified requirements, to be submitted in accordance with Section 01300.

1.4 PRODUCT DELIVERY, STORAGE, AND HANDLING

- A. Storage - Store form to prevent warpage. Protect panels from damage and contamination which would affect concrete.
- B. Handling - Lift form panels by means which will protect panels from damage and distortion.

1.5 JOB CONDITIONS

- A. Allow sufficient time between erection of forms and placing of concrete for the various trades to properly install their Work.

B. Do not apply lateral and vertical external or superimposed loads to structure until either adequate reshoring and rebracing has been placed or until such concrete has developed specified 28-day compressive strength.

1.6 MEASUREMENT - The Work of this Section will not be measured.

1.7 PAYMENT - The Work of this Section will be paid for as part of the Contract Unit Price for the associated concrete Work.

PART 2 - PRODUCTS

2.1 MATERIALS

A. Lumber - Stress-graded.

1. Side of lumber which will contact concrete: dressed and have dressed or tongue-and-groove edges, for forming concrete not exposed to public view.
2. Other lumber: dressed or rough.

B. Plywood - grade marked.

1. B-B Plyform, Exterior Class 1 or 2, or HDO High Density Concrete Form plywood, Class 1 or 2 conforming to U.S. Product Standard PS-1, for forming concrete not exposed to public view.
2. Thickness: as required to maintain surface smoothness, but not thinner than 3/4 inch.

C. Form Lining

1. Fiberglass Reinforced Plastic - Moisture-resistant sheet comprised of 25 percent fiberglass embedded in polyester resin gelcoat and coated, on sides which will contact concrete, with alkali-resistant gelcoat formulated for use with concrete.
2. Fiberglass Laminated Plywood - APA, FRP, 3/4 inch thick with fiberglass facing and back laminations.

D. Insulating Fiberboard Formboards - ASTM C532.

E. Glass-fiber Reinforced Plastic Panel

1. Type - One piece dome system form-molded under heat and pressure using matched dies.
2. Reinforcement and surface finish - As required to form concrete surfaces which will be smooth and free from irregularities.

3. Wall - Not thinner than 0.11 inches.

F. Steel

1. Sheet - Commercial Grade, uncoated steel, 3/16 inch minimum thickness, to be used to form concrete exposed to public view.

2. Structural plates and shapes - ASTM A36.

G. Leakage Control Materials - Capable of producing flush, water-tight and nonabsorbent surfaces and joints, and compatible with forming material and concrete ingredients. Seal form edges by such means as gasketing material or sealant placed in the joint in such a way that neither a fin nor groove is made in the face of the cast concrete.

1. Calking compound - GE-silicone Products Div.'s "Series 1200 Construction Calking," Dow Corning Co.'s "781 Calking" or accepted equal.

2. Tapes - Preco Industries "Seam-Strip," United Mineral and Chemical Co.'s "Tesa Formstik Tape Number 720," a form film tape of polypropylene plastic treated with waterproof adhesive for joint conditions not exposed to public view.

H. Form Release Agent - Commercial formulation form-coating compounds which will neither bond with, stain, nor adversely affect concrete surfaces, and which will neither impair subsequent treatment of concrete surfaces requiring bond or adhesion nor impede wetting of surfaces which will be cured with water or curing compounds.

I. Plugged Cone Form Ties - Rod type, with ends or end fasteners which can be removed without spalling the concrete and which leave a hole equal in depth to the required reinforcement clearance. Form ties shall be of a design in which the hole left by the removed end or end fastener is easily filled to match the surface of the hardened concrete. Provide removable cones 1 1/4 inches in diameter by 1 1/2 inches deep. Provide performed mortar plugs to match the color of the concrete, recessed 1/4 inch, adhered with an approved two part epoxy.

J. Inserts - Inserts - Galvanized cast steel or galvanized welded steel, complete with anchors to concrete and fittings such as bolts, wedges and straps. Provide hanger inserts spaced to match grid of suspended ceilings.

K. Circular Column Forms - Shall be fabricated of two pieces, clamped watertight without horizontal joints. Horizontal construction joints will be installed as indicated.

- L. Chamfer Strips - 3/4 inch by 3/4 inch triangular fillets milled from clear, straight-grain pine, surfaced each side, or extruded vinyl type with or without nailing flange.
- M. Miscellaneous Joint Strips - Preformed strips for reveals, rustications, and similar joints fabricated of wood, metal, or plastic.
- N. Water Stops - To meet the requirements of Section 03253, Waterstops.

2.2 SHOP FABRICATED FORMS

- A. Fabricate forms in accordance with accepted shop drawings.
 - 1. Maintain forms clean, smooth, and free from imperfections and distortion.
 - 2. Joints
 - a. Arrange form panels in symmetrical patterns conforming to general lines of structure.
 - b. Unless otherwise indicated, orient panels on vertical surfaces with long dimension horizontal, and make horizontal joints level and continuous.
 - c. Precisely align form panels on each side of the panel joint with fasteners common to both panels, and in a manner which will result in a continuous, unbroken concrete plane surface.
 - d. Use largest stock size practicable.
- B. Steel forms - Use stock material which is clean, smooth, and free from warps, bends, kinks, rust, cracks, and matter which could stain concrete. Fabricate panels in accordance with accepted shop drawings. Reinforce outward facing surfaces in a manner which will prevent distortion during concrete placement. The maximum deflection between form supports shall be 1/240 span length.
 - 1. Pan forms - Provide with covers and with standard or tapered end forms, as indicated, end closures to form a true, clean, smooth surface.
- C. Form liners
 - 1. Cut form liners in stock size which will produce the least joints.

2. Orient liners as indicated on accepted working drawings.
3. Secure form liners to forms with either adhesives, galvanized staples or galvanized head nails.

PART 3 - EXECUTION

3.1 INSPECTION

- A. Examine surfaces to receive formwork and eliminate unsatisfactory conditions.
- B. Secure shoring and bracing against settlement and displacement.

3.2 CONSTRUCTION

- A. Construct formwork in accordance with the accepted working drawings, and in a manner which will produce finished concrete surfaces conforming to indicated design and within allowable tolerances.
 1. Make joints and seams mortar-tight. Install leakage control materials in accordance with the manufacturer's printed instructions, and in a manner which will maintain a smooth continuity of plane between abutting form panels and resist displacement by concreting operations.
 2. Kerf wood inserts for forming keyways, reglets, and recesses in a manner which will prevent swelling and ensure ease of removal.
 3. Maintain forms clean and free from indentations and warpage.
 4. Brace temporary closures and door frames, to prevent warpage or displacement, and set tightly against forms in a manner which will prevent loss of concrete mortar.
 5. Tie door frames' jam anchors to nearest wall reinforcing.
 6. Support joints with extra studs or girts, and in a manner which will ensure true, square intersections.
 7. Assemble forms in a manner which will facilitate their removal without damage to the concrete.
 8. Construct molding shapes, recesses, and projections with smooth finish materials and install in forms with sealed joints.

9. Provide camber in formwork which to compensate for deflections caused by weight and pressures of fresh concrete and construction loads.
 10. Support form facing materials by sufficiently close spacing of frame members.
 11. Provide temporary inspection and cleanout openings in wall forms, and elsewhere.
 12. Drill air escape holes in bottom members of blockouts.
- B. Pan Forms
1. Provide pan forms having covers and end closures which have been designed to form a true, clean, smooth concrete surface.
 2. Block adjoining pan units in a manner which will preclude lateral deflection of formwork during concrete placement and compaction.
- C. Lined Panels
1. Line areas narrower than five feet with single width of form liner.
 2. Secure form liner to backing with adhesives, galvanized staples or galvanized head nails, unless otherwise indicated or required by District or its designee.
- D. Cylindrical Columns and Supports
1. Form round-section members with steel tubes. Use tube walls of that thickness which will resist loads, imposed by wet concrete, without deforming.
 2. Form round-section members of not less than 3/16 inch steel sheets. Butt sections together, and either bolt or key-and-weld joints. Finish interior joints of forms smooth, and in a manner which produces no visible seam on finished concrete surfaces.
- E. Edge Forms and Screeds Strips for Slabs - Set edge forms or bulkheads and intermediate screed strips for slabs to obtain required elevations and contours in the finished slab surface. Support screeds.
- F. Corner Treatment - Form chamfers with 3/4 inch on each leg, unless otherwise indicated, and accurately shape and surface in a manner which will produce uniformly straight lines and edge joints which will prevent mortar runs. Extend terminal edges to limits, and miter chamfer strips at changes in direction.

G. Joints

1. Construction joints

- a. Locate joints as indicated; and support joint forms in such manner as to rigidly maintain their positions during placement, vibration and hardening of concrete. Install keys in all joints.
- b. Locate and install construction joints, for which locations are not indicated, so as not to impair strength and appearance of the structure, as acceptable to the District or its designee.
- c. Position joints perpendicular to axis of pier, beam or slab as the case may be.
- d. Locate joints in walls, vertically at not more than 60 feet apart in any horizontal direction; at top of footing; at top of slabs on grade; at top and bottom of door and window openings and at underside of the deepest beam or girder framing into wall; or as required to conform to indicated details.
- e. Provide keyways at least 1 1/2 inches deep in construction joints in walls and slabs, and between walls and footings unless otherwise indicated. Place construction joints perpendicular to the main reinforcement. Continue reinforcement across construction joints.

2. Control joints

- a. In columns and piers - Locate joints at top of footings, at top of slabs on ground, and at underside of deepest beam or girder framing into the column or pier.
- b. In slabs on ground - Conform to slab placement diagrams or pattern layout placement, where indicated.
- c. Provide control joints in slabs on ground to form panels or patterns as indicated. Use inserts 1/4 inch wide by one fifth to one quarter slab depth, unless otherwise indicated.
- d. Form control joints by inserting premolded hardboard or fiberboard strip into fresh concrete until top surface of strip is flush with slab surface. After concrete has cured for at least seven days, remove inserts and clean groove of debris.

3. Isolation joints - Provide isolation joints in slabs on ground at all points of contact between slabs on

ground and vertical surfaces, such as column pedestals, foundations, walls, grade beams, and elsewhere as indicated.

3.3 EMBEDDED ITEMS AND DUCT OPENINGS

- A. Install conduit, appliance boxes, door frames, drains, metal ties, nailing strips, blocking grounds, and other fastening devices required for attachment of other Work. Secure products in position before beginning concrete placement.
- B. Where openings are left in concrete for passage of ducts, provide clearances as indicated on accepted working drawings.

3.4 FORM RELEASE AGENT

- A. Coat form contact surfaces with acceptable form release agent before reinforcement is placed. Do not allow excess form release agent material to accumulate in the forms or to come into contact with surfaces which are required to be bonded to fresh concrete such as concrete reinforcement and embedded items. Apply form release agent in compliance with manufacturer's instructions.
- B. Coat steel forms with non-staining, rust-preventive form release agent or otherwise protect against rusting. Do not use rust-stained steel surfaces for forms in contact with concrete.
- C. Apply release agent to bolts and rods that are to be completely removed or that are to be free to move.

3.5 FALSEWORK

- A. Erect, support, brace and maintain falsework to safely support vertical, lateral and asymmetrical loads in accordance with working drawings, until such loads can be supported by in-place concrete structures. Construct falsework so that adjustments can be made for take-up and settlement during placement of concrete.
- B. Provide wedges, jacks or camber strips to facilitate vertical adjustments. Carefully inspect falsework and formwork before concrete placement operations begin and while concrete is plastic to determine abnormal deflection or signs of failure; make necessary adjustments to produce Work of required dimensions.

3.6 REMOVAL OF FORMS, FALSEWORK, AND CENTERING

- A. Maintain formwork in place for the following structural condition until the concrete has attained the minimum

percentage of indicated design compressive strength or for the period of time specified in the following table:

<u>STRUCTURAL MEMBER OR CONDITION</u>	<u>NORMAL STRENGTH CONCRETE</u>	<u>NORMAL HIGH-EARLY STRENGTH CONCRETE</u>	<u>MINIMUM COMPRESSIVE STRENGTH FOR FORM REMOVAL (PERCENT OF REQUIRED DESIGN STRENGTH)</u>
Cantilevers	12 days	7 days	90
Over 20 feet between supports	12 days	7 days	90
Centering under girders	10 days	5 days	80
Stairways	10 days	5 days	80
Floor slabs, and bottom of caps	5 days	3 days	70
Free standing walls, column and piers	5 days	3 days	70
Walls, piers, columns, sides of beams, footings, slabs on grade, and vertical surfaces	24-48 hours	12-24 hours	70
Front face form of curbs	6-24 hours	6 hours	70

- B. Remove forms by methods which will neither injure concrete surfaces, overstress concrete members, nor distort formwork.
- C. Forms supporting concrete deck of box girders and forms for interior surfaces of hollow abutments and piers may be left in-place. Remove other box girder forms and sweep inside of box girders in a manner which will remove loose material.
- D. Do not release falsework sooner than 14 days after last concrete has been placed, except do not release falsework supporting a span of a continuous or rigid frame structure sooner than 14 days after the last concrete, excluding concrete above aerial structure or bridge deck, has been placed in that span and in adjoining spans, unless

otherwise permitted by District or its designee. If compressive strength of the last placed concrete, 14 days after placing, is less than that indicated in Paragraph 3.6A for the particular type of structure, do not release falsework and centering until last placed concrete has attained that compressive strength.

- E. Plan reshoring operations in a manner which will ensure that areas of new construction will not be required to support their own weight. During reshoring do not permit live loads on the new construction. Do not locate reshores in a manner and location which will significantly alter stress pattern determined by structural analysis or to induce tensile stresses where reinforcing bars have not been provided. Remove shoring and reshoring supports in accordance with requirements of Sections 2.7 and 2.8 of ACI-347, except as modified herein.
- F. Do not release falsework supporting a simple span and other members subject to direct bending stress until last concrete placed in the span or member has attained a compressive strength of not less than the minimum percentages of compressive strength indicated in Paragraph 3.6A.

3.7 FIELD QUALITY CONTROL

- A. Before placing concrete, check lines and levels of erected formwork and positioning of embedded inserts, block-outs, and joints for correctness. Make corrections and adjustments to ensure proper size and location of concrete members and stability of forming systems.
- B. While placing concrete, ensure that formwork and related supports have not been displaced, that joints are preventing loss of cement paste, and that completed work will be within specified tolerances.
- C. At least 24 hours before placing any concrete submit signed concrete placement certification as required by Section 03300, Cast-in-Place Concrete.

3.8 DETECTION OF MOVEMENT - Use means such as plumb lines, tell-tales and survey equipment, as required by District or its designee, to detect movement of formwork during concrete placement.

3.9 RE-USE OF FORMS

- A. Clean and repair surfaces of forms to be reused in the work. Split, frayed, delaminated, and otherwise damaged form facing material will not be acceptable; remove that material from worksite. Renew form coating as specified for new formwork.

B. Align and secure joints in a manner which will preclude offsets. Do not use "patched" forms for exposed concrete surfaces unless acceptable to District or its designee, in which case patch holes and defects in forms by means which will not be reflected in the concrete.

END OF SECTION

SECTION 03200

CONCRETE REINFORCEMENT

PART 1 - GENERAL

1.1 DESCRIPTION - The Work specified in this Section consists of furnishing, fabricating, and installing, and electrically bonding reinforcing steel for concrete structures.

1.2 REFERENCE STANDARDS

A. American Concrete Institute (ACI)

1. 315, Manual for Standard Practice for Detailing Reinforced Concrete Structures.
2. 318, Building Code Requirements for Reinforced Concrete.
3. 301-84 - Specification for structural concrete for buildings. Chapter 5 - Reinforcement.

B. American Welding Society (AWS) - D1.4-79 Structural Welding Code - Reinforcing Steel.

C. (AWS) A5.1, low hydrogen, E70 series.

D. Concrete Reinforcing Steel Institute (CRSI) Manual.

1.3 QUALITY ASSURANCE

A. Provide supervisor experienced in installation of reinforcing bars for concrete and has been in responsible charge of Work similar to that of this Contract.

B. Provide Welders certified to have passed the qualification test during the past year as prescribed in AWS D12.1 for the specified welding method.

C. Welding procedures as required in AWS D1.4-79.

D. Allowable Tolerances - Section 5.4, ACI 30-84.

1.4 SUBMITTALS

A. Refer to Section 01300, Submittals for submittal procedures.

B. Manufacturer's specifications and installation instructions for proprietary materials and reinforcement accessories.

- C. Shop Drawings for fabrication, bending and placement of concrete reinforcement in conformance with ACI 315 and showing bar schedules, stirrup spacing, diagrams of bent bars, arrangements and assemblies, as required for fabrication and placement of concrete reinforcement.
- D. Certified copy of mill reports to include steel sources, heat number, and indicating chemical and physical analysis.
- E. Welders certification submittal to the District or its designee, indicating evidence of welder's qualifications to perform the pertinent type of welding.
- F. Manufacturer's catalog data and printed requirements for the application and repair of epoxy coating.

1.5 PRODUCT DELIVERY, STORAGE, AND HANDLING

- A. Ship concrete reinforcement from source in bundles of one size and length, securely tied and identified with plastic tag indicating grade and size of bar, melt or heat number, bundle number, and name and location of mill. Deliver bars to the job site properly identified in accordance with approved shop drawings.
- B. Handle epoxy coated reinforcement in a manner that will prevent excessive sagging of bars and damage to coating.
- B. Store concrete reinforcement off ground and support as required to prevent formation of kinks, distortions, excessive rusting, contamination by oil, mud, and other material that will destroy its usefulness.

1.6 MEASUREMENT

- A. The Work of this Section will be measured for payment by the pound of reinforcing steel furnished and acceptably installed in walls, slabs, beams, columns and other structural elements of cut and cover structures, complete in place. Weights will be determined from computations based on the nominal weights as listed in ASTM A615.
- B. Reinforcement steel furnished and acceptably installed in walkway, invert of tunnel structure, crosspassage, break-out framing, cast-in-place and precast tunnel liners, and other associated tunnel structural elements will not be measured for payment. It will be incidental to the concrete and will be paid as part that concrete furnished and acceptably installed.

1.7 PAYMENT will be made under:

Item No. 03200.01 - Reinforcement - per pound.

- A. Reinforcement steel for walkway invert of tunnel structure, cross passage, breakout framing cast-in-place and precast tunnel liners and other associated tunnel structural elements will be paid for as part of this respective tunnel Work.

PART 2 - PRODUCTS

2.1 REINFORCEMENT MATERIALS

- A. Reinforcing Steel Bars - ASTM A615, Grade 60 unless otherwise indicated.
- B. Spiral Reinforcement - ASTM A82.
- C. Welded Steel Wire Fabric - ASTM A185.
- D. Metal Accessories - As recommended by CRSI Manual. Where concrete surfaces will be exposed to public view in the finished structure, use supports with plastic coated or stainless steel legs.

2.2 CORROSION CONTROL - As specified in Section 16645, Cathodic Protection.

2.3 GALVANIZING - ASTM A123; average weight of 2.3 ounces per square foot of actual surface.

2.4 EPOXY COATING

- A. Conforming to requirements of NBS, and suitable for the intended purpose.
- B. Either as manufactured by Polymer Corporation, Reading Pennsylvania, 19603; or, E.I. Dupont de Nemours Company, Incorporated, Wilmington, Delaware 19898 or approved equal.
- C. Green in color.
- D. Material for repairing damaged or uncoated areas:
 - 1. Compatible with the epoxy coating.
 - 2. Inert in concrete.
- E. Coating thickness:
 - 1. Seven mils +/-two mils, applied in a uniform smooth coat.
 - 2. Measured in accordance with ASTM G12.

F. Repair damaged or uncoated surfaces by application of material and in accordance with manufacturer's printed instructions.

2.5 METAL FILLED SLEEVE COUPLER

- A. Capable of developing 125 percent of the yield strength of adjoining reinforcing bars.
- B. Designed to produce complete fusion with 100 percent penetration of joint.
- C. Connection produced by a standard exothermic process whereby molten filler metal, contained by a high strength steel sleeve of larger inside diameter than adjoining bars, is introduced into the annular space between the bars and the sleeve as well as between the ends of the bars.
- D. Either Cadweld as manufactured by Erico Products, Incorporated, 034600 Solon Road, Solon, Ohio, 44139 or approved equal.

2.6 MECHANICAL SLEEVE COUPLER

- A. Capable of developing in tension 125 percent of the yield strength of adjoining reinforcing bars.
- B. Connection produced by threaded reinforcing bar ends and threaded coupler or by metal sleeves hydraulically pressed or forged onto butt ended reinforcing bars.
- C. Capable of being installed in clear space noted on drawings.
- D. "No-Slip" as manufactured by Fox-Howlett Industries, 722 Folger Avenue, Berkley, California 94710; "Bar-Grip" as manufactured by Dayton Barsplice, Inc., P.O. Box 366, Miamisburg, Ohio 45324; "Sylgab Stricon" as manufactured by Sylgab Steel & Wire Corp., 19-26 Steinway Street, Long Island City, New York 11105 or approved equal.

PART 3 - EXECUTION

3.1 INSPECTION

- A. Verify that surface, over which concrete is to be placed, is clean and in proper condition for installing reinforcement.
- B. Verify that items to be embedded and block-outs are secured in place as required.

3.2 PREPARATION - Reinforcement steel shall be free of rust and mill scale, dirt, oil, grease, and other materials which reduce or destroy bond with concrete.

3.3 INSTALLATION

- A. Arrange and place reinforcement as indicated on the accepted placement plans and within tolerances specified in ACI 318 or ACI 301-84 Chapter 5 whichever is more stringent.
- B. Positively secure reinforcement against displacement during placement of concrete.
- C. Wire or clip bars together at all intersection in accordance with ACI recommendations. Turn wires back which project within indicated clearances.
- D. With formwork for as-cast finish, use spacers which will not be visible in exposed finish and which will be plastic coated or has stainless steel legs to the depth of minimum cover as specified below for the particular type of location.
- E. Embed reinforcement, including stirrups, to a clear depth, measured from outside of bar to surface of concrete, as follows and in accordance with ACI318, Article 7.7, whichever is more stringent, unless otherwise indicated.

	<u>INCHES OF MINIMUM COVER</u>
1. Underground box structures:	
a. Invert Slab - Top steel	2
- Bottom steel	3
b. Roof Slab - Top steel	2
- Bottom steel	1 1/2
c. Exterior Walls - Outer face steel	2
- Inner face steel	1 1/2
d. Center Walls	1 1/2
2. Beams, Girders, and Columns	1 1/2
3. Intermediate Floors, Platform Slabs, and Stairs	3/4
4. Retaining walls	
a. Footing - Top steel	2
- Bottom steel	3

b. Wall - Front face steel	2
- Back face steel	2
5. All other underground structures -	
a. Outer face steel	3
b. Inner face steel	2
c. Drainage slot	1 1/2
d. Service walkway	1 1/2
e. Beams, girders, and columns	1 1/2
f. Intermediate floors, platform slabs, and stairs	3/4
6. Above ground structures - As recommended by ACI 318.	

3.4 BAR AND SUPPORTS AND SPACERS

- A. Support reinforcing bars in position by means of accepted spacers, chairs, or hangers.
- B. Install sufficient number of supports and of strength to withstand deflection of reinforcement from indicated cross sectional position. Do not place reinforcing bars more than two inches beyond the last leg of any continuous bar support. Do not use supports as bases for runways for concrete conveying equipment and similar construction loads.
- C. Support reinforcing steel located in bottom of slabs resting on earth, on precast concrete mortar blocks of proper size and dimensions to position and support steel.
- D. Do not use stones, brick, wood blocks, and pieces of broken concrete to support reinforcing steel.

3.5 SPLICING

- A. Locate splices only as indicated.
- B. Where splices are permitted, they may be made in the following manner:
 - 1. Tied lap splices shall be in accordance with requirements of ACI 318.
 - 2. Metal filled sleeve couplers shall be used at locations indicated on the drawings and may be used in lieu of tied lap slices with the approval of the District or its designee. Couplers shall be installed by trained personnel in accordance with manufacturer's

recommended practices. Field testing shall be by the District or its designee in accordance with ASTM E94 and E99.

3. Mechanical sleeve couplers shall be used at locations indicated on the drawings and may be used in lieu of tied lap splices with the approval of the District or its designee. Couplers shall be installed by trained personnel in accordance with manufacturer's recommended practices. Sample couplers made by each installation crew using actual reinforcing bar sizes shall be static tested in accordance with ASTM A370 and applicable portions of ASTM E8. The coupled reinforcing bars shall each contain at least three deformation patterns. Three splice specimens shall be tested for each installation crew and reinforcing bar size. Splice capacity shall be at least 125 percent of the yield strength of the reinforcing bars. Reinforcing bars without splices shall be similarly tested to determine their yield strength. Additional tests shall be made at the rate of one per each 25 couplers/crew. Should these latter tests fail, field splices shall be cut from actual installations and tested as above. The number of field specimens shall be determined by the District or its designee based on test results.

3.6 ELECTRICAL BONDING

- A. Bond concrete reinforcement and other embedded metal in the invert concrete of structures to establish electrical continuity for the control of stray currents where indicated.
- B. Make connections between copper conductors, concrete reinforcement, and embedded metal components by either exothermic-thermite welding or brazing. Procedures, materials, and equipment for thermite welding shall conform to the manufacturer's printed welding recommendations accepted by the District or its designee. For brazing, conform to AWS standard practices. Join concrete reinforcement for purposes of establishing electrical continuity, by either arc or gas fusion welding.
- C. Weld longitudinal reinforcing bars at splices, as indicated, to form an electrically continuous path parallel to the trackway.
- D. Install transverse collector bars of the type indicated at blockouts, openings, changes in section, and other locations where longitudinal reinforcement is interrupted. Arrange collector bars to transfer stray current from those bars which are interrupted to those bars which continue. Do not place concrete until collector bar

welds have been inspected and accepted by the District or its designee.

- E. Where expansion joints occur, connect longitudinal bars by collector bars on both sides of the joint. Where part of the structure such as a footing, contains continuous reinforcement, connect the collector bars on each side of the joint to the continuous bars. Where longitudinal bars are interrupted at a joint, bond the collector bars on each side of the joint together with No. 1/0 XHHW copper cables. Install Cables with sufficient slack to accommodate the anticipated movement of the joint.
- F. At each end of a structure and at distances along the structure not to exceed 500 feet, connect longitudinal bars by collector bars. Install test box for either each collector bar or pair of collector bars at a structure joint. Install test box at an accessible location, as indicated. Bond Number Two XHHW cable to the collector bar and route to the test box. Allow a slack of 12 inches of cable in the box.
- G. Welding and other Work done to establish electrical continuity for reinforcement must be inspected and accepted by the District or its designee prior to the placing of concrete. Inspection will include visual observation and mechanical and electrical tests as outlined in Article 3.9.

3.7 WIRE FABRIC - Install in as long lengths as practicable. Lap adjoining pieces at least one full mesh and lace splices with 16-gauge wire. Do not make end laps midway between supporting beams, or directly over beams of continuous structures. Offset end laps in adjacent widths to prevent continuous laps.

3.8 FIELD QUALITY CONTROL

- A. Welding - Tests may be made by the District or its designee for reinforcing bar welds, as follows:
 - 1. Inspection of reinforcing bar welds.
 - 2. Two tensile tests of sample welds made by each welder on the largest size bar indicated.
- B. If testing reveals defective weld, pay cost of testing. Where a weld is determined by the District or its designee to be defective, repair or replace defective weld to the satisfaction of the District or its designee.

3.9 CORROSION CONTROL TESTING - Test corrosion control products to verify the adequacy of the installation. After thermite weld has cooled and slag has been removed, and while pulling on wire, strike weldment perimeter in presence of the

SECTION 03300

CAST-IN-PLACE CONCRETE

PART 1 - GENERAL

1.1 DESCRIPTION - The Work specified in this Section consists of placing, preliminary finishing, and curing cast-in-place concrete as indicated.

1.2 QUALITY ASSURANCE

A. Qualifications of Concreting Supervisor: Experience in placing, consolidating, and curing portland cement concrete in structures similar to those in this Contract, and shall have been in responsible charge of that Work.

B. Reference Standards - Requirements of Regulatory Agencies: Work shall be performed in accordance with ACI 318.

1. Use Tests as listed in ASTM C94.

2. Reference Standards - Have available in the field office a copy of the ACI Field Reference Manual SP-15(81) containing Specifications for Structural Concrete for Buildings, ACI 301, With Selected ACI and ASTM References.

3. American Concrete Institute (ACI)

ACI304, Recommended Practice for Measuring, Mixing, Transporting, and Placing Concrete.

ACI305, Recommended Practice for Hot Weather Concreting.

ACI308, Standard Practice for curing concrete.

ACI309, Recommended Practice for Consolidation of Concrete.

4. American Society for Testing and Materials (ASTM)

a. Refer to ACI Manual of Concrete Practice of 1984 for ASTM references.

b. C173, Air Content of Freshly Mixed Concrete by the Volumetric Method or C231 Pressure method as applicable.

c. C172, Sampling Fresh Concrete.

5. Federal Specifications (FS)
 - a. HH-I-521, Insulation Blankets, Thermal (Mineral Fiber for Ambient Temperature).
 - b. MMM-G-650, Grout Adhesive, Epoxy Resin, Filled.
 6. U. S. Military Specification (MIL) - MIL-D-19235, Chemical Bonding Agent for Concrete.
- C. Construction Tolerances - Allowable Deviations from Indicated Dimensions and Elevations on the drawings - Do not allow adjacent units to have cumulative deviations.
1. Footings
 - a. Misplacement and eccentricity, as measured to centroid of footing - Two percent of footing width or two inches, whichever is the lesser.
 - b. Elevation of top: $\pm 1/4$ inch.
 - c. Other footing dimensions: Minus $1/4$ inch or plus two inches.
 2. Concrete Substrate Surfaces
 - a. Slab to receive dry shake aggregate topping: Adjust to accommodate finished surface tolerances.
 - b. Top of station platform concrete substrate surface above top of rail: $\pm 1/4$ inch.
 - c. All Others - Variation from indicated elevation: $\pm 1/4$ inches.
 - 2) Variation from indicated elevation on sloped surface: $\pm 1/4$ inch.
 3. Variations in thickness of finished monolithic slabs: $1/4$ inch.
 4. Top of track slab (Invert Concrete) finish course: $\pm 1/4$ inch.
 5. Horizontal distance from centerline of track to edge of station platform: Plus $1/8$ inch, minus $1/4$ inch.
 6. Concrete walkway dimensions: $\pm 1/4$ inch.
 7. Deviation of horizontal distance from edge of walkway to centerline of track: Plus zero minus $1/4$ inch.
 8. Tops of slabs not otherwise specified: $\pm 1/4$ inch.

9. Variation from a ten-foot straightedge placed in all directions on horizontal and inclined surfaces: $1/8$ inch.
10. Top elevation of columns, piers, walls, and arrises: $\pm 1/4$ inch.
11. Flatness of wall and column surfaces in ten feet in all directions: $1/4$ inch.
12. Flatness of finished horizontal surfaces: Eliminate depressions which could hold water.
13. Out-of-plumb of columns, piers, walls, centerlines of elevator shafts, and joints not exposed to view in public areas of finished structure: $1/4$ inch in 10 feet, not to exceed one inch total.
14. Out-of-plumb of columns, piers, walls, vertical joints and grooves, openings for doors, windows, and louvers, lines exposed to view in public areas of finished structure: $1/4$ inch in 20 feet, not to exceed $1/2$ inch total.
15. Clearance between door, window, and louver frames: Not less than $1/4$ inch nor more than $3/8$ inch.
16. Level and grades of exposed lintels, sills, parapets, horizontal grooves, and other conspicuous lines: $1/4$ inch in 20 feet, not to exceed $1/2$ inch in entire line.
17. Level and grade of slab soffits, ceilings, beam soffits, and arrises: $1/4$ inch in any 10 feet length; $3/8$ inch in any 20 feet length; not to exceed $3/4$ inch for entire surface.
18. Cross sectional dimensions of columns, beams, and slabs: Plus $1/4$ inch, minus zero.
19. Elevation of bottom of slabs on grade: Plus zero, minus has no minimum.
20. Thickness of walls and columns: Plus $1/2$ inch, minus $1/4$ inch.
21. Position of linear building lines and distance from centerlines of columns, walls, and partitions: $1/2$ inch.
22. Rise of steps: $1/16$ inch in consecutive steps, not to exceed $1/8$ inch in total rise of flight.
23. Tread of steps: $1/8$ inch in consecutive steps, not to exceed $1/4$ inch in total flight.

24. Size and location of sleeves and floor openings: 1/4 inch.
25. Difference between the diagonal dimensions of a rectangular opening: Not more than two percent of the sum of the diagonal dimensions.
26. Escalator and elevator sections: As required to fit accepted equipment as determined by coordination with the equipment contractor and actual measurements of that equipment taken by the Contractor.

1.3 SUBMITTALS

- A. Refer to Section 01300 for submittal procedures.
- B. Submit following in accordance with Section 01342, Working Drawings, for each concrete placement operation:
 1. Detailed descriptions of intended equipment and methods for conveying, placing, consolidating, preliminary finishing, and curing concrete.
 2. Trial Concrete Mix Designs - Submit proposed trial concrete mix designs in accordance with ACI 301-84, Trial mix designs shall be made:
 - a. For 50 to 90° Fahrenheit temperature range;
 - b. With accelerator added (if required);
 - c. With retarder added (if required);
 - d. With highrange water reducer added;
 - e. Air entraining admixture (if required) AASHTO MI54 or ASTM C260.
 - f. Fly ash and raw or calcined natural pozzolans admixture (if required) ASTM C618.
 3. Submit ready-mix delivery tickets in accordance with ASTM C94.
 4. Detailed description of intended means of protecting fresh concrete from extremes of temperature and inclement weather.
 5. Location and scheduled date of concrete placement, intended rate of placing, and mix design designation with updates.
 6. Composite working drawings, for each concrete lift, indicating locations and sizes of pipe sleeves, conduits, inserts, reglets, anchor bolts, openings,

recesses, and construction joints in coordination with Section 03100, Concrete Formwork.

C. Materials - Certification:

1. Submit Certificates of Compliance to specifications of materials in accordance with Section 01322, Certificates and Reports.
2. Submit the manufacturer's certification that materials meet or exceed specification requirements.

D. Tests - Submit required test data in accordance with Section 01410.

E. Samples - Submit the following:

1. 100 pounds of:
 - a. Coarse Aggregate
 - b. Fine Aggregate
 - c. Cement
2. One bag of each dry admixture used.
3. One gallon of each liquid admixture used.
4. Standard container of curing compound
5. Bonding agent
6. Five pound bag of abrasive aggregate
7. Cure and sealer or sealer/hardener
8. Joint sealant
9. Water stops
10. Vapor barrier
11. Caulking compound.

1.4 PRODUCT DELIVERY, STORAGE, AND HANDLING

- A. Transport and deliver concrete in accordance with ASTM C94.
- B. Arrange and maintain delivery schedules so that once placement has begun no delay of more than 30 minutes will occur between fresh deposits and previously placed deposits.

- C. Handle, store and batch concrete materials in a manner that will ensure that materials are not contaminated, damp, unclean, segregated or affected in any way that will damage the final finish.

1.5 JOB CONDITIONS

A. Environmental Requirements

1. Maximum temperature in hot weather - as recommended in ACI 305.
 - a. Do not allow the temperature of the concrete when deposited to exceed 90°F during hot weather and provide a lower temperature if so required by the District or its designee. Submit the methods proposed for controlling the temperature of the concrete to the District or its designee for acceptance.
 - b. After placement, protect the concrete from direct sunlight and keep the forms moist by means of cool water sprinkling, the application of wet burlap or cotton mats, or other approved method which will not adversely affect the concrete.
 - c. Hot weather conditions will be deemed to exist when the temperature in the forms is 75°F or above. If concrete would otherwise become warmer than 90°F, pre-cool aggregates.
2. Wet Weather: Do not place concrete in locations exposed to weather if rain intensity is expected to be sufficient to wash cement paste off aggregate, unless adequate shelter for concrete has been provided.

B. Inspection Immediately Before Concreting.

1. Substrate Surface Condition:
 - a. Verify that bearing capacity of subgrade is satisfactory and that surface is hard, reasonably level, slightly moist, and free from loose, saturated, and frosty material and debris.
 - b. Verify that previously-placed concrete has been prepared for bonding as specified in Paragraph 3.1H, and is free from loose and extraneous matter.
2. Products to be Embedded:
 - a. Inspect anchorage devices, remove defective pieces and install new pieces, and correct improper positioning, omission, and weaknesses in fastenings against displacement.

- b. Verify that pipes and conduits which will be embedded have been satisfactorily tested, that external threads have been completely capped, that internally-threaded and non-threaded ends have been acceptably plugged, and that anchorage devices have been secured in their indicated locations.
3. Formwork - Inspect formwork for defects in alignment, grade, and integrity of bracing, tie-bolts, falsework, camber, waterstops, and joints; eliminate defects.
4. Concrete Reinforcement: Inspect reinforcement for quantity, sizes, and positioning. Verify that fastenings will prevent displacement.
5. Do not place concrete until inspection has been completed and defects have been eliminated.

1.6 MEASUREMENT

- A. Cast-In-Place Concrete will be measured complete in place including forms, water stops inserts, and other embedded items, computed from the dimensions and within the limits shown on the Contract Drawings, or as ordered by the District or its designee. No deductions will be made for chamfers, reinforcing steel, embedded items, and openings and recesses having an area of less than two square feet.
- B. Cast-In-Place Concrete which is included for payment in other items listed in the Unit Price Schedule, will not be measured for payment under this Section.
- C. Cast-In-Place Concrete complete accepted, in-place will be measured as follows:
 1. Fill Concrete will be measured by the cubic yard as shown on the Contract Drawings as Fill Concrete, placed and accepted.
 2. Concrete Slabs on Grade will be measured by the cubic yard as shown on the Contract Drawings as Slab On Grade Concrete, placed and accepted.
 3. Foundation Concrete will be measured by the cubic yard as shown on the Contract Drawings as Foundation Concrete, placed and accepted.
 4. Concrete Columns will be measured by the cubic yard as shown on the Contract Drawings as Column Concrete, placed and accepted.
 5. Exterior Concrete Walls will be measured by the cubic yard as shown on the Contract Drawings as Exterior Wall Concrete, placed and accepted.

6. Concrete Walkway (service, safety, or emergency) will be measured by the Cubic Yard as indicated on the Contract Drawings as Walkway Concrete placed and accepted.
7. Interior Concrete Walls will be measured by the cubic yard as shown on the Contract Drawings as Interior Wall Concrete, placed and accepted.
8. Invert Concrete will be measured by the Cubic Yard as indicated on the Contract Drawings as part of Slab on Grade Concrete.
9. Invert Concrete within the limits of tunnel structure will be measured by the Linear Foot to the nearest one tenth of a foot along the centerline of track of each tunnel as indicated on the Contract Drawings, placed and accepted.
10. Supported Slabs and Beams will be measured by the Cubic Yard as shown on the Contract Drawings as Supported Concrete Slabs and Beams, placed and accepted.
11. Concrete Platform Slabs will be measured by the Cubic Yard as shown on the Contract Drawings as Platform Slab Concrete, placed and accepted.
12. Concrete within the limits of cross-passage structure, will not be measured separately for payment. It will be included in mined cross passage each with or without sump structure.

1.7 PAYMENT will be made under:

- Item No. 03300.01 - Fill Concrete - per cubic yard
- Item No. 03300.02 - Slab on Grade Concrete - per cubic yard
- Item No. 03300.03 - Foundation Concrete - per cubic yard
- Item No. 03300.04 - Columns, Concrete - per cubic yard
- Item No. 03300.05 - Exterior Wall Concrete - per cubic yard
- Item No. 03300.06 - Walkway Concrete - per cubic yard
- Item No. 03300.07 - Interior Wall Concrete - per cubic yard
- Item No. 03300.08 - Tunnel Invert Concrete - per linear foot
- Item No. 03300.09 - Supported Concrete Slabs and Beams - per cubic yard

Item No. 03300.10 - Platform Slab Concrete - per cubic yard

Item No. 03300.11 - Mined Cross Passages - per each

PART 2 - PRODUCTS

- 2.1 PORTLAND CEMENT CONCRETE - Class 4000, as specified in Section 03301, Portland Cement Concrete, unless otherwise indicated on Contract Drawings.
- 2.2 FILL CONCRETE - Class 2500. Unless otherwise indicated on Contract Drawings.
- 2.3 NON-SLIP MATERIAL - Non-metallic, shake-on, emery or silica quartz abrasive aggregate.
- 2.4 CHEMICAL BONDING AGENTS - Film-forming compound suitable for brush or spray application conforming to MIL-D-19235.
- 2.5 CURING MATERIALS
 - A. Burlap - Double thickness conforming to AASHTO M-182, Class 3.
 - B. Waterproof paper - Conform to ASTM C171.
 - C. White polyethylene sheeting - Conform to AASHTO M171.
 - D. Membrane forming curing compound - Conform to ASTM C309, Types 1 or 2 as selected by the District or its designee. Certify that curing agent will not affect bond of subsequent finishes.
 1. Type 1 compound containing a fugitive dye that is readily distinguished upon the concrete surface and that will become inconspicuous within seven days after application.
 2. Type 2 compound containing a white pigment that when applied to the surface exhibits a reflectance of not less than 60 percent of that of magnesium oxide, to be used where surfaces are subjected to sunlight.
- 2.6 SURFACE SEALER
 - A. Provide surfaces to be sealed free of dirt, dust, and other foreign materials immediately prior to application of the sealer. Do not apply sealer until elastomeric sealants have been installed. Provide a two-coat clear, water-white sealer, non-glossy, non-staining and non-darkening sealer system with a minimum of 20 percent solids, pressure spray applied in accordance with manufacturer's recommendations. Concrete sealers include the following or accepted equal.

1. Umbrella #9100-VIP Enterprises, Inc.
 2. Thoro Glaze H20-Thoro Systems Products.
 3. Rainstopper 200 - Textured Coatings of America.
- B. Where indicated to use graffiti resistant sealer, the following is approved or accepted equal.
- Raylite WE-48 - The Raylite Company.
- C. Upon completion of the Contract and immediately prior to final clean-up, reclean the surface with a mild detergent cleaner as recommended by the sealer manufacturer, and apply the second coat of the same sealer.
- 2.7 HARDENER
- A. Non-metallic, penetrating compound, leaving no residue, compatible with abrasive aggregate, curing compound, sealer and subsequent floor finishes.
 - B. Hardener may be combined with a curing agent and sealer to form a single compound conforming to these requirements.
- 2.8 WATER AND WATERSTOP - Water-CRD.C400 water stops CRD-C513 or CRD-C572.
- 2.9 MORTAR FOR PATCHING CONCRETE - One part Portland cement of type and manufacture used in impinged concrete to two parts fine aggregate conforming to ASTM C33.
- 2.10 AGENT FOR BONDING NEW CONCRETE TO SET CONCRETE - Either grout or epoxy resin.
- A. Grout - equal parts of Portland cement and fine aggregate by weight and not more than six gallons of water per sack of cement.
 - B. Epoxy resin - Two-component, mineral-filled, epoxy-poly-sulphide polymer conforming to FS MMM-G-650, Type I or Type II, Grade A.
- 2.11 VAPOR BARRIER - Six-mil polyethylene.
- 2.12 SAND - Clean, dry, natural or manufactured sand, free from clay lumps, rocks and debris for under/over vapor barrier.
- 2.13 JOINT SEALANT - One of the following ASTM D1190, ASTM D1850.
- 2.14 PIGMENTED CURING COMPOUND - ASTM C309, Type 2 pigmented except limit loss of water retention to 0.04 grams per square centimeter of surface.

2.15 EXPANSION JOINT FILLER - ASTM D1751.

2.16 SELF-SEALING EXPANSION JOINT FILLER - ASTM D994.

PART 3 - EXECUTION

3.1 PREPARATION

A. Installing Vapor Barrier

1. Prior to placing reinforcement and concrete, verify that subgrade or base is smooth and free from debris.
2. Place a one inch layer of sand, uniformly over the areas to receive a vapor barrier.
3. Lay vapor barrier on undisturbed sand. Lap side and end joints not less than four inches and seal water-tight. Inspect vapor barrier for puncture and tears, patching the penetrations in the same manner as the joints.
4. Place a one inch layer of sand uniformly over the vapor barrier, moisten, grade level and roll to a smooth even surface. Keep sand cover moist during subsequent work to reduce displacement.

B. Ensure that equipment has been cleaned before allowing fresh concrete to be placed in it.

C. Provide ready-mixed concrete in accordance with ASTM C94.

D. Working Platforms - Arrange temporary runways for bug-gies; support runways on formwork; not on reinforcing.

E. Immediately prior to placing concrete, make certain that the required volume of concrete will be delivered in such manner as to permit placement at a constant rate. Use equipment in conveying concrete that has no aluminum component in direct contact with the concrete.

F. Immediately prior to placing concrete, check forms, falsework and centering and make adjustments to assure that the finished Work will conform to the indicated lines and grades. To permit ready measurement by the District or its designee to determine settlement or deviation from Contract Drawings requirements provide plumb lines and tell-tales.

G. Do not place concrete until formwork, vapor barrier or hydrocarbon resisting membrane where indicated, reinforcing steel, embedded items and waterstops have been checked and appropriate placement clearance form has been signed by the District or its designee.

H. Uncoated Wood Forms - Thoroughly wet forms immediately before placing concrete.

I. Bonding New Concrete to Existing Concrete

1. Roughen surfaces of set concrete at joints, except if bonding will be with concrete bonding agent; remove laitance, coatings, loose particles, and foreign matter; and uniformly expose aggregate.
2. Bond fresh concrete to new concrete which has set, but has not fully cured, as follows:
 - a. At joints between footings and walls or columns, and between beams or slabs and elsewhere, unless otherwise indicated - dampen with water, but do not saturate, roughen and clean concrete surfaces immediately before placing fresh concrete.
 - b. At joints in exposed work, vertical joints in walls, joints in girders, beams, supported slabs, other structural members, and at joints designed to contain liquids: dampen with grout, but do not saturate, roughen and cleaned concrete surfaces. Apply epoxy resin to dry surfaces.
 - 1) Apply grout with a stiff broom or brush to a thickness of not less than 1/16 inch. Deposit fresh concrete before grout has attained its initial set.
 - 2) Or apply epoxy resin to cleaned concrete surfaces in accordance with resin manufacturer's printed instructions.
3. Bond fresh concrete to fully-cured concrete as follows:
 - a. Mix epoxy-resin bonding agent in accordance with manufacturer's printed instructions and safety precautions.
 - b. Thoroughly roughen and clean hardened concrete surfaces by sandblasting and wash thoroughly prior to applying a coat of epoxy-resin bonding agent not thinner than 1/16 inch. Place fresh concrete while epoxy-resin is tacky, without removing in-place coat, and in accordance with epoxy-resin bonding agent manufacturer's printed instructions.

3.2 CONVEYING OR PUMPING CONCRETE

- A. Conveying - Provide equipment for conveying concrete from the mixer such as to ensure a continuous flow of concrete to the point of placement without segregation or loss or

mortar, as acceptable to the District or its designee. Provide ferrous metal surfaces of metal chutes, troughs, and pipes in contact with concrete during conveying or pumping of concrete.

B. Belt Conveyors - Slope belt conveyors so they will not cause segregation or loss of mortar. Provide an approved arrangement at the discharge end of the conveyor to prevent segregation. Discharge long conveyor runs of concrete into a hopper, without segregation, before it is deposited in the forms.

C. Provide metal or metal-lined chutes and open troughs, where steep slopes are required. Equip the chutes or troughs with baffles to minimize segregation of the aggregates. Keep chutes or open troughs clean of hardened concrete by thoroughly flushing with water after each use. Discharge water used for cleaning outside of the line of the structure. Provide chutes or open troughs having a slope not exceeding one foot vertical in two feet horizontal and not less than one foot vertical to three feet horizontal. Discharge chutes 20 feet or more in length into a hopper before final distribution.

D. Adjustable Length Pipes (Elephant Trunks)

1. The use of flexible pipes of metal, rubber or plastic will be permitted provided they are of six-inch minimum diameter and used in a manner that will not allow segregation of the concrete.

2. Locate pipe and flexible pipe so that the concrete is delivered in a continuous flow to points not more than five feet horizontally and five feet vertically from its final location. In the vicinity of expansion and contraction joints, reduce the horizontal distance to a maximum of three feet.

3. Clean flexible pipes or elephant trunks after each usage.

E. Buggies - Construct runways on which the buggies will operate so that they will not come in contact with or be supported by the reinforcing steel.

F. Pumping

1. Provide suitable pumping and pneumatic conveying equipment sized to adequately handle the volumes of concrete to be conveyed. Provide equipment acceptable to the District or its designee. Control pneumatic equipment so that there is no segregation in the discharged concrete. Operate the pump or pneumatic equipment such that a continuous stream of concrete without air pockets is produced. Position the

discharge end of the line as near the final position of the concrete as possible but in no case more than five feet. Position discharge lines horizontal, inclined upwards or vertical from the machine. After each operation and at the conclusion of placement, thoroughly clean equipment, and waste debris and flushing water outside of forms.

2. Equipment:

- a. Furnish, install, operate, and maintain equipment in accordance with the accepted working drawings and the recommendations of ACI 304.
- b. Maintain spare equipment on site to minimize delay should equipment breakdown occur.

3. Preparations:

- a. Before charging pipe line, operate pump and verify that moving parts will operate satisfactorily.
- b. Pump Portland cement grout through line immediately ahead of concrete. Unless pumped grout will be for bedding at construction joints, transport pumped grout off worksite.

4. Conveyance:

- a. Operate pumps at low speed until concrete has filled line and is moving steadily.
- b. If placement is impeded either by delay of concrete delivery or by repairs or other circumstances, slow pumping rate to that which will barely move concrete. During long delays, limit pump operation to occasional single strokes.
- c. For placement in confined areas during long delays, recirculate concrete to receiving hopper.
- d. If delays become of that duration which renders concrete in the line immovable, cleanout line and restart work cycle as described above.
- e. When form is nearly filled and there is enough concrete in line to complete placement, stop pump and force go-devil through line.

5. Field Quality Control:

- a. Sample pumped concrete in accordance with ASTM C172 at points of placement, for each change of location, as required by the District or its designee.

b. Immediately test samples, in presence of the District or its designee; determine if changes in water cement ratio, slump, air content, and other significant mix characteristics have occurred. Should tests show that those changes have occurred, effect corresponding adjustments to mix design. Use test methods as follows:

1) Air content - ASTM C173.

2) Slump - ASTM C143.

3) Mortar-to-coarse aggregate ratio - Observe surface texture of a light trowelled sample as described in Portland Cement Association's Design and Control of Concrete Mixes, Figure 19(a).

6. Clean-Up:

a. At the end of a pumping operation, purge line from placement area to pumping area with water. Dump waste concrete in a container and remove it from worksite.

b. Immediately after line has been purged, thoroughly clean lines and pumping system equipment.

3.3 JOINTS - Make construction joints as shown on the Contract Drawings unless otherwise proposed by the contractor and approved by the District or its designee. Make joints on concrete structure and joints forming knockout panels as indicated on the Contract Drawings. Extend no reinforcement through the expansion and contraction joints, except where specifically noted or detailed on the plans.

A. Where keyways are shown on the Contract Drawings form by beveled strips or boards.

B. Continue reinforcing steel or wire fabric across construction joints.

C. Provide rough surface with aggregate exposed (1/4" min.), and thoroughly cleaned by wet sandblasting, by cutting with high pressure water jet having a minimum pressure of 2,000 psi, or by equivalent methods, to the satisfaction of the District or its designee. The cleaning shall be done after concrete has hardened sufficiently to prevent raveling of the surface below the desired depth.

D. Immediately after the Work of placing concrete is halted, remove accumulations of mortar splashed upon the reinforcement and surfaces of the forms before the concrete takes its initial set. Take care when cleaning reinforc-

ing steel to prevent damage to or breakage of the concrete-steel bond.

- E. Mix epoxy-resin bonding agent as recommended by the manufacturer.
- F. Before fresh concrete is placed, coat the hardened surface of previously placed concrete with not less than 1/16 inch thickness of bonding agent or as recommended by bonding agent manufacturer.
- G. Place fresh concrete while the bonding agent is tacky, exercising care not to remove the bonding agent, and as recommended by the bonding agent manufacturer.

3.4 PLACING CONCRETE

A. Depositing

1. Deposit concrete continuously and as rapidly as practicable after mixing.
2. Use of vibrators for shifting the mass of fresh concrete is not permitted.
3. Do not deposit concrete at a rate such as to endanger the formwork or at a rate faster than the placing crew can compact it properly. Do not deposit concrete on concrete which has hardened sufficiently to cause the formation of seams (cold joints) or planes of weakness within the section. Cover each layer of concrete with fresh concrete within a period not to exceed 30 minutes.
4. Deposit the concrete in a continuous flow to points not more than five feet horizontally and five feet vertically from its final location. In the vicinity of expansion or contraction joints reduce the horizontal distance to a maximum of three feet.
5. Remove temporary spreaders in forms when the concrete has reached an elevation rendering their service unnecessary. They may remain embedded in the concrete only if made of concrete or nonstaining metal and with the prior acceptance of the District or its designee.
6. Place column concrete through adjustable length flexible pipes or "elephant trunks."
7. In monolithic placements, do not commence the depositing of concrete in the supported elements, such as beams, girders and slabs, until the concrete previously deposited on columns or walls has completed its settlement shrinkage, but prior to the point at which the concrete in the supporting members will not permit

the vibrator to sink into its mass by its own weight. In consolidating the concrete in the haunches, beams or slabs, penetrate with vibration and revibrate the concrete in the top of the supporting members.

- B. Where a schedule for placing concrete is shown on the Contract Drawings, no deviations will be permitted therefrom unless acceptable to the District or its designee. Placing will not be permitted when, in the opinion of the District or its designee, the sun, heat, wind, or limitations of facilities furnished by the Contractor, prevent proper finishing and curing of the concrete.
- C. Deposit concrete as near as possible to final position, and in a continuous flow. Do not allow mortar to separate from aggregate. Do not use vibrators to move concrete. If concrete must be dropped more than four feet, drop concrete through adjustable length pipe or flexible tube.
- D. Deposit concrete against leading face of lift being placed.
- E. Deposit concrete continuously in level layers of that thickness which can be properly consolidated; cover previously-placed layers before concrete has begun to harden. Cover each layer with fresh concrete within 30 minutes. Start placing at the low point and proceed up grade unless otherwise permitted by the District or its designee.
- F. When a truck or agitator is used for transporting concrete to the delivery point, discharge shall be completed within 1 1/2 hours, or before 250 revolutions of the drum or blades, whichever comes first, after the introduction of the cement to the aggregates. Under conditions contributing to quick stiffening of the concrete, or when the temperature of the concrete is 85°F, or above, a time less than 1 1/2 hours may be required.
- G. Concrete Slabs: Deposit and consolidate concrete between indicated construction joints in a continuous operation.
- H. Construct construction joints.
- I. Thoroughly clean concrete handling equipment immediately on suspension of its use.
- J. Remove cement paste and debris from reinforcement to which additional reinforcement will be attached.
- K. Concrete Deposited Under Water - Do not deposit concrete under water except in a manner acceptable to the District or its designee.

- L. Fresh concrete is not permitted to fall from a height greater than 8 feet without the use of adjustable length pipes.
- M. Do not retemper any partially hardened concrete with additional water.

3.5 CONSOLIDATING CONCRETE.

A. Consolidate concrete during placement until voids have been filled and free mortar appears on surface.

B. Compaction

1. As concrete is being placed, compact it thoroughly and uniformly by means of mechanical vibration in order to secure a dense mass, close bond with reinforcement, and a smooth surface. Work the concrete well around the reinforcement, embedded items and into the corners of forms.
2. Use internal vibration unless the use of external vibrators for compacting is specifically requested by the District or its designee when the concrete is inaccessible for adequate consolidation. When external vibration is required, the forms are to be constructed sufficiently rigid to resist displacements and damage from vibrations.
3. Provide vibrators capable of generating vibration at frequencies of not less than 9000 impulses per minute. Check vibrators and assure good condition before starting the placement of concrete. Provide a sufficient number of vibrators to properly compact each batch of concrete immediately after it is deposited in the forms. Determine the size of the vibrators by the space available for their use in the forms between the reinforcing bars. Make available at least one spare vibrator, for each size in good working condition, at the site of the pour for use in case of emergency.
4. Use external vibrators of the size, type and operation acceptable to the District or its designee.
5. Operate vibrators by experienced workmen in accordance with ACI 309. Provide location, manner and duration of the application such as to secure maximum consolidation of the concrete without causing segregation of mortar and coarse aggregate. Vibrate the deposited concrete in such a manner as to prevent damage to forms, damage or displacement of reinforcement and embedded materials or segregation in the concrete. Make every effort to avoid formation of laitance and the accumulation of excessive water on the surface of the concrete as it is deposited. Remove excessive

water accumulating, by pumping, bailing or other methods satisfactory to the District or its designee before other concrete is placed. Do not penetrate previously placed layers more than two inches in order to consolidate the layers and prevent overvibration of the previously vibrated layer. Where, in the opinion of the District or its designee, internal vibration is impractical or might cause damage to electrical conduits, spading will be required and internal vibration will not be permitted.

6. When spading, thoroughly compact the coarse aggregate away from the form and into the plastic mass. Do spading with approved equipment and rod the concrete around embedded materials, and into the corners and spaces to be filled in order to secure even, dense surface, free from aggregate pockets or honeycomb.
- C. Vibrate concrete only for that time which is necessary to obtain maximum consolidation without segregating mortar and coarse aggregate, and without causing water and cement paste to flush to surface.
 - D. Space the points of vibrator insertion at 1 1/2 times the radius of action recommended by ACI 309, Table 5.1.4 for the particular application.
 - E. Penetrate previously-placed layer of fresh concrete 2 inches at regular intervals.

3.6 FINISHES

A. Unformed Surfaces:

1. Before beginning preliminary finishing operation, verify that supports and headers have been set to required elevation with allowances for settlement, camber, and deflection in accordance with Section 03100, Concrete Formwork.
2. Consolidate concrete with a compacting type screed operated on and between support or headers, until a uniform surface has been obtained.
3. Tamp and strike-off concrete with templates and strike boards alternatively; remove templates and boards in a combined longitudinal and transverse motion.
4. Leave a uniform film of mortar of suitable consistency on the concrete surface after last pass of template and strikeboard.
5. Finish concrete surfaces as specified in Section 03346, Unformed Concrete Finish, unless otherwise indicated.

B. Formed Surface: Immediately following form removal:

1. Remove fins and irregular projections from surfaces which are exposed to view and from surfaces on which waterproofing will be applied.
 2. Fill holes vacated by removable components of form ties with mortar of same type mix and ingredients as in surrounding concrete.
 3. Prepare pointing mortar not more than 30 minutes before using.
 4. Maintain mortar patches wet and cure as specified in Paragraph 3.7.
 5. Leave contraction and articulated joints tooled and free from mortar and concrete.
 6. Leave joint filler, having clean and true edges, exposed for its full length.
- C. Form concrete surfaces which will be exposed to public view in completed structures by fiberglass, or by large continuous panels or other approved materials that will produce a smooth surface without fins or other projections.
1. When forms are removed do not repair voids, stone pockets, and other defects until the District or its designee has inspected them and given remedial instructions.
 2. Protect floor and slabs by approved methods during the entire process of the Work and thoroughly clean before final acceptance.
 3. Round edges and joints to a 1/4 inch radius, after finishing unless indicated otherwise.
 4. Finish concrete surfaces as specified in Section 03347, Exposed Finish Concrete, unless otherwise indicated.

3.7 CURING

- A. Protect freshly deposited concrete from excessively hot or cold temperatures, in accordance with Paragraph 1.5, and maintain without drying for the period of time necessary for the hydration of the cement and the proper hardening of the concrete. Provide material for the curing and protection of the concrete at the site and ready for use before actual placement of concrete is started.

1. Provide, and use when necessary, sufficient tarpaulins or other approved material to cover completely, or enclose forms and working areas during placing and finishing operations.
2. Except as otherwise specified herein, keep newly placed concrete continuously wet for a cumulative period of seven days (three days for high-early strength) at an air temperature above 50°F.
3. Cure concrete by normal curing methods as set forth herein under Normal Curing and Protection, except as otherwise permitted by the District or its designee.
4. Provide clean and potable water for use in curing concrete.
5. Keep steel forms, exposed to the sun, and wood forms in contact with concrete wet during the curing period. If forms are removed during the curing period, employ one of the following curing materials or methods immediately and continue for the remainder of the curing period.

B. Normal Curing and Protection

1. Moist curing of concrete by one of the methods specified below, as selected by Contractor:
 - a. Ponding may be used on horizontal surfaces providing the surface is submerged at all times for the required curing period.
 - b. Continuous sprinkling with a nozzle or nozzles which, during the first 24 hours, atomizes the flow of water, providing a mist and not a spray. Do not apply the moisture under pressure directly upon the concrete and do not allow water to flow or wash the surface and cause erosion.
 - c. By covering the entire surface of the concrete with burlap or an absorptive mat or fabric laid directly on the concrete and kept wet at all times.
 - d. By sprinkling, as set forth above, for at least 18 hours and then immediately covering the concrete surface with waterproof paper or plastic sheeting, free from holes or tears and at all times held in position in such manner that the entire surface of the concrete being cured is fully covered.
2. When using burlap or cotton mats for curing concrete, exercise care to avoid damage to, or the marring of, the concrete surfaces.

C. Membrane-Forming Curing Compound may be authorized by the District or its designee under certain circumstances where the application of moisture is impracticable and where such compounds will not jeopardize the appearance of the concrete. Apply compounds, where authorized, uniformly over the surface at the thickness recommended by the manufacturer.

1. Do not apply these compounds to surfaces where a bond is required for additional concrete, or where a bonded surface coating such as paint, or tile is to be applied unless certified as compatible with subsequent finish and acceptable to District or its designee.
2. Warm curing compound that has become chilled to such a degree that it is too viscous for satisfactory application in accordance with the manufacturer's recommendations. Should the film of the compound be damaged before the expiration of the curing period, repair the damaged portions immediately with additional compound.
3. Give surfaces the required surface finish prior to application of the curing compounds. Provide concrete, cured by this method, applications of the curing compound as recommended by the manufacturer for the desired effect. Apply immediately after stripping of forms and acceptance of the concrete finish. If the surface is dry, wet the concrete with water and apply the curing compound just as the surface film of water disappears. Apply the second coat, if required, after the first application has set. During curing operations wet unsprayed surfaces with water. Protect the coating against marring for a period of at least ten days after application. Should the surface coating be subjected to disturbance, the District or its designee may require that water curing be applied at once. If the use of a curing compound results in a streaked or blotchy appearance, stop the method and perform water curing, as herein before specified, until the cause of the defective appearance is corrected.
4. Uniformly apply compound over surface at thicknesses recommended by compound manufacturer.
 - a. Surfaces exposed to sunlight: apply pigmented type.
 - b. Surfaces protected from sunlight: apply clear type.
5. Apply non-wax resin type curing compounds to a surface where bond is required for additional concrete or where a bonded surface coating such as paint, tile, dampproofing, waterproofing, or roofing will be applied.

6. Do not apply curing compound to construction joints, to permanently exposed concrete floors, and to walls within eight feet of floor level if those floors and walls will be chemically sealed.

3.8 PROTECTION OF COMPLETED WORK

- A. During the curing period, protect concrete from damage mechanical disturbances, water flow, loading, shock, and vibration.
- B. Protect concrete from physical damage or visual defects until the Work is accepted by the District or its designee.

3.9 SURFACE SEALER - Apply sealer to concrete which will be permanently exposed to eight feet above floor level, including horizontal, inclined, and vertical surfaces, in accordance with sealer manufacturer's printed installation instructions and as follows:

1. Apply to unformed surfaces immediately following completion of finishing and formed surfaces immediately following form removal or patching, as the case may be.
2. Apply second coat, if required, not later than one day after applying the first coat.
3. Apply third coat, if required, immediately before inspection for final acceptance.

3.10 REPAIR - District or its designee will determine extent and manner of action to be taken to repair defective concrete revealed by surface defects or otherwise. Fill holes extending through concrete, with plunger-type gun or other suitable device, from the least exposed face; hold a flush stop at exposed face.

A. Repair of Formed Surfaces:

1. Patch defective areas with cement mortar of mix proportions and materials identical to those used in surrounding concrete. Before starting to patch, produce a finish on patch which is indistinguishable from finish on surrounding concrete, immediately after removing forms and in a manner and by a method accepted by District or its designee in writing.
2. Patch surfaces indicated to receive abrasive blasted finish or other type of exposed aggregate finish with a patching mortar which contains cement and coarse aggregate of type embodied in surrounding concrete, and in proportions identical to those in surrounding concrete.

3. Cut-out honeycomb, rock pockets, and voids having a diameter more than 1/2 inch to solid concrete but not shallower than one inch. Make edges of cuts perpendicular to exposed concrete surface. Before placing cement mortar, thoroughly clean, dampen, and brush neat cement grout area to be patched.

B. Repair of Unformed Surfaces:

1. Test surfaces for smoothness and verify conformance of surface plane to tolerances specified. Eliminate low and high areas.
2. Test sloped surfaces for trueness of slope and smoothness; use a template having required slope. Eliminate high and low areas.
3. Repair finished surfaces containing defects which adversely affect durability of concrete.
4. Grind high areas of surfaces after concrete has cured sufficiently to permit repairs to be made without damaging adjacent areas.
5. Cut-out low areas in surfaces either during or immediately after completing surface finishing, and fill with fresh concrete. Finish repaired areas to blend into adjacent concrete.
6. Cut-out defective areas, except random cracks and single holes not larger than one inch in diameter, and fill with fresh concrete. Remove defective areas to sound concrete; leave clean, square cuts. Expose reinforcing steel at least 3/4 inch all around. Dampen concrete surfaces which will contact patching concrete and brush with either neat cement grout or concrete bonding agent. Place patching concrete before grout initially sets. Mix patching concrete of same type materials and in same proportions as adjacent concrete. Place, compact, and finish patch in a manner which will result in patch blending with adjacent concrete. Cure patch in same manner as adjacent concrete.
7. Repair isolated random cracks and single holes not larger than one inch in diameter by the dry-pack method. Groove tops of cracks, cut-out holes to sound concrete, and remove dust, dirt, and loose particles. Dampen cleaned concrete surfaces and brush with neat cement grout. Mix dry-pack, consisting of one part portland cement to 2 1/2 parts fine aggregate passing No. 16 sieve; use only that water which will facilitate handling and patching. Place dry-pack before grout initially sets. Compact dry-pack in-place and

finish to match adjacent concrete. Keep patched areas continuously moist for not less than 72 hours.

C. The District or its designee may require defective work to be removed and replaced.

1. Sample concrete in place that is deemed defective by drilling and test in accordance with the requirements of ACI 318 Section 4.7.4. The coring operation will be monitored by the District or its designee.
2. If average of three cores specimen shows less than 85 percent of specified compressive strength, and single core is less than 75 percent of the specified compressive strength, the District or its designee will have the right to require, at his discretion, either replacement or strengthening of the defective portion of the structure.
3. Concrete will also be considered defective if it is structurally unsound, not watertight, or improperly finished, as determined by the District or its designee. The District or its designee, at his discretion shall have the right to require replacement, strengthening or correction of the defective portion of the structure. Strengthening or correction of the defective portion of the structure shall be at no additional cost to the District.
4. When directed by the District or its designee remove defective concrete, roughen or key the surface and soak with water before patching with concrete or mortar of a color to match the surrounding concrete. White cement may be added to the patching material to produce the same color as the original concrete. Clean, saturate with water and point with a mortar paste consisting of cement and fine aggregate mixed in generally the same proportions to give the same appearance as the concrete being finished. The cavities produced by form ties, and other holes, honeycomb spots, broken corners or edges and other defects shall be filled with mortar. Mortar to be used in pointing shall be prepared not more than 30 minutes prior to use. Properly cure the mortar patches. Contraction and articulated joints in the completed Work shall be left carefully tooled and free of mortar and concrete. Joint filler, where required, shall be left exposed for its full length with clean and true edges.
5. Protect the concrete structure from rust staining by structural steel members or from other substances during the Work. If staining does occur, remove stains and restore the concrete to its original color.

3.11 DAMAGED WORK - Before final acceptance of the Work, repair damaged surfaces, corners of concrete, and concrete finish, whether such damage has resulted from the action of the elements or from any cause whatsoever. Bring damaged places where surface repairs are permitted to a smooth, dense, watertight condition to the satisfaction of the District or its designee.

3.12 FIELD QUALITY CONTROL

A. Sampling of Concrete - Representative samples of concrete for testing shall be taken by the Contractor in accordance with ASTM C172.

B. Testing of Concrete

1. Determine the strength of concrete from standard test specimens molded by the Contractor according to ASTM C31, and cure and test using the laboratory retained by the Contractor in accordance with ASTM C39, and C78.
2. Compute and evaluate the strength of concrete in accordance with ASTM C94, by the Contractor's designated testing laboratory.
3. Determine air content of concrete using the Contractor's designated testing laboratory in accordance with ASTM C231 or ASTM C173.
4. Determine the cement factor (water cement ratio) using the Contractor's designated testing laboratory in accordance with ASTM C138.
5. Determine slump of concrete using the Contractor's designated testing laboratory in accordance with ASTM C143.
6. Furnish approved molds and concrete for casting of specimens and for testing. Furnish standard testing equipment and tools to perform sampling, slump tests and yield tests. Testing will be monitored by the District or its designee.

C. Frequency of Sampling and Testing of Concrete and Ingredients

1. Sample concrete ingredients prior to their use and have them tested by an approved laboratory in accordance with the methods specified. Subsequently test materials shall be tested as often as necessary to verify that the materials conform to the specifications. Make arrangements for the District or its designee to witness sampling and testing. Submit a

record of the results of the tests to the District or its designee.

2. Perform strength tests by making not less than one set of standard cylindrical test specimens for each 100 cubic yards of concrete or portion thereof of each concrete class.
3. For each Work shift, when concrete is delivered, make at least one set of test specimens. A set of test specimens shall consist of at least six standard cylinders from a batch. At least one specimen tested at seven days and two specimens of the set will be tested for 28-day strength.
4. Perform slump tests, yield tests, and air content tests with no less frequency than that of casting strength specimen sets; however, the District or its designee reserves the right of having the concrete tested as often as he deems necessary.

D. Field or Job Cured Specimens

1. If at any time the Contractor wishes to remove forms and backfill around freshly placed concrete or place any concrete structure into service earlier than specified herein, he shall demonstrate the attainment of acceptable strength by job curing concrete specimens placed in the field alongside of the related structures.
2. Mold test specimens using the Contractor's designated testing laboratory. The tests shall be monitored by the District or its designee.
3. Do not use the test data derived from the field cured specimens in the determination of the average strength of concrete for acceptance of Work.
4. The District or its designee may at any time mold and test field or standard cured specimens for his own information.

END OF SECTION

SECTION 03301

PORTLAND CEMENT CONCRETE

PART 1 - GENERAL

1.1 DESCRIPTION

A. The Work specified in this Section consists of furnishing and maintaining equipment at the worksite; developing and controlling concrete mix design; controlling storage and quality of concrete ingredients; and batching, mixing, controlling quality, furnishing, and delivering cast-in-place concrete of indicated strength and water-cement ratio designation having indicated slump and sized aggregate, in accordance with ASTM C94, Alternative No. 2.

B. DEFINITIONS

1. Strength Designation - The nominal compressive strength required of concrete is indicated by the word "class" followed by a four digit number which expresses the nominal compressive strength, in pounds per square inch, of test specimens at 28 days when prepared in accordance with ASTM C31 and tested in accordance with ASTM C39.
2. The word, "concrete," followed only by a strength class designation (e.g., Concrete Class 4000) indicates normal weight aggregate concrete, i.e., concrete having a unit weight of approximately 144 pounds per cubic foot without reinforcement.
3. The term "insulating concrete" indicates a concrete which has a maximum unit weight of 50 pounds per cubic foot at 28 days, a walkability and nailability as recommended by ACI 523, Cast-in-Place Low Density Concrete, Articles 3.1.2 and 3.1.3, and thermal conductivity not greater than 1.40 as determined by ASTM C177.
4. The term "lean concrete" (Fill Concrete) indicates a concrete containing sufficient cement to develop a 28-day compressive strength of 2500 psi.

1.2 QUALITY ASSURANCE

A. Concrete Supplier - Purchase concrete from a plant which has recently furnished the specified concrete for incorporation in a District project or furnish evidence of the plant's capacity to produce and deliver concrete conforming to the specified requirements at the required rate and which has laboratory capability to develop acceptable

concrete mix designs and to control quality of concrete production.

B. Mix Design Criteria:

1. Develop the proportioning of concrete ingredients in accordance with ACI 211.1 and 211.2.
2. Nominal compressive strength of concrete - Class 4000, unless otherwise indicated or specified for Cast-in-Place Concrete, - Class 6500 for precast concrete. Tunnel liners, and Class 4000 for non-tensioned precast concrete.
3. Frequency of adjustments of mix designs - For every change in source and type of ingredient.
4. Concrete indicated to be air-entrained - Verify that the required air content, as determined by ASTM C173, conforms to the value and is within the tolerance recommended by ACI 130 and ACI 318, corresponding to the maximum size of coarse aggregate.
5. Do not exceed slump of average of three successive batches of concrete at placement as determined by ASTM C143.

- a. Paving.....2 inches
- b. Nonreinforced concrete, other than paving.....3 inches
- c. Reinforced concrete slabs, beams, girders, walls and other structural members after addition of high range water reducer.....6 inches
- d. Concrete placed by pumping.....7 inches
- e. Drilled-pier concrete.....6 inches
- f. Lightweight structural concrete
 - 1) Average of three successive batches.....3-4 inches
 - 2) Limitation on each batch.....4 inches

C. Concrete Pump Plant Design Criteria - Conform to recommendations of ACI 304. Maintain equipment in those quantities which will preclude stopping concreting because of failed equipment.

D. Source Quality Control

1. Perform continuous batch plant Quality Control inspection during batching operations using an independent testing laboratory and perform tests as stated in Paragraph 1.2 F. Provide concrete from an approved, batching plant meeting the following requirements:

a. Arrangement

- 1) Provide separate bins or compartments for each size or classification of aggregate and for bulk Portland cement.
- 2) Provide the compartments of ample size and so constructed that the materials will be maintained separately under working conditions. Equip the batching plant so the flow of each material into its batcher is stopped automatically when the designated weight has been reached. Aggregates may be weighed in separate scale in a separate weight batcher. Water may be measured by weight or by volume. If measured by weight, do not weigh cumulatively with another ingredient. So interlock batching controls that the charging mechanism cannot be opened until the scales have returned to zero. These requirements can be satisfied by a semi-automatic batching system as defined in the Standards of the Concrete Plant Manufacturer's Bureau with interlocking as described above or by an automatic batching system as defined in the Contract Plant Standards.
- 3) Arrange the plant to facilitate the inspection of operations. Provide suitable facilities for obtaining representative samples of aggregate from each of the bins or compartments for test purposes. Provide delivery of materials from the batching equipment to within the accuracies specified in ASTM C94.
- 4) Batching accomplished in accordance with ASTM C685 may be used subject to acceptance by the District or its designee in lieu of weight batching, provided batching plant is approved to comply with requirements of Standards of the Concrete Plant Manufacturer's Bureau.

b. Water Batcher and Dispensers for Admixtures

- 1) Provide equipment for batching water and air-entraining or other admixtures at the batching plant except in cases where the mixing is to be

performed at the job site in paving mixers or in truck mixers.

- 2) Provide a suitable water measuring device that is capable of measuring the mixing water within the specified requirements for each batch. Provide a mechanism for delivering water to the mixers such that leakage will not occur when the valves are closed. Interlock the filling and discharge valves for the weighing batcher so the discharge valve cannot be opened before the filling valve is fully closed.
 - 3) Provide measuring devices for admixtures capable of ready adjustment to permit varying the quantity of admixture to be batched that has at least three percent accuracy. Interlock the dispenser for admixtures with the batching and discharging operations so the batching and discharging of the admixture will be automatic.
 - 4) Non-interlocked dispensers may be permitted, provided the calibration of the dispensers is checked by the Contractor at intervals as required by the District or its designee. Record the results of such calibration and make available for inspection by the District or its designee.
- c. Moisture Control - Provide a plant capable of ready adjustment to compensate for the varying moisture contents of the aggregate and to change the weights of the materials being batched. Provide an electric moisture meter acceptable to the District or its designee for measurement of moisture in the fine aggregate and calibrate it as often as required. Do not exceed eight percent moisture content of the fine aggregate. Arrange the sensing element so the measurement is made near the batcher charging gate of the sand bin or in the sand batcher.
- d. Scales - Provide adequate facilities for the accurate measurement and control of each of the materials entering each batch of concrete. Conform to the applicable requirements of National Bureau of Standards, Handbook 44, "Specifications, Tolerances and Other Technical Requirements for Commercial Weighing and Measuring Devices," for the accuracy of the weighing equipment. Provide each weighing unit with a visual springless dial or electronic readout which will indicate the scale load at all stages of the weighing operation or include a beam scale with a beam balance indicator which will show the scale in balance at zero load and at any beam

setting. Provide an indicator having an over and under travel equal to at least five percent of the capacity of the beam. Provide standard test weights and any other auxiliary equipment for checking the operating performance of each scale or other measuring device. Make periodic tests in the presence of the District or its designee in a manner and at intervals as directed. Upon completion of each check test and before further use of indicating, recording or control devices, the concrete supplier shall make such adjustments, repairs or replacements as required to secure satisfactory performance.

e. Recorders

- 1) Provide an accurate graphical or digital print-out record of the scale readings after each of the aggregates, water, cement and admixtures, if any, including zero initial readings have been batched prior to delivery to the mixer using an accurate recorder or recorders.
- 2) Record water - Show on each printout, the date and time of batching; identification number should be identical to that of the concrete ticket and codes for the mix design and for the contract Section.
- 3) House each recorder in a locked, dust-tight cabinet.
- 4) Clearly indicate the different types of mixes used by stamped letters, numerals, colored ink or other suitable means on the charts or tapes that variations in batch weights of each type of mix can be readily observed.
 - a) Show on the charts or tapes, date and time of day (stamped or preprinted) at intervals of not more than 15 minutes.
 - b) Provide recorders of a type that prints the required information in duplicate. One copy of the recorded batch weights for each load shall accompany each delivery ticket as supplied by the producer. Verify that the identification number is identical to that of the concrete delivery ticket. Deliver one copy with its corresponding concrete ticket to the District or its designee at the time and site of concrete placement.

5) Place the recorders in a position convenient for observation by the plant operator and the District or its designee.

f. Protect weighing, indicating and control equipment against exposure to dust and weather and insulate against vibration or movement caused by operating equipment in the plant.

2. Aggregates

a. Coarse aggregate - Sample and test coarse aggregate in accordance with methods prescribed in ASTM C33.

1) Deleterious Substance - Do not allow the amount of deleterious substance present in coarse aggregate to be in excess of the following percentages by weight.

<u>SUBSTANCE</u>	<u>MAXIMUM PERCENT BY WEIGHT</u>
Soft particles	5.0
Coal and lignite particles	0.5
Friable particles	0.25
Material passing a No. 200 sieve	1.5
Thin or elongated pieces (length greater than five times the smallest dimensions of a circumscribing rectangular prism)	15.0
Other deleterious substances	1.0

2) Abrasion - Not to exceed 52 percent of wear when the coarse aggregate is tested in accordance with ASTM C131 or ASTM C535 based on 500 revolutions.

3) Soundness - Not to exceed 15 percent of the weighted percentage of loss when the coarse aggregate is subjected to five cycles of the magnesium sulphate soundness test in accordance with ASTM C88.

4) Provide coarse aggregate from a source with gradations in accordance with Table Two, ASTM C33 and represented by a smooth gradation curve within the required limits.

- 5) Course aggregates of different gradations and identical sources may be combined provided the corresponding concrete mix has been accepted by the District or its designee. The use of alternate batches of gravel, crushed gravel or crushed stone of one size will not be permitted.
- 6) Blend uniform, consistent percentages of crushed rock and gravel.

b. Fine Aggregate

- 1) Sample and test the fine aggregates in accordance with the methods prescribed in ASTM C33. Do not mix or store fine aggregate from different sources of supply in the same pile or used alternately in the same class of construction mix.
- 2) Provide fine aggregate gradation represented by a smooth granulometric curve within the limits specified, using U.S. standard sieves, square openings.

<u>SIEVE SIZE</u>	<u>PERCENT PASSING BY WEIGHT</u>
3/8 inch	100
No. 4	95-100
No. 8	80-100
No. 16	50-85
No. 30	25-60
No. 50	10-30
No. 100	2-10
No. 200	0-5

- 3) Soundness - Do not exceed 12 percent by weight of the weighted percentage of loss when the fine aggregate is subjected to five cycles of the magnesium sulphate soundness test in accordance with ASTM C88.
- 4) Deleterious Substances - Do not allow the following substances to be present individually in amounts exceeding the following percentage by weight.

<u>SUBSTANCE</u>	<u>MAXIMUM PERCENT BY WEIGHT</u>
Friable particles	1.0
Coal and lignite	0.5
Material passing the No. 200 sieve	0.5

Other deleterious substances
(such as shale, alkali, mica,
coated grains, soft and flaky
particles)

2.0

- 5) Organic Impurities - Provide fine aggregate free from injurious amounts of organic impurities as determined by ASTM C40. Should material fail to pass the test for organic impurities in sand for concrete, it will be acceptable after passing test described in ASTM C87. If at any time the fine aggregate shows by the colorimetric test a darker color than that of the sample originally approved for the Work, withhold its use until tests satisfactory to the District or its designee have been made to determine whether the change in color is indicative of an injurious amount of deleterious substances.

E. Equipment - Conforming to the requirements of ASTM C94.

F. Reference Standards

1. American Association of State Highway and Transportation Officials (AASHTO) - T199, air Content of Freshly-Mixed Concrete by the Chace Indicator.
2. American Concrete Institute (ACI):
 - a. 211.1, Recommended Practice for Selecting Proportions for Normal Weight Concrete.
 - b. 211.2, Recommended Practice for Selecting Proportions for Structural Lightweight Concrete.
 - c. 318, Building Code Requirements for Reinforced Concrete.
 - d. 523, Guide for Low Density Concrete.
2. American Society for Testing and Materials (ASTM)
 - a. C31, Making and Curing Concrete Test Cylinders in the Field.
 - b. C33, Concrete Aggregates.
 - c. C39, Compressive Strength of Cylindrical Concrete Specimens.
 - d. C94, Ready-mixed Concrete.
 - e. C143, Slump of Portland Cement Concrete.
 - f. C150, Portland Cement.

- g. C173, Air Content of Freshly Mixed Concrete by the Volumetric Method.
- h. C177, Steady-state Thermal Transmission Properties by Means of the Guarded Hot Plate Method.
- i. C260, Air-entraining Admixtures for Concrete.
- j. C330, Lightweight Aggregates for Structural Concrete.
- k. C332, Lightweight Aggregates for Insulating Concrete.
- l. C470, Molds for Forming Concrete Test Cylinders.
- m. C494, Chemical Admixtures for Concrete.
- n. C618, Fly Ash or Natural Pozzolans for Use as a Mineral Admixture in Portland Cement Concrete.
- o. E-1, ASTM Thermometers

1.3 SUBMITTALS

- A. Refer to Section 01300, Submittals, for submittal procedures.
- B. Mix design for each concrete class and for each change of ingredients and ingredient sources; including admixtures.
- C. Methods for cold and hot weather mixing. Use methods capable of producing concrete with a temperature not more than 90°F or less than 55°F at the time of placement.
- D. Certifications by the concrete supplier of conformance of concrete ingredients to the specified requirements.
- E. Certifications by the concrete supplier of design mixes to specified requirements in respect to strength, unit weight, maximum size aggregate, air entrainment, slump, and water cement ratio.
- F. Copy of recorder printout with its corresponding concrete delivery ticket.

1.4 PRODUCT DELIVERY, STORAGE AND HANDLINGS

- A. Deliver packaged materials in manufacturer's original, unopened containers bearing manufacturer's name and brand.
- B. Load, transport, handle, store and batch concrete materials in a manner that will ensure that materials are not

contaminated, unclean, segregated or affected in any way that will damage the final finish.

- C. If bagged cement is used, store cement on raised platforms in a dry area. Use bagged cement on the basis of first received, first used. Do not store bagged cement over six months.
- D. Store cement in weather-tight enclosures and protect against dampness and contamination.
- E. Stockpile aggregates to prevent segregation or contamination with other materials or other sizes of aggregate. Use only one supply source for each aggregate stockpile.
- F. Store admixtures to prevent contamination, evaporation or damage. Protect liquid admixtures from harmful temperature ranges.

- 1.5 TRANSPORTATION - Verify that each transit mix truck used for delivery of concrete to worksite has been satisfactorily inspected by the District or its designee as evidenced by his placing a District seal thereon. Seals on transit mix trucks will indicate that truck is acceptable in accordance with Sections 9 and 10 of ASTM C94. The District or its designee may remove seals from transit mix truck if it determines that condition of the truck, its mixing equipment, discharge mechanism, or other components are not conducive to the maintenance of the concrete transported therein; do not use that vehicle again on a District Contract until resealed by the District or its designee.
- 1.6 MEASUREMENT -The Work of this Section will be measured as a unit, acceptably performed.
- 1.7 PAYMENT - The Work of this Section will be paid for as part of the Contract unit price for the particular concrete incorporated in the Contract.

PART 2 - PRODUCTS

2.1 CONCRETE

- A. Portland Cement - Conforming to the requirement of ASTM C150 Type V, with additives.
- B. Aggregates for Normal Weight Concrete - ACI 318, Article 3.3, except those for encasing ductwork or conduit shall be Gradation 7.
- C. Aggregates for Lightweight Structural Concrete
 - 1. Fine aggregate - ASTM C330 or ASTM C33.

- 2. Coarse aggregate - ASTM C330.
 - D. Aggregates for Insulating Concrete
 - 1. Fine aggregate - ASTM C332 or ASTM C33.
 - 2. Coarse aggregate - ASTM C332.
 - E. Aggregates for Lean Concrete - ASTM C33.
 - F. Water - Free from substance which would interfere with chemical action by which concrete is formed, detract from concrete strength and durability, cause variations of concrete color, or cause a combination of such defects. Chloride concentration shall not exceed 200 ppm.
- 2.2 ADMIXTURES - If permitted by the District or its designee, free of chlorides and alkalines.
- A. Air Entraining Agents - ASTM C260.
 - B. High range water reducers, retarders, accelerators, water reducer/retarders, and water reducer/accelerators conforming to ASTM C494..
 - C. Fly Ash - ASTM C618
- 2.3 EQUIPMENT
- A. Standard slump cone and tamping rod specified in ASTM C143.
 - B. Chace air indicator kit conforming to AASHTO-T-199, or approved equal, for determining air content of freshly-mixed concrete.
 - C. Thermometer registering in a range between 36.5°F and 107.5°F conforming to ASTM E1 thermometer number 33F.
 - D. Storage box for simultaneously curing 30 test specimens. Maintain temperature of cylinders between 68°F and 75°F and prevent loss of moisture. Equip storage box with maximum-minimum registering thermometer and locking system, acceptable to the District or its designee, with three keys. Deliver keys to the District or its designee.
 - E. Three molds, conforming to ASTM C470 for casting test specimens in accordance with ASTM C31, for each 100 cubic yards, and fractions thereof, of each class of concrete, and for daily pours of less than 100 cubic yards of concrete.

PART 3 - EXECUTION

3.1 INSPECTION

- A. Verify that aggregates from different sources are not mixed, except as required to satisfy the accepted mix design.
- B. Verify that mix designs and sources of aggregates are not changed without written acceptance by the District or its designee.
- C. Verify that aggregate mixtures have not become segregated.

3.2 TEMPERATURE CONTROL

- A. Verify that aggregates are prepared by methods which produce concrete having a temperature of not more than 90°F and not less than 50°F at the time of placement.
- B. Cool concrete ingredients only if ambient air temperature becomes warmer than 85°F; heat and cool ingredients only by methods acceptable to the District or its designee.

3.3 PROPORTIONING - Verify that concrete ingredients are proportioned in conformance with the established mix design, as accepted by the District or its designee, for the particular strength class and usage.

3.4 MEASURING, BATCH PLANT, MIXERS AND AGITATORS, MIXING, AND DELIVERY - Verify that ASTM C94, Sections 7, 8, 9, and 10 are satisfied by concrete supplier.

3.5 ADMIXTURES - Verify that admixtures are dispensed for each batch from a dispenser having capacity to measure the quantity required for one batch.

3.6 FIELD QUALITY CONTROL. Permit the District or its designee to take concrete for molding test specimens at points of delivery of concrete to worksite, for testing in accordance with ASTM C39 and ASTM C94 (Section 16).

END OF SECTION

SECTION 03410

NON-TENSIONED PRECAST CONCRETE

PART 1 - GENERAL

1.1 DESCRIPTION - The Work specified in this Section consists of furnishing and installing non-tensioned precast concrete as indicated, and of designing and testing concrete mixes therefor.

1.2 QUALITY ASSURANCE

A. Fabricator Qualifications

1. Provide a fabricator having experience in casting non-tensioned concrete members, similar to those specified, as a major part of fabricator's Work.
2. Provide experienced personnel, equipped with adequate physical facilities, operating under established quality control procedures, and at required rate of delivery.

B. Erector Qualifications - Regularly engaged in erecting non-tensioned precast concrete members similar to those specified.

C. Qualifications of Welders and Tackers - Comply with AWS D1.1 and D1.4.

D. Concrete Mix Design Criteria - Section 03301, Portland Cement Concrete.

E. Form Design - PCI MNL 117, Division V, Section 2. Face of casting shall be not thinner than one inch nor 1 1/2 times the maximum aggregate size, whichever is the larger, except as indicated on the Contract Drawings.

F. Lifting Device Criteria - PCI MNL 117, Division IV, Article 4.24.

G. Tolerances, General - Conform to recommendations of following articles of PCI MNL 117.

1. Article 2.3.1, Tolerance for Finished Product.
2. Article 6.2.4, Tolerances for Erection.

H. Tolerances, Light-Fixture Bollard Bases

1. Length: +/-1/2 inch
2. Width: +/-1/4 inch
3. Depth: +/-1/4 inch
4. Squareness of ends (Vertical and Horizontal Alignment): +/-1/4 inch

I. Source Quality Control - Conform to Section 03347 Exposed Finish Concrete.

1. Fabricating, testing, and identifying procedures - Precast concrete fabricator shall comply manufacturing and testing procedures stipulated in PCI MNL 117, Division II.
2. Test castings - Cast at least two full-size castings of each type and size indicated.
 - a. Cast test castings to simulate a production run, incorporating reinforcing and other embedded items.
 - b. Have completed and finished test castings inspected by the District or its designee to determine castings' acceptability.
 - c. Maintain a complete record of proportions, mixing, consolidating, and curing procedures.
 - d. Retain at least one test unit, of a lot having a particular architectural finish, at the casting plant until entire lot of castings having that finish has been accepted and delivered to worksite. Accepted finished mock-ups maintained at the casting plant may be considered as accepted production run casting. Each test casting installed in the Work shall be identified in accordance with PCI MNL 117, Article 2.2.3, Record Keeping.
3. Inspection - Inspect production runs; ensure that castings conform to specified requirements.
4. Test reports - Precast concrete fabricator shall maintain records, for inspection by the District or its designee, in accordance with PCI 117, Articles 2.2.3 and 2.2.4, and Appendix C.
5. Casting Plant Precautions - Comply with environmental requirements specified in Section 03300, Cast-in-Place Concrete.
6. Verify that castings have attained their specified 28-day strength as determined in accordance with Section 03301, Portland Cement Concrete.

J. Concrete Testing

1. Make one compression test at 28 days for each day's production of each type of concrete.
2. Specimens
 - a. Provide two test specimens for each compression test.
 - b. Obtain concrete for specimens from actual production batch.
3. Match finishes on accepted job mock-up.

K. Reference Standards

1. American Society for Testing and Materials (ASTM)
 - a. A27, Mild- to Medium-Strength Carbon-Steel Castings for General Application.
 - b. A36, Structural Steel.
 - c. A97, Malleable Iron Casting.
 - d. A123, Zinc (Hot-Galvanized) Coatings on Products Fabricated from Rolled, Pressed, and Forged Steel Shapes, Bars, and Strip.
 - e. A167, Stainless and Heat-Resisting Chromium-Nickel Steel Plate, Sheet, and Strip.
 - f. A615, Deformed and Plain Billet-Steel Bars for Concrete Reinforcement.
 - g. A675, Requirements for Steel Bars and Bar Size Shapes, Carbon, Hot-Rolled, Special Quality Subject to Mechanical Property Requirements.
 - h. C31, Making and Curing Concrete Test Specimens in the Field.
 - i. C185, Air Content of Hydraulic Cement Mortar.
 - j. C330, Lightweight Aggregates for Structural Concrete.
 - k. C509, Cellular Elastomeric Preformed Gasket and Sealing Material.
 - l. C881, Epoxy-Resin-Base Bonding Systems for Concrete.

2. American Welding Society

- a. AWS D1.1 - Structural Welding Code
- b. AWS D1.4 - Structural Welding Code - Reinforcing Steel

3. Federal Specifications (FS) - QQ-C-40, Calking - Lead Wool and Lead Pig.

4. Precast Concrete Institute Manual (PCI) - MNL-117- Manual for Quality Control for Plant and Production of Architectural Precast Concrete Products.

1.3 SUBMITTALS

A. Refer to Section 01300 for submittal procedures.

- c. Six inch by 12 inch or four inch by eight inch concrete test cylinders, in accordance with ASTM C31.

A. Shop drawings, product data, and manufacturers' literature - Indicate dimensions; design, reinforcement; welds; radius of corners; lifting positions or devices; and details of lifting inserts, anchors, connections, accessories, joints, shim arrangement, conduits, pipe sleeves, reglets, recesses, penetrations, openings and similar configurations required for civil, structural, architectural, mechanical, electrical, and other Work. Submit installation instructions.

B. Working Drawings - Submit erection drawings and procedures. Indicate method and sequence of operations and location of precast sections in the Work with same identification marks used in fabrication.

C. Certificates and Reports - Submit reports of concrete tests, and fabricator's certificates of material compliance with specifications.

D. Samples of each type finish, adequate in size to show range of color and texture, typical joints, inserts, finished edges and corners.

E. 50 pounds of selected coarse aggregate for exposed aggregate surfaces of light-fixture bollard bases.

1.4 PRODUCT DELIVERY, STORAGE, AND HANDLING - Conform to recommendations of PCI 117, as follows:

A. Handling Equipment - Division III, Article 3.3.6.

B. Storage Area - Division III, Section 4.

- C. Handling and Lifting Devices for Reinforcement - Division IV, Article 4.2.4.
- D. Transporting, Handling, Loading, and Delivery - Division VI, Article 6.2.1 and Article 6.2.2.
 - 1. Lift, support, and erect castings in a manner which will prevent damage and overstressing. Handle castings by means of lifting inserts.
 - 2. Level, align, and temporarily brace castings securely in position.
 - 3. After erection, remove lifting inserts to a depth of 3/4 inch inwards from surface of concrete.
 - 4. Plug resulting hole with stiff mortar which matches color and finish of casting.

1.5 JOB CONDITIONS

- A. Maintain clear, well-drained unloading areas and road access around and in the area to a degree that precast concrete hauling and erection equipment will be able to operate under their own power.
- B. Erect barricades, warning lights, and signs in a manner which will safeguard traffic in immediate area of hoisting and handling operations.
- C. Remove mortar, plaster, grout, and other construction droppings before they harden.
- D. Protect castings from being stained by adjacent construction operations.
- E. Protect adjacent surfaces from welding operations.
- F. Perform masonry Work only if ambient temperature is warmer than 40°F and only during dry weather.

1.6 MEASUREMENT - The Work of this Section will be measured as a unit acceptably performed.

1.7 PAYMENT will be made under:

Item No. 04000.01 - Masonry - per lump sum.

- A. Work of this Section, which is not indicated to receive an Architectural finish, will be paid for as part of the Contract Unit Price for the concrete involved.

PART 2 - PRODUCTS

2.1 MATERIALS

- A. Concrete Reinforcement - ASTM A615.
- B. Concrete Formwork - PCI 117 Division V Section 2, Article 5.2.1.
- C. Gaskets - Preformed, firm, cellular, neoprene conforming to ASTM C509, sized to be under constant compression at the joints, and manufactured in those lengths which will either minimize or eliminate field splices.
- D. Anchors and Inserts.
 - 1. Completely encased anchors - ASTM A675 Grade 65 Hot-Dip galvanized in accordance with ASTM A123.
 - 2. Steel clip anchors - ASTM A36 Hot dip galvanized in accordance with ASTM A123.
 - 3. Steel plate - ASTM A283 Grades A,B,C, or D Hot Dip Galvanized in accordance with ASTM D123.
 - 4. Cast-steel casting clamps - ASTM A27, Grades 32510 or 35018, hot-dip galvanized in accordance with ASTM A123.
 - 5. Stainless steel joint connections - ASTM A167, Type 304.
 - 6. Malleable iron castings - ASTM A47, Grades 32510 and 35018.
- E. Lifting Inserts - As indicated on accepted working drawings.
- F. Forming Materials.
 - 1. Precast structural units - PCI 117, Division V, Section 2.
 - 2. Lining - PCI 117, Division V, Section 2.
- G. Form Release Agent - Synthetic resin or organic compound containing no wax, oil, silicates or varnish, and compatible with specified coatings, sealants, contact surfaces of forming materials, fresh concrete, curing process, and adhesives to be applied to wall panels.
- H. Surface Sealers - Acrylic or epoxy resin sealing compound which neither peels nor affects color of concrete, has low viscosity surface penetration, is non-absorbent,

colorless, non-glossy, and water-repellent, and acts as a permanent barrier to moisture.

- I. Shims - Nylon, lead, or PVC.
- J. Calking - lead, FS QQ-C-40, Type II, Grade C.
- K. Welding Materials - AWS D1.1 and AWS D1.4 as applicable.
- L. Aggregates.
 - 1. For normal weight concrete
 - a. Fine aggregate - Section 03301, Portland Cement Concrete.
 - b. Coarse aggregate - Section 03301, Portland Cement Concrete.
 - c. Maximum size - Conform to ACI 318 article 3.3.
 - 2. For lightweight structural concrete
 - a. Fine aggregate - ASTM C33.
 - b. Low density filler - ASTM C330.
 - c. Nominal density - Weight not more than 110 pounds per cubic foot at 28 days.
- M. Additional requirements for bollard bases.
 - 1. Cement - ASTM C150, Type I, White.
 - 2. Fine aggregate - Clean, hard, strong, durable, natural, and well-graded, with 15 to 30 percent passing a No. 50 sieve.
 - 3. Coarse aggregate - Hard, durable, uncoated, crushed stone (quartz or granite), uniform in size, range 1/4 inch to 3/8 inch, surface dry, and spherical or near-cubical shaped for adequate embedment in the concrete.
 - 4. Water - Potable and free from impurities harmful to concrete, reinforcement and inserts.
 - 5. Air Entraining Admixture - ASTM C260.
 - 6. Retarder - Form type Control Set conforming to ASTM C494 and equal to ANTI HYDRO specification 8-8B, Preco Industries Ltd. Hi-V Retarder, or acceptable equal.
 - 7. Formwork - Concrete mold, slightly tapered to facilitate removal of casting, having a casting surface free from flaws and defects.

8. Form Sealer - Preco Industries Ltd., Form Cote Sealer or acceptable equal.

9. Concrete

- a. 5000 psi at 28 days.
- b. Slump - Preferably one inch but not more than three inches.
- c. Air entrainment - Adequate for workability.
- d. Cement - six bags per cubic yard.
- e. Mix - one part cement, one part sand, three parts coarse aggregate, or as required to obtain desired finish.

2.2 MIXES

- A. Water-cement ratio - Not more than 40 pounds of water to 100 pounds of cement.
- B. Air Entrainment - Neither less than 16 percent nor more than 22 percent entrained air in standard 1 to 4 sand mortar ratio when tested in accordance with ASTM C185.
- C. Coloring Agent - No effect on concrete, but not more than ten percent of cement weight.
- D. Six inch by 12 inch cylinder 28 day Compressive Strength - Not less than 5000 psi when tested.
- E. Water-cement and cement-aggregate ratios of face and back-up mixes shall be similar.

2.3 GROUT

- A. Cement Grout - Portland cement, sand, and water sufficient for placement and hydration.
- B. Nonshrink Grout - Premixed, packaged ferrous and non-ferrous aggregate, shrink-resistant.
- C. Epoxy-resin Grout - Two-component, mineral-filled, epoxy-resin conforming to ASTM C-881 of the Type, Grade and Class required for the specific application.

2.4 FABRICATION

- A. Formwork - Conform to accepted working drawings.
- B. Molds - Conform to accepted working drawings and PCI MNL 117, Division V, Section 2.
 - 1. Before placing concrete, scrupulously clean molds and coat with form release agent.

2. Fabricate molds in a manner which will result in molds' surfaces which will contact fresh concrete being smooth and having no irregularities and discernable joint marks.
- C. Concrete Reinforcement - PCI MNL 117, Division V, Section 3.
- D. Embedments - PCI MNL 117, Division, Section 4.
- E. Lifting Devices - Conform to accepted working drawings.
- F. Placing and Consolidating Concrete - PCI MNL 117, Division V, Section 5.
- G. Finishes - Provide exposed face matching accepted samples of mock-up panel.
1. Smooth finish - As-cast using flat smooth nonporous molds.
 2. Textured finish
 - a. Achieve finish on face surface of castings with form liners applied to inside of forms.
 - b. Distress finish by breaking-off portion of face of each flute.
 - c. Alternately strike opposite sides of flutes in a manner which will produce uniform cleavage.
 3. Sandblasted finish - Sandblast away 1/16th inch of cement-sand matrix to expose aggregate face.
 4. Honed or polished finish - Mechanically polish surface with fine grit, fill surface holes, and rub.
 5. Veneer-faced finish
 - a. Cast concrete over ceramic tile, brick, or cut stone placed in bottom of mold.
 - b. Mechanically connect cut stone face material to concrete.
 - c. Smooth float finish back surface of precast concrete units after striking surface flush to form finish lines.
 6. Light-reveal exposed aggregate - Produced by applying retarder to properly sealed form surfaces, for light-fixture bollard bases.

H. Curing

1. Methods other than steam - Section 03300, Cast-in-Place Concrete.
2. Steam curing - Conform to PCI MNL 116, Division II, except disregard Section 2.4.2 Steam Curing.
 - a. Keep concrete continuously covered for not less than 24 hours after casting.
 - b. Initial curing - Maintain temperature of concrete at its placement temperature, but not warmer than 100°F, until concrete has developed its final set but not less than two hours after casting has been completed.
 - c. Final curing - Allow concrete temperature to increase, in increments of not more than 25°F per hour, to not warmer than 150°F; maintain that temperature until concrete has developed indicated design strength.
 - d. Cooling - Cool concrete gradually, at a rate of not more than 20°F per hour.
 - e. Protection - After removing castings from casting bed, or mold, prohibit castings from cooling at a rate faster than 20°F per hour.

I. Identifying Castings

1. Mark each casting to correspond to identification mark on shop drawings for casting location.
2. Mark each casting with date cast.

PART 3 - EXECUTION

3.1 INSPECTION

- A. Verify that structure and anchorage inserts have been placed.
- B. Verify that bearing surfaces for castings are smooth and level.

3.2 PREPARATION

- A. Thoroughly scrub surface, which will bear castings, with detergent, clean water, stiff fiber brushes, and sponges immediately before installing castings.

B. Provide concrete foundations with anchor bolts and stainless steel mounting plate to receive light-fixture bollard bases. Coordinate size and location.

3.3 ERECTION

A. Architectural Wall Panels

1. Set panels dry and without mortar; attain specified joint dimension with concealed spacing shims. Place shims in accordance with accepted working drawings.
2. Fasten panels in place by bolting or welding, or both. Protect panels and adjacent surfaces from damage caused by construction activities.
3. Either tack-weld nut to bolt, tack-weld nut to square washer which has been restrained by 1/4 inch square keeper bar, or otherwise secure nuts to prevent loosening under future loading or use condition.
4. Use temporary erection anchorage device for handling panels in-place while panel anchorage system is being welded.
5. Clean field welds with wire brush and coat materials, other than stainless steel, with same material used for shop coat or, if galvanized, with zinc-rich coating.
6. Remove shims and spacers from joints of non-load bearing panels after fastening but before applying sealant.

B. Horizontal Structural Members

1. Adjust differential camber between members to within specified tolerance before making final connection.
2. Grout members in-place and seal joints with specified joint filler compound.

C. Light-Fixture Bollard Bases

1. Following curing and removal from the mold, remove the cure retarded matrix with high pressure water spray to expose approximately 1/8 inch of aggregate to match the accepted sample.
2. Remove loose aggregate and patch in manner and appearance acceptable to the District and its designee.

3.4 ADJUSTING - Correct castings which do not conform to specified requirements.

118A: Prepare surface to be patched with bonding agent.

- B. If District or its designee has given written permission to repair damage by patching, repair coatings in accordance with PCI MNL 117, Division II, Section 4, to the extent that cured patching will be indistinguishable from surrounding surface.

3.5 CLEANING

- A. Clean installed castings with detergent, water, fiber brush, and sponge, and rinse castings thoroughly with clean water.
- B. Remove stubborn stains with acid, but only after more conservative methods have been unsuccessful; thoroughly rinse casting with clean water.

END OF SECTION

SCRTD 1985 .C66 T726

Southern California Rapid
Transit District 44562

Contract specifications,
trackwork installation



MTA LIBRARY