

27316933

CIVIL SPEED LIMITS

On

HORIZONTAL AND VERTICAL CURVES

The preparation of this document has been financed in part through a grant from the U.S. Department of Transportation, Urban Mass Transportation Administration, under the Urban Mass Transportation Act of 1964, as amended, the State of California, and the Los Angeles County Transportation Commission.

Metro Rail Transit Consultants
DMJM/PBQD/KE/HWA
October 1986

TABLE OF CONTENTS

	<u>Page</u>
EXECUTIVE SUMMARY	i
1. REPORT OBJECTIVE	1
2. REASONS FOR SPEED LIMITS ON CURVES	2
3. SPEED REGULATION	3
4. HORIZONTAL CURVES	5
4.1 Curve Components and Superelevation	5
4.2 Passenger Comfort and Acceleration in 'g's	6
4.3 Metro Rail Criteria for Superelevation	8
4.4 Spirals	8
4.5 Metro Rail Criteria for Spirals	9
4.6 Horizontal Curve Criteria Revisions	10
4.7 Horizontal Curve Recommendations	13
5. VERTICAL CURVES	15
5.1 Vertical Curve Length and Acceleration	16
5.2 Methodology of Calculating Acceleration on Vertical Curves	17
5.3 Vertical Curve Criteria Revisions	17
5.4 Vertical Curve Recommendations	20
6. CONCLUSIONS AND RECOMMENDATIONS	21
6.1 Conclusions	21
6.2 Recommendations	22
7. REFERENCES	25
Appendixes	
Appendix A - Metro Rail Design Criteria for Superelevation, Spirals, and Vertical Curves	
Appendix B - Derivation of Superelevation Formula	
Appendix C - Spiral Length Criteria of Various Properties	
Appendix D - Derivation of Spiral Length Formula $L_s = 1.17E_a V$	
Appendix E - Calculation of Jerk, Derivation of Jerk Formula	
Appendix F - Derivation of Spiral Length Formula $L_s = 0.99E_u V$	
Appendix G - Vertical Curve Criteria of Various Properties	

LIST OF FIGURES

	<u>Page</u>
Figure 1 - Geometric Relationships of Transit Vehicle on Superelevated Curve	6a
Figure 2 - Proposed Changes to Figure II-1-3	14
Figure 3 - Required Vertical Curve Length vs. Change in Grade for Design Speeds 40 mph - 70 mph for L.A. Metro Rail	17a
Figure 4 - L.A. Metro Rail Vertical Acceleration Levels as a Function of Change in Grade	19a

EXECUTIVE SUMMARY

This report examines the civil design criteria of Volume II, Section 1, of the Metro Rail System Design Criteria and Standards to determine the feasibility of increasing the minimum design speed along the 18-mile Starter Line to 45 mph (from 40 mph). The impact on passenger comfort resulting from the lateral acceleration on horizontal curves and vertical acceleration on vertical curves is the primary consideration.

Most curves in the currently defined 18-mile system already have a minimum design speed of 45 mph. However, two horizontal curves have a maximum design speed limit of 40 mph. Curves located in the designated CORE (Congressionally Ordered Re-engineering) study area are excluded from this report, since redesign of the route alignment and profile in this region is imminent.

This report recommends minor revisions to horizontal and vertical curve criteria, to be applied to the current and future system design. An absolute minimum spiral curve length criterion is proposed to be added, which is consistent with industry standards for passenger comfort. Application of this new criterion permits a design speed increase to 45 mph on the two horizontal curves currently having a design speed of 40 mph. One of these curves is located in MOS-1. No trackwork or alignment design changes are required, except to show a design speed of 45 mph where 40 mph is currently listed on the contract drawings.

All vertical curves have a minimum design speed of 45 mph. Application of the criterion of Section 1.5.3.A.1 (minimum desired vertical curve length), or proposed criterion of Section 1.5.3.A.2 (absolute minimum vertical curve length) for design speeds under 60 mph, ensures that passenger comfort standards are maintained.

Stated simply, the minimum civil design speed limit on the entire alignment can be increased from 40 mph to 45 mph, without any design changes to existing curves, and without exceeding industry standards for passenger comfort.

Section 1

REPORT OBJECTIVE

This report examines the basis of selected Metro Rail civil design criteria relating to horizontal and vertical curves, to determine the potential of raising the minimum required design speed on the route alignment. Metro Rail civil criteria currently require a minimum design speed of 40 mph. It is proposed that this speed be raised to 45 mph if the impacts on passenger comfort and safety are not significantly affected.

Section 2

REASONS FOR SPEED LIMITS ON CURVES

Civil speed limits on horizontal and vertical curves are established primarily to maintain vehicle stability and passenger comfort. A secondary benefit of imposing speed limits for passenger comfort is the avoidance of excessive rail and vehicle wheel wear.

On horizontal curves, passenger comfort is maintained by limiting the lateral acceleration (and force) which acts radially outward from the center of track curvature. Similarly, limiting vertical acceleration maintains passenger comfort on vertical curves. Where both horizontal and vertical curves are located in the same area, both accelerations need to be controlled to ensure passenger comfort.

Maintaining acceptable passenger comfort is much more restrictive in terms of allowable speeds on horizontal and vertical curves than maintaining vehicle stability. Therefore, passenger comfort is the controlling speed criterion and satisfying it ensures adequate vehicle stability and safety.

Section 3

SPEED REGULATION

The civil speed limit governs the maximum allowable train speed on curves in both Automatic Train Operation (ATO) and Manual Train Operation (MTO). The ability of trains to stay below the speed limit is controlled differently but enforced similarly in the two modes of operation.

In ATO, Automatic Speed Regulation (ASR) is achieved with two P-signal generators on each train. The primary function of ASR is to regulate train speed below the Automatic Train Protection (ATP) speed limit. The ATP speed limit is the maximum train speed enforced by the ATP system. Eight ATP speed codes are planned which will serve as the ATP speed limits: 0, 8 (coast), 9, 25, 40, 45, 55, and 70 mph. These ATP speed codes have been established to correspond most nearly to the planned civil speed limits on the alignment. The ASR equipment is designed to regulate actual maximum train speed to three mph lower than the ATP speed limit, with a tolerance of ± 2 mph, for ATP speed limits above 25 mph. For example, with a 45 mph ATP speed limit, the ASR equipment will regulate actual train speed to 42 mph ± 2 mph, or between 40 and 44 mph. A failure of the ASR equipment is protected by the ATP system by the issuance of a service brake command in response to an overspeed condition. As added protection, a brake assurance command will initiate emergency braking if the non-vital service brake command does not function properly.

In MTO, the train operator has the responsibility of maintaining train speed below the ATP speed limit via the manual controller. For example, in an area of track with a 45 mph ATP speed limit, the train operator controls train speed up to 45 mph. If the

operator causes the train to exceed the ATP speed limit, the ATP system responds the same way it does in ATO. Automatic service braking at a nominal rate of 2.2 mphps will begin. Vehicle cab equipment will give visual and (in MTO only) audible indication of an overspeed condition. Two scenarios are then possible. The first scenario is that the train operator, in response to the indication of overspeed condition, will follow operating procedures and move the manual controller to the brake position within an allotted three second interval. This will prevent the train from coming to an irretrievable service brake stop. Service braking will continue until the train speed drops below the ATP speed limit, when the train operator can resume normal manual train operation. The second scenario is that the train operator does not move the manual controller to the brake position within three seconds of overspeed indication, which then causes an irretrievable service brake stop. Finally, a brake assurance command initiating emergency braking will occur if the non-vital service brake command does not function properly, just as it would in ATO.

Section 4

HORIZONTAL CURVES

4.1 CURVE COMPONENTS AND SUPERELEVATION

Horizontal curves in transit alignments typically consist of a circular curve connected at both ends to a spiral curve. The circular curve has a constant radius of curve, whereas the spiral curve has a varying radius of curve, which provides a gradual transition to or from tangent track. The track is usually superelevated (the outer rail is situated higher than the inner rail) on horizontal curves to minimize both the lateral acceleration experienced by the patron and the lateral forces exerted by the train wheels on the outer rail.

A limit is placed on the amount of actual track superelevation to be constructed (known as E_a) to prevent excessive forces on the inner rail and to minimize passenger discomfort when trains travel slower than the design speed. Vehicle/tunnel clearances and construction costs are additional reasons for limiting E_a . If E_a equals the total superelevation required (E_r) on a curve, an equilibrium state exists whereby the forces exerted by the train wheels on both the inner and outer rails are equal at the design speed.

Attaining relatively high speeds on curves with short radius usually requires some actual track superelevation since required superelevation is inversely proportional to the radius and directly proportional to the square of the train speed. Track superelevation required is often greater

than that allowed by criteria. In such cases, the difference between required superelevation and actual track superelevation, known as unbalanced superelevation (E_u), is limited to restrict lateral acceleration to acceptable levels. Limiting E_u is achieved in practice by establishing a speed limit on curves which is significantly lower than that for tangent (straight) track. This increases run time as well as associated labor and equipment costs. Thus, benefits accrue with higher civil speed limits.

4.2 PASSENGER COMFORT AND ACCELERATION IN g's

Two factors affect passenger comfort through horizontal curves: the lateral acceleration of the train, which is proportional to E_u (which itself is a function of the curve radius, train speed, and track superelevation); and the jerk (change in acceleration), which is a function of the spiral length and the total unbalanced superelevation. The following discussion describes this in more detail.

Acceleration on curves is commonly expressed in terms of "g," which is simply the gravitational constant (the acceleration of free-falling objects at sea level), 32.2 ft/sec². For example, a value of 0.1g refers to an acceleration of 3.22 ft/sec².

On superelevated curves, the acceleration identified as "lateral acceleration" is that component of acceleration which is parallel to the plane of the track, not to the horizontal. Figure 1 shows the geometric relationships on a superelevated curve. Lateral acceleration acts in the direction shown by A_1 . Based on the relationship between unbalanced superelevation and lateral acceleration (acceleration in

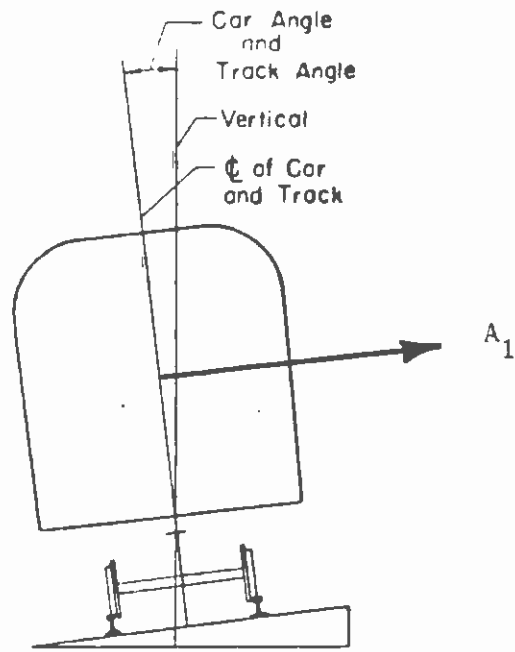

A_1 = Lateral Acceleration

FIGURE 1
 Geometric Relationships of Transit Vehicle
 on Superelevated Curves

in $g = 0.0167 E_u$),¹ the following acceleration (A_1) values would result on curves having the indicated unbalanced track conditions:

For $E_u = 3$ in.: $A_1 = 0.050 g = 1.6 \text{ ft/sec}^2$
For $E_u = 4\text{-}\frac{1}{2}$ in.: $A_1 = 0.075 g = 2.4 \text{ ft/sec}^2$
For $E_u = 6$ in.: $A_1 = 0.100 g = 3.2 \text{ ft/sec}^2$

Researchers have concluded from tests that 0.1 g is the maximum comfortable horizontal acceleration for rapid transit from a passenger comfort standpoint (Reference 1). This amount of acceleration results from an unbalanced superelevation of six inches. With a maximum vehicle roll contributing 1-1/2 inches of unbalanced superelevation, that leaves 4-1/2 inches of unbalanced superelevation that can be tolerated within recommended comfort levels. The latter represents the maximum value Metro Rail Design Criteria allows.

The effect of vehicle roll on lateral acceleration is discussed in Reference 1 (Pg. 142), which explains the relationship:

"The carbody assumes a position with respect to the vertical on curved track that is dependent on the elevation of the track, curvature, speed, and mechanical characteristics of the car. The principal effect of the (vehicle) roll is that at speeds greater than the equilibrium (design) speed, the direction of the roll is such that the carbody becomes more nearly vertical than the inclination the track gives to the (vehicle) trucks, and the effectiveness of the track elevation in reducing the centrifugal force on the passenger is impaired. The greater the angle of carbody roll, the less the

¹ Does not include effect of vehicle roll. Reference 1 contains this derivation.

effectiveness of the outer rail elevation in aiding passenger comfort."

4.3 METRO RAIL CRITERIA FOR SUPERELEVATION

The relevant civil design criteria on superelevation are contained in Volume II, Section 1.4.4.B, of the Metro Rail System Design Criteria and Standards, and are listed in Appendix A.

The formula listed in criterion 1.4.4.B.5 for determination of superelevation ($E_r = E_a + E_u = 4.011 \frac{V^2}{R}$ where V is design speed in mph and R is the radius of the curve in feet) is derived from an equilibrium force diagram of a rail vehicle traversing a superelevated curve, where the wheels bear equally on the inner and outer rails. Reference 2 contains this derivation.² Other properties have identical or similar criteria. Baltimore MTA and WMATA have identical criteria to Metro Rail, using the same formula of criterion Section 1.4.4.B.5. MARTA uses a similar formula requiring slightly less superelevation for a given speed and curve radius: $E_r = 3.96V^2/R$.

4.4 SPIRALS

The spiral portion of a horizontal curve provides a gradual buildup of actual superelevation from tangent to superelevated curve track. Its length influences the rate of change of lateral acceleration, or jerk. In addition, the buildup of superelevation per foot distance is limited to a prescribed value, which varies in the industry, to prevent excessive torsional and racking (bending) forces in the

² Included in Appendix B.

passenger vehicle. These forces result from one vehicle end being superelevated while the remaining one is still on tangent track.

The American Railway Engineering Association (AREA), which issues engineering standards for the railroads, concluded in a study (Reference 1) that the recommended maximum allowable jerk is 0.03 g/sec, based on tests involving passengers riding in trains on curved track. This conservative value was based on test data that indicated a jerk of 0.04 g/sec was acceptable, but to account for variability of test data, the recommended allowable rate was reduced by 25 percent. Based on the results of that study, this report defines the maximum desirable jerk limit as 0.03 g/sec, and the absolute maximum jerk limit as 0.04 g/sec.

4.5 METRO RAIL CRITERIA FOR SPIRALS

The relevant civil criteria on spirals are contained in Volume II, Section 1 of the Metro Rail System Design Criteria and Standards and are listed in Appendix A. Criteria of Baltimore MTA, MARTA, Miami Metro-Dade, and WMATA are listed in Appendix C.

Equation $L_s = 1.17 E_a V$ from Section 1.4.4.C.3 on Page II-1-6 of Design Criteria, is derived from the relationship of the longitudinal distance traveled by a rail vehicle's inner wheels along a spiral's inner rail during the time that the vertical superelevation height of the outer rail is climbed by the outer wheels. This is known as the "run-in" rate. Reference 2 recommends a maximum run-in rate of 1-1/4 inches/

second for speeds up to 60 mph, which results in the spiral formula, $L_s = 1.17 E_a V$. Reference 2 contains this derivation.³

The remaining Metro Rail formula, $L_s = 1.22 E_u V$ from Design Criteria Section 1.4.4.C.3, is found in the AREA Manual (Reference 3), which terms it a secondary formula to be used where site constraints would impose excessive construction costs on building a spiral whose length is determined by AREA's first equation, $L_s = 1.63 E_u V$. A survey of three rail transit properties (Baltimore MTA, MARTA, and Miami Metro Dade) reveals that none of them use this latter equation ($L_s = 1.63 E_u V$); instead allowing shorter spiral lengths than AREA's first equation.

The 100-foot minimum length in the Metro Rail criteria ensures a gradual transition even for relatively large radius curves. The Metro Rail spiral length criteria essentially limit the rate of superelevation buildup to 1-1/4 inches/second, and the jerk below 0.03 g/sec.⁴ Since a jerk up to 0.04 g/sec does not cause discomfort, the spiral criteria could be made more liberal without exceeding comfort standards.

4.6 HORIZONTAL CURVE CRITERIA REVISIONS

The two formulae used in the Metro Rail criteria for spiral length, $L_s = 1.17 E_a V$ and $L_s = 1.22 E_u V$ require relatively

³ Contained in Appendix D.

⁴ Appendix E contains discussion of jerk calculation.

long spirals. However, analysis shows that passenger comfort and safety can be maintained with shorter spirals.

The formula, $L_s = 1.17 E_a V$, is based on a maximum run-in rate (rate that a rail vehicle rises to maximum track superelevation height) of 1-1/4 inches of actual superelevation per second. This run-in rate is considered rather low and could be made higher (Reference 1). A British article written by Loach and Maycock of the Institution of Civil Engineers (Reference 6) noted the same point and recommended up to 2-1/4 inches per second as being acceptable. Based on this information, a more liberal spiral requirement is justified. A maximum allowable run-in rate of 1-1/2 inches superelevation per second allows shorter spirals than ones permitted by a run-in rate of 1-1/4 inches per second, and still maintains passenger comfort. This would be achieved by use of the formula $L_s = 0.98 E_a V$. This spiral length requirement is the same as the recommendation of the British report for curves with large superelevations.

The remaining formula, $L_s = 1.22 E_u V$, limits jerk below 0.03 g/sec and is based on a maximum allowable unbalanced superelevation of 4 inches. Since maximum acceptable jerk is 0.04 g/sec and Metro Rail allows a greater maximum unbalanced superelevation of 4-1/2 inches, the formula can be made more lenient without exceeding comfort criteria. The methodology contained in References 1 and 2 indicates a spiral length defined by $L_s = 0.99 E_u V$ is acceptable, based on a maximum allowable unbalanced superelevation of 4-1/2 inches.⁵

⁵ See Appendix F.

This allows a 19 percent reduction in required spiral length while still limiting the jerk to 0.04 g/sec. Appendix C lists other rail transit properties (Baltimore MTA, Miami Metro-Dade, MARTA, and WMATA) using shorter spiral lengths.

Both of these formulae, $L_s = 0.98 E_a V$ and $L_s = 0.99 E_u V$, should be added to Metro Rail System Design Criteria and Standards as the "absolute minimum" spiral length requirements, with the current formulae retained as representing the "desired minimum" spiral length requirements.

The addition of these two formulae to the civil criteria would permit a design speed of 45 mph on curve #1250, located just beyond the west end of the 7th/Flower Station platform, which currently has an undesirably restrictive design speed of 40 mph on both of its spiral curves.

All other curves (except those located in the CORE region) already have a minimum design speed of 45 mph. Therefore, an increase in the minimum design speed on the Metro Rail system can be improved without any redesign of existing contract drawings, simply by revising Metro Rail Design Criteria and Standards, Volume II, Section 1.4.1.C, to permit a designated design speed of 45 mph rather than the currently stated 40 mph on the restricted-length spirals. Design of the alignment in the CORE study area should be allowed to make use of the proposed criteria revision to avoid undesirable speed restrictions.

4.7 HORIZONTAL CURVE RECOMMENDATIONS

- A. Revise Metro Rail Design Criteria and Standards, Volume II, Section 1.4.4.C.3, and add new Section 1.4.4.C.4. as shown. Revise Figure II-1-3, "Spiral Length Chart," of Section 1.4.4.C.3 as shown in Figure 2.

1.4.4.C.3 The desired minimum length of spiral (L_s) shall be the greater of the lengths as determined by the following formulae, but not less than 100 feet:

$$\begin{aligned}L_s &= 1.17 E V \\L_s^S &= 1.22 E_u^a V\end{aligned}$$

The relationship between superelevation and spiral length is shown in Figure II-1-3.

1.4.4.C.4 The absolute minimum length of spiral (L) shall be the greater of the lengths as determined by the following formulae, but not less than 100 feet:

$$\begin{aligned}L &= 0.98 E V \\L_s^S &= 0.99 E_u^a V\end{aligned}$$

District approval shall be required for each use of these alternative formulae.

- B. Raise speed limit on both spirals of curve #1250AR (2250AL) to 45 mph.

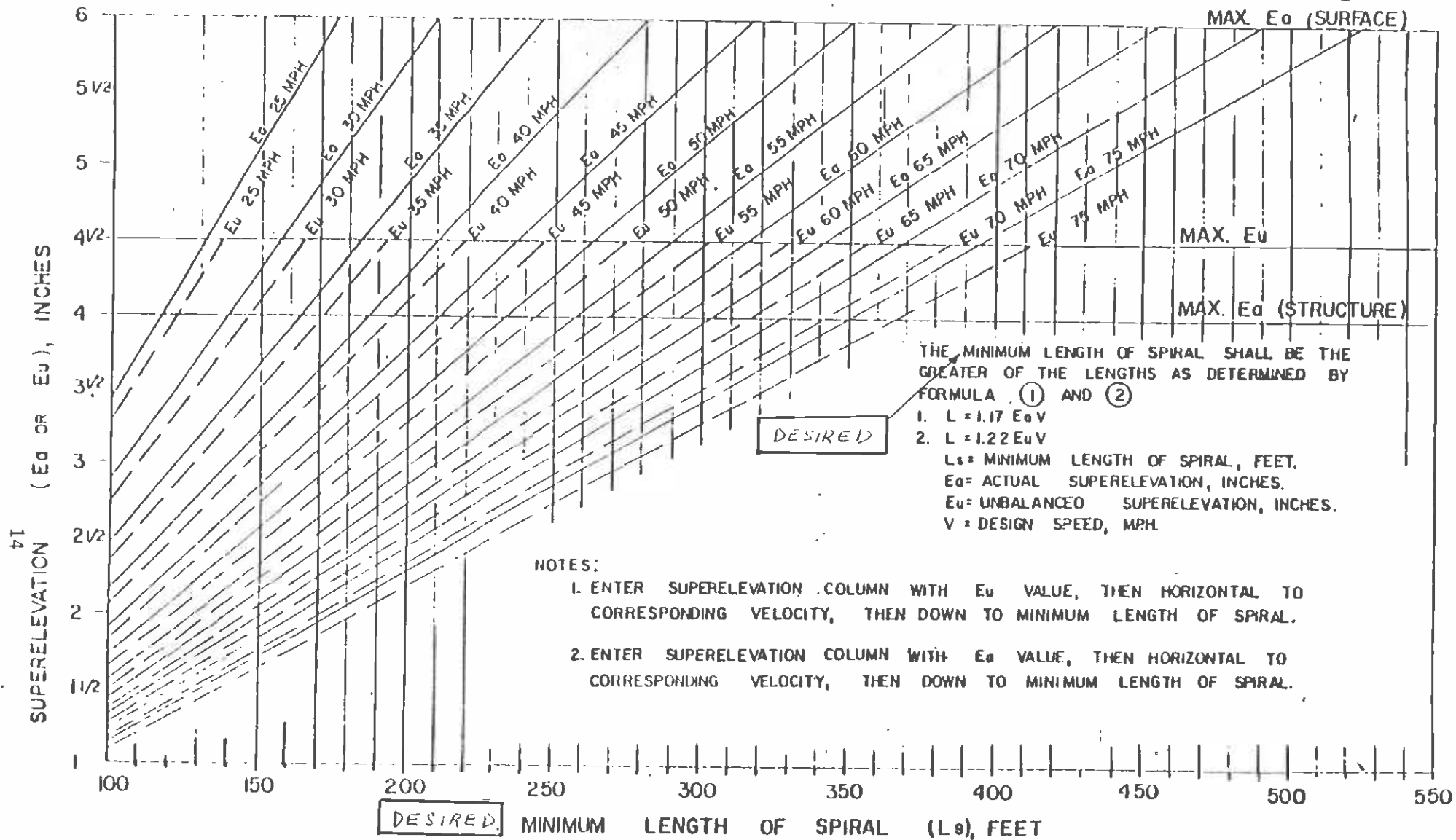

SPIRAL LENGTH CHART

FIGURE II - 1 - 3

FIGURE 2

Proposed Changes To Figure II-1-3

C. Revise Metro Rail Design Criteria and Standards, Volume II, Section 1.4.1.C to increase minimum design speed to 45 mph (from 40 mph), as shown.

1.4.1.C. Curvature and superelevation shall be related to design speed, with consideration for the acceleration and deceleration characteristics of the design vehicle. Whenever possible, the geometrics shall accommodate the maximum design speed of 75 mph, depending on the location of curves, station stop spacings, construction limitations, and the performance characteristics of the design vehicle. The minimum design speed shall be 45 mph.

Section 5

VERTICAL CURVES

5.1 VERTICAL CURVE LENGTH AND ACCLERATION

On vertical curves, patron comfort and, to a lesser extent, vehicle clearance considerations apply when determining allowable speeds. Vehicle stability and acceptable lateral forces are achieved on vertical curves. Of the clearance and patron comfort (vertical acceleration) considerations, the latter is controlling. In vertical curves, the main alignment concern is the length of curve connecting the two grades. The transition between these two grades is a parabola, treated in this report and the industry as an equivalent radius curve for determining the vertical acceleration.

In contrast to horizontal curves, the transit industry does not have a commonly accepted value for maximum allowable vertical acceleration on vertical curves. There are, however, some guidelines available. Automated Guideway Transit (AGT) design uses a value of 0.06g as an acceptable vertical acceleration for passenger comfort (Reference 4). MARTA uses more conservative values of 0.02g for crest or summit curves (where gradient goes from positive to negative), and 0.04g for trough or sag curves (where gradient goes from negative to positive), based on Reference 4. However, this is not an industry-wide practice, as Baltimore MTA, Miami Metro Dade, and WMATA do not have any prescribed vertical acceleration limits. Instead, these three properties require a minimum curve length that is directly proportional to the magnitude of change in track gradient, and is independent of train

speed.⁶ Vertical accelerations resulting from different design speeds using these formulae are shown in Figure 4 (page 19a).

5.2 METHODOLOGY OF CALCULATING ACCELERATION ON VERTICAL CURVES

Acceleration values on vertical curves are calculated in this report using the methodology in Reference 4. The formulae used to obtain them are:

$$\begin{aligned} &\text{Equivalent Radius of Curvature } R \text{ (ft):} \\ &R = L \times 100/A \qquad \qquad \qquad \text{(equation 1)} \end{aligned}$$

$$\begin{aligned} &\text{Acceleration (g):} \\ &(g) = (V \times 1.4667)^2 / (R \times 32.2) \qquad \qquad \text{(equation 2)} \end{aligned}$$

Where L = Length of vertical curve (ft)
 A = Algebraic difference in grades (%)
 V = Design speed (mph)

5.3. VERTICAL CURVE CRITERIA REVISIONS

As previously stated and shown in Appendix G, the methods for determining vertical curve length and allowable speed vary among transit systems.

The Metro Rail System Design Criteria and Standards contain pertinent vertical curve length criteria in Volume II, Sect. 1.5.3.A.1 and 1.5.3.A.2 as reproduced in Appendix A.

Figure 3 shows the curve lengths required by Sections 1.5.3.A.1 and 1.5.3.A.2 for design speeds from 40 to

⁶ Vertical curve criteria of selected rail transit systems are contained in Appendix G.

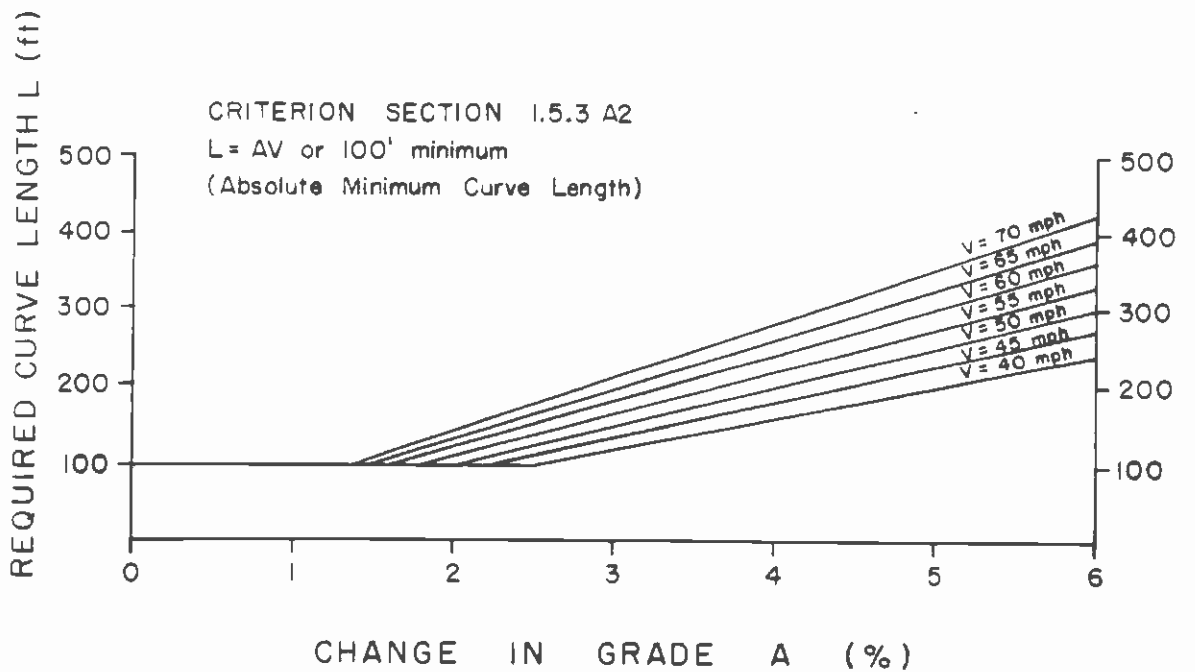
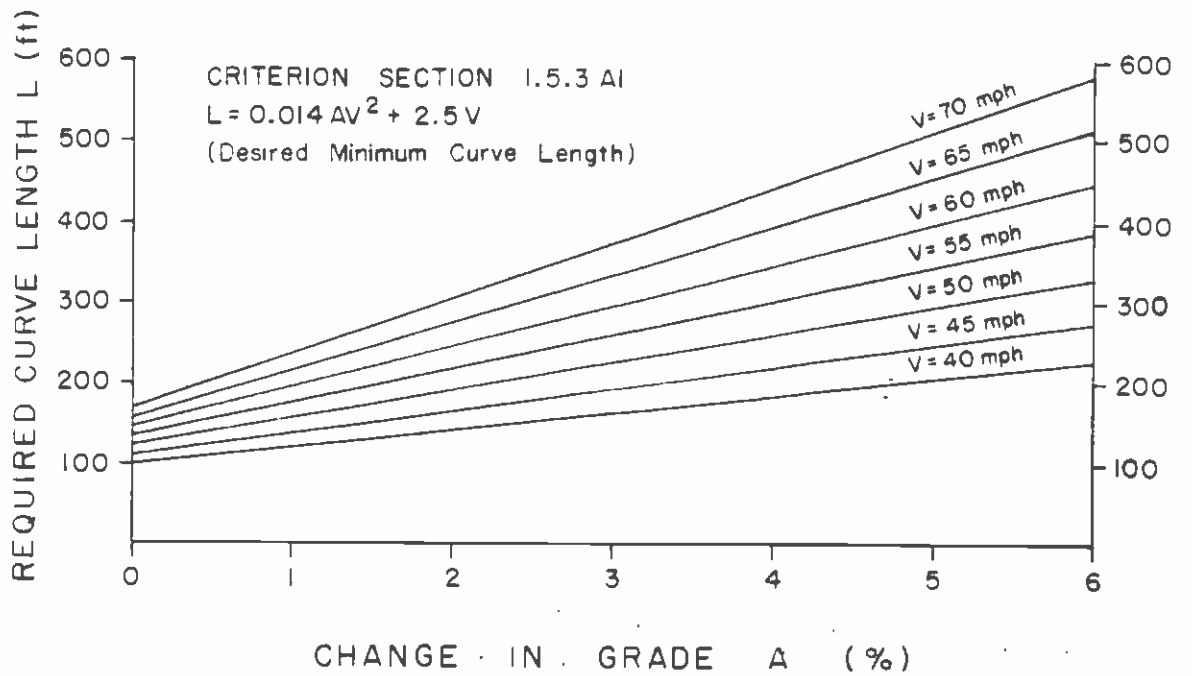

Figure 3 - Required Vertical Curve Length vs. Change in Grade For Design Speeds 40 mph - 70 mph For LA Metro Rail.

70 mph, with values of A ranging from 0 to 6 percent. In general, Section 1.5.3.A.1 requires longer curves than Section 1.5.3.A.2. However, at relatively low design speeds, Section 1.5.3.A.2 actually requires longer curves than Section 1.5.3.A.1. This occurs for example, with a design speed of 40 mph with values of A greater or equal to 5.7 percent.

The formula of Section 1.5.3.A.1 limits vertical acceleration in g's to the following quotient, obtained by substituting the curve length value into equation (1) of report Section 5.2, which in turn is substituted into equation (2).

$$\text{Max } g = \frac{1}{20.95 + \frac{3742.1}{AV}}$$

As seen from this equation, the vertical acceleration is proportional to the product of change in grade (A) and train speed (V). As the grade change and/or train speed increase, so does the vertical acceleration.

Metro Rail Design Criteria and Standards Section 1.5.2.A.1 permits an absolute maximum sustained grade of four percent. Although six percent grades are permitted by this criterion on short lengths of track, the practice has been to limit all grades to four percent or less. The maximum change of grade (A) consequently is eight percent, where both approaches have four percent grades. Substituting the maximum train speed of 70 mph and a value of eight percent for A into the formula, the maximum vertical acceleration is 0.036g.

Figure 4 shows the vertical acceleration levels resulting from Metro Rail vertical curve criteria as a function of change in grade, for design speeds of 40, 50, 60, and 70 mph. These acceleration levels are based on curves designed according to Section 1.5.3.A.1 of the civil criteria. Maximum acceleration values of other rail transit systems are also shown in Figure 4. This comparison shows that the highest acceleration levels on Metro Rail curves are comparable to those on other rail transit systems, such as Miami Metro-Dade, Baltimore MTA, WMATA, and MARTA. MARTA has vertical curves that produce vertical accelerations up to 0.04g; more than Metro Rail is expected to incur.

The remaining criterion, $L = AV$, which is the absolute minimum allowable curve length, limits vertical acceleration to:

$$\text{Max } g = 6.68 \times 10^{-4} V \quad \text{where } V = \text{train speed (mph)}$$

This equation is obtained by substituting the value of L from criteria Section 1.5.3.A.2 into the equation (1) of report Section 5.2, which is then substituted into equation (2). Application of this criterion for design speeds above 60 mph results in a vertical acceleration above 0.04g. This report defines 0.04g as the maximum allowable acceleration on vertical curves. Thus, for design speeds above 60 mph, criterion 1.5.3.A.1 should apply and criterion 1.5.3.A.2 should only be used with District approval.

This analysis of the vertical acceleration resulting from application of Metro Rail Design Criteria shows that the current maximum 40 mph speed limit on vertical curves can be raised to 45 mph without producing unacceptable levels of vertical acceleration.

Figure 4 - LA Metro Rail Vertical Acceleration Levels as a Function of Change in Grade.

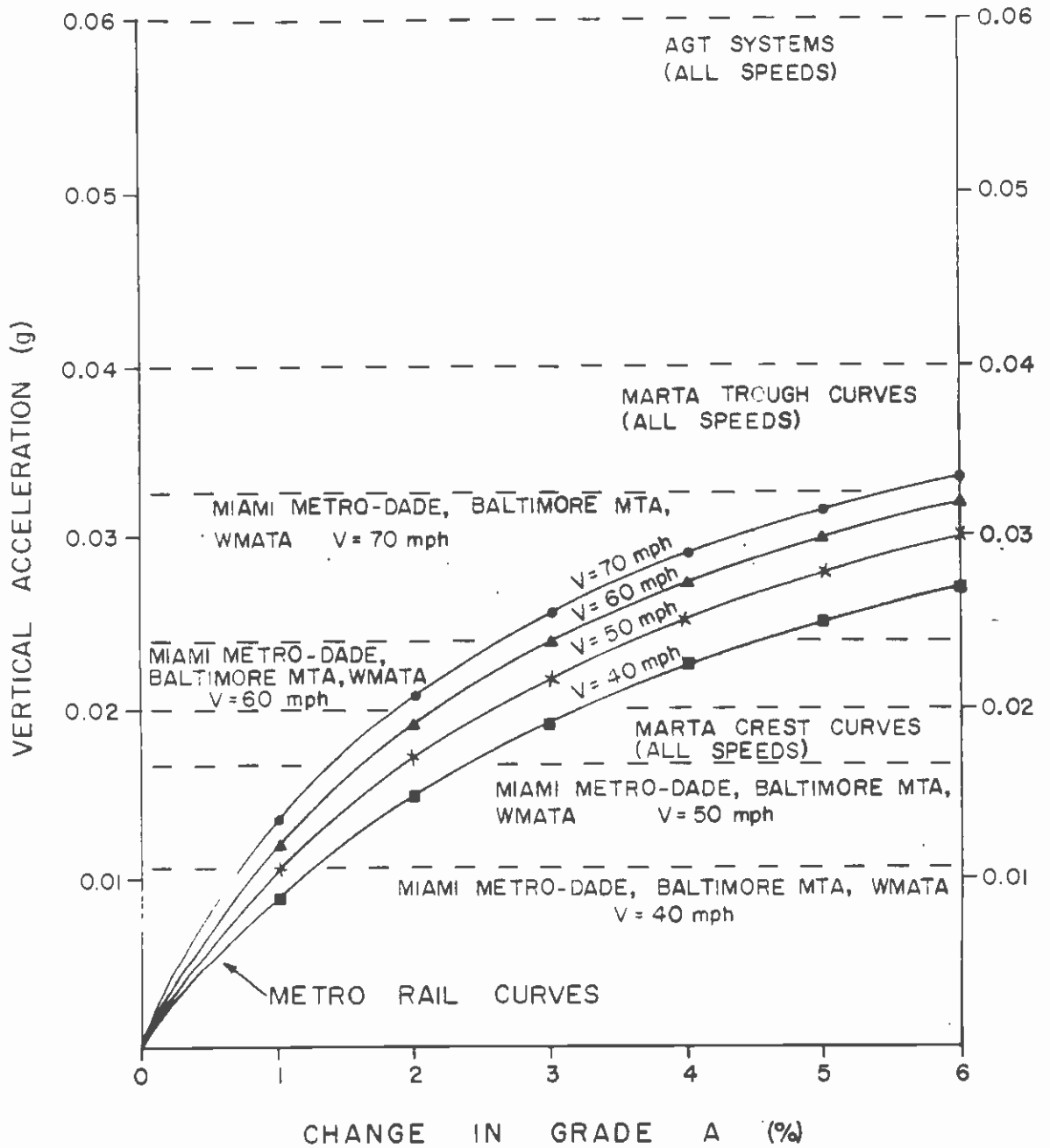

- NOTES:**
- 1) METRO RAIL CURVES DETERMINED BY SECTION 1.5.3 A1 OF CIVIL CRITERIA.
 - 2) MAXIMUM ACCELERATION LEVELS ARE SHOWN OF OTHER RAIL TRANSIT SYSTEMS, INDEPENDENT OF CHANGE IN GRADE.

5.4 VERTICAL CURVE RECOMMENDATIONS

- A. Add the following criterion to Metro Rail Design Criteria and Standards, Section 1.5.1, and apply it to all curves including the CORE alternative alignments to avoid undesirable speed restrictions. MOS-1 is not affected by this recommendation.

- 1.5.1.C The minimum design speed on the vertical track profile shall be 45 mph.

- B. Revise Section 1.5.3.A.2 from:

- 1.5.3.A.2 The absolute minimum length of vertical curve for main line track shall be determined by the equation $L = AV$ or 100 feet, whichever is greater.

To:

- 1.5.3.A.2 The absolute minimum length of vertical curve for main line track shall be determined by the equation $L = AV$ or 100 feet, whichever is greater. District approval shall be required to use this criterion.

Section 6

CONCLUSIONS AND RECOMMENDATIONS

6.1 CONCLUSIONS

This review and analysis of the civil design criteria for horizontal and vertical curves, contained in Volume II of the Metro Rail System Design Criteria and Standards, indicates the following:

- o The minimum design speed for the MOS-1 alignment can be upgraded to 45 mph from 40 mph without alignment or trackwork design changes while maintaining acceptable passenger comfort and without jeopardizing safety.
- o The spiral curve length formulae are conservative, requiring longer curves than the minimum required for passenger comfort. Shorter spiral curves can be used in cases where insufficient space exists to accommodate a curve length required by current criteria, without causing unacceptable passenger discomfort.
- o With the adoption of alternative shorter spiral length criteria, a minimum design speed of 45 mph for horizontal curves is practical, would not require design changes to any existing alignment, and should be used for CORE study alignments to avoid undesirable speed restrictions.
- o Existing vertical curve criteria are reasonable and sufficiently permissive to allow adoption of 45 mph as

the minimum design speed. The absolute minimum curve length requirement of the criterion in Section 1.5.3.A.2, should only be used on an exceptional basis with specific District approval.

6.2 RECOMMENDATIONS

The following actions are recommended:

A. Change the civil criteria for curves in Metro Rail System Design Criteria and Standards, Volume II, as follows:

1. Revise Section 1.4.4.C.3

From: The minimum length of spiral (L_s) shall be the greater of the lengths as determined by the following formulae, but not less than 100 feet:

$$L_s = 1.17 E_a V$$

$$L_s = 1.22 E_u V$$

The relationship between superelevation and spiral length is shown in Figure II-1-3.

To: The desired minimum length of spiral (L_s) shall be the greater of the lengths as determined by the following formulae, but not less than 100 feet:

$$L_s = 1.17 E_a V$$

$$L_s = 1.22 E_u V$$

The relationship between superelevation and spiral length is shown in Figure II-1-3.

2. Revise text on Figure II-1-3 of civil criteria to state "desired minimum length of spiral," to be consistent with proposed change in Recommendation A.1.

3. Add new section 1.4.4.C.4:

1.4.4.C.4 The absolute minimum length of spiral (L_s) shall be the greater of the lengths as determined by the following formulae, but not less than 100 feet:

$$L_s = 0.98 E_a V$$

$$L_s = 0.99 E_u V$$

Approval by the District shall be required for each use of these alternative formulae.

Re-number existing sections 1.4.4.C.4 through 1.4.C.7 to 1.4.4.C.5 through 1.4.4.C.8.

4. Revise Section 1.4.1.C:

From: Curvature and superelevation shall be related to design speed, with consideration for the acceleration and deceleration characteristics of the design vehicle. Whenever possible, the geometrics shall accommodate the maximum design speed of 75 mph, depending on the location of curves, station stop spacings, construction limitations, and the performance characteristics of the design vehicle. The minimum design speed shall be 40 mph.

To: Curvature and superelevation shall be related to design speed, with consideration for the acceleration and deceleration characteristics of the design

vehicle. Whenever possible, the geometrics shall accommodate the maximum design speed of 75 mph, depending on the location of curves, station stop spacings, construction limitations, and the performance characteristics of the design vehicle. The minimum design speed shall be 45 mph.

5. Add new section 1.5.1.C:

1.5.1.C The minimum design speed on the vertical alignment shall be 45 mph.

6. Revise Section 1.5.3.A.2:

From: The absolute minimum length of vertical curve for main line track shall be determined by the equation $L = AV$ or 100 feet, whichever is greater.

To: The absolute minimum length of vertical curve for mainline track shall be determined by the equation $L = AV$ or 100 feet, whichever is greater. District approval shall be required to use this criterion.

B. Seek District approval to raise the the speed limit on both spirals of curve #1250AR (#2250AL) to 45 mph by applying proposed Section 1.4.4.C.4 criterion.

Section 7

References

1. American Railway Engineering Association Proceedings, Volume 56, "Passenger Ride Comfort on Curved Track," 1955
2. William W. Hay, Railroad Engineering, Second Edition, 1982
3. American Railway Engineering Association - Manual, Volume I, Part 3, Pag. 1-2 (Revised 1965)
4. B. Dayman and L. Rubenstine, Jet Propulsion Laboratory - Pasadena, California, Gravity Assisted Rapid Transit, "Energy Savings of Dipped Guideways, Supplemental Analysis to Gibbs and Hill Report," January 1982
5. MARTA, "Chapter 3 - Geometrics" of MARTA Criteria (Revised November 1982)
6. Proceedings, Institution of Civil Engineers, Volume I, Part II, 1952
"Recent Developments in Railway Curve Design"

APPENDICES

SCRTD METRO RAIL SYSTEM DESIGN CRITERIA & STANDARDS

VOLUME II, SECTION 1

CIVIL

1.1 SCOPE

1.1.1 This section establishes the basic Civil Engineering Criteria to be used in the design of the Southern California Area Rapid Transit District Metro Rail Project and the related work that:

- A. Includes criteria for the design of transit system alignments, trackwork, and drainage and related utility work for determination of rights-of-way, control of access, and service roads
- B. Establishes the minimum dimensions required to assure proper clearances between the transit vehicles, or transit structures, and the obstructions involved.
- C. Specifies the minimum amounts of earth cover to be maintained above the various underground transit system components.

1.2 BASIS FOR CRITERIA

1.2.1 The basic requirement of any transit geometric design is to provide comfortable, economical, and efficient transportation for passengers while maintaining adequate factors of safety with respect to overall operation, maintenance, and vehicle stability.

- A. The criteria presented herein relating to the design of operational components emphasize safety and passenger comfort and follow accepted engineering practices used in current operating rapid transit and railroad systems.
- B. The criteria relating to other elements of design, such as transit system drainage, and to work items necessitated by transit system construction, such as miscellaneous utility work, are based on the current specifications and practices of the agencies concerned in the jurisdiction involved.

SCRTD METRO RAIL SYSTEM DESIGN CRITERIA & STANDARDS

VOLUME II, SECTION 1 CIVIL (Cont'd.)

1.3 SURVEY CONTROL SYSTEM

1.3.1 Horizontal Control

- A. All horizontal controls shall be based on the California Coordinate System, Zone 7, as defined beginning at Section 8801 of the Public Resource Code of California as it existed on January 1, 1982.
- B. The accuracy of the horizontal ground control and of supporting ground surveys shall as a minimum be Second Order, Class I, as defined by the Federal Geodetic Control Committee and published under the title "Classification, Standards of Accuracy and General Specifications of Geodetic Control Stations," authored by the National Geodetic Survey in February 1974.

1.3.2 Vertical Control

- A. Vertical controls for this project shall be based on the National Geodetic Vertical Datum of 1929 as established in Los Angeles County through the 1980 adjustment of the Southern California Cooperative Leveling Net.
- B. The accuracy of the vertical ground control and of supporting vertical ground surveys shall be at least Second Order, Class I, as defined by the Federal Geodetic Control Committee and published under the title "Classification, Standards of Accuracy and General Specifications of Geodetic Control Stations," authored by the National Geodetic Survey in February 1974.

→ 1.4 HORIZONTAL ALIGNMENT AND SUPERELEVATION

1.4.1 General

- A. The parameters for the design of horizontal alignments have been established in accordance with the recommendations of the Manual for Railway Engineering, published by the American Railway Engineering Association, current August 1, 1981 to July 31, 1982. Riding comfort requirements are based on the AREA Joint Committee Report, "Passenger Ride Comfort on

SCRTD METRO RAIL SYSTEM DESIGN CRITERIA & STANDARDS

VOLUME II, SECTION 1 CIVIL (Cont'd.)

Curved Track," published in Bulletin 516, June-July, 1954.

- B. The horizontal alignment of main line tracks shall consist of tangents joined to circular curves by spiral transition curves. Spirals shall not be used in yards and service areas.
- C. Curvature and superelevation shall be related to design speed, with consideration for the acceleration and deceleration characteristics of the design vehicle. Whenever possible, the geometrics shall accommodate the maximum design speed of 75 miles per hour, depending on the location of curves, station stop spacings, construction limitations, and the performance characteristics of the design vehicle. The minimum design speed shall be 40 miles per hour.
- D. Each route shall be stationed independently along the centerline of the right hand track. Stationing shall be continuous throughout the length of this track, designated Track "R," and shall be the basic control for locating all other system facilities along the route.
- E. Separate stationing shall be used for the left hand track, designated Track "L," where tracks are neither parallel nor concentric, where widened track centers are required around curves, or where tracks are in separate structures.
- F. Geometrics shall be developed for all tracks.

1.4.2 Track Spacing

- A. Track spacing will vary, depending on the type of construction used for the particular section of line structure.
- B. Minimum center to center dimensions for parallel tracks shall be 14' - 0".
- C. Center to center dimensions for parallel tracks generally will be dependent upon the width of station platform.

SCRTD METRO RAIL SYSTEM DESIGN CRITERIA & STANDARDS

VOLUME II, SECTION 1 CIVIL (Cont'd.)

1.4.3 Tangent Alignment

A. Line Structures

1. The desired minimum tangent length shall be determined by the following formula:

$$L = 3V$$

Where L = Minimum tangent length, feet
V = Design speed through the curve, mph

2. The absolute minimum tangent length between curves or spirals shall be 75 feet.

B. Station Structures

1. At rapid transit stations, the desired horizontal alignment shall be tangent for a minimum of 600 feet, beginning 75 feet before the station platform and extending 75 feet beyond the 450-foot length of platform.
2. Formal approval shall be obtained from the District prior to any deviation from the tangent length criteria.

1.4.4 Curved Alignment

A. Circular Curves

1. Circular curves shall be defined by the arc definition of curvature and specified by their radii. Curve functions and abbreviations are shown in Figure II-1-1.
2. For main line tracks, the desired minimum radius shall be 1,000 feet; the absolute minimum radius shall be 750 feet.
3. For secondary tracks, the desired minimum radius shall be 750 feet; the absolute minimum radius shall be 500 feet.
4. For yard tracks, the desired minimum radius shall be 350 feet; the absolute minimum radius shall be 250 feet. Prior to assuming absolute minimum radius for the tracks, underbody characteristics of the car shall be considered for clearance purposes.

SCRTD METRO RAIL SYSTEM DESIGN CRITERIA & STANDARDS

VOLUME II, SECTION 1 CIVIL (Cont'd.)

5. The desired minimum length of circular curve shall be determined by the formula:

$$L = 3V$$

Where

L	=	Minimum Length of curve, feet
V	=	Design speed through the curve, mph

→ B. Superelevation

- 1. In the design of horizontal alignments, the allowable speed throughout curved sections shall be determined by passenger comfort as related to superelevation. Superelevation is defined as the height difference in inches between high rail and low rail, and is divided into the following elements:

$$E_r = E_a + E_u$$

- Where
- | | | |
|-------|---|---|
| E_r | = | Total amount of superelevation required for equilibrium, inches |
| E_a | = | Actual superelevation to be constructed, inches |
| E_u | = | Unbalanced superelevation, (the difference between the equilibrium superelevation and the actual superelevation), inches. |

2. For running track in cut-and-cover, tunnel, and aerial construction, the absolute maximum actual superelevation (E_a) shall be 4 inches. Formal approval must be obtained from the District to exceed $E_a = 4$ inches.
3. For running track on surface construction, the desired maximum actual superelevation (E_a) shall be 4 inches. However, where the design speed of a section of alignment can be increased by the addition of actual superelevation above 4 inches, an absolute maximum of 6 inches may be used. Formal approval must be obtained from the District to exceed $E_a = 4$ inches.
- 4. The absolute maximum unbalanced superelevation (E_u) throughout the system shall be 4-1/2 inches.

SCR TD METRO RAIL SYSTEM DESIGN CRITERIA & STANDARDS

VOLUME II, SECTION 1 CIVIL (Cont'd.)

- 5. Superelevation shall be determined by the formula:

$$E_r = E_a + E_u = 4.011 \frac{V^2}{R}$$

Where V = Design speed through the curve,
mph

R = Radius of curve, feet

6. Calculated values for actual superelevation (E) shall be rounded to the nearest 1/4 inch. For^a a calculated total superelevation (E) of 1/2 inch or less, no actual superelevation^r (E_a) shall be applied.
7. Actual superelevation (E) shall be attained and removed linearly throughout the full length of the spiral transition curve by raising the outside rail while maintaining the top of the inside rail at the profile grade.
8. Yard and secondary tracks shall not be superelevated without prior approval from the District.

→ C. Spiral Transition Curves

1. Spiral transition curves shall be used in main-line tracks to connect tangents to circular curves or to connect compound circular curves. The spiral used shall be the Barnett spiral. Spiral curve functions and abbreviations are shown in Figure II-1-2.
2. No spirals shall be required for curves with radii 10,000 feet or greater.
- 3. The minimum length of spiral (L_s) shall be the greater of the lengths as determined by the following formulae, but not less than 100 feet:

$$L_s = 1.17 E V$$
$$L_s = 1.22 E_u^a V$$

The relationship between superelevation and spiral length is shown in Figure II-1-3.

SCR TD METRO RAIL SYSTEM DESIGN CRITERIA & STANDARDS

VOLUME II, SECTION 1 CIVIL (Cont'd.)

4. Normally, E_u shall be required to vary from 0 inch to a maximum of 4-1/2 inches in the following manner:
 - a. For $E_a = 4$ inches maximum, E_u shall equal 0 inch until $E_a = 4$ inches is reached. E_u shall then be maintained at 4 inches until the total $E_a + E_u$ is equal to 8-1/2 inches. At this point, a limit shall be placed on the design speed.
 - b. For $E_a = 6$ inches maximum, the same technique shall be used until $E_a = 6$ inches. E_u shall then be maintained at 6 inches until the total $E_a + E_u$ is equal to 10-1/2 inches. At this point, a limit shall be placed on the design speed.
5. Where insufficient space is available to accommodate the length of spiral required to maintain $E_u = 0$ until maximum E_a is reached, E_a shall be reduced and E_u increased in order to achieve maximum design speed.
6. Where E_a is reduced and E_u increased, the maximum design speed for a given length of spiral shall be obtained by separating E_r into E_a and E_u as follows:

$$V = \frac{41E_a}{E_u}$$

7. Where spirals are not required, E_r shall be attained linearly over a length equal to $1.5 E_r V$ (rounded to the next 10 feet) and divided equally between the tangent and the curve.

D. Compound Circular Curves

1. Where compound circular curves are required, a spiral shall be inserted between the circular curves. The minimum length of the spiral shall be the greater of the lengths determined by the following:

Or

$$L_s = 1.17 (E_{a2} - E_{a1})V$$
$$L_s = 1.22 (E_{u2} - E_{u1})V$$

SCRTD METRO RAIL SYSTEM DESIGN CRITERIA & STANDARDS

VOLUME II, SECTION 1 CIVIL (Cont'd.)

Where	L_s	=	Minimum length of spiral, feet
	E_{a1}	=	Actual superelevation on the first circular curve, inches
	E_{a2}	=	Unbalanced superelevation on the second circular curve, inches
	E_{u1}	=	Unbalanced superelevation on the first circular curve, inches
	E_{u2}	=	Unbalanced superelevation on the second circular curve, inches
	V	=	Design speed through the circular curves, mph

2. The desired minimum length of spiral between compound curves shall be 100 feet.
3. If the calculated minimum length of spiral is 25 feet or less, no spiral will be required. The difference in superelevation shall be attained throughout a length of 25 feet measured back from the PCC within the curve of larger radius.

E. Reverse Curves

1. If the minimum tangent length specified in Article 1.4.3, Paragraph A.2, cannot be accommodated between reverse curves, the transition spiral curves of the two curves shall be extended to meet at the point of reverse curvature. The point of reverse curvature shall be set so that $L_{s1} E_{a2} = L_{s2} E_{a1}$. A maximum separation of 3 feet between the spirals is acceptable in lieu of meeting at a point. The superelevation transition through the spirals shall be accomplished by sloping both rails throughout the entire transition spiral as shown in Figure II-1-4. Through the transition, both rails will be at an elevation above profile grade.
2. This method of superelevation transition presents problems with respect to increased ballast at

SCR TD METRO RAIL SYSTEM DESIGN CRITERIA & STANDARDS

VOLUME II, SECTION 1 CIVIL (Cont'd.)

Point A of Figure II-1-4 and to vehicle clearances. If the alignment permits, reverse curves shall be separated by minimum tangent lengths to avoid these complications.

F. Double Reverse Curves

Double reverse curves shall not be used in the system unless the total length of line between the first and third curves is at least 600 feet, i.e., unless the distance from the ST of the first curve to the TS of the third curve is at least 600 feet. The intent of this criterion is to prevent the head and tail cars in any one train being rotated by superelevation in one direction while the intermediate cars are rotated in the opposite direction.

→ 1.5 VERTICAL ALIGNMENT

1.5.1 General

- A. The profile grade shall represent the elevation of the top of the low rail.
- B. In areas of curved alignment where profile is given for one track only, the elevations of the second track shall be adjusted uniformly to accommodate the differences in lengths throughout the curves.

1.5.2 Grades

A. Line Structures

1. For standard track installation, the maximum desired sustained grade for mainline and for secondary tracks shall be 3.0 percent; the absolute maximum sustained grade shall be 4.0 percent. For short lengths of track, grades may be increased to, but shall not exceed, 6.0 percent.
2. No minimum grade is specified, but adequate drainage shall be provided for all trackage.
3. For main line track, the desired minimum length of constant profile grade between vertical curves shall be determined by the following formula:

SCRTD METRO RAIL SYSTEM DESIGN CRITERIA & STANDARDS

VOLUME II, SECTION 1 CIVIL (Cont'd.)

$L = 3V$
Where L = Minimum tangent length,
feet
 V = Design speed in the
area, mph

4. The absolute minimum length of constant profile grade between vertical curves shall be 100 feet.
5. Grade adjustments shall be applied to compensate for horizontal curves, where applicable. Where horizontal curves are present, the allowable grade shall be reduced by 229.18 divided by the radius of the horizontal curve.

B. Yard and Shop Tracks

1. For yard track, the absolute maximum grade shall be 1.0 percent; no minimum grade is specified, but adequate drainage at subballast level shall be provided for all trackage.
2. Track located within shop buildings shall be level.

C. Storage Tracks

1. It is desired that the grade of a stub end storage track descend toward the stub end, and, if adjacent to a main line or secondary track, be curved away from such track at its stub end. If it is necessary to grade the storage track up toward the stub end, the grade shall not exceed 0.20 percent. For yard secondary tracks, it is desirable to have a slight grade, maximum 1.0 percent and minimum 0.35 percent, to achieve good drainage at the subballast level.
2. Through storage tracks shall have a sag in the middle of their profile, to prevent rail cars from rolling to either end.

D. Station Structures

1. No minimum grade is specified at passenger stations provided adequate track drainage can be maintained.

SCRTD METRO RAIL SYSTEM DESIGN CRITERIA & STANDARDS

VOLUME II, SECTION 1 CIVIL (Cont'd.)

2. The absolute maximum allowable grade through passenger stations shall be 1.0 percent.
3. Vertical curves shall not encroach within 75 feet of station platforms.

→ 1.5.3 Vertical Curvature

A. Main Line Tracks

- 1. All changes in grade shall be connected by parabolic vertical curves. For main line tracks the desired minimum length of vertical curve shall be determined by the formula:

$$L = 0.014AV^2 + 2.5V$$

Where L = Length of vertical curve, feet
A = Algebraic difference in grades connected by the vertical curve, percent
V = Design speed in area, mph

Where possible, vertical curves longer than the desired minimum length shall be used.

- 2. The absolute minimum length of vertical curve for main line track shall be determined by the equation $L = AV$ or 100 feet, whichever is greater.
3. Reverse vertical curves may be used, provided each vertical curve conforms to requirements stated in Article 1.5.3, Paragraph A.1.
 4. Compound and unsymmetrical vertical curves may be used, provided each curve conforms to requirements stated in Article 1.5.3, Paragraph A.1.

B. Combined Horizontal and Vertical Curves

1. Where possible, combining horizontal and vertical curves shall be avoided.
2. Where the combination of horizontal and vertical curves cannot be avoided, the minimum distance between vertical control points (PVC and PVT) and horizontal control points (TS, SC, CS, and ST) shall be 75 feet. Where a vertical curve occurs within a horizontal curve, the length of the

SCRTD METRO RAIL SYSTEM DESIGN CRITERIA & STANDARDS

VOLUME II, SECTION 1 CIVIL (Cont'd.)

vertical curve shall be increased beyond the minimum desired length defined in Article 1.5.3, Paragraph A.1.

1.6 CLEARANCE AND COVER REQUIREMENTS

1.6.1 Clearance Envelope

The clearance envelope is defined as the space occupied by the dynamic outline of the design vehicle plus an additional running clearance allowance of 2 inches around the dynamic outline.

The following factors shall be considered in developing the clearance envelope:

A. Dynamic Outline

The dynamic outline of the design vehicle shall be developed in accordance with data as described in Volume V, Section 1 - "Passenger Vehicle" of the SCRTD Metro Rail Project Design Criteria, and illustrated in Figure II-1-7.

B. End and Middle Ordinate Displacement

For design purposes, the end overhang and middle ordinate of the vehicle shall be considered. They shall be based on a vehicle 73' - 9" long, centered in the coupling-to-coupling distance of 75' - 0". Use 54' - 0" truck centers-for-center overhang and 52' - 0" truck centers for end overhang clearance requirements. Rounding at car corners shall not be considered.

C. Effect of Superelevation

1. The effect of superelevation shall be considered independently in determining the clearance envelope, and shall be taken into account in establishing the dimensional clearances for the various construction sections. The width of the design vehicle dynamic outline on superelevated track, exclusive for values for midordinate and end overhang, is called the dynamic width. This width includes the dynamic width toward the curve center, and the dynamic width away from the curve



Appendix B

Derivation of Superelevation Formula
(Reference Section 4.3 of report)

9. Superelevation

In rounding a curve, a train is subject to a centrifugal force F_c acting radially outward:

$$F_c = wv^2/gR \quad (26.12)$$

where w = weight of the car or locomotive in pounds
 v = speed in feet per second
 R = radius of the curve in feet
 g = acceleration due to gravity, 32.2 ft/sec/sec.

To counteract the effects of F_c , the outside rail of the curve is raised or superelevated a distance e in. above the inside rail. A state of equilibrium is reached in which both wheels bear equally on the rails, where e is sufficient to bring the resultant force F_r at right angles to the plane of the top of rails. A proportion can be set between terms in the force triangle and corresponding terms in the triangle formed by e and by the horizontal projection of the distance between the bearing points of the wheels on the rails. This projected distance is taken as 4.9 ft for values of e up to 8 in. (Figure 26.5a):

$$\begin{aligned} e/F_c &= 4.9/W \\ e &= 4.9wv^2/gWR \end{aligned} \quad (26.13)$$

To convert these terms to common usage, v in feet per second is expressed as V in miles per hour, g has the value 32.2 ft/sec/sec, W is multiplied by 2000 to change tons to pounds, R is replaced by $5730/D$, and the entire expression is multiplied by 12 to change feet to inches. Thereby

$$e = 0.0007DV^2 \quad (26.14)$$

Since $D = 5730/R$

$$e = 4.011V^2/R$$

where e = equilibrium superelevation in inches
 V = train speed in miles per hour
 D = degree of curve.

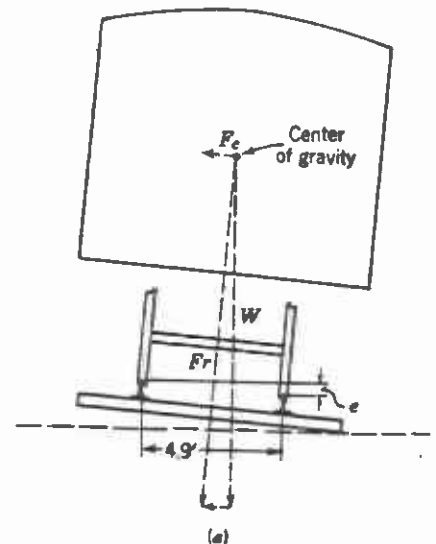

Source: Railroad Engineering,
Second Edition,
William W. Hay

copyright ©
 copyright 1982,
 John Wiley & Sons,
 Reprinted by permission of
 John Wiley & Sons Inc.



11
12

13

APPENDIX C

Spiral Length Criteria of Various Properties
(Reference Section 4.5 of Report)

PROPERTY	CRITERIA*	COMMENT
Balt. MTA	$L_s = 50 E_a$	Limits superelevation buildup to one inch between truck centers
Miami		
WMATA	$L_s = 1.22 E_u V$	Limits jerk to 0.020g/sec

	$L_s = 100'$	Absolute minimum length for Miami and WMATA

MARTA	$L_s = 62 E_a$	Limits superelevation buildup to one inch every 62' of track (originated from railroads having 62' truck spacings)
	$L_s = 1.38 E_a V$	Limits rate of actual superelevation increase to a given speed V to 1-1/16 inch/sec ("run-in" rate)

	Absolute Minimum	
	$L_s = 50 E_a$	Limits superelevation buildup to one inch between truck centers
	$L_s = 1.17 E_a V$	Limits rate of actual superelevation increase at a given speed V to 1-1/4 inch/sec
	$L_s = 1.0 E_u V$	Limits jerk below 0.035g/sec

LA	$L_s = 1.17 E_a V$	Limits rate of actual superelevation increase at a given speed V to 1-1/4 inch/sec
	$L_s = 1.22 E_u V$	Limits jerk below 0.030g/sec

	$L_s = 100'$	Absolute Minimum

* Longest spiral length governs



Derivation of Spiral Length Formula $L_s = 1.17E_aV$
 Source: Railroad Engineering, Second Edition,
 William W. Hay
 (reference Section 4.5 of report)

12. Length of Spiral

Knowing the actual superelevation, the spiral length can be computed. Let L_s be the length of spiral, then $L_s = vt$ and $t = L_s/v$, where v is the train speed in miles per hour and t is the time in seconds to travel L_s ft. Also, in time t the outer wheels of the train are rising a distance e , the actual superelevation in inches, so that $e_a = v't$, where v' is the rate at which superelevation is increasing in inches per second (Figure 26.6). From this, $t = e_a/v'$. The times t are the same in both situations, so that

$$L_s/v = e_a/v'$$

and

$$L_s = e_a v/v' \quad (26.17)$$

The rate at which superelevation runs in largely determines the comfort and smoothness of spiral operation. A minimum run-in rate of $1\frac{1}{4}$ in./sec has been used for speeds up to 60 mph. For speeds in the 60-80 mph range $1\frac{1}{6}$ in./sec has been advocated. Some roads operating at speeds of 80-100+ mph have used $1\frac{1}{8}$ in./sec.

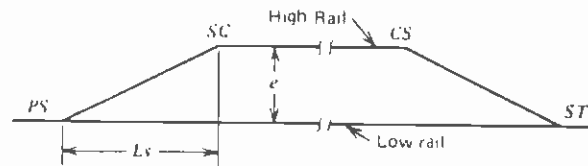

Figure 26.6. Rate of superelevation run-in.

The length of spiral is obtained from equation (26.13), with the conversion factor changing v from feet per second to miles per hour, and the value for v' , included in one term, to C :

$$L_s = CeV \quad (26.18)$$

For $v' = 1\frac{1}{4}$ in./sec

$$L_s = 1.17eV \quad (26.19)$$

For $v' = 1\frac{1}{6}$ in./sec

$$L_s = 1.26eV \quad (26.20)$$

For $v' = 1\frac{1}{8}$ in./sec

$$L_s = 1.30eV \quad (26.21)$$

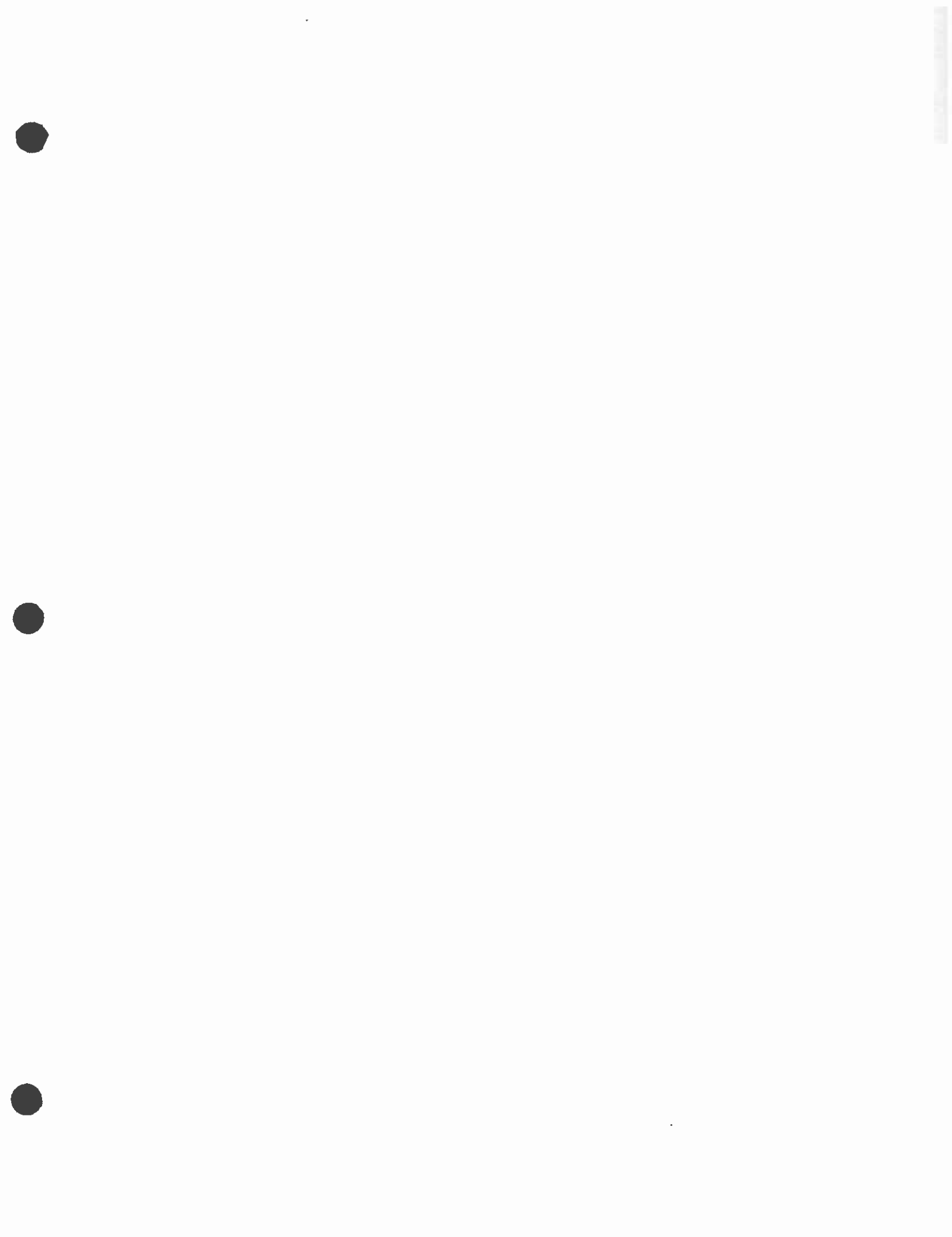

APPENDIX E

Calculation of Jerk (Reference Section 4.5 of This Report)

The jerk is calculated using the following formula:

$$\begin{aligned} \text{jerk (g/sec)} &= \frac{(\text{max } g) \times (V)}{L_s} \\ &= \frac{(0.0167) (E_{uV} + E_u) \times (V \times 1.4667)}{L_s} \end{aligned}$$

where E_u = unbalanced track superelevation (in)

E_{uV} = equivalent unbalanced track superelevation
to account for effect of vehicle roll

L_s = spiral length (ft)

V = train speed (mph)

Note: 1.4667 is conversion factor from mph to fps.

The quotient maximum g/L_s is the change in lateral acceleration per linear foot of spiral track upon entering or exiting the spiral. The rate of lateral acceleration increase (or decrease) which the passenger feels is directly dependent on the speed that a train travels through the spiral. The faster the train travels, the greater the change in acceleration (jerk). Thus, the quotient is multiplied by V , the train speed.

Lateral
Acceleration
(g)

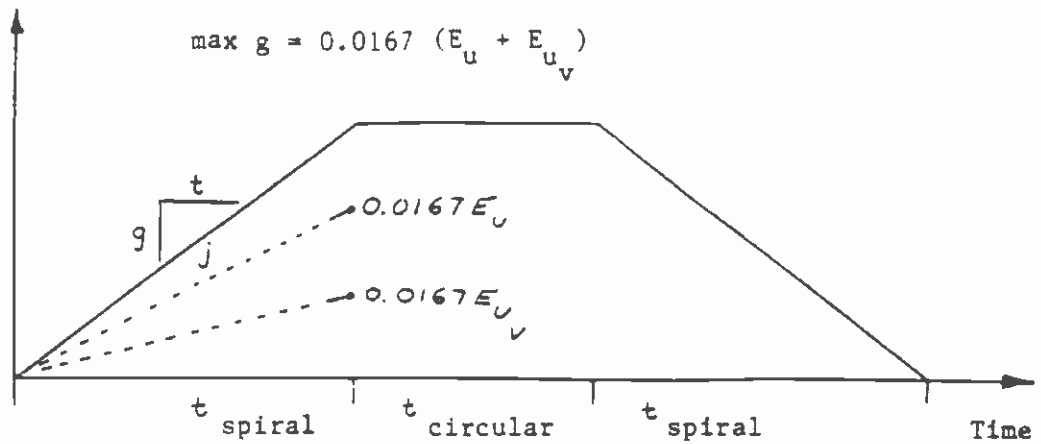

t_{spiral} = time to traverse spiral

t_{circular} = time to traverse circular curve

t_{spiral} = time to traverse spiral

t = time g = accel j = jerk

Jerk (g/sec)

$$= \frac{\Delta y}{\Delta x} = \frac{\max g - 0}{t_{\text{spiral}} - 0} = \text{slope of acceleration curve}$$

$$= \frac{0.0167 (E_u + E_{u_v}) - 0}{L_s / V - 0}$$

$$= \frac{0.0167 (E_u + E_{u_v}) \times V}{L_s}$$

$$= \frac{0.0167 (E_u + E_{u_v}) \times (V \times 1.4667)}{L_s}$$

Where: v = train speed (mph)

E_u = equivalent track unbalanced
 E_{u_v} = superelevation for vehicle roll

L_s = spiral length (ft)

Appendix E (Cont'd)
Derivation of Jerk Formula



APPENDIX F
(Reference Section 4.6 of Report)

Derivation of Spiral Length Formula: $L_s = 0.99E_u V$
(Methodology Contained in References 1 and 2)

Knowing the acceptable jerk range is 0.03g/sec - 0.04g/sec, a value in the lower third portion is selected as the maximum allowable jerk. With a maximum allowable jerk of 0.033g/sec, the time required to attain a maximum allowable acceleration of 0.1g is:

$$\text{Time} = \frac{\text{max. allowable acceleration}}{\text{max. allowable jerk}} = \frac{0.10g}{0.033g/\text{sec}} = 3.03 \text{ sec}$$

The distance a rail vehicle travels during this time is:

$$\begin{aligned} L_s \text{ (ft)} &= vt = (V \times 1.4667) (3.03\text{sec}) \\ &= 4.44V \quad (V \text{ in mph}) \end{aligned}$$

To include a term for unbalanced superelevation, this last equation is modified in equivalent form based on a maximum allowable unbalanced superelevation of 4-1/2 inches:

$$\begin{aligned} L_s &= \frac{4.44}{(\text{max. allowable unbalanced superelevation})} \times (E_u) \times (V) \\ &= \frac{4.44}{4.5} \times E_u \times V \\ &= 0.99 E_u V \end{aligned}$$



APPENDIX G
(Reference Section 5.1 of Report)

Vertical Curve Criteria of Various Properties

PROPERTY	CRITERIA	COMMENT
Balt. MTA, Miami	$L = (G_1 - G_2) 100$	Minimum Length
	$L = (G_1 - G_2) 200$	Desired Minimum Length
	$L = 100'$	Absolute Minimum - Balt. MTA
	$L = 200'$	Absolute Minimum - Miami
		Formulae do not limit acceleration
WMATA	$L = (G_1 - G_2) 100$	Desired Minimum Length
	$L = 200'$	Absolute Minimum
		Formulae do not limit acceleration
MARTA	$L = V^2A/30$	Limit acceleration to 0.02g on crest curves
	$L = V^2A/60$	Limit acceleration to 0.04g on trough curves
	$L = 3V$	Throwback to highway design - primarily for stepping sight distance
	$L = 70A$	Throwback to highway design - primarily for aesthetic reason
	$L = 100'$	-----
LA Metro Rail	$L = 0.014AV^2 + 2.5V$	Limits acceleration in g's $1 / [20.95 + (3742.1/AV)]$
	$L = AV$	Absolute Minimum. Limits acceleration to $6.68 \times 10^{-4}V$ in g's
	$L = 100$	Absolute Minimum

G_1 & G_2 are grades (%) of connecting segments.

$A = G_1 - G_2$ $V =$ Train Velocity (mph)