

=====

GENERAL PLANNING CONSULTANT
TECHNICAL MEMORANDUM 87.7.2
OPERABLE SEGMENTS SELECTION,
METHODOLOGY, AND OSA
RECOMMENDATIONS

=====

Prepared for:
Southern California Rapid Transit District

Prepared by:
Schimpeler Corradino Associates

in association with
Cordoba Corporation
Myra L. Frank & Associates
Manuel Padron
The Planning Group, Inc.

August, 1986

SCRTD
1986
.063

21889488

SCHIMPELER CORRADINO ASSOCIATES

GENERAL PLANNING CONSULTANT to the Southern California Rapid Transit District



425 South Main Street

Los Angeles, California 90013

213/972-3239

Associate Consultants:
Barton-Aschman Associates
Deloitte Haskins & Sells
Robert J. Harmon & Associates, Inc.
The Planning Group, Inc.
Cordoba Corporation
Myra L. Frank & Associates
Manuel Padron

Mr. Gary S. Spivack, Director
Department of Planning
Southern California Rapid Transit District
425 South Main Street
Los Angeles, CA 90013

Re: Technical Memorandum 87.7.2
Operable Segments Selection, Methodology, and OSA Recommendations
August, 1986

September 16, 1986

Dear Gary:

Please find attached Technical Memorandum 87.7.2 on "Operable Segments Selection, Methodology, and OSA Recommendations." This document contains capital cost estimates as provided by TSD in August, 1986 and defines potential Operable Segment As for each of the CORE candidate alignments. It also identifies the Operable Segment As that are currently being used in the draft SEIR. Taking the Operable Segment As defined in this Technical Memorandum and the SEIR, there exist two alternative sets of Operable Segments, one with costs in the vicinity of \$700 million, and one with costs in the vicinity of \$900 million.

As new information becomes available, Operable Segment A definitions could be revised. The ones contained in this document are preliminary and are for purposes of further study and review.

If you have any questions or comments on this Technical Memorandum, please let me know.

Sincerely,

PETER R. STOPHER, Ph. D.
Deputy Project Director

MTA LIBRARY

TABLE OF CONTENTS

	<u>Page No.</u>
SECTION I - REFINING AND SEQUENCING OPERABLE SEGMENTS-- METHODOLOGY.....	1
1.0 <u>OVERVIEW</u>	1
2.0 <u>CONSTRUCTION SEGMENT IDENTIFICATION</u>	2
2.1 PURPOSE.....	2
2.2 METHODOLOGY.....	2
2.3 PRODUCTS.....	3
3.0 <u>IDENTIFICATION OF OPERABLE SEGMENTS</u>	3
3.1 PURPOSE.....	3
3.2 METHODOLOGY.....	3
3.2.1 <u>Cost Criteria</u>	4
3.2.2 <u>Operation Viability</u>	4
3.2.3 <u>Key Link Inclusion</u>	5
3.3 PRODUCTS.....	5
4.0 <u>REQUIRED SIMULATIONS</u>	6
4.1 PURPOSE.....	6
4.2 METHODOLOGY.....	6
4.3 PRODUCTS.....	6
5.0 <u>PATRONAGE AND OPERATING COST ESTIMATES</u>	6
5.1 PURPOSE.....	6
5.2 METHODOLOGY.....	6
5.3 PRODUCTS.....	7
6.0 <u>DEVELOP EVALUATION FACTORS</u>	7
6.1 PURPOSE.....	7
6.2 METHODOLOGY.....	7
6.3 PRODUCTS.....	8

7.0	<u>EVALUATION OF OPERABLE SEGMENTS</u>	8
7.1	PURPOSE.....	8
7.2	METHODOLOGY.....	8
7.3	PRODUCTS.....	8
8.0	<u>SELECTION OF OPERABLE SEGMENTS</u>	8
8.1	PURPOSE.....	8
8.2	METHODOLOGY.....	8
8.3	PRODUCTS.....	9
9.0	<u>POTENTIAL REVISIONS TO SEIS DOCUMENT</u>	9
9.1	PURPOSE.....	9
9.2	METHODOLOGY.....	9
9.3	PRODUCTS.....	10
SECTION II - APPLICATION OF METHODOLOGY FOR SELECTION OF OSA'S...		11
1.0	<u>IDENTIFICATION OF CONSTRUCTION SEGMENTS</u>	11
2.0	<u>CAPITAL COSTS ESTIMATES</u>	15
3.0	<u>IDENTIFICATION</u>	15
4.0	<u>IDENTIFICATION OF ADDITIONAL OPERABLE SEGMENTS</u>	21
4.1	CANDIDATE ALIGNMENT A.....	21
4.2	CANDIDATE ALIGNMENT C.....	24
4.3	CANDIDATE ALIGNMENT H.....	27
4.4	CANDIDATE ALIGNMENT J.....	30
5.0	<u>EVALUATION OF OPERABLE SEGMENT CANDIDATES</u>	33
5.1	CRITERIA FOR EVALUATION.....	33
	5.1.1 Cost.....	33
	5.1.2 <u>Operational Viability of An End-Station</u>	33
	5.1.3 <u>Key Link</u>	34
5.2	CANDIDATE ALIGNMENT A.....	34
5.3	CANDIDATE ALIGNMENT C.....	36

5.4	CANDIDATE ALIGNMENT H.....	38
5.5	CANDIDATE ALIGNMENT J.....	38
5.6	SUMMARY.....	41

APPENDIX A - BASIS FOR \$960M COST LIMITATION

LIST OF FIGURES

Figure No.		<u>Page No.</u>
1	CONSTRUCTION SEGMENT DEFINITION.....	14
2	CONSTRUCTION SEGMENT COST ESTIMATES.....	16
3	ALIGNMENT A SEGMENT ANALYSIS.....	17
4	ALIGNMENT C SEGMENT ANALYSIS.....	18
5	ALIGNMENT H SEGMENT ANALYSIS.....	19
6	ALIGNMENT J SEGMENT ANALYSIS.....	20
7	ALIGNMENT A ADDITIONAL SEGMENT ANALYSIS.....	22
8	ALIGNMENT A OPERABLE SEGMENT CANDIDATE.....	23
9	ALIGNMENT C ADDITIONAL SEGMENT ANALYSIS.....	25
10	ALIGNMENT C OPERABLE SEGMENT CANDIDATE.....	26
11	ALIGNMENT H ADDITIONAL SEGMENT ANALYSIS.....	28
12	ALIGNMENT H OPERABLE SEGMENT CANDIDATE.....	29
13	ALIGNMENT J ADDITIONAL SEGMENT ANALYSIS.....	31
14	ALIGNMENT J OPERABLE SEGMENT CANDIDATE.....	32
15	ALIGNMENT A EVALUATION OF OPERABLE SEGMENTS.....	35
16	ALIGNMENT C EVALUATION OF OPERABLE SEGMENTS.....	37
17	ALIGNMENT H EVALUATION OF OPERABLE SEGMENTS.....	39
18	ALIGNMENT J EVALUATION OF OPERABLE SEGMENTS.....	40

SECTION I

REFINING AND SEQUENCING OPERABLE SEGMENTS--METHODOLOGY

1.0 OVERVIEW

The goal of this task is to define a methodology to generate operable segments and to select a best set of operable segments for each of the four candidate alignments. The assumption is that the alignment of MOS-1 extending to the Wilshire Boulevard-Alvarado Street intersection is fixed. The Congressionally Ordered Re-Engineering (CORE) study thus far has identified four potential alignments for completing the heavy rail portion of the transit system.

There is general agreement that whichever of the four candidate alignments ultimately is selected, construction will be divided into three Operable Segments designated as OS-A, OS-B, and OS-C. The primary purpose of this portion of the CORE study is to select the best one or two of the proposed OS-A's for each of the four candidate alignments. A secondary purpose is to establish a procedure for selecting the OS-B and OS-C which best complement the selected OS-A configuration.

The methodology proposed for performing this task has been divided into several subtasks:

a. Identification of Construction Segments.

Each candidate alignment must be broken up into construction segments small enough to be combined into several meaningful choices for operable segments.

b. Identification of Operable Segments.

In this initial phase, proposals for OS-A only will be identified. The identification process is based on a set of guidelines developed for this purpose.

c. Required Simulations.

Reliable estimates of patronage and operating costs are needed for each proposed OS-A. A number of simulations needed to provide such data for other networks have been run earlier. In this subtask, the necessity for performing new simulations will be determined.

d. Patronage and Operating Cost Estimates.

The required simulations will be performed and estimates will be made for operating costs and revenues as required for the analysis.

e. Develop Evaluation Factors.

The factors to be used for evaluating alternative OS-A proposals will be determined and value measures for each will be developed.

f. Operable Segment Evaluation.

All of the proposed operable segments will be evaluated by a Ranker-Rater exercise to measure the overall utility of each alternative.

g. Operable Segment Selection.

The best operable segment for each candidate alignment will be selected on the basis of all information collected and all analytical work carried out. The process now reverts to subtask b. to select the best Operable Segment B, starting with the best Operable Segment A for each candidate alignment.

h. Impact on Environmental Documents.

The best operable segment for a candidate alignment may include a terminus station for which environmental impact analyses have not been performed. In this event, adequate environmental documentation is produced and environmental procedures followed.

2.0 CONSTRUCTION SEGMENT IDENTIFICATION

2.1 PURPOSE

The purpose of this subtask is to identify construction segments for each of the four candidate alignments.

2.2 METHODOLOGY

Each candidate alignment will be divided up into construction segments. The construction segments must be small enough to be combined into several feasible possibilities for operable segments. In general, the smallest segment probably extends from just beyond one station to just beyond the next station. Thus, the maximum number of segments is limited to the number of stations.

There are about 19 stations on the entire project, and five are included in MOS-1. That leaves 14 stations, and two of those are permanent termini. Thus, there are about 10 to 12 choices for construction segments at intermediate locations. When these possible choices are reduced further by the guidelines for operable segments discussed below in Part 3., the number of construction segments is limited to about seven or eight for each candidate alignment.

A construction cost estimate is required for each construction segment. Each such segment is costed such that, when three or four such segments are combined into a possible OS-A configuration, the operable segment cost may be determined easily by summation. Construction costs are needed because funding constraints limit the maximum size of operable segments.

Cost estimates as calculated by CORE for each candidate alignment are available for analysis. Costs are given in terms of several construction categories including guideway, stations, trackwork, communications, fare collection, and rolling stock. A cost factor is determined for each construction category. Consider trackwork as an example. The sum of trackwork costs for each candidate alignment divided by the sum of alignment lengths in miles yields a weighted cost factor for trackwork in dollars per mile.

The construction cost of trackwork for any construction segment is calculated by multiplying the cost factor by the segment length. A total of 18 cost factors are used in the analysis: ten on a per-mile cost basis and eight on a unit-cost basis. The total cost of any one segment is calculated by summing the products of the cost factor and the system characteristic for each construction category included on the segment.

The construction cost of the proposed OS-A is determined by summing up the cost of all construction segments included in the operable segments.

2.3 PRODUCTS

The product of this subtask will be a list of construction segments and associated capital costs for each of the four candidate alignments.

3.0 IDENTIFICATION OF OPERABLE SEGMENTS

3.1 PURPOSE

The purpose of this subtask is to develop a set of logical operable segments generally limited to three sets designated as OS-A, OS-B, and OS-C. This will be accomplished independently for each of the four candidate alignments.

3.2 METHODOLOGY

Operable Segment A (OS-A) will consist of a set of construction segments which extend the HRT system from the terminus station of MOS-1, Wilshire and Alvarado, in a westerly or northerly direction, or in both directions. Guidelines which will be followed to ensure feasibility of the operable segment include:

- o A maximum capital cost of OS-A of \$960 million which approximates the funds made available by provisions of the current draft Congressional Authorization bill;
- o A length in miles equal to or greater than that of MOS-1;
- o Operational viability of end stations to serve as temporary termini; and
- o The inclusion of a key link.

3.2.1 Cost Criterion

The cost of OS-A should be limited to a maximum of about \$960 million in 1986 dollars. This figure is arrived at as follows:

- o The funding mark in the current draft Congressional Authorization Bill is \$870 million. A sum of \$203 million of this amount is recovery of the Federal shortfall of funds to cover full-funding authorization of MOS-1.
- o The balance of \$667 million represents the funding for OS-A or MOS-2 as phrased in the Authorization Bill. This gives a construction price tag of \$1,334 million for OS-A when local matching funds are included.
- o In general, OS-A is projected to be a project of 6 years duration and to begin operation in 1995. A construction project under construction from 1989 to 1994 with current inflation projections will cost 1.39 current dollars for every dollar of 1986 cost. Dividing \$1334 million by 1.39 yields a 1986 cost of \$960 million for OS-A as the upset figure. (See Appendix A)

3.2.2 Operational Viability

The operational viability of an end station will be measured as a function of several factors:

- o Environment.

The area in the vicinity of an end station will be subject to impacts including increased automobile and bus traffic, noise, and parking problems. In other words, there will be a substantial increase in virtually all forms of activity throughout the area. Such activity increases will be beneficial in proximity to land uses such as commercial or retail sales. However, such activity impacts are especially detrimental to land uses such as residential, hospitals, and schools. Temporary termini in these locations should be dropped from consideration as end stations.

- o Bus Access and System Interface.

A characteristic of terminal activity includes the attraction of bus and auto passengers who will continue their trip on rail. This activity is intensified at terminal stations. Consequently, sufficient space must be available to provide for parking and vehicle maneuvers, especially bus turnarounds.

There should exist as well a potentially strong interface between the bus and rail systems to permit the effective utilization of both systems and allow for efficient passenger transfers.

- o Engineering/Design Considerations.

A minimum of from 500 to 600 feet of straight tail track should be constructed beyond the end station. This tail track serves as vehicle storage and as a safety device in the event the station is accidentally bypassed by the rail cars. Use of the tail track is greatly enhanced if it is straight.

3.2.3 Key Link Inclusion

The determination of status as a key link is based on several factors:

- o A segment is considered a key link if, upon its inclusion in an Operating Segment, the extension to the next station virtually guarantees, on the basis of previous studies, substantial ridership leading to a high level of system utilization.
- o A segment is considered a key link if it provides for construction in both north and west directions, thus demonstrating a commitment to both travel sheds.
- o A segment is considered a key link if it extends the system in a direction enjoying broad-based business, public, and political support. Segments with strong opposition should be avoided and further study scheduled until all issues are resolved and consensual agreement reached.

Any construction segments not included in a particular OS-A will be part of OS-B or OS-C and selected according to the same guidelines as for OS-A. The selections of construction segments to be included in OS-B and OS-C will be made after the selection of the best OS-A for a candidate alignment.

3.3 PRODUCTS

The product of this subtask will be a description of all logical and feasible OS-A possibilities for each of the four candidate alignments.

4.0 REQUIRED SIMULATIONS

4.1 PURPOSE

The purpose of this subtask is to determine the simulation runs required to provide estimates of patronage and operating costs for the proposed Operating Segments.

4.2 METHODOLOGY

The OS-A possibilities for each of the four candidate alignments will be checked for the necessity of running new simulations. Some of the proposed operating segments may have been simulated earlier. For others, the background bus network will have to be determined and a new simulation run. In other instances, it may be possible to pivot off an existing simulation rather than do a completely new one.

In all simulations, no attempt will be made to include any light rail lines.

When the list of required new simulations is completed, they will be performed.

4.3 PRODUCTS

The product of this subtask is the compilation of all simulation runs required to analyze properly each operating segment (OS-A) proposed for the four candidate alignments.

5.0 PATRONAGE AND OPERATING COST ESTIMATES

5.1 PURPOSE

The purpose of this subtask is to utilize the simulation results to develop estimates of patronage, operating costs, and revenues for the bus-rail system in question.

5.2 METHODOLOGY

A new simulation will be performed for each defined operable segment that is different from any previous ones and that is considered too different to pivot. A new background bus system will be defined and coded as a UNET network. A full simulation will be performed with each such network to produce estimates of total rail patronage, station boardings by mode of access and time of day, and statistics of bus operations needed to estimate bus operating costs. Estimates of rail operating costs for each tested operable segment will be obtained from TSD. Revenue estimates will be prepared for each operable segment using the same methodology as for the analyses input to the draft SEIS/SEIR.

If pivoting is considered feasible for an operable segment, patronage and station boardings will be obtained by calculating adjustment factors for station boardings to account for the addition or subtraction of construction segments. Station-to-station volumes needed to develop the factors will be obtained for the operable segment(s) used as the basis for pivoting. Bus operating costs are expected to be set at the same value as for the nearest operable segment for which a full simulation has been prepared. TSD will be asked to prepare new rail operating costs or to recommend the use of rail operating costs from a similar operating segment. Revenue estimates also are expected to be taken or factored from the most similar operable segment for which a full simulation has been performed.

5.3 PRODUCTS

The products of this subtask are estimates of patronage, operating costs, and revenues for the bus and rail components for each of the Operable Segment A's generated for the candidate alignments.

6.0 DEVELOP EVALUATION FACTORS

6.1 PURPOSE

The purpose of this subtask is to determine the qualities of the proposed Operable Segment A's which will be used in the evaluation process. Descriptive text or numerical values will be developed as appropriate for each evaluation factor.

6.2 METHODOLOGY

One of the primary evaluation factors to be used in the evaluation process is cost effectiveness. In this regard, the UMTA Guidelines on cost effectiveness will be followed to develop both of the cost effectiveness measures promulgated by UMTA.

Other factors which may be used and developed include the following:

- o Annualized cost per passenger.
- o Ridership.
- o Operability of the entire segment.
- o Efficacy of the end-stations which serve as temporary termini.
- o Capital and Operating Costs.
- o Other socioeconomic and environmental factors deemed appropriate to the analysis.
- o Stand-Alone quality of the segment.

Descriptive or numerical measures will be developed for the Factors selected for use in the evaluation process.

6.3 PRODUCTS

The products of this subtask will consist of:

- o A list of evaluation criteria.
- o For each criterion, a measure of its value for each of the OS-A's to be evaluated. In some cases, the value measure will be numerical and in other cases, descriptive.

7.0 EVALUATION OF OPERABLE SEGMENTS

7.1 PURPOSE

The purpose of this subtask is to evaluate the Operable Segment A's proposed and select the best for each candidate alignment.

7.2 METHODOLOGY

The evaluation process proposed is an in-house Ranker-Rater exercise. About four representatives of the GPC and four from RTD will determine the utilities of the criteria to be used. The group then will evaluate the effectiveness of each operable segment in the realization of each criterion.

The overall utility of each operable segment will be calculated.

7.3 PRODUCTS

The product of this subtask is a measure of overall utility for each operable segment proposed for analysis.

8.0 SELECTION OF OPERABLE SEGMENTS

8.1 PURPOSE

The purpose of this subtask is to select the best Operable Segments for each of the candidate alignments.

8.2 METHODOLOGY

The proposed segments still under consideration will be evaluated according to a format which incorporates construction duration, expeditious construction timetable, balanced cash flow, cost effectiveness, etc. Streamlined LODESTAR runs will be performed as appropriate to aid in this analysis.

On the basis of all information gathered, the ranker-rater results and the analytical work carried out, the best Operable Segment A will be

selected for each candidate alignment.

At this point in the procedure, the next step will be to return to subtask 2 outlined in Section 3. and to repeat the exercise for Operable Segment B. It is anticipated that Operable Segment C will consist of those construction segments not included in OS-A or OS-B. The same guidelines and evaluation criteria will be used for OS-B as for OS-A.

8.3 PRODUCTS

The product of this subtask will be a Technical Memorandum documenting the entire process. The Technical Memorandum will feature the recommendation of the Study Team for the best Operable Segments for each candidate alignment.

9.0 POTENTIAL REVISIONS TO SEIS DOCUMENT

9.1 PURPOSE

In the event that a selected operable segment includes a potential new terminus station, the environmental documents must be amended and revised as appropriate.

9.2 METHODOLOGY

In the event that the above-described process identifies an operable segment(s) that deserves final analysis, and if this segment would introduce a terminus station(s) (e.g., Sunset/Edgemont (A3), Sunset/Vine (H)) that was not analyzed in the Preliminary Draft SEIS, it will be necessary to assure that adequate environmental documentation is produced and environmental procedures followed. Two possibilities exist:

- o Incorporate the additional information for the new terminus station(s) into the SEIS/SEIR. This process may be possible, given changes to the CORE schedule in response to the Vince Marella letter and given that the SEIS/SEIR will not be sent immediately to UMTA.
- o Develop a separate environmental document concerning the new operable segment(s) and terminus station(s) and circulate this document to UMTA and the public at the earliest possible date, consistent with environmental regulation requirements.

If feasible, the first approach appears preferable.

Should an alternative terminus station(s) be selected, subjects requiring major emphasis and revision in the Environmental documents include: Capital Cost, Operating Cost, Operating Characteristics, Patronage, Bus Interface, Traffic Impacts, Parking Impacts, and Social and Community Impacts.

9.3 PRODUCTS

The product of this subtask will be amended, and environmental documents revised in accordance with the findings of the environmental analyses will be produced.

SECTION II

APPLICATION OF METHODOLOGY FOR SELECTION OF OSA'S

The first step in the selection of a best operable segment for a given alignment is the identification of feasible operable segments. In Section I, a methodology is outlined in which subtasks a. and b. consist of the identification of construction segments and operable segments, respectively. The application of the methodology to complete subtasks a. and b. is documented in this section which describes the following sequence of steps:

1. Segregation of the candidate alignments into construction segments.
2. Development of capital-cost estimates for each construction segment utilizing cost factors derived from CORE project cost estimates.
3. Identification of construction segment combinations to form operable segment candidates.
4. Identification of any additional segments which appear to meet the cost criterion by either including or deleting stations on the associated guideway.
5. Evaluation of all identified operable segment candidates by a fatal-flaw analysis in which any candidate not meeting all criteria is eliminated from further study.

1.0 IDENTIFICATION OF CONSTRUCTION SEGMENTS

Each candidate alignment is segregated into construction segments which are small enough to be combined into several feasible operable segments. Often, a construction segment extends from just beyond one station to just beyond the next station. Each candidate alignment is segregated into about seven or eight construction segments.

The four candidate alignments are segregated into 15 construction segments which, in various combinations, provide the first-level identification of operable segments. These 15 segments are identified as follows:

Segment B - That portion of the alignment extending beyond the Alvarado Station and through the Vermont/Wilshire Station. It consists of 1.1 miles of subway and includes the Vermont/Wilshire Station. Segment B is common to all four candidate alignments.

Segment C - That portion of the alignment which begins west of the Vermont Station and extends along Wilshire through the Western Station. The segment consists of 1.1 miles of subway and includes two subway stations, namely the Normandy/Wilshire and the Western/Wilshire stations. This segment does not include the 'Y' section which is considered separately and added to the construction cost of the

appropriate operable segment. The 'Y' section extends the alignment both west and north. Segment C is common to all four candidate alignments.

Segment D - That portion of the alignment which begins west of Western and extends through the Pico/San Vicente Station. The segment consists of 2.3 miles of subway and includes two stations, namely the Crenshaw/Olympic and the Pico/San Vicente subway stations. Segment D is common to the A, C, and H candidate alignments.

Segment E - That portion of the alignment which begins west of Western and extends along Wilshire through the Fairfax/Wilshire station. The segment consists of 0.3 miles of subway and 2.8 miles of aerial. It includes three aerial stations, namely the Crenshaw/Wilshire, the La Brea/Wilshire, and the Fairfax/Wilshire stations. Segment E applies for candidate alignment J only.

Segment F - That portion of the alignment which extends from the Vermont/Wilshire station through the Sunset/Vermont Station on both subway and aerial configuration. The segment consists of 0.9 miles of subway and 1.7 miles of aerial and includes three aerial stations, namely the Vermont/Beverly, the Vermont/Santa Monica and the Vermont/Sunset Stations. Segment F applies to Alignment J only.

Segment N - That portion of the alignment which begins north of the Sunset/Vermont Station and extends through the Hollywood/Vine Station with both aerial and subway sections. The segment consists of 0.5 miles of subway and 1.9 miles of aerial, and includes one aerial station (Hollywood/Western) and one subway station (Hollywood/Vine). This segment applies to alignment J only.

Segment P - That portion of the alignment which extends from west of the Vermont/Wilshire Station through the Vermont/Santa Monica Station in subway configuration. This segment consists of 2.1 miles of subway and includes two subway stations, the Beverly/Vermont and the Santa Monica/Vermont Stations. The segment applies to alignment A only.

Segment K - That portion of the alignment which begins west of the Santa Monica/Vine Station and extends through the Hollywood/Cahuenga Station along Sunset Avenue. The segment consists of 2.8 miles of subway and includes the Sunset/Edgemont, the Sunset/Western, and the Hollywood/Cahuenga Stations. Segment K applies to alignment A only.

Segment G - That portion of the alignment which extends from the Western/Wilshire Station to the Western/Santa Monica Station and which is a subway configuration along Western Avenue. The alignment consists of 2.1 miles of subway and includes 2 subway stations, the Beverly/Western and the Santa Monica/Western Stations. Segment G applies to alignments C and H.

Segment L - That portion of the alignment which begins north of the Santa Monica/Western Station and extends along Sunset through the Hollywood/Cahuenga Station. The segment consists of 1.8 miles of subway and includes one station, namely the Hollywood/Cahuenga Station.

Segment L applies to alignment C only.

Segment I - That portion of the alignment which extends from either the Hollywood/Cahuenga or Hollywood/Vine Station through the Universal City Station in subway configuration. The alignment consists of 3.4 miles of subway and includes 2 subway stations, the Hollywood Bowl Station and the Universal City Station. Segment I applies to alignments A, C and J.

Segment H - That portion of the alignment which extends north of the Santa Monica/Western Station around the curve and through the Sunset/Vine Station. The segment includes 1.2 miles of subway and includes 1 subway station, the Sunset/Vine Station. The segment applies to alignment H only.

Segment Q - That portion of the alignment which begins west of the Sunset/Vine Station and extends along Sunset Avenue through the Fairfax/Sunset Station. The segment consists of 1.8 miles of subway and includes two stations, the La Brea/Sunset and the Fairfax/Sunset Stations. The segment applies to alignment H.

Segment M - That portion of the alignment which begins west of the Fairfax/Sunset Station and extends under the mountain and through the Universal City Station. The segment consists of 4 miles of subway and includes one station, the Universal City Subway Station. The segment applies to alignment H only.

Segment J - That portion of the alignment which begins north of the Universal City Station and extends through the Lankershim Station in the Valley. The segment consists of 2.4 miles of subway and includes one subway station, the Lankershim Station. Segment J is common to all four candidate alignments.

The 'Y' Section represents that portion of the alignment at which the branch occurs. It is identified separately in order that one segment (i.e., C) may be utilized for all four alignments. The 'Y' Section is added to each of the segment sequences to provide more accurate capital costs estimates. This will become apparent as the methodology for the cost estimates is more adequately defined.

In summary, each of the four candidate alignments is defined through the appropriate assignment of construction segments:

Alignment A: Segments B, C, D, P, K, I, J, and Y

Alignment C: Segments B, C, D, G, L, I, J, and Y

Alignment H: Segments B, C, D, G, H, Q, M, J, and Y

Alignment J: Segments B, C, E, F, N, I, J, and Y

A building-up process of combining segments into potential operable segments is observed through reference to Figure 1.

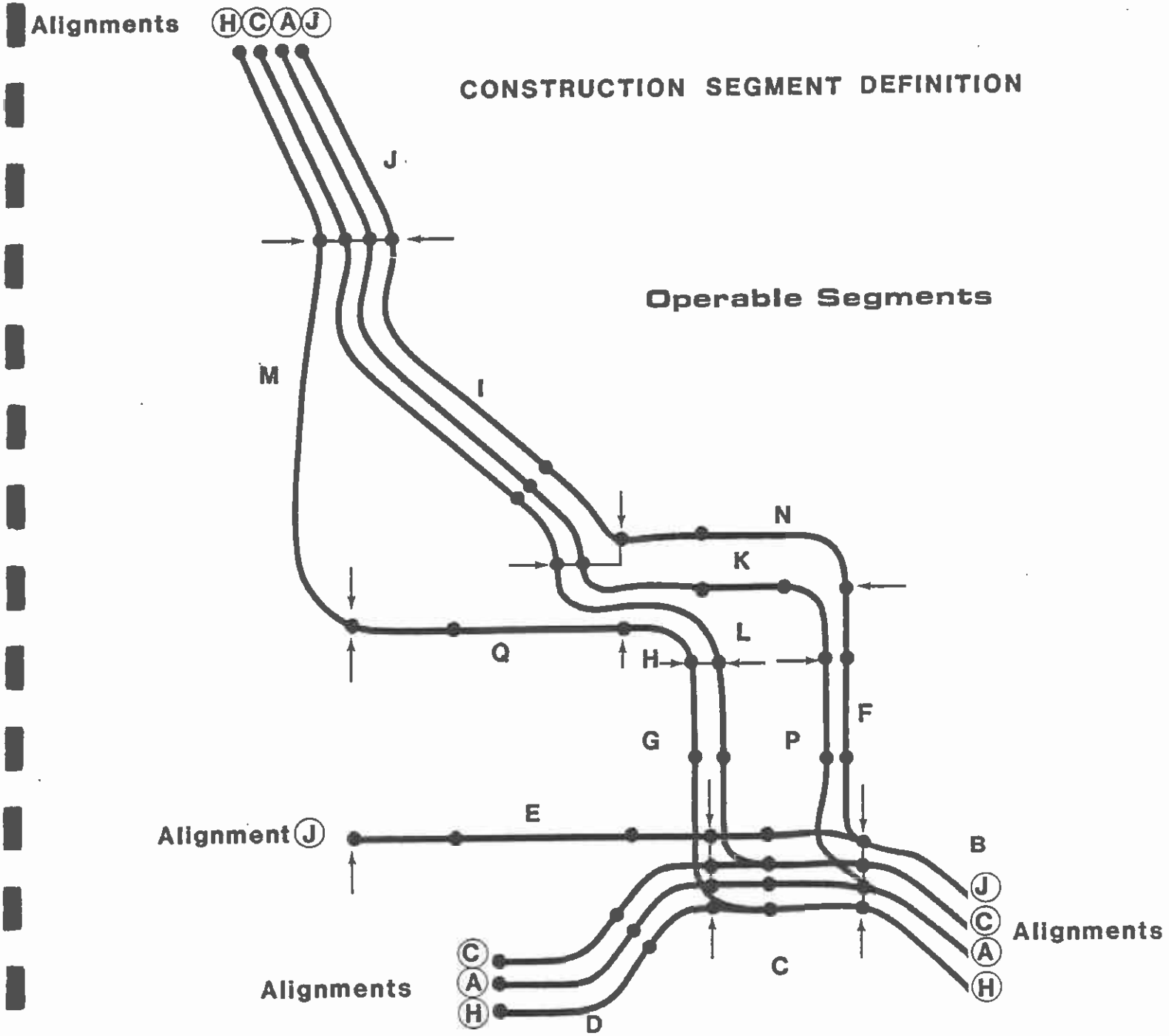

Figure 1 CONSTRUCTION SEGMENT DEFINITION

2.0 CAPITAL COSTS ESTIMATES

Capital costs estimates are derived for each construction segment through utilization of Module 4 (Project Costs Estimates from LODESTAR). Cost factors included in Module 4 are developed from the CORE cost estimates of the four candidate alignments. In general, cost factors are weighted averages of costs for specific construction categories. A list of categories and related cost factors are included in Figure 2. Some factors are based upon cost per mile of project length, while others are based upon cost per station.

System characteristics are a measure of the parameter represented by each cost factor for each construction segment identified in the analysis. The summation of products of cost factors and system characteristics over all system elements for a particular segment yields a cost estimate for the construction of that segment. Segment costs are summed for the specific group of construction segments which are combined into an identified operable segment. In this manner, cost estimates for any candidate operable segment are determined quickly and easily.

Cost factors may be modified as construction cost estimates are refined for each candidate alignment. Thus, the most up-to-date cost estimate available is used at all times.

3.0 IDENTIFICATION OF OPERABLE SEGMENT CANDIDATES

All possible combinations of segments and, hence, all possible operable segments within the segment analysis framework are shown in Figures 3, 4, 5, and 6 for candidate alignments A, C, H, and J, respectively. The graphic simulates the building up of operable segments through the inclusion of additional segments as one moves down the page. Segments in a westerly direction are added as one moves from right to left through the graphic. A left-to-right movement signifies the addition of a segment in a northerly direction. Therefore, movement down the page and one cell to the right represents the addition of one segment to the north. Movement down the page and one cell to the left represents the addition of one segment to the west.

Each cell represents a group of construction segments which make up a possible operable segment. The numerical entry in each cell represents the cumulative construction cost, excluding MOS-1, of the construction segments designated by the letter identifications within each cell.

Only those operable segments with cumulative cost estimates ranging from \$650 million to \$960 million are considered as candidates for Operable Segment-A (OS-A). All such segments are described in the next section.

MODULE 4 PROJECT COST ESTIMATE

	COST FACTORS (FY86, \$M)			LRT	BSWAY	SYSTEM CHARACTERISTICS													
	HRT	A	B			C	D	E	F	G	H	I	J	K	L	M	N	P	Q
SUBWAY CONSTRUCTION /MI	33.99			0.00	0.00														
AERIAL CONSTRUCTION /MI	15.06			0.00	0.00														
TRACKWORK /MI	2.12			0.00	0.00														
TRAIN CONTROL /MI	2.38			0.00	0.00														
COMMUNICATIONS /MI	1.31			0.00	0.00														
TRACTION POWER /MI	2.15			0.00	0.00														
VEHICLES EACH	1.06			0.00	0.00														
FARE COLLECTION EACH	1.17			0.00	0.00														
SUBWAY STA EACH	36.00			0.00	0.00														
SUBWAY X-OVER EACH	4.50			0.00	0.00														
SUB OVER/UNDER EACH	44.00			0.00	0.00														
SUB POCKET EACH	3.00			0.00	0.00														
SUB TAIL TRACK EACH	10.00			0.00	0.00														
SUBWAY SYSTEMS EACH	4.25			0.00	0.00														
AERIAL STATIONS EACH	13.00			0.00	0.00														
AERIAL X-OVER EACH	4.00			0.00	0.00														
AER TAIL TRACK EACH	2.50			0.00	0.00														
AERIAL SYSTEMS EACH	3.27			0.00	0.00														
ROW /MI	5.63			0.00	0.00														
CONTROL/YARD/SHOP EACH	34.80			0.00	0.00														
PROJECTS																			
MILES OF SUBWAY	4.4	1.0	1.1	2.3	0.3	0.3	1.9	1.2	3.5	2.4	2.8	1.7	3.6	0.3	2.1	1.8	0.0		
MILES OF AERIAL	0.0	0.0	0.0	0.0	2.9	1.8	0.0	0.0	0.0	0.0	0.0	0.0	0.0	2.1	0.0	0.0	0.0		
# OF VEHICLES	27	7	8	20	20	16	13	8	21	14	17	11	19	14	13	11	0		
# OF SUBWAY STATIONS	5	1	2	2	0	0	2	1	2	1	3	1	1	1	2	2	0		
# OF SUBWAY X-OVERS	0	0	0	1	0	0	1	0	0	2	0	0	0	0	2	0	1		
# OF SUB POCKETS	0	0	0	0	0	0	1	0	0	0	1	1	0	1	0	1	0		
# OF AERIAL STATIONS	0	0	0	0	3	3	0	0	0	0	0	0	0	1	0	0	0		
# OF AERIAL X-OVERS	0	0	0	0	1	1	0	0	0	0	0	0	0	0	0	0	0		
PARKING SPACES 100s	3	0.00	0.00	0.00	0.00	0.00	0.00	0.00	0.00	0.00	0.00	0.00	0.00	0.00	0.00	0.00	0.00		
TOTAL MILES	4.4	1.0	1.1	2.3	3.2	2.1	1.9	1.2	3.5	2.4	2.8	1.7	3.6	2.4	2.1	1.8	0.0		
TOTAL STATIONS	5	1	2	2	3	3	2	1	2	1	3	1	1	2	2	2	0		
CONTROL/YARD/SHOP	1	0	0	0	0	0	0	0	0	0	0	0	0	0	0	0	0		
CONSTRUCTION ESTIMATE (FY86, \$M)																			
PROJECT DESCR (HRT=1 LRT=2 BSWY=3)	1	1	1	1	1	1	1	1	1	1	1	1	1	1	1	1	1	1	1
FACILITIES																			
GUIDEWAYS	177	34	37	88	55	37	65	41	122	92	95	58	124	42	71	61	0		
STATIONS	270	80	72	77	43	43	90	36	75	45	111	39	38	52	81	75	5		
TOTAL FACILITIES	448	114	109	165	98	80	154	77	197	137	206	97	162	94	152	136	5		
SYSTEMS																			
CONTROL/YARDS/SHOP	34	0	0	0	0	0	0	0	0	0	0	0	0	0	0	0	0		
TRACKWORK	16	2	2	5	7	4	4	3	7	5	6	4	8	5	4	4	0		
TRAIN CONTROL	19	2	3	5	8	5	5	3	8	6	7	4	9	6	5	4	0		
COMMUNICATIONS	18	1	1	3	4	3	2	2	5	3	4	2	5	3	3	2	0		
TRACTION POWER	10	2	2	5	7	5	4	3	8	5	6	4	8	5	5	4	0		
FARE COLLECTION	8	1	2	2	4	4	2	1	2	1	4	1	1	2	2	2	0		
VEHICLE PASSENGE	44	7	8	21	21	17	14	8	22	15	18	12	20	15	14	12	0		
VEHICLE AUX	1	0	0	0	0	0	0	0	0	0	0	0	0	0	0	0	0		
STATION SYSTEMS	0	4	9	9	10	10	9	4	9	4	13	4	4	8	9	9	0		
TOTAL SYSTEMS	149	21	28	51	60	47	40	24	61	40	57	31	54	44	41	37	0		
CAPITAL COST	597	135	138	215	158	127	194	100	258	176	263	128	217	138	194	173	5		
CONTING (15%F+10%S)	51	19	19	30	21	17	27	14	36	24	37	18	30	18	27	24	1		
DESIGN/CONSTR (13%F+10%S)	165	17	17	26	19	15	24	12	32	22	32	16	27	17	24	21	1		
ROW	97	6	6	13	2	12	11	7	20	14	16	10	20	14	12	10	0		
AGENCY (5%FAC+SYS)	128	7	7	11	8	6	10	5	13	9	13	6	11	7	10	9	0		
INSURANCE (7.5%FAC+SY)	47	10	7	11	8	6	10	5	13	9	13	6	11	7	10	9	0		
TOTAL COST \$86, M	1085	193	194	306	216	184	275	143	371	253	374	183	315	200	276	246	6		
TOTAL COST (TSD)																			
DIFFERENCE																			

Figure 2 Construction Segment Cost Estimates

**ALIGNMENT A
SEGMENT ANALYSIS**

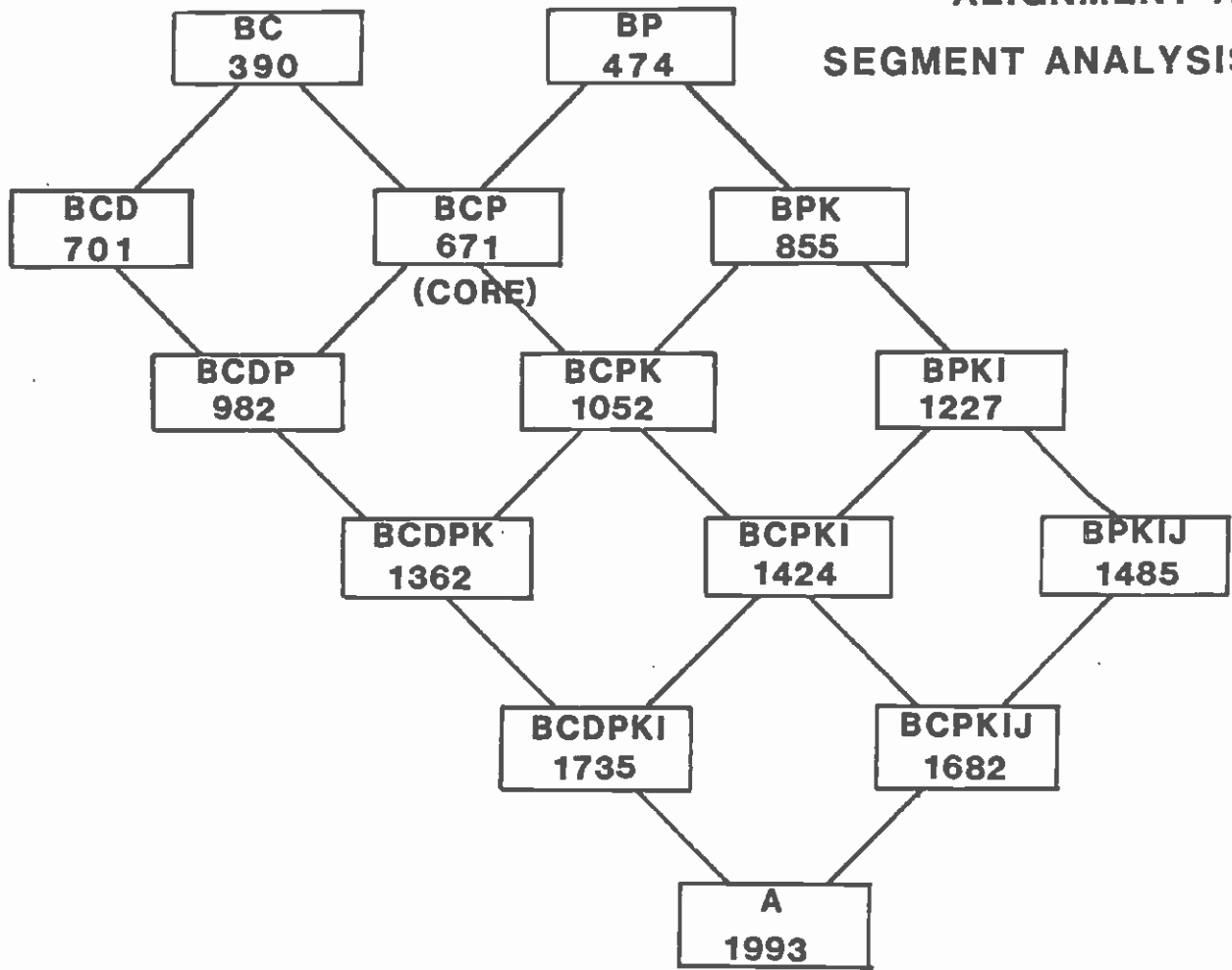

Figure 3

Alignment A Segment Analysis

ALIGNMENT C
SEGMENT ANALYSIS

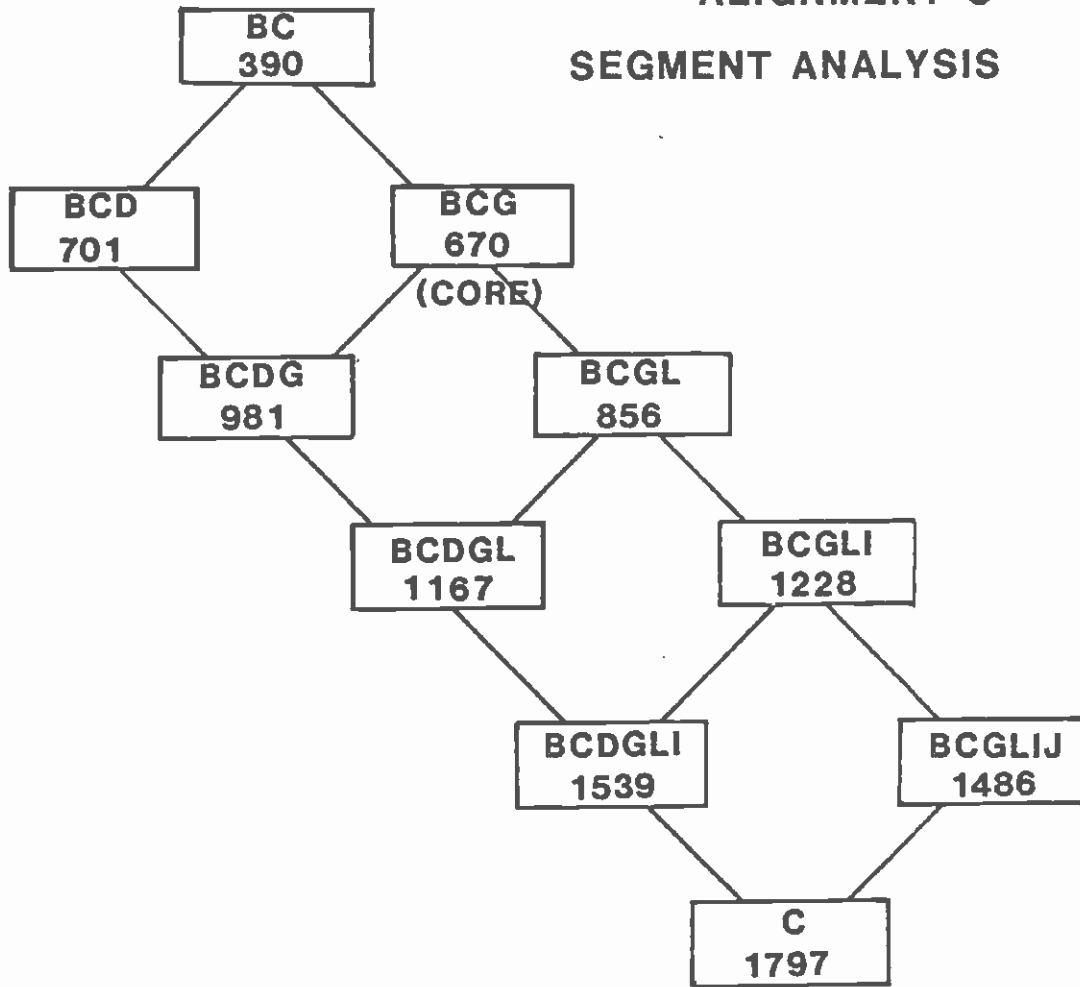

Figure 4

Alignment C Segment Analysis

ALIGNMENT H
SEGMENT ANALYSIS

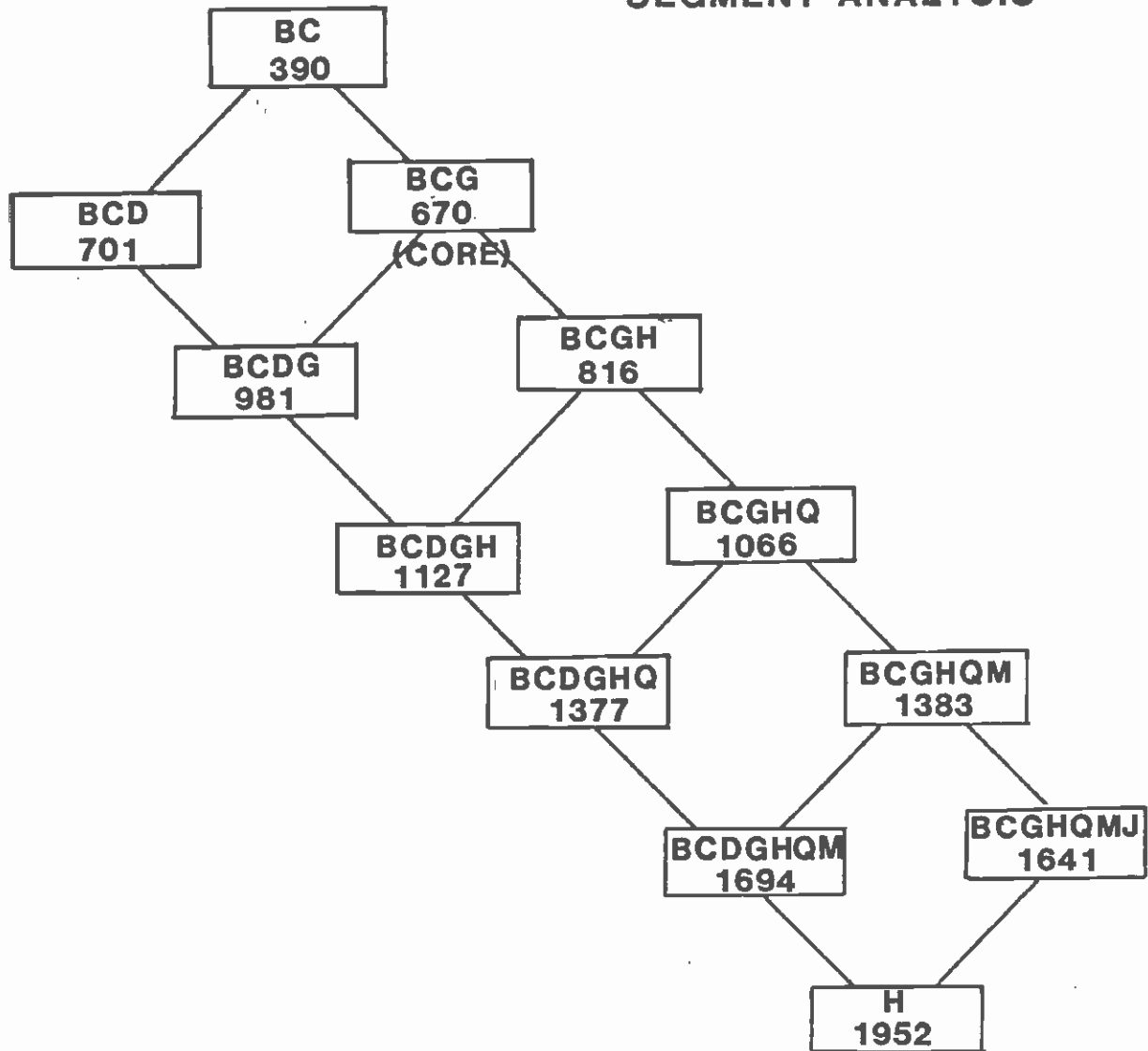

Figure 5 Alignment H Segment Analysis

ALIGNMENT J
SEGMENT ANALYSIS

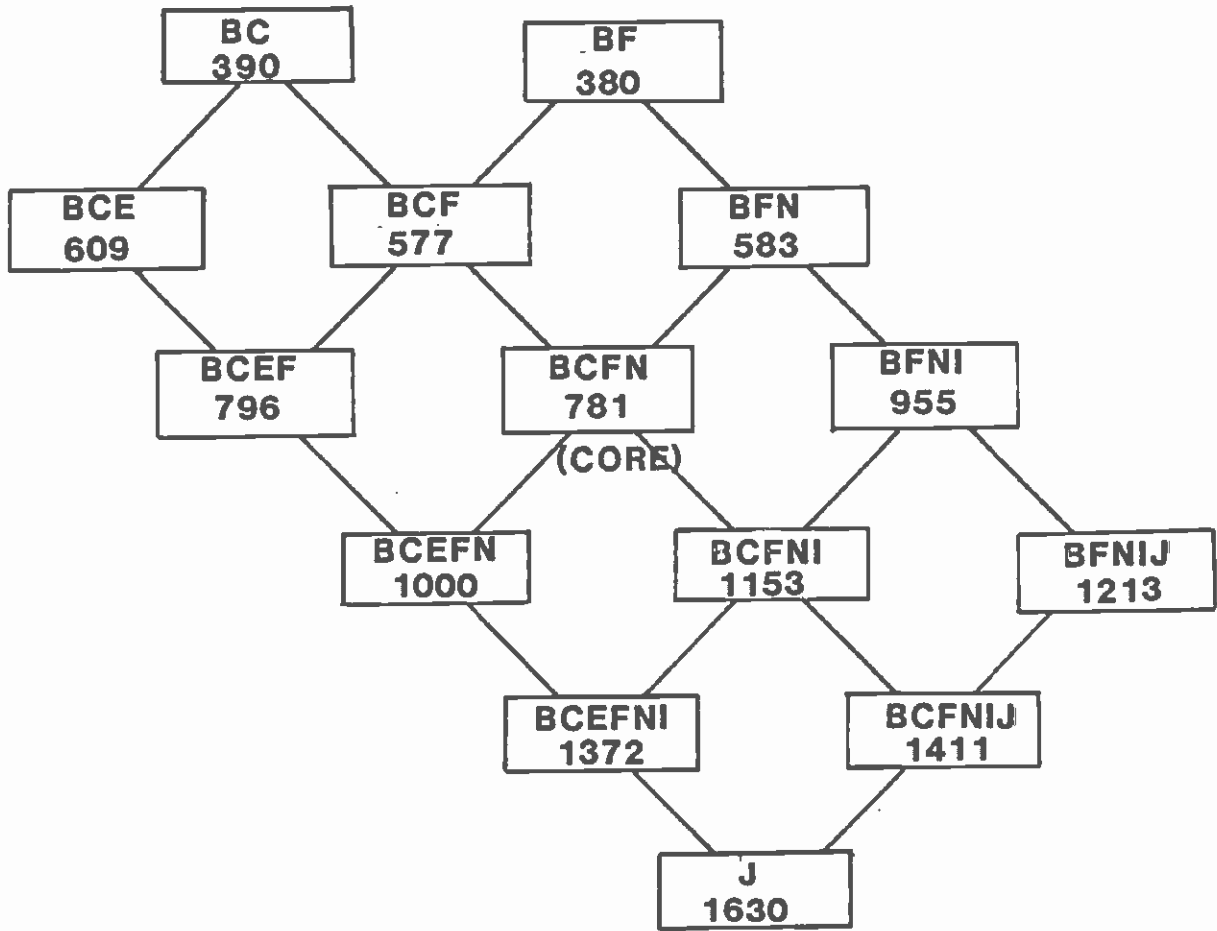

Figure 6

Alignment J Segment Analysis

4.0 IDENTIFICATION OF ADDITIONAL OPERABLE SEGMENTS

Operable segments with cost estimates near the \$700 million level are likely to be eliminated as candidates due to the underutilization of the \$960 million in available funding. However, the addition of a construction segment often drives the cost estimate well beyond the funding mark of \$960 million. Sometimes a construction segment includes more than one station. If it is feasible, a new operable segment candidate may be derived by adding only a portion of a construction segment to include an intermediate station in the operable segment. This strategy results in cost estimates nearer to, but not more than, the funding mark.

4.1 CANDIDATE ALIGNMENT A

An analysis of Figure 3, "Alignment A Segment Analysis," reveals a substantial gap in the capital-cost estimates of an operable segment with four construction segments and one with three construction segments. The three possible operable segments with three construction segments each are estimated to cost \$701 million (BCD), \$671 million (BCP), and \$855 million (BPK). Four construction segments brings the costs to \$982 million (BCDP) or \$1,052 million (BCPK), both of which exceed the available funds of \$960 million. Figure 7 identifies four additional operable segments created by adding one or two stations to those operable segment candidates which include only three construction segments. Operable segment candidate BCD with a cost estimate of \$701 million is modified by adding one station to the north, which creates an operable segment candidate with a cost estimate of \$841 million. The addition of one station to operable segment candidate BCP either to the west or to the north results in two operable segment candidates with cost estimates of \$813 million and \$779 million, respectively. Adding two stations to the north on BCP creates an operable segment candidate with a cost estimate of \$883 million. Thus, a total of seven operable segment candidates have been identified for alignment A, as shown in Figure 8. These are evaluated utilizing the methodology outlined in Section I.

Operable Segment A-OSA-1 is the combination of Segments B, C, and D, which forms an operable segment with a cost estimate of \$701 million and has a terminal station located at Pico/San Vicente.

Operable Segment A-OSA-2 is the combination of Segments B, C and P, which forms an operable segment with a cost estimate of \$671 million. It includes the 'Y' section and two terminal stations located at Western/Wilshire and Santa Monica/Vermont.

Operable Segment A-OSA-3 is developed by combining Segments B, P, and K, which yields a cost estimate of \$855 million and has a terminal station at Hollywood/Cahuenga.

ALIGNMENT A SEGMENT ANALYSIS

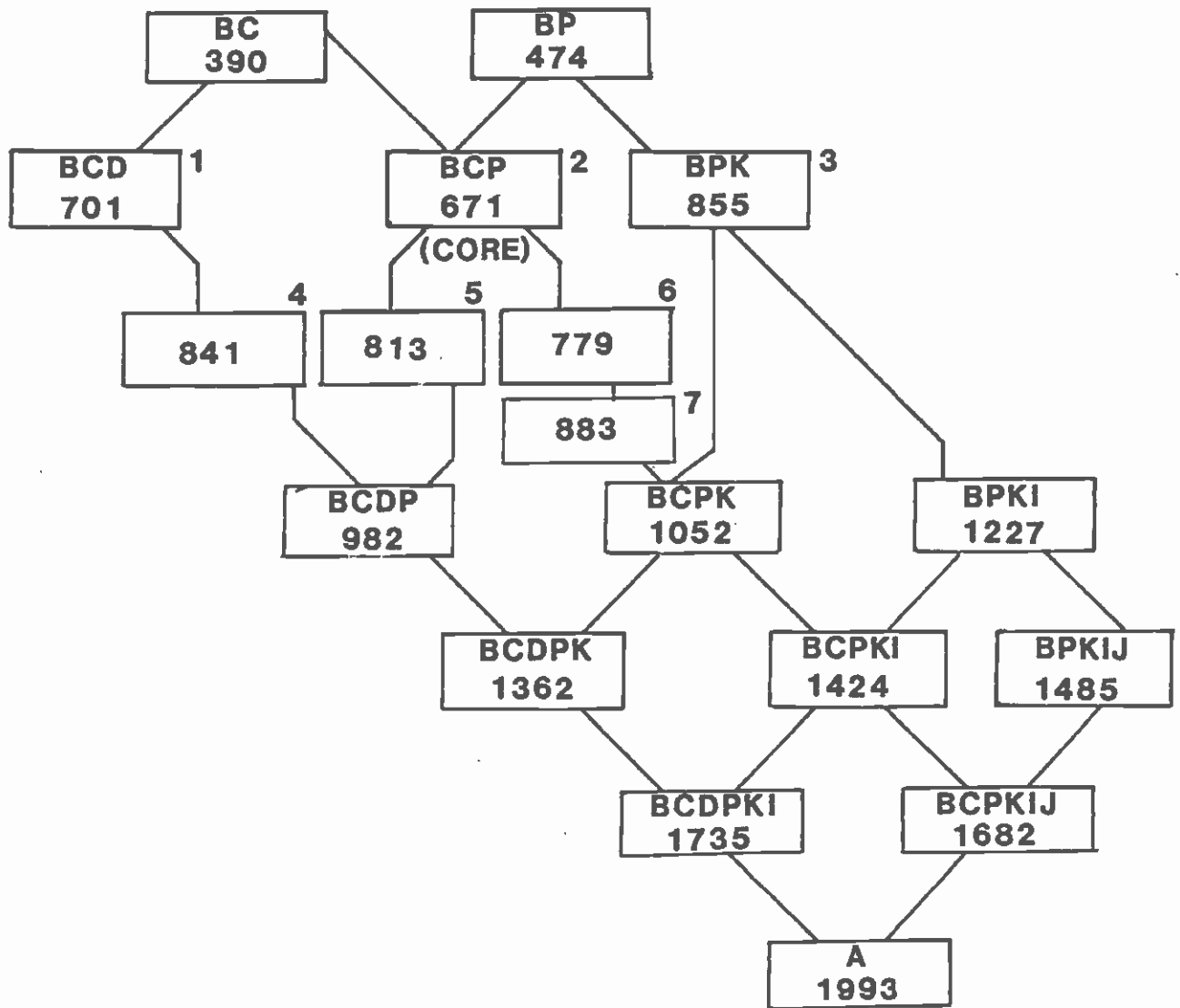
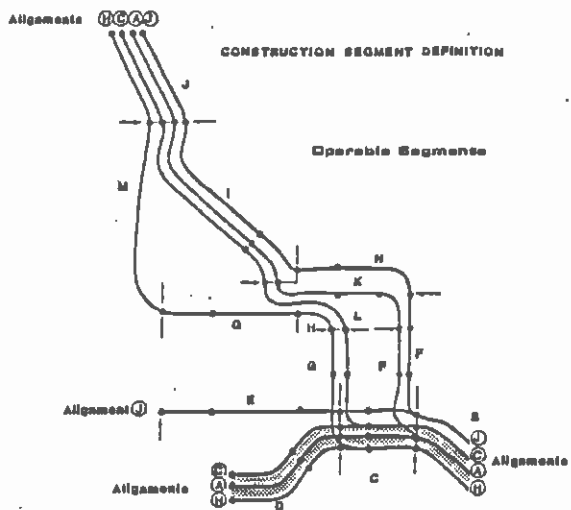
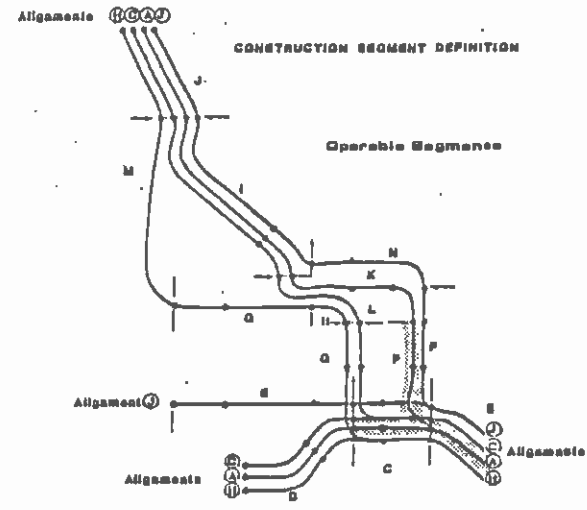

Figure 7

Alignment A Additional Segment Analysis



A-OSA-1 701



**A-OSA-2 671
(CORE)**

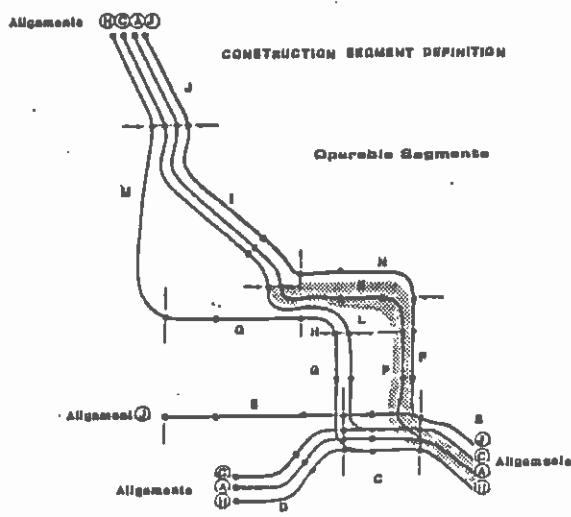

A-OSA-3 855

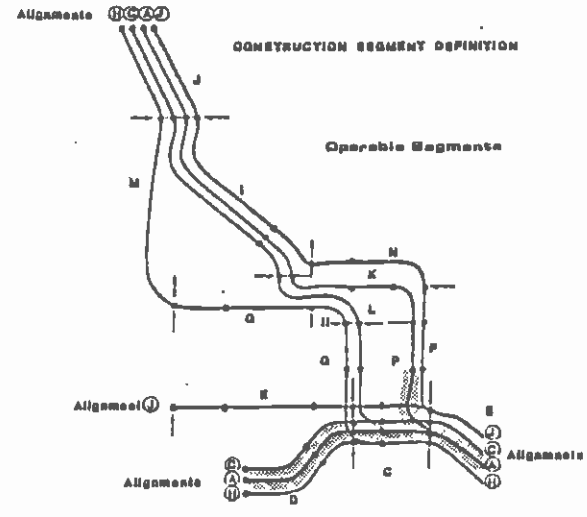

A-OSA-4 841

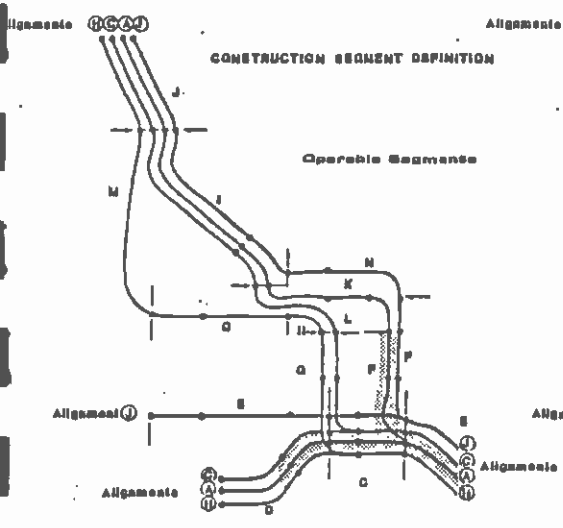

A-OSA-5 813

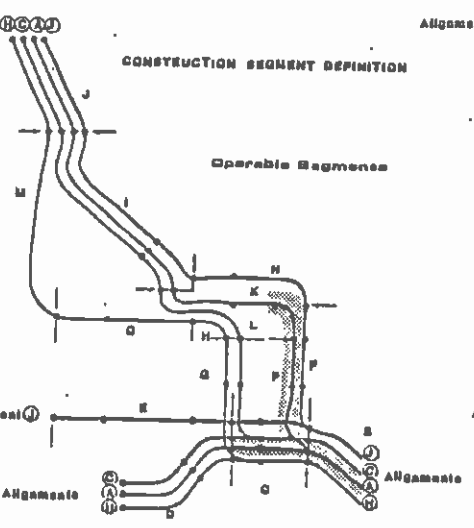

A-OSA-6 779

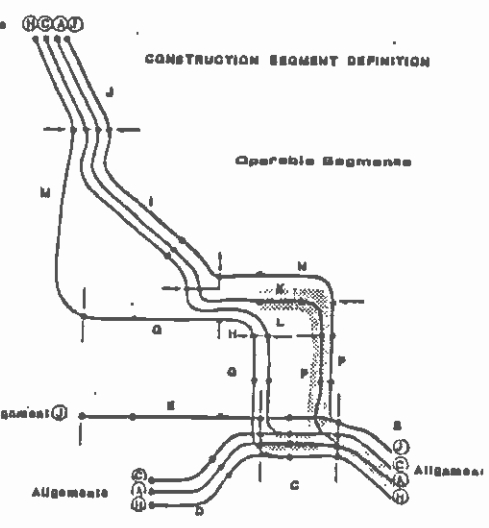

A-OSA-7 883

Figure 8 Alignment A Operable Segment Candidate

Operable Segment A-OSA-4 is developed by combining Segments B, C, and D (i.e., A-OSA-1) with one additional station to the north and including the 'Y'. This combination yields a cost estimate of \$841 million and has two terminal stations located at Pico/San Vicente and Vermont/Beverly.

Operable Segment A-OSA-5 is developed by combining Segments B, C and P (i.e., A-OSA-2) with an additional station to the west. This plan yields a cost estimate of \$813 million and has two terminal stations located at Santa Monica/Vermont and Olympic/Crenshaw.

Operable Segment A-OSA-6 is developed by combining Segments B, C and P (i.e., A-OSA-2) with one additional station to the north. This configuration yields a cost estimate of \$779 million and has two terminal stations located at Western/Wilshire and Sunset/Edgemont.

Operable Segment A-OSA-7 is developed by combining Segments B, C and P (i.e., A-OSA-2) with two additional stations to the north. This configuration yields a cost estimate of \$883 million and has two terminal stations located at Western/Wilshire and Sunset/Western.

4.2 CANDIDATE ALIGNMENT C

A review of Figure 4, "Alignment C Segment Analysis," reveals the same situation that prevailed for alignment A with regard to the large gap in capital-cost estimates for operable segments. Two additional operable segment candidates are generated by the addition of one station rather than by adding an entire construction segment. Operable segment candidate BCD is modified by adding one station to the north. Operable segment candidate BCG is modified by adding one station to the west. Thus, there are a total of five Operable Segment Candidates on alignment C which must be evaluated. These additional operable segments are shown in Figure 9, and all the operable segment candidates are shown in Figure 10.

Operable Segment C-OSA-1 is developed by combining Segments B, C, and D, which yields a cost estimate of \$701 million and has a terminal station located at Pico/San Vicente.

Operable Segment C-OSA-2 is developed by combining Segments B, C, and G, which yields a cost estimate of \$670 million and has terminal stations located at Santa Monica/Western and at Western/Wilshire.

Operable Segment C-OSA-3 is developed by combining Segments B, C and D (i.e., C-OSA-1) with one additional station to the north and including the 'Y'. This plan yields a cost estimate of \$856 million and includes terminal stations located at Pico/San Vicente and at Beverly/Vermont.

Operable Segment C-OSA-4 is developed by combining Segments B, C and G (i.e., C-OSA-2) with an additional station to the west. This configuration yields a cost estimate of \$812 million and has terminal stations located at Santa Monica/Western and at Olympic/Crenshaw.

**ALIGNMENT C
SEGMENT ANALYSIS**

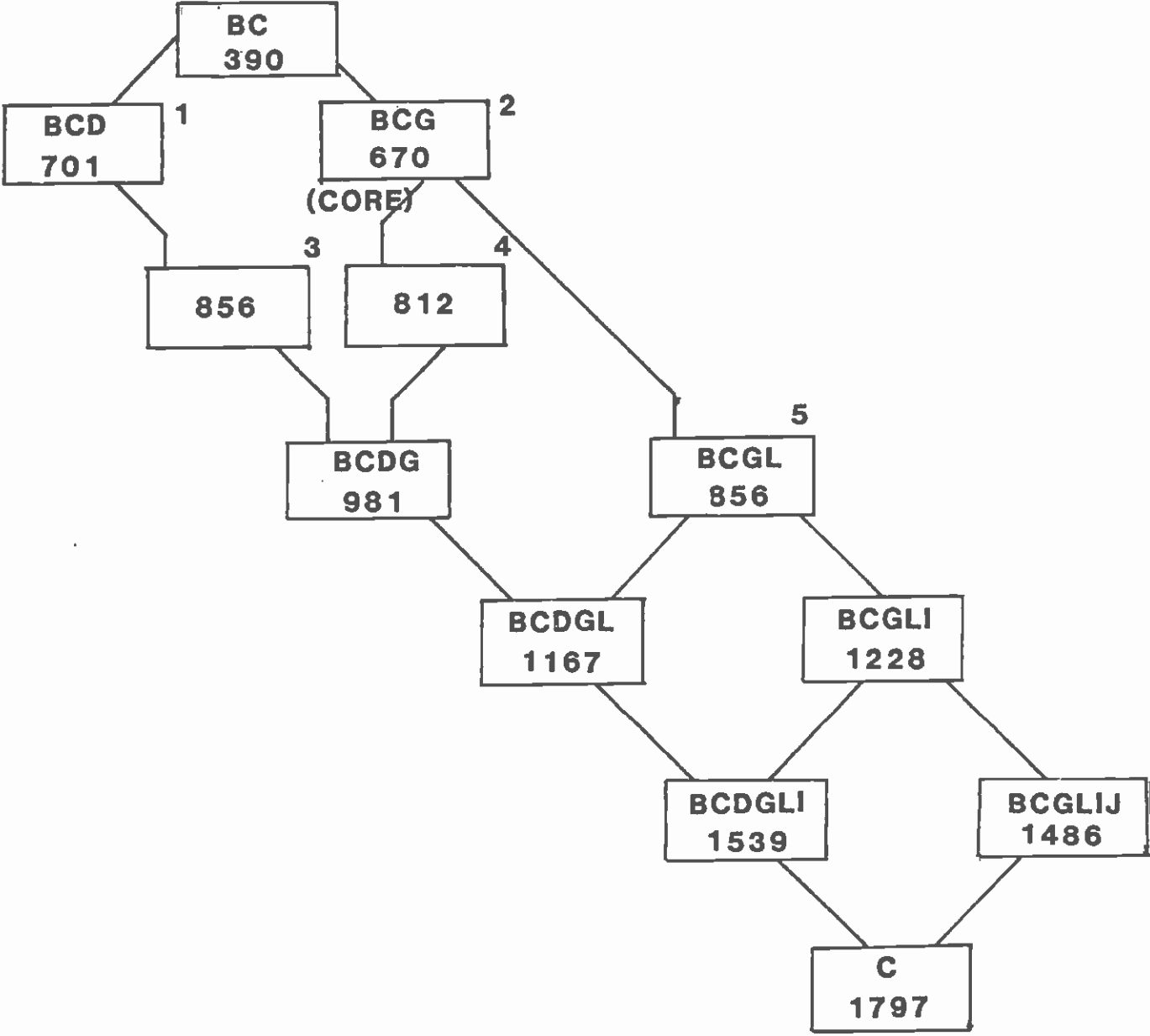

Figure 9 Alignment C Additional Segment Analysis

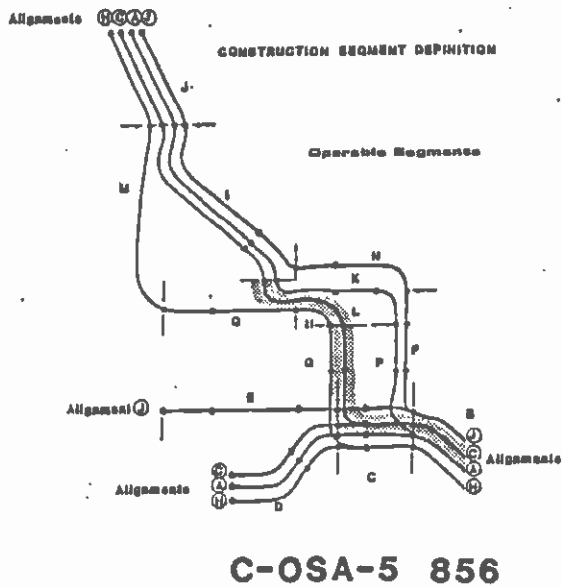
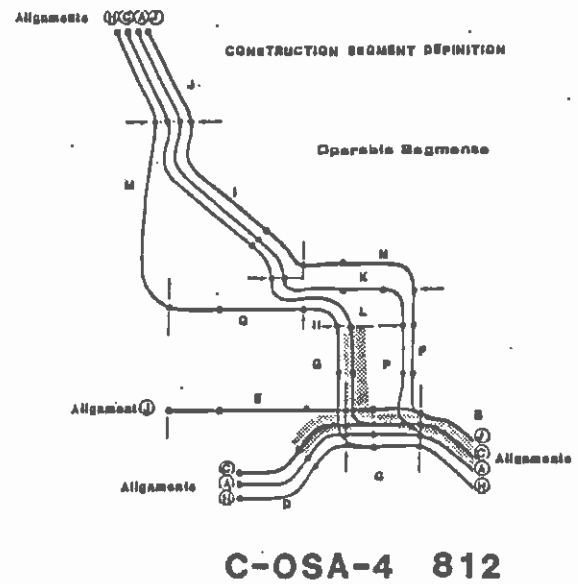
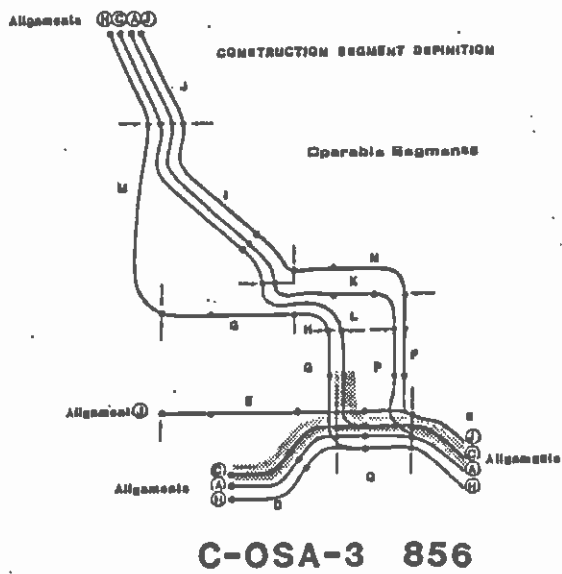
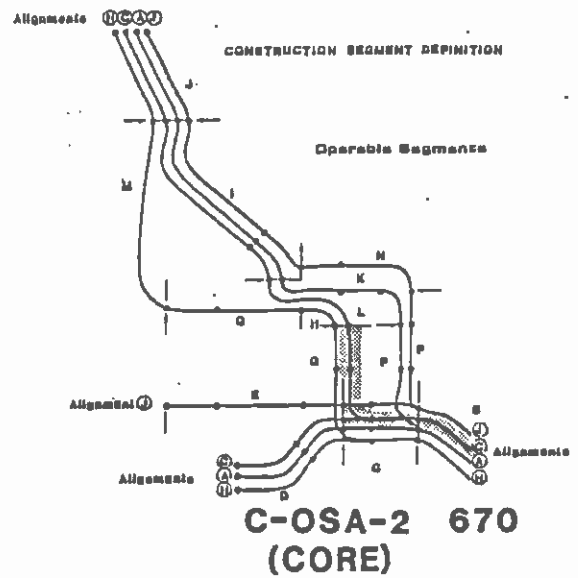
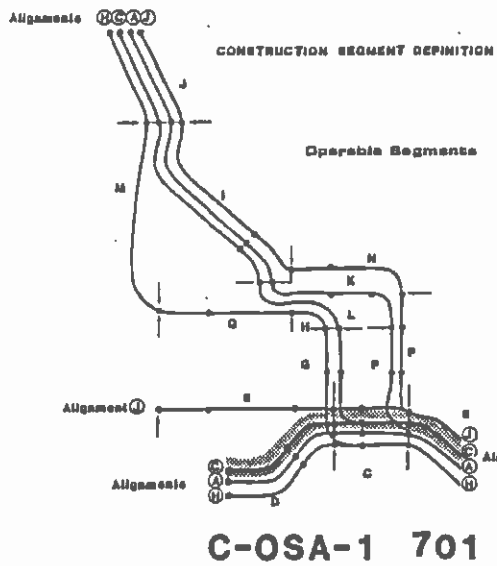

Figure 10 Alignment C Operable Segment Candidate

Operable Segment C-OSA-5 is developed by combining Segments B, C, G, and L, which yields a cost estimate of \$856 million and has terminal stations located at Hollywood/Cahuenga and at Western/Wilshire.

4.3 CANDIDATE ALIGNMENT H

A review of Figure 5, "Alignment H Segment Analysis," shows the necessity for additional operable segments to fill the large gap that exists in the cost estimates. Operable segment candidate BCD is modified by adding one station to the north, while operable segment candidate BCG is modified by adding one station to the west. Operable segment candidate BCGH is also modified by adding one station to the west. These additions are shown in Figure 11. As shown in Figure 12, there are a total of six operable segments for Alignment H that must be evaluated.

Operable Segment H-OSA-1 is developed by combining Segments B, C, and D. This Operable Segment yields a cost estimate of \$701 million and has a terminal station at Pico/San Vicente.

Operable Segment H-OSA-2 is developed by combining Segments B, C and G, which yields a cost estimate of \$670 million and includes two terminal stations located at Santa Monica/Western and at Western/Wilshire.

Operable Segment H-OSA-3 is developed by combining Segments B, C and D (i.e., H-OSA-1) with an additional station to the north. This combination yields a cost estimate of \$856 million and has terminal stations located at Beverly/Western and at Pico/San Vicente.

Operable Segment H-OSA-4 is developed by combining Segments B, C and G (i.e., H-OSA-2) with an additional station to the west. This combination yields a construction-cost estimate of \$812 million and has two terminal stations located at Santa Monica/Western and at Olympic/Crenshaw.

Operable Segment H-OSA-5 is developed by combining Segments B, C, G, and H. This combination yields a cost estimate of \$816 million and has terminal stations at Sunset/Vine and at Western/Wilshire.

Operable Segment H-OSA-6 is developed by combining Segments B, C, G, and H (i.e., H-OSA-5) with an additional station to the west. This combination yields a cost estimate of \$946 million and has terminal stations at Sunset/La Brea and at Western/Wilshire.

**ALIGNMENT H
SEGMENT ANALYSIS**

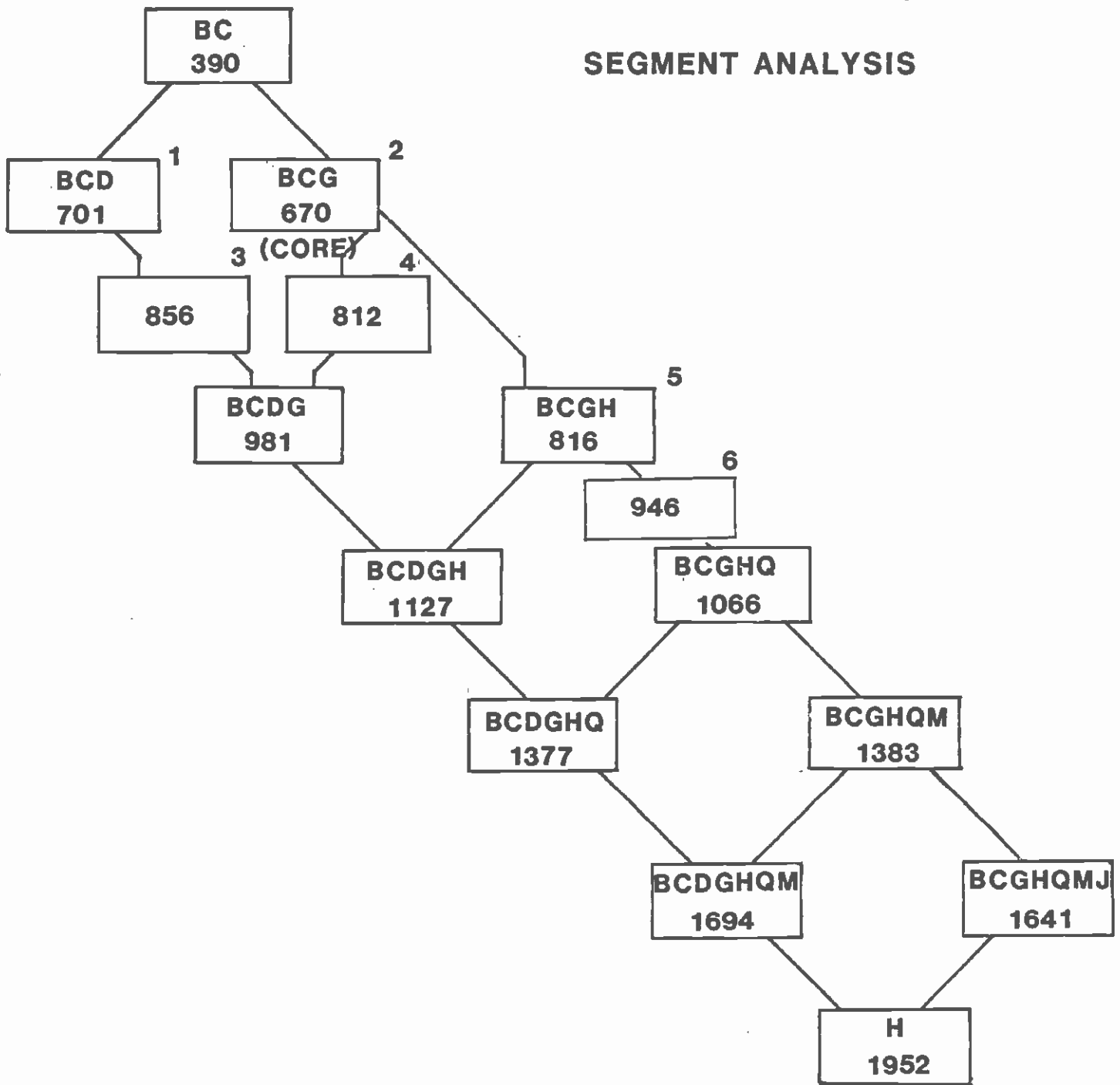

Figure 11 Alignment H Additional Segment Analysis

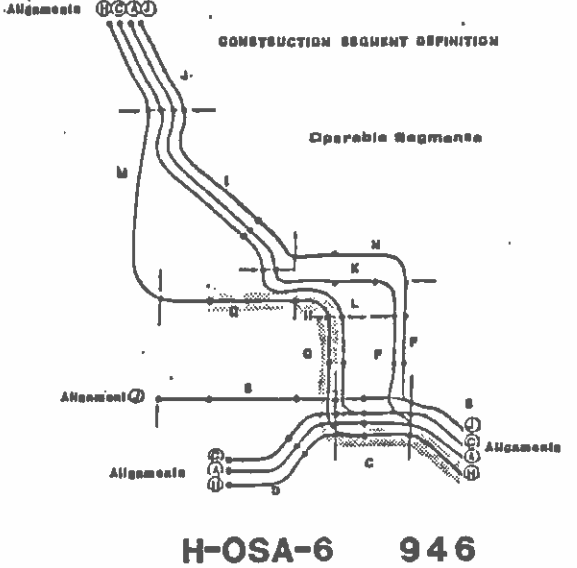
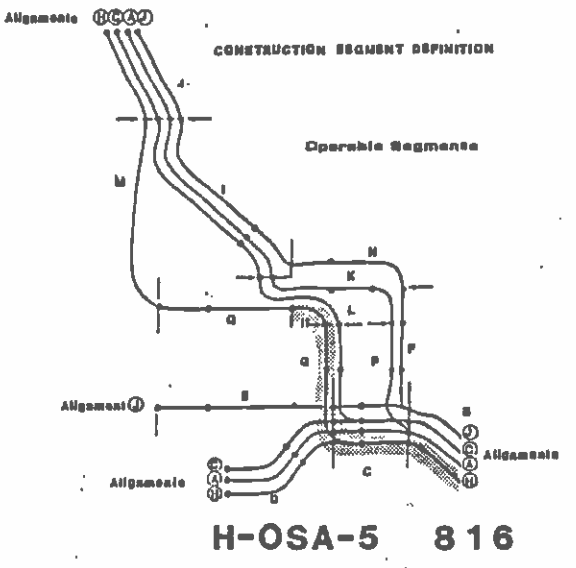
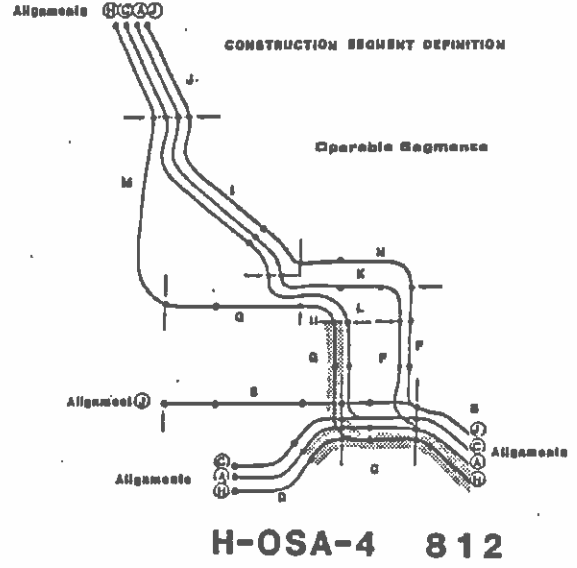
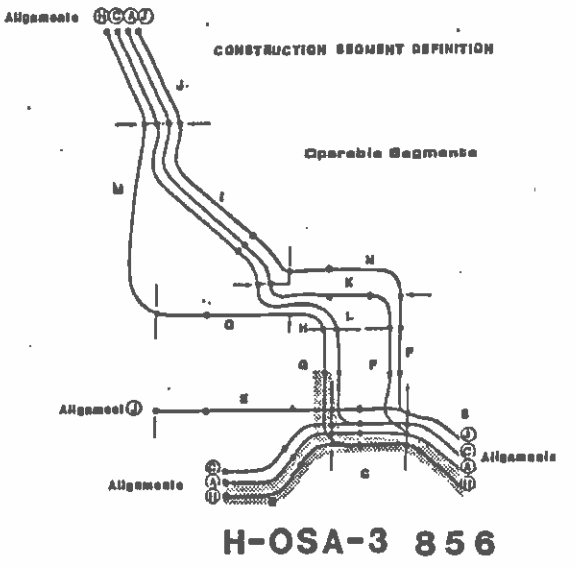
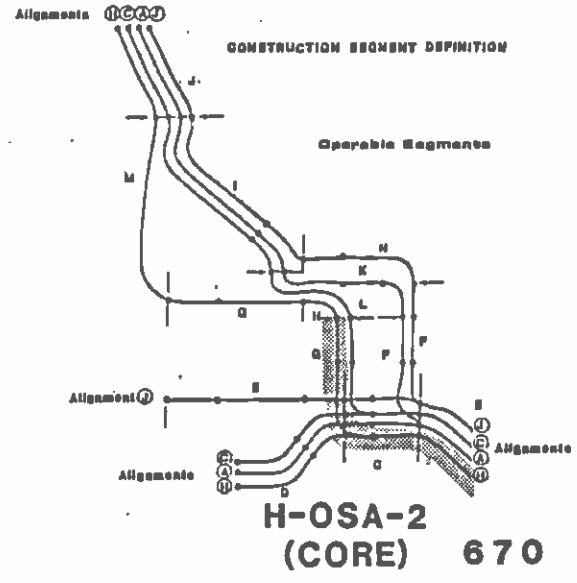
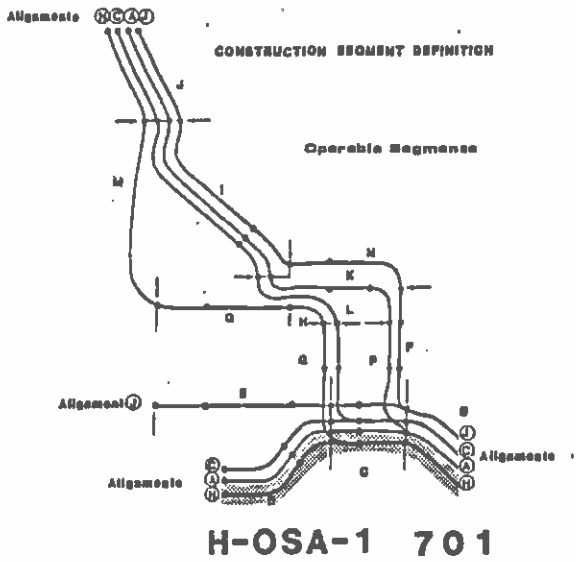

Figure 12 Alignment H Operable Segment Candidate

CANDIDATE ALIGNMENT J

Additional operable segment candidates are warranted for alignment J, just as for each of the other alignments. Reference to Figures 6 and 13 pinpoints the five additional candidate operable segments developed for alignment J. An operable segment candidate is generated by adding two stations to the west to the combination of Segments B, C, and F. This candidate is modified further by the addition of a third station, but to the north in this instance. The third candidate stems from the addition of a northbound station to Segments B, F, and N. The fourth candidate is obtained by adding one station to the north to segments B, C, F, and N; and the fifth candidate is obtained by adding two stations to the west to segments B, C, F, and N. There are a total of nine operable segments to be evaluated for alignment J, as shown in Figure 14.

Operable Segment J-OSA-1 is developed by combining Segments B, C, and F with two additional stations to the west. This plan has a cost estimate of \$730 million and includes terminal stations located at La Brea/Wilshire and at Sunset/Vermont.

Operable Segment J-OSA-2 is developed by combining Segments B, F, and N with an additional station to the north, which yields a construction estimate of \$751 million and includes a terminal station at the Hollywood Bowl.

Operable Segment J-OSA-3 is developed by combining Segments B, C, E, and F, which yields a construction cost estimate of \$796 million. This configuration has two terminal stations located at Sunset/Vermont and at Fairfax/Wilshire.

Operable Segment J-OSA-4 is developed by combining J-OSA-1 (i.e., Segments B, C, and F, and two additional stations to the west) with an additional station to the north. This plan yields a cost estimate of \$814 million and includes two terminal stations located at Western/Hollywood and at La Brea/Wilshire.

Operable Segment J-OSA-5 is developed by combining Segments B, C, F, and N. This combination yields a construction cost estimate of \$781 million and has two terminal stations located at Hollywood/Vine and at Western/Wilshire.

Operable Segment J-OSA-6 is developed by combining Segments B, F, N, and I. This combination yields a construction cost estimate of \$955 million and has one terminal station located at Universal City.

Operable Segment J-OSA-7 is developed by combining J-OSA-3 (i.e., Segments B, C, E, and F) with an additional station to the north. This combination yields a construction cost estimate of \$880 million and has two terminal stations located at Wilshire/Fairfax and Hollywood/Western.

**ALIGNMENT J
SEGMENT ANALYSIS**

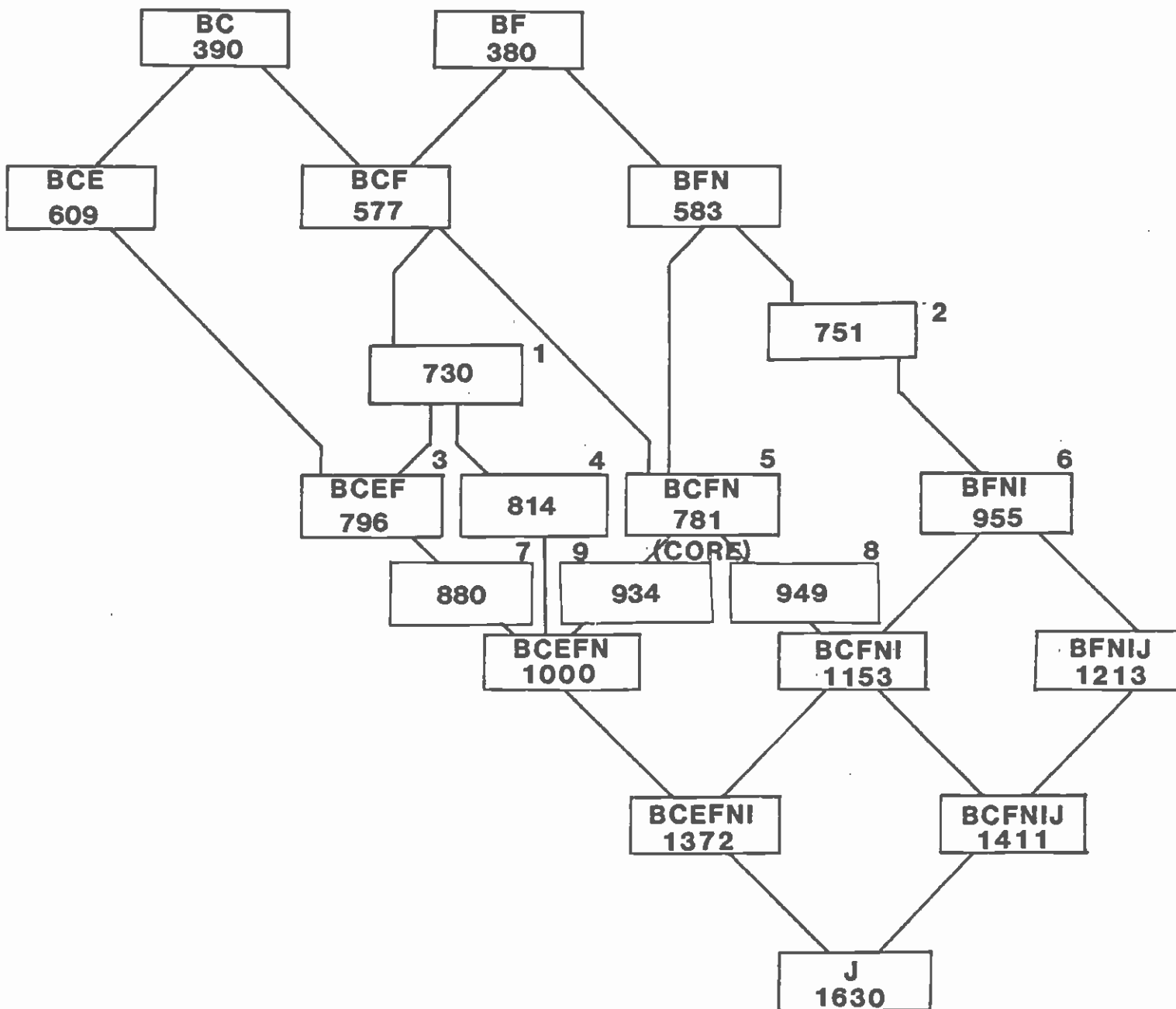

Figure 13

Alignment J Additional Segment Analysis

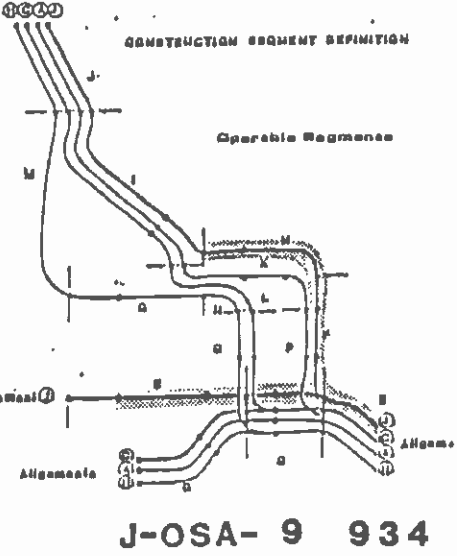
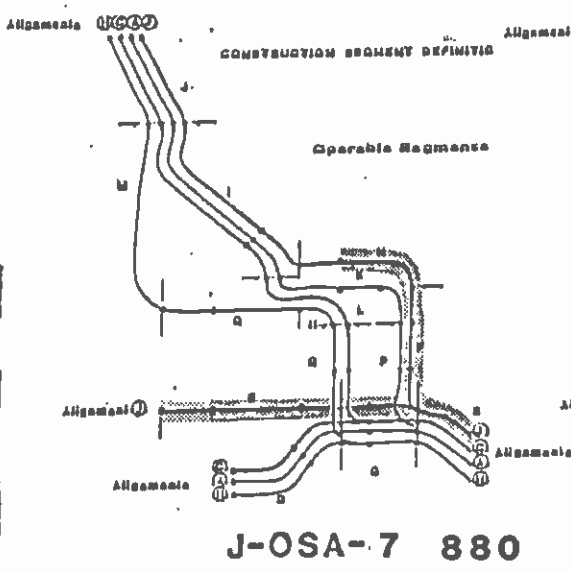
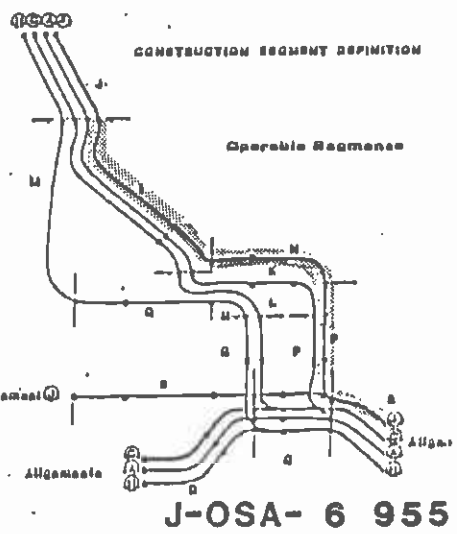
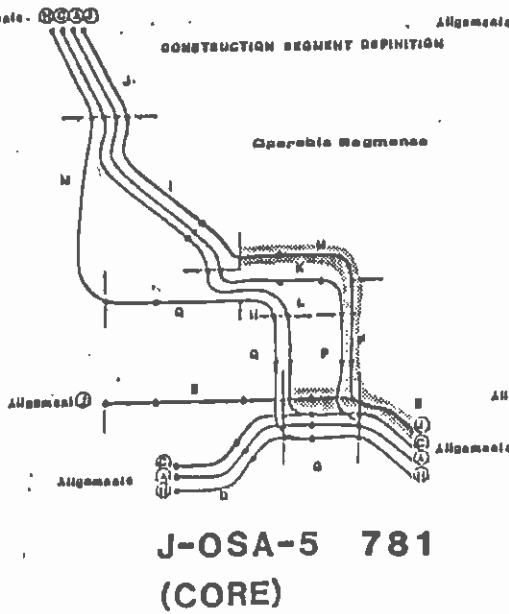
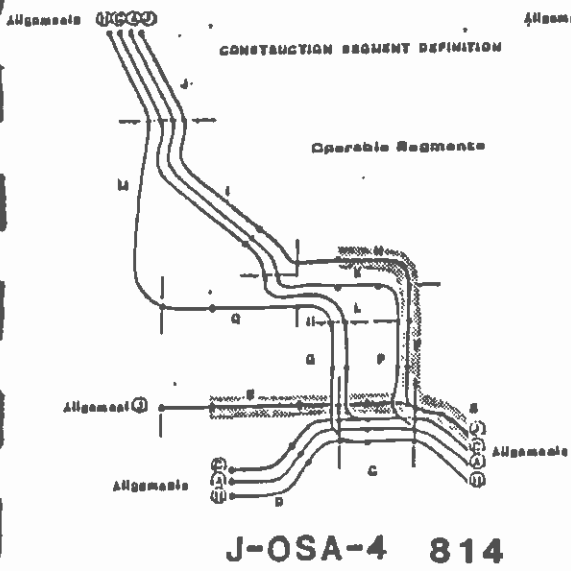
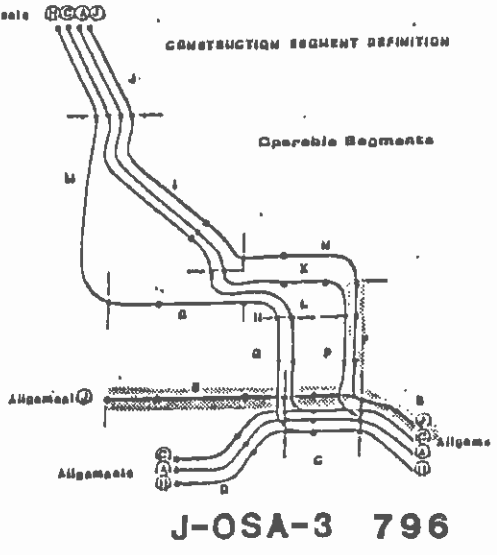
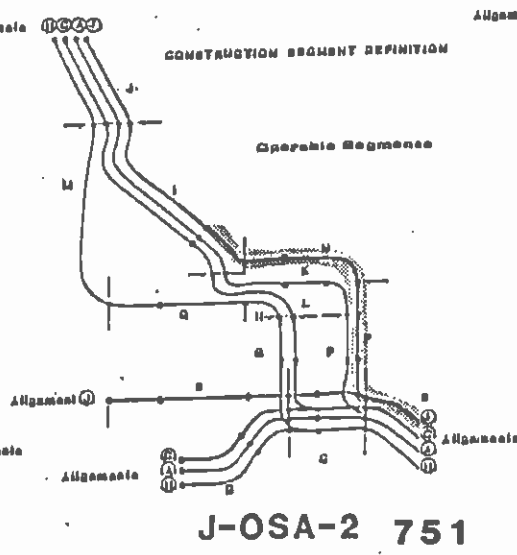
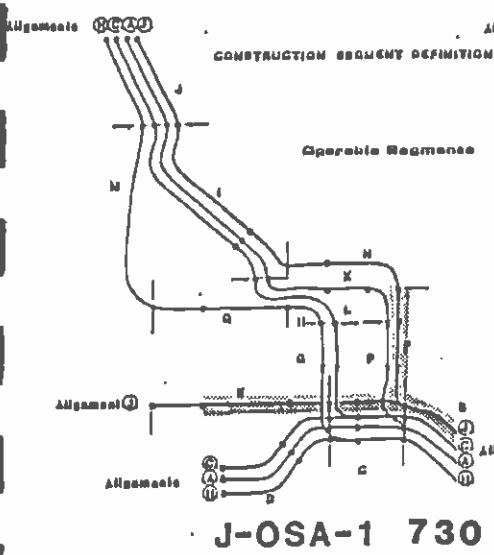

Figure 14

Alignment J Operable Segment Candidate

Operable Segment J-OSA-8 is developed by combining J-OSA-5 (i.e., Segments B, C, F, and N) with an additional station to the north. This combination yields a construction cost estimate of \$949 million and has two terminal stations located at Wilshire/Western and Hollywood Bowl.

Operable Segment J-OSA-9 is developed by combining J-OSA-5 (i.e., Segments B, C, F, and N) with two additional stations to the west. This combination yields a construction cost estimate of \$934 million and has two terminal stations located at Wilshire/La Brea and Hollywood/Cahuenga.

5.0 EVALUATION OF OPERABLE SEGMENT CANDIDATES

A total of 27 operable segments for the four candidate alignments are identified. Each is evaluated on the basis of the three criteria described in the Methodology Section: cost, operational feasibility as end stations, and key link inclusion. A fourth criterion, length equal to or greater than MOS-1, is mentioned in the Methodology. However, only a few operable segments are as much as 0.1 miles shorter than MOS-1. These are characterized by low cost as well and are eliminated on that count. Thus, the length criterion is not considered applicable in this evaluation.

The basis of this evaluation process is the so-called fatal-flaw analysis. Any operable segment that does not satisfy all three criteria is eliminated from further consideration. Each of the proposed operable segments is discussed, and the nature of the fatal flaw, if any, is identified.

5.1 CRITERIA FOR EVALUATION

5.1.1 Cost

The funding mark is \$960 million in 1986 dollars, as discussed in Section I. An operable segment is said to satisfy this criterion if the construction-cost estimate is between \$840 and \$960 million. This range of \$120 million specifies a project cost of \$900 million plus or minus \$60 million. From another point of view, it appears desirable to have the project cost be no less than 85-90 percent of the funding mark, perhaps higher. This is difficult if each added section must extend to just beyond the next station. The figure of \$840 million is 87.5 percent of the mark.

5.1.2 Operational Viability of An End-Station

The operational viability of end stations is discussed in the Methodology Section. Basically, there are three elements covered by this criterion: land use in the station area; bus access, parking, and maneuverability; and engineering/design issues. In general, a potential station falls into one of three categories in its viability as an end station: the station area is well-suited as an end station; the station is totally unacceptable as an end station; or the adverse impacts may be mitigated by an appropriate strategy.

A representative group of District and GPC personnel studied the potential end stations and categorized each as described above. An operable segment is said to satisfy this criterion if the potential end stations are well-suited as such or if any adverse impacts are subject to mitigation. The final resolution of the effectiveness of mitigation strategies is the result of an adequate environmental analysis.

5.1.3 Key Link

A segment is considered a key link if any of the following factors are characteristic of the segment:

- o The inclusion of the segment, on the basis of previous studies, suggests that a substantial increase in ridership is probable;
- o The segment provides for extension of the system toward both the Valley and Wilshire travel sheds;
- o The segment extends the system into areas enjoying broad-based support for the transit system.

The evaluation of an operable segment for key link inclusion is based on the entire operable segment. Key links are included if the three factors mentioned above are characteristic of the operable segment. Conversely, a fatal flaw is said to exist if the operable segment has poor ridership potential, if it does not extend the system toward both travel sheds, or if it penetrates areas with strong opposition to the system as proposed.

5.2 CANDIDATE ALIGNMENT A

The results of the fatal-flaw analysis for alignment A are detailed in Figure 15. Reference to this figure is inferred in the discussion which follows.

Segment A-OSA-1 fails to meet two criteria. Its cost estimate of \$701 million is well short of the \$840 million target and it does not provide service to the Valley travel shed. Moreover, the segments which extend the system west beyond the Western/Wilshire station penetrate an area of strong opposition to the system as proposed. Serious objections are raised relative to the scheduling of aerial construction down Wilshire Boulevard. It appears reasonable to delay construction west of Western on any alignment until issues are resolved and a consensus is reached.

Segment A-OSA-2 satisfies two criteria, but its cost estimate of \$671 million falls far short of the \$840 million target.

Segment A-OSA-3 satisfies two criteria, but it does not provide service toward the Wilshire travel shed or to the Valley travel shed.

ALIGNMENT A

	COST (\$MILLIONS)	END STATIONS	COST CRITERIA	OPERATIONAL FEASIBILITY	KEY LINK	ALL CRITERIA MET
OSA 4	841	Pico/San Vicente Vermont/Beverly			No Service to Valley Shed Construction West of Western	
OSA 6	779	Western/Wilshire Sunset/Edgemont	Short of Target			
OSA 3	855	Hollywood/Cahuenga			No Service to Wilshire Shed or Valley Shed	
OSA 7	883	Western/Wilshire Sunset/Western				
OSA 2 (CORE)	671	Western/Wilshire Santa Monica/Vermont	Short of Target			
OSA 5	813	Santa Monica/Vermont Olympic/Crenshaw	Short of Target	Olympic/ Crenshaw Terminal	Construction West of Western	
OSA 1	701	Pico/San Vicente	Short of Target		No Service to Valley Shed Construction West of Western	

35

Figure 15 Alignment A-Evaluation of Operable Segments

Segment A-OSA-4 does not provide service toward the Valley shed, and the system extends beyond the Western/Wilshire station. It does satisfy two criteria.

Segment A-OSA-5 satisfies none of the criteria. The Olympic/Crenshaw station is unacceptable as an end station, the system extends beyond the Western/Wilshire station, and the cost of \$813 million is short of the target.

Segment A-OSA-6 meets two of the three criteria. Its cost estimate of \$779 million is short of the target. Operational feasibility does not appear to be a problem but more study of the Sunset/Edgemont station is necessary.

Segment A-OSA-7 meets all three criteria. Its cost estimate of \$883 million is within the target cost range. Operational feasibility does not appear to be a problem, but more study of the Sunset/Western station is necessary.

Segment A-OSA-7 is the only one of the six proposed operable segments for alignment A to satisfy all criteria.

5.3 CANDIDATE ALIGNMENT C

The results of the fatal-flaw analysis for alignment C are detailed in Figure 16.

Segment C-OSA-1 fails to meet two criteria with only the end stations meeting standards. Its cost of \$701 million is far short of the target. Moreover, the proposed segment extends beyond the Western/Wilshire station and provides no service toward the Valley travel shed.

Segment C-OSA-2 satisfies two criteria, but its cost of \$670 million falls far short of the \$840 million target.

Segment C-OSA-3 extends the system west of the Western/Wilshire station. Otherwise, all other criteria are satisfied.

Segment C-OSA-4 satisfies none of the three criteria. The estimated cost of \$812 million is almost \$30 million below the low end of the target range. The Olympic/Crenshaw station is unacceptable as an end station, and the system extends beyond the Western/Wilshire station.

Segment C-OSA-5 meets all three criteria. The terminal stations at Hollywood/Cahuenga and Western/Wilshire are acceptable, and the cost of \$856 million is within the target range. All key link elements are satisfied.

Segment C-OSA-5 is the only one of the five proposed operable segments for alignment C which satisfies all criteria.

ALIGNMENT C

	COST (\$MILLIONS)	END STATIONS	COST CRITERIA	OPERATIONAL FEASIBILITY	KEY LINK	ALL CRITERIA MET
OSA 3	856	Pico/San Vicente Beverly/Vermont			Construction West of Western	
OSA 5	856	Hollywood/Cahuenga Western/Wilshire				
OSA 2 (CORE)	670	Santa Monica/Western Western/Wilshire	Short of Target			
OSA 4	812	Santa Monica/Western Olympic/Crenshaw	Short of Target	Olympic/ Crenshaw Terminal	Construction West of Western	
OSA 1	701	Pico/San Vicente	Short of Target		No Service to Valley Construction West of Western	

37

Figure 16 Alignment C-Evaluation of Operable Segments

5.4 CANDIDATE ALIGNMENT H

The results of the fatal-flaw analysis for alignment H are detailed in Figure 17.

Segment H-OSA-1 is operationally feasible, but its cost of \$701 million falls far short of the target. Moreover, the segment does not provide service toward the Valley travel shed, and the system extends west beyond the Western/Wilshire station.

Segment H-OSA-2 fails to meet the cost criterion with a cost of \$670 million. All other criteria are satisfied.

H-OSA-3 has two acceptable end stations and its cost estimate of \$856 million is within the target range. However, the system extends beyond the Western/Wilshire station.

H-OSA-4 has an unacceptable cost estimate of \$812 million, and the Olympic/Crenshaw station is not acceptable as an end station. Moreover, the system extends west beyond the Western/Wilshire station. This candidate operable segment fails on all three criteria.

H-OSA-5 meets two of the three criteria. The cost estimate is \$816 million, which is short of the target. However, all key link elements are satisfied, and operational feasibility is assured with end stations at Western/Wilshire and at Sunset/Vine.

H-OSA-6 meets two of the three criteria. The cost estimate is \$946 million, which is acceptable, and all key link elements are satisfied. However, operational feasibility of a station at Sunset/La Brea is a fatal flaw.

None of the six candidate operable segments are acceptable on all three criteria. On the basis that failure to meet the cost criterion is the least severe flaw, segment H-OSA-5 is recommended as the only one of the six proposed operable segments for alignment H that should be considered as a feasible operable segment.

5.5 CANDIDATE ALIGNMENT J

The results of the fatal-flaw analysis for alignment J are detailed in Figure 18.

Segment J-OSA-1 has a cost estimate of \$730 million, which is short of the \$840 million target. Moreover, the system extends west of the Western/Wilshire station.

Segment J-OSA-2 also fails to meet all three criteria. Its cost estimate of \$751 million is short of the target, the Hollywood Bowl is not an acceptable terminus station, and the segment provides no service toward the Wilshire travel shed. Additionally, it does not penetrate the Valley shed.



	COST (\$MILLIONS)	END STATIONS	COST CRITERIA	OPERATIONAL FEASIBILITY	KEY LINK	ALL CRITERIA MET
OSA 3	856	Beverly/Western Pico/San Vicente			Construction West of Western	
OSA 5	816	Sunset/Vine Western/Wilshire				
OSA 1	701	Pico/San Vicente	Short of Target		No Service to Valley Shed Construction West of Western	
OSA 2 (CORE)	670	Santa Monica/Western Western/Wilshire	Short of Target			
OSA 4	812	Santa Monica/Western Olympic/Crenshaw	Short of Target	Olympic/ Crenshaw Terminal	Construction West of Western	
OSA 6	946	Sunset/La Brea Western/Wilshire		Sunset/ La Brea Terminal		

39

Figure 17 Alignment H-Evaluation of Operable Segments

	COST (\$MILLIONS)	END STATIONS	COST CRITERIA	OPERATIONAL FEASIBILITY	KEY LINK	ALL CRITERIA MET
OSA 1	730	La Brea/Wilshire Sunset/Vermont	Short of Target		Construction Past Western	
OSA 2	751	Hollywood Bowl	Short of Target	Hollywood Bowl Terminal	No Service to Wilshire Shed	
OSA 3	796	Sunset/Vermont Fairfax/Wilshire	Short of Target		Construction West of Western	
OSA 4	814	La Brea/Wilshire Hollywood/Western	Short of Target	Hollywood/ Western Terminal	Construction West of Western	
OSA 5	781	Hollywood/Vine Western/Wilshire	Short of Target			
OSA 6	955	Universal City				
OSA 7	880	Hollywood/Western Wilshire/Fairfax		Hollywood/ Western Terminal	Construction West of Western	
OSA 8	949	Hollywood Bowl Western/Wilshire		Hollywood Bowl Terminal		
OSA 9	934	La Brea/Wilshire Hollywood/Vine			Construction West of Western	

Figure 18 Alignment J-Evaluation Operable Segments

Segment J-OSA-3 extends west beyond the Western/Wilshire station, and the cost estimate of \$796 million is short of the target. However, the end stations are operationally feasible.

Segment J-OSA-4 fails the key link criterion because the system extends west beyond the Western/Wilshire station. Moreover, the Hollywood/Western Station is not acceptable as an end station, and the cost estimate of \$814 million is below the target range.

Segment J-OSA-5 meets two of the three criteria. The cost estimate is \$781 million, which is below the target. However, the Hollywood/Vine and Western/Wilshire stations are acceptable end stations; and all key link elements are satisfied.

Segment J-OSA-6 meets all three criteria. The cost estimate is \$955 million, which is near the top of the target range. The Universal City station is an acceptable end station; and two key link elements are satisfied. Although the segment does not provide service to the Wilshire shed, it does penetrate to the Valley shed.

Segment J-OSA-7 fails the key link criterion because the system extends west beyond the Western/Wilshire station. Moreover, the Hollywood/Western Station is not acceptable as an end station, although the cost estimate of \$880 million is within the target range.

Segment J-OSA-8 meets two of the three criteria. The cost estimate is \$949 million, which is within the target; and all key link elements are satisfied. However, the Hollywood Bowl station is not an acceptable end station.

Segment J-OSA-9 meets two of the three criteria. The cost estimate is \$934 million, which is within the target range, and the Wilshire/La Brea and Hollywood/Vine stations are acceptable end stations. However, the key link criterion is not satisfied because of construction west of Wilshire/Western.

Segment J-OSA-6 is the only one of the nine proposed operable segments for alignment J which satisfies all criteria, although it does not provide service to the Wilshire shed. However, J-OSA-5 meets all except the cost criterion, and is also recommended for study as a candidate operable segment.

5.6 SUMMARY

Only one operable segment satisfied all criteria for candidate alignments A and C; none met all three criteria for alignment H, so the one failing only to meet the cost criterion was selected; and two operable segments have been selected for alignment J:

A-OSA-7
 C-OSA-5
 H-OSA-5
 J-OSA-5
 J-OSA-6

A total of sixteen operable segments failed the cost criterion, eight failed the operational viability of end-station criterion, and sixteen failed the key-link criterion.

The operational segment 5 recommended for alignment J is identical to the recommendation of CORE. The operational segments recommended for the three other candidate alignments include all construction segments recommended by CORE but extend the system to more closely approach the funding mark. Furthermore, the recommended operable segments for alignments A, C, H, and one of those for J (OSA-5) have a western terminus at the Western Avenue/Wilshire Boulevard Station.

RECOMMENDATIONS

EVALUATION OF CANDIDATE OPERABLE SEGMENTS

A	OSA-7	\$883 M	CORE Plus Extension to Sunset/Western
C	OSA-5	\$856 M	CORE Plus Extension to Hollywood/Cahuenga
H	OSA-5	\$816 M	CORE Plus Extension to Sunset/Vine
J	OSA-5	\$781 M	CORE
J	OSA-6	\$955 M	CORE Less Vermont to Western on Wilshire, Plus extension to Universal City

APPENDIX A

BASIS FOR \$960M COST LIMITATION

The cost of OS-A should be limited to a maximum of about \$960 million in 1986 dollars. This figure is derived as follows.

The current draft Congressional Authorization Bill includes a funding mark of \$870 million for Los Angeles Metro Rail. A sum of \$203 million of this amount represents recovery of the Federal shortfall of funds to cover full funding authorization of MOS-1.

The balance of \$667 million represents funding for OS-A. This amounts to a construction price tag of \$1,334 million in current dollars when 50-50 local matching funds are included.

In general, OS-A is projected to be a project of 6 years duration and to begin operation in 1995. A project under construction from 1989 to 1994 will cost 1.39 current dollars for every dollar of 1986 cost. Division of \$1,334 million by 1.39 yields a 1986 cost of \$960 million for OS-A as the maximum amount.

The discount factor, 1.39, to convert current dollars to 1986 constant dollars is calculated as follows:

Fiscal Year	Construction Percentage Completed During Year	H.C.I. Growth Rate	H.C.I. Index	Product
1986	-		1.000	
1987	-	6.0	1.060	
1988	-	6.6	1.130	
1989	0.120	6.5	1.203	0.1444
1990	0.231	6.7	1.284	0.2966
1991	0.242	6.6	1.369	0.3313
1992	0.197	6.6	1.459	0.2874
1993	0.142	6.6	1.555	0.2208
1994	0.068	6.6	1.658	0.1127
			SUM	1.3932 =====

Product is construction percentage completed times the H.C.I. index for each construction year.