

SCRTD METRO RAIL PROJECT

RAIL SAFETY ISSUES

EMERGENCY PREPAREDNESS

"EMERGENCY PREPAREDNESS DESIGN FEATURES  
OF THE LOS ANGELES METRO RAIL  
SUBWAY SYSTEM"

Harold E. Storey  
Director, Systems and Construction Safety  
Southern California Rapid Transit District  
Los Angeles, California

APTA  
1990 RAPID TRANSIT CONFERENCE  
Vancouver, British Columbia  
June 2-7, 1990

**MTA LIBRARY**

EMERGENCY PREPAREDNESS DESIGN FEATURES  
OF THE LOS ANGELES METRO RAIL SUBWAY SYSTEM

- \* SLIDE-1, Title - Metro Rail
- \* SLIDE-2, Route Map - 18 Mile

In addition to general safety planning for the SCRTD Metro Rail, special considerations have been made for emergency preparedness with respect to both fires and natural disasters. Many aspects of fire/life safety planning involve the structural characteristics of the facilities and equipment. Thus the special requirements for fire/life safety were incorporated into the system design at an early stage. When fire/life safety planning takes place early in a project, allowances can be made for every aspect of safe emergency evacuation procedures, and minimal harm to life and property can be ensured.

The main purpose of the SCRTD fire/life safety program is to guide the design, construction, and operation of the Metro Rail System so that fire/life safety levels will equal or exceed those of other rapid transit systems. In developing specific requirements early in the planning process, an awareness of the importance of fire/life safety was established in all phases of the system design, construction, manufacturing, and operation. Additionally, operational personnel, fire, police, and other emergency response organizations have been receiving training to prepare them to handle Metro Rail emergency situations.

- \* SLIDE-3, Characteristics, MOS-I/Full System

FIRE/LIFE SAFETY OVERVIEW

A fire-safe rail rapid transit system is important to governmental and regulatory agencies, as well as to the designers and planners of the system. However, it is the general public who must be assured that thorough and appropriate fire/life safety planning and implementation continues throughout the life of the project and who must continually perceive the system as safe and secure.

Types of Fire/Life Safety Problems

The most prevalent fire and fire-related hazards reported by transit systems are:

- \* SLIDE-4, BART Vehicle Fire
  - o Vehicle Fires - Vehicle fires usually originate under the vehicle floor. Because of the fire-retardant materials used in present day vehicle construction, the rate of fire spread is minimized so that there is ample

# THE METRO

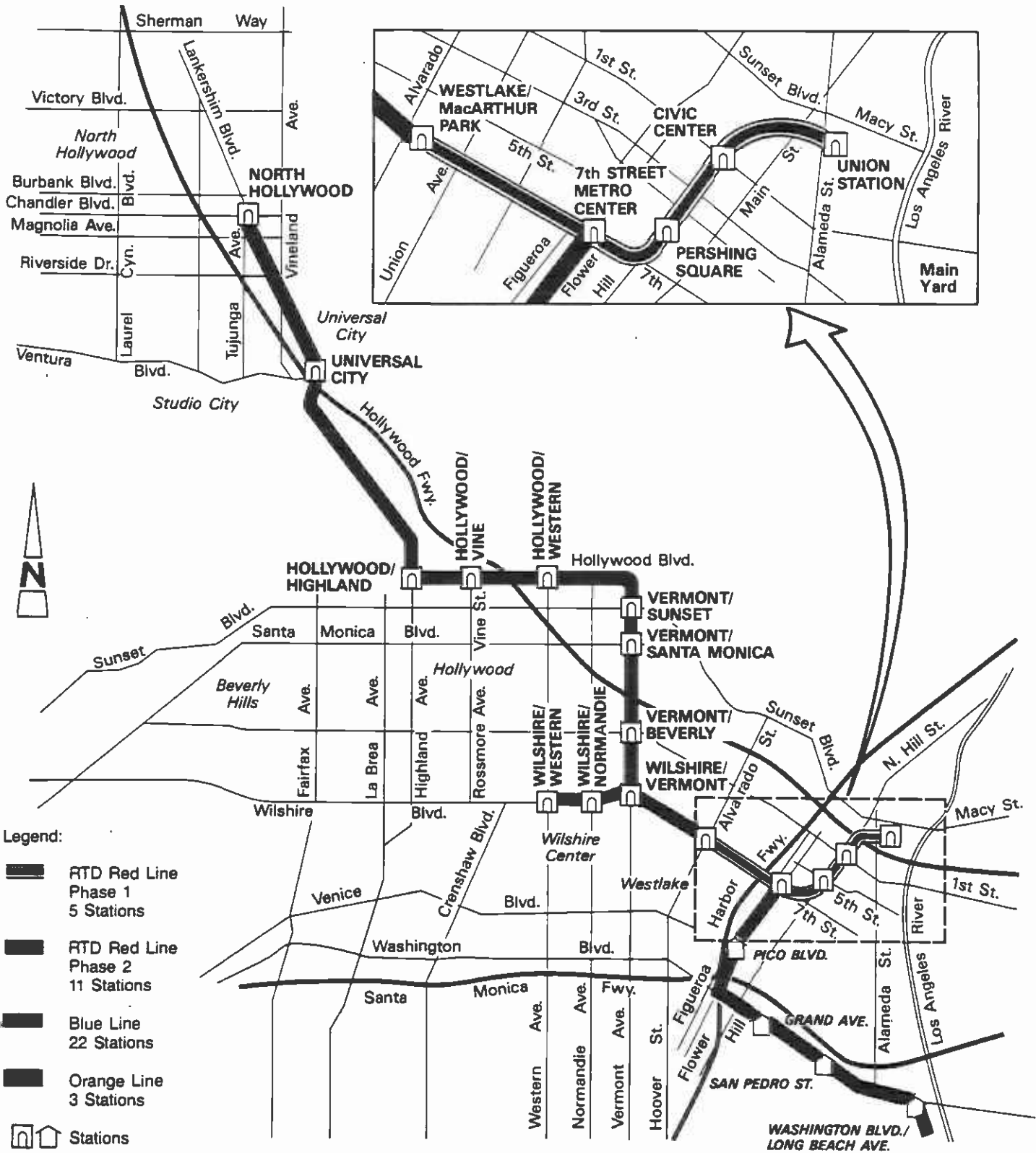

# **CHARACTERISTICS - MOS-1 / FULL SYSTEM**

---

|  | <u>MOS-1</u> | <u>Full System<br/>(Including MOS-1)</u> |
|--|--------------|--|
| <b>Length (Miles)</b>                  | 4.4          | 17.3                                     |
| <b>Number of Stations</b>              | 5            | 16                                       |
| <b>Travel Time (Minutes) - One Way</b> |              |  |
| <b>From Union Station to:</b>          |              | -  |
| <b>North Hollywood</b>                 | --           | 30                                       |
| <b>Western Terminus</b>                | 7            | 13                                       |
| <b>Average Daily Boardings</b>         | 55,000       | 298,000                                  |
| <b>Maximum No. of Cars/Train</b>       | 4            | 6  |
| <b>Fleet Size</b>                      | 30           | 100                                      |

time for passenger evacuation. Non-metallic materials used by some transit systems in the past have contributed significantly to flame spread and smoke toxicity. These types of materials are not being used in the Metro Rail vehicle. If the fire occurs while the train is in a tunnel, adequate lighting along walkways, ventilation for smoke control and fresh air, and orderly evacuation procedures are being built and planned to minimize risks to passengers.

- o Trainway Electrical Fires - These fires are usually caused by traction power short circuits. They can be readily controlled by the appropriate use of fire detectors and trip stations. Ready access routes provided to all sections of the system for fire-fighting personnel as well as emergency evacuation procedures for passengers are being instituted to minimize risk.
- o Station and Facility Fires - Electrical short circuits, trash fires, and vandalism cause the majority of station and facility fires. Most can be readily isolated and quickly extinguished. However, should station evacuation be required, Metro Rail stairways have been designed to accommodate a peak time patron load. Signs are being installed to identify the exit routes.
- o Smoke and Toxic Fume-Generating Fires - These fires occur anywhere in a system. Metro Rail has selected appropriate materials for vehicle and facility construction that minimize harmful fire byproducts. Any smoke and toxic fumes will be removed by the ventilation systems.

A special concern for those in the Los Angeles area is the possibility of seismic activity. One of the advantages, if it can be called that, of living in an active seismic area is the wealth of relevant technical and scientific data on which to base earthquake engineering practices and principles. Additionally, there are well thought-out and stringently enforced city, county, and state earthquake construction codes. In fact, since the 1971 Los Angeles area San Fernando earthquake, the California design codes have been strengthened to preclude the failure of newly built structures. In designing and constructing the Metro Rail System, the staff and their seismic consultants have applied the most recent information to all phases of the design and construction and have met or exceeded earthquake safety standards set forth in applicable codes and regulations.

## FIRE/LIFE SAFETY PROGRAM PLAN

Through a comprehensive fire/life safety program, the SCRTD has ensured a safe environment and protection for Metro Rail patrons, employees, and equipment. The plan for this program identifies tasks and activities to be performed by SCRTD, its contractors and consultants throughout all phases of the Metro Rail Project. The plan was prepared early in the system's life so that Metro Rail managers were able to bring together all of the technical and management skills needed to construct a safe system.

The Metro Rail fire/life safety program plan presents the management controls and analysis processes that have been developed to ensure that:

- o Fire/life safety considerations, compatible with system requirements, have been incorporated into the subsystems during the design phase.
- o Hazards associated with each subsystem have been identified and then eliminated or minimized to obtain an acceptable level of fire/life safety.
- o The fire/life safety philosophy emphasizes preventive measures over corrective measures as the way to eliminate unsafe conditions.
- o Historical fire/life safety data generated by newer transit properties throughout the U.S. have been analyzed and used to support the fire/life safety program.

Responsibility for coordinating the fire/life safety-related activities of the Metro Rail Project lies with the Director, Systems and Construction Safety (SCS), to whom pertinent SCRTD Project and consultant systems engineering and design groups report. In addition, SCS Department safety specialists have responsibility for the following tasks:

- o Organizing and coordinating Metro Rail fire/life safety programs
- o Developing and recommending fire/life safety goals and standards
- o Analyzing procedures, rules, and practices to ensure adequate hazard control
- o Participating in design reviews and planning sessions pertaining to safety, security, and systems assurance; auditing design changes

- o Collecting fire/life safety and related documentation from other properties
- o Investigating accidents and failures reported during test and operation phases to determine their causes.

The fire/life safety program focuses on specialized safety-related activities that are required throughout the life of the SCRTD Metro Rail System. The Metro Rail fire/life safety program has been segmented into discrete phases: preliminary engineering, final design, construction/acquisition, pre-operational test, and start-up operations. In terms of fire/life safety, significant activities within these phases include:

- o Fire/Life Safety Analysis - preparing data input related to fire/life safety for the hazards analyses.
- o Materials Fire/Safety Performance Standards - compiling acceptable fire/safety performance standards for materials to be used in the vehicles, trainways or other transit-related facilities.
- o Passenger Exit Calculations - determining the volume of passengers that may need to be evacuated through tunnels, loading platforms, vertical circulation elements, and station exits so that exiting capacity requirements can be accounted for in the design of all structures.
- o Fire-Test Planning - developing requirements for testing critical system areas and materials under simulated fire scenarios.
- o Methane and Other Combustible Gases Study - reviewing and studying effects of the presence of methane and/or other combustible gases in underground sections of the Metro Rail System and developing countermeasures.
- o Seismic Activity Study - conducting studies of the potential effects of seismic activity on the Metro Rail System and working with design groups to develop countermeasures.

#### FIRE/LIFE SAFETY DESIGN CRITERIA

Many fire/life safety requirements are imposed through codes or standards. A fire/life safety code study was accomplished to assure compliance to the intent of codes and standards. The fire/life safety criteria covers:

- o Stations
- o Trainways

- o Passenger vehicles
- o Ventilation
- o Communications
- o Vehicle yard and maintenance facilities
- o Fire/life safety procedures
- o Central Control
- o Operational procedures and training

#### STATIONS

In the discussion which follows, those fire/life safety requirements presented are those which minimize fire risks and enhance fire protection in Metro Rail station construction.

- \* SLIDE-5, Civic Center Station

#### Station Construction

Construction of the stations must conform to appropriate codes whenever possible. Necessary changes from code requirements must receive a full review by concerned and appropriate personnel to ascertain that the required levels of safety are maintained. Local fire safety officials have participated in the code review.

- o Steel reinforced concrete or steel members suitably fire rated are used in construction of underground stations.
- o Portions of the station, where potentially hazardous operations are located, are appropriately separated from other areas.
- o The station design features open construction of main stairways, escalators, and level separation while still providing adequate fire/life safety protection.
- o Construction materials throughout the stations are noncombustible; interior finish and trim are of low combustion rate materials.

#### Electrical Systems

Portions of the electrical system including equipment control, communications, and other critical operations, are of primary importance in emergency situations. Therefore, electrical equipment has been designed to operate under anticipated emergency conditions.



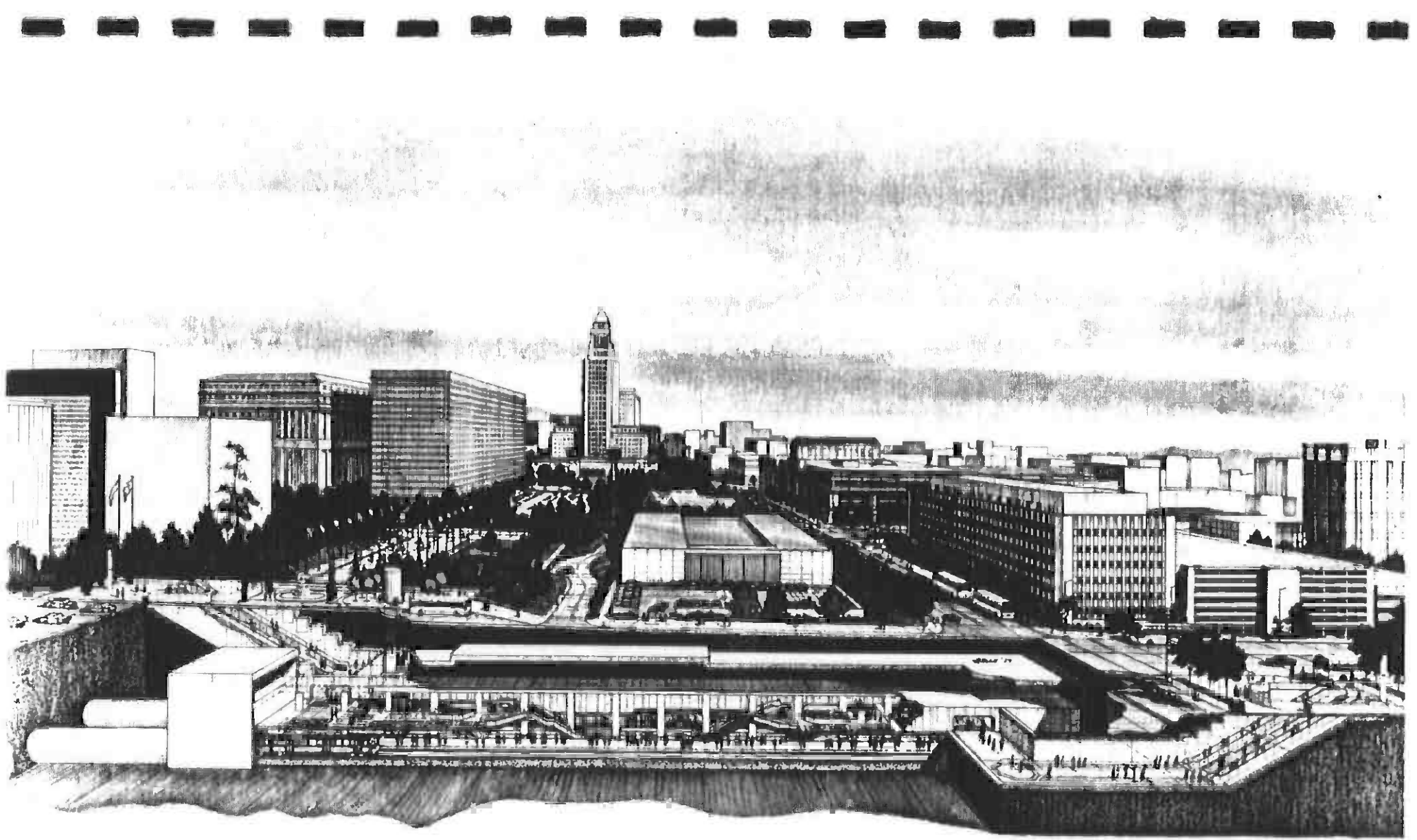

**CIVIC CENTER STATION**

SOUTHERN CALIFORNIA RAPID TRANSIT DISTRICT  
METRO RAIL PROJECT



\* SLIDE-6, 5th/Hill (Pershing Square) Station

Exit and Access Routes

The stations have been designed so that safe exit routes for patrons are provided and emergency personnel are able to quickly reach the problem area. Stairways and walkways are designed to accommodate emergency evacuation of patrons as well as entry of emergency personnel according to NFPA-130 criteria (see Attachment A) and additional SCRTD 7-square foot per patron platform area criteria, NFPA 101, (see Attachment B) along with time requirements from stalled trains in tunnels to crosspassages.

- o Occupant loads to determine exit capacity have been derived from analysis of predicted transit patronage.
  - oo The calculated train load which is no less than the maximum passenger capacity of a single train.
  - oo The entraining load which is equal to the number of passengers that would accumulate on the platform in the time period equivalent to four headways during the peak 15-minute operating period.
- o Emergency exit routes have been analyzed to consider all potential fire scenarios or other emergency situations requiring evacuation of stations.
- o Sufficient emergency lighting and clear signage are provided to facilitate safe exit.

\* SLIDE-7, 7th/Flower Station

Fire Protection Systems

Because of the unique demands of rail rapid transit systems, the Metro Rail station has achieved a level of fire protection superior to that of other building structures. Specially designed station protection features are:

- o Automatic sprinkler protection extended to areas that contain combustible loads.
- o Automatic fire detection apparatus used in those non-public areas of the station not equipped with automatic sprinklers.
- o Standpipe and hose connections suitably sized, provided for use by fire department personnel and Metro Rail employees.

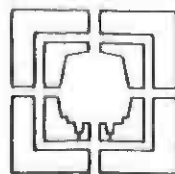
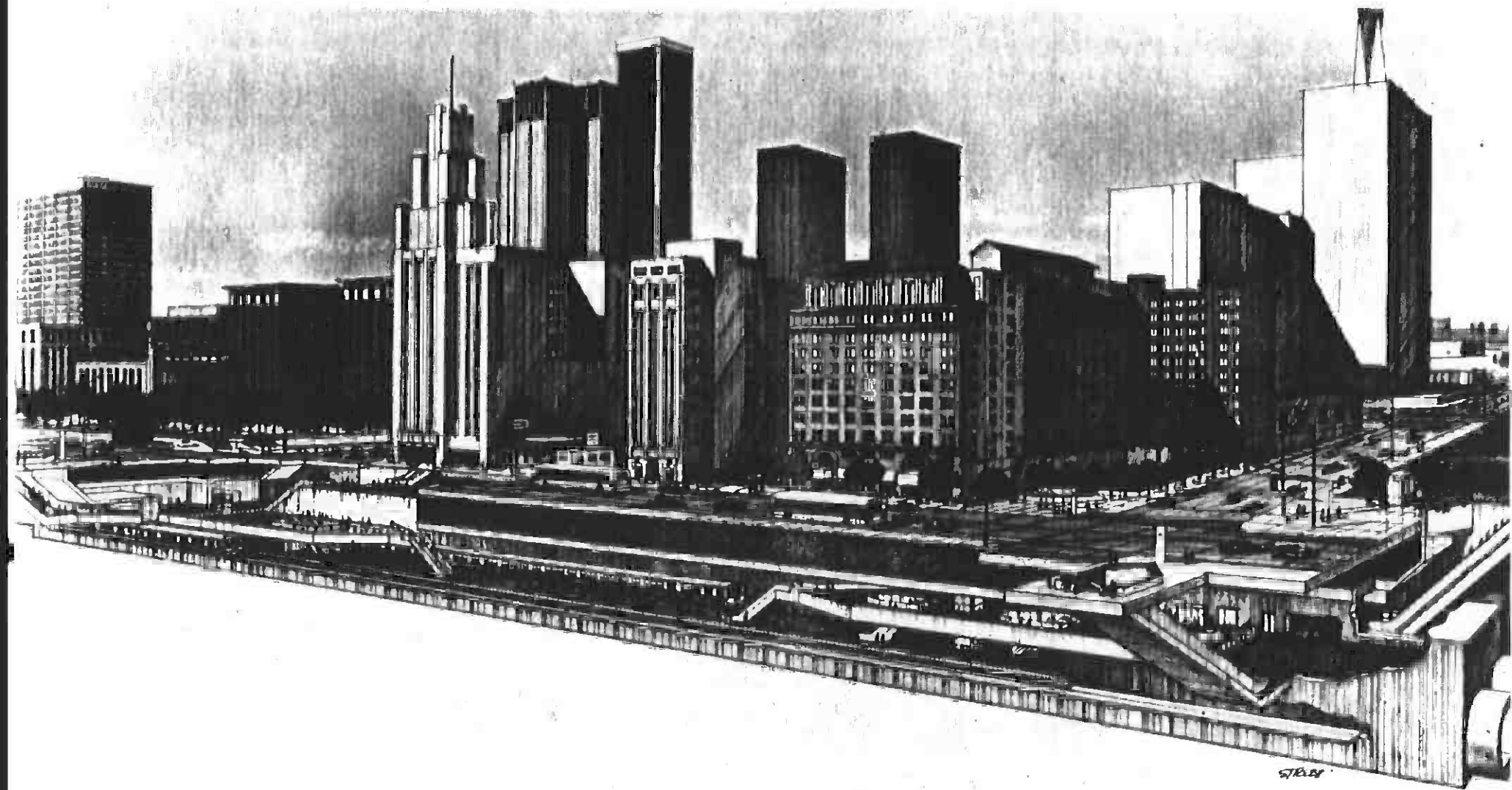

METRO RAIL TRANSIT CONSULTANTS

DMJM/PBQD/KE/HWA

5TH/HILL (PERSHING SQUARE) STATION

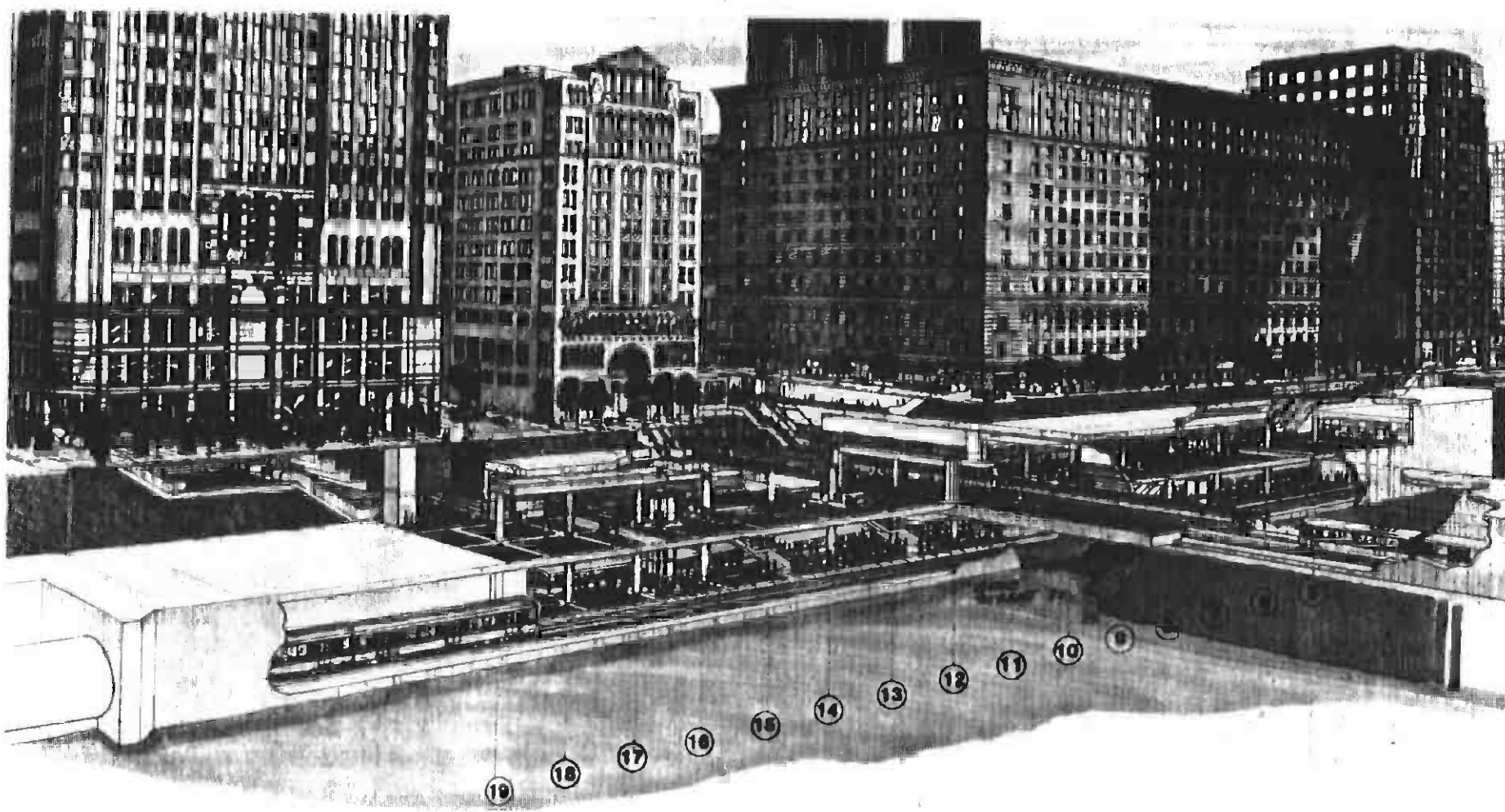

11

7TH/FLOWER STATION A-165

METRO RAIL TRANSIT CONSULTANTS  
DANIEL, MANN, JOHNSON & MANN

SOUTHERN CALIFORNIA RAPID TRANSIT DISTRICT  
METRO RAIL PROJECT



- o Portable fire extinguishers provided in the stations for ease of access and use consistent with rapid transit industry standards.
- o Fire detection, alarm control, and annunciation systems to facilitate prompt warning to Metro Rail Central Control, and to help arriving fire service personnel.
- o A system of emergency phones located in strategic areas of the stations.
- o Station access for fire fighting apparatus, e.g., hoses, and other emergency equipment provided and maintained.
- o Fire hose connections and other utilities necessary to support station emergency needs, in convenient locations.

\* SLIDE-8, Tunnel Cross Section

TRAINWAYS

The trainway includes track areas in tunnels and surface right-of-way.

Evacuation

During peak use, trains often carry capacity loads. In an emergency it may be necessary to offload a fully loaded train and evacuate patrons via the trainway.

Passenger train load for calculation purposes is the maximum passenger capacity of the vehicles. Trainway evacuation is to be used only when train-to-train transfer is not possible and a train cannot safely be moved to a station. Traction power will be shut off prior to evacuation.

Construction and Protective Separation

Construction of underground trainways is of several different configurations. All configurations are built to safety withstand a potential fire. If the trainway is adjacent to another structure such as an office building, additional provisions are necessary, such as 2 and 3-hour rated walls, doors, etc.

- o Underground trainway construction is of noncombustible materials.
- o Structures adjoining the trainway are of three-hour fire-rated construction. Passageways are protected by fire doors or other fire-retardant construction.

# TYPICAL TUNNEL CROSS-SECTION

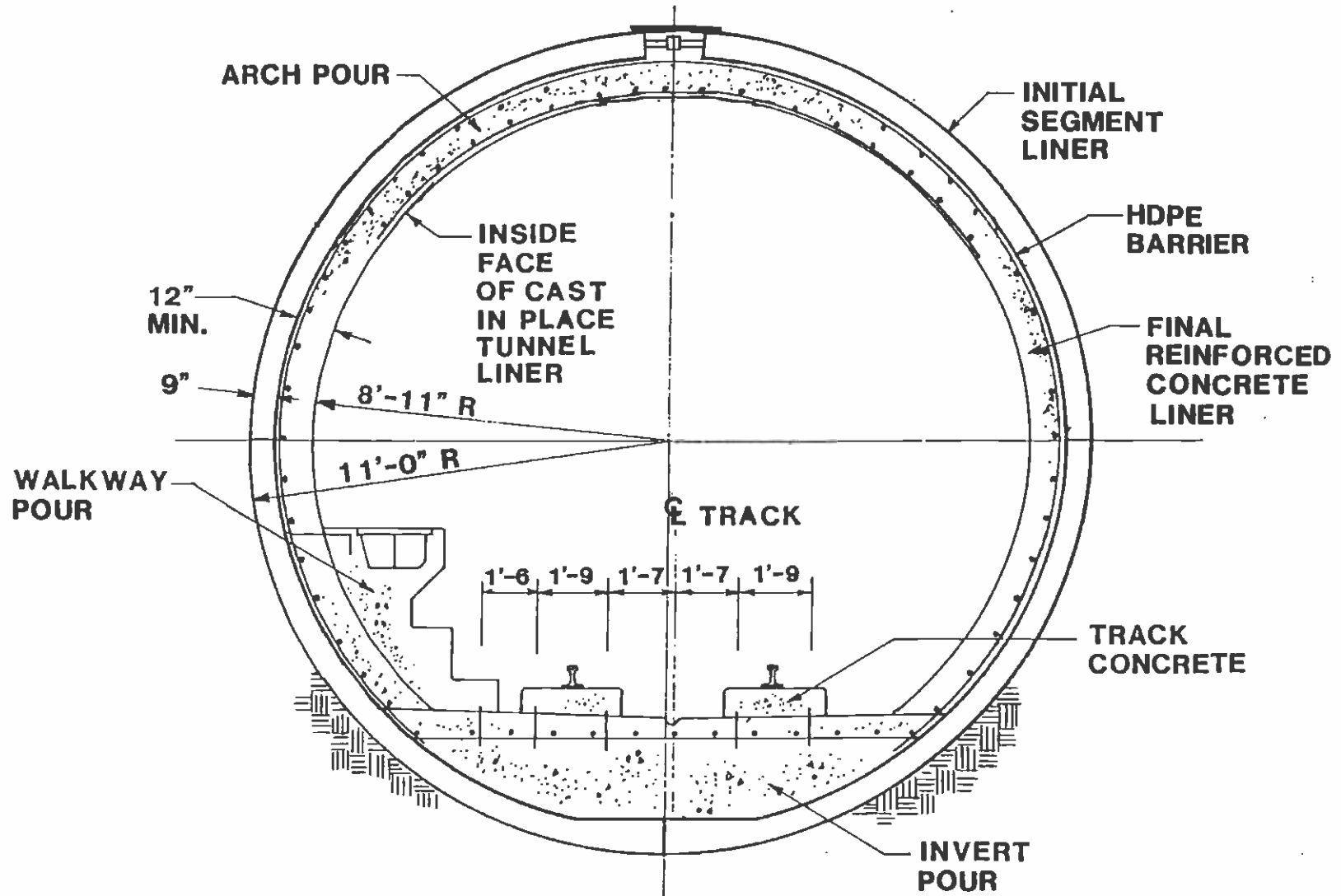

-13-

G30371.08

\* SLIDE-9, Tunnel High Density Polyurethane Membrane (HDPE)

- o Provisions have been made to protect the trainway from flammable gas or liquid intrusion from either natural sources or adjacent facilities through use of an HDPE membrane and vent shafts with protective curbs/gutters and drains and/or off-street locations.

Trainway Traction Power and Facility Wiring

The elements of traction power (the electric power used to operate the trains), including the third rail and facility wiring, are located in the trainway.

- o Traction power cables are being installed such that they will not present an electrical or tripping hazard to patrons and personnel.
- o Signs warning of the third rail and signs identifying pieces of electrical equipment are to be posted at access points to the trainway and throughout the system as well.
- o Protective coverboards are being installed to protect patrons and employees from inadvertently contacting the third rail. These coverboards will be rigid, and their materials meet appropriate fire, smoke and toxicity requirements.
- o Emergency means for disconnecting the traction power (ETS) are located at points throughout the trainway.

\* SLIDE-10, Train in Tunnel

Emergency Exit and Access for Underground Trainways

In the event of a fire or other emergency, patrons need to get out of the trainway, and emergency personnel need to get in. The design of the trainway takes these requirements into consideration.

- o Safety walkways are provided on one side of the tunnel. Walkways are approximately vehicle floor height and arranged in a continuous path to an exit or refuge area. They are located opposite the electrically powered third rail except at crossings which will be specially protected. Walkways are of noncombustible concrete construction with a non-slip walking surface. The walkway is free of wall protrusions.
- o Where adjacent trainways are used as an area of refuge, they are separated by a fire-rated barrier wall, have





SLIDE A171-35  
AL tunnel invert concrete (view  
facing west) (1/89)



SLIDE A171-36      3/89  
Arch reinforcement at A L tunnel  
prior to form and concreting.  
East view.



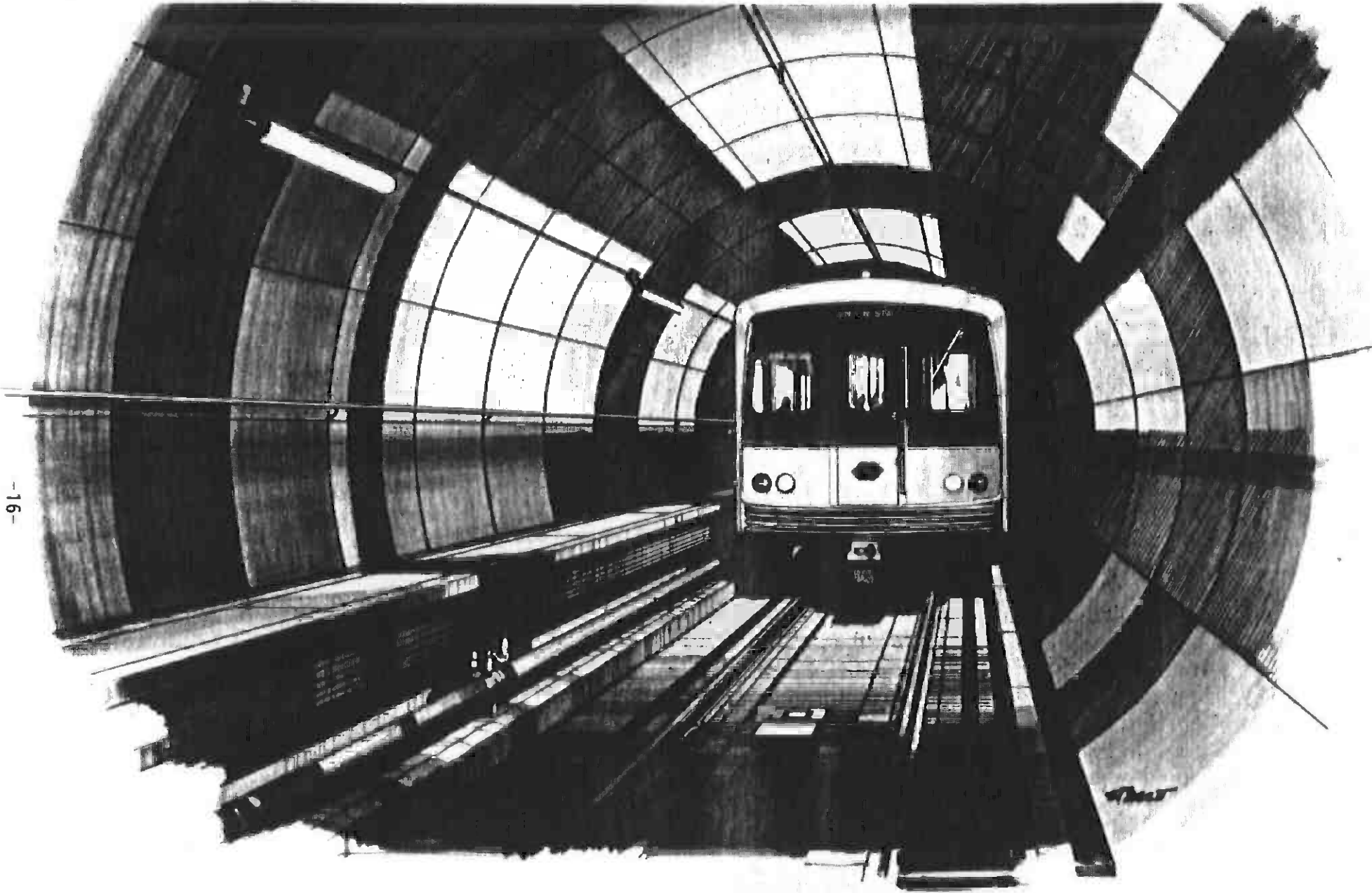

-16-

RTD VEHICLE IN TUNNEL  
OCTOBER 26 1963

protected openings, and are equipped with emergency ventilation facilities.

- o Wherever possible, emergency exits to the surface are provided at regular intervals per time/distance criteria.
- o Crosspassages or emergency exit doors are built at appropriate intervals not to exceed 750' except for special conditions. (See Attachment-C)
- o The exit pathway is identified by signs and lights. Emergency lighting with 1 Foot Candle on walkways is provided throughout the underground system.

#### Fire Protection Systems

To maximize fire department efficiency during emergencies occurring underground, special attention has been given to facilities and equipment to support their operation.

- o A wet standpipe system has been installed throughout the underground trainways, with regularly spaced outlets of 250 feet to enable firemen carrying 100 feet of hose to reach any fire.
- o Fire hydrants, with sufficient connections and valves and with a sufficient water supply, are built at designated locations throughout the system.
- o Portable fire extinguishers will be located at each ETS and at other appropriate locations.

#### SEISMIC ACTIVITY

SCRTD will evaluate a gas probe and monitoring system. The emphasis will be to assure that the gas sensing system provides adequate detection capability during operations. The evaluation will identify appropriate locations for probes that will achieve thorough systems sensing.

SCRTD will review a Metro Rail emergency operations plan for when gas is detected. A change to the control software should automatically activate the ventilation system if no action is taken by the communications controller within a prescribed period of time. The communications controller will be provided some time to ascertain that the prescribed emergency fan activation regimen is correct considering all events that may be taking place.

\* SLIDE-11, Recorder/Switch Location

## SEISMIC DETECTION SYSTEM

### Earthquake Hazard

The District reviewed in detail all available literature including U.S.G.S. Professional Paper 1360, "Evaluating Earthquake Hazards in the Los Angeles Region." Selection of earthquake design values for the Metro Rail Project involved consideration of several factors, including:

- o The design values are not the maximum ground acceleration (spike or peak) values, but rather represent the effective values for the design earthquake.
- o Attenuation of peak ground acceleration occurs and must be considered in selecting the design value.
- o There is a very small probability of exceeding the 0.6 g design acceleration during the life of the Metro Rail structures.
- o The 0.06 g design value represents a conservative and appropriate earthquake design approach that addresses the postulated earthquake condition of 6.5 Richter magnitude and 0.42 g ground acceleration.

Fault crossings were analyzed in detail, including numerical analysis of flexibility of various tunnel structures and dynamic laboratory tests on models prepared for the District by the California Institute of Technology. From these analyses, it was concluded that fabricated steel linings, because of their ductility, were the appropriate linings for the alignment in the vicinity of identified faults.

The Metro Rail seismic detection system consists of switches to alert Central Control of Warning level and Alarm level seismic events, a recorder to provide a record of the event, and a play back unit to decode the information from the recorder. In consideration of the local soil variations, seismic switches and recorders were considered to have a five mile range and located so that the ranges overlapped.

- o A switch is located in each terminal station, therefore, MOS-1 has three switches and one recorder, all located in the ancillary areas on the platform level of the stations (see Attachment A. The switches are set at 0.1 g to detect Warning level events and 0.2 g (considered to be the threshold of structural damage) Alarm level events.
- o Detection of either event will trigger the recorder and be annunciated at Central Control. An Alarm level event will also trigger additional ventilation startup,

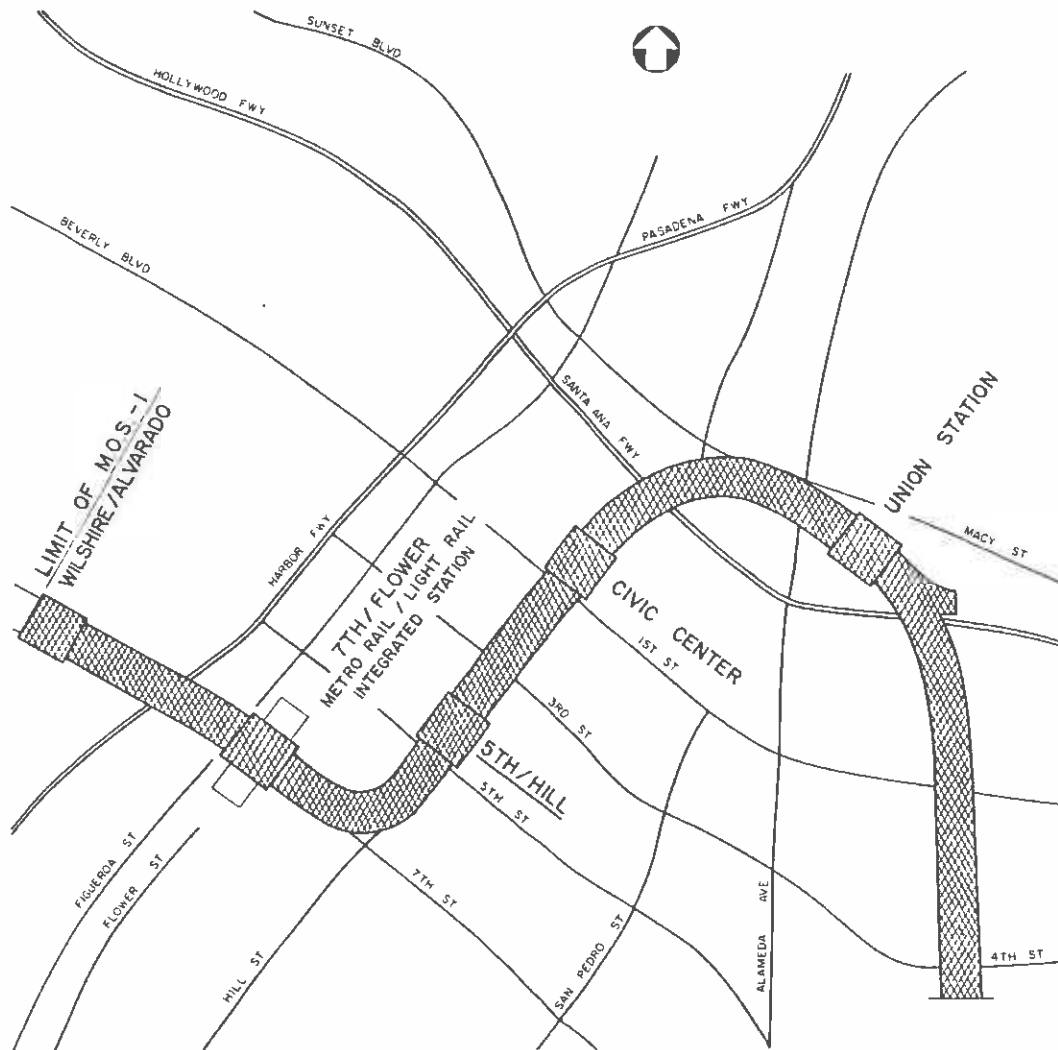

WILSHIRE /ALVARADO EMERGENCY EQPT ROOM NO 54  
UNION STATION TC & C ROOM NO P5

CIVIC CENTER  
EMERGENCY EQUIPMENT ROOM NO P21

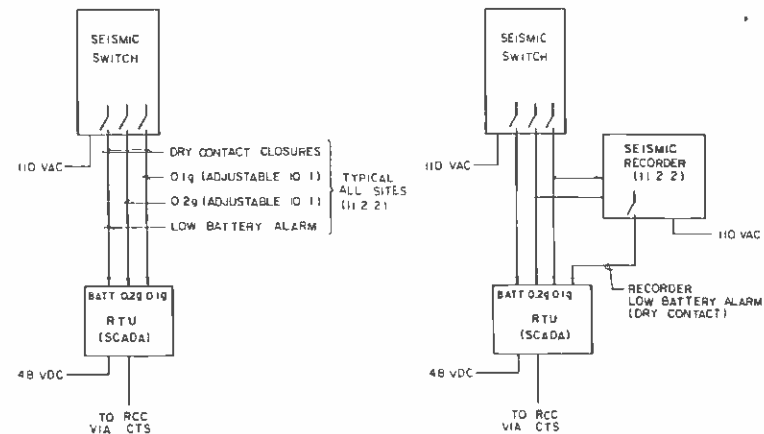

1. PARENTHETICAL NUMBERS DEMOTE A640 SPECIFICATION ARTICLE NUMBERS



| STATION            | SEISMIC RECORDER | SEISMIC SWITCHES | LOCATION                 | REFERENCE DRAWING SHEET NO |
|--------------------|------------------|------------------|--------------------------|----------------------------|
| UNION              | NO               | YES              | TC & C ROOM              | A640/22                    |
| CIVIC CENTER       | YES              | YES              | EMERGENCY EQUIPMENT ROOM | A640/32                    |
| 5TH / HILL         | NO               | NO               | ---                      | NA                         |
| 7TH / FLOWER       | NO               | NO               | ---                      | NA                         |
| WILSHIRE /ALVARADO | NO               | YES              | EMERGENCY EQUIPMENT ROOM | A640/376                   |

| REV | DATE | BY | APP | DESCRIPTION |
|-----|------|----|-----|-------------|
|     |      |    |     |             |

THE PREPARATION OF THIS DRAWING HAS BEEN FINANCED IN PART THROUGH A GRANT FROM THE U.S. DEPARTMENT OF TRANSPORTATION UNDER THE URBAN MASS TRANSPORTATION ADMINISTRATION UNDER THE URBAN MASS TRANSPORTATION ACT OF 1964 AS AMENDED, AND IN PART BY THE TAXES OF THE CITIZENS OF LOS ANGELES COUNTY AND OF THE STATE OF CALIFORNIA.

DESIGNED BY: TK MCCRANIE  
DRAWN BY: [Signature]  
CHECKED BY: [Signature]  
IN CHARGE: [Signature]  
DATE: 26 SEP 86

ADD BLOCK DIAGRAM & REF AND SHEET NO.  
PROPOSAL ISSUE

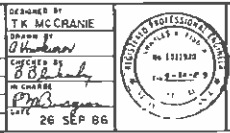

SOUTHERN CALIFORNIA RAPID TRANSIT DISTRICT  
METRO RAIL PROJECT

DMJM PBOO/KE MWA  
GENERAL CONSULTANT

APPROVED: [Signature]

LA CBD TO NORTH HOLLYWOOD COMMUNICATIONS SEISMIC DETECTION SEISMIC RECORDER AND SWITCH LOCATION SCHEMATIC

CONTRACT NO: A64D  
DRAWING NO: N-112  
SCALE: NO SCALE  
SHEET NO: 24

after a 30 second delay, to preclude infiltrating gas accumulations from occurring.

- o Other response actions are determined by operation management, and, based on the experiences at BART, will usually be visual inspection. The playback unit is to be kept at Central Control and the recording, in the form of a floppy disk, will be retrieved and decoded there.

#### PASSENGER VEHICLES

##### \* SLIDE-12, Car Exterior

The total number of patrons on-board a train has significant impact on emergency procedures, including the removal of patrons from trains and their evacuation through stations. For purposes of developing emergency procedures, train and vehicle occupancy are calculated based on full occupancy in peak periods. Emergency procedures are developed for a patron profile which includes adults and children, as well as elderly, handicapped, and non-English speaking persons.

#### Vehicle Construction Materials

##### \* SLIDE-13, Car Interior

When certain materials burn, the smoke and toxic fumes can often create more problems than the fire. To minimize or control this hazard, the following vehicle design measures have been taken:

- o Total Combustible Content - Total combustible fire load means that although one part of the vehicle (i.e., the seats) may be constructed of fire-retardant materials, when all the materials are combined, the burn rate becomes unacceptable. Total combustible fire load directly affects the type of station construction, station and tunnel ventilation operations, and fire suppression requirements as well as other aspects of the planning process. Therefore, Metro Rail designs, including vehicle design, meet a pre-established goal for total fire loads. This goal for the vehicle is 60 Million BTU per car.
- o Flammability of Vehicle Materials - To adequately plan for management of transit-related fires, it is essential to know the rate of fire spread for all materials used. During the passenger vehicle design stage, the fire performance of materials are being evaluated against specific acceptability levels.

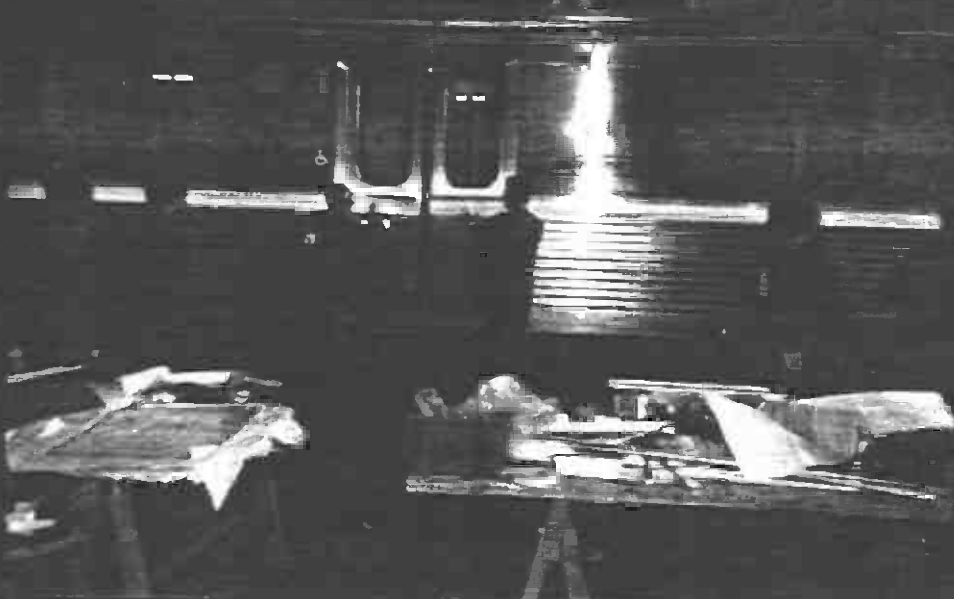

SLIDE A650-7 5/89  
CAR MOCK-UP SHOWS SIDE VIEW WITH GRAPHIC  
APPLICATION.

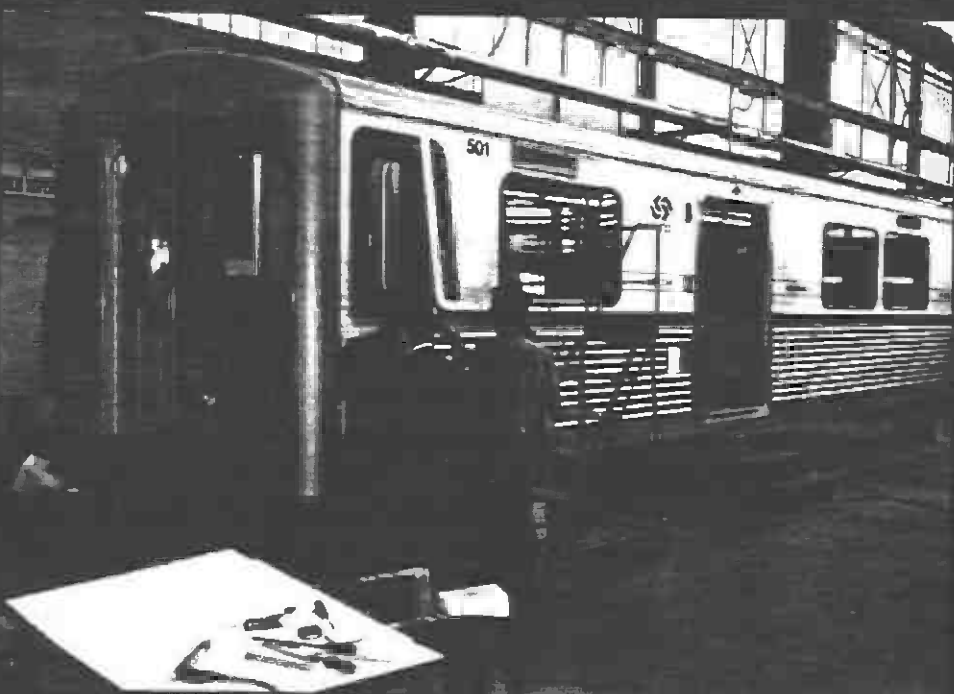

SLIDE A650-8 5/89  
FRONT AND SIDE VIEW OF CAR MOCK-UP.

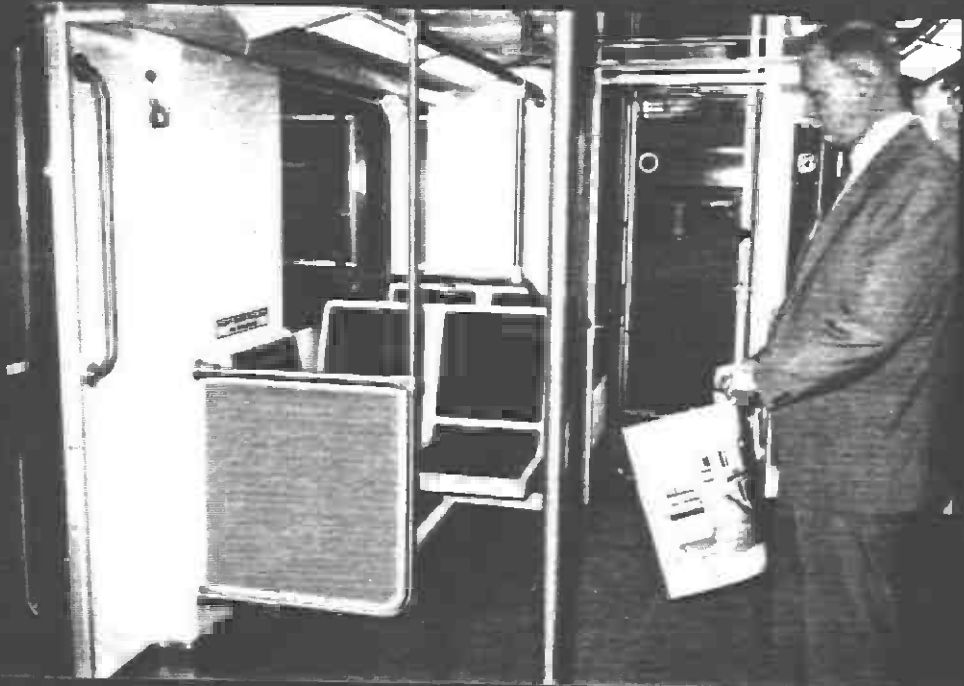

SLIDE A650-11                      5/89  
INTERIOR VIEW OF CAR MOCK-UP SHOWS WIND  
SHIELD AND SEATING ARRANGEMENT.

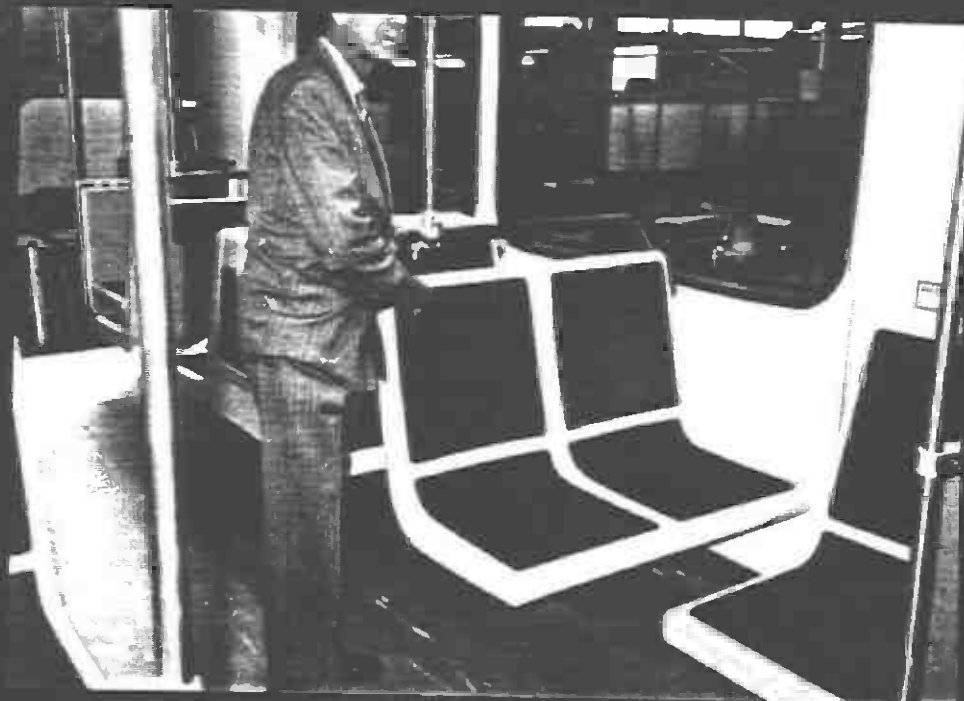

SLIDE A650-12                      5/89  
CAR MOCK-UP FOCUSES ON INTERIOR SEAT  
GRAB RAIL.

- o Smoke Emission of Vehicle Interior Materials - As smoke will be present during a fire, the smoke producing characteristics of materials for passenger vehicle use are being required to meet specific levels as part of the acceptance process.
- o Toxicity - When certain materials burn, they produce toxic vapors harmful to humans at even relatively low levels of concentration. Materials used in Metro Rail passenger vehicles are being selected to minimize toxic levels when burned. Highly toxic materials, such as polyvinyl chloride and urethane, are not being used in the vehicles.
- o Fire Separations of Underfloor Equipment - Typically, fires involving transit vehicles have originated under the floor of the vehicle. In this event, passengers in the vehicle must be protected long enough to permit safe evacuation. The vehicle floor assembly has been designed as a barrier to prevent the fire from spreading. The period of protection provided by the floor assembly is one hour and consistent with projected fire evacuation scenarios.

#### Electrical Fire Safety Requirements

There is extensive use of electricity on transit vehicles. It is primarily used for propulsion power. All wiring, motors, motor control apparatus, current collectors, and auxiliary electrical apparatus on the Metro Rail vehicle conform to appropriate standards.

#### Emergency Exit and Access Means

In the event of a fire or other emergency, a means of evacuating passengers in a safe and expeditious manner has been developed.

- o Metro Rail passenger vehicles are designed for emergency door operation from either the inside or outside of the vehicle.
- o Aids such as lights and signs, for exiting to trainway and/or emergency walkways, are provided.
- o Emergency on-board electrical power will allow minimum lighting and operation of critical systems (including the public address system) needed for emergency evacuation.

#### Fire Extinguishers

With proper equipment and training, most small fires on transit vehicles can be extinguished promptly and property damage or a



threat to life can be avoided. On-board fire extinguishers are strategically located throughout the train, one in the operator's cab and one between the back-to-back seats at the middle of the car.

#### VENTILATION SYSTEMS

##### \* SLIDE-14, Ventilation Shaft

Ventilation is a prime fire/life safety design element for the Metro Rail System. Smoke, heat and other potentially combustible products build up rapidly in confined spaces even under normal operating conditions, but especially during fires or similar emergencies. Therefore, it is important to design the ventilation systems so that smoke and toxic or flammable gases can be removed and patron safety can be ensured.

Emergency ventilation controls are incorporated as part of the underground system. They provide directional control of smoke- and fire-generated gases and will send fresh air into exit pathways.

- o Tunnel ventilation equipment has been designed to operate at full performance under adverse conditions, operate in either direction at high and low speed flows as needed, and be capable of maintaining a survivable environment for a time period sufficient to evacuate all patrons. In addition, the equipment has local and remote controls, and two separate and redundant power supplies serve each fan group.
- o On the passenger vehicle, protective devices detect heater malfunctions and disable the heater and air distribution system if a potential hazard exists. A method of isolating the vehicle ventilation is provided to prevent passenger compartment air contamination from fires in the trainway.

#### GAS MONITORING SYSTEM

##### \* SLIDE-15, Gas Probe Locations

The Los Angeles area has numerous producing and nonproducing oil and gas fields. Test drilling along the Metro Rail alignment located and identified hazardous gas areas and provided data needed for designing a safe subway system, even though the route is classified as "potentially gassy" with some areas classified as "gassy" by CAL/OSHA.

The design uses passive and active measures to ensure safety. The passive measures include an impervious liner cocooning all underground structures and massive concrete exterior walls and tunnel liners. The primary active measure is continuous ventilation in both the stations and tunnels, albeit during

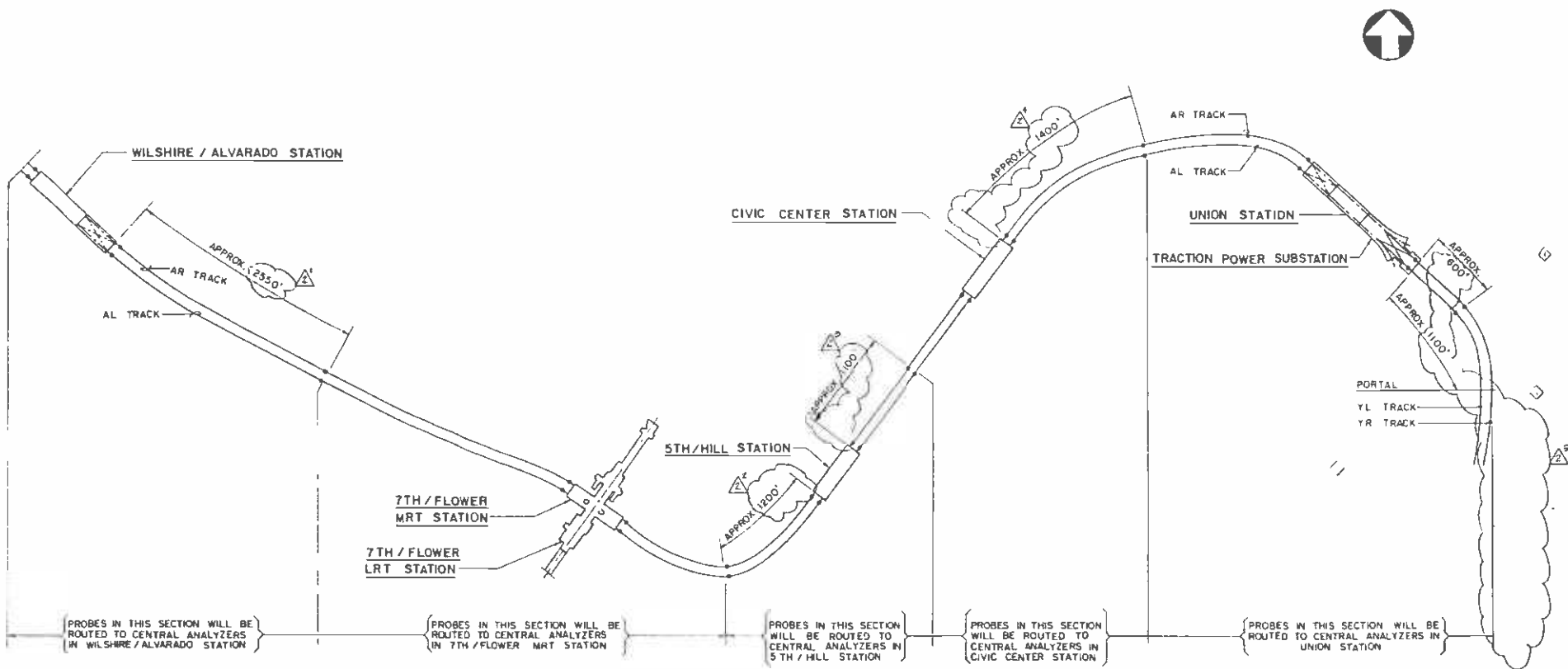

**LEGEND:**

- PROBE
  - CROSSOVER
  - STATION
- SEE DWG N-160 FOR ADDITIONAL SYMBOLS

| REV | DATE | BY | CHK | APP | DESCRIPTION |
|-----|------|----|-----|-----|-------------|
|     |      |    |     |     |             |
|     |      |    |     |     |             |

THE PREPARATION OF THIS DRAWING HAS BEEN FINANCED IN PART THROUGH A GRANT FROM THE U.S. DEPARTMENT OF TRANSPORTATION UNDER THE URBAN MASS TRANSPORTATION ADMINISTRATION, UNDER THE URBAN MASS TRANSPORTATION ACT OF 1964 AS AMENDED AND IN PART BY THE TAXES OF THE CITIZENS OF LOS ANGELES COUNTY AND OF THE STATE OF CALIFORNIA.

DESIGNED BY  
T. MCCRANIE

DRAWN BY  
*[Signature]*

CHECKED BY  
*[Signature]*

DATE  
18 AUG 86

REVISOR  
DMJIM, PBQD KE, HWA

GENERAL CONSULTANTS

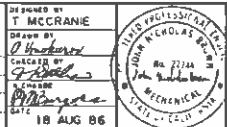

SOUTHERN CALIFORNIA RAPID TRANSIT DISTRICT  
METRO RAIL PROJECT

RTD

DMJIM, PBQD KE, HWA  
GENERAL CONSULTANTS

APPROVED *[Signature]*

LA CBD TO NORTH HOLLYWOOD  
COMMUNICATIONS  
GAS MONITORING  
MOS-1  
TUNNEL PROBE LOCATION DIAGRAM

|              |          |
|--------------|----------|
| CONTRACT NO. | A640     |
| DRAWING NO.  | N-150    |
| SCALE        | NO SCALE |
| SHEET NO.    | 94       |

revenue hours the tunnel ventilation is provided by the piston action from the trains. The ventilation system is supplemented by a sophisticated gas monitoring system.

\* SLIDE 16, Civic Center Probe Schematic

- o The gas monitoring system selected is similar to the systems used by the EPA for atmospheric monitoring. Rather than monitoring the atmospheric levels of, say, carbon monoxide, the District's system monitors the atmospheric level of methane and levels above 100 parts per billion of hydrogen sulfide, the two prevalent hazardous gases identified along our route. In Los Angeles, the normal ambient level of methane is 1.5 parts per million, and of hydrogen sulfide is less than 1 part per billion. The ventilation system conveys any infiltrating gases to sampling points in the stations or tunnels. (See Figure-1.) The samples are transported to centrally located analyzers by a vacuum system. The SCADA system reports the findings of the analyzers to Central Control, which will look for deviations from the normal gas levels and for trends that suggest infiltration may have occurred. (See Figure-2.) There are two levels of alarm, a Warning level (initially about 5 parts per million for methane) and an Alarm level (initially about 15 parts per million for methane).
- o Response to the Warning level is at the discretion of operation management. Typically, it is expected that the ventilation will be increased and technicians will be dispatched to the suspect area to pinpoint any leak so that the appropriate remedy can be applied. At an Alarm level annunciation, Central Control Room operator response must be within 30 seconds, if delay of 30 seconds occurs, additional ventilation to be started automatically. Operation management will decide on further appropriate measures, depending upon the current situation and experience with the system. Even at the Alarm level, it is anticipated that response will be similar to that at the Warning level, because the gas mixture will be sufficiently below the potential danger level (for methane, the lower flammability limit of 50,000 parts per million) to allow for a planned, systematic response.
- o A local sensor type system - such as those used to detect gasoline spilled into a system - was investigated and found to be unsatisfactory for the Metro Rail application. The sensors were not sensitive enough to ensure that a flammable accumulation of gases could not occur before the alarm was sounded.

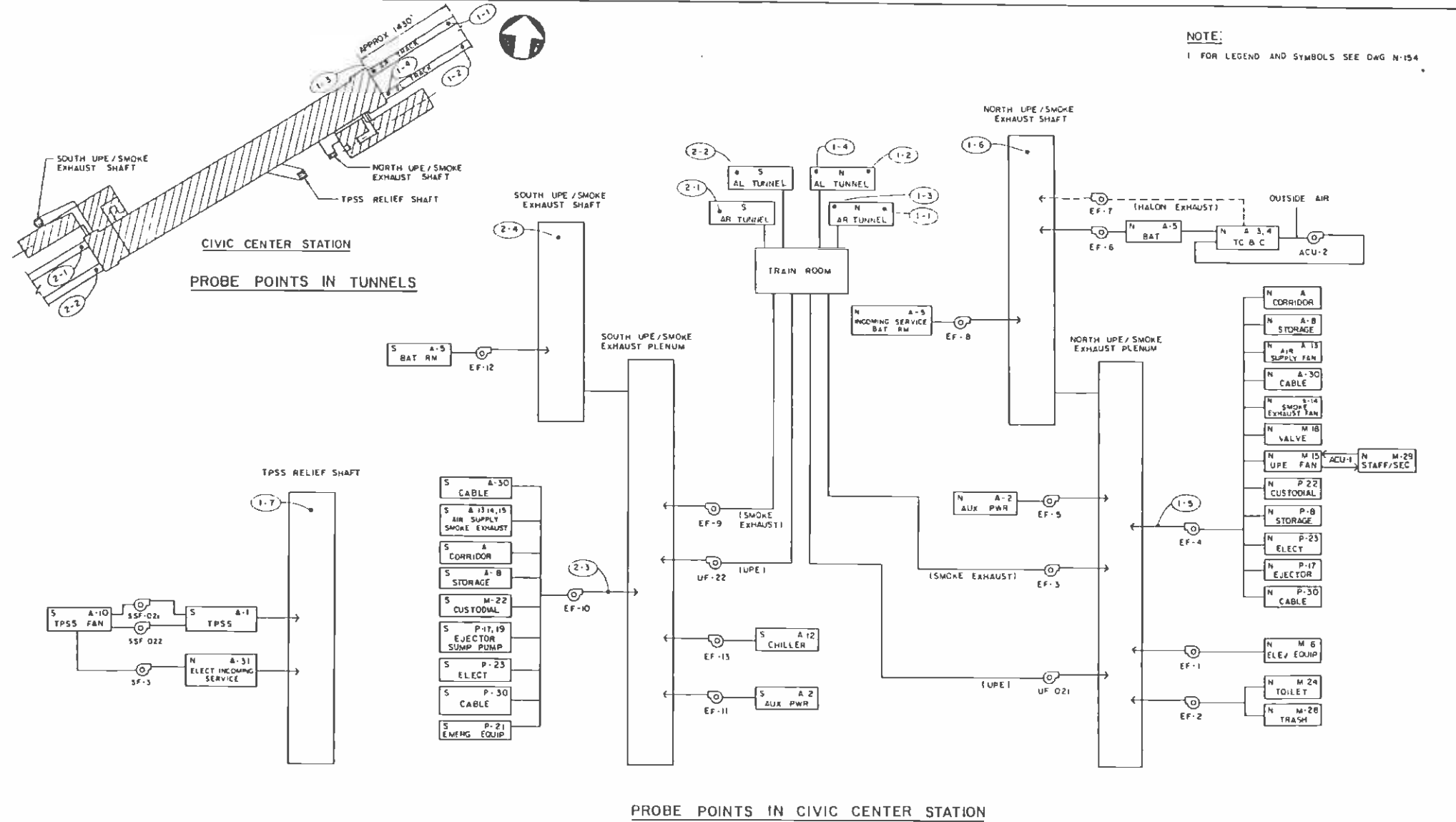

|  |  |  |  |  |  |  |  |  |  |
|--|--|--|--|--|--|--|--|--|--|
|  |  |  |  |  |  |  |  |  |  |
|  |  |  |  |  |  |  |  |  |  |
|  |  |  |  |  |  |  |  |  |  |
|  |  |  |  |  |  |  |  |  |  |
|  |  |  |  |  |  |  |  |  |  |

THE PREPARATION OF THIS DRAWING HAS BEEN FINISHED IN FULL IN ACCORDANCE WITH THE PROVISIONS OF THE METRO RAIL TRANSPORTATION ACT OF 1985 AS AMENDED AND IN PART BY THE LAWS OF LOS ANGELES COUNTY AND THE STATE OF CALIFORNIA.

DATE: 19 88 08 25

PROPOSAL ISSUE

DESIGNED BY  
S. GOLDSMITH

CHECKED BY  
*[Signature]*

DATE  
20 AUG 88

SOUTHERN CALIFORNIA RAPID TRANSIT DISTRICT  
METRO RAIL PROJECT

DESIGN PROJECT NUMBER  
GENERAL CONSULTANTS

DATE: 22 88

LA CBD TO NORTH HOLLYWOOD COMMUNICATIONS GAS MONITORING CIVIC CENTER STATION PROBE LOCATION SCHEMATIC SHEET 2 OF 2

CONTRACT NO. AG40  
DRAWING NO. N-155  
SCALE: ND SCALE  
SHEET NO. 99

## COMMUNICATIONS

Comprehensive and dependable communications are essential during emergency conditions. The communications equipment used during normal operations includes design features that allow operation under emergency conditions. Plans for emergency communications are incorporated into the design. Any emergency communications needs not met by normal operating systems require special systems.

- o Emergency telephones are provided throughout the underground trainways to allow notification of emergencies to Central Control, and to permit continuous communications throughout an emergency period.
- o Depending upon the volume of emergency communication traffic, one or more radio channels are required. Provisions have been made to accommodate radio communications for fire service needs throughout the Metro Rail System, including underground areas.
- o The PA system can be used by Central Control for emergency announcements, station evacuation instructions, or other general instructions.

## VEHICLE YARD AND MAINTENANCE FACILITIES

### \* SLIDE-17, Main Yard and Shop

When planning the design of vehicle yards and maintenance facilities, problems unique to rail rapid transit systems must be considered. Concentration of the fleet in the storage yard during non-revenue periods presents the high risk of equipment loss should a fire occur. Therefore, special consideration has been given to protection of vehicles and equipment in storage. Also, the vehicle yard and maintenance facilities are designed in accordance with local codes, utilizing exceptions only where special needs are recognized.

### Yard Facilities

The design of the yard facilities permits normal fire-suppression activities and accommodates existing fire service equipment. Where this is not possible, alternative fire suppression and fire service equipment and methods are provided.

- o An adequate water supply, through appropriately spaced fire hydrants and hose outlets, is available throughout the storage yard.
- o ETS and emergency telephones are located throughout the storage yard to provide a rapid means for initiating



-29-

METRO RAIL TRANSIT CONSULTANTS  
DANIEL, MANN, JOHNSON & MANN

SOUTHERN CALIFORNIA RAPID TRANSIT DISTRICT  
METRO RAIL PROJECT



prompt removal of traction power and for communicating emergency messages to an attended location.

### Building Structures

Buildings constructed to house Metro Rail vehicles during maintenance, service, and/or inspections require special design, both of the buildings and their protective systems.

- o Buildings conform to local codes and are protected by a fully automatic sprinkler system.
- o Special consideration has been given to waste and drainage systems to reduce the risk of fire, explosion, or other hazards.
- o Emergency trip stations to disconnect traction power in emergencies is provided.
- o Open areas in large buildings have powered venting, fire partitions, and draft curtains to remove smoke or heat.

### Fire Protection Systems

Although the maintenance facilities utilize conventional fire protection features, some adaptations have been made to meet unique Metro Rail operational needs. The fire protection system is also compatible with the other transit system fire protection elements.

- o The vehicle maintenance facilities are protected by automatic sprinkler systems.
- o Electronic data processing and control areas are protected with Halon fire extinguishing systems.
- o Automatic fire detection, suppression, and alarm systems are provided. The public address system will be used for fire alarm annunciation and other emergency alerting.
- o Standpipe systems are installed with adequate access on all sides.
- o Portable fire extinguishers are provided throughout the facility.

### Operations and Maintenance

\* SLIDE-18, Shop Interior

Spray painting, welding, and fuel handling are all activities where there is a high fire hazard potential. As these

operations are similar to those found in other industries, they will be performed in accordance with recognized safety standards. Special consideration has been given, where necessary, to certain operations involving the transit vehicles.

- o Vehicles in storage and maintenance areas are arranged to permit safe evacuation of employees and provide access for emergency personnel in case of fire or other incidents.
- o Vehicle electric systems can be de-energized during maintenance periods unless the activity in progress requires power.
- o Special facilities for handling, charging, storing, and maintaining batteries are built in accordance with recognized standards.
- o The facilities for storage and handling of flammable liquids and gases (including fuels) are constructed in accordance with local codes and recognized standards.

#### FIRE/LIFE SAFETY EMERGENCY PROCEDURES

The type and extent of emergencies or hazards that could occur in the Metro Rail System are many and varied. A comprehensive list of all conceivable emergency scenarios and the procedures to be followed are being compiled for use in developing emergency plans.

#### Emergency Procedure Plans

Successful response to and management of emergencies is largely dependent on adequate preparation. Before activating the Metro Rail System for revenue operations, procedures will be written and a comprehensive emergency preparedness plan completed. Specific emergency preparedness procedures described in the plan will then be tested and implemented.

#### Interagency Cooperation

The most effective and efficient way of responding to transit emergencies is by using agencies with personnel trained to deal with these situations. Los Angeles City and County law enforcement and fire departments will be able to assist Metro Rail personnel. Other local agencies may also be of assistance. Agreements are being made and drills conducted with these agencies to assure satisfactory response in case of emergency.

- o The Systems and Construction Safety Department within the Metro Rail Project is responsible for emergency planning.



- o A list of those agencies which can assist Metro Rail personnel during emergencies has been developed, along with the services available.
- o These agencies are involved throughout the various project phases. Liaison established with these agencies includes identification of responsible key individuals and alternates.

### Emergency Facilities

Equipment and facilities used during normal operations serve somewhat different functions during emergency situations. Facilities and equipment which are most key to emergency operations will be identified and procedures as to their emergency use developed. These include but are not limited to the Central Control, temporary command posts, temporary auxiliary command posts, and traction power control.

- o For purposes of alarm reception, emergency reporting, and system supervision, Central Control will function as the central supervisory station.
- o At stations, or other designated external access points to the transit system, locations of Emergency Management Panels have been selected and suitably equipped to function as a secondary command post.

### Training, Drills and Critiques

Those agencies with responsibility for responding to fires or other emergencies must become thoroughly familiar with Metro Rail facilities, vehicles, and operations. Emergency plans are being prepared and tested under simulated conditions. In addition to each agency developing emergency preparedness plans, interagency joint exercises simulating a variety of emergency scenarios will be carried out. Critiques of these simulated tests, exercises, plans, and drills will be utilized to improve and update the emergency plans.

### CENTRAL CONTROL FACILITY

The Central Control facility is a controlled area which will house offices, equipment, and supporting facilities to be used by those responsible for train control, electrification control, system communications, emergency operation, and security surveillance.

### Central Supervising Station/Command Post Relationship

During normal operations, Central Control is the focal point of communications for the Metro Rail System. Central Control also serves as the focal point for fire alarms and other emergency notifications. During emergencies, Central Control and another

designated location near the incident will become the primary coordination points.

#### Basic Construction

Central Control is protected from the potential hazards of smoke, heat, fire, toxic vapors, etc. This facility is of 2 to 4-hour fire-resistive construction. Fire-rated separations are provided between the operational areas of Central Control and other areas of the facility, including both public and non-public areas. Interior finishes and trim are of low combustible materials.

#### Building Services and Utilities

Support facilities for Central Control are considered critical to maintaining safety in the system under potentially adverse conditions. Emergency power from an uninterruptible power supply is provided for Central Control. There is suitable access to the Central Control facility from public streets.

#### Fire Protection, Alarm, and Communications

Protection measures incorporated in Central Control are designed to minimize service disruption.

- o A fire detection and alarm system, automatic sprinklers and Halon suppression systems are located throughout the Central Control facility.
- o Adequate water supplies for outside hydrants in the fixed systems and for standpipe systems are located throughout the facilities.

#### OPERATIONS PROCEDURES AND TRAINING

Developing appropriate emergency procedures prior to emergency situations and training personnel to follow these procedures are vital steps in the Metro Rail planning.

#### Operational Procedures

As part of the design and construction of the Metro Rail System, equipment and facilities are provided to support the fire/life safety program. The testing, inspection, and maintenance of equipment and facilities are a part of the regular operation of the transit system. The availability and reliability of this equipment is considered critical to Metro Rail safety.

- o A regular program for testing and inspection of fire protection, fire alarm, and emergency communication systems is being developed for implementation.

- o A scheduled maintenance program for fire protection, fire alarm, and emergency communication systems, including support documentation, is being developed for implementation.
- o The scheduled inspection program will include shop and guideway equipment.

### Training

Metro Rail employees will be trained to handle emergency situations to include, at a minimum, an appropriate level of first aid and fire suppression measures. The emergency personnel (i.e., fire service), will in turn be prepared for situations unique to Metro Rail facilities. Additionally, emergency preparedness training will be provided to assure that joint operations are coordinated when an emergency arises.

- o A comprehensive program of training and familiarization for fire service personnel is being developed jointly by the Metro Rail staff and the Los Angeles City and Los Angeles County Fire Departments and other involved local emergency services, for implementation prior to revenue service.
- o A transit employee training program is being developed and implemented for operating during emergencies. Special training emphasis is given to train operators, Central Control personnel and all others on duty during emergencies.

SOUTHERN CALIFORNIA RAPID  
TRANSIT DISTRICT

METRO RAIL SUBWAY PROJECT  
MOS-I

NFPA 130

SECTION 2-5, MEANS OF EGRESS  
SECTION, APPENDIX C, EMERGENCY EGRESS

H. E. Storey  
APTA Conference  
Vancouver, BC  
June 2-7, 1990

© 1988 NFPA. All Rights Reserved

## NFPA 130

### Standard for Fixed Guideway Transit Systems

#### 1988 Edition

This edition of NFPA 130, *Standard for Fixed Guideway Transit Systems*, was prepared by the Technical Committee on Fixed Guideway Transit Systems, and acted on by the National Fire Protection Association, Inc. at its Fall Meeting held November 9-11, 1987 in Portland, Oregon. It was issued by the Standards Council on December 2, 1987, with an effective date of December 22, 1987, and supersedes all previous editions.

The 1988 edition of this standard has been approved by the American National Standards Institute.

Changes other than editorial are indicated by a vertical rule in the margin of the pages on which they appear. These lines are included as an aid to the user in identifying changes from the previous edition.

#### Origin and Development of NFPA 130

The Fixed Guideway Transit Systems Committee was formed in 1975 and immediately began work on the development of NFPA 130. One of the primary concerns of the Committee in the preparation of this document centered on the potential for entrapment and injury of large numbers of people who routinely utilize these mass transportation facilities.

During the preparation of this document, several significant fires occurred in fixed guideway systems where, fortunately, the loss of life was limited. The Committee stated that the minimal loss of life was due primarily to chance events more than any preconceived plan or the operation of protective systems.

The Committee developed material on fire protection requirements to be included in NFPA 130, *Standard for Fixed Guideway Transit Systems*. This was adopted by the Association in 1983. The 1983 edition was partially revised in 1986 to conform with the NFPA Manual of Style and incorporated revisions including a new Chapter 8, new Appendix F, "Creepage Distance," additional minor revisions to the first four chapters and Appendices A, B, C, and E, and a complete revision of Appendix D.

The scope of this 1988 Edition was expanded to include Automated Guideway Transit (AGT) Systems. The sample calculations in Appendix C were revised and Appendix D was also completely revised in 1988.

to provide a stream of noncontaminated air to passengers in a path of egress.

#### 2-3.4 Emergency Ventilation Fans. (See B-2.4.)

2-3.4.1 Ventilation fans used for emergency service, their motors, and all related components exposed to the ventilation airflow shall be designed to operate in an ambient atmosphere of 300°F (148.8°C) for a period of at least one hour.

2-3.4.2 Local fan motor starters and related operating control devices shall be isolated from the ventilation airflow by a separation having a fire resistance rating of at least one hour.

2-3.4.3 Fans required for emergency operation shall be capable of satisfying emergency air velocity criteria in either supply or exhaust modes.

2-3.4.4 Discharge air from fans designed to exhaust smoke shall be directed to the outside atmosphere, discharging in a manner so as not to create a hazard.

2-3.4.5 Operation and fail-safe verification of proper operation of emergency fans shall be effected from a central supervising station with indication provided for all modes of operation for each fan, as well as from a local control isolated as in 2-3.4.2.

2-3.4.6 Thermal overload protective devices shall not be located on motor controls of fans used for emergency ventilation.

2-3.4.7 Local controls shall permit overriding remote central supervising control. Local control shall be capable of operating the fans in all modes in the event the remote controls become inoperable.

2-3.5 Ancillary Spaces. Storage battery or similar ancillary rooms in which hydrogen gas or other hazardous gases may be released, and mechanical ventilation is required, shall be ventilated in accordance with NFPA 91, *Standard for the Installation of Blower and Exhaust Systems for Dust, Stock, and Vapor Removal or Conveying*. Rooms containing such occupancies shall not be located beneath any means of egress.

#### 2-4 Wiring Requirements. (See B-2.5.)

2-4.1 All wiring materials and installations within stations other than for traction power shall conform to requirements of NFPA 70, *National Electrical Code*®, and, in addition, shall satisfy the following requirements:

2-4.1.1 Materials manufactured for use as conduits, raceways, ducts, boxes, cabinets, equipment enclosures, and their surface finish materials shall be capable of being subjected to temperatures up to 932°F (500°C) for one hour, and shall not support combustion under the same temperature condition. Other materials when encased in concrete are acceptable.

2-4.1.2 All conductors shall be insulated. Ground wires may be bare. All thicknesses of insulation and all thicknesses of jackets shall conform to NFPA 70, *National Electrical Code*.

2-4.1.3 All insulations shall conform to Article 310 of NFPA 70, *National Electrical Code*, and be moisture and heat resistant types carrying temperature ratings corresponding to the conditions of application and in no case lower than 90°C (194°F).

2-4.1.4 Wire and cable constructions intended for use in operating vital train signal circuits and power circuits to emergency fans, lights, etc., shall pass the flame propagating criteria of the IEEE Standard 383, *Standard for Type Tests of Class 1E Electric Cables, Field Splices and Connections for Nuclear Generating Stations*.

2-4.1.5 All conductors, except radio antennas, shall be enclosed in their entirety in armor sheaths, conduits, or enclosed raceways, boxes, and cabinets except in ancillary areas or other nonpublic areas. Conductors in conduits or raceways may be embedded in concrete or run in concrete electrical duct banks but shall not be installed exposed or surface mounted in air plenums that may carry air at the elevated temperatures accompanying fire-emergency conditions.

2-4.1.6 Overcurrent elements that (1) are designed to protect conductors serving emergency equipment motors (fans, dampers, pumps, etc.), emergency lighting, and communications equipment, and (2) that are located in spaces other than the main electrical distribution system equipment rooms, shall not depend on thermal properties for operation.

2-4.1.7 The power supply for fans essential for emergency ventilation service shall consist of two separate electrical feeders. Each feeder shall originate from a different source (substation) and shall be separated physically to the extent possible.

2-4.1.8 Conductors for emergency fans, emergency lighting, communications, etc., shall be protected from physical damage by transit vehicles or other normal transit system operations and from fires in the transit system by suitable embedment or encasement, or by routing such conductors external to the interior underground portions of the transit system facilities.

#### 2-5 Means of Egress. (See Appendix C.)

2-5.1 General. To provide minimum criteria for design of egress facilities, a station shall comply with the provisions of NFPA 101®, *Life Safety Code*®, Chapters 8 and 9, "Places of Assembly," except as herein modified.

#### 2-5.2 Occupant Load. (See Appendix C.)

2-5.2.1 The occupant load for a transit station shall be determined based on the emergency condition requiring evacuation of that station to a point of safety. The occupant load shall be based on the "Calculated Train Load" of trains simultaneously entering the station on all tracks in normal traffic direction during the peak fifteen-minute period plus the simultaneous entraining load awaiting a train. As a basis for computing the detraining load during an emergency, not more than one train will unload at any one track to a platform during an emergency.

2-5.2.2 Special consideration shall be given to station servicing areas where events occur that establish occupant loads not included in normal passenger loads. These would include such areas as civic centers, sports complexes, and convention centers. Consideration of control of access to platform may be necessary to provide the appropriate level of safety.

2-5.2.3 At multiplatform stations, each platform shall be considered separately and the arrival of trains from all normal traffic directions plus entraining loads shall be considered. At concourses, mezzanines, or multilevel stations, simultaneous loads shall be considered for all exit lanes passing through that area.

### 2-5.3 Number and Capacity of Exits.

2-5.3.1 Exit capacities shall be calculated on the basis of 22 in. (558.8 mm) wide exit lanes. Width shall be measured in the clear at the narrowest point except that individual handrails may project 3½ in. (88.9 mm) into required width. Fractional lanes shall not be counted in measuring exit capacities except that 12 in. (304.8 mm) added to one or more lanes shall be counted as one-half a lane.

2-5.3.2 There shall be sufficient exit lanes to evacuate the station occupant load as defined in 2-5.2.1 from the station platforms in four minutes or less. The maximum travel distance to an exit from any point on the platform shall not exceed 300 ft (91.4 m).

2-5.3.3 The station shall also be designed to permit evacuation from the most remote point on the platform to a point of safety in six minutes or less. In at-grade or elevated structures so designed that the station platform is open to the elements and, when the concourse is below or protected from the platform by distance or materials as determined by an appropriate engineering analysis, that concourse may be defined as a point of safety.

2-5.3.4 The capacity in persons per minute (ppm), passenger travel speeds in feet per minute (fpm), and requirements for exit lanes shall be as follows:

2-5.3.4.1 **Platforms, Corridors, and Ramps of 4 Percent Slope or Less.** Exit corridors and ramps shall be a minimum of 5 ft 8 in. (1.73 m) wide. In computing the number of exit lanes available, 1 ft 0 in. (304.8 mm) shall be deducted at each side wall and 1 ft 6 in. (457.2 mm) at platform edges.

Per Exit Lane:

Capacity — 50 ppm

Travel Speed — 200 fpm (61 m/m)

2-5.3.4.2 **Stairs, Stopped Escalators, and Ramps of Over 4 Percent Slope.** Exit stairs shall be a minimum of 44 in. (1.12 m) wide. Stopped escalators may be considered as emergency exits of two-lane capacity provided they are of standard 48 in. (1.22 m) width, of 1½-lane capacity provided they are of standard 32 in. (813 mm) width, and of one-lane capacity if less than 32 in. (813 mm) width. Exit ramps shall be a minimum of 6 ft 0 in. (1.83 m) wide.

Escalators shall not account for more than half of the units of exit at any one level.

Per Exit Lane "up" direction  
Capacity — 35 ppm  
Travel Speed — 50 fpm\* (15.24 m/m)  
Per Exit Lane "down" direction  
Capacity — 40 ppm  
Travel Speed — 60 fpm\* (18.3 m/m)

2-5.3.4.3 **Doors and Gates.** Exit doors and gates shall be a minimum of 3 ft 0 in. (914.4 mm) in width.

Per Exit Lane  
Capacity — 50 ppm

2-5.3.4.4 **Fare Collection Gates.** Fare collection gates, when deactivated, shall provide a minimum 20 in. (508 mm) clear, unobstructed aisle. Console shall not exceed 40 in. (1016 mm) in height.

Per Gate  
Capacity — 50 ppm

A turnstile-type fare collection gate is one that consists of a minimum 18 in. (457.2 mm) aisle and maximum 36 in. (914.4 mm) height of the turnstile bar. When deactivated the turnstile bar shall free wheel in the exit direction.

Per Gate  
Capacity — 25 ppm

2-5.3.5 Emergency exit gates shall be in accordance with *NFPA 101*. Gate-type exits shall be provided for at least 50 percent of the required emergency exit capacity unless fare collection equipment provides unobstructed exiting under all conditions.

2-5.3.6 A second means of egress at least two lanes wide shall be provided from each station platform and shall be remote from the major egress route.

### 2-5.4 Escalators. (See also Appendix C-2.)

2-5.4.1 Escalators equipped to operate in both directions shall be acceptable as emergency exits.

Escalators running in the exit direction may be left in operating mode. Escalators running reverse to exiting shall be capable of being stopped remotely, manually, or automatically. (See Appendix C-2.)

2-5.4.1.1 Because of the possibility of maintenance or malfunction, one escalator at each station shall be considered as being out of service in calculating egress requirements. The escalator chosen shall be that one having the most adverse effect upon exiting capacities.

2-5.4.2 Escalators with or without intermediate landings shall be acceptable as emergency exits, regardless of vertical rise.

2-5.4.3 If escalators are exposed to the outdoor environment, the landing and floor plates shall have a nonslip surface and, if they are also exposed to freezing temperatures, the landing and floor plates and steps shall be heated to keep those areas free of ice and snow.

\*Indicates vertical component of travel speed.

(b) *The passengers' exposure time is reduced.* The passengers' exposure time can be reduced by limiting the length of time that the smoke is generated, or by evacuation procedures that will enable the passenger to get away from the smoke quickly.

**B-2.5.3** The amount of material available for smoke generation and the evacuation procedures to be used involve consideration of numerous design features, while the amount of air flowing through the tunnels is directly related to the fan capacity installed.

**B-2.5.3.1** The decomposition rate of materials that cannot support combustion depends on the rate and quantity of heat externally applied to the materials and not on the airflow to the materials. Potential smoke evolution from these materials can be limited by material selection, control, and correction of electrical shorts, and by minimizing the accumulation of oily substances in the materials. Increased airflow is desirable to dilute whatever smoke is generated.

**B-2.5.3.2** All insulations should be resistant to moisture as demonstrated by an essentially flat response of a plot of power factor vs. time when tested by immersion of a No. 14 AWG wire with 47 mils of insulation in 90°C (194°F) continuously for six months while energized with 600 volts dc continuous with the power factor measured every month at 80 volts mil. Other physical and electrical properties of the insulations should conform to those given for the type of insulation in ICEA S-19-81/NEMA WC3, *Rubber-Insulated Wire and Cable for the Transmission and Distribution of Electrical Energy*, for rubber insulated wire and cable and to ICEA S-66-524 /NEMA WC7, *Cross-Linked-Thermo-Setting-Polyethylene-Insulated Wire and Cable for the Transmission and Distribution of Electrical Energy*, for crosslinked polyethylene wire and cable or ICEA S-68-516/NEMA WC8, *Ethylene-Propylene Rubber-Insulated Wire and Cable for the Transmission and Distribution of Electrical Energy*, for ethylene-propylene-rubber-insulated wire and cable.

**B-2.5.4** Insulation and jacketing materials yielding lowest amounts of toxic and/or corrosive products during combustion are preferred; however, the electrical integrity of the wire and cable systems and the nonfire propagating properties in a fire of the constructions of wire and cable systems should be given a high priority when selecting materials.

## Appendix C Emergency Egress

*This Appendix is not a part of the requirements of this document, but is included for information purposes only.*

**C-1** Transit station dimensions are determined as a function of the length of trains employed in a transit system. Thus the areas of station platforms in light density outlying stations will be equal to those of heavy density downtown central business district transit stations. Consequently, occupancy loads in rapid transit stations,

based on the emergency condition requiring evacuation of that station to a point of safety, are a function of the train carrying capacities rather than platform areas categorized as a "place of assembly." The tunnel may be considered as an auxiliary exit from the station under certain fire scenarios.

**C-1.1 Calculating Occupant Load Exit Capacity.** The occupant load as used in this section is the basis on which most new or expanding transit systems are designed. The methodology for determining passenger use of transit systems varies considerably between specific systems, but a study usually will permit a determination of "peak hour loads." Most systems will also determine "peak hour" reversal from morning to afternoon to reflect commuter loads.

The basis on which the occupant load data is determined should be carefully considered in establishing the need for emergency egress. In new transit systems, a survey of actual usage should be made within two years of completion of the project to verify design predictions. In operating systems, predicted passenger loads should be established to determine the need for expansion of the system or significant operating changes. Verification by survey should be made following any extension or significant operating change, or at a maximum of five-year intervals.

The basis for calculating occupant loads should be the peak hour patronage figures as commonly projected for design of new transit systems or as established by survey for operating systems.

For new transit systems, the projected peak hour passenger figures can be converted to the peak 15-minute loads by dividing by 4 and multiplying by 1½. The 1½ is a distribution curve correction and may be varied for a particular system if sufficient data is available for verification. Both link loads (number of passengers traveling between two stations over a given period) and entraining loads (number of passengers entering a station to board trains during a given period) are converted in this manner.

For existing transit systems, where actual patronage data is available, statistical methods may be used to calculate occupant load data. The use of statistical methods for calculation of "calculated train loads" and "calculated entraining loads" will provide a more accurate indication of exiting needs.

The station occupant load is composed of two parts: the entraining load and the calculated train load. The entraining load as used for exit calculations is calculated from peak 15-minute entraining loads by dividing by 15 minutes and multiplying by 12 minutes or two times the headway, whichever is greater.

When trains arrive at a platform from only one direction, the "calculated train load" as used for exit calculations is calculated from the peak 15-minute link load by dividing the number of trains arriving at the station during 15 minutes based on headways and multiplying by two to allow for one missed headway. The maximum for the "calculated train load" should be the most passengers capable of occupying a train.

When trains arrive at a platform from more than one direction, the entraining load and calculated train load



for the peak direction are computed as described above. In the off-peak direction, the entraining load and calculated train load are computed from the peak 15-minute entraining load and the peak 15-minute link load, respectively, by dividing by the number of trains arriving at the station during 15 minutes based on headway.

The total exit time is the sum of the walking travel time for the longest exit route plus the waiting times at the various circulation elements.

The walking travel time is calculated using station geometry data and the travel speeds indicated in 2-5.3.4. The exit route is broken down into sequential horizontal and vertical segments, and tabulated. The travel distance for each segment is then divided by the appropriate travel speed to determine the time needed to traverse each segment. The walking travel time is the sum of the times for each segment.

The flow time (the time for the last person to pass through the particular element) for each of the various circulation elements (e.g., platform exits, fare barriers, concourse exits) is calculated using the capacities and conditions specified in 2-5.3, 2-5.4, and 2-5.5 along with the occupant load calculated as described above. Care must be taken to be sure that the most restrictive elements are included in the calculations.

For instance, if a nominal 3-ft (1-m) wide door provides access to a 44-in. (1.22-m) wide stair, the clear width of the door opening, with the door in the fully open position, is usually about 32 in. (0.91 m). This door would be considered to provide 1 unit of exit width. The stair, with code-complying handrails, would be considered to provide 2 units of exit width. Using the capacities specified in 2-5.3.4, the door has a capacity of 50 ppm per lane (unit) of exit width. The stair has a capacity of 35 ppm per lane (unit) in the up direction or 40 ppm per lane (unit) in the down direction. So, the capacity of this stair is either 70 ppm or 80 ppm, depending on direction of travel. In this case, the door is more restrictive than either stair condition, meaning that the door should be used in the capacity calculations. If the door were wider, for example, enough to provide 2 units of exit width, the capacity of the door would be 100 ppm. The stair capacity would then be more restrictive, meaning that the stair capacity should be used.

Where exit paths divide, i.e., where a choice of exit paths is presented, it is presumed (as it is in the Model Codes) that the passengers will divide into groups roughly in proportion to the exit capacity provided by the various paths at the decision point. It is also presumed that passengers, once having made a decision (selecting an exit path), will stay on that path until another decision point is reached or egress is achieved.

The waiting time at each of the various circulation elements is calculated, for the platform exits, by subtracting the walking travel time on the platform from the platform exits flow time, and for each of the remaining circulation elements, by subtracting the maximum of all previous element flow times.

The symbols used in the sample calculations that follow represent the walking times, flow times, and waiting times where:

- T = Total walking travel time for the longest exit route.
- $T_1$  = Walking travel time on the platform.
- TX = Walking travel time for the Xth segment of the exit route.
- $W_1$  = Platform exits flow time.
- $W_2$  = Fare barrier flow time.
- $W_3$  = Concourse exits flow time.
- WN = Flow time for any additional circulation element.
- $W_p = W_1 - T_1$  = Waiting time at platform exits.
- $W_f = W_2 - W_1$  = Waiting time at fare barriers.
- $W_c = W_3 - \text{MAX}(W_1 \text{ or } W_2)$  = Waiting time at concourse exits.
- $W_n = W_N = \text{MAX}(W_3, W_2, \text{ or } W_1)$  = Waiting time at any additional circulation element.

NOTE: The waiting time at any circulation element cannot be less than zero.

### C-1.2 Center Platform Station Sample Calculation.

The sample center platform station is an elevated station with the platform above the concourse, which is at grade. The platform is 600 ft (183 m) long to accommodate the train length. The vertical distance from the platform to the concourse is 30 ft (9 m).

The station has one paid area separated from the outside by a fare array containing 4 electronic fare gates, and one 48 in. (1.22 m) handicapped/service gate. In addition, two 72-in. (1.83-m) wide emergency exits are provided. Six open wells communicate between the platform and the concourse. Each well contains one stair or one escalator. Station ancillary spaces are located at the concourse level.

Elevators (although not shown on the sketch) are provided for use by the handicapped or service personnel. Open emergency stairs are provided at each end of the platform. They discharge directly to grade through grill doors with panic hardware.

Escalators are nominal 48 in. (1.22 m) wide. Stairs regularly used by patrons are 72 in. (1.83 m) wide; emergency stairs are 48 in. (1.22 m) wide. Gates to emergency stairs are 48 in. (1.22 m) wide.

The station occupant load is 2498 persons.

In the sample calculation, in Test No. 1, the time to clear the platform is found to be 3.469 minutes. This meets the requirement of 2-5.3.2.

In Test No. 2, the time to reach a point outside any enclosing structure is found to be 4.289 minutes. This meets the requirement of 2-5.3.3.

Were the concourse of this station considered to meet the point of safety definition by the authority having jurisdiction, the calculation for Test No. 2 would be modified. The time to reach a point of safety would include the walking travel time from the remote point on the platform to the concourse only, plus the waiting time at the platform exits. The area of the concourse would have to be large enough to accommodate the concourse occupant load calculated in Test No. 2.

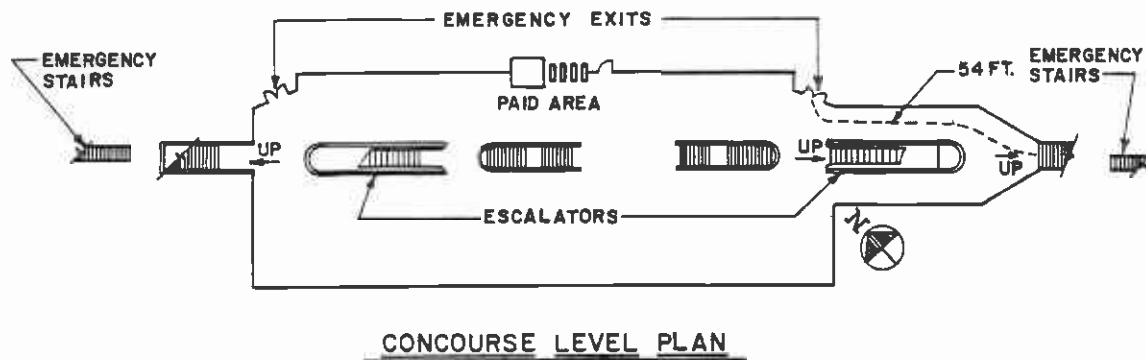
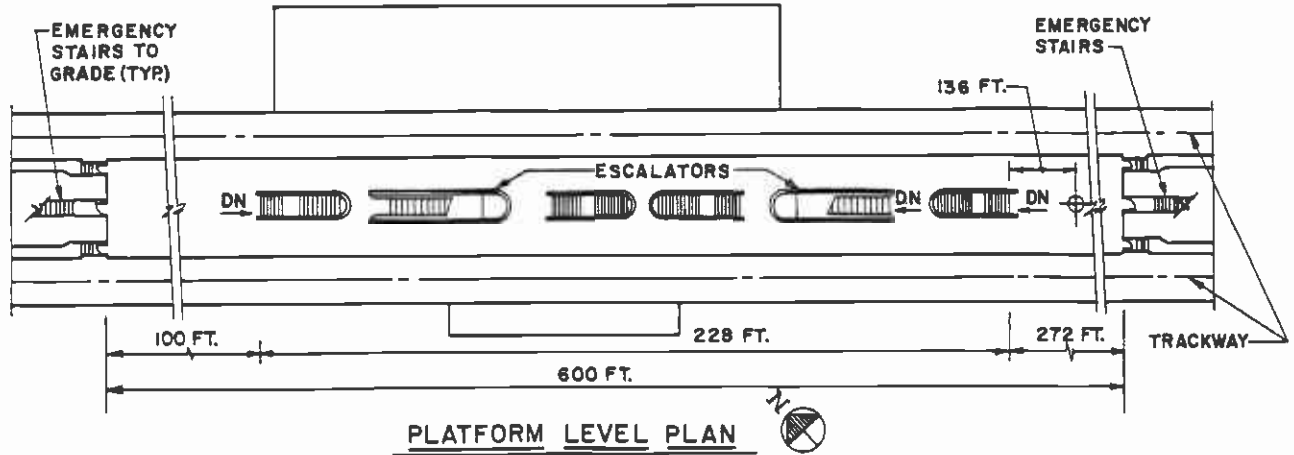

**NFPA 130 EXITING ANALYSIS**

STATION: SAMPLE CENTER DATE: APR 1, 87 BY: DRF

**EXIT LANES AND CAPACITY PROVIDED**

| ELEMENT                            | DIRECTION | NO. LANES | CAPACITY /LANE | =  | PPM   |     |
|------------------------------------|-----------|-----------|----------------|----|-------|-----|
| Platform to Concourse              |           |           |                |    |       |     |
| Stairs                             | -Up       | 0         | 3              | 35 | = 0   |     |
|                                    | -Down     | 4         | 3              | 40 | = 480 |     |
| Escalator                          | -Up       | 0         | 2              | 35 | = 0   |     |
|                                    | -Down*    | 1         | 2              | 40 | = 80  |     |
| Emer. Sta                          | -Up       | 0         | 2              | 35 | = 0   |     |
|                                    | -Down     | 2         | 2              | 40 | = 160 |     |
| Escalator Test: 11.11% [Not > 50%] |           |           |                |    | Total | 720 |

\*One escalator discounted per 2-5.4.1.1

**Through Fare Barriers**

|                 |   |   |    |   |     |
|-----------------|---|---|----|---|-----|
| Turnstiles      | 0 | 1 | 25 | = | 0   |
| Fare Gates      | 4 | 1 | 50 | = | 200 |
| Service Gates   | 1 | 2 | 50 | = | 100 |
| Emergency Gates | 2 | 3 | 50 | = | 300 |

Fare Barrier Test: 33.33% [Not > 50%] Total 600

**Fare Barriers to Safe Area \*\* FARE BARRIERS DISCHARGE TO OUTSIDE\*\***

|                                   |       |   |   |    |       |   |
|-----------------------------------|-------|---|---|----|-------|---|
| Stairs                            | -Up   | 0 | 3 | 35 | =     | 0 |
|                                   | -Down | 0 | 0 | 40 | =     | 0 |
| Escalator                         | -Up   | 0 | 2 | 35 | =     | 0 |
|                                   | -Down | 0 | 0 | 40 | =     | 0 |
| Emer. Sta                         | -Up   | 0 | 0 | 35 | =     | 0 |
|                                   | -Down | 0 | 0 | 40 | =     | 0 |
| Escalator Test: 0.00% [Not > 50%] |       |   |   |    | Total | 0 |

**WALKING TIME FOR LONGEST EXIT ROUTE**

| Platform to Safe Area |                              | Feet | /FPM | Min.  |
|-----------------------|------------------------------|------|------|-------|
| On platform           | T1                           | 136  | 200  | 0.680 |
| Platform to concourse | T2                           | 30   | 60   | 0.500 |
| On concourse          | T3                           | 54   | 200  | 0.270 |
| Concourse to grade    | T4                           | 0    | 50   | 0.000 |
| On grade to safe area | T5                           | 10   | 200  | 0.500 |
| Total walking time    | T = T1 + T2 + T3 + T4 + T5 = |      |      | 1.500 |

**NFPA 130 EXITING ANALYSIS**

STATION: SAMPLE CENTER DATE: APR 1, 87

**TEST #1**

Evacuate PLATFORM OCCUPANT LOAD(S) from Platform(s) in 4 Minutes or less.  
 $W1$  (time to clear platform) = PLATFORM OCCUPANT LOAD / PLATFORM EXIT CAPACITY  
 $W1 = 2498 / 720 = 3.469$  Minutes

**TEST #2**

Evacuate PLATFORM OCCUPANT LOAD from most remote point on platform to a point of safety in 6 minutes or less.

Waiting Time at Platform Exits.  $Wp$  [=  $W1 - T1$ ]  
 $Wp = [W1 - T1] = 3.469 - 0.680 = 2.789$  Minutes

Concourse Occupant Load = Platform Occupant Load - ( $W1 \times$  Emergency Stair Capacity)  
 Concourse Occupant Load = 2498 - 555 = 1943 Persons

Waiting Time at Fare Barriers.  $Wf$  [=  $W2 - W1$ ]  
 $W2 =$  Concourse Occupant Load / Fare Barrier Exit Capacity  
 $W2 = 1943 / 600 = 3.238$  Minutes  
 $Wf = W2 - W1 = 3.238 - 3.469 = 0.000$  Minutes

Waiting Time at Concourse Exits.  $Wc$  [=  $W3 - \text{MAX}(W2 \text{ or } W1)$ ]  
 $W3 =$  Concourse Occupant Load / Concourse Exit Capacity  
 $W3 = 1943 / 0 = 0.000$  Minutes  
 $Wc = W3 - \text{Max}(W2 \text{ or } W1) = 0.000 - 3.469 = 0.000$  Minutes

Total Exit Time [=  $T + Wp + Wf + Wc$ ]  
 Total = 1.500 + 2.789 + 0.000 + 0.000 = 4.289 minutes

**C-1.3 Side Platform Station Sample Calculation.** The sample side platform station is a subway station with a concourse above the platform level, but below grade. The platform is 600 ft (183 m) long to accommodate the train length. The vertical distance from grade to concourse is 26 feet (8 m). The concourse is 18 ft (5.5 m) above the platform.

The station has two entrances normally used by patrons, each containing one escalator and one stair. The entrances are covered at grade level to a point 10 ft (3 m) beyond the top of the stairs.

The concourse is divided into two free areas and one paid area separated by fare arrays. Each fare array contains twelve fare gates of the turnstyle type and one swinging service gate, 48 in. (1.22 m) wide, equipped with panic hardware for use by the handicapped and service personnel. Three open wells, containing two stairs and one escalator, communicate between each platform and the concourse.

Elevators are provided from grade level to concourse and from the concourse to each platform for use by the handicapped and service personnel. Station ancillary spaces are located at concourse level.

Enclosed emergency stairs, discharging directly to

grade, are provided at both ends of each platform. Escalators are nominal 48 in. (1.22 m) wide. Stairs regularly used by patrons are 72 in. (1.83 m) wide. Emergency stairs are 48 in. (1.22 m) wide. Doors to emergency stairs are 48 in. (1.22 m) wide.

The station occupant load is 1600 persons, 228 on the outbound platform and 1372 on the inbound platform.

The sample calculation shown is one of several that need to be done to properly analyze this type of station. The sample calculation shows the effect of discounting one of the escalators from concourse to grade. The exit capacity from platform to concourse meets the criteria of 2-5.3.2 in Test No. 1, where the time to clear the platform is found to be 3.267 minutes for the inbound platform and 0.543 minutes for the outbound platform.

In Test No. 2, however, the total exit time (the maximum for the two paths examined) is found to be 6.591 minutes. This does not meet the criteria of 2-5.3.3. Additional exit capacity is needed from concourse to grade.

Additional calculations must also be made to examine the results of discounting an escalator between platform and concourse (rather than an escalator between concourse and grade) to verify that the inbound platform can still be cleared in 4 minutes or less under this condition.

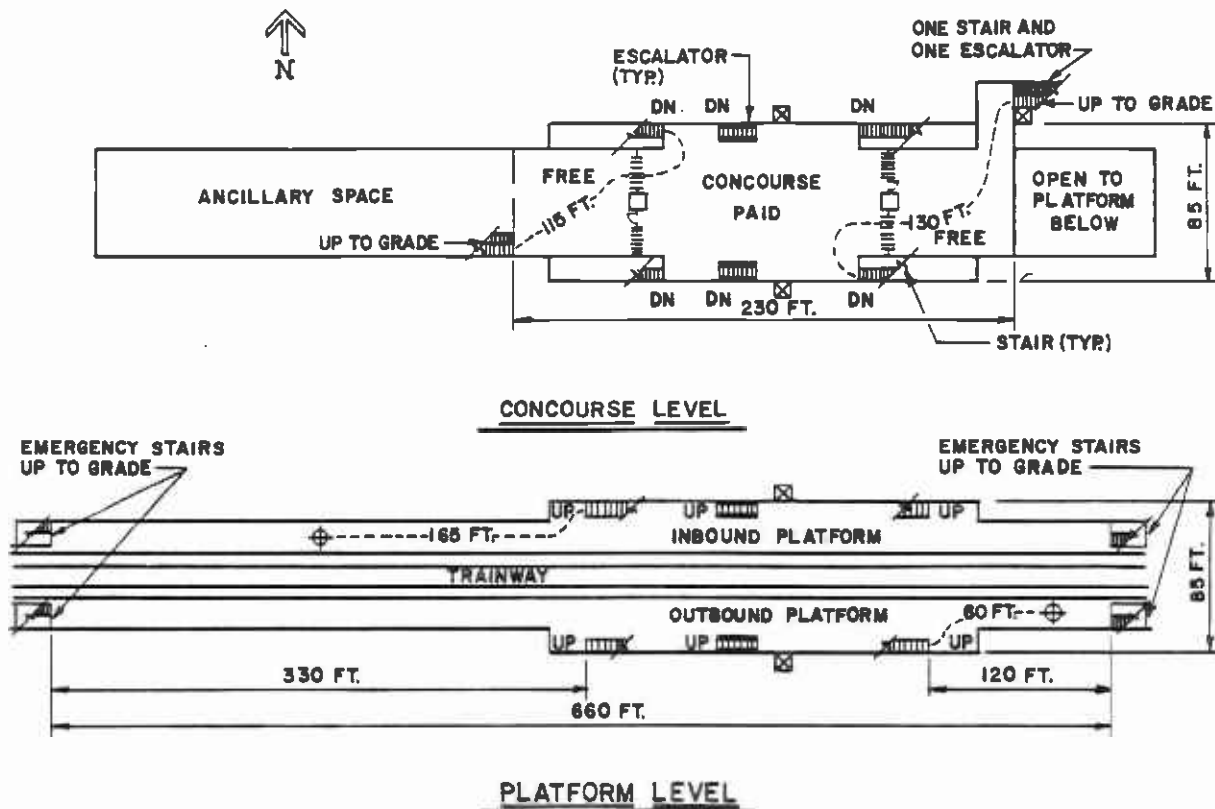

NFPA 130 EXITING ANALYSIS

STATION: SAMPLE CENTER DATE: APR 1, 87 BY: DRF  
EXIT LANES AND CAPACITY PROVIDED

| ELEMENT                       | DIRECTION | NO. LANES | CAPACITY /LANE | =  | PPM   |
|-------------------------------|-----------|-----------|----------------|----|-------|
| Inbound Platform to Concourse |           |           |                |    |       |
| Stairs                        | Up        | 2         | 3              | 35 | = 210 |
|                               | Down      | 0         | 0              | 40 | = 0   |
| Escalator                     | Up        | 1         | 2              | 35 | = 70  |
|                               | Down*     | 0         | 0              | 40 | = 0   |
| Emer. Sta                     | Up        | 2         | 2              | 35 | = 140 |
|                               | Down      | 0         | 0              | 40 | = 0   |
| Total                         |           |           |                |    | 420   |

| ELEMENT               | DIRECTION | NO. LANES | CAPACITY /LANE | =  | PPM   |
|-----------------------|-----------|-----------|----------------|----|-------|
| Through Fare Barriers |           |           |                |    |       |
| Turnstiles            |           | 12        | 1              | 25 | = 300 |
| Fare Gates            |           | 0         | 1              | 50 | = 0   |
| Service Gates         |           | 0         | 0              | 50 | = 0   |
| Emergency Gates       |           | 1         | 2              | 50 | = 100 |
| Total                 |           |           |                |    | 400   |

| ELEMENT                    | DIRECTION | NO. LANES | CAPACITY /LANE | =  | PPM   |
|----------------------------|-----------|-----------|----------------|----|-------|
| Fare Barriers to Safe Area |           |           |                |    |       |
| Stairs                     | Up        | 1         | 3              | 35 | = 105 |
|                            | -Down     | 0         | 0              | 40 | = 0   |
| Escalator                  | -Up*      | 0         | 2              | 35 | = 0   |
|                            | Down      | 0         | 0              | 40 | = 0   |
| Emer. Sta                  | -Up       | 0         | 0              | 35 | = 0   |
|                            | -Down     | 0         | 0              | 40 | = 0   |
| Total                      |           |           |                |    | 105   |

\*One escalator Test. per 2-5.4.1.1

WALKING TIME FOR LONGEST EXIT ROUTE

| Inbound Platform                                |    | Feet | /FPM | Min.  |
|---|----|------|------|-------|
| On platform                                     | T1 | 165  | 200  | 0.825 |
| Platform to concourse                           | T2 | 18   | 50   | 0.360 |
| On concourse                                    | T3 | 115  | 200  | 0.575 |
| Concourse to grade                              | T4 | 26   | 50   | 0.520 |
| On grade to safe area                           | T5 | 10   | 200  | 0.500 |
| Total walking time T = T1 + T2 + T3 + T4 + T5 = |    |      |      | 2.330 |

ELEMENT DIRECTION NO. LANES CAPACITY /LANE = PPM

| ELEMENT                        | DIRECTION | NO. LANES | CAPACITY /LANE | =  | PPM   |
|--------------------------------|-----------|-----------|----------------|----|-------|
| Outbound Platform to Concourse |           |           |                |    |       |
| Stairs                         | -Up       | 2         | 3              | 35 | = 210 |
|                                | Down      | 0         | 0              | 40 | = 0   |
| Escalator                      | -Up       | 1         | 2              | 35 | = 70  |
|                                | Down      | 0         | 0              | 40 | = 0   |
| Emer. Sta                      | -Up       | 2         | 2              | 35 | = 140 |
|                                | -Down     | 0         | 0              | 40 | = 0   |
| Total                          |           |           |                |    | 420   |

| ELEMENT               | DIRECTION | NO. LANES | CAPACITY /LANE | =  | PPM   |
|-----------------------|-----------|-----------|----------------|----|-------|
| Through Fare Barriers |           |           |                |    |       |
| Turnstiles            |           | 12        | 1              | 25 | = 300 |
| Fare Gates            |           | 0         | 1              | 50 | = 0   |
| Service Gates         |           | 0         | 0              | 50 | = 0   |
| Emergency Gates       |           | 1         | 2              | 50 | = 100 |
| Total                 |           |           |                |    | 400   |

| ELEMENT                    | DIRECTION | NO. LANES | CAPACITY /LANE | =  | PPM   |
|----------------------------|-----------|-----------|----------------|----|-------|
| Fare Barriers to Safe Area |           |           |                |    |       |
| Stairs                     | -Up       | 1         | 3              | 35 | = 105 |
|                            | -Down     | 0         | 0              | 40 | = 0   |
| Escalator                  | -Up       | 1         | 2              | 35 | = 70  |
|                            | -Down     | 0         | 0              | 40 | = 0   |
| Emer. Sta                  | -Up       | 0         | 0              | 35 | = 0   |
|                            | -Down     | 0         | 0              | 40 | = 0   |
| Total                      |           |           |                |    | 175   |

| Outbound Platform                               |    | Feet | /FPM | Min.  |
|---|----|------|------|-------|
| On platform                                     | T1 | 60   | 200  | 0.300 |
| Platform to concourse                           | T2 | 18   | 50   | 0.360 |
| On concourse                                    | T3 | 130  | 200  | 0.650 |
| Concourse to grade                              | T4 | 26   | 50   | 0.520 |
| On grade to safe area                           | T5 | 10   | 200  | 0.050 |
| Total walking time T = T1 + T2 + T3 + T4 + T5 = |    |      |      | 1.880 |

NFPA 130 EXITING ANALYSIS

STATION: SAMPLE CENTER DATE: APR 1, 87

TEST #1

Evacuate PLATFORM OCCUPANT LOAD(S) from Platform(s) in 4 Minutes or less.  
W1 (time to clear platform) = PLATFORM OCCUPANT LOAD / PLATFORM EXIT CAPACITY

|                   |       |       |               |
|-------------------|-------|-------|---------------|
| Inbound Platform  |       |       |               |
| W1 =              | 1372/ | 420 = | 3.267 Minutes |
| Outbound Platform |       |       |               |
| W1 =              | 228/  | 420 = | 0.543 Minutes |

TEST #2

Evacuate PLATFORM OCCUPANT LOAD from most remote point on platform to a point of safety in 6 minutes or less.

|  |         |         |               |
|--|---------|---------|---------------|
| Inbound Platform                               |         |         |               |
| Waiting Time at Platform Exits. Wp [= W1 - T1] |         |         |               |
| Wp = [W1 - T1]                                 | 3.267 - | 0.825 = | 2.442 Minutes |

|  |        |             |  |
|--|--------|-------------|--|
| Concourse Occupant Load = Platform Occupant Load - (W1 x Emergency Stair Capacity) |        |             |  |
| Concourse Occupant Load =  | 1372 - | 457         |  |
| Concourse Occupant Load =  |        | 915 Persons |  |

Total Concourse Occupant Load = Concourse Load (Inbound) + Concourse Load (Outbound) = 915 + 152 = 1067

|   |         |         |               |
|---|---------|---------|---------------|
| Waiting Time at Fare Barriers. Wf [= W2 - W1]             |         |         |               |
| W2 = Concourse Occupant Load / Fare Barrier Exit Capacity | 534/    | 400 =   | 1.335 Minutes |
| Wf = W2 - W1  | 1.335 - | 3.267 = | 0.000 Minutes |

|   |         |         |               |
|---|---------|---------|---------------|
| Waiting Time at Concourse Exits. Wc [= W3 - MAX (W2 or W1)] |         |         |               |
| W3 = Concourse Occupant Load / Concourse Exit Capacity      | 534/    | 105 =   | 5.086 Minutes |
| Wc = W3 - Max (W2 or W1)                                    | 5.086 - | 3.267 = | 1.819 Minutes |

OUTBOUND PLATFORM

|  |         |         |               |
|--|---------|---------|---------------|
| Waiting Time at Platform Exits. Wp [= W1 - T1] |         |         |               |
| Wp = [W1 - T1]                                 | 0.543 - | 0.300 = | 0.243 Minutes |

|  |       |             |  |
|--|-------|-------------|--|
| Concourse Occupant Load = Platform Occupant Load - (W1 x Emergency Stair Capacity) |       |             |  |
| Concourse Occupant Load =  | 228 - | 76          |  |
| Concourse Occupant Load =  |       | 152 Persons |  |

|   |         |         |               |
|---|---------|---------|---------------|
| Waiting Time at Fare Barriers. Wf [= W2 - W1]             |         |         |               |
| W2 = Concourse Occupant Load / Fare Barrier Exit Capacity | 534/    | 400 =   | 1.335 Minutes |
| Wf = W2 - W1  | 1.335 - | 0.543 = | 0.792 Minutes |

|   |         |         |               |
|---|---------|---------|---------------|
| Waiting Time at Concourse Exits. Wc [= W3 - MAX (W2 or W1)] |         |         |               |
| W3 = Concourse Occupant Load / Concourse Exit Capacity      | 534/    | 175 =   | 3.051 Minutes |
| Wc = W3 - Max (W2 or W1)                                    | 3.051 - | 1.335 = | 1.716 Minutes |

Total Exit Time [= T + Wp + Wf + Wc]  
Total = 2.330 + 2.442 + 0.000 + 1.819  
Total = 6.591 minutes

**C-1.4 Multilevel Platform Stations.** The procedures for calculating exiting times for such stations is similar to the prior sample calculations (C-1.3 and C-1.4). The changes in the exiting calculations are primarily a function of the concurrent occupancy load determinations for the two platform levels.

The step-by-step procedure relating to the occupancy load calculations is generally recommended as follows:

(a) Calculate the occupancy load for each platform level as per the appropriate examples in C-1.3 and C-1.4 for the same assumed time(s) of day.

(b) If the fire is on the upper level platform (for an underground station), an assumption may be made as to the percentage of occupants who may be expected to evacuate the lower level through the normal egress routes versus those who may be expected to exit via emergency stairs. These assumptions will be unique for each system as a function of various parameters including physical configuration of stations, means of egress, and location of emergency exits; communications facilities to advise passenger, both verbal and signing; level of transit personnel manning in stations; and transit personnel emergency procedure responsibilities established for the transit operating authority.

(c) The upper-level occupant load is increased by the people evacuating from the lower level through the normal egress routes per the above.

(d) For a fire on the lower level, appropriate assumptions relative to distribution of the occupancy loads to the available means of egress are calculated in a fashion similar to the procedures described above.

The remainder of the exiting calculations are essentially unchanged from the other sample calculations in sections C-1.2 and C-1.3.

#### C-2 Escalators.

ANSI Code A17.1, *Safety Code of Elevators and Escalators*, which governs the design of escalators is generally recognized as one of the strictest consensus standards. However, considering the critical operational nature of the escalators in rapid-transit stations, specially designed units with additional safety features should be provided.

The number of flat steps at the upper landings should be increased in proportion to the vertical rise of the escalator. For a rise up to 20 ft (6.1 m), use the manufacturers' standard number of flat steps. From 20 ft (6.1 m) to 60 ft (18.3 m) rise, use three flat steps, and over 60 ft (18.3 m) rise, use four flat steps.

A remote monitoring panel should be provided in the station that displays the following for each escalator: direction of travel, operating speed (if more than one), out of service, and a flashing light that indicates the escalator stopped because of activation of a safety device.

A remote stopping device should only be provided if the entire escalator is visible from the remote location or stop is delayed until it is preceded by an appropriate warning.

#### Appendix D Suggested Test Procedures for Fire Risk Assessment

*This Appendix is not a part of the requirements of this NFPA document, but is included for information purposes only.*

A complete fire risk assessment for transit vehicles includes material characteristics other than fire propagation resistance, such as smoke emission, ease of ignition, and rate of heat and smoke release. One example is that proposed by the Department of Transportation as shown in Federal Register, Vol. 49, No. 158 (August 14, 1984), a copy of which is reproduced in Table 1.

SOUTHERN CALIFORNIA RAPID  
TRANSIT DISTRICT

METRO RAIL SUBWAY PROJECT  
MOS-I

EMERGENCY EXITING  
CALCULATIONS

STATIONS

H. E. Storey  
APTA Conference  
Vancouver, BC  
June 2-7, 1990

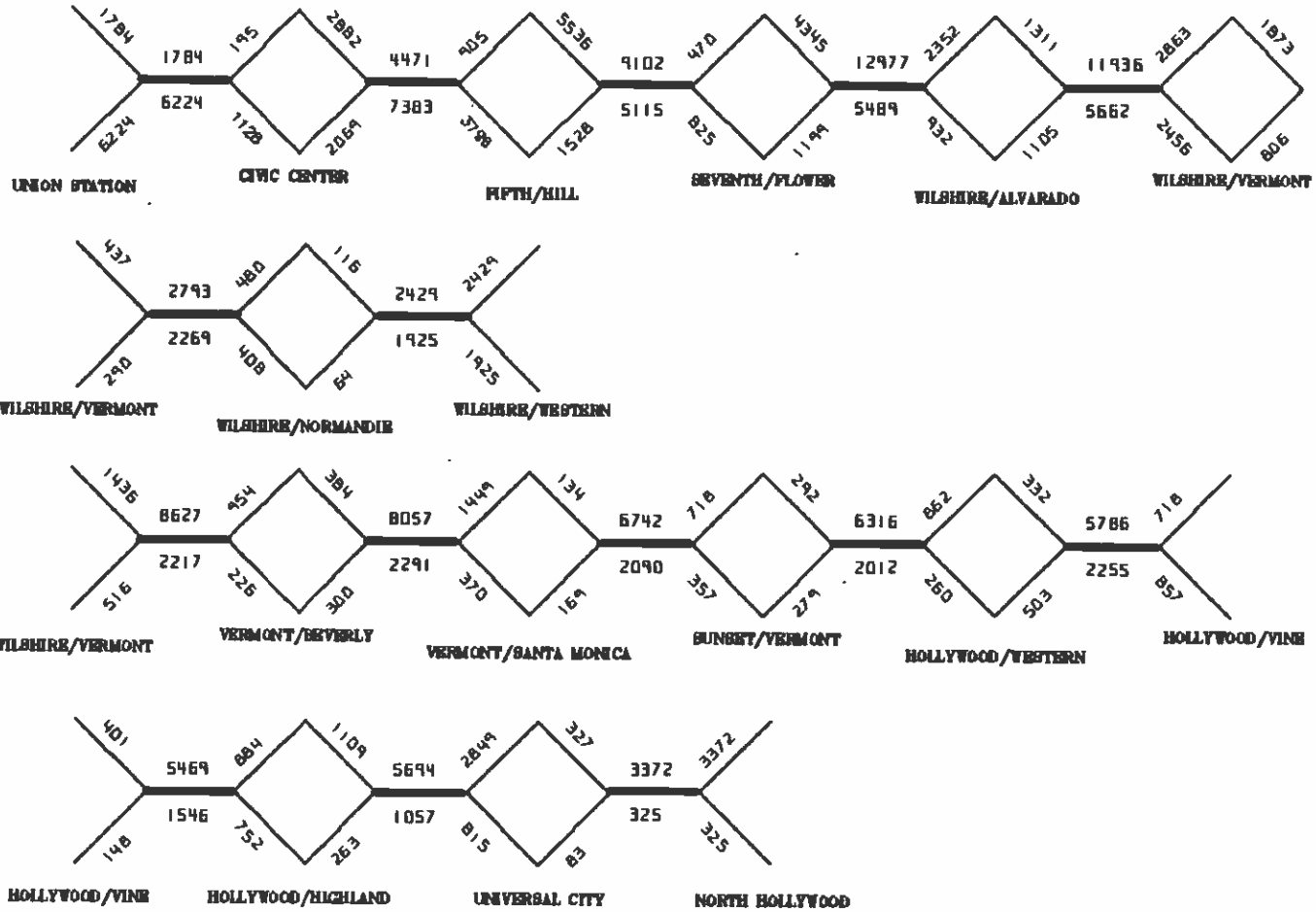

SCRTD METRO RAIL PROJECT  
 AM PEAK-HR BOARDINGS, ALIGHTINGS, LINK LOADS  
 YEAR 2000 - DESIGN YEAR

LOCALLY PREFERRED ALTERNATIVE ADOPTED JULY 14, 1988  
 SOURCE OF DATA: SCRTD PLANNING DEPARTMENT

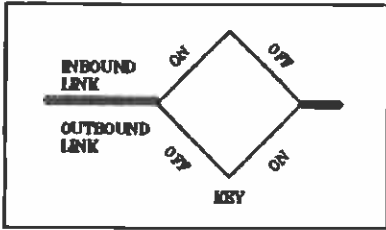

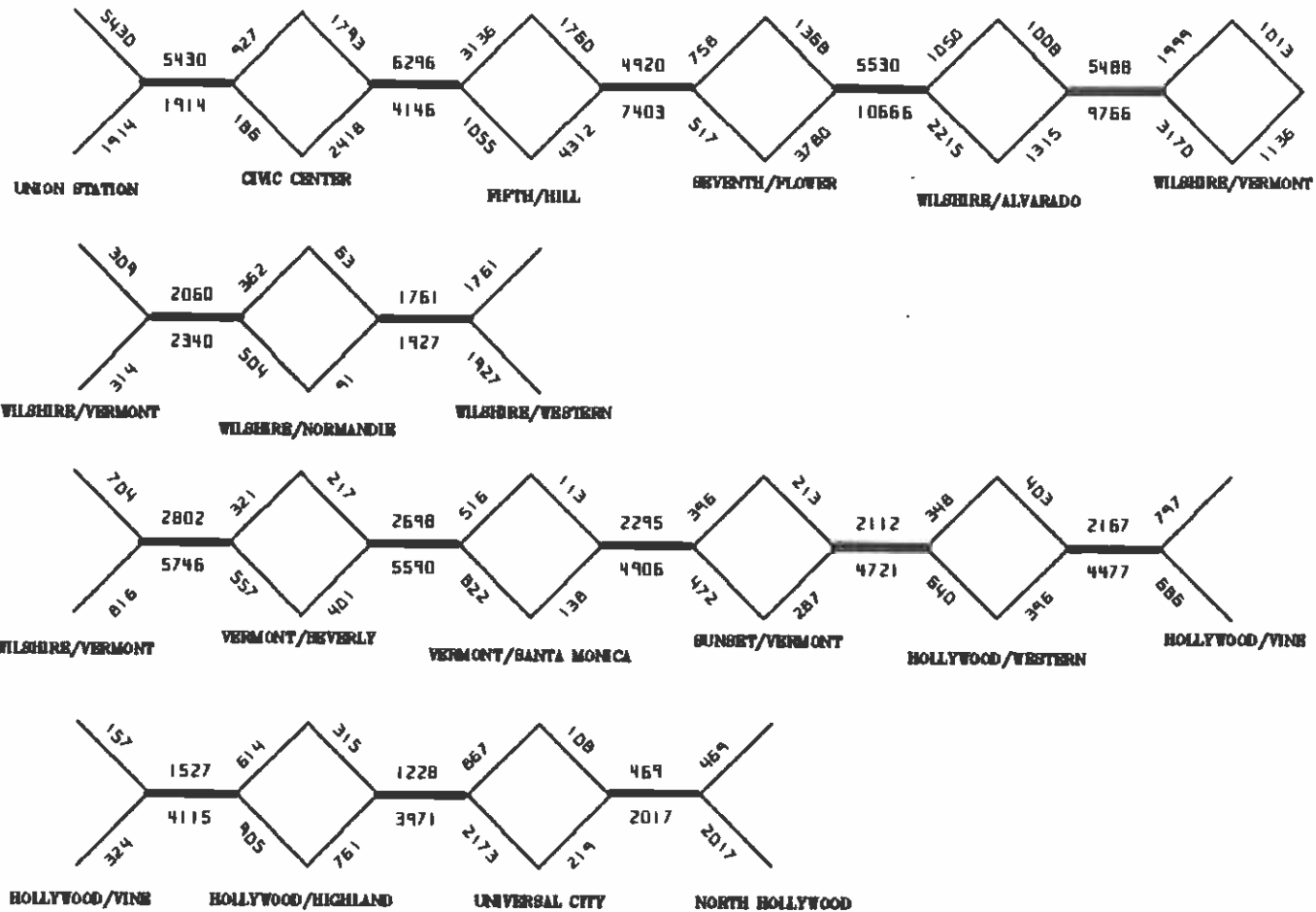

SCR TD METRO RAIL PROJECT  
 PM PEAK-HR BOARDINGS, ALIGHTINGS, LINK LOADS  
 YEAR 2000 - DESIGN YEAR

LOCALLY PREFERRED ALTERNATIVE ADOPTED JULY 14, 1988  
 SOURCE OF DATA: SCR TD PLANNING DEPARTMENT

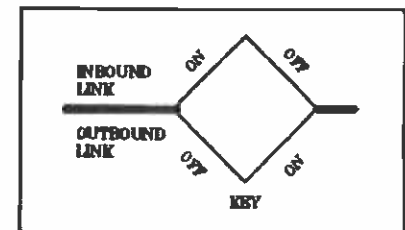

-47-



## EMERGENCY/ EXITING CALCULATIONS

SHT 1 OF 3

WILMORRY, PE

STATION: WILSHIRE / NORMANDIE DATE: 07/25/90 BY: DRF

NET PLATFORM AREA = 10160

OCCUPANT LOAD CALCULATION TERMINAL UP

PEAK HOUR A.M. P.M.

LINK LOADS: INBOUND 3427 1751  
OUTBOUND 2269 2741ENTRAINING LOADS: INBOUND 197 352  
OUTBOUND 54 91

PEAK 15 MINUTE LOAD (=PEAK HR. LOAD \* 1.15) 41

LINK LOADS: INBOUND 699 507  
OUTBOUND 653 670ENTRAINING LOADS: INBOUND 132 115  
OUTBOUND 19 27PEAK HEADWAY: INBOUND 3.5 4.0  
OUTBOUND 3.5 4.0

CALCULATED TRAIN LOAD (=PEAK 15 MIN. LINK LOAD / (NO. OF HEADWAYS))

(NO. OF HEADWAYS = INTEGER (15 MIN. / HEADWAY))

|                | A.M. | P.M. |
|----------------|------|------|
| INBOUND        | 175  | 169  |
| OUTBOUND       | 164  | 225  |
| TOTAL          | 339  | 394  |
| USE (NOT 1000) | 1000 | 1000 |

PEAK ENTRAINING LOAD (=PEAK 15 MIN. LOAD \* 1.4 = HEADWAY / 15 MIN.)

|          | A.M. | P.M. |
|----------|------|------|
| INBOUND  | 129  | 111  |
| OUTBOUND | 18   | 29   |
| TOTAL    | 147  | 140  |

TOTAL OCCUPANT LOAD (=CALCULATED TRAIN LOAD + PEAK ENTRAINING LOAD)

|       | A.M. | P.M. |
|-------|------|------|
| TOTAL | 1457 | 1420 |

DENSITY (=NET PLATFORM AREA / PEAK ENTRAINING LOAD)

|                         | A.M.  | P.M.  |
|-------------------------|-------|-------|
| (NOT 4 SQ.FT. / PERSON) | 69.17 | 70.58 |

Lesser of AREA/4 or Total Occupant Load 1467 1460

TOTAL OCCUPANT LOAD FOR CALCULATIONS 1467

## EMERGENCY EXIT CAPACITY

SHT 2 OF 3

WILNORDY.PE

STATION: WILSHIRE / NORMANDIE      DATE: 3/26/91      BY: DRF

## EXIT LANES AND CAPACITY PROVIDED

| ELEMENT                    | DIRECTION | NUMBER | # LANES | x CAPACITY<br>/ LANE | =     | PPM   |
|----------------------------|-----------|--------|---------|----------------------|-------|-------|
| Platform to Concourse      |           |        |         |                      |       |       |
| Stairs                     | -up       | 2      | 3       | 75                   | =     | 210   |
|                            | -down     | 0      | 0       | 40                   | =     | 0     |
| Escalators                 | -up       | 1      | 2       | 35                   | =     | 71    |
|                            | -down     | 0      | 0       | 40                   | =     | 0     |
| Emer.                      | -up       | 1      | 4       | 35                   | =     | 280   |
| Stairs                     | -down     | 0      | 0       | 40                   | =     | 0     |
| * - 1 escalator discounted |           |        |         |                      |       | ----- |
|                            |           |        |         |                      | Total | 560   |
| Through Fare Barriers      |           |        |         |                      |       |       |
| Turnstiles                 |           | 4      | 1       | 75                   | =     | 100   |
| Fare Gates                 |           | 0      | 1       | 50                   | =     | 0     |
| Service Gates              |           | 1      | 1       | 50                   | =     | 100   |
| Emergency Gates            |           | 1      | 1       | 50                   | =     | 100   |
|                            |           |        |         |                      | Total | 300   |
| Fare Barriers to Safe Area |           |        |         |                      |       |       |
| Stairs                     | -up       | 1      | 1       | 75                   | =     | 210   |
|                            | -down     | 0      | 0       | 40                   | =     | 0     |
| Escalators                 | -up       | 1      | 1       | 35                   | =     | 140   |
|                            | -down     | 0      | 0       | 40                   | =     | 0     |
| Emer.                      | -up       | 1      | 2       | 35                   | =     | 70    |
| Stairs                     | -down     | 0      | 0       | 40                   | =     | 0     |
|                            |           |        |         |                      | Total | 420   |

## FARE BARRIER TEST

|                                       | Array | No. 1 | No. 2 |           |
|---------------------------------------|-------|-------|-------|-----------|
| Capacity of Fare Gates and Turnstiles |       | 100   | NA    | PPM       |
| Percent of Total Capacity             |       | 33.33 | NA    | [NOT 50%] |

## EMERGENCY EXIT WIDTH TEST

Minimum Platform Exit Width

[=Net Platform Area / (75sq.Ft. per Person x 50 Persons per Ft.)]  
 Minimum Width Required = 29.07  
 Width Provided = 29.33 [NOT A REQUIRED]

STATION: WILSHIRE / NORMANDIE      DATE: 3/26/90      BY: DAF  
 Test 1  
 -----

Evacuate Total Occupant Load from Platform in 4 minutes or less.

$W1$  (waiting time at platform exits) = Occupant Load / Exit Capacity

$W1 = 1467 / 560 = 2.620$  Minutes

Test 2  
 -----

Evacuate Total Occupant Load from the most remote point on the platform to a point of safety in 3 minutes or less.

Walking Time for longest exit route  
 -----

$T = T1 + T2 + T3 + T4 + T5$

|                               | Feet  | SPM | = | Minutes |
|-------------------------------|-------|-----|---|---------|
| T1 (platform)                 | 114   | 200 | = | 0.570   |
| T2 (platform to concourse)-up | 16.25 | 50  | = | 0.325   |
| T3 (on concourse)             | 179   | 200 | = | 0.895   |
| T4 (concourse to grade)-up    | 37    | 50  | = | 0.740   |
| T5 (grade)                    | 0     | 200 | = | 0.000   |

$T = 2.530$

Additional Waiting Time at Platform Exits  
 -----

$(W1 - T1) = 2.620 - 0.570 = 2.050$  Minutes

Additional waiting Time at Fare Barrier  
 -----

Occupant Load at Concourse = Total Occupant Load - Emergency Stair 4 Minute Capacity

$1467 - 4 \times 250 = 347$  Patrons

$W2 =$  Concourse Occupant Load / Gate Capacity

$W2 = 347 / 300 = 1.157$  Minutes

$(W2 - W1) = 1.157 - 2.620 = 0.000$  Minutes

Additional Waiting Time at Concourse Exits  
 -----

$W3 =$  Concourse Occupant Load / Exit Capacity

$W3 = 347 / 420 = 0.826$  Minutes

$(W3 - W1) = 0.826 - 2.620 = 0.000$  Minutes

Total Exit Time  $(=T+(W1-T1)+(W2-W1)+(W3-W1))$   
 -----

TOTAL = 4.580 MINUTES [NOT 6 MINUTES]

SOUTHERN CALIFORNIA RAPID  
TRANSIT DISTRICT

METRO RAIL SUBWAY PROJECT  
MOS-I

EMERGENCY EXITING  
CALCULATIONS  
UNDERGROUND TRAINWAYS

H. E. Storey  
APTA Conference  
Vancouver, BC  
June 2-7, 1990



Rolf Jensen & Associates, Inc.  
Fire Protection Engineers  
Building Code Consultants

RECEIVED

JUL 13 1984

DOCUMENT CONTROL

EXPRESS MAIL

July 12, 1984

Mr. Thomas J. Tanke  
Metro Rail Transit Consultants  
548 South Spring Street, Eleventh Floor  
Los Angeles, California 90013

CALCULATED TUNNEL  
EVACUATION TIMES

Tom:

As we discussed on July 11, 1984, data from the literature suggests a lower walkway capacity for tunnel exiting than that specified in the Design Criteria for station exiting. As a result, I have prepared the attached calculations. They present, perhaps, a more realistic picture of probable tunnel evacuation time.

Walkway capacity of 35 ppm was derived from the 40 ppm capacity observed for a 34-inch wide walkway. The data was extracted from "A Report on the Berkeley Hills Tunnel Preferred Evacuation Method" dated January, 1980.

Sincerely,

David R. Fiedler, P. E.

DRF:pkj - H3275

Enclosure

RECEIVED  
SCRTD - TSD  
SYSTEMS & CONSTRUCTION SAFETY

MAY 07 1990

ITEM # 7350  
FILE # \_\_\_\_\_

ATTACHMENT"A"



|                       |                     |                   |
|-----------------------|---------------------|-------------------|
| IN TUNNEL EVACUATION! | JOB NO H3275        | SHEET NO 1 OF 1   |
|                       | DESIGNED BY FAE     | DATE JUL 10, 1981 |
|                       | APPROVED J.N. TANKE |                   |

- ASSUME:
1. USE TUNNEL SAFETY WALK
  2. TRAVEL IN ONE DIRECTION ONLY
  3. END DOOR = 30" ; SIDE DOOR = 54"

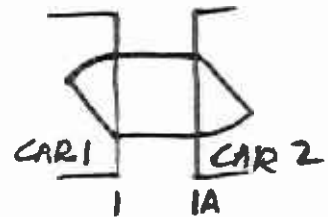
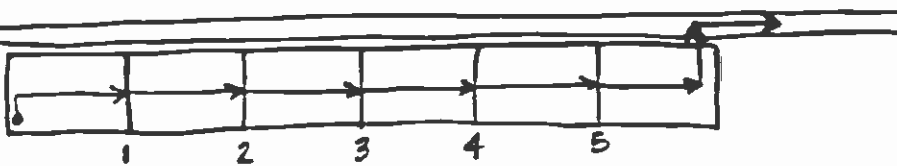

TRAIN LOAD = 1320 ∴ CAR LOAD = 220

WALKING TRAVEL TIME (THRU TRAIN)

|                            | Distance, ft | Speed, fpm | Time, min    |
|----------------------------|--------------|------------|--------------|
| end of car 1 to end door 1 | 78           | 200        | 0.39         |
| end door 1 to end door 1A  | 2            |            | 0.01         |
| end of car 2 to end door 2 | 73           |            | .365         |
| 2 to 2A                    | 2            |            | .01          |
| 3 to 3A                    | 73           |            | .365         |
| 3 to 3A                    | 2            |            | .01          |
| 4 to 4A                    | 73           |            | .365         |
| 4 to 4A                    | 2            |            | .01          |
| 5 to 5A                    | 73           |            | .365         |
| 5 to 5A                    | 2            |            | .01          |
| 6 to side door 6           | 66           |            | .33          |
|                            |              |            | <u>2.230</u> |

FLOW TIMES

|            |  |                           |
|------------|--|---------------------------|
| end door 1 | $\frac{220}{1 \times 50} = 4.4 \text{ min.}$   | 2 $440/50 = 8.80$         |
|            |  | 3 $660/50 = 13.20$        |
|            |  | 4 $880/50 = 17.60$        |
|            |  | 5 $1100/50 = 22.00$       |
| side door  | $\frac{1320}{2 \times 50} = 13.2 \text{ min.}$ | walkway $1320/50 = 26.40$ |



|                      |                     |                 |
|----------------------|---------------------|-----------------|
| IN TUNNEL EVACUATION | JOB No. 1-2275      | SHEET No. 2     |
|                      | DESIGNED BY E.P.F.  | DATE JUL 10, 84 |
|                      | APPROVED T.J. TORRE |                 |

SINCE WALKWAY CONTROLS FLOW WAITING TIME IS

$$26.40 - 2.23 = 24.17 \text{ MIN.}$$

$$37.71 - 2.97 = 34.74$$

THEN TRAVEL TO AN EXIT (CROSS PASSAGE OR STATION)

| TRAVEL DISTANCE, FT | SPEED, FPM | TIME, MIN. | WCF    |
|---------------------|------------|------------|--------|
| 4532                | 200        | 22.66      | 11.33  |
| 2288                | ↓          | 11.44      | 5.72   |
| 3138                |            | 18.69      | 9.345  |
| 1888                |            | 9.44       | 4.72   |
| 1957                |            | 9.785      | 4.8925 |
| 1912                |            | 9.56       | 4.78   |
| 1794                |            | 8.97       | 4.485  |
| 1602                |            | 8.01       | 4.005  |
| 4587                |            | 22.935     |        |
| 2299                |            | 11.495     |        |

30.21  
@ 150

↓  
5.3  
@

TOTAL EVACUATION TIME

$$\text{MIN: } 2.230 + 24.170 + 4.005 = 30.405$$

$$\text{MAX: } 2.230 + 24.170 + 22.66 = 49.06$$

2538  
1871

12.69  
9.355

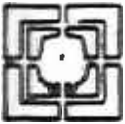

|                   |                     |                 |
|-------------------|---------------------|-----------------|
| TUNNEL EVACUATION | JOB NO. H3275       | SHEET NO. 3 OF  |
|                   | DESIGNED BY TTF     | DATE JUL 11, 86 |
|                   | APPROVED T.W. TRINE |                 |

BASED ON CAPACITIES REPORTED IN BART EXIT DRILLS

FLOW TIMES

CAR 5/6 END DOORS  $1100/35 = 31.42$  MIN

CAR 6 SIDE DOOR  $1320/(2 \times 35) = 18.86$  MIN.

WALKWAY  $1320/35 = 37.71$  MIN.

USING  $\sim 150$  FPM FOR SPEED ( $\sim 7$  LB/PERSON)

TOTAL EVACUATION TIME

MIN:  $2.97 + 34.74 + \overset{6.24}{\cancel{5.72}} = \overset{43.95}{\cancel{43.05}}$  MIN.

MAX:  $\textcircled{2.97} + \textcircled{34.74} + \textcircled{30.21} = \overset{67.92}{\cancel{68.09}}$  MIN.

Use 150 fpm:

|       | min          | $\Sigma$ wac. |
|-------|--------------|---------------|
| 1888' | 12.59        | 50.30         |
| 1957' | 13.05        | 50.76         |
| 4587' | <u>30.58</u> | 68.29         |
| 2299' | 15.33        | 53.04         |
| 2538' | 16.92        | 54.63         |
| 1871' | 12.47        | 50.18         |
| 1520' |              | 47.84         |
| 2288' | <u>15.25</u> | 52.96         |
| 849'  | 5.66         | 43.37         |
| 1200' | 8.00         | 45.71         |
| 1850' | 12.33        | 50.04         |
| 789'  |              | 42.97         |





CALCULATED TUNNEL EVACUATION TIME NEAR WILSHIRE/FAIRFAX STATION  
 JOB NO. \_\_\_\_\_  
 DESIGNED BY J. YON  
 APPROVED T.J. TAYLOR  
 SHEET NO. \_\_\_\_\_  
 DATE DEC 14, 1984

| STATIONING OF SECTION             | LENGTH OF SECTION                    | EVACUATION TIME (MINUTES) |                    |                |                         |                         |                       |                         |                      |                         |
|-----------------------------------|--------------------------------------|---------------------------|--------------------|----------------|-------------------------|-------------------------|-----------------------|-------------------------|----------------------|-------------------------|
|                                   |                                      | (1) WALKING THRU TRAIN    | (1) FLOW THRU DOOR | (2) 100 FPM    |                         | (2) 150 FPM             |                       | (2) 200 FPM             |                      |                         |
|                                   |                                      |                           |                    | TUNNEL WALKING | TOTAL                   | TUNNEL WALKING          | TOTAL                 | TUNNEL WALKING          | TOTAL                |                         |
| WIL./LA BREA TO WIL./FAIRFAX      | 479+51<br>493+30<br>513+20<br>525+38 | 1379<br>1990<br>1218      | 2.97               | 34.74          | 13.79<br>19.90<br>12.18 | 51.5<br>57.61<br>49.89  | 9.19<br>13.27<br>8.12 | 46.90<br>50.98<br>45.83 | 6.90<br>9.95<br>6.09 | 44.61<br>47.66<br>43.80 |
| (3) WIL./FAIRFAX TO FAIR./BEVERLY | 534+10<br>549+45<br>556+96<br>564+47 | 1535<br>751<br>751        | 2.97               | 34.74          | 15.35<br>7.51<br>7.51   | 53.06<br>45.22<br>45.22 | 10.23<br>5.01<br>5.01 | 47.94<br>42.72<br>42.72 | 7.69<br>3.76<br>3.76 | 45.39<br>41.47<br>41.47 |

NOTES:  
 (1) WALKING THRU TRAIN TRAVEL TIME & FLOW THRU DOOR TIME ARE TAKEN FROM "CALCULATED TUNNEL EVACUATION TIME" BY R. JENSEN & ASSOC., JULY 12, 1984  
 (2) TRAVEL SPEED ON SAFETY WALK IN TUNNEL.  
 (3) VERTICAL CROSS PASSAGE IS REQUIRED AT END OF WIL./FAIRFAX CUT & COVER BOX.