

**SR-14 REVERSIBLE HOV LANE FEASIBILITY STUDY  
JULY 2006**

**FINAL DRAFT**

Prepared for:  
Los Angeles County  
Metropolitan Transportation Authority

Prepared by:  
**Katz, Okitsu & Associates**  
1055 Corporate Center Drive, Suite 300  
Monterey Park, California 91754-7642  
(323) 260-4703  
Fax: (323) 260-4705

Job No.: JA5177





ACKNOWLEDGEMENT

This report represents the work of a Technical Advisory Committee. The following is a list of the members and participants that assisted in the preparation of this report:

Los Angeles County Metropolitan Transportation Authority

State of California Department of Transportation, District 7

City of Los Angeles Department of Transportation

City of Palmdale

City of Santa Clarita

Count of Los Angeles Department of Public Works

County of Los Angeles Supervisorial District 5

Federal Highway Administration

California Highway Patrol

Southern California Association of Governments

North County Transportation Coalition

Antelope Valley Transportation Summit Committee (Chairman: Michael D. Antonovich)



Table of Contents

EXECUTIVE SUMMARY ..... 1
INTRODUCTION AND HISTORY ..... 1
Existing Constraints and Design Challenges ..... 1
Identification of Alternatives ..... 1
Existing Conditions..... 2
REVIEW AND EVALUATION OF ALTERNATIVES ..... 2
Alternative One Divided System versus Alternative Two Combined System ..... 2
Alternative One – Evaluation of Three Segments ..... 3
Benefit Cost Analysis ..... 3
Benefits ..... 3
Costs ..... 4
Benefit-Cost Ratio ..... 4
CONCLUSIONS AND RECOMMENDATIONS ..... 5
CHAPTER ONE ..... 15
PROJECT HISTORY AND INTRODUCTION ..... 15
HISTORY OF PROJECT ..... 15
TECHNICAL ADVISORY COMMITTEE AND PLANNING PROCESS ..... 15
CONSENT BUILDING AND ALTERNATIVE ANALYSIS PROCEDURE ..... 16
PREFERRED ALTERNATIVE SELECTION..... 16
CHAPTER TWO..... 19
PROJECT BACKGROUND ..... 19
RECITAL AND SUMMARY OF PREVIOUS STUDIES AND FINDINGS ..... 19
The North County Combined Highway Corridors Study ..... 19
Other Prior Studies ..... 21
EXISTING CONDITIONS ..... 21
Level of Service ..... 22
Segment One ..... 22
Segment Two ..... 23
Segment Three ..... 23
FUTURE PROJECTED CONDITIONS ..... 24
Level of Service ..... 24
Segment One ..... 24
Segment Two ..... 24
Segment Three ..... 24
CURRENT AND PROGRAMMED IMPROVEMENTS IN THE CORRIDOR ..... 25
POTENTIAL IMPACT FROM IMPROVEMENTS IN PROGRESS ..... 25
CHAPTER THREE ..... 31
PURPOSE AND NEED ..... 31
FOCUS OF STUDY ..... 31
LOGICAL TERMINI ..... 31
FUTURE TRAFFIC SCENARIO (2030) ..... 31
POTENTIAL BENEFIT IMPLICATION ..... 31
REGIONAL IMPACT AND SIGNIFICANCE ..... 32
CHAPTER FOUR ..... 33



**REVERSIBLE HOV LANE ENGINEERING ALTERNATIVES .....33**

DESCRIPTION OF EXISTING FACILITIES IN OTHER CITIES .....33

*Washington D.C. / Virginia; Interstate 95 / Interstate 395* .....33

*Chicago, Illinois; Interstate 90 / Interstate 94* .....34

*San Diego, California; Interstate 15* .....34

ALTERNATIVES OF TYPICAL STANDARD AND NON-STANDARD SECTIONS .....44

EXISTING SR-14 PHYSICAL CONSTRAINTS AND DESIGN CHALLENGES .....44

EVALUATION OF INGRESS/EGRESS POINTS .....46

REVIEW AND EVALUATION OF ALTERNATIVES .....46

ANALYSIS OF THE PREFERRED ALTERNATIVE BY SEGMENT .....47

**CHAPTER FIVE .....48**

**BENEFIT/COST AND PRIORITIZATION BY SEGMENT .....48**

DESIGN YEAR (2030) TRAFFIC OPERATION ANALYSIS .....49

PRELIMINARY CONSTRUCTION, ROW, AND OPERATIONAL COST ESTIMATE .....49

BENEFIT ANALYSIS (CAPACITY AND DELAY SAVING) .....50

BENEFIT COST ANALYSIS .....50

IMPROVEMENT PHASING PLAN .....51

**List of Figures**

FIGURE ES-1. SR-14 RHOV FEASIBILITY STUDY AREA ..... 7

FIGURE ES-2. SEGMENT ONE – NORTH OF I-5 TO SAND CANYON ROAD .....8

FIGURE ES-3. SEGMENT TWO – SAND CANYON ROAD TO WARD ROAD .....9

FIGURE ES-4. SEGMENT THREE – WARD ROAD TO PEARBLOSSOM HIGHWAY ..... 10

FIGURE ES-5. ALTERNATIVE ONE TYPICAL CROSS SECTION ..... 11

FIGURE ES-6. ALTERNATIVE TWO TYPICAL CROSS SECTION ..... 12

FIGURE ES-7. ALTERNATIVE THREE TYPICAL CROSS SECTION ..... 13

FIGURE ES-8. STANDARD VS. NON-STANDARD (MINIMUM) CROSS SECTION COMPARISON ..... 14

FIGURE 2-1. COMBINED STUDY AREA .....20

FIGURE 4-1. WASHINGTON D.C. / VIRGINIA METROPOLITAN AREA RHOV SYSTEM .....37

FIGURE 4-2. VIRGINIA RHOV SYSTEM – ENTRANCE GATES .....38

FIGURE 4-3. CHICAGO SYSTEM – COMBINED REVERSIBLE EXPRESS LANES .....39

FIGURE 4-4. CHICAGO SYSTEM – SWING-OUT GATES AND DROP-DOWN BARRICADES .....40

FIGURE 4-5. SAN DIEGO RHOV SYSTEM .....41

FIGURE 4-6. SAN DIEGO RHOV SYSTEM - POP-UP DELINEATORS .....42

FIGURE 4-7. SAN DIEGO RHOV SYSTEM - SWING GATE .....43

FIGURE 4-8. STANDARD VERSUS NON-STANDARD SECTION DESIGN REQUIREMENTS .....45

**List of Tables**

TABLE ES-1. STANDARD VS. NON-STANDARD BENEFIT/COST RATIOS .....5

TABLE ES-2. BI-DIRECTIONAL SPLIT .....6

TABLE 1-1. COMPARISON OF “COMBINED” AND “DIVIDED” REVERSIBLE HIGH OCCUPANCY VEHICLE (RHOV) SYSTEMS ..... 18

TABLE 2-1. SEGMENT ONE LEVEL OF SERVICE AND BI-DIRECTIONAL FLOW (NORTH OF I - 5 TO SAND CANYON ROAD) .....26

TABLE 2-2. SEGMENT TWO LEVEL OF SERVICE AND BI-DIRECTIONAL FLOW (SAND CANYON ROAD TO WARD ROAD) .....26

TABLE 2-3. SEGMENT THREE LEVEL OF SERVICE AND BI-DIRECTIONAL FLOW (WARD ROAD TO PEAR BLOSSOM HIGHWAY) .....27

TABLE 2-4. SEGMENT ONE LEVEL OF SERVICE AND BI-DIRECTIONAL FLOW (NORTH OF I - 5 TO SAND CANYON ROAD) .....27



LOS ANGELES COUNTY METROPOLITAN TRANSPORTATION AUTHORITY

TABLE 2-5. SEGMENT TWO LEVEL OF SERVICE AND BI-DIRECTIONAL FLOW (SAND CANYON ROAD TO WARD ROAD) .....28

TABLE 2-6. SEGMENT THREE LEVEL OF SERVICE AND BI-DIRECTIONAL FLOW (WARD ROAD TO PEAR BLOSSOM HIGHWAY).....28

TABLE 2-7. SEGMENT ONE LEVEL OF SERVICE AND BI-DIRECTIONAL FLOW (NORTH OF I - 5 TO SAND CANYON ROAD) .....29

TABLE 2-8. SEGMENT TWO LEVEL OF SERVICE AND BI-DIRECTIONAL FLOW (SAND CANYON ROAD TO WARD ROAD) .....29

TABLE 2-9. SEGMENT THREE LEVEL OF SERVICE AND BI-DIRECTIONAL FLOW (WARD ROAD TO PEAR BLOSSOM HIGHWAY).....30

TABLE 2-10. GENERAL CHARACTERISTIC FOR LEVEL OF SERVICE.....30

TABLE 4-1. COMPARISON OF RHOV SYSTEMS.....36

TABLE 5-1. STANDARD VS. NON-STANDARD BENEFIT/COST ANALYSIS .....48

**Appendices**

---



## EXECUTIVE SUMMARY

### INTRODUCTION AND HISTORY

This report presents the results of a feasibility study of reversible high occupancy vehicle (RHOV) lanes that have been proposed for State Route 14 from just north of the connection with Interstate 5 to the Sierra Highway/Angeles Forest Highway/Pearblossom Highway on-off Ramps (hereinafter referred to as Pearblossom Highway) just south of the City of Palmdale.

This project was initially conceived in the North County Combined Highway Corridor Study, SR-14, SR-138 and I-5, Final Report, June 2004 (hereinafter, the "Combined Study"). The Combined Study identified SR-14 as a commute corridor with a pronounced imbalance in the directional traffic volumes (relatively heavy southbound volumes in the AM peak hours, and relatively heavy northbound volumes in the PM peak hours). Accordingly, the Combined Study identified the SR-14 corridor as a potential candidate for the implementation of reversible HOV lanes.

#### Existing Constraints and Design Challenges

There are several physical constraints and design challenges confronting the implementation of a RHOV system in the SR-14 corridor. Physical challenges are posed by the corridor topography and existing configuration of the roadway. These challenges are most evident in Segment Three (from Ware Road to Pearblossom Highway), where the northbound and southbound lanes are separated by a wide median and travel through topography that will require extensive earthwork in order to implement a RHOV system.

The main operational issue presented is whether the RHOV system will consist of a combined lane system or a divided lane system. Other operational challenges are presented by the extensive length of the proposed RHOV system, and the remote regions where it would operate. These factors make it more difficult to change the direction of travel.

#### Identification of Alternatives

The study of RHOV lanes in the SR-14 corridor began with the efforts of a technical advisory committee (TAC) consisting of representatives from various agencies and interested parties. The TAC identified three potential alternatives for the implementation of RHOV lanes:

- Alternative One – a two lane combined RHOV system.
- Alternative Two – a two lane divided RHOV system.
- Alternative Three – a three lane divided RHOV system.

The TAC eliminated Alternative Three from consideration due to the inferior benefit-cost ratio in comparison to the other two alternatives. Alternative Three was considered too





expensive since the construction of a three lane system would entail additional cost associated with the expanded footprint and related earthwork and retaining wall construction.

Currently, SR-14 has one (non-reversible) HOV lane in each direction, from just north of the Interstate 5 (I-5) interchange to Pearblossom Highway, a distance of approximately 30 miles. Construction is underway to extend these HOV lanes from Pearblossom Highway to Avenue P in Palmdale.

For the purposes of this Feasibility Study, the SR-14 Corridor is divided into three segments. Segment One begins just north of the I-5 interchange and continues to the north and east for approximately 8.0 miles to Sand Canyon Road. Segment Two begins just north of Sand Canyon Road and continues to the north and east for approximately 13.5 miles to Ward Road. Segment Three begins just north of Ward Road and continues to the north and east for approximately 8.5 miles to Pearblossom Highway. The TAC eliminated the portion of SR-14 between Pearblossom Highway and Avenue P from further consideration in this study because the HOV lanes are now under construction in this area, and the expenditure of public funds and the major reconstruction needed to convert this new HOV facility into reversible HOV lanes would likely not be well accepted by the public. Figures ES-1, ES-2, ES-3 and ES-4 show the SR-14 RHOV Feasibility Study Area and the Segments One, Two and Three.

### **Existing Conditions**

The three segments were evaluated by analyzing data from the Southern California Association of Governors (SCAG) traffic model. Existing conditions were evaluated using model year 2000 data. Although the model projects volumes for years that are closer to the current year, the year 2000 model output was calibrated by comparison to actual counts taken in the field, and therefore is used in this study to describe existing conditions.

A review of the SCAG year 2000 data reveals that the level of service can be characterized as poor in Segment One, good in Segment Two and adequate in Segment Three. The data also reveals that Segment One operates with the most pronounced bi-directional split in traffic at 70% southbound (SB) to 30% northbound (NB) in the AM peak hours. The bi-directional split becomes less pronounced further to the north and east. The split is 61% SB to 39% NB in Segment Two during the AM peak hours, and 55% SB to 45% NB in Segment Three during the AM peak hours. In all three segments, the bi-directional split is less pronounced in the PM peak hours, as compared with the split in the AM peak hours.

## **REVIEW AND EVALUATION OF ALTERNATIVES**

### **Alternative One Divided System versus Alternative Two Combined System**

Initially Alternatives One and Two were evaluated against each other to determine the relative merits of each alternative. This analysis resulted in the elimination of Alternative Two – the divided RHOV system from consideration. Alternative Two was eliminated primarily as a result of the cost of a divided system. The cost of a divided system is much





higher than the cost of a combined system due to the increased footprint and right-of-way area needed to construct a divided system. As can be seen from Figures ES-5 and ES-6, the typical cross section of a divided system is much wider than the typical cross section of a combined system. The increased width of the divided system translates into additional costs associated with acquiring right-of-way, grading costs, general construction costs, retaining wall installation, drainage, bridge widening and modification and other construction related matters imposed by the requirement for a wider cross section.

Furthermore, a divided system is relatively more expensive than a combined system with respect to operation and maintenance costs. The increased complexity of operation would require additional man-hours in order to operate a divided system. Additional cost is also associated with the maintenance of wider cross sections. Finally, although Alternative Two does provide for more flexible operations, the increased complexity also adds to driver confusion and can give rise to safety concerns. In summary, the additional cost of a divided system outweighs the operational flexibility offered by a divided system. For these reasons, Alternative Two was eliminated from further consideration.

### **Alternative One – Evaluation of Three Segments**

The analysis then proceeded to consider the implementation of Alternative One in three separate segments. This analysis was accomplished by considering the Benefit to Cost ratio of the combined RHOV system in each segment. Additional analysis was performed to evaluate both a “standard” design implementation, and a “non-standard” design. The non-standard design alternative includes modifications to the standard requirements for lane widths and shoulders. Figure ES-8 shows typical cross sections of both standard and non-standard systems.

### **Benefit Cost Analysis**

The review and evaluation of the Alternative One was conducted by performing an economic analysis pursuant to the California Life-Cycle Benefit-Cost Analysis Model (hereinafter, the “Cal B/C”). Given certain inputs, this model can be used to calculate a benefit to cost ratio (hereinafter, the “B/C”). In the present study, the Cal B/C was used to evaluate each segment in Alternative One under both standard design provisions and non-standard design provisions.

A B/C ratio in excess of 1.0 indicates that the economic benefit of implementing the alternative exceeds the cost of the alternative, and therefore implementation is economically advisable. On the other hand a B/C ratio less than 1.0 indicates that the economic benefits of the alternative are surpassed by the cost of the alternative, and therefore, implementation of the alternative is not recommended.

### **Benefits**



The economic benefit associated with the implementation of a RHOV system is primarily a savings in travel time, which is translated into an economic savings based upon an assumption regarding the value of time for each occupant of a vehicle in the system. Additional economic benefits that are considered include reduction in emissions, and decrease in accidents. These benefits are offset by the capital construction cost of the system, as well as the operation and maintenance costs.

The California Life-Cycle Benefit/Cost Analysis Model, or Cal-B/C, was used to calculate the benefits, as well as conduct the benefit-cost analysis. This model was provided in the form of a Microsoft Excel spreadsheet. For the SR-14 project, the "HOV" option in Cal-B/C was flagged, so that the model would calculate both the net benefits created by both the HOV lanes and the other mixed-use lanes. Model inputs were provided first for the southbound direction for each of the three segments, so that the benefits of two HOV lanes serving southbound traffic in the morning could be calculated. A subsequent model run was performed for the northbound traffic to measure the benefits of reversing the HOV operation to provide two northbound HOV lanes.

Cal-B/C predicted total benefits for the first 20 years of operation to be a present value of \$1.037 billion. By far, travel time savings accounted for most of the benefits at \$828.1 million. Fuel savings accounted for \$232.3 million. Emissions actually worsened at a negative \$22.8 million due to higher travel speeds causing an increase in carbon monoxide and oxides of nitrogen. (An increase in emissions of these particular gases is a common result of freeway improvements.) Among the three segments, Segment 1 accounted for most of the benefits with \$723.1 million. Segment 2 accounted for \$192.3 million in benefits, and Segment 3 accounted for \$122.2 million.

### **Costs**

The Cal-B/C model used the construction costs as input, along with a "Project Support Cost" equivalent to 15% of construction cost. Annual maintenance/operations cost were assumed to be \$500,000 for each of the first 20 years of operation. For the standard lane dimensions alternative, these costs figures were converted into present value life cycle costs of \$259.8 million for Segment 1, \$343.8 million for Segment 2, and \$168.1 million for Segment 3. The present value life cycle costs for all three segments combined to the amount of \$771.7 million. For the minimum lane width dimensions alternative, the present value life cycle costs for Segments 1, 2 and 3 were \$216.5 million, \$258.7 million, and \$151.8 million, respectively, for a total cost of \$627.1 million.

### **Benefit-Cost Ratio**

The benefits used in the Cal-B/C model were assumed to be the same under both the standard lane width and the minimum lane width alternatives. Benefit-to-cost ratios for the standard lane width alternative were 2.8, 0.6, and 0.7 for Segments 1, 2, and 3, respectively, and 1.3 for the three segments combined. For the minimum lane width alternative, the benefit-to-cost ratios were 3.3, 0.7, and 0.8 for Segments 1, 2, and 3, respectively, and 1.7 for the three





segments combined. Clearly, only Segment 1 is a candidate for recommendation, since Segments 2 and 3 have benefits that are less than the cost.

The Benefit Cost analysis yielded the following results:

Table ES-1. Standard vs. Non-Standard Benefit/Cost Ratios

	Segment One	Segment Two	Segment Three
Standard Design	2.8	0.6	0.7
Non-Standard Design	3.3	0.7	0.8

**CONCLUSIONS AND RECOMMENDATIONS**

According to the B/C analysis the implementation of a RHOV system is not efficient in Segments Two or Three using either the Standard Design requirements or a Non-Standard Design. In Segment One it can be seen that the B/C ratio is better for the Non-Standard Design, as expected, due to the decrease in the cost of the implementing a non-standard design.

It should be noted that the planning, design and operation manual, entitled High-Occupancy Vehicle Facilities, published by Parsons, Brinckerhoff Quade & Douglas (1990) states in relevant part that practitioners from various projects agree that there generally should be a peak-hour directional split of at least 65% to 35% for the practical application of a RHOV system (citing Boyle 1985, Caltrans, HOV Guidelines, 1990, and Cechini 1989). This criteria suggests that the application of a RHOV system is best suited to Segment One.

While the B/C ratio indicates that a RHOV system should be implemented in Segment One, this analysis needs to be considered in the context of the "bottle-neck" problem that is presently occurring near the I-5 / SR-14 interchange. The bottle-neck occurs as a result of capacity constraints, merging, and weaving that occurs at and beyond the I-5 / SR-14 interchange. The vehicles exiting the SR-14 HOV lanes are presently required to merge into the SR-14 general purpose lanes just prior to the interchange. This merge also adds to the congestion.

The benefit cost analysis of RHOV lanes assumes that all of the traffic exiting the RHOV system at the termini is capable of being absorbed. This is not the case at the southern terminus, where not all of the traffic is readily absorbed, as is evident by the bottleneck situation. Therefore, while the present analysis is valid for the purpose of evaluating the implementation of a RHOV system, this analysis also suggests that further study be performed to evaluate improvements to the I-5 / SR-14 interchange.





**Table ES-2. Bi-directional Split**

Southbound-Northbound Bi-directional split		Segment One	Segment Two	Segment Three
<i>AM</i>	2000	70-30	61-39	55-45
	2010	82-18	71-29	66-34
	2030	80-20	64-36	58-42
<i>PM</i>	2000	43-57	47-53	50-50
	2010	34-66	40-60	43-57
	2030	34-66	43-57	46-54



No.	DIRECTION	TYPE	SEGMENT
1	N/B & S/B	INGRESS & EGRESS	1
2	N/B	EGRESS	
3	S/B	EGRESS	
4	N/B	INGRESS	
5	N/B	EGRESS	
6	S/B	INGRESS	
7	N/B	INGRESS	
8	S/B	EGRESS	2
9	N/B	EGRESS	
10	S/B	INGRESS	
11	S/B	INGRESS	
12	N/B	EGRESS	
13	N/B	INGRESS	3
14	S/B	EGRESS	
15	N/B & S/B	EGRESS & INGRESS	

**SEGMENT 1**  
North of I-5 to Sand Canyon Rd.  
(Approx. 8 miles)

**SEGMENT 2**  
Sand Canyon Rd. to Ward Rd.  
(Approx. 13.5 miles)

**SEGMENT 3**  
Ward Rd. to Pearblossom Highway  
(Approx. 8.5 miles)

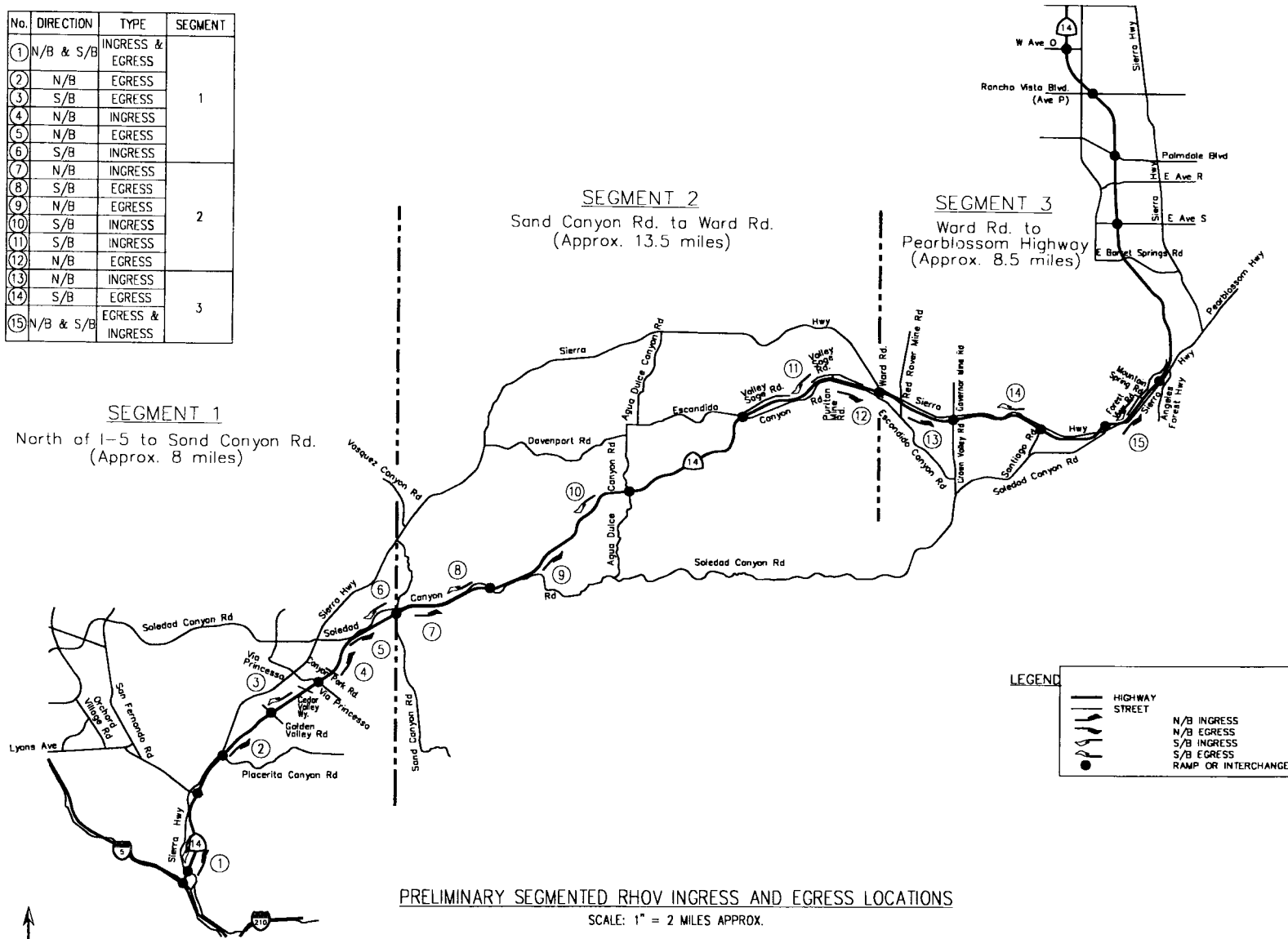

↑  
N  
Not To Scale

**Figure ES-1**  
**SR-14 RHOV Feasibility Study Area (Segments 1-3)**



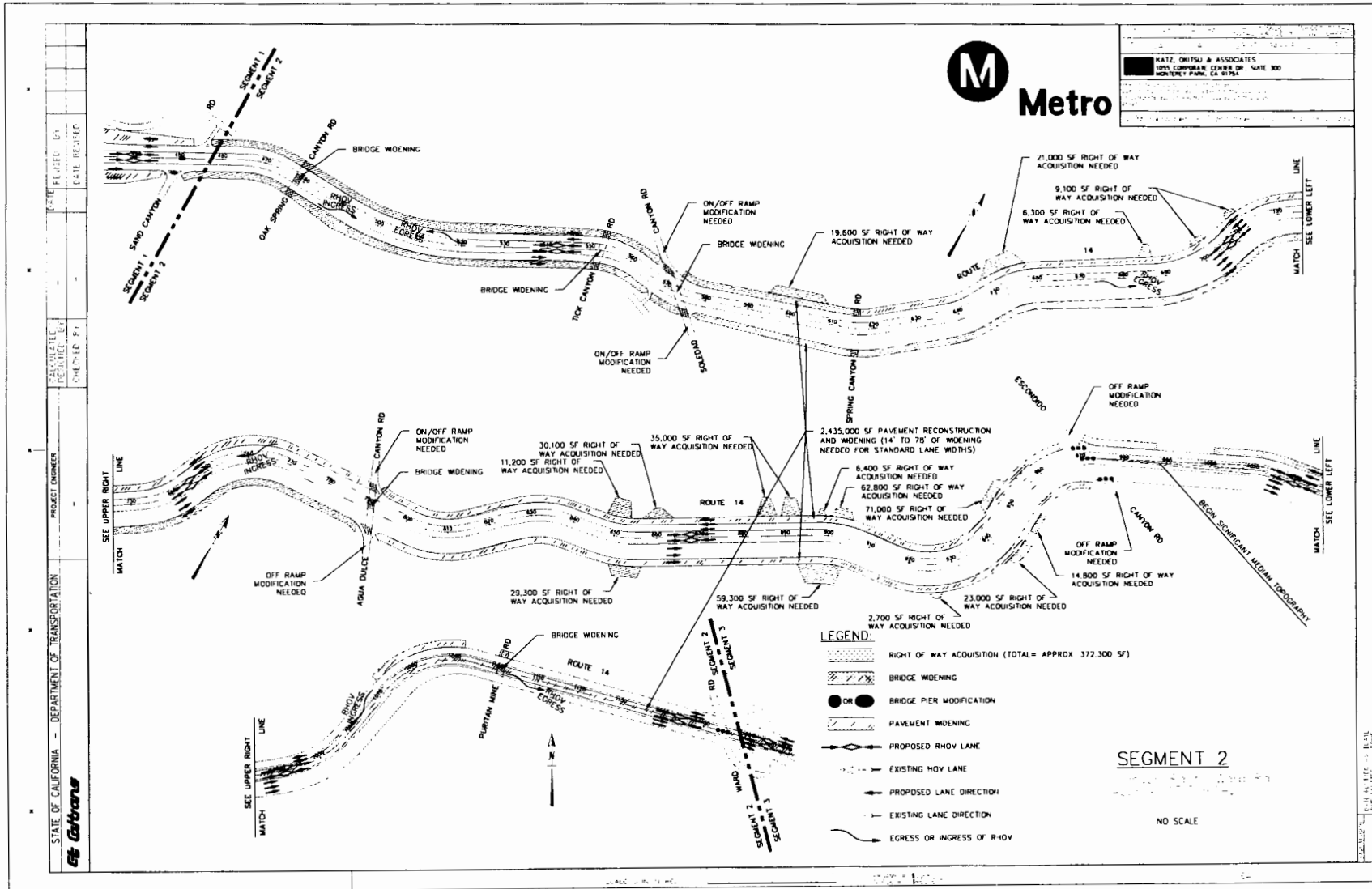

Not To Scale

Figure ES-3  
Segment Two - Sand Canyon Road to Ward Road

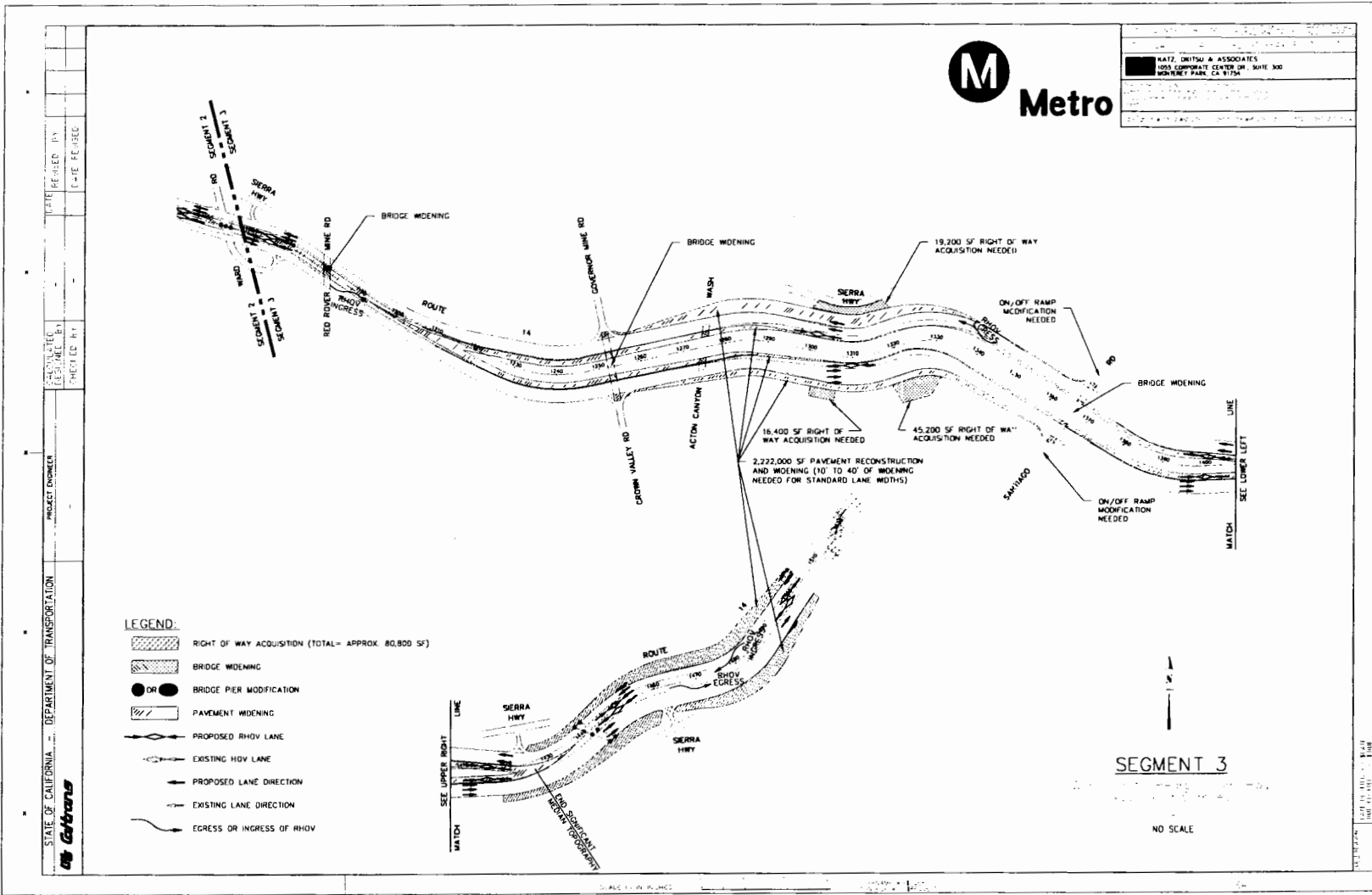

↑  
N  
Not To Scale

Figure ES-4  
Segment Three - Ward Road to Pearblossom Highway



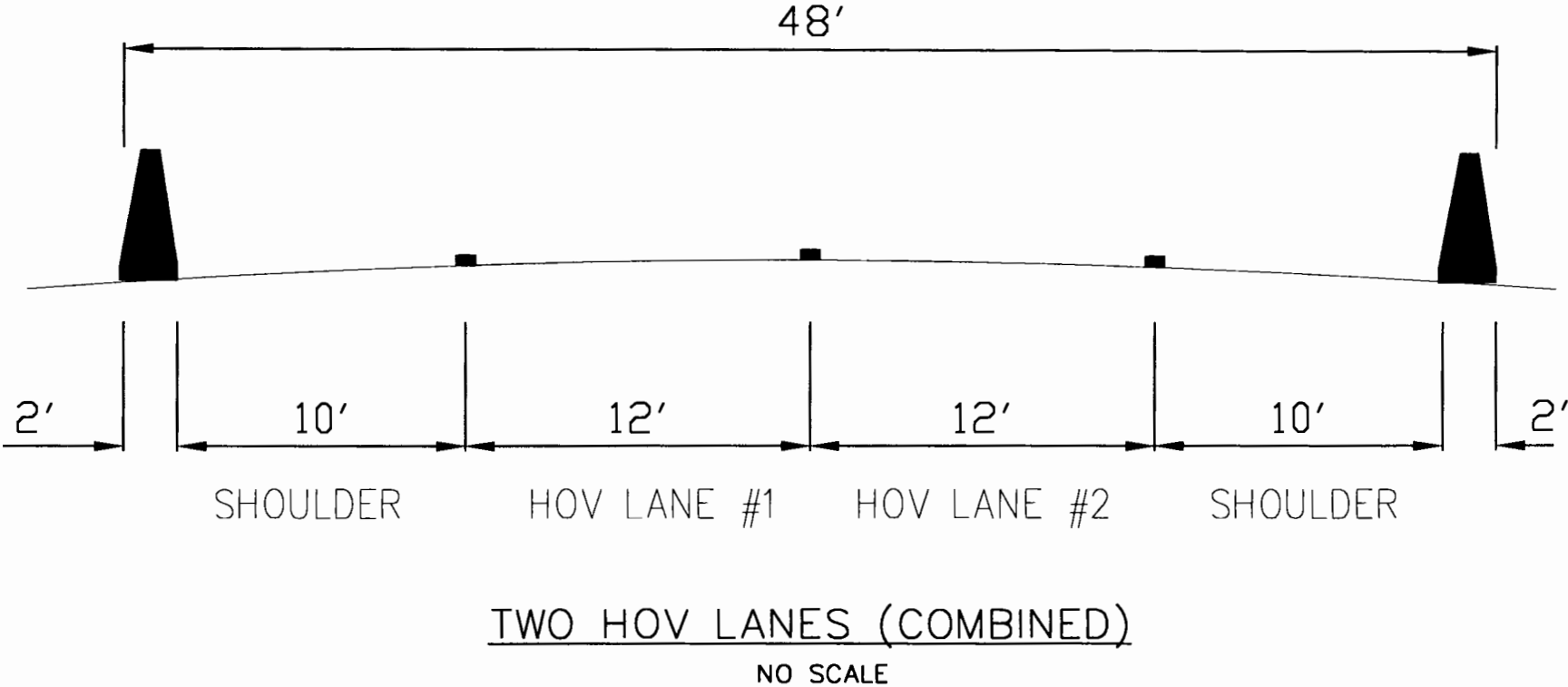

N  
↑  
Not To Scale

Figure ES-5  
Alternative One - Typical Cross Section

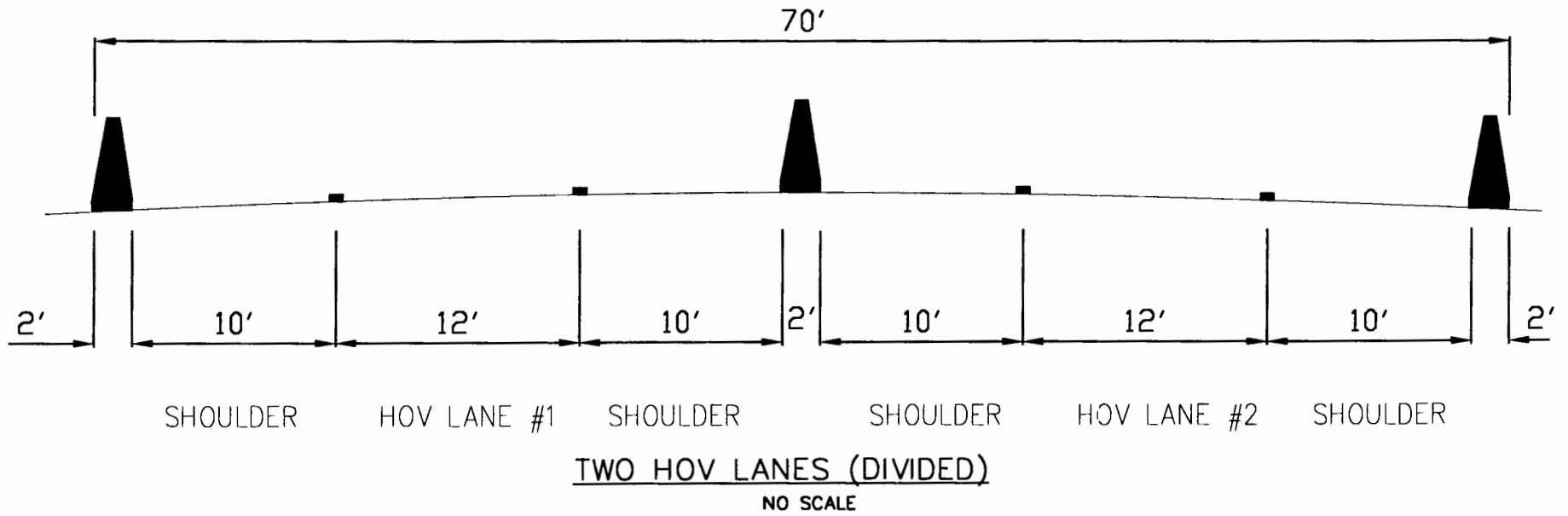

↑  
N  
Not To Scale

Figure ES-6  
Alternative Two - Typical Cross Section

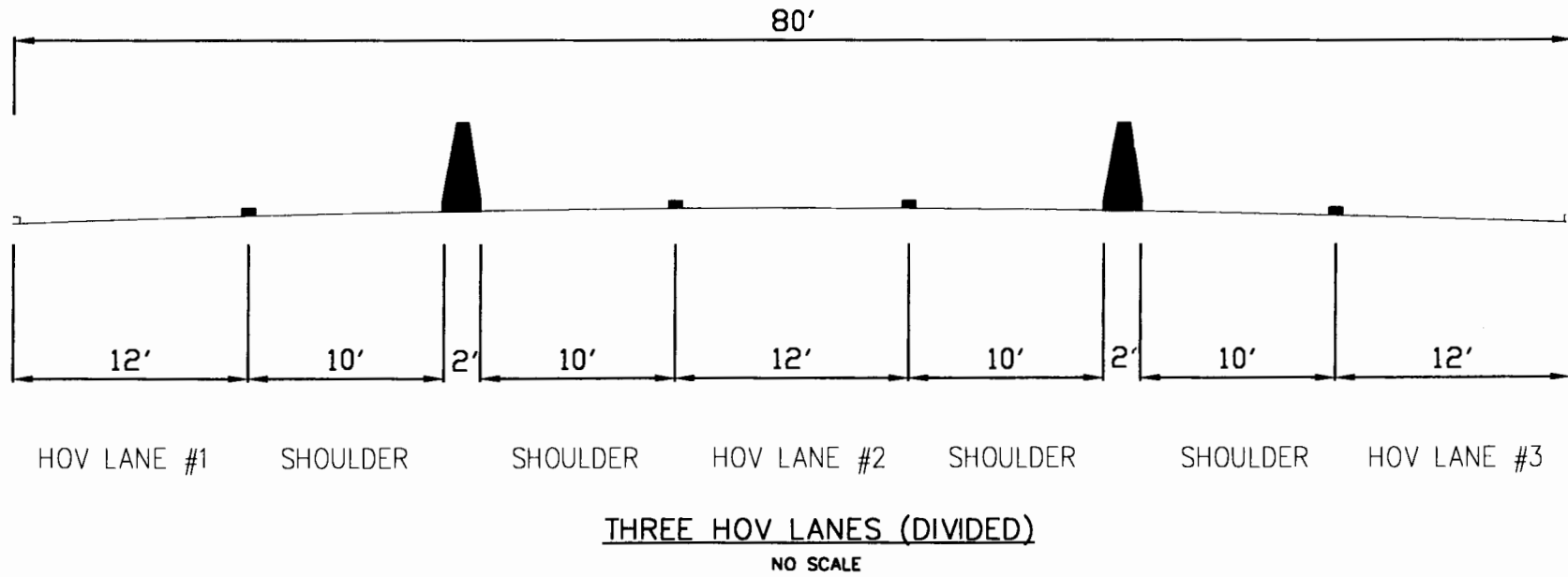

↑  
N  
Not To Scale

Figure ES-7  
Alternative Three - Typical Cross Section  
(eliminated from consideration)

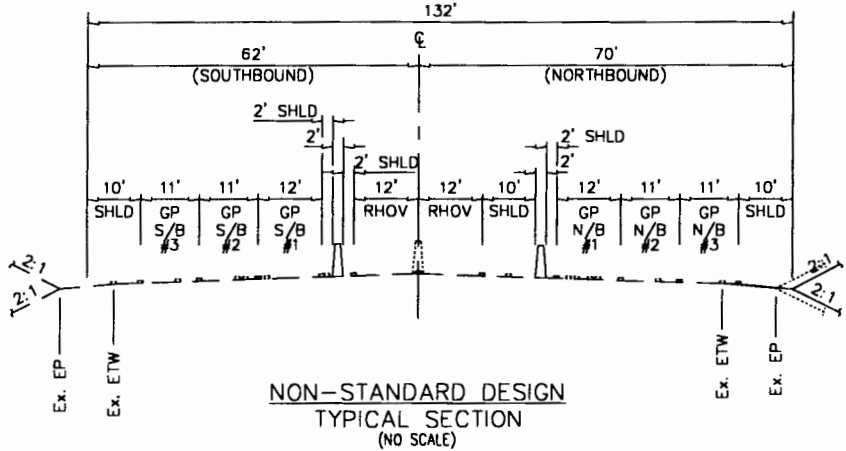
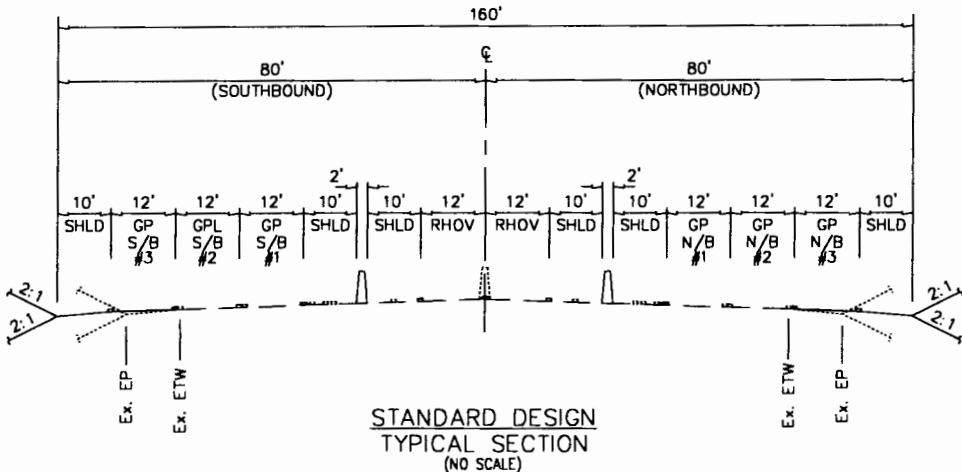

Not To Scale

Figure ES-8  
Standard vs. Non-Standard (Minimum) Cross Section Comparison



## CHAPTER ONE

### PROJECT HISTORY AND INTRODUCTION

#### HISTORY OF PROJECT

A combined study of the State Route 14 (SR-14) corridor, the State Route 138 (SR-138) corridor, and the Interstate 5 (I-5) corridor was completed in June of 2005. The findings of this study were presented in a report entitled "North County Combined Highway Corridors Study, SR-14, SR-138 and I-5, Final Report, June 2004" (hereinafter, the "Combined Study"). The Combined Study was undertaken to develop a multi-modal transportation plan for the northern portion of Los Angeles County, addressing both short-term (2010) and long-term (2025) concerns. The Combined Study developed an individual plan, or Locally Preferred Strategy (LPS), for each of the three corridors.

The Combined Study integrated the three individual LPSs to provide an analysis of the future regional travel patterns along the integrated network. Locations were identified where the LPSs could work together to improve the anticipated level of service or reduce costs. In addition, a "sensitivity analysis" was performed, including several targeted investigations to determine the impact of newly emerging land use patterns, and to evaluate opportunities for operational applications such as reversible high occupancy vehicle (RHOV) lanes.

The Combined Study characterized the SR-14 corridor as a commute corridor with an anticipated tripling of the commute population. As a commute corridor, there is a pronounced imbalance in the directional traffic in both the AM and PM peak hours. Accordingly, the Combined Study identified the implementation of RHOV lanes in the SR-14 corridor as part of the SR-14 LPS.

This report presents the development and analysis of alternatives for the implementation of RHOV lanes in the SR-14 corridor. As discussed in the following sections, the alternatives for implementing RHOV lanes were developed through a Technical Advisory Committee and Planning Process. The selection of the alternatives to be evaluated, as well as the criteria for evaluation, was made through a Consent Building and Alternative Analysis Procedure. The results of this procedure are presented as the Preferred Alternative Selection.

#### TECHNICAL ADVISORY COMMITTEE AND PLANNING PROCESS

The development and selection of the alternatives evaluated in this feasibility study was accomplished by a Technical Advisory Committee and Planning Process. This process grew out of the process used to perform the Combined Study of the SR-14, SR-138 and I-5 corridors. The Combined Study was sponsored by the following agencies: the Los Angeles County Metropolitan Transportation Authority; the California Department of Transportation; the County of Los Angeles; the cities of Los Angeles, Lancaster, Palmdale and Santa Clarita; the Southern California Association of Governments; and the Federal Highway Administration. As a result of the participation of this broad spectrum of interested parties, the Combined Study represents the result of a collaborative effort and consensus building





process. The results of the Combined Study also represent the beginning point of the identification of alternatives that are analyzed in this report.

Much like the Combined Study, this report is the result of a collaborative effort. The development and selection of alternatives was accomplished through the efforts of a Technical Advisory Committee. This TAC consisted of the representatives from the following agencies and interested parties: the Los Angeles County Metropolitan Transportation Authority, the California Department of Transportation; the County of Los Angeles; the cities of Los Angeles, Palmdale and Santa Clarita; the Southern California Association of Governments; the Federal Highway Administration; the California Highway Patrol; and the consultant, Katz, Okitsu & Associates. The TAC participants developed alternatives and conducted monthly meetings that began in July, 2005 and continued through April, 2006. During the course of this period, the TAC considered potential alternatives for implementing RHOV lanes in the SR-14 corridor.

### **CONSENT BUILDING AND ALTERNATIVE ANALYSIS PROCEDURE**

The consent building and alternative analysis procedure was accomplished through the efforts of the TAC. Various alternatives were identified by TAC participants. The alternatives were then developed through a collaborative process. The predominant issues considered during the development of the alternatives were identified in the TAC's initial meeting and consisted of the following items:

1. location of chute points and ingress/egress feasibility
2. operations and safety
3. I-5 / SR-14 system interchange operation
4. physical corridor alignment
5. ITS technology
6. implementation issues and construction disruptions to traffic
7. cost-benefit of the alternatives

Other factors were also considered by the TAC, including, but not limited to: definition of the study area; part-time HOV lanes; geometric issues; ingress/egress points and the effect of roadway elevation differences between existing northbound and southbound lanes; emergency vehicle access; maintenance; HOT lane concept; identification of potential fatal flaws; design guidelines and standards; as well as aerial data and topographic issues.

The foregoing factors that were identified by the TAC were first used to develop the alternatives to be analyzed in this feasibility study. These same factors were then used to more fully evaluate the alternatives that were selected for analysis in this feasibility study.

### **PREFERRED ALTERNATIVE SELECTION**

The TAC identified three potential alternatives, and ultimately decided to subject one of the three to a full feasibility study. The three potential alternatives were:





- Alternative One – a two lane combined RHOV system. Figure ES-5 shows a typical cross section for Alternative One. It should be noted that the direction of travel needs to be reversed in both lanes at the same time to keep the two lanes operating in the same direction, since the lanes are “combined” and are not separated by a barrier.
- Alternative Two – a two lane divided RHOV system. Figure ES-6 shows a typical cross section for Alternative Two. It should be noted that the direction of travel in each lane can be reversed independently, since the lanes are “divided” by a barrier. On the contrary, a combined RHOV system requires all lanes to operate in the same direction and to be reversed together. While the divided system has operational flexibility, it is also apparent from Figures ES-5 and ES-6 that Alternative Two requires a considerably larger footprint to implement. Another disadvantage to this alternative is that it presents a more confusing configuration to drivers who are required to decide which of the two RHOV lanes they would like to enter. The resulting driver confusion raises concerns about safety issues. Other disadvantages associated with a divided system include the increased complexity in operations, together with higher costs for operations and maintenance. A comparison of the relative merits of “combined” and “divided” RHOV concepts is presented below in Table 1-1.
- Alternative Three – a three lane divided RHOV system. Figure ES-7 shows a typical cross section for Alternative Three. The third alternative was eliminated from consideration by the TAC. This alternative was evaluated by the TAC, and was eliminated primarily as a result of the excessive cost-benefit performance relative to the first two alternatives. The excessive cost is associated primarily with the additional footprint of a three lane system. The additional footprint expense is compounded by the area geography, which would require extensive cut and fill work, retaining wall installation, and bridge widening/modification to accommodate a three lane cross section.





Table 1-1. Comparison of “Combined” and “Divided” Reversible High Occupancy Vehicle (RHOV) Systems

Factors	Combined RHOV	Divided RHOV
<i>Min. Width Reqs.</i>	48'	70'
<i>Operating Hours</i>	10/10(up to 20 hrs total)	5/5/8 or 6/6/6 or ?(up to 18 hrs total)
<i>Onramps/Access</i>	Simple	Complex
<i>Driver Perception</i>	Straightforward	More Confusing
<i>Safety</i>	Better	Worse
<i>Operations Flexibility</i>	Less	More
<i>Cost</i>	Lower	Higher
<i>Maintenance</i>	Easier	More Difficult
<i>Monitoring</i>	Normal	Normal







## CHAPTER TWO PROJECT BACKGROUND

### RECITAL AND SUMMARY OF PREVIOUS STUDIES AND FINDINGS

#### The North County Combined Highway Corridors Study

As discussed above, this feasibility study was preceded by the North County Combined Highway Corridors Study, SR-14, SR-138 and I-5, Final Report, June 2004. The Combined Study was undertaken to develop a multi-modal transportation plan for the northern portion of Los Angeles County, addressing both short-term (2010) and long-term (2025) concerns. The Combined Study developed an individual plan, or Locally Preferred Strategy (LPS), for each of the three corridors (the SR-14, SR-138 and I-5 corridors). The Combined Study integrated the three individual LPSs to provide an analysis of the future regional travel patterns along the integrated network.

The Combined Study identified the need to determine the impact of newly emerging land use patterns, and to evaluate opportunities for operational applications such as reversible high occupancy vehicle (RHOV) lanes. Additionally, the Combined Study examined the need for continuity in the system south of the I-5 / SR-14 interchange, through the I-5 “throat” or “choke point” where nearly all North County traffic must travel to reach the Los Angeles Basin. This section was identified as being particularly troublesome because of the massive weaving movements that different streams of traffic must make to get from SR-14 and I-5 north to the I-210, the I-405, and the I-5 south. Lack of system redundancy was also identified as a major issue in this section.

As a result of the integrated analysis and detailed sensitivity testing performed during the Combined Study, an integrated multi-modal long range plan was developed to serve the long range demands of the North County. The Combined Study made recommendations to allow the three North County corridors to function together in a seamless system to serve the diverse transportation needs in northern Los Angeles County. Figure 2-1 shows the Combined Study Area.

The three North County corridors are each unique in terms of function, capacity, and operational issues. Broadly speaking, the I-5 corridor is a goods movement corridor linking the Central Valley with the Ports of Los Angeles/Long Beach. In contrast, the SR-14 corridor may be generally described as a commute corridor with an anticipated tripling of the commute population. The general description of the I-138 corridor is based on its function as a bypass corridor, which relieves congestion in the central region by routing traffic around congested Los Angeles freeways.

The major recommendation of the Combined Study for SR-14 was to implement a RHOV system, and to provide for “Gap Closure” to eliminate areas where the general purpose lanes drop from 3 lanes in each direction down to 2 lanes in certain areas.





↑  
N  
Not To Scale

Figure 2-1  
Combined Study Area



## Other Prior Studies

In addition to the Combined Study, several other prior studies of the SR-14 corridor have been performed, including, but not limited to the following:

North County Combined Highway Corridors Study, Integration and Sensitivity Analyses, Parsons, November, 2004

Initial Study, Environmental Assessment, Interstate 5 / State Route 14 High Occupancy Vehicle Connector, Caltrans District 7 Office of Environmental Planning, October, 2000

Project Study Report, High Occupancy Vehicle Connector, Interstate 5 / State Route 14, Caltrans, March, 1997

Final Value Analysis Study Report, Interstate 5 / State Route 14 HOV Connectors, TVI International, June, 2000

Supplemental Project Study Report, High Occupancy Vehicle Connector, Interstate 5 / State Route 14, Caltrans, January, 2001

It should be noted that the planning, design and operation manual, entitled High-Occupancy Vehicle Facilities, published by Parsons, Brinckerhoff Quade & Douglas (1990) states in relevant part that practitioners from various projects agree that there generally should be a peak-hour directional split of at least 65% to 35% for the practical application of a RHOV system (citing Boyle 1985, Caltrans, HOV Guidelines, 1990, and Cechini 1989).

## EXISTING CONDITIONS

The SR-14 corridor is one of three corridors serving North Los Angeles County. The other two corridors are the SR-138 corridor and the I-5 corridor. These corridors function together as an integrated system serving the North County. The North County includes the high growth Santa Clarita Valley and Antelope Valley communities (Santa Clarita, Palmdale, and Lancaster) that provide affordable housing for commuters traveling south on congested routes into the relatively high employment area of the San Fernando Valley and the Los Angeles Basin (see Figure 2-1). This area also includes a large area of unincorporated Los Angeles County that contains much rural area and many small towns such as Acton and Aqua Dulce. The two primary north-south corridors are I-5 and SR-14. These north-south corridors are physically constrained by topography and, in some areas, by development along the freeway segments. The east-west travel is served primarily by the SR-138 corridor, which is considered to be an underdeveloped roadway network.

Currently, SR-14 has one HOV lane in each direction between I-5 and Pearblossom Highway, a distance of 30 miles. There are eleven points of access to local streets along this segment. Further north, construction is underway to provide HOV lanes in the 7 mile segment from Pearblossom Highway to Avenue P in Palmdale.



Overall, only a portion of the corridor provides adequate median width to convert the existing HOV lanes into reversible HOV lanes. Northbound and southbound lanes on the segment between Crown Valley Road and Escondido Canyon Road are separated by a wide grass median (between 40 and 130 feet wide). However, in this segment the southbound lanes are situated at a significantly higher elevation than the northbound lanes. Most segments in the corridor have limited median width available, especially if standard lane and shoulder widths are to be provided. The segments with limited median width include the segment between Pearblossom Highway/Angeles Forest Highway and Soledad Canyon Road, and the segment between Escondido Canyon Road and I-5. In most cases widening along one or both sides of SR-14 will be required to accommodate the reversible HOV lanes, particularly if standard widths are to be implemented.

This study examines the implementation of RHOV lanes on SR-14 beginning just north of the I-5 interchange and proceeding to the north to a point near Pearblossom Highway (See Figure ES-1). Furthermore, due to the anticipated high cost of implementation of RHOV lanes, the feasibility study area was broken into three segments in order to evaluate the effectiveness in separate segments. The determination of the proposed segments was based primarily on the geographic and traffic flow characteristics of each segment. The three segments (See Figures ES-2, ES-3, ES-4) consist of the following:

Segment One: North of I-5 to Sand Canyon Road, approximately 8.0 miles.

Segment Two: Sand Canyon Road to Ward Road, approximately 13.5 miles

Segment Three: Ward Road to Pearblossom Highway, approximately 8.5 miles

### **Level of Service**

Existing conditions in the three segments were evaluated by examining the volume of traffic and the capacity of the General Purpose (GP) lanes, the High Occupancy Vehicle (HOV) lanes, and the Segment as a whole. The ratio of the volume of traffic to the capacity in a segment provides an indication of the Level of Service (LOS) for the segment. The LOS is reported on a "report card" scale, ranging from A to F. To evaluate existing conditions, volumes were taken from the SCAG model year 2000 data. Engineering judgment was used to select the appropriate data point used to characterize the level of service within each segment. The level of service under existing conditions is reported for Segments One, Two and Three in the corresponding Tables 2-1, 2-2, and 2-3.

### **Segment One**

Segment One begins just north of the connection with I-5 and continues to the north and east for approximately 8.0 miles to Sand Canyon Road. In this segment SR-14 consists of 2 to 5 general purpose (GP) lanes and 1 high occupancy vehicle (HOV) lane in each direction. There is presently a plan to construct a direct connection between the HOV lanes that serve I-5 and the HOV lanes on SR-14. There are 14 bridge crossings in this segment, and 6 ramp locations (this segment does not include the ramp location at the I-5 connection).

Existing conditions in Segment One were determined by examining the volume to capacity ratio. The volume to capacity ratio was used to define the level of service in the segment. Level of service (LOS) is reported on a report card scale, from A to F. Table 2-1 shows the level of service in Segment One. The overall level of service in Segment One can generally be characterized as poor. This is due to the volume of traffic in the southbound direction in the AM peak hours, and to a lesser degree, due to the volume of northbound traffic in the PM peak hours.

The nature of the bi-directional flow in Segment One was evaluated by examining the difference between the northbound and southbound volumes. The bi-directional flow is expressed as the relative volume in each direction as a percent of the total volume in both directions. The bi-directional flow was determined for both the AM and PM peak hours.

Under existing conditions, Segment One operates with a bi-directional split of 70% southbound (SB) to 30% northbound (NB) in the AM peak hours, and a split of 43% SB to 57% NB in the PM peak hours.

Other existing conditions of concern in this study include the segment topography, the roadway cross section and profile, the location of the existing HOV lanes, and the availability of sufficient right of way.

### **Segment Two**

Segment Two begins just north of the Sand Canyon Road and continues to the north and east for approximately 13.5 miles to Ward Road. In this segment SR-14 consists of 2 to 3 general purpose lanes and 1 high occupancy vehicle (HOV) lane in each direction. There are 8 bridge crossings in this segment, and 4 ramp locations.

Table 2-2 shows the level of service in Segment Two. The overall level of service in Segment Two can generally be characterized as good. Under existing conditions, Segment Two operates with a bi-directional split of 61% SB to 39% NB in the AM peak hours, and a split of 47% SB to 53% NB in the PM peak hours.

### **Segment Three**

Segment Three begins just north of the Ward Road and continues to the north and east for approximately 8.5 miles to Pearblossom Highway. In this segment SR-14 consists of 2 to 3 general purpose lanes and 1 high occupancy vehicle (HOV) lane in each direction. There are 6 bridge crossings in this segment, and 4 ramp locations.

Table 2-3 shows the level of service in Segment Three. The overall level of service in Segment Three can generally be characterized as adequate. Under existing conditions, Segment Three operates with a bi-directional split of 55% SB to 45% NB in the AM peak hours, and a split of 50% SB to 50% NB in the PM peak hours.



In general, the evaluation of the existing conditions revealed that Segment One operates with the worst levels of service, where it is characterized as poor. The level of service then improves to good in Segment Two, but deteriorates in Segment Three where it is characterized as adequate. An examination of the bi-directional split in traffic across the corridor reveals a pronounced split in Segment One, especially in the AM peak hours. The bi-directional character is then less pronounced in Segment Two, and is even more balanced in Segment Three. Therefore, the existing conditions strongly suggest that the best segment for implementation of a RHOV system is Segment One, based on both the existing levels of service and the bi-directional flow in that segment.

## **FUTURE PROJECTED CONDITIONS**

### **Level of Service**

Future conditions were evaluated using volumes taken from the SCAG model years 2010 and 2030. The data used to evaluate these time periods was selected using engineering judgment, and is consistent with the data selected to evaluate existing conditions. The year 2010 represents the year in which the project could be fully implemented, and the year 2030 represents the future condition of the corridor. The level of service for year 2010 is reported for Segments One, Two and Three in the corresponding Tables 2-4, 2-5, and 2-6. The level of service for the year 2030 is reported for Segments One, Two and Three in the corresponding Tables 2-7, 2-8, and 2-9.

Future projected conditions were evaluated by examining levels of service and the bi-directional flow characteristic in each segment. Table 2-10 summarizes the general characteristic for level of service in each segment for years 2000, 2010 and 2030.

### **Segment One**

The overall level of service in Segment One remains characterized as poor in both 2010 and 2030. Additionally, the overall volume in Segment One increases from 53,623 ADT in 2000, to 66,799 in 2010 and 70,749 in 2030. Segment One shows a pronounced bi-directional flow in 2010 and 2030, especially in the AM peak hours.

### **Segment Two**

The overall level of service in Segment Two goes from good in year 2000 to good-to-adequate in year 2010, and continues to degrade to adequate in the year 2030. The overall volume in Segment Two increases from 26,414 in 2000, to 37,508 in 2010, and 43,290 in 2030. Segment Two shows a pronounced bi-directional flow in year 2010 in the AM peak hours. Segment Two shows much less of a bi-directional flow in the year 2030, and may be considered to be inappropriate for the implementation of a RHOV system.

### **Segment Three**





The overall level of service in Segment Three goes from adequate in year 2000 to adequate-to-poor in 2010, and remains adequate-to-poor in 2030. The overall volume in Segment Three goes increases from 26,271 in year 2000, to 38,344 in year 2010, and 43,234 in year 2030.

In general, the evaluation of the future conditions revealed that Segment One operates with the worst levels of service, where it continues to be characterized as poor. The level of service in Segment Two continuously degrades over time from good in year 2000 to adequate in year 2030. The level of service also continuously degrades in Segment Three where it goes from adequate in year 2000 to adequate-to-poor in year 2030. An examination of the bi-directional split in traffic across the corridor continues to reveal a pronounced split in Segment One, especially in the AM peak hours. The bi-directional character is then less pronounced in Segment Two, and is even more balanced in Segment Three. Therefore, the future conditions strongly suggest that the best segment for implementation of a RHOV system is Segment One, based on both the levels of service and the bi-directional flow in that segment.

### **CURRENT AND PROGRAMMED IMPROVEMENTS IN THE CORRIDOR**

Current and programmed improvements include improvements to both the I-5 Corridor and the SR-14 Corridor, as they function as an integrated system. Short term improvements include: the implementation of HOV lanes on I-5 from SR-14 to SR-126; the implementation of truck climbing lanes on I-5; and the implementation of RHOV lanes on SR-14, as discussed herein.

The implementation of RHOV lanes on SR-14 will convert the existing part-time HOV lanes in each direction from I-5 to Pearblossom Highway into a two lane reversible HOV system. This system also leaves open the option to install a third lane in the existing freeway median at a later date, which would result in a three lane reversible HOV system. The short term objectives for the SR-14 Corridor also call for Gap Closure, which would eliminate drop lanes between Sand Canyon Road and Avenue P, where various freeway segments narrow from three to two lanes. This objective would require "Call for Projects" funding.

### **POTENTIAL IMPACT FROM IMPROVEMENTS IN PROGRESS**

Potential improvements in progress in and around the area of the SR-14 corridor include the addition and/or extension of HOV lanes on SR-14 from Sierra Highway/Pearblossom Highway to Avenue P in Pearblossom, and the addition and/or extension of HOV lanes on I-5. Additionally, construction is presently underway to create a direct connection for HOV lanes on SR-14 and I-5. These improvements will obviously expand the capacity and the efficiency of the HOV network in the region. These improvements will enhance the benefits normally associated with HOV systems in general, such as time savings, increased capacity and improved levels of service in the general purpose lanes.





**Table 2-1. Segment One Level of Service and Bi-Directional Flow (North of I - 5 to Sand Canyon Road)**

Year 2000		Volume	Capacity	V / C	LOS	Bi Directional Split SB Tot / NB Tot
<b>AM Peak</b>	SB HOV	4626	6300	0.73	D	70 % / 30 %
	SB GP	19490	18900	1.03	F0	
	SB Total	24116	25200	0.96	E	
	NB HOV	1800	6300	0.29	B	
	NB GP	8582	18900	0.45	C	
	NB Total	10382	25200	0.41	B	
	Segment Total	34498	50400	0.68	D	
<b>PM Peak</b>	SB HOV	4922	8400	0.59	C	43 % / 57 %
	SB GP	18063	25200	0.72	D	
	SB Total	22985	33600	0.68	D	
	NB HOV	5943	8400	0.71	D	
	NB GP	24695	25200	0.98	E	
	NB Total	30638	33600	0.91	E	
	Segment Total	53623	67200	0.80	D	

**Table 2-2. Segment Two Level of Service and Bi-Directional Flow (Sand Canyon Road to Ward Road)**

Year 2000		Volume	Capacity	V / C	LOS	Bi Directional Split SB Tot / NB Tot
<b>AM Peak</b>	SB HOV	1495	6300	0.24	B	61 % / 39 %
	SB GP	8288	18900	0.44	B	
	SB Total	9783	25200	0.39	B	
	NB HOV	1074	6300	0.17	B	
	NB GP	5146	18900	0.27	B	
	NB Total	6220	25200	0.25	B	
	Segment Total	16003	50400	0.32	B	
<b>PM Peak</b>	SB HOV	9722	25200	0.39	B	47 % / 53 %
	SB GP	2801	8400	0.33	B	
	SB Total	12523	33600	0.37	B	
	NB HOV	2425	8400	0.29	B	
	NB GP	11466	25200	0.46	C	
	NB Total	13891	33600	0.41	B	
	Segment Total	26414	67200	0.39	B	







**Table 2-3. Segment Three Level of Service and Bi-Directional Flow (Ward Road to Pear blossom Highway)**

Year 2000		Volume	Capacity	V / C	LOS	Bi Directional Split SB Tot / NB Tot
<i>AM Peak</i>	SB HOV	0	0	--	--	55 % / 45 %
	SB GP	8735	12600	0.69	D	
	SB Total	8735	12600	0.69	D	
	NB HOV	0	0	--	--	
	NB GP	7101	12600	0.56	C	
	NB Total	7101	12600	0.56	C	
	Segment Total	15836	25200	0.63	C	
<i>PM Peak</i>	SB HOV	0	0	--	--	50 % / 50 %
	SB GP	13172	16800	0.78	D	
	SB Total	13172	16800	0.78	D	
	NB HOV	0	0	--	--	
	NB GP	13099	16800	0.78	D	
	NB Total	13099	16800	0.78	D	
	Segment Total	26271	33600	0.78	D	

**Table 2-4. Segment One Level of Service and Bi-Directional Flow (North of I - 5 to Sand Canyon Road)**

Year 2010		Volume	Capacity	V / C	LOS	Bi Directional Split SB Tot / NB Tot
<i>AM Peak</i>	SB HOV	8297	6300	1.32	F1	82 % / 18 %
	SB GP	28989	18900	1.53	F3	
	SB Total	37286	25200	1.48	F3	
	NB HOV	1491	6300	0.24	B	
	NB GP	6653	18900	0.35	B	
	NB Total	8144	25200	0.32	B	
	Segment Total	45430	50400	0.90	E	
<i>PM Peak</i>	SB HOV	5406	8400	0.64	C	34 % / 66 %
	SB GP	17426	25200	0.69	D	
	SB Total	22832	33600	0.68	D	
	NB HOV	10237	8400	1.22	F0	
	NB GP	33730	25200	1.34	F1	
	NB Total	43967	33600	1.31	F1	
	Segment Total	66799	67200	0.99	E	





**Table 2-5. Segment Two Level of Service and Bi-Directional Flow (Sand Canyon Road to Ward Road)**

Year 2010		Volume	Capacity	V / C	LOS	Bi Directional Split SB Tot / NB Tot
<i>AM Peak</i>	SB HOV	3595	6300	0.57	C	71 % / 29 %
	SB GP	13469	18900	0.71	D	
	SB Total	17064	25200	0.68	D	
	NB HOV	1237	6300	0.20	B	
	NB GP	5599	18900	0.30	B	
	NB Total	6836	25200	0.27	B	
	Segment Total	23900	50400	0.47	C	
<i>PM Peak</i>	SB HOV	3803	8400	0.45	C	40 % / 60 %
	SB GP	11326	25200	0.45	B	
	SB Total	15129	33600	0.45	C	
	NB HOV	5217	8400	0.62	C	
	NB GP	17162	25200	0.68	D	
	NB Total	22379	33600	0.67	D	
	Segment Total	37508	67200	0.56	C	

**Table 2-6. Segment Three Level of Service and Bi-Directional Flow (Ward Road to Pear blossom Highway)**

Year 2010		Volume	Capacity	V / C	LOS	Bi Directional Split SB Tot / NB Tot
<i>AM Peak</i>	SB HOV	3465	6300	0.55	C	66 % / 34 %
	SB GP	12381	12600	0.98	E	
	SB Total	15846	18900	0.84	D	
	NB HOV	1707	6300	0.27	B	
	NB GP	6381	12600	0.51	C	
	NB Total	8088	18900	0.43	B	
	Segment Total	23934	37800	0.63	C	
<i>PM Peak</i>	SB HOV	3643	8400	0.43	B	43 % / 57 %
	SB GP	12937	16800	0.77	D	
	SB Total	16580	25200	0.66	D	
	NB HOV	4995	8400	0.59	C	
	NB GP	16769	16800	1.00	E	
	NB Total	21764	25200	0.86	E	
	Segment Total	38344	50400	0.76	D	





**Table 2-7. Segment One Level of Service and Bi-Directional Flow (North of I - 5 to Sand Canyon Road)**

Year 2030		Volume	Capacity	V / C	LOS	Bi Directional Split SB Tot / NB Tot
<i>AM Peak</i>	SB HOV	8406	6300	1.33	F1	80 % / 20 %
	SB GP	28111	18900	1.49	F3	
	SB Total	36517	25200	1.45	F2	
	NB HOV	1749	6300	0.28	B	
	NB GP	7280	18900	0.39	B	
	NB Total	9029	25200	0.36	B	
	Segment Total	45546	50400	0.90	E	
<i>PM Peak</i>	SB HOV	5996	8400	0.71	D	34 % / 66 %
	SB GP	18219	25200	0.72	D	
	SB Total	24215	33600	0.72	D	
	NB HOV	11060	8400	1.32	F1	
	NB GP	35474	25200	1.41	F2	
	NB Total	46534	33600	1.38	F2	
	Segment Total	70749	67200	1.05	F0	

**Table 2-8. Segment Two Level of Service and Bi-Directional Flow (Sand Canyon Road to Ward Road)**

Year 2030		Volume	Capacity	V / C	LOS	Bi Directional Split SB Tot / NB Tot
<i>AM Peak</i>	SB HOV	4173	6300	0.66	D	64 % / 36 %
	SB GP	13018	18900	0.69	D	
	SB Total	17191	25200	0.68	D	
	NB HOV	2202	6300	0.35	B	
	NB GP	7325	18900	0.39	B	
	NB Total	9527	25200	0.38	B	
	Segment Total	26718	50400	0.53	C	
<i>PM Peak</i>	SB HOV	4900	8400	0.58	C	43 % / 57 %
	SB GP	13710	25200	0.54	C	
	SB Total	18610	33600	0.55	C	
	NB HOV	6263	8400	0.75	D	
	NB GP	18417	25200	0.73	D	
	NB Total	24680	33600	0.73	D	
	Segment Total	43290	67200	0.64	C	





**Table 2-9. Segment Three Level of Service and Bi-Directional Flow (Ward Road to Pear blossom Highway)**

Year 2030		Volume	Capacity	V / C	LOS	Bi Directional Split SB Tot / NB Tot
<i>AM Peak</i>	SB HOV	3960	6300	0.63	C	58 % / 42 %
	SB GP	11871	12600	0.94	E	
	SB Total	15831	18900	0.84	D	
	NB HOV	2927	6300	0.46	C	
	NB GP	8663	12600	0.69	D	
	NB Total	11590	18900	0.61	C	
	Segment Total	27421	37800	0.73	D	
<i>PM Peak</i>	SB HOV	5306	8400	0.63	C	46 % / 54 %
	SB GP	14754	16800	0.88	E	
	SB Total	20060	25200	0.80	D	
	NB HOV	6394	8400	0.76	D	
	NB GP	16780	16800	1.00	E	
	NB Total	23174	25200	0.92	E	
	Segment Total	43234	50400	0.86	E	

**Table 2-10. General Characteristic for Level of Service**

Year	Segment One	Segment Two	Segment Three
2000	Poor	Good	Adequate
2010	Poor	Good to Adequate	Adequate to Poor
2030	Poor	Adequate	Adequate to Poor





## CHAPTER THREE PURPOSE AND NEED

### FOCUS OF STUDY

The focus of the present study is to determine the feasibility of implementing reversible HOV lanes in the SR-14 Corridor. The main issues identified by the TAC include, but are not limited to, traffic operations, safety, design, maintenance, costs, cost effectiveness, impact on the SR-14 / I-5 HOV direct connectors, and funding for an expanded RHOV system or other projects in the SR-14 Corridor. The primary focus of the study is to examine engineering feasibility, as opposed to providing information more typically associated with a traffic study.

In that regard, some of the key points include the location of the RHOV system terminal points, the number and location of ingress/egress points, the system profile and cross section (whether the RHOV lanes will be combined or divided), and the segments appropriate for implementation based on the bi-directional flow characteristics of each segment.

### LOGICAL TERMINI

The north and south termini for the RHOV system were developed by the TAC. The termini were evaluated by the TAC by considering: interaction with other HOV systems (I-5 and Pearblossom Highway); existing HOV usage and general traffic patterns in the corridor; and physical constraints and existing roadway configuration. The TAC conducted a field trip to examine potential locations for system termini. As a result of the TAC planning process (See Chapter One) the system terminus in the south was selected to be a location north of the I-5/SR-14 interchange. This selection recognizes that a “bottleneck” condition exists at the I-5/SR-14 interchange. However, the solution to the bottleneck condition is considered to be beyond the scope of this feasibility study, which is limited to determining the feasibility of the RHOV system. The system terminus in the north was selected to be located just south of the Pearblossom Highway/SR-14 interchange. This selection was made in consideration of the RHOV system usage and utility in the northern segment, as well as consideration of the fact that new (non-reversible) HOV lanes are currently being constructed on SR-14 between Avenue P and Pearblossom Highway. Conversion of this segment to RHOV lanes would involve major reconstruction at considerable expense and therefore would not likely be well accepted publicly and politically.

### FUTURE TRAFFIC SCENARIO (2030)

The future traffic scenario for the SR-14 corridor has been modeled by the Southern California Association of Governors (SCAG). The model provides projections of volumes for roadway and freeway segments using assumptions about the area roadway capacities and free flow speeds. These assumptions are based upon the physical characteristics of the roadways and the land use in the surrounding areas.

### POTENTIAL BENEFIT IMPLICATION





The proposed implementation of a RHOV system in the SR-14 corridor has the potential to expand the capacity and the efficiency of the HOV network in the region. These improvements will enhance the benefits normally associated with HOV systems in general, such as time savings, increased capacity and improved levels of service in the general purpose lanes.

### **REGIONAL IMPACT AND SIGNIFICANCE**

The proposed implementation of a RHOV system in the SR-14 corridor has the potential to have a regional impact. The RHOV system in the SR-14 corridor will ultimately be an essential component of the area freeway network which includes the SR-138 and I-5. These three corridors are part of a combined corridor system that has been the subject of much interest due to the potential for the three corridors to interact and function as a regional system. Attempts are being made to ensure that the three corridors operate more efficiently and complement each other. This is evident by the effort to create a direct connection between the HOV lanes on I-5 and SR-14, which is presently underway. The regional system is also the subject of much study in terms of the growth that is anticipated for the region, and its importance in providing a network that is capable of supporting a population of commuters in the northern part of the county. These commuters will impose greater demands on the regional system in the future, as the LA Basin and the San Fernando Valley will continue to be important employment areas in the future.





## CHAPTER FOUR

### REVERSIBLE HOV LANE ENGINEERING ALTERNATIVES

#### DESCRIPTION OF EXISTING FACILITIES IN OTHER CITIES

Reversible HOV lanes are currently operating in other areas, including examples in Washington D.C. / Virginia on Interstate 95 / Interstate 395; Chicago, Illinois on Interstate 90 / Interstate 94; and San Diego, California on Interstate 15. These examples are described in turn below.

#### **Washington D.C. / Virginia; Interstate 95 / Interstate 395**

A system consisting of two combined reversible HOV lanes are currently operating in Washington D.C. / Virginia on Interstate 95 / Interstate 395 (hereinafter, the "Virginia RHOV system"). This system extends for approximately 28 miles and serves commuter traffic from communities in Virginia traveling to and from the Washington D.C. metropolitan area (See Figure 4-1). The relevant portion of the I-95/395 corridor serves a volume of 280,000 vehicles, average daily traffic (ADT). This volume has a pronounced northbound/southbound bi-directional split of 85% to 15%, making it an ideal candidate for the implementation of RHOV lanes.

The Virginia RHOV system operates Mondays through Fridays. The RHOV lanes operate in the northbound direction from 11:00 p.m. to 11:00 a.m. to serve the morning commuter traffic. This period of northbound operation is followed by a two hour switch over period from 11:00 a.m. to 1:00 p.m. The system then operates in the southbound direction from 1:00 p.m. to 9:00 p.m. to serve the evening commuter traffic. The southbound operation period is then followed by a two hour switch over period from 9:00 p.m. to 11:00 p.m.

On weekdays, the operation of the RHOV lanes in the Virginia system is further defined by the requirement for a minimum of three passengers in each vehicle in the morning (between 6:00 a.m. and 9:00 a.m.), and during the evening (from 3:30 p.m. to 6:00 p.m.). At other times, non-HOVs are permitted to use the reversible lanes.

On weekends, the RHOV lanes are kept open in the southbound direction from Friday evening until 2:00 p.m. on Saturday. A switch over period occurs from 2:00 p.m. to 4:00 p.m. on Saturday, after which the RHOV lanes operate in the northbound direction through Monday morning. On weekends, the RHOV lanes are open to all traffic (HOV and non-HOV).

The Virginia RHOV system consists of 14 entrances and 4 exits in the northbound direction; and 4 entrances and 13 exits in the southbound direction. Some of the entrance/exit locations are configured to serve a dual function as either an entrance or an exit. During each two hour switch over period traffic is only permitted to exit the system and all entrances are closed. Operation of the entrances and exits is accomplished primarily through the use of gates (See Figure 4-2). There is a series of gates at each entrance. The entrance taper length is typically





on the order of 1200 feet. The gates are operated remotely from a traffic management center, and are monitored by cameras. The Virginia Department of Transportation also checks the system clearance during the switch over period with field inspection by department personnel.

#### **Chicago, Illinois; Interstate 90 / Interstate 94**

A system consisting of two combined reversible express lanes are currently operating in Chicago, Illinois on Interstate 90 / Interstate 94 (hereinafter, the “Chicago system”). This system is not an HOV system, as it provides reversible express lanes that are open to all traffic. The system extends for approximately 7 miles (See Figure 4-3). The relevant portion of the I-90/94 corridor serves an average daily traffic (ADT) volume of 300,000 vehicles. This volume has a pronounced eastbound/westbound bi-directional split making it an ideal candidate for the implementation of reversible lanes.

The Chicago system operates each day of the week. The reversible lanes operate in the eastbound direction from 1:00 a.m. to 11:00 a.m. to serve the morning commuter traffic. This period of eastbound operation is followed by a two hour switch over period from 11:00 a.m. to 1:00 p.m. The system then operates in the westbound direction from 1:00 p.m. to 11:00 p.m. to serve the evening commuter traffic. The westbound operation period is then followed by a two hour switch over period from 11:00 p.m. to 1:00 a.m. On weekends, the operational hours for the reversible lanes may be adjusted and have additional switch over periods to accommodate weekend event traffic.

The Chicago system consists of 2 entrances and 2 exits in the eastbound direction; and 2 entrances and 2 exits in the westbound direction. During each two hour switch over period traffic is only permitted to exit the system and all entrances are closed. Operation of the entrances and exits is accomplished primarily through the use of swing out gates and drop down barricades (See Figure 4-4). There are approximately 16 swing out gates per entrance/exit location. The drop down barricades consist of chain-link gates.

#### **San Diego, California; Interstate 15**

A system consisting of two combined reversible HOV lanes are currently operating in San Diego, California (hereinafter, the “San Diego RHOV system”). The system serves two passenger high occupancy vehicles as well as FasTrak vehicles. This system extends for approximately 8 miles and serves commuter traffic from communities in San Diego County traveling to and from the San Diego metropolitan area (See Figure 4-5). The relevant portion of the I-15 corridor serves a volume of 250,000 vehicles, average daily traffic (ADT). This volume has a pronounced northbound/southbound bi-directional split, making it an ideal candidate for the implementation of RHOV lanes.

The San Diego RHOV system operates Mondays through Fridays. The RHOV lanes operate in the southbound direction from 5:45 a.m. to 11:00 a.m. to serve the morning commuter traffic. This period of southbound operation is followed by a one hour switch over period







from 11:00 a.m. to 12:00 p.m. The system then operates in the northbound direction from 12:00 p.m. to 7:00 p.m. to serve the evening commuter traffic. The system is then closed after 7:00 p.m. on weekdays. However, the system is open to northbound traffic over the weekend.

The San Diego RHOV system operates with only two entrance/exit locations (one location at each end of the system). This system has been the subject of some criticism as a result of the absence of ingress/egress points along the length of the system. The entrance/exit locations are configured to serve a dual function as either an entrance or an exit. During the switch over period traffic is only permitted to exit the system. Operation of the entrances and exits is accomplished primarily through the use of pop-up delineators and one swing gate (See Figures 4-6 and 4-7).

The above systems illustrate important features to be considered when evaluating RHOV systems, such as: width requirements; operating schedules and operating flexibility; requirements for usage (number of vehicle occupants, payment for access, express traffic and transit); points of access; driver perception and safety; maintenance and monitoring; and overall cost. A comparison of RHOV systems is summarized in Table 4-1 below.

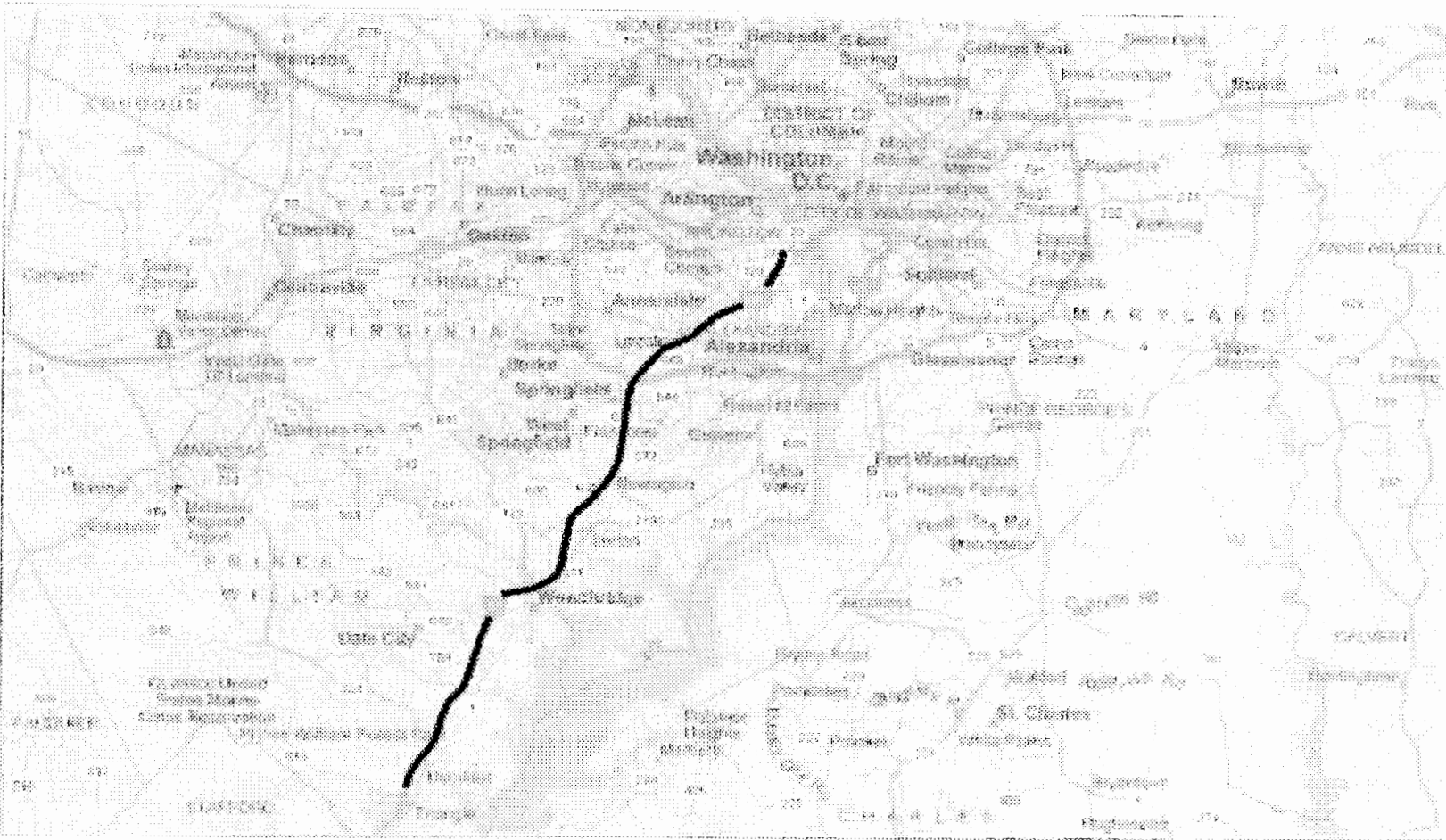



Table 4-1. Comparison of RHOV Systems

Attributes	I-95/I-395 (Shirley Hwy.) Washington D.C./Virginia	I-90/I-94 (Kennedy Exprwy.) Chicago, Illinois	I-15 San Diego, California	SR-14 North L.A. County, Calif.
Length of Facility	28 miles	7 miles	8 miles	38 miles (I-5 to Ave. P) 30 miles (I-5 to Sierra Hwy / Pearblossom Hwy)
Avg. Daily Traffic (all lanes)	280,000	300,000	250,000	164,000 (south end) 100,000 (north end)
Directional Peak	NB peak in AM, SB peak in PM (85% going in peak dir.)	EB peak in AM, WB peak in PM	SB peak in AM, NB peak in PM	SB peak in AM, NB peak in PM (70% going in peak dir.)
No. of Lanes:				
- mixed flow	3-5 lanes NB / 3-5 lanes SB	4 lanes EB / 4 lanes WB	4-6 lanes NB / 4-6 lanes SB	2-5 lanes NB / 2-5 lanes SB
- reversible	2 combined rev. HOV lanes	2 combined rev. expr. Lanes	2 combined rev. HOV lanes	To be determined
Access Locations	NB: 14 entrances, 4 exits SB: 4 entrances, 13 exits	EB: 2 entrances, 2 exits WB: 2 entrances, 2 exits	NB: 1 entrance, 1 exit SB: 1 entrance, 1 exit	NB (proposed): 4 entrances, 5 exits SB (proposed): 4 entrances, 4 exits
Hours of Operation	NB: 11 PM to 11 AM (HOV-3: 6 AM-9AM) SB: 1 PM to 9 PM (HOV-3: 3:30 PM-6 PM)	EB: 1 AM to 11 AM WB: 1 PM to 11 PM (on weekends, may differ depending on traffic)	NB: 12 PM to 7 PM (closed after 7 PM weekdays, but kept open NB over weekend) SB: 5:45 AM to 11 AM	To be determined
Usage Limitations	HOV-3 during designated peak hours (i.e. min. 3 passengers per vehicle during peak). Otherwise, open to all vehicular traffic during non-peak hours)	Express lanes open to all vehicular traffic. No minimum passenger requirements.	HOV-2 & FasTrak (open to vehicles with minimum of 2 passengers, FasTrak subscribers, motorcycles, or low emission vehicles).	To be determined





↑  
N  
Not To Scale

Figure 4-1  
Virginia RHOV System

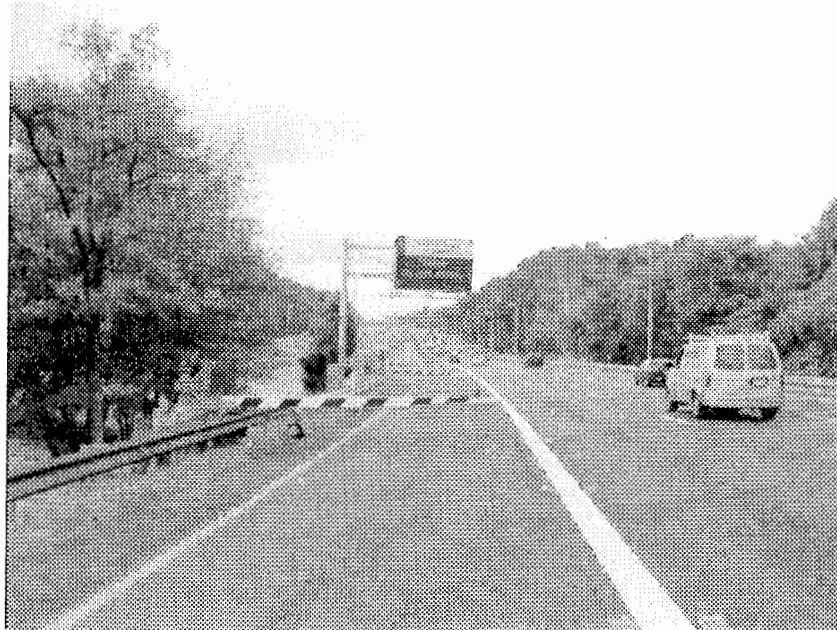

Entrance Gates

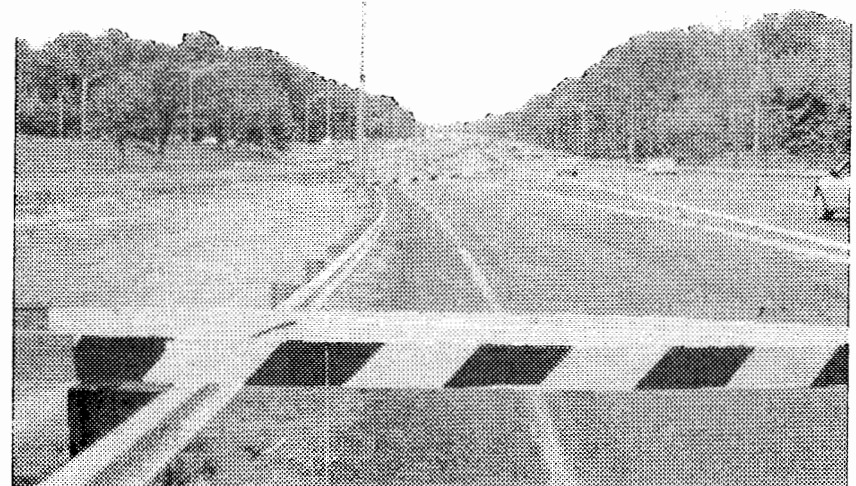

Entrance Gates (close-up)



Not To Scale

Figure 4-2  
Virginia RHOV System - Entrance Gates





Swing-out Gates

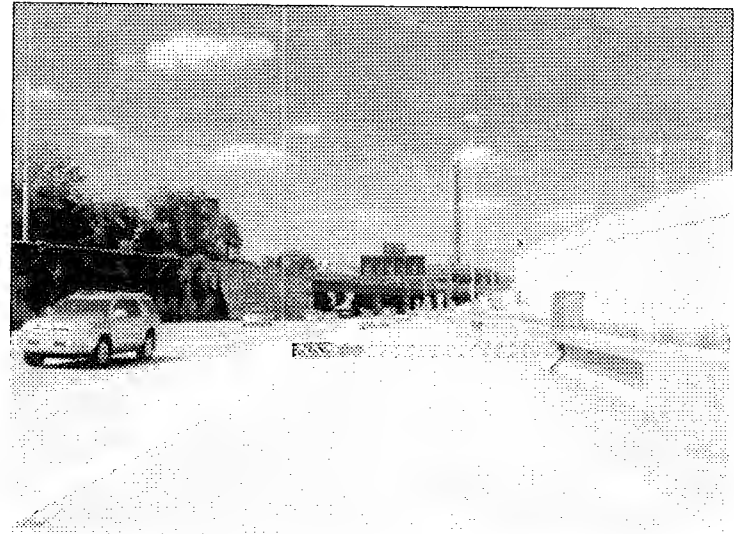

Swing-out Gates (alternate view)

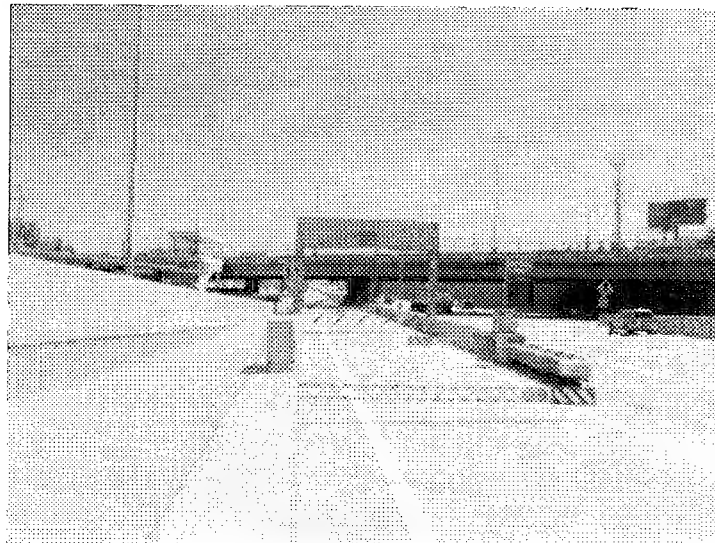

Swing-out Gates and Drop-down Barricades

↑  
N  
Not To Scale

Figure 4-4  
Chicago System - Swing-out Gates and Drop-down Barricades



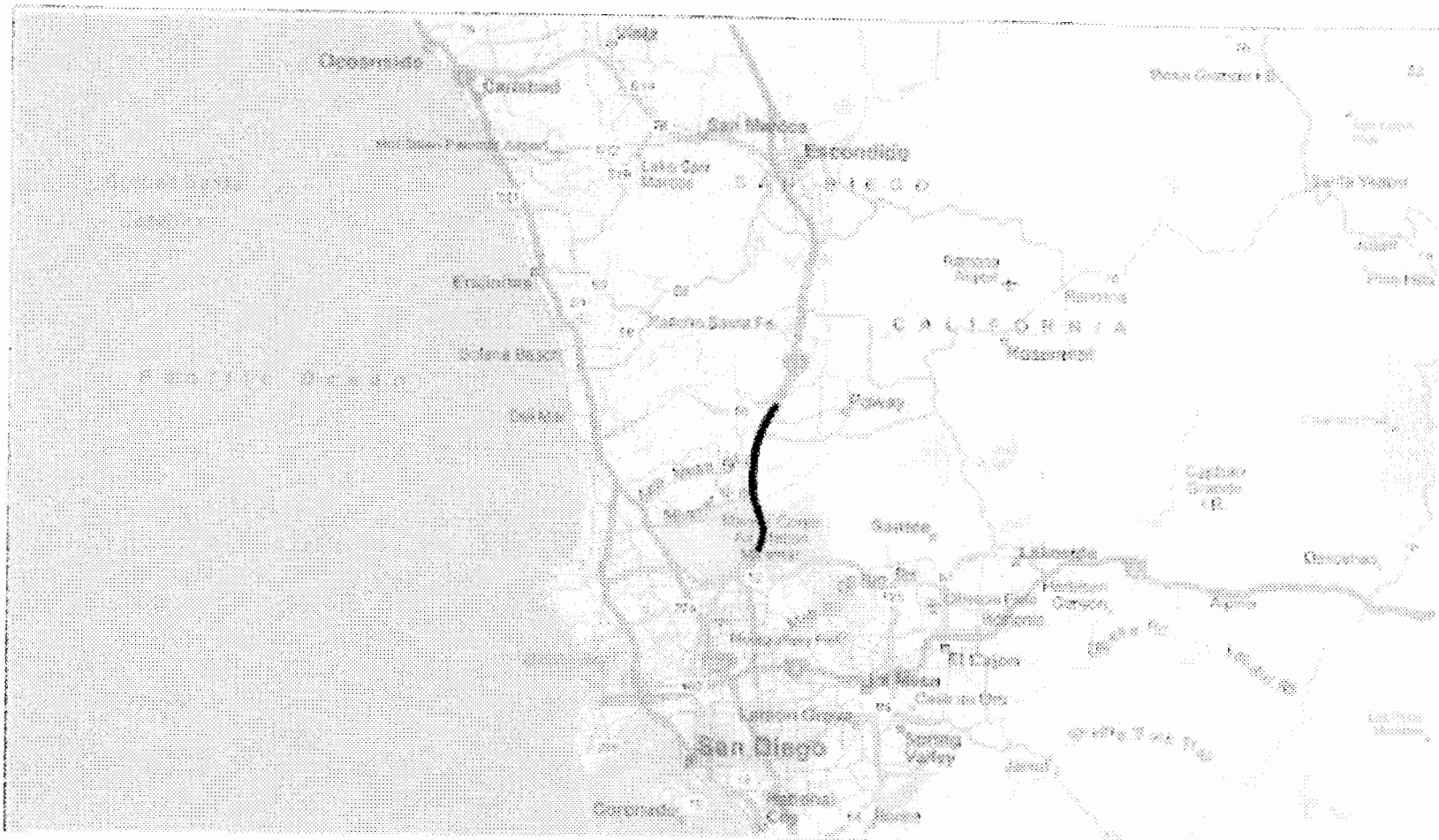

N

Not To Scale

Figure 4-5  
San Diego RHOV System

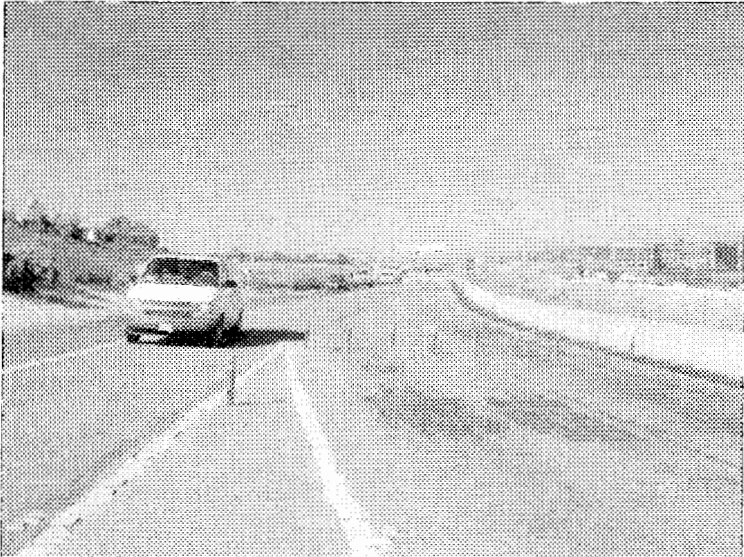

Pop-up Delineators

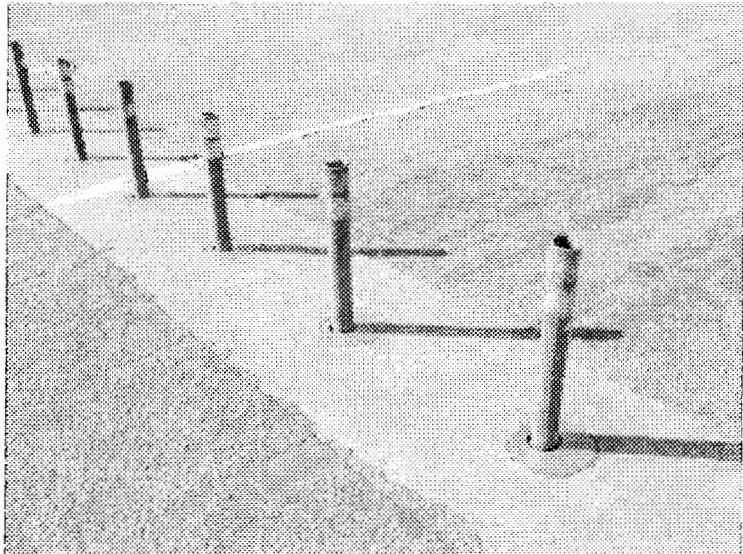

Pop-up Delineators (close-up)

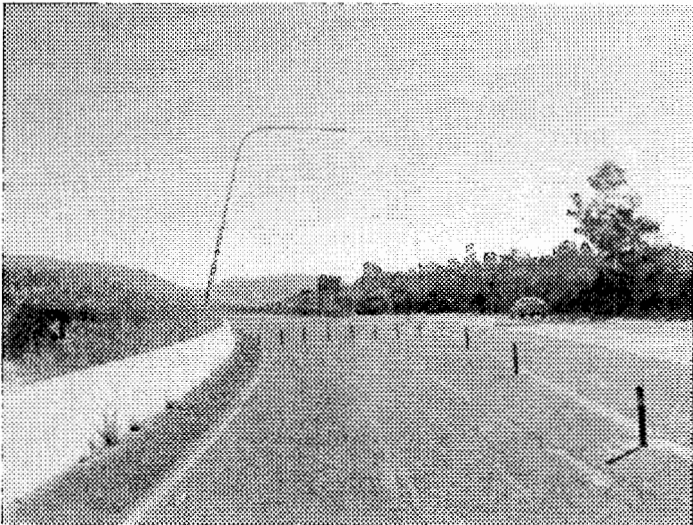

Pop-up Delineators

↑  
N  
Not To Scale

Figure 4-6  
San Diego RHOV System - Pop-up Delineators



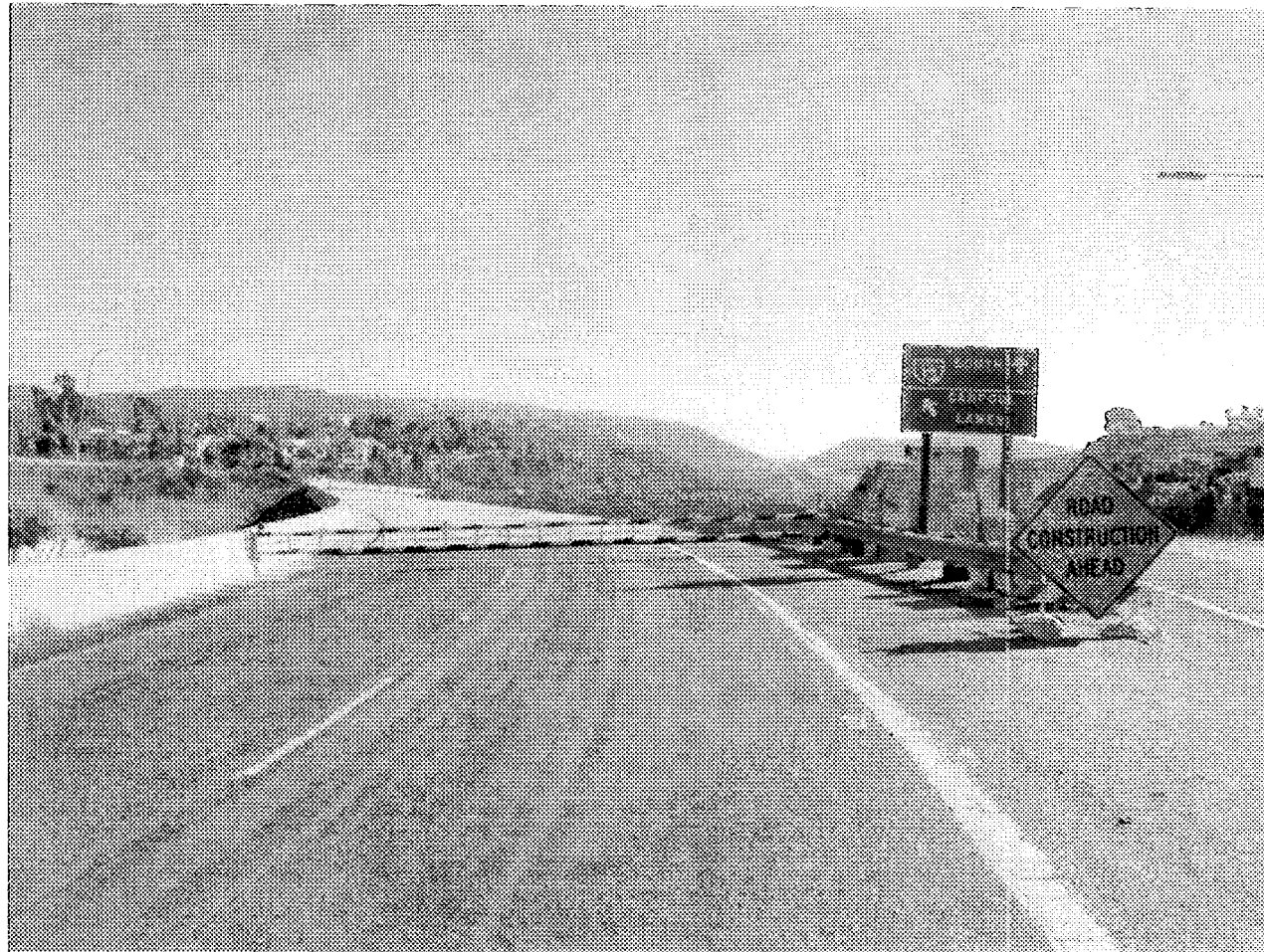

N

Not To Scale

Figure 4-7  
San Diego RHOV System - Swing Gate



## ALTERNATIVES OF TYPICAL STANDARD AND NON-STANDARD SECTIONS

The alternatives evaluated in this feasibility study include both typical standard and non-standard sections. The typical standard sections conform to all applicable design requirements. As a result of the right of way requirements, the configuration of the existing roadway and the topography of the SR-14 corridor, the TAC determined that this feasibility study should also consider non-standard sections. These non-standard sections contain certain elements that do not strictly conform to all standard design requirements. However, the design exceptions may be considered to be acceptable in order to implement the RHOV system in the corridor.

The non-standard sections deviate from the standard design requirements in terms of the widths of the lanes and shoulders. This variation is illustrated in the cross sections shown in Figure 4-8.

## EXISTING SR-14 PHYSICAL CONSTRAINTS AND DESIGN CHALLENGES

There are several physical constraints and design challenges confronting the implementation of a RHOV system in the SR-14 corridor. The physical challenges are the result of the corridor topography and the existing configuration of the roadway. This is most evident north of Escondido Canyon Road where the northbound and southbound freeways lanes travel through an area of hills and valleys. In this area the northbound and southbound lanes are separated by a wide median and are at significantly different vertical elevations. This topography and roadway configuration will require extensive earthwork in order to implement a RHOV system. In addition to cut and fill work, extensive areas will require the installation of retaining walls, some as high as ten feet or more. Finally, the physical topography and existing roadway configuration will require extensive design and construction work in some areas in order to provide adequate roadway drainage.

In addition to the physical challenges, the implementation of a RHOV system imposes challenges relating to the operation of the system. The main operational issue presented is whether the RHOV system will consist of a combined lane system or a divided lane system. The overall length of a RHOV system also presents a challenge to the operation, especially as the switch over period becomes more difficult to manage as the length of the system increases. In addition to the length of the system, the operation is also more difficult to implement in remote areas, such as the northern portion of the SR-14 corridor. These factors make it more difficult to change the direction of travel.







## EVALUATION OF INGRESS/EGRESS POINTS

Ingress and egress points were developed by the TAC. A preliminary layout of ingress/egress locations was developed by KOA and was presented to the TAC. Points of concern that were addressed in the selection of ingress/egress points included: interaction with other HOV systems (I-5 and Pearblossom Highway); existing HOV usage and general traffic patterns in the corridor; and physical constraints and existing roadway configuration. As a result of the TAC planning process discussed in Chapter One 15 ingress/egress locations were identified as shown on Figure ES-1.

## REVIEW AND EVALUATION OF ALTERNATIVES

The alternatives were evaluated by analyzing data from the Southern California Association of Governors (SCAG) traffic model. Existing conditions were evaluated using model year 2000 data. Although the model projects volumes for years that are closer to the current year, the year 2000 model output was calibrated by comparison to actual counts taken in the field, and therefore is used in this study to describe existing conditions. The year 2010 model projections were examined in this study for an understanding of the anticipated conditions for the year in which the project would be fully implemented, and the year 2030 model projections were examined for an understanding of the future condition of the corridor.

As discussed in Chapter One, Preferred Alternative Selection, the following alternatives were selected for evaluation by the TAC:

Alternative One is a two lane combined RHOV system. A typical cross section of this alternative is shown in Figure ES-5.

Alternative Two is a two lane divided RHOV system. A typical cross section of this alternative is shown in ES-6.

The criteria for evaluating the alternatives consisted primarily of the cost effectiveness of the alternative, especially in relation to capacity and travel times in the corridor.

The cost of each alternative was developed by considering various components of cost, including: capital cost (design, earthwork, grading, construction, equipment, material, labor); finance cost (schedule of capital expenditures, interest expense, time value of capital commitments); operations and maintenance costs (equipment operation costs (e.g. Changeable Message Signs, Motor Driven Gates, CCTV cameras, etc.), personnel operation costs (staffing required for switch over period, on call emergency and towing operations), and other maintenance costs (roadways and related equipment).

In addition to cost, each alternative is evaluated according to the following criteria: width requirements; operating schedules and operating flexibility; requirements for usage (number of vehicle occupants, payment for access, express traffic and transit); points of access; driver perception and safety; maintenance and monitoring.





Initially Alternative One and Two were evaluated against each other to determine the relative merits of each alternative. This analysis resulted in the elimination of Alternative Two – the divided RHOV system from consideration. Alternative Two was eliminated primarily as a result of the cost of a divided system. The cost of a divided system is much higher than the cost of a combined system due to the increased footprint and right-of-way area needed to construct a divided system. As can be seen from Figures ES-5 and ES-6, the typical cross section of a divided system is much wider than the typical cross section for a combined system. The increased width of the divided system translates into additional costs associated with acquiring right-of-way, grading costs, general construction costs, retaining wall installation, drainage, bridge widening and modification and other construction related matters imposed by the requirement for a wider cross section.

Furthermore, a divided system is relatively more expensive than a combined system with respect to operation and maintenance costs. The increased complexity of operation would require additional man-hours in order to operate a divided system. Additional cost is also associated with the maintenance of wider cross sections. Finally, although Alternative Two does provide for more flexible operations, the increased complexity also adds to driver confusion and can give rise to safety concerns. In summary, the additional cost of a divided system outweighs the operational flexibility offered by a divided system. For these reasons, Alternative Two was eliminated from further consideration. By default, Alternative One became the only logically preferred alternative for further consideration and analysis.

### **ANALYSIS OF THE PREFERRED ALTERNATIVE BY SEGMENT**

The analysis then proceeded to consider the implementation of Alternative One in three separate segments:

Segment One (North of I-5 to Sand Canyon Road),  
Segment Two (Sand Canyon Road to Ward Road), and  
Segment Three (Ward Road to Pearblossom Highway).

This analysis was accomplished by considering the Benefit to Cost ratio of the combined RHOV system in each segment. Additional analysis was performed to evaluate both a “standard” design implementation, and a “non-standard” design. The non-standard design alternative includes modifications to the standard requirements for lane widths and shoulders.





## CHAPTER FIVE

### BENEFIT/COST AND PRIORITIZATION BY SEGMENT

The review and evaluation of the each segment in Alternative One was conducted by performing an economic analysis pursuant to the California Life-Cycle Benefit-Cost Analysis Model (hereinafter, the “Cal B/C”). Given certain inputs, this model can be used to calculate a benefit to cost ratio (hereinafter, the “B/C”). In the present study, the Cal B/C was used to evaluate each segment in Alternative One under both standard design provisions and non-standard design provisions.

A B/C ratio in excess of 1.0 indicates that the economic benefit of implementing the alternative exceeds the cost of the alternative, and therefore implementation is economically advisable. On the other hand a B/C ratio less than 1.0 indicates that the economic benefits of the alternative are surpassed by the cost of the alternative, and therefore, implementation of the alternative is not recommended.

The economic benefit associated with the implementation of a RHOV system is primarily a savings in travel time, which is translated into an economic savings based upon an assumption regarding the value of time for each occupant of a vehicle in the system. Additional economic benefits that are considered include reduction in emissions, and decrease in accidents. These benefits are offset by the capital construction cost of the system, as well as the operation and maintenance costs.

**Table 5-1. Standard vs. Non-Standard Benefit/Cost Analysis**

	Segment One	Segment Two	Segment Three
<b>Standard Design</b>	2.8	0.6	0.7
<b>Non-Standard Design</b>	3.3	0.7	0.8

According to the B/C analysis the implementation of a RHOV system is not efficient in Segments Two or Three using either the Standard Design requirements or a Non-Standard Design. In Segment One it can be seen that the B/C ratio is better for the Non-Standard Design, as expected, due to the decrease in the cost of the implementing a non-standard design.

While the B/C ratio indicates that a RHOV system should be implemented in Segment One, this analysis needs to be considered in the context of the “bottle-neck” problem that is presently occurring near the I-5 / SR-14 interchange. The bottle-neck occurs as a result of capacity constraints, merging, and weaving that occur at and beyond the I-5 / SR-14 interchange. The vehicles exiting the SR-14 HOV lanes are presently required to merge into the SR-14 general purpose lanes just prior to the interchange. This merge also adds to the congestion.



**DESIGN YEAR (2030) TRAFFIC OPERATION ANALYSIS**

SCAG model data indicates that with respect to levels of service, the worst level of service will occur in Segment One in year 2030. Furthermore, in year 2030, the bi-directional flow characteristic of Segment One is the most pronounced of all segments. Level of service in year 2030 is considered adequate in Segment Two, and poor in Segment Three (although not as bad as Segment One). Bi-directional flow in year 2030 is more balanced in Segment Two than it is in Segment One, and the balance is fairly even in Segment Three.

**PRELIMINARY CONSTRUCTION, ROW, AND OPERATIONAL COST ESTIMATE**

The estimated construction costs for each segment (based on a standard design) are as follows:

Segment One: \$223,428,000  
Segment Two: \$297,024,000  
Segment Three: \$142,062,000

Adding in estimated right-of-way acquisition costs (\$100,000 for Segment One; \$3,723,000 for Segment Two; and \$808,000 for Segment 3) plus an assumed 15% of construction costs for project support costs, the estimated capital improvement costs for each segment (standard design) are as follows:

Segment One: \$257,042,000  
Segment Two: \$345,301,000  
Segment Three: \$164,179,000

Total capital improvement cost for all three segments would be approximately 767 million.

In addition to the capital costs, there will also be on-going maintenance and operations costs. For each segment, the annual maintenance and operations cost is assumed to range between \$500,000 and \$600,000. This figure is based on one full-time staff equivalent at \$200,000 per year, plus an assumed \$50,000 per each ingress/egress combination, plus an assumed \$20,000 per mile of reversible HOV lanes.

By going with non-standard lane and shoulder widths where possible, the capital costs can be reduced. Additionally, right-of-way acquisitions costs will become negligible or unnecessary. The total capital improvement costs for each segment for a "minimum" design will be as follows:

Segment One: \$211,394,000  
Segment Two: \$289,702,000  
Segment Three: \$155,682,000





Total capital improvement cost for all three segments would be approximately \$657 million.

### **BENEFIT ANALYSIS (CAPACITY AND DELAY SAVING)**

The California Life-Cycle Benefit/Cost Analysis Model, or Cal-B/C, was used to calculate the benefits, as well as conduct the benefit-cost analysis. This model was provided in the form of a Microsoft Excel spreadsheet. For the SR-14 project, the "HOV" option in Cal-B/C was flagged, so that the model would calculate both the net benefits created by both the HOV lanes and the other mixed-use lanes. Model inputs were provided first for the southbound direction for each of the three segments, so that the benefits of two HOV lanes serving southbound traffic in the morning could be calculated. A subsequent model run was performed for the northbound traffic to measure the benefits of reversing the HOV operation to provide two northbound HOV lanes.

### **BENEFIT COST ANALYSIS**

The Cal-B/C spreadsheet model calculated the benefits expected for the first 20 years of reversible HOV lane operation. The benefits were based on the expected reduction in travel time, fuel use, and emissions due to the reversal of the HOV lanes during the peak hour. Travel time was valued at \$8.16 per hour for person in autos, and \$27.72 per truck. Fuel was priced at \$3.00 per gallon.

The traffic volumes used in the Cal-B/C model were derived from SCAG's travel demand model. Adjustments were made to SCAG's HOV lane usage, to account for Cal-B/C not being able to handle more than 1500 vehicles per lane without encountering severe congestion, and to prevent the HOV lane from operating worse than the adjacent mixed flow lanes. It should be noted that in order for the SR-14 Reversible HOV Lane Project to handle these volumes, adequate capacity to handle two southbound and two northbound lanes-worth of HOV demand must be provided to the south of the project, through the I-5/SR-14 interchange. The traffic volumes traveling in the direction opposite of the peak direction are sufficiently low, even in 2030, so that the loss of an HOV lane in the off-peak direction is not expected to cause an increase in travel time to motorists traveling opposite the peak flow.

The benefit cost analysis of RHOV lanes assumes that all of the traffic exiting the RHOV system at the termini is capable of being absorbed. This is not the case at the southern terminus, where not all of the traffic is readily absorbed, as is evident by the bottleneck situation. Therefore, while the present analysis is valid for the purpose of evaluating the implementation of a RHOV system, this analysis also suggests that further study be performed to evaluate improvements to the I-5 / SR-14 interchange.

Cal-B/C predicted total benefits for the first 20 years of operation to be a present value of \$1.037 billion. By far, travel time savings accounted for most of the benefits at \$828.1 million. Fuel savings accounted for \$232.3 million. Emissions actually worsened at a negative \$22.8 million due to higher travel speeds causing an increase in carbon monoxide and oxides of nitrogen. (An increase in emissions of these particular gases is a common result





of freeway improvements.) Among the three segments, Segment 1 accounted for most of the benefits with \$723.1 billion. Segment 2 accounted for \$192.3 billion in benefits, and Segment 3 accounted for \$122.2 billion.

The Cal-B/C model used the construction costs as input, along with a "Project Support Cost" equivalent to 15% of construction cost. Annual maintenance/operations cost were assumed to be \$500,000 for each of the first 20 years of operation. For the standard lane dimensions alternative, these costs figures were converted into present value life cycle costs of \$259.8 million for Segment 1, \$343.8 million for Segment 2, and \$168.1 million for Segment 3. The present value life cycle costs for all three segments combined amount to \$771.7 million. For the minimum lane width dimensions alternative, the costs for Segments 1, 2 and 3 were \$216.5 million, \$258.7 million, and \$151.8 million, respectively, for a total cost of \$627.1 million.

The benefits used in the Cal-B/C model were assumed to be the same under both the standard lane width and the minimum lane width alternatives. Benefit-to-cost ratios for the standard lane width alternative were 2.8, 0.6, and 0.7 for Segments 1, 2, and 3, respectively, and 1.3 for the three segments combined. For the minimum lane width alternative, the benefit-to-cost ratios were 3.3, 0.7, and 0.8 for Segments 1, 2, and 3, respectively, and 1.7 for the three segments combined. Clearly, only Segment 1 is a candidate for recommendations, since Segments 2 and 3 have benefits that are less than the cost (See Table 5-1).

### **IMPROVEMENT PHASING PLAN**

The foregoing analysis clearly indicates that the appropriate phasing plan is to implement a RHOV system in Segment One, followed by Segments Two and Three. The construction costs are roughly equal in each segment, but the benefits of a RHOV system are clearly more applicable to Segment One. However, it appears that there are greater construction challenges in Segments Two and Three, especially relating to the challenges stemming from the area topography and roadway configuration. It should also be noted that the implementation of a RHOV system in Segment One would be of much greater practical application if the I-5 / SR-14 interchange was reconfigured to alleviate the existing bottleneck, and to accommodate the absorption of traffic from the proposed RHOV system.

