

National Cooperative Transit Research & Development Program

FOR THE PERIOD
JANUARY 1 THROUGH JUNE 30, 1984
CONTRACTS DTUM60-81-C-72012
and DTUM60-83-C-71226

PRIVILEGED DOCUMENT

This report, not released for publication, is furnished only for review to members of or participants in the work of the National Cooperative Transit Research and Development Program. It is to be regarded as fully privileged, and dissemination of the information included herein must be approved by the NCTRP.

HE
192.5
.N37
no.6

TRANSPORTATION RESEARCH BOARD

NATIONAL RESEARCH COUNCIL

PROGRESS REPORT 6

NATIONAL COOPERATIVE TRANSIT RESEARCH & DEVELOPMENT PROGRAM

TRB EXECUTIVE COMMITTEE SUBCOMMITTEE FOR THE NCTRP

JOSEPH M. CLAPP, *Chairman*

LAWRENCE D. DAHMS
WILLIAM J. HARRIS, JR.
JACK R. GILSTRAP

JOHN A. CLEMENTS
RALPH STANLEY
THOMAS B. DEEN

CHAIRMEN OF PROJECT PANELS

Field of Administration

- G. J. FIELDING
- P. G. DRAKE
- R. M. WORKS
- F. D. SWIFT
- D. P. CLAYTON

Field of Design

- E. K. FARRELLY
- J. P. GREENWAY

Field of Operations

- O. N. SHARMA
- J. W. VIGRASS
- J. R. HATHAWAY

Field of Planning

- MANUEL PADRON
- T. W. HOCHBEIN
- T. W. FRIEDMAN
- JOHN MEYER
- J. C. ECHOLS
- K. E. STEIN-HUDSON

Field of Materials and Construction

- JACK DONAHUE

Field of Special Projects

- R. R. BIEGE, JR.

PROGRAM STAFF

KRIEGER W. HENDERSON, JR., *Director, Cooperative Research Programs*
LOUIS M. MACGREGOR, *Administrative Engineer*
CRAWFORD F. JENCKS, *Projects Engineer*
R. IAN KINGHAM, *Projects Engineer*
ROBERT J. REILLY, *Projects Engineer*
HARRY A. SMITH, *Projects Engineer*
ROBERT E. SPICHER, *Projects Engineer*
HELEN MACK, *Editor*

S.C.R.T.D. LIBRARY

National Cooperative Transit Research & Development Program

TRANSPORTATION RESEARCH BOARD

NATIONAL RESEARCH COUNCIL

PROGRESS REPORT 6

FOR THE PERIOD JANUARY 1 THROUGH JUNE 30, 1984

TO THE U.S. DEPARTMENT OF TRANSPORTATION/URBAN MASS TRANSPORTATION ADMINISTRATION
(DOT CONTRACTS DTUM60-81-C-72012 and DTUM60-83-C-71226)

06683

HE
192.5
.N37
no.6

CONTENTS

	Foreword	
1	Introduction	
2	Management Practices in the NCTRP	
6	TABLE I—SUMMARY OF STATUS THROUGH JUNE 30, 1984 FOR FY '80 THROUGH FY '82/'83 PROJECTS	
8	TABLE II—PUBLISHED REPORTS OF THE NATIONAL COOPERATIVE TRANSIT RESEARCH & DEVELOPMENT PROGRAM	
8	TABLE III—NCTRP RESEARCH RESULTS DIGESTS	
9	Summary of Administrative Progress	
53	PROGRESS BY PROJECT	
55	Area Thirty:	Economics
	Area Thirty-One:	Finance
	Area Thirty-Two:	Policy Development
57	Area Thirty-Three:	Personnel Management
	Area Thirty-Four:	Labor Relations
	Area Thirty-Five:	Procurement
64	Area Thirty-Six:	Alternative Analysis
	Area Thirty-Seven:	Forecasting
66	Area Thirty-Eight:	System Planning
68	Area Thirty-Nine:	Route Planning
70	Area Forty:	Impact Analysis
	Area Forty-One:	Vehicles
	Area Forty-Two:	Vehicle Auxiliary Systems
76	Area Forty-Three:	Track and Ancillary Systems
	Area Forty-Four:	Stations
	Area Forty-Five:	Bridges and Tunnels
78	Area Forty-Six:	General Design
80	Area Forty-Seven:	General Materials
	Area Forty-Eight:	Specifications, Procedures, and Practices
	Area Forty-Nine:	Vehicles
	Area Fifty:	Vehicle Auxiliary Systems
	Area Fifty-One:	Maintenance of Way and Structures
	Area Fifty-Two:	Scheduling
	Area Fifty-Three:	Control Systems
	Area Fifty-Four:	Energy Efficiency
82	Area Fifty-Five:	Performance Effectiveness and Efficiency
	Area Fifty-Six:	Fare Collection
	Area Fifty-Seven:	Supplemental Services
84	Area Sixty:	Special Projects
87	HOW TO ORDER PUBLICATIONS AND OTHER MATERIALS	

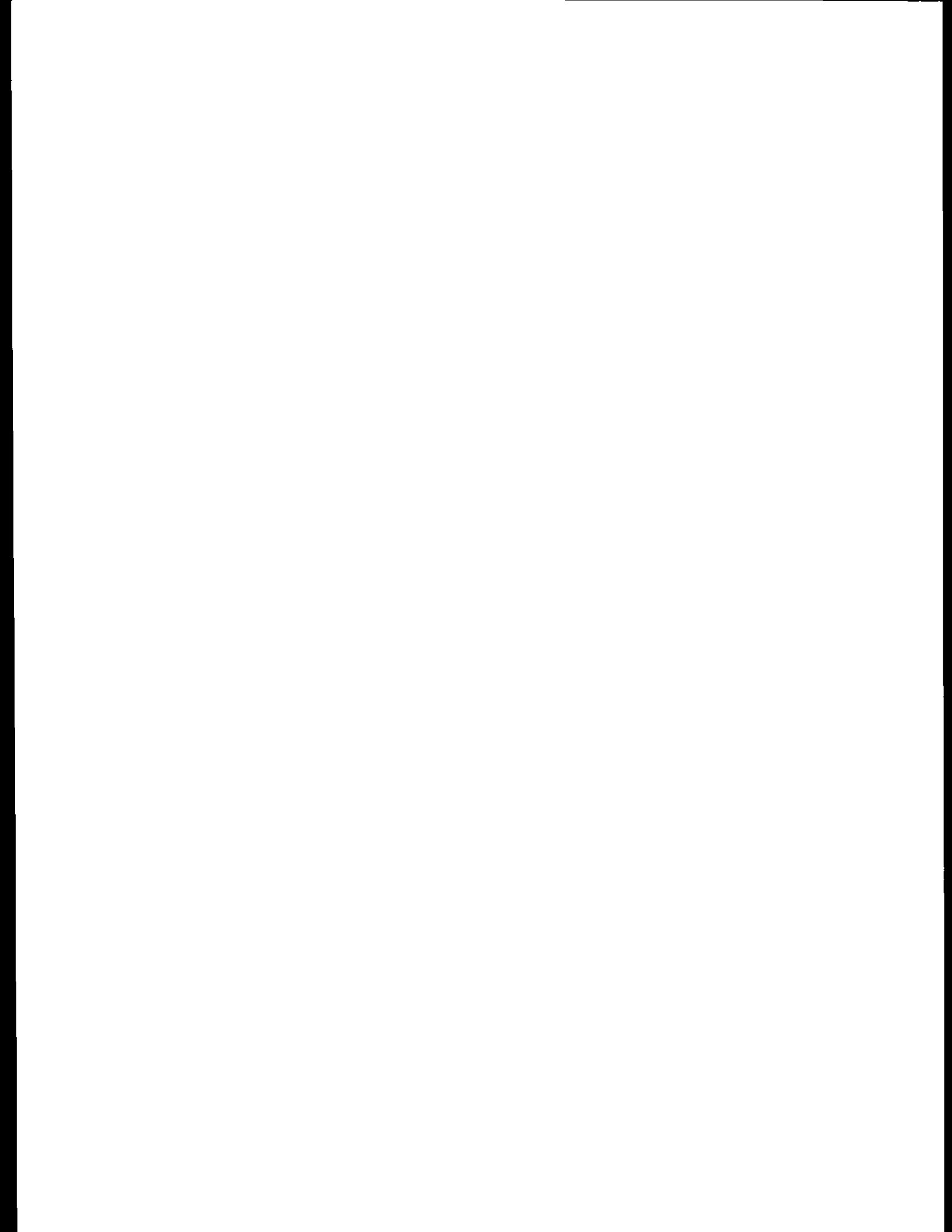

FOREWORD

This document responds to Article II, Deliverable Items and Delivery Schedule, of DOT Contracts DTUM60-81-C-72012 and DTUM60-83-C-71226 between the U.S. Department of Transportation/Urban Mass Transportation Administration and the National Academy of Sciences, National Research Council, designated the Primary Technical Contractor(PTC), for technical and administrative services relative to the Urban Mass Transportation Administration's National Cooperative Transit Research & Development Program(NCTRP). Distribution of this document is made only to the sponsors and others participating officially in the conduct of the NCTRP.

Annual NCTRP activity consists of five(5) distinct phases: (1) Problem Identification, (2) Program Formulation, (3) Project Formulation, (4) Project Execution, and (5) Project Reporting. The PTC's obligation is relative to Phases 2 through 5, and responsibilities for administration of technical matters under these phases have been assigned to the Transportation Research Board, a major unit of the National Research Council. The TRB consists of four(4) divisions with Division D, Cooperative Research Programs, being the one to which NCTRP administration is assigned.

Research programs are referred annually by UMTA to the PTC for administration, and semi-annual progress reporting includes: (1) general coverage of the historical development of the NCTRP and the means by which the Program is carried forward, (2) elaboration on the management practices exercised by the TRB in behalf of the PTC and UMTA, (3) summarization of management activities and deliverables in the six months reported, and (4) provision of detailed reports on each project under contract during the report period as to the: (a) general research need, (b) specific research objectives, (c) progress in achieving project objectives, (d) availability of any reports emanating from the study, and (e) prognosis for ultimate success. Each project report includes identification of the TRB staff engineer having surveillance responsibility and with whom contact may be made for additional insight concerning any details of the contractor's work. Opinions and/or conclusions conveyed by the project reports are those of the research agencies and do not necessarily reflect the position of the Transportation Research Board, the National Research Council, or the Urban Mass Transportation Administration, U.S. Department of Transportation, and no official endorsement should be inferred.

A detailed overview of all aspects of NCTRP operation may be obtained from the following:

- NCTRP Annual Summary of Progress
- NCTRP Information and Instructions for Preparing Proposals

These are available from the Transportation Research Board on request through:

Cooperative Research Programs
Transportation Research Board
2101 Constitution Avenue, N.W.
Washington, D.C. 20418
(202) 334-3224

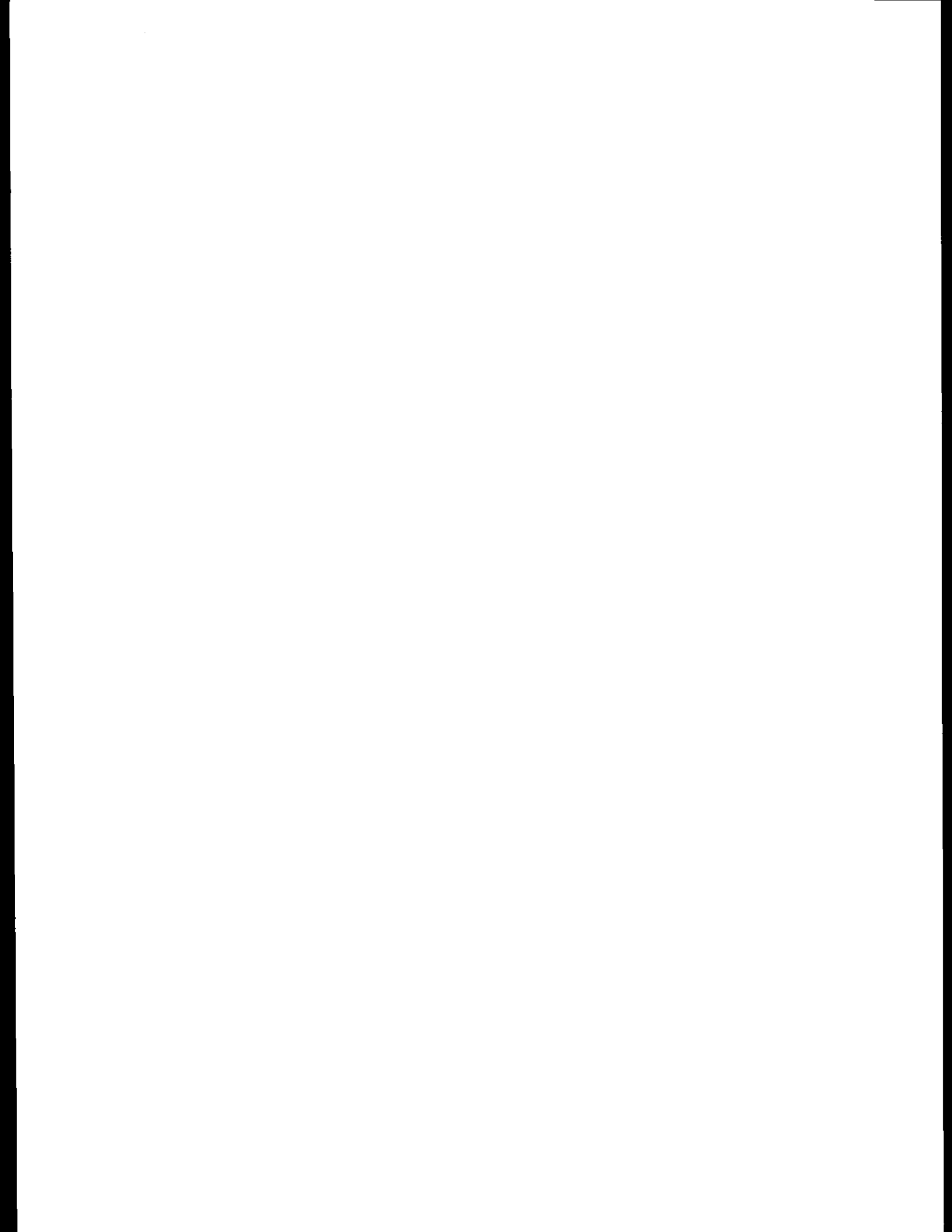

NATIONAL COOPERATIVE TRANSIT RESEARCH & DEVELOPMENT PROGRAM

INTRODUCTION

Administrators, engineers, and many others in the transit industry are faced with a multitude of complex problems that range between local, regional, and national in their prevalence. How they might be solved is open to a variety of approaches; however, it is an established fact that a highly effective approach to problems of widespread commonality is one in which operating agencies join cooperatively to support, both in financial and other participatory respects, systematic research that is well designed practically oriented, and carried out by highly competent researchers. As problems grow rapidly in number and escalate in complexity, the value of an orderly, high-quality cooperative endeavor likewise escalates.

Recognizing this in light of the many needs of the transit industry at large, the Urban Mass Transportation Administration, U.S. Department of Transportation, got under way in 1980 the National Cooperative Transit Research and Development Program (NCTRP). This is an objective national program that provides a mechanism by which UMTA's principal client groups across the nation can join cooperatively in an attempt to solve near-term public transportation problems through applied research, development, test, and evaluation. Particularly noteworthy is the fact that the client groups now have a channel through which they can directly influence a portion of UMTA's annual activities in transit technology development and deployment. Although present funding of the NCTRP is entirely from UMTA's Section 6 funds, the planning leading to inception of the Program envisioned that UMTA's client groups would join ultimately in providing additional support, thereby enabling the Program to address a larger number of problems each year.

The NCTRP operates by means of agreements between UMTA as the sponsor and (1) the National Academy of Sciences, National Research Council, as the Primary Technical Contractor (PTC) responsible for administrative and technical services, (2) the American Public Transit Association responsible for operation of a Technical Steering Group (TSG) comprised of representatives of transit operators, local government officials, State DOT officials, and officials from UMTA's Office of Technical Assistance, and (3) the Urban Consortium for Technology Initiatives/Public Technology, Inc., responsible for providing the local government officials for the Technical Steering Group.

Annual NCTRP activity consists of five (5) distinct phases: (1) Problem Identification, (2) Program Formulation, (3) Project Formulation, (4) Project Execution, and (5) Project Reporting. The PTC's role is relative to Phases 2 through 5.

Research programs are developed annually by the Technical Steering Group, which identifies key problems, ranks them in order of priority, and establishes programs of projects for UMTA approval. Once approved, they are referred to the PTC for administration through the Transportation Research Board.

The Board, established in 1920, operates within the National Research Council, which serves as the principal operating agency of both the National Academy of Sciences and the National Academy of Engineering, and is uniquely suited for the administrative role because: it has a record of successful management of the National Cooperative Highway Research Program (NCHRP) since 1962, the program after which the NCTRP has been modeled; it maintains an extensive committee structure from which authorities on any transportation subject may be drawn; it possesses the avenues of communications and cooperation with federal, state, and local government agencies, universities, and industry; it is recognized for its objectivity and understanding of modern research practices; its relationship to its parent organization is an insurance of objectivity, and it maintains a full-time staff of research specialists in transportation matters to take the findings of research directly to those who are in a position to use them.

Research projects addressing the problems annually referred from UMTA are defined by panels of experts established by the TRB to provide technical guidance and counsel in the problem areas. The projects are advertised widely for proposals, and qualified agencies are selected on the basis of research plans offering the greatest probabilities of success. The research is carried out by these agencies under contract to the PTC, and administration and surveillance of the contract work are the responsibilities of the PTC and the Board.

The needs for transit research are many, and the National Cooperative Transit Research and Development Program is a mechanism for deriving timely solutions for transportation problems of mutual concern to many responsible groups. In doing so, the Program operates complementary to, rather than as a substitute for or duplicate of, other transit research programs.

MANAGEMENT PRACTICES IN THE NCTRP

The commentary that follows is to provide insight into the Academy's functions directed to TRB's management of UMTA's resource allocation for NCTRP research under Contracts DTUM60-81-C-72012 and DTUM 60-83-C-71226. Highlighted are those activities in which all possible opportunity is taken to weight the odds in favor of obtaining implementable solutions to near-term public transportation problems. A more detailed overview of all aspects of Program operation may be obtained from the following:

- NCTRP Annual Summary of Progress
- NCTRP Information and Instructions for Preparing Proposals

Organizationally, the TRB consists of four divisions, each headed by an assistant director reporting to an executive director, who in turn reports to an executive committee. Division D, renamed in 1979 as *Cooperative Research Programs*, was established in 1962 as a special-purpose activity to administer contracts for research under the NCHRP, and it now encompasses the NCTRP. Division D's activities are thus distinctly different from the Board's traditional role of information gathering and dissemination on behalf of a variety of sponsors. Among the differences in operation is the fact that the funds supporting Division D are obtained through channels outside those pertaining to the Board's other divisions; they are budgeted separately; they are accounted for separately; and they are audited independently of those for the Board's other activities. Furthermore, the funds can be spent only on the research designated by the sponsors of the programs administered under Division D.

It should also be recognized that the overall policies and procedures, including the formulation of annual research programs, are entirely the responsibilities and prerogatives of the sponsors. Neither the regular committees nor the Board's staff have a role in the submission or selection of research problems.

UMTA's goal for the NCTRP is a program within which its resources will be managed well and appropriately directed in the search for solutions to near-term public transportation problems. Applied, or mission-oriented, research is a means to the end as regards the technological approach.

The findings from basic research completed elsewhere are brought into play to bring about new technologies. The expectation from the sponsor is that the resource allocation will result in the development of technology that, when implemented, will make life a little easier—not merely the development of scientific knowledge that has no direct practical application. Meeting this expectation is somewhat comparable to new-product research in industry, and, in addition to being extremely costly, the probability of failure is high. Furthermore, although projects may begin as applied research, the synergistic nature of research often catapults them back into the realm of basic studies, because true solutions are not achieved without understanding the underlying causes for the problem so that they may be accounted for in the future.

Although each year's funding base is targeted at about \$1 million, which represents about one-fourth the

amount contemplated in the planning processes leading to establishment of the NCTRP, the actual amounts being made available are falling short of the target. Consequently, an urgent need for supplementary support from UMTA's client groups joined in a cooperative venture. In any event, proper management of resources is the sole basis for establishment of the Board's entire philosophy, organization, and functions regarding work under Division D—*only the sponsor's expectations matter*. Toward this end, network control is employed in the classic sense of network utilization for project management. Primary focus is on those milestones where the best opportunities lie for positively weighting the odds of success. These opportunities are afforded through the use of common-sense strategies to control various circumstances surrounding each milestone. Subtle processes result that will, through the natural evolution of interdependent events, increase the probability of research results being implemented and improving transportation practices. Such an approach is based on game theory, is admittedly idealistic, is complex and must be monitored constantly. Nonetheless, its practical validity cannot be denied if, in the context of total administrative responsibility, one wants to take advantage of all possible opportunities to insure the best return on the sponsor's investment.

As a first element of strategy, the NCTRP establishes the research agency and personnel qualifications that are mandatory if the projects are to have any chance of success. These are spelled out to potential proposers and are adhered to in selecting research agencies. By means of the project statements and various other widely distributed publications, the NCTRP clearly states the agency attributes deemed essential and thereby hopefully precludes proposals from any but qualified researchers having practical experience in the problem area. Emphasis is placed on the importance of a record of successful past performance in endeavors similar to those to be undertaken. The specifications for proposals are demanding in the sense of requiring the agencies to lay their knowledge, experience and accomplishments on the line, and proposals simply are not accepted if, among other factors, they do not contain specific statements as to how the contemplated results can be used to improve practice.

The next element of strategy comes into play when a research problem and its objectives are first defined in the form of an NCTRP Project Statement by which research proposals will be solicited. A continuing responsibility of the Board is to see that the projects are sensibly structured around the practical facts of operational life and that they represent current circumstances. Therefore, this task is carried out by persons not only very knowledgeable in the problem area but who also have a complete understanding of the needs of the practitioners with whom the problem originated and the best format by which the practitioner can utilize the results. Improved odds therefore become immediately inherent.

Toward the goal of sensible projects, the Board has established seven broad research fields under which project panels are organized to deal with research in specific problem areas falling within the broad fields (refer to Figure 1).

NCTRP RESEARCH FIELDS AND AREAS

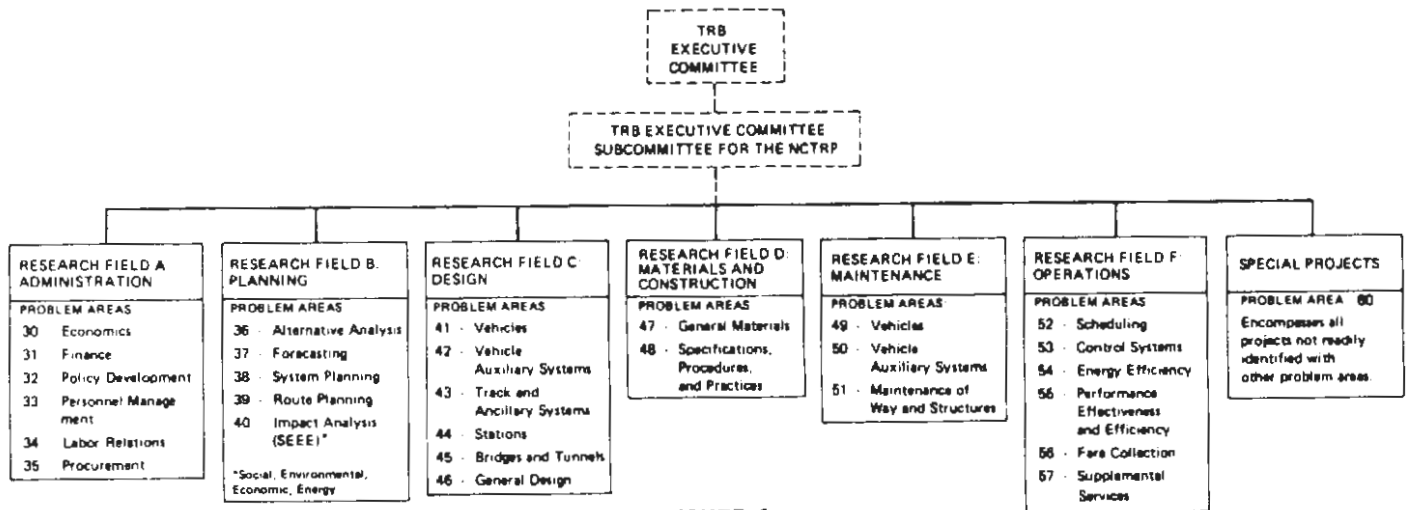

FIGURE 1

For example, in the broad subject field of Operations each project falling within the more specific subject areas of Energy Efficiency—Area 54—is assigned a project panel comprised of outstanding individuals who are very knowledgeable in the specifics of the particular project and who are looked to for guidance and counsel throughout the research and reporting phases. Those projects that do not conveniently fit under one of the first six general fields are assigned to the seventh one, Special Projects.

When the project panels meet for the first time to prepare project statements, it is stressed to them that a first-class statement is the first of the two most important factors bearing on the ultimate success of any project. Accordingly, extreme care is exercised in the development of clear, concise project statements that are distributed to the research community at large. These statements contain objectives designed to result in the most extensive work possible for the available funding. They spell out what is expected of a contractor in terms of findings from innovative research that can be applied practically; they do not spell out how to go about the research. Statements of explicit objectives, matched to funding, places proposers in the position of knowing exactly what is expected of them, because the available funding is made known along with the objectives. Not only does this result in more realistic proposals, but it most assuredly eases each project panel's task of comparative evaluation. Of the members of the NCTRP's project panels to date, about 32 percent come from transit operating agencies. Because of their intimate involvement in the development of the various research projects, their knowledge of what is to be expected, and the "spreading of the word" among their associates, there is yet another step toward improving the odds that results will be put to use.

The second of the two most important factors, and the next element of strategy, concerns the process of evaluating proposals to select research agencies. The odds can be advanced materially if extreme care is exercised throughout this activity. Indeed, this activity constitutes the milestone on which the success of the project can become totally

dependent, irrespective of the strengths built in at the preceding milestones. Prior to contracting, there *must* be satisfaction not only that the proposed research plan is the best possible in addressing the specifics of the objectives, but also that it culminates with the best promise for providing transit agencies with a product that is both usable and readily implementable; otherwise, the proposal process—and possibly that of project definition—should be repeated. The importance of this activity is made abundantly clear to the project panels when they meet to select agencies and suggest minor modifications of the research plans as a means for keeping them squarely on target. A comprehensively detailed research plan not only aids the selection process but also serves as the yardstick by which the staff exercises day-to-day surveillance of research progress.

Two top proposals are chosen for each project. The deliberations of the project panel include a review of all known aspects of agency performance on other research projects under NCTRP or elsewhere and a determination that the first-choice research plan offers the best promise for providing a product that is both usable and readily implementable. A key factor is the merit of the research approach and the experiment design. There is nothing anywhere in the Program's specifications that says the project statements must be adhered to strictly in every detail and that any deviation in research thrust or from the proposed project period warrants outright rejection. The key element is that the agencies must present a strong, convincing case for whatever approaches they take. These always receive just consideration because the sole interest of the project panels is to determine the plan with the best probability of success.

Prior to contracting, any suggested modifications are taken by the Program staff to the agencies, and a clear meeting of the minds is established regarding what is specifically expected from the research and the personnel carrying it out. By means of the "Procedural Manual for Agencies Conducting Research in the National Cooperative Transit Research and Development Program," further emphasis is placed on the requirement for practically

oriented research and the proper means for reporting it. Experience has demonstrated that, once the research is under way, the practical fact of life is that the destiny of the research is pretty well committed, no matter how extensive the staff surveillance or how many administrative processes are available to accommodate changes. Rarely are changes accompanied by gains when having to stay within the original funding; rather, the effects are usually negative.

A first requirement of the research agency immediately after subcontracting is the development of a working plan that is intended to be a comprehensively detailed amplification of the approved research plan, inclusive of a specific schedule of events for the major tasks. This document is used by the staff in the day-to-day surveillance of the project's progress. Should review of this document by the staff and project panel bring to light necessary changes that were not previously apparent, these can be accommodated without hindering prosecution of the work. Through this activity, an additional opportunity is afforded for improvement of the odds of success.

As a means of mutual assistance while work is under way, two types of progress reports are required from the agencies. On a monthly basis, one-page progress schedules are submitted that graphically depict several aspects of progress. On a calendar quarter basis, narratives are required that fully describe accomplishments to date and outline future activities based on the accomplishments. Based on these reports and information gained through surveillance visits, Program staff prepares its own progress reports that are sent to UMTA and the Technical Steering Group as a measure of providing a current awareness of on-going work. By these controls the Program is, to some degree, able to appraise the agency's level of performance, while at the same time the agency is provided with tools to assist its own management responsibility in both administrative and technical respects. All too often in the administration of research programs problems arise because there is insufficient communication between the agency's management staff and the technical staff performing the research.

Project surveillance constitutes a major element of strategy in achieving the administrative goal. The gains here reflect the effort that the NCTRP staff exerts (a) to keep the research in line with the approved research plan; (b) to keep the researchers continually aware of the needs of the practicing engineer; and (c) to see that all project developments, through final reporting, center around these practical needs. Projects engineers with wide-ranging experience are assigned to the NCTRP by the Board and are responsible for administrative and technical surveillance of the contracts. Their activities include visiting each research agency at least once every six months to discuss the status of the work with the principal investigator(s) and to determine if the research is being pursued in line with the approved research plan. Any need for change in the plan is referred to the project's panel for review and approval. Finally, the staff engineer and the project panel evaluate the final report on the completed research to determine the degree of technical compliance with the subcontract and to ensure adherence to the Program's specifications for report writing.

Research agencies are required to report their results in language that is understandable and succinctly summarizes the results so that the transit administrator and others may easily determine their usefulness to their operations. The objectives are accomplished through a "Summary of Findings" and a chapter on "Interpretation, Appraisal, and Application of Results." The detailed research techniques and analyses in which a researcher would be interested are presented as report appendices. Available to the researchers in report preparation are guidelines that have been developed with the objective of providing a report of maximum utility to the transit industry. Each report, as finally published in the regular NCTRP series (Reports or Syntheses of Transit Practice) also contains a staff-prepared foreword that directs the attention of the busy reader to the persons who would be most interested in the results and, also, to how the results fit into present knowledge and practice.

Prior to publication, extraordinary measures are taken to ensure that useful research results are made immediately available to the appropriate personnel. One means consists of forwarding copies of the research agency drafts of final reports. According to the urgency of the particular circumstances, these drafts may be either uncorrected or corrected on the basis of an acceptance review. Several copies of unedited drafts of the agency reports are retained until formal publication and are available, on a loan basis, to others having an interest in the research. Once published in their entirety, the drafts are destroyed.

After publication, each report is distributed widely through the TRB's selective distribution system. Copies go automatically to about 100 libraries, TRB transit representatives, educational institution liaison representatives, appropriate project panels and committees of the Board, and individual members who have selected publications in the particular subject area of the report. As a further means of disseminating the research reports, announcements of their availability are made to the trade press. Also, the Technical Activities Staff comprising the Board's Division A follow the progress of the work throughout its conduct and consequently are able to discuss application of the research results with potential users during visits to operating agencies.

A tragic result of much research is a compilation of findings that, because of language and form, simply cannot be used until the sponsor devotes considerable supplementary effort to translating the findings into the language and working tools of the users. This kind of time cannot be afforded in the sponsor's scheme of day-to-day operation. In an applied research program such as the NCTRP, the sponsor rightfully expects a product that has immediate applicability to practice. This is not asking too much, because improvements are going to occur mostly in the form of moderate refinements of existing practices, rather than as dramatic innovations or breakthroughs that one might expect from extensive basic research. Therefore, where necessary as an integral part of administration, staff assumes the role of interpreter and interjects itself as a third party between the sponsor and the researcher by means of a very brief publication titled *NCTRP Research Results Digest*. The Digests are issued as a series of flyers

to provide in understandable language an early awareness of project results so as to encourage early implementation. They are brief in summarizing specific findings—they do not deal with methodology—and require the reader to expend very little time in determining the usefulness of the findings. Reference is made in each to the fact that uncorrected draft copies of the agency's report are available on a loan basis for those desiring more extensive information. Where circumstances warrant, staff does not wait for requests for reports but distributes copies of the agencies' draft final reports to appropriate personnel.

With the culmination of the formal reporting activity, plus any of the special measures just described, the NCTRP reaches the final milestone of its administrative network. What happens beyond that point—how successful the projects really turn out to be—is entirely up to UMTA and the operating agencies. Projects that have accomplished their objectives in providing useful products might just as well have been failures if, at least, consideration is not given to how the results might be used to improve operations. It simply does not make good sense to invest millions in research on critical problems and then not give adequate attention to a determination of the implementation value of the products. Such determination can range from mere thought to total, immediate incorporation as standard prac-

tice. Certainly, any action must be temperate to avoid the pitfalls that are present in pushing too hard too fast. To aid decisions as to the course to be pursued, future NCTRP publications will report on all known uses of results, be they limited or extensive. Given the fact that the NCTRP addresses critical, national problems, documented payoff to any one agency should attract study by others. So should documented failures, for they also contain lessons by which all can profit. Research is a venture into risk and uncertainty, the risk being particularly high in applied or mission-oriented research such as the NCTRP undertakes. The wisdom of accepting risk is impossible to determine without studious inquiry into the benefits derived.

In summary, the NCTRP is an applied, contract research program that has been structured along specific lines to enable it to respond to specific needs of the nation's transit industry. The needs are expressed through problem statements referred from UMTA, and each problem is accompanied by the funds to see it through. From the preparation of project statements through final reporting on the projects results, the goal of the NCTRP is administration that, in the final analysis, will prove to be fully effective in obtaining the best return on the investment supporting the Program.

TABLE I
SUMMARY OF STATUS THROUGH JUNE 30, 1984, FOR FY '80 THROUGH FY '82/'83 PROJECTS

PROJECT NO.	TITLE	RESEARCH AGENCY	SUBCONTRACT AMOUNT OR SUBCONTRACT COST (\$)
AREA 30: ADMINISTRATION—ECONOMICS			
30-1	Small Transit Buses: A Manual for Improved Purchasing, Use, and Maintenance	Arthur D. Little	\$299,378
AREA 31: ADMINISTRATION—FINANCE			
31-1	The Impacts of Federal Grant Requirements on Transit Agencies	Booz-Allen	49,522 *
AREA 33: ADMINISTRATION—PERSONNEL MANAGEMENT			
33-1	Transit Bus Operator Selection and Training for Dealing with Stress	GAMS Inc.	150,000
33-2	Assessment of Job Enrichment Programs for the Transit Industry	Public Admin. Service	97,821 *
33-3	Public Transit Bus Maintenance Manpower Planning	Fleet Maintenance	100,000
AREA 36: PLANNING—ALTERNATIVE ANALYSIS			
36-1	Improving Decision-Making for Major Urban Transit Investments	System Des. Concepts	200,000
AREA 38: PLANNING—SYSTEM PLANNING			
38-1	National Transit Computer Software Directory	COMSIS Corp.	100,000
AREA 39: PLANNING—ROUTE PLANNING			
39-1	A Modular Approach to On-Board, Automatic Data Collection Systems	The MITRE Corp.	148,787
AREA 40: PLANNING—IMPACT ANALYSIS			
40-1	Simplified Guidelines for Evaluating Transit Options in Small Urban Areas	Barton-Aschman	149,960
40-2	Estimating Incremental Costs of Bus-Route-Service Changes	System Des. Concepts	150,000
40-3	Strategies to Implement Benefit-Sharing for Fixed Transit Facilities	SG Associates	99,957
AREA 43: DESIGN—TRACK AND ANCILLARY SYSTEMS			
43-1	Detection of Low-Level Fault Currents on Rail Transit Systems	Chas. T. Main, Inc.	99,953
AREA 46: DESIGN—GENERAL DESIGN			
46-1	Single Cable Communications Technology for Rail-Transit Systems	Poly Inst of NY	100,000
AREA 47: MATERIALS AND CONSTRUCTION—GENERAL MATERIALS			
47-1	Improved Service Life of Urban Transit Coach Brakes	Battelle Mem Inst	300,000
AREA 54: OPERATIONS—ENERGY EFFICIENCY			
54-1	Improve Transit Bus Energy Efficiency and Productivity	Booz-Allen	39,976*
54-2	Energy Management of Electric Rail Transit Systems	Carnegie-Mellon	150,000
AREA 55: OPERATIONS—PERFORMANCE, EFFECTIVENESS, AND EFFICIENCY			
55-1	Conversion to One-Person Operation of Heavy-Rail Rapid-Transit Trains	Battelle Mem Inst	150,000
AREA 60: SPECIAL PROJECTS			
60-1	Synthesis of Information Related to Transit Problems	TRB	460,000 ^a
	TS-1: Cleaning Equipment and Procedures for Transit Buses	ATE Mgmt	75,000 ^b
	TS-2: Priority Treatment for Buses on Urban Streets	PAWA	75,000 ^b
	TS-3: Effects of Fuel Additives and Alternative Fuel Grades for Transit Buses	Southwest Res Inst	30,000 ^b
	TS-4: Guidelines for Allocation of Time for Transit Coach Maintenance Functions	XYZYX Info Corp.	30,000 ^b
	TS-5: Extraboard Management Procedures and Tools	L. C. McDorman	40,000 ^b
	TS-6: Traffic Control and Regulation at Transit Stops	—	45,000 ^b
	TS-7: Bus Communications Systems	Mitre	45,000 ^b
	TS-8: Passenger Information Systems for Transit Transfer Facilities	J. J. Fruin	45,000 ^b
	TS-9: Transit Fare Collection: Problems and Alternatives to Paper Currency	Mitre	75,000 ^b

* Final subcontract cost.

^a Continuing activity through FY '82/'83. Annual amount varies; total to date shown.

^b Allocated—Balances are carried forward to support future synthesis studies.

START- ING DATE	EXPECTED COMPLE- TION DATE	PROJECT STATUS (for details, see latest Summary of Progress)	PROJECT NO.
11/8/82	8/7/84	Research in progress	30-1
11/30/81	12/15/82	Completed—Published as NCTRP Report 2	31-1
10/15/81	4/14/84	Completed—To be published as NCTRP Report 7	33-1
11/1/82	2/29/84	Completed—Published as NCTRP Reports 5 and 6	33-2
11/1/83	10/31/84	Research in progress	33-3
11/2/81	11/1/83	Completed—Published as NCTRP Report 4	36-1
1/3/83	8/31/84	Research in progress	38-1
11/1/82	8/31/84	Research in progress	39-1
10/25/82	4/23/84	Completed—To be published as NCTRP Report 8	40-1
11/15/83	8/14/85	Research in progress	40-2
11/1/83	2/1/85	Research in progress	40-3
1/3/83	9/30/84	Research in progress	43-1
5/1/84	2/28/85	Research in progress	46-1
12/1/81	7/30/84	Research in progress	47-1
10/1/81	6/30/82	Completed—Published as NCTRP Report 1	54-1
10/1/81	12/31/83	Completed—Published as NCTRP Report 3	54-2
5/5/84	4/4/85	Subcontract pending	55-1
11/7/80	"	Research in progress	60-1
2/16/81	12/31/81	Completed—Published as NCTRP Synthesis 1	(TS-1) 60-1
3/16/81	12/31/81	Completed—Published as NCTRP Synthesis 2	(TS-2) 60-1
10/1/82	9/30/83	Completed—Published as NCTRP Synthesis 3	(TS-3) 60-1
12/9/82	11/30/83	Completed—To be published as NCTRP Synthesis 4	(TS-4) 60-1
11/31/83	9/30/84	Research in progress	(TS-5) 60-1
—	—	In developmental stage	(TS-6) 60-1
11/21/83	10/31/84	Research in progress	(TS-7) 60-1
11/21/83	9/30/84	Research in progress	(TS-8) 60-1
12/2/83	10/31/84	Research in progress	(TS-9) 60-1

**TABLE II
PUBLISHED REPORTS OF THE NATIONAL COOPERATIVE TRANSIT RESEARCH & DEVELOPMENT PROGRAM**

<i>Rep.</i>			
<i>No.</i>	<i>Title, Project, Pages, Price</i>		
1	Transit Bus Energy Efficiency and Productivity—Bus Equipment Selection Handbook (Project 54-1), 55 p., \$7.20.		
2	Impacts of Federal Grant Requirements on Transit Agencies (Project 31-1), 73 p., \$7.60		
3	Reduction of Peak-Power Demand for Electric Rail Transit Systems (Project 54-2), 142 p., \$10.40		
4	Improving Decision-Making for Major Urban Transit Investments (Project 36-1), 47 p., \$7.20		
5	Assessment of Quality of Work-Life Programs for the Transit Industry—Research Report (Project 33-2), 99 p., \$8.80		
6	Assessment of Quality-of-Work-Life Programs for the Transit Industry—Model Programs (Project 33-2), 37 p., \$6.80		
Synthesis of Transit Practice			
<i>No.</i>	<i>Title, Pages, Price</i>		
1	Cleaning Transit Buses: Equipment and Procedures (Proj. 60-1, Topic TS-1), 39 p., \$6.80		
2	Enforcement of Priority Treatment for Buses on Urban Streets (Proj. 60-1, Topic TS-2), 30 p., \$6.40		
3	Diesel Fuel Quality and Effects of Fuel Additives (Proj. 60-1, Topic TS-3), 62 p., \$7.60		
4	Guidelines for Allocation of Time for Transit Bus Maintenance Function (Proj. 60-1, Topic TS-4), (In Press)		

**TABLE III
NCTRP RESEARCH RESULTS DIGESTS ***

DIGEST NO.	PROJ. NO.	TITLE, PAGES, PRICE
1	33-1	Review of Literature Related to Bus Operator Stress, 15p., \$3.00

* See Table I for project titles. Orders must be prepaid if for less than \$10.00. Make request to Publications Office, Transportation Research Board, 2101 Constitution Avenue NW, Washington, DC 20418.

SUMMARY OF ADMINISTRATIVE PROGRESS

The following summary addresses the research programs for fiscal years 1980, 1981, 1982/1983, and 1984, and it pertains to activities in the 6 months subsequent to December 31, 1983. The narrative for each year is cross-referenced to the networks included at the end of the summary. Accompanying the networks are descriptions of the activities (subtasks), and those underlined represent the deliverables to which the PTC is committed.

There are five (5) networks representing the PTC's overall perception of the nature and sequence of activities required by all NCTRP participants for an efficient, fully coordinated operation. All five are included in this report for FYs 1980 and 1981; only those pertinent through the end of the report period are included for subsequent years. Progress on tasks and subtasks is indicated by shading of the activity nodes. A fully shaded node represents completion of a subtask; a partially shaded node represents partial accomplishment of a subtask. Accordingly, progress for the respective fiscal-year programs is as follows.

FY 1980 Program

I. Reference: Network #1, Tasks 1.1 and 2.1 (subtasks 2.1.1 through 2.1.13)

All work under Task 1.1 of this network is covered by the APTA contract for conduct of the TSG operation relative to formulation of annual programs and other responsibilities. Task 2.1 work is carried out by the PTC in support of the TSG, and it was completed and reported on earlier.

II. Reference: Network #2, Tasks 3.0 (beginning with subtask 3.0.1), 3.1, 3.2, and 3.3 (ending with subtask 3.3.7)

All work under the referenced tasks was completed and reported on earlier (see NCTRP Progress Report 1).

III. Reference: Network #3, Tasks 3.3 (beginning with subtask 3.3.9), 3.4, and 4.1 (ending with subtask 4.1.5)

All work under the referenced tasks was completed and reported on earlier (see NCTRP Progress Report 1).

IV. Reference: Network #4, Tasks 4.2, 5.2, and 5.4 (beginning with subtask 4.2.1 and ending with subtask 5.4.1)

Activity covered by this network consisted of surveillance of research in progress on two projects. One (33-1) was completed during the report period; the other (47-1) is expected to be completed toward the end of the summer after having been extended at no cost to account for field test problems.

V. Reference: Network #5, Task 5.4 (beginning with subtask 5.4.3 and ending with subtask 5.4.111)

Activity covered by this network focused on publication of final reports. Of the seven projects under FY '80, one (47-1) remained under contract at the end of the report period. It is scheduled for completion toward the end of summer. A brief summary of the status of the FY '80 projects is:

- 31-1 Completed—Published as NCTRP Report 2
- 33-1 Completed—To be published as NCTRP Report 7

- 36-1 Completed—Published as NCTRP Report 4
- 47-1 Research in progress—Extension forthcoming
- 54-1 Completed—Published as NCTRP Report 1
- 54-2 Completed—Published as NCTRP Report 3
- 60-1 Completed—Published as NCTRP Syntheses 1 and 2

As appropriate to completion circumstances, steps were taken to close contracts (33-1 and 54-2) and pay final vouchers. Disbandment of project panels was scheduled and will occur in due course.

In general, the full details of status of all FY '80 projects that were active during the report period will be found in the "Progress by Project" section and Tables I, II, and III of this document.

VI. Reference: Synthesis Task (Unnumbered)

All work in the synthesis area for this year was completed and reported on earlier (see NCTRP Progress Report 4 and/or Table I herein).

VII. Reference: Contract DTUM60-81-C-72012

In line with the requirements of Article XIX, Subcontracting Reporting Requirements, it is reported that no subcontracts for research under the FY 1980 program were entered into during the 6 months ending June 30, 1984. There was, however, the contract amendment action referred to earlier.

FY 1981 Program

I. Reference: Network #1, Tasks 1.1 and 2.1 (subtasks 2.1.1 through 2.1.13)

All work under Task 1.1 of this network is covered by the APTA contract for conduct of the TSG operation relative to formulation of annual programs and other responsibilities. Task 2.1 work is carried out by the PTC in support of the TSG, and it was completed and reported on earlier (see NCTRP Progress Report 1).

II. Reference: Network #2, Tasks 3.0 (beginning with subtask 3.0.1), 3.1, 3.2, and 3.3 (ending with subtask 3.3.7)

All work under this network was completed and reported on earlier (see NCTRP Progress Report 2).

III. Reference: Network #3, Tasks 3.3 (beginning with subtask 3.3.9), 3.4, and 4.1 (ending with subtask 4.1.5)

All activity under this network was completed and reported on earlier (see NCTRP Progress Report 3).

IV. Reference: Network #4, Tasks 4.2, 5.2, and 5.4 (beginning with subtask 4.2.1 and ending with subtask 5.4.1)

Activity covered by this network consisted of surveillance of research in progress on seven projects, including the TRB synthesis project. Six of the seven were scheduled for completion during the report period; however, three (38-1, 39-1, 43-1) required short, no-cost extensions, and one other (30-1) will need to be extended on the order of 3 months. Synthesis work on Topics TS3 and TS4 was completed, and the final reports are due to be published in July. All work on this program should be completed by late fall.

V. Reference: Network #5, Task 5.4 (beginning with subtask 5.4.3 and ending with subtask 5.4.111)

Activity covered by this network focused on publication of final reports. Companion reports from Project 33-2 have been published as NCTRP Reports 5 and 6, and NCTRP Report 8 will emanate from Project 40-1 toward the end of the summer. A brief summary of the status of the FY '81 projects is:

- 30-1 Research in progress—Extension forthcoming
- 33-2 Completed—Published as NCTRP Reports 5 and 6
- 38-1 Research in progress—Termination date of 8/31/84
- 39-1 Research in progress—Termination date of 8/31/84
- 40-1 Completed—NCTRP Report 8 in publication process
- 43-1 Research in progress—Termination date of 9/30/84
- 60-1 Completed—NCTRP Syntheses 3 and 4 in publication process

As appropriate to completion circumstances, steps were taken to close the contract for Project 33-2 and disband the project panel.

VI. Reference: Synthesis Task (Unnumbered)

Work was completed on Topics TS-3 and TS-4, and the final reports were near publication at the end of June. Topic titles will be found in Table I of this document, and specific progress details are included in the "Progress by Projects" section.

VII. Reference: Contract DTUM60-81-C-72012

In line with the requirements of Article XIX, Subcontracting Reporting Requirements, it is reported that no subcontracts for research under the FY 1981 program were entered into during the 6 months ending June 30, 1984. There were, however, the contract amendment actions referred to earlier.

FY 1982/1983 Program

NOTE: Formerly designated as the FY 1982 Program, the new designation was requested by UMTA so that succeeding-year designations will correspond more closely with actual fiscal years.

I. Reference: Network #1, Tasks 1.1 and 2.1 (subtasks 2.1.1 through 2.1.13)

All work under Task 1.1 is covered by the APTA contract for conduct of the TSG operation relative to formulating annual programs and other responsibilities. The PTC supports this activity (Task 2.1) through TRIS searches for information relevant to problems submitted to the TSG for evaluation, provides such information to the TSG, and then participates as appropriate in the meetings of the TSG for selection of the problems for the annual programs. All work in these regards was completed and reported on earlier (see NCTRP Progress Report 3).

II. Reference: Network #2, Tasks 3.0 (beginning with subtask 3.0.1), 3.1, 3.2, and 3.3 (ending with subtask 3.3.7)

All work under this network has completed and reported on earlier (see NCTRP Progress Report 4).

III. Reference: Network #3, Tasks 3.3 (beginning with subtask 3.3.9), 3.4, and 4.1 (ending with subtask 4.1.5)

Project panel meetings were held in August, selections of subcontractors were made, and a report identifying the subcontractors and the reasons for their selections was submitted to UMTA and the TSG. Action on matters necessary to contracting had been initiated with the subcontractors in the preceding report period; however, execution of subcontracts was deferred pending receipt of program year funds. Some subcontracts were issued just prior to December 1983 (33-3, 40-2, 40-3), and others (46-1, 55-1) were issued during the current reporting period. Project 46-1 is proceeding at less than full funding (\$100,000 vs. \$150,000) in order to get underway, and its full completion depends on receipt of program-year funding. Synthesis work on topics TS5 through TS9 has been taken as far as current funding permits and is now dormant pending receipt of program-year funding. Likewise, two continuations (33-2, 38-1) cannot be acted on until funding is received.

IV. Reference: Network #4, Tasks 4.2, 5.2, and 5.4 (beginning with subtask 4.2.1 and ending with subtask 5.4.1)

Activity under this network consisted of routine surveillance of research in progress, which included visits with subcontractor personnel at the site of the research.

V. Reference: Network #5, Task 5.4 (beginning with subtask 5.4.3 and ending with subtask 5.4.111)

Network activities were initiated relative to three project draft interim reports (33-3, 40-2, 40-3). It was originally intended that the report for Project 40-3 would be published as a synthesis in the formal publication series; however, the review by the UMTA Liaison Representative was 3 months late, which controverted the planning. The report will now be processed with a view toward inclusion in the project final report. Further initiation of network activities hinges on receipt of preliminary draft final reports.

VI. Reference: Synthesis Task (Unnumbered)

As earlier reported, some synthesis work was initiated with funds then existing. With the addition of some program-year funds in September 1983, the remaining syntheses have begun and are progressing normally.

VII. Reference: Contract DTUM60-83-C-71226

In line with the requirements of Article XIX, Subcontracting Reporting Requirements, it is reported that 3 subcontracts were entered into during the 6 months ending June 30, 1984.

FY 1984 Program

I. Reference: Network #1, Tasks 1.1 and 2.1 (subtasks 2.1.1 through 2.1.13)

All activity under this network has been completed by virtue of PTC's participation in the February 1, 1984, meeting of the TSG.

II. *Reference: Network #2, Tasks 3.0 (beginning with subtask 3.0.1), 3.1, 3.2, and 3.3 (ending with subtask 3.3.7)*

There has been partial completion of the activities covered by this network. UMTA authorization to proceed with certain work preliminary to requesting proposals was received on May 10, 1984. PTC processes relative to acceptance of the program for administration were completed, and requests were made for nominations of panel members. Structuring of the panels is yet to begin as this step has been deferred pending better assurance that the FY '84 funding is going to be received.

FY 1985 Program

I. *Reference: Network #1, Tasks 1.1 and 2.1 (subtasks 2.1.1 through 2.1.13)*

All work under Task 1.1 of this network is covered by the APTA contract for conduct of the TSG operation relative to formulation of annual programs and other responsibilities. Task 2.1 work is carried out by the PTC in support of the TSG, and it was approximately 75 percent complete at the end of the report period.

General—All Programs

Distribution was made early in the report period of NCTRP Progress Report 4 and the NCTRP Annual Summary of Progress. The first was distributed to UMTA and others participating directly in NCTRP work; the latter received very wide distribution through the TRB selective distribution process and the TRB Annual Meeting in January. Likewise widely distributed was a preliminary announcement of the projects making up the FY '84 program.

Difficulties Encountered During Report Period

NCTRP Progress Report 5 covered the matter of delayed research under the FY '82/'83 program and limitation on the size of the FY '84 program due to UMTA funding for those years not measuring up to that committed by the contract. These circumstances prevail. Until the FY '84 funding is received, the balance of the FY '82/'83 work cannot be undertaken, nor can any further administrative action be taken relative to advancing the FY '84 program. Negotiations with UMTA during the past 6 months resulted in a sizeable reduction in the administrative budget. This, coupled with the need for a stretchout of the funds to account for prevailing uncertainties, results in staff activity being held to an absolute minimum. Unquestionably, a time extension of the first contract (DTUM60-81-C-72012) will be necessary as the administrative money from the last year of that contract, being applied to the first year of Contract DTUM60-C-83-

71226, will not be exhausted by the contract's termination date.

Also because of prevailing circumstances, steps have been taken to consolidate all but the NCTRP synthesis work and one other project under one staff engineer. Staff attention to the program will continue to be on a part-time basis.

Previous progress reports have noted that information retrieval services in support of the TSG's evaluation of problem submittals are costing as much as 14 times the contract budget amount that was predicated on UMTA direction that only 6 to 8 problems should be anticipated in the initial years of the NCTRP. Conversely, the problems numbered 48 for the first year and have subsequently ranged to 166. The overrun has been covered through economies elsewhere in the budget, and some adjustment for the problem was made at the time of revising the administrative budget as noted above. To eliminate the problem entirely, further adjustment in the administrative budget will eventually have to be made if the number of submittals remains high.

Submission of the FY '83 problem submittals to the information retrieval process was virtually completed during the report period; however, the process was hindered by the problems not being forwarded from APTA on an as-received basis. Rather, they were held and forwarded in groups ranging up to 51 problems. Consequently, it will be most difficult to provide retrievals in a timely fashion according to the needs of the TSG schedule for evaluations prior to an October meeting.

Difficulties Projected for Next Report Period

What happens here depends on availability in the near future of the second-year funds to support the balance of the FY '82/'83 program and the new projects under the FY '84 program. No matter a reduced level of administrative effort, administrative funds are being expended, and this can impact negatively on the ability to carry the programs forward if the present delay is protracted.

PTC Activities in the Next Report Period

1. Routine surveillance of subcontracts in being.
2. Follow-up as appropriate on projects reaching expiration dates.
3. Support, according to established procedures, of the TSG processes for formulating the FY '85 program.
4. Formulation of project panels and meetings to write Project Statements for FY '84 research.
5. Preparation of a 6-month progress report for the period ending December 31, 1984.
6. Preparation of an Annual Summary of Progress report.
7. Evaluation of proposals leading to selection of sub-contractors for FY '84 research.

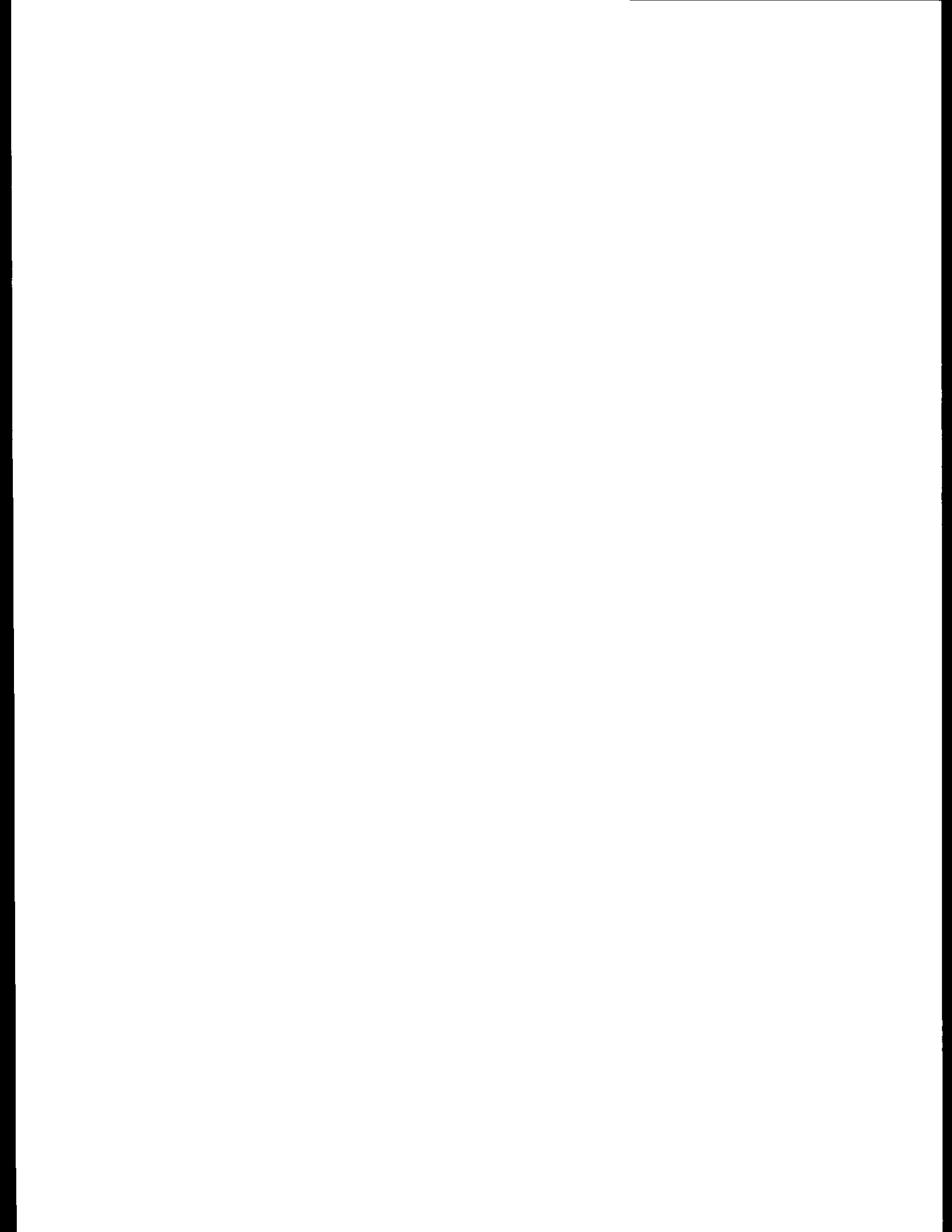

Networks
FY 1980 Program

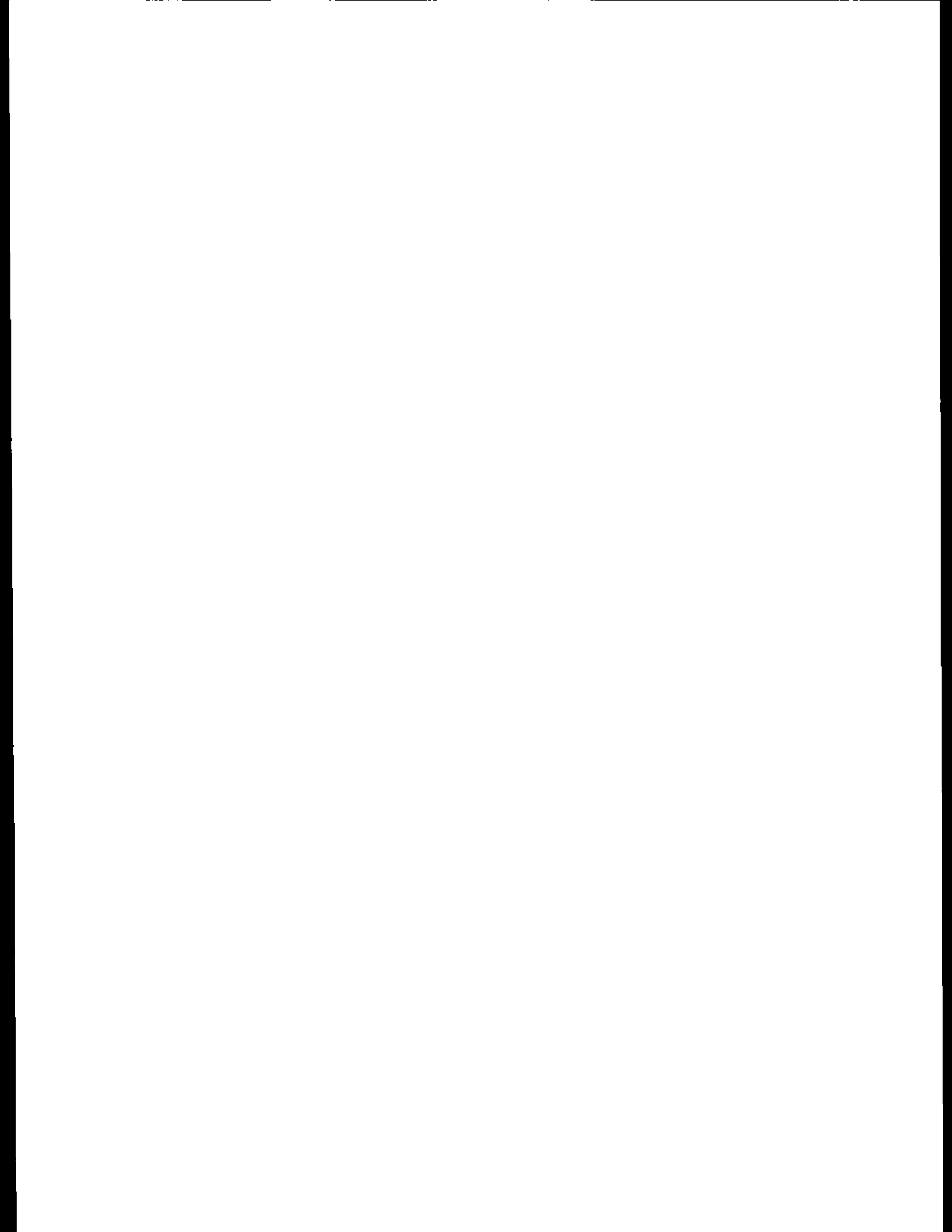

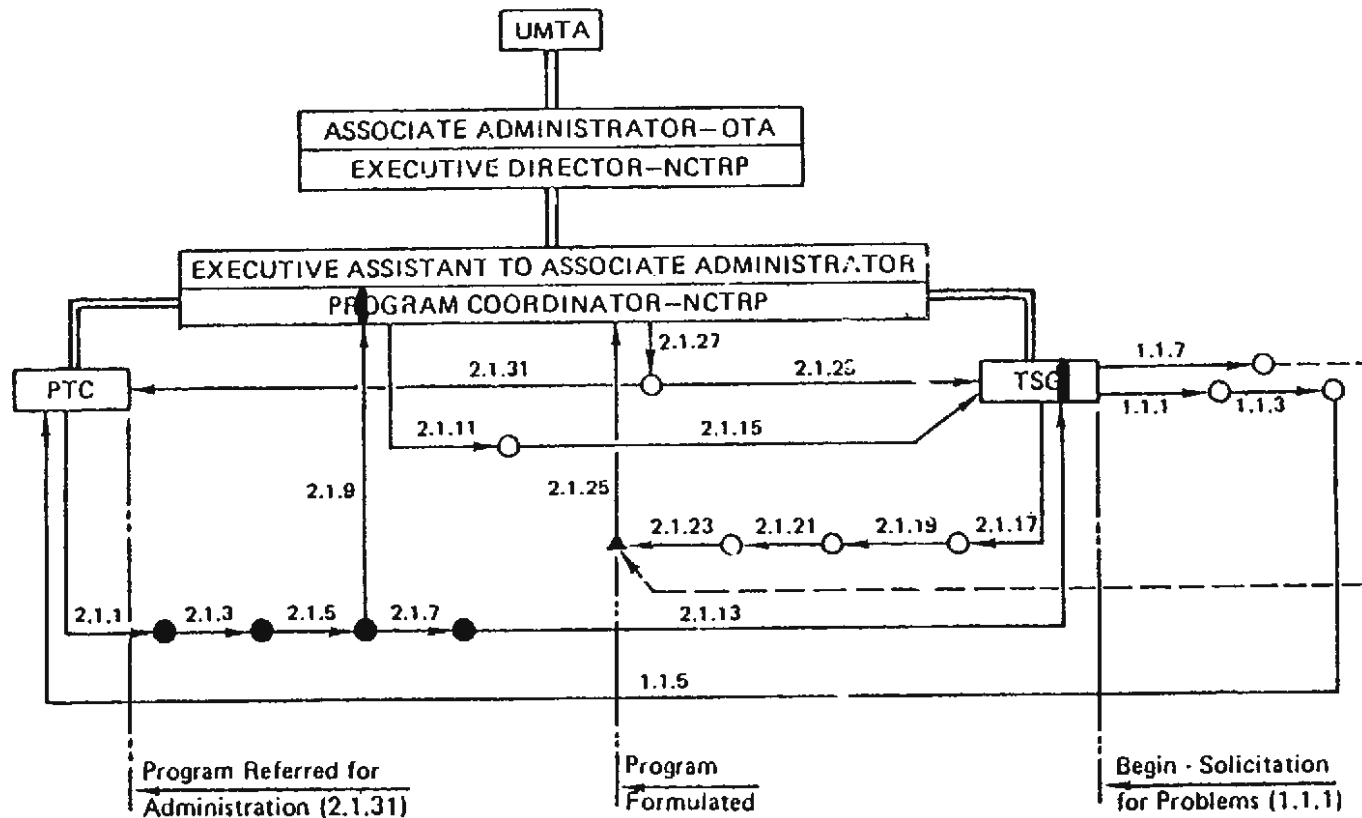

NCTRP NETWORK #1
TSG Initiation of Program
through Referral to PTC
 Prep.: KWH May '79
 Rev.: KWH May '83

RE: FY 1980 PROGRAM
CONTRACT DTUM60-81-C-72012

30 JUNE 1984

NOTE: Fully shaded nodes represent completed tasks; partially shaded nodes represent partially completed tasks.

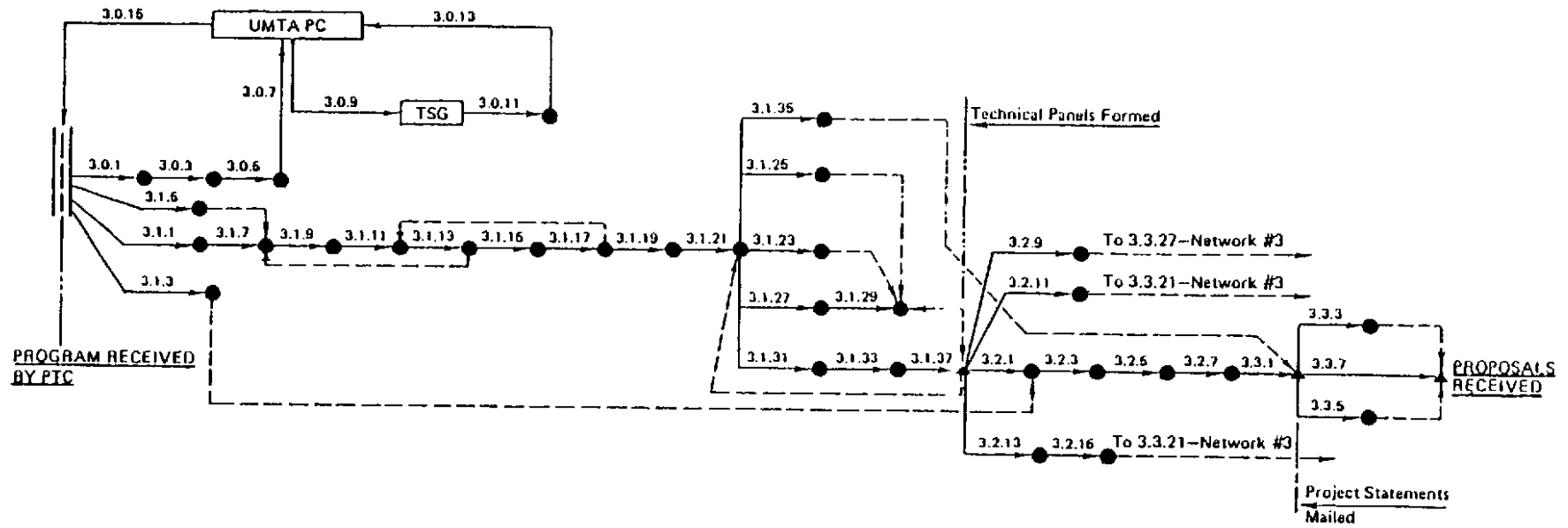

RE: FY 1980 PROGRAM
CONTRACT DTUM60-81-C-72012
30 JUNE 1984

NCTRP NETWORK #2
PTC Receipt of Program
through Receipt of Proposals

Prep.: KWH May '79
Rev.: KWH May '83

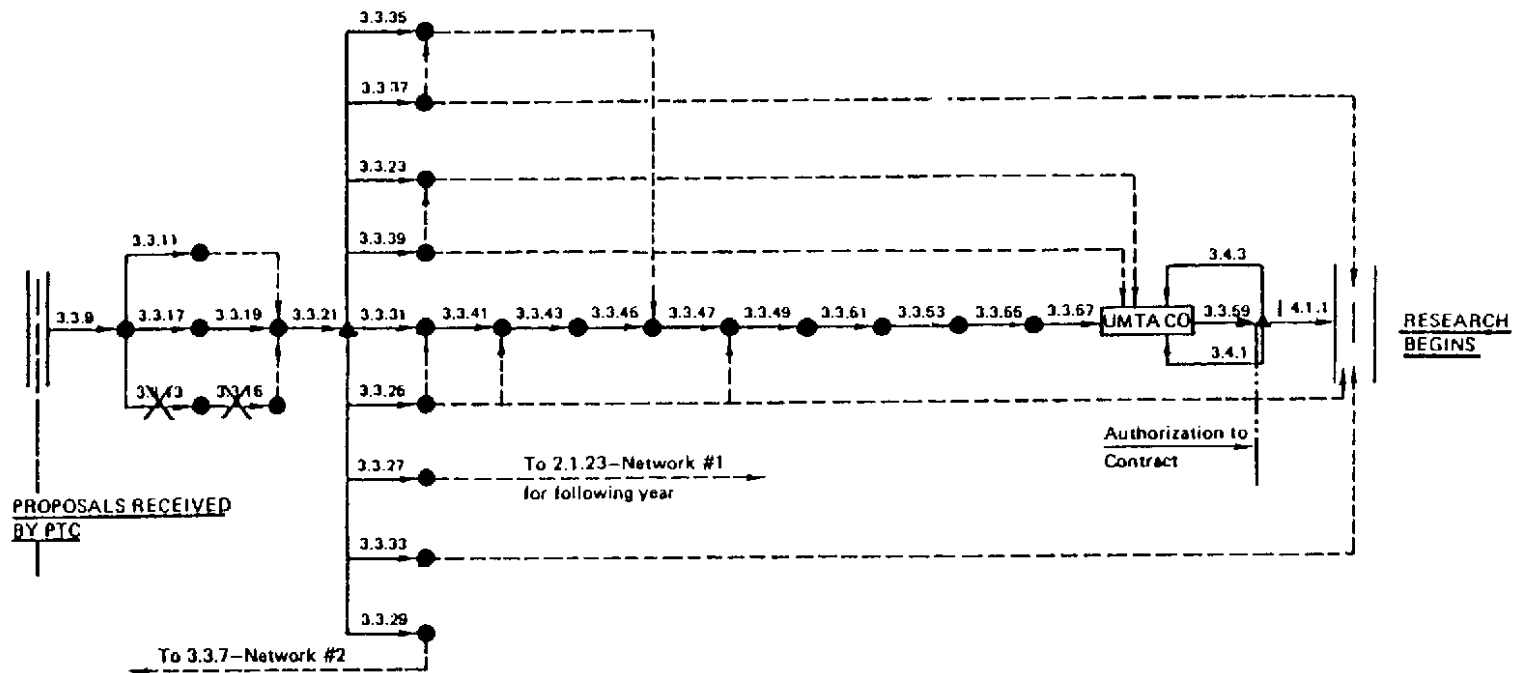

NCTRP NETWORK #3
 Receipt of Proposals through
 Initiation of Research

Prep.: KWH May '79

Rev.: KWH May '83

RE: FY 1980 PROGRAM
CONTRACT DTUM60-81-G-72012
 30 JUNE 1984

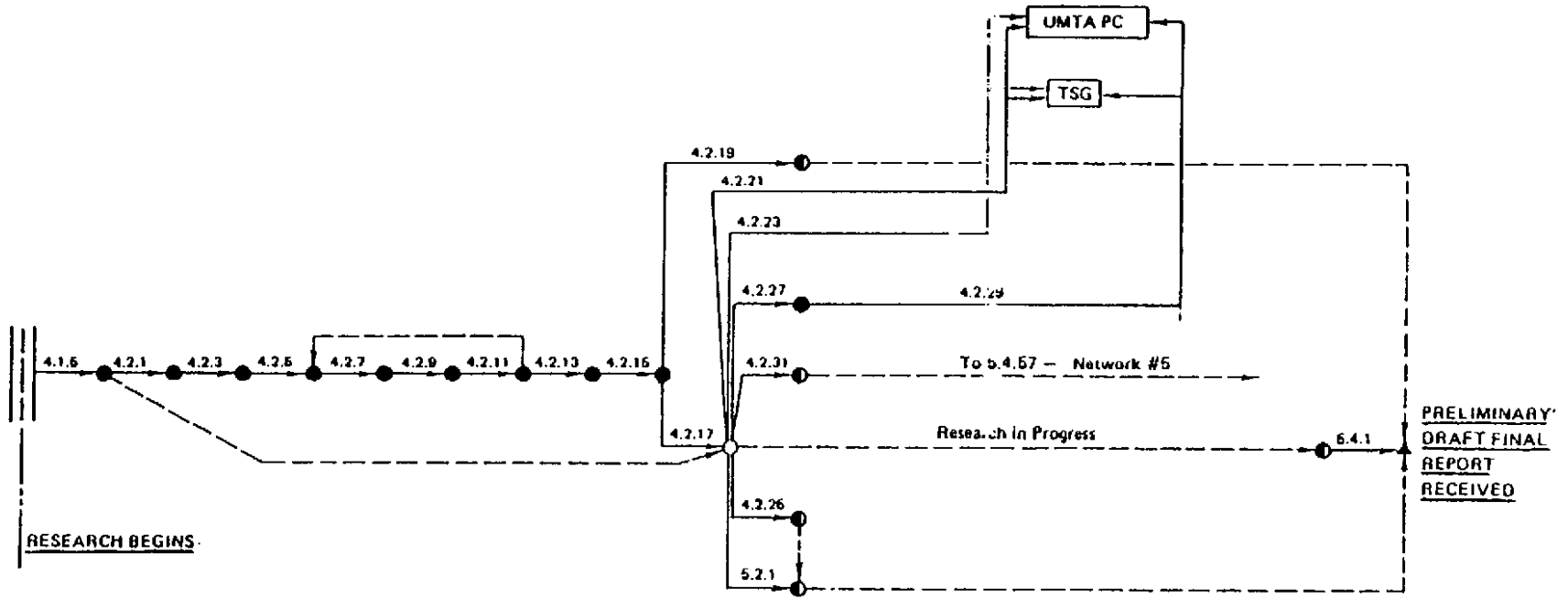

NCTRP NETWORK #4
 Initiation of Research through Receipt
 of Preliminary Draft Final Report
 Prep.: KWH May '79
 Rev.: KWH May '83

RE: FY 1980 PROGRAM
CONTRACT DTUM60-81-C-72012
 30 JUNE 1984

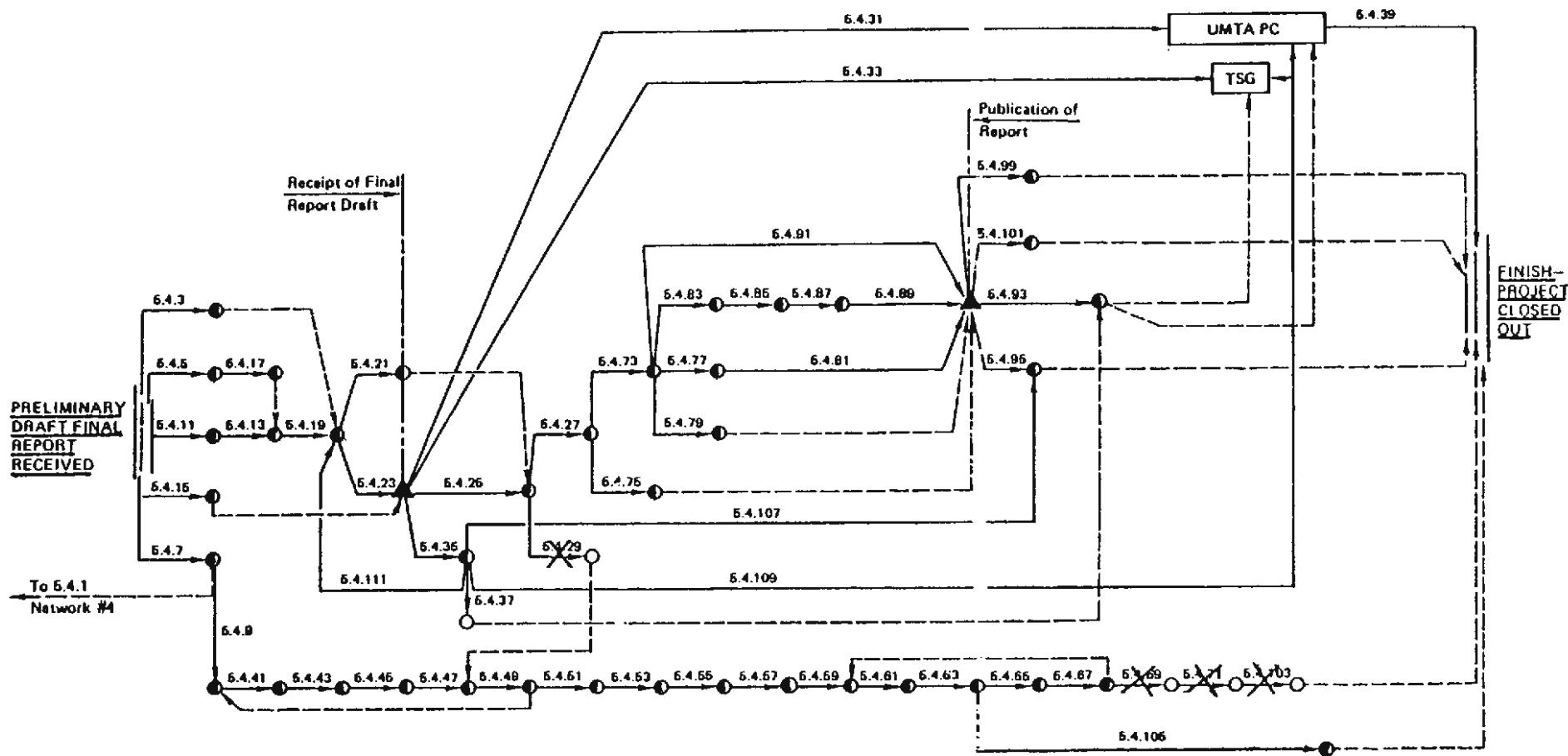

NCTRP NETWORK #5
 Receipt of Preliminary Draft Report
 through Project Close Out
 Prep.: KWH May '79
 Rev.: KWH May '83

RE: FY 1980 PROGRAM
 CONTRACT DTUM60-81-C-72012
 30 JUNE 1984

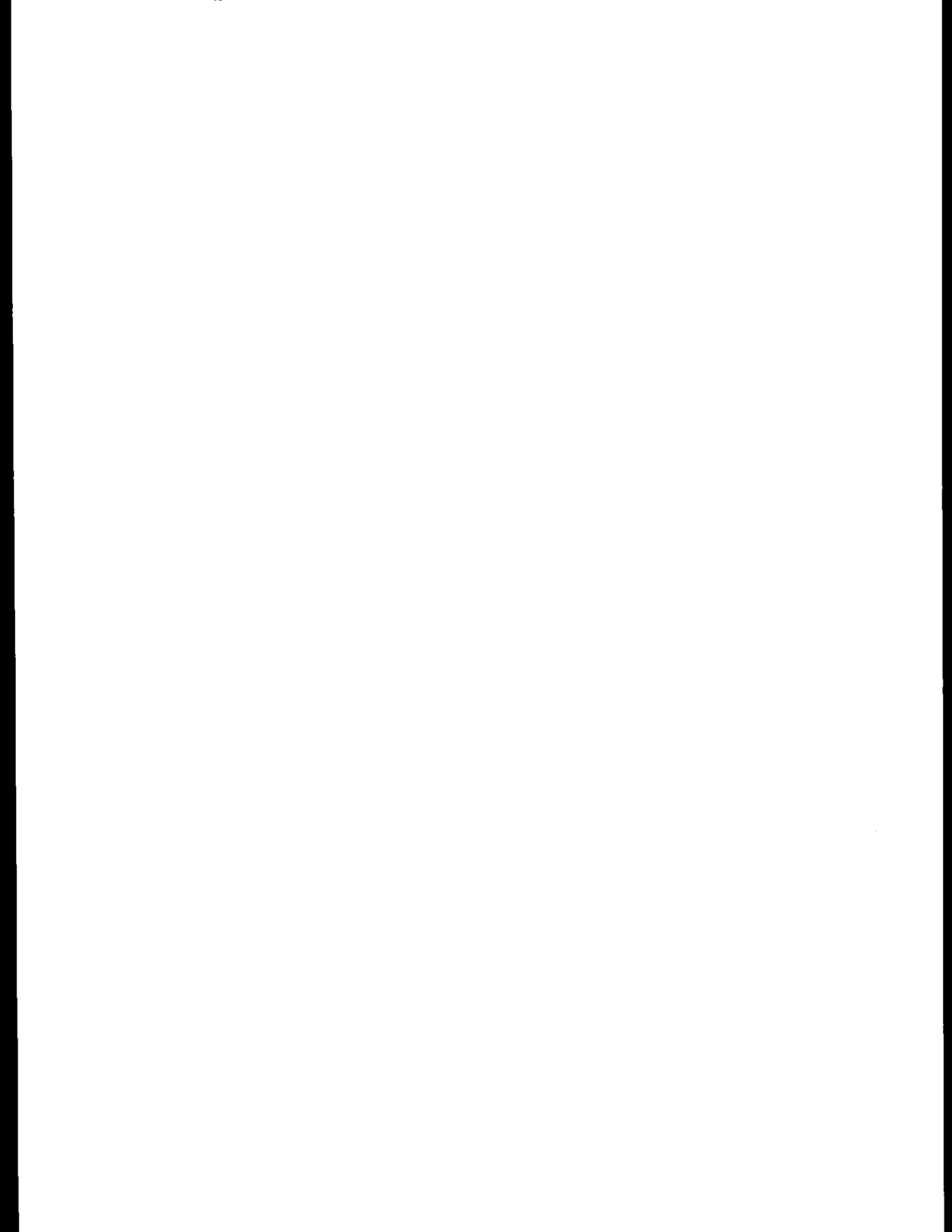

Networks
FY 1981 Program

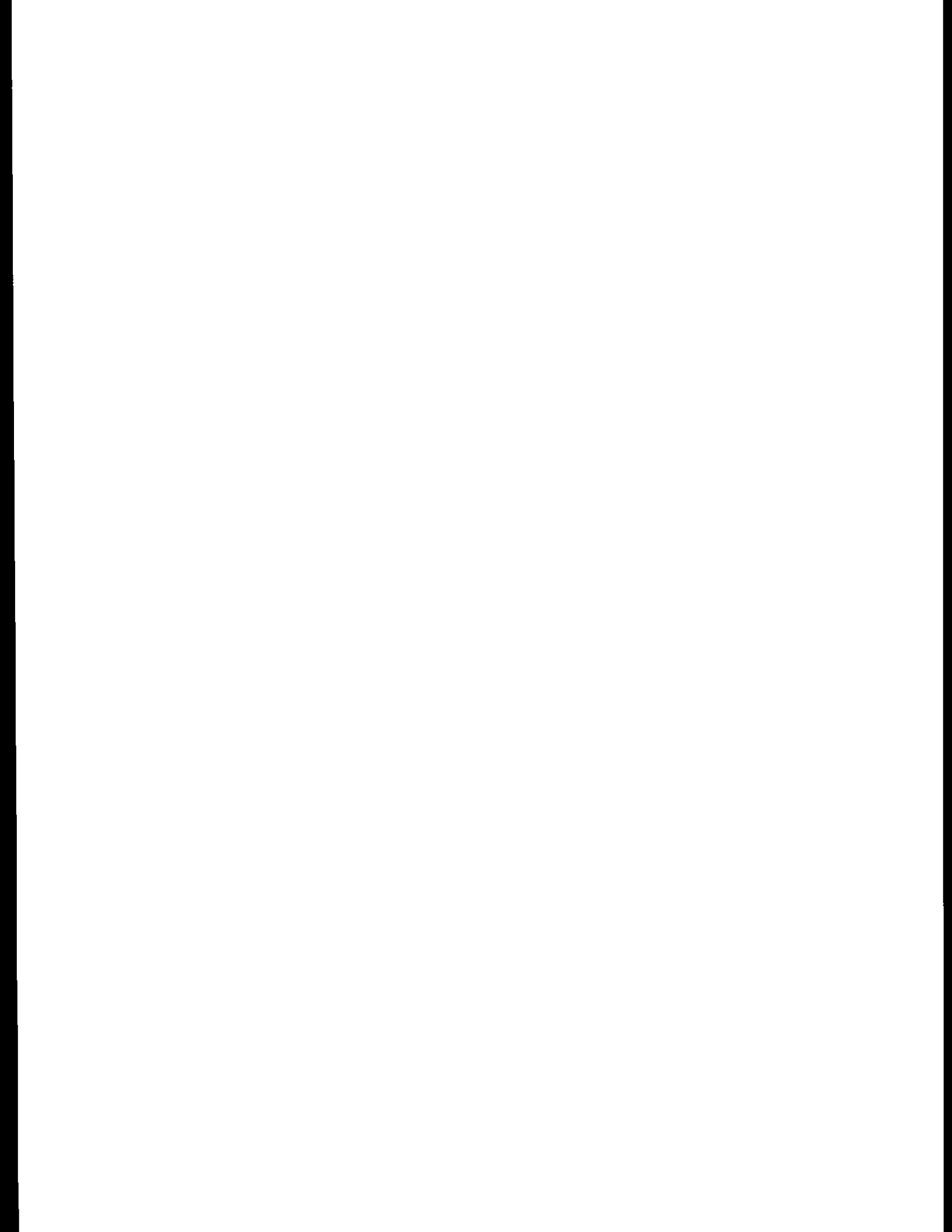

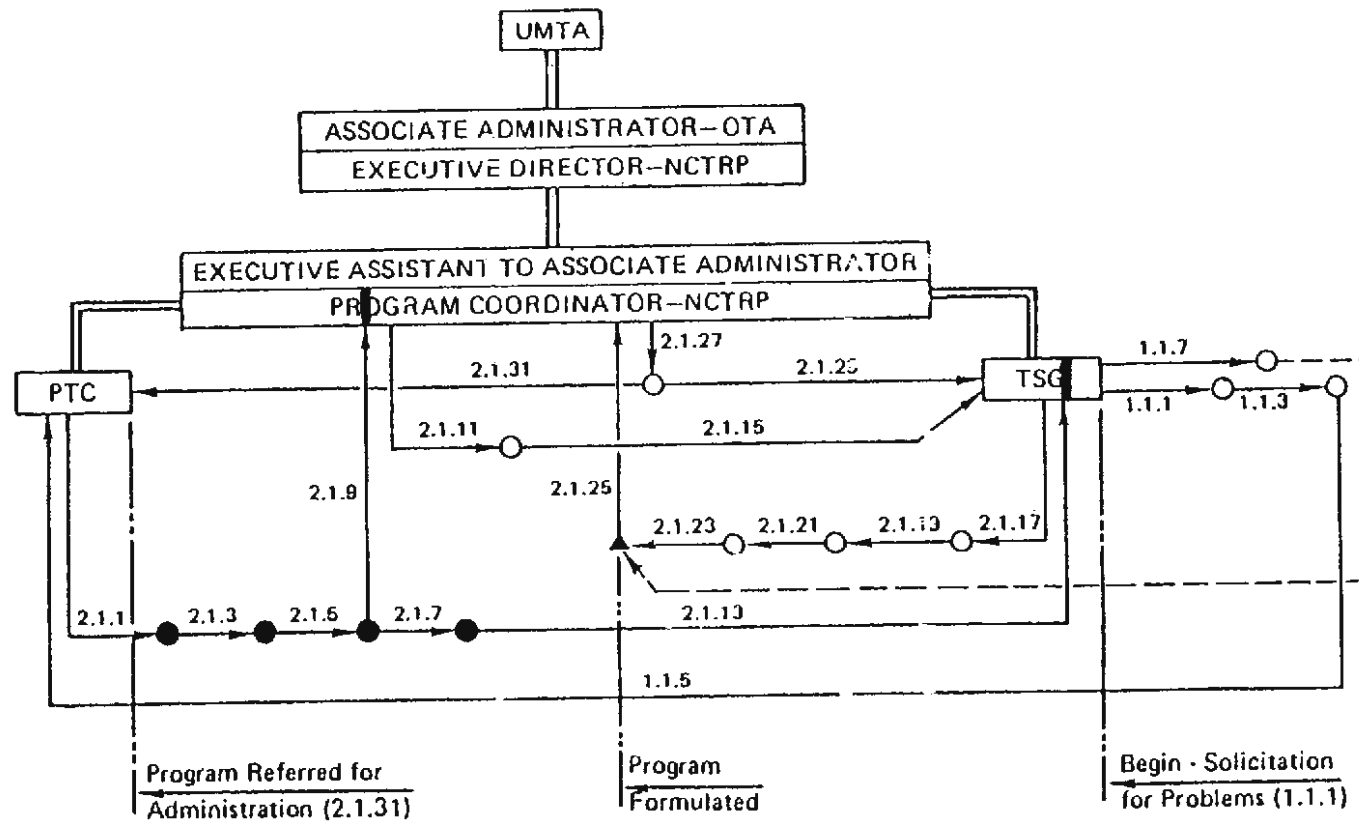

RE: FY 1981 PROGRAM
CONTRACT DTUM60-81-C-72012
 30 JUNE 1984

NCTRP NETWORK #1
 TSG Initiation of Program
 through Referral to PTC
 Prep.: KWH May '79
 Rev.: KWH May '83

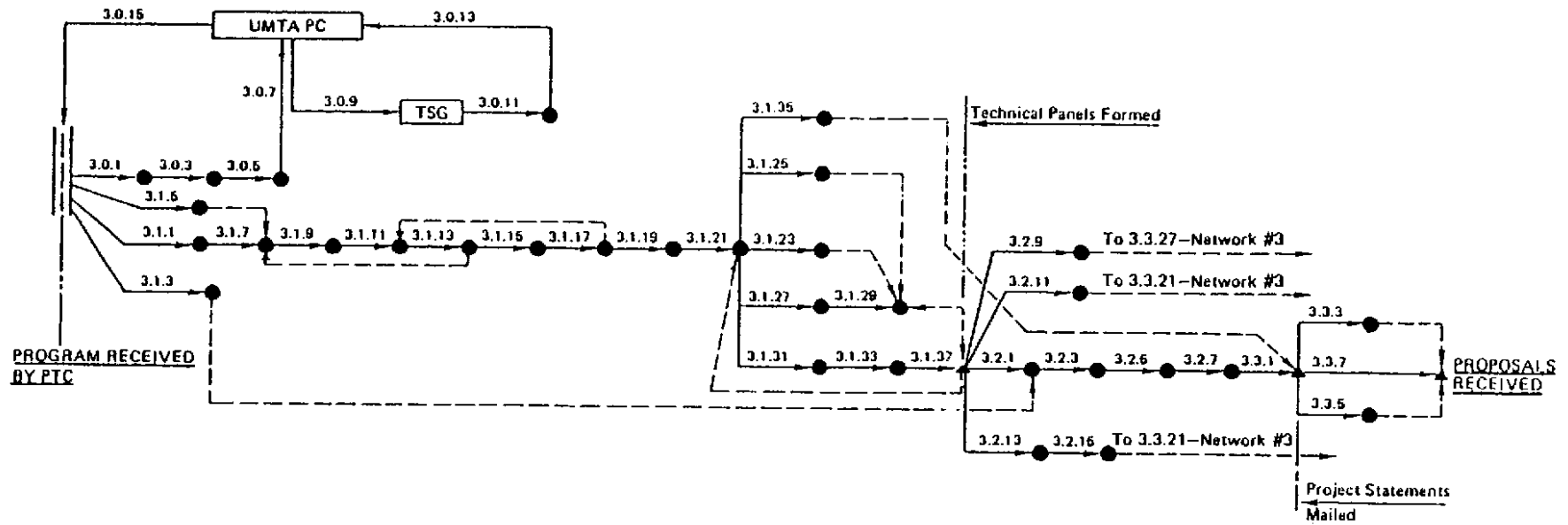

RE: FY 1981 PROGRAM
CONTRACT DTUM60-81-C-72012
 30 JUNE 1984

NCTRP NETWORK #2
 PTC Receipt of Program
 through Receipt of Proposals
 Prep.: KWH May '79
 Rev.: KWH May '83

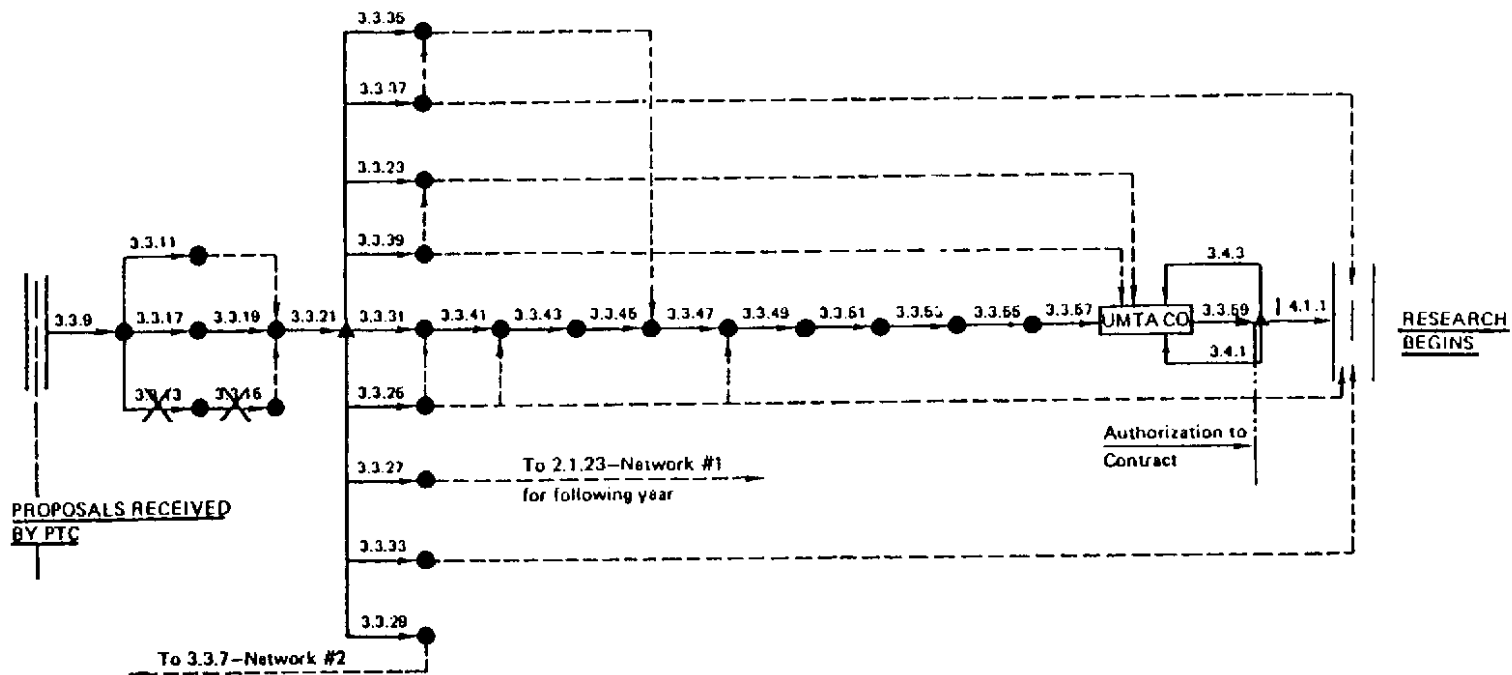

NCTRP NETWORK #3
 Receipt of Proposals through
 Initiation of Research

Prep.: KWI May '79
 Rev.: KWI May '83

RE: FY 1981 PROGRAM
CONTRACT DTUM60-81-C-72012
 30 JUNE 1984

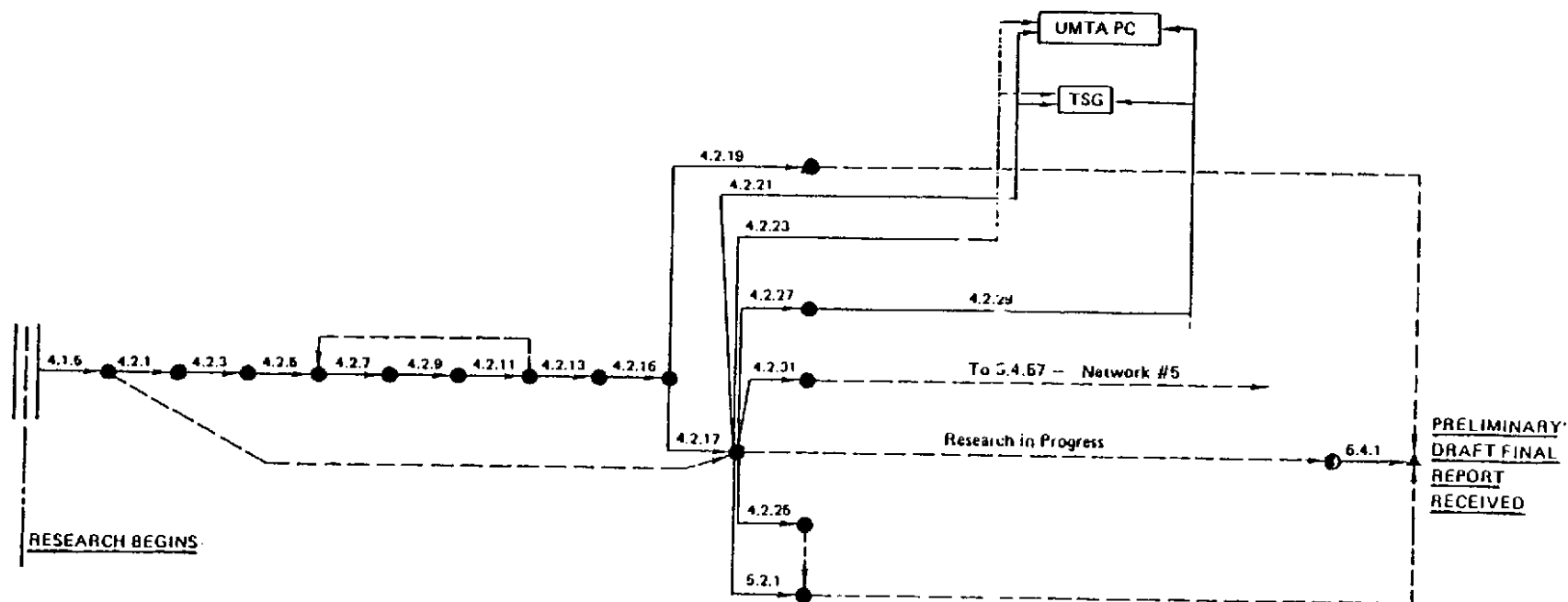

NCTRP NETWORK #4
Initiation of Research through Receipt
of Preliminary Draft Final Report
Prep.: KWH May '79
Rev.: KWH May '83

RE: FY 1981 PROGRAM
CONTRACT DTUM60-81-C-72012
30 JUNE 1984

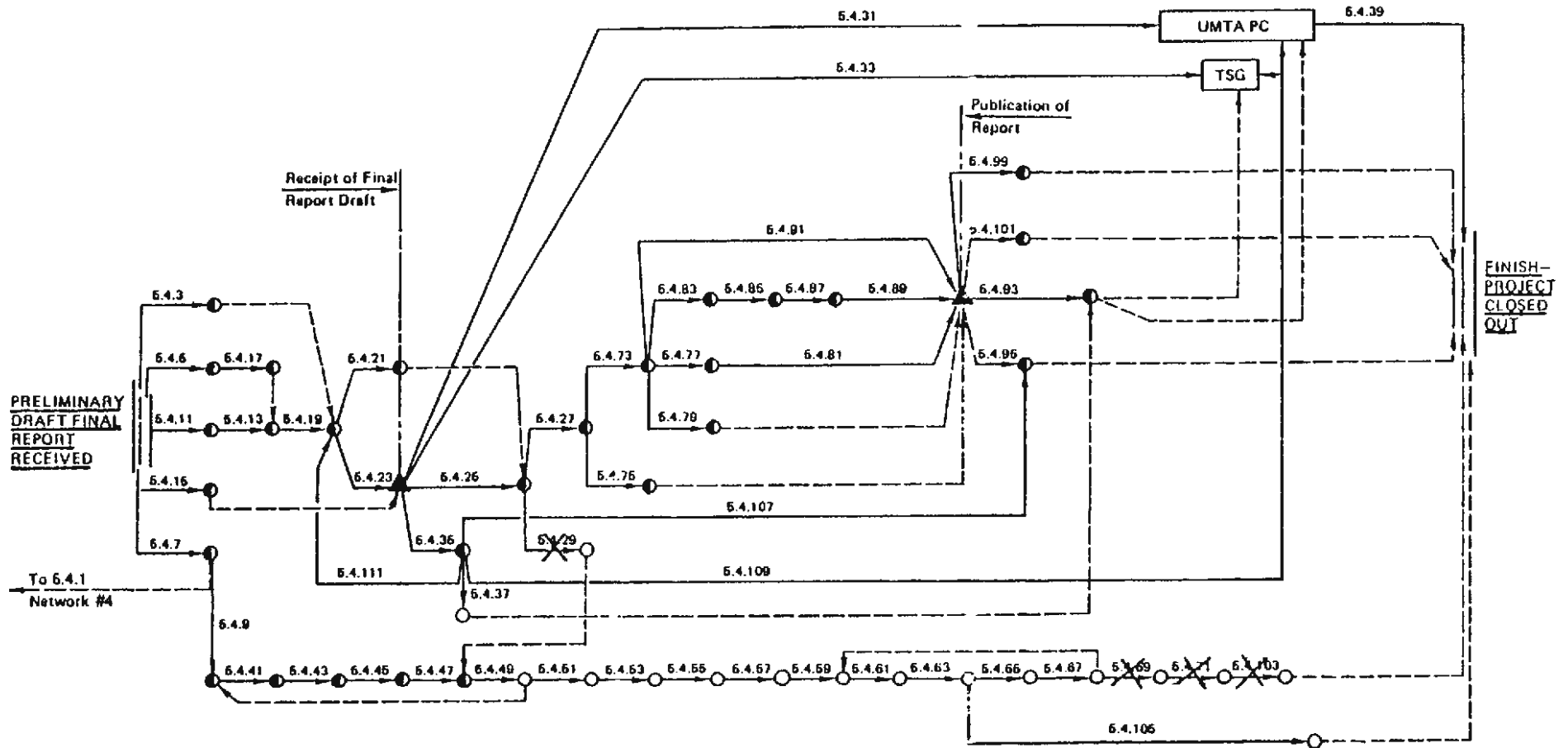

PRELIMINARY
DRAFT FINAL
REPORT
RECEIVED

To 6.4.1
Network #4

Receipt of Final
Report Draft

Publication of
Report

FINISH-
PROJECT
CLOSED
OUT

NCTRP NETWORK #6
Receipt of Preliminary Draft Report
through Project Close Out
Prep.: KWH May '79
Rev.: KWH May '83

RE: FY 1981 PROGRAM
CONTRACT DTUM60-81-C-72012
30 JUNE 1984

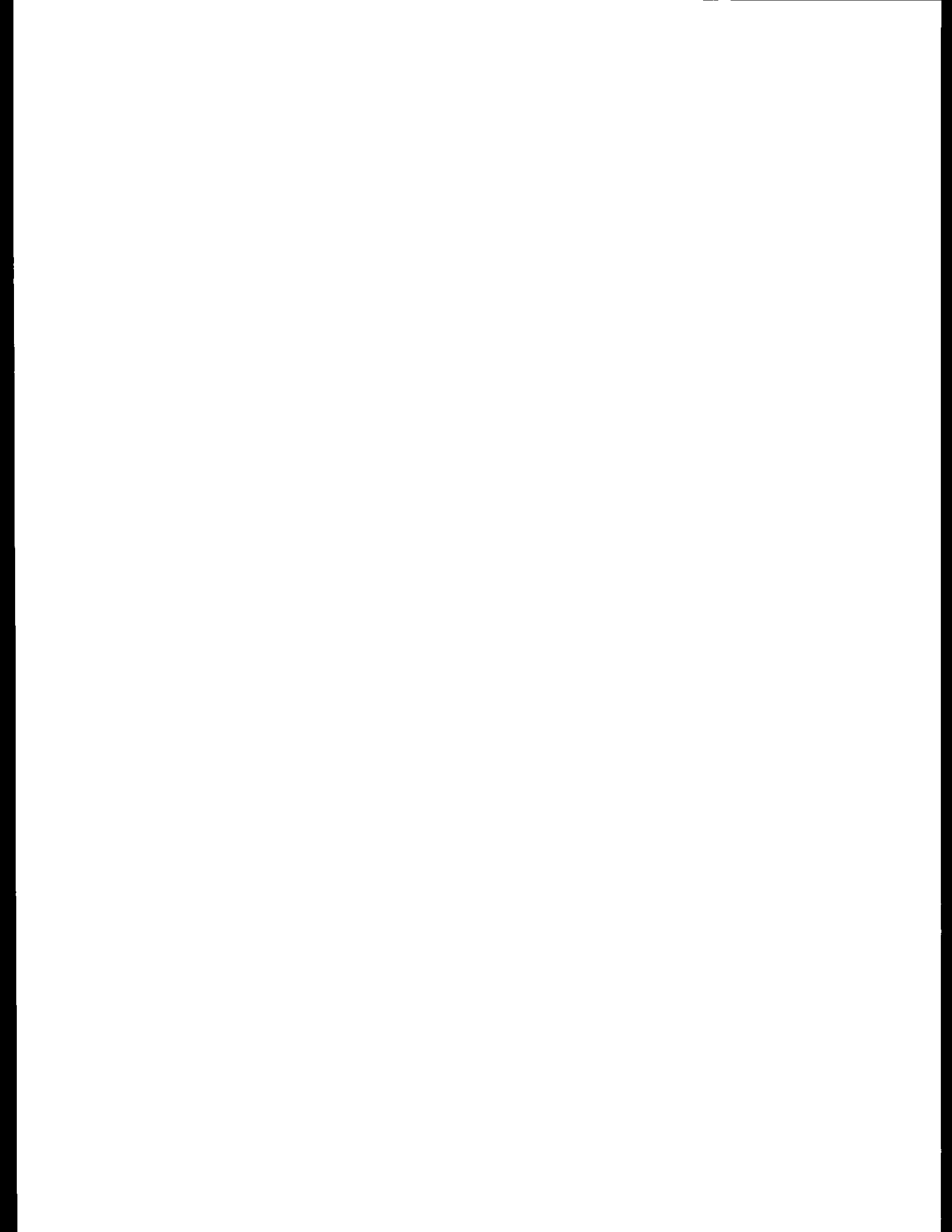

Networks
FY 1982/1983 Program

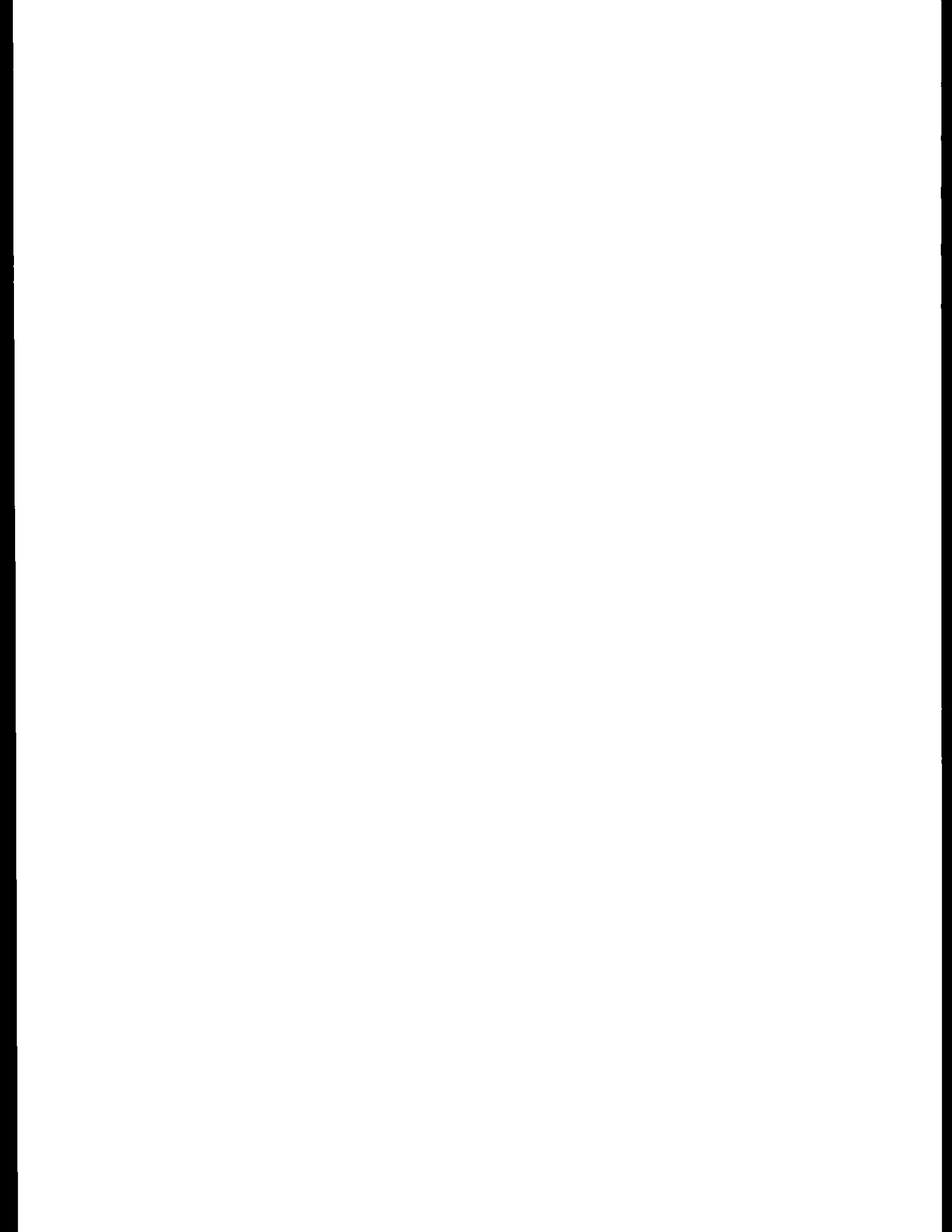

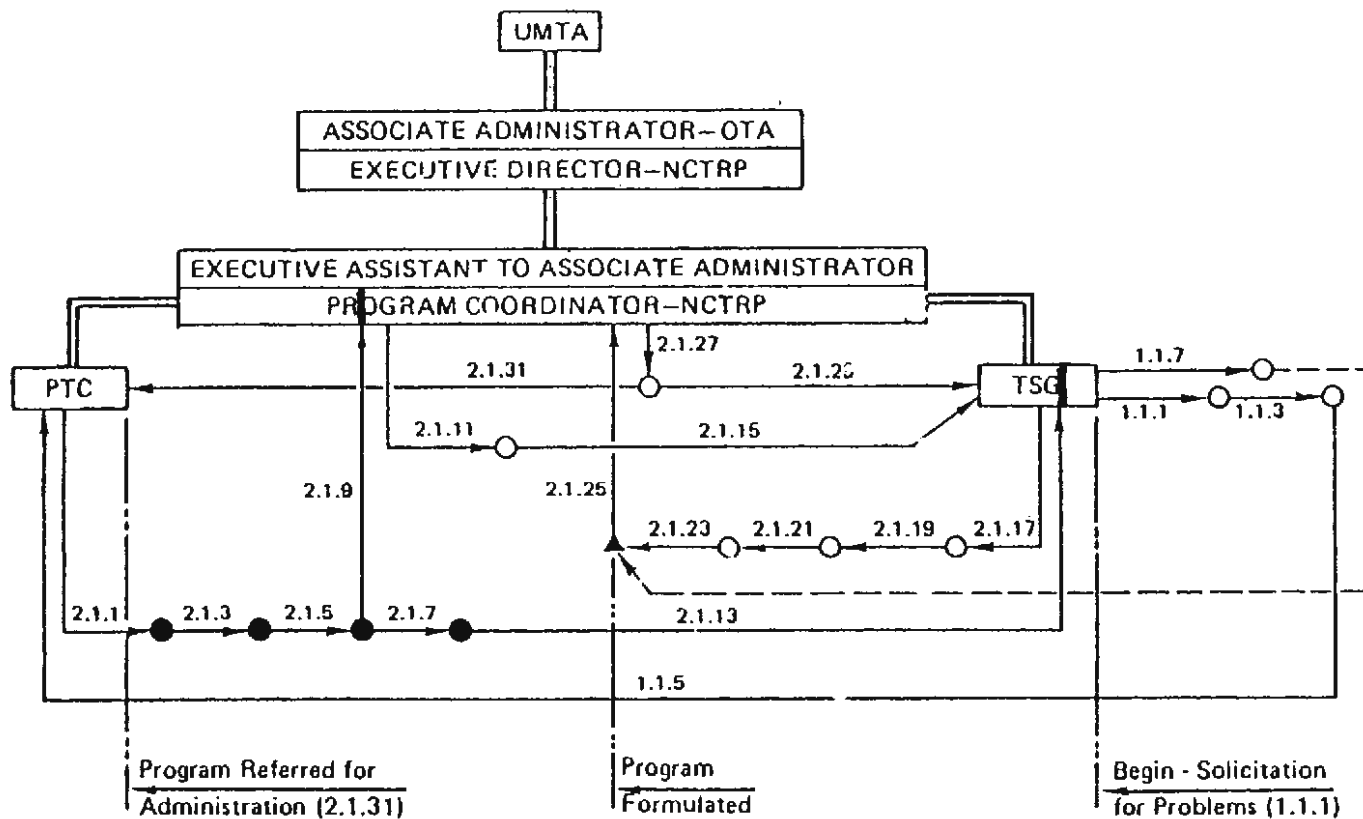

RE: FY 1982/1983 PROGRAM
CONTRACT DTUM60-83-C-71226
 30 JUNE 1984

NCTRP NETWORK #1
 TSG Initiation of Program
 through Referral to PTC
 Prep.: KWH May '79
 Rev.: KWH May '83

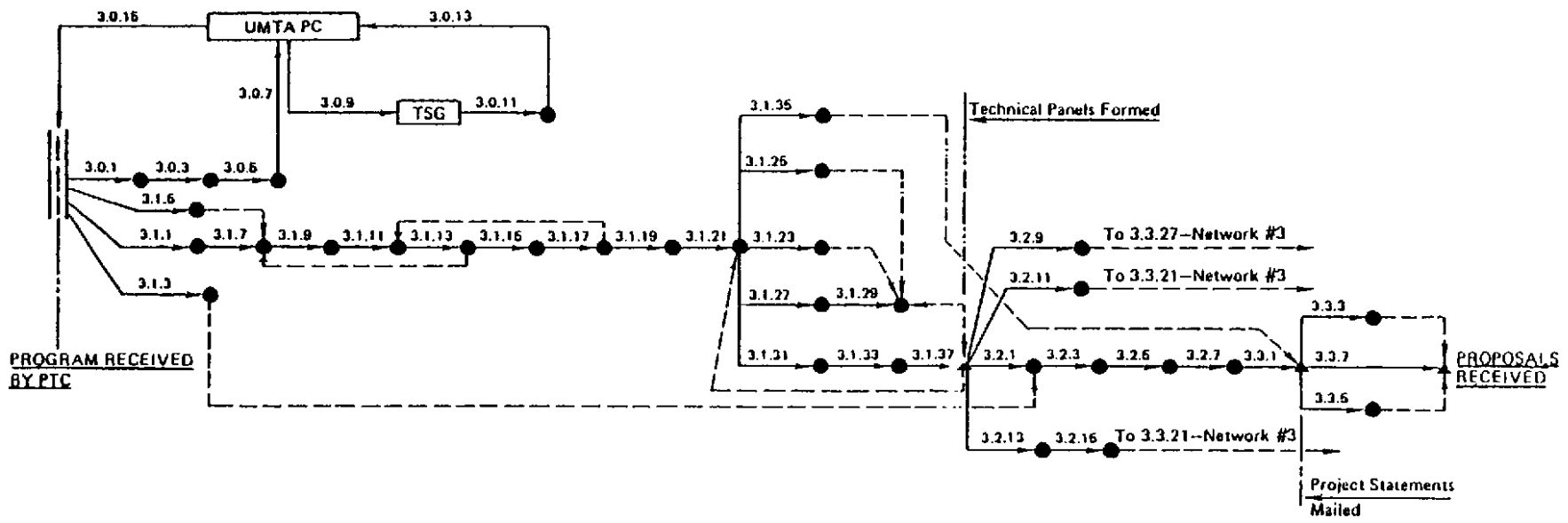

RE: FY 1982/1983 PROGRAM
CONTRACT DTUM60-83-C-71226
 30 JUNE 1984

NCTRP NETWORK #2
 PTC Receipt of Program
 through Receipt of Proposals
 Prep.: KWI May '79
 Rev.: KWI May '83

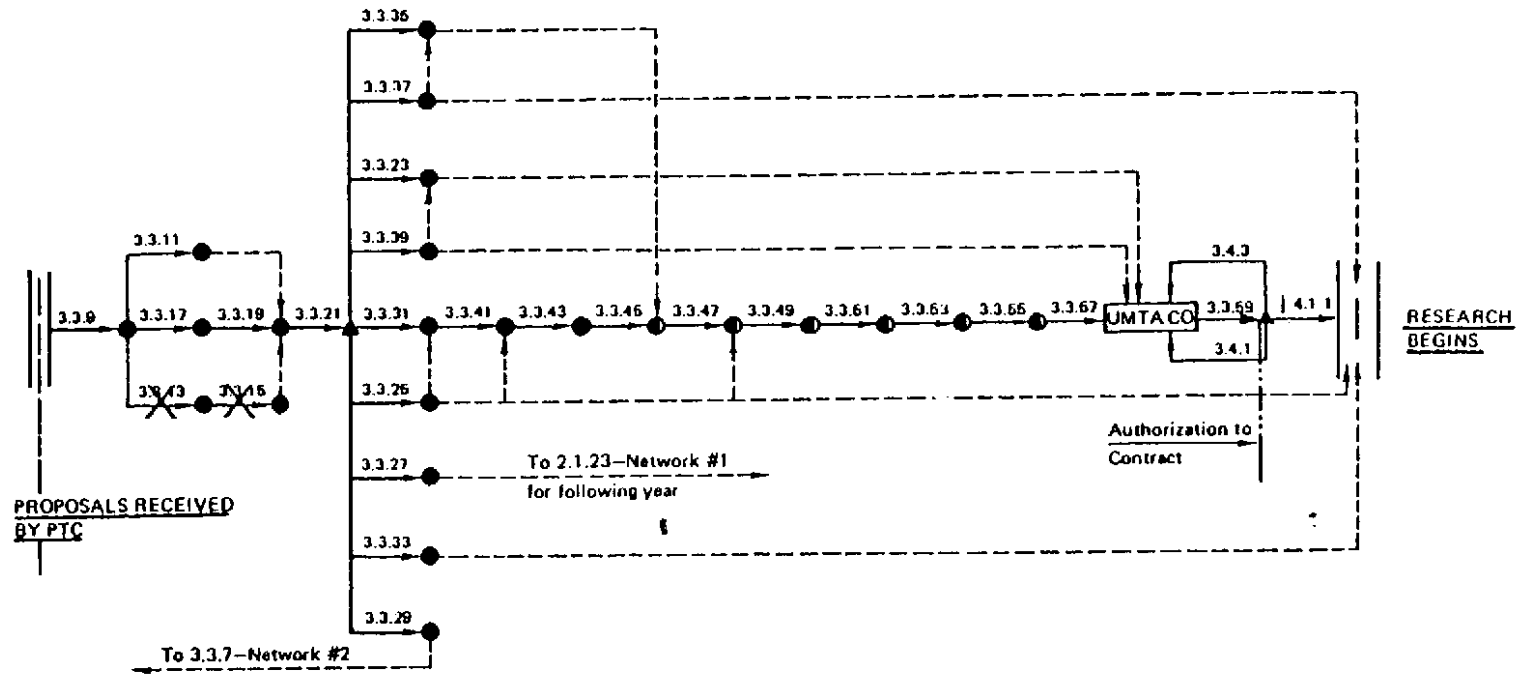

NCTRP NETWORK #3
 Receipt of Proposals through
 Initiation of Research

Prep.: KWH May '79
 Rev.: KWH May '83

RE: FY 1982/1983 PROGRAM
CONTRACT DTUM60-83-C-71226
 30 JUNE 1984

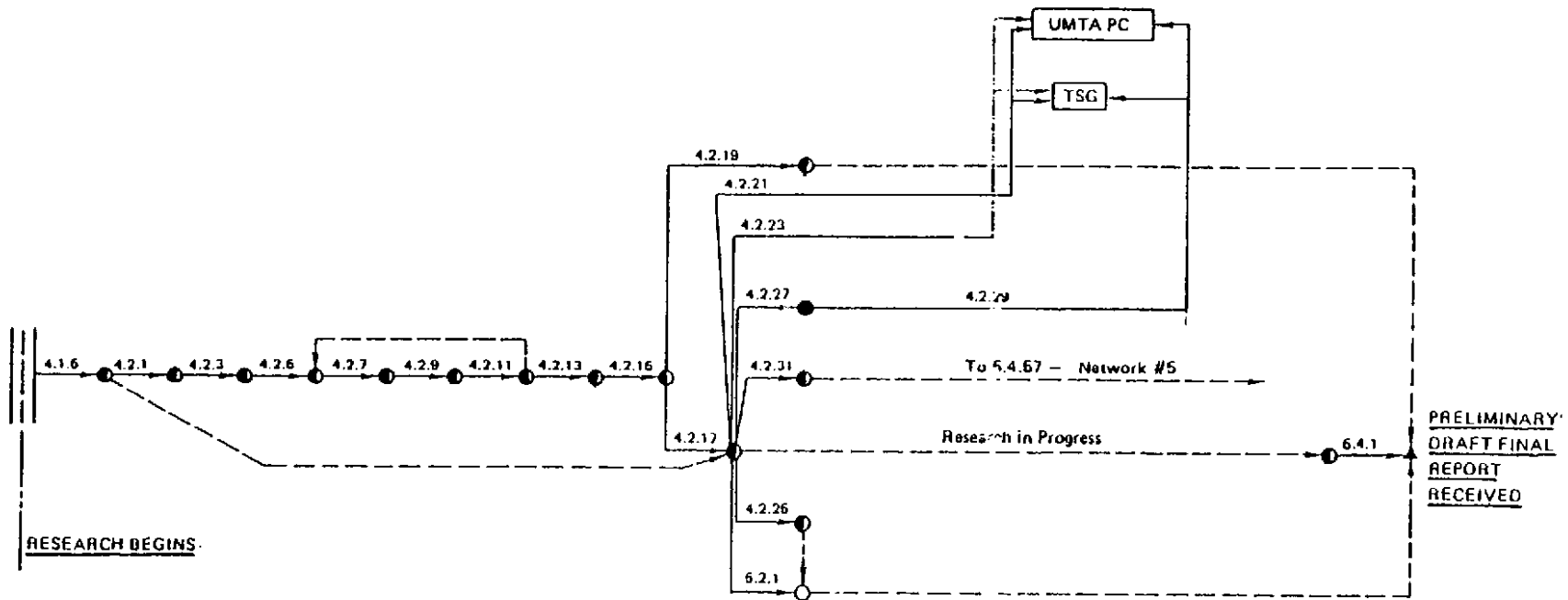

NCTRP NETWORK #4
 Initiation of Research through Receipt
 of Preliminary Draft Final Report
 Prep.: KWH May '79
 Rev.: KWH May '83

RE: FY 1982/1983 PROGRAM
CONTRACT DTUM60-83-C-71226
 30 JUNE 1984

Networks
FY 1984 Program

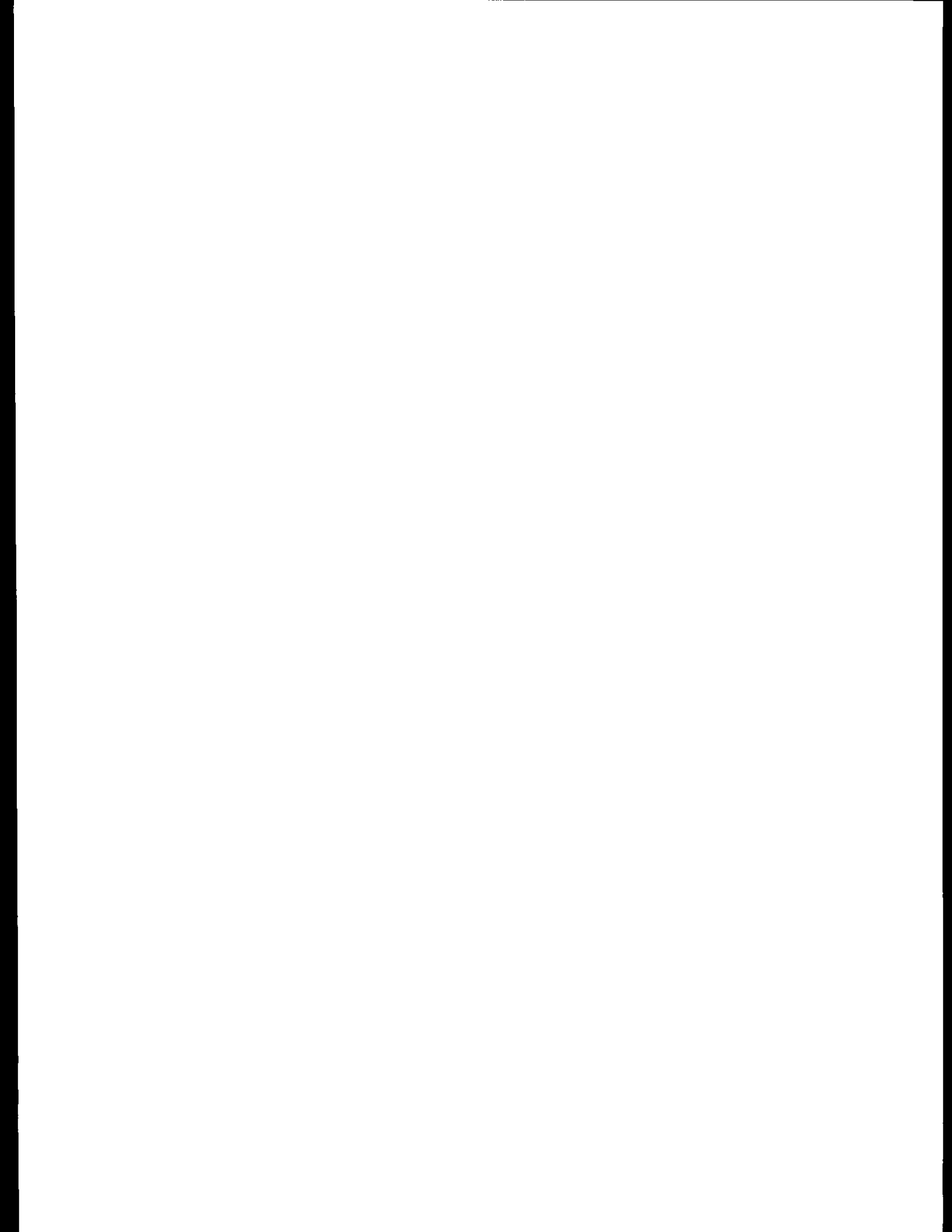

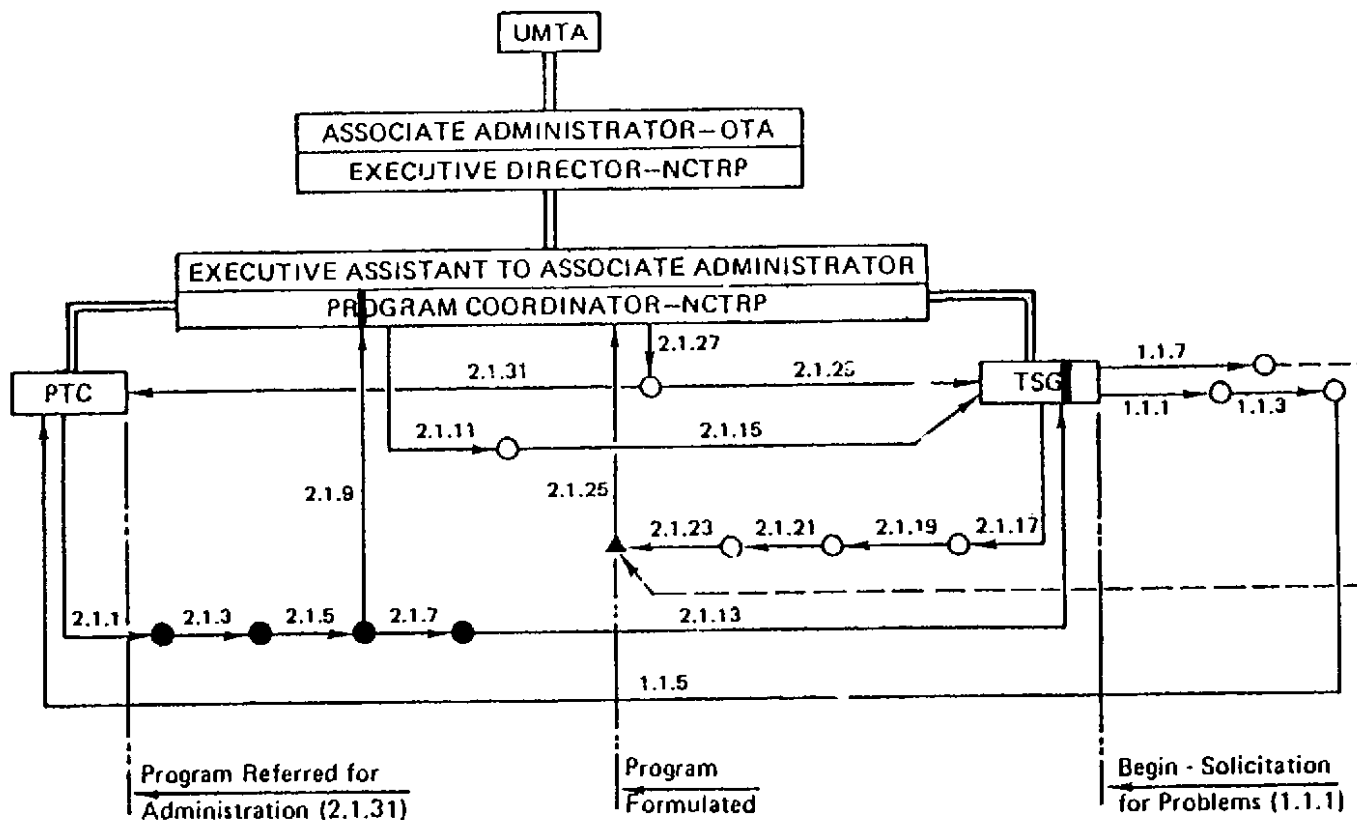

RE: FY 1984 PROGRAM
 CONTRACT DTUM60-83-C-71226
 30 JUNE 1984

NCTRP NETWORK #1
 TSG Initiation of Program
 through Referral to PTC
 Prep.: KWH May '79
 Rev.: KWH May '83

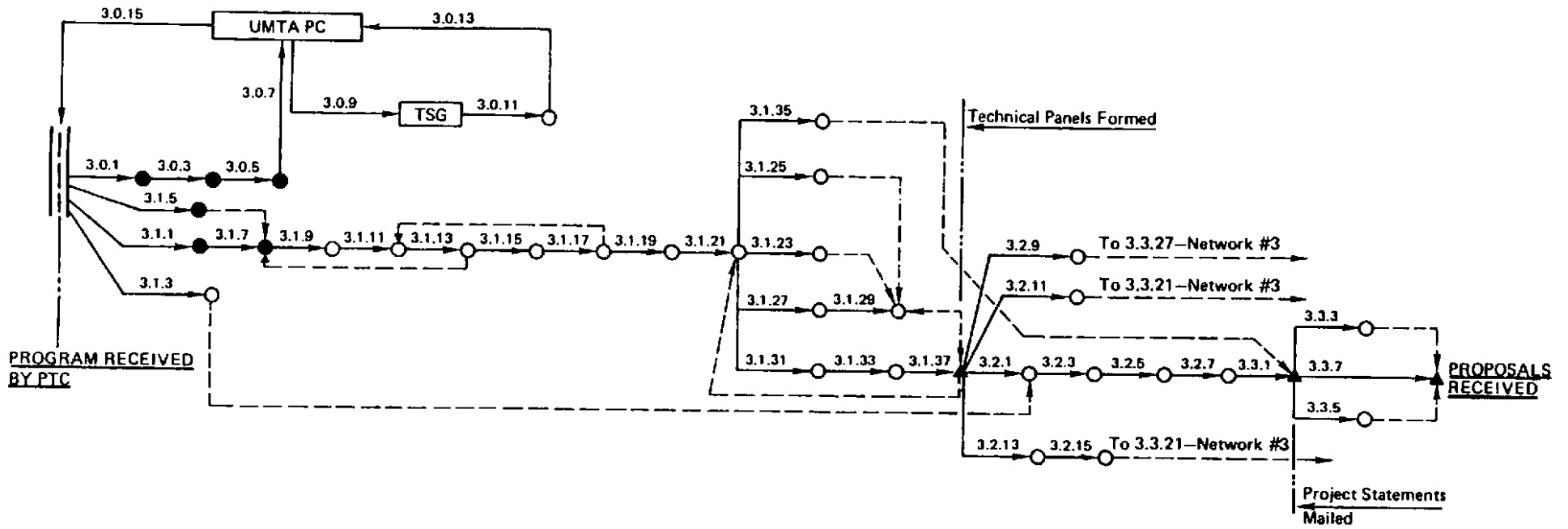

RE: FY 1984 PROGRAM
CONTRACT DTUM60-83-C-71226
 30 JUNE 1984

NCTRP NETWORK #2
 PTC Receipt of Program
 through Receipt of Proposals

Prep.: KWH May '79
 Rev.: KWH May '83

Networks
FY 1985 Program

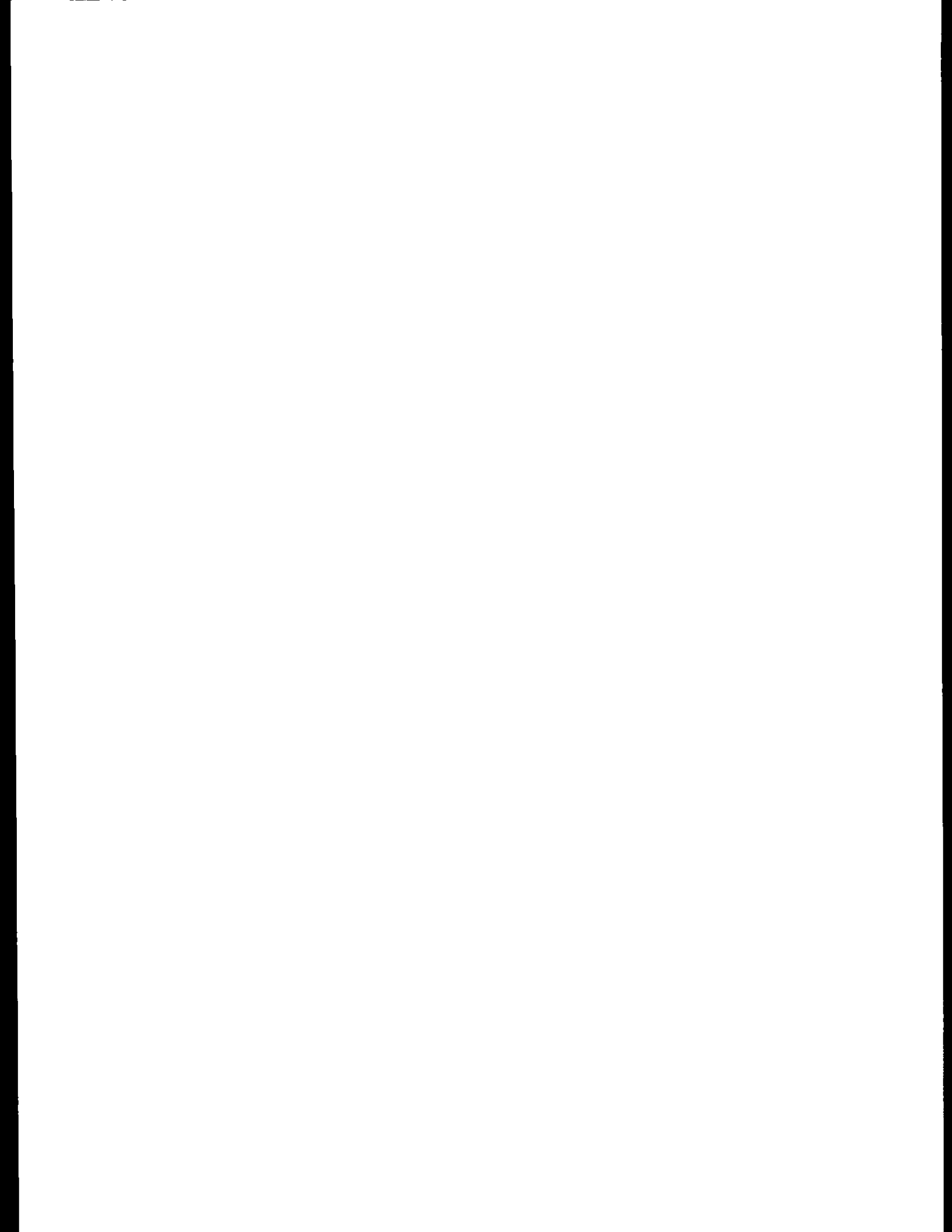

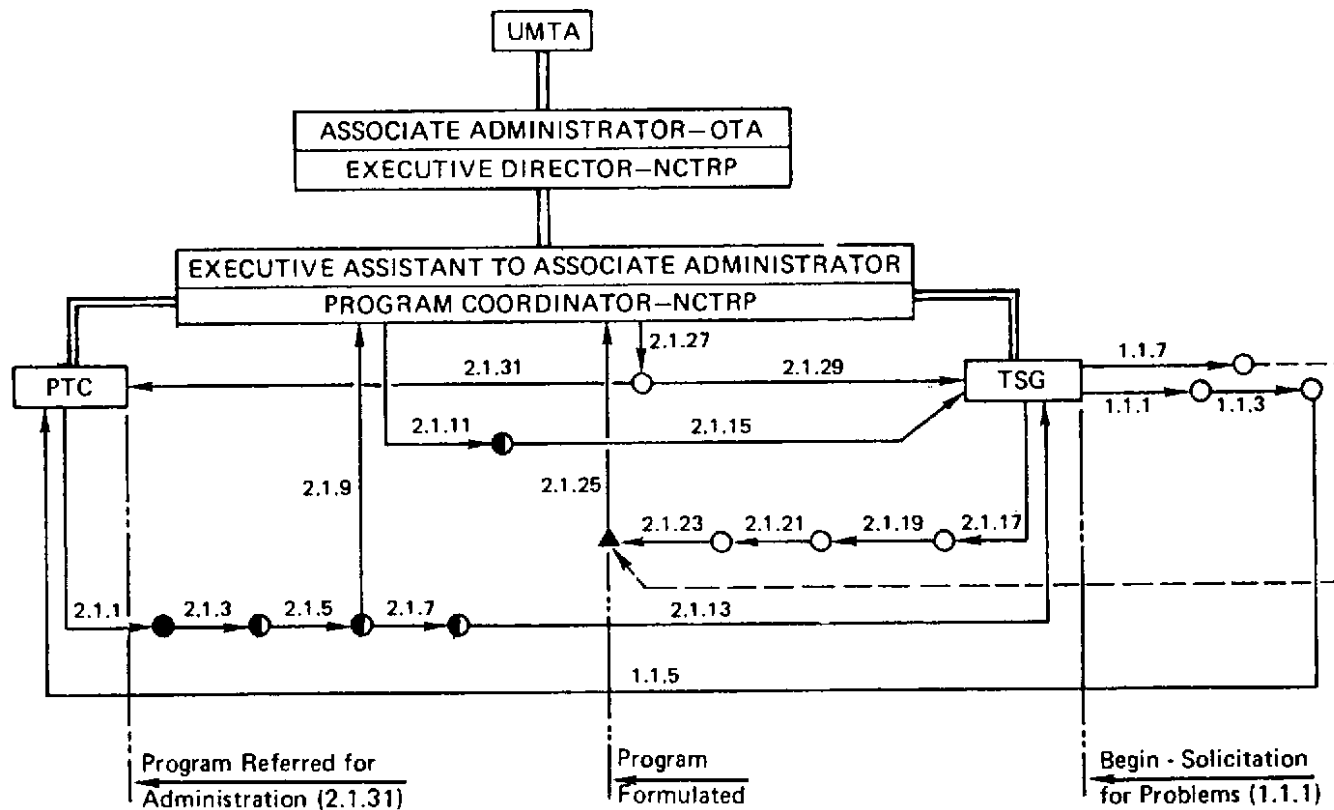

RE: FY 1985 PROGRAM
 CONTRACT DTUM60-83-C-71226
 30 JUNE 1984

NCTRP NETWORK #1
 TSG Initiation of Program
 through Referral to PTC
 Prep.: KWH May '79
 Rev.: KWH May '83

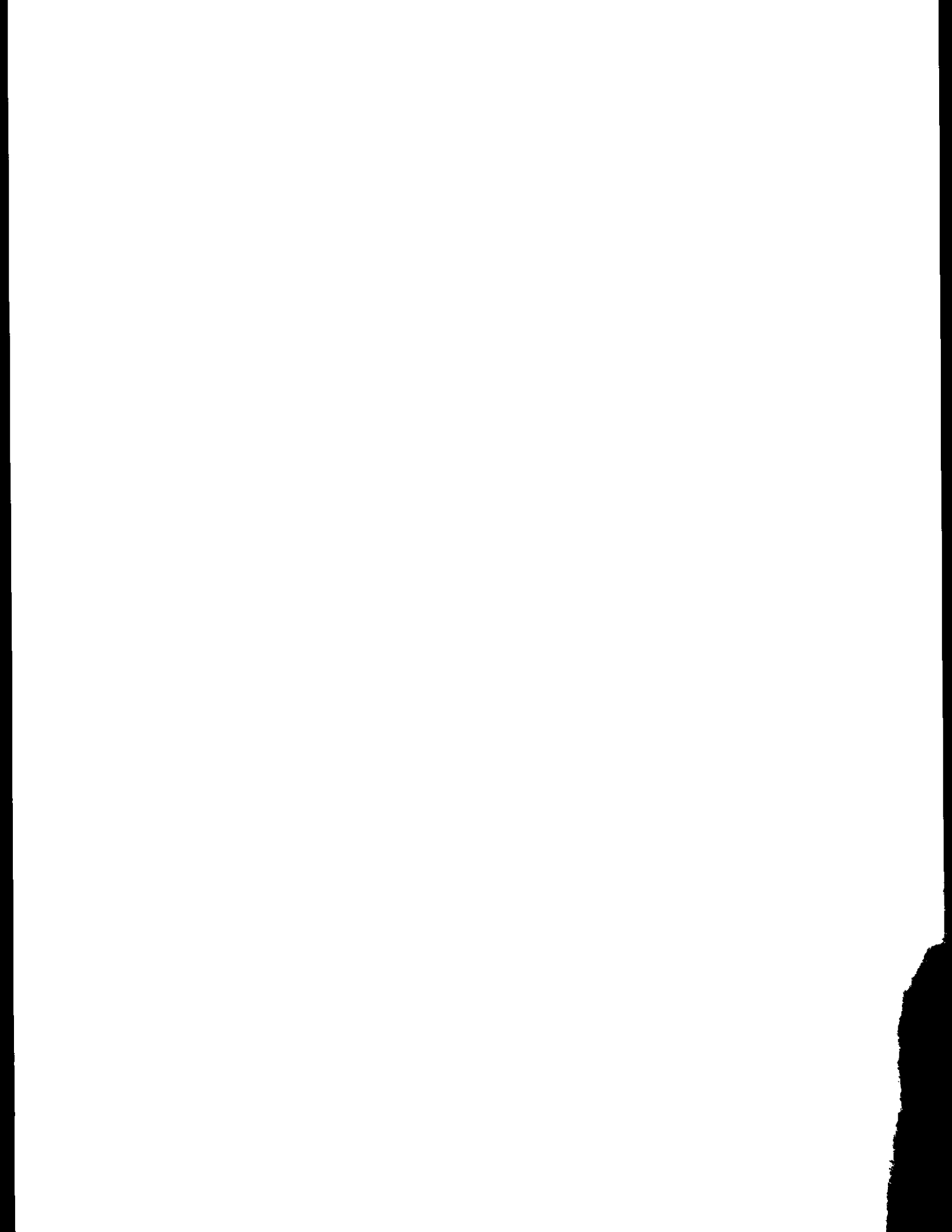

**Activity Descriptions
for
All Networks**

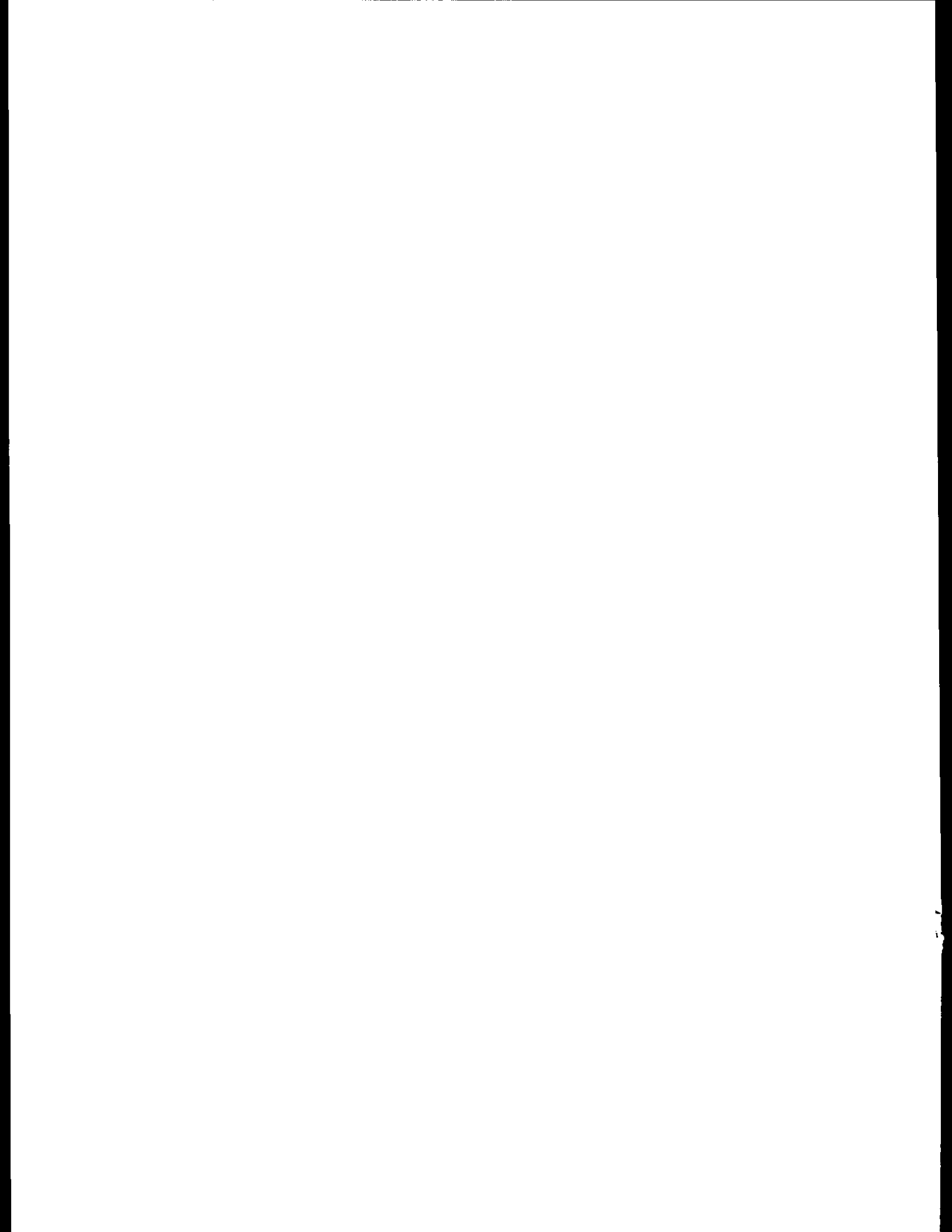

<u>TASK</u>	<u>SUBTASK AND DESCRIPTION OF ACTIVITIES</u>	<u>DELIVERY DATE</u>
1.1	1.1.1 TSG solicits problem statements in detailed format	
	1.1.3 Problem statements prepared and submitted	
	1.1.5 As received, problem statements are forwarded to PTC	
	1.1.7 TSG sets date for meeting to formulate annual work program	
2.1	<u>2.1.1</u> PTC (TRB staff) extracts key words and sends to TRIS	As required
	<u>2.1.3</u> TRIS searches files, forwards output to PTC	As required
	<u>2.1.5</u> PTC staff screens out nonrelevant materials	As required
	<u>2.1.7</u> PTC staff prepares evaluations	As required
	<u>2.1.9</u> PTC sends copy of problem statement and TRIS output to UMTA Program Coordinator to obtain UMTA evaluation	
	2.1.11 UMTA staff prepares evaluations	
	<u>2.1.13</u> As made, PTC staff evaluations and TRIS output are forwarded to TSG	As required
	2.1.15 As made, UMTA evaluation are forwarded to TSG	
	2.1.17 Based on evaluations, TSG modifies details of problem	
	2.1.19 By letter ballot, TSG members rate revised problem statements	
	2.1.21 TSG ratings are converted to rankings and circulated to membership	
	2.1.23 TSG meets to formulate annual work program	
	2.1.25 TSG sends annual work program to UMTA for approval	
	2.1.27 UMTA acts on approval of program	
	2.1.29 UMTA and TSG coordinate as needed if revision of recommended program is necessary	
	2.1.31 UMTA refers approved program to PTC, with copy of correspondence to TSG	
3.0	<u>3.0.1</u> Ballot on acceptability of problems to be identified with the Academy is prepared and sent to the Executive Committee Subcommittee for the NCTRP	+1 week*
	<u>3.0.3</u> Subcommittee acts on ballot	+3 weeks
	<u>3.0.5</u> Acceptance action recommendation is made to PTC	+3.5 weeks
	<u>3.0.7</u> PTC acts on acceptance recommendation and so notifies UMTA	+4.0 weeks
	3.0.9 UMTA notifies TSG of PTC acceptance	
	3.0.11 TSG acts as appropriate re PTC rejection of problems or programs	
	3.1.13 TSG submits revisions to UMTA	
	3.0.15 UMTA submits revisions to PTC	
	<u>3.0.17</u> 3.0.1 through 3.0.9 repeated as needed	As required

*Accumulative from date PTC receives work program.

<u>TASK</u>	<u>SUBTASK AND DESCRIPTION OF ACTIVITIES</u>	<u>DELIVERY DATE</u>
3.1	<u>3.1.1</u> Concurrently with 3.0.1, NCTRP Director assigns problems to research areas and staff	+4.2 weeks
	<u>3.1.3</u> NCTRP Director sets panel meeting dates	+4.5 weeks
	<u>3.1.5</u> PTC prepares background materials for soliciting nominees for panels	+6.0 weeks
	<u>3.1.7</u> Staff determines balance of expertise required by problem	+6.0 weeks
	<u>3.1.9</u> Solicitation letters are mailed	+6.5 weeks
	<u>3.1.11</u> Nominees are submitted	
	<u>3.1.13</u> Staff balances nominee expertise against problem needs and recommends panels to NCTRP Director	As required
	<u>3.1.15</u> NCTRP Director and staff agree on tentative roster	As required
	<u>3.1.17</u> NCTRP Director sends invitation-to-serve letter	As required
	<u>3.1.19</u> Responses are returned	
	<u>3.1.21</u> NCTRP Director sends additional invitations in instances of turndowns	As required
	<u>3.1.23</u> NCTRP Director sets tentative rosters	As required
	<u>3.1.25</u> NCTRP Director sends acknowledgement letter to those accepting	As required
	<u>3.1.27</u> Concurrent with 3.1.25, NCTRP Director submits tentative rosters to Academy for approval	As required
	<u>3.1.29</u> Academy acts on approvals and notifies NCTRP	As required
	<u>3.1.31</u> Concurrent with 3.1.27, NCTRP Director prepares formal appointment letters for TRB Executive Director's signature	As required
	<u>3.1.33</u> Appointment letters are mailed	+15 weeks
	<u>3.1.35</u> NCTRP Director begins coordination with UMTA and TSG to develop mailing list for Project Statements	+12 weeks
	<u>3.1.37</u> Cards confirming acceptance of appointment are mailed to TRB	
3.2	<u>3.2.1</u> Technical panels meet to prepare Project Statements	+19.5 weeks
	<u>3.2.3</u> Project Statements are submitted to editorial and production processes	As required
	<u>3.2.5</u> Project Statements are printed	As required
	<u>3.2.7</u> Project Statements are forwarded to mailer	+23.5 weeks
	<u>3.2.9</u> Panels prepare Problem Evaluation Forms	+19.5 weeks
	<u>3.2.11</u> Panels review guidelines for proposal evaluation and agree on weights for key elements	+19.5 weeks

<u>TASK</u>	<u>SUBTASK AND DESCRIPTION OF ACTIVITIES</u>	<u>DELIVERY DATE</u>
	<u>3.2.13</u> Staff drafts meeting notes and circulates for approval	+21.5 weeks
	<u>3.2.15</u> Meeting notes types, duplicated, and mailed	+23.5 weeks
3.3	<u>3.3.1</u> Project Statements mailed	+24 weeks
	<u>3.3.3</u> Staff responds to inquiries as necessary	As required
	<u>3.3.5</u> Staff coordinates with Minority Business Enterprises as necessary	As required
	<u>3.3.7</u> Agencies prepare and submit proposals	
	<u>3.3.9</u> Proposals processed	+32.5 weeks
	<u>3.3.11</u> Notifications of rejections mailed	As required
	<u>3.3.13</u> Deleted	
	<u>3.3.15</u> Deleted	
	<u>3.3.17</u> Proposals mailed to panel	+33 weeks
	<u>3.3.19</u> Panels evaluate proposals and prepare pros and cons	As required
	<u>3.3.21</u> Panels meet to rank proposals and make selections	+41-45 weeks
	<u>3.3.23</u> Panels prepare statements of reasons behind selections	+41-45 weeks
	<u>3.3.25</u> Panels prepare Proposal Review and Recommendation Form (PRRF)	+41-45 weeks
	<u>3.3.27</u> Panels update Problem Evaluation Form (PEF)	+41-45 weeks
	<u>3.3.29</u> Notification to unsuccessful proposers prepared and mailed	+42-46 weeks
	<u>3.3.31</u> 1st-choice letters prepared and mailed	+42-46 weeks
	<u>3.3.33</u> 2nd-choice letters prepared and mailed	+42-46 weeks
	<u>3.3.35</u> OCG sent 1st-choice proposal	+41.5-45.5 weeks
	<u>3.3.37</u> Comptroller's Office sent 1st-choice proposal and asked to determine agency's financial responsibility	+41.5-45.5 weeks
	<u>3.3.39</u> PTC report to UMTA on agency selections is prepared and mailed to UMTA, a copy to TSG	+47 weeks
	3.3.41 Agencies respond to PRRF	As required
	<u>3.3.43</u> Panels act on approvals of agencies' responses	As required
	<u>3.3.45</u> Subcontract Information Summary is prepared and sent to OCG	+51.5-55.5 weeks
	<u>3.3.47</u> OCG & NCTRP resolutions as necessary	As required
	<u>3.3.49</u> OCG prepares subcontract	+52-56 weeks
	<u>3.3.51</u> OCG forwards subcontract to agency	+52-56 weeks

<u>TASK</u>	<u>SUBTASK AND DESCRIPTION OF ACTIVITIES</u>	<u>DELIVERY DATE</u>
	<u>3.3.53</u> Agencies review and respond to OCG	+54-58 weeks
	<u>3.3.55</u> OCG and NCTRP coordinate as needed re agency response	As required
	<u>3.3.57</u> OCG sends copy to UMTA	+56-59 weeks
	<u>3.3.59</u> UMTA coordinates, as required, with OCG re subcontract	As required
3.4	<u>3.4.1</u> PTC provides UMTA with a statement of safeguards against personal or organizational conflicts of interest	As required
	<u>3.4.3</u> PTC provides UMTA with copy of Procedural Manual for Agencies Conducting Work in the NCTRP	As required
4.1	<u>4.1.1</u> Research begins	+56-59 weeks
4.2	<u>4.2.1</u> Agencies submit Working Plan (WP)	+57-60 weeks
	<u>4.2.3</u> PTC forwards WP to panels for review and approval	As required
	<u>4.2.5</u> Panels act and notify PTC	As required
	<u>4.2.7</u> Panel review comments on WP sent to agencies	As required
	<u>4.2.9</u> Agencies revise WP as needed and resubmit	
	<u>4.2.11</u> PTC coordinates with panels as necessary re revised submittal	As required
	<u>4.2.13</u> Agencies notified of approval action	As required
	<u>4.2.15</u> PTC staff makes first surveillance visit	As required
	<u>4.2.17</u> PTC staff monitors research in progress through contacts, visits, progress reports - monthly and quarterly	Continuous
	<u>4.2.19</u> PTC staff keeps panels abreast of work	Continuous
	<u>4.2.21</u> PTC staff distributes quarterly progress reports from agencies, coordinates re review comments, and prepares quarterly letter report.	Calendar quarter
	<u>4.2.23</u> PTC staff prepares semi-annual progress report for UMTA and TSG	December & July
	<u>4.2.25</u> PTC staff participates in briefings as required	As required
	<u>4.2.27</u> PTC staff prepares annual report on PTC progress in administration of NCTRP activities	Dec. annually
	<u>4.2.29</u> Annual report is distributed	March 15
	<u>4.2.31</u> PTC checks and approves agency invoices	As required
5.2	<u>5.2.1</u> As necessary and appropriate to circumstances, PTC staff will see to preparation and distribution of digests, technical articles, etc., reporting to the transit community on useful products soon after they are developed	As required

<u>TASK</u>	<u>SUBTASK AND DESCRIPTION OF ACTIVITIES</u>	<u>DELIVERY DATE</u>
5.4	5.4.1 Final report received in preliminary draft	As completed
	<u>5.4.3</u> Copy is sent to editor	On receipt
	<u>5.4.5</u> Copy is sent to responsible staff engineer	On receipt-
	<u>5.4.7</u> Acknowledgement of receipt prepared and sent to Principal Investigator, copy to OCG, with request for inventory of data and equipment	On receipt
	<u>5.4.9</u> OCG requests inventory of data and equipment, certification form, and reminds re final voucher	On receipt & equipment
	<u>5.4.11</u> Staff engineer prepares and mails memo requesting panel review of report re technical compliance with subcontract requirements	On receipt
	<u>5.4.13</u> Panels complete reviews and mail to staff engineer	As required
	<u>5.4.15</u> Two (2) copies are sent to file	On receipt
	<u>5.4.17</u> Staff engineer completes his review	Receipt +30 days
	<u>5.4.19</u> Staff engineer summarizes review comments and mails to Principal Investigator	Receipt +7 weeks
	5.4.21 Principal Investigator prepares point-by-point letter response to review comments and mails to NCTRP	As required
	5.4.23 Principal Investigator revises report according to panel review comments and ships prescribed number of copies to NCTRP	As required
	<u>5.4.25</u> Copy of final draft is sent to staff engineer	On receipt
	<u>5.4.27</u> Staff engineer reviews final draft and accumulates information, materials, etc., as appropriate to needs of editorial and publication processes	As necessary
	<u>5.4.29</u> Delete	On receipt
	<u>5.4.31</u> Copy of staff memo (see 5.4.11) and final draft report are sent to UMTA for review	On receipt
	<u>5.4.33</u> NCTRP Director sends one (1) copy of final draft report to each member of the TSG	On receipt
	<u>5.4.35</u> PTC staff arrives at decision as to manner of publication and distribution of report	As necessary
	<u>5.4.37</u> Reports not to be published are put on microfiche	
	5.4.39 UMTA reviews report and forwards any comments to NCTRP	Receipt +30 days
	5.4.41 Subcontractor prepares and mails response re data and equipment inventory to PTC OCG	As required

<u>TASK</u>	<u>SUBTASK AND DESCRIPTION OF ACTIVITIES</u>	<u>DELIVERY DATE</u>
<u>5.4.43</u>	OCG requests NCTRP comments on agency recommendation for disposition of data and equipment	As required
<u>5.4.45</u>	Staff engineer advises OCG of instructions to agency	As required
<u>5.4.47</u>	OCG responds to agency	As required
<u>5.4.49</u>	Agency acknowledges instructions and forwards final voucher	
<u>5.4.51</u>	NCTRP forwards final voucher to Accounting and requests project audit	As required
<u>5.4.53</u>	DCAA performs audit and notifies PTC	As required
<u>5.4.55</u>	Accounting forwards to OCG the audit results, copy to NCTRP	As required
<u>5.4.57</u>	OCG sends letter or final amendment to subcontractor; copy to Accounting triggers payment of final voucher	As required
<u>5.4.59</u>	Agency prepares and submits final voucher and subcontractor's certification	As required
<u>5.4.61</u>	OCG distributes fully executed amendments, if applicable	As received
<u>5.4.63</u>	Accounting pays final voucher, copies to NCTRP and OCG	As required
<u>5.4.65</u>	Comptroller's Office invoices UMTA	As necessary
<u>5.4.67</u>	UMTA acts on invoice	
<u>5.4.69</u>	Delete	
<u>5.4.71</u>	Delete	
<u>5.4.73</u>	Staff engineer writes Foreword and puts report into editorial and publication process	As appropriate
<u>5.4.75</u>	Staff engineer forwards report abstract to TRIS	On receipt
<u>5.4.77</u>	Staff editor places copy of Foreword in in suspense file for retrieval at galley stage	On receipt
<u>5.4.79</u>	Staff editor acquires Library of Congress number	As appropriate
<u>5.4.81</u>	Editor and staff engineer review Foreword to ensure relevancy to current circumstances at galley stages	As appropriate
<u>5.4.83</u>	Staff engineer forwards Foreword to Principal Investigator for checking	As prepared
<u>5.4.85</u>	Principal Investigator reviews and returns to staff engineer with comments	
<u>5.4.87</u>	Editor completes work and sends report for publication	As appropriate
<u>5.4.89</u>	Report is published	As appropriate
<u>5.4.91</u>	Staff editor coordinates with staff engineer to prepare summary sheet necessary for placing published report in NTIS (Form NTIS-35, Rev. 10/73)	As appropriate

<u>5.4.93</u>	Report is distributed through PTC (TRB) selective distribution processes to UMTA, TSG, and many others	As appropriate
<u>5.4.95</u>	PTC staff prepares and mails letters sending published report to panel members	As appropriate
<u>5.4.97</u>	TRB advises Academy of panel disbandment	As appropriate
<u>5.4.99</u>	PTC prepares and mails letter of appreciation to Principal Investigator (includes copy of published report)	As appropriate
<u>5.4.101</u>	PTC mails copies as prescribed in sub-contract, of published report to sub-contractor's contracts officer	As appropriate
5.4.103	Delete	
<u>5.4.105</u>	PTC project records closed on receipt of final payment information	As appropriate
<u>5.4.107</u>	When decision is made re publication of report, panel is so notified via letter of appreciation. They are also told that PTC will take steps to disband panel and that they will receive copy of report when published	As appropriate
<u>5.4.109</u>	UMTA is advised of publication decision, copy to TSG	As appropriate
<u>5.4.111</u>	Principal Investigator is advised of publication decision	As appropriate

Project Completed

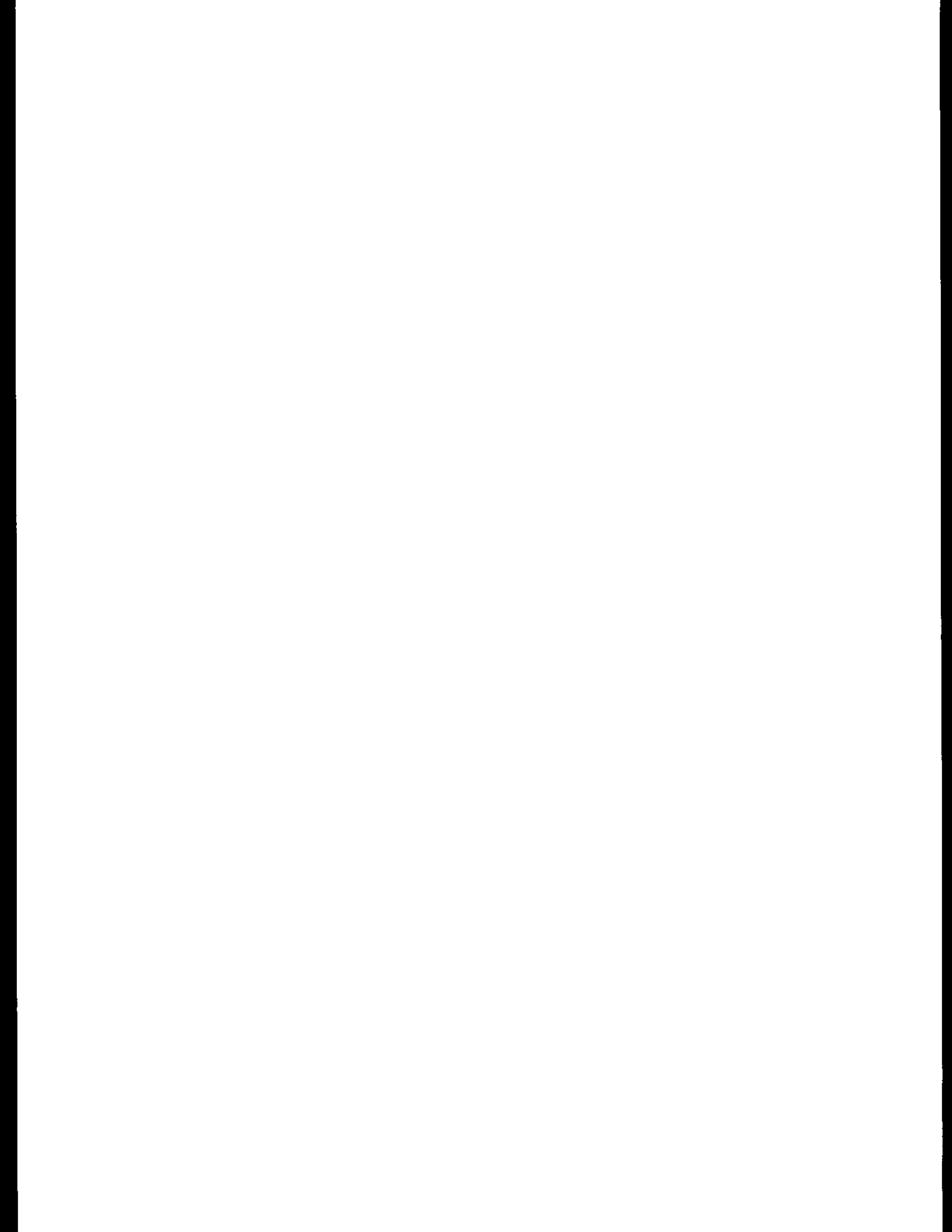

PROGRESS BY PROJECTS

The following pages present detailed status reports on those projects for which there remains any type of contractual activity. The status of *all* projects can be found in Table I.

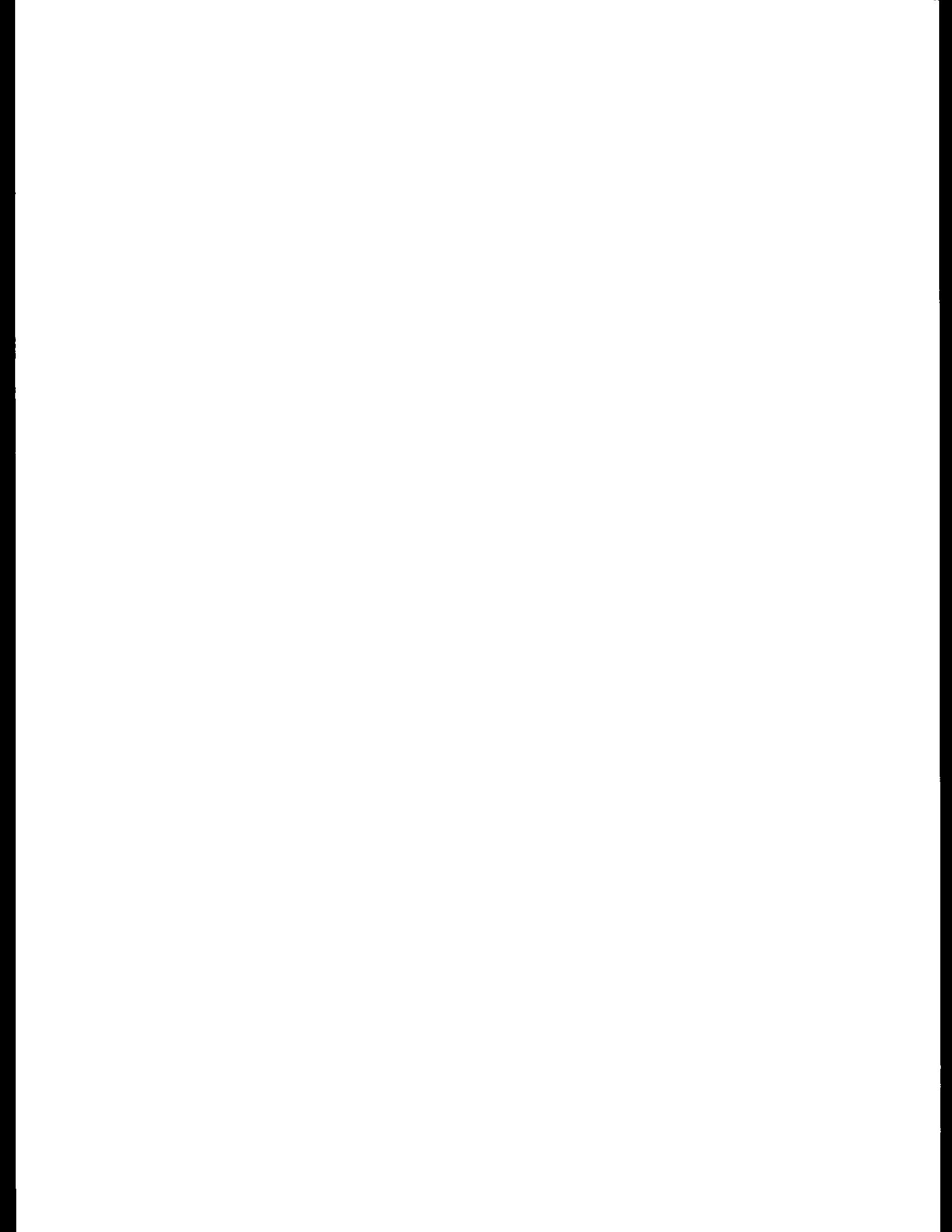

AREA THIRTY: ECONOMICS

Project: 30-1, FY '81
Title: Small Transit Buses: A Manual for Improved Purchasing, Use, and Maintenance

Research Agency: Arthur D. Little, Inc.
Principal Investigator: Dr. P. Ranganath Nayak

Effective Date: November 8, 1982
Completion Date: August 7, 1984

AGENCY PERFORMANCE

1. Is the project on schedule: No* Percent project complete: 95
2. Is the research in keeping with the approved research plan: Yes
3. Subcontract Amount: \$299,378
4. Estimated Expenditures to 6/30/84: \$297,378
5. Are the expenditures in keeping with the project progress: No*

*Data base preparation has taken greater funds and time than anticipated. The project is expected to be completed within budget and with a two to three month time extension.

PROJECT DESCRIPTION

One of the important decisions facing both rural and urban transit decisionmakers is whether to invest scarce funds in more expensive or less expensive small transit buses. Available small buses (i.e., ranging from van conversions to 31-ft heavy-duty small buses) are highly diverse in both capital costs and technology. Their uses are also highly diverse, spanning the range from large transit fleets in major urban areas to small rural operators, and including fixed-route, demand-responsive, shuttle and other services. The complexity of both needs and possible solutions has led to many poor choices of buses for specific duties. In addition, uncertainties with respect to the small bus market have led to a lack of continuity in design and development; perceived problems in bus operation, maintenance, and reliability; a lack of clear definition of bus demand; and little standardization within realistic price ranges. Consequently, no guidelines exist with which transit providers, seeking to purchase or replace small buses, can make objective decisions concerning the best bus type to be procured.

The general objective of this research is to develop a workbook-style manual for local transit operators and to identify key recommendations that might feasibly be taken by transit operators, local governments, states, and UMTA to substantially improve the procurement, appropriate use, and maintenance processes for small transit buses. The manual is intended for use by individuals experienced and inexperienced in the procurement and operation of small transit buses. Furthermore, the manual is intended to assist individuals in the cost-effective procurement, maintenance, and operation of buses in a wide range of local, institutional, service, and operating environments. (Included in the definition of service and operating environments are maximum and average loads; type of service; range requirements (i.e., distance between refueling); wheelchair-lift or ramp needs, and actual usage; types, conditions, and grades of roads/streets; dwell-time constraints; weather extremes; frequency and degree of acceleration/braking; communication equipment requirements; and fare collection equipment requirements). The manual will be based on research requiring the collection, tabulation, and analyses of primary information and data. While performing the research, investigators must be particularly cognizant of bus maintainability and fuel efficiency. (Included in the definition of maintainability are life expectancy of the bus's power train, body, and major components; minimum mean time before failure (MTBF) rates of components; availability and cost of parts; maintenance and servicing facilities required; skill levels and representative times and costs required for servicing and repair; complexity of subsystems (i.e., lifts and air conditioning).) Fuel efficiency studies should consider duty cycle, propulsion technology, maintenance, bus size and weight, gearing, etc. Transit operators will be the principal users of the research results, although they should also be of interest to manufacturers and funding agencies. To accomplish this objective the following tasks are considered essential but not limiting:

Task 1 - Determine the present capital and operating costs, and performance of small transit buses in U.S. operations as affected by (1) service and operating environments, (2) institutional environments, and (3) maintenance availability and sophistication.

A. Develop a classification system for small buses by type (life expectancy, maintainability, operating cost) and size.

B. Develop a classification system for operational environments and maintenance programs.

C. Develop a detailed data collection plan for use in determining capital and operating costs for various classes of buses, maintenance programs, and operating environments.

D. Collect data and summarize results for various bus and component classes to provide transit operators with relevant design characteristics and operating experience. Analyze MTBF data (as developed in this study or available elsewhere), design characteristics, and general operating experience for key components, subsystems, chassis types, etc. that are critical to the development of minimum specifications for various service and operating environments, appropriate maintenance actions, and realistic replacement

Project 30-1 continued

intervals. Develop from these data an engineering analysis of each bus class describing its suitability for various types of service and likely operating results. Assess the practicality of using life-cycle costs to assist in the description of operating results.

E. Identify problems for transit operators and manufacturers in using or producing small transit buses that are supported by the data.

Task 2 - Develop practical recommendations for resolution of key problems, identified in the research, for improving the purchase, maintainability, and cost-effective use of small transit buses. These recommendations should be oriented towards actions that can be taken by transit operating agencies to improve delivery of service.

Task 3 - Based on the results of Task 1, develop a workbook (flow-chart type) manual that can be used by transit operators to make appropriate small bus choices. The manual should be designed to take as input such planning factors as service type, anticipated passenger loads, typical speeds, maintenance and institutional factors. Its output should include the classes of small transit buses that are best suited to the projected operating environment, special specification items or options that should be required, the range of maintenance and fuel costs likely to be experienced, and special maintenance provisions that should be undertaken.

STATUS OF RESEARCH

Through June 30, 1984, all research tasks have been completed. Nineteen (19) of the 27 agencies have provided data sufficiently complete to warrant entering them into a large computer-based data base. The 19 agencies represent a total of 223 buses, almost eight thousand maintenance events, 2.6 million bus-miles, and 1,200 bus-months of operation. The preliminary draft manual is in the review process. It allows the user to determine the required small-bus size and other features and to evaluate its operation and life-cycle costs based on generic bus type and duty cycle. The research report supporting the manual is in preparation.

AMENDMENT(S) THIS REPORTING PERIOD

None

PROBABILITY OF SUCCESS: Good

REPORT(S) AVAILABILITY: None

PRINCIPAL INVESTIGATOR(S): Dr. P. Ranganath Nayak
Mgr., Transportation Systems Group
Arthur D. Little, Inc.
Acorn Park
Cambridge, MA 02140
617/864-5770

RESPONSIBLE NCTRP STAFF ENGINEER: R. Ian Kingham - 202/334-3224

AREA THIRTY-THREE: PERSONNEL MANAGEMENT

Project: 33-1, FY '80
Title: Transit Bus Operator Selection and Training for Dealing with Stress

Research Agency: Group Associated Management Services, Inc.
Principal Investigator: Dr. Brownlee Elliott

Effective Date: October 15, 1981
Completion Date: October 14, 1983
Revised Completion Date: April 14, 1984

AGENCY PERFORMANCE

1. Is the project on schedule: Yes Percent project complete: 100
2. Is the research in keeping with the approved research plan: Yes
3. Subcontract Amount: \$150,000
4. Estimated Expenditures to 6/30/84: \$150,000
5. Are the expenditures in keeping with the project progress: Yes

PROJECT DESCRIPTION

Some bus operators possessing the basic skills to operate the vehicle may still experience difficulties in performing their job satisfactorily because of inability to cope effectively with the public. Use of all possible training and disciplinary action does not help when the individual hired does not have the psychological strengths necessary to deal effectively with continuous public contact, and the resultant stress may lead to more workers' compensation claims for nonvisible physical injury (i.e., heart and psychological problems) as well as to more accidents, absenteeism, and personnel turnover.

Various selection and training methods are currently being used by individual transit agencies. Some of these methods have been developed specifically for application in the transit industry, some have evolved from practice within individual agencies, and others represent modifications to methods originally developed for agencies outside of the transit industry. At present, however, no one single method of selecting or training bus operators from the viewpoint of their ability to deal with stress is considered to be generally acceptable for wide application by transit agencies. To ensure that methods have general applicability, the range of needs and capabilities of different size transit agencies, regional differences, and the makeup of the bus operator population (i.e., male/female and minorities) must be fully considered.

The objective of this research is to provide an evaluative device or questionnaire for use as part of the bus-driver-selection process that will validly indicate the applicant's susceptibility to stress which is likely to affect job performance. The research will also provide two training modules: one designed to help newly hired operators anticipate and deal with typical stressful situations, and one designed to help supervisors recognize stress symptoms displayed by operators and provide guidance on appropriate courses of action.

The following tasks are included:

Task 1. Review applicable literature, actual training programs, and studies currently being undertaken in the transit industry that deal with how to treat stress or its causes, how to understand the problem, and how to cope with it. Identify the various environmental, physiological, and psychological factors commonly used in stress analysis.

Task 2. Identify representative fixed-route bus transit agencies to participate in Tasks 3 and 5 including a minimum of one large agency (more than 500 buses), two medium agencies (100 to 500 buses), and three small agencies (less than 100 buses).

Task 3. Prepare and verify a set of stress factors and job characteristics to use in the preparation of the selection device (Task 4) and training modules (Task 6). Contact managers, operators (primary emphasis), and labor representatives from the selected transit agencies for suggested additions and deletions.

Task 4. Evaluate existing operator-selection-test mechanisms for general applicability in measuring an individual's tolerance for stress and then either modify an existing device or develop a new test device or questionnaire.

Task 5. Field test the device or questionnaire using existing operators from the agencies selected in Task 2 to establish its usefulness (e.g., readable and understandable).

Task 6. Prepare two sample training modules: one for newly hired operator training and one for supervisor training. The primary focus of the new operator training will be to alert the driver to typical stress-causing situations and to provide specific guidance on how to cope with each situation. The supervisor's training module will focus on the recognition of stress symptoms and tendencies and on the identification of appropriate courses of action. Both modules will be adaptable by an individual transit agency so that through property-specific modifications they can be made part of existing training programs.

Project 33-1 continued

Task 7. Provide a listing of appropriate pertinent data and resources (films, videotapes, surveys, models, books, papers, etc.) identifying concomitant costs, sources, and transit agencies that are using such methods for selection and stress management of bus operators and supervisors.

STATUS OF RESEARCH

Research has been completed and the final report will be published as NCTRP Report 7. Also, NCTRP Research Results Digest 1 provides a summary of the literature review. An operator-selection-test device was prepared and pilot tested at the six sites. A survey of various transit properties was conducted through APTA for the purpose of determining the training needs related to stress management.

Six training models were developed, two are introductory in nature, two are directed to the specific needs of bus operators, and two are directed to supervisors.

AMENDMENT(S) THIS REPORTING PERIOD

<u>Date</u>	<u>No.</u>	<u>Type</u>	<u>Amounts and/or Dates (From - To)</u>	<u>Comments</u>
2/17/84	1	Time	10/14/83 - 4/14/84 (6 mos.)	Substantial delays resulted during the collection of data from transit properties and in pilot testing the selection instrument.

PROBABILITY OF SUCCESS: Good

REPORT(S) AVAILABILITY: NCTRP Research Results Digest 1. NCTRP Report 7 should be available in July. (See final page of this document for ordering information.)

PRINCIPAL INVESTIGATOR(S): Dr. Brownlee Elliott, Research Director
Group Associated Management Services, Inc.
1914 Hyde Park Drive
Detroit, MI 48205
313/259-1666

RESPONSIBLE NCTRP STAFF ENGINEER: Robert E. Spicher - 202/334-3224

AREA THIRTY-THREE: PERSONNEL MANAGEMENT

Project: 33-2, FY '81
Title: Assessment of Job Enrichment Programs for the
 Transit Industry

Research Agency: Public Administration Service
Principal Investigator: Dr. Susan G. Clark

Effective Date: November 1, 1981
Completion Date: October 31, 1983
Revised Completion Date: February 29, 1984

AGENCY PERFORMANCE

1. Is the project on schedule: Yes Percent project complete: 100
2. Is the research in keeping with the approved research plan: Yes
3. Subcontract Amount: \$97,821
4. Estimated Expenditures to 6/30/84: \$97,821
5. Are the expenditures in keeping with the project progress: Yes

PROJECT DESCRIPTION

The political and fiscal environment of transit agencies is in a period of significant change. Scarcity of funds will mean a renewed emphasis on productivity and redoubled efforts to retain and motivate quality employees in the absence of financial incentives. New federal policies stressing local initiative will encourage management to be more sensitive to innovative ideas, and a changing work force will make different demands.

Although the transit industry is highly labor-intensive, a great deal of emphasis has been placed in the past on capital development, financial controls, and transportation planning. Potentially, one of the most important areas for improving transit agency effectiveness is the development and management of human resources through job enrichment programs. There is a need for a systematic investigation of the feasibility of job enrichment programs, such as job restructuring, quality circles, and other techniques that utilize the full talents and abilities of transit employees. It is anticipated that the greatest benefit of job enrichment efforts could be derived from first-line supervisors and those they supervise.

For purposes of this study, job enrichment is defined as making the elements of the job both physically and psychologically more stimulating, resulting in more productive behavior. The organization thus provides an environment that allows and influences self-esteem and promotes a positive attitude about one's employment through an individual's own initiatives. Job enrichment offers several possible benefits to the transit industry. For the organization, it provides the prospect of improving the operating environment by enhancing the effective management of human resources. For the individual employee, the concept fosters greater job satisfaction, improved self-esteem, and higher productivity.

The general objective of this research is to assess the feasibility of job enrichment programs for the transit industry for first-line supervisors and those they supervise. The assessment would include a survey and analysis of current techniques used to improve job satisfaction and productivity in transit as well as other fields with similar characteristics. The assessment would identify common barriers to the implementation of job enrichment programs in transit agencies including, but not limited to, cost, labor-management relationships, political climate, and resistance to change. The assessment would also include specific methods for measuring, monitoring, and evaluating the effectiveness and cost benefit of job enrichment programs. These objectives involve the following tasks:

- Task 1. Review of job enrichment literature.
- Task 2. Inventory and assessment of current status of job enrichment in transit.
- Task 3. Select and evaluate, for application, at least 5 job enrichment techniques from Tasks 1 and 2. The evaluation should include an assessment of the feasibility of these techniques when applied to different size properties (small, 50 buses or less; medium, 51 to 200 buses; and large, over 200 buses).
- Task 4. Develop sample detailed job enrichment programs for bus and rail operators, mechanics, first line supervisors, and one other support position.
- Task 5. Develop strategy for dissemination to the industry of job enrichment programs.
- Task 6. Prepare final report that also contains an appendix that catalogs specific job enrichment techniques applicable to the transit industry.

STATUS OF RESEARCH

Research is complete. The agency's final report describes quality of work life (QWL) techniques in general (NOTE: The term "quality of work life" has been substituted for "job enrichment" to better describe the techniques intended for investigation), characterizes the transit environment, and assesses the potential application of QWL techniques to transit agencies. A separate document contains model programs to guide the implementation of five techniques: incentives, job enrichment, quality circles, task forces, and labor-management committees.

Project 33-2 continued

AMENDMENT(S) THIS REPORTING PERIOD

<u>Date</u>	<u>No.</u>	<u>Type</u>	<u>Amount and/or Dates (From/To)</u>	<u>Comments</u>
2/28/84	2	Time	12/31/83 - 2/29/84 (2 mos.)	Time extension approved to accommodate final report revisions.

PROBABILITY OF SUCCESS: The panel consensus was that of a successfully completed project. A decision has been made to disseminate the results through regional seminars under NCTRP Project 33-2(2).

REPORT(S) AVAILABILITY: NCTRP Report 5, "Assessment of Quality-of-Work-Life Programs for the Transit Industry - Research Report," and NCTRP Report 6, "Assessment of Quality-of-Work-Life Programs for the Transit Industry - Model Programs." (See final page of this document for ordering information.)

PRINCIPAL INVESTIGATOR(S): Dr. Susan G. Clark
Public Administration Service
1497 Chain Bridge Road
Suite 202
McLean, VA 22101
707/734-8970

RESPONSIBLE NCTRP STAFF ENGINEER: Crawford F. Jencks - 202/334-3224

AREA THIRTY-THREE: ADMINISTRATION - PERSONNEL MANAGEMENT

Project: 33-2(2), FY '82/83
Title: Quality-of-Work-Life Programs for the Transit Industry-Regional Seminars

Research Agency: Public Administration Service
Principal Investigator: Dr. Susan G. Clark

Effective Date:
Completion Date: (15 months)

AGENCY PERFORMANCE

1. Is the project on schedule: Percent project complete:
2. Is the research in keeping with the approved research plan:
3. Contract Amount:
4. Estimated Expenditures to 6/30 84:
5. Are the expenditures in keeping with the project progress:

PROJECT DESCRIPTION

Under an initial NCTRP project, recommendations were made on the potential application of quality-of-work-life programs to transit agencies. These recommendations and the supporting research were documented in two reports: NCTRP Report 5, "Quality-of-Work-Life Programs for the Transit Industry - Final Report," and NCTRP Report 6, "Quality-of-Work-Life Programs for the Transit Industry - Model Programs." In order to ensure proper consideration of these findings and recommendations, a second project is needed to disseminate the results to the transit industry. After reviewing an array of strategies, NCTRP Project Panel A33-2 concluded that with the help of local sponsors, regional seminars would be the most productive means, given the financial resources anticipated for the project. The Panel has also judged that sufficient interest exists to warrant the seminar approach. The regional seminars will be based on the previous research and will address issues facing management, practitioners, labor, and others concerned with the development of human resources.

The objective of Project 33-2(2) is to conduct at least four regional seminars at locations geographically distributed across the nation. Maximum use will be made of volunteer, local sponsors and support in arranging and conducting the seminars. The agency selected to accomplish the project objective will be required to:

1. Provide the lead in organizing and conducting the seminars including arrangements with local sponsors for support. The selected agency will be responsible for preparing and making announcements to potential seminar participants with NCTRP approval.
2. Provide the agenda and prepare all seminar material, such as audiovisual aids, lesson plans, and handouts. Maximum advantage will be taken of the sequencing of seminars to appropriately modify the seminar material as needed. The NCTRP will be given the opportunity for prior reviews of all seminar material.
3. Turn over to the NCTRP, at the conclusion of the project, all seminar materials and a brief summary description of the seminars conducted. The seminar material will be in a form suitable for use by others in conducting additional group seminars and as instructional information for individuals. The seminar material and summary will be treated as the final report for the project.

FUNDS AVAILABLE \$50,000

AMENDMENTS(S) THIS REPORTING PERIOD

PROBABILITY OF SUCCESS:

REPORT(S) AVAILABILITY:

PRINCIPAL INVESTIGATOR:

RESPONSIBLE NCTRP STAFF INVESTIGATOR: R. Ian Kingham - 202/334-3224

AREA THIRTY-THREE: PERSONNEL MANAGEMENT

Project: 33-3, FY '82/'83
Title: Public Transit Bus Maintenance Manpower Planning

Research Agency: Fleet Maintenance Consultants, Inc.
Principal Investigators: Richard W. Drake and Subhash R. Mundle

Effective Date: November 1, 1983
Completion Date: October 31, 1984

AGENCY PERFORMANCE

1. Is the project on schedule: Yes Percent project complete: 70
2. Is the research in keeping with the approved research plan: Yes
3. Subcontract Amount: \$100,000
4. Estimated Expenditures to 6/30/84: \$66,500
5. Are the expenditures in keeping with the project progress: Yes

PROJECT DESCRIPTION

Proper manpower planning for bus maintenance is crucial to the efficient and economical operation of transit agencies. However, this crucial element is often determined in a very inexact manner based heavily on past experience and guesswork that may not be appropriate, particularly for transit agencies experiencing major changes in services, equipment, or facilities.

Transit agencies have recognized that operator manpower planning is necessary to ensure service reliability and maximum labor efficiency. However, equal attention has not been given to manpower planning for bus maintenance functions. This is, in part, because maintenance department job assignments often preclude the interchangeability of personnel among functions, skills are often specialized, and the need for maintenance personnel is dependent on many variables relating to equipment and facilities. In addition, multiplicity of work rules and other factors frustrate efforts to apply planning techniques to maintenance manpower. The result is that many transit agencies merely use such simple ratios as buses per mechanics or maintenance man-hours per miles of operation as the primary tools for performing this extremely critical function.

This project will focus on manpower planning techniques for bus maintenance only. Results of the project will provide transit management (1) better planning tools for maintenance staffing adjustments, (2) data for comparison with representative transit agency data, and (3) assistance in projecting maintenance manpower for optional equipment or subsystems. Successful completion of this project would set the stage for possible future research addressing similar areas in rail maintenance as well as bus and rail operator manpower planning.

The objectives of this project are to (1) develop a methodology for establishing labor estimates required for maintaining specific bus vehicle subsystems and (2) utilizing this methodology, gather data from several transit agencies and prepare standard labor estimates. These estimates must account for variance among agencies in such areas as bus reliability, operating environment, labor efficiency, and equipment characteristics, and must be presented in a format that facilitates their use by bus transit agencies for manpower planning and analysis purposes. Attainment of the project objectives will necessitate, at least, the following tasks:

Task 1. Identify major bus vehicle subsystems such as power plant, lifts, electrical, brakes, etc., for which maintenance manpower data would be gathered.

Task 2. Develop a standard glossary of terms; e.g., qualified mechanic man-hour, maintenance procedures and standards for each system to ensure uniformity of data.

Task 3. Identify site specific criteria; e.g., operating environment, vehicle subfleet, vehicle age that would impact on maintenance manpower requirements.

Task 4. Develop procedures for gathering data; e.g., site visits, questionnaires, etc.

Task 5. Develop procedures for analyzing data, establishing comparisons among properties, and evaluating work-force utilization. These must account for site specific factors from Task 3.

Task 6. Develop methodology for identifying representative agencies for collection of data.

Task 7. Select agencies for collection of data.

Task 8. Obtain approval of panel for project methodology and agency selection.

Task 9. Collect data from bus agencies and perform analysis according to procedures developed in Task 5.

Task 10. Develop methodology to permit bus agencies to use the information for maintenance manpower planning, estimating, and analysis purposes.

Task 11. Prepare a draft report for review by the NCTRP.

Task 12. Review the draft report and submit the final version in fulfillment of the technical obligations under the contract for the project.

Project 33-3 continued

STATUS OF RESEARCH

Through June 30, 1984, research is complete through Task 8. Data have been collected as part of Task 9 and analysis is in progress. Inasmuch as transit agencies are only beginning to computerize their maintenance management information systems, such data had to be obtained by hand during on-site visits. The data base has been "cleaned" and the data have been summarized in a format to permit bus agencies to use the information for maintenance manpower planning. The draft report is in preparation.

AMENDMENT(S) THIS REPORTING PERIOD

None

PROBABILITY OF SUCCESS: Based on accomplishments to date, the probability of success is good.

REPORT(S) AVAILABILITY: None

<u>PRINCIPAL INVESTIGATOR(S):</u> Mr. Richard W. Drake Fleet Maintenance Consultants, Inc. 1830 Kirkwood Suite 201 Houston, TX 77077 713/496-7717	Mr. Subhash R. Mundle Principal Booz, Allen & Hamilton, Inc. 400 Market Street Philadelphia, PA 19106 215/627-5450
---	---

RESPONSIBLE NCTRP STAFF ENGINEER: R. Ian Kingham - 202/334-3224

AREA THIRTY-SIX: ALTERNATIVE ANALYSIS

Project: 36-1, FY '80
Title: Improving Decision-Making for Major Urban Transit Investments

Research Agency: System Design Concepts, Inc.
Principal Investigators: Joseph R. Stowers and Arlee T. Reno

Effective Date: November 2, 1981
Completion Date: February 1, 1983
Revised Completion Date: November 1, 1983
Anticipated Completion Date: December 31, 1984

AGENCY PERFORMANCE

1. Is the project on schedule: No* Percent project complete: 99
2. Is the research in keeping with the approved research plan: Yes
3. Subcontract Amount: \$200,000
4. Estimated Expenditures to 6/30/84: \$200,000
5. Are the expenditures in keeping with the project progress: Yes

*By project panel action, the scope of work was modified to include additional case studies, and additional time for them was provided. Funding to support the added work came from money held in a project reserve in anticipation of the need for more work (see amendment information). Beyond this circumstance, the agency fell behind in revising the final draft; the underlying causes have been rectified.

PROJECT DESCRIPTION

The environment for transportation planning and investment decisions is in a period of dramatic change. Fiscal constraints, a possible reorientation of federal transportation policies, and an increasing reliance on local commitment and decision-making are all likely to influence significantly the future of transportation in urban areas. Even with these pressures, however, urban areas will still be facing decisions on major investments in transit systems. Thus, there will be a need in future years for a planning and analysis process that examines major transportation options and that informs decision-makers so that most cost-effective investment decisions can be effected.

Since 1975, the Urban Mass Transportation Administration has required, as a condition for federal funding support, a structured process termed alternatives analysis for proposed major investments in urban mass transit facilities. This process is used to identify priority corridors for possible major investments and to assess the cost-effectiveness of these investments in comparison to less costly transit improvements. Information generated in the process is used both by federal officials in administering a discretionary capital grant program and by state and local officials in determining priorities and identifying needed improvements in mass transportation services. Three important decision points occur within the UMTA major transit investment planning process. First, appropriate local officials identify the corridor(s) where major investments appear to be most needed. Second, local and federal officials agree on a small set of investment alternatives that encompass a reasonably broad range of options. Finally, local, state, and federal officials agree on one (or more) of these alternatives for advancement into preliminary engineering.

Since the advent of the alternatives analysis requirement, a significant number of urban areas have been involved in some aspect of the process. Concerns have been expressed with the process. For example, there is uncertainty regarding both the effect on the timing of transit investment decisions and the use of information in the federal review process and in local decision-making. Although adjustments to the process have been made to enhance its usefulness in local, state, and federal decision-making, no comprehensive assessment has been made of the degree to which analytical requirements have provided appropriate information at key decision points.

There is a need to evaluate past experience with alternatives analysis and to recommend improvements in the process that will result in more effective local, state, and federal decision-making. Such an assessment would be useful, for example, in identifying points where decision-makers have not had complete information, where the process has constrained appropriate decisions, or where significant efforts are invested in the development of information that is not used in decision-making. Although it is unclear what direction federal policy will take in regard to alternatives analysis, the need for some form of alternatives analysis for such investments will continue.

The general objective of this research is to assess the federal, state, and local decision-making process for major urban mass transportation investments by evaluating recent alternatives analysis experiences. The purpose of the assessment is to identify potential improvements in policy, procedures, and use of technical information; and to formulate planning procedures recommendations for use by federal, state, and local agencies. Such improvements would be in terms of time, costs, scale, presentation of information, role of participants, and the like. (The assessment is not intended to prescribe specific analytical techniques or to judge the appropriateness of previous major urban transit decisions.)

Research tasks to satisfy the general objective are as follows:

Project 36-1 continued

Task 1--Inventory all applicable regulations and requirements concerning the evaluation of proposed major urban mass transportation investments.

Task 2--Review relevant literature on alternatives analysis and transit investment decision-making.

Task 3--Prepare methodologies for (a) the analysis and assessment of recent alternatives analysis decision-making experiences and (b) the selection of case studies.

Task 4--Select and conduct case studies, including those undertaken pursuant to the 1976 guidelines as well as other cases.

Task 5--Evaluate the usefulness of information developed in alternatives analysis for decision-making at each level of government.

Task 6--Formulate recommendations to Federal DOT and to state and local agencies.

STATUS OF RESEARCH

Research is complete; however, several case study reports need to be finalized. Case studies were conducted in Baltimore, Houston, Milwaukee, Pittsburgh, Portland, San Diego, San Jose, Toronto, Dayton, St. Louis, Cleveland, Boston, Calgary, Edmonton, and Denver. Their selection was based on the following criteria upon which evaluation in Task 6 was based: (1) decision following preliminary alternatives analysis, (2) difficulty selecting priority corridor, (3) intensity of corridor evaluation process, (4) complexity of potential alternatives, (5) reason for undertaking alternatives analysis, (6) types of investment, (7) status of project, (8) level of effort in analysis process, (9) lead agency conducting study, (10) role of referenda in decision process, and (11) work conducted by consultants. Based on the evaluation a set of recommendations was developed.

AMENDMENT(S) THIS REPORTING PERIOD

<u>Date</u>	<u>No.</u>	<u>Type</u>	<u>Amounts and/or Dates (From - To)</u>	<u>Comments</u>
8/22/83	2	Time	5/1/83 - 11/1/83 (7 mos.)	Based on project panel recommendation, the scope of work was revised to include additional case studies. Funds were increased using money held in a project reserve in anticipation of a need for more work. A time extension at no increase in cost is required due to an underestimate of time required to do the additional work.

PROBABILITY OF SUCCESS: Good

REPORT(S) AVAILABILITY: NCTRP Report 4, "Improving Decision-Making for Major Urban Transit Investments"

<u>PRINCIPAL INVESTIGATOR(S):</u>	Dr. Joseph R. Stowers Vice President System Design Concepts, Inc. One Farragut Square South Washington, DC 20006 202/393-5910	Mr. Arlee T. Reno Director of Finance and Policy Studies System Design Concepts, Inc. One Farragut Square South Washington, DC 20006 202/393-5910
-----------------------------------	--	---

RESPONSIBLE NCTRP STAFF ENGINEER: R. Ian Kingham - 202/334-3224

AREA THIRTY-EIGHT: SYSTEM PLANNING

Project: 38-1, FY '81
Title: National Transit Computer Software Directory

Research Agency: COMSIS Corporation
Principal Investigator: David M. Levinsohn

Effective Date: January 3, 1983
Completion Date: January 2, 1984
Revised Completion Date: August 31, 1984

AGENCY PERFORMANCE

1. Is the project on schedule: Yes Percent project complete: 95
2. Is the research in keeping with the approved research plan: Yes
3. Subcontract Amount: \$100,000
4. Estimated Expenditures to 6/30/84: \$90,000
5. Are the expenditures in keeping with the project progress: Yes

PROJECT DESCRIPTION

Over the past decade, computer (software) systems have gained widespread acceptance as important management and operating tools in public transit agencies. Representative software applications include planning (UTPS), scheduling (RUCUS), operations control, maintenance (SIMS), finance, and personnel. It is estimated that the public transit industry spends several million dollars each year on the design of software. Because there are great similarities in the structure and operation of transit agencies, software developed by one agency can often be adapted for use by other agencies with much less cost and effort than custom-designing completely new software. The lack of knowledge of existing software and its applications results in the spending of significant amounts of money by many transit agencies to develop new software that may not be as effective as it could be or may be "reinventing the wheel." Therefore, there is a need for the design and implementation of a detailed and complete national transit computer software directory that can be continuously updated to function as a central clearinghouse, making information available to individual public transit agencies that are planning software development. The anticipated benefit from the design and implementation of the directory is lower costs for software users. Use of the directory should lead directly to commonality of systems, faster software implementation, and public domain software that can be obtained at minimal cost. The benefit of identifying and using transportable software can only be realized if there are provisions for maintenance of the directory on a continuing basis.

The objective of this research is to develop and pilot test a methodology for the establishment and continuous updating of an automated directory of computer software useful to the public transit industry. The directory shall have the capability of including (1) software suitable for use by transit agencies of all sizes, and (2) existing and future software for use on computers of all types and sizes.

To accomplish the objective, the following tasks are to be conducted:

Task 1 -- Directory Content. Review and cite the applicable literature describing the availability of computer software programs for use by public transit agencies. Examples of such references include, but are not limited to, the American Public Transit Association (APTA) "Catalog of Management Information System Applications within the Transit Industry," the American Association of State Highway and Transportation Officials (AASHTO) "Computer System Index," and work of the Institute of Transportation Engineers (ITE). Using these references, and in consultation with the transit industry as appropriate, the researchers shall propose content, structure, and format for a directory of computer software. The content of the directory shall focus on the principal categories of transit operation, such as finance, operations, maintenance, administration, planning, as well as others deemed appropriate.

The researchers shall provide a detailed format, specifying the description for each principal category and software application. In order to assist users in identifying software that is potentially useful to them, sufficient detail should be provided, for example, hardware environment, operating system, programming language, and the like.

Task 2 -- Methodology. The researchers shall investigate existing information systems, such as the Transportation Research Information System (TRIS), the International Road Research Documentation, and others, to evaluate their capabilities regarding the recommended directory as part of those existing systems. The researchers shall review and evaluate other methods of designing and maintaining the automated transit directory. This evaluation should include:

- Description of methods reviewed.
- Review criteria used.
- Pros/cons of each method.
- Recommended method.

Project 38-1 continued

Documentation of the recommended method should include an overview, description of major functions, copies of forms/screens/reports used for input/inquiry/output, and necessary procedures.

Task 3 -- Management Procedures. The ultimate success of this project requires the existence of an organization (not yet identified) that will be responsible for the provision and maintenance of an up-to-date directory. The researchers shall define the management function required of this organization. This function shall be based on a thorough examination of existing software directories and their deficiencies. The management function should assure that the system will serve the need of both large and small transit agencies. It should include methods for attracting and holding participation by the transit agencies. Particular attention should be paid to providing incentives to the participants for supplying and updating the entries in the directory. Methods should be described for making all transit agencies, and others who can benefit from the services offered, aware of the existence of the directory. The description of the management function should also include the methods by which information can be collected from and disseminated to interested parties or transit agencies.

Task 4 -- Case Study. As a means of demonstrating the capabilities of the proposed methodology, the researchers shall provide an updated "1980 APTA Catalog of Management Information Systems Applications within the Transit Industry." This catalog is to be provided in both hardcopy and machine-readable format. It should contain all of the data elements as defined in Task 1.

Contact should be made in person with all APTA members to solicit updates to the existing data. The purpose of this contact is to demonstrate the procedures, forms, and incentives of the proposed methodology.

Additionally, agencies should be asked to request items from the directory as a method of testing the validity and flexibility of the recommended search criteria.

Researchers shall provide sample output reports that illustrate the output types as defined in Task 3.

Task 5 -- Directory Maintenance. Evaluate and recommend potential organizations that can provide the management functions as described in Task 3.

Consideration must be given to the following issues:

- How and by whom should the directory be maintained?
- How should directory information be disseminated?
- What will be the estimated cost of this function?
- What permanent funding sources are recommended?

Because the ultimate selection of the organization to maintain the directory will depend on these issues, a complete discussion should be provided, particularly with respect to recommending funding sources; including consideration of applicable laws, regulations, policies, and institutional inter-relationships.

STATUS OF RESEARCH

Research as been completed. The preliminary draft report has been submitted and is in the review process.

AMENDMENTS(S) THIS REPORTING PERIOD

<u>Date</u>	<u>No.</u>	<u>Type</u>	<u>Amount and/or Dates (From/To)</u>	<u>Comments</u>
5/16/84	2	Time	4/30/84-8/31/84 (4 mos.)	A time extension was required due to some delay in submittal of the preliminary draft report and further delays in receiving project panel review comments.

PROBABILITY OF SUCCESS: Based on progress to date, the probability of success is judged to be good.

REPORT(S) AVAILABILITY: None

PRINCIPAL INVESTIGATOR(S): Mr. David M. Levinsohn
COMSIS Corporation
11501 Georgia Avenue
Wheaton, MD 20902
301/933-9211

RESPONSIBLE NCTRP STAFF ENGINEER: Harry A. Smith - 202/334-3224

AREA THIRTY-NINE: ROUTE PLANNING

Project: 39-1, FY '81
Title: A Modular Approach to On-Board, Automatic Data Collection Systems

Research Agency: The MITRE Corporation
Principal Investigator: Lawrence E. Deibel

Effective Date: November 1, 1982
Completion Date: April 30, 1984
Revised Completion Date: August 31, 1984

AGENCY PERFORMANCE

1. Is the project on schedule: Yes* Percent project complete: 94
2. Is the research in keeping with the approved research plan: Yes
3. Subcontract Amount: \$148,787
4. Estimated Expenditures to 6/30/84: \$144,000
5. Are the expenditures in keeping with the project progress: Yes*

*See "Status of Research" section.

PROJECT DESCRIPTION

Current economic conditions require that a transit system improve productivity while making the best use of limited resources. Increasing emphasis is being placed on improving route productivity through such means as better schedules, on-time performance, and service allocation. These requirements place an increasing importance on good ridership and schedule adherence data so that responsible decisions on routing and scheduling can be made. In addition, fare-box revenue is becoming increasingly important to the stability of transit systems. Accurate fare payment information by fare category is needed to calculate effects of alternative fare adjustment proposals, including an analysis of the equity of fare structures. The need for ridership, schedule adherence, and fare information is expected to continue for the foreseeable future.

Currently the most predominant form of gathering ridership data in the transit industry is collecting data manually by ride checks or load (point) checks. Information gathered in this manner is expensive to collect and process, limited in scope, and usually infrequent because of the number of "checkers" required. For example, some systems have reported that a point check may provide accurate load data at one location, but may understate true route ridership by as much as 50 percent. Fare/revenue data are generally available only on a systemwide basis. Special efforts that usually rely on driver participation or cumbersome fare-box handling are required to collect route-level fare-payment information.

In recent years, a few transit systems have turned to automated methods to collect ridership, schedule adherence, and fare data. The levels of sophistication of these systems have varied from real-time data collection and analysis systems to more basic systems that provide information in summary form on an historical basis. Although, in general, transit properties that have used these automated systems have been satisfied, widespread use has not occurred.

There are several reasons why the majority of transit systems have not implemented automated technology: (1) a general lack of understanding of the options available in terms of hardware to provide the information; (2) an uncertainty as to how much of what type of hardware and software is needed; (3) the lack of commitment by transit management to implement the technology; (4) the difficulty in quantifying benefits, together with costs, and in determining the net benefit to the transit system; (5) the general unavailability of funding for much of this equipment at the federal level; and (6) the lack of standardization of functional requirements of the technologies, which, in turn, dampens the availability of hardware and discourages manufacturer participation.

The general objective of this research is to develop requirements and implementation guidelines for the use of automated on-board passenger/fare information collection systems. The system hardware should be constructed on a modular basis. Depending on the complexity of information desired, the modules should include, but not be limited to: (1) basic passenger counters (e.g., treadle, infrared), (2) location detection devices (e.g., odometer, signposts), (3) fare category counter (e.g., electronic fare-box), and (4) data storage/retrieval equipment (e.g., radio, cassette, solid state). Functional specifications for each of these systems are to be developed so that one module or component is compatible with another regardless of manufacturer. Requirements for modules or components will depend on the decisions a transit property must make, which, in turn, determines the level of detail the data collection system must provide. The levels of detail range from systemwide information to detailed stop-by-stop information. The system should be designed so that a transit property can choose, in modular fashion, the level and type of hardware needed for the data desired. Research to satisfy the general objective requires the following tasks:

Project 39-1 continued

Task 1 - Review existing literature and acquire other information as needed to determine the state of the art of automated data collection systems and information needs requiring passenger counts, schedule adherence, and fare data.

Task 2 - a. Determine modular hardware requirements to provide the information desired for various levels of decision-making. Standardize the functional requirements and develop uniform specifications for the hardware by module type. Upon completion of this task, a technical paper containing the specifications will be submitted to NCTRP for review. b. Recommend transit properties of different sizes to test the application of the manual that will be developed under Task 7. NCTRP approval of the recommendations will be required.

Task 3 - Develop methods to permit transit properties to select the modules and supporting hardware in sufficient quantity, on the basis of a sampling plan, to meet their data needs.

Task 4 - Develop a format for quantifying all benefits and all costs so that a transit property can determine the overall net benefit compared with alternative means of collecting the data.

Task 5 - Investigate other considerations that affect implementation, such as labor restrictions, organizational commitment, and maintenance support capability.

Task 6 - Define data processing requirements (hardware/software) and develop flow charts that describe how various outputs can be produced using the data collected, together with such external information as schedule data or mileage data.

Task 7 - Prepare a manual that describes the methods a transit property would follow to design, select, and implement an automated ridership and fare data collection system. NCTRP approval of the manual will be required before initiation of Task 8.

Task 8 - Demonstrate the validity of the procedures in the manual by applying the techniques to two (2) transit properties and revise the manual accordingly.

Task 9 - Prepare a technical specification for procurement that describes the electronic/mechanical requirements of the module interfaces.

Task 10 Prepare a final report that includes the revised manual as a stand-alone appendix.

STATUS OF RESEARCH

Research is essentially complete and the preliminary draft final report has been submitted in 3-volume: Research Summary, Implementation Manual, and Technical Specifications. Project panel review of the final report is nearing completion. Reviews received to date are favorable but offer many comments and suggestions. If major modifications of the final report are deemed appropriate, project funds may be tight. However, the principal investigator has assured the NCTRP that an acceptable report will be submitted in any event.

AMENDMENT(S) THIS REPORTING PERIOD

<u>Date</u>	<u>No.</u>	<u>Type</u>	<u>Amounts and/or Dates (From-To)</u>	<u>Comments</u>
04/23/84	1	Time	4/30/84-6/30/84 (2 mos.)	A time extension is necessary due to an underestimate of time required to arrange for the field trials.
In process	2	Time	6/30/84-8/31/84 (2 mos.)	Additional time needed to perform field trials and significantly modify the initial version of the Task 7 manual.

PROBABILITY OF SUCCESS: For the development of logical and reasonable research products as specified, the probability of success is good. However, acceptance of the products industry-wide is difficult to determine at the present time.

REPORT(S) AVAILABILITY: None.

PRINCIPAL INVESTIGATOR(S): Mr. Lawrence E. Deibel
The MITRE Corporation
1820 Dolley Madison Blvd.
McLean, VA 22101
703/827-6910

RESPONSIBLE NCTRP STAFF ENGINEER: Crawford F. Jencks - 202/334-3224

AREA FORTY: IMPACT ANALYSIS

Project: 40-1, FY '81
Title: Simplified Guidelines for Evaluating Transit Options
in Small Urban Areas

Research Agency: Barton-Aschman Associates, Inc.
Principal Investigator: Dr. David R. Miller

Effective Date: October 25, 1982
Completion Date: January 24, 1984
Revised Completion Date: April 23, 1984*

AGENCY PERFORMANCE

1. Is the project on schedule: Yes* Percent project complete: 100
2. Is the research in keeping with the approved research plan: Yes
3. Subcontract Amount: \$149,960
4. Estimated Expenditures to 6/30/84: \$149,960
5. Are the expenditures in keeping with the project progress: Yes

*See "Status of Research" section.

PROJECT DESCRIPTION

Small transit systems, as well as larger systems, are caught in a continuing struggle of determining the impacts of transit system investment decisions on users as well as on the community at large. The actual impacts of a transit system are difficult to determine. In addition to the obvious potential impacts, such as changes in vehicle-miles of travel, fuel consumption, pollution, etc., there is also a group of not-so-obvious impacts that relate to the costs and benefits of a transit investment (e.g., vehicle accidents, peak-hour congestion, traffic volume changes, commercial parking space requirements, and changes in future capital costs for street construction). Nonquantifiable impacts must also be considered, such as changes in mobility for the economically disadvantaged and for those who cannot drive (i.e., handicapped, elderly, and young people).

To ensure that city managers and councils have information on which to make intelligent and consistent appraisals pertaining to such investments, many types of factors must be fully considered. Typical factors are (1) socioeconomic (e.g., percentage of elderly population, minority population, chronic unemployment problems, diversity of existing industries, existence of large institutions), (2) political (e.g., attitude of the "affected parties," social-economic advocate groups), (3) current local concerns (e.g., ecology, air quality, traffic congestion), (4) business decisions, and (5) geographic (e.g., climate, topography, proximity to major urban areas).

Transit planning methods for cost-benefit analysis and for alternatives analysis have been well documented in studies sponsored by AASHTO, FHWA, UMTA, and the Office of the Secretary, U.S. DOT. Typically, however, these studies have been too complex and, in many cases, too data-intensive for understandable public presentation and use in small cities. Therefore, research is needed to prepare a technically based, yet simple, analytical tool for use in the public decision process relating to the potential impacts of transit alternatives.

The objective of Project 40-1 is to develop procedural guidelines for use by transit and municipal agencies in guiding their analysis of proposed transit and paratransit alternatives and in presenting their proposals to the decision-making bodies. Use of these guidelines will result in the public's better understanding of proposed investments for a new transit system or improvements to an existing system. Also, increased use of sound cost-benefit techniques to safeguard against inadequate analyses should result from the availability and use of these guidelines. The guidelines will be designed for application by nontechnical persons and will be directed to the types of decisions faced in urban areas up to 200,000 population. Considerations such as total costs, avoided costs, transportation alternatives, ridership, urban development factors, conservation of energy and other resources, and typical transit evaluation criteria will be addressed.

The following tasks are included:

Task 1. Identify the priceable and nonpriceable factors that need to be included in the guidelines to address the specific concerns of small urban areas (i.e., the factors that are important to the community, city council, etc.). These factors include the anticipated impacts on the transit system itself, on transportation in general, and on the community at large (nonuser impacts).

Task 2. Assemble relevant resource materials that have applicability to the evaluation of alternatives for public transit and prepare a synthesis of information relevant to decision-making options in small urban areas. Identify information requirements, availability, and sources used in existing analysis techniques.

Task 3. Develop a set of procedural guidelines utilizing the best available techniques to describe how to handle both priceable and nonpriceable factors.

Task 4. Develop an educational and portable package for use in demonstrating the analysis procedures and the factors considered in evaluating transit improvements and alternatives. A package suitable for presentations to city councils and transportation planning boards is desired.

Project 40-1 continued

STATUS OF RESEARCH

Research has been completed. As part of Task 1, a 2-day workshop was held to identify the primary factors of interest to transit decisions in small urban areas. City mayors, city managers, and transit board members participated in this workshop. A work paper describing the findings of Tasks 1 and 2 was prepared. A 2-tier approach is being used in the guidelines. One tier is directed to the needs of the transit agency's staff for developing and assessing transit alternatives, and the second tier is directed to the specific data and information needs of the decision-maker.

The final report will be published as NCTRP Report 8 and is now in the editorial and publication process.

AMENDMENT(S) THIS REPORTING PERIOD

None.

PROBABILITY OF SUCCESS: Good

REPORT(S) AVAILABILITY: NCTRP Report 8 should be available in September 1984.

PRINCIPAL INVESTIGATOR(S): Dr. David R. Miller
Barton-Aschman Associates, Inc.
820 Davis Street
Evanston, IL 60201
312/491-1000

RESPONSIBLE NCTRP STAFF ENGINEER: Robert E. Spicher - 202/334-3224

AREA FORTY: IMPACT ANALYSIS

Project: 40-2, FY '82/'83
Title: Estimating Incremental Costs of Bus-Route Service Changes
Research Agency: System Design Concepts, Inc.
Principal Investigator: Harry S. Cohen
Effective Date: November 15, 1983
Completion Date: August 14, 1985

AGENCY PERFORMANCE

1. Is the project on schedule: Yes Percent project complete: 52
2. Is the research in keeping with the approved research plan: Yes
3. Subcontract Amount: \$150,000
4. Estimated Expenditures to 6/30/84: \$56,300
5. Are the expenditures in keeping with the project progress: Yes

PROJECT DESCRIPTION

In the face of continuing financial pressure on and within the transit industry it is increasingly important to allocate resources in the most effective manner. Accordingly, a better understanding of the cost changes accompanying both service expansions and reductions is required.

To this end, various costing techniques have been developed and used by transit agencies to estimate the incremental or extra transit costs that stem from either service reductions or increases. Thus far there is some doubt about the reliability, accuracy, and applicability of these techniques, especially with respect to bus route (as opposed to system) changes. As a consequence, there is a need to assess and validate available or improved techniques to provide simple, but more reliable and accurate, methods for estimating the incremental (or additional variable) costs stemming from service changes on bus routes.

The objective of this research is to develop simple, reliable procedures that permit transit agencies to estimate the incremental cost implications of various bus-route-service changes in a variety of operating environments (e.g., those of differing density, system size, and the like). In a broad context, it should provide a means for helping to address the question: If a specific service should be changed, what is the incremental change in cost? More specifically, it should provide procedures that identify the incremental short-run costs to transit agencies of changes in bus-route-service frequencies (seasonal, day of week, time of day), expanding, curtailing or eliminating routes, or changing periods of operation. The research should also build upon and extend previous cost-analysis studies.

The research approach will involve, but not necessarily be limited to, the following.

A. Identify and evaluate existing cost models (including those listed in the following citation: Booz-Allen Inc., "Bus Route Costing Procedures: A Review," UMTA Report No. IT-09-9014-81-1, May 1981. Available from the National Technical Information Service, Springfield, Va 22161, NTIS No. PB-82-105198, cost \$13.00).

B. Review/update current industry practice (this should consist of polling properties to determine the models (or rules of thumb) that they currently use).

C. Develop simplified incremental cost estimation procedures. Criteria suggested are:

1. Simplicity (emphasis should be on a reasonable level of accuracy with a limited number of variables, and be easy to compute and apply).
2. Minimization of data collection requirements.
3. Wide range application in terms of system size, type, route, and type of changes.
4. Easy update of the cost variables to reflect expected changes in component costs.
5. Design that facilitates the orientation of key staff (scheduling, maintenance, and others) to incremental costing methods.
6. Design that lends itself to intuitive interpretation of results so that it is easy to explain to decision-makers and is viewed as reflecting reality by transit staff.
7. Design that is disaggregate in nature so that it can be used to evaluate individual routes or frequency changes.
8. Consideration of the effects of fixed and variable costs, different management operating policies, different contract work rules, different service contracting procedures, and cost changes that occur both before and after rescheduling.

D. Prepare an interim report that summarizes the findings for review by the NCTRP.

E. Develop and implement a testing method for validating the proposed procedure(s) and comparing the results with those for existing procedures. Consideration should be given to existing procedures, such as the two-variable cost model (bus-hours and miles), the Adelaide model, the Booz-Allen model developed from the UMTA bus-route-costing study, and the procedure currently being used by the participating study agency. It is anticipated that the procedure will be tested at three transit agencies--a large agency (over 200 buses), a medium-sized agency (100 to 200 buses), and a small rural Section 18 agency (less than 100 buses). As a minimum the testing should address the following types of bus-service changes:

Project 40-2 continued

1. Effect of service changes at various times of day, days of week, and season.
2. Effect of route extensions or contractions.
3. Effect of route consolidations, additions, and deletions.
4. Effect of service frequency changes.
5. Effect of hours of service changes.

It is desirable that the incremental cost be measured both before and after run and driver assignments. Testing refinement should be done iteratively as appropriate.

F. Identify planning - policy implications and develop typical applications.

1. Show how procedures can help (a) assess service alternatives, including deficit/revenue implications; and (b) make strategic service change decisions.
2. Give sample prototypical applications of procedures.

G. Prepare a draft report for review by the NCTRP.

H. Revise the draft report and submit the final version in fulfillment of the technical obligations under the contract for the project.

STATUS OF RESEARCH

Tasks A through D have been completed and are documented in the Interim Report noted below. Important cost concepts and their relationship to costing problems faced by transit agencies have been defined. An overview of available models, including those developed as part of a recently completed UMTA-sponsored study, has been provided. The results of a survey of transit agencies, which was conducted for Task B, is presented. Among other things, the survey developed information on methods currently in use, problems with these methods, and suggestions for improvements. Simplified procedures have been developed as part of Task C. These include three procedures for estimating the effects of bus route service changes on driver costs and a fourth procedure for estimating non-driver incremental costs associated with service changes.

AMENDMENT(S) THIS REPORTING PERIOD

None

PROBABILITY OF SUCCESS: Too early to assess.

REPORT(S) AVAILABILITY: "Estimating Incremental Costs of Bus-Route Service Changes" Interim Report developed as Task D. Available only on a loan basis from the Program Director, NCTRP.

PRINCIPAL INVESTIGATOR(S): Mr. Harry S. Cohen
 Vice President
 System Design Concepts, Inc.
 One Farragut Square South
 Suite 200
 Washington, DC 20006
 202/393-5910

RESPONSIBLE NCTRP STAFF ENGINEER: R. Ian Kingham - 202/334-3224

AREA FORTY: IMPACT ANALYSIS

Project: 40-3, FY '82/'83
Title: Strategies to Implement Benefit-Sharing for Fixed Transit Facilities

Research Agency: SG Associates, Inc.
Principal Investigator: Jane Howard

Effective Date: November 1, 1983
Completion Date: February 1, 1985

AGENCY PERFORMANCE

1. Is the project on schedule: Yes Percent project complete: 50
2. Is the research in keeping with the approved research plan: Yes
3. Subcontract Amount: \$99,957
4. Estimated Expenditures to 6/30/84: \$49,200
5. Are the expenditures in keeping with the project progress: Yes

PROJECT DESCRIPTION

Fixed transit facilities, such as transit terminals, rapid transit stations, and LRT lines and stops, generate substantial passenger traffic and improved accessibility. Consequently, space in the vicinity of such facilities may become more valuable because of its potential for higher intensity use. Opportunities for sharing benefits occur in the development of new transit facilities, the direct connection of developments to transit facilities, the use of air rights over transit rights-of-way, and the development of other real estate holdings. Furthermore, as a consequence of building fixed transit facilities, various other public facilities and utilities are rehabilitated. These opportunities for benefit-sharing by transit agencies are frequently lost, however, because they are not an important consideration in the planning and design phases (i.e., in the location and design of routes and stations).

There is little quantitative information available to transit agencies to assist them in formulating benefit-sharing approaches and arriving at reasonable charges or other contributions for these transit benefits. Therefore, in order to assist operators in planning and financing transit facilities, there is a need to provide (1) information about existing practices, (2) insights into the development process, (3) guidance in relating to private and public sector beneficiaries, and (4) strategies for negotiating benefit-sharing.

The general objective of this research is to assist transit agencies in implementing benefit-sharing. To accomplish this objective, a synthesis of existing information on development-related benefits followed by case studies is required. The report will be written primarily for use by transit planners, operators, and designers, and will reflect the concerns of policy-makers (government officials) and business organizations.

Following is a suggested three-part research approach. Part I, addressing items 1 through 6 and comprising not more than one-third of the research effort, consists of a broad-based investigation of the development impacts of fixed transit facilities. It is to be based on a review of the literature and current practice, and will conclude with an interim report. Part II, pertaining to items 7 and 8 and comprising one-third to one-half of the research effort, covers an in-depth study of experiences in implementing benefit-sharing. Part III, consisting of items 9, 10, and 11 and comprising the balance of the research effort, entails (1) the development of generalizations from the interim report and case studies, and (2) preparation of the draft and final reports.

Part I

1. List fixed transit facilities likely to produce benefits to organizations in the public and private sectors. Include rail and bus stations as well as LRT lines/stops.
2. Identify and describe the benefits. These benefits may accrue to property owners and businesses as increases in land value and economic activity. They may also be realized by the public in the form of improved streets and traffic circulation, reconstructed utilities, provision of transit rights-of-way, and new recreation facilities.
3. Describe methods to measure benefits.
4. Identify and describe such benefit-sharing techniques as those provided in the following four categories:
 - a. Planning and Acquisition
 - (1) Contributing of land for rights-of-way, stations, and parking facilities by developers or townships.
 - (2) Purchasing of extra land for land-banking (e.g., for later conversion of parking into more intensive land use).
 - (3) Selling air rights.
 - (4) Sharing facilities (e.g., parking in shopping centers, intercity transit terminal).

Project 40-3 continued

- b. Design and Construction
 - (1) Providing concession facilities.
 - (2) Constructing station accesses by developers.
 - (3) Constructing special features by developers (e.g., lighting, plazas, escalators, LRT platforms).
 - (4) Locating and designing facilities to preserve development options.
 - c. Public Infrastructure
 - (1) Rehabilitating utilities.
 - (2) Improving street reconstructing and beautification, plazas, malls, etc.
 - (3) Improving traffic through intersection channelization, pedestrian underpasses, skywalk systems, etc.
 - (4) Establishing parks and recreational areas.
 - d. Special Financial Arrangements
 - (1) Creating special assessment districts.
 - (2) Establishing tax increment financing.
5. Identify transit agencies that have attempted or are attempting to share transit costs with private and public beneficiaries. Transit agencies should be described by at least (1) organizational context (ownership and operation), (2) benefit-sharing techniques, (3) transit system characteristics, (4) benefit assessment techniques, and (5) character of local economy. Proposed case studies, four of which should be concerned with each of the four benefit-cost categories noted in item 4.
6. Prepare the Interim Report (addressed earlier) on items 1 through 5.

Part II

- 7. Select Transit agencies for an in-depth study of successes and failures in benefit-sharing. Prepare the interview design and conduct the case studies.
- 8. Evaluate experience with benefit-sharing to identify elements contributing to or impeding implementation.

Part III

- 9. Develop recommendations for transit agencies to follow in implementing benefit-sharing practices.
- 10. Prepare a draft report for review by the NCTRP.
- 11. Revise the draft report and submit the final version in fulfillment of the technical obligations under the contract for the project.

STATUS OF RESEARCH

Substantial progress has been made through June 30, 1984. Transit facilities have been identified and classified for the purpose of identifying appropriate benefit-sharing opportunities. Benefits to public and private sector participants together with some measurement techniques have been identified. Transit benefit-sharing strategies have been identified and classified. Findings are described in the Interim Report noted below. Part II case studies involving cities (areas) have begun.

AMENDMENT(S) THIS REPORTING PERIOD

None

PROBABILITY OF SUCCESS: Good

REPORT(S) AVAILABILITY: None

PRINCIPAL INVESTIGATOR(S) Mrs. Jane Howard
 SG Associates, Inc.
 316 Stuart Street
 Boston, MA 02116
 617/542-1416

RESPONSIBLE NCTRP STAFF ENGINEER: R. Ian Kingham - 202/334-3224

AREA FORTY-THREE: TRACK AND ANCILLARY SYSTEMS

Project: 43-1, FY '81
Title: Detection of Low-Level Fault Currents on Rail Transit Systems

Research Agency: Chas. T. Main, Inc.
Principal Investigator: Navin S. Sagar

Effective Date: January 3, 1983
Completion Date: April 2, 1984
Revised Completion Date: September 30, 1984

AGENCY PERFORMANCE

1. Is the project on schedule: Yes Percent project complete: 90
2. Is the research in keeping with the approved research plan: Yes
3. Subcontract Amount: \$99,953
4. Estimated Expenditures to 6/30/84: \$75,000
5. Are the expenditures in keeping with the project progress: Yes

PROJECT DESCRIPTION

Devices presently in use by the rail transit industry can adequately detect and respond to overload fault currents. Detection of less than overload fault currents is particularly difficult because the fault current characteristics tend to resemble characteristics normally associated with train or power switching operations. Rapid and reliable detection of low-current electrical faults on direct-current rail transit systems would provide a significant improvement to safety and operation of these systems.

The objective of this research is to identify and evaluate detection methods and equipment to enhance transit system safety through reliable detection of electrical faults that are not detected by circuit breaker overload protection. Cooperation by transit systems and associated industries is essential to the success of the project, inasmuch as this research seeks a solution that can easily be adapted to various transit systems.

To accomplish this objective, the following tasks shall be conducted:

Task 1 - Perform an in-depth survey of rail transit systems worldwide, under the auspices of an international institution, such as the International Union of Public Transport, to determine how the problem being researched is handled in each system. Concurrently, survey the electrical industry organizations and suppliers worldwide for methods and equipment that are potential solutions to the detection problem. Review the work of other industries that may also be relevant to the problem and its solution.

Task 2 - Using information obtained in Task 1, identify the electrical system characteristics that will define the parameters of the required detection systems for various types of vehicle propulsion systems and network configurations.

Task 3 - Using the parameters developed in Task 2, determine the extent to which available methods and equipment meet the research objectives.

Task 4 - Prepare a final report describing the research and its results, including a detailed evaluation of the performance and economics of available methods and equipment.

STATUS OF RESEARCH

Research is in progress. Survey forms for collecting information from transit agencies have been prepared, reviewed, and pilot tested with several agencies. After revisions, the survey forms were distributed to all transit agencies and other organizations in the United States. The forms have been translated into French and German and distributed to transit agencies outside the United States by the International Union of Public Transport. Because of several unavoidable delays in the conduct of Task 1, the in-depth survey of rail transit systems worldwide, the project is about 3 months behind schedule. Inasmuch as the survey information provides the basis for the conduct of the other tasks, it is not likely that the delay can be recovered. A contract amendment extending the completion date was extended during this reporting period. Research has been completed and the preliminary draft report is expected by the end of July.

AMENDMENT(S) THIS REPORTING PERIOD

<u>Date</u>	<u>No.</u>	<u>Type</u>	<u>Amounts and/or Dates (From-To)</u>	<u>Comments</u>
3/21/84	1	Time	4/4/84-9/30/84 (6 mos.)	Additional time required because of delays in obtaining survey information from foreign countries.

Project 43-1 continued

PROBABILITY OF SUCCESS: Based on accomplishments to date, the probability of success is good at this time.

REPORT(S) AVAILABILITY: None

PRINCIPAL INVESTIGATOR(S): Mr. Navin S. Sagar
Lead Electrical Engineer
Chas. T. Main, Inc.
Prudential Center
Boston, MA 02199
617/262-3200 x3807

RESPONSIBLE NCTRP STAFF ENGINEER: Harry A. Smith - 202/334-3224

AREA FORTY-SIX: GENERAL DESIGN

Project: 46-1, FY '82/'83
Title: Single Cable Communications Technology for Rail Transit Systems

Research Agency: Polytechnic Institute of New York
Principal Investigator: Dr. Frank A. Cassara

Effective Date: May 1, 1984
Completion Date: February 28, 1985

AGENCY PERFORMANCE

1. Is the project on schedule: Yes Percent project complete: 11
2. Is the research in keeping with the approved research plan: Yes
3. Subcontract Amount: \$100,000
4. Estimated Expenditures to 6/30/84: \$5,850
5. Are the expenditures in keeping with the project progress: Yes

PROJECT DESCRIPTION

Rail-transit systems vary from those that have been in existence since the early 1900's to systems presently under design. These systems have typically used, or are planning the use of, multiple cables for the transmission of voice, data, and video information. The various cables provide for long-haul trunk facilities and access to local distribution networks. Additionally, the necessity for VHF or UHF-FM radio transmissions in underground portions of the system may require a separate radiating (or leaky) coaxial cable.

The large numbers of multipair and special-use cables used are expensive to install and maintain. A reduction in the number of cables needed for the communication requirements of transit systems can result in reduced acquisition, installation, and maintenance costs. The ultimate goal of this research is to replace all special-use cables with a single, multipurpose cable.

The objective of this research is to identify and develop recommended system parameters that will permit use of a single, multipurpose, wideband cable to support all rapid-transit communications requirements including, but not limited to: voice, data, video as well as VHF or UHF-FM two-way radio signals. For reliability, the single-cable concept should allow for a backup cable and cable span switching equipment. This research proposes a nonsite-specific solution that considers retrofits and extensions to existing rail-transit systems as well as the requirements of new systems. Proposed solutions to the reduction in the number of cables should include consideration of coaxial cables, fiber optics, and other viable technologies. Any proposed solution must also take into account compatibility with existing communications equipment and systems, improved reliability and maintainability, reduced life-cycle costs, and system expansion (extension and spare capacity).

To accomplish the objective of this research, at least the following tasks are required:

Task 1. Survey the current communication systems and installation practices of rail-transit agencies to define the scope of the problem. (Some information on North American systems may be available at APTA.) Concurrently, survey the electronic industry for developments that offer potential solutions. Review the work of railroad, mining, and other industries that may be relevant to the problem and its solution.

Task 2. Establish the operational parameters that will be required for a single-cable communication system(s). Generate a range of technical characteristics that will define the nature of the proposed cable system(s) and its (their) configurations.

Task 3. Using the operational parameters and cable characteristics developed in Task 2, prepare design criteria to establish the technical and economic feasibility of the single-cable concept. Submit a fully documented feasibility study showing all alternatives studied and the recommended solution(s) for review and approval by the NCTRP. (Twenty (20) copies of the study report shall be submitted within 7 months after the beginning date of the contract period. NCTRP approval will be required before the initiation of subsequent tasks. It is anticipated that the necessary review and approval will be completed within 2 months after receipt of report.)

Task 4. Using design criteria established in Task 3, prepare a system description in sufficient detail so that user agencies can prepare procurement specifications for specific applications. In addition, prepare a sample system design for a hypothetical 10-mile rail-transit system (5 miles underground and 5 miles on the surface) that includes basic equipment elements, local distribution networks, and its attendant costs.

Task 5. Prepare a draft report for review by the NCTRP.

Task 6. Revise the draft report and submit the final version in fulfillment of the technical obligations under the contract for the project.

Project 46-1 continued

STATUS OR RESEARCH

The total allowable funding for conducting the 6 tasks noted above was \$150,000. However, because of present NCTRP funding limitations, a subcontract for only \$100,000 has been executed with the agency for completing Tasks 1, 2, and 3. The NCTRP anticipates continued funding of the program to accomplish all tasks, but in the event this does not occur, the Task 3 feasibility study will be the final report.

The project is in its early stages. The researchers have been conducting literature searches on the different types of technologies and visiting rail-transit agencies to become familiar with the communications requirements of both new and old systems.

PROBABILITY OF SUCCESS: Good

REPORT(S) AVAILABILITY: None

PRINCIPAL INVESTIGATOR(S): Dr. Frank A. Cassara
Polytechnic Institute of New York
333 Jay Street
Brooklyn, NY 12201
516/454-5075

RESPONSIBLE NCTRP STAFF ENGINEER: Crawford F. Jencks - 202/334-3224

AREA FORTY-SEVEN: GENERAL MATERIALS

Project: 47-1, FY '80
Title: Improved Service Life of Urban Transit Coach Brakes

Research Agency: Battelle Memorial Institute
Principal Investigator: Dr. Allen T. Hopper

Effective Date: December 1, 1981
Completion Date: November 30, 1983
Revised Completion Date: July 30, 1984

AGENCY PERFORMANCE

1. Is the project on schedule: No* Percent project complete: 95
2. Is the research in keeping with the approved research plan: Yes
3. Subcontract Amount: \$300,000
4. Estimated Expenditures to 6/30/84: \$285,000
5. Are the expenditures in keeping with the project progress: Yes

*See "Status of Research" section.

PROJECT DESCRIPTION

The operation and maintenance history of advanced design urban transit coaches shows a dramatic decline in brake life compared with "new look" coaches. Major factors associated with this decline in brake life appear to be, but are not limited to: increased gross vehicle weight, increased operating speed, body configuration, and changed regulations.

The resultant increased brake temperatures are believed to be the cause of reduced brake life that has increased operational costs to unacceptable levels. Therefore, the need exists to identify and develop methods to increase brake life to previous levels.

The overall project objective is to develop methodologies for improving existing and future urban transit coach brake life. This will include quantification of in-service brake operating temperatures plus identification of methods of reducing brake operating temperatures and/or alternate friction materials.

The project objective will be accomplished in two phases. Phase I includes the following tasks:

Task 1--Confirmation of the premise that temperature is the cause of reduced brake life by the collection and evaluation of brake operating temperatures. This is to be accomplished in cooperation with a major metropolitan transit operator that has experienced the problem. As a minimum, temperature levels will be established for advanced design and early "new look" transit coaches.

Task 2--Development of practical methods for reduction of operating temperatures and/or identification of friction materials for compatibility with the service temperatures determined in Task 1. The following factors must be considered: (a) adaptability to coaches in service, (b) initial and operating costs, (c) regulations, (d) serviceability, (e) reliability, (f) public acceptability, and (g) feasibility.

Task 3--Cost-benefit prioritization of methods for increasing brake life based on Tasks 1 and 2.

Task 4--Preparation of an interim report with recommendations for implementation of Phase II demonstration.

The Phase II effort includes:

Task 5--Demonstration of one or more suggested corrective methods selected by the NCTRP from those recommended in Phase I. This will be accomplished in cooperation with a major metropolitan transit operator.

Task 6--Preparation and submittal of the final report.

STATUS OF RESEARCH

Research has been completed on Phase I of the study. The design and experimental work on Task 1 involved (1) detailed design and construction of brake drum and shoe instrumentation, (2) installation and trial testing of instrumentation on a bus in Columbus, Ohio, (3) obtaining and instrumenting brake drums and shoes for Los Angeles buses, (4) installation of instrumented brake drums and shoes on 3 buses in Los Angeles, and (5) collection of in-service brake temperature from instrumented buses in Los Angeles. Brake temperatures of up to 600F were recorded during the data collection phase. The data appear to verify and quantify the brake temperature problem. After further analysis of the data, acceptable brake operating temperatures were defined and temperature reducing schemes evaluated. The interim report submitted in fulfillment of Phase I has been submitted and approved. Research has also been completed on Phase II. The retrofitting of buses and conduct of the demonstration was conducted in Los Angeles in January 1984. The preliminary draft report is in the final stages of preparation and is expected to be submitted by the end of July. A time amendment of approximately two months will be needed to provide for review and revision of the report.

Project 47-1 continued

AMENDMENT(S) THIS REPORTING PERIOD

None

PROBABILITY OF SUCCESS: Based on the background and experience of the research agency and cooperating agencies, and progress to date, prospects for success appear good.

REPORT(S) AVAILABILITY: None

PRINCIPAL INVESTIGATOR(S): Dr. Allen T. Hopper
Structural Materials & Tribology Section
Battelle Memorial Institute
Columbus Laboratories
505 King Avenue
Columbus, OH 43201
614/424-6424

RESPONSIBLE NCTRP STAFF ENGINEER: Harry A. Smith - 202/334-3224

AREA FIFTY-FIVE: PERFORMANCE, EFFECTIVENESS, AND EFFICIENCY

Project: 55-1, FY '82/'83
Title: Conversion to One-Person Operation of Heavy-Rail Rapid-Transit Trains

Research Agency: Battelle Memorial Institute, Columbus Laboratories
Principal Investigator: Joseph A. Hoess

Effective Date: May 5, 1984
Completion Date: April 4, 1985

AGENCY PERFORMANCE

1. Is the project on schedule: No* Percent project complete: 15%
2. Is the research in keeping with the approved research plan:
3. Subcontract Amount: \$150,000
4. Estimated Expenditures to 6/30/84: \$25,000
5. Are the expenditures in keeping with the project progress: Yes

*The research agency was unable to begin work on the effective date. By agreement with the NCTRP, a contract amendment for a one month time extension is deferred until a month before the completion date.

PROJECT DESCRIPTION

There is increasing pressure to provide more cost-effective operation of heavy-rail rapid-transit trains. A major candidate for improving productivity is reduction of crew size to one person. This has been accomplished in the following systems:

- Lindenwold/Philadelphia--Port Authority Transit Corporation
- San Francisco--Bay Area Rapid Transit District
- Washington, DC--Washington Metropolitan Area Transit Authority
- Atlanta--Metropolitan Atlanta Rapid Transit Authority

The reduction will soon be implemented in Miami and Baltimore.

The older rapid transit systems, however, continue to require a second crew member aboard each train. These systems include the following:

- Boston--Massachusetts Bay Transportation Authority
- New York--New York City Transit Authority
- New York/New Jersey--Port Authority Trans-Hudson Corporation
- Philadelphia--Southeastern Pennsylvania Transportation Authority
- Cleveland--Greater Cleveland Regional Transit Authority
- Chicago--Chicago Transit Authority

To provide one-person operation on the older rapid transit systems, it will be necessary to address problems at least in the areas of:

1. Operational safety.
2. Operational practices.
3. Manpower/labor relations.
4. Regulatory matters.
5. Plant and equipment.

The objectives of this research are (1) to evaluate the issues that must be addressed in contemplating conversion of two-person systems to one-person operation including the identification of those issues unique to the particular system and (2) to develop a framework for an economic assessment of the effects of implementation of one-person operation. The research should include, but not be limited to, the following tasks:

Task 1. Perform a survey of each two-person heavy-rail rapid-transit system in the United States to determine the specific issues or problems that need to be addressed if such system were to be converted to one-person train operation. This survey shall be based on consultation with organizations including system management, employee representatives, regulatory agencies or advisory boards, and other appropriate organizations.

Task 2. Perform a survey of one-person conversions implemented by heavy-rail rapid-transit systems in Europe and identify the issues and problems addressed; the methods of solving them; and the effectiveness of such solutions as measured by such indicators as operational efficiency and reliability, safety statistics, and changes in the workforce. These systems shall include, but not be limited to, London, Paris, Hamburg, and Berlin.

Task 3. Evaluate the issues and problems identified in Tasks 1 and 2 as they would affect the conversion to one-person operation from the technological, operational, institutional, and human resource

Project 55-1 continued

perspectives. The evaluation shall include the need for, and degree of, recommended application of closed-circuit TV, automatic train operation, radio communications, and other elements.

Task 4. Prepare a framework for an economic assessment of the effects of implementation of one-person operation. This framework shall include identification of cost elements that must be considered in a site-specific analysis and plan such as:

- a. Changes to car equipment.
- b. Changes to wayside and station equipment.
- c. Changes in workforce, such as reduction in train crews and additions to wayside equipment maintenance staff.
- d. Operating practice revisions.
- e. Changes in wage rates resulting from implementation of one-person operation.

STATUS OF RESEARCH

Site visits to transit agencies having two-man and one-man train crews have begun. Literature relating to six 2-person operation and four 1-person operations in the survey design has been collected. The surveys made at each site are documenting solutions, their advantages and disadvantages, to the problem of converting from 2-man to 1-man operations.

PROBABILITY OF SUCCESS: Too early to determine.

REPORT(S) AVAILABILITY: None.

PRINCIPAL INVESTIGATOR(S): Mr. Joseph A. Hoess
Battelle Memorial Institute
Columbus Laboratories
505 King Avenue
Columbus, OH 43201
614/424-5135

RESPONSIBLE NCTRP STAFF ENGINEER: R. Ian Kingham - 202/334-3224

AREA SIXTY: SPECIAL PROJECTS

Project: 60-1, FY '80 and continuing
Title: Synthesis of Information Related to Transit Problems

Research Agency: Transportation Research Board
Principal Investigator: Mr. Thomas L. Copas

Effective Date: November 7, 1980
Completion Date: Continuing

AGENCY PERFORMANCE

1. Is the project on schedule: Yes Percent project complete: *
2. Is the research in keeping with the approved research plan: Yes
3. Subcontract Amount: \$460,000 (see Table I, footnote a)
4. Estimated Expenditures to 06/30/84: \$290,000
5. Are the expenditures in keeping with the project progress: Yes

*Project is carried out on a continuing basis with new topics being incorporated each year. See below for status of each topic.

PROJECT DESCRIPTION

Transit administrators, engineers, and researchers are continually faced with problems on which much information already exists either in documented form or in terms of undocumented experience and practice. Unfortunately this information is often fragmented, scattered, and unevaluated. As a consequence, full information on what has been learned about a problem is frequently not brought to bear on its solution. Costly research findings may be unused, valuable experience may be overlooked, and due consideration may not be given to recommended practices for solving or alleviating the problem.

In this project, particular transit problems, or sets of closely related problems, will be selected by the NCTRP Technical Steering Group as topics for information syntheses.

For each topic the objectives are:

1. To locate and assemble documented information.
2. To learn what practice has been used for solving or alleviating the problem.
3. To identify all ongoing research.
4. To learn what problems remain largely unsolved.
5. To organize, evaluate, synthesize, and document the useful information that is acquired.

STATUS OF RESEARCH

The two published syntheses of transit practice prepared under this project are listed in Table II of this progress report. The topics of concern and the status of each as of June 30, 1984, are:

TS-3 -- Effects of Fuel Additives and Alternative Fuel Grades for Transit Buses

Topic Consultant: Norman R. Sefer; Southwest Research Institute, San Antonio, Texas
 Effective Date (Consultant Agreement): October 1, 1982
 Expiration Date (Consultant Agreement): September 30, 1983

Fuel additives and related products are purported to improve engine performance, reduce fuel consumption, or have other beneficial effects. The synthesis included a compilation of data on the effects, costs, and benefits of available fuel additives and related products based on experience and research. Also examined were the effects on long-term engine maintenance, pollutant and odor emissions, fuel economy, fuel storage, and engine performance. Research has been completed and the findings published as NCTRP Synthesis 3

TS-4 -- Guidelines for Allocation of Time for Transit Coach Maintenance Functions

Topic Consultant: Kay Inaba; XYZYX Information Corporation; Canoga Park, California
 Effective Date (Consultant Agreement): December 9, 1982
 Expiration Date (Consultant Agreement): November 30, 1983

Proper allocation of employee time to specific bus maintenance tasks is an important supervisory responsibility. The availability of comparative time requirements for major maintenance tasks would assist in the employee work scheduling process. This study included a review of available information on standard maintenance practices for transit coaches and an investigation of current use of and attempts to develop standard maintenance job times. Research has been completed and the findings published as NCTRP Synthesis 4.

Project 60-1 continued

TS-5 -- Extraboard Management: Procedures and Tools

Topic Consultant: L. C. MacDorman; Arlington, Virginia
 Effective Date: November 21, 1983
 Expiration Date: October 31, 1984

When an open run occurs in a transit system, the extraboard clerk has several choices: fill it with an extraboard or part-time person, fill it with an operator working overtime on a regular day off, or leave the run open. The synthesis will survey transit agencies that have a structured extraboard management system to determine the complexities encountered, development costs, potential and actual benefits, etc. The Consultant is collecting information for the synthesis.

TS-6 -- Traffic Control and Regulation at Transit Stops

Topic Consultant: Woodrow W. Rankin
 Effective Date: January 1, 1984
 Expiration Date: December 31, 1984

This synthesis will develop a consensus of recommended practices for signing and marking at bus stops. Conditions to be covered would include coordination of bus stop signs with traffic control signs, far and near side stops, minimum signing in residential areas, signing in areas without curbs and shoulders, coordination with bicycle paths, part-time stops, and coordination with exclusive bus lanes. The first panel meeting was held on November 18, 1983. The Consultant is collecting information for the synthesis.

TS-7 -- Bus Communications Systems

Topic Consultant: MITRE Corporation; McLean, Virginia
 Effective Date: November 21, 1983
 Expiration Date: November 30, 1984

Transit agencies face difficult problems in procuring, installing, and maintaining bus communication systems. The synthesis will include detailed information on equipment, personnel training, design, cost, source of funds, installation, warranty, maintenance, problems, effectiveness, benefits, and unique features. The ability of the communications system to enable the transit agency to meet its operating objectives will also be considered. The Consultant is collecting information for the synthesis.

TS-8 -- Passenger Information Systems for Transit Transfer Facilities

Topic Consultant: J. J. Fruimm; Massapequa, New York
 Effective Date: November 21, 1983
 Expiration Date: October 31, 1984

Currently, policies, guidelines, or principles for signing and information systems for transit transfer facilities vary widely. A transit transfer facility serves the role of interfacing between two or more modes or from one vehicle to another. The synthesis deals with those aspects of passenger information required in order to make the transfer safely and with minimal effort. The Consultant is collecting information for the synthesis.

TS-9 -- Transit Fare Collection: Problems with and Alternatives to Paper Currency

Topic Consultant: MITRE Corporation; McLean, Virginia
 Effective Date: December 2, 1983
 Expiration Date: November 30, 1984

Although most transit systems are fully equipped to accept coins, existing fare collection equipment and revenue handling procedures are inadequate for dealing with paper currency. The synthesis will identify, coordinate, and assess current activity addressing bill-handling problems and solutions including alternatives that preclude on-board use of paper currency. This topic, which was originally NCTRP Project 56-1, was referred to Project 60-1 to be carried out as a synthesis when the panel for Project 56-1 met on April 18-19, 1983. The Consultant is collecting information for the synthesis.

TS-10 - Use of Part-Time Operators

Topic Consultant: Contract Pending
 Effective Date:
 Expiration Date:

Project 60-1 continued

Part-time operators may decrease costs for transit agencies. The synthesis will identify how transit agencies are using part-time operators, including contract constraints, run-cutting methods used to allocate part-time operators, and relationship of service needs to benefits of using part-time operators, and will develop guidelines for evaluating the use of part-time operators. The first panel meeting was held on June 14, 1984; further work on this topic will await receipt of FY '84 funds.

TS-11 - Transit Marketing: Successes and Failures

Topic Consultant: Contract Pending
Effective Date:
Expiration Date:

Many transit agencies have undertaken various marketing programs. The synthesis will include successful and unsuccessful aspects of these programs and will cover the importance of marketing and the use of price, service, and promotion in marketing, with emphasis on promotion. The first panel meeting was held on April 10, 1984; further work on this topic will await receipt of FY '84 funds.

TS-12 - Use of Incentives to Attain Specified Performance Standards in Collective Bargaining Agreements

Topic Consultant: In Developmental Stage FY '84
Effective Date:
Expiration Date:

Research on this topic will begin when FY '84 funds are received.

TS-13 - Bus Inspection Procedures

Topic Consultant: In Developmental Stage FY '84
Effective Date:
Expiration Date:

Research on this topic will begin when FY '84 funds are received.

AMENDMENT(S) THIS REPORTING PERIOD

None--Continuing Project

PROBABILITY OF SUCCESS: High - Experienced investigators using a proven system ensure continued success.

REPORT(S) AVAILABILITY: See Table II

PRINCIPAL INVESTIGATOR(S): Mr. Thomas Copas
Special Projects Engineer
Transportation Research Board
National Academy of Sciences
2101 Constitution Avenue, N.W.
Washington, DC 20418
202/334-3242

RESPONSIBLE NCTRP STAFF ENGINEER: Dr. Robert J. Reilly - 202/334-3224

HOW TO ORDER

Items for Sale

1. NCTRP Series Reports, Syntheses, and Research Results Digests (see Tables II and III for prices).
2. Research agencies' final reports (see project summaries for prices).
3. Microfiche (\$5.00 per report).
4. Other TRB publications

A check or money order, payable to Transportation Research Board, must accompany orders totalling \$10.00 or less. Mail to:

Publications Office
Transportation Research Board
2101 Constitution Avenue, N.W.
Washington, D.C. 20418

Items for Loan

1. Some research agencies' final reports, manuals, videotapes, etc., are identified in the project progress reports and are available on a loan basis upon written request to the NCTRP, 2101 Constitution Avenue, N.W., Washington, DC 20418.
2. Loan requests for films and tapes should be directed to:

TRB Audio-Visual Library
Transportation Research Board
2101 Constitution Avenue, N.W.
Washington, D.C. 20418

Mailing and handling charges may be assessed, especially where 1st-class delivery is requested; an invoice will accompany the loaned item.

S.C.R.T.D. LIBRARY