

National Cooperative Transit Research & Development Program

FOR THE PERIOD
JANUARY 1 THROUGH JUNE 30, 1985
CONTRACTS DTUM60-81-C-72012
and DTUM60-83-C-71226

PRIVILEGED DOCUMENT

This report, not released for publication, is furnished only for review to members of or participants in the work of the National Cooperative Transit Research and Development Program. It is to be regarded as fully privileged, and dissemination of the information included herein must be approved by the NCTRP.

PROGRESS REPORT 8

TRANSPORTATION RESEARCH BOARD

NATIONAL RESEARCH COUNCIL

SECRETED LIBRARY

2.5
37
48

NATIONAL COOPERATIVE TRANSIT RESEARCH & DEVELOPMENT PROGRAM

TRB EXECUTIVE COMMITTEE SUBCOMMITTEE FOR THE NCTRP

JOHN A. CLEMENTS, *Chairman*

LESTER A. HOEL
LAWRENCE D. DAHMS
WILLIAM J. HARRIS, JR.

JACK R. GILSTRAP
RALPH STANLEY
THOMAS B. DEEN

CHAIRMEN OF PROJECT PANELS

Field of Administration

- P. G. DRAKE
- R. M. WORKS
- F. D. SWIFT
- D. P. CLAYTON
- F. M. COLE

Field of Design

- E. K. FARRELLY
- J. P. GREENWAY

Field of Operations

- J. W. VIGRASS

Field Of Planning

- MANUEL PADRON
- T. W. HOCHBEIN
- T. W. FRIEDMAN
- J. C. ECHOLS
- K. E. STEIN-HUDSON

Field of Materials and Construction

- JACK DONAHUE
- E. K. FARRELLY

Field of Special Projects

- R. R. BIEGE, JR.

PROGRAM STAFF

ROBERT J. REILLY, *Director, Cooperative Research Programs*
KRIEGER W. HENDERSON, JR., *Director, Cooperative Research Programs (Ret. 1/31/85)*
LOUIS M. MACGREGOR, *Administrative Engineer*
IAN M. FRIEDLAND, *Projects Engineer*
CRAWFORD F. JENCKS, *Projects Engineer*
R. IAN KINGHAM, *Projects Engineer*
HARRY A. SMITH, *Projects Engineer*
ROBERT E. SPICHER, *Projects Engineer*
HELEN MACK, *Editor*

National Cooperative Transit Research & Development Program

TRANSPORTATION RESEARCH BOARD

NATIONAL RESEARCH COUNCIL

PROGRESS REPORT 8

FOR THE PERIOD JANUARY 1 THROUGH JUNE 30, 1985

TO THE U.S. DEPARTMENT OF TRANSPORTATION/URBAN MASS TRANSPORTATION ADMINISTRATION
(DOT CONTRACTS DTUM60-81-C-72012 and DTUM60-83-C-71226)

S.C.R.T.D. LIBRARY

07273

HE
192.5
.N37
no.8

CONTENTS

	Foreword	
1	Introduction	
2	Management Practices in the NCTRP	
6	TABLE I—SUMMARY OF STATUS THROUGH JUNE 30, 1985 FOR FY '80 THROUGH FY '84 PROJECTS	
8	TABLE II—PUBLISHED REPORTS OF THE NATIONAL COOPERATIVE TRANSIT RESEARCH & DEVELOPMENT PROGRAM	
8	TABLE III—NCTRP RESEARCH RESULTS DIGESTS	
9	Summary of Administrative Progress	
57	PROGRESS BY PROJECT	
59	Area Thirty:	Economics
61	Area Thirty-One:	Finance
	Area Thirty-Two:	Policy Development
63	Area Thirty-Three:	Personnel Management
	Area Thirty-Four:	Labor Relations
	Area Thirty-Five:	Procurement
67	Area Thirty-Six:	Alternative Analysis
	Area Thirty-Seven:	Forecasting
69	Area Thirty-Eight:	System Planning
71	Area Thirty-Nine:	Route Planning
72	Area Forty:	Impact Analysis
	Area Forty-One:	Vehicles
	Area Forty-Two:	Vehicle Auxiliary Systems
	Area Forty-Three:	Track and Ancillary Systems
	Area Forty-Four:	Stations
	Area Forty-Five:	Bridges and Tunnels
76	Area Forty-Six:	General Design
78	Area Forty-Seven:	General Materials
80	Area Forty-Eight:	Specifications, Procedures, and Practices
	Area Forty-Nine:	Vehicles
	Area Fifty:	Vehicle Auxiliary Systems
	Area Fifty-One:	Maintenance of Way and Structures
	Area Fifty-Two:	Scheduling
	Area Fifty-Three:	Control Systems
	Area Fifty-Four:	Energy Efficiency
82	Area Fifty-Five:	Performance Effectiveness and Efficiency
	Area Fifty-Six:	Fare Collection
	Area Fifty-Seven:	Supplemental Services
84	Area Sixty:	Special Projects
87	HOW TO ORDER PUBLICATIONS AND OTHER MATERIALS	

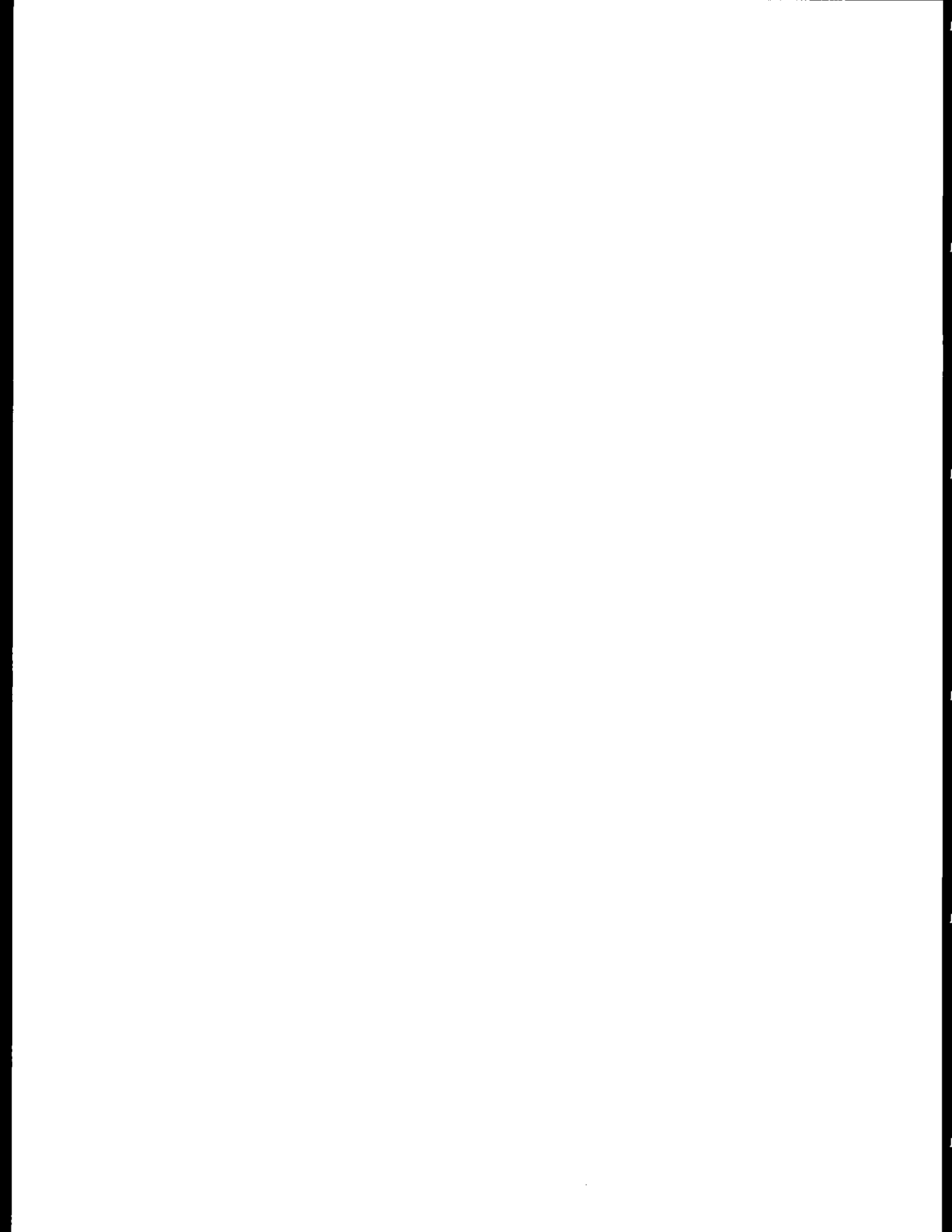

FOREWORD

This document responds to Article II, Deliverable Items and Delivery Schedule, of DOT Contracts DTUM60-81-C-72012 and DTUM60-83-C-71226 between the U.S. Department of Transportation/Urban Mass Transportation Administration and the National Academy of Sciences, National Research Council, designated the Primary Technical Contractor(PTC), for technical and administrative services relative to the Urban Mass Transportation Administration's National Cooperative Transit Research & Development Program(NCTRP). Distribution of this document is made only to the sponsors and others participating officially in the conduct of the NCTRP.

Annual NCTRP activity consists of five (5) distinct phases: (1) Problem Identification, (2) Program Formulation, (3) Project Formulation, (4) Project Execution, and (5) Project Reporting. The PTC's obligation is relative to Phases 2 through 5, and responsibilities for administration of technical matters under these phases have been assigned to the Transportation Research Board, a major unit of the National Research Council. The TRB consists of four(4) divisions with Division D, Cooperative Research Programs, being the one to which NCTRP administration is assigned.

Research programs are referred annually by UMTA to the PTC for administration, and semi-annual progress reporting includes: (1) general coverage of the historical development of the NCTRP and the means by which the Program is carried forward, (2) elaboration on the management practices exercised by the TRB in behalf of the PTC and UMTA, (3) summarization of management activities and deliverables in the six months reported, and (4) provision of detailed reports on each project under contract during the report period as to the: (a) general research need, (b) specific research objectives, (c) progress in achieving project objectives, (d) availability of any reports emanating from the study, and (e) prognosis for ultimate success. Each project report includes identification of the TRB staff engineer having surveillance responsibility and with whom contact may be made for additional insight concerning any details of the contractor's work. Opinions and/or conclusions conveyed by the project reports are those of the research agencies and do not necessarily reflect the position of the Transportation Research Board, the National Research Council, or the Urban Mass Transportation Administration, U.S. Department of Transportation, and no official endorsement should be inferred.

A detailed overview of all aspects of NCTRP operation may be obtained from the following:

- NCTRP Annual Summary of Progress
- NCTRP Information and Instructions for Preparing Proposals

These are available from the Transportation Research Board on request through:

Cooperative Research Programs
Transportation Research Board
2101 Constitution Avenue, N.W.
Washington, D.C. 20418
(202) 334-3224

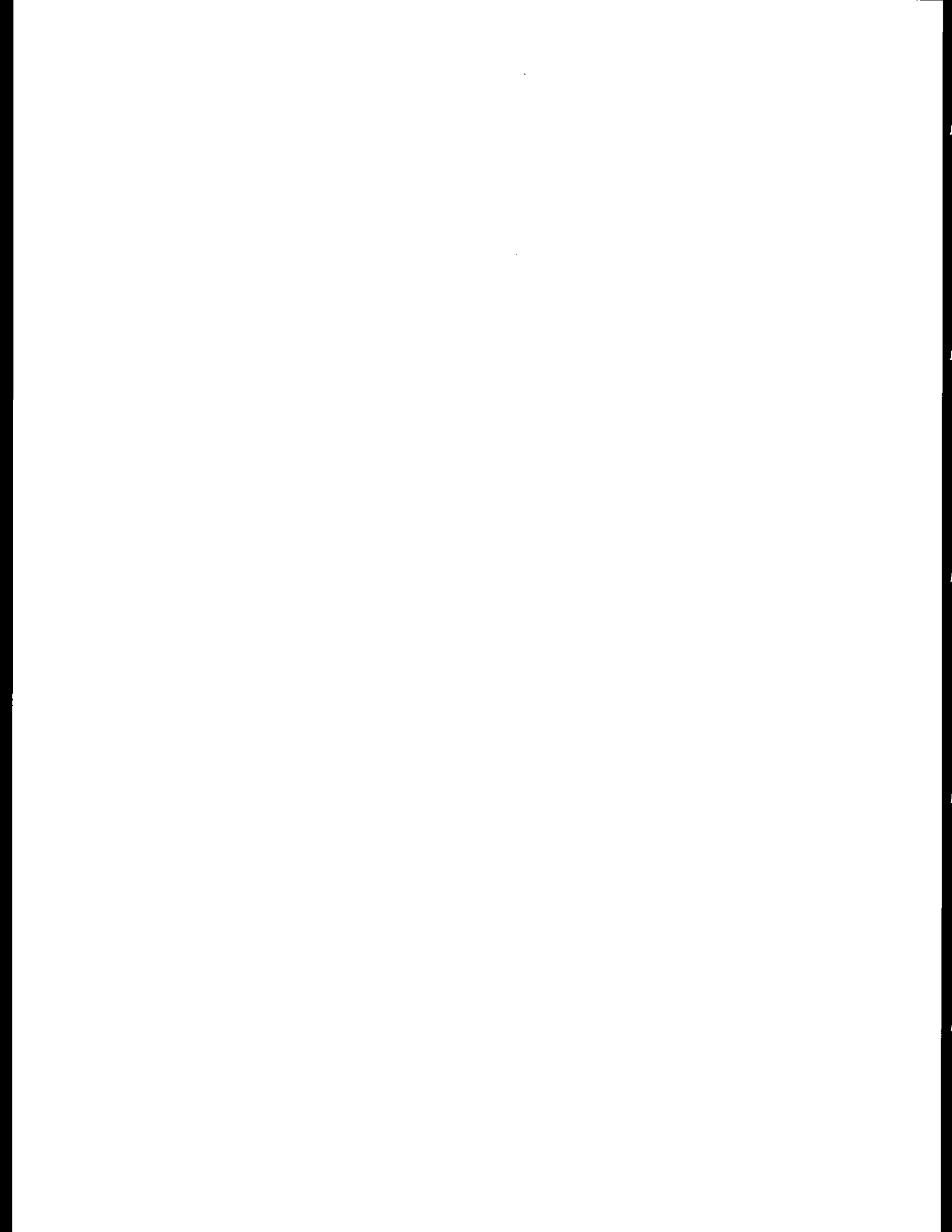

NATIONAL COOPERATIVE TRANSIT RESEARCH & DEVELOPMENT PROGRAM

INTRODUCTION

Administrators, engineers, and many others in the transit industry are faced with a multitude of complex problems that range between local, regional, and national in their prevalence. How they might be solved is open to a variety of approaches; however, it is an established fact that a highly effective approach to problems of widespread commonality is one in which operating agencies join cooperatively to support, both in financial and other participatory respects, systematic research that is well designed, practically oriented, and carried out by highly competent researchers. As problems grow rapidly in number and escalate in complexity, the value of an orderly, high-quality cooperative endeavor likewise escalates.

Recognizing this in light of the many needs of the transit industry at large, the Urban Mass Transportation Administration, U.S. Department of Transportation, got under way in 1980 the National Cooperative Transit Research and Development Program (NCTRP). This is an objective national program that provides a mechanism by which UMTA's principal client groups across the nation can join cooperatively in an attempt to solve near-term public transportation problems through applied research, development, test, and evaluation. Particularly noteworthy is the fact that the client groups now have a channel through which they can directly influence a portion of UMTA's annual activities in transit technology development and deployment. Although present funding of the NCTRP is entirely from UMTA's Section 6 funds, the planning leading to inception of the Program envisioned that UMTA's client groups would join ultimately in providing additional support, thereby enabling the Program to address a larger number of problems each year.

The NCTRP operates by means of agreements between UMTA as the sponsor and (1) the National Academy of Sciences (NAS), a private, nonprofit institution, as the Primary Technical Contractor (PTC) responsible for administrative and technical services, and (2) the American Public Transit Association responsible for operation of a Technical Steering Group (TSG) comprised of representatives of transit operators, local government officials, State DOT officials, and officials from UMTA's Office of Technical Assistance.

Annual NCTRP activity consists of five (5) distinct phases: (1) Problem Identification, (2) Program Formu-

lation, (3) Project Formulation, (4) Project Execution, and (5) Project Reporting. The PTC's role is relative to Phases 2 through 5.

Research programs for the NCTRP are developed annually by the Technical Steering Group, which identifies key problems, ranks them in order of priority, and establishes programs of projects for UMTA approval. Once approved, they are referred to the PTC for administration through the Transportation Research Board.

The Board, established in 1920, is a unit of the National Research Council, which serves as the principal operating agency of both the National Academy of Sciences and the National Academy of Engineering, and is uniquely suited for the administrative role because: it has a record of successful management of the National Cooperative Highway Research Program (NCHRP) since 1962, the program after which the NCTRP has been modeled; it maintains an extensive committee structure from which authorities on any transportation subject may be drawn; it possesses the avenues of communications and cooperation with federal, state, and local government agencies, universities, and industry; it is recognized for its objectivity and understanding of modern research practices; its relationship to the National Research Council is an insurance of objectivity, and it maintains a full-time staff of research specialists in transportation matters to take the findings of research directly to those who are in a position to use them.

Research projects addressing the problems annually referred from UMTA are defined by panels of experts established by the TRB to provide technical guidance and counsel in the problem areas. The projects are advertised widely for proposals, and qualified agencies are selected on the basis of research plans offering the greatest probabilities of success. The research is carried out by these agencies under contract to the PTC, and administration and surveillance of the contract work are the responsibilities of the PTC and the Board.

The needs for transit research are many, and the National Cooperative Transit Research and Development Program is a mechanism for deriving timely solutions for transportation problems of mutual concern to many responsible groups. In doing so, the Program operates complementary to, rather than as a substitute for or duplicate of, other transit research programs.

MANAGEMENT PRACTICES IN THE NCTRP

The commentary that follows is to provide insight into the Academy's functions directed to TRB's management of UMTA's resource allocation for NCTRP research under Contracts DTUM60-81-C-72012 and DTUM 60-83-C-71226. Highlighted are those activities in which all possible opportunity is taken to weight the odds in favor of obtaining implementable solutions to near-term public transportation problems. A more detailed overview of all aspects of Program operation may be obtained from the following:

- NCTRP Annual Summary of Progress
- NCTRP Information and Instructions for Preparing Proposals

Organizationally, the TRB consists of four divisions, each headed by an assistant director reporting to an executive director, who in turn reports to an executive committee. Division D, renamed in 1979 as *Cooperative Research Programs*, was established in 1962 as a special-purpose activity to administer contracts for research under the NCHRP, and it now encompasses the NCTRP. Division D's activities are thus distinctly different from the Board's traditional role of information gathering and dissemination on behalf of a variety of sponsors. Among the differences in operation is the fact that the funds supporting Division D are obtained through channels outside those pertaining to the Board's other divisions; they are budgeted separately; they are accounted for separately; and they are audited independently of those for the Board's other activities. Furthermore, the funds can be spent only on the research designated by the sponsors of the programs administered under Division D.

It should also be recognized that the overall policies and procedures, including the formulation of annual research programs, are entirely the responsibilities and prerogatives of the sponsors. Neither the regular committees nor the Board's staff have a role in the submission or selection of research problems.

UMTA's goal for the NCTRP is a program within which its resources will be managed well and appropriately directed in the search for solutions to near-term public transportation problems. Applied, or mission-oriented, research is a means to the end as regards the technological approach.

The findings from basic research completed elsewhere are brought into play to bring about new technologies. The expectation from the sponsor is that the resource allocation will result in the development of technology that, when implemented, will make life a little easier—not merely the development of scientific knowledge that has no direct practical application. Meeting this expectation is somewhat comparable to new-product research in industry, and, in addition to being extremely costly, the probability of failure is high. Furthermore, although projects may begin as applied research, the synergistic nature of research often catapults them back into the realm of basic studies, because true solutions are not achieved without understanding the underlying causes for the problem so that they may be accounted for in the future.

Although each year's funding base is targeted at about \$1 million, which represents about one-fourth the amount contemplated in the planning processes leading to establishment of the NCTRP, the actual amounts being made available are falling short of the target. Consequently, an urgent need exists for supplementary support from UMTA's client groups joined in a cooperative venture. In any event, proper management of resources is the sole basis for establishment of the Board's entire philosophy, organization, and functions regarding work under Division D—*only the sponsor's expectations matter*. Toward this end, network control is employed in the classic sense of network utilization for project management. Primary focus is on those milestones where the best opportunities lie for positively weighting the odds of success. These opportunities are afforded through the use of common-sense strategies to control various circumstances surrounding each milestone. Subtle processes result that will, through the natural evolution of interdependent events, increase the probability of research results being implemented and improving transportation practices. Such an approach is based on game theory, is admittedly idealistic, is complex and must be monitored constantly. Nonetheless, its practical validity cannot be denied if, in the context of total administrative responsibility, one wants to take advantage of all possible opportunities to insure the best return on the sponsor's investment.

As a first element of strategy, the NCTRP establishes the research agency and personnel qualifications that are mandatory if the projects are to have any chance of success. These are spelled out to potential proposers and are adhered to in selecting research agencies. By means of the project statements and various other widely distributed publications, the NCTRP clearly states the agency attributes deemed essential and thereby hopefully precludes proposals from any but qualified researchers having practical experience in the problem area. Emphasis is placed on the importance of a record of successful past performance in endeavors similar to those to be undertaken. The specifications for proposals are demanding in the sense of requiring the agencies to lay their knowledge, experience and accomplishments on the line, and proposals simply are not accepted if, among other factors, they do not contain specific statements as to how the contemplated results can be used to improve practice.

The next element of strategy comes into play when a research problem and its objectives are first defined in the form of an NCTRP Project Statement by which research proposals will be solicited. A continuing responsibility of the Board is to see that the projects are sensibly structured around the practical facts of operational life and that they represent current circumstances. Therefore, this task is carried out by persons not only very knowledgeable in the problem area but who also have a complete understanding of the needs of the practitioners with whom the problem originated and the best format by which the practitioner can utilize the results. Improved odds therefore become immediately inherent.

Toward the goal of sensible projects, the Board has established seven broad research fields under which project panels are organized to deal with research in specific

NCTRP RESEARCH FIELDS AND AREAS

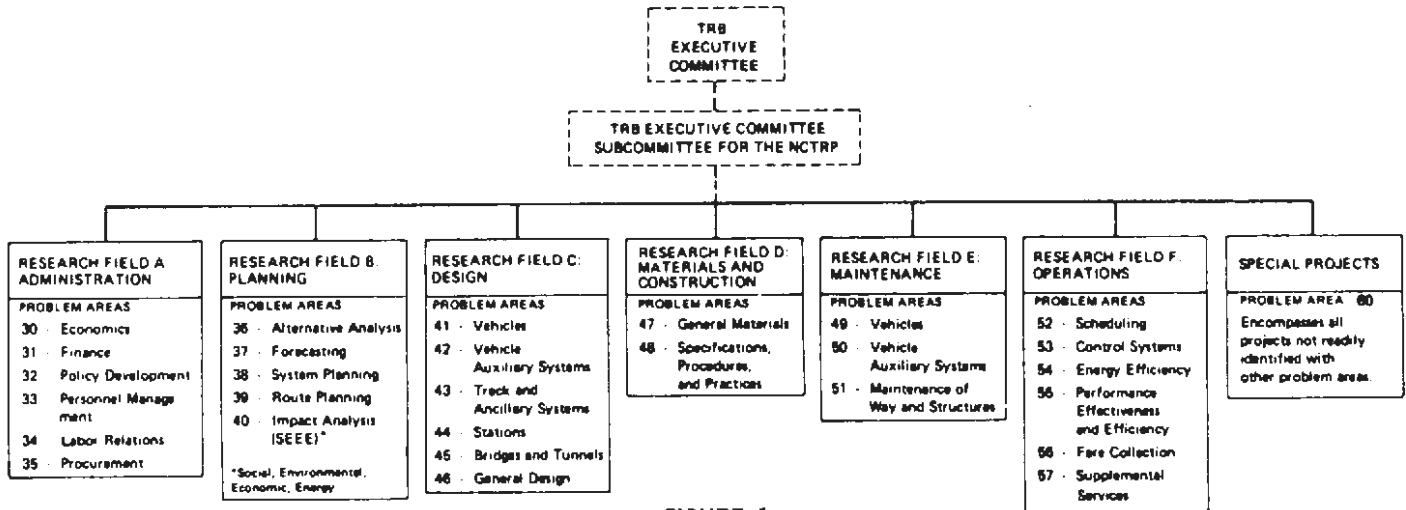

FIGURE 1

problem areas falling within the broad fields (refer to Figure 1). For example, in the broad subject field of Operations each project falling within the more specific subject areas of Energy Efficiency—Area 54—is assigned a project panel comprised of outstanding individuals who are very knowledgeable in the specifics of the particular project and who are looked to for guidance and counsel throughout the research and reporting phases. Those projects that do not conveniently fit under one of the first six general fields are assigned to the seventh one, Special Projects.

Each project is assigned a panel consisting of outstanding individuals very knowledgeable in the project area and who are looked to for technical guidance and counsel throughout the research and reporting phases. A search is made far and wide for these individuals, and the Board usually receives about four to five times as many nominees as can be used in the available panel positions. Panels are appointed by the National Research Council for the life of their projects and, with the coming and going of projects, usually involve some 200 people at any one time. All members serve without compensation, and their total yearly contribution to the Program runs to thousands of man-days. The panel members are drawn from all walks of professional life, and heavy dependence is placed on the sponsor for providing members. Their perspective, in defining the research needed for operational problems, is most important if projects that are both practical and "doable" within the limits of available funds are to be structured.

When the project panels meet for the first time to prepare project statements, it is stressed to them that a first-class statement is the first of the two most important factors bearing on the ultimate success of any project. Accordingly, extreme care is exercised in the development of clear, concise project statements that are distributed to the research community at large. These statements contain objectives designed to result in the most extensive work possible for the available funding. They spell out what is expected of a contractor in terms of findings from

innovative research that can be applied practically; they do not spell out how to go about the research. Statements of explicit objectives, matched to funding, places proposers in the position of knowing exactly what is expected of them, because the available funding is made known along with the objectives. Not only does this result in more realistic proposals, but it most assuredly eases each project panel's task of comparative evaluation. Of the members of the NCTRP's project panels to date, about 32 percent come from transit operating agencies. Because of their intimate involvement in the development of the various research projects, their knowledge of what is to be expected, and the "spreading of the word" among their associates, there is yet another step toward improving the odds that results will be put to use.

The second of the two most important factors, and the next element of strategy, concerns the process of evaluating proposals to select research agencies. The odds can be advanced materially if extreme care is exercised throughout this activity. Indeed, this activity constitutes *the* milestone on which the success of the project can become totally dependent, irrespective of the strengths built in at the preceding milestones. Prior to contracting, there *must* be satisfaction not only that the proposed research plan is the best possible in addressing the specifics of the objectives, but also that it culminates with the best promise for providing transit agencies with a product that is both usable and readily implementable; otherwise, the proposal process—and possibly that of project definition—should be repeated. The importance of this activity is made abundantly clear to the project panels when they meet to select agencies and suggest minor modifications of the research plans as a means for keeping them squarely on target. A comprehensively detailed research plan not only aids the selection process but also serves as the yardstick by which the staff exercises day-to-day surveillance of research progress.

Two top proposals are chosen for each project. The deliberations of the project panel include a review of all known aspects of agency performance on other research

projects under NCTRP or elsewhere and a determination that the first-choice research plan offers the best promise for providing a product that is both usable and readily implementable. A key factor is the merit of the research approach and the experiment design. There is nothing anywhere in the Program's specifications that says the project statements must be adhered to strictly in every detail and that any deviation in research thrust or from the proposed project period warrants outright rejection. The key element is that the agencies must present a strong, convincing case for whatever approaches they take. These always receive just consideration because the sole interest of the project panels is to determine the plan with the best probability of success.

Prior to contracting, any suggested modifications are taken by the Program staff to the agencies, and a clear meeting of the minds is established regarding what is specifically expected from the research and the personnel carrying it out. By means of the "Procedural Manual for Agencies Conducting Research in the National Cooperative Transit Research and Development Program," further emphasis is placed on the requirement for practically oriented research and the proper means for reporting it. Experience has demonstrated that, once the research is under way, the practical fact of life is that the destiny of the research is pretty well committed, no matter how extensive the staff surveillance or how many administrative processes are available to accommodate changes. Rarely are changes accompanied by gains when having to stay within the original funding; rather, the effects are usually negative.

A first requirement of the research agency immediately after subcontracting is the development of a working plan that is intended to be a comprehensively detailed amplification of the approved research plan, inclusive of a specific schedule of events for the major tasks. This document is used by the staff in the day-to-day surveillance of the project's progress. Should review of this document by the staff and project panel bring to light necessary changes that were not previously apparent, these can be accommodated without hindering prosecution of the work. Through this activity, an additional opportunity is afforded for improvement of the odds of success.

As a means of mutual assistance while work is under way, two types of progress reports are required from the agencies. On a monthly basis, one-page progress schedules are submitted that graphically depict several aspects of progress. On a calendar quarter basis, narratives are required that fully describe accomplishments to date and outline future activities based on the accomplishments. Based on these reports and information gained through surveillance visits, Program staff prepares its own progress reports that are sent to UMTA and the Technical Steering Group as a measure of providing a current awareness of on-going work. By these controls the Program is, to some degree, able to appraise the agency's level of performance, while at the same time the agency is provided with tools to assist its own management responsibility in both administrative and technical respects. All too often in the administration of research programs problems arise because there is insufficient communication between the

agency's management staff and the technical staff performing the research.

Project surveillance constitutes a major element of strategy in achieving the administrative goal. The gains here reflect the effort that the NCTRP staff exerts (a) to keep the research in line with the approved research plan; (b) to keep the researchers continually aware of the needs of the practicing engineer; and (c) to see that all project developments, through final reporting, center around these practical needs. Projects engineers with wide-ranging experience are assigned to the NCTRP by the Board and are responsible for administrative and technical surveillance of the contracts. Their activities include visiting each research agency at least once every six months to discuss the status of the work with the principal investigator(s) and to determine if the research is being pursued in line with the approved research plan. Any need for change in the plan is referred to the project's panel for review and approval. Finally, the staff engineer and the project panel evaluate the final report on the completed research to determine the degree of technical compliance with the subcontract and to ensure adherence to the Program's specifications for report writing.

Research agencies are required to report their results in language that is understandable and succinctly summarizes the results so that the transit administrator and others may easily determine their usefulness to their operations. The objectives are accomplished through a "Summary of Findings" and a chapter on "Interpretation, Appraisal, and Application of Results." The detailed research techniques and analyses in which a researcher would be interested are presented as report appendices. Available to the researchers in report preparation are guidelines that have been developed with the objective of providing a report of maximum utility to the transit industry. Each report, as finally published in the regular NCTRP series (Reports or Syntheses of Transit Practice) also contains a staff-prepared foreword that directs the attention of the busy reader to the persons who would be most interested in the results and, also, to how the results fit into present knowledge and practice.

All reports are reviewed by the project's panel to determine if the report indicates reasonable accomplishment of the technical aspects of the research plan; if the conclusions are adequately supported; if the clarity of presentation is satisfactory; and if the report is free from statements on sensitive matters. If the report qualifies for publication at this point, it is further reviewed by the Committee on NRC Oversight (CNO) when a question of sensitivity is involved. Outside reviewers, i.e., reviewers having no responsibility in the conduct of the research, may be asked to review a report at any stage either for the benefit of their technical expertise or for opinions relating to broader issues underlying the report including public sensitivity.

Prior to publication, extraordinary measures are taken to ensure that useful research results are made immediately available to the appropriate personnel. One means consists of forwarding copies of the research agency drafts of final reports. According to the urgency of the particular circumstances, these drafts may be either uncorrected or

corrected on the basis of an acceptance review. Several copies of unedited drafts of the agency reports are retained until formal publication and are available, on a loan basis, to others having an interest in the research. Once published in their entirety, the drafts are destroyed.

After publication, each report is distributed widely through the TRB's selective distribution system. Copies go automatically to about 100 libraries, TRB transit representatives, educational institution liaison representatives, appropriate project panels and committees of the Board, and individual members who have selected publications in the particular subject area of the report. As a further means of disseminating the research reports, announcements of their availability are made to the trade press. Also, the Technical Activities Staff comprising the Board's Division A follow the progress of the work throughout its conduct and consequently are able to discuss application of the research results with potential users during visits to operating agencies.

A tragic result of much research is a compilation of findings that, because of language and form, simply cannot be used until the sponsor devotes considerable supplementary effort to translating the findings into the language and working tools of the users. This kind of time cannot be afforded in the sponsor's scheme of day-to-day operation. In an applied research program such as the NCTRP, the sponsor rightfully expects a product that has immediate applicability to practice. This is not asking too much, because improvements are going to occur mostly in the form of moderate refinements of existing practices, rather than as dramatic innovations or breakthroughs that one might expect from extensive basic research. Therefore, where necessary as an integral part of administration, staff assumes the role of interpreter and interjects itself as a third party between the sponsor and the researcher by means of a very brief publication titled *NCTRP Research Results Digest*. The Digests are issued as a series of flyers to provide in understandable language an early awareness of project results so as to encourage early implementation. They are brief in summarizing specific findings—they do not deal with methodology—and require the reader to expend very little time in determining the usefulness of the findings. Reference is made in each to the fact that uncorrected draft copies of the agency's

report are available on a loan basis for those desiring more extensive information. Where circumstances warrant, staff does not wait for requests for reports but distributes copies of the agencies' draft final reports to appropriate personnel.

With the culmination of the formal reporting activity, plus any of the special measures just described, the NCTRP reaches the final milestone of its administrative network. What happens beyond that point—how successful the projects really turn out to be—is entirely up to UMTA and the operating agencies. Projects that have accomplished their objectives in providing useful products might just as well have been failures if, at least, consideration is not given to how the results might be used to improve operations. It simply does not make good sense to invest millions in research on critical problems and then not give adequate attention to a determination of the implementation value of the products. Such determination can range from mere thought to total, immediate incorporation as standard practice. Certainly, any action must be temperate to avoid the pitfalls that are present in pushing too hard too fast. To aid decisions as to the course to be pursued, future NCTRP publications will report on all known uses of results, be they limited or extensive. Given the fact that the NCTRP addresses critical, national problems, documented payoff to any one agency should attract study by others. So should documented failures, for they also contain lessons by which all can profit. Research is a venture into risk and uncertainty, the risk being particularly high in applied or mission-oriented research such as the NCTRP undertakes. The wisdom of accepting risk is impossible to determine without studious inquiry into the benefits derived.

In summary, the NCTRP is an applied, contract research program that has been structured along specific lines to enable it to respond to specific needs of the nation's transit industry. The needs are expressed through problem statements referred from UMTA, and each problem is accompanied by the funds to see it through. From the preparation of project statements through final reporting on the projects results, the goal of the NCTRP is administration that, in the final analysis, will prove to be fully effective in obtaining the best return on the investment supporting the Program.

PERSONNEL

Effective February 1, 1985, Dr. Robert J. Reilly assumed the directorship of the Cooperative Research Programs following the retirement of Krieger W. Henderson, Jr. Dr. Reilly has served 13 years on the Cooperative Research Programs' staff. Dr. Reilly came to the Transportation Research Board in 1972 from the University of Maryland where he was assistant professor of civil engineering. He is a graduate of Manhattan College and received M.S. and Ph.D. degrees from the University of Maryland. He has also completed several courses at the Catholic University School of Law. At the University of

Maryland, Reilly taught undergraduate and graduate courses in the areas of structural engineering, applied mathematics, engineering materials, computer methods, and solid and fluid mechanics.

Over the past 13 years, Dr. Reilly was responsible for the technical administration of numerous research projects, including the very popular synthesis studies in the NCHRP and NCTRP programs. He has lectured in programs sponsored by AISC, AASHTO, and AISI, and has published papers in the *ASCE Structural Division Journal* and the *International Journal of Computers and Struc-*

TABLE I
SUMMARY OF STATUS THROUGH JUNE 30, 1985, FOR FY '80 THROUGH FY '84 PROJECTS

PROJECT		RESEARCH AGENCY	SUBCONTRACT AMOUNT OR SUBCONTRACT COST (\$)
NO.	TITLE		
AREA 30: ADMINISTRATION—ECONOMICS			
30-1	Small Transit Buses: A Manual for Improved Purchasing, Use, and Maintenance	Arthur D. Little	\$299,378
AREA 31: ADMINISTRATION—FINANCE			
31-1	The Impacts of Federal Grant Requirements on Transit Agencies	Booz-Allen	49,522 *
31-2	Controlling Rising Operating Deficit Through Capital Investments	—	150,000
AREA 33: ADMINISTRATION—PERSONNEL MANAGEMENT			
33-1	Transit Bus Operator Selection and Training for Dealing with Stress	GAMS Inc.	150,000
33-2	Assessment of Job Enrichment Programs for the Transit Industry	Public Adm. Service	97,821 *
33-2(2)	Quality-of-Work-Life Programs for the Transit Industry—Regional Seminars	Public Adm. Service	52,454
33-3	Public Transit Bus Maintenance Manpower Planning	Fleet Maintenance	100,000
AREA 36: PLANNING—ALTERNATIVE ANALYSIS			
36-1	Improving Decision-Making for Major Urban Transit Investments	System Des. Concepts	200,000 *
AREA 38: PLANNING—SYSTEM PLANNING			
38-1	National Transit Computer Software Directory	COMSIS Corp.	98,457 *
38-1(2)	National Transit Computer Software Directory, Phase II	COMSIS Corp.	50,000
AREA 39: PLANNING—ROUTE PLANNING			
39-1	A Modular Approach to On-Board, Automatic Data Collection Systems	The MITRE Corp.	148,787
39-1(2)	A Modular Approach to On-Board, Automatic Data Collection Systems—Seminar	The MITRE Corp.	26,213
AREA 40: PLANNING—IMPACT ANALYSIS			
40-1	Simplified Guidelines for Evaluating Transit Options in Small Urban Areas	Barton-Aschman	149,960 *
40-2	Estimating Incremental Costs of Bus-Route-Service Changes	System Des. Concepts	150,000
40-3	Strategies to Implement Benefit-Sharing for Fixed Transit Facilities	SG Associates	99,957 *
AREA 43: DESIGN—TRACK AND ANCILLARY SYSTEMS			
43-1	Detection of Low-Level Fault Currents on Rail Transit Systems	Chas. T. Main, Inc.	99,913 *
AREA 46: DESIGN—GENERAL DESIGN			
46-1	Single Cable Communications Technology for Rail-Transit Systems	Poly Inst of NY	150,000
AREA 47: MATERIALS AND CONSTRUCTION—GENERAL MATERIALS			
47-1	Improved Service Life of Urban Transit Coach Brakes	Battelle Mem Inst	300,000
AREA 48: MATERIALS AND CONSTRUCTION—SPECIFICATIONS, PROCEDURES, AND PRACTICES			
48-1	Electrolytic Corrosion in DC Powered Transit Systems	—	200,000
AREA 54: OPERATIONS—ENERGY EFFICIENCY			
54-1	Improve Transit Bus Energy Efficiency and Productivity	Booz-Allen	39,976 *
54-2	Energy Management of Electric Rail Transit Systems	Carnegie-Mellon	150,000
AREA 55: OPERATIONS—PERFORMANCE, EFFECTIVENESS, AND EFFICIENCY			
55-1	Conversion to One-Person Operation of Heavy-Rail Rapid-Transit Trains	Battelle Mem Inst	150,000
AREA 60: SPECIAL PROJECTS			
60-1	Synthesis of Information Related to Transit Problems	TRB	660,000 *
	TS-1: Cleaning Equipment and Procedures for Transit Buses	ATE Mgmt	75,000 ^b
	TS-2: Priority Treatment for Buses on Urban Streets	PAWA	75,000 ^b
	TS-3: Effects of Fuel Additives and Alternative Fuel Grades for Transit Buses	Southwest Res Inst	30,000 ^b

STARTING DATE	EXPECTED COMPLETION DATE	PROJECT STATUS (for details, see latest Summary of Progress)	PROJECT NO.
11/8/82	8/7/84	Completed—Manual published as NCTRP Report 11; research report in review stage	30-1
11/30/81	12/15/82	Completed—Published as NCTRP Report 2	31-1
	18 months	In developmental stage	31-2
10/15/81	4/14/84	Completed—Report summarized in RRD 3; see Prog. by Proj. section for rpt. avail.	33-1
11/1/82	2/29/84	Completed—Published as NCTRP Reports 5 and 6	33-2
12/1/84	3/1/86	Research in progress	33-2(2)
11/1/83	10/31/84	Completed—Published as NCTRP Report 10	33-3
11/2/81	11/1/83	Completed—Published as NCTRP Report 4	36-1
1/3/83	1/31/85	Completed—Report summarized in RRD 4; see Prog. by Proj. section for rpt. avail.	38-1
2/15/85	7/1/86	Research in progress	38-1(2)
11/1/82	8/31/84	Completed—Published as NCTRP Report 9	39-1
	9 months	Contract pending	39-1(2)
10/25/82	10/23/84	Completed—Published as NCTRP Report 8	40-1
11/15/83	1/31/86	Research in progress	40-2
11/1/83	2/1/85	Completed—To be published as NCTRP Report 12	40-3
1/3/83	11/30/84	Completed—Published as NCTRP Report 7	43-1
5/1/84	7/31/85	Research in progress	46-1
12/1/81	12/31/84	Report in review stage	47-1
	15 months	In developmental stage	48-1
10/1/81	6/30/82	Completed—Published as NCTRP Report 1	54-1
10/1/81	12/31/83	Completed—Published as NCTRP Report 3	54-2
5/5/84	10/31/85	Research in progress	55-1
11/7/80		Research in progress	60-1
2/16/81	12/31/81	Completed—Published as NCTRP Synthesis 1	(TS-1) 60-1
3/16/81	12/31/81	Completed—Published as NCTRP Synthesis 2	(TS-2) 60-1
10/1/82	9/30/83	Completed—Published as NCTRP Synthesis 3	(TS-3) 60-1

TABLE I (Continued)
SUMMARY OF STATUS THROUGH JUNE 30, 1985, FOR FY '80 THROUGH FY '84 PROJECTS

PROJECT		RESEARCH AGENCY	SUBCONTRACT AMOUNT OR SUBCONTRACT COST (\$)
NO.	TITLE		
	TS-4: Guidelines for Allocation of Time for Transit Coach Maintenance Functions	XYZYX Info Corp.	30,000 ^b
	TS-5: Extraboard Management Procedures and Tools	L. C. McDorman	40,000 ^b
	TS-6: Traffic Control and Regulation at Transit Stops	W. W. Rankin	45,000 ^b
	TS-7: Bus Communications Systems	Mitre	45,000 ^b
	TS-8: Passenger Information Systems for Transit Transfer Facilities	J. J. Fruin	45,000 ^b
	TS-9: Transit Fare Collection: Problems and Alternatives to Paper Currency	Mitre	75,000 ^b
	TS-10: Use of Part-Time Operators	L. C. McDorman	50,000
	TS-11: Transit Marketing: Success and Failures	Richard L. Oram	50,000
	TS-12: Use of Incentives to Attain Specified Performance Standards in Collective Bargaining for Mass Transit	Darold T. Barnum	50,000
	TS-13: Bus Inspection Guidelines	C. I. Giuliani	50,000

* Final Subcontract cost.

^a Continuing activity through FY '84. Annual amount varies; total to date shown.

^b Allocated—Balances are carried forward to support future synthesis studies.

TABLE II
PUBLISHED REPORTS OF THE NATIONAL COOPERATIVE TRANSIT RESEARCH & DEVELOPMENT PROGRAM

Report

No.	Title, Project, Pages, Price
1	Transit Bus Energy Efficiency and Productivity—Bus Equipment Selection Handbook (Project 54-1), 55p., \$7.20.
2	Impacts of Federal Grant Requirements on Transit Agencies (Project 31-1), 73 p., \$7.60
3	Reduction of Peak-Power Demand for Electric Rail Transit Systems (Project 54-2), 142 p., \$10.40
4	Improving Decision-Making for Major Urban Transit Investments (Project 36-1), 47 p., \$7.20
5	Assessment of Quality of Work-Life Programs for the Transit Industry—Research Report (Project 33-2), 99 p., \$8.80
6	Assessment of Quality-of-Work-Life Programs for the Transit Industry—Model Programs (Project 33-2), 37 p., \$6.80
7	Detection of Low-Current Short Circuits 216 p., \$14.00
8	Simplified Guidelines for Evaluating Transit Service in Small Urban Areas (Project 40-1), 119 p., \$10.40
9	Modular Approach to On-Board Automatic Data Collection Systems (Project 39-1), 123 p., \$10.40
10	Public Transit Bus Maintenance Manpower Planning (Project 33-3), 56 p., \$8.00
11	Small Transit Vehicles: How to Buy, Operate, and Maintain Them (Project 30-1), 49 p., \$7.60
12	Strategies to Implement Benefit Sharing for Fixed Transit Facilities (In Preparation)

Synthesis of Transit Practice

No.	Title, Pages, Price
1	Cleaning Transit Buses: Equipment and Procedures (Proj. 60-1, Topic TS-1), 39 p., \$6.80
• 2	Enforcement of Priority Treatment for Buses on Urban Streets (Proj. 60-1, Topic TS-2), 30 p., \$6.40
3	Diesel Fuel Quality and Effects of Fuel Additives (Proj. 60-1, Topic TS-3), 62 p., \$7.60
4	Allocation of Time for Transit Bus Maintenance Function (Proj. 60-1, Topic TS-4), 24 p., \$6.40

• Out of print.

TABLE III
NCTRP RESEARCH RESULTS DIGESTS^a

DIGEST NO.	PROJ. NO.	TITLE, PAGES, PRICE
1	33-1	Review of Literature Related to Bus Operator Stress, 15p., \$3.00
2	60-1	Project to Synthesize Information on Transit Problems, 3p., \$1.00
3	33-1	Predicting and Dealing with Bus Operator Stress, 4 p., 1.00
4	38-1	National Transit Computer Software Directory, 9 p., \$1.00

^a See Table I for project titles. See final page of this document for ordering information.

STARTING DATE	EXPECTED COMPLETION DATE	PROJECT STATUS (for details, see latest Summary of Progress)	PROJECT NO.
12/9/82	11/30/83	Completed—Published as NCTRP Synthesis 4	(TS-4) 60-1
11/31/83	9/30/84	Completed—Report in review stage	(TS-5) 60-1
1/1/84	12/31/84	Completed—Report in editorial and publication process	(TS-6) 60-1
11/21/83	12/31/84	Completed—Report in editorial and publication process	(TS-7) 60-1
11/21/83	6/30/85	Completed—Report in editorial and publication process	(TS-8) 60-1
12/2/83	12/31/84	Completed—Report in editorial and publication process	(TS-9) 60-1
9/16/84	9/30/85	Research in progress	(TS-10) 60-1
9/16/84	9/30/85	Research in progress	(TS-11) 60-1
12/15/84	11/30/85	Research in progress	(TS-12) 60-1
11/1/84	10/31/85	Research in progress	(TS-13) 60-1

tures. He is a past director of the Maryland section of ASCE and a Registered Professional Engineer.

On July 1, 1985, Robert E. Spicher will be appointed to the position of Deputy Director of The Cooperative Research Programs. Formerly a Projects Engineer on the CRP staff, Mr. Spicher will now be responsible for assisting Dr. Robert J. Reilly, Director, CRP, in all administrative and technical matters arising from day-to-day CRP management and will also continue his project-related activities in the operations and safety areas.

Mr. Spicher, formerly a transportation planner with the Comsis Corporation in Washington, D.C., joined the staff of the National Cooperative Highway Research Program in 1975. A native of Pennsylvania, Mr. Spicher has worked for the Maryland State Roads Commission, the District of Columbia Department of Highways and Traffic, and the Highway Users Federation.

Mr. Spicher is a graduate of Drexel Institute of Technology and the Yale Bureau of Highway Traffic and, prior to joining the staff, he chaired the Transportation Research Board's Committee on Planning, Programming, and Evaluation. He has long been active in the Institute of Transportation Engineers and is past president of its Washington, D.C., section.

Ian M. Friedland joined the Cooperative Research Programs on May 23, 1985, as a Projects Engineer. Mr. Friedland will be working on the administration and supervision of a number of research projects in the areas of structural design and specifications, procedures, and practices for construction and materials.

Mr. Friedland received his Bachelor of Science degree from Cornell University and his Master of Science degree from the University of Maryland. Both degrees were in Civil/Structural engineering.

Prior to joining TRB, Mr. Friedland worked for Stone and Webster Engineering Corporation in Cherry Hill, N.J., and for Bechtel Power Corporation. He is a registered Professional Engineer in New Jersey and Pennsylvania.

SUMMARY OF ADMINISTRATIVE PROGRESS

The following summary addresses the research programs for fiscal years 1980 through 1986, and it pertains

to activities in the 6 months subsequent to January 1, 1985. The narrative for each year is cross-referenced to the networks included at the end of the summary. Accompanying the networks are descriptions of the activities (subtasks), and those underlined represent the deliverables to which the PTC is committed.

There are five (5) networks representing the PTC's overall perception of the nature and sequence of activities required by all NCTRP participants for an efficient, fully coordinated operation. All five are included in this report for FYs 1980, 1981 and 1982/1983; only those pertinent through the end of the report period are included for subsequent years. Progress on tasks and subtasks is indicated by shading of the activity nodes. A fully shaded node represents completion of a subtask; a partially shaded node represents partial accomplishment of a subtask. Accordingly, progress for the respective fiscal-year programs is as follows.

FY 1980 Program

I. Reference: Network #1, Tasks 1.1 and 2.1 (subtasks 2.1.1 through 2.1.13)

All work under Task 1.1 of this network is covered by the APTA contract for conduct of the TSG operation relative to formulation of annual programs and other responsibilities. Task 2.1 work is carried out by the PTC in support of the TSG, and it was completed and reported on earlier.

II. Reference: Network #2, Tasks 3.0 (beginning with subtask 3.0.1), 3.1, 3.2, and 3.3 (ending with subtask 3.3.7)

All work under the referenced tasks was completed and reported on earlier (see NCTRP Progress Report 1).

III. Reference: Network #3, Tasks 3.3 (beginning with subtask 3.3.9), 3.4, and 4.1 (ending with subtask 4.1.5)

All work under the referenced tasks was completed and reported on earlier (see NCTRP Progress Report 1).

IV. Reference: Network #4, Tasks 4.2, 5.2, and 5.4 (beginning with subtask 4.2.1 and ending with subtask 5.4.1)

All work under the referenced tasks was completed and reported on earlier (see NCTRP Progress Report 7).

V. Reference: Network #5, Task 5.4 (beginning with subtask 5.4.3 and ending with subtask 5.4.111)

On receipt of the Project 47-1 report, the primary technical activity under this network concerned publication of final reports as research on all seven FY '80 projects had been completed. A brief summary of the status of these projects is:

- 31-1 Completed—Published as NCTRP Report 2
- 33-1 Completed—Unpublished (see report availability in Progress by Project Section.
- 36-1 Completed—Published as NCTRP Report 4
- 47-1 Completed—Report undergoing modification from special reviews
- 54-1 Completed—Published as NCTRP Report 1
- 54-2 Completed—Published as NCTRP Report 3
- 60-1 Completed—Published as NCTRP Syntheses 1 and 2

Steps were taken as appropriate to circumstances to close contracts and pay final vouchers. Disbandment of project panels has been scheduled and will occur in due course.

In general, the full details of the status of all FY '80 projects that were active during the report period will be found in the "Progress by Project" section and Tables I, II, and III of this document.

VI. Reference: Synthesis Task (Unnumbered)

All work in the synthesis area for this year was completed and reported on earlier (see NCTRP Progress Report 4 and/or Table I herein).

VII. Reference: Contract DTUM60-81-C-72012

In line with the requirements of Article XIX, Subcontracting Reporting Requirements, it is reported that no subcontracts for research under the FY 1980 program were entered into during the 6 months ending June 30, 1985.

FY 1981 Program

I. Reference: Network #1, Tasks 1.1 and 2.1 (subtasks 2.1.1 through 2.1.13)

All work under Task 1.1 of this network is covered by the APTA contract for conduct of the TSG operation relative to formulation of annual programs and other responsibilities. Task 2.1 work is carried out by the PTC in support of the TSG, and it was completed and reported on earlier (see NCTRP Progress Report 1).

II. Reference: Network #2, Tasks 3.0 (beginning with subtask 3.0.1), 3.1, 3.2, and 3.3 (ending with subtask 3.3.7)

All work under this network was completed and reported on earlier (see NCTRP Progress Report 2).

III. Reference: Network #3, Tasks 3.3 (beginning with subtask 3.3.9), 3.4, and 4.1 (ending with subtask 4.1.5)

All activity under this network was completed and reported on earlier (see NCTRP Progress Report 3).

IV. Reference: Network #4, Tasks 4.2, 5.2, and 5.4 (beginning with subtask 4.2.1 and ending with subtask 5.4.1)

With the exception of Project 30-1, for which the final revision of the research report is pending (Manual Published as NCTRP Report 11), all activity covered by this network has been completed.

V. Reference: Network #5, Task 5.4 (beginning with subtask 5.4.3 and ending with subtask 5.4.111)

Activity covered by this network consisted of surveillance of the final steps of contract activity on seven projects, including the TRB synthesis project. Six of the seven were completed during the report period; the seventh will be completed early in the next report period. A brief summary of the status of the FY '81 projects is:

- 30-1 Completed—Manual published as NCTRP Report 11; research report in review stage.
- 33-2 Completed—Published as NCTRP Reports 5 and 6.
- 38-1 Completed—Final report in and available for loan; FY '82/'83 continuation is under way.
- 39-1 Completed—Published as NCTRP Report 9.
- 40-1 Completed—Published as NCTRP Report 8.
- 43-1 Completed—Published as NCTRP Report 7.
- 60-1 Completed—This year's work published as NCTRP Syntheses 3 and 4.

Steps were taken as appropriate to circumstances to close contracts and pay final vouchers. Disbandment of project panels has been scheduled and will occur in due course.

In general, the full details of the status of all FY '81 projects that were active during the report period will be found in the "Progress by Project" section and Tables I, II, and III of this document.

VI. Reference: Synthesis Task (Unnumbered)

As noted above, published Syntheses 3 and 4 represent completion of work under this network. Topic titles are given in Table I of this document.

VII. Reference: Contract DTUM60-81-C-72012

In line with the requirements of Article XIX, Subcontracting Reporting Requirements, it is reported that no subcontracts for research under the FY 1981 program were entered into during the 6 months ending December 31, 1984.

FY 1982/1983 Program

NOTE: Formerly designated as the FY 1982 Program, the new designation was requested by UMTA so that succeeding-year designations will correspond more closely with actual fiscal years.

I. Reference: Network #1, Tasks 1.1 and 2.1 (subtasks 2.1.1 through 2.1.13)

All work under Task 1.1 is covered by the APTA contract for conduct of the TSG operation relative to formulating annual programs and other responsibilities. The PTC supports this activity (Task 2.1) through TRIS searches for information relevant to problems submitted to the TSG for evaluation, provides such information to the TSG, and then participates as appropriate in the meetings of the TSG for selection of the problems for the annual programs. All work in these regards was completed and reported on earlier (see NCTRP Progress Report 3).

II. Reference: Network #2, Tasks 3.0 (beginning with subtask 3.0.1), 3.1, 3.2, and 3.3 (ending with subtask 3.3.7)

All work under this network has been completed and was reported on earlier (see NCTRP Progress Report 4).

III. Reference: Network #3, Tasks 3.3 (beginning with subtask 3.3.9), and 3.4

With one exception pertaining to Project 46-1, all work on five new projects under this network was completed and reported on earlier (see NCTRP Progress Report 7).

IV. Reference: Network #4, Tasks 4.2, 5.2, and 5.4 (beginning with subtask 4.2.1 and ending with subtask 5.4.1)

Activity under this network consisted of routine surveillance of research in progress on four projects (including the TRB syntheses under Project 60-1); processing of the final report for Project 40-3; and execution of continuation subcontracts for two continuation projects. A brief summary of the status of the FY '82/'83 projects is:

33-2(2)	Agency execution of continuation subcontract
33-3	Completed—Published as NCTRP Report 10
38-1(2)	Agency execution of continuation subcontract
40-2	Research is in progress
40-3	Completed—To be published as NCTRP Report 12
46-1	Research is in progress
55-1	Research is in progress
60-1	Syntheses are in progress

V. Reference: Network #5, Task 5.4 (beginning with subtask 5.4.3 and ending with subtask 5.4.111)

Activity under this network has been limited to processing of the final reports from Project 33-3 and 40-3.

VI. Reference: Synthesis Task (Unnumbered)

Syntheses TS5 through TS9 are in the editorial and publication process.

VII. Reference: Contract DTUM60-83-C-71226

In line with the requirements of Article XIX, Subcontracting Reporting Requirements, it is reported that two

subcontracts were entered into during the 6 months ending June 30, 1985, Projects 33-2(2) and 38-1(2).

To accommodate this ongoing research, a subcontract extension for time only will be requested.

FY 1984 Program

I. Reference: Network #1, Tasks 1.1 and 2.1 (subtasks 2.1.1 through 2.1.13)

All activity under this network has been completed by virtue of PTC's participation in the February 1, 1984, meeting of the TSG.

II. Reference: Network #2, Tasks 3.0 (beginning with subtask 3.0.1), 3.1, 3.2, and 3.3 (ending with subtask 3.3.7)

Activities covered by this network have been completed. UMTA authorization to proceed with certain work preliminary to requesting proposals was received on May 10, 1984. PTC processes relative to acceptance of the program for administration were completed, and requests were made for nomination of panel members. Based on the returns, panels were defined and invitations to serve were issued. Project panels for two new projects, Projects 31-2 and 48-1, met during the period February 25 through March 1 to prepare project statements. Project 60-1 was continued with starts on four synthesis projects, TS10 through 13.

III. Reference: Network #3, Tasks 3.3 (beginning with subtask 3.3.9 and ending with subtask 3.3.21)

Activities covered by this network have been covered in part. Seven and twelve proposals were received for Projects 31-2 and 48-1, respectively. Panel members were allowed approximately four weeks for review of proposals. At meetings during the week of June 24, research agencies were chosen.

IV. Reference: Synthesis Task (Unnumbered)

Preliminary drafts were reviewed for TS10, 11, and 13. Research is in progress for TS12.

FY 1985 Program

I. Reference: Network #1, Tasks 1.1 and 2.1 (subtasks 2.1.1 through 2.1.13)

All work under Task 1.1 of this network is covered by the APTA contract for conduct of the TSG operation relative to formulating annual programs and other responsibilities. The PTC supports this activity (Task 2.1) through TRIS searches for information relevant to problems submitted to the TSG for evaluation, provides such information to the TSG, and then participates as in the meetings of the TSG for selection of the problems for the annual programs. All work in these regards was completed as of the TSG meeting of December 14.

II. Reference: Network #2, Tasks 3.0 (beginning with subtasks 3.0.1), 3.1, 3.2, and 3.3 (ending with subtask 3.3.7)

Work according to this network hinges on UMTA's referral of an approved research program for PTC admin-

istration. Although expected early in the period, that referral is still pending.

FY 1986 Program

I. Reference Network #1, Tasks 1.1 and 2.1 (subtasks 2.1.1 through 2.1.13)

All work under Task 1.1 of this network is covered by the APTA contract for conduct of the TSG operation relative to formulation of annual programs and other responsibilities. The APTA process began January 1985 with the call for problems. Problems have not been submitted to the PTC for action to be taken on subtasks in this network.

General—All Programs

Distribution was made early in the report period of NCTRP Progress Report 7 to UMTA and others participating directly in NCTRP work. The Annual Summary of Progress for 1984 was published near the end of 1984 and received wide distribution through the TRB selective distribution process. Further distribution was made at the January 1985 TRB Annual Meeting. Also published and widely distributed was Research Results Digest 2 summarizing the work under Project 60-1, "Synthesis of Information Related to Transit Problems," Research Results Digest 3 summarizing the work under Project 33-1, "Predicting and Dealing with Transit Bus Operator Stress," and Research Results Digest 4 summarizing the work under Project 38-1, "National Transit Computer Software Directory."

Difficulties Encountered During Report Period

1. Staff activity relative to administration of the program remains at a low-level, part-time basis for the rea-

sons given in Progress Report 7 and will continue so until there is a realistic approach to the matter of costs necessary for proper administration of the program.

2. Progress Report 7 continued previous references to the unplanned high cost of TRIS retrievals relative to annual problem evaluations. The resultant overrun of the retrieval item in the PTC budget has thus far been accounted for through sacrifice of other efforts, and it will have to be resolved when the next prime contract for follow-on work is negotiated.

Difficulties Projected for Next Report Period

As has been the past case, what happens here depends on availability of funds to support the FY 1985 program developed by the TSG. Certain administrative functions can be carried forward to some extent; however, the bulk of program activity will have to await a contract amendment by which funds to support subcontracts will be provided.

PTC Activities in the Next Report Period

1. Routine surveillance of subcontracts in being.
2. Follow-up as appropriate on projects reaching expiration dates.
3. Approval and acceptance processes on receipt of FY '85 program officially referred from UMTA.
4. Formulation of project panels and meetings to write Project Statements for FY '85 research.
5. Solicit for proposals.
6. Preparations for project panel meetings to select research agencies.
7. Preparation of a 6-month progress report for the period ending December 31, 1985.

Networks
FY 1980 Program

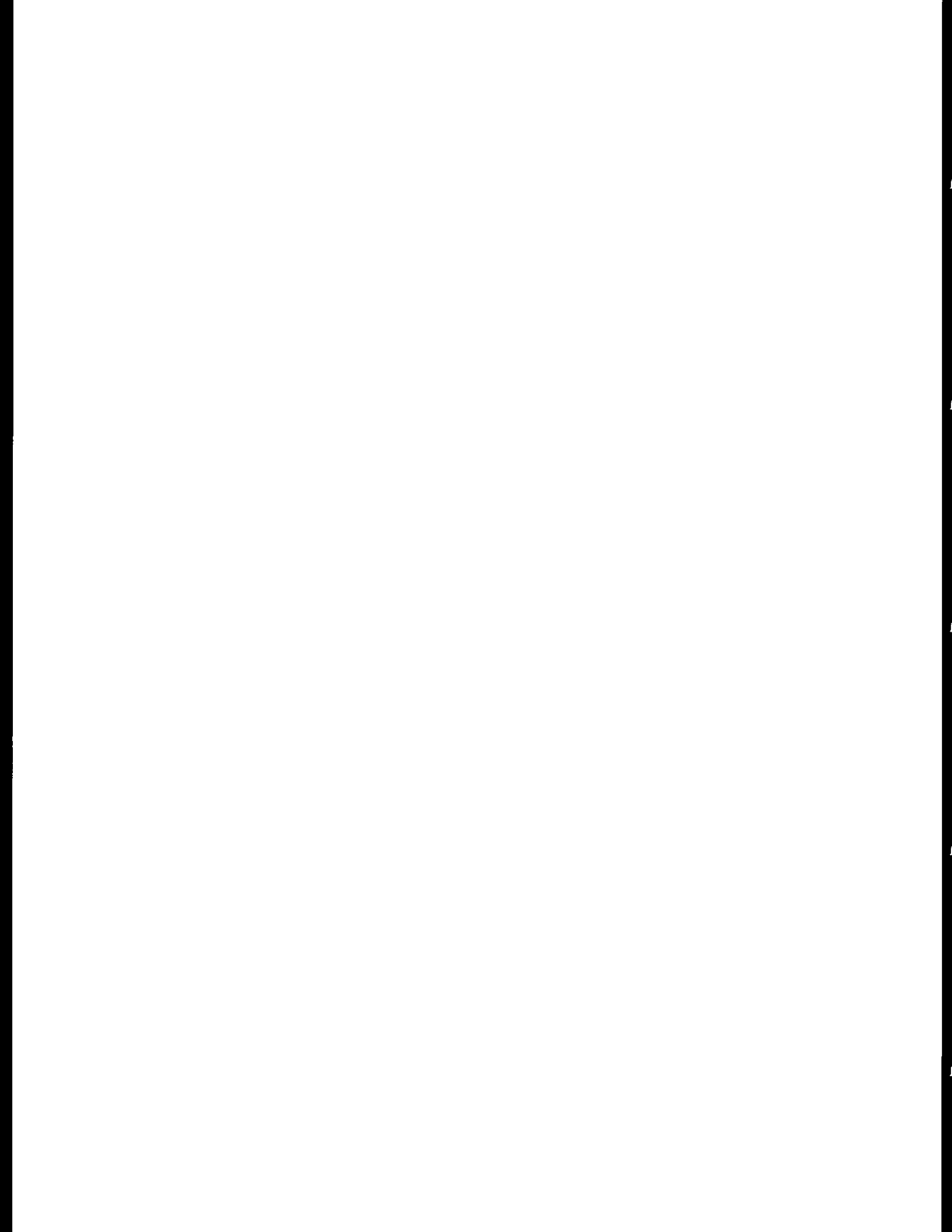

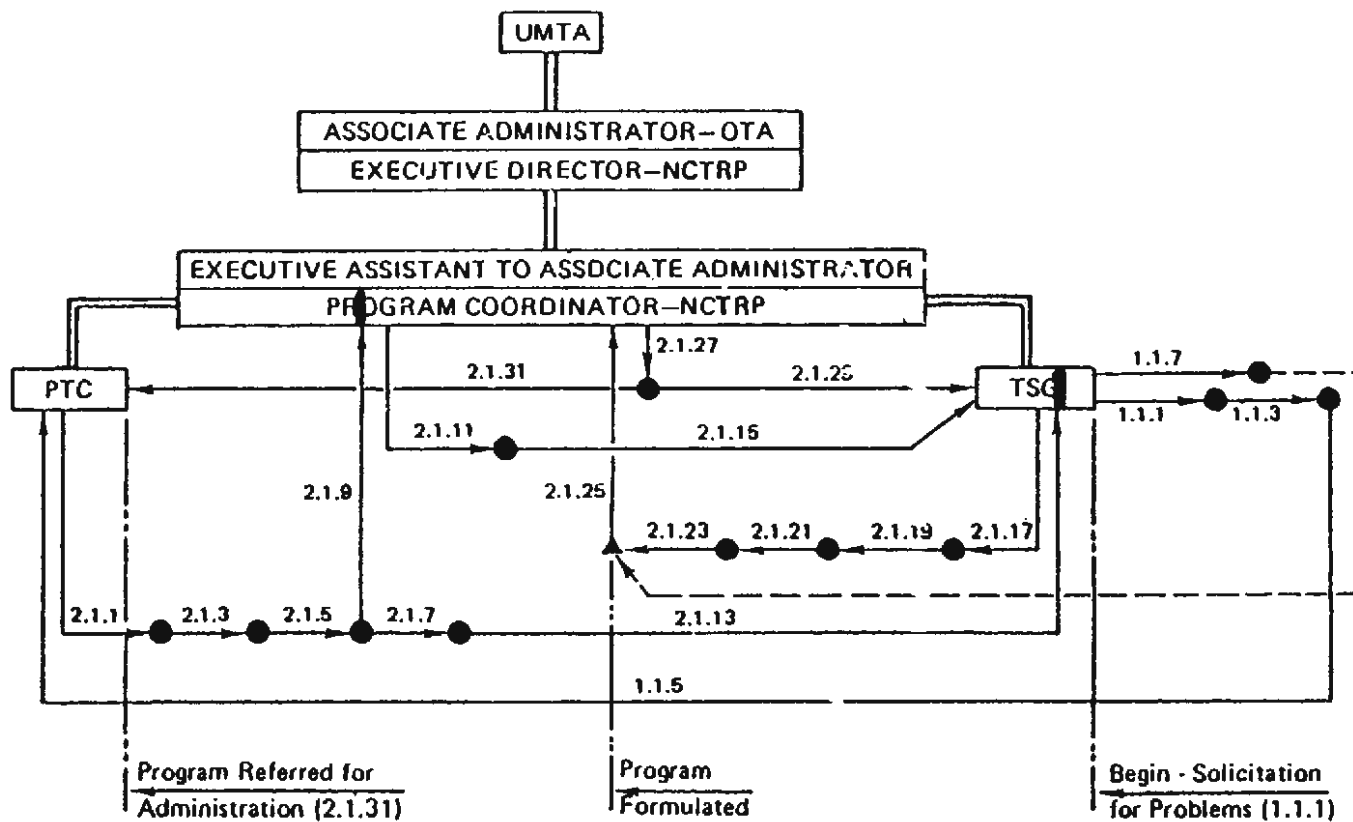

NCTRP NETWORK #1
TSG Initiation of Program
through Referral to PTC
 Prep. : KWH May '79
 Rev. : KWH May '83

NOTE: Fully shaded nodes represent completed tasks; partially shaded nodes represent partially completed tasks.

RE: FY 1980 PROGRAM
CONTRACT DTUM60-81-C-72012

30 JUNE 1985

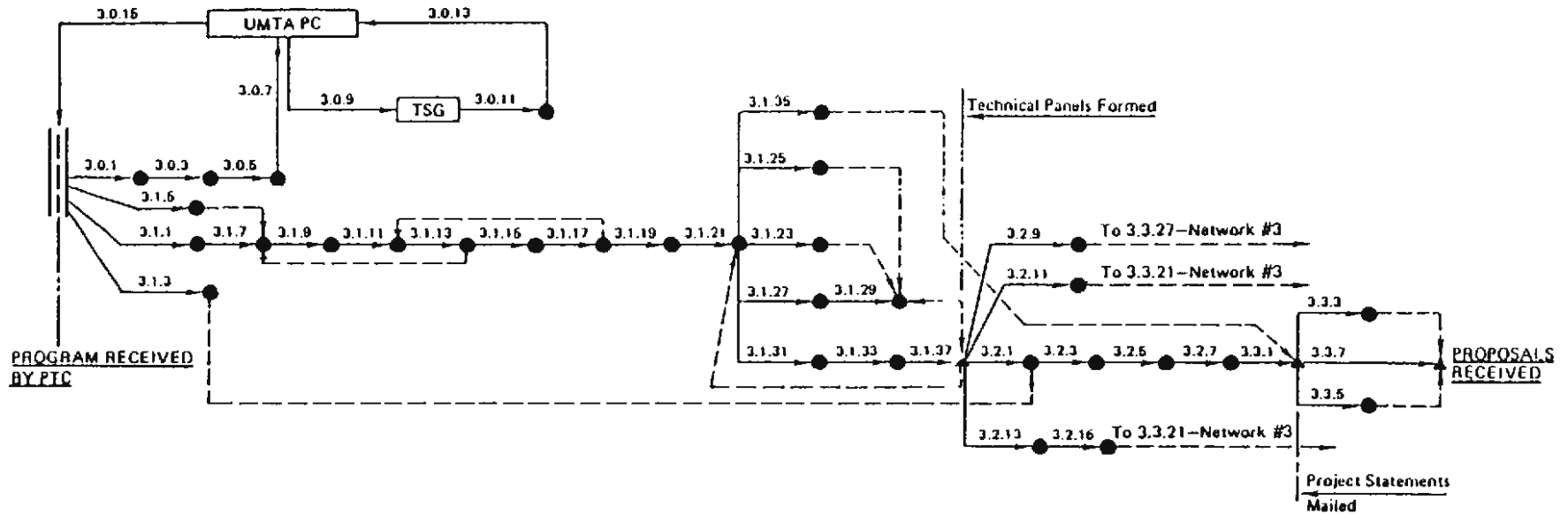

RE: FY 1980 PROGRAM
CONTRACT DTUM60-81-C-72012

30 JUNE 1985

NCTRP NETWORK #2
 PTC Receipt of Program
 through Receipt of Proposals

Prep.: KWH May '79
 Rev.: KWH May '83

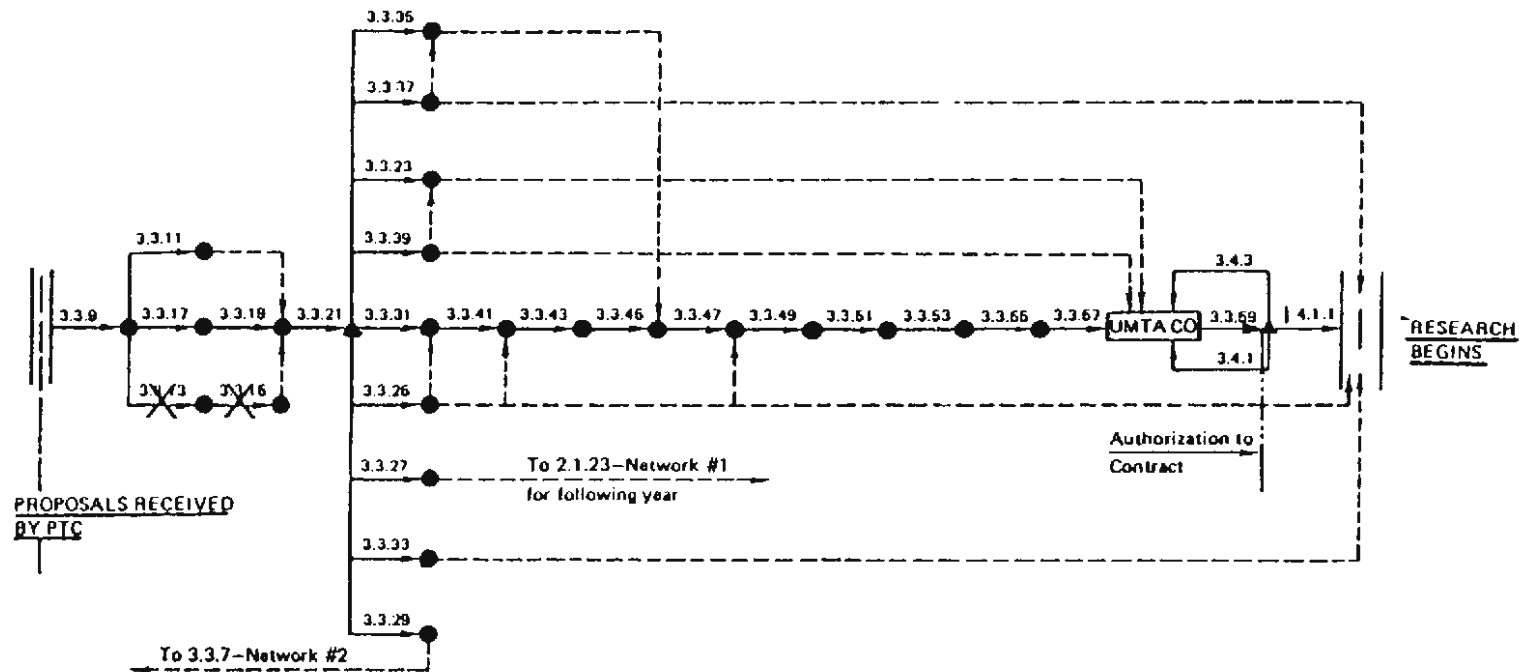

NCTRP NETWORK #3
 Receipt of Proposals through
 Initiation of Research

Prep.: KWH May '79
 Rev.: KWH May '83

RE: FY 1980 PROGRAM
CONTRACT DTUM60-81-G-72012

30 JUNE 1985

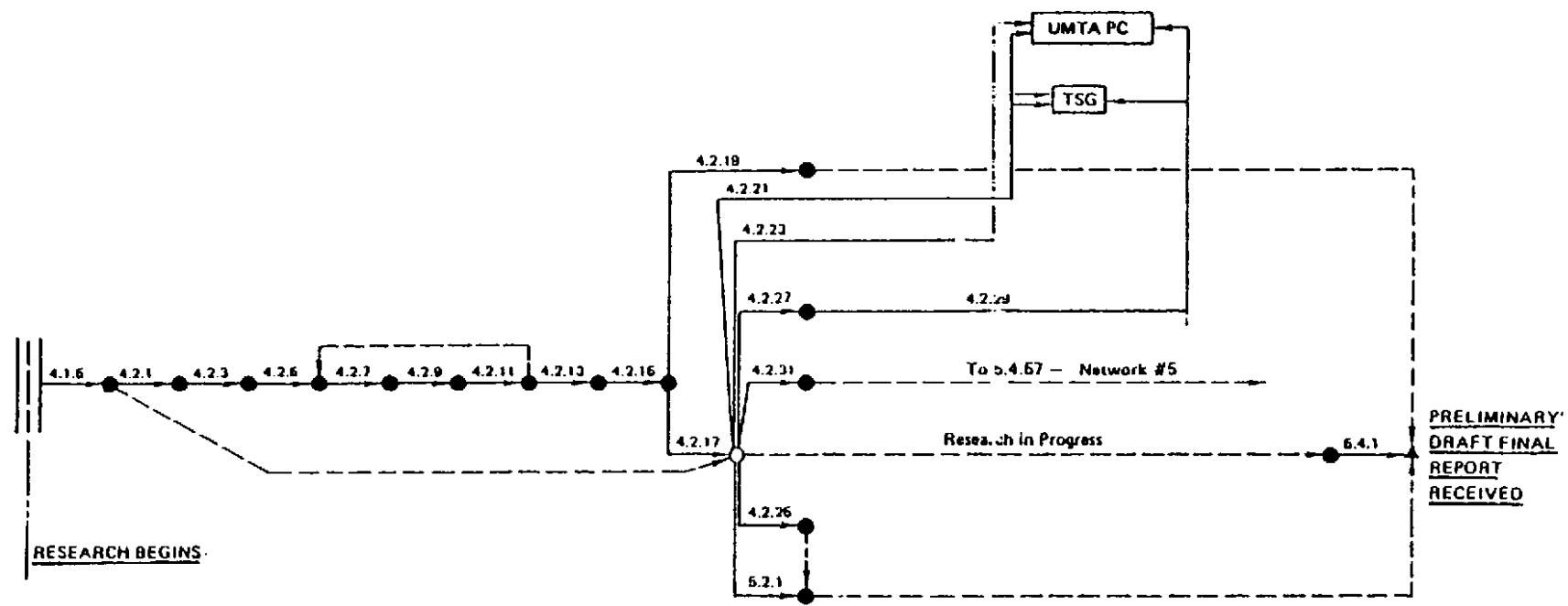

NCTRP NETWORK #4
 Initiation of Research through Receipt
 of Preliminary Draft Final Report
 Prep.: KWH May '79
 Rev.: KWH May '83

RE: FY 1980 PROGRAM
CONTRACT DTUM60-81-C-72012

30 JUNE 1985

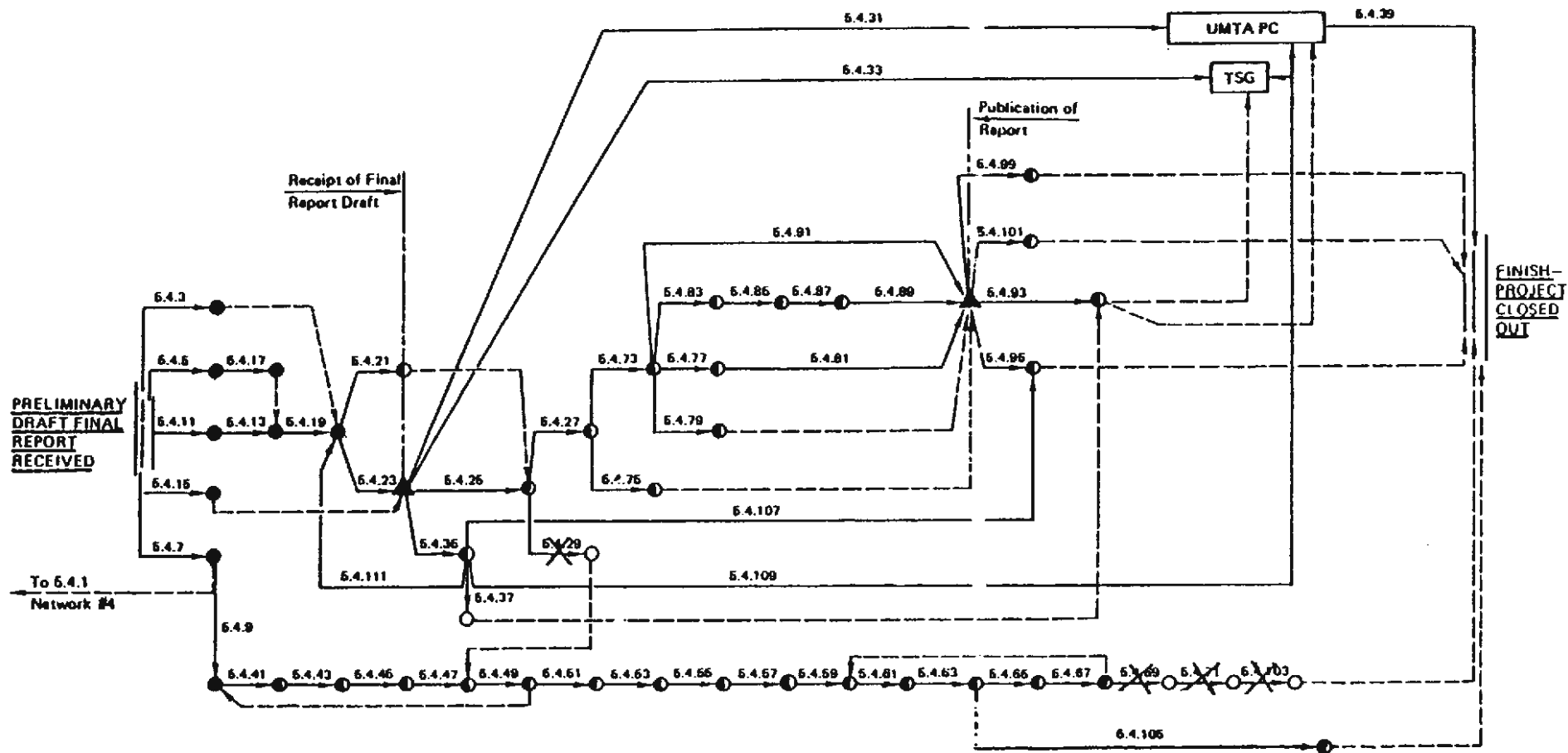

NCTRP NETWORK #5
 Receipt of Preliminary Draft Report
 through Project Close Out
 Prep.: KWH May '79
 Rev.: KWH May '83

RE: FY 1980 PROGRAM
CONTRACT DTUM60-81-C-72012

30 JUNE 1985

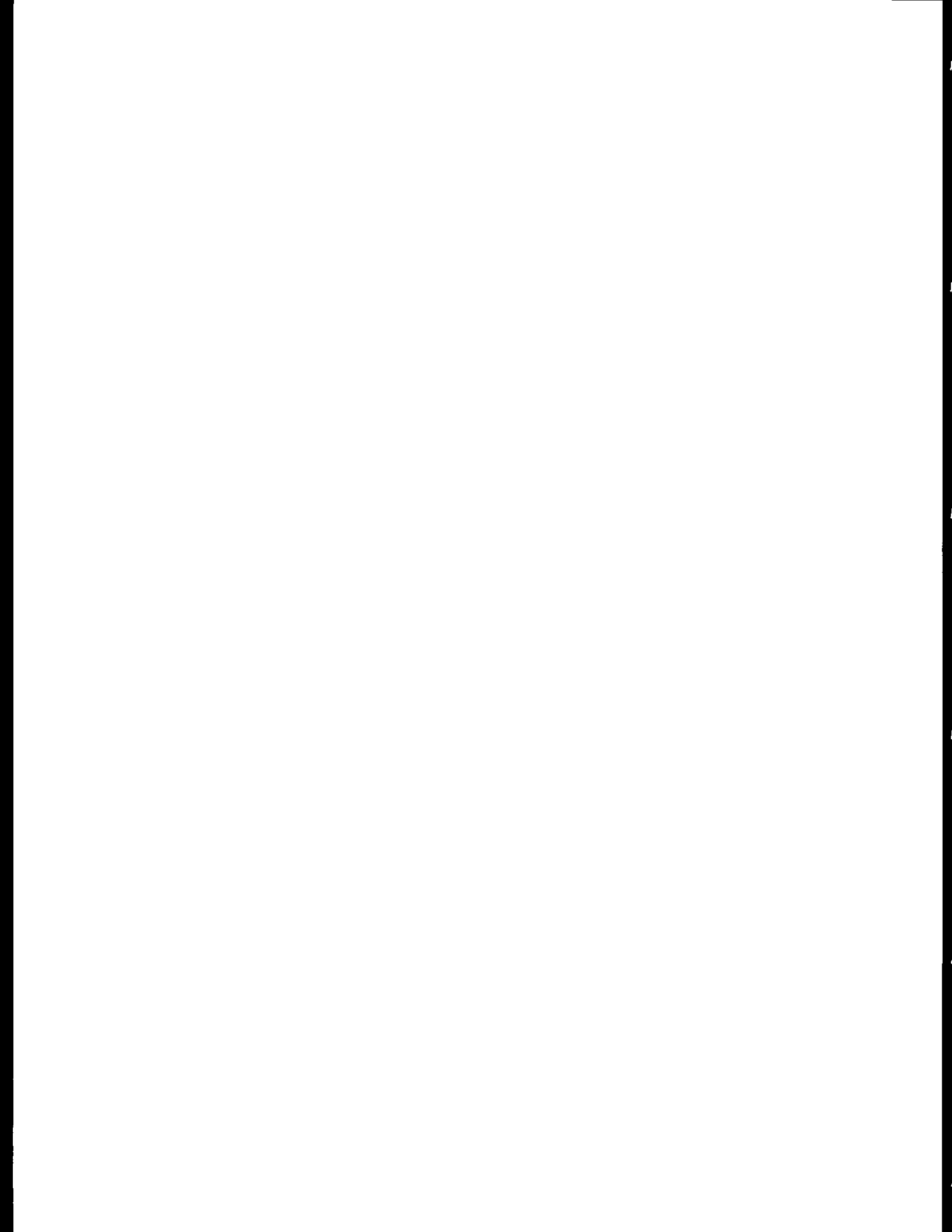

Networks
FY 1981 Program

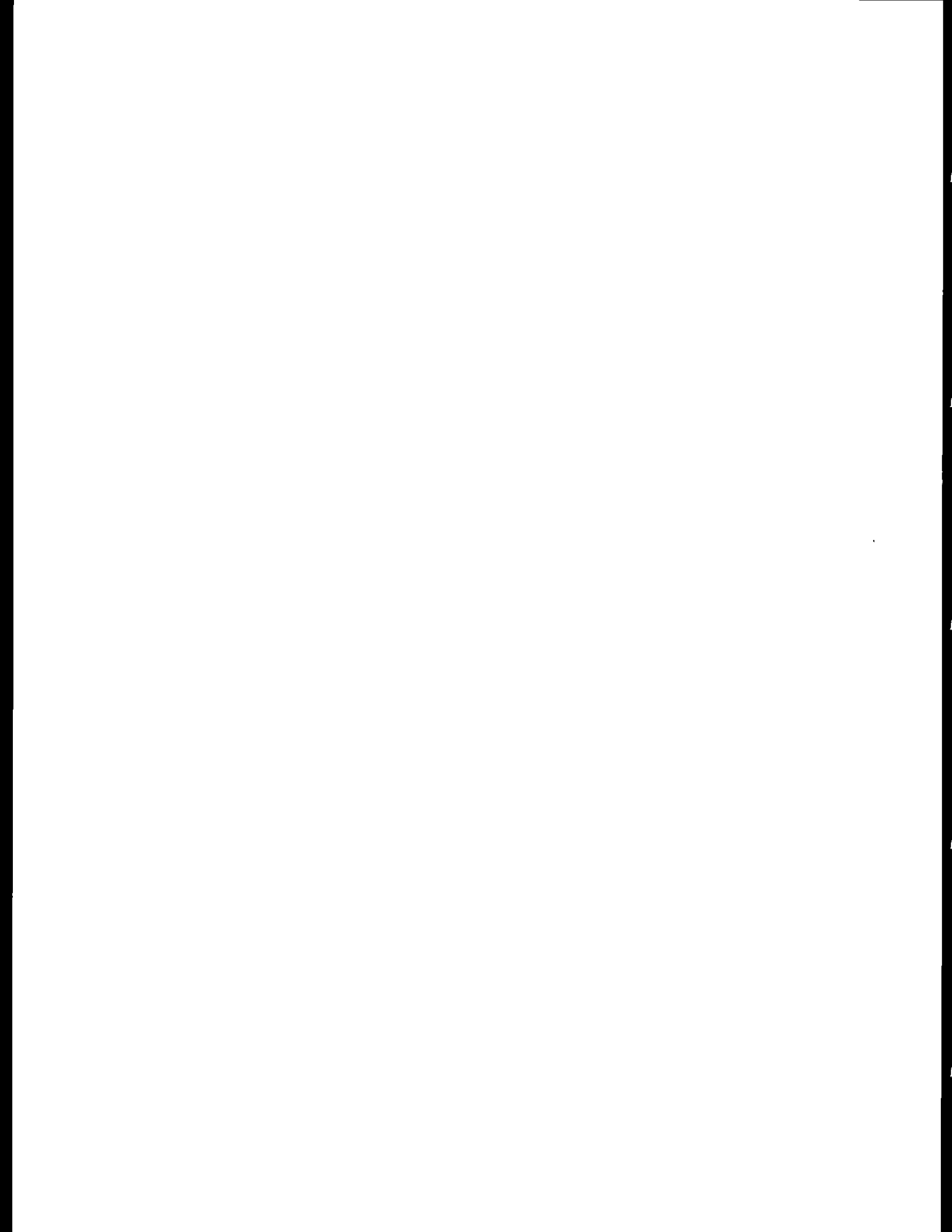

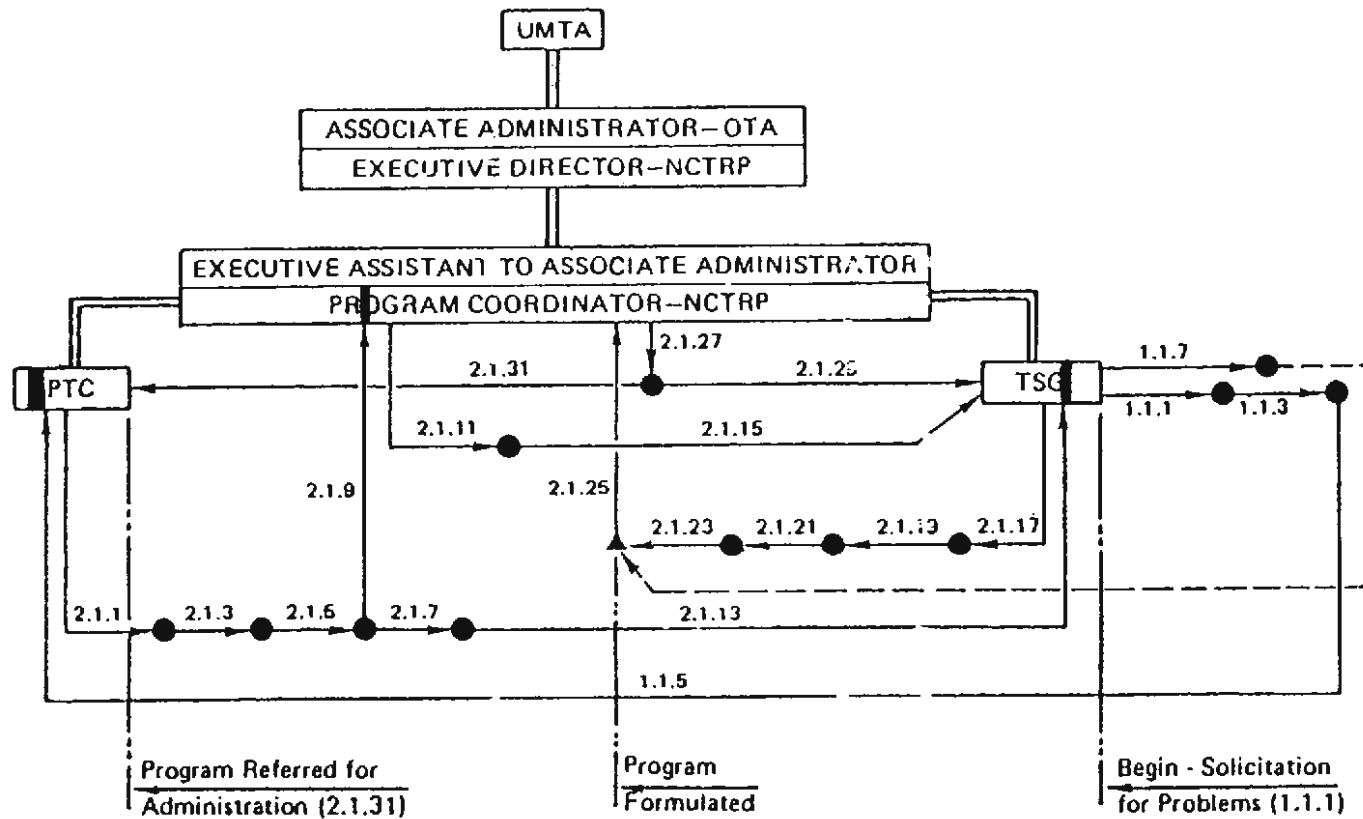

RE: FY 1981 PROGRAM
CONTRACT DTUM60-81-C-72012

30 JUNE 1985

NCTR NETWORK #1
 TSG Initiation of Program
 through Referral to PTC
 Prep.: KWH May '79
 Rev.: KWH May '83

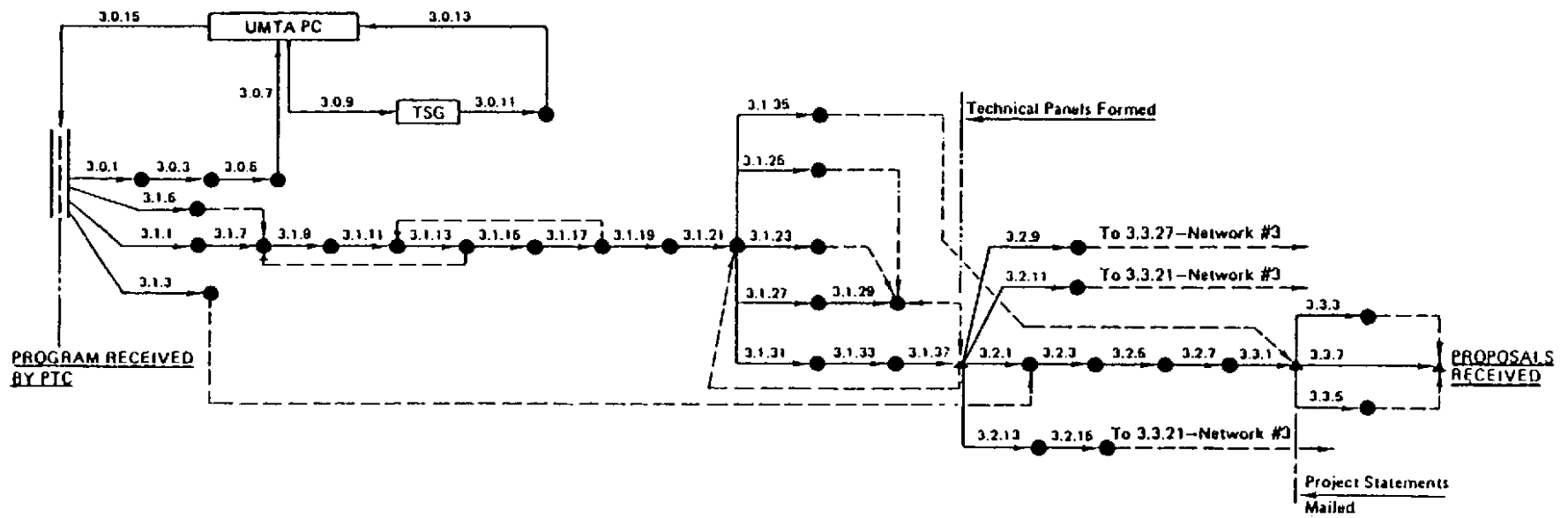

RE: FY 1981 PROGRAM
CONTRACT DTUM60-81-C-72012

30 JUNE 1985

NCTRP NETWORK #2
PTC Receipt of Program
through Receipt of Proposals

Prep.: KWH May '79
Rev.: KWH May '83

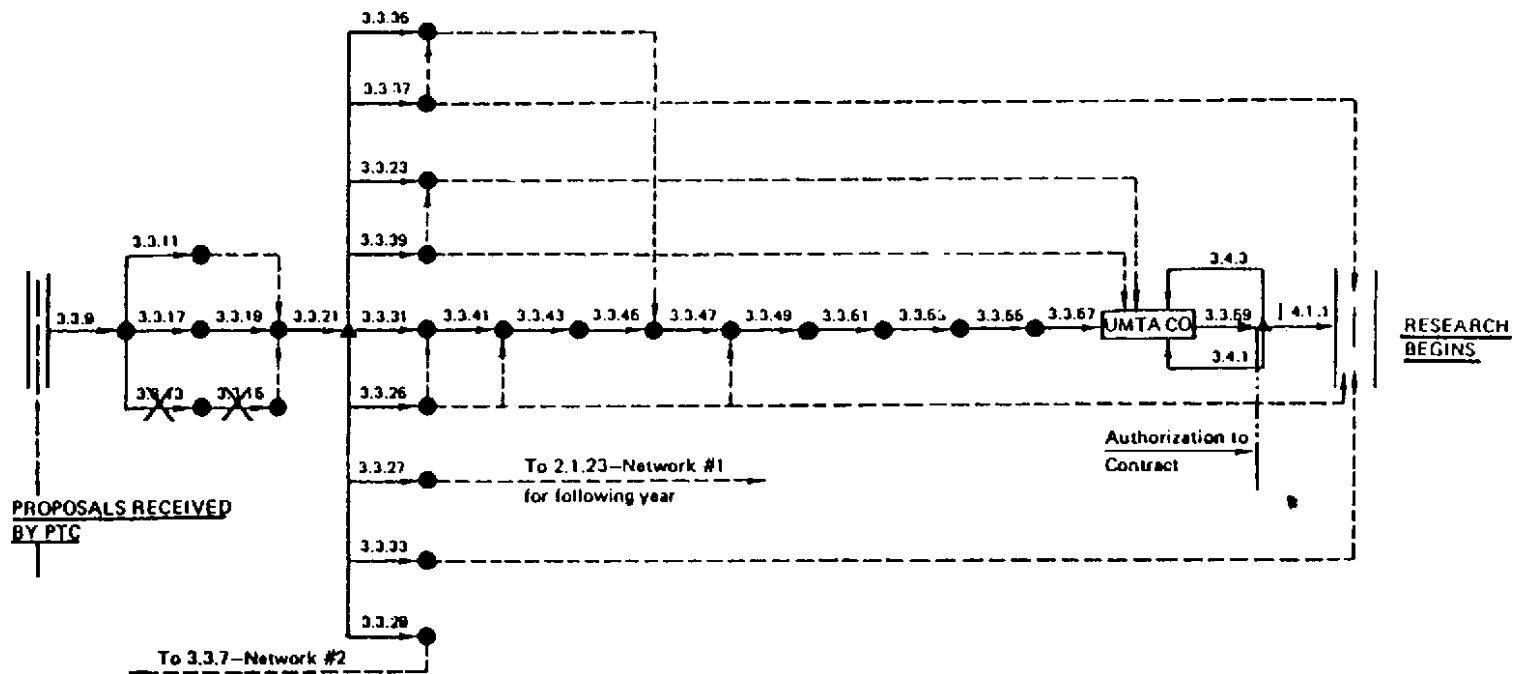

NCTRP NETWORK #3
 Receipt of Proposals through
 Initiation of Research

Prep.: KWH May '79
 Rev.: KWH May '83

RE: FY 1981 PROGRAM
CONTRACT DTUM60-81-C-72012

30 JUNE 1985

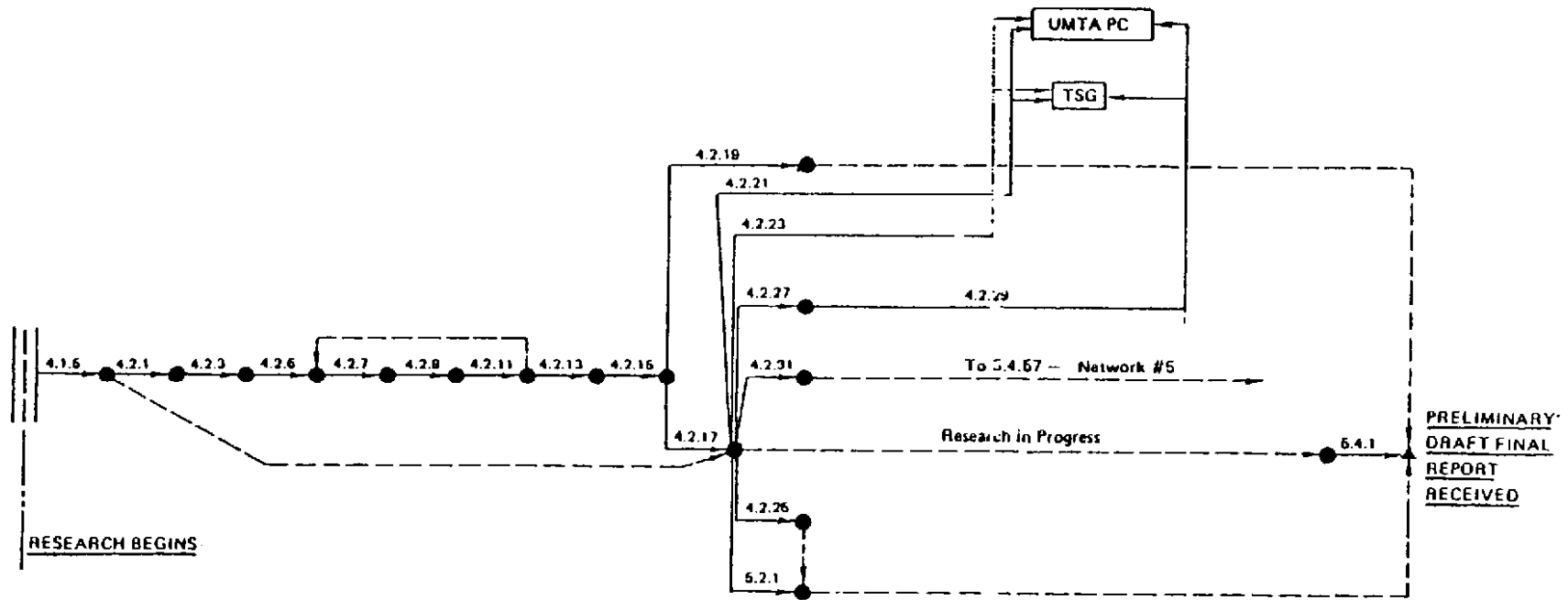

NCTRP NETWORK #4
 Initiation of Research through Receipt
 of Preliminary Draft Final Report
 Prep.: KWH May '79
 Rev.: KWH May '83

RE: FY 1981 PROGRAM
CONTRACT DTUM60-81-C-72012

30 JUNE 1985

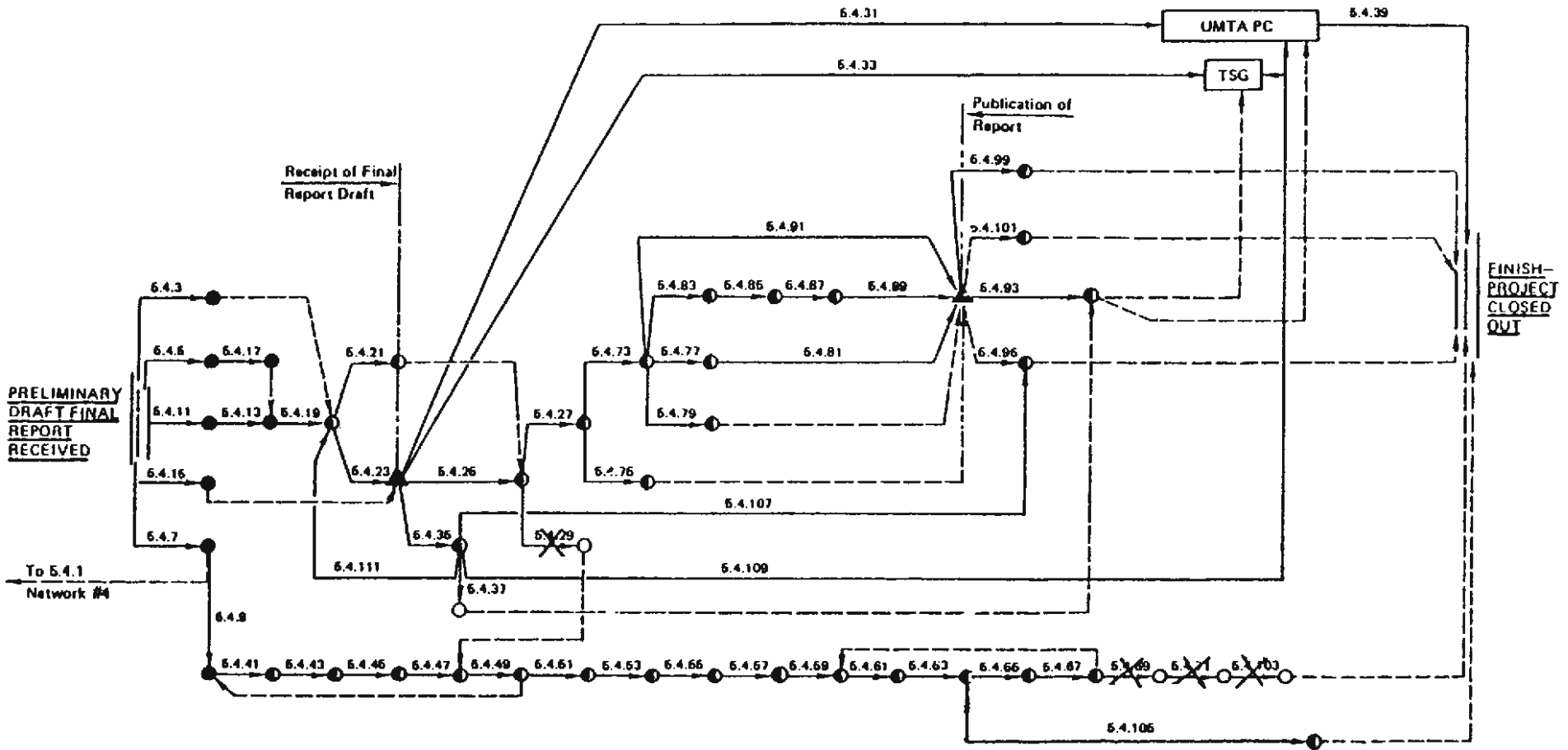

PRELIMINARY
DRAFT FINAL
REPORT
RECEIVED

Receipt of Final
Report Draft

Publication of
Report

FINISH-
PROJECT
CLOSED
OUT

To 5.4.1
Network #4

RE: FY 1981 PROGRAM
CONTRACT DTUM60-81-C-72012

NCTRP NETWORK #5
Receipt of Preliminary Draft Report
through Project Close Out
Prep.: KWH May '79
Rev.: KWH May '83

30 JUNE 1985

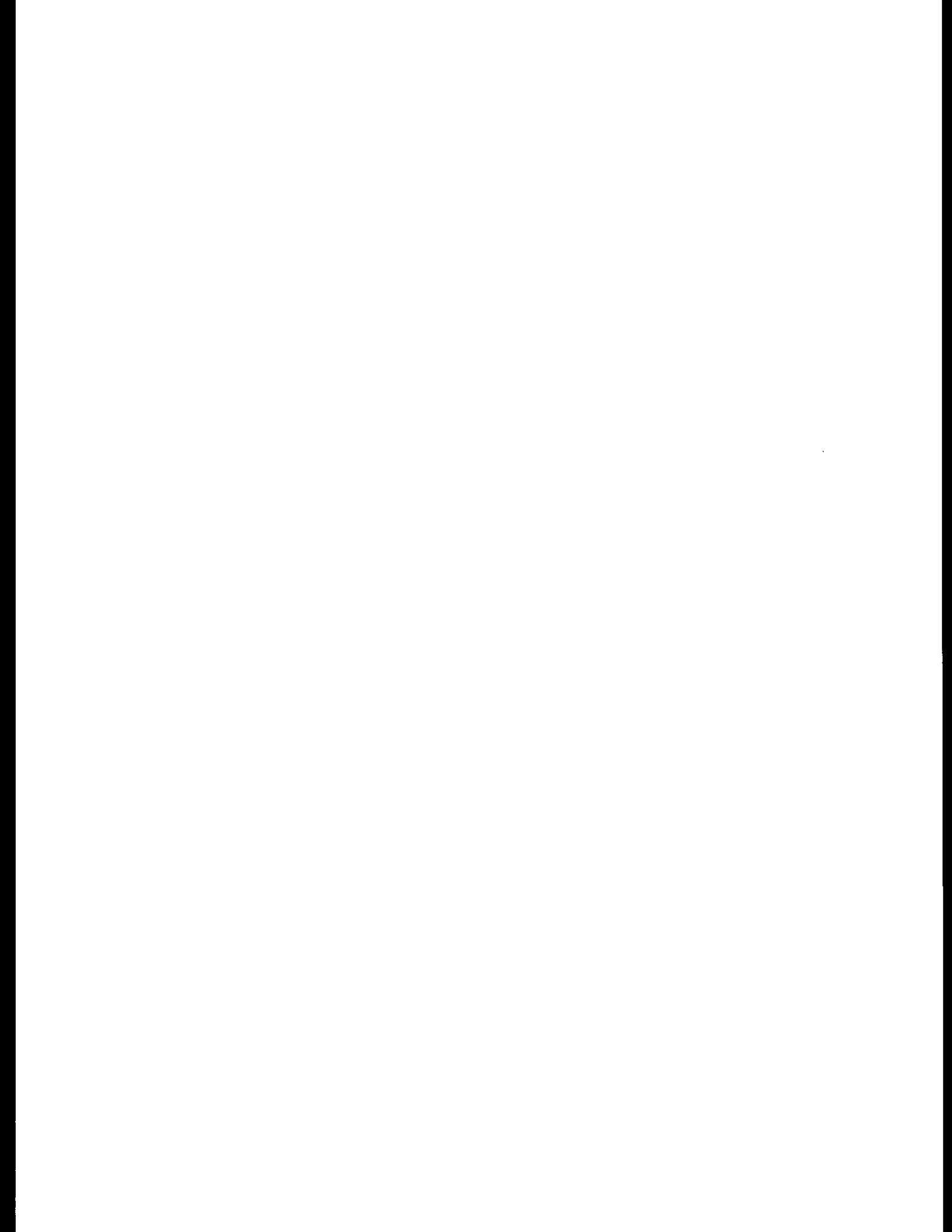

Networks
FY 1982/1983 Program

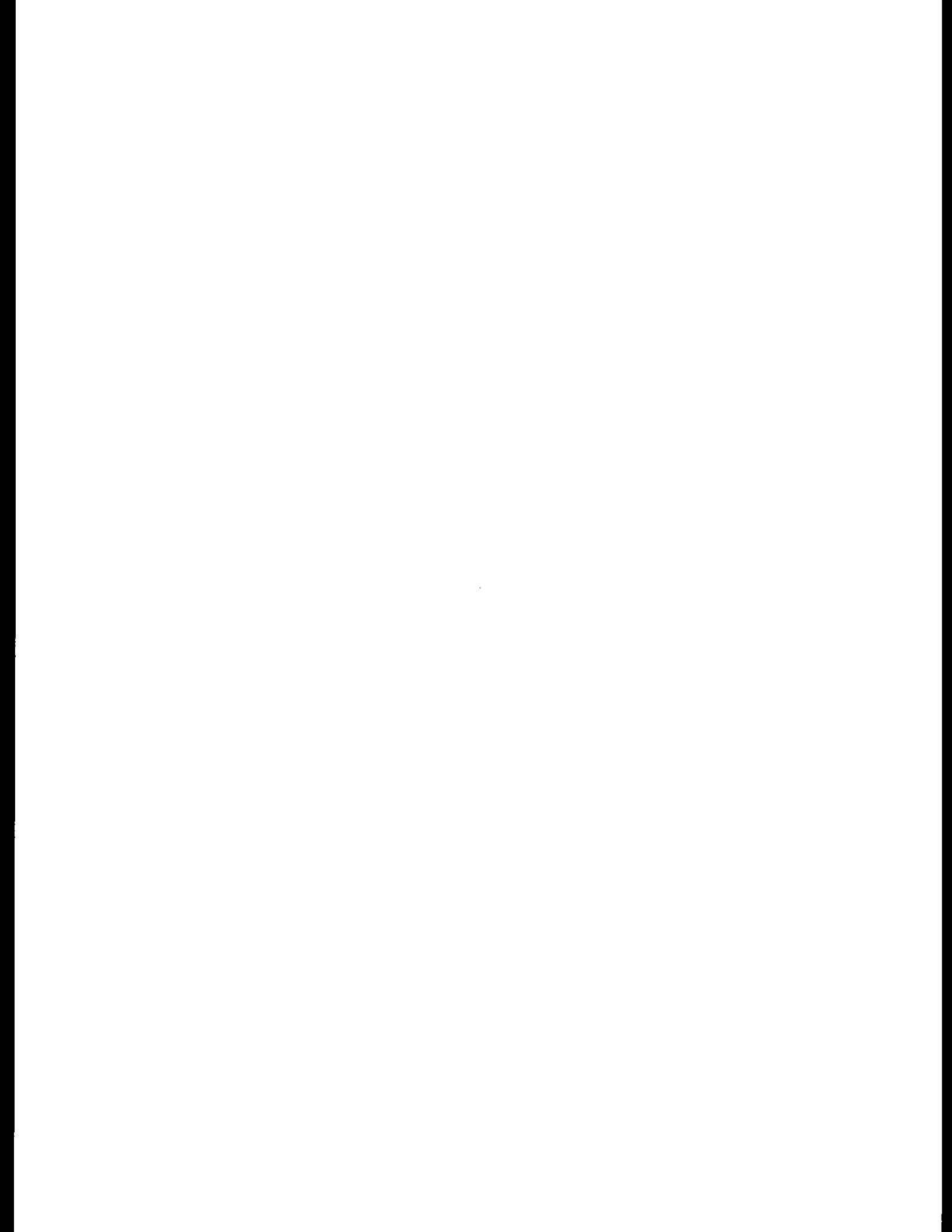

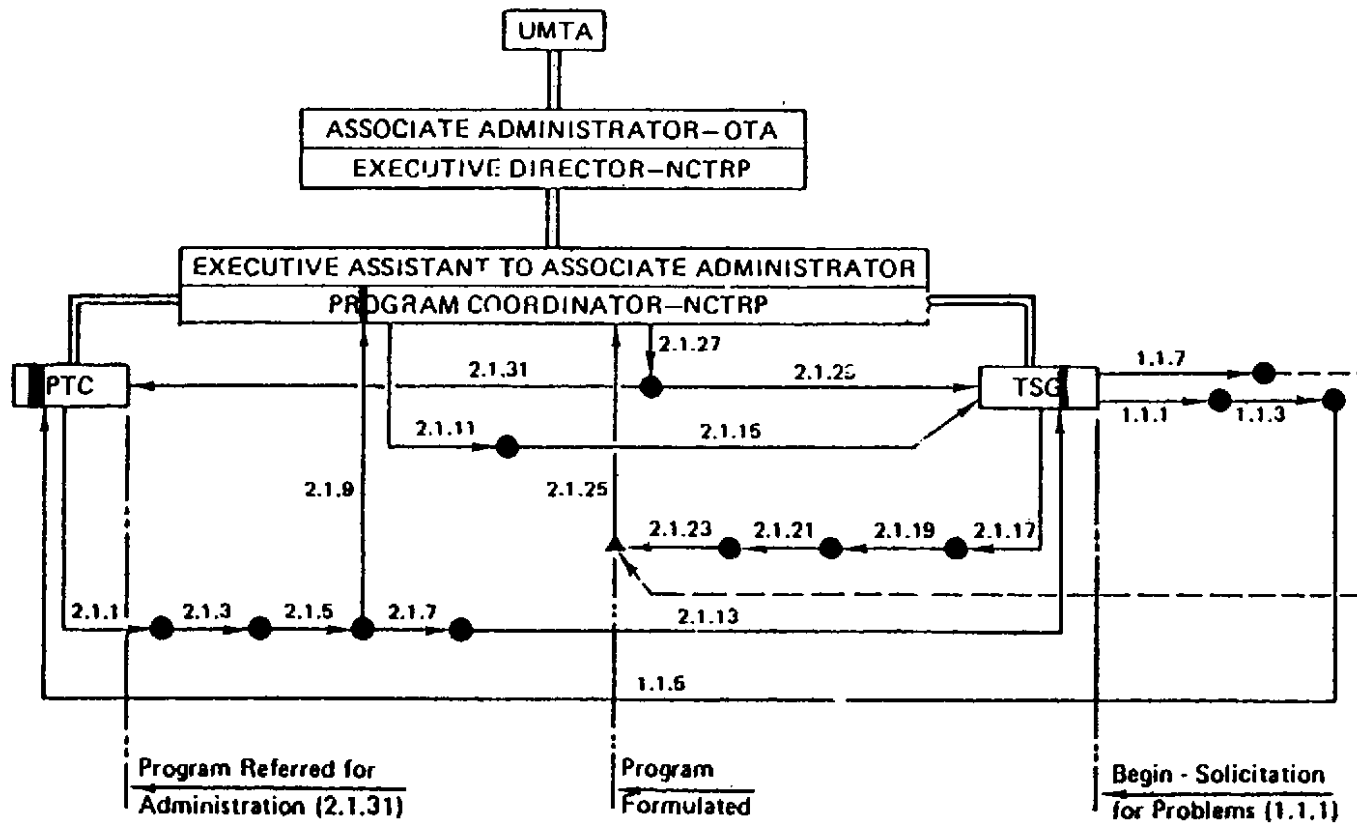

RE: FY 1982/1983 PROGRAM
CONTRACT DTUM60-83-C-71226

30 JUNE 1985

NCTRP NETWORK #1
TSG Initiation of Program
through Referral to PTC
 Prep.: KWH May '79
 Rev.: KWH May '83

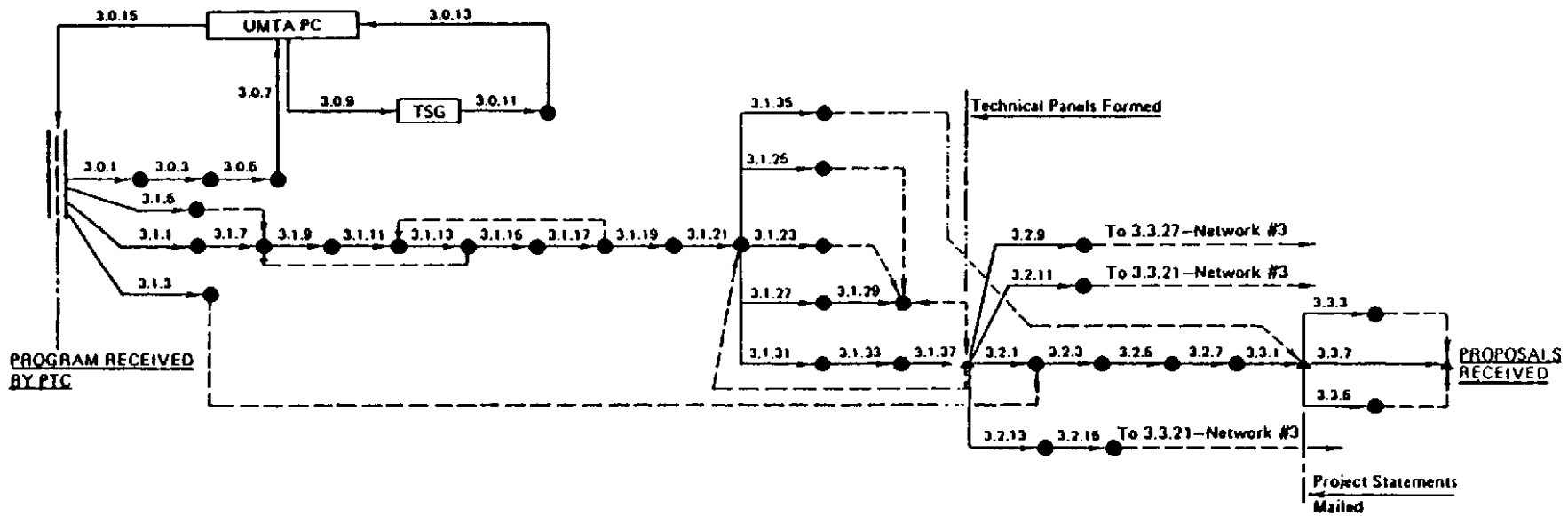

RE: FY 1982/1983 PROGRAM
CONTRACT DTUM60-83-C-71226

30 JUNE 1985

NCTRP NETWORK #2
 PTC Receipt of Program
 through Receipt of Proposals

Prep.: KWI May '79
 Rev.: KWI May '83

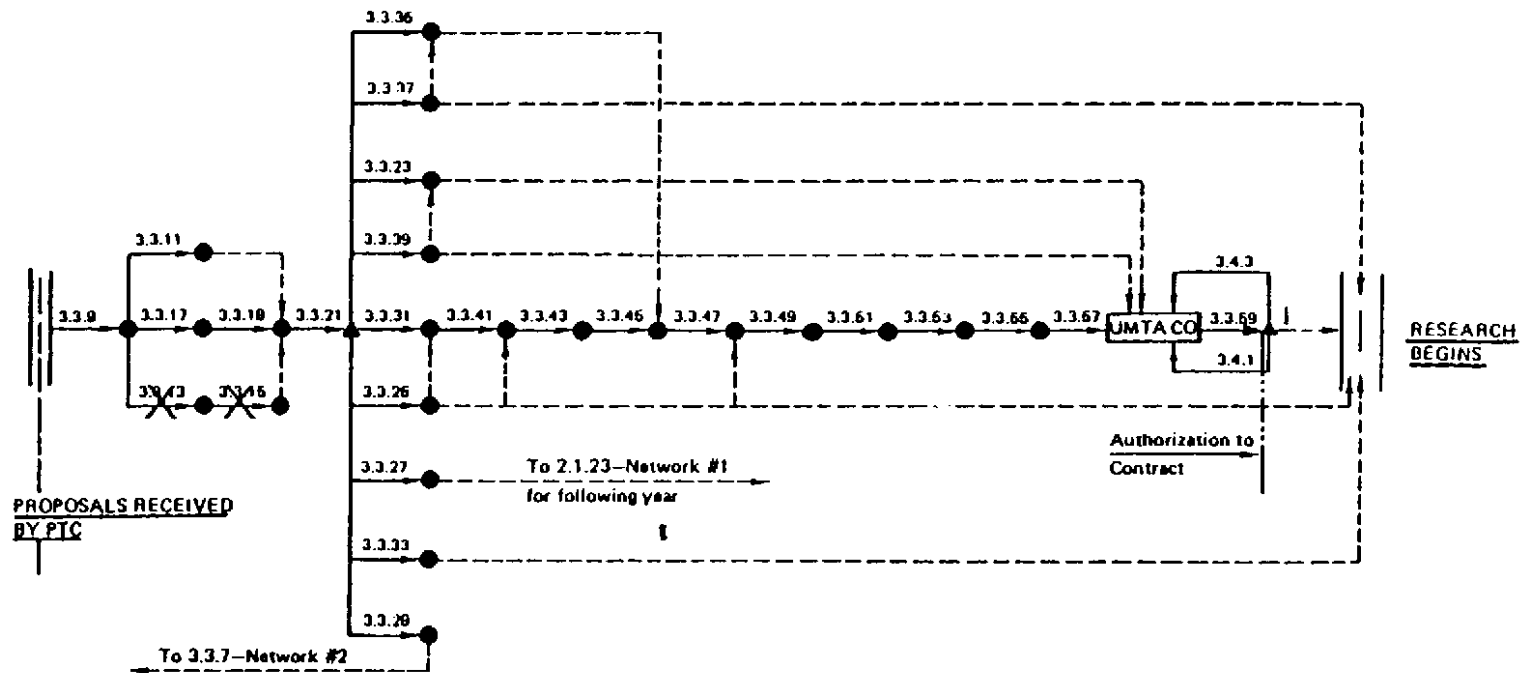

NCTRP NETWORK #3
 Receipt of Proposals through
 Initiation of Research
 Prep.: KWH May '79
 Rev.: KWH May '83

RE: FY 1982/1983 PROGRAM
CONTRACT DTUM60-83-C-71226

30 JUNE 1985

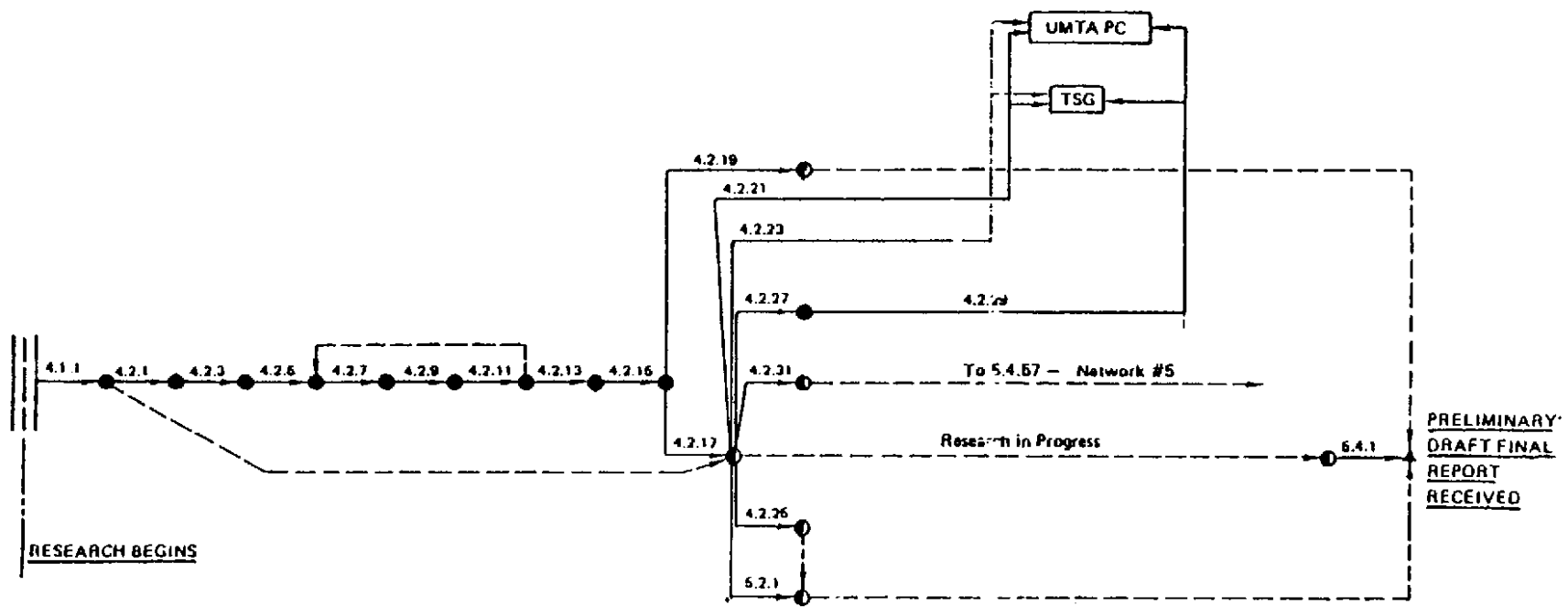

NCTRP NETWORK #4
 Initiation of Research through Receipt
 of Preliminary Draft Final Report
 Prep.: KWH May '79
 Rev.: KWH May '83

RE: FY 1982/1983 PROGRAM
CONTRACT DTUM60-83-C-71226

30 JUNE 1985

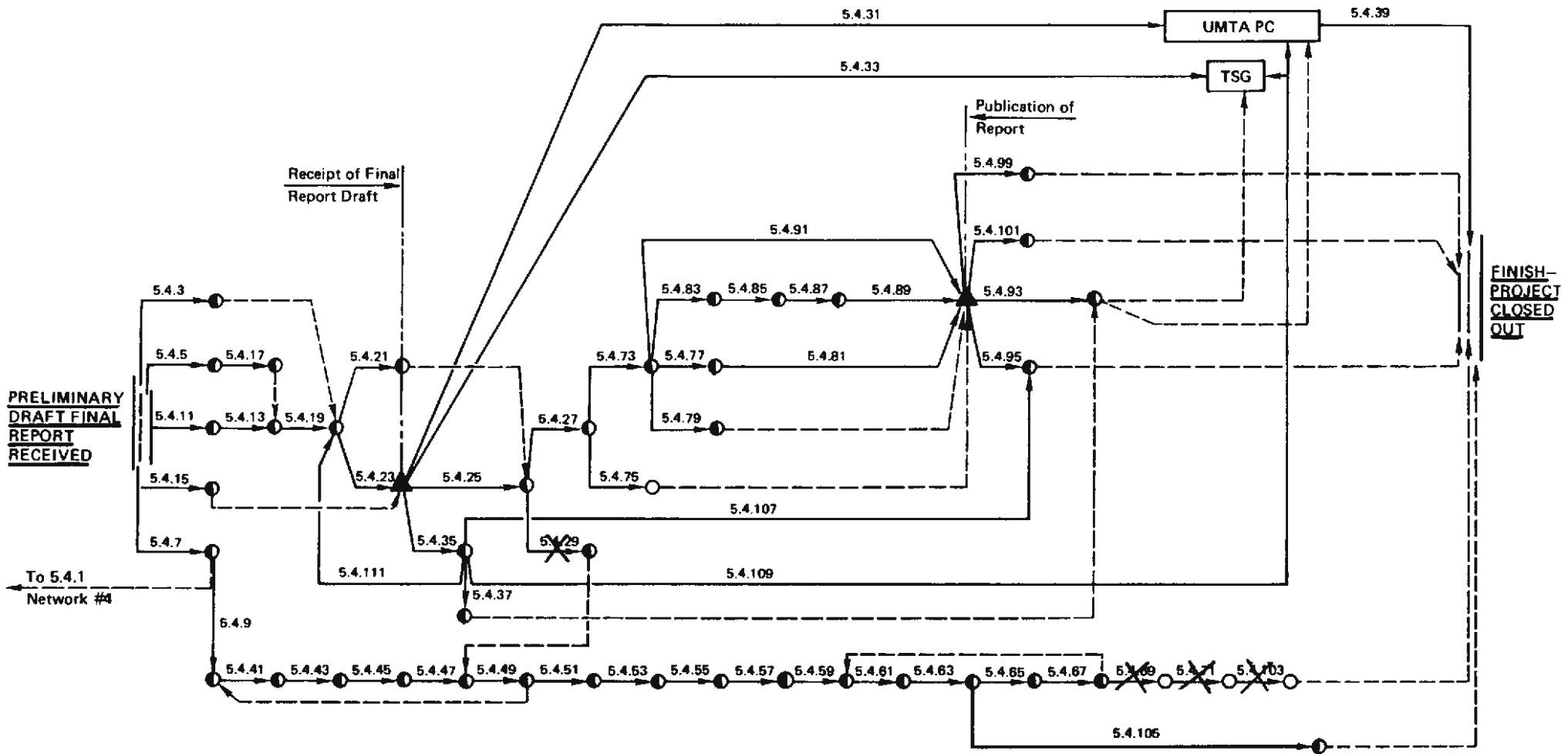

RE: FY 1982/1983 PROGRAM
CONTRACT DTUM60-83-C-71226

30 JUNE 1985

NCTRP NETWORK #5
 Receipt of Preliminary Draft Report
 through Project Close Out
 Prep.: KWH May '79
 Rev.: KWH May '83

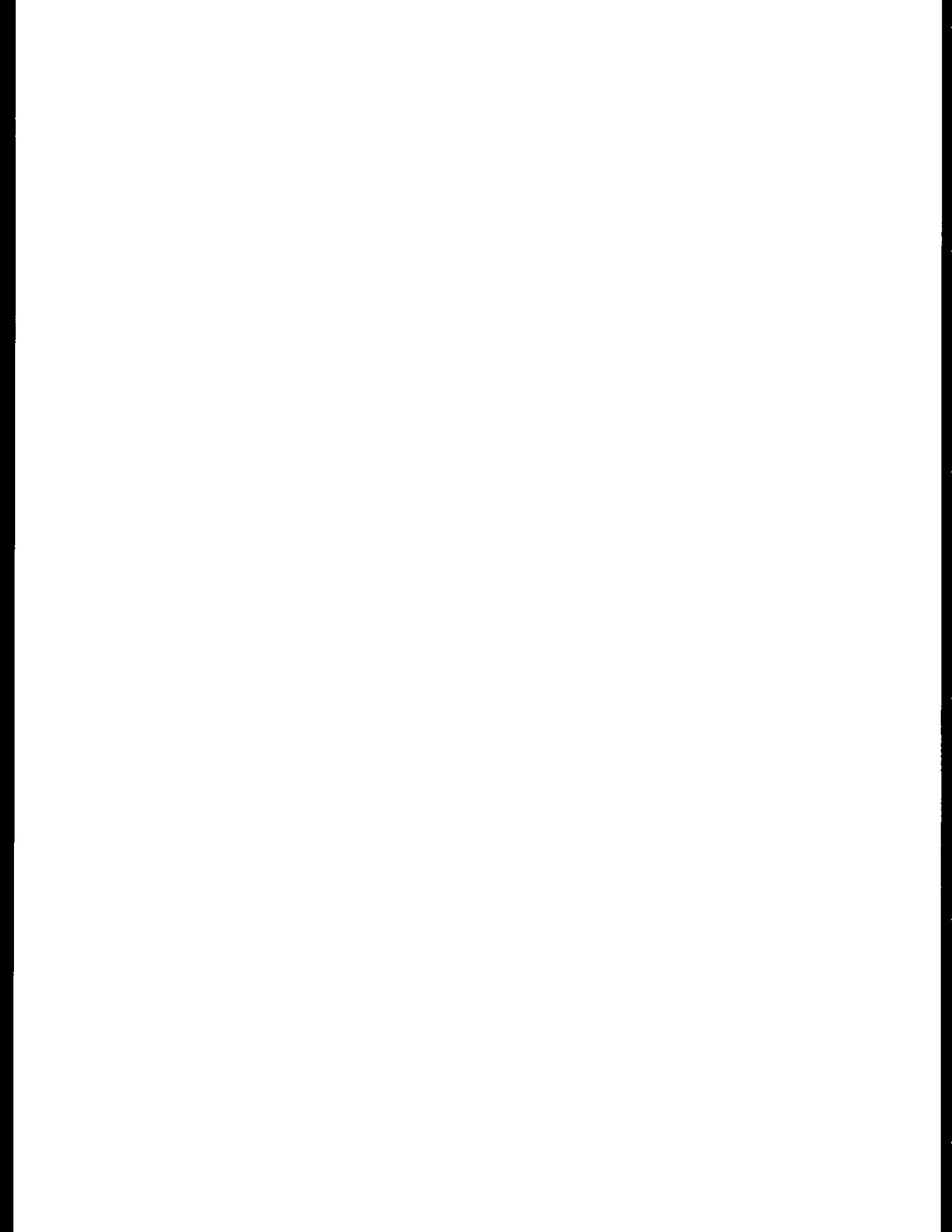

**Networks
FY 1984 Program**

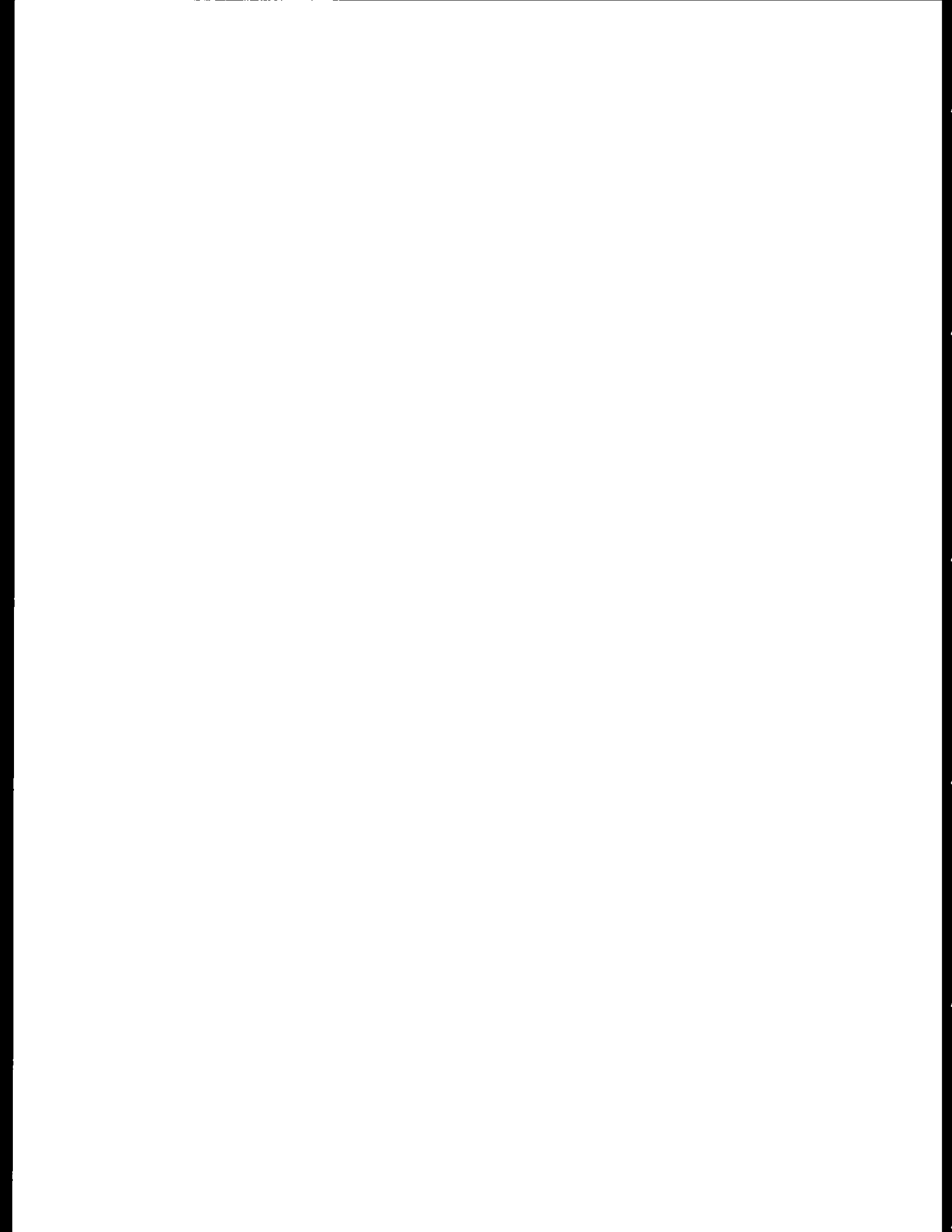

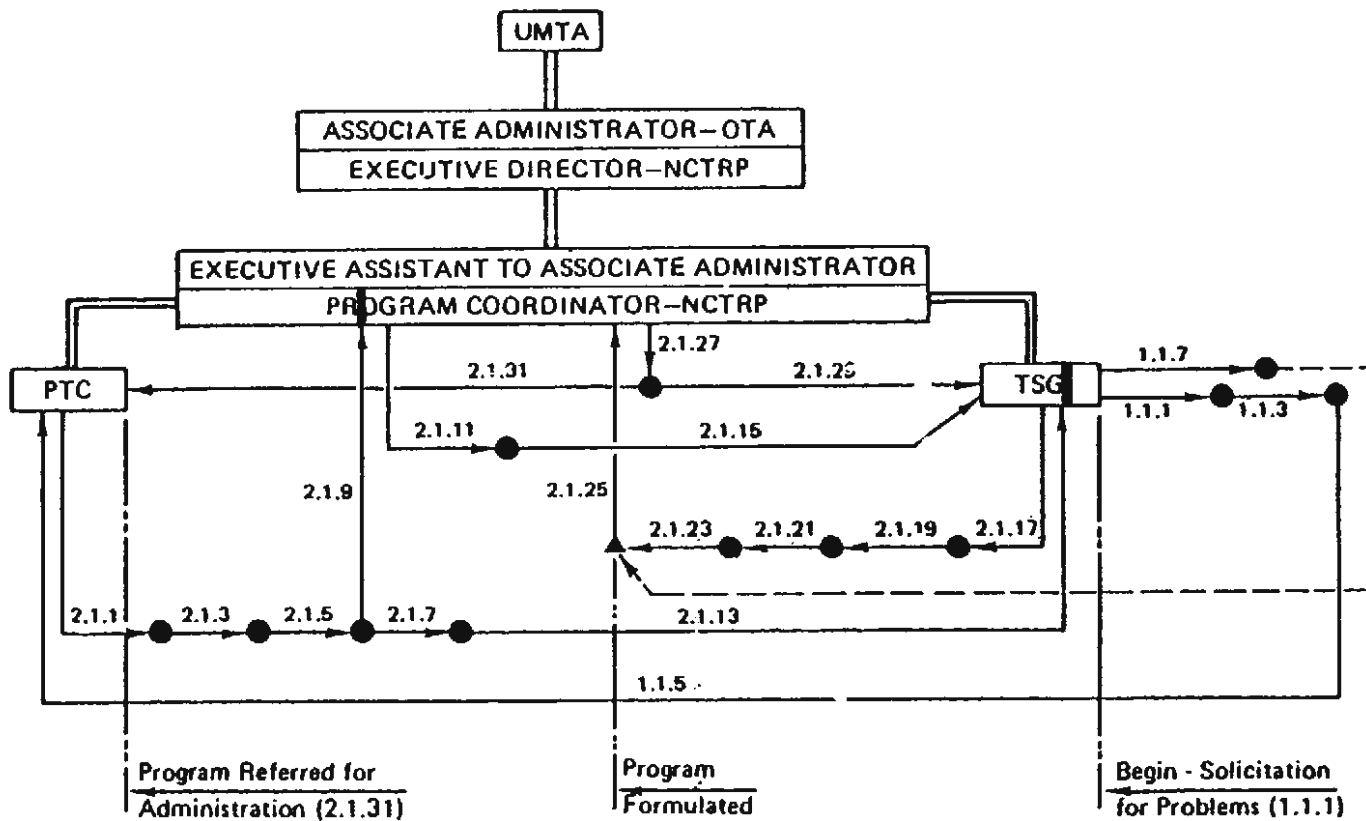

NCTRP NETWORK #1
TSG Initiation of Program
through Referral to PTC
 Prep.: KWH May '79
 Rev.: KWH May '83

RE: FY 1984 PROGRAM
CONTRACT DTUM60-83-C-71226

30 JUNE 1985

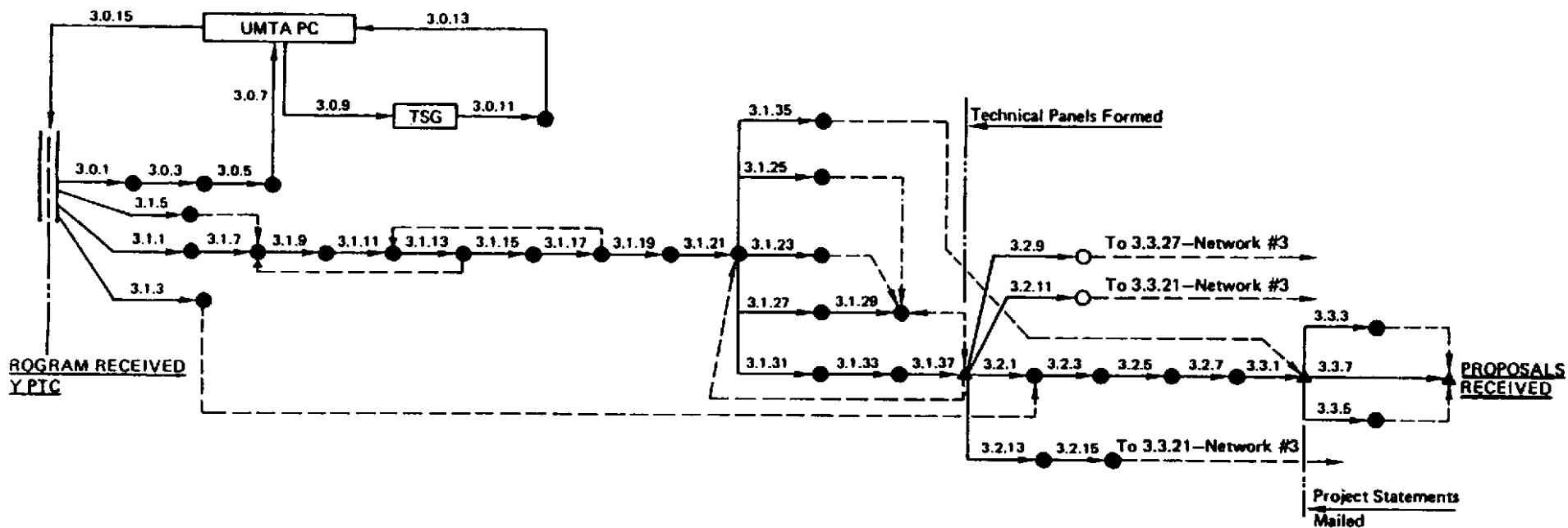

RE: FY 1984 PROGRAM
CONTRACT DTUM60-83-C-71226

30 JUNE 1985

NCTRP NETWORK #2
 PTC Receipt of Program
 through Receipt of Proposals

Prep.: KWH May '79
 Rev.: KWH May '83

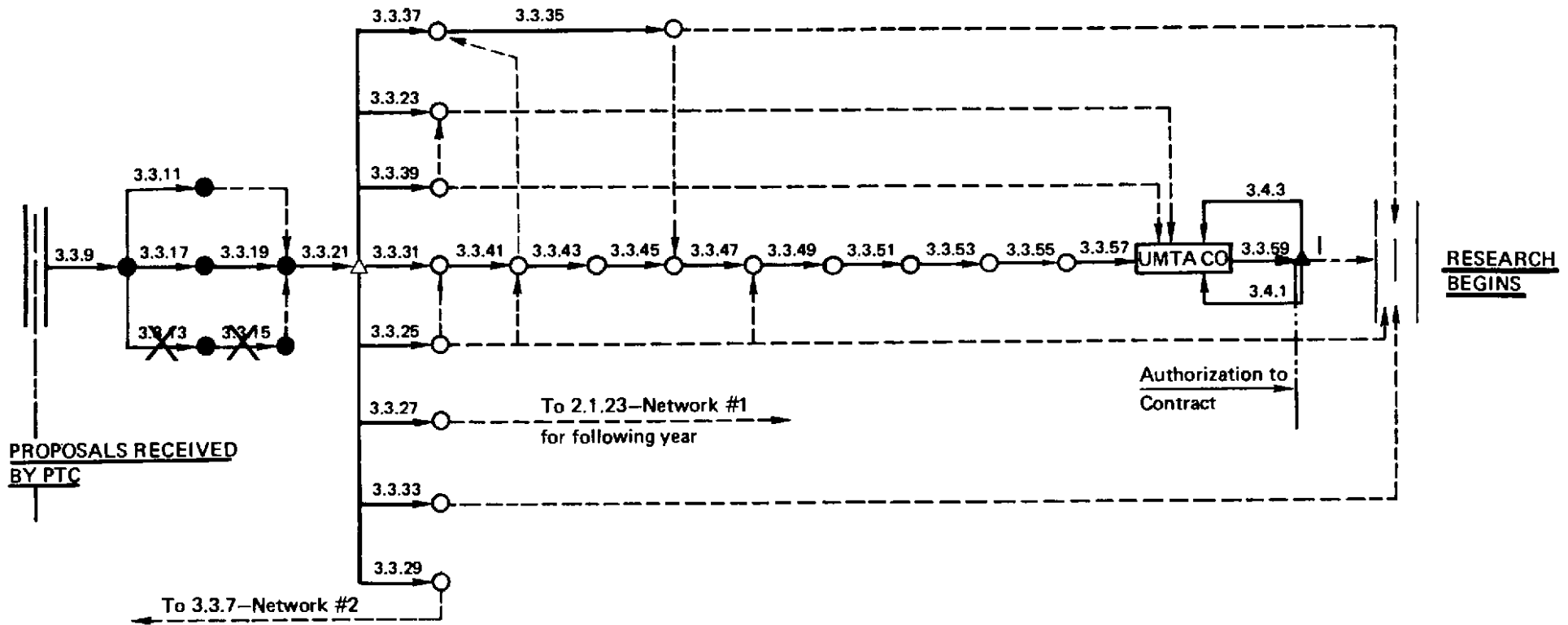

RE: FY 1984 PROGRAM
CONTRACT DTUM60-83-C-71226
 30 JUNE 1985

NCTRP NETWORK #3
 Receipt of Proposals through
 Initiation of Research

Prep.: KWH May '79
 Rev.: KWH May '83

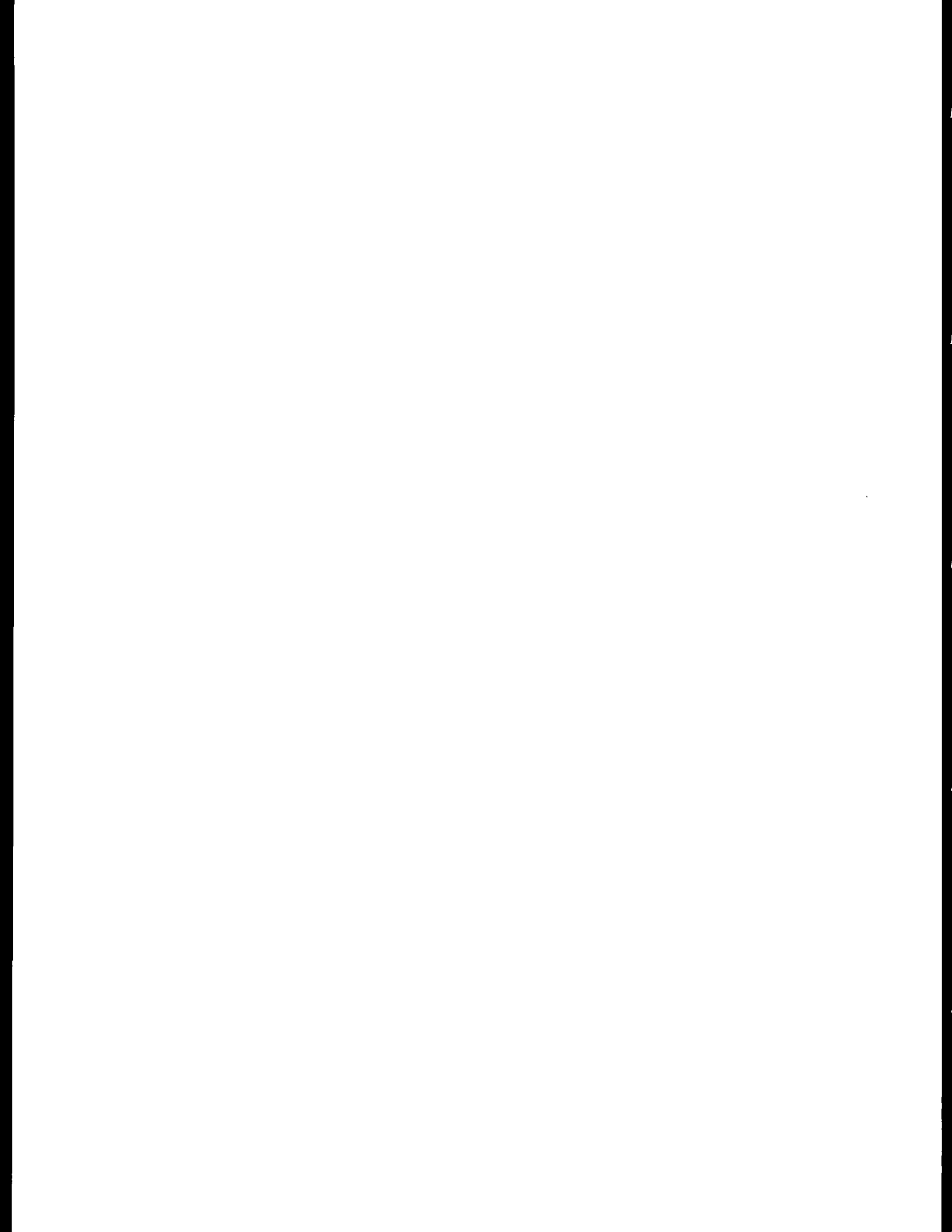

Networks
FY 1985 Program

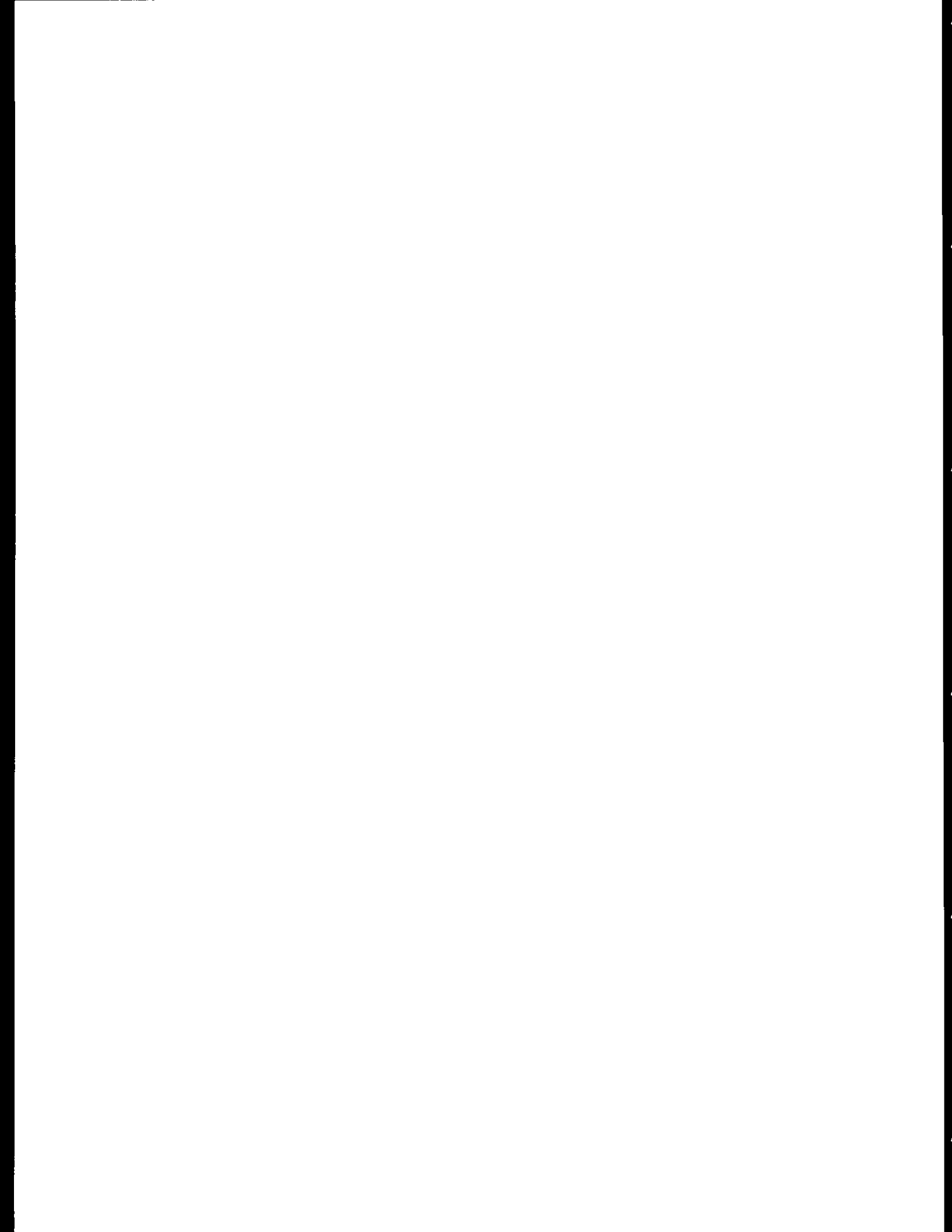

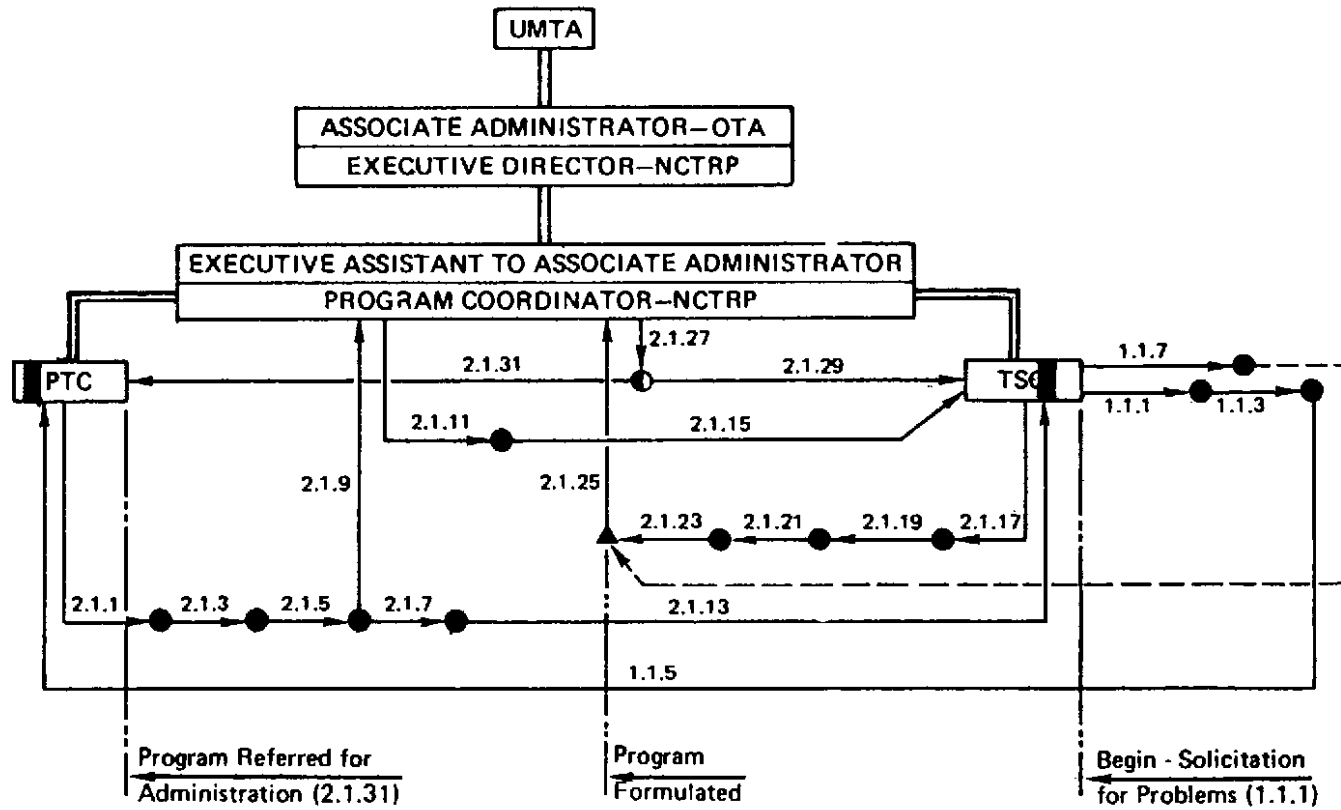

RE: FY 1985 PROGRAM
CONTRACT DTUM60-83-C-71226

30 JUNE 1985

NCTRP NETWORK #1
 TSG Initiation of Program
 through Referral to PTC
 Prep.: KWH May '79
 Rev.: KWH May '83

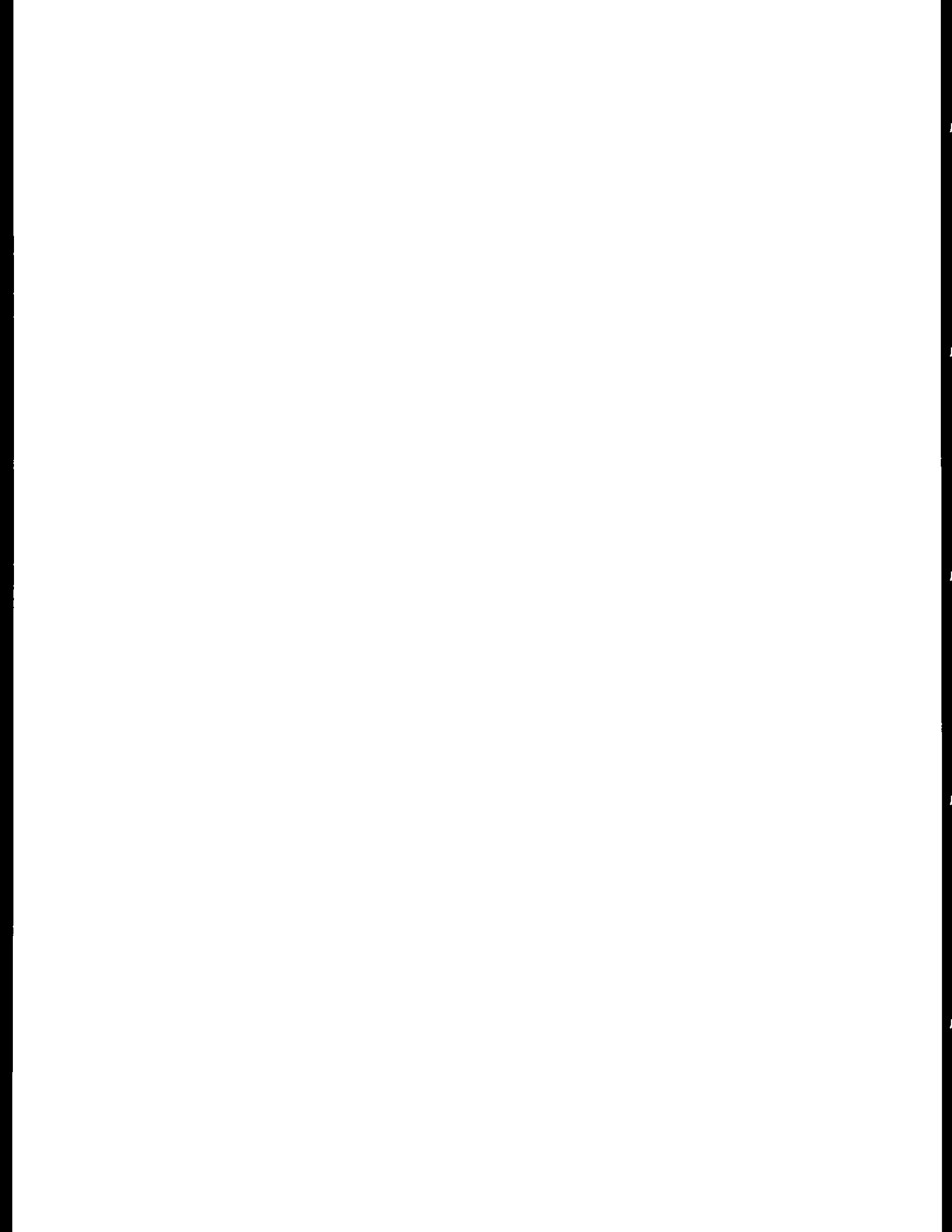

**Activity Descriptions
for
All Networks**

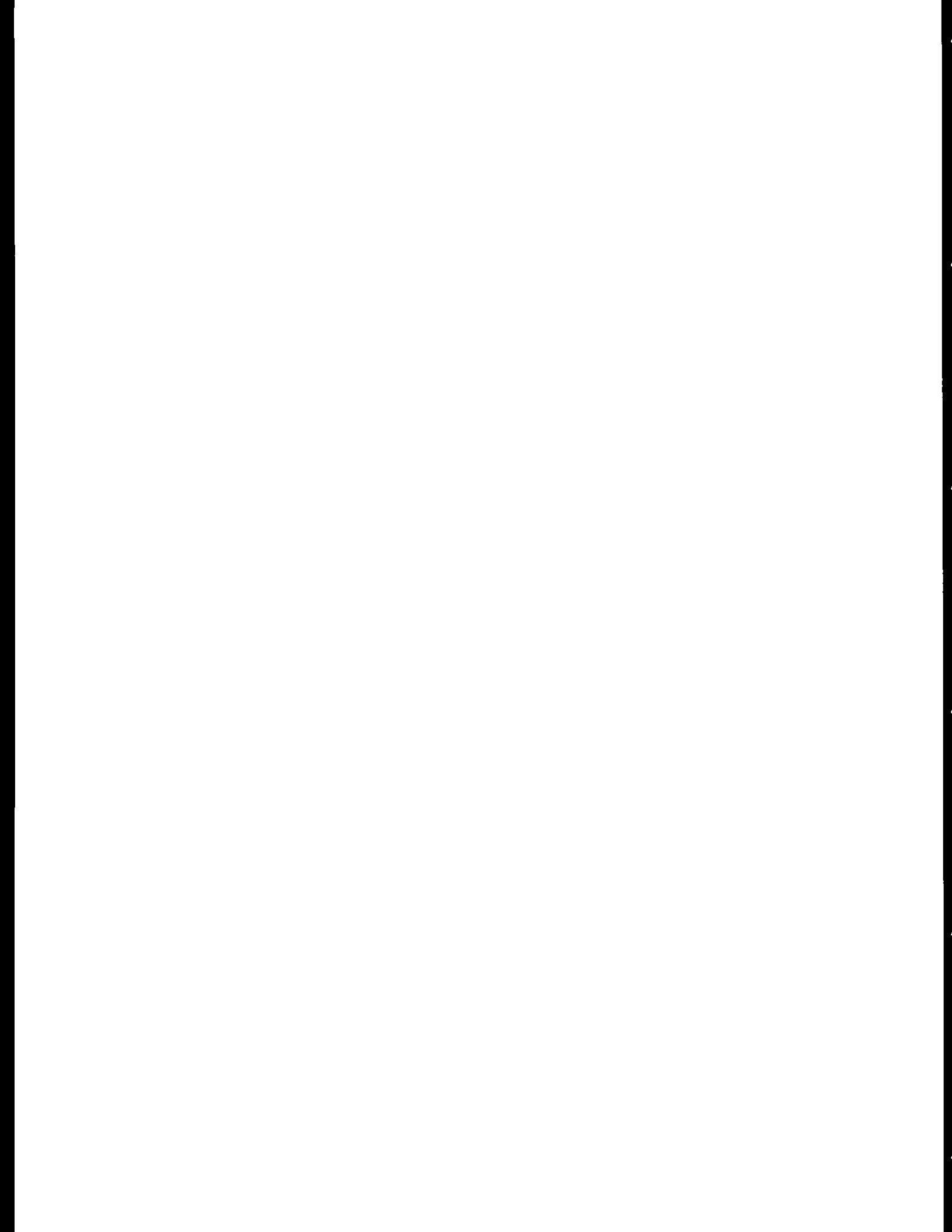

<u>TASK</u>	<u>SUBTASK AND DESCRIPTION OF ACTIVITIES</u>	<u>DELIVERY DATE</u>
1.1	1.1.1 TSG solicits problem statements in detailed format	
	1.1.3 Problem statements prepared and submitted	
	1.1.5 As received, problem statements are forwarded to PTC	
	1.1.7 TSG sets date for meeting to formulate annual work program	
2.1	<u>2.1.1</u> PTC (TRB staff) extracts key words and sends to TRIS	As required
	<u>2.1.3</u> TRIS searches files, forwards output to PTC	As required
	<u>2.1.5</u> PTC staff screens out nonrelevant materials	As required
	<u>2.1.7</u> PTC staff prepares evaluations	As required
	<u>2.1.9</u> PTC sends copy of problem statement and TRIS output to UMTA Program Coordinator to obtain UMTA evaluation	
	2.1.11 UMTA staff prepares evaluations	
	<u>2.1.13</u> As made, PTC staff evaluations and TRIS output are forwarded to TSG	As required
	2.1.15 As made, UMTA evaluation are forwarded to TSG	
	2.1.17 Based on evaluations, TSG modifies details of problem	
	2.1.19 By letter ballot, TSG members rate revised problem statements	
	2.1.21 TSG ratings are converted to rankings and circulated to membership	
	2.1.23 TSG meets to formulate annual work program	
	2.1.25 TSG sends annual work program to UMTA for approval	
	2.1.27 UMTA acts on approval of program	
	2.1.29 UMTA and TSG coordinate as needed if revision of recommended program is necessary	
	2.1.31 UMTA refers approved program to PTC, with copy of correspondence to TSG	
3.0	<u>3.0.1</u> Ballot on acceptability of problems to be identified with the Academy is prepared and sent to the Executive Committee Subcommittee for the NCTRP	+1 week*
	<u>3.0.3</u> Subcommittee acts on ballot	+3 weeks
	<u>3.0.5</u> Acceptance action recommendation is made to PTC	+3.5 weeks
	<u>3.0.7</u> PTC acts on acceptance recommendation and so notifies UMTA	+4.0 weeks
	3.0.9 UMTA notifies TSG of PTC acceptance	
	3.0.11 TSG acts as appropriate re PTC rejection of problems or programs	
	3.1.13 TSG submits revisions to UMTA	
	3.0.15 UMTA submits revisions to PTC	
	<u>3.0.17</u> 3.0.1 through 3.0.9 repeated as needed	As required

*Accumulative from date PTC receives work program.

<u>TASK</u>	<u>SUBTASK AND DESCRIPTION OF ACTIVITIES</u>	<u>DELIVERY DATE</u>
3.1	<u>3.1.1</u> Concurrently with 3.0.1, NCTRP Director assigns problems to research areas and staff	+4.2 weeks
	<u>3.1.3</u> NCTRP Director sets panel meeting dates	+4.5 weeks
	<u>3.1.5</u> PTC prepares background materials for soliciting nominees for panels	+6.0 weeks
	<u>3.1.7</u> Staff determines balance of expertise required by problem	+6.0 weeks
	<u>3.1.9</u> Solicitation letters are mailed	+6.5 weeks
	<u>3.1.11</u> Nominees are submitted	
	<u>3.1.13</u> Staff balances nominee expertise against problem needs and recommends panels to NCTRP Director	As required
	<u>3.1.15</u> NCTRP Director and staff agree on tentative roster	As required
	<u>3.1.17</u> NCTRP Director sends invitation-to-serve letter	As required
	<u>3.1.19</u> Responses are returned	
	<u>3.1.21</u> NCTRP Director sends additional invitations in instances of turndowns	As required
	<u>3.1.23</u> NCTRP Director sets tentative rosters	As required
	<u>3.1.25</u> NCTRP Director sends acknowledgement letter to those accepting	As required
	<u>3.1.27</u> Concurrent with 3.1.25, NCTRP Director submits tentative rosters to Academy for approval	As required
	<u>3.1.29</u> Academy acts on approvals and notifies NCTRP	As required
	<u>3.1.31</u> Concurrent with 3.1.27, NCTRP Director prepares formal appointment letters for TRB Executive Director's signature	As required
	<u>3.1.33</u> Appointment letters are mailed	+15 weeks
	<u>3.1.35</u> NCTRP Director begins coordination with UMTA and TSG to develop mailing list for Project Statements	+12 weeks
	<u>3.1.37</u> Cards confirming acceptance of appointment are mailed to TRB	
3.2	<u>3.2.1</u> Technical panels meet to prepare Project Statements	+19.5 weeks
	<u>3.2.3</u> Project Statements are submitted to editorial and production processes	As required
	<u>3.2.5</u> Project Statements are printed	As required
	<u>3.2.7</u> Project Statements are forwarded to mailer	+23.5 weeks
	<u>3.2.9</u> Panels prepare Problem Evaluation Forms	+19.5 weeks
	<u>3.2.11</u> Panels review guidelines for proposal evaluation and agree on weights for key elements	+19.5 weeks

<u>TASK</u>	<u>SUBTASK AND DESCRIPTION OF ACTIVITIES</u>	<u>DELIVERY DATE</u>
	<u>3.2.13</u> Staff drafts meeting notes and circulates for approval	+21.5 weeks
	<u>3.2.15</u> Meeting notes types, duplicated, and mailed	+23.5 weeks
3.3	<u>3.3.1</u> Project Statements mailed	+24 weeks
	<u>3.3.3</u> Staff responds to inquiries as necessary	As required
	<u>3.3.5</u> Staff coordinates with Minority Business Enterprises as necessary	As required
	<u>3.3.7</u> Agencies prepare and submit proposals	
	<u>3.3.9</u> Proposals processed	+32.5 weeks
	<u>3.3.11</u> Notifications of rejections mailed	As required
	<u>3.3.13</u> Deleted	
	<u>3.3.15</u> Deleted	
	<u>3.3.17</u> Proposals mailed to panel	+33 weeks
	<u>3.3.19</u> Panels evaluate proposals and prepare pros and cons	As required
	<u>3.3.21</u> Panels meet to rank proposals and make selections	+41-45 weeks
	<u>3.3.23</u> Panels prepare statements of reasons behind selections	+41-45 weeks
	<u>3.3.25</u> Panels prepare Proposal Review and Recommendation Form (PRRF)	+41-45 weeks
	<u>3.3.27</u> Panels update Problem Evaluation Form (PEF)	+41-45 weeks
	<u>3.3.29</u> Notification to unsuccessful proposers prepared and mailed	+42-46 weeks
	<u>3.3.31</u> 1st-choice letters prepared and mailed	+42-46 weeks
	<u>3.3.33</u> 2nd-choice letters prepared and mailed	+42-46 weeks
	<u>3.3.35</u> OCG sent 1st-choice proposal	+41.5-45.5 weeks
	<u>3.3.37</u> Comptroller's Office sent 1st-choice proposal and asked to determine agency's financial responsibility	+41.5-45.5 weeks
	<u>3.3.39</u> PTC report to UMTA on agency selections is prepared and mailed to UMTA, a copy to TSG	+47 weeks
	<u>3.3.41</u> Agencies respond to PRRF	As required
	<u>3.3.43</u> Panels act on approvals of agencies' responses	As required
	<u>3.3.45</u> Subcontract Information Summary is prepared and sent to OCG	+51.5-55.5 weeks
	<u>3.3.47</u> OCG & NCTRP resolutions as necessary	As required
	<u>3.3.49</u> OCG prepares subcontract	+52-56 weeks
	<u>3.3.51</u> OCG forwards subcontract to agency	+52-56 weeks

<u>TASK</u>	<u>SUBTASK AND DESCRIPTION OF ACTIVITIES</u>	<u>DELIVERY DATE</u>
	<u>3.3.53</u> Agencies review and respond to OCG	+54-58 weeks
	<u>3.3.55</u> OCG and NCTRP coordinate as needed re agency response	As required
	<u>3.3.57</u> OCG sends copy to UMTA	+56-59 weeks
	<u>3.3.59</u> UMTA coordinates, as required, with OCG re subcontract	As required
3.4	<u>3.4.1</u> PTC provides UMTA with a statement of safeguards against personal or organizational conflicts of interest	As required
	<u>3.4.3</u> PTC provides UMTA with copy of Procedural Manual for Agencies Conducting Work in the NCTRP	As required
4.1	<u>4.1.1</u> Research begins	+56-59 weeks
4.2	<u>4.2.1</u> Agencies submit Working Plan (WP)	+57-60 weeks
	<u>4.2.3</u> PTC forwards WP to panels for review and approval	As required
	<u>4.2.5</u> Panels act and notify PTC	As required
	<u>4.2.7</u> Panel review comments on WP sent to agencies	As required
	<u>4.2.9</u> Agencies revise WP as needed and resubmit	
	<u>4.2.11</u> PTC coordinates with panels as necessary re revised submittal	As required
	<u>4.2.13</u> Agencies notified of approval action	As required
	<u>4.2.15</u> PTC staff makes first surveillance visit	As required
	<u>4.2.17</u> PTC staff monitors research in progress through contacts, visits, progress reports - monthly and quarterly	Continuous
	<u>4.2.19</u> PTC staff keeps panels abreast of work	Continuous
	<u>4.2.21</u> PTC staff distributes quarterly progress reports from agencies, coordinates re review comments, and prepares quarterly letter report.	Calendar quarter
	<u>4.2.23</u> PTC staff prepares semi-annual progress report for UMTA and TSG	December & July
	<u>4.2.25</u> PTC staff participates in briefings as required	As required
	<u>4.2.27</u> PTC staff prepares annual report on PTC progress in administration of NCTRP activities	Dec. annually
	<u>4.2.29</u> Annual report is distributed	March 15
	<u>4.2.31</u> PTC checks and approves agency invoices	As required
5.2	<u>5.2.1</u> As necessary and appropriate to circumstances, PTC staff will see to preparation and distribution of digests, technical articles, etc., reporting to the transit community on useful products soon after they are developed	As required

<u>TASK</u>	<u>SUBTASK AND DESCRIPTION OF ACTIVITIES</u>	<u>DELIVERY DATE</u>
5.4	5.4.1 Final report received in preliminary draft	As completed
	<u>5.4.3</u> Copy is sent to editor	On receipt
	<u>5.4.5</u> Copy is sent to responsible staff engineer	On receipt
	<u>5.4.7</u> Acknowledgement of receipt prepared and sent to Principal Investigator, copy to OCG, with request for inventory of data and equipment	On receipt
	<u>5.4.9</u> OCG requests inventory of data and equipment, certification form, and reminds re final voucher	On receipt & equipment
	<u>5.4.11</u> Staff engineer prepares and mails memo requesting panel review of report re technical compliance with subcontract requirements	On receipt
	<u>5.4.13</u> Panels complete reviews and mail to staff engineer	As required
	<u>5.4.15</u> Two (2) copies are sent to file	On receipt
	<u>5.4.17</u> Staff engineer completes his review	Receipt +30 days
	<u>5.4.19</u> Staff engineer summarizes review comments and mails to Principal Investigator	Receipt +7 weeks
	5.4.21 Principal Investigator prepares point-by-point letter response to review comments and mails to NCTRP	As required
	5.4.23 Principal Investigator revises report according to panel review comments and ships prescribed number of copies to NCTRP	As required
	<u>5.4.25</u> Copy of final draft is sent to staff engineer	On receipt
	<u>5.4.27</u> Staff engineer reviews final draft and accumulates information, materials, etc., as appropriate to needs of editorial and publication processes	As necessary
	<u>5.4.29</u> Delete	On receipt
	<u>5.4.31</u> Copy of staff memo (see 5.4.11) and final draft report are sent to UMTA for review	On receipt
	<u>5.4.33</u> NCTRP Director sends one (1) copy of final draft report to each member of the TSG	On receipt
	<u>5.4.35</u> PTC staff arrives at decision as to manner of publication and distribution of report	As necessary
	<u>5.4.37</u> Reports not to be published are put on microfiche	
	5.4.39 UMTA reviews report and forwards any comments to NCTRP	Receipt +30 days
	5.4.41 Subcontractor prepares and mails response re data and equipment inventory to PTC OCG	As required

<u>TASK</u>	<u>SUBTASK AND DESCRIPTION OF ACTIVITIES</u>	<u>DELIVERY DATE</u>
<u>5.4.43</u>	OCG requests NCTRP comments on agency recommendation for disposition of data and equipment	As required
<u>5.4.45</u>	Staff engineer advises OCG of instructions to agency	As required
<u>5.4.47</u>	OCG responds to agency	As required
<u>5.4.49</u>	Agency acknowledges instructions and forwards final voucher	
<u>5.4.51</u>	NCTRP forwards final voucher to Accounting and requests project audit	As required
<u>5.4.53</u>	DCAA performs audit and notifies PTC	As required
<u>5.4.55</u>	Accounting forwards to OCG the audit results, copy to NCTRP	As required
<u>5.4.57</u>	OCG sends letter or final amendment to subcontractor; copy to Accounting triggers payment of final voucher	As required
<u>5.4.59</u>	Agency prepares and submits final voucher and subcontractor's certification	As required
<u>5.4.61</u>	OCG distributes fully executed amendments, if applicable	As received
<u>5.4.63</u>	Accounting pays final voucher, copies to NCTRP and OCG	As required
<u>5.4.65</u>	Comptroller's Office invoices UMTA	As necessary
<u>5.4.67</u>	UMTA acts on invoice	
<u>5.4.69</u>	Delete	
<u>5.4.71</u>	Delete	
<u>5.4.73</u>	Staff engineer writes Foreword and puts report into editorial and publication process	As appropriate
<u>5.4.75</u>	Staff engineer forwards report abstract to TRIS	On receipt
<u>5.4.77</u>	Staff editor places copy of Foreword in in suspense file for retrieval at galley stage	On receipt
<u>5.4.79</u>	Staff editor acquires Library of Congress number	As appropriate
<u>5.4.81</u>	Editor and staff engineer review Foreword to ensure relevancy to current circumstances at galley stages	As appropriate
<u>5.4.83</u>	Staff engineer forwards Foreword to Principal Investigator for checking	As prepared
<u>5.4.85</u>	Principal Investigator reviews and returns to staff engineer with comments	
<u>5.4.87</u>	Editor completes work and sends report for publication	As appropriate
<u>5.4.89</u>	Report is published	As appropriate
<u>5.4.91</u>	Staff editor coordinates with staff engineer to prepare summary sheet necessary for placing published report in NTIS (Form NTIS-35, Rev. 10/73)	As appropriate

<u>5.4.93</u>	Report is distributed through PTC (TRB) selective distribution processes to UMTA, TSG, and many others	As appropriate
<u>5.4.95</u>	PTC staff prepares and mails letters sending published report to panel members	As appropriate
<u>5.4.97</u>	TRB advises Academy of panel disbandment	As appropriate
<u>5.4.99</u>	PTC prepares and mails letter of appreciation to Principal Investigator (includes copy of published report)	As appropriate
<u>5.4.101</u>	PTC mails copies as prescribed in sub-contract, of published report to sub-contractor's contracts officer	As appropriate
5.4.103	Delete	
<u>5.4.105</u>	PTC project records closed on receipt of final payment information	As appropriate
<u>5.4.107</u>	When decision is made re publication of report, panel is so notified via letter of appreciation. They are also told that PTC will take steps to disband panel and that they will receive copy of report when published	As appropriate
<u>5.4.109</u>	UMTA is advised of publication decision, copy to TSG	As appropriate
<u>5.4.111</u>	Principal Investigator is advised of publication decision	As appropriate

Project Completed

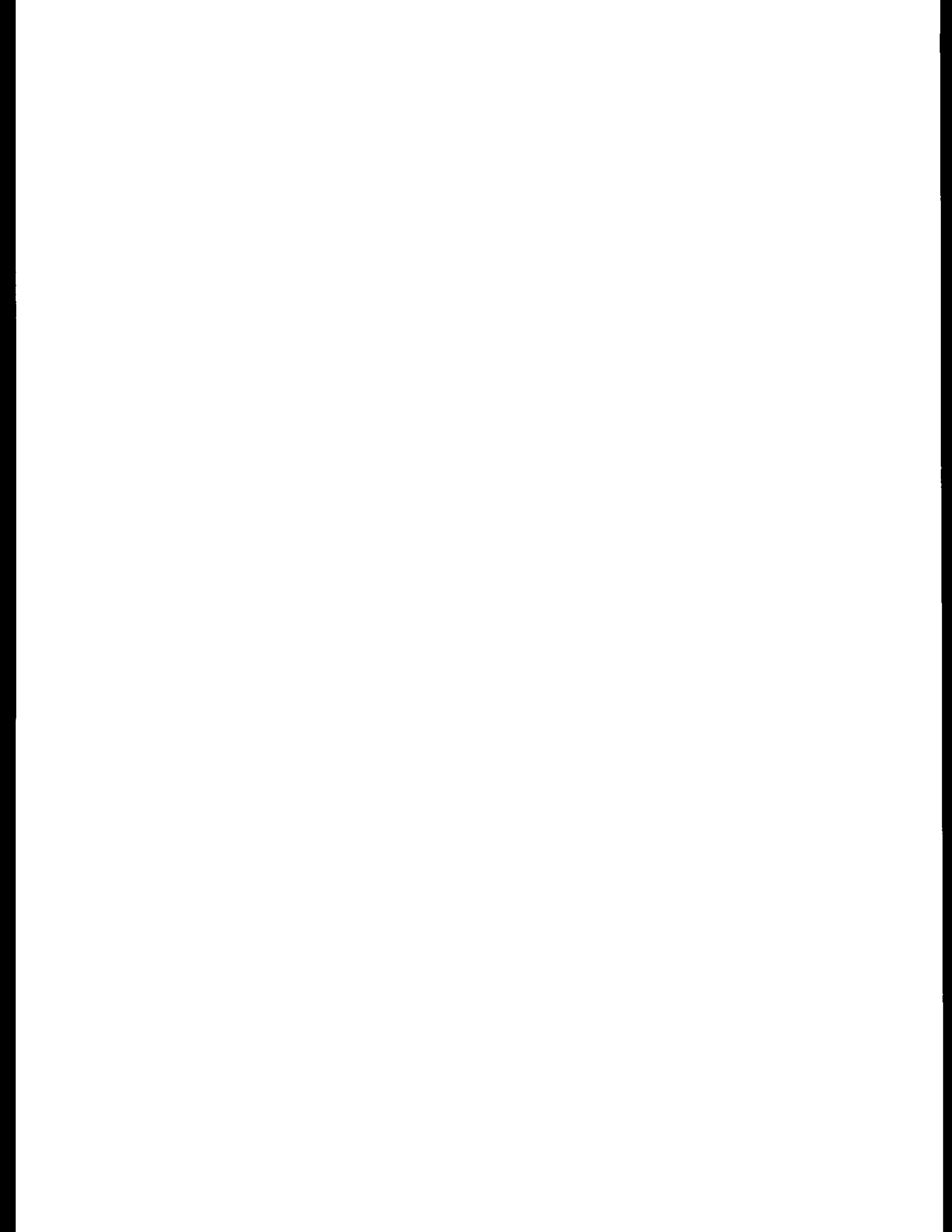

PROGRESS BY PROJECTS

The following pages present detailed status reports on those projects for which there remains any type of contractual activity. The status of *all* projects can be found in Table I.

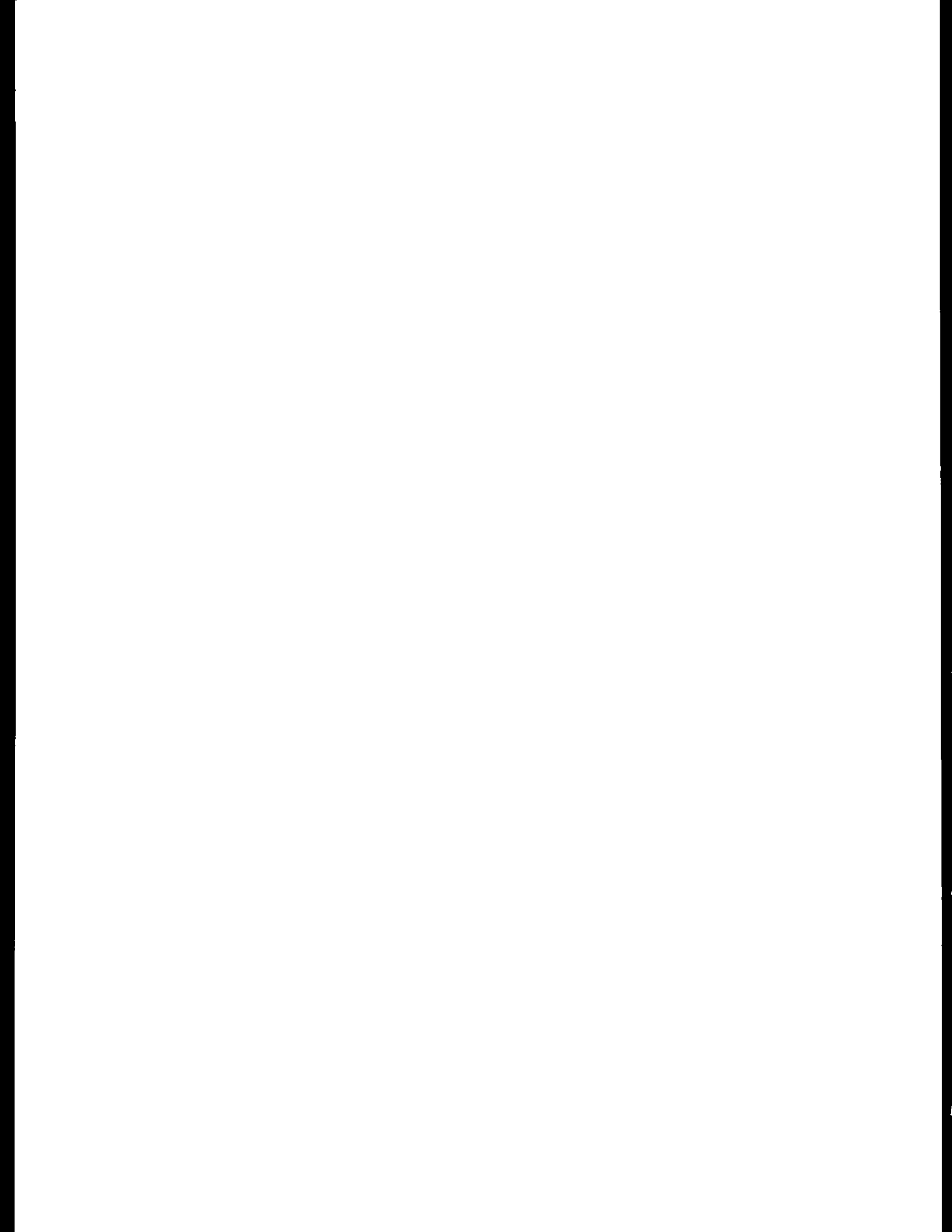

AREA THIRTY: ECONOMICS

Project: 30-1, FY '81
Title: Small Transit Buses: A Manual for Improved Purchasing, Use, and Maintenance

Research Agency: Arthur D. Little, Inc.
Principal Investigator: Dr. P. Ranganath Nayak

Effective Date: November 8, 1982
Completion Date: August 7, 1984

AGENCY PERFORMANCE

1. Is the project on schedule? No* Percent project complete: 99
2. Is the research in keeping with the approved research plan? Yes
3. Subcontract Amount: \$299,378
4. Estimated Expenditures to 6/30/85: \$299,378
5. Are the expenditures in keeping with the project progress? No*

*Data base preparation took greater funds and time than anticipated. The project has been completed within budget but may require a contract extension to modify the research report.

PROJECT DESCRIPTION

One of the important decisions facing both rural and urban transit decisionmakers is whether to invest scarce funds in more expensive or less expensive small transit buses. Available small buses (i.e., ranging from van conversions to 31-ft heavy-duty small buses) are highly diverse in both capital costs and technology. Their uses are also highly diverse, spanning the range from large transit fleets in major urban areas to small rural operators, and including fixed-route, demand-responsive, shuttle and other services. The complexity of both needs and possible solutions has led to many poor choices of buses for specific duties. In addition, uncertainties with respect to the small bus market have led to a lack of continuity in design and development; perceived problems in bus operation, maintenance, and reliability; a lack of clear definition of bus demand; and little standardization within realistic price ranges. Consequently, no guidelines exist with which transit providers, seeking to purchase or replace small buses, can make objective decisions concerning the best bus type to be procured.

The general objective of this research is to develop a workbook-style manual for local transit operators and to identify key recommendations that might feasibly be taken by transit operators, local governments, states, and UMTA to substantially improve the procurement, appropriate use, and maintenance processes for small transit buses. The manual is intended for use by individuals experienced and inexperienced in the procurement and operation of small transit buses. Furthermore, the manual is intended to assist individuals in the cost-effective procurement, maintenance, and operation of buses in a wide range of local, institutional, service, and operating environments. (Included in the definition of service and operating environments are maximum and average loads; type of service; range requirements (i.e., distance between refueling); wheelchair-lift or ramp needs, and actual usage; types, conditions, and grades of roads/streets; dwell-time constraints; weather extremes; frequency and degree of acceleration/braking; communication equipment requirements; and fare collection equipment requirements.) The manual will be based on research requiring the collection, tabulation, and analyses of primary information and data. While performing the research, investigators must be particularly cognizant of bus maintainability and fuel efficiency. (Included in the definition of maintainability are life expectancy of the bus's power train, body, and major components; minimum mean time before failure (MTBF) rates of components; availability and cost of parts; maintenance and servicing facilities required; skill levels and representative times and costs required for servicing and repair; complexity of subsystems (i.e., lifts and air conditioning).) Fuel efficiency studies should consider duty cycle, propulsion technology, maintenance, bus size and weight, gearing, etc. Transit operators will be the principal users of the research results, although they should also be of interest to manufacturers and funding agencies. To accomplish this objective the following tasks are considered essential but not limiting:

Task 1 - Determine the present capital and operating costs, and performance of small transit buses in U.S. operations as affected by (1) service and operating environments, (2) institutional environments, and (3) maintenance availability and sophistication.

A. Develop a classification system for small buses by type (life expectancy, maintainability, operating cost) and size.

B. Develop a classification system for operational environments and maintenance programs.

C. Develop a detailed data collection plan for use in determining capital and operating costs for various classes of buses, maintenance programs, and operating environments.

D. Collect data and summarize results for various bus and component classes to provide transit operators with relevant design characteristics and operating experience. Analyze MTBF data (as developed in this study or available elsewhere), design characteristics, and general operating experience for key components, subsystems, chassis types, etc. that are critical to the development of minimum specifications for various service and operating environments, appropriate maintenance actions, and realistic replacement

Project 30-1 continued

intervals. Develop from these data an engineering analysis of each bus class describing its suitability for various types of service and likely operating results. Assess the practicality of using life-cycle costs to assist in the description of operating results.

E. Identify problems for transit operators and manufacturers in using or producing small transit buses that are supported by the data.

Task 2 - Develop practical recommendations for resolution of key problems, identified in the research, for improving the purchase, maintainability, and cost-effective use of small transit buses. These recommendations should be oriented towards actions that can be taken by transit operating agencies to improve delivery of service.

Task 3 - Based on the results of Task 1, develop a workbook (flow-chart type) manual that can be used by transit operators to make appropriate small bus choices. The manual should be designed to take as input such planning factors as service type, anticipated passenger loads, typical speeds, maintenance and institutional factors. Its output should include the classes of small transit buses that are best suited to the projected operating environment, special specification items or options that should be required, the range of maintenance and fuel costs likely to be experienced, and special maintenance provisions that should be undertaken.

STATUS OF RESEARCH

Research on this project is complete. A manual (NCTRP Report 11) has been developed that is based on a method to determine life-cycle costs that are, in turn, based on a maintenance data base representing 187 small buses from transit agencies geographically distributed throughout the United States. The method's strength lies in its sensitivity to duty cycle, climate, and other factors. It calls for the analyst to (1) determine capacity requirements, and (2) document the characteristics of the working environment. Through the use of simple equations, the analyst is led to the service type of bus (van, body on van chassis, body on truck chassis, purpose-built) providing the lowest life-cycle cost. Ranges in life cycle cost for a given bus type may also be determined.

Inasmuch as maintenance costs were found to vary with changes in duty cycle and climate, an analyst can use the maintenance cost results to determine appropriate operations for small buses.

The manual has been published as NCTRP Report 11, "Small Transit Vehicles: How to Buy, Operate, and Maintain Them." The research report is in the review process.

AMENDMENT(S) THIS REPORTING PERIOD

None

PROBABILITY OF SUCCESS: Good

REPORT(S) AVAILABILITY: NCTRP Report 11, "Small Transit Vehicles: How to Buy, Operate and Maintain Them"

PRINCIPAL INVESTIGATOR(S): Dr. P. Ranganath Nayak
Mgr., Transportation Systems Group
Arthur D. Little, Inc.
Acorn Park
Cambridge, MA 02140
617/864-5770

RESPONSIBLE NCTRP STAFF ENGINEER: R. Ian Kingham - 202/334-3224

AREA THIRTY-ONE: FINANCE

Project: 31-2, FY '84
Title: Transit Capital Investment to Reduce Operating Deficits:
 Alternative Bus Replacement Strategies

Research Agency: In Developmental Stage
Principal Investigator:

Effective Date: (18 months)
Completion Date:

AGENCY PERFORMANCE

1. Is the project on schedule? Percent project complete:
2. Is the research in keeping with the approved research plan:
3. Subcontract Amount:
4. Estimated Expenditures to:
5. Are the expenditures in keeping with the project progress?

PROJECT DESCRIPTION

The prudent expenditure of already limited capital and operating funds is especially important as plans to reduce federal contributions take shape. Budget proposals, if enacted, will eliminate federal operating funds while reducing transit capital funds to the proceeds of the \$0.01 gasoline tax. Beyond the federal cutbacks, raising money at state and local levels becomes increasingly difficult as transit programs are forced to compete with other community needs.

In the past, tradeoff decisions between capital and operating budgets were not necessary because funds were segregated by program category. More recently, it has been possible to use capital funds for operating purposes under certain conditions. Transit authorities are being asked to review the bases on which both capital and operating expenditures are made. Past policies and practices have tended to favor capital expenditures based on federal and state contributions as well as on regulations and requirements of different levels of government.

Since there are reasonable expectations that the availability of some level of capital funding will continue, even as operating assistance declines, it is prudent to explore the hypothesis that selected capital investments can reduce the need for operating funds in individual transit agencies.

There are numerous areas where capital expenditure can have a favorable impact on operating costs. For example, building a new maintenance facility, installing a two-way radio system, providing automatic vehicle monitoring, developing a computerized maintenance capability, replacing aging vehicles -- these and many other projects can be evaluated in terms of their impact on operating dollars. In particular, development of an appropriate strategy for replacement of the bus fleet is an area where additional research could result in significant operating cost savings. Past UMTA policy prescribed a minimum 12-year lifespan before a 40-ft conventional bus was eligible for replacement. UMTA is considering 500,000 miles, or similar yardsticks, as alternative bases for replacement. Because no replacement strategy has been validated technically, capital funds may be spent in advance of real need. Scarce operating dollars, in contrast, may continue to be expended in an inefficient manner to prolong the service life of a bus at inordinately high operating cost. A well timed expenditure of capital funds to buy new buses actually could reduce the total of annual operating and capital costs, and improve reliability of passenger service.

The overall objective of this research is to adapt or develop methods for evaluating various capital investment opportunities that would provide transit operating agencies and transit funding agencies the means to measure improvements in operating efficiency and service which reduce or help control operating costs.

This study is expected to lead to the identification of various types of transit capital projects that can improve system performance including ridership, vehicle productivity, reliability, fleet availability, trip time savings, and cost savings. The first phase of research will focus specifically on bus replacement strategies and will include development of one or more methods for transit and funding agencies to evaluate alternative strategies. Annual operating and capital cost impacts should be outputs of the method(s) developed. If funds are available, it is possible that future research will concentrate on other types of capital expenditures.

The following tasks are suggested to further the overall general objective and to accomplish the specific objective of Phase I.

Task 1. Identify capital investment opportunities, other than bus replacement considered in Tasks 3 through 6, which would reduce transit operating deficits. From successes and failures described in the literature, recommend investment opportunities for research in future studies.

Project 31-2 continued

Task 2. For two or three of the recommended investment opportunities from Task 1, suggest tasks and data requirements necessary to accomplish possible future research, which is presently unfunded, to (a) develop appropriate methods to evaluate their impact on operating costs and operating deficits, and (b) develop appropriate methods for transit agencies to prioritize and select capital investment opportunities to produce cost-effective improvements in operating efficiency and service levels that reduce or help control operating costs. Include time and cost estimates for the research on each investment opportunity.

Task 3. Summarize past and current research on bus replacement schedules, life-cycle costing analyses, and bus purchasing guidelines. Describe the rationale for the 12-year replacement cycle. Identify the data bases to be used for Tasks 5 and 6.

Task 4. Identify current bus replacement practices of selected U.S. transit agencies of various sizes and geographic locations.

Task 5. Develop or adapt methods for transit and funding agencies' consideration to determine optimal fleet replacement schedules for different environments and funding sources. Such methods should consider vehicle-miles, vehicle-hours, duty cycle (terrain, number of stops), climate, fleet size and mix, level of preventive maintenance, spare ratio, bus rehabilitation policy, and data availability for use in the methods.

Task 6. Provide a total of three geographically diverse examples of methods application for hypothetical cases reflecting the real world for small, medium, and large agencies.

Funds Available: \$150,000

AMENDMENT(S) THIS REPORTING PERIOD:

PROBABILITY OF SUCCESS:

REPORT(S) AVAILABILITY:

PRINCIPAL INVESTIGATOR(S):

RESPONSIBLE NCTRP STAFF ENGINEER: R. Ian Kingham - 202/334-3224

AREA THIRTY-THREE: PERSONNEL MANAGEMENT

Project: 33-1, FY '80
Title: Transit Bus Operator Selection and Training for Dealing with Stress

Research Agency: Group Associated Management Services, Inc.
Principal Investigator: Dr. Brownlee Elliott

Effective Date: October 15, 1981
Completion Date: October 14, 1983
Revised Completion Date: April 14, 1984

AGENCY PERFORMANCE

1. Is the project on schedule? Yes Percent project complete: 100
2. Is the research in keeping with the approved research plan? Yes
3. Subcontract Amount: \$150,000
4. Estimated Expenditures to 6/30/85: \$150,000
5. Are the expenditures in keeping with the project progress? Yes

PROJECT DESCRIPTION

Some bus operators possessing the basic skills to operate the vehicle may still experience difficulties in performing their job satisfactorily because of inability to cope effectively with the public. Use of all possible training and disciplinary action does not help when the individual hired does not have the psychological strengths necessary to deal effectively with continuous public contact, and the resultant stress may lead to more workers' compensation claims for nonvisible physical injury (i.e., heart and psychological problems) as well as to more accidents, absenteeism, and personnel turnover.

Various selection and training methods are currently being used by individual transit agencies. Some of these methods have been developed specifically for application in the transit industry, some have evolved from practice within individual agencies, and others represent modifications to methods originally developed for agencies outside of the transit industry. At present, however, no one single method of selecting or training bus operators from the viewpoint of their ability to deal with stress is considered to be generally acceptable for wide application by transit agencies. To ensure that methods have general applicability, the range of needs and capabilities of different size transit agencies, regional differences, and the makeup of the bus operator population (i.e., male/female and minorities) must be fully considered.

The objective of this research is to provide an evaluative device or questionnaire for use as part of the bus-driver-selection process that will validly indicate the applicant's susceptibility to stress which is likely to affect job performance. The research will also provide two training modules: one designed to help newly hired operators anticipate and deal with typical stressful situations, and one designed to help supervisors recognize stress symptoms displayed by operators and provide guidance on appropriate courses of action.

The following tasks are included:

Task 1. Review applicable literature, actual training programs, and studies currently being undertaken in the transit industry that deal with how to treat stress or its causes, how to understand the problem, and how to cope with it. Identify the various environmental, physiological, and psychological factors commonly used in stress analysis.

Task 2. Identify representative fixed-route bus transit agencies to participate in Tasks 3 and 5 including a minimum of one large agency (more than 500 buses), two medium agencies (100 to 500 buses), and three small agencies (less than 100 buses).

Task 3. Prepare and verify a set of stress factors and job characteristics to use in the preparation of the selection device (Task 4) and training modules (Task 6). Contact managers, operators (primary emphasis), and labor representatives from the selected transit agencies for suggested additions and deletions.

Task 4. Evaluate existing operator-selection-test mechanisms for general applicability in measuring an individual's tolerance for stress and then either modify an existing device or develop a new test device or questionnaire.

Task 5. Field test the device or questionnaire using existing operators from the agencies selected in Task 2 to establish its usefulness (e.g., readable and understandable).

Task 6. Prepare two sample training modules: one for newly hired operator training and one for supervisor training. The primary focus of the new operator training will be to alert the driver to typical stress-causing situations and to provide specific guidance on how to cope with each situation. The supervisor's training module will focus on the recognition of stress symptoms and tendencies and on the identification of appropriate courses of action. Both modules will be adaptable by an individual transit agency so that through property-specific modifications they can be made part of existing training programs.

Project 33-1 continued

Task 7. Provide a listing of appropriate pertinent data and resources (films, videotapes, surveys, models, books, papers, etc.) identifying concomitant costs, sources, and transit agencies that are using such methods for selection and stress management of bus operators and supervisors.

STATUS OF RESEARCH

Research has been completed.

AMENDMENT(S) THIS REPORTING PERIOD

None

PROBABILITY OF SUCCESS: Good

REPORT(S) AVAILABILITY:

NCTRP Research Results Digests 1 and 3. NCTRP Research Results Digest 1 provides a summary of the literature review and NCTRP Research Results Digest 3 announces the availability of the following report.

A 3-volume report prepared by Group Associated Management Services, Inc., is available from the NCTRP. The first volume, "Predicting and Dealing with Transit Bus Operator Stress," includes the research report and the preliminary stress prediction device. Because the device has not been validated and is, therefore, not appropriate for use by operating agencies, this volume is not being widely distributed. However, copies are available on a loan basis from NCTRP, 2101 Constitution Avenue, N.W., Washington, D.C. 20418, to afford interested researchers access to the findings as background for future developmental work.

The second volume, "The Stress Connection - A Stress Management Program for New Bus Operators and Supervisors," contains the training modules, and the resource guide is contained in the third volume entitled, "Transit Bus Operator Stress - Resource Guide." Both Volumes II and III can be ordered from the Publications Office, Transportation Research Board, 2101 Constitution Avenue, N.W., Washington, D.C. 20418, at a cost of \$10.00 and \$5.00, respectively. Because the audience for these two volumes was considered to be relatively small, a decision was made not to publish them in the regular NCTRP series for wide distribution.

PRINCIPAL INVESTIGATOR(S): Dr. Brownlee Elliott, Research Director
Group Associated Management Services, Inc.
1914 Hyde Park Drive
Detroit, MI 48205
313/259-1666

RESPONSIBLE NCTRP STAFF ENGINEER: Robert E. Spicher - 202/334-3224

AREA THIRTY-THREE: ADMINISTRATION - PERSONNEL MANAGEMENT

Project: 33-2(2), FY '82/83
Title: Quality-of-Work-Life Programs for the Transit Industry-Regional Seminars

Research Agency: Public Administration Service
Principal Investigator: Dr. Susan G. Clark

Effective Date: December 1, 1984
Completion Date: March 1, 1986

AGENCY PERFORMANCE

1. Is the project on schedule? Yes Percent project complete: 34
2. Is the research in keeping with the approved research plan? Yes
3. Contract Amount: \$52,454
4. Estimated Expenditures to 6/30/85: \$17,100
5. Are the expenditures in keeping with the project progress? Yes

PROJECT DESCRIPTION

Under an initial NCTRP project, recommendations were made on the potential application of quality-of-work-life programs to transit agencies. These recommendations and the supporting research were documented in two reports: NCTRP Report 5, "Quality-of-Work-Life Programs for the Transit Industry - Final Report," and NCTRP Report 6, "Quality-of-Work-Life Programs for the Transit Industry - Model Programs." In order to ensure proper consideration of these findings and recommendations, a second project is needed to disseminate the results to the transit industry. After reviewing an array of strategies, NCTRP Project Panel A33-2 concluded that with the help of local sponsors, regional seminars would be the most productive means, given the financial resources anticipated for the project. The Panel has also judged that sufficient interest exists to warrant the seminar approach. The regional seminars will be based on the previous research and will address issues facing management, practitioners, labor, and others concerned with the development of human resources.

The objective of Project 33-2(2) is to conduct at least four regional seminars at locations geographically distributed across the nation. Maximum use will be made of volunteer, local sponsors and support in arranging and conducting the seminars. The agency selected to accomplish the project objective will be required to:

1. Provide the lead in organizing and conducting the seminars including arrangements with local sponsors for support. The selected agency will be responsible for preparing and making announcements to potential seminar participants with NCTRP approval.
2. Provide the agenda and prepare all seminar material, such as audiovisual aids, lesson plans, and handouts. Maximum advantage will be taken of the sequencing of seminars to appropriately modify the seminar material as needed. The NCTRP will be given the opportunity for prior reviews of all seminar material.
3. Turn over to the NCTRP, at the conclusion of the project, all seminar materials and a brief summary description of the seminars conducted. The seminar material will be in a form suitable for use by others in conducting additional group seminars and as instructional information for individuals. The seminar material and summary will be treated as the final report for the project.

STATUS OF RESEARCH:

Progress to June 30, 1985 includes identifying seminar agenda and discussants, selecting locations, workshop design, and logistical arrangements. Approximately 14 discussants (transit managers and union leaders) who have experience with Quality-of-Worklife Programs were identified and agreed to participate in the seminars. Seminars are scheduled for the June to December 1985 reporting period.

AMENDMENTS(S) THIS REPORTING PERIOD:

<u>Date</u>	<u>No.</u>	<u>Type</u>	<u>Amounts and/or Dates (From-To)</u>	<u>Comments</u>
6/28/85	1	Funds	\$49,454 - \$52,454	Increase in funds to accommodate travel for seminar discussants from transit agencies.

Project 33-2(2) continued

PROBABILITY OF SUCCESS: Too early to assess

REPORT(S) AVAILABILITY: Phase I reports, NCTRP Report 5, "Assessment of Quality-of-Work-Life Programs for the Transit Industry: Research Report," and NCTRP Report 6, "Assessment of Quality-of-Life Work Programs for the Transit Industry: Model Programs"

PRINCIPAL INVESTIGATOR: Dr. Susan G. Clark
Public Administration Service
1497 Chain Bridge Road
Suite 202
McLean, VA 22101
703/734-8970

RESPONSIBLE NCTRP STAFF ENGINEER: R. Ian Kingham - 202/334-3224

AREA THIRTY-SIX: ALTERNATIVE ANALYSIS

Project: 36-1, FY '80
Title: Improving Decision-Making for Major Urban Transit Investments

Research Agency: System Design Concepts, Inc.
Principal Investigators: Joseph R. Stowers and Arlee T. Reno

Effective Date: November 2, 1981
Completion Date: February 1, 1983
Revised Completion Date: November 1, 1983

AGENCY PERFORMANCE

1. Is the project on schedule? Yes Percent project complete: 100 (Phase I)*
2. Is the research in keeping with the approved research plan? Yes
3. Subcontract Amount: \$200,000
4. Estimated Expenditures to 6/30/85: \$200,000
5. Are the expenditures in keeping with the project progress? Yes

*A continuation (Phase II) of this project is under development to evaluate experience with UMTA's new Alternatives Analysis Policy.

PROJECT DESCRIPTION

The environment for transportation planning and investment decisions is in a period of dramatic change. Fiscal constraints, a possible reorientation of federal transportation policies, and an increasing reliance on local commitment and decision-making are all likely to influence significantly the future of transportation in urban areas. Even with these pressures, however, urban areas will still be facing decisions on major investments in transit systems. Thus, there will be a need in future years for a planning and analysis process that examines major transportation options and that informs decision-makers so that most cost-effective investment decisions can be effected.

Since 1975, the Urban Mass Transportation Administration has required, as a condition for federal funding support, a structured process termed alternatives analysis for proposed major investments in urban mass transit facilities. This process is used to identify priority corridors for possible major investments and to assess the cost-effectiveness of these investments in comparison to less costly transit improvements. Information generated in the process is used both by federal officials in administering a discretionary capital grant program and by state and local officials in determining priorities and identifying needed improvements in mass transportation services. Three important decision points occur within the UMTA major transit investment planning process. First, appropriate local officials identify the corridor(s) where major investments appear to be most needed. Second, local and federal officials agree on a small set of investment alternatives that encompass a reasonably broad range of options. Finally, local, state, and federal officials agree on one (or more) of these alternatives for advancement into preliminary engineering.

Since the advent of the alternatives analysis requirement, a significant number of urban areas have been involved in some aspect of the process. Concerns have been expressed with the process. For example, there is uncertainty regarding both the effect on the timing of transit investment decisions and the use of information in the federal review process and in local decision-making. Although adjustments to the process have been made to enhance its usefulness in local, state, and federal decision-making, no comprehensive assessment has been made of the degree to which analytical requirements have provided appropriate information at key decision points.

There is a need to evaluate past experience with alternatives analysis and to recommend improvements in the process that will result in more effective local, state, and federal decision-making. Such an assessment would be useful, for example, in identifying points where decision-makers have not had complete information, where the process has constrained appropriate decisions, or where significant efforts are invested in the development of information that is not used in decision-making. Although it is unclear what direction federal policy will take in regard to alternatives analysis, the need for some form of alternatives analysis for such investments will continue.

The general objective of this research is to assess the federal, state, and local decision-making process for major urban mass transportation investments by evaluating recent alternatives analysis experiences. The purpose of the assessment is to identify potential improvements in policy, procedures, and use of technical information; and to formulate planning procedures recommendations for use by federal, state, and local agencies. Such improvements would be in terms of time, costs, scale, presentation of information, role of participants, and the like. (The assessment is not intended to prescribe specific analytical techniques or to judge the appropriateness of previous major urban transit decisions.) Research tasks to satisfy the general objective are as follows:

Project 36-1 continued

Task 1--Inventory all applicable regulations and requirements concerning the evaluation of proposed major urban mass transportation investments.

Task 2--Review relevant literature on alternatives analysis and transit investment decision-making.

Task 3--Prepare methodologies for (a) the analysis and assessment of recent alternatives analysis decision-making experiences and (b) the selection of case studies.

Task 4--Select and conduct case studies, including those undertaken pursuant to the 1976 guidelines as well as other cases.

Task 5--Evaluate the usefulness of information developed in alternatives analysis for decision-making at each level of government.

Task 6--Formulate recommendations to Federal DOT and to state and local agencies.

STATUS OF RESEARCH

Research is complete, and all reports have been submitted to the NCTRP. The research report is published as described below under "Report Availability." Improvements to the planning process were recommended based on 15 in-depth case studies that were conducted in Baltimore, Houston, Milwaukee, Pittsburgh, Portland, San Diego, San Jose, Toronto, Dayton, St. Louis, Cleveland, Boston, Calgary, Edmonton, and Denver.

A continuation of this project is under development to update this research to reflect UMTA's new alternative analysis policy and agency experience with it.

AMENDMENT(S) THIS REPORTING PERIOD

None

PROBABILITY OF SUCCESS: Project objectives have been successfully accomplished.

REPORT(S) AVAILABILITY:

1. NCTRP Report 4, "Improving Decision-Making for Major Urban Transit Investments"
2. Individual case-study reports on a loan basis from the NCTRP Program Director

PRINCIPAL INVESTIGATOR(S):

<p>Dr. Joseph R. Stowers Vice President System Design Concepts, Inc. One Farragut Square South Washington, DC 20006 202/393-5910</p>	<p>Mr. Arlee T. Reno Director of Finance and Policy Studies System Design Concepts, Inc. One Farragut Square South Washington, DC 20006 202/393-5910</p>
--	--

RESPONSIBLE NCTRP STAFF ENGINEER: R. Ian Kingham - 202/334-3224

AREA THIRTY-EIGHT: SYSTEM PLANNING

Project: 38-1(2), FY '82/'83
Title: National Transit Computer Software Directory, Phase II

Research Agency: COMSIS Corporation
Principal Investigator: Ellen Krett

Effective Date: February 1, 1985
Completion Date: July 1, 1986

AGENCY PERFORMANCE

1. Is the project on schedule? Yes Percent project complete: 25
2. Is the research in keeping with the approved research plan? Yes
3. Subcontract Amount: \$50,000
4. Estimated Expenditures to 6/30/85: \$11,900
5. Are the expenditures in keeping with the project progress? Yes

PROJECT DESCRIPTION

Project 38-1 has produced a National Transit Computer Software Directory containing almost 300 transit application programs. These programs are listed in a catalog by: (1) the function they perform, (2) the submitting organization, and (3) the type of hardware on which the program operates. The catalog is accompanied by full-page descriptions for each of the approximately 300 programs. Furthermore, software has been developed to retrieve programs meeting various specifications. The software for this search process is described in a third document, "A Programming Guide." It is the full-page program descriptions that will be of greatest interest to transit agencies. These full-page descriptions need to be disseminated throughout the industry in an effective way. Furthermore, additional programs are known to UMTA which are believed to be of sufficient importance to add to the Directory immediately.

The general objective of this continuation research is to supplement the Directory and disseminate program descriptions among interested parties in the transit industry. Through dissemination of the program descriptions, it is envisioned that additional programs will be requested of agencies and subsequently added to the Directory. The following tasks will be performed.

Task 1. Categorize the full-page program descriptions by hardware type into six major groupings as follows:

<u>Hardware Type</u>	<u>Approximate Number of Programs</u>
IBM 360/370 IBM 30xx Series (3033,3081) AMDAHL	38
BURROUGHS 1855, 1955	29
IBM 43xx Series (4331, 4341)	50
IBM System 3x Series (System 34, 338)	45
ALL OTHER MAINFRAME & MINI (CDC, DG, VAX, DEC, HP3000, IME, UNIVAC)	64
ALL MICROCOMPUTERS (Apple, PC, XT, TRS)	54

Within each of these hardware types, programs could be classified by functional type. Each of the six hardware types should be bound separately and produced in sufficient quantity to satisfy user request. Furthermore, each type should have an appendix containing the program documentation forms to be used for submitting new programs for the Directory.

Task 2. Prepare a Research Result Digest of not more than 10 printed pages to describe the accomplishments of Phase I, the availability of the six Directory material groupings, and the opportunity to request program descriptions meeting more specific criteria.

Task 3. Contact should be made with Tom Hillegass of UMTA or his designee to identify those programs known to UMTA that are not presently included in the Directory. Documentation for these programs should be obtained and added to the Directory.

Task 4. A follow-up should be made of requestors for program descriptions to evaluate the usefulness of the information sent them and to request programs that they might have that would be useful additions to the Directory.

Project 38-1(2) continued

Task 5. Prepare a final report that will update the preliminary draft report from Phase I. This report will be reviewed by the NCTRP.

Task 6. Revise the draft final report and submit the final version in fulfillment of the technical obligations under the contract for the project.

STATUS OF RESEARCH

Progress to June 30, 1985 includes the completion of Tasks 1 through 3. The Directory in six volumes is available as described below. Computer software searches may be requested. A number of new software programs have been received as a result of the Research Results Digest 4 distribution requesting same.

AMENDMENT(S) THIS REPORTING PERIOD

None

PROBABILITY OF SUCCESS:

Too early to assess.

REPORT(S) AVAILABILITY:

1. NCTRP Research Results Digest 4, "National Transit Computer Software Directory" (see final page of this document for ordering information).
2. "Software Directory", six-volume directory categorized by hardware type as described in Task 1, containing page-long descriptions of almost 300 transit-related computer programs. These volumes are available for purchase or loan from the research agency.

COMSIS CORPORATION
11501 Georgia Avenue
Wheaton, MD 20902

3. Software Computer Searches - available on request to the research agency (see 2, above for address).

PRINCIPAL INVESTIGATOR(S): Ms. Ellen Krett
COMSIS Corporation
11501 Georgia Avenue
Bethesda, MD 20902
301/933-9211

RESPONSIBLE NCTRP STAFF ENGINEER: R. Ian Kingham - 202/334-3224

AREA THIRTY-NINE: ROUTE PLANNING

Project: 39-1(2), FY '81
Title: A Modular Approach to On-Board, Automatic Data Collection Systems--Seminar

Research Agency: In Developmental Stage
Principal Investigator:

Effective Date: (9 months)
Completion Date:
Revised Completion Date:

AGENCY PERFORMANCE

1. Is the project on schedule? Percent project complete:
2. Is the research in keeping with the approved research plan?
3. Subcontract Amount:
4. Estimated Expenditures to:
5. Are the expenditures in keeping with the project progress?

PROJECT DESCRIPTION

NCTRP Project 39-1 demonstrated the potential for using a modular approach to automatically collect data on board transit buses. The findings of this project have been published in National Cooperative Transit Research & Development Program Report 9, "Modular Approach to On-Board Automatic Data Collection Systems." The report contains technical specifications for various modular units and for the totally configured system on board a bus. Guidelines to help the practitioner evaluate the utility of automatically collecting data and to assist in the design and implementation of automatic data collection on a systemwide basis are also provided.

The recommended modular configuration is intended to provide flexibility to transit agencies and encourage competition in the marketplace. A truly modular system permits step-by-step implementation, which may be required by budget constraints or perceived present needs. A modular approach also provides the capability to accommodate unforeseen future data requirements or to update modules without the need to redesign or purchase an entirely new system. However, because a universally applicable modular approach is not now standardized, implementation of the concept will require agreement among at least several transit agencies or manufacturers, or preferably both. Specific agreement will also be necessary on a standard interface to allow the greatest degree of flexibility in the selection of the various modules.

The objective of Project 39-1(2) is to provide a forum for the discussion and advancement of the planning techniques and the modular approach for on-board automatic data collection systems for transit buses as reported in National Cooperative Transit Research & Development Program Report 9. To accomplish this objective, at least the following tasks are envisioned.

Task 1. Plan and make all preparations for the seminar that will include transit users and the manufacturers or suppliers of automatic fare and passenger data collection equipment including associated hardware and software. Contact with the American Public Transit Association (APTA) and the Urban Mass Transportation Administration (UMTA) should be made for any additional support their organizations could provide. (For example, this seminar could be conducted in conjunction with other meetings attended by participants having similar interests.) This task will include making announcements to potential seminar participants with NCTRP approval and making arrangements for the seminar facilities.

Task 2. Provide the agenda and prepare all seminar materials, such as audiovisual aids and handouts. (A supply of NCTRP Report 9 copies can be provided by TRB for the participants.) The NCTRP will be given the opportunity for prior review of all seminar material.

Task 3. Conduct the seminar. It is expected that the seminar will include not only presentation but working type sessions to assess the findings of NCTRP Report 9 and draw conclusions for needed future activity.

Task 4. After completion of the seminar the contract research agency will provide a copy of all seminar material, a summary of the seminar, and conclusions and recommendations drawn from the seminar as a result of the contract research agency's overall evaluations. Documentation of this task will constitute the final report.

Funds Available: \$26,213

PROBABILITY OF SUCCESS:

REPORT(S) AVAILABILITY

PRINCIPAL INVESTIGATOR(S)

RESPONSIBLE NCTRP STAFF ENGINEER: Crawford F. Jencks - 202//334-3224

AREA FORTY: IMPACT ANALYSIS

Project: 40-2, FY '82/'83
Title: Estimating Incremental Costs of Bus-Route Service Changes

Research Agency: System Design Concepts, Inc.
Principal Investigator: Harry S. Cohen

Effective Date: November 15, 1983
Completion Date: August 14, 1985
Revised Completion Date: January 31, 1986

AGENCY PERFORMANCE

1. Is the project on schedule? No* Percent project complete: 70
2. Is the research in keeping with the approved research plan? No*
3. Subcontract Amount: \$150,000
4. Estimated Expenditures to 6/30/85: \$101,700
5. Are the expenditures in keeping with the project progress? Yes

*Project is 5 months behind schedule because of delays in gaining transit agency participation in the testing, Task E. In the absence of UMTA funding for transit agencies to participate, it has been necessary to identify volunteers and to reduce the scope of testing. Further delays have occurred due to necessary reliance on transit agency testing. The project is expected to be completed within budget.

PROJECT DESCRIPTION

In the face of continuing financial pressure on and within the transit industry it is increasingly important to allocate resources in the most effective manner. Accordingly, a better understanding of the cost changes accompanying both service expansions and reductions is required.

To this end, various costing techniques have been developed and used by transit agencies to estimate the incremental or extra transit costs that stem from either service reductions or increases. Thus far there is some doubt about the reliability, accuracy, and applicability of these techniques, especially with respect to bus route (as opposed to system) changes. As a consequence, there is a need to assess and validate available or improved techniques to provide simple, but more reliable and accurate, methods for estimating the incremental (or additional variable) costs stemming from service changes on bus routes.

The objective of this research is to develop simple, reliable procedures that permit transit agencies to estimate the incremental cost implications of various bus-route-service changes in a variety of operating environments (e.g., those of differing density, system size, and the like). In a broad context, it should provide a means for helping to address the question: If a specific service should be changed, what is the incremental change in cost? More specifically, it should provide procedures that identify the incremental short-run costs to transit agencies of changes in bus-route-service frequencies (seasonal, day of week, time of day), expanding, curtailing or eliminating routes, or changing periods of operation. The research should also build upon and extend previous cost-analysis studies.

The research approach will involve, but not necessarily be limited to, the following.

A. Identify and evaluate existing cost models (including those listed in the following citation: Booz-Allen Inc., "Bus Route Costing Procedures: A Review," UMTA Report No. IT-09-9014-81-1, May 1981. Available from the National Technical Information Service, Springfield, Va 22161, NTIS No. PB-82-105198, cost \$13.00).

B. Review/update current industry practice (this should consist of polling properties to determine the models (or rules of thumb) that they currently use).

C. Develop simplified incremental cost estimation procedures. Criteria suggested are:

1. Simplicity (emphasis should be on a reasonable level of accuracy with a limited number of variables, and be easy to compute and apply).
2. Minimization of data collection requirements.
3. Wide range application in terms of system size, type, route, and type of changes.
4. Easy update of the cost variables to reflect expected changes in component costs.
5. Design that facilitates the orientation of key staff (scheduling, maintenance, and others) to incremental costing methods.
6. Design that lends itself to intuitive interpretation of results so that it is easy to explain to decision-makers and is viewed as reflecting reality by transit staff.
7. Design that is disaggregate in nature so that it can be used to evaluate individual routes or frequency changes.
8. Consideration of the effects of fixed and variable costs, different management operating policies, different contract work rules, different service contracting procedures, and cost changes that occur both before and after rescheduling.

D. Prepare an interim report that summarizes the findings for review by the NCTRP.

Project 40-2 continued

E. Develop and implement a testing method for validating the proposed procedure(s) and comparing the results with those for existing procedures. Consideration should be given to existing procedures, such as the two-variable cost model (bus-hours and miles), the Adelaide model, the Booz-Allen model developed from the UMTA bus-route-costing study, and the procedure currently being used by the participating study agency. It is anticipated that the procedure will be tested at three transit agencies--a large agency (over 200 buses), a medium-sized agency (100 to 200 buses), and a small rural Section 18 agency (less than 100 buses). As a minimum the testing should address the following types of bus-service changes:

1. Effect of service changes at various times of day, days of week, and season.
2. Effect of route extensions or contractions.
3. Effect of route consolidations, additions, and deletions.
4. Effect of service frequency changes.
5. Effect of hours of service changes.

It is desirable that the incremental cost be measured both before and after run and driver assignments. Testing refinement should be done iteratively as appropriate.

F. Identify planning - policy implications and develop typical applications.

1. Show how procedures can help (a) assess service alternatives, including deficit/revenue implications; and (b) make strategic service change decisions.
2. Give sample prototypical applications of procedures.

G. Prepare a draft report for review by the NCTRP.

H. Revise the draft report and submit the final version in fulfillment of the technical obligations under the contract for the project.

STATUS OF RESEARCH

Tasks A through D have been completed and are documented in the Interim Report noted below. Important cost concepts and their relationship to costing problems faced by transit agencies have been defined. An overview of available models, including those developed as part of a recently completed UMTA-sponsored study, has been provided. The results of a survey of transit agencies, which was conducted for Task B, is presented. Among other things, the survey developed information on methods currently in use, problems with these methods, and suggestions for improvements. Simplified procedures have been developed as part of Task C. These include three procedures for estimating the effects of bus route service changes on driver costs and a fourth procedure for estimating non-driver incremental costs associated with service changes. Agency participation from three agencies in Task E has been obtained with some difficulty inasmuch as intended UMTA funding for the agencies has not materialized. The number of testing situations (service changes) has been reduced from 60 to 20 in order to match volunteered, transit-agency resources. Testing is nearly complete at two agencies and will be conducted at the third agency in the next reporting period. The agency anticipates completing the project as modified within present financial resources.

AMENDMENT(S) THIS REPORTING PERIOD

<u>Date</u>	<u>No.</u>	<u>Type</u>	<u>Amounts and/or Dates (From - To)</u>	<u>Comments</u>
7/24/85	1	Time	8/14/85 - 1/31/86	See "Status of Research" section

PROBABILITY OF SUCCESS: Fair, because of the necessary cutback on the Task E work due to agencies having to volunteer resources.

REPORT(S) AVAILABILITY: "Estimating Incremental Costs of Bus-Route Service Changes" Interim Report developed in Task D. Available only on a loan basis from the Program Director, NCTRP.

PRINCIPAL INVESTIGATOR(S): Mr. Harry S. Cohen
Vice President
System Design Concepts, Inc.
One Farragut Square South
Suite 200
Washington, DC 20006
202/393-5910

RESPONSIBLE NCTRP STAFF ENGINEER: R. Ian Kingham - 202/334-3224

AREA FORTY: IMPACT ANALYSIS

Project: 40-3, FY '82/'83
Title: Strategies to Implement Benefit-Sharing for Fixed Transit Facilities

Research Agency: SG Associates, Inc.
Principal Investigator: Jane Howard

Effective Date: November 1, 1983
Completion Date: February 1, 1985

AGENCY PERFORMANCE

1. Is the project on schedule? Yes Percent project complete: 100
2. Is the research in keeping with the approved research plan? Yes
3. Subcontract Amount: \$99,957
4. Estimated Expenditures to 6/30/85: \$99,957
5. Are the expenditures in keeping with the project progress? Yes

PROJECT DESCRIPTION

Fixed transit facilities, such as transit terminals, rapid transit stations, and LRT lines and stops, generate substantial passenger traffic and improved accessibility. Consequently, space in the vicinity of such facilities may become more valuable because of its potential for higher intensity use. Opportunities for sharing benefits occur in the development of new transit facilities, the direct connection of developments to transit facilities, the use of air rights over transit rights-of-way, and the development of other real estate holdings. Furthermore, as a consequence of building fixed transit facilities, various other public facilities and utilities are rehabilitated. These opportunities for benefit-sharing by transit agencies are frequently lost, however, because they are not an important consideration in the planning and design phases (i.e., in the location and design of routes and stations).

There is little quantitative information available to transit agencies to assist them in formulating benefit-sharing approaches and arriving at reasonable charges or other contributions for these transit benefits. Therefore, in order to assist operators in planning and financing transit facilities, there is a need to provide (1) information about existing practices, (2) insights into the development process, (3) guidance in relating to private and public sector beneficiaries, and (4) strategies for negotiating benefit-sharing.

The general objective of this research is to assist transit agencies in implementing benefit-sharing. To accomplish this objective, a synthesis of existing information on development-related benefits followed by case studies is required. The report will be written primarily for use by transit planners, operators, and designers, and will reflect the concerns of policy-makers (government officials) and business organizations.

Following is a suggested three-part research approach. Part I, addressing items 1 through 6 and comprising not more than one-third of the research effort, consists of a broad-based investigation of the development impacts of fixed transit facilities. It is to be based on a review of the literature and current practice, and will conclude with an interim report. Part II, pertaining to items 7 and 8 and comprising one-third to one-half of the research effort, covers an in-depth study of experiences in implementing benefit-sharing. Part III, consisting of items 9, 10, and 11 and comprising the balance of the research effort, entails (1) the development of generalizations from the interim report and case studies, and (2) preparation of the draft and final reports.

Part I

1. List fixed transit facilities likely to produce benefits to organizations in the public and private sectors. Include rail and bus stations as well as LRT lines/stops.
2. Identify and describe the benefits. These benefits may accrue to property owners and businesses as increases in land value and economic activity. They may also be realized by the public in the form of improved streets and traffic circulation, reconstructed utilities, provision of transit rights-of-way, and new recreation facilities.
3. Describe methods to measure benefits.
4. Identify and describe such benefit-sharing techniques as those provided in the following four categories:
 - a. Planning and Acquisition
 - (1) Contributing of land for rights-of-way, stations, and parking facilities by developers or townships.
 - (2) Purchasing of extra land for land-banking (e.g., for later conversion of parking into more intensive land use).
 - (3) Selling air rights.
 - (4) Sharing facilities (e.g., parking in shopping centers, intercity transit terminal).

Project 40-3 continued

- b. Design and Construction
 - (1) Providing concession facilities.
 - (2) Constructing station accesses by developers.
 - (3) Constructing special features by developers (e.g., lighting, plazas, escalators, LRT platforms).
 - (4) Locating and designing facilities to preserve development options.
 - c. Public Infrastructure
 - (1) Rehabilitating utilities.
 - (2) Improving street reconstructing and beautification, plazas, malls, etc.
 - (3) Improving traffic through intersection channelization, pedestrian underpasses, skywalk systems, etc.
 - (4) Establishing parks and recreational areas.
 - d. Special Financial Arrangements
 - (1) Creating special assessment districts.
 - (2) Establishing tax increment financing.
5. Identify transit agencies that have attempted or are attempting to share transit costs with private and public beneficiaries. Transit agencies should be described by at least (1) organizational context (ownership and operation), (2) benefit-sharing techniques, (3) transit system characteristics, (4) benefit assessment techniques, and (5) character of local economy. Proposed case studies, four of which should be concerned with each of the four benefit-cost categories noted in item 4.
6. Prepare the Interim Report (addressed earlier) on items 1 through 5.

Part II

7. Select Transit agencies for an in-depth study of successes and failures in benefit-sharing. Prepare the interview design and conduct the case studies.
8. Evaluate experience with benefit-sharing to identify elements contributing to or impeding implementation.

Part III

9. Develop recommendations for transit agencies to follow in implementing benefit-sharing practices.
10. Prepare a draft report for review by the NCTRP.
11. Revise the draft report and submit the final version in fulfillment of the technical obligations under the contract for the project.

STATUS OF RESEARCH

Research is complete and the final report published as noted below. The research concluded that many opportunities for benefit-sharing exist, and that techniques are increasingly being pursued in all parts of the country. The major recommendations were centered around the need for transit agencies to establish some level of internal expertise in land use, development, and finance so that the agency can both identify opportunities and interact more effectively with local planning agencies and the private sector.

Several caveats about the contribution of benefit-sharing to transit finance were noted. First, benefit-sharing can contribute only a small total financial benefit. Private monies are most likely to fund enhancements to the system which are perceived as a direct site-specific benefit by property owners. Second, public agencies must be credible in terms of delivering promised construction to secure private investment, and businesslike in dealing with the private sector. Finally, in an era where many local agencies are competing for scarce funds, the transition from a philosophy of using Federal funds as a catalyst for urban revitalization to using private funds to decrease the Federal share is likely to be difficult in most urban areas.

AMENDMENT(S) THIS REPORTING PERIOD

None

PROBABILITY OF SUCCESS: Excellent

REPORT(S) AVAILABILITY: "Strategies to Implement Benefit-Sharing for Fixed-Transit Facilities," NCTRP Report 12 (see final page of this document for ordering information).

PRINCIPAL INVESTIGATOR(S) Mrs. Jane Howard
 SG Associates, Inc.
 316 Stuart Street
 Boston, MA 02116
 617/542-1416

RESPONSIBLE NCTRP STAFF ENGINEER: R. Ian Kingham - 202/334-3224

AREA FORTY-SIX: GENERAL DESIGN

Project: 46-1, FY '82/'83
Title: Single Cable Communications Technology for Rail Transit Systems

Research Agency: Polytechnic Institute of New York
Principal Investigator: Dr. Frank A. Cassara

Effective Date: May 1, 1984
Completion Date: July 31, 1985
Estimated Completion Date: August 31, 1985

AGENCY PERFORMANCE

1. Is the project on schedule? No* Percent project complete: 92
2. Is the research in keeping with the approved research plan? Yes
3. Subcontract Amount: \$150,000
4. Estimated Expenditures to 6/30/85: \$125,000
5. Are the expenditures in keeping with the project progress? Yes

*See "Status of Research" section

PROJECT DESCRIPTION

Rail-transit systems vary from those that have been in existence since the early 1900's to systems presently under design. These systems have typically used, or are planning the use of, multiple cables for the transmission of voice, data, and video information. The various cables provide for long-haul trunk facilities and access to local distribution networks. Additionally, the necessity for VHF or UHF-FM radio transmissions in underground portions of the system may require a separate radiating (or leaky) coaxial cable.

The large numbers of multipair and special-use cables used are expensive to install and maintain. A reduction in the number of cables needed for the communication requirements of transit systems can result in reduced acquisition, installation, and maintenance costs. The ultimate goal of this research is to replace all special-use cables with a single, multipurpose cable.

The objective of this research is to identify and develop recommended system parameters that will permit use of a single, multipurpose, wideband cable to support all rapid-transit communications requirements including, but not limited to: voice, data, video as well as VHF or UHF-FM two-way radio signals. For reliability, the single-cable concept should allow for a backup cable and cable span switching equipment. This research proposes a nonsite-specific solution that considers retrofits and extensions to existing rail-transit systems as well as the requirements of new systems. Proposed solutions to the reduction in the number of cables should include consideration of coaxial cables, fiber optics, and other viable technologies. Any proposed solution must also take into account compatibility with existing communications equipment and systems, improved reliability and maintainability, reduced life-cycle costs, and system expansion (extension and spare capacity).

To accomplish the objective of this research, at least the following tasks are required:

Task 1. Survey the current communication systems and installation practices of rail-transit agencies to define the scope of the problem. (Some information on North American systems may be available at APTA.) Concurrently, survey the electronic industry for developments that offer potential solutions. Review the work of railroad, mining, and other industries that may be relevant to the problem and its solution.

Task 2. Establish the operational parameters that will be required for a single-cable communication system(s). Generate a range of technical characteristics that will define the nature of the proposed cable system(s) and its (their) configurations.

Task 3. Using the operational parameters and cable characteristics developed in Task 2, prepare design criteria to establish the technical and economic feasibility of the single-cable concept. Submit a fully documented feasibility study showing all alternatives studied and the recommended solution(s) for review and approval by the NCTRP. (Twenty (20) copies of the study report shall be submitted within 7 months after the beginning date of the contract period. NCTRP approval will be required before the initiation of subsequent tasks. It is anticipated that the necessary review and approval will be completed within 2 months after receipt of report.)

Task 4. Using design criteria established in Task 3, prepare a system description in sufficient detail so that user agencies can prepare procurement specifications for specific applications. In addition, prepare a sample system design for a hypothetical 10-mile rail-transit system (5 miles underground and 5 miles on the surface) that includes basic equipment elements, local distribution networks, and its attendant costs.

Task 5. Prepare a draft report for review by the NCTRP.

Task 6. Revise the draft report and submit the final version in fulfillment of the technical obligations under the contract for the project.

Project 46-1 continued

STATUS OR RESEARCH

The agency's preliminary draft final report has been submitted and is now under review by the NCTRP. The primary recommendation for the single cable concept is a "closed loop fiber optic" system. If a rail transit system includes tunnels, a suggestion is made to place the optical fibers within the inner conductor of a leaky coaxial cable to also accommodate VHF FM transmissions and, yet, maintain the single cable concept. A hypothetical system description and design are also provided. Progress on the project is approximately one month behind -- considered to be a minor situation. A relatively early and successful completion of the project is expected.

AMENDMENT(S) THIS REPORTING PERIOD

None

PROBABILITY OF SUCCESS: Good

REPORT(S) AVAILABILITY: None

PRINCIPAL INVESTIGATOR(S): Dr. Frank A. Cassara
Polytechnic Institute of New York
333 Jay Street
Brooklyn, NY 12201
516/454-5075

RESPONSIBLE NCTRP STAFF ENGINEER: Crawford F. Jencks - 202/334-3224

AREA FORTY-SEVEN: GENERAL MATERIALS

<u>Project:</u>	47-1, FY '80
<u>Title:</u>	Improved Service Life of Urban Transit Coach Brakes
<u>Research Agency:</u>	Battelle Memorial Institute
<u>Principal Investigator:</u>	Dr. Allen T. Hopper
<u>Effective Date:</u>	December 1, 1981
<u>Completion Date:</u>	November 30, 1983
<u>Revised Completion Date:</u>	December 30, 1984
<u>Estimated Completion Date:</u>	October 31, 1985

AGENCY PERFORMANCE

1. Is the project on schedule? No* Percent project complete: 98
2. Is the research in keeping with the approved research plan? Yes
3. Subcontract Amount: \$300,000
4. Estimated Expenditures to 6/30/85: \$295,000
5. Are the expenditures in keeping with the project progress? Yes

*See "Status of Research" section.

PROJECT DESCRIPTION

The operation and maintenance history of advanced design urban transit coaches shows a dramatic decline in brake life compared with "new look" coaches. Major factors associated with this decline in brake life appear to be, but are not limited to: increased gross vehicle weight, increased operating speed, body configuration, and changed regulations.

The resultant increased brake temperatures are believed to be the cause of reduced brake life that has increased operational costs to unacceptable levels. Therefore, the need exists to identify and develop methods to increase brake life to previous levels.

The overall project objective is to develop methodologies for improving existing and future urban transit coach brake life. This will include quantification of in-service brake operating temperatures plus identification of methods of reducing brake operating temperatures and/or alternate friction materials.

The project objective was accomplished in two phases. Phase I included the following tasks:

Task 1--Confirmation of the premise that temperature is the cause of reduced brake life by the collection and evaluation of brake operating temperatures. This is to be accomplished in cooperation with a major metropolitan transit operator that has experienced the problem. As a minimum, temperature levels will be established for advanced design and early "new look" transit coaches.

Task 2--Development of practical methods for reduction of operating temperatures and/or identification of friction materials for compatibility with the service temperatures determined in Task 1. The following factors must be considered: (a) adaptability to coaches in service, (b) initial and operating costs, (c) regulations, (c) serviceability, (e) reliability, (f) public acceptability, and (g) feasibility.

Task 3--Cost-benefit prioritization of methods for increasing brake life based on Tasks 1 and 2.

Task 4--Preparation of an interim report with recommendations for implementation of Phase II demonstration.

The Phase II effort included:

Task 5--Demonstration of one or more suggested corrective methods selected by the NCTRP from those recommended in Phase I. This will be accomplished in cooperation with a major metropolitan transit operator.

Task 6--Preparation and submittal of the final report.

STATUS OF RESEARCH

Research has been completed with accomplishment of project objectives in terms of confirming the premise that increases in brake lining temperature have resulted in reduced brake life and of identifying procedures for reducing brake lining temperature on existing buses. However, the retrofitting of existing buses with air blowers to reduce brake temperatures was found to be only marginally cost effective and the further development of brake lining materials having better temperature wear properties should continue to be explored. The final report is in the review and revision process. Because of the desire to obtain additional bus and brake industry review comments on the preliminary draft report, a contract amendment extending the completion date to October 31, 1985 will be necessary.

Project 47-1 continued

AMENDMENT(S) THIS REPORTING PERIOD

None

PROBABILITY OF SUCCESS: Research has been completed with accomplishment of objectives.

REPORT(S) AVAILABILITY: None

PRINCIPAL INVESTIGATOR(S): Dr. Allen T. Hopper
Structural Materials & Tribology Section
Battelle Memorial Institute
Columbus Laboratories
505 King Avenue
Columbus, OH 43201
614/424-6424

RESPONSIBLE NCTRF STAFF ENGINEER: Harry A. Smith - 202/334-3224

AREA FORTY-EIGHT: SPECIFICATIONS, PROCEDURES, AND PRACTICES

Project: 48-1, FY '84
Title: Corrosion Attributed to DC Powered Transit Systems

Research Agency: In Developmental Stage
Principal Investigator:

Effective Date: (15 months)
Completion Date:

AGENCY PERFORMANCE

1. Is the project on schedule: Percent project complete:
2. Is the research in keeping with the approved research plan:
3. Contract Amount:
4. Estimated Expenditures to:
5. Are the expenditures in keeping with the project progress:

PROJECT DESCRIPTION

Structural damage to transit system properties and neighboring underground facilities due to corrosion caused by DC stray currents is a significant, persistent problem. Existing procedures and materials for prevention or mitigation are not sufficiently effective. The transit industry needs authoritative work that summarizes existing knowledge of damage caused by DC stray currents. Furthermore, there is a need to demonstrate the enormity of the problem and to design a research program that can provide cost-effective prevention and mitigation procedures.

The primary objectives of this research are to document and call attention to the severity of the corrosion problem caused by DC stray currents in terms of its economic, public safety, institutional and liability dimensions; to develop practical recommendations to transit agencies based on today's knowledge; and to design a research program to provide cost-effective solutions. Emphasis should be given to quantifying the dimensions to develop credibility. Furthermore, the research should stimulate coordination between key institutions involved in the DC stray current corrosion problem.

The following tasks are suggested.

Task 1. Review, together with significant unpublished reports in rail transit agencies, published literature from both North America and abroad. Such a review should include literature concerned with stray current corrosion problems stemming back to the turn of the century for DC powered rail transit systems. Significant issues with respect to economics, public safety, institutions, and liability should be identified and priorities developed. From the review, elements of effective practice in such areas as track and structure construction, power system configuration, negative return and grounding, and corrective methods to reduce stray current magnitudes should be identified and evaluated. Prepare a report synthesizing this information for use by transit agencies.

Task 2. Conduct an in-depth study of four transit agencies, and neighboring underground facilities, to document the severity of the problem in terms of economics, public safety, involved institutions, and liability. Furthermore, the study should identify agency practices to prevent or mitigate the problems. Consideration should be given to Boston, Chicago, Washington, and Toronto to provide a range of age and type of rail systems.

Task 3. Integrate the results of Task 2 into the report developed in Task 1.

Task 4. Develop a plan and conduct a workshop to serve the following purposes:

- a. Promulgation and review of the report.
- b. Development of practical recommendations to transit agencies.
- c. Development of a research action plan that reflects problems faced by neighboring institutions (such as utilities and agencies owning underground structures) affected by stray currents. Identify means and stimulate joint institutional support for such research. The plan should identify research projects and provide estimates of times and costs.

Task 5. Prepare reports to serve the following purposes:

- a. To call to the attention of transit and business executives, governmental officials, and the media, the stray current corrosion problem.
- b. To present practical recommendations for improving transit industry practice for preventing and mitigating stray current corrosion.
- c. To provide an annotated bibliography defining areas of importance for important engineering references on the subject matter.
- d. To present the research action plan that identifies means for interagency coordination and institutional support together with the identification of research projects.

Project 48-1 continued

Funds Available: \$200,000

AMENDMENT(S) THIS REPORTING PERIOD:

PROBABILITY OF SUCCESS:

REPORT(S) AVAILABILITY:

PRINCIPAL INVESTIGATOR(S):

RESPONSIBLE NCTRP STAFF ENGINEER: R. Ian Kingham - 202/334-3224

AREA FIFTY-FIVE: PERFORMANCE, EFFECTIVENESS, AND EFFICIENCY

Project: 55-1, FY '82/'83
Title: Conversion to One-Person Operation of Heavy-Rail Rapid-Transit Trains

Research Agency: Battelle Memorial Institute, Columbus Laboratories
Principal Investigator: Joseph A. Hoess

Effective Date: May 5, 1984
Completion Date: April 4, 1985
Revised Completion Date: October 31, 1985 *

AGENCY PERFORMANCE

1. Is the project on schedule? No* Percent project complete: 95
2. Is the research in keeping with the approved research plan? Yes
3. Subcontract Amount: \$150,000
4. Estimated Expenditures to 6/30/85: \$143,700
5. Are the expenditures in keeping with the project progress? Yes

*The research agency was unable to begin work on the effective date and has been further delayed on account of illness of the principal investigator. The contract was amended for a 3-month time extension at no increase in cost and is expected to be amended again to October 31, 1985 because of delays in obtaining reviews of the final report.

PROJECT DESCRIPTION

There is increasing pressure to provide more cost-effective operation of heavy-rail rapid-transit trains. A major candidate for improving productivity is reduction of crew size to one person. This has been accomplished in the following systems:

- Lindenwold/Philadelphia--Port Authority Transit Corporation
- San Francisco--Bay Area Rapid Transit District
- Washington, DC--Washington Metropolitan Area Transit Authority
- Atlanta--Metropolitan Atlanta Rapid Transit Authority

The reduction will soon be implemented in Miami and Baltimore.

The older rapid transit systems, however, continue to require a second crew member aboard each train. These systems include the following:

- Boston--Massachusetts Bay Transportation Authority
- New York--New York City Transit Authority
- New York/New Jersey--Port Authority Trans-Hudson Corporation
- Philadelphia--Southeastern Pennsylvania Transportation Authority
- Cleveland--Greater Cleveland Regional Transit Authority
- Chicago--Chicago Transit Authority

To provide one-person operation on the older rapid transit systems, it will be necessary to address problems at least in the areas of:

1. Operational safety.
2. Operational practices.
3. Manpower/labor relations.
4. Regulatory matters.
5. Plant and equipment.

The objectives of this research are (1) to evaluate the issues that must be addressed in contemplating conversion of two-person systems to one-person operation including the identification of those issues unique to the particular system and (2) to develop a framework for an economic assessment of the effects of implementation of one-person operation. The research should include, but not be limited to, the following tasks:

Task 1. Perform a survey of each two-person heavy-rail rapid-transit system in the United States to determine the specific issues or problems that need to be addressed if such system were to be converted to one-person train operation. This survey shall be based on consultation with organizations including system management, employee representatives, regulatory agencies or advisory boards, and other appropriate organizations.

Project 55-1 continued

Task 2. Perform a survey of one-person conversions implemented by heavy-rail rapid-transit systems in Europe and identify the issues and problems addressed; the methods of solving them; and the effectiveness of such solutions as measured by such indicators as operational efficiency and reliability, safety statistics, and changes in the workforce. These systems shall include, but not be limited to, London, Paris, Hamburg, and Berlin.

Task 3. Evaluate the issues and problems identified in Tasks 1 and 2 as they would affect the conversion to one-person operation from the technological, operational, institutional, and human resource perspectives. The evaluation shall include the need for, and degree of, recommended application of closed-circuit TV, automatic train operation, radio communications, and other elements.

Task 4. Prepare a framework for an economic assessment of the effects of implementation of one-person operation. This framework shall include identification of cost elements that must be considered in a site-specific analysis and plan such as:

- a. Changes to car equipment.
- b. Changes to wayside and station equipment.
- c. Changes in workforce, such as reduction in train crews and additions to wayside equipment maintenance staff.
- d. Operating practice revisions.
- e. Changes in wage rates resulting from implementation of one-person operation.

STATUS OF RESEARCH

Research is complete and the preliminary draft report is being reviewed. The economic analysis framework has been developed.

PROBABILITY OF SUCCESS: Excellent

AMENDMENTS THIS REPORTING PERIOD

None

REPORT(S) AVAILABILITY: None

PRINCIPAL INVESTIGATOR(S):

RESPONSIBLE NCTRP STAFF ENGINEER: R. Ian Kingham - 202/334-3224

AREA SIXTY: SPECIAL PROJECTS

Project: 60-1, FY '80 and continuing
Title: Synthesis of Information Related to Transit Problems

Research Agency: Transportation Research Board
Principal Investigator: Mr. Thomas L. Copas

Effective Date: November 7, 1980
Completion Date: Continuing

AGENCY PERFORMANCE

1. Is the project on schedule? Yes Percent project complete: *
2. Is the research in keeping with the approved research plan? Yes
3. Subcontract Amount: FY '84 \$200,000
4. Estimated Expenditures to 6/30/85: \$140,000
5. Are the expenditures in keeping with the project progress? Yes

*Project is carried out on a continuing basis with new topics being incorporated each year. See below for status of each topic.

PROJECT DESCRIPTION

Transit administrators, engineers, and researchers are continually faced with problems on which much information already exists either in documented form or in terms of undocumented experience and practice. Unfortunately this information is often fragmented, scattered, and unevaluated. As a consequence, full information on what has been learned about a problem is frequently not brought to bear on its solution. Costly research findings may be unused, valuable experience may be overlooked, and due consideration may not be given to recommended practices for solving or alleviating the problem.

In this project, particular transit problems, or sets of closely related problems, will be selected by the NCTRP Technical Steering Group as topics for information syntheses.

For each topic the objectives are:

1. To locate and assemble documented information.
2. To learn what practice has been used for solving or alleviating the problem.
3. To identify all ongoing research.
4. To learn what problems remain largely unsolved.
5. To organize, evaluate, synthesize, and document the useful information that is acquired.

STATUS OF RESEARCH

Thirteen synthesis topics have been referred to Project 60-1 during the first four years of NCTRP. Studies on the first four topics have been completed, and the remaining nine are in various stages of progress. The operations, procedures, and status of the synthesis program are summarized in NCTRP Research Results Digest 2, published in December 1984.

The four published syntheses of transit practice prepared under this project are listed in Table II of this progress report. The topics of concern and the status of each as of June 30, 1985, are:

TS-5 -- Extraboard Management: Procedures and Tools

Topic Consultant: L. C. MacDorman; Arlington, Virginia
 Effective Date: November 21, 1983
 Expiration Date: September 30, 1984

When an open run occurs in a transit system, the extraboard clerk has several choices: fill it with an extraboard or part-time person, fill it with an operator working overtime on a regular day off, or leave the run open. The synthesis will survey transit agencies that have a structured extraboard management system to determine the complexities encountered, development costs, potential and actual benefits, etc. Research has been completed and the report is in the editorial process (Synthesis 5).

TS-6 -- Traffic Control and Regulation at Transit Stops

Topic Consultant: Woodrow W. Rankin; Bethesda, Maryland
 Effective Date: January 1, 1984
 Expiration Date: June 30, 1985

Project 60-1 continued

This synthesis will develop a consensus of recommended practices for signing and marking at bus stops. Conditions to be covered would include coordination of bus stop signs with traffic control signs, far and near side stops, minimum signing in residential areas, signing in areas without curbs and shoulders, coordination with bicycle paths, part-time stops, and coordination with exclusive bus lanes. The first draft of the synthesis has been reviewed by the Topic Panel and the Consultant is preparing a revised draft.

TS-7 -- Bus Communications Systems

Topic Consultant: Peter Wood; MITRE Corporation; McLean, Virginia
 Effective Date: November 21, 1983
 Expiration Date: June 30, 1985

Transit agencies face difficult problems in procuring, installing, and maintaining bus communication systems. The synthesis will include detailed information on equipment, personnel training, design, cost, source of funds, installation, warranty, maintenance, problems, effectiveness, benefits, and unique features. The ability of the communications system to enable the transit agency to meet its operating objectives will also be considered. The Consultant has submitted the final draft of the synthesis.

TS-8 -- Passenger Information Systems for Transit Transfer Facilities

Topic Consultant: J. J. Fruin; Massapequa, New York
 Effective Date: November 21, 1983
 Expiration Date: June 30, 1985

Currently, policies, guidelines, or principles for signing and information systems for transit transfer facilities vary widely. A transit transfer facility serves the role of interfacing between two or more modes or from one vehicle to another. The synthesis deals with those aspects of passenger information required in order to make the transfer safely and with minimal effort. The final draft of the synthesis has been reviewed, and will be in the editorial process in July.

TS-9 -- Transit Fare Collection: Problems with and Alternatives to Paper Currency

Topic Consultant: Lawrence Deibel; MITRE Corporation; McLean, Virginia
 Effective Date: December 2, 1983
 Expiration Date: December 31, 1984

Although most transit systems are fully equipped to accept coins, existing fare collection equipment and revenue handling procedures are inadequate for dealing with paper currency. The synthesis will identify, coordinate, and assess current activity addressing bill-handling problems and solutions including alternatives that preclude on-board use of paper currency. This topic, which was originally NCTRP Project 56-1, was referred to Project 60-1 to be carried out as a synthesis when the panel for Project 56-1 met on April 18-19, 1983. Research has been completed and the report is in the editorial process (Synthesis 6).

TS-10 - Use of Part-Time Operators

Topic Consultant: L. C. MacDorman; Arlington, Virginia
 Effective Date: September 16, 1984
 Expiration Date: September 30, 1985

Part-time operators may decrease costs for transit agencies. The synthesis will identify how transit agencies are using part-time operators, including contract constraints, run-cutting methods used to allocate part-time operators, and relationship of service needs to benefits of using part-time operators, and will develop guidelines for evaluating the use of part-time operators. The first draft of the synthesis has been reviewed by the Topic Panel and the Consultant is preparing a revised draft.

TS-11 - Transit Marketing: Successes and Failures

Topic Consultant: Richard L. Oram; New York, New York
 Effective Date: September 16, 1984
 Expiration Date: September 30, 1985

Many transit agencies have undertaken various marketing programs. The synthesis will include successful and unsuccessful aspects of these programs and will cover the importance of marketing and the use of price, service, and promotion in marketing, with emphasis on promotion. The first draft of the synthesis has been reviewed by the Topic Panel and the Consultant is preparing a revised draft.

Project 60-1 continued

TS-12 - Use of Incentives to Attain Specified Performance Standards in Collective Bargaining for Mass Transit

Topic Consultant: Darold T. Barnum; University of Illinois; Chicago, Illinois
 Effective Date: December 15, 1984
 Expiration Date: November 30, 1985

Some transit agencies have employee incentive programs that provide for awards based on attainment of specified performance standards. The synthesis will examine use of incentives as related to system performance, identify conditions and attitudes necessary for use of incentive programs, and discuss how to analyze a system to see if an incentive program will work. The consultant is collecting information for the synthesis.

TS-13 - Bus Inspection Guidelines

Topic Consultant: Clarence I. Giuliani; Maple Glen, Pennsylvania
 Effective Date: November 1, 1984
 Expiration Date: October 31, 1985

Bus inspection programs are the cornerstone of an effective vehicle preventive maintenance program. The synthesis will include information on frequency of inspections, use of prerun inspections, items included in the inspection process, organization for inspection, effect of work rules, record-keeping, facilities and equipment, and reinspection. The consultant has submitted the first draft of the synthesis, which will be reviewed by the Topic Panel at a meeting in July.

AMENDMENT(S) THIS REPORTING PERIOD

None--Continuing Project

PROBABILITY OF SUCCESS: High - Experienced investigators using a proven system ensure continued success.

REPORT(S) AVAILABILITY: See Table II

PRINCIPAL INVESTIGATOR(S): Mr. Thomas Copas
 Special Projects Engineer
 Transportation Research Board
 National Academy of Sciences
 2101 Constitution Avenue, N.W.
 Washington, DC 20418
 202/334-3242

RESPONSIBLE NCTRP STAFF ENGINEER: Harry A. Smith - 202/334-3224

HOW TO ORDER

Items for Sale

1. NCTRP Series Reports, Syntheses, and Research Results Digests (see Tables II and III for prices).
2. Research agencies' final reports (see project summaries for prices).
3. Microfiche (\$5.00 per report).
4. Other TRB publications.

A check or money order, payable to *Transportation Research Board*, must accompany orders totalling \$20.00 or less. Mail to:

Publications Office
Transportation Research Board
2101 Constitution Avenue, N.W.
Washington, D.C. 20418

Items for Loan

1. Some research agencies' final reports, manuals, videotapes, etc., are identified in the project progress reports and are available on a loan basis upon written request to the NCTRP, 2101 Constitution Avenue, N.W., Washington, DC 20418.
2. Loan requests for films and tapes should be directed to:

TRB Audio-Visual Library
Transportation Research Board
2101 Constitution Avenue, N.W.
Washington, D.C. 20418

Mailing and handling charges may be assessed, especially where 1st-class delivery is requested; an invoice will accompany the loaned item.

