



R T D

# HEADQUARTERS

GATEWAY CENTER AT UNION STATION

Owner: CATELLUS DEVELOPMENT CORPORATION 800 North Alameda Street, Suite 100 Los Angeles, California 90012 (213) 625-5865  
Owner: SOUTHERN CALIFORNIA RAPID TRANSIT DISTRICT 425 South Main Street Los Angeles, California 90013 (213) 972-4718

Architect: McLARAND, VASQUEZ & PARTNERS, INC. 695 Town Center Drive, Suite 300 Costa Mesa, California 92626 (714) 549-2207  
Planner: EHRENKRANTZ & ECKSTUT, ARCHITECTS 3780 Wilshire Boulevard Los Angeles, California 90010 (213) 252-9465  
Construction Manager: CHARLES PANKOW BUILDERS 2476 North Lake Avenue Altadena, California 91001 (213) 684-2320  
Structural: MARTIN & HUANG INTERNATIONAL, INC. 1800 Wilshire Boulevard Los Angeles, California 90057 (213) 483-4916  
Mechanical: TSUCHIYAMA & KAINO 2010 Main Street #450 Irvine, California 92714 (714) 756-0565  
Electrical: LEVINE SEEDEL ASSOCIATES 2601 Ocean Park Boulevard Santa Monica, California 90405 (213) 450-1990  
Civil: MOLLENHAUER, HIGASHI & MOORE 411 West Fifth Street Los Angeles, California 90013 (213) 624-2661



**SPECIFICATIONS**

**MTA HEADQUARTERS  
Los Angeles, California  
91-400**

**PRICING ISSUE BID DRAFT**  
**December 7, 1993**

**McLarand, Vasquez & Partners, Inc.  
695 Town Center Drive, Suite 300  
Costa Mesa, California 92626  
(714) 549-2207**

**December 7, 1993**



**TABLE OF CONTENTS**

**SPECIFICATIONS**

		<b>PAGES</b>	<b>Issue or Last Revision Date</b>
<b><u>Division 1</u></b>			
	<b><u>General Requirements</u></b>		
01010	Summary of Work	1 only	12/07/93
01015	Definitions	1 - 2	5/01/93
01020	Allowances	1 only	12/07/93
01030	Alternates	1 only	12/07/93
01050	Field Engineering	1 only	5/01/93
01060	Regulatory Requirements	1 - 2	5/27/93
01070	Abbreviations	1 - 3	5/27/93
01090	Reference Standards	1 only	5/01/93
01300	Submittals	1 - 5	5/27/93
01400	Quality Control	1 - 6	12/07/93
01450	Mock-up (By CWDC)	1 - 6	10/08/93
01500	Construction Facilities and Temporary Controls	1 - 3	5/27/93
01600	Material and Equipment	1 - 3	5/01/93
01700	Contract Closeout	1 - 4	5/01/93
01740	Warranties	1 - 4	10/05/93
<b><u>Division 2</u></b>			
	<b><u>Sitework</u></b>		
02200	Earthwork	1 - 7	5/27/93
02210	Trenching & Backfilling for Utilities	1 - 5	5/01/93
02580	Pavement Marking & Wheel Stops	1 - 2	5/01/93
<b><u>Division 3</u></b>			
	<b><u>Concrete</u></b>		
03100	Concrete Formwork	1 - 5	5/27/93
03200	Concrete Reinforcement	1 - 5	10/05/93
03300	Cast-In-Place Concrete	1 - 14	10/05/93
03360	Shotcrete	1 - 6	10/15/93
03420	Precast Structural Concrete	1 - 7	5/27/93
<b><u>Division 4</u></b>			
	<b><u>Masonry</u></b>		
04220	Concrete Masonry Units	1 - 5	5/01/93
04400	Facade Stonework (By CWDC)	1 - 23	10/08/93

		PAGES	Issue or Last Revision Date
<b><u>Division 5</u></b>			
	<b><u>Metals</u></b>		
05065	Welded Stud Connectors	1 - 5	10/05/93
05120	Structural Steel	1 - 17	10/15/93
05130	Steel Frame Support System for Stone Veneer (By CWDC)	1 - 18	10/08/93
05330	Metal Floor and Roof Decking	1 - 4	10/05/93
05410	Cold Formed Structural Steel (By CWDC)	1 - 9	10/08/93
05500	Metal Fabrications	1 - 5	12/07/93
05510	Metal Stairs	1 - 3	5/27/93
05700	Ornamental Metal	1 - 4	12/07/93
<b><u>Division 6</u></b>			
	<b><u>Woods and Plastics</u></b>		
06100	Rough Carpentry	1 - 2	5/01/93
06200	Finish Carpentry	1 - 4	5/01/93
<b><u>Division 7</u></b>			
	<b><u>Thermal and Moisture Protection</u></b>		
07115	Fluid-Applied Waterproofing	1 - 8	12/07/93
07120	Water Tank Coating	1 - 2	12/07/93
07130	Below Grade Waterproofing	1 - 8	5/27/93
07175	Water Repellant Sealer	1 - 4	12/07/93
07201	Facade Insulation & Firesafing (By CWDC)	1 - 5	10/08/93
07210	Building Insulation	1 - 2	12/07/93
07240	Insulation and Finish Systems	1 - 5	12/07/93
07255	Cementitious Fireproofing	1 - 2	10/05/93
07270	Firestopping	1 - 2	5/01/93
07550	Elastomeric Roofing	1 - 5	12/07/93
07600	Sheet Metal	1 - 4	12/07/93
07900	Caulking and Sealants	1 - 2	12/07/93
07901	Facade Sealant (By CWDC)	1 - 8	10/08/93
<b><u>Division 8</u></b>			
	<b><u>Doors and Windows</u></b>		
08110	Hollow Metal Work	1 - 4	12/07/93
08210	Wood Doors	1 - 3	12/07/93
08335	Coiling Doors	1 - 2	5/27/93
08500	Fixed Windows	1 - 26	10/08/93
08710	Finish Hardware	1 - 21	7/07/93
08800	Exterior Glass and Glazing (By CWDC)	1 - 11	10/08/93
<b><u>Division 9</u></b>			
	<b><u>Finishes</u></b>		
09100	Metal Support Systems	1 - 6	5/27/93
09200	Lath and Plaster	1 - 6	5/27/93
09250	Gypsum Wallboard	1 - 4	5/01/93
09270	Gypsum Shaft System	1 - 3	5/01/93
09300	Ceramic, Stone & Quarry Tile	1 - 8	12/07/93
09515	Metal Ceiling Systems	1 - 6	5/01/93
09650	Resilient Flooring	1 - 3	5/01/93
09830	Elastomeric Coatings	1 - 5	5/01/93
09900	Painting	1 - 8	5/27/93

		PAGES	Issue or Last Revision Date
<b><u>Division 10</u></b>			
	<b><u>Specialties</u></b>		
10010	Building Specialties	1 - 3	5/01/93
10160	Metal Toilet Partitions	1 - 2	12/07/93
10200	Louvers and Vents	1 - 5	12/07/93
10350	Flag Pole	1 - 2	12/07/93
10800	Toilet Accessories	1 only	5/01/93
<b><u>Division 11</u></b>			
	<b><u>Equipment</u></b>		
11012	Window Washing Equipment	1 - 7	10/05/93
<b><u>Division 14</u></b>			
	<b><u>Conveying Systems</u></b> (By LBA)		
14200	Traction Elevators	1 - 50	7/26/93
14210	Traction Elevators	1 - 45	7/26/93
14240	Hydraulic Elevators	1 - 33	7/26/93
14300	Escalators	1 - 13	7/26/93
<b><u>Division 15</u></b>			
	<b><u>Mechanical</u></b> (By Tsuchiyama & Kaino U.N.O)		
15050	Plumbing Noise & Vibration Control (PVA)	1 - 4	5/01/93
15051	HVAC Equipment Seismic Restraints and Vibration Isolation (PVA)	1 - 14	5/01/93
15400	Plumbing	1 - 24	12/07/93
15500	Fire Protection	1 - 8	12/07/93
15800	Heating, Ventilating, & Air Conditioning	1 - 52	12/07/93
15900	Temperature Control System	1 - 14	12/07/93
<b><u>Division 16</u></b>			
	<b><u>Electrical</u></b> (By LSA and PAMA U.N.O.)		
16000	Scope of Work	1 - 2	12/22/92
16050	Basic Materials and Methods	1 - 6	12/22/92
16111	Conduits	1 - 5	5/27/93
16112	Bus Ducts	1 - 3	12/22/92
16114	Cable Trays	1 - 2	12/22/92
16116	Wireways	1 - 2	12/22/92
16120	Wire and Cable	1 - 4	12/22/92
16130	Outlet, Pull, and Junction Boxes	1 - 2	12/22/92
16132	Floor Boxes	1 - 2	12/22/92
16133	Terminal Cabinets	1 - 2	12/22/92
16140	Wiring Devices	1 - 3	12/22/92
16155	Motor Controllers	1 - 2	12/22/92
16160	Panelboards	1 - 3	12/22/92
16163	Distribution Switchboards	1 - 2	12/22/92
16170	Disconnects	1 - 2	12/22/92
16182	Circuit Breakers	1 - 2	12/22/92
16191	Electrical Equipment Noise Control Vibration Isolation and Seismic Restraints (PVA)	1 - 8	5/01/93
16250	Automatic Transfer Switches	1 - 3	12/22/92
16322	480-Volt Main Switchgear	1 - 5	12/22/92

	<b>PAGES</b>	<b>Issue or Last Revision Date</b>
16324 480-Volt Generator Switchgear for Non-Parallel Operation	1 - 5	12/22/92
16450 Grounding System	1 - 2	12/22/92
16460 Dry Type Transformers	1 - 2	12/22/92
16501 Lamps and Ballasts	1 - 2	12/22/92
16510 Lighting Fixtures	1 - 2	12/22/92
16610 Emergency Generators	1 - 6	12/22/92
16700 General Communications System Space Conditions (By ESA)	1 - 11	12/07/93
16701 Low Voltage Support System (By ESA)	1 - 9	12/07/93
16702 High Speed Voice/Data Network Backbone (By ESA)	1 - 11	12/07/93
16720 Fire Alarm System	1 - 23	5/27/93
16740 Telephone System	1 - 2	5/27/93
16780 Security System (By PAMA)	1 - 28	12/07/93
16920 Motor Control Centers	1 - 3	12/22/92
16930 Lighting Control Equipment	1 - 2	12/22/92
16996 Lighting Control Panels	1 - 2	12/22/92

END OF TABLE OF CONTENTS



**SECTION 01010**

**SUMMARY OF WORK**

**PART 1 - GENERAL**

1.01 DESCRIPTION: The Work includes the complete construction of:

RTD Headquarters  
Los Angeles, California

in strict conformance with the Drawings and Specifications prepared by:

McLarand, Vasquez & Partners, Inc.  
695 Town Center Drive, Suite 300  
Costa Mesa, California 92626  
(714) 549-2207

1.02 WORK NOT IN THE CONTRACT: The term "NIC" means "Not in Contract". Following portions of the Work will be provided by the Owner under separate Contract or other arrangement:

- A. **Tenant improvements** in Lease Space areas indicated on Drawings or specified unless included by Modification procedure based on accepted Alternate Bids and Unit Prices or otherwise as ordered by the Owner.
- B. **All other items** indicated or specified as NIC.
- C. **The following items** are not included with the December 7, 1993 pricing issue:
  - 1. Interior main building lobby includes all fixtures, equipment, doors, hardware, etc., which adjoin the lobby space U.N.O.
  - 2. Bronze entrances at Plaza Level and Level 3 lobby.
  - 3. Microwave screen wall and testing criteria.
  - 4. Custom designed and fabricated exterior (bronze) grilles.

1.03 CHARGES: The Owner will pay all fees and assessments separate from the Contract.

END OF SECTION



## SECTION 01015

### DEFINITIONS

#### PART 1 - GENERAL

- 1.01 DESCRIPTION: This Section covers additional definitions supplementary to those given in the Conditions of the Contract.
- 1.02 DEFINITIONS
- A. **Drawings:** Words such as "shown", "indicated", "detailed", "noted", "scheduled", or words of similar import shall mean that reference is made to the information on the Drawings unless stated otherwise.
  - B. **Actions of Architect:** Such words as "directed", "designated", "selected", and words of similar import shall mean that the direction, designation, selection, or similar action of the Architect is intended unless stated otherwise.
  - C. **Required:** The word "required" and words of similar import shall mean "required to complete the Work" and "required by the Architect", as is applicable to the context of the place where used, unless stated otherwise.
  - D. **Perform:** The word "perform" shall be understood to mean that the Contractor, at his expense, shall perform all the operations necessary to complete the Work or mentioned portions of the Work, including furnishing and installing materials as are indicated, specified, or required to complete such performance.
  - E. **Provide:** The term "provide" shall be understood to mean that the Contractor, at his expense, shall furnish and install the Work and the mentioned portion of the Work, complete and ready for the intended use. These definitions apply the same to future, present, and past tenses except "provided" may mean "contingent upon" where such is the context.
  - F. **Equal:** Terms such as "equal", "approved equal", "equivalent", and all terms of similar import shall be understood to be followed by the phrase "in the opinion of the Architect" unless stated otherwise.
  - G. **Approval:** Such words as "approved", "approval", "acceptable", "acceptance", or words of similar import shall mean that approval, acceptance, or similar import of the Architect is intended unless stated otherwise.
  - H. **Submit:** Such words as "submit", "submittal", "submission" and terms of similar import shall include the meaning of the phrase "submit to the Architect for his review" unless otherwise stated.

- I. **Expense:** Such terms as "at no extra cost to Owner", "with no extra compensation to Contractor", "at Contractor's expense", or phrases of similar import shall be understood to mean that the Contractor shall perform or provide the operation or Work with no increase to the Contract Sum stated in the Agreement.
  
- J. **Language:** Specifications are written in a modified brief style consistent with clarity. Generally the words "the", "shall", "will" and "all" are not stated. Words requiring an action or performance, such as "perform", "provide", "erect", "install", "furnish", "connect", "test", "coordinate", and words and phrases of similar import, shall be understood to be preceded by the phrase "The Contractor shall" unless otherwise stated. The requirements indicated and specified apply to all Work of the same kind, class, and type, even though the word "all" is not stated.
  
- K. **Titling and Arrangement:** Article, Paragraph, and Subparagraph titles and other identifications of similar matter in the Specifications are intended as an aid in locating and recognizing various requirements in the Specifications. Except where titling forms a part of the text, such as beginning words of a sentence or where the title establishes the subject, the titles are subordinate to and do not define, limit, or otherwise restrict the Specification text. Underlining or capitalizing of any words in the text does not signify or mean that such words convey special or unique meanings having precedence over any other part of the Contract Documents. Specification text shall govern over titling and shall be understood to be and interpreted as a whole. The order of Articles, Subparagraphs and Sub-subparagraphs in the Specifications text is defined by the sequence of indentations.

PART 2 - PRODUCTS (Not Applicable)

PART 3 - EXECUTION (Not Applicable)

END OF SECTION

SECTION 01020

ALLOWANCES

PART 1 - GENERAL

- 1.01 DESCRIPTION. Furnish following portions of the Work under the Allowance amounts stated. Include total of all Allowance amounts in the Contract Price.
- A. **Items Covered.** Items covered by the Allowances shall be supplied for such amounts and by such persons as the Owner may direct, but the Contractor will not be required to employ any person against whom he makes a reasonable objection.
  - B. **Costs Covered by Allowances.** Unless otherwise stipulated in the executed Contract, allowances shall cover the cost to the Contractor, less any applicable trade discount, of materials and equipment required by the Allowance delivered to site, and applicable taxes. Contractor's costs for unloading and handling on the site, labor, installation costs, overhead, profit and all other expenses contemplated for the original Allowance shall be included in the Contract Price and not in the Allowance.
  - C. **Adjustment of Allowance Amount.** Whenever the cost is more than or less than the Allowance, the Contract Price shall be adjusted accordingly by Change Order, the amount of which will recognize changes, if any, in handling costs, on site labor and installation costs.
- 1.02 SUBMITTALS. Refer to Section 01300 for procedures. Prepare and submit the Shop Drawings, Samples, and Product Data requested by Architect.
- 1.03 ALLOWANCE ITEMS. Furnish material selections for the Owner's and Architect's review and acceptance.
- A. **Graphics**
  - B. **Finish Hardware** (Level 1 through roof.)

END OF SECTION



**SECTION 01030**

**ALTERNATES**

**PART 1 - GENERAL**

- 1.01      **DESCRIPTION:** This Section summarizes various Alternate Bids to be submitted to the General Contractor. Alternate Bids shall state the net amount to be added to or deducted from the Contract Sum.
- A.      **Acceptance or rejection** of each Alternate Bid is at the discretion of the Owner. Any or all Alternate Bids may be rejected or accepted in any sequence.
  - B.      **Costs:** Include in each Alternate Bid all the changes in costs, whether additive or deductive, resulting to the Work of all Sections affected by Alternate bids.
  - C.      **Extent of Alternate Bids:** Bidders shall determine full extent of Work affected by each Alternate Bid and make full and proper allowance for such extent in the preparation of Bids.
- 1.02      **DESCRIPTION OF ALTERNATE BIDS:** Following are the minimum requirements and shall govern except as exceeded by requirements of Drawings, other Sections, or Code. Workmanship and materials not modified under the Alternate Bids shall conform to pertaining Sections of the Specifications, as applicable.
- Bid Alternate:** Provide Alternate Bid pricing for items as indicated on drawings or within the specifications.

END OF SECTION





**SECTION 01050**

**FIELD ENGINEERING**

**PART 1 - GENERAL**

1.01 DESCRIPTION: This Section covers survey work and engineering responsibilities.

**PART 2 - PRODUCTS** (Not Applicable)

**PART 3 - EXECUTION**

3.01 LAYOUT OF THE WORK: Owner shall employ a registered Civil Engineer or Land Surveyor to furnish layout for base lines and benchmarks for the Work. The Contractor shall provide layout thereafter throughout the site as required for the Work. The Contractor shall be responsible for the accuracy of the building lines and levels, including ancillary structures and other improvements on the site.

3.02 AS WORK PROCEEDS: Contractor shall verify all grades, lines, levels and dimensions indicated on the Drawings, and report errors or inconsistencies to the Architect in writing. Do not proceed until all errors and inconsistencies are corrected.

3.03 CONTROL POINTS: Contractor shall establish control points adequate for the use of all trades for reference so that all parts of the Work will be within the tolerances specified or standard with the industry when not specified. Remove, re-establish and relocate control points as necessitated by the construction progress. Maintain such control points in an undisturbed condition until final completion and final acceptance by the Owner.

3.04 BENCHMARKS: Civil Engineer or Licensed Surveyor shall establish benchmarks adequate for the use of all trades for reference so that all parts of the Work will be within the tolerances specified or standard with the industry when not specified. Remove, re-establish and relocate benchmarks as necessitated by the construction progress. Maintain such benchmarks in an undisturbed condition until final completion and final acceptance by the Owner.

3.05 FINAL SURVEY: As soon as practicable, the Civil Engineer or Licensed Surveyor employed by the Owner shall verify the layout and furnish certified original drawings of the survey showing exact locations of all portions of the Project.

1. Work that is not correctly located shall be relocated or altered to conform to the Contract Drawings, as the Architect may direct.
2. Additional copies of the survey shall be furnished to the Owner at their request.

END OF SECTION



**SECTION 01060**

**REGULATORY REQUIREMENTS**

**PART 1 - GENERAL**

- 1.01      **DESCRIPTION:** This Section covers general requirements for codes and standards pertaining to the Work and is supplementary to the codes and standards mentioned or referenced elsewhere in the Contract Documents.
- 1.02      **CODES AND STANDARDS**
- A.      Requirements of Regulatory Agencies:** All pertaining statutes, ordinances, laws, rules, codes, regulations, standards and lawful orders of public authorities having jurisdiction of the Work of this Contract are hereby incorporated into the Contract Documents the same as if repeated in full herein and are intended wherever reference is made in either the singular or plural to Code or Building Code except as otherwise specified, including, but not limited, those in the following listing. Contractor shall make available at the site such copies of the listed documents applicable to the Work as Architect or Owner may request, including mentioned portions of the California Code of Regulations (CCR).
1.      1991 Uniform Building Code with current State of California and City of Los Angeles Amendments of jurisdiction including Department approvals for materials, equipment, systems, and designs as applicable to the Work. Where reference is made to the 1991 Uniform Building Code (1991 U.B.C.), it shall include the 1992 State of California and City of Los Angeles Amendments.
  2.      Title 8 CCR, Industrial Relations, including Chapter 4, Div. of Industrial Safety, Safety Orders (CAL/OSHA).
  3.      Title 19 CCR, Public Safety.
  4.      Title 22 CCR, Social Security.
  5.      Title 24 CCR, Building Standards, including ADA regulations, architectural barrier laws and regulations regarding persons with disabilities.
  6.      Local Mechanical Code.
  7.      Local Plumbing Code.
  8.      Local and State Elevator Codes.
  9.      Local and National Electrical Codes.
  10.     National Fire Protection Association.

11. State and Local Public Health Codes.
12. All other laws, regulations, rules, orders, codes, and ordinances specified in other Sections of these Specifications or bearing on the Work.

END OF SECTION

**SECTION 01070**

**ABBREVIATIONS**

**PART 1 - GENERAL**

1.01 DESCRIPTION: This Section covers abbreviations for the documents mentioned or referenced elsewhere in the Contract Documents, and language abbreviations used in the text of the Specifications. Abbreviations in Drawings and Specifications shall be interpreted according to recognized and well-known technical, industry, or trade meanings.

1.02 TRADE ABBREVIATIONS include, but are not limited to, the following:

AA	Aluminum Association
AABC	Associated Air Balance Council
AAMA	Architectural Aluminum Manufacturers Association
AASHTO	American Association of State Highway and Traffic Officials
ACI	American Concrete Institute
ADA	Americans with Disabilities Act
ADC	Air Diffusion Council
AEIC	Association of Edison Illuminating Companies
AFBMA	Anti-Friction Bearing Manufacturers Association
AFI	Air Filter Institute
AGA	American Gas Association
AGMA	American Gear Manufacturers Association
AIMA	Acoustical and Insulating Materials Association
AISC	American Institute of Steel Construction, Inc.
AISI	American Iron and Steel Institute
AITC	American Institute of Timber Construction
AMCA	Air Moving and Conditioning Association, Inc.
ANSI	American National Standards Institute
ARI	Air Conditioning and Refrigeration Institute
ASHRAE	American Society of Heating, Refrigerating and Air Conditioning Engineers
ASME	American Society of Mechanical Engineers
ASSE	American Society of Sanitary Engineers
ASTM	American Society for Testing and Materials
AWPA	American Wood Preservers Association
AWPB	American Wood Preservers Bureau
AWPI	American Wood Preservers Institute
AWS	American Welding Society
AWWA	American Water Works Association
CBM	Certified Ballast Manufacturers
CCR	California Code of Regulations (formerly CAC)
CDA	Copper Development Association
CGA	Compressed Gas Association
CISPI	Cast-Iron Soil Pipe Institute
CRSI	Concrete Reinforcing Steel Institute
CS	Commercial Standard, US Department of Commerce

CTI	Cooling Tower Institute
DEMA	Diesel Engine Manufacturers Association
DOD-	Department of Defense (leading symbol)
EIA	Electronic Industries Association
ETL	Electrical Testing Laboratories
FAA	Federal Aviation Association
FCC	Federal Communications Commission
Fed Spec	Federal Specification or Standard
FIA	Factory Insurance Association
FM	Factory Manual
GA	Gypsum Association
HI	Hydraulic Institute
IAPMO	International Association of Plumbing and Mechanical Officials
ICBO	International Conference of Building Officials
IEEE	Institute of Electrical and Electronic Engineers
IES	Illuminating Engineering Society
IPCEA	Insulated Power Cable Engineers Association
ISO	International Standards Organization
MIL-	Military Specification or Standard (leading symbol)
MSS	Manufacturers Standardization Society
NAAMM	National Association of Architectural Metal Manufacturers
NAFM	National Association of Fan Manufacturers
NBS	National Bureau of Standards
NEBB	National Environmental Balancing Bureau
NEC	National Electrical Code
NEMA	National Electrical Manufacturers Association
NFC	National Fire Code
NFPA	National Fire Protection Association
NSF	National Sanitation Foundation
NWWDA	National Wood Window and Door Association
OSA	Office of the State Architect
PCA	Portland Cement Association
PDI	Plumbing and Drainage Institute
PS	Product Standard, US Department of Commerce
REA	Rural Electrification Administration
RIS	Redwood Inspection Service
RR	Research Reports
SAE	Society of Automotive Engineers
SDI	Steel Door Institute
SFM	State Fire Marshal
SMACNA	Sheet Metal and Air Conditioning Contractors National Association, Inc.
SSPC	Steel Structures Painting Council
STC	Sound Transmission Control
UBC	Uniform Building Code
UPC	Uniform Plumbing Code
UMC	Uniform Mechanical Code
UFC	Uniform Fire Code
UL	Underwriters' Laboratories, Inc.
WCLIB	West Coast Lumber Inspection Bureau

WIC                   Woodwork Institute of California  
WWPA                Western Wood Products Association

1.03           TEXT ABBREVIATIONS include, but are not limited to, the following:

AMP or amp	Ampere
CFM or cfm	Cubic feet per minute
do	Ditto, repeat
F.O.	Face of ....
FPM or fpm	Feet per minute
FPS or fps	Feet per second
GPM or gpm	Gallons per minute
Kip or kip	Thousand pounds
Ksi or ksi	Thousand pounds per square inch
Ksf or ksf	Thousand pounds per square foot
KV or kv	Kilovolt
KVA or kva	Kilovolt amperes
KW or kw	Kilowatt
KWH or kwh	Kilowatt hour
lb or #	Pound
LF or lf	Linear foot or left hand
MPH or mph	Miles per hour
o.c.	On Center
OPP	Opposite
OPP HD	Opposite hand
PCF or pcf	Pounds per cubic foot
PSF or psf	Pounds per square foot
PSI or psi	Pounds per square inch
R or RH	Right hand
SF or sf	Square foot
SIM	Similar
SY or sy	Square yard
N.I.C.	Not in Contract
N.T.S.	Not to scale
U.N.O.	Unless noted otherwise
□	Square

**PART 2 - PRODUCTS** (Not applicable to this Section)

**PART 3 - EXECUTION** (Not applicable to this Section)

END OF SECTION





**SECTION 01090**

**REFERENCE STANDARDS**

**PART 1 - GENERAL**

- 1.01 DESCRIPTION: This Section covers the general requirements for reference standards pertaining to the Work and is supplementary to the reference standards mentioned or referenced elsewhere in the Contract Documents.
- 1.02 REFERENCE AND STANDARD TYPE SPECIFICATIONS: Specifying by reference to reference and standard type specification documents or to another portion of the Contract Documents shall be the same as if the referenced document or portion referred to were exactly repeated at the place where reference is made. In case of conflict between the requirements of regulatory agencies and the referenced reference and standard type specification documents, Contractor shall conform to the most restrictive requirement if such conformance is legal. The reference or standard type specification documents shall be the current issue at the time the Construction Documents Phase, defined in AIA Document B141, is completed unless otherwise specified. Contractor shall make available at the site such copies of the reference or standard type specification documents as Architect or Owner may request.

END OF SECTION

transmitted submittals with allowance for the checking and review periods. Extension of contract time will not be granted for submittals requiring a resubmission.

- C. Transmittals:** Deliver submittals with a dated and sequence numbered transmittal letter typed on forms provided by Architect or on Contractor's letterhead forms as approved by Architect, noted as to the initial or resubmittal status, and describing the submittal contents. Submittals are not acceptable directly from Subcontractors, suppliers, or manufacturers. In each transmittal state the Drawing numbers and Specification Section, Articles, and paragraphs to which the submittal pertains and identify accompanying data, catalogs, Drawings, sketches, and brochures in the same manner.
- D. Deviations:** Notify the Architect in the transmittals of all deviations from the requirements of the Contract Documents. Fully describe each deviation and all other changes required to correlate the Work including the related Work. State in writing all variations in costs caused by each deviation and the Contractor's assumption of costs for the deviation and of all related costs if any deviation is approved.
- E. Contractor's Review and Approval:** Each submittal and resubmittal upon which proper execution of Work is dependent shall bear Contractor's review and approval stamp, dated and signed by Contractor in every case, certifying that Contractor:
1. Has reviewed, checked, and approved the submittal, and
  2. Has coordinated the submittal contents and dimensions with the requirements of the Work and the Contract Documents including related Work, and
  3. Has determined and verified all quantities, dimensions, field measurements, construction criteria, materials, equipment, catalog numbers and identifications, and similar data, or will do so, and
  4. States that Work illustrated or described in the submittal is accepted by Contractor and that Contractor's warranty will fully apply thereto.
- F. Corrections and Resubmittals:** Contractor shall make corrections required by the Architect, resubmit corrected submittals until they are satisfactory to Architect, and shall direct specific attention in writing to all revisions other than corrections called for on previous submittals, and shall state in writing all changes in costs for such revisions and assumption of all costs for revisions and related changes the same as if required for deviations in Paragraph "Deviations".
- G. Check of Returned Submittals:** Contractor shall check and review the submittals returned for his correction and ascertain whether required corrections result in extra cost above that included under the Contract, and shall give written notice to the Architect within 5 working days if, in Contractor's opinion, extra costs result from corrections. The Contractor's failure to give such written notice or the starting of any Work covered by a returned submittal constitutes a waiver by the Contractor of claims for extra costs resulting from required corrections.

- H. **Review and Approval of Submittals by the Architect:** Submittals will be reviewed with reasonable promptness, but only for conformance with the design concept of the Project and with the information indicated on the Drawings and stated in the Specifications. Review of a separate item as such will not indicate approval of the assembly in which the item functions. Review of submittals shall not relieve the Contractor of responsibility for any deviation from the requirements of the Contract Documents or for any revision in resubmittals unless Contractor has given written notice of such deviation or revision at the time of submission or resubmission and written authorization has been given to the specific deviation or revision, nor shall review relieve the Contractor of responsibility for errors or omissions in the submittals or for the accuracy of dimensions and quantities, the adequacy of connections, and the proper and acceptable fitting, execution, functioning and completion of the Work.
- I. **Incomplete or Inadequate Submittals,** including those not correctly transmitted, titled, and identified, or not bearing Contractor's review and approval stamp, will be returned to the Contractor without review.
- J. **Interrelated Submittals:** Except where the preparation of submittal information is dependent upon the review of any prior submittal, submittals pertaining to the same class or portion of the Work shall be submitted simultaneously.
- K. **Expense:** All costs for the preparation, correction, delivery, and return of the submittals shall be borne by the Contractor.

**PART 2 - PRODUCTS** (Not Applicable)

**PART 3 - EXECUTION**

3.01 **SHOP DRAWINGS:** Prepare each submittal complete including all dimensions, design criteria, materials, connections, bases, foundations, anchors, and the like, and further include such technical and performance data as is necessary to confirm the information in the Shop Drawings. Prepare Shop Drawings of same size as the Drawings or on 8-1/2 by 11" 3-hole punched vellum sheets suitable for ozalid or xerox reproduction. Copies of the Contract Drawings marked to show Shop Drawing Information are not acceptable. Each Shop Drawing shall have an adequate title block showing the following identification:

- Name and address of the Work.
- Name and address of Contractor.
- Name and address of the Subcontractor, Sub-subcontractor, manufacturer, supplier, or distributor, as applicable.
- Name and address of Architect.
- Date, scale of Drawings, and identification number.
- Contractor's review and approval stamp, dated and signed.

- A. **Initial and Resubmittals:** Submit Shop Drawings in sets consisting of one sepia reproducible and six blue-line prints to the General Contractor. General Contractor to submit the sepia reproducible with General Contractors review and approval stamp and two blue-line prints to the Architect.

- B. Correction and Review of Shop Drawings:** Architect will mark the corrections, notations, or review on the reproducible sepia transparencies and return the sepia reproducible and two blue-line prints to General Contractor. Resubmit in same manner if Shop Drawings are not acceptable.
- C. Final Distribution:** General Contractor to furnish and distribute prints of reviewed Shop Drawings as required for performance of the Work.

3.02 **SAMPLES:** Unless otherwise specified, each submittal shall include not less than two complete sets of Samples. One set of acceptable samples and all unacceptable samples will be returned to Contractor. Samples of value retained by Architect will be returned to Contractor after completion of the Work if the Contractor's first transmittal for the Sample requests its return. Approved Samples of items returned to Contractor may be installed in the Work if the location is recorded and the Samples bear temporary identification as such.

3.03 **PRODUCT AND EQUIPMENT DATA SUBMITTALS**

- A. Product Data** shall include materials lists, catalogs, brochures, performance and technical data, service history, characteristics, and like information to fully describe the products covered by the submittal.
  - 1. **Submittal Preparation:** Bind submittal copies with sturdy labeled covers and include a typed index listing the contents. Loose or unbound submittals will be returned unreviewed. For each item listed, include the manufacturer's name and address, trade or brand and conditions of manufacturer's guarantee and warranty, other information to fully describe each items, and supplementary information as may be required for review. Mark cuts, brochures, and other data to indicate the items proposed and the intended use.
  - 2. **Product Data Submittals:** Unless otherwise specified, every submittal shall include four bound copies. One copy will be returned to the Contractor marked to show the required corrections or approval. If corrections are required, the final submittal shall include four bound corrected copies.
- B. Equipment Data:** Submit complete technical, performance, and catalog information for every item of mechanical and electrical equipment and machinery proposed for installation in the Work, bound, indexed, and containing information and data as required in Paragraph "Product Data" above. Include information on performance and operating curves, ratings, capacities, characteristics, power efficiencies, manufacturers' standard guarantees and warranties with the terms and conditions fully described, and all other information to fully illustrate and describe the items as may be specified or required for review. Submit in sets which cover complete systems or functioning units. Unless otherwise specified, submittals shall be as required in Paragraph "Product Data Submittals". When applicable, incorporate the equipment data into and submit in the manuals required under Section 01700.

- 3.04      **MANUFACTURERS' INSTRUCTIONS:** Submit manufacturers' installation instructions and directions for materials specified to be installed in accordance with such instructions to demonstrate the adequacy of the instructions. Furnish copies to all trades involved.
- 3.05      **MATERIALS FURNISHED UNDER STANDARD SPECIFICATIONS:** For materials specified by reference to standard or reference type specifications, prepare and submit for approval a list of such materials by manufacturer's names and identifications to the extent requested by the Architect or Owner.
- 3.06      **CERTIFICATES:** Deliver all certificates to Architect. Each certificate required under the Contract Documents shall be signed by the individual, officer, or the agent lawfully authorized to execute the certificate, and such authority shall be cited in the certificate by title, description, or other acceptable evidence. All certificates shall be sworn and notarized as to the correctness and validity of the contents, and duplicate copies shall be notarized to be true copies.

END OF SECTION



SECTION 01400

QUALITY CONTROL

PART 1 - GENERAL

1.01 DESCRIPTION: This Section covers general requirements for quality control of the Work, including testing and inspection procedures.

**A. Work In This Section:**

1. Testing laboratory or agency.
2. Geotechnical (Soils or Foundation) Engineer.
3. Coordination of tests and inspections.
4. Test costs and reports.
5. Inspections, continuous and special, and inspection costs.
6. Contractor-furnished assistance.
7. Verification of conditions.

**B. Work Not In This Section:**

1. Specific test procedures to be performed in accordance with this Section.
2. Testing of mechanical and electrical work.
3. Testing of conveying systems.
4. Testing of materials specified to be tested by other agencies under other Section.

1.02 GENERAL QUALITY CONTROL REQUIREMENTS

- A. General Test Requirements:** Materials to be furnished under the Contract are subject to testing and inspection for compliance with requirements of Drawings and Specifications.
- B. Testing Laboratory or Agency** shall be a licensed Testing Laboratory or Agency meeting the requirements of ASTM D3666, D3740, E329, E543 and E548 as applicable to the Work and approved by the Owner, and referred to hereafter as the Testing Laboratory. Perform all testing under supervision and control of a California registered professional engineer employed by the Testing Laboratory.
- C. Soils or Foundation Engineer** will be the registered professional Geotechnical Engineer employed and paid by Owner.
- D. Disqualified Material:** Any material shipped or delivered to the site by the Contractor from the source of supply prior to having satisfactorily passed the required testing and inspection, or prior to the receipt of a notice from the Architect that such testing and inspection will not be required, shall not be incorporated in the Work.

1.03 COORDINATION OF TESTS AND INSPECTIONS: Contractor shall initiate and coordinate testing and inspections required by Contract Documents and public authorities having jurisdiction of the Work.

A. **Notification:** Contractor shall notify the Owner a sufficient time in advance of the manufacture of material to be supplied by him which, by requirements of the Contract Documents, must be tested at the source of supply in order that the Owner may arrange for the testing.

1.04 TEST SAMPLES AND PROCEDURES

A. **Test Samples:** Furnish and deliver samples of materials to be tested at no extra cost to Owner. Test samples will be selected by the Architect, Inspector, or Testing Laboratory and not by the Contractor.

B. **Test Procedures:** Testing Laboratory shall perform tests according to ASTM or other methods of test specified for the various materials under other Sections. If no procedure or test method is specified, testing shall conform to material specification referenced unless otherwise directed by Architect. The Testing Laboratory shall tag, seal, label, record, or otherwise suitably identify the materials for testing and no such materials shall be used in the Work until the test result reports are submitted and approved, excepting only the materials specified to be placed or installed prior to testing.

C. **Test Repeating:** Repeat applicable tests at specified intervals, whenever the source of supply is changed, or whenever the characteristics of the materials change or vary in the opinion of Owner or Architect.

1.05 TEST COSTS: Owner will pay for testing performed by Testing Laboratory except Contractor shall reimburse the Owner for retesting costs caused by failure of materials to pass initial tests. Contractor shall arrange and pay for all other testing.

1.06 TEST REPORTS: Furnish copies of each test result report, signed and certified by the Testing Laboratory supervising engineer, as follows:

	<u>Copies</u>
Owner	1
Architect	1
Structural Engineer (structural test only)	1
Contractor	2
Building Department	1

1.07 INSPECTIONS, CONTINUOUS AND SPECIAL

A. **Inspections,** continuous and special, shall be performed by Registered Deputy or Special Inspectors (hereinafter referred to as the Inspector) as required by the Contract Documents and Building Code. During course of Work under the inspection, each Inspector shall submit detailed reports relative to progress and condition of Work



including variances from the Contract Documents, and stipulating dates, hours, and locations of the inspections.

- B. Inspection Costs:** Owner will pay for required continuous and special inspections.
- C. Reimbursement of Inspection Costs:** The Contractor shall reimburse to the Owner all or any part, as the Owner may deem just and proper, of the actual excessive inspection costs incurred by the Owner due to any or all of the following:
1. Contractor's failure to complete the Work within the Contract Time stated in the Agreement, and any previously authorized extensions thereof.
  2. Claims between separate contractors.
  3. Covering of any of the Work before the required inspections or tests are performed.
  4. Extra inspections required for Contractor's correction of defective Work.
  5. Overtime costs for acceleration of Work done for Contractor's convenience.
- D. Approvals Required by Others:** If the laws, ordinances, rules, regulations, or orders of any public agency having jurisdiction require any of the Work to be specifically inspected, tested, or approved by some authority other than the Owner, Architect, or Contractor, the Contractor shall give all required notices and make all arrangements, shall deliver to the Architect the certificates of inspection, testing, or approval of such public agency.

1.08 **CONTRACTOR-FURNISHED ASSISTANCE:** Whenever requested, Contractor shall furnish access, facilities, and labor assistance as necessary for duties to be performed at the site by Testing Laboratory and Inspector including furnishing ladders, hoisting, temporary lighting and water supply, and like services.

1.09 **VERIFICATION OF CONDITIONS:** Prior to installation of any portion of the Work, the installing Contractor, Subcontractor, or Sub-subcontractor shall arrange for correction of defects in existing workmanship, material, or conditions that may adversely affect the Work to be installed. Installation of materials or Work in place constitutes acceptance by the installing Contractor, Subcontractor, or Sub-subcontractor of such Work in place as being in proper condition to receive the materials to be applied and waiver of claim that Work in place is defective as pertains to warranty requirements, excluding unascertainable or concealed conditions. Where the Specifications require a material to be installed under supervision of the material manufacturer or his representative, manufacturer or his representative also shall inspect the Work in place and issue a letter of approval to Architect.

**PART 2 - PRODUCTS** (Not Applicable)

**PART 3 - EXECUTION**

- 3.01 TESTS AND INSPECTIONS: Owner will pay for the following testing and inspections except as stated otherwise for specific items.
- A. Site Work:** Tests and inspections performed by Geotechnical Engineer of record for the Foundation Investigation Report.
1. Foundations, compaction, and fill and backfill inspection and testing.
  2. Shoring of cut banks and slope at cuts, except as otherwise specified under Division 2.
  3. Approval of site and imported earthwork materials.
  4. Unauthorized over excavation or retesting.
  5. Verification of shoring stability and monitoring.
- B. Reinforcing Steel:**
1. Conformance to testing of bars -- cost paid by Owner. Initial testing cost paid by Contractor (Mill Certifications are acceptable U.N.O.).
  2. Inspector for welding of bars.
  3. Inspector during placement of bars.
- C. Cast-In-Place Concrete:**
1. Mix design of concrete -- costs paid by Contractor.
  2. Conformance testing of materials -- costs paid by Owner. Initial testing cost paid by Contractor (Mill Certifications are acceptable U.N.O.).
  3. Casting and testing of cylinders.
  4. Inspector during placing of concrete.
- D. Masonry:**
1. Conformance testing of materials -- costs paid by Owner. Initial testing cost paid by Contractor (Mill Certifications are acceptable U.N.O.).
  2. Testing of mortar and grout.
  3. Continuous inspection required by Drawings and Specifications.

**E. Structural Steel:**

1. Conformance testing of materials -- costs paid by Owner. Initial testing cost paid by Contractor unless specified otherwise (Mill Certifications are acceptable U.N.O.).
2. Inspector for high-strength bolting, groove welding, and field welding.
3. Inspector for shop fabrication of structural steel unless shop is approved by the Building Department -- costs paid by Contractor.
4. Inspector to verify grouting under column base plates.
5. Ultrasonic inspection of groove welds and lamination check of materials.

**F. Metal Decking:**

1. Inspector for welding.
2. Inspector for shear stud installation.

**G. Fireproofing:**

1. Inspector for spray on fireproofing.
2. Density measurements in field.
3. Thickness measurements in field.

**H. Waterproofing and Roofing:**

1. Inspector during placing of waterproofing materials.
2. Inspector during testing and ponding.
3. Continuous inspection required by Drawings and Specifications.

**I. Shotcrete:**

1. Mix design of concrete - cost paid by Contractor.
2. Conformance testing of material - cost paid by Owner. Initial testing cost paid by Contractor (Mill Certifications are acceptable U.N.O.).
3. Casting and testing of cylinders.
4. Inspector during placement of concrete.

**J. Shoring:**

1. Continuous inspection of shoring installation as required by the City.
2. Monitoring of the shoring to detect movement (lateral or vertical) of the shoring.

**K. Stone Masonry:**

1. Conformance testing of materials -- costs paid by Owner. Initial testing cost paid by Contractor unless specified otherwise (Mill Certifications are acceptable U.N.O.).
2. Testing of mortar and grout.
3. Continuous inspection required by Drawings and Specifications.
4. Coefficient of friction testing with three (3) sealors.
5. Independent stone inspection.

**L. Precast Concrete:**

1. Mix design of concrete - cost paid by Contractor.
2. Conformance testing of material - cost paid by Owner. Initial testing cost paid by Contractor unless specified otherwise (Mill Certifications are acceptable U.N.O.).
3. Casting and testing of cylinders.
4. Inspector during placement of concrete.

**M. Curtain Wall/Window Wall:**

1. See Section 01450.

**N. Microwave Transmission Testing:**

1. See Section \_\_\_\_\_.

END OF SECTION

**SECTION 01450**

**MOCK-UP**

**1.00 GENERAL**

**1.01 DESCRIPTION:** Division 1 applies to this section. Provide mock-up as indicated, specified and required.

**A. Principle Work in this Section:**

1. Performance mock-up test specimens **M.1 and M.2 as attached with this section of specifications.**

**B. Related Work Not in This Section:**

1. Facade Stonework: Section 04400.
2. Steel Frame Support Systems for Stone Veneer: Section 05130.
3. Cold Formed Metal Framing for Stone Veneer: section 05410.
4. Facade Insulation & Firesafing: Section 07201.
5. Facade Sealants: Section 07901.
6. Exterior Glass & Glazing: Section 08800.
7. Fixed Windows: Section 08500.

**1.02 SUBMITTALS**

- A. Provide shop drawings showing all mock-up materials in place including coordination of related and adjoining work. Details shall be full size and fully drawn, not outlined. Provide isometric details of any conditions, as requested by the Architect. Drawings shall bear the seal and signature of a licensed professional engineer in the state of California who shall be the same engineer that signs the calculations.
- B. Provide structural calculations, bearing the seal and signature of a licensed professional engineer in the state of California, for all components of mock-up construction.
- C. Submit laboratory's proposed test procedure for Architect's approval, a minimum of four weeks prior to mock-up construction. Erection at testing laboratory shall not commence prior to review of laboratory's proposed test procedure by Architect.
- D. Test laboratory shall provide chamber steel drawings identifying method for conducting seismic drift test prior to installation of test specimen.
- E. Mock-up drawings and calculations shall include all requirements stipulated in the related sections.

- F. Laboratory test report must be accompanied by as-built mock-up drawings showing any revisions or corrective measures taken during testing. Any modifications done on mock-up must be done on job unless Architect specifically approves otherwise. Mock-up must be supervised and installed by same workmen that will do actual job.
- G. Prior to mockup installation or fabrication, provide to sealant manufacturer samples of all relevant substrates, including finished aluminum, glass, gaskets, stone, flashing, backers and any other substrates which may require sealant contact. Samples shall be labeled and identified for this project. Sealant manufacturer shall perform tests to verify adhesion, staining and chemical compatibility. Use sealants and substrates only in combinations for which favorable adhesion and compatibility results have been obtained. Submit for record sealant manufacturer's written test reports and recommendations regarding cleaning and priming required to obtain acceptable adhesion.

**1.03 LABORATORY MOCK-UPS**

- A. Exterior Wall Subcontractor shall finish, build and test mock-ups which are representative of all materials used in the exterior building enclosure for the building on which material is used. The scope of the mock-up will be representative of the area of work that is found on the building. **The exact scope of mock-ups M.1 and M.2 is attached with this section of specifications.**
- B. Exterior Wall Subcontractor is to include all costs for materials, transportation of materials, and all labor required for the installation of mock-ups. Laboratory testing fees shall be paid by the Owner.
- C. Tests shall be conducted at an independent testing laboratory as approved by the Architect. The test laboratory shall be responsible for conducting and reporting the tests, shall state whether or not the test specimen conforms to all requirements of the contract documents, and shall specifically note any deviations there from. Construction Research Laboratory in Miami, Florida is acceptable for mock-up tests, other laboratories or test facilities are subject to approval. Manufacturer's laboratories are not acceptable test facilities.
- D. The testing laboratory shall not act as consultant to the contractor for this project, modify contract document requirements, modify mock-up configuration, or dismantle mock-ups until notified that no further testing is required. At the direction of the Architect, deliver mock-up or selected portions of the mock-up, boxed to the jobsite, contractors plant, or dispose of mock-up properly.
- E. Mock-ups are subject to observation by Owner, **General Contractor**, Architect and their Consultants throughout their construction and testing. Provide minimum three weeks notice before beginning construction of mock-ups. Provide material and personnel for prompt continuous construction of mock-ups. Delays in mock-up construction due lack of materials or personnel could result in the contractor being charged for fees and travel expenses of observers. **Exterior Wall Subcontractor** shall coordinate chamber availability, shipping schedules and mock-up construction schedules directly with the laboratory.

- F. If failures occur, revise and retest mock-up. Modifications must be realistic in terms of job conditions, must maintain standards of quality and durability, and are subject to approval.
- G. Mock-up test specimens shall be tested in the following order, according to testing criteria stated or amended herein:
1. Preload specimen at 50% of inward (positive) design pressure.
  2. Air leakage per ASTM E283 using a pressure of 6.24 psf (50 mph wind). Air leakage not to exceed 0.06 cfm per square foot of fixed wall area. Individual components of the wall system shall not exceed 0.06 cfm per square foot of component for fixed wall areas. Verify air flow through each component of the specimen.
  3. Static water penetration per ASTM E331 using a pressure of 10 psf. No uncontrolled water penetration as defined in related sections is allowed.
  4. Dynamic water penetration per AAMA 501.1 using a pressure of 10 psf. No uncontrolled water penetration as defined in related sections is allowed.
  5. Structural performance per ASTM E330 using 40 psf positive and 50 psf negative design load pressures. Deflections to be measured and recorded.
  6. Repeat test 4.
  7. Perform a seismic test by displacing the intermediate level mock-up support system to produce displacement (story drift) between successive floor levels, equal to a probable movement of .0075 times the story height. Direction of displacement shall be both parallel and perpendicular to the face of the mock-up. Displacement shall be to the left and right, returning to the neutral position in each case. Then displacement shall be in and out, returning to the neutral position in each case. The wall shall be subjected to three cycles in each direction.  
  
Glass breakage, stone breakage, adjacent component contact, structural failure, or disengagement must not occur. Permanent distortion may not exceed 0.1% of span length or 1/16", whichever is less. Make written observations of behavior of wall, describing flex at anchors, racking of framing, glass movements, stone reactions, panel movements, etc.
  8. Repeat test 2.
  9. Repeat test 3.
  10. Repeat test 4.
  11. Structural overload test per ASTM E330 using 1.5 times the design load pressures. Deflection to be measured and recorded. No permanent set of more than L/1000 is allowed. No permanent set in anchors of more than

1/16 is allowed. No stone breakage or permanent structural damage is allowed.

12. Repeat the above seismic test step #7, except use a credible movement based on a drift of .015 times the story height. Cycle wall 3 times in each direction as above. Loss of glass retention, stone retention, structural failure or disengagement must not occur. Permanent distortion may not exceed 0.4% of span length. Sealants and gaskets may disengage only if they are repairable and replaceable without removing any exterior stonework or panel work. Make written observations of behavior of wall and components.
  13. Test to failure or two times the worst case design pressure, whichever comes first.
- H. Where the test sequence requires successive water infiltration tests, the only means used to drain water from internal cavities shall be gravity drainage through the weep system for a minimum of 15 minutes. Air pressure, removal of parts, or other means of draining water shall not be used.
- I. Where test results indicate specimen does not comply with the performance criteria, repairs, acceptable to the Architect, shall be made and the specimen tested until satisfactory results are achieved. No testing out of sequence shall be performed without approval of the Architect.

## 2.00 PRODUCTS

### 2.01 MATERIALS

- A. As specified in individual specification sections.

## 3.00 EXECUTION

### 3.01 INSTALLATION

- A. Fabricate and erect test specimens **M.1 and M.2 as attached with this section of specifications.**
- B. The mock-up shall be used to demonstrate quality of materials, finish and workmanship as well as to show compliance with visual and performance criteria. Use the same workers to do all work in conjunction with construction of the mock-ups as covered by the work of their respective contracts.
- C. Provide mock-up with all details complete and identical to those proposed for use in the building and as indicated on the drawings. Do not use excessive amounts of sealant, nor other special measures or techniques, which are not representative of those to be used in the building. Finish the various components to show the maximum variation that will exist in the actual building construction between adjacent and non-adjacent components.



- D. Submit as-built shop drawings for approved mock-ups including all revisions for various components. **All details used, approved and/or modified in passing test requirements shall be fully documented upon completion of testing in "checklist fashion". Mock-up drawings shall be revised to reflect all changes. Upon completion, revise mock-up drawings to include isometric details of the critical seal areas whether modified or not, i.e., transitions between horizontal/vertical joints and intersections.**

**END OF SECTION 01450**



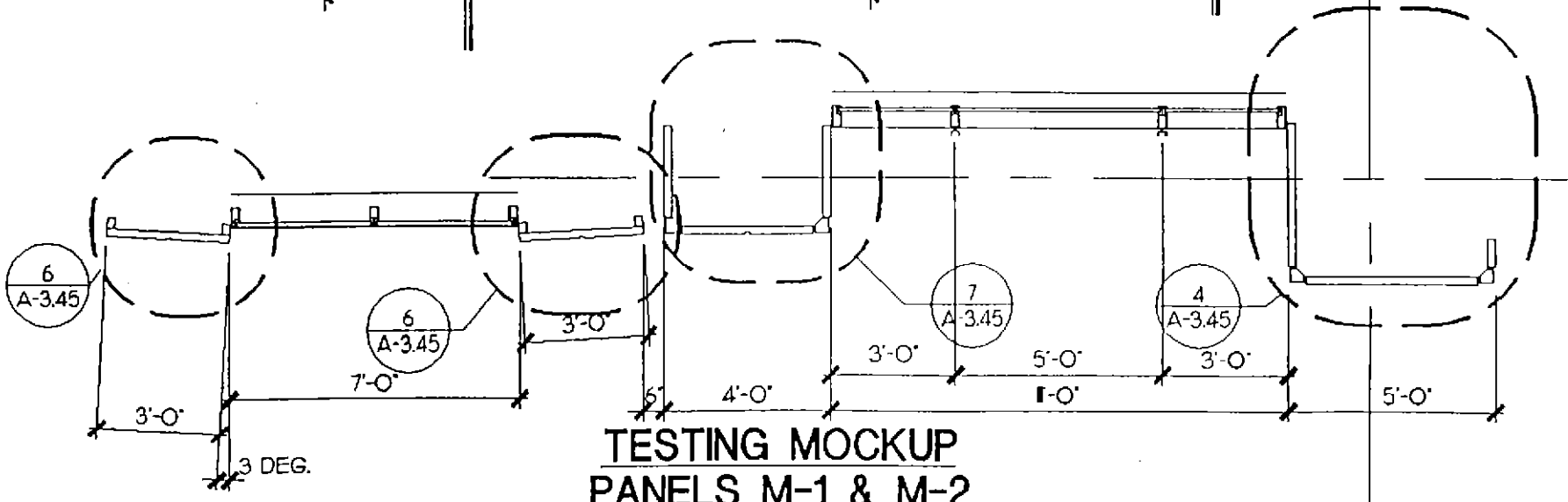
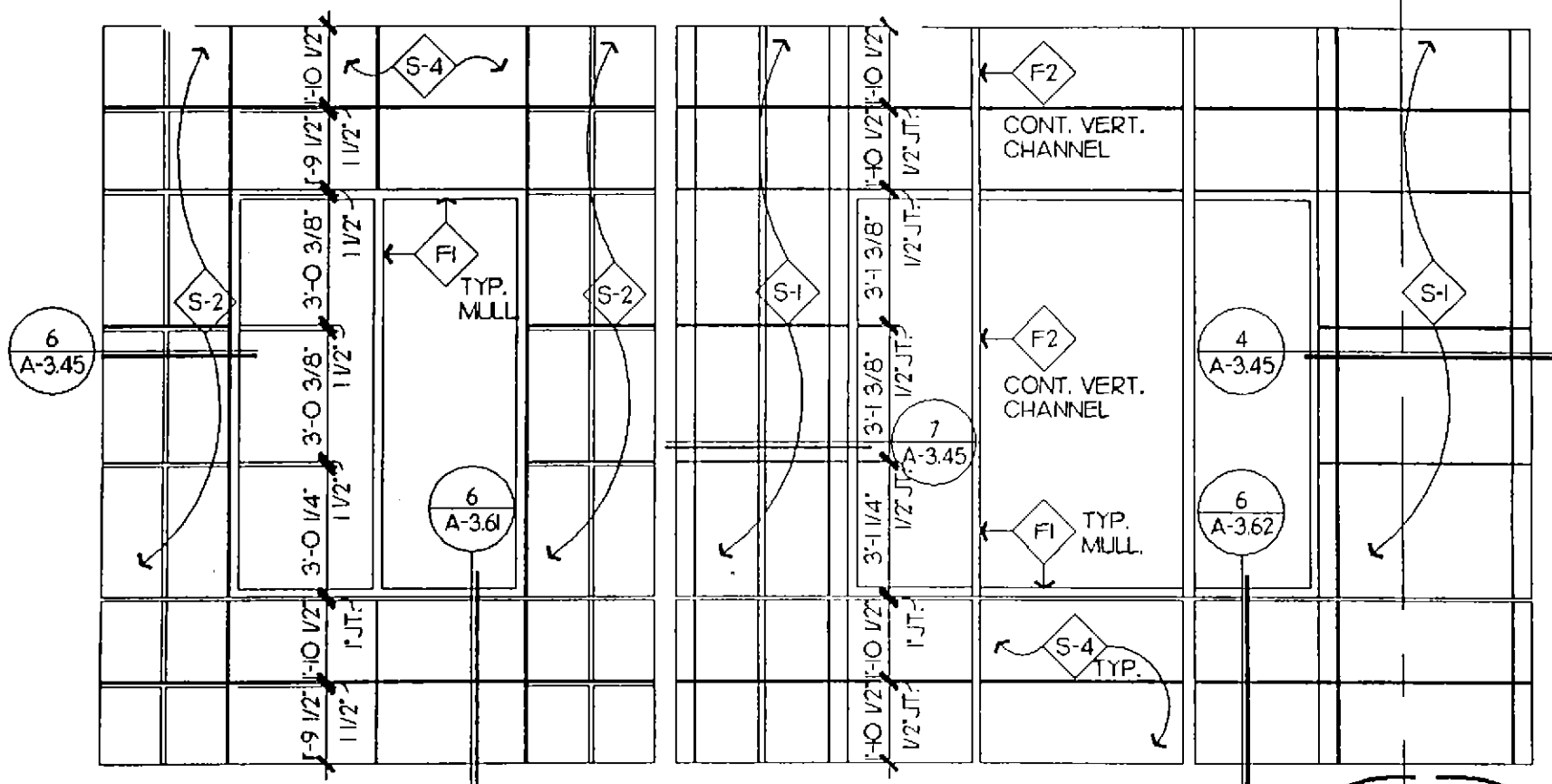

**TESTING MOCKUP  
PANELS M-1 & M-2**

1/4"=1'-0"  
10-8-93



## SECTION 01500

### CONSTRUCTION FACILITIES AND TEMPORARY CONTROLS

#### PART 1 - GENERAL

- 1.01 **DESCRIPTION:** This Section covers general requirements for temporary facilities and controls for the Work.
- A. **Work In This Section:** Principal items include:
1. Temporary barricades.
  2. Temporary storage facilities.
  3. Temporary offices and telephones.
  4. Temporary toilet facilities.
  5. Temporary utility services.
  6. Temporary heat.
  7. Removal of temporary facilities.
- 1.02 **GENERAL:** Drawings indicate building site and related areas of Owner's property available for the Work. Keep areas orderly, free of hazards, and leave in clean condition acceptable to Architect, Owner, and governing public authorities. The Contractor may utilize the site within the area bounded by the temporary construction fence. The Contractor shall prepare a drawing depicting how he intends to utilize the site for offices, parking storage and staging of the construction activities for the duration of the work. These drawings shall be approved by the Owner prior to any such use of the site by the Contractor.

#### PART 2 AND 3 - PRODUCTS AND EXECUTION

- 2.01 **TEMPORARY BARRICADES:** Provide solid or fencing type barricades. Construct and relocate or alter as required by Architect, Code, or public authorities having jurisdiction. Paint solid barricades exposed to public view with 2 coats of graffiti resistant paint in colors designated by Architect. Secure and pay for building and street use permits and inspections required by Code.
- 2.02 **TEMPORARY STORAGE FACILITIES:** Provide temporary storage facilities necessary to protect materials and equipment delivered to site from damage. Maintain sheds in a clean and sightly condition. Distribute all materials stored in permanent structures to prevent overloading of floors or structure. If on-site storage area is inadequate, arrange and pay for necessary off-site facilities.
- 2.03 **OFFICES AND TELEPHONES:** Provide office space on site as required. Office may be temporary construction but waterproof, weathertight, insulated, well lighted, floored, heated, and accessible to Owner, Architect, and their representatives; approved mobile units having equivalent facilities may be furnished. Provide a separate office adequate for the combination use by the Owner and Architect and a separate office space for Inspector equipped with an adequate table, plan rack, desk, and chairs, and a non-pay telephone for business use without charge. The office, equipment, and furniture shall remain the property of the Contractor.

- 2.04 **TOILET FACILITIES:** Install temporary toilets for workmen and maintain toilets in a clean and sanitary condition. Locate as approved and connect to existing sewers when feasible. Chemical toilets may be used if approved by local Code.
- 2.05 **UTILITY SERVICES:** Send proper notices, make necessary arrangements, provide services required in care and maintenance of public utilities, and assume the responsibility concerning same for which Owner may be liable. Do all necessary enclosing or boxing in for protection of public utilities. Upon completion of the Work, remove enclosures, fill in openings in concrete or masonry with like materials, grout watertight, and leave in finished condition.
- A. Water:** Furnish and pay for all water required for the Work, with the necessary temporary piping or hose from source to points on the site where used. Furnish potable water from domestic source.
- B. Light and Power:** Furnish and pay for electric service required for the Work and provide temporary poles and overhead construction, transformers, meters, drops, wiring panels, circuit and ground fault protection, and fittings for both light and power at locations required. Pay charges and fees for making the temporary service connections.
- C. Gas:** Furnish and pay for fuel gas required for the Work. Make the necessary arrangements and pay charges required by the serving utility company. Furnish temporary distribution piping as required.
- 2.06 **TEMPORARY HEAT:** Furnish and pay for heat, fuel, and services to protect the Work against injury from dampness and cold until final acceptance. Building heating system may be used for temporary heating. Furnish a competent engineer to operate system and be solely responsible for damage to the heating equipment during such temporary operation. Operate the heating system as necessary to maintain correct temperatures within building during finishing operations, with provision to vent obnoxious, flammable, or hazardous fumes to the exterior.
- A. Drywall:** Maintain building temperature at minimum 50 degrees F for not less than 48 hours prior to drywall application and during application, drying of tape, and finishing. Maintain adequate ventilation for drying of tape and finish.
- B. Finishes:** Maintain building temperature at minimum 65 degrees F or published industry standards/recommendations before finish lumber and millwork are delivered, and throughout placing of finish and other finishing operations such as painting and installation of resilient coverings.
- C. Filters:** During temporary heating, equip ventilating system(s) with temporary throwaway type filters to prevent dust entering supply system. Be responsible for delivering system free of dust and lint at time of final acceptance.
- 2.07 **REMOVAL OF TEMPORARY CONSTRUCTION:** Remove all temporary facilities and other construction of temporary nature from site as soon as progress of the Work will permit in opinion of the Architect. When authorized, Contractor may move his facilities into designated areas of completed portions of the building. Upon completion of the Work, recondition and restore portions of site and building occupied by temporary facilities to acceptable condition.

RTD Headquarters  
Los Angeles, California  
91-400

5/27/93  
Construction Facilities and Temporary Controls  
01500 - 3

END OF SECTION





**SECTION 01600**

**MATERIAL AND EQUIPMENT**

**PART 1 - GENERAL**

1.01 **DESCRIPTION:** This Section covers the general requirements for materials and equipment for the Work. Specific requirements for materials and equipment are covered under other Sections of the Specifications.

**A. Requirements In This Section:**

1. Submittals for:
  - a. Factory finish colors.
  - b. Standard materials.
2. Proposed substitutions.
3. Materials, regarding:
  - a. Equal materials.
  - b. Optional materials.
  - c. Plurality of terms.
  - d. Factory finish colors.
4. Transporting and handling.
5. Storage and protection.

1.02 **SUBMITTALS:** Refer to Section 01300.

- A. Submittals for Factory Finish Colors:** Whether or not required elsewhere, submit color samples of materials specified to have a factory finish for selection and approval.
- B. Submittal for Standard Materials:** For the products specified by reference to standard or reference specifications, prepare and submit for approval a list of such materials or equipment by manufacturers' names and identifications to the extent requested by Architect.

1.03 **PROPOSED SUBSTITUTIONS**

**A. Procedures:**

1. **Prior to Receiving Bids:** Submit proposed substitutions to Architect not less than 10 working days prior to the date set for receipt of Bids. Bidders will be notified of approved substitutions by Addendum. Architect may require the submission of Drawings, Product Data, Samples and other information, in an acceptable form, for consideration of proposed substitutions.
2. **After Award of Contract:** Submit proposed substitutions to Architect within 35 days after date Notice to Proceed is issued or the Agreement is executed, whichever is earlier. Submit proposed substitutions relating to a particular Subcontract or trade at one time on Contractor's letterhead, listing proposed

items for indicated or specified items, and stating amounts for all variations in costs. Include Shop Drawings, Product Data, Samples, and other information to extent requested by Architect.

3. Approval or rejection of proposed substitution is entirely at Architect's discretion, whose judgment will be final and will include consideration of the following factors among others in comparing equality of proposed substitutions with indicated or specified requirements:

- a. Quality of materials, structural strength, and details of construction or fabrication.
- b. Performance and function, mechanically and technically.
- c. Appearance and finish, or characteristics permitting required finish to be applied.
- d. If proposed substitutions require altering arrangement of adjoining or related Work, resulting arrangement must be equal in convenience and practicality to original arrangement.
- e. Products equal in quality and utility are generally competitive products and are approximately equal in price. If approval is requested for materials or equipment that are more economical than the specified products, Architect may require the specified products.
- f. An inequality in the availability of replacement parts or maintenance services may be a determining factor.
- g. Code approvals and service history.

4. Resubmittal of Proposed Substitutions: Do not resubmit in modified form proposed substitutions that have been rejected. Upon rejection of a proposed substitution, the Contractor will be allowed 15 calendar days to submit another proposed substitution. If the second proposed substitution is rejected or not received by Architect within the specified time, provide only the indicated and specified Work at no additional cost to Owner.

**B. Use of Approved Substitutions** does not relieve Contractor from compliance with Contract Documents. Contractor shall bear all extra expense resulting from approved substitutions where substitutions affect adjoining or related Work, including cost of any design services performed by the Architect, Engineers or Consultants to incorporate and coordinate the substitution into the Work.

**C. Unauthorized Substitutions:** If substitute materials are installed without prior approval, remove all the unauthorized materials and install those indicated or specified, at no extra cost to Owner.

## PART 2 - PRODUCTS

- 2.01      **MATERIALS:** Provide new materials and equipment unless otherwise indicated or specified.
- A.      **Equal Materials:** Any materials, apparatus, equipment, or process indicated or specified by patent or proprietary name or name of manufacturer shall be deemed to be followed by "or equal as approved in writing by the Architect".
  - B.      **Optional Materials:** Where more than one proprietary brand name is specified, Contractor may provide any one of the materials or equipment specified. Before placing orders, advise Architect in writing of each named material, appliance, or piece of equipment proposed for the Work and its intended use. Provide only one brand, kind, or make of material for each purpose throughout the Work notwithstanding that similar material or equipment of two or more manufacturers may be specified for the same purpose.
  - C.      **Plurality of Terms:** For materials or equipment referred to in the singular number, it is intended, unless otherwise limited that such references apply, to as much material or equipment as is required to complete the Work.
  - D.      **Factory Finish Colors:** Colors of material specified to be furnished with a factory finish are subject to Architect's approval. Where available colors are not acceptable, modify factory finish color to conform to Architect's color instructions or provide another manufacturer's approved product which has an acceptable finish color, at no extra cost to Owner.

## PART 3 - EXECUTION

- 3.01      **TRANSPORTATION AND HANDLING:** Transport and handle materials and equipment by methods that prevent damage, defacing, or overstressing. Lift the equipment, machinery and heavy fabricated products only at the lifting points designated by the manufacturer or, if not so designated, at the points or along the members designed to support the items when installed. Contractor shall bear all loss which may result from transporting and handling materials and equipment and shall provide approved replacements for damaged or defective items at no extra cost to Owner. Conform handling procedures to Title 8, CCR, as applicable.
- 3.02      **STORAGE AND PROTECTION:** Materials and equipment designed for permanent weather exposure may be stored off the ground without covering provided the equipment closures and seals are intact. Store all other materials and equipment off the ground and in dry, covered, weather-protected locations. Exercise special care to protect moisture-sensitive materials and other materials damaged by light (ultraviolet) or heat. Arrange adequate ventilation under protective covering to prevent condensation. Contractor shall be responsible for cleaning, repairing and renovating any stored material to its new condition and appearance prior to installation. If any such material can not be restored to its new condition, Contractor shall replace it with new materials at no additional cost to the Owner. This stipulation shall also apply to materials for which the Contractor has received payment as "Stored Material".

END OF SECTION



**SECTION 01700**

**CONTRACT CLOSEOUT**

**PART 1 - GENERAL**

1.01 DESCRIPTION: This Section covers general requirements for contract closeout.

**A. Requirements In This Section:**

1. Clean up and disposal.
2. Record as-built drawings.
3. Operation and maintenance manuals.
4. Maintenance materials.

1.02 SUBMITTALS: Submittals under this Section shall conform to the Article "General Submittal Requirements" of Section 01300.

**PART 2 - PRODUCTS** (Not Applicable)

**PART 3 - EXECUTION**

3.01 CLEAN UP AND DISPOSAL: Requirements herein form a part of all other Sections of the Specifications and shall be coordinated with such additional clean up and disposal requirements as may be specified in other Sections.

**A. General:** Leave the entire Work clean except where vacuum clean or other condition is specified.

1. Control During The Work: Take precautions to avoid spread of dust, dirt, debris, water, paint, cement, sprayed materials, and other substances about the site or to adjacent property. Clean up splatterings or spills of materials at time of occurrence. Remove dirt, debris, waste, and rubbish frequently, and do not allow to accumulate in the structure or on the site. Do not store flammable or toxic materials in the structure.
2. Contractor's Supervision: Inform all trades and workmen of the cleaning up requirements specified, and monitor where Work is in progress to ensure full compliance with all clean up requirements in this and other Sections.
3. Architect's Inspection: Give the Architect at least 3 working days advance notice of readiness for inspection as each phase or area of Work is completed for occupancy. Correct any deficient cleaning operations, as determined and directed by Architect.
4. Disposal: Do not place rubbish or waste material in fills or backfills. Remove debris, rubbish, and waste material from Owner's property to a lawful disposal

area and pay all hauling and dumping charges. Conform to pertaining Federal, State, and local laws, ordinances, rules, regulations, and orders.

- B. Final Clean Up - Exterior:** Clean surfaces of construction and site including fixtures, walls, soffits, floors, hardware, roofs, window and opening ledges and sills, horizontal projections, steps and platforms, walkways, rails and all like surfaces, and adjoining private and public property to the extent soiled by the Contractor's operations to bring the surfaces to their new appearance.
- C. Final Clean Up - Interior:** Leave surfaces in vacuum clean condition with all dust, dirt, stains, handmarks, paint spots, droppings, and other blemishes and defects completely removed, and conform to following requirements:
1. **Hard Floors:** Wash and dry concrete, tile, elastomeric, and similar floors, free of streaks or stains.
  2. **Resilient Flooring:** Freshly wax and buff as specified in Division 9.
  3. **Resilient Bases:** Clean off adhesive smears and wipe clean.
  4. **Carpet:** Vacuum clean free of lint, soil, and dust.
  5. **Bare and Painted Surfaces:** Clean off dust, lint, streaks, or stains.
  6. **Tile Walls:** Clean and polish.
  7. **Vinyl Wall Covering:** Remove all adhesive on surfaces.
  8. **Hardware and Metal Surfaces:** Clean and polish all exposed surfaces using noncorrosive and nonabrasive materials.
  9. **Glass:** Wash and polish both sides, and leave free of dirt, spots, streaks, and labels. Clean and polish mirrors.
  10. **Ceilings:** Clean and free of stains, handmarks, and defacing.
  11. **Fixtures and Equipment:** Clean and polish mechanical and electrical fixtures and like items. Leave lighting fixtures free of dust, dirt, stains, or waste material. Clean and service equipment and machinery, ready for use.
  12. **Surfaces Not Mentioned:** Clean according to the intent of this Section and as required for Architect's approval.
- D. Contaminated Earth:** Final clean up operation includes removal and disposal of earth that is contaminated or unsuitable for support of plant life in planting areas, and filling of resulting excavations with suitable soil as directed and approved. Contaminated areas include those used for disposal of waste concrete, mortar, plaster, masonry, and similar materials, areas in which washing out of concrete and plaster mixers or washing of tools

and like cleaning operations have been performed, and all areas that have been oiled, paved, or chemically treated. Do not dispose of waste oil, solvents, paints, solutions, or similar material of a penetrating nature by depositing or burying on Owner's property.

### 3.02 RECORD AS-BUILT DOCUMENTS

- A. **Record Set During The Work:** At site, maintain at least one set of Drawings as a Field As-Built Record set; apportion copies to the various Subcontractors for recording of their portions of the Work. Also maintain at least one copy of all Addenda, Modifications, approved submittals, correspondence, and transmittals at the site. Keep in good order and readily available to Architect, Owner, and their representatives.
- B. **Changes:** Clearly and correctly mark Record Drawings to show all changes and interpretations (bulletins, R.F.I.s, etc.) made during the construction process at the time the changed Work is installed. No such changes shall be made in the work unless authorized by a Modification or by specific approval of deviations or revisions in submittals.
- C. **Final As-Built Record Drawings:** Prior to Substantial completion of the Work, Architect will order for the Contractor, at Contractor's expense, one complete set of Drawings, including clarification and Interpretation Drawings and the Drawings issued by Addenda, printed as reproducible mylar transparencies.
- D. **Preparation of Final Record As-Built Drawings:** Contractor shall transfer all recorded changes in the Work indicated on the Field As-Built Record Set and as occurrences by interpretations (bulletins, R.F.I.s, etc.) to the permanent as-built reproducible mylar transparencies. Changes for all trades shall be neatly and clearly drawn and noted in ink by skilled draftsmen, and shown technically correct.
- E. **Approval:** Prior to Architect's inspection for Substantial Completion, submit both the Field As-Built Record Set and the Final Record As-Built Documents to the Architect for review. Make such revisions as may be necessary, and obtain Architect's opinion that the Final Record As-Built Documents represent a true, complete, and accurate record of the Work.
- F. **Conferences:** Contractor and any Subcontractors involved shall attend post-construction conferences to clarify the Final Record As-Built Documents as may be required by Architect, at no extra cost to Owner.

### 3.03 MANUALS: Obtain data from the various manufacturers and submit instruction, operation and maintenance manuals to the extent required under other Sections of the Specifications.

- A. **Contents:** Each manual shall have an index listing the contents. Information in the manuals shall include not less than (a) general, instructions and overall equipment description, purpose, functions, and simplified theory of operation; (b) specifications; (c) installation instructions, procedures, sequences, and precautions, including tolerances for level, horizontal, and vertical alignment; (d) grouting requirements including grout spaces and materials; (e) list showing lubricants for each item of mechanical equipment,

approximate quantities, needed per year, and recommended lubrication intervals; where possible, the types of lubricants shall be consolidated with equipment manufacturers' approval in order to minimize the number of different lubricants required for maintenance; (f) start-up and beginning operation procedures; (g) operational procedures; (h) shut-down procedures; (i) short- and long-term inactivation procedures; (j) repair, maintenance, and calibration instructions; (k) parts lists and all spare parts recommendations; (l) lists of all special tools, instruments, accessories, and special lifting and handling devices required for periodic maintenance, repair, adjustment, and calibration, and (m) other information as may be specified or required for approval.

- B. **Format and Binding:** Include drawings and pictorials to illustrate the text as necessary to fully present the information. Where the information includes a family of similar items, strike out the inapplicable information or identify applicable portions by heavily weighted arrows, boxes, or circles. Bind each manual in sturdy covers labeled to indicate the equipment to which it applies. Bind manuals less than one-inch thick in standard three-ring binders; others shall have sturdy covers secured with removable fasteners and, when more than two inches thick, shall be bound in locking-bar post binders with rigid covers.
- C. **Manual Submittals:** Unless otherwise specified, each submittal shall include two copies of each manual, one of which will be returned to the Contractor marked to show the required corrections or approval. When approved, deliver four copies to Architect unless otherwise specified.

3.04 **MAINTENANCE MATERIALS:** Furnish and deliver all the special tools, instruments, accessories, spare parts, and maintenance materials required by the Contract Documents, and furnish and deliver the special tools, instruments, accessories, and the special lifting and handling devices shown in the instruction manuals approved above. Unless otherwise specified or directed, deliver the items to the Owner, with the Contractor's written transmittal accompanying each shipment, in the manufacturer's original containers labeled to describe the contents and the equipment for which it is furnished. Deliver a copy of each transmittal to Architect for record purposes.

END OF SECTION



**SECTION 01740**

**WARRANTIES**

**PART 1 - GENERAL**

- 1.01      **DESCRIPTION:** This Section covers general requirements for written warranties required under the Contract Documents. The submission to and approval by the Owner of the warranties is a prerequisite to final payment under the Contract.
- 1.02      **MANUFACTURERS' WARRANTIES:** Deliver all the manufacturers' warranties required by the Contract Documents, with Owner named as the beneficiary. In addition, for all equipment and machinery, or components thereof, bearing a manufacturers' warranty that extends for a longer time period than the Contractor's warranty, secure and deliver the manufacturers' warranties in the same manner. Refer to Section 01300, Paragraph "Equipment Data", for the submission of manufacturers' warranty data.
- 1.03      **FORM OF WARRANTY:** Written warranties, except manufacturers' standard printed warranties, shall be on the Contractor's, Subcontractor's, material supplier's, or manufacturer's own letterhead, addressed to the Owner. All warranties shall be submitted in duplicate, and in the form shown on the following page, modified as approved to suit the conditions pertaining to the warranty.
- 1.04      **SUBMISSION OF WARRANTIES:** Collect and assemble all written warranties into a bound booklet form, and deliver them to Architect for delivery to the Owner's Counsel for final review and approval.
- 1.05      **PROVISIONS FOR WARRANTIES:** See attached warranty coverage list.

**MTA HEADQUARTERS**

Location \_\_\_\_\_

**GENERAL CONTRACTOR GUARANTEE**

\_\_\_\_\_ (General Contractor)  
hereby guarantees all work furnished and as installed under our Contract with  
\_\_\_\_\_ (Design/Builder) for the  
\_\_\_\_\_ Project/Location) against defects in material  
and workmanship for a period of **ONE (1) YEAR** from the date of Substantial Completion of the Project as  
noted below. **The Design/Builder or Owner shall be responsible for the enforcement of the guarantee  
and warranty upon completion of the general one (1) year warranty.**

Specifically excluded are all costs necessary to remove, repair or replace any material or work not part of the  
original agreement between the Design/Builder and the General Contractor.

Facility

Date of Substantial Completion

- 1.
- 2.
- 3.
- 4.
- 5.
- 6.

Date this \_\_\_\_ day of \_\_\_\_\_

By: \_\_\_\_\_

Title: \_\_\_\_\_

**MTA HEADQUARTERS**

Location \_\_\_\_\_

**SUBCONTRACTOR GUARANTEE**

Subcontractor/Supplier, \_\_\_\_\_,  
Hereby guarantees the work/material furnished under Contract \_\_\_\_\_ for the  
\_\_\_\_\_ project against defects in workmanship, materials and  
equipment for a period of \_\_\_\_\_ ( ) year(s) from date of Certificate of Substantial Completion of the  
Project and for any longer period specifically called out in the Project Specifications.

**Upon written notice (within 10 days of first knowledge of defect) from Owner, Subcontractor/Supplier agrees to replace or repair to a new condition any defective product furnished under this Contract, including replacing or repairing, to a new condition, all other work affected by the Subcontractor's repair or replacement of his work, at no additional cost to the Design/Builder or Contractor. Costs to remove, repair or replace any materials or work not a part of the Construction Agreement between the Design/Builder and the Contractor are specifically excluded. This Guarantee shall be assignable directly to the Design/Builder or Owner. Design/Builder or Owner shall be responsible for the enforcement of the guarantee and warranty upon completion of the general one (1) year warranty.**

**DESCRIPTION OF MATERIALS FURNISHED/SPECIFICATION SECTION**

<u>Section No.</u>	<u>Description</u>
_____	_____
_____	_____
_____	_____
_____	_____

Dated this \_\_\_\_\_ day of \_\_\_\_\_, 19 \_\_\_\_\_

\_\_\_\_\_  
(Subcontractor/Supplier)

\_\_\_\_\_  
(Address)

\_\_\_\_\_  
(Telephone Number)

By: \_\_\_\_\_

Title: \_\_\_\_\_

ATTACHMENT - PROVISIONS FOR WARRANTIES:

1 year warranty (parts, material replacement, & labor)

Window Washing Equipment  
Elevator System  
HVAC System  
Domestic House Pumps  
Landscape & Irrigation  
Security Systems

2 year warranty (parts, material replacement, & labor)

Energy Management System  
Fire Life Safety Systems

Emergency call out service & work request to be done after business hours at no additional cost to owner

Elevator System  
HVAC System  
Energy Management System  
Fire Life Safety Systems  
Domestic House Pumps  
Security Systems

Proposal to provide preventative maintenance contract for a 5 year period

Elevator System  
Energy Management System  
Fire Life Safety Systems  
Security Systems

Full maintenance contract in effect during the warranty period

Window Washing Equipment  
Elevator System  
Energy Management System  
Fire Life Safety Systems  
Landscape & Irrigation  
Security Systems

Software fine tuning as occurs and in depth operator training at no additional cost during the warranty period

HVAC System  
Energy Management System  
Fire Life Safety Systems  
Security Systems

END OF SECTION

**SECTION 02200**

**EARTHWORK**

**PART 1 - GENERAL**

- 1.01 **DESCRIPTION:** Division 1 applies to this Section. Provide materials and preform earthwork for structures as indicated, specified, and required.
- A. Principal work in this Section:**
1. Site demolition and clearing.
  2. All excavating, filling, backfilling, compacting and grading required for the Project, except as excluded in Paragraph B below.
  3. Pumping, draining, shoring, cribbing and other protective measures.
  4. Importing fill materials.
  5. Removing excess and unsatisfactory excavated materials from the site.
- B. Related work:**
1. Trenching, backfilling and compacting for utilities: Section 02210.
  2. Demolition and site clearing.
- C. Definition:** "Compaction", as specified herein, is expressed as a percentage of the maximum density obtainable when tested in accordance with ASTM D1557-78.
- 1.02 **QUALITY ASSURANCE**
- A. Lines and levels:** Refer to Section 01050. Owner to furnish base lines and benchmarks by a licensed surveyor or civil engineer. Contractor to provide layout of the work and establish the necessary markers, batter boards stakes, etc., as required.
- B. Inspections and tests:**
1. The Owner will employ a Geotechnical Engineer to inspect and test the work of this Section.
  2. The responsibilities of the Geotechnical Engineer are outlined in Article 3.08 of this Section.

- C. **Shoring:** Owner, under separate contract, shall employ and pay a California registered civil engineer to prepare and stamp drawings and calculations showing the shoring methods, tie back anchoring, wall support systems, and other systems used for protection of all adjacent existing structures and improvements and for all earth banks, shall submit shoring drawings and calculations to Geotechnical Engineer and Structural Engineer for discussions but not for approval, shall obtain Building Department approval and required permits prior to start of any construction involving shoring and pay fees and charges. The Contractor shall establish and maintain any and all deflection monitoring devices or procedures as may be required by the City of Los Angeles Building Department or other governmental agencies having jurisdiction.

1.03 GEOTECHNICAL INVESTIGATION REPORT

- A. **Geotechnical Investigation:** Refer to report by Law/Crandall, Inc., Project No. L91291.ADEO dated December 13, 1991.
- B. **Summary of Ground-Water Conditions and Related Design Criteria:** Refer to report by Levine-Fricke, LF 2460 dated September 23, 1992 (Draft).

1.04 WARRANTY

- A. **Any settling of backfill** which may occur during the one-year period after Substantial Completion shall be repaired to Owner's satisfaction by Contractor without expense to Owner, including complete restoration of damaged paving, walks, and other materials or installations of every kind.

PART 2 - PRODUCTS

2.01 FILL AND BACKFILL MATERIALS

- A. **Materials:** All fill and backfill materials shall conform to requirements of the Geotechnical Report and be reviewed by the Geotechnical Engineer.
- B. **Granular fill under building slabs-on-grade:** Clean gravel or crushed rock graded as follows. Exception: slabs-on-grade to receive waterproofing assembly per Section 07130 will not receive granular fill unless so directed by Geotechnical Engineer.

<u>Sieve Size</u>	<u>Percent Passing</u>
3/4"	90-100
No. 4	0-10
No. 100	0-3

- C. **All other fill and backfill:** One or both of the following.
  1. On-site materials, less debris, matter and cobbles less than 6 in. in diameter.

2. Imported materials consisting of relatively non-expansive and predominantly granular soils with an expansion index of less than 35, and containing sufficient fines (binder material) to be relatively impermeable when compacted resulting in a stable subgrade.

### **PART 3 - EXECUTION**

#### **3.01 PROTECTIVE MEASURES**

##### **A. Underground utilities:**

1. Before starting excavations, locate existing underground utilities in work areas. If utilities are to remain in place, provide adequate protection during earthwork operations to prevent damaging them.
2. If uncharted, or incorrectly charted utilities are encountered during excavations, notify the utility owner for instructions. Cooperate with utility owner in keeping respective services and facilities in operation. Repair damaged utilities to the satisfaction of the utility owner.
3. Should old lines be encountered which prove to be "Out of Service", they shall be removed as part of excavation, or if sufficiently below grade, as determined by the Geotechnical Engineer, may be capped and left in place.

##### **B. Moisture control:**

1. Dewatering Requirements: Contractor shall provide dewatering system(s) including continued operation in compliance with the report entitled "Construction Dewatering Scheme for Stage 1 Union Station Gateway, Los Angeles, California, by Levine-Fricke, Report No. LF 2825-01, dated February 9, 1993.
  - A. **Required:** Provide necessary facilities and equipment to dewater excavation and provide treatment for any discharged water to construct the below-grade work. The Contractor shall obtain all necessary approvals and permits for water disposal. Maintain dewatering system in place and operable until below-grade construction in dewatering areas is complete, tested as required, and removal is approved.
  - B. **Operation:** Perform dewatering as a continuous uninterrupted operation until new work in dewatered excavation is entirely constructed, waterproofing is tested.
  - C. **Testing of Waterproofed Structure:** After construction is complete below the Historic high water mark, allow the ground water to rise to natural elevation. Examine structure interior for leakage for at least ten (10) days. If leakage occurs, perform dewatering, repair and re-testing until leakage is eliminated as approved.

- C. **Shoring, cribbing and bracing:** Shore, crib and brace the excavations as necessary to prevent cave-ins and to support and protect adjacent construction, in accordance with Federal, State and local laws.
- D. **Benchmarks and monuments:** Protect benchmarks, monuments and other reference points against displacement and damage.
- E. **Dust palliation:** Keep down dust at the site by intermittent watering and sprinkling while the work of this Section is being performed.

### 3.02 EXCAVATING AND FILLING

- A. Remove all debris, remaining after demolition and site clearing, in areas affected by the Contract.
- B. Remove all existing fill soils and disturbed natural soils for their entire depth.
  - 1. Excavate all materials encountered regardless of their nature to the lines and levels indicated or necessary to complete the Work.
  - 2. Size excavations to allow for placing and removing formwork, installing protective shoring and bracing as may be necessary to prevent caving or sloughing of banks, and to allow for installation of waterproofing and other services.
  - 3. Where gravel and cobbles make excavations difficult at the planned subgrade elevation, leave the bottom of the excavation uneven instead of removing same and filling excavated depressions.
- C. Stockpile satisfactory excavated materials which will be used for fill and backfill.
- D. Remove large cobbles encountered at the planned subterranean level and replace with fine compacted material compacted to 90% of maximum density. Geotechnical Engineer to determine size of cobble requiring removal.
- E. Before placing fill remove debris then scarify exposed natural soils to a depth of 6" and compact to a density of at least 90% of maximum density.
- F. Place fill on compacted natural soil in loose layers not more than 8" thick when compacted with heavy compaction equipment; 4" when compacted with hand-held compactors. Bring each layer to optimum moisture content and compact to at least 90% of maximum density. Continue filling until the desired levels are reached.
- G. Treat soils so that the moisture content at the time of compaction does not vary more than 2% from optimum.
  - 1. Do not place fill or backfill during unfavorable weather conditions.
  - 2. If work is interrupted by heavy rain, do not resume operations until the proper moisture content and density of the materials have been achieved.



### 3.03 BACKFILLING

- A. Place backfill as specified for "fill" above, as construction operations permit, but not before the following is done:
1. Work to be covered has been inspected and approved.
  2. Concrete formwork, and loose soils and debris have been removed from the excavations.
  3. Underground utility locations have been recorded.
  4. Shoring and bracing have been removed, and voids have been filled and compacted.
  5. Waterproofing has been inspected and approved.
  6. Permanent or temporary horizontal bracing is in place on walls supported by a floor or roof.
- B. Place backfill on compacted natural soil in loose layers not more than 8" thick (except as specified below in constricted areas) when compacted with heavy compaction equipment; 4" when compacted with hand-held compactors. Bring each layer to optimum moisture content and compact to at least 90% of maximum density. Continue backfilling until the desired levels are reached.
1. In areas where space is too narrow to perform density tests, backfill with gravel or crushed rock material specified. Vibrate this backfill in layers not exceeding 12" during placement to densify the material. Cap the upper 24" of this backfill with relatively impervious soils compacted to 90% of maximum density.
  2. Where density tests can be performed on compacted backfill, use on site or imported materials complying with the provisions of these Specifications.
  3. Do not place backfill during unfavorable weather conditions.
  4. If work is interrupted by heavy rain, do not resume operations until the proper moisture content and density of the materials have been achieved.
- C. Where backfill is required on both sides of a structure, place it simultaneously so that the height of backfill remains approximately equal on both sides at all times.
- D. Brace construction which has not been designed to withstand eccentric loading during backfilling.
- E. Backfill only after the structure to be backfilled against has attained its design strength or has been properly braced to resist the load of the backfill. No compacting by jetting permitted.
- F. Keep rollers and other heavy equipment at least 4 ft. from footings, foundations, piers and walls of building and auxiliary structures.

### 3.04 GRADING

- A. The locations and elevations of all constructions are indicated on the Drawings and, unless inconsistencies are brought to the Architect's attention prior to commencement of work, the Contractor will be held responsible for the proper location and elevations of the completed work.
- B. Grade all areas to the lines and levels required. Finish areas free from irregular and abrupt surface changes. Keep grades straight between changes in elevations.
  - 1. Rough grading tolerance shall be within 2" of required elevations.
  - 2. Finish grading tolerances shall not exceed +3/8" and (minus) -1" of required elevations, when evenly distributed.
- C. The required subgrade elevation shall be such that when subbase and indicated construction are added the final elevations will be those shown on the Drawings.

### 3.05 GRANULAR BASE COURSE

- A. Where field conditions from construction operations result in soils at excavated level to become wet or spongy, place granular base course under building slabs-on-grade, on properly compacted subgrade, in layers of uniform thickness conforming to lines and levels indicated.
- B. Approximately 12 in. of base course will be required placed in two layers of equal thickness.
- C. Roll and vibrate base course to obtain maximum compaction.

### 3.06 DISPOSAL

- A. Satisfactory excavated materials, in excess of that required for filling and backfilling, and unsatisfactory materials, including those resulting from drilling of elevator cylinders, shall be removed from the site and disposed of legally. Burning and burying materials on-site is prohibited.

### 3.07 PROTECTION OF COMPLETED WORK

- A. Protect finished areas from weather damage to prevent erosion and raveling of graded areas.
- B. Hauling and other activities on prepared grades which will deform them from required cross sections will not be permitted.
- C. Repair and recompact damage to prepared grades caused by subsequent construction operations or adverse weather.

3.08 FIELD QUALITY CONTROL

- A. Site preparation, foundation excavations and placement of fill and backfill will be monitored by the Geotechnical Engineer.
- B. The responsibilities of the Geotechnical Engineer will include, but may not be limited to the following:
  - 1. Observe the clearing and grubbing operations to verify that unsuitable materials have been properly removed.
  - 2. Observe the exposed subgrade in areas to receive fill and in areas where excavation has resulted in the desired finished subgrade, observe proof-rolling, and delineate areas requiring overexcavation.
  - 3. Perform visual observation to evaluate the suitability of on-site and import soils for fill placement. Collect and submit soil samples for required laboratory testing.
  - 4. Perform field density and compaction tests to determine the percentage of compaction achieved during fill placement.
  - 5. Observe and probe foundation bearing materials to confirm that appropriate bearing materials are present at the design foundation levels. Recommend adjustments needed to construct footings.
  - 6. Observe excavated areas to determine material and cobbles requiring removal from site.

END OF SECTION



3.08 FIELD QUALITY CONTROL

- A. Site preparation, foundation excavations and placement of fill and backfill will be monitored by the Geotechnical Engineer.
- B. The responsibilities of the Geotechnical Engineer will include, but may not be limited to the following:
  - 1. Observe the clearing and grubbing operations to verify that unsuitable materials have been properly removed.
  - 2. Observe the exposed subgrade in areas to receive fill and in areas where excavation has resulted in the desired finished subgrade, observe proof-rolling, and delineate areas requiring overexcavation.
  - 3. Perform visual observation to evaluate the suitability of on-site and import soils for fill placement. Collect and submit soil samples for required laboratory testing.
  - 4. Perform field density and compaction tests to determine the percentage of compaction achieved during fill placement.
  - 5. Observe and probe foundation bearing materials to confirm that appropriate bearing materials are present at the design foundation levels. Recommend adjustments needed to construct footings.
  - 6. Observe excavated areas to determine material and cobbles requiring removal from site.

END OF SECTION



**SECTION 02210**

**TRENCHING AND BACKFILLING  
FOR UTILITIES**

**PART 1 - GENERAL**

- 1.01 DESCRIPTION: Division 1 applies to this Section. Provide materials and preform trenching and backfilling for utilities as indicated, specified, and required.
- A. Principal work in this Section:**
1. Trenching, backfilling and compacting for utilities.
  2. Bedding material for pipes.
- B. Related work:**
1. All other trenching, shoring and bracing, backfilling, and compacting: Section 02200.
  2. Installation and tests of utilities: Division 15 and 16.
- 1.02 QUALITY ASSURANCE
- A. General:** Obtain Geotechnical Engineer's approval of backfill materials, method of placement, and the completed work. Requirements of Section 02200 apply to the work of this Section.
- B. Reference data:** Maps, soil investigation reports, and similar reference data are made available to Contractor for information only. Architect assumes no responsibility for any conclusions the Contractor may draw therefrom.
- C. Reference standard:**
1. Perform all work in accordance with applicable provisions of "Standard Specifications for Public Works Construction" (SSPWC). Mention herein of section numbers refers to sections of the reference standard.
  2. Where reference standard refers to "Agency", substitute the word "Owner". Where reference standard is in conflict with these Specifications, these Specifications govern.
- 1.03 GEOTECHNICAL INVESTIGATION REPORT
- A. Geotechnical Investigation:** Refer to report by Law/Crandall, Inc., Project No. L91291.ADEO dated December 13, 1991.

**1.04 WARRANTY**

- A. Any settling of backfill in trenches which may occur during the one-year period after Substantial Completion shall be repaired to Owner's satisfaction by Contractor without expense to Owner, including complete restoration of damaged paving, walks, and other materials or installations of every kind.

**PART 2 - PRODUCTS**

**2.01 IMPORTED MATERIAL**

**A. Imported fill:**

1. Non-expansive granular material with an expansion index of less than 35.
2. Material shall not contain fines in excess of 40% passing No. 200 sieve, but it shall include sufficient fines (binder material) to produce a compacted fill which will not rut under construction traffic, and remain stable in shallow trenches.
3. Imported fill is subject to Geotechnical Engineer's approval before transporting to site.

**2.02 LOCAL MATERIAL**

- A. Local materials from cuts or excavations, approved by the Geotechnical Engineer, free of debris and without soft, spongy, organic and other deleterious materials.

1. Do not use cobbles or boulders larger than 4" in largest dimensions at any depth.
2. Do not use rocks greater than 2-1/2" in largest dimension in backfill within 12" of the top of pipe or structure, and within 12" of the top of pavement subgrade.
3. Where rocks are included in backfill, mix with suitable materials to eliminate voids.

**2.03 BEDDING MATERIALS**

- A. Complying with section 306.1.2.1, Bedding, of the reference standard.

**PART 3 - EXECUTION**

**3.01 INSPECTION**

- A. Verify conditions and measurements affecting the work of this Section at site. Make sure that detrimental conditions are corrected before proceeding with installation.



3.02 PROTECTIVE MEASURES

- A. **General:** Comply with the following and the provisions of Section 02200 on the same subject.
- B. **Utilities:** Protect existing utility lines.
- C. **Settlement:**
  - 1. In areas where compacted backfill has been placed, additional consolidation will occur after completion due to changes in moisture content and surcharge.
  - 2. Install utility connections crossing this backfill to the building, and improvements adjoining the building at the backfill line, to take into account this additional consolidation, or schedule sufficient time between backfilling operations and such improvements to allow this consolidation to take place.

3.03 COMPACTION CONTROL

- A. **Notification:** Notify the Geotechnical Engineer whenever trench backfill work is being performed as part of this Section.
- B. **Replacement:** Geotechnical Engineer will determine if work performed without inspection meets the requirements of these Specifications. Where directed by Geotechnical Engineer, uncover and replace work performed without inspection at no additional cost to the Owner.

3.04 TRENCH EXCAVATION

- A. Before opening any new excavations, uncover all intersecting existing utility lines located between the ground surface and one foot below the bottom of the new trench line.
  - 1. **General:**
    - a. Where unidentified existing utilities are encountered, determine whether these are active or abandoned.
    - b. Remove interfering portions of abandoned utilities and cap or plug open ends of pipe to remain.
    - c. The cap or plug must seal the opening in such a manner that would permit remaining portion of the utility to be reactivated.
    - d. Notify Construction Manager for instructions on utilities which are determined to be active. Any relocation work performed on an active utility without obtaining prior approval of Construction Manager will be done at the Contractor's risk and expense.
    - e. Do not proceed without instructions, except to correct an immediate hazard or emergency condition.

2. Trench width:

- a. Maximum width of trench shall be 20" more than greatest diameter of pipe up to a point 6" above top of the pipe, except that it may be widened enough to place sheeting.
- b. Make trenches at least 12" wider than greatest exterior diameter of pipe or conduit except that trenches for concrete-encased ducts may be the same width as duct encasement.

3. Dimensional tolerance:

- a. Maintain accuracy of gravity utility lines designated for gradients less than 1% to 1/8" at any point and cumulative within 1/2" per 100 ft.
- b. For all gravity lines, check each section of pipe for proper gravity slope direction with a string line set over the pipe by a surveyor.
- c. Non-gravity utility line subgrades shall be accurate within  $\pm 2"$ .

3.05 PIPE BEDDING

- A. **Where bedding is required**, provide a minimum of 4" of bedding material in the bottom of the trench, in addition to the requirements of section 306-1.2.1 of the reference standard, before installing pipes or conduits.
- B. **Prior to jetting the bedding material**, where jetting is permitted by the Geotechnical Engineer, make provisions at the downstream end of the trench to remove the excess water.
- C. **Do not allow water** to accumulate in the trench.

3.06 DEWATERING

- A. **Comply with the requirements** of Section 02200 on the same subject.
- B. **At no time shall water** be allowed to back up into pipe in place. Securely plug terminal ends of pipe before work is abandoned at end of day or when laying is interrupted.

3.07 TRENCH BACKFILL

- A. **Backfilling of utility trenches** shall not be undertaken (1) for 24 hours after Geotechnical Engineer has been notified of same, (2) until required tests and inspections have been completed, and (3) until "as-built" location notes have been recorded.
- B. **Place backfill material** in accordance with section 306-1.3.2 of the reference standard, and to achieve at least 90% of the maximum density in accordance with ASTM D 1557. The top 12" of backfill in the building and under paved areas shall be compacted to 95% of maximum density.

- C. **Unless otherwise** authorized by the Geotechnical Engineer, compaction by ponding or flooding will not be permitted.
- D. **Remove surplus earth** left after backfilling, and grade top of trench to match adjacent grades.
- E. **Backfill voids left** by removal of sheeting, piles, and similar sheeting supports immediately with clean sand to assure dense and complete filling of voids.

END OF SECTION



**SECTION 02580**

**PAVEMENT MARKINGS  
AND WHEEL STOPS**

**PART 1 - GENERAL**

1.01 DESCRIPTION

**A. Principal work in this Section:**

1. Pavement markings.
2. Precast concrete wheel stops.

**B. Related work:**

1. All other field painting: Section 09900.

**PART 2 - PRODUCTS**

2.01 MATERIALS

**A. Paint:** One of the following; (color(s) selected by the Architect)

TTP-115F by Morton International Inc.  
Traffic Marking Paint 1P-901 or Vinyl-Stripe vinyl epoxy paint W-801 by Dunn Edwards Corp.  
160 Vinyl Traffic Paint by Sinclair Paint Co.  
Traffic Zone Paint B46 Series by Sherwin-Williams.

**B. Wheel stops:** Standard precast concrete units formed of 3,500 psi (minimum) concrete reinforced with two No. 4 deformed bars. Exposed surfaces shall be dense and smooth, free of honeycombs.

**C. Epoxy adhesive:** 2-part adhesive suitable for adhering concrete-to-concrete by Hunt Process Co., Delta Plastic Co., Fiber-resin Corp, Sika Chemical Co. or Grove Specialties, Inc.

**PART 3 - EXECUTION**

3.01 INSPECTION

**A. Verify conditions** and measurements affecting the work of this Section at site. Make sure that detrimental conditions are corrected before proceeding with installation.

3.02 PREPARATION

- A. **Remove dust, debris, curing and sealing compounds, and other foreign substances** detrimental to epoxy adhesive and paint bond. Use a commercial degreasing solution to remove grease and oil.
- B. **Take field** measurements and make layouts required.

3.03 PAVEMENT MARKINGS

- A. **Clean surfaces** to be painted, and mix and apply paint in accordance with the paint manufacturer's printed instructions.
- B. **Paint pavement** lines and legends in accordance with the layout shown on the Drawings. The work shall be straight or curved as indicated, of uniform color and texture with edges parallel, clean, sharply defined and accurate.
- C. **Dry film thickness** of cured paint film shall be 15 mils or more where required for complete opacity.
- D. **Erect temporary barriers** and signs, and leave them in place until the paint has thoroughly dried.

3.04 WHEEL STOPS

- A. **Install in the locations** shown, in even alignment over clean and dry surfaces using epoxy adhesive. Apply adhesive to provide a bond of 75% minimum of contact surface.
- B. **If paving is irregular,** level with a mixture of adhesive and sand before installing the stops. Follow adhesive manufacturer's instructions.

3.05 HANDICAPPED SIGNAGE

- A. **Provide Los Angeles** reflectorized International Symbol of Accessibility signs with porcelain finish and steel frame. Mount and finish as detailed on Drawings.
- B. **Coordinate installation** with project signage graphic consultant.

END OF SECTION

**SECTION 03100**

**CONCRETE FORMWORK**

**PART 1 - GENERAL**

- 1.01 DESCRIPTION: Division I applies to this Section. Provide concrete construction as indicated, specified, and required.
- A. Principal work in this Section:**
1. Forms for cast-in-place concrete.
  2. Shoring, bracing, accessories and form coating.
  3. Shoring for precast members furnished under Section 03420.
- B. Work installed but furnished in other Sections:**
1. Inserts, bolts, anchors and other items furnished by other trades for installation in formed concrete.
- C. Related work:**
1. Forms for precast concrete: Section 03450.
  2. Falsework and shoring for masonry: Section 04220.
- 1.02 SUBMITTALS
- A. Submit the following in accordance with the requirements of Section 01300:**
1. Shop drawing submittals shall be for design compliance only. Structural integrity of the formwork shall be the Contractor's responsibility.
  2. Dimensioned shop drawings for all formwork of concrete to remain exposed to view showing tie placement, plywood panel layout, construction joint and other pertinent details. Prepare shop drawings at a scale appropriate to adequately describe the work, but in no case at a scale smaller than the construction documents.
  3. Full size samples of the ties and plugs for concrete to remain exposed to view.
  4. Manufacturer's data for form facing material, form coating, ties, joint sealant or tape, for formwork of concrete to remain exposed to view.
- B. Keep an accurate record of the dates of all form removal and furnish copies to the Architect.**
- 1.03 QUALITY ASSURANCE
- A. Design of forms and formwork shall be the sole responsibility of the Contractor. Contractor shall have all formwork designed by a California licensed Structural or Civil Engineer who shall be the engineer responsible for their formwork design.**

- B. **Allowable Tolerances:** Construct forms conforming to the tolerances specified in latest issue of ACI A-117.
- C. **Lumber and plywood** shall be grade-marked by a grading agency acceptable to the Building Department.

1.04 HANDLING

- A. **Comply with the** requirements of Section 01600.
- B. **Store form facing** materials above ground on framework or blocking. Handle form facing materials to prevent damages which could be transferred to the concrete.

PART 2 - PRODUCTS

2.01 MATERIALS

- A. **Forms for exposed concrete surfaces:**
  - 1. Plywood, metal, or metal-framed/plywood-faced which will provide continuous, flat, or curved as applicable, smooth exposed concrete surfaces. Furnish in largest practicable sizes to minimize number of joints and to conform to joint system shown on Drawings, where indicated.
  - 2. Plywood shall comply with US Product Standard PS-1, mill-oiled and edge-sealed, with each piece bearing legible inspection trademark. Slab Soffit plywood shall be B-B plyform. Wall and column form plywood shall be MDO.
- B. **Forms for concealed concrete surfaces:** Plywood, lumber, metal, or other acceptable material. Provide lumber dressed on at least 2 edges and one side for tight fit.
- C. **Form ties and spreaders:**
  - 1. For concrete which will remain exposed to view use Burke "Standard BA Penta-Tie" with BA plastic cones, or equal.
  - 2. At all other locations, provide cone or snap type ties designed to be completely removed from wall, or to break off and provide minimum 1-1/2" coverage over ends of the portion of snap tie remaining in the concrete.
  - 3. Do not use wire ties, wood spreaders, or embedded types in which embedded portion is less than 1-1/2" from exterior face of concrete.
- D. **Chamfer strips:** Extruded PVC, with 3/4" diagonal faces unless otherwise indicated, by The Burke Co., Greenstreak Plastic Products Co., or Sonneborn-Rexnord, Inc., or oiled softwood shapes with the same profile.



- E. **Form coatings:** Commercial formulation form-coating compounds with a maximum VOC of 350 mg/l that will not bond with, stain, or adversely affect concrete surfaces and will not impair subsequent treatments of concrete surfaces.
- F. **Prefabricated construction joint keyways:** Key-Loc by Form-A-Key Products Div., or Keyed Kold Joint by The Burke Co., complete with all accessories.

### PART 3 - EXECUTION

#### 3.01 INSPECTION

- A. **Verify conditions** and measurements affecting the work of this Section at site. Make sure that detrimental conditions are corrected before proceeding with installation.

#### 3.02 FORM TYPES

- A. **General:** Comply with the applicable provisions of ACI 347, Guide to Formwork for Concrete, and APA Design/Construction Guide, Concrete Forming.
  - 1. The design and construction of forms and shoring is the Contractor's responsibility but shall comply with specified requirements.
  - 2. Form contact surfaces shall be clean, free from dents, holes and other imperfections.
  - 3. Establish and maintain benchmarks, lines and controls necessary to achieve specified tolerances. Take an accurate survey of the form location just prior to concrete pour.
- B. **Earth bank:**
  - 1. Except for exterior face of wall footings and grade beams which must be formed, earth banks may be used to form footings and grade beams if the soil is firm, neatly trimmed, and will retain concrete in the required size and shape.
  - 2. The concrete coverage shall be increased as noted on the Drawings when concrete is cast against earth.
- C. **Wood forms:**
  - 1. Construct with plywood panels as large as practicable. Where because of their height walls or columns have a horizontal form joints, the horizontal joint shall be aligned throughout the same floor, or area, unless otherwise acceptable to the Architect.
  - 2. For concrete wall surfaces which will remain exposed in the Work, fill voids, fastener heads, and other imperfections in form contact surfaces with body putty sanded smooth, and seal joints between plywood panels flush with compound specifically designed to seal forms or other approved material to prevent concrete paste leakage. For concrete slab soffits, contractor to prepare an in-place mock-up for review by the Architect showing quality of finish to the satisfaction of the Architect.
  - 3. Kerf backside of wood inserts used for forming keyways, reglets, recesses and similar treatments, to allow wood to swell without spalling concrete, and to assure easy removal.

- D. **Metal forms:** Fasten sections of forms tightly and interlock securely. Provide precisely cut openings required by other trades. Cut or drill forms for attaching sleeves or other items to be embedded in concrete.
- E. **Re-use of forms:** Form materials may be re-used if they produce finished surfaces equal to finished surfaces where new form materials are used. Before re-use, thoroughly clean, recondition in every respect, suitable for their re-use purpose.
- F. **Tolerances:** To obtain cast-in-place concrete not exceeding the tolerances specified in Section 03300, except support form facing material to limit deflection to L/360 between supports for concrete exposed to view, and L/270 for all other concrete.

3.03 FORM CONSTRUCTION

A. **Construction:**

- 1. Rigidly support and construct forms to the lines, surfaces and profiles necessary to produce concrete of the design indicated.
- 2. Construct forms to be removable without prying against concrete.
- 3. Make forms tight, without cracks or holes, to prevent leakage of mortar or loss of fine particles from concrete.
- 4. Cover or fill holes that are not used, and cracks that have opened up, flush with adjacent surfaces.

B. **Wales and studs:** Of adequate size and spacing to prevent form failure and to obtain concrete within the tolerances specified.

C. **Ties and spreaders:** Place ties symmetrically, equally spaced as required, in plumb and level rows. Do not permit wood, other than built-in treated bucks or nailing blocks, to remain permanently in the forms.

D. **Form contact surfaces:**

- 1. As specified above and as best suited to prevailing conditions; may be constructed of plywood, FRP, plastic, or steel.
- 2. Block plywood edges, which do not occur at bearing points, to eliminate joint offsets.

E. **Special features:**

- 1. **Chamfers:** Install chamfer strips in corners of forms, unless otherwise indicated or detailed.
- 2. **Reglets, rebates, seats and pockets:** Form as indicated or as necessary to receive or engage work of other trades.
- 3. **Openings, chases and recesses:** Form as indicated or necessary to receive, pass and clear other work. Verify sizes and locations with other trades before forming. Closely cooperate in locating boxes, cans and sleeves furnished by other trades.

- F. **Form release agent:** Thoroughly clean forms and coat with release agent prior to initial use (except when mill-oiled) and before each reuse.
1. Apply form coating in accordance with its manufacturer's printed instructions and coverage rates.
  2. Coat steel forms with a non-staining, rust-preventative material. Rust-stained steel formwork is not acceptable.
  3. Provide a coating of uniform thickness. Do not allow excess form-coating material to accumulate in forms or to come into contact with in-place concrete against which fresh concrete will be placed.
  4. Apply form coating before reinforcement is placed.

3.04 FORM REMOVAL

- A. **Remove forms only** after concrete has developed sufficient strength to safely sustain its own weight and superimposed loads, as determined by testing field cured concrete cylinders, but not sooner than specified in ACI 347 or permitted by City of Los Angeles requirements. The longer required time of removal shall prevail.
- B. **Take care when** removing forms that concrete surfaces are not marred or gouged, that corners are true, sharp and unbroken. Do not pry against concrete when removing forms.
- C. **Cut-off nails flush** in concealed concrete surfaces. Cut back tie wires and nails in exposed concrete surfaces at least 1-1/2". Remove rod and cone ties and separators or similar devices and pull inward away from finished surfaces.

END OF SECTION

ACI 308-81 "Standard Practice for Curing Concrete."  
ACI 315-80 "Details and Detailing of Concrete Reinforcement."  
ACI 318, Building Code Requirements for Reinforced Concrete.

1.04 REGULATORY REQUIREMENTS:

- A. Conform to current UBC with current State of California and Los Angeles Building Code amendments and all applicable codes.

1.05 TESTS

- A. Testing and analysis of concrete will be performed under provisions of Section 01400.
- B. Submit proposed mix design of each class of concrete to testing agency firm for approval and to structural engineer for review prior to commencement of work.

PART 2 - PRODUCTS

2.01 MATERIALS

- A. Portland cement: ASTM C150, Type I or II low alkali. Type II cement shall have a maximum alkali content of .60% calculated as  $(Na_2O + .658K_2O)$ . Do not change brand or type of cement without Architect's written approval.
- B. Aggregates:
1. General: Submit pit source and characteristics of each type aggregate to Architect prior to designing mixes. Aggregate which may cause excessive drying shrinkage will not be permitted.
  2. Aggregates:
    - a. Hardrock aggregate: ASTM C33 graded so that coarse aggregate nominal size is not larger than 1/5 of the narrowest dimension between form faces; nor 3/4 of the minimum clear spacing between individual reinforcing bars or bundles of bars, whichever is less, but never greater than 1" in any dimension for slabs 4" thick or less; 1-1/2" at all other locations.
    - b. Lightweight aggregate: ASTM C330, processed aggregate from approved sources with the exception of pumice and its derivatives.
- C. Admixtures:
1. Air entraining admixtures shall conform to ASTM C260.
  2. Chemical admixtures shall conform to ASTM C494 or ASTM C1017.
  3. Other admixtures, including plasticizers, proposed for use and not covered by the above specifications may be used but must be approved by the Architect and/or Engineer of record and by the Los Angeles Department of Building and Safety.

4. Pozzolan: ASTM C618, Type F or C. May be used only with the Architect's and Structural Engineer's review and approval, and shall be limited to 12% of total cementitious material content by weight.
  5. Submit manufacturer's data for products proposed for use to the Architect in accordance with the requirements of Section 01300.
  6. **Calcium chloride will not be permitted.**
- E. Water:** Fresh, clean, and free of oil and other materials injurious to concrete.
- F. Sealer:** Lapidolith by Sonneborn, Samiseal 50 by Master Builders Co., or Ashford Formula by Curecrete Chemical Co.
- G. Curing compound:**
1. Liquid membrane-forming compound containing a fugitive dye, conforming to ASTM C309, Type I, guaranteed not to affect the bond, adhesion, or effectiveness of finishes and surface treatment specified herein to be applied to concrete.
  2. Curing compound used on exposed concrete surfaces shall be non-discoloring, fast drying and shall be conclusively demonstrated not to darken or yellow with age.
- H. Expansion joint materials:**
1. Joint filler: Homex Expansion Joint by Homasote Co. or equal non-bituminous product compatible with sealant specified in Section 07900. Use in combination with plastic joint cap made by Greenstreak, Quaker Plastic Corp., or equal.
  2. Joint sealant and back-up rod: As specified in Section 07900.
- I. Dry-pack and grout:** One of the following:  
Masterflow 713 by Master Builders.  
Five Star Grout by US Grout Corp.  
Fondag Nonshrink Grout by Specrete Products, Ltd.
- J. Abrasive aggregates:** Silicone carbide 12/30 grading, aluminum oxide 14/36 grading or emery grits made by one of the following manufacturer. Use only one type on Project.
- Conrad Sovig Co., Inc.  
Chemrex, Inc./Sonneborn  
Carborundum Co.  
Norton Co.  
Anti-Hydro Co.
- K. Bonding agent:** Weldcrete by Larsen Products Corp. or Proweld by Protex Industries Inc.
- L. Water stop:** Furnished per Section 07130

## 2.02 SOURCE QUALITY CONTROL

**A. Employ a testing laboratory**, acceptable to the Owner and Architect, to test the materials for conformance with these Specifications before concrete mixes are established or when source is changed. Submit test reports for review.

### **B. Testing coarse aggregates:**

1. Test aggregates before and after concrete mix is established and whenever the character source of material is changed, but not less than one test for each 500 cubic yards.
2. Perform a sieve analysis to determine conformity with limits of gradation. Perform sampling and testing according to ASTM C33, and as follows:
  - a. Sampling of aggregates: ASTM D75. Take samples of aggregates at source of supply, or if source of supply has been approved, from storage bunkers at ready-mixed concrete plant.
  - b. Testing of aggregates shall include:
    - (1) Sieve analysis: ASTM C136
    - (2) Organic impurities: ASTM C40. Fine aggregate shall develop a color not darker than the referenced standard color.
    - (3) Soundness: ASTM C88. Loss after 5 cycles not over 8% for coarse aggregate, nor 10% for fine aggregate.
    - (4) Abrasion: ASTM C131. Weight loss not over 10-1/2% after 100 revolutions, nor 42% after 500 revolutions.
    - (5) Deleterious materials: ASTM C33.
    - (6) Materials passing No. 200 sieve: ASTM C117, not over 1% for gravel, 1.5% for crushed aggregate per ASTM C33.
    - (7) Reactive materials: ASTM C289. Aggregates shall indicate no potential deleterious reactivity.
    - (8) Definitions: ASTM C125.

### **3. Cement test:**

- a. The cement mill laboratory will be acceptable as testing laboratory for this purpose when approved by the Building Department. Submit evidence to show that the cement mill laboratory is qualified to perform tests. The laboratory shall make tests for every 500 barrels or fraction thereof of cement used, in accordance with ASTM C150.
- b. Make tensile strength test at 7 days. Tag the cement for identification at the location of sampling. A representative of the Testing Agency shall certify that materials being used are taken from the lots sampled and tested for this report.

## 2.03 MIXES

### **A. Mix design:**

1. Mix designs shall be generated from a licensed commercial laboratory or agency, approved by the Architect. Structural concrete mixes required for the Project to provide:
  - a. Concrete of the compressive strength indicated on the Drawings.
  - b. Adequate workability and proper consistency to permit concrete to be worked readily into the forms and around reinforcement without segre-

- gation and excessive bleeding.
- c. Other requirements noted on the Drawings and specified herein.
2. Determine proper proportions for design mixes in accordance with ACI 211 or ACI 318.
  3. Determine proper water-cement ratio by preliminary test made in accordance with ASTM C192.
  4. Proportion and design mixes shall result in concrete slump(s) at point of placement not exceeding the maximum recommended by ACI 301 and as accepted in the mix design.
  5. Tests shall be conducted in accordance with ASTM C39.
- B. Submit reports** showing results of sieve analysis, mix design and results of compression tests.
1. Make test specimens from not less than 3 batches of each design mix.
  2. The trial batch strength for each mix shall exceed indicated  $f'c$  by 25% or a lesser amount based on standard deviations of strength test records according to ACI 318.
  3. Do not start concrete production until mixes have been reviewed and are acceptable to the Architect.
- C.** For each batch, weigh the fine and coarse aggregate separately, measure cement and water separately and introduce separately into the mix so that proportions can be accurately controlled and easily checked.
- D. Do not change** proportions established by the accepted mix design without the Architects's written approval.
1. Cement: If concrete develops less than required minimum strength, adjust mix proportions and increase the amount of cement, as necessary.
  2. Water: Do not exceed predetermined amount of water because of slowness of discharge from mixer or any other reason, but reduce water to minimum necessary to produce concrete that will work readily into corners and angles of forms and around reinforcements, without segregation of materials and without free water collecting on the surface.
  3. Aggregates: Reasonable variations in grading will be allowed by the Architect because of characteristics of available materials and the need for workability and strength.
- E. Concrete mixing:**
1. Mixing and delivery shall comply with ASTM C94, these Specifications, and Building Code requirements.
  2. The Owner's Testing Agency will perform check sieve analysis of the aggregates being used, check compliance with mix design and the cement being used against mix design; check that water has been removed from the drum before adding mix ingredients for the following load and shall witness the loading of mixing trucks. The Owner's Testing Agency will send a written report of each inspection to Architect indicating compliance with these Specifications.

3. In addition to the requirements of ASTM C94 section 16.1, provide the following information on delivery tickets signed by an authorized representative of the batching plant with each mixer truck of concrete delivered to the site.

Type and brand of cement.  
Cement content per cu. yd., of concrete.  
Maximum size of aggregate.  
Total water content expressed as water/cement ratio.

4. Deliver batch tickets to Inspector at the site when concrete is delivered.
5. Maintain equipment in proper operating condition, with drums cleaned before charging each batch. Schedule rates of delivery in order to prevent delay of placing the concrete after mixing, or holding dry-mixed materials too long in the mixer before the addition of water and admixtures.
6. Remove all materials, including water remaining in the ready-mix truck drum, completely before ingredients for the following loads are introduced in the drum.
7. Do not use concrete which has not been placed 30 minutes after leaving the mixer, or concrete that is not placed within 90 minutes after water is introduced into the mix.

#### F. Shrinkage Tests

1. Prior to placing any concrete for walls or horizontal surfaces, a trial batch of each mix design of structural concrete shall be prepared using the aggregates, cement and admixture (if any) proposed for the project. From each trial batch at least 3 specimens for determining drying shrinkage shall be prepared. The drying shrinkage specimens shall be a 4" x 4" x 11" prisms fabricated, cured, dried, and measured in accordance with the requirements of Tentative Method of Test for Length Change of Cement Mortar and Concrete, ASTM C157. The measurements shall be made and reported separately for 7 and 28 days of drying after 7 days of moist curing. The effective gage length of the specimens shall be 10", and except for the foundation concrete, the average drying shrinkage at 35 days shall not exceed .054%.
2. Previous Test: Ready-mixed concrete manufacturer may furnish certified test reports from approved Testing Laboratory as proof of meeting shrinkage requirements, provided aggregate used and concrete coverage by such test report conform to mix design approved for use on this project. Method used, use an independent testing facility acceptable to Architect for preparing and reporting proposed mix designs.

### PART 3 - EXECUTION

#### 3.01 PREPARATION

- A. Inspect excavations, subgrades and formwork, as applicable for each placing operation, for accuracy of lines, levels, elevations and dimensions.
- B. Inspect placement of reinforcement and accessories for proper position, sizes, clearances, fastenings, laps and splices.



- C. **Moisten**, do not saturate, earth subgrade and bearing surfaces. Do not place concrete on muddy subgrade.
- D. **Wet wood forms** thoroughly when they are not treated with form release agent. Wet other materials sufficiently to reduce suction and maintain concrete workability.
- E. **Recompact disturbed** granular base course, where used under building slabs-on-grade.
- F. **Place items to be embedded** in concrete, including but not limited to, conduits, sleeves, nailers, anchors and rough hardware, built into concrete as indicated or required.
  - 1. Do not embed piping and conduits, other than electrical conduits, in structural concrete. Locate conduits so as to reduce strength of the structure the least amount, as approved by the Architect, and as indicated on the Drawings.
  - 2. Embed bolts, inserts and other items in the concrete. Secure accurately so that they are not displaced during concrete placing, compacting and finishing operations. Wire tie, nail or bolt embeds securely to forms.
  - 3. Set embedded bolts for materials and equipment attached to concrete to template, layouts and shop drawings. Verify size, length and location of electrical conduits with respect to equipment supports.
  - 4. Fill voids in sleeves, inserts and anchor slots temporarily with readily removable material to prevent entry of concrete in the voids.
  - 5. Install expansion joint fillers where indicated, and as required to isolate concrete slabs-on-grade from other building elements such as walls and equipment pads. Cover filler with plastic joint cap and leave in place until ready to receive sealant.
  - 6. Install water stops in all perimeter wall and slab on grade construction joints below grade and elsewhere as indicated.
    - 1. Place water stop on the exterior face of the outermost dowel line. Keep a concrete cover of 2" minimum.
    - 2. Butt ends of water stop and nail to concrete to avoid displacement during concrete placing and consolidation.
- G. **Do not proceed** with placement of concrete until all conditions are satisfactory.

### 3.02 CONVEYING

- A. **Rapid handling:** Transport concrete from the mixer to location of placing as rapidly as practical to avoid separation or loss of ingredients.
- B. **Transporting methods:**
  - 1. Use cranes, carts, buggies or other approved means to deliver concrete to final locations. Do not use delivery systems (pipe, chutes, etc.) formed of aluminum for transporting concrete.
- C. **Free fall:**
  - 1. As dictated by job conditions at each location, limit height of pour to prevent segregation of concrete ingredients

2. Smooth form finish:
    - a. Provide as-cast smooth form finish for formed concrete surfaces to be exposed-to-view, or to be covered with a coating material applied directly to the concrete, or a covering material bonded to the concrete such as waterproofing, painting, or other similar system.
    - b. Provide smooth form finish by selecting form material to impart a smooth, hard, uniform texture and arranging the orderly and symmetrical with a minimum of seams. Repair and patch defective areas with all fins or other projections completely removed and smooth. Tamp and float, or trowel patches flush with adjacent surface and to match adjacent concrete texture.
      - 1) Flush out form tie holes and fill with dry-pack mortar.
  3. Related unformed surfaces: At tops of wall, horizontal offsets, and similar unformed surfaces occurring adjacent to formed surfaces, strike off smooth and finish with textured matching the adjacent formed surfaces. Continue the final surface treatment of formed surfaces uniformly across the adjacent unformed surface, unless otherwise shown.
- B. Top of grade beams and footings: Screed to elevations indicated.**
- C. Slabs:**
1. Protection:
    - a. Protect work of other trades from damage by covering it with heavy kraft paper securely taped in place. Leave protection in place as long as its need exists.
    - b. Control the use of water and other contaminants within the structure so that no damage to previously installed work or existing structure and finish occurs.
  2. Compacting and floating:
    - a. Bring slabs to proper elevations and strike off with a straightedge. Remove excess water and laitance.
      - (1) Compact and consolidate to embed coarse aggregates.
      - (2) Float and test surfaces with a 10 ft. straightedge and eliminate high and low spots to comply with tolerances specified.
      - (3) From this point, use the methods and tools necessary to produce surface tolerances and finishes specified.
    - b. Use screeds of type and spacing required to produce specified slab tolerances.
  3. Moisture control: In addition to other finishing requirements, use a water fog spray to reduce plastic shrinkage cracks during flatwork finishing operations when temperature and humidity conditions at job site require special consideration.
    - a. Immediately after concrete has been brought to a flat surface and the shiny film of moisture disappears, restore it and maintain until final troweling by applying a light film of moisture with an atomizing type fog sprayer.

- b. Use frequent light applications of moisture rather than excessive amounts at any one time. Adjust the amount and frequency of fog spray as required by variable conditions of weather, wind, temperature and humidity.
4. General requirements:
- a. Finish surfaces to produce a uniform appearance throughout area involved and throughout adjacent areas with the same treatment.
  - b. Where concrete finishing occurs adjacent to finished metal and similar surfaces, particularly where serrated or indented surfaces occur, remove all traces of cement film before allowing to harden.
  - c. Use no troweling machines within 12" of electrical junction and outlet boxes which are set to finish flush with concrete floors. Float and trowel such areas by hand with wood floats and steel trowels, taking care to see that concrete is finished flush with box cover and matches adjacent surfaces.
5. Schedule of finishes:
- a. Float monolithic slab surfaces unless otherwise specified.
    - (1) After placing concrete slabs, do not work the surface further until ready for floating.
    - (2) Begin floating when the surface water has disappeared or when the concrete has stiffened sufficiently to permit the operation of power-driven float, or both.
    - (3) Consolidate the surface with power-driven floats, or by hand-floating if area is small or inaccessible to power units.
  - b. Steel trowel surfaces to receive quarry tile and concrete slabs which have no other specified finish, to a hard, dense, burnished surface.
    - (1) After floating, begin the first trowel finish operation using a power-driven trowel. Begin final troweling when the surface produces a ringing sound as the trowel is moved over the surface.
    - (2) Consolidate the concrete surface by final hand troweling operation, free of trowel marks, uniform in texture and appearance, and with surface plane tolerance specified. Grind smooth surface defects which would telegraph through applied floor covering system.
    - (3) After steel troweling, texture surfaces to be tiled and slabs to receive elastomeric coating with a fiber broom to provide a mechanical bond with the mortar, or omit the burnishing. These slabs must be approved by the subcontractors installing the tiles and the elastomeric coatings as satisfactory to receive their work.
  - c. Use abrasive aggregate (slip-resistant) finish for stair treads and landings where applied finishes are not used.
    - (1) Broadcast abrasive aggregate on the concrete, after first troweling operation uniformly at the rate of 25 lbs. per 100 sq. ft. Use caution not to bury the abrasive aggregates during second troweling.
    - (2) After second troweling, rub surface with pads of steel wool to remove film of cement and expose the abrasive aggregates, or as an option etch concrete with a 10% solution of muriatic acid followed by flushing with water to remove all traces of acid and expose the abrasive aggregates.
  - d. Finish parking area slabs with a medium broom finish, with tooled edges, as approved by the Architect. Draw broom against a straightedge at right angle to the direction of traffic.

6. **Markings:**
  - a. At expansion joints and elsewhere as indicated, mark slabs with a 1/4" radiused edging or marking tool. In textured work edge and mark slabs, after texturing, with a combination edging/smoothing tool approximately 1-1/2" wide.
  - b. Where saw cutting is indicated, time this operation so that it is performed as soon as concrete has hardened sufficiently to prevent aggregates being dislodged by the saw, but before shrinkage stresses have developed sufficiently to produce cracking.
  - c. Make marking lines straight, or curved as indicated, equally spaced and parallel to adjacent lines and/or walls, edges and other construction, and of uniform depth and cross section, with intersections accurately formed.
- D. **Curbs:** Immediately after removing forms, finish faces and top with a steel trowel.

### 3.05 CURING

#### A. Formed concrete:

1. Wet the tops and exposed portions of formed concrete and keep moist until forms are removed.
2. If forms are removed before 14 days after concrete is cast, coat concrete with curing compound as specified for flatwork below.

#### B. Concrete flatwork:

1. After finishing, spray the specified curing compound uniformly in 2 coats at 90 deg. to each other not exceeding coverage rates recommended by the manufacturer.
  - a. Inspect treated surfaces daily for 14 days for evidence of drying.
  - b. Re-wet the surfaces and apply a new application of curing compound, if premature drying occurs, as soon as can be done after finishing without marring the surfaces.
2. Seal concrete floors not scheduled to receive a deferred finish and where indicated on Drawings in accordance with sealer manufacturer's printed instructions. Remove sealer residue after curing period is completed.

### 3.06 MISCELLANEOUS CONCRETE WORK

#### A. Equipment bases and foundations:

1. Provide machine, and equipment bases and foundations where indicated on Drawings.
2. Set anchor bolts for machines and equipment to template at correct elevations, complying with diagrams or templates of the manufacturer furnishing the machines and equipment.

- #### B. Concrete fill in stair pans:
- Coat steel with bonding agent and fill pans with a mix with coarse aggregate passing a 3/8" sieve to obtain a compressive strength of 3,000 psi at 28 days. Reinforce with 2" x 2" x 16 gage welded wire mesh at midpoint.

- C. **Pits, trenches, curbs, integrally-cast equipment pads and other miscellaneous concrete work:** Construct to the profiles and dimensions indicated.
- D. **Grouting and dry-packing:** Comply with the grout manufacturer printed instructions and the following.
  - 1. Mix material with sufficient water so it flows under its own weight for grout, and to just moisten and bind the material together for dry-pack.
  - 2. Place dry-pack by forcing and rodding to fill all voids and provide complete bearing under plates. Place fluid grout from one side only and puddle to completely fill voids; do not remove dams or forms until grout attains initial set. Finish exposed surfaces smooth and damp cure at least 3 days.
- E. **Waterproof membranes:**
  - 1. Perform work over waterproof membranes to prevent damage to the membranes.
  - 2. Schedule this work to reduce to a practical minimum the period when the installed membrane is left without protection.
  - 3. Prior to placing concrete, inspect the membrane and repair damage which may have occurred.
  - 4. Insure waterproof membrane compatibility with curing compound.
- F. **Concrete encased columns:** When not carried to deck above, stop concrete perpendicular to column axis at the same elevation throughout the garage. Float top neatly to column.

3.07 PROTECTING/CLEANING

- A. Take suitable precautions in compliance with applicable ACI requirements to secure satisfactory concrete in either hot or cold weather.
- B. Avoid construction vehicular traffic on slabs-on-grade. Loads not in excess of the design load may be permitted after the concrete has reached 28 day specified strength, subject to review by Architect.
- C. Protect concrete to prevent damage resulting from impact or from subsequent work or rubbish.
- D. Protect work of other trades from damage by work of this Section with heavy kraft paper securely taped in place.
  - 1. Maintain protection in effective condition for as long as need for protection exists.
  - 2. Control use of water within the building so that no damage to previously installed work or existing structure and finish will occur.
- E. Upon completion, wash and clean exposed concrete and leave free of oil, paint, plaster and foreign substances, ready to receive applied finishes or to be left exposed.

3.08 DEFECTIVE CONCRETE

- A. Concrete which does not meet the requirements of the Contract Documents will be deemed defective.**
- B. Repair, or remove and replace defective concrete, as directed by Architect, with concrete meeting the requirements of the Contract Documents, at no additional cost to the Owner.**

3.09 FIELD QUALITY CONTROL

- A. Concrete quality control (refer also to Section 01400): The following will be performed by the Owner's Testing Agency.**
1. Samples will be taken during progress of the work to determine slump, compression strength, aggregate sieve analysis, and grout-mix tests, with assistance furnished by the Contractor.
  2. 3 cylinders will be made for each day's pour or for each 150 cubic yards or once for each 5,000 square feet of surface area, whichever is less, for each type of concrete being cast.
  3. 1 cylinder will be tested at 7 days, and 2 cylinder at 28 days.
  4. Samples will be made in accordance with ASTM C172.
  5. Specimens will be made and laboratory cured in accordance with ASTM C31.
  6. The 28-day values will be the criteria for acceptance of concrete regarding strength only.
    - a. 7-day tests may be regarded as indicative of compliance or non-compliance with the 28-day strength requirements, and the Contractor should be guided accordingly in matter of adjusting proportions, if necessary, and notify the Architect.
    - b. 7-day tests shall also be a guide to the Contractor regarding time for form removal.
  7. Slump tests will be made for each set of tests cylinders in accordance with ASTM C143.
- B. Tests evaluation:**
1. Concrete cylinder test will be evaluated in accordance with ACI 214 and 318.
  2. If 28-day test results indicate that concrete strength is not as specified, core concrete as directed by the Architect in accordance with ASTM C42.
    - a. Plug core hole solid as specified in Article 3.04 of this Section.
    - b. The cost of cores, tests and patching shall be borne by the Contractor.
  3. In the event that additional core tests do not show strength required, or as determined by load tests made in accordance with ACI 318, the defective concrete shall be removed and replaced, or shall be reinforced as directed by the Architect, at the Contractor's expense.
  4. If core tests results fall below design strength specified, adjust the concrete mix or water content for future batches, at no additional cost to the Owner.

END OF SECTION

**SECTION 03360**

**SHOTCRETE**

**PART 1 - GENERAL**

1.01 DESCRIPTION: Division 1 applies to this Section. Provide shotcrete (pneumatically placed concrete) as indicated, specified, and required.

**A. Principal work in this Section:**

1. Shotcrete (pneumatically-applied concrete).
2. Preparation of surfaces to receive shotcrete.
3. Forms and ground wires.
4. Installation of reinforcing steel.
5. Mixing, delivery, placing, finishing and curing of shotcrete.
6. Protection and cleaning of adjacent surfaces.

**B. Related work:**

1. Formwork and reinforcing steel for shotcrete: Sections 03100 and 03200.
2. Cast-in-place concrete: Section 03300.

1.02 SUBMITTALS

**A. Submit the following in accordance with the requirements of Section 01300:**

1. Information concerning the source and quality of materials.
2. Representative samples of materials for materials testing, and preparation of test panels.
3. Recommended mix proportions and test results for acceptance.

1.03 QUALITY ASSURANCE

**A. Reference standards:** The applicable provisions of the following govern the work of this Section.

City of Los Angeles Rule of General Application for Wet Mix Shotcrete.  
ACI 506, Recommended Practice for Shotcreting.  
ACI 506.2, Specification for Materials, Proportioning and Application of Shotcrete.

**B. Testing:** The Owner's Testing Laboratory will,

1. Secure production samples of materials at stockpiles during construction and test for compliance with Specifications.
2. Review and check proposed mix proportions.
3. Test preconstruction test panels.
4. Test strength of the shotcrete as work progresses.

- C. **Inspections:** Shotcreting will be continuously inspected by Deputy Building Inspector(s) employed by the Owner, including preparations for this work, placement of reinforcement, and finishing and curing (refer to Section 01400).
- D. **Subcontractor's qualifications:** Must have written approval from City of Los Angeles as a shotcrete contractor.
- E. **Test panels:** Prepare 48" X 48" test panels as required by City of Los Angeles Rule of General Application and as specified below:
  - 1. Provide test panel(s) made by each application crew using the equipment, materials, and mix proportions proposed for the Project.
  - 2. Make preconstruction test panels: Sample panels shall be representative of the Project and job conditions. Panel thickness and reinforcing shall reproduce the thickest and most congested area specified in the structural design. It shall be shot at the same angle, using the same nozzleman, and with the same concrete mix design that is proposed for use on the Project.
  - 3. After shooting, but before the concrete has fully set, the Testing Agency shall disassemble the panel(s) to assure that the team and equipment to be used is capable of providing sound shotcrete, free of voids, sags, segregation, honeycombing, lamination, dry patches, slugs and similar defects.
  - 4. Repeat test panels when the first one proves unsatisfactory, until the Testing Agency's approval is obtained.
  - 5. Application of shotcrete in the Work shall not proceed until the test panels have been disassembled, inspected and approved.
  - 6. After approval remove debris from the Project site.

1.04 HANDLING

- A. Comply with the requirements of Section 01600 and City of Los Angeles.

PART 2 - PRODUCTS

2.01 MATERIALS

- A. **Cement:** ASTM C 150 Type I or II low alkali; no fly ash permitted.
- B. **Aggregate:** Conform to ACI 506.2, gradation No. 1 or No. 2, complying with ASTM C 33.
- C. **Water:** Potable and fresh.
- D. **Water stops:** As specified in Section 03300.
- E. **Curing compound:** As specified in Section 03300.

2.02 MIX

- A. **Mix design:** Provide mix design as required to produce the minimum compressive strength indicated on the Structural Drawings, but the ratio of cement to aggregates, in loose dry volume, shall not be less than one cement to 4-1/2 parts of aggregate. Mix design shall be approved by Owner's Testing Agency and reviewed by the Structural Engineer of record.



- B. **Mixing:** Mix cement and aggregates dry in a suitable batch mixer for not less than one minute, but not until all ingredients are thoroughly mixed. Discharge mixer completely before recharging.

**PART 3 - EXECUTION**

3.01 INSPECTION

- A. **Verify conditions and** measurements affecting the work of this Section at site. Make sure that detrimental conditions are corrected before proceeding with installation.

3.02 PREPARATION

- A. **Verify that waterproofing** membranes have been inspected, approved and is undamaged before proceeding with installation.
- B. **Place rigid backing** against the earth where soil might be dislodged during shotcreting, or where a void in the embankment is to be bridged. Should the embankment slough or ravel during shotcreting, cease work in the affected area immediately, remove the contaminated shotcrete, and provide a rigid backing as specified above.
- C. **Remove unsound and** loose materials before shotcreting.
  - 1. Chip or scarify areas to be repaired to remove offsets which would cause an abrupt change in thickness without suitable reinforcement.
  - 2. Taper edges to leave no square shoulders at the perimeter of a cavity.
  - 3. Do not wet bentonite waterproofing materials before installation.
- D. **Remove rust, oil, scale,** and previously applied paint from steel to receive shotcrete.
- E. **Reinforcement placement:** Conform to Applicable sections of the City of Los Angeles Rule of General Application for Wet Mix Shotcrete. Lap splices in reinforcing bars shall be non-contact with at least two-inch clearance between bars.

3.03 PLACING

- A. **Place shotcrete using** suitable delivery equipment and procedures that will result in shotcrete in place meeting the requirements of these Specifications.
- B. **Control thickness,** method of support, air pressure, and water content of shotcrete to preclude sagging or sloughing off.
  - 1. The height of a layer shall be limited to 3 ft. maximum and a succeeding layer shall not be placed in less than 3 hours after lower section is in place.
  - 2. Discontinue shotcreting or provide suitable means to screen the nozzle stream if wind or air currents cause separation of the nozzle stream during placement.
- C. **Dampen absorptive substrates** before placing shotcrete to facilitate bond and to reduce the possibility of shrinkage cracking developing from premature loss of mixing water.

- D. **Broom or scarify** the surface of freshly-placed shotcrete to which, after hardening, additional layers of shotcrete are to be bonded. Dampen surfaces just before application of succeeding layers.
- E. **Fill corners of forms**, and any area where rebound cannot escape or be blown free, with sound material.
- F. **Provide a supply** of clean, dry air adequate for maintaining sufficient nozzle velocity for all parts of the work and for simultaneous operation of a suitable blow pipe for clearing away rebound.
1. An experienced nozzleman's helper must assist the nozzleman to keep the work free of rebound build-up with the blow pipe.
  2. Provide additional workmen if required to keep the work area free of rebound if it cannot be removed by the blow pipe.
- G. **Placement around reinforcement:**
1. Shotcreting around reinforcement will be demonstrated to the satisfaction of the Building Inspector.
  2. Hold the nozzle at such distance and angle to place material behind reinforcement before any material is allowed to accumulate on its face. In the dry-mix process additional water may be added to the mix when encasing reinforcement to facilitate a smooth flow of material behind the bars.
  3. Do not place shotcrete through more than one layer of reinforcing steel in one application unless demonstrated by preconstruction tests that steel is properly encased.
    - a. Test to see if voids or sand pockets have developed around or behind reinforcement by probing with an awl or other pointed tool after the shotcrete has achieved its initial set; by removal of randomly selected bars; or by coring or other suitable means.
    - b. In areas where congestion makes the proper placement of shotcrete difficult, the dry method shall be used, or the concrete shall be cast as specified in Section 03300.
- H. **Cover of reinforcement:** Place shotcrete to provide 1-1/2" minimum cover over reinforcement. Minus tolerance on cover shall not be greater than 1/3 of the specified cover.
- I. **Line and thickness control:** Use high tensile ground wires or other accepted means to establish the thickness, surface planes, and finish lines of the shotcrete. Maintain specified tolerances by keeping wires secure and taut.

**J. Placement precautions:**

1. Do not place shotcrete if drying or stiffening of the mix takes place at any time prior to delivery to the nozzle.
2. Do not use previously expended material in the shotcrete mix.
3. Remove overspray or rebound before set and before placement of shotcrete on such surfaces.

**K. Water stops:** Place in all construction (cold) joints as this work progresses, as specified in Section 03300 and 07130.

3.04 FINISHING

- A. Float surfaces** of unformed shotcrete to a uniform finish, as demonstrated on sample panel approved in advance by the Architect, and to a tolerance of 3/8" in 10 ft. non-cumulative.
- B. After form removal** patch voids and holes in formed shotcrete surfaces. Prepare a patch sample with color and texture to match adjacent surfaces as closely as possible. Obtain Architect's approval of patch sample. All subsequent patching and repair operations shall match approved sample as a minimum level of acceptable quality.

3.05 CURING/PROTECTING

- A. Curing:** Immediately after finishing, keep shotcrete continuously moist per code and City of Los Angeles RGA 1-85 after placement.
1. Sprinkle with water or fog-spray so that surface is continuously wet.
  2. Absorbent mat, or other covering kept continuously wet.
- B. Formed surfaces:** If forms are removed during curing period, proceed as specified above. When forms remain in place, keep them continuously wet for a minimum of 14 days.

3.06 FIELD QUALITY CONTROL

**A. As specified in Section 01400 and as follows.**

1. During the course of the work of this Section the Owner's Testing Agency will preform strength tests and inspections in accordance with UBC 1991, Section 2621 and the following:
  - a. Within 2 to 5 days of placement of the concrete, take a minimum of three 4" diameter cores from the wall, at the rate of one core for each 50 cubic yards of shotcrete, and a minimum of 2 cores for each day's application by any one nozzle team, at locations selected by the Building Department and the Architect.

- b. The Testing Agency shall visually examine the cores to make sure that they are free of voids and rebounds, and replace the cores into the holes from which they were cut.
- c. The surface of the cores shall then be drypacked to the Structural Engineers and Architects satisfaction to prevent dehydration and shall be properly identified to aid in the recovery of the cores at the conclusion of the 28 day curing period.
- d. After 28 days the cores shall be tested in accordance with ASTM C 42, except that no further curing shall be permitted.

**B. Repairing:**

1. Remove and replace shotcrete which does not comply with these Specifications, exhibits segregation, honeycombing, or lamination, or which contains dry patches, slugs, voids, or sand pockets.
2. Also remove and replace damaged shotcrete.
3. Repair defective areas to the Structural Engineer's and Architect's satisfaction.

- C. Repair core holes in accordance with Chapter 9 of ACI 301 and to the satisfaction of the Structural Engineer and Architect. Do not fill core holes with shotcrete.

END OF SECTION

SECTION 03420

PRECAST STRUCTURAL CONCRETE

PART 1 - GENERAL

1.01 DESCRIPTION: Division 1 applies to this Section. Provide precast structural assemblies as indicated, specified and required.

A. Principal work in this Section:

1. Precast concrete units consisting of columns, girders and beams.
2. Grouting precast units.
3. Furnishing embeds to be cast in cast-in-place concrete.

B. Related Work Not In This Section:

1. Cast-in-place concrete: Section 03300.
2. Formwork: Section 03100.

1.02 SUBMITTALS

A. Submit **large scale**, dimensioned shop drawings in accordance with the requirements of Section 01300. Show the following:

1. Plan, elevation and section of each unit, fabrication details, unit identification marks, reinforcement, connection details, dimensions and relationship to adjacent material in sufficient detail to cover manufacture, handling and erection.
2. Location and details of anchorage devices to be embedded in other construction. Furnish templates, if required, for accurate placement.
3. Revise shop and erection drawings to correspond with changes made in the field.

B. **Concrete mixes:** Submit proposed concrete mixes, and materials and cylinder test results to verify the fabricator's quality control procedures.

C. **Product data:** Submit a list of all materials used in the precast concrete units together with evidence of compliance with accepted industry standards such as ANSI and ASTM.

1.03 QUALITY ASSURANCE

- A. Codes and standards:** Applicable provisions of the following govern the work of this Section, except as noted on the Drawings or specified herein.

ACI 301, Specifications for Structural Concrete.  
ACI 311, Recommended Practice for Concrete Inspection.  
ACI 310, Building Code Requirements for Reinforced Concrete.  
ACI 347, Guide to Formwork for Concrete.  
ACI 304, Recommended Practice for Measuring, Mixing, Transporting and Placing Concrete.  
CRSI, Manual of Standard Practice.  
PPCI, Manual for Quality Control.

- B. Manufacturer's qualifications:** Precast concrete panels and units shall be products of a manufacturer who has demonstrated capability to produce precast concrete products of the quality specified.

1. Manufacturer must be able to show that he has experienced personnel, physical facilities, established quality control procedures, and a management capability sufficient to execute the work shown on the Drawings and specified herein.
2. When requested by the Owner, the manufacturer shall submit written evidence of the above requirements.

- C. Allowable fabrication tolerances:** Comply with PPCI recommendations.

1.04 HANDLING

- A. Comply with the requirements of Section 01600 and the following.**

1. Transport and handle precast concrete using equipment which will protect units from staining and damage. Do not place precast units on ground.
2. Storage:
  - a. Store precast units to protect them from contact with soil and from other damage, in same position as transported, with nonstaining, resilient supports located in same positions as when transported.
  - b. Store precast units on firm, level, and smooth surfaces. Place stored units so that identification marks are visible.
3. Lift and support units at the designated lift points only.

## PART 2 - PRODUCTS

### 2.01 MATERIALS

- A. **Reinforcing bars:** ASTM A615, Grade 60 or ASTM A706, except stirrups and ties may be Grade 40.
- B. **Steel wire:** ASTM A82, plain, cold-drawn, steel.
- C. **Welded wire fabric:** ASTM A185.
- D. **Supports for reinforcement:** Bolsters, chairs, spacers and other devices for spacing, supporting and fastening reinforcing, complying with CRSI recommendations. For exposed-to-view concrete surfaces, where legs of supports are in contact with forms, provide supports with hot-dip galvanized or plastic coated legs.
- E. **Prestressing tendons:**
  - 1. Uncoated, 7 wire stress-relieved strand complying with ASTM A416. 270K low relaxation.
  - 2. Tendon anchorages: Provide tendon anchorages for retensioning capable of anchoring reinforcement for prestressed concrete without slippage after seating. Provide steel cases for prestressing steel strand which have been proof tested by the manufacturer to at least 90% of the ultimate strength of the strand.
- F. **Portland cement:** ASTM A150, Type I or II. Use only one brand and type of cement throughout the Project, unless otherwise acceptable to Architect.
- G. **Aggregates:** ASTM C33. Provide aggregates from a single source for all concrete. Maximum aggregate size; not larger than 1/5 of the narrowest dimension between sides of forms, 1/3 of the depth of slabs, nor 3/4 of the minimum clear spacing between individual reinforcing bars or bundles of bars.
- H. **Water:** Potable, fresh.
- I. **Admixtures:** Selected by the manufacturer, subject to the Architect's approval.
- J. **Connection materials:**
  - 1. Steel plates: Structural quality, hot-rolled carbon steel, ASTM A283, Grade C.
  - 2. Steel shapes: ASTM A36.
  - 3. Anchor bolts: ASTM A307, low-carbon steel bolts, regular hexagon nuts and carbon steel washers.
  - 4. Finish of steel units: Exposed units galvanized per ASTM A153; others painted with rust-inhibitive primer.
- K. **Form materials:** Provide forms, and where required form facing materials, of metal, plastic, wood or other acceptable materials that are non-reactive with concrete and will produce the required finish surfaces.

**L. Bearing pads:**

1. Chloroprene (Neoprene): Conform to Division II, Section of AASHTO Standard Specifications for Highway Bridges, having a minimum durometer hardness of 70.
2. Random oriented fiber reinforced: Shall support a compressive stress of 3,000 psi with no cracking, splitting or delaminating in the internal portions of the pad.

**M. Grout:**

1. Cement grout: Portland cement, ASTM FT, Type I, and clean, natural sand, ASTM FAA.
2. Shrinkage resistant grout: Premixed and packaged type as specified in Section 03300.

**N. Accessories:** Provide all clips, hangers, and other accessories required for installation of precast units and for support of construction or finishes attached to, or supported by precast units.

2.02 PROPORTIONING AND DESIGN OF MIXES

- A. **Prepare design mixes** for each type of concrete required. Design mixes may be prepared by an independent testing facility or by qualified precast manufacturing plant personnel, at precast manufacturer's option.
- B. **Proportion mixes** by either laboratory trial batch or field experience methods, using materials to be employed on the project for each type of concrete required, complying with ACI 211.1.
- C. **Submit written reports** to the Architect of proposed mix for each type of concrete at least 15 days prior to start of precast unit production. Do not begin concrete production until mixes and evaluations have been reviewed by the Architect.
- D. **Do not change** mix design without Architect's authorization after production is started.

2.03 FABRICATION

- A. **General:** Manufacture precast concrete units in accordance with approved shop drawings. Fabricate precast concrete units complying with the manufacturing and testing procedures, quality control recommendations, and dimensional tolerances of PPCI MNL-116, and as specified for the type of units required.
- B. **Mixing concrete:** As specified in Section 03300.
- C. **Built-in anchorages:** Accurately position built-in anchorage devices and secure to the formwork. Locate anchorages where they do not affect the position of main reinforcement or the placing of concrete. Do not relocate bearing plates in units unless acceptable to Architect.
- D. **Cast-in holes** for openings in accordance with final shop drawings.



- E. Forms:**
1. Accurately construct forms, mortar-tight, and of sufficient strength to withstand all pressures due to concrete placement, temperature changes, and when prestressed, pretensioning and detensioning operations.
  2. Maintain forms to provide completed precast units of the shapes, lines, and dimensions indicated, within the specified fabrication tolerances. Coat surfaces of forms with a bond-breaking compound before reinforcement is placed.
  3. Coat forms with compound that will not bond with, stain nor adversely affect concrete surfaces, and will not impair subsequent treatments of concrete surfaces requiring bond or adhesion. Apply coating in compliance with manufacturer's instructions.
- F. Clean reinforcement** of loose rust and mill scale, earth and other materials which reduce or destroy bond with concrete.
- G. Accurately position**, support and secure reinforcement against displacement by formwork, construction, or concrete placement operations. Locate and support reinforcing by metal chairs, runners, bolsters, spacers and hangers, as required.
- H. Place reinforcement** to obtain at least the minimum coverage for concrete protection. Arrange, space and securely tie bars and bar supports to hold reinforcement in position during concrete placement operations. Set wire ties so ends are directed into concrete, not toward exposed concrete surfaces.
- I. Place tendons and anchorages** for prestressed concrete in accordance with ACI recommendations. Keep anchorages which will be enclosed in concrete free of any material which would affect bond.
- J. Pretensioning of tendons** for prestressed concrete may be accomplished either by the single strand tensioning method or the multiple-strand tensioning method. Comply with PPCI MNL-116 requirements.
- K. Place concrete** in a continuous operation to prevent the formation of seams or planes of weakness in precast units, complying with requirements of ACI 304. Thoroughly consolidate placed concrete in each precast unit by internal and external vibration without dislocation or damage to reinforcement and built-in items.
- L. Identification:** Provide permanent markings in precast units to identify pick-up points and orientation in the structure, complying with the markings indicated on the final shop drawings. Imprint the date of casting on each precast unit where it will not show in the finished structure.
- M. Curing by low-pressure steam**, by steam vapor, by radiant heat and moisture, or other similar process may be employed to accelerate concrete hardening and to reduce the curing time.

- N. Delay detensioning** of prestressed units until the concrete has attained a minimum design strength, as established by test cylinders at the direction of the Structural Engineer of Record.
1. If the concrete has been heat-cured, perform detensioning while the concrete is still warm and moist, to avoid dimensional changes which may cause cracking or undesirable stresses in the concrete.
  2. Detension pretensioned tendons to prevent shock and unbalanced loading.
- O. Finish:**
1. Formed surfaces: Normal plant run finish produced in forms that impart a smooth finish to the concrete. Small surface holes caused by air bubbles, normal form joint marks, and minor chips and spalls will be tolerated, but no major or unsightly imperfections, honeycomb, or structural defects will be permitted.
  2. Unformed surfaces: Other members: Smooth steel trowel finish.

### PART 3 - EXECUTION

#### 3.01 INSPECTION

- A. Verify conditions** and measurements affecting the work of this Section at site. Make sure that detrimental conditions are corrected before proceeding with installation.

#### 3.02 INSTALLATION

- A. Lift, place, and secure** units in accordance with manufacturer's instructions and final shop drawings, keeping units tight and perpendicular to bearing supports. Set units straight, level, plumb, and square.
1. Do not install units until supporting members are in place and secured.
  2. Shore members during erection as noted on Drawings and where necessary to minimize camber between adjacent units.
  3. Follow erection procedures and sequence of erection recommended by unit manufacturer. Comply with PPCI recommendations for tolerances.
- B. Bearing pads:** Install flexible bearing pads where indicated, as precast units are being erected. Set pads on level, uniform bearing surfaces and maintain in correct position until precast units are placed.
- C. Welding:** In compliance with AWS D1.1 and D1.4, including qualification of welders.
- D. Protect units** from damage by field welding or cutting operations and provide non-combustible shields as required.
- E. Repair damaged metal** surfaces by cleaning and applying a coat of zinc-rich paint to galvanized surfaces and compatible primer to painted surfaces.
- F. Powder-actuated fasteners:** Do not use powder-actuated fasteners for surface attachment of items in any precast, prestressed unit unless otherwise accepted by the precast manufacturer.

- G. Grouting connections and joints:** After precast concrete units have been placed and secured, grout open spaces at connection and joints.
1. Provide forms or other acceptable method to retain the grout in place until sufficiently hard to support itself.
  2. Pack spaces with stiff grout material, tamping until voids are completely filled.
  3. Place grout to finish smooth, plumb, and level with adjacent concrete surfaces.
  4. Keep grouted joints damp for not less than 24 hours after it had taken its initial set. Promptly remove any grout material from exposed surfaces before it hardens.

3.03 DEFECTIVE WORK

- A. Precast concrete units** which do not conform to the specified requirements, including strength, tolerances, and finishes, shall be replaced with units that meet the requirements of the Contract Documents.
- B. The Contractor shall** also be responsible for the cost of corrections to any other work affected by or resulting from corrections to the precast concrete work.

END OF SECTION



**SECTION 04220**

**CONCRETE MASONRY UNITS**

**PART 1 - GENERAL**

- 1.01      **DESCRIPTION:** Division 1 applies to this Section. Provide concrete unit masonry as indicated, specified and required.
- A. Work in this Section:** Principal items include:
1. Concrete block masonry.
  2. Grouting of masonry.
  3. Installing reinforcing steel bars in masonry.
  4. Built-in anchors required for attachment to structure.
- B. Related Work Not In This Section:**
1. Furnish and delivery of steel bar reinforcing.
  2. Dowels in concrete for masonry.
  3. Water repellant and anti-graffiti sealers Section 07175.
- 1.02      **SUBMITTALS**
- A. Prior to delivery,** submit certificates attesting compliance of the CMU with the applicable specifications for grades, types or classes in accordance with the requirements of Section 01300.
- 1.03      **HANDLING**
- A. Comply with the requirements** of Section 01600.
- B. Deliver reinforcement** to the site bundled, tagged and marked; handle to prevent damage to material. Use metal tags indicating size, length and other markings shown on placement drawings. Maintain tags after bundles are broken.
- C. Use caution not to damage** CMU which will remain exposed in the Work. Store materials off the ground to prevent rusting, staining and damage.

## PART 2 - PRODUCTS

### 2.01 MATERIALS

- A. **Concrete masonry units:** Medium weight load-bearing units conforming to ASTM C90, Grade N-1, except for special shape units. Use open end units for grouted masonry.
1. Provide all CMU from a plant approved by Owner's Testing Agency and City of Los Angeles.
  2. CMU which will remain exposed in the Work shall have a uniform texture and color.
  3. Provide special shapes such as open-end units and channel blocks, as required by job conditions.
  4. CMU shall have cured not less than 28 days when placed in structure.
  5. CMU shall have a maximum linear shrinkage of 0.06% from saturated to oven dry condition, when tested according to methods published in the Quality Control Standards of CMA.
- B. **Portland cement:** ASTM C150, Type I, II or III.
- C. **Lime:** ASTM C207, Type S.
- D. **Aggregates:**
1. For grout: ASTM C404. Modify coarse aggregate grading requirements so that not more than 5% pass a No. 8 sieve and 100% passes a 3/8" sieve.
  2. For mortar: ASTM C144, natural sand.
- E. **Admixture for grout:** As selected by the Contractor but subject to the Architect's approval.
- F. **Water:** Potable and fresh.
- G. **Reinforcing steel:** ASTM A615, grade shown.

### 2.02 MIXING MORTAR AND GROUT

- A. **Mix in the proportions** complying with ASTM C207 unless otherwise indicated on the Drawings. Place 1/2 of water and sand in operating mixer. Then add cement, lime, admixture and the remainder of sand and water.
- B. **Mortar may be retempered** with water as required to maintain high plasticity.
1. Retemper on mortar boards only by adding water within a basin formed with the mortar and reworking the mortar into the water.
  2. Mix mortar and grout uniformly. Use admixture according to its manufacturer's printed instructions.
  3. Discard mortar and grout which are unused after 90 minutes from initial mixing time.
- C. **After all ingredients** are in the mixer, mix mechanically for not less than 3 minutes. Do not hand-mix ingredients.
- D. **Secure manufacturer** or distributor initial supervision by a qualified field representative to assure proper use of admixture.

- E. **Use grout as fluid as possible** for placing without segregation of constituent parts.

### **PART 3 - EXECUTION**

#### 3.01 INSPECTION

- A. **Verify conditions** and measurements affecting the work of this Section at site. Make sure that detrimental conditions are corrected before proceeding with installation.

#### 3.02 PROTECTION

- A. **Protect exposed masonry** at grade from soil stains, and when concrete is poured, by covering walls with 6 mil polyethylene or other suitable non-staining material extending at least 30" above grade. This protective covering must be maintained until adjacent concrete work is cured.
- B. **Stained CMU** and units with chipped faces or edge damage will not be acceptable in exposed work.

#### 3.03 SHORES AND CENTERING

- A. **Design, erect, support, brace and maintain** shoring and centering for temporary support of masonry elements.
- B. **Construct true to required shape, size and form, well braced and made rigid** in all parts, and capable of supporting and sustaining the loads to which they are subjected.
- C. **Leave shores and centering in place** until masonry can safely carry its own weight and the added loads of construction.
- D. **Brace CMU walls** adequately to withstand all forces they will be subjected to during construction. Walls are not designed to be self-supporting for lateral loads until attached to floor and roof elements.

#### 3.04 WORKMANSHIP

- A. **Erect masonry plumb, square, straight and true to indicated lines, position and dimensions,** in level courses with joints properly aligned and within tolerances of ACI 117.
- B. **Use deep-cut bond** beam CMU to form bond beams, and special shapes for openings and offsets, and to maintain a proper bond throughout entire length of wall.
- C. **Lay-out CMU** to minimize cutting and use of odd joint sizes or bond. Do not use fractional parts of CMU where whole units can be used. Do not use fragments of CMU.
- D. **Use sound, dry, clean CMU, free from cracks** when placed in the structure.
- E. **Cut CMU accurately** to fit openings for other work. Cut and patch holes in CMU neatly and accurately.
- F. **When moving a unit after it has been once set in place, remove the unit from the wall, clean of mortar and set in fresh mortar.**

- G. **Sawcut CMU** to conform to adjacent construction, to maintain uniform joint widths, and to maintain indicated joint pattern. Sawcut CMU to produce straight, sharp edges without spalling or other defects.

3.05 REINFORCEMENT

- A. **When a foundation** dowel does not line up with a vertical core, do not slope more than one horizontal in 6 vertical. Grout dowels into a core in vertical alignment, even though it is in an adjacent cell to the vertical wall reinforcement.
- B. **Embed reinforcement** completely in grout with minimum coverage specified.

3.06 BONDING

- A. **For bonding the masonry** to the foundation, clean top of concrete foundation, remove laitance and expose aggregates before starting masonry construction.
- B. **Lay-up walls** in straight uniform courses in regular running bond.
- C. **Form corners** with a standard masonry bond by overlapping CMU.

3.07 JOINTS

- A. **Lay the starting** joint on foundations with full mortar coverage on the bed joint. Keep area where grout occurs free from mortar so that grout will contact the foundation.
- B. **Mortar joints shall be** straight, clean and uniform in width.
  - 1. Tool with a round bar to produce a dense, slightly concave surface well bonded to the CMU on each side where masonry will remain exposed in the Work.
  - 2. Strike joints of masonry which will be concealed from view flush with the face of the CMU.
- C. **Perform tooling** when mortar is partially set but still sufficiently plastic to bond. Use a tool which compacts the mortar, pressing excess mortar out of joint rather than dragging it out.
- D. **Rake out joints** which are defective at the time of tooling, point and then tool.
- E. **Unless otherwise** specified or detailed, make joints 3/8" thick with full mortar coverage on face shells and on the webs surrounding cells to be filled.
- F. **Butter vertical head** joints well for a thickness equal to the face shell of the unit and shove these joints tightly so that the mortar bonds well to both units.
- G. **Set lintels,** capping units and bearing plates in a full bed of mortar.
- H. **Do not wet CMU** except that in very dry weather the contact surfaces of the CMU shall be moistened immediately before laying.



### 3.08 GROUTING

- A. **Keep mortar droppings** out of, or remove from the grout space before grouting. Fill only cells containing reinforcing steel, unless otherwise indicated.
- B. **Puddle grout and rod** to encase steel and to insure contact with masonry cells. Encase reinforcement in a minimum of 1/2" of grout between CMU and reinforcement.
- C. **Vibrate grout after** initial absorption of water by the CMU, but before plasticity is lost.
  - 1. Vertical cells to be filled shall have vertical alignment to maintain a continuous unobstructed cell area.
  - 2. Grout beams over opening in one continuous operation.
- D. **Grout bolts and anchors** inserted in the wall solidly so that there is a minimum of 1" of grout between the bolt, the anchor and the masonry unit.

### 3.09 HOLLOW METAL FRAMES

- A. **Locate frames** accurately with head level, and jambs plumb and square. Attach securely to floor and brace in position prior to start of masonry erection.
  - 1. Frames are specified to be furnished with adjustable anchors. Adjust anchors to coincide with horizontal joints in masonry.
  - 2. Fill frames solid with mortar or grout as erection progresses.
- B. **Provide temporary** wood spreaders from jamb to jamb to ensure that jambs do no bow in or distort from straight line as frames are filled with mortar.
- C. **Provide temporary** shores to support heads of metal frames and prevent deflection from superimposed loads during erection.

### 3.10 FIELD QUALITY CONTROL

- A. **Inspection by** a Registered Deputy Inspector (RDI) is required and will be provided by the Owner, unless noted otherwise on the Drawings.
- B. **Whenever there is** any evidence that materials to be used in masonry construction do not conform to the Contract Documents, the materials shall be tested for compliance before being used in the Work. The Owner will pay for tests if they prove compliance with the Contract Documents; otherwise costs of tests shall be paid by the Contractor.

### 3.11 CLEANING

- A. **Remove grout scum** and grout stains from CMU walls and all other surfaces immediately.
- B. **After the wall** is constructed, do no saturate with water for curing or any other purpose, except that when atmosphere is dry, dampen surfaces with a very light fog spray for 3 days.

END OF SECTION

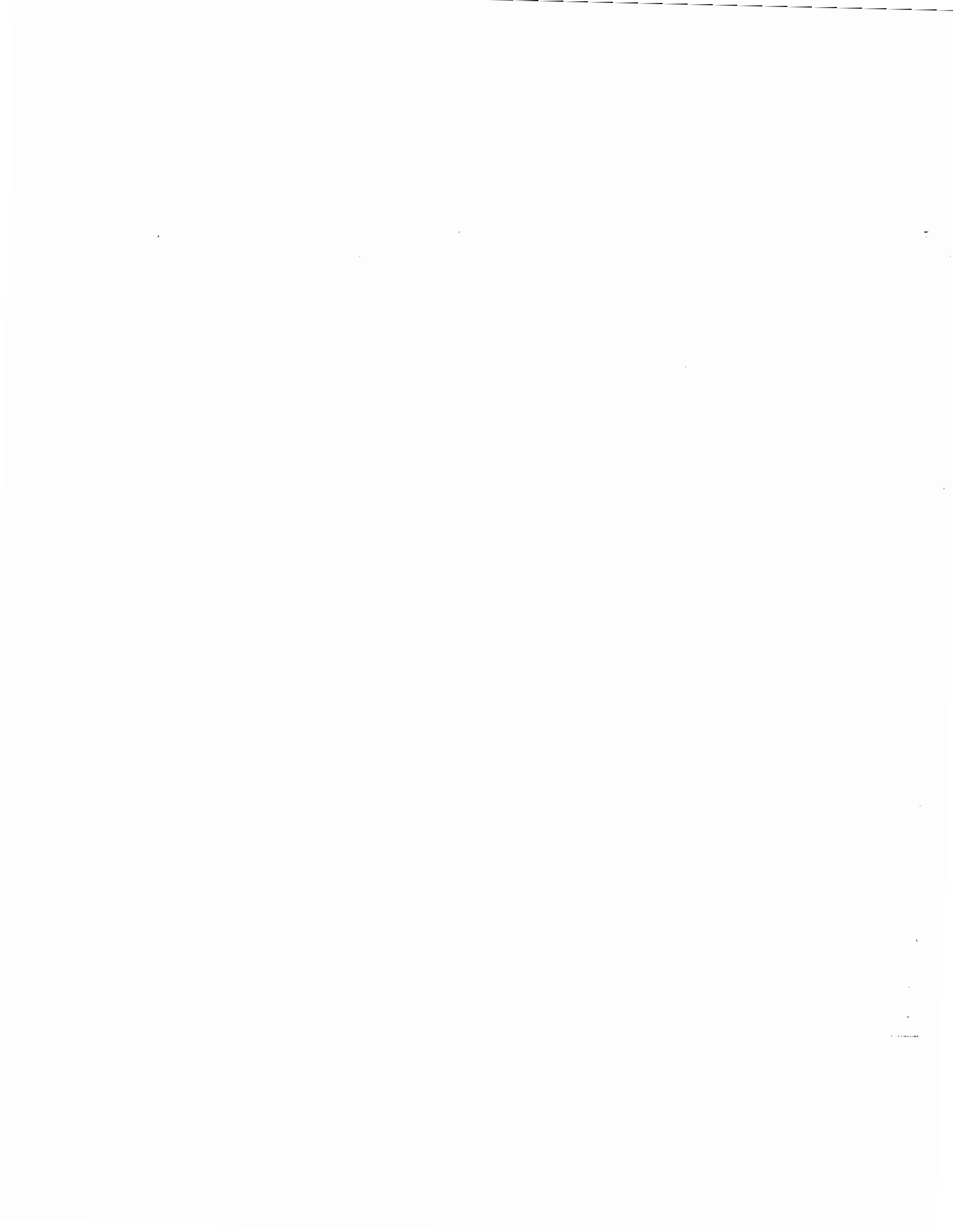

SECTION 04400

FACADE STONEWORK

1.00 GENERAL

**1.01 DESCRIPTION:** Division 1 applies to this Section. Provide facade stonework as indicated, specified and requested.

- A. Work in this Section:** Furnish Facade Stonework in accordance with requirements of the contract documents. This work includes, but is not limited to, the following:
1. All exterior stone facing panels, special shapes, piecework and all other stone elements for the building facade.
  2. Stonework set to units or steel frames, on or off the job site prior to installation including stone anchorage, flashing, water control gutters, and weep drains as specified hereinafter.
  3. Handset stonework on CMU, cast in place concrete, hot rolled or cold formed steel back-up systems including stone anchorage, back-up water-proofing, flashings, and vent and weep drains as specified herein-after.
  4. Quarrying, fabrication, drilling, fitting and cutting of stonework as required for the proper completion of the work.
  5. Testing as specified herein, including but not limited to full scale testing of individual panels, physical property testing, anchorage testing, integrated wall system testing, and sealant compatibility testing.
  6. Delivery of stone to job site or wall assembly facility including protection during transit.
  7. Samples for full size visual quality control samples at quarry and job site.
  8. Accessories and hardware required for complete installation.
  9. Shop drawings, engineering calculations, erection drawings, and any special tag or marking drawings required.
  10. Cleaning of stone prior to acceptance.
  11. Make provisions for anchors, including slotted type, dowels, clamps, rods, hangers, clips, ties, bolts, or other fastening devices as required to securely attach the stone to the support material or to the structure. Where such items are to be built into or cast into the support material or the structure by other sections, coordinate same and provide locations drawings. Inspect

fabricate to ensure proper location and method of installation is being performed.

12. Bid proposal drawings.
13. No attic stock is required.
14. Cornerstone, including supply, design, fabrication, transportation per MTA requirements.
15. This work is to be included in the single point of responsibility by the Exterior Wall subcontractor.
16. **Full size visual mock-up (V-1) at the job site. See the scope of the visual mock-up (V-1) at the end of specification Section 08500.**

**B. Related Work Specified Elsewhere**

1. Steel Frame Support System for Stone Veneer: Section 05130.
2. Cold Formed Metal Framing System for Stone Veneer: Section 05410.
3. Facade Sealant: Section 07901.
4. Facade Insulation and Firesafing: Section 07201.
5. Fixed Windows: Section 08500.
6. Exterior Stonework Installation: Section 04401.
7. **Mock-Up: Section 01450.**

**1.02 QUALIFICATIONS**

- A. Engage a firm with a minimum of 5 years successful experience in the fabrication of stone of similar sizes, shapes and finishes to the units required for this project, and which has ample production facilities to produce, furnish and supply the units as required for installation without delay to the work.
- B. Stone suppliers shall provide a **bid review mock-up** at their facility for review by the design team. The mock-up scope will be provided by the Architect and General Contractor. The stone suppliers shall provide three 24" x 24" samples and finish specified including historical testing data for each.
- C. Quarrying shall be supervised and coordinated by the stone fabricator to insure that the as-quarried block orientations will yield finished material with characteristics as described herein. Only one source of each type of stone shall be used throughout the work.
- D. The Exterior Wall Subcontractor, by commencing the work of this section, assumes as a part of his warranty of the work, to assure that components and parts shown or required within the work of this section, comply with the contract documents. The Exterior Wall Subcontractor shall further warrant that all components, specified or required to satisfactorily complete the installation are compatible with each other and

with the conditions of installation and expected use and warrant the overall effective integration and correctness of individual parts and the whole of the system.

- E. All pieces of stone shall be subject to the Architect's approval. Stone rejected for non-conformance to approved **range** samples or approved shop drawings shall be replaced with material meeting the specified requirements.
- F. Stone shall match the type, pattern, color, texture and finish of samples available for inspection in the office of the Architect.
- G. Architect's inspection of the stone does not relieve the Exterior Wall Subcontractor from his responsibility to provide all stonework in accordance with the approved contract documents, samples and shop drawings.
- H. All examinations, selections and approvals shall be for the purpose of achieving a final appearance of stone with the greatest possible uniformity, and will be based upon the following criteria:
  - 1. Color and value within approved, pre-selected color ranges and finishes.
  - 2. Finish, within approved, pre-selected ranges of variation.
  - 3. Uniformity of texture and graining within approved, pre-selected ranges of variation.
  - 4. Conformance to approved shop drawings and details with specified dimensions and tolerances.
  - 5. Sequence matching of adjacent stone units as approved **and as shown** by the Architect.
- I. Quarried blocks shall be made available for inspection by the Architect at his request.
- J. Production units shall be made available for inspection by the Architect at his request. To this end, the fabricator shall advise the Architect when production has begun and of the earliest possible opportunity to inspect a representative sampling of production work.
- K. All examinations, selections and approvals shall be for the purpose of achieving a final appearance of stone with the greatest possible uniformity. Rejection will be based upon the following criteria:
  - 1. Color and value not within approved typical full size, pre-selected color range and finish samples signed by architect and located at the quarry and job site.
  - 2. Inadequate sequence matching of adjacent stone units, not approved by the Architect.

3. Graining, from finishing work, in excess of reasonable minimum as approved by the Architect, and not running generally parallel on all finished surfaces.
4. Non-conformance to approved shop drawings and details within specified dimensions and tolerances.
5. Any stone with a crack may be rejected and require replacement, as determined by the Architect.
6. A suspected loss in stone strength demonstrated via production testing.
7. Other failures as specified herein.

### 1.03

#### PLANS AND SPECIFICATIONS

- A. The character of these requirements is intended to provide a performance type specification for the design, fabrication and installation of the Facade Stonework. The Exterior Wall Subcontractor is responsible for the engineering, and design of all components and materials as well as the fabrication, installation and performance of the Facade Stonework.
- B. Drawings are diagrammatic. The details shown are intended as a guide for the aesthetic and interfacing requirements of the stone and its support system work to and with other work. The requirements shown by the details are intended to establish basic dimensions of the module and the sight lines, jointing and profiles of members. The Exterior Wall Subcontractor is responsible for the design and engineering of the system within these aesthetic parameters. The drawings are not to be construed as engineering design, or adequate to meet the engineering design requirements.
- C. It is recognized that the design details do not cover some conditions or modifications, which may be required. It is, however, intended that conditions not detailed shall be developed through the Exterior Wall Subcontractor's shop drawings to the same level of aesthetics and in compliance with performance criteria as indicated for detailed areas and as stipulated in these specifications.
- D. All stone projections and coping to slope for drainage.
- E. Provide water drip cuts at all horizontal returns and soffits.

### 1.04

#### CODES AND STANDARDS

The work, except as otherwise shown or specified, shall comply with the latest edition of the following. **Stone and workmanship quality shall be in accordance with the best industry standards and practice as set forth by the following.** When conflicting requirements arise, follow the more stringent requirement.

- A. Standards of the American Society for Testing and Materials (ASTM Standards).
- B. National Building Granite Quarries Association (NBGQA).

- C. American National Standards Institute (ANSI).
- D. Uniform Building Code, 1991 edition, for seismic criteria.
- E. Marble Institute of America (MIA).
- F. Building Stone Institute (BSI).
- G. Indiana Limestone Institute (ILI).
- H. Los Angeles Building Code.
- I. New Stone Technology, Design and Construction for Exterior Wall Systems, ASTM STP996.

**1.05 SUBMITTALS**

- A. Exterior Wall Subcontractors seeking to secure a contract to provide work for this section shall provide proposal drawings showing stone installation methods and relationship to adjacent construction with bid for work of this section. Drawings shall be accompanied by previous test reports which demonstrate stone meets the physical and structural requirements of the specifications. Tests shall have been performed by a laboratory in the United States.
- B. Submit shop and fabrication drawings stamped by a licensed California engineer for facade stonework. Coordinate drawings and drawing submittal with anchorage system. Show in detail, the jointing, anchors and dowels, if any, dimensions, sizes and locations of cut-outs, relation to work of other trades, and all other pertinent data and information. Detail all stone, shapes, thicknesses, dimensions of slots or holes for anchors, finishes, miter and corner conditions. Coordinate stone sizes with window, curtain wall, and ground floor entrances and storefront details to ensure adequate sealant coverage at perimeters. Number each piece of stone to correspond to the markings as shown on the fabrication drawings. Mark the identification number on the back of each stone. The drawings shall bear the seal of a registered professional engineer licensed in the state of California. This engineer shall also perform and submit structural calculations to document all stone stress conditions.
- C. The Exterior Wall Subcontractor shall prepare and submit performance mock-up drawings showing the scope, method of attachments, finishes, edge finishes, thickness, tolerances, and any other pertinent information. Mock-up drawings shall be accompanied by structural calculations for stone strength and anchorages shown in drawings. Both drawings and calculations shall be stamped by the same engineer. Engineer must be licensed in the state of California. Drawings shall be incorporated into the exterior wall drawings. The drawings shall then be included in the coordinated mock-up drawings with all other trades as prepared by the Exterior Wall Subcontractor.

- D. Provide duplicate **24" x 24"** quality control sample slabs of stone in each finish required and incorporating notches, edge conditions and reveals, indicative of the entire range of materials and respective finishes. Prior to fabrication, provide a visual display of these samples at the quarry or stone fabricators plant for the Architect's review and approval. These samples will serve as the control for limiting the acceptable range of appearance. The samples will be signed and dated by the Architect and the **General Contractor**. One set of signed stones shall be shipped to the job site for use as quality control samples. The other set of samples shall be retained at the quarry or stone fabricators facility for their quality control. Also, provide samples of facade stonework necessary for test mock-up and other testing, as specified hereafter. Provide 12" x 12" samples of stone that depict corners, special shapes, edge finishes, rebates or other conditions and finishes as may be required by the Architect.
- E. Submit manufacturer's data sheet or equivalent printed literature indicating product information for stone, stone anchorages, epoxies, setting accessories and other related materials. Data shall substantiate that materials comply with specified requirements.
- F. After review of samples by Architect, and prior to fabrication, certify in writing, and submit any additional evidence required, indicating that a sufficient quantity of materials within the range of accepted mock-up materials is available from a single quarry to satisfy the total requirements of the project. The stone supplier shall be responsible for any costs, and associated costs incurred, if they fail to comply with this certification. Submit evidence that stone fabricator meets the requirements of the Qualifications Section.
- G. Submit test reports per ASTM **E575** for results of the physical properties testing, as specified hereinafter. Submit test results of anchorage (see 4400.1.07 C and D) and full size panel tests (see 4400.1.07 E) as specified hereinafter. Submit test results of production testing (see 4400.1.08) as specified hereinafter.
- H. Submit calculations for review by Architect, certified by a professional engineer licensed in the state of California, for structural adequacy of stones and anchorage system. Coordinate calculations submitted with shop drawing submittals. Calculations to be stamped by said engineer. Analyses shall include seismic criteria as required by the 1991 UBC.
- I. Submit manufacturers instructions for storage, protection and handling at the exterior wall plant or jobsite. Indicate Exterior Wall Subcontractor have received same data.
- J. Submit quarry surveys information for job production and testing materials.
- K. Submit stone fabricators quality control procedures regarding rift, thickness, cracks, finishing and other concerns. As a minimum, fabricators quality control procedure shall include the following:
1. After slabbing stone, measure and record thickness at four corners of one slab per block.



2. Permanently mark rift direction on back of each slab.
  3. After finishing, measure and record thickness at four corners of every 20th slab. Remove any slabs that do not meet tolerance criteria specified herein.
  4. Examine each slab under bright daylight at an oblique angle to finished surface for evidence of hairline cracks. Remove any slabs containing hairline cracks.
  5. Wet surface of every 20th slab and observe while surface dries to find evidence of hairline cracks. Remove any slabs containing hairline cracks.
  6. After fabrication, measure and record all dimensions of cuts, and drilled holes on every 20th panel. Compare to tolerances specified herein and remove any slabs that do not conform.
  7. **General Contractor's** representative shall visit and review fabricators operations and records.
- L. Submit stone repair procedures in a detailed outline of materials and methods one month prior to commencement of job site erection of any panels.
- M. Submit stone replacement procedure details. Provide two replacement stone panels on test mock-up as selected by architect. Replacement anchorage to be subjected to the same performance requirements as for original stone anchors.
- N. The successful stone supplier shall provide a full size visual mock-up at the jobsite showing the full range of the approved stone(s). The scope of the mock-up shall be as indicated on the architectural elevations.

1.06 **PERFORMANCE CRITERIA**

- A. Granite
1. Granite shall have a minimum modulus of rupture of 1500 psi as tested per ASTM C99, and shall meet the minimum requirements of ASTM C615 and ASTM C119. Stone shall have a minimum flexural or bending strength of 1200 psi as tested per ASTM C880 modified.
  2. Nominal granite thickness shall be a minimum 3cm after finishing.
  3. Theoretical structural calculations of granite stress shall be based on the lowest average of the four group averages of ASTM C99 or C880 modified tests. The working stress values shall have a minimum safety factor of 3.0 when compared to this average and are to be based on minimum section thickness tolerance after fabrication.
  4. Adequate number and size of anchors for granite retention shall be provided to satisfy the load requirements and design criteria set out in this specification. In any case, anchors shall not be less in size and number

than required by code. The ratio of the granite anchor ultimate strength to actual load at design pressure shall be at least 4.0. A 1/3 increase in allowable stresses for wind is not allowed. Design for seismic loading shall be as required by 1991 UBC.

**B. Limestone**

1. Limestone shall have a minimum modulus of rupture of **800** psi as tested per ASTM C99 and shall meet the minimum requirements of ASTM C568 Class III (High Density) for limestone. Limestone shall have a minimum flexural or bending strength of **800** psi as tested per ASTM C880 modified.
2. Theoretical structural calculations of limestone stresses shall be based on the lowest average of the four group averages of ASTM C99 or C880 modified tests minus one standard deviation. The working stress values for limestone shall have a minimum safety factor of **6** when compared to this modified average. Calculations shall be based on the minimum thickness tolerance section after finishing.
3. Adequate number and size of anchors for limestone retention shall be provided to satisfy the load requirements and design criteria set out in this specification. The ratio of the stone anchor ultimate strength to actual load at design pressure shall be at least **8**. A 1/3 increase in allowable stresses for wind is not allowed. Design for seismic loading shall be as required by the 1991 UBC.
4. Nominal stone thickness for limestone shall be a minimum 2". Increase thickness for strength, type selected, shape, mounting/erecting system, location, or aesthetics, as required.

C. Methods of fabrication, anchorage, and assembly shall be in compliance with the project documents, however they shall be at the discretion of the Exterior Wall Subcontractor, with Architects review, provided that the visible architectural effect is not changed.

D. Coordinate all stone anchorages with the design of the stone support systems.

**1.07 TESTING**

A. Testing of specified stones shall be performed by the **Owner** independent testing laboratory located in the United States prior to all other testing programs. Testing to be completed prior to mock-up testing or fabrication of stone.

B. The testing samples shall be taken at random locations from at least 4 different blocks from areas which will be quarried for the project. Identify and transmit to the independent testing laboratory a record of the samples and quarry locations from which they were taken. Identify finish, surface, rift and other necessary data for proper testing per the test procedures specified. Provide stone samples for each type and finish of stone of sizes and shapes, notched and rabbeted, as required by

the approved independent testing laboratory for the following tests. Each different finish and stone type must be tested.

Physical Property	Test Method	No. of Tests
1. Compressive Strength	ASTM C170	3
2. Modulus of Rupture	ASTM C99	
Tested Dry Parallel		5
Tested Wet Parallel		5
Tested Dry Perpendicular		5
Tested Wet Perpendicular		5
3. Density	ASTM C97	3
4. Absorption (% of weight)	ASTM C97	3
5. Flexural Strength	ASTM C880 Modified*	
Tested Dry Parallel		5
Tested Wet Parallel		5
Tested Dry Perpendicular		5
Tested Wet Perpendicular		5

\*Modify specimen size to be 9" wide x 38" long x job thickness with finished face loaded in flexural tension. Finish to be same finish as that used on the project. All different finishes must be tested.

6. Volumetric and Chemical Stability	ASTM C295 Modified**	10
---	-------------------------	----

- a. \*\*Select 10 pieces of used C880 or C99 specimens which displayed the lowest strength values as tested above for thin section examination of susceptibility to freeze-thaw damage, inherent crack exacerbation mechanisms, soluble compounds, and other items which affect durability or strength.
- b. Conduct the petrographic examination, on thin sections using petrographic and scanning electron microscopes and other instruments as needed. Use samples oriented parallel and perpendicular to the plane of stone panels and to the rift, noting orientations in the report. The source and method of selecting samples must be reported.
- c. Provide estimated modal compositions of the stone. Neither quantitative chemical analyses of whole rock or individual minerals or point counts are required. The presence of any mineral or feature that may adversely affect the durability or aesthetics of the stone must be reported. Provide data on texture, including the following:

- i. Nature, density, and orientation of cracks and microcracks.
- ii. Secondary mineralization.
- iii. Nature and distribution of porosity.
- iv. Nature of mineral intergrowths.
- v. Extent and nature of alteration/weathering of minerals.
- vi. Systematic fabric elements.
- vii. Grain size and shape of mineral species.

Physical Property (cont'd)	Test Method	No. of Tests
7. Durability Testing	ASTM C67 Section 8 Modified***	10 Parallel 10 Perpendicular

\*\*\*Modify specimen size to be 9" wide x 38" long x job thickness; add testing of 5 parallel and 5 perpendicular specimens per ASTM C880 (modified) after completion of 50 cycles and after weight loss measurements. Compare results to initial flexural strength tests. If post freeze-thaw strength average is less than 80% of initial strength average then architect may require additional thickness or redesign of cladding at no cost to the Owner. Continue testing for an additional 50 cycles and perform C880 modified tests and weight loss measurements. Apply same design criteria comparison as above for evaluation of results.

- C. Prior to mock-up testing, prepare and test a minimum of six 12" x 12" stone specimens for each type of anchor design proposed in each direction of anticipated load, i.e. tension, shear, etc.. Test set-up and load apparatus shall be submitted to Architect or Consultant for review prior to testing. Materials used and fabrication methods shall match those to be used for project production. The reports shall identify exact material specifications that were tested and dimensions for all components involved in testing. Load shall be incremented in negative steps at 10 psf increments, to ultimate failure. Deflections shall be recorded and reported at each load increment. Observation of initial yield shall be reported. Mode of ultimate failure shall be reported as well as load value at failure. Consistent failure mode shall be required for each type of specimen and load category. Deflection values in excess of 0.032" at 150% design load are not allowed. All specimens must exceed 3.0 times the design load without failure. All limestone test specimens must exceed 6.0 times the designs load without failure. Any failures less than the specified criteria shall require redesign at no cost to the owner.
- D. For anchorage systems utilizing stainless steel pins set into stone and secured with epoxy materials the following criteria and testing procedures shall be maintained:

1. Stainless steel pins to be 5/16" or 1/4" dia. threaded full length with the exception of point at which bend occurs. Shop installation only shall be provided.
  2. Pins shall be set into stone in holes not exceeding 1/16" greater diameter than size of pin used. Such holes must be drilled with diamond drills. If design is based upon a bent bolt type anchor, bolt shall be at 22 1/2 degrees from horizontal. A minimum clearance to outside face of stone of 1/4" must be maintained.
  3. Prior to placement in hole, the hole shall be dry and completely cleaned. Hole shall then be filled with a high modulus epoxy. Such epoxy shall be identified by name and manufacturer. Manufacturer's literature shall be supplied. Exterior Wall Subcontractor shall warrant that the epoxy formulation is satisfactory to provide adhesion to granite. The use of polyester based epoxies are prohibited except as filler materials for chip repair.
  4. Sufficient time for epoxy to thoroughly set must be allowed prior to securing pins to connected elements. Bent bolt and nut shall be torqued to 4 foot lbs. minimum, if this design is used.
  5. Pins shall be tested in shear as follows: (Load vs. deflection readings shall be charted for each test specimen.)
    - a. Apply basic load of 50#, hold for ten seconds and release.
    - b. Re-apply load to 50#, 75#, 100#, 125#, 150# and 175# in increments pausing ten seconds between each increment.
    - c. Continue applying 25# increments and hold each ten seconds until failure.
  6. Pins shall be tested in tension as follows: (Record deflections)
    - a. Apply tensile load starting at 50# and increase loads in 25# increments to failure, pausing ten second between each increment.
  7. Samples tested shall be performed on project finished samples 12" x 12" x thickness of stone (minimum 3 cm after finishing for granite and 2" for limestone). Five samples shall be tested wet, five samples dry, five samples perpendicular to rift and five samples parallel to the rift (total 20 samples).
- E. Prior to testing of the mock-up prepare and test a minimum of 10 full sized granite panels, and 10 full size limestone panels including the anchorage used to secure the stone to the back up system. Test specimens shall be representative of the critical combination of load and span conditions along with any required reveals or notches. Test assembly until failure using alternately + or - 10 psf increments. Record deflections at each increment, the mode of failure and value at failure. Load shall be accomplished via static uniform air pressure difference. Prior to testing, submit for approval by the Architect, a detailed description of the test assembly and method

of testing. Include exact identification of all material specifications and illustrate all pertinent dimensions and details. Performance of each granite test panel must meet or exceed 3.0 times the design wind pressure without breakage of stone or permanent deformation of anchors. Limestone panel must meet or exceed 6.0 times design. Any breakages less than the specified criteria will require redesign at no cost to the **General Contractor or Owner**.

- F. Submit stone sample, finished per the job conditions to the sealant manufacturer for testing of adhesion, compatibility and stain testing. Refer to section 07910 for further requirement.
- G. Provide stone for the laboratory mock-up test specimen. Type, quantities and sizes to be same stone as stone for project Stone must come from quarry location to be used for job stone. Scope to be suggested on the Architectural drawings but the responsibility of Exterior Wall Subcontractor. Failure of stone or stone anchorage shall require replacement and/or redesign at no cost to **General Contractor or Owner**.

#### 1.08 STONE TESTING DURING PRODUCTION

- A. The purpose of this testing is to examine the complete range of variation in physical properties of stone supplied so assurance is obtained that job material provides a known minimum level of strength.
- B. The scope of testing is limited to flexural strength testing and the reporting of the results for comparison to original design data. **The pre-construction testing data and approved flexural test results shall be the bench mark for testing during fabrication.**
- C. Production test specimens shall be taken from every **twentieth** quarry block for each type of stone supplied to job. After slabbing, prepare and record per ASTM C880, six specimens, measuring 9" x 38". Test three wet and three dry for each type of stone supplied to job, per the ASTM C880 modified flexural strength procedure as specified elsewhere herein.
  - 1. Identify the specimens with the unique quarry block numbers.
  - 2. Report the individual specimen strengths and the average strength of each group of three.
  - 3. If any of the test results show the production block average strengths having less than 80% of the minimum design strength from the original data, then additional testing or a reduction in allowed working stress shall be required as directed by the Architect.

#### 1.09 DELIVERY, STORAGE AND HANDLING

- A. Stone supplier/installer must deliver stone to wall fabricator or job site using protection and handling equipment which will ensure that there will be no breakage, chipping, soiling or other damage. Store above grade on wood dunnage or other

suitable surfaces using polyethylene film to separate stone from wood or other supporting or protecting members. Protect from weather, soiling and damage of every kind. Crate stone to prevent accumulation of moisture between stones.

- B. Any costs arising from breakage of stone or discoloration of stone during shipment, handling and installation shall be borne by the stone supplier.
- C. Furnish other materials, except bulk materials, in manufacturer's unopened containers with name, brand, type, grade and color fully indicated thereon. Store bulk materials as required to avoid any deleterious effects of weather, soiling or contamination.
- D. All delivered items whether F.O.B. jobsite or fabrication facility and/or job site, for unloading by others, or whether fabricated and installed by the Exterior Wall Subcontractor, shall be properly crated. Crates shall be marked with installation location, fabrication/piece numbers, shop drawings reference, etc...as applicable.

#### 1.10

#### WARRANTY

- A. Before final acceptance, the General Contractor shall guarantee the Owner in writing that all parts of the work will meet the specified overall performance requirements of the specifications, and will be free from defects in materials and workmanship and remain watertight for a period of five (5) years from final payment and acceptance of the work by the Owner. The Exterior Wall Subcontractor shall certify in writing that all work is in accordance with the contract documents and authorized alterations and/or additions thereto and that, should any defect develop during the guarantee period due to improper workmanship or materials under his jurisdiction, such defects will upon written request, be repaired or replaced at no additional cost to the Owner. If exploratory work is required to determine the cause of the defects, the cost of such work shall be borne by the Exterior Wall Subcontractor only in case his work is found in the judgment of the Architect to be at fault.
- B. Defective materials and workmanship are hereby defined to include evidence of abnormal deterioration or aging or weathering of work, structural failure of components resulting from exposure to normal load and forces, sealant failures, deterioration or discoloration of finishes in excess of normal weathering and aging, and failure to fulfill other specified performance requirements.
- C. The guarantee, the enforcement or lack of enforcement thereof, shall not deprive the Owner of other actions, rights or remedies available to him. Guarantee shall be in form approved by Architect. **Sample warranty shall be submitted for review and approval.**

**2.00**      **PRODUCTS**

**2.01**      **MATERIALS**

**A.**      **Stone**

1. Provide stone of soundness (hardness and density) **as required per the respective ASTM standard**, texture, graining, color, tone, matching the samples in the Architect's field office and subject to the Architect's acceptance. Stone shall be sound and free from defects which will impair strength, durability or appearance, and provided from a single quarry source to satisfy the total requirements of the project. Quarry and fabrication plant facilities shall be available for the Architect's inspection at any time. Physical properties shall comply with **ASTM C615 and ASTM 568 for limestone**.
2. Provide stones of type, color and finish as scheduled on the Architectural Drawings. Finish all exposed edges as scheduled.
3. Nominal granite thickness shall be a minimum of 3 cm after finishing. Nominal limestone thickness shall be a minimum of 2.0". These thicknesses are based on assumption that intermittent anchor supports are provided. Increase thickness for strength or aesthetics as required. Also, increase thickness as required relative to span provided by support system selected by Exterior Wall Subcontractor.
4. The finish, range of texture uniformity, degree of graining, direction of grain drift and the range of color and value of all material shall match or otherwise conform to the properties as evidenced in quality control approval samples, sample quarry slabs, and full size mock-ups **and pre-construction testing**.
5. Stone quantities for each stone type to satisfy the total requirements of the project shall be provided from a single quarry as described herein.
6. Stone finish, as scheduled on the architectural drawings shall be on all visible surfaces and exposed edge returns. Locations shall be as shown on drawings, or approved shop drawings. Degree of finish must meet with samples approved by the Architect.
7. Direction of grain drift shall run generally parallel on all finished surfaces. Erected work shall be oriented in **direction as noted on approved shop drawings and approved by the Architect**.
8. All stone shall be free from holes, seams, shakes, clay pockets, spalls, stains, starts, and other defects which would impair the strength, durability and appearance of the work, as determined by the Architect.



9. The following minimum criteria for quality control of stone cracks should be maintained:
  - a. Cracks greater than 0.002" in width and 0.125" in depth are not acceptable.
  - b. Cracks less than 0.002" in width can be no longer than 4.0 inches.
10. All quarry cracks, seams, fissures, veins and other natural cracks are to be prequalified by the Architect as healed, partially healed or open. Partially healed and open cracks are not acceptable and should not be supplied to the project.
11. All stone shall be selected for background color, and veining. Marking and matching shall run in even shades and shall be set accordingly. Inherent variations characteristic of the stone and the quarry from which the stone is obtained shall have been brought to the attention of the Architect at time when the stone samples were submitted to the Architect. These conditions shall be subject to Architects approval.

**B. Stone Types:**

1. Stone Type S1: Limestone (Dolomite), Kasota - Mankato, Minnesota Glacier Buff, Veine Cut, Honed Finish, Gold-Cream by Vetter Stone Co.
2. Alternate Stone Type S1A: Limestone (Dolomite), Kasota - Mankato, Minnesota Mankato Cream, Veine Cut, Honed Finish, Gold Cream by Mankato - Kasota Stone, Inc.
3. Alternate Stone Type S1B: Limestone (Dolomite), Kasota - Mankato, Minnesota Glacier Buff, Fleuri Cut Finish, Gold-Cream by Vetter Stone Co.
4. Alternate Stone Type S1C: Limestone (Dolomite, Kasota - Mankato, Minnesota Cream, Fleuri Cut, Honed Finish, Gold Cream by Mankato - Kasota Stone, Inc.
5. Alternate Stone Type S1D: Limestone, Italy Giallo Dorato (Pietra di Vicenza), Polished Finish, Gold-Cream. Mariotti, Glomati, Palladio or approved equal.
6. Alternate Stone Type S1E: Limestone Bavarian Gold, Honed Finish, Gold-Cream-Brown by Solnhofen Natural Stone, Inc.
7. Stone Type S2: Limestone (Dolomite) Kasota - Mankato, Minnesota Northern Grey Buff, Veine Cut Honed Finish, Cream Grey by Vetter Stone Co.
8. Alternate Stone Type S2A: Limestone (Dolomite), Kasota - Mankato, Minnesota Northern Grey Buff, Fleuri Cut, Honed Finish, Cream Grey by Vetter Stone Co.

9. Alternate Stone Type S2B: same as Stone Type S1A.
10. Alternate Stone Type S2C: Same as Stone Type S1C.
11. Alternate Stone Type S2D: Same as Stone Type S1D, except with Cream-Grey Color.
12. Alternate Stone Type S2E: Same as Stone Type S1E, except with Gold-Grey Color.
13. Stone Type S3: Granite, Brazil Gialo Veniziano, Veine Cut, Honed Finish, Golden-Brown-Black (Light, no Pink), Glomati or approved equal.
14. Stone Type S4: Granite, Gries Carmel, Polished Finish, Gold-Brown-Grey-Black (Light), Glomati or approved equal.

#### C. Stone Accessories

1. Anchor bolts, pins, dowels, nuts and washers shall be AISI type 302/304 stainless steel, if in contact with concrete or stone. **Anchors shall have an approved City of Los Angeles Research Report.**
2. Rubber or neoprene grommets/tubes, shall be of the diameter required to install around dowel pins that anchor into the concrete. Wall thickness of tube to accommodate the differential volumetric expansion of the stone and concrete.
3. Epoxy Resins: **Minimal** field application of epoxy is allowed on this project.
  - a. Epoxy resins shall be selected from the following manufacturers:
    - i. Sikadur
    - ii. Adhesives Technologies
    - iii. Adhesive Engineering Co.
    - iv. Akemi
    - v. Bonstone
  - b. The epoxy shall have a minimum heat deflection temperature of 145 degrees F. per ASTM D648.
  - c. Epoxy used structurally shall only be used in conjunction with 300 series stainless steel mechanical retention mechanisms. Joints shall maintain structural stability under design loads in the event of total adhesion failure.

- d. The epoxy shall not be considered as the primary retaining mechanism. The epoxy may be used to enhance the structural capacity of assemblies.
  - e. Epoxy manufacturer shall state in writing that the selected epoxy is acceptable for use with the stone and the application for which it is being used.
  - f. Polyester based epoxies are prohibited for structural applications. They may be used as fillers for chip repairs only.
4. Shims shall be stainless steel or aluminum or approved equal. Shim size shall distribute the loads so point loading does not affect stones performance.
  5. Where permanent setting pads are required, use 90 durometer neoprene, lead or Korolath. Use wood wedges for temporary shims and remove after installation is set.
  6. Stone kerf details, if used, shall provide a minimum clearance of 1/16" at all metal surfaces within kerf cut. Stone shall not bear directly against or on metal. No nibs nor bulbs on kerf legs shall be allowed. Dead load of stone shall be isolated from metal supports by elastomeric materials. All kerfs shall be sealed with an elastomeric sealant prior to setting of kerf clip into stone kerf. Kerf cut shall be completely filled with sealant.
  7. Anchorage systems for handset stonework shall be galvanized continuous or clip steel support members anchored to hot rolled or cold formed steel back-up systems, CMU, or cast in place concrete with field installed anchors as required and approved at each condition. Continuous or clip deadload and wind load anchors supporting stone panels shall be formed 316 stainless steel or extruded 6061-T6 aluminum members as required and approved and shall provide a minimum clearance of 1/16" at all surfaces within kerf. All kerfs shall be sealed with an elastomeric sealant prior to setting of stone support members into stone kerf. Kerf cut shall be completely filled with sealant.
  8. Provide 316 stainless steel flashing members as indicated or required in relation to handset stonework.
  9. Provide vent and weep member at grade level of each major vertical stone joint. Vent and weep prefab assembly shall be 3/8" x 1" high and of 316 stainless steel, and shall be set flush to exterior face of stonework.

## 2.02

### FABRICATION

- A. Quarrying shall be supervised and coordinated by the stone fabricator to insure that the as-quarried block orientation will yield finished material with characteristics as described herein.

- B. All stone shall be cut from matched blocks. Matched blocks shall mean blocks extracted from a single bed of stratum in the quarry. The use of blocks chosen at random though similar in general character and color to that of approved stone shall not be permitted, except by written permission of the Architect.
- C. Accurately cut, dress, drill, fit and finish stone work to shapes and dimensions shown on drawings and/or final shop and setting drawings. Make exposed plane surfaces true in line. Work shall be in compliance with recommendations of the National Building Granite Quarries Association, Inc., the Marble Institute of America and the Indiana Limestone Institute.
- D. Cut all joints and edges square and at right angles to face, and with backs parallel to face except at radial stone make joints radial. Make arises straight, sharp, true, and continuous at joints. Gage all exposed stone edges so as to maintain a continuous edge dimension. No kerf cuts nor rebated cuts at exposed edges shall be permitted.
- E. Cut, kerf, rabbet, back check and drill stones in shop as required for supports and anchors or for lifting as required by stone support system.
- F. Allow for expansion and contraction within the limits of the joint material when cutting for anchorage devices. Back-check stone as required for tolerances, and to accommodate imposed movements or stone anchorages.
- G. Provide greater stone thickness than indicated where thicknesses indicated are insufficient for the sizes or where extent of cut-outs shown decreases effective strength of the remaining material, or for proper and sufficient anchorage, suitable and adequate bearing areas or surfaces. The use of liners properly sized and secured to stone facing will be permitted only where shown on drawings and/or final shop drawings and shall be mechanically secured in addition to adhesive connection.
- H. All stone work shall be executed by mechanics skilled in the trade. Cut stone units with bed, unless otherwise approved by Architect.
- I. Stone shall be accurately cut to sizes, shapes, profiles and dimensions. There shall be no deviation from jointing. Cut with rift in same direction throughout.
- J. Stone kerf details, if used, shall provide a minimum clearance of 1/16" at all metal surfaces within the kerf cut. Stone shall not bear directly against or on metal. Dead load of stone shall be isolated from metal supports by elastomeric materials. Stone support clips or elements shall be extruded aluminum with strength equal to or greater than 6063-T6. All kerfs in stone shall be completely filled with an elastomeric sealant prior to setting of kerf clip or kerf extrusion. Sealant to be compatible with perimeter sealant. Sealant to be tested in accordance with testing herein before specified.
- K. Patching or repair of stone shall be performed only in accordance with the procedures as approved by the Architect. No repair shall be done until procedures are approved. Chips or broken stones where breakages occur in non-exposed areas shall be considered repairable only if stone strength is not compromised and only if

the area of repair is less than thirty six (36) square inches and the length of one dimension does not exceed 9 inches.

- L. Cut stone units full and true on faces, reveals, beds, joints and top to the full dimensions required by drawings. All edges shall be straight and true with sharp and true arises. All stone shall fit together accurately.
- M. Make faces of stone units in the same plane flush at joints. All finished surfaces shall be true in line and face.
- N. Saw-cut back surfaces which will be concealed in the finished work. Maintain mill finish on face of panels that form sealant joint from overlapping stone panel. Backs of stone units shall be sawn to true planes, parallel to face plane. Sawn surfaces and edges shall be cleaned of all rust stains and iron particles.
- O. Dress joints (bed and vertical) straight and at 90 degree angle to face. Except at radial stone cut radial joints.
- P. Provide stone panel of 3 cm after finishing for granite and 2.0" for limestone nominal thickness or thicker as required by test results. Provide greater stone thickness than shown where thickness shown is insufficient for sizes per test results or where extent of cutouts shown decreases effective strength of remaining material.
- Q. Provide reveals, reglets, openings, and other similar features or spaces as required for contiguous work. Coordinate with drawings and final shop drawings showing contiguous work.
- R. Stone to receive anchors, dowels, and other necessary items. Lewis holes and holes for other back anchoring devices shall not be closer than 2" of edges.

## 2.03 TOLERANCES

- A. Tolerances are not cumulative. The following tolerances shall be used for stone fabrication. Coordinate all tolerances with the stone support system.
  - 1. Thickness: minus zero and plus 2mm.
  - 2. Hole Diameter: plus or minus 1/32 inch.
  - 3. Face Dimension: plus or minus 1/16 inch.
  - 4. Angle of Cut or Drill: plus or minus 2 degrees.
  - 5. Depth or Width of Cut: plus or minus 1/16 inch.
  - 6. Deviation from Squareness: plus or minus 3/32 inch.
  - 7. Joint Dimensions between Stones: plus or minus 3/32" for 1" joints and  $\pm$  1/16" at 3/8" joints.

**2.04 FINISHES FOR STONE**

- A. No hiding of defects will be permitted. Units having flaws or imperfections are not acceptable and will be rejected. Replace with acceptable units without additional compensation. Patching of stone shall only be done in accordance with the specified criteria herein and with approval of the Architect (**See 3.03 for repair of stone**).
- B. Examine finished stone for microcracking. Report instances of excessive or potentially damaging cracks in crystalline structure.
- C. All exposed-to-view surfaces shall be finished. Exposed-to-view edges shall match face finish. Face finish shall be as noted on Drawings. If a surface finish is undefined, verify with Architect.

**3.00 EXECUTION**

**3.01 INSPECTION/PREPARATION**

- A. Prior to installation examine surfaces to receive stone and do not proceed until any defects detrimental to the finished work are corrected, including the moisture protection, structural supports, provisions for expansion, or any other condition which might affect the finished work in appearance, water tightness or integrity of the completed installation.
- B. Verify all measurements and dimensions. Coordinate the installation of inserts for this work. Coordinate and schedule this work with the work of other trades. Give particular attention to the location and size of cut-outs required to accommodate other work or adjoining construction, in accordance with the reviewed shop drawings for such trade.
- C. Review shop drawings of items or assemblies related to the support of anchorage for stone work, including requirements for clearances for proper installation.
- D. Obtain written certification from the respective manufacturers of all proprietary products such as epoxies, sealants and anchorage devices that the materials are proper for the expected use and exposure of the stonework. No materials soluble in water after set shall be used. Submit data and documentation of these confirmations to Architect for review.
- E. Advise installers of other work about specific requirements relating to his placement of inserts or anchorages to be used by stone work. Furnish installers of other work with drawings or templates showing location of inserts for stone anchors and supports.
- F. Coordinate all stone work and anchorages with the stone support system so as to produce work in compliance with the performance and aesthetic requirements set forth herein.

- G. Provide a bituminous coating with a minimum 10 mil thickness to all CMU and cast in place concrete at handset stonework below Level 2 prior to setting handset stone anchorage members.

### 3.02 INSTALLATION

- A. Install stone as shown and as detailed on Final Shop drawings, or in compliance with recommendations of the National Building Granite Quarries Association, Inc., the Indiana Limestone Institute, **and the Marble Institute of America.**
- B. Anchors shall be as shown and as detailed on approved shop drawings. All anchors which directly support stone shall be stainless steel.
- C. Erect all parts of the exterior stone wall plumb and true in proper alignment and relation to established lines and grades, with uniform joints and reveals and as shown on approved shop and/or erection drawings. Tolerances shall be as established in other wall sections, or as stated herein.
- D. Do not install component parts which are defective in any way, including warped, bowed, abraded, chipped, cracked or broken stone. Remove and replace stone which has been damaged during installation or thereafter before the time of final acceptance.
- E. Seal around all anchors, connections and penetrations with approved elastomeric sealant, which is compatible with the perimeter sealant. Prepare all joints for sealant application.
- F. Seal around all pin and dowel connections with epoxy. No field application of epoxy is allowed at any time on this project.
- G. Laminated or composite assemblies of stone shall employ mechanical connections in combination with adhesive materials. The mechanical connections shall be the primary source of anchorage for all designs. No field application of epoxy is allowed.
- H. Erection Tolerances: The installed exterior stonework system components shall conform to the following erection tolerances.
  - 1. Deviation for Vertical Members: 1/8 inch maximum in one story height and 1/4 inch maximum in a 30 foot run and 3/8" for height of building.
  - 2. Deviation for Horizontal Members: 1/8 inch maximum in a 30 foot run and 1/4" total for building.
  - 3. Offset from true alignment between two abutting members: 1/16 inch.
  - 4. Stonework joints, vertically and horizontally, below Level 2 shall be within  $\pm$  1/16" of nominal joint size shown on documents and approved shop drawings.

- I. Execute exterior stone work by skilled mechanics, and employ skilled stone fitters at the site to do necessary field cutting as exterior stone is set.

### 3.03 REPAIR OF STONE

- A. It is the intent to have all exposed surfaces and edges of stone units free from cracks, broken corners, chipped edges, scratches or other defects affecting appearance. **Repairs shall be made in accordance with limits established herein and/or with the Architect's approval.**
- B. Replace any stones which in the opinion of the Architect do not meet the intent stated.
- C. **Chips at the corner or edge of granite may be patched, providing the structural integrity of the stone is not affected and providing the patch matches the color and finish of the natural stone so that the patch does not detract from the appearance. In such cases, the Architect shall approve of such conditions.**
- D. **Repair of limestone is permitted as described herein. Some chipping and cracking is expected; repair of small chips is not required if it does not detract from the overall appearance of the work, or impair the effectiveness of weather seals. Where damage does occur, and it is judged to be repairable, it is industry practice to make the repair and ship the affected stone. In such cases, the Architect shall approve of such conditions.**

### 3.04 SEALANTS

- A. Sealants, backer rods, and related components shall comply with requirements of Section 07901.

### 3.05 CLEANING AND PROTECTION

- A. The **General Contractor** shall maintain the exterior stone wall work in a reasonably clean condition throughout the construction period so that it will be without any evidence of deterioration or damage other than the effects of normal weathering at the time of final acceptance. Select methods of cleaning which will achieve a uniform appearance and stabilized colors and textures for materials that weather or age with exposure.
- B. Clean stonework after completion of work, using clean water and stiff-bristle brushes. Do not use wire brushes, acid type cleaning agents or other cleaning compounds with caustic or harsh fillers. Remove excess sealant by moderate use of mineral spirits or other solvent acceptable to sealant manufacturer and stone supplier, or other approved cleaning method.
- C. Provide proper and adequate means for protecting portions of the work which are exposed to likely sources of damage during the remainder of the construction period, including the probable areas of exterior stone breakage or deterioration.



- D. Remove and replace exterior stone units which are broken, chipped, stained or otherwise damaged. Where directed, remove and replace units which do not match adjoining stone work. Provide new matching units, install as specified and seal joints to eliminate evidence of replacement.
- E. Protect exterior stone from edge damage at all time. Exterior stone breakage during the guarantee period will be considered a form of faulty material or workmanship unless known to result from vandalism or other causes not related to materials and workmanship.

**3.06 ACCEPTANCE**

- A. **Within the limits of the approved range samples**, each and every piece of stone shall be subject to the Architect's approval, and any piece or pieces may be rejected after having been set or erected. Rejected stones shall be carefully removed and replaced with new suitable stone without delay and without cost to the **General Contractor**. Any piece or pieces damaged in the removal and resetting of defective or rejected pieces shall also be removed, with new and acceptable pieces provided and set at no cost to the **General Contractor**.
- B. Installed units which are chipped, cracked or otherwise damaged, or which in the opinion of the Architect do not conform to the Specification requirements, shall be removed and replaced with acceptable material at no additional cost to the **General Contractor**.
- C. Exterior Wall Subcontractor to coordinate and furnish final clean-up with **General Contractor**.

**END OF SECTION 04400**



SECTION 05065

WELDED STUD CONNECTORS

PART 1 - GENERAL

- 1.01 DESCRIPTION: Division 1 applies to this Section. This Section covers technical requirements for welded stud connectors and forms a part of other Sections which require stud connectors, anchor studs, stud shear connectors, and the like to be provided in accordance with this Section.
- 1.02 QUALITY ASSURANCE
- A. Reference Specifications:
1. American Society for Testing and Materials (ASTM): A108 Steel Bars, Carbon, Cold-Finished, Standard Quality.
  2. American Welding Society (AWS): D1.1 Structural Welding Code, Steel.
  3. ICBO Report No. 2614 or equivalent.
- B. Welder's Qualifications: Qualified in accordance with AWS D1.1
- 1.03 SUBMITTALS: Refer to Section 01300 for procedures.
- A. Product Data: Submit the following for information only if requested; however, maintain copies of the following readily available at the site whenever welded stud connectors are being installed:
1. Certified evidence that stud bases are qualified in accordance with Code.
  2. Copies of Building Department's approvals for all studs, stud bases and arc shields.
  3. Stud manufacturer's installation instructions with listing, by manufacturer and model, of stud welding equipment approved by stud manufacturer.
- B. Samples: Submit such samples Architect may request.
- 1.04 PRODUCT DELIVERY, STORAGE AND HANDLING: Protect materials from damage during shipping, handling and storage at the site. Deliver studs to site in unbroken sealed packages bearing manufacturer's name and label identifying the contents.

## PART 2 - PRODUCTS

- 2.01 **STUDS:** Standard product steel stud units intended for welding by automatically timed stud-welding equipment, furnished complete with an arc shield (ferrule) of heat-resistant ceramic or equivalent for all studs and, for studs 5/16" diameter or larger, a deoxidizing and arc stabilizing flux; none painted, galvanized or cadmium plated prior to welding and all finished by cold heading, cold rolling or machining. Furnish studs of uniform quality and condition, free of injurious laps, fins, seams, cracks, twists, bends not indicated, rust, rust pits, scale, oil or other injurious defects or substances.
- A. Stud Steel:** Furnish end-welding studs manufactured of steel conforming to ASTM A108, Grade C-1015 or C-1020 cold-drawn steel of minimum 60 Ksi tensile strength with 20% elongation in 2" and 50% area reduction.
- B. Manufacturer:** Nelson Stud Welding of TRW Nelson Division, KSM Division of Omark Industries, or equal.

## PART 3 - EXECUTION

- 3.01 **INSPECTION:** Verify existing conditions as specified in Section 01400. (Verify that galvanizing on metal decking does not exceed the zinc coating approved for stud installation.) Report in writing to Architect all conditions that prevent or interfere with the proper installation of studs, including loose or improper fitting decking.
- 3.02 **PREPARATION**
- A. Cleaning:** Clean steel surfaces to receive studs of all paint, scale, rust, and other injurious substances by wire brushing, peening, prick-punching, grinding or other method as required to produce clean bare substrates.
- B. Preparation for Replacement Studs and Repairs:** Repair steel surfaces as follows wherever a defective stud is removed. Make areas where a stud is removed flush and smooth if the surface remains exposed in the Work. Complete repairs before installing a replacement stud on a defective area.
1. **Areas Subject To Tensile Stress:** Make areas flush and smooth. If the base metal has been pulled out by stud removal, fill the pocket by shielded metal-arc welding conforming to the AWS D1.1 using low-hydrogen electrodes, and grind the weld surfaces flush.
  2. **Areas Subject To Compression:** Where stud failures are confined to shanks or fusion zones of the studs, a new stud may be installed adjacent to the defective area in lieu of repairing the defective area and installing a replacement stud, subject to approval. If metal is pulled out of the base metal, fill the pocket as above for tensile areas except, if defect depth is not more than the lesser of 1/8" or 7% of the base metal thickness, the defect may be faired by grinding in lieu of weld filling.
- 3.03 **STUD WELDING:** Conform installations to Code and Building Department approvals, approved submittals and requirements herein.

- A. Welding Equipment:** Furnish automatically timed stud welding equipment together with a suitable power source, type and manufacturer listed as approved by stud manufacturer. Interlock the welding equipment supplying current to two or more stud-welding guns so that only one gun can operate at a time and so that power source has fully recovered from making one weld before another weld is started.
- B. Installation:** Do not install studs on wet surfaces, nor studs showing defects, rusting, rust pits, scale, oil or other deleterious substances. Decking shall be held tight to the support member prior to installation. Install studs promptly after cleaning and preparation. Hold welding gun in correct position and without movement until the weld metal has solidified. Break and remove arc shields after welding. Produce welded studs free from any defect or substance that interferes with intended functions.
1. **Placing locations:** The longitudinal and lateral spacings for all stud connectors with respect to each other and to edges of member flanges may vary 1 inch maximum from locations shown provided adjacent studs are not closer than 2-1/2 inch on centers. Provide a minimum distance between edges of stud bases and flange edges equal to the stud diameter plus 1/8 inch, but minimum 1-1/2 inch clearance where possible. Location accuracy of other types of studs shall permit the assembly of attachments without alterations or reaming.
- C. Stud Lengths:** Stud lengths indicated are minimum net lengths after welding. If reduction in length of a stud as it is welded is such that the length of the stud is more than 1/16" greater than specified by stud manufacturer, discontinue installation until cause is determined and eliminated and pre-production testing is satisfactorily repeated.
1. **Defective Fillets:** Studs not showing a full 360° weld fillet after welding may be repaired by adding a 3/16" fillet weld in lieu of missing weld fillet in accordance with AWS D1.1 and using low-hydrogen electrodes.
- D. Studs on Metal Decking:** Exercise extreme caution to prevent defective welds or damage when welding through metal decking.
1. **Preparation:** When stud shear connectors are to be welded through metal deck or corrugated metal forming, the top flange of beams to receive such studs shall be unpainted and free of debris prior to installation of the deck or forming. Studs shall be field welded to the structural members only after all steel framing, deck or forms are in place and shored when required. Deck or forming shall be installed so that the bottom rib or plate is in continuous contact with the surface to receive the studs.
  2. Use through-deck shear connector welding where deck material thickness permits proper weld fusion to develop required connector capacity. Provide adequate test results to verify the feasibility of through-deck welding for the particular connector sizes and deck thicknesses involved.
  3. If through-deck shear connector welding is not feasible, install shear connectors through pre-punched holes in the deck. Provide pre-punched holes only for the shear connectors involved and keep hole oversize to the minimum required to develop a proper weld.



**SECTION 05120**

**STRUCTURAL STEEL**

**PART 1 - GENERAL**

1.01 DESCRIPTION: Division 1 applies to this Section. Provide structural steel and provided items as indicated, specified and required.

**A. Work in This Section:**

1. Beams, girders, bracings, elevator divider beams, and weldments.
2. Columns, posts, struts, and hangers.
3. Base plates, bearing plates, and grillages.
4. Seat angles for concrete slabs.
5. Shop painting and field touch-up.
6. Bracing, guying, and surveying of structural steel.

**B. Work furnished but installed in other Sections:**

1. Anchor bolts and wall plates.

**C. Related Work Not in This Section:**

1. Testing laboratory services.
2. Setting embedded items in concrete.
3. Grouting base and setting plates.
4. Metal decking.
6. Structural steel shapes for miscellaneous metal work.
7. Finish painting exposed structural steel.

1.02 SUBMITTALS

**A. General:** Make submittals in accordance with the requirements of Section 01300.

**B. Mill test reports:**

1. Submit certified copies of mill tests reports for steel and high strength bolts furnished. Include name and locations of mills and shops and analysis of chemical and physical properties of steel. Comply with ASTM standards specified. Reports shall be in English with American units of measurement.
2. In addition to the normal information, mill orders shall include ASTM specifications description, marking, and invoicing requirements. The mill shall be instructed to include the following marking: Heat number, size, type and grade of material, and appropriate color coding. See Article 2.04 herein for color code. Such markings may be by any means permitted by ASTM A6.

- C. **Manufacturer's certification:** Submit certifications of filler metal for welding.
- D. **Records:** Maintain records of welding procedures, welders employed, date of qualification, and identification symbol or mark. Make certified copies of records available to the Architect.
- E. **Order sheets and material and shipping bills:** When requested, furnish duplicate copies of order sheets and material and shipping bills.
- F. **Testing by the fabricator for joint forms and welding procedures that are not pre-qualified.**
  - 1. Submit test results by the fabricator.
  - 2. Testing laboratory retained by the fabricator is subject to the Architect's approval.
- G. **Shop drawings:**
  - 1. Submit detailed drawings showing grade of steel, identification marks of members, dimensions, sizes, orientation, and location of each member, setting elevation for base plates and bearing plates, locations, types, sizes and extent of welds, welding sequences; identify and show all connections.
  - 2. Submit erection drawings and index sheets at the same time as shop details. The use of Contract Drawings as erection drawings will not be allowed.
  - 3. Show and identify temporary members and connections which may be required for erection.
  - 4. Submit proposed erection procedures including loads and details of erection equipment and temporary bracing. The erection procedure shall also be signed by a California-registered civil engineer.
  - 5. The details shall be prepared in such a way as to avoid having connections, bracing, etc., interfere with other building components.
  - 6. If shop drawings are prepared for foreign fabrication, they shall be in the English language with American units of measurements. A sample shop drawing shall be submitted for review by Architect prior to start of shop drawing production.
- H. **Provide design and details** for temporary frame stabilization, as noted on Drawings.
- I. **Prior to fabrication,** structural steel subcontractor shall submit, in writing, the welding procedures, including sequencing, preheat requirements, and methods for retarding cooling as required by AWS D1.1 and by the Los Angeles City Building Code. The subcontractor shall also submit impact tests for filler metal where required. The format of appendix E of AWS D1.1 may be used for this submittal.
- J. **Manufacturer's data** for structural steel primer.

1.03 QUALITY ASSURANCE

- A. **Welders' qualifications:**



1. Before assigning welders to work covered by this Section of the Specifications, provide the Architect with the names of welders to be employed on the Work, together with certification that each of these welders has passed qualification tests using procedures covered in AWS B3.0, Part 11, and the Los Angeles Building Code.
  2. The Contractor shall require any welder to retake the test when, in the opinion of the Architect, the work of the Welder creates a reasonable doubt as to his proficiency as a welder.
  3. Tests, when required, shall be conducted at no additional expense to the Owner. Recertification of the welder shall be made to the Architect only after the welder has taken and passed the required retest.
  4. The Architect may require coupons to be cut from any location in any joint for testing. Owner to pay for all test results which are not failures.
    - a) Sections of welds found defective shall be chipped or cut-out to base metal and properly re-welded before proceeding with additional welding.
    - b) Should 2 coupons cut from the work of a welder show strength, under test, that are less than that of the base metal, it will be considered evidence of negligence or incompetence and such welder shall be permanently removed from the Work.
    - c) When coupons are removed from any part of a structure, the members cut shall be repaired, at no additional cost to the Owner, in a neat and workmanlike manner with joints of proper type to develop the full strength of the member and joints cut, with peening as necessary or directed to relieve residual stress.
- B. **Codes and standards:** Except as modified by these Specifications and/or details on Drawings, work of this Section shall conform to applicable provisions of the following codes and standards.

Los Angeles Building Code, latest edition.

AISC Specifications for the Design, Fabrication and Erection of Structural Steel Buildings.

AISC Code of Standard Practice Sections 6, 7, and 8 only, and as modified in these Specifications.

Section 10 "Architecturally Exposed Structural Steel" of the AISC Code of Standard Practice for Steel Buildings and Bridges for exposed structural steel framework supporting roof parapets.

Research Council Specification for Structural Joints Using ASTM A325 or A490 Bolts.

Research Council Specification for Structural Joints Using ASTM A307 Unfinished Bolts.

AWS - Structural Welding Code, including supplements, addenda, and Special Rulings applicable to building construction.

SSPC Volume 2 Systems and Specifications.

ASTM specifications referred to for particular materials or tests specified herein.

1. In addition, work of this Section shall conform to applicable Federal, State, and local laws and regulations.

2. Where requirements indicated on the Drawings or specified herein differ from the requirements of governmental authorities having jurisdiction, the one having more stringent requirements shall govern.

**C. Charpy-V-Notch impact tests:**

1. Charpy-V-Notch impact tests for base metal shall be performed for all rolled shapes listed under Group 4 and 5 of Table 2, page 1.8 of the 9th Edition of the AISC Manual of Steel Construction and for plates exceeding 2-inches thick used for built-up members if such members are spliced using full penetration welds.
2. Test requirements shall be as given in the AISC Manual, pages 5.26 and 5.27.
3. Components requiring mandatory toughness requirements shall be designated on the steel shop drawings.

**D. Fastener certifications:**

1. Test certificates shall be furnished for high strength bolts, nuts, and washers with each lot supplied. Certificates shall indicate tensile strength (wedge test) and hardness for bolts, hardness and proofload for nuts, and hardness for washers.
2. Lot number shall be indicated on containers and on corresponding certificates.
3. Manufacturer of bolts and nuts, both high strength and common, shall submit a suggested test procedure that can be used to detect out-of-specification fasteners. Such tests may be required to be performed at the Architect's discretion.

1.04 HANDLING

- A. Comply with the requirements of Section 01600.
- B. Store steel materials, either plain or fabricated, above ground, on platforms, pallets, skids, or other supports. Keep materials free from dirt, grease, other foreign matter, and protect from corrosion.
- C. Unload, handle, and erect the work of this Section to avoid bends, twists, and other distortions or damages.

1.05 TESTS AND INSPECTIONS

- A. Tests and inspections of structural steel work not specified herein to be performed by the fabricator will be performed by a Testing Agency retained and paid for by the Owner in accordance with requirements of the Los Angeles Building Code and as specified. Provide the Owner's Testing Agency with the following:
  1. A complete set of reviewed shop and erection drawings.
  2. Cutting lists, order sheets, material bills, shipping bills, and mill test reports.
  3. Information as to the shipment of material to the shop.
  4. Representative sample pieces as requested by the testing agency.
  5. Full and ample means and assistance for testing materials.

6. Proper facilities, including scaffolding, temporary work platforms, etc. for inspection of the work in the shop and field.
- B. Each person installing connections** shall be assigned an identifying symbol or mark. Shop and field connections shall be so identified so that the Owner's Inspector can identify the person making the connection.
- C. Costs of tests** will be paid by the Owner, except as specified in Section 01400 or elsewhere in the Contract Documents. Furnish free of charge necessary materials, access to or handling of materials required to perform material tests.
- D. High strength bolts** shall be continuously visually inspected. At least 10% of high-strength bolted connections shall be tested at random for bolt tightness using procedures described in the AISC "Specification For Structural Joints Using ASTM A325 or A490 Bolts" by Research Council on Riveted and Bolted Joints.
- E. Welding:** Inspect and test during fabrication and erection of structural steel assemblies as follows:
1. Certify welders as required by Paragraph 1.03, A., above and conduct inspections and tests as required. Record types and locations of defects found. Record work required and performed to correct deficiencies.
  2. Perform visual inspection of all welds.
  3. Inspect full penetration groove welded connections of column-to-column, column-to-girder, girder-to-girder and like connections by ultrasonic or other approved non-destructive tests. Such inspection shall occur not more than 48 hours after welding. Also inspect each weld layer of shop butt welds using magnetic particle tests. Fabricator may pretest any welds for its own convenience to prevent costly field repairs but this shall not preclude field testing. The fabricator shall submit written quality control procedures to the Registered Deputy Inspector (RDI).
  4. Ultrasonic testing shall be performed by a specially trained and qualified technician in accordance with the American Society for Nondestructive Testing requirements for Level 2 who shall operate the equipment, examine welds, and maintain a record of welds examined, defects found, and disposition of each defect. The tested region shall also encompass the Heat Affected Zone (HAZ) but not less than 1-1/2" from weld unless a greater distance is specified. In addition, the root pass of all penetration welds shall be visually inspected 100% by RDI. Defective welds, as determined by AWS D1.1 criteria, shall be repaired and costs for retesting defective welds shall be paid by Contractor.
  5. All complete penetration groove welds contained in joints and splices shall be tested 100% either by ultrasonic testing or by radiography whichever method is compatible with the weld size.  
Exception: When approved, the non-destructive testing rate for an individual welder or welding operator may be reduced to 25% provided the reject rate is demonstrated to be 5% or less of the welds tested for the welds or welding operator. A sampling of at least 40 completed welds for a job shall be made for such reduction evaluation. Reject rate is defined as the number of welds containing rejectable defects divided

by the number of welds completed. For evaluating the reject rate of continuous welds over 3 feet in length where the effective throat thickness is 1" or less, each 12" increment or fraction thereof shall be considered as one weld. For evaluating the reject rate on continuous welds over 3 feet in length where the effective throat thickness is greater than 1", each 6" of length or fraction thereof shall be considered one weld.

6. Partial penetration groove welds when used in column splices shall be tested either by ultrasonic testing or radiography, whichever method is compatible with the weld size. Non-pre-qualified Full and Partial Penetration Groove Weld Joints: All combinations of materials, procedures, and joint configurations that do not meet the requirements of AWS D1.1-83 for pre-qualified joints shall have the joints qualified in accordance with the requirements of AWS D1.1-83, Section 5.
7. Base metal thicker than 1-1/2" and all base plates, when subjected to through-thickness weld shrinkage strains, shall be ultrasonically inspected for discontinuities directly behind such welds. Test shall be performed not less than 48 hours after joint completion.
8. Any material discontinuities shall be accepted or rejected on the basis of the defect rating in accordance with the criteria of AWS D1.1 and the City of Los Angeles Building Code.
9. Doubler plate welds when specified as partial penetration shall be visually inspected. Magnetic particle testing is optional.
10. In addition to welding inspections specified above, the welded connections between members of trusses, including column base plate assemblies, and the base metal in the region of welded joints shall be tested by suitable methods for compliance with AWS D1.1, in accordance with the proposed welding procedure specified in Paragraph 1.02, J. Welding sequence and techniques employed shall be such that stresses and distortion due to shrinkage are minimized.
11. Defects and discontinuities in welds and base metal revealed by testing shall be rejected or accepted on the basis of criteria in AWS D1.1, Table 8.15.3. Ultrasonic tests on a welded connection or assembly shall not be made until at least 48 hours after completion of welding.
12. Welds inspected by visual or ultrasonic testing or other approved method that do not meet the requirements of AWS D1.1 shall be repaired or replaced as prescribed by Section 3.7 of AWS D1.1. Additional testing of repaired or replaced areas shall be done at the Contractor's expense.
13. Should defects appear in base metal and/or in welds tested, repairs of defects in base metal or welds shall be similarly inspected, as directed, at the Contractor's expense until satisfactory performance is assured.
14. Other methods of non-destructive testing and inspection, such as liquid dye penetrate testing, magnetic particle inspection, or radiographic inspection, may be used on welds if directed.
15. Lamellar tearing resulting from welding is a crack (of zero tolerance) and shall be repaired in accordance with AWS D1.1.
16. Laminations are defects in the base metal. The rejection criteria shall be based on ASTM A435.
17. Where laminations or conditions of lamellar tearing in base metal are revealed by testing, the steel fabricator shall submit a proposed method of repair for approval.

Retesting of repaired areas is required. Costs of repair and retesting shall be borne by the Contractor.

18. Magnetic particle testing shall be provided in accordance with AWS D1.1-83, Section 6.75, for procedure and technique. The standard of acceptance shall be in accordance with AWS D1.1-83, Section 5.

**F. Testing by the fabricator:**

1. When mill reports identifying heat or melt numbers and analysis are not available, tension and bend tests of the materials may be required by the Contractor's testing laboratory.
2. Test specimens shall be taken by the fabricator under the direction of the testing laboratory and shall be machined by the Contractor's testing laboratory to dimensions required by the related applicable standard ASTM specifications.

**G. Lamellar tearing:**

1. The base material that occurs both within the joint and for a distance 6" beyond the limits of the joint welds for all plates 1-1/2" thick or greater and for all rolled members with web or flange thicknesses that are 1-1/2" or greater shall be ultrasonically tested for lamellar tearing after welding.
2. Should these defects occur, members will be rejected or corrections made subject to approval.
3. Welding procedures specified in Paragraph 1.02, I., shall address proper clean-up, sequencing, stringer passes, peening, and other good welding practices to prevent lamellar tearing.

**H. Prior testing of base material:**

1. The Contractor, at its own expense, may elect to also test the base material prior to fabrication in order to detect possible defects that would require difficult and expensive field repair.
2. Prior testing does not, however, take the place of the testing of base material specified elsewhere.

1.06 FOREIGN STEEL FABRICATION ALLOWANCE

**A. Should structural steel be fabricated outside the continental United States, the following allowances shall be included in the Contractor's bid price:**

1. Allowance for inspections:
  - a) Include an allowance in the structural steel bid for the services of a US testing laboratory, acceptable to the Structural Engineer, to provide full time inspection at each foreign steel fabricating plant.
  - b) The Owner will pay costs for the inspection, including transportation, housing, subsistence, fees, and incidental costs associated with the inspection, and the inspection costs shall than be deducted from payments due the Contractor. Such allowance shall be \$150,000.00.

2. Allowance for shop drawing review of steel fabricated outside the USA:
  - a) An allowance of \$150,000.00 shall be included in the structural steel bid to permit the Structural Engineer to perform shop drawing review in the US and to visit the foreign fabrication shop as required.
  - b) The allowance shall cover all costs incurred, including transportation, housing, subsistence, fees, wages, necessary additional review time, traditionally associated with shop drawings prepared in a foreign country, and incidental costs associated with review of shop drawings.
  - c) The Owner will pay costs incurred by the structural engineer which will then be deducted from payments due the Contractor.
  - d) If less than \$150,000.00 is expended, then the difference shall be credited to the Owner. If more than \$150,000.00 is required, then written documentation to explain and verify the additional expenditure shall be submitted for approval.
  - e) If a domestic firm prepares the shop drawings for a foreign fabricator's use, the fabricator's shop practice should be known and the metric system shall be referenced to minimize conflicts and errors.

#### 1.07 PRE-FABRICATION CONFERENCE

- A. Prior to fabrication of structural steel, a conference shall be held to review welding procedures, techniques, and testing requirements. The meeting shall be attended by the following:
  1. Steel fabricator's representative who will be directing and supervising this work.
  2. Testing laboratory representative(s) who will be specifically assigned to the project steel testing and inspection.
  3. Representatives from the Owner, Architect, General Contractor and Structural Engineer.

### PART 2 - PRODUCTS

#### 2.01 GENERAL

- A. **Materials shall be new** and meeting the requirements of ultrasonic testing in accordance with Paragraph 1.05, E., for members required to be so tested on the drawings.
- B. **Stock items** shall be manufactured by concerns specializing in particular articles, subject to the Architect's approval.

#### 2.02 MATERIALS

- A. **Structural steel, shapes, bars, plates, and appurtenant materials:** ASTM A36, except where high strength steel is indicated. High strength steel: ASTM A572, grade 50. Those members of moment frames, transfer girders and trusses consisting of rolled shapes and built-up members that have a thickness dimension of 2" or greater shall be manufactured from fully killed or semi-killed fine grain practice having a grain size number equal to or better than 5 as determined by the ASTM grain size comparison.

1. The sample for grain size determination shall be taken from the flange at a distance "k" measured from the intersection of the face of the web with the face of the flange. The "k" dimension shall be as shown in the AISC Manual of Steel Construction.
2. The carbon equivalent range shall be determined by tests based on formula in Appendix X of AWS D1.1 to determine preheat requirements. Architect shall be furnished with copies of such tests for review.

**B. Bolts and nuts:** American National coarse-thread series, manufactured in the USA.

1. Unfinished bolts and nuts, anchors, and fastening: ASTM A307.
2. High-strength bolts and nuts: Conform to Specifications for Structural Joints, using ASTM A325 or A490 bolts.
3. Washers:
  - a) Round washers, other than those in contact with high-strength bolt heads and nuts, shall conform to American Standard B27-2, Type B.
  - b) Beveled washers shall be square, smooth, and sloped so that contact surface of bolt head and nut are parallel.
  - c) The diameter of hole of square-beveled washer shall be 1/16" greater than the bolt size for bolts larger than 1".
  - d) Washers in contact with high-strength bolt heads and nuts shall be hardened washers in accordance with Specifications for Structural Joints using ASTM A325 or A490 bolts. Washers shall be installed or turned on side of bolt for torquing, as required.

**C. Filler metal for welding:** Arc-welding electrodes shall conform to requirements of AWS D1.1. Electrodes shall be as recommended by their manufacturers to suit the position of other conditions of actual use.

1. Shielded metal arc-welding: Use E70 Series.
2. Submerged arc-welding: Use F7 Series.

2.03 MISCELLANEOUS ITEMS

**A. Miscellaneous structural steel items** and their related components required to complete work of this Section:

1. Provide in accordance with Drawings and Specifications.
2. Such items include, but are not limited to, built-in items, leveling plates, anchors, bearing plates, base, reinforcing angles, straps, brackets, hangers, etc.
3. Items to be built-in shall be supplied in ample time for incorporation in the work of other trades.

**B. Paint for shop coat primer** (and for field touch-up painting):

1. For exterior structural steel: Tnemec 66 High-Build Epoxoline, PA72-11 by Sinclair Paint Co., or equal.

2. For structural steel including misc. structural steel and their related components at all other locations: Thneme 10-99, or equal.

C. **Coating for milled surfaces:** Magnofilms by Magnus Chemical Co., Varcroft 1711, Blue Lacquer, by Varcroft Paint Co., or M-2658, Blue Lacquer by US Steel Corp.

## 2.04 COLOR CODING

A. **Steel types shall be color coded** in accordance with ASTM A6.

## 2.05 FABRICATION

### A. **General:**

1. Structural steel work shall conform with the applicable provisions of "Codes and Standards" referenced above and these Specifications.
2. Workmanship shall be performed by mechanics skilled in type of work required.
3. Fabricate and assemble structural steel in the shop to the greatest extent possible.
4. Shearing, flame cutting, and chipping shall be done carefully and accurately. Sole plates of beams and girders shall have full contact with the flanges. Fit stiffeners neatly between the flanges of girders, and, where tight fit is required to transmit bearing, mill and grind ends of stiffener to secure an even bearing against the flanges. Splice plates and fillers under stiffeners shall fit within 1/8" of the flanges.
5. Take assembled pieces apart, if necessary, for the removal of burrs and shavings produced by the reaming operation.
6. Where practicable, secure parts not completely bolted in the shop by temporary bolts to prevent damage in shipment and handling.
7. Exposed members shall be straight, true, shall fit closely together, be free from bends, twists or open joints.

### B. **Provision for other work:**

1. **General:**
  - a) Work of this Section includes required cutting, punching, drilling, tapping, welding for attachment of other work coming in contact with structural steel where indicated, and/or required for proper subsequent installation of work of other trades, or where directions for same are given prior to or with approval of shop drawings.
  - b) Furnish templates for accurate location of items to be set under other Sections or under separate contracts.
2. **Holes in structural steel members:**
  - a) Where noted on Drawings, or where directed, provide holes in structural steel members for support of other materials, for passage of pipes or for reasons necessary to construction.



- b) Structural steel members shall not have holes except as detailed on the Drawings or approved by the Architect. Reinforce holes as required by the Architect.
- C. Mill column and compression truss members, and bearing stiffeners to give full bearing over the cross section. Plane contact surfaces of grillages and bearing plates. It is not necessary to plane bottom surfaces of plates or grillages on grout beds.**
- D. Connections:**
- 1. All bolted connections shall be made with high-strength bolts unless shown otherwise. Friction type bolts will be required at lateral load resisting moment and braced frames. Unfinished bolts shall not be used except where indicated. Surface of joints for welded or high-strength bolted connections shall comply with the cleanliness requirements of all joint surfaces and contact surfaces within friction-type joints.
  - 2. Unless otherwise shown on Drawings, grade of connection material shall be same as that of connecting member, unless it can be shown by calculations that lower grade steel is adequate.
  - 3. Where specific details are shown on Drawings, alternate details proposed by the fabricator shall be submitted to the Architect for review.
  - 4. Unless shown otherwise on Drawings, make the splices in columns or beams with complete penetration welds to develop full capacity of member. Their locations shall be subject to Architect's approval.
  - 5. Unless otherwise shown on Drawings, welds in built-up members shall be continuous and shall be designed to transfer stresses caused by forces on members framing into the built-up members. Stiffeners inside box columns or at W shape columns shall be provided as shown.
- E. Holes:**
- 1. Cut, drill, or punch holes at right angle to the surface of the metal. Do not make or enlarge holes by burning.
  - 2. Drill holes in base or bearing plate.
  - 3. Provide holes in members to permit connecting the work of other trades.
  - 4. Holes shall be clean-cut without torn or ragged edges.
  - 5. Remove outside burrs resulting from drilling or reaming operations with a tool making a 1/16" bevel.
- F. Bolting, except high-strength bolting:**
- 1. Drive bolts accurately into the holes without damaging the thread. Protect bolt heads from damage during driving.
  - 2. Bolt heads and nuts shall rest squarely against the metal.
  - 3. Where bolts are to be used on beveled surfaces having slopes greater than 1 to 20 with a plane normal to the bolt axis, provide beveled washers to give full bearing to the head or nut.
  - 4. Upset bolt threads to prevent the nuts from backing off.

**G. Unfinished bolts:**

1. Unfinished bolts shall be of the length that will extend entirely through but no more than 1/4" beyond the nuts.
2. Draw bolt heads and nuts tight against the work with a suitable wrench not less than 15" long.
3. Tap bolt heads with a hammer while the nut is being tightened. After having been finally tightened, upset bolt threads to prevent the nuts from backing off.

**H. High strength bolting:**

1. Assemble joints in accordance with Specifications for Assembly of Structural Joints Using High Strength Steel Bolts", as approved by Research Council on Riveted and Bolted Structural Joints of the Engineering Foundation.
2. Tighten bolts with impact wrenches to a torque not less than recommended for size of bolt.
3. Keep contact surfaces of joints free of paint, lacquer, and other friction reducing coatings.

**I. Welded connections:**

1. Do not begin structural welding until joint elements are bolted or tacked in intimate contact and adjusted to dimensions shown, with allowance for any weld shrinkage that is expected. Weld heavy sections and those having a high degree of restraint with low hydrogen type electrodes. Do not splice members without prior review by the Architect.
2. Weld in accordance with AWS D1.1.
3. Perform intermittent welding, continuous welding, and straightening of built-up sections to minimize internal stresses. Built-up sections assembled by welding shall be free of warpage. Each axis shall have true alignment.
4. Welds not otherwise specified shall be continuous fillet welds. Use minimum fillet in accordance with AWS.
5. Clean surfaces to be welded of paint, grease, loose scale, and foreign matter. Clean welds each time electrode is changed or a new pass started. Chip clean, in accordance with AWS code, burned or flame cut edges before depositing welds.
6. Same electrode may be used with various thickness of plate, but change current used and number of passes made proportionately.
7. After being deposited, wire brush welds. Welds shall exhibit uniform section, smoothness of welded metal, feather edges without undercuts or overlays, and freedom from porosity and clinkers. Visual inspection at edges and ends of fillets, and butt joint welds shall indicate good fusion with penetration into base metal.
8. During assembling and welding, hold component parts of built-up member with clamps or other means to keep parts straight and in close contact. Take precautions to minimize "lock-up" stress and distortion due to heat. Do not weld in a wind unless wind protection is provided. Cut-out and replace welds found defective.

9. The maximum space between pieces or members to be butt welded shall not exceed 1/4". Bevel pieces or members up to 3/8" thickness to form single or double "Vee" before being welded. Bevel pieces over 3/8" thickness to form a double "Vee" whenever possible. Lay and size fillet welds as shown. Measure only effective portion of fillet welds. Maximum space between pieces or member to be fillet welded shall not exceed 1/16".
10. At groove welds between thick plates or between plates and thick members (generally greater than 3" plates), preheating temperatures higher than AWS minimums may be required to prevent lamellar tearing or weld cracking. Peening of weld passes, except the root pass and last pass, will be required to prevent lamellar tearing or weld cracking.

**J. Stress relieving:**

1. Stress relieving shall be provided using one of the following methods at all locations listed below:
  - a) Thermal, using an oven (in conformance with AWS D1.1).
  - b) Thermal, using localized heating with insulation blankets.
  - c) Mechanical, using vibration.
2. Whichever method is used, the proposed procedures shall be reviewed and approved by the structural engineer prior to start of work and the company doing the work must be approved by the Building Department.
3. If mechanical stress relieving is used, it shall include a method for proof of stabilization, such as:
  - a) Energy input feedback monitor.
  - b) Response frequencies monitor.
  - c) A clamped-on weld test specimen that can be machined and checked for movement (distortion).
4. Stress relieving shall be provided for both shop and field welded assemblies at the following locations:
  - a) The welded joints of the truss shown on Drawing 2/5 -5.13.
  - b) The field welded joints in the frames shown on Drawing S-5.11 and S-5.12 where box columns occur, up to and including 5th floor.

**2.06 FINISHING/PAINTING**

**A. General:**

1. Steel and painted and unpainted iron materials furnished under this Section shall be thoroughly cleaned of rust, scale, and grease.
2. Paint structural steel that does not receive galvanized coating or sprayed fire proofing with one shop coat of specified primer. This will be required generally for all exposed structural steel, for elevator separator beams, supplementary steel required for stone and glass support, and other steel exposed to the elements. Cleaning method for steel to be painted shall conform to SSPC SP-3-63 Power Tool Cleaning, except for exterior steel to be painted which shall be cleaned in accordance with SSPC-SP6 Commercial Blast Cleaning.
3. Paint shall be applied at the rate and to obtain the dry film thickness recommended by the paint manufacturer.

4. No painting, except touch-up and priming shall be done in the field. Paint with brushes entire surface to be covered smoothly, thoroughly with paint worked into all joints.
5. Clean work arriving at site which has been carelessly painted and paint with an additional coat of paint before being erected, except that work which will be exposed to view in the finished construction shall be returned to shop for recleaning and repainting.
6. Protect painted work until paint is thoroughly dry. Do not load material for shipment until shop coat is fully dry.

**B. Contact surfaces with aluminum:** Steel surfaces which will be in contact with aluminum shall receive an additional coat of paint consisting of 2 lbs. of aluminum paste pigment (ASTM D962 Type II, Class B) per gallon of varnish meeting FS TT-V 8 lbs., Type II or equivalent.

### PART 3 - EXECUTION

#### 3.01 FIELD MEASUREMENTS AND TEMPLATES

- A. **Secure field measurements** required for proper fabrication and installation of work covered by this Section. Exact measurements are Contractor's responsibility.
- B. **Furnish templates for exact location** of items to be embedded in concrete and masonry, with setting instructions required for installation of embedded item.
- C. **Verify conditions and measurements** affecting the work of this Section at site. Make sure that detrimental conditions are corrected before proceeding with installation.

#### 3.02 ERECTION

- A. **Responsibility:** The Contractor shall accept full responsibility for the design, strength, safety, and adequacy of temporary bracing and methods of handling and erection, and sequencing of erection of work of this Section.
- B. **During construction** the erected structural steel with steel deck welded in place shall not proceed any further than 8 floors above a completely poured concrete slab.
  1. The welding and bolting of lateral load resisting frame shall be completed 4 floors below the erected steel.
  2. The stability of the frame during erection is the Contractor's responsibility.
  3. Vertical and/or horizontal temporary bracing may be required to diaphragm lateral forces to the lateral force resisting structural elements. Deviation from these recommendations are subject to the Architect's review.
- C. **Temporary erection facilities:**
  1. Provide temporary braces, guys, connections, supports, flooring, planking, work platforms, scaffolding and other facilities necessary for the safe and proper

- erection of the work of this Section and the support and bracing of erection equipment.
2. As erection progresses, the work shall be securely connected to safely resist all dead loads, wind, and erection forces.
  3. Install temporary bracing where necessary to safely resist all loads to which the structure may be subjected, including loads of erection equipment and its operation. Leave such bracing in place as long as may be required until, as a minimum, after the permanent structure is capable of resisting the imposed loads. See note on Drawings regarding temporary bracing.
  4. A California licensed structural or civil engineer employed by the Contractor shall design and supervise the use of each of the above temporary facilities as well as the removal of temporary bracing.
- D. **Set base plates and bearing plates** level to correct elevations and support temporarily on steel wedges, shims, leveling devices, or as shown on Drawings, until corresponding supported member has been positioned, plumbed, and anchor-bolted.
1. Installation of embedded base plates into the concrete is specified in Section 03300.
  2. Do not grout column base plates until beams, girders, trusses, etc. are permanently anchored to column.
- E. **Erect structural steel** in accordance with the approved shop drawings and within the specified tolerances. Erect plumb and true to the lines and levels shown on the Drawings.
- F. **Align, level, and adjust members** accurately prior to final fastening. Clean bearing surfaces and surfaces that will be in permanent contact prior to final assembly of members.
- G. **Fasten compression member splices** only after abutting surfaces have been brought completely into contact. Clean bearing surfaces prior to final assembly of members.
- H. **Oxygen cutting in the field** shall be done only with the Architect's prior written permission.
- I. **Bolted field connections at supports:**
1. Standard bolts shall be of a length that will extend not less than 1/4" beyond the nuts. Enter bolts into holes without damaging the threads.
  2. Correct poor matching of holes by drilling to next larger size and use of larger size bolt. Obtain written approval of Architect before proceeding with corrective work.
  3. For high-strength bolts, use pre-calibrated (break-off) bolts or bolts with direct tension indicators; install bolts in accordance with their manufacturer's instructions, engaging both the bolt and the nut and driven until the torque control groove of the bolt shears off, or until the indicator element yields. Tensioning of group of bolts shall be done first to snug tight condition and subsequently in proper sequence to obtain required tension.

**J. Field welding;**

1. Welding operations and the welds shall conform to the applicable provisions of the AWS Code.
2. Each welder working on the Project shall be assigned an identification symbol or mark and shall mark or stamp his identification symbol at each completed weldment.
3. Allow for weld shrinkage so that welded connected members will be accurately aligned and level after completion of the welding work.

**K. Erection tolerances:**

1. Dimensional tolerances as stated by the AISC Code of Standard Practice Paragraph 6.4 and Frame tolerances as stated in AISC Code of Standard Practice Paragraph 11, shall be considered the minimum acceptable standard for structural framing members except for the following:
  - a) At elevator shafts, the cumulative tolerances of columns and beams around the shafts shall not exceed 1" toward the shaft.
  - b) Exposed structural steel framework tolerances shall further comply with Section 10 of AISC Code.
2. Allowance shall be made in fabrication to provide for column shortening during construction. Magnitude of anticipated shortening will be provided by the Architect.

**L. Field touch-up painting:**

1. After erection, clean exposed surfaces of field connections, unpainted areas adjacent to field connections and damaged areas in shop coat to the same standards as required for the shop coat and paint with the same primer used in the shop coat.
2. Correct damaged zinc coating of galvanized surfaces as specified above.

3.03 FIELD QUALITY CONTROL

**A. Survey:**

1. Lines and levels of erected steel shall be maintained by the Contractor.
2. Should member locations vary beyond the allowable tolerances, take necessary corrective measures and modify details or procedures as required and approved by the Architect and Structural Engineer.

**B. Corrective work:**

1. Members or assemblages of work of this Section having fabrication errors, or which exceed permissible tolerances, or which have errors or deformations preventing proper assembly and fitting of parts, shall be reported immediately to the Architect and not incorporated in the finished work.
2. Such members or assemblies shall be corrected if permitted by Architect, and otherwise shall be replaced.

MTA Headquarters  
Los Angeles, California  
91-400

10/15/93  
Structural Steel  
05120 - 17

3. Submit drawings showing the errors and obtain approval prior to performing any corrective work.

END OF SECTION





SECTION 05130

STEEL FRAME SUPPORT SYSTEM FOR STONE VENEER

1.00 GENERAL

- 1.01 Description:** Division 1 applies to this Section. Provide steel frame support system for stone veneer as indicated, specified and required.
- A. Work in this Section:** Perform and provide all work required to complete, as indicated by the Contract Documents, and furnish all supplementary items necessary for the proper installation of the Structural Steel Frame Support System for Stone Veneer.
- B.** The Structural Steel Frame Support System for Stone Veneer contractor shall be referred to as the Exterior Wall Subcontractor in these specifications. The Exterior Wall Subcontractor shall be the single point of responsibility for the entire envelope of the project. Refer to Section 08500: Fixed Windows.
1. This is a performance specification for the prefabricated steel framing system required to support the stone veneer, as well as the miscellaneous framing elements required for the handset stone which is directly attached to the structure. The Exterior Wall Subcontractor shall be responsible for the complete design and engineering required to meet the specified performance requirements within the physical and aesthetic requirements established.
  2. The plans and specifications are an outline of the criteria and performance requirements for the System. The requirements shown by the details are intended to establish basic dimensions of the module and the sight lines and profiles of members. Within these parameters the system manufacturer is responsible for the design and engineering of the System, including whatever modifications or additions may be required to meet the specified requirements and maintain the visual design concept.
  3. As performance documents, the drawings and specifications do not necessarily indicate or describe all the work required for the performance and completion of the Work. The Exterior Wall Subcontractor shall furnish and install all items required for proper completion of the work.
  4. Work shall be of sound and quality construction. The Exterior Wall Subcontractor shall be solely responsible for the inclusions of adequate labor and materials to cover the proper and timely installation of the items indicated, described or implied.
  5. Dimension and profile adjustments may be made in the proposed design in the interest of fabrication or erection methods or techniques, the weatherability factor, or the ability of the design to satisfy the design and

performance requirements, provided that the design intent and the intent of the specification are maintained.

6. **Structural Requirements:** Design the strength and stiffness for the work of this section and all its related components to successfully withstand the following:
  - a. Design wind pressure normal to the surface acting outward and inward shall be a uniformly distributed load. Typical loads are to be 40 psf positive and negative, and 50 psf within 20'- 0" of corners.
  - b. Maximum allowable deflection perpendicular or parallel to wall surface of metal framing elements which directly support stone shall be limited to SPAN/600, at design wind pressures. No permanent deformation is allowed at design wind pressure. Stone members are to remain uncracked at design wind pressures. The net deflection along an individual stone panel edge shall be limited to 1/16" maximum. For typical framing members, deflection shall be limited to SPAN/360 or 2 x cantilever span/360, provided the span does not directly engage stone anchors.
  - c. Typically provide for 1/4" vertical differential live load movement, unless stone support system is anchored directly to column, at which time design shall accommodate 1/16" per floor, long term column shortening.
  - d. Safety factors required will be as per the recommendations of the Codes and Standards, as per manufacturer's recommendations, or as specified in related project specification sections, whichever is more stringent. Stone breakage, component disengagement, permanent deformation of framing members in excess of 0.2% of their clear span, or permanent deformation of anchorages beyond 1/16" shall not occur at less than twice the design wind pressure.
  - e. Stiffen support members as necessary if the design of the stone due to span or stone strength requires stiffer members in order to satisfy the performance criteria.
  - f. Reinforce the system as necessary to accommodate the exterior building maintenance equipment loads and load imposed by the tie-ins for this equipment.
7. **Thermal Requirements:** Design the wall system and size the component members for thermal expansion and contraction movement capability for an metal temperature range of 180 degrees F. Consideration of building deflections, construction shrinkage and erection tolerances shall be made to maintain proper performance. No buckling, joint seal failure, or undue stress in fasteners or other detrimental effects shall occur from this movement.

8. The stone support system shall incorporate an internal gutter system to collect and control any secondary water or condensation which may occur within the system. This gutter system shall be positively drained to the exterior either directly or in conjunction with the adjacent glazing systems.
9. **Tolerances:** The final position of the wall system shall meet the following tolerances, including consideration of fabrication, erection and dead load deflections.
  - a. Rough opening dimension: plus or minus 1/8" at head, plus or minus 1/8" at sill, and plus or minus 1/8" at jamb.
  - b. Deviation from plumb: 1/8 inch maximum per one story height and maximum of 1/4 inch in a 45 foot run.
  - c. Deviation from horizontal: 1/8 inch maximum in a 30 foot run.
10. **Water Infiltration:** No uncontrolled water penetration shall occur when the wall system is tested in accordance with ASTM E331 at a differential static pressure of 10 psf, and AAMA 501.1-83 equal to 10 psf.

**C. Related Work Not in This Section**

1. Facade Stonework: Section 04400.
2. Facade Sealant: Section 07901.
3. Facade Insulation & Firesafing: Section 07201.
4. Exterior Glass and Glazing: Section 08800.
5. Fixed Windows: Section 08500.
6. Cold Formed Metal Framing for Stone Veneer: Section 05410.
7. **Mock-Up: Section 01450.**

**1.02 REFERENCES**

**A. American Society for Testing and Materials (ASTM)**

1. ASTM A 6: Specification for General Requirements for Rolled Steel Plates, Shapes, Sheet Piling, and Bars for Structural Use.
2. ASTM A 29: Specification for Steel Bars, Carbon and Alloy, Hot-Wrought and Cold-Finished, General Requirements of ASTM Volume 1.05.
3. ASTM A 36: Specification for Structural Steel
4. ASTM A 123: Specification for Zinc (Hot-Dip Galvanized) Coatings on Iron and Steel Products.
5. ASTM A 153: Specification for Zinc Coating (Hot-Dip) on Iron and Steel Hardware.

6. ASTM A 307: Specification for Carbon Steel Externally Threaded Standard Fasteners.
7. ASTM A 325: Specification for High-Strength Bolts for Structural Steel Joints.
8. ASTM A 446: Specification for Steel Sheet, Zinc-Coated (Galvanized) by the Hot-Dip Process, structural (Physical) Quality.
9. ASTM A 500: Specification for Cold-Formed Welded and Seamless Carbon Steel Structural Tubing in Rounds and Shapes.
10. ASTM A 501: Specification for Hot-Formed Welded and Seamless Carbon Steel Structural Tubing.
11. ASTM A 570: Specification for Hot-Rolled Carbon Steel Sheet and Strip, Structural Quality.
12. ASTM A 575: Specification for Steel Bars, Carbon, Merchant Quality, M-Grades.
13. ASTM A 576: Specification for Steel Bars, Carbon, Hot-Wrought, Special Quality.
14. ASTM A 606: Specification for Steel Sheet and Strip Hot-Rolled and Cold-Rolled, High Strength, Low-Alloy, with Improved Atmospheric Corrosion Resistance.
15. ASTM A 607: Specification for Steel Sheet and Strip, Hot-Rolled and Cold-Rolled, High-Strength, Low-Alloy Columbium and or Vanadium.
16. ASTM A 611: Specification for Steel, Cold-Rolled Sheet, Carbon, Structural.

**B. American Institute of Steel Construction (AISC)**

1. AISC, latest edition, "Specification for Design, Fabrication and Erection of Steel for Buildings."

**C. American Iron and Steel Institute**

1. AISI, latest edition, "Specification for the Design of Light Gage Cold-Formed Steel Structural Members."
2. AISI: "Tentative Criteria for Structural Applications of Steel Tubing and Pipe".

**D. American Welding Society (AWS)**

1. AWS D1.1: Structural Welding Code - Steel

- E. **Industrial Fasteners Institute (IFI)**
  - 1. "Handbook on Bolt, Nut and Rivet Standards"
- F. **Steel Structures Painting Council (SSPC)**
  - 1. "Steel Structures Painting Manual, Volume 2, Systems and Specifications"
- G. **Aluminum Association (AA)**
  - 1. "Specifications for Aluminum Structures", 4th edition
- H. **Federal Specifications (FS)**
  - 1. FS FF-W-84: Washers, Lock (Spring)
  - 2. FS FF-W-92: Washer, Flat (Plain)
- I. **Building Code**
  - 1. Uniform Building Code - 1991 Edition.
  - 2. Los Angeles Building Code - Latest Edition.
- J. The Steel Frame Support System for Stone Veneer shall comply with the latest edition of the above referenced standards. Where conflicting requirements arise, follow the more stringent.

**1.03 SUBMITTALS**

- A. Submit in exact accordance with Section **01300** - Shop Drawings, Product Data and Samples.
- B. **Design Data:**
  - 1. Submit complete, exact and specific design data for exact products specified.
  - 2. Submittals shall bear the seal of a structural or civil engineer duly licensed in the State of California.
- C. **Design Calculations:**
  - 1. Submit a complete set of structural calculations certified by a professional engineer licensed in the State of California, for the structural adequacy of all the steel frame support members for stone veneer, including connections to the structure, the stone, the embedments, fasteners, welds, and framing member design. All stresses and deformations shall be presented to demonstrate compliance with the performance requirements of this

specification. Submit only die drawings for any aluminum shapes which are used in conjunction with this work.

2. These calculations shall include face loads, wind loads, thermal loads, dead loads, lifting and handling loads, and imposed loads caused by the window systems and entrance frames.
3. Design the stone support system including the anchors, fasteners, and welds in accordance with AISC, AISI, and AA specifications, the governing building code, and generally accepted good engineering practices.
4. Base deflection calculations upon the combination of maximum direct loadings, building deflections, thermal stresses, and erection tolerances.
5. All stone support framing shall be designed for seismic load requirements as prescribed by the Uniform Building Code, Latest Edition.
6. Stone support framing connections to structure shall be designed to **comply with local codes** and accommodate a probable seismic drift equal to .0075 times the story height without any permanent set or damage.
7. Under a credible seismic drift, the truss anchoring system must be designed to accommodate a drift equal to .015 times the story height. Allowance for a permanent set in anchors of no more than L/1000.

**D. Product Data:**

1. Submit manufacturer's specifications to evidence compliance with these specifications.
2. Submit manufacturer's installation instructions.
3. Manufacturer's Product Data shall be clearly and specifically marked to indicate the specific models or types intended for submittals and desired approval.
4. Product Data which is unmarked or unclear as to exact intended submittal will be returned unreviewed to submitter.
5. Submit schedules, charts, literature, and illustrations to indicate the performance, fabrication procedures, product variations, metal preparation, paint application and accessories.

**E. Shop Drawings:**

1. No work shall be fabricated until shop drawing for the work has been reviewed and accepted by the Architect.
2. Submit complete fabrication details and erection drawings. Drawings shall be stamped by same engineer who performs the structural calculations.

3. Indicate size, material, finish, fasteners, anchors, and surrounding conditions.
4. Show locations and installation procedures for frames that are preassembled.
5. Include details of joints, sealants in joints, attachments, welds, clearances and tolerances, and all surrounding conditions.
6. Include plans and elevations at not less than 1" to 1'- 0" scale, and include details of sections and connections at not less than 3" to 1'- 0" scale.
7. Show anchorage and accessory items, including secondary water gutter systems and flashings.
8. Indicate lifting points for pre-assembled frames.
9. Show locations and procedures of installation for window washing tie-in devices.
10. Detail granite replacement procedures and methods.
11. Shop drawings for stone support frames shall be fully coordinated by the **General Contractor** and submitted simultaneously with submittals required under Section 04400, Facade Stonework, and Section 08500, Fixed Windows.
12. Provide embed location drawings for preset inserts or embedments which are required to be cast in the structure or in adjacent construction. Show type, location, elevation and acceptable tolerances in setting. Drawings to be coordinated with other trades to determine any interferences.
13. Shop drawings shall bear the seal of a registered engineer licensed in the State of California.

**F. Samples:**

1. Submit two (2) samples of welded corner frame section made from typical framing members. Samples to be finished as specified herein.
2. Submit two (2) samples of each type of kerf clip or stone anchor.
3. Submit two (2) samples of each type of gutter system, showing jointery and joint seals.
4. Submit two (2) samples of each type of fastener, screw, nut, bolt, washer, shim, separator, tape, etc. to be used.

**G. Quality Control Submittals:** Submit to evidence exact compliance with the specified requirements for Design Data, Test Reports, Certificates, Manufacturer's Instructions and Manufacturer's Field Reports.

1. Submit written certified test reports for sealant compatibility with frames and stone anchorages
2. Submit welders certificates which demonstrate that all welders are certified per AWS.

**1.04 QUALITY ASSURANCE**

**A. Manufacturer and Supplier Qualifications:**

1. All Structural Steel Frame Support System for Stone Veneer products covered under this Section shall be produced by a single manufacturer unless otherwise specified.
2. Provide specialists in the design and manufacturer of the specified products, who maintain adequate and experienced engineering and shop facilities to produce these products in the time required.
3. Manufacturer shall submit evidence of having not less than five (5) years successful production of this type system.
4. Execute exterior stone work by skilled mechanics, and employ skilled stone fitters at the site to do necessary field cutting as exterior stone is set.

**B. Subcontractor Qualifications:**

1. Exterior Wall Subcontractor shall submit evidence of skill and not less than five (5) years specialized experience with this type system.
2. Employ only experienced tradesmen for both fabrication and installation, who are capable of producing work of the highest standards of quality in the industry.

**C. Engineer Qualification:**

1. Each component of the Structural Steel Frame Support System for Stone Veneer shall be designed by a registered professional engineer, in accordance with the local building code, and said engineer must be employed by the Structural Steel Frame Support System for Stone Veneer manufacturer.
2. Submit a statement certified by the registered professional engineer that the design of all components of the Structural Steel Frame Support System for Stone Veneer, including connections to the structural frame, is in compliance with all provisions of the Contract Documents and the Local Building Code, and is in keeping with generally accepted engineering practice.
3. If requested, submit design calculations and erection drawings, bearing the registered professional engineer's stamp, to the Local Building Code Official.



4. Execute exterior stone work by skilled mechanics, and employ skilled stone fitters at the site to do necessary field cutting as exterior stone is set.

**D. Welder Qualification:**

1. AWS (American Welding Society) D1.1
2. AWS Certified

**E. Sample Installation:**

1. Erect on the building a portion of the wall, complete with granite, anchorages, gutter systems, and sealants for review by Architect for aesthetics and workmanship. This **sample area** shall be used to establish the acceptability of work for the rest of the project.

**F. Pre-Installation Conference:**

1. Prior to the commencement of erection of the structural steel frame support system for stone veneer and at the contractor's or architect's direction, meet at the project site to review the material selection, handling and storage instructions, **the weather and incidental sealing**, and erection techniques, the shop drawings and the reference standards which pertain to the erection, the sealing, and the stone installation for this work. Review acceptable weather conditions under which the work can be performed. Review acceptable tolerances, granite handling and installation, use of temporary anchorages or materials, and sealant compatibility. Meeting shall include General Contractor, Steel Frame Fabricator and Erector, Sealant Manufacturer's Representative, Sealant Contractor, Stone Supplier/Contractor, Fixed Window Contractor, Architect Representatives of other trades or subcontractors affected by the Structural Steel Frame Support System for Stone Veneer work.
2. At the conclusion of the meeting, examine the field sample installation which has been prepared to determine and record whether everyone present is in agreement that the proposed installation is likely to perform as required. This accepted control installation shall be the standard to which other work must conform.

**1.05 DELIVERY, STORAGE AND HANDLING**

- A. Deliver, store and handle products in exact accordance with the manufacturer's latest published requirements and specifications.
- B. Deliver completed stone support frame assemblies to an offsite staging area or to the project site, depending upon scheduling and sequencing of the work.
- C. Upon delivery, inspect shop coatings and repair any damaged or abraded areas with 2 coats of Z.R.C. cold galvanizing compound.

- D. Store upright on raised platforms. Provide temporary weather protection as required by industry standards. This requirement will not be waived.

**1.06 PROJECT/SITE CONDITIONS**

- A. **Existing Conditions:** Per manufacturer's latest published specifications.
- B. **Field Measurements:** As required.
- C. Provide acceptable and adequate means or methods to prevent debris or other detrimental materials from collecting in the secondary water gutter system during the erection and during subsequent construction.

**1.07 SEQUENCING AND SCHEDULING**

- A. Coordinate with other work, by furnishing shop drawings, inserts and similar items at appropriate times for proper sequence of construction without delays. Verify dimensions of structure and other elements which precede the installation of the support system for the stone veneer, before fabrication of required components; however, do not delay the work. Provide for erection tolerances corresponding with specified tolerances for other work where field measurements cannot be obtained.
- B. Coordinate locations of embedments in concrete so as to minimize use of drilled expansion anchors.
- C. Coordinate the secondary guttering systems with adjacent work.
- D. Coordinate the installation of the insulation and vapor barrier with the erection of the stone support system.

**1.08 WARRANTY**

- A. Warrant in writing the Work specified herein for five (5) years from the date of final acceptance against becoming unserviceable or causing an objectionable appearance resulting from either defective or nonconforming materials and workmanship or performance.
- B. Certify in writing that all work is in accordance with the contract documents and authorized revisions thereto and that, should any defect develop during the guarantee period due to improper workmanship or materials under his jurisdiction such defects will, upon written request, be repaired or replaced by this **Exterior Wall Subcontractor** at his own expense.
- C. If exploratory work is required to determine the cause of the defects, the cost of such work shall be borne by this **Exterior Wall Subcontractor** only in case his work is found in the judgement of the Architect to be at fault.
- D. Defects shall include, but not be limited to, the following:
  - 1. Structural failure.

2. Permanent deformation or loosening of parts by winds within design criteria.
3. Deterioration of the finish.
4. Failure of the system to collect and remove secondary water through the gutter system and any damage to materials caused by this failure.

## **2.00 PRODUCTS**

### **2.01 ACCEPTABLE PRODUCT/MATERIAL MANUFACTURERS**

- A. A specific product or material manufactured by any of the following listed manufacturers is "acceptable" (not "approved") only if the specific product or material can evidence exact compliance with the Contract Documents.
1. **System:** Per criteria as specified in paragraph 1.04 - QUALITY ASSURANCE, above.
  2. **Shop Paint Primer**
    - a. Tnemec Company, Inc., as specified.
    - b. Ameron Paint Co., as specified.
    - c. Carboline Co., as specified.
  3. **Cold Galvanizing Compound Shop Touch-Up**
    - a. ZRC Products Company, A Division of Norfolk Corporation.

### **2.02 BASIC MATERIALS**

- A. **Sheet and Strip Steel:** ASTM A515 Grade 55, ASTM A606, ASTM A607, ASTM A570, ASTM A611, and ASTM A446 Grade B.
- B. **Structural Steel:** ASTM A 36.
- C. **Steel Plate for Cold-Forming:** ASTM A6 and ASTM A192.
- D. **Hot-Rolled Steel Bars (Including Bar-Size Shapes):** ASTM A575 (Merchant Quality) or ASTM A576 (Special Quality), Quality and Grade as selected by fabricator, and ASTM A29.
- E. **Bars, Bolts, Nuts and Washers:** ASTM A325, ASTM A307.
- F. **Hot-Dipped Galvanizing:** Hot-Dip galvanize all ferrous metals, to comply with ASTM A123, G-90 coating classification.

- G. Hot-Formed Rectangular Steel Tubing: ASTM A501.
- H. Cold-Formed Steel Tubing: ASTM A500, welded, cold-finished and stress relieved.

**2.03 MANUFACTURED UNITS**

- A. The design intent is to use pre-fabricated and pre-assembled units to the greatest extent possible, especially at areas where there is no immediate structural back-up for stone support.
- B. At false column type units, where the units are anchored to the slab or to the underside of the slab, the units are required to accept the live load deflection from the slab above. These column units shall also serve as the structural support of the adjoining glazing system.
- C. The manufactured units shall be pre-assembled and pre-painted prior to arriving at the project.
- D. At areas commonly referred to as hand-set stone; where the stone veneer is anchored directly to, and supported by, the building structure, such as at columns or spandrel beams, the design shall incorporate embedments, and mechanical attachment of stone retention devices as required to meet the performance criteria specified herein.

**2.04 FABRICATION**

- A. Fabricate stone support frames and accessories system in accordance with final shop drawings.
- B. All welding shall be performed by currently AWS certified welders.
- C. Fabricate items in shop to greatest extent possible, so as to minimize field splicing and assembly of units at project site.
- D. Clearly mark units for reassembly and coordinated installation.
- E. All framing components shall be cut squarely or at an angle to fit squarely against abutting members.
- F. Members shall be held firmly in position until properly fastened.
- G. Panels shall be square and braced against racking.
- H. Attachments of similar components shall be done by welding.
- I. Make adequate provisions for expansion and contraction of the component parts of the system and its fastenings to prevent harmful damage fastenings or other detrimental effects.

**2.05 SHOP PRIMING**

- A. For stone support frames and their anchorage systems, use one of the following:
1. Tnemec Co., Inc. "90E92 Tnerme-Zinc" with minimum thickness of 3.0 dry mils, with a topcoat of "Series 66 Hi-Build Epoxoline" with minimum thickness of 5.0 dry mils.
  2. Ameron "Dimetoccte 3" with minimum thickness of 3.0 dry mils, with a topcoat of "Amercoat 66" with minimum thickness of 5.0 dry mils.
  3. Carboline Co. "Carbozinc #11", minimum thickness of 3.0 dry mils, with a topcoat of "#190B HiBuild Epoxy", with minimum thickness of 5.0 dry mils.
  4. Hot-Dipped Galvanized per ASTM A 123, G-90 coating classification.
- B. All copes, holes, slots, forming, welding, cuts, etc. shall be fabricated prior to preparation for application of coatings. Any subsequent modifications, in the shop or field which expose the base metal must be touched-up with 2 coats of Z.R.C. cold galvanized compound.
- C. Prepare metals, after fabrication, to receive shop coatings in full accordance with manufacturer's recommendations and SSPC-SP6 Commercial Blast Cleaning requirements.
- D. Mix and apply prime coatings in accordance with manufacturer's recommendations.

**2.06 FASTENERS, ANCHORS AND SEALANTS**

- A. Only Elco Dril-Flex self-drilling, self tapping type fasteners are allowed for wind or dead load connections, or which support stone retention extrusions, or other structural connections.
- B. Dielectric insulators, in addition to metal coatings, shall be used when connecting dissimilar metals.
- C. Connections shall include locking devices which prevent movement due to dynamic or vibration loads, thermal or other cyclical conditions when appropriate.
- D. All Bolts and Nuts shall be 300 series stainless steel for any exposed fasteners or fasteners in wet areas. Unexposed fasteners or fasteners in dry areas shall be cadmium and colored chromate plated meeting F.S. QQ-P-416E, type II, Class I.
- E. Washers shall be stainless steel, plain round, complying with FS FF-W-84.
- F. Nuts used at expansion or dynamic moving connections shall be designed to provide a positive means against disengagement. Staking or deforming of threads, Loctite or lockwashers at these connections is not acceptable.
- G. Welding Electrodes shall be E70XX.

- H. Metal in Contact with stone shall be 300 series stainless steel, or extruded aluminum.
- I. Anchor brackets or clips, shall be extruded aluminum or structural steel hot dipped galvanized per ASTM A153 or finished to match stone support framing.
- J. Concrete Embeds shall be headed concrete studs welded to steel elements and cast-in-place with structural concrete shall have a minimum safety factor of 2.0 against ultimate failure. Unistrut type concrete inserts shall have a minimum safety factor of 3.0 against ultimate failure. Expansion type anchors or fasteners shall have a minimum safety factor of 4.0 against ultimate failure. Where inserts have not been provided in structural concrete or masonry, provide drilled-in steel expansion bolt anchors.
- K. Stone anchorages shall be coordinated with the Fixed Window Contractor. Kerf type anchors shall have a true profile. No bulbs or nibs on the extruded aluminum kerf are acceptable. Kerf clip design shall prevent any horizontal migration of secondary water on the kerf anchor.
- L. Provide sealants and gaskets in the fabrication, assembly and installation of the work, which are recommended and guaranteed by the manufacturer to remain permanently elastic, non-shrinking, non-migrating, compatible with adjacent material and weatherproof.

**2.07 FIELD WELDING TOUCH-UP COATING**

- A. Clean and prepare all field welds for touch up coating.
- B. Apply two coats of Z.R.C. cold galvanized compound to all field welds.
- C. Make each coat a minimum of 3 dry mils, for a total minimum thickness of 6.0 dry mils.

**2.08 SECONDARY WATER SYSTEM**

- A. Provide a metal guttering and flashing system to divert leakage, condensation or other secondary water into the adjacent glazing system if system is designed to accommodate this, or directly to the exterior surface with weeps and baffles as required at each floor.
- B. Fabricate concealed flashings, guttering, etc. of one of the following:
  - 1. 5005 alloy aluminum sheet with as fabricated mill finish.
  - 2. 6061 and 6063 aluminum alloys, extruded with temper as required, with as fabricated mill finish.
  - 3. AISI Type 302/304 stainless steel, 2D finish, fully annealed or dead-soft temper.

**2.09 ANCHORAGE AND SUPPORT OF EXTERIOR STONE WALL ELEMENTS:**

- A. Except where specifically shown otherwise on Structural Drawings, provide all support and connection elements and assemblies for the support of the structural steel frame support system for stone veneer.
- B. Design supporting elements for exterior stone support system anchorage and lateral support bracing to the structure and all structural connections of the wall system, in conformance with applicable codes and the following requirements:
  - 1. Supports must not cause excessive stress in the structure, cause excessive deflection, inhibit thermal movement or conflict with other requirements such as clearance for mechanical equipment, etc.
  - 2. All points of support for the exterior stone support system shall be properly braced in the three orthogonal directions (vertical, transverse and longitudinal) to resist all loads from any direction (both positive and negative pressure).
  - 3. Provisions have been made in the base building structural design for gravity supports at the cantilevered conditions.
  - 4. Knee bracing (if any) must be carried to the floor slab. Arrange attachment so as to avoid penetration of decking reinforcements.
  - 5. Patch all fireproofing on structural elements where kickers, bracing or anchorage attach to any fireproofed structure.
  - 6. Design supports to accommodate all building movements such as live load long term shrinkage, and building sway.
  - 7. Supports and anchorages shall accommodate the loads imposed by the storefront and window wall systems, and their attachments to the stone support system.
  - 8. Adhesives, copper tie wires, mortar spots or other non-mechanical fasteners for use in the exterior granite veneer support system are strictly prohibited.

**2.10 SEPARATION OF METALS**

- A. Protection against galvanic action shall be provided wherever dissimilar metals are in contact. This protection shall be provided either by painting the contact surfaces with a heavy coat of zinc rich primer or by application of an appropriate sealant or permanent isolators at static areas as noted on Architect's Drawings.
- B. Aluminum which is to be in contact with cured concrete shall have the contact surfaces protected. Apply a bituminous coating of approximately 30-mil dry film thickness, or other suitable permanent separator, on concealed contact surfaces of aluminum before assembly or installation.

- C. Items of carbon steel, unless galvanized or scheduled for other finishes, shall be painted in accordance with the criteria for shop priming as specified herein before.

**3.00 EXECUTION**

**3.01 EXAMINATION**

- A. Examine and verify that receiving substrate surfaces of the structure have no defects or errors which would result in poor or potentially defective application or cause latent defects in workmanship.
  - 1. **Conditions of Surfaces**
    - a. Flat, plumb, level
    - b. Clean, free of oil, water, moisture, laitance, or any other deleterious substances.
  - 2. **Conditions of Opening Size (dimension and tolerances):** Per manufacturer's latest published specifications.
- B. Examine all structural elements over which system is to be applied and all adjoining work in which the system is in any way dependent.
- C. Report any unsatisfactory conditions to the Architect.
- D. Starting installation shall imply acceptance of surfaces.

**3.02 PREPARATION**

- A. **Structural Adequacy**
  - 1. Prepare the structure to insure proper and adequate structural support for the materials specified and indicated.
  - 2. Structural supports and anchor clips shall be securely held in place to preclude misplacement of anchor bolts. The bolts shall be installed at locations and with projections established by approved stone support frames shop drawings.
  - 3. The Exterior Wall Subcontractor shall check and subsequently agree on the correct positioning of the work before stone support frames are placed.
- B. Prepare substrate surfaces to insure proper and adequate installation, in exact accordance with the Contract Documents and approved Shop Drawings, or manufacturer's requirements.



- C. Field measure and verify dimensions as required.
- D. Protect adjacent areas or surfaces from damage as a result of the Work of this Section.

**3.03 ERECTION**

- A. Assemble and erect the System in exact accordance with System manufacturer's latest published requirements, instructions, specifications, details and approved shop drawings.
- B. Erect members according to the most economical method and sequence available consistent with the Plans and Specifications. Provide all necessary hoisting, handling, and erection equipment to satisfactorily install the work.
- C. As erection progresses, provide temporary bracing to properly align the stone support framing.
- D. Align the various steel frame assemblies accurately to the lines and elevations indicated within the specified erection tolerances.
- E. Make adjustments as required prior to making permanent connections.
- F. Introduce temporary guying or bracing wherever necessary to accommodate all loads to which the stone support frames may be subjected. Leave this bracing in place as required by the erection procedures. The adequacy of the temporary bracing shall be the sole responsibility of the **Exterior Wall Subcontractor**.
- G. Permanently connect this work as required by the final shop drawings in a sequence that will minimize lock-in stress.
- H. Burning and drifting to align unfair holes in secondary bracing members shall be only upon specific written approval by the Architect.
- I. Perform welded construction in accordance with AWS D.1.1.
- J. Do no cutting of any stone support frame member, unless specifically shown on the Drawings.
- K. Install flashings of the materials and profiles indicated. Continuous flashings shall be in longest length possible. Joints, where necessary and approved, shall be lapped 12 inches minimum and sealed completely over the entire lapped area with sealing compound. Mechanical fasteners shall be added where necessary to maintain contact of overlapping elements.
- L. **Postponement of Complete Enclosure:** If so directed by the General Contractor, installation of the stone support system shall be postponed, in areas specifically designated by the General Contractor, for a specific period of time, so as to facilitate moving material into and out of the building during construction. Exterior Wall

Subcontractor's installation shall proceed along guidelines as directed by the General Contractor.

**3.04 ADJUSTING**

- A. Comply with requirements of Section 00000: Contract Closeout.
- B. Adjust and leave the Structural Steel Frame Support System for Stone Veneer **shall conform to the specifications and/or industry standards.**

**3.05 CLEANING**

- A. Clean in exact accordance with Section 00000: Cleaning.
- B. Clean all secondary gutters and flashings.
- C. Immediately remove all spots, smears, stains, residues, adhesives, etc., from the Work of this Section and/or upon adjacent areas or surfaces which result from the Work of this Section.
- D. Upon the completion of the Work of this Section, dispose of, away from the site, all falsework, supports, debris, trash, containers, residue, remnants and scraps which result from the work of this Section.

**3.06 PROTECTION**

- A. After erection and until Owner acceptance, protect the system from damage.
- B. Remove damaged items, elements, units, materials, or panels and replace with new, undamaged ones, all at no cost to the Owner.

**END OF SECTION 05130**

**SECTION 05330**

**METAL FLOOR AND ROOF DECKING**

**PART 1 - GENERAL**

1.01 DESCRIPTION: Division 1 applies to this Section. Provide composite metal floor decking and composite metal roof decking as indicated, specified, and required.

**A. Work In This Section:** Principal items include:

1. Composite steel floor decking with accessories.
2. Composite or non-composite metal roof decking with accessories as indicated.
3. Bent plate and sheet metal closures at decking edges and openings.
4. Holes through decking, with reinforcing and framing for openings up to and including 24 inches, perpendicular to the deck span.
5. End-welded shear studs.

**B. Related Work Not In This Section:**

1. Hoisting of decking.
2. Structural steel framing and supports for metal decking.
3. Structural concrete fill on metal floor decking.
4. Sprayed fireproofing.

1.02 QUALITY ASSURANCE:

**A. Qualifications of Welders:** Employ welding operators that are currently tested and certified in accordance with Code.

**B. Requirements of Regulatory Agencies:** Provide metal floor and roof deck systems that, with concrete fill, meet UL and Code requirements for two-hour, fire-rated deck systems.

**C. Source Quality Control:** Furnish decking manufacturer's certified mill analyses and test reports covering all decking.

**D. Performance Requirements:** Design metal decking in accordance with SDI Design Manual for Composite Decks, Form Decks, and Roof Decks or per ICBO reports. Design decking to conform to requirements noted on the drawings.

1.03 SUBMITTALS: Refer to Section 01300 for procedures.

**A. Shop Drawings:** Submit Shop Drawings detailing and dimensioning metal decking including accessories, offsets in decking, fastenings, welding, holes with reinforcing, flashings, closures, and shear studs and layouts. Indicate welding according to AWS Standard Welding Symbols. Show dimensioned layouts for openings and reinforcing details. Indicate temporary shoring of decking where required.

- B. Calculations and Data:** Refer to Section 01600 regarding proposed substitutions. If metal decking of type differing from that indicated or specified is proposed, submit the manufacturer's calculations and supporting data showing that proposed decking conforms to requirements indicated and specified. Include the decking manufacturer's technical Product Data and copies of Code approvals for proposed decking. Submit with Shop Drawings and obtain approval prior to fabrication and delivery of decking.

1.04 REFERENCES:

- A. **AISI** - Specification for the Design of Cold-Formed Steel Structural Members.
- B. **ASTM A36** - Structural Steel.
- C. **ASTM A108** - Steel Bars, Carbon, Cold-Finished, Standard Quality.
- D. **ASTM A446** - Steel Sheet, Zinc-Coated (Galvanized) by the Hot-Dip Process, Structural Quality.
- E. **ASTM A525** - Steel Sheet, Zinc-Coated, Galvanized by the Hot-Dip Process.
- F. **AWS D1.1** - Structural Welding Code.
- G. **AWS D1.3** - Code for Welding Sheet Steel in Structures.
- H. **SDI** - Design Manual for Composite Decks, Form Decks, Roof Decks.
- I. **ICBO** Evaluation Reports.

1.05 DELIVERY, STORAGE AND HANDLING:

- A. Delivery and Storage:** Deliver, store and handle decking and accessories in such manner not to damage or overload the decking during construction period. Do not use decking for storage or as a working platform until units have been welded in position. Stack decking stored at the site before erection on platforms or pallets and cover with watertight ventilated covering, slope for positive drainage.

**PART 2 - PRODUCTS**

2.01 DECKING MATERIALS: Furnish metal decking having galvanized coating conforming to ASTM A525, Class 60 for roof and floor decking.

- A. **Roof Decking:** Type and manufacturer noted on the Drawings, lengths to span over at least three supports unless otherwise indicated, each panel factor slotted or having rolled-in moisture venting provisions where insulating concrete fill or elastomeric coatings are applied over decking; when roof decking is composite, then see Composite Floor Decking, including but not limited to, all roof area, deck and balcony areas.
- B. **Composite Floor Decking:** Type and manufacturer noted on the Drawings, lengths to span over at least three supports unless otherwise indicated, manufactured of ASTM A446 Grade A or E steel. Provide slotted or rolled-in moisture venting provisions where elastomeric coatings are applied over decking. Where not exposed and with Owner's

written permission, the following may be used: ASTM A611, Grade C which has been cleaned and etched with an iron phosphate wash both sides. The bottom side of the deck shall be painted with a rust inhibitive light gray primer applied by a roller coat process, oven cured 0.3 mil nominal dry film thickness. Where elastomeric coatings are to be applied over decking, use only galvanized coating as specified above.

- C. **Accessories:** Furnish all indicated and necessary decking accessories including, without limitation, offsets between deck units, welding washers and welding anchors, closures, transitions, and filler strips, as required for complete installation. Provide bent plate closures, angles, channels, and other attachments as required for all openings through decking for ducts, shafts, piping, and other penetrations; where decking changes direction; and at decking perimeter; fabricated of 16 gage galvanized steel unless otherwise shown. Provide roof drain and overflow sumps of minimum 14 gage galvanized steel.
- D. **Manufacturers:**
  - 1. Provide product of a manufacturer who is regularly engaged in production of steel deck units and accessories.
  - 2. For decking to be used on this project, manufacturer must have a current Los Angeles Research Report.
- E. **Shear Studs.** Welded shear stud connectors conforming to Section 05065.

### PART 3 - EXECUTION

#### 3.01 EXAMINATION:

- A. **Verify that field conditions are acceptable and are ready to receive work.**
- B. **Beginning of installation means installer accepts existing conditions.**

#### 3.02 INSTALLATION:

- A. **Erect metal decking** in accordance with manufacturer's instructions, and Los Angeles City approvals.
- B. **Bear decking on masonry or concrete support surfaces** with 4 inches minimum bearing. Align and level.
- C. **Bear decking on steel supports** with two inch minimum bearing. Align and level.
- D. **Fasten deck to steel support members** at ends and intermediate supports with Arc-spot welding as shown on drawings.
- E. **Weld in accordance with AWS D1.1, and D1.3.**
  - 1. **Qualifications of Welders:** Welding shall be performed by qualified light gage welders. Qualification of welders and duration of qualification period in accordance with applicable requirements of AWS D1.3. Any welder producing

unsatisfactory welding, even though they have passed qualification tests, shall be immediately recertified or replaced with a qualified welder.

2. **Inspection of Welds:** Inspect welds visually, when operators are making welds at commencement of work and after the work is completed, for penetration of weld, metal, fusion, and general ability of operator. Correct defective welds in accordance with applicable provisions of AWS D1.1.

**F. Openings:** Reinforce deck and/or frame as necessary for rigidity and load carrying capacity. Neatly cut or drill holes or other openings required for work of other trades.

**G. Accessories:** Install as follows:

1. **Adjusting Plates:** Provide in locations too narrow to accommodate full-size deck units and install as recommended by the deck manufacturer, as approved.
2. **End Closures:** Provide metal cover plates, or joint tape, at joints between decking sheets to be covered with concrete fill, to prevent concrete leakage.
3. **Column Flashing:** Provide for spaces between floor decking and columns which penetrates the deck. Cut flashing to fit in the field and tack weld to decking and columns.
4. **Access Hole Covers:** Provide to seal holes cut in decking to facilitate welding of decking to structural supports.

**H. To contain wet concrete,** install stops at floor edge upturned to top surface of slab. Provide stops of sufficient strength to remain stationary without distortion.

**I. Position floor drain pans** with flange bearing on top surface of deck. Fusion weld at each deck flute.

**J. Shear Studs:** Install studs in accordance with Section 05065.

**K. Damaged Decking:** Remove, replace or reinforce all metal decking showing denting or damage that adversely affects the decking strength or subsequent materials, as directed.

3.03 **CLEANING AND TOUCH-UP:** Remove surplus materials. Clean and touch-up raw edges or decking cut for openings with repair material. Leave decks ready to receive subsequent materials.

3.04 **FIELD QUALITY CONTROL:** Refer to Section 01400.

**A. Inspection:** Install metal decking under continuous inspection, welding approved by Inspector before being covered.

**B. Inspection and Testing of Welded Stud Connectors.** In accordance with Section 05065 including pre-production and production inspection and testing.

END OF SECTION

**SECTION 05400**

**COLD FORMED STRUCTURAL STEEL  
FOR STONE BACK-UP**

**1.00 GENERAL**

**1.01 DESCRIPTION:** Division 1 applies to this Section. Provide cold formed structural steel for stone back-up as indicated, specified and required.

**A. Principle Work in This Section:**

1. Furnish and install cold-formed metal framing including all accessories as shown on the drawings or inferable therefrom including, but not limited to the following:
  - a. Stone veneer support framing of exterior walls up through the cornice at level 4. (Interior stud framing specified elsewhere).
  - b. Accessories such as clips, stiffeners, bridging, bracing, and fasteners, including anchorage to building structure.
  - c. Fabrication, drilling, fitting, welding and cutting as required for the proper completion of the work.
  - d. Shop drawings, engineering, calculations, permits, erection drawings, and any special tag or marking drawings required.
2. Obtain all necessary permits required for the work.
3. Coordinate with the requirements of Section 04400, Facade Stonework.
4. The Exterior Wall Subcontractors shall be responsible for construction means, methods, techniques, sequences or procedures for all safety precautions and programs associated with the work of this section.

**B. Related Work Not in This Section:**

1. Facade Stonework: Section 04400.
2. Facade Insulation & Firesafing: Section 07201.
3. Facade Sealant: Section 07901.
4. Steel Frame Support Systems for Stone Veneer: Section 05130.
5. Mock-Up: Section 01450.

**1.02 QUALIFICATIONS**

- A. Provide cold-formed metal framing and accessories manufactured by a firm specializing in the production of cold-formed framing systems and which publishes load tables, structural data, and installation manuals for the system.
- B. Engage a single firm with a minimum of 5 years successful experience in the installation of cold formed metal framing systems and which is approved by the materials manufacturer.
- C. The Exterior Wall Subcontractor, by commencing work of this section, assumes as a part of his warranty of the work, those components and parts shown or required within the work of this section, comply with the contract documents. The Exterior Wall Subcontractor shall further warrant that all components, specified or required to satisfactorily complete the installation are compatible with each other and with the conditions of installation and expected use and warrant the overall effective integration and correctness of individual parts and the whole of the system.

**1.03 PLANS AND SPECIFICATIONS**

- A. The character of these requirements is intended to provide a performance type specification for the design, fabrication, shipment to job site, and installation of the cold formed metal framing. The Exterior Wall Subcontractor is responsible for the engineering, and design of all components and materials, as well as fabrication, performance and coordination of the design with the design of other components of the exterior enclosure.
- B. Architectural drawings are diagrammatic. The details shown are intended as a guide for the aesthetic and interfacing requirements of the metal framing to and with other work. The Exterior Wall Subcontractor is responsible for the design and engineering of the metal framing within these aesthetic parameters. The drawings are not to be construed as engineering design, or adequate to meet the engineering design requirements.
- C. It is recognized that the design details do not cover some conditions or modifications, which may be required. It is, however, intended that conditions not detailed architecturally shall be developed through the Exterior Wall Subcontractor's shop drawings to the same level of aesthetics and in compliance with performance criteria as indicated for detailed areas and as stipulated in these specifications.
- D. The cold formed steel stud framing shall not be designed to carry any dead load from floors, roofs nor any structural loads other than those tributary from individual exterior facade systems.

**1.04 CODES AND STANDARDS**

- A. The work, except as otherwise noted or specified, shall comply with the latest edition of the following. When conflicting requirements arise, follow the more stringent requirement.
  - 1. AISI - "Cold Formed Steel Design Manual" - 1986 or 1991 Edition.



2. AISC - "Steel Construction Manual", ASD, 9th Edition or LRFD, 1st Edition.
3. ANSI/AWS D1.3 - "Structural Welding Code Sheet Steel" American Welding Society.
4. ASTM A-90 - "Standard Test Method for Weight of Coating on Zinc-Coated (Galvanized) Iron or Steel Articles".
5. ASTM A 446/A 446M - "Standard Specification for Steel Sheet, Zinc-Coated (Galvanized) by the Hot-Dip Process, Structural (Physical) Quality".
6. ASTM C 1007 - "Standard Specification for Installation of Load Bearing (Transverse and Axial) Steel Studs and Related Accessories".
7. ASTM A525 - "General Requirements for Steel Sheet, Zinc-Coated (galvanized) by the Hot-Dip Process".
8. Standard Building Code (SBCCI) 1988 Edition.

**1.05 BID SUBMITTALS**

- A. Exterior Wall Subcontractors seeking to secure a contract to provide work for this section shall provide proposal drawings and calculations showing framing installation methods and relationship to adjacent construction with bid for work on this section.

**1.06 SUBMITTALS**

- A. For information only, submit copies of the manufacturer's specifications, load tables, dimension diagrams, anchor details, and installation instructions for each type of steel stud, including other data as may be required to show compliance with these specifications. Indicate by transmittal form that copy of each instruction has been distributed to the installer.
- B. Submit shop drawings for cold formed metal framing with full size details showing framing in plan and elevation and showing extent of any prefabrication. Include details of attachments of member-to-members within system, bridging, attachment to slabs and other framing systems, and showing all unusual conditions in connection with cold-formed framing. Include reveals, special hangers, special runners, deflection channels and additional reinforcing. The drawings shall bear the seal of a registered structural engineer licensed in the State of California. Coordinate with other components of exterior enclosure. Design for loads imposed by window framing, metal panels, stone and any other elements attached to framing.
- C. Submit calculations for all cold formed metal framing, connections, assemblies and anchors, bearing the seal of a registered professional structural engineer licensed in the State of California. Both drawings and calculations shall be stamped by the same engineer.
- D. Submit manufacturer's instructions for storage, protection and handling at the job site.

## 1.07 PERFORMANCE CRITERIA

- A. The exterior building enclosure systems, including work of this section and related sections, shall be developed by a single source contractor to provide a primary air, water, and structurally sound barrier system behind the facade stonework.
- B. The cold formed metal framing system shall be designed by a professional engineer registered in the State of California to meet or exceed the following structural and weather resistance requirements as demonstrated by engineering calculations.
1. Perpendicular to the plane of the wall, net deflection of framing members shall not exceed  $L/600$  times span, or  $1/2"$ , whichever is less. Span is defined as the distance between anchor centerline. For cantilevers, span is defined as two times the distance between anchor centerline and end of cantilever. In addition, net deflections within the height or width of any individual stone supported by this framing can not exceed  $L/600$ . "L" being defined as the stone height or width.
  2. Perpendicular to the plane of a soffit, net deflection of framing members shall not exceed  $L/600$  times span, or  $1/4"$ , whichever is less, using the dead load combined with wind load forces. Span is defined as the distance between anchor centerline.
  3. In the plane of the wall, deflection of horizontal framing members shall not exceed  $1/16$  inch. This includes sag due to dead load.
  4. At connection points of framing members to anchors, combined movement of anchor relative to building structure, and framing member relative to anchor, shall not exceed  $1/16$  inch in any direction.
  5. Framing system shall be so designed to support concentrated loads that may be imposed by window, panel, or stone framing elements without exceeding performance criteria specified herein. To this end, contractor shall obtain all necessary projected data and make such provision in the work as may be necessary.
  6. Stresses shall not exceed the allowable values established by the specifications listed in code standards. In no case shall allowable values exceed the yield stress. Where permitted by code, a  $1/3$  increase in allowable stress for wind or seismic load is generally acceptable, but not in combination with any reduction applied to combined loads.
  7. Vibration harmonics, wind whistles, noises caused by thermal movement, thermal movement transmitted to other building elements, loosening, weakening or fracturing of attachments or components of system are not permitted in the installed work.
  8. Headed concrete studs welded to steel elements and cast-in-place with structural concrete shall have a minimum safety factor of 2.0 against ultimate failure for vertical walls and 5 for soffit supports. Unistrut type or ferrule type concrete inserts shall have minimum safety factor of 3.0 against ultimate

failure for vertical walls and 5 for soffit supports. All drilled expansion or wedge type anchors shall have a minimum safety factor of 4.0 against ultimate failure for vertical walls and 10 for soffit supports.

9. Use of power actuated fasteners or self tapping concrete fasteners are not acceptable.
10. Design and analysis of bolted assemblies or fasteners to connect thin walled members shall use washers to avoid pull-over and tearing effects of the steel. Safety Factors shall be as required per Table A5.1 of AISI, "Commentary on Cold-Formed Steel" Specification.

#### 1.08 DELIVERY STORAGE AND HANDLING

- A. Protect cold formed metal framing materials from rusting and damage.
- B. Deliver to project site in manufacturer's original, unopened containers or bundles, fully identified with name, type, and grade. Immediately store clear of grade, and protected from damage and deterioration.
- C. Handle any prefabricated components to prevent distortion or undue stress.

#### 1.09 WARRANTY

- A. Before substantial completion, the Exterior Wall Subcontractor shall guarantee to the Owner in writing that all cold-formed metal framing system elements will meet the specified overall performance requirements of the specifications, and will be free from defects in the materials and workmanship and remain watertight for a period of five (5) years after final acceptance by the Owner. The **Exterior Wall Subcontractor** shall certify in writing that all work is in accordance with the contract and that, should any defect develop during the guarantee period due to improper workmanship or materials under his jurisdiction, such defects will upon written request, be repaired or replaced at no additional cost to the Owner. If exploratory work is required to determine the cause of the defects, the cost of such work shall be borne by the Exterior Wall Subcontractor only in case his work is found in the judgment of the Architect to be at fault.
- B. Defective materials and workmanship are hereby defined to include evidence of abnormal deterioration, structural failure of components resulting from exposure to normal load and forces, and failure to fulfill other specified performance requirements.
- C. The guarantee, the enforcement or lack of enforcement thereof, shall not deprive the Owner of other actions, rights or remedies available to him. Guarantee shall be in form approved by Architect. **Submit sample warranty for review and approval.**

## 2.00      PRODUCTS

### 2.01      ACCEPTANCE PRODUCT MANUFACTURERS

A.      A specific product or material manufactured by any of the following listed manufacturers is "acceptable" (not "approved") only if the specific product or material can evidence exact compliance with the contract documents:

1.      Gold Bond Building Products, a National Gypsum Division.
2.      Dale/Incor.
3.      Marino Industries Corporation.
4.      USG Corporation.

### 2.02      MATERIALS

A.      Cold Formed Metal Framing

1.      All stud and joist framing members shall be pre-punched cold-formed members of the type, size, gage, and spacing required to meet specified load and deflection criteria. Punch-outs may not be located within six inches of structural anchors.
2.      All studs, joists, track and bridging shall be galvanized and shall be a minimum of nominal 16 gauge steel that corresponds to the requirements of ASTM A446, Grade D, with a minimum yield of 50,000 KSI. Thickness tolerance shall not exceed +/- .006 inches.

B.      Fasteners

1.      Any exposed fasteners or fasteners in wet areas shall be series 300 stainless steel. Unexposed fasteners in dry areas shall be cadmium and colored chromate plated and shall meet Federal Specification QQ-P-416E, Type II, Class #1 (.0005 inches thick plating). All non stainless fasteners being used in a structural application must meet the minimum requirements of SAE J429 Grade 5. Grade 8.0 or higher fasteners, high strength bolts of non U.S. origin, or high strength bolts that are zinc plated shall not be used. Mill test reports for all structural grade bolts shall be submitted to the Architect for his approval prior to installation of those bolts on the job. Self drilling fasteners shall be Dril-Flex as manufactured by Elco Industries, Inc. No substitutions accepted. Nuts used at expansion or moving connections shall be designed to provide a positive means of preventing disengagement. Staking of bolts, use of lock washers, or threads being deformed is not acceptable. Matched bolts, nuts and washers shall be used at all friction connections. Use of powder actuated fasteners or self-tapping concrete fasteners are not acceptable.
2.      Steel for anchorage shall be of shapes and thicknesses required to meet structural requirements for their use. All steel shall meet AISI requirements and be given a shop prime coat of zinc chromate paint meeting FS TT-P-

645. Touch up after welding in the field shall be by the **Exterior Wall Subcontractor**.

**C. Welding**

1. All welding shall be in accord with pertinent recommendations of the American Welding Society and shall be done with electrodes and/or by methods recommended by the suppliers of the metals being welded. Type, size and spacings of welds shall be as shown on approved shop drawings and structural calculations.

**2.03 FABRICATION**

- A. All framing components shall be cut squarely for attachment to perpendicular members, or as required for an angular fit against abutting members. Members shall be held positively in place until properly fastened.
- B. Axially loaded studs shall be installed in a manner which will assure that ends of the studs are positioned against the inside track web, prior to stud and track attachment.

**3.00 EXECUTION**

**3.01 EXAMINATION**

- A. All work shall be performed by skilled workmen, especially trained and experienced in this type of work. If the Exterior Wall Subcontractor chooses to sub-contract the installation of work, the proposed sub-contractors qualifications shall be approved by the Architect and General Contractor.
- B. Bench marks for elevation and building line offset marks for alignment shall be established on each floor level by the General Contractor, who shall be responsible for their accuracy. Should any error be found in their location, the Exterior Wall Subcontractor shall so notify the General Contractor in writing, and installation work shall not proceed in the affected area until the errors have been corrected.
- C. After lines and grades have been established, and before beginning installation in any area, the Exterior Wall Subcontractor shall examine all parts of the structure on which the framing is to be placed in that area. Should any conditions be found which, in his opinion will prevent the proper execution of his work, he shall report such condition in writing to the Architect and the General Contractor. Installation of work shall not proceed in that area until such conditions are corrected or adjusted to the satisfaction of the Architect and the Exterior Wall Subcontractor. Commencement of work shall constitute acceptance of surrounding conditions.
- D. All framing members shall be inspected on the jobsite prior to installation for possible shipping and handling damage. Bent or otherwise damaged pieces shall be replaced.

### 3.02 INSTALLATION/ERECTION

- A. Install cold formed metal framing components plumb, level, accurately aligned and accurately located in reference to column lines and floor levels. Adjust work to conform with the following tolerances (maximum variations).
1. Permissible dimensional tolerances in the building frame are as follows:
    - a. Plumb variations such as faces of exterior column and walls are 1 inch in 100 feet.
    - b. Variation from levels shown on drawings such as top and bottom surfaces of floor slabs and spandrel beams shall be plus or minus 1 inch.
    - c. Variation from location shown on drawings such as outer face of floor slabs shall be plus or minus 1 inch.
- B. Anchorage of the tracks to the structure shall be by approved methods in strict accordance with accepted shop drawings and structural calculations. Coordinate all shop drawings with the accepted structural calculations.
- C. At track butt joints, abutting pieces of track shall be securely anchored to a common structural element, or they shall be butt-welded or spliced together.
- D. Studs shall be plumbed, aligned and securely attached to the flanges or webs of both upper and lower tracks.
- E. Jack studs or cripples shall be installed below window sills, above window and door heads and elsewhere to furnish support, and shall be securely attached to supporting members. Construct corners using minimum of three studs. Double stud at wall openings, door jambs, and window jambs.
- F. Erect studs one piece, full length. Splicing of studs not permitted, except where specifically indicated on accepted shop/erection drawings. Brace and reinforce to develop full strength.
- G. Wall stud bridging shall be attached in a manner to prevent stud rotation. Bridging shall be fastened to studs by fusion welding, by self-drilling, self-tapping screws as specified herein, or by special snap-in attachment if specifically recommended in manufacturer's printed recommendations.
- H. Provision for building structure vertical movement shall be provided using slotted clips or other recommended methods, as necessary to prevent transfer of structural loads into non-load bearing framing system.
- I. Frame both sides of expansion and control joints, as shown for the wall system, with separate studs and discontinuous runner. Do not bridge the joint with system components or accessories.
- J. Handling and lifting of any prefabricated frame panels shall be done in a manner as to not cause distortion in any member.

- K. Temporary bracing shall be provided until erection is completed.
- L. Coordinate installation of flashings, anchors, and similar items necessary to construct and weatherproof wall systems.
- M. Touch-up all welds in field with galvalloy paint or zinc rich paint.

**3.03 POSTPONEMENT OF COMPLETE ENCLOSURE**

- A. If so directed by the General Contractor, installation of the framing shall be postponed in specific locations so as to facilitate moving material into and out of the building during construction.

**3.04 ACCEPTANCE**

- A. Installed materials which are damaged, or which in the opinion of the Architect do not conform to the specification requirements, shall be removed and replaced with acceptable material at no additional cost to Owner.

**END OF SECTION 05410**





SECTION 05500

METAL FABRICATIONS

PART 1 - GENERAL

1.01 DESCRIPTION: Division 1 applies to this Section. Provide miscellaneous metal fabrications as indicated, specified, and required.

**A. Work In This Section:** Principal items include:

1. Steel ladders.
2. Grating and frames.
3. Steel pipe railings.
4. Above-ceiling supports.
5. Closure angles.
6. Elevator threshold angles.
7. Guard posts.
8. Duct protectors.
9. Tube framing for coiling doors, where detailed.
10. Lavatory counter supports, where detailed.
11. Elevator pit screens.
12. Pit pump covers.
13. Water storage tank hatch.
14. Embedded steel items.
15. Wire mesh items.
16. Steel pipe bollards.
17. Helipad safety net - include supports.
18. Plumbing pipe protectors.
19. All other miscellaneous metal fabrications required to complete the Work.

**B. Related Work Not In This Section:**

1. Finish painting.
2. Setting of anchor bolts and inserts in concrete.
3. Steel backing plates on steel stud walls.
4. Steel stairs and pipe handrails in connection with stairs.

1.02 QUALITY ASSURANCE

**A. Reference Standards:** Conform to the following as applicable:

1. AISC Standards: Code of Standard Practice for Steel Buildings and Bridges; Specification for the Design, Fabrication and Erection of Structural Steel for Buildings; and Steel Construction Manual, modified as per Section 05120, 1.02, A, 1.
2. AWS Standards: AWS D1.1, Structural Welding Code.

- 1.03 SUBMITTALS: Refer to Section 01300 for procedures.
- A. Shop Drawings:** Submit Shop Drawings fully detailing all Work of this Section, including accessories, fastenings, and welding. Include minor connections and fastenings not indicated or specified to meet required conditions; indicate in detail on Shop Drawings.
- B. Samples:** Submit samples as required by the Architect.
- 1.04 PRODUCT DELIVERY AND HANDLING: Protect materials from damage during shipping, handling and storage. Work showing dents, creases, deformations, weathering or other defects is not acceptable. Deliver welding electrodes to site in unbroken packages bearing manufacturer's name and contents identification.
- 1.05 JOB CONDITIONS: Verify conditions according to Section 01400. Verify all field measurements as required. Report any major discrepancy between the Drawings and field dimensions to Architect before fabrication of Work. Exercise caution to protect concrete floor surfaces and adjacent Work from damage.

## PART 2 - PRODUCTS

- 2.01 BASIC MATERIALS: Furnish materials conforming to the following:
- |                              |  |
|------------------------------|--|
| Steel shapes:                | ASTM A36.  |
| Steel tubing:                | ASTM A501, or ASTM A36.  |
| Safety plate:                | Raised diamond steel checkerplate, 3/16" thickness unless otherwise shown, or approved pattern.  |
| Steel pipe:                  | ASTM A120 standard weight for general use; ASTM A53 Grade B where used for structural purposes.  |
| Bolts and nuts:              | ASTM A307.   |
| Electrodes:                  | AWS D1.1, E70XX Series as required for intended use.   |
| Primer:                      | Sinclair No. 15 Red Oxide Primer or approved equal.  |
| Non-shrink grout:            | Master Builders "Embeco", W.R. Grace "Vibrofoil", or approved equal.   |
| Galvanizing:                 | ASTM A123, hot dip, 2.0 ounce psf on actual surface with minimum 1.8 ounce on any specimen.  |
| Galvanizing repair material: | All States Galvanizing Powder, Drygalv by American Solder and Flux, or equal hot applied material, or anodic zinc-rich galvanizing repair paint conforming to MIL-P-21035. |
- 2.02 GENERAL FABRICATION REQUIREMENTS: Conform to the approved submittals, reference standards as applicable to the Work, and the requirements herein. Fabricate and form the Work to meet actual installation conditions as verified at the site. Obtain necessary templates and information and provide all holes and drilling indicated or required for securing Work of other trades to metal fabrications.

- A. **Welding:** Conform to AWS D1.1, as modified by referenced AISC Standards, and as indicated or noted on Drawings. Unless otherwise indicated or specified, weld joints by shielded electric-arc method. Grind exposed welds subject to contact to smooth surfaces free of holes, slag, or other defects, flush with adjoining surfaces. No finishing treatment is required for permanently concealed welds and other exposed welds except as specified herein. Cut out defective welding with chisel or air arc and replace.
- B. **Shop Priming:** Clean surfaces according to AISC Specifications. Apply shop coat of metal primer to minimum 1.0 mil dry film thickness. Work primer into joints. Do not prime galvanized items or items embedded in concrete or masonry.
- C. **Galvanizing:** Galvanize specified items after fabrication is completed. Produce coating free of roughness, whiskers, unsightly spangles, icicles, barbs, sags, and other surface blemishes.
- D. **Miscellaneous Items:** Fabricate items not specifically mentioned according to the Drawings, approved Shop Drawings, and as required to complete the entire Work. Galvanize exterior items and shop prime interior items unless otherwise shown or specified.

### PART 3 - EXECUTION

#### 3.01 GENERAL INSTALLATION REQUIREMENTS

- A. **Grouting:** Provide grouting for Work of the Section as shown, specified, and required. Use non-shrink grout and conform to manufacturer's directions.
- B. **Galvanizing Repair:** Wire brush welds and damaged coating to clean bright metal. Apply one coat of galvanizing repair paint where surfaces are concealed or are to be finish painted. Use the specified hot-applied galvanizing repair compound where surfaces remain exposed and unpainted.
- C. **Shop Prime Coat Repair:** Do not apply metal primer in wet weather unless steel is protected from dampness and is dry. Clean field welds, field bolts, and all damaged shop primer after erection and apply a spot coat of the same primer used for the shop coat.
- D. **Fasteners:** Provide fasteners and connectors of approved types as required for the installations, whether or not indicated. Provide galvanized fasteners for galvanized items and for exterior use.

#### 3.02 SPECIFIC ITEMS: List of items hereinafter is not necessarily complete. Check all Drawings, other Sections of the Specifications, and with other trades, and provide miscellaneous metal fabrications as required to complete the entire Work.

- A. **Miscellaneous Metal Items for Elevators:** Shop prime coat finish. Coordinate with the requirements of Elevator Shop Drawings.
  - 1. Elevator Threshold Angles: Sizes and connections shown.

2. Pit Screen: Of 1-1/2" diamond mesh 10-gage woven wire fabric, with frames of 1-inch steel channels and shapes, frame joints full welded and ground smooth or mortised and tenoned and peen riveted, wires extended through holes in frames, clinched, and spot welded at 6-inch intervals.
- B. **Steel Ladders:** Continuously weld joints and grind smooth and flush. Galvanize exterior ladders only.
  - C. **Pipe Railings:** Standard weight steel pipe, joints with preformed sections at angles and coped at intersections unless otherwise shown, and continuously welded, welds ground smooth and flush. Provide cast malleable steel brackets with mounting plates for all railings on walls. Return exposed rail ends to walls unless otherwise shown.
  - D. **Above-Ceiling Supports:** Provide steel hangers, supports, attachments, and other framing for support of ceiling-hung items such as toilet compartments. Conform to approved Shop Drawings of related trades.
  - E. **Trench Gratings and Frames.** As manufactured by Alhambra Foundry, Borden, Irving, IKG Industries, Grating Pacific Inc., galvanized steel grating and frames, all grating edges banded full height. Space bearing bars for maximum 1/2" clear opening and size for 100 psf live load based on the required spans. Grating shall be designed by a California licensed civil or structural engineer and submitted, together with shop drawings for review by the Architect and the City of Los Angeles Department of Building and Safety prior to fabrication. Fabricate gratings in sections weighing not over 75 pounds per panel. Include galvanized steel pans, angles, or shape frames as shown or required.
  - F. **Countertop Supports:** Provide supports for toilet room countertops, joints full welded and ground smooth; coordinate with Section 04400.
  - G. **Strap, Pipe, and Channel Guards:** In parking levels, provide various steel guard assemblies as detailed, welds continuous and ground smooth.
  - H. **Embedded Steel Items:** Provide miscellaneous embedded steel shapes, angles, and channels, complete with welded anchors and galvanized as detailed. Exception: Without limitation, all loading dock and pit nosings and embedded items exposed to the exterior to be galvanized.
  - I. **Wire Mesh Items:** Fabricate of 1-1/2" diamond mesh 10-gauge woven wire fabric, with frames of 1" steel channels and shapes, frame joints full welded and ground smooth or mortised and tenoned and peen riveted, mesh wires extended through holes in frames, clinched, and spot welded at 6" intervals. Galvanize items after fabrication where located in parking areas.
  - J. **Water Storage Tank Hatch and Rungs:** Provide flush floor hatch (manhole cover) and frame per plumbing drawings.
  - K. **Pump Pit Covers:** Steel angle frame, intermediate beam where indicated or required, cover of 3/16" thick steel checkerplate, all galvanized. Secure cover with galvanized steel flat-head screws at corners and mid-points of edges.

- L. **Steel Pipe Bollards:** Fabricate bollards from extra heavy galvanized steel pipe. Provide steel cap at top of bollard: weld all around, grind smooth, radius edge.ginal design.
- M. **Steel Equipment Grates:**
- N. **Helipad Safety Net:**

END OF SECTION

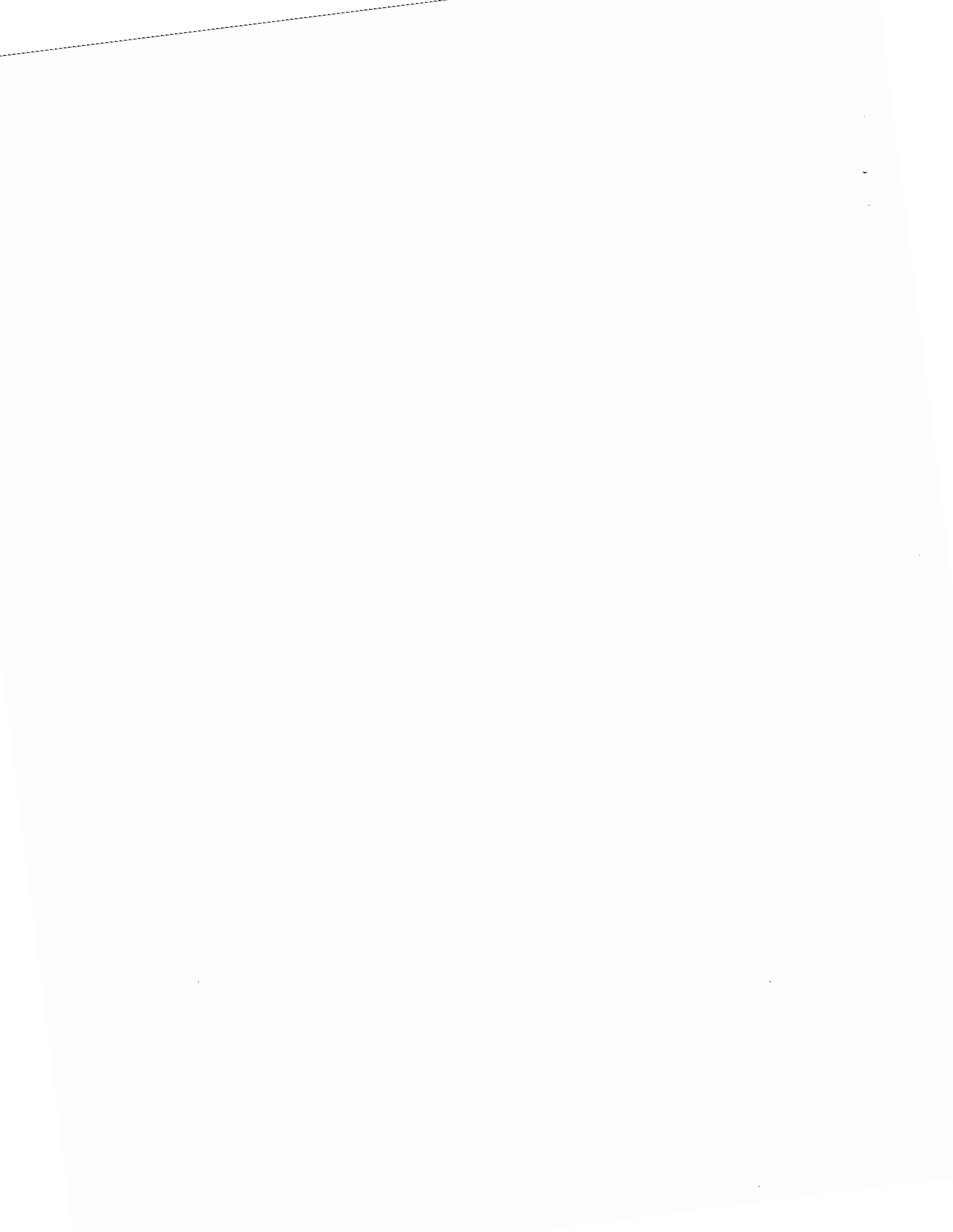

**SECTION 05510**

**METAL STAIRS**

**PART 1 - GENERAL**

- 1.01 DESCRIPTION: Division 1 applies to this Section. Provide metal stairs and pipe railings as indicated, specified, and required.
- A. Work In This Section.** Principal items include:
1. Steel checkerplate stairs where indicated.
  2. Pipe railings in connection with steel stairs.
  3. Shop priming and field touch-up.
- B. Related Work Not In This Section.**
1. Structural supports.
  2. Finish painting.
  3. Setting of anchor bolts and inserts in concrete.
  4. Steel backing plates on steel stud walls.
- 1.02 QUALITY ASSURANCE: Conform to Code Titles 8 and 24 CCR, ADA regulations and to AISC Code of Standard Practice for Steel Buildings and Bridges modified as per Section 05120, 1.02, A, 1; AISC Specification for the Design, Fabrication and Erection of Structural Steel for Buildings; AISC Steel Construction Manual; and AWS D1.1, Structural Welding Code and City of Los Angeles.
- 1.03 SUBMITTALS: Refer to Section 01300 for procedures.
- A. Shop Drawings.** Submit shop drawings fully detailing all Work of this Section, including showing materials, fabrication details, fastenings, welding, layout and erection diagrams, and method of anchorage of and to adjacent construction. Include minor connections and fastenings not indicated or specified to meet required conditions; indicate in detail on Shop Drawings. Shop drawings to be submitted to and approved by the City of Los Angeles. All shop drawings shall be signed by and bear the seal of a State of California licensed structural engineer thereby signifying that he has designed and approves said shop drawings. Material fabricated or delivered to site prior to approval of shop drawings will be subject to rejection. Building Department plan check fees and building permit fees to be paid by Owner.
- B. Structural Calculations.** Furnish certified copies of structural calculations prepared, signed and bearing the seal of a State of California licensed structural engineer signifying that the metal stairs and railings were designed, fabricated and erected so that they will safely withstand the loads (live and dead) to be imposed thereon and to fulfill the seismic requirements of authorities having jurisdiction thereof.
- 1.04 PRODUCT DELIVERY AND HANDLING: Protect materials from damage during shipping, handling and storage. Materials showing dents, creases, deformations, rust, or other defects will be rejected. Deliver welding electrodes to site in unbroken packages bearing manufacturer's name and contents identification on each container.

- 1.05      **JOB CONDITIONS:** Verify conditions according to Section 01400. Verify all field measurements as required. Report any major discrepancy between the Drawings and field dimensions to Architect before fabrication of Work. Exercise caution to protect concrete floor surfaces and adjacent Work from damage.

## PART 2 - PRODUCTS

- 2.01      **BASIC MATERIALS:** Furnish materials conforming to the following:
- |                   |   |
|-------------------|---|
| Steel shapes:     | ASTM A36.   |
| Safety plate:     | Raised diamond steel checkerplate, 3/16" thickness unless otherwise shown, or approved pattern. |
| Steel tubing:     | ASTM A500, ASTM A501, or ASTM A36.  |
| Steel pipe:       | ASTM A120 standard weight for general use; ASTM A53 Grade B where used for structural purposes. |
| Bolts and nuts:   | ASTM A307.  |
| Electrodes:       | AWS D1.1, E70XX Series as required for intended use.  |
| Primer:           | Sinclair No. 15 Red Oxide Primer or approved equal.   |
| Non-shrink grout: | Master Builders "Embeco", W. R. Grace "Vibrofoil", or equal.                                    |
| Bolt inserts:     | Phillips "Redheads", Wej-lts, or equal.   |
- 2.02      **GENERAL FABRICATION REQUIREMENTS:** Conform to the approved submittals, reference standards as applicable to the Work, and the requirements herein. Fabricate and form the Work to meet actual installation conditions as verified at the site. Obtain necessary templates and information and provide all holes and drilling indicated or required for securing Work of other trades to metal stairs.
- A.      **Welding.** Conform to AWS D1.1, as modified by referenced AISC Standards, and as shown or noted. Weld joints by shielded electric-arc method with low hydrogen electrodes unless otherwise indicated. Grind exposed welds to smooth surfaces free of holes, slag, or other defects, flush with adjoining surfaces. No grinding is required for permanently concealed welds. Cut out all defective welding with chisel or air arc and replace.
- B.      **Shop Priming.** Clean surfaces according to AISC Specifications. Apply shop coat of metal primer to minimum 1.0 mil dry film thickness. Work primer into joints.

## PART 3 - EXECUTION

- 3.01      **GENERAL INSTALLATION REQUIREMENTS:** Provide grouting as indicated, specified, and required. Use non-shrink grout and conform to manufacturer's directions.
- A.      **Shop Prime Coat Repair.** Do not apply metal primer in wet or damp weather unless steel is protected and is dry. Clean field welds, field bolts, and all damaged shop primer after erection and apply a spot coat of the same primer used for the shop coat.
- B.      **Fasteners.** Provide fasteners and connectors of approved types as required for the installations, whether or not indicated.
- C.      **Checkerplate Steel Stairs.** Safety plate treads, structural, and riser closures of minimum 12 gage steel. Weld riser closures to back side of tread nosings and back edge turn-up, and to stringers at both ends.



- D. **Pipe Railings.** Standard weight steel pipe, joints mitered at angles and coped at intersections unless otherwise shown, and continuously welded, welds ground smooth and flush. Provide cast malleable steel brackets with mounting plates for all railings on walls. Return exposed rail ends to walls unless otherwise shown and conform to Code handicapped requirements for rail and extensions.

END OF SECTION



SECTION 05700

ORNAMENTAL METAL

PART 1 - GENERAL

1.01 DESCRIPTION: Division 1 applied to this Section. Provide all ornamental metal items, complete:

**A. Work In This Section.** Principal items include:

1. Custom Aluminum Panel Siding System.
2. Custom Ornamental Metal Items.
3. Elevator Door Cladding.

**B. Related Work Not In This Section.**

1. Caulking and sealants.
2. Structural supports to receive architectural metal items.
3. Wood and metal frame work to support cladding.
4. Standard pipe railing systems.

1.02 QUALITY ASSURANCE:

**A. Reference Standards:**

1. AAMA - American Architectural Aluminum Manufacturers Association.
2. NIDI - Nickel Development Institute.

Drawing details and requirements herein govern. Conform to the current publications from the AAMA and NIDI for conditions not indicated or specified and for general fabrication of ornamental metal.

**B. Qualification of Fabricator:** All Work of this Section shall be fabricated and installed by a specialist architectural metals fabricator, whose qualifications and experience are subject to Owner's review.

**C. Reference Sections:** Requirements specified in Section 07900 form a part of this Section, including submittal and warranty requirements.

1.03 SUBMITTALS: Refer to Section 01300 for procedures.

**A. Shop Drawings:** Submit showing details for all Work of this Section. Showing details of girts and attachment methods, jointing methods, anchors and fastening, thicknesses and gages of metals, sections, and profiles, and details of all accessory items including copings and flashings. Include structural calculations for wind loadings and deflections, prepared and sealed by a California registered civil engineer.

**B. Samples and Product Data:** Submit following listed Samples and such other Samples Architect may require, with copies of Code approvals and manufacturer's catalog and technical installation instructions for each material.

1. Samples of paint finish in accordance with Section 05900.
2. Samples of metal finishes for architects approval prior to fabrication.
3. Mock-up systems as required by architect for approval including girt, connections to adjoining panels, and fastenings.
4. Sample of finished coping, 12" long.
5. Sample of accessory.

1.04 **PRODUCT DELIVERY, STORAGE, AND HANDLING:** Deliver products to the site in manufacturer's original intact labeled containers or wrappings and store under cover in a dry location until installed. Apply a strippable pressure-sensitive plastic sheet protection material on polished or finished surfaces as required to prevent scratching or defacing during handling and installation. Also meet requirements specified in Section 05900.

1.05 **JOB CONDITIONS:** Coordinate installation with all related trades. Protect installed units until completion of entire Work.

## PART 2 - PRODUCTS

### 2.01 MATERIALS:

- A. **Bronze Plate:** Provide metal alloy where indicated on drawings. Finish matching approved sample in Architect's office.
- B. **Aluminum Panels:** Fabricate the panels of minimum 0.125" thick aluminum, faces flat and free of waves, oil canning, or fabrication marks, edges precision formed to the reveal size indicated. Panel design shall have all panel edges returned and concealed after installation. Provide aluminum channels or angles epoxy bonded to concealed side of panels as required to meet specified wind load requirements without buckling or distortion. Design vertical joints to be the male and female interlocking type with caulking bead space, and design horizontal joints with overlap for positive watertight sealing.
- C. **Wind Loads:** Base panel design on Code required wind loads except use minimum 25 pounds per square foot wind loading where Code allows a lesser load.
- D. **Girts:** Extruded aluminum or stainless steel channels, structural properties as shown in approved submittals. Provide a horizontal girt at top and bottom of wall and a girt at each horizontal reveal. Provide additional horizontal girts as required to meet wind load requirements and for secure attachment and support of all the accessories and flashings.
- F. **Copings:** Profile as detailed, fabricated of minimum 0.062" thick aluminum with factory made corners, intermediate joints spaced at nominal 8-foot centers and butted over a matching splice plate; at joints, set copings in a 1/2" wide bead of sealant.
- G. **Accessories:** Fabricate corner units and opening jamb and head closures as specified for panels and as indicated. Fabricate flashings of minimum 0.032" thick aluminum or stainless steel exposed edges blind hemmed and all corners locked and finished watertight.
  1. **Welding:** Perform by "Heli-Arc" process under controlled shop conditions.

Welding at the site is not acceptable for installation. Finish exposed welds smooth and flush with adjoining metal surface and free of pits and slag.

2. Construction: Form true to the shapes, profiles, and radii shown, free of distortion and surface defects. Where plates abut at joints, return the edges 1/2" to provide a sealant space with joint width not less than 3/16" nor more than 5/16" wide. Weld corners where returned edges intersect and finish welds smooth, flush, and free of pits or slag. Provide concealed stiffeners, formers, and stringers as required for formed shapes to retain uniform curvature and resist installation and imposed loads, welded in place, and welded concealed anchorages required for connection of panels to structural supports. Construct all joints and connections to allow for thermal expansion and contraction of the connected parts without distortion, distress, or oil-canning.
  3. Fasteners and Connectors: Do not place fasteners on exposed surfaces unless indicated on the Drawings or on approved Shop Drawings. Design connections to use concealed fasteners wherever feasible.
- H. Fasteners: Where in connection with aluminum, heat-treated aluminum or Type 316 non-magnetic stainless steel. Finish exposed fasteners to match the adjoining painting surfaces. Provide screw type fasteners. Do not place fasteners on exposed surfaces unless indicated on the Drawings or on approved Shop Drawings. Design connections to use concealed fasteners wherever feasible.
- I. Elevator Door Cladding: Provide cladding metal finished matching approved sample in Architect's office. Temper best suited for purpose, minimum thickness of 0.050" with patterns etched (where detailed) to a depth of .010" insets. After etching, (where detailed) recessed backgrounds are hand grained into metal. A clear lacquer coating is then applied over entire surface. Patterns as indicated on drawings and approved by the Architect. Manufactured by Surface Design and Technology. Match finish sample of metal in Architect's office.

2.02 ALUMINUM FINISH: For all exposed aluminum surfaces, provide finish in accordance with Section 05900 and 08500, finish and color as selected by Architect.

### **PART 3 - EXECUTION**

3.01 INSPECTION: Refer to Section 01400, Article "Verification of Conditions", and report to Architect in writing those conditions that prevent or interfere with correct installation of Work of this Section.

3.02 INSTALLATION: Install and connect MCBC materials according to drawings and approved submittals. Carefully erect materials and check for correct alignment before completing permanent connections. Tighten fasteners to firm pressure without over-stressing oil canning or distorting connected materials. After installing, caulk all exposed joints in accordance with Section 07900 using sealant of color matching finish color. Remove defaced or damaged items and provide sound proper replacements as directed and approved, at no extra cost to Owner. Securely anchor to the building structure. Set frames level, plumb, and in true alignment, and construct completely waterproof assemblies.

- 3.03 CAULKING: Caulk and seal panel siding and accessory joints as required for fully weatherproof and watertight installations; detail all conditions in the Shop Drawings. Use sealant caulking and conform to Section 07900 including submittals and warranty.
- 3.04 CLEANING AND FINISHING: Conform to Section 01700. After installation is completed, clean exposed painted surfaces in accordance with Section 05900.

END OF SECTION

**SECTION 06100**

**ROUGH CARPENTRY**

**PART 1 - GENERAL**

1.01 DESCRIPTION: Division 1 applies to this Section. Provide rough carpentry as indicated, specified, and required.

**A. Work In This Section:** Principal items include:

1. Blocking, backing, nailers, grounds, stripping, and like items as indicated and required for securing other Work.
2. Rough hardware.
3. Lumber treatments as specified.

**PART 2 - PRODUCTS**

2.01 MATERIALS

**A. Standard Grade Douglas Fir:** Non-structural wood furring, blocking, stripping, grounds, and miscellaneous nailers and backing, grade-marked per WCLIB Grading Rules 16 or equivalent grade-mark by WWPA.

1. Nails: Common wire nails, galvanized for roof blocking and nailers:
2. Bolts: ASTM A307, galvanized for exterior items and where embedded in concrete or masonry. Provide matching washers as required.
3. Screws:

**B. Lumber Treatments:**

1. Pressure Preservative Treatment: Pressure treat wood items resting on or embedded in concrete or masonry, and blocking and nailers for roof insulation and flashings, in accordance with American Wood Preservers Association Standard C2 and American Wood Preservers Bureau Standard LP-2 or LP-4, with each piece of treated lumber bearing mark of approved testing agency. Do not use creosote. Re-dry as necessary to maximum 14% moisture content.
2. Fire-retardant treatment is required for all blocking and nailers in metal framed walls, partitions, and ceilings, and where required by the Building Code. Pressure treat to flame spread rating of 25 or less and fuel contribution of 30 or less when tested in accordance with ASTM E84, each piece bearing the UL label of conformance. Re-dry to maximum 14% moisture content.

**PART 3 - EXECUTION**

- 3.01      **WORKMANSHIP:** Provide and securely fasten wood nailing strips, plates, blocking, and like items indicated or required. Bolt wood nailings strips and blocking in connection with metal. Recess bolt heads and nuts below surface, and provide washers where bearing directly on wood.

END OF SECTION



SECTION 06200

FINISH CARPENTRY

PART 1 - GENERAL

1.01 DESCRIPTION: Division 1 applies to this Section. Provide and perform finish carpentry as indicated, specified, and required.

A. **Work In This Section:** Principal items include:

1. Plastic laminate trim.
2. Wood wall panels.
3. Wood trim.
4. Back priming to extent specified.
5. Telephone and electrical backboards.
6. Installation of hollow metal doors and frames.
7. Installation of wood doors.
8. Installation of finish hardware except as otherwise specified.
9. Janitor shelving and mop racks.

B. **Related Work Not In This Section:**

1. Finish staining.
2. Finish painting.
3. Furnishing hollow metal doors and frames
4. Furnishing wood doors.
5. Furnishing finish hardware for doors.
6. Installation of hardware on aluminum doors.

1.02 QUALITY ASSURANCE: Work of this Section shall conform to the Manual of Millwork of the Woodwork Institute of California (WIC), Current Edition, grades as specified herein or indicated. Prior to delivery to site, submit WIC Certified Compliance Certificates indicating each millwork product for the Work and that all products will fully conform to the WIC grades and other requirements shown and specified.

1.03 SUBMITTALS: Refer to Section 01300 for procedures.

A. **Shop Drawings:** Submit for following items, bearing the WIC Certified Compliance Grade Stamp.

1. Steel backing plate or blocking locations required for the anchoring of wall panels and other Work of this Section.
2. Plastic laminate trim, each typical type.
3. Wood wall panels, each typical type.
4. Wood trim, each typical type.

B. **Samples and Product Data:** Submit the following for selection and approval:

1. Full range of plastic laminate patterns and colors.
2. Catalog data for each proposed cabinet hardware item.
3. Finished wood wall panels.

## PART 2 - PRODUCTS

2.01 MATERIALS AND MANUFACTURE: Conforming to WIC Manual unless otherwise specified. Details on Drawings and requirements specified herein govern arrangement, sizes, construction, and fabrication. In all other respects, manufacture Work of this Section to conform to the WIC grades specified.

- A. **Plastic Laminate Trim.** WIC Section 16, "Premium" grade, all self-edged unless otherwise shown. Seal the edges of trim with resin sealer. Make trims up to 12-foot length in one piece; for longer lengths, use not over two pieces, assembled with draw-bolts and splines, jointed flush and smooth as shown on approved Shop Drawings. Seal joints at splices with mastic.
- B. **Janitor Shelving.** "Custom" grade softwood or Grade B-B plywood all 3/4" thick, edge banding of full glued birch strips, for opaque paint finish.
- C. **Mop Racks.** Clear Douglas fir back board with 1/2" diameter bullet pointed maple dowels driven into tight holes.
- D. **Wood Paneling:** Wood paneling shall comply with requirements of WIC "Premium" Grade. Wood paneling shall be given fire retardant treatment as specified in Section 06100, Rough Carpentry. Paneling shall be installed as indicated on the drawings and as specified herein by skilled craftsmen capable of producing high quality work.
  1. Wood paneling shall be surface veneer over plywood core, nominal thickness 3/4" unless indicated otherwise.
  2. Face veneer as approved by Architect shall be plain sliced Sapele Pomele Flitch #91-03 and Australian Lacewood by U.S. Veneer and Company, (213) 399-3050, (local representative - Manny Greenberg). The same flitch and species is to be used for the veneer on doors and guard desk to match approved sample in the office of the Architect.
  3. Book match panel face assembly, as approved by Architect.
  4. Balance match panel face assembly, as approved by Architect.
  5. Matching of adjacent panels.
  6. Panel Finish: Veneer panels shall be filled and match approved sample in the office of the Architect.
- E. **Hardwood Trim:** As indicated on drawing or selected by Architect.
- F. **Adhesive:** Approved type for required installation.
- G. **Back Priming:** Use exterior wood primer or enamel undercoater of type specified in Section 09900, except use a tinted resin sealer on natural finished woodwork with tannin to coat exposed surfaces. Back prime the following items:

1. Items so specified.
2. Wood, particleboard, or hardboard against plaster, concrete, or masonry.
3. Concealed surfaces of exterior wood opening frames.
4. Exterior wood trim and finish.

### PART 3 - EXECUTION

#### 3.01 INSTALLATION OF FINISH CARPENTRY:

- A. **General:** Conform to Drawings, approved submittals, and WIC Manual. Repair all damage as approved.
- B. **Telephone and Electrical Backboards:** Install Grade B-B Exterior plywood panels, 3/4" thick by 8 feet high. Secure to walls with stripes of contact adhesive and molly-bolts at 24" centers around perimeter of each panel. Run backboards from top of wall base.
- C. **Paneling: Provide where shown.** All paneling to be edge banded (or as detailed) with solid lumber to match face veneers full glued with mitered tongue and groove joint. Plywood to be applied over furring strips. Anchor with approved adhesive unless other method is reviewed by Architect.
- D. **Trim:** Provide trim in single lengths where possible. Make allowance for scribing by cutting on job. Cope or miter corners. Use waterproof glue for all gluing. Species as shown.
- E. **Janitor Shelves and Mop Racks:** Provide 2 shelves and 2 mop racks in each janitor room. Verify final location with the Architect.

#### 3.02 INSTALLATION OF HOLLOW METAL WORK: Conform installation to submittals approved under Section 08110 and manufacturer's instructions. Install all frames plumb, straight, in true alignment, rigidly connected to walls and building structure. Erect in proper sequence with other trades to prevent delays. Erect within the tolerances specified or shown in the approved submittals.

- A. **Install frames in completed concrete and masonry openings with flat head expansion anchors.** Ground and sand head and frame smooth and fill with body putty. Sand smooth for invisible appearance of anchor.

#### 3.03 INSTALLATION OF WOOD DOORS: Install doors in accordance with NWWDA and WIC requirements except as modified herein. Field trimming of prefit doors is not allowed. Fit doors square and plumb with frames with due allowance for possible swelling and shrinking, minimum 1/8" clearance at top, edges, and meeting stiles, and 3/8" clearance at sill unless otherwise indicated or required by floor or threshold finish. Round arises to 1/16" radius. Bevel lock stiles to conform to lock and latch hardware.

#### 3.04 INSTALLATION OF FINISH HARDWARE: Install hardware supplied under Section 08710, excluding only hardware specified to be installed at the factory or under other Sections. Drill pilot holes for screws and screw home; hammer driving of screws is not allowed. After installation and fitting, remove finish hardware items on surfaces to be painted, except prime coat items, repack

RTD Headquarters  
Los Angeles, California  
91-400

5/01/93  
Finish Carpentry  
06200 - 4

in original containers, and perform final installation, testing, and adjustment after finish painting is completed. Adjust hinges to swing smoothly but not loosely, without sticking or hinge-bound conditions. Adjust hardware for correct operation.

END OF SECTION

**SECTION 07115**

**FLUID-APPLIED WATERPROOFING**

**PART 1 - GENERAL**

1.01 **DESCRIPTION:** Division 1 applies to this Section. Provide fluid-applied waterproofing as indicated, specified, and required. As used in this Section, the term "waterproofing" means "fluid-applied waterproofing" or waterproof membrane unless otherwise defined or specified.

**A. Work In This Section:**

1. Submittals.
2. Preparation of surfaces.
3. Fluid-applied waterproofing membranes as indicated on drawing and on the following areas and surfaces:
  - a) Between slab waterproofing membrane.
  - b) Slabs to receive pavers.
  - c) Planter walls indicated to receive membrane waterproofing.
  - d) Furnish and Install Protection Board.

**B. Related Work Not In This Section:**

1. Elastomeric roofing.
2. Latex waterproofing.
3. Flashing and Sheet Metal (Section 07500)
4. Cast-in-Place Concrete
5. Parge coat.
6. Concrete and concrete unit masonry substrates.
7. Liquid waterproofing.
8. Bentonite waterproofing.

1.02 **QUALITY ASSURANCE**

**A. Inspection:** The work will be inspected and test cuts taken by Waterproofing Consultant approved by the Owner and having a minimum of 10 years experience in the supervision and inspection of waterproofing systems. Consultant shall have the authority to regulate the quality of the Work so that it conforms to the Contract Documents and to order discontinuance of any operation causing non-conforming Work. Consultant shall submit a written report to Architect upon completion of the Work.

**B. Qualifications of Fluid-Applied Waterproofing System:** System shall have City of Los Angeles approval and have been issued a current City of L.A. Research Number.

**C. Qualifications of Subcontractor:** Employ waterproofing system manufacturer or manufacturer's authorized applicator to prepare surfaces and install all the waterproofing systems required under this Section.

- D. Manufacturer's Participation:** At least 35 days before application of any fluid-applied waterproofing, Contractor shall notify waterproofing manufacturer in writing, with a copy delivered to Architect, of requirements of this Section pertaining to the waterproofing manufacturer's obligations to either install the waterproofing systems or designate an approved applicator, to inspect completed waterproofing, execute specified certificate, and to execute the specified warranty. Waterproofing manufacturer shall respond in writing to the Contractor and Architect acknowledging acceptance of these obligations and responsibilities with respect to the Work of this Section, and Work of this Section shall not be installed until Architect has received such written response free of exceptions or qualification. As used in this Section, the term "manufacturer" includes the waterproofing manufacturer's technically qualified factory representative who is legally empowered to execute required certificate and warranty for manufacturer.
- E. Pre-Installation Conference and Inspection:** After approval of submittals but prior to starting installation of Work of this Section, the Contractor shall hold a meeting at the site attended by representatives of the Owner, Architect, Contractor, and the Earthwork, Concrete, Masonry, Waterproofing, Landscaping, Mechanical, and Electrical Subcontractors, and a technical representative of the waterproofing material manufacturer to describe in detail waterproofing system to be installed and to establish agreement, coordination, and responsibilities among involved trades. Contractor shall prepare a detailed memo of this meeting and furnish copies to the Architect and all involved trades. The Waterproofing Subcontractor and material manufacturer's technical representative shall inspect the substrates to receive Work of this Section and report defective conditions to the Architect and Contractor for correction; refer to Article "Verification of Conditions" in Section 01400.
- F. Testing Agency:** (Refer to Section 01400) Owner will engage, at his own expense, Testing Agency to inspect fluid applied waterproofing, to perform tests specified, and submit reports to Architect.
1. Testing Agency will be responsible for conducting and interpreting tests, will state in reports whether or not test deviations therefrom, and will indicate corrective measures required and taken.
  2. Provide Testing Agency with the following:
    - a. Shop drawings.
    - b. Manufacturer's application instructions.
    - c. Information as to time of application.
    - d. Representative sample materials requested for testing.
    - e. Full and ample means and assistance for testing.
    - f. Proper facilities, including scaffolding and temporary work platforms for inspection of work.

1.03 SUBMITTALS: Refer to Section 01300 for procedures.

- A. Waterproofing Manufacturer's Specification:** Not more than 60 days after execution of the Contract, submit specifications covering Work of this Section, specially prepared

in detail by the waterproofing manufacturer and based on the requirements of Drawings and this Section. With the specifications, include a certification that the waterproofing manufacturer has reviewed the Drawings and this Section, and that products and systems in specifications prepared by the waterproofing manufacturer are correct for the Work as designed and comply with or exceed requirements of this Section. Specifications prepared and submitted by Waterproofing Subcontractor in lieu of waterproofing material manufacturer are not acceptable. Without limitation include complete instructions covering the preparation of substrates and adjoining or related Work, application of all materials including priming, lapping, reinforcement, membrane coatings, and the protection courses.

- B. Product Data:** With the manufacturer's specifications submit waterproofing manufacturer's complete technical product data covering all materials, systems, certified laboratory test reports, preparation, application instructions, and published specifications, and copies of Code approval for each system proposed for use. Including:
1. Primer.
  2. Fluid Applied Waterproofing.
  3. Protection Board.
  4. Pavers
- C. Samples:** Submit such Samples as Architect may request.
- D. Service History:** Submit typed list of at least ten installations, with the Owner's names and addresses, on which the materials and systems proposed for use for the Work have been in satisfactory service, without failure of any kind, for at least five years.
- E. Subcontractor's Qualifications:** Submit written evidence that manufacturer will install systems or Subcontractor is licensed and approved by manufacturer.
- F. Certificate:** At completion, Contractor and manufacturer shall inspect all waterproofing and jointly certify to the Architect that installed waterproofing systems conform to this Section and approved submittals.

1.04 **PRODUCT DELIVERY:** Deliver materials to the site in system manufacturer's original unopened containers with the seals unbroken, factory labels intact and bearing name of manufacturer and date of manufacturer. Store materials in unopened containers. Store off ground and under cover, protect from damage.

1.05 **JOB CONDITIONS**

- A. Coordination:** Coordinate with related trades and verify concrete surfaces are correctly finished, water or sheet cured without the use of curing compound and are dry.
- B. Protection:** Place temporary coverings and protection to prevent staining or marring of surfaces not to be coated. Wherever waterproofing systems abut or lap on surfaces to remain exposed, apply non-staining pressure-sensitive masking tape to prevent staining

and apply additional covering to supplement the masking tape. Keep traffic off waterproofing until covered with protection course.

- C. **Weather Conditions:** Do not apply waterproofing in exterior areas during rainy, damp, foggy, or excessively windy weather, or when rain is imminent.

- 1.06 **WARRANTY:** Conform to Section 01740. The contractor and the waterproofing manufacturer shall furnish to Owner a joint and several written warranties against defects in materials or workmanship for three years covering the waterproofing performance of the installed waterproofing systems for the full warranty period and accepting responsibility for ruptures in waterproofing caused by cracking of substrates up to 3/16" width. Defects covered under the warranty shall include, without limitation, loosening, softening, blistering, loss of either adhesion or cohesion, delamination, and penetration of water.

## PART 2 - PRODUCTS

### 2.01 ACCEPTABLE MANUFACTURERS:

- A. **Manufacturer:** Subject to compliance with requirements provide products from one of the following manufacturers.

1. American Hydrotech, Inc.

### 2.02 MATERIALS:

- A. **Asphalt Primer:**ASTM D41 (American Hydrotech, Inc.)
- B. **Waterproofing:**"Hydrotech Monolithic Membrane 6125" (American Hydrotech, Inc.)
- C. **Heavy Duty Reinforcing:** "Flex-Flash UN" (American Hydrotech, Inc.)
- D. **Standard Duty Reinforcing:** "Flex-Flash F" (American Hydrotech, Inc.)
- E. **Pavers:** "Terra Pavers on Terra Tabs" (American Hydrotech, Inc.)
- F. **Other Materials:** Manufacturer's standard for items required or type best suited for intended use.

### 2.03 PROTECTION COURSE

- A. **Horizontal Surfaces:** Furnish the "Hydro-Flex 30" Protection Panels by American Hydrotech, Inc.
- B. **Vertical Surfaces:** Furnish the Amaco Foam Board.
- C. **Irregular Surfaces:** Where installation of rigid board protection course is impractical, use minimum thickness .060 inch thick uncured neoprene sheet flashing or comparable sheet flashing compatible with waterproofing cut and formed to fit tight against waterproofing



membranes and secured with suitable mastic compatible with the membrane material. Irregular surfaces include stairs and similar locations.

- D. **Planters:** Same as for between-slab and sloping surfaces except 1/2" thick asphalt-treated fiberboard conforming to ASTM C208 may be used on surfaces that are lower than 6" below planter fill finish elevation.

### **PART 3 - EXECUTION**

- 3.01 **INSPECTION:** Refer to Section 01400 regarding verification of conditions, and verify that substrates are correctly finished, water or paper cured without the use of membrane-forming curing compounds, and are dry. Report to Architect in writing all conditions that prevent proper installation of the Work of this Section and do not proceed until corrections are completed. Application of the first coat of any waterproofing system constitutes acceptance of substrates for warranty purposes. Inspection does not relieve the Contractor and applicator of responsibility for proper preparation of surfaces.
- 3.02 **PREPARATION:**
- A. **Preparation of Surfaces:** Clean substrate of materials which would impair work. Patch cracks, voids and honeycombs to provide smooth, structurally sound surface. Cut off high spots and grind smooth.
- B. **Protection:** Protect building from damage resulting from spillage, dripping and dropping of materials. Prevent material from entering and clogging drains and water conductors. Repair and restore or replace other work which is spoiled or damaged in connection with performance of waterproofing work.
- 3.03 **APPLICATION:**
- A. **Install** fluid applied waterproofing in accordance with manufacturer's printed instructions except as hereinafter specified.
- B. **Prime concrete:** Use products and methods recommended by manufacturer.
- C. **Heat materials** to proper temperature recommended by manufacturer, but do not exceed upper temperature limit. Remove over-heated materials from site. Provide clearly visible thermometer on kettles and keep in proper working order.
- D. **Unless otherwise** indicated, extend fluid applied waterproofing 8 inches on vertical surfaces where waterproofing is turned up or down.
- E. **Detailing:** Provide detailing, flashings and termination in accordance with waterproofing manufacturers standard guideline details. Use the longest pieces of flashing/reinforcing practicable based on job site conditions.
1. **Cracks:** Cracks over 1/16" but less than 1/4" in width apply membrane, 125 mils thick, over crack area. Center a 6" wide strip of reinforcing (standard or heavy

- duty reinforcing) over crack and embed firmly into warm membrane. Apply another coat of membrane, 125 mils thick, over reinforcing sheet, totally encapsulating in membrane.
2. Construction or control joints: Apply membrane, 125 mils thick, over joint area. Center 6" wide strip of reinforcing (standard or heavy duty reinforcing) over joint and embed firmly into warm membrane. Apply another coat of membrane 125 mils thick, over reinforcing sheet, totally encapsulating in membrane.
  3. Expansion Joints:
    - a. Expansion joints up to 1/2" in width (50% total designed movement): Apply membrane, 125 mils thick, over the expansion joint area. Center strip of heavy duty reinforcing extending minimum of 3" onto either side of joint and embed firmly into warm membrane. Apply another coat of membrane, 125 mils thick over reinforcing sheet, totally encapsulating in membrane.
    - b. Expansion joints up to 2" in width (50% total designed movement): Apply membrane, 125 mils thick, over expansion joint area. Embed firmly into warm membrane sheet of heavy duty reinforcing looped down into joint 1 1/2 times joint width, and extending minimum of 6" onto either side of joint. Insert expansion joint foam rod (1" larger in diameter than maximum joint opening) snugly into top of heavy duty reinforcing loop. While membrane is still warm install another strip of heavy duty reinforcing extending minimum of 8" onto either side of joint, looping it upward at its center to accommodate foam rod. Apply final coat of membrane, 125 mils thick, over heavy duty reinforcing except at loop, totally encapsulating reinforcing sheet edges.
    - c. Anticipated deck movement at expansion joints is designed to be taken by excess reinforcing "looped" material. Do not design or construct joint so stress would occur within flashing sheet.
  4. Drains:
    - a. Apply membrane, 125 mils thick, around drain, extending it into drain bowl flange and out 12" onto deck.
    - b. Embed firmly one sheet of heavy duty reinforcing centered over drain bowl into membrane while it is warm. Extend reinforcing beyond drain bowl flange onto deck, minimum 6" in all directions.
    - c. Install drain clamping ring making sure bolts are properly tightened. Cut out center of reinforcing covering drain bowl.
    - d. Apply membrane 125 mils thick over exposed reinforcing totally encapsulating it.

5. Flashing-penetrations:
    - a. Flash penetrations (pipes, supports, vents) passing through membrane.
    - b. Seal flashing directly to penetration passing through membrane. Do not terminate flashing to intermediate element (metal flashing, insulation, surface treatment).
    - c. Enclose flexible penetration in stable "goose neck" set in membrane and secure to deck. Use field fabricated pipe seal to flash "goose neck".
    - d. Hot pipes: Flash to intermediate "cool" sleeve in accordance with membrane manufacturer's recommendations.
  6. Exposed flashings: To flash conditions such as curbs, parapets, walls, etc., Hydroflash or Flex-flash UN as follows:
    - a. Extend flashing or heavy duty reinforcing sheet onto deck minimum of 3" and up curb, parapet or wall, a minimum of 8" above finished roof surface (whenever possible). Adhere flashing sheet to the vertical surface with bonding adhesive starting 2" off deck up its full height. Firmly set the 2" of unbounded flashing on vertical and 3" of flashing which extends out onto deck into membrane, 125 mils thick, while it is still warm. Coat flashing that extends onto deck with more membrane, 125 mils thick, totally encapsulating sheet edge. Firmly embed flashing corners into membrane so no air pockets are present.
- F. Membrane System Application:** Heat membrane material 350 to 425 degrees F. and apply at a rate to provide a continuous monolithic coating of 90 mil minimum, into which is fully embedded standard duty reinforcing fabric, followed by a second continuous monolithic coating of 125 mil. minimum.
- G. Protection Board:** Embed in fluid applied waterproofing not receiving insulation. Lap seams 3".
- H. Concrete Cover:** Coordinate placement of concrete covering to prevent damage to membrane system.
- 3.04 **POND TESTING AND INSPECTION:** When membrane is completed and fully cured, set temporary dams and cover horizontal waterproofing membranes with at least 3" of standing water and maintain water level for not less than 48 hours. Repair all leaks disclosed by pond testing and repeat entire test procedure until test results are satisfactory and no leakage occurs. Visually inspect waterproofing that cannot be pond tested for voids, skips, damage, rupture, or other defects and repair all defective conditions before protection course is installed.
- 3.05 **ON-GRADE PLANTER WALLS AND FEATURE WALLS:** Reinforce all corners and angles with a layer of glass reinforcing cloth, strips 12" wide and centered on corner or angle, and embedded

in and coated with membrane material. Apply waterproofing membrane in two coats as specified in 3.03 above.

- 3.06 SUBSEQUENT TOPPING MATERIAL PLACEMENT: Examine waterproofed area to be covered with subsequent topping materials in order to insure that all areas have received membrane, membrane is free of damage, properly protected, and all flashing subsequent topping materials.
- 3.07 COMPLETION: Protect membrane systems from injury during application and until finished installation is approved. Perform cleanup and disposal according to Section 01700.
- 3.08 FIELD QUALITY CONTROL: Refer to Section 01400. Install all fluid-applied waterproofing under continuous inspection of a Waterproofing Consultant who will observe installation and perform wet gage testing of applied coatings and dry film thickness testing of the cured in place coating. One dry film test cut must be taken from each 2500 square feet of coated surface area. Do not install any waterproofing unless inspector is present.

END OF SECTION

**SECTION 07120**

**TANK COATING**

**PART 1 - GENERAL**

- 1.01 **DESCRIPTION:** Division 1 applies to this Section. Provide coating on interior concrete surfaces of water sumps or tanks as indicated, specified, and required.
- A. Work In This Section:** Principal items include:
1. Water storage tank.
- 1.02 **QUALITY ASSURANCE:** Employ coating manufacturer or his authorized applicator to perform preparation and install coating system.
- 1.03 **SUBMITTALS:** Refer to Section 01300 for procedures.
- A. Product Data:** Submit manufacturer's technical materials, systems, preparation, and application data and specifications for system proposed for use. Prepare specifications specifically for the conditions shown on the Drawings.
- B. Service History:** Submit a typed list of at least five installations, including owner's name and address, where proposed coating has satisfactorily performed for at least three years.
- C. Certificate:** Upon completion, inspect coating and submit a certificate that the installed coating conforms to Specifications.
- 1.04 **PRODUCT DELIVERY:** Deliver coating materials in unopened factory labeled containers with seals unbroken, labels intact and bearing date of manufacture and brand name.

**PART 2 - PRODUCTS**

- 2.01 **COATING:** Polyurethane Type, Multi-Chemical Products. "Mult-I-Tuff 8800", LA approval #5277 or approved equal, applied to minimum dry film thickness of 80 mils.

**PART 3 - EXECUTION**

- 3.01 **INSPECTION:** Refer to Section 01400 for verification of conditions. Coordinate with related trades and verify that concrete is correctly finished and water or sheet cured without the use of curing compound, and is dry. Notify Architect in writing of any conditions that prevent proper installation for correction. The application of the first coat indicates acceptance of surfaces. This does not relieve Contractor and applicator from responsibility for proper preparation of surfaces.
- 3.02 **PREPARATION:** Conform to manufacturer's directions. Sandblast, acid etch and rinse, mechanically clean, or perform other cleaning operations as necessary for clean sound dry surfaces in proper condition for coating. Cut out substrate cracks over 1/32" wide and fill flush with compatible sealant.

- 3.03 APPLICATION: Use equipment designed for the coating. Seal all cracks less than 1/32" wide with double application of finish coat material. Apply each coat to the required thickness. Produce finished coating of uniform appearance, free of sags, skips or holidays, thin areas, and other defects. Do not apply coating on hatch.
- 3.04 COMPLETION: Remove protective coverings. Clean materials from surfaces not to be coated and restore finish as required. If such surfaces are stained and the cleaning is not acceptable, remove all affected Work and provide new conforming Work as directed, at no extra cost to Owner.

END OF SECTION

SECTION 07130

BELOW GRADE WATERPROOFING

PART 1 - GENERAL

- 1.01            **DESCRIPTION:** Division 1 applies to this Section. Provide Below grade waterproofing as indicated, specified, and required.
- A.            Work in this Section:**
1.            Waterproofing under concrete slabs-on-grade and on all exterior faces of below grade walls in contact with earth up to grade, whether these walls are formed concrete or gunit-ed. The intent of this Section is to provide a watertight below grade structure up to the elevation indicated.
2.            This Section includes a combination of bentonite and rubber-modified asphalt waterproofing.
- B.            Related work not in this Section:**
1.            Bentonite waterstops in concrete work: Division 3.
2.            All other waterproofing.
- C.            Alternate:** Submit an Alternate Bid to provide Swelltite 6000 consisting of 30 mils MDPE/150 mils butyl-bentonite in lieu of Type 1C panels on lagging only.
- 1.02            **SUBMITTALS:**
- A.            Submit the following** in accordance with the requirements of Section 01300:
1.            Large scale, dimensioned shop drawings detailing water-proofing at junction of footings and walls, penetrations through waterproof membrane, flanges of soldier beams, tie plates and anchors, and other unusual conditions.
2.            Letter from the manufacturer of each type of waterproofing membrane to verify its acceptance of the waterproofing subcontractor and acceptance of substrates as satisfactory to receive this work.
- 1.03            **QUALITY ASSURANCE**
- A.            Subcontractor's qualifications:** Firm with a minimum of 3 consecutive years of experience in application of the types of waterproofing proposed for use on projects of similar size and scope.

**B. Manufacturer's inspections:**

1. Request the bentonite manufacturer's presence before start of this work to verify substrate acceptability, and as required thereafter to review installation procedures and completed work, and to issue warranty specified.
2. Unsatisfactory conditions disclosed by the manufacturer's visits to the site shall be promptly and satisfactorily repaired and the areas re-inspected by the manufacturer before work starts or resumes in affected areas.

**C. Inspection:** A waterproofing consultant employed by the Owner will monitor installation of the waterproofing system. The duties and responsibilities of the consultant will be confirmed at a later date.

1.04 HANDLING

**A.** Comply with the requirements of Section 01600.

1.05 WARRANTY

- A.** Warrant waterproofing against defective materials and workmanship for 5 years after Substantial Completion.
- B.** Make repairs to the waterproofing for water leaks during this period at no cost to the Owner in accordance with Manufacturer Warranty.

PART 2 - PRODUCTS

2.01 MATERIALS

- A. Bentonite waterproofing:** The following by American Colloid Co.
1. Bentonite panels: 48 in. x 48 in. x 3/16 in. thick Volclay Panels; Type 1C in elevator and other pits below slabs-on-grade, and under slabs-on-grade; Type 1 elsewhere.
  2. Joint sealer: Volclay Bentoseal.
  3. Bentonite tubes: Volclay Hydrobar Tube, 2 in. diameter x 24 in. long, weighing not less than 3 lbs.
  4. Protective covering: 4 mil polyethylene sheet.
  5. Incidental materials: As required by job conditions and recommended by American Colloid Co.
  6. Waterstops: Waterstop RX 101 3/4" X 1" at all construction joints.
- B. Rubber-modified asphalt waterproofing:** 6125 by American Hydrotech, Inc, (180 mils thick minimum), or LDC 60 as manufactured by the American Colloid Co. (90 mils thick minimum).



**PART 3 - EXECUTION**

**3.01 INSPECTION**

- A. Verify conditions affecting the work** of this Section at site. Make sure that detrimental conditions are corrected before proceeding with installation.

**3.02 PREPARATION**

- A. Verify that surfaces to be waterproofed** are free of voids and sharp projections.
1. Cover holes and cracks in lagging exceeding 2 in. in width with 1/2 in. thick plywood. Fill holes and cracks exceeding 1/2 in. in width with sand/cement grout finished flush with the face of the lagging or equal as recommended by the product manufacturer.
  2. As an alternate to the above, lagging may be covered with a geotextile fabric, recommended by American Colloid Co., securely nailed to the lagging before the bentonite panels are installed.
- B. Moisture control:**
1. Proceed with this work only under favorable weather conditions.
  2. Surfaces to which bentonite waterproofing will be applied may be damp, but do not apply bentonite waterproofing or joint sealer to wet surfaces.
    - a) If the soil is dry, the bentonite panels may be applied directly to well compacted earth; if soil is wet or muddy, either pour a mud slab of lean unreinforced concrete, or provide a layer of gravel or crushed rock so that the bentonite panels can be installed on a dry surface.
    - b) If gravel or crushed rocks are used, they must be covered with geotextile fabric before installing the bentonite panels.
  3. Surface to which asphalt waterproofing will be applied shall be smooth, clean, dry, and free of loose materials.
  4. Protect installed bentonite waterproofing and joint sealer from becoming wet until concrete is cast, for slabs-on-grade, shotcrete is applied for lagged walls, or walls are backfilled.

5. Schedule the work so that the waterproofing does not remain exposed longer than per manufacturer's published recommendations. Defer this work during rainy weather until the weather clears and job conditions are satisfactory.

3.03 INSTALLATION - ASPHALT WATERPROOFING

- A. **Trowel rubber-modified asphalt waterproofing** on footing, as indicated, prior to installation of under-slab bentonite panels. Make sure that dowel reinforcement will be free of waterproofing material so that bond with concrete will not be inhibited.
- B. **Install asphalt waterproofing** prior to installing bentonite panels. Bridge joint between bentonite and asphalt waterproofing as detailed on shop drawings.

3.04 INSTALLATION - BENTONITE WATERPROOFING

- A. **Install in accordance with** the manufacturer's printed installation instructions, the approved shop drawings, and the following.
- B. **Free-standing wall installation:**
  1. Wall preparation.
    - a) Install panels on walls after forms are removed and surface defects have been repaired.
    - b) Do not install panels in standing water, rain, or on wet surfaces.
    - c) Apply Volclay Bentoseal to fill indentations and seal imperfections in concrete surfaces.
    - d) Fill major honeycombed areas as specified in Section 03300. Fill areas of minor honeycombing with Volclay Bentoseal.
    - e) Knock off protrusions over 1/4 in. from the wall to smooth the surface. Fill indentations that might result with Volclay Bentoseal.
    - f) Footings shall be swept clean of soil, rocks and debris to provide good contact in the application area.
  2. Treatment at pour joints in wall, including wall/ footing junction: Pour joints must contain a Volclay Waterstop RX strip as specified in Section 03300.
  3. Bentonite waterproofing installation:
    - a) Install the first panel with flutes (and printing) vertical. Begin at a bottom corner of the wall.

- b) Position panel so that the line identified as "Starter Line" is directly on the corner of the wall.
- c) Nail the first panel in position.
- d) Position succeeding panels (not folded) on the bottom course so that the flutes (and the printing) are horizontal.
- e) Overlap the preceding panel by 1-1/2 in. to the line printed around the edge of the panel and identified as "Lap Line".
- f) Place Hydrobar tube in position after the first course of panel is installed. Not required at lagging walls, use waterstop RX 101, refer to manufacturer details and details on drawings.
- g) Treat inside corners on the outside of a wall with a 2 in. thick bead/cant of Bentoseal.
- h) The excavated area may be backfilled immediately and used as a platform in applying succeeding courses of panels. 2 courses may be installed before backfilling.
- i) Install protection board over the panels such as American Colloid "Protection Board for Membrane Waterproofing", or equal at backfill conditions only.

**C. Lagging conditions:**

**1. Surface preparation and installation:**

- a) Where panels will be applied against lagging, gaps between lagging pieces must be no wider than 1/2 in.
- b) Fill gaps exceeding 1/2 in. with sand/cement grout or with 1/2 in. plywood to provide a suitable substrate for panel installation.
- c) Where gaps between lagging are prevalent over large areas, a geotextile such as ACC WCF-200 may be used on the surface of the lagging. Provide sufficient containment for panels after concrete is placed.
- d) Use washer-head nails to securely fasten geotex-tile to the lagging.
- e) Treat tieback rods and plates with Bentoseal around the anchor bolt and plate. After removal of the tieback rods, install Waterstop RX 101 around perimeter of the tieback block-out against the Volclay panels in strict accordance with the manufacturers details and written instructions. Shotcrete contractor shall grout the block-out after Waterstop RX 101 is installed with high strength non-shrinking grout, free of void pockets.

- f) Trowel Volclay Bentoseal around all tieback plates and bolts as part of surface preparation prior to installing panels. Install panels after surface preparation is complete.
- g) Attach panels with flutes and printing horizontally. Install an additional layer of Volclay panels at tiebacks.
- h) Continue panel installation up the edge of the slab and up the lagging for approximately 10 in. above the top of each slab, where panels have already been installed.
- i) Lap this and each subsequent panel over the preceding by 1-1/2 in.
- j) After the first concrete lift is cast, inspect the exposed section of panels remaining exposed, to provide the overlap for the next pour, for damage before placing panels for the next lift.
- k) Replace damaged panels or repair with Bentoseal applied in a minimum 1/4 in. layer to damaged areas.
- l) Lap subsequent courses, with flutes horizontal, over the preceding panels by 1-1/2 in. with joints staggered as specified for free-standing wall installation.
- m) Protect panels from rain by draping a sheet of polyethylene over them prior to placing concrete. Remove polyethylene just prior to concrete or shotcrete placement. If water is seeping between the lagging, place a layer of polyethylene against the lagging prior to installation of panels to channel water away from panels.

2. Pour joint treatment:

- a) Extend panels a minimum of 10 in. beyond the end of a pour to insure adequate surface area for overlap of the next course.
- b) Waterstop RX 101 is required in all pour joints as specified in Sections 03300 and 03361

D. Underslab installation:

1. Application:

- a) Overlap panels 1-1/2 in. to the lap line printed on the panels. Stagger lap points.
- b) Nail panels in position after placement to hold them in position during installation of steel reinforcement and concrete pouring.

2. Pour joints:
  - a) Extend panels 6 to 8 in. beyond pour joints.
  - b) Drive stakes through the extended panels when forms are set up. Fill holes when stakes are removed with Volclay Bentoseal or dry granular bentonite panel material.
  - c) Overlap and cover the holes made by the stakes with panel cut to fit.
  - d) Nail panels to substrate.
  - e) Remove the forms for the pour joint and continue panel installation. Place Waterstop RX against the first pour and secure with adhesive and/or concrete nails so it is not displaced prior to, or during concrete placement.
  
3. Edge of slab at free-standing wall:
  - a) Continue panel installation up the form for a minimum of 8 in. or continue to the top of the form when the installation reaches form for the outer edge of the slab.
  - b) Bend panels to a sharp 90 degree angle to maintain close contact with the substrate and the inside of the form.
  - c) When form is removed, the exposed portion of the panel turned-up at the edge of the slab may be overlapped to continue the vertical installation.
  - d) Form a trough and fill with dry bentonite to contact the underslab installation if panels become torn along the lower edge of the slab. Seat the vertical panel on the edge of the slab into dry bentonite.
  
4. Edge of footing against soldier beam and lagging:
  - a) Where soldier beams and lagging are used at the outside perimeter as outside wall forms, the installation of Bentonite panels shall lap below the top of footing by 6" to 1'-0". Lagging will not be installed below the top of footing as approved by Geotechnical Engineer. Additional layers of Bentonite panels and Volclay Bentoseal shall be applied to this 90 degree corner as required to establish a waterproof seal.

5. Penetration through slabs:
- a) Waterproof penetrations through slabs, such as pipes, ducts, etc., by cutting panels for a snug fit around the penetration.
  - b) Liberally wet the edges of the panels cut across the flutes to form bentonite gel.
  - c) Apply Volclay Bentoseal around the penetration and out onto the panel surface after fitting around the penetration filler.
  - d) Embed Waterstop RX 101 in Bentoseal Fillet.

END OF SECTION

**SECTION 07175**

**WATER REPELLANT SEALER**

**PART 1 - GENERAL**

- 1.01 DESCRIPTION: Division 1 applies to this Section. Provide water repellant and anti-graffiti sealers treatment as indicated, specified and required.
- A. **Work In This Section:** Principal items include:
1. Inspection of surfaces.
  2. Water repellant sealer on following unpainted exterior surfaces:
    - a) Concrete except walking surfaces.
    - b) Plaster/EIFS.
    - c) Exposed concrete unit masonry.
  3. Anti-Graffiti sealer applied to all surfaces within 10 feet of exterior finish grade, except glass, aluminum widow mullions, and finish metals (bronze or stainless steel).
- B. **Related Work Not In This Section.**
1. Painting.
- 1.02 DEFINITION: The term "waterproof" shall mean resistant to penetration of water from driving rain under normal weather conditions of the area. The term "anti-graffiti" shall mean the protection of all substrates including paints against graffiti penetration with a clear colorless membrane. The membrane is hard, durable, and able to be cleaned many times before recoating is indicated.
- 1.03 QUALITY ASSURANCE:
- A. **Manufacturer's Supervision:** Start sealer application under supervision of the sealer manufacturer. Notify manufacturer at least 72 hours prior to starting application.
- B. **Preliminary Tests:** Sealer manufacturer and the Subcontractor for Work of this Section shall make tests on each kind of surface to be treated to establish the actual application rates required to waterproof and anti-graffiti involved surfaces and meet warranty requirements. On field mock-up panels, test that sealers do not darken, mottle, or discolor treated surface and that surfaces to be treated are dry. Established application rates must not be less than those recommended in the sealer manufacturer's technical data for the kind of material surfaces.
- 1.04 SUBMITTALS: Refer to Section 01300 for procedures.

- A. **Samples and Data:** Submit Samples of the sealer accompanied by manufacturer's technical data application instructions, and recommended coverage rates for types of surfaces to be treated, and evidence that sealers conform to all requirements specified.

1.03 QUALITY ASSURANCE:

- A. **Manufacturer's Supervision:** Start sealer application under supervision of the sealer manufacturer. Notify manufacturer at least 72 hours prior to starting application.
- B. **Preliminary Tests:** Sealer manufacturer and the Subcontractor for Work of this Section shall make tests on each kind of surface to be treated to establish the actual application rates required to waterproof involved surfaces and meet warranty requirements. Tests shall demonstrate that sealer does not darken, mottle, or discolor treated surface, compatibility with joint sealant, and that surfaces to be treated are dry. Established application rates must not be less than those recommended in the sealer manufacturer's technical data for the kind of material surfaces.

1.04 SUBMITTALS: Refer to Section 01300 for procedures.

- A. **Samples and Data:** Submit samples of the sealer accompanied by manufacturer's technical data application instructions, and recommended coverage rates for types of surfaces to be treated, and evidence that sealers conform to all requirements specified.
- B. **Subcontractor:** Submit written evidence that Subcontractor for the Work of this Section is skilled and experienced in application of type required, with a list of previous projects successfully treated by Subcontractor with sealer of the type specified.
- C. **Certificate and Summary Statement:** Prior to completion of Work, submit a certificate signed by Contractor and Subcontractor for Work of this Section that sealers applied conform to approved submittals and all requirements specified; in the certificate include a summary statement giving following information:
  - 1. Number of square feet of each surface treated with sealer, classified as to kind of material treated, open pore or closed pore type, and whether vertical or horizontal.
  - 2. The number of gallons of each type, class or grade of sealer required to treat all involved surfaces calculated on basis of number of square feet of each kind and orientation of material classified above and in accordance with results of preliminary tests specified above.
  - 3. Total gallons of sealer type, class or grade actually applied.

1.05 PRODUCT DELIVERY: Deliver all sealer materials to site in containers bearing name and batch number of manufacturer, with seals intact.

1.06 JOB CONDITIONS



- A. **Protection:** Install temporary coverings and protection, and do not allow sealer to contact plastic, planting soils, plants, asphaltic paving, roofing membranes, or other materials damaged by sealer.
  - B. **Weather Conditions:** Do not apply sealer during windy, wet, or excessively hot or dry weather conditions.
- 1.07 **WARRANTY:** Refer to Section 01740. The Contractor and Subcontractor shall jointly and severally warrant that repellant sealer treated surfaces will remain waterproof and free of water intrusion for at least 2 years, and that they will immediately repair and correct any deficiencies or leaks that appear in the treated surfaces during the warranty period at no cost to Owner. Sealer manufacturer shall warrant to furnish all sealer materials required to correct leakage that appears within 5 years from Date of Substantial Completion at no additional cost to Owner. Leakage caused by structural cracking or movement are excepted from the warranty.
- 1.08 **ANTI-GRAFFITI WARRANTY:** This warranty is for five years from date of application. The surface film will not peel nor chip. Exceptions: destruction of membrane due to cleaning, damage due to structural cracking, vandalism and acts of God. This warranty is for replacement of material necessary to repair damaged surfaces and does not include labor. The sealer must withstand 4 to 5 cleanings before surface must be resealed.

## PART 2 - PRODUCTS

- 2.01 **SEALER MATERIALS:** Furnish sealer materials conforming to the requirements specified herein, manufactured by Ven-Chem Inc., P.O. Box 3186, Santa Barbara, California 93105, (213) 342-1195 or (805) 967-7600, or an equal pre-approved as a substitution in accordance with Section 01600. Dilution of sealer at the site is not allowed. Paint thinner may be stored at site for cleaning of tools only.
- A. **Organo Silane Type Sealer:** Clean non-silicone wax-free organo-silane type polymer solids dissolved in a water-base solvent, type that does not darken or discolor treated surfaces, non-toxic, compatible with all standard polymer type caulking and sealing materials, meeting local AQMD requirements, and certified by sealer manufacturer as suitable to receive all oil, alkyd, or water based paint finish, "Deep-Seal" by Ven-Chem Inc., or pre-approved equal as specified above.
  - B. **Water Based Anti-Graffiti Sealer:** Clean water based blend of polymers which contain no petroleum based solvents, type that does not darken or discolor treated surfaces, non-toxic, compatible with all standard polymer type caulking and sealing materials, conforming to all local AQMD requirements and is certified by sealer manufacturer, "Super-Kote A-G-Five" by Ven-Chem Inc., or ProSoCo, Inc. Stand-Off Graffiti as specified above. Los Angeles City approval numbers are R1422 for Ven-Chem and R25079T for ProSoCo.

## PART 3 - EXECUTION

- 3.01 INSPECTION: Refer to Section 01400, Article "Verification of Conditions", and report to Architect in writing conditions that prevent or interfere with the correct preparation of surfaces and application of sealer.
- 3.02 PREPARATION: Remove dust, dirt, oil, grease, other deleterious substances and stains, and efflorescence or laitance from surfaces. Repair cracks or holes over 1/16" size. Spot prime cracks and holes 1/16" size and smaller and prime all horizontal surfaces other than soffits with a heavy duty sealer supplied by same sealer manufacturer. Mask and protect adjoining surfaces and glass unless sealer is harmless and easily removed.
- 3.03 APPLICATION: By experienced mechanics using methods and spray equipment recommended by sealer manufacturer, after surfaces to be treated are dry.
- A. **Application Rates:** Apply sealer in one or more coats as required, in the quantity of sealers, and coverage rates per coat established by preliminary tests except total quantity not less than the rate recommended for the involved surface in manufacturer's technical data.
- B. **Spray Application:** Apply sealer coat by an airless spray using nominal 20 psi nozzle pressure. Obtain complete coverage of coat. Indicate to the General Contractor areas that are coated when application is stopped for lunch or at end of the day.

END OF SECTION

SECTION 07201

FACADE INSULATION & FIRESAFING

1.00 GENERAL

**1.01 DESCRIPTION:** Division 1 applies to this Section. Provide facade insulation and firesafing as indicated, specified and required.

**A. Work in this Section**

1. Perform all work required to complete the Facade Insulation and Firesafing indicated by the Contract Documents. Furnish all supplementary items and back up support as necessary for its proper installation.
2. **If required,** the Exterior Wall Subcontractor is responsible for the coordination of insulation work at laboratory mock-up per mock-up drawings and in same manner as will be used on project. **See Section 01450 for scope.**
3. Obtain all necessary permits, variances, inspections and approvals as required by the City of Los Angeles.
4. Furnish and install a complete and continuous vapor barrier on the inboard side of wall insulation to prevent flow of warm humid air from building interior to exterior wall components.
5. This work shall be included in the single point responsibility by the Exterior Wall Subcontractor.

**B. Related Work Not in this Section**

1. Fixed Windows: Section 08500.
2. Exterior Glass and Glazing: Section 08800.
3. Facade Sealants: Section 07901.
4. Facade Stonework: Section 04400.

**1.02 CODES AND STANDARDS**

**A.** The facade insulation work, except as otherwise shown or specified shall comply with the minimum requirements of the latest edition of the following codes, specifications and standards. Where conflicting requirements arise, follow the more stringent.

1. Uniform Building Code, 1991 edition.

2. American Society for Testing and Materials Annual Book of Standards (ASTM).
3. American Architectural Manufacturers Association (AAMA)
4. Los Angeles Building Code, latest edition.
5. Nation Fire Protection Association (NFPA).
6. American Society of Heating, Refrigerating and Air-Conditioning Engineers, Inc. (ASHRAE).

**1.03 PLANS AND SPECIFICATIONS**

- A. The character of these requirements is intended to provide a performance type specification for the design, fabrication, and installation of the exterior wall insulation work. The Exterior Wall Subcontractor is responsible for the engineering and design of all components and materials as well as the fabrication, installation and performance of the facade insulation and firesafing in the wall system.

**1.04 SUBMITTALS**

- A. Submit shop drawings showing each type of insulation indicating manufacturer, location, extent, material, method of fastening.
- B. Submit five (5) samples of each type of insulation, size 12" x 12", and adhesives and fasteners of each type to be used with manufacturer's printed instructions.

**1.05 DELIVERY, STORAGE AND HANDLING**

- A. Deliver materials to the job site in original unopened packages, clearly marked with product brand name and manufacturer's labels. Store under cover and protect from weather and construction activities. Damaged or deteriorated materials shall be removed from the premises.

**1.06 WARRANTY**

- A. Furnish a written guarantee to the Contractor stating that all material and workmanship for this section has been performed in accordance with the manufacturer's recommendations to provide a continuous thermal barrier and are guaranteed against defects for a period of five (5) years after completion and final acceptance of work. Defects due to faulty material or workmanship developed during the guarantee period will be satisfactorily repaired or replaced by the Exterior Wall Subcontractor at his expense.

**2.00**            **PRODUCTS**

**2.01**            **ACCEPTABLE MANUFACTURERS**

- A.     Material manufactured by any of the following manufacturers is acceptable, provided it complies with the Contract Documents.
1.     United States Gypsum Company.
  2.     Fibrex, Inc.
  3.     Manville

**2.02**            **MATERIALS**

- A.     Mineral Wool Wall Insulation shall be spun mineral wool fibers faced with reinforced aluminum foil vapor barrier, UL rated flame spread less than 25 and smoke developed less than 5, with density of 8 pcf, 2" thick, k-value of 0.27 and a "U" value of 0.11.
- B.     Insulation shall be retained by use of fastening devices which are mechanically retained. Adhesive fasteners will be accepted, only at precast areas. Adhesive fasteners will not be accepted at glass spandrel areas or metal panel areas. Use only fire resistive and water resistant adhesives.
- C.     Insulation shall be installed with the least number of pieces possible. If piecing must occur, all joint spans in excess of 24" shall have aluminum or galvanized steel back-up support members with retainers.
- D.     Vapor tape to be Foil/Scrim/Kraft facestock coated tape coated on one side with a rubber based adhesive protected by a bleached kraft release liner. Reinforcing scrim arranged in a tri-directional pattern. Tape to be FasTape 0821 by Fasson or architect approved equal.
- E.     Firesafing at slab edge shall be "USG Thermafiber Safing" or architect approved equal. Provide a minimum of 4" vertical thickness or as required, held in place by impaling "Z" clips at a maximum of 24" on center. Friction fit between slab and insulation is not acceptable. The fire safing dimensions for span from slab to exterior wall system dimension shall not exceed 8".
- F.     Where spandrel insulation runs vertically past the floor slab edge and where the horizontal span exceeds 24", an aluminum or galvanized steel back-up stiffener shall occur within 4" of the firesafing location. If the spandrel insulation top edge terminates less than 8" above the floor slab surface and is retained, the horizontal aluminum or galvanized steel stiffeners may be omitted.
- G.     Loose Fill Insulation shall be in-core type, lightweight, water repellent free-flowing, non-toxic, non-combustible, non-settling, inorganic vermiculite, ASTM C516-80, Type II material.
- H.     Formed 22 gauge galvanized steel closure angle at underside of slabs if gap is larger than 8" from slab edge to mineral wool insulation plane.

**3.00 EXECUTION**

**3.01 EXAMINATION**

- A. Examine the areas and conditions where building insulation is to be installed and notify the Construction Contractor of conditions detrimental to the proper and timely completion of the work. Verify that adjacent materials are dry and ready to receive insulation. Do not proceed with the work until unsatisfactory conditions have been corrected by the Construction Contractor in a manner acceptable to the Architect.

**3.02 INSTALLATION**

A. General

1. Comply with manufacturer's instructions for the particular condition of installation in each case and as shown on the approved shop drawings. If printed instructions are not available, or do not apply to the project conditions, consult the manufacturer's technical representative for specific recommendations before proceeding with the work.
2. Extend insulation full thickness as shown over entire area to be insulated. Cut and fit tightly around obstructions, and fill voids with insulation. Remove projections which interfere with placement.
3. Apply a single layer of insulation to the required thickness, unless a double layer is required, to make up the total thickness shown.
4. Set vapor barrier faced units with vapor barrier to inside of construction, except as otherwise shown. Do not obstruct ventilation spaces. All joints at vapor barriers shall be sealed with 4" wide, foil faced scrim reinforced tape to prevent vapor and air migration.
5. Tape joints and ruptures in vapor barriers, using the **Foil/Scrim/Kraft face stock coated tape** specified above, and seal each continuous area of insulation to surrounding construction so as to ensure a continuous vapor barrier.
6. Where insulation is impaled on stick clips, provide clips not less than 3" from corners or edges and not more than 12" o.c.
7. Install per manufacturer's printed directions fasteners 12" o.c. each way. Use adhesive as specified herein per fastener manufacturer's recommendations. Mechanical retaining devices cannot be adhered to the glass or metal panels.
8. Insulation shall be secured in place so that it remains at least 3/4" away from any adjacent surface of glass, stone or metal panel.
9. Furnish a horizontal spandrel support member at the floor line to resist insulation coming in contact with spandrel glass or stone, or metal panel due to pressure exerted by firesafing material. **The glass manufacturer shall approve the "air space" between the glass inboard face and insulation.**

- B. Install wall insulation with edges closely butted, with joints square, straight and in alignment (not staggered), and with aluminum foil facing on warm side of building, and with exposed faces flush and in the same plane without warp or twist. Cut and fit insulation to closely fit intersecting or penetrating surfaces. Seal joints between insulation, between insulation and intersecting or penetrating surfaces and between insulation and perimeter surfaces with 4" wide vaporproof aluminum colored tape applied on the aluminum foil facing side. Seal fastener punctures with aluminum colored vaporproof mastic or use tape used for sealing joints. Provide insulation at all locations required to meet the overall thermal resistance requirements of the exterior wall.
- C. Firesafing shall be installed between slab and insulation. Insulation and firesafing shall not contact the glass spandrels, or the back face of precast concrete panels when installed in its final form. All firesafing shall be supported by metal "Z" clips at 24" O.C. maximum.
- D. Firesafing and insulation shall not be allowed to get damaged or wet. Any wet or damaged insulation or firesafing shall be replaced.
- E. All vertical aluminum framing members that run continuous past floor slabs shall be protected with 2" (1 HR) of firesafing between window head and underside of floor slab edge firesafing. Provide a minimum of 3' vertical dimension.

### 3.03

#### INSPECTION

- A. Insulation shall be installed so it does not interfere with the condensation removal system of the exterior wall.
- B. Do not proceed with interior finish work until the vapor barrier has been inspected to insure that all joints have been taped and all punctures or tears are sealed. Obtain written certification from Construction Contractor that inspection is complete and repairs have been approved.

**END OF SECTION 07201**





SECTION 07210

BUILDING INSULATION

PART 1 - GENERAL

- 1.01 DESCRIPTION: Division 1 applies to this Section. Provide building insulation as indicated, specified, and required.
- A. Work In This Section:
1. Thermal batt insulation.
  2. Safing insulation.
  3. Rigid board type insulation in walls where scheduled, indicated, or required.
- B. Related Work Not In This Section:
1. Insulation above roof decks.
  2. Sound insulation in interior partitions.
  3. Insulation for mechanical systems.
  4. Curtain wall insulation specified in Section 07201.
- 1.02 SUBMITTALS: Refer to Section 01300 for procedures. Submit insulation and prong anchor manufacturers' printed specifications and installation instructions.

PART 2 - PRODUCTS

- 2.01 MATERIALS
- A. **Thermal Batt Insulation:** ASTM C665, Type III (foil faced), labeled flame spread of 25 or less per ASTM E84 where exposed or required by Code, R-19 (foil faced) under roof decks and R-11 in walls unless other R values are indicated, batts with flanges for use under roof decks and friction-fit batts for use in studs and metal framing. Type II batts with kraft facing may be used if enclosed by incombustible finish materials provided such batts and usage are approved by Building Department.
- B. **Hanger Wires:** (Use to anchor insulation to underside of metal decking). Minimum 12-gage galvanized annealed steel wires with matching retainer washers.
- C. **Safing Insulation:** UL approved, incombustible, by USG or approved equal, with Code approved galvanized steel closures, clips, and ties to secure insulation and conform to Code.
- D. **Rigid Board Insulation:** Owens-Corning Fiberglass CW225FRK thermal insulation labeled flame spread of 25 or less per ASTM C612-83, thickness indicated. Foil faced or not as indicated on drawings or required for proper installation.

**PART 3 - EXECUTION**

- 3.01 **INSTALLATION OF BATTS:** Install batts with close fit, free of gaps, holes, or sagging. Maintain nominal 3/4" air space between insulation and interior wall or ceiling finish. Supplement the installation with wire ties, adhesive, spindle anchors, or staples to prevent sagging. Provide spindle anchors where shown or necessary in accordance with manufacturer's instructions, including required setting time, spaced at maximum 12" centers in both directions.
- A. Metal Framing:** Provide friction-fit batts, tightly fitted to stud webs and to metal furring.
- B. Roof Decks:** Install hanger wires through metal decking. Wires to be installed prior to concrete roof deck pour. Wires to have "pig-tail" spiral loop to prevent withdrawal. Install foil-faced flange-type batts secured with prong anchors and staple flanges together at 4" centers. Seal all stapled flanges and the joints at abutting vertical surfaces with pressure-sensitive plastic tape, forming a continuous vapor barrier. Provide 18 gage galvanized string wires under batts where necessary to prevent sagging, stretched taut.
- C. Walls:** Provide thermal batt insulation at all walls as indicated and at exterior curtain wall areas not insulated per Section 07201.
- 3.02 **SAFING INSULATION:** Pack indicated voids and other voids as required by Code, and secure with metal closures, clips, and ties according to Code.
- 3.03 **INSTALLATION OF RIGID INSULATION:** Installation boards in maximum feasible sizes with close fit, free of gaps, fasteners to be located with 4" of corners and spaced at not more than 12" centers along edges and in the field and ensure boards form a continuous vapor barrier.

END OF SECTION

**SECTION 07240**

**INSULATION AND FINISH SYSTEMS**

**PART 1 - GENERAL**

1.01 DESCRIPTION: Division 1 applies to this Section. Provide field applied acrylic finish STO System, complete as indicated, specified, and required.

**A. Work In This Section. Principal items include:**

1. EIFS system including woven glass fiber fabric embedded in plaster veneer base, finish plaster coating with integral color and texture.
2. Caulking and accessories for finish system.
3. Exterior cementitious sheathing.

**B. Related Work Not In This Section:**

1. Metal studs and framing.
2. Flashing and sheet metal.
3. Painting, if integral color not selected.

1.02 QUALITY ASSURANCE:

**A. Requirements of Regulator Agencies:**

1. The system shall be approved by Los Angeles City Research Report for Projects in the City of Los Angeles.

**B. Qualifications:**

1. Manufacturer shall have marketed this acrylic finish system in the United States for at least five years.
2. The applicator shall be experienced and competent in the application of plaster materials and shall have completed a minimum of 5 projects of similar size and scope.

**C. Design and detailing:**

1. General: For use on wall and soffits only.
2. Sheathing substrate system:
  - a) Deflection of substrate systems shall not exceed  $L/360$ .
  - b) Substrates shall be straight and true to 1/8" in 10' minimum.
  - c) Waterproof paper shall be installed behind sheathing.
  - d) Sheathing shall be fastened to studs with rust-proof screws.
  - e) Where the surface area requires the use of more than one sheet, joints between the boards must be firmly attached and tightly abutted.

- f) Where sheathing terminates, edge shall be cut back from adjoining material a minimum of 1/4" to form a caulk joint and sealed.
  - g) Where sheathing terminates, all edges of sheathing shall be sealed with trim or backwrapped with mesh and ground coat.
  - h) Expansion joints are required at a minimum of 150 square feet at building expansion joints where substrates change and where significant structural movement occurs.
- 3. The trained applicator shall verify that the proposed substrate is acceptable to the applicable regulatory authorities prior to application of the system.
  - 4. Substrate system shall be engineered with regard to structural performance.
  - 5. Follow manufacturer's published details and specific recommendations.

1.03 SUBMITTALS: Refer to Section 01300 for procedures.

- A. **Shop Drawings:** Submit covering all Work of this Section. Show terminations expansion joints and interface with other materials.
- B. **Samples:** Obtain Architect's color and texture instructions and submit a 12" by 12" sample of each color and texture required.
- C. **Site Samples:** After preliminary approval of the above samples, apply samples on the building for final approval. Site samples shall extend from roof to top of parapet where indicated by Architect, sample to be constructed as required for actual installation, and shall include one expansion joint. Prepare as many site samples as are required for approval. Approved site samples shall remain in place and govern all other installations.
- D. **Manufacturer's Directions:** Submit system manufacturer's long form specifications and operation instructions, modified as required by conditions indicated and specified.
- E. **City of Los Angeles Research Report.**
- F. **Applicator training certificate, signed by manufacturer.**

1.04 **PRODUCT DELIVERY, STORAGE, AND HANDLING:** Deliver manufactured materials in original unopened packages, containers, or bundles with manufacturer's label in tact and legible. Keep materials dry until ready to be used. Store off the ground, under cover, and away from sweating walls and other damp surfaces. Store at temperature not less than 38 degrees F. Remove wet or deteriorated materials from site.

1.05 **JOB CONDITIONS.** Protect surrounding areas and surfaces to preclude damage during application of system. Protect finish work when stopping for the day or when completing an area in order that water will not penetrate behind the insulation or finish. Ambient air temperature shall be at 40 degrees F or greater and rising at the time of installation of the system and shall remain at 40 degrees F or greater for at least 24 hours after application.

1.06 **WARRANTY:** Refer to Section 01740. Furnish a written warranty against all defects in materials and/or water tightness of the work of this section for a period of five (5) years. Warranty for caulking under this section in accordance with Section 07900.

## PART 2 - PRODUCTS

- 2.01 MATERIALS: All as supplied by or approved by STO Industries, Inc. or prior approved equal.
- A. **Cementitious Sheathing:** Aggregate portland cement board with polymer-coated, woven glass-fiber mesh embedded in front and back surfaces.
1. Thickness: 1/2" unless otherwise indicated on the drawings.
  2. Size: 4' wide x 8' long.
  3. Faces: Smooth on one side, coarse on other side.
  4. Edges: Formed, smooth, reinforced edges; square cut ends.
  5. Weight: 3 pounds per square foot maximum.
  6. Flexural Strength: 1000 psi minimum per ASTM C 947.
  7. Water Absorption: 10% by weight maximum; 24 hour per ASTM C 948.
  8. Nail Pull Resistance: 125 pounds minimum, 0.4" head diameter, wet or dry, per ASTM C 473.
  9. Freeze/Thaw: 100 cycles with no deterioration per ASTM C 666 Procedure A.
  10. Flame Spread Smoke Developed: 5, 0 per ASTM E 84.
- B. **Reinforcing Mesh:** Fabric shall be STO armor mat heavy reinforcing fabric at least 44 grams per square yard coated to be alkaline resistant.
- C. **Ground Coat:** STO Flexyl - a hydrostatic waterproofing ground coat.
- D. **Primer:** Acrylic-based primer with silica sand. Tinted to match color of finish.
- E. **Exterior Finish:** STO finish acrylic coating in texture matching approved Architects sample and installed site sample.
- F. **Caulking Materials:** Use the following caulking and sealant materials; no substitutions. Use colors matching the approved samples.
1. Sealant: Tremco Inc. "Dymeric" 3-part polyepoxide urethane sealant or Pecorea "Dynatrol II" sealant conforming to Fed Spec TT-S-00227E, Class A, Type III. Include primer as recommended by sealant manufacturer.
  2. Joint Filler: Dow Chemical, "Ethafoam" or as recommended by sealant manufacturer.
  3. Bond Breaker: 3-M Corp., 226, 481, or 710 or as recommended by sealant manufacturer.
  4. Sealant Mixing: Conform to label directions.
- G. **Miscellaneous Materials:**
1. Screws: ASTM C646, corrosion-resistant self-tapping bugle-head spiral threaded type, minimum 1" long, lengths to penetrate all supporting metal at least 3/8". Furnish specially hardened type screws for supports heavier than 25 gage.
  2. Trim: Exterior grade vinyl or zinc trim pieces.

- a) J-Bead - Vinyltech CB-1-25 for 2 layers of 5/8" Type X sheathing or equal Vinyltech 200-58 for 1 layer of cementitious sheathing or equal.
  - b) Expansion Joint - Vinyltech 2027-16 or equal.
  - c) Corner Bead - as required for straight corners - Vinyltech 1 or equal.
- H. **Cement:** Type I portland cement meeting ASTM C150.
- I. **Water:** Clean and potable.
- J. **Mixing and Preparation:**
- 1. Ground Coat: Mix 1/2 bath at a time by 22-1/2 pounds cement to 1/2 pail ground coat in a clean mixing pail. Mix with a clean, rust-free, high speed electric drill mixer. Allow to set approximately 5 minutes, adjust mix if necessary, then remix to a uniform consistency.
  - 2. Primer and Finish: Using a clean, rust-free high speed mixer, stir to a uniform consistency.

### PART 3 - EXECUTION

- 3.01 INSPECTION: Refer to Section 01400, Article "Verification of Conditions", and report to Architect in writing those conditions that prevent or interfere with correct installation of Work of this Section.
- 3.02 INSTALLATION OVER FRAMING: Conform to approved submittals, system manufacturer's directions, specifications, and requirements herein.
- A. **J-Bead:** Install J-bead at level base line, butting trim tightly together.
  - B. **Cementitious Sheathing:** Install into J-bead with long edges vertical with end joints staggered and centered on furring channels, except with long edges horizontal with end joints triggered and centered on studs where applied directly to studs. Screw fasten according to code approval for the systems and sheathing manufacturer's recommendations. Hold sheathing back minimum 1/4" from dissimilar materials to create a caulk joint.
  - C. **Expansion Joints:** Break sheathing as shown on drawings or required by manufacturer.
  - D. **Trim:** Install at expansion joints and board termination edges to seal board edges and install corner bead to corners as required to create true, straight corners.
  - E. **Base Coats:**
    - 1. All joints between sheathing shall be taped with a 9" wide strip of mesh embedded in ground coat. Trim flanges shall be embedded and fastener heads shall be coated with ground coat. The ground coat shall be feathered into the field at the edges to eliminate the noticeability of taping, trim edges and fasteners and allowed to dry fully.

2. Using approved spray equipment or stainless trowel, apply 1/8" coating of ground coat over entire field. Trowel smooth to achieve a plane that is true and plumb to within 1/16" in 10'. Allow to dry. A skim coat may be required if using a finish with aggregate size 1.0 mm or smaller.

F. **Using a brush or roller**, apply primer to dry ground coat. Allow to dry.

G. **Exterior Finish:** Using clean stainless steel trowel, apply tight coat of the finish directly to the reinforced coating. Upon completion, surfaces shall be uniform in texture with no telegraphing of joints in cementitious sheathing or mesh. Exactly match the approved site samples.

3.03 **CAULKING:** Provide as indicated and as required for properly completed and watertight installations. Conform to sealant manufacturer's instructions.

A. **Preparation:** Clean joint spaces of all deleterious substances and dry. Remove soil, grease, and temporary protective coatings.

B. **Priming:** After proper cleaning, apply primer and allow to fully dry before applying sealant.

C. **Sealant Application:**

1. Joint depth for sealant shall not exceed the width of joint from 1/4" to 3/8" wide. For joints larger than 3/8" wide, depth of joint shall be no more than 3/8". In no case shall the joint sealant applications be less than 1/4" wide and 1/4" deep.
2. Apply sealant with a gun with proper size nozzles. Use sufficient pressure to fill all voids and joints solid to the back-up material. Surface of sealant shall be a full smooth bead, free of ridges, wrinkles, sags, air pockets and embedded impurities. After joints are completely filled, neatly tool to eliminate air pockets or voids, and to provide a smooth neat appearing finish and intimate contact with joint substrates.

END OF SECTION





## SECTION 07255

### CEMENTITIOUS FIREPROOFING

#### PART 1 - GENERAL

- 1.01 **DESCRIPTION:** Division 1 applies to this Section. Provide spray applied cementitious fireproofing as indicated, specified, and required.
- A. Work In This Section:** Principal items include:
1. Cementitious fireproofing.
- 1.02 **SUBMITTALS:** Refer to Section 01300 for procedures.
- A. Manufacturer's Instructions:** Submit copies of the manufacturer's specifications for fireproofing materials and application methods, with copies of Code, ICBO, and UL approvals and City of Los Angeles Research Report approval.
- B. Certification:** Upon completion, the Contractor shall inspect sprayed fireproofing and deliver to Architect a written certification that installed materials and workmanship conform to Specifications.

#### PART 2 - PRODUCTS

- 2.01 **MATERIALS:** Cementitious fireproofing, certified to be 100% free of containments, nominal dry density of a minimum average of 15 pcf, published average bond strength of 200 psf, minimum individual bond strength of 150 psf per ASTM E736, minimum 1000 psf compression strength per ASTM E761, maximum .005 grams psf air erosion per ASTM E859, maximum 15 cc abrasion resistance and 6 cc impact penetration per City of San Francisco test method, UL listed 0 flame spread and 0 contribution and smoke development per ASTM E84 test, W.R. Grace & Co. "Monokote" MK-6 CBF or approved equal. Deliver materials in original factory containers bearing manufacturer's name, identification, UL approval label, and date verifying material is current. Store in a dry place until used. The material shall conform to EPA and all other applicable governmental regulations. Provide "Hardkote" protective coating conforming to ICBO Report 4607 (L.A.R.R. 24924) consisting of 1/8" thick spray applied mixture of one part gypsum and either 3 parts sand or one part monokote, where required, including all parking areas.

#### PART 3 - EXECUTION

- 3.01 **APPLICATION:** Conform preparation of surfaces, mixing, and application to the manufacturer's instructions, UL, ICBO, and Building Code approvals. Thicknesses shown are for Building Department review only; increase thickness as required to provide fire resistance ratings meeting Code requirements based on material actually installed, at no extra cost to Owner.
- A. Fireproofing:** Apply fireproofing to those thicknesses providing approved fire protection as shown or required by Code.

- B. Coordination:** Coordinate application with adjoining Work. Apply before ducts, pipes, boxes, conduits, and like items are installed and after hangers, supports and steel framing for these items are secured to steel members.
- C. Defective Work:** Fireproofing which becomes loose or is damaged during course of construction shall be corrected by fireproofing applicator. Cost of repairs for damage caused by other trades shall be borne by trade causing damage, with no additional cost to Owner.

3.02 FIELD QUALITY CONTROL: Refer to Section 01400. Before application of the fireproofing, the Testing Laboratory shall inspect condition of the substrates and issue a report of required corrections to Architect. Upon completion of the installation, Testing Laboratory shall inspect fireproofing and furnish to the Building and Safety Department a certificate attesting to the correct material, thickness, and coverage of the fireproofing material for fire ratings required and for compliance with UBC Standard No. 43-8. The certificate shall include the following types of information:

Section 43.802	Application conforms to manufacturer's instructions.
Section 43.803(b)	Condition of substrate (condition of the protected member).
Section 43.803(d)(f)	Thickness on columns, beams, and floors complies.
Section 43.804	Density of the material.

3.03 CLEANING: After the completion of fireproofing work, application equipment shall be removed. Except as detailed, walls, floors, and other surfaces are to be left in a scraped clean condition.

END OF SECTION

**SECTION 07270**

**FIRESTOPPING**

**PART 1 - GENERAL**

- 1.01 **DESCRIPTION:** Division 1 applies to this Section. Provide firestopping and smoke seals as indicated, specified, and required.
- A. Work In This Section:** Principal items include:
1. All openings in fire-rated floors and walls both empty and those accommodating penetrating items such as cables, conduits, pipes, ducts, etc.
  2. Head of wall openings between walls and connecting floors or roof assemblies.
  3. Expansion joints in fire-rated walls and floors.
  4. Openings at each floor level in shafts or stairways.
  5. Curtain wall openings between walls and connecting floor slabs.
- B. Related Work Not In This Section:**
1. Documents affecting work of this Section include, but are not necessarily limited to, General Conditions, Supplementary Conditions, and Section in Division 1 of these Specifications.
- 1.02 **QUALITY ASSURANCE:** Firestopping materials shall conform to ratings as per ASTM E814 (UL 1479). The ratings must be a minimum of one hour, but not less than the fire resistance rating of the assembly being penetrated. Fire tests shall be conducted with a minimum positive pressure differential of 0.03" of water column. Materials must be listed by one of the following agencies: ICBO, Calif. State Fire Marshal or have and LA Research Report.
- 1.03 **SUBMITTALS:** Refer to Section 01300 for procedures.
- A. Product Data:** Within 35 calendar days after the Contractor has received the Owner's notice to proceed, submit:
1. Materials list of items proposed to be provided under this Section.
  2. Manufacturer's specifications, test data, and other data required to provide compliance with the specified requirements.
  3. Manufacturer's recommended installation procedures which, when approved by the Architect, will become the basis for accepting or rejecting actual installation procedures used on the Work.
- 1.04 **PRODUCT HANDLING:** Protect the materials of this Section before, during and after installation, and protect the work and materials of all other trades. In the event of damage, immediately make replacements and repair to the approval of the Architect.

## PART 2 - PRODUCTS

### 2.01 FIRESTOPPING

**A. Manufacturers:** Where firestopping or smoke seals are called for on the Drawings or as specified herein, provide materials manufactured by one (1) of the following manufacturers:

1. Dow Corning Corp., P.O. Box 0994, Midland, Michigan 04864, (517) 496-4000.
2. 3M Contractor Products, St. Paul, MN, (800) 328-1687.

**B. Materials:** All materials shall restrict the transmission of temperature as well as the passage of flame, smoke and water. Materials shall be tested under ASTM E814 (UL 1479) and pass tests.

1. Firestop Mortar: Single component Portland cement/fly ash mortar. Requiring no support or anchoring devices to pass water hose stream tests.
2. Firestop Sealant: Single component silicone sealant, use gun grade for walls and overhead. Use self leveling for floor applications. Intumescent, endothermic sealant, caulk or mastic.
3. Firestop Sleeve: Fabricated sleeve, collar or boot used around plastic pipe and other penetrations in fire-rated floors and walls.

## PART 3 - EXECUTION

3.01 SURFACE CONDITIONS: Examine the areas and conditions under which work of this Section will be performed. Correct conditions detrimental to timely and proper completion of the Work. Do not proceed until unsatisfactory conditions are corrected.

3.02 PREPARATION: Prepare the surface in accordance with approved manufacturer's recommendations.

3.03 APPLICATION: Apply the approved product to the designated surfaces in strict accordance with the manufacturer's recommended application procedures as approved by Architect.

END OF SECTION

**SECTION 07550**

**ELASTOMERIC ROOFING**

**PART 1 - GENERAL**

1.01 DESCRIPTION: Division 1 applies to this Section. Provide elastomeric roofing as indicated, specified and required.

A. **Work In This Section:** Principal items include:

1. Surface preparation.
2. Protection of adjacent surfaces and clean-up.
3. Samples and supporting technical data.
4. Urethane rubber roofing system.

B. **Related Work Not In This Section:**

1. Concrete substrates.
2. Caulking and sealing except as specified herein.

1.02 QUALITY ASSURANCE

A. **Inspection:** The work will be inspected and test cuts taken by a professional member of the Institute of Roofing and Waterproofing (800) 837-4792 or Roofing Consultants Institute (919) 859-0742 approved by the owner having a minimum of 10 years experience as a roofing consultant with supervision and inspection expertise. Consultant to regulate the quality of the work so that it conforms to the contract documents and to order discontinuance of any operation in non-conformance. Consultant to submit a written report to the Architect upon completion of the work.

B. **Qualifications of Subcontractor:** Employ elastomeric roofing system manufacturer or manufacturer's authorized applicator to prepare surfaces and install all the elastomeric roofing systems required under this Section.

C. **Manufacturer's Participation:** At least 35 days before application of any fluid-applied elastomeric roofing, Contractor shall notify elastomeric manufacturer in writing, with a copy delivered to Architect, of requirements of this Section pertaining to the elastomeric manufacturer's obligations to either install the elastomeric roofing systems or designate an approved applicator, to inspect completed roof and to execute specified certificate, and to execute the specified warranty. Elastomeric roofing manufacturer shall respond in writing to the Contractor and Architect acknowledging acceptance of these obligations and responsibilities with respect to the Work of this Section, and Work of this Section shall not be installed until Architect has received such written response free of exceptions or qualification. As used in this Section, the term "manufacturer" includes the elastomeric manufacturer's technically qualified factory representative who is legally empowered to execute required certificate and warranty for manufacturer.

- D. **Requirements of Regulatory Agencies:** Provide systems that comply with governing AQMD rules and regulations and that bear a UL Class A or better label or listing.
- E. **Pre-Installation Conference and Inspection:** After approval of submittals but prior to starting installation of Work of this Section, the Contractor shall hold a meeting at the site attended by representatives of the Owner, Architect, Contractor, and the Earthwork, Concrete, Masonry, Roofing, Waterproofing, Landscaping, Mechanical, and Electrical Subcontractors, and a technical representative of the roofing material manufacturer to describe in detail roofing system to be installed and to establish agreement, coordination, and responsibilities among involved trades. Contractor shall prepare a detailed memo of this meeting and furnish copies to the Architect and all involved trades. The Roofing Subcontractor and material manufacturer's technical representative shall inspect the substrates to receive Work of this Section and report defective conditions to the Architect and Contractor for correction; refer to Article "Verification of Conditions" in Section 01400.

1.03 SUBMITTALS: Refer to Section 01300 for procedures.

- A. **Technical Data:** Submit material manufacturer's technical preparation, and application data with copies of Code approval for each of the materials and systems proposed for use.
- B. **Samples:** Submit samples for each system in designated colors, showing texture and colors for approval. After selection, submit 12" square samples of complete systems on cement asbestos board, with 2" wide strips showing each undercoat.
- C. **Quality and Experience:** Submit a typed list of at least five installations, including Owner's name and addresses, on which the materials and systems proposed for use have been in satisfactory service for at least three years.
- D. **Applicator's Qualifications:** Submit written evidence that manufacturer will install coatings or that applicator is licensed and approved by manufacturer and has a minimum of two years' experience in successfully applying this same or similar materials.
- E. **Certificate:** Upon completion, the Contractor and manufacturer's representative shall jointly inspect elastomeric coating and deliver to Architect a written certification that installed materials and workmanship conform to Specifications.

1.04 PRODUCT DELIVERY: Deliver materials in unopened factory labeled containers with seals unbroken, labels intact and bearing date of manufacturer and brand names.

1.05 JOB CONDITIONS

- A. **Existing Conditions:** Refer to Section 01400 regarding verification of conditions. Coordinate with related trades and verify that concrete surfaces are correctly finished, water or cured as per manufacturer's recommendations and are dry. Notify Architect in writing of any conditions that prevent proper installation of coatings for corrections. Application of first coat of any system indicates the acceptance of the surface for warranty

purposes. This requirement does not relieve Contractor and applicator from responsibility for proper preparation of surfaces.

- B. **Protection:** Install temporary coverings and protection to prevent staining or marring of surfaces not to receive coatings. Keep traffic off membranes until fully cured and hardened. Cover traffic areas with heavy non-staining building paper or plastic sheeting and prevent damage during following construction operations.

- 1.06 **WARRANTY/GUARANTEE:** Contractor and manufacturer jointly and severally shall furnish to Owner a written warranty/guarantee against defects in material and workmanship for three years covering a waterproofing performance of the systems for the entire warranty period and responsibility for ruptures caused by cracking of the substrates up to 1/16" in width.

## PART 2 - PRODUCTS

- 2.01 **ELASTOMERIC COATING:** Work of this Section is based upon Multi-I-Thane Systems 4556-75 mils of Multi-Chemical Products, Inc., South El Monte, California. Approved equivalent systems by Neogard may be acceptable, subject to Architect's approval. Refer to Section 01600 regarding substitutions. The following system establishes intended type and quality.

### 2.02 MATERIALS

- A. **Caulking Components:** MC-283 or MC-284, two component polyurethane compounds.
- B. **Flashing:** Uncured Neoprene 60 mils minimum and/or as recommended by the coating manufacturer. Color compatible with roofing color in areas exposed to view.
- C. **Primer:** MIP-607CAL epoxy-polyamide, low viscosity, clear primer/sealer.
- D. **Base Membrane:** Multi-I-Thane 4000 single component, moisture-cured polyurethane membrane.
- E. **Elastomeric Membrane:** Multi-I-Thane 5000 single component, moisture-cured, elastomeric polyurethane.
- F. **Weather Resistant Top Coating:** Multi-I-Thane 6000 single component, abrasion-resistant and weather-resistant polyurethane membrane.
- G. **Aggregate:** Shall be equal to or finer than #3 Monterey Sand. Aggregate shall be hard and stable to atmospheric conditions. Where foot traffic is anticipated, finer aggregates shall be used.
- H. **Color:** Custom color as selected by Architect.

## PART 3 - EXECUTION

3.01 **PREPARATION:** Comply with system manufacturer's directions. Broom, sandblast, acid etch and rinse, mechanically clean, or perform other cleaning operations as necessary to produce clean sound dry surfaces in correct condition to receive coatings.

- A. **Cracks** over 1/16" in width shall be routed out to 1/8" minimum in width and depth and filled flush with elastomeric sealant.
- B. **Joint Depth Regulation:** Apply backing into all expansion and control joints after cleaning and preparation but prior to the coating installation.
- C. **Prior to Commencing** with the application, all surfaces to be coated shall be dry and free from any surface contaminants or cleaning residues. Wash and protect all adjacent areas not to be coated.
- D. **Flashing:** All required flashing shall be installed as recommended by the coatings manufacturer.

3.02 **APPLICATION OF MEMBRANES**

- A. **Primer:** Apply at a rate of 300 s.f. per gallon, within 16 hours of application of the primer, the base coat must be applied. If the base coat cannot be applied within 16 hours then reprime.
- B. **Base Membrane** shall be spray or trowel applied in one uniform coat at the rate of one gallon minimum per 50 square feet, or as needed in order to obtain a minimum thickness of 26 dry mils. Allow a minimum of 24 hours curing time before applying the next coat.
- C. **Elastomeric Membrane** shall be spray or trowel applied in one uniform coat at the rate of one gallon minimum per 50 square feet, or as needed in order to obtain a minimum thickness of 26 dry mils. Allow a minimum of 24 hours curing time before applying the next coat.
- D. **Elastomeric Membrane** shall be spray or trowel applied in one uniform coat at the rate of one gallon per 40 square feet, as needed in order to obtain a minimum thickness of 13 dry mils. Immediately and uniformly broadcast aggregate into the wet coating at the approximate rate of 15 to 20 pounds aggregate per 100 square feet. Allow the coating to cure a minimum of 24 hours before the next coat.
- E. **Top Coats** shall be spray or roller applied at the rate of one gallon minimum per 100 square feet to obtain a minimum thickness of 10 dry mils.
- F. **Thickness:** The minimum overall average dry film thickness of the completed waterproofing system shall be an average of 75 mils, exclusive of aggregate.
- G. **Double Top Coat** shall be provided as indicated, 6 feet in width along parapets.



3.03      COMPLETION: Remove temporary protective coverings. If surfaces adjoining coatings are stained and cleaning is not acceptable, remove affected Work and provide new Work conforming to applicable requirements as directed, at no extra cost to Owner.

END OF SECTION



**SECTION 07600**

**SHEET METAL**

**PART 1 - GENERAL**

1.01 **DESCRIPTION:** Division 1 applies to this Section. Provide sheet metal items as indicated, specified, and required.

**A. Work In This Section:** Principal items include:

1. Sheet metal flashings in connection with roofing.
2. Reglet and counterflashing assemblies.
3. Miscellaneous metal flashing and counterflashing as required, except where provided by mechanical and electrical trades.
4. Coping caps.
5. Prefabricated curbs.
6. Roof hatch.
7. Drip flashings.
8. Scuppers.
9. Downspouts.
10. Pitch pockets.
11. Shop priming and field touch-up.
12. Caulking.

**B. Related Work Not In This Section:**

1. Sheet metal in connection with Plumbing, Air Conditioning, and Electrical.
2. Metal accessories for drywall, lathing, and acoustical treatments.
3. Finish painting.
4. Sleeves for embedded items.
5. Metal decking.

1.02 **QUALITY ASSURANCE:** Drawing details and requirements herein govern. Conform to the current "Architectural Sheet Metal Manual" published by Sheet Metal and Air Conditioning Contractors National Association, Inc. (SMACNA), 1611 North Kent Street, Arlington, VA 22209 for conditions not indicated or specified and for general fabrication of sheet metal items.

1.03 **SUBMITTALS:** Refer to Section 01300 for procedures.

**A. Shop Drawings:** Submit for fabricated sheet metal showing details, methods of joining, anchoring and fastening, thicknesses and gages of metals, concealed reinforcement, expansion joint details, sections, and profiles.

**B. Samples and Product Data:** Submit samples and data for materials or assemblies as Architect may request.

## PART 2 - PRODUCTS

### 2.01 BASIC MATERIALS

- A. **Galvanized Steel:** ASTM A525, coating G90, mill phosphatized for paint adhesion, 24 gage minimum unless otherwise indicated or specified.
- B. **Solder:** ASTM B32, B284.
- C. **Solder Flux:** Standard brand non-corrosive acid-base type.
- D. **Fasteners:** Zinc or cadmium coated steel or stainless steel.
- E. **Felt:** ASTM D226, 15-pound type.
- F. **Primer:** Approved brand of zinc-dust zinc-oxide primer per Section 09900 with manufacturer's pretreatment materials.
- G. **Sealant:** Conforming to Section 07900.

### 2.02 RELATED MATERIALS

- A. **Reglets and Counterflashings:** Fry Reglet Corp. flashing systems complete with unions and preformed corners of necessary types for particular locations as detailed, or 24-gage galvanized steel, as approved by the Architect, by Metco Metal Products Co., Pacific Loxtite Flashing Co., National Cornice Works, Redco, Lane-Air, or equal. Use single manufacturer's products throughout, equivalent to Type CO at concrete, Type MA at masonry, Type ST at plaster, or Type SM, as required by Drawings and details.
- B. **Roof Hatch:** Single leaf unit having 12" high curb of minimum 14 gage galvanized steel with integral deck flange and integral cap flashing of the same metal and gage, welded corners, and insulated with 1" thick fiber glass rigid insulation; cover of 14 gage galvanized steel with minimum 3" beaded flange, neatly welded, insulated with 1" thick fiberglass rigid insulation; insulation covered with a 22 gage galvanized liner; complete with zinc-coated hardware including heavy pintle hinges, enclosed counterbalancing and hold-open mechanism, a snap latch with turn handles, padlock lugs inside and outside, and neoprene or equal draft seals. Provide standard products of Bilco, Dur-Red, Babcock-Davis, or equal.

- 2.03 **GENERAL FABRICATION REQUIREMENTS:** Fabricate to avoid distortion and overstress of fastenings due to expansion and contraction. Provide expansion joints where necessary in continuous runs of sheet metal, constructed watertight and spaced 30 feet apart maximum. Lock and solder corners and blind hem exposed edges. Make joints with 4" lap and solder unless otherwise shown or specified. Fill single lock seams with sealant where soldering is not feasible. Extend flanges 4" minimum onto roof and wall surfaces or as detailed. Fabricate sheet metal items in nominal 8-foot lengths unless otherwise shown or specified.

- A. **Soldering:** Do soldering slowly, immediately after application of flux, seams showing evenly flowed solder. Clean and neutralize finished soldering.
- B. **Shop Priming:** Clean completed items, apply pretreatment, and prime all exposed surfaces with specified primer.

2.04 FABRICATED ITEMS: Of 24-gage galvanized steel except as otherwise indicated or specified.

- A. **Coping Caps:** Corner units having maximum 18"-long lets and joints locked and soldered watertight, intermediate joints at maximum 8 foot centers and equally spaced. Make intermediate joints of the flush-buttet type, edges spaced about 1/4" apart and centered over an 8"-long backing plate of same profile with gage as the cap, set in a 1/2"-wide bead of sealant. Secure both edges with 1-1/2"-wide 20-gage galvanized steel cleats spaced at maximum 32" centers and locked into drip hem.
- B. **Drip Flashings:** Hemmed exposed edges, 1-piece lengths.
- C. **Scuppers:** All joints locked and soldered watertight, flanges extending at least 4" into roofing, outer edges hemmed.
- D. **Downspouts:** All joints riveted and soldered tight or filled with sealant, all galvanized. Provide 1/4" mesh balloon strainers at all downspout outlets. Provide covered expansion joints midway between outlets.
- E. **Pitch Pockets:** Of 20 galvanized, joints locked and soldered watertight.

### PART 3 - EXECUTION

3.01 GENERAL INSTALLATION REQUIREMENTS: Install metal items as indicated, according to approved submittals, and as required to complete the Work. Securely fasten and assemble, and make watertight and weathertight.

- A. **Coordinate Sheet Metal Items** in connection with roofing for proper installation, and furnish in sufficient time to avoid delay in roofing construction. Install roofing sheet metal simultaneously with roofing.
- B. **Caulking:** Provide sealant caulking as indicated and required to seal and complete Work of this Section. Conform to Section 07900.
- C. **Isolation:** Isolate sheet metal from contact with concrete or masonry with one layer of roofing felt, except embedded items.
- D. **Miscellaneous Items:** Provide miscellaneous flashings as shown and required to complete entire project, except for items provided under other sections. Use 24-gage galvanized steel unless otherwise directed.

MTA Headquarters  
Los Angeles, California  
#91-400

12/07/93  
Sheet Metal  
07600 - 4

3.02      COMPLETION: Examine installed sheet metal, water test if necessary or directed, and correct damaged or defective items.

END OF SECTION

## SECTION 07900

### CAULKING AND SEALANTS

#### PART 1 - GENERAL

- 1.01 **DESCRIPTION:** Division 1 applies to this Section. This Section covers caulking of openings and joints indicated, specified, and required to make the entire building weatherproof and watertight, covers caulking requirements for the entire Work, and pertains to any Section requiring caulking, unless specified otherwise.
- 1.02 **QUALITY ASSURANCE:** Employ a specialist caulking contractor having not less than 5 years experience in caulking installations of size and complexity required for the work. Prior to award of any subcontract for caulking, submit qualifications and project history of the proposed Caulking Subcontractor, including bid price information. If proposed Caulking Subcontractor is not approved, provisions of the General Conditions will apply.
- 1.03 **SUBMITTALS:** Refer to Section 01300 for procedures.
- A. Samples and Date:** Submit the following:
1. Samples of cured sealants showing full range of designated colors; obtain color instructions from Architect prior to submittal.
  2. Technical data by manufacturers of proposed materials.
  3. Material manufacturers' printed preparation and application instructions; when approved, furnish copies to other trades.
- 1.04 **PRODUCT DELIVER:** Deliver caulking and sealant materials in unopened factory-labeled containers, each label bearing statement of conformance to standards specified for each material.
- 1.05 **WARRANTY:** Refer to Section 01740. Furnish a written warranty against defects in materials for 5 years and defects in workmanship for 2 years, covering all loss of adhesion or cohesion, deterioration, color changes, leaking, and other defects.

#### PART 2 - PRODUCTS

- 2.01 **MATERIALS:** Furnish sealants meeting following in-service requirements: Normal curing schedules are acceptable; non-staining, color fastness (resistance to color change), and durability when subjected to intense actinic (ultra-violet) radiation are required. Furnish the products of only one manufacturer unless otherwise approved, sealant colors as selected to match the adjoining surfaces; special colors may be required.
- A. Sealant and Primer:** Non-sagging one-part sealant meeting requirements of Fed. Spec. TT-S-00230C(2), "Sealing Compound; Elastomeric Type, Single Component", or Fed. Spec. TT-S-00543A, "Sealing Compound, Silicone Rubber Base", with sealant manufacturer's recommended primer. Non-silicone self-leveling sealant may be furnished for joints in horizontal surfaces.

- B. Exception:** Furnish multi-component non-tracking sealant with Shore "A" Hardness range of 40 to 55 where subject to foot or vehicle traffic, meeting or exceeding requirements of Fed. Spec. TT-S-0027E(3), "Sealing Compound, Elastomeric Type, Multi-Component".
- C. Backing Material:** Type approved by sealant manufacturer as both physically and chemically compatible with primer and sealant. Oakum, jute, cotton tape, and vegetable base materials are not acceptable. Furnish uncoated untreated fibrous glass rope or polyethylene, vinyl, silicone, or urethane-type polymer sponge or tubing, medium to firm density, not containing oil, butyl, asphalt loading, or neoprene. For bond breaker, use polyethylene film or tape, or aluminum foil.

### PART 3 - EXECUTION

- 3.01 **INSPECTION:** Refer to Section 01400. Inspect surfaces and joints to be caulked. Report to Architect in writing all conditions that prevent correct preparation, priming, and caulking installation.
- 3.02 **PREPARATION AND PROTECTION:** Conform to sealant manufacturer's published instructions. Apply materials to clean, dry surfaces free of grease, oil, wax, or other matter that destroys or impairs adhesion. Remove lacquer and like coatings on aluminum contacting sealants. Protect all adjoining surfaces and apply temporary masking tape on both sides of joints where surface staining may occur. Provide bond breaker to prevent bonding of sealant to backing materials wherever joints exceed 1/2" width, or joint width is shown or required to exceed depth. Prime surfaces as required by manufacturer's instructions.
- 3.03 **APPLICATION:** Do not exceed 3/8" sealant depth unless specifically dimensioned. Minimum joint width is 1/8" for metal-to-metal joints and maximum 3/4" width elsewhere unless otherwise shown. Apply all sealant under sufficient pressure to fill voids. Finish exposed joints smooth and flush with adjoining surface unless recessed joints are shown. Remove temporary masking as soon as joint is completed.
- 3.04 **CLEANING:** Clean material from surfaces not to receive sealant and restore the finish as required. If surfaces adjoining joints are stained and cleaning is not acceptable, remove the affected Work and provide new Work as directed and approved, at no extra cost to Owner.

END OF SECTION



SECTION 07901

FACADE SEALANT

1.00 GENERAL

**1.01 DESCRIPTION:** Division 1 applies to this Section. Provide facade sealant as indicated, specified and required.

**A. Work in this Section**

1. Perform all work required to complete the joint preparation, joint packing, priming, caulking and sealing indicated by the Contract Documents and furnish all supplementary items necessary to completely seal the joints in the facade such as those joints in the Curtain Wall and Fixed and Operable Windows, using approved sealant technique, with weeps or vents as required at the dual lines of defense. **Dual lines of defense shall mean a primary weather seal, and secondary water control and removal system.** Furnishing and installing of sealants and backer rods for mock-up test and visual mock-up specimens is also included as part of this work.
2. This work shall be included in the single point responsibility by the Exterior Wall Subcontractor.

**B. Related Work Not in this Section**

1. Fixed Windows: Section 08500.
2. Exterior Glass and Glazing: Section 08800.
3. Facade Insulation and Safing: Section 07201.
4. Facade Stonework: Section 04400.

**1.02 QUALIFICATIONS**

- A. The character of these requirements is intended to provide a performance type specification for the design selection and installation of the exterior wall sealants. The Exterior Wall Subcontractor is responsible for the design selection and installation of the sealants, as well as the performance of the sealant system.
- B. Except as otherwise indicated, joint sealants are required to establish and maintain airtight and waterproof continuous seals on a permanent basis, with recognized limitations of wear and aging as indicated for each application. Failures of installed sealants to comply with this requirement will be recognized as failures of materials and workmanship.

- C. Engage a single firm to assume undivided responsibility for sealing all components of the exterior facade. This firm must demonstrate not less than 5 years successful experience in installation of work similar to the work of this project. Credentials and data must be submitted to Architect for review and approval.
- D. The manufacturer of sealants used for exterior caulking is to provide additional on-site testing by authorized personnel, in addition to the sealant tests specified in herein, to assure materials are suitable for the application, have not suffered detrimental loss of shelf life, and will be fully covered by the Warranty in event of failure or staining of the sealed components including stone.
1. Method(s) of testing to be at manufacturers option.
  2. Provide testing as follows:
    - a. Between 24 and 72 hours prior to initial application.
    - b. Prior to use of each new shipment of materials.
    - c. Not less than twice a month for existing stored materials.
    - d. At any time when storage conditions have exceeded manufacturer's recommended limits.
  3. Manufacturer and Exterior Wall Subcontractor to submit log of testing, on company letterhead for each test performed indicating, but not limited to the following:
    - a. Date
    - b. Project identification
    - c. Sealant identification including name, type and batch number
    - d. Test performance, i.e., acceptable, marginal, not acceptable
    - e. Storage conditions
    - f. Signature of person conducting test
- E. If tests that indicate sealant material is marginal or not acceptable it is not to be used. Tester to immediately notify Architect and Construction Contractor. The Exterior Wall Subcontractor is to immediately remove materials from site.
- F. Manufacturer of sealants for exterior building enclosure to provide instruction to the Exterior Wall Subcontractor foreman and mechanics, and **General** Contractor on proper installation techniques required to achieve maximum life and weather tightness from the sealant installation. Special emphasis to be directed to practices required to avoid staining or other changes in appearance of sealed components

such as stone in the completed work, and to the installation of the dual lines of defense.

- G. All materials and workmanship shall be subject to inspection by the Architect at all times. Such inspections do not relieve the Exterior Wall Subcontractor from obligations to provide a water tight and weather tight seal at all facade systems, surfaces, and related materials.

#### 1.03 CODES AND STANDARDS

- A. The work of this section shall comply with the latest edition of the following standards. When conflicts arise between standards, the more stringent shall apply.
- B. Federal Specification TT-S - 00230C and TT-S-001543A
- C. Uniform Building Code, 1991 edition
- D. American Society for Testing and Materials
- E. Los Angeles Building Code, latest edition.

#### 1.04 SUBMITTALS

- A. Submit the following information from the manufacturer:
  - 1. Certification in the form of standard data sheet or letter that each type of compound and sealant to be furnished complies with these specifications.
  - 2. Statement that each product to be furnished is recommended for the application shown for this project.
  - 3. Complete instructions for handling, storage, mixing, priming, installation, curing and protection of each type of sealant.
  - 4. Certification in writing that sealant will not cause staining nor change appearance of adjacent substrate materials. **Stain testing must be performed in advance of mock-up or installation work.**
- B. Submit five (5) samples of specified products, 12 in. long and installed between samples of the materials to be sealed for the project. Architect's acceptance will be for color only. Compliance with other requirements is the Exterior Wall Subcontractor's responsibility.
- C. Submit copy of statement, in an approved form, signed by the Exterior Wall Subcontractor and Manufacturer, certifying that the products comply with these specifications and were the proper selections for the applications made, and that the installation methods complied with the manufacturer's printed instructions and their field representatives' verbal instructions and were proper and adequate for the condition of installation and use.

- D. For each type of stone used provide test reports per ASTM E575 on the stone and sealant materials and methods proposed for this project which will demonstrate successful behavior of sealant systems under limiting design stresses with respect to adhesion, compatibility, migration, stability, cohesion, staining, recovering and any other deleterious effects. Provide a procedure detailing the cleaning, priming, taping, tooling and other steps recommended to ensure satisfactory function and appearance.
1. Submit for record only sealant manufacturer's test reports for weather seal silicone adhesion to all relevant substrates. Tests must include **seven day** water immersion after which silicone must have excellent adhesion to substrates **per ASTM C794-94**. Report adhesion strength in terms of shear stress and tensile stress. Test samples shall approximate sealant joint sizes and configurations intended for production materials.
  2. Submit documentation of product performance as required per ASTM C920. Also, perform the same testing but substitute actual job substrate materials in lieu of standard test materials, e.g. in ASTM C510, use job stone samples in lieu of white cement mortar. Long term behavior, under compression shall be tested.
- E. Provide a procedure detailing the cleaning, priming, taping, tooling and other steps recommended to ensure satisfactory function and appearance.
- F. Submit copy of pig-tail type field adhesion tests results as sealant work at each floor is completed.

#### 1.05 INSPECTIONS

- A. Coordinate as required and be totally responsible for the full and satisfactory compatibility and performance between all sealants used under this section with all other applicable and related sections using sealants which may be in direct contact with work of this section or adjacent to the other.
- B. Take all required steps and precautions to properly isolate and prevent any degree of incompatibility between said sealants, all in strict accordance with manufacturer's specifications, recommendations and instructions.
- C. Periodically test sealants in place in addition to the manufacturer's field testing, for adhesion, using methods recommended by sealant manufacturer. Promptly replace any sealant which does not adhere or fails to cure.
- D. **General Contractor** shall arrange to meet the sealant manufacturer at the jobsite and witness initial installation of sealant on the project wall with the Contractor, Architect and other Consultants.

#### 1.06 DELIVERY, STORAGE AND HANDLING

- A. Deliver, store and handle all Sealant Work materials so to prevent deterioration, contamination or damage at all times, per manufacturers recommendations.

- B. Deliver sealant work materials to project site in manufacturer's unopened containers with name, brand, type, grade and color fully indicated thereon.
- C. Do not use materials stored for a period of time exceeding the maximum recommended shelf life of the material.

**1.07 SPECIAL PROJECT WARRANTY**

- A. Submit a written warranty agreeing to repair or replace sealant compounds which have failed to provide airtight and watertight joints **which** have failed in adhesion, cohesion, abrasion-resistance, migration-resistance, stain-resistance, general durability or any other form of apparent deterioration (excluding inherent qualities and limitations clearly specified in the manufacturer's data which was submitted). Period of guarantee shall be twenty (20) years, from date of final payment and acceptance of the work by the Contractor. Guarantee shall be signed by both the Exterior Wall Subcontractor, the **Installer**, and the Sealant Manufacturer. Comply with these specifications for repair or replacement of work.

**2.00 PRODUCTS**

**2.01 ACCEPTABLE MANUFACTURERS**

- A. Materials manufactured by the following manufacturers are acceptable, provided it complies with the contract documents.
  - 1. Dow Corning Corporation
  - 2. Tremco
  - 3. General Electric Company

**2.02 MATERIALS**

**A. Silicone Sealants**

- 1. Medium-Modulus Silicone Sealant, one-part, non acidic, neutral curing, Type S, Grade NS, Class 25, Use NT, capable of withstanding movements from +50 to -50 percent of original joint width. Custom colors to be as selected by Architect to match colors as provided by Architect and used in performance mock-up.
- 2. Primer, as recommended by manufacturer of sealant in writing to the Architect, having been tested for staining and durability on samples of actual surfaces to be sealed.
- 3. Preformed joint filler, nonstaining, compatible with sealant and primer, resilient, closed cell polyurethane foam, free of asphalt, oils or creosote, of size required for the joint width, as recommended by sealant manufacturer in writing to the Architect.

4. Backer rod materials shall be closed cell non-gassing polyethylene foam such as "Cceva Rod" or skinned reticulated open cell, non-gassing, extruded polyolefin foam rod such as "Sof-Rod" as recommended by the sealant manufacturer.
5. Polyethylene tape or other type bond breaker as recommended by the manufacturer of the sealant in writing to the Architect.
6. Cleaning agent recommended by the manufacturer of the sealant in writing to the Architect.
7. All materials shall be delivered in original, unopened containers with expiration date indicated.

### 3.00 EXECUTION

#### 3.01 EXAMINATION

- A. Prior to the installation of sealant, and at the General Contractor's direction, meet at the project site to review the material selections, joint preparations, installation procedures, weather conditions and coordination with other trades. Meeting shall include the Exterior Wall Subcontractor, **Installation Contractor**, **General Contractor**, Architect, manufacturer's representative, and representatives of other trades or subcontractors affected by the sealant installation. Examine sample installations which have been prepared and determine and record whether everyone present is in agreement that the proposed installations are likely to perform as required. Accepted control section shall be standard to which all other sealant work must conform.
- B. Examine the substrates, adjoining construction and the conditions under which the work is to be installed. Do not proceed with the work until unsatisfactory conditions have been corrected. Proceeding with work indicates acceptance of conditions.

#### 3.02 PREPARATION

- A. Clean all joints thoroughly, removing all foreign matter, dust, oil, grease, water, surface dirt, frost, old caulking material and loose or latent materials.
- B. Clean porous materials where necessary by grinding, sand or water-blast cleaning, mechanical abrading, acid washing or combination of these methods as required to provide a clean, sound base surface for sealant adhesion. Clean nonporous surfaces, either mechanically or chemically.
- C. Remove laitance by acid washing, grinding or mechanical abrading. Remove form oils by sand or water-blast cleaning. Remove all loose particles present or resulting from grinding, abrading or blast cleaning by blowing out joints with oil free compressed air or by vacuuming joint prior to application of primer or sealant.

- D. Remove protective coatings on metallic surfaces by a solvent that leaves no residue. Use clean white cloths or lintless paper towels for cleaning with solvent and drying. Clean joint areas protected with masking tape or strippable film with solvent after removal of tape or film. Do not allow solvent to air dry without wiping.
- E. Joint widths, depths, and conditions detailed on shop drawings by related work contractors shall be considered as minimum allowable requirements except where they may conflict with sealant manufacturer's recommendations. In all cases, joints must be uniform in width. Do not seal joints until they are in compliance with drawings, or meet the control section standard.
- F. Clean out and rake to full width and depth, joints to receive sealant, back-up material or preformed joint filler. Make joints of sufficient width and depth to accommodate specified back-up material or preformed joint filler and sealant.

### 3.03 APPLICATION

- A. Follow sealant manufacturer's instruction regarding surface preparation, priming, application life, and application procedure. Consult sealant manufacturer for recommendation for application procedure. Consult sealant manufacturer for recommendation for application of sealant when air temperature is below 40 degrees F., or surface temperatures of sealant contact surfaces are above 120° F.
- B. Apply masking tape, where required, in continuous strips in alignment with joint edge. Remove tape immediately after joints have been sealed and tooled as directed.
- C. Prime surfaces, where required, with primer as recommended by sealant manufacturer. Prime metals where moisture or joint movement occurs. Prime all concrete and masonry surfaces, as required by sealant manufacturer.
- D. Install back-up material or joint filler at proper depth in joint to provide specified sealant dimensions. Compress back-up material 25% to 50% into the joints as required. Do not apply sealant without back-up materials. Install bond breaker strip between sealant and nonrelease type back-up material. Three side adhesion is acceptable only for the sealing at joinery of members that are to be rigidly attached to each other by means of screws or welding restricting all movement.
- E. Install back-up rod stock into the joint to avoid length-wise stretching. Rod stock shall not be twisted or braided. Use bond breaker strip in all joints where sufficient room for back-up does not exist.
- F. Apply sealant under pressure with power actuated gun having nozzle of proper size, or other appropriate means. Provide sufficient pressure to completely fill joints as detailed.
- G. Neatly point or tool sealant to provide proper contour. Dry tool joints. Do not use water-wet tool or tooling solution.
- H. Sealant on face of adjacent stone or other materials will not be acceptable.

- I. At areas with two lines of defense against water penetration, any cavities between sealants to be bridged, weeped and vented at locations designated by Architect. Install zone dam seals between sealant beads to isolate areas of building seals.
- J. Surfaces of joints to be sealed must be dry. Do not attempt sealant work on wet surfaces or where frost is present.

**3.04 FIELD TESTING**

- A. The Facade Sealant Work shall be tested in the field during the testing of the other exterior building facade elements. Area and time of test shall be as per Architect's recommendation. Perform out of sequence or scheduled sealant installation at test areas as necessary and as directed so that the testing of the facade elements can be performed at the specified intervals of erection. **See Section 08500, 1.08.**
- B. Refer to related sections for criteria pertaining to Field testing.
- C. Perform and record results of pig-tail type adhesion tests on at least two different elevations per floor as the work progresses.

**3.05 CLEANING**

- A. Clean adjacent surfaces free of sealant or soil resulting from this work as the work progresses. Use solvent or cleaning agent as recommended by sealant manufacturer. Leave all finished work in a neat, clean condition.
- B. Final cleaning shall be provided by the Exterior Wall Subcontractor.

**END OF SECTION 07901**



SECTION 08110

HOLLOW METAL WORK

PART 1 - GENERAL

1.01 DESCRIPTION: Division 1 applies to this Section. Provide hollow metal doors and frames as indicated, specified, and required.

**A. Work In This Section:** Principal items include:

1. Hollow metal doors, including:
  - a. Door louvers.
  - b. Frames for glazed lights in doors.
  - c. Transom panels (as detailed and/or scheduled).
2. Hollow metal frames.
3. Steel thresholds integral with frames.
4. STC rated hollow metal door and frame assemblies.
5. Bronze metal doors and frames.
6. One sided wood veneer hollow metal stair doors.

**B. Related Work Not In This Section:**

1. Installation of hollow metal doors and frames.
2. Furnishing finish hardware for hinged metal doors.
3. Glazing in hollow metal.
4. Grouting or back-plastering of hollow metal frames.
5. Sheet metal louvers in hollow metal transom openings.

1.02 QUALITY ASSURANCE

**A. Requirements of Regulatory Agencies:** Construct labeled openings in accordance with manufacturer's standard procedures filed with and approved by I.C.B.O. or other acceptable agency. Provide required approval labels on doors and frames.

**B. Tolerances:** Provide hollow metal door and frame assemblies having applicable tolerances per code and labeling approvals and per industry standards.

1.03 SUBMITTALS: Refer to Section 01300 for procedures.

**A. Shop Drawings:** Submit Shop Drawings fully detailing materials, finishes, sizes, profiles, moldings, location of hardware items with reinforcement, and methods for anchoring, assembly, and erection.

**B. Samples:** Submit samples of door panel, edge, and frame corner construction if requested by Architect.

- C. **Product Data:** Submit certified test reports for STC-rated doors and complete shop drawings of the door, seal, frame and miscellaneous hardware.
- D. **Certificate:** Certificate from labeling agency verifying compliance of fire rated door assemblies with schedule and specifications.

## PART 2 - PRODUCTS

2.01 HOLLOW METAL WORK: As supplied by one of the following manufacturers; refer to Section 01600 for substitutions:

1. Overly Manufacturing Co.
  2. Kreiger Steel Products Co.
  3. Steelcraft Manufacturing Co.
  4. Amweld Metal Doors and Frames.
  5. Americraft.
  6. J-Door Company.
  7. Dawson Doors.
- A. **General:** Sizes, types, thicknesses, profiles, details and features indicated for doors and frames govern. In all other respects, provide doors and frames as standard with manufacturer except as specified herein.
  - B. **Hollow Metal Doors:** Flush seamless type, minimum 18-gage steel U.N.O. one-piece face panels, all parts welded and finished flush and smooth. Reinforce face panels with internal welded stiffeners, or bond to a plastic-treated honeycomb core or a foamed plastic core except foamed plastic is not allowed for labeled doors. Fill hollow-core doors with mineral wool material to eliminate all metallic ring. Provide flush top edges of exterior doors. Reinforce the top, bottom, and both edges according to manufacturer's standards. Finish both face panels and all edges smooth and free of distortion. Provide 1-3/4" by 12-gage full-height astragal on active leaf of pairs of doors.
    1. **One-sided Wood Veneer:** Provide wood veneer to match 08210. Finish wood per Section 06200.
    2. **Bronze Doors:** Provide bronze stile doors fabricated from .06 thick min. Muntz Metal, satin finish U.N.O. Doors to be blanked out from one sheet of metal. No welding to be permitted on face of door. All doors to be reinforced for finish hardware. Stile doors to have required stile width with removable glass stops or pocket glazing.
  - C. **Transom Panels:** (When Scheduled). Same construction as the door over which panel is located.
  - D. **Hollow Metal Frames:** Form the stops integral with frames. Reinforce heads over 42" wide with a full-length 12-gage channel. Provide frame anchors as required, not less than 3 anchors per jamb, except 4 anchors for openings over 7'-0" high. Provide galvanized steel plaster guards back of cutouts for hinges or mortised

hardware on frames installed in concrete, masonry, or plaster. Fabricate frames of 14-gage or heavier gage steel if required by UL label requirements.

1. Exterior Frames: Fabricate exterior frames of minimum 16-gage steel U.N.O., welded joints, all exposed welds ground smooth and flush.
  2. Interior Frames: Fabricate interior frames of minimum 18-gage steel, welded joints ground smooth and flush.
  3. Pre-punch and dimple all frames to be set in finished concrete or masonry openings. Coordinate dimple to be sufficient to provide flush surface for flat head anchor bolts.
  4. Bronze Frames: Provided bronze frames fabricated from .09 thick min. Muntz Metal. Frames welded and ground smooth with satin finish U.N.O.
- E. **Louvers:** Door manufacturer's standard inverted chevron steel type for interior doors, stormproof profile type with removable insect screens on interior side for exterior doors and fusible link type as scheduled.
- F. **Glazed Lights In Doors:** Manufacturer's standard steel assembly, one side integral with door and other side equipped with applied steel stops of minimum 20 gage steel, one piece lengths, secured within 3" of ends and at 9" centers with oval-head screws. Provide rated and wire glass as scheduled.
- G. **Hardware Preparation:** Prepare, reinforce, mortise, drill, and tap the doors and frames according to the templates supplied by the hardware supplier, as standard with the hollow metal manufacturer except minimum 10-gage steel behind butts and 12-gage steel for mortised or surface-applied hardware.
- H. **Finish:** Thoroughly clean all surfaces and chemically treat for primer adhesion. Paint inaccessible surfaces before assembling. Sand exposed surfaces of doors, frames, and accessories and fill smooth as required. Apply one baked-on coat of manufacturer's standard rust inhibitive primer, including the interior surfaces of frames.

## 2.02 STC-RATED HOLLOW METAL DOORS AND FRAME ASSEMBLIES

- A. **Provide door manufacturer standard** sound door and frame assembly, including steel sound doors, frames, perimeter seals, hinges, thresholds, and automatic door bottoms (finish to match typical door hardware throughout project).
- B. **The sound transmission** loss of the door shall be certified by a test from an independent acoustical laboratory. The test method shall meet ASTM E90-75 or more recent one for laboratory measurements of airborne sound transmission loss.
- C. **Furnish door assemblies** of S.T.C. rating as noted in the door schedule as follows:
1. STC-48 sound control doors shall be 1-3/4" thick, constructed of steel faces internally braced and reinforced with insulation in the core. Door weight: 12.7 lbs/S.F. minimum.

- a) Acceptable door assembly:
  - 1) Krieger Steel Products Company NC6-16-8848.
  - 2) Overly Manufacturing Company 1 4781 HCHBG.
  - 3) Pioneer Industries Ultra-Sonic F-48.
  
2. STC-35 sound control doors shall be 1-3/4" thick, constructed of 18 gauge steel with a stiffened core of mineral fiber, polystyrene or kraft honeycomb and surface weight of 5.3 lbs/S.F.
  - a) Acceptable door assembly:
    - 1) Krieger Steel Products Company.
    - 2) Pioneer Industries.
    - 3) Aubertin.
    - 4) Mester-Clark International.
    - 5) Curries.
  
  - b) Acceptable seals:
    - 1) Zero - 770 Compress-O-Matic 3001 Series.
    - 2) Pemko - 322 ASN.
    - 3) Reese - 499.
    - 4) National Guard - 1038.
  
  - c) Acceptable thresholds:
    - 1) Pemko - 420 AV.
    - 2) Reese - 372.
    - 3) National Guard - 320.

### PART 3 - EXECUTION

3.01 INSTALLATION: Refer to Division 6, Section 06200.

END OF SECTION

SECTION 08210

WOOD DOORS

PART 1 - GENERAL

- 1.01 DESCRIPTION: Division 1 applies to this Section. Furnish hardwood veneered wood doors as indicated, specified, and required.
- A. **Work In This Section:** Principal items include:
1. Wood doors, including:
    - a) Door louvers.
    - b) Frames for glazing in wood doors.
    - c) Transom panels matching wood doors.
  2. Special flush wood doors.
- B. **Related Work Not In This Section:**
1. Installation of wood doors including hardware.
  2. Hollow metal door frames.
  3. Furnishing finish hardware for wood doors.
  4. Finish painting except for prefinished wood doors.
  5. Glass and glazing.
  6. One sided wood veneer hollow metal doors at stairs.
- 1.02 QUALITY ASSURANCE
- A. **Reference Standard:** Furnish doors conforming to National Wood Window and Door Association (NWWDA) and WIC Standards for Hardwood Veneered Flush Doors unless otherwise required herein.
- B. **Rejected Doors:** Furnish new doors conforming to requirements of this Section as replacements for doors rejected because of damaged surfaces, improper fitting or hardware preparation, or other cause, at no extra cost to Owner. Patching is not permitted for correction of defects.
- C. **Label Service.** Provide where indicated 20 minute labeled pairs of special flush wood doors by Durand conforming with test conducted by Warnock Hersey International Inc., #WHI 495-0443. All doors shall be properly labeled with special Warnock Hersey labels. No metal edges nor metal AST shall be required.
- 1.03 SUBMITTALS: Refer to Section 01300 for procedures.
- A. **Samples:** Submit samples of face veneers and door constructions.
- B. **Certificates:** Submit certificates by manufacturer that doors supplied conform to or exceed requirements of these Specifications.

- 1.04      **WARRANTY:** Refer to Section 01740 for warranty form. Furnish to Owner a written warranty, subject to provisions of WIC and the NWWDA "Standard Door Guarantee", except as modified herein, against all defects in materials and workmanship for the following periods:
- A.      Interior wood doors** - lifetime of the installation.

**PART 2 - PRODUCTS**

- 2.01      **MANUFACTURE:** By one of the following manufacturers; for substitutions, refer to Section 01600.
- A.      Algoma Hardwoods.** (800) 558-8032.
- B.      Buell Door Company.** (800) 556-0155.
- C.      Weyerhaeuser, Cal-Wood Doors.** (707) 584-9663.
- D.      VT Industries, Inc.** (712) 368-4381.
- E.      Weyerhaeuser Co.** (715) 387-6331.
- F.      Eggers Industries, Arch Door Div.** (414) 772-6444.
- 2.02      **SOLID CORE WOOD DOORS:** Hardwood veneered, solid core, 5-ply, conforming to the above-referenced standard and to the following requirements.
- A.      Core:** Staved glued low-density lumber core, or solid particleboard core with minimum 28 pcf density conforming to Type 1, Density C, Class 1 of CS 236, hot press resin bonded.
- B.      Edges:** Minimum total 1-1/18" wide top and bottom rails with minimum 1/2" thick hardwood edge banding, and minimum total 1-3/8" wide stiles with minimum 1/2" thick hardwood edge banding, 1-piece or laminated. Fully bond laminated edge strips together and to core before cross banding is applied. Provide vertical edge banding of species to match face veneers for transparent finished doors.
- C.      Crossbanding:** Minimum 1/16" thick hardwood, extending to four door edges, grain applied vertical and horizontal.
- D.      Face Veneer:** Provide NWMA, plain sliced American Cherry matching approved sample in Architect's offices, for natural finish. Provide "Sound" grade birch where opaque finish is scheduled.
- E.      Adhesives:** Type I or II for cores, crossbanding and face veneers.
- F.      Door Louvers:** Door manufacturer's standard hardwood sightproof louvers complete with removable hardwood frame, fully closing core. Provide louvers of species matching face veneer for transparent finished doors.

- G. **Glazed Light Frames:** Door manufacturer's standard hardwood glass stops, fully closing core. Secure with countersunk oval-head brass or stainless steel wood screws. Provide stops of species matching face veneer for transparent finished doors.
  - H. **Transom Panels** (when scheduled): Same construction as the door over which panel is located.
- 2.03 **LABELED SOLID CORE WOOD DOORS:** Face veneers as specified above, conforming to UL label requirements for the rating scheduled, bearing appropriate UL label on hinge stile.
- 2.04 **SEALING:** Seal all door edges with one or more coats of clear resin sealer at the factory or mill.
- 2.05 **OPTIONAL FACTORY PREPARATION OF DOORS:** Wood doors may be prefit and premachined for hardware at factory or mill.
- A. **Prefitting:** Prefit doors in accordance with referenced NWWDA and WIC standard except as otherwise detailed, lock stiles beveled to conform to hardware. Apply clear resin sealer on edges after sizing.
  - B. **Hardware Preparation:** Prepare doors to receive hardware, including mortises for butts, locksets, concealed closers, and all other door hardware furnished under Section 08710. Obtain templates from hardware supplier. Coordinate placement with the metal frame supplier so that doors and frames are properly fitted and equipped when installed, 3/64" maximum tolerance allowed in placing hardware.
  - C. **Seal** all mortises and cutouts with clear resin sealer.

**PART 3 - EXECUTION**

- 3.01 **INSTALLATION:** Refer to Division 6, Section 06200.

END OF SECTION





**SECTION 08335**

**COILING DOORS**

**PART 1 - GENERAL**

- 1.01 DESCRIPTION: Division I applies to this Section. Provide coiling metal doors as indicated, specified, and required.
- A. **Work In This Section:** Principal items include:
1. Coiling steel service door.
  2. Labeled coiling steel service door.
  3. Coiling Aluminum Grille.
- B. **Related Work Not In This Section:**
1. Structural supports for doors.
  2. Finish painting.
  3. Electrical services and wiring.
- 1.02 SUBMITTALS: Refer to Section 01300 for procedures. Submit Shop Drawings with Product Data covering all Work of this Section.
- 1.03 JOB CONDITIONS: Verify all measurements and field conditions at site prior to submittal of Shop Drawings and fabrication.

**PART 2 - PRODUCTS**

- 2.0 MANUFACTURE: Specifications are based on the products of the Cookson Company to establish intended types and qualities. Equivalent products of Mahon, Lawrence, Kinneer, Cornell, Jim Walter Doors, Overhead Door Corp., J. G. Wilson, Windsor, or Pacific Rolling Doors are acceptable. All motor operator assemblies to be rated for "heavy use" conditions.
- 2.02 MOTOR-OPERATED SERVICE DOOR: Cookson Type FCM with Model 13 or Model 21 motor operator as required by door size and gage, correct operator mounting for site conditions and equipped with an emergency chain operator, and No. 4 galvanized bonderized steel slats. Equip with end locks, galvanized steel guides and hood, all operating and counterbalancing devices, and "Detectedge" device on bottom bar. Furnish keyed-alike pushbutton station for each door and 3 keys. Include complete weatherstripping and wind locks for exterior doors.
- 2.03 LABELED CHAIN-OPERATED SERVICE DOOR: Cookson Type FD-2 and UL Label of class indicated, No. 4 galvanized bonderized steel slats, with end locks, galvanized steel guides and hood, manual chain operation, operating and counterbalancing devices, bottom bar angles, wind locks and weatherstripping for exterior door, automatic closing activated by a magnetic release, 160 degree fusible link.
- 2.04 MOTOR-OPERATED ALUMINUM GRILLE: Cookson Type FMG as shown or required, Model 13 or Model 21 motor operator as required by grille size, correct operator mounting for the site

conditions and equipped with an emergency chain operator, heavy link G5015, curtain (unless otherwise selected by Architect) with self-activating concealed lock, a tubular bottom bar, and extruded aluminum guides with wear strips. Provide keyed-alike pushbutton station with 3 keys for each grille. Provide finish as selected by Architect. The into after-hours controls per plans as occurs.

- 2.06 ELECTRICAL COMPONENTS AND CONTROLS: Provide electrical items conforming to Code and UL Bulletin 325, including constant pressure down circuit unless the door is equipped with a conforming door safety device.
- 2.07 FACTORY PRIMING: Provide door manufacturer's standard gray baked metal primer on galvanized surfaces and operating devices to be field painted.
- 2.08 SAFETY DEVICE: Provide an electrically-activated sensor mounted on the bottom bar of all doors and grilles to automatically stop and reverse the door/grille travel when it hits an object in its path prior to touching the floor. Connecting electrical cable must retract with the door/grille when it opens.

### PART 3 - EXECUTION

- 3.01 INSTALLATION: Employ an authorized representative of manufacturer to install Work of this Section in accordance with manufacturer's printed recommendations and approved submittals. Produce secure completed installations that operate freely without bind or stoppage. Touch-up damaged or abraded primed surfaces after erection.

END OF SECTION

SECTION 08500

FIXED WINDOWS

1.00 GENERAL

**1.01 DESCRIPTION:** Division 1 applies to this Section. Provide glazed fixed windows as indicated, specified and required.

**A. Work in This Section:** Provide all labor, materials, necessary equipment and services necessary to complete the fixed windows as indicated on the drawings, as specified herein or both, including but not necessarily limited to the following.

1. Submittal of bid proposal scope drawings.
2. The complete heavy commercial (HC) fixed windows as indicated, detailed, specified and shown in final shop drawings.
3. All interior and exterior aluminum trim members, window head and sill gutters for secondary water and condensation removal.
4. All glass and glazing of above components. See Exterior Glass and Glazing Section 08800 for requirements.
5. Internal sealants, or caulking, joint fillers and gaskets in conjunction with above components. See Facade Sealant Section 07901 for requirements.
6. Anchorage on above components, including but not limited to pre-set embeds in structural concrete, bracing, kickers, and reinforcing as required. (Other trades to install pre-set embeds.)
7. Support systems required for insulation around perimeter of windows. See Facade Insulation Section 07201 for requirements.
8. Furnish and install glazing on performance mock-up. The Exterior Wall Subcontractor shall be responsible for coordination of all trades and for the preparation of a single mock-up drawing showing and detailing the scope of the combined mock-up components.
9. Coordination of chamber construction with laboratory shall be the responsibility of the Exterior Wall Subcontractor. Testing of mock-up to be conducted at an independent testing laboratory, approved by General Contractor and Architects. Laboratory fees for specified tests to be paid for by the Owner.
10. Bronze clad aluminum frames where indicated.
11. Aluminum panels and louvers.

12. Provision for replacement reglazing of vision lites from the interior.
13. All necessary steel or aluminum members where required to strengthen and/or reinforce aluminum members, including any reinforcements for the aluminum panels.
14. All vents, weeps, weep tubes, bellows, baffles, closures, end dams, gutters, flashings, trim as shown or as may be required in conjunction with the fixed windows or to join the fixed window system to adjacent construction.
15. Shop drawings, engineering calculations, erection drawings, samples, mock-up drawings, and conformance testing, as required.
16. Field testing for water leakage per AAMA 501.2.
17. Protection and cleaning as defined herein.
18. Window design shall be such that two lines of defense can be installed at the perimeter. **Two lines of defense shall mean a primary weather seal and a secondary water control and removal system.**
19. Visual mock-ups, furnish and install.
20. Any permits, variances and controlled inspection for wall system as required by the City of Los Angeles.
21. No attic stock of any materials is required.

**B. Related Work not in This Section**

1. Exterior Glass and Glazing: Section 08800.
2. Facade Sealant: Section 07901.
3. Facade Insulation: Section 07201.
4. Facade Stonework: Section 04400.
5. Window Washing Systems: Section 11014.
6. Aluminum Louvers: Section 10200.
7. Exterior Wall Laboratory Mock-Up Testing: Section 01450.
8. Steel Frame Support System for Stone Veneer: Section 05130.

- C. The Fixed Window contractor shall be referred to as the Exterior Wall Subcontractor in these specifications. The Exterior Wall Subcontractor shall be the single point of responsibility for the entire envelope of the project.

**1.02 QUALIFICATIONS**

- A. Engage a single firm to assume undivided responsibility for fabrication and installation and total coordination all components of the fixed window work. This firm must demonstrate not less than 5 years successful experience in fabrication and installation of work similar to the work of this project. The work of this section shall be performed by a contractor, who is regularly engaged in the engineering,

fabrication, finishing, installation, of similar work in connection with the fixed windows.

- B. The Sub-Contracting of any work included hereunder is specifically prohibited, except for that which may be accepted by the Architect in writing prior to award of the contract.
- C. The **General Contractor** and the Architect reserve the right to visit the fabricating and manufacturing facilities of the approved Fixed Window Contractor, any approved sub-contractor or material supplier, and the accepted testing laboratory at any time when the work is in progress. All shop and field materials and workmanship shall be subject to inspection by the Architect or his representatives at all times. Such inspections do not relieve the Exterior Wall Subcontractor from obligations to provide the fixed windows conforming to all requirements of the Contract Documents.
- D. The Exterior Wall Subcontractor is responsible for coordination, compatibility and design integrity to secure a weather and water tight seal with all systems, surfaces and related materials.

#### 1.03 PLANS AND SPECIFICATIONS

- A. The character of these documents are intended to provide a performance type specification for the design, fabrication and installation of the fixed window system. The Exterior Wall Subcontractor is responsible for the engineering and design of all components and materials as well as the fabrication, installation and performance of the fixed window systems.
- B. Drawings are diagrammatic. The details shown are intended as a guide for the aesthetic and interfacing requirements of the windows to and with other work. The requirements shown by the details are intended to establish basic dimensions of the module and the sight lines, jointing and profiles of members. The Exterior Wall Subcontractor is responsible for the design and engineering of the system within these aesthetic parameters. The drawings are not to be construed as engineering design, or adequate to meet the engineering design requirements.
- C. It is recognized that the design details do not cover some conditions or modifications, which may be required. It is, however, intended that conditions not detailed shall be developed through shop drawings to the same level of aesthetics and in compliance with performance criteria as indicated for detailed areas and as stipulated in these specifications.

#### 1.04 CODES AND STANDARDS

- A. The work of this section shall comply with the latest edition of the following standards. When conflicts arise between standards, the more stringent shall apply.
  - 1. AAMA "Metal Curtain - Wall Specifications Manual".
  - 2. AAMA "Aluminum Curtain - Wall Design Guide Manual".

3. Aluminum Association "Specifications for Aluminum Structures".
4. "Specifications for the Design, Fabrication and Erection of Structural Steel for Buildings", including commentary of the AISC Specifications, AISC.
5. "Specifications for the Design of Cold - Formed Steel Structural Members", AISI.
6. "Structural Welding Code", AWS D1.1.
7. "General Requirements for Delivery of Rolled Steel Plates, Shapes, Sheet Piling and Bars for Structural Use", ASTM A36.
8. "Handbook on Bolt, Nut and Rivet Standards", Industrial Fasteners Institute.
9. "Glazing Manual" Flat Glass Marketing Association.
10. Uniform Building Code, 1991 edition.
11. American Society for Testing and Materials, various specifications.
12. American National Standards Institute, various standards.
13. AAMA, "Methods of Test for Metal Curtain Walls," AAMA 501 83.
14. ANSI/AAMA 101-85.
15. Los Angeles Building Code.

**1.05 SUBMITTALS**

- A. Exterior Wall Subcontractors seeking to secure a contract to provide work of this section shall submit with his bid proposal scope drawings for all typical areas of the building including its relationship to adjacent construction. Quality and content of scope drawings shall be the same as required for building drawings, except that non-typical conditions need not be included.
- B. Prior to submitting any documents required for approval, provide an itemized list of specification requirements and architectural drawing requirements which are not embodied in the contract, or intended contract, for work of this section. Identify the specification page and paragraph, or the architectural drawing sheet, elevation, plan, section or detail for each item. Deviations not specifically identified in this manner shall not be deemed valid in submittal review, and shall be cause for disapproval at the reviewers' discretion. In the event that there are no deviations, provide a written statement of full compliance with architectural drawings and specifications. Failure to provide an itemized list of deviations in the required form or a statement of full compliance shall, at the reviewer's discretion, be cause for return of any and all submittals for approval without review, with the Exterior Wall Subcontractor bearing full responsibility for any resultant delay.

- C. Prior to or simultaneous with first submittal of structural calculations for approval, provide dimensioned die drawings for all aluminum extrusions. In the event that extrusion profiles are not finalized, provide die drawings for the profiles contemplated at that time. If profiles are revised, provide revised die drawings with the first calculation or shop drawing submittal which follows the revision. Die drawings shall show all profile dimensions, metal thickness, alloy and temper.
- D. Prior to building construction, provide die drawings of gaskets and weatherstrips. If profiles are revised, provide revised die drawings within one month after the revision. Die drawings shall show all profile dimensions and shall identify materials.
- E. Prior to building construction, provide glass manufacturers wind, thermal, and shadow line stress analysis, showing that specified maximum probabilities of breakage are not exceeded.
- F. Prior to building construction, provide sealant manufacturers test reports confirming adhesion of silicone sealant to all relevant substrates. Provide samples of production materials to sealant manufacturer for adhesion tests. Adhesion shall be evaluated, and is required to be acceptable, after initial cure and after water immersion for seven days. Evaluate adhesion of immersed samples immediately after removal from water. Provide stain test reports on the granite. Provide written certification from the sealant manufacturer that sealant selected is compatible with all adjacent materials and finishes. Provide a shop drawing review from sealant manufacturer.
- G. Prior to building construction, provide glass manufacturer's written statement that any insulated, heat treated, coated, spandrel or laminated glass is suitable for such application. Submit letter stating manufacturer has reviewed the window shop drawings and has approved the glazing details shown therein.
- H. Prior to award of contract, if the window design is based upon a poured and debridged structural thermal break or other structural thermal break system, the Exterior Wall Subcontractor shall submit previous test results on the design. These test results shall demonstrate compliance with the performance criteria as outlined herein in these specifications. Include technical specifications from the material manufacturer which define the engineering properties including application life at room temperature, cure time, hardness, thermal conductivity, tensile strength, shear strength, application temperature range and service temperature range.
- I. Prior to mock-up construction, submit test results performed on thermally broken extrusions which demonstrate compliance with the performance criteria specified herein.
- J. Provide the following submittals for acceptance. First submittals and resubmittals shall be complete and in the required form. Provide written certification that submittal is correct and complete. Resubmittals shall include requested corrections and shall respond to previous comments. Each sheet that is revised shall bear a revision date and number. Revisions shall be flagged with a conspicuous revision symbol and number. Failure of a submittal to be complete, in the proper form, responsive to comments or identify revisions shall, at the reviewers' discretion, be cause for disapproval and return of documents without review, with the Exterior Wall

Subcontractor bearing full responsibility for any resultant delay. Failure to review comments or to note a noncompliance with plans and specifications shall not relieve the Exterior Wall Subcontractor from his obligation to comply. Failure to review comments or to note a noncompliance on a given submittal shall not preclude a directive to comply on future submittals. Allow sufficient time for preparation and processing of submittals and resubmittals to avoid conflicts with schedules.

1. Prior to mock-up fabrication, prepare for review by the Architect a set of mock-up drawings showing all components of the Fixed Windows including but not limited to the same information as listed hereafter for the project shop drawings. Submit a complete set of structural calculations for the mock-up demonstrating that the mock-up conditions represent the same or greater conditions as those which will be experienced on the project. Drawings and calculations to be stamped by same structural engineer. Engineer must be licensed in the State of California.
2. Provide shop drawings showing materials in place on the building including coordination of related and adjoining work, insert drawings and erection diagrams. Show relative layout for all adjacent walls, beams, columns slabs, ceilings, perimeter or adjoining conditions etc. Drawings shall include elevations, floor plans, sections and full size details. Details shall be full size and fully drawn, not outlined. Provide isometric details of any conditions, as requested by the Architect **and General Contractor**. Drawings shall include the following information:
  - a. Joinery and internal weather seals.
  - b. Glass and metal thicknesses, including tolerances.
  - c. Metal alloy, temper and finish.
  - d. Glass manufacturer strength, thickness, tint, coating, opacifier or frit, safety backing, and rating of insulated units.
  - e. Fastener manufacturer, material alloy, plating, diameter, length, spacing, embedment and edge distances.
  - f. Glazing materials identification.
  - g. Sealants identification by product name and manufacturer, including cleaning and priming requirements.
  - h. Relative layout of walls, beams, columns and slabs with dimensions noted. Dimension all tolerances required or which can be accommodated.
  - i. Field connections, weld sizes, anchorages, and fasteners, embedment length and edge distances.
  - j. Dimensioned position of glass edge relative to metal daylight.



- k. Reglazing and glazing procedures.
  - l. Dimension limits of movements for all moving joints and provisions for expansion and contraction.
  - m. Spotting plans for preset inserts in structure or in adjacent construction.
  - n. Perimeter sealant joint sizes, including tolerances and minimum/maximum joint sizes required.
  - o. Panel thickness, alloy, finish, method of attachment, replacement procedure, reinforcements and manufacturer.
  - p. Insulation and vapor barrier conditions and methods of attachment.
  - q. Seal and signature of professional engineer currently registered in the State of California. This shall be same engineer who signs the calculations.
3. Provide structural calculations, sealed by a licensed professional engineer in state of California prepared in compliance with referenced documents and these specifications. Where specifications and code differ, the more severe requirements shall govern. Test reports are not an acceptable substitute for calculations. Calculations shall include the following information:
- a. Analysis for all applicable loads on framing members.
  - b. Analysis for all applicable loads on anchors, including anchors embedded in concrete.
  - c. Section property computations for framing members.
  - d. Seal and signature of professional engineer currently registered in the State of California, on drawings and calculations.
4. Submit samples of all materials to be encompassed in the work in the size and quantity as required by the project documents. These will include but not be limited to, five (5) samples each of:
- a. Extrusions, flat sheet, or formed shapes showing finish. Show any variations in color or texture, if any, by providing range samples.
  - b. Architect reserves right to require submittal of fabrication samples, showing prime members, joinery, anchorage, expansion provisions, glazing, sealant details and similar details, profiles and intersections.
  - c. Glass samples, 12" square, of all types specified.
  - d. Tech data on all proposed sealants, along with color chart, and cured samples.

- e. All extrusion die drawings and 12" long samples of the production run on all extrusion shapes involving a snap fit. Snap fits are to be designed using 1/2 standard tolerances.
  - f. Glass setting blocks, side spacers, gaskets and shims.
  - g. Samples of fire knock-out decals or markings, if required.
  - h. Samples of gaskets, rods, tapes, glazing accessories. Gasket test reports, sealant test reports, and technical data on all glazing accessories.
  - i. Bronze cladding samples, 12" square. A formed bronze sample to demonstrate a typical 90° corner condition. **Submit bronze finish warranty for review and approve including, protective coating maintenance instructions.**
5. Submit manufacturer's product data and specifications for materials, and fabrication of the window work. Include instructions/recommendations for installation and maintenance. Include certified test reports showing compliance with requirements where a test method is indicated.
6. If the design of the windows incorporates a structural thermal break system, submit an itemized procedure from the material fabricator which describes the preparation, pouring, debridging, crimping or installing of the thermal barrier material and the quality control used during the installation of the material.
- K. The Exterior Wall Subcontractor shall provide a full size **visual mock-up (V-1)** at the jobsite. See the scope of the **visual mock-up (V-1) at the end of this section of specifications**. The framing members shall be suitable to represent the specified finish and the profiles as indicated in these documents. See Exterior Glass and Glazing, Section 08800, 105.C.4. for glass requirements.
- L. Provide as-built drawings of wall after construction is finished, with written certification that all work is correct and complete.

#### 1.06 PERFORMANCE REQUIREMENTS

- A. The work, as erected, shall meet or exceed the following structural and weather resistance requirements, as demonstrated by engineering calculations and testing of mock-ups.
- B. Methods of fabrication and assembly (except as specified herein, or as recommended by the Architect as a consequence or result of testing) shall be at the discretion of the Exterior Wall Subcontractor (subject to acceptance by the Architect) provided that the exterior and interior visible architectural effect is not changed, the work of other Subcontractors is not affected, and the weather tightness and strength qualities, as demonstrated by engineering calculations and measured by the results of the tests for performance requirements, are not reduced.

- C. Remedial measures, which may be necessary on the mock-ups or the building, shall maintain standards of quality and durability, and are subject to acceptance by the Architect.

**D. Provision for Thermal Movements**

1. The work shall be designed to provide for such expansion and contraction of component materials, as will be caused by an exterior ambient temperature ranging from 0 degrees F. to metal surface temperature of 180 deg. F., and an interior temperature range of +50 deg. F. to +100 deg. F., without causing buckling stresses on glass or stone, failure of glass, metal, stone or joint seals, undue stress on structural elements, damaging loads on fasteners, reduction of performance or other detrimental effects. The amount of such movement that is accommodated in the Exterior Wall Subcontractor's design shall be identified on Exterior Wall subcontractor's submittal drawings, and shall be accompanied by thermal calculations.

**E. Structural Properties**

1. The wall shall be designed to withstand the service wind loads as indicated on the building elevation drawings which delineate the results of the wind tunnel study for the project. Design corners for simultaneous inward design pressure on both surfaces, and simultaneous outward design pressure on both surfaces. Partial loading on one surface shall be considered.
2. Performance criteria at design pressures and loads for metal members supporting glass and panels (but not stone) shall be as follows:
  - a. Perpendicular to the plane of the window, net deflection of framing members shall not exceed  $1/240$  times span, or  $3/4$  inch, whichever is less. Span is defined as the distance between anchor centerline. For cantilevers, span is defined as two times the distance between anchor centerline and end of cantilever. Where a sealant joint occurs between a framing member and a relatively stiff building element, framing member deflection shall not exceed  $1/2$  of the nominal joint width, or less if required by sealant manufacturer. Where a framing member runs continuously past a deflecting support, the support deflection shall be considered in the analysis.
  - b. In the plane of the window, deflection of framing members shall not exceed 0.125 inch. This includes horizontal rail sag due to dead load. Corner mullion in-plane deflection due to wind pressure shall be limited to  $1/4$ " maximum at any time. Reduce deflection further if required for assembly and fit of component, or performance of sealant in joints.
  - c. At connection points of framing members to anchors, combined movement of anchor relative to building structure, or adjoining surface and framing member relative to anchor, shall not exceed  $1/16$  inch in any direction.

- d. The center deflection of the stool trim, when subjected to a 250 pound vertical concentrated load, is to be a maximum of 1/4". No permanent set is allowed when load is removed.
- e. Stresses shall not exceed the allowable values established by the specifications listed in code standards. In no case shall allowable values exceed the yield stress. Where permitted by code, a 1/3 increase in allowable stress for wind or seismic load is generally acceptable, but not in combination with any reduction applied to combined loads.
- f. Sealants and interior finishes shall not be assumed to contribute to framing member strength or stiffness.
- g. Thermal breaks shall be assumed to have no ability to transfer shear stress for composite action of flexural members. Elements joined by a thermal break shall be assumed to act additively.
- h. The deflection of metal panels, facias, or other sheet fabricated elements shall not exceed  $L/120$  of the span or 1/2" whichever is less when tested in accordance with ASTM E-330-79 at specified design pressure. Deflection shall be measured relative to the horizontal and vertical support members with the allowable deflection being determined by the lesser dimension.
- i. At 1.5 times the design pressure loads for metal members supporting glass and panels (but not stone) the net permanent deflection of framing members shall not exceed 1/1000 times span. There shall be no failure or gross permanent distortion of framing members, anchors or connections. At connection points of framing members to anchors, combined movement of anchor relative to building structure, and framing member relative to anchor, shall not exceed 1/16 inch set after load is removed.
- j. Vibration harmonics, wind whistles, noises caused by thermal movement, thermal movement transmitted to other building elements, loosening, weakening or fracturing of attachments or components of system are not permitted in the installed work.
- k. Headed concrete studs welded to steel elements and cast-in-place with structural concrete shall have a minimum safety factor of 2.0 against ultimate failure. Unistrut type or ferrule type concrete inserts shall have minimum safety factor of 3.0 against ultimate failure. All drilled expansion or wedge type anchors shall have a minimum safety factor of 4.0 against ultimate failure. Use of 1/3 increase for allowable stresses is not acceptable unless written approval by manufacturer is provided.

**F. Provision for Movement of the Structure**

1. The work shall be designed to accommodate dead load and live load deflection, thermal expansion, seismic, elastic shortening and/or sway and torsion of the building, as may be anticipated.
2. To this end, the Exterior Wall Subcontractor shall obtain all necessary projected data and make such provision in the work as may be necessary. The amount of such movement that is accommodated in the Exterior Wall Subcontractor's design shall be identified on Exterior Wall Subcontractors submittal drawings.
  - a. Allow for 1/16" per floor for creep, shrinkage and elastic column shortening and 1/4" upward and downward liveload at the mid-point of each bay for floor slab deflection.
3. The work shall be designed to accommodate seismic movements as indicated in Facade Stonework specification section 04400.

**G.** Glass probability of breakage at design pressure shall not exceed 8 lites per 1000. Glazing details shall permit glass replacement after initial construction, reuse of original gaskets and shall permit replacement glass using the same nominal size as original glass. Vision glass shall be replaceable from the interior without removal of adjacent construction.

**H. Air Infiltration**

1. Air leakage through the work shall not exceed 0.06 cfm per square foot of fixed wall area tested in accordance with ASTM E-283 at a test pressure of 6.24 psf.

**I. Water Penetration**

1. Water penetration, in this specification, is defined as the appearance of uncontrolled water on the indoor face of any part of the work. "Controlled" water or condensation is that which is demonstrably drained harmlessly to the exterior of the work without endangering or wetting adjacent surfaces or insulation, and not visible in the final construction.
2. Provision shall be made to drain to the exterior face of the work, any water entering at joints, and/or any condensation occurring within the work. The wall shall be designed to collect and remove all secondary water from the surrounding conditions. At the window head the gutter shall extend to the inside vertical plane of the insulation. It shall be designed to remove any collected water to the exterior by draining through clear plastic tubing down to the window sill gutter.
3. No uncontrolled water penetration shall occur when the work is tested in accordance with ASTM E-331-79 at a pressure differential of 10 psf. Before tests are conducted the test specimen shall be subjected to a positive

pressure differential equal to 50% of the full positive design load for a period of 10 seconds.

4. No uncontrolled water penetration shall occur when the wall is tested in accordance with AAMA 501.1, using a dynamic pressure equal to 10 psf.

#### **J. Condensation Resistance Requirements**

1. It is intended to prevent excessive condensation on the indoor face of the work, with the heating and ventilating system in operation and under the following conditions. Fabricate, assemble and erect the work to achieve and maintain this design intention.
  - a. Outdoor: Ambient temperature of 20 deg. F.; 15 miles per hour wind.  
  
Indoor: Ambient of 72 deg. F.; relative humidity of 35% during working hours.
  - b. Excessive condensation is defined as water, ice or frost on more than 5% of the non visible interior surface of any module or component of the window or the accumulation of uncontrolled flow of water from condensation or melted frost on the window at any location. An interior surface of any module is any surface other than an exterior surface. No condensation nor frost is allowed on visible interior surfaces.

#### **K. Variations in Structure**

The work shall be designed to accommodate variation in location of surrounding and supporting work, as specified in other sections of these specifications or as may exist at the site, as determined by field measurements of the existing work as measured by the Exterior Wall Subcontractor. Window anchorage shall be designed to accommodate the mislocation of embedded inserts by 1/2" in any direction or a 5 degree variation from level or plumb of embed inserts.

### **1.07 MOCK-UPS FOR TESTING**

- A. **At the direction of the General Contractor, the Exterior Wall Subcontractor shall furnish, build and test mock-ups (T-1 and T-2) containing the glazed fixed windows with: stone clad frame system. Scope of mock-ups T-1 and T-2 is attached at the end of specification Section 01450. General Contractor shall be responsible for scheduling and coordination of mock-up at an independent testing facility. Mock-up shall accurately represent job conditions including joints, sealants, glass, glazing, anchors and finishes. Install sufficient thermal insulation to demonstrate details of installation unless thermal test is required, in which case all thermal insulation shall be completely installed. Delay installation of thermal insulation until completion of initial air, water and structural tests.**

- B. Provide at least one extra light of glass for each type and size on the mock-up. Glass which breaks during testing shall be replaced with new glass and the test continued. Repeated glass breakage at design pressures shall constitute failure.
- C. Construct mock-ups in strict accordance with approved mock-up shop drawings. Any deviation from or additions to details shown on drawings are subject to approval. Do not use excessive amounts of sealant, nor other special measures or techniques, which are not representative of those to be used on the building.
- D. Test procedures are specified in Section 01450.
- E. All fixed windows are required to meet performance criteria hereinbefore specified.
- F. **All details used, approved and/or modified in passing test requirements shall be fully documented upon completion of testing in "checklist fashion". Mock-up drawings shall be revised to reflect all changes. Upon completion, revise mock-up drawings to include isometric details of critical seal areas whether modified or not.**

#### 1.08 FIELD TESTING

- A. The fixed windows **and surrounding construction** shall receive a minimum of three water hose tests in field during construction. These tests are in addition to the tests specified for the curtain wall system. Area and time of tests shall be per the direction of the Architect. Tests to be conducted per AAMA 501.2. Water penetration is as defined previously herein. Provide powered scaffold, hose, water supply, communication system and manpower to perform tests. Test windows at 15%, 50% and 75% completion. Schedule any work necessary, such as out of sequence sealant work, so that wall can be tested as specified.
- B. Depending upon the prevalence or absence of leakage in initial water penetration test, and upon measures adopted by Exterior Wall Subcontractor to eliminate source of leakage, Architect will determine necessity for, and scope of additional tests and test methods. Remedial measures shall maintain standards of quality and durability and are subject to approval.
- C. All cost of additional tests, including fees and costs incurred by the **Owner, General Contractor, Architect** and their Consultants shall be paid for by the **Exterior Wall Subcontractor**.

#### 1.09 WARRANTY/GUARANTEE

- A. Unless stated otherwise in these specifications, guarantee shall state that all work is in accord with drawings and specifications, as amended by any changes thereto authorized by the Architect, free from defects in materials and workmanship for a period of five (5) years from the date of final acceptance and payment of the work by the **Owner**. See "Facade Sealant" specification section 07901 for special project warranty for sealants. **Exterior Wall Subcontractor and Glazing Contractor** shall agree to repair or replace defective materials and workmanship to "like new condition," including such exploratory work, as necessary to determine the cause,

during the guarantee period, at no additional cost to the Contractor. Exterior Wall Subcontractor shall include with bid proposed copy of proposed warranty.

- B. Guarantee shall further state that glass shall be guaranteed against breakage due to defects in glass materials, fabrication of insulating units, and/or installation for a period of five (5) years after final acceptance and payment of the work by the **Owner**. Exterior Wall Subcontractor shall include with his bid copy of proposed warranty.
- C. Insulating glass units, both vision and spandrel shall carry a ten (10) year warranty from final acceptance and payment by the **Owner**, from their manufacturer against delamination, obstruction of vision by fogging up and collection of dust or dirt in the enclosed space or cracking, peeling or flaking of coatings and/or opacifiers as applicable and in a form acceptable to the **Owner**. Exterior Wall Subcontractor shall include with his bid proposed copy of warranty from proposed glass manufacturer for each type of unit.
- D. The silicone sealants shall carry a twenty (20) year warranty from final acceptance and payment of the work by the **Owner** from the sealant manufacturer against adhesive or cohesive failure and staining in a form acceptable to the **Owner**. Exterior Wall Subcontractor shall include with his bid proposed copy of proposed warranty. Exterior Wall Subcontractor shall include with his bid proposed copy of warranty from silicone sealant manufacturer.
- E. Kynar paint finishes shall carry a ten (10) year warranty from final acceptance and payment of the work by the **Owner** from the applicator and paint manufacturer against defective, workmanship and materials.
- F. The manufacturer of the structural thermal break material and the installer of the material, if used, shall warrant that the material supplied meets the performance properties as stated in the submitted technical data and shall warrant its performance for a period of twenty years from final acceptance and payment of the work by the **Owner**. Exterior Wall Subcontractor shall include with his bid proposed copy of proposed warranty.
- G. Defective materials and workmanship is hereby defined to include, but not be limited to, evidence of:
  - 1. Penetration of water into the building.
  - 2. Air infiltration exceeding specified limits.
  - 3. Structural failure of components resulting from forces within specified limits.
  - 4. Delamination of laminated glass or failure of insulated glass units.
  - 5. Cracking, crazing, flaking, of coatings or opacifiers on glass.
  - 6. Discoloration or fading, excessive non-uniformity, pitting, cracking, peeling, or crazing or corrosion of finish.



7. Glass breakage.
  8. Secondary glass damage and/or damage due to falling fixed window curtain wall components.
  9. Adhesive or cohesive failure of sealant.
  10. Crazeing on surface of non-structural sealant.
  11. Non-structural sealant hardening beyond Shore A durometer 50 or softening below 20.
  12. Failure to fulfill other specified performance requirements.
  13. Excessive deflection or oil canning of metal panels in installed condition.
- H. Exterior Wall Subcontractor shall be responsible for damage to the building and furnishings occasioned by defective materials or workmanship or damage as part of repairs to the work.
- I. The guarantee, the enforcement or lack of enforcement thereof, shall not deprive the **Owner** of other actions, rights or remedies available to him. Guarantee shall be in form approved by the **Owner**. Guarantee does not cover damage resulting from vandalism or acts of nature exceeding performance criteria.
- J. The terms used in conjunction with finish Guarantee are defined as follows:
1. "Discoloration or fading": means a change in appearance which is perceptible and objectionable as determined by the Architect when viewed visually in comparison with the original color range standards.
  2. "Excessive non-uniformity": means non-uniform fading during the period of the guarantee to the extent that adjacent parts have a color difference greater than the original acceptable color range.
  3. "Pitting, cracking, peeling, crazing or corrosion": means there shall be no pitting, surface cracks, blistering, bubbles, or non-uniform surface texture or other type of corrosion discernible from a distance of ten (10) feet, resulting from the natural elements in the atmosphere at the project site.

#### **1.10 DELIVERY, STORAGE AND HANDLING**

- A. Deliver, store and handle all window assemblies so as to prevent damages at all times, as per manufacturer's recommendations.
- B. All materials delivered to the site shall be stored in spaces provided on each floor of the building. These spaces shall be located where the stored materials will not be exposed to wetting or damage, and shall permit easy access to the handling of the materials. Materials shall be stored neatly, properly stacked.

- C. Deliver other materials, except bulk materials, to project site in manufacturer's unopened containers with name, brand, type, grade and color fully indicated thereon. Store bulk materials as required to avoid any deleterious effects of weather, soiling or contamination.

## 1.11 PROJECT CONDITIONS

- A. Exterior Wall Subcontractor shall coordinate as required, and be totally responsible for, the full and satisfactory compatibility and performance between all sealants used under this section and those sealants used by other trades that may be in direct contact with or adjacent to sealants in this work.
- B. Take all required steps and precautions to properly isolate and prevent any degree of incompatibility between said sealants, all in strict accordance with manufacturer's specifications, recommendations and instructions.
- C. Periodically test sealants in place for adhesion, using methods recommended by sealant manufacturer. Promptly replace any sealant which does not adhere or fails to cure.
- D. **At the direction and scheduling of the General Contractor, and prior to commencement of work, the General Contractor shall conduct a pre-installation meeting with the Architect, Exterior Wall Subcontractor, sealant Subcontractor and any other relative representatives to review the installation of the work and the sealant techniques required.**

## 2.00 PRODUCTS

### 2.01 MATERIALS

- A. Provide aluminum shapes and thicknesses as shown and as required to fulfill performance requirements. Use suitable alloy for extruding with adequate structural characteristics, and suitable for finishing as specified. Comply with ASTM B221 for extrusions and ASTM B209 for sheet and plate. Formed sheet members shall be .090 minimum thickness. For any curved shapes form accurately to radius shown. Continuously weld and grind smooth where flanges are not permitted. Caulked joints are not permitted in lieu of welding. Sheet panels shall be 0.160 unless otherwise designated. Sheet panels shall meet the following criteria:
  - 1. Panel bow: 0.2% of width/length, 0.250" maximum.
  - 2. Width or length:  $\pm 0.032"$  to 48",  $\pm 0.064"$  to 144".
  - 3. Squareness: 0.1875" maximum difference between diagonals.
  - 4. Camber: 0.032" maximum.

- B. Provide bronze alloy #280 (Muntz Metal), .062 thick where indicated on the architectural documents. Weld joints and finish blend to match adjacent surfaces. Bronze finish to match sample in Architect's office.
- C. Any exposed fasteners or fasteners in wet areas shall be series 300 stainless steel. Finish exposed fasteners to match adjacent aluminum. Exposed fasteners may only be used if approved by the Architect. The work shall be designed to conceal all fasteners. Unexposed fasteners shall be cadmium and colored chromate plated and shall meet Federal Specification QQ-P-416C, Type II, Class #1. (.0005 inches thick plating). All non stainless fasteners being used in a structural application must meet the minimum requirements of SAE J429 Grade 5. Grade 8.2 fasteners, high strength bolts of non U.S. origin, or high strength bolts that are zinc plated shall not be used. Mill test reports for all structural grade bolts shall be submitted to the Architect for his approval prior to installation of those bolts on the job. Self drilling fasteners shall be Drill-Flex as manufactured by Elco Industries, Inc. No substitutes accepted or Architect approved equal. Nuts used at expansion or moving connections shall be designed to provide a positive means of preventing disengagement. Staking of bolts, use of lock washers, or threads being deformed is not acceptable.
- D. Steel for Anchorage shall be of shapes and thicknesses required to meet structural requirements for their use. All steel shall meet ASTM-A36 requirements and be hot-dipped galvanized. Touch up after welding in the field shall be by this Contractor.
- E. Embeds shall be designed and furnished by the Exterior Wall Subcontractor for placement in surrounding conditions per layout and placement drawings furnished by the Exterior Wall Subcontractor. Installation of embeds shall be by others per these drawings.

## 2.02 FINISHES

- A. All exposed exterior aluminum shall receive a 3 coat spray applied fluorocarbon coating containing a minimum of 70% Kynar 500 Resin similar to P.P.G. Duranar XL. Coating must meet the high performance requirements of AAMA 605.2-1980. Custom colors, as selected by the Architect, to match color sample supplied by Architect.
  - 1. P.P.G. Duranar XL Color - Medium Bronze Metallic.
- B. Interior exposed aluminum shall receive a spray applied thermal setting acrylic coating. Coating must meet the performance requirements of AAMA 603.8-1980. Custom colors as selected by the Architect.
  - 1. P.P.G. Duracron Color - Medium Bronze to match Duranar.
- C. Concealed members may be mill finish, providing they cannot be seen through the glass. All exposed interior surfaces from window operation or stack joints will utilize finish coating.
- D. It is the intention of the specification that the color variation between adjacent parts of the same finish be imperceptible to the naked eye under normal daylight conditions. This end, the Exterior Wall Subcontractor shall submit range samples

defining the maximum variation of color than can be anticipated in the work. Samples shall be on lengths of extrusions not less than 12" and on sheet/plate/panels not less than 24" square. Pieces abutting or within 6" of each other in the construction shall not vary in color by more than 1/2 the range so as the variation to be imperceptible to the naked eye under normal daylight conditions. Parts shall be carefully inspected in the shop and graded for assembly compatibility and marked for installation location.

- E. Exterior Wall Subcontractor shall, in the construction of testing mock-ups, finish the various components to show the maximum variation that will exist in the actual building construction between adjacent and non-adjacent components.
- F. The Exterior Wall Subcontractor shall establish and submit for approval a quality control program to assure compliance with the specified requirements. The program shall include documented procedures, processes, etc. Exterior Wall Subcontractor shall maintain complete certified inspection, testing and process records of finishing procedures. Said records shall be available to the Architect upon request. No finishing shall be performed prior to approval of this quality control program.
- G. Exterior Wall Subcontractor shall not ship any material that has not been inspected, tested and marked in the prescribed manner, does not fall within the prescribed color range, or has been rejected by the Architect.
- H. The finishing of the panels for the windows shall be performed by the same applicator who finishes the window frame components.

## 2.03

### GLASS AND GLAZING

- A. All glass at fixed windows shall be as shown on the contract drawings, and as specified in the exterior Glass and Glazing Section 08800 of the Specifications. It shall be designed using a probability of breakage of 8 lites per 1000.
- B. All glass shall be heat strengthened tempered or laminated as required to meet wind loads, thermal stresses, safety or building codes.
- C. Setting blocks must be 80 to 90 durometer extruded neoprene or EPDM and a minimum of 4" long. Actual size of setting blocks to conform to the FGMA Guidelines. All setting blocks shall be positively restricted from lateral movement.
- D. Insulation to be offset 1" behind the aluminum panel and attached in a secure and permanent manner. Insulation joints to be taped with a pressure sensitive scrim type tape, as recommended by the insulation manufacturer. Butt all ends and edges closely together, filling all voids and sealing completely around all penetrations, and perimeter, to provide a complete vapor barrier. Insulation or its support can not be adhered to the panel. Refer to Facade Insulation - Section 07201, for requirements.
- E. Vision glass reglazing at fixed windows to be from the interior. Vision glass reglazing shall be done without removal of adjacent surrounding condition.

- F. Side spacer blocks shall be  $65 \pm 5$  durometer extruded neoprene, ASTM C864, properly sized and profiled for intended application.
- G. The Exterior Wall Subcontractor shall make a 100% inspection of the edge seal on the insulating units prior to setting.
- H. **Provide and apply fire knock-out decals as required by code and where noted on the Architectural documents.**

#### **2.04 GASKETS/WEATHERSTRIPPING**

- A. All gaskets/weatherstripping shall be neoprene. All gaskets/weatherstripping/spacers shall have continuous mechanical engagement to framing members. All weatherstrips and gaskets shall be continuous with vulcanized/molded corners.
- B. Sponge gaskets/weatherstripping/spacers shall be extruded black neoprene with a hardness of  $40 \pm 5$  durometer Shore A and conform to ASTM C-509. Sponge gaskets shall be compressed 20% to 35% in the final installed position.
- C. Dense gaskets/weatherstripping shall be extruded black neoprene conforming to ASTM C-864 with a hardness of  $75 \pm 5$  durometer Shore A for hollow profiles and  $60 \pm 5$  for solid profiles.

#### **2.05 SEALANT MATERIALS**

- A. All perimeter and internal sealants and backers are to be defined on shop drawings and are subject to Architect's approval. Perimeter sealants shall be installed in conjunction and coordinated with the two lines of defense to form a continuity of seal against leakage.
- B. Sealant use shall be in agreement with submitted written sealant manufacturer recommendations.
- C. All exterior sealants shall be silicone and meet applicable Federal Specification. Provide custom colors as selected by the Architect to match color sample supplied by Architect.
- D. All internal sealants which contact the perimeter sealants must be compatible with, and adhere to, the perimeter sealant. All internal sealants used to seal glass pockets, end dams and splices shall be silicone installed per manufacturer recommendations. Splice details shall be designed to accommodate the anticipated movement of the joints.
- E. Backer rod materials shall be open cell polyurethane foam or closed cell as recommended by the Sealant Manufacturer.

#### **2.06 THERMAL BARRIER**

- A. If the fixed window proposed incorporates a structural poured and debrided thermal isolator barrier or other structural thermal isolator material or system, the following criteria and testing must be performed to satisfy the performance criteria of these

specifications. Tests to be conducted on each type of extrusion which incorporates this barrier.

- B. If the thermal insulator is poured in place it shall be polyurethane. The polyurethane shall be self-adhering to the adjacent aluminum surfaces. Contact with mill finish aluminum is prohibited. There will be a minimum of 3/8" separation between the exterior and interior metal surfaces after the bridge is removed. The structural thermally isolated sections of aluminum must be tested at an accredited independent laboratory with the following results:
1. **Tension Pull Test:** On five samples secure the interior and exterior faces of a 12" long sections mechanically in a fixed horizontal position. Tests shall be performed at room temperature, 0 degree F and +180 degree F. Load each specimen at each temperature stipulated. Cycle temperature and loading of each specimen for 3 cycles. Heat tape or other temperature control mechanisms shall be applied to the exterior face and shall control the surface temperature at specified test level three to five minutes before loading, as indicated by a thermocouple wire operated by an automatic controller. Direct tension (pull) to be applied by use of a Universal Testing machine set in the 12,000 pound load range. Test results using the above shall show no loss of bond at 4,000 pound load with load applied at a strain rate of .050" per inch per minute.
  2. **Shear Test:** On five samples secure the interior face of the 12" long section mechanically in a fixed vertical position. Tests shall be performed at room temperature, 0 degree F and +180 degree F. Load each specimen at each temperature stipulated. Cycle temperature and loading of each specimen for 3 cycles. Heat tape or other temperature control mechanisms shall be applied to the exterior face and shall control the surface temperature at specified test level three to five minutes before loading, as indicated by a thermocouple wire operated by an automatic controller. Apply load to the exterior face by a bearing plate resting on the top of the exterior face. Shear to be applied by a Universal Testing machine set in the 12,000 pound load range at a strain rate of .050" per minute. Test results using the above shall show no loss of bond at 5,500 pound loading.
  3. **Combined Torsion Shear Test:** On samples of five secure the interior face of the 12" long section mechanically in a fixed horizontal position. Tests shall be performed at a room temperature, 0 degree F and +180 degree F. Load each specimen at each temperature stipulated cycle temperature and loading of each specimen for 3 cycles. Heat tape or other temperature control mechanism be applied to the exterior face and shall control the surface temperature at specified level three to five minutes before loading, as indicated by a thermocouple wire operated by an automatic controller. Apply load to exterior element directly next to the thermal break isolator by use of a 3" x 1/4" bearing plate. Torsion/shear load shall be applied by a Universal Testing machine set in the 12,000 pound load range at a strain rate of 0.050" per inch per minute. Tests results using the above shall show no loss of bond at 3,500 pound loading.

4. Moment of Inertia Determinations: Bending tests shall be performed at 0 degree F, room temperature and +180 degree F on twenty seven samples of 36" long sections to determine percentage of calculated moment of inertia, which can be used in structural calculations. One load shall be applied about the weak axis and loads shall be applied about the strong axis, to place the thermal break in tension and compression. Heat tape or other temperature control mechanisms shall be applied to the exterior face and shall control surface temperature at specified heat level three to five minutes before loading, as indicated by a thermocouple wire operated by an automatic controller. Cycle each specimen to the high and low temperatures stated for 3 cycles prior to measuring load and failure at each specified temperature. Deflections shall be recorded at 300 lb. intervals to failure.

## **2.07 MISCELLANEOUS MATERIALS**

- A. Provide aluminum and/or steel brackets, clips, shims and reinforcements as required.
- B. Provide stainless steel sleeve spacers and/or suitable bearing pads, as required, to insure free movement between surfaces where expansion and deflection movements are intended. Provide "Eel Slip", "Nylatron" washers or pads of sizes and thicknesses (minimum 1/16" except 1/8" for Eel Slip") recommended by the manufacturer to permanently prevent "freeze up" of joints. Provide high impact polystyrene shim pads for static shims.
- C. Flashing required within the system shall be aluminum of acceptable design.
- D. Flashing required to join the system to adjacent construction shall be aluminum of acceptable design.
- E. Provide PVC coated open cell reticulated urethane foam baffles. Size, length and porosity to meet water and air infiltration design requirements.

## **2.08 FABRICATION**

- A. All parts of the windows shall be of the materials, design, sizes and thicknesses shown or called for on the drawings and/or herein specified. Windows shall be designed to interface with two lines of defense. Methods of fabrication and assembly however, unless otherwise specifically stated, shall be at the discretion of the window manufacturer subject to the acceptance by the Architect.
- B. Fabricate components of the system at factory, ready for field installation. Make all cutouts for penetrations at the factory, wherever possible. Reinforce panels as required.
- C. Fabricate components and assemble units to comply with fire and/or performance requirements specified.
- D. Changes of plane, parallel or transverse to longitudinal axis shall be accomplished as detailed on the drawings in the factory wherever practical and with a minimum of field fabrication.

- E. All fitting and assembly work shall be done in the shop.
- F. Exposed fasteners on finished surfaces will not be permitted.
- G. Protection against galvanic action shall be provided wherever dissimilar metals are in contact, except in the case of aluminum in contact with galvanized steel, zinc or relatively small areas of stainless steel or nickel silver (white bronze). This protection shall be provided by painting the dissimilar metal surfaces with a heavy coat of zinc chromate primer or by application of an appropriate sealant or tape or other approved galvanic isolator.
- H. Aluminum which is to be in contact with cured concrete, mortar or plaster shall have the contact surfaces protected. This shall be accomplished by the use of a heavy coat of bituminous paint applied to the aluminum, or other permanent separator on concealed contact surfaces of the aluminum before assembly or installation.
- I. Items of carbon steel, unless galvanized or scheduled for other finish, shall be thoroughly cleaned of all loose scale, filings, dirt and other foreign matter and shall be painted with zinc rich primer, complying with Specification FS TT-P-645. Surface preparation shall meet the minimum requirements of SSPC-SP6.
- J. All welding shall be in accord with pertinent recommendations of the American Welding Society and shall be done with electrodes and/or by methods recommended by the suppliers of the metals being welded. Type, size and spacings of welds shall be as shown on approved shop drawings and structural calculations.
- K. Welds behind finished surfaces shall be done as to minimize distortion and/or discoloration on the finished side. Weld splatter and welding oxides on finished surfaces shall be removed by descaling and/or grinding. Telegraphing of welds through a finished surface will not be accepted.

### 3.00 EXECUTION

#### 3.01 EXAMINATION

- A. All work shall be performed by skilled workmen, especially trained and experienced in the type of work. If the Exterior Wall Subcontractor chooses to sub-contract the installation of work, the proposed sub-contractors qualifications shall be approved by the Architect and **General Contractor**.
- B. Bench marks for elevation and building line offset marks for alignment shall be established on each floor level by the **General Contractor**, who shall be responsible for their accuracy. Should any error be found in their location, the Exterior Wall Subcontractor shall so notify the Architect and **General Contractor** in writing, and installation work shall not proceed in the affected area until the errors have been corrected.



- C. After lines and grades have been established, and before beginning installation in any area, the Exterior Wall Subcontractor shall examine all parts of the facade in which the work is to be placed in that area. Should any conditions be found which, in his opinion will prevent the proper execution of his work, he shall report such condition in writing to the Architect and the **General Contractor**. Installation work shall not proceed in that area until such conditions are corrected or adjusted to the satisfaction of the Architect and the Exterior Wall Subcontractor. Commencement of work shall constitute acceptance of surrounding conditions.

### 3.02 INSTALLATION/ERECTION

- A. Embeds shall be designed and furnished by the Exterior Wall Subcontractor for placement, in surrounding conditions per layout and placement drawings furnished by the Exterior Wall Subcontractor. Design to be based upon the concrete slab strength.
- B. Erection Tolerances: Install the window components plumb, level, accurately aligned and accurately located in reference to ceiling lines and floor levels and adjacent work. Adjust work to conform with the following tolerances (maximum variations).
1. Permissible dimensional tolerances in the building frame and other work adjacent to the wall are as follows:
    - a. Plumb variations such as faces of exterior column and walls are 1" in height of building.
    - b. Variation from levels shown on drawings such as top and bottom surfaces of floor slabs and spandrel beams shall be plus or minus 1".
    - c. Variation from location shown on drawings such as outer faces of walls, framing members and floor slabs shall be plus or minus 1".
    - d. Variation from location shown on drawings for adjacent surfaces of spandrel materials or jamb materials is a maximum of 1/4".
  2. The window system shall be designed to accommodate above tolerances. Provided irregularities do not exceed them, and clearances shown on approved shop drawings are maintained, all parts of the windows, when completed, shall be within the following tolerances:
    - a. Maximum offset from true alignment between two similar members abutting end to end in line: 1/32".
    - b. Maximum vertical and horizontal variation from plane or location shown on approved shop drawings: 1/8" per 12 foot length or 1/4" per 30' length and 3/8" for total building.

- C. Anchorage of the windows to the adjoining work shall be by approved methods in strict accordance with accepted shop and/or erection drawings. Supporting brackets shall be so designed as to provide three-dimensional adjustment and accurate location. Once work is properly positioned, all connections so designated on accepted shop drawings shall be rigidly fixed by welding or other positive means.
- D. Expansion anchorage shall be so designated to provide for thermal and building movements. Anchorage design shall provide for unrestricted movement. Molybdenum-disulfide filled nylon ("nylatron") slip pads or washers shall be used at all thermal or dynamic anchors.
- E. All exposed work shall be carefully matched to produce continuity of line and design with all joints, unless otherwise shown or specified being accurately fitted and rigidly secured. Exposed edges shall be finished to match face of the work.
- F. All welding shall be done by skilled mechanics qualified or licensed in accord with local building regulations, and shall conform to the recommended practices of the American Welding Society. Special care shall be taken to protect glass and other finished surfaces from damage and to prevent causing fires. All welds must be prepared and touched up with zinc rich paint.
- G. Any weld splatter on glass or exposed surfaces will be cause for rejection of glass or other exposed material. Glass with weld splatter will be replaced at no cost to the Contractor.
- H. Sealing materials specified shall be used in strict accordance with the manufacturer's printed instructions, and shall be applied only by mechanics specially trained or experienced in their use. Before applying sealant, all mortar, dirt, dust, moisture and other foreign matter shall be completely removed from surfaces it will contact. Adjoining surfaces shall be masked when required to maintain a clean and neat appearance. Sealing compounds shall be tooled to fill the joint and provide a smooth finished surface.

### **3.03 POSTPONEMENT OF COMPLETE ENCLOSURE**

- A. If so directed by the Construction Contractor, installation of the work shall be postponed in specific locations so as to facilitate moving material into and out of the building during construction.

### **3.04 PROTECTION AND CLEANING**

- A. The Exterior Wall Subcontractor shall remove from the installed work all mastic smears or other unsightly marks caused by his workmen, and shall be responsible for any damage to or disfigurement of the work caused at any time by other trades, as well as final cleaning and washing of glass and aluminum. The Exterior Wall Subcontractor shall advise the **General Contractor** of proper and adequate protection and cleaning procedures during remainder of construction period so that system will be without damage and deterioration at time of acceptance.

**3.05 ACCEPTANCE**

- A. Installed materials which are damaged, or which in the opinion of the Architect do not conform to the specification requirements, shall be removed and replaced with acceptable material at no additional cost to the **Owner**.
- B. Clean debris and excess fireproofing debris from behind the fixed windows and window system secondary gutters during erection. Provide temporary closures to prevent accumulation.
- C. Demonstrate proper cleaning methods and materials to Owner's maintenance personnel. **Submit complete operation and maintenance instructions for all elements of the exterior wall system.**
- D. Provide "As built" shop drawings and maintenance manuals per requirements of the project documents.
- E. The Exterior Wall Subcontractor **to coordinate and furnish final clean-up with the General Contractor.**

**END OF SECTION 08500**

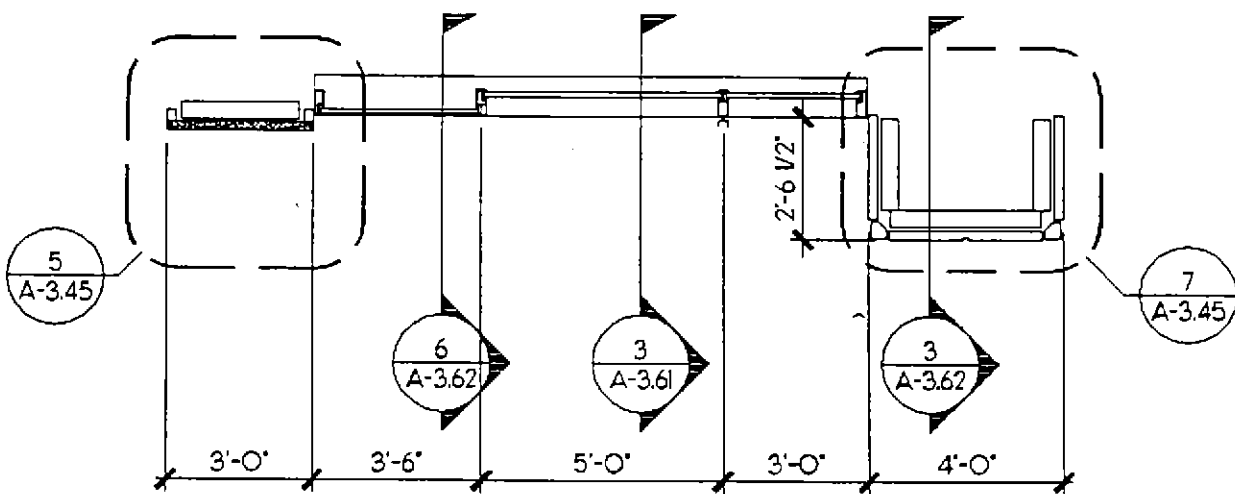
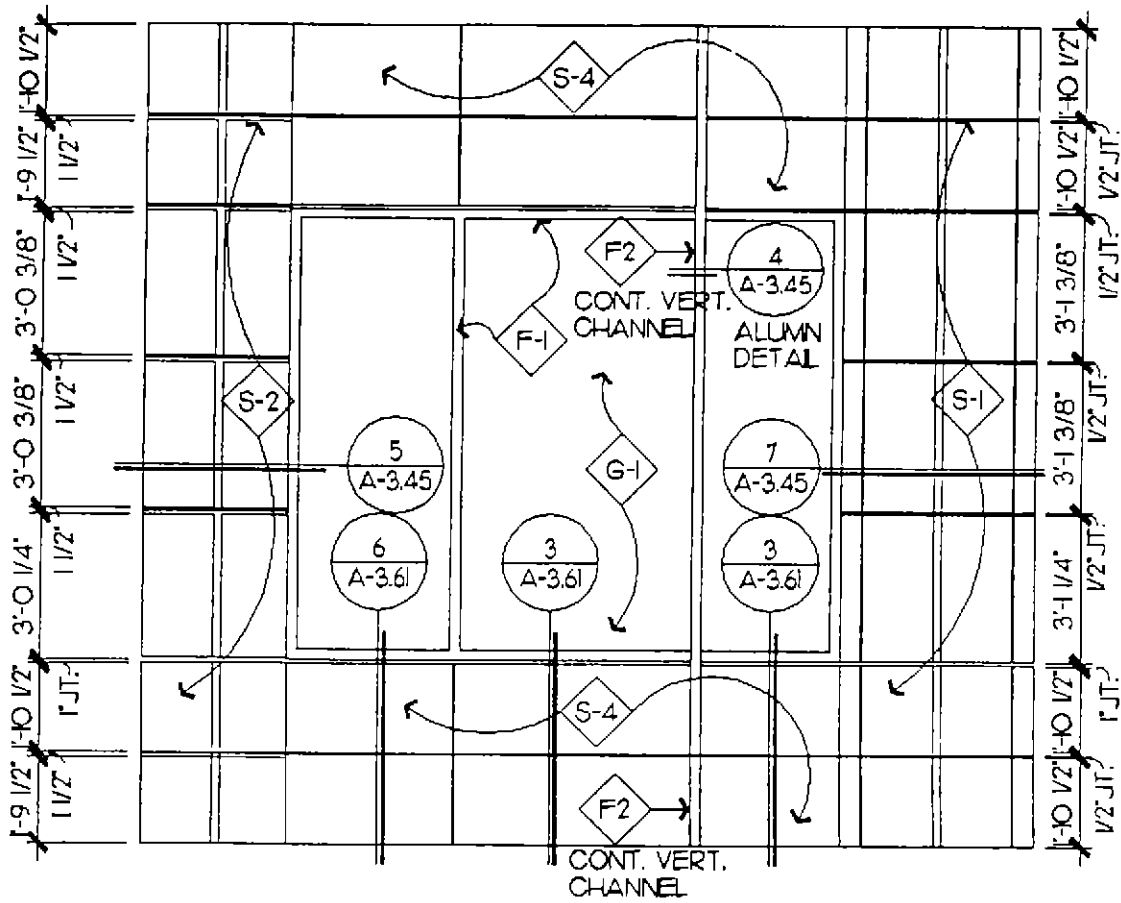

**VISUAL MOCK-UP**  
**PANEL V-1**

1/4"-1'-0"  
10-8-93

SECTION 08710

FINISH HARDWARE

PART 1 - GENERAL

1.01 RELATED DOCUMENTS:

General provisions and special provisions of these Specifications apply to the work specified in this Section.

1.02 DESCRIPTION:

Furnish all finish hardware required to complete the work as indicated on the drawings and as herein specified. Provide all trim, attachments and fastenings specified or required for proper and complete installation. Include all hardware under this Section of the specifications that is not specified in other sections, whether or not such hardware is herein scheduled.

1.03 RELATED WORK NOT INCLUDED IN THIS SECTION:

- A. **Installation of finish hardware.**
- B. **Rough hardware.**
- C. **Roll-up door hardware.**
- D. **Sound door seals and door butts.**
- E. **Smoke detectors.**

1.04 SUBMITTALS: Refer to Section 01300 for Procedures.

A. Hardware List:

Prepare and submit a hardware list, identifying each hardware item by manufacturer, manufacturer's catalog number and exact location in the work. Hardware list shall be in suitable form to facilitate ready checking by the Architect. Acceptance of the hardware list by the Architect does not relieve the hardware supplier from the responsibility of furnishing the job complete. The hardware supplier shall furnish to the Owner a copy of purchase orders showing the date of placing order.

B. Samples:

Submit a sample of the following type(s) hardware proposed in the work:

- 1) Lockset Design
- 2) Door Pulls
- 3) Head and jamb seals
- 4) Astragal Seals
- 5) Thresholds

C. Catalog Cuts:

Submit two (2) catalog cuts of every item furnished for the project. Show all finishes, sizes, catalog numbers and pictures. Explain fully all abbreviations.

1.05 GENERAL REQUIREMENTS:

**A. Packing, Marking and Delivery:**

Each unit of hardware shall be individually packaged, complete with proper fastenings and all appurtenances. Each package shall be clearly marked on the outside to show the contents and specific location in the work. Except where otherwise specified, deliver all hardware to the job site.

**B. Templates:**

In order to insure proper placement and fit, all hardware in connection with metal doors or metal frames shall be made to template. Templates or physical hardware items shall be supplied to manufacturers concerned and shall be supplied sufficiently in advance to avoid delay in the work.

**C. Warranty:**

All hardware shall be warranted for a period of two (2) years from the date of acceptance of the work. Defects in materials and workmanship occurring during the warranty period shall be corrected to the complete satisfaction of the Architect.

**D. Adjustments and Inspection:**

During the installation of hardware, a periodic inspection in company with the Architect will be made by the Architectural Hardware Supplier, or his Agent. Any hardware improperly installed shall be removed and reinstalled at the Contractor's expense. At the completion of the work, a final inspection shall be made by the Architectural Hardware Supplier, or his Agent. Make any and all adjustments recommended by the Architect, Architectural Hardware Supplier, or his Agent.

**E. Electrical Security Coordination:**

Before any electrical controlled and/or operated hardware is ordered, voltages must be coordinated with the electrical contractor.

**PART 2 - PRODUCTS**

2.01 FINISH OF HARDWARE:

**A. The finish of hardware** shall be as hereinafter specified. Special care shall be taken to coordinate the finish of the various manufacturers to insure a uniform acceptable finish. The finish of all hardware shall match the finish of the locksets unless otherwise specified.

**B. Head Seals and Jamb Seals** noted in specification as USP finish, shall be furnished in US28 finish and are to be painted to match color of door frame.

2.02 LOCK UNIFORMITY:

Except where otherwise specified, all locksets, latchsets, cylinders and component parts, as

specified hereinafter, shall be by one manufacturer.

2.03 LOCK STRIKES:

All lock strikes shall have a curved lip of sufficient length to protect the trim and jamb and shall be furnished with wrought boxes.

2.04 KEYING AND MASTER KEYING:

- A. **All locksets and cylinders** shall be keyed, master keyed and grand master keyed at the factory where records shall be established and maintained as directed.
- B. **All master keys and grand master keys** shall be identified with a registry number, NOT stamped with MASTER or letter "M". Individual room keys shall not be stamped with a key cut, but with a plain identification number. All keys shall be factory cut and stamped "DO NOT DUPLICATE."
- C. In **order to maintain** the established existing master key system, all cylinders and locksets shall be furnished with Best keyways to match keyway of record.
- D. **All locksets and cylinders** shall be construction keyed. Contractor and Hardware Supplier shall be held responsible for permanent keys until all are delivered to the Inspector or otherwise cleared to the Owners complete satisfaction.
- E. **It is a requirement that a meeting** be held with the Owner and Hardware Supplier to establish the Keying Schedule to provide correct Grand Master Keying, Master Keying, Pass Key and Change Key groups to function the system.

2.05 DOOR CLOSERS:

- A. **All door closers attached** to mineral core or particle filled doors shall be installed with sex bolts.
- B. **Provide drop brackets**, mortise shoes, and long arms, as required.
- C. **All door closers shall be adjusted** for spring setting, latch and sweep speeds, and back check.
- D. **Closer Certification:** The Contractor shall furnish a certificate executed by a Representative of the Manufacturer of the Door Closers that all Closers have been inspected and adjusted, and are operating as designed and have been installed in accordance with the Manufacturer's instructions.
- E. **Maximum allowable Door Closer** opening pressure shall be:

5.0 Pounds for Interior Doors.  
8.5 Pounds for Exterior Doors.  
15 Pounds for Fire Doors.

2.06 DOOR HARDWARE:

Hand of lock shall be as indicated on the drawings. If door hand is changed during construction, Contractor shall make necessary changes in hardware at no additional expense to the Owner.

2.07 DOOR BUTTS:

Hinges shall be full mortise, template type, unless half mortise hinges are required. Hinges shall have non-rising loose pins, ball or oilite bearings, and flat button tips, except when otherwise specified. Where necessary to keep door leaf clear of walls, casings, jambs or reveals in door openings, wide throw hinges of an approved type shall be furnished. Exterior door butts shall be steel, sheridized. For outswinging doors, hinges shall have a set screw in the barrel to prevent removal of pin when door is closed. All doors over 7'-6" shall have one extra hinge for each two and one half feet of height.

2.08 MAINTENANCE RELATED ITEMS:

The Contractor shall provide one (1) set of Adjusting Tools, four (4) sets of Maintenance Manuals, for Locksets, Door Closers, Floor Hinges and Panic Devices, direct to the Owners representative in charge of maintenance. If special cleaning instructions exist for finish material they shall be fully described in the maintenance manuals.

2.09 MATERIAL LIST:

A. DOOR BUTTS:

Door Butt No. 1

Hager	BB 1279
McKinney	TA 2714
Stanley	FBB 179

Door Butt No. 2

Hager	BB 7510
McKinney	TA 5792
Stanley	CB 1909

Door Butt No. 3

Hager	BB 1168
McKinney	T 4 A 3786
Stanley	FBB 168



**B. LOCKSETS:**

Lockset No. 1

Best	35 H 7 EW
Corbin/Russwin	ML-2257
Falcon	LM 581
Sargent	18-8104
Schlage	L 9080
Yale	8705 FL

Lockset No. 2

Security Door Controls	Z 2750 x 7500 EB x SC 10
------------------------	--------------------------

Lockset No. 3

Best	35 H 7 E
Corbin/Russwin	ML-2251
Falcon	LM 521
Sargent	18-8105
Schlage	L 9050
Yale	8707 FL

Latchset No. 4

Best	35 HON
Corbin/Russwin	ML-2210
Falcon	LM 101
Sargent	18-8115
Schlage	L 9010
Yale	8701 FL

Lockset No. 5 - Furnish with DWP keyway cylinder

Best	35 H 7 EW
Corbin/Russwin	ML-2257
Falcon	LM 581
Sargent	18-8104
Schlage	L 9080
Yale	8705 FL

Lockset No. 6

Best	35 H 7 J
Corbin/Russwin	ML-2255
Falcon	LM 561
Sargent	18-8137
Schlage	L 9070
Yale	8708 FL

Lockset Design

Best	3 H
Corbin/Ruswin	LWA
Falcon	SG
Sargent	LNH
Schlage	0 3 A
Yale	CRR

**C. DOOR CLOSERS:**

Door Closer No. 1

L.C.N.	P 4040
Norton	P 7500
Yale	P 4400

Door Closer No. 2

L.C.N.	4040
Norton	7500
Yale	4400

**D. PANIC DEVICES:**

Panic Device No. 1

Monarch	FXX-C-LE Omni x FXX-C-N
Von Duprin	8847 LF x 03 x 8847 EOF

Panic Device No. 2

Monarch	FXX-C-N x FXX-C-N
Von Duprin	8847 EOF x 8847 EOF

**E. DOOR STOPS:**

Door Stop No. 1

Builders Brass Works	8061 X
Quality	331 ES
Trimco	1211 ES

Door Stop No. 2

Builders Brass Works	W 12
Quality	W 307
Trimco	W 1276

**F. DOOR PULLS:**

Door Pull No. 1

Builders Brass Works  
Quality  
Trimco

2988 - 1-1/2" projection  
473 - 1-1/2" projection  
1741 - 1-1/2" projection

**G. AUTOMATIC FLUSH BOLTS:**

Hollow Metal Doors

Door Controls  
Glynn-Johnson

842 x NH x 80  
FB-7 x DP-1 or 2

**H. COORDINATORS:**

Door Controls

Glynn-Johnson

600 Series x 100 x Brackets as  
required  
COR x CB x Brackets as  
required

**I. HEAD SEALS:**

Head Seal No. 1

Pemko  
Ultra

293 CS  
WS 242 S

Head Seal No. 2

Pemko  
Ultra

S 88  
WS 176

**J. JAMB SEALS:**

Jamb Seal No. 1

Pemko  
Ultra

293 CS  
WS 242 S

**K. ASTRAGAL SEALS:**

Astragal Seal No. 1

Pemko  
Ultra

293 CS  
WS 242 S

**L. DOOR BOTTOMS:**

Door Bottom No. 1

Pemko 420 A  
Ultra DB 044 S

Door Bottom No. 2

Pemko 430 CR  
Ultra DB 043 S

**M. MAGNETIC HOLDERS:**

Magnetic Holder No. 1

Rixson 998

Magnetic Holder No. 2

Rixson 990

**N. FLOOR HINGES:**

Floor Hinge No. 1

Rixson F 5103

**O. SIDE JAMB PIVOTS:**

Side Jamb Pivot No. 1

Rixson FM 19

**P. THRESHOLD ASSEMBLIES:**

Threshold Assembly No. 1

Pemko 13-195 B x 192 B x 196 B  
(welded)  
Ultra C - BTH 121 x BTH 116 x BTH  
120 welded

**Q. THRESHOLDS:**

Threshold No. 1

Pemko 171  
Ultra THO 15

Threshold No. 2

Pemko 154  
 Ultra THO 18

**R. KEY CABINET:**

Lund 1807  
 Tel-Key DWT 1200 S

**S. COAT HOOK:**

Trimco 3071

**T. SILENCERS:**

Builders Brass Works W-07  
 Glynn-Johnson 64  
 Trimco 1337 A

2.10 HARDWARE SCHEDULE:

This schedule is a guide only. Furnish all Finish Hardware required for the project. Hardware required for any particular location, but not specified shall be the same as that specified for similar location. All doors shall be covered by a listing of hardware in the Finish Hardware schedule whether specified or not. Hardware shall be as hereinafter specified.

HARDWARE TYPE 1

1-1/2	Pair Butts	No. 1	4-1/2 x 4	USP
1	Lockset	No. 1		US 32 D
1	Door Closer	No. 1		Alum
1	Door Stop	No. 1		US 26 D
1	Head Seal	No. 2		-
2	Jamb Seals	No. 1		USP
1	Threshold	No. 1		US 28

HARDWARE TYPE 2

1-1/2	Pair Butts	No. 1	4-1/2 x 4	USP
1	Lockset	No. 2		US 32 D
1	Door Closer	No. 2		Alum
1	Door Stop	No. 2		US 32 D
1	Head Seal	No. 1		USP
2	Jamb Seals	No. 1		USP
1	Door Bottom	No. 1		USP
1	Threshold	No. 1		US 28

HARDWARE TYPE 3

2	Floor Hinges	No. 1		US 10 B
2	Side Jamb Pivots	No. 1		US 10 B
16	Door Pulls	No. 1 (back to back)		US 10 B
2	Magnetic Holders	No. 1		Bronze
1	Head Seal	No. 1		USP
2	Jamb Seals	No. 1		USP
2	Astragal Seals	No. 1		D
1	Threshold Assembly	No. 1		US 10 B

HARDWARE TYPE 4

3	Pair Butts	No. 1	4-1/2 x 4	USP
1	Lockset	No. 3		US 32 D
1	Set Automatic Flush Bolts		US 26 D	
1	Coordinator			USP
2	Door Closers	No. 1		Alum
1	Magnetic Holders	No. 1		Alum
1	Magnetic Holder	No. 2		Alum
1	Head Seal	No. 2		-
2	Jamb Seals	No. 1		USP
2	Astragal Seals	No. 1		USP
1	Threshold	No. 2		US 28

HARDWARE TYPE 5

3	Pair Butts	No. 1	4-1/2 x 4	USP
1	Lockset	No. 1		US 32 D
1	Set Automatic Flush Bolts		US 26 D	
1	Coordinator			USP
2	Door Closers	No. 1		Alum
2	Door Stops	No. 2		US 32 D
1	Head Seal	No. 2		-
2	Jamb Seals	No. 1		USP
2	Astragal Seals	No. 1		USP
2	Door Bottoms	No. 2		USP
1	Threshold	No. 1		US 28

HARDWARE TYPE 6

3	Pair Butts	No. 1	4-1/2 x 4	USP
1	Lockset	No. 1		US 32 D
1	Set Automatic Flush Bolts		US 26 D	
1	Coordinator			USP
2	Door Closers	No. 1		Alum
2	Door Stops	No. 2		US 32 D
1	Head Seal	No. 2		-
2	Jamb Seals	No. 1		USP
2	Astragal Seals	No. 1		USP
1	Threshold	No. 1		US 28

HARDWARE TYPE 7

All hardware not part of this Section.

HARDWARE TYPE 8

1-1/2	Pair Butts	No. 1	4-1/2 x 4	USP
1	Lockset	No. 3		US 32 D
1	Door Closer	No. 2		Alum
1	Door Stop	No. 2		US 32 D
1	Head Seal	No. 1		USP
2	Jamb Seals	No. 1		USP
1	Threshold	No. 1		US 28

HARDWARE TYPE 9

1-1/2	Pair Butts	No. 1	4-1/2 x 4	USP
1	Lockset	No. 1		US 32 D
1	Door Closer	No. 1		Alum
1	Door Stop	No. 2		US 32 D
1	Head Seal	No. 2		-
2	Jamb Seals	No. 1		USP
1	Threshold	No. 1		US 28

HARDWARE TYPE 10

1-1/2	Pair Butts	No. 1	4-1/2 x 4	USP
1	Lockset	No. 1		US 32 D
1	Door Closer	No. 1		Alum
1	Door Stop	No. 1		US 26 D
1	Head Seal	No. 2		-
2	Jamb Seals	No. 1		USP
1	Door Bottom	No. 1		USP
1	Threshold	No. 1		US 28

HARDWARE TYPE 11

1-1/2	Pair Butts	No. 1	4-1/2 x 4	USP
1	Latchset	No. 4		US 32 D
1	Door Closer	No. 1		Alum
1	Door Stop	No. 2		US 32 D
1	Head Seal	No. 2		-
2	Jamb Seals	No. 1		USP
1	Door Bottom	No. 1		USP
1	Threshold	No. 1		US 28

RTD Headquarters  
Los Angeles, California  
#91-400

7/07/93  
Finish Hardware  
08710 - 12

HARDWARE TYPE 12

3	Pair Butts	No. 1	4-1/2 x 4	USP
1	Lockset	No. 1		US 32 D
1	Set Automatic Flush Bolts		US 26 D	
1	Coordinator			USP
2	Door Closers	No. 2		Alum
2	Door Stops	No. 1		US 26 D
1	Head Seal	No. 1		USP
2	Jamb Seals	No. 1		USP
2	Astragal Seals	No. 1		USP
1	Threshold	No. 1		US 28

HARDWARE TYPE 13

1-1/2	Pair Butts	No. 1	4-1/2 x 4	USP
1	Lockset	No. 1		US 32 D
1	Door Closer	No. 2		Alum
1	Door Stop	No. 2		US 32 D
1	Head Seal	No. 1		USP
2	Jamb Seals	No. 1		USP
1	Door Bottom	No. 1		USP
1	Threshold	No. 1		US 28

HARDWARE TYPE 14

3	Pair Butts	No. 1	4-1/2 x 4	USP
1	Panic Device	No. 1		US 26 D
1	Cylinder	As required	US 26 D	
2	Door Closers	No. 1		Alum
2	Door Stops	No. 2		US 32 D
1	Head Seal	No. 2		-
2	Jamb Seals	No. 1		USP
2	Astragal Seals	No. 1		USP
2	Door Bottoms	No. 2		USP
1	Threshold	No. 1		US 28

HARDWARE TYPE 15

1-1/2	Pair Butts	No. 1	4-1/2 x 4	USP
1	Latchset	No. 4		US 32 D
1	Door Closer	No. 1		Alum
1	Door Stop	No. 2		US 32 D
1	Head Seal	No. 2		-
2	Jamb Seals	No. 1		USP
1	Threshold	No. 1		US 28



HARDWARE TYPE 16

1-1/2	Pair Butts	No. 1	4-1/2 x 4	USP
1	Lockset	No. 5		US 32 D
1	Door Closer	No. 1		Alum
1	Door Stop	No. 2		US 32 D
1	Head Seal	No. 2		-
2	Jamb Seals	No. 1		USP
1	Threshold	No. 1		US 28

HARDWARE TYPE 17

2	Floor Hinges	No. 1		US 10 B
4	Side Jamb Pivots	No. 1		US 10 B
16	Door Pulls	No. 1		US 10 B
2	Magnetic Holders	No. 2		Bronze
1	Head Seal	No. 1		USP
2	Jamb Seals	No. 1		USP
2	Astragal Seals	No. 1		D
1	Threshold Assembly	No. 1		US 10 B

HARDWARE TYPE 18

4	Pair Butts	No. 1	4-1/2 x 4	USP
1	Lockset	No. 3		US 32 D
1	Set Automatic Flush Bolts		US 26 D	
1	Coordinator			USP
2	Door Closers	No. 1		Alum
1	Magnetic Holder	No. 1		Alum
1	Magnetic Holder	No. 2		Alum
1	Head Seal	No. 2		-
2	Jamb Seals	No. 1		USP
2	Astragal Seals	No. 1		USP
1	Threshold	No. 1		US 28

HARDWARE TYPE 19

2	Sets Butts	No. 2		USP
1	Panic Device	No. 2		US 26 D
2	Door Closers	No. 1		Alum
2	Magnetic Holders	No. 1		Alum
1	Head Seal	No. 2		-
2	Jamb Seals	No. 1		USP
2	Astragal Seals	No. 1		USP

RTD Headquarters  
Los Angeles, California  
#91-400

7/07/93  
Finish Hardware  
08710 - 14

HARDWARE TYPE 20

1	Set Butts	No. 2		USP
1	Lockset	No. 1		US 32 D
1	Door Closer	No. 1		Alum
1	Door Stop	No. 2		US 32 D
1	Head Seal	No. 2		-
2	Jamb Seals	No. 1		USP
1	Threshold	No. 1		US 28

HARDWARE TYPE 21

Doors and Hardware N.I.C.

HARDWARE TYPE 22

1-1/2	Pair Butts	No. 1	4-1/2 x 4	USP
1	Lockset	No. 3		US 32 D
1	Door Closer	No. 1		Alum
1	Door Stop	No. 2		US 32 D
1	Head Seal	No. 2		-
2	Jamb Seals	No. 1		USP
1	Threshold	No. 1		US 28

HARDWARE TYPE 23

1-1/2	Pair Butts	No. 1	4-1/2 x 4	USP
1	Lockset	No. 6		US 32 D
1	Door Closer	No. 1		Alum
1	Door Stop	No. 2		US 32 D
3	Silencers			Gray
1	Coat Hook			US 26 D
1	Threshold	No. 1		US 28

HARDWARE TYPE 24

1-1/2	Pair Butts	No. 1	4-1/2 x 4	USP
1	Lockset	No. 3		US 32 D
1	Door Closer	No. 1		Alum
1	Door Stop	No. 1		US 26 D
3	Silencers			Gray
1	Threshold	No. 1		US 28

HARDWARE TYPE 25

2	Sets Butts	No. 2		USP
1	Pair Butts	No. 3	5 x 4-1/2	USP
1	Latchset	No. 4		US 32 D
1	Set Automatic Flush Bolts		US 26 D	
1	Coordinator			USP
2	Door Closers	No. 1		Alum
2	Door Stops	No. 2		US 32 D
2	Silencers			Gray

HARDWARE TYPE 26

4	Pair Butts	No. 1	4-1/2 x 4	USP
1	Lockset	No. 6		US 32 D
1	Set Automatic Flush Bolts		US 26 D	
1	Coordinator			USP
2	Door Closers	No. 2		Alum
2	Door Stops	No. 2		US 32 D
1	Head Seal	No. 1		USP
2	Jamb Seals	No. 1		USP
2	Astragal Seals	No. 1		USP
1	Threshold	No. 1		US 28

HARDWARE TYPE 27

1-1/2	Pair Butts	No. 1	4-1/2 x 4	USP
1	Lockset	No. 1		US 32 D
1	Door Closer	No. 2		Alum
1	Door Stop	No. 1		US 26 D
1	Head Seal	No. 1		USP
2	Jamb Seals	No. 1		USP
1	Threshold	No. 1		US 28

HARDWARE TYPE 28

2	Sets Butts	No. 2		USP
2	Pair Butts	No. 3	5 x 4-1/2	USP
1	Panic Device	No. 2		US 26 D
2	Door Closers	No. 1		Alum
2	Magnetic Holders	No. 1		Alum
1	Head Seal	No. 2		-
2	Jamb Seals	No. 1		USP
2	Astragal Seals	No. 1		USP

HARDWARE TYPE 29

3	Pair Butts	No. 1	4-1/2 x 4	USP
1	Lockset	No. 3		US 32 D
1	Set Automatic Flush Bolts		US 26 D	
1	Coordinator			USP
2	Door Closers	No. 1		Alum
2	Door Stops	No. 2		US 32 D
1	Head Seal	No. 2		-
2	Jamb Seals	No. 1		USP
2	Astragal Seals	No. 1		USP
1	Threshold	No. 1		US 28

HARDWARE TYPE 30

3	Pair Butts	No. 1	4-1/2 x 4	USP
1	Lockset	No. 3		US 32 D
1	Set Automatic Flush Bolts		US 26 D	
1	Coordinator			USP
2	Door Closers	No. 1		Alum
2	Magnetic Holders	No. 1		Alum
2	Head Seal	No. 2		-
2	Jamb Seals	No. 1		USP
2	Astragal Seals	No. 1		USP
1	Threshold	No. 2		US 28

HARDWARE TYPE 31

1-1/2	Pair Butts	No. 1	4-1/2 x 4	USP
1	Lockset	No. 2		US 32 D
1	Door Closer	No. 1		Alum
1	Door Stop	No. 2		US 32 D
1	Head Seal	No. 2		-
2	Jamb Seals	No. 1		USP
1	Door Bottom	No. 1		USP
1	Threshold	No. 1		US 28

HARDWARE TYPE 32

2	Sets Butts	No. 2		USP
1	Lockset	No. 3		US 32 D
1	Set Automatic Flush Bolts		US 26 D	
1	Coordinator			USP
2	Door Closers	No. 1		Alum
2	Door Stops	No. 2		US 32 D
1	Head Seal	No. 2		-
2	Jamb Seals	No. 1		USP
2	Astragal Seals	No. 1		USP
1	Threshold	No. 1		US 28

HARDWARE TYPE 33

2	Floor Hinges	No. 1		US 10 B
4	Side Jamb Pivots	No. 1		US 10 B
16	Door Pulls	No. 1		US 10 B
1	Magnetic Holder	No. 1		Bronze
1	Magnetic Holder	No. 2		Bronze
1	Head Seal	No. 1		USP
2	Jamb Seals	No. 1		USP
2	Astragal Seals	No. 1		D
1	Threshold Assembly	No. 1		US 10 B

HARDWARE TYPE 34

3	Pair Butts	No. 1	4-1/2 x 4	USP
1	Latchset	No. 4		US 32 D
1	Set Automatic Flush Bolts		US 26 D	
1	Coordinator			USP
2	Door Closers	No. 2		Alum
2	Door Stops	No. 2		US 32 D
1	Head Seal	No. 1		USP
2	Jamb Seals	No. 1		USP
2	Astragal Seals	No. 1		USP
1	Threshold	No. 1		US 28

HARDWARE TYPE 35

1-1/2	Pair Butts		Furnished by Door Supplier	
1	Lockset	No. 3		US 32 D
1	Door Closer	No. 1		Alum
1	Door Stop	No. 2		US 32 D
1	Threshold	No. 3		US 28

HARDWARE TYPE 36

4	Pair Butts	No. 1	4-1/2 x 4	USP
1	Latchset	No. 4		US 32 D
1	Set Automatic Flush Bolts		US 26 D	
1	Coordinator			USP
2	Door Closers	No. 2		Alum
2	Door Stops	No. 2		US 32 D
1	Head Seal	No. 1		USP
2	Jamb Seals	No. 1		USP
2	Astragal Seals	No. 1		USP
1	Threshold	No. 2		US 28

HARDWARE TYPE 37

Miscellaneous Items

1	Key Cabinet	Locate as directed	-
12	Construction Keys		-
6	Master & Grand Master Keys		

2.11 DOOR INFORMATION SHEET:

<b>DOOR NUMBER</b>	<b>HARDWARE TYPE</b>
PARKING LEVEL 4	
P401	NOT USED
P402	NOT USED
P403	1
P404	9
P405	NOT USED
P406	2
P407	2
P408	2
P409	2
P410	3
P411	4
P412	4
P413	3
P414	5
P415	5
P416	5
P417	6
P418	7
P419	6
P420	6
P421	6
P422	10
PARKING LEVEL 3	
P301	3
P302	7
P303	8
P304	1
P305	9
P306	2
P307	2
P308	2
P309	2
P310	3
P311	30
P312	4

DOOR NUMBER	HARDWARE TYPE
P313	27
P314	10
P315	6
P316	11
P317	10
P318	NOT USED
P319	11
P320	NOT USED
P321	NOT USED
P322	6
P323	12
P324	13
P325	10
P326	7
P327	6
PARKING LEVEL 2	
P201	14
P202	15
P203	7
P204	5
P205	16
P206	2
P207	2
P208	2
P209	14
P210	17
P211	18
P212	19
P213	19
P214	7
P215	20
P216	5
P217	10
P218	NOT USED
P219	21
P220	21
P221	8
P222	10
P223	22
P224	7
P225	29
P226	10
P227	10
P228	23
P229	6
P230	24
P231	22

RTD Headquarters  
Los Angeles, California  
#91-400

7/07/93  
Finish Hardware  
08710 - 20

DOOR NUMBER	HARDWARE TYPE
P232	25
P233	25
P234	22
P235	NOT USED
P236	2
P237	7
P238	7
P239	7
P240	26
P241	15
P242	16
P243	10
P244	7
P245	7
P246	NOT USED
P247	5
P248	31
P249	22
P250	10
P251	10
P252	5
PARKING LEVEL 1	
P101	2
P102	7
P103	
P104	29
P105	32
P106	2
P107	2
P108	2
P109	2
P110	33
P111	28
P112	34
P113	8
P114	8
P115	7
P116	NOT USED
P117	10
P118	5
P119	22
P120	2
P121	21
P122	35
P123	28
P124	36
P125	7



RTD Headquarters  
Los Angeles, California  
#91-400

7/07/93  
Finish Hardware  
08710 - 21

DOOR NUMBER	HARDWARE TYPE
P126	6
P127	22
P128	7
P129	2
P130	29
P131	21
P132	17
P133	29
P134	6
P135	9

END OF SECTION



**SECTION 08800**

**EXTERIOR GLASS AND GLAZING**

**1.00 GENERAL**

**1.01 DESCRIPTION:** Division 1 applies to this Section. Provide exterior glass and glazing as indicated, specified, and required.

**A. Work in this Section:** Provide all Exterior Glass and Glazing indicated on drawings or specified herein. Include all labor, materials, equipment, and services necessary to complete the Exterior Glass and Glazing, including, but not limited to, the following:

1. Glass and glazing for test mock-ups and visual mock-ups.
2. No attic stock of glass and glazing materials is required.
3. Glazing of the fixed windows, operable windows and access doors and aluminum entrances.
4. Glazing accessories.
5. Glazing of the aluminum curtain wall system.

**B. Related Work not in this Section:**

1. Fixed Windows. Section 08500.
2. Miscellaneous Glass and Glazing. Section 08801.
3. Mock-up. Section 01450.

**C.** The Exterior Wall Subcontractor shall be the single point of responsibility for the entire exterior envelope of the project.

**1.02 QUALIFICATIONS**

**A.** Submit manufacturer's certified identification, showing strength, grade, thickness, type and quality for each type of glass used. Mark tempered and laminated glass with permanent identification labels.

**B.** Comply with all building, fire, and safety codes relating to the work and ASTM C1048-85. Safety glazing shall conform to the requirements of Federal rules and regulations titled "Safety Standards for Architectural Glazing materials" (16 CFR Part 1201), and ANSI Z97.1-1975. Use tempered glass for safety glazing unless shown otherwise. Provide certification that the glazing used conforms to the referenced standards.

- C. Each glass type is to match the approved samples, and to be uniform in appearance, free from irregularities and differences in appearance when viewed from exterior as judged by the Architect. Glass not complying with this requirement to be replaced with conforming glass at no additional cost to **Owner**.
- D. Engage a single firm to assume undivided responsibility for the exterior glass and glazing and coordination with the Exterior Wall Subcontractor. This firm must demonstrate not less than 5 years successful experience at work similar to the work of this project. Provide at least one person who shall be thoroughly trained and experienced in the skills required, who shall be completely familiar with the referenced standards and the requirements of this work, and who shall personally direct all installation performed under this Section of these specifications.

### 1.03 PLANS AND SPECIFICATIONS

- A. The character of these documents are intended to provide a performance type specification for the design, fabrication and installation of the exterior glass and glazing. The Exterior Wall Subcontractor is responsible for the engineering and design of all components and materials as well as the fabrication, installation and performance of the glass and glazing.
- B. Drawings are diagrammatic. The details shown are intended as a guide for the aesthetic and interfacing requirements of the glass and glazing to and with other work. The requirements shown by the details are intended to establish basic dimensions, locations and changes in glass panels and locations of different glass types. The Exterior Wall Subcontractor is responsible for the design and engineering of the glass and glazing within these aesthetic parameters. The drawings are not to be construed as engineering design, or adequate to meet the engineering design requirements.
- C. It is recognized that the design details do not cover some conditions or modifications, which may be required. It is, however, intended that conditions not detailed shall be developed through the shop drawings to the same level of aesthetics and in compliance with performance criteria as indicated for detailed areas and as stipulated in these specifications.
- D. If conflicts exist between this section of the specification and the glass framing specifications, the more stringent specification shall apply.

### 1.04 CODES AND STANDARDS

- A. The glass and glazing work, except as otherwise shown or specified shall comply with the minimum requirements of the latest edition of the following codes, specifications and standards. Where conflicting requirements arise, follow the more stringent.
  - 1. FGMA Glazing Manual - 1986 Edition.
  - 2. ASTM 1036-85, Standard Specification for Flat Glass.

3. ASTM C1048-85, Standard Specification for Heat Treated Flat Glass.
4. Federal Standard CPSC 16 CRF 1201.
5. ANSI Z97.1-1984, Safety Glazing Materials.
6. ASTM E774-84a, Standard Specification for Sealed Insulating Glass Units.
7. ASTM E773-83, Standard Test Method for sealed durability of insulating glass units.
8. AAMA CWS-12, Structural Properties of Glass.
9. ASTM E997, Test for Glass Under Static Loads by Destruction Methods.
10. ASTM C998, Test for Glass Under Static Loads by Non-Destructive Methods.
11. Los Angeles Building Code, latest edition.
12. Uniform Building Code - 1991 Edition.
13. AAMA "Metal Curtain Wall Specification Manual".
14. ASTM E 546-75 Standard Test Method for Frost Point of Sealed Insulating Glass Units.
15. ASTM E 576-76 Standard Test Method for Dew/Frost Point of Sealed Insulating Glass Units in Vertical Position.
16. ASTM C509-84 Cellular Preformed Rubbers.
17. ASTM C864-84 Compression Seals Spacers and Setting Blocks.
18. F.S. TT-S-001543, Class A Structural Glazing Sealant.
19. AAMA 807.1 Glazing tapes.
20. AAMA SG-1.76 Glazing gaskets.

#### **1.05**

#### **SUBMITTALS**

- A. Submit shop drawings showing details of each type glazing system indicating sizes, shapes, material and quantity. Show details indicating sealant thickness and profile, bite on glass, glass edge clearance, depth of rabbet and thickness of glass. Identify gasket materials, side spacer blocks, and setting blocks. Show weepage system in glass pockets.
- B. Submit manufacturer's published data for glazing material specified and recommended installation requirements. Include documentation of structural integrity with respect to wind pressure diagrams.

- C. Submit the following samples for review or testing:
1. Submit samples of each type glass specified. Minimum size of glass shall be 12" x 12". All submittals shall identify thickness and type of glass (annealed, heat strengthened, or tempered) and the maximum design wind load it can accommodate based upon the maximum sizes required for that glass type. Submit five (5) of each.
  2. Furnish glass for mock-up test unit, scope as suggested on the Architectural Drawings. Provide one extra lite of glass for each glass size used in the mock-up. Coordinate glass and glazing requirements with the Exterior Wall Subcontractor.
  3. Submit samples of all gaskets, spacers, setting blocks and edge blocks. Submit five (5) of each.
  4. Prior to final bid approval, the Exterior Wall Subcontractor shall provide full size Glass Type 1 insulating glass units on a minimum of three glass types for review. Additional glass types may be requested by the Architect. The glass units shall be installed in a mock-up at the job site. The scope of the mock-up shall be as indicated on the architectural elevations.
- D. Submit calculations demonstrating the structural integrity of the glass in meeting the design load pressures which are specified in the respective glass framing systems. Glass shall be designed using the probability of breakage of 8 lites per 1000. Include thermal stress and shadow line analysis calculations and center deflection calculations as part of this submittal. Calculations shall be performed by the glass manufacturer. Where glass manufacturer cannot assure adequate structural performance of insulating glass units based upon combination of inner and outer light, assume outer light alone must satisfy structural requirements.
- E. Provide certification from glass producer/fabricator that glass producer fabricator has reviewed all glazing details, project conditions and thicknesses and compositions of all glass and finds same suitable for the purpose intended in accordance with these specifications. Glass manufacturer's recommendations are to be accompanied by wind load and thermal stress and shadow line analyses.
- F. Submit certification from manufacturer stating that insulated glass units meet standards specified herein.

**1.06**

**JOB CONDITIONS**

- A. **General Contractor** to meet with Exterior Wall Subcontractor or other trades affected by glass installation, prior to beginning of installation to review the glazing requirements and specifications. Do not perform work under adverse weather or job conditions. Install liquid sealants when temperatures are within lower or middle third of temperature range recommended by manufacturer.

**1.07 DELIVERY AND STORAGE**

- A. Deliver glass to site with manufacturer's labels showing thickness, quality and type.
- B. Deliver glazing compound and other glazing items to site in manufacturer's original unopened packages on containers.
- C. Remove from the jobsite and replace with acceptable material all cracked, broken, chipped or otherwise damaged glass, and all glazing and sealing materials unfit for use.
- D. Store glass in dry, well-vented location at a temperature maintained above dew point. Minimize the handling of glass and protect from soiling, atmospheric condensation and other moisture.
- E. No attic stock on any glass is required. No additional gaskets, reglazing beads, or other accessories shall be provided.
- F. All delivered items whether F.O.B. jobsite for unloading and installation by others or whether fabricated and installed by the Exterior Wall Subcontractor shall be properly crated. Crates shall be marked with installation location and fabrication/piece numbers, shop drawing references, and other items as applicable.

**1.08 SPECIAL PROJECT WARRANTIES**

- A. The manufacturer of coated glass shall warrant and guarantee direct to **Owner** that the reflective glass will not develop peeling, cracking or deterioration in the metallic film under normal conditions, for a period of 10 years from final acceptance and payment by the **Owner**.
- B. The manufacturer of the insulated glass shall warrant and guarantee direct to the **Owner** each insulating glass unit installed to be free from material obstructions of vision as a result of dust or film formation on the internal glass surfaces caused by failure of the hermetic seal other than glass breakage; and free from discoloration, mottling or deteriorating of the coating regardless of loss of insulating glass seal, for a period of 10 years from final acceptance and payment by the **Owner**.
- C. The spandrel glass manufacturer and opacifier manufacturer shall warrant and guarantee direct to the **Owner** that the opacifier will not develop peeling, cracking, discoloration, deteriorating or mottling for a period of 10 years. This warranty also applies to any ceramic frit coating from final acceptance and payment by the **Owner**.
- D. Guarantee glazing occurring on the exterior of the building to be weather and watertight for a period of **five (5)** years after date of final acceptance and payment by the **Owner**.
- E. All warranties shall agree to replace the glass F.O.B. project site, including labor, at no cost to the **Owner**, provided the manufacturer's instructions for protection and maintenance have been adhered to during the warranty period and failure is not due to vandalism or glass breakage caused by external projectiles.

- F. The glass manufacturer shall warrant against glass breakage for a period of five (5) years from final acceptance and payment by the **Owner**. **Glass manufacturer shall submit copy of warranty for review and approval.**

**2.00** PRODUCTS

**2.01** **MATERIALS**

- A. Viracon, Inc. shall be considered the glass fabricator for base bid purposes. Other glass manufacturers or fabricators will be considered. Glass manufactured or fabricated by other manufacturers must meet all of the structural, performance and aesthetic characteristics of the base bid glass.

**2.02** **GLASS TYPES**

- A. Vision Glass Type 1: Viracon VE 4-85, 1" insulating unit. 1/4" bronze float with 85% visible light transmission and a low-emissivity coating on number two (2) surface, 1/2" air space, and 1/4" clear float. Shading coefficient: 0.43. Glass to be heat strengthened or tempered as required by code, thermal stress analysis and wind loading information.
- B. Vision Glass Type 2: Viracon VE 1-55, 1" insulating unit. 1/4" clear float with 55% visible light transmission, 1/2" air space, 1/4" clear float. Shading coefficient: 0.42. Glass to be heat strengthened or tempered as required by code, thermal stress analysis and wind loading information.
- C. Vision Glass Type 3: Break-out lites shall occur as indicated in the documents. Maximum centers shall be 50'- 0". Lights shall have an identifying marker of type and at location required by governing authorities. Provide 1" insulating units per Vision Glass Type 1 except full temper both inboard and outboard lites to meet requirements of the ANSI Z97.1 Standard and Federal Standard CPSC 16 CRF 1201.
- D. Alternate Vision Glass Type 1A: Provide 1 5/16" insulating units per Vision Glass Type 1 except inboard lite shall be 9/16". 1/4" clear float, 1/16" PVB interlayer, 1/4" clear float. Alternate shall be for vision glass at the west face of tower and base, and west end of north and south base.
1. Provide 12" x 12" samples with performance data including acoustical characteristics.
  2. Provide full size samples to meet requirements of Section 1.05.C.4.
- E. Alternate Vision Glass Type 2A: 1" insulating unit. 1/4" clear float, 1/2" air space, 1/4" clear float. Glass to be heat strengthened or tempered as required by code, thermal stress analysis and wind loading information.



## 2.03 COMPONENTS

- A. Float Glass: 1/4" thickness minimum, unless otherwise noted or required thicker by glass manufacturer. Clear as indicated, meeting ASTM 1036-85, type 1, class 1 or class 2.
- B. Heat Treated Float Glass: 1/4" thickness minimum, unless otherwise noted or required thicker by glass manufacturer. Clear as indicated, meeting ASTM C 1048-85, Federal Standard 16 CFR 1201 and ANSI Z97.1-1984. Glass shall be treated using a horizontal process. No tong marks shall be allowed. Heat strengthened as recommended by the glass manufacturer due to thermal stress or structural considerations. Tempered as required to meet code requirements. The orientation of the inherent roller marks in the heat strengthened shall be horizontal, not vertical when the glass is in installed position.
- C. Coated: 1/4" thickness minimum, unless otherwise noted or required thicker by the glass manufacturer. Clear as required. Heat strengthened or tempered as required. Coating on 2nd surface.
- D. Insulating Glass: Double glazed, dual sealed units, with air space between panes hermetically sealed with silicone at the perimeter of the unit. Units to meet Class CBA of the IGCC, ASTM E 773-83, ASTM E-576, and ASTM E774-84a, level CBA.
- E. The vision and spandrel glass used is to be heat strengthened or tempered as recommended by the manufacturer due to thermal stress, or structural considerations. Tempered glass should only be used to meet safety glazing codes. Increase glass thickness as necessary to meet other performance criteria.
- F. If and where the need for fully-tempered glass is required, due to safety glazing or loading effects that can not be compensated for by increasing the glass thickness or other means, then the glass must be heat soaked. To waive this requirement, the Exterior Wall Subcontractor and glass manufacturer are required to provide the labor, equipment and materials necessary to replace all spontaneous glass breakages for a period 5 years after completion of installation. In addition, the Exterior Wall Subcontractor and glass manufacturer will be responsible for other property damages or personal injury liabilities caused by such breakages for the same 5 year period.
- G. The lites comprising insulating glass units shall be annealed, heat strengthened, or fully tempered, as specified, required, or as recommended by the specified glass manufacturer to insure against heat breakage and to assure adequate glass performance at the specified design pressures and under test conditions specified under the performance criteria specified in the respective glass framing specification sections. The exterior lite in all insulating glass units shall be fabricated from the same materials and strengthening process in order to maintain visual uniformity throughout the project.
- H. Method of installation must be accordance with the manufacturer's published literature, as well as the latest standards of the FGMA and SIGMA. The Exterior Wall Subcontractor shall coordinate these requirements and standards as they apply to the exterior wall systems.

## 2.04 GLAZING ACCESSORIES

- A. Exterior glazing gaskets to be cellular neoprene complying with ASTM C509-84. Exterior gaskets to have shop molded corners. Interior wedge gaskets to be non-cellular neoprene complying with ASTM C864-84, option 1, with molded corners.
- B. Setting blocks must be 80 to 90 durometer extruded neoprene, EPDM or silicone, minimum 4" long, sized per FGMA guidelines. Side spacer blocks must be 65 $\pm$ 5 durometer extruded neoprene or EPDM, sized and profiled for intended use.
- C. Where wet seal is required, use a one part non-acidic moisture-curing, neutral curing silicone sealant complying with F.S. TT-S-001543, Class A.
- D. Glazing Tapes shall be preformed macro-polyisobutylene with a continuous integral shim of a Shore "A" of 40 to 60. Tape shall comply with AAMA 807.1. Tape should compress to the shim without excessive force being required, as recommended by the glass manufacturer, to avoid pressure points or breakage. Tape shall be used only at storefront glazing if the frame system design incorporates this glazing method.
- E. Compressible Filler Rod shall be closed-cell or waterproof-jacketed rod stock of synthetic rubber or plastic foam, proven to be compatible with sealants used. Rod is not to be used in the glazing rabbet.
- F. Cleaners, Primers and Sealers shall be type as recommended by manufacturers of sealant or gasket.

## 3.00 EXECUTION

### 3.01 EXAMINATION

- A. Examine the areas and conditions where glass and glazing are to be installed and notify in writing the Architect and **General** Contractor of conditions detrimental to the proper and timely completion of the work. Do not proceed with the work until unsatisfactory conditions have been corrected in a manner acceptable to the Architect.

### 3.02 STANDARDS AND PERFORMANCE

- A. Watertight and airtight installation of each glass product is required. Each installation must withstand normal temperature changes, wind loading, and impact loading for operating sash and doors, without failure including loss or breakage of glass, failure of sealants or gaskets to remain watertight and airtight, deterioration of glazing materials and other defects in the work.
- B. Protect glass from edge damage during handling and installation, and subsequent operation of glazed components of the work. During installation, discard units with significant edge damage or other imperfections.

- C. Glazing channel dimensions as shown are intended to provide for necessary bite on glass, minimum edge clearance, and adequate sealant thicknesses, with reasonable tolerances. Adjust as required by job conditions at a time of installation, but stay within the minimum bites as stipulated by the glass framing shop drawings, the specifications, or the FGMA guidelines.
- D. Comply with combined recommendations and technical reports by manufacturers of glass and glazing products as used in each glazing system and with recommendations of Flat Glass Marketing Assoc. "Glazing Manual" except where more stringent requirements are indicated by the specifications, or the framing systems.
- E. Install insulating glass units to comply with recommendations by Sealed Insulating Glass Manufacturers Assoc., except as otherwise specifically indicated or recommended by glass and sealant manufacturers. Insulating glass units shall be installed in such a manner as to adequately drain the glazing rabbet as approved in writing by the Insulating Glass manufacturer.

### 3.03

#### PREPARATION

- A. Thoroughly clean all joints, gutters and glass pockets, removing all foreign matter such as dirt, oil, grease, fireproofing, surface dust, foreign debris and frost.
- B. Loose particles present or resulting from cleaning shall be removed by blowing out joints with oil free compressed air, or by vacuuming joints. Remove protective coatings or fabrication oils and residue on metallic surfaces with solvents that leave no residue. Do not allow solvent to air dry without wiping. Use only clean lint free towels for wiping of surfaces.
- C. Do not glaze when the ambient temperature and weather conditions cause frost or moisture/condensation on framing, or during damp weather unless approved measures to eliminate these conditions are used. Cut all glass accurately to sizes required to the openings and in such a way that edges are smooth and straight. Clean glass free from dust, oil, etc., and wipe clean immediately before installation.
- D. Set, remove and later reset glazing stops so as to avoid marking or defacing any portion of the frames, stops, settings, etc. Prime surfaces of openings properly where recommended by the sealant manufacturer.
- E. All glazed openings shall be checked prior to glazing to make certain that the openings are square, plumb, and secure in order that uniform face and edge clearances are maintained. Inspect all framing joint intersections to insure that the offset in the jointery will not inflect undue edge pressure on the glass in accordance with FGMA Guidelines.
- F. All ventilators, as applicable, shall be properly adjusted.
- G. Maintain minimum face distances on both sides of glass as per FGMA Guidelines.

### 3.04 INSTALLATION AND APPLICATION

- A. Set all glass in a true plane, tight and straight, with proper and adequate clearance, firmly anchored to prevent rattling and looseness, with all edges cleanly cut.
- B. Install glass in accordance with instructions contained in the Flat Glass Jobber's Glazing Manual and FGMA guidelines. Use workmen specialized in the application of glass and sealants and apply glazing compound or gaskets in accordance with manufacturer's recommendations.
- C. Install setting blocks at quarter points or at location as recommended by FGMA or glass manufacturer. In no case shall edge of block be closer than 6" to the vertical edge of the glass unless specifically approved otherwise in writing by the glass manufacturer. Setting blocks shall be restricted from lateral movement. Setting blocks at insulated glass units and laminated glass shall support both lites of glass.
- D. Apply glazing sealants under pressure with hand or power actuated gun or other appropriate means. Use gun having nozzle of proper size and provide sufficient pressure to completely fill joint. Neatly point or tool all joint surfaces to provide the proper contour.
- E. Cut glass at factory to exact size with proper edge clearance so that glass will not contact frame at any point. Do not nip or seam the edges.
- F. Do not mark installed glass with an "X", or other symbol, or with any material whatsoever. Tapes or banners may be fastened to the frame head and suspended over the glass.
- G. Apply masking tape, where required by glazing operation, in continuous strips in alignment with joint edge. Remove tape immediately after joints have been sealed and tooled. Use clean, water-wet tool or tooling solution recommended by sealant manufacturer.
- H. Follow sealant manufacturer's instructions regarding mixing, surface preparation, priming, application procedure.
- I. Any stickers, separators or glass identification markings applied to the glass must be on the fourth surface of the insulating units. No stickers or separators shall be on the exterior (number one surface) when glass is installed.
- J. Fabricate and install all glass so roller marks from heat strengthening process are in the horizontal position. Mixing the direction will not be acceptable.
- K. Use of temporary wedge gaskets or dutchmans shall be in accordance with FGMA and glass manufacturers recommendation.
- L. Factory molded corners on gaskets must be set in a wet compatible non-curing sealant or compatible wet silicone.

**3.05 PROTECTION**

- A. The Exterior Wall Subcontractor shall exercise extreme caution and care to protect coating on coated glass and exposed non-coated surfaces from scratching or abrading until Owner occupies the building.
- B. Scratches and abraded or otherwise damaged coating on coated glass which are in excess of manufacturer's published standards will not be allowed or accepted.
- C. Any and all scratched, abraded or otherwise damaged glass shall be removed and replaced with new damage-free glass by the Exterior Wall Subcontractor, at no expense or cost to the Owner. **Scratches, abrasions, pinholes, and other glass imperfections shall be acceptable if within the printed limits of the glass manufacturer and/or industry standards. The glass manufacturer's printed literature and policies regarding this issue shall be submitted for review and approval.**
- D. Any glass with weld splatter or burns shall be removed and replaced at no expense or cost to the Owner.

**3.06 CLEANING**

- A. Replace cracked, scratched, broken or otherwise damaged glass. Remove adhered matter and excess glazing material.
- B. Prior to date of final acceptance, wash glass on interior and exterior of buildings to remove paint, soil prints and foreign matter. Clean glass only with a mild detergent and water recommended by the glass manufacturer. Do not use abrasive materials. Use professional window washers.
- C. Glass scratched or otherwise damaged during cleaning shall be removed and replaced at no additional cost to the Owner. Dispose of excess materials, containers and debris from site.

**3.07 CLEAN UP**

- A. Immediately upon completion of this work, remove from site all debris and scrap material and clean up all dust and dirt resulting from this work, including caulk, sealant, glazing compound, daubs, smears and droppings.
- B. The Exterior Wall Subcontractor **to coordinate and furnish final clean-up with the General Contractor.**

**END OF SECTION 08800**

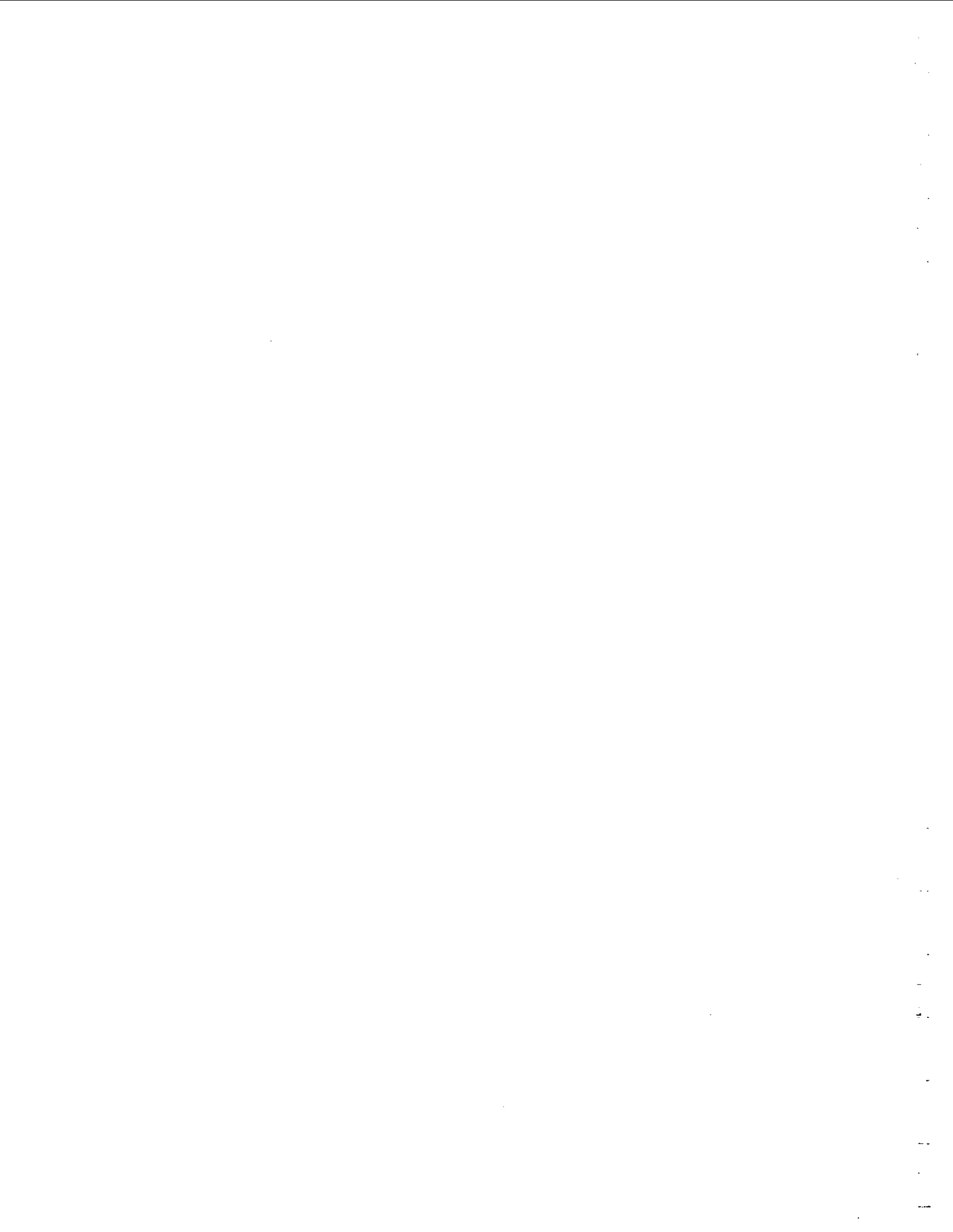

**SECTION 09100**

**METAL SUPPORT SYSTEMS**

**PART 1 - GENERAL**

1.01 DESCRIPTION: Division 1 applies to this Section. Provide metal support systems as indicated, specified and required.

A. **Work in this Section:** Principal items include:

1. Metal stud framing and furring for plaster and/or E.I.F.S. walls and ceilings.
2. Metal framing for gypsum wallboard walls and ceilings.
3. Metal backing plates for securing materials of other trades.
4. Installation of access panels on metal framing as furnished by other trades.
5. Provide access panels indicated on architectural drawings.

B. **Related Work Not In This Section:**

1. Lath and plaster.
2. Gypsum wallboard.
3. Hanger wires and framing for suspended grid acoustical or metal ceilings.
4. Thermal and sound insulation.
5. Furnishing access panels for mechanical and electrical trades.

1.02 QUALITY ASSURANCE

A. **Code:** Conform all installations to Code. In case of conflict between Contract Documents and Code, the more stringent requirements shall govern.

B. **Reference Specification:** Except as modified herein or required by Code, conform metal support systems for plaster to the Plaster/Metal Framing/Lath Manual of the California Lathing and Plastering Contractors Association, Inc., hereinafter referred to as Ref Spec.

C. **Tolerances:** Erect walls and partitions on straight lines, plumb, free of twists or other defects, and contacting a 10-foot straightedge for its entire length at any location. Erect all horizontal framing level within a tolerance of 1/8" in 12 feet in any direction. Erect sloped framing in true planes to same tolerance as horizontal framing.

1.03 SUBMITTALS: Refer to Section 01300 for procedures.

A. **Shop Drawings:** Submit Shop Drawings showing details for each typical partition, wall, ceiling and shaft support framing system.

B. **Product Data:** Submit complete materials list for all Work of this Section.

C. **Samples:** Submit such samples as Architect may request.

**PART 2 - PRODUCTS**

2.01 MATERIALS

**A. Standard Plaster Studs:** Pressed steel load-bearings and non-load-bearing type, punched, minimum 16 gage at exterior and 18 gage at interior, by Angelus, Inryco, USG, Western Metal Lath, or equal, with floor and ceiling tracks of same gage as studs, and shoes. Studs and tracks shall have the manufacturer's standard rust-inhibitive paint finish except furnish hot-dip galvanized studs with matching tracks where indicated or specified.

1. Structural Plaster Studs: Same as standard plaster studs except of gage and properties as required.
2. Wide-Flange Plaster Studs: Same as standard studs and structural plaster studs except having minimum 1-3/8" wide flanges knurled for drywall type screws.

**B. Screw-On Drywall Studs:** ASTM C645 and following requirements:

1. Standard Drywall Studs: Of 25-gage electrogalvanized steel having punched utility openings and knurled flanges at least 1-1/4" wide, with flange returns, except where 20 gage or heavier is shown or specified.
2. Stud Height: Gages specified above are minimum. Where required stud height exceeds Code approvals, provide heavier gage studs and/or decrease stud spacing as necessary to conform to Code approvals, at no extra cost to Owner.
3. Stud Accessories: Provide all standard related accessories including floor and ceiling tracks, clips, fasteners, and the like, of the same manufacture as each type of stud specified, as required for complete installations.

**C. Furring and Runner Channels:** Hot-rolled or cold-rolled steel channels coated with rust-inhibitive paint and weighing per 1,000 lineal feet, before coating, not less than:

<u>Size</u>	<u>Hot-Rolled</u>	<u>Cold-Rolled</u>
3/4 inch	300 lbs.	300 lbs.
1-1/2 inch	1120 lbs.	475 lbs.
2 inch	1260 lbs.	590 lbs.

- D. Screw-On Drywall Furring Channels:** ASTM C645, minimum 0.222" thick zinc-coated steel, minimum 1-3/4" face, 2-3/4" base span, and 7/8" furring depth.
- E. Wires:** Soft-annealed galvanized steel wire, 8 gage for hanger wires and 16 gage for framing unless otherwise specified.
- F. Sound Insulating Tape Seals:** "Bear Tape" by Norton Industries, or equal.
- G. Acoustical Sealant:** By USG, Gold Bond, or equal, permanently resilient type.



- H. **Metal Primer:** Sinclair No. 15 Red Oxide Primer or approved equal.
  - I. **Steel Backing Plates:** Fabricate of minimum 4" wide by 16-gage steel except as otherwise indicated. Apply shop coat of metal primer.
- 2.02 **ACCESS PANELS:** KARP or Milcor; Style K at plaster; Style DW for wallboard finish; Style M-Standard at masonry; Style M-Stainless at ceramic tile; Style AP or AT as required at ceilings. For fire-rated walls, provide fire-rated access doors bearing UL 2 hour fire-resistive label.

### **PART 3 - EXECUTION**

- 3.01 **INSTALLATION OF STUD TRACKS:** Bolt, weld or screw fasten to metal and anchor at least 1-1/4" into concrete with bolts and expansion shields, sleeved "dryvins", cinch anchors, screws and lead plugs, drilled and bolted steel shells, powder-driven fasteners, or other approved device. Concrete nails are not acceptable. Secure all tracks within 6" of ends and at maximum 36" centers between unless otherwise indicated. Install clips, channels or fasteners to structural steel support members prior to placement of fireproofing.
- 3.02 **PLASTER WALL FRAMING AND FURRING**
- A. **Standard Plaster Studs:** Install for walls not otherwise indicated or specified, spaced at 16" centers, complete with tracks and shoes. Allow for deflection of structure above. Provide doubled studs at jambs of openings more than 16" wide.
    - 1. **Bridging:** Stiffen walls and partitions with minimum 3/4" furring channels placed horizontally, wire tied or welded to each stud, and spaced at maximum 5-foot intervals vertically.
    - 2. **Wall Openings:** At doors and other openings more than 16" wide, install one 1-1/2" runner channel placed horizontally through stud webs not over 6" above opening head. Extend channel beyond the second stud on each side of opening and saddle tie or weld to each stud. Provide 1-1/2" runner channel 6" below sill of wall openings in same manner.
  - B. **Structural Plaster Studs:** Provide where shown or specified. Weld connections in accordance with AWS D1.1, Structural Welding Code. Provide a 1-1/2" horizontal bridging channel in exterior walls, set at the mid-height of building story and welded to each stud, unless otherwise shown or required by the wall openings. Install structural studs the same as standard plaster studs for interior walls and partitions, including bridging and channels at opening heads except channels shall be welded.
  - C. **Wide-Flange Plaster Studs:** Provide these studs wherever plastered walls receive gypsum wallboard finish on one side.
  - D. **Wall Furring for Plaster:** Install metal stud or channel furring as indicated. Secure channel furring with adjustable steel brackets at maximum 32" centers vertically and horizontally.

- E. **Welding Repair:** Wire brush, scrape and remove burned or damaged factory paint finish. Coat all welds and bare metal with metal primer.

### 3.03 WALL FRAMING AND FURRING FOR GYPSUM DRYWALL

- A. **Screw-On Drywall Studs:** Provide 25-gage studs at maximum 24" centers except as otherwise shown, specified or required under Subparagraph "Stud Height". Cut studs 1/2" short and secure to top track in manner that allows for deflection of structure above. Provide full height doubled studs at jambs of openings. Form heads and sills of openings with track sections screwed or bolted to jamb studs, unless otherwise shown. Install 16-gage studs at wall-hung lavatories, urinals, grab bars, wall-hung equipment, and elsewhere shown.
- B. **Walls Over 6" Wide:** Where partitions are shown with stud dimensions more than 6" in depth, install two rows of 2-1/2" minimum wide studs, using 1-1/2" runner channel cross ties at 16" centers vertically and 24" centers horizontally, all bolted, screw fastened or welded in place. In lieu thereof, install systems equal to Expandable Partition No. 7 (Blue Diamond Company) in conformance with manufacturer's requirements.
- C. **Wall Bridging:** Provide 3/4" channel bridging or stud manufacturer's standard bridging at maximum 60" vertical intervals in walls. At heads of all doors, and heads and sills of wall openings, provide 1-1/2" channel bridging extending to the second stud beyond each side of jambs.
- D. **Wall Furring:** Install metal stud or channel furring as indicated.

### 3.04 WALL FRAMING FOR EXTERIOR & INTERIOR STONE VENEER

- A. **Backing Studs:** Provide 16 gage studs at maximum 16" o.c. except as otherwise shown, specified or required under Subparagraph "Stud Height". Allow for deflection of structure above. Provide full height doubled studs at jambs of openings. Form heads and sills of openings with track sections welded to jamb studs unless otherwise shown. Provide a 1-1/2" horizontal 16 gage cold rolled channel bridging at 2'-0" vertically welded to each stud as recommended by Inryco/Milcor "Stud and Joist Bridging".
- B. **Steel Shelf Angle:** Provide steel shelf angle weld to each steel as required by stone veneer subcontractor. Provide at least one at the base of all stone veneer walls located per recommendations of Masonry Institute of America.

- 3.05 **SOUND INSULATED WALLS AND PARTITIONS:** Embed floor runner tracks in two beads of acoustical sealant or two runs of compressed tape seal. Install the top track in same manner for full-height insulated walls. Where wall ends abut concrete, masonry or steel, use unpunched track sections for end studs, set in two beads of acoustical sealant or two tape seals and secure at 4-foot centers vertically.

### 3.06 SUSPENDED CEILINGS, SOFFITS AND FURRING

- A. **Hanger Wires:** Secure to the structure above according to Code and the approved submittal. Allow sufficient length for two or more complete turns around runner channels at proper ceiling height.
  - B. **Suspended Plaster Framing:** Provide 8-gage hanger wires at maximum 36" centers along 1-1/2" runner channels spaced at maximum 48" centers, and 3/4" furring channels spaced at maximum 16" centers, all wire tied. Install the framing for unrestrained ceilings and soffits unless otherwise shown.
  - C. **Suspended Gypsum Wallboard Framing:** Provide 8-gage hanger wires at maximum 48" centers along 1-1/2" runner channels spaced at maximum 48" centers, and screw-on drywall furring channels spaced at maximum 16" centers; secure to runners with Code approved galvanized steel clips or wire ties.
  - D. **Connections:** Turn twice or saddle tie hanger wires around runner channels and twist three times around standing wire. Adjust hanger wire to bring furring and ceilings to level and true plans. Lap runner channels a minimum 12" at splices and tie with a double wrap of 16-gage wire 2" from each end of splices. Saddle tie furring channels to each runner channel with not less than two strand of 16-gage tie wire. Lap furring channels 8" minimum at splices and tie with a double wrap of 16-gage tie wire 1" from each end of splices.
  - E. **Suspension Under Ducts:** For hangers spaced at 4 to 5-1/2 foot centers, provide 6-gage hanger wires with minimum 2" runner channel at maximum 48" centers. For greater spans, design system for live load of 10 pounds per square foot of area plus dead load and detail in Shop Drawings.
  - F. **Furring:** Provide framing for horizontal furring as shown and required. Conform to above requirements as applicable.
- 3.07 **BACKING PLATES AND ANCHORAGE:** Install and attach to metal studs or furring for anchoring items indicated or specified in other Sections. Comply with reviewed submittals specified under other Sections as applicable to steel backing plates. Backing plates may be omitted where anchorage for wall-hung items is directly into steel studs of 18 gage or heavier, or items are furnished with equivalent mounting devices. Install plates of lengths to span over at least two supports, equipped with two countersunk machine screws at each support except plates may be welded to supports 18 gage or heavier. Wall-mounted items requiring backing plates include without limitation the following:
- Wall railings.
  - Grab bars.
  - Toilet compartments and urinal screens.
  - Toilet room accessories.
  - Plumbing fixtures.
  - Steel ladders.
  - Elevator pit screens.

- 3.08 **CONNECTION TO METAL DECKING:** Provide premolded neoprene filler strips matching the flute profile for non-fire-rated walls and partitions covered on one or both sides up to metal decking. For fire-rated walls and partitions, provide minimum 26 gage galvanized steel closure plates at tops of partitions fastened to metal decking. Use plates precision cut to fit the decking profile, installed on both sides, and pack the void spaces with UL listed and labeled incombustible mineral wool safing insulation. Where the top tracks are parallel to flutes and do not fully close flute spaces, provide a safing insulation filler and minimum 18 gage galvanized steel plates screw fastened to close the flute spaces and secure the top tracks to the plates. Alternate Method: Pack open flute areas with the approved spray-on fireproofing. Contractor to secure the City of Los Angeles approval for this method prior to application. Fully detail all conditions on Shop Drawings.
- 3.09 **ACCESS PANELS:** Install and rigidly connect to metal framing. Coordinate the exact required locations with related trades. On acoustical unit ceilings, install the panels to align with and maintain the grid pattern. Check all other Sections of Specifications for access panels specified to avoid duplication.
- 3.10 **CODE:** Installation to comply with all code requirements.

END OF SECTION

**SECTION 09200**

**LATH AND PLASTER**

**PART 1 - GENERAL**

- 1.01 DESCRIPTION: Division 1 applied to this Section. Provide lath and plaster as indicated, specified herein, and required.
- A. Work In This Section.** Principal items include:
1. Exterior lath and plaster.
  2. Plaster accessories as required.
  3. Lath and scratch coat backing for mortar-set stone or tile on framed wall surfaces.
  4. Skim coat plaster finish on masonry (as detailed or noted on drawings).
- B. Related Work Not In This Section:**
1. Metal studding, furring, and support framing for plaster.
  2. Liquid waterproofing.
  3. E.I.F.S.
  4. Water repellent and anti-graffiti sealers Section -07175.
- 1.02 QUALITY ASSURANCE:
- A. Reference Sections:** Requirements specified in Section 07900 form a part of this Section, including submittal and warranty requirements in those Sections.
- B. Reference Specifications:** Except as otherwise indicated or specified, conform to applicable requirements of the Plaster/Metal Framing Systems/Lath Manual as published by California Lathing and Plastering Contractors Association, Inc., Los Angeles, California, hereinafter referred to collectively as Ref Spec. In case of conflict between any code, law, ordinance, Ref Spec, and requirements herein, comply with the better or most restrictive requirements.
- C. Scaffolds and Equipment:** Install and maintain all necessary scaffolds, staging, trestles and planking, in strict conformance with CCR Title 8 and all applicable laws and ordinances.
- 1.03 SUBMITTALS: Refer to Section 01300 for procedures:
- A. Preliminary Samples:** Submit the following:
1. Exterior plaster texture and finish, 24" square, prepared at site.
  2. Each type and size of plaster trim accessory.
- 1.04 JOB CONDITIONS: Do not apply lathing and exterior plaster during periods of inclement weather, and protect from damage. Ensure adequate ventilation for drying and curing of interior plaster, and furnish temporary fans as required.

**PART 2 - PRODUCTS**

2.01 METAL LATH AND ACCESSORY MATERIALS: Each bundle of lath shall be sealed with a metal tag bearing the lath designation, weight and manufacturer's name.

- A. **Expanded Metal Lath:** Small diamond mesh, 3.4 pounds per square yard, expanded from galvanized steel sheets. For installation on exterior metal stud surfaces, furnish lath having factory-applied waterproofed paper backing meeting Fed Spec UU-B-790A(1), Type I, Grade B, by USG, Cemco, Amico, Western Metal Lath, or equal. Furnish paper-backed lath for use over solid backing except of the self-furring type. For incombustible building construction, paper backings shall have flame spread rating of 25 or less when tested according to ASTM E84 and shall bear UL label.
- B. **Corner and Strip Reinforcing Lath:** Flat or shaped reinforcing units, metal or galvanized wire lath types, no less than 2.5 pounds per square yard, outstanding legs minimum of 2" for wire lath and 3" for metal lath when formed for angle reinforcing. Use galvanized type for use with galvanized metal lath.
- C. **Waterproofing Paper:** Double-ply reinforced laminated paper, waterproof rating conforming to requirements of Fed Spec UU-B-790B and Building Code Standard 17-1 Type I, Grade B, having flame spread of 25 or less per ASTM E84 test, and approved by SFM.
- D. **Plastering Accessories:** Minimum 24 gage galvanized steel with expanded wings. Include casing beads, expansion screeds, and other items as shown or specified.
  - 1. **Exterior Expansion Screeds:** Sizes and profiles indicated or directed, with expanded wings unless otherwise shown or required by installation.
  - 2. **Casing Beads:** Amico, Cemco, Superior, USG, Western Metal Lath or equal, similar to Type 66 by 7/8" high for exterior plaster.
  - 3. **Exterior Corner Reinforcement:** Woven wire type with longitudinal wires, zinc coated as manufactured by Stockton Wire Products Co., K-Lath Division of Tree Island, Stucco-Lok by Western Metal Lath or equal per Detail 15-A, Section 2 of Ref Spec.
  - 4. **Aluminum Accessories:** Extruded types shown by Fry Reglet, or equal.

2.02 PLASTER MATERIALS:

- A. **Exterior Stucco:** Conforming to general requirements of the "Specifications and Standards for Manufactured Stucco Finishes" of the Stucco Manufacturers Association, manufactured by California Stucco, LaHabra Highland Stucco Company, Omega, MerLex, or equal delivered in manufacturer's sealed containers, requiring only addition of water for use. Sand shall pass a No. 20 sieve. Mix and sand shall be suitable for finish as designated by Architect and matching approved sample in Architect's office.
- B. **Portland Cement:** ASTM C150, Type II, low alkali.
- C. **Hydrated Lime:** ASTM C206, Type S.

- D. **Water:** Clean, potable and from domestic source.
- E. **Waterproofing Admix:** Red Label Suconem by Super Concrete Emulsions Ltd., Anti-Hydro, or approved equal.
- F. **Sand:** Washed natural sand conforming to ASTM C897, except sand gradation shall conform to Section 6 of Ref Spec for portland cement plaster; ASTM C35 for gypsum plaster.

2.03 **PLASTER PROPORTIONS AND MIXING:** Plaster proportions are by volume unless otherwise specified. Use calibrated measuring boxes for proportioning. Use of "shovel measure" is not acceptable.

- A. **Portland Cement Plaster:** All portland cement plaster base coats shall contain at least 2 pounds of treated alkali-resistant glass fiber shorts per 94 pound of portland cement. Exterior plaster base coats shall contain waterproofing admix in proportion recommended by manufacturer. Sand proportions are based on sum of the volumes of the portland cement and lime in the mix.
  - 1. On Metal Lath:
    - a. Scratch coat - 1 part portland cement, up to 1 part hydrated lime, and maximum 4 parts sand.
    - b. Brown coat - 1 part portland cement, up to 1 part hydrated lime, and maximum 4-1/2 parts sand.
    - c. Stucco finish - as specified.
  - 2. On Concrete or Masonry: Basecoats as specified above for the brown coat of portland cement plaster on metal lath.
- B. **Plaster Mixing:** Machine mix all plaster in the proportions specified with only sufficient water to attain proper consistency for application. Clean mixers and tools and keep free of hardened plaster materials. If plaster base coats are machine applied, take samples of plaster from nozzle of the plastering machine hose and perform slump tests using a 2" by 4" by 6" cone; mix plaster to maximum slump of 2-1/2".

### PART 3 - EXECUTION

3.01 **INSTALLATION OF METAL LATH AND PLASTER ACCESSORIES:** Conform to Ref Spec Sections 4 and 5 except as exceeded by Building Code or requirements herein. Use of shot-in type fasteners for securing lath is not permitted.

- A. **Lathing:** Conform to ASTM C841, as applicable, and to requirements herein. Use galvanized expanded metal lath without paper backing for exterior horizontal plaster and for interior portland cement plastering. Use expanded metal lath with paper backing for exterior vertical or sloping exterior plaster. Use of painted expanded metal lath is limited to interior gypsum plaster.

1. **Expanded Metal Lath:** Apply lath with long dimension across bearings. Lap sides 1/2" and ends 1". Break lath continuity at expansion screeds. Wire tie lath to all supports at 6" centers. Tie each lap with 18-gage wire midway between supports at sides and 6" intervals on ends.
  2. **Expanded Metal Lath With Paper Backing:** Install lap backings, handle and screw fasten in strict conformance with manufacturer's printed instructions and Code approvals. In all cases, install waterproofed paper backings "shingle" fashion to ensure positive drainage of water to the outside, including proper "shingling" with flanges of accessories and metal joints. Do not run the paper backing continuous behind expansion joints, control joints, and like fittings and flashings; extend up and behind the metal flanges above and down over metal flanges below. At vertical expansion joints, cut lath, overlap paper backings, and wire tie lath to expanded wings of joints. Maintain full waterproof continuity. Use same lath of self-furring type where installed on gypsum sheathing. Space screws at maximum 6" centers along all supports.
  3. **Ceiling and Soffit Lath:** On metal supports, provide an additional 11 gage wire ties at 24" along all supports.
- B. Lathing Accessories;** Set metal accessories plumb, level and true and shim where necessary. Miter accessories at corners and accurately and tightly fit exposed joints. Install sections in longest practicable length with minimum splicing. Fasten at not more than 12" centers.
1. **Exterior Corner Reinforcing:** Install for full length of external angles of exterior portland cement plastering and marblecrete.
  2. **Casing Beads and Plaster Stops:** Install at free edges of plaster, wherever plaster abuts against other finish material, and elsewhere as shown.
  3. **Plaster Expansion Joints:** Install types as shown and approved, joints and connections coped and shingled to prevent entry of water. Where directed or necessary, seal connections with sealant conforming to Section 07900, at no extra cost to Owner. Where not shown, provide expansion joints for exterior plaster at maximum 20-foot intervals and as required to divide plaster into maximum 120 square foot areas, located as directed.
  4. **Weep Screeds:** Install at bottom of exterior walls.
  5. **Drip Screeds:** Install where shown, approved type for each location.
- 3.02 **APPLICATION OF PORTLAND CEMENT PLASTER:** Apply plaster on metal lath to minimum 7/8" total thickness measured from face of studs.
- A. Measuring and Mixing Plaster:** Machine mixing, measuring, and proportions shall conform to Ref Spec Sections 7 and 8. Apply either portland cement plaster or portland cement-lime plaster for base coats. Use a factory prepared stucco for finish coat. Apply plaster within 1/2 hour of mixing. Do not retemper or use material that has partially set, or is caked or lumpy.



- B. **Waterproofing Additive:** Add to all exterior cement plaster scratch, brown, and leveling coats in conformance with manufacturer's directions.
- C. **Base Coat Reinforcement:** Include 2 pounds of Alkali-resistant fiberglass shorts per each 94 pounds of portland cement in base coats for exterior plaster.
- D. **Exterior Plaster:** Scratch and brown coat of portland cement plaster or portland cement-lime plaster, with a minimum 1/8" thick stucco finish coat having a texture finish matching approved sample in Architect's office.
  - 1. **Application of Base Coats on Lath:**
    - a. **Scratch Coat:** Apply scratch coat not less than 1/2" thick from face of supports to crest of scores, completely embedding wire fabric lath and forming good key on metal lath. Thoroughly scratch in one direction only and keep at optimum moisture content with fog spray for 48 hours minimum before second coat is applied.
    - b. **Brown Coat:** Set temporary wood or metal spot or strip grounds and bring plaster to true planes between metal joints. Apply brown coat plaster not less than 3/8" thick. Use long rigid darbies controlled by the grounds and bring the surfaces to a straight, plumb, and true condition about 1/8" back of metal trim edges and flanges. As each area is applied, check the surface with stringlines, or equivalent, and immediately correct low or high areas. After straightening, remove temporary grounds and fill the voids with plaster. Float the surface to correct texture for finish coat, keep moist for 72 hours, and allow to air cure for 5 to 8 days before applying finish coat.
    - c. **Curing:** Apply fine fog spray of water as soon as plaster base coats are sufficiently set to prevent injury. Do not let plaster dry out between water applications.
  - 2. **Application of Finish Coat:** Retest brown coat surfaces for straight and true before applying and correct defects. Apply finish coat at least 8 days after application of brown coat. Dampen surface of brown coat evenly to obtain uniform suction. Lay out finish coats to permit completion of an entire area between joints and screeds, or carry work to a natural break point. Work the top and bottom of walls and areas within screeds simultaneously with no dry laps, producing uniform finish and appearance, free of lap and tool marks, crazing, checking, waviness, low or high spots, offsets or other defects. Finish to be medium sand finish. Finish surface to be painted.
- E. **Backing for Mortar Set Wall Stone or Tile:** Cover metal framing with minimum 20 mil thick PVC sheeting, applied shingle fashion and returned around jambs of openings. Over the sheeting, apply self-furring galvanized expanded metal lath secured at 6" centers to supports with screws fitted with neoprene washers; do not use wire ties pushing through the sheeting. In other areas, apply galvanized expanded metal lath wire tied to supports at 6" centers. Apply portland cement plaster scratch coat as specified above, minimum 1/2" thick from supports to crest of scores and fully embedding lath.

RTD Headquarters  
Los Angeles, California  
91-400

5/27/93  
Lath and Plaster  
09200 - 6

3.03 SKIM COAT ON MASONRY (Parge Coat): Apply leveling coat of scratch coat portland cement plaster as required to correct irregularities in masonry surfaces; keep damp for 72 hours. Apply brown coat and finish coat as specified above.

END OF SECTION

**SECTION 09250**

**GYPSUM WALLBOARD**

**PART 1 - GENERAL**

- 1.01 DESCRIPTION: Division 1 applies to this Section. Provide gypsum wallboard as indicated, specified and required.
- A. **Work in this Section:** Principal items include:
1. Gypsum wallboard finish on walls and ceilings.
  2. Joint, edge, corner and fastener finishing.
  3. Sound insulation in gypsum wallboard partitions.
  4. Sound and air sealing Work of this Section.
  5. Skim coat finish where scheduled.
- B. **Related Work Not In This Section:**
1. Metal framing.
  2. Thermal insulation.
  3. Painting and wall coverings.
  4. Wall access panels for Mechanical and Electrical Work.
  5. Gypsum shaft systems.
- 1.02 QUALITY ASSURANCE
- A. **Fire Rated Assemblies:** Provide fire rated assemblies as detailed or required. All such assemblies shall conform to the tested and approved assemblies as described in ICBO, Gypsum Association Fire Resistance Design Manual, Eleventh Edition, or other approved code authority. Submit all fire test assembly details, approval numbers and STC ratings.
- 1.03 SUBMITTALS: Refer to Section 01300 for procedures.
- A. **Product Data:** Submit covering wallboard installations, including accessories, finishing, sealing, and manufacturer's written installation instructions with copies of Code approvals for each wall, ceiling and shaft system.
- B. **Samples:** Submit such samples as Architect may request.
- 1.04 JOB CONDITIONS: Make a detailed inspection of areas and surfaces to be enclosed or covered by gypsum drywall and arrange for correction of defective workmanship or materials. Ascertain that other Work enclosed by drywall has been inspected and approved before starting installation; otherwise, uncover as directed at no extra cost to Owner.

## PART 2 - PRODUCTS

### 2.01 MATERIALS

- A. **Gypsum Wallboard:** ASTM C36, recessed edges for exposed surfaces, Type X. For walls in toilets, and where indicated, provide Type X M/R water resistant boards as required.
- B. **Furring Channels:** Formed of minimum 0.022" thick steel, full galvanized minimum 1-3/4" face width, 2-3/4" base span, and 7/8" furring depth.
- C. **Wires:** Soft-annealed galvanized steel wires; 8 gage for hanger wires and 16 gage for framing, unless otherwise specified.
- D. **Screws:** ASTM C646, corrosion-resistant self-tapping bugle-head spiral-threaded type, minimum 1" long except 1-5/8" for double layer walls, lengths to penetrate all supporting metal at least 3/8". Furnish specially hardened type screws for supports heavier than 25 gage.
- E. **Metal Trim and Corner Beads:** Of electrogalvanized steel with tapping flanges, as manufactured or recommended by drywall manufacturer, corner beads at all outside corners and "J"-shaped trim members where abutting other material.
- F. **Finishing Materials:** ASTM C475, joint tape, joint bedding compound, finishing cement, adhesive and laminating compounds supplied or recommended by wallboard manufacturer.
- G. **Caulking Compound:** Permanently non-hardening type as supplied or recommended by wallboard manufacturer.
- H. **Sound Insulation:** Friction fit fibrous glass batts of minimum 3-1/2" thickness unless otherwise indicated, nominal 2.50 pcf density.
- I. **Control Joints:** Install expansion and contraction joints in ceilings and walls in accordance with ASTM C840, System XIII, unless indicated otherwise.

## PART 3 - EXECUTION

### 3.01 INSTALLATION OF GYPSUM WALLBOARD

- A. **General:** Perform wallboard installation and finishing according to ANSI A97.1 and the wallboard manufacturer's instructions. Do not install wallboard until building is weathertight. Conform to fire-rating requirement, Building Code approvals, and requirements herein.
- B. **Temperature:** Maintain minimum temperature within building during installation per manufacture's published standards. Furnish ventilation to eliminate excessive moisture.

- C. **Fasteners:** Install screws so heads are below wallboard surface without breaking surface paper to stripping steel framing member around the screw. Space screws according to Code approvals.
  - D. **Openings:** Accurately cut and fit the wallboard at openings. At door and other openings, cut wallboard to continue across area above opening head; do not cut board to both jambs and fill in area over openings with separate pieces. Make the dimension from joint over head of an opening to jamb of openings 6" minimum. Stagger joints on opposite side of partition.
  - E. **Single Layer Walls:** Place wallboard horizontally with long dimension across the studs or in one-piece vertical heights, vertical joints centered on supports and staggered on walls so as not to occur on opposite sides of same stud. Secure to each stud and track with screws keeping screws 3/8" from edges.
  - F. **Multi-Layer Walls:** Apply first layer same as for single layer walls, all joints in subsequent layers staggered with respect to first layer, or as required by Code.
  - G. **Suspended Ceilings:** Apply wallboard with long dimension at right angles to the furring channels, end joints staggered and centered over furring channels. Use board of maximum practical length to minimize end joints and properly support around cutouts and openings. Secure with screws. Where noted provide one hour protection for structure as detailed. Attach directly to underside of joints with nails. Construction to conform to noted ICBO reports.
- 3.02 JOINT TREATMENT AND FINISHING: Apply tape bedding compound, tape and at least three coats of finishing cement on exposed joints, and other joints as required for sound insulating or fire-rated construction. Apply joint cement and two or more layers of finishing cement over screw heads. Treat all inside corners with joint cement, tape and finishing cement. Treat all outside corners with corner beads and finishing cement. Provide metal casing beads at all edges of gypsum wallboard which abut ceiling, wall or column finish, and elsewhere as required, such as openings, offsets, etc. Make all exposed joints, trims and attachments non-apparent following application of paint or other finishes; if the joints and fasteners are apparent, correct defects as directed with no extra cost to Owner. Seal the raw edges of plumbing openings and of boards that have been cut to fit with manufacturer's recommended sealant brushed on. When entire installation is completed and prior to installation of finish materials by other trades, correct and repair broken, dented, scratched or otherwise damaged wallboard surfaces.
- 3.03 SOUND-INSULATED PARTITIONS: Install sound insulation continuously between studs from finish floor to top of wall in which it occurs. Where cutouts are made for J-boxes, conduit, piping, and like items, back wall insulation with insulation so that one additional layer of insulation at least 24" wide and high is placed in back of cutout. Snugly fit in place free of gaps or holes. Caulk between the wallboard edges and floors, walls, and at structure above other than acoustical ceilings with caulking compound, forming a complete perimeter seal. Caulk around outlet boxes and other penetrations in the same manner.
- 3.04 SKIM COAT FINISH: Where scheduled, apply USG SHEETROCK First Coat product. Apply after taping and screw head finishing is dry and sanded smooth, and produce smooth surfaces free

RTD Headquarters  
Los Angeles, California  
91-400

5/01/93  
Gypsum Wallboard  
09250 - 4

of trowel marks or other defects. Whether or not scheduled, also apply same USG SHEETROCK First Coat finish on gypsum board walls and ceilings in corridors and on all gypsum board surfaces scheduled to receive an enamel type finish. CAUTION: USG SHEETROCK FIRST COAT CONTAINS MICA AND TITANIUM DIOXIDE. Use with adequate ventilation. Use of respirator is recommended if sprayed. The use of safety glasses is recommended. Do not take internally.

END OF SECTION

**SECTION 09270**

**GYP SUM SHAFT SYSTEMS**

**PART 1 - GENERAL**

- 1.01 DESCRIPTION: Division 1 applies to this Section. Provide gypsum shaft systems as indicated, specified and required.
- A. **Work In This Section:** Principal items include:
1. Gypsum shaft systems at shaft penetrations in the project.
  2. Joint, edge, corner and fastener finishing.
  3. Sound insulation in gypsum shaft systems.
  4. Sound and airsealing Work of this Section.
- B. **Related Work Not In This Section:**
1. Metal framing.
  2. Thermal insulation.
  3. Painting and wall coverings.
  4. Wall access panels for Mechanical and Electrical Work.
- 1.02 QUALITY ASSURANCE
- A. **Fire Rated Assemblies:** Provide fire rated assemblies as detailed or required. All such assemblies shall conform to the tested and approved assemblies as described in ICBO, Gypsum Association Fire Resistance Design Manual, Eleventh Edition, or other approved code authority. Submit all fire test assembly details, approval numbers and STC ratings.
- 1.03 SUBMITTALS: Refer to Section 01300 for procedures.
- A. **Product Data:** Submit manufacturer's written installation instruction with copies of Code approvals for each wall, ceiling and shaft system.
- B. **General Standard:** ANSI/ASTM C840 except where more detailed or stringent requirements are indicated including recommendations of manufacturer.
- C. **Fire-Resistance Ratings:** Provide shaft systems with ratings indicated and conforming to assemblies tested and listed by recognized authorities.
- D. **System Design Loading:** Provide shaft systems capable of withstanding 10 psf lateral loading (air pressure) applied continuously and cyclically, within deflection limit of 1/240 of partition height.
- E. **Sound Transmission Class:** Provide shaft system with 50 STC minimum rating as per ASTM E90.

**F. Acceptable Manufacturers** include the following:

1. The Flintkote Co.
2. Georgia Pacific Corp.
3. Gold Bond Building Products, Div., National Gypsum Co.
4. United States Gypsum Co.

**PART 2 - PRODUCTS**

**2.01 MATERIALS**

- A. Metal Framing and Furring:** ANSI/ASTM C645 for 25-gage members, ANSI/ASTM A446, G90 for heavier members.
- B. Gypsum Shaftwall Boards:** Manufacturer's special gypsum coreboard or backing board, thickness and type as indicated and as needed to comply with system performance requirements.
- C. Exposed Gypsum Board:** ASTM C36, Type X.
- D. Gypsum Backing Board:** ASTM C442, Type X where required; moisture resistant where exposed in shaft or used as substrate for tile.
- E. Drywall Trim Accessories:** ASTM C840 and as indicated.
- F. Joint Treatment Materials:** ASTM C475.
- G. Miscellaneous Materials:** Provide auxiliary materials as recommended by manufacturer, including fasteners, laminating adhesive, acoustical sealant, and sound attenuation blankets, if required for system performance.
- H. Cavity Shaftwall Systems:** Provide assemblies consisting of gypsum shaftwall boards inserted between U-shaped metal floor and ceiling tracks; specially shaped studs engaged in tracks and fitted between shaftwall boards; and gypsum boards on finished side or sides, applied to studs in number of layers, thicknesses and arrangement indicated.
  1. Shaftwall Board Thickness: Not less than one inch.
  2. Stud Shape: C-H or double E.
  3. Stud Thickness: As indicated or required.
  4. Stud Depth: 2-1/2" and 4".
  5. Room-Side Finish: Two layers of 5/8"-thick gypsum board.



6. Cavity Insulation: Provide sound attenuation blankets in stud cavity as detailed.

### PART 3 - EXECUTION

#### 3.01 INSTALLATION OF GYPSUM SHAFT SYSTEM

- A. **General:** Perform wallboard installation and finishing according to ANSI A97.1 and the wallboard manufacturer's instructions. Do not install wallboard until building is weathertight sufficient to protect wallboard installation from moisture, humidity and adverse temperatures. Conform to fire-rating requirement, Building Code approvals, and requirements herein.
- B. **Temperature:** Maintain minimum temperature within building during installation per manufacture's published standards. Furnish ventilation to eliminate excessive moisture.
- C. **Fasteners:** Install screws so heads are below wallboard surface without breaking surface paper to stripping steel framing member around the screw. Space screws according to Code approvals.
- D. **Openings:** Accurately cut and fit the wallboard at openings. At door and other openings, cut wallboard to continue across area above opening head; do not cut board to both jambs and fill in area over openings with separate pieces. Make the dimension from joint over head of an opening to jamb of openings 6" minimum. Stagger joints on opposite side of partition.
- E. **Single Layer Walls:** Place wallboard horizontally with long dimension across the studs or in one-piece vertical heights, vertical joints centered on supports and staggered on walls so as not to occur on opposite sides of same stud. Secure to each stud and track with screws keeping screws 3/8" from edges.
- F. **Multi-Layer Walls:** Apply first layer same as for single layer walls, all joints in subsequent layers staggered with respect to first layer.
- G. **Install supplementary framing,** blocking and bracing to support fixtures, equipment services, heavy trim, railings, door frames, and similar work which cannot be adequately supported directly by drywall shaft system.
- H. **In elevator shafts** where inner face of shaftwall surface is located more than 2" from shaft face of structural beams, floor edges and similar projections, provide 5/8" gypsum board cants to cover tops of projections.

- 3.02 **AIR SEALING:** Seal connections between shaft walls, ducts, plenums and building structure airtight with specified calking compound or tape and cement, including vertical shafts.

END OF SECTION

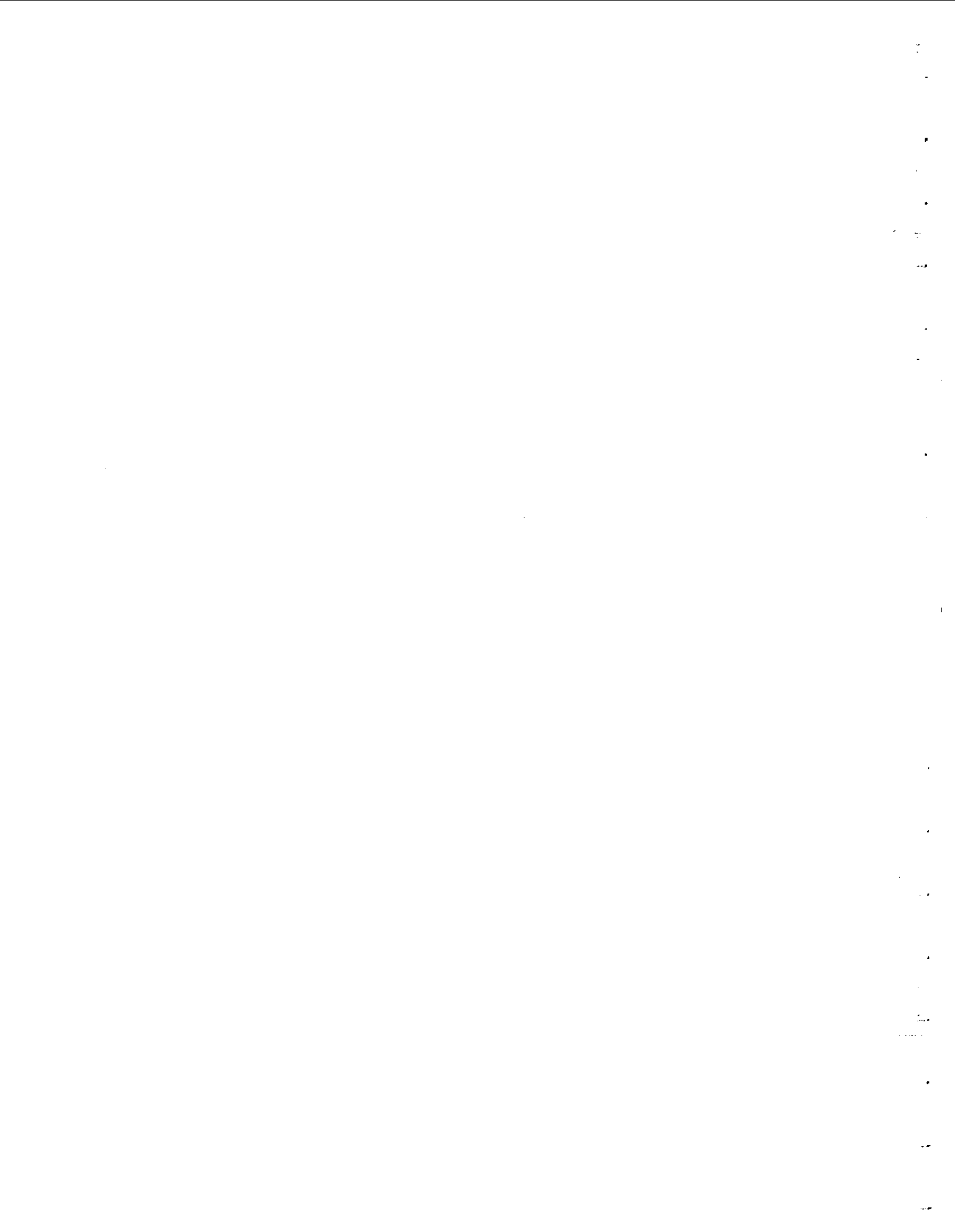

SECTION 09300

CERAMIC, STONE AND QUARRY TILE

PART 1 - GENERAL

1.01 DESCRIPTION: Division 1 applies to this section. Provide and install ceramic, stone and quarry tile as indicated, specified, and required.

**A. Principal work in this Section:**

1. Quarry floor tile.
2. Ceramic wall and floor tile. (Lobby Areas.)
3. Glazed ceramic tile walls and bases.
4. Unglazed ceramic mosaic tile floors.
5. Expansion joints.
6. Latex waterproofing membranes under tile floors.
7. Granite thresholds at tile floors.
8. Aluminum edging angles at exposed floor tile edges.
9. Trim shapes.
10. Setting materials, grouts and sealants.
11. Stone wall tile.

**B. Related work:**

1. Sealant other than specified herein.
2. Stone Masonry.
3. Gypsum wallboard backing for tile walls and bases.
4. Concrete wallboard backing for tile walls and bases.
5. Bituminous membrane waterproofing.
6. Elastomeric membrane waterproofing.
7. Metal thresholds.

1.02 SUBMITTALS (Refer to Section 01300 for procedures. Submit the following:)

**A. Samples:** Obtain Architect's instruction and submit the following for selection and approval:

1. Each type, shape, and trimmer of tile in each color proposed for use.
2. Grout colors for tile.
3. Cured sealant colors for expansion joints in tile.
4. Granite thresholds, 12" lengths, with one end cut and finished to fit typical door jamb.
5. Aluminum edging angles, 12" lengths.
6. At decorative ceramic wall tile at lobby area provide 24" square samples of each type and color of tile glued to hardboard backing with grout joints. Samples of each type, color and shape of trim and base.
7. Manufacturer's data for pre-mixed mortars and grouts, with certification that they meet ANSI standards specified when applicable.

- B. **Product Data:** Submit the manufacturer's printed directions for latex mortar and latex waterproofing.
- C. **Master Grade Certificates:** Submit for each lot of tile before installing.
- D. **Maintenance materials:** With closeout submittals, provide the Owner one full box of each type, color and size of tile properly packaged and identified, by room or area, for future repair.

1.03 QUALITY ASSURANCE

- A. **Uniformity:**
  - 1. Obtain each color, grade, finish, type, composition, and variety of tile from a single source with resources to provide products of consistent quality in appearance and physical properties without delaying progress of the Work.
  - 2. Obtain materials of a uniform quality from one manufacturer for each cementitious and admixture component and from one source or producer for each aggregate.
- B. **Installer's qualifications:** Experienced firm who has successfully completed tile installations similar in material, design, and extent to that indicated for Project.
- C. **Sample panels:** Before continuing with tile installation, erect an in-place mock-up of the Parking Structure Lobby tiles. Build mock-ups to comply with the following requirements, using materials indicated for final Work.
  - 1. Make mock-up panel a minimum of 4 ft. wide by the full height of the Lobby. Locate where directed by the Architect.
  - 2. Make modifications to the mock-up panel as requested by the Architect, or remove unsatisfactory panel.
  - 3. Obtain Architect's acceptance of mock-up panel before completing installation.
- D. **Master grade certificate:** Submit a Master Grade Certificate bearing the Certification Mark of the Tile Council of America, Inc., signed by the tile manufacturer, stating the type and quality of each type of tile delivered to the job site.
- E. **Reference standards:** The applicable provisions of the following govern the work of this Section, except as otherwise specified.

TCA, Handbook for Ceramic Tile Installation.

ANSI A108.1, Glazed Wall Tile, Ceramic Mosaic Tile, Quarry Tile and Paver Tile Installed With Portland Cement Mortar.

ANSI A108.4, Latex-Portland Cement Mortar.

ANSI A108.5, Ceramic Tile Installed With Dry-Set Portland Cement Mortar or Latex-Portland Cement Mortar.

ANSI A108.10, Installation of Grout In Tilework.

ANSI A118.6, Ceramic Tile Grouts.

ANSI A137.1, Standard Specifications for Ceramic Tile.

1.04 HANDLING

- A. **Comply with the** requirements of Section 01600. Deliver tile cartons with grade seals unbroken.
- B. **Comply with requirement** of ANSI A137.1 for labeling sealed tile packages.

1.05 JOB CONDITIONS

- A. **Set and grout this work** when ambient temperature is at least 50 deg. F or higher. Do not install materials on surfaces (or when ambient temperature) is less than 40 deg. F.
- B. **Illuminate interior** work areas during installation to provide the same or greater level of illumination, as required to properly perform this work, as will occur in the room or space after the building is in operation.
- C. **Conditions: Inspect and verify surfaces** according to Section 01400 and report defects to Architect for correction before proceeding.
- D. **Protection:** Provide protection wherever required. Do not use lumber or other material likely to stain or deface installed materials. Close tile flooring to traffic completely for 24 hours after installation; thereafter, permit traffic only over protective covering of heavy paper or equivalent.

PART 2 - PRODUCTS

2.01 MATERIALS

- A. **Colors, textures, and patterns:**
  - 1. Match Architect's samples.
  - 2. **Decorative ceramic wall tile:** Match existing tiles in Union Station.
  - 3. Stone tiles: As scheduled on the drawings.
  - 4. **Manufacturer and pattern as scheduled and shown on drawing.**
  - 5. **Glazed and Unglazed Wall Tile:** Colors as selected, dust pressed, white body, square edged, with two integral joint spacing lugs on all edges, matte glazed, with matching integral cove base having spherical corner and angle units, integral bullnose for external angles and exposed edges, and integral cove for internal angles, square unless otherwise shown.
  - 6. **Unglazed Floor Tile:** Colors and patterns as selected, porcelain type unglazed ceramic mosaic tile, cushion or all-purpose edges, premium colors and patterns 2" square unless otherwise shown.
  - 7. **Edge Strips:** Provide punched galvanized steel channel strip conforming to TCA Handbook for countertop edges, with galvanized nails or screws.
- B. **Factory blending:** For tile exhibiting color variations within the ranges selected during sample submittals, factory-blend tiles and package accordingly so that tiles taken from one package show the same color range as those taken from other packages, and match approved samples.
- C. **Tile and trim:**
  - 1. Floor tile: Coefficient of friction shall meet or exceed the City of Los Angeles

and ADA requirements when sealer is applied when tested in accordance with ASTM C 1028. **Contractor shall submit test data from an approved testing laboratory acceptable to the City of Los Angeles indicating actual coefficient of friction. Testing to be per Section 01400.** Contractor to submit and obtain the City of Los Angeles, Department of Building and Safety, Disabled Access Division approval prior to installation. Owner will be required to execute a Building and Maintenance Agreement with the City of Los Angeles to maintain the floor tile sealant in a slip resistant state as directed by the sealant manufacturer.

- a) Quarry tile: Vitreous body, frost-proof unglazed, non-slip, V-backed, ground four sides after firing 6" square, and 1/2" thick. Colors selected by Architect.
- b) Ceramic tile: As selected by Architect.
2. Wall tile: Ceramic tile; glazed, size and color selected by Architect.
3. Ceramic wall tile "terra cotta tile": Ceramic tile, glazed, selected by Architect.
4. Trim: Provide matching base, caps, stops, returns, and trimmers required to complete the installation.
5. Stone wall tile: Stone tile; 3/8" thick, polished, size as noted on drawings.

**D. Setting materials:**

1. Latex dry-set mortar: Pre-sanded, latex-modified complying with ANSI A118.4, specifically formulated for the substrates to which tile is applied.
2. Latex admix: For joint grout, by same manufacturer as above latex mortar.
3. Latex waterproofing: By same manufacturer as above latex mortar, fibrous glass reinforced, 1/16" to 1/8" thickness, for thin-set tile installations.
4. Waterproofing admix: Anti-Hydro, Sika Red Label Suconem, or equal.  
Reinforcing mesh: Galvanized welded wire mesh, 1-1/2" by 2" mesh or 2" square mesh, minimum 16 gage, or equivalent or equal steel cross-section area.  
Metal lath: Expanded from galvanized steel sheets, 3.4 pounds per square yard, self furring type, galvanized nails, or as specified for reinforcing mesh.  
Latex mortar: ANSI A118.4 (factory inclusion of aggregate is not required), one of the following, or equal:  
Mer-Krete Tile Setting Adhesive.  
Lat-A-Set of Pearsall Chemical Corp.  
Custom-Crete Custom Building Products.  
Tex-Crete Technical Adhesives, Inc.  
Laticrete by Laticrete International.
5. Portland cement: ASTM C 150, Type 1.
6. Dry-set portland cement mortar: ANSI A118.1, white or gray as specified.
7. Hydrated lime: ASTM C207, Type S.
8. Sand: ASTM C 144.
9. Water: Potable, fresh.
10. Setting bed reinforcing mesh: 2" x 2" x 16/16, 3" x 3" x 13/13 or 1-1/2" x 2" x 16/13 wire complying with ASTM A 82 or A 185.
11. Color pigments: Pure ground mineral oxides, non fading alkali and lime proof, factory weighed and packaged.

- E. **Grout:** Sanded or unsanded Portland cement grout, as applicable to the joint width and recommended by the grout manufacturer, complying with ANSI A118.6 by Mapei Bostik Construction Products, Custom Building Products, or WR Bonsal Co. of the color(s) selected by the Architect.
- F. **Sealant and back-up for control joints in tiles:** As specified in Section 07900.
- G. **Cleavage membrane:** 4-mil thick polyethylene complying with ASTM D 2103, Type 13300, or 15 lbs. asphalt-saturated felt complying with ASTM D 226 and the TCA.
- H. **Leveling coat for CMU walls:** Kerabond/Keralastic by Mapei, or equal.
- I. **Quarry tile sealer:** Non-penetrating, surface-type (high gloss) sealer by Aqua Mix, Inc. (213) 946-6877, or Hillyard Floor Treatment (800) 365-1555 matching appearance, as approved by the Architect, of the Union Station floor tile sealer, and meeting the requirements of these Specifications.
- J. **Setting bed mortar:** Machine mix mortar after first dry mixing materials. Mix mortar not less than 5 minutes after water is first added. Accurately measure materials using calibrated measuring boxes; shovel measurement is not permitted. Discard mortar that is not placed and compacted before initial set is reached. Measure all materials by volume.
  - 1. For Wall Tile. Quantity ranging from 1-part portland cement, 1/2 part hydrated lime, and 5 parts damp sand to 1 part portland cement, 1 part hydrated lime, and 7 parts damp sand.
  - 2. For Floor Tile. Quantity of 1 part portland cement, up to 1/10 part hydrated lime, and 6 parts damp sand, mixed to consistency and workability that allows maximum compaction during tamping of mortar bed.
- K. **Bond coat:** White or gray portland cement mixed with water and latex admix to a creamy consistency. For glazed wall tile only, gray or white dry-set portland cement mortar mixed in the same manner may be used. Do not add water or cement after initial mixing, and discard material not used prior to initial set.
- L. **Stone thresholds:** Provide stone thresholds of granite, one piece accurately cut to profile of door jambs, color and finish as selected, matching approved sample in Architect's office. Refer to Section 04400 Stone Masonry for sealer materials and application recommendations.
- M. **Edging angles:** Extruded aluminum of minimum 1/8" leg thickness, as approved.

### PART 3 - EXECUTION

#### 3.01 INSPECTION/PREPARATION

- A. **Verify conditions** and measurements affecting the work of this Section at site.
- B. **Remove glaze and contaminants**, including remaining curing compounds, from floors

by wire-brushing or sandblasting.

- C. **Apply leveling** coat to CMU walls in accordance with manufacturer's printed instructions.
- D. **Make sure that** surfaces to be tiled are firm, dry, clean, and free from oil or waxy films and curing compounds that are not approved or would inhibit the tile bond, and within industry tolerances.
- E. **Verify that** installation of grounds, anchors, recessed frames, electrical and mechanical work, and similar items located in or behind tile has been completed before installing tile.
- F. **Make sure that** other detrimental conditions are corrected before proceeding with installation.
- G. **Concrete Slabs To Receive Mortar Setting Beds.** Keep concrete damp for at least 8 hours and scrub with a neat portland cement slurry just before placing setting bed mortar.
- H. **Gypsum Wallboard:** Prime with latex primer or admix if required by instructions of latex mortar manufacturer.

### 3.02 TILE INSTALLATION

- A. **General:** Install proprietary materials in accordance with their manufacturer's printed instructions. Press or beat the tiles to obtain 100% coverage of mortar on back of tile; back butter tile if necessary.
  - 1. Maintain minimum temperature limits and installation practices recommended by mortar and grout materials manufacturers in areas where this work is performed.
  - 2. Terminate work neatly at obstructions, edges and corners without disrupting pattern or joint alignment. Saw-cut tiles to obtain clean, sharp, undamaged cut edges.
  - 3. Install tile in patterns indicated with uniform, aligned joints and perimeter units not less than 1/2 unit wide. Adjust to minimize cutting.
    - a) Joint width:
      - Ceramic wall tile: 3/16", plus or minus 1/16"
      - Stone wall tile: 1/16" or less
      - Quarry tile flooring: 1/2", plus or minus 1/8"
  - 4. **Where glazed or unglazed wall tiles, 1/16" with maximum 1/8" at any location unglazed floor tile, 1/16" selected by the Architect are installed in the same plane, but are of a different thickness, it is the Contractor responsibility to adjust the setting bed or mortar thickness so that all tiles are flush.**
  - 5. Maximum deviation from true lines and levels shall not exceed TCA recommendations for walls.
  - 6. Calk penetrations in tile with sealant and backing rod specified in Section 07900. Provide expansion joints where indicated or as recommended by TCA Method EJ171.
- B. **Tile blending:**
  - 1. For tile exhibiting color variations within the ranges selected during sample



submittals, verify that tiles have been factory-blended and packaged accordingly so that tiles taken from one package show the same color range as those taken from other packages, and match approved samples.

2. If not factory-blended, either return to manufacturer or blend tiles at Project site before installing.

**C. Tile installations:**

1. **Wall tiles:**

- a) **On gypsum board:** Install in accordance with ANSI A108.5 and TCA installation method W243.
- b) **On Masonry:** Install in accordance with ANSI A108.5 and TCA installation method W202.

2. **Floor tiles:**

- a) **Quarry tile:** Install in accordance with ANSI A108.1 and TCA installation method F111.
- b) **Ceramic tile:** Install in accordance with ANSI A108.5 and TCA installation method F113.

- D. Latex Waterproofing:** Apply according to manufacturer's directions, sealed into floor drains and turned up at walls. Pond test for 24 hours, repair all leaks, and retest until no leakage occurs.

3.03 GROUTING/CLEANING/CURING

- A. Grouting:** Comply with ANSI A108.10. Finish joints of square edge tiles flush with tile surfaces; finish joints of cushion edge tiles to depth of cushion. Grout shall be free of voids and pits.

**B. Cleaning:**

1. Clean tile and repair faulty grouting. Sponge and clean surfaces with clean water and soft brushes.
2. Polish glazed tile after cleaning with clean, dry cloths.

3.04 SEALING QUARRY TILE

- A. Seal quarry tile floors,** after cleaning and after grout has cured, with one of the sealer specified applied in accordance with its manufacturer's printed instructions.

1. Try the sealer on a test panel in a location designated by the Architect.
2. After the test panel has been approved, apply the remainder of the sealer in accordance with its manufacturer printed instructions leaving no bare spots or sealer residue.
3. Test surfaces after sealing and re-apply additional sealer if water stains tiles after 8-hour test.

3.05 PROTECTION

- A. Protect completed installations** until acceptance by the Owner. Protect floor tiles with kraft paper or other heavy covering securely taped in place during the construction period to prevent damage and stains. Remove protection when no longer needed.

- B. When recommended** by tile manufacturer, apply a protective coat of neutral

protective cleaner to completed tilework.

- C. **Prohibit foot and wheel traffic from freshly grouted floors.**
- D. **Before final inspection, remove protective coverings and rinse neutral cleaner from tile surfaces.**
- E. **Leave finished installation clean and free of cracked, chipped, broken, unbonded, or otherwise defective tiles. Replace tiles damaged before acceptance at no additional cost to the Owner.**

END OF SECTION

SECTION 09515

METAL CEILING SYSTEMS

PART 1 - GENERAL

- 1.01 DESCRIPTION: Division 1 applies to this Section. The Work specified in this Section consists of providing modular Metal Ceilings as indicated. Contractor shall provide final coordinated details and layouts, including the installation of such items as suspension ceiling framing, ducts, cables, lights, speakers, and cameras.
- 1.02 QUALITY ASSURANCE:
- A. **General Performance Criteria:** The technical acoustical terminology used in this Section is defined in publications by the Acoustical and Insulating Materials Association (AIMA), including the current edition of Performance Data, Architectural Acoustical Materials, which also lists recognized acoustical performance data for many available acoustical panels.
    - 1. Lighting Reflectance Ratings: Except as otherwise indicated, provide factory-finished acoustical panels which have been tested by a recognized testing laboratory in accordance with ASTM C523 to show a rating of light reflection of not less than 0.75 (AIMA value "a").
    - 2. Noise Reduction Coefficient (NRC): Not used.
    - 3. Sound Transmission Class (STC): Not used.
  - B. **Classification:** Class A, incombustible rating. Flame spread 25 or less in accordance with ASTM E84.
  - C. **Suspension System:** ASTM C635, heavy duty classification and ASTM C636 as applicable.
  - D. **Installer Qualifications:** Use an installer who has a minimum of three years experience in the Work required and is approved by the ceiling system manufacturer.
  - E. **Requirements of Regulatory Agencies:** Comply with requirement of local code enforcing agencies for material and installation criteria.
  - F. **Design Criteria:**
    - 1. Design systems to withstand a positive or negative pressure of 30 psf.
    - 2. System shall be entirely mechanically fastened directly to concrete or metal support members.
    - 3. Panels shall be positive mechanically fastened directly to suspension systems, removable, with finished edges.
  - G. **Acceptable manufacturers include the following:**
    - 1. Air Performance as represented by LaVigne-Muffie, Inc.
    - 2. Alcan Ceiling Company

**H. Reference Standards:**

1. Acoustical and Insulating Materials Association (AIMA)  
AIMA Test Procedure for Sag Resistance of Ceiling Panels
2. American Society for Testing and Materials (ASTM)  
ASTM C523 Light Reflectance of Acoustical Materials by the Integrating Sphere Reflectometer  
ASTM C635 Metal Suspension Systems for Acoustical Tile and Lay-In Panel Ceilings  
ASTM C636 Installation of Metal Ceiling Suspension Systems for Acoustical Tile and Lay-In Panels  
ASTM E84 Surface Burning Characteristics of Building Materials

1.03 SUBMITTALS: Refer to Section 01300 for procedures.

- A. Samples:** Submit samples for each type of ceiling required. In each set of samples, show the full range of exposed components to be expected in the completed Work. Submit the following:
1. Full size samples of panels, each type and color.
  2. 12 inch long samples of closure strip, trim, carrier, and other accessories.
- B. Shop Drawings:** Submit Shop Drawings showing complete layout of integrated ceiling. Drawings shall clearly show the following:
1. Suspension system layout showing locations of main runners, cross runners, sub-cross runners and edge trims. Show locations of items of Work which are to be coordinated with adjacent Work or are to be supported by the ceiling system including light fixtures, speakers, sprinkler heads, and other equipment to be installed herein.
  2. Hanger wire locations
  3. Details including but not limited to:
    - a. Main runner
    - b. Cross runner intersection
    - c. Sub-cross runner intersection
    - d. Seismic restraints
    - e. All edge conditions
    - f. All coordination installations with electrical and mechanical fixtures, etc.
- C. Product Data:**
1. Submit manufacturer's specifications and installation instructions for each type of ceiling panel required and for each suspension system. Include certified laboratory test reports and other data required to show compliance with these specifications.

2. Include manufacturer's recommendations for cleaning and refinishing ceiling panels and precautions against materials and methods which may be detrimental to finishes.
- D. Maintenance Stock:** Furnish one percent of whole panels and hardware of each type of ceiling panel system to the commission and store at the site where directed. Box maintenance stock and label each container with content.
- 1.04 **PRODUCT HANDLING:** Deliver materials in manufacturer's original unopened packages, fully identified with type, finish, performance data, and compliance labels. Handle and store in accordance with manufacturer's instructions and recommendations.
- 1.05 **JOB CONDITIONS:** Do not install ceilings until space has been enclosed and until Work above ceilings has been completed and so approved by the Commission or its designee. Ambient conditions of temperature and humidity closely resemble those indicated for final occupancy.
- 1.06 **MEASUREMENT:** The Work of this Section will be measured as a unit, acceptably completed.

## PART 2 - PRODUCTS

- 2.01 **ALUMINUM PANELS:**
- A. **Perforated with silicon polyester matte finish.** 24" X 24" Panels with 3/4" perforations at 2" on center. Panel to match ceiling panel in the Union Station Metro Rail Station and the Sample in the office of the Architect.
  - B. **Generally easily removable,** mechanically fastened panels, factory finished edges. Panel sizes as indicated.
  - C. **Aluminum thickness:** 0.063 inch thick.
  - D. **Size:** Varies as indicated.
  - E. **Panel thickness:** Minimum one inch.
  - F. **Sag Resistance:** Provide panels which have been tested and certified by the manufacturer for maximum of 1/4 inch sag at 90 degrees F and 70 percent relative humidity; in accordance with AIMA Test Procedure for Sag Resistance of Ceiling Panels.
  - G. **Mechanical Attachment:** Primary. Provide attachment to the suspension system by concealed spring-loaded twist locks or other approved mechanical connectors engaging the primary suspension tee-bar. Access to the mechanical fasteners shall be from below and through perforations. Mechanical connectors shall have the following properties:
    1. Manufactured from metal.
    2. Permanently attached to the interior core of the ceiling panel.

3. Concealed by the ceiling panel face when engaged in the locked position.
4. Accessible through the perimeter panel face perforations.
5. Connector receptacles integral with the panel suspension system.
6. Interchangeable connector receptacles throughout the entire ceiling system.

H. **Mechanical Fastening: Secondary.** Provide four concealed torsion springs of heavy-duty wire for each panel to eliminate deflection. The torsion spring wire shall be capable of supporting the panel weight.

## 2.02 GENERAL CRITERIA FOR SUSPENSION SYSTEMS

- A. **Comply with ASTM C635.** Structural classification specified in Paragraph 1.02. In addition, comply with CCR requirements for seismic bracing.
- B. **Coordination of Components:** Provide fastening system compatible with light fixtures, HVAC components and similar work indicated to be supported by, or located in, ceilings. Include the necessary components for a complete mechanically fastened system.
- C. **Components:**
  1. **Attachment Devices:** Type as recommended by the system manufacturer for attachment or anchorage of ceiling hangers to structure above ceiling, sized for not less than five times the hanger design load for the structural classification indicated; ASTM C635, Table 1, Direct Hung.
  2. **Fastening System:** Manufacturer's standards, complete with required accessories. Include the required framing and support for items occurring in, or on, the ceiling with maximum deflection not to exceed 1/360 of the span.
  3. **Edge-Trim Molding:** Of profiles indicated; finish to match panels.

## 2.03 CEILING MECHANICAL SUSPENSION SYSTEM (FLAT OR SLOPED)

- A. **Comply with the requirements of ASTM C635,** as applicable to the acoustical panel ceilings system materials indicated. Structural Classification: Heavy-duty system except as otherwise indicated.
- B. **Coordination of Components:** Provide fastening system which is coordinated with the indicated limitations and requirements for hanging from structure and supporting light fixtures, HVAC components and similar work indicated to be supported by or located in suspended acoustical panel ceilings. Include the necessary components for a complete mechanically fastened system as applicable.
- C. **Components:**
  1. **Attachment Devices:** Stainless steel type as recommended by the system manufacturer for attachment or anchorage of ceiling hangers to structure above ceiling, sized for not less than five times the hanger design load for the structural classification indicated; ASTM C635, Table 1, Direct Hung.

2. Fastening Suspension System: Manufacturers standard, complete with utility angles, tee bars and slip molds formed of extruded aluminum.
  - a) Tee-bar suspension system shall be formed from extruded aluminum with a cross section measure web height of two inches and a face flange of two inches. Extrusion 0.125 inches thick.
  - b) Include the required framing and support for light fixtures and other items occurring in or on the ceiling with maximum deflection not to exceed  $1/360$  of the span.
3. Edge-Trim Molding: Profiles indicated, finish to match panels.

### **PART 3 - EXECUTION**

3.01 **CONDITION OF SUBSTRATE:** Examine the substrates and adjoining construction and the conditions under which the Work is to be installed and do not proceed with the Work until unsatisfactory conditions have been corrected and so approved by the Commission or its designee.

3.02 **INSTALLATION:**

**A. General:**

1. Codes and Standards: Install materials in accordance with the approved Shop Drawings and manufacturer's printed instructions and comply with governing regulations, fire resistance rating requirements indicated, and applicable industry standards.
2. Pattern: Arrange and orient panels and slats as shown on the reflected ceiling plans to produce a uniform direction of patterns as indicated.
3. Verify measurements and dimensions at the site and coordinate the Work with the work of other trades.

**B. Ceiling Installation:**

1. Comply with ASTM C636, except if more stringent requirements are indicated or required for compliance with governing regulations or fire resistance ratings.
2. Install the suspension system in accordance with manufacturer's instructions to support required loads and to prevent deflection in excess of  $1/360$  of the span. Plane of ceiling shall be parallel to the top of rail.
3. Coordinate this Work with electrical and mechanical trades so that components of the ceiling fit properly aligning hairline joints. Where fixtures occur, fit panels below the fixtures with torsion springs to allow them to be removed directly downward.
4. Supporting members shall be invisible from public areas and shall permit each panel and slat to be easily removable with no disturbance to adjacent panels.
5. The system shall be rigid, free of lateral movement, and of sufficient strength to support itself and the required loads.
6. Install edge moldings of the type indicated at edges of ceiling areas and at locations where edges of panels would otherwise be exposed after completion of the Work.
7. Scribe and cut corners of panels and moldings accurately to provide hairline joints at borders and at interruptions and penetrations through the ceilings of other Work.

- C. **Tolerances:** Completed ceiling installation shall be within 1/8 inch in ten feet from theoretical lines indicated, whether level, sloped, or curved.

3.03 CLEANING AND PROTECTION:

- A. **Clean exposed surfaces of panels, slats, trim, edge moldings and suspension members.** Comply with manufacturer's instructions for cleaning and touch-up of minor finish damage. Remove and replace Work which cannot be successfully cleaned and repaired to permanently eliminate evidence of damage.
- B. **Provide protection for the ceilings,** including temperature and humidity limitations and dust control so that the Work will be without damage and deterioration at the time of acceptance by the Architect.
- C. **Isolate contact surfaces of dissimilar materials** with a thick coat of bitumastic paint or with tape, as recommended by the manufacturer of metal ceiling systems and as approved by the Architect.

END OF SECTION



SECTION 09650

RESILIENT FLOORING

PART 1 - GENERAL

1.01 DESCRIPTION: Division 1 applies to this Section. Provide resilient flooring and base as indicated, specified, and required.

**A. Work In This Section.** Principal items include:

1. Vinyl composition tile flooring.
2. Rubber base.
3. Reducer strips.

**B. Related Work Not In This Section.**

1. Raised metal thresholds.

1.02 QUALITY ASSURANCE. Furnish products by the following manufacturers, or approved equals:

Resilient Flooring

Armstrong World Industries  
Flintkote Company  
GAF Corporation  
Kentile Floors, Inc.

Rubber Base

Burke Rubber Company  
GAF Corporation  
Roppe Rubber Corporation

1.03 SUBMITTALS. Refer to Section 01300 for submittal procedures.

**A. Samples.** Submit the following for selection and approval:

1. Chip Samples showing the full range of flooring and base colors and patterns for preliminary selection.
2. After preliminary selection, submit full-size Samples of each selected color or pattern of flooring and base for final approval.
3. Reducer strips and trims.

**B. Data.** Submit copies of the flooring manufacturer's recommended standard dryness testing and required test results, and installation instruction for each type of flooring and base.

**C. Moisture Testing Results.** Submit written reports covering all moisture test results for record purposes only and not for approval.

**D. Maintenance Materials.** At completion, deliver following maintenance materials to the Owner in unopened factory containers or in sealed cartons with labels identifying the contents, matching installed materials. Include unopened cans of adhesives adequate to install the maintenance materials.

1. Vinyl composition tile, 5 unopened boxes of each color and pattern.

2. Rubber base, at least 100 lineal feet with 10 end stop units, 15 outside corner units, and 15 inside corner units.
- 1.04 **PRODUCT DELIVERY AND STORAGE.** Deliver materials to site in the manufacturer's original unopened labeled containers. Maintain all resilient flooring at temperature and in storage conditions per manufacture's printed recommendations prior to installation.
  - 1.05 **JOB CONDITIONS.** Do not start flooring installation until satisfactory moisture testing results are obtained and the Work of all other trades is substantially completed, including painting. Keep the areas of the installation and materials at minimum 70 degrees F during and for 10 days after installation is completed. Maintain adequate ventilation for the removal of moisture and fumes. Verify conditions as specified in Section 01400.

## PART 2 - PRODUCTS

### 2.01 MATERIALS.

- A. **Vinyl composition tile:** Quality equal to or exceeding Fed Spec SS-T-312, Type IV, 12" by minimum 1/8", as schedule and shown on drawings.
- B. **Rubber Base:** Coved top-set and straight carpet types, 4" high unless otherwise indicated, colors as selected by Architect, non-shrinking, 1/8" thick with matching molded inside and outside corners and end stops.
- C. **Setting materials:** Adhesives, primers, and fillers of type and composition recommended by materials manufacturers, cut-back or equal types not containing water, factory labeled as to substrates on which application is approved by the manufacturer.
- D. **Reducer strips:** Extruded aluminum, edge-butting (not lapping) type.
- E. **Wax:** Slip-resistant water-emulsion carnuba wax, UL labeled.

## PART 3 - EXECUTION

- 3.01 **INSTALLATION.** Conform to flooring manufacturer's recommended moisture testing and installation procedures and to requirements herein.
  - A. **Preparation.** Clean substrates of all deleterious substances and foreign matter. Fill cracks or depressions with latex leveling compound of the type recommended by flooring manufacturer to specific job conditions. Prior to laying flooring, test concrete for adequate dryness using the testing procedure conforming to flooring manufacturer's directions. Prime concrete floor slabs on grade; prime other slabs if so recommended by flooring manufacturer.
  - B. **Vinyl Composition Tile Installation.** Mix sufficient quantity of tiles to complete each area before laying to avoid color variations. Install flooring with tight joints, pattern direction as approved. Lay flooring square with axis of rooms, starting on center lines with tile joint or tile center so that border tiles are not less than 4" wide, accurately aligned. Install reducer strips at exposed edges of flooring and where show. Cut flooring mechanically to produce square true edges. Closely trim to pipes, jambs, outlets, and like conditions. Extend flooring into cabinets and casework without bottoms.

C. **Base Installation.** Securely cement to backing in long lengths, minimum 18" long filler pieces, top and toe continuously contacting wall and floor; all joints tight. Provide factory-made internal and external corners, and end stops where cove base ends at jambs and offsets.

3.02 **CLEANING, WAXING, AND COMPLETION.** Keep all flooring and base surfaces clean as installation progresses. Clean flooring and base when sufficiently seated and remove foreign substances. Immediately prior to Owner's acceptance of building, apply at least two coats of wax on resilient tile flooring in accordance with manufacturer's instructions, each coat machine buffed. Clean adjacent surfaces or adhesive or other defacement. Replace all damaged or defective Work to the original specified condition.

END OF SECTION

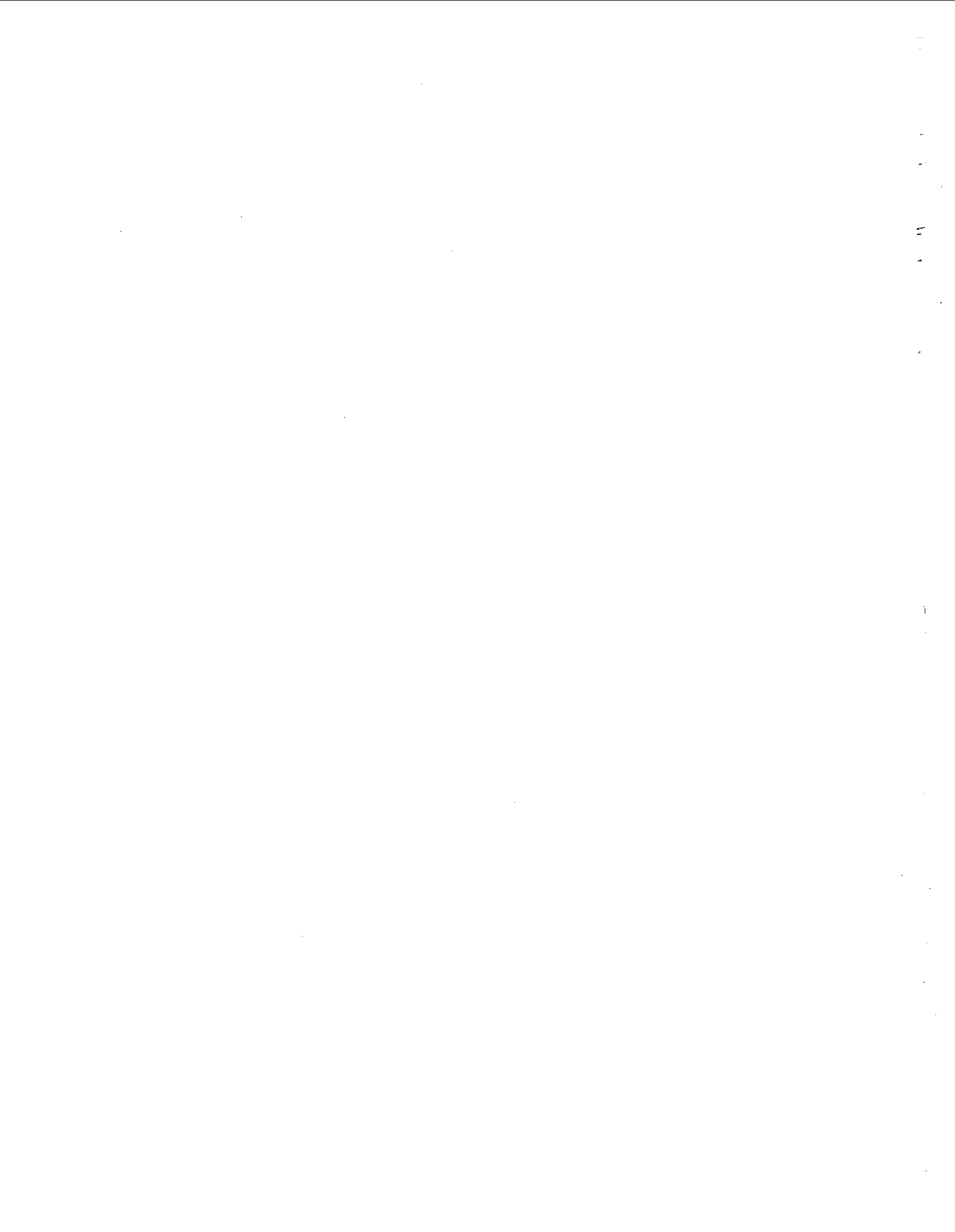

**SECTION 09830**

**ELASTOMERIC COATINGS**

**PART 1 - GENERAL**

- 1.01 DESCRIPTION: Division 1 applies to this Section. Provide elastomeric coatings as indicated, specified, and required.
- A. **Work In This Section:** Principal items include:
1. Surface preparation.
  2. Elastomeric coatings in mechanical rooms.
  3. Protection of adjacent surfaces and clean-up.
  4. Samples and supporting technical data.
- B. **Related Work Not In This Section:**
1. Concrete substrates.
  2. Caulking and sealing except as specified herein.
- 1.02 QUALITY ASSURANCE
- A. **Requirements of Regulatory Agencies:** Provide systems that comply with governing APCD rules and regulations and that bear UL Class B or better label or listing.
- B. **Qualifications of Subcontractor:** Employ elastomeric system manufacturer or manufacturer's authorized applicator to prepare surfaces and install all the waterproofing systems required under this Section.
- 1.03 SUBMITTALS: Refer to Section 01300 for procedures.
- A. **Technical Data:** Submit material manufacturer's technical preparation, and application data with copies of Code approval for each of the materials and systems proposed for use.
- B. **Samples:** Submit samples for each system in designated colors, showing texture and colors for approval. After selection, submit 12" square samples of complete systems on cement plywood board, with 2" wide strips showing each undercoat.
- C. **Quality and Experience:** Submit a typed list of at least five installations, including Owner's name and addresses, on which the materials and systems proposed for use have been in satisfactory service for at least three years.
- D. **Applicator's Qualifications:** Submit written evidence that manufacturer will install coatings or that applicator is licensed and approved by manufacturer and has a minimum of two years experience in successfully applying the same or similar materials.

**E. Certificate:** Upon completion, the Contractor and manufacturer's representative shall jointly inspect elastomeric coating and deliver to Architect a written certification that installed materials and workmanship conform to Specifications.

1.04 **PRODUCT DELIVERY:** Deliver materials in unopened factory labeled containers with seals unbroken, labels intact and bearing date of manufacture and brand names.

**A. Existing Conditions:** Refer to Section 01400 regarding verification of conditions. Coordinate with related trades and verify that concrete surfaces are correctly finished, water or cured as per manufacturer's recommendations and are dry. Notify Architect in writing of any conditions that prevent proper installation of coatings for correction. Application of first coat of any system indicates the acceptance of the surface for warranty purposes. This requirement does not relieve Contractor and applicator from responsibility for proper preparation of surfaces.

**B. Protection:** Install temporary coverings and protection to prevent staining or marring of surfaces not to receive coatings. Keep traffic off membranes until fully cured and hardened. Cover traffic areas with heavy non-staining building paper or plastic sheeting and prevent damage during following construction operations.

1.06 **WARRANTY:** Contractor and manufacturer jointly and severally shall furnish to Owner a written warranty against defects in material and workmanship for three years covering the performance of the systems for the entire warranty period and responsibility for ruptures caused by cracking of the substrates up to 1/8" in width.

## PART 2 - PRODUCTS

2.01 **ELASTOMERIC COATING:** Work of this Section is based upon Multi-I-Thane Systems of Multi-Chemical Products, Inc., So. El Monte, California. Approved equivalent systems by Tremco or Crossfield Products may be acceptable. Refer to Division 1 regarding substitutions. The following system establishes intended type and quality:

**A. Multi-I-Thane System No. 456 (60 mil.):** For Mechanical Equipment Room Floors and open stairs, treads, risers, bases and landing where indicated on Drawings.

1. Caulking compound shall be MC-283 or MC-284, two compartment polyurethane compounds.
2. Flashing: Shall be uncured neoprene sheet at 45-60 mils thickness, nonwoven reinforcing fabric, or as recommended by the coatings manufacturer.
3. Primer: Shall be MIP-607 epoxy-polymide low viscosity, two-component, primer/sealer. Apply primer at the approximate rate of 250 sq. ft. per gallon. Within 16 hours of application of the primer, the base coat must be applied. If the base coat cannot be applied within 16 hours, then reprime.

4. **Base Membrane:** Shall be Mult-I-Thane 4000 single-component, moisture-cured, elastomeric polyurethane. Spray, trowel, or roller applied in one uniform coat at the rate of one gallon minimum per 50 square feet.
  5. **Elastomeric Membrane:** Shall be Mult-I-Thane 5000 single-component, moisture-cured, liquid applied elastomeric polyurethane. Spray, trowel, or roller applied in one uniform coat at a rate of one gallon minimum per 50 square feet. Allow the coating to cure a minimum of 24 hours before applying the next coat.
  6. **Abrasion-Resistant Top Coat:** Shall be Mult-I-Thane 6000 single-component, abrasion-resistant and chemical resistant aliphatic polyurethane membrane. Spray or roller applied on one application at the rate of one gallon minimum per 100 square feet, or as needed to obtain a minimum thickness of 8 dry mils. Immediately and uniformly broadcast the 20 mesh aggregate into the wet coating at the approximate rate of 15 lbs. per 100 square feet and re-roll in order to completely encapsulate the aggregate. Allow the coating to cure a minimum of 24 hours before applying next coat.
  7. **Aggregate:** Shall be equivalent to 20 mesh Flint Shot Silica of #1 Monterey Sand.
  8. **Field Quality Control:** As the application progresses and before the Mult-I-Thane has attained its final set, verify the applied thickness by use of a mil-thickness gauge. To those areas which are deficient, immediately apply additional membrane to produce the required thickness.
  9. **Thickness:** The overall dry film thickness of the completed waterproofing system shall be a minimum of 60 mils, exclusive of aggregate.
  10. **Color:** As indicated on Drawings or as selected by the Architect.
- B. Mult-I-Thane System 4556 (75 Mil.) for Helipad:**
1. **Caulking Compound.** Shall be Mult-I-Sea 287 two-component or Mult-I-Seal 1000 one-component polyurethane compounds.
  2. **Flashing.** Shall be Neoprene sheet at 45-60 mils thickness, non-woven reinforcing fabric or as recommended by the coating manufacturer.
  3. **Primer.** Shall be MIP-607 Epoxy-Polyimide low viscosity, two-component, primer/sealer. Apply MIP-607 Epoxy Primer at the approximate rate of 300 sq.ft. per gallon. Within 16 hours of application of the primer, the base coat must be applied. If the base coat cannot be applied within 16 hours, then re-prime.
  4. **Base Membrane.** Shall be Mult-I-Thane 4000 single-component, high adhesion moisture cured, liquid polyurethane membrane. Membrane shall be spray, or squeegee applied in one uniform coat at the rate of one gallon minimum per 50 square feet or as needed in order to obtain a minimum thickness of 26 dry mils. Allow a minimum of 24 hours curing time before applying the next coat.

5. **Elastomeric Membrane.** Shall be Mult-I-Thane 5000 tan color single-component, high tensile strength, liquid applied elastomeric polyurethane and shall meet or exceed the following typical performance properties. Shall be spray, or squeegee applied in one uniform coat at a rate of one gallon minimum per 50 square feet, or as needed in order to obtain a minimum thickness of 26 dry mils. Allow the coating to cure a minimum of 24 hours before applying the next coat.
6. **Elastomeric Membrane.** Shall be Mult-I-Thane 5000 white color Elastomeric Membrane shall be spray or squeegee applied in one uniform coat at the rate of one gallon minimum per 100 square feet, or as needed in order to obtain a minimum thickness of 13 dry mils. Immediately and uniformly broadcast aggregate into the wet coating at the approximate rate of 20 to 30 pounds of aggregate per 100 square feet. Allow the coating to cure a minimum of 24 hours before applying the next coat.
7. **Traffic-Resistant Top Coat.** Shall be Mult-I-Thane 6000 single-component, aliphatic, abrasion-resistant and weather-resistant liquid polyurethane membrane. Shall be spray or roller applied on one application at the rate of one gallon minimum per 100 square feet, or as needed in order to obtain a minimum thickness of 10 dry mils.
8. **Thickness.** The overall dry film thickness of the completed waterproofing system shall be an average of 75 mils, exclusive of aggregate. Color as selected by Architect.

### PART 3 - EXECUTION

- 3.01 **PREPARATION:** Comply with system manufacturer's directions. Broom sandblast, acid etch and rinse, mechanically clean, or perform other cleaning operations as necessary to produce clean sound dry surfaces in correct condition to receive coatings.
- A. **Cracks:** Cracks over 1/16" in width shall be routed out to 1/4" minimum in width and depth and filled flush with elastomeric sealant.
  - B. **Joint Depth Regulation:** Apply backing into all expansion and control joints after cleaning and preparation but prior to the coating installation.
  - C. **Surfaces:** Prior to commencing with the application, all surfaces to be coated shall be dry and free from any surface contaminants or cleaning residues.
  - D. **Flashing:** All required flashing shall be installed at this time as recommended by the coatings manufacturer.
    1. Mult-I-Thane 4000 Base Membrane can be used as an adhesive and as a coating for the flashing material. All routed and caulked joints and hairline cracks should be coated with a 30 mil detailed coat of Mult-I-Thane 4000 and allowed to cure.



2. Sheet flashing shall be installed as recommended by the coating manufacturer.
- 3.02 **APPLICATION:** Use application equipment designed for the coating systems. Apply complete coating system on entire equipment bases before equipment is installed. Apply each coat to required thickness. Produce finished coats of uniform appearance free of sags, lap marks, and other defects so that the minimum dry film thickness of the completed system shall not be less than the specified mil thickness, exclusive of aggregate where used.
  - 3.03 **TRAFFIC ON COATED SURFACE:** The completed system shall not be subject to any pedestrian traffic during the first 24 hours after application is complete, nor to any heavy pedestrian traffic during the first 4 days after application of the final coat nor to any vehicular traffic during the first 5 days after application of the final coat. If the work of the applicator has not been approved by the Prime Contractor during the first 4 days after application is completed, then the period during which there shall be no traffic of any type shall be extended until such acceptance and approval is given.
  - 3.04 **COMPLETION:** Remove temporary protective coverings. If surface adjoining coatings are stained and cleaning is not acceptable, remove affected Work and provide new Work conforming to applicable requirements as directed, at no extra cost to Owner.

END OF SECTION

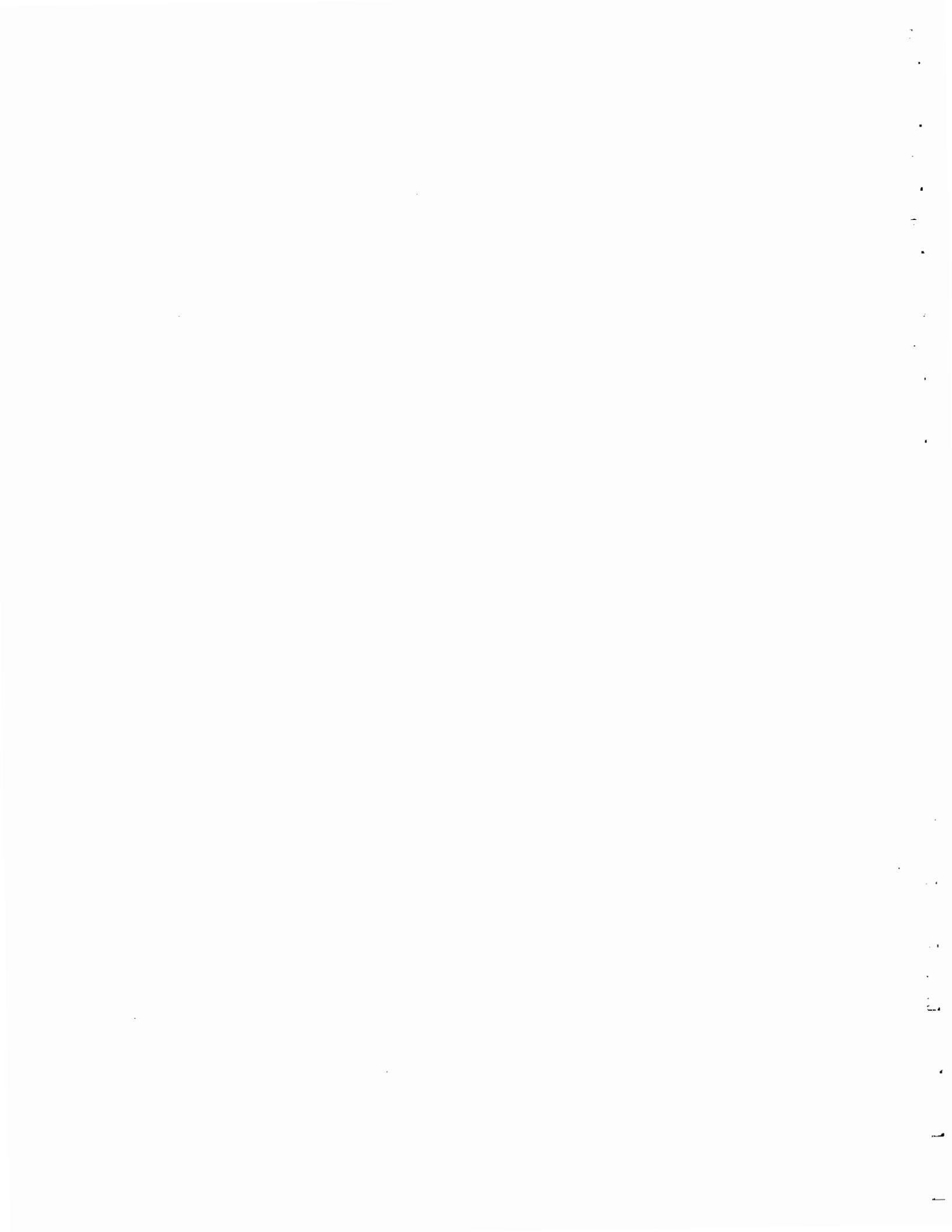

**SECTION 09900**

**PAINTING**

**PART 1 - GENERAL**

1.01 DESCRIPTION: Division 1 applies to this Section. Provide and perform painting as indicated, specified and required.

**A. Work In This Section:** Principal items include:

1. Submittals.
2. Preparation of surfaces.
3. Painting of all interior surfaces, except as otherwise specified.
4. Painting of exterior surfaces, except as otherwise specified.

**B. Related Work Not In This Section:**

1. Shop prime coats and factory finishes.
2. Painting specified as Work of other Sections.
3. Caulking and sealants.
4. Water repellant and anti-graffiti sealers Section 07175.

**C. Surfaces Not To Be Painted:**

1. Non-ferrous metal work (other than zinc-coated surfaces) and plated metal.
2. Integrally colored concrete.
3. Exterior concrete surfaces and walls.
4. Surfaces concealed in walls and above ceilings.
5. Non-metallic walking surfaces unless specially shown or specified to be painted.
6. Factory finished surfaces.
7. Ceramic tile and plastic surfaces.
8. Resilient flooring and base.
9. Elastomeric coatings.
10. Surfaces to receive vinyl wall coverings.
11. Galvanized gratings.
12. Surfaces indicated not to be painted.
13. Surfaces specified to be finish painted under other Sections.
14. Interior shotcrete walls except as noted or scheduled.
15. Interior slab soffits, columns and beams except as noted or scheduled.
16. Mechanical and electrical work except as noted or scheduled.
17. Shotcrete Walls

1.02 SUBMITTALS: Refer to Section 01300 for procedures.

- A. **List of Paint Materials:** Prior to submittal of samples, submit a complete list of paint materials proposed for use, identifying each material by manufacturer's name, product name and number, including primers, thinners and coloring agents, together with manufacturers' catalog data fully describing each material as to contents, recommended usage, and preparation and application methods. Identify surfaces to receive various paint materials. Do not deviate from approved list.
- B. **Color and Texture Samples:** Prior to preparing samples, obtain color, gloss and texture selections and instructions from Architect. Using materials from approved list, prepare and submit 8-1/2" by 11" samples of each complete opaque paint and texture finish.
- C. **Natural or Stain Finish Samples as scheduled:** Prepare sample on 12" squares of the same species and appearance of wood as used in the Work.
- D. **Field Samples:**
  - 1. 10' section of railing.
  - 2. 1 exterior door and frame.
  - 3. 1 restroom ceiling.
  - 4. 25 square feet of each lobby ceiling color.

1.03 JOB CONDITIONS

- A. **Protection:** Protect painting while in progress and cover and protect adjoining surfaces and property of others from damage. Exercise care to prevent paint from contacting surfaces not to be painted. During painting of exterior work, cover windows, doors, concrete and other surfaces not to receive the coating being applied.
- B. **Examination of Surfaces:** Examine surfaces to be finished under this Section and verify satisfactory conditions; refer to Section 01400. Notify the Architect in writing of any unsatisfactory surfaces. Application of the first coat of any finishing system constitutes acceptance of the surface by painter. This does not relieve Contractor from proper preparation of surfaces.
- C. **Weather Conditions:** Apply paint to clean, dry, prepared surfaces. Do not apply exterior paint during rainy, damp, foggy or excessively windy weather. Arrange for temporary heat and ventilation required for interior painting.
- D. **Precaution:** Place oily rags and waste in self-closing metal containers, removed from building and destroyed at the end of each day's work. Do not let rag and waste accumulate.

## PART 2 - PRODUCTS

### 2.01 MATERIALS

- A. Paint Systems:** Use the paint products of only one manufacturer unless otherwise specified or approved. In any case, primers, intermediate, and finish coats in each paint system must be products of same manufacturer, including thinners and coloring agents, except materials furnished with prime coat by other trades. Sinclair products specified designated intended types and qualities. Furnish paints from one of the following manufacturers; refer to Section 01600 for substitutions:

Frazer  
Decratrend  
Pratt and Lambert  
Dunn-Edwards  
Sinclair  
Vista

## PART 3 - EXECUTION

- 3.01 **WORKMANSHIP:** Apply materials in accordance with manufacturer's instructions by brush or roller; spray painting is not allowed without specific approval in each case. Apply each coat at the proper consistency, free of brush or roller marks, sags, runs or other evidence of poor workmanship. Do not lap paint on glass, hardware and other surfaces not to be painted; apply masking as required. Sand between enamel coats.
- 3.02 **PREPARATION:** Properly prepare surfaces to receive finishes.
- A. Concrete:** Fill cracks, holes and other blemishes with Portland cement patching plaster or a stiff paste mixed of finish paint and fine sand, finished to match adjoining surface. Remove glaze by sanding, wire brushing or light brush-off sandblasting. Neutralize alkali conditions according to paint manufacturer's directions. Dry the surfaces to receive breathing type latex paints at least two weeks, free of visible moisture. Dry the surfaces to receive oil, alkyd or epoxy based paint until moisture content does not exceed 8% when tested with an electronic moisture-measuring instrument.
- B. Masonry:** Repair minor holes and cracks with a stiff paste of finish paint and fine sand or vinyl type block filler. Report major or unsightly defects to the Architect for correction. Neutralize all alkali and efflorescence according to paint manufacturer's directions.
- C. Exterior Plaster:** Fill hairline cracks with Portland cement patching material; report larger cracks to Architect for correction. Test and ensure plaster is sufficiently dry to receive the paint finish.
- D. Interior Plaster:** Fill small cracks with spackle or equal. Report large cracks and unsightly defects to Architect for correction. Test plaster to receive oil or alkyd-based paint and verify plaster is sufficiently dry.

- E. **Gypsum Wallboard:** Touch up minor defects with spackle, sanded smooth. Report other defects as specified.
- F. **Shop Coated Metal:** Degrease and clean of foreign matter. Clean and spot paint field connections, welds, soldered joints, burned or abraded portions with same material used in shop coats. After complete hardening, sand entire surfaces for coat to follow.
- G. **Uncoated Ferrous Metal:** Degrease and clean of dirt, rust, mill scale, and other foreign matter using rotary brushes, solvent or sandblasting. Remove pits and welding slag, and clean to bright metal before priming. Apply metal primer not more than three hours after preparation.
- H. **Galvanized Metal:** Degrease and clean of foreign matter, apply pretreatment, and immediately apply primer paint.
- I. **Enameled Woodwork:** Sand smooth with grain and dust clean. After priming, putty nail holes, cracks or other defects with putty matching color of finish paint. Cover knots and sappy areas with shellac or approved knot sealer. Sand each base coat smooth when dry.
- J. **Transparent Finished Woodwork:** Sand smooth with the grain and dust clean. Repair all defects with filler tinted to match stain or wood color, as required, after first coat of sanding sealer and remove all smears.
- K. **Fixtures, Equipment and Hardware:** Cooperate with other trades and coordinate removal of fixtures, equipment and hardware as required for painting. Items to removed include: Switch and receptacle plates, escutcheons and like plates; surface-mounted equipment; free-standing equipment blocking access; grilles and louvers at ducts opening into finished spaces; and other items as required and directed.
- L. **Surfaces Not Mentioned:** Prepare surfaces according to the paint manufacturer's recommendations and as approved.

3.03 **COATS AND COLORS:** Number of coats specified to be applied are minimum. Ensure acceptable paint finishes of uniform color, free from cloudy or mottled areas and evident "thin" areas of insufficient coverage. "Spot" or undercoat surfaces as necessary to produce such results. Tint each coat a sufficiently different shade of finish color to permit identification. Conform to approved samples. Obtain approval of each coat before applying next coat; otherwise apply an additional coat over entire surface involved at no additional cost to Owner.

3.04 **EXTERIOR PAINTING**

**A. Concrete:**

1st Coat:	18 Epoprime
2nd Coat:	1300 Stuc-O-Life

**B. Cement Plaster and \*E.I.F.S.:**

1st Coat: 1300 Stuc-O-Life  
2nd Coat: 1300 Stuc-O-Life

\*E.I.F.S. System shall be painted in accordance with manufacturer's recommendations.

**C. Concrete Block Masonry:**

1st Coat: 1010 Vinyl Block Primer  
2nd Coat: 1300 Stuc-O-Life

**D. Metal - Ferrous:**

1st Coat: 15 Red Oxide Primer  
2nd Coat: 14 Corro Prime  
3rd Coat: 4800 Aqua Sash Enamel

**Exception:** On exposed surfaces of steel stairs and steel pipe or steel tubing railings, metal doors and frames apply 2 coats of 7500 Sintec Industrial Enamel in lieu of the 2nd and 3rd coats above.

All exterior metal railings to receive a "splatter texture". Use conventional spray (not airless) pressure pot system. Do not thin material. Approximately pot pressure psi air 15 - 18 psi material flow.

**E. Metal - Galvanized:** Treat with 7113 Vinyl Wash Primer before priming.

1st Coat: 14 Corro Primer  
2nd Coat: 248 Sash & Trim Primer  
3rd Coat: 4800 Aqua Sash Enamel

**Exception:** On roof and wall flashings, wall louvers and other sheet metal flashing visible on building exterior, apply two coats of 1300 Stuc-O-Life in lieu of 3rd Coat above.

3.05 INTERIOR PAINTING: Provide finishes as scheduled on Drawings or directed, gloss of finishes as scheduled. Enamel for finish shall be of the following glosses:

Semi-Gloss Enamel 1400 Sinco Satin II Enamel  
or 4000 Aqua Satin Enamel (Latex)

Eggshell Enamel 700 Sinco Suede II Enamel  
or 3000 Aqua Suede (latex)

**A. Flat - Drywall:**

1st Coat: 1770 Pigmented PVA Sealer  
2nd Coat: 1700 Sinwall

**B. Flat - Plaster and Concrete:**

1st Coat: 895 X-Tra Seal  
2nd Coat: 1700 Sinwall

**C. Flat - Concrete Block Masonry:**

1st Coat: 1010 Vinyl Block Primer  
2nd Coat: 1700 Sinwall

**D. Enamel - Drywall:**

1st Coat: 1770 Pigmented PVA Sealer  
2nd Coat: 975 Sinco Prime Undercoater  
3rd Coat: Enamel, gloss as selected or designated

**E. Enamel - Concrete and Plaster:**

1st Coat: 895 X-Tra Seal  
2nd Coat: 975 Sinco Prime Undercoater  
3rd Coat: Enamel, gloss as selected

**F. Enamel - Concrete Block:**

1st Coat: 1010 Vinyl Block Primer  
2nd Coat: 975 Sinco Prime Undercoater  
Enamel, gloss as selected

**G. Enamel - Wood:**

1st Coat: 975 Sinco Prime Undercoater  
2nd Coat: Enamel, gloss as scheduled or designated

**H. Stain and Varnish:**

1st Coat: 3350 Series Colormatic Stain  
2nd Coat: 50 Paste Wood Filler, tinted as required  
3rd Coat: 407 Velvet Varnish  
4th Coat: 407 Velvet Varnish



**I. Stain and Lacquer:**

1st Coat:	3350 Series Colormatic Stain
2nd Coat:	50 Paste Wood Filler, tinted as required
3rd Coat:	2600 Sanding Sealer
4th Coat:	2603 Velvet Lacquer
5th Coat:	2603 Velvet Lacquer

**J. Oil Rubbed Finish:** Apply Watco-Dennis Corp. "Danish Oil Finish" in strict accordance with manufacturer's published specifications with regard to surface preparation, staining and dye toning, application, number of coats, and liquid carnauba wax finish.

**K. Flat - Metal:** Treat galvanized metal with 7113 Vinyl Wash Primer.

1st Coat:	14 Carro Prime for galvanized metal 15 Red Oxide Primer for ferrous metal
2nd Coat:	1700 Sinwall
3rd Coat:	1700 Sinwall

**L. Enamel - Metal:** Treat galvanized metal with 7113 Vinyl Wash Primer.

1st Coat:	14 Corro Prime for galvanized metal 15 Chrome Oxide for ferrous metal
2nd Coat:	975 Sinco Prime Undercoater
3rd Coat:	Enamel, gloss as scheduled or designated

**Exception:** On all exposed surfaces of steel stairs and steel pipe or steel tubing railings, apply 2 coats of 7500 Sintec Gloss Enamel in lieu of the 2nd and 3rd coats above.

3.06 MISCELLANEOUS PAINTING

**A. Duct Interiors:** Paint with flat black fire-retardant paint to extent visible through grilles and registers in finished rooms and spaces.

**B. Fire Extinguisher and Fire Hose Cabinets:** Apply 2 coats of paint finish, inside and out, matching finish and color of adjoining areas, unless otherwise noted or directed.

**C. Weatherstripping and Sound Seals:** Paint exposed metal surfaces to match the door frame, whether or not unfinished, furnished with factory prime coat, or factory treated for paint adhesion.

**D. Elevator Hoistway Frames and Doors:** Coordinate with Division 14 requirements. If either the frames or doors are furnished with prime coat finish only, apply two coats of 7500 Sintec Industrial Enamel of designated colors and gloss on the primed surfaces by the electrostatic spray method. Repair all defects in primed surfaces prior to painting. Cover and protect surfaces not to be painted.

- E. **Interior Parking Areas:** Paint CMU and concrete walls and finished ceilings as scheduled per Section 3.04 and 3.05 A.
- F. **Painted Signs:** Refer to Section (Graphic Signage not issued, refer to Allowance Section 01020).
- G. **Mechanical and Electrical Work:** Carefully review Division 15 and 16 of the specifications regarding painting performed thereunder and other painting required to be performed under this Section. Perform all painting of mechanical and electrical equipment and materials that are specified to be painted under Division 15 or 16, including required identification and color code painting, stenciling, and banding.
- H. **Miscellaneous:** For any items not specifically shown or specified that require a paint finish, apply 3 coats of paint as directed.

3.07 **CLEANING AND TOUCH-UP WORK:** Make detailed inspection of paint finishes after painting is completed, remove splatterings of paint from adjoining surfaces, and make good all damage that may be caused by such cleaning operations. Carefully touch up all abraded, stained or otherwise disfigured painting, as approved, and leave entire painting in first-class condition.

END OF SECTION

**SECTION 10010**

**BUILDING SPECIALTIES**

**PART 1 - GENERAL**

1.01 DESCRIPTION: Division 1 applies to this Section. Provide building specialties as indicated, specified and required.

**A. Work In This Section:** Principal items include:

1. Directories.
2. Recessed telephone box.
3. Fire extinguisher cabinet.
4. Mail boxes.
5. Dock bumpers.
6. Hoist (monorail at penthouse).
7. Floor access door.
8. Trash and Ash Urns.
9. Parking Control Booth.

**B. Related Work Not In This Section:**

1. Toilet accessories.

1.02 SUBMITTALS: Refer to Section 01300 for procedures.

**A. Shop Drawings and Samples:** Submit for various items as specified hereinafter. Shop materials, finish, characteristics, construction and fabrication details and procedure, layout and erection diagrams, methods of anchorage to building construction, templates for backing or anchorage, and other criteria.

**B. Product Data:** Submit catalog data for the standard manufactured items and as applicable to shop-fabricated or shop-assembled items.

**PART 2 - PRODUCTS**

2.01 MANUFACTURE: Use products of only one manufacture throughout for each specialty item specified unless otherwise noted or approved.

2.02 MAIL BOXES: Where detailed, Supreme Series as manufactured by Cutter-Federal Inc., front loading meeting all U.S. Postal Service approvals. Five pin cylinder key lock with self locking spring bolt and two keys. Boxes to be provided with number plastic inserts. #4 bronze finish. Quantity as shown. Provide Shop Drawings.

2.03 RECESSED TELEPHONE HOUSING: Where detailed, model BPH-R fully recessed housing, overall height 24-11/16" x 6-29/32" deep by 18-1/2" wide as manufactured by Acoustic Development Corp., St. Joseph, Missouri or approved equal. #4 bronze finish.

- 2.04 DIRECTORIES: Where detailed, provide 350 A Series illuminated directory as manufactured by Vomar Products, Inc., (818) 894-7174 complete, unless otherwise selected by Architect. Finish to be selected by Architect, unframed full recessed directory, with black-out glass, size as indicated on drawings, information panels as directed. Provide with film strip carriers and film name strips.
- 2.05 FIRE EXTINGUISHER CABINETS: Provide as required at each fire extinguisher, cabinets manufactured by Potter-Roemer Recessed Alta, Model No. 7060-DV, stainless steel. #4 stainless steel finish except at garage use surface Buena Series, Model No. 7160-E-18-VR.
- A. Provide portable fire extinguishers by Potter-Roemer as follows:
1. Electrical rooms, mechanical rooms, elevator machine room:
    - a) 10BC rating Model 3305 with wall bracket.
  2. Parking garage:
    - a) 10BC rating Model 3305 in cabinet.
  3. Interior areas and courtyard/balcony:
    - a) 2-A10BC rating Model 3005 in cabinet.
- 2.06 DOCK BUMPERS: Provide where indicated of sizes and shapes shown molded dock bumpers, 4" thick, manufactured by Durable Mat Company, (800) 537,1603, or approved equal. Bumpers molded into one piece from new nylon and polyester reinforced rubber. Bumpers shall have a durometer reading 80 and tensile strength of 950 - 1150 psi and an impact recovery of 95% according to ASTM 1170. Provide shop drawing showing proposed method of installation.
- 2.07 HAND CHAIN HOIST AND TROLLEY: Provide a hand chain hoist and trolley rated at 4,000 pounds manufactured by Duff-Norton Manufacturers, distributed by Arrow Craine Hoise Corporation, (310) 921-8328. Hand chain hoist unit to be "Duff Lynx" Model No. L.H.H.-2A. Lift height as selected by Architect, head treated gearing with lubricated gear and bearings, with latch-type swivel hooks complete. Trolley unit to be "Duff Lynx" Model No. TL-4000 adjustable for beam sizes, cast iron wheels with permanently lubricated, shielded ball bearings, with dual tread wheels or approved equal.
- 2.08 FLOOR ACCESS DOOR: Where detailed, provide floor access door type No. KD as manufactured by Bilco Company. Frame shall be 1/4" extruded aluminum with built-in neoprene cushion and with strap anchors bolted to exterior. Door leaf shall be 1/4" aluminum diamond plate reinforced with aluminum stiffness as required. Cast steel hinges bolted to underside and pivot on torsion bars that counterbalance the door, the door open 90 degrees and lock automatically in that position, provide handle to release door from this position. Doors to withstand a live load of 150 psf and have a snap lock with a removable handle. Aluminum shall have a mill finish or approved equal.

- 2.09 GARAGE LOBBY ENTRY TRASH AND ASH RECEPTACLES: Provide 8 each trash and ash receptacle as manufactured by Dora Art Stone, Fontana, California, (800) 821-1120. Trash receptacles to be Model Number TR-J. Ash urns to be Model Number AV-J. Concrete finish and color selected by the Architect.
- 2.10 PARKING BOOTH: Northern Hytech Modular Shelter, standard series, (315) 463-1431, or ParKut International, Inc., or BIG Enterprise, Inc. or approved equal, see drawing and site for proper location and size. Parking booths to match booths located in the adjacent Public Transit Parking Garage. Provide complete with 3/4" plywood floor covered with resilient flooring, insulated walls, R= 4.3 and ceiling, R=17.4. 1/4" clear abrasion resistant polycarbonate windows set in heavy duty neoprene gaskets with integral locking strips. Panels shall be reinforced with 1-1/4" x 1-1/4" x .040 encapsulated into each panel. Finish shall be smooth gel coat with custom color on exterior and interior walls are carpeted with color as selected by Architect. Provide complete with roof mounted 13500 BTU air conditioner, heater with thermostat, ceiling mounted fluorescent lighting and locks on access door to both power and control center. Power load center shall be complete with breakers for 125 amp, 120/240 volts, with air conditioning, 3-wire, 12-pole. Conduit runs shall be concealed. Booth shall have a rear lockable control center cabinet with adjustable shelves and formica countertop over. Conform to State of California handicap standards. Colors as selected by Architect. Booth shall have a slide window in the door for cashiering. Booths to meet all applicable ADA and City of Los Angeles, Department of Building and Safety, Disabled Access Division requirements. Provide complete shop drawings per Section 01300.

### PART 3 - EXECUTION

- 3.01 INSTALLATION: Conform to the submittals review and the various manufacturers instructions.

END OF SECTION



**SECTION 10160**

**METAL TOILET PARTITIONS**

**PART 1 - GENERAL**

- 1.01 DESCRIPTION: Division 1 applies to this Section. Provide painted metal toilet partitions as indicated, specified and required.
- A. **Work In This Section:** Principal items include:
1. Ceiling-hung toilet partitions.
- B. **Related Work Not In This Section:**
1. Toilet accessories.
  2. Concealed backing or blocking in walls.
- 1.02 SUBMITTALS: Refer to Section 01300 for procedures.
- A. **Shop Drawings:** Submit Shop Drawings showing dimensional layouts, the required location of backing in walls and ceilings, preparation and reinforcing of panels to receive various toilet accessories and grab bars, and erection diagrams.
- B. **Product Data:** Submit catalog data for each hardware item and fitting.
- C. **Samples:** Submit samples of metal finishes in designated colors.
- D. **Certificate:** Submit manufacturer's certificate attesting that steel, treatment, and finish provided conform to requirements specified.

**PART 2 - PRODUCTS**

- 2.01 TOILET PARTITIONS: Ceiling-hung flush panel painted steel type, of exotic colors as selected, one of the following, or equal:
- Global Steel Products Corp. "Imperial"  
Sanymetal Products Co. "Century"
- A. **Construction:** As standard with manufacturer, modified as necessary to suit the installation requirements, using galvanized bonderized steel of minimum 22 gage for doors, 20 gage for partitions, and 18 gage for pilasters, with galvanized double-bolted steel adjustable connector to secure the pilasters to supports and one-piece polished stainless steel shoes with concealed clips at ceilings. Make reinforced cutouts in the partitions where required for the toilet accessories. Provide concealed reinforcements for grab bar connections to panels, designed for at least 300 pound shear load.

- B. **Hardware:** Of polished stainless steel, chrome-plated non-ferrous metal, or of polished anodized aluminum, as standard with the partition manufacturer. Equip doors with concealed adjustable hinges, coat hook and bumper, latch bolt, and combination stop and keeper. Assemble compartments with metal brackets matching hardware. Use theft-proof fasteners of matching materials. Provide latch bolts that release when door is lifted, allowing emergency access to compartments.
  
- C. **Finish:** Exotic color, factory-applied oven-baked inhibiting primer and baked enamel paint coats on exposed zinc-coated surfaces, minimum total dry mil thickness of 1.5 mils. Color as selected by Architect.

**PART 3 - EXECUTION**

- 3.01      **INSTALLATION:** Form and assemble work plumb, square, and in true plane without warp or wind, connections made tight and secure. Remove punctured or scratched material and provide conforming material. Leave the entire installation clean and free of oil, grease, handmarks or other foreign matter, and with hardware adjusted for correct operation.

END OF SECTION



SECTION 10200

LOUVERS AND VENTS

PART 1 - GENERAL

- 1.01            **DESCRIPTION:** Division 1 applies to this Section. Provide louvers and vents as indicated, specified, and required.
- A.    Work In This Section.** Principal items include:
1.    Extruded aluminum louvers.
2.    Formed sheet metal louvers.
3.    Formed sheet metal door louvers.
- B.    Related Work Not In This Section.**
1.    Caulking and sealants.
2.    Paint.
3.    Air-handling louvers connected to ductwork.
4.    Blank-off plates for air-handling louvers.
5.    Louvers in hollow metal doors and frames.
- 1.02            **QUALITY ASSURANCE:**
- A.    Performance:** Where louvers are indicated to comply with specific performance requirements, provide units whose performance ratings have been determined in compliance with Air Movement and Control Association (AMCA) Standard 500.
- B.    AMCA Certification:** Where indicated, provide louvers with AMCA Certified Ratings Seal evidencing that product complies with above requirements.
1.    Comply with SMACNA "Architectural Sheet Metal Manual" recommendations for fabrication, construction details and installation procedures, except as otherwise indicated.
- C.    Field Measurements:** Verify size, location and placement of louver units prior to fabrication, wherever possible.
- D.    Shop Assembly:** Coordinate field measurements and shop drawings with fabrication and shop assembly to minimize field adjustments, splicing, mechanical joints and field assembly of units. Preassemble units in shop to greatest extent possible and disassemble as necessary for shipping and handling limitations. Clearly mark units for reassembly and coordinated installation.
- 1.03            **SUBMITTALS:** Refer to Section 01300 for procedures.
- A.    Product Data:** Submit manufacturer's specifications; certified test data, where applicable; and installation instructions for required products, including finishes.

- B. **Shop Drawings:** Submit shop drawings for fabrication and erection of louver units and accessories. Include plans, elevations and details of sections and connections to adjoining work. Indicate materials, finishes, fasteners, joinery and other information to determine compliance with specified requirements.
- C. **Samples:** Submit six-inch square of each required aluminum finish. Prepare samples on metal of the same gauge and allow to be used in work. Where normal color and texture variations are to be expected, include two or more units in each sample showing the limits of such variations.

## PART 2 - PRODUCTS

### 2.01 ACCEPTABLE MANUFACTURERS:

- A. **Available Manufacturers:** Subject to compliance with requirements, manufacturers offering products which may be incorporated in the work include, but are not limited to, the following:

Airline Products Company  
The Airlite Company  
American Warming and Ventilating Company  
Construction Specialties, Inc.  
Industrial Louvers, Inc.  
Ruskin Manufacturing Company

### 2.02 MATERIALS:

- A. **Galvanized Sheet Steel:** ASTM A526 and A527, with ASTM A525, G90 zinc coating, mill phosphatized.
- B. **Cold-rolled Sheet Steel:** ASTM A366, Class 1, matte finish.
- C. **Aluminum Sheet:** ASTM B209, Alloy 3003 or 5005 with temper as required for forming, or as otherwise recommended by metal producer to provide required finish.
- D. **Aluminum Extrusions:** ASTM B221, Alloy 6063-T52.
- E. **Fastenings:** Use same material as items fastened, unless otherwise indicated. Fasteners for exterior applications may be hot-dip galvanized stainless steel or aluminum. Provide types, gauges and lengths to suit unit installation conditions. Use Phillips flat-head machine screws for exposed fasteners, unless otherwise indicated.
- F. **Anchors and Inserts:** Use non-ferrous metal or hot-dip galvanized anchors and inserts for exterior installations and elsewhere as required for corrosion resistance. Use steel or lead expansion bolt devices for drilled-in-place anchors. Furnish inserts, as required, to be set into concrete or masonry work.
- G. **Bituminous Paint:** SSPC-Paint 12 (cold-applied asphalt mastic).

2.03 FABRICATION, GENERAL:

- A. **Provide louvers and accessories of design**, materials, sizes, depth, arrangement, and metal thicknesses indicated, or if not indicated, as required for optimum performance with respect to airflow; water penetration; air leakage, where applicable (for adjustable units, if any); strength; durability; and uniform appearance.
- B. **Fabricate frames including integral skills to suit** adjacent construction with tolerances for installation including application of sealants in joints between louvers and adjoining work, where applicable.
- C. **Include supports, anchorages, and accessories** required to achieve a complete assembly.
- D. **Provide vertical mullions of type** and at spacings indicated but not further apart than recommended by manufacturer or seventy-two inch on center whichever is less. At horizontal joints between louver units provide horizontal mullions except where continuous vertical assemblies are indicated.
- E. **Provide sill extensions and loose sills** made of same material as louvers where indicated, or required for drainage to exterior and to prevent water penetrating to interior.
- F. **Join frame members to one another** and to stationary louver blades by welding, except where indicated otherwise or where field bolted connections between frame members are made necessary by size of louvers. Maintain equal blade spacing, including separation between blades and frames at head and sill, to produce uniform appearance.

2.04 STATIONARY EXTRUDED ALUMINUM WALL LOUVERS:

- A. **Horizontal Drainable Blade Louvers:** Units designed to collect and drain water to exterior at sill by means of gutters in front edges of blades, and channels in jambs and mullions. Furnish units with extrusions not less than 0.081-inch thick, of depth and sizes indicated, complying with following performance requirements.
  - 1. Free Area: Not less than 50 percent for a 48" x 48" size.
  - 2. Static Pressure Loss: Not more than 0.15-inch of water gauge at airflow of 1050 fpm free area velocity in intake direction.
  - 3. Water Penetration: Not more than 0.052 ounces per square foot of area at an airflow of 1000 fpm free area velocity.
  - 4. AMCA Certification: Furnish units bearing AMCA Certified Ratings Seal.
  - 5. Furnish units complying with following performance requirements.

2.05 STATIONARY FORMED SHEET METAL LOUVERS:

- A. **Horizontal Drainable Blade Louvers:** Unit designed to collect and drain water to exterior at sill by means of gutters on front edges of louver blades and channels in jambs and mullions; of depth and sizes indicated, fabricated from the following metal:

1. Aluminum: Not less than 14 gauge.

2.06 ADJUSTABLE LOUVERS:

**A. Operation:** Provide adjustable blade louvers (AdjLvr) at locations and of type indicated; with manufacturer's recommended bearings and operating mechanisms to suit louver size and method of operation.

1. Hand operation with spring, chain, wall bracket, and 160 degree F (71 degrees C) fusible link.

2.07 LOUVER SCREENS: Provide removable screens for exterior louvers where indicated. Fabricate screen frames of same metal and finish as louver units to which secured, unless otherwise indicated. Provide rewireable frames consisting of formed or extruded metal with a driven spline or insert for securing screen mesh. Use bird screen where indicated, of the following:

1/2 inch square mesh, 0.063 inch aluminum wire.

**A. Locate screens on inside face of louvers,** unless otherwise indicated. Secure screens to louver frames with machine screws, spaced at each corner and at twelve inch on center between.

2.08 FIRE RATED LOUVERS: Provide tightly fitted spring loaded automatic closing louvers with operable blades equipped with smoke activated closing device.

2.09 METAL FINISHES: Comply with NAAMM "Metal Finishes Manual" for finish designations and application recommendations, except as otherwise indicated. Apply finishes in factory after products are assembled. Protect finishes on exposed surfaces with protective covering, prior to shipment. Remove scratches and blemishes from exposed surfaces which will be visible after completing finishing process. Provide colors or color matches as indicated, if not otherwise indicated, as selected by Architect from manufacturer's standard colors.

**A. Aluminum Finishes:**

1. Fluorocarbon paint finish.

**B. Ferrous Metal Finishes:**

1. Preparation: Clean surfaces of dirt, grease and loose rust or mill scale, including items fabricated from galvanized steel, if any. Apply finish to surfaces of fabricated and assembled units, whether exposed or concealed when installed, after pretreating with a conversion coating suited to organic coating applied over it.
2. Factory-Primed Finish: Where painting after installation is indicated (not work of this section), apply air-dried primer immediately following cleaning and pretreatment.

**PART 3 - EXECUTION**

3.01 PREPARATION: Coordinate setting drawings, diagrams, templates, instructions and directions for installation of anchorages which are to be embedded in concrete or masonry construction.

Coordinate delivery of such items to project site.

3.02

**INSTALLATION:** Locate and place louver units plumb, level and in proper alignment with adjacent work.

- A. Use concealed anchorages wherever possible.** Provide brass or lead washers fitted to screws where required to protect metal surfaces and to make a weather-tight connection.
- B. Form tight joints with exposed connections** accurately fitting together. Provide reveals and openings for sealants and joint fillers, as indicated.
- C. Repair finishes damaged by cutting, welding, soldering and grinding operations** required for fitting and jointing. Restore finishes so there is no evidence of corrective work. Return items which cannot be refinished in the field to shop, make required alterations, and refinish entire unit, or provide new units, at Contractor's option.
- D. Protect galvanized and non-ferrous metal surfaces** from corrosion of galvanic action by application of a heavy coating of bituminous paint on surfaces which will be in contact with concrete, masonry or dissimilar metals.
- E. Provide concealed gaskets, flashings, joint fillers, and insulation, and install as work progresses** to make the installations weather-tight.
- F. Refer to Section 07900 for sealants** in connection with installation of louvers.

END OF SECTION



SECTION 10350

FLAG POLE

PART 1 - GENERAL

1.01 DESCRIPTION: Division 1 applies to this Section. Provide flat pole as indicated, specified, and required.

**A. Work In This Section.** Principal items include:

1. Flag pole.
2. Templates for concrete embedded items.
3. Clean-up and disposal.

**B. Related Work Not In This Section.**

1. Concrete work, including setting concrete embedded items.
2. Furnishing concrete embedded items.
3. Flags.

1.02 QUALITY ASSURANCE:

**A. Manufacturer:** Baartol Co., American Flag Pole Co., Morgan-Frances Co., Babcock-David Associates, Inc., or Acme Flag Pole Co.

1.03 SUBMITTALS: Refer to Section 01300 for procedures.

**A. Samples:** Submit 18" length samples of pole for review.

**B. Shop Drawings:** Submit for approval, indicating materials, finishes, accessories, fabrication, design calculations, and erection diagrams.

**C. Certificate:** Deliver to Architect stating that finishing and protective coatings conform to requirements herein specified.

PART 2 - PRODUCTS

2.01 DESIGN CRITERIA: Design flag poles, braces, and anchorage devices to withstand wind velocities unflagged of 90 mph.

2.02 POLES: Bronze alloy, seamless with cone taper for length of pole and wall thickness of .188. Overall exposed length as selected by Architect. Stationary pole without flag or halyard.

2.03 FLASHING COLLAR: Diameter as required, finished to match pole.

2.04 FINISH: Bronze - directional satin bronze to match architect's sample.

MTA Headquarters  
Los Angeles, California  
#91-400

12/07/93  
Flag Pole  
10350 - 2

PART 3 - EXECUTION

3.01      INSTALLATION: Install plumb, secure, and full operative in accordance with approved Shop Drawings.

END OF SECTION



SECTION 10800

TOILET ACCESSORIES

PART 1 - GENERAL

- 1.01 DESCRIPTION: Division 1 applies to this Section. Provide accessories for toilet rooms as indicated, specified and required.
- 1.02 SUBMITTALS
- A. **Shop Drawings:** Submit Shop Drawings showing installation details and required backing plate locations.
  - B. **Samples:** Submit such samples as Architect may request, which will be returned to Contractor. Approved samples may be installed in the Work.

PART 2 - PRODUCTS

- 2.01 MATERIALS: Accessories as scheduled on Drawings, stainless steel products of Bobrick. Refer to Section 01600 regarding substitutions.
- 2.02 TOILET ROOM MIRRORS: Mirror quality 1/4" thick polished plate, ground edges, double-silvered, copper backed, and organic coating, bearing 15-year warranty against silver spoilage. Secure with adhesive supplied by mirror manufacturer.
- 2.03 UNFRAMED MIRRORS: All clear mirror quality float glass, Type I, Class 1, Quality q1 silvering and 1/4" thick unless otherwise indicated, edges ground and polished, double silvered, with electro-deposited copper backing and protective back paint coat equal to Palmer Products "Mirro-Bac Paint". Provide unequal leg channels at top and bottom edges unless otherwise shown or directed, of stainless steel.
- A. **Glass Adhesive:** Standard product adhesive expressly manufactured for glass installations, equal to Palmer Products "Mirro-Mastic" with "Mirr-Mastic Bond".

PART 3 - EXECUTION

- 3.01 INSTALLATION: Install accessories square, plumb and level. Securely anchor by mechanical means only using stainless steel fasteners. Obtain required rough-in and installation templates. Exact locations shall be as indicated or directed by the Architect. All locations of items shall comply with the handicapped code requirements.

END OF SECTION

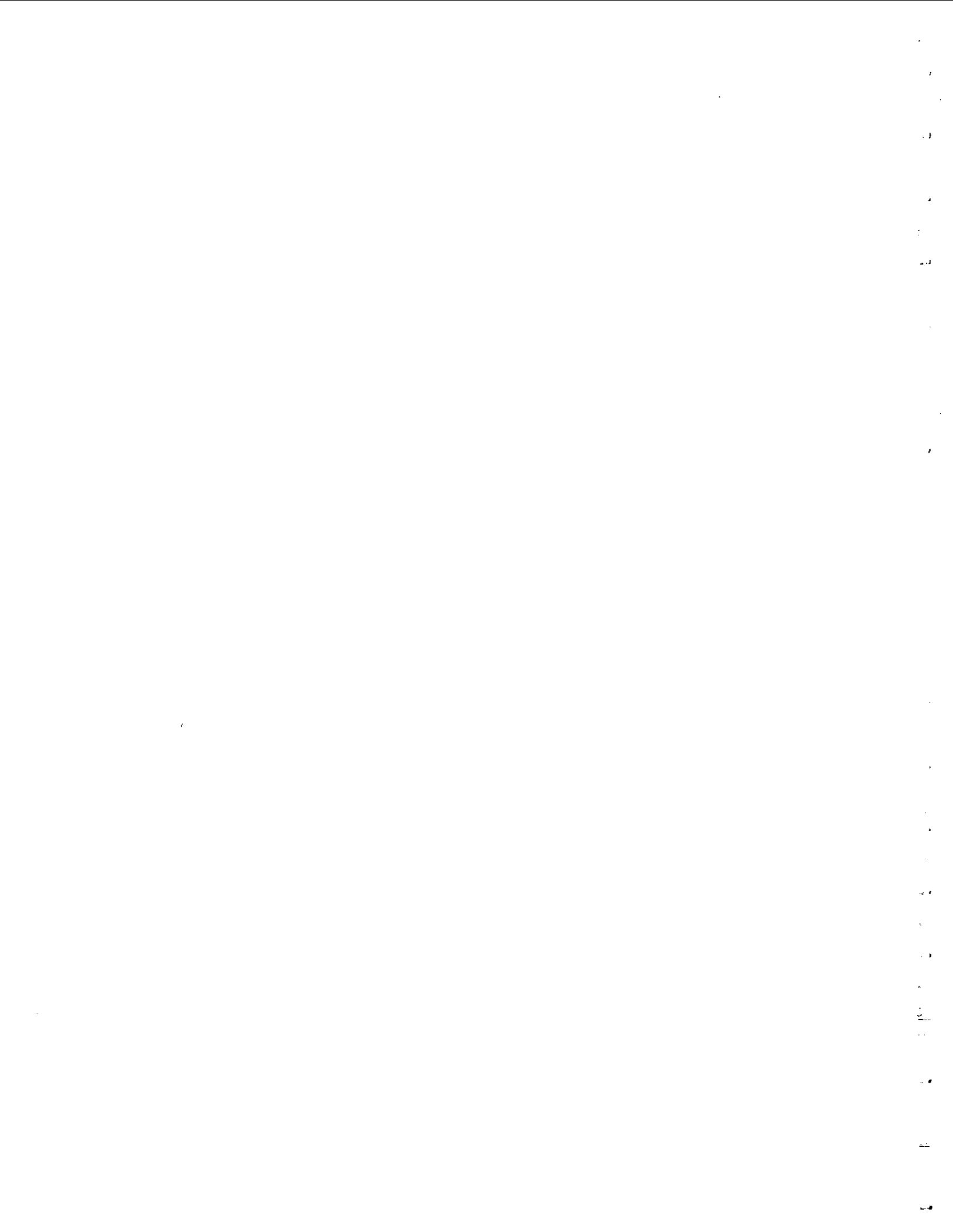

**SECTION 11012**

**WINDOW WASHING EQUIPMENT**

**PART 1 - GENERAL**

1.01 DESCRIPTION: Division 1 applies to this Section. Provide window washing system equipment as indicated, specified and required.

**A. Work In This Section: Principal items include:**

1. Design and Engineering of all items by a Registered Professional California Engineer.
2. Instruction and Maintenance Manuals.
3. Delivery of all items to the job site.
4. Procuring of all Federal, State, and Local approvals.
5. I-beam track including corner sections.
6. Powered I-beam track carriage.
7. Standard socket pedestals.
8. Heavy duty socket pedestals.
9. Standard hinging davit sockets.
10. Standard elevated hinging davit sockets.
11. Safety line tie-backs.
12. Eyebolt tie-backs.
13. Dog line fall restraint cable.
14. Standard portable davit sockets.
15. Heavy duty portable davit sockets.
16. Medium heavy duty davit arms.
17. Heavy duty davit arms.
18. Sectional self powered work platform with two (2) additional 5'-0" filler sections.
19. Self powered one man work basket with powered wire winders.
20. Stainless steel intermittent tie in insert sleeves.
21. Tie in lanyard assemblies.
22. Davit erection winch.

**B. Related Work Not In This Section:**

1. Building structure and roof runway.
2. Electrical conduit, wiring and outlets on the roofs including eyebolts located adjacent to each other for the purpose of attaching the electric cord strain relief grip. Power required: 208 VAC 3 Phase 30 Amp 60 Hertz.
3. Water supply and faucets on roof.
4. The supply and installation of the I-beam track supports and required bracing.
5. Installation of the stainless steel intermittent tie in insert sleeves.
6. Any additional supporting steel that may be required including beams, beam stiffeners, support plates, angle bracing, rebar, etc.
7. Unloading equipment from carrier at job site.

8. Hoisting of material to the roof, including labor.
9. Installation of any embedded items.

1.02 QUALITY ASSURANCE

- A. **Manufacturer shall provide** equipment conforming to pertaining requirements of all public agencies including Federal, State and Local. Without limitation, conform to the following:
1. ANSI A120.1, 1992 - Safety Requirements for Powered Platforms for Exterior Building Maintenance.
  2. ANSI A39.1, 1987 - Safety Requirements for Window Cleaning.
  3. OSHA 1910.66 - Powered Platforms for Exterior Building Maintenance.
  4. General Industry Safety Orders, CAL-OSHA, Articles 5 and 6.
  5. Current applicable building codes.
- B. **Approval:** Manufacturer shall submit structural calculations and drawings prepared by a Registered Civil Engineer, licensed in the State of California, to the Building Department for check and approval and pay all fees and charges.
- C. **Equipment Design:** Equipment design shall provide for total coverage of building exterior glass not accessible from ground level or low roof areas.

1.03 SUBMITTALS: Refer to Section 01300 for procedures.

- A. **Shop Drawings and Calculations.** Submit the Building Department approved Shop Drawings and calculations which illustrate the following:
1. All equipment being supplied including the work positions of the equipment.
  2. Details of all equipment.
  3. Load reactions from the equipment to the building structure.
  4. Structural calculations certified by a registered civil engineer in the State of California.
  5. Location and method of attachment of all equipment to the building structure.
- B. **Wiring Diagrams:** Two sets of "as installed" straight line wiring diagrams showing electrical connections of all equipment. A legend sheet with the appropriate project reference numbers shall be furnished with the drawings to provide the following information:
1. Name and symbol of each relay, switch, or apparatus.
  2. Location on drawings, drawing sheet number, and area and location of contacts.
  3. Location on apparatus - whether on controller, powered platform, etc.
- C. **Parts Catalog:** Three complete parts catalog listings of replacement parts including identifying numbers and ordering instructions.
- D. **Printed Instructions:**

1. Three sets of neatly bound instructions explaining all operating features including all apparatus on the powered platform.
  2. A lubrication chart, indicating all equipment lubrication points, frequency of lubrication required, and type of lubricant for all equipment.
- 1.04 WARRANTY: Refer to Section 01740 for form of warranty. Furnish to Owner a one year warranty covering all Work of this Section. (Parts, material replacement and labor) - full maintenance contract to be included and in effect during the warranty period.

## **PART 2 - PRODUCTS**

### **2.01 MATERIALS**

#### **A. Socket Pedestals**

1. Each pedestal assembly shall be designed to support a maximum load of 1,000 pounds with a minimum safety factor of 4 to 1 against the overturning moment when compared to the ultimate strength of the weakest part.
2. All pedestal assemblies shall be fabricated from A36 steel plates and A53 grade B pipe and shall be of a welded construction. All welds shall be made by certified welders in accordance with Code for Welding in Business Construction, A.W.S. D1.01, latest edition of American Welding Society.
3. All pedestal assemblies shall be designed and fabricated for attachment to the building structural steel.
4. All pedestal assemblies shall be designed and fabricated with a top mounting plate to allow the portable davit sockets with the davit arms to be mounted on to the pedestals and rigidly support the portable davit sockets and davit arms when subjected to the loading of a powered platform or one man work basket.
5. All pedestals shall be hot dipped galvanized after fabrication according to ASTM A123 or ASTM 153, as applicable.

#### **B. Portable Davit Sockets**

1. Each portable davit socket shall be designed to support a maximum load of 1,000 pounds with a minimum safety factor of 4 to 1 when compared to the ultimate strength of the weakest part.
2. All portable davit sockets shall be fabricated from A36 steel plates and shapes and A53 grade B pipe and shall be of a welded construction. All welds shall be made by certified welders in accordance with Code for Welding in Business Construction, A.W.S. D1.01, latest edition of American Welding Society.
3. All portable davit sockets shall be designed and fabricated so that when they are engaged on to the top pedestal plate, they will be positively locked and maintained in position without the use of any tools.
4. All portable davit sockets shall be provided with two (2) eight inch diameter rubber tired wheels and shall have two handle bars to allow the socket to be tilted back and rolled to each work location.
5. All portable davit sockets shall be designed to hinge down to a predetermined angle to facilitate insertion and removal of the davit arms.

6. All portable davit sockets shall be designed with a positive locking device to prevent removal of the davit arm when it is in an upright position.
7. All portable davit sockets shall have a 3/4 inch diameter locking pin to positively lock the socket pipe in a vertical position when it is in use. Note: 1" diameter used on heavy duty sockets.
8. All portable davit sockets shall be provided with a 2 inch inside diameter loop welded directly to the frame for the purpose of securing a 5/8 inch diameter workman's safety line. The loop shall be designed to support a maximum load of 5,400 pounds applied in any direction.
9. All portable davit sockets shall be hot dipped galvanized after fabrication according to ASTM A123 or AS 153 as applicable.

**C. Hinging Davit Sockets**

1. All hinging davit sockets shall be designed to support a maximum load of 1,000 pounds with a minimum safety factor of 4 to 1 against the overturning moment when compared to the ultimate strength of the weakest part.
2. All hinging davit sockets shall be fabricated from A36 steel plates and shapes and A53 grade B pipe and shall be of a welded construction. All welds shall be made by certified welders in accordance with Code for Welding in Business Construction, A.W.S. D1.01, latest edition of American Welding Society.
3. All hinging davit sockets shall be designed and fabricated for attachment to the building structural steel.
4. All hinging davit sockets shall be designed to hinge down to a vertical predetermined angle to facilitate insertion and removal of the davit frame.
5. All hinging davit sockets shall be provided with 3/4 inch diameter locking pin to positively lock the socket pipe in a vertical position when it is in use.
6. All hinging davit sockets shall be provided with a 2 inch inside diameter loop welded directly to the frame for the purpose of securing a 5/8 inch diameter workman's safety line. The loop shall be designed to support a maximum load of 5,400 pounds applied in any direction.
7. The hinging davit sockets on level 4 shall be an elevated type due to the high parapet wall condition and shall meet all of the above requirements for the hinging davit sockets.
8. All hinging davit sockets shall be hot dipped galvanized after fabrication and shall conform to ASTM A123 or ASTM 153 as applicable.

**D. Unscheduled Maintenance Safety Tie-Backs (Roof Levels 4 and 5)**

1. The unscheduled maintenance safety line tie-backs shall be designed to withstand a load of 5,400 pounds in any direction.
2. All of the tie-backs shall be fabricated from A36 steel plates and tubing and shall be of a welded construction. All welds shall be made by certified welders in accordance with Code for Welding in Business Construction, A.W.S. D1.01, latest edition of American Welding Society.
3. All tie-backs shall be designed and fabricated for attachment to the building structural steel.
4. All tie-backs shall be hot dipped after fabrication according to ASTM A123 or ASTM 153, as applicable.

**E.     **Unscheduled Maintenance Eyebolt Tie-Backs (Roof Level 3)****

1.     The unscheduled maintenance eyebolt tie-backs shall be designed to withstand a load of 5,400 pounds in any direction.
2.     The eyebolt tie-backs shall be 1 inch diameter galvanized drop forged eyebolts.

**F.     **Fall Restraint Dog Line (Roof Level 4)****

1.     The fall restraint dog line shall be a 5/16 inch diameter galvanized wire rope for attachment of a workman's lanyard.
2.     The dog line shall be connected at each end by three clamps to the tie-back support and passed through the loop on top of the intermediate supports.

**G.     **Davit Arms****

1.     Davit arms shall be provided for insertion into davit sockets to support a self powered platform.
2.     Davits shall be fabricated from 6061-T6 aluminum pipe of proper length to provide optimum workability.
3.     The base end of each davit shall be enclosed with a cast aluminum thrust bearing to insure ease of rotation. The arm end shall be closed with a cast aluminum end cap.
4.     The upper base section shall be fitted with a tubular steel bearing sleeve to prevent abrasion to davit when rotating in socket.
5.     Each davit shall be equipped with one or more 3/4" diameter galvanized steel eyebolts for attachment of suspension wire ropes.
6.     A fabricated steel handle shall be fitted to each davit for rotating and lifting.
7.     Each davit socket shall be equipped with a fabricated steel electrical cord support eye to be located on the outer arm section.
8.     Each davit shall be load tested to four times its rated load of 1,000 pounds prior to affixing a durable metal plate to the outer arm end bearing the following information:
  - a)     Manufacturer's name.
  - b)     Rated load of davit.
  - c)     Precautionary warning message prohibiting use within 10 feet of energized high voltage lines.
9.     Finish of each davit to be mill finish. All ferrous appurtenances to be either hot dipped galvanized or cadmium plated.

**H.     **Intermittent Scaffold Stabilizer Insert Sleeves****

1.     The intermittent scaffold stabilizer insert sleeves shall be designed to withstand a pull out load of 600 pounds.
2.     The inserts shall be fabricated from stainless steel.
3.     The insert shall be designed for attachment to the precast concrete or aluminum curtain wall by others.
4.     The insert shall be designed to accept a 3/8 inch diameter ball lock pin.

**I.     **Scaffold Stabilizer Lanyard****

1. The scaffold stabilizer lanyards shall be designed to make a connection between the tie in insert sleeve and the suspension wire rope.
2. The lanyard assemblies shall be adjustable in length.

**J. Davit Erection Winch**

1. A portable davit erection winch shall be used on the heavy duty portable davit sockets to facilitate raising of the heavy duty davit arms.

**K. Work Platform**

1. The work platform shall conform to all OSHA requirements and shall be a type "T", two line suspension.
2. The work platform shall be fabricated using aluminum materials.
3. The work platform shall have a 750 pound live load capacity.
4. Two 3 phase 208 VAC 60 Hz 1-1/2 H.P. traction hoist motors will be used to raise and lower the work platform. The hoists shall run at 35 F.P.M. The hoist shall be equipped with an over-speed sensing and wire locking device that is electrically interlocked.
5. The work platform suspension wire ropes shall be 5/16 inch diameter galvanized wire ropes with a safety factor of 10 to 1.
6. Passive wire winders shall be provided on the work platform that automatically accumulates the wire rope as the work platform travels up the building.
7. The work platform shall be equipped with polyurethane non-marking, non-scuffing rollers to ensure perfect protection of the building.
8. 4" diameter swivel casters shall be installed on the work platform.

**L. One Man Work Basket**

1. The one man work basket shall conform to all OSHA requirements and shall be suspended by two 5/16" diameter galvanized wire ropes.
2. The wire ropes shall be collected on reels that are driven by an electric motor.

**M. I-Beam Track**

1. The I-beam track shall be A36 steel galvanized I-beam.
2. The I-beam track shall be attached to supports supplied and installed by others.

**N. Powered I-Beam Track Carriage**

1. The track carriage shall conform to all OSHA requirements.
2. The track carriage shall be fabricated from A36 steel shapes and of a welded construction. All welds shall be made by certified welders in accordance with Code for Building Construction, A.W.S. D1.01, latest edition of American Welding Society.
3. The carriage will be designed to support a maximum load of 2,000 pounds with a safety factor of 4 to 1.
4. The carriage will be designed to positively lock onto the track I-beams and shall be electrically driven along the track.



5. The carriage mast will electrically telescope up and down.
6. The outrigger beam will be electrically rotated for proper positioning of the work platform.
7. The work platform will be suspended from a spreader bar which is electrically driven in and out.
8. All weather proof controls will be provided.
9. All required safety limit switches and interlocks required by code will be provided.
10. The track carriage will be hot dipped galvanized after fabrication.

### PART 3 - EXECUTION

#### 3.01 INSTALLATION

- A. All work shall be installed in strict compliance with approved shop and erection drawings, manufacturer's recommendations as approved, and to provide sufficient scaffold means to allow all windows to be cleaned in a safe and efficient manner.
- B. All work shall be installed under direct supervision of manufacturer or by a superintendent experienced in this type of work.
- C. All work shall be coordinated with other construction operations to properly facilitate installation.

END OF SECTION

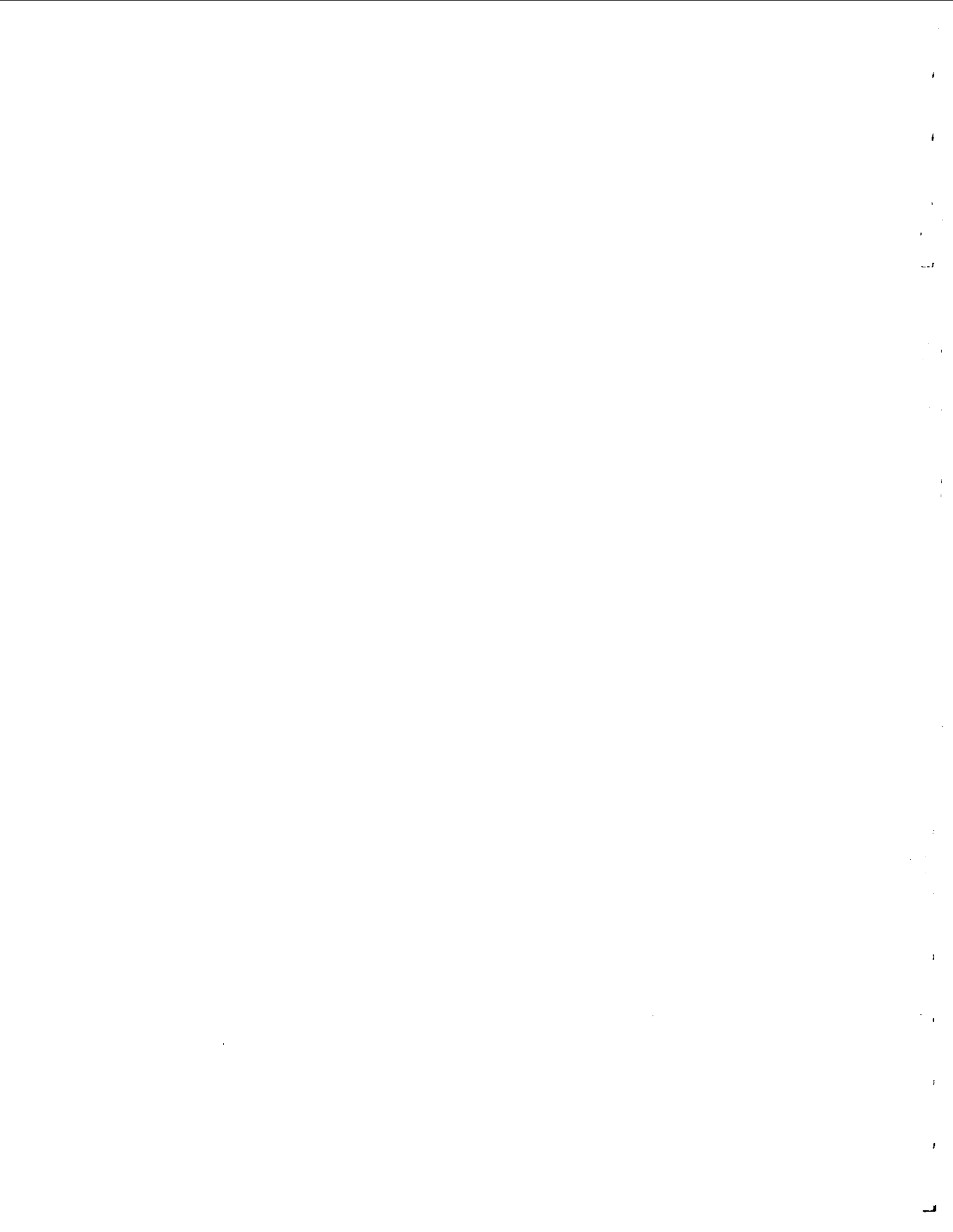

SECTION 14200

TRACTION ELEVATORS

PART 1 - GENERAL CONDITIONS

1.01 WORK INCLUDED

- A. 12 Gearless Traction Elevators.
- B. Provide everything necessary for and incidental to the satisfactory completion of the equipment installation as specified and conforming to all contract documents.
- C. Conform to applicable conditions of General, Special, and Supplemental Conditions and Division 1.

1.02 RELATED WORK SPECIFIED ELSEWHERE

A. Legal Elevator Hoistway and Pit:

- 1. Clear plumb elevator hoistway with variations not to exceed 1" at any point. Glass shall be laminated in accordance with the requirements of ANSI Z97.1.
- 2. Bevel cants (75 degrees from horizontal) over any rear or side wall ledges and beams that project 2" or more into the hoistway. Hoistway divider beams excepted.
- 3. Divider beams between adjacent elevators at each floor, pit, and overhead. Intermediate rail supports where floor heights exceed 14'-0" (building supports not to deflect in excess of 1/8" under 0.5g horizontal seismic acceleration). Intermediate rail support is not required where double main rail bracketing is employed to maintain 14'-0" or less bracket to bracket.
- 4. Install guide rail bracket supports in concrete, (concrete inserts or imbeds will be provided by Elevator Contractor and installed by General Contractor as indicated on Elevator Contractor's shop drawings).
- 5. Cut and patch walls and floors. Grout at hoistway door sills. Cutting and patching and redecorating around new hall lanterns, pushbuttons, smoke detector stubout conduits, and entrances.
- 6. Wall pockets and/or structural beams for adequate support of the elevator machine beams and deadend hitch beams. Support deflection shall not exceed 1/1666 of the span under static load.
- 7. Wall blockouts for pushbutton stations, hall lanterns, position indicators or other signal fixtures.
- 8. After entrances are set, fill each side of entrance with concrete.

9. Pit ladders and pit screens where pit ladders are adjacent pit screen shall be extended 6'-0" high. Structural supports for car and counterweight buffer impact loads, and rail loads.
10. Waterproof pit. Sump pump or indirect waste drain as indicated on contract drawings. Seal pit with non-permeable epoxy.
11. Finish painting of primed hoistway entrances.
12. Finish flooring in elevator car enclosure.
13. Protect open elevator hoistways, wellways, and entrances during construction per OSHA regulations.
14. Protect cars, door entrance assemblies, and special metal finishes from damage after installation.
15. Vent elevator hoistways to outside air. Minimum 3'-0" sq. ft. per hoistway, or 3.5% of the total hoistway area (whichever is greater) per U.B.C. See contract drawings for size and location of vents.
16. Pit support framing for jack cylinder and buffer loads.
17. Opening in hoistway wall for hydraulic piping. All remote piping shall be encased in PVC casing and shall be run overhead.
18. 3'-0" square hole in pit floor for Elevator Contractor to install protective, secondary containment casing. Fill hole with concrete after jack and membrane installation.

B. Escalator. Wellways, and Pits:

1. Provide properly framed openings in the floors, necessary supports for the truss per the drawings and information, the required enclosures, wellway railings, baffles, and barricades around the wellway as required.
2. Covering for the exterior of the escalator from the edges of the decks, including covering for the truss and soffit. Covering for the truss shall run the full length, including that portion which is in the ceiling space. The materials used shall be fire resistant as required by the ASME A17.1 Code and shall weigh not more than eight pounds per square foot.
3. Finished flooring at landing plates and its base over contractor's floor support.
4. Fire protection of escalator openings in accordance with the Life Safety Code NFPA No. 101, latest edition and supplements.
5. Provide escalator step treads and landing plates with a minimum of five foot candles of illumination.
6. Protective enclosures of openings in accordance with OSHA during construction.

7. Structural Requirements: Provide escalator truss mounting angles and intermediate truss supports with attachments, sized as required to securely attach escalators to wellway structural support system.

C. Legal Machine Rooms:

1. Self-closing and self-locking elevator machine room access doors or gates. Lock shall have be as specified in hardware section.
2. Access plates to escalator machine areas (top and bottom) shall require no more than 70 lbs to open.
3. Machine Room: Provide constant cooling and heating, including truss ventilation, to maintain a minimum temperature of 65 degrees and a maximum of 90 degrees Fahrenheit, and humidity shall not exceed 85%. Cooling and heating unit shall be located outside of the machine room enclosure.
4. Paint elevator machine room walls, ceiling and floor. Cementitious beam, column, and roof fireproofing shall be sealed to prevent flaking.
5. Provide a Class "C" fire extinguisher in each elevator machine room.
6. Coordinate secondary containment of hydraulic tank with elevator installer.
7. Self-closing and self-locking 30" x 30" clear, fire-rated governor access door.
8. Governor access ladder and platform.

D. Electrical Services, Conductors and Devices:

1. Permanent Guarded Lighting (minimum 10 footcandles) and convenience outlets, per Code in elevator and escalator pits, machine rooms, governor locations, and mechanical areas (at both ends for escalators).
2. Run conduits from the closest elevator hoistway of each elevator group or single elevator to the fire control room and/or main level lobby control console at employee entrance. Coordinate size, number, and location of conduits with Elevator Contractor.
3. All remote conduits shall be run overhead.
4. Three-phase mainline power feeders to terminals of each elevator and escalator controller unit in the elevator and escalator machine room. Include protected lockable "off" disconnect switch (copper conductors to terminals). Provide auxiliary disconnects in multi-level machine rooms, label existing disconnects with proper elevator numbers.
5. Verify adaptability of existing disconnect and power for new equipment to be installed.

6. Single-phase power feeders to each elevator and escalator controller for lighting and exhaust blower. Include individual disconnect switch at location shown on elevator contractor's shop drawings.
7. Single-phase power feeder to elevator intercom amplifier located in the elevator machine room.
8. Signal fixture power feeders to machine room elevator to each group control panel.
9. Products-of-combustion sensors (NFPA No. 72D) in each elevator lobby, hoistway, and machine room for each group of elevators, including single elevator units, to initiate fireman's return feature, per Code requirements. Run sensing wires to each group elevator controller and single elevator unit in each elevator machine room, including exiting units.
10. Standby Power Provisions
  - a. Provide standby power of the same voltage characteristics via the normal electrical feeders to run one elevator at a time in each elevator group, including single elevator units, at full-rated car speed.
  - b. Conductors, as necessary, from the standby power transfer switch to a single elevator control panel in each elevator group and/or single elevator unit, as designated by the Elevator Contractor, to signal the presence of standby power. Transfer switch shall provide a dry, form "C" output with a time delay of approximately 15 seconds for pretransfer signal upon restoration of normal power.
  - c. Standby single-phase power to each elevator controller for lighting, exhaust blower, emergency alarm bell, intercom amplifier, and hoist machine, and/or controller cooling fans.
  - d. Means for absorbing regenerated power during an overhauling load (such as full load down) in accordance with ANSI A17.1, Rule 210.10.  
  
(Note: Elevator drives may employ solid-state SCR devices for conversion of AC to DC power).
11. Individual phone connection at car controllers in elevator machine rooms.
12. Temporary power and illumination as required by Elevator Contractor to install, test and adjust elevator and escalator equipment.
13. Provide all necessary CCTV cameras and hardware for camera installation by Elevator Contractor.

1.03 QUALITY ASSURANCE

A. Definitions:

1. In all cases, where a device or a part of the equipment is herein referred to in the singular number, it is intended that such reference shall apply to as many such devices or parts as are required to complete the installation.
2. All terms in these specifications have their definition given in the latest edition of the American National Standards Institute, Safety Code for Elevators, Dumbwaiters, and Escalators ASME A17.1, including revisions and authorized changes in effect on the date of these specifications.

B. Document Verification: In order to discover and resolve conflicts or lack of definition which might create construction problems, Elevator Bidders must review schematic design documents, and existing conditions for compatibility with their products prior to bidding. Attach specific, written exceptions and/or clarifications with quotation. Bidder's compliance with all provisions of contract documents is assumed and required in absence of written exceptions. Owner will not pay for changes to structural, mechanical, electrical or other systems required to accommodate Bidders' equipment if not identified before contract award.

C. Acceptable Elevator Bidder:

1. General:

- a. Manufacturers: Provide manufacturer's equipment and other components produced by the manufacturer or by firms experienced and specialized not less than five years in the types of components required that comply with these specifications.
- b. Installer: Either the manufacturer or a licensee of the manufacturer, who has not less than five years successful experience with the installation of similar units and who is currently under contract for maintenance of similar units in the area, and who maintains a service center in the Los Angeles basin.
- c. Welders: Qualify welding processes and welding operators in conformance with AWS D1.1, Structural Welding Code - Steel.
- d. Maintainability: Parts subject to wear and replacement shall be readily and easily removable and replaceable without requiring modification of the units or the equipment.
  - (1) Parts subject to wear shall be standard production items that are interchangeable.
  - (2) Replacement parts, whether produced in the Contractor's factories or secured from commercial factories or distributors, shall be precisely identified. Replacement parts shall be made available to the Owner or its designee without prejudice. The required quantities, uniform price, and delivery time of replacement parts

shall be on the same basis as the Contractor's most favored maintenance consumer.

- (3) Replacement parts, maintenance methods, technical information, wiring diagrams, testing procedures, design criteria, or any other publication related to the equipment provided, even though labeled PROPRIETARY, shall be made available to the Owner or its designee without prejudice or delay.

2. Companies: The units shall be installed by Dover Elevator Company, Fujitec Elevator Company, Mitsubishi Elevator Company, Montgomery Elevator Company, Otis Elevator Company, or Schindler Elevator Corporation. Alternate suppliers or installers must receive approval of the Architect and/or Consultant a minimum of 5 days prior to bid date. The equipment shall be provided by:

- a. Geared Elevator Machines: Dover, Fujitec, General Electric, Holister-Whitney, Mitsubishi, Montgomery, Otis, Schindler.
- b. Traction Control Systems: Dover, Fujitec, Mitsubishi, Montgomery, Otis, and Schindler.
- c. Car Enclosures: Amtech/Reliable, Dover, Elevator Cabs, Elevator Decorators, Fujitec, Globe Van Doorn, Hauenstein & Burmeister, Mitsubishi, Montgomery, Otis, Schindler, and Tyler.
- d. Hoistway Entrances: Elevator Doors, Fujitec, Hauenstein & Burmeister, Montgomery, Otis, Tyler.
- e. Escalators Manufactured By: Mitsubishi, Montgomery, O & K, Otis, Schindler.
- f. Fixtures: Adams or approved equal.
- i. Use of alternate manufacturers must receive approval of the Architect and/or Consultant at least 5 days prior to bid date.

D. Design Criteria:

1. General:
  - a. Equipment shall be of the heavy-duty type.
  - b. No wood or wood products will be permitted in elevator and escalator systems.
2. Seismic Requirements: All equipment shall be designed for the appropriate Seismic Zone.

E. On-Site Conditions:

1. Complete verification of on-site conditions, including, but not limited to, elevator hoistway, pit, machine room, overhead clearances, electrical power characteristics,



structural loads, etc., as they relate to the Elevator Contractor's equipment applications, and Code compliance shall be the responsibility of the Elevator Contractor. On-site review shall be completed prior to submittal of the Elevator Contractor's proposal. Deficiencies noted shall be included in writing with the Elevator Contractor quotation. Special attention shall be paid to verifying field dimensions, drilling accessibility, and overhead heights. Submission of bid indicates acceptance of all on-site conditions.

2. Drawings or measurements included with the bidding material shall be for the convenience of the bidders only. Complete responsibility for detailed dimensions lies with the Elevator Contractor. Prior to the execution of the work, the Contractor shall verify all dimensions with the actual on-site conditions. Where the work of the Elevator Contractor is to join another trade, the shop drawings shall show the actual dimensions and the method of joining the work of the two trades.
  3. Modification of existing electrical supply shall be the responsibility of the elevator contractor.
- F. Compliance with Regulatory Agencies and Agreements: Comply with most-stringent applicable provisions of following Codes and/or Authorities, including revisions and changes in effect on date of these specifications (latest editions and supplements shall apply):
1. Safety Code for Elevators and Escalators ASME A17.1.
  2. Inspectors' Manual, for Elevators and Escalators ASME A17.2.
  3. Safety Code for Existing Elevators and Escalators, ASME A17.3.
  4. National Electrical Code, No. ANSI/NFPA 70.
  5. Structural Welding Code, Steel AWS D1.1, latest edition.
  6. California Code of Regulations (CCR), Title 8, Title 23, and Title 24.
  7. Life Safety Code, ANSI/NFPA No. 101, CCR Title 19, and local fire authority.
  8. Requirements of local building code and any other Codes, Ordinances and Laws applicable within the governing jurisdiction.
  9. Underwriters' Laboratories, Inc., materials and test report descriptions as required.
  10. International Union of Elevator Constructors (IUEC).
  11. Providing Accessibility and Usability For Physically Handicapped People, per Americans with Disabilities Act, Titles II and III.
  12. Applicable UBC requirements.
  13. As directed by local fire jurisdiction.
  14. Soils reports - special attention to, but not limited to, any corrosive soil conditions.

15. In the event of conflict, the more-stringent Code requirements shall apply.

G. Applicable Standards, Rules, and Regulations:

1. American National Standards Institute (ANSI).
2. American Society of Civil Engineers (ASCE).
3. American Society of Mechanical Engineers (ASME).
4. American Society for Testing and Materials (ASTM).
5. Electronic Industries Association (EIA).
6. Insulated Cable Engineers Association (ICEA).
7. Institute of Electrical and Electronics Engineers (IEEE).
8. National Electrical Manufacturers Association (NEMA).
9. National Fire Protection Association (NFPA).
10. OSHA.
11. Underwriters' Laboratories, Inc. (UL).
12. CCR Titles 8, 23, and 24.

H. Safety: Conform safety devices, running clearance, testing, and maintenance methods to the requirements of ASME A17.1 and Supplements and ASME A17.2 and supplements, and local Codes.

I. Warranty:

1. Materials and workmanship of the elevator installation shall comply in every respect with contract documents. Unless due to ordinary wear and tear, or improper use or care by Purchaser, correct defects which develop within one year from date of final acceptance of work to the satisfaction of the Architect, Owner, and Consultant at no additional cost.
2. Make modifications, adjustments, improvements, etc., to meet all performance requirements.
3. Neither the final payment nor any provision of the contract documents shall relieve the Contractor of the extent and period provided by law and upon written notice he shall remedy any defects due thereto and pay all expenses for any damage to other work resulting therefrom.
4. The same guarantee shall be applicable to the total job in the event equipment is reused or modified.

5. The one-year guarantee, as outlined above, for all units shall start from the date of final acceptance by the Owner of all work associated with these contract documents.

#### 1.04 SUBMITTALS

##### A. Dimensioned Shop Drawings:

1. Scaled shop drawings shall be provided for all work. Before beginning fabrication, shop drawings showing the plan views of the pit, hoistway, wellways, machine room, elevation section of the hoistway, car details, entrance details, secondary containment provisions, and details of the signal fixtures shall be prepared and submitted for approval. Also provide electrical, structural, and/or mechanical data. Three reproducible sets (sepias or mylars) shall be provided for each drawing submittal.
2. Refer to Division 1 for submittal procedures, including preparation and transmittals. Shop drawings shall be submitted within 28 days of Contract award, verbal or written. Each shop drawing shall be clearly identified by title and owner's elevator number. Corrections made to shop drawings during the review process shall be incorporated on the drawings and/or responded to and acknowledged by the Elevator Contractor. Elapsed time due to "revise and resubmit" or "rejected" action, indicated on submittals due to inaccurate data or incomplete definition shall not affect equipment delivery or installation schedule.

- B. Calculations: Structural and electrical calculations shall be submitted. These calculations shall include, but are not limited to, rail loads, loads from machines, seismic forces, etc. Submit layout which clearly indicates structural loadings that will be applied to the building structure by the elevator system. Indicate the magnitude of each type of load (dead, live, impact, seismic) separately, along with its point of application to the building structure and its sense (vertical, horizontal, torsional). Additionally, indicate the nature of load combinations. The purpose of this submittal is verification of the capacity of the building structure.
- C. Samples: Submit three samples of each required finish, not including those intended for painting after installation. Submit 3" x 10" samples or 10" lengths of actual finished materials. Samples shall be reviewed by Architect for color, pattern and texture only. Compliance with other requirements is the exclusive responsibility of the Elevator Contractor. Include signal equipment units, to show pushbuttons, lights, graphics, Braille plates, and mounting provisions. Submittals shall be made within 28 days of award, verbal or written.
- D. Allotted approval process time shall be a minimum of four weeks from date individual submittals are received by Architect.

#### 1.05 PERMITS, TESTS, AND INSPECTIONS

##### A. Elevator Contractor Shall Obtain, Pay For and/or Provide:

1. All necessary legal requirements, permits, licenses and inspection fees necessary to complete the elevator and escalator installation.

2. Tests as required by governing authorities and/or the ANSI current A17.2 Elevator Inspectors' Manual.
  3. Any submittals required by local building/permit authorities.
- B. Perform such tests in the presence of authorized representatives of such authorities.
- C. Provide manpower and equipment to perform tests and final reviews as required by governing authorities and/or to meet the ASME/ANSI current A17.2 elevator inspectors' manual and tests, indicated in Specification Part 3.

1.06 MAINTENANCE

- A. General Guidelines:
1. Breakdowns and Shutdowns:
    - a. Breakdowns and shutdowns, such as electrical troubles, burned out control coils, open circuits, electrical or mechanical adjustments, will not keep the respective elevator out of service longer than one (1) day (24 hours).
    - b. Under no circumstances will any shutdown or breakdown last longer than three (3) days (72 hours). This includes the locating of the trouble, procurement of parts, the installation of these parts and the replacing of the respective unit back into safe uninterrupted operation. The Contractor must be so equipped to meet the above conditions. The excuse of not being able to obtain parts, necessary technical and engineering advice, etc., will not be acceptable, and the Contractor will be considered in default, giving sufficient justification to the Owner to obtain these services from Contractors who can provide the Owner with uninterrupted service.
    - c. The Owner may take over the work and prosecute it to completion by contract or otherwise, and the Contractor and his/her sureties (if any), shall be liable to the Owner for any additional cost occasioned by the Owner, previous to the termination of the contract.
  2. Material Inventory: The Contractor shall maintain a supply of contacts, coils, leads, fuses, motor and generator brushes, hanger rollers, clutch rollers, lubricants, wiping cloths, and other minor parts for the performance of routine preventive maintenance properly stored in the machine room.
  3. Spare Parts Inventory:
    - a. The Contractor shall maintain a supply of spare lending and replacement parts in their warehouse inventory. This inventory shall include, but is not limited to, generator rotating elements, door operator motors, brake magnets, generator and motor brushes, controller switch contacts, selector switch contacts, solid state components, selector tapes, door hangers, hardware, hoistway limit switches, etc.
    - b. All replacement parts and materials shall be specifically designed for the elevators on which they are to be used. The Contractor shall provide for

replacement parts from the original manufacturer of the transportation system or suppliers of such original manufacturer's parts. Substitute parts may be utilized on approval of the Owner or his/her designee.

4. **Experience and Parts:** The Elevator Contractor shall be able to show that he has had successful experience in the complete maintenance of elevators and escalators, employs competent personnel to handle this service, maintains an adequate stock of parts locally for replacement or emergency purposes and has qualified men available to ensure the fulfillment of this service without unreasonable loss of time in reaching the job site. The Elevator Contractor shall supply a list, acceptable to the Owner, of locally stocked parts, particular to the equipment designs. The Contractor shall supply a list, acceptable to the Owner, of long lead items that apply to the equipment. This list shall include delivery dates of long lead items.

**B. Construction Maintenance:**

1. When one or more elevators have been installed to a stage near completion and declared ready for service, the Owner or Contractor may accept the elevators for interim use and place them in service before the entire installation of all elevators has been completed and accepted.
2. During this period the General Contractor may agree to pay the Elevator Contractor a mutually agreed amount per elevator for preventive maintenance of elevators on interim service. Bidders shall indicate the amount per unit per month with their bids.
3. Before an elevator is placed in temporary service, General Contractor shall sign Elevator Contractor's temporary acceptance form. Form shall contain provisions acceptable to both parties.
4. As agreed upon between General Contractor and Elevator Contractor, the Elevator Contractor shall provide temporary hoistway enclosures and perform all cleaning, repairs or replacement of materials as necessary to restore elevator to its original condition.
5. The maintenance and warranty periods herein specified shall not commence for units accepted on an interim basis or accepted and shut down due to lack of need.

**C. Warranty Maintenance:** Include with new equipment contract (new installation service period):

1. The Elevator Contractor shall furnish weekly scheduled preventive maintenance on all equipment described herein for a period of 12 months, including 24-hour emergency callbacks, per unit, commencing on date of final acceptance by Owner. The maintenance shall include systematic examinations, adjustment, cleaning, and lubrication of all equipment. The Elevator Contractor shall also repair or replace electrical and mechanical parts whenever required and shall use only parts produced by the manufacturer of the equipment installed. Maintain machine rooms, wellways, hoistways, and pits in clean condition.

2. All maintenance work shall be performed by competent personnel under the supervision and direct employee of the Elevator Contractor.
3. The Owner, at his option, may choose to delete this maintenance from the capital contracts and to pay this amount in 12 equal installments directly to the Elevator Contractor during the period in which the work is being accomplished.

Reference L.B.A. contract and bid form.

D. Contract Maintenance (Ongoing Preventive Maintenance Program):

1. Bidders shall also quote the monthly cost for a 5-year maintenance agreement to commence on completion of the 12-month period of warranty maintenance. That quotation shall be submitted based upon the terms and conditions of the standard Lerch, Bates and Associates' preventive maintenance agreement. Under this agreement, the equipment performance requirements, as herein specified, shall be provided at all times.
2. If this contract is accepted, the contract price is subject to adjustment at the expiration of the new installation service period and thereafter as provided in the contract.

PART 2 - PRODUCTS

2.01 SUMMARY

A. Passenger Low-Rise Elevators:

NUMBER:	5, ELEVATOR NOS. 1-5
CAPACITY:	3500#
SPEED:	700 F.P.M.
ROPING:	2:1
SUPERVISORY CONTROL:	DOVER TRAFLOMATIC IV FUJITEC FLEX 8830 MITSUBISHI OS 2100 MONTGOMERY MIPROM 21 OTIS ELEVONIC 411 SCHINDLER MICONIC V
MOTOR CONTROL:	APPROVED DC, VARIABLE VOLTAGE OR A.C. VARIABLE VOLTAGE VARIABLE FREQUENCY WITH CLOSED LOOP FEEDBACK
POWER CHARACTERISTICS:	VERIFY ON DRAWINGS
STOPS:	12 STOPS IN LINE - VERIFY ON DRAWINGS

OPENINGS:  
12 OPENINGS IN LINE - VERIFY ON DRAWINGS

FLOORS SERVED: 3, 5, 6, 7, 8, 9, 10, 11, 12, 13, 14, 15 - VERIFY ON DRAWINGS

TRAVEL: 166'-8" +/- VERIFY ON DRAWINGS

PLATFORM SIZE: 7'-6" WIDE X 6'-0" DEEP

ENTRANCES:

SIZE: 4'-0" WIDE X 8'-0" HIGH

TYPE: SINGLE-SPEED, CENTER OPENING

SILLS: SATIN BRONZE

SILL ANGLES: 5" X 5" X 1/2" FASTENED AT A MAXIMUM 18" ON CENTER

DOORS: SATIN BRONZE AT L-3 WITH CUSTOM ETCHED FINISH; 16 GAUGE STEEL SANDWICH CONSTRUCTION

FRAMES: 14 GAUGE. SATIN BRONZE AT L-3. BOLTED SUBFRAMES AT L-3; MITERED AND WELDED BAKED ENAMEL AT TYPICAL.

LABELS U.L. LABELS ON ASSEMBLIES

DOOR OPERATION: HIGH-SPEED, HEAVY-DUTY, MASTER DC DOOR OPERATOR (MINIMUM OPENING SPEED 2-1/2 F.P.S.)

DOOR PROTECTION: INFRARED, OPTICAL FULL SCREEN DEVICES WITH DIFFERENTIAL TIMING FEATURE, AND NUDGING

MACHINE: GEARLESS OVERHEAD

SAFETY: FLEXIBLE GUIDE CLAMP - CAR AND COUNTERWEIGHT (TYPE "B" ONLY)

GUIDE RAILS: PLANED STEEL TEES

BUFFERS: OIL, SPRING RETURN

COMPENSATION: WIRE ROPE WITH TIE DOWN

CAR ENCLOSURE: VERIFY ON DRAWINGS

THRESHOLD: SATIN BRONZE WITH EXTENSIONS TO FRONT RETURNS

FLOOR: CARPE/STONET (NOT BY ELEVATOR COMPANY).  
SUBFLOOR AND PREPARATION TO RECEIVE FINISH  
FLOORING BY ELEVATOR COMPANY

DOORS: SATIN BRONZE; 16 GAUGE SANDWICH  
CONSTRUCTION

FRONTS: SATIN BRONZE; 14 GAUGE FULL SWING RETURNS  
WITH CONCEALED 3 POINT LATCHING

SIDE/REAR WALLS: SEE ARCHITECTURAL DRAWINGS

DROP CEILING/CANOPY: SEE ARCHITECTURAL DRAWINGS

LIGHTING: SEE ARCHITECTURAL DRAWINGS

HANDRAIL: #4 SATIN BRONZE, 1-1/2" DIAMETER ON REAR WALL,  
SEE ARCHITECTURAL DRAWINGS

HEIGHT: 10'-0" TO CANOPY

PLATFORM: ISOLATION REQUIRED

SIGNALS: CUSTOM FIXTURES AT LO-3 SHALL BE PROVIDED.  
SEE ARCHITECTURAL DRAWINGS

REGISTRATION LIGHTS: CAR AND CORRIDOR PUSHBUTTONS, DUAL RISER -  
DUAL CAR STATIONS; SATIN BRONZE FACEPLATES  
AT TYPICAL FLOORS

POSITION INDICATORS: CAR (DUAL), FIRE CONTROL ROOM PANEL, LOBBY  
CONTROL PANEL

HALL LANTERNS: AT ALL FLOORS WITH ELECTRONIC CHIME OR TONE  
(TWICE FOR DOWN DIRECTION). CUSTOM FIXTURE  
AT L-3, SATIN BRONZE TYPICAL AT ALL FLOORS

COMMUNICATION SYSTEM: INTERCOM WITH DISTRESS SIGNAL

FIXTURE SUBMITTALS: SUBMIT BROCHURES DEPICTING MANUFACTURER'S  
PROPOSED DESIGNS WITH BID

B. Passenger High-Rise Elevators:

NUMBER: 5, ELEVATOR NOS. 6-10

CAPACITY: 3500#

SPEED: 800 F.P.M.

ROPING: 2:1



SUPERVISORY CONTROL:	DOVER TRAFLOMATIC IV FUJITEC FLEX 8830 MITSUBISHI OS 2100 MONTGOMERY MIPROM 21 OTIS ELEVONIC 411 SCHINDLER MICONIC V
MOTOR CONTROL:	APPROVED DC, VARIABLE VOLTAGE OR A.C. VARIABLE VOLTAGE VARIABLE FREQUENCY WITH CLOSED LOOP FEEDBACK
POWER CHARACTERISTICS:	VERIFY ON DRAWINGS
STOPS:	12 STOPS IN LINE - VERIFY ON DRAWINGS
OPENINGS:	12 OPENINGS IN LINE - VERIFY ON DRAWINGS
FLOORS SERVED:	3, 13, 16, 17, 18, 19, 20, 21, 22, 23, 24, 25 - VERIFY ON DRAWINGS
TRAVEL:	320'-0" +/- VERIFY ON DRAWINGS
PLATFORM SIZE:	7'-6" WIDE X 6'-0" DEEP
ENTRANCES:	
SIZE:	4'-0" WIDE X 8'-0" HIGH
TYPE:	SINGLE-SPEED, CENTER OPENING
SILLS:	SATIN BRONZE
SILL ANGLES:	5" X 5" X 1/2" FASTENED AT A MAXIMUM 18" ON CENTER
DOORS:	SATIN BRONZE AT L-3 WITH CUSTOM ETCHED FINISH; 16 GAUGE STEEL SANDWICH CONSTRUC- TION
FRAMES:	14 GAUGE. SATIN BRONZE AT L-3. BOLTED SUBFRAMES AT L-3; MITERED AND WELDED BAKED ENAMEL AT TYPICAL
LABELS	U.L. LABELS ON ASSEMBLIES

DOOR OPERATION:	HIGH-SPEED, HEAVY-DUTY, MASTER DC DOOR OPERATOR (MINIMUM OPENING SPEED 2-1/2 F.P.S.)
DOOR PROTECTION:	INFRARED, OPTICAL FULL SCREEN DEVICES WITH DIFFERENTIAL TIMING FEATURE, AND NUDGING
MACHINE:	GEARLESS OVERHEAD
SAFETY:	FLEXIBLE GUIDE CLAMP - CAR AND COUNTERWEIGHT (TYPE "B" ONLY)
GUIDE RAILS:	PLANED STEEL TEES
BUFFERS:	OIL, SPRING RETURN
COMPENSATION:	WIRE ROPE WITH TIE DOWN
CAR ENCLOSURE:	VERIFY ON DRAWINGS
THRESHOLD:	SATIN BRONZE WITH EXTENSIONS TO FRONT RETURNS
FLOOR:	CARPE/STONET (NOT BY ELEVATOR COMPANY). SUBFLOOR AND PREPARATION TO RECEIVE FINISH FLOORING BY ELEVATOR COMPANY
DOORS:	SATIN BRONZE; 16 GAUGE SANDWICH CONSTRUCTION
FRONTS:	SATIN BRONZE; 14 GAUGE FULL SWING RETURNS WITH CONCEALED 3 POINT LATCHING
SIDE/REAR WALLS:	SEE ARCHITECTURAL DRAWINGS
DROP CEILING/CANOPY:	SEE ARCHITECTURAL DRAWINGS
LIGHTING:	SEE ARCHITECTURAL DRAWINGS
HANDRAIL:	#4 SATIN BRONZE; 1-1/2" DIAMETER ON REAR WALL, SEE ARCHITECTURAL DRAWINGS
HEIGHT:	10'-0" TO CANOPY
PLATFORM:	ISOLATION REQUIRED
SIGNALS:	CUSTOM FIXTURES AT LO-3 SHALL BE PROVIDED. SEE ARCHITECTURAL DRAWINGS
REGISTRATION LIGHTS:	CAR AND CORRIDOR PUSHBUTTONS, DUAL RISER - DUAL CAR STATIONS; SATIN BRONZE FACEPLATES AT TYPICAL FLOORS

RTD Headquarters  
Los Angeles, California  
LBA No. 900048

07/26/93  
Traction Elevators  
14200 - 17

POSITION INDICATORS:

CAR (DUAL), FIRE CONTROL ROOM PANEL, LOBBY  
CONTROL PANEL

HALL LANTERNS: AT ALL FLOORS WITH ELECTRONIC CHIME OR TONE  
(TWICE FOR DOWN DIRECTION). CUSTOM FIXTURE  
AT L-3 SATIN BRONZE, STANDARD SATIN BRONZE  
TYPICAL

COMMUNICATION SYSTEM: INTERCOM WITH DISTRESS SIGNAL

FIXTURE SUBMITTALS: SUBMIT BROCHURES DEPICTING MANUFACTURER'S  
PROPOSED DESIGNS WITH BID

C. Service Elevator:

NUMBER: 1, ELEVATOR NO. 15

CAPACITY: 4500#

SPEED: 500 F.P.M.

ROPING: 2:1

SUPERVISORY CONTROL: DOVER TRAFLOMATIC IV  
FUJITEC FLEX 8830  
MITSUBISHI OS 2100  
MONTGOMERY MIPROM 21  
OTIS ELEVONIC 411  
SCHINDLER MICONIC V

MOTOR CONTROL: DC, VARIABLE VOLTAGE WITH CLOSED LOOP  
FEEDBACK AND AUTOMATIC LEVELING (A.C. MOTOR  
CONTROL UNACCEPTABLE)

POWER CHARACTERISTICS: VERIFY ON DRAWINGS

STOPS: 31 STOPS

OPENINGS: 32 OPENINGS; 1 FRONT, 31 REAR

FLOORS SERVED: FRONT: PL4, PL3, PL2, T-1, T-2  
REAR: PL1, TL2 THROUGH TL27  
VERIFY ON DRAWINGS

TRAVEL: 409'-0" +/- VERIFY ON DRAWINGS

PLATFORM SIZE: 6'-6" WIDE X 8'-11" DEEP - VERIFY ON DRAWINGS

ENTRANCES:

SIZE: 4'-0" WIDE X 8'-0" HIGH AT FRONT- VERIFY ON  
DRAWINGS FOR BOTH

TYPE:	TWO-SPEED, SIDE OPENING
SILLS:	REINFORCED TO CARRY CONCENTRATED LOADS. STAIN BRONZE AT L-3; ALUMINUM AT TYPICAL FLOORS
SILL ANGLES:	5" X 5" X 1/2"; FASTENED AT A MAXIMUM 12" ON- CENTER
DOORS:	SATIN BRONZE AT L-3 WITH CUSTOM ETCHING; TEXTURED STAINLESS STEEL AT TYPICAL (6WL RIGITEX OR EQUIVALENT); 16 GAUGE CRS STEEL SANDWICH CONSTRUCTION
LABELS:	U.L. LABEL ON ASSEMBLIES
FRAMES:	BULLNOSE BOLTED DESIGN AT TYPICAL FLOORS; WITH STAINLESS STEEL FINISH, BOLTED SQUARE SUBFRAMES AT L-3 WITH BAKED ENAMEL FINISH
DOOR OPERATION:	HIGH-SPEED, HEAVY-DUTY, MASTER DC DOOR OPERATOR (MINIMUM OPENING SPEED 2-1/2 F.P.S.), FRONT AND REAR SELECTIVE DOOR OPERATION
DOOR PROTECTION:	INFRARED, OPTICAL FULL SCREEN DEVICES WITH DIFFERENTIAL TIMING FEATURE, AND NUDGING (HORIZONTAL BEAM DESIGN), FRONT AND REAR
MACHINE:	GEARLESS OVERHEAD
SAFETY:	FLEXIBLE GUIDE CLAMP - CAR (TYPE "B" ONLY)
GUIDE RAILS:	PLANED STEEL TEES
BUFFERS:	OIL, SPRING RETURN
COMPENSATION:	WIRE ROPE WITH TIE DOWN
CAR ENCLOSURE:	
CAR THRESHOLD:	EXTRUDED ALUMINUM; REINFORCED TO CARRY CONCENTRATED LOADS
CAR FLOORS:	MONDO RUBBER FLOORING (BY ELEVATOR COMPANY)
CAR DOORS:	TEXTURED STAINLESS STEEL (6WL RIGIDTEX OR EQUIVALENT); 16 GAUGE CRS

CAR FRONTS: BRUSHED STAINLESS STEEL; 14 GAUGE CRS

CAR SIDE/REAR PANELS: 18 GAUGE TEXTURED STAINLESS STEEL (6WL RIGIDTEX OR EQUIVALENT) APPLIED TO 14 GAUGE CRS WALLS

CANOPY AND LIGHTING: 12 GAUGE CRS; WHITE BAKED ENAMEL; VANDAL-RESISTANT FLUORESCENT LIGHTS RECESSED INTO CAR TOPS; PROVIDE TWO AUXILIARY FLUORESCENT LIGHT FIXTURES RECESSED INTO THE SIDE WALLS AT 8'-6" ABOVE FINISHED FLOOR (AFF)

HANDRAILS: TOP RAIL: 1-1/2" DIAMETER SOLID RAIL AT 32" AFF; BOTTOM RAIL: 6" X 1/2" AT 12" AFF. BOTH RAILS SHALL BE FASTENED 18" ON-CENTER, MAXIMUM. BOTH RAILS SHALL HAVE A BRUSHED STAINLESS STEEL FINISH

HEIGHT: 10'-0" TO CANOPY

PLATFORM: ISOLATED AND REINFORCED TO CARRY CONCENTRATED LOADS

SIGNALS: ALL FIXTURES SHALL BE VANDAL-RESISTANT EXCEPT AT L-3 WHICH SHALL MATCH MAIN TOWER CAR DESIGN

REGISTRATION LIGHTS: CAR AND CORRIDOR PUSHBUTTONS, SINGLE CORRIDOR RISER - DUAL CAR STATIONS. FRONT CAR STATION SHALL BE MOUNTED RECESSED INTO CAR SIDE WALL; REAR CAR STATION SHALL BE RECESSED INTO CAR RETURN

POSITION INDICATORS: CAR (DUAL), FIRE CONTROL ROOM PANEL, LOBBY CONTROL PANEL

HALL LANTERNS: AT ALL FLOORS WITH ELECTRONIC CHIME OR TONE (TWICE FOR DOWN DIRECTION). CUSTOM AT L-3 SATIN BRONZE

CORRIDOR CAR POSITION INDICATORS: AT P-1

COMMUNICATION SYSTEM: INTERCOM WITH DISTRESS SIGNAL

D. Service Elevator:

NUMBER: 1, ELEVATOR NO. 16

CAPACITY: 4500#

SPEED: 500 F.P.M.

ROPING: 2:1

SUPERVISORY CONTROL: DOVER TRAFLOMATIC IV  
FUJITEC FLEX 8830  
MITSUBISHI OS 2100  
MONTGOMERY MIPROM 21  
OTIS ELEVONIC 411  
SCHINDLER MICONIC V

MOTOR CONTROL: DC, VARIABLE VOLTAGE WITH CLOSED LOOP  
FEEDBACK AND AUTOMATIC LEVELING (A.C. MOTOR  
CONTROL UNACCEPTABLE)

POWER CHARACTERISTICS: VERIFY ON DRAWINGS

STOPS: 5 STOPS - VERIFY ON DRAWINGS

OPENINGS: 5 OPENINGS; 3 FRONT, 2 REAR - VERIFY ON  
DRAWINGS

FLOORS SERVED: P2, P1, 1, 2, 3 - VERIFY ON DRAWINGS

TRAVEL: 54'-8" + \ - VERIFY ON DRAWINGS

PLATFORM SIZE: 6'-0" WIDE X 9'-7" DEEP - VERIFY ON DRAWINGS

ENTRANCES:

    SIZE: 4'-6" WIDE X 8'-0" HIGH - VERIFY ON DRAWINGS

    TYPE: TWO-SPEED, SIDE OPENING

SILLS: REINFORCED TO CARRY CONCENTRATED LOADS.  
EXTRUDED ALUMINUM AT ALL FLOORS

SILL ANGLES: 5" X 5" X 1/2"; FASTENED AT A MAXIMUM 12" ON-  
CENTER

DOORS: TEXTURED STAINLESS STEEL AT TYPICAL (6WL  
RIGITEX OR EQUIVALENT); 16 GAUGE CRS

FRAMES: BRUSHED STAINLESS STEEL; 14 GAUGE CRS;  
BOLTED BULLNOSE SIDE JAMBS

LABELS: U.L. LABEL ON ASSEMBLIES

DOOR OPERATION: HIGH-SPEED, HEAVY-DUTY, MASTER DC DOOR OPERATOR (MINIMUM OPENING SPEED 2-1/2 F.P.S.), FRONT AND REAR; SELECTIVE DOOR OPERATION

DOOR PROTECTION: INFRARED, OPTICAL FULL SCREEN DEVICES WITH DIFFERENTIAL TIMING FEATURE, AND NUDGING (HORIZONTAL BEAM DESIGN), FRONT AND REAR

MACHINE: GEARED OVERHEAD

SAFETY: FLEXIBLE GUIDE CLAMP - CAR AND COUNTER-WEIGHT (TYPE "B" ONLY)

GUIDE RAILS: PLANED STEEL TEES

BUFFERS: OIL, SPRING RETURN

COMPENSATION: ENCAPSULATED CHAIN

CAR ENCLOSURE:

CAR THRESHOLD: BRUSHED ALUMINUM; REINFORCED TO CARRY CONCENTRATED LOADS

CAR FLOORS: MONDO RUBBER FLOORING (BY ELEVATOR COMPANY)

CAR DOORS: TEXTURED STAINLESS STEEL (6WL RIGITEX OR EQUIVALENT); 16 GAUGE CRS

CAR FRONTS: BRUSHED STAINLESS STEEL; 14 GAUGE CRS

CAR SIDE/REAR PANELS: TEXTURED STAINLESS STEEL (6WL RIGIDTEX OR EQUIVALENT) APPLIED TO 14 GAUGE CRS WALLS

CANOPY AND LIGHTING: WHITE BAKED ENAMEL; 12 GAUGE CRS VANDAL-RESISTANT FLUORESCENT LIGHTS RECESSED INTO CAR TOPS; PROVIDE TWO AUXILIARY FLUORESCENT LIGHT FIXTURES RECESSED INTO THE SIDE WALLS AT 8'-6" ABOVE FINISHED FLOOR (AFF)

HANDRAILS: TOP RAIL: 1-1/2" DIAMETER SOLID RAIL AT 32" AFF; BOTTOM RAIL: 6" X 1/2" AT 12" AFF. BOTH RAILS SHALL BE FASTENED 18" ON-CENTER, MAXIMUM. BOTH RAILS SHALL HAVE A BRUSHED STAINLESS STEEL FINISH

HEIGHT: 10'-0" TO CANOPY

PLATFORM: ISOLATED AND REINFORCED TO CARRY CONCENTRATED LOADS



SIGNALS: ALL FIXTURES SHALL BE VANDAL-RESISTANT

REGISTRATION LIGHTS: CAR AND CORRIDOR PUSHBUTTONS, SINGLE CORRIDOR RISER - DUAL CAR STATIONS. CAR STATIONS SHALL BE MOUNTED RECESSED INTO CAR SIDE WALL. CERTIFICATE WINDOW LOCATED IN MAIN CAR STATION

POSITION INDICATORS: CAR (DUAL), FIRE CONTROL ROOM PANEL, LOBBY CONTROL PANEL

HALL LANTERNS: AT ALL FLOORS WITH ELECTRONIC CHIME OR TONE (TWICE FOR DOWN DIRECTION)

CORRIDOR CAR POSITION INDICATORS: AT P-1

COMMUNICATION SYSTEM: INTERCOM WITH DISTRESS SIGNAL

FIXTURE SUBMITTALS: SUBMIT BROCHURES DEPICTING MANUFACTURER'S PROPOSED DESIGNS WITH BID

E. COMMON TO ALL CARS  
ADDITIONAL FEATURES:

- CAR AND COUNTERWEIGHT ROLLER GUIDES
- CAR TOP INSPECTION STATION
- BUFFER ACCESS LADDERS AND PLATFORMS
- EMERGENCY CAR LIGHTING - BATTERY PACK
- EMERGENCY OPERATION [CCR, TITLE 8, RULE 3041(C) FIREMAN'S SERVICE, INCLUDING ALTERNATE FLOOR RETURN]
- CONTACTED ESCAPE HATCH WITH OPERATION PER A.S.M.E., A17.1 APPENDIX F
- STANDBY POWER TRANSFER (AUTOMATIC TO MAIN FLOOR) WITH MANUAL OVERRIDE
- DISABLED ACCESS ACCOMMODATION PLATES (NO STICK-ON OR RIVETED PLATES); PROVIDE RECESSED REAR MOUNTED PLATES AS MANUFACTURED BY VISIONMARK, OR APPROVED EQUIVALENT
- INTERNATIONAL STAR OF LIFE ON SERVICE ELEVATORS
- DUAL CAR OPERATING PANELS

HINGED CAB FRONT RETURN PANELS FOR  
APPLICATION OF INTEGRAL CAR STATIONS

CERTIFICATE WINDOW IN CAR FRONT RETURN

HOISTWAY ACCESS SWITCHES

INDEPENDENT SERVICE FEATURE

LOAD WEIGHING DEVICE

ANTI-NUISANCE FEATURE

LOBBY CONTROL PANEL AND REMOTE WIRING

FIRE CONTROL PANEL AND REMOTE WIRING

MOUNT ALL FIXTURE FACEPLATES WITH  
TAMPER-RESISTANT SCREWS

12-MONTH MAINTENANCE WITH 24-HOUR CALL-BACK  
SERVICE

SOUND POWERED CAB EMERGENCY TELEPHONE  
JACKS AND PAGING SPEAKERS

MACHINE AND SCR SOUND ISOLATION

SEISMIC DESIGNS AND OPERATIONS

INDIVIDUAL FLOOR LOCKOFF SWITCHES

VERIFY ALL CONDITIONS WITH FIELD  
MEASUREMENTS AND EXISTING CONDITIONS.  
MANUFACTURE EQUIPMENT TO MEET EXISTING  
CONDITIONS.

ELEVATOR CONTRACTOR SHALL MAKE PROVISIONS  
FOR CUSTOM CAR INTERIOR FINISHED INCLUDING  
ADEQUATE SIZING OF EQUIPMENT TO  
ACCOMMODATE ADDITIONAL WEIGHTS

CARD READER PROVISIONS IN ALL ELEVATOR  
CARS WITH EXTRA TRAVELING CABLE

PAD HOOKS AND 1 SET OF PADS

WIRING DIAGRAMS, OPERATING INSTRUCTIONS, AND  
PARTS ORDERING INFORMATION

ALL SPECIFIED ENGRAVING SHALL BE FILLED WITH  
BLACK PAINT UNLESS OTHERWISE NOTED

NO VISIBLE COMPANY NAME OR LOGO

PRIME FINISH TEMPORARY FRONT CAR DOORS  
DURING CONSTRUCTION FOR ELEVATORS NOS. 15  
AND 16

CCTV CAMERA PROVISIONS FOR ALL CARS

SEPARATE LIGHT SWITCH IN SERVICE CABINET FOR  
AUXILIARY CAR LIGHT FOR ELEVATORS NOS. 15 AND  
16

## 2.02 PERFORMANCE

- A. Speed:  $\pm$  3% contract speed under any loading condition.
- B. Capacity: Safely lower, stop and hold up to 125% of rated load.
- C. Stopping Accuracy:  $\pm$  1/4" under any loading condition.
- D. Door Opening Time: Passenger elevators: 1.6 seconds from start of opening to fully open.
- E. Floor-to-Floor Performance Time: seconds from start of doors closing until doors are 3/4 open and car level and stopped at next successive floor under any loading condition or travel direction.
- F. All elevator equipment (including hoist machines, deflector sheaves, solid-state, A.C. conversion units, and support equipment) shall be mechanically isolated from the structure and electrically isolated from the building power supply and each other to prevent noise and vibration in occupied areas of the building.

Design, install, and adjust elevator equipment to comply with the following:

- 1. Horizontal acceleration within the elevator cars during all riding and door operating conditions shall not exceed 15 mg in the 1-10 Hz range.
  - 2. Acceleration and deceleration shall be constant and not exceed 5 feet/second/second with an initial ramp between 0.5 and 0.75 seconds.
  - 3. Sustained jerk shall not exceed 8 feet/second/ second.
- G. Measured noise levels in a moving car outside the acceleration/deceleration zone shall not exceed 55 dBa under any condition including ventilation system on highest speed. Measured noise levels in the car within the leveling zone or stopped shall not exceed 60 dBa.
  - H. Noise/Sound Isolation Provisions:
    - 1. Roller Guides: roller assemblies for cars and counterweights shall have rollers with a minimum diameter of 6".

2. Platform Isolation: Double thickness isolation between car and car frame; plunger and platen head.
3. Guide Rails and Fishplates: Provide a minimum of 15 pound guide rails with double thick fishplates.
4. Machine Isolation: All machines shall be mounted on isolation pads engineer, with minimal direct attachment to structure.
5. Rope/Smoke Guards: Wherever ropes penetrate through to the hoistway, guards shall be provided to minimize any openings.
6. Submit details of isolation pads and sound isolation provisions.
7. To minimize noise and vibration in occupied areas, mechanically isolate elevator equipment (including hoist machines, deflector sheaves, power-conversion units and support equipment) from the structure; electrically isolate controllers, machine motors, and power conversion units.
8. Limit noise level relating to elevator equipment and its operation to no more than 55 Dba in running elevator cars. No more than 60 Dba including door operation and exhaust blower on highest speed.

## 2.03 OPERATION

### A. Operational Control:

1. Microprocessor-based, group dispatch, car control and motion control systems as follows, including as a minimum, the features described hereafter:
  - a. Armor TMS 900.
  - b. Dover IV.
  - c. Motion Control VVMC 1000 TURBO DF
  - d. Mitsubishi OS 2100/M.
  - e. Montgomery Miprom 21.
  - f. Otis Elevonic 311.
  - g. Schindler Miconic V.
  - h. Swift 5000.
2. Operate elevators without attendants as a group capable of balancing service and continuing operation with one or more cars removed from the system.

3. Operate elevators from buttons located at each floor and in each car. Slow down and automatically stop cars at landings corresponding to registered calls. Make stops at successive floors for each direction of travel irrespective of order in which calls are registered except when bypassing hall calls to balance and improve overall service. Stop only one car in response to any particular hall call. Assign hall calls to specific elevators and periodically review and modify these assignments to improve service. Simultaneous to initiation of the slow down of a car for a hall call, cancel that call. Render hall button ineffective until car doors begin to close after passenger transfer. Cancel car calls in the same manner. Give priority to coincidental car and hall calls in call assignment. Cancel car calls upon direction reversal.
4. At other than dispatching floors, hold doors open an adjustable interval of 5 to 8 seconds. Cancel initial door open interval when door protective system is actuated, and establish an adjustable door open interval from .5-1.0 second following actuation of door protective system.
5. Operate system to meet changing traffic conditions on demand basis. (Dispatch from terminal landings may be used when most traffic is in one direction.) Include provisions for handling traffic which may be heavier in either direction, intermittent or very light. As traffic demands change, automatically and continually modify elevator response to provide the most-effective means to handle traffic conditions. Assign hall calls to individual cars, review assignments; provide means to sense long-wait hall calls and preferentially serve them; and accomplish direction reversal without closing and reopening doors.
6. Dual-Loading Lobby Features: When the input traffic is equally heavy from the first and second floors, the supervisory control system shall provide a car for loading at each level. The dual loading lobby feature shall be automatically activated by the control system or manually by a selection switch in the lobby control panel.
7. Use reprogrammable system software. Design basic algorithm to optimize service based on equalizing system's response to registered hall calls at shortest possible level and equalizing trip time at shortest possible level.
8. Required Features:
  - a. Dispatch Protection: Backup dispatching in the event primary dispatcher fails.
  - b. Delayed Car Removal: Remove delayed car from group operation.
  - c. Position Sensing: Reset at each floor when stop made.
  - d. Landing Button Failure: Multiple power sources for button risers.

- E. Motion Control: D.C., variable voltage or A.C. variable voltage, variable frequency type with closed-loop feedback suitable for operation specified and capable of providing smooth, comfortable acceleration, retardation, and dynamic braking. Limit the difference in speed between full load and no load to not more than the performance of requirements of 2.02.

Design, install, and adjust elevator equipment to meet the performance requirements of 2.02, F.

- F. Firefighter's Service: Per CCR Title 8 and ASME A17.1 to operate and recall elevators to designated or alternate designated floors in fire or other emergency condition. Provide sensor signal wiring from hoistway or machine room connection point to controller terminals. Provide similar operation and fixtures on all elevators. Operate visual/audible signal until return is complete or automatic operation restored.
- G. Standby Lighting and Alarm: Car-mounted, battery unit with solid-state charger to operate alarm bell and lighting, per Code. Battery to be rechargeable with 5-year minimum-life expectancy. Provide spring return test button in service cabinet of car station which causes illumination of standby lighting bulbs. Locate lights so they are part of normal car lighting system and not exposed to view.
- H. Standby-Power Transfer: Arrange elevators to return to 1st floor at inspection speed, open doors, and be removed from service. Elevators shall not operate on emergency power, except to return to 1st floor.
1. Provide controls to automatically start and run the elevators nonstop to the designated terminal, one car in each group at a time.
  2. Provide SCR-controlled equipment with filters to stabilize the voltage and ensure that the wave form distortion and harmonic content will not adversely affect operation of standby generator.
- I. Elevator-to-Lobby Switches: Provide a switch for each elevator to return the car to the main floor. Return elevators non-stop after answering registered car calls, and park with its doors open until switch is returned to normal position.
- J. Seismic Operation: Provide counterweight derailment operation, per C.C.R. Title 8. Provide operating per A.N.S.I. A17.A, Appendix F, when emergency exit is opened.

## 2.04 MACHINE ROOM EQUIPMENT

- A. Arrange equipment in machine room space(s). Provide identifying numbers on machine, power conversion unit, controller, and disconnect switch. Comply with N.E.C., Article 110-16a., working clearances.
- B. Geared Traction Machine: Single worm geared traction type with motor, brake, worm, gear, drive shaft and gear case mounted in proper alignment on an isolated bedplate. Machine shall have ball or roller bearings.
- D. For hoist machine installations which require blockouts through machine room slab for other than hoist ropes, provide No. 14 gauge, galvanized sheet metal enclosure over entire blockout on underside of floor slab.
- E. Power Conversion and Regulation Unit: Provide a solid-state device. Solid-state unit shall be designed to limit current, suppress noise and prevent transient voltage feedback into building power supply. Isolate unit to minimize noise and vibration transmission. Provide isolation transformers, filter networks, and chokes.
  - 1. Elevator Contractor responsible to suppress solid-state converter noises, radio frequency interference, and eliminate regenerative voltage transients induced into the mainline feeders or the standby power generator.
  - 2. Supply supplemental direct-current power for operation of dispatch logic processors, brake, door operator.
- F. Encoder: Provide memory capability in event of power interruption. Solid-state, optical, digital-count type, mechanically coupled to pit-tensioning sheave, or driven from the car top or governor. Update parity at each floor and restore automatically after power loss. Locate in machine room to monitor car position and provide absolute floor position for stopping
- G. Controller: Cabinet type, with removable doors and adequate ventilation to dissipate heat. Wire to identified terminal block studs. Identifying symbols or letters identical to those on wiring diagrams shall be permanently marked adjacent to each component on the controller. Provide means on group dispatch or master car controller to facilitate monitoring of group operation with electronic tabulating devices. Features to be monitored shall include, but not be limited to: up corridor calls, down corridor calls, car in service, automatic bypass, on/off, etc. Provide auxiliary electrical power disconnecting means where required by Code.
  - 1. Frame: Securely mount all assemblies, power supplies, chassis switches, relays and other items on a substantial, self-supporting steel frame. Completely enclose equipment with covers and ventilate to prevent overheating.
  - 2. Switch and Relay Design: Direct-current type, magnet operated with contacts of design and material to insure maximum conductivity, long

life and reliable operation without overheating or excessive wear, and provide a wiping action to prevent sticking due to fusion. Provide switches carrying highly inductive currents with arc deflectors or suppresses.

3. **Microprocessor-Related Hardware:**
  - a. Fabricate printed circuit boards with FR4 or G10 glass epoxy material with a minimum equivalent one-ounce copper.
  - b. Coat all printed circuitry with tin lead.
  - c. Include built-in noise suppression devices which provide a high level of noise immunity on double-sided printed circuit boards and on all solid-state hardware and devices.
  - d. Provide power supplies with noise-suppression devices.
  - e. Isolate inputs from external devices (such as pushbuttons) with opto-isolation modules.
  - f. Provide separate regulated power supply for each computer chassis.
  - g. Design control circuits so that one side of power supply is grounded.
  - h. Design the system so that it will start properly when power is restored in the event of a power failure or interruption.
  - i. Provide system memory so that data is retained in the event of power failure or disturbance.
  - j. Design or protect equipment so it will operate with a 500 KHZ to 1300 MHZ radio frequency signal at a power level of 100 watts at a distance of 10 feet.
  - k. Design or protect equipment to provide electromagnetic interference (E.M.I.) shielding within F.C.C. guidelines.
4. **Power Supplies:** U.L. or C.S.A. approved with short-circuit protection.
5. **Wiring:** U.L. or C.S.A. labeled copper wires for factory wiring. Neatly route all wiring interconnections and securely attach wiring connections to studs or terminals.
6. Permanently mark components (relays, fuses, PC board, etc.) with symbols shown on drawings.



7. Provide extender boards when computing devices are used inside a computer chassis to facilitate access to the printed circuit cards utilized.
  8. Use stable capacitor or crystals as the time base for electronic time-delay devices.
- H. Sleeves and Guards: Provide sleeves for conduit and other holes through concrete slabs. Provide 2" steel angle guards around cable or duct slots. Provide rope and smoke guards for all sheaves, cables, and cable slots. Provide sheet metal enclosure where hoist ropes and/or sheaves penetrate machine room wall. Minimize opening sizes as much as possible.
- I. Machine Beams: Provide structural steel beams required for direct support of the elevator machine, deflector sheaves, overhead sheaves, governor and dead-end hitches. Provide bearing plates, anchors, shelf angles, blocking, embedments, etc., to support machine beams and equipment. Provide and set in place machine hold down bolts. Isolate machine beams as necessary to eliminate noise and vibration transmission to building structure. Provide sheave maintenance ladders and platforms as required within bounds of the elevator machine room.
- J. Governor: Centrifugal type, car or counterweight driven, with pullthrough jaws and provided with an electrical shutdown switch. Provide any overhead supports required for attachment to building structure. Provide governor access platform within bounds of hoistway as required. Governors shall be located as shown on drawings.
- K. Hoist and Machine Drip Pans: Provide any and all hoist machine drip pans to restrict lubricant seepage from entering hoistways.
- L. All elevator equipment (including hoist machines, deflector sheaves, solid-state, A.C. conversion units, and support equipment) shall be mechanically isolated from the structure and electrically isolated from the building power supply and each other to prevent noise and vibration in occupied areas of the building. Design, install, and adjust elevator equipment to meet the performance requirements.
- M. Contractor shall make provisions in their equipment to accommodate custom design interior finishes, including sufficient equipment tolerances for applied panels and finished flooring.

## 2.05 HOISTWAY EQUIPMENT

- A. Guide Rails: Provide planed steel T-sections suitable for elevator travel, weight of car, weight of counterweight, and seismic reactions, including brackets for attachment to building structure at support locations shown on drawings. Double main rail bracketing shall be employed to maintain 14'-0" or less bracket to bracket.

- B. **Buffers:** Provide blocking and supports. Provide buffer access ladders and platforms, where required. Provide switch on buffers to limit elevator speed in appropriate direction if buffer is compressed.
- C. **Sheaves:** New machined grooves with ball or roller bearings. Provide mounting means to machine beams, machine bedplate, car and counterweight structural members, or other structure support. Provide drip pans under deflector sheaves.
- D. **Governor and Encoder Pit Tensioning Sheaves:** Mount new sheaves and frames on pit support members or guide rails. Provide with guides or pivot points to enable free vertical movement and properly tension cables/tapes.
- E. **Compensation:** Provide new for all elevators if required. Whisperflex-chain type with pit guide. Pad areas where compensation may strike car or hoistway items. Wire rope centered on safety plank with pit mounted tie down guide sheave assembly.
- F. **Counterweight:** Steel frame with roller guides and metal filler weights. Provide counterweight frame with 4 sets of new roller guides consisting of at least 3 rollers of a durable, resilient, oil-resistant material, mounted on a substantial metal base. Rollers shall have continuous contact with the corresponding guide rail surface under all conditions of loading. Provide seismic retainer plates top and bottom.
- E. **Counterweight Guard:** Metal guard around counterweight in pit.
- F. **Ropes:** Provide 8 x 19 Seale construction traction steel type ropes.
  - a. Governor rope to suit manufacturer's governor specification.
  - b. Fasten with adjustable shackles.
- G. **Normal and Final Terminal Stopping Devices:** Provide new, per Code.
- H. **Electrical Wiring:** All new wire and cable installed and must meet current requirements of National Electrical Code.
  - 1. **Conductors:** Provide copper throughout with individual wires coded and all connections on identified studs or terminal blocks. Use no splices or similar connections in any wiring except at terminal blocks, controllers, junction boxes or condulets. Provide 10% spare conductors throughout. All spare wiring shall be in addition to those required by features of this specification and shall run from car connection points to individual elevator controller. Provide and tag in each elevator controller four pairs of spare, shielded communication wire.
  - 2. **Conduit:** Painted or galvanized steel conduit and duct. Conduit size shall be 1/2" minimum. Flexible conduit exceeding 18" in length shall not be used. Flexible heavy-duty service cord may be used between fixed car wiring and car door control devices.

3. Traveling Cables: Flame and moisture resistant outer cover. Prevent traveling cables from rubbing or chafing against hoistway or elevator equipment.

H. Pit Stop Switch: Per Code.

## 2.06 HOISTWAY ENTRANCES ition necessary to meet current code stanards.

- A. Frames: Frames shall be bull nose type, hollow metal fabricated from not less than No. 14 U.S. gauge steel, bolted to form a one piece unit. Jamb and head depth and profiles shall be as shown on the architectural drawings. Provide permanently attached, rear mounted, handicapped floor designations at a height of 60" above the finished floor. Designations shall be 2" high, raised 0.030", of a lettering style and color as approved by the Architect. The braille indications shall be at the left of the arabic numeral per A.D.A. requirements and California Code of Regulations, Title 24 Accessibility Standards. A star designation shall be provided at the main egress landing. Stick-on or riveted plates are unacceptable.  
  
An international star of life symbol permanently attached, rear mounted at a height of 78" to 84" above finished floor on both frames at each floor shall be provided on the designated medical emergency elevator. Designation shall be 3" in size. Stick-on or riveted plates are unacceptable.
- B. Door Panels: Fabricate from not less than No. 14 U.S. gauge steel, sandwich construction. Provide leading edges of center-opening doors with rubber astragals to cushion closing impact. Each door panel shall include a minimum of two gibs, one at leading edge and one at trailing edge. Door gibs shall be in the sill groove their entire length of travel.
- C. Sight Guards: No. 14 U.S. gauge material, same material and finish as hoistway entrance door panels.
- D. Fire Rating: Provide complete entrances bearing UL fire labels or equivalent approved by local Code jurisdiction.
- E. Sills: Nickel silver.: Provide and install sill support angles at all floors, so as not to require grouting beneath the sills. Sill angles shall be 5" x 5" x 1/2" and fastened 12" on center, minimum.
- F. Hangers: Provide new two-point suspension with upthrust adjustment not to exceed 3/8" between door panels.
- G. Tracks: Provide new bar or formed, cold drawn steel with smooth hanger contact surface. Tracks shall be removable for replacement or provided with renewable surface.
- H. Interlocks: Provide new type operable without retiring cam. Interlocks that are visible when doors are open shall be painted flat black.
- I. Closer: Provide new spring, spirator, or weighted closer shall operate quietly. Weighted closer shall be strut mounted.

- J. Fascia, Toe Guards, and Fascia Width Hanger Covers: No. 14 U.S. gauge furniture steel with flat black enamel finish. Paint fire floor identifying numbers per Code. Provide blind fascia above rear openings.
- K. Struts and Headers: Provide for necessary support of entrances and related material. Door open bumpers are required on entrances equipped with vertical struts.

## 2.07 CAR EQUIPMENT

- A. Car Frame: Welded or bolted. Rolled or formed steel channel construction.
- B. Car Safety Device:: Type "B," flexible guide clamp.
- C. Platform: Isolated type, constructed of steel or wood which is fireproofed on the underside.
- D. Guides: Spring loaded adjustable roller type with three or more sound--deadening rollers per guide assembly. Rollers shall not exceed 350 r.p.m. at rated speed.
- E. Car Sills: Nickel silver with extruded extensions to face of car front return. Extruded extension in same finish as sill.
- F. Toe Guard: Per Code. Paint flat black.
- G. Car Doors, Hangers and Tracks: Provide as specified for hoistway entrance doors, hangers and tracks.
- H. Header: Fabricate of steel; shape to provide stiffening flanges. Existing to be reused. All fastenings shall be properly secured.
- I. Car Door Electrical Contact: Electrical contact to operate in conjunction with the car doors so that the elevator cannot operate unless doors are closed within tolerance allowed by Code.
- J. Door Operator and Operation: High-speed, heavy-duty, DC master door operator isolated from car top. Operator shall be capable of opening doors at no less than 2-1/2 f.p.s. and accomplishing reversal in no more than 2-1/2" of door movement. Door operation shall be no louder than 55 decibels.
- K. Car Door Clutches: New heavy-duty clutches or vanes, linkage arms, drive blocks and pickup rollers or cams to provide positive, smooth, quiet door operation. Design clutches so car doors can be closed for maintenance purposes, while hoistway doors remain open.
- L. Door Control Devices:
  - 1. Infrared Optical Full Screen Devices: Provide infrared, optical full screen devices. Devices shall extend along the leading edge of each car door and be designed to initiate door reversal at normal

- speed if the devices sense a person or object while the car doors are closing, except during nudging action. Devices shall be: T.L. Jones, Microscan II, Otis-enhanced Lambda, Adams I.C.U.-47, Innovation Smart Edge 2002, or Janus Panaforty. Two additional devices shall be mounted inside the elevator cars in the front returns. They will recycle the doors and activate an audible signal.
2. Nudging Action: In the event an optical beam is obstructed for an adjustable time interval (20.0-30.0 seconds), a buzzer shall sound, the doors shall attempt to close with a maximum of 2.5 foot pounds kinetic energy.
  3. Interrupted Beam Time: In the event the optical beams are interrupted while the doors are opening or after the doors are fully open, the normal dwell time that the doors remain open after the beams are reestablished shall be reduced to an adjustable time between .5 and 1.0 second, depending upon whether a landing call or a car call predominated. This time shall also be a minimum time that the doors remain open if the optical beams are interrupted and reestablished before the door is fully open.
  4. Differential Door Time: Provide separately adjustable timers to enable varying the time that the doors remain open after stopping in response to a car call or a landing call. The dwell time for a car call stop shall be adjustable between 3.0 and 4.0 seconds, and the timing for a landing call stop shall be adjustable between 4.0 and 8.0 seconds. If a stop is made in response to both a landing call and a car call, the timing of the landing call shall predominate.
- M. Elevator Car Stations: Two car stations per car. Service elevators to have recessed flush type: one at front and one at the rear openings front return and one at the solid rear sidewall. Recessed stations shall have stainless steel faceplates. The main passenger elevators shall have full swing front returns with a satin bronze finish.
1. Elevators shall have vandal-resistant buttons.
  2. The raised floor buttons, alarm button, door open button and emergency stop switch shall be suitably identified by raised, painted letters or symbols per A.D.A. requirements and California Code of Regulations, Title 24, including Braille. All operating controls shall be located no higher than 48" above the car floor (locate stop switch and alarm button 35" above finished floor).
    - a. Provide 1/8" raised floor pushbuttons with 5/8" numbers in the face of button corresponding to the floors served for registration of the car stops. Call registration lights, located within or behind the buttons, shall illuminate the floor number corresponding to the call registered. Where practical, pushbuttons shall be mounted in a vertical row beginning at 48" off finish floor.

- b. An alarm button shall be provided at the bottom of the elevator station to ring a bell located on the elevator. Actuation shall ring bell, illuminate button, and sound distress signal at main lobby control panel.
- c. A red emergency stop push/pull button shall be provided at the bottom of the elevator station to interrupt the power supply independently of the regular operating devices. The push/pull button shall be so arranged that when operated, it will sound the alarm bell and illuminate the alarm button described above. The actuation of this device shall not cancel registered calls. The device shall be marked to show "run" and "stop" positions. Actuation shall sound distress signal at main lobby control panel. They shall be arranged push to run, pull to stop.
- d. Provide a door open button which shall stop closing motion of doors and cause them to return automatically to their fully open position. This button shall be effective while the car is at a landing and until the elevator starts into motion, regardless of any special operational features (except fireman's service).
- e. Provide door close button to initiate door closing during normal operation by momentary pressure and for door closing by continuous pressure on Phase II fire service. Alternatively, the floor pushbuttons may be used.
- f. Provide an extended door hold open button on the service elevators.
- g. A visual indication shall be provided to indicate activation of the emergency communication system.
- h. Provide one fireman's service key switch, light jewel, and fireman's telephone jack.
- i. Provide a scratch-resistant lens on the swing front return or car station behind which shall be located the certificate of inspection.
- j. A lockable service panel with flush cover plate shall be provided. The service panel shall contain the following controls with each control and its operating positions identified by engraved letters painted black:
  - (1) An inspection switch, conforming to the ANSI Code, for disconnecting all automatic operation, limiting the car speed and rendering effective the hoistway access switch when the car is at the top or bottom terminal.
  - (2) A light switch.

- (3) A three-position exhaust blower switch.
- (4) An independent service switch to permit the selection of independent or automatic operation.
- (5) A duplex 120 volt, A.C., electrical convenience outlet.
- (6) A start button for closing the doors and starting the elevator when operating on independent service. Alternately, the floor pushbuttons may be used for this function.
- (7) Spring return test button or switch for battery pack standby lighting.
- (9) Auxiliary light switch for the service elevators.

M. Signage: Provide the following black paint filled engraving. Size and style as approved by Architect.

1. Elevator Car:

- a. "No Smoking - L.A.M.C. No. 41.51 - Subject to Fine" over main car station.
- b. Elevator number on both main and auxiliary car stations.
- c. Elevator capacity in pounds and the number of persons allowed to ride the elevator over main car station.
- d. Engrave service panel or telephone cover plate with:  
  
"Should the elevator doors fail to open or the elevator become inoperative:  
Please do not become alarmed.  
Please use the button marked Alarm to summon assistance, or telephone if furnished.  
Remain in the car until assistance arrives and do not attempt to force doors or hatch open."

2. Provide engraved signage in elevator lobbies:

- a. "In case of fire use stairways for exit. Do not use elevator." Include as part of corridor pushbutton plates or separate sign at each floor, as selected by Architect. Separate sign shall be same material and finish as corridor pushbutton cover plate.
- b. Provide engraved plate at main lobby adjacent to fire return switch with Phase I and Phase II operating instructions per

Code. Material and finish same as corridor pushbutton faceplate.

- N. Car Top Control Station: Per Code. Provide with minimum 4'-0" long, permanently attached, extension cord for remote operation.
- O. Emergency Exits: Provide contact and operation per A.S.M.E. A17.1, Appendix F.
- P. Work Light and Duplex Plug Receptacle: Provide on top and bottom of elevator car. Provide lights with on-off switch and bulb guard.
- Q. Exhaust Blower: Morrison Products model "AA" or approved equivalent. Two-speed, squirrel cage 300-350 c.f.m. exhaust blower. Isolate blower from car steel canopy on rubber grommets.
- R. Provide push to talk telephone instrument, and wiring from individual elevator controllers in machine room to each car. Engrave face of service cabinet with building name and address. Locate speaker grille as directed by Architect. Instrument shall meet the requirements of the Americans with Disabilities Act.

#### 2.08 CAR ENCLOSURES

- A. Provide as specified in Articles 2.01 and 3.03, F.
- B. Passenger Elevator Nos. 1 - 10; 11 - 14: Provide as specified in Articles 2.01 and 3.03, F.
  - 1. Sides and Rear Walls: 14 gauge (.075") cold rolled furniture quality steel, stretcher leveled, substantially reinforced for rigidity, lightproof joints, baked enamel finish, cutouts reinforced, flush panel construction with all panels fastened to the platform in an approved manner.
  - 2. Doors: 16 gauge (.048") steel, clad with satin bronze 1" thick, flush design both sides, core interior for sound deadening. Same construction as specified for hoistway doors.
  - 3. Canopy: 12 gauge (.090") cold rolled furniture quality steel, stretcher leveled, suitably reinforced to meet Code requirements and fastened to the side walls in a suitable manner for rigidity, top exit included.
  - 4. Front Returns and Entrance Columns: 14 gauge (.075") steel, clad with satin bronze integral construction, swing type with continuous hinge and three point concealed latching.
  - 5. Transom: 14 gauge (.075") steel, clad with satin bronze running full width of car.
  - 6. Wall Covering: SEE ARCHITECTURAL DRAWINGS



7. Handrail: SEE ARCHITECTURAL DRAWINGS
  8. Base: SEE ARCHITECTURAL DRAWINGS. Include hidden ventilation slots.
  9. Drop Ceiling: SEE ARCHITECTURAL DRAWINGS
  10. Pads and Hooks: Provide one set of pads for each elevator bank. Provide hooks in all cars. Pads shall be of fire-resistant material, vinyl covered and when hung shall cover all walls and returns of each car.
  11. Elevator Contractor shall make provisions in their equipment to accommodate custom design interior finishes, including sufficient equipment tolerances for applied panels and finished flooring.
  12. Elevator Contractor shall be responsible for temporary lighting and permanent wiring as defined in Articles 2.01 and 3.03, F.
- C. Elevators Nos. 15, 16, 17 and 18:
1. Side and Rear Walls: Reinforced 14 (.075") gauge furniture steel fabricated with textured stainless steel in pattern selected by the Architect. Wall panels shall not exceed 15" widths and shall be suitable reinforced. Install an infrared unit as specified above the side walls at  $\pm 1'-0"$  from front returns. Car stations shall be recessed flush mounted on the side walls  $\pm 36"$  from the front returns.
  2. Canopy: Reinforced 12 gauge (.090") furniture steel with hinged exit and baked enamel finish.
  3. Stationary Front Return Panels and Integral Entrance Columns: 14 gauge (.075") #4 stainless steel. The car stations shall be recessed flush with the front returns.
  4. Transom: 14 gauge (.075") #4 stainless steel.
  5. Car Door Panels: Same construction as hoistway door panels clad with 14 gauge textured stainless steel in pattern selected by Architect.
  6. Base: None. Include ventilation slots.
  7. Handrails: Double row, two side walls. One row 12" off finish floor with 4" x 3/8" stainless steel bars, second row 32" off finish floor with a 1-1/2" diameter grabbing surface (measured to top of hand-rail). Both rails shall be fastened to wall at maximum 12" intervals. Solid stainless steel rail shall be provide.
  8. Lighting: Adequate lighting to provide a minimum of 5 foot candles of illumination on the car sill. Flush mounted incandescent down lights, suitably guarded.

9. Flooring: Provide adequate subfloor and reinforced platform for concentrated loading. Condition floor surfaces so that they are clean, smooth, firm, and free from dirt or any other damaging material. Cracks wider than 1/8" and holes larger than 1/4" in diameter shall be filled. All ridges or other uneven surfaces shall be planed, scraped, or sanded smooth. Lining felt shall be applied over wood floor surfaces and seams in felt shall be butted. Adhesive shall be applied in accordance with manufacturer's recommendations.
  1. Install new flexible homogenous vinyl tile flooring not less than 1/8" thick, color and type as approved by the Owner. Lay tile flush with sill.
- D. Pads and Pad Buttons: Provide one set. Provide satin stainless steel buttons in both cars. Pads shall be of fire-resistant material, canvas covered and when hung shall cover all walls and returns of the car.

## 2.09 LANDING CONTROL STATIONS

All fixtures and buttons for service and security elevators shall be vandal-resistant.

- A. Pushbuttons: Provide each elevator group with a single riser at front openings. Pushbutton stations shall include flush-mounted faceplates constructed of satin stainless steel. Each fixture shall contain push-buttons for each direction of travel which illuminate to indicate call registration.
- B. Provide engraved signage, including pictorials, in elevator lobbies:
  1. "In case of fire use stairways for exit. Do not use elevator" and pictorial per U.B.C. Include as part of corridor pushbutton plates or separate sign at each floor, as selected by Architect. Separate sign shall be same material and finish as corridor pushbutton cover plate.
  2. Provide engraved plate at main lobby adjacent to fire return switch with Phase I and Phase II operating instructions per Code. Material and finish shall be the same as corridor pushbutton faceplate.
- C. Hoistway Access Switches: Mount in entrance frame side jamb at all top terminals. Mount in entrance frame at bottom terminals where walk-in pits are not provided. Provide fixture without faceplate.

## 2.10 SIGNALS

All lenses and fixtures for service and security elevators shall be vandal-resistant.

- A. Hall Lanterns: A signal fixture shall be provided at each entrance to indicate the intended direction of travel of the elevator to waiting passengers. The fixture shall contain projecting lights suitably shielded, and an electronic tone mechanism mounted in a metal box fastened in the

wall. The up or down light shall be illuminated and the tone sounded (twice for down direction travel) 5 seconds prior to the car's arrival at a floor. The light shall remain illuminated until shortly before the elevator doors start to close. Hall lantern notification time shall be adjustable between 4-10 seconds prior to car arrival. Illumination of hall lantern lights shall be sufficient to be easily visible within well-lighted lobbies. The tone shall be adjustable from 40-92 dBa in corridor. Passenger and garage elevators will have custom fixtures at Level 3 and plug in lens at typical floors. The hall lanterns for the service/security elevators shall consist of arrow lenses with faceplates. Provide faceplates fabricated of stainless steel.

- B. Car Position Indicators: Position indicators for passenger and garage cars shall be mounted in the front returns without faceplates. Position indicators for service and security elevators shall be provided in each elevator transom. The fixture shall consist of a metal box mounted behind the transom and shall contain multiple indications representing the floor served and the direction of car travel. When a car leaves or passes a floor, the numeral representing the floor shall be visible, thereby indicating the position of the car in the hoistway at all times. The proper direction arrow shall be continuously visible to indicate the direction of travel. Provide fixture with stainless steel finish faceplate for service and security elevators.
- C. Service and security elevators: Lobby Car Position Indicator: Provide a multi-light type position indicator with directional arrows mounted above the entrance. Provide fixture with a stainless steel finish faceplate.

## 2.11 CONTROL PANELS AND SECURITY SYSTEM

- A. The group control panel shall contain operating equipment and switches for all elevators, as defined below. This station shall have satin bronze cover plate and shall be provided with a CRT and keyboard.
  - 1. A key-operated on/off switch operate to place that specific elevator in or out of service. The pilot light shall illuminate to indicate cars in service. Identify each switch by permanently engraved car number and function.
  - 2. Special operation switches, etc., required by these specifications, which shall include car-to-lobby switches, standby power selection switches, card reader override switches for each individual car, individual floor lockoff switches, etc. Identify each switch by permanently engraved car number and function.
  - 3. Car position indicators and direction indicators for each elevator to be of the digital readout type. Identify each position indicator by permanently engraved car number.
  - 4. Other indicators such as bypass loading lights and seismic operation lights. Engrave and fill with black paint, operating instructions for all controls.

Fixture shall be located as directed by Architect. Coordinate size with building. Provide all wiring to the control panel (remote conduit by others).

- B. Fire Control Room Panel: A panel containing operating equipment and switches for all elevators shall be located in the lobby floor fire control room. The panel shall have a #4 brushed finish stainless steel faceplate and shall include:
1. Car position indicators with direction indicators for each elevator to be of the digital readout type. Identify each position indicator by permanently engraved car number.
  2. Emergency Return Keyed Switch and Box: Provide flush-mounted box with lockable hinged cover to contain keys and instructions for each elevator. Box faceplate material to be same as fire control station and contain engraved legend, EMERGENCY ONLY, in 1/2" letters. Mount in fire department panel faceplate and identify purpose and operating instructions with permanent engraving filled with black paint.
  3. Provide all wiring to the panel (conduit from closest elevator hoistway of each group, if required by others).
  4. Manual standby power selection switch and power status indicators.
  5. Fireman's phone jack.
  6. Standby power light jewel.

## 2.13 SEISMIC PROTECTION

Provide counterweight derailment device per CCR, Title 8 with the following clarifications: Counterweight retainer plates: Plates must be bolted to the counterweight frame, welded plates are not acceptable.

## PART 3 - EXECUTION

### 3.01 SITE CONDITION INSPECTION

- A. Prior to beginning installation of equipment, examine wellways, hoistways, and machine room areas. Verify that no irregularities exist which affect execution of work specified.
1. Hoistway size and plumbness.
  2. Sill supports and pockets.
  3. Support areas for brackets, beams, etc.
  4. Divider beams.

5. Wellway widths and lengths.
  6. Structural supports.
- B. If field dimensions are found to be the same as shown on reference drawings for each unit, and should modifications be required, the Elevator Contractor shall perform structural alterations, or modify mechanical systems as required, at no additional cost.
- C. Do not proceed with installation until work in place conforms to project requirements.

### 3.02 PRODUCT DELIVERY, STORAGE, AND HANDLING

- A. Deliver materials in Manufacturer's original, unopened protective packaging.
- B. Store material in original protective packaging. Prevent soiling, physical damage, and wetting.
- C. Protect equipment and exposed finishes during transportation, erection, and construction against damage and stains, and until equipment is fully operative, against damage, stains, deterioration, and environmental conditions.
- D. Completely protect exposed surfaces from adjacent construction activity until final acceptance of the work. Remove and replace damaged or discolored material with new material at no additional cost to the Owner. No use shall be made of the equipment by any other trade.

### 3.03 COORDINATION REQUIREMENTS

- A. Immediately upon award Elevator Contractor shall: provide exact location of all jack holes; be prepared to drill jack holes; and provide steel and PVC casings. Elevator Contractor shall be responsible for this coordination of work with the General Contractor and the steel erector.
- B. Cladding: Review all contract drawings. Coordinate methods of securing cladding (i.e. to truss) with General Contractor, Architect, and affected subcontractors prior to such actual work.
- C. Floor Finish at Elevator Sills, Cars, Landing Plates and Newels: Coordinate with other trades.
- D. Machine Room Air Conditioning, and Ventilation: Coordinate with other trades for the installation of air conditioners and ventilating fans. Units shall not be installed in the machine rooms.
- E. Security Requirements: Contractor shall be responsible for securing contents of machine room, he shall control access to rooms and ensure that they remain secure.
- F. Truss Supports: Elevator Contractor shall coordinate connection points and attachment requirements. No intermediate supports shall be provided.
- G. Painting: Provide information to painting subcontractor on prime finish used on hoistway entrances and use of compatible products for final painting.

H. Local Conditions Covering Work:

1. The Contractor shall cooperate with those in authority on the premises to prevent the entrance and exit of all workmen and/or others whose presence is forbidden or undesirable and in bringing, storing or removal of all materials and equipment, (to observe all rules and regulations in force on the grounds), to avoid unnecessary dust, or accumulated debris or the undue interference with the convenience, sanitation or routine of the Owner (and to prevent the loss of, or damage to the property of the Owner and/or his/her employees). The Contractor shall repair any and all damage he/she may cause to the building or property, to the full satisfaction of the Owner.
  2. Contractor shall maintain the machine room, machinery spaces, hoistways and pits in reasonably clean condition at all times.
- I. Job Supervisor: The Contractor shall indicate one person who shall be responsible for the scheduling control and performance of work specified in the Contract. This person shall be available upon request by the Owner to review any aspect of this contract. The Contractor shall notify the Owner if there is a change in job supervisors.

3.04 INSTALLATION

- A. Install each equipment item in accordance with accepted Manufacturer's direction, referenced codes, and specifications.
- B. Install machine room equipment with clearances in accordance with referenced codes and specifications.
- C. Install items so they may be easily removed for maintenance and repair.
- D. Install items so that access for maintenance is safe and readily available.
- E. Install equipment to afford maximum safety and continuity of operation in the event of seismic activity.
- F. Provide elevator car enclosure as detailed on architectural drawings and herein specified. The Elevator Contractor shall supervise and coordinate all drawings and materials included in this specification and also install the cars. The Elevator Contractor shall also be responsible for the following:
  1. Furnish and install all electrical controls and signal fixtures, lighting fixtures, and wire complete. Provide a minimum of 5 foot candle illumination at car sill with doors closed. Provide temporary lighting as required.
  2. Furnish and install emergency lighting. Locate to provide minimum 0.2 foot candle illumination 12" in front of main car station measured 48" above finish floor.
  3. Furnish and install on-board conduit and wiring to lighting and ventilating fixtures, as required.
  4. Furnish and install headers, tracks and threshold.

5. Furnish and install hangers and gibs on car doors and hang doors.
  6. Furnish and install car fixtures complete.
  7. Furnish and install communication system as herein specified.
  8. Basic construction shall be all steel, minimum 14 gauge.
  9. Furnish and install two-speed squirrel cage 300 - 350 c.f.m. exhaust blower. Blower to be isolated from car steel canopy on rubber grommets.
  10. Provide vent slots per Code.
  11. All enclosures shall be installed per International Union of Elevator Constructors' agreement.
- G. Paint all non-galvanized ferrous metal work, except where paint would interfere with operating mechanisms.
- H. Clean the following items of oil, grease, scale, and other foreign matter, and apply one coat of field-applied machinery enamel.
1. All equipment and metal work installed as part of this work which does not have architectural finish and which is exposed in the hoistway.
  2. Machine Room Equipment: machine, power conversion device, controller, and selector.
  3. Neatly touch up damaged factory-painted surfaces with original paint and color. Protect machine finish surfaces against corrosion.

### 3.05 MATERIALS

- A. Stainless Steel:
1. Shapes and Bars: ASTM 276, Type 316.
  2. Plate, Sheet, and Strip:
    - a. Over 1/8-inch: ASTM A264 with ASTM 240, Type 316 on A36 base.
    - b. Under 18-inch: ASTM 167, type 316.
  3. Pipes and Tubes:
    - a. Welding: ASTM A312, Grade TP 316, Schedule 10 minimum.
    - b. For Screwed Connections: ASTM A312, TP 316, Schedule 50S.
    - c. For Press Fits: ASTM A312, Grade TP 316, Schedule 5S minimum.
- B. Die Cast Aluminum: ASTM B108, Alloy 356.0, T6.

- C. Extruded Aluminum: FS QQ-A 200/8, Alloy 6061, T6.
- D. Fasteners:
  - 1. Provide bolts, nuts, washers, screws, nails, rivets, and other fastenings necessary for proper erection and assembly of work.
  - 2. Fasteners shall be compatible with material(s) being fastened.
  - 3. Exposed:
    - a. Match adjacent material in appearance, finish, and color.
    - b. Countersink, unless otherwise indicated.
    - c. Screws: Provide Phillips flathead type.
- E. Welding Electrodes: E70XX per AWS A5.1 or A5.5.

3.06 FINISHES

- A. All equipment and metal work installed or reused under this contract, which does not have a baked enamel or special architectural finish and which is exposed in the hoistway, shall be cleaned and painted one field coat of enamel. The shank and base of the T-Section of the guide rails shall be thoroughly cleaned and painted one field coat of black metal enamel.
- B. All machine room equipment shall be painted upon completion of the installation with the manufacturer's standard machinery enamel.
- C. All natural metals shall be of the best grade and shall have the grain of belting in the direction of the longest dimension with a fine, brushed finish. All surfaces shall be perfectly smooth and without waves.
- D. Clean and paint machine room floor upon completion of new and modernization work.
- E. All natural metals shall be stretcher-leveled, resquared sheets. Sheets shall be .063" minimum for door facings, and .074" minimum for entrance frames and front returns. The grain of belting shall run in the direction of the longest dimension. A satin finish shall be provided by first removing tool-and-die marks and then finishing with No. 80, 100, and 120 grit sanding belts. All surfaces shall be perfectly smooth and without waves.
- F. Provide detailed information relative to recommended methods of preparation, cleaning and application of primed elevator door entrances for final paint.
- G. All metal surfaces requiring bronze finishes shall be manufactured from material of not less than 60% copper, 40% zinc, containing no lead or nickel. Finish metal with #120 grit. Apply two coats of lacquer to protect surface unless surface is to be field oxidized.
- H. Stainless Steel: Manufacturer's Standard Type 316, No. 4 finish.



- I. Aluminum Castings and Extrusions: Manufacturer's Standard Commercial mill finish.

### 3.07 FIELD QUALITY CONTROL

- A. Work at the jobsite will be checked during the course of installation. Full cooperation with reviewing Lerch, Bates and Associates' personnel is mandatory. All procedures shall be established in a pre-construction conference. Accomplish corrective work required prior to performing further installation.
- B. Have Code Authority acceptance inspection performed and complete corrective work.

### 3.08 ADJUSTMENTS

- A. Align guide rails vertically with tolerance of 1/16" in 100'. Secure joints without gaps and file any irregularities to a smooth surface.
- B. Balance cars to equalize pressure of guide shoe rollers on rails.
- C. Lubricate all equipment in accordance with Manufacturer's instructions.
- D. Adjust motors, pumps, valves, generators, brakes, controllers, leveling switches, limit switches, stopping switches, door operators and switches, interlocks and safety devices, etc., to achieve required performance levels.
- E. Fabricate and assemble various parts in shop to minimize field assembly. Assemble parts which require close field fit in the shop and mark for field erection.

### 3.09 CLEANUP

- A. Keep work areas orderly and free from debris during progress of project. Remove packaging materials on a daily basis as equipment is installed.
- B. Remove all loose materials and filings resulting from work on a daily basis.
- C. Clean machine room equipment, floor, and truss interiors of dirt, oil and grease.
- D. Clean balustrades, handrails, skirts, steps, hoistways, cars, car enclosures, entrances, operating and signal fixtures, and trim of dirt, oil, grease, and fingermarks.

### 3.10 ACCEPTANCE INSPECTION AND TESTS

- A. General: Furnish labor, materials, and equipment necessary for tests. Notify Elevator Consultant 30 days in advance when ready for final review of entire work. Final acceptance of installation will be made only after all field-quality control reviews have been completed, identified deficiencies have been corrected, all submittals and certificates, including certificates by authorities having final legal jurisdiction have been received, and the following items have been completed to satisfaction of Owner and Elevator Consultant's satisfaction.

- 1. Workmanship and equipment comply with specification.

2. Contract speed, capacity and floor-to-floor performance comply with specification.
3. Performance of following are satisfactory:
  - a. Starting, accelerating, running, stopping.
  - b. Decelerating, stopping accuracy.
  - c. Door operation and closing force.
  - d. Equipment noise levels.
  - e. Signal fixture utility.
  - f. Overall ride quality.
4. Escalators: Each switch shall be tripped by hand and reset to determine that switches and circuits are operational. Reinspect each running clearance, guard, and material surface specified in ANSI A17.1 that is exposed to public contact for Code compliance.

In addition, perform the following tests without load on each escalator:

- a. Overspeed Protection Device: Test by operating escalator at rated speed and tripping overspeed device manually. Device shall have been separately tested and set in factory to operate at escalator's speed as specified herein.
- b. Handrail Tension Malfunction Device: Test manually.
- c. Broken Chain Protection: Test by operating escalator at rated speed and tripping broken chain device by hand.
- d. Device Providing Protection Against Sudden and Unusual Strains on Step Chains: Test by operating device by hand.
- e. Pushbuttons, Starting Switches, Starters, Relays, Interlocks, and Controls Required in Connection with Work: Inspect and test to prove that complete escalator functions properly under any and all condition of operation within limits specified.
- f. Brakes and Driving Machinery: Test for operating efficiency, ease of adjustment and temperature limits.
- g. Escalator shall produce no noise louder than 55 dBA measured five feet above the floor or stair level at the entrance combs at both ends with the escalator operating normally and either free running or under load. For multiple escalator installations, the noise measurements at each group shall be made with only the one escalator unit under evaluation in operation. Ambient noise level not to exceed 49 dBA.

5. Test Results:
  - a. In all test conditions, obtain specified speed, performance times, floor accuracy without releveling, and ride quality to satisfaction of the Owner and Elevator Consultant.
  - b. Temperature rise in windings limited to 50 degrees Celsius above ambient. Conduct a full-capacity, one-hour running test, stopping at each floor for 10 seconds in up and down directions. Replace equipment if equipment performance is questionable in Elevator Consultant's opinion.
- B. Performance Guarantee: Should tests reveal defects, poor workmanship, variance or noncompliance with requirements of specified Codes and/or ordinances, or variance or noncompliance with the requirements of specifications, complete corrective work to satisfaction of Owner at no cost:
  1. Replace equipment that does not meet Code or specification requirements.
  2. Perform work and furnish labor, materials and equipment necessary to meet specified operation and/or performance.
  3. Perform and assume cost for retesting required by Governing Code Authority, Consultant, and Owner to verify specified operation and/or performance.
- C. Field Review Scheduling: The Elevator Consultant shall schedule all installation progress reviews and final equipment and installation reviews with the Elevator Contractor. The Consultant anticipates that schedules shall be met. The Elevator Contractor is required to reply in writing to all corrective measures indicated on Elevator Consultant's progress and/or final review reports. The Consultant also anticipates that corrective measures indicated in his written review shall require no more than one follow-up review to verify Elevator Contractor's compliance. It is agreed that Elevator Contractor shall reimburse the Elevator Consultant at his normal billing rates for appointments not kept or additional follow-up reviews required due to the Elevator Company's gross non-compliance with initial review requirements.

### 3.11 OWNER'S INFORMATION

- A. Submittals: Provide written information necessary for proper maintenance and adjustment of the equipment prior to final acceptance. Final retention will be held until data is received by Owner.
  1. Straight-line wiring diagram of as-installed elevator/escalator circuits with index of location and function of all components. Provide three neatly bound final corrected sets within 30 days after job acceptance for the Owner's file.
  2. Lubricating instructions, including recommended grade of lubricants. Provide three neatly bound copies.
  3. Parts catalogs for all replaceable parts including ordering forms and instructions. Provide three neatly bound copies.

4. Six sets of each key for each key switch. All keys shall be properly tagged.
5. Three sets of secondary containment monitoring instruction manuals and equipment catalogs.
6. Provide any special tools which may be required to maintain, troubleshoot, repair or replace parts of any equipment furnished.
7. Safety barriers for maintenance and repair work on escalators; one set per escalator unit.
8. Instruct Owner in general operation and use of elevators and procedures to follow in the event of an emergency, including cleaning procedures.

END OF SECTION

SECTION 14210

TRACTION ELEVATORS

PART 1 - GENERAL CONDITIONS

1.01 WORK INCLUDED

- A. 6 Geared Traction Elevators.
- B. Provide everything necessary for and incidental to the satisfactory completion of the equipment installation as specified and conforming to all contract documents.
- C. Conform to applicable conditions of General, Special, and Supplemental Conditions and Division 1.

1.02 RELATED WORK SPECIFIED ELSEWHERE

A. Legal Elevator Hoistway and Pit:

- 1. Clear plumb elevator hoistway with variations not to exceed 1" at any point. Glass shall be laminated in accordance with the requirements of ANSI Z97.1.
- 2. Bevel cants (75 degrees from horizontal) over any rear or side wall ledges and beams that project 2" or more into the hoistway. Hoistway divider beams excepted.
- 3. Divider beams between adjacent elevators at each floor, pit, and overhead. Intermediate rail supports where floor heights exceed 14'-0" (building supports not to deflect in excess of 1/8" under 0.5g horizontal seismic acceleration). Intermediate rail support is not required where double main rail bracketing is employed to maintain 14'-0" or less bracket to bracket.
- 4. Install guide rail bracket supports in concrete, (concrete inserts or imbeds will be provided by Elevator Contractor and installed by General Contractor as indicated on Elevator Contractor's shop drawings).
- 5. Cut and patch walls and floors. Grout at hoistway door sills. Cutting and patching and redecorating around new hall lanterns, pushbuttons, smoke detector stubout conduits, and entrances.
- 6. Wall pockets and/or structural beams for adequate support of the elevator machine beams and deadend hitch beams. Support deflection shall not exceed 1/1666 of the span under static load.
- 7. Wall blockouts for pushbutton stations, hall lanterns, position indicators or other signal fixtures.
- 8. After entrances are set, fill each side of entrance with concrete.

9. Pit ladders and pit screens where pit ladders are adjacent pit screen shall be extended 6'-0" high. Structural supports for car and counterweight buffer impact loads, and rail loads.
10. Waterproof pit. Sump pump or indirect waste drain as indicated on contract drawings. Seal pit with non-permeable epoxy.
11. Finish painting of primed hoistway entrances.
12. Finish flooring in elevator car enclosure.
13. Protect open elevator hoistways, wellways, and entrances during construction per OSHA regulations.
14. Protect cars, door entrance assemblies, and special metal finishes from damage after installation.
15. Vent elevator hoistways to outside air. Minimum 3'-0" sq. ft. per hoistway or 3.5% of the total hoistway area (whichever is greater) per U.B.C. See contract drawings for size and location of vents. Special mechanical venting of Hoistway No. 15 will be required to reduce wind noise.
16. Pit support framing for jack cylinder and buffer loads.
17. Opening in hoistway wall for hydraulic piping. All remote piping shall be encased in PVC casing and shall be run overhead.
18. 3'-0" square hole in pit floor for Elevator Contractor to install protective, secondary containment casing. Fill hole with concrete after jack and membrane installation.

B. Escalator, Wellways, and Pits:

1. Provide properly framed openings in the floors, necessary supports for the truss per the drawings and information, the required enclosures, wellway railings, baffles, and barricades around the wellway as required.
2. Covering for the exterior of the escalator from the edges of the decks, including covering for the truss and soffit. Covering for the truss shall run the full length, including that portion which is in the ceiling space. The materials used shall be fire resistant as required by the ASME A17.1 Code and shall weigh not more than eight pounds per square foot.
3. Finished flooring at landing plates and its base over contractor's floor support.
4. Fire protection of escalator openings in accordance with the Life Safety Code NFPA No. 101, latest edition and supplements.
5. Provide escalator step treads and landing plates with a minimum of five foot candles of illumination.
6. Protective enclosures of openings in accordance with OSHA during construction.

7. Structural Requirements: Provide escalator truss mounting angles and intermediate truss supports with attachments, sized as required to securely attach escalators to wellway structural support system.

C. Legal Machine Rooms:

1. Self-closing and self-locking elevator machine room access doors or gates. Lock shall have be as specified in hardware section.
2. Access plates to escalator machine areas (top and bottom) shall require no more than 70 lbs to open.
3. Machine Room: Provide constant cooling and heating, including truss ventilation, to maintain a minimum temperature of 65 degrees and a maximum of 90 degrees Fahrenheit, and humidity shall not exceed 85%. Cooling and heating unit shall be located outside of the machine room enclosure.
4. Paint elevator machine room walls, ceiling and floor. Cementitious beam, column, and roof fireproofing shall be sealed to prevent flaking.
5. Provide a Class "C" fire extinguisher in each elevator machine room.
6. Coordinate secondary containment of hydraulic tank with elevator installer.

D. Electrical Services, Conductors and Devices:

1. Permanent Guarded Lighting (minimum 10 footcandles) and convenience outlets, per Code in elevator and escalator pits, machine rooms, governor locations, and mechanical areas (at both ends for escalators).
2. Run conduits from the closest elevator hoistway of each elevator group or single elevator to the fire control room and/or main level lobby control console at employee entrance. Coordinate size, number, and location of conduits with Elevator Contractor.
3. All remote conduits shall be run overhead.
4. Three-phase mainline power feeders to terminals of each elevator and escalator controller unit in the elevator and escalator machine room. Include protected lockable "off" disconnect switch (copper conductors to terminals). Provide auxiliary disconnects in multi-level machine rooms, label existing disconnects with proper elevator numbers.
5. Verify adaptability of existing disconnect and power for new equipment to be installed.
6. Single-phase power feeders to each elevator and escalator controller for lighting and exhaust blower. Include individual disconnect switch at location shown on elevator contractor's shop drawings.
7. Single-phase, power feeder to elevator intercom amplifier located in the elevator machine room.

8. Signal fixture power feeders to machine room elevator to each group control panel.
9. Products-of-combustion sensors (NFPA No. 72D) in each elevator lobby, hoistway, and machine room for each group of elevators, including single elevator units, to initiate fireman's return feature, per Code requirements. Run sensing wires to each group elevator controller and single elevator unit in each elevator machine room, including exiting units.
10. Standby Power Provisions
  - a. Provide standby power of the same voltage characteristics via the normal electrical feeders to run one elevator at a time in each elevator group, including single elevator units, at full-rated car speed.
  - b. Conductors, as necessary, from the standby power transfer switch to a single elevator control panel in each elevator group and/or single elevator unit, as designated by the Elevator Contractor, to signal the presence of standby power. Transfer switch shall provide a dry, form "C" output with a time delay of approximately 15 seconds for pretransfer signal upon restoration of normal power.
  - c. Standby single-phase power to each elevator controller for lighting, exhaust blower, emergency alarm bell, intercom amplifier, and hoist machine, and/or controller cooling fans.
  - d. Means for absorbing regenerated power during an overhauling load (such as full load down) in accordance with ANSI A17.1, Rule 210.10.  
  
(Note: Elevator drives may employ solid-state SCR devices for conversion of AC to DC power).
11. Individual phone connection at car controllers in elevator machine rooms.
12. Temporary power and illumination as required by Elevator Contractor to install, test and adjust elevator and escalator equipment.

### 1.03 QUALITY ASSURANCE

#### A. Definitions:

1. In all cases, where a device or a part of the equipment is herein referred to in the singular number, it is intended that such reference shall apply to as many such devices or parts as are required to complete the installation.
2. All terms in these specifications have their definition given in the latest edition of the American National Standards Institute, Safety Code for Elevators, Dumbwaiters, and Escalators ASME A17.1, including revisions and authorized changes in effect on the date of these specifications.

- B. Document Verification: In order to discover and resolve conflicts or lack of definition which might create construction problems, Elevator Bidders must review schematic design documents, and existing conditions for compatibility with their products prior to bidding. Attach



specific, written exceptions and/or clarifications with quotation. Bidder's compliance with all provisions of contract documents is assumed and required in absence of written exceptions. Owner will not pay for changes to structural, mechanical, electrical or other systems required to accommodate Bidders' equipment if not identified before contract award.

C. Acceptable Elevator Bidder:

1 General:

- a. **Manufacturers:** Provide manufacturer's equipment and other components produced by the manufacturer or by firms experienced and specialized not less than five years in the types of components required that comply with these specifications.
- b. **Installer:** Either the manufacturer or a licensee of the manufacturer, who has not less than five years successful experience with the installation of similar units and who is currently under contract for maintenance of similar units in the area, and who maintains a service center in the Los Angeles basin.
- c. **Welders:** Qualify welding processes and welding operators in conformance with AWS D1.1, Structural Welding Code - Steel.
- d. **Maintainability:** Parts subject to wear and replacement shall be readily and easily removable and replaceable without requiring modification of the units or the equipment.
  - (1) Parts subject to wear shall be standard production items that are interchangeable.
  - (2) Replacement parts, whether produced in the Contractor's factories or secured from commercial factories or distributors, shall be precisely identified. Replacement parts shall be made available to the Owner or its designee without prejudice. The required quantities, uniform price, and delivery time of replacement parts shall be on the same basis as the Contractor's most favored maintenance consumer.
  - (3) Replacement parts, maintenance methods, technical information, wiring diagrams, testing procedures, design criteria, or any other publication related to the equipment provided, even though labeled PROPRIETARY, shall be made available to the Owner or its designee without prejudice or delay.

2. **Companies:** The units shall be installed by Dover Elevator Company, Fujitec Elevator Company, Mitsubishi Elevator Company, Montgomery Elevator Company, Otis Elevator Company, or Schindler Elevator Corporation. Alternate suppliers or installers must receive approval of the Architect and/or Consultant a minimum of 5 days prior to bid date. The equipment shall be provided by:

- a. Geared Elevator Machines: Dover, Fujitec, General Electric, Holister-Whitney, Mitsubishi, Montgomery, Otis, Schindler.
  - b. Traction Control Systems: Dover, Fujitec, Mitsubishi, Montgomery, Otis, and Schindler.
  - c. Car Enclosures: Amtech/Reliable, Dover, Elevator Cabs, Elevator Decorators, Fujitec, Globe Van Doorn, Hauenstein & Burmeister, Mitsubishi, Montgomery, Otis, Schindler, and Tyler.
  - d. Hoistway Entrances: Dover Elevator Doors, Fujitec, Hauenstein & Burmeister, Montgomery, Otis, Tyler.
  - e. Escalators Manufactured By: Mitsubishi, Montgomery, O & K, Otis, Schindler.
  - f. Fixtures: Adams or approved equal.
  - i. Use of alternate manufacturers must receive approval of the Architect and/or Consultant at least 5 days prior to bid date.
- D. Design Criteria:
1. General:
    - a. Equipment shall be of the heavy-duty type.
    - b. No wood or wood products will be permitted in elevator and escalator systems.
  2. Seismic Requirements: All equipment shall be designed for the appropriate Seismic Zone.
- E. On-Site Conditions:
1. Complete verification of on-site conditions, including, but not limited to, elevator hoistway, pit, machine room, overhead clearances, electrical power characteristics, structural loads, etc., as they relate to the Elevator Contractor's equipment applications, and Code compliance shall be the responsibility of the Elevator Contractor. On-site review shall be completed prior to submittal of the Elevator Contractor's proposal. Deficiencies noted shall be included in writing with the Elevator Contractor quotation. Special attention shall be paid to verifying field dimensions, drilling accessibility, and overhead heights. Submission of bid indicates acceptance of all on-site conditions.
  2. Drawings or measurements included with the bidding material shall be for the convenience of the bidders only. Complete responsibility for detailed dimensions lies with the Elevator Contractor. Prior to the execution of the work, the Contractor shall verify all dimensions with the actual on-site conditions. Where the work of the Elevator Contractor is to join another trade, the shop drawings shall show the actual dimensions and the method of joining the work of the two trades.

3. Modification of existing electrical supply shall be the responsibility of the elevator contractor.

F. Compliance with Regulatory Agencies and Agreements: Comply with most-stringent applicable provisions of following Codes and/or Authorities, including revisions and changes in effect on date of these specifications (latest editions and supplements shall apply):

1. Safety Code for Elevators and Escalators ASME A17.1.
2. Inspectors' Manual, for Elevators and Escalators ASME A17.2.
3. Safety Code for Existing Elevators and Escalators, ASME A17.3.
4. National Electrical Code, No. ANSI/NFPA 70.
5. Structural Welding Code, Steel AWS D1.1, latest edition.
6. California Code of Regulations (CCR), Title 8, Title 23, and Title 24.
7. Life Safety Code, ANSI/NFPA No. 101, CCR Title 19, and local fire authority.
8. Requirements of local building code and any other Codes, Ordinances and Laws applicable within the governing jurisdiction.
9. Underwriters' Laboratories, Inc., materials and test report descriptions as required.
10. International Union of Elevator Constructors (IUEC).
11. Providing Accessibility and Usability For Physically Handicapped People, per Americans with Disabilities Act, Titles II and III.
12. Applicable UBC requirements.
13. As directed by local fire jurisdiction.
14. Soils reports - special attention to, but not limited to, any corrosive soil conditions.
15. In the event of conflict, the more-stringent Code requirements shall apply.

G. Applicable Standards, Rules, and Regulations:

1. American National Standards Institute (ANSI).
2. American Society of Civil Engineers (ASCE).
3. American Society of Mechanical Engineers (ASME).
4. American Society for Testing and Materials (ASTM).
5. Electronic Industries Association (EIA).

6. Insulated Cable Engineers Association (ICEA).
  7. Institute of Electrical and Electronics Engineers (IEEE).
  8. National Electrical Manufacturers Association (NEMA).
  9. National Fire Protection Association (NFPA).
  10. OSHA.
  11. Underwriters' Laboratories, Inc. (UL).
  12. CCR Titles 8, 23, and 24.
- H. Safety: Conform safety devices, running clearance, testing, and maintenance methods to the requirements of ASME A17.1 and Supplements and ASME A17.2 and supplements, and local Codes.
- I. Warranty:
1. Materials and workmanship of the elevator installation shall comply in every respect with contract documents. Unless due to ordinary wear and tear, or improper use or care by Purchaser, correct defects which develop within one year from date of final acceptance of work to the satisfaction of the Architect, Owner, and Consultant at no additional cost.
  2. Make modifications, adjustments, improvements, etc., to meet all performance requirements.
  3. Neither the final payment nor any provision of the contract documents shall relieve the Contractor of the extent and period provided by law and upon written notice he shall remedy any defects due thereto and pay all expenses for any damage to other work resulting therefrom.
  4. The same guarantee shall be applicable to the total job in the event equipment is reused or modified.
  5. The one-year guarantee, as outlined above, for all units shall start from the date of final acceptance by the Owner of all work associated with these contract documents.

#### 1.04 SUBMITTALS

##### A. Dimensioned Shop Drawings:

1. Scaled shop drawings shall be provided for all work. Before beginning fabrication, shop drawings showing the plan views of the pit, hoistway, wellways, machine room, elevation section of the hoistway, car details, entrance details, secondary containment provisions, and details of the signal fixtures shall be prepared and submitted for approval. Also provide electrical, structural, and/or mechanical data. Three reproducible sets (sepias or mylars) shall be provided for each drawing submittal.

2. Refer to Division 1 for submittal procedures, including preparation and transmittals. Shop drawings shall be submitted within 28 days of Contract award, verbal or written. Each shop drawing shall be clearly identified by title and owner's elevator number. Corrections made to shop drawings during the review process shall be incorporated on the drawings and/or responded to and acknowledged by the Elevator Contractor. Elapsed time due to "revise and resubmit" or "rejected" action, indicated on submittals due to inaccurate data or incomplete definition shall not affect equipment delivery or installation schedule.
- B. Calculations: Structural and electrical calculations shall be submitted. These calculations shall include, but are not limited to, rail loads, loads from machines, seismic forces, etc. Submit layout which clearly indicates structural loadings that will be applied to the building structure by the elevator system. Indicate the magnitude of each type of load (dead, live, impact, seismic) separately, along with its point of application to the building structure and its sense (vertical, horizontal, torsional). Additionally, indicate the nature of load combinations. The purpose of this submittal is verification of the capacity of the building structure.
  - C. Samples: Submit three samples of each required finish, not including those intended for painting after installation. Submit 3" x 10" samples or 10" lengths of actual finished materials. Samples shall be reviewed by Architect for color, pattern and texture only. Compliance with other requirements is the exclusive responsibility of the Elevator Contractor. Include signal equipment units, to show pushbuttons, lights, graphics, Braille plates, and mounting provisions. Submittals shall be made within 28 days of award, verbal or written.
  - D. Allotted approval process time shall be a minimum of four weeks from date individual submittals are received by Architect.
- 1.05 PERMITS, TESTS, AND INSPECTIONS
- A. Elevator Contractor Shall Obtain, Pay For and/or Provide:
    1. All necessary legal requirements, permits, licenses and inspection fees necessary to complete the elevator and escalator installation.
    2. Tests as required by governing authorities and/or the ANSI current A17.2 Elevator Inspectors' Manual.
    3. Any submittals required by local building/permit authorities.
  - B. Perform such tests in the presence of authorized representatives of such authorities.
  - C. Provide manpower and equipment to perform tests and final reviews as required by governing authorities and/or to meet the ASME/ANSI current A17.2 elevator inspectors' manual and tests, indicated in Specification Part 3.
- 1.06 MAINTENANCE
- A. General Guidelines:
    1. Breakdowns and Shutdowns:

- a. Breakdowns and shutdowns, such as electrical troubles, burned out control coils, open circuits, electrical or mechanical adjustments, will not keep the respective elevator out of service longer than one (1) day (24 hours).
  - b. Under no circumstances will any shutdown or breakdown last longer than three (3) days (72 hours). This includes the locating of the trouble, procurement of parts, the installation of these parts and the replacing of the respective unit back into safe uninterrupted operation. The Contractor must be so equipped to meet the above conditions. The excuse of not being able to obtain parts, necessary technical and engineering advice, etc., will not be acceptable, and the Contractor will be considered in default, giving sufficient justification to the Owner to obtain these services from Contractors who can provide the Owner with uninterrupted service.
  - c. The Owner may take over the work and prosecute it to completion by contract or otherwise, and the Contractor and his/her sureties (if any), shall be liable to the Owner for any additional cost occasioned by the Owner, previous to the termination of the contract.
2. **Material Inventory:** The Contractor shall maintain a supply of contacts, coils, leads, fuses, motor and generator brushes, hanger rollers, clutch rollers, lubricants, wiping cloths, and other minor parts for the performance of routine preventive maintenance properly stored in the machine room.
  3. **Spare Parts Inventory:**
    - a. The Contractor shall maintain a supply of spare lending and replacement parts in their warehouse inventory. This inventory shall include, but is not limited to, generator rotating elements, door operator motors, brake magnets, generator and motor brushes, controller switch contacts, selector switch contacts, solid state components, selector tapes, door hangers, hardware, hoistway limit switches, etc.
    - b. All replacement parts and materials shall be specifically designed for the elevators on which they are to be used. The Contractor shall provide for replacement parts from the original manufacturer of the transportation system or suppliers of such original manufacturer's parts. Substitute parts may be utilized on approval of the Owner or his/her designee.
  4. **Experience and Parts:** The Elevator Contractor shall be able to show that he has had successful experience in the complete maintenance of elevators and escalators, employs competent personnel to handle this service, maintains an adequate stock of parts locally for replacement or emergency purposes and has qualified men available to ensure the fulfillment of this service without unreasonable loss of time in reaching the job site. The Elevator Contractor shall supply a list, acceptable to the Owner, of locally stocked parts, particular to the equipment designs. The Contractor shall supply a list, acceptable to the Owner, of long lead items that apply to the equipment. This list shall include delivery dates of long lead items.

B. Construction Maintenance:

1. When one or more elevators have been installed to a stage near completion and declared ready for service, the Owner or Contractor may accept the elevators for interim use and place them in service before the entire installation of all elevators has been completed and accepted.
2. During this period the General Contractor may agree to pay the Elevator Contractor a mutually agreed amount per elevator for preventive maintenance of elevators on interim service. Bidders shall indicate the amount per unit per month with their bids.
3. Before an elevator is placed in temporary service, General Contractor shall sign Elevator Contractor's temporary acceptance form. Form shall contain provisions acceptable to both parties.
4. As agreed upon between General Contractor and Elevator Contractor, the Elevator Contractor shall provide temporary hoistway enclosures and perform all cleaning, repairs or replacement of materials as necessary to restore elevator to its original condition.
5. The maintenance and warranty periods herein specified shall not commence for units accepted on an interim basis or accepted and shut down due to lack of need.

C. Warranty Maintenance: Include with new equipment contract (new installation service period):

1. The Elevator Contractor shall furnish weekly scheduled preventive maintenance on all equipment described herein for a period of 12 months, including 24-hour emergency callbacks, per unit, commencing on date of final acceptance by Owner. The maintenance shall include systematic examinations, adjustment, cleaning, and lubrication of all equipment. The Elevator Contractor shall also repair or replace electrical and mechanical parts whenever required and shall use only parts produced by the manufacturer of the equipment installed. Maintain machine rooms, wellways, hoistways, and pits in clean condition.
2. All maintenance work shall be performed by competent personnel under the supervision and direct employee of the Elevator Contractor.
3. The Owner, at his option, may choose to delete this maintenance from the capital contracts and to pay this amount in 12 equal installments directly to the Elevator Contractor during the period in which the work is being accomplished.

Reference L.B.A. contract and bid form.

D. Contract Maintenance (Ongoing Preventive Maintenance Program):

1. Bidders shall also quote the monthly cost for a 5-year maintenance agreement to commence on completion of the 12-month period of warranty maintenance. That quotation shall be submitted based upon the terms and conditions of the standard Lerch, Bates and Associates' preventive maintenance agreement. Under this agree-

ment, the equipment performance requirements, as herein specified, shall be provided at all times.

2. If this contract is accepted, the contract price is subject to adjustment at the expiration of the new installation service period and thereafter as provided in the contract.

## PART 2 - PRODUCTS

### 2.01 SUMMARY

#### A. Passenger Garage Shuttle Elevators:

NUMBER:	4, ELEVATOR NOS. 11-14
CAPACITY:	4000#
SPEED:	350 F.P.M.
ROPING:	1:1
SUPERVISORY CONTROL:	DOVER TRAFLOMATIC IV FUJITEC FLEX 8830 MITSUBISHI OS 2100 MONTGOMERY MIPROM 21 OTIS ELEVONIC 411 SCHINDLER MICONIC V
MOTOR CONTROL:	DC, VARIABLE VOLTAGE WITH CLOSED LOOP FEEDBACK AND AUTOMATIC LEVELING (A.C. MOTOR CONTROL UNACCEPTABLE)
POWER CHARACTERISTICS:	VERIFY ON DRAWINGS
STOPS:	7 STOPS IN LINE - VERIFY ON DRAWINGS
OPENINGS:	7 OPENINGS IN LINE - VERIFY ON DRAWINGS
FLOORS SERVED:	P4, P3, P2, P1, 1, 3, 4 - VERIFY ON DRAWINGS
TRAVEL:	92'-8" + \- VERIFY ON DRAWINGS
PLATFORM SIZE:	8'-0" WIDE X 6'-2" DEEP
ENTRANCES:	
SIZE:	4'-0" WIDE X 7'-0" HIGH AT P4 TO P1 - VERIFY ON DRAWINGS 4'-0" WIDE X 8'-0" HIGH AT 1, 3, AND 4 - VERIFY ON DRAWINGS



TYPE:	SINGLE-SPEED, CENTER OPENING
SILLS:	SATIN BRONZE
SILL ANGLES:	5" X 5" X 1/2" FASTENED AT A MAXIMUM 18" ON CENTER
DOORS:	SATIN BRONZE. 16 GAUGE CUSTOM ETCHING AT L-3, STEEL SANDWICH CONSTRUCTION
FRAMES:	SATIN BRONZE, 14 GAUGE MITRED AND WELDED WITH U.L. LABELS ON ASSEMBLIES
BLACK-OUT PANELS:	TO CONCEAL ENTRANCE EQUIPMENT AT P4 TO P1. 14 GAUGE WITH BLACK BAKED ENAMEL FINISH
DOOR OPERATION:	HIGH-SPEED, HEAVY-DUTY, MASTER DC DOOR OPERATOR (MINIMUM OPENING SPEED 2-1/2 F.P.S.)
DOOR PROTECTION:	INFRARED, OPTICAL FULL SCREEN DEVICES WITH DIFFERENTIAL TIMING FEATURE, AND NUDGING
MACHINE:	GEARED; SEMI-BASEMENT AT LEVEL P4
SAFETY:	FLEXIBLE GUIDE CLAMP - CAR (TYPE "B" ONLY)
GUIDE RAILS:	PLANED STEEL TEES
BUFFERS:	OIL, SPRING RETURN
COMPENSATION:	ENCAPSULATED CHAIN WITH TIE DOWN
CAR ENCLOSURE:	VERIFY ON DRAWINGS
THRESHOLD:	SATIN BRONZE WITH EXTENSIONS TO FRONT RETURNS
FLOOR:	CARPE/STONET (NOT BY ELEVATOR COMPANY). SUBFLOOR AND PREPARATION TO RECEIVE FINISH FLOORING BY ELEVATOR COMPANY
DOORS:	SATIN BRONZE; 16 GAUGE SANDWICH CONSTRUCTION
FRONTS:	SATIN BRONZE; 14 GAUGE FULL SWING RETURNS WITH CONCEALED 3 POINT LATCHING
SIDE/REAR WALLS:	SEE ARCHITECTURAL DRAWINGS
DROP CEILING/CANOPY:	SEE ARCHITECTURAL DRAWINGS

LIGHTING: SEE ARCHITECTURAL DRAWINGS

HANDRAIL: #4 SATIN BRONZE; 1-1/2" DIAMETER ON REAR WALL,  
SEE ARCHITECTURAL DRAWINGS

HEIGHT: 9'-0" TO CANOPY

PLATFORM: ISOLATION REQUIRED

SIGNALS:

REGISTRATION LIGHTS: CAR AND CORRIDOR PUSHBUTTONS, DUAL RISER -  
DUAL CAR STATIONS

POSITION INDICATORS: CAR (DUAL), FIRE CONTROL ROOM PANEL, LOBBY  
CONTROL PANEL

HALL LANTERNS: AT ALL FLOORS WITH ELECTRONIC CHIME OR TONE  
(TWICE FOR DOWN DIRECTION). SATIN BRONZE  
CUSTOM ALL FLOORS

COMMUNICATION SYSTEM: INTERCOM WITH DISTRESS SIGNAL

FIXTURE SUBMITTALS: SATIN BRONZE CUSTOM

B. Passenger Security Elevators:

NUMBER: 2, ELEVATOR NOS. 17-18

CAPACITY: 3500#

SPEED: 350 F.P.M.

ROPING: 1:1 OR 2:1

SUPERVISORY CONTROL: DOVER TRAFLOMATIC IV  
FUJITEC FLEX 8830  
MITSUBISHI OS 2100  
MONTGOMERY MIPROM 21  
OTIS ELEVONIC 411  
SCHINDLER MICONIC V

MOTOR CONTROL: DC, VARIABLE VOLTAGE WITH CLOSED LOOP  
FEEDBACK AND AUTOMATIC LEVELING (A.C. MOTOR  
CONTROL UNACCEPTABLE)

POWER CHARACTERISTICS: VERIFY ON DRAWINGS

STOPS: 7 STOPS - VERIFY ON DRAWINGS

OPENINGS:  
7 OPENINGS; 3 FRONT, 4 REAR - VERIFY ON DRAWINGS

FLOORS SERVED: P4, P3, P2, P1, 1, 2, & 3 - VERIFY ON DRAWINGS

TRAVEL: 63'-6" + \ - VERIFY ON DRAWINGS

PLATFORM SIZE: 7'-6" WIDE X 6'- 6-1/2" DEEP

ENTRANCE SIZE: 4'-0" WIDE X 7'-0" HIGH AT P4 TO P1 - VERIFY ON DRAWINGS  
4'-0" WIDE X 8'-0" HIGH AT 1, 2, AND 3 - VERIFY ON DRAWINGS

ENTRANCE TYPE: SINGLE-SPEED, CENTER OPENING; FRONT AND REAR

DOOR OPERATION: HIGH-SPEED, HEAVY-DUTY, MASTER DC DOOR OPERATOR (MINIMUM OPENING SPEED 2-1/2 F.P.S.), FRONT AND REAR; SELECTIVE DOOR OPERATION

DOOR PROTECTION: INFRARED, OPTICAL FULL SCREEN DEVICES WITH DIFFERENTIAL TIMING FEATURE, AND NUDGING; FRONT AND REAR

MACHINE: GEARED BASEMENT; MACHINE ROOM AT P4 AT SIDE OF HOISTWAYS

SAFETY: FLEXIBLE GUIDE CLAMP

GUIDE RAILS: PLANED STEEL TEES

BUFFERS: OIL, SPRING RETURN

CAR ENCLOSURE: VERIFY ON DRAWINGS

THRESHOLD: SATIN BRONZE WITH EXTENSIONS TO FRONT RETURNS

FLOOR: VINYL (PROBABLY) OR CARPET (NOT BY ELEVATOR COMPANY). SUBFLOOR AND PREPARATION TO RECEIVE FINISH FLOORING BY ELEVATOR COMPANY

DOORS: STAINLESS STEEL; GAUGE CRS STEEL SANDWICH CONSTRUCTION

FRONTS: STAINLESS STEEL; 14 GAUGE CRS FULL SWING RETURNS WITH CONCEALED LATCHING

SIDE/REAR WALLS: SEE ARCHITECTURAL DRAWINGS

DROP CEILING/CANOPY: SEE ARCHITECTURAL DRAWINGS

LIGHTING: BRONZE CUSTOM PENDANT, DOWN LIGHTS SEE ARCHITECTURAL DRAWINGS

HANDRAIL: #4 SATIN BRONZE; 1-1/2" DIAMETER ON REAR WALL,  
SEE ARCHITECTURAL DRAWINGS

HEIGHT: 9'-0" TO CANOPY

PLATFORM: ISOLATION REQUIRED

ENTRANCES:

SILLS: SATIN BRONZE AT ALL FLOORS

SILL ANGLES: 4" X 4" X 1/2" FASTENED AT A MAXIMUM 18" ON  
CENTER

DOORS: SATIN BRONZE AT L-3, BAKED ENAMEL. 16 GAUGE  
CRS PANELS, STEEL SANDWICH CONSTRUCTION

FRAMES: SATIN BRONZE AT L-3, BAKED ENAMEL. 14 GAUGE  
CRS WITH U.L. LABELS ON ASSEMBLIES

BLACK-OUT PANELS: TO CONCEAL ENTRANCE EQUIPMENT AT P4 TO P1,  
14 GAUGE WITH BLACK BAKED ENAMEL FINISH

SIGNALS:

HALL LANTERNS: AT ALL FLOORS WITH ELECTRONIC CHIME. SATIN  
BRONZE TYPICAL, CUSTOM AT L-3.,

REGISTRATION LIGHTS: CAR AND CORRIDOR PUSHBUTTONS, SINGLE  
CORRIDOR RISER - DUAL CAR STATIONS, ONE AT  
FRONT AND ONE AT REAR

CERTIFICATE WINDOW ON CAR STATION

POSITION INDICATORS: CAR (DUAL), FIRE CONTROL ROOM PANEL, LOBBY  
CONTROL PANEL

CORRIDOR CAR POSITION  
INDICATORS: AT FIRST AND THIRD FLOORS WITH DIRECTION  
ARROWS

COMMUNICATION SYSTEM: INTERCOM WITH DISTRESS SIGNAL

FIXTURE SUBMITTALS: STANDARD SATIN BRONZE, CUSTOM AT L-3

C. Common to all cars:

ADDITIONAL FEATURES: CAR AND COUNTERWEIGHT ROLLER GUIDES  
CAR TOP INSPECTION STATION

BUFFER ACCESS LADDERS AND PLATFORMS

EMERGENCY CAR LIGHTING - BATTERY PACK

EMERGENCY OPERATION [CCR, TITLE 8, RULE  
3041(C) FIREMAN'S SERVICE, INCLUDING ALTERNATE  
FLOOR RETURN]

CONTACTED ESCAPE HATCH WITH OPERATION PER  
A.S.M.E., A17.1 APPENDIX F

STANDBY POWER TRANSFER (AUTOMATIC TO MAIN  
FLOOR) WITH MANUAL OVERRIDE

DISABLED ACCESS ACCOMMODATION PLATES (NO  
STICK-ON OR RIVETED PLATES); PROVIDE RECESSED  
REAR MOUNTED PLATES AS MANUFACTURED BY  
VISIONMARK, OR APPROVED EQUIVALENT

INTERNATIONAL STAR OF LIFE ON SERVICE  
ELEVATORS

DUAL CAR OPERATING PANELS

HINGED CAB FRONT RETURN PANELS FOR  
APPLICATION OF INTEGRAL CAR STATIONS

CERTIFICATE WINDOW IN CAR FRONT RETURN

HOISTWAY ACCESS SWITCHES

INDEPENDENT SERVICE FEATURE

LOAD WEIGHING DEVICE

ANTI-NUISANCE FEATURE

LOBBY CONTROL PANEL AND REMOTE WIRING

FIRE CONTROL PANEL AND REMOTE WIRING

MOUNT ALL FIXTURE FACEPLATES WITH  
TAMPER-RESISTANT SCREWS

12-MONTH MAINTENANCE WITH 24-HOUR CALL-BACK  
SERVICE

SOUND POWERED CAB EMERGENCY TELEPHONE  
JACKS AND PAGING SPEAKERS

MACHINE AND SCR SOUND ISOLATION

SEISMIC DESIGNS AND OPERATIONS

INDIVIDUAL FLOOR LOCKOFF SWITCHES

VERIFY ALL CONDITIONS WITH FIELD MEASUREMENTS AND EXISTING CONDITIONS. MANUFACTURE EQUIPMENT TO MEET EXISTING CONDITIONS.

ELEVATOR CONTRACTOR SHALL MAKE PROVISIONS FOR CUSTOM CAR INTERIOR FINISHED INCLUDING ADEQUATE SIZING OF EQUIPMENT TO ACCOMMODATE ADDITIONAL WEIGHTS

CARD READER PROVISIONS IN ALL ELEVATOR CARS WITH EXTRA TRAVELING CABLE

PAD HOOKS AND 1 SET OF FIRE RESISTANT PADS

WIRING DIAGRAMS, OPERATING INSTRUCTIONS, AND PARTS ORDERING INFORMATION

ALL SPECIFIED ENGRAVING SHALL BE FILLED WITH BLACK PAINT UNLESS OTHERWISE NOTED

NO VISIBLE COMPANY NAME OR LOGO

PRIME FINISH TEMPORARY FRONT CAR DOORS DURING CONSTRUCTION FOR ELEVATORS NOS. 15 AND 16

CCTV CAMERA PROVISIONS FOR ALL CARS

SEPARATE LIGHT SWITCH IN SERVICE CABINET FOR AUXILIARY CAR LIGHT FOR ELEVATORS NOS. 15 AND 16

2.02 PERFORMANCE

- A. Speed:  $\pm$  3% contract speed under any loading condition.
- B. Capacity: Safely lower, stop and hold up to 125% of rated load.
- C. Stopping Accuracy:  $\pm$  1/4" under any loading condition.
- D. Door Opening Time: 1.6 seconds from start of opening to fully open.

- E. Floor-to-Floor Performance Time: Seconds from start of doors closing until doors are 3/4 open and car level and stopped at next successive floor under any loading condition or travel direction. Passenger elevators:

Elevator Nos. 11 - 14	350 F.P.M.	10.4 seconds
Elevator Nos. 17 - 18	350 F.P.M.	10.4 seconds
Elevator Nos. 15 - 16	500 F.P.M.	11.87 seconds

- F. All elevator equipment (including hoist machines, deflector sheaves, solid-state, A.C. conversion units, and support equipment) shall be mechanically isolated from the structure and electrically isolated from the building power supply and each other to prevent noise and vibration in occupied areas of the building.

Design, install, and adjust elevator equipment to comply with the following:

1. Horizontal acceleration within the elevator cars during all riding and door operating conditions shall not exceed 15 mg in the 1-10 Hz range.
  2. Acceleration and deceleration shall be constant and not exceed 5 feet/second/second with an initial ramp between 0.5 and 0.75 seconds.
  3. Sustained jerk shall not exceed 8 feet/second/ second.
- G. Measured noise levels in a moving car outside the acceleration/deceleration zone shall not exceed 55 dBA under any condition including ventilation system on highest speed. Measured noise levels in the car within the leveling zone or stopped shall not exceed 60 dBA.
- H. Noise/Sound Isolation Provisions:
1. Roller Guides: roller assemblies for cars and counterweights shall have rollers with a minimum diameter of 6".
  2. Platform Isolation: Double thickness isolation between car and car frame; plunger and platen head.
  3. Guide Rails and Fishplates: Provide a minimum of 15 pound guide rails with double thick fishplates.
  4. Machine Isolation: All machines shall be mounted on isolation pads engineer, with minimal direct attachment to structure.
  5. Rope/Smoke Guards: Wherever ropes penetrate through to the hoistway, guards shall be provided to minimize any openings.
  6. Submit details of isolation pads and sound isolation provisions.

7. To minimize noise and vibration in occupied areas, mechanically isolate elevator equipment (including hoist machines, deflector sheaves, power-conversion units and support equipment) from the structure; electrically isolate controllers, machine motors, and power conversion units.
8. Limit noise level relating to elevator equipment and its operation to no more than 55 Dba in running elevator cars. No more than 60 Dba including door operation and exhaust blower on highest speed.

## 2.03 OPERATION

### A. Operational Control:

1. Microprocessor-based, group dispatch, car control and motion control systems as follows, including as a minimum, the features described hereafter:
  - a. Dover IV.
  - b. Fujitec 8830
  - c. Motion Control VVMC 1000 TURBO DF
  - d. Mitsubishi OS 2100/M.
  - e. Montgomery Miprom 21.
  - f. Otis Elevonic 311.
  - g. Schindler Miconic V.
2. Operate elevators without attendants as a group capable of balancing service and continuing operation with one or more cars removed from the system.
3. Operate elevators from buttons located at each floor and in each car. Slow down and automatically stop cars at landings corresponding to registered calls. Make stops at successive floors for each direction of travel irrespective of order in which calls are registered except when bypassing hall calls to balance and improve overall service. Stop only one car in response to any particular hall call. Assign hall calls to specific elevators and periodically review and modify these assignments to improve service. Simultaneous to initiation of the slow down of a car for a hall call, cancel that call. Render hall button ineffective until car doors begin to close after passenger transfer. Cancel car calls in the same manner. Give priority to coincidental car and hall calls in call assignment. Cancel car calls upon direction reversal.
4. At other than dispatching floors, hold doors open an adjustable interval of 5 to 8 seconds. Cancel initial door open interval when



door protective system is actuated, and establish an adjustable door open interval from .5-1.0 second following actuation of door protective system.

5. Operate system to meet changing traffic conditions on demand basis. (Dispatch from terminal landings may be used when most traffic is in one direction.) Include provisions for handling traffic which may be heavier in either direction, intermittent or very light. As traffic demands change, automatically and continually modify elevator response to provide the most-effective means to handle traffic conditions. Assign hall calls to individual cars, review assignments; provide means to sense long-wait hall calls and preferentially serve them; and accomplish direction reversal without closing and reopening doors.
6. Dual-Loading Lobby Features: When the input traffic is equally heavy from the first and second floors, the supervisory control system shall provide a car for loading at each level. The dual loading lobby feature shall be automatically activated by the control system or manually by a selection switch in the lobby control panel.
7. Use reprogrammable system software. Design basic algorithm to optimize service based on equalizing system's response to registered hall calls at shortest possible level and equalizing trip time at shortest possible level.
8. Required Features:
  - a. Dispatch Protection: Backup dispatching in the event primary dispatcher fails.
  - b. Delayed Car Removal: Remove delayed car from group operation.
  - c. Position Sensing: Reset at each floor when stop made.
  - d. Landing Button Failure: Multiple power sources for button risers.
9. Provide group control with on-site and remote monitoring and diagnostic capability. Lobby panel for building use which displays status of each elevator, each car, and each registered call. Located in employee service center at 3rd floor.
10. Include accumulation of hall call registration information as part of monitoring capability. Provide memory capacity for at least the immediate five, 24-hour periods, in hourly blocks of 10 or 15-minute segments, running from hour to hour (i.e., 2 p.m. to 3 p.m.).

Accumulate information for the Owner's retrieval and use as follows:

- a. Summary of hall call registration events by floor, direction, and duration, totaled in minute segments (10 or 15 minutes)

and 60-minute blocks with breaks made on the hour using an internal clock.

- b. Indication of hall call registration duration averaged for minute and hourly periods.
- c. Indication of percentage of calls answered within 30 and 60 seconds in each minute and hourly period.
- d. Indication of time periods during which individual elevators are not in group operation (operating separately or out of service).

Owner has printer and IBM compatible computer which can be used in the machine room to download data and/or produce a hard copy of stored data. Provide RS-232 port for connection to elevator control using standard connector or clip-on wiring, directions, software, etc., to accomplish information retrieval. (Or provide machine room printer and keyboard, with instructions, to accomplish same purpose.)

- B. Door Operation: For front and rear, automatically open door when car arrives at main landing if a car call has been registered. When another car is at main landing loading for departure, close arriving car doors. Reopen when car is designated for loading. If no other car is at main landing, leave doors open until car is dispatched or loading interval expires with no demand. Extended open times with adjustments shall be provided. Selective door operation shall be provided where front and rear doors occur at the same landing.
- C. Automatic Stopping Accuracy: Stop car within 1/4" above or below the landing sill. Avoid overtravel, as well as undertravel, and maintain stopping accuracy regardless of load in car, direction of travel, rope slippage or stretch.
- D. Independent Service: Provide controls for operation of each elevator from car buttons only. Close doors by constant pressure on desired destination floor button. Open doors automatically upon arrival at selected floor.

- E. Motion Control: D.C., variable voltage or A.C. variable voltage, variable frequency type with closed-loop feedback suitable for operation specified and capable of providing smooth, comfortable acceleration, retardation, and dynamic braking. Limit the difference in speed between full load and no load to not more than the performance of requirements of 2.02.
- Design, install, and adjust elevator equipment to meet the performance requirements of 2.02, F.
- F. Firefighter's Service: Per CCR Title 8 and ASME A17.1 to operate and recall elevators to designated or alternate designated floors in fire or other emergency condition. Provide sensor signal wiring from hoistway or machine room connection point to controller terminals. Provide similar operation and fixtures on all elevators. Operate visual/audible signal until return is complete or automatic operation restored.
- G. Standby Lighting and Alarm: Car-mounted, battery unit with solid-state charger to operate alarm bell and lighting, per Code. Battery to be rechargeable with 5-year minimum-life expectancy. Provide spring return test button in service cabinet of car station which causes illumination of standby lighting bulbs. Locate lights so they are part of normal car lighting system and not exposed to view.
- H. Standby-Power Transfer: Arrange elevators to return to 1st floor at inspection speed, open doors, and be removed from service. Elevators shall not operate on emergency power, except to return to 1st floor.
1. Provide controls to automatically start and run the elevators nonstop to the designated terminal, one car in each group at a time.
  2. Provide SCR-controlled equipment with filters to stabilize the voltage and ensure that the wave form distortion and harmonic content will not adversely affect operation of standby generator.
- I. Elevator-to-Lobby Switches: Provide a switch for each elevator to return the car to the main floor. Return elevators non-stop after answering registered car calls, and park with its doors open until switch is returned to normal position.
- J. Seismic Operation: Provide counterweight derailment operation, per C.C.R. Title 8. Provide operating per A.N.S.I. A17.A, Appendix F, when emergency exit is opened.

## 2.04 MACHINE ROOM EQUIPMENT

- A. Arrange equipment in machine room space(s). Provide identifying numbers on machine, power conversion unit, controller, and disconnect switch. Comply with N.E.C., Article 110-16a., working clearances.
- B. Geared Traction Machine: Single worm geared traction type with motor, brake, worm, gear, drive shaft and gear case mounted in proper alignment on an isolated bedplate. Machine shall have ball or roller bearings.
- D. For hoist machine installations which require blockouts through machine room slab for other than hoist ropes, provide No. 14 gauge, galvanized sheet metal enclosure over entire blockout on underside of floor slab.
- E. Power Conversion and Regulation Unit: Provide a solid-state device. Solid-state unit shall be designed to limit current, suppress noise and prevent transient voltage feedback into building power supply. Isolate unit to minimize noise and vibration transmission. Provide isolation transformers, filter networks, and chokes.
  - 1. Elevator Contractor responsible to suppress solid-state converter noises, radio frequency interference, and eliminate regenerative voltage transients induced into the mainline feeders or the standby power generator.
  - 2. Supply supplemental direct-current power for operation of dispatch logic processors, brake, door operator.
- F. Encoder: Provide memory capability in event of power interruption. Solid-state, optical, digital-count type, mechanically coupled to pit-tensioning sheave, or driven from the car top or governor. Update parity at each floor and restore automatically after power loss. Locate in machine room to monitor car position and provide absolute floor position for stopping
- G. Controller: Cabinet type, with removable doors and adequate ventilation to dissipate heat. Wire to identified terminal block studs. Identifying symbols or letters identical to those on wiring diagrams shall be permanently marked adjacent to each component on the controller. Provide means on group dispatch or master car controller to facilitate monitoring of group operation with electronic tabulating devices. Features to be monitored shall include, but not be limited to: up corridor calls, down corridor calls, car in service, automatic bypass, on/off, etc. Provide auxiliary electrical power disconnecting means where required by Code.
  - 1. Frame: Securely mount all assemblies, power supplies, chassis switches, relays and other items on a substantial, self-supporting steel frame. Completely enclose equipment with covers and ventilate to prevent overheating.
  - 2. Switch and Relay Design: Direct-current type, magnet operated with contacts of design and material to insure maximum conductivity, long

life and reliable operation without overheating or excessive wear, and provide a wiping action to prevent sticking due to fusion. Provide switches carrying highly inductive currents with arc deflectors or suppresses.

3. Microprocessor-Related Hardware:
  - a. Fabricate printed circuit boards with FR4 or G10 glass epoxy material with a minimum equivalent one-ounce copper.
  - b. Coat all printed circuitry with tin lead.
  - c. Include built-in noise suppression devices which provide a high level of noise immunity on double-sided printed circuit boards and on all solid-state hardware and devices.
  - d. Provide power supplies with noise-suppression devices.
  - e. Isolate inputs from external devices (such as pushbuttons) with opto-isolation modules.
  - f. Provide separate regulated power supply for each computer chassis.
  - g. Design control circuits so that one side of power supply is grounded.
  - h. Design the system so that it will start properly when power is restored in the event of a power failure or interruption.
  - i. Provide system memory so that data is retained in the event of power failure or disturbance.
  - j. Design or protect equipment so it will operate with a 500 KHZ to 1300 MHZ radio frequency signal at a power level of 100 watts at a distance of 10 feet.
  - k. Design or protect equipment to provide electromagnetic interference (E.M.I.) shielding within F.C.C. guidelines.
4. Power Supplies: U.L. or C.S.A. approved with short-circuit protection.
5. Wiring: U.L. or C.S.A. labeled copper wires for factory wiring. Neatly route all wiring interconnections and securely attach wiring connections to studs or terminals.
6. Permanently mark components (relays, fuses, PC board, etc.) with symbols shown on drawings.

7. Provide extender boards when computing devices are used inside a computer chassis to facilitate access to the printed circuit cards utilized.
  8. Use stable capacitor or crystals as the time base for electronic time-delay devices.
- H. Sleeves and Guards: Provide sleeves for conduit and other holes through concrete slabs. Provide 2" steel angle guards around cable or duct slots. Provide rope and smoke guards for all sheaves, cables, and cable slots. Provide sheet metal enclosure where hoist ropes and/or sheaves penetrate machine room wall. Minimize opening sizes as much as possible.
- I. Machine Beams: Provide structural steel beams required for direct support of the elevator machine, deflector sheaves, overhead sheaves, governor and dead-end hitches. Provide bearing plates, anchors, shelf angles, blocking, embedments, etc., to support machine beams and equipment. Provide and set in place machine hold down bolts. Isolate machine beams as necessary to eliminate noise and vibration transmission to building structure. Provide sheave maintenance ladders and platforms as required within bounds of the elevator machine room.
- J. Governor: Centrifugal type, car or counterweight driven, with pullthrough jaws and provided with an electrical shutdown switch. Provide any overhead supports required for attachment to building structure. Provide governor access platform within bounds of hoistway as required. Governors shall be located as shown on drawings.
- K. Hoist and Machine Drip Pans: Provide any and all hoist machine drip pans to restrict lubricant seepage from entering hoistways.
- L. All elevator equipment (including hoist machines, deflector sheaves, solid-state, A.C. conversion units, and support equipment) shall be mechanically isolated from the structure and electrically isolated from the building power supply and each other to prevent noise and vibration in occupied areas of the building. Design, install, and adjust elevator equipment to meet the performance requirements.
- M. Contractor shall make provisions in their equipment to accommodate custom design interior finishes, including sufficient equipment tolerances for applied panels and finished flooring.

## 2.05 HOISTWAY EQUIPMENT

- A. Guide Rails: Provide planed steel T-sections suitable for elevator travel, weight of car, weight of counterweight, and seismic reactions, including brackets for attachment to building structure at support locations shown on drawings. Double main rail bracketing shall be employed to maintain 14'-0" or less bracket to bracket.

- B. Buffers: Provide blocking and supports. Provide buffer access ladders and platforms, where required. Provide switch on buffers to limit elevator speed in appropriate direction if buffer is compressed.
- C. Sheaves: New machined grooves with ball or roller bearings. Provide mounting means to machine beams, machine bedplate, car and counterweight structural members, or other structure support. Provide drip pans under deflector sheaves.
- D. Governor and Encoder Pit Tensioning Sheaves: Mount new sheaves and frames on pit support members or guide rails. Provide with guides or pivot points to enable free vertical movement and properly tension cables/tapes.
- E. Compensation: Provide new for all elevators if required. Whisperflex-chain type with pit guide. Pad areas where compensation may strike car or hoistway items.
- F. Counterweight: Steel frame with roller guides and metal filler weights. Provide counterweight frame with 4 sets of new roller guides consisting of at least 3 rollers of a durable, resilient, oil-resistant material, mounted on a substantial metal base. Rollers shall have continuous contact with the corresponding guide rail surface under all conditions of loading. Provide seismic retainer plates top and bottom. Provide Type "B" counterweight safeties where necessary.
- E. Counterweight Guard: Metal guard around counterweight in pit.
- F. Ropes: Provide 8 x 19 Seale construction traction steel type ropes.
  - a. Governor rope to suit manufacturer's governor specification.
  - b. Fasten with adjustable shackles.
- G. Normal and Final Terminal Stopping Devices: Provide new, per Code.
- H. Electrical Wiring: All new wire and cable installed and must meet current requirements of National Electrical Code.
  - 1. Conductors: Provide copper throughout with individual wires coded and all connections on identified studs or terminal blocks. Use no splices or similar connections in any wiring except at terminal blocks, controllers, junction boxes or condulets. Provide 10% spare conductors throughout. All spare wiring shall be in addition to those required by features of this specification and shall run from car connection points to individual elevator controller. Provide and tag in each elevator controller four pairs of spare, shielded communication wire.
  - 2. Conduit: Painted or galvanized steel conduit and duct. Conduit size shall be 1/2" minimum. Flexible conduit exceeding 18" in length shall not be used. Flexible heavy-duty service cord may be used between fixed car wiring and car door control devices.

3. Traveling Cables: Flame and moisture resistant outer cover. Prevent traveling cables from rubbing or chafing against hoistway or elevator equipment.

H. Pit Stop Switch: Per Code.

#### 2.06 HOISTWAY ENTRANCES tion necessary to meet current code stanards.

- A. Frames: Frames shall be bull nose type, hollow metal fabricated from not less than No. 14 U.S. gauge steel, bolted to form a one piece unit. Jamb and head depth and profiles shall be as shown on the architectural drawings. Provide permanently attached, rear mounted, handicapped floor designations at a height of 60" above the finished floor. Designations shall be 2" high, raised 0.030", of a lettering style and color as approved by the Architect. The braille indications shall be at the left of the arabic numeral per A.D.A. requirements and California Code of Regulations, Title 24 Accessibility Standards. A star designation shall be provided at the main egress landing. Stick-on or riveted plates are unacceptable.

An international star of life symbol permanently attached, rear mounted at a height of 78" to 84" above finished floor on both frames at each floor shall be provided on the designated medical emergency elevator. Designation shall be 3" in size. Stick-on or riveted plates are unacceptable.

- B. Door Panels: Fabricate from not less than No. 14 U.S. gauge steel, sandwich construction. Provide leading edges of center-opening doors with rubber astragals to cushion closing impact. Each door panel shall include a minimum of two gibs, one at leading edge and one at trailing edge. Door gibs shall be in the sill groove their entire length of travel.
- C. Sight Guards: No. 14 U.S. gauge material, same material and finish as hoistway entrance door panels.
- D. Fire Rating: Provide complete entrances bearing UL fire labels or equivalent approved by local Code jurisdiction.
- E. Sills: Nickel silver.: Provide and install sill support angles at all floors, so as not to require grouting beneath the sills. Sill angles shall be 5" x 5" x 1/2" and fastened 12" on center, minimum.
- F. Hangers: Provide new two-point suspension with upthrust adjustment not to exceed 3/8" between door panels.
- G. Tracks: Provide new bar or formed, cold drawn steel with smooth hanger contact surface. Tracks shall be removable for replacement or provided with renewable surface.
- H. Interlocks: Provide new type operable without retiring cam. Interlocks that are visble when doors are open shall be painted flat black.
- I. Closer: Provide new spring, spirator, or weighted closer shall operate quietly. Weighted closer shall be strut mounted.



- J. Fascia, Toe Guards, and Fascia Width Hanger Covers: No. 14 U.S. gauge furniture steel with flat black enamel finish. Paint fire floor identifying numbers per Code. Provide blind fascia above rear openings.
- K. Struts and Headers: Provide for necessary support of entrances and related material. Door open bumpers are required on entrances equipped with vertical struts.

#### 2.07 CAR EQUIPMENT

- A. Car Frame: Welded or bolted. Rolled or formed steel channel construction.
- B. Car Safety Device: Type "B," flexible guide clamp.
- C. Platform: Isolated type, constructed of steel or wood which is fireproofed on the underside.
- D. Guides: Spring loaded adjustable roller type with three or more sound--deadening rollers per guide assembly. Rollers shall not exceed 350 r.p.m. at rated speed.
- E. Car Sills: Nickel silver with extruded extensions to face of car front return. Extruded extension in same finish as sill.
- F. Toe Guard: Per Code. Paint flat black.
- G. Car Doors, Hangers and Tracks: Provide as specified for hoistway entrance doors, hangers and tracks.
- H. Header: Fabricate of steel; shape to provide stiffening flanges. Existing to be reused. All fastenings shall be properly secured.
- I. Car Door Electrical Contact: Electrical contact to operate in conjunction with the car doors so that the elevator cannot operate unless doors are closed within tolerance allowed by Code.
- J. Door Operator and Operation: High-speed, heavy-duty, DC master door operator isolated from car top. Operator shall be capable of opening doors at no less than 2-1/2 f.p.s. and accomplishing reversal in no more than 2-1/2" of door movement. Door operation shall be no louder than 55 decibels.
- K. Car Door Clutches: New heavy-duty clutches or vanes, linkage arms, drive blocks and pickup rollers or cams to provide positive, smooth, quiet door operation. Design clutches so car doors can be closed for maintenance purposes, while hoistway doors remain open.
- L. Door Control Devices:
  - 1. Infrared Optical Full Screen Devices: Provide infrared, optical full screen devices. Devices shall extend along the leading edge of each car door and be designed to initiate door reversal at normal

speed if the devices sense a person or object while the car doors are closing, except during nudging action. Devices shall be: T.L. Jones, Microscan II, Otis-enhanced Lambda, Adams I.C.U.-47, Innovation Smart Edge 2002, or Janus Panaforty. Two additional devices shall be mounted inside the elevator cars in the front returns. They will recycle the doors and activate an audible signal.

2. Nudging Action: In the event an optical beam is obstructed for an adjustable time interval (20.0-30.0 seconds), a buzzer shall sound, the doors shall attempt to close with a maximum of 2.5 foot pounds kinetic energy.
  3. Interrupted Beam Time: In the event the optical beams are interrupted while the doors are opening or after the doors are fully open, the normal dwell time that the doors remain open after the beams are reestablished shall be reduced to an adjustable time between .5 and 1.0 second, depending upon whether a landing call or a car call predominated. This time shall also be a minimum time that the doors remain open if the optical beams are interrupted and reestablished before the door is fully open.
  4. Differential Door Time: Provide separately adjustable timers to enable varying the time that the doors remain open after stopping in response to a car call or a landing call. The dwell time for a car call stop shall be adjustable between 3.0 and 4.0 seconds, and the timing for a landing call stop shall be adjustable between 4.0 and 8.0 seconds. If a stop is made in response to both a landing call and a car call, the timing of the landing call shall predominate.
- M. Elevator Car Stations: Two car stations per car. Recessed stations shall have stainless steel faceplates. The garage passenger elevators shall have full swing front returns with a satin bronze finish.
1. Security elevators shall have vandal-resistant buttons.
  2. The raised floor buttons, alarm button, door open button and emergency stop switch shall be suitably identified by raised, painted letters or symbols per A.D.A. requirements and California Code of Regulations, Title 24, including Braille. All operating controls shall be located no higher than 48" above the car floor (locate stop switch and alarm button 35" above finished floor).
    - a. Provide 1/8" raised floor pushbuttons with 5/8" numbers in the face of button corresponding to the floors served for registration of the car stops. Call registration lights, located within or behind the buttons, shall illuminate the floor number corresponding to the call registered. Where practical, pushbuttons shall be mounted in a vertical row beginning at 48" off finish floor.
    - b. An alarm button shall be provided at the bottom of the elevator station to ring a bell located on the elevator. Actuation

shall ring bell, illuminate button, and sound distress signal at main lobby control panel.

- c. A red emergency stop push/pull button shall be provided at the bottom of the elevator station to interrupt the power supply independently of the regular operating devices. The push/pull button shall be so arranged that when operated, it will sound the alarm bell and illuminate the alarm button described above. The actuation of this device shall not cancel registered calls. The device shall be marked to show "run" and "stop" positions. Actuation shall sound distress signal at main lobby control panel. They shall be arranged push to run, pull to stop.
- d. Provide a door open button which shall stop closing motion of doors and cause them to return automatically to their fully open position. This button shall be effective while the car is at a landing and until the elevator starts into motion, regardless of any special operational features (except fireman's service).
- e. Provide door close button to initiate door closing during normal operation by momentary pressure and for door closing by continuous pressure on Phase II fire service. Alternatively, the floor pushbuttons may be used.
- f. Provide an extended door hold open button on the service elevators.
- g. A visual indication shall be provided to indicate activation of the emergency communication system.
- h. Provide one fireman's service key switch, light jewel, and fireman's telephone jack.
- i. Provide a scratch-resistant lens on the swing front return or car station behind which shall be located the certificate of inspection.
- j. A lockable service panel with flush cover plate shall be provided. The service panel shall contain the following controls with each control and its operating positions identified by engraved letters painted black:
  - (1) An inspection switch, conforming to the ANSI Code, for disconnecting all automatic operation, limiting the car speed and rendering effective the hoistway access switch when the car is at the top or bottom terminal.
  - (2) A light switch.
  - (3) A three-position exhaust blower switch.

- (4) An independent service switch to permit the selection of independent or automatic operation.
- (5) A duplex 120 volt, A.C., electrical convenience outlet.
- (6) A start button for closing the doors and starting the elevator when operating on independent service. Alternately, the floor pushbuttons may be used for this function.
- (7) Spring return test button or switch for battery pack standby lighting.
- (9) Auxiliary light switch for the service elevators.

M. Signage: Provide the following black paint filled engraving. Size and style as approved by Architect.

1. Elevator Car:

- a. "No Smoking - L.A.M.C. No. 41.51 - Subject to Fine" over main car station.
- b. Elevator number on both main and auxiliary car stations.
- c. Elevator capacity in pounds and the number of persons allowed to ride the elevator over main car station.
- d. Engrave service panel or telephone cover plate with:  
  
"Should the elevator doors fail to open or the elevator become inoperative:  
Please do not become alarmed.  
Please use the button marked Alarm to summon assistance, or telephone if furnished.  
Remain in the car until assistance arrives and do not attempt to force doors or hatch open."

2. Provide engraved signage in elevator lobbies:

- a. "In case of fire use stairways for exit. Do not use elevator."  
Include as part of corridor pushbutton plates or separate sign at each floor, as selected by Architect. Separate sign shall be same material and finish as corridor pushbutton cover plate.
- b. Provide engraved plate at main lobby adjacent to fire return switch with Phase I and Phase II operating instructions per Code. Material and finish same as corridor pushbutton faceplate.

- N. Car Top Control Station: Per Code. Provide with minimum 4'-0" long, permanently attached, extension cord for remote operation.
- O. Emergency Exits: Provide contact and operation per A.S.M.E. A17.1, Appendix F.
- P. Work Light and Duplex Plug Receptacle: Provide on top and bottom of elevator car. Provide lights with on-off switch and bulb guard.
- Q. Exhaust Blower: Morrison Products model "AA" or approved equivalent. Two-speed, squirrel cage 300-350 c.f.m. exhaust blower. Isolate blower from car steel canopy on rubber grommets.
- R. Provide push to talk telephone instrument, and wiring from individual elevator controllers in machine room to each car. Engrave face of service cabinet with building name and address. Locate speaker grille as directed by Architect. Instrument shall meet the requirements of the Americans with Disabilities Act.

#### 2.08 CAR ENCLOSURES

- A. Provide as specified in Articles 2.01 and 3.03, F.
- B. Passenger Elevator Nos. 1 - 10; 11 - 14: Provide as specified in Articles 2.01 and 3.03, F.
  - 1. Sides and Rear Walls: 14 gauge (.075") cold rolled furniture quality steel, stretcher leveled, substantially reinforced for rigidity, lightproof joints, baked enamel finish, cutouts reinforced, flush panel construction with all panels fastened to the platform in an approved manner.
  - 2. Doors: 16 gauge (.048") steel, clad with satin bronze 1" thick, flush design both sides, core interior for sound deadening. Same construction as specified for hoistway doors.
  - 3. Canopy: 12 gauge (.090") cold rolled furniture quality steel, stretcher leveled, suitably reinforced to meet Code requirements and fastened to the side walls in a suitable manner for rigidity, top exit included.
  - 4. Front Returns and Entrance Columns: 14 gauge (.075") steel, clad with satin bronze integral construction, swing type with continuous hinge and three point concealed latching.
  - 5. Transom: 14 gauge (.075") steel, clad with satin bronze running full width of car.
  - 6. Wall Covering: SEE ARCHITECTURAL DRAWINGS
  - 7. Handrail: SEE ARCHITECTURAL DRAWINGS

8. Base: SEE ARCHITECTURAL DRAWINGS. Include hidden ventilation slots.
  9. Drop Ceiling: SEE ARCHITECTURAL DRAWINGS
  10. Pads and Hooks: Provide one set of pads for each elevator bank. Provide hooks in all cars. Pads shall be of fire-resistant material, vinyl covered and when hung shall cover all walls and returns of each car.
  11. Elevator Contractor shall make provisions in their equipment to accommodate custom design interior finishes, including sufficient equipment tolerances for applied panels and finished flooring.
  12. Elevator Contractor shall be responsible for temporary lighting and permanent wiring as defined in Articles 2.01 and 3.03, F.
- C. Elevators Nos. 15, 16, 17 and 18:
1. Side and Rear Walls: Reinforced 14 (.075") gauge furniture steel fabricated with textured stainless steel in pattern selected by the Architect. Wall panels shall not exceed 15" widths and shall be suitably reinforced. Install an infrared unit as specified above the side walls at  $\pm 1'-0"$  from front returns. Car stations shall be recessed flush mounted on the side walls  $\pm 36"$  from the front returns.
  2. Canopy: Reinforced 12 gauge (.090") furniture steel with hinged exit and baked enamel finish.
  3. Stationary Front Return Panels and Integral Entrance Columns: 14 gauge (.075") #4 stainless steel. The car stations shall be recessed flush with the front returns.
  4. Transom: 14 gauge (.075") #4 stainless steel.
  5. Car Door Panels: Same construction as hoistway door panels clad with 14 gauge textured stainless steel in pattern selected by Architect.
  6. Base: None. Include ventilation slots.
  7. Handrails: Double row, two side walls. One row 12" off finish floor with 4" x 3/8" stainless steel bars, second row 32" off finish floor with a 1-1/2" diameter grabbing surface (measured to top of hand-rail). Both rails shall be fastened to wall at maximum 12" intervals. Solid stainless steel rail shall be provide.
  8. Lighting: Adequate lighting to provide a minimum of 5 foot candles of illumination on the car sill. Flush mounted incandescent down lights, suitably guarded.

9. Flooring: Provide adequate subfloor and reinforced platform for concentrated loading. Condition floor surfaces so that they are clean, smooth, firm, and free from dirt or any other damaging material. Cracks wider than 1/8" and holes larger than 1/4" in diameter shall be filled. All ridges or other uneven surfaces shall be planed, scraped, or sanded smooth. Lining felt shall be applied over wood floor surfaces and seams in felt shall be butted. Adhesive shall be applied in accordance with manufacturer's recommendations.
  1. Install new flexible homogenous vinyl tile flooring not less than 1/8" thick, color and type as approved by the Owner. Lay tile flush with sill.
- D. Pads and Pad Buttons: Provide one set. Provide satin stainless steel buttons in both cars. Pads shall be of fire-resistant material, canvas covered and when hung shall cover all walls and returns of the car.

## 2.09 LANDING CONTROL STATIONS

All fixtures and buttons for service and security elevators shall be vandal-resistant.

- A. Pushbuttons: Provide each elevator group with a single riser at front openings. Pushbutton stations shall include flush-mounted faceplates constructed of satin stainless steel. Each fixture shall contain push-buttons for each direction of travel which illuminate to indicate call registration.
- B. Provide engraved signage, including pictorials, in elevator lobbies:
  1. "In case of fire use stairways for exit. Do not use elevator" and pictorial per U.B.C. Include as part of corridor pushbutton plates or separate sign at each floor, as selected by Architect. Separate sign shall be same material and finish as corridor pushbutton cover plate.
  2. Provide engraved plate at main lobby adjacent to fire return switch with Phase I and Phase II operating instructions per Code. Material and finish shall be the same as corridor pushbutton faceplate.
- C. Hoistway Access Switches: Mount in entrance frame side jamb at all top terminals. Mount in entrance frame at bottom terminals where walk-in pits are not provided. Provide fixture without faceplate.

## 2.10 SIGNALS

All lenses and fixtures for service and security elevators shall be vandal-resistant.

- A. Hall Lanterns: A signal fixture shall be provided at each entrance to indicate the intended direction of travel of the elevator to waiting passengers. The fixture shall contain projecting lights suitably shielded, and an electronic tone mechanism mounted in a metal box fastened in the

wall. The up or down light shall be illuminated and the tone sounded (twice for down direction travel) 5 seconds prior to the car's arrival at a floor. The light shall remain illuminated until shortly before the elevator doors start to close. Hall lantern notification time shall be adjustable between 4-10 seconds prior to car arrival. Illumination of hall lantern lights shall be sufficient to be easily visible within well-lighted lobbies. The tone shall be adjustable from 40-92 dBA in corridor. Passenger and garage elevators will have custom fixtures at Level 3 and plug in lens at typical floors. The hall lanterns for the service/security elevators shall consist of arrow lenses with faceplates. Provide faceplates fabricated of stainless steel.

- B. Car Position Indicators: Position indicators for passenger and garage cars shall be mounted in the front returns without faceplates. Position indicators for service and security elevators shall be provided in each elevator transom. The fixture shall consist of a metal box mounted behind the transom and shall contain multiple indications representing the floor served and the direction of car travel. When a car leaves or passes a floor, the numeral representing the floor shall be visible, thereby indicating the position of the car in the hoistway at all times. The proper direction arrow shall be continuously visible to indicate the direction of travel. Provide fixture with stainless steel finish faceplate for service and security elevators.
- C. Service and security elevators: Lobby Car Position Indicator: Provide a multi-light type position indicator with directional arrows mounted above the entrance. Provide fixture with a stainless steel finish faceplate.

## 2.11 CONTROL PANELS AND SECURITY SYSTEM

- A. The group control panel shall contain operating equipment and switches for all elevators, as defined below. This station shall have satin bronze cover plate and shall be provided with a CRT and keyboard.
  - 1. A key-operated on/off switch operate to place that specific elevator in or out of service. The pilot light shall illuminate to indicate cars in service. Identify each switch by permanently engraved car number and function.
  - 2. Special operation switches, etc., required by these specifications, which shall include car-to-lobby switches, standby power selection switches, card reader override switches for each individual car, individual floor lockoff switches, etc. Identify each switch by permanently engraved car number and function.
  - 3. Car position indicators and direction indicators for each elevator to be of the digital readout type. Identify each position indicator by permanently engraved car number.
  - 4. Other indicators such as bypass loading lights and seismic operation lights. Engrave and fill with black paint, operating instructions for all controls.



Fixture shall be located as directed by Architect. Coordinate size with building. Provide all wiring to the control panel (remote conduit by others).

- B. Fire Control Room Panel:** A panel containing operating equipment and switches for all elevators shall be located in the lobby floor fire control room. The panel shall have a #4 brushed finish stainless steel faceplate and shall include:
1. Car position indicators with direction indicators for each elevator to be of the digital readout type. Identify each position indicator by permanently engraved car number.
  2. Emergency Return Keyed Switch and Box: Provide flush-mounted box with lockable hinged cover to contain keys and instructions for each elevator. Box faceplate material to be same as fire control station and contain engraved legend, EMERGENCY ONLY, in 1/2" letters. Mount in fire department panel faceplate and identify purpose and operating instructions with permanent engraving filled with black paint.
  3. Provide all wiring to the panel (conduit from closest elevator hoistway of each group, if required by others).
  4. Manual standby power selection switch and power status indicators.
  5. Fireman's phone jack.
  6. Standby power light jewel.

## 2.13 SEISMIC PROTECTION

Provide counterweight derailment device per CCR, Title B with the following clarifications: Counterweight retainer plates: Plates must be bolted to the counterweight frame, welded plates are not acceptable.

## PART 3 - EXECUTION

### 3.01 SITE CONDITION INSPECTION

- A.** Prior to beginning installation of equipment, examine wellways, hoistways, and machine room areas. Verify that no irregularities exist which affect execution of work specified.
1. Hoistway size and plumbness.
  2. Sill supports and pockets.
  3. Support areas for brackets, beams, etc.
  4. Divider beams.

5. Wellway widths and lengths.

6. Structural supports.

- B. If field dimensions are found to be the same as shown on reference drawings for each unit, and should modifications be required, the Elevator Contractor shall perform structural alterations, or modify mechanical systems as required, at no additional cost.
- C. Do not proceed with installation until work in place conforms to project requirements.

### 3.02 PRODUCT DELIVERY, STORAGE, AND HANDLING

- A. Deliver materials in Manufacturer's original, unopened protective packaging.
- B. Store material in original protective packaging. Prevent soiling, physical damage, and wetting.
- C. Protect equipment and exposed finishes during transportation, erection, and construction against damage and stains, and until equipment is fully operative, against damage, stains, deterioration, and environmental conditions.
- D. Completely protect exposed surfaces from adjacent construction activity until final acceptance of the work. Remove and replace damaged or discolored material with new material at no additional cost to the Owner. No use shall be made of the equipment by any other trade.

### 3.03 COORDINATION REQUIREMENTS

- A. Immediately upon award Elevator Contractor shall: provide exact location of all jack holes; be prepared to drill jack holes; and provide steel and PVC casings. Elevator Contractor shall be responsible for this coordination of work with the General Contractor and the steel erector.
- B. Cladding: Review all contract drawings. Coordinate methods of securing cladding (i.e. to truss) with General Contractor, Architect, and affected subcontractors prior to such actual work.
- C. Floor Finish at Elevator Sills, Cars, Landing Plates and Newels: Coordinate with other trades.
- D. Machine Room Air Conditioning, and Ventilation: Coordinate with other trades for the installation of air conditioners and ventilating fans. Units shall not be installed in the machine rooms.
- E. Security Requirements: Contractor shall be responsible for securing contents of machine room, he shall control access to rooms and ensure that they remain secure.
- F. Truss Supports: Elevator Contractor shall coordinate connection points and attachment requirements. No intermediate supports shall be provided.
- G. Painting: Provide information to painting subcontractor on prime finish used on hoistway entrances and use of compatible products for final painting.

H. Local Conditions Covering Work:

1. The Contractor shall cooperate with those in authority on the premises to prevent the entrance and exit of all workmen and/or others whose presence is forbidden or undesirable and in bringing, storing or removal of all materials and equipment, (to observe all rules and regulations in force on the grounds), to avoid unnecessary dust, or accumulated debris or the undue interference with the convenience, sanitation or routine of the Owner (and to prevent the loss of, or damage to the property of the Owner and/or his/her employees). The Contractor shall repair any and all damage he/she may cause to the building or property, to the full satisfaction of the Owner.
  2. Contractor shall maintain the machine room, machinery spaces, hoistways and pits in reasonably clean condition at all times.
- I. Job Supervisor: The Contractor shall indicate one person who shall be responsible for the scheduling control and performance of work specified in the Contract. This person shall be available upon request by the Owner to review any aspect of this contract. The Contractor shall notify the Owner if there is a change in job supervisors.

3.04 INSTALLATION

- A. Install each equipment item in accordance with accepted Manufacturer's direction, referenced codes, and specifications.
- B. Install machine room equipment with clearances in accordance with referenced codes and specifications.
- C. Install items so they may be easily removed for maintenance and repair.
- D. Install items so that access for maintenance is safe and readily available.
- E. Install equipment to afford maximum safety and continuity of operation in the event of seismic activity.
- F. Provide elevator car enclosure as detailed on architectural drawings and herein specified. The Elevator Contractor shall supervise and coordinate all drawings and materials included in this specification and also install the cars. The Elevator Contractor shall also be responsible for the following:
  1. Furnish and install all electrical controls and signal fixtures, lighting fixtures, and wire complete. Provide a minimum of 5 foot candle illumination at car sill with doors closed. Provide temporary lighting as required.
  2. Furnish and install emergency lighting. Locate to provide minimum 0.2 foot candle illumination 12" in front of main car station measured 48" above finish floor.
  3. Furnish and install on-board conduit and wiring to lighting and ventilating fixtures, as required.
  4. Furnish and install headers, tracks and threshold.

5. Furnish and install hangers and gibs on car doors and hang doors.
  6. Furnish and install car fixtures complete.
  7. Furnish and install communication system as herein specified.
  8. Basic construction shall be all steel, minimum 14 gauge.
  9. Furnish and install two-speed squirrel cage 300 - 350 c.f.m. exhaust blower. Blower to be isolated from car steel canopy on rubber grommets.
  10. Provide vent slots per Code.
  11. All enclosures shall be installed per International Union of Elevator Constructors' agreement.
- G. Paint all non-galvanized ferrous metal work, except where paint would interfere with operating mechanisms.
- H. Clean the following items of oil, grease, scale, and other foreign matter, and apply one coat of field-applied machinery enamel.
1. All equipment and metal work installed as part of this work which does not have architectural finish and which is exposed in the hoistway.
  2. Machine Room Equipment: machine, power conversion device, controller, and selector.
  3. Neatly touch up damaged factory-painted surfaces with original paint and color. Protect machine finish surfaces against corrosion.

### 3.05 MATERIALS

- A. Stainless Steel:
1. Shapes and Bars: ASTM 276, Type 316.
  2. Plate, Sheet, and Strip:
    - a. Over 1/8-inch: ASTM A264 with ASTM 240, Type 316 on A36 base.
    - b. Under 18-inch: ASTM 167, type 316.
  3. Pipes and Tubes:
    - a. Welding: ASTM A312, Grade TP 316, Schedule 10 minimum.
    - b. For Screwed Connections: ASTM A312, TP 316, Schedule 50S.
    - c. For Press Fits: ASTM A312, Grade TP 316, Schedule 5S minimum.
- B. Die Cast Aluminum: ASTM B108, Alloy 356.0, T6.

- C. Extruded Aluminum: FS QQ-A 200/8, Alloy 6061, T6.
- D. Fasteners:
  - 1. Provide bolts, nuts, washers, screws, nails, rivets, and other fastenings necessary for proper erection and assembly of work.
  - 2. Fasteners shall be compatible with material(s) being fastened.
  - 3. Exposed:
    - a. Match adjacent material in appearance, finish, and color.
    - b. Countersink, unless otherwise indicated.
    - c. Screws: Provide Phillips flathead type.
- E. Welding Electrodes: E70XX per AWS A5.1 or A5.5.

### 3.06 FINISHES

- A. All equipment and metal work installed or reused under this contract, which does not have a baked enamel or special architectural finish and which is exposed in the hoistway, shall be cleaned and painted one field coat of enamel. The shank and base of the T-Section of the guide rails shall be thoroughly cleaned and painted one field coat of black metal enamel.
- B. All machine room equipment shall be painted upon completion of the installation with the manufacturer's standard machinery enamel.
- C. All natural metals shall be of the best grade and shall have the grain of belting in the direction of the longest dimension with a fine, brushed finish. All surfaces shall be perfectly smooth and without waves.
- D. Clean and paint machine room floor upon completion of new and modernization work.
- E. All natural metals shall be stretcher-leveled, resquared sheets. Sheets shall be .063" minimum for door facings, and .074" minimum for entrance frames and front returns. The grain of belting shall run in the direction of the longest dimension. A satin finish shall be provided by first removing tool-and-die marks and then finishing with No. 80, 100, and 120 grit sanding belts. All surfaces shall be perfectly smooth and without waves.
- F. Provide detailed information relative to recommended methods of preparation, cleaning and application of primed elevator door entrances for final paint.
- G. All metal surfaces requiring bronze finishes shall be manufactured from material of not less than 60% copper, 40% zinc, containing no lead or nickel. Finish metal with #120 grit. Apply two coats of lacquer to protect surface unless surface is to be field oxidized.
- H. Stainless Steel: Manufacturer's Standard Type 316, No. 4 finish.

- I. Aluminum Castings and Extrusions: Manufacturer's Standard Commercial mill finish.

3.07 FIELD QUALITY CONTROL

- A. Work at the jobsite will be checked during the course of installation. Full cooperation with reviewing Lerch, Bates and Associates' personnel is mandatory. All procedures shall be established in a pre-construction conference. Accomplish corrective work required prior to performing further installation.
- B. Have Code Authority acceptance inspection performed and complete corrective work.

3.08 ADJUSTMENTS

- A. Align guide rails vertically with tolerance of 1/16" in 100'. Secure joints without gaps and file any irregularities to a smooth surface.
- B. Balance cars to equalize pressure of guide shoe rollers on rails.
- C. Lubricate all equipment in accordance with Manufacturer's instructions.
- D. Adjust motors, pumps, valves, generators, brakes, controllers, leveling switches, limit switches, stopping switches, door operators and switches, interlocks and safety devices, etc., to achieve required performance levels.
- E. Fabricate and assemble various parts in shop to minimize field assembly. Assemble parts which require close field fit in the shop and mark for field erection.

3.09 CLEANUP

- A. Keep work areas orderly and free from debris during progress of project. Remove packaging materials on a daily basis as equipment is installed.
- B. Remove all loose materials and filings resulting from work on a daily basis.
- C. Clean machine room equipment, floor, and truss interiors of dirt, oil and grease.
- D. Clean balustrades, handrails, skirts, steps, hoistways, cars, car enclosures, entrances, operating and signal fixtures, and trim of dirt, oil, grease, and fingermarks.

3.10 ACCEPTANCE INSPECTION AND TESTS

- A. General: Furnish labor, materials, and equipment necessary for tests. Notify Elevator Consultant 30 days in advance when ready for final review of entire work. Final acceptance of installation will be made only after all field-quality control reviews have been completed, identified deficiencies have been corrected, all submittals and certificates, including certificates by authorities having final legal jurisdiction have been received, and the following items have been completed to satisfaction of Owner and Elevator Consultant's satisfaction.

- 1. Workmanship and equipment comply with specification.

2. Contract speed, capacity and floor-to-floor performance comply with specification.
3. Performance of following are satisfactory:
  - a. Starting, accelerating, running, stopping.
  - b. Decelerating, stopping accuracy.
  - c. Door operation and closing force.
  - d. Equipment noise levels.
  - e. Signal fixture utility.
  - f. Overall ride quality.
4. Escalators: Each switch shall be tripped by hand and reset to determine that switches and circuits are operational. Reinspect each running clearance, guard, and material surface specified in ANSI A17.1 that is exposed to public contact for Code compliance.

In addition, perform the following tests without load on each escalator:

- a. Overspeed Protection Device: Test by operating escalator at rated speed and tripping overspeed device manually. Device shall have been separately tested and set in factory to operate at escalator's speed as specified herein.
- b. Handrail Tension Malfunction Device: Test manually.
- c. Broken Chain Protection: Test by operating escalator at rated speed and tripping broken chain device by hand.
- d. Device Providing Protection Against Sudden and Unusual Strains on Step Chains: Test by operating device by hand.
- e. Pushbuttons, Starting Switches, Starters, Relays, Interlocks, and Controls Required in Connection with Work: Inspect and test to prove that complete escalator functions properly under any and all condition of operation within limits specified.
- f. Brakes and Driving Machinery: Test for operating efficiency, ease of adjustment and temperature limits.
- g. Escalator shall produce no noise louder than 55 dBA measured five feet above the floor or stair level at the entrance combs at both ends with the escalator operating normally and either free running or under load. For multiple escalator installations, the noise measurements at each group shall be made with only the one escalator unit under evaluation in operation. Ambient noise level not to exceed 49 dBA.

5. Test Results:
  - a. In all test conditions, obtain specified speed, performance times, floor accuracy without releveling, and ride quality to satisfaction of the Owner and Elevator Consultant.
  - b. Temperature rise in windings limited to 50 degrees Celsius above ambient. Conduct a full-capacity, one-hour running test, stopping at each floor for 10 seconds in up and down directions. Replace equipment if equipment performance is questionable in Elevator Consultant's opinion.
- B. Performance Guarantee: Should tests reveal defects, poor workmanship, variance or noncompliance with requirements of specified Codes and/or ordinances, or variance or noncompliance with the requirements of specifications, complete corrective work to satisfaction of Owner at no cost:
  1. Replace equipment that does not meet Code or specification requirements.
  2. Perform work and furnish labor, materials and equipment necessary to meet specified operation and/or performance.
  3. Perform and assume cost for retesting required by Governing Code Authority, Consultant, and Owner to verify specified operation and/or performance.
- C. Field Review Scheduling: The Elevator Consultant shall schedule all installation progress reviews and final equipment and installation reviews with the Elevator Contractor. The Consultant anticipates that schedules shall be met. The Elevator Contractor is required to reply in writing to all corrective measures indicated on Elevator Consultant's progress and/or final review reports. The Consultant also anticipates that corrective measures indicated in his written review shall require no more than one follow-up review to verify Elevator Contractor's compliance. It is agreed that Elevator Contractor shall reimburse the Elevator Consultant at his normal billing rates for appointments not kept or additional follow-up reviews required due to the Elevator Company's gross non-compliance with initial review requirements.

### 3.11 OWNER'S INFORMATION

- A. Submittals: Provide written information necessary for proper maintenance and adjustment of the equipment prior to final acceptance. Final retention will be held until data is received by Owner.
  1. Straight-line wiring diagram of as-installed elevator/escalator circuits with index of location and function of all components. Provide three neatly bound final corrected sets within 30 days after job acceptance for the Owner's file.
  2. Lubricating instructions, including recommended grade of lubricants. Provide three neatly bound copies.
  3. Parts catalogs for all replaceable parts including ordering forms and instructions. Provide three neatly bound copies.



4. Six sets of each key for each key switch. All keys shall be properly tagged.
5. Three sets of secondary containment monitoring instruction manuals and equipment catalogs.
6. Provide any special tools which may be required to maintain, troubleshoot, repair or replace parts of any equipment furnished.
7. Safety barriers for maintenance and repair work on escalators; one set per escalator unit.
8. Instruct Owner in general operation and use of elevators and procedures to follow in the event of an emergency, including cleaning procedures.

END OF SECTION



SECTION 14240

HYDRAULIC ELEVATORS

PART 1 - GENERAL CONDITIONS

1.01 WORK INCLUDED

- A. 1 Hydraulic Passenger Elevators.
- B. Provide everything necessary for and incidental to the satisfactory completion of the equipment installation as specified and conforming to all contract documents.
- C. Conform to applicable conditions of General, Special, and Supplemental Conditions and Division 1.

1.02 RELATED WORK SPECIFIED ELSEWHERE

- A. Legal Elevator Hoistway and Pit:
  - 1. Clear plumb elevator hoistway with variations not to exceed 1" at any point. Glass shall be laminated in accordance with the requirements of ANSI Z97.1.
  - 2. Bevel cants (75 degrees from horizontal) over any rear or side wall ledges and beams that project 2" or more into the hoistway. Hoistway divider beams excepted.
  - 3. Divider beams between adjacent elevators at each floor, pit, and overhead. Intermediate rail supports where floor heights exceed 14'-0" (building supports not to deflect in excess of 1/8" under 0.5g horizontal seismic acceleration). Intermediate rail support is not required where double main rail bracketing is employed to maintain 14'-0" or less bracket to bracket.
  - 4. Install guide rail bracket supports in concrete. (concrete inserts or imbeds will be provided by Elevator Contractor and installed by General Contractor as indicated on Elevator Contractor's shop drawings).
  - 5. Cut and patch walls and floors. Grout at hoistway door sills. Cutting and patching and redecorating around new hall lanterns, pushbuttons, smoke detector stubout conduits, and entrances.
  - 6. Wall pockets and/or structural beams for adequate support of the elevator machine beams and deadend hitch beams. Support deflection shall not exceed 1/1666 of the span under static load.
  - 7. Wall blockouts for pushbutton stations, hall lanterns, position indicators or other signal fixtures.
  - 8. After entrances are set, fill each side of entrance with concrete.

9. Pit ladders and pit screens where pit ladders are adjacent pit screen shall be extended 6'-0" high. Structural supports for car and counterweight buffer impact loads, and rail loads.
10. Waterproof pit. Sump pump or indirect waste drain as indicated on contract drawings. Seal pit with non-permeable epoxy.
11. Finish painting of primed hoistway entrances.
12. Finish flooring in elevator car enclosure.
13. Protect open elevator hoistways, wellways, and entrances during construction per OSHA regulations.
14. Protect cars, door entrance assemblies, and special metal finishes from damage after installation.
15. Vent elevator hoistways to outside air. Minimum 3'-0" sq. ft. per hoistway or 3.5% of the total hoistway area (whichever is greater) per U.B.C. See contract drawings for size and location of vents.
16. Pit support framing for jack cylinder and buffer loads.
17. Opening in hoistway wall for hydraulic piping.
18. 3'-0" square hole in pit floor for Elevator Contractor to install protective, secondary containment casing. Fill hole with concrete after jack and membrane installation.

**B. Legal Machine Rooms:**

1. Self-closing and self-locking elevator machine room access doors or gates. Lock shall have be as specified in hardware section.
2. Machine Room: Provide constant cooling and heating, including truss ventilation, to maintain a minimum temperature of 65 degrees and a maximum of 90 degrees Fahrenheit, and humidity shall not exceed 85%. Cooling and heating unit shall be located outside of the machine room enclosure.
3. Paint elevator machine room walls, ceiling and floor. Cementitious beam, column, and roof fireproofing shall be sealed to prevent flaking.
4. Provide a Class "C" fire extinguisher in each elevator machine room.
5. Coordinate secondary containment of hydraulic tank with elevator installer.

**C. Electrical Services, Conductors and Devices:**

1. Permanent Guarded Lighting (minimum 10 footcandles) and convenience outlets, per Code in elevator and escalator pits, machine rooms, governor locations, and mechanical areas (at both ends for escalators).

2. Run conduits from the closest elevator hoistway of each elevator group or single elevator to the fire control room and/or main level lobby control console at employee entrance. Coordinate size, number, and location of conduits with Elevator Contractor.
3. Three-phase mainline power feeders to terminals of each elevator and escalator controller unit in the elevator and escalator machine room. Include protected lockable "off" disconnect switch (copper conductors to terminals). Provide auxiliary disconnects in multi-level machine rooms, label existing disconnects with proper elevator numbers. Additional contacts as required to interface with elevator company's emergency battery lowering device.
4. Verify adaptability of existing disconnect and power for new equipment to be installed.
5. Single-phase power feeders to each elevator and escalator controller for lighting and exhaust blower. Include individual disconnect switch at location shown on elevator contractor's shop drawings.
6. Single-phase, power feeder to elevator intercom amplifier located in the elevator machine room.
7. Signal fixture power feeders to machine room elevator to each group control panel.
8. Products-of-combustion sensors (NFPA No. 72D) in each elevator lobby, hoistway, and machine room for each group of elevators, including single elevator units, to initiate fireman's return feature, per Code requirements. Run sensing wires to each group elevator controller and single elevator unit in each elevator machine room, including exiting units.
9. Individual phone connection at car controllers in elevator machine rooms.
10. Temporary power and illumination as required by Elevator Contractor to install, test and adjust elevator and escalator equipment.

### 1.03 QUALITY ASSURANCE

#### A. Definitions:

1. In all cases, where a device or a part of the equipment is herein referred to in the singular number, it is intended that such reference shall apply to as many such devices or parts as are required to complete the installation.
2. All terms in these specifications have their definition given in the latest edition of the American National Standards Institute, Safety Code for Elevators, Dumbwaiters, and Escalators ASME A17.1, including revisions and authorized changes in effect on the date of these specifications.

#### B. Document Verification: In order to discover and resolve conflicts or lack of definition which might create construction problems, Elevator Bidders must review schematic design documents, and existing conditions for compatibility with their products prior to

bidding. Attach specific, written exceptions and/or clarifications with quotation. Bidder's compliance with all provisions of contract documents is assumed and required in absence of written exceptions. Owner will not pay for changes to structural, mechanical, electrical or other systems required to accommodate Bidders' equipment if not identified before contract award.

C. Acceptable Elevator Bidder:

1. General:

- a. Manufacturers: Provide manufacturer's equipment and other components produced by the manufacturer or by firms experienced and specialized not less than five years in the types of components required that comply with these specifications.
- b. Installer: Either the manufacturer or a licensee of the manufacturer, who has not less than five years successful experience with the installation of similar units and who is currently under contract for maintenance of similar units in the area, and who maintains a service center in the Los Angeles basin.
- c. Welders: Qualify welding processes and welding operators in conformance with AWS D1.1, Structural Welding Code - Steel.
- d. Maintainability: Parts subject to wear and replacement shall be readily and easily removable and replaceable without requiring modification of the units or the equipment.
  - (1) Parts subject to wear shall be standard production items that are interchangeable.
  - (2) Replacement parts, whether produced in the Contractor's factories or secured from commercial factories or distributors, shall be precisely identified. Replacement parts shall be made available to the Owner or its designee without prejudice. The required quantities, uniform price, and delivery time of replacement parts shall be on the same basis as the Contractor's most favored maintenance consumer.
  - (3) Replacement parts, maintenance methods, technical information, wiring diagrams, testing procedures, design criteria, or any other publication related to the equipment provided, even though labeled PROPRIETARY, shall be made available to the Owner or its designee without prejudice or delay.

2. Companies: The units shall be installed by Dover Elevator Company, Fujitec Elevator Company, Mitsubishi Elevator Company, Montgomery Elevator Company, Otis Elevator Company, or Schindler Elevator Corporation. Alternate suppliers or installers must receive approval of the Architect and/or Consultant a minimum of 5 days prior to bid date. The equipment shall be provided by:

- a. Hydraulic Elevator Machines: Corbett Elevator Manufacturing Company Inc. (Cemco), Elevator Electric Company (EECO), Dover, Fujitec, General Electric, Hollister-Whitney, Montgomery.
  - b. Hydraulic Control Systems: Cemco, Dover, Elevator Electric Company, Fujitec, Maxton, Mitsubishi, Montgomery, Motion Control Engineering.
  - c. Car Enclosures: Amtech/Reliable, Dover, Elevator Cabs, Elevator Decorators, Fujitec, Globe Van Doorn, Hauenstein & Burmeister, Mitsubishi, Montgomery, Otis, Tyler.
  - d. Hoistway Entrances: Elevator Doors, Fujitec, Hauenstein & Burmeister, Montgomery, Otis, Tyler.
  - e. Fixtures: Adams or approved equal.
  - i. Use of alternate manufacturers must receive approval of the Architect and/or Consultant at least 5 days prior to bid date.
- D. Design Criteria:
1. General:
    - a. Equipment shall be of the heavy-duty type.
    - b. No wood or wood products will be permitted in elevator and escalator systems.
  2. Seismic Requirements: All equipment shall be designed for the appropriate Seismic Zone.
- E. On-Site Conditions:
1. Complete verification of on-site conditions, including, but not limited to, elevator hoistway, pit, machine room, overhead clearances, electrical power characteristics, structural loads, etc., as they relate to the Elevator Contractor's equipment applications, and Code compliance shall be the responsibility of the Elevator Contractor. On-site review shall be completed prior to submittal of the Elevator Contractor's proposal. Deficiencies noted shall be included in writing with the Elevator Contractor quotation. Special attention shall be paid to verifying field dimensions, drilling accessibility, and overhead heights. Submission of bid indicates acceptance of all on-site conditions.
  2. Drawings or measurements included with the bidding material shall be for the convenience of the bidders only. Complete responsibility for detailed dimensions lies with the Elevator Contractor. Prior to the execution of the work, the Contractor shall verify all dimensions with the actual on-site conditions. Where the work of the Elevator Contractor is to join another trade, the shop drawings shall show the actual dimensions and the method of joining the work of the two trades.

3. Modification of existing electrical supply shall be the responsibility of the elevator contractor.

F. Compliance with Regulatory Agencies and Agreements: Comply with most-stringent applicable provisions of following Codes and/or Authorities, including revisions and changes in effect on date of these specifications (latest editions and supplements shall apply):

1. Safety Code for Elevators and Escalators ASME A17.1.
2. Inspectors' Manual, for Elevators and Escalators ASME A17.2.
3. Safety Code for Existing Elevators and Escalators, ASME A17.3.
4. National Electrical Code, No. ANSI/NFPA 70.
5. Structural Welding Code, Steel AWS D1.1, latest edition.
6. California Code of Regulations (CCR), Title 8, Title 23, and Title 24.
7. Life Safety Code, ANSI/NFPA No. 101, CCR Title 19, and local fire authority.
8. Requirements of local building code and any other Codes, Ordinances and Laws applicable within the governing jurisdiction.
9. Underwriters' Laboratories, Inc., materials and test report descriptions as required.
10. International Union of Elevator Constructors (IUEC).
11. Providing Accessibility and Usability For Physically Handicapped People, per Americans with Disabilities Act, Titles II and III.
12. Applicable UBC requirements.
13. As directed by local fire jurisdiction.
14. Soils reports - special attention to, but not limited to, any corrosive soil conditions.
15. In the event of conflict, the more-stringent Code requirements shall apply.

G. Applicable Standards, Rules, and Regulations:

1. American National Standards Institute (ANSI).
2. American Society of Civil Engineers (ASCE).
3. American Society of Mechanical Engineers (ASME).
4. American Society for Testing and Materials (ASTM).



5. Electronic Industries Association (EIA).
  6. Insulated Cable Engineers Association (ICEA).
  7. Institute of Electrical and Electronics Engineers (IEEE).
  8. National Electrical Manufacturers Association (NEMA).
  9. National Fire Protection Association (NFPA).
  10. OSHA.
  11. Underwriters' Laboratories, Inc. (UL).
  12. CCR Titles 8, 23, and 24.
- H. Safety: Conform safety devices, running clearance, testing, and maintenance methods to the requirements of ASME A17.1 and Supplements and ASME A17.2 and supplements, and local Codes.
- I. Warranty:
1. Materials and workmanship of the elevator installation shall comply in every respect with contract documents. Unless due to ordinary wear and tear, or improper use or care by Purchaser, correct defects which develop within one year from date of final acceptance of work to the satisfaction of the Architect, Owner, and Consultant at no additional cost.
  2. Make modifications, adjustments, improvements, etc., to meet all performance requirements.
  3. Neither the final payment nor any provision of the contract documents shall relieve the Contractor of the extent and period provided by law and upon written notice he shall remedy any defects due thereto and pay all expenses for any damage to other work resulting therefrom.
  4. The same guarantee shall be applicable to the total job in the event equipment is reused or modified.
  5. The one-year guarantee, as outlined above, for all units shall start from the date of final acceptance by the Owner of all work associated with these contract documents.

#### 1.04 SUBMITTALS

##### A. Dimensioned Shop Drawings:

1. Scaled shop drawings shall be provided for all work. Before beginning fabrication, shop drawings showing the plan views of the pit, hoistway, wellways, machine room, elevation section of the hoistway, car details, entrance details, secondary containment provisions, and details of the signal fixtures shall be prepared and submitted for approval. Also provide electrical, structural, and/or

mechanical data. Three reproducible sets (sepias or mylars) shall be provided for each drawing submittal.

2. Refer to Division 1 for submittal procedures, including preparation and transmittals. Shop drawings shall be submitted within 28 days of Contract award, verbal or written. Each shop drawing shall be clearly identified by title and owner's elevator number. Corrections made to shop drawings during the review process shall be incorporated on the drawings and/or responded to and acknowledged by the Elevator Contractor. Elapsed time due to "revise and resubmit" or "rejected" action, indicated on submittals due to inaccurate data or incomplete definition shall not affect equipment delivery or installation schedule.
- B. Calculations: Structural and electrical calculations shall be submitted. These calculations shall include, but are not limited to, rail loads, loads from machines, seismic forces, etc. Submit layout which clearly indicates structural loadings that will be applied to the building structure by the elevator system. Indicate the magnitude of each type of load (dead, live, impact, seismic) separately, along with its point of application to the building structure and its sense (vertical, horizontal, torsional). Additionally, indicate the nature of load combinations. The purpose of this submittal is verification of the capacity of the building structure.
- C. Samples: Submit three samples of each required finish, not including those intended for painting after installation. Submit 3" x 10" samples or 10" lengths of actual finished materials. Samples shall be reviewed by Architect for color, pattern and texture only. Compliance with other requirements is the exclusive responsibility of the Elevator Contractor. Include signal equipment units, to show pushbuttons, lights, graphics, Braille plates, and mounting provisions. Submittals shall be made within 28 days of award, verbal or written.
- D. Allotted approval process time shall be a minimum of four weeks from date individual submittals are received by Architect.

#### 1.05 PERMITS, TESTS, AND INSPECTIONS

- A. Elevator Contractor Shall Obtain, Pay For and/or Provide:
1. All necessary legal requirements, permits, licenses and inspection fees necessary to complete the elevator and escalator installation.
  2. Tests as required by governing authorities and/or the ANSI current A17.2 Elevator Inspectors' Manual.
  3. Any submittals required by local building/permit authorities.
- B. Perform such tests in the presence of authorized representatives of such authorities.
- C. Provide manpower and equipment to perform tests and final reviews as required by governing authorities and/or to meet the ASME/ANSI current A17.2 elevator inspectors' manual and tests, indicated in Specification Part 3.

1.06 MAINTENANCE

A. General Guidelines:

1. Breakdowns and Shutdowns:

- a. Breakdowns and shutdowns, such as electrical troubles, burned out control coils, open circuits, electrical or mechanical adjustments, will not keep the respective elevator out of service longer than one (1) day (24 hours).
- b. Under no circumstances will any shutdown or breakdown last longer than three (3) days (72 hours). This includes the locating of the trouble, procurement of parts, the installation of these parts and the replacing of the respective unit back into safe uninterrupted operation. The Contractor must be so equipped to meet the above conditions. The excuse of not being able to obtain parts, necessary technical and engineering advice, etc., will not be acceptable, and the Contractor will be considered in default, giving sufficient justification to the Owner to obtain these services from Contractors who can provide the Owner with uninterrupted service.
- c. The Owner may take over the work and prosecute it to completion by contract or otherwise, and the Contractor and his/her sureties (if any), shall be liable to the Owner for any additional cost occasioned by the Owner, previous to the termination of the contract.

2. Material Inventory: The Contractor shall maintain a supply of contacts, coils, leads, fuses, motor and generator brushes, hanger rollers, clutch rollers, lubricants, wiping cloths, and other minor parts for the performance of routine preventive maintenance properly stored in the machine room.

3. Spare Parts Inventory:

- a. The Contractor shall maintain a supply of spare lending and replacement parts in their warehouse inventory. This inventory shall include, but is not limited to, generator rotating elements, door operator motors, brake magnets, generator and motor brushes, controller switch contacts, selector switch contacts, solid state components, selector tapes, door hangers, hardware, hoistway limit switches, etc.
- b. All replacement parts and materials shall be specifically designed for the elevators on which they are to be used. The Contractor shall provide for replacement parts from the original manufacturer of the transportation system or suppliers of such original manufacturer's parts. Substitute parts may be utilized on approval of the Owner or his/her designee.

4. Experience and Parts: The Elevator Contractor shall be able to show that he has had successful experience in the complete maintenance of elevators and escalators, employs competent personnel to handle this service, maintains an adequate stock of parts locally for replacement or emergency purposes and has qualified men available to ensure the fulfillment of this service without unreason-

able loss of time in reaching the job site. The Elevator Contractor shall supply a list, acceptable to the Owner, of locally stocked parts, particular to the equipment designs. The Contractor shall supply a list, acceptable to the Owner, of long lead items that apply to the equipment. This list shall include delivery dates of long lead items.

**B. Construction Maintenance:**

1. When one or more elevators have been installed to a stage near completion and declared ready for service, the Owner or Contractor may accept the elevators for interim use and place them in service before the entire installation of all elevators has been completed and accepted.
2. During this period the General Contractor may agree to pay the Elevator Contractor a mutually agreed amount per elevator for preventive maintenance of elevators on interim service. Bidders shall indicate the amount per unit per month with their bids.
3. Before an elevator is placed in temporary service, General Contractor shall sign Elevator Contractor's temporary acceptance form. Form shall contain provisions acceptable to both parties.
4. As agreed upon between General Contractor and Elevator Contractor, the Elevator Contractor shall provide temporary hoistway enclosures and perform all cleaning, repairs or replacement of materials as necessary to restore elevator to its original condition.
5. The maintenance and warranty periods herein specified shall not commence for units accepted on an interim basis or accepted and shut down due to lack of need.

**C. Warranty Maintenance: Include with new equipment contract (new installation service period):**

1. The Elevator Contractor shall furnish weekly scheduled preventive maintenance on all equipment described herein for a period of 12 months, including 24-hour emergency callbacks, per unit, commencing on date of final acceptance by Owner. The maintenance shall include systematic examinations, adjustment, cleaning, and lubrication of all equipment. The Elevator Contractor shall also repair or replace electrical and mechanical parts whenever required and shall use only parts produced by the manufacturer of the equipment installed. Maintain machine rooms, wellways, hoistways, and pits in clean condition.
2. All maintenance work shall be performed by competent personnel under the supervision and direct employee of the Elevator Contractor.
3. The Owner, at his option, may choose to delete this maintenance from the capital contracts and to pay this amount in 12 equal installments directly to the Elevator Contractor during the period in which the work is being accomplished.

Reference L.B.A. contract and bid form.

D. Contract Maintenance (Ongoing Preventive Maintenance Program):

1. Bidders shall also quote the monthly cost for a 5-year maintenance agreement to commence on completion of the 12-month period of warranty maintenance. That quotation shall be submitted based upon the terms and conditions of the standard Lerch, Bates and Associates' preventive maintenance agreement. Under this agreement, the equipment performance requirements, as herein specified, shall be provided at all times.
2. If this contract is accepted, the contract price is subject to adjustment at the expiration of the new installation service period and thereafter as provided in the contract.

PART 2 - PRODUCTS

2.01 SUMMARY

A. Child Care Passenger Elevator:

QUANTITY/NUMBER: 1, ELEVATOR NO. 19

CAPACITY: 4000#

SPEED: 125 F.P.M. - UP, DOWN - NO LOAD, FULL LOAD

MACHINE: DIRECT PLUNGER OIL HYDRAULIC WITH SECONDARY CONTAINMENT AND MONITORING; WYE-DELTA MOTOR; ADJACENT TO PIT AT P2 - VERIFY ON DRAWINGS

SUPERVISORY CONTROL: SELECTIVE COLLECTIVE - MICROPROCESSOR-BASED

MOTOR CONTROL: A.C. WITH WYE-DELTA START

STOPS: 3 STOPS - VERIFY ON DRAWINGS

OPENINGS:  
3 OPENINGS - VERIFY ON DRAWINGS

FLOORS SERVED: P-1, 1 & 2; 280.5 (R); 296.0 (F); 311.33 (F) - VERIFY ON DRAWINGS

TRAVEL: 30'-8" ± VERIFY ON DRAWINGS

PLATFORM SIZE: 8'-0" WIDE X 6'- 7-1/2" DEEP - VERIFY ON DRAWINGS

CLEAR CAR INSIDE: 7'-4" WIDE X 5'- 5-1/2" DEEP MINIMUM

ENTRANCES -  
SIZE: 4'-0" WIDE X 8'-0" HIGH - VERIFY ON DRAWINGS

TYPE: SINGLE-SPEED, CENTER OPENING

CONSTRUCTION: MITERED AND WELDED 14 GAUGE JAMBS AND 16 GAUGE DOORS

FINISH: SATIN STAINLESS STEEL DOORS AND FRAMES

SILL FINISH: EXTRUDED ALUMINUM

SUPPORT: SILL SUPPORT ANGLES

DOOR OPERATION: HIGH-SPEED, HEAVY-DUTY, MASTER DC DOOR OPERATOR (MINIMUM OPENING SPEED 1-1/2 F.P.S.). FRONT AND REVERSE OPENINGS; SELECTIVE DOOR OPERATIONS

DOOR PROTECTION: INFRARED OPTICAL FULL SCANNING SCREEN DEVICE; DIFFERENTIAL TIMING FEATURE AND NUDGING; FRONT AND REVERSE OPENINGS

CAR ENCLOSURE: AS SHOWN ON DRAWINGS

SHELL: 14 GAUGE CAR SHELL; 12 GAUGE CANOPY; BAKED ENAMEL FINISH, APPLIED 18 GAUGE CLADDING ON WALLS

HEIGHT: CAB HEIGHT TO CANOPY 10'-0"

FRONTS: 14 GAUGE, FULL SWING CAR FRONT RETURNS (2) WITH SATIN BRONZE FINISH

DOORS: 16 GAUGE WITH SATIN BRONZE FINISH, SAME CONSTRUCTION AS HOISTWAY DOORS

LIGHTING/DROP CEILING: FLUORESCENT PERIMETER LIGHT WITH A STAINLESS STEEL DROP CEILING

SIGNALS:

REGISTRATION LIGHTS: CAR AND CORRIDOR PUSHBUTTONS, SINGLE CORRIDOR RISER - DUAL CAR STATIONS. CAR STATIONS RECESSED FLUSH WITH FRONT RETURNS.

POSITION INDICATORS: CAR (DUAL), FIRE AND LOBBY CONTROL PANEL

HALL LANTERNS: AT ALL FLOORS WITH ELECTRONIC CHIME OR TONE (TWICE FOR DOWN DIRECTION)

COMMUNICATION SYSTEM: SELF-DIALING, A.D.A COMPLIANT PHONE, PHONE BOX, AND SHIELDED WIRING FROM BOX IN EACH CAR TO EACH CAR CONTROLLER IN ELEVATOR MACHINE ROOM. PROVIDE A SEPARATE TRAVELING CABLE. ALL EQUIPMENT SHALL BE COMPATIBLE WITH THE BUILDING SYSTEM.

B. Additional Features: PROVIDE EQUIPMENT TO ACCOMMODATE SPECIAL FINISHES

BUMPER RAILS AT STROLLER HEIGHT

CAR ROLLER GUIDES

CAR TOP INSPECTION STATION

EMERGENCY CAR LIGHTING - BATTERY PACK

EMERGENCY OPERATION [CCR, TITLE 8, RULE 3041(C) FIRE-FIGHTER'S SERVICE, INCLUDING ALTERNATE FLOOR RETURN]

STANDBY POWER PROVISIONS - RSQ - PAK BATTERY OPERATED LOWERING

HANDICAPPED IDENTIFICATION PLATES WITH STAR AT MAIN EGRESS LANDING, CAR AND CORRIDOR. CAST OR FORGED TYPE, REAR MOUNTED APPLICATION. STICK-ON OR RIVETED PLATES ARE UNACCEPTABLE

INTERNATIONAL STAR OF LIFE FOR APPLICABLE ELEVATORS

HOISTWAY ACCESS SWITCHES

INDEPENDENT SERVICE FEATURE

PLATFORM ISOLATION - JACK TO PLATEN CONNECTION

HYDRAULIC PUMP ASSEMBLY AND CONTROLLER SOUND ISOLATION

CYLINDER SUPPORTS AS REQUIRED

JACK HOLE, OUTER CASING AND WATERTIGHT PVC SLEEVE WITH SECONDARY CONTAINMENT AND MONITORING PROVISIONS

WATERTIGHT PVC SLEEVE FOR UNDERGROUND PIPING WITH SECONDARY CONTAINMENT AND MONITORING PROVISIONS

REMOTE PIPING TO BE RUN OVERHEAD AND TO BE ENCASED IN PVC WITH SECONDARY CONTAINMENT PROVISIONS

CONTROL PANEL AND REMOTE WIRING LOCATED AT EMPLOYEE SERVICE CENTER ON 3RD FLOOR

FIREFIGHTER'S CONTROL PANEL AND REMOTE WIRING

MOUNT ALL FIXTURE FACEPLATES WITH VANDAL-RESISTANT FASTENERS

12-MONTH WARRANTY MAINTENANCE WITH 24-HOUR CALL-  
BACK SERVICE

PROVIDE PAD HOOKS AND FIRE-RETARDANT CANVAS  
COVERED PADS

INDIVIDUAL FLOOR LOCKOFF SWITCHES (SEE 14200)

CARD READER PROVISIONS (SEE 14200)

WIRING DIAGRAMS, OPERATING INSTRUCTIONS, AND PARTS  
ORDERING INFORMATION

ALL SPECIFIED ENGRAVING SHALL BE FILLED WITH BLACK  
PAINT UNLESS OTHERWISE NOTED

NO VISIBLE COMPANY NAME OR LOGO

ELEVATOR CONTRACTOR SHALL MAKE PROVISIONS FOR  
CUSTOM CAR INTERIOR FINISHES, INCLUDING ADEQUATE  
SIZING OF EQUIPMENT TO ACCOMMODATE ADDITIONAL  
WEIGHTS

VERIFY ALL CONDITIONS WITH FIELD MEASUREMENTS AND  
EXISTING CONDITIONS. MANUFACTURE EQUIPMENT TO  
MEET EXISTING CONDITIONS

## 2.02 PERFORMANCE

- A. Speed:  $\pm$  10% contract speed under any loading condition.
- B. Capacity: Safely lower, stop and hold up to 125% of rated load.
- C. Stopping Accuracy:  $\pm$  1/4" under any loading condition.
- D. Door Opening Time: 1.6 seconds from start of opening to fully open.
- E. Floor-to-Floor Performance Time: seconds from start of doors closing until doors are 3/4 open and car level and stopped at next successive floor under any loading condition or travel direction.
- F. Fluid system components shall be designed and factory tested for 500 p.s.i. Maximum operating pressure shall be 400 p.s.i.
- G. Measured noise levels in a moving car outside the acceleration/deceleration zone shall not exceed 55 dBa under any condition including ventilation system on highest speed. Measured noise levels in the car within the leveling zone or stopped shall not exceed 60 dBa.
- H. Noise/Sound Isolation Provisions:
  - 1. Roller Guides: roller assemblies shall have rollers with a minimum diameter of 6".



2. Platform Isolation: Double thickness isolation between car and car frame; plunger and platen head.
3. Guide Rails and Fishplates: Provide a minimum of 15 pound guide rails with double thick fishplates.
4. Machine Isolation: All machines shall be mounted on isolation pads with minimal direct attachment to structure.
5. Submit details of isolation pads and sound isolation provisions.
6. To minimize noise and vibration in occupied areas, mechanically isolate elevator equipment from the structure; electrically isolate controllers, machine and motors.
7. Sound Isolation Couplings: Provide a minimum to two between the pump unit and oil line and oil line and jack unit.
8. Piping: All remote piping and conduit shall be protected with PVC and suspended on sound isolated brackets.

## 2.03 OPERATION

### A. Operational Control

#### Selective Collective:

##### a. General:

- (1) Elevator shall operate without an attendant from buttons located in each floor entrance jamb and in the car. The registration of a hall call, when the car is idle, shall automatically start the elevator and dispatch it to the corresponding floor. If a call is registered at the floor where the car is idle, the doors shall automatically open.
- (2) Once the direction of travel has been established, the car will not reverse direction until all car calls have been answered or until all hall calls, ahead of the car and corresponding to the direction of travel, have been answered.
- (3) Cars shall slow down and stop automatically at floors corresponding to registered calls, in the order in which they are approached in each direction of travel. As slow down is initiated for a hall call, that call shall be automatically canceled and the hall button for that direction of travel remain ineffective until the car leaves the floor. Car calls shall be similarly canceled. The car shall remain at the arrival floor an adjustable time interval to allow passenger transfer.
- (4) The car shall only answer calls corresponding to the direction in which the car is traveling except that it may answer a call in the opposite direction if that call is the highest (or lowest) call registered.

- (5) Registration of a call shall cause the appropriate button to illuminate. When the call is answered, the light shall go out.
- B. Door Operation: Automatically open door when car arrives at main landing if a car call has been registered. When another car is at main landing loading for departure, close arriving car doors. Reopen when car is designated for loading. If no other car is at main landing, leave doors open until car is dispatched or loading interval expires with no demand. Extended open times with adjustments from 30 seconds to 2 minutes shall be provided.
- C. Automatic Stopping Accuracy: Stop car within 1/4" above or below the landing sill. Avoid overtravel, as well as undertravel, and maintain stopping accuracy regardless of load in car, direction of travel.
- D. Independent Service: Provide controls for operation of each elevator from car buttons only. Close doors by constant pressure on desired destination floor button. Open doors automatically upon arrival at selected floor.
- E. Firefighter's Service: Per CCR Title 8 to operate and recall elevators to designated or alternate designated floors in fire or other emergency condition. Provide sensor signal wiring from hoistway or machine room connection point to controller terminals. Provide similar operation and fixtures on all elevators. Operate visual/audible signal until return is complete or automatic operation restored.
- F. Standby Lighting and Alarm: Car-mounted, battery unit with solid-state charger to operate fan, alarm bell and lighting, per Code. Battery to be rechargeable with 5-year minimum-life expectancy. Provide spring return test button in service cabinet of car station which causes illumination of standby lighting bulbs. Locate lights so they are part of normal car lighting system and not exposed to view.
- G. Standby-Power Transfer: Provide standby power of the same voltage characteristics via the normal electrical feeders to run one elevator at a time in each elevator bank, including single elevator units, at full-rated car speed.
1. Conductors, as necessary, from the standby power transfer switch to a single elevator control panel in each elevator bank and/or single elevator unit, as designated by the Elevator Contractor, to signal the presence of standby power. Transfer switch shall provide a time delay of approximately 15 seconds for pretransfer signal in either direction.
  2. Standby single-phase power to each elevator controller for lighting, exhaust blower, emergency call bell. Include intercom amplifier and hoist machine cooling fans where utilized.
  3. Means for absorbing regenerated power during an overhauling load (such as full load down) in accordance with ANSI A17.1, Rule 210.10.
- (Note: Elevator drives may employ solid-state SCR devices for conversion of AC to DC power).
- H. Elevator-to-Lobby Switches: Provide a switch for each elevator to return the car to the main floor. Return elevators non-stop after answering registered car calls, and park with its doors open until switch is returned to normal position.

- I. Seismic Operation: Provide per C.C.R. Title 8.

#### 2.04 MACHINE ROOM EQUIPMENT

- A. Arrange equipment in machine room space(s). Provide identifying numbers on machine, controller, and disconnect switch. Comply with N.E.C., Article 110-16a., working clearances.
- B. Pump Unit: Assembled unit consisting of positive displacement pump, induction motor, master-type control valves combining safety features, holding, direction, bypass, stopping and manual lowering functions, shut off valve, oil reservoir with protected vent opening, oil gauge and outlet strainer, drip pan and connections all mounted on isolating pads. Provide thermal unit or comparable means to maintain oil at operating temperature. Enclose with removable sheet steel panels lined with sound-absorbing material. Provide secondary containment with monitoring.
- C. Muffler: Provide in discharge oil line near pump unit. Design shall dampen and absorb pulsation and noise in the flow of hydraulic fluid.
- D. Piping and Oil: Provide piping, connections and oil for the system. Piping shall be secondarily contained and monitored with watertight Schedule 40 PVC sleeves between elevator machine room and pit. A minimum of two isolation couplings shall be provided between the pump unit and oil line and the oil line and jack unit. Provide pipe stands as required. Provide secondary containment and PVC pipe enclosure for all piping to remote machine rooms. Remote piping shall be run overhead.
- E. Shut off valve: Provide manual valve in line adjacent to pump unit.
- F. Controller: Cabinet type, with removable doors and adequate ventilation to dissipate heat. Wire to identified terminal block studs. Identifying symbols or letters identical to those on wiring diagrams shall be permanently marked adjacent to each component on the controller. Provide means on group dispatch or master car controller to facilitate monitoring of group operation with electronic tabulating devices. Features to be monitored shall include, but not be limited to: up corridor calls, down corridor calls, car in service, automatic bypass, on/off, etc. Provide auxiliary electrical power disconnecting means where required by Code. Motor control shall be A.C. with wye delta starting.
- G. Frame: Securely mount all assemblies, power supplies, chassis switches, relays and other items on a substantial, self-supporting steel frame. Completely enclose equipment with covers and ventilate to prevent overheating.
- H. Wiring: U.L. or C.S.A. labeled copper wires for factory wiring. Neatly route all wiring interconnections and securely attach wiring connections to studs or terminals.
- I. Permanently mark components (relays, fuses, PC board, etc.) with symbols shown on drawings.
- J. Provide extender boards when computing devices are used inside a computer chassis to facilitate access to the printed circuit cards utilized.
- K. Use stable capacitor or crystals as the time base for electronic time-delay devices.

- L Contractor shall make provisions in their equipment to accommodate custom design interior finishes, including sufficient equipment tolerances for applied panels and finished flooring.

## 2.05 HOISTWAY EQUIPMENT

- A. **Guide Rails:** Provide planed steel T-sections suitable for elevator travel, weight of car, and seismic reactions, including brackets for attachment to building structure at support locations shown on drawings.
- B. **Buffers:** Spring type with blocking and supports where necessary.
- C. **Cylinder:** Seamless steel pipe. Design head to receive unit type packing and provide means to collect oil at cylinder head and return to oil reservoir. Provide secondary containment and monitoring provisions per CCR Title 23.
- D. **Plunger:** Polished seamless steel tubing or pipe. If plunger length exceeds 24', provide two or more sections not exceeding 16' in length, or coordinate installation of longer unit at the job site. Join section by internal threaded couplings. Multiple section jack units shall be factory polished while assembled and marked for proper future reassembly. Isolate plunger from car sling.
- E. **Well Hole, Casing:** A concrete outer well hole shall be provided, by others. Elevator Company shall be responsible for field verifying location and shall manufacture equipment to meet existing conditions. Modifications to the existing hole location shall not be made.  
  
Install steel outer casing minimum 18" diameter. Install watertight sleeve for secondary containment over jack assembly prior to insertion into the outer casing. Extend PVC sleeve through pit floor slab to underside of jack support beams and seal with non-permeable membrane. I.D. of PVC sleeve shall be capable of containing 100% of system capacity. Seal well opening at the pit floor with hydraulic quick setting cement. Provide vision ports, similar to those required by C.C.R. Title 23.
- F. **Jack Support:** Provide steel pit channels to support jack and transmit loads to building structure. Provide intermediate stabilizers as required.
- G. **Shut off Valve:** Manual valve in oil line adjacent to each jack unit.
- H. **Normal and Final Terminal Stopping Devices:** Provide new, per Code.
- I. **Electrical Wiring:** All new wire and cable installed and must meet current requirements of National Electrical Code.
  - 1. **Conductors:** Provide copper throughout with individual wires coded and all connections on identified studs or terminal blocks. Use no splices or similar connections in any wiring except at terminal blocks, controllers, junction boxes or condulets. Provide 10% spare conductors throughout. All spare wiring shall be in addition to those required by features of this specification and shall run from car connection points to individual elevator controller. Provide and tag in each elevator controller four pairs of spare, shielded communication wire.

2. Conduit: Painted or galvanized steel conduit and duct. Conduit size shall be 1/2" minimum. Flexible conduit exceeding 18" in length shall not be used. Flexible heavy-duty service cord may be used between fixed car wiring and car door control devices.
  3. Traveling Cables: Flame and moisture resistant outer cover. Prevent traveling cables from rubbing or chafing against hoistway or elevator equipment.
- J. Pit Stop Switch: Per Code.

## 2.06 HOISTWAY ENTRANCES

- A. Frames: Frames shall be bull nose type, hollow metal fabricated from not less than No. 14 U.S. gauge steel, bolted to form a one piece unit. Jamb and head depth and profiles shall be as shown on the architectural drawings. Provide permanently attached, rear mounted, disabled access floor designations at a height of 60" above the finished floor. Designations shall be 2" high, raised 0.030", of a lettering style and color as approved by the Architect. The braille indications shall be at the left of the arabic numeral per A.D.A. requirements and California Code of Regulations, Title 24 Accessibility Standards. A star designation shall be provided at the main egress landing. Stick-on or riveted plates are unacceptable.
- An international star of life symbol permanently attached, rear mounted at a height of 78" to 84" above finished floor on both frames at each floor shall be provided on the designated medical emergency elevator. Designation shall be 3" in size and shall meet Los Angeles City requirements. Stick-on or riveted plates are unacceptable.
- B. Door Panels: Fabricate from not less than No. 14 U.S. gauge steel, sandwich construction. Provide leading edges of center-opening doors with rubber astragals to cushion closing impact. Each door panel shall include a minimum of two gibs, one at leading edge and one at trailing edge. Door gibs shall be in the sill groove their entire length of travel.
- C. Sight Guards: No. 14 U.S. gauge material, same material and finish as hoistway entrance door panels.
- D. Fire Rating: Provide complete entrances bearing UL fire labels.
- E. Sills: Nickel silver.: Provide and install sill support angles at all floors, so as not to require grouting beneath the sills. Sill angles shall be 5" x 5" x 1/2" and fastened 12" on center, minimum.
- F. Hangers: Provide new two-point suspension with upthrust adjustment not to exceed 3/8" between door panels.
- G. Tracks: Provide new bar or formed, cold drawn steel with smooth hanger contact surface. Tracks shall be removable for replacement or provided with renewable surface.
- H. Interlocks: Provide new type operable without retiring cam. Interlocks that are visible when doors are open shall be painted flat black.
- I. Closer: Provide new spring, spirator, or weighted closer shall operate quietly. Weighted closer shall be strut mounted.

- J. Fascia, Toe Guards, and Fascia Width Hanger Covers: No. 14 U.S. gauge furniture steel with flat black enamel finish. Paint fire floor identifying numbers per Code.
- K. Struts and Headers: Provide for necessary support of entrances and related material. Door open bumpers are required on entrances equipped with vertical struts.

## 2.07 CAR EQUIPMENT

- A. Car Frame: Welded or bolted. Rolled or formed steel channel construction.
- B. Platform: Isolated type, constructed of steel or wood which is fireproofed on the underside.
- C. Guides: Spring loaded adjustable roller type with three or more sound-deadening rollers per guide assembly. Rollers shall not exceed 350 r.p.m. at rated speed.
- D. Car Sills: Nickel silver with extruded extensions to face of car front return. Extruded extension in same finish as sill.
- E. Toe Guard: Per Code. Paint flat black.
- F. Doors, Hangers and Tracks: Provide as specified for hoistway entrance doors, hangers and tracks.
- G. Header: Fabricate of steel; shape to provide stiffening flanges. Existing to be reused. All fastenings shall be properly secured.
- H. Car Door Electrical Contact: Electrical contact to operate in conjunction with the car doors so that the elevator cannot operate unless doors are closed within tolerance allowed by Code.
- I. Door Operator and Operation: High-speed, heavy-duty, DC master door operator isolated from car top. Operator shall be capable of opening doors at no less than 2-1/2 f.p.s. and accomplishing reversal in no more than 2-1/2" of door movement. Door operation shall be no louder than 55 decibels.
- J. Door Control Devices:
  - 1. Infrared Optical Full Screen Devices: Provide infrared, optical full screen devices. Devices shall extend along the leading edge of each car door and be designed to initiate door reversal at normal speed if the devices sense a person or object while the car doors are closing, except during nudging action. Devices shall be: T.L. Jones, Microscan II, Otis-enhanced Lambda, Adams I.C.U.-47, Innovation Smart Edge 2002, or Janus Panaforty.
  - 2. Nudging Action: In the event an optical beam is obstructed for an adjustable time interval (20.0-30.0 seconds), a buzzer shall sound, the doors shall attempt to close with a maximum of 2.5 foot pounds kinetic energy.
  - 3. Interrupted Beam Time: In the event the optical beams are interrupted while the doors are opening or after the doors are fully open, the normal dwell time that the doors remain open after the beams are reestablished shall be reduced to an adjustable time between .5 and 1.0 second, depending upon whether a landing call

or a car call predominated. This time shall also be a minimum time that the doors remain open if the optical beams are interrupted and reestablished before the door is fully open.

4. **Differential Door Time:** Provide separately adjustable timers to enable varying the time that the doors remain open after stopping in response to a car call or a landing call. The dwell time for a car call stop shall be adjustable between 3.0 and 4.0 seconds, and the timing for a landing call stop shall be adjustable between 4.0 and 8.0 seconds. If a stop is made in response to both a landing call and a car call, the timing of the landing call shall predominate.

K. **Elevator Car Stations:** Two car stations per car recessed flush on fronts. Recessed stations shall have stainless steel faceplates.

1. All Elevators shall have vandal-resistant buttons.
2. The raised floor buttons, alarm button, door open button and emergency stop switch shall be suitably identified by raised, painted letters or symbols per A.D.A. requirements and California Code of Regulations, Title 24, including Braille. All operating controls shall be located no higher than 48" above the car floor (locate stop switch and alarm button 35" above finished floor).
  - a. Provide 1/8" raised floor pushbuttons with 5/8" numbers in the face of button corresponding to the floors served for registration of the car stops. Call registration lights, located within or behind the buttons, shall illuminate the floor number corresponding to the call registered. Where practical, pushbuttons shall be mounted in a vertical row beginning at 48" off finish floor.
  - b. An alarm button shall be provided at the bottom of the elevator station to ring a bell located on the elevator. Actuation shall ring bell, illuminate button, and sound distress signal at main lobby control panel.
  - c. A red emergency stop push/pull button shall be provided at the bottom of the elevator station to interrupt the power supply independently of the regular operating devices. The push/pull button shall be so arranged that when operated, it will sound the alarm bell and illuminate the alarm button described above. The actuation of this device shall not cancel registered calls. The device shall be marked to show "run" and "stop" positions. Actuation shall sound distress signal at main lobby control panel. They shall be arranged push to run, pull to stop.
  - d. Provide a door open button which shall stop closing motion of doors and cause them to return automatically to their fully open position. This button shall be effective while the car is at a landing and until the elevator starts into motion, regardless of any special operational features (except fireman's service).
  - e. Provide door close button to initiate door closing during normal operation by momentary pressure and for door closing by continuous pressure on Phase II fire service. Alternatively, the floor pushbuttons may be used.

- f. Provide an extended door hold open button.
  - g. A visual indication shall be provided to indicate activation of the emergency communication system.
  - h. Equip the elevators with control system to operate and recall the cars in fire or other emergency condition. Provide terminals on controller for connection of signal from sensors provided in other sections of the work. Operation shall be similar on all elevators and visual/audible signal shall operate until return is complete or automatic operation restored.
  - i. Provide one fireman's service key switch, light jewel, and fireman's telephone jack. Jack to be compatible with building system and at a minimum shall have four (4) shielded source wires.
  - j. Provide a scratch-resistant lens on the swing front return or car station behind which shall be located the certificate of inspection.
  - k. A lockable service panel with flush cover plate shall be provided. The service panel shall contain the following controls with each control and its operating positions identified by engraved letters painted black:
    - (1) An inspection switch, conforming to the ANSI Code, for disconnecting all automatic operation, limiting the car speed and rendering effective the hoistway access switch when the car is at the top or bottom terminal.
    - (2) A light switch.
    - (3) A three-position exhaust blower switch.
    - (4) An independent service switch to permit the selection of independent or automatic operation.
    - (5) A duplex 120 volt, A.C., electrical convenience outlet.
    - (6) A start button for closing the doors and starting the elevator when operating on independent service. Alternately, the floor pushbuttons may be used for this function.
    - (7) Spring return test button or switch for battery pack standby lighting.
- L Signage: Provide the following black paint filled engraving. Size and style as approved by Architect.
- 1. Elevator Car:
    - (a) "No Smoking - L.A.M.C. No. 41.51 - Subject to Fine" over main car stations.
    - (b) Elevator number over main and auxiliary car stations.



- (c) Elevator capacity in pounds over main car station.
  - (d) Engrave service panel or telephone cover plate with:  
  
"Should the elevator doors fail to open or the elevator become inoperative:  
Please do not become alarmed.  
Please use the button marked Alarm to summon assistance, or telephone  
if furnished.  
Remain in the car until assistance arrives and do not attempt to force  
doors or hatch open."
  - (e) Engrave front return or car station faceplate with Phase II fire service  
verbiage per A.S.M.E. A17.1.
  - (f) Locate engraving as directed by code enforcing authority.
  - (g) Building name and address to be engraved on the service cabinet.
- M. Car Top Control Station: Per Code. Provide with minimum 4'-0" long, permanently  
attached, extension cord for remote operation.
- N. Emergency Exits: Provide contact and operation per CCR Title 8.
- O. Work Light and Duplex Plug Receptacle: Provide on top and bottom of elevator car.  
Provide lights with on-off switch and bulb guard.
- P. Exhaust Blower: Morrison Products model "AA" or approved equivalent. Two-speed,  
squirrel cage 300-350 c.f.m. exhaust blower. Isolate blower from car steel canopy on  
rubber grommets.
- Q. Communication system: Provide push to talk telephone instrument, with shielded wiring  
from individual elevator controllers in machine room to each car. Engrave face of service  
cabinet with building name and address. Locate speaker grille as directed by Architect.  
Instrument shall meet the requirements of the Americans with Disabilities Act.

## 2.08 CAR ENCLOSURES

- A. Provide as specified in Articles 2.01 and 3.03, F.
- B. Side and Rear Walls: Reinforced 14 (.075") gauge furniture steel fabricated with textured  
stainless steel in pattern selected by the Architect. Wall panels shall not exceed 15" widths  
and shall be suitable reinforced. Apply sound deadening mastic to exterior.
- C. Canopy: Reinforced 12 gauge (.090") furniture steel with hinged exit and baked enamel  
finish.
- D. Stationary Front Return Panels and Integral Entrance Columns: 14 gauge (.075") #4 stain-  
less steel. The car stations shall be recessed flush with the front returns.
- E. Transom: 14 gauge (.075") #4 stainless steel.

- F. Car Door Panels: Same construction as hoistway door panels clad with 14 gauge textured stainless steel in pattern selected by Architect.
- G. Base: None. Include ventilation slots.
- H. Handrails: Double row, two side walls. One row 12" off finish floor with 4" x 3/8" stainless steel bars, second row 32" off finish floor with a 1-1/2" diameter grabbing surface (measured to top of handrail). Both rails shall be fastened to wall at maximum 12" intervals.
- I. Lighting: Adequate lighting to provide a minimum of 5 foot candles of illumination on the car sill. Incandescent down lights, mounted in a mirror stainless steel drop ceiling shall be provided.
- J. Flooring: Provide adequate subfloor and reinforced platform for concentrated loading. Condition floor surfaces so that they are clean, smooth, firm, and free from dirt or any other damaging material. Cracks wider than 1/8" and holes larger than 1/4" in diameter shall be filled. All ridges or other uneven surfaces shall be planed, scraped, or sanded smooth. Lining felt shall be applied over wood floor surfaces and seams in felt shall be butted. Adhesive shall be applied in accordance with manufacturer's recommendations.  
  
Install flexible homogenous vinyl tile flooring not less than 1/8" thick, color and type as approved by the Owner. Lay tile flush with sill.
- K. Pads and Pad Buttons: Provide one set. Provide satin stainless steel buttons in all cars. Pads shall be of fire-resistant material, canvas covered and when hung shall cover all walls and returns of the car.

## 2.09 LANDING CONTROL STATIONS

All fixtures and buttons shall be vandal-resistant.

- A. Pushbuttons: Provide each elevator group with a single riser at front openings. Pushbutton stations shall include flush-mounted faceplates constructed of satin stainless steel. Each fixture shall contain pushbuttons for each direction of travel which illuminate to indicate call registration.
- B. Provide engraved signage, including pictorials, in elevator lobbies:
  - 1. "In case of fire use stairways for exit. Do not use elevator" and pictorial per U.B.C. Include as part of corridor pushbutton plates or separate sign at each floor, as selected by Architect. Separate sign shall be same material and finish as corridor pushbutton cover plate.
  - 2. Provide engraved plate at main lobby adjacent to fire return switch with Phase I and Phase II operating instructions per Code. Material and finish shall be the same as corridor pushbutton faceplate.
- C. Hoistway Access Switches: Mount in entrance frame side jamb at all top terminals. Mount in entrance frame at bottom terminals where walk-in pits are not provided. Provide fixture without faceplate.

## 2.10 SIGNALS

All lenses and fixtures shall be vandal-resistant.

- A. Hall Lanterns: A signal fixture shall be provided at each entrance to indicate the intended direction of travel of the elevator to waiting passengers. The fixture shall contain projecting lights suitably shielded, and an electronic tone mechanism mounted in a metal box fastened in the wall. The up or down light shall be illuminated and the tone sounded (twice for down direction travel) 5 seconds prior to the car's arrival at a floor. The light shall remain illuminated until shortly before the elevator doors start to close. Hall lantern notification time shall be adjustable between 4-10 seconds prior to car arrival. Illumination of hall lantern lights shall be sufficient to be easily visible within well-lighted lobbies. The tone shall be adjustable from 40-92 dBa in corridor. The hall lanterns shall consist of arrow lenses with faceplates. Provide faceplates fabricated of stainless steel.
- B. Car Position Indicators: Position indicators shall be provided in each elevator transom. The fixture shall consist of a metal box mounted behind the transom and shall contain multiple indications representing the floor served and the direction of car travel. When a car leaves or passes a floor, the numeral representing the floor shall be visible, thereby indicating the position of the car in the hoistway at all times. The proper direction arrow shall be continuously visible to indicate the direction of travel. Provide fixture with stainless steel finish faceplate.
- C. Lobby Car Position Indicator: Provide a multi-light type position indicator with directional arrows mounted above the main lobby entrance. Provide fixture with a stainless steel finish faceplate.

## 2.11 CONTROL PANELS AND SECURITY SYSTEM

SEE SECTION 14200. This elevator panel shall be incorporated into the same faceplate as the panel specified in Section 14200. All requirements as set forth in 14200 shall apply.

## 2.12 SEISMIC PROTECTION

Provide per CCR, Title 8.

## PART 3 - EXECUTION

### 3.01 SITE CONDITION INSPECTION

- A. Prior to beginning installation of equipment, examine wellways, hoistways, and machine room areas. Verify that no irregularities exist which affect execution of work specified.
  - 1. Hoistway size and plumbness.
  - 2. Sill supports and pockets.
  - 3. Support areas for brackets, beams, etc.
  - 4. Divider beams.

5. Wellhole location, depth, and size.
  6. Structural supports.
- B. If field dimensions are found to be the same as shown on reference drawings for each unit, and should modifications be required, the Elevator Contractor shall perform structural alterations, or modify mechanical systems as required, at no additional cost.
- C. Do not proceed with installation until work in place conforms to project requirements.

### 3.02 PRODUCT DELIVERY, STORAGE, AND HANDLING

- A. Deliver materials in Manufacturer's original, unopened protective packaging.
- B. Store material in original protective packaging. Prevent soiling, physical damage, and wetting.
- C. Protect equipment and exposed finishes during transportation, erection, and construction against damage and stains, and until equipment is fully operative, against damage, stains, deterioration, and environmental conditions.
- D. Completely protect exposed surfaces from adjacent construction activity until final acceptance of the work. Remove and replace damaged or discolored material with new material at no additional cost to the Owner. No use shall be made of the equipment by any other trade.

### 3.03 COORDINATION REQUIREMENTS

- A. Elevator Contractor shall be responsible for using the existing jack hole location.
- B. Cladding: Review all contract drawings. Coordinate methods of securing cladding (i.e. to truss) with General Contractor, Architect, and affected subcontractors prior to such actual work.
- C. Floor Finish at Elevator Sills, Cars: Coordinate with other trades.
- D. Machine Room Air Conditioning, and Ventilation: Coordinate with other trades for the installation of air conditioners and ventilating fans. Units shall not be installed in the machine rooms.
- E. Security Requirements: Contractor shall be responsible for securing contents of machine room, he shall control access to rooms and ensure that they remain secure.
- F. Painting: Provide information to painting subcontractor on prime finish used on hoistway entrances and use of compatible products for final painting.
- G. Local Conditions Covering Work:
  1. The Contractor shall cooperate with those in authority on the premises to prevent the entrance and exit of all workmen and/or others whose presence is forbidden or undesirable and in bringing, storing or removal of all materials and equipment, (to observe all rules and regulations in force on the grounds), to avoid unnecessary

dust, or accumulated debris or the undue interference with the convenience, sanitation or routine of the Owner (and to prevent the loss of, or damage to the property of the Owner and/or his/her employees). The Contractor shall repair any and all damage he/she may cause to the building or property, to the full satisfaction of the Owner.

2. Contractor shall maintain the machine room, machinery spaces, hoistways and pits in reasonably clean condition at all times.

H. Job Supervisor: The Contractor shall indicate one person who shall be responsible for the scheduling control and performance of work specified in the Contract. This person shall be available upon request by the Owner to review any aspect of this contract. The Contractor shall notify the Owner if there is a change in job supervisors.

### 3.04 INSTALLATION

- A. Install each equipment item in accordance with accepted Manufacturer's direction, referenced codes, and specifications.
- B. Install machine room equipment with clearances in accordance with referenced codes and specifications.
- C. Install items so they may be easily removed for maintenance and repair.
- D. Install items so that access for maintenance is safe and readily available.
- E. Install equipment to afford maximum safety and continuity of operation in the event of seismic activity.
- F. Provide elevator car enclosure as detailed on architectural drawings and herein specified. The Elevator Contractor shall supervise and coordinate all drawings and materials included in this specification and also install the cars. The Elevator Contractor shall also be responsible for the following:
  1. Furnish and install all electrical controls and signal fixtures, lighting fixtures, and wire complete. Provide a minimum of 5 foot candle illumination at car sill with doors closed. Provide temporary lighting as required.
  2. Furnish and install emergency lighting. Locate to provide minimum 0.2 foot candle illumination 12" in front of main car station measured 48" above finish floor.
  3. Furnish and install on-board conduit and wiring to lighting and ventilating fixtures, as required.
  4. Furnish and install headers, tracks and threshold.
  5. Furnish and install hangers and gibs on car doors and hang doors.
  6. Furnish and install car fixtures complete.
  7. Furnish and install communication system as herein specified.

8. Basic construction shall be all steel, minimum 14 gauge.
  9. Furnish and install two-speed squirrel cage 300 - 350 c.f.m. exhaust blower. Blower to be isolated from car steel canopy on rubber grommets.
  10. Provide vent slots per Code.
  11. All enclosures shall be installed per International Union of Elevator Constructors' agreement.
- G. Paint all non-galvanized ferrous metal work, except where paint would interfere with operating mechanisms.
- H. Clean the following items of oil, grease, scale, and other foreign matter, and apply one coat of field-applied machinery enamel.
1. All equipment and metal work installed as part of this work which does not have architectural finish and which is exposed in the hoistway.
  2. Machine Room Equipment: machine, power conversion device, controller, and selector.
  3. Neatly touch up damaged factory-painted surfaces with original paint and color. Protect machine finish surfaces against corrosion.

3.05 MATERIALS

- A. Stainless Steel:
1. Shapes and Bars: ASTM 276, Type 316.
  2. Plate, Sheet, and Strip:
    - a. Over 1/8-inch: ASTM A264 with ASTM 240, Type 316 on A36 base.
    - b. Under 1/8-inch: ASTM 167, type 316.
  3. Pipes and Tubes:
    - a. Welding: ASTM A312, Grade TP 316, Schedule 10 minimum.
    - b. For Screwed Connections: ASTM A312, TP 316, Schedule 50S.
    - c. For Press Fits: ASTM A312, Grade TP 316, Schedule 5S minimum.
- B. Die Cast Aluminum: ASTM B108, Alloy 356.0, T6.
- C. Extruded Aluminum: FS QQ-A 200/8, Alloy 6061, T6.

D. Fasteners:

1. Provide bolts, nuts, washers, screws, nails, rivets, and other fastenings necessary for proper erection and assembly of work.
2. Fasteners shall be compatible with material(s) being fastened.
3. Exposed:
  - a. Match adjacent material in appearance, finish, and color.
  - b. Countersink, unless otherwise indicated.
  - c. Screws: Provide Phillips flathead type.

E. Welding Electrodes: E70XX per AWS A5.1 or A5.5.

3.06 FINISHES

- A. All equipment and metal work installed or reused under this contract, which does not have a baked enamel or special architectural finish and which is exposed in the hoistway, shall be cleaned and painted one field coat of enamel. The shank and base of the T-Section of the guide rails shall be thoroughly cleaned and painted one field coat of black metal enamel.
- B. All machine room equipment shall be painted upon completion of the installation with the manufacturer's standard machinery enamel.
- C. All natural metals shall be of the best grade and shall have the grain of belting in the direction of the longest dimension with a fine, brushed finish. All surfaces shall be perfectly smooth and without waves.
- D. Clean and paint machine room floor upon completion of new and modernization work.
- E. All natural metals shall be stretcher-leveled, resquared sheets. Sheets shall be .063" minimum for door facings, and .074" minimum for entrance frames and front returns. The grain of belting shall run in the direction of the longest dimension. A satin finish shall be provided by first removing tool-and-die marks and then finishing with No. 80, 100, and 120 grit sanding belts. All surfaces shall be perfectly smooth and without waves.
- F. Provide detailed information relative to recommended methods of preparation, cleaning and application of primed elevator door entrances for final paint.
- G. All metal surfaces requiring bronze finishes shall be manufactured from material of not less than 60% copper, 40% zinc, containing no lead or nickel. Finish metal with #120 grit. Apply two coats of lacquer to protect surface unless surface is to be field oxidized.
- H. Stainless Steel: Manufacturer's Standard Type 316, No. 4 finish.
- I. Aluminum Castings and Extrusions: Manufacturer's Standard Commercial mill finish.

3.07 FIELD QUALITY CONTROL

- A. Work at the jobsite will be checked during the course of installation. Full cooperation with reviewing Lerch, Bates and Associates' personnel is mandatory. All procedures shall be established in a pre-construction conference. Accomplish corrective work required prior to performing further installation.
- B. Have Code Authority acceptance inspection performed and complete corrective work.

3.08 ADJUSTMENTS

- A. Align guide rails vertically with tolerance of 1/16" in 100'. Secure joints without gaps and file any irregularities to a smooth surface.
- B. Balance cars to equalize pressure of guide shoe rollers on rails.
- C. Lubricate all equipment in accordance with Manufacturer's instructions.
- D. Adjust motors, pumps, valves, generators, brakes, controllers, leveling switches, limit switches, stopping switches, door operators and switches, interlocks and safety devices, etc., to achieve required performance levels.
- E. Fabricate and assemble various parts in shop to minimize field assembly. Assemble parts which require close field fit in the shop and mark for field erection.

3.09 CLEANUP

- A. Keep work areas orderly and free from debris during progress of project. Remove packaging materials on a daily basis as equipment is installed.
- B. Remove all loose materials and filings resulting from work on a daily basis.
- C. Clean machine room equipment, floor, and truss interiors of dirt, oil and grease.
- D. Clean balustrades, handrails, skirts, steps, hoistways, cars, car enclosures, entrances, operating and signal fixtures, and trim of dirt, oil, grease, and fingermarks.

3.10 ACCEPTANCE INSPECTION AND TESTS

- A. General: Furnish labor, materials, and equipment necessary for tests. Notify Elevator Consultant 30 days in advance when ready for final review of entire work. Final acceptance of installation will be made only after all field-quality control reviews have been completed, identified deficiencies have been corrected, all submittals and certificates, including certificates by authorities having final legal jurisdiction have been received, and the following items have been completed to satisfaction of Owner and Elevator Consultant's satisfaction.
  - 1. Workmanship and equipment comply with specification.
  - 2. Contract speed, capacity and floor-to-floor performance comply with specification.



3. Performance of following are satisfactory:
    - a. Starting, accelerating, running, stopping.
    - b. Decelerating, stopping accuracy.
    - c. Door operation and closing force.
    - d. Equipment noise levels.
    - e. Signal fixture utility.
    - f. Overall ride quality.
  4. Test Results:
    - a. In all test conditions, obtain specified speed, performance times, floor accuracy without releveling, and ride quality to satisfaction of the Owner and Elevator Consultant.
    - b. Temperature rise in windings limited to 50 degrees Celsius above ambient. Conduct a full-capacity, one-hour running test, stopping at each floor for 10 seconds in up and down directions. Replace equipment if equipment performance is questionable in Elevator Consultant's opinion.
- B. Performance Guarantee: Should tests reveal defects, poor workmanship, variance or noncompliance with requirements of specified Codes and/or ordinances, or variance or noncompliance with the requirements of specifications, complete corrective work to satisfaction of Owner at no cost:
1. Replace equipment that does not meet Code or specification requirements.
  2. Perform work and furnish labor, materials and equipment necessary to meet specified operation and/or performance.
  3. Perform and assume cost for retesting required by Governing Code Authority, Consultant, and Owner to verify specified operation and/or performance.
- C. Field Review Scheduling: The Elevator Consultant shall schedule all installation progress reviews and final equipment and installation reviews with the Elevator Contractor. The Consultant anticipates that schedules shall be met. The Elevator Contractor is required to reply in writing to all corrective measures indicated on Elevator Consultant's progress and/or final review reports. The Consultant also anticipates that corrective measures indicated in his written review shall require no more than one follow-up review to verify Elevator Contractor's compliance. It is agreed that Elevator Contractor shall reimburse the Elevator Consultant at his normal billing rates for appointments not kept or additional follow-up reviews required due to the Elevator Company's gross non-compliance with initial review requirements.



3.11 OWNER'S INFORMATION

- A. Submittals: Provide written information necessary for proper maintenance and adjustment of the equipment prior to final acceptance. Final retention will be held until data is received by Owner.
1. Straight-line wiring diagram of as-installed elevator/escalator circuits with index of location and function of all components. Provide three neatly bound final corrected sets within 30 days after job acceptance for the Owner's file.
  2. Lubricating instructions, including recommended grade of lubricants. Provide three neatly bound copies.
  3. Parts catalogs for all replaceable parts including ordering forms and instructions. Provide three neatly bound copies.
  4. Six sets of each key for each key switch. All keys shall be properly tagged.
  5. Three sets of secondary containment monitoring instruction manuals and equipment catalogs.
  6. Provide any special tools which may be required to maintain, troubleshoot, repair or replace parts of any equipment furnished.
  7. Instruct Owner in general operation and use of elevators and procedures to follow in the event of an emergency, including cleaning procedures. Instruction seminar with written material to be conducted at the jobsite with preselected employees.

END OF SECTION



SECTION 14300

ESCALATORS

PART 1 - GENERAL CONDITIONS

See Section 14200 for common requirements.

PART 2 - PRODUCTS

2.01 SUMMARY

A. Escalators:

NUMBER:	FOUR, ESCALATOR NOS. 1, 2, 3, 4
FLOORS SERVED:	1 TO 2; 2 TO 3 - VERIFY ON DRAWINGS
RISE:	14'-4" +/- - VERIFY ON DRAWINGS
SIZE:	48" WIDE
SPEED:	100 F.P.M.
MANUFACTURERS:	OTIS 510 MONTGOMERY CRYSTAL 2000 FUJITEC PLS-22 MITSUBISHI JSS-A SCHINDLER SWE O AND K TRANSLIGHT
ARRANGEMENT:	PARALLEL
OPERATION:	REVERSIBLE, TRAVEL UP OR DOWN
BALUSTRADES:	TEMPERED GLASS WITHOUT MULLIONS
DECK BOARDS:	SATIN BRONZE FINISH
MOLDING AND TRIM:	SATIN BRONZE FINISH
SKIRT PANELS:	SATIN BRONZE FINISH
HANDRAIL COLOR:	BLACK
STEP RISER:	CLEATED
POWER SUPPLY:	VERIFY ON DRAWINGS
ADDITIONAL EQUIPMENT:	DEMARCATON LIGHTING - TOP AND BOTTOM

NARROW COMBPLATES

HINGED FLOOR PANS

ANTI-SLIDE KNOBS AND FLOOR INTERSECTION BARRIERS

TRUSS EXTENSIONS AS REQUIRED TO MEET STRUCTURAL  
SUPPORTS - VERIFY ON STRUCTURAL DRAWINGS

### PART 3 - EXECUTION

- A. Installation: Comply with applicable codes, manufacturer's instructions, shop drawings and recommendations. Comply with National Electrical Code (ANSI C1 by NFPA) for electrical work required during construction.
- B. Final Inspection and Test: Comply with ANSI A17.2, latest edition including supplements, Inspector's Manual. Comply with requirements of Owner's consultant.

#### 2.02 PERFORMANCE

The escalator shall be capable of operating at full-speed with full-load in either direction of travel, 16 to 20 hours a day, seven days a week.

#### 2.03 MACHINE ROOM EQUIPMENT

- A. Drive Machine:
  - 1. The machine shall be of worm gear type especially designed for escalator service. The machine shall be mounted within the truss and connected by chain to the main drive shaft of the escalator or to teeth of each end of each step.
  - 2. Worm Gear Requirements:
    - a. The worm member shall be of steel and worm gear shall be of special alloy bronze. The thrust shall be taken up by ball bearings. The worm and gear shall be provided with roller bearings having ample bearing surfaces and shall run in oil in an oil tight housing.
    - b. Provide single stage type, with positive engagement.
    - c. Worm gear bearings shall be housed in an oil tight dustproof case provided with a means of determining oil level in case and for draining of oil.
    - d. Lubricant compartment shall contain lubricant heaters for street level or above ground installations unless synthetic lubricants are used.
    - e. Gear assembly shall be coupled to motor by worm shaft, brake unit, and non-metallic coupling and motor flange fastened to gear case having no openings to minimize accumulation of dust and debris.

b. Service Brake:

- (1) Brake shall be manually applied, mechanically engaged to prevent movement of linkages, while escalator is disconnected from its power supply.
- (2) Provide electrical interlock that shall prevent escalator drive motors from starting while service brake is engaged.

C. Motor:

1. The electric motor shall be integrally mounted on the drive machine, shall have ball bearings and be designed and manufactured for use with escalators, and shall develop adequate starting torque.
2. The motors shall be totally enclosed with external cooling fans.
3. The motor protection class must be equivalent to I 65.
4. Insulation Group: B.
5. The motor shall be flange mounted to the main drive gear case and separated from worm shaft by a non-metallic energy absorbing coupling.
6. Driving motors and motor switchgear shall be designed in such a way to provide a smooth start which will prevent possible passenger accident as well as undue strain on drive components.
7. The rated efficiency shall be designed for a continuous operation.

D. Controller:

1. The controller shall be electromagnetic type designed for escalator use. It shall include electromagnetic switches and thermal overload relays which shall be designed to protect motor, and interrupt power to the motor should a safety device be actuated. The switches and relays shall be mounted on a panel, supported by a metal frame.
2. A separate fused disconnect switch shall be provided in the upper landing of the escalator truss.
3. Wire to identified terminal block studs. Identifying symbols or letters identical to those on wiring diagrams permanently marked adjacent to each component on the controller.
4. Provide mainline circuit breaker and means to protect motor against overload and single phasing.
5. Controller Cabinets-Switchgear:
  - a. Control switchgear shall be mounted in a portable NEMA cabinet. Removable from machine room for easy access to switches and wiring.

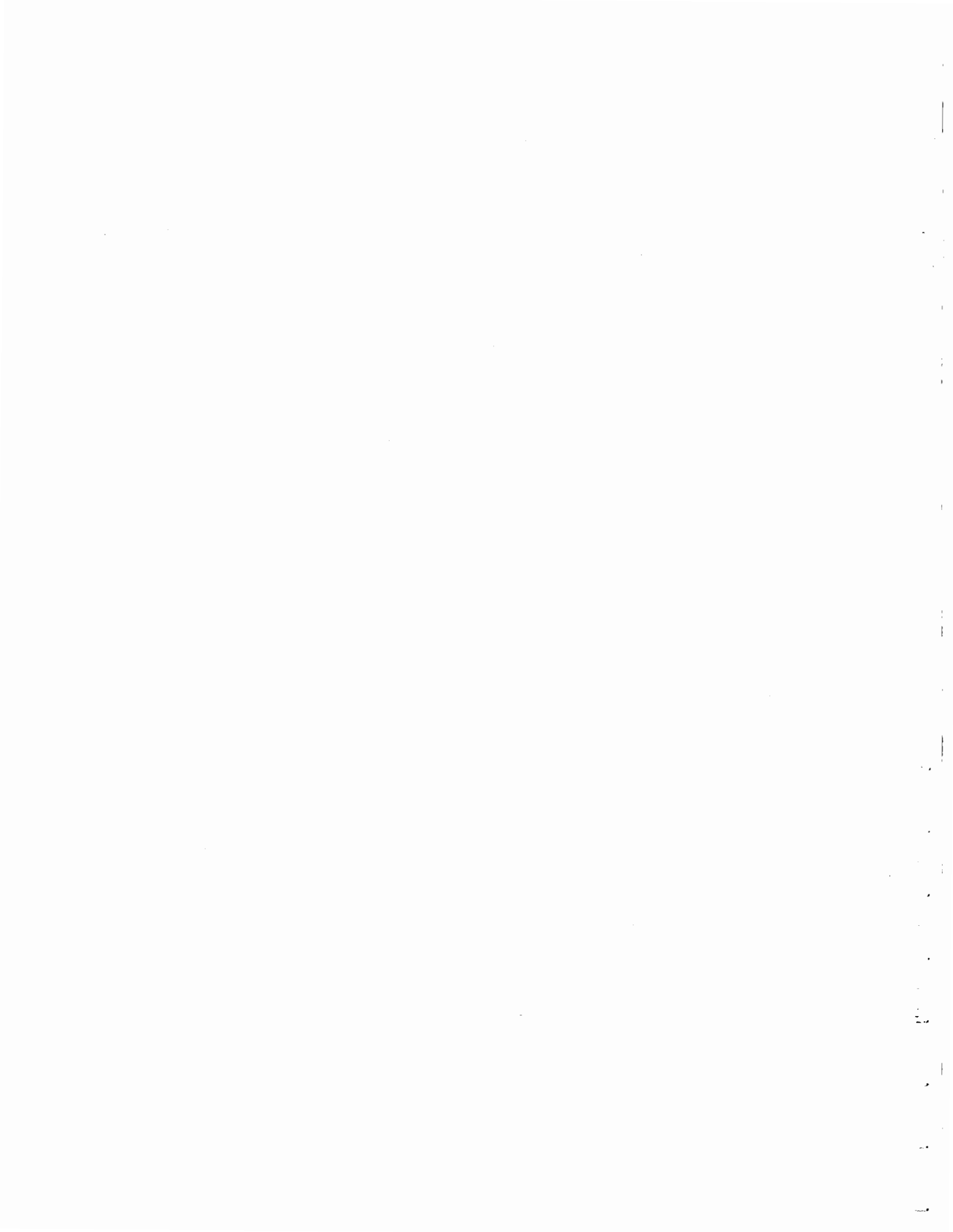



- b. The main control switchgear of an escalator shall contain at least the following devices:
    - (1) Lockable main switch.
    - (2) Thermal and magnetic motor protection starter for up and down travel.
    - (3) Hour counter.
    - (4) Auxiliary contactors.
    - (5) Phase failure device.
    - (6) Phase sequence monitor.
    - (7) Ground fault monitor.
    - (8) Key switches to start and/or reverse direction of travel.
    - (9) Interlocks to bring the escalator to a smooth stop before a change of direction may be made.
  - c. All terminals shall have identification markings and cables shall be provided with cable markers.
- E. Driving Sprocket: Machine sprockets at each side over which step chains or step chain rollers shall pass and transmit motion from machine to steps. If chain drive is used between machine and drive sprocket, provide emergency brake on drive assembly to automatically function if drive chain fails. Provide roller type sealed bearings with means for lubrication and adjustment for wear.
- F. Idler Sprocket: Spring tensioning device to take up slack in step chain and maintain constant tension on chain. Provide roller type sealed bearings with means for lubrication and adjustment for wear.
- G. Vents: Provide requirements for vents and/or grilles for expelling heat from machine room spaces.
- 2.04 WELLWAY EQUIPMENT
- A. Truss: Heavy-duty type; painted with a gray, high solid lead and chromate-free primer with a gray, high solid epoxy primer, to safely carry entire load of escalator, including all parts of escalator, full-capacity load and weight of exterior truss and balustrade covering material. Provide factor of safety per Code.
- 1. The structural steel truss shall be of lattice-type construction to facilitate inspection of the interior of the escalator. It shall be designed to support the load of the passengers, the mechanism of the escalator, and the exterior covering panels. It shall have a factor of safety as prescribed by the latest edition A.S.M.E. A17.1. In the event of track system failure, the truss shall retain the running gear in its guides.

2. The truss shall span the distance between the support points as indicated. The working points as indicated shall not be moved. The truss extension method shall be used to size the truss.
3. Trusses shall be sufficient width to accommodate the width of the finished escalator.
4. Intermediate supports shall not be provided.
5. Trusses shall be designed to set on the top and bottom support beams.
6. Trusses shall be of ample strength to maintain alignment of tracks and moving parts and so designed that they shall safely retain steps and running gear, and in case of failure of track systems, retain step mechanism within guides and envelope of the truss.
7. The truss shall be designed to support the dead weight of the escalator and a passenger load which is required by Code.
8. Provide access panels for access to escalator parts for inspection and maintenance.
9. The truss shall not vibrate when the escalator is in use.
10. The working points are located as indicated on the contract drawings.

**B. Drip Pans:**

1. Oil-tight, 14 gauge steel pans painted with a zinc chromate primer, welded to the underside of the truss with sufficient rigidity to withstand weight of workman beneath truss to run entire width and length of truss.
2. Provide drip pans extending the full inside length and of sufficient width to collect and maintain, within truss areas, oil and grease drippings from step linkage and all forms of loose debris that may be deposited in drip pans from steps at turn-around point at upper and lower portions of truss.
3. Drip pan collectors in lower ends of escalator wellways shall be removable for cleaning, or be otherwise accessible for easy cleaning.

**C. Tracks:** Ensure perfect alignment and smooth operation of running gear under all conditions.

1. Design and fabricate tracks to retain steps and running gear safety under load requirements and highest design speeds specified.
2. Assemble and secure sections of track together for easy removal and replacement. System shall be adjustable.
3. Design mechanical components for easy installation and removal without dismantling parts of the structure.

4. Tracks shall be properly supported on trusses to provide correct alignment and smooth transition to return stations.

D. Electrical Wiring:

1. Conductors: Braided copper cores throughout with individual wires coded and all connections on identified studs or terminal blocks.
2. Conduit, Etc: Conduit size shall be 1/2" minimum except that 3/8" can be used for runs containing only two wires. Flexible conduit exceeding 18" in length shall not be used.

E. Step Chains: Two main step chains shall be supplied, connected through solid steel axles in precision matched lengths and be manufactured from high quality steel incorporating links, pins, bushes, and rollers with hermetically sealed, prelubricated bearings. The pins, bushings, and roller shall be hardened and ground. The chains shall be designed to suit the basic loadings and safety factor, relative to the vertical rise of each escalator. Step chains shall be lubricated by an automatic lubrication system.

1. Only endless precision roller-fishplate chains of high grade, heat treated steel shall be used as step chains.
2. These chains shall be made for heavy-duty escalator application and designed to prevent upthrust bucking at lower end return.
3. The breaking factor of safety of a step chain defined as a ratio of chain braking load to chain traction force, assuming the maximum operating load per step must be at least ten, except when the chain is composed of annealed cast links, in which case the factor of safety shall be not less than 20.
4. Step chains shall be of laminated or forged construction, supported at intervals by linkage wheels. The chain rollers shall have polyurethane tires on metallic hubs, hermetically sealed, requiring no additional lubrication and mounted outside the chain link.
5. Provide automatic tension devices where required, to maintain tension under load and to compensate for wear.
6. Provide means for individual fine adjustment of tension for each linkage, if required.
7. Step chains shall be constructed to permit removal of segments as may be required for replacement purposes.
8. Provide support wheels spaced to distribute load and to guide linkage throughout run. Construct wheels of polyurethane material, with diameter sufficient to provide reliability, maintainability, smoothness of motion, and to operate within noise level requirements specified.

F. Step Assembly: Die-cast aluminum step fastened to the drive chain axles. Step rollers shall have sealed ball bearings and be made of synthetic composition material. Treads and risers shall be constructed of cleated die cast aluminum with black reveals. The

design shall permit the easy removal of the step without disturbing the balustrade. Steps shall be covered on the underside with sound-deadening material and shall be removable from unit without disturbance of balustrade or step chains.

1. Provide yellow step demarcation strips on the rear and sides of each step. Side demarcation strips to be raised type.
2. Provide step demarcation lights at the top and bottom landing of each escalator per Code.
3. Riser:
  - a. Risers shall be of cast aluminum, furnished with full height vertical cleats.
  - b. Risers shall form an interlocking unit with the step tread of the adjacent step. Step risers shall include vertical cleats designed to pass between the cleats of the adjacent steps thus providing a combing action with minimum clearances.
  - c. Paint grooves on risers black.
4. Treads:
  - a. Treads shall be die-cast aluminum, cleat type, designed to assure foothold and comfortable tread surface. Paint black.
  - b. Provide chamfered or radius nosings of 1/8" at riser edge of tread.
5. Step Frames: The step frame shall be of aluminum cast, reinforced and braced to carry the step treads.
6. Step Wheels:
  - a. Provide tires of polyurethane or approved equivalent on metallic hub and hermetically sealed prelubricated bearing.
  - b. Locate and arrange step wheels to minimize tilting or rocking of steps.
  - c. Step rollers shall run in ball bearings and shall be enclosed in a completely dust and watertight manner.

## 2.05 HANDRAILS

- A. Moving Handrails: Each balustrade shall be provided with a handrail moving at substantially the same speed as the steps and in the same direction. The handrails shall have a specially coated finish on underside to minimize friction. The handrail shall be constructed of rubber or neoprene covered canvas with suitable reinforcement and made endless by suitable vulcanized joints. They shall run on formed guides attached to the balustrade. Handrails, handrail drive system, and guides shall be so designed and installed that handrail cannot be easily pulled off or disengaged while running, and special design attention shall be given to area where handrail passes from drive system

to guides. Hand or finger guards shall be provided where the handrails enter or leave the escalator newels. Handrail color to be black.

- B. Tensioning Device: Provide means to adjust handrail tension and to release tension for repair or removal of handrails. Provide slack tension device to stop the escalator if handrail tension becomes too loose.
- C. Handrail Drive: Handrail drive shall have one coat of zinc chromate primer and one coat of aluminum enamel.
- D. Handrail Wheels: Handrail wheels shall have sealed bearings that have provision for retention of lubricant to ensure satisfactory lubrication and operation. No additional lubrication shall be required.
- E. Friction Drive Wheels and Idlers: Friction drive wheels and idlers shall be designed and positioned so that lubricant cannot reach surface of handrail. Marking and spotting of handrail by drive equipment shall not be permitted.
- F. Handrail Guides: Handrail guides shall be continuous on exposed portion of handrails, constructed of material not subject to corrosion of pitting and having polished or specially coated permanent finish to minimize frictional wear to under surface of handrail. On the unexposed portion guiding is to be by rollers having sealed bearings, adjustable and shall not to be set in a way to cause wear on the handrail.

#### 2.06 BALUSTRADE, SKIRT PANELS, AND DECKING

- A. Balustrade: The balustrade shall be of the extended newel type and shall consist of the following materials:
  - 1. Moldings: 16 gauge with satin bronze cladding.
  - 2. Interior Panels: 1/2" thick tempered glass.
- B. Skirt Panels: Skirt panels shall be 14 gauge with a Teflon impregnated steel or satin bronze cladding with friction reducing material to prevent binding. Backing panels where used, shall be noncombustible. Attach panels to permit easy removal for inspection, lubrication, and adjustment of safety devices.
  - 1. Construct panels in equal lengths for interchangeability where practical.
  - 2. Size of panels shall be designed so that not more than two persons may remove a panel without aid of special handling equipment.
  - 3. Panel Fastener Requirements: Panels shall be fastened to their respective supports or mating portions with tamper-resistant, captive flathead machine screws.
    - a. Fastener removal shall be possible with aid of simple tools.
    - b. When framework to which panels are fastened is less than 1/4"-thick, steel backup plates with a minimum 1/4" thickness shall be added which have tapped holes or clearance holes where necessary.

c. Supports: Support paneling, decking, and other enclosures on steel framework.

C. Deck Boards: U.S. No. 14 gauge minimum with a satin bronze cladding reinforced to provide rigid panels with a smooth, flat upper surface. All horizontal joints shall be butted to provide a smooth surface.

D. Trim and Moldings: 16 gauge, with a satin bronze cladding.

## 2.07 LANDINGS

### A. Combplates:

1. Locate sectional type yellow combplates at the top and bottom landings, designed to properly mesh with the cleats on the step treads.
2. Fabricate combplate assemblies of Textolight, aluminum, or other alloy with a wear-resisting, non-corrosive material, and exposed anti-slip surfaces.
3. Provide comb teeth sections meeting the following requirements:
  - a. Comb teeth shall be made in sections so that a section can be readily replaced without the use of special tools. All special tools shall be provided to the Owner.
  - b. Make provisions for fine lateral and vertical adjustment so that cleats of step treads shall pass between comb teeth with minimum clearances.
  - c. Teeth shall be designed to engage treads on escalator steps with danger of injury to passengers reduced to a minimum and to prevent breakage and wear of teeth caused by interference with step treads.

### B. Landing Plates:

1. Plate shall extend from combplates to access panel at upper and lower ends. Plate shall extend full width of truss where it extends beyond newel.
2. Structural steel frames with extruded aluminum floor plates to match the combplates.
3. Plate shall be designed for live load of 150 pounds per square foot. Each plate shall have a maximum deflection of 1/16".
4. Plates shall be extruded or cast aluminum in a ribbed pattern transverse to the escalator axis. Ribs shall be designed to provide maximum traction, and will be finished in the same manner as the combplates.
5. Plates have exposed portions constructed of material and finish to harmonize with steps and combplates.

6. Plates shall be lightweight and hinged for ease of access to machinery and maintenance areas below and shall require no more than 70 l.b.f. to open; fabricate in sections of size and weight capable of being handled by one person.

- C. Access Door: Special hinged access door designed to accept a terrazzo finish shall be provided in the floor at the upper and lower terminal truss for entry into machine room or equipment areas. The door surface shall be constructed of non-slip aluminum. Space between individual access doors shall be the same material and finish as the access doors and shall be provided by the escalator manufacturer. The doors shall be hinged and counter-balanced if necessary.

#### 2.08 SIGNAL AND CONTROL FIXTURES

Provide in upper and lower newels with flush-mounted faceplates matching deck finish. Function and operation positions of switches and buttons shall be identified with engraved characters which are readily visible from a standing position. Each station shall contain the following:

- A. Red "emergency stop" buttons, which when actuated shall disconnect power supply to motor, automatically set brake and bring escalator to smooth stop. Cover with a spring loaded, hinged, clear safety shield that when lifted will ring an alarm buzzer located within the unit.
- B. Key directional start switch. The switch shall start and/or reverse direction of travel of the escalator.

#### 2.09 SIGNS

Provide "HOLD HANDRAIL" signs, emergency stop button cover signs, and warning signs, per Code. All signage to be approved by Architect prior to installation. Include verbiage "No strollers on escalators" same lettering and size as hold handrail signs. Sandblasted or engraved verbiage shall be provided on the outer deck. Applied signage shall not be acceptable.

#### 2.10 SAFETY AND OPERATING DEVICES

- A. Provide safety devices required by ASME A17.1 and other regulatory agencies.
- B. Safety switches shall be moisture-resistant type.
- C. At the upper and lower landing newels mount a fixture which includes a momentary pressure emergency-stop button and a key actuated direction start switch. This switch starts or reverses the direction of travel of the escalator. Detail graphics and location are indicated. Switch locations shall be as required by code. Provide a clear plastic hinged cover for the emergency-stop button that will ring a bell when opened. Locate escalator's keyed-operated switches on control panel, accessible, at both upper and lower landings located with graphics as indicated.
- D. Overspeed Device: Device shall be employed to remove power if the escalator speed varies more than allowed by Code.
- E. Handrail Entry Guards: Provide guards to prevent hands or foreign objects from being carried into the handrail entrance of the newel.

- F. Handrail Entry Stop Switch: Provide switch to stop the escalator if a hand or foreign object enters the handrail entrance of the newel. Provide at top and bottom for each handrail.
- G. Stopped Handrail Stop Device: Device shall be provided to remove power and stop escalator should handrail break, or stop moving, or stretch beyond a preset amount.
- H. Combplate Sensor: Provide device to stop the escalator if there is interference between the steps and combplate.
- I. Step Sag Device: Provide device to stop the escalator if the gap between the step and combplates becomes too great.
- J. Step Chain Tension Device: The escalators shall be provided with a device at the lower landing to maintain tension in the step chains. Safety switches shall be provided which will interrupt power to the motor if the tension should vary between pre-determined limits or should either step chain break.
- K. Missing Step Device: Provide a device to stop the escalator before a missing step emerges from the combplate or is exposed.
- L. Broken Drive Chain Device: An emergency brake, mounted on the main drive shaft, shall be provided so that, should the main drive chain part, the brake will operate and stop and hold the escalator and its load.
- M. Skirt Obstruction Device: Means shall be provided to cause the opening of the power circuit to the escalator driving machine motor and brake should an object become wedged between the stop and the skirt panel as the step approaches the upper or lower combplates.
- N. Non-Reversing Device: The controller shall include a device designed to stop the escalator should the direction of travel be accidentally reversed while the escalator is operating in the ascending direction.
- O. Step Demarcation Lights: Green step demarcation lights located below the step shall be provided at both landings within 16" of the combplate. There shall be a minimum of two fluorescent lamp fixtures at each landing. The lamps shall be activated whenever the escalator is in operation.

## 2.11 OPERATION REQUIREMENTS

- A. Sound Level: Escalators shall operate at or below 65 DbA measured 5 feet above the escalator at all locations with no load and full load. Measurement will be made with one escalator at a time running.
- B. Operation: Hours of operation will be 12 to 16 hours per day, seven days per week.



PART 3 - EXECUTION

Same as Section 14200, Part 3 - Execution.

END OF SECTION



**SECTION 15050**

**PLUMBING NOISE & VIBRATION CONTROL**

**PART 1 - GENERAL**

**1.01 RELATED DOCUMENTS**

General Provisions, General Conditions and General Requirements of the Contract apply to this Section, and SECTION: PLUMBING, GENERAL apply to this Section.

**1.02 DESCRIPTION**

A. Work Included:

1. Vibration isolation of Plumbing Pumps and Pumped Lines including Seismic restraints where required by code.
2. Isolation of domestic hot and cold water water lines, waste and vent lines.
3. Quiet valves and fixtures.

**1.03 GENERAL REQUIREMENTS**

A. Codes and Standards

1. Comply with all applicable codes

B. Submittals

1. See: PLUMBING, GENERAL
2. Seismic restraint calculations
3. Shop drawings for vibration isolated equipment

C. Vibration Isolation

1. Equipment

- a. Domestic Water Booster Pumps - 0.3 in deflection neoprene mounts

2. Piping
  - a. Pumped
    - (1) Main domestic water horizontal lines from booster pump to risers.
      - (a) 2" diameter or less - 0.2 inch deflection neoprene hangers
      - (b) Greater than 2" diameter - 1 inch deflection spring hangers
    - (2) Domestic hot and cold risers - 0.06" deflection Tpye PN neoprene pads with load distribution pads under riser clamps
    - (3) Other attachments of domestic water lines not described above - Trisolators
  - b. Non-Pumped Water Piping - Trisolators
3. Seismic Restraints
  - a. Mounted Equipment - snubbers to meet code
  - b. Suspended equipment and Piping - cables as required by code.
- D. Select pumps so that they operate at 1750 rpm or less utilizing an impeller which has a diameter of no more than 85% of the volute cutwater diameter.
- E. Plumbing fixtures
  1. No blowout - except where required by owner
  2. Siphon jet toilets and urinals
- F. Flush Valves
  1. Quiet type
  2. Adjust for minimum flow noise

## PART 2 - PRODUCTS

### 2.01 VIBRATION ISOLATORS

- A. Type PN: Neoprene pad. Waffle, ribbed, or other forms. Typically 1/4 to 5/16 inch thick. Durometers of 40 to 65. Static deflections from 0.01 to 0.07 inches. Nominal design 40 durometer for 0.05 inches static deflection. Provide steel load distribution plates. Size of pad to be specified by isolator supplier based on load per pot. Mason W and WM, Vibrex R, or equivalent.

- B. Type MN: Neoprene Mount. Conical with base plate or other forms. Durometers 40 to 70. Static deflections from 0.10 to 0.30 inches. Isolator to be sized by isolator supplier based upon load. Mason ND, Vibrex FU, or equivalent.
- C. Type HN: Neoprene hangers. Molded neoprene units in a steel hanger frame. Double deflection types with static deflection range from 0.1 to 0.3 inches. Designed to preclude contact of hanger rods with frame (30 degrees misalignment). Mason HD, Vibrex HSS, or equivalent.
- D. Type HS: Spring hangers. Steel spring with neoprene cap in steel hanger frame. Static deflection range 1.2 to 2.0 inches nominal. Designed to preclude contact of hanger rods with frame (30 degree misalignment.) Mason 30, Vibrex RMSA, or equivalent.
- E. Type T: Trisolators. Sheet metal sleeve with felt insert to be installed at attachment points of hangers or piping. Semco, Elcen, or equivalent shop fabricated device.
- F. Type SF: Flexible Pipe connectors: Flexible neoprene pipe connector manufactured of multiple plies of nylon tire cord fabric and neoprene both molded and cured in hydrolic rubber presses. Equivalent to Mason Industries, Type MFTNC.

## 2.02 SEISMIC RESTRAINTS

- A. General Properties of Seismic Restraints:
  - 1. Restraints shall permit adjustment during installation to ensure sufficient clearance between vibration isolated element and rigid restraining device.
  - 2. Restraints shall not be installed until vibration isolators have been loaded and adjusted to achieve the specific static deflection and clearances.
  - 3. Restraints at base supported equipment shall include resilient neoprene pads at all potential contact areas between isolated equipment and rigid restraining element.
- B. Seismic Restraint Description:
  - 1. Restraining devices at all base supported vibration equipment may be separate components sized and installed to meet the requirement specified above, or may be built into vibration isolation mounts.
  - 2. Restraint at all suspended piping and equipment shall consist of steel cables, arranged to achieve the required all-directional restraint and sized to resist the seismic forces as specified above. Shop drawings shall indicate proposed method of achieving vertical restraint for ceiling suspended piping. Cables shall have sufficient slack to avoid short-circuiting the vibration isolators.

**PART 3 - EXECUTION**

**3.01 INSTALLATION**

**A. Vibration Isolation**

1. All by single manufacturer
2. According to manufacturer's directions
3. To avoid stresses on piping and equipment
4. Isolation hanger boxes directly against building structure

**B. Seismic Restraints**

1. According to vibration isolation manufacturer's directions
2. Adjust so that there is no short-circuit of vibration isolators.

END OF SECTION

SECTION 15051

HVAC EQUIPMENT SEISMIC RESTRAINTS AND VIBRATION ISOLATION

PART 1 - GENERAL

1.01 SCOPE

All general conditions and supplementary general conditions apply to the work of this section. Provide and perform the vibration isolation work as indicated, specified, and required.

A. Work Included in this Section.

Principal items of work include the following, as outlined in the schedule:

1. All seismic restraints.
2. All vibration isolators.
3. All vibration isolation frames and brackets.
4. Flexible pipe connections and couplings.

B. Related Work Not Included in this Section.

1. Flexible electrical connections to all motors.
2. Pipe clamps and hanger rods.
3. Canvas connections.

1.02 GENERAL REQUIREMENTS

A. Submittal.

Refer to general conditions for requirements pertaining to submittals, including preparation and transmittals. The submittal shall contain the following information:

1. Catalog cuts and data sheets on specific vibration isolators to be utilized, showing compliance with the specification.
2. An itemized list showing the items of equipment, piping, etc., to be isolated, the isolator type and model number selected, isolator loading and deflection including isolator free height and deflected height, and reference to specific drawing showing frame construction where applicable. For steel spring isolators include solid height and diameter of spring coil.
3. Drawings showing equipment frame construction for each item of equipment, including dimensions, structural member sizes, support point locations, etc.

4. Written approval of the frame design to be used, obtained from the manufacturer.
5. Drawings showing methods for suspension, support, guides, etc., for piping and ductwork, etc.
6. Drawings showing methods for isolation of pipes, etc., piercing walls, slabs, beams, etc.
7. Seismic restraint requirements including:
  - a. Seismic restraints.
  - b. Seismic restraint calculations.
  - c. Number and location of seismic restraints for each piece of equipment.
  - d. Specific details for restraints including anchor bolts for mounting and maximum loading at each location.
  - e. Provide signature of a licensed engineer for all calculations on the seismic snubbers.
8. Final inspection and report.

B. Coordination.

The contractor shall coordinate his work with other trades to avoid rigid contact with the building. He shall inform other trades following his work, such as plastering or electrical, to avoid any contact which would reduce the vibration isolation.

C. Conflicts and Discrepancies.

1. The contractor shall bring to the architect's attention prior to installation any conflicts with other trades which will result in unavoidable contact to the equipment, piping, etc., described herein, due to inadequate space, etc. Corrective work necessitated by conflicts after installation shall be at the responsible contractor's expense.
2. The contractor shall bring to the architect's attention any discrepancies between the specifications and field conditions, changes required due to specific equipment selection, etc., prior to installation. Corrective work necessitated by discrepancies after installation shall be at the contractor's expense.

D. Inspection and Instruction.

1. The contractor shall obtain inspection and approval from the architect of any installation to be covered or enclosed prior to such closure.



2. The contractor shall notify the architect prior to the general installation of vibration isolation devices so that the vibration isolator manufacturer can instruct and demonstrate the technique of proper installation with the contractor's foremen.
3. The contractor shall obtain written and/or oral instructions from the vibration isolation manufacturer as to the proper installation and adjustment of vibration isolation devices and seismic restraints.

1.03 ISOLATOR CONFIGURATION FOR FLOOR-MOUNTED OR SUSPENDED EQUIPMENT

- A. Provide a maximum of four vibration isolators located at the corners of the equipment unless approval is obtained for additional isolators.
- B. Where feasible, provide three isolators.

1.04 SEISMIC RESTRAINT REQUIREMENTS

- A. Seismic restraint shall be in accordance with all relevant State and Local code requirements.
- B. Restrain all equipment, piping and ductwork to resist a lateral force loading of not less than 0.5 G for rigid mounting and 1.0G for flexible mounting.

1.05 RESPONSIBILITY OF MANUFACTURER

- A. Vibration isolation manufacturer shall have the following responsibilities:
  1. Determine vibration isolation sizes and locations.
  2. Provide piping and equipment isolation system as scheduled or specified.
  3. Guarantee specified isolation system deflection.
  4. Provide installation instructions and drawings.
  5. Provide calculations by a licensed engineer or a certified test substantiating seismic restraint capability to safely accept specified external forces without failure and to maintain equipment in captive position. Snubber shall be capable of withstanding twice the design load without any obvious deformation.
  6. Provide approved resilient restraining devices as required to limit equipment and piping motion in excess of 3/8 inch.
  7. Provide signature of a licensed engineer for all calculations on the seismic snubbers.

8. Provide final inspection report in accordance with submittal requirements of seismic restraints and vibration isolation. The report shall be signed by the engineer who signed the calculations.

## PART 2 - PRODUCTS

### 2.01 VIBRATION ISOLATORS

#### A. General Properties

1. All vibration isolators shall have either known undeflected heights or other markings so that, after adjustment, when carrying their load, the deflection under load can be verified, thus determining that the load is within the proper range of the device and that the correct degree of vibration isolation is being provided according to the design.
2. All isolators shall operate in the linear portion of their load versus deflection curve. Load versus deflection curves shall be furnished by the manufacturer and must be linear over a deflection range 50% above the design deflection.
3. The ratio of lateral to vertical stiffness shall not be less than 0.5 or greater than 1.0.
4. The vertical natural frequency for each support point, based upon the load per isolator and isolator stiffness, shall not differ by more than + or - 10%.
5. Wave motion through the isolator shall be reduced to the following extent: isolation above the resonant frequency shall follow the theoretical prediction based upon an undamped single degree of freedom system, with a minimum isolation of 50 decibels above 150 cycles per second.
6. All neoprene mountings shall have a shore hardness of 50 to 60 after minimum aging of 20 days or corresponding oven aging.
7. All vibration isolation equipment including but not limited to isolators, mountings, brackets, frames etc. that are exposed to moisture or an outdoor environment shall be coated as follows:
  - a. All steel parts to be hot-dipped galvanized.
  - b. All bolts to be cadmium plated.
  - c. All springs to be cadmium plated and neoprene coated.

B. Type and Description

Type MS is a bare, steel spring isolator, free standing and laterally stable without any housing and complete with a molded neoprene cup or 1/4" neoprene acoustical friction between the baseplate and the support. All mountings shall have leveling bolts that must be rigidly bolted to the equipment. Spring diameters shall be no less than 0.8 of the compressed height of the spring at rated load. Springs shall have a minimum additional travel to solid equal to 50% of the rated deflection. Bolt holes shall be provided in the baseplate to permit attachment to the building structure where required.

Type MSL is a bare, stable, steel spring isolator, free standing and laterally stable with a 1/4 inch thick ribbed neoprene pad between the base plate and the support. Bolt holes shall be provided in the baseplate to permit attachment to the building structure. Spring diameters shall be no less than 0.8 of the compressed height of the spring at rated load. Springs shall have a minimum additional travel to solid equal to 50% of the rated deflection. Limit stops shall be provided to prohibit spring extension if the load is removed. These stops may also serve as rigid blocking during erection so that the installed and operating heights shall be the same. Clearance shall be maintained around restraining bolts and between the limit stops and the housing so as not to interfere with the spring action.

Type HS is a suspension hanger with a steel box frame and a steel spring resting on a neoprene cup. The cup shall contain a steel washer designed to distribute the load evenly to the neoprene and prevent its size shall be larger enough to permit the hanger rod to swing through a 30 degree arc before contacting the hole and short circuiting the spring. A neoprene grommet shall be provided at the location where the hanger rod passes through the hanger box so that no metal-to-metal contact occurs. Hangers shall be provided with an eye bolt, eye socket or hanger rod on the spring end as required.

Type CMS is a prefabricated spring isolation curb for rooftop equipment. The lower member shall consist of a rectangular steel tube containing adjustable and removable steel springs that support the upper floating section. The upper frame must provide continuous support for the equipment and must be captive so as to resiliently resist wind and seismic forces. All-directional neoprene snubber bushings shall be a minimum of 1/4 inch thick. Steel springs shall rest on 1/4 inch thick neoprene acoustical pads and be available with either 1 inch, 2 inch, or 3 inch static deflection. Hardware must be cadmium plated or galvanized and the springs plated or provided with an approved rust-resistant finish. Weatherproofing shall be provided by a continuous flexible aluminum seal joined at the corners by a flexible frictionless neoprene bellows. The aluminum seal must be nailed over and provide counterflashing to the curb's waterproofing. Provision shall be made for access ports with waterproof covers at the spring location and 2 inch thermal insulation on the sides of the lower curb.

Type TR The horizontal thrust restraint shall consist of a spring element in series with a neoprene pad with the same deflection as specified for the mountings or hangers. The spring element shall be contained with a steel frame and designed so it can be present for trust at the factory and adjusted in the field to allow for a maximum of 1/4" movement at start and stop. The assembly shall be furnished with one rod and angle brackets for attachment for both the equipment and ductwork or the equipment and the structure. Horizontal restraints shall be attached at the centerline of thrust and symmetrically on either side of the unit.

Type SF - Flexible Pipe Connectors: Flexible neoprene pipe connectors shall be used at pump connections as shown on the drawings. They shall be manufactured of multiple piles of nylon tire cord fabric and neoprene both molded and cured in hydraulic rubber presses. No steel wire or rings shall be used as pressure reinforcement. Straight connectors shall have two spheres. Neoprene elbows shall be manufactured with a single sphere forming the corner of the joint itself. Connectors up to and including 2 inch diameter may have threaded ends. connectors 2-1/2 inches and larger shall be manufactured with floating steel flanges recessed to lock the connector's raised face neoprene flanges. All connectors shall be rated a minimum of 150 psi at 220 degrees F. All straight through connections shall be made with either flanged or screwed twin spheres properly pre-extended as recommended by the manufacturer to prevent additional elongation under pressure. Connectors shall be provided with control units, in accordance with the manufacturer's recommendations, to limit expansion.

Type PGA is an all direction acoustical pipe anchor or guide consisting of a telescopic arrangement of two sizes of steel tubing separated by a minimum half inch thickness of heavy duty neoprene material. Vertical restraints shall be provided by similar material arranged to prevent vertical travel in either direction. Allowable loads on the isolation material shall not exceed 500 psi and the design shall be balanced for equal resistance in any direction.

Type HMN is a neoprene isolator incorporating a steel housing capable of resisting a seismic load of 1.0 G in all directions. The mount shall consist of a captive steel insert embedded into a neoprene element which is enclosed by a steel housing which also includes floor mounting holes. The isolator shall have a rated deflection of 0.20 inches compression, 0.175 inches in tension and 0.125 inches in shear.

MANUFACTURER'S COMPARISON

Type	Description	Manufacturer's Code - Isolator Type			
		A	B	C	D
MS	Spring Mount	SW	SS	SLFH	RMS
MSL	Spring Mount with Limit Stop	CT	OS	SLR	RMLS
HS	Spring Hanger	BSS	CH30	W30	RMX
CMS	Roof Top Isolation Curb	RTIR	-	RSC	Vibrocurb II
TR	Horizontal Thrust Restraint	TRK	-	WB	TR
SF	Flex Connector	2600	-	MFTNC	CFLEX
PGA	Pipe Guide or Anchor	AG	-	ADA	RPA
HMN	Housed Neoprene Mount	BRD	RQ	BR	FUP-EQ

Notes:

1. Availability - contact manufacturer
2. Notwithstanding this table, the manufacturer's isolator must meet all the requirements of this specification.

Manufacturer's Code:

- A) Amber/Booth.
- B) California Dynamics.
- C) Mason Industries.
- D) M. W. Sausse (Vibrex).

2.02 EQUIPMENT FRAMES

A. General

Mounting frames and/or brackets shall be provided to carry the load of the equipment without causing mechanical distortion or stress to the equipment.

B. Frame Types

1. Type A frame is a wide flange structural steel base rectangular in shape for all equipment other than centrifugal refrigeration machines and pump bases which may be "T" or "L" shaped. Pump bases for split case pumps shall include supports for suction and discharge base elbows. Pump bases for end suction pumps shall include supports for suction elbow or suction diffuser.

All perimeter members shall be beams with a minimum depth equal to 1/10th of the longest dimension of the base. The maximum allowable deflection of any point on the loaded frame relative to the unloaded frame shall be 0.05 inch. Height savings brackets shall be provided in all mounting locations to provide a base operating clearance of one inch.

2. Type B frame is a channel structural steel base with rectangular in shape for all equipment other than pump bases which may be "T" or "L" shaped. Pump bases for split case pumps shall include supports for suction and discharge base elbows. Pump bases for end suction pumps shall include supports for suction elbow or suction diffusers.

All perimeter members shall be beams with a minimum depth equal to 1/10th of the longest dimension of the base. The maximum allowable deflection of any point on the loaded frame relative to the unloaded frame shall be 0.005 inch. Height saving brackets shall be provided in all mounting locations to provide a base operating clearance of one inch.

2.03 SEISMIC RESTRAINTS

A. Type I, Equipment Not Vibration Isolated:

1. Attach to the structure with attachments capable of resisting the forces resulting from the loading specified in Paragraph 1.04 above.

B. Type II, Vibration Isolated Equipment:

1. Mount all vibration isolated equipment on rigid steel frames as described in the vibration control specifications unless the equipment manufacturer certifies direct attachment capability.
2. Each vibration isolated frame shall have a minimum of four all directional seismic snubbers that are double acting and located as close to the vibration isolators as possible to facilitate attachment to the base and the structure.
3. The snubber shall consist of interlocking steel members restrained by snubbing material made of bridge bearing neoprene.

4. The snubbers shall contain an elastomeric one-piece bushing that is replaceable and a minimum of 1/4 inch thick. Snubbers shall be manufactured with an air gap between hard and resilient material of not less than 1/8 inch or more than 1/4 inch. Shim snubbers as required to maintain clearances.
5. The snubber end cap shall be removable for inspection of snubber internal clearances.
6. The neoprene bushing shall be capable of rotation to verify that no short circuiting of the vibration isolator exists.

C. Type III, Seismic Restraint of Vibration Isolated Suspended Piping:

1. Use a slack cable system of a minimum diameter of 1/8 inch of steel at a minimum of 40 feet on center.
2. The cable size and attachment to the pipe and structure shall be designed and signed by a licensed engineer.
3. Restrain all piping systems per SMACNA, "Guidelines for Seismic Restraints of Mechanical Systems and Plumbing Piping Systems", 1991; NFPA Pamphlet 13 and State Building Code.
4. Provide restraints for all trapeze mounted piping where the total supported weight is greater than or equal to a 2-1/2" pipe, except in equipment rooms where all trapeze mounted piping weight is greater or equal to 1-1/4" pipe.
5. Provide restraints for all piping 1-1/4" and larger located in boiler rooms, mechanical equipment rooms and refrigeration machinery rooms.
6. Provide restraints for all fuel gas and oil piping, medical gas piping and compressed air piping 1" and larger.
7. Submittal drawing shall indicate proposed method of vertical restraint.
8. Cable shall be installed with sufficient slack to avoid short circuiting the vibration isolation.

D. Type IV, Piping and Ductwork - Rigidly Supported:

1. Support all piping and ductwork systems per SMACNA "Guidelines for Seismic Restraints of Mechanical Systems and Plumbing Piping Systems", 1991; NFPA Pamphlet 13 and State Building code.
2. Provide restraints for all trapeze mounted piping where the total supported weight is greater than or equal to a 2-1/2" pipe, except in equipment rooms where all trapeze mounted piping weight is greater or equal to 1-1/4" pipe.

3. Provide restraints for all piping 1-1/4" and larger located in boiler rooms, mechanical equipment rooms and refrigeration machinery rooms.
  4. Provide restraints for all piping 1-1/4" and larger located in boiler rooms, mechanical equipment rooms and refrigeration machinery rooms.
- E. Type V, Suspended Vibration Isolated Equipment:
1. Utilize a slack cable restraint system.
  2. The cable size and attachment shall be designed and signed by a licensed engineer.
  3. Submittal drawing shall indicate proposed method of vertical restraint.
  4. Cables shall be installed with sufficient slack to avoid short circuiting the vibration isolation.

#### 2.04 AUXILIARY STEEL

- A. General: Provide auxiliary structural steel member for supports, anchors, guides, seismic restraints and vibration isolators for piping systems.
- B. All structural steel systems to be designed in accordance with AISC Steel Handbook.
- C. All systems to be secured to building structure in a method acceptable to and approved by the project Structural Engineer.
- D. Steel Work: Fabricate neatly. Grind off excess burrs and welding spatter. Paint with rust inhibitive primer.

### PART 3 - EXECUTION

#### 3.01 INSTALLATION OF VIBRATION ISOLATION DEVICES

- A. General
  1. Transmission of perceptible vibration or structure borne noise to occupied area by equipment installed under this Contract will not be permitted.
  2. All vibration isolation devices, including auxiliary steel bases and pouring forms, shall be designed and furnished by a single manufacturer, or supplier, who will be responsible for adequate coordination of all phases of this work.



3. The vibration isolation manufacturer, or his representative, shall be responsible for providing such supervision as may be necessary to assure correct installation and adjustment of the isolators. Upon completion of the installation and after the system is put into operation, the manufacturer, or his representative, shall make a final inspection and submit his report to the Architect in writing, certifying the correctness of installation and compliance with approved submittal data.
4. The contractor shall not install any equipment or pipe which makes rigid contact with the "building" unless it is approved in this specification or by the architect. "Building" includes slabs, beams, studs, walls, lathe, etc.
5. The contractor shall provide access doors for all vibration isolators and snubbers if located above inaccessible ceilings or in shafts.

B. Equipment Isolator Installation

1. The equipment to be isolated shall be supported by a structural steel frame or by brackets attached directly to the machine where no frame is required.
2. Brackets shall be provided to accommodate the isolator and provide a mechanical stop as shown on the drawings. The vertical position and size of the bracket shall be specified by the isolator manufacturer.
3. The minimum operating clearance between the frame and the pad or floor shall be 1 inch.
4. The frame shall be placed in position and supported temporarily by 1 inch shims prior to the installation of the machine or isolators.
5. After the entire system installation is completed and under full operational load, the isolator shall be adjusted so that the load is transferred from the shims to the isolator. When all isolators are properly adjusted, the shims will be barely free and shall be removed. Thereafter, the shims shall be used as a gauge to check that the 3/8" clearance is maintained so that the system will remain free of stress.

C. Piping Isolator Installation-Horizontally Supported Piping

The objective and installation procedure is similar to the Equipment Isolator Installation procedures above.

1. The isolators shall be installed with the isolator hanger box as close as possible to the structure.
2. The isolators shall be suspended from massive beams, never from slab diaphragms between beams unless specifically approved.
3. Hanger rods shall be aligned to clear the hanger box and be plumb.

4. Load transfer isolators, when utilized, shall temporarily maintain the piping in a rigid position until installation is complete and fully loaded.

D. Piping Isolator Installation - Vertical Risers

1. Vertical pipe risers shall be fully isolated, guided by telescoping acoustical pipe guides and anchored by all directional acoustical pipe anchors. Auxiliary steel beams shall be provided as required.
2. Maximum load change on any support shall be limited to 25% of the initial load.
3. Guides and anchors shall be selected to provide restraint of horizontal pipe motion and be capable of supporting the full weight of the pipe and its water.

3.02 INSTALLATION OF SEISMIC RESTRAINTS

A. General

1. All seismic restraints must be installed and adjusted so that the equipment and piping vibration isolation is not degraded by utilization of the restraints.

B. Equipment

1. All seismic restraints shall be anchored in place with equipment in operation for proper operating clearances.

C. Piping

1. Seismic restraint spacing shall be in accordance with hanger spacing.
2. Provide seismic restraint for all piping in equipment rooms, in shafts, and in ceilings of occupied spaces.
3. Comply with SMACNA, NFPA Pamphlet 13 and State Building Code Guidelines.
4. Compensate for thermal movement in the piping systems.

END OF SECTION

**HVAC EQUIPMENT VIBRATION ISOLATION SCHEDULE**

Mark	Design Defl.	Isolator		Frame		Mtg. Detail	Seismic Restraint	
		Type	Detail	Type	Detail		Type	Detail
AH-1 to AH-8 (Internal)	2.0"	MS	4	B	14	-	II	SE-1
HP-1, HP-2	1.0"	MS	4	B	14	-	II	SE-1
CH-1, CH-2	2.0"	MS	4	A	14	-	II	SE-1
CT-1	3.0"	MSL	5	A	14	23	II	SE-1
B-1	0.3"	HMN	42	A	12	-	-	-
C-1 and C-2	1.0"	HS	6	-	-	-	V	SE-25
P-1 to P-3	2.0"	MS	4	A	12	67	-	SE-1
CAC-1	2.0"	MSL	5	A	14	23	II	SE-1
Exhaust Fans (Curb Mount)	1.0"	CMS	63	-	-	-	-	-
Exhaust Fans (Base Mount)	1.0"	MS	4	B	14	-	II	SE-1
Exhaust Fans (In Line)	1.0"	HS	6	-	-	-	V	SE-25
EF-1 to EF-3	3.0"	MS	4	B	14	-	II	SE-1
SF-4 to SF-6	3.0"	MS	4	B	14	-	II	SE-1
SF-7 to SF-8	1.0"	MS	4	B	14	-	II	SE-1
<b>PROJECT: RTD Headquarters</b> <b>DATE: 24 June 1992</b> <b>PAGE: 1 of 2</b>				<b>PAUL S. VENEKLASSEN AND ASSOCIATES</b> <b>CONSULTANTS IN ACOUSTIC</b> <b>1711 16th STREET, SANTA MONICA, CA 90404</b> <b>(213) 870-9268 - (310) 450-1733</b>				

**HVAC PIPING VIBRATION ISOLATION SCHEDULE**

Description	Design Defl.	Isolator		Mtg. Detail	Seismic Restraint	
		Type	Detail		Type	Detail
Condenser and Chiller Water Supply and Return:						
Main Horizontal Runs:						
Roof and Plaza Levels						
Suspended	1.0"	HS	6	9	III	SE-3,4,5
Floor Supported	1.0"	MSL	5	9	-	-
Main Vertical Risers:						
1. Support at Roof Level	1.0"	MSL	5	10	-	-
2. Guide at Other Floor As Required	-	-	-	59	-	-
3. Pipe Penetration						
a) Typical Floor	-	-	-	18	-	-
b) Roof	-	-	-	27	-	-
All pumps must be selected such that the impeller diameter is less than or equal to 85% of the cutwater volute diameter.						
Provide flexible connections Type (SF) at all connections to pumps - see detail 72.						
<b>PROJECT: RTD Headquarters</b>			<b>PAUL S. VENEKLASSEN AND ASSOCIATES</b>			
<b>DATE: 24 June 1992</b>			<b>CONSULTANTS IN ACOUSTICS</b>			
<b>PAGE: 2 of 2</b>			<b>1711 16TH STREET, SANTA MONICA, CA 90404</b>			
			<b>(213) 870-9268 - (310) 450-1733</b>			

SECTION 15400

PLUMBING

PART 1 - GENERAL

1.01 GENERAL CONDITIONS

The General Conditions, Supplementary Conditions and Division 1, are a part of this section and the contract for this work and shall apply to this section as fully as if repeated herein.

1.02 SCOPE OF WORK

Furnish all labor, materials, equipment, appliances and necessary incidentals for the complete installation of all plumbing as shown on the drawings and as specified herein.

A. Work Specified in this Section

1. Sanitary soil, waste and vent systems.
2. Storm drainage systems.
3. Domestic hot and cold water systems.
4. Gas systems.
5. Floor sinks and floor drains.
6. Domestic water heaters and circulating pumps.
7. Furnish and set all sleeves for pipes passing through walls and floors.
8. Connections to storm drain, sanitary sewer water, and gas mains.
9. Pipe covering, insulation and wrapping.
10. Excavation and backfill.
11. Rough-in and final connections to air conditioning equipment of condensate drains.
12. Rough-in and final connections to fixtures and equipment furnished under other sections of the specifications or by the Owner.
13. All plumbing fixtures, water heaters, valves, and other miscellaneous items of equipment required for a complete installation.
14. Safing of all penetrations through fire walls and floors.
15. Water for construction and temporary connections.

B. Related Work in Other Sections

1. Temporary facilities as specified in Section 01500.
2. Cutting and patching as specified in Section 01045.
3. Concrete work as specified in Division 3; however, furnish templates for spacing and size of concrete pads and anchor bolts for equipment under plumbing.
4. Electrical work as follows will be provided under Division 16:
  - a. Conduit and wiring as indicated on the drawings and as required.
  - b. Installing electrical devices such as disconnects, and when indicated, furnishing such devices.

1.03 QUALITY ASSURANCE

A. Codes and Standards

1. All items indicated on site, architectural or mechanical drawings are to be provided complete from point of connection to finished fixture in conformance with all governing authority requirements. Nothing in these drawings or specifications shall be construed to permit work in violation of governing codes.
2. In addition to the requirements of all governing codes, ordinances and agencies, conform to the requirements of the following codes and standards:
  - a. Los Angeles City Building Code, 1991 Edition.
  - b. Los Angeles City Plumbing Code, 1991 Edition.
  - c. City of Los Angeles requirements.
  - d. State Fire Marshal/N.F.P.A.
  - e. City of Los Angeles Fire Department requirements.
  - f. State Health Department requirements.
  - g. All requirements of Federal/OSHA.
  - h. California Administrative Codes.
  - i. All other regulatory agencies having jurisdiction over this work.
  - j. South Coast Air Quality Management District.

- B. Guarantees: Furnish a written guarantee form required under Division 1, against defects in materials and workmanship for one year. Guarantee shall include repair of damage to, or replacement (if so required) of any part of premises caused by water, oil, or gas leaks or breaks in pipe, fixtures or equipment provided under this section.

#### 1.04 SUBMITTALS

- A. Refer to Section 01300 for procedures.
- B. Submittals
  - 1. Shop Drawings.
  - 2. Sterilization test report.
  - 3. Test data.
  - 4. Manufacturers literature.
- C. Operation and Maintenance Instructions: Deliver to Architect four complete sets in bound booklet form of written operating and maintenance instructions and brochures for equipment specified in this section. Fully instruct Owner's operating personnel and demonstrate performance, operation and maintenance of equipment. Amount of time allocated for said instruction and demonstrations of equipment and systems shall be part of these obligations. One additional set of approved instructions shall be suitably framed behind glass and mounted as directed.
- D. Record Drawings: Comply with requirements of Division 1. Keep an accurate dimensioned record of as-built locations and elevations, as referred to approved base datum, of buried concealed lines, manholes, cleanouts, valves, plugged tees, capped ends, and of work which is installed different from that indicated.

#### 1.05 PRODUCT HANDLING

- A. Protection: Take all precautions necessary to protect the materials of this section before, during, and after installation.
- B. Replacements: In the event of damage, immediately repair all damaged and defective work to the approval of the Architect at no additional cost to the Owner.

#### 1.06 MISCELLANEOUS

- A. Examination of the Site: Exercise care in examining the site and coordinate all work indicated on the drawings with existing conditions. Report to Architect in writing conditions that will prevent proper provisions of this work. By submission of the bid, the contractor warrants that he has familiarized himself with the existing conditions and will perform all work as required for hookup and as required by the contract documents at no additional cost to the Owner.
- B. Permits and Fees: Arrange and pay for all permits, inspections and fees required by all governing agencies. Deliver all certificates to General Contractor for delivery to Owner.
- C. Drawings: Coordinate all space requirements with other trades. Drawings indicate desired location and arrangement of piping, equipment, and other items and are to be followed as closely as possible.

## PART 2 - PRODUCTS

### 2.01 GENERAL

- A. Pipe Sleeves and Wrapping: Provide polished chromium plate and brass set screw flanges where plumbing pipes pass through walls, floors, ceilings, and partitions in finished portions of building, including flanges on pipes at fixtures. All sleeves in concealed and exterior walls shall be 20 gal. galvanized iron one inch o.d. larger than the pipe, caulked if below grade in a moisture proof manner.
- B. Pipe Identification
1. Piping Identification per ANSI and OSHA standards in mechanical equipment areas only: Each individual pipeline shall be marked for quick and easy identification as to content and character of material carried in the pipes by Seton SNA or STR markers.
  2. Markers shall be installed and spaced at not more than 8 ft. intervals and so located that markers shall be visible where piping system is exposed.
    - a. One marker shall be installed at each side of valves, special fittings and at branch take-off. In furred spaces install one band 2 ft. above floor and 19 in. below ceiling line.
    - b. Furnish two identification charts complete with glass and frame showing list of materials carried in the piping system, classified by nature of its contents and respective identifying colors.
  3. Color scheme shall be approved. Base color for markers shall be as follows:
    - Domestic hot water - Orange
    - Domestic cold water - Green
    - Fuel gas - Yellow
    - Sanitary sewer - Green
    - Sanitary vent - Green
    - Industrial cold water - Green
    - Storm drains - Green
    - Irrigation - Green
- C. Valve Identification
1. Valve charts: Two typewritten charts not less 8 in. X 10 in. shall be made showing assigned number controlled in each system by each valve in mechanical rooms only. Charts shall be mounted behind aluminum framed glass as directed.
  2. Valve tags: Provide a tag consisting of a 2 in. dia. 20 gal. stainless steel or copper disk for each main line shut-off valve or cock. Fasten tags in place with continuous steel ring or chain around stem of valves and around pipe for cocks. Two inch letters and figures stenciled in contrasting colors on pipe or pipe covering may be substituted for tags on OS & Y valves. Disks shall be stamped with a number corresponding to identification (or location) number shown on valve chart and with service designation, with 1/4 in. high letters.



- D. **Materials:** Materials when not otherwise definitely specified shall conform to the applicable ASTM, ASME, AGA, and ASA standards.
- E. **Equal Materials and Substitutions:** In addition to manufacturers specified, the following shall also be considered equal, provided corresponding models meet specified requirements. Equivalent substituted equipment named herein shall be submitted to Architect for approval. Submit alternate selections at time of bid, listing major equipment.

<u>ITEM</u>	<u>MANUFACTURER</u>
Strainers:	Walworth, Bailey, Mueller
Solders:	Handy-Harman, Lucas, Milhaupt
Cleanouts:	Josam
Valves:	Walworth, Milwaukee
Pipe Hangers & Supports:	Elcen
Access Panels:	Milcor
Gas Vents:	Metalbestos, Amerivent
Insulation:	Manville, Gustin Bacon, Fiberglas
Plumbing Fixtures:	Crane, Eljer
Toilet Seats:	Church, Beneke
Electric Water Coolers:	Elkay, Sunroc
Drains & Floor Sinks:	Zurn
Backflow Preventers:	Hersey
Water Pressure Reducing Valves:	Bailey
Pressure Gauges:	Marsh, Marshalltown, Trerice
Water Heaters:	American, State, Rheem
Soil Pipe:	Tyler, Universal

## 2.02 PIPE AND FITTING SCHEDULE

- A. Soil, waste, vent and storm drain piping and to 5 ft. outside building: Service weight no-hub cast-iron pipe and fittings CISPI-301.
- B. Domestic hot and cold water piping above ground: Type L hard-drawn copper tube, ASTM B88, and wrought copper fittings, ANSI B16.22.
- C. Domestic cold water piping below ground and outside the building:
- 3 in. and smaller: Type K hard-drawn copper tube, ASTM B88, and wrought copper fittings ANSI B16.22, silver soldered joints (refer to paragraph "Pipe Wrapping" herein).
- D. Indirect and Condensate Drains: Type M copper tube, ASTM B88 and wrought copper fittings, ANSI B16.22, solder joint type.
- E. Gas Piping
- 2 in. and smaller above ground: Schedule 40 black steel pipe, ASTM A53, A120, with 300 lb. WOG black banded malleable iron screwed fittings.
  - 2-1/2 in. and larger above ground: Schedule 40 black steel pipe, ASTM A53, A120, with tube-turn econo-weight welded fittings.

- F. Sump pump and sewage ejector discharge piping: Schedule 40 galvanized steel pipe and fitting with Victaulic 75 couplings grooved pipe ends or screwed fittings.

## 2.03 MATERIALS FOR JOINTS, FITTINGS AND VALVES

### A. Soil, Waste, Vent and Storm Drain Cast-Iron Pipe Above Ground

1. Vertical: "No-Hub" couplings as approved by the cast-iron soil pipe institute CISPI-301.
2. Horizontal: 4 in. and smaller, "No-Hub" couplings, 5 in. and larger, "M.G." cast-iron or Clamp-All couplings.

### B. Solder and Flux

1. Water Piping: Equivalent to Harris "Bridgit" silver solder alloy. 95-5 solders are not approved.
2. Copper Indirect and Condensate Drainage Piping: 50-50 solder with non-corrosive paste flux.

- C. Welded Joints: Welding shall be performed only by qualified welders, and shall comply with ASME Boiler Construction Code, ANSI Code for pressure piping, and state requirements.

### D. Unions and Gaskets

1. 2 in. and under for steel pipe: Screwed malleable-iron ground joint, 300 lb. WOG. Class with brass-to-iron seat, galvanized or black to suit service.
2. 2-1/2 in. and larger for steel pipe: Cast-iron flanged gasket type, conforming to ANSI B16.1, galvanized or black to suit service, or 150 lb. forged steel slip-on flanges.
3. Unions for copper tubing: Cast bronze, ground joint pattern, soldered joint connection, ASTM B62 and ANSI B16.18.
4. Dielectric Unions: EpcO, complete with Isolators and gaskets of same size as pipe, galvanized or black to suit service.
5. Dielectric Flanges: F.H. Maloney Co., Type E flanges for cathodic insulation.
6. Gaskets: 1/16 in. Garlock #17022.

- E. Strainers: Y-type with semi-steel body and stainless steel screen with perforations suitable for service requirements, or same size as pipeline in which installed. Provide gate valve with hose connection at each strainer blow-off.

1. 2-1/2 in. and smaller: Bailey 100-A series, 125 lb. or 250 lb., screwed ends with screwed gasketed cap.
2. 3 in. and larger: Bailey 100-A series, 125 lb. or 250 lb., flanged ends and bolted gasket cap.

F. Valves: Valves shall be of same manufacturer, or following numbers or equivalent by comparator chart of approved manufacturer. Provide adaptors for valves in copper tubing where necessary.

1. Eccentric valves, 2 in. and smaller, gas: DeZurik #425 valve with RS49, plug seals, iron body, screwed or flanged, U.L. listed.

2. Gate valves, 2-1/2 in. and larger, domestic water: 200 psi WOG, solid wedge disc, union bonnet, rising stem, flanged.

Nibco	F-617-0
Crane	465 1/2
Stockham	G-623

3. Gate valves, 2-1/2 in. and larger: 500 psi WOG, union bonnet, rising stem, flanged.

Nibco	F-667-0
Stockham	F-667
Crane	7-1/2-E

4. Partition stop valves: T&S B415, loose-key type with wall flange.

5. Ball valves, domestic water and fuel oil: 400 psi WOG, bronze, fullport, threaded.

Nibco	T-585
Jamesbury	300

Note: Flanged iron body valves or equipment used in copper piping systems shall be installed with Maloney Flange and Bolts insulating kits.

G. Check Valves

1. Horizontal swing:

a. 2 in. and smaller (200 psi WOG), bronze screwed cap, swing.

	<u>Threaded</u>	<u>Solder</u>
Nibco	T-413(BWY)	S-413(BWY)
Crane	37	1342
Stockham	320	B-309

b. 2 in. and smaller (300 psi WOG), bronze screwed cap, swing.

Nibco	T-433-B
Crane	27
Stockham	B22B

- c. 2-1/2 in. and larger (200 psi WOG), iron body, bronze trim, screwed cap, swing, Y-pattern, regrinding, flanged.

Nibco	F-918-B
Crane	373
Stockham	G-931

- d. 2-1/2 in. and larger (300 psi WOG), cast-iron with bronze trim.

Nibco	F-968-B
Stockham	F947

H. Pressure Reducing Valves

1. 1 in. and smaller: Cla-Val #990. No substitutions.
2. 1-1/4 in. and larger: Cla-Val #90-01. No substitutions.

I. Gas Pressure Regulators

1. Rockwell model 143, 3/4 in. and 1 in.
2. Rockwell model 243, 1-1/4 in. and larger.

2.04 BACKFLOW PREVENTERS

- A. Reduced Pressure Type: Cla-Val model RP series for industrial water. Pipe relief to floor sink. No substitutions.

2.05 HOSE BIBBS

- A. HB-1: Equivalent to Woodford 24P-3/4, polished chrome-plated wall faucet with vacuum breaker and loose tee key.
- B. HB-2: Equivalent to Woodford Y24, chrome-plated yard type with vacuum breaker and loose tee key.
- C. HB-3: Equivalent to Woodford B75, wall hydrant with vacuum breaker.

2.06 PIPE HANGERS

- A. Hangers shall be supplied with factory installed isolation and di-chromate finish.
1. 2 in. and smaller: Super Strut C-727-F.
  2. 2-1/2 in. and larger: Super Strut C-710-F.
  3. Concrete inserts: Super Strut 452.
  4. Riser clamps for copper piping: Super Strut C-720-P, plastic coated.
  5. Riser clamps for other piping: Super Strut C-720.

- B. Hanger rods shall conform to the following table:

Pipe size 2 inches and smaller:	3/8 inch rods
Pipe size 2-1/2 inches and 3 inches:	1/2 inch rods
Pipe size 3 inches and larger:	5/8 inch rods

## 2.07 ROOF FLASHING

- A. Sanitary Vent Flashings: Semco 1100-3 or 1100-5, with one-piece lead flashing and counterflashing sleeve.
- B. Other Pipe Through Roof Flashing: Semco 1100-2 or 1100-4, one-piece 4 lb. lead flashing and counterflashing sleeve.

## 2.08 PIPE SLEEVES

- A. At concrete walls or floors, Adjust-to-Crete, Paramount, Hole-Out or Sperzel Cretesleeve. Floor sleeves shall extend to top of concrete curbs for piping rising through floors. Wall sleeves shall be flush with finished surface. Sleeves shall be sized to allow 1/2 in. clearance around pipe insulation. Insulation and covering shall be continuous through wall and floor sleeves.
- B. For exterior walls and water tanks, use Link-Seal LS series with 316 stainless steel bolts and sleeve.

## 2.09 ACCESS PANELS

- A. Access Panels in Plaster Walls and Ceilings: Karp #DSC214PL, Elmdor PW, 24x24 in. with metal access door and frame, prime coated steel and painted to match adjacent surfaces. For fire rated areas use Karp #KRP-150 FR 1-1/2 hour "B" Label access panels, U.L. listed.
- B. Access Panels in Acoustic Tile Ceilings: Karp #DSC-210, Elmdor AT, 24x24 in. with metal access door and frame, 24x24 in. minimum size, prime coated steel, recessed to accept standard tile in full opening door.
- C. Access Panels in Ceramic Tile Walls: Karp #DSC214M, Smith 4730, chrome-plated cover and frame of suitable size for purpose intended, but not less than 8x8 in. size. For fire rated areas use Karp #FRP-150 FR 1-1/2 hour "B" Label access panels, U.L. listed.

## 2.10 CLEANOUTS

For cast-iron soil pipe, iron body with extra heavy bronze plugs screwed into caulking ferrules; for steel pipe, extra heavy bronze plugs; and for vitrified clay pipe, vitrified clay plugs.

Where cleanouts occur in finished interior walls, provide access panels, plates, and frames for flush mounting. Exposed parts of floor cleanouts shall have adjustable top. All cleanouts and cleanout plugs shall be accessible. Cleanout shall be the following:

- A. In finished floors: Cast-iron with polished nickel bronze round top, non-skid diamond tread set flush with the floor. Provide flashing flange when used with waterproofing membrane.

Smith - 4023  
Wade - W-6000  
Zurn - ZN-1420-2  
Josam - 56010-22

- B. In mechanical equipment areas: Cast-iron with heavy cast-iron round top, non-skid diamond tread set flush with the floor. Provide flashing flange when used with waterproofing membrane.

Smith - 4223  
Wade - W-6000  
Zurn - Z-1420-25  
Josam - 56050-22

- C. In walls: Cleanout tee with squared polished nickel bronze access plate with vandalproof screws and frames. Opening 8x8 in. minimum.

Smith - 4558-U  
Wade - W-8460-S  
Zurn - ZN-1445-3  
Josam - 58770-22-15

#### 2.11 SHOCK ABSORBERS

Zurn "Shocktrol" with stainless steel continuous bellows which shall expand and dissipate the shock pressure into a Hydro-Pneumatic cushion, installed as indicated or as recommended by PDI pamphlet WWH-201. Provide access panel for a single multiple fixture installation (not of flush valve type). In no case shall a fixture be installed without shock protection.

#### 2.12 PRESSURE TEMPERATURE RELIEF VALVE

Provide domestic water heater with ASME rated pressure/temperature relief valve set to relieve at 125 psi pressure and at 188 degrees to 208 degrees F temperature range.

#### 2.13 THERMOMETERS

H.O. Trerice BX91403-1/21/2 (scale 30 degrees to 240 degrees F) adjustable angle red mercury type with 7 in. chrome-plated bronze case, 3-1/2 in. stem and swivel nut 3/4 in. NPT brass separable socket, and etched scale with graduations as shown or required.

#### 2.14 TRAP PRIMER ASSEMBLIES

Provide for drains and floor sinks where trap primer is not provided from a water closet and as indicated and specified, each including trap primer valve, standpipe, and distribution unit(s) required for the specified distribution. Provide each concealed assembly with access panel, 8 in. by 8 in. size when distribution units are not required and 12 in. by 12 in. size when one or two distribution units are required. Provide trap primer piping same as specified for domestic water, including pipe wrapping. Provide Precision Plumbing Products model P-1 or P-2, or equal.

## 2.15 PRESSURE GAUGES

Potter-Roemer 6240-U.L. - F.M. 0-300 psi range, complete with 3-1/2 in. diameter dial and gauge cock. Install pressure gauges where indicated and as required.

## 2.16 INSULATION

- A. All pipe insulation shall comply with the State of California Energy Conservation Standards. Insulation thicknesses indicated are based on insulation having thermal resistances in the range of R-4.0 to R-4.6 per inch of thickness on a flat surface at a mean temperature of 75 degrees F. Thicknesses indicated are minimum and shall be increased proportionately for materials having R values less than 4.0 per inch of thickness or may be reduced for materials having R values greater than 4.6 per inch thickness. Install pipe insulation after piping is installed, tested and approved and is in clean, dry condition. Firmly butt insulation joints.
- B. Insulate all hot water and interior condensate drain piping with glass fiber pipe insulation with factory applied white jacket, J-M Micro-Lok 650 AP, 1 in. thick for pipe sizes of 1/2 in. to 1 in., and 1-1/2 in. thick for pipe sizes to 1-1/4 in. and larger. Insulate fittings and valves with performed insulation with PVC premolded one-piece fitting cover, J.M. Zeston cover. Adhere longitudinal laps and butts of strips of jacket with factory applied pressure sensitive tape system, J-M AP-T. Flanges and unions shall not be covered.
- C. Insulate all piping under lavatories accessible to the physically handicapped with Plumberex Specialty Products (619-322-1772) hot water supply and 'P' trap prefabricated insulation.
- D. All interior fuel oil supply, return and vent piping outside of two-hour enclosure shall be insulated with "Manville Thermo-12" two-hour calcium silicate, a minimum of two (2) inches thick with FRP jacketing. Install per manufacturer's recommendations.

## 2.17 PLUMBING FIXTURES

- A. General: Plumbing fixtures trim and exposed supplies and wastes shall be brass with polished chrome-plated finish. Provide individual loose key stops or, if so specified, screw driver stops for supplies and, unless integral with valves or faucets, mount under fixture. Separately trap all wastes. Provide exposed supplies and wastes to wall with polished chrome-plated cast brass wall escutcheons. All lavatories shall have 1-1/2 in. 17 gauge chrome-plated cast brass P-traps. All plumbing fixtures shall be white, unless otherwise noted.
- B. Wall-Hung Fixtures: Fixtures specified with hangers or supporting arms shall have hangers or arms securely mounted on a 1/4 in. thick by 6 in. wide steel wall plate which extends at least one stud beyond first and last fixture mounting points, or a total of three studs minimum. Attach wall plate to each structural stud it crosses by tack welding each side of stud flange at top and bottom of plate. Fixture or supporting arms shall be securely and firmly attached to steel wall plate in accordance with manufacturer's instructions. If structural studs are not being installed behind wall-hung fixtures, plumbing contractor shall notify Architect and Mechanical Engineer immediately.
- C. Wall-Hung Water Closets: Provide with chair carrier supports as required with foot supports anchored to concrete slab with two 1/2" dia. x 3" long cinch anchors per foot. Install at heights indicated on the Architectural drawings.

- D. Urinals: Install with brass nipples. Install at heights indicated on the Architectural drawings.
- E. Drains: Where installed in construction with waterproof membrane, provide drains with flashing clamp device with corrosion-resistant clamping bolts.
- F. Fixture Sealer: Install wall-hung fixtures with white silicone sealer between fixture and wall, applied smooth and even.
- G. Fixtures, trim and accessories shall be equal to the following:
1. Water Closets:
    - a. Item WC-1: Vitreous china, siphon jet action, elongated bowl, wall-hung, 1.5 gallon flush.  

American Standard	2257.103 "Afwall"
Kohler	K-4330 "Kingston"

Solid plastic white open-front seat less cover: Olsonite 95CC.

Flush valve: Sloan Royal 111-YB flush valve with vacuum breaker.

Provide one F-72-A1 trap primer in each toilet with flush valve where indicated.

Carriers: 

Smith 210 Series Horizontal
Smith 260 Series Vertical

Alternate Price: Sloan 110ES-S, 1.5 gallon flush electronic system.
    - b. Item WC-2: Same as WC-1, except mount for the physically handicapped. Do not interfere flush valve with handle bar, see Architectural drawings. Flush valve handle shall be on the wide side of stall.
  2. Lavatory:
    - a. Item L-1: Vitreous china, under-counter mount, 19x15 in.:  

American Standard	0470.013 "Ovalyn"
-------------------	-------------------

Faucet: Equivalent to Grohe 20.783 with lever handles, 1/2 GPM flow restrictor, grid drain with chrome-plated tailpiece.

Angle stops and supplies: Equivalent to Brasscraft CR1915A.

Trap: Chrome-plated 17 gauge tubular "P" trap.

Alternate Price: Sloan ETF-80, electronic system.
  3. Urinal:
    - a. Item U-1: Vitreous china, washout, wall-hung, 1.0 gallon flush:





- e. Item RD-1: Cast-iron drain, adjustable extension sleeve, flashing collar, gravel stop cast-iron dome strainer, sump receiver and underdeck clamp:

Smith	1010ERC
Wade	W-3000-DF-52-53
Zurn	Z-100ERC
Josam	21500-3-10

- f. Item RD-2: Cast-iron drain, adjustable with extension sleeve, flashing collar, gravel stop, cast-iron dome strainer, sump receiver and underdeck clamp.

Smith	1330Y
Wade	3200
Zurn	125-5
Josam	22080-1-2-10

- g. Item OD-1: Cast-iron drain, extension sleeve, flashing collar, 2 in. high standpipe water dam, cast-iron dome strainer, sump receiver and underdeck clamp:

Smith	1070Y
Wade	3000-52-53-D
Zurn	ZP-9974-Z-103
Josam	21500-1-2-10-17

- h. Item OD-2: Same as RD-2, except 2 in. high standpipe water dam.

Josam	26010-1-2-10
-------	--------------

- i. Item FS-1: Cast-iron acid-resisting, white enameled, 12 in. square top, 8 in. deep, flashing flange, aluminum dome strainer, acid-resisting enameled top grate. Provide with part grate, where required, for discharge pipes.

Zurn	ZN-1806
Smith	3120
Wade	W-2530-F
Josam	49340A

- j. Item FS-2: Acid-resisting enameled cast-iron drain, solid water dam collar, cast-iron dome strainer, sump receiver and underdeck clamp.

Smith	3980-Y
Wade	W-3500-RS
Josam	25500-1-2

- k. Item DD-1: Cast-iron body and bronze flashing clamp with secured bronze 7-1/2 in. square top, extension, sump receiver and underdeck clamp.

Smith	1470-YERC
Josam	23730-1-2-12

- I. Item ODD-1: Same as FD-1, except use overflow standpipe Smith-Y. Modify standpipe so inlet is 2 in. above DD-1.  

Josam	30000-2M-2-24
-------	---------------
  - m. Item PD-1: Cast-iron body, bronze flashing clamp with stainless steel mesh screen.  

Smith	2671
Josam	24500-27-33
  - n. Item PD-2: Cast-iron body, flashing clamp stainless steel standpipe cover with stainless steel mesh. Modify standpipe as required.  

Smith	2680Y
Josam	39600
- 6. Emergency Shower and Eyewash:
  - a. Item ESEW-1: 1-1/4 in. galvanized pipe with 9 in. diameter floor flange, shower head ABS plastic with instant action ball valve and rigid pull-rod, stainless steel bowl, eye/face wash fountain complete with emergency sign.  

Haws	8346
------	------

2.18 SPECIALTY ITEMS

- A. Domestic Gas Water Heaters WH-1, WH-2: Natural gas-fired water heaters, of storage capacity and recovery indicated, complete with insulated steel jacket, glass-lined tank, drain valve with hose connection, draft diverter, temperature controls, heater gas cock, pilot gas cock, 100% safety pilot and AGA approved. Water heater shall have a recovery efficiency of not less than 75% and a standby loss percentage not exceeding  $2.3 + 67/\text{volume}$  with the method of test as described in Section 2.8 of ANSI Z21.10.3 1975, Gas Water Heaters, Volume III. Manufacturer's certification of compliance shall be included with equipment submittals. Automatic temperature controls shall be capable of adjustment from the lowest to the highest temperature settings for the intended use as listed in Table 1 of ASHRAE 1973, Handbook and Product Directory, Systems Volume, Chapter 37.
- B. Hot Water Circulating Pump CP-1: B & G, all bronze construction close-coupled, centrifugal type, complete with mechanical seals, wearing rings, and characteristics as indicated. Provide high static spring isolation hanger per B & G requirements. Provide automatic water temperature control and seven-day time clock with carryover and interlock with pump.
- C. Hot Water Circulating Pump CP-2, CP-3, CP-4: Grundfos close-coupled regenerative turbine pump, bronze fitted gray iron body, bronze impeller, 416 stainless steel shaft, bronze 660 shaft sleeve and bronze impeller busing. Characteristics as indicated. Provide automatic water temperature control and seven-day time clock with carryover and interlock with pump.

- D. Fire Safing: Safe all pipe penetrations through fire rated walls and floors with U.L. listed Proset or Nelson fire safing. Install per manufacturer's directions.
- E. Off-Hours Shut Down System HP-4:
1. Furnish and install where shown on the plans a complete off-hours water booster system, Weil Aquatronics Model BP1CT-OHS. The system shall shut down the main building booster pumping system and maintain pressure during preselected periods.
  2. Pumps shall be close-coupled, horizontal, multi-stage diffuser type with mechanical seal and 3/4 HP, 3500 RPM, 115V., single phase, 60 Hz., AC, drip-proof ball bearing motor.
  3. Control panel to be NEMA 1, U.L. listed, containing pressure switch with independent high and low set points for automatic starting, magnetic starter, fusible disconnect switch with external handle, hand-off-automatic selector switch, control relays and terminal strip with clearly labeled connection points.
  4. A pressure switch shall be provided to shut down the pump in the event of a low suction pressure condition.  
  
On retrofit systems control panel will be furnished with programmable time clock and main system restart pressure monitor.
  5. The control panel shall be completely prewired by the manufacturer. The electrical contractor will wire and connect the incoming power service and leads from the main pumping system.

### PART 3 - EXECUTION

#### 3.01 SURFACE CONDITIONS

- A. Inspection: All plumbing shall be installed in accordance with the requirements of all governing authorities, the original design, and the referenced standards.
- B. Discrepancies
1. In the event of discrepancy, immediately notify the Architect.
  2. Do not proceed with installation in areas of discrepancy until all such discrepancies have been fully resolved.
  3. Interferences between installed work of various trades due to lack of coordination shall be resolved by Architect whose decision is final. Relocate or offset any work as required to accommodate work of other trades at no extra cost to the owner when so directed by the Architect.

### 3.02 LOCATIONS AND SPACE REQUIREMENTS

- A. Contractor shall fully inform himself regarding peculiarities and limitations of spaces available for installation of work under this division. Drawings indicate desired location and arrangement of piping, equipment and other items, and are to be followed as closely as possible. Work specified and not clearly defined by drawings shall be installed and arranged in a manner satisfactory to Architect. In event changes in indicated locations and arrangements are deemed necessary by Architect, they shall be made by Contractor without additional charge provided the change is ordered before work is installed and no extra materials are required.
- B. Verify all spaces, dimensions for all fixtures, equipment, tenant or Owner-furnished equipment and equipment furnished under other sections.
- C. Obtain all necessary rough in data and dimensions for all fixtures, equipment, tenant or Owner-furnished equipment and equipment furnished under other sections.
- D. Maintain ample headroom clearances and accessibility. Maintain ceiling heights.
- E. Constantly check work of other trades to prevent interference with this installation.

### 3.03 PIPE INSTALLATION

- A. Make pipe runs straight and true. Springing or forcing piping into place is not permitted. Install in manner to prevent any undue strain on equipment. Make joints smooth and unobstructed inside and out, and ream pipe ends thoroughly to remove burrs. Conceal piping in finished portions of the buildings, except as otherwise directed or indicated. Cap or plug ends and openings in pipe and fittings immediately to exclude dirt until equipment is installed or final connections are made. Make pipe size reductions with reducing fittings. Use no bushings unless specifically authorized. Use no close nipples. Proceed to rough in as rapidly as general construction of building will permit and complete and test before any lathing, plastering, or drywall, or other finish work is started. Fit work to available space and accurately  
  
rough in. Grade and valve water piping so as to provide for complete drainage and control of the system. Provide clamps and/or concrete thrust blocks at dead ends, angles, or other points where separation of joints may occur. Grade vent piping to allow piping to free itself of condensation or water.
- B. Install piping to clear beams unless sleeving is indicated. Constantly check work of other trades to prevent interference with this installation. Obtain approval from Architect if coring or cutting of concrete work is necessary due to failure to install required sleeves prior to the time of concrete pour. Cost of coring and cutting work shall be borne by the subcontractor.
- C. Exposed Plated or Enameled Pipe: Make connections to equipment with special care. Show no tool marks or threads.
- D. Dielectric Unions: Make connections between two dissimilar metal pipes with dielectric unions.

- E. Unions: Provide a union on one side of each shutoff valve, at both sides of automatic valves, at equipment connections and elsewhere indicated or required, unless flanges are indicated.
- F. Floor, Wall and Ceiling Plates: Provide where pipes pierce finished surfaces.
- G. Noise: Install soil, waste, and water piping in manner that prevents any unusual noise from flow of water under normal conditions.
- H. Shutoff Valves: Provide where indicated and required for adequate control of systems and for isolation of fixture groups and equipment.
- I. Buried Piping: Install with minimum 36 in. coverage unless otherwise indicated. Lay piping accurately to grade where invert elevations are indicated. When required, provide thrust blocks per manufacturer's recommendations.
- J. Equipment and Materials: Install per manufacturer's recommendations.
- K. Accessibility: Install work readily accessible for normal operation, reading of Instruments, adjustment, service, inspection and repair. Provide access panels where indicated and required.
- L. Pipe Joints: Make screwed joints with a minimum amount of compound applied to the male thread only. All joints shall be made per code requirements.
- M. Sleeves
  - 1. All sleeves in concealed interior walls shall be 20 gauge galvanized iron 1 inch O.D. larger than the pipe. All pipes penetrating through fire walls and floors shall be properly safed with Dow-Corning 3-6548 silicone RTV Foam. Install per fire department and manufacturer's directions.
  - 2. All penetrations through exterior and water tank, use Link-Seal LS series with 316 stainless steel bolts and Link-Seal sleeves. Install per Link-Seal and tank and wall water-proofing manufacturer's directions.

### 3.04 HANGERS AND SUPPORTS

- A. Hold horizontal pipe runs firmly in place using approved steel and iron hangers, supports, and/or pipe rests unless otherwise indicated. Suspend hanger rods from concrete inserts or from approved brackets, clamps or clips. Hang pipes individually or in groups if supporting structure is adequate to support weight of piping and fluid. Except for buried piping, hang or support pipe runs so that they may expand or contract freely without strain to pipe or equipment.
  - 1. Horizontal steel piping: Provide hangers or supports every 10 ft., except every 8 ft. for piping 1-1/4 in. and smaller.
  - 2. Horizontal copper tubing: For 2 in. diameter and over, provide hangers every 10 ft.; for 1-1/2 in. diameter and smaller, every 6 ft.

3. Horizontal cast-iron hub and spigot piping: Provide hangers or supports at each hub.
  4. Horizontal cast-iron no-hub piping: Provide hangers or supports at each side of a no-hub fitting. Provide anti-separation bracing at each 90 degree change of direction.
  5. Vertical piping: Support at floor with iron pipe clamps.
  6. Sway brace in accordance with NFPA 13.
- B. Branches: Provide separate hangers or supports for branch lines 6 ft. or more in length.
- C. Sound and Electrolysis Isolators: Provide at all hangers and supports for hot and cold domestic water lines. Securely attach pipe to walls, studs, etc. All such piping isolated from structure by "Trisolators".

### 3.05 EXPANSION AND CONTRACTION

Install piping subject to expansion and contraction with expansion loops made up of bends, fittings, or Victaulic couplings, expansion joints, swing joints, or other approved methods or devices. Branch lines from mains subject to expansion and contraction shall have a swing joint at a point of connection with the main. Risers which pass through one or more floors shall have swing joints at their base. Anchor lines subject to expansion and contraction by approved methods to restrict movement.

### 3.06 CORROSION PREVENTION

Make joint between cuprous and ferrous materials with approved nylon insulating couplings. Separate contact surfaces of dissimilar metals with non-conducting coating or sheet.

### 3.07 CLEANOUTS

- A. Provide cleanouts where indicated and required. Unless otherwise indicated, cleanouts shall be accessible with extensions to grade, to outside of buildings, or to floors above as indicated or required. Do not locate cleanouts in public lobbies and public corridors unless approved by Architect.
- B. Membranes: Where waterproofing membrane occurs under floor, bring membrane to cleanout without puncturing, and permanently anchor to integral anchoring flange with a heavy cast-iron clamping collar and rustproofed bolts.
- C. Covers: Set cleanout covers with all finished wall, floor or grade. In all cases securely anchor by means of integral lugs and bolts. Where surfacing material, such as resilient covering is specified, ascertain thickness being used and set cleanout top so finished floor is smooth.
- D. Use Acorn 3500 thread compound.

### 3.08 ACCESS BOXES AND PANELS

- A. Provide valve boxes for valves located below grade. Provide metal access panels of size and type hereinbefore specified for valves or shock absorbers located in concealed areas.
- B. Access Boxes and Panels: Set flush with finished wall, floor or ceiling. Those in finished walls shall have door or plate removed during construction or be otherwise suitably covered to protect finish.
- C. Outside General Service Access Boxes: Provide with metal, asbestos cement, or clay pipe sleeve extensions where added depth is necessary. Do not locate boxes in public walks, driveways or covered passages unless indicated.

### 3.09 WRAPPING FOR BURIED STEEL AND COPPER PIPING

- A. All buried steel pipe shall be factory coated with Plexco 20 mil high density polyethylene coating (yellow color). Finished coating shall have continuous imprinting of coating type and applicator and pipe type and manufacturer. All fittings and field joints of buried steel piping shall be cleaned, primed then fully protected by wrapping with two separate wrappings (each half lapped) of 0.010x2 in. wide pressure-sensitive polyvinyl tape equivalent to Johns-Manville "Trantex." All fitting and joint wrapping shall overlap pipe wrapping a minimum of 2 in.
- B. Affidavit: Deliver coated pipe to jobsite accompanied by applicator's affidavit certifying that wrapped pipe has been given high voltage holiday detector test and that pipe was free of holidays when pipe was shipped from applicator's yard. Submit one copy of every affidavit to Architect prior to installation.
- C. Field Joints: Test field applications for holidays by a high voltage holiday test method (steel pipe only) in Architect's presence.
- D. Damage: Handle wrapped piping with extreme care to avoid damage. Repair and retest marred or damaged pipe wrapping.
- E. Install cathodic protection for steel or ferrous piping per Corrosion Engineer's recommendations and/or applicator contractor familiar with cathodic protection having a minimum of 5 years experience in the fabrication and installation of cathodic protection.
- F. Copper tubing, pipe wrap same as for field wrap steel fittings, no holiday test required. Backfill with alkalized clean sand.
- G. Backfill steel and copper piping with clean alkalized sand (1/2 sack lime per cubic yard of sand) a minimum of 4 inches all around pipe and fittings.

### 3.10 PROTECTION FOR UNDERGROUND DUCTILE AND CAST-IRON PIPE AND FITTINGS

Wrap all pipe and fittings with 10 mil PVC pipe tape and prime per manufacturer's directions, or install in 8 mil polyethylene encasement in accordance with ANSI/AWWA Standard C105/A21.5-82. Bed and backfill with clean alkalized sand (1/2 sack lime per cubic yard) a minimum of 4 inches all around pipe and fittings.



3.11 EXCAVATION AND BACKFILLING

Perform excavation and backfilling required work under this section unless otherwise specified. Conform to requirements of Division 2 and of public authorities having jurisdiction.

3.12 SPECIALTY ITEMS

Install as indicated on the drawings, as herein specified, and as recommended by manufacturer.

3.13 STERILIZATION

Sterilize each unit of water supply and distribution system with liquid chloride or hypochloride before acceptance for operation in accordance with AWWA C601, "Standard for Disinfecting Water Mains." Work shall be done by Contractor and, unless otherwise required by public authorities having jurisdiction, shall conform to the following:

A. Materials

1. Liquid chlorine: U.S. Army Specification 4-1.
2. Hypochloride: Liquid shall conform to Fed. Spec. O-C-11RA (Int. 4).

B. Method: Amount of chlorine shall provide a dosage of 50 ppm minimum. Introduce chlorinating materials into lines and distribution system in approved manner. After a contact period of 24 hours minimum during which period chlorine residual shall be maintained at 5 ppm minimum, flush out systems with clean water until residual content is not greater than 0.2 ppm. Flush entire system open and close valves in lines being sterilized several times during contact period.

C. Test Reports: Furnish one copy of test report of complete and adequate sterilization to Architect before final acceptance of work. Certificates shall bear signature of an official of laboratory responsible for test. Cost of testing laboratory services shall be included in this subcontract.

3.14 TESTS

A. Perform tests to Architect's satisfaction. Make tests in presence of Architect and at a time suitable to him if requested. Furnish necessary labor and equipment and bear costs for testing. Cost of replacing and/or repairing damage resulting therefrom shall be borne by this Contractor. Should the Contractor refuse or neglect to make tests necessary to satisfy the Architect that requirement of specifications and drawings are met, such tests may be made by an independent testing company and the Contractor charged for all expenses.

B. Hydrostatic Tests: Make by completely filling piping system with water and eliminating accumulations of air so that leakage, no matter how small, will be apparent on testing gauge immediately. Maintain pressure until pipe under test has been examined, but in no case less than 24 hours. Test systems at following pressure:

SYSTEM

TEST PRESSURE

Domestic cold water  
Domestic hot water

Test 150% of system pressure  
Test 150% of system pressure

- C. Sanitary Soil, Waste, Vent System Tests: Before Installation of fixtures, cap ends of system and fill lines with water to 10 ft. above the section being tested (including vents) and allow to stand until a thorough inspection is made. Make tests in sections if necessary or convenient. However, include interconnections between new sections and previously tested sections in the new test.
- D. Storm drainage system: Test as specified for sanitary system.
- E. Gas systems: Test with compressed air for 4 hours or longer as directed to prove tight without leaks. Use pressure recorder to record pressure of all lines for duration of test. Test gas systems at 60 PSIG.

### 3.15 ADJUSTING

Upon completion of work and after cleaning of system, fixtures and equipment, and automatic parts of plumbing system shall be carefully adjusted normal operation. All flush valves and fixture stops shall be checked for proper operation and final adjustments made where required. System shall operate quietly without vibration or noise.

END OF SECTION

PLUMBING BID FORM

Project:

From: Firm Name \_\_\_\_\_  
Address \_\_\_\_\_  
\_\_\_\_\_  
Signature \_\_\_\_\_

Date: \_\_\_\_\_

We are pleased to submit our quotation to furnish and install complete the plumbing systems indicated on Drawings and Specifications prepared by McLarand, Vasquez & Partners, Inc.

A. Total Price Complete \$ \_\_\_\_\_

Above price includes State Sales Tax, Permits, Fees, Inspections and all utility connections and is in complete accordance with the final plans and specifications and all addendums issued.

B. The following unit prices are offered which are firm until one year after substantial completion of the base shell work with an annual price escalation of \_\_\_\_\_ % for one additional year.

1. Water Closet (WC-3): Same as specified in Stage 1 Specifications.  
\$ \_\_\_\_\_

2. Lavatory (L-2): Same as specified in Stage 1 Specifications.  
Coring and vertical piping.  
\$ \_\_\_\_\_

3. Piping:

- a. 2" Waste and Vent per foot \$ \_\_\_\_\_
- b. 3" Waste and Vent per foot \$ \_\_\_\_\_
- c. 4" Waste and Vent per foot \$ \_\_\_\_\_
- d. 1/2" Water Line per foot \$ \_\_\_\_\_
- e. 3/4" Water Line per foot \$ \_\_\_\_\_
- f. 1" Water Line per foot \$ \_\_\_\_\_
- g. 1-1/4" Water Line per foot \$ \_\_\_\_\_

- h. 1-1/2" Water Line per foot \$ \_\_\_\_\_
  - i. 3/4" Water Line with  
Insulation per foot \$ \_\_\_\_\_
  - j. 1" Water Line with  
Insulation per foot \$ \_\_\_\_\_
4. Hourly rate for each of the following trades based on straight time, including all benefits, insurance and payroll taxes. Overtime shall be charged at regular union rates and all incidentals listed above.
- a. Plumbers \$ \_\_\_\_\_/hr.

SECTION 15500

FIRE PROTECTION

PART 1 - GENERAL

1.01 GENERAL CONDITIONS

The General Conditions, Supplementary Conditions and Division 1, are a part of this section and the contract for this work and apply to this section as fully as if repeated herein.

1.02 SCOPE OF WORK

Furnish all labor, materials, equipment, appliances and necessary incidentals for the complete installation of all fire protection systems as shown on the drawings and as specified herein.

A. Work Specified in this Section

1. A complete hydraulically calculated combined standpipe and automatic fire sprinkler system for the entire building, including provisions for future tenant development. This is intended to generally describe the scope of work, but shall not be considered a list of work to be performed under this contract. All work necessary for a complete operating fire protection system with all fixtures and equipment shall be provided, including trenching and compaction.

B. Work Related to Other Sections

1. Cutting and patching as specified in Division 1.
2. Concrete work as specified in Division 3; however, furnish templates for spacing and sizing of concrete pads and anchor bolts for equipment under this section.
3. Hookup of alarms and electrical work as specified in Division 16.

1.03 QUALITY ASSURANCE

A. Applicator Qualifications: Contractor shall provide evidence of having a minimum of five years experience in the fabrication and installation of fire protection systems.

B. Design Criteria

1. A complete hydraulically calculated combined standpipe and automatic fire sprinkler system for the entire Stage 2 building areas.
2. Fire sprinkler pressure design shall be calculated on zero pressure at fire pump suction.
3. Refer to Architectural reflected ceiling plan for type and head locations in core areas. Coordinate all fire sprinkler head location and type with Architect.

4. Base bid for a complete fire protection system of the core areas. In future tenant areas, base bid on one head per 225 square feet spacing with piping sized for future tenant development at 110 square feet per head. Piping system shall be capable of connecting two heads off of one existing head location. Piping in future tenant areas shall include main loop, branch piping and fire sprinkler heads and sheet metal heat collector plates. Size of heat collector plates shall be determined by fire department.
  5. Prove seismic calculations and restraints for piping and equipment as required by the City of Los Angeles Building Codes.
- C. Requirements of Governing Agencies: Conform to all requirements of the agencies listed below, in addition to all other agencies having jurisdiction.
1. Los Angeles City Building and Plumbing Codes, 1991 Edition.
  2. Los Angeles City Fire Code, 1991 Edition.
  3. National Fire Protection Agency.
  4. State Fire Marshal.
  5. Los Angeles City Fire Department.
  6. California Administrative Codes.
  7. Insurance Underwriters.
- D. Guarantees: Furnish a written guarantee, form required under Division 1, against defects in materials and workmanship for one year. Guarantee shall include repair of damage to, or replacement if so required, of any part of premises caused by water leaks or breaks in pipe, fixtures, or equipment provided under this section.

#### 1.04 SUBMITTALS

- A. Refer to Section 01300 for procedures.
1. Prior to submittal of shop drawings and hydraulic calculations submit to Los Angeles City Fire Department and Owner's fire insurance underwriters and obtain their approval.
  2. Pay all costs related to preparation of plans.
  3. Minimum information required on plans:
    - a. Section of building showing risers.
    - b. Floor plans of building showing all lights, air conditioning ducts and equipment.
    - c. Clearly indicate all sprinkler heads, control valves, points of entry in building, pipes and sizes, sleeves, alarm systems, fire department connections, and other requirements.

- d. Completely coordinate clearances required with other trades.
- e. Provide service utility diagram indicating location of underground pipes, meters, valves and other items installed.

B. Operating Instructions

- 1. Deliver to Architect four complete sets, in bound booklet form, of written operating and maintenance instructions and brochures for equipment specified in this section. Fully instruct Owner's operating personnel and demonstrate performance, operation and maintenance of equipment. Amount of time allocated for said instructions and demonstrations of equipment and systems shall be part of these obligations.
- 2. Provide in fire department control room a complete set of record drawings and operating instructions in a box with transparent cover. Indicate emergency procedures in red. Coordinate location with Architect.

C. Test Approval Letter: Obtain letter in triplicate from Los Angeles City Fire Department and Owner's fire insurance underwriters. Letter to indicate satisfactory installation in all respects. Submit letter prior to final acceptance.

D. Record Drawings: Maintain complete project record drawings in accordance with Division 1 of these specifications.

1.05 PRODUCT HANDLING

- A. Protection: Take all precautions necessary to protect the materials of this section before, during and after installation.
- B. Replacements: In the event of damage, immediately repair all damaged and defective work to the approval of the Architect at no additional cost to the Owner.

1.06 MISCELLANEOUS

- A. Examination of the Site: Exercise care in examining the site and coordinate all work indicated on the drawings with existing conditions. Report to Architect in writing conditions which will prevent proper provisions of this work. Verify depth and location of service lines with servicing companies having jurisdiction before excavating. By submission of the bid, the Contractor warrants that he has familiarized himself with the existing conditions and will perform all work as required for hookup and as required by the contract documents at no additional cost to the Owner.
- B. Permits and Fees: Arrange and pay for all permits, inspections and fees required by all governing agencies. Deliver all certificates to General Contractor for delivery to the Owner.
- C. Drawings: Coordinate all space requirements with other trades. Drawings indicate desired location and arrangement of piping, equipment and other items, and are to be followed as closely as possible.

## PART 2 - PRODUCTS

### 2.01 EQUAL MATERIALS AND SUBSTITUTIONS

In addition to manufacturers specified, the following shall also be considered equal, provided models meet specified requirements. Equivalent substituted equipment named herein shall be submitted to Architect for approval. Submit alternate selections at bid time.

<u>ITEM</u>	<u>MANUFACTURER</u>
A. Valves:	Grinnell, Nibco
B. Pipe Hangers:	Grinnell, Elcen, Superstrut
C. Fire Protection Equipment:	Reliable, Viking, Standard, Central
D. Mechanical Couplings:	Gustin-Bacon, Gruvlok
E. Pressure Gauges:	Trerice, Marsh
F. Automatic Sprinkler Heads:	Viking, Star
G. Flow and Tamper Switches:	Potter Electric, Notifier

### 2.02 MATERIALS

- A. General: All materials to be used in this project shall be new and conform to NFPA requirements and shall have U.L.-F.M. and Los Angeles City Fire Department approval.
- B. Pipe and Fittings Above Ground
  - 1. Branch piping, schedule 40 black steel pipe, ASTM A120 with class 125 standard cast-iron screwed fittings, ASTM A126.
  - 2. Main Piping:
    - a. Schedule 40 black steel pipe, ASTM A120, welded rolled groove without metal removal or grooved and in accordance with Victaulic's directions or threaded ends.
    - b. Fittings shall be standard weight weld or class 125 standard cast-iron screwed fittings, ASTM A126 or Victaulic fittings with Grade E gaskets. Pressures in excess of 155 psi use Class 300 malleable Iron screwed fittings.
    - c. Light wall pipe, ASTM A120, roll grooved without metal removal with Victaulic fittings with Style 75 coupling with Grade E gaskets.
    - d. Mechanical couplings and fittings shall be of same manufacturer.
    - e. Victaulic hookers and FIT fittings are not approved.



C. OS&Y Valves

1. 175-lb. WWP, 2 inches and smaller: Stockham B-133, Crane 459 or Nibco T-104-0, bronze body, screwed. U.L. listed. (Pressures up to 165 psi.)
2. 175-lb. WWP, 2-1/2 inches and larger: Stockham G-634, Crane 467 or Nibco F-607-0, iron body, flanged, U.L. listed. (Pressures up to 165 psi.)
3. 500-lb. WWP, 2-1/2 in. and larger: Stockham 30-OFU-S, Nibco F-667-0, Grinnell 6100A, U.L. listed.

D. Butterfly Valves

1. 175-lb. WWP, Grinnell 8000FP, lug, cast-iron, EPDM, bronze disc, gear operator, 416 S.S. stem with bronze bushing, UL/FM, with tamper switch mounting.)

E. Check Valves

1. 2 inches and smaller: 200-lb. OWG, Nibco KT-403-W screwed.
2. 2-1/2 inches and larger: 175-lb. WWP, Stockham G-940, Nibco F-908-W, iron body, flanged. (Pressures up to 165 psi.)
3. 2-1/2 inches and larger: 500-lb. WWP, Stockham F-947, Crane 39E, Nibco F-9688, Grinnell 6350A.

F. Alarm Bell: U.L. approved, equivalent to Potter-Roemer 6230, located as indicated or as directed by the Architect.

G. Tamper Switches: U.L. approved, equivalent to Potter-Roemer 6220, double pole, double throw, approved enclosure for wet and dry installation.

H. Flow Switches: U.L. approved, equivalent to Potter-Roemer 6200, two single pole, double throw switches.

I. Floor Control Valves Auto-Sprinklers: Pressures in excess of 165 psi: Standard Z3005 MSA, 2-1/2 in. female inlet and outlet with monitor switch adapter.

J. Fire Department Roof Connections: Standard S295, three (3)-way body 6" x 2-1/2" x 2-1/2" x 2-1/2" with V6L 2-1/2" hose valves with caps and chains.

K. Hose Valves (HV-1): Static water pressure below 120 psi, use Standard V6L hose valve with 1-1/2" reducer with cap and chain. Static water pressure above 120 psi, use Standard Z3000 with 1-1/2" reducer with cap and chain.

L. Fire Sprinkler Heads: In finished ceiling areas, fire sprinkler heads shall be satin chrome-plated Reliable Model G (recessed) or G1 concealers (color as selected by Architect). In areas where there are no finished ceilings, upright or pendent type shall be provided as required to suit installation. Coordinate with Architect before fabrication as to the type and location of sprinkler heads in finished areas.

M. Relief Valve: Peerless Pump casing relief valve, set at 175 psi. Use down stream of pressure regulating type floor control valves.

- N. Pressure Gauges: U.L. approved equivalent to Potter-Roemer 6240, 0-300 psi rating.
- O. Pressure Regulating Hose Valve Test Connection: Potter-Roemer 2815, 2-1/2", with cap and chain.
- P. Test Drain: AGF test and drain unit.
- Q. Strainers: Bailey S100, carbon steel, 600 psi WWP. Provide 400 psi ball valve at strainer blow down opening with 1" hose connection.
- R. Helistop Fire Hose Cabinets: Standard 5008 surface mounted with breakglass door with weather stripping, 100 ft. of 1-1/2 in. lined hose and 1500J fog nozzle, and 4A-60 B:C, 10 lb. fire extinguisher. Pressure gauge and pet cock. Provide decal or sign "Caution - for Fire Fighting by Trained Personnel Only." Waterproof between wall and cabinet flange with weatherstripping.

### PART 3 - EXECUTION

#### 3.01 SURFACE CONDITIONS

- A. Inspections: All fire protection systems shall be installed in accordance with the requirements of all governing authorities, the original design, and the referenced standards.
- B. Discrepancies
  - 1. In the event of discrepancy, immediately notify the Architect.
  - 2. Do not proceed with installation in areas of discrepancy until all such discrepancies have been fully resolved.
  - 3. Interferences between installed work of various trades due to lack of coordination shall be resolved by Architect whose decision is final. Relocate or offset any work as required to accommodate work of other trades, at no extra cost to the Owner when so directed by the Architect.

#### 3.02 INSTALLATION

- A. Conform to all requirements of agencies having jurisdiction.
- B. Attention is called to requirements that air conditioning, plumbing and electrical systems are to be installed in locations adjacent to sprinkler system piping. Coordinate efforts with other trades doing work on site to avoid interference. Work specified shall be installed and arranged as directed in a satisfactory manner. Check conditions at site and examine pertinent drawings before preparing working drawings. Take measurements for this work, verify drawings of other trades and be responsible for proper installation in available space for appurtenances herein specified or indicated. Before making any changes considered necessary, secure approval of Architect for such variations.

- C. Sleeves
  - 1. All sleeves in concealed interior walls shall be 20 gauge galvanized iron 2 inch for pipes 3 inch and smaller and 4 inch for pipes 4 inch O.D. larger than the pipe. All pipes penetrating through fire walls and floors shall be properly safed with Dow-Corning 3-6548 silicone RTV Foam. Install per fire department and manufacturer's directions.
  
- D. Tests: Test systems in accordance with NFPA #13 and #14, State Fire Marshal, and Los Angeles City Fire Department requirements. Attention is called to NFPA pamphlets 13 and 14 requiring flushing and testing in the presence of a witness acceptable to local fire insurance rating organization having jurisdiction before admitting water to overhead sprinkler piping.
  
- E. Certification: Upon completion, subcontractor and general contractor's representative shall jointly inspect work of this Section and deliver a written certification to Architect that installed materials and workmanship conform to specifications.

END OF SECTION

FIRE SPRINKLER BID FORM

Project:

From: Firm Name \_\_\_\_\_  
Address \_\_\_\_\_  
Signature \_\_\_\_\_  
Date: \_\_\_\_\_

We are pleased to submit our quotation to furnish and install complete, the fire protection system indicated on Drawings and Specifications prepared by McLarand, Vasquez & Partners, Inc.

\$ \_\_\_\_\_

A. Unit Prices

Submit unit prices for each of the following items, firm to one year after substantial completion of base shell work with an annual escalation of \_\_\_\_% for one additional year.

1. Chrome-plated type sprinkler recessed head.  
Unit Add Price \$ \_\_\_\_\_
2. Relocation of type sprinkler recessed head installed in tenant area under base shell work.  
Unit Relocation Price \$ \_\_\_\_\_
3. Pendant or upright type head.  
Unit Add Price \$ \_\_\_\_\_

SECTION 15800

HEATING, VENTILATING AND AIR CONDITIONING

PART 1 - GENERAL

1.01 WORK SPECIFIED IN THIS SECTION

- A. Air conditioning for entire area on all floors complete with main supply ducts, air distribution equipment and controls.
- B. Water chillers, cooling towers, pumps, piping and controls to provide chilled water to cooling coils of air handling units on every floor.
- C. Air handling units complete with supply fans, cooling coils, filters, variable speed inverter drives; ductwork, diffusers, grilles, controls and other items herein specified.
- D. Boilers, pumps, piping and controls to provide heating hot water to every floor.
- E. Exhaust piping and radiator discharge ducting for emergency generators.
- F. Closed circuit cooling towers, circulating pumps, piping and controls for auxiliary air conditioning systems, and hydronic heat pump units.
- G. Air conditioning for elevator equipment rooms, complete with heat pump units, piping, ductwork and controls.
- H. Air conditioning for indicated area on all floors complete with main supply ducts, air distribution equipment and controls.
- I. Ventilation and smoke evacuation from the subterranean garage areas, complete with fans, control dampers and ductwork.
- J. Supply and relief for each stairwell complete with fans, dampers and hoods as indicated on drawings.
- K. Ventilation of miscellaneous rooms (as shown on the drawings) complete with exhaust and supply fans, ducting and controls.
- L. Fresh air supply systems, complete with supply, filters, ductwork and controls.

1.02 RELATED WORK INCLUDED IN THIS SECTION

- A. Temperature Control System as specified in Section 15900.
- B. Furnishing electrical devices necessary for mechanical work, except disconnects unless indicated otherwise.
- C. Line and low voltage wiring for mechanical controls including final connections as indicated on wiring diagrams.
- D. Conduit for line and low voltage wiring for mechanical controls as indicated on wiring diagrams.

- E. Responsibility for obtaining clarification of discrepancies between mechanical and electrical work from Architect prior to proceeding with the work.
- F. Responsibility for proper operation of automatic pneumatic/electric controls and equipment and of electric power driven equipment furnished under this section.

1.03 RELATED WORK IN OTHER SECTIONS

- A. Painting of exposed piping, ductwork and unfinished portions of fixtures and equipment as specified in Section 09900.
- B. Concrete work including miscellaneous metal in connection with pits, trenches and catch basins with foundations or concrete pads under boilers, pumps, air handling units and other mechanical equipment. However, furnishing templates for spacing and sizes of concrete pads and anchor bolts under this section.
- C. Miscellaneous equipment furnished by Owner or under other sections, except exhaust and ventilation connections for the equipment shall be made under this section.
- D. Air louvers as specified in Section "Sheet Metal".
- E. Electrical work as follows will be provided under Division 16:
  - 1. Conduit for line wiring for equipment and devices as indicated or specified, except conduit for line and low voltage wiring for mechanical controls as specified under Division 15.
  - 2. Line wiring for equipment and devices as indicated or specified herein, except line and low voltage wiring for mechanical controls as specified under Division 15.
  - 3. Providing disconnect switches.
  - 4. Installing electrical devices such as starters and disconnects, and when indicated, furnishing all such devices.

1.04 QUALITY ASSURANCE

- A. Codes and Standards:

In addition to the requirements of all governing codes, ordinances and agencies, conform to the requirements of the following codes and standards:

- 1. State of California Administrative Code.
- 2. Health and Safety Code, State of California.
- 3. National Board of Fire Underwriter's Publications:
  - a. Pamphlet 70: National Electrical Code.
  - b. Pamphlet 90A: Air Conditioning Systems.

1.05 SUBMITTALS

A. Shop Drawings:

Refer to Section 01300 for procedures.

B. Product Data:

1. Submit six copies of all manufacturer's product data in accordance with Section 01300 simultaneous with all shop drawing submittals.
2. Product data to include all air conditioning equipment, hangers, fans, ductwork construction, and other standard items as required to complement shop drawings.
3. Manufacturers and suppliers of equipment shall provide all data necessary for compliance with the State of California Energy Conservation Standards. Compliance certification for all equipment shall be included in equipment submittals.

C. Record Drawings:

Maintain throughout the progress of the work project record drawings in accordance with Section 01720 and submit to the Architect in compliance with the above section.

D. Operating Manuals and Maintenance Manuals:

1. Submit four copies of all operating instructions and maintenance manuals in accordance with Division 1.
2. Fully instruct Owner's operating personnel and demonstrate performance, operation and maintenance of equipment. Amount of time allocated for said instruction and demonstrations of equipment and systems shall be part of these obligations. Submit a letter to Architect signed by Owner's representative who will operate system stating that he has been fully instructed by contractor about operation and maintenance of equipment and system.
3. Submit one additional set of approved instructions and one additional set of approved control diagram suitably framed behind glass for mounting as directed.

E. Guarantees:

In addition to equipment warranties, furnish a written guarantee against defects in materials and workmanship for one year. Guarantee shall include repair of damage to or replacement of any part of equipment or premises caused by leaks or breaks in pipe or equipment provided under this section.

1.06 PRODUCT HANDLING

A. Protection

Take all precautions necessary to protect the materials of this section before, during, and after installation.

B. Replacements

In the event of damage, immediately repair all damaged and defective work to the approval of the Architect at no additional cost to Owner.

1.07 JOB CONDITIONS

A. Examination of the Site

Examine the site and include all conditions in bid proposal under which work is to be performed.

1.08 MISCELLANEOUS

A. Permits and Fees

Arrange, apply and pay for all necessary permits, inspections, examinations and fees or charges required by public authorities having jurisdiction. Deliver all certificates to General Contractor for delivery to the Owner.

B. Locations and Accessibility

Contractor shall fully inform himself regarding peculiarities and limitations of spaces available for installation of work under this section. Valves, motors, controls and other devices requiring service, maintenance and adjustment shall be placed in fully accessible positions and locations. Provide access doors where required in ductwork or construction whether specially detailed or not, and render all such devices accessible.

C. Scaffolding

Furnish all scaffolding, rigging and hoisting as required for the proper execution of the work.

D. Drawings

Drawings indicate desired location and arrangement of piping, equipment and other items, and are to be followed as closely as possible. Assume the responsibility for coordinating the work with all other trades. Work specified and not clearly defined by the drawings shall be installed and arranged in a manner satisfactory to Architect. In the event changes in indicated locations and arrangements are deemed necessary by Architect, they shall be made by Contractor without additional charges provided the change is ordered before work is installed and no extra materials are required.

**PART 2 - PRODUCTS**

2.01 CENTRIFUGAL WATER CHILLERS

- A. Provide Trane CVHE hermetic, centrifugal, refrigeration machine of size and capacity indicated for use with refrigerant 123. Full load amperage of each machine, and water pressure drops through each machine shall not exceed that indicated on Drawings unless otherwise approved by the Architect.



B. Verification of Capacity and Efficiency

1. Manufacturers shall run test their chiller either in the factory or in the field to verify its capacity and efficiency. This test shall be conducted in accordance with ARI Standard 550-77, including use of the test instrumentation and procedures set forth in that standard. For a field test, the manufacturer must supply bypass lines with modulating valves to simulate the design conditions. Contractor is responsible for the entire cost of the run test and the subsequent cost of removing all the test equipment to leave the condition of the equipment room unchanged.
2. The Engineer/Owner may witness or request a report on both the method of simulating design conditions and the final results of the run test. The Engineer/Owner will accept the equipment if the test procedures and results meet the performance submitted within the tolerances set forth in ARI Standard 550-77. If the equipment fails to perform within these tolerances, necessary revisions will be made and a retest as required.

C. Evaporator and Condenser

1. Evaporator and condenser shall be of separate shell and tube and designed in accordance with requirements of the ANSI/ASHRAE 15/1978 Safety Code for unfired pressure vessels. The refrigerant side shall be proof-tested per applicable code or at 1.5 times maximum design working pressure, but not less than 45 psig. A safety rupture disk in accordance with ANSI/ASHRAE 15/1978 safety code shall be provided for the refrigerant circuit.
2. Each tube shall be integral externally finned and fabricated of a minimum 3/4 inch nominal diameter seamless copper tube. These tubes shall be individually replaceable with tube ends rolled into annular grooves in the tube sheets. Each evaporator tube shall be rolled into the intermediate support sheets. At each tube support, the tubes shall be landed to increase overall tube life.
3. Water boxes shall be designed for 150 psig maximum working pressure. Water side shall be hydrostatically tested at 1.5 times working pressure. Taps for vents and drains shall be provided.
4. The evaporator and condenser water piping connections shall be flanged.
5. Chiller designs with flooded evaporators shall have eliminators installed along its complete length above the tubes in addition to space separation to prevent liquid refrigerant from entering the compressor.
6. Liquid refrigerant entering the evaporator shall be distributed uniformly across the entire length of shell and without direct impingement of high velocity refrigerant on the tubes.
7. Units with multi-stage compressors shall incorporate an inner stage flash vessel "economizer" in the refrigerant cycle. The economizer shall maintain differential between condensing and economizer inner stage pressure. Economizers shall meter liquid to the motor jacket for cooling the motor at 80 deg. F maximum. Units with single stage compressors shall have the condensers circuited for a minimum of 10 deg. F of liquid subcooling and be provided with thermometer well to verify the amount of subcooling.

D. Compressor and Motor

1. The compressor shall be centrifugal with fully shrouded impellers.
2. Capacity control shall be by variable inlet guide vanes, capable of modulating performance from 10 to 100 percent of rated unit capacity. Single stage units, or multi-stage units with movable inlet vanes in front of only one-stage of compression, shall be provided with automatic hot gas bypass to allow operation to 10 percent load. KW input at 10 percent load shall not exceed 25 percent of full load rated KW.
3. Oil pumps shall be a positive displacement direct connected pump with maximum 1/4 HP motor. Oil sump temperature shall be controlled by a temperature controller to maintain a constant oil temperature with heater outside sump wall replaceable without breaking the machine vacuum. An oil sump thermometer shall be provided to indicate oil sump temperature. Power for the oil pump shall be same as controlled voltage and shall be factory wired through the control panel without requiring and additional power connections.
4. Motor shall be hermetically sealed, two-pole low slip squirrel cage induction motor for continuous operation at nameplate rating. Complete rotating assembly shall operate well below the first critical speed. Motor shall utilize positive means to prevent exceeding selected maximum running current, i.e., monitor motor current directly and partially unload the chiller before exceeding the selected maximum running current.
5. Hermetic compressor motor shall have a liquid refrigerant cooling system. Compressors shall be interlocked so as to be inhibited from starting unless the inlet vanes are fully closed.

E. Unit Control Panel

1. A microprocessor-based Unit Control Panel (UCP) shall be included with each chiller that monitors and controls chiller operation and associated sensors, actuators, relays, and switches. Include all necessary refrigeration, electric and electronic controls in a completely factory assembled and tested control package.
2. The microprocessor-based controller shall compare leaving chilled water temperature to the set point and transmit a modulating signal to the inlet guide vane actuator. The microprocessor based control shall incorporate P-I-D (Proportional-Integral-Derivative) control strategies.
3. Motor current limit control for electrical demand limiting shall be provided. As motor current draw approaches the current limit set point, corrective control action is taken to reduce demand. The UCP shall include the following control capabilities:
  - a. Evaporator Limit Control and Freeze Protection: An evaporator limit control feature that helps prevent low refrigerant temperature trip-outs shall be provided. The UCP constantly monitors the evaporator refrigerant temperature. As the temperature approaches the low temperature safety trip point, corrective control action is taken to keep the chiller on-line and operating safely as long as possible.

- b. **Condenser Limit Control:** A condenser limit control feature that helps prevent high refrigerant pressure trip-outs shall be provided. If the high pressure safety limit is approached, corrective control action is taken to keep the chiller on-line as long as possible. A head relief request relay is energized signalling for corrective action, such as a lowering of the entering condenser water temperature. The chiller will operate safely at the maximum load it is capable of producing without tripping the high pressure cutout.
  - c. **Chilled Water Reset:** Two methods of implementing chilled water reset shall be provided, load based and temperature based. With load based control, reset is based on the direct load on the chiller. The microprocessor-based controller monitors the return chilled water temperature, determines the load on the chiller and resets the leaving chilled water temperature accordingly. With temperature-based control, reset is based on a measured varying temperature, such as outdoor ambient temperature.
4. **Unit Control Panel - Safety Controls:**
- a. The UCP shall incorporate all appropriate and necessary safety controls to assure proper, safe chiller operation including monitoring of motor starting and running; time between compressor/motor starts; high refrigerant pressure condition in the condenser; low refrigerant temperature condition in the evaporator; condenser and evaporator water flows; oil pressure and temperature, and proper operation of unit controls and input elements, such as sensors.
  - b. Safety trip-outs for operating conditions that indicate chiller system malfunction shall shut the machine down and require manual resetting of the chiller. Safety trip-outs for operating conditions external to the chiller shall result in chiller shutdown until the condition is corrected. The chiller shall then be automatically brought back on-line to resume normal operation. An auxiliary terminal connections shall be provided for Owner installed latching safety trip-out.
  - c. When a safety trip-out occurs, a diagnostic message indicating the source of the trip-out plus the operating mode of the chiller at the time of trip-out shall be displayed on the front panel.
5. **Advanced Motor Protection:**
- a. The microprocessor-based controller shall monitor three-phase current through three current transformers. The chiller motor shall be protected throughout its starting and running cycles from the adverse affects of phase unbalance, phase reversal, or electrical distribution fault. The controller shall instantly trip-out the motor if any of these system faults are detected.

- b. The Advanced Motor Protection package shall include surge protection. The microprocessor-based controller shall detect when a unit is operating in surge and signal and alert. A head relief request relay shall be energized signalling that the condenser water from the cooling tower should be lowered in temperature. If the surge condition is not corrected within 15 minutes, the chiller shall shutdown.
6. Unit Control Panel - Status and Diagnostics Monitoring:
- a. The following operating status shall be monitored by the UCP and accessible at the front panel:
    - 1) Status indicator lights for:
      - a) Chilled water flow proven.
      - b) Cooling required.
      - c) Unit running.
      - d) Unit loading.
      - e) Manual reset required.
      - f) Remote chilled water set point active.
      - g) Remote current limit set point active.
    - 2) Set point and water temperature display.
    - 3) Starts counter and running hours meter.
    - 4) Dial type pressure gauges for:
      - a) Evaporator refrigerant pressure.
      - b) Condenser refrigerant pressure.
      - c) Low oil (oil sump) pressure.
      - d) High oil (oil supply) pressure.
  - b. The following chiller functions and components shall be automatically diagnosed. The specific diagnostic code shall be displayed at the front panel for:
    - 1) Power loss Surge trip-out.
    - 2) Condenser water flow overdue.
    - 3) Loss of condenser water flow.
    - 4) Loss of chilled water flow.
    - 5) Maximum acceleration time exceeded.
    - 6) Starter fault - failure to complete transition.
    - 7) Low evaporator refrigerant temperature trip-out.
    - 8) High condenser refrigerant pressure trip-out.
    - 9) Low oil pressure trip-out.
    - 10) High oil temperature trip-out.

- 11) High motor temperature trip-out.
- 12) Distribution fault trip-out.
- 13) Phase imbalance trip-out.
- 14) Phase loss trip-out.
- 15) Phase reversal trip-out.
- 16) Maximum motor current exceeded trip-out.
- 17) High bearing temperature 1 trip-out.
- 18) High bearing temperature 2 trip-out.
- 19) Running external interlock trip-out.
- 20) External interlock trip-out.
- 21) Inlet guide vane actuator failure.
- 22) Motor temperature sensor 1 failure.
- 23) Motor temperature sensor 2 failure.
- 24) Motor temperature sensor 3 failure.
- 25) Oil temperature sensor failure.
- 26) Leaving chilled water temperature sensor failure.
- 27) Evaporator refrigerant temperature sensor failure.
- 28) Condenser refrigerant pressure sensor failure.
- 29) Bearing temperature sensor 1 failure.
- 30) Bearing temperature sensor 2 failure.
- 31) Differential oil pressure switch failure.
- 32) Stop relay failure.
- 33) Improper unit identification.
- 34) Evaporator refrigerant temperature trip point set below minimum allowable.
- 35) Maximum acceleration time setting above maximum allowable  
Unit control module failure.

F. Purge System: Units shall have purge system operated by a motor-driven purge compressor and solenoid valves to automatically isolate purge system from centrifugal machine when purge compressor is not in operation.

G. Starters

1. Compressor motor starter shall be supplied by the centrifugal chiller manufacturer. Starters shall be Star-Delta closed transition installed under Division 16. Starter accessories shall include running hour meter and ammeter with 3 leg selector switch.
2. The starter panel door shall be hinged and shall be capable of being padlocked to prevent access by unauthorized personnel.
3. The ambient temperature inside the starter panel shall not exceed 155 deg. F with all components energized at rated load conditions and 104 deg. F ambient outside the starter panel. Temperature rise of components shall be per related NEC, NEMA, and UL codes.
4. A permanent nameplate shall be provided and mounted on the starter panel. It shall identify the manufacturer, serial or model number identifying the date of manufacture and component replacement parts, and all current and voltage ratings.

5. Power supply terminals shall be identified by permanent markers. The maximum temperature of terminals shall not exceed 167 deg. F when the equipment is tested in accordance with its rating.
6. Contactors shall be UL recognized for air conditioning and refrigeration (definite purpose) use. They shall be rated in voltage, continuous rated load amperes (RLA) and locked rotor amperes (LRA). The rating shall be equal to or greater than the requirements specified on the compressor motor nameplate.
7. All wires, bus bars and fittings shall be copper only, except the internal wire of the control transformer which may be aluminum, if copper termination is provided.
8. Disconnecting means in the form of knife switches or nonfused disconnects (switches without circuit trip devices) shall not be used due to the possibility of injury if they are opened under load and due to the possibility of failure as a result of improper sizing of these devices.
9. A 120-volt single-phase power supply shall be developed within the three-phase compressor motor starter and shall be in accordance with the chiller manufacturer's specifications.
10. The starter shall be equipped with two "pilot" relays to initiate the main centrifugal starter sequence. These relays shall be a self-monitoring safety circuit which shall indicate improper operation (slow operation, welding of contacts, etc.) and shall cause the unit to be shut down and a fault trip indicator to be displayed. The "starter circuit fault" indicator shall be located in the door of the enclosure and shall require manual reset.
11. A lockout transition safety circuit shall be provided to prevent damage from prolonged energization due to malfunction of the transition contactor. Malfunction shall cause the machine to be shut down and the "starter circuit fault" indicator to be displayed.
12. The electronic, three-phase overload system shall provide protection to the compressor motor.
  - a. The overload system shall be coordinated with the current control system to provide fail-safe circuitry. A single adjustment shall be used to set all three overloads and the current control signal. All three phases shall be monitored by using current transformers.
  - b. The electronic overload system shall be coordinated with the compressor motor and factory set and labeled with the compressor motor rated load amps (RLA), locked rotor amps (LRA) and overload trip (OLT) setting.
  - c. The electronic overload system shall provide:
    - 1) Excessive locked rotor current protection.
    - 2) Excessive locked rotor time protection.
    - 3) Current control of transition from start to run configurations.

- 4) Maximum current protection to prevent the compressor motor from exceeding its OLT setting.
  - 5) Protection of equipment against transition resistor failure.
- d. A fault trip indicator, "motor overload," shall be located in the door of the starter panel enclosure. This fault indicator shall be displayed if any of the above conditions are sensed and shall cause the machine to be shut down. This fault shall require manual reset. Electronic digital timing shall be provided by the overload system for repeatability and accuracy.
  - e. The electronic, three-phase overload system shall be field adjustable for purposes of coordination with other electrical protection devices.
13. Terminal connection pads shall be provided to which customer applied lugs can be attached.
  14. Ammeter and volt meter system shall be provided and mounted on starter door.
- H. Insulation: Evaporator shell and water boxes, refrigerant piping and other items as required shall be insulated as hereinafter specified.
  - I. Start-up Service: Manufacturer shall furnish a factory trained service engineer without additional charge to start the unit(s).

## 2.02 ROTARY WATER CHILLERS

Provide Trane model RTHA factory-assembled water-cooled hermetic rotary compressor liquid chilling package of size and capacity indicated for use with Refrigerant 22. Fouling factor shall be .0005 in cooler and .0005 in condenser. Cooler and condenser water pressure drop shall not exceed that scheduled.

### A. Ratings

Construction and ratings shall be in accordance with latest ARI Standard 550-88 and shall comply with ASA B9.1 safety code, National Electrical Code and applicable ASME Code.

### B. Compressor-Motor

Semi-hermetic, accessible direct-drive, 3600 rpm, rotary compressor with capacity control slide valve, integral single stage economizer with no moving parts, oil sump heater and differential refrigerant pressure oil pump. Four pressure lubricated rolling element bearing groups shall support the rotating assembly. Motor is liquid refrigerant cooled, hermetically sealed, two-pole, squirrel cage induction motor.

### C. Evaporator-Condenser

1. Shells shall be carbon steel plate. Evaporator and condenser shall be designed, tested and stamped in accordance with ASME Code for refrigerant side working pressure of 300 psig.

2. Carbon steel tube sheets shall be drilled, reamed and grooved to accommodate tubes. Evaporator and condenser tubes shall be individually replaceable, externally finned, internally enhanced seamless copper with lands at all tube sheets. Evaporator tubes shall be 1" diameter. Condenser tubes shall be 3/4" diameter. Tubes shall be mechanically expanded into tube sheets. Condenser tubes shall be mechanically fastened to tube supports. A condenser baffle shall prevent direct impingement of compressor discharge gas upon the tubes.
3. Water boxes shall be designed for 300 psig maximum waterside working pressure with flat face flanged connections. Waterside shall be hydrostatically tested at 1-1/2 times design working pressure.

D. Refrigerant Circuit

A multiple orifice control system with no moving parts shall maintain proper refrigerant flow.

E. Controls

1. Control panel shall be microprocessor-based control panel. Automatic shutdown protection with manual reset shall be provided for low evaporator refrigerant temperature and pressure, high condenser refrigerant pressure, high compressor discharge temperature, high motor temperature, motor current overload, phase reversal and low oil flow. Automatic shutdown protection with automatic reset when condition is corrected shall be provided for low line voltage, loss of chilled water flow and loss of condenser water flow.
2. The unit control module (UCM) shall automatically take action to prevent automatic shutdown in the event of low evaporator refrigerant temperature, high condenser refrigerant pressure, motor current overload and prevents motor current from exceeding set point current limit.
3. A solid state chilled water temperature sensor shall be provided for accurate control. A four-position selector switch shall allow the machine to load, unload, hold, or to allow automatic operation.
4. A menu driven display shall indicate the operating code, the last diagnostic code, chilled water set point, current limit set point, and leaving chilled water temperature. Control panel mounted gauges shall display suction and discharge refrigerant pressure and include shutoff valves.

F. Starter

1. To be mounted in NEMA 1 enclosure with top power wiring access, starter door designed to accommodate padlock and three phase solid state overload protection. Starter shall be in Star Delta configuration, unit mounted.
2. Factory installed and wired control power transformer shall provide all unit control power (120 volt secondary).
3. Starter shall include circuit breaker, mechanical disconnect, and ammeter and voltmeter set, three each, mounted on starter door.



G. Power

Unit shall operate on 460 volt, 3 phase, 60 hertz power and shall be capable of operating within line voltage limits of +/- 10% centerline voltage listed above.

H. Chillers

Chillers shall bear firmly attached metal plates which state the name of the manufacturer, chiller unit model number, compressor type and refrigerant used.

I. Operating and Maintenance Instructions

Operating and maintenance instructions prepared by chiller manufacturer shall be included in Operating and Maintenance Instructions hereinbefore specified.

J. Unit shall be provided with flow switch, cycle counter and hour meter and power supply monitor.

K. Water chiller unit performance data shall be submitted for approval.

L. Insulation

Evaporator shell and water boxes, refrigerant piping and other items as required shall be insulated as specified hereinafter.

M. Testing

Chillers shall be tested, charged, started by factory trained service engineer. Oral operations and maintenance instructions shall be given to the County's personnel while chiller is being tested. Minimum of 4 hours.

N. Isolators

Vibration isolators shall be as hereinbefore specified.

O. Substitution of approved equal manufacturer of equivalent material shall meet the scheduled operating requirements and be comparably equipped as to circulating, unloading, etc. The Contractor is responsible for all electrical, piping or wiring changes, occasioned by this change.

2.03 COOLING TOWERS: Provide Evapco model AT induced draft counterflow of size, capacity and guaranteed performance indicated on drawings.

A. Casing: Casing panels and fan cowl shall be constructed of fiberglass-reinforced polyester (FRP). All FRP components shall be of high grade isophthalic polyester resin and gel coated. FRP shall also be UV resistant and color impregnated. Mechanical supports and interior steel components shall be constructed of Type 304 stainless steel.

B. Basin: Entire cold water basin area shall be constructed of Type 304 stainless steel. Standard basin accessories shall include overflow, drain, Type 304 stainless steel anti-vortexing hoods, Type 304 stainless steel strainers, and brass make-up valve with plastic float.

- C. Fans: Fans shall be heavy-duty axial propeller type, statically and dynamically balanced. Fans shall be constructed of aluminum alloy blades installed in a closely fitted cowl with Venturi air inlet. Fan cowl shall be covered with a galvanized steel fan guard. Fan shaft bearings shall be heavy-duty, self-aligning ball type with grease fittings extended to outside of unit. Bearings shall be designed for a minimum L-10 life of 75,000 hours.
- D. Louvers: Louvers shall be constructed from P.V.C. and shall be mounted in removable frames for access to the pans for maintenance. Louvers shall have minimum two (2) changes in air direction to prevent splashout and to block direct sunlight.
- E. Fan Motor: Fan motor shall be two-speed single winding T.E.F.C. ball bearing with 1.15 service factor, suitable for outdoor service. Fan drive shall be a multigroove solid backed V-belt type with taperlock sheaves designed for 150 percent of motor nameplated horsepower. Fan sheave shall be mounted on the shaft with a cadmium plated bushing to provide maximum corrosion protection. Motors shall be mounted on an adjustable base which is accessible from outside the unit. The belt material shall be neoprene reinforced with polyester cord and specifically designed for cooling tower service. Fan sheave shall be aluminum alloy construction. Belt adjustment shall be accomplished from the exterior of the unit. Bearing lubrication lines shall be extended to the side of the unit for easy maintenance.
- F. Fill: Fill shall be PVC of cross-fluted (bonded together) design for optimum heat transfer and efficiency. The PVC fill shall be self-extinguishing for fire resistance and shall have a maximum flame spread rating of 5 per ASTM E84-81A. It shall also be resistant to rot, decay and biological attack.
- G. Water Distribution Section: Water distribution section shall have large orifice non-clog water diffusers made of ABC plastic with minimum orifice size of 3/8" x 1". The spray header and branches shall be schedule 40 PVC for corrosion resistance with a steel connection to attach external piping. The branches shall have removable plugs in the ends of cleaning purposes. Nozzles shall be threaded into the distribution piping to assure positive positioning.
- H. Eliminators: Eliminators shall be PVC, treated to resist ultra-violet light and have a hooked leaving edge to direct the discharge air away from the fans to minimize recirculation. The eliminator design shall incorporate three changes in air direction to assure complete removal of all entrained moisture from the discharge air stream. Maximum drift rate shall be .001% or less of the circulating water rate.
- I. Access: Sloped ladder with grab rail shall extend from roof deck to the tower access door.
- J. Vibration Isolators: Vibration isolators shall be as hereinbefore specified.

#### 2.04 CLOSED CIRCUIT COOLERS

Provide Evapco model ATW of size, capacity and guaranteed performance indicated on the drawings.

- A. Coils shall be hot-dip galvanized and tested to 350 psig air pressure underwater.

- B. **Water Distribution Section:** System shall provide not less than 6 gpm per SF face area. Spray header shall be constructed of schedule 40 PVC. All spray branches shall be removable and include a threaded end plug for cleaning. Water shall be distributed over entire coil surface by (1" x 5/16" orifice) moulded ABS spray nozzles with internal sludge ring to eliminate clogging. Nozzles shall be threaded into headers to facilitate easy removal.
- C. **Eliminators:** Eliminators shall be PVC, treated to resist ultra-violet light and have a hooked leaving edge to direct the discharge air away from the fans to minimize recirculation. The eliminator design shall incorporate three changes in air direction to assure complete removal of all entrained moisture from the discharge air stream. Maximum drift rate shall be .001% or less of the circulating water rate.
- D. **Pan and Casing:** Casing panels and fan cowl shall be constructed of fiberglass-reinforced polyester (FRP). All FRP components shall be of high grade isophthalic polyester resin and gel coated. FRP shall also be UV resistant and color impregnated. Mechanical supports and interior steel components shall be constructed of Type 304 stainless steel.
- E. **Louvers:** Louvers shall be constructed from P.V.C. and shall be mounted in removable frames for access to the pans for maintenance. Louvers shall have minimum two (2) changes in air direction to prevent splashout and to block direct sunlight.
- F. **Fans:** Fans shall be axial type, statically and dynamically balanced. Fans shall be constructed of cast aluminum alloy blades installed in a closely fitted cowl with Venturi air inlet. Fan shaft bearings shall be heavy-duty, self-aligning ball type with grease fittings extended to outside of unit in cast-iron housings. Fan cowl shall be fitted with heavy duty hot-dip galvanized wire fan guard.
- G. **Fan Motor:** Fan motor shall be two-speed single winding T.E.F.C. ball bearing with 1.15 service factor, suitable for outdoor service. Fan drive shall be a multigroove solid backed V-belt type with taperlock sheaves designed for 150 percent of motor nameplated horsepower. Fan sheave shall be mounted on the shaft with a cadmium plated bushing to provide maximum corrosion protection. Motors shall be mounted on an adjustable base which is accessible from outside the unit. The belt material shall be neoprene reinforced with polyester cord and specifically designed for cooling tower service. Fan sheave shall be aluminum alloy construction. Belt adjustment shall be accomplished from the exterior of the unit. Bearing lubrication lines shall be extended to the side of the unit for easy maintenance.
- H. **Heat Transfer Coil:** The coils shall be all prime surface steel, encased in steel framework, with the entire assembly hot-dip galvanized after fabrication. Tubes shall be arranged in a self-spacing pattern in the direction of air flow without the use of additional spacers between coil tubes. Coils shall have sloping tubes to facilitate drainage and shall be tested to 300 psig air pressure under water.
- I. **All steel in cooler shall be hot-dip galvanized, further protected inside and out with a zinc-chromatized paint.**
- J. **Access:** Sloped ladder with grab rail shall extend from roof deck to the tower access door.
- K. **Recirculation Pump:** Pump(s) shall be close coupled centrifugal type with mechanical seal, installed vertically at factory to allow drainage at shutdown. Pump motor(s) shall be T.E.F.C.

2.05 SPACE HEATING WATER BOILERS. Ajax model WGFD high-efficiency boiler natural gas-fired, of size and capacity indicated, complete with baked enamel finish, insulated steel jacket and forced draft cast iron burners complete with 120V. blower, motor, control panel, electric pilot and transformer. Boiler shall be manufactured, hydrostatically tested and labeled for 125 lbs./sq. in. water working pressure in accordance with ASME Code for low pressure heating boilers. Boiler shall be UL listed, AGA approved and furnished with California code controls.

- A. Relief Valves. Provide McDonnell-Miller No. 240 relief valves ASME rated. Discharge piping of the same size as the outlet of the valve shall be extended down and shall terminate 3 inches above floor. Provide McDonnell-Miller #63 operating low water cutoff, a McDonnell-Miller No. 63M auxiliary low after cutoff, installed 2 inches below operating low water cutoff.
- B. Electronic Control System. Complete, including electronic ignition, intermittent pilot, manual gas valve, gas pressure regulator, two automatic main gas valves, on/off type, (high fire 2/3, low fire 1/3), MH 14006E manual reset high limit temperature control, auxiliary gas valve, pilot gas cock, regulator and valve for 100% shutoff of pilot gas. Boiler controls shall be approved by the State of California.
- C. Precaution: Any lever, switch or other device which will permit the gas burners to function even though the controls do not shall be factory removed.
- D. Boiler piping and control diagrams prepared by the boiler manufacturer shall be submitted for approval.
- E. Operating and maintenance instructions prepared by the boiler manufacturer shall be included in operating and maintenance instructions hereinbefore specified.
- F. Complete package shall be fire tested prior to shipping.

2.06 WATER PUMPS

- A. Bell & Gossett of model indicated, end suction centrifugal type, complete with steel base, mechanical seals, wearing rings, flexible coupling with guard, and of capacities, heads and minimum efficiencies indicated.
- B. Pumps shall not overload the motors on the pump curves at heads reduced 30% below specified heads. Pumps for heating system shall be suitable for hot water service.
- C. Performance curves shall be submitted for approval.
- D. Motors shall be Lincoln, General Electric, Reliance or Westinghouse with ball bearings, 1750 rpm.
- E. Pumps shall bear firmly attached metal nameplates which state name of manufacturer, type or model number, specified capacities in gallons per minute and specified heads in feet.

## 2.07 WATER TREATMENT

- A. Provide chemicals for flushing and prestart cleanup and feeding equipment for continued treatment and protection of above systems for one year. All chemicals shall be in compliance with the applicable Water Quality Control District, local sewage agency and applicable Industrial waste regulations. All microbiocides shall be California and FPA registered. Chemicals and service shall be by Nalco.
- B. Supplier shall furnish:
1. Field supervision for the prestart flushing and cleaning of the system.
  2. Field supervision for correct equipment installation.
  3. On-site training and technical assistance to the building engineers.
  4. Monthly visits and the service of a field engineer, with water samples to be taken and a complete analysis and written recommendations to be furnished to the responsible party.
- C. Chemicals and Equipment
1. Chilled Water, Heating Water and Closed Circuit Condenser Water:
    - a. No. 5 chemical pot feeder, tied into the recirculating water line across circulating pumps.
    - b. Flush system, refill and add cleaning compound. Circulate for a minimum of eight (8) hours. Drain and flush until water is clear and all traces of cleaning compound are removed. Clean strainers and certify that "M" alkalinity is same as city water.
    - c. Add initial charge of Borate Nitrite inhibitor and microbiocide for control of bacteria contamination.
  2. Condenser Water and Open Side of Closed Circuit Cooler:
    - a. Provide pretreatment to remove oil and grease and establish a corrosion-resistant film. Provide Molybdate corrosion and scale inhibitor and alternating biocides for slime and algae control.
    - b. Recirculating condenser water chemical feed control system shall be a Lakewood Instruments Model 173, conductivity controller to activate bleed off and chemical feed and Model 63-DT-A biocide timer.
    - c. Equipment
      - (1) Three LMI Model A-Series, chemical metering pumps, PVC liquid end construction. One each for inhibitor, biocide and alternating biocide.
      - (2) Lakewood Instruments Model 9007 injection tee, pressure relief valve and PVC double union ball valve.

- (3) Corporation stop for mid-stream injection of chemical.
- (4) Normally closed solenoid valve sized for service required.
- (5) 50 gallon polyethylene chemical storage tank.
- (6) All chemical feed piping to be CPVC schedule 80.

3. Quantity of Chemicals and Test Kits

- a. Deliver to site for a period of one year in increments of 45-day supply.
- b. Provide test kits for closed system, cooling tower inhibitor test and a hand-held TDS meter (0-500 umhos).

2.08 COMPRESSION TANKS

- A. Age of size and capacity indicated. Tanks shall be manufactured, hydrostatically tested for 125 psig working pressure in accordance with the ASME code for unfired pressure vessels. Tanks shall be complete with sight glass and reinforced tapping for drainpipe.
- B. Sight glasses: Crane 630 or Ernst 5, 175 lb. bronze body gauge with bronze rods and pet cock.
- C. Tanks shall be UL approved, piped and installed as indicated.
- D. Shop drawings shall be submitted for approval.

2.09 PIPING ACCESSORIES

- A. Pressure Gauges: Ashcroft Duragauge 1379-A, complete with 4-1/4 inch diameter dial and gauge cock. One pressure gauge cock and gauge shall be installed on suction and discharge side of each pump and elsewhere indicated to accept a master pressure gauge.
- B. Thermometers: Weiss 7VS 3-1/2 inch Vari-Angle adjustable angle red mercury industrial thermometers with 7 inch chrome-plated bronze case, 3-1/2 inch stem with swivel nut, 3/4 inch NPT brass separable socket and etched scale with gradations as indicated or required.
- C. Air Vent Valves:
  1. Water: 75 psi working pressure. Hoffman No. 79
  2. Water: 150 psi working pressure. Hoffman No. 78
  3. Air vent valves shall be installed where indicated and elsewhere as required to prevent air pocket formation.
- D. Tank Fittings: Bell & Gossett series ATF of size corresponding to compression tank diameters.

- E. Blowoff Valves: Crane 432, 150 lb., screwed, all bronze renewable composition DSC, 1 inch size, complying with ASME boiler code. A blowoff valve shall be installed in drain line of each water feeder boiler drains and where indicated.
- F. Flexible Pipe Connections: Provide at chiller refrigerant pressure relief disc, at the point of connection to the piping through roof.

#### 2.10 CHILLED WATER, HEATING HOT WATER AND CONDENSER WATER PIPING

- A. 2 Inches and smaller: Schedule 40 black steel pipe with 300 lb. WOG black banded malleable iron screwed fittings.
- B. 2-1/2 Inches to 6 Inches: Schedule 40 black steel pipe with econo-weight welded fittings.
- C. 8 in. and larger: Schedule 30 black steel pipe with econo weight welded fittings.
- D. Where Indicated or required, use 125 lb. black cast iron flanged fittings and make connections with 150 lb. forged steel slip-on flanges.

#### 2.11 EMERGENCY GENERATOR EXHAUST PIPING

Ductwork shall be from schedule 40 seamless steel pipe with 2" of calcium silicate insulation and aluminum sheathing.

#### 2.12 UNIONS AND GASKETS

- A. 2 inches and under for steel pipe: Screwed malleable iron ground joint, 300 lb. WOG class with brass to iron seat, galvanized or black to suit service.
- B. 2-1/2 inches and larger for steel pipe: Cast iron flanged gasket type, conforming to ANSI B16.1, galvanized or black to suit service, or 150 lb. forged steel slip-on flanges.
- C. Unions for copper tubing: Anaconda 1633 or 1733.
- D. Dielectric unions: EPCO, complete with isolators and gaskets of same size as pipe, galvanized or black to suit service.
- E. Dielectric flanges: F.H. Maloney Co. flanges for cathodic insulation.
- F. Gaskets: 1/16 inch Garlock 17022.

#### 2.13 VALVES

Shall be of same manufacturer or following numbers or equivalent by comparator chart or approved manufacturer, gate type unless otherwise noted or specified. Provide adapters for valves in copper tubing where necessary. Provide chain operated valves where indicated.

- A. Gate Valves
  - 1. 3 inches and smaller:
    - a. 200 lb. WOG: Jenkins 47U bronze body, screwed or 1242, bronze body, solder.

- b. 300 lb. WOG: Jenkins 49U, bronze body, screwed.
    2. 4 inches and larger:
      - a. 200 lb. WOG: Jenkins 651A, iron body, flanged.
      - b. 400 lb. WOG: Jenkins 253, iron body, flanged.
  - B. Globe Valves:
    1. 2-1/2 inches and smaller: Jenkins 106A or 1200.
    2. 3 inches and larger: Jenkins 613.
  - C. Check Valves:
    1. Horizontal Swing:
      - a. 3 inches and smaller: Jenkins 92-A bronze, screwed or 1222, bronze, solder.
      - b. 4 inches and larger: Jenkins 624 iron body, flanged.
    2. Silent type (at pump discharge): All sizes: Miller 162 (all bronze in copper pipe system).
  - D. Balancing Valves:
    1. 1-1/4 inches and smaller: Crane 252, bronze, screwed.
    2. 1-1/2 inches through 2-1/2 inches: Crane 142, screwed.
    3. 2-1/2 inches and larger: Rockwell 175 lb. WOG lubricated semi-steel plug valves with plugs and bolted yokes, operating wrench, with adjustable locking step indicator and arc when balancing cock is used as a shutoff valve.
  - E. Butterfly valves for chilled heating condenser water systems are acceptable in lieu of gate valves. Crane No. 42F quartermaster, cast iron body, lug wafer type with EPT seats and no position trigger lock lever. 200 lb. OWG pressure tight shut-off at differential pressures up to 200 psi. Provide extended stem for insulated lines.
  - F. Flow Control Valves: Griswald to maintain a constant rate of flow regardless of fluctuations in upstream pressure. Valve shall have a five (5) year warranty. Provide one dual hose meter kit.

## 2.14 STRAINERS

- A. Y-type with semi-steel body and stainless steel basket with 1/8" perforations and lined with 20 mesh stainless steel screen. Strainer shall be of same size as pipeline in which installed. Provide hose gate valve with each strainer blowoff.
  1. 2-1/2 inches and smaller: Armstrong AISC series, 250 lb., screwed ends with screwed gasket cap.



2. 3 inches and larger: Armstrong AIFL series, 125 lb., flanged ends and bolted gasketed cap.

#### 2.15 PIPE SLEEVES

At concrete walls or floors, Adjust-to-Crete, Paramount, Holeout, or Sperzel Cretesleeve. Wall sleeves shall be flush with finished surface. Sleeves shall be sized to allow 1/2 inch clearance around pipe and insulation. Insulation and covering shall be continuous through wall and floor sleeves. Where piping passes thru floor provide resilient fire safing between pipe and sleeve. Where indicated on plans provide Vibrex type PG-EQ pipe guide/seismic restraint.

#### 2.16 PIPE HANGERS

Hangers shall be complete with threaded steel rods and vibration isolators, sound and electrolysis isolators as required and hereinafter specified. Concrete inserts shall be furnished and installed under this section.

- A. 2-1/2 inches and smaller: Grinnell 104 or approved equal.
- B. 3 inches and larger: Grinnell 260.
- C. Concrete inserts: Grinnell 280.

#### 2.17 REHEAT COILS

A. Provide Pace coils of size and capacity indicated. Tubes shall be 5/8" O.D. seamless copper expanded into copper fin collar to provide mechanical seal. Headers shall be out of air stream, nonferrous seamless copper with all joints and connections brazed. Casing shall be 16 gauge galvanized steel. Coils shall be rated and tested to meet ARI certification.

1. Coil: Coil fins of continuous aluminum plate fin surface of 5/8" O.D. seamless copper tubes expanded into fully drawn fin collars for secure bonding and spacing. Height of fin collars shall automatically and accurately space fins and provide fin-to-fin contact. Mechanically expand tubes into fins. Fabricate U-bends, where used, machine die-forming and silver braze to tube ends.
2. Coil Casing: Construct of 16 gauge continuous coated galvanized steel with formed end supports; include top and bottom channels for rigidity and strength. Provide foam sealing strip between fins and casing channels to eliminate air bypass and prevent moisture carry-over.

#### 2.18 HUMIDIFIER: Dri-Steam Vapourstream self-contained, all electric steam generating humidification system of the size shown on the plans.

- A. Vaporizing chamber, cover and fittings shall be constructed of stainless steel with heli-arc welded seams.
- B. Vaporizing chamber cover and/or front clean-out plate shall be easily removable for access to the vaporizing chamber for physical removal of mineral build-up.

- C. Heater(s) shall be Incoloy alloy sheathed resistance type heater(s) designed for up to 90 watts per square inch. They shall be threaded and screwed into the front face plate of the vaporizing chamber, thus, providing for convenient removal for inspection.
- D. Electronic water level control system shall provide for automatic refill, low water cut-off and skimmer blow-down functions. System shall consist of:
  - 1. A water level sensing unit comprised of three Teflon coated stainless steel probes screwed into a threaded probe head. Probe head shall incorporate probe isolation skirts and be mounted on the face plate of the vaporizing chamber.
  - 2. A solenoid operated fill valve factory mounted on the face plate.
  - 3. A solid state electronic logic control module mounted and wired in the control panel.
- E. Surface skimmer shall be provided which is field adjustable to provide for optimum mineral removal with minimum water waste.
- F. Provide dispersion tube bank consisting of vertical headers and horizontal dispersion tubes, capable of achieving the necessary steam absorption distance. Dispersion tubes shall span the width of the unit and shall incorporate (2) rows of high temperature thermoplastic inserts arranged in a vee pattern discharging against the flow of air. Each insert shall extend into the center of the dispersion tube and shall incorporate a properly calibrated orifice.
- G. Control cabinet shall be UL listed and factory mounted on humidifier. Sub-panel shall be enclosed in a UL listed JIC enclosure and contain magnetic contactor(s), control circuit transformer, multiple heater fuses, logic control system module, numbered terminal strip and all interconnecting wiring.
- H. Motor-driven brass bodied drain valve shall be factory mounted and wired. Timer and drain controls shall be incorporated into electronic level control system which provides for drain and flush at timed intervals. Frequency of drain shall be field adjustable from 5 to 50 hours of "on" time, the duration of drain period shall be field adjustable from 1 to 30 minutes.
- I. Model RH-3, diaphragm operated, air flow proving switch shall be provided for field installation. Switch shall have an adjustable control point range of 0.05" W.C. to 12" W.C. and be rated for 1/4 H.P. at 125 VAC.
- J. Compatible high limit duct humidistat shall be shipped loose for field installation. Humidistat shall sense humidity level within the duct and provide protection against saturation of air stream.
- K. Start-up shall be by a factory trained technician.

## 2.19 VANE-AXIAL GARAGE EXHAUST FANS

Provide Joy vane-axial of the size, arrangement and capacities indicated.

- A. Fan housing shall be hot rolled steel (ASTM A283) with a minimum 7 gauge thickness on fans up to 38" I.D.; 1/4" thickness of 42" I.D. and larger. End flanges shall be 1/4" thick on fan sizes 18" diameter through 48" diameter and 3/8" thick on fans 54" diameter through 84" diameter. All flanges shall be continuously welded around the entire periphery of fan housing. End flanges shall be provided with bolt holes for bolting to inlet bell, cones, companion flanges, duct, etc. Housing up to 60" diameter shall be continuously welded and shall be expanded by mechanical means to ensure concentricity. Housing shall be shot- or sand-blasted to near white condition inside and out in order to ensure good paint adherence. Fan/cone length shall not exceed what is shown on drawings. Fan diameter and hub diameter specified by model number are minimum. Tube axial fans are not acceptable.

Not less than eight (8) die-formed stationary guide vanes of minimum 7 gauge steel shall be welded inside the fan housing. The motor support plate shall be 3/4" plate steel, recessed and rabbeted to receive the C-face flange of the motor, and welded to the fan housing by means of a motor support ring and guide vanes. Motor support ring shall be not less than 1/4" on hub sizes 17" and under, not less than 3/8" on hub sizes 21" and larger, and shall be continuously welded to the motor support plate to ensure the rigidity of the entire structure. All welding shall be in accordance with ASME Section IX Standards.

- B. Fan Impeller (hub and blades) shall be of cast aluminum construction. Hub to be cast of 356-T6 aluminum alloy, heat treated. Blades shall be cast of 356 aluminum alloy. Fan hub shall have an integral steel insert, properly keyed for attachment to the motor shaft. The impeller hub and insert shall be positively locked to the motor shaft by means of a ball bearing locknut and washer.

Fan blades shall be airfoil shaped for maximum efficiency and shall vary in twist and width from hub to tip to obtain equal air distribution along the blade length. Blade tip clearance to fan housing shall not exceed 0.075" for fans 18" to 36" diameter, 0.125" for 38" to 60" diameter, and 0.185" for 66" to 84" diameter. Fan blades shall be cast around a forged steel stud to form an integral unit and shall be securely fastened to the hub by means of an elastic stop nut. The fan impeller shall be whirl tested to 125% of design speed and shall be statically and dynamically balanced on the motor shaft to a maximum tolerance, guaranteed in writing, of one and one-half (1-1/2) mils double amplitude (.0015") at design operating speed.

- C. Fan blade adjustment shall be accomplished by the use of individually, manually adjustable blades. Each blade must be index marked for various pitch settings and shall be capable of field adjustment without removal of the impeller from the motor shaft.

- D. Motors: Motors shall be Reliance XE, or equal, 2 speed, 1 winding, full speed RPM as listed in table below. Vane axial fans shall be in Arrangement #4 with the motor located inside the housing downstream of the impeller, to avoid air disturbance at the inlet and to allow easy access to the fan impeller. Motors shall be NEMA Standard, cast-iron, open bearing construction with inner bearing caps, equipped with ball bearings, AFBMA rated with a minimum of 20,000 hour B-10 life, with Class "F" insulation using thermo setting nonhygroscopic insulating varnish to allow operation in a 40° C ambient and at Class "B" temperature rise. Motors shall be totally enclosed air-over (TEAO), "C" face, flange mounted, squirrel cage induction, single speed, single winding, continuous duty variable torque, suitable for operation in either vertical, horizontal or angular position. Motor shall be capable of operating at the voltages specified on the fan scheduled. Provide compatible reduced voltage start motors as shown on equipment schedule. Motor horsepower scheduled is minimum. NEMA nominal motor efficiencies shall be shown below:

<u>MOTOR HORSEPOWER</u>	<u>RPM</u>	<u>EFFICIENCY</u>
75	1185	95.0
100	1185	95.0

Motor flange shall be recessed into motor support plate to prevent any shear effect misalignment. External copper grease leads for lubrication of motor bearings shall be provided by the fan manufacturer. Lead wires from the motor shall be continuously extended to an oversized conduit box mounted on the exterior of fan housing and wired in compliance with NEC 1990 and NFPA 70 Standards. Lead wires from the motor shall be protected from the airstream by being encased in an airtight metal conduit pipe. Flexible conduit is not acceptable. Lead wires shall be permanently numbered and non-wicking.

- E. Accessories: All vane axial fans shall be provided with supports for horizontal, angular or vertical mounting where indicated on drawings or fan schedule. Horizontal fan floor supports shall be provided by the fan manufacturer and shall be bolted to the inlet and discharge flanges of the fan. Supports for 48" to 84" diameter fans (and fans using motor frames 404T and larger) shall be cross-braced to prevent misalignment and add structural rigidity. Supports shall be constructed of the fan equivalent or heavier gauges of carbon steel. Horizontal ceiling supports shall consist of clips welded to the fan housing for field furnished support rods. When required, inlet bell, inlet screen, outlet cone, companion flanges, etc. shall be provided by the fan manufacturer.
- F. Performance Curves: The fan manufacturer shall furnish published performance curves with data based on tests conducted in an AMCA registered laboratory in accordance with AMCA Standard 210-85. Curves shall be drawn in accordance with AMCA Standard 210-85, paragraph 10.2.1. Manufacturers not submitting performance data in full accordance with this paragraph will be required to perform a witnessed AMCA test for each fan/motor sized specified. All costs for such testing and witness shall be borne by the fan manufacturer.
- G. Sound Power Levels: Sound power data shall be submitted for review by the mechanical engineer. Fan sound power data shall be derived from tests done on the same sizes and types of fans scheduled. Data extrapolated from non-like fan sizes and types scheduled is not acceptable. All measurements shall be performed in an AMCA certified lab in accordance with AMCA standard 300 or ASHRAE 12.12. The mechanical engineer may, at his option, request copies of such tests. Fan sound power levels shall not exceed those shown below.

If data submitted exceeds levels of units specified, the Contractor shall require the services of an acoustical consultant to recommend additional sound reduction elements to maintain design noise criteria in space served by this fan or fans. The Contractor shall submit a 1/4 inch scale plan and elevation drawing to verify fitting in of additional acoustical reduction elements in the system. This drawing shall be approved by the mechanical engineer prior to ordering or submitting of any fans.

Sound Power Levels (dB Re: 10E-12 Watts)

Octave Bands	63	125	250	500	1K	2K	4K	8K
EF-1 & 2	104	109	108	106	103	98	95	92
EF-3	99	105	110	109	107	104	99	96
SF-5	102	107	106	104	101	96	93	90

- H. Performance: The manufacturer shall have regularly engaged in the manufacture of controllable pitch vane axial fans, and shall furnish to the engineer a list of at least five (5) locations within the USA where fans meeting performance and construction criteria of these specifications have been in satisfactory use for a minimum of five (5) years.
- I. Exceptions to any part of this specification must be approved, in writing, by the engineer two (2) weeks prior to the bid date of this project.

2.20 PLUG FANS

- A. Fan Assembly: Fan performance shall be based on tests run in an AMCA certified laboratory and administered in accordance with AMCA Standard 210. All fan performance shall be available in manufacturer's published catalogs. Each fan shall be sized to perform as indicated on the Equipment Schedule. The wheel diameter shall not be less than that shown on the equipment schedule. The fans shall be constructed to AMCA Standards for Class I rating.
  - 1. The fan wheel and shaft assembly shall be statically and dynamically balanced prior to assembly. Following assembly, the fan balance shall be tested using an electronic balance analyzer with tunable filter and stroboscope. Vibration measurements shall be taken on each bearing housing in two radial and one axial direction in relation to shaft centerline. Accept/reject criteria shall be I.A.W. The 1980 ASHRAE Systems Guide, Chapter 35, Table 26 "Equipment Vibration Criteria." The fan assembly shall also be vibration tested at design RPM with the tunable filter utilized and frequencies from 500 cycles per minute to 50,000 CPM shall be scanned to detect misalignment, bearing defects, mechanical looseness or foundation weakness.

2. Fan and motor shall be mounted on a fully welded, rigid structural steel base. Rolled or formed galvanized steel bases are not acceptable. Base shall be free-floating at all four corners on spring type isolators. The motor shall be mounted on an adjustable slide rail motor base. The bearings shall be mounted on a structural steel channel or machined surface. The structure supporting the bearing bar shall be fabricated from structural steel and detachable to allow for removal of the fan wheel and shaft as one piece. The fan assembly shall be isolated by steel springs with 2" deflection. The springs shall be free-standing, unhoused, stable steel springs, with leveling bolts, selected to a maximum transmittability of 5% to 10% depending on the fan RPM and flexibility of the structure on which they are mounted. Vibration isolation base shall have earthquake restraints capable of containing the fan in all directions with up to 1/2 g of force applied. A thrust restraint shall be provided when the thrust of the fan during operation and start may cause the fan assembly to ground against the floor, walls, seismic restraints, or when required to keep the flexible connection from becoming taut.
3. The fans shall be vertical Arrangement #9 or horizontal Arrangement #1 centrifugal air foil blade plug type and shall be designed to operate at cataloged performance without an involute housing. The wheels shall be fabricated from heavy gauge steel. The wheel blades shall be solid welded to the back plate and inlet shroud at both the top and bottom surface of the blade. No other form of blade attachment is acceptable. Inlet cones shall be configured and designed so that wheel inlet efficiency and stall-free performance are insured.
4. Fan bearings shall be ball or roller type. Sleeve bearings are not acceptable due to excessive maintenance requirements. Bearings shall have replaceable bearing inserts so the entire housing need not be replaced. The bearing shall be self-aligning to assist in the shaft alignment. Self-locking collars shall be provided to secure the bearing to the shaft. The bearing housing shall be cast-iron for strength and long life. To avoid over lubrication, the housing shall be provided with a pressure relief type grease fitting. All grease fittings shall be extended to the accessible side of the fan framing for ease of relubrication. The lubrication lines shall be clear PVC material to facilitate visual confirmation of grease in the line. Bearings shall have a minimum life hour of 100,000 L-10 hours on all fans.
5. Provide V-belt, cast-iron sheaves, and reinforced rubber belts. The belts shall be selected for 150% of the motor nameplate horsepower. Adjustable motor sheaves shall be provided on 7-1/2 horsepower motors and below. Fixed motor sheaves shall be provided on 10 HP motors and above due to problems with vibration and shortened belt life. The belts shall be of matched sets and factory pre-tensioned for normal operation.
6. Motors shall be open dripproof 1750 RPM and mounted on a adjustable base. Voltage as scheduled. Motor shall be Reliance XE high efficiency type or equal.
7. Sound Power Levels: Sound power data shall be submitted for review by the mechanical engineer. Fan sound power data shall be derived from tests done on the same sizes and types of fans scheduled. Data extrapolated from non-like fan sizes and types scheduled is not acceptable. All measurements shall be performed in an AMCA certified lab in accordance with AMCA standard 300 or ASHRAE 12.12. The mechanical engineer may, at his option, request copies of such tests. Fan sound power levels shall not exceed those shown below.

If data submitted exceeds levels of units specified, the Contractor shall require the services of an acoustical consultant to recommend additional sound reduction elements to maintain design noise criteria in space served by this fan or fans. The Contractor shall submit a 1/4 inch scale plan and elevation drawing to verify fitting in of additional acoustical reduction elements in the system. This drawing shall be approved by the mechanical engineer prior to ordering or submitting of any fans.

Sound Power Levels (dB Re: 10E-12 Watts)

Octave Bands	63	125	250	500	1k	2k	4k	8k
EF-4	101	98	97	89	86	88	79	73
EF-5	99	92	90	84	81	79	73	65
SF-4	99	95	94	85	83	84	76	70

2.21 UTILITY SET FANS

- A. SWDI or DWDI centrifugal fans shall be Pace. The fan wheel and shaft assembly shall be statically and dynamically balanced prior to assembly. Following assembly, the fan balance shall be tested. Vibration measurements shall be taken on each bearing housing in two radial and one axial direction in relation to shaft centerline. Accept/Reject criteria shall be in accordance with the 1984 ASHRAE Systems Guide, Chapter 32, Table 29 "Equipment Vibration Criteria." The fan assembly shall also be vibration tested at design RPM with the tunable filter utilized and frequencies from 500 cycles per minute to 50,000 CPM shall be scanned to deter misalignment, bearing defects, mechanical looseness or foundation weakness. Fan performance ratings shall be based on tests made in accordance with AMCA Standard 210 and shall have ratings certified by AMCA, and bear the AMCA label.
- B. Fan rotor shall be removable through an inlet and discharge. Fan wheel shall be fully welded backward inclined airfoil. The shafting of the fan shall be sized not to exceed 75% of the first critical speed under the specified operating conditions, and the lateral static deflection of the shaft shall not exceed 0.003 inches/foot of the length of the shaft. Scroll shall be fully welded.
- C. Pillowblock ball bearings selected for  $L_{10}$  life of 100,000 hours. All bearings shall be pressure lubricated ball type with safety pressure relief grease fittings. All grease fittings extended to accessible position. Fan and bearing support shall be of structural channels or heavy extruded steel angles of sufficient size and strength to insure flat bearing mounting surface and proper structural support.
- D. Provide the fans with a motor-driven V-belt drive designed for not less than 150% of connected motor horsepower, statically and dynamically balanced. Non-adjustable motor sheaves shall be used for motors 7-1/2 HP and larger. If, for any reason, it becomes necessary to change the sheave to produce specified capacity, replacement will be done at no additional cost to the Owner.
- E. Motors shall be O.D.P. high efficiency as manufactured by Reliance XE or equal.

- F. Fans shall be provided with OSHA approved belt guard.
- G. The fan and motor shall be mounted on a structural steel vibration isolation base. Rolled or formed galvanized bases are not acceptable. Vibration Isolation base shall have earthquake restraints to restrain fan assembly in vertical and horizontal direction. The spring isolators shall be unhooused stable type with a minimum of 2 inches of deflection. The fan wheel and shaft assembly shall be statically and dynamically balanced prior to and after assembly with motor and drive in place as described in paragraph A.
- H. Sound Power Levels: Sound power data shall be submitted for review by the mechanical engineer. Fan sound power data shall be derived from tests done on the same sizes and types of fans scheduled. Data extrapolated from non-like fan sizes and types scheduled is not acceptable. All measurements shall be performed in an AMCA certified lab in accordance with AMCA standard 300 or ASHRAE 12.12. The mechanical engineer may, at his option, request copies of such tests. Fan sound power levels shall not exceed those shown below.

If data submitted exceeds levels of units specified, the Contractor shall require the services of an acoustical consultant to recommend additional sound reduction elements to maintain design noise criteria in space served by this fan or fans. The Contractor shall submit a 1/4 inch scale plan and elevation drawing to verify fitting in of additional acoustical reduction elements in the system. This drawing shall be approved by the mechanical engineer prior to ordering or submitting of any fans.

Sound Power Levels (dB Re: 10E-12 Watts)

Octave Bands	63	125	250	500	1K	2K	4K	8K
EF-6	89	88	87	80	76	75	68	61
EF-8	95	88	83	76	74	75	65	63
EF-13	87	87	83	78	75	73	68	63
EF-17	89	90	82	77	75	74	69	64
SF-6	99	93	86	79	77	79	68	65
SF-7	90	82	76	68	67	68	57	55
SF-13	96	93	88	79	77	78	70	63

2.22 IN-LINE CENTRIFUGAL FANS

- A. Cook model SQI, complete with centrifugal wheel, steel housing, motor and adjustable V-belt drive. Fans shall be AMCA rated.
- B. Backward inclined single width or double-width air foil centrifugal wheel, statically and dynamically balanced.
- C. Motor sheave shall be adjustable and V-belt drives sized to a minimum of 150% of driven horsepower.



2.23 ROOF-MOUNTED CENTRIFUGAL FAN

- A. Cook model ACRU complete with aluminum construction housing, aluminum backward inclined wheel and tapered inlet shroud. Fan shall be AMCA rated.
- B. Fan and motor shall be statically and dynamically balanced. Drive shall be rated for 165% of rated horsepower.

2.24 ROOF-MOUNTED FILTERED SUPPLY FAN

- A. Cook model CFS complete with belt-driven DWDI airfoil centrifugal blower. Fan shall be AMCA rated.
- B. Hood shall be louvered construction of extruded aluminum with continuous welds and mitered corners.
- C. Drives shall be statically and dynamically balanced and rated for 165% of rated capacity.
- D. Unit shall be equipped with 2" removable washable aluminum filters.

2.25 CHILLED WATER AIR HANDLING UNITS

- A. General: Provide Pace vertical or horizontal single duct draw-thru type as indicated on the drawings and in the schedule. Units shall include supply fan sections, coil section, internal vibration isolation, filter sections with filters and other accessories as specified or shown on the drawings. Units shall be completely factory fabricated. All major components used to assemble air handling unit, with exception of electrical devices, drives, bearings, and controls shall be manufactured by air handling unit manufacturer. Fans, coils and dampers not manufactured by air handling unit manufacturer are not acceptable. Knocked down or Contractor fabricated components will not be acceptable. Entire unit shall be built on a structural steel channel base. Unit must meet dimensional, opening size and weight details as shown on schedule and in the drawings.
- B. Features
  - 1. Casing shall be standing seam constructed of minimum 16 gauge steel, bolted together on the outside with cadmium plated bolts. Drive screw attachment of panels is not acceptable. Maximum panel airway length is 21 inches. There shall be no bolts or screws protruding through the inside of the units. Insulation shall be 3" - 6 lb. density rockwool covered with 1" - 1-1/2 lb. density neoprene coated fiberglass. Insulation shall be covered with 20 gauge perforated metal liner. The unit panel system shall consist of individually insulated panels designed such that removal of a single panel does not disturb any insulation on adjacent panels. Entire floor of the units shall be lined on the inside with 18 gauge galvanized steel.
    - a. After final assembly, units shall be wired brushed and cleaned as necessary prior to painting. Units shall be painted with one coat of oxide primer 1.0 to 2.0 mils thick and one finish coat of semi-gloss alkyd enamel applied by air brush to 3 mils plus or minus .05 mils thick. Bright galvanized components do not require painting.

- b. Access doors into all sections shall be 16 gauge steel, double skin with one-piece unitary aluminum frame. Heavy duty adjustable hinges, straps and catches. Piano hinges are not acceptable. Access doors shall be sized suitable for a man to walk through. Access doors shall have airtight seals, and shall be designed to swing against fan pressure. Include #6 viewing window in panel adjacent to fan access door.
  - c. Provide pre-wired marine lights in fan and plenum sections with switch located on exterior of unit, adjacent to fan access door.
2. Fan sections shall include fully welded direct-drive Arrangement #4 SWSI air foil blade plug fans as scheduled with taperlock or straight bore hub system directly connected to motor shaft. Belt drive fans are not acceptable. Fan diameters scheduled by model number are minimum. Fan wheel shall be aluminum and be designed to utilize full motor horsepower potential. The fan and motor shall be mounted on a structural steel vibration isolation base inside the cabinet. Rolled or formed galvanized bases are not acceptable. Vibration isolation base shall have earthquake restraints to restrain fan assembly in vertical and horizontal direction. The spring isolators shall be unhused stable type with a minimum of 2-1/2 inches of deflection. The fan wheel/motor assembly shall be statically and dynamically balanced prior to and after assembly. Complete fan wheel/motor assembly shall be balanced at rotational speed to 125 mils/second RMS peak-to-peak displacement in 3 axis. Unit manufacturer shall provide catalog ratings of fan performance with fans running inside the cabinets. Fan performance shall be based on tests performed in an AMCA certified lab per AMCA test standard 210.
- a. Motors shall be Reliance XE hi-efficiency type with O.D.P. enclosures. Motors shall have RPM as required for direct-drive application. Motor manufacturer to coordinate with fan manufacturer to insure proper motor application for direct-drive. The induction motor shall be the "premium efficient" type and shall conform to the latest applicable standards of NEMA, IEEE, ANSI and NEC. Only motors meeting or exceeding the NEMA MG1 table 12-6C efficiency standard shall be acceptable. The NEMA nominal efficiency index shall be provided on the motor nameplate in accordance with NEMA standard MG1-12.54.2. The guaranteed minimum efficiency of the motors shall be as shown below. Motors shall have Class B insulation and shall be designed for continuous duty operation of AFC power. They should also utilize phase-to-phase insulation for added protection between the phases of the motor. Motors shall be all cast iron construction. Rolled steel or aluminum enclosures shall not be acceptable. Motors shall be UL component recognized.

<u>Horsepower</u>	<u>Minimum Efficiency</u>
15	90.2
20	91.0
25	91.7

- b. Fan section shall have openings as sized and shown on drawings.

3. Coil section shall include cooling coils as specified. Cooling coil sections shall include a drain pan of double construction type with internal insulation and 304 stainless steel liner. On coils over 48" in finned height, provide an intermediate drain pan separately piped to lower drain pan. Coil shall be completely encased in cabinet with no coil headers past outside dimensions of casing. Area surrounding coils upstream and downstream shall be blanked off and insulated.
  4. Coils shall be seamless 5/8 inch O.D. copper tubes, .020 inch minimum tube wall thickness with aluminum corrugated plate fins of .008 inch thickness. Coils to have minimum .025 inch wall thickness brazed replaceable return bends. Coils shall have reinforcing rods for all coils over 60 inches long and shall have copper headers and shall be ARI certified. Coil areas scheduled are minimum.
  5. Filter sections shall be factory fabricated as part of the air handling unit. Filters shall be arranged for rear loading as shown on the drawings. Filter manufacturers frames shall be used. They shall be welded in place and caulked airtight. Filter areas specified are minimum. Provide units with filter gauge across filter sections. Surface mount gauges on exterior of unit. See drawings for filter types and sizes.
  6. Variable air volume shall be provided by variable speed drive as specified hereinafter.
- C. Sound Power Levels: Air handling unit sound power data shall be submitted for review. Sound power data shall be given at the supply connection(s) and return connection(s). Raw fan sound power data shall be derived from tests done on the same sizes and type of fans scheduled. Data extrapolated from non-like fan sizes and types scheduled is not acceptable. Attenuation assumed for cabinet configuration, type of insulation, opening locations and sizes, etc., shall be verified through actual test measurements. All measurements shall be performed in an AMCA certified lab in accordance with AMCA standard 300 or ASHRAE 12.12. The mechanical engineer may, at his option, request copies such tests. Sound power data shall not exceed values listed below.

Sound Power Levels (dB Re: 10E-12 Watts)

Octave Bands	63	125	250	500	1k	2k	4k	8k
AH-10	MODEL P33, 15,000 CFM @ 4.0" S.P.							
INLET PWL	88	90	90	84	81	77	74	70
OUTLET PWL	83	85	85	78	75	71	79	64
OUTLET PWL	82	84	84	77	74	70	68	63
AH-11	MODEL P33, 16,000 CFM @ 4.0" S.P.							
INLET PWL	88	90	90	84	81	77	75	71
OUTLET PWL	84	85	85	78	75	72	69	65
OUTLET PWL	83	84	84	77	74	71	68	64
AH-12	MODEL P33, 17,000 CFM @ 4.0" S.P.							
INLET PWL	89	90	90	85	81	78	75	71
OUTLET PWL	84	85	85	79	76	72	69	65
OUTLET PWL	83	84	84	78	74	71	68	64

- D. Performance Test: A flow/static pressure and sound performance test shall be made on one (1) air handling unit prior to shipment of any air handling units. The air handling unit to be tested shall be at the discretion of the mechanical engineer. All measurements shall be performed in an AMCA Certified Laboratory that is certified for both sound and fan performance measurements. The sound measurements shall be taken in accordance with the AMCA Standard 300-85 Method and/or The Sound Intensity Method. Fan performance shall be evaluated using the AMCA Standard 210-85 Method. Sound power for inlet and outlet openings shall be measured in all 8 octave bands. Measured sound power levels are acceptable if they do not exceed the specified values by the tolerance of 6 dB in the first octave band and 3 dB in the remaining octave bands. The test results will be submitted to the Owner's Representative for approval prior to shipment of any equipment.
- E. Complete air handling unit to be listed to UL Standard 1995.

## 2.26 CHILLED WATER FAN-COIL UNITS

- A. General: Provide Pace vertical (FC-1 and 2) and horizontal (FC-3) single duct draw-thru type as indicated on the drawings and in the schedule. Units shall include supply fan sections, coil section, motors, drives, internal vibration isolation, filter sections with filters and other accessories as specified or shown on the drawings. Units shall be completely factory fabricated. All major components used to assemble air handling unit, with exception of electrical devices, drives, bearings, and controls shall be manufactured by air handling unit manufacturer. Knocked down or Contractor fabricated components will not be acceptable. Entire unit shall be built on a structural steel channel base. Unit must meet dimensional, opening size and weight details as shown on schedule and in the drawings.
- B. Features
1. Casing shall be standing seam constructed of minimum 16 gauge steel, bolted together on the outside with cadmium plated bolts. Drive screw attachment of panels is not acceptable. Maximum panel airway length is 21 inches. One inch thick, one and one-half pound density insulation shall be provided on inside of casing. It shall be glued and pinned. Provide perforated metal liner over insulation in all plug fan sections. The unit panel system shall consist of individually insulated panels designed such that removal of a single panel does not disturb any insulation on adjacent panels. Entire floor of the units shall be lined on the inside with 18 gauge galvanized steel.
    - a. After final assembly, units shall be painted with two (2) coats of red oxide primer and one coat of enamel (color subject to Architect's approval).
    - b. Access doors into all sections shall be 16 gauge steel, double skin with one-piece unitary aluminum frame. Heavy duty adjustable hinges, straps and catches. Piano hinges are not acceptable. Access doors shall be sized suitable for a man to walk through. Access doors shall have airtight seals, and shall be designed to swing against fan pressure. Include #6 viewing window in panel adjacent to door.

2. Fan sections shall include Arrangement #9 vertical (FC-1 and 2) and Arrangement #1 horizontal (FC-3) SWSI fully welded airfoil plug fans with hollow or steel taperlock bushings and ball bearings with relief plugs and lubrication tube extension terminated to a common point near the motor. Fan wheel shall be designed to operate at cataloged performance without an involute housing. The wheel blades shall be solid welded to the back plate and inlet shroud at both the top and bottom surface of the blade. No other form of blade attachment is acceptable. Inlet cones shall be configured and designed so that wheel inlet efficiency and stall-free performance are insured. The fan and motor shall be mounted on a structural steel vibration isolation base inside the cabinet. Vibration isolation base shall have earthquake restraints to restrain fan assembly in vertical and horizontal direction. The spring isolators shall be unshoused stable type with a minimum of 2 inches of deflection. The fan wheel and shaft assembly shall be statically and dynamically balanced prior to assembly. Following assembly, the fan balance shall be tested using an electronic balance analyzer with tunable filter and stroboscope. Vibration measurements shall be taken on each bearing housing in two radial and one axial direction in relation to shaft centerline. Accept/reject criteria shall be I.A.W. the 1987 ASHRAE System Guide, Chapter 52, Table 26 "Equipment Vibration Criteria." The fan assembly shall also be vibration tested at design RPM with the tunable filter utilized and frequencies from 500 cycles per minute to 50,000 CPM shall be scanned to detect misalignment, bearing defects, mechanical looseness or foundation weakness. Unit manufacturer shall provide catalog ratings of fan performance with fans running in the cabinets. Fan performance shall be based on tests performed in an AMCA certified lab per AMCA Test Standard 210.
  - a. Motors shall be open dripproof 1750 RPM and mounted on a adjustable base. Voltage as scheduled. Motors shall be Reliance high efficiency type.
  - b. Drives shall be adjustable multiple V-belt for 7-1/2 HP and smaller and fixed pitch for 10 HP and larger, sized for 150% of connected motor horsepower. Drives shall be mounted, tensioned and set to speed as required for balancing. Drives shall be Browning or Dodge.
  - c. Fan section shall have openings as sized and shown on drawings.
3. Coil section shall include cooling coils as specified. Cooling coil sections shall include a drain pan of double construction type with internal insulation and 304 stainless steel liner. An intermediate drain pan shall be separately piped to lower drain pan. Coil shall be completely encased in cabinet with no coil headers past outside dimensions of casing. Area surrounding coils upstream and downstream shall be blanked off and insulated.
4. Coils shall be seamless 5/8 inch O.D. copper tubes, .020 inch minimum type wall thickness with aluminum corrugated plate fins of .008 inch thickness. Coils to have minimum .049 inch wall thickness brazed replaceable return bends. Coils shall have reinforcing rods for all coils over 60 inches long and shall have copper headers and shall be ARI certified. Coil areas scheduled are minimum.
5. Filter sections shall be factory fabricated as part of the air handling unit. Filters shall be arranged for face loading as shown on drawings. Filter manufacturers frames shall be used. Filter areas specified are minimum.

- C. Sound Power Levels: Air handling unit sound power data shall be submitted for review. Sound power data shall be given at the supply connection(s) and return connection(s) in addition to radiated sound power from the cabinet. Raw fan sound power data shall be derived from tests done on the same sizes and type of fans scheduled. Data extrapolated from non-like fan sizes and types scheduled is not acceptable. Attenuation assumed for cabinet configuration, type of insulation, opening locations and sizes, etc., shall be verified through actual test measurements. All measurements shall be performed in an AMCA certified lab in accordance with AMCA standard 300 or ASHRAE 12.12. The mechanical engineer may, at his option, request copies such tests. Sound power data shall not exceed values listed below for the typical floor unit AH-1.

Sound Power Levels (dB Re: 10E-12 Watts)

Octave Bands	63	125	250	500	1k	2k	4k	8k
<u>FCU-1 MODEL P16, 3370 CFM @ 3.0" S.P.</u>								
INLET PWL	92	88	83	80	79	74	69	63
OUTLET PWL	89	85	80	77	76	71	66	60
CASING RAD	85	74	67	60	54	45	38	30
<u>FCU-2 MODEL P22, 5600 CFM @ 3.0" S.P.</u>								
INLET PWL	80	73	79	72	69	64	61	55
OUTLET PWL	78	71	77	70	67	63	60	53
CASING RAD	73	59	62	51	44	34	29	21
<u>FCU-3 MODEL P22, 4900 CFM @ 3.0" S.P.</u>								
INLET PWL	83	75	82	75	71	65	62	60
OUTLET PWL	79	71	76	69	65	60	57	54
CASING RAD	74	60	63	51	42	32	27	22

2.27 WATER-COOLED HEAT PUMP UNITS

- A. Provide Mammoth Hydrobank system of size, capacity and guaranteed performance as indicated on the drawings.
- B. All units shall carry ARI certification (per STD. 320-76) and UL listing via appropriate labeling. All electrical and/or refrigeration components shall be UL recognized devices.
- C. Cabinetry shall be galvanized commercial grade steel, primed and painted to manufacturer's standard color. Interior shall be insulated with 1/2 inch fiberglass. There shall be an insulated partition between blower compartment and compressor compartment to minimize compressor sound transmission. All water connection shall be female pipe thread and mounted flush to cabinet exterior. Service panels shall be large, easily removable and allow access to all components.

All units shall allow sufficient service access to replace compressor without removing unit. Standard construction shall include factory mounted discharge air duct collar, and filter retaining rack.

- D. Refrigerant Circuit: Hermetic compressor shall be internally sprung, externally isolated, and railmounted to minimize sound transmission. Coaxial (tube-in-tube) refrigerant to water heat exchanger shall be copper inner water tube and steel refrigerant outer tube design rated to withstand 450 psi water or refrigerant working pressure. Fin tube refrigerant to air heat exchanger shall be aluminum fin plate and copper tube constructed rated to withstand 425 psi refrigerant working pressure. Four-way solenoid activated refrigerant reversing valve shall allow heating operation should the solenoid fail to function. R-22 refrigerant change shall be precisely metered and refrigerant metering device (capillary tube(s) or expansion valve(s)) shall be carefully selected for optimum performance. Refrigerant high and low pressure cutouts shall protect system against hazardous operation. All interconnecting tubing shall be copper and high/low refrigerant Schrader valves shall be factory installed to facilitate field service.
  - E. Electrical: Unit control circuit shall be 24 volt; include manufacturer's mercury bulb auto remote wall thermostat and unit mounted 24 volt terminal board; compressor lock-out circuit shall allow reset at main power break. Blower motor(s) shall be permanently lubricated. Single phase blow motor(s) shall be PSG type. All units through 5 nominal tons capacity shall be direct-drive with 3-speed taps. All units over 5 tons shall be belt-drive with variable pitch sheaves. Compressors and blower motor(s) shall be individually protected against current and/or heat overload.
- 2.28 VARIABLE SPEED DRIVES: Provide fan capacity control by an electronic variable speed drive as manufactured by Reliance Electric.
- A. A single manufacturer of both motors and controllers shall provide, coordinate and start-up, a drive package to ensure both proper application of the motor to the control and of the drive package to the driven load. The adjustable frequency controller (AFC) shall convert three phase 60 Hertz utility power to adjustable voltage and frequency, three phase, AC power for stepless motor control from 10% to 110% of base speed. The AFC shall be a VTAC V design as manufactured by Reliance Electric. Motor/drive manufacturer shall provide two (2) year parts and labor warranty.
  - B. The AFC shall be a voltage source type with a PWM output utilizing power transistor semiconductors.
  - C. The AFC together with all options and modifications shall mount within standard NEMA-1 enclosure suitable for continuous operation at a maximum ambient temperature of 40 degrees C. All high voltage components within enclosure shall be isolated with steel covers. The complete unit shall be U.L. approved and labeled.
  - D. The controller shall have advanced flux vector PWM control techniques to enable quiet controller operation.
  - E. Circuits shall provide DV/DT and DI/DT protection for semiconductors. AFC shall be capable of starting into a rotating load without delay. Protective circuits shall cause instantaneous trip (IET) should any of the following faults occur:

1. 110% of controller maximum sine wave current rating is exceeded.
2. Output phase to phase and phase to ground (gnd. fault) short circuit condition.
3. High input line voltage.
4. Low input line voltage.
5. Loss of Input phase.
6. External fault. This protective circuit shall permit, by means of the terminal strip, wiring of remote NC safety contacts such as high static, pressure, firestat, etc., to shut down the drive.

F. The following adjustments shall be available in the controller and retained in non-volatile memory:

1. Maximum frequency (15 to 400 Hz) factory set at 60 Hz.
2. Minimum frequency (3 to 400 Hz) factory set at 6 Hz.
3. Acceleration (.1 to 360 seconds) factory set at 20 seconds.
4. Deceleration (.1 to 360 seconds) factory set at 20 seconds.
5. Volts/Hertz ratio factory set for 460V at 60 Hz.
6. Voltage offset or boost factory set at 100% torque.
7. Current limit (50% to 110% sine wave current rating) factory set at 100% current.

The AFC shall be capable of following a 4-20 MA signal.

G. AFC shall be furnished with door mounted operator controls consisting of auto/manual switch, start/stop (reset) switch, and manual speed control. In automatic mode, controller will follow an external signal and respond to remote start-stop contact wired to terminal strip. While in auto mode the controller will attempt up to three restarts after a power outage, drive fault or external fault.

H. The controller shall have three critical frequency avoidance bands.

I. The controller shall have a first fault LED panel which shall also indicate current, voltage or frequency.

J. The controller shall have an input line reactor.

K. The inverter shall provide a remote meter interface for speed (frequency in hertz), voltage and amperage. Signals shall be 0-10 VDC.

L. Input disconnect shall provide a positive disconnect between the controller and all phases of the incoming A-C line. This disconnect shall be designed to mount inside the controller enclosure and include a mounting bracket and through-the-door interlocking handle with provisions for padlocking. The basic switch shall be thermal magnetic, molded case circuit breaker.

M. Manual bypass shall provide all the circuitry necessary to safely transfer the motor from the AFC to the power line, or from the line to the controller while the motor is at zero speed. Two motor contactors, electrically interlocked, shall be utilized. One contactor is to be between the controller output and the motor, controlled by the controller regulator; and the other one is to be between the bypass power line and the motor, providing across-the-line starting. Motor protection is to be provided in both the "controller" mode and the "bypass" mode by motor overload relays. The 115 VA-C relay control logic, allowing common start-stop commands in the "controller" mode and the "bypass" mode shall also be included within this enclosure.



- N. The bypass circuit shall include a second input disconnect installed in the AFC. This disconnect shall provide the ability to safely troubleshoot and test the controller, both energized and de-energized, while operating in the "bypass" mode. This option shall mount within the controller enclosure.
- O. The AFC manufacturer shall maintain and staff nationwide service centers. These service engineers shall be employed by the manufacturer and provide start-up service including physical inspection of drive and connected wiring and final adjustments to meet specified performance requirements.

## 2.29 AIR FILTERS

- A. Prefilters shall be 2" Farr 30/30, medium efficiency, pleated, disposable type. Each filter shall consist of a non-woven cotton fabric media, media support grid and enclosing frame. Prefilters shall be capable of being installed or removed, using the Farr C-79 fastener, without disturbing the seal on the Riga-Flo filter.
- B. Additional alternate filters shall be Farr 6" Riga-Flo 15. Filter media shall be of high density microfine glass fibers which are laminated to a non-woven synthetic backing to form a lofted filter blanket. The filter media shall have an average efficiency of 60-65% on the ASHRAE Test Standard 52-76. It shall have an average arrestance of not less than 97% on that Standard. Filters shall be listed by Underwriters' Laboratories as Class 2.

## 2.30 DUCTS AND SHEET METAL WORK

- A. Provide ducts, plenums, access doors, fresh air intakes and exhausts as indicated and required. All ductwork shall be constructed, erected and tested in accordance with the most restrictive of local regulations, procedures detailed in the ASHRAE Handbook of Fundamentals or the applicable standards adopted by the Sheet Metal and Air Conditioning Contractors National Association. Garage exhaust and make-up air shall be medium pressure, 4 inch S.P., outside air, stairwell supply, and miscellaneous supply and exhaust air ducting shall be low pressure, 2 inch S.P. Primary cold air ducting shall be medium pressure 4 inch S.P. Distribution ducting downstream of the VAV boxes shall be low pressure 2 inch S.P. Vertical outside air and exhaust risers shall be low pressure 2 inch S.P.
- B. Final connections to ceiling diffuser boxes and linear diffusers shall be made with flexible glass fiber duct. Casco Silent Flex-II. Connections of flexible duct to round ducts shall be made with 1 inch wide positive locking steel straps.
- C. All connections to main ducts shall be made with low loss fittings.
- D. Flat duct surfaces shall be crimped diagonally regardless of size. Longitudinal joints in all duct sizes may be flat-lock joints. Transverse joints and intermediate bracing shall be constructed of galvanized sheet metal or galvanized structural angles in accordance with requirements of the ASHRAE guide and public authorities having jurisdiction.
- E. Ductwork Sealing
  - 1. Garage Exhaust and Make-up Air Ducting: Provide airtight gaskets at flanged joints.

2. Miscellaneous Supply and Exhaust, Outside Air and Stairwell Pressurization Ducting: Seal all joints and seams with canvas saturated with arabol or a two pack hardcast sealing system.
  3. Primary Cold Supply Air Duct Transverse Joints: Seal with 4" wide 4 oz. canvas saturated with arabol. Apply additional coats of arabol to make ducting completely airtight.
  4. Transverse Joints on Ducting Downstream of VAV Boxes: Seal with mastic.
  5. Longitudinal Joints on Supply Ducts with Static Pressure in Excess of 0.75" WG: Seal with mastic.
- F. Lock joints shall be hammered to make them airtight. Inside of duct shall present a smooth surface to flow of air.
- G. Changes in size of ducts shall increase gradually with a slope of not more than 12 inches in 5 feet where possible, but not more than 12 inches in 3 feet in any event.
- H. Turns shall be made with a throat radius of not less than the duct width.
- I. Horizontal ductwork shall be strongly supported with galvanized hangers in accordance with the requirements of the ASHRAE Guide and public authorities having jurisdiction.
- J. Provide double thickness turning vanes at all sharp right angle turns.
- K. Plenums shall be made of 18 gauge galvanized sheet steel reinforced horizontally on a maximum of 48 inch centers by 1-1/2 x 1-1/4 x 1/8 inch galvanized angles and reinforced vertically by 1-1/2 inch standing seams.
- L. Plenum access doors 24 x 54 inch minimum size shall be galvanized sheet steel doors and frames properly reinforced to prevent breathing. Door shall be of same gauge as the duct or casing and shall have 1 inch insulation with galvanized sheet steel on both sides. Each door shall be hung on 5% tee hinges and with one or more catches which are operable from both sides and similar to Ventfabrics, Inc. 260 Ventlock Hatch. Doors shall be hung to open against pressure and shall be fitted with felt to insure airtightness.
- M. Flexible connections for air ducts shall be 16 oz. airtight "Ventglass" noncombustible fabric with fire retardant neoprene coating on outside. Attach to ductwork by lock seam. Install not more than 6 inches long. Provide where required or indicated.
- N. Where ducts offset (vertically or horizontally), provide smooth radius duct elbows.

#### 2.31 DIFFUSERS, REGISTERS AND GRILLES

- A. Air distribution equipment shall be of sizes and capacities indicated, furnished in factory finished enamel of color selected. Submit paint samples for approval.

B. Square Ceiling Diffusers

1. Supply air shall be introduced into conditioned space in such a manner that conditioned air and room air is rapidly and evenly mixed, resulting in equalization of temperature and draftless air distribution throughout zones of occupancy with temperature differentials up to 25 degrees F for both cooling and heating. Air quantities and throws shall be as indicated.
2. Velocity of moving air below 5 foot level, during cooling cycle, shall not exceed limits of either 50 fpm at 1.5 degrees F below average room temperature or 70 fpm at 1 degree F below average room temperature. During heating cycle, velocity of moving air at the one foot level shall not be less than 10 fpm. Temperature difference at or below the 5 foot level shall not exceed the following: 2 degrees F below average room temperature at 30 fpm, 1.5 degrees F below average room temperature at 50 fpm, 1 degree F below average room temperature at 70 fpm. Sound pressure level in all octave bands for each diffuser shall not exceed NC 30 noise criteria curve at task level when units operate at designed capacities.
3. Lay-In Tile Ceiling:  
  
Supply Air Diffusers - Titus model PCS  
Exhaust/Return/Relief Air Registers - Titus model PAR
4. Hard Ceiling:  
  
Supply Air Diffusers - Titus model PMC  
Exhaust/Return/Relief Air Registers - to match supply

C. Continuous Linear Diffusers

Titus series TBD-30 and TBR-30 with mounting adapted to ceiling system, end caps, pattern blades and damper blades. Installation shall incorporate concealed fixing.

D. Garage Exhaust and Make-up Air Registers, Exhaust Registers in Vertical Face of Loading Dock

Titus series 30RL with opposed blade volume damper.

E. Wall Registers

Supply - Titus model 300RL  
Exhaust/Relief - Titus model 355RL

Note: Wall registers shall incorporate concealed fixing.

F. Diffusers/Grilles/Registers for Exposed Ducting

Supply Air Register - Titus model 300RL  
Supply Air Diffuser - Titus model MCD  
Exhaust Air Register - Titus model 50F with 1/2"x 1/2"x 1/2" egg-crate

## 2.32 TURNING VANES

- A. Both dimensions less than 48 inches; Barber-Colman air turns without splicing or approved double thickness airfoil vanes.
- B. Either dimension greater than 48 inches: Double thickness airfoil vanes of approved pattern.
- C. Rectangular smooth radius elbows - provide multiple splitter vanes.

## 2.33 DAMPERS

- A. Provide balancing volume dampers in each branch duct and in each main duct to provide for complete air balancing. Fit each manual volume damper with bearings and an adjusting device having a locking mechanism. Provide access panels if concealed or inaccessible through ceiling or wall.
- B. Balancing dampers where neither dimension of duct exceeds 17 inches may be job fabricated butterfly type consisting of a blade constructed of 18 gauge galvanized steel securely riveted or welded at its center axis to a square operating rod.
- C. Balancing dampers where either dimension exceeds 18 inches shall be Air Balance AC-116, opposed blade type.
- D. Fire dampers: Fusible link out of airstream type manufactured in accordance with requirements of State Fire Marshal and public authorities having jurisdiction, with permanent labeling identification. Provide suitable access for servicing dampers.
- E. Combination Smoke/Fire Dampers: Greenheck model FSD 23 leakage rated reopenable combination fire/smoke dampers. Dampers shall be 1-1/2 hour rated per U.L. Standard 555, and also shall be classified by Underwriters Laboratories as a leakage rated damper for use in smoke control systems, with a minimum Class 1 / 250 degree F leakage / temperature rating, per U.L. Standard 555S (maximum leakage of 4 cfm per square foot of damper area at 1" W.G.). The dampers shall bear U.L. labels attesting to the above.

Damper frame shall be of rigid, structurally designed, galvanized steel hat section with integral reinforced corner braces, designed for insert application. Blades shall be minimum 16 gauge galvanized steel with bronze oilite sleeve type bearings turning in an extruded frame raceway. Blade edge seals shall be silicone rubber for high temperature resistance. Jamb seals shall be silicone rubber backed flexible stainless steel specifically designed for air pressure assist sealing. Axles shall be minimum 1/2" square, plated steel with .125" plated steel tiebar linkage, concealed in frame, out of the airstream. Closure spring shall be stainless steel. Damper shall be factory installed in a minimum 16" long, 20 gauge galvanized steel sleeve.

Each damper assembly shall be equipped with a positive override device for remote control of heat induced damper closure to provide complete discretionary control of smoke management functions during a fire/smoke emergency. Control device shall include two blade position indicator switches, each controlling the 120-VAC signal to remote indication lamps of a control panel, to enable it to positively indicate the status of the damper as being full-open or full-closed.

Each damper section shall be factory equipped with a pneumatic actuator as an integral part of the damper assembly. The actuator shall be specifically listed and approved as fire/smoke damper actuator for the damper to which it is applied.

For openings greater than 72" wide x 50" high, the contractor shall construct and install mullions meeting the requirements of UL555. The damper manufacturer shall provide instructions on construction of mullion system.

## 2.34 SOUND TRAPS

- A. IAC of size and performance indicated herein
- B. Outer casings shall be made of 22 gauge type #G-90 galvanized steel in accordance with ASHRAE Guide recommended construction for high pressure rectangular duct work. Seams shall be locked, formed and mastic filled.
- C. Interior partitions shall be made of not less than 26 gauge type #G-90 galvanized perforated steel.
- D. Filler material shall be of inorganic mineral or glass fiber of a density sufficient to obtain the specified acoustic performance and be packed under not less than 5% compression to eliminate voids due to vibration and settling. Material shall be inert, vermin and moisture proof.
- E. Combustion rating for the silencer acoustic fill shall be not less than the following when tested in accordance with ASTM-E-84, NFPA Standard 255 or UL No. 723:  
  
Flamespread Classification - 25  
Smoke Development Rating - 20  
Fuel Contribution - 20
- F. Units shall be constructed in accordance with the ASHRAE Guide recommendations for high pressure ductwork. Seams shall be lock formed and mastic filled. Rectangular casing seams shall be in the corners of the silencer shell to provide maximum unit strength and rigidity. Interior partitions shall have die-formed entrance and exit shapes so as to provide the maximum aerodynamic efficiency and minimum self-noise characteristics in the sound attenuator. Blunt noses or squared off partitions will not be accepted. Attachment of the interior partitions to the casing shall be solid galvanized steel and shall be welded to the outer casing. Attachment of the interior partitions to the tracks shall be such that a minimum of 4 thickness of metal exist at this location. The track assembly shall stiffen the exterior casing, provide a reinforced attachment detail for the interior partitions and shall maintain a uniform airspace width along the length of the silencer for consistent aerodynamic and acoustic performance.

Interior partitions shall be additionally secured to the outer casing with welded nose clips at both ends of the sound attenuator.

Sound attenuating units shall not fail structurally when subjected to a differential air pressure of 8 inches water gauge from inside to outside the casing.

Airtight construction shall be provided by use of a duct sealing compound on the job site, material and labor furnished by the contractor.

- G. Silencers ratings shall be determined in a duct-to-reverberant room test facility which provides for airflow in both directions through the test silencer in accordance with ASTM specification E 477. The test set-up and procedure shall be such that all effects due to reflection, directivity, flanking transmission, standing waves and test chamber sound absorption are eliminated. Acoustic rating shall include Dynamic Insertion Loss (DIL) and Self-Noise (SN) Power Levels both for FORWARD FLOW (air and noise in same direction) and REVERSE FLOW (air and noise in opposite directions) with airflow of at least 2000 fpm entering face velocity.
- H. Static pressure loss of silencers shall not exceed those listed in the silencer schedule as the airflow indicates. Airflow measurements shall be made in accordance with ASTM specification E 477 and applicable portions of ASME, AMCA and ADC airflow test codes. Tests shall be reported on the identical units for which acoustic data is presented.
- I. With submittals, the manufacturer shall supply certified test data on Dynamic Insertion Loss, Self-Noise Power Levels and Aerodynamic Performance for Reverse and Forward Flow test conditions. Data shall be tested and certified by the manufacturers ASTM conforming lab or from an independent acoustical lab. Test data shall be for a standard product. All rating tests shall be conducted in the same facility, shall utilize the same silencer, and shall be open to inspection upon request from the Architect/Engineer.

## 2.35 INSULATION

All insulation shall comply with the State of California Energy Conservation Standards. Install pipe insulation after piping is installed, tested and approved, and is in clean dry condition. Firmly butt insulation joints.

- A. Chilled Water Supply and Return, Heating Water Supply and Return: Insulate piping with glass fiber pipe insulation with factory applied white vapor barrier jacket, J-M Micro-Lok 650 AP, 1 inch thick for pipe sizes 2 inches and below, and 1-1/2 inches thick for pipe sizes 2-1/2 inches and above. Insulate fittings, flanges and valves with performed insulation with PVC pre-molded and piece fitting covers, J-M Zeston. Apply vapor barriers mastic coating Foster 30-35 to form an isolating vapor seal between pipe insulation jacket and pipe at butt joint of insulation at fittings, flanges, valves, hangers and at 21 foot intervals on continuous runs. Adhere longitudinal laps and butt strips of jacket with factory applied pressure sensitive tape system, J-M AP-T.
- B. Unions: Insulate in same manner as fittings, flanges and valve bodies. Conspicuously mark locations on pipe coverings.
- C. Shields: For pipes 4 inches and larger, at each hanger protect insulation with 12 inches long 18 gauge galvanized metal shield over heavy density calcium silicate insulation insert. For pipes 3 inches and smaller, at each hanger protect insulation with 4 inch long 18 gauge galvanized metal shield.
- D. Thermal Duct Insulation: Insulate all concealed cold supply air ducts and plenums unless otherwise specified, with J-M Microlite fiberglass duct insulation, foil-faced, 1 lb. density, 1-1/2 inch thick insulation wrapped entirely around duct with joints lapped at least 2 inches and secured with 16 gauge galvanized wire on 12 inch centers. Insulation shall cover all surfaces including standing seams.

- E. Exposed Cold Supply Air Ducts: Shall be lined with J-M Linacoustic, 1-1/2 inch thick, 1 lb. density coated fiberglass duct liner complying with NFPA 90-A requirements. The cut liner shall have an air friction correction factor not greater than 1.1 at a velocity of 3000 fpm. Apply insulation to inside of ducts with an approved fire retardant adhesive to provide 100% coverage and a smooth surface. In ducts with one side more than 12 inches, secure insulation with mechanical fasteners in addition to adhesive, spaced at 14 inch centers in both direction.

Mechanical fasteners shall be flush with the liner surface and shall start within 2 inches of the leading edge of each section and within 3 inches of the leading edge of all cross joints within the duct section. All exposed edges and the leading edge of all cross joints of the liner shall be heavily coated with an approved fire resistant adhesive. The duct liner shall be cut to assure snug closing corner joints, the black surface of the liner shall face the air stream, transverse joints shall be neatly butted, and all damaged areas shall be heavily coated with an approved fire resistant adhesive.

- F. Contractor's Option: Concealed main supply air ducts and plenums may be lined in lieu of external wrapping as hereinbefore specified.
- G. Sound Duct Insulation: Where indicated, sound insulate air ducts as hereinbefore specified for exposed cold supply air ducts.
- H. All insulation shall have a minimum thermal resistance of 4.0 exclusive of film resistance.

#### 2.36 CARBON MONOXIDE DETECTION SYSTEM

- A. A Murcurco carbon monoxide detection system shall be furnished. The system shall include Maintenance Free solid state electronic carbon monoxide detectors located strategically throughout the Parking Structure. Each detector shall cover a maximum area of 5,000 square feet. The continuous carbon monoxide detection and fan control system shall be provided for monitoring the carbon monoxide levels in the area shown and to control the exhaust and supply fans for energy conservation.
- B. Carbon Monoxide to Voltage Transducers: Provide sensors to measure the level of CO and provide information to the system controllers in an analog mode. The voltage transducers shall mount in standard electrical boxes and operate on low voltage.
1. Power: 12 volt DC or 12 volt AC at 0.15 amps.
  2. Output Level: 1.0 to 4.0 volts at 10 MA.
  3. Sensors: Solid State, supervised.
  4. Type: Macurco SS102/103
- C. Sequence of Operation:
1. Normal Mode: The exhaust and supply fans shall be controlled by the carbon monoxide detection system. At 50 ppm, fans will operate until the carbon monoxide levels drop below 35 ppm. An alarm will be given in the event CO concentrations reach 150 ppm for more than 11 minutes.

D. Start-Up Testing and Warranty:

1. The Manufacturer or Manufacturer's Representatives shall review and test the system after it is complete and operating and shall submit his report to the Architect.
2. The Manufacturer shall warrant the equipment 24 months (2 years) from the date of Manufacturer's or Manufacturer's Representative's final report to the Architect.

2.37 VIBRATION ISOLATION EQUIPMENT: Provide vibration isolation equipment for all mechanical equipment and piping as specified herein and indicated on the drawings. The vibration isolation system shall be installed in a manner to prevent the transmission of vibration to the structure. No rigid connections between rotating or oscillating equipment or piping and the building will be permitted.

A. General Requirements

1. Vibration Isolation manufacturer shall furnish written instructions covering the installation and adjustment of all isolators. The manufacturer shall replace any isolation that has been improperly sized.
2. Mechanical subcontractor shall coordinate his work with the other trades. Contractor following him, such as plastering or electrical, shall be notified and instructed to avoid any contact with his installation that would reduce the effectiveness of the system.
3. Inspections: Vibration isolation manufacturer shall make an inspection of the vibration installation, and inform the Architect in writing of any necessary corrections and/or adjustments.
4. Bases: Where called for in the specifications and on the drawings, all structural steel bases, including concrete pouring form bases, shall be designed and fabricated by the vibration isolation manufacturer. The concrete for the pouring form bases shall be by others.
5. Vibration isolation shall be manufactured by a single manufacturer. All isolation shall be in strict accordance with the following specifications and manufactured by M.W. Sausse and Co., Inc. or approved equal. The isolation manufacturer shall include in the submittal the following information:
  - a. Type of isolator.
  - b. Deflection.
  - c. Free or unloaded height.
  - d. All physical characteristics of springs used.
  - e. Size of structural members.
  - f. Efficiency calculations.
  - g. Any other pertinent information to make the submittal complete.



B. Technical Requirements

1. Isolators shall be designed or treated for resistance to corrosion. Structural steel bases shall be cleaned of welding slag and painted with a coat of red lead primer-finish composed of basic lead silicon chromate. All nuts, bolts and washers shall be zinc-electroplated.
2. All equipment shall be equipped with seismic restraints in accordance with the requirements of all governing agencies. These restraints shall be designed and supplied by the vibration isolation manufacturer. Suspended equipment and piping shall be restrained by steel cable. This cable and the method of installation shall be the responsibility of the mechanical contractor. The cable restraints shall be installed in such a manner as to not short circuit the vibration isolation. The contractor shall submit details for approval.

2.38 EQUAL MATERIALS AND SUBSTITUTIONS

In addition to manufacturers specified, the following shall also be considered equal, providing corresponding models meet specified requirements. Equivalent substituted equipment named herein shall be submitted to Architect for approval. Submit alternate selections at time of bid listing major equipment.

<u>ITEM</u>	<u>MANUFACTURER</u>
STRAINERS	CRANE, WALWORTH, STRONG, KECKLEY, MUELLER
SOLDERS	SILFOS, EASY-FLOW
PIPE HANGERS & SUPPORTS	FEE & MASON, ELCEN
GAS VENTS	METALBESTOS
INSULATION	JOHNS MANVILLE, GUSTIN BACON, FIBERGLAS
WATER PRESSURE REDUCING	
VALVES	BAILEY, FISHER
PRESSURE GAUGES	MARSH, MARSHALLTOWN, TRERICE
THERMOMETERS	PALMER, TRERICE, MUELLER
HOT WATER BOILERS	RITE, PARKER
AIR FILTERS	AAF, AIRGUARD
WATER TREATMENT	BETZ-ENEC
VARIABLE VOLUME BOXES	TITUS, ANEMOSTAT
WATER PUMPS	PEERLESS, ALLIS-CHALMERS, WEINMAN
WATER-COOLED HEAT PUMPS	MC QUAY
CHILLERS	CARRIER
STRAINERS	CRANE, WALWORTH, STRONG, KECKLEY, MUELLER
LINEAR DIFFUSERS	AIR MANAGERS, ANEMOSTAT, KRUEGER
DIFFUSERS, REGISTERS,	
GRILLES	ANEMOSTAT, KRUEGER
AXIAL FANS	CHICAGO
PLUG FANS	BUFFALO
SWSI & DWDI UTILITY FANS	BUFFALO
MISCELLANEOUS SMALL FANS	GREENHECK
CO DETECTION SYSTEM	MSA

### PART 3 - EXECUTION

#### 3.01 SURFACE CONDITIONS

##### A. Inspection

1. Prior to commencing work required by this section, inspect the work of other trades and verify that such work has been properly completed and installed to allow for proper installation of all materials and methods required of this section.
2. All heating, ventilation and air conditioning shall be installed in accordance with the requirements of all governing authorities, the original design, and the referenced standards.

##### B. Discrepancies

1. In the event of discrepancy, immediately notify the Architect.
2. Do not proceed with installation in areas of discrepancy until all such discrepancies have been fully resolved.

#### 3.02 EQUIPMENT IDENTIFICATION

A. All major equipment shall bear firmly attached metal nameplates which state name of manufacturer, model number and electrical data. An additional permanent label shall be affixed to each equipment which will clearly indicate by number which operating and maintenance manual explains maintenance requirements in detail.

##### B. Valve Identification

1. Valve charts: Two typewritten charts not less than 8x10 inches shall be made showing assigned numbers controlled in each system by each valve in mechanical equipment rooms only. Charts shall be mounted behind aluminum framed glass as directed.
2. Valve tags: Provide tag consisting of 2 inch diameter, 20 gauge, stainless steel or copper disk for each main line shut-off valve or cock. Fasten tags in place with continuous steel ring or chain around stem of valves and around pipe for cock. Two inch letters and figures stenciled in contrasting colors on pipe or pipe coverings may be substituted for tags on OS&Y valves. Disks shall be stamped with a number corresponding to identification (or location) number shown on valve chart and with service designation with 1/4 inch high letters.

##### C. Pipe Identification

Mark each individual pipe in mechanical equipment rooms only for quick and easy identification with Identobands, aluminum with enamel finish, 1-1/2 inches wide, installed as recommended by manufacturer after completion of piping and finish painting. Unless otherwise specified, coding shall conform to "Scheme for the Identification of Piping Systems" (ANSI A13.1-1956). Color scheme shall be approved. Base color for markers shall be as follows:

Compressed air: Orange  
Chilled water: Green  
Space heating hot water: Orange  
Closed circuit cooler water: Green  
Condenser water: Green  
Make-up water: Green  
Refrigerant piping: Yellow

### 3.03 SAFETY PROVISIONS

Equipment and piping with temperatures above 140 degrees F or temperatures below 25 degrees F, located as to endanger personnel or create a fire hazard, shall be properly guarded or covered with insulation of type specified. Bolts, gears, chains, pulleys, couplings, projecting set screws, keys and other rotating or reciprocating parts shall be enclosed or properly guarded. Provide guard rails, etc., required for safe operation and maintenance of equipment.

### 3.04 INITIAL LUBRICATION, ADJUSTING AND FILLING SYSTEMS

Before operating any mechanical systems, equipment bearings shall be lubricated and bolts, pulleys, and other moving parts checked for alignment and tolerances in accordance with manufacturer's operating instructions. Piping and liquid systems shall be flushed out and filled with operating fluids. After tests, valves and other parts of work shall be adjusted for quiet operation. Strainers shall be cleaned out by removing and washing basket or screen. Compressors shall have lubricating oil changed. Vibrations and noise shall be suppressed.

### 3.05 CLEANING OF EQUIPMENT, MATERIALS AND PREMISES

Refer to section "Cleanup and Disposal." Clean equipment and materials thoroughly. Leave surfaces to be painted smooth, clean, and ready for painters. Clean entire premise of unused materials, rubbish, debris, grease spots and dirt left by subcontractors. Remove, clean and replace pipeline strainers after systems have been in operation for a period of 30 calendar days.

### 3.06 HANGERS AND SUPPORTS

A. Hold horizontal pipe runs firmly in place using approved steel and iron hangers, supports, and/or pipe rests, unless otherwise indicated. Suspend hanger rods from concrete inserts or from approved brackets, clamps or clips. Hang pipes individually or in groups if supporting structure is adequate to support weight of piping and fluid. Except for buried piping, hang or support pipe runs so they may expand or contract freely without strain to pipe or equipment.

#### B. Horizontal Steel Piping

Provide hangers or supports every 10 feet except every 8 feet for piping under 1 inch in diameter, unless otherwise specified.

#### C. Horizontal Copper Tubing

For 2 inch diameter and over, provide hangers, every 10 feet, for 1-1/2 inch diameter and smaller, every 6 feet.

D. Vertical Piping

Support at every floor with wrought iron pipe clamps.

E. Branches

Provide separate hangers or supports for branch lines 6 feet or more in length.

3.07 EQUIPMENT AND MATERIALS

Install per manufacturer's recommendations.

3.08 ACCESSIBILITY

Install work readily accessible for normal operation, reading of instruments, adjustment, service, inspection and repair. Provide access panels where indicated and required. Access panels shall be the responsibility of the respective subcontractor.

3.09 EXCAVATION AND BACKFILL

Perform excavation and backfilling required for mechanical work under this division unless otherwise specified. Conform to requirements of Division 2 and of public authorities having jurisdiction.

3.10 EXPANSION AND CONTRACTION

Install piping subject to expansion and contraction with expansion loops made up of bends or fittings, expansion joints, swing joints, or other approved methods or devices. Branch lines from main subject to expansion and contraction shall have a swing joint at point of connection with the main. Risers which pass through one or more floors shall have swing joints at their base. Anchor lines subject to expansion and contraction by approved methods to restrict movement.

3.11 SYSTEM BALANCING

- A. Balancing data shall be submitted for air flow at each outlet, outside air, return air, total supply air, fan rpm, fan pressures, water quantities and temperatures and any other data deemed necessary to show that proper adjustments have been made. If in the opinion of Architect test results are not acceptable and the Contractor does not satisfy system balancing requirements, an independent balancing company will be retained to balance all systems. All costs for this service shall be paid by Contractor.
- B. Tests shall be witnessed by Owner's representative and submittal data signed by Owner's representative before final inspection.
- C. Air balance subcontractor shall verify that dampers have been installed for adequate air balancing and that air loss in ductwork will not prevail. Duct joints shall be repaired by contractor.

- D. Balancing Work Included:
1. Complete testing and balancing of all systems, distribution piping, air testing and balancing of all exhaust systems, air handling units, and air distribution equipment complete as herein specified.
  2. System balancing shall be performed by independent agency certified by AABC. Submit proof of qualifications for each Specialty Contractor certified to perform such services.
  3. All balancing shall be to the satisfaction of the Architect. Should the contractor refuse or neglect to balance the system to the Architect's satisfaction, such balancing shall be made by an independent agency at the Contractor's expense.
  4. The Contractor shall make drive changes, install additional dampers, vanes, grille baffles, or other items, as may be required on the job, to balance the system to the Architect's satisfaction.
- E. Verification of Conditions: Prior to testing and balancing, inspect equipment and materials and arrange with Contractor for satisfactory correction of all defects in workmanship and/or material that could disaffect the work specified herein.
- F. Protection: As specified hereinbefore.
- G. Agency: All system balancing shall be supervised by an Independent Agency which specializes in balancing and testing of mechanical systems, hereinafter referred to as the Agency.
- H. System Operation: Contractor shall put all parts of systems in full operation and shall continue the operation of same during each working day of testing and balancing.
- I. Submittals: Within 90 days after the start of construction, submit a complete testing and balancing procedure showing all test equipment that will be used, testing procedures, test data sheets, systems schematics, and point of testing.
1. Test Data: Submit 10 copies of test data to Architect on completion of work under this Section.
  2. Certificate: Agency shall certify in writing that system has been adjusted and balanced and design conditions have been attained in all areas of building.
- J. Instruments: Instruments used by Contractor shall be accurately calibrated and maintained in good working order. Instruments shall have certified by the manufacturer or an approved test laboratory within one year of the testing date; submit this certificate to Architect. Test instruments furnished by Contractor for delivery to Owner may be used to perform part of the system balancing.
- K. Air Distribution Testing and Balancing:
1. Make pitot tube transverse of main supply ducts and obtain design CFM at fans at simulated full load conditions.

2. Test and adjust system for design return and exhaust air CFM.
3. Test and adjust system for design CFM outside air.
4. Adjust all main supply and return air ducts to proper design CFM.
5. Adjust all zones to proper static pressure, design minimum and maximum CFM and air temperature.
6. Test and adjust each diffuser, grille and register to within +/- 10% of design requirements.
7. Each grille, diffusers, and register shall be identified as to location and area.
8. Size, type and manufacturer of diffusers, grilles, registers and all tested equipment shall be identified and listed. Manufacturer's ratings on all equipment shall be used to make required calculations.
9. Readings and tests of diffusers, grilles, and registers shall include the required FPM velocity and test result velocity, required CFM, and test result CFM after adjustment.
10. In cooperation with the control manufacturer's representative, the setting adjustment of automatically operated controls to operate as specified, indicated, and/or noted.
11. All diffusers, registers and grilles and all equipment shall be adjusted to maintain the design and conditions at design loads.

L. Air Moving Equipment:

1. Manufacturer
2. Total CFM (Fan & Outlet)
3. RA CFM
4. OA CFM
5. Inlet & Outlet Static Pressures
6. Fan RPM
7. Motor Manufacturer, HP & BHP
8. Phase, Voltage, Amperage
9. Motor RPM

M. Pumping Equipment:

1. Manufacturer, Size, Impeller
2. GPM, FT HD, Inlet & Outlet Pressures
3. Motor Manufacturer, HP & BHP
4. Phase, Voltage, Amperage
5. Motor RPM

N. Cooling Towers and Closed Circuit Coolers:

1. Manufacturer
2. GPM
3. ENT & LVG Water Temperatures
4. ENT WFT Bulb °F
5. LVG WFT Bulb °F
6. Ambient Dry Bulb °F
7. Fan & Pump HP, BHP, Voltage, Phase, Amperage, RPM

O. Chillers:

1. Manufacturer
2. Evaporator GPM, Water Temperature In & Out, Pressure Drop
3. Condenser GPM, Water Temperature In & Out, Pressure Drop
4. Voltage, Amperage

P. Cooling and Heating Coils:

1. Air CFM & PD, Temperature In & Out (WB & DB)
2. GPM, Water Temperature In & Out, Water PD

Q. Coordinate tests with the manufacturer of each equipment.

R. Witness: Notify Architect in writing two weeks prior to testing and balancing of all major equipment in order to arrange that Architect's representative will witness the tests.

3.12 INSTALLATION

Water chillers, cooling tower, water boiler, pumps, air handling units, exhaust fans and other equipment shall be installed on concrete bases and bolted to vibration isolators and then anchored to structures as indicated.

3.13 DISCHARGE PIPING

Valves shall be extended down from automatic air vents to nearest floor sink. Discharge piping from refrigerant pressure reliefs shall be extended above the roof with the pipe discharge facing down.

3.14 DRAIN LINES

Drain lines from expansion tanks shall be extended down to nearest floor sink.

3.15 QUICK OPENING BLOWOFF VALVES

Quick opening blowoff valves shall be installed at boiler water level safety switches with drain piping extended down to nearest floor sink.

3.16 COCKS

Upon balancing of system, all balancing cocks shall have body plug permanently set to indicate balance position of plug.

### 3.17 AIR DISTRIBUTION EQUIPMENT LOCATIONS

Air distribution equipment locations shall be coordinated with architectural drawings.

### 3.18 TURNING VANES

Turning vanes shall be installed in all right angle sharp turns in ducts.

### 3.19 SOUND INSULATION

Where indicated, specified duct dimensions are net clear dimensions, i.e., clear dimensions, after sound insulation has been installed.

### 3.20 FIRE DAMPERS

Fire dampers in supply air ducts and return air ducts shall have fusible links with melting temperature 50 degrees F above maximum normal operating temperature. Fire dampers shall be provided with adequate access doors by this contractor. Where fire dampers are installed directly behind wall registers or grilles, the register or grille shall be oversized to allow for the fire damper curtain.

### 3.21 DUCTWORK

Ductwork connected to louvered openings shall be adapted to size of these openings.

### 3.22 CONNECTIONS

Connections between two dissimilar metal pipes shall be made with dielectric unions.

END OF SECTION



**SECTION 15900**

**TEMPERATURE CONTROL SYSTEM**

**PART 1 - GENERAL**

1.01 GENERAL

- A. The Building Management and Control System (BMCS) shall consist of an information sharing network of standalone Direct Digital Control Panels (DDCP's) to monitor and control equipment per the control sequence.
- B. "Information sharing" shall be defined as: the function of each DDCP to exchange data on the network trunk with other DDCP's without the need for additional devices such as network managers, gateways or central computers.
- C. "Standalone" shall be defined as: the function of each DDCP to independently monitor and control connected equipment through its own microcomputer.
- D. Provide all work for the complete installation of automatic temperature controls.
  - 1. Principal items include:
    - a. Pneumatic, electronic and electric controls, including sensors, switches, relays, thermostats, control panels for instruments.
    - b. Pneumatic motors for air dampers, valves, etc.
    - c. Pneumatic tubing for temperature control systems.
    - d. Local control panels.
    - e. Complete instrument air system including air compressor and receiver, refrigerated air dryer and appropriate accessories.
    - f. Adjustment and validation of control system. Instruction of Owner's representative on maintenance and operation of control equipment.
    - g. Pneumatic and electric diagrams showing interlock between equipment furnished under this and other sections and controls furnished herein.
    - h. Direct digital control for systems as indicated on the drawings.
    - i. Wiring and conduit. Low and line voltage for the control system under Division 15, Power Wiring under Division 16.

1.02 ACCEPTABLE BIDDERS

- A. Landis & Gyr Powers
- B. Honeywell
- C. Robertshaw

### 1.03 COMMUNICATIONS PROCESSING

- A. The BMCS shall operate as a true token-pass peer-to-peer communication network. Resident processors in each DDCP shall provide for full exchange of system data between other DDCP's on the network trunk. Systems that limit data exchange to a defined number of system points are not acceptable.
- B. Systems that operate via polled response or other types of protocols that rely on a central processor or similar device to manage DDCP to DDCP communications may be considered only if a similar device is provided as a stand-by. Upon a failure or malfunction of the primary device, the stand-by shall automatically, without any operator intervention, assume all BMCS network management activities.
- C. The failure of any DDCP on the network shall not affect the operation of other DDCP's. A DDCP failure shall be annunciated at the specified alarm printers or terminals.

### 1.04 DDCP HARDWARE

- A. Each DDCP shall consist of a 16 bit microprocessor and controller, power supply, input/output boards and communication board. All program and point data bases shall be stored in non-volatile EEPROM or a minimum of 100 hour battery backup shall be provided. Provide a minimum of 128K RAM expandable to 256K, in each DDCP to allow for point expansion and trend data storage.
- B. Each DDCP shall incorporate a real-time clock.
- C. Each DDCP shall be provided with two (2) RS232 communications ports. Connecting an operator terminal or modem, whether portable or stationary, shall allow the user to communicate with the entire network.
- D. Each DDCP shall provide for input/output point connections to field equipment. The following point types shall be supported:
  - 1. Analog inputs - For measuring sensed variables. Inputs shall be capable of accepting voltage, resistance, current or pressure signals.
  - 2. Analog outputs - For controlling end devices. Outputs shall be capable of producing voltage, resistance, current or pressure signals. Pneumatic outputs shall be provided with a manual override for adjusting outputs in the event of a power loss at the DDCP.
  - 3. Digital inputs - For monitoring dry contacts such as relays, switches, pulses, etc.
  - 4. Digital outputs - To control two position devices such as starters, actuators, relays, etc.
- E. As an option, provide DDCP's without input/output point connections (LAN Controller) should the points be remote from the DDCP location.
- F. Each DDCP shall be listed under UL916 (Energy Management Systems), UL864-UDTZ (Signal Systems Unit), UL864-UUKL (Smoke Control Systems) and shall be tested to comply with sub-part J of Part 15 FCC rules for Class A computing equipment.

#### 1.05 PROGRAMMING FUNCTIONS

- A. Resident software in each DDCP shall provide for custom programming of control strategies, point database, operator interface, network communications, facilities and energy management functions.
- B. Programming of control and energy management strategies shall be accomplished via a high level computer language such as BASIC. A standard math processor shall be part of the programming language. All analog loops shall be capable of proportional, integral, and derivative control.
- C. Each DDCP shall incorporate an operator interface program (OIP) that provides an English language user interface. The OIP shall allow the user to program, interrogate, command and edit the BMCS via a self prompting method. Operator terminals, whether textual or graphical, shall be able to access the entire network from any DDCP. Access shall be accomplished in a transparent fashion; that is, the operator shall not be required to address specific DDCP's in order to display or command system points.

#### 1.06 FACILITY MANAGEMENT SOFTWARE

- A. The BMCS shall be provided with standard and custom report generation functions that include:
  - 1. Alarm summaries
  - 2. Motor status summaries
  - 3. Point displays by type, system, status, overrides, failures, location, equipment and enable/disabled.
  - 4. Program listings
- B. All reports shall be either displayed or printed by:
  - 1. Operator request
  - 2. Time of day
  - 3. Event conditions (such as in response to an alarm, interlock, etc.)
- C. All reports shall be time and date stamped.
- D. An alarm processing program shall be provided to annunciate those points designated as alarmable. Alarm points shall, upon alarm occurrence, be displayed or printed at designated terminals.
- E. DCP's shall contain a password access routine that will assign an operator to one of three levels of access. Level 1 shall permit display function only, Level 2 shall additionally permit commanding of system points and level 3 shall additionally permit full program and data base editing.

#### 1.07 ENERGY MANAGEMENT SOFTWARE

- A. The BMCS shall be provided with an adjustable width sliding window electric demand limiting (EDL) program and shall be user programmable to reduce the peak electric demand as user definable target values are approached.
- B. A duty cycle control (DCC) program shall provide user definable variable "on" and "off" times throughout the day once the mechanical or electric equipment is started by Time Program Commands, Optimum Start, or Manual Command.
- C. The BMCS shall be provided with an optimal start program such that the building may be divided into zones for optimum start. Warm-up and cool-down shall occur in sequence with succeeding zones starting only after the preceding zone has completed its warm-up or cool-down.
- D. The BMCS shall be provided with an operator interactive time of day (TOD) program. TOD programming and modifying shall be accomplished in a calendar-like format that prompts the user in English language to specify month, year, day, time and associated point commands.
- E. In addition to the previously specified management functions, the BMCS shall be provided complete with the following programs:
  - 1. Enthalpy optimization
  - 2. Supply air reset
  - 3. Chilled water reset
  - 4. Volumetric control
  - 5. Dead band control:

All specified energy management programs, whether or not applicable to this project shall be provided such that the owner may enable the programs at a future date without the need to purchase or modify additional software.

#### 1.08 POINT EXPANSION MODULES

- A. Each DDCP shall be capable of extending its input/output capabilities via special purpose modules. Said modules may be mounted remote from the DDCP and shall communicate with the DDCP over a pair of twisted cables. Each DDCP shall support a minimum of 50 such modules.

#### 1.09 APPLICATION SPECIFIC CONTROLLERS

- A. Provide application specific controllers (ASC's) as required for each mechanical system or piece of equipment. Each ASC shall be a microprocessor-based direct digital control unit and shall be capable of operating either as a standalone controller or on a multi-drop communications network origination at the DDCP. Provide each ASC with sufficient memory to operate in a truly independent manner; that is, each ASC shall support its own inputs and outputs, operating system, database and programs necessary to perform control sequences and energy management routines.

Provide the following types of ASC's as a minimum:

1. Central system controllers
  2. Terminal equipment controllers
- B. Central system controllers shall be provided for control of central HVAC systems and equipment including, but not limited to, the following:
1. Rooftop units
  2. Packaged air handling units
  3. Chilled and condenser water systems

Provide a door-mounted interface terminal to allow for direct-user access to the controller. The terminal shall provide the user with the following functionality as a minimum:

1. View and set date and time
2. Modify and override time-of-day schedules
3. View points and alarms
4. Monitor points
5. Command and modify setpoints

#### 1.10 TELECOMMUNICATIONS CAPABILITIES

- A. A telecommunications interface shall be furnished as necessary to allow direct connection of DDCP's and networks to public and private phone lines.
- B. As a result of a predefined event or command, the telecommunications interface shall automatically initiate a call to establish communications with a central computer and/or a remote terminal.
- C. The telecommunications interface, when operating in an automatic dialing mode, shall be able to perform any of the following functions:
1. Retry a single primary number at a fixed interval a finite or infinite number of times and quit if unsuccessful. (If the number is busy, retry it until successful). In addition, call a minimum of three additional secondary numbers.
  2. Retry successive numbers arranged in a priority scheme at fixed intervals a finite number of times and quit if unsuccessful.
  3. Inform the requesting device that a successful connection has been made. (If the numbers are busy, retry until successful).
  4. Inform the requesting device that a connection cannot be made.
  5. Detect loss of communication of its network and dial an appropriate device (CPU, Terminal, etc.), and upon successful connection transmit a message identifying a network failure.

- D. The telecommunications interface shall maintain an error file that contains a tabulation of the following events on a per number basis:
- Calls attempted
  - Calls no answered
  - Calls busy
  - Calls successful
  - Calls prematurely terminated
  - Calls voice
- E. The telecommunications interface shall be capable of being utilized with a network of DDCP's so that any unit on the network can control the interface and accomplish the following:
- Initiate call (s)
  - Access the error file
  - Reset the error file
- F. The telecommunications interface shall also have automatic answer capabilities to allow it to be accessed from a remote control computer or terminal with modem. The interface unit shall be able to allow the person calling access to any information of the network, provided that the standard log-on security screening is met.

#### 1.11 OPERATOR'S TERMINALS

Provide a video display terminal with keyboard to access the DDC Controller Network and a report and alarm printer. Printer shall be independently interfaced to the network such that its operation is not dependent on a connection to the video terminal. Locate terminal and printer in Building Engineer's office.

- A. Personal computer workstation shall be provided for command entry, information management, network alarm management and database management functions. All real-time control functions shall be resident in the DDC Controllers to facilitate greater fault tolerance and reliability.
1. Workstation shall consist of a color monitor, personal computer with minimum 4 MB RAM, 80 MB hard drive and controller, 3-1/2" diskette drive, mouse and 101-key enhanced keyboard. Personal computer shall be an IBM PS/2 Model 70 or equivalent and shall include a minimum 20 MHZ 80386 processor.
  2. The display provided for system operation shall have a diagonal screen measurement of no less than 20" and a minimum display resolution of no less than 640 x 480 pixels. Separate controls shall be provided for color, contrasts and brightness. The screen shall be non-reflective.
- B. Printer shall be provided for recording alarms, operator transactions and systems reports, and shall meet the following minimum requirements:
1. 132 column/160 character per second print speed.
  2. 9 x 9 DOT matrix character structure switchable to 9 x 18 DOT matrix for letter quality output.
  3. Compressed mode option for 220 characters per line.

4. Software selectable under, emphasized, double strike and expanded (double width) characters capability.
5. Adjustable line spacing of 6 or 8 lines per inch.
6. Adjustable tractor for 5 inch to 15 inch paper widths.
7. 96 ASCII upper and lower case character set.

#### 1.12 SENSORS

Provide the following instrumentation as required by the monitoring, control and optimization functions:

##### A. Temperature Sensors:

1. Liquid Immersion Temperature
  - Temperature monitoring range +32/+260 F (0/126 C)
  - Output signal changing resistance
  - Installation adjustments none required
  - Calibration adjustment none required
  - Factory calibration point 77 deg F (25 C)
  - Accuracy at calibration point +/-0.5 F (+/-0.3C)
  - Thermistor resistance at calibration point 1000,000 Ohms
  - Dimensions
    - Sensor probe length 4.75"L (121 mm)
    - Overall size 4"H x 2"W x 10"D
2. Duct (Single Point) Temperature
  - Temperature monitoring range 32/+140 F (0/60 C)
  - Output signal changing resistance
  - Installation adjustments none required
  - Calibration adjustments none required
  - Factory calibration point 77 deg F (25 C)
  - Accuracy at calibration point +/-0.5 F (+/-0.3 C)
  - Thermistor resistance at calibration point 1000,000 Ohms
  - Dimensions
    - Sensor probe length 18" L (457 mm)
    - Overall size 4"H x 2"W x 20.44"D

3. Duct (Averaging Temperature)
- |                               |                      |
|-------------------------------|----------------------|
| Temperature monitoring range  | +20/120 F (-7/+49 C) |
| Output signal                 | 4 - 20 MA DC         |
| Installation adjustments      | none required        |
| Calibration adjustments       | zero & span          |
| Factory calibration point     | 70 deg F (21 C)      |
| Accuracy at calibration point |                      |
| Platinum RTD element          | +/-1 F (+0.6 C)      |
| Sensor                        | +/-1.1 F (+/-0.6 C)  |
| RTD resistance                | 100 Ohms +/-         |
|                               | .1% at 32 F          |
| Voltage                       | 12 VDC               |
| Power consumption             | 0.25 watts           |
| Dimensions                    |                      |
| Sensor probe length           | 25"L (7.3m)          |
| Overall size                  | 4"H x 2.125"W x 24"L |
4. Outside Air Temperature
- |  |                        |
|--|------------------------|
| Temperature monitoring range               | -40. +120 F (-40/49 C) |
| Output signal                              | changing resistance    |
| Factory calibration point                  | 77 deg F (25 C)        |
| Accuracy at calibration point              |                        |
| Thermistor element                         | +/-0.5 F (+/-0.3 C)    |
| Thermistor resistance at calibration point | 100,000 Ohms           |
| Dimensions                                 | 8"L x 1.25"H x 1.44"D  |

B. Air Flow Measurement:

1. Primary element shall be Dieterich standard Annubar.
- |               |          |
|---------------|----------|
| Accuracy      | +/-1%    |
| Rangeability  | 3.5:1    |
| Repairability | +/-0.01% |
2. Transmitter shall be Robinson-Halpern Model 153 industrial pressure transducer.
- |                         |  |
|-------------------------|--|
| Ranges                  | 0-5/30 inches H2O<br>0-25/150 Inches H2O<br>0-125/750 inches H2O |
| Output                  | 4-20 mA DC   |
| Calibration adjustments | zero & span  |
| Accuracy                | +/-0.2% of span  |
| Linearity               | +/-0.1% of span  |
| Hysteresis              | +/-0.05% of span   |

C. Differential Pressure:

1. Unit for fluid flow proof shall be Penn A74.
- |                               |             |
|-------------------------------|-------------|
| Range                         | 8 to 70 psi |
| Differential                  | 3 psi       |
| Maximum differential pressure | 200 psi     |
| Maximum pressure              | 325 psi     |
2. Unit for air flow proof shall be Powers SW141.
- |                  |  |
|------------------|--|
| Set point ranges | .05"WG to 1.0" WG<br>1.0" WG to 12.0" WG |
|------------------|--|



D. Humidity Sensors

1. Outside Air Dew Point Temperature  
Dew point monitoring range -40/+115 F DP, 12%  
to 99% RH  
Output signal 4-20 mA  
Calibration adjustments zero & span  
Factory calibration point 70 F (21 C)  
Accuracy at calibration point  
Dew point element +/-1.1 F DP (+/-0.6C)  
Sensor +/-1.5 F DP (+/-0.8C)  
Dew point range -40 F to 115 F  
Power  
Probe heater 0.5 watts  
(10 watts inrush)  
Transmitter 0.55 watts  
Voltage  
Probe heater 120VAC  
Transmitter 26VDC  
Dimensions  
Probe .625"OD x 5" L  
(16 mm x 127 mm)  
Weatherproof housing/probe/  
bracket 13"H x 6"W x 13"D  
Transmitter housing 5.5" H x 6.5" W x  
4.25"D

2. Room/Duct Relative Humidity  
Sensor  
Humidity range 0 to 99%  
Operating temperature 15 F to 170 F  
Accuracy +/-5 RH Full range  
Sensing element bulk polymer sensor  
Transmitter  
Output signal 4/20 mA DC  
Installation adjustments zero & span  
Operating temperature 30 F to 130 F  
Voltage requirement 12 to 36 VDC

E. Freeze Detection Thermostats: Freeze detection thermostats shall be of electric two-position type with 20 foot (6m) bulb and manual reset. They shall be capable of opening the stat circuit if any one foot segment of the bulb is subjected to a temperature below the stat setting.

## PART 2 - PRODUCTS

### 2.01 AUTOMATIC CONTROL VALVES

- A. Shall be fully proportioning with modulating plugs for equal percentage of linearflow characteristics. The valves shall be sized by the control manufacturer and be provided with actuators of sufficient power for the duty intended. Valve body and actuator selection shall be sufficient to handle systems pressure and shall close against the differential pressures encountered. Valves shall shut tight against 25 PSID with actuator air pressure 1 PSID above modulating range. Where sequencing is required, the actual spring range, when adjusted for spring shift, shall be such that no causes and overlap, a pilot positioning operator shall be provided.
- B. Control valves shall be sized to meet the flow and pressure drops for each application as shown on the schedules. Plug style valves shall be either 2-way or 3-way as shown on the drawings.
- C. Small valves 1/2" through 1": Valves shall be constructed with a cast brass body and pipe thread ends. Trim shall consist of a removable cage providing valve stem guiding throughout the entire travel range. A stainless steel stem shall be provided. Bonnet cage, and the stem and plug assembly shall be removable for servicing. Actuator shall be cast aluminum with spring return piston operated by synthetic rubber diaphragm.
- D. Valves 1-1/4" through 2": Valves shall be constructed with a cast brass or bronze body and screwed ends. For special duty, valves may have cast iron bodies with screwed or flanged ends. Valves shall have either piston or diaphragm actuator as required.
- E. Valves 2-1/2" and Above: Valves shall be constructed with a cast iron body and have flanged connections. Actuators shall be of the synthetic rubber, spring return, diaphragm type sized for the duty.

### 2.02 THERMOSTATS

- A. All room thermostats shall be of the pneumatic relay type. The room thermostat shall have separate and independent band width adjustments for both direct-acting and reverse-acting output.
- B. Room thermostats shall be encased in metal locking covers for horizontal or vertical mounting with concealed set point and exposed thermometers.
- C. Room thermostats shall only be used with terminal equipment such as VAV boxes, reheat coils, etc.

### 2.03 DAMPER OPERATORS

- A. All damper operators shall be of the synthetic elastomer diaphragm piston type and shall be fully proportioning unless otherwise specified. Damper operators shall have metal bodies. The operators shall have ample power to overcome friction of damper blades. The damper operator mounting arrangement shall be outside the airstream wherever possible. The operators shall have external adjustable stops to limit the stroke. The operator linkage arrangement shall be such as to permit normally open or normally closed positions of the damper as indicated.

- B. Damper operators on modulating dampers that are to be sequenced with other control devices shall, where indicated on the plans or required to meet sequencing needs, have a pilot positioner of the full relay type with an interconnecting linkage to provide mechanical feedback so as to accurately position and control the damper.

#### 2.04 INSTRUMENT AIR SUPPLY

- A. An instrument air supply shall be furnished to provide clean, dry control quality instrument air to the temperature control system.
- B. The duplex air compressor shall be installed as indicated on the plans. The air compressor shall be sized in accordance with temperature control manufacturer to provide adequate air for the system without operating more than 33-1/3% of the time. Air Compressor and after-cooler sizing shown on the plans shall represent minimums only. The air compressor shall be of the instrument air quality operating at low piston speeds and low temperature to minimize oil vaporization and carryover.
- C. A receiver tank shall be furnished complete with A.S.M.E. label, pressure gauge, relief valve, automatic openings. The compressor receiver tank shall be sized to require no more than ten starts per hour of an individual compressor. The receiver tank shall comply with applicable state and local codes as well as OSHA standards.
- D. Driers: Driers shall be furnished to remove condensable contaminants from the air such as oil and water. The after-cooler drier shall be of the mechanical refrigeration type rated at not less than 1/6HP with a refrigeration capacity to assure a dew point of 39 degrees F, operating at 100 degrees F ambient temperature. Drier shall be provided for full system capacity. The assembly shall include the following:
  - 1. Integral 40 micron particulate afterfilter.
  - 2. Automatic condensate drain trap.
  - 3. "Power on" green pilot light.
  - 4. "High air temperature" red warning pilot light.
  - 5. Provision for connection of a remote alarm.
- E. The following instrument air accessories shall be provided:
  - 1. Submicron filter assembly including replaceable cartridge type filter with transparent bowl and metal bowl guard. Filter element shall be effective in removing 98% of any oil leaving the after cooler and solid particles as small as 0.6 microns. A trap shall be provided to automatically discharge any liquid contaminants retained in the filter bowl.
  - 2. Pressure reducing stations shall be provided at locations to ensure adequate quantity and pressure of instrument air to all controls furnished herein. A pressure gauge shall indicate the output of the PRV. For systems operating at 20 psig a pop safety shall be furnished to protect instruments from excess air pressure.

## 2.05 AIR PIPING

- A. Tubing exposed to sight and in inaccessible locations above gypsum board and plastered ceilings, shall be seamless copper tubing.
- B. Tubing in accessible locations, above lay-in acoustical tile ceilings and in temperature control panel, shall be polyethylene tubing.
- C. In ceiling return air plenums, tubing shall be seamless copper or Type FR polyethylene tubing.
- D. Tests on piping shall be made during the progress of the installation to insure against leaks.
- E. Use not less than 3/8" tubing for all mains with four or more controllers and/or controlled devices.

## 2.06 SUBMITTALS

The following shall be submitted for approval:

- A. Data sheets for all control systems and components.
- B. Valve, humidifier, damper, and well and tap schedules showing size, configuration, capacity and location of all equipment.
- C. Control system drawings containing pertinent data to provide a functional operating system, including a sequence of operation. Detailed shop drawings may be submitted in as-built form upon project completion.

## 2.07 WIRING

- A. All electric wiring required for the control system and any interlock wiring required for the control sequences shall be installed under this Section.
- B. All line voltage interlock wiring is to be run in thinwall conduit in concrete walls and exposed equipment rooms, and in rigid conduit when installed in floor slabs or underground areas. Line voltage control wiring for the Electric Control System shall also be installed in the manner described above for line voltage interlock wiring.

Low voltage (below 30 volts AC or DC) electronic control wiring may, as local codes allow, be installed without conduit (EMT), but where exposed and subject to physical damage shall be protected by suitable "Troughs", "Panduit" Bindings or other means consistent with proper NEC procedures for similar class wiring.

- C. All power wiring to the starters, and from the starters to the motors shall be furnished under division 16, ELECTRICAL.
- D. Wire shall be minimum of No. 18 gauge, color-coded, stranded wire for all low voltage, electronic circuit with "spares" installed (one for every group of 10 wires) in a piece of conduit or pre-engineered multiconductor cable.

### PART 3 - EXECUTION

#### 3.01 SYSTEM COMMISSIONING AND SERVICE

- A. **Acceptance Procedure:** Submittal data relevant to point index, functions, sequences, interlocks, and associated parameters, and other pertinent information for the operating system and data base shall be forwarded from the Contractor to the Owner. Prior to full operation, a complete demonstration of the system operation shall be performed in the presence of the Owner. This demonstration, having satisfactorily met previously approved submittals, shall, with the Owner's written acceptance, allow commissioning of the systems. Upon successful completion of the system operation, the Owner shall be requested, in writing, to inspect and approve the satisfactory operation of the system, subsystems and accessories.
- B. **System Start-Up and Acceptance:** Upon completion of the installation, the Contractor shall start up the system and perform all necessary testing and debugging operations. An acceptance test in the presence of the Owner's representative, the Architect, and the Engineer shall be performed. When the system performance is deemed satisfactory in whole or in part by these observers, the system parts will be accepted for beneficial use and placed under warranty.
1. Upon receipt of a detailed punch list from the Owner, an installation inspection report shall be prepared by the Contractor showing, by system, each outstanding item on the punch list. After all items appearing on the installation inspection report are completed, a second written request for system approval shall be made to the Owner. As each or all items are approved, an appropriate notation shall be entered at the time of joint inspection on the system report, with counter signature of the Owner and date. A copy of this report shall be made for the Owner.
  2. Where it is required for the Contractor to modify, alter, add or remove hardware or software programs of the system, or related accessories for the purpose of eliminating punch list items, off-line operation and testing to implement them shall be done as required by the Contractor until such time acceptable performance of the system has been established.
  3. Problems which occur within approved hardware, or software, shall be corrected in an appropriate fashion under warranty. Any such occurrence shall not void previous approval; however, the Contractor shall be responsible to attend to, and remedy, such items within the warranty period. Appropriate logs, schedules, and reports shall be maintained to reflect these items and their redress.

#### 3.02 EQUIPMENT OPERATION INSTRUCTION AND MAINTENANCE MANUALS

- A. On completion and acceptance of the work, furnish for review copies of written instructions on the proper operation and maintenance of all equipment and apparatus furnished under this Division.
- B. Each manual shall be provided with an index sheet listing the contents in alphabetical order and shall contain the following material:
1. Manufacturer's equipment parts list of all functional components of the system, control diagrams and wiring diagrams.
  2. Description of sequence of operations.

3. "As-built" interconnection wiring diagrams, or wire lists of the complete, properly identified ordering number of each system component and device.
4. Operator's Manual with pictures and step-by-step operating procedures. This manual shall be indexed, and shall have a separate tabbed section for each operator function.
5. Trunk cable schematic showing Remote Unit locations, and all trunk data conductors.
6. System architecture or configuration complete with all processors, terminals, other peripheral devices, modems, etc., with interconnecting diagrams.
7. Maintenance instructions for each type of equipment or device.

### 3.03 OWNER'S INSTRUCTION

The Contractor shall provide 3 copies of operator's manual describing all operating and routine maintenance service procedures to be used with the system. The Contractor shall instruct the Owner's designated representatives in these procedures during the start-up and test period. The duration of the instruction period shall be no less than 8 hours. The instructions shall consist of both hands-on and classroom training at the jobsite.

### 3.04 WARRANTY

The system, including all hardware and software components, shall be warranted for a period of one year following the date of beneficial use. Any manufacturing defects arising during this warranty period shall be corrected without cost to the Owner.

END OF SECTION

SECTION 16000

SCOPE OF WORK

PART 1 - GENERAL

1.01 DESCRIPTION

- A. **General:** This Section describes generally the scope of the work called for by Division 16. Specific requirements are detailed in pertinent Sections.
- B. **Principal Items Included:** Electrical work will include, but not be limited to, the supply and installation of all materials necessary to provide the following complete, functional, building electrical systems.
1. Temporary and permanent power services including coordination with the utility, and provision of facilities necessary for utility metering.
  2. Power distribution including switchboards, motor control centers, protective devices, panelboards, transformers, switches and enclosures, etc., as well as switches and meters to check voltage and current of incoming phases.
  3. 480Y/277 volt and 208Y/120 volt feeders, busways, conduits, conductors, pull boxes, bus tap-off devices, supports, etc., between distribution switchboards and subdistribution devices and equipment such as:
    - a. Panelboards.
    - b. Motor control centers.
    - c. Large separate motor controllers.
    - d. Elevator disconnects and controllers.
    - e. Large packaged mechanical equipment.
    - f. Large individual electrical loads.
  4. 480/277 volt and 208Y/120 volt branch circuit wiring from panelboards and motor control centers to lighting and individual small electrical loads.
  5. Wiring devices including switches, receptacles, plates, etc.
  6. Luminaires, lamps and associated equipment.
  7. Individual motor controllers and disconnect switches.
  8. Wiring for control of mechanical systems, between all devices involved, whether supplied under Divisions 15 or 16, unless noted otherwise.
  9. Lighting controls.

10. Backboards, cabinets, conduits, cable trays, outlet boxes, box fittings, plates, etc., for telephone service and distribution, including coordination with the Telephone Company.
11. Life safety and fire alarm system.
12. Emergency engine/generator sets including daytank, transfer switch, controls, etc.
13. Emergency power distribution including switchboards, motor control centers, feeders, panelboards, transformers, branch circuit wiring, devices, luminaires, lamps, connections, etc.
14. Power supply and connections for equipment supplied under other Divisions.
15. Grounding.
16. Supports, clamps, hangers, fastening devices, sleeves, slots, concrete bases, physical protection, caulking, weatherproofing, sealing, closing, etc.
17. Identification and instructional plates, tags, labels, etc.

C. **Other Applicable Sections:** Requirements of Division 1 and Section 16050 apply to all work of Division 16.

1.02 WORK NOT IN CONTRACT

- A. **Instruments and wiring** for telephones.
- B. **Utility company** service charges.

1.03 ELECTRICAL ITEMS IN RELATED DIVISIONS

- A. **Building signs.**
- B. **Mechanical equipment** requiring power and/or control wiring, including motors, dampers, temp/press/flow level switches, PE & EP relays, packaged equipment, heaters, etc.
- C. **Elevators.**
- D. **Window washing** equipment.
- E. **Door holders** and locks.

END OF SECTION



SECTION 16050

BASIC MATERIALS AND METHODS

PART 1 - GENERAL

1.01 DESCRIPTION

- A. **General:** This Section contains general requirements for the Sections in Division 16.
- B. **Other Applicable Sections:** Requirements of Division 1 apply to work of this Section.
- C. **Related Work Not Included In Division 16:** Refer to individual Sections of Division 16.

1.02 REQUIREMENTS OF REGULATORY AGENCIES

- A. **Codes:** Entire installation shall comply with requirements of all authorities having jurisdiction.
- B. **Permits:** Contractor shall pay for all permits required by work under this Division.
- C. **Inspections:** Contractor shall arrange for all inspections and correct non-complying installations.

1.03 SUBMITTALS

- A. **Procedures:** Refer to Division 1.
- B. **Material and Equipment:** Prior to start of any work, six copies of a list of all materials and equipment covered by Division 16 shall be submitted for approval. Contractor shall allow ample time for checking and processing and shall assume all responsibility for delays incurred due to rejected items. No installation of material concerned shall be made until written approval has been obtained. Approval of materials and equipment shall in no way obviate compliance with Contract Documents. Each item proposed shall be referenced to section, page, and paragraph of Specifications. For each item proposed, give name of manufacturer, trade name, catalog data and performance data.
- C. **Equipment Layout Drawings:** Submit "Equipment Layout Drawings" for each equipment room or area containing items of equipment furnished under this Division. Layout drawings shall consist of plan view of room, to scale, showing projected outlines of all equipment, complete with dotted indication of all required clearances including those needed for removal or service. Location of all conduit and pullboxes shall be indicated.
- D. **Service Manuals:** Indexed Service Manuals shall be provided; which shall include test reports, service instructions and renewal parts lists of all equipment.

1. **Submission and Information:** Service Manuals shall be submitted for approval at least 30 days before final inspection. The following information together with any pertinent data, shall be included in Service Manual:
    - a. Renewal part numbers of all replaceable items.
    - b. Manufacturer's cuts and rating data.
    - c. Serial numbers of all principal pieces of equipment.
    - d. Supplier's name, address and phone number.
    - e. Final settings for all breakers, relays and control devices.
  2. **Copies:** Four copies of the Service Manual shall be delivered on or before date required.
- E. **Shop Drawings:** Where required by specific sections of Division 16, Equipment Shop Drawings shall be submitted in accordance with procedures outlined in Division 1. When marked Shop Drawings are returned, make corrections noted and resubmit one set for record to Electrical Engineer prior to equipment construction. At completion of project, one set of all Record Shop Drawings shall be included with each set of Service Manuals.
- F. **Record As-Built Construction Drawings:** Refer to Division 1. Contractor shall make any notations, neat and legible, daily as the work proceeds. Drawings shall be available for inspection at all times and shall be kept at job site. All buried conduit and/or indicated future connections outside of any building shall be located both by depth and by accurate measurement from a permanently established landmark such as a building or structure.
- G. **Seismic Calculations:** See Paragraph 3.01.A.
- H. **Spare Parts:** Deliver following spare parts to Owner and obtain receipts. Submit at same time as Operating Instructions.
  1. Spare fuses; one set for each size combination fused breaker.
  2. Spare fuses for low voltage fused switch; two sets for each size used on project.
  3. Spare pilot light lamps of each type used on the project, in quantity of 10%, but not less than two.
  4. Overload heater elements; two sets for each size used on the project.
  5. Spare fuses for medium voltage switches; two sets for each size fuse used on project.
- I. **Special Tools:** If any part of equipment furnished under these Specifications requires a special tool for assembly, adjustment, resetting or maintenance thereof

and such tool is not readily available on the commercial tool market, it shall be furnished with equipment as a standard accessory and delivered to Owner.

- J. **Maintenance Paint:** One can of touch-up paint shall be delivered to Owner for each different color factory finish which is to be the final finished surface of the product.

#### 1.04 DRAWINGS

- A. **Diagrammatic Drawings:** For purposes of clarity and legibility, Drawings are essentially diagrammatic and although size and location of equipment is drawn to scale wherever possible, Contractor shall make use of data in all of the Contract Documents and verify information at building site.
- B. **Routing of Conduit and Piping:** Drawings indicate required size and termination of conduits and raceways, suggest proper routes to conform to structure, to avoid obstructions and to preserve clearance. It is not the intent to indicate all necessary offsets and it shall be the responsibility under this Division to install conduit in such a manner as to conform to structure, avoid obstructions, preserve headroom, keep openings and passageways clear, and make all equipment requiring inspection, maintenance and repair accessible without extra cost to Owner.
- C. **Coordination With Other Trades:** Check with other Divisions of Specifications so that no interference shall occur and in order that elevations may be established for the work. Installed work which interferes with the work of other trades shall be removed and rerouted at the discretion of the Architect.

#### 1.05 DAMAGE AND REPAIRS

- A. **Emergency Repairs:** Owner reserves the right to make temporary repairs as necessary to keep equipment in operating condition without voiding the Contractor's warranty or relieving the Contractor of his responsibility during the warranty period.
- B. **Responsibility for Damage:** Contractor shall be responsible for damage to the grounds, buildings, or equipment due to work furnished or installed under this Division.

#### 1.06 PROTECTION, CARE AND CLEANING

- A. **Protection:** Provide adequate protection for all finished parts of the materials and equipment against physical damage from any cause during the progress of work and until final completion. Sensitive electrical equipment shall not be installed until major construction is completed.
- B. **Care:** During construction, properly cap all lines and equipment to prevent the entrance of sand and dirt. Protect equipment against moisture, plaster, cement, paint or work of other trades by covering with polyethylene sheets.
- C. **Cleaning:** After installation has been completed, clean all systems as follows:
  - 1. **Field-Painted Items:** Clean exterior of conduits, raceways, piping and equipment exposed in completed structure; removing rust, plaster, cement

and dirt by wire brushing. Remove grease oil and similar materials by wiping with clean rags and suitable solvents.

2. Factory-Finished Items: Remove grease and oil on factory-finished items such as cabinets and controllers, and leave surfaces clean and polished. Vacuum inside of all electrical equipment to remove dust and debris.
- D. **Connections:** Prior to energizing, check all electrical connection hardware and torque where necessary.

## PART 2 - PRODUCTS

### 2.01 PRODUCTS

- A. **Products and materials** shall be as specified in the pertinent Sections of Division 16.

### 2.02 MATERIALS AND EQUIPMENT

- A. **Wherever possible**, all materials and equipment used in the installation of this work shall be of the same Manufacturer throughout for each class of material or equipment. Materials shall be new and bear U.L. label, or the City of Los Angeles Test Laboratory label. Comply with ANSI, IEEE and NEMA standards, where applicable.

## PART 3 - EXECUTION

### 3.01 SEISMIC REQUIREMENTS

- A. **General:** Electrical equipment for emergency systems shall be braced to withstand lateral forces that result from earthquakes. The Electrical Contractor shall provide seismic calculations stamped and signed by a registered California Structural Engineer confirming size, number and location of all required anchoring hardware. Electrical equipment vendors shall submit weights, dimensions and center of gravity location for all emergency electrical equipment for this purpose.

### 3.02 GENERAL LATERAL BRACING REQUIREMENTS

- A. **Additional bracing** requirements shall conform to the specific requirements indicated on the drawings or in other Sections of Division 16. Anchorages for equipment subject to thermal expansion and movement shall be made in accordance with the manufacturer's recommendation and the intent of the general bracing requirements. When the general and specific bracing requirements enumerated above are in conflict with referenced standards, the most stringent requirements shall govern.

### 3.03 EXCAVATION AND BACKFILL

- A. **General:** Perform all excavation and backfill required to install work of this Division, both inside and outside. Perform all excavation and backfilling in accordance with Division 2.

- B. **Excavation:** Bury conduits outside the building to a depth of not less than 18" (or as required by Code) below finish grade unless noted otherwise.
- C. **Backfilling:** Do not backfill until after final inspection and approval of conduit installation by all legally constituted authorities.

#### 3.04 CUTTING AND PATCHING

- A. **Cutting of Existing Structural Work:** Holes in existing slabs and concrete walls shall be cored to the minimum size required. Contractor shall submit dimensioned drawings showing dimensioned sizes and locations for all holes to Architect for approval before cutting. Where required for conduit installation, grade slabs shall be saw-cut to minimum required width. Approval drawings shall be submitted to Architect before cutting.
- B. **Patching:** All holes or chases shall be patched to match adjacent surfaces.

#### 3.05 CONCRETE WORK

- A. **General:** All concrete required for electrical work shall be provided under the work of this Division.

#### 3.06 PAINTING

- A. **General:** All finish painting of electrical equipment will be as specified in Division 9, unless equipment is hereinafter specified to be furnished with factory-applied finish coats. Equipment to be field-painted shall be supplied with factory-applied prime coat.
- B. **Touch-Up:** If factory finish on any equipment furnished under this Division is damaged in shipment or during construction of the building, equipment shall be refinished by Contractor to the satisfaction of the Architect.
- C. **Concealed Equipment:** All uncoated cast iron or steel that will be concealed or will not be accessible when installations are completed shall be given one heavy coat of black asphaltum before installation.

#### 3.07 OPERATING INSTRUCTIONS

- A. **Contractor shall** provide services of an experienced engineer to instruct Owner in operation of entire installation. Instructional period shall be during the hours of a normal work day. This instruction period may be simultaneous with compliance tests.

#### 3.08 COMPLIANCE TESTS

- A. **Conduct such tests** of all portions of the installation as may be necessary to ensure full compliance with Drawings and Specifications. Tests shall be made in presence of the Owner and Architect. Costs of test shall be borne by Contractor and Contractor shall provide all instruments, equipment, labor and materials to complete test. These tests may be required on any item between installation of work and end

of one year warranty period. Should these tests detect any defective materials, poor workmanship or variance with requirements of Specifications, Contractor shall make any changes necessary and remedy any defects at his expense.

**B. All feeders shall be measured and recorded as follows:**

1. 600 volt conductors shall be tested with 500 volt megger to ground on each phase. Megger is to be on test for one minute before readings are taken. Minimum values on all feeders shall be 100,000 OHMS. Copies of certified test readings shall be transmitted to Owner.

**3.09 SYSTEM ACCEPTANCE**

**A. Final Review:** Contractor shall request a final review prior to system acceptance after:

1. Completion of installation of all systems required under the Contract Documents.
2. Submission and acceptance of operating and maintenance data.
3. Completion of identification program.

**B. Acceptance Is Contingent On:**

1. Completion of final review and correction of all deficiencies.
2. Satisfactory completion of acceptance tests which demonstrate compliance with all performance and technical requirements of Contract Documents.
3. Satisfactory completion of training program and submission of all manuals and drawings required by Contract Documents.

**3.10 PRELIMINARY OPERATION**

**A. Owner reserves** the right to operate portions of electrical system on a preliminary basis without voiding the warranty or relieving the Contractor of his responsibilities.

**3.11 CLEAN-UP**

**A. Upon completion** and at other times during the progress of the work, when required, remove all surplus materials, rubbish and debris resulting from the work.

**END OF SECTION**

SECTION 16111

CONDUITS

PART 1 - GENERAL

1.01 DESCRIPTION

- A. **General:** Provide conduits, complete, as shown, specified or required per Contract Documents. Principal items include:
1. Rigid aluminum conduit.
  2. Rigid steel conduit.
  3. Intermediate metal conduit (IMC).
  4. Electric metallic tubing (EMT).
  5. Flexible metal conduit (FLEX).
  6. Polyvinyl chloride conduit (PVC).
- B. **Other Applicable Sections:** Requirements of Division 1 and Section 16050 apply to work of this Section.

PART 2 - PRODUCTS

2.01 MINIMUM SIZE

- A. **Conduit and EMT** shall be 1/2" minimum except that conduits in earth shall be 3/4" minimum size. All raceways and fittings shall be new and bear U.L. label.

2.02 RIGID CONDUIT

- A. **Conduit:** Rigid conduit including couplings, locknuts, bushings, and nipples shall be galvanized steel or aluminum, thick wall, threaded. No running thread will be accepted; use nipples, unions or other fittings.
- B. **Fittings:** Conduit fittings shall be galvanized steel or aluminum, threaded type, compatible with conduit material.

2.03 INTERMEDIATE METAL CONDUIT (IMC)

- A. **Conduit:** IMC conduit shall be galvanized with protective coating on inside.
- B. **Fittings:** Couplings shall be galvanized steel with threads on one end and swivel fitting on other end. Locknuts, bushings and nipples shall be galvanized steel, threaded type.

2.04 ELECTRICAL METALLIC TUBING (EMT)

- A. **Tubing:** Electrical metallic tubing shall be galvanized steel with protective coating on inside.
- B. **Fittings:** Fittings for use in EMT runs shall be galvanized steel. Connectors and couplings shall be steel setscrew type.

#### 2.05 FLEXIBLE METAL CONDUIT (FLEX)

- A. **Conduit:** Flexible metal conduit shall be galvanized steel.
- B. **Fittings:** Connectors shall be galvanized and shall give positive continuity of ground by a squeeze or setscrew method. When flex is cut square, "jake" type connectors properly screwed into the convolutions of the conduit will be approved. Angle connectors shall be accessible at all times.
- C. **Where exposed** to moisture or weather, flex and fittings shall be watertight.

#### 2.06 POLYVINYL CHLORIDE CONDUIT (PVC)

- A. **Conduit:** Polyvinyl chloride conduit shall be Schedule 40 with round smooth bore for direct burial. Type EB for concrete encasement may be used for utility services.
- B. **Fittings:** Couplings, bends, elbows, adapters and other fittings and materials, including jointing cement, shall be the product of, or as approved by, the conduit manufacturer. Fittings shall be of same basic material as conduit.

### PART 3 - EXECUTION

#### 3.01 LOCATIONS

- A. **Rigid steel or IMC** conduit above 3/4" shall be used for installation in concrete or where exposed to physical injury in all sizes. In dry locations, rigid aluminum conduit may be used in lieu of steel. All power and lighting feeders shall be in rigid conduit or IMC.
- B. **Polyvinyl chloride conduit** shall be used for installation in earth for exterior branch circuit wiring and communications and may be used for feeders in earth. Provide ground wire in all power and lighting conduit per NEC Table 250-95. PVC conduit used for power and communications services and for power feeders shall be concrete-encased.
- C. **Electric metallic tubing** may be installed for wiring above ground in dry places, where not subject to mechanical damage, in sizes up through 2" diameter. EMT may be used in sizes no larger than 3/4" in concrete. EMT may be used for telephone and signal wiring in sizes larger than 2" diameter.
- D. **Flexible Metallic Conduit:** Short wiring connections to motor and equipment shall be installed in flexible metallic conduit. Connections for fixed motors and other fixed equipment installed under this and other Sections affected by vibration or expansion due to heat shall be made with a short, suitable run of flexible metallic conduit.



Install separate green ground conductor in all flexible conduits supplying motors or equipment.

3.02 PREPARATION

- A. **Conduit runs** shall be clean and dry before pulling in conductors. Provide nylon pull-line in all empty conduits.

3.03 INSULATED BUSHINGS

- A. **All conduits** entering panels, junction boxes, outlets and devices shall be provided with insulated bushings or insulated throat connectors. Bushings for conduits 2" and larger shall be O-Z/Gedney Type "B".

3.04 BUSHINGS

- A. **Where a data**, telephone, intercom, control, etc., conduit terminates in space, that is, not attached to a box or other fitting, a bushing shall be provided to the end of the conduit to protect the future wire from abrasion.

3.05 CAPPING

- A. **Conduit shall** be capped during construction by means of manufactured conduit seals or caps to prevent entrance of water or debris, and shall remain closed until ready for use.

3.06 JOINTS

- A. **Conduit joints** in concrete, masonry walls, or where exposed to weather or moisture, shall be made with an approved joint compound.

3.07 PENETRATIONS OF WALLS BELOW GRADE

- A. **Conduit penetrations** of walls below grade shall be made using O-Z/Gedney Type WSK through-wall waterproofing fittings. Install per fitting manufacturer's specifications and wall waterproofing manufacturer's directions.

3.08 SUPPORTS

- A. **General:** Fastenings for raceways shall be made by means of not smaller than 3/16" diameter bolts, expansion bolts, or toggle bolts; or by equivalent approved fastenings. Fastenings, where exposed to weather or moisture, shall be galvanized. Nails or wooden or fiber inserts in masonry, shall not be used.
- B. **Masonry and Concrete:** On masonry or concrete walls, columns or flooring, fastenings shall be made by means of lead expansion shields not smaller than 3/8" diameter by 5/8" long for use with No. 10-24 round head machine screws. Machine screws shall be not less than 1-1/4" long for installation on ceiling and not less than 1" long elsewhere.

- C. **Steel Expansion Shield:** Shall be Tampins Union Catalog Stock #2M5275 or an equivalent as manufactured by Star or Phillips. Holes for shields shall be carefully and accurately drilled, using sharp drills, to a depth which will afford the maximum practical engagement of threads (depth no less than 1-1/4" into solid concrete) and installation shall develop full strength for screws.
- D. **Exposed or Accessible Locations:** In accessible spaces or where exposed, rigid steel conduit smaller than 1", and EMT smaller than 1-1/4" shall be supported by means of approved galvanized clamps and fastenings. Conduit shall be secured so that it cannot be moved without use of tools.
- E. **Exposed Raceways:** Exposed wireway runs shall be made horizontal and vertical and parallel to structural members and lines of building. Bends shall be neat and of not less than minimum radii permitted by Code, or fittings shall be used to obtain a neat appearance.

### 3.09 INSTALLATION OF PVC CONDUIT

- A. **General:** Installation of PVC conduit and fittings and preparation of permanent joints shall be performed in a manner, using cement, as recommended by conduit manufacturer. Care shall be practiced in performing cutting, using guides, proper heating and jigs to prevent crimping or deforming during the bending process. All bends should be made to conform with NEC Table 346-10, "Bends: How Made."
- B. **Risers Into Equipment:** All risers including bends or sweeps from PVC conduit into pull boxes or panelboards shall be coated rigid steel conduit and suitable adapters shall be furnished and installed as required for such transition. Risers outside of partitions and equipment enclosures shall terminate with threaded steel coupling flush with floor.

### 3.10 EXCAVATION, TRENCHING AND BACKFILLING

- A. **General:** All excavations, trenching, backfilling and compacting for raceways shall be performed under the work of this Section and shall conform to the requirements of Division 2.
- B. **Record Drawings:** Accurately locate and dimension all underground runs on the record drawings.

### 3.11 OPENINGS IN WALLS, CEILINGS AND FLOORS

- A. **General:** Openings in existing walls, partitions, ceilings and floors shall be made under this Section. Care shall be taken to avoid piping and equipment and unnecessary damage. Holes shall be a practicable minimum in size and number. Patch, repair and paint in workmanlike, approved manner. Penetrations shall be sealed to maintain existing fire rating.
- B. **Sleeving:** Provide galvanized steel sleeving extending 2" above slab for conduit floor penetration.
- C. **Approval:** Request written approval from the Architect prior to any core drilling.

### 3.12 CONNECTIONS TO VIBRATION-ISOLATED EQUIPMENT

- A. **All wiring** (conduit and conductors) shall be arranged to avoid short circuiting of the vibration isolation system.
1. **Distribution Transformer:** When terminating conduit on transformer enclosure, provide a minimum of 36" of flexible conduit with grounding conductor.
  2. **Substations:**
    - a. When transformer core and coil is separated from enclosure frame by Mason vibration isolators, conduit may terminate on substation enclosure.
    - b. Where Mason vibration isolators do not separate transformer core and coil from enclosure frame, provide a minimum of 36" of flexible conduit with grounding conductor where conduit terminates on substation enclosure.
  3. **Rotating Equipment:**
    - a. When feeding from floor stub-up locations, locate the stub-up so as to provide not less than 12 diameters of flexible conduit length with green ground wire, both parallel to, and at right angles to, the equipment rotational centerline.
    - b. When feeding from an overhead drop, where conduit is supported below an occupied floor, provide maximum length of flexible conduit with green ground wire in the drop and support the rigid horizontal conduit on spring hangers, similar to Mason Industries, Type 30N, within 30' of the vibrating equipment.
    - c. Circuits to mechanical or electrical equipment in roof penthouses shall be overhead, not through floor below or in conduit buried in slab.

### 3.13 CONNECTIONS TO MECHANICAL DUCTS

- A. **There shall be no** connection to, or contact with, supply or return ducts or the insulation thereon, in any way. Violation will require removal.

### 3.14 CONNECTIONS TO PLUG-IN BUS DUCT

- A. **Provide minimum** of 36 inches of flexible conduit length for connection to plug-in device. Provide separate green grounding conductor in all flexible conduits.

END OF SECTION



SECTION 16112

BUS DUCTS

PART 1 - GENERAL

1.01 DESCRIPTION

- A. **General:** Provide bus ducts, complete, as shown, specified or required per Contract Documents. Principal items include:
1. Feeder bus ducts.
  2. Plug-in bus ducts.
  3. Plug-in units.
- B. **Other Applicable Sections:** Requirements of Division 1 and Section 16050 apply to work of this Section.

1.02 SUBMITTALS

- A. **Procedures:** Refer to Division 1.
- B. **Requirements:** In addition to the requirements of Section 16050, the submittal material shall include six copies of descriptive data for all products and materials.
- C. **Shop Drawings:**
1. Submit for all work of this Section.
  2. Shop drawings shall provide detailed installation data and field-verified dimensions for bus duct runs, including all required bends and offsets.

PART 2 - PRODUCTS

2.01 FEEDER BUS DUCTS

- A. **Busway:** Totally enclosed, non-ventilated type, low-impedance, with totally insulated aluminum conductors; 480 volt, 3- or 4-wire, as indicated; ampere ratings as shown on the drawings; fault current rating 50,000 AMP symmetrical or higher, where noted on the drawings. Joints shall be silver- or tin-plated and secured with a single bolt and constant-pressure washer. Neutral bus, where indicated, shall be full size, and ground bus shall be provided. All housing seams, top, bottom and sides, and covers on vertical and horizontal runs shall be sealed to prevent entrance of water. Provide drain holes where required.

2.02 PLUG-IN BUS DUCTS

- A. **Busway:** Totally enclosed, non-ventilated type, low-impedance with totally insulated aluminum conductors; 480 volts, 3- or 4-wire, as indicated; ampere ratings as shown

on the drawings; fault current rating 50,000 AMP symmetrical or higher where noted on the drawings. Joints shall be silver- or tin-plated and secured with a single bolt and constant-pressure washer. Neutral bus, where indicated, shall be full size, and ground bus shall be provided. Provide plug-in openings at 24" on center with polyester glass plug-in insulators with a minimum of 4 plug-in openings per floor. Cover for plug-in openings shall be hinged and secured in place with captive bolt through cover. Plug-in openings to be arranged to accommodate one 400 amp and three 200 amp fused switch plug-in units per floor. All housing seams, top, bottom and sides, and covers on vertical and horizontal runs shall be sealed to prevent entrance of water. Gasket all plug-in door openings. Provide drain holes where required.

## 2.03 FITTINGS

- A. **Provide suitable** floor and wall flanges to seal penetration openings and assure proper fire ratings. Provide all required elbows and offsets to suit actual building conditions. Provide switchboard stubs where indicated or required; fully coordinate with switchgear. Provide expansion and deflection fittings where required at building expansion joints and as otherwise required to avoid undue stresses on busway or building structure.
- B. **Supports** for vertical bus runs shall be spring-type with adjustment. Horizontal hangers shall be sliding clamp-type with steel hanger rods as required, 1/2" minimum size.

## 2.04 PLUG-IN UNITS

- A. **Fusible Units:** Quick-make, quick-break mechanism, heavy-duty type, with Buss time delay current limiting Class J and Class L HICAP for transformer and motor loads and fast acting Class J and Class L Limitron for all other loads. Switch shall be rated 100,000 AMP symmetrical with fuses. Switches shall have external operating handle with padlocking provisions; shall be in NEMA I enclosure with gasketed hinged covers and gasket seal into plug opening to restrict entrance of water. Where plug-in device cover is hinged on end of cabinet, hinge shall be at top so cover falls "closed."
- B. **Circuit Breaker Units:** Current-limiting circuit breakers, rated 100,000 AMP symmetrical. Breakers shall have external operating handle with padlocking provisions and shall be in NEMA I enclosure with gasketed hinged covers and gasket seal to plug into opening to restrict entrance of water.
- C. **Provide minimum** of 36 inches of flexible conduit for connection to plug-in device. Provide separate green grounding conductor in all flexible conduits.

## 2.05 MANUFACTURERS

- A. **General Electric "Spectra"** or Westinghouse "Pow-R-Way".

## PART 3 - INSTALLATION

### 3.01 SUPPORTS

- A. **Feeder and plug-in** bus duct hangers shall be supported from building steel structural elements and attached by bolting or welding and sway braced for seismic restraint; except that supports for vertical runs may be anchored to floor slabs. Spring hangers on vertical runs shall be properly adjusted to equalize load on all hangers.

3.02 CLOSURES

- A. **Install closures** at all penetrations through floors and walls.

END OF SECTION





## SECTION 16114

### CABLE TRAYS

#### PART 1 - GENERAL

##### 1.01 DESCRIPTION

- A. **General:** Provide cable trays, complete, as shown and specified per Contract Documents.
- B. **Other Applicable Sections:** Requirements of Division 1 and Section 16050 apply to this Section.

##### 1.02 SUBMITTALS

- A. **Procedures:** Refer to Division 1.
- B. **Requirements:** In addition to the requirements of Section 16050, submittal material shall include copies of descriptive data for all products and materials.
- C. **Shop Drawings:** Submit for all work of this Section, including dimensional floor plan layouts.

#### PART 2 - PRODUCTS

##### 2.01 TRAYS

- A. **Steel cable type, 4" loading depth, ladder design with 12" rung spacing, width as shown on the drawings.** Trays shall be hot dip galvanized after fabrication and welding.

##### 2.02 FITTINGS

- A. **Provide elbows, tees, connectors, and closures and other fittings required.**

##### 2.03 HANGERS

- A. **Provide holes and hanger fittings at required locations.** Hangers shall be 1/2" threaded steel rods.

##### 2.04 GROUNDING

- A. **Provide bonding jumpers at all fittings and connections**

##### 2.05 MANUFACTURER

- A. **CHALFANT Series 64, or equivalent products of PW or Cope.**

#### PART 3 - EXECUTION

3.01 INSTALLATION

- A. **Trays shall** be located approximately as shown on the drawings. Exact layout shall be developed and trays shall be located to clear other utilities and arranged to be continuously accessible.
- B. **Penetrations** through rated walls shall be properly sealed to provide required fire and smoke separation.
- C. **Hangers** shall be spaced no further than 10' on center and shall have horizontal bracing as required for seismic bracing and to prevent deformation with unequal cable loading.

END OF SECTION

SECTION 16116

WIREWAYS

PART 1 - GENERAL

1.01 DESCRIPTION

- A. **General:** Provide wireways, complete, as shown and specified per Contract Documents.
- B. **Other Applicable Sections:** Requirements of Division 1 and Section 16050 apply to this Section.

1.02 SUBMITTALS

- A. **Procedures:** Refer to Division 1.
- B. **Requirements:** In addition to the requirements of Section 16050, submittal material shall include copies of descriptive data for all products and materials.
- C. **Shop Drawings:** Submit for all work of this Section, including dimensional floor plan layouts.

PART 2 - PRODUCTS

2.01 STEEL WIREWAYS

- A. **Steel enclosed wiring** through 6"x6" cross-section with hinged cover. Wireways shall be Underwriters' Laboratories listed as wireways and auxiliary gutters, and shall meet all requirements of National Electric Code Articles 362 and 374. Knockouts shall be 3/4" and 1" tangential or concentric, 4" on center, and shall be provided on both sides adjacent to door.

2.02 FITTINGS

- A. **A complete set** of fittings shall be available so that an entire wireway system can be installed regardless of bends, offsets, or other building contours which may be encountered. Fittings shall have removable covers and sides to permit complete "lay-in" installation and to permit access to wires throughout the entire length without any alterations to the system.

2.03 HANGERS

- A. **Provide holes** and hanger fittings at required locations.

2.04 MANUFACTURER

- A. **Square-D square duct** combination wireway with hinged cover or equal by Circle A-W Products.

**PART 3 - EXECUTION**

3.01 INSTALLATION

- A. **Wireways shall** be located approximately as shown on the drawings. Exact layout shall be developed and wireways shall be located to clear other utilities and arranged to be as continuously accessible as possible.
- B. **Penetrations through** rated walls shall be properly sealed to provide required fire, smoke and sound separation.
- C. **Hangers for wireways tray** shall be spaced no further than 5' on center and shall have horizontal bracing as required to prevent deformation with unequal cable loading. At a minimum provide horizontal bracing every 50' or less. Use trapeze type hangers from slab above by 1/2" diameter steel rods. In rooms with RFI shielding, coordinate supports with RFI shielding installer to maintain integrity of shield.

END OF SECTION

## SECTION 16120

### WIRE AND CABLE

#### PART 1 - GENERAL

##### 1.01 DESCRIPTION

- A. **General:** Provide wire and cable, complete, as shown and specified per Contract Documents.
- B. **Other Applicable Sections:** Requirements of Division 1 and Section 16050 apply to work of this Section.
- C. **Related Work Not In This Section:** Grounding conductors.

#### PART 2 - PRODUCTS

##### 2.01 600-VOLT CONDUCTORS

- A. **Conductors for building wiring** shall be standard annealed copper wire with NEC 600-volt insulation. Conductors No. 4 and larger shall be stranded with Type THWN insulation. Conductors No. 6 and smaller shall be color-coded with Type THHN or THWN insulation. Conductors No. 12 and smaller shall be solid. Size Nos. 6, 8 and 10 shall be stranded. Conductors in conduits above roof shall be Type THWN.
- B. **Wiring:** Wire sizes shall be as shown on drawings and herein specified. Minimum wire size shall be No. 12 for lighting and power, and No. 14 for control, signal and communication wiring. Wire shall be delivered to job in original, unbroken packages or reels bearing U.L. approval, and conductors shall be marked as required by NEC.

##### 2.02 5,000-VOLT CONDUCTORS

- A. **5,000 Volt Cables:** Shall be single conductor, stranded copper, non-shielded, rated 5kV. Insulation shall be Type HTK Kerite, 125 mil. thickness, rated for 90°C conductor temperature. Jacket shall be Type FR, 80 mil. thickness. Cable shall be Kerite, guaranteed for the life of the installation.

#### PART 3 - EXECUTION

##### 3.01 INSTALLATION OF 600-VOLT CONDUCTORS

- A. **Taps and splices** for sizes No. 8 AWG or smaller shall be made with insulated, wound-wire connectors; Scotch-lok or approved equal. Taps and splices for sizes No. 6 AWG or larger shall be made with compression-type connectors, Hy-press or approved equal, and insulated with 3M materials.
- B. **Terminal Connections:** Terminal lugs shall be used at stranded conductor terminal points except where equipment is provided with approved compression means for securing conductors. Bent-eared wire washers will not be accepted in lieu of Stakon lugs. A terminal lug shall not be used for more than one conductor unless it is specially designed for multiple connection. Not more than two lugs shall be installed

under one binding screw. Where two wires are connected to one binding screw, they shall be separated by a brass washer of correct size.

- C. **Connections in electrical equipment**, such as switchboards, transformers, load centers, motor control centers, panelboards, etc., whether factory preassembled or fieldconnected, shall be checked for tightness and retightened as necessary. Clipping of wires from standard cable to fit connectors and terminal lugs is not permitted. All terminals shall be compression type for copper cables of sizes indicated.
- D. **Looping or Pigtailling**: At outlets, junction boxes and fittings, conductors shall be looped or pigtailed to extend at least 6" without splice beyond such wiring enclosures, and where used, pigtails added to loops for connection to fixtures or devices shall be at least 6" long.
- E. **Vertical Runs of Conductors**: Shall be supported as required by Section 300-19 of NEC.

### 3.02 TESTING OF 600 VOLT CONDUCTORS

- A. **All Circuits**: 400 AMP and larger shall be measured and recorded as follows:
  - 1. 600 volt conductors shall be tested with 500 volt megger to ground on each phase. Megger is to be on test for one minute before readings are taken. Minimum values on all feeders shall be 100,000 OHMS. Copies of certified test readings shall be transmitted to Owner.

### 3.03 INSTALLATION OF 5KV CONDUCTORS

- A. **Pulling**: Basket grips shall be used for pulling and tension shall not exceed manufacturer's listed recommendations. Only manufacturer's recommended pulling compounds shall be used.
- B. **Splices and Terminations**: Shall be made in strict conformance with manufacturer's recommendations. Shielding tape shall be grounded at all splices and terminations. Waterproof seals shall be made at all splices. All terminals shall be compression type for copper cables of sizes indicated.
- C. **Mandrelling**: Iron sled mandrel shall be pulled through each conduit before conductors are installed. Mandrel shall be fitted with rubber gasket not more than 1/4" smaller than inside diameter of conduit.
- D. **Installation in Manholes**: Conductors in manholes shall be supported on racks, looped around manhole walls and fireproofed.
- E. **Vertical Runs of Conductors**: Shall be supported as required by Section 300-19 of NEC, using basket-type supports.

### 3.04 TESTING OF 5KV CONDUCTORS

- A. **Test all cable** per IPCEA Standards for high voltage DC test. Notify Engineer of proposed date of test sufficiently in advance so arrangements can be made to witness test.
- B. **Perform test** after all splices, terminations and connections are complete. During test disconnect all equipment from cable system. Test voltage shall be IPCEA Standards for 5kV DC system. Use DC tester specifically designed for purpose with overload or current limiting devices to limit short circuit current.
- C. **Raise voltage gradually** in 10% steps to 80% of final voltage, then in 5% steps to final test voltage, which shall be left on for five minutes. Take current readings at each step after current has been stabilized. Plot readings on graph paper. If breakdown is indicated during test by sudden increase in current, discontinue test, locate and remedy trouble, and repeat test. If breakdown is again indicated, replace cable.
- D. **Submit two copies** of tests, properly labeled, for review. Include all necessary test information such as ambient temperature, weather conditions, current, voltage, cable, length, size, etc.

3.05 PHASE IDENTIFICATION

- A. **All circuits and feeders** shall have phase conductors identified with a band of colored plastic tape. Single conductor wires or cables shall be coded to agree with main panel designation and connected to terminal points as indicated below.
  - 1. 120/208 Volt System:
    - a. A Phase - Black
    - b. B Phase - Red
    - c. C Phase - Blue
    - d. Neutral - White
  - 2. 277/480 Volt System:
    - a. A Phase - Brown
    - b. B Phase - Orange
    - c. C Phase - Yellow
    - d. Neutral - Grey
  - 3. 5,000 Volt System:
    - a. A Phase - Yellow
    - b. B Phase - Red

c. C Phase - Blue

B. **Phasing Arrangement:** Busing shall be arranged as follows:

1. A Phase - Top, left or front
2. B Phase - Center
3. C Phase - Bottom, right or rear

### 3.06 IDENTIFICATION MARKING

A. **Before any wiring installation** is initially energized, the Contractor shall identify each branch and feeder circuit. Identification of circuits shall be by means of numbered tape markers.

END OF SECTION



SECTION 16130

OUTLET, PULL AND JUNCTION BOXES

PART 1 - GENERAL

1.01 DESCRIPTION

- A. **General:** Provide outlet, pull and junction boxes, complete, as shown and specified per Contract Documents.
- B. **Other Applicable Sections:** Requirements of Division 1 and Section 16050 apply to work of this Section.
- C. **Related Work Not In This Section:** Cabinets.

PART 2 - PRODUCTS

2.01 MATERIALS

- A. **Outlets Boxes, Extensions and Covers:** One-piece pressed steel, hot-dip galvanized, knock-out type, 4" trade size by 1-1/2" deep or larger, whenever noted or required.
- B. **Cast Metal Boxes:** Threaded-hub type with gasketed covers similar and equal to Crouse-Hinds Type "FD" or "FS", or equivalent.
- C. **Pull and Junction Boxes:** Provide as shown or as necessary to facilitate the pulling of wire. Boxes less than 100 cu.in. in volume shall comply with the requirements given for outlet boxes. Boxes 100 cu.in. in volume and larger shall be constructed in accordance with the requirements given for cabinets, except that covers shall be of the same thickness as the boxes and shall be secured by bolts. Boxes having one dimension greater than 24" shall be fitted with interior braces and reinforcements. Boxes required to be weatherproof, shall be cast iron with threaded hubs and bolted and gasketed covers similar and equal to O-Z/Gedney Type "YS".
- D. **Gaskets:** Gaskets for weatherproofing junction boxes, pull boxes and fittings shall be of an approved type. Improvised gaskets made from rubber tape or other material will not be accepted.
- E. **Concrete Pull Boxes:** Parkway or traffic type as indicated, of the sizes shown, pre-cast in sections, with cast iron cover marked, "Electric" or "Telephone", Brooks or Associated (Quickset).

PART 3 - EXECUTION

3.01 INSTALLATION

- A. **General:** Installations shall be secure and substantial.
- B. **Bolts and Fastening:**

1. Fastening shall be by means of 3/16" minimum diameter bolts, expansion bolts or toggle bolts.
2. Fastenings exposed to weather or moisture shall be galvanized.
3. Not less than two fastenings shall be used to secure each box.
4. Nails, or wooden or fiber inserts in masonry shall not be used.

**C. Expansion Shield Fasteners:**

1. **Size:** On masonry or concrete walls, columns or flooring, fastenings shall be made by means of lead expansion shields not smaller than shield size 3/8" diameter by 5/8" long for use with No. 10-24 round head machine screws. Machine screws shall not be less than 1-1/4" long for installation on ceiling and not less than 1" long elsewhere.
2. **Type:** Lead expansion shields shall be Tampins Union Catalog Stock No. 2M5275 or an equivalent as manufactured by Star or Phillips.
3. Holes for lead expansion shields shall be carefully and accurately drilled, using sharp drills, to a depth which will afford the maximum practical engagement of threads (depth not less than 1-1/4" into solid concrete) and installation shall develop full strength of screws.

**D. Stud Partitions:** In metal stud construction, boxes shall be securely attached to structural members with approved bar hangers connecting to two studs.

**E. Recessed Installations:** Outlet boxes shall be installed in walls so that front edge of box or cover is within 1/4" of surface of incombustible materials; and front shall be flush with surface of wood or other combustible materials. Where cuts or penetration of fire rated walls or other surfaces are made, provisions shall be made to maintain fire ratings.

**F. Access and Adjacent Locations:** All boxes installed shall be accessible at the time of completion. Where outlets are shown at same location, they shall be installed at same height, in line and closely adjacent, unless otherwise noted.

**G. Lighting Fixture Outlets:** Every light outlet shall be provided with a fixture stud. Boxes shall be secured (fastenings described above) using two diametrically opposite holes of widest spacing, or as otherwise required for supporting medium. Ceiling boxes shall be securely and directly supported by metal runner channels, minimum 1-1/2". Boxes with fixture studs shall be tested for supporting strength and shall develop a holding strength of 200 lb. without movement of box. Installation shall be secure and substantial.

END OF SECTION

SECTION 16132

FLOOR BOXES

PART 1 - GENERAL

1.01 DESCRIPTION

- A. **General:** Provide floor boxes and fittings, complete, as shown and specified per Contract Documents.
- B. **Other Applicable Sections:** Requirements of Division 1 and Section 16050 apply to the work of this section.
- C. **Work Not In This Section:**
  - 1. Conduit - See Section 16111.
  - 2. Wiring - See Section 16120.
  - 3. Wiring Devices - See Section 16140.

PART 2 - PRODUCTS

2.01 FLOOR BOXES - CAST IRON

- A. **Type I, fully adjustable**, suitable for use in slabs on grade. They shall be shallow size with removable square top. Adjust-ment screws shall allow "after pour" angular and vertical adjustment. Box and top shall be cast iron and shall accept any standard duplex receptacle. Equal to Hubbell B-2437.

2.02 FLOOR BOXES - FORMED STEEL

- A. **Shall be the same** as the cast iron boxes but constructed of economical, concrete tight-formed steel suitable for use in other than slab on grade applications. Equal to Hubbell B-2429.

2.03 FLUSH POWER COVERS

- A. **Shall be brass** or aluminum (as required by the Architect), flush with floor ring and plate with lift-up, duplex, captive flaps. Equal to Hubbell S-3825 (brass) or SA-3825 (aluminum).

2.04 POWER PEDESTAL FITTINGS

- A. **Formed aluminum surface devices** suitable for single- or back-to-back duplex receptacles. Thomas and Betts FPT401A, or approved equal.

2.05 TELEPHONE PEDESTAL FITTINGS

- A. **Formed metallic surface devices** suitable for single or back-to-back telephone wiring. Thomas and Betts FPT401A, or approved equal.

2.06 COMBINATION POWER/TELEPHONE PEDESTAL FITTINGS

- A. **Formed metallic surface devices** suitable for single-duplex receptacle and single telephone outlet. Thomas and Betts FPT421, or approved equal.
- B. **Formed metallic surface devices** suitable for double-duplex receptacle and telephone outlet. Thomas and Betts FPT421, or approved equal.

2.07 RECEPTACLES

- A. **Size and type indicated** on the Drawings and specified in Section 16140.

**PART 3 - EXECUTION**

3.01 GENERAL

- A. **Cast boxes shall** be used for slabs on grade or installations subject to corrosion. Formed steel boxes shall be used for other areas.

3.02 COORDINATION

- A. **All boxes shall** be installed in accord with any architectural details and in cooperation with other trades.

3.03 FITTINGS

- A. **Generally, flush covers shall** be used for all tiled, concrete surface or terrazzo floors and pedestal fittings for all carpeted floors or other than floor mounting, unless noted otherwise.

END OF SECTION

SECTION 16133

TERMINAL CABINETS

PART 1 - GENERAL

1.01 DESCRIPTION

- A. **General:** Provide terminal cabinets, complete, as shown and specified per Contract Documents. Principal items include, cabinets for signal and communications terminals.
- B. **Other Applicable Sections:** Requirements of Division 1 and Section 16050 apply to work of this Section.
- C. **Related Work Not In This Section:**
  - 1. Outlet, pull and junction boxes.
  - 2. Panelboards for lighting and power.

PART 2 - PRODUCTS

2.01 MATERIALS

- A. **Cold-rolled sheet steel**, with hinged door and cylinder lock keyed to match panelboard cabinets.

2.02 DESIGN

- A. **To suit applicable system requirements**; surface- or flush- mounting, as shown on drawings; knockouts as required. Design to match panelboard cabinets.

2.03 FABRICATION

- A. **One-piece, die-formed** or continuously welded; assembled in factory.

2.04 FINISH

- A. **Baked enamel** on suitable primer; color as specified elsewhere, required by standards, or as directed.

2.05 INTERIORS

- A. **Provide 5/8" plywood backing** in all signal and communications terminals.

PART 3 - EXECUTION

RTD Headquarters  
Los Angeles, California  
91-400

12/22/92  
Terminal Cabinets  
16133 - 2

3.01 INSTALLATION

- A. **Installations shall be secure and substantial;** cabinets shall be attached to building walls or structure.

3.02 IDENTIFICATION

- A. **Provide identification nameplates;** engraved bakelite; riveted or screwed to each cabinet. Text shall be taken from the drawings and as approved by the Architect.

END OF SECTION

**SECTION 16140**

**WIRING DEVICES**

**PART 1 - GENERAL**

1.01 DESCRIPTION

- A. **General:** Provide wiring devices, complete, as shown and specified per Contract Documents. Principal items include:
1. Lighting switches.
  2. Receptacle outlets.
  3. Wall plates.
- B. **Other Applicable Sections:** Requirements of Division 1 and Section 16050 apply to work of this Section.

**PART 2 - PRODUCTS**

2.01 MATERIALS

- A. **Manufacturers:** Representative general purpose wiring devices and device plates, as listed herein, are intended to indicate type, function and quality of the products. Provide the products specified, or products of equal type, function and quality from any of the following listed manufacturers. Provide specification grade devices where available for the device listed:
1. Arrow-Hart
  2. Bryant
  3. Hubbell
  4. Leviton
  5. Sierra
  6. Slater
- B. **Lighting Switches:**
1. **Lighting Switches:** Local light switches shall be AC-type, 20A, specification-grade, flush-tumbler type with bakelite or composition completely enclosing base, handle color as selected.

Single-Pole	-	Hubbell No. 1221
Two-Pole	-	Hubbell No. 1222

Three-Pole - Hubbell No. 1223  
Four-Way - Hubbell No. 1224

2. Lock type shall be of same finish and capacity as specified above and shall be Hubbell No. 1221L Series with No. 1209 key.

**C. Receptacles:**

1. General-Use Duplex Receptacles: NEMA 5-15R, Leviton No. 5320, 15A, 120 volt, color as selected by the Architect.
2. General-Use Duplex Receptacles: NEMA 5-20R, 20A, 125 volt (to be installed wherever single duplex receptacles are supplied by a 20A, 120 volt circuit), Leviton No. 5896, color as selected by the Architect.
3. Ground-Fault-Indicating Receptacles: NEMA 5-15R, (to be installed where required by Code), Leviton No. 6198, color as selected by Architect.
4. Special Receptacles: Provide as shown on drawings.

- D. Enclosures:** Provide receptacles with weatherproof enclosures where indicated. Use cast metal back boxes and stainless steel gasketed cover plates having gasketed, spring-loaded, hinged covers over each receptacle.

- E. Plates:** Provide device plates for all general-purpose wiring devices, for telephone outlets, and for outlet boxes used as junction or pull boxes. Plates shall be of material and color selected by Architect. Provide 3/16" high block letter, black enamel (or as otherwise specified or indicated) filled machine engraving for switch plates under any of the following conditions. Use designations indicated or select words to best describe purpose of each device. Device plates with engraved 3/16" block-type letters filled with black enamel, or of other letter sizes and/or colors, if otherwise specified.

1. Plates containing more than three switch devices.
  2. Plates for switches controlling loads not visible from the switch location.
  3. Selector switches.
  4. Manual motor-starting switches.
5. Special outlets, where indicated.

**PART 3 - EXECUTION**

**3.01 INSTALLATION**

- A. Mount switch and receptacle devices in vertical position, unless indicated otherwise, or approved to comply with job conditions. Position receptacles so that ground contact in grounding type receptacles is nearest floor. Install adjacent devices of same type and with same mounting height in a common outlet box.**



Install adjacent devices of different types in same manner when common mounting is indicated. Prior to installation of switch outlets, examine architectural plans and verify locations. Place switches in wall at latch side of door.

- B. **Coordinate electrical installation** with other trades to ensure that wiring device flush outlets are positioned with box openings aligned with face of surrounding finish material.

END OF SECTION



**SECTION 16155**

**MOTOR CONTROLLERS**

**PART 1 - GENERAL**

1.01 DESCRIPTION

- A. **General:** Provide motor controllers, complete, as shown and specified per Contract Documents.
- B. **Other Applicable Sections:** Requirements of Division 1 and Section 16050 apply to this Section.
- C. **Related Work Not In This Section:**
  - 1. Motor control centers.
  - 2. Disconnects.

1.02 SUBMITTAL DATA

- A. **Procedures:** Refer to Division 1.
- B. **Requirements:** In addition to the requirements of Section 16050, the submittal material shall include six copies of descriptive data for all products and materials including, but not limited to: Motor controllers.
- C. **Shop Drawings:** Submit for all work in this Section.

**PART 2 - PRODUCTS**

2.01 MANUAL MOTOR STARTERS

- A. **Toggle-type, quick-make, quick-break,** with thermal over-load protection in each ungrounded conductor; single-pole or two-pole as required; Westinghouse type MS, or equal.

2.02 MAGNETIC STARTERS

- A. **Full voltage, non-reversing type,** unless otherwise noted, with thermal overload element, ambient compensated, in each ungrounded conductor. Each starter shall be provided with external reset button, 120V control transformer, hand-off-auto switch, red and green push-to-test pilot lights and two auxiliary contacts. Two-speed starters shall include a fast-off-slow-auto control switch with amber, red and green push-to-test lights and a decelerating timer relay for fast-to-slow motor speed transition. Select heaters to suit actual motor nameplate ratings.

2.03 COMBINATION MAGNETIC STARTERS

- A. **Where noted**, provide combination magnetic starter and disconnect device in common enclosure. Non-fused disconnect switches shall be load-break type with visible blades. Circuit breakers shall be motor circuit protector type or molded case circuit breaker, as noted on Drawings.

#### 2.04 ENCLOSURES

- A. **Provide NEMA 1 enclosures** for units installed indoors in dry locations. Units designated "weatherproof" or installed in wet locations shall have NEMA 3R enclosures. Provide other special type enclosures where noted.

#### 2.05 NAMEPLATES

- A. **Provide engraved nameplate** for each starter unit, showing load served and voltage.

### PART 3 - EXECUTION

#### 3.01 INSTALLATION

- A. **Mount securely** to building structure where possible. Provide supplemental steel supports where required.

END OF SECTION

SECTION 16160

PANELBOARDS

PART 1 - GENERAL

1.01 DESCRIPTION

- A. **General:** Provide panelboards, complete, as shown and specified per Contract Documents. Principal items include:
1. Distribution panelboards.
  2. Branch circuit panelboards.
- B. **Other Applicable Sections:** Requirements of Division 1 and Section 16050 apply to work of this Section.

1.02 SUBMITTALS

- A. **Procedures:** Refer to Division 1.
- B. **Requirements:** In addition to the requirements of Section 16050, the submittal material shall include six copies of descriptive data for all products and materials.
- C. **Shop Drawings:** Submit for all work in this Section.

PART 2 - PRODUCTS

2.01 DISTRIBUTION PANELBOARDS

- A. **Dead front, dead rear,** equipped with automatic circuit breakers for each circuit and paneled for accessibility. Provide minimum 8" gutter space at top and bottom of panelboard. Provide individual engraved laminated plastic nameplate, screwed to interior trim, for each breaker. Breakers shall be of the size and arrangement as shown on drawings. Panels shall be fully bused, drilled and tapped; copper or aluminum busing. Voltages and ratings shall be as shown on the drawings. Provide lock-offs for each breaker.

2.02 BRANCH CIRCUIT PANELBOARDS

- A. **Interior:** Shall consist of automatic circuit breakers (one for each branch circuit) properly secured and mounted in a dead front, dead rear code gauge, galvanized steel cabinet with wiring gutter of sufficient width to provide ample space for branch circuit wires and feeders; in no case less than 4" wide. Barrired wireway shall be provided for feedthrough panels.

Provide minimum 8" gutter space at top and bottom of panelboard. Panels shall be fully bused; copper or aluminum busing. Each panel to be furnished with 42-20 AMP 1-pole circuit breakers unless shown otherwise on drawings or panel schedules.

- B. **Exterior:** Shall consist of trim with hidden mounting screws for flush mounted panelboards, and door constructed of code gauge sheet steel with factory finish. Door shall be fitted with hidden hinges and spring catch latch with cylinder lock. Provide directory card holder on inside of door. Mounting screws shall allow adjustable alignment of trim and interior panel.

## 2.03 CIRCUIT BREAKERS

- A. **Circuit breakers shall be automatic trip-free, quick-make, quick-break, thermal-magnetic type; with handles clearly indicating tripped position. Multi-pole breakers shall have common trip and single handle. Breaker sizes, trip ratings and arrangement in panelboards shall be in accordance with panel schedules. Breaker sizes shall be clearly stamped on handles or on laminated plastic nameplate attached to trim. Spaces for future breakers shall have bus drilled and tapped. Multi-pole breakers shall not be used for lighting or 120 volt receptacle circuits except where specifically required by Codes. Provide lock-off or lock-on devices, where required.**
- B. **Breakers for Distribution Panels:** Westinghouse Type EHD, JDB, KDB; minimum interrupting rating 14,000 AMP, symmetrical at 480 volts. Provide high-interrupting rated breakers where noted or required. Breakers shall be bolted to busing.
- C. **Breakers for 480Y/277 Volt Lighting Panelboards:** Shall be Westinghouse Type GHB; minimum interrupting rating 14,000 AMP symmetrical at 277 volts, bolted to busing. Provide lock-off device for each breaker.
- D. **Breakers for 208Y/120 Volt or 120/240 Volt Receptacle Panel-boards:** Shall be Westinghouse Type BA; minimum interrupting rating 10,000 AMP, symmetrical at 240 volts, bolted to busing. All panelboards shall have 22,000 AIC integrated rating where 22,000 AIC or 25,000 AIC main breakers or upstream feeder breakers are used. Provide sub-feed breakers where indicated on schedules. Provide approved GFI breakers for all exterior receptacle circuits and where elsewhere required by Code.

## 2.04 AUXILIARY DEVICES

- A. **Provide relays, contactors, time switches, etc., in panel-board where shown on the drawings or schedules. Contactors shall be electrically operated, mechanically held with 3-wire control and coil-clearing contacts. Relays shall be electrically operated, electrically held with 20 AMP contacts. Auxiliary devices shall be located in separately barred compartment with separate door. Contactors shall be rubber-mounted for sound isolation.**

## 2.05 MANUFACTURERS

- A. **General Electric or Westinghouse.**

## PART 3 - EXECUTION

### 3.01 IDENTIFICATION

- A. **Nameplates:** Provide identification nameplates on all panel-boards. Nameplates shall be engraved black lamincoid with minimum 1/4"-high white letters. Nameplate shall state panel designation, voltage and bus ampere rating, and shall be riveted or screwed to panelboard housing. Provide engraved branch circuit breaker numbering strip, screwed or riveted, on panelboard internal trim.
- B. **Schedules:** Provide load schedules for all branch circuit panelboards identifying type, size and location of load. Schedules shall be typewritten and protected by transparent plastic cover.

### 3.02 INSTALLATION

- A. **In general,** panels shall be supported on building structure. Provide auxiliary supports where required. Auxiliary supports shall be Unistrut or equal.
- B. **Panels shall be mounted** so that the tops of trims are at 6'-6" above finished floor, unless noted otherwise.

END OF SECTION

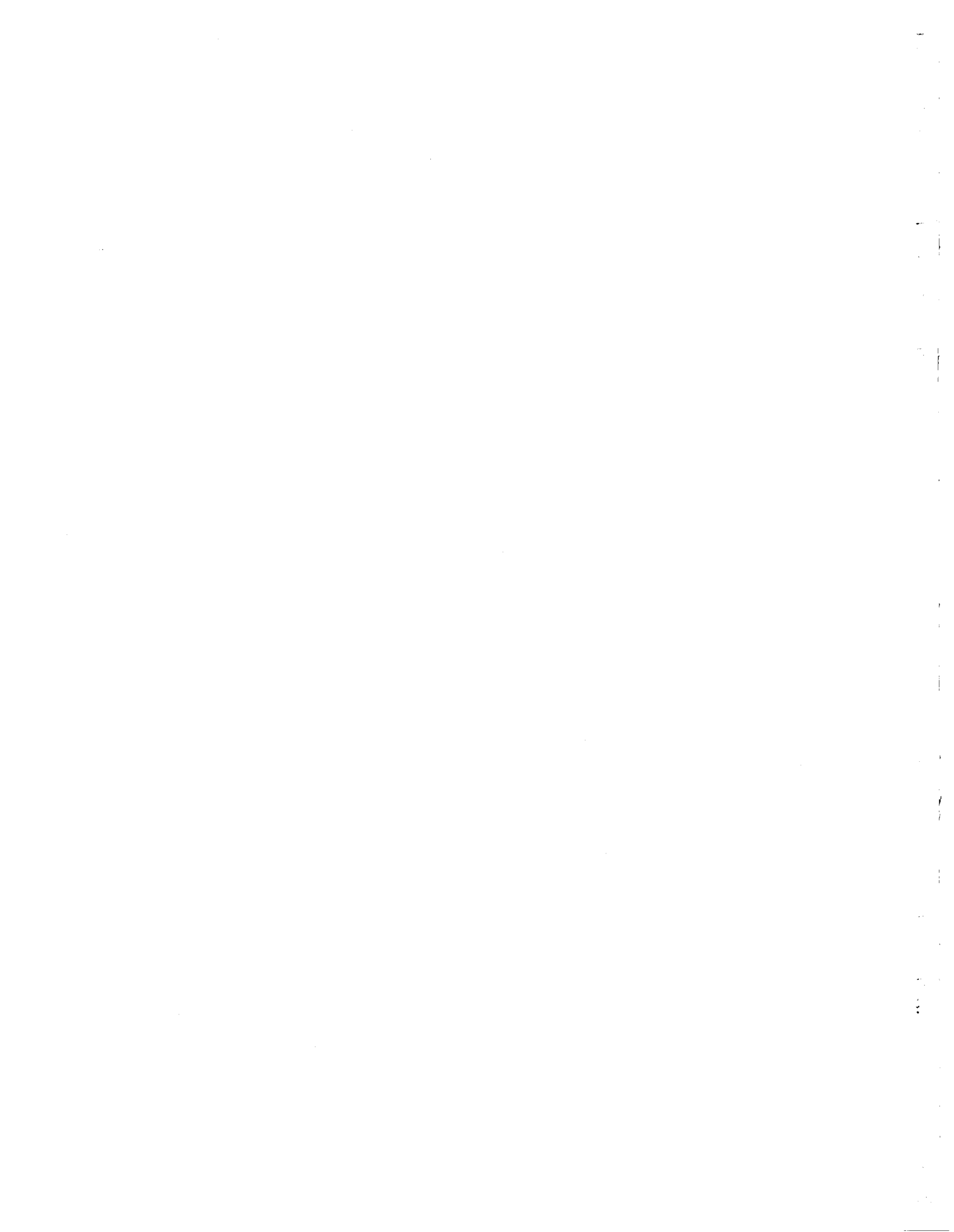



SECTION 16163

DISTRIBUTION SWITCHBOARDS

PART 1 - GENERAL

1.01 DESCRIPTION

- A. **General:** Provide distribution switchboards, complete, as shown and specified per Contract Documents.
- B. **Other Applicable Sections:** Requirements of Division 1 and Section 16050 apply to work of this Section.

1.02 SUBMITTALS

- A. **Procedures:** Refer to Division 1.
- B. **Requirements:** In addition to the requirements of Section 16050, submittal material shall include six copies of descriptive data for all products and materials.
- C. **Shop Drawings:** Submit for all work of this Section.

PART 2 - PRODUCTS

2.01 DISTRIBUTION SWITCHBOARDS

- A. **General:** Switchboards shall be floor-standing, dead-front, dead-rear, NEMA I construction, with circuit breakers mounted horizontally and front-accessible. Busing shall be copper or aluminum, sized as shown on the drawings and braced for 50,000 AMP, symmetrical or higher, as noted on the drawings or as required. Busing shall be full height of sections and shall accommodate future breakers to maximum space in each section. Provide main compression lugs or main breakers required. Steel shall be Code gauge with standard factory finish. All switchboards shall have neutral bus.
- B. **Circuit Breakers:** Shall be automatic, trip-free, quick-make, quick-break with ambient-compensated, thermal magnetic trips. Multi-pole breakers shall have common trip and single handle. Breaker sizes, trip ratings and arrangement shall be as shown on the drawings. Provide main breakers where shown. Spaces for future breakers shall have bus drilled and tapped. Provide lock-off device for each breaker. Circuit breakers shall be Type FD, JDB, KDB; minimum interrupting rating 14,000 AMP at 480 volts or greater where shown; bolted to busing. Provide current-limiting circuit breakers where shown on the Drawings or required for interrupting rating or series rating.
- C. **Ground Bus:** Provide separate ground bus in all switchboards.
- D. **Manufacturers:** Switchboards shall be General Electric or Westinghouse.

PART 3 - EXECUTION

3.01 IDENTIFICATION

- A. **Provide engraved nameplate** for each circuit breaker stating trip value and load supplied. Include breaker frame size and type on nameplate unless readily identifiable without removing trim. Provide main unit nameplates. Rivet or screw nameplates to switchboard housing.

3.02 INSTALLATION

- A. **Switchboards shall** be bolted to concrete floor.

END OF SECTION

SECTION 16170

DISCONNECTS

PART 1 - GENERAL

1.01 DESCRIPTION

- A. **General:** Provide disconnects, complete, as shown and specified per Contract Documents.
- B. **Other Application Sections:** Requirements of Division 1 and Section 16050 apply to work of this Section.
- C. **Related Work Not In This Section:**
  - 1. Wiring devices.
  - 2. Motor controllers.

1.02 SUBMITTAL DATA

- A. **Procedures:** Refer to Division 1.
- B. **Requirements:** In addition to the requirements of Section 16050, the submittal material shall include six copies of descriptive data for all products and materials including, but not limited to, the following:
  - 1. Fused switches and fuses.
  - 2. Non-fused switches.
- C. **Shop Drawings:** Submit for all work in this Section.

PART 2 - PRODUCTS

2.01 DISCONNECT SWITCHES

- A. **EX-0 heavy duty** switches quick-make, quick-break mechanism, interlocked cover unopenable when switch is "ON"; except that for motors 2 horsepower or less, manual starting switch may be used. Provide current limiting style fuses, where shown on the drawings, equal to Amp-trap time delay Class J and Class L for transformer and motor loads and Amp-trap fast acting Class J and Class L for all other loads. All switches on motor circuits shall be horsepower rated.

2.02 WEATHERPROOF SWITCHES

- A. **Switches designated as "Weatherproof"** shall have NEMA 3R enclosure.

PART 3 - EXECUTION

3.01 REQUIREMENTS

- A. **Provide disconnects** where shown on the drawings for equipment furnished under other Divisions of the Specifications, and where required by Codes.

3.02 INSTALLATION

- A. **Mount on building structure** whenever possible. Provide supplemental steel supports as necessary. Mount switches at 5'-0" above finished floors unless otherwise indicated.

3.03 IDENTIFICATION

- A. **Provide engraved nameplate** to indicate load controlled, circuit number and source designation.

END OF SECTION

SECTION 16182

CIRCUIT BREAKERS

PART 1 - GENERAL

1.01 DESCRIPTION

- A. **General:** Provide circuit breakers, complete, as shown and specified per Contract Documents.
- B. **Other Applicable Sections:** Requirements of Division 1 and Section 16050 apply to work of this Section.
- C. **Related Work Not In This Section:**
  - 1. Transformers.
  - 2. Motor controllers.

1.02 SUBMITTAL DATA

- A. **Procedures:** Refer to Division 1.
- B. **Requirements:** In addition to the requirements of Section 16050, the submittal material shall include six copies of descriptive data for all products and materials including, but not limited to, the following:
  - 1. Enclosed circuit breakers.
- C. **Shop Drawings:** Submit for all work in this Section.

PART 2 - PRODUCTS

2.01 CIRCUIT BREAKERS

- A. **Shall be in wall** mounted NEMA 1 sheet steel enclosure with interlocked cover unopenable when breaker is closed. Breakers through 400A rating shall be automatic trip free, quick-make, quick-break with ambient compensated thermal magnetic trips and solid state trips for all higher ratings. Circuit breakers shall be Type FD, JDB, KDB; minimum interrupting rating 14,000 amp at 480V or greater where shown on drawings. Provide current limiting breakers where indicated, where required for interrupting capacity or for protection of downstream series rated interrupting devices.

2.02 WEATHERPROOF SWITCHES

- A. **Breakers designated** as "Weatherproof" shall have NEMA 3R enclosure.

PART 3 - EXECUTION

3.01 REQUIREMENTS

- A. **Provide circuit breakers** where shown on the drawings for equipment furnished under other Divisions of the Specifications, and where required by Codes.

3.02 INSTALLATION

- A. **Mount on building structure** whenever possible. Provide supplemental steel supports as necessary. Mount breakers at 5'-0" above finished floors unless otherwise indicated.

3.03 IDENTIFICATION

- A. **Provide engraved nameplate** to indicate load controlled, circuit number and source designation.

END OF SECTION

**SECTION 16191**

**ELECTRICAL EQUIPMENT NOISE CONTROL,  
VIBRATION ISOLATION AND SEISMIC RESTRAINTS**

**PART 1 - GENERAL**

**1.01 Scope.**

All general conditions and supplementary general conditions apply to the work of this section. Provide and perform the vibration isolation work as indicated, specified, and required.

A. Principal work included in this Section:

1. Vibration isolation of transformers.
2. Flexible conduits at transformer connections.
3. Flexible conduits at connections to motors and other vibrating equipment.
4. Electrical box-pads at stud partitions where sound insulation is provided.
5. Vibration isolation of the emergency generator.
6. Noise control for the emergency generator.
7. Seismic restraint for vibration isolated equipment.

**1.02 General Requirements.**

A. Submittal.

Refer to general conditions for requirements pertaining to submittals, including preparation and transmittals. The submittal shall contain the following information:

1. Catalog cuts and data sheets on specific vibration isolators, mufflers, electrical box pads and other equipment to be utilized, showing compliance with the specification.
2. An itemized list showing the items of equipment to be isolated, the isolator type and model number selected, isolator loading and deflection.

B. Coordination.

The contractor shall coordinate his work with other trades to avoid rigid contact between isolated transformers, raceways and the building. He shall inform other trades following his work to avoid any contact which would reduce the vibration isolation.

C. Conflicts and Discrepancies.

1. The contractor shall bring to the architect's attention prior to installation any conflicts with other trades which will result in unavoidable contact to the equipment, raceways, etc., described herein, due to inadequate space, etc. Corrective work necessitated by conflicts after installation shall be at the responsible contractor's expense.
2. The contractor shall bring to the architect's attention any discrepancies between the specifications and field conditions, changes required due to specific equipment selection, etc., prior to installation. Corrective work necessitated by discrepancies after installation shall be at the contractor's expense.

D. Inspection and Instruction

1. The contractor shall obtain inspection and approval from the architect of any installation to be covered or enclosed prior to such closure.
2. The contractor shall obtain written and/or oral instructions from the vibration isolation manufacturer as to the proper installation and adjustment of vibration isolation devices and seismic restraints.

**1.03 Isolator Configuration for Floor Mounted or Suspended Equipment**

- A. Provide a maximum of four vibration isolators located at the corners of the equipment unless approval is obtained for additional isolators.

**1.04 Seismic Restraint Requirements**

- A. Seismic restraint shall be furnished and installed in accordance with all relevant State and local code requirements.

**1.05 Responsibility of Manufacturer**

- A. Vibration isolation manufacturer shall have the following responsibilities:
1. Determine vibration isolation sizes and locations.
  2. Provide equipment isolation system as scheduled or specified.
  3. Guarantee specified isolation system deflection.
  4. Provide installation instructions and drawings.
  5. Provide calculations signed by a structural engineer licensed in the State in which the work is to take place certifying that the seismic restraints will act in accordance with the relevant State and local codes and will maintain equipment in captive position.



## 1.06 Vibration Isolation and Noise Control Requirements

- A. Floor Mounted Transformers
  - 1. Type HMN, 0.3 inch static deflection.
  - 2. Locate at 4 corners of transformer.
  - 3. Bolt to floor.
- B. Suspended Transformers
  - 1. Type HN isolation hangers, 0.2 inch static deflection.
  - 2. Locate at 4 corners.
  - 3. Provide seismic restraints.
- C. Flexible Electrical Connections.
  - 1. At all transformers within buildings.
  - 2. At connections to motors or other vibrating equipment.
- D. Emergency Generator
  - 1. Generator set: spring vibration isolators - type MSL, 2.0 inch static deflection type with type A frame.
  - 2. Generator exhaust: critical muffler.
  - 3. Suspend muffler and exhaust piping from structure by type HS hangers, 2.0 inch static deflection. Utilize cables for seismic restraints.
  - 4. Noise level at air intake or exhaust to be controlled to meet Local Noise Codes.

## 1.07 Electrical Box Pads

- A. Provide at all junction boxes located within sound insulated drywall partitions.

## PART 2 - PRODUCTS

### 2.01 Vibration Isolators

- A. General Properties
  - 1. All vibration isolators shall have either known undeflected heights or other markings so that, after adjustment, when carrying their load, the deflection under load can

be verified, thus determining that the load is within the proper range of the device and that the correct degree of vibration isolation is being provided according to the design.

2. All isolators shall operate in the linear portion of their load versus deflection curve. Load versus deflection curves shall be furnished by the manufacturer and must be linear over a deflection range 50% above the design deflection.
3. The ratio of lateral to vertical stiffness shall not be less than 1.0 or greater than 2.0.
4. The vertical natural frequency for each support point, based upon the load per isolator and isolator stiffness, shall not differ by more than + or - 10%.
5. Wave motion through the isolator shall be reduced to the following extent: isolation above the resonant frequency shall follow the theoretical prediction based upon an undamped single degree of freedom system, with a minimum isolation of 50 decibels above 150 cycles per second.
6. All neoprene mountings shall have a shore hardness of 50 to 60 after minimum aging of 20 days or corresponding oven aging.
7. All vibration isolation equipment exposed to moisture or an outdoor environment shall be coated as follows:
  - a. All steel parts to be hot-dipped galvanized.
  - b. All bolts to be cadmium plated.
  - c. All springs to be cadmium plated and neoprene coated.

B. Isolator Types and Descriptions

Type HN is a suspension hanger with a steel box frame and a molded neoprene in shear element. A neoprene grommet shall be provided at the location where the hanger rod passes through the hanger box so that no metal-to-metal contact occurs.

Type MSL is a bare, stable, steel spring with a ribbed neoprene pad under the base plate. Bolt holes shall be provided in the baseplate to permit attachment to the building structure. Limit stops shall be provided to prohibit spring extension if the load is removed. These stops may also serve as rigid blocking during erection so that the installed and operating heights shall be the same. Clearance shall be maintained around restraining bolts and between the limit stops and the housing so as not to interfere with the spring action.

Type HS is a suspension hanger with a steel box frame and a steel spring resting on a neoprene cup. The cup shall contain a steel washer designed to distribute the load evenly to the neoprene and prevent its overload or extrusion. The spring diameter and hanger box lower hole size shall be large enough to permit the hanger rod to swing through a 30 degree arc before contacting the hole and short circuiting the spring. A neoprene grommet shall be provided at the location where the hanger rod passes through the hanger box so

that no metal-to-metal contact occurs. Hangers shall be provided with an eye bolt on the spring end.

Type HMN is a neoprene isolator incorporating a steel housing capable of resisting a seismic load of 1.0 G in all directions. The mount shall consist of a captive steel insert embedded into a neoprene element which is enclosed by a steel housing which also includes floor mounting holes. The isolator shall have a rated deflection of 0.15 inches compression, 0.12 inches in tension and 0.09 inches in shear.

**MANUFACTURER'S COMPARISON**

Type	Description	Manufacturer's Code - Isolator Type			
		A	B	C	D
HN	Neoprene Hanger	BR	RH	HD	HSS
MSL	Spring Mount with Limit Stop	CT	RJEQ	SLR	RMLS
HS	Spring Hanger	BSA	CH30	30	RMXA
HMN	Housed Neoprene Mount	BRD	RQ	HNM	FUP-EQ

Notes:

1. Availability - contact manufacturer
2. Notwithstanding this table, the manufacturer's isolator must meet all the requirements of this specification.

Manufacturer's Code:

- A) Amber/Booth.
- B) California Dynamics.
- C) Mason Industries.
- D) Sausse (Vibrex).

**2.02 Flexible Connections**

- A. Conduit over 1 inch OD: Make electrical connections to vibrating equipment via flexible expansion/deflection conduit coupling sized as required. Coupling shall have a flexible and watertight outer jacket, an internal grounding strap, plastic inner sleeve to maintain smooth wireway, and end hubs with threads to fit standard threaded metal conduit. Acceptable units include:
  1. XD Expansion Deflection Coupling by Crouse-Hinds of Syracuse, N.Y.
  2. Type DF Expansion and Deflection fitting by Spring City Electrical Mfg. Co. of Spring City, PA.
- B. For conduit under 1 inch OD: Use "flexible" conduit with slack at least 3 feet or 15 diameters

long, whichever is the longer or provide a flexible coupling as defined above.

**2.03 Electrical Box Pads**

- A. Equal to Lowry's Outlet Box Pads as manufactured by Harry A. Lowry Associates, Sun Valley, California.

**2.04 Emergency Generator Muffler: Critical Type**

- A. Equal to Nelson 400.

**2.05 Emergency Generator Noise Control**

- A. Silencers, enclosures etc. equal to Industrial Acoustics Company.

**2.06 Equipment Frames**

- A. General

Mounting frames and/or brackets shall be provided to carry the load of the equipment without causing mechanical distortion or stress to the equipment.

- B. Frame Types

1. Type A frame is a wide flange structural steel frame with brackets as shown on the drawings. The maximum allowable deflection of any point on the loaded frame relative to the unloaded frame shall be 0.005 inch. A wide flange section depth greater than 1/10th the length of the longest frame member will be accepted as satisfying the deflection requirement.
2. Type B frame is a channel steel structural frame with brackets as shown on the drawings. The section depth shall be greater than 1/10th the length of the longest frame member.
3. Type C frame is a steel bracket or gusset welded or bolted directly to the machine frame in order to accommodate the isolator.

**2.07 Seismic Restraints**

- A. Emergency Generator:

1. Provide isolation mounts with integral seismic restraints.

- B. Suspended Transformers:

1. Utilize a slack cable restraint system.
2. The cable size and attachment shall be approved with calculations signed by a structural engineer licensed in the State in which the work is to take place.

3. Submittal drawing shall indicate proposed method of vertical restraint.
4. Cables shall be installed with sufficient slack to avoid short circuiting the vibration isolation.

### **PART 3 - EXECUTION**

#### **3.01 Installation of Vibration Isolation Devices**

- A. Transmission of perceptible vibration or structure borne noise to occupied areas by equipment installed under this Contract will not be permitted.
- B. Install vibration isolators per manufacturer's directions.
- C. Flexible electrical connections.
  1. Installation of flexible electrical connections to vibration isolated equipment shall in no way impair or restrain the function of the aforementioned vibration isolation.
  2. Option 1: Install the flexible conduit in a grossly slack loop form or shallow "U" form. Install the stranded conductors with sufficient slack to accommodate maximum possible movement.
  3. Option 2: The flexible coupling shall be free and not in contact with any nearby building construction and shall be installed slack and free of strain in any direction. Install stranded conductors as above.
- D. All vibration isolation devices, including auxiliary steel bases shall be designed and furnished by a single manufacturer or supplier, who will be responsible for adequate coordination of all phases of this work.
- E. The vibration isolation manufacturer, or his representative, shall be responsible for providing such supervision as may be necessary to assure correct installation and adjustment of the isolators. Upon completion of the installation and after the system is put into operation, the manufacturer, or his representative, shall make a final inspection and submit his report to the Architect in writing, certifying the correctness of installation and compliance with approved submittal data.
- F. Vibration Isolation Hangers
  1. The isolators shall be installed with the isolator hanger box as close as possible to the structure.
  2. Hanger rods shall be aligned to clear the hanger box and be plumb.

#### **3.02 Outlet Box Pads:**

All holes in outlet boxes in sound rated walls shall be completely covered with electrical box pads molded and pressed to the back side of the box.

RTD Headquarters  
Los Angeles, California  
91-400

5/01/93  
Electrical Equipment Noise Control,  
Vibration Isolation and Seismic Restraints  
16191 - 8

**3.03 Coordination**

The contractor shall coordinate his work with other trades to avoid rigid contact between isolated equipment and raceways with the building. He shall inform other trades following his work to avoid any contact which would reduce the vibration isolation.

- END OF SECTION -

SECTION 16250

AUTOMATIC TRANSFER SWITCHES

PART 1 - GENERAL

1.01 DESCRIPTION

- A. **General:** Provide automatic transfer switches, complete, as shown and specified per Contract Documents.
- B. **Other Applicable Sections:** Requirements of Division 1 and Section 16050 apply to this Section.

1.02 SUBMITTAL DATA

- A. **Procedures:** Refer to Division 1.
- B. **Requirements:** In addition to the requirements of Section 16050, the submittal material shall include copies of descriptive data for all products and materials requested in this Section.
- C. **Shop Drawings:** Submit for all materials in this Section.

PART 2 - PRODUCTS

2.01 GENERAL

- A. **Automatic transfer switch** shall be furnished, mounted and installed as shown on the drawings, and as specified herein. The number of poles, voltage, full-load current, withstand and close-in ratings shall be as shown on the Drawings. Transfer switch shall be listed per U.L. 1008 Standard for Emergency Systems and rated for all classes of loads including 100% tungsten lamp loads. Four-pole transfer switches shall be supplied when connected to four-wire feeder circuits where required on drawings and with all four poles on a common shaft, having withstand and close-in rating of the 4th pole identical to the main poles.
- B. **Transfer switches** shall be double-throw, actuated by a momentarily energized electrical operator. Switch shall be capable of transferring successfully in either direction with 70% of rated voltage applied to the switch terminals. Normal and emergency contacts shall be positively interlocked mechanically and electrically to prevent simultaneous closing. Main contacts shall be mechanically locked in place in both the normal and emergency positions and shall be of silver tungsten alloy. Separate arcing contacts, with magnetic blowouts, shall be provided on all transfer switches.
- C. **Neutral plate**, where required, shall be same ampere rating as main poles.
- D. **Switch shall be freestanding**, in wall mounted cabinet, or may be incorporated in switchboard enclosure.

- E. **Terminals:** Where transfer switch is cable connected, all terminals shall be compression type suitable for copper cables of the sizes indicated.
- F. **Manual operator shall** be provided with same contact transfer speed as the electrical operator to prevent flashover from switching main contacts slowly, and shall be operable without opening transfer switch enclosure door.
- G. **Relays, timers, control wiring** and accessories shall be front accessible. All adjustable times and relays shall be capable of being adjusted, while energized, through calibrated dials. All control wire connections shall use ring or locking spade terminals, and all wiring shall be identified by sleeve-type markers.
- H. **Transient Suppression:** The entire transfer switch and relay plate assembly shall be capable of withstanding a 2500-volt crest transient per IEEE Standard 472-1974. The transient voltage test shall be conducted across the normal source terminals, the emergency source terminals, and between adjacent normal and emergency source terminals.
- I. **Load control** of automatic transfer switches, where described in emergency generator switchboard specification and/or shown on the Drawings, shall interlock transfer switches with generator load control logic to pick up or load shed emergency generator source in a predetermined sequence depending on available generator capacity. Automatic transfer switch control relays shall allow transfer switch load pick up and load shed operation in both automatic and manual control mode from the emergency generator switchboard.
- J. **Controls and Accessories:**
  - 1. Three-phase normal source supervision relays, 65%-70% D.O. and 92%-95% P.U. adjustable.
  - 2. Voltage frequency lockout relay supervision of emergency source, 90% voltage and 57 cycles P.U.
  - 3. Keyed test switch to simulate loss of normal power, cover mounted with maintained contact.
  - 4. Time delay on engine start to override momentary power outage, adjustable 1/2 to 6 seconds.
  - 5. Engine start contacts.
  - 6. One N.O. and one N.C. contact when transfer switch is in normal position and normal source is present.
  - 7. One N.O. and one N.C. contact when transfer switch is in emergency position and emergency source is present.
  - 8. One green and one red pilot light for normal/emergency transfer switch position, mounted on door.



9. Time delay on re-transfer from emergency to normal, adjustable 2 to 25 minutes, with immediate re-transfer overriding time delay if emergency source fails during timing interval.
10. Time delay for engine cool-off, adjustable 1 to 5 minutes.
11. Pre-transfer time delay contact for elevator shutdown signal, adjustable 1 to 15 seconds, to be provided where transfer switch provides power to static-powered elevator drives.
12. In-phase monitor or equivalent to control transfer/ re-transfer operation between live sources to avoid excessive motor inrush currents where transfer switch provides power to motor loads. In-phase monitor must not "lock out" with same source on normal and emergency sides of transfer switch.
13. On loss of normal power source, all transfer switch time delays in engine start up sequence and throw over to generator source, other than override timer for momentary power outage, shall be bypassed.

## 2.02 MANUFACTURERS

- A. **Transfer switches** shall be Russelectric, Asco or approved equal.

## PART 3 - EXECUTION

### 3.01 INSTALLATION

- A. **Mount on building structure** whenever possible. Provide supplemental steel supports as necessary. If floor-mounted, bolt to concrete floor. Where transfer switch is shown mounted within switchboard enclosure, the transfer switch shall be installed and bus connected by switchboard vendor.

### 3.02 IDENTIFICATION

- A. **Provide engraved nameplate** showing load served and voltage.

END OF SECTION



SECTION 16322

480-VOLT MAIN SWITCHGEAR

PART 1 - GENERAL

1.01 DESCRIPTION

- A. **General:** Provide 480-volt main switchboard, complete, as shown, specified or required per Contract Documents.
- B. **Other Applicable Sections:** Requirements of Division 1 and Section 16050 apply to work of this Section.

1.02 SUBMITTALS

- A. **Procedures:** Refer to Division 1.
- B. **Requirements:** In addition to the requirements of Section 16050, submittal material shall include six copies of descriptive data for all products and materials including, but not limited to, the following:
  - 1. **Descriptive Data:** Before final acceptance of the work, Contractor shall deliver to the Architect an "Operating and Maintenance" manual in flexible binder covering all equipment and one complete set of sepia transparencies of all shop and circuit drawings, wiring schedules, and one-line overall Diagrams of the switchgear. Schematic diagrams shall describe replacement parts. In addition, a copy of the approved System Parts List shall be included in each manual.
- C. **Shop Drawings:** Submit drawings and specifications for all parts, components and assemblies under this Section. Submit complete coordination curves for approval.

PART 2 - PRODUCTS

2.01 GENERAL

- A. **480-Volt Switchgear:** Shall be complete, unitized, integral- assembly, metal-enclosed, dead-front, dead-rear, indoor type.
- B. **Switchgear:** Shall be General Electric or Westinghouse.
- C. **Ratings:** Shall be not less than required by the NEC and not less than indicated on the Drawings. Short-circuit current ratings shall be not less than the maximum short circuit currents available where switchgear is being installed, as herein specified.
- D. **Arrangements:** Switchgear shall conform to the arrangements and details indicated on the drawings.

- E. **Coordination:** Coordinate all components and their arrangements electrically and mechanically. Coordinate all circuit entrances including method of entrance and connections.
- F. **Design:** To withstand the mechanical stresses caused by rough handling during shipping in addition to the electrical and mechanical stresses which will occur during operation.
- G. **Interlocks:** Incorporate interlocking, as indicated on the drawings, and as required for the safe operation. All hinged doors shall have locks.
- H. **Assemblies:** Assemble, connect and wire switchgear at the factory so that minimal work will be required at the construction site.
- I. **Finish:** Thoroughly clean, phosphatize and paint metal surfaces at factory with primer and enamel or lacquer, light grey finish.
- J. **Switchgear Enclosures:** Steel assemblies, braced and welded to ensure rigidity and alignment. Sheet steel shall be standard gauge, stretcher-leveled. Holes for connecting adjacent sections shall be die-pierced to ensure alignment and provide for future extensions. All bolts, nuts, washers and fittings shall be rustproof metal. Provide adequate space within each enclosure for equipment and cables. All switchgear sections shall be mounted on structural steel supports, front and rear, for entire length of unit.
- K. **Busing and Connections:** All buses shall be copper or aluminum sized for continuous ratings and braced to withstand short-circuit stresses as herein specified. All joints shall be silver plated and connections shall be made with a minimum of two high-strength bolts with spring washers. Buses shall be supported on high strength, non-hygroscopic insulators. Suitably sized ground bus shall extend through all sections with cable connectors in each section.
- L. **Identification:** Provide engraved nameplate for each circuit breaker stating trip rating and load supplied. Include breaker frame size and type on nameplate unless readily identifiable without removing switchboard covers. Provide main unit nameplates. Attach nameplates with self-tapping screws.
- M. **Auxiliary Wiring:** Necessary fuse blocks and terminal blocks within the switchboard shall be furnished when required. All groups of control wires leaving the switchboard shall be provided with terminal blocks with suitable numbering strips. All hardware used on conductors shall have a high tensile strength and an anti-corrosive zinc plating.
- N. **Switchgear:** Shall be provided with adequate lifting means and shall be capable of being rolled or moved into installation position and bolted directly to the floor without the use of floor sills.
- O. **Individual Shipping Sections:** Shall be designed for bolting together at installation site. All necessary bolting hardware as well as main bus splices shall be supplied between adjacent shipping sections.

- P. **Adequate Conduit Space:** Shall be provided to meet NEC requirements.
- Q. **All Terminals:** Shall be two hole compression-type suitable for copper cable of sizes indicated.
- R. **Minimum Short Circuit Bracing:** Shall be 100,000 AMP.
- S. **A-B-C Type Bus Arrangement:** Left-to-right, top-to-bottom, and front-to-rear, as viewed from the front, shall be used throughout.
- T. **Main Horizontal Bus Bars:** Shall be mounted with all three phases arranged in same vertical plane. Provide full-capacity neutral.
- U. **All Vertical Sections:** Shall align front and rear with depth as shown on drawings.
- V. **All Circuit Breakers, Mains and Feeders:** Shall be individually mounted, barriered and rear-accessible with load-side insulated bus extensions. Lock-off capability shall be provided on all breakers.
- W. **Future Breakers:** All blank breaker space in the switchboard shall be suitable for future addition of breaker units.
- X. **Cable Supports:** Provide brackets in all cable enclosures for support of cable.

2.02 MAIN BREAKERS

- A. **4,000 AMP Breakers:** Shall be large air circuit breakers, Westinghouse Type DS, or equivalent, electrically operated, 100% rated.
- B. **Large Air Circuit Breakers:** Shall have silver-tungsten butt-type contacts which operate under high pressure. Arcing contacts will be of arc-resisting silver-tungsten. Breaker shall be equipped with arc chutes which effectively enclose arcing contacts and confine arc to reduce the disturbance caused by short-circuit interruption. Breaker interrupting ratings shall be 85,000 AMP, RMS symmetrical.
- C. **Each Breaker:** Shall be equipped with solid-state trips. Adjustments shall be: Long delay pickup between 50% and 125% of the trip rating; long time delay between 4 and 36 seconds at 6 times trip rating; short delay pickup between 4 and 10 times trip rating; short time delay between 0.18 and 0.5 seconds at 2.5 times short delay pickup. Adjustments shall be of the continuous type and each shall be independent of all others. Both electrically operated and manually operated breakers shall have stored energy operating mechanisms. Only one stroke of the operating handle shall be necessary to charge stored energy spring when operating breaker manually. Release of energy to close breaker manually shall be by means of mechanical pushbutton which ensures positive control of the closing operation. Electrical close shall be initiated by means of a release solenoid. Provide a portable plug-in test device to test time and current characteristics and trip circuit. Breaker shall be equipped with resettable trip indicators, ground, overload and short-circuit.

- D. **3,000 AMP and Smaller Main Breakers:** Shall be same type as listed for feeder breakers, manually operated and 100% rated in 2,000 AMP and 3,000 AMP frame sizes.

#### 2.03 FEEDER BREAKERS

- A. **Breakers 100 AMP Through 800 AMP Frame:** Breakers through 400 AMP shall be Westinghouse Type Limit-R or equivalent. Breakers 600 AMP through 800 AMP shall be Westinghouse Tri-Pac, or equivalent, combination molded case breaker with current limiters. Breakers shall be selected to protect downstream equipment.
- B. **Breakers 1,000 AMP Through 3,000 AMP Frame:** Shall be Westinghouse Seltronic, complete with built-in current transformers, solid state trip unit and flux transfer shunt trip. Breakers shall have easily changed trip rating plugs with trip ratings as indicated on the drawings. Rating plugs shall be interlocked so they are not interchangeable between frames and interlocked such that breaker cannot be latched with rating plug removed. Breaker shall have built-in test points for testing long delay and instantaneous, and ground fault (where specified) functions of the breaker by means of a 120-volt operated test kit. Provide test kit capable of testing all breakers 1,000 AMP and above. Breakers shall be 100% rated.
- C. **Solid State Trip Element:** Shall have independently adjustable short delay pickup and short delay time with high range fixed instantaneous override for high magnitude faults.

#### 2.04 GROUND FAULT

- A. **Provide ground fault protection** on all main breakers with adjustable pickup from 20% of trip rating to 100% of trip rating, but not exceeding 1,200 AMP; ground fault time delay shall be adjustable 0.1 to 0.5 seconds. Provide neutral ground fault current transformer, where required. Supply integral ground trip on all static trip breakers and ground relay on all thermal magnetic breakers.

#### 2.05 TRIP INDICATORS

- A. **Provide ground overcurrent resettable trip indicators** for all main breakers through 3,000 AMP frames, equipped with ground fault relaying.

#### 2.06 INSTRUMENTATION

- A. **Provide current transformers, ammeter, ammeter switch, and wattmeter** for main breakers. Provide voltmeter, potential transformers and voltmeter switch for main bus. Provide test blocks, for portable recording ammeter and voltmeter. Include 4-20 mA transducers for remote indication of 3-phase amperes, 3-phase watts and single phase volts. Contractor, as an option, may furnish a Westinghouse Type IQ microprocessor metering device in lieu of ammeter, ammeter switch, voltmeter, voltmeter switch and wattmeter.
- B. **Power Company Metering:** Provide bused metering compartments in accordance with the applicable utility standards.

### PART 3 - EXECUTION

3.01 FACTORY ASSEMBLY AND TESTS

- A. **Switchgear shall** be completely assembled, wired, adjusted and tested at factory. After assembly, complete switchgear shall be tested for operation under simulated service conditions to assure accuracy of wiring and functioning of equipment.

3.02 LOW VOLTAGE

- A. **Main circuits will** be given a dielectric test of 2,200 volts for one minute between live parts and ground and between opposite polarities. Wiring and control circuits will be given a dielectric test of 1,500 volts for one minute between live parts and ground.

3.03 SHIPPING

- A. **Each multi-unit section shall** be shipped completely assembled and shall be equipped with shipping angles to permit handling with a crane. Installation work shall be reduced to a minimum.

3.04 INSTALLATION

- A. **Switchgear shall** be securely bolted to concrete floor. Shipping sections shall be electrically connected with connectors furnished with the gear.

3.05 CHECK-OUT AND TESTING

- A. **Switchboard manufacturer shall** provide breaker and/or relay coordination curve showing coordination between power company over current protective device and 480-volt service switchboard main and feeder devices. Manufacturer's service representative shall test and set breaker and/or relay trip devices and submit written report.

END OF SECTION





SECTION 16324

480-VOLT GENERATOR SWITCHGEAR FOR NON-PARALLEL OPERATION

PART 1 - GENERAL

1.01 DESCRIPTION

- A. **General:** Provide 480-volt service switchgear, complete, as indicated, specified or required per Contract Documents.
- B. **Other Applicable Sections:** Requirements of Division 1 and Section 16050 apply to work of this Section.

1.02 SUBMITTALS

- A. **Procedures:** Refer to Division 1.
- B. **Requirements:** In addition to the requirements of Section 16050, submittal material shall include six copies of descriptive data for all products and materials including, but not limited to, the following:
  - 1. **Descriptive Data:** Before final acceptance of the work, Contractor shall deliver to the Architect an Operating and Maintenance Manual in flexible binder covering all equipment and one complete set of sepia transparencies of all shop and circuit drawings, wiring schedules, and one-line overall diagrams of the switchgear. Schematic diagrams shall describe replacement parts. In addition, a copy of the approved system Parts List shall be included in each Manual.
- C. **Shop Drawings:** Submit drawings and specifications for all parts, components and assemblies under this Section. Submit complete coordination curves for approval.

PART 2 - PRODUCTS

2.01 GENERAL

- A. **480-Volt Switchgear:** Shall be complete, unitized, integral- assembly, metal-enclosed, dead-front, dead-rear, indoor type.
- B. **Switchgear:** Shall be General Electric or Westinghouse.
- C. **Ratings:** Shall be not less than required by the NEC and not less than indicated on the drawings. Short-circuit current ratings shall be not less than the maximum short-circuit currents available where switchgear is being installed, as herein specified.
- D. **Arrangements:** Switchgear shall conform to the arrangements and details indicated on the drawings.

- E. **Coordination:** Coordinate all components and their arrangements electrically and mechanically. Coordinate all circuit entrances including method of entrance and connections.
- F. **Design:** To withstand the mechanical stresses caused by rough handling during shipping in addition to the electrical and mechanical stresses which can occur during operation.
- G. **Interlocks:** Incorporate interlocking as indicated on the drawings and as required for the safe operation. All hinged doors shall have locks.
- H. **Assemblies:** Assemble, connect and wire switchgear at the factory so that minimal work will be required at the construction site.
- I. **Finish:** Thoroughly clean, phosphatize and paint metal surfaces at factory with primer and enamel or lacquer, light grey finish.
- J. **Switchgear Enclosures:** Steel assemblies, braced and welded to ensure rigidity and alignment. Sheet steel shall be standard gauge, stretcher-leveled. Holes for connecting adjacent sections shall be die-pierced to ensure alignment and provide for future extensions. All bolts, nuts, washers and fittings shall be rustproof metal. Provide adequate space within each enclosure for equipment and cables. All switchgear sections shall be mounted on structural steel supports, front and rear, for entire length of unit.
- K. **Busing and Connections:** All buses shall be copper or aluminum, sized for continuous ratings and braced to withstand short-circuit stresses as herein specified. All joints shall be silver-plated and connections shall be made with a minimum of two high-strength bolts with spring washers. Buses shall be supported on high-strength, non-hygroscopic insulators. Suitably sized ground bus shall extend through all sections with cable connectors in each section.
- L. **Identification:** Provide engraved nameplate for each circuit breaker stating trip rating and load supplied. Include breaker frame size and type on nameplates unless readily identifiable without removing switchboard covers. Provide main unit nameplates. Attach nameplates with self-tapping screws.
- M. **Auxiliary Wiring:** Necessary fuse blocks and terminal blocks within the Switchboard shall be furnished when required. All groups of control wires leaving the switchboard shall be provided with terminal blocks with suitable numbering strips. All hardware used on conductors shall have a high-tensile strength and an anti-corrosive zinc plating.
- N. **Switchgear:** Shall be provided with adequate lifting means and shall be capable of being rolled or moved into installation position and bolted directly to the floor without the use of floor sills.
- O. **Individual Shipping Sections:** Shall be designed for bolting together at installation site. All necessary bolting hardware, as well as main bus splices, shall be supplied between adjacent shipping sections.

- P. **Adequate Conduit Space:** Shall be provided to meet NEC requirements.
- Q. **All Terminals:** Shall be two hole compression-type suitable for copper cable of sizes indicated.
- R. **Minimum Short-Circuit Bracing:** Shall be 100,000 AMP.
- S. **A-B-C Type Bus Arrangement:** Left-to-right, top-to-bottom, and front-to-rear, as viewed from the front, shall be used throughout.
- T. **Main Horizontal Bus Bars:** Shall be mounted with all three phases arranged in same vertical plane. Provide full-capacity neutral.
- U. **All Vertical Sections:** Shall align front and rear with depth as shown on Drawings.
- V. **All Circuit Breakers, Mains and Feeders:** Shall be rear- accessible with load-side insulated bus extensions. Lock-off capability shall be provided on all breakers.
- W. **Cable Supports:** Provide brackets in cable enclosures for cable support.

## 2.02 GENERATOR BREAKER

- A. **1,600 and 2,000 AMP Breakers:** Shall be insulated case circuit breakers, Westinghouse Type SPB or equivalent, manually operated, 100% rated, 65,000 AMP RMS symmetrical interrupting capacity.
- B. **Breakers:** Each breaker shall be equipped with solid-state trips. Adjustments shall be: Long-delay pickup between 80% and 100% of the trip rating; long-time delay between 2.7 and 23 seconds at 6 times trip rating; short-delay pickup between 4 and 10 times trip rating; short-time delay between 0.1 and 0.3 seconds at 2.5 times short-delay pickup. Manually operated breakers shall have stored energy operating mechanisms. Release of energy to close breaker manually shall be by means of mechanical pushbutton which ensures positive control of the closing operation. Provide a portable plug-in test kit to test time and current characteristics and trip circuit. Breaker shall be equipped with resettable trip indicators, overload and short circuit.

## 2.03 FEEDER BREAKERS

- A. **Breakers 100 AMP Through 225 AMP Frame:** Shall be Westinghouse Type AB or equivalent, molded case breaker.
- B. **Breakers 600 AMP Through 2,000 AMP Frame:** Shall be Westinghouse Seltronic, complete with built-in current transformers, solid-state trip unit and flux transfer shunt trip. Breakers shall have easily changed trip rating plus with trip ratings as indicated on the drawings. Rating plugs shall be interlocked so they are not interchangeable between frames and interlocked such that breaker cannot be latched with rating plug removed. Breaker shall have built-in test points for testing long-delay and instantaneous, and ground fault (where specified) functions of the breaker by means of a

120-volt operated test kit. Provide test kit capable of testing all breakers 600 AMP frame and above. Provide lock-offs for all breakers.

- C. **Solid-State Trip Element:** Shall have independently adjustable short-delay pickup and short-delay time with instantaneous override for high-magnitude fault.

#### 2.04 GROUND FAULT

- A. **Provide ground fault** red lamp alarm indication only (no trip), for all breakers in generator switchboard. Provide terminal connections for remote ground alarm signal; ground fault relay to be adjustable for pickup value and time delay.

#### 2.05 INSTRUMENTATION

- A. **Provide current transformers,** ammeter, ammeter switch, potential transformers, voltmeter and wattmeter for each generator breaker. Provide test blocks for portable recording meters.

### PART 3 - EXECUTION

#### 3.01 FACTORY ASSEMBLY AND TESTS

- A. **Switchgear shall** be completely assembled, wired, adjusted and tested at factory. After assembly, complete switchgear shall be tested for operation under simulated service conditions to assure accuracy of wiring and functioning of equipment.

#### 3.02 LOW VOLTAGE

- A. **Main circuits will** be given a dielectric test of 2,200 volts for one minute between live parts and ground and between opposite polarities. Wiring and control circuits will be given a dielectric test of 1,500 volts for one minute between live parts and ground.

#### 3.03 SHIPPING

- A. **Each multi-unit section shall** be shipped completely assembled and shall be equipped with shipping angles to permit handling with a crane. Installation work shall be reduced to a minimum.

#### 3.04 INSTALLATION

- A. **Switchgear shall** be securely bolted to concrete floor. Shipping sections shall be electrically connected with connectors furnished with the gear.

#### 3.05 CHECK-OUT AND TESTING

- A. **Switchboard manufacturer shall** provide breaker and/or relay coordination curve showing coordination between 480-volt generator switchboard mains and feeder over-current devices. Manufacturer's service representative shall test and set breaker and/or relay trip devices and submit written report.

RTD Headquarters  
Los Angeles, California  
91-400

12/22/92  
480-Volt Generator Switchgear for  
Non-Parallel Operation  
16324 - 5

END OF SECTION



SECTION 16450

GROUNDING SYSTEM

PART 1 - GENERAL

1.01 DESCRIPTION

- A. **General:** Provide grounding systems, complete, as indicated, specified and required per Contract Documents. Principal items include:
  - 1. System grounding.
  - 2. Equipment grounding.
  - 3. Metallic pipe system grounding.
  - 4. Grounding to structural steel.
  - 5. Raceway grounding.
- B. **Other Applicable Sections:** Requirements of Division 1 and Section 16050 apply to work of this Section.
- C. **Codes:** Grounding systems for electrical equipment and system neutrals shall conform with all applicable Code requirements in addition to the requirements of this Section.

PART 2 - PRODUCTS

2.01 CONDUCTORS

- A. **Insulated:** Conductors shall be green, 600-volt TW insulation, annealed copper, as per Section 16120. Conductors shall be sized per NEC; No. 12 AWG minimum size.
- B. **Bare:** Conductors shall be medium-hard drawn stranded copper. Conductors shall be sized per NEC; No. 12 AWG minimum size.

2.02 CONNECTING MATERIALS AND METHODS

- A. **Inaccessible Locations:** Make connections by isothermic welding.
- B. **Accessible Locations:** Make connections with bolted-through approved solderless bronze grounding device.

PART 3 - EXECUTION

3.01 SYSTEM GROUNDING

- A. **System neutrals shall** be connected to UFER grounding system. Neutrals for diesel generators and transformers, shall be connected to grounding system or to ground bus in feeder bus ducts connected to the generators or the transformers.
- B. **Resistance:** Ensure maximum 5 ohm ground resistance at all transformers.

3.02 EQUIPMENT GROUNDING

- A. **Non-Current Carrying Metal Parts:** Ground non-current carrying metal parts of electrical apparatus and equipment provided under the work of any Division of the Specifications.
- B. **Raceways:** Connect interrupted metallic raceways with insulated ground conductors. Provide insulated ground conductors in non-metallic raceways and connect to metallic terminations at each end.
- C. **Piping Systems:** Bond all metallic pipe systems to building steel to ensure ground continuity. Provide jumpers at all isolating fittings.

3.03 TEST AND CERTIFICATES

- A. **Test:** Contractor shall perform grounding tests in accordance with IEEE 81-1983 to certify resistance to ground of 5 ohms or less. Tests shall be performed in the presence of Architect's Representative. Notify Architect one week in advance of scheduled tests. Test for continuity and resistance.
- B. **Certificates:** Continuity and resistance test reports shall be certified by witness. Submit Certificates of Compliance to the Architect.

END OF SECTION



SECTION 16460

DRY TYPE TRANSFORMERS

PART 1 - GENERAL

1.01 DESCRIPTION

- A. **General:** Provide dry type transformers, complete, as shown and specified per Contract Documents. Principal items include:
  - 1. Power transformers.
  - 2. Control transformers.
- B. **Other Applicable Sections:** Requirements of Division 1 and Section 16050 apply to work of this Section.

1.02 SUBMITTALS

- A. **Procedures:** Refer to Division 1.
- B. **Requirements:** In addition to the requirements of Section 16050 submittal material shall include copies of descriptive data for all products and materials.
- C. **Shop Drawings:** Submit for all work of this Section.

PART 2 - PRODUCTS

2.01 POWER TRANSFORMERS

- A. **Dry Type:** Integral, self-cooled, enclosed distribution transformers of the two-winding type.
- B. **Capacity and voltage ratings** as indicated.
- C. **NEMA Standard Taps:** If taps are not standard, equip transformer with two 2-1/2% FCAN and four 2-1/2% FCBN taps. Tap leads shall be terminated on internal block with lugs for connection of incoming conductors.
- D. **Where neutral connection** is indicated, attach to bolt and lug inside enclosure and extend bolt through enclosure to permit external ground connection.
- E. **Vibration dampers** (Korfund Company or equivalent) separating core and coil assembly from the structural members of the enclosures. Sound levels shall be 3 dB lower than NEMA Standard for each particular size.
- F. **Class H insulation**, having a 150°C temperature rise above a 40°C ambient, when operating continuously at full load without loss of normal life. Construct enclosures of heavy gauge steel, coated inside and out with zinc chromate or iron oxide rust

inhibiting primer. Finish with gray enamel. Use manufacturer's standard gray color unless a particular ASA color is indicated or specified.

- G. **Ventilation openings shall** be located to permit placing transformer with two adjacent sides against walls.
- H. **Terminal compartment**, shall be located below the level of the transformer winding. Provide access to terminals from front for wall-and floor-mounted transformers, and from front and bottom for suspended transformers. Support all terminals.
- I. **Manufacturers:** G. E. or Westinghouse.

## 2.02 CONTROL TRANSFORMERS

- A. **Dry type, integral, self-cooled**, two-winding type. Capacity and voltage ratings as indicated, Class H insulation; NEMA I enclosure except where installed in control centers or switchboards. Provide secondary fusing.

## PART 3 - EXECUTION

### 3.01 INSTALLATION

- A. **Do not install transformers** with ventilation openings closer than 12" from any wall surface. Use flexible conduit for primary and secondary connections, or other approved mechanical isolation method. Provide a separate equipment ground conductor in such flexible connections. Do not attach transformer mounting brackets to walls or structure of other than poured concrete construction unless approved. Provide Korfund or equivalent vibration isolators separating the transformer support points and the supporting structure.

END OF SECTION

SECTION 16501

LAMPS AND BALLASTS

PART 1 - GENERAL

1.01 DESCRIPTION

- A. **General:** Provide lamps, ballasts and accessories, complete, as shown and specified per Contract Documents. Principal items include:
1. Fluorescent lamps and ballasts.
  2. Incandescent lamps.
  3. HID lamps and ballasts.
- B. **Other Applicable Sections:** Requirements of Division 1 and Section 16050 apply to work of this Section.
- C. **Related Work Not in This Section:**
1. Luminaires and fixtures.
  2. Control devices, i.e. photoelectric timer, etc.

1.02 SUBMITTAL DATA

- A. **Procedures:** Refer to Division 1.
- B. **Requirements:** In addition to the requirements of Section 16050, the submittal material shall include six copies of Specifications and ratings for all items under this Section. Submit lamping schedule specified hereinafter.

PART 2 - PRODUCTS

2.01 BALLASTS

- A. **Ballasts for fluorescent fixtures** shall be of the energy- saving, super-low-heat type capable of operating standard 40 watt rapid-start lamps at full light output with minimum input watts. Ballasts shall be Universal type SLH or approved equal. All fluorescent lamps other than 40 watt rapid start shall be operated by the most energy-efficient ballast available. All ballasts shall be Class P equipped with automatic resetting thermal protectors built in adjacent to the transformer coils. All ballasts shall be ETL tested and CBM certified. Ballasts shall meet applicable ASI and U.L. specifications regarding reliable starting, radio interference, dielectric and sound ratings. All ballasts shall be high power factor; voltages shall be as specified in the fixture schedule. Provide a two-year written warranty for materials and labor on ballasts. Provide ballasts as required for switching as indicated on the drawings. One-lamp or three-lamp fluorescent luminaires, pendant or surface mounted within 1' of each other, recess mounted within 10' of each other, shall be tandem wired to

eliminate unnecessary use of single lamp ballasts, i.e., a two-lamp ballast shall be mounted in one of the luminaires to serve the single odd lamp in each of the two luminaires.

- B. **Ballasts for H.I.D. Lamps:** Shall be high-power factor, constant wattage type of the quietest sound rating available and shall be mounted in weatherproof enclosures where required. Ballast voltages shall be as specified in the fixture schedule.
- C. **Approved Manufacturers:** Valmont, Phillips, GTE-Sylvania, Advance and Universal.

## 2.02 LAMPS

- A. **Fluorescent Lamps:** Shall be standard warm white, rapid-start, unless otherwise specified in the fixture schedule.
- B. **H.I.D. Lamps:** Metal halide lamps shall be equal to Sylvania Metalarc phosphor coated. HPS lamps shall be equal to G.E. Mercury vapor lamps shall be of the deluxe white type.
- C. **Incandescent Lamps:** Shall be inside-frosted, rated at 120 volts unless otherwise specified in the fixture schedule.
- D. **Approved Manufacturers:** GTE Sylvania, General Electric, Phillips.

## PART 3 - EXECUTION

### 3.01 GENERAL

- A. **At time of final inspection,** ballasts and lamps shall be installed and in operating condition. Faulty lamps shall be removed and new lamps installed.

END OF SECTION

SECTION 16510

LIGHTING FIXTURES

PART 1 - GENERAL

1.01 DESCRIPTION

- A. **General:** Provide lighting fixtures, complete, as shown and specified per Contract Documents.
- B. **Other Applicable Sections:** Requirements of Division 1 and Section 16050 apply to work of this Section.
- C. **Related Work Not Included in This Section:** Lamps, ballasts and accessories.

1.02 SUBMITTAL DATA

- A. **Procedure:** Refer to Division 1.
- B. **Requirements:** In addition to the requirements of Section 16050 submittal material shall include six copies of descriptive data for all products and materials.
- C. **Shop Drawings. Submit for:**
  - 1. Lighting fixtures.
  - 2. Supports.

PART 2 - PRODUCTS

2.01 GENERAL

- A. **Recessed fixtures shall** be equipped with the proper frames and supports as required for the particular type of ceiling. Units shall be properly sealed to prevent light leaks.
- B. **Labels:** Fixtures shall be inspected, approved and bear the label of the Underwriters' Laboratories, Inc.
- C. **Diffusers:** Plastic diffusers or lenses shall be 100% pure virgin acrylic, unless otherwise specified.
- D. **Description:** Type of fixture is denoted on the drawings by capital letters and numbers adjacent to, or in the general area of, the outlets. All fixtures of each type shall be by one manufacturer and shall be as scheduled on the drawings.

2.02 MANUFACTURERS

- A. **Products of equivalent quality** by manufacturers other than those scheduled on the drawings may be accepted if submitted for approval in accordance with applicable requirements; refer to Division 1.

### **PART 3 - EXECUTION**

#### 3.01 INSTALLATION

- A. **General:** Fixtures shall be installed level, plumb and in line on outlets and connected to the wiring, ready for operation. Fixtures shall be assembled with screw and nuts tight, and parts securely mounted, and all necessary additional parts, wire, screws, nuts, washers, locknuts, bushings or required structural supports shall be furnished and installed by Contractor to make fixture installation complete, safe and substantial. Parts, including paint and finish, shall be clean and undamaged.
- B. **Connections between** branch circuit conductors and fixture conductors, and circuit connections for continuous row installation, shall be as specified under Wiring Methods. Internal fixture connections shall be manufacturer's standard and shall conform to Code requirements.

#### 3.02 SUPPORTS

- A. **Fixture Supports:** Surface-mounted fluorescent fixtures shall have minimum of two supports per 4' fixture, one near each end, fastened directly to structural members; method of installation shall be approved. Fixtures shall be grounded by fastening to outlet box fixture stud or conduit connection to fixture.
- B. **Stems for pendant fixtures** shall have approved swivel hanger and canopy at the ceiling.
- C. **Plaster Frames:** For recessed fixtures with plaster frames using yoke-suspended installation, outlet boxes shall be accessible through covered opening from within fixture.
- D. **Recessed Fixtures in Demountable Ceilings:** Shall be supported from ceiling framing system and in addition shall have two 12-gauge slack steel wires from diagonally opposite corners to building structure.

END OF SECTION

SECTION 16610

EMERGENCY GENERATORS

PART 1 - GENERAL

1.01 DESCRIPTION

- A. **General:** Provide emergency generators, complete, as indicated, specified or required per Contract Documents.
- B. **Work In This Section:** Diesel engine generator set.
- C. **Other Applicable Sections:** Division 1 and Section 16050 apply to this Section.
- D. **Work Not In This Section:** The following items are included in Division 15.
  - 1. Fuel oil system, including storage tanks, pumps and piping.
  - 2. Installing muffler and providing exhaust piping.

1.02 SUBMITTALS

- A. **Procedures:** Refer to Division 1.
- B. **Requirements:** In addition to the requirements of Section 16050, the submittal material shall include copies of descriptive data for all products and materials requested in this Section of the work.
- C. **Shop Drawings:** Submit for all work in this Section.

PART 2 - PRODUCTS

2.01 ENGINE GENERATOR SET

- A. **Diesel-engine-driven generator set** complete with starting battery, charger, day tank, muffler and all controls. Unit shall have weatherproof enclosure when located outdoors.
- B. **Rating:** Engine-generator shall be capable of producing output kW as noted on the drawings for a period of six hours without overheating.
- C. **Engine:**
  - 1. **Design:** Two-cycle or four-cycle, diesel without inherent unbalanced reciprocating forces. Entire unit shall be designed to withstand 0.5 G. force.
  - 2. **Rating:** B.H.P. not less than 1.5 HP per kW at 1,200 or 1,800 RPM.
  - 3. **Governor:** Isochronous electronic speed sensing type, to maintain a steady state condition of zero droop. Re-establish operating conditions within three

seconds upon any sudden change from no load to full load with zero droop setting of governor. Maximum transient frequency drop shall not exceed 3% of rated frequency as indicated on proper recording meter operating at 12" or more per minute chart speed.

4. Oil and Fuel Filters: Replaceable element type.
5. Air Cleaner: Oil bath or dry type.
6. Cooling System: Provide unit-mounted radiator, blower fan and fan drive, as well as a gear-driven, jacket water pump, for engine cooling. All components to be matched to the size of the engine/generator. System to be complete with all necessary connections and facilities for jacket cooling of engine and sized for 110% of engine full load requirements.
7. Charging Generator: 24-volt AC, 30 AMP.
8. Starter Motor: 24-volt DC, with starting contactor.
9. Alarm Horn Signal: Mounted on the unit; activated by switches which operate due to low oil pressure, high water temperature, overspeed or overcrank; battery-powered.
10. Overspeed Device: Mechanically driven on engine; to shut down the unit when speed is in excess of 110% of operating RPM; to be manually reset.
11. Signal Lights: Mounted on the unit; individual lights with manual resets, for oil pressure, water temperature, overcrank and overspeed.
12. Immersion Heater: Installed in engine jacket of ample capacity, with adjustable thermostat to maintain the water temperature of the engine at 90°F under minimal outdoor conditions.
13. Piston travel shall not exceed 2,250 FPM at synchronous speed.
14. Provide thermal blankets for exhaust manifolds flexible exhaust connectors and turbocharger custom fitted and attached with stainless steel fasteners, ATP or equal. Insulation of exhaust system external to engine is covered under Division 15.

**D. Generator:**

1. Description: Single ball-bearing generator, bolted to the flywheel housing of the engine; connected to the engine flywheel with flexible steel disc coupling piloted therein; to be free of injurious vibrations at speed of 10% above or below synchronous speed.
2. Rating: Capable of delivering rated kW for eight hours at 0.80 power factor at 480/277 volts, 3-phase, 4-wire, 60-cycle, with brushless revolving solid-state exciter, in accordance with IEEE Standards for Class F insulation 105°C rise machines.



3. **Excitation System:** Shall be capable of providing fault current of three times full load amperes under sustained fault conditions with inherent generator protection to match generator thermal limit for 3 phase, single phase or phase to ground faults.
  4. **Strip Heater:** Weatherproof installations shall be provided with strip heater and control contactor in generator to prevent condensation.
- E. **Base and Mounting:** The engine/generator set to be mounted on a structural steel base; the structural steel base to be mounted on vibration spring isolators with seismic restraints; provide seismic calculations.
- F. **Battery, Battery Rack and Charger:**
1. **Battery:** 24-volt starting battery, lead-acid type in plastic containers. Capacity as recommended by engine manufacturer and verified by battery manufacturer.
  2. **Battery Rack:** Steel strap iron, welded to form a single structural unit, as recommended by manufacturer; with at least two coats of anti-corrosive protective coating on all surfaces. Rack shall be designed to withstand 1/2 G. force in any direction when fully loaded with batteries. Batteries shall be held in rack.
  3. **Charger:** 24-volt, 60-cycle, full wave trickle charger with controls for adjusting the rate of charge from 1/3 to 30 AMP. Similar to La Marche Model No. A-46-30-24V.
- G. **Fuel System:**
1. **Day Tank:** 25 gallon capacity, with gauge, fill-plug drain and vent connection unless indicated otherwise on the drawings.
  2. **Engine Fuel Pump:** Engine-driven, suction lift capacity through 3/4" line as required to transfer fuel from day tank to engine. Provide fuel cooler to allow recirculating fuel to day tank.
  3. **Float Switches:** Provide switches in day tank to operate high- and low-level alarms and to start and stop two pumps. Provide relays and solenoid valves as required.
- H. **Exhaust System and Muffler:**
1. **Muffler:** High-degree type, three-chamber critical class construction Donaldson Model TCU, size as recommended by engine manufacturer, with 18" long stainless steel flexible exhaust connection at inlet; supported on unit.
  2. **Drain Fitting:** Provide in each chamber.

- I. **Emissions:** In accordance with BACT as published by SCAQMD, engine shall be equipped with turbocharger(s) and aftercooling. Injection timing shall be retarded 4 degrees. Submittal shall include emissions expected at rated load and other information as required to fill out SCAQMD applications.
  
- J. **Control Panel:** Unit-mounted sheet steel or angle iron frame with hinged door for access to internal components, vibration- mounted. Instruments and devices.
  1. Ammeter and ammeter switch on generator output.
  2. Voltmeter and voltmeter switch.
  3. kW meter.
  4. Frequency meter.
  5. Water temperature gauge.
  6. Oil pressure gauge.
  7. Battery charging rate ammeter.
  8. 24-volt panel lights with switch.
  9. Three-pole main output molded case circuit breaker, sized as shown on the drawings.
  10. Running time meter.
  11. Emergency start button to bypass all automatic controls.
  12. Voltage regulator, capable of maintaining voltage at generator terminals plus or minus 2% with instantaneous drop when full load is applied at .8 power factor no more than 20% and recovery to normal within one second. Necessary controls to ensure that engine/ generator starts and picks up load within 10 seconds of normal power failure (i.e., meets "Emergency" requirement).
  13. Field rheostat and resistors.
  14. Necessary relays and time delays to permit automatic cycling cranking. Cycling starting shall consist of five attempts to start, of approximately ten second duration, with three to five second rest periods, before disconnecting battery from starter.
  15. Controls to automatically run engine at no load and governed speed for an adjustable period of five to 30 minutes after load is transferred from emergency back to normal source. This period to be called "cool- off".

16. Individual indicator lights and common audible alarm horn with necessary control for:
  - a. Failure to start (overcrank).
  - b. Overspeed trip.
  - c. High water temperature.
  - d. Low oil pressure.
  - e. Control switch out of "Auto" position (no horn).
17. Time delays and timers shall be either dashpot, motor-driven or solid-state types. Thermal types will not be accepted.
18. All control components and overspeed reset shall be marked with engraved laminated plastic nameplate.
19. Relays for remote engine alarms and indication of generator running.

K. **Manufacturers:** Caterpillar, G.M. Diesel.

### PART 3 - EXECUTION

#### 3.01 ENGINE GENERATOR TESTS

- A. **Before delivery** to the site, each set shall be given a preliminary operation and load test. This test will be witnessed by the Architect.
- B. **Tests shall** include load tests with resistance load of a minimum of 100% of the specified continuous full-load capacity of the generator, and shall assure performance of all specified functions. The Contractor shall furnish complete records of the preliminary test in quintuplicate to the Architect for approval.
- C. **Delivery:** Upon approval of preliminary performance, the sets, complete with equipment and controls, shall be delivered to the site and installed by the Contractor at least 30 days before completion of the Contract. Wiring diagrams for the complete installation shall be framed and mounted on the wall.
- D. **Site Tests:** Upon completion of the installation work, including electrical connections, grounding switchgear and controls, the Contractor shall provide all necessary facilities, instruments and equipment, including approved electrical loads and fuel oil required for the load tests, and arrange for final test runs as follows:
  1. Load test at 0, 1/4, 1/2, 3/4, and full load until readings are constant for 10 minutes.
  2. 100% generator full-load test for eight hours shall be made consecutively with the above test.

3. Vibration analysis to ensure that final installation conforms to engine and generator manufacturer's certified performance.

E. **Readings required during both preliminary and final tests shall be taken on recently calibrated laboratory instruments as well as those on equipment and shall include the following:**

1. Frequency.
2. Voltage.
3. Current.
4. Wattage.
5. Ambient temperature.
6. Generator room air inlet temperature - for indoor installations only.
7. Water temperature.
8. Exhaust air temperature.
9. Generator frame temperature at hottest spot.
10. Oil pressure temperature.
11. Frequency and voltage tests shall include a record of response time for recovery from load changes.

END OF SECTION

**SECTION 16700**

**GENERAL COMMUNICATINS SYSTEMS SPACE CONDITIONS**  
**N.I.C. - FOR REFERENCE ONLY**

**PART 1 - GENERAL**

- 1.01 DESCRIPTION: Division 1 applies to this Section. The intent of this specification is to define the specific requirements to the General Contractor (hereinafter referred to as Contractor) for implementation of the General Communications Systems (GCS) for the new Metropolitan Transit Authority of Los Angeles (MTA) to be located in Los Angeles, California. This specification defines the systems and environmental considerations for each of the facility areas impacted by the various communications systems being installed.

Deviations from, exceptions to, or modifications of any aspect of this specification, its attachments, or the contract drawings shall be submitted as an 'alternate' to MTA management and/or their representative for their consideration.

1.02 SCOPE

- A. The GCS is composed of several facility areas, such as:
1. Basement Levels
  2. Data Center
  3. LAN and Equipment Closets (LEC's)
  4. Computer Aided Dispatch (CAD) area
  5. Radio Room
  6. General Floor Spaces (office spaces)
- B. The Contractor will supply, deliver, install, and test the proposed General Communications System (GCS) for MTA as defined in this specification.
- C. All work performed shall be done in a thorough, and craftlike manner according to industry standards and is subject to inspection and acceptance.
- D. Contractor shall coordinate all work through proper channels, and with any affected contractor for installation and connection of the GCS.
- E. Contractor shall hold a current and valid State of California Contractor License.
- F. Contractor shall obtain all required permits and inspections and pay all required fees necessary for the successful completion of all work performed under this specification.

1.03 SUBMITTALS

- A. Contractor shall submit shop drawings and documentation on the complete subsystem for approval prior to the commencement of any field installation work or in-house programming efforts. Submittals shall be brochure form, indexed and

tabbed to cross reference the specification.

- B. Contractor shall provide the following items:
1. A narrative description of each system and its sequence of operation.
  2. An itemized listing of each device, by tag number, being supplied containing that device's make, model number, and any other pertinent device information such as range, operating characteristics, setpoint values, etc.
  3. Point-to-point wiring diagrams, device installation details, riser diagram, equipment and device location plans, and conduit and wire routing layouts.
- C. Submittals shall be reviewed for general design and compliance with contract documents. No deviation from the contract documents or from an approved submittal shall be permitted unless a written request to do so has been submitted by the Contractor to MTA or their representative for consideration. Contractor shall not act on or proceed with any proposed deviation until written approval to do so has been received from MTA or their representative.

#### 1.04 QUALITY ASSURANCE

- A. It is the responsibility of the Contractor to be familiar with all city, county, state, and federal codes, rules, ordinances, and regulations of the Authorities Having Jurisdiction (AHJ) and their interpretations which are in effect for this project.
- B. Where any of the above are at variance with the contract documents and specifications, the more stringent requirements shall take precedence. Any cost necessary to meet any AHJ requirements shall be included in the Contractor's bid price.
- C. The latest issue of all applicable standards and recommended practices of the following agencies in effect on the date of invitation for bid or request for proposal, shall form a part of this specification to the extent each agency's relative standards or recommended practices apply to the GCS and its components as specified herein.

Americans with Disabilities Act (ADA)  
American National Standards Institute (ANSI)  
Building Industry Consulting Service International (BICSI)  
California State Fire Marshal (CSFM)  
Electronic Industries Association (EIA)  
Federal Communications Commission (FCC)  
Institute of Electrical and Electronics Engineers (IEEE)  
National Electric Code (NEC)  
National Electrical Manufacturers Association (NEMA)  
National Fire Protection Association (NFPA)  
Occupational Safety and Health Administration (OSHA)  
Office of Statewide Architect (OSA)  
Underwriters Laboratories Standards (UL)

- D. Each subsystem of the GCS shall be installed by skilled technicians and factory trained system technicians in that trade. The Contractor shall be solely responsible for compliance with all health and safety regulations, performing the work in a safe

and competent manner, and use industry accepted installation procedures required for the work as outlined in these documents.

- E. All GCS engineering, design, installation checkout, startup, and system commissioning shall be by local branch personnel directly or indirectly employed by the Contractor.
- F. All GCS equipment, components, accessories, and installation hardware shall be new and free from defects and shall be UL listed where required by code. All components shall be in current production and shall be a standard product of the manufacturer. Each component shall bear the make, model number, and the UL label as applicable. All GCS components of a given type shall be the product of the same manufacturer.
- G. At least two (2) currently operating installations in the Southern California area similar in size and functionality to this project, shall be available to MTA to visit if they so desire.
- H. Contractor shall furnish for each system of the GCS all submittal information, as-built documentation, Operation and Equipment Maintenance (OEM) Manuals, system commissioning procedures, and system training as defined in this specification.
- I. Manufacturers Qualifications: Manufacturers components shall have been regularly engaged in manufacture of components of the performance specified for not less than five (5) years.

#### **1.05 MATERIALS - DELIVERY, STORAGE, HANDLING**

- A. Delivery of system components and cabling shall be in factory-fabricated containers, or wrappings, which will properly protect components from damage.
- B. Storage of components shall be in the original packaging. Store inside a well-ventilated space protected from weather, damage, breaking, and scoring of finishes. Damaged units or components shall be replaced with new.
- C. It shall be the responsibility of the contractor to inventory all materials upon arrival at the customers location and to notify MTA if there are any missing components.

#### **1.06 PRE-INSTALLATION**

- A. An appropriate installation schedule shall be developed by the contractor and will be subject to approval by MTA and shall include a minimum of one installation supervisor, or lead technician for on-site management of the project.
- B. Prior to starting installation, the assigned installation supervisor, or lead technician, shall participate in a walkthrough of the project location to review the engineering/installation documentation. This walkthrough will also verify that all construction necessary for the installation has been completed and to verify all installation methods and cable routes.
- C. The Contractor shall be responsible for providing a standardized report addressing the weekly progress of the installation schedule.

## 1.08 SYSTEM COMMISSIONING AND WARRANTY

- A. Upon completion of each GCS subsystem installation, the Contractor shall checkout, debug, perform all component testing and calibration, and system burn-in to ensure that system's proper operation as part of the GCS.
- B. The Contractor shall provide MTA certifications, test data, test equipment printouts, manufacturers certificates, and documentation attesting that the cabling and equipment has been properly installed, certified, and tested in accordance with the manufacturer's instructions. This written certification shall be signed by an executive officer of the contracting firm, and submitted to MTA.
- C. An acceptance test and demonstration of the GCS's performance shall be performed in the presence of MTA and their representative following a pre-approved test procedure prepared by the Contractor. When the GCS is deemed acceptable by MTA, it shall be accepted for beneficial use and be placed under warranty.
- D. After being accepted for beneficial use, the GCS shall be warranted in its entirety by the Contractor to be free of all mechanical, electrical, and electronic defects or deficiencies for a period of one (2) years. During the warranty period, any malfunctioning system component shall be repaired, replaced, or corrected promptly by the Contractor at no cost to MTA. During the warranty period, all software upgrades shall be provided to MTA at no additional cost.
- E. Prior to acceptance for beneficial use of GCS, the Contractor shall provide MTA, in writing, the various levels, types, and cost of service agreements available to them to maintain the GCS in proper operating condition after the expiration of the initial warranty period.

## 1.09 TRAINING

- A. Upon completion and testing of the GCS, the Contractor shall provide training to MTA personnel covering the operation, fault isolation, and maintenance of the GCS.
- B.. Instruction shall be on the MTA system installed, and shall utilize 'hands-on' techniques with the system using the contractor provided GCS documentation.

## PART 2 - SYSTEM REQUIREMENTS / FACILITIES

### 2.01 GENERAL SYSTEM REQUIREMENTS

- A. The GCS shall combine advanced network architecture with microprocessor technology and shall allow operation of IBM compatible personal computers with color monitors and software capable of supporting a minimum of 80386 operating parameters. Additional features of the network OS shall provide security access levels and archiving of information.
- B. In addition, the GCS shall allow operation of digital PBX voice processing system to each floor of the facility.
- C. The system hardware and components shall be capable of operating without special environmental controls in the temperature range of 50 degrees to 95 degrees



Fahrenheit and from 20% to 60% relative humidity, non-condensing. Acceptable input voltages shall be 120/208/240 VAC, 60Hz.

- D. Specific power and power outlet requirements will be provided by MTA.

**2.02 BASEMENT B-3**

- A. The Basement level B3 will have conduits feeding the space for voice and data applications that emanate from the 2nd floor Computer Room. The conduits shall have either Category 3 or 5 (4) Unshielded Twisted Pairs and Fiberoptic by type of service and all shall terminate in the outlets or multiplexer racks as shall be indicated in the Tenant drawings that shall be generated before the building is completed.

**2.03 BASEMENT B-2**

- A. The Main Building Entrance Facility from Pacific Bell shall enter the Vault Room from Macy Street below grade in EMT conduit and shall terminate in Pacific Bell Multiplexers in that room.. The room has complete finish requirements as specified in the Low Voltage (EC) drawings, the Mechanical (M) drawings and the Electrical Drawings(E). Architectural drawings also reflect finish requirements and must be reviewed.

**2.04 BASEMENT B-1**

- A. The Basement level B1 containing the MTA Police Offices will have conduits feeding the space for voice and data applications that emanate from the 2nd floor Computer Room. The conduits shall have either Category 3 or 5 (4) Unshielded Twisted Pairs and Fiberoptic per type of service and all shall terminate in the outlets or multiplexer racks as shall be indicated in the Tenant drawings that shall be generated before the building is completed.

**2.05 FLOOR 1**

- A. Floor 1 of the building is the main reception area housing multiple shops and tenants, elevator lobby, and security station. These areas shall also have either Category 3 or 5 (4) Unshielded Twisted Pairs and Fiberoptic per type of service and all shall terminate in the outlets or multiplexer racks as shall be indicated in the Tenant drawings that shall be generated before the building is completed.
- B. Distribution of telecommunication, data and security will come from the 2nd floor above, and floors above through conduit and sleeves LAN and Equipment Closet (LEC) located in the center (core) of the building.

**2.06 FLOOR 2**

- A. The Second floor of the facility houses the Data Center, having all the Data Systems processors and support equipment and shall also house the PBX System and its related equipment. There shall also be multiplexer racks that support the entire backbone network of Copper UTP, Fiberoptic and any other specialized wiring or coaxial cable that route through the Nelson Grid located in the Core.

**2.07 FLOOR 3 - 27**

- A. This floor starts the open systems for furniture and continues up through the structure excluding the Radio Room and the CAD dispatch area. From the LEC's the copper and 1/2 the fiberoptic shall emerge to terminate to the racks and connectors on the opposite side LEC. From The LEC with the Nelson Grid, UTP Category 5 copper will run to each workstation to carry signals for both voice and data applications. From the opposing LEC, the same arrangement is apparent, feeding the workstations from that LEC with UTP Category 5 copper pairs. 4 pairs for each application are required, having as many as 4 - 4 pair UTP drops per workstation outlet. The walls and overhead plenums are to be used where possible, resorting to poke-through techniques for feeding workstations where no other method can work effectively. No flat cable is allowed. The poke-through shall use two cores. one at the wall nearest the island workstation, and one under the workstation so that cable does not emanate from the floor above or below. This means that each floor has the connectivity for each workstation located on that floor.
- B. For all hardwall offices, the same pairs for service are required. The only difference is that no poke-throughs are envisioned as necessary.

## 2.08 RADIO ROOM

- A. The Radio Room will house all the radio microwave equipment and shall be equipped with ladder rack and electrical outlets as specified in the Electrical and Mechanical drawings. The Nelson Grid shall terminate in the Radio Room and from the room to the antennas described in the next section, there shall be microwave waveguides penetrating into the roof space. The Radio Room shall also house any and all multiplexer equipment deemed required by MTA. the space shall be configured to allow maximum utilization through placement of racks and panels along the walls, and ancillary equipment where desired. The systems shall also be supported by Battery Back-up systems that are to be determined later in the project. The entrance shall be card access as required, having its definition in the Tenant documents released later.

## 2.09 ROOF SYSTEMS

- A. At a minimum, the Microwave dishes that are expected to be at least 10 ft. in diameter are to be located at the 28th floor level and shall be placed behind non-metallic fiberglass screenwall. The screen wall shall be tested by independent testing laboratories for total attenuation and deflection via a specification to be determined later. Microwave waveguides are to be routed from the Radio Room to each dish with a minimum of bends and/or distance. The dish declination and azimuth shall be determined by the MTA vendor before installation via a path study.
- B. Other envisioned systems on the roof shall be:

**Radio Antennas** - To be Determined and installed by MTA

**Muzak Ku Band Satellite Dish** - This shall be at least a 1.2 meter dish for receiving program music to be routed throughout the building.

## 2.10 COMPUTER-AIDED DISPATCH (CAD) CENTER

- A. This space shall require at least a 6" raised floor and specialized lighting, power, and HVAC requirements, similar to the Data Center. All the CAD equipment shall reside in this space in its own minihub arrangement. Radio systems shall support the CAD effort by having certain radio systems elements present in the space. Refer to the Mechanical, Electrical, and Architectural sections on preparations for this space.

### **PART 3 - EXECUTION**

#### **3.01 GENERAL**

- A. The Contractor shall install the GCS as defined in this specification, and in accordance with applicable Federal, State, and Local regulations. Contractor shall use the MTA Bid Documents for all references to location of components.
- B. The Contractor shall obtain installation guides from manufacturers, distributors, and vendors, and become familiar with the installation requirements prior to commencement of the work. Any discrepancies between plans and specifications shall be brought to the attention of the authority.
- C. The Contractor shall maintain a clean work area free from debris, trash, empty cable reels, scrap wire, etc., and dispose of such items on a daily basis.
- D. Precautions shall be taken by the contractor to avoid damage to MTA premises and property, and shall perform and restoration if any damage should occur.
- E. Necessary screws, anchors, clamps, tie wraps, distribution rings, miscellaneous grounding and support hardware, etc., to complete the installation shall be provided by the contractor and included in the bid price.
- F. The installation contractor is responsible to furnish any special installation equipment or tools necessary to properly complete the installation. This may include tools for terminating copper/fiber cables, testing equipment, communications devices, cable wenchers, etc..
- G. The Contractor shall clearly label all cables, distribution frames, and outlet locations, etc., as defined in Appendix A (LABELING CODES). Labels shall be computer generated, or type written, and distinguishable as voice or data circuits.
- H. Cables shall be continuous, with no factory splices, field splices, or intermediate couplings. Contractor shall provide, where necessary, cable support bridges over obstructions, underfloor conduit, pipes, supports, etc..
- I. Cables shall be secured to raceways, and strain relieved where necessary.
- J. Installation of the GCS shall be in a "physical star" topology from the MDF to the LEC facilities.
- K. If a winch is used during cable installation, the contractor shall monitor tension of the cable to ensure that maximum pulling tensions are not exceeded. Hand pulls do not require monitoring.
- L. No section of conduit shall have more than two 90 degree changes of direction in

any single cable pull. Appropriate sized pull boxes shall be used for cable runs longer than 100 ft., or contains greater than two 90 degree bends.

- M. When penetrating ceilings, walls, and floors appropriately sized sleeves or slots shall be used. Slots and sleeves shall be fire stopped using approved fire stopping materials.
- N. The Contractor shall be responsible for all coordination with the General Contractor for installation timing and site entry permission. This shall be confirmed in writing in advance of any work.

### **3.02 BACKBONE/RISER (FIBER OPTIC)**

- A. The Contractor shall observe the cable manufacturers specification for minimum bend radius and shall be no less than 20 times the outside diameter of the cable.
- B. The Contractor and installation team shall observe the cable maximum pulling tensions of the specified fiber optic cabling and secure the cable at the top of the vertical rise, and every third floor.
- C. Twenty four (24) feet of slack cable shall be left coiled and mounted to the wall behind each equipment rack at each end of the cable prior to termination. Attention to manufacturers minimum bend radius shall be considered when attaching the slack cable.
- D. All fiber optic cables shall be run in innerduct and marked with precautionary labels as defined in section 2.02.
- E. When pulling fiber optic cable through innerduct, the contractor shall use less than fifty (50) percent of the fill ratio by cross sectional area.
- F. Fiber optic cables that run horizontally shall be supported and secured in cable trays.

### **3.03 BACKBONE/RISER (COPPER/VOICE)**

- A. The Contractor shall observe the cable manufacturers specification for minimum bend radius and shall be no less than 20 times the outside diameter of the cable.
- B. The Contractor and installation team shall observe the cable maximum pulling tensions of the specified copper cabling and secure the cable at the top of the vertical rise, and every third floor.
- C. Twenty four (24) feet of slack cable shall be left coiled and mounted to the wall. Attention to manufacturers minimum bend radius shall be considered when attaching the slack cable.

## **PART 4 - CERTIFICATION**

### **4.01 GENERAL**

- A. All certification and testing will be supported with complete documentation of tests

performed and test equipment printouts for each test where applicable.

- B. Test results shall only be considered acceptable if they fall within specified parameters, or manufacturers specifications, whichever is more stringent.

#### 4.02 BACKBONE/RISER (FIBER OPTIC)

- A. The Contractor shall perform Optical Time Domain Reflectometer (OTDR) tests on all fiber optic cabling in the GCS. Documentation of the test results shall be provided to MTA prior to customer acceptance.
- B. Contractor shall test for an maximum attenuation as follows:  
  
3.75 db/km at 850 nm.  
1.5 db/km at 1300 nm.
- C. Contractor shall test for minimum bandwidth as follows:  
  
160 MHz/km at 850 nm.  
500 MHz/km at 1300 nm.
- D. Every fiber optic cable that makes up the backbone of the GCS shall be tested. Tests shall be performed END to END from the MDF to the LEC facilities.
- E. Test equipment printouts certifying the cables, identifying the cable, location, attenuation, and bandwidth levels, shall be presented to MTA as part of the AS-BUILT documentation prior to acceptance.

#### 4.03 BACKBONE/RISER (COPPER/VOICE)

- A. The Contractor shall perform continuity tests of every pair comprising the COPPER BACKBONE of the GCS. Documentation of the test results shall be provided to MTA prior to customer acceptance.
- B. Failure of more than one percent (1%) of the conductors within the sheath will be considered a faulty cable and the entire run from the MDF to the LEC shall be replaced.
- C. Test equipment printouts certifying the cables, identifying the cable, location, attenuation, and bandwidth levels, shall be presented to MTA as part of the AS-BUILT documentation prior to acceptance.

#### 4.04 GROUNDING AND BONDING

- A. The Contractor shall verify the integrity of the grounding system. Resistance to ground, as part of the GCS, shall be less than 10 ohms. If the resistance is over 2.5 ohms the contractor shall alert the MTA, and assist in coordinating resolution through the appropriate contractor.
- B. The Contractor shall verify the ground potential between the electrical ground and LEC frames. Acceptable voltage potential is less than 2.8 VAC.

1. Disconnect the ground lug from the LEC frame
2. Measure the voltage between the rack ground lug and the ground wire; record the voltage.
3. Re-connect the ground wire to the frame ground lug.

If the voltage potential is unacceptable, the contractor shall alert the MTA, and assist in coordinating resolution through the appropriate contractor.

## **PART 5 - MAINTENANCE AND SERVICE**

### **5.01 GENERAL**

- A. The GCS shall be warranted by the contractor for a period of not less than one (1) year after acceptance of the installation. During the warranty period, any material showing any mechanical, or electrical defects shall be replaced promptly by the contractor at no expense to MTA.
- B. Maintenance and repair services shall be available locally and shall respond within four (4) hours of being notified by MTA of an emergency situation and within twenty-four (24) hours for non-emergency situations.
  1. NON-EMERGENCY - Where less than two (2) percent of the network is effected or non-functional.
  2. EMERGENCY - Any network backbone (fiber optic) related problem, or where two (2) percent or more of the network is effected. Issues where a file-server is not available to network users due to a cabling plant malfunction.
- C. Prior to acceptance for beneficial use, the contractor shall provide, in writing, various types of service agreements available, including equipment covered, costs, response times, etc., after the warranty period expires.

## **PART 6 - ACCEPTANCE**

### **6.01 FINAL ACCEPTANCE**

- A. Once the contractor completes the certification, and demonstrates the functionality of the GCS to MTA the project shall be signed off by an officer of the contracting company and by the MTA project manager.
- B. Upon signoff by MTA, the warranty period shall begin.

## **PART 7 - APPENDIX A**

### **7.01 CABLE MARKING**

All Voice Riser Pairs shall be marked as follows:

Each 600 Pair bundle marked at both ends with digit number, i.e.,

B-3 - pairs 1 through 250  
B-2 - pairs 251 through 500  
B-3 - pairs 501 through 750  
1st -pairs 1000 through 1600  
2nd - pairs 2000 through 2600  
26th - pairs 26000 through 26600  
28th - pairs 28000 through 28600

All Data Riser Fiber Pairs shall be marked as follows

All - pairs 1 through 18 with the floor prefix added, i.e.,  
B-3 - B3-1 through B3-18  
28th - 28-1 through 28-18

Any coaxial cable occurring in the riser shall be numbered the same as Fiber cables, i.e.,

B-3 - B3-1 through B3 -X  
26th - 26-1 through 26-X

#### 7.02 Marking of Components

All panels, racks, devices supplied under this section and connector blocks and information outlets shall be marked according to the system determined by MTA before installation proceeds. No installation shall commence without written approval by MTA on the system and the marker types to be applied to all components.

END OF SECTION





**SECTION 16701**

**LOW VOLTAGE SUPPORT STRUCTURES SYSTEM**

**PART 1 - GENERAL**

**1.01 DESCRIPTION:** Division 1 applies to this section. The intent of this specification is to define the equipment and performance requirements for the Low Voltage Support Structure System (LVSSS) for the new Metropolitan Transit Authority of Los Angeles (MTA) to be located in Los Angeles, California. The Contractor shall base their primary bid on the LVSSS requirements as specified herein. Deviations from, exceptions to, or modifications of any aspect of this specification, its attachments, or the contract drawings shall be submitted as an 'alternate' to MTA management and/or their representative for their consideration.

**1.02 SCOPE**

- A. The LVSSS is composed of several components, such as:
1. Telephone service pathways. (Into Vault from Macy St. and From Vault to 2nd Floor)
  2. Cable Trays and accessories. (NIC)
  3. Shell & Core Distribution Conduits. (Risers Only)
  4. Nelson Fire-Stop Assembly System.
  5. Conduit Fire Stop
- B. The Contractor shall furnish and install all equipment, support structures, accessories, and conduit.
- C. Contractor shall coordinate all work through the proper channels; to the electrical contractor for providing power, lighting, and grounding requirements; to the mechanical/HVAC contractor for providing BTU's requirements; and to the structural contractor for firestop and floor/wall penetrations.
- D. Contractor will obtain all required permits and inspections and pay all required fees necessary for the successful completion of all work performed under this specification. All permits and certificates of compliance will be turned over to MTA management.

**1.03 QUALITY ASSURANCE**

- A. It is the responsibility of the Contractor to be familiar with all city, county, state, and federal codes, rules, ordinances, and regulations of the Authorities Having Jurisdiction (AHJ) and their interpretations which are in effect for this project.
- B. Where any of the above are at variance with the contract documents and specification, the more stringent requirements shall take precedence. Any cost necessary to meet any AHJ requirements shall be included in the Contractor's bid price.
- C. The latest issue of all applicable standards and recommended practices of the following agencies in effect on the date of invitation for bid or request for proposal shall form a

part of this specification to the extent each agency's relative standards or recommended practices apply to these systems and their components as specified herein.

Office of Statewide Health Planning and Development (OSHPD)  
California State Fire Marshal (CSFM)  
American National Standards Institute (ANSI)  
Electronic Industries Association (EIA)  
Institute of Electrical and Electronics Engineers (IEEE)  
National Electrical Manufacturers Association (NEMA)  
National Fire Protection Association (NFPA)  
Underwriters Laboratories Standards (UL)  
Underwriters Laboratories Standard UL 1076 and 1409  
Occupational Safety and Health Administration (OSHA)  
Federal Communications Commission (FCC)

- D. Each components of the LVSSS shall be installed by skilled electricians being system technicians in that trade. The Contractor shall be solely responsible for compliance with all health and safety regulations, performing the work in a safe and competent manner, and use industry accepted installation procedures required for the work as outlined in these documents.
- E. All LVSSS engineering, design, installation checkout, startup, and system commissioning shall be by local branch personnel directly or indirectly employed by the Contractor.
- F. All LVSSS components, accessories, and installation hardware shall be new and free from defects and shall be UL listed where applicable and where required by code. All components shall be in current production and shall be a standard product of the system or device manufacturer. Each component shall bear the make, model number, and the UL label as applicable. All LVSSS components of a given type shall be the product of the same manufacturer.
- G. Each components which comprises the LVSSS shall be by a manufacturer of established reputation and experience who has been regularly engaged in the manufacture of that type of equipment for a period of not less than three (3) years. Contractor shall be an authorized factory representative of the LVSSS being installed for the Los Angeles County area, if not the system manufacturer, and shall present a signed letter from the system manufacturer stating this fact. At least two (2) currently operating installations in the Southern California area similar in size and functionality to this project, shall be available to MTA to visit if they so desire.
- H. Maintenance and repair services shall be available locally and shall respond within four (4) hours of being notified by MTA of an emergency situation and within twenty-four (24) hours for non-emergency situations.
- I. Contractor shall furnish for each component of the LVSSS all submittal information, as-built documentation, Operation and Equipment Maintenance (OEM) Manuals, system commissioning procedures, and system training as defined in this specification.

#### 1.04 SUBMITTALS

- A. Contractor shall submit LVSSS documentation and data in accordance with Section XXXXX - Submittals, contained under Division 1 - General Requirements for this project and as specified herein.
- B. Contractor shall submit shop drawings indicating size, type, dimensions, support points and finishes.
- C. In addition to that required under Section XXXXX, Contractor shall provide the following items:
  - 1. A narrative description of each component.
  - 2. Product date for each system component, fittings, and accessories.
  - 3. Manufacturer's Instructions; indicating application conditions and limitations of use stipulated by products testing agency specified under Regulatory Requirements. Instructions for storage, handling, protection, examination, preparation, and installation of products should be included.
- D. Submittals shall be reviewed for general design and compliance with contract documents. No deviation from the contract documents or from an approved submittal shall be permitted unless a written request to do so has been submitted by the Contractor to MTA or their representative for consideration. Contractor shall not act on or proceed with any proposed deviation until written approval to do so has been received from MTA or their representative.

#### 1.05 SYSTEM COMMISSIONING AND WARRANTY

- A. Upon completion of each LVSSS components installation, the Contractor shall checkout the installation to ensure that it complies with the contract documents, applicable code requirements, and accepted industry standards. An acceptance test and demonstration of the LVSSS's performance shall be performed in the presence of MTA and their representative following a pre-approved test procedure prepared by the Contractor. When the system is deemed acceptable by MTA, it shall be accepted for beneficial use and be placed under warranty.
- B. After being accepted for beneficial use, the LVSSS shall be warranted in its entirety by the Contractor to be free of all mechanical, electrical (Bonding for Grounding), and installation defects or deficiencies for a period of one (1) year. During the warranty period, any defect or deficiencies shall be repaired, replaced, or corrected promptly by the Contractor at no cost to MTA. During the warranty period, all software upgrades shall be provided to MTA at no additional cost.

### **PART 2 - GENERAL SYSTEM COMPONENTS:**

#### **2.01 Telephone Service Pathways**

- A. Telephone Service Entrance Pathway shall be EMT duct from point of telephone utility connection at manhole to building service terminal backboard.
- B. Telephone Utility: Pacific Bell Telephone Company
- C. Perform work in accordance with telephone utility's rules and regulations.

- D. Telephone Termination Backboards;
  - 1. Material: Plywood
  - 2. Size: As indicated on drawings, 3/4 inch thick.

- E. Backbone Cable (NIC)

## 2.02 Cable Tray and Accessories

- A. Ladder Rack Type Cable Tray
  - 1. Manufacturer: B-line, Model 444 G06-12-144
  - 2. Description: NEMA VE 1, class 20A ladder type, 12 feet long sections.
  - 3. Material: Steel.
  - 4. Finish: ASTM A 123, hot dipped galvanized after fabrication.
  - 5. Inside Width: As indicated on drawings.
  - 6. Inside Depth: 4 inches.
  - 7. Straight Section Rung Spacing: 6 inches.
  - 8. Inside Radius of Fitting: 24 inches.
  - 9. Provide manufacturer's standard clamps, hangers, brackets, splice plates, reducer plates, blind ends, barrier strips, connectors, and grounding straps.
  - 10. Warning Signs: Engraved Nameplates; 1/2 inch high black letters on yellow laminated plastic nameplate, engraved with the following wording:  
**WARNING! DO NOT USE CABLE TRAY AS WALKWAY, LADDER, OR SUPPORT. USE ONLY AS MECHANICAL SUPPORT FOR CABLES (AND EMT TUBING WHERE NECESSARY)!**

## 2.03 Distribution Conduits

- A. Electrical Metallic Tubing- EMT
  - 1. General: EMT shall be minimum of 3/4 inch I.D.
  - 2. EMT shall be galvanized steel with protective coating on inside, ten ft length - no couplings.
  - 3. EMT is used for telephone and signal wiring above ground, in dry places where not subject to mechanical damage. Sizes vary from 3/4" to 4" I.D.
  - 4. Provide continuous conduit home-runs from Main Telephone Vault to the 2nd floor Data Center and to below rooms to each LAN and Equipment Closet (LEC) and to Telecom/Satellite Closets- Below 2nd floor Riser Distribution.
  
- C. Fittings and Pull Wires
  - 1. Fittings for use in EMT runs shall be galvanized steel. Connectors and couplings shall be steel setscrew type.
  - 2. Provide nylon pull line in each EMT distribution conduit and conduit for telephone and signal outlets. This pull line shall be installed with or without cables in the conduit.
  - 3. Pull Boxes shall be provided in conduit runs as required by the telephone and/or data processing system supplier.

D. Supporting Devices

1. Provide appropriate materials, sizes and types of anchors, fasteners, pipe bracket saddle and clamps, hanger and standard pipe guides.
2. Provide proper fittings and support hardware to accommodate expansion and deflection where conduit runs across facility seismic and/or controlled expansion joints.

**2.04 Fire-Stop Assembly System**

- A. Manufacturer: Hevi-Duty/Nelson
- B. Manufactured Assemblies (devices): Hevi-Duty/Nelson MCT- Multi Cable Transit; an assembly consisting of steel frames(RGS) welded together in a honeycomb arrangement, a compression mechanism and grooved insert modules sized for a variety of penetrating elements.
- C. Provide Nelson System in each slab above 2nd floor as per the drawings for the MTA Riser System

**PART 3 - EXECUTION**

**3.01 GENERAL**

- A. Installation and testing of all LVSSS components shall be in accordance with the manufacturer's instructions, recommended industry practices and standards, and codes and regulations of government and local authorities having jurisdiction.
- B. Installation of cable trays and accessories, fire-stop assembly system, and conduit shall conform with the requirements noted in the applicable sections of Division 16, and the vendors' recommendations.

**3.02 INSTALLATION - CONDUIT**

- A. Conduits for telephone and signal service, riser, and horizontal distribution shall be electrical metallic tubing (EMT) galvanized steel with compression fittings.,
- B. Conceal conduit runs within finished shafts, walls, and accessible ceiling spaces. Conduit may be run exposed in equipment rooms or other areas where other piping or infrastructure utilities are exposed. Exposed conduit runs and conduit runs installed in accessible ceiling space shall be installed parallel with and at right angles to the building walls. Avoid moisture traps and provide junction boxes with a drain fitting at all low points in the conduit system.
- C. Cover open ends of conduit prior to the installation of wire. Plug and/or cap all unused conduit openings and stub-ups with the proper fitting. Do not use caulking compound. All conduits shall have at least a 3/8 inch pull cord with the room origination and termination location clearly marked on a white nondestructible label.

- D. Route all conduit to clear beams, plates, footings, and structural members. Do not run conduit through any facility structural element unless a path has been already established for this use.
- E. Conduit, outlets, junction boxes, and pull boxes shall be installed in accessible locations, avoiding obstructions, preserving headroom, and keeping openings and passageways clear.
- F. Conduit runs shall be clean and dry before pulling in conductors. provide nylon pull-line in all empty conduits.
- G. All conduits entering junction boxes, outlets and devices shall be provided with insulated bushings or insulated threaded connectors.
- H. All conduits shall be capped during construction by means of manufactured conduit seals or caps to prevent entrance of water or debris and shall remain closed until ready to use.
- I. Conduit joints in concrete, masonry walls, or where exposed to weather or moisture, shall be made with an approved joint compound.
- J. Support single one inch and smaller exposed conduit runs from the building wall with one-hole malleable iron or steel galvanized pipe clamps spaced as required by code. Do not use perforated iron strap (plumber's tape). Small conduit may be installed on pipe or conduit support racks where they are installed provided earlier spacing requirements are not voided. Suspend conduits larger than one inch on conduit racks (trapezes) or with split ring hangers and rods.
- K. Where short runs of hard conduit are inappropriate or where conduit is attached to vibrating equipment, flexible weatherproof sealtite-type metal conduit with a minimum length of 18 inches shall be installed and anchored. Flexible conduit runs shall not exceed 36 inches in length.
- L. Where installed outdoors or exposed to damp or wet environments, waterproof rigid and/or flexible conduit, outlet boxes, and fittings shall be used.
- M. Provide proper penetration plates and/or seals for all conduits passing through walls, floors, or ceilings to preserve the structural, weatherproof, and/or fire resistance integrity of the breached member. In exposed situations, coordinate plate type and finish selection with the Architect.
- N. All outlet boxes shall be galvanized steel, appropriately sized for each application with a suitable cover plate. Where exposed to damp or wet conditions or installed outdoors, outlet boxes shall be weatherproof with a gasketed cover plate.
- O. Pull boxes, junction boxes, wire duct, etc. shall be sized and fabricated in accordance with code and shall be finished in a manner suited to the location.
- P. Provide proper fittings and support hardware to accommodate expansion and deflection where conduit runs cross facility seismic and/or controlled expansion joints.

### 3.03 INSTALLATION - CABLE TRAY (LADDER RACK)

- A. Install in accordance with manufacturer's instructions.
- B. Install metallic cable trays in accordance with NEMA VE 1.
- C. Support cable trays in accordance with Section 16190. Provide supports at each connection point, at the end of each run, and at other points to maintain spacing between supports of 6 ft. maximum.
- D. Use expansion connectors where required.
- E. Ground and bond cable tray under provisions of Section 16450.
  - 1. Provide continuity between tray components.
  - 2. Provide flexible braided tinned copper bonding jumper, rated 600A, B-LINE, catalog number 99-1610; or equal.
  - 3. Use antioxidant compound to prepare aluminum contact surfaces before assembly.
  - 4. Connections to tray may be made using mechanical or exothermic connectors.
- F. At points where cable trays cross the seismic joints, provide expansion connectors/plates on both sides of seismic joint in order to loop the loose cables crossing the seismic joints.
- G. Install warning signs at 50 ft. centers along cable tray, located to be visible.
- H. Exclusions

The Contractor will not be held responsible for failures resulting from the following:

- 1. An outage of the facility main power supply.
- 2. Failure of a communications link, provided that the LVSSS operates as specified and the failure was not due to contractor furnished components or installation.
- 3. Failure of existing MTA owned equipment, provided that the failure was not due to Contractor furnished equipment, installation, or software

### 3.05 DOCUMENTATION

- A. All items of technical data, which is specifically identified in this specification, will be delivered strictly in accordance with the requirements of MTA as they apply to contract purchased items. All data delivered shall be identified by reference to the particular specification paragraph against which it is furnished.
- B. Group I Technical Documentation - System Drawings

System drawings shall be complete and clear. Details shall be identified by reference to sheet and detail, schedule, or room numbers noted on contract drawings. Wiring

diagrams must include the entire system as installed. The submittals shall include but not be limited to the following:

1. Hardware block diagrams
2. Details of connections to power sources, including grounding
3. Details of surge protection device installations
4. One reproducible set of transparencies and five copies of diagrams

The materials shall be delivered to MTA at least 60 days before the agreed on training date for review and approval. Changes requested by MTA are to be included and resubmitted for approval 10 days prior to training.

C. Group III Technical Documentation - Quality Assurance

The Contractor shall deliver a written quality assurance plan acceptable to MTA. The plan shall contain details sufficient to guarantee the accuracy of all documentation. At a minimum, the quality assurance plan shall define:

1. The authority, functions, and duties of those responsible for the preparation and quality assurance of the manual
2. Equipment design modification control procedures
3. Record maintenance and manual validation and verification procedures
4. Quality control checklists, inspection points, and validation procedures

D. Acceptance Criteria

Each manual shall be completed and delivered in total. Partial manuals shall not be accepted. Acceptance of the final manual shall be based on, but not be limited to, the following:

1. Conformance to quality assurance provisions
2. Technical accuracy, completeness, readability, clarity, and workmanship
3. Validation and verification

All manual materials and data developed by the Contractor are subject to MTA review and approval. When any material submitted to MTA contains excessive and/or obvious errors, inconsistencies, and omissions, it shall be reason to reject all or any part of those materials, with or without complete review and comments.

E. Hardware Manual

The hardware manual shall describe all equipment provided. It shall include but not be limited to:

1. General description and specifications
2. Installation and checkout procedures
3. Equipment electrical schematics and layout drawings
4. Schematics
5. Manufacturer's repair parts list including recommended spares and supply sources



F. Maintenance Personnel Training

The maintenance course shall be taught at the project site after completion of the endurance test for a period of two training days. A maximum of six (6) personnel will attend the course. The training shall include but not be limited to:

1. Physical layout of each piece of hardware
2. Troubleshooting and diagnostics procedures
3. Repair instructions

**3.07 MAINTENANCE AND SERVICE**

A. The Contractor shall provide all services, materials, and equipment required to maintain the entire LVSSS in an operational state for a period of one year after final acceptance by MTA.

B. The Contractor shall provide a list of recommended spare parts. The list shall include but not be limited to:

1. OEM numbers
2. Parts description
3. Unit price
4. Recommend quantities
5. Alternate sources of supply

After acceptance by MTA, the Contractor shall use parts from the spare parts kit to perform maintenance. Parts used to replace failed components shall be replaced by the Contractor in a timely manner. The Contractor shall maintain the spare parts kit at the original inventory level. The spare parts kit shall be considered to be the property of MTA.

**3.08 OWNER ACCEPTANCE**

Upon the successful completion of the acceptance tests, correction of all punch list items, the LVSSS shall be considered acceptable to MTA. At this time, MTA shall issue a letter to the Contractor signifying acceptance as installed. The date of the letter shall signify the start of the system warranty period.

END OF SECTION



SECTION 16702

HIGH SPEED VOICE/DATA NETWORK BACKBONE

PART 1 - GENERAL

- 1.01 DESCRIPTION: Division 1 applies to this section. The intent of this specification is to define the equipment and performance requirements for the voice and data backbones for the new Metropolitan Transit Authority (MTA) building located in Los Angeles, California. The Contractor shall adhere to and base his primary bid on the requirements specified herein. Deviations from, exceptions to, or modifications of any aspect of this specification, its attachments, or the contract drawings shall be submitted as an 'alternate' to MTA and or their representative for consideration.

The proposed Universal Backbone System (UBS) is composed of three major subsystems:

**Intended Use:**

- w Ethernet (IEEE 802.3) Local Area Network (LAN)
- w Token Ring (IEEE 802.5) Local Area Network (LAN)
- w Digital PBX System and Telephones
- w Low speed data over voice backbones

**Future Use:**

- w Asynchronous Transfer Mode (ATM) Local Area Network (LAN)

The UBS provides a flexible means of communicating between the Mainframe, Personal Computers, Minicomputers, telephones, and the Northern Telecom PBX system.

1.02 SCOPE

- A. The Contractor will supply, deliver, install, and test the proposed Universal Backbone System (UBS) for MTA as defined in this specification.
- B. All work performed shall be done in a thorough, and craftlike manner according to industry standards and is subject to inspection and acceptance.
- C. Contractor shall coordinate all work through proper channels with the electrical contractor and any other affected contractor for installation and connection of the UBS.
- D. Contractor shall hold a current and valid State of California Communications Contractor License. Contractor shall obtain all required permits and inspections and pay all required fees necessary for the successful completion of all work performed under this specification.

1.03 SUBMITTALS

- A. Contractor shall submit shop drawings and documentation on the complete subsystem for approval prior to the commencement of any field installation work or

in-house programming efforts. Submittals shall be brochure form, indexed and tabbed to cross reference the specification.

- B. Contractor shall provide the following items:
1. A narrative description of each system and its sequence of operation
  2. An itemized listing of each device, by tag number, being supplied containing that device's make, model number, and any other pertinent device information such as range, operating characteristics, setpoint values, etc.
  3. Point-to-point wiring diagrams, device installation details, riser diagram, equipment and device location plans, and conduit and wire routing layouts.
- C. Submittals shall be reviewed for general design and compliance with contract documents. No deviation from the contract documents or from an approved submittal shall be permitted unless a written request to do so has been submitted by the Contractor to MTA or their representative for consideration. Contractor shall not act on or proceed with any proposed deviation until written approval to do so has been received from MTA or their representative.

#### 1.04 QUALITY ASSURANCE

- A. It is the responsibility of the Contractor to be familiar with all city, county, state, and federal codes, rules, ordinances, and regulations of the Authorities Having Jurisdiction (AHJ) and their interpretations which are in effect for this project.
- B. Where any of the above are at variance with the contract documents and specifications, the more stringent requirements shall take precedence. Any cost necessary to meet any AHJ requirements shall be included in the Contractor's bid price.
- C. The latest issue of all applicable standards and recommended practices of the following agencies in effect on the date of invitation for bid or request for proposal, shall form a part of this specification to the extent each agency's relative standards or recommended practices apply to the UBS and its components as specified herein.

Americans with Disabilities Act (ADA)  
American National Standards Institute (ANSI)  
Building Industry Consulting Service International (BICSI)  
California State Fire Marshal (CSFM)  
Electronic Industries Association (EIA)  
Federal Communications Commission (FCC)  
Institute of Electrical and Electronics Engineers (IEEE)  
National Electric Code (NEC)  
National Electrical Manufacturers Association (NEMA)  
National Fire Protection Association (NFPA)  
Occupational Safety and Health Administration (OSHA)  
Office of Statewide Architect (OSA)  
Underwriters Laboratories Standards (UL)

- D. Each subsystem of the UBS shall be installed by skilled technicians and factory

trained system technicians in that trade. The Contractor shall be solely responsible for compliance with all health and safety regulations, performing the work in a safe and competent manner, and use industry accepted installation procedures required for the work as outlined in these documents.

- E. All UBS engineering, design, installation checkout, startup, and system commissioning shall be by local branch personnel directly or indirectly employed by the Contractor.
- F. All UBS equipment, components, accessories, and installation hardware shall be new and free from defects and shall be UL listed where required by code. All components shall be in current production and shall be a standard product of the manufacturer. Each component shall bear the make, model number, and the UL label as applicable. All UBS components of a given type shall be the product of the same manufacturer.
- G. At least two (2) currently operating installations in the Southern California area similar in size and functionality to this project, shall be available to MTA to visit if they so desire.
- H. Contractor shall furnish for each system of the UBS all submittal information, as-built documentation, Operation and Equipment Maintenance (OEM) Manuals, system commissioning procedures, and system training as defined in this specification.
- I. Manufacturers Qualifications: Manufacturers components shall have been regularly engaged in manufacture of components of the performance specified for not less than five (5) years.

#### 1.05 MATERIALS - DELIVERY, STORAGE, HANDLING

- A. Delivery of system components and cabling shall be in factory-fabricated containers, or wrappings, which will properly protect components from damage.
- B. Storage of components shall be in the original packaging. Store inside a well-ventilated space protected from weather, damage, breaking, and scoring of finishes. Damaged units or components shall be replaced with new.
- C. It shall be the responsibility of the contractor to inventory all materials upon arrival at the customers location and to notify the customer if there are any missing components.

#### 1.06 PRE-INSTALLATION

- A. An appropriate installation schedule shall be developed by the contractor and will be subject to approval by MTA and shall include a minimum of one installation supervisor, or lead technician for on-site management of the project.
- B. Prior to starting installation, the assigned installation supervisor, or lead technician, shall participate in a walkthrough of the project location to review the engineering/installation documentation. This walkthrough will also verify that all construction necessary for the installation has been completed and to verify all installation methods and cable routes.

- C. The Contractor shall be responsible for providing a standardized report addressing the weekly progress of the installation schedule.
- D. The Contractor shall ensure that the maximum pulling tensions of the specified distribution cables are not exceeded at any time. Failure to follow the appropriate guidelines may require the contractor to provide the additional material necessary to rectify the situation.

#### 1.07 GROUNDING AND BONDING

- A. Grounding and bonding of the UBS shall be in accordance with Article-250 and Article-800 of the NEC, except where other authorities or codes impose more stringent requirements. Proper grounding and bonding shall be installed to drain Electro-Magnetic Interference (EMI), and to ensure personal safety from possible shock hazards.
- B. The Contractor shall provide an appropriately-sized conductor (6 AWG minimum), green in color, from an Approved Floor Ground (AFG) or the Building Principal Ground (BPG) to the Main Distribution Frame (MDF) and LAN and Equipment Closet (LEC) facilities.
- C. The Contractor shall provide a copper ground bar a minimum of 12 inches long, 1 inch wide, and 1/4 inch thick, connected to the AFG or BPG in each LEC facility. Copper ground bars shall be mounted to the wall of each facility on insulated standoffs.
- D. Equipment racks, metallic enclosures, etc., shall be appropriately grounded to the copper bus bars in each facility.
- E. Acceptable ground continuity shall be verified as outlined in Section-4 Certification and Testing prior to customer acceptance.

#### 1.08 SYSTEM COMMISSIONING AND WARRANTY

- A. Upon completion of each UBS subsystem installation, the Contractor shall checkout, debug, perform all component testing and calibration, and system burn-in to ensure that system's proper operation as part of the UBS.
- B. The Contractor shall provide MTA certifications, test data, test equipment printouts, manufacturers certificates, and documentation attesting that the cabling and equipment has been properly installed, certified, and tested in accordance with the manufacturer's instructions. This written certification shall be signed by an executive officer of the contracting firm, and submitted to MTA.
- C. An acceptance test and demonstration of the UBS's performance shall be performed in the presence of MTA and their representative following a pre-approved test procedure prepared by the Contractor. When the UBS is deemed acceptable by MTA, it shall be accepted for beneficial use and be placed under warranty.
- D. After being accepted for beneficial use, the UBS shall be warranted in its entirety by the Contractor to be free of all mechanical, electrical, and electronic defects or deficiencies for a period of one (2) years. During the warranty period, any malfunctioning system component shall be repaired, replaced, or corrected promptly.

by the Contractor at no cost to MTA. During the warranty period, all software upgrades shall be provided to MTA at no additional cost.

- E. Prior to acceptance for beneficial use of UBS, the Contractor shall provide MTA, in writing, the various levels, types, and cost of service agreements available to them to maintain the UBS in proper operating condition after the expiration of the initial warranty period.

#### **1.09 TRAINING**

- A. Upon completion and testing of the UBS, the Contractor shall provide training to MTA personnel covering the operation, fault isolation, and maintenance of the UBS.
- B. Instruction shall be on the MTA system installed, and shall utilize 'hands-on' techniques with the system using the contractor provided UBS documentation.

### **PART 2 - SYSTEM HARDWARE**

#### **2.01 GENERAL SYSTEM REQUIREMENTS**

- A. The UBS shall combine advanced network architecture with microprocessor technology and shall allow operation of IBM compatible personal computers with color monitors and software capable of supporting a minimum of 80386 operating parameters. Additional features of the network OS shall provide security access levels and archiving of information.
- B. In addition, the UBS shall allow operation of digital PBX voice processing system to each floor of the facility.
- C. The system hardware and components shall be capable of operating without special environmental controls in the temperature range of 50 degrees to 95 degrees Fahrenheit and from 20% to 60% relative humidity, non-condensing. Acceptable input voltages shall be 100VAC to 120 VAC, 50Hz to 60Hz.
- D. Hubs, bridges, routers, connectors, cross connects, patch panels, patch cords, extension cables, etc., of all types attached to the UBS shall be provided by MTA.

#### **2.02 BACKBONE/RISER (FIBER OPTIC)**

- A. The Main Distribution Frame (MDF) shall be located in the second floor computer room. Fiber optic cables shall be run from the MDF to each LAN and Equipment Closet (LEC) to comprise the FIBER BACKBONE of the UBS. All fiber optic vertical distribution shall be installed using fiber optic cable specified. Additionally 32 strand fiberoptic as specified below shall be run from the B-2 Communications Vault up to the Computer Room in EMT conduit as specified in the drawings. This special fiber cable shall serve as the extension of the 45 Mbit DS3 demarcation entering the building on Pacific Bell Fiberoptic cable from below Macy Street. This cable shall be terminated by others. Leave 24 feet of slack cable coiled and secured to the wall adjacent to the entrance facilities supplied by Pacific Bell.
- B. The BACKBONE of the UBS shall be SIECOR MIC 36 STRAND 62.5/125/900micron

(core/clad/buffer) multimode plenum TIGHT BUFFER FIBER CABLE, NEC OFNP rated or equivalent.

- C. Fiberoptic cables shall be run in interduct, FIBERTRON CORRI-DUCT part number Q30RX4 (1.049 inch diameter) ORANGE.
- D. Innerduct shall be identified using FIBERTRON WRAP AROUND FIBER OPTIC CABLE MARKERS, part number DN-34 or equivalent. Markers shall read "CAUTION FIBER OPTIC CABLE" and shall be marked when penetrating every room and every 10 feet when run horizontally in a cable tray.
- E. When entering a LEC facility the contractor shall secure the cabling at every floor, leaving a minimum of twenty-four (24) feet of cable slack coiled and secured to the wall of the LEC facility.
- F. Termination and connectorization of the UBS fiber optic cabling is beyond the scope of this work and shall be specified and performed separately.
- G. The Contractor shall verify the fiber optic cabling installation as defined in Part-4 of this specification.

#### 2.03 BACKBONE/RISER (COPPER/VOICE)

- A. The Main Distribution Frame (MDF) shall be located in the second floor computer room. Fiber optic cables shall be run from the MDF to each LEC comprising the COPPER BACKBONE of the UBS. All copper/voice vertical distribution shall be installed using riser cable specified. See Appendix B (Backbone Diagram).
- B. The COPPER BACKBONE of the UBS shall be plenum AT&T Western Electric AR Series Riser Cable, 24 AWG, 600 pair, NEC CMP rated or equivalent.
- C. When entering a LEC facility the contractor shall secure the cabling at every floor, leaving a minimum of twenty-four (24) feet of cable slack coiled and secured to the wall of the LEC facility.
- D. Termination, cross connects, and connectorization of the UBS Copper/Voice cabling is beyond the scope of this work and shall be specified and performed separately.
- E. The Contractor shall verify the fiber optic cabling installation as defined in Part-4 of this specification.

#### 2.04 HORIZONTAL DISTRIBUTION (COPPER UTP)

- A. Horizontal distribution from the BACKBONE to the information outlets are beyond the scope of this specification and will be addressed separately.

### PART 3 - EXECUTION

#### 3.01 GENERAL

- A. The Contractor shall install the UBS as defined in this specification, and in accordance with applicable Federal, State, and Local regulations. Contractor shall



use the MTA Bid Documents for all references to location of components.

- B. The Contractor shall obtain installation guides from manufacturers, distributors, and vendors, and become familiar with the installation requirements prior to commencement of the work. Any discrepancies between plans and specifications shall be brought to the attention of the authority.
- C. The Contractor shall maintain a clean work area free from debris, trash, empty cable reels, scrap wire, etc., and dispose of such items on a daily basis.
- D. Precautions shall be taken by the contractor to avoid damage to MTA premises and property, and shall perform and restoration if any damage should occur.
- E. Necessary screws, anchors, clamps, tie wraps, distribution rings, miscellaneous grounding and support hardware, etc., to complete the installation shall be provided by the contractor and included in the bid price.
- F. The installation contractor is responsible to furnish any special installation equipment or tools necessary to properly complete the installation. This may include tools for terminating copper/fiber cables, testing equipment, communications devices, cable wenchers, etc..
- G. The Contractor shall clearly label all cables, distribution frames, and outlet locations, etc., as defined in Appendix A (LABELING CODES). Labels shall be computer generated, or type written, and distinguishable as voice or data circuits.
- H. Cables shall be continuous, with no factory splices, field splices, or intermediate couplings. Contractor shall provide, where necessary, cable support bridges over obstructions, underfloor conduit, pipes, supports, etc..
- I. Cables shall be secured to raceways, and strain relieved where necessary.
- J. Installation of the UBS shall be in a "physical star" topology from the MDF to the LEC facilities.
- K. If a winch is used during cable installation, the contractor shall monitor tension of the cable to ensure that maximum pulling tensions are not exceeded. Hand pulls do not require monitoring.
- L. No section of conduit shall have more than two 90 degree changes of direction in any single cable pull. Appropriate sized pull boxes shall be used for cable runs longer than 100ft., or contains greater than two 90 degree bends.
- M. When penetrating ceilings, walls, and floors appropriately sized sleeves or slots shall be used. Slots and sleeves shall be fire stopped using approved fire stopping materials.
- N. The Contractor shall be responsible for all coordination with the General Contractor for installation timing and site entry permission. This shall be confirmed in writing in advance of any work.

### **3.02 BACKBONE/RISER (FIBER OPTIC)**

- A. The Contractor shall observe the cable manufacturers specification for minimum bend radius and shall be no less than 20 times the outside diameter of the cable.
- B. The Contractor and installation team shall observe the cable maximum pulling tensions of the specified fiber optic cabling and secure the cable at the top of the vertical rise, and every third floor.
- C. Twentyfour (24) feet of slack cable shall be left coiled and mounted to the wall behind each equipment rack at each end of the cable prior to termination. Attention to manufacturers minimum bend radius shall be considered when attaching the slack cable.
- D. All fiber optic cables shall be run in innerduct and marked with precautionary labels as defined in section 2.02.
- E. When pulling fiber optic cable through innerduct, the contractor shall use less than fifty (50) percent of the fill ratio by cross sectional area.
- F. Fiber optic cables that run horizontally shall be supported and secured in cable trays.

### 3.03 BACKBONE/RISER (COPPER/VOICE)

- A. The Contractor shall observe the cable manufacturers specification for minimum bend radius and shall be no less than 20 times the outside diameter of the cable.
- B. The Contractor and installation team shall observe the cable maximum pulling tensions of the specified copper cabling and secure the cable at the top of the vertical rise, and every third floor.
- C. Twentyfour (24) feet of slack cable shall be left coiled and mounted to the wall. Attention to manufacturers minimum bend radius shall be considered when attaching the slack cable.

## PART 4 - CERTIFICATION

### 4.01 GENERAL

- A. All certification and testing will be supported with complete documentation of tests performed and test equipment printouts for each test where applicable.
- B. Test results shall only be considered acceptable if they fall within specified parameters, or manufacturers specifications, whichever is more stringent.

### 4.02 BACKBONE/RISER (FIBER OPTIC)

- A. The Contractor shall perform Optical Time Domain Reflectometer (OTDR) tests on all fiber optic cabling in the UBS. Documentation of the test results shall be provided to MTA prior to customer acceptance.
- B. Contractor shall test for an maximum attenuation as follows:

3.75 db/km at 850 nm.  
1.5 db/km at 1300 nm.

- C. Contractor shall test for minimum bandwidth as follows:  
  
160 MHz/km at 850 nm.  
500 MHz/km at 1300 nm.
- D. Every fiber optic cable that makes up the backbone of the UBS shall be tested. Tests shall be performed END to END from the MDF to the LEC facilities.
- E. Test equipment printouts certifying the cables, identifying the cable, location, attenuation, and bandwidth levels, shall be presented to MTA as part of the AS-BUILT documentation prior to acceptance.

#### 4.03 BACKBONE/RISER (COPPER/VOICE)

- A. The Contractor shall perform continuity tests of every pair comprising the COPPER BACKBONE of the UBS. Documentation of the test results shall be provided to MTA prior to customer acceptance.
- B. Failure of more than one percent (1%) of the conductors within the sheath will be considered a faulty cable and the entire run from the MDF to the LEC shall be replaced.
- C. Test equipment printouts certifying the cables, identifying the cable, location, attenuation, and bandwidth levels, shall be presented to MTA as part of the AS-BUILT documentation prior to acceptance.

#### 4.04 GROUNDING AND BONDING

- A. The Contractor shall verify the integrity of the grounding system. Resistance to ground, as part of the UBS, shall be less than 10 ohms. If the resistance is over 2.5 ohms the contractor shall alert the MTA, and assist in coordinating resolution through the appropriate contractor.
- B. The Contractor shall verify the ground potential between the electrical ground and LEC frames. Acceptable voltage potential is less than 2.8 VAC.
  - 1. Disconnect the ground lug from the LEC frame
  - 2. Measure the voltage between the rack ground lug and the ground wire; record the voltage.
  - 3. Re-connect the ground wire to the frame ground lug.

If the voltage potential is unacceptable, the contractor shall alert the MTA, and assist in coordinating resolution through the appropriate contractor.

### PART 5 - MAINTENANCE AND SERVICE

## 5.01 GENERAL

- A. The UBS shall be warranted by the contractor for a period of not less than one (1) year after acceptance of the installation. During the warranty period, any material showing any mechanical, or electrical defects shall be replaced promptly by the contractor at no expense to MTA.
- B. Maintenance and repair services shall be available locally and shall respond within four (4) hours of being notified by MTA of an emergency situation and within twenty-four (24) hours for non-emergency situations.
  - 1. NON-EMERGENCY - Where less than two (2) percent of the network is effected or non-functional.
  - 2. EMERGENCY - Any network backbone (fiber optic) related problem, or where two (2) percent or more of the network is effected. Issues where a file-server is not available to network users due to a cabling plant malfunction.
- C. Prior to acceptance for beneficial use, the contractor shall provide, in writing, various types of service agreements available, including equipment covered, costs, response times, etc., after the warranty period expires.

## PART 6 - ACCEPTANCE

### 6.01 FINAL ACCEPTANCE

- A. Once the contractor completes the certification, and demonstrates the functionality of the UBS to MTA the project shall be signed off by an officer of the contracting company and by the MTA project manager.
- B. Upon signoff by MTA, the warranty period shall begin.

## PART 7 - APPENDIX A

### 7.01 CABLE MARKING

All Voice Riser Pairs shall be marked as follows:

Each 600 Pair bundle marked at both ends with digit number, i.e.,

- B-3 - pairs 1 through 250
- B-2 - pairs 251 through 500
- B-3 - pairs 501 through 750
- 1st -pairs 1000 through 1600
- 2nd - pairs 2000 through 2600
- 26th - pairs 26000 through 26600
- 28th - pairs 28000 through 28600

All Data Riser Fiber Pairs shall be marked as follows

- All - pairs 1 through 18 with the floor prefix added, i.e.,
- B-3 - B3-1 through B3-18
- 28th - 28-1 through 28-18

Any coaxial cable occurring in the riser shall be numbered the same as Fiber cables, i.e.,

- B-3 - B3-1 through B3 -X
- 26th - 26-1 through 26-X

## **7.02 Marking of Components**

**All panels, racks, devices supplied under this section and connector blocks and information outlets shall be marked according to the system determined by MTA before installation proceeds. No installation shall commence without written approval by MTA on the system and the marker types to be applied to all components.**

END OF SECTION



SECTION 16720

FIRE ALARM SYSTEM

PART 1 - GENERAL

1.01 DESCRIPTION

- A. **The contractor shall furnish**, install and place in operating condition an electrically operated, electrically supervised, multiplexed fire alarm system as described herein. The system shall be microcomputer based. The system shall use multiplex techniques for alarm reporting, central signaling and selection of speaker circuits.
- B. **The system shall provide** individually identified fire alarm sensors, fire alarm indicating and control devices. Each identified device shall be given a unique address, with operator assigned English language descriptor.
- C. **The system shall include**, but not be limited to, primary computer, power supplies, CRT display terminals, printers, fire alarm initiating and indicating devices. Fire Command Station (FCS), amplifiers, speakers, telephones, conduit, wire, fittings and accessories required to provide a complete operating system. All units shall be located as shown on the drawings or as herein specified.
- D. All equipment shall be furnished and installed according to the requirements for a NFPA 72D, Style 6 Proprietary Fire Alarm System. All equipment and devices shall be the latest current model, U.L. listed, listed by the California State Fire Marshal and accepted by the local approving authority.
- E. **Fire alarm system** for the parking garage shall be installed as a stand-alone system for the garage areas, including primary computer, power supply, CRT display terminal and printer. Amplifiers for garage speakers are to be included. The above listed equipment will be temporarily installed in the garage area in a location to be determined. After the office building has been constructed, primary computer, power supply, CRT, printer and amplifiers will be relocated to the building Fire Control Room and the Garage Fire Alarm System will be connected to the Building Fire Alarm System.
- F. **This system** shall be capable of accepting alarm devices as required in the office building and shall be capable of controlling speaker zones in the office building. Amplifiers for office building speakers will be added with the office building.

1.02 MAJOR SYSTEM COMPONENTS

- A. **The major components or subsystems of the Life/Safety System shall include:**
  - 1. Data Gathering Panels (DGP).
  - 2. Primary Computer (PC).
  - 3. Addressable Manual Fire Alarm Stations.
  - 4. Intelligent Automatic Products of Combustion Detectors.
  - 5. Addressable Sprinkler Waterflow Alarm.

6. Addressable Sprinkler Valve Supervision.
7. Building Evacuation System.
8. Fireman's Phone System.
9. Annunciator Panel.
10. Stairwell and Exit Door Lock Control.
11. Magnetic Door Holder Control.
12. Smoke Control System.

B. **Other Applicable Sections:** Requirements of Section 16050 apply to the work of this Section.

C. **Related Work Not In This Section:** Items include:

1. Electric door locks (Hardware Division).
2. Electric/magnetic door holders (Hardware Division).
3. Water flow switches (Mechanical Division).
4. Sprinkler valve supervisory switches (Mechanical Division).
5. Damper switches and EP switches (Mechanical Division).
6. Elevators' monitor/control panel (Elevator Division).

1.03 **SUBMITTALS:** Refer to Section 01300 for procedures.

A. **Manufacturer's shop drawings** and submittals of the following equipment, giving full specification compliance and other pertinent facts, shall be submitted and approval secured before apparatus in general ordered, built or installed.

1. Catalog information for all devices and equipment.
2. Floor plans showing locations of all devices (including control/monitor modules) for all systems and complete conduit layouts.
3. Complete wiring diagrams including riser and point-to-point details.
4. Detailed layout for all graphic panels.
5. Automatic Control System: Integrated diagrams showing function of Life/Safety System with the mechanical systems control and interlock wiring per sequence of operation.

1.04 **APPROVALS**

A. **Obtain all necessary approvals** from local authorities for all materials to be supplied, methods of installation and system operations, as required herein and by the local authorities.

B. **Provide a registered engineer's stamp** as required by the Authorities.



1.05 WARRANTY

- A. **All components**, parts and assemblies supplied by the manufacturer shall be guaranteed against defects in materials and workmanship for a period of 12 months following acceptance.
- B. **Warranty service** shall be provided by a trained specialist of the equipment manufacturer who shall be based in a fully staffed, fully stocked (replacement parts and test equipment) branch office, located within 50 miles of the site.

1.06 AUTOMATIC OPERATION

- A. **Actuation of** any manual station or automatic fire or sprinkler flow detector shall cause the following:
  - 1. Full English language annunciation of the alarm condition, type and location on each CRT. An audible signal shall sound and the alarm condition shall flash on the screen until acknowledged. Emergency instructions shall be displayed in English for the operator. The device address and its condition shall also be displayed at the DGP.
  - 2. Printout in English of the alarm condition, type and location plus time and date. All fire alarm initiated event commands shall be recorded automatically.
  - 3. Tripping the central station connection.
  - 4. Activate the emergency audio and visual signals to the fire floor.
  - 5. Initiate smoke control procedures, position dampers and/or control fans. Such actions shall override the regular Mechanical Systems Controls and the HOA switch at the equipment.
  - 6. Release self closing fire and smoke doors on the floor in alarm.
  - 7. Upon activation of an elevator lobby smoke detector, a smoke detector in the elevator machine room or a smoke detector at top of elevator shaft, recall the elevators to the ground floor. If the fire is on the ground floor, the elevators shall be recalled to the alternate floor.
  - 8. Indicate the alarm location on the matrix annunciator.
  - 9. Unlock stairwell doors.
  - 10. Store the event for future recall.
- B. **For increased reliability**, all individual smoke sensors shall be provided with alarm verification with field adjustable time from 0 to 60 seconds. A verified alarm shall initiate the sequence in A. above.
- C. **The DGP shall** differentiate between a long term drift above the pre-alarm threshold (indicative of a need to clean the sensor chamber) and a fast rise above the pre-

alarm threshold (indicative of a smoldering fire). A maintenance condition shall be annunciated as a trouble condition at the CRT and recorded on the printer. A verified fire condition shall initiate the sequence in A. above.

- D. **Upon activation** of a sprinkler valve supervisory switch, the sequence in A.1 and A.2 shall be initiated. Supervisory alarms shall be differentiated from a trouble condition.
- E. **A break in the initiating wiring** or failure of a device to respond when addressed shall be annunciated as a trouble condition at the DGP and CRT and recorded on the printer. Subsequent alarms on that circuit shall be reported.
- F. **A break in the speaker** or strobe circuit wiring, shall be annunciated as a trouble condition at the DGP and CRT and recorded on the printer.

#### 1.07 MANUAL OPERATION

- A. **Authorized personnel shall be able to manually command the system as follows:**
  - 1. Display the alarm and pre-alarm threshold values of any or all sensors.
  - 2. Change the sensor thresholds; the system will not allow excursions beyond U.L. allowed values.
  - 3. Change the device type in DGP memory to eliminate mismatched device trouble condition.
  - 4. Test the system for alarm. When so tested, the sensors will transmit a value that is above the alarm threshold value to test end-to-end system response, including sensor electronics.
  - 5. Transmit the emergency signal and strobe activation to any or all areas.
  - 6. Override automatic actions to control fans or dampers for smoke control.
  - 7. Display or print a log of the system with English language descriptor, sensor value, threshold values, device status for every device on the system. The operator shall be capable of changing the descriptor at any time while on-line.
  - 8. Display or print a trend log of selected sensor values with selected interval times to determine smoke level as a function of time. The resulting log can compare actual smoke movement within an area to expected smoke movement characteristics.
  - 9. Display or print a log showing smoke sensors which have activated an alarm verification cycle.
  - 10. Display or print a log which identifies the location of open circuit faults.

11. Change the status of an intelligent device from enable to disabled. This shall only be allowed by the highest level of operator assignment. A complete log of disabled points shall also be provided.

#### 1.08 BACK-UP OPERATION

- A. **To increase the system's ability to survive damage from fire, premature component failure, etc., the fire alarm system shall provide the following back-up features:**
  1. Style D operation of the initiating circuits, per NFPA 72D, such that a break in the circuit shall be annunciated as a trouble condition at the DGP and CRT and recorded on the printer. Subsequent alarms from that circuit shall be reported.
  2. Fault tolerant (Style 6) operation of the data transmission trunk such that any fault on that line shall be annunciated as a trouble condition at the CRT and recorded on the printer.
  3. Each DGP shall operate in a standalone manner, independent of the PC. The DGP shall contain the complete data file for all connected devices and shall operate in the same manner whether or not connected to the PC. This includes:
    - a. Annunciation of device address and condition. 100% of all connected devices shall be capable of operating for alarm simultaneously.
    - b. Event initiated control, signaling and/or annunciation sequence. 100% of all connected devices shall be capable of being operated simultaneously.
    - c. Priority display of multiple alarms.
    - d. Complete supervision of all connected devices with no degraded operation.
  4. Loss of all communication between the PC and Data Gathering Panels shall still allow the following actions at the Fire Command Station:
    - a. The "All-Call" function of the paging system.
    - b. Unlocking of stairwell locks.
    - c. Activation of stair pressurization fans.
    - d. Activation of central station alarm.
    - e. Annunciate a verified alarm and trouble condition.
    - f. Activation of elevator recall.

- g. Activation of smoke evacuation systems.
- 5. System operating software and data file shall be resident in nonvolatile memory. Loss of power, momentary or for a sustained period, shall not require reloading of the software.
- 6. Primary power shall be provided to DGPs and to smoke dampers from the building emergency system.
- 7. Standby batteries capable of operating the Fire Command Station, shall be provided for failure of primary power; the system shall transfer automatically to the standby battery power source. The batteries shall have the capacity to operate the system for twenty four (24) hours and then operate all of the fire alarm speakers/strobes for at least five (5) minutes. When power is restored, the system shall transfer automatically to primary power. System power supply shall be equipped with battery charging circuits sufficient to recharge fully depleted batteries to within 70% of their maximum capacity within twelve (12) hours.
- 8. PC, CRT and printer shall be provided with a UPS system. Batteries shall power these devices for minimum of ten (10) minutes. During transfer from normal to emergency power, no data shall be lost. System shall not have to reboot itself after this transfer.

## PART 2 - PRODUCTS

### 2.01 GENERAL

- A. **All equipment** and materials used shall be standard components, regularly manufactured.
- B. **All systems** and components shall have been thoroughly tested and proven in actual use.
- C. **All equipment** shall be listed and labelled by Underwriters Laboratories, California State Fire Marshal and local authorities as required.
- D. **Equipment** shall be supplied by Honeywell Inc. or Pyrotronics.

### 2.02 PRIMARY COMPUTER (PC)

- A. **The Primary Computer** shall have a minimum of 4 megabytes RAM, 1.2 megabyte diskette drive, one 90 megabyte hard disk drive, one serial and one parallel port, built-in clock/calendar, keyboard, color monitor and a 32 bit processor, 20 megahertz minimum clock speed.

The PC shall be listed by U.L. as a primary man machine interface under the UL864, UOJ2 control unit system listing.

- B. **To eliminate confusion** during an alarm situation, CRT screen shall have dedicated areas for the following functions:

1. Alarms and returns to normal.
  2. Commands, reports and programming.
  3. Time, day, date.
- C. **To enhance operator understanding**, full English language shall be used throughout to describe all system activity and instructions. Full English language descriptors defining system points shall be user definable to more accurately describe building areas.
- D. **Alarms and all other changes of status shall be displayed in the screen area reserved for this information.** The following information shall be provided in English.
1. Condition of point (alarm/trouble).
  2. Type of point (smoke/waterflow/holdup, etc.).
  3. Location of point numerical system address.
  4. Emergency instructions.

Upon receipt of alarm, an audible shall sound and the condition and point type shall flash until acknowledged by the operator. Returns to normal shall also be annunciated and shall require operator acknowledgment.

- E. The system shall have multiple levels of priority for display alarms to conform with U.L. Standards 864 and 1076. Should multiple alarms occur, the first received, highest priority alarm shall be displayed on the screen until acknowledged by the operator. Then the next highest priority alarm shall be displayed until acknowledged, etc. Should a higher priority alarm be received before a lower priority alarm is acknowledged, the higher priority alarm shall replace the lower priority alarm on the screen and the lower priority alarm shall be retained in memory and redisplayed after the higher priority alarm is acknowledged.
- F. The system shall provide memory so that no alarm shall be lost. A message shall advise operator when other unacknowledged alarms are in the system.
- G. **The CRT keyboard shall use function keys with English descriptions to initiate all system functions.** Typing numeric abbreviations or using unlabeled or numerical function buttons is unacceptable. When a function key is pressed, the CRT shall lead the operator through the function by asking him to choose one of several clearly defined options (menu penetration). When a specific point must be addressed, a distinct numerical keypad shall be used to speed and simplify the operation. On command from the operator, system reports either can be displayed on the CRT or listed on the printer.
- H. **Multiple levels of access to the system shall be provided for operators and supervisors via user defined passwords.** The following functions shall be provided for each level:
1. Operator Level Access Functions:
    - a. Display systems directory, definable by point type.

- b. Display status of an individual point.
  - c. Manual command (alarm point with an associated command - i.e., secure/access/alarm - shall use the same system address for both functions).
  - d. Report generation, definable by point type. Reports shall be output on either the CRT or printer, as desired by the operator.
2. Supervisor Level Access Functions:
- a. Reset time and date.
  - b. Holiday scheduling.
  - c. Enable/disable event initiated programs, printouts, initiators.
  - d. Enable/disable individual hardware points and system components.
3. The above supervisory level functions shall not require computer programming skills but rather shall be accomplished by the menu penetration method described previously. All changes to system programs shall be recorded on the printer.

For reasons of system integrity, it shall not be possible to leave the system in the supervisory level access mode after a programming function is performed.

- I. **The PC shall come complete** with a 14 inch diagonal full color monitor capable of displaying 16 colors with VGA resolution. Communications shall be supervised. Faults shall be recorded on the printer. Power shall be 120VAC, 60 Hz.
- J. **A history file function** shall be provided to direct critical real time system data and activity to a mass storage device for later recall and analysis.
  - 1. All alarm and return to normal activity shall automatically be routed to history files.
  - 2. Operator shall be able to select, via the CRT terminal keyboard, the interval at which samples are taken.
  - 3. History files shall be the source data for system logging rather than requiring selective polling of system devices.
- K. **A graphic mode of operation** shall be provided allowing full color displays of site layouts; building floor plans with locations of fire alarm points, mechanical representations of smoke containment supply fans and exhaust systems.
  - 1. Dynamic data such as fire alarm conditions, smoke removal, fan and motor status, etc. is to be embedded in the graphics at the sensing location.

2. Dynamic data shall automatically update at a preprogrammed interval not to exceed 60 seconds. Manual update shall be provided via a screen update key.
  3. Commandable points, both digital and analog, shall be uniquely identified by color and/or discrete symbol and shall be directly addressable and commandable from the graphic display. Direct entry of commandable point address or positioning of the cursor to the point shall cause a display of associated command states for digitals, the setpoint value and valid range for analogs. Entry of appropriate command or new setpoint value, shall cause the display of associated command states for digitals, the setpoint value and valid range for analogs. Entry of appropriate command or new set point value shall cause the display to update to the current state/setpoint value.
  4. All graphic displays shall be on-line program able via keyboard, trackball or mouse selection of graphic library stored symbols and system profiles. Provide, in addition, the capability to create custom symbols, system profiles, floor plans, etc., and to store them in the graphics library.
  5. It shall be possible to associate a graphic with any level of the menu penetration path; i.e., an area, a building, a floor or a group of points.
  6. Fully implemented graphic displays are to be provided for a minimum of each floor of the building and for each smoke evacuation system. Each fire alarm device smoke damper and smoke pressurization equipment shall be represented.
- L. **PC shall be located** in Fire Control Room. Remote color CRT and keyboard shall be located in the Engineer's Office. Remote color CRT and keyboard with graphics representation shall be located at the Security Console.

#### 2.03 SYSTEM PRINTER

- A. **The System Printer** shall be wide format (at least 80 columns) and have a 96 ASCII character set. The printer shall have a microprocessor controlled bidirectional logic seeking head capable of printing 58 lines per minute.
- B. **The printer shall automatically** record in English, all alarms, troubles, acknowledgments and returns to normal, manual commands, plus those automatic commands selected by the user. On command from the CRT, the printer shall generate the following English language reports which shall be selectable by point type:
  1. All Points Log - condition and status of all points within selected point type category.
  2. Alarm Summary - all points within selected point type category that are in alarm or trouble condition.

3. Status Summary - status of all commandable points within selected point type category.
  4. Diagnostic Report - to determine alarm verification cycles initiated by a smoke sensor, the location of a wiring fault and devices which fail automatic tests.
- C. Alarms shall be highlighted differently than other traffic and shall be recorded in English, including type, location, time, date and numerical address of alarm point. Unlike the CRT, multiple alarms shall be recorded in the order received, regardless of alarm priority. If an alarm is received during the preparation of reports, the printer shall interrupt the report to record the alarm and afterwards resume the report automatically.
- D. Automatic EIP commands shall be recorded automatically. Supervisory level access to the CRT shall permit the enabling or disabling of this automatic printout function on a per EIP basis.
- E. All changes to system programming shall be recorded automatically.
- F. A system fault log used for troubleshooting, shall provide a record of system errors.
- G. Printer shall use fanfold paper and shall accommodate an original and two copies. Paper shall be tractor fed. Each page shall be automatically timed, dated and page numbered to detect unauthorized removal.
- H. Communications with the PC shall be supervised. Faults shall be displayed on the CRT. Power shall be 120VAC, 60 Hz.
- I. Remote printers shall be located in the Engineer's Office and at the Security Console.
- J. The printer shall have an indicator to alert the operator that paper has run out.
- K. The printer shall have a self test feature to verify printer operability even when off-line. Test shall generate a complete character set in a specific pattern to verify operation.

#### 2.04 DATA GATHERING PANEL (DGP)

- A. The DGP shall function as a communications interface between the PC and the intelligent system devices described hereinafter. Each DGP shall be intelligent with its own microprocessor and memory. Each DGP shall be U.L. listed independently as a Fire Alarm Control Unit in addition to being listed as a critical component of a proprietary multiplex system.
- B. DGPs shall supervise each individual device on an intelligent loop circuit such that excursion beyond trouble, normal, pre-alarm and alarm thresholds are individually annunciated. These devices shall be fire alarm sensors and fire alarm and security modules described hereinafter.



- C. **Up to 99 sensors** and up to 99 modules shall be supported on a single circuit. Each sensor and module shall be capable of being operated for alarm simultaneously.
- D. **Up to 1,000** individually identified sensors and modules as well as conventional initiating and indicating circuit zones shall be supported within a single DGP.
- E. **DGPs shall provide** general purpose inputs for monitoring such functions as low battery or AC power failure. DGPs shall provide tamper protection and commandable outputs which can operate relays or logic level devices. Output commands shall take any of the following modes:
  - 1. Maintained command.
  - 2. Momentary command.
  - 3. Alarm follow.
  - 4. Alarm latch.
- F. **Power sufficient** for the DGP and initiating and indicating devices shall be provided. An automatic battery charger shall continuously apply the proper voltage to panel mounted batteries in order to maintain a fully charged state. Battery charger circuit shall be designed to operate with DGP manufacturer recommended batteries.

Standby batteries of sufficient capacity to provide the indicated operation shall be DGP mounted (24 hours of standby). Batteries shall be maintenance free, sealed lead acid type. Battery connection to the power supply/battery charger shall be fused or provided with equivalent protection.

To assure the ability of the internal batteries to deliver their stated capacity, supervision of the standby batteries shall be provided. Supervision of presence alone will not be acceptable.

- 1. The panel shall automatically remove the batteries from the panel power supply at no more than 60 minute intervals. A suitable load shall be applied to simulate operating conditions. During this period, no less than three separate battery measurements shall be automatically sampled. If all measurements sampled are below the stated battery capacity, the panel shall indicate a "low" battery condition by flashing a separate low battery LED and the Panel Common Trouble LED while sounding a local audible. The low battery indication shall remain until it has been manually acknowledged and the battery capacity has returned to normal levels. When acknowledged, both LEDs shall go to a steady state and the audible will be silenced. The LEDs shall return to OFF when the batteries have returned to a good state.
  - 2. Removal of the batteries, a blown fuse or a battery wiring fault, shall cause the same indication as low battery voltage.
- G. **DGP electronics** shall be contained in an enclosure made of minimum 16 gauge steel. Access to DGP switches and all electronics shall be via keylock; no other tools shall be required. Visual indicators of DGP status for each circuit and for each off normal device shall be visible without opening the key locked cover.

- H. **All hardware and software** which define the DGP configuration and operation, shall be provided. Memory data shall be contained in nonvolatile memory.
- I. **For increased reliability**, all smoke sensors shall be provided with alarm verification with field adjustable time from 0 to 60 seconds. Only a verified alarm shall initiate the alarm sequence.
- J. **Devices or intelligent loop circuits** shall be identified by display of their address and by their condition (alarm, pre-alarm, trouble). In addition, the condition shall be displayed on the appropriate Intelligent Loop Interface Board.
- K. **It shall be possible** to command test, reset and alarm silence from both the DGP and the PC.
- L. **Intelligent Circuits:** Bidirectional fault tolerant circuits of addressable analog fire/smoke sensing, signaling and monitoring devices shall be provided. The loop shall be self powered for all sensing, monitoring and communication functions. Upon an open circuit fault anywhere on the loop, a trouble shall be reported and the loop shall remain fully operational. Loops shall be circuited and protected such that in the event of a loop short circuit, no more than 15 loop devices shall be left nonfunctional.

Loops shall be arranged to allow for 10 additional devices per tenant floor without the addition of additional circuits. Layout of circuits shall be shown on submittal drawings.

- M. **If communications** with the PC is interrupted for any reason, the following critical control actions shall still occur at the DGP. Upon determination of an alarm condition, the DGP shall:
  - 1. Activate the fire alarm speaker/strobes.
  - 2. Activate stairwell pressurization fans, shut down floor fans and operate smoke control sequences.
  - 3. Release fire doors.
  - 4. Release electrically locked stairway doors.
  - 5. Capture the elevators and return them to the ground floor.
  - 6. Initiate the central station connection.
  - 7. Display the sensor or module address and condition.
  - 8. Transmit a common alarm and/or trouble condition to the Fire Command Station (FCS).
  - 9. All wiring required to perform the above critical operations shall be fully supervised.

- N. **DGP's switches** shall allow authorized personnel to accomplish the following, independent of the main operating console:
1. Initiate a general alarm condition.
  2. Silence the local audible.
  3. Silence the alarm signals.
  4. Reset all zones after all initiating devices have been returned to normal.
  5. Perform a complete operation test of the microprocessor with visual indication of satisfactory communications with each board.
  6. Test all panel LEDs for proper operation without causing a change in the condition on any zone.
- O. **DGPs shall be located** throughout the building. No more than eight (8) floors shall be connected to any one DGP location.
- P. **Panel shall be provided** with a permanent label showing appropriate description.

2.05 FIRE CONTROL PANEL (FCP)

- A. **The FCP shall** provide audio communications capabilities and shall serve as a command post for directing fire fighting activities. The FCP shall provide LED indication and controls for the following:
1. Zones of fire tone signaling.
  2. Zones of one way voice communications.
  3. Fireman's telephone system.
  4. Alarm and trouble annunciation for fire initiating devices.
  5. Smoke control/testing functions.
- B. **The Emergency Signaling and Paging Subsystem (ESPS)** shall include a handheld microphone with push-to-talk switch. The microphone shall have priority over the fire alarm evacuation signal. The microphone shall be dynamic noise cancelling type with frequency response from 200 to 5000 Hz.
1. The fire alarm signal shall be applied to specific speaker loops upon automatic command and DGP event programs or manual command from switches on the FCS. LEDs shall indicate which zones are receiving the fire tone.
  2. Voice paging announcements shall be applied to specific speaker loops upon manual command from switches on the FCS. LEDs shall indicate which zones are receiving the voice message.
  3. The ESPS shall be electrically supervised. Detection of an open, short or ground shall light an LED at the FCS and sound a trouble signal. Acknowledgment of the trouble shall silence the audible.

4. A switch at the FCS shall be provided to reset the ESPS and restore the speaker circuits to the normal supervisory mode. The ESPS and FCS can be reset only after all detectors have been returned to normal and the audio zone selection switches placed in the normal position.
5. Individual speaker circuits shall be electrically supervised. Speaker trouble conditions shall be isolated so as not to impair the functioning of any other part of the system. If a speaker voice coil should fail, all other speakers on that circuit shall remain operational. A short on one speaker circuit shall not impair the functioning of any other speaker circuit.
6. Amplifiers shall be arranged so that an amplifier trouble condition automatically transfers operation to a standby amplifier. If a distributed amplifier system is supplied, each amplifier in the system shall have its own standby amplifier. This arrangement assures that in the case of a single amplifier failure, every audio zone will be able to receive the emergency signal.
7. The fire tone signal generator and preamplifier shall be so arranged that a trouble condition automatically transfers the operations to standby equipment. Both standby and primary equipment shall be electrically supervised at all times.
8. Provide a speaker circuit zone including adequate amplification for each floor of the building plus a circuit for each stairway and each bank of elevators. Each speaker circuit on tenant floors shall be capable of supplying up to 40 speakers.
9. Provide U.L. approved speakers, with strobes, as shown on the drawings for the base building. Additional speaker/strobes shall be provided under tenant development.
10. Furnish a speaker with integral enclosure in each elevator cab. Traveling cable requirements will be provided by the Elevator Contractor. Speakers shall be installed above cab ceiling by Elevator Contractor.

**C. Audio Cabinet (AUDC):**

1. The AUDC shall house tone generators, preamplifiers, system power supply and supervisory electronics. Redundant fire tone generators and preamplifiers shall be provided. Both main and backup equipment shall be supervised at all times. Switchover to backup equipment shall be automatic.
2. A trouble condition in the amplifier(s) shall light the trouble LED and sound the trouble signal at the FCS as well as annunciate trouble on the FAP.
3. The AUDC shall be powered by 24V DC provided by the Fire Management System power supply. Standby power shall be provided as previously described.
4. Amplifiers may be centrally located with the tone generators and preamplifiers or remotely located at the DGPs. If centrally located, a backup

amplifier shall be paired with a primary amplifier. Each remote location shall contain redundant amplifiers. Amplifiers shall deliver rated power with less than 0.5% total harmonic distortion over a 45 to 20,000 Hz bandwidth.

**D. Fireman's Phone System:**

1. Description of Operation: The fireman's phone system shall be a sound powered system which will provide a means for two way conversation between the Fire Control Room and each stairway and elevator lobby. System shall be supervised as required by the Los Angeles Fire Department.
2. Zoning: Provide one common talk circuit for all stations and Fire Control Room.
3. Devices:
  - a. Install one telephone jack outlet on each floor landing of each stairwell, at grade level exit from each stair at roof exit from each stair and at other locations shown. Exterior stations shall be weatherproof with No. 4 stainless steel plate. Install telephone jack in each elevator machine room.
  - b. Install one telephone jack at Fire Control Room.
  - c. Permanently install one telephone handset at the Fire Control Panel. Cord shall reach to furthest corner of room.
  - d. Provide six portable handsets with plugs in locking cabinet.
  - e. Provide telephone jack for each elevator car to Elevator Contractor for installation.

**E. Fireman's Annunciator Panels:**

1. General: The fireman's control and annunciator panels shall be provided in the Fire Control Room for the purpose of locating fire areas, directing building evacuation, directing fire fighting crews and providing smoke evacuation.
2. Description of Operation:
  - a. The Fireman's matrix panel shall provide for annunciation on a per floor basis of:
    - 1) Manual pull stations.
    - 2) Area smoke detectors.
    - 3) Passenger and service elevator lobby smoke detectors.
    - 4) Smoke detectors in fan rooms.
    - 5) Sprinkler waterflow alarm.
    - 6) Elevator Machine Room smoke detectors.
    - 7) Smoke detectors at top of elevator shafts.
    - 8) Sprinkler valve tamper trouble.
    - 9) Emergency generator status and trouble.
    - 10) Common FCS trouble.

- 11) Each fire pump status and trouble.
- 12) Fire water storage low level alarm.
- 13) Space for one special extinguishing systems per floor for tenant development.
- 14) Common power on LED.
- 15) Lamp test.

b. Fire alarm annunciator panels shall utilize the following criteria:

- 1) Terminology used for zone identification shall be as directed by the Architect/ Engineer and LAFD.
- 2) Lights to indicate alarms shall be red; lights to indicate trouble condition shall be yellow or amber. Other lights used to indicate status (fans, emergency generator, dampers, etc.) shall be green.
- 3) Zones intended for future development such as those for special extinguishing systems shall be left blank until used.

F. **Smoke Control Panels:** An approved "Smoke Control" panel or adjacent panels shall be provided. These panels shall contain the following:

1. A single three position control switch ("on", "off" and "auto") for each mechanical smoke control system and stairwell system. Such switch shall control all elements of the system served.
  - a. "Auto" shall be the normal position. This position will activate automatic smoke removal under alarm conditions.
  - b. "On" shall be for manual activation of the system. This position will be for Fire Department use under emergency conditions.
  - c. "Off" shall shutdown all fans in the system. Audible and visual "trouble" signals shall be activated in the fire control room when the switch is in the "off" position.
2. Positive status indication of all fans and dampers for each system shall be displayed.
  - a. A single status light shall be located adjacent to each system master control switch. This light shall provide positive status indication that all fans and dampers are in the proper mode for smoke control. Such light shall be labeled "System Operating".
  - b. Fan status shall be achieved with a pressure differential or sail switch. Multi-speed fans may achieve status by a pressure differential or sail switch in series with the magnetic starter for the emergency speed of the fan.

3. A panel enable/disable key switch shall be provided. If panel is left in the disable mode, a LED shall light and a siren-alert shall sound. A silence switch shall be provided. A trouble condition shall display on the PC. Lamp test shall also be provided.

**G. Mechanical Test and Inspect Panel:**

1. In addition to the smoke control panel, provide a separate panel with On/Off/Auto switches with status LEDs for each fan associated with smoke removal. Open/Auto/ Close switches with status LEDs shall also be provided for each damper associated with smoke removal.
2. Positive status of fan and dampers shall be provided. End switches shall be provided for damper. Current relays or MCC/Aux contacts shall not be acceptable for fan status.
3. For a complete listing of all fans and dampers to be controlled, see mechanical matrix chart.
4. A fire alarm shall override all actions of the test and inspect panel and put fans and dampers in their proper sequence.
5. Lamp test shall also be provided.
6. Status of each fan and damper shall also be displayed on the FCS and Engineer's CRT and printed on the FCS printer.

- H. **Equipment Labeling:** All equipment in the FCP shall be provided with permanent labels. Each panel shall be described as to function.

2.06 INTELLIGENT SYSTEM DEVICES

**A. General:**

1. Each device shall be assigned a unique address via easily understood decade (01 to 99) switch. Address selection via binary switches or by jumpers is not acceptable.

Devices which take their address from their position in the circuit, are unacceptable because if devices are later added, existing addresses, descriptors and commands must be reprogrammed.

2. Devices shall receive power and communication from the same pair of wires. For fault tolerant circuits, any separate power wiring shall also be made fault tolerant.
3. Each device shall contain screw terminals with rising plates for positive termination of up to 12 AWG wire.

**B. Sensors:**

1. All fire sensors shall mount on a common base to facilitate the changing of sensor type if building conditions change. The base shall be incompatible with conventional detectors to preclude the mounting on a non-intelligent device.
2. Each sensor shall contain a LED which blinks each time it is scanned by the DGP. If the DGP determines that the sensor is in alarm, the DGP shall command the sensor LED to remain on to indicate alarm.
3. Each sensor shall contain a magnetically actuated test switch such that it can be tested for alarm from the sensor location.
4. Each sensor shall be capable of being tested for alarm via command from the DGP.
5. Each sensor shall respond to DGP scan for information with its type identification to preclude inadvertent substitution of another sensor type. The DGP shall operate with the installed type but shall initiate a mismatch (trouble) condition until the proper type is installed or the programmed sensor type changed.
6. Each sensor shall respond to DGP scan for information with an analog representation of measured fire related phenomena (smoke density, particles of combustion, temperature). Such response proves end-to-end sensor response including the operation of the sensor electronics. Systems which only monitor the presence of a conventional detector in an addressable base, shall not be acceptable.
7. Provide photoelectronic smoke sensors as indicated on the plans. Sensors shall contain an optical sensing chamber with nominal sensitivity of 2.3%/foot obscuration.
8. Provide ionization smoke sensors as indicated on the plans. Sensors shall contain a unipolar dual chamber configuration with nominal sensitivity of 1.5%/foot obscuration.
9. Provide thermal sensors as indicated on the plans. Sensors shall provide temperature measurement when scanned by the DGP for information.

**C. Monitor Modules:**

1. The monitor module shall provide an addressable input for N.O. or N.C. contact devices such as waterflow switches, sprinkler supervisory devices, door contacts, intrusion detectors, etc.
2. The monitor module shall provide a supervised initiating circuit. An open circuit fault shall be annunciated at the DGP. Subsequent alarms shall be reported.
3. The module shall contain a LED which blinks upon being scanned by the DGP. Upon determination of an alarm condition, the LED shall be latched on.



4. The module shall mount in a standard electrical box and be located in an accessible location.

**D. Control Modules:**

1. The control module shall provide an addressable output for a separately powered alarm indicating circuit or for a control relay.
2. The control module shall provide a supervised indicating circuit where indicated on the plans. An open circuit fault shall be annunciated at the DGP.
3. The control module shall provide a control relay where indicated on the plans. The relay contacts shall be SPDT (Form "C") rated at 2 amps at 28V DC.
4. The module shall contain a LED which blinks upon being scanned by the DGP. Upon activation of the module, the LED shall be latched on.
5. The module shall mount in a standard electrical box and be located in an accessible location.

**E. Fault Isolator Module:**

1. The fault isolator module shall detect and isolate a short circuited segment of a fault tolerant loop.
2. The module shall automatically determine a return to normal condition of the loop and restore the isolated segment.
3. As a minimum, modules shall be placed at every floor penetration of an intelligent circuit with a maximum of 15 devices between units to limit the number lost in the event of a short circuit.

**F. Manual Stations:** Manual stations shall be of rugged die cast construction designed for semi-flush mounting. Stations shall be of break glass design and must be opened to be reset. Closing the box after opening it, shall automatically perform the reset function. It shall be possible for testing purposes, to initiate an alarm without breaking the glass. All stations shall be furnished with a spare glass rod.

**G. Paging Speakers:**

1. Flush ceiling mounted speakers shall be single voice coil type. Speakers shall be 4" diameter cone type suitable for 70V - RMS primary voltage and with a frequency range of 400-4000 Hz. Speakers shall be complete with multi-tapped transformer (.125, .25, 0.5, 1.0, 2.0, 4.0 and 8.0 watts) and axial sensitivity at 4.0' at 1.0 watt of 870 kB. Speakers shall mount in suitable back box and shall have round white perforated grill.
2. Flush surface wall speakers shall be the same as above except unit shall be square and standard manufacturer's red finish.

3. Surface mounted horns shall have single or double projector type as shown on the drawings.
- H. **Strobes:** A strobe shall be supplied with each speaker and horn (one enclosure shall incorporate both devices). Strobe shall flash on alarm occurrence. The bezel shall extend 1-1/2 inches minimum from the finished wall and be approximately 3-1/2 x 5 inches engraved "FIRE".
- I. **End-of-line resistors** for speakers and strobes shall be mounted in floor terminal cabinet.
- J. **Door Holders:** Door holders shall be provided by the hardware supplier. Contractor shall install electrical portion of unit. Electrical wall boxes shall be securely mounted and tested to withstand a minimum of eighty (80) pounds pull. Coordinate voltage with supplier.
- K. **Sprinkler Waterflow Switches:**
  1. Supplied and installed as part of the Mechanical Division of work.
  2. All electrical connections and wiring to the switch shall be provided as part of the work of this Section.
- L. **Sprinkler Valve Supervisory Switches:**
  1. Supplied and installed as part of the Mechanical Division of work.
  2. All electrical connections and wiring to the switch shall be provided as part of the work of this section.

## 2.07 UNIT PRICES

- A. **Submit unit prices** for the following items. Each unit price shall include cost of the item, applicable taxes, overhead, profit, etc., delivered to the job site and installed, complete.
  1. Ionization Area Smoke Detector - extra for adding one unit.
  2. Photoelectric Area Smoke Detector - extra for adding one unit.
  3. Ionization Duct Smoke Detector - extra for adding one unit.
  4. Ceiling Speaker with Strobe Light, including Back Box and Baffle - extra for adding one unit; credit for deleting one unit.

## PART 3 - EXECUTION

### 3.01 GENERAL

- A. **Installation shall** be supervised and tested by the manufacturer of the system equipment. The work shall be performed by skilled technicians under the direction of experienced engineers, all of whom shall be properly trained and qualified for this work. The supplier shall have the engineered system installation drawings approved by the Fire Department, Building Standards Unit and by the Mechanical Bureau of the Department of Building & Safety prior to construction.

### 3.02 WIRING

- A. **All wiring** shall be installed in metal conduit or within equipment. Conductors shall be installed in accord with Section 16120. Conductors within equipment enclosures shall be carefully cabled and laced. They shall be color coded and individual conductors shall be tagged with E-Z code markers indicating circuit number and type. Markers shall be used on all conductors at each outlet or pull box and at each equipment enclosure.
- B. **Outlet pull and junction boxes** shall be painted red on the exterior and shall be installed in accord with Section 16130.
- C. **Conduits shall** be installed in accord with Section 16111.
- D. **All splices or connections** shall be made within approved junction boxes and with approved fittings. All connection and splices made in equipment enclosures or floor terminal cabinets shall be made directly to terminal strips.

### 3.03 DEVICE LOCATIONS

- A. **Contractor shall verify** all device locations in field before installation. Coordination drawings are required for all panel locations. Particular attention to be paid to those locations that may interfere with future tenant work. No device shall be installed without shop drawing approval.

### 3.04 TESTING

- A. **The contractor is responsible** for assuring that conduit size and wire quantity, size and type are suitable for the equipment supplied. The contractor shall review the proper installation of each type of device with the equipment supplier. Final connections between the wiring and equipment shall be made under the supervision of the equipment supplier's representative.
- B. **Upon completion,** the contractor shall conduct functional tests of the system for the Owner, Architect, Fire Department and Building Department personnel.
  - 1. To assure that wire size, power supply, number of devices on a circuit, etc., are suitable to support 100% of devices being in alarm or operated simultaneously, this test shall include the following:
    - a. Place all sensors and monitor modules in alarm. Each shall display its address and alarm condition.
    - b. Operate all control modules for the alarm or operated condition. Each module shall display its address and condition.

- c. Reset all alarmed and operated devices. The panel shall display the address of any off normal devices.
2. Test all sensors for alarm verification by momentarily testing for alarm. The sensor shall not initiate an alarm. Then, test by placing the sensor in alarm such that it remains in alarm for the selected verification time. The sensor shall initiate an alarm.
3. Test a representative number of sensors for trouble by removing the sensor from its base. The address and trouble condition for each sensor shall be displayed. Insert a different type of sensor into the base. The address and trouble condition will be displayed. The sensor shall return to normal only when the proper sensor type is reinserted into the base.
4. Print out the English language descriptor. Current sensed value, pre-alarm threshold value, alarm threshold value and status of each sensor in the system. Also print out the English language descriptor and status of each module in the system. The printout shall also include the date and time.
5. A functional test of all components of each mechanical smoke control system shall be required prior to final approval. Such testing shall be witnessed by representatives from both the Building and Fire Departments. Test shall include, but not be limited to, the following:
  - a. A check of the sequence of operation.
  - b. Actuation of system initiating devices.
  - c. Operation of control switches.
  - d. Operating of standby power systems.
  - e. Verification of status indicators.

A performance test to demonstrate smoke removal shall be required. Such testing shall be witnessed by representatives from both the Building and Fire Departments.

Performance testing of a mechanical smoke control system shall be performed under emergency power.

Performance testing of a mechanical smoke control system shall include release of an approved test smoke in area(s) selected for testing. Approved test smoke shall not contain nor generate zinc chloride or other toxic substance.

- C. **All equipment, devices and materials** required for smoke removal testing shall be furnished by this Contractor.

### 3.05 TRAINING

- A. **Two half day** training sessions shall be presented by a fully qualified, trained representative of the equipment manufacturer who is thoroughly knowledgeable of this specific installation. Sessions shall be given to:

1. Personnel responsible for operating the systems and representative of local Fire Department.
  2. Personnel responsible for maintaining the systems if other than manufacturer.
- B. **Deliver to Architect 4 copies of operator's manual describing all operating and routine maintenance service procedures to be used with the system. The Contractor shall instruct the Owner's designated representatives in these procedures during the start-up and test period. The duration of the instruction period shall be no less than 20 hours. The instructions shall consist of both hands-on and classroom training at the job site. Contractor shall provide additional training support for operators throughout warranty period.**

END OF SECTION

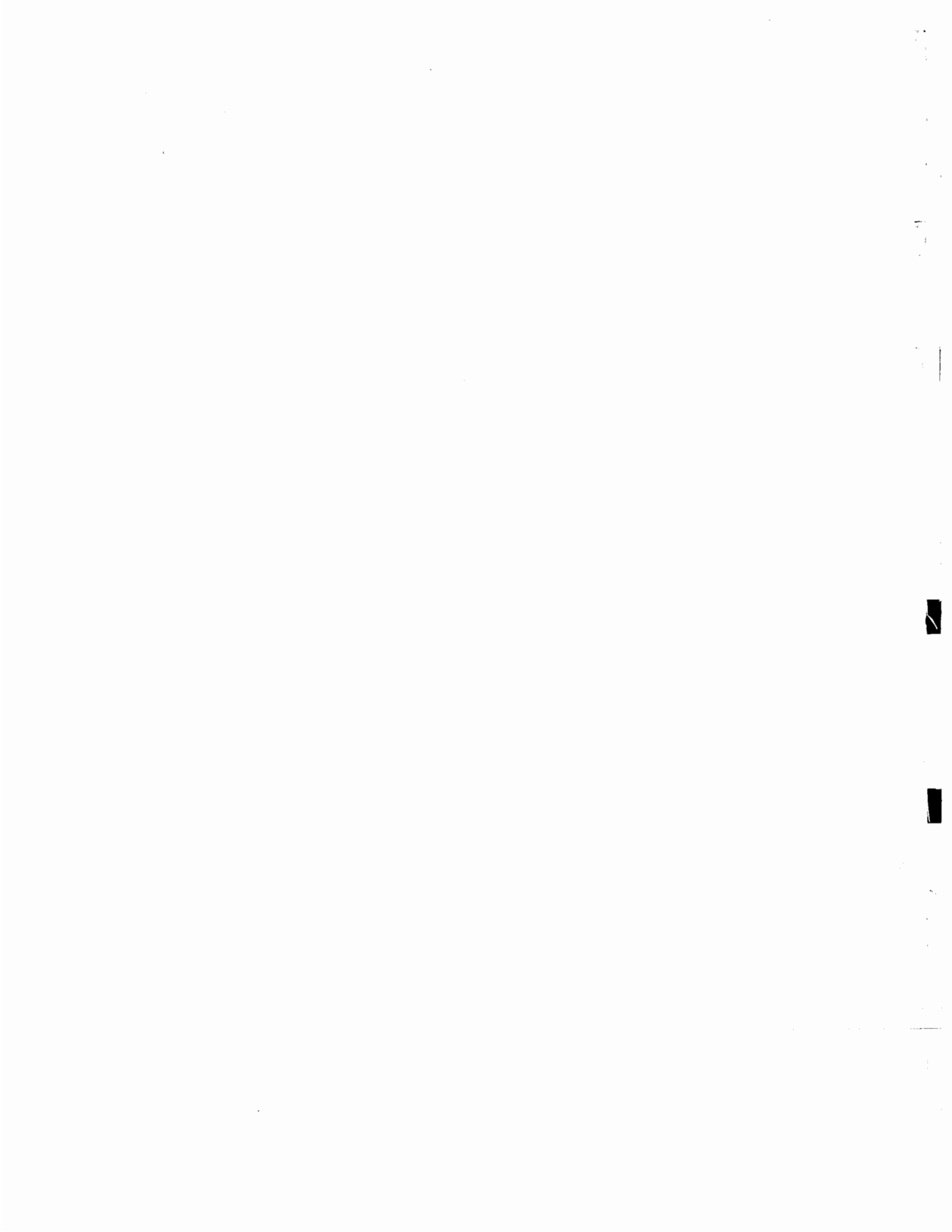

SECTION 16740

TELEPHONE SYSTEM

PART 1 - GENERAL

1.01 DESCRIPTION

- A. **General:** Provide telephone system, complete, as shown and specified per Contract Documents. Principal items include:
  - 1. Service ducts.
  - 2. Distribution conduits.
  - 3. Backboards.
  - 4. Grounding.
  - 5. Outlets.
- B. **Other Applicable Sections:** Requirements of Division 1 and Section 16050 apply to work of this Section.
- C. Telephone installation shall comply with requirements of Pacific Telephone Company.

PART 2 - PRODUCTS

2.01 SERVICE DUCTS

- A. Provide PVC ducts for telephone service, as described in Section 16111.

2.02 DISTRIBUTION CONDUITS

- A. Provide underground PVC conduits and above-grade EMT, IMC or aluminum conduits as described in Section 16111.

2.03 CONDUIT FOR TELEPHONE OUTLETS

- A. Shall be EMT or IMC as described in Section 16111. Minimum conduit size shall be 3/4".

2.04 PULL WIRES

- A. Provide nylon pull line in each service duct, distribution conduit and conduit for telephone outlets.

2.05 TELEPHONE OUTLETS

- A. **Wall outlets shall** have 4" square box and covers, as described in Section 16130.

2.06 GROUNDING

- A. **Provide ground** at each terminal backboard, connected to building steel or equipment grounding system as described in Section 16450.

**PART 3 - EXECUTION**

3.01 CONDUITS

- A. **Shall be installed** as described in Section 16111.

3.02 HOLES

- A. **Holes in terminal room floors** shall be sealed after riser cables are installed, as required by Code, to maintain floor fire rating.

3.03 PULLBOXES

- A. **Pullboxes shall** be provided in conduit runs as required by Telephone Company.

3.04 SLEEVES

- A. **Sleeves shall** be installed as described in Section 16111.

END OF SECTION



**SECTION 16780**  
**SECURITY SYSTEMS**

**PART 1 - GENERAL**

1.01 CONDITIONS

- A. Refer to the General Conditions of Division 16 for requirements which may affect the work of this section.

1.02 RELATED WORK

- A. Conduit and Boxes.
- B. Electrical Power Distribution.
- C. Elevators and Control Systems.
- D. Motorized Roll-Down Doors and Control Systems.
- E. Doors and Door Hardware.
- F. Parking Revenue and Access Control System.
- G. Parking Intercommunication System.
- H. Site Alarm and Access Control System.
- I. Site Intercom System.
- J. Site Video Surveillance System.

1.03 SCOPE

- A. Provide all materials, services and tools to realize the following, or "the work".
- B. Furnish, install, place into operation, adjust, test, collect and enter all data, program, debug, document, warrant and provide operational instruction as described, hereinafter "provide", wire, cable, devices, equipment, equipment racks, and furnish specialty boxes for installation by the Electrical Contractor, associated with the following systems:
  - 1. RTD Security Alarm and Access Control System.
  - 2. RTD Security Intercommunication System.
  - 3. RTD Video Surveillance System.
- C. Ensure compatibility with the Parking Revenue and Access Control System and Site Alarm and Access Control System access cards.
- D. Provide all items not indicated on the Drawings or mentioned in the Specifications that are necessary, required or appropriate for safe, complete and stable operation of the work.

- E. Provide a Warranty Bond effective upon Acceptance of the installation work, terminating one calendar year thereafter.

#### 1.04 REFERENCE STANDARDS

- A. Perform the work in accordance with the latest revisions of all applicable standards and specifications including but not limited to the following:
  - 1. Electrical Industries Association
  - 2. Institute of High Fidelity
  - 3. National Association of Broadcasters
  - 4. National Electric Code
  - 5. National Television Standards Committee
  - 6. Society of Motion Picture and Television Engineers
  - 7. Underwriters Laboratories

#### 1.05 TESTS AND INSPECTIONS

- A. Furnish material and workmanship for this work in conformance with all applicable legal and code requirements.
- B. Perform all tests required herein, or as may be reasonably required to demonstrate conformance with the Specifications or with the requirements of any legal authority having jurisdiction.

#### 1.06 DELIVERY AND STORAGE OF MATERIALS

- A. Schedule, receive, store and place items required by this work.
- B. Deliver materials to the jobsite in manufacturer's containers, as applicable, with each container and each item within each container clearly marked as to item, quantity, size and/or model number.
- C. Receive and store materials in designated areas.

#### 1.07 SAFEGUARDS AND PROTECTION

- A. Protect materials and equipment to prevent the entry or adhesion of concrete, plaster, unintended paint, or other damaging debris or materials. Replace damaged or defective work or material at no additional costs, prior to Acceptance.
- B. Check, and if necessary, clean systems, equipment, devices and components included in the work after Acceptance and completion of the work of other trades.
- C. Replace damaged or defective work or material at no additional cost to the Owner, prior to Acceptance.

1.08 WORK LAYOUT AND COORDINATION

- A. Regularly examine all construction, and the work of others which may affect the work to ensure proper conditions for the equipment and devices before their manufacture, fabrication or installation. Be responsible for the proper fitting of the systems, equipment, materials, and devices provided as part of this work.
- B. Provide additional support or positioning members as required for the proper installation and operation of equipment, materials and devices provided as part of this work as approved by the Architect, without additional expense to the Owner.
- C. Comprehensively check and verify pertinent dimensions and sizes and the appropriateness of all equipment and devices, both on the Drawings and in the field, before proceeding with the work.

1.09 ACCEPTANCE OF WORK

- A. Upon completion of the work, and compliance with all requirements of the Specifications and Drawings, including submittals, tests, etc., required herein, the Owner may elect to verify test data as part of the acceptance procedure. Provide personnel and equipment, at the convenience of the Owner, to reasonably demonstrate any aspect or parameter of performance and to assist with such tests without additional cost.
- B. Failure of any component or system to meet specifications shall require immediate remedial action. In the event that material, device, equipment, system, or workmanship is found unacceptable 10 days prior to the completion date, assume all costs associated with the temporary installation of operational components or systems satisfactory to the Owner until Acceptance of the work.

1.10 TEST EQUIPMENT

- A. Furnish, store, and maintain test equipment at the jobsite as required for both routine and performance testing of this work, thereafter, remove all of the latter equipment from the site.
- B. Provide the following items of professional grade test equipment, as required for the work.
  - 1. Continuity tester.
  - 2. Volt-ohm-milliammeter.
  - 3. 15 Megahertz dual-trace oscilloscope.
  - 4. Test amplifier and full-range loudspeaker assembly.
  - 5. Test video monitor.
  - 6. Low-distortion audio frequency sine wave oscillator.
  - 7. Regulated, variable 50 VDC power supply.
  - 8. Video waveform monitor.
  - 9. Video multi-burst signal generator.

1.11 WARRANTY

- A. Warrant the work to be free from defects in materials and workmanship for 12 months from Acceptance.
- B. Maintain regular service facilities and provide a qualified technician familiar with this work at the site within 4 hours of receipt of a notice of a "critical malfunction" including weekends and holidays. Provide all material, devices, equipment, and personnel necessary for repairs. Install approved temporary, alternate equipment, if required by the Owner, complete and operational within 8 hours after notification of a malfunction, at no additional cost.
- C. Conduct all warranty repairs and service at the jobsite unless in violation of manufacturer's warranty; in the latter event, provide substitute systems, equipment, and/or devices, acceptable to the Owner, for the duration of such off-site repairs. Transport warranty, substitute and/or test systems, equipment, devices, materials, parts, and personnel to and from the jobsite at no additional cost.

1.12 RENEWABLE ANNUAL MAINTENANCE AGREEMENT

- A. Submit a renewable annual maintenance agreement proposal, to commence upon conclusion of the Warranty, for the servicing and adjustment of this work, as part of the Bid Submittal.
  - 1. Perform bi-monthly examinations by trained personnel including all necessary measurements, adjustment, lubrication, and parts replacement to keep the equipment in efficient and proper operation.
  - 2. Perform all maintenance work, except emergency repairs, during regular working hours of regular working days. Perform emergency repairs when a system or component malfunctions during use, and on an immediate basis. Maintenance work shall not be subcontracted or assigned unless the Owner has approved such assignment in writing.
- B. Provide the following costs as part of the proposal:
  - 1. Unit costs for typical replacement materials.
  - 2. Hourly labor rates for emergency or extraordinary repair work.

1.13 BIDDER QUALIFICATION

- A. This work shall be provided by a security systems subcontractor having at least 8 years direct experience with devices, equipment, and systems of the type and scope specified herein, maintaining a fully staffed and equipped maintenance and repair facility within 60 miles of the jobsite.
- B. Supervisors shall have at least 5 years direct experience in similar work.
- C. Installation, adjustment, and testing personnel shall have at least 3 years direct experience in similar work.

#### 1.14 ALTERNATE BIDS

- A. Refer to the "Bid Submittals" portion of these Specifications for stipulated, mandatory Alternate Bid work. The work described for each of these Alternate Bids shall be performed if so directed by the Owner in writing, pursuant to the review of the attendant costs as included in the Bid Submittal.
- B. Optionally submit "Alternate Bids" which may specifically differ from but are generally consistent with the components, devices, equipment, concepts, and practices specified herein, and indicated on the Drawings.
- C. Do not submit any Optional Alternate Bids unless accompanied by a "Base Bid" which is in absolute compliance with the Specifications and Drawings.
- D. Document each "Optional Alternate Bid" with the following, at a minimum.
  - 1. A general description of modifications or changes proposed and the associated cost or savings.
  - 2. A statement enumerating the benefits which would accrue if the alternate bid is accepted.
  - 3. Complete specifications and characteristics of the proposed materials and methods to be used in lieu of those specified.
  - 4. A complete list of changes or modifications to the work which could be required if the alternate is accepted.
  - 5. A complete list of changes or modifications of related work which could be required if the alternate is accepted.

#### 1.15 SUBMITTALS

- A. Notwithstanding requirements elsewhere, submit all of the following:
- B. Bid Submittals: Submit 6 copies of the following as part of the Bid Proposal:
  - 1. A list describing at least 3 installations comparable in scope and nature to that specified herein including the name, current position and telephone number of a representative of each Owner, respectively.
  - 2. Proof that the firm has been regularly engaged in the business of designing, installing, and servicing systems and equipment of the type and scope specified herein for at least the past 8 consecutive years.
  - 3. Verification that the firm has fully licensed, competent design, installation, service and maintenance personnel and facilities with a maintained stock of service parts within 60 miles of the jobsite.
  - 4. A statement of arrangements, distributorships, franchises, and agreement with manufacturers of equipment to be used for this work.
  - 5. A "Base Bid" for this work itemizing the cost of each system stipulating a "Lens Replacement Allowance" of \$2,000 and the total cost of the work. That portion of

the Allowance not expended in material and labor costs for video camera lens changes in the field shall be refunded to the Owner.

6. "Unit Prices" for the following in each instance, state the all-inclusive material and labor cost to "provide" the indicated work, based upon the quantity shown and presuming that all cable, conduit and standard boxes are in place.
    - a) Standard door magnetic door switch and splice box and associated Transponder "input".
    - b) Roll-down door magnetic switch and associated Transponder "input".
    - c) Wall-mounted card reader assembly, associated Transponder "inputs" and "outputs", standard door magnetic door switch and "exit device".
    - d) Wall-mounted intercom station.
    - e) Wall-mounted 1/2-inch camera with 8mm, f/1.2, automatic iris lens and tamper resistant enclosure.
    - f) Ceiling-mounted, 1/2-inch and fixed camera dome assembly with 8mm, f/1.2 automatic iris lens.
    - g) Ceiling-mounted, motorized 1/2-inch motorized camera dome assembly with 8-80mm, f/2.1 zoom lens and single channel receiver/driver.
    - h) Videocassette tape deck.
  7. Optional Alternate Bids with required supporting documentation.
  8. Renewable Annual Maintenance Agreement.
- C. Post Award Submittals: Submit one reproducible of each drawing and 6 copies of each text item within 30 days of Award.
1. A complete Bill of Quantities, including all materials, components, devices, and equipment required for this work. The Bill of Quantities shall be tabulated respective of each and every system as specified, and shall contain the following information for each item listed:
    - a) Quantity
    - b) Description
    - c) Manufacturer's name and model number
    - d) Corresponding Specifications item
    - e) Manufacturer's specification sheet (in separate volume)
  2. Preliminary single-line diagrams including all equipment within each system, coordinated with the Bill of Quantities.
  3. A complete list of all drawings to be submitted including actual drawing number and titles, which may later be revised.

- D. Field and Shop Drawing Submittal: Submit one reproducible of each drawing and 6 copies of each text item within 45 days of Award
1. Corrected items as may have been required for resubmittal above.
  2. Complete, comprehensive, single-line diagrams, including all equipment, devices, connection devices and wiring, completely identified, including equipment and device generic name, manufacturer and model number, cable and connector designations, and locations.
  3. Complete, scaled floor plans utilized "screened", full-sized architectural backgrounds procured from the Architect, or pre-approved equal, with all conduit, boxes, devices, equipment and supporting annotation in the foreground. Annotate the drawings to include room names and numbers, conduit and box size, cable fill, circuit designations, box, devices and equipment mounting elevations.
  4. Complete, comprehensive schematic wiring diagrams as described above for the single line diagrams except showing all wiring and points of connection.
  5. Complete, scaled (1" = 1'-0", minimum) security console elevation drawings, including all equipment, stating the manufacturer's name and model number.
  6. Complete, scaled, detail drawings of all Contractor-fabricated items, including front panels, mounting assemblies, components, devices, equipment, dimensions, component values, terminal designations, types, locations, manufacturer's name and model number.
  7. A bound volume or volumes of comprehensive specifications for all material, devices, components, and equipment where modified or not provided as required under Post Award Submittals, above.
  8. A schedule of proposed keying of all lockable panels, equipment racks, or other enclosures.

#### 1.16 FINAL SUBMITTALS

- A. Record Drawings: Submit one reproducible of the following drawings developed from the final "as-built" systems:
1. 6 copies and one reproducible of each of the floor plans.
  2. 6 copies and one reproducible of each of the single-line diagrams.
  3. 6 copies and one reproducible of each of the schematic wiring diagrams.
  4. 8 copies of the console elevation drawings.
  5. All reproducible material shall be on pre-printed mylar material at least 3 mils thick, in a form acceptable to the Architect.
- B. Manuals: Submit 4 copies of each of the following in bound manuals with labeled dividers. Printed materials within Contractor-Fabricated Equipment Instruction Manuals shall be plain (bond) paper copied, offset or letterpress printed; print or photocopy drawings on bond paper. Compose Contractor-Fabricated Equipment Instruction

Manuals using a consistent, visual format and writing style; text shall be derived from component equipment manufacturer's instruction manuals and may include reproductions of artwork and other copied artwork if not in violation of copyrights.

1. Contractor-Fabricated Equipment Instruction Manuals: Complete, comprehensive instructions for the operation of all Contractor-fabricated devices and equipment items provided as part of this work.
  2. Manufacturer's Instruction Manuals: All brochures, manuals, and service sheets published by the manufacturers of the components, devices and equipment provided.
  3. Final Bill of Quantities: Bill of Quantities including a separate schedule of portable equipment.
  4. Performance, Test and Adjustment Data: Comprehensive documentation of all performance verification and correction procedures and measurements.
- C. Keys: Provide at least 4 duplicates of each different key required for the operation of all cabinet, door, drawer, switch, and other locks furnished as part of this work, as scheduled in the Field and Shop Drawing submittal, and 4 copies of the completed key schedule.
- D. Certificates: Provide all certificates of acceptance, operation and/or compliance, as required.

## PART 2 - PRODUCTS

### 2.01 GENERAL

- A. Material and equipment specified herein have been selected on the basis of acceptable quality and performance and have been coordinated to function as components of the included systems. Where a particular material, device, equipment or system is specified directly, the current manufacturer's specification for same is a part of these specifications, as if completely elaborated herein.
- B. Materials specified herein shall be new and shall be the manufacturer's latest design, permanently labeled with the manufacturer's name, model number, and serial number. Similar devices shall be of the same manufacturer.
- C. Active circuitry shall be solid state and shall be rated for continuous use.
- D. Electronic equipment shall be designed for 19-inch rack mounting unless otherwise noted. Steel frames and enclosures shall be designed and wired to eliminate all induced currents within the units and the system. Bolted connections shall be made with self-locking devices.
- E. Coordinate all control panels so that their general appearance is similar, panels shall be at least 0.125-inch thick aluminum. Do not provide engraving, labels, decals or other identification on any device, equipment or miscellaneous component without approval of such provisions as indicated on the associated Field or Shop Drawing.
- F. Steel shall be treated with zinc phosphate and finish painted with baked enamel or painted with a thermosetting epoxy paint. Aluminum panels, except operating surfaces, shall be anodized and then painted with a thermosetting epoxy paint. Finish colors shall



be as directed by the Architect, excluding pre-finished, manufactured panels and equipment.

- G. Provide intelligible, permanent, engraved identification on or adjacent to all controls; fuses and/or circuit breakers; patching jacks; connectors; receptacles; terminal blocks; meters; indicators; switches; monitors; video tape decks; etc. The identification shall be directly engraved on all Contractor-fabricated equipment and devices, clearly indicate the function of the item and be numbered or lettered to correspond with the function, circuit and/or locations, consistent with the Field and Shop Drawings. Identification of fuses and circuit breakers on Contractor-fabricated equipment shall also indicate:
1. Protected circuitry.
  2. Rating of protective device.
  3. Voltage across open circuited protected device.
- H. Devices connected to the protected electrical system and auxiliary equipment necessary for the operation of the equipment associated with systems specified herein shall be designed to operate from 105 to 130 volt, 60 Hertz, alternating current service, with stable performance, fully in accordance with these specifications, and shall have integral fuse or circuit breaker protection.
1. Contractor-fabricated items shall be provided with fuses of the clear glass cartridge type, and mounted in fuseholders which indicate when a fuse is blown or defective.
  2. Protection devices shall be located to facilitate replacement, resetting, or observation of status without demounting the associated unit and/or de-energizing adjacent equipment.
- I. Operate all circuit components in accordance with recommendations of the component manufacturer and shall verify sufficient permanent identification to facilitate replacement.
- J. Utilize consistently identified terminal strips for all external connections to principal elements of each system. Show these same designations on all drawings where such connections are referenced or drawn.
- K. Contractor-fabricated printed circuit boards shall be G-10 glass fabric base epoxy of at least 0.0625-inch thickness, copper plated to a density of at least 2 oz./sq. ft. in one or both sides of the board. Boards shall be finished with 60/40 tin-lead solder, either hot rolled or plated over the copper; holes through boards shall be plated through and solder filled. Printed circuit boards shall be permanently identified with a designation matching that of the mating connector or board "position".
1. Boards shall be mechanically secured by bolt or friction-loading guide in addition to any electrical connector attachment, and shall include an integral extraction grip or handle.
  2. Printed circuit boards shall only be connected to associated circuitry via soldered connections or precious metal positively-keyed card-edge connectors.
- L. Auxiliary and incidental equipment necessary for the operation and protection of the systems specified in this Section shall be furnished and installed as if specified in full.

## 2.02 DEFINITIONS AND CONVENTIONS

- A. The following voltage or power levels shall be associated with the respective circuitry unless otherwise noted:
1. Microphone Level: Less than -32 dbV (0 dbV = 1.0 volt)
  2. Line Level Circuits: -32 dbV to +22 dbV
  3. Loudspeaker Level: Greater than +22 dbV
  4. Intercommunication: -32 dbV to +22 dbV
- B. The following impedance characteristics shall be associated with the respective circuitry unless otherwise noted:
1. Microphone Circuits: 50-250 ohms, source; and not less than 10 times the source impedances, terminating, line-to-line, electromagnetically and electrostatically balanced to signal ground.
  2. Line Circuits: 600 ohms, maximum, source; 600 ohms, minimum, terminating; electromagnetically and electrostatically balanced to signal ground.
  3. Video Circuits: 75 ohms to shield and signal ground, 1.4 VSWR, maximum.

## 2.03 MISCELLANEOUS PRODUCTS

- A. Refer to Drawings for additional information.
- B. Switches, Indicators and Sounding Devices:
1. Interior Illuminated Pushbutton Switches: Switch-craft PL-Series, Clare-Pendar, Marco-Oak.
  2. Exterior Illuminated Pushbutton Switches: Staco 40 Series with Splash Shield.
  3. Illuminated Three-Position Lever Switches: Switchcraft Lever-Lite II, Series 27000.
  4. Sounding Devices: Mallory Model SC628K "Sonalert".
- C. Cable Termination Devices:
1. Screw-Type Barrier Blocks (Loudspeaker and control circuits): TRW-Cinch, 140, 141 and 142 Series, Buchanan.
- D. Relays:
1. Control Circuits Relays: Potter & Brumfield KRP Series, R10 Series.
  2. Line Circuit Relays: Potter & Brumfield, KHP Series, R11-E Series.
  3. Loudspeaker Circuit Relays: Potter & Brumfield, KNP Series, KAP-DY Series.

E. Video Equipment:

1. Video Selection and Camera Control System: American Dynamics AD1650 with AD1678 Executive Keyboard, or Vicon VPS1200 with V1200X-XFP Desktop Control Panel incorporating time, date and camera identification on all outputs.
2. Lenses: Canon, Cosmocar, Fujinon, Rainbow.
  - a) Fixed Lenses: f/1.2, maximum aperture; provide manual iris and focus capability unless otherwise indicated. Refer to the Drawings for specific focal lengths.
  - b) Motorized (Zoom) Lenses: f/1.8, maximum aperture; provide remote control of iris function or remote selection of automatic iris operation unless otherwise indicated.
    1. Interior, General use: 8-80MM.
    2. Exterior, General use: 8-80MM, with "2X Extender" remotely controlled by "Auxiliary" function.
3. Pan and Tilt Drives: Refer to the Drawings for specific pan and tilt drive models.
4. Video Cameras: Elmo SE360, Sanyo VDC2524.
5. Nine-inch Video Monitors: Panasonic TR-932A, Ikegami PM-930A, Sanyo VM4509.
6. Seventeen-inch Video Monitors: Ikegami PM-175A, Panasonic WV-5470.
7. Video Motion Detectors: American Dynamics AD1461.
8. Video Quad Splitters: American Dynamics AD1474VP.
9. VHS Video Cassette (Time Lapse, Alarm, Remote Control) Recorders: GYYR TLC1800. Furnish six (6) two (2) hour video cassettes.

F. Detection Equipment:

1. Passive Infrared Detectors (Curtain): Aritech Model DR321.
2. Exit Devices: Pulnix Model DMP620.
3. Magnetic Door Switches (General): Sentrol Model 1078C-W.
4. Magnetic Door Switches (Roll-Down Door) Sentrol Model 2207A.
5. Junction Boxes with Tamper Switch: Sentrol Model 1990S.

G. Intercommunication Equipment:

1. Master (Console) Stations: Aiphone Model NDR-10A/ND-40AS.
2. Submaster Stations: Aiphone Model NEM-30/NBJ-40.

3. Remote Stations: Custom, refer to Drawings.

#### H. Parking Revenue and Access Control Equipment

1. Motorized Gate-Arms (Articulated), Vehicle (Loop) Detectors, Machine Readable Ticket Dispensers, Fee Computers and Accessories: Amano, Federal Signal, Stanley.
2. Vehicle Identification Tag (Loop) Readers: Cotag, with "Wiegand Output".
3. Access Control System: See "Alarm Monitoring and Access Control System Equipment", immediately below.

### 2.04 ALARM MONITORING AND ACCESS CONTROL SYSTEM EQUIPMENT

- A. General: Provide the Security Alarm and Access Control System as described herein and indicated on the Drawings. Provide wholly compatible components of a single system to realize the following:

1. System-Assisted Operator Interaction:
  - a) Operator-Initiated Interaction: Automatic or Operator-requested display of menu from tree-style menu architecture, consistent with "Operator Level", when Operator wishes to initiate System function or activity.
  - b) System-Initiated Interaction: Automatic display of "prompt" whenever System requires Operator response.
  - c) Online or Context-Sensitive "Help": Operator execution of "Help" function realizes accesses "look-up table" comprising all operator initiated functions, with explanations, or provides a similar, limited schedule of current options, with explanations.
2. Real-Time Operation: System functions are or may be conditioned under program control to the time of day, day of week and a floating holiday, at a minimum.
3. Multi-tasking Operation: Maintain System response time and speed regardless of simultaneous terminal and printer activity.
4. Self-Diagnosis: Constantly monitor the integrity of System componentry and provide specific diagnostic messages.
5. Supervision and Line Security: Continuously supervise the (two-wire) alarm circuits, regardless of status, as previously described. Similarly monitor the integrity of all "Transponder loops" on a continuous basis.
6. Programmable Alarm Circuit Monitoring: Arm or disarm alarm circuit(s) either upon Operator demand, as directly programmed in real time or as conditioned to the occurrence of one or more System input or output "events" pursuant to user-supplied information stored by the System in an "Alarm Point Data" file.
7. Programmable Remote Control: Activate or deactivate control circuit(s), on a maintained or momentary basis, either upon Operator demand, as directly programmed in real time or as conditioned to one or more other System input or

output "events" pursuant to user-supplied information stored by the System in a "Control Point Data" file.

8. Coordinated, Programmable Access Control: Automatic and coordinated operation of an access (door) control output and "shunting" of an associated door monitor alarm circuit input upon "acceptance" of an access card at an associated card reader. Door release shall occur in two seconds or less after presentation of an authorized card; during non-peak (System) activity periods, door release shall occur within 1 second or less. Acceptance is conditioned to real time, locational and sequential data pursuant to user-supplied information stored by the System in a "Card Reader Data", "Cardholder Data", "Alarm Point Data" and "Control Point Data".
9. Automatic "Event" Display: Automatically display data associated with each type of System "event" respective of its programmed "Event Priority Level", including alarm, trouble, line security, diagnostic, access granted and access denied events, on the "Guard Terminal".
10. Automatic Event Printout: Automatically print data associated with each type of System "event" in real time sequence, including alarm, trouble, line security, diagnostic, access granted and access denied events, on the "Event Printer".
11. Automatic Event Storage: Automatically store data associated with each type of System "event" including alarm, trouble, line security, diagnostic, access granted and access denied events.
12. Database Storage, Editing and Retrieval: Provide stable, non-volatile, long term storage for the user programmed System database. Incorporate the following data, where the number and parenthesis indicate the nominal number of characters required for that data "field":
  - a) Alarm Point Data File: User Number (5), Designation (35), Priority Level (1), Time Program (2), Message (160).
  - b) Control Point Data File: User Number (5), Designation (35), Time Program (3), Normal State Code (open, close), Contact Action Code (momentary, maintained), Initiating Alarm No. 1 (5) through Initiating Alarm No. 5 (5).
  - c) Card Reader Data File: User Number (5), Designation (35), Mode (degraded, normal, entry, exit), Release Time (3), Shunt Time (3).
  - d) Cardholder Data File: Last Name (25), First Name (15), Middle Initial (1), Address Field No. 1 (35), Address Field No. 2 (35), City (15), State (2), Zip (9), Area Code (3), Telephone Number (7), Car Make (15), Car Model (15), Car Color (15), Car License (8), Employer (35), Work Phone (7), Access Card Number (8), Last Issued Date (6), Access Level No. 1 (3) through Access Level No. 2 (3), Time Program No. 1 (3) through Time Program No. 2 (3).
  - e) Console Operator Data File: Last Name (25), First Name (15), Middle Initial (1), Address Field No. 1 (35), Address Field No. 2 (35), City (15), State (2), Zip (9), Area Code (3), Telephone Number (7), Car Make (15), Car Model (15), Car Color (15), Car License (8), Access Card Number (8), Last Issued Date (6), Access Level No. 1 (3) through Access Level No. 2 (3), Time Program No. 1 (3) through Time Program No. 2 (3), Password (10).

- f) Access Level Definitions: Access Group Number (3), Access Group Designation (35), Card Reader No. 1 (3)...; for elevator card readers, additionally assignable to the particular elevator card reader, Floor No. 1 (2) through Floor No. 50 (2).
- g) Time Program Definitions: Time Program No. (3), Time Program Designation (35) for each of Sunday through Saturday and a "Holiday", Start Time No. 1 (4) through Start Time No. 2 (4) and Stop Time No. 1 (4) through Stop Time No. 2 (4).
- h) Group Data Files: Facilitate programming of alarm points, control points, status points, card readers and cardholders in user defined and named groups. Provide "Group Files" including the User Number (5) of all included points, the Group File Name (35), the Valid Date (6), Valid Time (4), Expire Date and Expire Time, and the balance of "variables" assigned to that group type. All Group members shall automatically assume the programmed parameter values of the then valid Group File of like name and type, overriding direct programming of the actual Point or Cardholder Data File.

B. Access Card:

- 1. General: An invisibly encoded "token", which is presumed to correctly correlate with its bearer, affording specific, programmed System response unique to the bearer, the reader at which the card is presented, and the current time.
- 2. Size: ABA standard for credit cards.
- 3. Thickness: 0.09373 inches, maximum.
- 4. Material: non-toxic, flame-resistant plastic.
- 5. Encoding Technique: Wiegand Effect.
- 6. Code Universe: 10 million, minimum.
- 7. Graphics: Indicate orientation and direction of card presentation; unique, numerical administrative designation unrelated to unique encoded (alpha) numerical designation. No other text or illustrative graphics.
- 8. Usable Life: 2 years, minimum, without abuse.

C. Card Reader:

- 1. General: Generates voltage waveform uniquely associated with (alpha) numerical designation encoded on access card. Explicitly annunciates "access granted" status, at a minimum. Implicitly or explicitly annunciates "access denied" status.
- 2. Encoding Technology: Wiegand Effect.
- 3. Card Presentation Technique: Longitudinal insertion exclusively; "swipe" unacceptable.
- 4. Reader Configuration: Flush or recessed; protrusion from mounting surface not to exceed 0.25 inches.

5. Status Annunciation: Dual non-incandescent indicators for "access granted" and "access denied", respectively, preferred; single LED or neon indicator for "access granted" acceptable.
6. Distance to Transponder: Up to 250 feet, minimum.
7. Operating Environment: 40 to 105 degrees, Fahrenheit; 0 to 90 percent relative humidity.

D. Intelligent Transponder:

1. General: Fully-enclosed and self-contained including CPU, ROM, RAM, power supplies, eight (8) hour battery back-up, automatic battery charger, tamper switch and circuitry to realize the following.
2. Retention of data for 2,048 cardholders, 128 alarm points, 128 control points and 4,096 events.
3. Automatic upload of non-resident cardholder and point data, as required. Automatic download of event data on first-in-first-out basis.
4. "Alarm Input" Circuit Supervision: Continuous scrutiny of an interconnected 2-wire alarm circuit for predetermined, undermining electrical conditions, or "faults", uniquely detected and identified as "trouble" events. Supervision is continuous regardless of the "armed" or "disarmed" status of the alarm circuit.
5. Alarm Circuit Monitoring: When "armed" as directed by the CPU, continuous scrutiny of an interconnected 2-wire circuit for a predefined electrocondition uniquely associated with violation of interconnected detection or initiating devices, uniquely annunciated as "alarm events".
6. "Status Input" Circuit Monitoring: When "active", as directed by the CPU, continuous scrutiny of an interconnected 2-wire circuit for changes in the status of the interconnected devices, not annunciated only "stored" for later recall.
7. "Control Output" Circuit Operation: Momentary or maintained electrical continuity or discontinuity on a 2-wire circuit under CPU control. Rated for not less than 24 volts open circuit and 1.0 amperes closed circuit.
8. Coordinated Access Control: Card reader or "exit device" initiated activation of a uniquely associated control output, typically associated with door release, concurrent with actual electrical shunting or software suppression of alarm detection on a uniquely associated alarm circuit.
  - a) Alarm "Shunt": Initiated upon access card acceptance or exit device triggering, maintained through "alarm shunt time" of 2 through 60 seconds, minimum or until door first closes. Alarm shunt time physically adjustable at Transponder or programmable in Card Reader Data File.
  - b) Door Release: Control output activation upon confirmation of access card or triggering of exit device, maintained for "Door Release Time" of 2 through 60 seconds, minimum or when door first opens. Alarm shunt time physically adjustable at Transponder or programmable in Card Reader Data File.

- c) Exit Initiation: Scrutiny of a 2-wire circuit interconnecting to one or more normally-open devices; electrical continuity of any one or more of the interconnected devices simultaneously initiates alarm shunting and door release as described above; however, "time out" of the attendant intervals only commences when electrical continuity is removed from this circuit.
  9. Floor-Selective Elevator Control: Up to 50 discrete control outputs associated with any one or more card readers which may be selectively activated depending upon the access group(s) associated with a particular access card.
  10. Battery Backup: Self-contained, supporting all Transponder functions for not less than 4 hours and initiating a System "diagnostic" annunciating local power failure, power restoration and 75 percent discharge of battery capacity, respectively.
  11. Expansion of Capacity: Modular construction to afford individual expansion of alarm circuit, control circuit and card reader capacity. Increases in capacity through the addition of Transponders is acceptable.
- E. Guard Terminal: A rack mounted VGA color monitor of not less than 11-inch diagonal measure with "non-glare" screen and front panel mounted intensity control. Flicker-free display of not less than 20 lines of 80 characters not less than 0.065 inches high in lower case and 0.0937 inches high in upper case. Screen blanking and display of any ASCII characters in any or all screen positions within 1 seconds. Incorporate a solid-state sounding device capable of producing a continuous sound pressure level of not less than 75 db, unweighted, as measured 8' from the CRT, in any direction.
- Provide a keyboard comprising tiered rows of contoured keys in the conventional "QWERTY" pattern. Membrane keyboards are not acceptable. Keyboard response shall not be less than 10 keystrokes per second, with a buffer of not less than thirty (30) characters.
- Provide the Guard Terminal to perform the following functions, at a minimum:
1. Date and Time Display: With each and every "event", and when the CRT is "idle".
  2. Event Aural Annunciation: Energize the integral sounding device until the event, as required, as acknowledged by the Operator.
  3. Automatic Alarm Display: Alarm occurrence, restoral and acknowledgement, alarm circuit number designation and message, all as programmed by the operator of appropriate operator access level.
  4. Hierarchical Alarm Queuing: Storage and/or display of alarm events, i.e., alarm occurrence, alarm restoral or alarm acknowledgement in the order of their assigned "Alarm Priority".
- F. Event Printer: Self-contained including "dot matrix" printhead, with ink ribbon cartridge and sprocket drive for 8 1/2 inch wide paper. Minimum printing speed of one hundred (100) characters per second, and a pitch of twelve (12) characters per inch. Incorporate LED annunciators to indicate "end of ribbon" and "end of paper supply" conditions. Implement appropriate hardware and software to ensure the cessation of printout upon the occurrence of either of the latter conditions, and its automatic resumption upon their correction. Verify that the occurrence of neither of the latter conditions or the accidental disconnection or deactivation of the printer will interrupt any other aspect of System operation. Provide a stand which will provide for storage of not less than two hundred



(200) sheets of Z-fold paper and will automatically fold and stack the paper as it exits from the printer.

Provide the Event Printer to chronologically print out all information associated with, and upon the occurrence of each and every System diagnostic, alarm event and, if programmed by the user, access denials of the specific type programmed by the user.

- G. Administrative Terminal: Technically equivalent to the Guard Terminal except configured for freestanding, desk-top implementation. Provide the terminal for operator initiated entry, retrieval, modification or purging of all user-programmable file data, as previously described. Additionally facilitate operator requested printout of formatted reports of alarm events or access events between specified dates and times.

Enable the latter functions only as allowable relative to the respective Operator Access Level and associated Operator Password as programmed only by an Operator(s) of the highest Operator Access Level.

1. Alarm Event Reports: All events occurring between the specified starting date and time and ending date and time, or a subset of the latter events, keyed to one or more alarm points.
2. Access Event Reports: All access events i.e. access granted or access denied from the specified starting date and time to the specified ending date and time or as keyed to one or more card readers or cardholders.
3. Chronological Report: All alarm, access and diagnostic events occurring between the specified starting date and time and ending date and time.

- H. Report Printer: Technically equivalent to the Event Printer. Provide the Report Printer to realize the reports described above associated with the Administrative Terminal. Provide the printer on a floor stand with supply paper shelf and a "bale" to automatically "capture" the paper as it exits the printer.

- I. Central Equipment: Includes the System central processing unit, dynamic memory, real time clock and calendar circuitry with one (1)-year battery backup, 3-1/2 inch floppy disk drive, one hundred twenty (120) Megabyte, minimum, hard disk and integral or "outboard" ventilation and power conditioning equipment, at a minimum.

- J. Acceptable Systems: Checkpoint, CASI-Rusco, Identicard and Receptors modified as required herein.

### **PART 3 - EXECUTION**

#### **3.01 GENERAL**

- A. Perform this work in accordance with acknowledged industry and professional standards and practices, and the procedures specified herein.
- B. Furnish and install all materials, devices, components, and equipment required for complete, operational systems.
- C. Maintain a competent supervisor and supporting technical personnel, acceptable to the Architect during the entire installation. Change of supervisor during the project shall not be acceptable without prior written approval from the Architect.

- D. Coordinate all efforts with those of related trades. In the event of any conflicts, delayed or improper preparatory work by others, notify the Architect; the Architect's decision will be binding.
- E. Verify all field conditions.

### 3.02 WIRE AND CABLE INSTALLATION

- A. Verify that all conduit has been de-burred and properly joined, coupled, and terminated prior to pulling of cables.
- B. Inspect all conduit bends to ensure proper radiusing, in accordance with recommendations of the wire, cable, or conduit manufacturer; in no case shall the radius be less than 12 times the conduit diameter.
- C. Verify that all conduit is clear of foreign matter and substances prior to pulling of wire or cable.
- D. Provide permanent identification of run origination at all conduit terminations.
- E. Apply a chemically inert conduit lubricant to all wire and cable prior to pulling. Do not subject wire and cable to tension greater than recommended by the manufacturer. Under no circumstances shall wire or cable be "jerked" through conduit.
- F. Provide a box loop for all wire and cable routed through junction boxes or distribution panels. Cable loops and bends shall not be bent at a radius greater than that recommended by the manufacturer.
- G. Identify all wire and cable clearly with permanent labels wrapped about the full circumference within 1-inch of each connection. Indicate the number designated on the associated field or shop drawings or run sheet, as applies. Assign wire or cable designations consistently throughout a given system; i.e., each wire or cable shall carry the same labeled designation over its entire run, regardless of intermediate terminations. Additionally provide labels where wire and cable first enter and exit from conduit, junction, or distribution boxes; labels shall be located within 6-inches of the point of exit. Labels shall be by Brady or Thomas and Betts.
- H. Secure all wire and cable run vertically in conduit for continuous distances greater than 30' at the vertical run terminations. Non-coaxial cables shall be secured by screw-flange nylon cable ties or similar approved devices, Thomas and Betts or equal. Symmetrical clamping devices with split, circular or other wire conforming, non-metallic bushings shall be provided for all other cables. Support racks shall be Unistrut or Kindorf.

### 3.03 BOX, PANEL, AND ENCLOSURE INSTALLATION

- A. Install all boxes, panels, and enclosures square and plumb. Set "flush-mounted" units so that the face of the cover, bezel, or escutcheon shall be in the same plane as the surrounding finished surface. Mount boxes, panels, and trim so that there are no gaps, cracks, or obvious lines between the trim and the adjacent finished surface, and ready them to receive final finish, as applicable.
- B. All floor boxes shall support 250 lb./sq. ft. over the entire cover, escutcheon, or bezel without internal structural failure of the frame or its mounting. Boxes shall be flush to finished floor level and shall include carpet escutcheon or trim plates.

- C. Provide access panels where needed to access boxes, panels and enclosures in walls or ceilings, and indicated and dimensioned on the shop drawings. Finish panels to match the adjoining surfaces.

### 3.04 EQUIPMENT, RACK AND CONSOLE INSTALLATION

- A. Provide a full-height outlet strip with not less than 10 outlets and in-line "work light" ready to be served by a separate branch circuit via a duplex receptacle box at the base of each equipment rack. Install a "rackwidth" outlet strip with not less than 6 outlets ready to be served by its own branch circuit via a duplex receptacle box in each console base "section". The outlet strip and box shall be electrically isolated from the rack or console frame, mounted near the left framing member, as viewed from the rear, of each rack.
- B. Provide each equipment rack with a locking rear door including retaining devices and protective plastic covers for run sheets, rack elevation and single-line drawings.
- C. Provide matching blank panels in all spare panel spaces.
- D. Provide access covers, hinged panels, or pull-out drawers to ensure complete access to terminals and interior components. In no case shall such access require demounting or de-energizing of same, or adjacent equipment.
- E. Fasten removable covers containing any wired component with a continuous hinge along with one side, with associated wiring secured and dressed to provide an adequate service loop. Appropriate stop locks shall be provided to hold all hinged panels and drawers in a serviceable position.
- F. Provide an unobtrusive permanent label on the front of each console section including its designation, as assigned and referenced consistently throughout this project, and the circuit breaker number and associated electrical distribution panel designation servicing the console section.

### 3.05 CAMERA ASSEMBLY INSTALLATION

- A. Provide positioning and support elements for camera assemblies, where required. All such provisions shall attach to and wholly reside within the areas designated for same.
  - 1. Submit scaled, dimensioned, detailed drawings of all camera assembly positioning and support elements. Obtain written approval of all such provisions prior to installation.
  - 2. Complete optical "back-focus", electrical focus, shutter speed and other camera adjustments, lens and pan and tilt operational checks prior to mounting.
  - 3. Coordinate mounting of camera assembly pan and tilt drives to ensure orientation of horizontal end limits towards approved "blind spot".
  - 4. Coordinate the location of all boxes and conduit serving camera assembly components to minimize the exposed run of camera assembly serving cable.
  - 5. Verify that camera assembly harnesses are properly dressed, routed and secured to preclude interference with camera motion and coverage.
  - 6. Provide safety cables and latches on all "bottom removable" domes or other camera enclosures.

7. Paint exposed camera assembly enclosures to match the adjacent surface, as approved by the Architect. Verify that enclosure ports and ventilation openings are clear of paint.
8. Provide lightning protection for all exterior camera assemblies and control transponders.

### 3.06 WIRING CLASSIFICATION

- A. Wiring specified herein shall be installed in accordance with standards established for the respective classification.
- B. Audio signal wiring classifications shall include:
  1. Type A-1: Microphone level, less than -32 dbV, 20 Hertz to 20 Kilohertz.
  2. Type A-2: Line level, -32 dbV to +22 dbV 20 Hertz to 20 Kilohertz.
  3. Type A-3: Loudspeaker level, greater than +22 dbV 20 Hertz to 20 Kilohertz.
- C. Video and associated signal wiring classifications shall include:
  1. Type V-1: Baseband video, 0 to 4 volts peak-to-peak into 75 ohms 0 to 8.0 Megahertz.
  2. Type V-2: Synchronization and switching pulse, 0 to 4 volts peak-to-peak into 75 ohms 15.63 to 15.75 Kilohertz 50 to 60 Hertz.
- D. Television distribution system wiring classifications shall include:
  1. Type TV-1: Outlet level, less than +12 dbmv; 47 to 890 Megahertz.
  2. Type TV-2: Riser level, +12 to +36 dbmv; 47 to 890 Megahertz.
  3. Type TV-3: Feeder level, greater than +36 dbmv; 47 to 890 Megahertz.
- E. Control signal wiring classifications shall include:
  1. Type C-1: DC control, 0 to 50 volts, largely resistive load, low duty cycle.
  2. Type C-2: DC control, 0 to 50 volts, largely reactive load.
  3. Type C-3: Synchronous control or data, 0 to 40 volts, peak-to-peak 0 to 12,000 PRF.
  4. Type C-4: AC control, 0 to 48 volts AC 60 Hertz.
- F. Additional wiring classifications shall include:
  1. Type M-1: DC power, 0 to 48 volts DC, resistive load.
  2. Type M-2: AC power, greater than 50 volts AC 60 Hertz.

### 3.07 WIRING PRACTICES

- A. Notwithstanding requirements elsewhere in these specifications, the following wiring combinations are acceptable in conduit, wireways, or cable harnesses.
  - 1. Types A-1, C-1, and M-1.
  - 2. Types A-2, C-1, C-3, and M-1, runs less than 20'.
  - 3. Types A-2, C-1, and M-1.
  - 4. Types A-3, C-1, C-3, and M-1.
  - 5. Types A-2, V-1, and V-3.
  - 6. Types V-1, V-2, V-3, and C-1.
  - 7. Types M-2 and C-4.
  - 8. Types A-2, TV-1, C-1, and M-1.
  - 9. Types A-2, TV-2, C-1, and M-1.
- B. Except as indicated herein, conduit wireways and cable bundles shall contain only wiring of a single classification.
- C. Wiring and cable shall be continuous and splice-free for the entire length of run between designated connections or terminations.
- D. Shielded cables shall be insulated. Do not permit shields to contact conduit, raceway, boxes, panels or equipment enclosures. Tin terminated shield drain wires and insulate with heat shrinkable tubing.
- E. Directly terminate video cables at equipment.
- F. Make connections to screw-type barrier blocks with insulated crimp-type spade lugs. Size all lugs properly to assure high electrical integrity, i.e., low resistance connections. Connect only one wire per spade lug and not more than 2 lugs per screw terminal.
- G. Solder microphone and line level connections; use only rosin core 60/40 tin/lead solder.
- H. Lace, tie, or harness wire or cable as required herein, and in accordance with accepted professional practice. Dress, lace or harness all wire and cable to prevent mechanical stress on electrical connections; no wire or cable shall be supported by a connection point. Provide service loops where harnesses of different classes cross, or where hinged panels are to be interconnected.
- I. Verify that coaxial cables have been properly routed, dressed and secured to preclude stress and/or deformation.
- J. Correct the following unacceptable wiring conditions:
  - 1. Deformed, brittle, or cracked insulation.

2. Insulation shrunken or stripped further than 1/8-inch away from the actual point of connection within a connector, or on a punch block.
3. Cold solder joints.
4. Flux joints.
5. Solder splatter.
6. Ungrommetted, unbushed or uninsulated wire or cable entries.
7. Deformation or improper radiusing of wire, or cable, especially coaxial cables.

### 3.08 CLEANUP

- A. Clean up after work is completed in each area, or at the end of each work day, whichever is soonest.
- B. Dispose of all debris and other discarded materials in designated receptacles.

### 3.09 PRELIMINARY CHECKS AND TESTING

- A. Conduct preliminary checks and testing prior to performance testing and subsequent to completion of related or adjacent work of other trades. Verify safe and proper operation of all components, devices or equipment, nominal signal levels within the systems and the absence of extraneous or degrading signals.
- B. Perform the following verification and/or testing procedure:
  1. Proper grounding of devices and equipment.
  2. Integrity of ground connections.
  3. Proper provision of power to devices and equipment.
  4. Integrity of all insulation, shield terminations and connections.
  5. Integrity of soldered connections.
  6. Absence of solder splatter, solder bridges, debris of any kind, tools, etc.
  7. Proper routing and dressing of wire and cable.
  8. "Wire-checking" of all circuitry, including phase and continuity, with reference to cable designations on run sheets, field and shop drawings.
  9. Preliminary aiming and setup of video camera assemblies.
  10. Mechanical integrity of all support and positioning provisions, i.e., as provided for video cameras, etc.
- C. Determine the proper sequence of energizing systems to minimize the risk of damage.
- D. After successfully energizing the systems, make all preliminary adjustments and document the setting of all controls, parameters of all corrective networks, voltages at key

system interconnection points, gains and losses, as applicable. Tabulate all data along with an inventory of test equipment, a description of testing conditions, and a list of test personnel as itemized below. Copies of preliminary test data shall accompany copies of performance testing data as part of the final submittal.

- E. Verify the performance parameters of the individual systems following established professional procedures, in addition to those specified herein.
- F. Document all acceptance testing, calibration and correction procedures described herein with the following information:
  - 1. Performance date of the given procedure.
  - 2. Condition of performance of procedure.
  - 3. Type of procedure, and description.
  - 4. Parameters measured and their values, including values measured prior to calibration or correction, as applicable.
  - 5. Parameters associated with calibration or corrective networks, components, or devices.
  - 6. The names of personnel conducting the procedure.
  - 7. The equipment used to conduct the procedure.
- G. Provide permanent "wedge" type labels on all controls, as applies, to indicate correct settings after performance testing and adjustment procedures have been successfully completed.

### 3.10 SYSTEMS PERFORMANCE TESTING AND ADJUSTING PROCEDURES

- A. Conduct testing and adjusting procedures to realize and verify the performance criteria specified herein. Notwithstanding any other requirements, standards, and miscellaneous criteria provided elsewhere within these specifications, performance testing, adjusting and documentation shall include the procedures itemized below.
- B. Perform testing, adjustment, and documentation for intercommunication systems shall include measurement (A-weighted) of the following, as applicable:
  - 1. Sensitivity; maximum continuous sound pressure level with no audible distortion measured 4' from the "Console Panel"; utilize an acoustic source of 2,000 Hertz sine waves placed 1' from the "remote station", calibrated for a free field level of 60 db, SPL at 4' from the source.
  - 2. Maximum continuous sound pressure level; measured 4' from a "remote station" with no audible distortion at 2,000 Hertz, utilize a low-distortion 2,000 Hertz sinusoidal source.
- C. Performance testing, adjustment, and documentation procedures for video systems shall realize verified measurement of the following parameters, as applies:
  - 1. Frequency response; apply multi-burst test signal covering 0.5 to 8.0 Megahertz at designated locations and observe waveform monitor connected to the incoming

line (switcher output) of the associated Monitor Station; for camera chain checkout, use frequency response wedge chart covering 2.0 to 8.0 Megahertz (Sierra Scientific Model SA-1A, or equal).

2. Vertical and horizontal resolution; use resolution wedge chart covering 200 to 600 lines vertically and horizontally (Sierra Model SA-1A, or equal), or pattern generator, as applies.
  3. Geometric distortion/linearity; use ball and circle (qualitative) chart, covering 1 to 2 percent (Sierra Model SA-2A and SA-1A, respectively, or equal), or pattern generator, as applies.
- D. Performance testing, adjustment, and documentation procedures for alarm/access control systems shall include:
1. Individual operation of all "point" detection or other alarm triggering devices, i.e., mechanical or magnetic switches, panic switches, cash register money-clip switches, optoelectronic devices, specialty detectors, etc., and observation of specified alarm annunciation, display and/or printout performance.
  2. "Walk-testing" of each "field" detection device, or transmitter/receiver pair, i.e., ultrasonic, microwave, electrostatic, passive infrared, active infrared, etc., and observation of stable, consistent, specified alarm annunciation, display and/or printout.
  3. Operation of all access control devices, i.e., card reader, pushbutton switches, etc., and observation of specified control functions, annunciation, display and/or printout functions.
- E. Conduct necessary performance testing; adjustment and documentation procedures to verify and realize compliance with the performance specifications herein. Make available at least one technician familiar with this work, and all required test equipment for the duration of performance testing verification.

### 3.11 FINAL PROCEDURES

- A. Perform remedial work to correct inadequate performance or unacceptable conditions of, or relating to any of this work, as determined by the Architect, at no additional expense to the Owner.
- B. Furnish all portable equipment to the Owner along with complete documentation of the materials presented. All portable equipment shall be presented in the original manufacturer's packing, complete with all included instructions and miscellaneous manuals and documents.
- C. Provide the services of an articulate, technically qualified person, familiar with the work, acceptable to the Owner to present, review and clarify all materials to the Owner's representatives and fully demonstrate the operation and maintenance of the systems, equipment, and devices specified herein. Allocate not less than 40 hours for such services at the reasonable convenience of the Owner.
- D. Check, inspect, and, if necessary, adjust all systems, equipment, devices, and components specified, at the Owner's convenience, approximately 60 days after the Owner Acceptance of this work.



### 3.12 ALARM CIRCUIT CONFIGURATION AND OPERATION

- A. Supervise all circuits interconnecting detection devices with a Transponder(s) and all circuits interconnecting the Transponder(s) the Security Alarm and Access Control System central processing unit.
1. Configure alarm circuits comprising only passive detection devices as a 2 conductor circuit wherein the respective detection devices demonstrate electrical continuity when the specifically associated detection mechanism is not violated (non-alarm condition) and to demonstrate an electrically discontinuous (infinite impedance) when the specifically associated detection mechanism is violated (alarm condition).
  2. Configure alarm circuits comprising passive detection devices and/or active detection devices as 4 conductors. Provide 2 of these conductors of appropriate size to realize the necessary operating voltage at the associated active detection device(s). Provide and interconnect the remaining two conductors to the actual detection device contact switches as described above.
  3. Interconnect "tamper switches", where provided as an integral part of a detection device, Transponder, or other System component, or where provided on any System box, panel or enclosure not located within a room which has been secured by a detection device, such that violation of the tamper switch will produce electrical continuity "across" or "shunting" the alarm conductors, thereby producing a "trouble alarm", as later described. Interconnect the "tamper switch" in series with the alarm circuit, in the same manner as the actual detection device contacts, if the latter configuration is not possible.
- B. Provide supervision and line security, and otherwise conform to the requirements of Underwriters Laboratories Standards #294 and #1076.
1. Incorporate circuitry to recognize and uniquely annunciate a normal electrical condition or "secure" condition for each and every alarm circuit i.e., uniquely associated with non-violation of either the detection device, tamper switch and interconnecting wiring. Additionally recognize the unique electrical condition associated with each alarm circuit wherein one or more detection devices have been violated and circuit continuity has been disrupted at the respective location; this being the "alarm condition". Finally, incorporate circuitry to recognize and uniquely annunciate any electrical condition other than the latter, i.e. neither "secure" or a "alarm condition"; this being the "trouble condition".

### 3.13 SECURITY ALARM AND ACCESS CONTROL SYSTEM

- A. General: Provide the Security Alarm and Access Control System as described herein and as indicated on the Drawings.
1. Guard Terminal: Provide the Terminal in a 2 piece configuration. Mount the CRT to a rack mounting panel of the same material and finish as the adjacent Console panels, as directed by the Architect. Provide a cut-out at the bottom of the panel to facilitate passage to the cable for the immediately adjacent and separate keyboard which shall reside on the adjacent writing surface.
  2. Event Printer: Provide the Printer on a "printer stand", both residing on a sliding shelf in the "base" of the Security Console. Provide the printer stand to "position" the Printer over the paper supply, and to guide the paper exiting the printer and cause automatic stacking.

3. Uninterruptible Power Supply (UPS): Provide a UPS within the base of the Security Console with sufficient capacity to maintain the Guard Terminal, Event Printer, CPU and other vital System components (with fifty (50) percent spare load capacity) for a period of not less than fifteen (15) minutes.
  4. Administrative Terminal: Provide the terminal in a configuration suited for desk top rather than rack-mounted configuration. Locate the terminal, within the "Office of the Building", not more than three hundred feet from the Security Console, as later directed by the Architect.
  5. Report Printer: Provide the Printer on a floor stand equipped with an acoustic enclosure, integral supply paper shelf and a bale for paper exiting from the Printer. Locate the Printer with the Administrative Terminal as later directed by the Architect.
  6. Central Equipment: Provide this equipment within the base of the Security Console. Coordinate the placement and mounting of the equipment to ensure proper access for operation and maintenance. Provide a low-noise ventilation fan(s) as may be necessitated by the associated heat load.
  7. Transponders: Provide Transponders as indicated on the Drawings. At each location, additionally provide the power supplies required for the attendant detection control functions. Provide a separate power supply as required for door hardware operation. Interconnect this power supply with the indicated "Life Safety Interface" circuitry to ensure the direct release of all electromechanical door hardware upon the occurrence of a life safety alarm, without System CPU intervention.
  8. Operating Supplies: Furnish two ribbon cartridges and two reams of Z-fold paper for each System printer.
  9. Access Cards: Furnish 2,000 Access Cards including only a visible numerical code for administrative purposes and "standard graphics" relating to orientation of the card for presentation at a card reader.
- B. System Capacities: Provide all necessary hardware and software to realize the following minimum capacities to be demonstrated by the System as installed, and the indicated expansion capability through subsequent System enhancements.
1. Alarm Circuits (System level, not via initial Transponders): 512, expandable to 2048.
  2. Alarm Priorities: 6.
  3. Alarm Messages: 512, expandable to 2048.
  4. Control Circuits: 512, expandable to 2048.
  5. Standard Card Readers: 128, expandable to 256.
  6. Elevator Card Readers: 24, expandable to 48.
  7. Active Cardholders: 5,000, expandable to 10,000.

8. Access Levels: 64, expandable to 128.
  9. Time Intervals (7-Day Week/Holiday): 64, expandable to 128.
  10. Operator Access Levels: 6.
  11. Operator Passwords: 16.
  12. Event Storage (Rigid Disk): 500,000, expandable to 2,000,000.
  13. Guard Terminals: 1, expandable to 2.
  14. Event Printers: 1, expandable to 2.
  15. Administrative Terminals: 1, expandable to 2.
  16. Report Printers: 1, expandable to 2.
- C. Elevator Control: Coordinate with the Elevator Contractor to realize floor-selective control of the indicated elevators via a card reader located within the Elevator cab.
1. "Security Mode" Operation: Provide all necessary hardware and software to ensure that floor selection within an elevator cab shall only be effective provided that the floor is comprised within the active access group for the particular cardholder. Additionally provide that conventional elevator operation may be realized, i.e., no access card is required, if so programmed at the Administrative Terminal.
  2. Elevator Control System Interface: Provide individual, 2-wire control circuits for each of the floors served by the respective elevator. Verify that each of these circuits shall not experience an open circuit voltage greater than 24 volts or a short circuit current in excess of 1 amperes, or as otherwise accommodated by the Transponder.
- D. Motorized Roll-Down Door Control: Interconnect System Transponder low voltage control outputs to effect opening and closing of all motorized roll-down doors. Ensure that these provisions do not interfere or otherwise interact with safety measures or Parking Control Equipment provisions.
- E. System Database Assembly and Entry: Provide a qualified technician or other representative thoroughly familiar with the work for not less than eighty (80) hours, to explain System operation and System database parameters, assemble and organize all database information, enter all of the latter data into the System and prepare printouts of all such data for Owner review at least fifteen (15) days prior to completion date.
- F. System Training: Provide an articulate, qualified, technical representative, thoroughly familiar with the work, for not less than sixty (60) hours to instruct designated Owner representatives in System operation.

### 3.14 SECURITY INTERCOMMUNICATION SYSTEM

- A. General: Provide the Security Intercommunication System as described herein and indicated on the Drawings.
- B. Performance: The System shall demonstrate sufficient sensitivity such that conversational level speech (approximately 55db SPL at 2'-0") at any "calling station" shall

realize a level not less than 85db SPL as measured 2'-0" on the axis of the loudspeaker within any "called station" without audible distortion. System frequency response shall be +2, -4db from 400 to 6,000 Hertz. Electronic signal-to-noise ratio shall be 45db, minimum.

### 3.15 VIDEO SURVEILLANCE SYSTEM

- A. General: Provide the Video Surveillance System as described herein and indicated on the Drawings. Coordinate interfacing of the video motion detection equipment with the Security Alarm and Access Control System.
- B. Furnish six (6) 2-hour "VHS" videocassettes.
- C. Performance: The System shall demonstrate not less than 450 lines horizontal resolution under lighting conditions in excess of 0.2 footlamberts scene brightness, assuming a nominal 50-percent reflectivity, with not less than 10 shades of grey scale rendition, and signal to noise ratio of not less than 40 db. Crosstalk, input and output isolation shall not be less than 50db to 5 Megahertz.

END OF SECTION

SECTION 16920

MOTOR CONTROL CENTERS

PART 1 - GENERAL

1.01 DESCRIPTION

- A. **General:** Provide motor control centers, complete, as shown and specified per Contract Documents. Principal items include motor control centers, including motor controllers and other devices inside motor control centers.
- B. **Other Applicable Sections:** Requirements of Division 1 and Section 16050 apply to work of this Section.
- C. **Related Work Not in This Section:** Motor control devices external to the motor control centers, when provided under other Sections.

1.02 SUBMITTALS

- A. **Procedures:** Refer to Division 1.
- B. **Requirements:** In addition to the requirements of Section 16050, submittal material shall include six copies of descriptive data for all products and materials.
- C. **Shop Drawings:** Submit for all work of this Section.

PART 2 - PRODUCTS

2.01 GENERAL

- A. **Motor control centers** shall be totally enclosed, dead-front, dead-rear, floor standing, of standard Code gauge metal with factory finish. Each vertical section shall be provided with necessary horizontal and vertical buses and wiring troughs. Units shall be plug-in type to plug into vertical section bus risers. Each unit shall be combination-type consisting of starter and externally-operated motor circuit protector. Externally operated handle shall be provided with means for padlocking in the open position. Motor circuit protector shall be Westinghouse "MCP" or equal. Combination starter unit shall be rated 65,000 amps RMS symmetrical interrupting capacity or higher where noted on the drawings.

2.02 WIRING

- A. **Of control center** shall be NEMA "1B", with individual terminal blocks.

2.03 STARTERS

- A. **Starters** shall be of size and arrangement as noted; magnetic type with external manual reset button, overcurrent protection units and low-voltage protection. Three ambient compensated, running over-current units shall be provided for all three-phase motors. Unit door shall be so interlocked that breaker must be in "off"

position before door can be opened. Provide individual control transformers for each unit.

- B. **De-Energizing:** When door is opened, compartment, including relays and control transformers shall be de-energized. Control voltage shall be 120 volt.

#### 2.04 ENCLOSURES

- A. **Sections:** Control center sections shall be 20" wide, 20" deep and 90" high, assembled to form a complete line-up of the size required. Spaces for future combination starter units shall be fully equipped except for the plug-in element. Enclosures shall be weatherproof where shown on the drawings.
- B. **Busing:** Busing shall be copper or aluminum; vertical busing 300 AMP minimum size; horizontal busing as shown on the drawings. Busing shall be braced to withstand 65,000 AMP RMS, symmetrical, or higher where noted on the drawings. Provide 1/4" by 2" ground bus in all sections. Provide proper size compression-type terminals for incoming feeder cables. Provide vertical bus isolation barrier.

#### 2.05 CONTROL DEVICES

- A. Provide individual control transformer and two normally open auxiliary contacts for each starter unit. Single-speed starters shall include hand/off/auto control switch with red and green push-to-test lights. Two-speed starters shall include a fast/off/slow/auto control switch with amber, red and green push-to-test lights and a decelerating timer relay for fast-to-slow motor speed transition.

#### 2.06 IDENTIFICATION

- A. Provide engraved nameplate for each control center and for each combination starter or circuit breaker unit. Name-plate shall show circuit number and load served.

#### 2.07 TERMINALS

- A. Terminals for control wiring shall be worked to correspond with approved designations supplied by control contractor.

#### 2.08 HEATER ELEMENTS

- A. Heater elements shall be selected to suit actual motor nameplate ratings; and shall be changed where improperly sized.

#### 2.09 TWO SPEED MOTOR STARTERS

- A. Contractor shall verify selection of two-winding or single-winding motor starter selection.

#### 2.10 MANUFACTURERS

- A. **General Electric** or Westinghouse.

**PART 3 - EXECUTION**

3.01 INSTALLATION

- A. **Motor control centers** shall be bolted to concrete floor at four corners of each section.

END OF SECTION

- A. **Provide terminal blocks** for all 24 volt wiring terminations from all relays. Provide 10% spare terminals.
- B. **24 volt control leads** from each relay shall be connected to terminal blocks and identified.

2.06 FIELD INTERFACE DEVICES

- A. **Provide field interface modules** in each control panel to operate relays in response to commands from the CPU. A number of command points shall be as scheduled on the drawings.
- B. **Field interface module** shall have local manual switch to turn all relays on or off if communication with CPU is lost.
- C. **Provide for at least eight local inputs** in each control panel. Local input shall control relays through the CPU, not directly.

PART 3 - EXECUTION

3.01 PANEL INSTALLATION

- A. Panels shall be securely attached to structure.
- B. Provide two 2-1/2" conduit from each relay panel to the associated lighting panel.

3.02 WIRING

- A. **24 volt wiring** shall be #20 AWG minimum size, 300 volt insulation.

END OF SECTION