



# ***STEAM BUS SYMPOSIUM PROCEEDINGS***

November 17, 1971  
Washington, D. C.

**S.C.R.T.D. LIBRARY**

RECEIVED

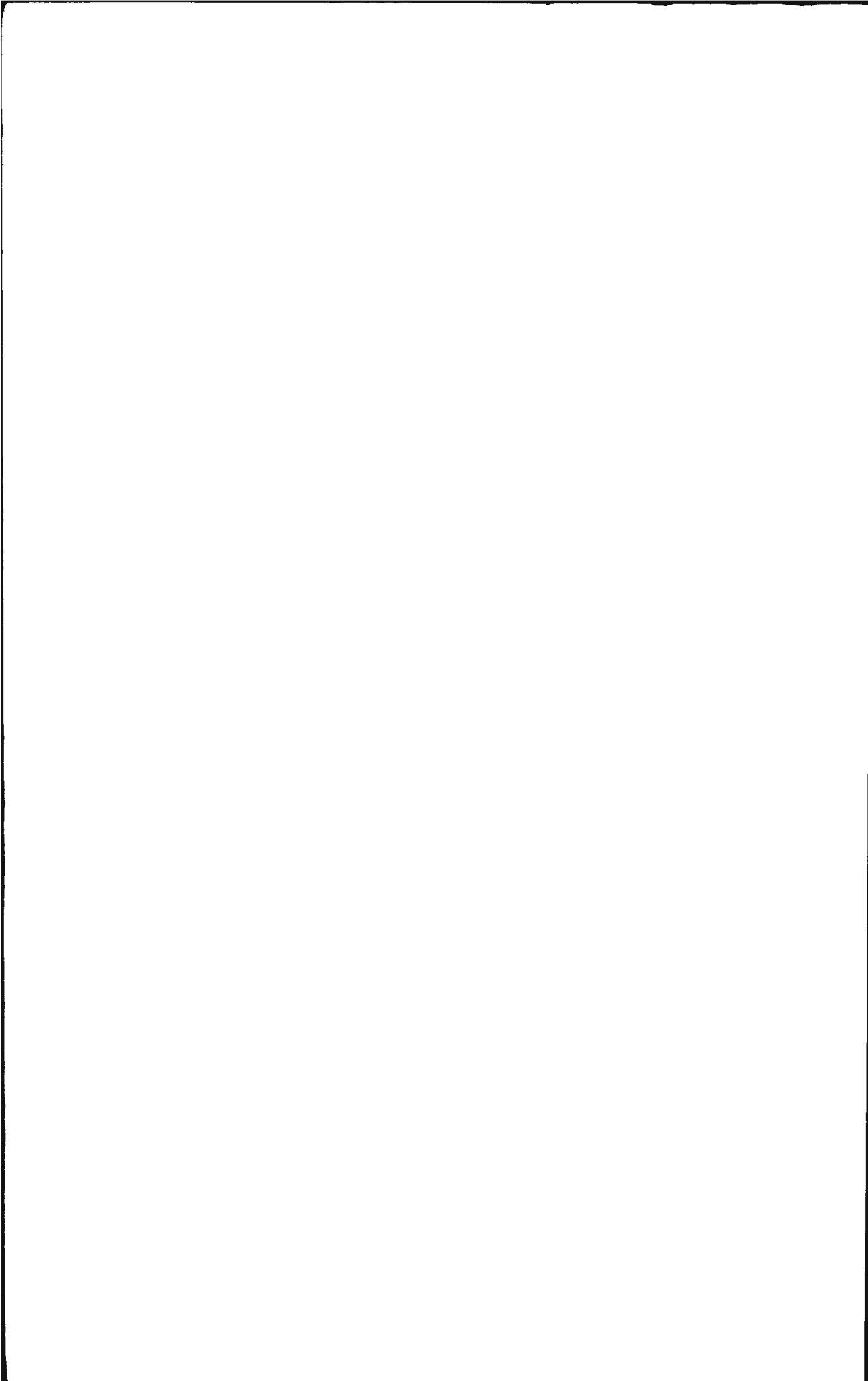
JAN 29 1973

G.W.H.

Sponsored By: **Urban Mass Transportation Administration**  
U. S. Department of Transportation  
Washington, D. C.

Prepared By: **Scientific Analysis Corporation**  
San Francisco, California

TL  
32  
573



# ***STEAM BUS SYMPOSIUM PROCEEDINGS***

November 17, 1971  
Washington, D. C.

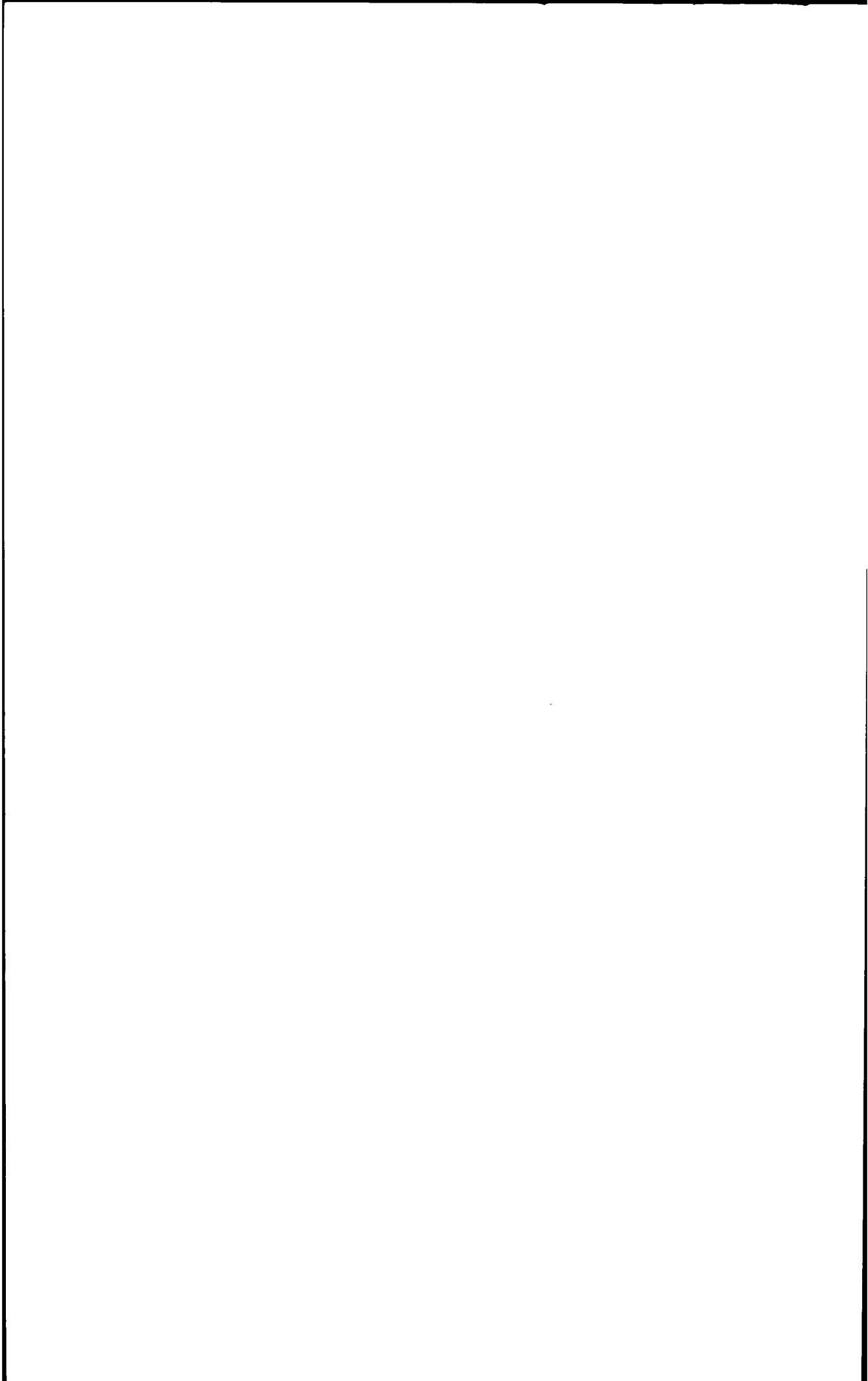
Sponsored By: **Urban Mass Transportation Administration**  
U. S. Department of Transportation  
Washington, D. C.

Prepared By: **Scientific Analysis Corporation**  
San Francisco, California

01354

## Table of Contents

<u>Speaker</u>	<u>Page</u>
Program Introduction by C. Carroll Carter . . . . .	1
Opening Remarks by C. C. Villarreal . . . . .	2
UMTA Research, Development and Demonstration Program by Dr. Robert Hemmes . . . . .	5
EPA Rankine Cycle Program by John Brogan . . . . .	13
Transit Industry Commentary by Alan L. Bingham . . . . .	17
Remarks by Honorable James M. Beggs . . . . .	19
Role of the California Legislature by James Lane . . . . .	22
Steam Power Systems Steam Bus by Richard Burtz . . . . .	29
William M. Brobeck & Associates Steam Bus by William Brobeck . . . . .	37
Remarks by Robert W. Fri . . . . .	47
Lear Motors Steam Bus by William P. Lear . . . . .	50
Combustor Research and Emission Goals by William Compton . . . . .	63
Vought Aeronautics Steam Bus by Dr. Walter J. Hesse . . . . .	83



## Program Introduction

*C. Carroll Carter, Assistant Administrator for Public Affairs,  
Urban Mass Transportation Administration,  
U.S. Department of Transportation*

Good morning and welcome to the Department of Transportation. To introduce myself to you, I am Carroll Carter, Assistant Administrator for Public Affairs in the Urban Mass Transportation Administration. In UMTA we're just delighted to be able to provide a forum for discussion on the very important subject assigned for this morning.

A couple of announcements on the mechanics of the meeting, so that all of you will know what the drill is going to be today. We would like to ask each of you to be sure to register with us. There are blue cards out in the lobby. At some point in the course of the day please fill one out – not name, rank and serial number – but name, title, company affiliation, street address and zip code, so that as our program develops we will be able to get to you the information concerning it. It will also be a very valuable list to us of those of you interested in this program.

You will notice on the schedule there is a break at 10:40 a.m. At 1:00 p.m. a demonstration of the steam engine powered bus is scheduled. The bus will be available for inspection in the circle in front of this building. That is the side of the building on Independence Avenue. The bus will be there at 1:00 p.m. and on display until 1:30. The bus will then be available for rides this afternoon between 4 and 5. If there are any press representatives in the room, will you kindly meet with Walter Gold at the back of the room: he has a press kit available for you.

There will be an opportunity to ask questions, but not until this afternoon. We have a great deal of material to cover and we want to keep the meeting on time as much as possible. Later this afternoon Chuck Daniels and Phil Morgan will make available to you an orange colored card like this. We'd like very much to have you write out your questions, and who you would like to have answer them so that you will get the kind of specific answer to the specific questions that you have have.

We will open this afternoon session at 2:15, but just prior to that, at 2:00 for those of you who may be interested, we'll show a short eleven minute film on Transpo, The International Transportation Exposition which will be held here in Washington in late May and early June of 1972. It is an informational film of what Transpo is all about for those who may be interested.

It is now a distinct pleasure for me to introduce to you our Administrator of the Urban Mass Transportation Administration to greet you this morning, Carlos Villarreal.

### Opening Remarks

*C. C. Villarreal, Administrator,  
Urban Mass Transportation Administration,  
U.S. Department of Transportation*

Good morning and welcome to the Urban Mass Transportation Administration's Steam Bus Symposium. I bring you the greetings of Secretary of Transportation John Volpe, who at this hour is on his way back from Denver, Colorado, to inspect and ride the nation's first modern steam bus later this afternoon. I am glad that so many of you could be here today. There are so many people and agencies to thank for making this event possible. In the interest of time, let me just ask each of you to thank each other. It's a good way to meet the person who is sitting next to you. But very special thanks should go to the Environmental Protection Agency, the California State Assembly, the contractors and the subcontractors, and the many, many more who are participating here today.

Later this morning Under Secretary James Beggs will talk to you about the new low pollution vehicle. But before we get into specifics, let me give you a quick bird's eye view of where the development of modern, local low-pollution transit vehicles fits into our overall goal of helping to develop and demonstrate new and better means of mass transit.

First of all, we have come a long way in the last three years under the leadership of a concerned President, a knowledgeable Congress, and a dynamic Secretary of Transportation. It was only a little more than a year ago that Congress passed by an overwhelming majority President Nixon's Urban Mass Transportation Assistance Act. This allows us, for the first time, to commit 3.1 billion dollars between 1970 and 1975 to upgrade, expand, improve and develop bus, rapid transit, and commuter rail systems across the nation. And Congress has announced its intent to appropriate at least ten billion dollars by 1982 for urban transit improvement.

And while we are helping cities get present day equipment at an accelerated rate, we are here today to do something about updating and upgrading the transit vehicles and systems of the future. Our immediate goal is to save and improve the existing transit systems. Buses are one of several immediate answers, and as long as we are going to use buses, we insist that they be more efficient, safer, less polluting and more attractive to the public. And that's not all; we're using the buses we have in better ways: on exclusive buslanes and freeways. For the first time, the bus rider is getting the same kind of right-of-



way advantage enjoyed by train commuters and car riders. A few months ago Secretary Volpe took us on a ride in one of the new express buses on the Shirley Highway, which now carries more than 20,000 Northern Virginia Commuters to and from their jobs in downtown Washington.

We are also luring frustrated motorists out of their cars in Seattle, Washington, with a similar service called "Blue Streak". And for the first time thousands of New Jersey residents are able to ride buses into New York City through the Lincoln Tunnel on a traffic-free, exclusive buslane.

Now, don't get the idea that we're only "buggy" about buses. We have been spending millions of dollars on new commuter railcars, subway cars, commuter station improvements, commuter traffic stands and other capital improvements for mass transit. We are helping the big cities and the small cities alike. Each share the urban transit problems except, of course, on a different scale.

In Miami, we are helping the buses; in San Francisco, UMTA is helping to build the BART System; and at West Virginia University at Morgantown we are out to build an entirely new concept which we call Personal Rapid Transit. (Some others call it the People Mover.) And in this horizontal elevator type of automated small car, if personal rapid transit works as well as we think it will, you may soon see the birth of a new form of mass transit in Morgantown.

Former and potential transit passengers are now looking for an alternative for the automobile because we find that in most cities we are plagued with exasperating congestion and traffic delays during peak hours despite a substantial and expensive highway program. Even worse, the automobile is contributing to 80% of the air pollution in our cities. The plain truth is that we have a massive imbalance in our transportation system. While building our new super highways, we have let our urban bus and transit system become old and outmoded. And most of our mass transit systems are in financial trouble. Some of them are in deep financial trouble. UMTA's first priority, out of dire necessity, then, has been to save our existing systems. Without them there would be nothing on which to build. Second priority goes to improving and extending our existing systems. In 1970, UMTA, through its capital grants program, helped communities purchase 1,995 buses, 563 new commuter railcars, and upgraded transit facilities in eighteen cities.

Another most important priority is UMTA's responsibility to conduct research, development, demonstrations, and evaluation of new systems, such as our external combustion engine program. New systems development is complicated by the fact that no single new system is the answer to the transit requirements of all cities.

We've done a lot during the first year of our new legislation to help mass transit get back on its collective feet. But there is much, much more to be done. The work on bus propulsion systems is just one example of how we are proceeding.

We appreciate your interest and participation here today. As you meet

here, keep in mind that transit watchers everywhere are anxious to see tangible proof. They have but one question in mind, "When can I ride on it?" All of us know that the answer has to be: "Soon, and very soon."

I want especially to thank Al Bingham and AC Transit for having the first bus that is underway with steam power. I will never forget — I think it was the second time that I was visiting AC Transit with Al Bingham and I was proud of the fact that I just earned my Bus Operator License after having taken the examination in Los Angeles — I went up to Oakland, and Al Bingham asked me if I would like to drive his articulated bus. And, of course, I wasn't checked out on an articulated bus! An articulated bus is a combination of fire-hook-and-ladder truck and a semi-trailer. But I drove it, and it was a great and wonderful experience. I think that Al Bingham and AC Transit deserve a lot of credit for having gone together with Brobeck to get the first steam powered bus underway. Thank you so much.

## UMTA Research, Development and Demonstration Program

*Dr. Robert Hemmes, Assistant Administrator for  
Research, Development and Demonstration,  
Urban Mass Transportation Administration,  
U.S. Department of Transportation*

Good morning. As Carlos points out, we would like to make you aware of our total program – not to take the emphasis off the important and historic bus symposium, but to put it in a broader perspective and to communicate to you how the Urban Mass Transportation Administration is addressing a very real and difficult problem facing all of urban America.

I would like to join our administrator in congratulating Al Bingham and Bill Brobeck for having met our budget and schedule and delivering the bus. Al's accomplishments go beyond the steam bus – articulated buses. He is one of the great innovative managers who also gives away free umbrellas and puts bicycles aboard the bus. Bill Brobeck is also a very impressive man who built the no-nonsense bus; he uses mirrors to look under the bus instead of building expensive lifting devices and runs a dynamometer which is taken off the project when it's finished so that we don't run up needless expenses. All of these are a great concern to me. When you are trying to work with extremely limited funds, with a broad spectrum of problems, spreading your personnel and money very thin, it's just a pleasure to work with a contractor who delivers the job at a minimum cost.

The steam bus is one of a number of attempts to meet the constraint in our legislation that requires that we shall not pollute the air. One of the primary objectives of the Environmental Protection Agency is the reduction of air pollution. We're not competing with them for a solution to that very difficult problem, but we are cooperating and coordinating. Our primary target is public mass transportation. Not polluting the air is a constraint imposed on us by legislation and so, naturally, we are interested in how to move buses and other vehicles with minimum air pollution.

In addition to steam, an experimental program should consider, of course, all propulsion alternatives for buses that offer improvements over the current diesel engine. This would include other working fluids besides water. Two of the four systems that are involved in the bus engine program have considered substances other than water as a working fluid. We could also convert conventional diesels to use liquid natural gas or compressed natural gas;

we could use gas turbines; we could use a hybrid engine that has a combination of an energy storage device and constant RPM prime mover. Anything that moves in a constant mode produces less pollution than something that accelerates and decelerates. So, if, in order to provide the ability to accelerate and decelerate, we store the energy in a battery or flywheel, and then combine it with a constant speed prime mover, we might reduce air pollution.

There are many alternatives that we could generate. Some of them are in active demonstration, some are in experimental and developmental stages, others are listed on a funding plan with nothing happening and we are just hoping that we can find the money to fund them.

In addition to buses, we have to consider all modes of transportation. We do not believe that one mode dominates another. We believe that, through an evolution based on use and demand, several modes have developed which play a role in the total picture.

In our rail program we are also addressing the problem of improving propulsion systems. We have planned demonstration projects to propel railcars with gas turbines. Other projects will substitute an AC motor in place of the currently used DC motor to see, if indeed, claims are true that AC motors are easier to maintain and give smoother acceleration. In particular, we're thinking about pertinent methodologies.

Railcars have grown so expensive that frequently when a local body writes its specifications, applies for a capital grant, puts up its one-third local share, gets the federal support, goes out for bid and bids come in, the cars are too expensive. The number of cars that can be bought won't do the job, and the increase of funds necessary would mean reprocessing the capital grant and a bigger drain on our program. So, how can we bring those prices down? Well, in addition to more efficient hardware, we're trying to take advantage of the commonality that exists among the various properties in their requirements for a railcar and, perhaps, get an economy of scale. It is not the desire of the Department to impose some federal compulsion of will on the local public bodies, but merely to assist them to see the light: if there is a commonality in their purchases, economy of production scale will drive prices down. If a car is unique to a transit property, the bidders see its specifications for the first time in the request for bid. Well, naturally, tailor-made cars for a specific property with unique designs are going to cost more than if all the properties had agreed on certain areas of commonality. Distinctions could be made to accommodate the various properties. Then, competition would take place in anticipation of future capital grants. If we could have some specification — a guideline specification first — which might turn into a performance specification — a guideline specification first — which might turn into a performance specification and which, in turn, might evolve into a hardware specification for the areas of commonality, then the car makers would not be taken by surprise by the specifications and true competition would develop. Of course, it's cheaper per car to build an order for several hundred cars than for less

than one hundred. One of the areas that we think about is making this economically feasible as well as technically feasible. This, of course, would be true of all hardware systems and we do have a similar type of guideline specification for buses already prepared for our bus program.

I would like to go back to the bus program for a moment and remind you that we are taking on a very ambitious program of redesigning the transit bus so that we will produce an entire new generation of buses to succeed the transit bus now in operation.

This is based on some assumptions. We are willing to take risks, which is this program's role. We provide the venture capital and risk money to stimulate and turn around an economically depressed but much needed industry. Transportation is a necessary condition for the survival of cities, even though it is the biggest economic loser. Perhaps, we ought to have another look at the way we support our transit system.

The first thing we want to do is to provide a reasonable and viable alternative to the automobile. Learning from our experiences of buses of the past, we would like to buy a bus that will be acceptable to the public in anticipation of the day when the public, in general, will have to support the bus. Not just the riders but the whole public. Then, the support base may be local or it may be federal. This is still under study, consideration and debate. If you are going to support the public transportation system in the form of taxation or other subsidy, you'd like it to be an adequate and reasonable transportation mode just as you demand that the university that you support through public funds provide efficient and comprehensive education, and just as you demand that the fire and police departments do their job well with the public money. We should provide a transportation system that isn't hard to find, to ride, or to get you where you want to go. It should be an actual and reasonable alternative.

One of the steps in this chain is to provide a piece of hardware that isn't a menace. In this bus we should not have noxious fumes, noise, vibrations. We should have a quiet, efficient and non-polluting engine. That is the emphasis today. The bus itself should also have means of access and egress so that loading and unloading take place with some dispatch in order that elderly and handicapped people will find it possible to get aboard and once aboard find it possible to survive and not be thrown to the floor. We would like a bus that is easier to maintain, and safe in operation to both the people inside and to the vehicles on the street.

We are assuming that, if we build a better bus, that public bodies will want to buy this bus with federal financial assistance. That is one assumption, and it is based on the argument that, if a better bus and better scheduling will attract more passengers, then the properties will be in a better financial position by paying a higher first cost for a better bus and this will reduce the deficit in the ensuing years.

Assumption number two: this better bus will allow better methods of

operating including exclusive bus lanes, such as Shirley Highway, and exclusive bus ramps, such as Seattle's blue streak. Streets dedicated to these and other methods of making the bus move faster will attract enough passengers so that the demand for bus transit will increase. We are predicting a demand. Even if we haven't increased demand, we're buying more buses and we then assume the bus market will turn around. At this time we don't know how far it will turn around. We've made our own guesses that certainly we will need more than 1,500 buses a year being sold to solve the important bus transportation problem. If we find, for example, that Shirley Highway continues to absorb more and more buses, we will put thirty more buses on there; if they fill up, we'll put a second thirty; and if they fill up, we'll put a third thirty. If we work it right, we may be able to project from this data how many buses we could add to the national inventory. If we get to manufacturing five or six thousand buses a year we could attract new industry interest in the building of this new bus. This would certainly be a healthier situation for the builders, the operators, and the public.

So the program is quite comprehensive and involves more than just a steam engine, or steam bus, or a single bus. It involves methods of operation, economic considerations and the viewpoints of the public, the rider and non-rider. All are included because they may all have to contribute to transit's eventual support. The viewpoints of the operators — there's no point in building something that nobody can operate or afford to operate — and the viewpoints of the manufacturers also must be considered. This is a national program and any national program, be it transportation or defense or agriculture, depends upon private enterprise. Under this system, government does not own the means of production; it is not socialistic. It is a capitalistic system in which government and industry are partners. We cannot set policies, or start initiatives, that cannot be fulfilled by private industry. We are quite aware we have to work with the industry and its several viewpoints.

I mentioned the rail program. I would also like to point out that in the long run we may have a mode that may replace the bus or the rail system in certain areas. An example is in the very congested urban areas where it is literally impossible to install a big rail system or buslane or a highway. A very congested urban area simply may not have room on the surface and, also, it may not have room underneath the surface because of utility tunnels and existing subway tunnels. Of course, the extreme example is downtown Manhattan where traffic is at almost a standstill and where there is no reasonable way to travel across town. Now a feasible but expensive solution would be Personal Rapid Transit. We hope that as we learn more about it and as more of these vehicles are built, the cost will go down, but right now they don't compete economically with the bus. Personal Rapid Transit is characterized by automatic operation that gives the passenger an express ride. This means that it uses a small vehicle because on an express ride you can't be stopping to let off your fellow passengers.

In order to maintain the high capacity necessary to meet the definition of mass transportation with a small vehicle, we have to have many vehicles. In order to provide a reasonable alternative to the flexible automobile and bus which go where the driver wants it to go, this vehicle operates on a fixed guideway and we'd have to have many of these fixed guideways going from many origins and to many destinations. This all adds up to a very difficult command and control problem because these vehicles must automatically accelerate and decelerate, switch and merge, and find their destinations in the shortest time, avoiding the other traffic. These are not only expensive but the technological problems are not entirely solved. We are making a start. In addition to Morgantown, which the Administrator mentioned, we have four systems being developed. I did not say demonstrated, because this is a research and development as well as a demonstration program. We're putting these developmental systems in public view at the site of the transportation exposition at Dulles Airport. It's not an exhibit, however. We're going to keep the vehicles on site after the nine day exposition and put them through all of the tests necessary to complete the development. While it is kind of bold and daring to put this development in public view, and we are willing to show the public what we are doing — we are not going to guarantee anything. If these weren't risky and if they weren't new and innovative, it would be an improper use of the research, development, and demonstration money. This money should assume the risk that the industry, the private industry on which we depend, cannot afford to assume at this time. So the government is playing its proper role in doing for industry what it, at this time, cannot do for itself in situations of high risk with no immediate promise of return.

We are trying to do this for all industry. Often we negotiate strong patent clauses favorable to the government. In other situations such as at Dulles, where there are four distinct proprietary systems, we relax and move toward a patent clause more favorable to private enterprise in order to stimulate their interest and to gain some cost-sharing. They are not going to put up money if there is not a prospective return. There is a great deal of cost-sharing at Dulles, not required, but motivated by the fact that we allowed patent clauses very reasonable and favorable to the companies. Now, the fact that we are building with competition protects the public. No one can gain a monopolistic advantage.

A further area, in addition to hardware that we've introduced in the last year in our demonstration, is a methodology to find out what it is we've demonstrated so that we don't just exhibit a vehicle and say, "Well, there it goes", and people remember, "Yeah, I saw that and it really ran."

Well, what was it that we demonstrated? In order to do this we need an experimental design to guide and structure each demonstration. An experimental design can best be described in terms of a little device that I've seen usually in bars I must admit, that sits in the corner and is labelled "Educational Computer Quiz" on the top. There's a slot where you can insert a

dime and a dial where you can select the quiz category: theater, sports, general, stage and screen. After selecting the category and putting in your dime, questions appear on the screen and it becomes your job to push a button that says "true" or "false" as to the validity of the assertion. Now, suppose you picked singers. "Gloria Swanson was famous for singing When the Moon Comes Over the Mountain" might be the assertion which appears. True or false? If you push the right button the green light flashes and your answer is correct. You might push "false", and if that is the correct button – you would get a green light. If you push the wrong button, you get a red light. Now you could have four situations: 1) "false" is correct, 2) "true" is incorrect, 3) "true" is correct, 4) "false" is incorrect. Now this is a lot like what we are facing in the demonstrations, except we don't have wires which know what the right answer is ahead of time. Nor are we given red lights and green lights behind our system the way the computer does. So we make an assertion that Personal Rapid Transit systems will work; moreover, our Personal Rapid Transit system will compete favorably for riders with an alternative mode. After we make that assertion, we test it with a demonstration project and collect enough data to get the red or green lights.

Now the fact that we do the demonstration means that we're pushing the "true" button. We don't have to push the "false" button because, if we have any evaluation technique, it doesn't matter which button we push just so we know whether we get a correct or incorrect result. All we have to know is which button we push. So for political reasons and just to look better, we say, "Everything is going to work." We push all the "true" buttons. The key to a successful program is when we gather data according to the experimental design to find out whether our "true" bet was correct or incorrect.

Putting the assertions in the demonstration is risky enough and indeterminant enough so that we don't know the answer ahead of time. If we knew the answer ahead of time, we would be wasting our money. Ours is an information seeking program. We make a bet and see if the bet was right. If we lose them all, we learn a lot. You can learn by making mistakes, it's true. If we can't win in the public eye, it doesn't look like we know what we are doing, say to the Appropriations Committee. We would like a reasonable amount of the demonstrations to work. If they all worked, our program would not have enough risk in it; it would be too timid. So, people understand ~~that~~ we can't have all successes.

We try to take bets that are reasonable and, probably, will have more of a chance for success than for failure. In that way we can be making some positive contributions that are immediately usable and, at the same time, we learn whether or not our particular bet was good.

Our main problem, of course, is funding. We have a very difficult problem to solve, and if you spread the funding too thin, nothing much comes of it. If you put too many eggs in one basket, the one success is overshadowed by overwhelming unsolved problems. We anticipate, and there are encouraging



signs, that attitudes toward mass transportation are changing. The necessity of it is being recognized. There are signals coming from the voters; that's where the signals really come from. There are examples such as the passage of a bond issue for transit support in Atlanta and an additional two cents per gallon tax on gasoline in California to be devoted to urban mass transportation.

To really solve the problem in the cities, we will need a large, dedicated national effort. Of course, again, it depends upon the voters. The political leaders interpret the will of the voters. If we were to set a national goal within this decade of moving a man across town and provide the necessary funding, we could solve the problem. I think our program is laying the ground work. We are trying to learn from our mistakes. We're sorry that we cannot fund all the excellent ideas and proposals that are presented to us, but we do appreciate the opportunity to hear about them. We regret the fact that our staff is so small that we can't spend more time with you, but we are always encouraged, I am in particular, by the fact that when we do have something to say and something to show that we have the enthusiasm and support of an audience such as this one right now.

*C. Carroll Carter, Assistant Administrator for Public Affairs,  
Urban Mass Transportation Administration,  
U.S. Department of Transportation*

Many thanks, Bob. From Bob Hemmes' remarks it should be perfectly clear that successful mass transit isn't going to be the work of any one agency, one enterprise, one company or one city. And even though the Department of Transportation, so to speak, rented the hall this morning and provides the place for this meeting, it should be perfectly apparent that these discussions on external combustion engine development and propulsion systems involve not only Department of Transportation effort. I think as we do on today it will become clear that progress is, indeed, being made here through a joint effort of a great many different organizations both public or private.

In conducting this steam bus symposium, we feel that, of course, it is perfectly proper and indeed very desirable for us to just simply provide the forum for the presentation of ideas and the discussion of a variety of different approaches to a problem. We don't expect, by any matter of means, there will be unanimity or complete agreement. And, in fact, we think a very important and useful service will be provided by us, if, indeed, those differences are better understood as a consequence of the meeting today.

One agency that is doing very significant work in this field is the Environmental Protection Agency under the very able direction of Bill Ruckelshaus. We certainly wish to compliment the EPA for the very excellent cooperation that they've given us in the workings that we've had with them. So moving on this morning, we would like to present to you the first speaker from the EPA for a general description of their overall low pollution engine development program, particularly as it related to passenger cars, but none the less, intimately related to work being done in bus propulsion. Your speaker this morning, prior to being with the Environmental Protection Agency, was with Lockheed Missiles and Space Systems in 1967-1968, and then prior to that, was with the National Air Pollution Control Administration. So, it's a very real pleasure for us in the Department of Transportation to introduce one of our colleagues and friends at EPA, John Brogan, who is the Director of the Division of Advanced Automotive Power Systems Development of the Environmental Protection Agency.

## EPA Rankine Cycle Program

*John Brogan, Director,  
Division of Advanced Automotive Power Systems Development,  
Office of Air Programs, Environmental Protection Agency*

To introduce this topic, I would like to explain briefly certain requirements delineated in the Clean Air Amendment of 1970. These amendments extended the authority of the federal government to become directly involved in essentially all activities where significant pollution arises. Particularly, stringent exhaust engine standards for automobiles appear in this legislation. This law requires a 90% reduction in hydrocarbons and carbon monoxide from the 1970 standards by 1975, and, by 1976, a similar reduction in nitrogen oxide from average 1971 levels on uncontrolled automobiles.

The automobile industry is working to meet these standards by "cleaning up" the conventional internal combustion engine with new fuel delivery systems, engine modifications and after-treatment. If it appears that to achieve these levels with the conventional engine drivability, road performance, and fuel economy will be degraded. Another approach is to develop alternate engine systems which offer the premise of meeting these standards without the marked reduction in these characteristics.

In 1970, a research and development activity called the Advance Automotive Power Systems Program, or the AAPS program, was initiated to develop alternate engine systems. The responsibility for its management rests with the Environmental Protection Agency.

The goal of the AAPS program is to demonstrate 1976 exhaust emission standards in practical engine systems at the earliest possible time. The program is intended to serve as a stimulus to industry to seriously consider alternate engine systems to do the job.

When comparing the original concept of a stratified charge combustion process demonstrated in the 1920's by Mr. Riccardo with the two versions under development today in our country, the Ford version and the Texaco version, it is apparent that there have been many evolutionary changes. Perhaps the most important change appears in the throttling of incoming air. In particular, in the Ford process air flow is controlled throughout the entire range of engine speeds and this permits the air/fuel ratio to be maintained between 15.5/16 to 1 from key-on to key-off. Features of the final form of the Texaco version will be made known shortly.

Recently, a series of tests were made on a 4-cylinder engine employing the

Ford Combustion Process in an Army jeep version. The tests included exhaust emissions. The 1976 standards were met on 9 of the 14 tests and, on the average all three standards were met in these preliminary tests. The system employed a thermal reactor, an oxidation catalyst and used exhaust gas recirculation. Nothing can be said as yet on the durability of this engine system. This was the first engine we know of that met the standards while matching the fuel economy of the engine which it might replace. Of course, since this type engine is a modification to the conventional spark ignition engine, on the whole its manufacture requires similar production techniques to those currently being used. Duplicate copies of this test engine are being tested and durability testing of the first engine will be initiated shortly. Engines employing the Texaco Combustion Process will be available to us for test in the December-January period. We are optimistic that similar test results are achievable with that engine. Based on the test results, one of the two contractors will be selected to detail design his engine, design soft tooling to produce it and to make 15 engines by June 1973. Now for the Rankine system work.

Consider a basic closed Rankine cycle engine. There is an enclosed working fluid which is heated in the vapor generator with the burner, expanded to do work, then condensed into a liquid, with the fluid being continuously recycled by the feedpump.

There are three types of Rankine systems which are presently in the system development and component test phase.

The major problem areas associated with the practical design of the Rankine cycle system for the automobile are mainly in large size and heavy weight of components, complexity of the controls and lubrication. You may observe that we do not show high exhaust emissions as a problem because we are confident that these Rankine systems will meet the 1976 standards. This confidence is a result of the technology advances made in the Rankine system burner designs coupled with our increased knowledge of the combustion process and pollutant forming mechanisms. Program scheduling shows technology programs running in parallel with engine and component development work. The technology program provides for independent contractors to work some of the problems which characterize the Rankine system for the automotive application. For example, the problem of excessive condenser size has always been a problem. Much headway has been made in this area. This advance in heat exchanger technology was made by Garrett-AiResearch Corporation under AAPS funding. The new slotted fin surface is more than twice as efficient as the best automotive configuration and nearly 50% better than the best aerospace design. Equally important, the projected cost to manufacture the new shape is comparable to the relative improvement in efficiency. Combustion research and burner development for the Rankine system has been successful and has led to several practical and very low pollution burners. For example, the successful work conducted

at Solar, a Division of International Harvester will be presented this afternoon. This work is a part of the AAPS Program. Another successful approach to a practical very low pollution burner was demonstrated by one of our system contractors, Thermo Electron. This latter work was sponsored by the Ford Motor Company.

Testing of the three complete Rankine systems is scheduled for December, 1972. Then, a maximum of two systems will be brought into the prototype phase where one type will be installed in test vehicles and demonstrated by July, 1974. Now for the gas turbine engine.

Gas Turbine Engine. The gas turbine program is directed toward problem solving research. The timing of this work is predicated on projected events. It assumes limited production of gas turbines by industry in the Spring of 1980, industry demonstrations in 1975 and the decision by industry to demonstrate by the fall of 1973. It follows then, that for the current program to be meaningful, convincing results in the form of practical solutions to most of the technical problems must be available by or before the Fall of 1973 date. Work has been initiated to update system configuration selection, that is, to determine the best type of turbine for the automobile on the basis of the total net cost of ownership to the consumer. This evaluation is being conducted in three parallel studies by three different teams of turbine specialists and covers all known turbine types from open cycle, simple cycle single shaft through to regenerated free turbine and also in one case includes closed cycle systems. Integral parts of the configuration selection studies include evaluations of new techniques and previously proven techniques for improving part load fuel economy and some fabrication techniques currently in their infancy.

Combustion research and gas generator development is underway by six teams of combustion specialists using conventional and radically different approaches toward reducing the nitrogen oxide emissions while maintaining desirable levels of combustion temperatures. Under an Environmental Protection Agency funding grant awarded to the City of New York a gas turbine powered automobile was developed. The turbine engine was designed by Williams Research in Walled Lake, Michigan. Initial emissions and road performance tests will commence on November 24 in our Ann Arbor facility. The system will then undergo considerable in-use testing in a very hostile environment for a turbine, namely on the streets of New York.

Although, it is too early to tell whether the gas turbine problem solving research will be successful, there are some preliminary indications that the emissions problem appears to be solveable. Within the next four months many of the analytical and experimental tasks that started early this year will be completed. At that time, the best turbine configuration with best fuel economy techniques will be selected and the results of the combustion work, should clearly show the directions available for practical low  $\text{NO}_x$  gas generator design. We anticipate that by approximately December 1972, we should

know with confidence whether the turbine is indeed a viable candidate to effectively compete with the conventional internal combustion engine.

Well, that has been a summary of the advanced Automotive Power System Program, our goal, the candidates, status of development, and where we are headed. Thank you for your attention.

*C. Carroll Carter, Assistant Administrator for Public Affairs,  
Urban Mass Transportation Administration,  
U.S. Department of Transportation*

As Carlos Villarreal said earlier this morning, we need our research and development program to incorporate the best in developments that are meaningful and relevant to the transit operator, to the public transportation rider and, in general, the people who are intended to benefit from this program.

Your next speaker this morning represents perhaps the best in a transit operator. I can't comment at all on the rumor that the name of AC Transit is going to be changed to AB Transit for Al Bingham. Sometimes he's introduced as the "Bear of the East Bay" or "Oakland's answer to Bill Stokes." Sometimes he is even called the "Bill Beck of Transit," because he has been such a successful promoter and developer of a fine system in Oakland. It's a pleasure to introduce Al Bingham to you.

### **Transit Industry Commentary**

*Alan L. Bingham, General Manager,  
Alameda-Contra Costa Transit District,  
Oakland, California*

It is quite an unusual experience, bringing a steam bus from California and having it on the streets of Washington, D.C. It is a proud time for AC Transit and for the William M. Brobeck engineering firm, which developed the steam power system.

This is an exciting moment in transit research. As a matter of fact, I feel this is a very exciting time in our industry.

Perhaps for the first time, we, the transit industry, are starting to have available the financial resources so we can be truly responsive to the public's demands. Certainly, this is the job we have to do, if we're going to get people out of their cars and into mass transportation vehicles.

To do this, the industry has to have funds available to improve the quality of the service and the vehicle and yet, hold the cost of the service — in terms of the fare structure — to some reasonable limit.

The actions of Congress and the President to get federal programs going in capital grants and research have been excellent. It gave us the shot in the arm

that we need to start reversing the downward riding trend and to build increased patronage.

The research that has gone into private corporations and consulting groups as a result of the federal programs has never before taken place in the history of our industry. This has been made possible by the federal programs which went into effect in 1964.

What we are seeing here today – the nation's first steam bus – is one result of this activity. We do not look at these research programs as finished prototypes, but as just the beginning of something that could work.

A lot of requirements are involved in the operating industry's needs as far as a new power plant is concerned. Certainly, we've heard a lot about emissions. The steam bus, as we understand it, is in pretty good shape on that count. And yet, as far as public demand is concerned, I think we are going to have to improve much further on air and noise pollution.

The weight of engines is very important to us – and is going to be more important as time goes by. As bus design improves and the amenities in the coach improve, we are going to find we have too much weight on the coach so far as various state and federal requirements on axle loading are concerned. So, if we are going to improve on the attractiveness and comfort of bus riding, we have got to cut down on weight of the power plant.

Lower maintenance and fuel costs are extremely important. As the costs in the operating side of transit continue to increase over the years, the speed of the vehicle is becoming a more important issue than it has been in the past – for two reasons: First, from the standpoint of the riding customer, who wants to get where he's going as soon as he can. This is related not only to acceleration, but also to top speeds maintained on freeways and especially, on the expanding use of exclusive busways. Second, if our buses travel faster, it reduces operating costs because we handle people faster, at a slightly lower cost.

Reliability of the vehicle and power plant is an extremely important issue again, for two reasons: First, the riding public cannot be inconvenienced by a breakdown; and, secondly, the additional expense to the operator in handling a road failure must be taken into consideration.

We're hearing more about noise in the operating industry than we ever have before. There's been problems in San Francisco and Seattle with some eight cylinder engine diesel coaches that recently have been acquired. We operate in the neighborhoods at night when people are asleep, but still our coaches are not commensurate with the ideal noise level at which they should be. Moreover, we are talking about interior and exterior noise levels.

These are generally the new system requirements, as I see them, that are going to become increasingly important to the transit operator in the years ahead. I think the steam bus is an excellent beginning as industry, government, research people and manufacturers are tackling this important problem. It is truly an historic time.



*C. Carroll Carter, Assistant Administrator for Public Affairs,  
Urban Mass Transportation Administration,  
U.S. Department of Transportation*

The Department of Transportation is, to say the least, a very large agency. The Urban Mass Transit Administration, as a very young and small agency, has been able to accomplish a lot largely because we have the strong support and interest of our top management. Every time our Administrator wants or needs something and our program requires something, we are helped and assisted by the very able direction and counsel of our Under Secretary. So, despite jetlag, the Atlantic Ocean, being in Europe yesterday, and arriving home just last night, it's a particular pleasure to introduce to you our able Under Secretary, James Beggs.

### **Remarks**

*Under Secretary James M. Beggs,  
Department of Transportation*

Thank you Carroll. Good morning ladies and gentlemen. It's my very great pleasure to be able to be with you this morning. As you know, the Secretary would like very much to be here this morning, but a previous commitment in Denver has prevented that. He has a deep and abiding interest in this program, and other programs in the Department that are related to environmental considerations. This one is particularly pleasing to the Secretary, to myself and to the entire Department. We have been able, in a relatively short period of time, to come up with an approach to the bus problem that shows great promise. While it's only an infant, it is nevertheless a very encouraging milestone along the way toward the time when we will have clean, comfortable and efficient buses. So we want to congratulate today the California Legislature which initiated this project some time ago — in 1968. They have stayed with it through thick and thin. They have three good contractors working for them, and all three are progressing quite well toward their objectives. We're very pleased that the legislature in California stayed with this project, and we are pleased that the federal government is able to participate with them in a financial way, in monitoring, and in pushing this program.

We are particularly appreciative of what the industrial developers have done, as we realize that the money we put into this program didn't cover the full cost of the development of these vehicles. In this bus by William Brobeck

and Associates, we see the first concrete results of a good industry-government cooperative effort. That is something we need to foster in order to solve other problems that confront us. I also want to congratulate the Environmental Protection Agency people who have worked with us in this project, who have watched with great interest and who have participated in reviews of the program as it has progressed. The EPA, as you know, has a very substantial program for cleaning up engines of all types.

Last but not least, I want to add my personal congratulations to the DOT personnel who have worked on this program from its inception. UMTA may be small but enthusiasm and confidence exude from top to bottom in that agency and that's very good to see. We've come a long way in the last two years. UMTA was confronted by an enormous challenge with the passage of the Urban Mass Transit Assistance Act of 1970. Their organization has grown and they have worked well with the industrial sector and with the congressional committees, who, incidently, have been quite responsive to the needs of this organization. I believe we are making significant progress. For example, in the next ~~three~~ three years ending in June of next year, we will have committed almost a billion and a quarter dollars, which substantially exceeds the federal funding for capital grants over the previous ten years. More important, and perhaps of longer lasting effect, is the fact that in the last three years we have put over a hundred million dollars into research, development and demonstration. The project that we are looking at today and other projects that we will be looking at today, are a part of that commitment. It has been very well spent. We anticipate that the research, development and demonstration budget will continue to grow. If there is anything that we need in urban mass transit, it is innovation and new approaches to the problems that we have in our cities.

Carroll Carter mentioned the fact that I just returned from Europe. I visited research establishments in the ground transportation mode in Germany, France and Great Britain, and it is most encouraging to see the progress that is being made in those countries toward the same kinds of programs and approaches we are attempting in this country. It provides a challenge to us to exchange information with them and conduct our programs in this country so they supplement the programs that are being conducted in other countries. I think we can learn a great deal by joining with them in a total program effort where we do not duplicate, but rather supplement their work. They are ahead of us in a number of fields, but we feel that we can offer more experience in the important areas of rail transport. We can all benefit from cooperation regarding the new innovative systems such as tracked air cushion vehicles, the magnetic levitation systems we see in Germany, and some of the other innovative approaches proposed for downtown metropolitan areas.

The last point I would like to make this morning is that in UMTA we have a three-part program which is very important to keep in mind. We are actively pursuing the bus program, of which the first steam bus is part, because in

smaller cities it is extraordinarily important. We also have a program, in light and heavy rail commuter-type vehicles, which we consider important for the larger metropolitan areas. And lastly, we have a program which we feel to be reasonably well-funded, although we hope that it will be better funded in the future, in new innovative approaches to the problems of the central city and the problems of the metropolitan commuter.

We think we are very well advised to proceed with the bus program. In the exclusive buslane programs that we have been running in several cities, we have found that with good, efficient service that competes favorably with the automobile, we can attract passengers. Indeed, on the Shirley Highway exclusive buslane in the Washington, D.C. area, patronage has increased 250% since its inauguration less than a year ago. And so we see that given good service, convenience, comfort and utility, the public will provide the patronage necessary to support those systems.

In conclusion, I would just like to add a few remarks about this project. As I mentioned earlier, it is an infant, and we do not yet believe we have proceeded far enough that we can make an operational system out of it. However, it is very encouraging, and we would like to pursue this system along with improved diesel cycle engines, improved gas turbine cycle engines, and perhaps liquid natural gas type engines. Then we can pick from the best for replacements for the standard fifty passenger bus. Certainly, the steam cycle is one of the very, very attractive parts of that program. We look forward to the testing phase. We look forward to watching this demonstration with an eye toward bringing it to an operational phase as early as possible. In summary, I think we have something here. Indeed, it looks very, very good. We have a program that is well-structured to provide answers to our bus problems in a very short time period. We are moving very fast, when you consider that this program started really in the first part of 1969. In two and a half years we have moved to a point where we are able to demonstrate and test. I submit that shows very good progress. The other programs are moving with equal velocity, and we expect to see a lot of new things available to us in the very near future. It has been my pleasure to be with you to celebrate this very, very auspicious event, and now I think we'll go ride the bus. Thank you very much.

*C. Carroll Carter, Assistant Administrator for Public Affairs,  
Urban Mass Transportation Administration,  
U.S. Department of Transportation*

Under Secretary Beggs spoke of the need for cooperation between industry and government. The fact of the matter is that when we speak of industry and government cooperation, it means not only federal government cooperating with industry but also with many other levels of government as well. It is our feeling that in order for federal mass transportation to go ahead, in order for new systems to be developed, and existing systems to be extended, and improved, priorities must change at the state level and at the local level to reflect new federal and national priorities for public transportation. To say it another way, state and local government need to think of the importance of public transportation and allocate their resources differently than they have in the past. With respect to the work under discussion today, perhaps the majority of you know that we deal principally with the California State Legislature and our funding goes to them. This is a very good example of the awareness of an enlightened state government participating in research work ultimately leading to improved public transportation.

We are very pleased to have this morning on the program the California State Legislature. Your speaker will be Jim Lane who is the Director of the Assembly Office of Research.

### **Role of the California Legislature**

*James Lane, Director,  
Assembly Office of Research,  
California State Assembly, Sacramento, California*

Motor vehicle smog in California is the worst in the nation. Every day hydrocarbons, carbon monoxide, oxides of nitrogen and particulates are released from automobiles, buses and trucks into the air through crankcase blowby, exhaust emissions, incomplete combustion and evaporation. While California prides itself on sunny days, its residents must suffer the photochemical fallout known as smog. This evil, whiskey-colored shroud does not limit its destruction to vistas, but burns the eyes, chokes the throat and corrodes the lungs.

It is not surprising that California has the largest air pollution problem in the United States. It has the most people, and consequently, the most vehicles. There are estimates that by 1980 California will have 28 million people and 20 million vehicles. California's air pollution problem differs from that of most states, because the greatest part of the problem is vehicular emissions. In Los Angeles, for example, industrial sources are attributed to be responsible for only five percent of the air pollution. While the San Francisco Bay Area is renown for clear skies swept by ocean winds, it is not uncommon to witness as little visability there as on the worst day in Los Angeles.

Because of this high amount of automobile created pollution, California was the first state in the nation to set and enforce standards for vehicular emissions. Los Angeles County established an Air Pollution Control District in 1947. During the 1950's the California Legislature directed the State Department of Public Health to adopt air quality standards and vehicular emission standards. In 1960, the Motor Vehicle Pollution Board was created by the California Legislature to test and to certify control devices to achieve the standards developed by the Public Health Department. In 1963, crankcase devices became mandatory on new cars and on some used cars. Beginning in 1966, most new cars sold in California were required to be equipped with controls that would meet the hydrocarbon and carbon monoxide standards. Beginning in 1968, imported cars were required to meet California standards.

California's legislative milestone was Assembly Bill 357, the Pure Air Act of 1968, which acted as a national model by establishing stringent vehicle emission standards. But this was not the end of legislative activity. Assembly Bill 356, enacted the same year, set a precedent by authorizing the Air Resources Board and General Services Department to test low emission vehicles; and, if they met requirements, to purchase up to one-fourth of the State's fleet at premium prices. Commencing with 1973 models, no vehicle can be sold in California that does not meet emission standards.

Yet even with this encouraging concern resulting in attempts to improve California's environment, we are victims of a cruel paradox. Controlling the internal combustion engine is, at best, a sometimes thing. Preliminary information has indicated that present controls begin to lose their effectiveness after a few thousand miles. If adequate controls can not be made for new cars produced under supervised and controlled conditions, what can be done about older vehicles? There is yet another problem with the internal combustion engine. Even if better controls are perfected, California's vehicle population is growing at such an alarming rate that most advances in exhaust controls are seriously undercut.

Given the California Legislature's twenty or more years of activity in air pollution legislation and given our concern about the difficulties in controlling the internal combustion engine, it was natural that the Legislature involved itself in a project of this sort. We had to see if there was some way that the State could work its way out of the dilemma of inadequate controls com-

pounded by a burgeoning automobile population. For these reasons and to determine how far we realistically could go toward setting tougher emissions standards, we chose to explore an alternate power system.

Nor was it any accident that steam was chosen. The Legislature held hearings on steam cars even before the Senate Commerce Committee hearings during 1968. Some of you might recall those senate hearings. They were highlighted in the morning by Detroit saying steam couldn't work and in the afternoon, the Williams brothers from Ambler, Pennsylvania, took committee members for a ride in their modern steam car that "couldn't work". We believed steam power systems should be explored, and so we contacted the Urban Mass Transportation Administration and requested that funds be committed for testing such systems in smog-ridden California. The federal government agreed and a new partnership was created.

Our original proposal was to demonstrate external combustion engines installed in buses in transit service, because testimony before California Assembly and Congressional Committees led federal and state officials to believe that steam systems were immediately available for testing. Experience soon proved that a demonstration project at this time was impossible. Rather, a development program would have to precede any demonstration. The Steam Bus Project, therefore, changed from merely a demonstration of non-existent hardware to development of that hardware during a 15-month Phase I; and, if that was successful, a demonstration of that hardware in public service during a nine month Phase II.

On March 9, 1970, the Urban Mass Transportation Administration approved the grant for Phase I. Three vendors, previously chosen by an independent selection panel of nationally recognized experts – William Brobeck and Associates, Steam Power Systems and Lear Motors Corporation – began development work in June 1970.

William M. Brobeck and Associates fabricated components and installed their system in an Alameda-Contra Costa Transit District coach in fifteen months, which ranks as a major engineering accomplishment. Lear Motors Corporation and Steam Power Systems are bench testing their complete systems, having chosen to undertake more sophisticated and, therefore, more difficult approaches.

The Brobeck system is installed and operating. It uses a three cylinder, double acting compound expansion engine which yielded 203 net horsepower during bench tests. Steam Power Systems is bench testing their six cylinder, double acting expander capable of 250 or more net horsepower. Both Brobeck and Steam Power Systems use water as their working fluid. Lear Motors' system, also under bench test, includes a lightweight turbine, using a working fluid other than water, which has the potential of 190 net horsepower. All three buses will burn standard Number One diesel fuel.

Other project participants include three California transit districts. Paired with Brobeck is the Alameda Contra Costa Transit District under the leader-

ship of Alan Bingham, with Tony Lucchesi, Technical Manager. AC Transit has proven most cooperative in their assistance, and the project is deeply appreciative of their efforts on behalf of our first steam bus. Lear Motors Corporation is supplying their own bus to be operated on routes of the San Francisco Municipal Railway, which is managed by Jack Woods and the City's Public Utilities Commission, with Fred Thomas, Jr., Project Manager. In Los Angeles the Southern California Rapid Transit District has provided a bus for Steam Power Systems. SCRTD's project manager is George Heinle, and the general manager is Jack Gilstrap.

The project also is receiving assistance from the California Air Resources Board, which is charged with the responsibility of conducting all emissions testing, and the California Highway Patrol, which is performing safety and noise level measurements.

Systems and project management is provided by Scientific Analysis Corporation in San Francisco, which also will survey patron and public attitudes towards steam propelled vehicles along the routes served. International Research & Technology, of Washington, D.C., is providing all technical monitoring and evaluation. Finally, the Bay Area Educational Television Association is making a documentary film of project activities.

This project represents the first federal grant ever made to any state legislature to conduct its own research, development and evaluation. The main objective is to demonstrate the feasibility of alternate power systems with low emission characteristics, well below the 1975 California standards for heavy duty vehicles. These emission standards are the first such requirements for diesel engines anywhere in the United States, having been created by California to take effect for the 1973 model year and to be tightened for 1975 models.

Besides examining emissions, the California Assembly will explore potential operational advantages and public acceptance of external combustion engines for urban mass transit buses. It should be stressed that this is an early demonstration of feasibility, rather than a detailed development and statement of technology. Design objectives for the steam engines include substantial reduction of exhaust emissions and noise when compared to diesel-powered equipment. A further goal is to obtain road performance at least equal to existing city buses. Operational safety has received the highest priority in design and construction of these systems.

A wide range of rigorous test conditions are provided in the participating transit districts. In San Francisco, heavy loads are superimposed upon traffic congestion, together with road gradients sometimes exceeding 19 percent. Los Angeles requires a capability for high speeds up to 65 miles per hour, while imposing the added burden of a substantial air conditioning load. The East San Francisco Bay Area provides an interesting mix of local and express lines.

In the Spring of 1969, the Commerce Committee of the United States

Senate issued a document entitled, "The Search for a Low-Emission Vehicle." The report called for a new approach to combat the air pollution which is still choking urban America, stating, "Perhaps the best long-range method of solving the vehicular air pollution problem is to substitute for present propulsion systems a new system which produces few pollutants and performs as well as or better than the present powerplant." In their survey of possible alternatives to the Internal Combustion Engine, the Committee concluded that "The Rankine Cycle (steam) Propulsion System is a satisfactory alternative to the present Internal Combustion Engine in terms of performance and a far superior engine in terms of emissions. Under normal operating conditions, without attempts at emission control, a steamcar produces almost no pollution. The combustion of fuel in the burner is almost complete. The low-emission characteristics of the external combustion engine are built in. As long as the engine functions, it will function with low-emission characteristics."

Preliminary data from various projects substantiate that conclusion. The California State Air Resources Board conducted emission tests using a chassis dynamometer provided by the San Francisco Municipal Railway. A standard 13 cycle mode test was conducted with three vehicles – the AC Transit bus with an engine built by William M. Brobeck and Associates of Berkeley, California, an AC Transit V-6 diesel, and a San Francisco Municipal Railway V-8 diesel with low sac injectors, the mainstay of General Motors' Environmental Improvement Package. It must be noted that the following emission figures represent limited and initial test data not considered absolute for this class of vehicle and are expressed in grams per brake horsepower hour. For carbon monoxides, the Steam Bus recorded 2.0 grams, the V-6 diesel 4.4 grams, the V-8 diesel, 7.9 grams. The 1975 standards call for a maximum of 25.0 grams. As expected, all three vehicles were below the 1975 ceiling, with the steam bus leading by a wide margin.

With respect to hydrocarbons (HC) and nitrogen dioxide (NO<sub>2</sub>) combined, the Steam Bus emitted 2.4 grams, the V-6 diesel 11.5 grams, and the V-8 diesel 9.3 grams. The 1975 standards called for a maximum 5.0 grams. While both diesels recorded hydrocarbons and nitrogen dioxide considerably in excess of the permissible 1975 standards, the steam bus produced emissions which were half of the 1975 limits. This is particularly significant because the burner and boiler were not designed to minimize emission characteristics. In other words, these are not the best results obtainable with a steam power system. But we are confident that equal or even better results will be achieved with steam systems built by Lear Motors Corporation and Steam Power Systems.

The Senate staff report also concluded noise levels were to be lower, because "noise pollution control, like air pollution control, is a built-in quality of the steam engine." The report attributed much of this noise reduction to a direct drive application, which would eliminate the use of a transmission. Even though all vendors in the California Steam Bus Project use transmissions in



their system conversions, outside noise was reduced significantly on the Brobeck bus. According to tests conducted by the California Highway Patrol on October 11, the steam bus registered 75 decibels and the V-6 diesel 78 decibels on the drive-by tests at full throttle. Because this scale is a logarithmic one, sound intensity doubles for every three decibels. The steam bus, therefore, was half as loud as the conventional diesel bus on this drive-by test. Tests involving acceleration from a standing start with a microphone 15 feet away, resulted in 78 decibels for the steam bus and 88 decibels for the diesel, making the steam bus more than eight times quieter. While substantial improvement in exterior noise levels was evidenced by the steam bus, interior noise was approximately equal to that of the diesel bus. This probably resulted from the particular layout of equipment in the AC Transit coach, with a boiler in the original engine compartment and the engine installed amidships. Future designs would reduce noise substantially by locating all major components in the original engine compartment and, thereby, minimizing plumbing required to transmit steam from the boiler to the engine.

The Senate report further stated that fuel consumption was to be lower than the internal combustion engine and a variety of fuels would be burned. While different fuels can be used in a steam engine, number one diesel was chosen for this project because of its widespread use in existing transit operations. Fuel consumption to date was approximately double that of the diesel, but emissions were significantly lower. Further development will have to improve the efficiency to bring fuel consumption at least to existing levels for the diesel.

Additional expectations for steam engines listed by the Senate Commerce Committee's staff in the areas of engine costs, maintenance, reliability, freeze-up, water consumption and start-up time remain to be tested. It is far too early to report any meaningful experience which might shed light on these factors.

However, AC Coach No. 555, the first California Steam Bus, which you will be able to examine, and, hopefully, ride today, verifies much of the Commerce Committee's expectations for Rankine Cycle engine systems. Its emissions are well below the 1975 California diesel standards. Noise levels are also substantially lower outside the vehicle. It is essential, however, that everyone realize and understand that the bus demonstrated today is a feasibility model, which was designed, fabricated and installed over a relatively short time period. Fuel consumption, engine costs, maintenance, reliability and other important factors will require further development. On the other hand, the point should be clear — steam engines offer a possible alternative to internal combustion engines on the basis of environmental considerations. The obvious necessity for a steam engine requires and demands further development to determine just how competitive steam systems can be made.

A timely question is where do we go from here. The California Legislature believes a definitive statement of feasibility of power systems is being made

on this project. The next step is to raise the level of development, improving these systems until they are brought to a production prototype and, eventually, to production.

We look forward to reviewing future development results to explore incentives for the transit industry to acquire fleets of low emission buses when commercially available. Under such a plan, the State Air Resources Board would certify all low emission vehicles much as it certifies automobile control devices today. This certification process combined with tax or cash incentives would assist development of a substantial market for clean power systems.

The California Legislature is committed to continue the future development of steam power systems. First, the urban transit bus can play a significant role in controlling environmental pollution by replacing a large number of private automobiles in downtown traffic. Second, if mass transit is to expand and buses are to play a vital role, it is mandatory that clean buses be developed. Third, if the California Legislature is to continue to improve California's air, we need alternate hardware that will prove a case for tighter standards. Fourth, if steam power becomes feasible for large vehicles, we will press for rapid application to automobiles.

In short, the California Legislature looks to this project and to further development efforts for use in drafting legislation to tighten vehicle emission standards and to provide incentives for introduction and use of low emission power systems.

Finally, let me commend the Department of Transportation, Urban Mass Transportation Administration, and especially Secretary John Volpe and Administrator Carlos Villarreal. They are to be commended for their foresight in seeing broad public interest to be served by devoting time, money and energy to developing a clean bus for mass transit use. I also want to express the appreciation of the California Assembly for the trust placed in us through this precedent-setting project, which is a first of its kind in the nation. It underscores the dedication of this administration to maintaining the vitality of our federal system and the re-affirmation of the important responsibilities state legislatures have and the role they can play in solving modern problems. I see this project as presenting us all with a major challenge. We are hopeful that the challenge of continuing with the massive effort necessary to produce clean propulsion systems will be met by the federal government and the transit industry. I can assure you that the California Assembly will continue its leadership in the fight for clean air and will actively support and continue accelerated research and development of steam power systems. Thank you very much.

*C. Carroll Carter, Assistant Administrator for Public Affairs,  
Urban Mass Transportation Administration,  
U.S. Department of Transportation*

Thank you Jim, for explaining the wonderful role played by the California State Assembly.

Now, we turn to the steam system developers themselves for first hand information. Our first speaker this morning is Richard Burtz, General Manager of Steam Power Systems in San Diego, California, who will discuss their system design and development.

### **Steam Power Systems Steam Bus**

*Richard Burtz, General Manager,  
Steam Power Systems, Inc.,  
San Diego, California*

Good morning. Our program for developing a steam power system for a standard city bus has entailed actually starting with modern engine technology, and a clean sheet of paper, and trying to incorporate as many innovations and features into the reciprocating steam engine as we possibly can during the time this program allows us. Being able to start with the engine design initially gave us the opportunity to develop several features of the engine that we think will be general improvements in efficiency, simplified operator control and better maintenance. In talking about low pollution engines, the maintenance in keeping those engines low polluting is quite a problem with any other type of engine except the external combustion engine, and is especially important here. These are inherently clean engines, and they stay that way. We have endeavored to do something with former engine technology. We still have a reciprocating type engine. It's a double-acting engine — a compound engine — and we have added several features. We have a hydraulically actuated valve system which is a unique device for which we have just received patents. We have incorporated, as part of the steam cycle, a reheat cycle, which has been used for years in steam generating plants, but as far as I know not yet in a vehicle application. The things that Mr. Lane referred to: increased efficiency, better fuel economy, better operations and so forth, we have at least partially achieved under the scope of this program.

We have developed two other engines prior to the engine that we have

right now for the bus project. We developed a pure experimental engine when we started out two years ago, and we have built a two cylinder prototype which we expect to produce someday for other reasons. So far, we've spent about a million and a half dollars of our money doing this work, and that's in addition to the money that we have gotten under the contract from the State of California.

Quite a few of the people here today are familiar with the Rankine Cycle, and some aren't. Since I am the first person to tell you about the engines, I will go around the loop one time so that you will know what I am talking about.

Starting at the bottom, these are common units to all the systems that are going to be shown today. We have a feed water pump, which is necessary to bring the working fluid to a high pressure so that it can enter the boiler on the left hand side and have heat energy added to it through a burner which then turns it to a vapor and goes around to the expander or engine where the energy is then taken out by the expansion of the working fluid. It comes back around out of the exhaust to the engine around to the condenser where it is converted back to a fluid. It enters a reservoir and is pumped to pressure again, and the cycle repeats itself.

Anybody who is involved in any of the developments of these engines today basically has this kind of system where the working fluid is 100% recovered. Our design criteria on that was a full power operative engine on a 105°F day. If you exceed 105° you get a slight degradation in power. That's the limitation of the condensers.

You can see the control system interacts with all of this. Our control system is partially electronic and partially electronic-mechanical. Basically all the safety considerations are taken care of electronically and by fail-safe modes which, if anything goes wrong, shut the system down.

We went into the development of our own water pump and have a couple of designs. This is the one that we are using on the bus program, which is a completely self-developed item. It pumps pure water with no lubrication at all and is about one-fifteenth the weight of the commercial units you see there.

The burner-boiler, or burner convection bank, has a burner at one end, similar to jet engine burners. The hot gas is then flowed over the convection bank which is primarily made of stainless steel tubing. The intake air and fuel and so forth are brought into the boiler. In our particular case, we have fans incorporated right into the boiler. Another feature is that it also has an air-cooled outer case. Even running at full output, it is warm to the touch. It's a very safe type of boiler. There is no large energy storage so there is no real danger of any explosion with these kinds of vapor generators.

I want to show you some details of the steam generator. These are the specifications. It produces 3,600 pounds of power of steam at a thousand pounds and 800°F. In addition to that, exhaust steam from the high pressure cylinders goes through the boiler once again and is reheated back to 600°

after it has been expanded one time, increasing efficiency by adding energy back to the low pressure system. Full load efficiency is about 85%; that's a test figure, actually, it's just a bit better than that. As you go down to partial load, it's better. Fuel consumption is relatively high, but that depends a lot on how the accessories are run and how the system is set up. Improvements can definitely be made here.

The burner end of the steam generator has an annular burner can, like a angel food cake tin. It has air atomizing nozzles which fit in the little holes in the center air vanes. We expect it to be a very low polluting device, because we have continuous modulation of the burner, continuous control over the air ratio. I think it's a general advance in burners. It is not as advanced as some of the research that has gone in burners. And we are not particularly concerned other than producing a low pollution device efficient to meet the 1975 standards. I think we will do that very easily. We would expect to incorporate some advanced technology in the later burners.

This is the convection bank as it was tested for static pressure by Roy Renner of IR&T, who represents the State in technical matters. It is designed with a great many safety factors. It's about one and a half times better than code, so that it has a very large safety margin. It is not necessary to build these entirely out of stainless steel, although we wanted to avoid as many problems as we could during this program. When you take an item like the one we have right now, you might find some hot spots on the burner and so forth, so we made it out of stainless. As it turns out, we don't. It has been a very, very clean unit.

The next thing, going around the loop, is the reciprocating expander. This gives you a basic idea of what all of our engines are like. Being double acting, it's virtually a one stroke engine. It has a power impulse every time the engine moves. As I mentioned before, high pressure steam is noted by the red area, goes to the small piston and then is exhausted back to the boiler, reheated, brought into the low pressure cylinder and expanded again. Both of these things contribute to the efficiency of the engine.

It is sealed from the lower unit, which is quite a lot like the standard automotive practice for crankshaft connecting rods — crossheads and so forth. We've had great success in sealing this. We've also been successful in running the upper totally unlubricated, and we have not added lubricant to the working fluid at all. The fact is that the crosshead engine does not sideload the steam pistons. In achieving this, which we think is a breakthrough too, the lower end of it is conventionally lubricated. Its crossheads are sprayed as the pistons are in the diesel and the crankshaft is pressure lubricated with a standard automotive lubricant.

Here are the specifications for the bus expander. It is a six cylinder expander. It has a modular type engine. It has three of the two compounded cylinder sets bolted to a six cylinder crankcase. So, whatever your power requirements were, you bolt the modules to the sides of the crankcase and

come up with different power ratings. It has a full emission poppet valve — that's a very technical term. It means that as you require power, the operator steps on the accelerator and either emits more or less steam depending on his power requirements into the cylinder. These poppet valves are hydraulically actuated and they are fully variable in timing and duration.

The design brake output is 240 horsepower at 2160 rpm, 825 foot-pounds. I think we were very conservative in using that torque figure for a design point. We have run the engine above 950 pounds, which is considerably over the design, and so we have potential power in the unit. The weight right now is 1100 pounds, and I'm sure that it can be reduced substantially. This is more or less a building block engine and casting techniques have not been used on that engine to make it flexible to develop for this program. The engine weight can be reduced substantially through just standard casting techniques.

There is a picture of the bottom end of a six cylinder expander inverted — upside down. The steam cylinder would be on the bottom when they were installed. This is meant to show really that they can use standard automotive practices in design and manufacture, and it shouldn't be a hard unit to put into production. There it is installed on the test engine. It has a lot of tubing and wires that are instrumental for testing. The driveshaft runs to the left into a 700 horsepower Clayton dynamometer. To give you an idea of its size, this is the way it sits in the bus — turned over like that — you'll see a picture of the installation. Compared to the six or eight cylinder diesel engine which it is capable of replacing, it is not very big, but of course, you have to take the boiler too, which is the other large component.

Here are the condensers that are used in the bus. These are really nothing more than standard truck radiator cores that are rated for 30 PSI. Actually, they will withstand about 90. There's a big safety factor in so many of these things. They are custom built, but no real effort has been made to reduce the size of these things or make them more efficient. Here, again, the scope of the program determined that that's about all you can do in this time period. We paid a lot of attention to the looks of the bus in trying to keep it looking like a standard city bus.

Here is the auxiliary gearbox that goes on the back of the engine. This does basically two kinds of things. It drives all the bus accessories, including the air pumps, operates the doors, brakes, the air conditioning system, the electrical generator for the bus, various fuel and lube pumps, and everything that works originally on a diesel engine, plus it drives the burner fan and the rear condenser fan through a hydraulic motor that operates the valves and the condenser fans and the feed water pump.

Basically, that is the scheme that we are using to perfect this kind of engine for a standard bus. We do use as mentioned above, the standard GM "V" drive transmission, which is two speed with a torque converter. Basically that was why the boiler turned out looking like it did. If we had a straight in expander we would have been able then to make the boiler more squat

and turn it around and set it down in the area where the transmission is. The transmission is a very large unit and takes up a lot of engine space. However, we've made an attempt to put everything in the original engine compartment, and we have been successful except for these forward condensers that run underneath the bus floor.

Let's walk around the system again and point out some of the features that we have in our engine. Up here at the top you will see that the high pressure steam comes over to the expander. It goes through the high pressure cylinder and comes back to the boiler. It is reheated back into the expander to the low pressure cylinder and is exhausted out. The first place that it goes is to the rear condenser which has a fan that is expander-driven and operates all the time. Since we use the transmission, we idle the expander so that it is not a problem here. It goes down to the forward condensers. If the heat is still too high to turn it into a liquid, these fans become operational through a thermo-sensing switch which then allows the fans to be driven hydraulically – up to the water pump – into the boiler again

Here we get into some of the variables of the cutoff point. You will notice that the torque and ideal cycle efficiency – as the torque goes up basically the efficiency drops down. This points out two things – that variable cutoff is a very good feature on these engines and that these engines operate in a range that is much more well suited to an urban driving cycle than is a diesel engine. This feasibility program will point out that these are viable replacement engines. They are, at least, reasonable alternatives. It could also be shown in some advanced program that these engines are more ideally suited to this kind of operation than almost any other. There is some testing available on the AC Transit buses that show that this is the range in which these engines operate. It is just ideal for this kind of engine.

This shows you some kinds of efficiency which operate with this engine. Full load efficiency is not very high, but then, if you're not going to use full load operation very often, you don't really care a lot about it. On the other hand, it's almost the reverse on any other kind of engine. As the load drops, the efficiency increases; as the vapor generator efficiency goes up, the expander brake efficiency goes up. The system output over the expander output goes up; and, what that means is, for instance, when you are running reduced power the forward fans don't take any horsepower at all, they just stop. They aren't needed anymore. They are not robbing horsepower from the system. This is true of quite a few of the accessories in the system.

Systems specifications call for net output of 270 horsepower. In other words, the design brake output of about 360 horsepower gets down to about 270 horsepower after you run all accessories. The approximate weight here is listed at 2800 pounds without the transmission.

Here's what we started with No. 6200 from SCRTD. In fact, they were kind enough to take the engine out for us and clean it up a bit. We set to work modifying the engine frame. We are at about this point with it now. We have

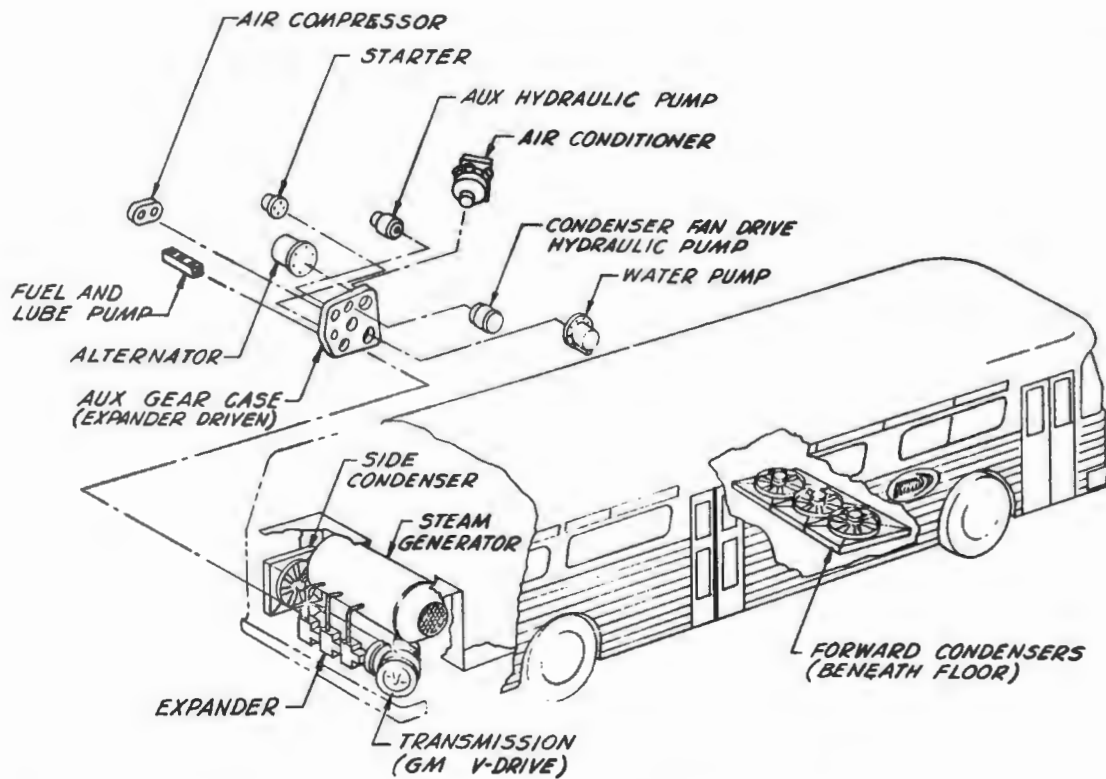
modified the carriage. We have made new doors and openings for the sides to accommodate the condenser. The pallet is highly modified and suspended on flexible mounts all the way around. You can see that the transmission to engine is mounted on the pallet here, which is painted black. This is currently coming out of the bus. It will be taken to the lab where all the components are going to be mounted on it and run into the dynamometer exactly the way they are in the bus. Then it will be taken as a unit and installed.

I don't have a good picture of the forward condensers but you can get an idea of them here. You see the front wheels of the bus; they are canted back and have the fan installed on the top and the air goes down onto the street. Warm air from the condensing fan – they are open basically in the front – can be taken in that way. You can see they are considerably up in the bus above the front suspension part and in no danger of hitting anything.

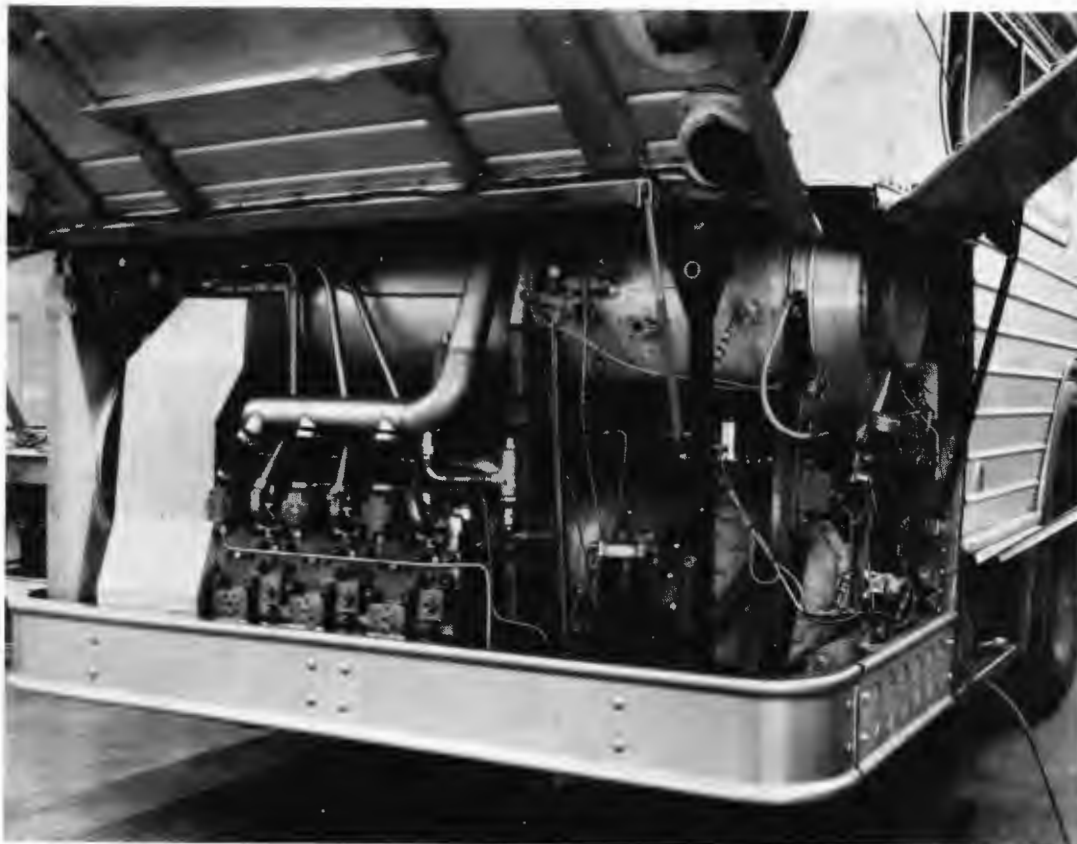
The lower curve here is what is required to run the bus up to 65 mph at the axle. In addition to that, going up to the second line, to 240 horsepower, that is what is required to also run the bus accessories, again the air conditioning, and so forth. Going up to the third line, that is the feed water and so forth, and it is substantially below the design output of the engine, although we do have some reserve power there. The torque required to run the bus to these speeds, up to 65 mph, by the way, which is a requirement of SCRTD, while the air conditioning is running, is shown there in the two torque curves which are really different ranges of the two speed transmission, but you can see there is considerable torque available then for the operation above those curves.

We probably could, knowing more after two years of work, make a more compact steam generator. One of the things you definitely want to do is to eliminate the transmission and have an inline expander with the direct drive. By the way, our engine has demonstrated reversing, it is self-reversing. It will run equally well in both directions which also simplifies any kind of installation with any kind of axle gearing. Condensers could be reduced in size and probably all fit into a small rear compartment. One thing we would do in eliminating the transmission would be to put in a small expander similar to the two cylinder expander that you saw in the background of lab picture. It would run at constant speed which would reduce the size and increase the efficiency of all the accessories that took so much horsepower. This is a very natural thing for an external combustion system – the boiler's sitting there running so you've got the power; all you have to do is add a small auxiliary engine and you have great advantages. Thank you.

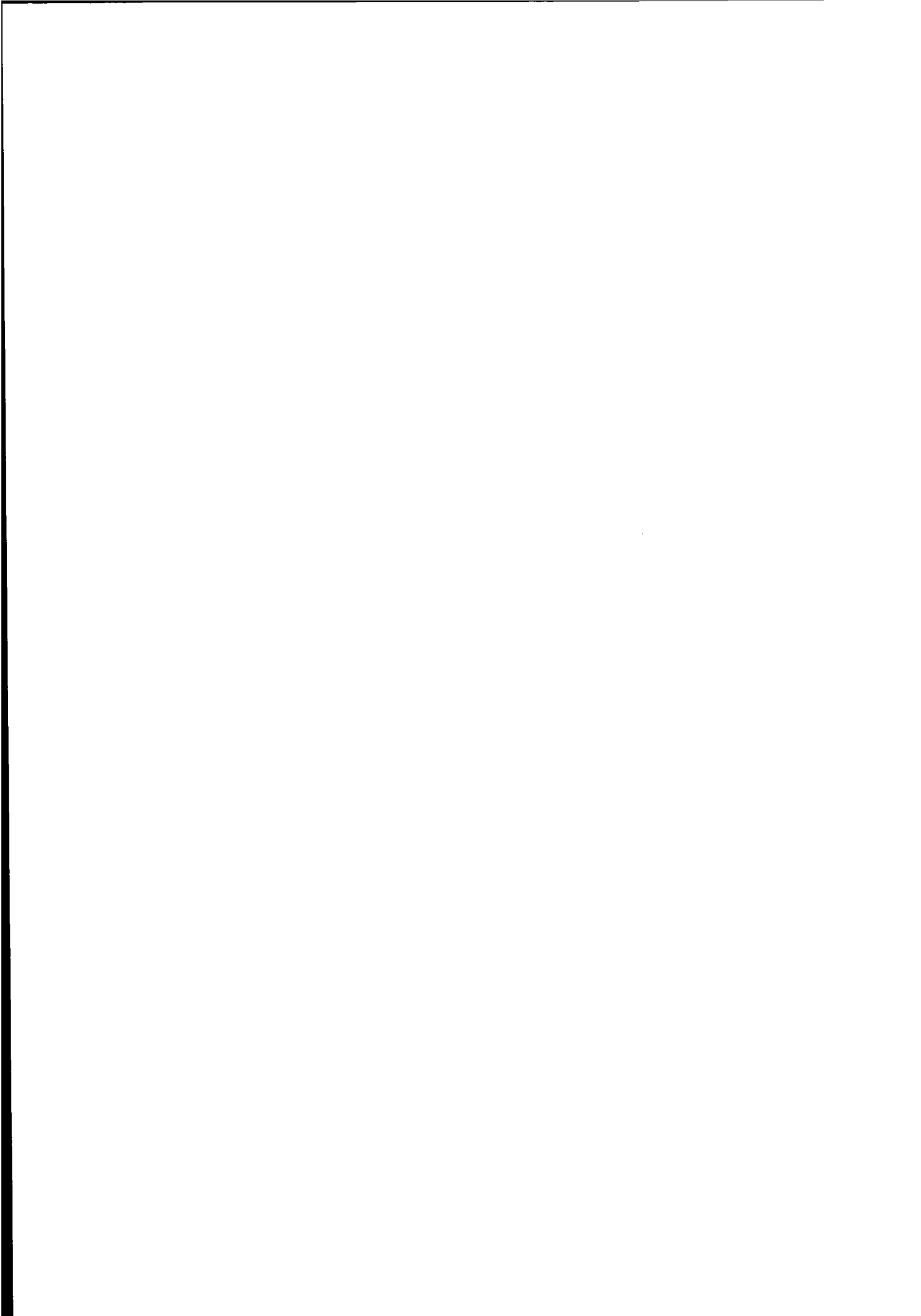




**Figure 1. Layout of Components in Steam Power Systems Demonstration Bus**



**Figure 2. Actual Installation of Boiler and Engine in Steam Power Systems Demonstration Bus (March 1972)**



*C. Carroll Carter, Assistant Administrator for Public Affairs,  
Urban Mass Transportation Administration,  
U.S. Department of Transportation*

Our last speaker of the morning before we break for lunch, is Bill Brobeck, the president of William Brobeck and Associates. His firm was founded in 1957. In addition to their work on external combustion engines, Brobeck and Associates are also known for their particle accelerators, or cyclotrons. Bill Brobeck has long experience with steam which extends back in the 30's. So, while his bus is up on Capitol Hill, being combed over by Congressmen and Senators and their people, it is a particular pleasure to introduce to you, Bill Brobeck.

### **William M. Brobeck & Associates Steam Bus**

*William Brobeck, President,  
William M. Brobeck and Associates,  
Berkeley, California*

I think I should start out by explaining that our work on this project is a little different than the other vendors. We are an engineering company, and we have undertaken this as one-type job. We don't have a proprietary product or an on-going sales program; we are doing this as a job, an engineering job.

We were asked by Chuck Daniels to concentrate on making this a demonstration device rather than a prototype, to concentrate on getting it done as soon as possible so that it could show the features of steam. And that's what we have done. The reason that our bus is running now is because of the difference in emphasis from the other vendors, who are looking at it as a longer range view and have put more innovation in their designs.

As was mentioned, I have been involved with steam for a long time; actually there was a very long gap in it. When I first got out of school, I worked for the Doble Company and then for their successors, the Beslers. In 1937, I joined the Radiation Laboratory at the University of California where I spent the next twenty years working on cyclotrons and such devices which have nothing to do with steam. In our engineering company, my work primarily has been on particle accelerators.

The design of our bus follows the development work of the Dobiles and the

Beslers which, I think deserves a great deal of respect even from space age scientists and technicians. I believe the problem of the early steam car was largely a matter of control. The Stanley Steamer was successful with its water level boiler, you might call it, which was not very difficult to control but was hazardous and took a long time to get up steam, as much as half an hour or so.

For practical vehicles, I think everyone agrees, it is necessary to avoid that type of boiler by using a once-through or monotube-type boiler. I'm sure all three vendors are using such boilers in this program, because of the hazard of the large pressure vessels of the Stanley-type boiler. However, the control of the once-through boiler is different, and only in its latter years of development, was it possible to have a satisfactory automatically controlled boiler. The problem is primarily maintaining the steam temperature constant, or reasonably constant, so that the power is always available on demand. The system that we use in the bus power plant, although isn't an exact copy of any of the Doble boilers or boiler controls, uses the principles developed by the Doble and the Beslers. We followed them, and I think it works quite satisfactorily. Those of you who are interested in this particular boiler control will be able to judge for yourself when the bus is running around later in the day.

Figure 1 shows the layout of the equipment in the bus. The steam generator is in the rear. The reciprocating engine is under the floor of the bus driving through a torque converter transmission to the forward side of the axle and there are four condenser units with hydraulically-driven fans. There's a fuel tank near the front of the bus, the water tank is back behind the axle, and on either side of the boiler there are auxiliary fuel pumps and water and fuel control equipment.

Figure 2 shows the engine. It is a three-cylinder compound engine with a high-pressure cylinder in the center and low pressure cylinders on each side. The engine is designed around a three-throw crankshaft of the type that is used in a six-cylinder diesel. The crankcase is an aluminum casting as are the crosshead guides. The engine is held together by through bolts. The cylinders are bolted to the crankshaft main bearing caps. The valve gear is driven by a counter-shaft which revolves at the same speed as the crankshaft but in the opposite direction. The valve events are fixed in the forward direction at fixed cut-offs. The reason for the number of cylinders is proper balance. Balance weights are carried on the valve shaft as well as on the crankshaft and the engine is in primary balance, both couples and forces. The cylinders are double-acting, the steam acts on both ends of the cylinders, and have piston valves of the conventional type.

The cylinders are cast iron with an aluminum crank-case. All of this is mounted under the bus. It occupies the full space from the floor to the clearance line. The clearance is not restricted but there isn't any extra room.

The weight of the engine and the torque reaction is taken in the extreme outside walls of the bus. The bus is a type of stress-skin bulkhead construction

similar to a ship. It's not provided with a frame like an automobile and so it was important that we attach the engine to a part of the bus that could take the concentrated loads.

The accessories, the air compressor and water pumps are driven from the pulley near the front end of the engine. The engine is mounted on three rubber cushions and the transmission is bolted on the back.

The boiler, shown in Figure 3, is the type that the Dobles and Beslers developed. The entire combustion space is lined with tubing. The feedwater enters at the left end of the boiler, passes through the spiral coils, enters the helical coil and the spiral coil facing the firebox and comes back through one of the pipes to the steam outlet. The diameters of the tubing coils increases from a half inch at the feedwater end to one inch at the steam outlet. There are two paths through the boiler and two feedwater inlets which join at the right head. The steam then passes through the last two spiral coils as it is being superheated. The thermostat is a mechanical type which uses the expansion of the tubing to operate electrical contacts. It actually responds to tubing temperature rather than steam temperature and so protects the boiler from over-heating although there is no steam inside the tube.

The burner entrance has an eccentric position so that the flame swirls around inside the firebox. The firebox is made of heat resistant steel and, of course, runs very hot and assists in the completion of combustion. It is very much like the exhaust reactors that are proposed for the internal combustion engines. Air Atomization and electric ignition are used. The exhaust gas comes out through the flue under the bus.

The next slide shows some of the spiral coils of the feedwater heating section and its construction. In the foreground is the flange to which the thermostat-contact box is attached. There is about 1,400 feet of tubing in this bank with 100 square feet of heating surface. The heating surface determines the steaming capacity of the boiler and, as far as rating steam plants is concerned, it is analagous to the displacement of an internal combustion engine.

Figure 4 shows the two principal elements of the power plant, the steam generator and the engine.

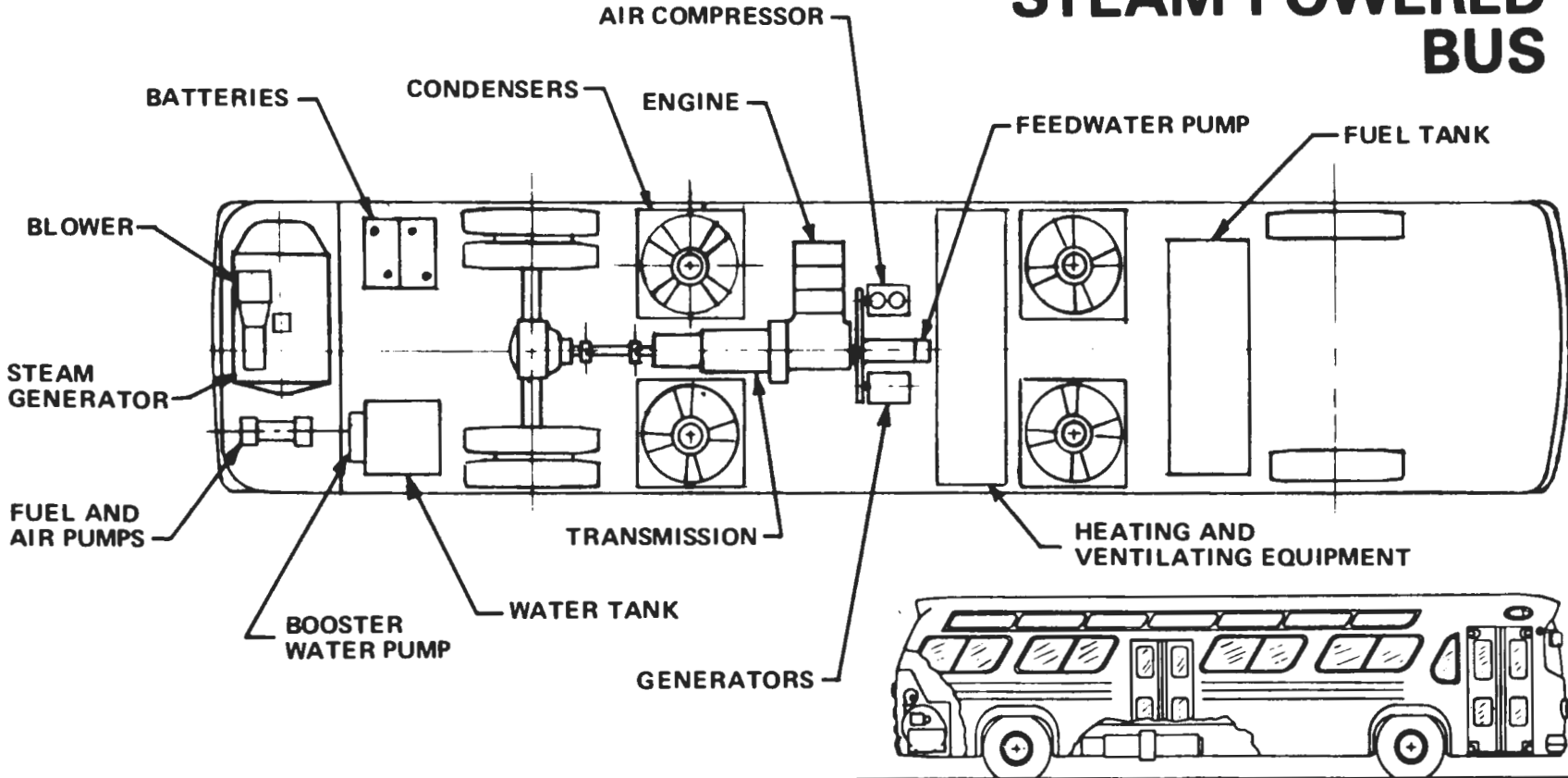
The next slide shows the four condensers set up during the lab testing. From this picture, you can get a rough idea of the piping required. All of this pipe is now under the bus. One of the things we've learned is how much pipe it takes to connect a hydraulically-driven fan and condenser. Steam cars usually have exhaust turbine-driven fans. We didn't go to those because we didn't think that exhaust turbines of the type required were commercially available. The exhaust turbine is more efficient and is also more compact because the steam goes through the turbine to the condensers which cuts down the number of pipes. If we have the opportunity to do this again, we would certainly use the exhaust turbine condensers.

We, of course, learned a lot in building this bus. Some of the results leave

room for improvement. I think the weight is one, the bus weighs more than it did when it had a diesel engine in it. The difference in the weight before and after is 1600 pounds which includes all accessories and the full water tank. It has fifty gallons of water when the tank is full. So weight reduction is, of course, an important thing. It also makes more noise than we would like. It's not as noisy as a diesel but there is much room for improvement. The performance of the bus on the road seems to be satisfactory. I'd say there is no shortcoming in that respect.

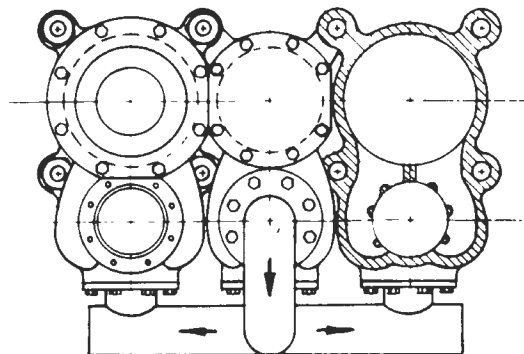
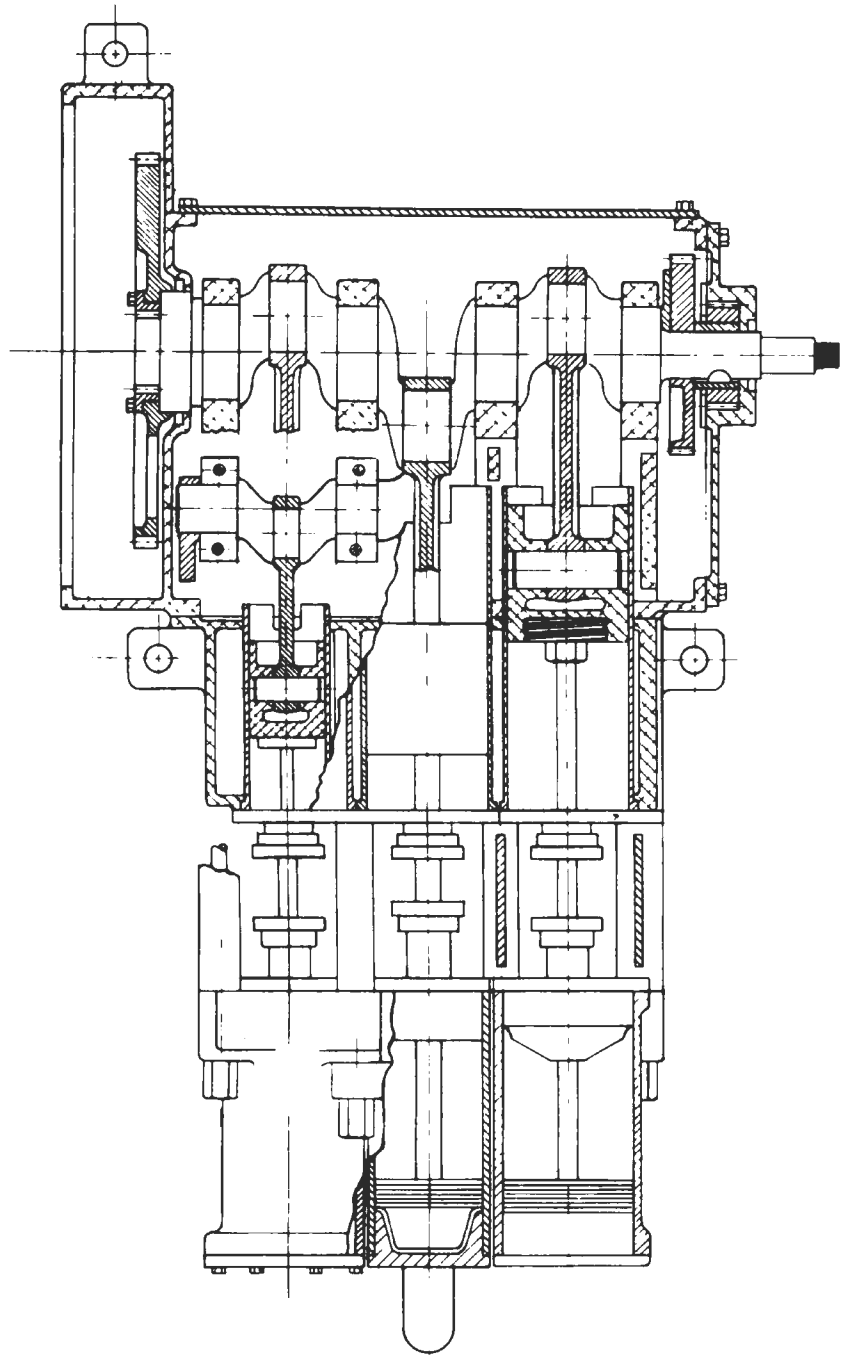
There are a large number of separate pieces and separate parts. Many of these should be redesigned to clean them up. We've used things we could buy whenever possible. Many of these units ought to be specially built and can be combined. For instance, our fuel system is like a carburetor that was built by a plumber, if you can imagine such a thing. But that's typical of the whole machine. It suffers from being an assembly rather than an integrated plant. But we are very pleased with the way it worked. I think we have accomplished the work that we set out to do. Thank you.

# STEAM POWERED BUS

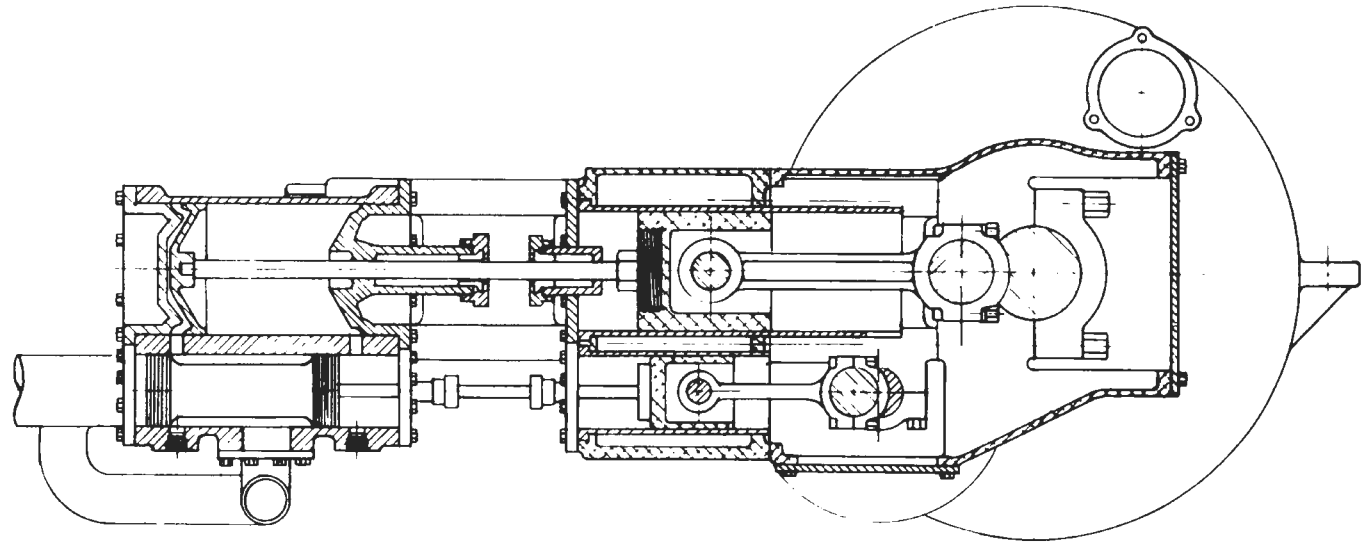


WILLIAM M. BROBECK and ASSOCIATES

Figure 1. Layout of Components in William Brobeck & Associates Demonstration Bus







## ENGINE

WILLIAM M. BROBECK and ASSOCIATES

Figure 2. Diagram of Engine Installed in William Brobeck & Associates Demonstration Bus

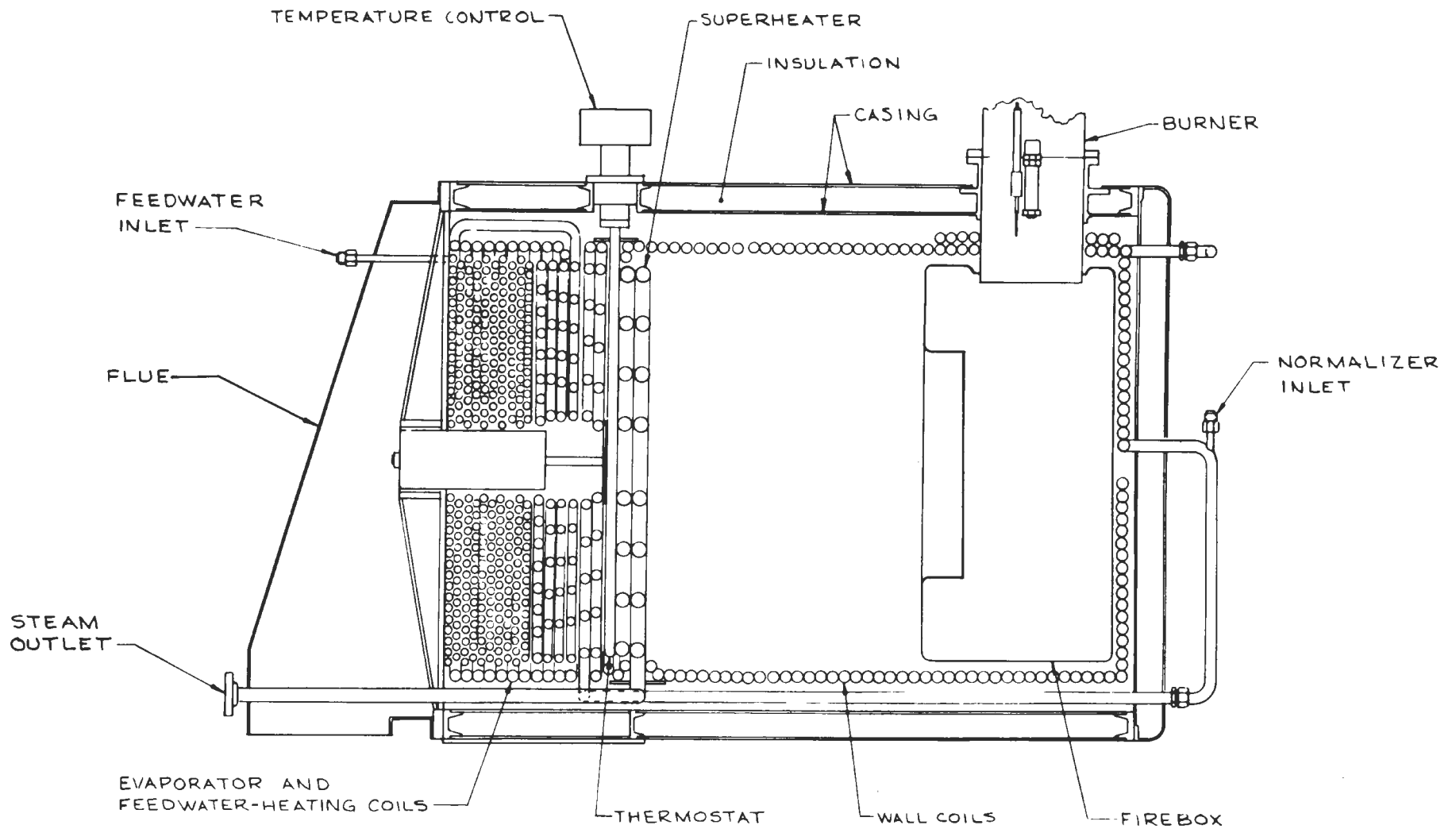
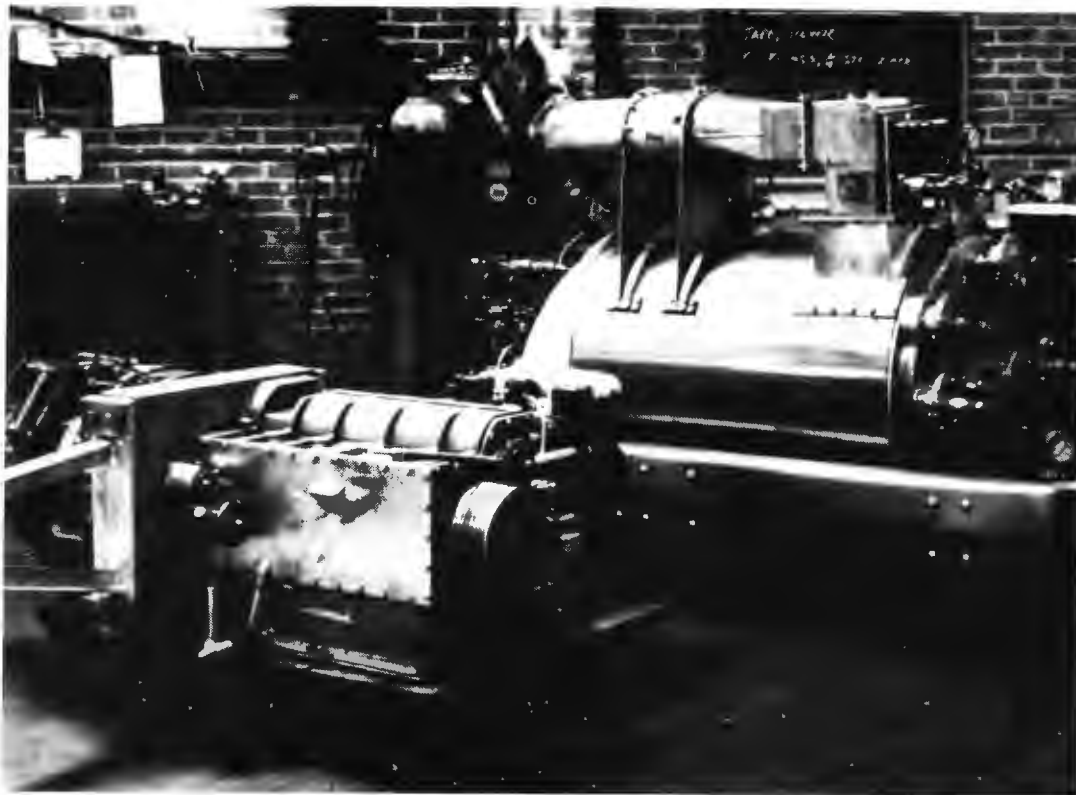
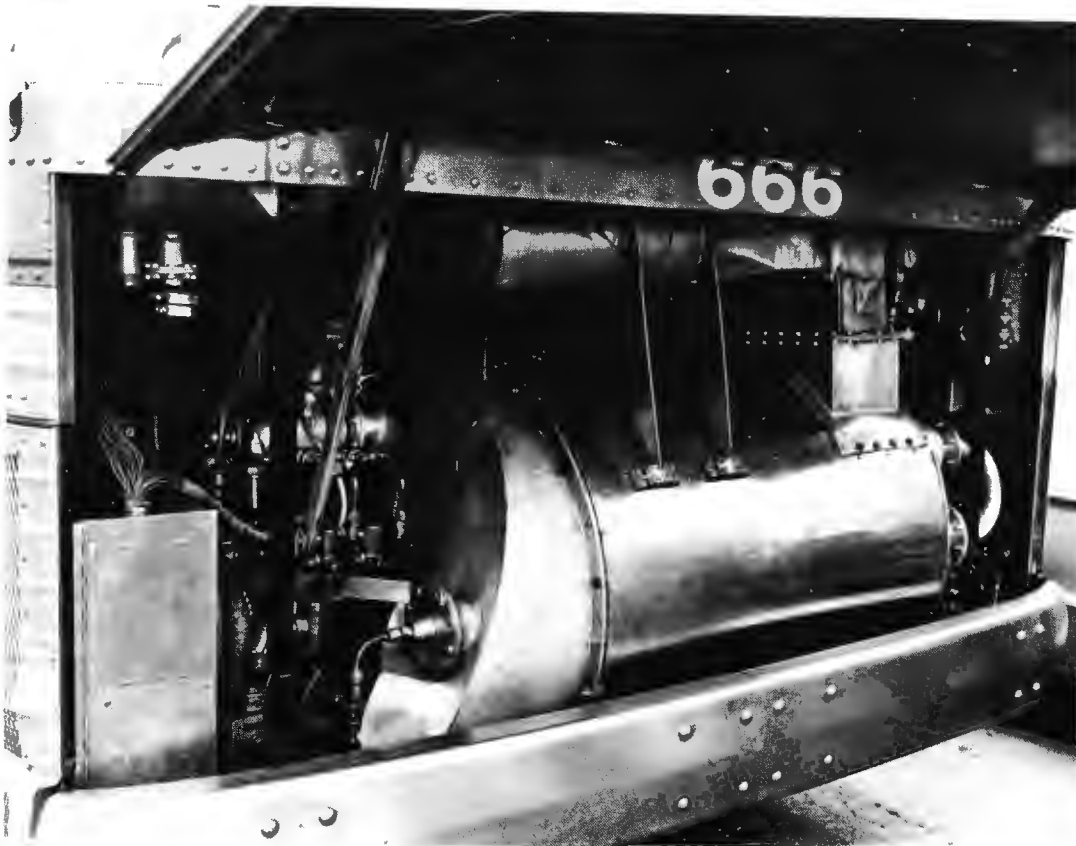


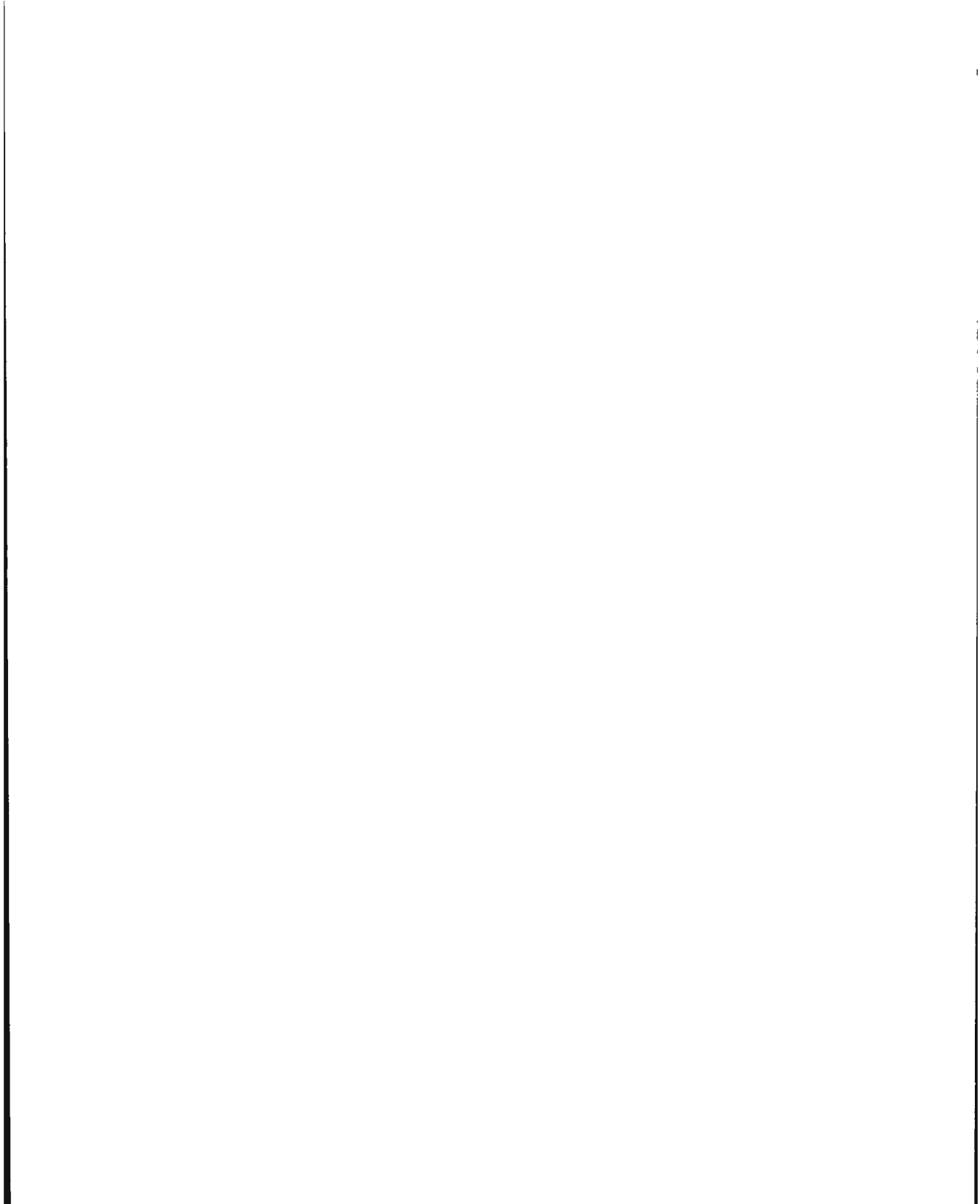
Figure 3. Diagram of Steam Generator Installed in William Brobeck & Associates Demonstration Bus



**Figure 4. Engine, Transmission and Steam Generator Before Installation in William Brobeck & Associates Demonstration Bus**



**Figure 5. Installation of Boiler in William Brobeck & Associates Demonstration Bus**



*C. Carroll Carter, Assistant Administrator for Public Affairs,  
Urban Mass Transportation Administration,  
U.S. Department of Transportation*

Under Secretary Beggs and the Administrator Villarreal spoke about the need for cooperation between government and industry as we proceed to attempt to find answers to the transportation dilemma. To whatever extent this may be true in other programs, it is especially true in research, development and demonstration projects. And to whatever extent it is true there, it is certainly true also among and between government agencies. So it is a particular pleasure to welcome the participation in this program of the Environmental Protection Agency. We heard this morning from Mr. Brogan, and it is a pleasure now for us to introduce to you the Deputy Administrator of the Environmental Protection Agency, Mr. Robert W. Fri.

### **Remarks**

*Robert W. Fri, Deputy Administrator,  
Environmental Protection Agency*

Thank you. It is a pleasure to be here, not only for the reason Mr. Carter mentioned, that it is very important for a number of government agencies to be involved in this kind of effort, but also because we in the Environmental Protection Agency find ourselves depending on and soliciting the support of other government agencies, particularly the Department of Transportation with its many activities. I am happy to hear that Jim Beggs was here this morning, because he and I have shared the platform on several occasions and I look forward to doing so again in the future.

I am also glad to be here today because what you are doing in this program is to develop a, hopefully, pollution-free steam bus, and you should know how EPA views your efforts.

The importance of this demonstration is not simply that this bus may be cleaner than conventional buses nor that it might have some practical advantage over other anti-pollution developments, but that it is part of a series of efforts, part of a widespread involvement throughout many sectors of the country, to bring a halt to the creeping deterioration of the environment.

To put this into perspective, let me say something about the objectives spelled out in the Clean Air Act passed last year. This Act required us to set national ambient air quality standards as well as emission standards for ve

hicles. We've asked the states, under the law, to implement these air quality standards by 1975. The states have several options to do this, and I want you to listen to this set of options because they are important in understanding the air pollution problem we face.

Beyond the straight emission limits of the cork-in-smokestack approach to emission control, we're asking states to consider such things as emission charges or taxes, closing or relocating residential, commercial and industrial facilities, changes in schedules and methods of operation of these facilities, inspection and testing of motor vehicle emission control devices, requiring vehicle emission controls such as mandatory maintenance, installation of devices and conversion to gaseous fuels, measures to reduce traffic such as commuter taxes, gasoline rationing, parking restriction and staggered working hours, a variety of other land use and transportation controls, and, of course, the expansion and promotion of mass transportation.

These are not just idle options. Based on merely preliminary data, EPA has already announced that the cities of Chicago, Denver, Los Angeles, New York, Philadelphia, Cincinnati and Washington, D.C. will not be able to bring their air quality up to the level of the 1975 standards if they limit their efforts to the cork-in-smokestack approach. In fact, they are going to have to consider these and perhaps even more drastic alternatives seriously.

Viewed in the complexity of this briefly sketched problem, it seems that a program such as the development of the steam bus has enormous significance, not only for EPA, but for the Department of Transportation. First of all, the bus represents the application of modern technology in an engineering approach to a social problem. In my judgment, we have seen too little of this application in the past. But there is an accelerating trend toward the application of technology to the solution of social problems, and I have every hope that this trend will continue as we begin to come to grips with our pollution problems.

More importantly, the bus gets at the root cause of our air pollution problem. It's not merely a palliative measure. It not only creates a low-pollution vehicle but gets other automobiles off the road, a measure that reduces total concentrations of pollutants, congestion and noise. Your program aims at the root of a problem instead of trying to treat its symptoms.

Ultimately, your efforts will have a very favorable impact on another of the problems we are all going to have to face, the economics of pollution control, a very expensive proposition. Unless we attempt to solve this problem with really creative thought, unless we aim at the root causes of the systems that pollute our environment, unless we make those systems less wasteful in and of themselves, we will not have a sound economic answer. Environmental degradation is a real problem that demands real answers really soon.

It is only a matter of time before the problem of wholesome air and other pollution problems are solved. But the period in which we must conquer these problems is limited. Efforts like this will shorten the time needed. So the

work that you are doing is a vital piece of the puzzle that determines how effectively and efficiently we're going to improve the quality of this nation's environment.

*C. Carroll Carter, Assistant Administrator for Public Affairs,  
Urban Mass Transportation Administration,  
U.S. Department of Transportation*

Thank you Deputy Administrator Fri. All of us appreciate the fine job EPA is doing to save the environment.

The next speaker is quite well known. He will discuss another system being developed under contract in the California Steam Bus Project. I take great pleasure in introducing William P. Lear of Lear Motors Corporation.

### **Lear Motors Steam Bus**

*William P. Lear, Chairman of the Board,  
Lear Motors Corporation,  
Reno, Nevada*

Without a doubt, a steam powered bus will again become the most desirable transporter and will have important features besides its basic low pollution characteristics with its lower cost, greater reliability and lesser weight. To market a modern transportation product, it has to be at least equivalent in every respect to a diesel vehicle. Three solid years of intensive research and development on the steam vehicle project assures its success beyond any doubt. The road test of such a vehicle, without first thoroughly determining the reliability and efficiency, indicates a much greater desire for publicity than practicability. We see no point at all in proving that a steam bus can operate. This was done at the turn of the century – why reinvent the wheel? Early steam buses in the 20's and 30's had some very desirable features, not the least of which was their multi-fuel capability. Rankine cycle buses were produced in the mid-30's in Germany and England and were used widely in Germany during the War because of their shortage of different kinds of fuels and the availability of other kinds. The diesel locomotive replaced the steam engine and likewise steam buses because of the greater fuel economy. At that time there was less concern with both noise and air pollution. Our efforts since 1968 were directed at developing a practical Rankine cycle engine having not only low pollution, but at the same time the efficiency of a diesel. Our vapor turbine system will exceed the efficiency of the ICE and be more desirable than the diesel in many respects including smaller size, weight,



quietness guaranteed, and lower cost. Eventually, we can equal the fuel economy of the diesel engine. Very large stationary Rankine cycle power plants already prove the possibility of accomplishing this.

The Lear Steam Project began in 1968 by first; thorough examination and study of every detail of old steam vehicles, special studies were made of the White Motor Car Bus Systems, and the Doble Car Systems which were considered the best of their time. He used temperatures higher than stationary power plants. In some instances temperatures of 1200°F and pressures of 1800 psi and still the Doble car had low efficiency. It must have been because of extremely low expander efficiency. We believe this clearly demonstrates the case against the piston type expander. After two years of research and development, with piston expanders and their deficiencies, we made the decision to use a steam turbine. Stories abounded about how a steam engine can be much smaller than an ICE of the same power. One story maintains that the steam engine can be single acting; the steam is expanded once each revolution of the crankshaft, and since the 4-cycle ICE expands only every other revolution, it would seem reasonable to expect the steam engine to be only half the size of the ICE of the same horsepower. This argument is even carried further by using a double acting steam engine; one that the steam acts on the top side of the piston on the down stroke and the bottom side of the piston on the up stroke, thus producing two complete expansions every stroke or revolution. Such schemes, however, proved impractical since size, weight, and horsepower of a piston engine is determined by the crankshaft size and an enormous crankshaft is needed to deliver this torque at low speed. Actually a steam engine must run much slower than an ICE for good reasons which will be disclosed shortly. Nevertheless, the crankshaft had to be very strong and in many cases much larger than a diesel engine for the same power output. Another argument advanced for a small size piston steam engine was that it could run at high speeds since it was not limited by the reaction time of the ICE. It was implied that the steam piston engine could be supplied, if necessary, with a rotary valve and operate at high speeds. In our early analysis and piston engine testing program, we found that the high speed steam engine theory was not practical because of valving problems. For efficient operation steam cannot be admitted for more than about 12% of the power stroke and this allows only an extremely short time to open the valve, admit the steam and close the valve – approximately 3 ten-thousandth's of a second with the engine only turning at 1800 rpm. This short period of admission requires a cam shaft with impractically steep rise inducing valve bounce even at low rpm's. The largest valves we were able to use allowed only 10% of available pressure due to wire drawing or pressure drop. Steam just won't flow that fast. The problem with rotary valves is even worse as the valve surface is traveling at a constant speed resulting in even more wire drawing or throttling losses upon opening and closing than a shaped profile cam. Furthermore, a rotary valve usually has enormous leakage. Another thing that caused us to turn our backs on the reciprocating steam engine was the fact that condensa-

tion of the steam at low throttle settings became a very difficult problem. In fact, until the engine warms up condensation is a general problem requiring the condensate to be drained continuously to avoid hydraulicing which can quickly destroy it. Finally we came to the conclusion that the piston expander would be equally as large and heavy as the ICE and with no better reliability. It would be as costly, if not more so, and since present ICE occupies most of the space under the hood – if the steam engine were as large it would leave no room for the boiler and auxiliary equipment. Repeated attraction to the piston engine was that its efficiency was not proportional to rpm and this eliminated the need for a variable ratio transmission. We could not confirm this in practice, theory, or tests. Therefore, we tried to find rotary type positive displacement engines such as the involute screw expander; but all to no avail despite earnest, expensive, and thorough research. We clearly saw why most of the ICE's were of the same configuration. For good efficiency the steam expander must operate at higher temperatures than the ICE with resulting lubrication difficulty. The cylinder must stay hot if the steam is not to condense and be wasted. With steam at a 1000 or even 1200 degrees, lubrication will pass through the engine but will form an oil film inside the condenser reducing its efficient heat transfer. This film of oil also lowers boiler efficiency. The decision to use steam turbines was for the same reasons that the stationary power plants adopted steam turbines – that is to get higher Rankine cycle efficiency by being able to use higher temperatures and pressures – so high in fact that there is no practical way to make a piston engine which could survive them. Naturally, if steam turbines are so good, why didn't the original steam cars use turbines? The answer probably lies in the lack of modern materials now readily available plus an enormous increase in knowledge of aerodynamics and high speed shaft and bearing techniques using high speed gearing. In other words, the arts of metallurgy, stress analysis, bearing design, and gearing design had to be developed. Abner Doble knew the value of steam turbines and used them where they could turn at low speed and where efficiency was not too important and where no gearing was necessary. Since his piston engine had large exhaust pressure losses he used this exhaust pressure to turn a steam turbine which powered the condenser fan and combustion draft blower. The early steam engineers refused to use a variable ratio transmission maintaining that by increasing cut-off you could increase power making a transmission unnecessary. Increased cut-off design is unacceptable for two reasons: 1) efficiency drops drastically with increased cut-off thus overloading the condensing system and 2) an engine must be stressed highly to obtain these enormous torques at low speeds. Today's inexpensive and sophisticated automatic transmissions enable operation of a steam turbine at high speeds near its design point or at its highest efficiency.

Our first attempts to design a modern automotive steam turbine were unsuccessful because our goals for expander efficiency were too high. We tried to design a turbine that was at least 80% efficient, a task extremely

difficult in large turbines and almost impossible in small ones. We reasoned that turbine efficiency plays a very important part in efficiency of the whole Rankine cycle so we would improve fuel consumption by highly efficient expanders but we neglected the Rankine cycle overall effect. Our first turbine design had five stages or five turbine wheels in series. Its design speed was 70,000 rpm and it was to be geared down to conventional motor vehicle transmission speeds. It would indeed achieve the high efficiency figure at its design point, however, its efficiency dropped rapidly when the machine was operating at partial power or low speed. This operating characteristic of multi-stage turbines does not matter much in huge stationary power plants with their more or less constant speed and load but it becomes very important, however, in a motor vehicle because it operates at varying load and power. Reducing the number of stages or turbine wheels to obtain more efficient operation at part load resulted in higher rpm. Speeds above 70,000 rpm for a geared turbine didn't seem practical. We needed a single wheel or single stage turbine which would be quite efficient at part load. This could be done by the use of a high molecular weight fluid – much heavier than water – which would reduce the nozzle spouting velocity. Our search for organic fluids included the investigation of several hundred fluids that would theoretically operate a turbine at a very high efficiency and relatively low speed. Water is an extremely inert fluid, non-corrosive, non-toxic, non-combustible, inexpensive but it has a low molecular weight. However, none of the organic fluids had all of these properties. We soon shifted our emphasis from turbine efficiency to fluid operating safety. The first fluid that we tested in our system proved to be extremely expensive. Despite its cost of over \$7.00 per pound, and the fact that we needed about 80 pounds, it still thought nothing at all of corroding a piece of equipment worth \$50,000 in 10 minutes. It also made a lot of sand and some teflon. We tested many of the fluorinated and chlorinated hydrocarbons, but they all had problems with corrosiveness and/or decomposition at relatively low temperatures. Most of the major chemical companies worked with us but gave us very little hope for increasing the practicality of working temperatures of these fluids, especially to a value that would provide acceptable Rankine cycle efficiency. Most of the organic fluids also had other undesirable characteristics. When they decomposed they had high toxicity, were lethal, obnoxious, and were quite inflammable. One of the fluid vapors even in very low concentrations of four or five parts per million of air, smelled very much like dead fish although you might say the smell was somewhat of a safety feature in that it was never necessary for us to tell the personnel to evacuate the laboratory when it leaked. We found some of the better organic fluids to be dangerous in other respects. Indeed one of the best, Toluene, has flammability properties very much akin to gasoline. Although we tested Toluene in a system, all of us had misgivings about such highly flammable vapor being present in a boiler and condenser system in a motor car without elaborate safety and fire protection measures. Even a

minor accident would more than likely result in a major fire. We found that Toluene and many other organic chemicals of the Benzene family would gum up a hot turbine in much the same fashion as a hot carburetor is gummed up by the same products. The only difference was that the turbine was five times as hot, and so it happened five times as quickly. Another undesirable characteristic of the high molecular weight organic working fluids was that they required enormous recuperators. After the fluid had expanded and done its work in the turbine, it was still several hundred degrees above the condensing temperature. Fluid pumping horsepower requirements were excessive and controls were difficult to build and maintain. There were many reasons why none of these organic fluids were nearly good enough to consider seriously. Our research included a number of fluids which were azeotropic mixtures of water and other fluids (an azeotrope is a mixture of two fluids that still has the same characteristics of turning from a fluid into a vapor). I have always said that any fluid we end up using will be called Learium. Our present working fluid is called Learium III. This fluid does not lack upper temperature stability. It may be operated at very high temperature pressures – for instance our present turbine now operates at 1000° temperature and 1100 psi pressures at the entrance to the nozzle box but the turbine wheel temperature is only approximately  $\frac{1}{4}$  that of conventional gas turbines. It runs at a maximum of 800°. This makes it unnecessary to use high nickel content wheels to maintain mechanical strength at high speeds. Our turbine has been operating routinely for over a year now and we have experienced neither turbine nor gear failure of any sort. Gear manufacturers assure us there is little or no problem running at gear speeds up to 100,000 rpm. Therefore we now see a bright future for our single stage geared turbines. It can easily swallow a pressure ratio unobtainable even in a triple expansion piston engine. The 240 hp turbine wheel that powers our bus is only about 6" in diameter and 6" long. It really looks lost on the front of the enormous Allison Automatic Transmission. In fact, it is difficult to convince many that such a small turbine can adequately power such a large bus. You can see it's not very large and not very complicated and certainly a lot simpler than a reciprocating engine. As you know, when the airplane industry went from the reciprocating engine, they increased their reliability of operation 200 times. I think that speaks well for the turbine engine.

The external combustor is, of course, the basic reason for the interest shown in a modern automotive Rankine cycle power plant. It is the one thing that is responsible for the possibility of lower pollution, lower than any other type of power plant known with the possible exception of the gas turbine. Someday someone may get real smart and design a gas turbine to do the job. The Rankine cycle power plant, in the meantime, is excellent for the purpose. It is not pressure limited, size limited, temperature limited, fuel air ratio limited – in fact it enjoys the greatest design versatility of any known type of heat engine. Not every Rankine cycle combustor will burn cleanly under

different operating conditions. In fact, given with all this combustor design latitude, it is still a difficult task to meet the 1976 air pollution requirements. Some of the requirements for low  $\text{NO}_x$  approach the theoretical limits achievable. One of the first things we learned in our combustor research is that a flame with stoichiometric mixture of fuel and air would burn much too hot to meet the  $\text{NO}_x$  standards. A maximum temperature limit was necessary to meet the  $\text{NO}_x$  limits and a minimum temperature limit was also necessary to meet the unburned hydrocarbons and carbon monoxide standards. A flame that is too cold produces unburned hydrocarbons and carbon monoxide by undue quenching. A flame that is too hot does produce  $\text{NO}_x$ .  $\text{NO}_x$  does not come from the fuel but from the air. When air is heated above a certain temperature it produces  $\text{NO}_x$ . If the combustor walls are too cold — under  $1500^\circ\text{F}$  — the reaction of the combustion can be stopped and frozen at the pollution level. Injection of too much secondary air can also be harmful, as well as improper and insufficient mixing of the flame. It was quite difficult designing combustors that would mix well at both low and high power settings. Our combustor systems are designed to provide complete proportional air fuel/air ratio control under all operating conditions including altitude, temperatures, and humidity. The burn level in our combustor is directly proportional to the momentary power level needed for the vehicle. The older steam systems used a bang-bang control system; that is, they would either be burning at full power or totally shut off. The bang-bang operation alternately heats and chills the combustor. The flame reaction is quenched at each start up and this results in the smoke and smell of kerosene which is, of course, unburned hydrocarbons or raw fuel. Bang-bang combustion control systems also require very large boilers or steam storage capacity and a longer warm up time. Since the amount of heat transfer surface stays constant in our boiler it is much more efficient than a bang-bang boiler at low power levels. Bang-bang or on-off operation can also produce undesirable thermal excursion, thermal shock, and noise. Continuous proportional control reduces noise by using large slow turning highly efficient combustion blowers and large low velocity exhaust stacks. Its combustion emission is so clean that on several occasions its operation has actually purified the laboratory air. The ambient air unburned hydrocarbon lab count was approximately 12 parts per million at the intake of the combustion blower, and after passing through the boiler and combustor it came out with only three parts per million. Since carbon monoxide is also combustible, in several instances we experienced a reduction of carbon monoxide content in our laboratory. Our current emissions from our bus combustion system are about 20% of the allowable emissions requirements of the 1975 California Standards for Heavy Road Vehicles. I am absolutely convinced that by 1975 these standards will be reduced by a ratio of 5 to 1. I believe the present ones are far too high to be consistent with the reduction we're calling for in automobiles. By incorporation of several techniques that we used to meet the 1976 Automobile Emission Standards the bus combustor can be made even cleaner.

Boiler efficiency must be given almost as much importance as low emission combustion, since boiler efficiency directly affects the system efficiency or fuel economy. The boiler has always been a problem with Rankine cycle systems, especially mobile systems in that efficiency usually meant such a large size that it couldn't fit under the hood and no one is going to forego the availability of the trunk space to house a large boiler. Our boiler efficiency problem was solved by application of modern heat transfer calculation techniques, much use of computers, and the information available from the aerospace industry. With this modern design technique we achieved boiler efficiencies of 96% at low power levels (50 hp) and 89% at the very highest power levels (250 hp). Previous automotive steam boilers had efficiencies that were seldom higher than 75%. Achievement of this very high boiler efficiency was accomplished without compromising reliability or simplicity. The present vapor generator is much less complicated than those of several early steam systems. Its high efficiency results in an exhaust temperature that is just warm to the touch. In other words, you can touch this exhaust pipe without burning your hand. We feel our prototype boiler can be mass produced at quite low cost.

The condenser is an important Rankine cycle system design detail. The condenser has traditionally been a problem in Rankine cycle automobiles. Even the mighty Doble operated with an open cycle when it was delivering over 40 hp (exhausted steam to the atmosphere). To make a mobile full condensing Rankine cycle system practical we had G.M.'s Harrison Radiator Corporation design, develop, and deliver to us at their expense a highly efficient condenser — more efficient than that procured by EPA and touted by them as a breakthrough. Even an elementary study of the Rankine cycle system indicates that the power plant will be limited only by the size and efficiency of the condenser; however, any increase of cycle or component efficiency reduces the condenser requirements and size. Our present Rankine cycle system can achieve the same efficiency as the ICE and this led us to believe that present frontal areas allotted to car radiators will be adequate for steam engines of the same power. The Harrison Division of G.M. had developed for our use a condenser system that is highly efficient. Indeed a federal contract was let for Rankine cycle condenser development involving several hundreds of thousands of dollars, resulting in a condenser design that is not as efficient as the one now supplied to us by Harrison Division of G.M. Despite this highly efficient design, our bus power plant system still requires two large condensers, as large as you would normally use on diesel truck radiators. Since the condenser is such a very important part of the Rankine cycle, LMC has been doing research and development on its own more efficient, more compact, and inexpensive condenser system. Several systems now being studied look very promising, however, we are not putting anything new or untried in the bus.

We owe a great deal of thanks to the General Motors Corporation for all

the help, data, bits, pieces, parts, accessories and for furnishing us a brand new 50-passenger bus and a Monte Carlo car supplied to us without cost or any obligation on our part except to inform them of the final results of our emission tests. We have chosen to incorporate modern efficient contemporary design rather than put any unproven components in the system, two large condensers are certainly not inappropriate for a 50-passenger bus. However, these condensers are mounted on the back of the bus, not under it, and will not provide any more heat to the passer-by on the sidewalk than they now get from the diesel system.

A bus system has to be reliable, quiet, efficient and exude very low air pollution if it is to be successful. Lear Turbines produce maximum torque at stall and will promote smooth and desirable driveability characteristics. Their cleanliness and quietness should make our cities a better place in which to live. Below are some calculated data which should be most interesting.

In this short paper, naturally, we had to omit many important items which required much effort, time, and expense to develop; such as a combustion blower three times as efficient and quiet as any available on the market; a variable displacement fluid pump which completely eliminates the possibility of any lubricant contamination by isolation and a rate control system which anticipates need for more heat in advance and shuts down at the instance of power reduction. The time limit also prevents us from explaining our turbine power control, which is not done by pressure reduction, but by area reduction which maintains efficiency even at very low power levels.

The present ICE and diesel power plants have cost many billions and taken half a century to develop. In much less time, and for a great deal less money, steam can equal and exceed their performance and economy while eliminating pollution outputs. We consider our present results as encouraging but far from the ultimate in steam vehicle power plants for both car and bus. The future is most promising; but, like all good things, will require more time and a lot more money than can be provided by one individual or a small corporation.

We have had all too little help and encouragement from EPA; and as a taxpayer, I believe that up until now EPA has demonstrated unlimited ineffectiveness in its efforts to solve the vehicle pollution problem.

Lear has only received assistance from UMTA and the California Assembly. However, the amount involved was only a small fraction of the total needed to achieve the desired end.

All of the design of a low pollution, low cost and high efficiency engine is far more important. In view of our personal expenditures and intensive efforts to solve the critical and difficult problems — my wife made me put this in here; you see she's the one who is spending her money, so she makes me put things in once in awhile — and you know I said I'd make a success of this thing even if it took every cent she had. It should be understandable why we take exception to EPA. They visited one of our potential customers; Fiat's Chief Engineer of Research and Development — Dr. Savonuzzi — who asked why

Lear was not mentioned in their list of contractors. They insulted Lear Motors by derogatory statements as to EPA's confidence in our product. Happily, Dr. Savonuzzi disagreed with them because of his more intimate knowledge of what is going on at Lear and elsewhere. I think it's important that, in our personal opinion, EPA's bureaucratic approach of developing components and studies to study studies will result in a shameful waste of the taxpayer's money. Thank goodness for at least one realistic program instituted by UMTA and the California Assembly, which thankfully we are a part of, and expect to eventually demonstrate — not just a steam bus — but one that represents desirable and necessary low pollution, quietness, reliability and low cost so greatly needed and anticipated by UMTA.

Solving the problem of an acceptable substitution for the current internal combustion engine and diesel is a major program calling for more money than now available for contractors. It calls for a system approach instead of component development, all of which can be done by spending more for the doing, less for the studies and far less for the bureaucracies. Again UMTA has shown more realistic approaches for the bus program than any other agency.

In summation, steam buses are practical, will be built, widely used and we hope to make some contribution to it. For your information we have some figures you might find interesting.

The Doble car, at its best, had a Rankine cycle efficiency of 33 percent; at a power setting of 20 percent, it had six percent. The actual measured cycle efficiency we have is 17 percent at 20 percent. At 50 percent the Doble system had 10 percent and had a basic fuel consumption of 1.3 pounds per horsepower, whereas the Lear System has an actual Rankine cycle efficiency of 18.5 percent and a basic fuel consumption of .749 pounds per horsepower hour. At 100 percent the Doble E24 Rankine cycle efficiency had a net efficiency of 14.9% with a basic fuel consumption just under one pound per horsepower, whereas the Lear system has 18.4 percent Rankine cycle efficiency but its fuel consumption is only .749. I believe .749 represents the actual efficiency that the internal combustion engines are now giving and possibly much less in internal combustion engines with the added clean air devices.

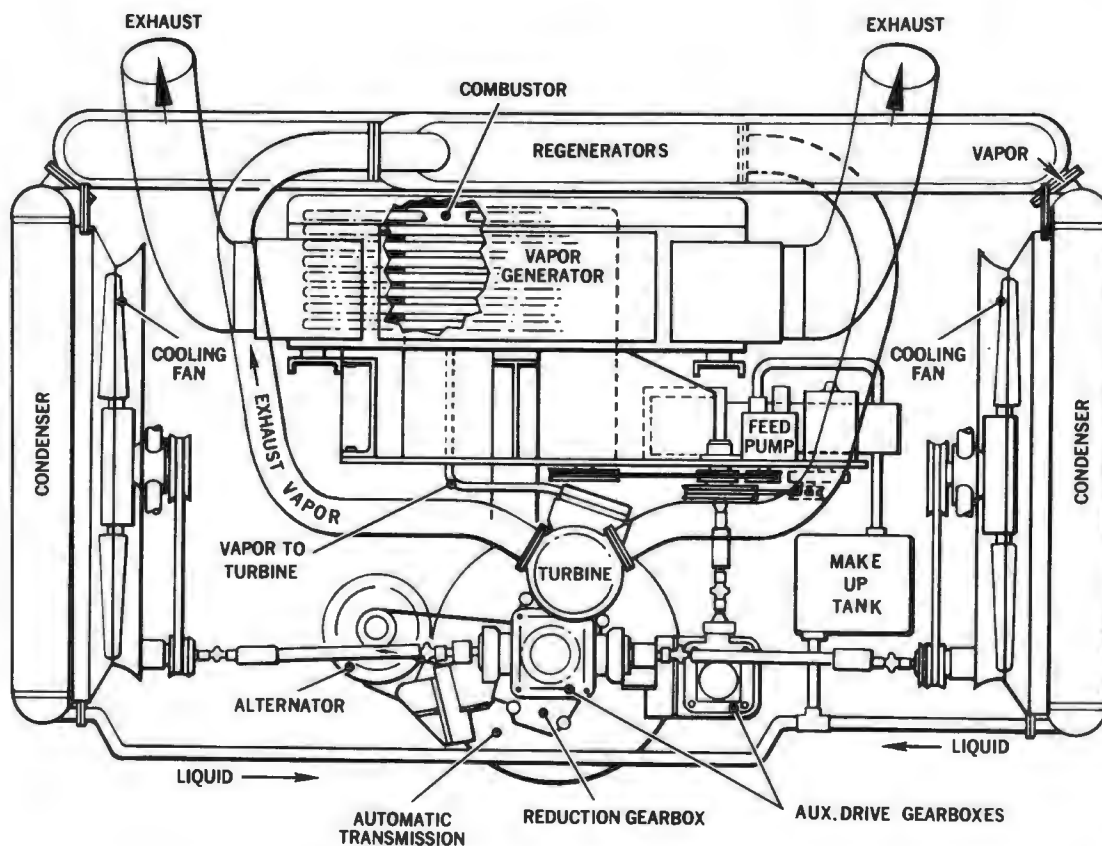
There's much to be done, it's going to take time and effort, and when you think of the number of years the present piston engines have been in production, the billions and billions that have been spent on them, I think that the three years' time is a very small time to produce anything.

Once again, I do not by any stretch of the imagination, want to impune the efforts of Brobeck and their bus. I think they made a great thing to get it out as fast as they have, but actually as Brobeck himself told you this morning, 'it's just a reproduction of what was done before and doesn't represent their ability to make something that will ultimately meet the requirements.' The requirement must be a smokeless, odorless, pollution free bus — but it's got to approach the efficiencies of the diesel if it's going to be acceptable in

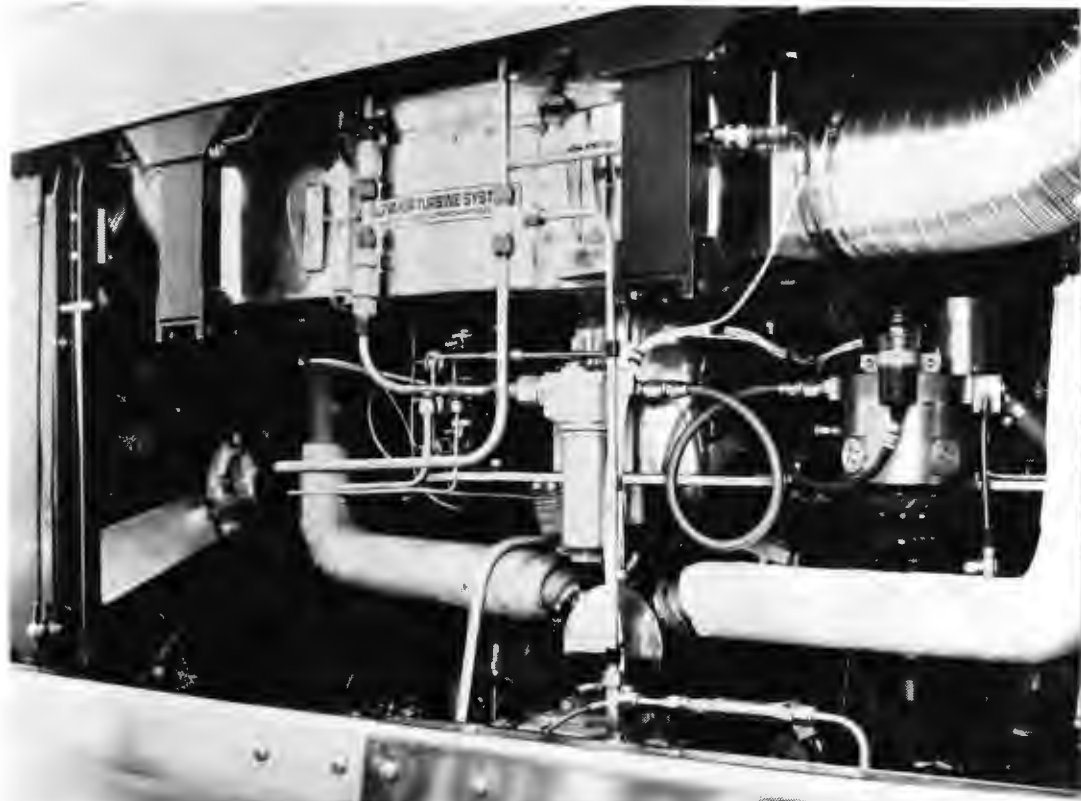


the market place. I think that our cooperating with General Motors and the other companies that we are working with will enable us to have such a bus available much sooner than any of us have expected. Thank you very much.

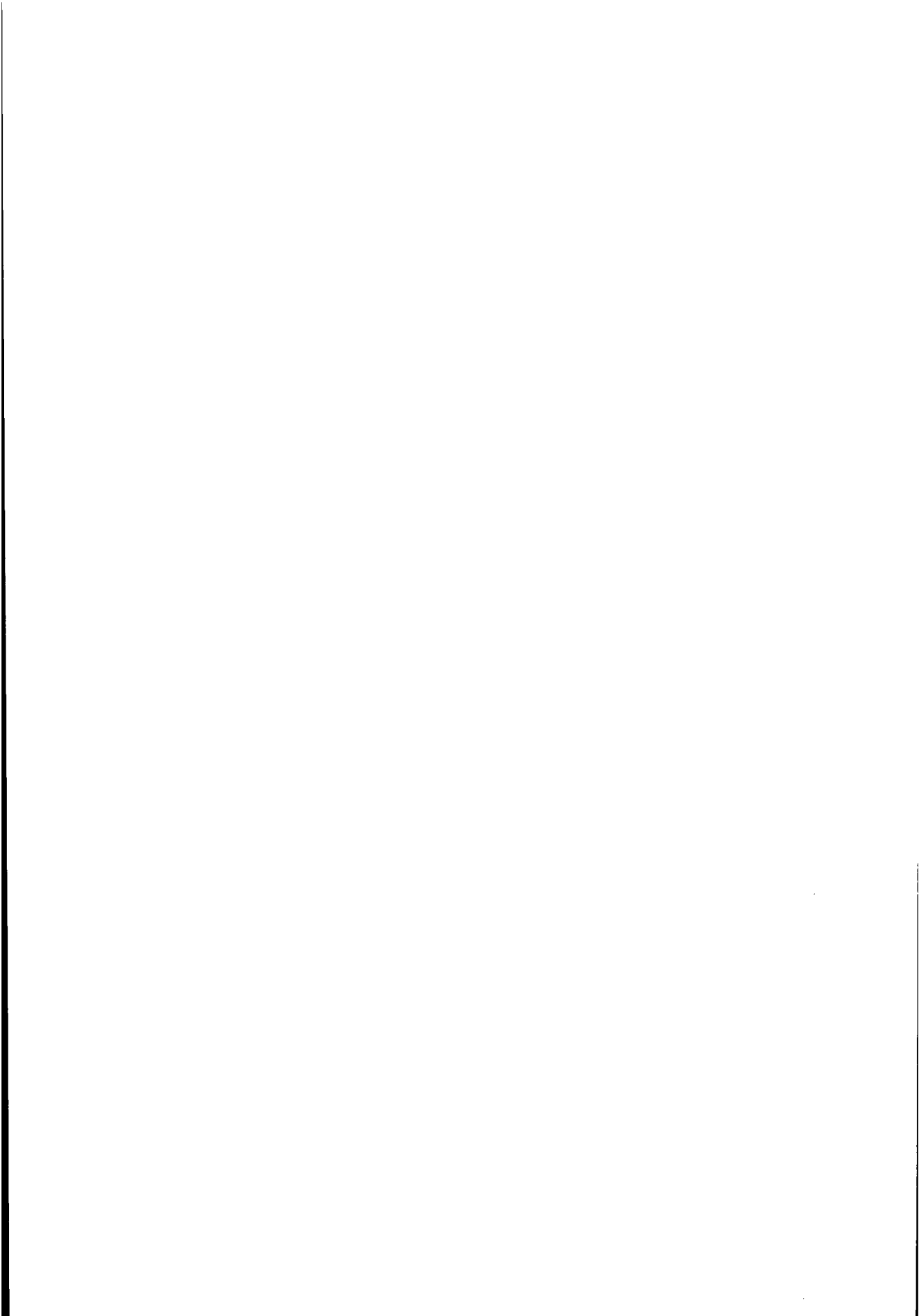
Vertical line on the left side of the page.



**Figure 1. Layout of Components in Lear Motors Corporation Demonstration Bus**



**Figure 2. Actual Installation of Boiler and Turbine in Lear Motors Corporation Demonstration Bus (January 1972)**



*C. Carroll Carter, Assistant Administrator for Public Affairs,  
Urban Mass Transportation Administration,  
U.S. Department of Transportation*

Not only should you hear from the contractors with the Department of Transportation, but you should also hear from those who are working under contract to the Environmental Protection Agency. You will now hear from Bill Compton, who is the assistant director of research of the SOLAR Division of International Harvester Corporation. Bill will discuss his combustor development work with EPA.

### **Combustor Research and Emission Goals**

*William Compton, Assistant Research Director,  
Solar Division, International Harvester Company,  
San Diego, California*

Thank you Carroll. I thought that before Mr. Lear's talk that I was one of the good guys, now I'm not sure. I feel somewhat like the bell hop in the hotel who got the call from the bridal suite. They were complaining about being thrown out of the bed. When he arrived at the suite he found the groom had gone to look for him and only the bride was there. The bride said, "Every time the train goes by the bed jumps up and down and throws us out." The bell boy couldn't believe it. She says, "Well now I insist you understand how this works. You get in this bed, there's a train coming right now and you can see." Just then the groom came back and discovered the bell boy in bed with his bride and he said, "What are you doing?" The bell boy said, "Would you believe I'm waiting for the train?" I feel somewhat like the bell boy - I know I should not be here but I don't know what to say. We are a contractor with EPA and very proud of it. We feel that we are doing a very essential part in the pollution game. I don't think you'll find anybody in Southern California that doesn't take this problem very seriously. We do at Solar, and I'd like to tell you about some of the things we are doing.

The first question we are going to consider is "Where does the Rankine cycle engine stand for low emission automobile power?" A program was conducted for EPA division of Advanced Automotive Power System Development by Solar to demonstrate the feasibility of a fully modulated two million

BTU/hour heat release, continuous flow atmospheric combustor for possible use as a Rankine cycle heat source. Goals of the program were to meet or better the 1975-76 pollution levels.

It was practical to consider Solar for this program since we are the largest producer of industrial turbines in the country. They are sold throughout the world. We have been developing a variety of models for the past 25 years and have achieved a reputation we are very proud of. In developing industrial gas turbines we have had to learn how to burn all kinds of fuel under all kinds of conditions. They operate on diesel, kerosene, and natural gas using all kinds of fuel atomization systems. This technology and expertise was applied to the problem of demonstrating a Rankine cycle combustor with low emission levels.

Figure 1 compares vehicle emission levels to the 1975-76 maximum allowable goals. It is a scaler plot showing the relative comparison between CO, H/C and  $\text{NO}_x$ . The most important point from this curve is that the conditions in the combustor that produce low CO and H/C normally produce very high  $\text{NO}_x$ , and conversely. Therefore the problem of efficient combustion with low  $\text{NO}_x$  requires a step forward in combustor technology.

To tackle the problem we established performance goals as shown on Figure 2 for a Rankine cycle automobile engine combustor. We specified a very high turndown ratio and continuous modulation to avoid many of the problems previously encountered with "on-off" combustion systems. The combustor must operate on various fuels – kerosene, gasoline and diesel and emission levels must be below the 1975-76 goals during rapid transient start-up, shutdowns, and in various climatic conditions.

The next figure (Fig. 3) shows 2 plot nitric oxide as a function of air-fuel ratio for various combustor residence times. It becomes apparent, in investigating the data, that the area of maximum  $\text{NO}_x$  production occurs at an air-fuel ratio of around 16, slightly in excess of stoichiometric. As the residence time at this air-fuel ratio increases, the  $\text{NO}_x$  production increases. We therefore must establish a stable combustion process that avoids long resident times near stoichiometric.

Designing a combustor to operate at low  $\text{NO}_x$  and oxidize the H/C and CO is not particularly difficult for a single point. However, it becomes very difficult when one has to modulate over a wide heat release range. Identifying the problem area we established a computer simulation program with reaction kinetics for NO, CO, and H/C and the other competing reactions to study the greatest problem areas. The next figure (Fig. 4) shows NO production on the ordinant versus distance along the central axis of the combustor. Fuel enters the combustor at the zero point and moves axially along the abscissa. At the 2 million BTU/hour heat release rate the residence time goes from zero position in the combustor to the 10 inch position in 10 milliseconds. Sizing at the 100 percent release rate indicates the NO production is quite low, however, the CO and H/C are quite high. We would prefer to raise the temperature

slightly giving higher NO but reducing the CO and H/C. When the heat release rates are turned down the residence time increases increasing the NO as shown. At a one percent heat release rate the NO production is well above the limits. It is interesting to note, however, that the CO is reduced considerably as the residence time increases, thus illustrating the point made earlier that the conditions for low CO and H/C are in opposition to the conditions for low NO.

The next figure (Fig. 5) shows a cross section through the combustor schematic that was decided had the best chance of meeting the goals established for emissions and turndown ratio. In this approach, we use a rotating cup atomizer over which the primary zone air is passed through a swirler. Primary zone is maintained as a fuel-rich mixture which gives us a relatively easy flame stability. Primary zone air-fuel ratio is maintained at about 12 well below the stoichiometric area where high NO production occurs. The dilution air is introduced in the precise quantity to increase the air-fuel ratio in the secondary zone to 18 to 1 well beyond the area again where high NO<sub>x</sub> production occurs. An additional dilution zone is used to condition the temperature in the tertiary zone for an overall fuel-air ratio of 26. This reduces the temperature entering the vaporizer to near 2500°F.

The next figure (Fig. 6) entitled "System Schematic" illustrates the relationship of the combustor to the fuel system; the air metering valve; the fuel metering valve; the fuel pump and the compensators for high altitude and fan decrease in power. The cup will be ultimately mounted on the fan, thus requiring only enough pressure in the fuel line to drip the fuel onto the cup. This concept is especially attractive in that it provides 180 degrees fuel spray angle in a very precise pattern regardless of the fuel flow or viscosity. A consistent fuel pattern and droplet sizes below 50 micron are needed to maintain efficient combustion and very low NO<sub>x</sub> production.

Figure 7 is a close up of the rotating cup fuel atomizer and the fuel tube used to drip the fuel onto the cup. The fuel tube is simply a 1/8 inch diameter line with no small orifices and thus is a very low maintenance system. The cup is relatively easy to manufacture and potentially quite economical. In our demonstration case we mounted the cup on an auxiliary motor to expedite demonstration of the low emission combustor.

The next figure (Fig. 8) shows the fuel metering valve for the 100 to 1 fuel modulation. An irregular slot in a moveable plate crosses a similar slot in a stationary plate forming an orifice where the two slots intercept. By moving the moveable plate over a two inch distance, we are able to establish a fuel measuring orifice over a 100 to 1 range with great accuracy. The next figure shows the calibration curve for the fuel metering valve indicating the linear range over the near 2 inch stroke and the fuel flow from 1 lb/hr to 110 lb/hr.

The air must likewise be metered over the same range in order to control air-fuel ratio over the entire heat release range. The next figure is the perform-

ance curve for an air-metering valve. It again shows the very linear range of air flow with valve position. Air flow is established on the basis of the 2 inch of water pressure drop across the orifice. The valve is shown on the next slide (Fig. 9) entitled "Air and Fuel Metering Valve Combustor Demonstration Unit". A multi-ported air valve is shown as being necessary to maintain the required aerodynamic smoothness, which was found to be absolutely essential for low  $\text{NO}_x$  production. Aerodynamics smoothness dictates that simple butterfly valves cannot be used. Demonstration combustor components are shown on the next slide with the rotating cup atomizer and combustor liner noted. The outer combustor can is shown in the middle with the exhaust stack properly noted. The combustor is seen to be about 10 inches in diameter and about 10 inches long for the 2 million BTU/hour heat release. The fan motor was a compact aircraft axial flow type.

The next slide (Fig. 10) shows the air-fuel ratio for minimum  $\text{NO}_x$  emissions versus air flow from 100 percent heat release down to the 1 percent heat release. It is observed that the air-fuel ratio decreases as the heat release decreases from 100 percent to 50 percent, then continuously rises down to minimum heat release. This is partly explained because of the lack of mixing as the air flow decreases through the combustor. With the proper air-fuel ratio for minimum  $\text{NO}_x$  established at the different heat release ranges, it now becomes possible to mechanically link the fuel metering valve to the air metering valve to maintain optimum air-fuel ratio at any heat release position.

The next curve "Emissions Integrated System, Test A", shows the  $\text{NO}_x$ , H/C and CO for the demonstrator unit with the  $\text{NO}_x$  well below the 1976 goals.

This test gave sufficient confidence that a Rankine cycle combustor could be produced that would meet the goals, and thus justified the next step, which was to impose the automotive vehicle packaging constraints and the vapor generator boundary conditions on the combustor.

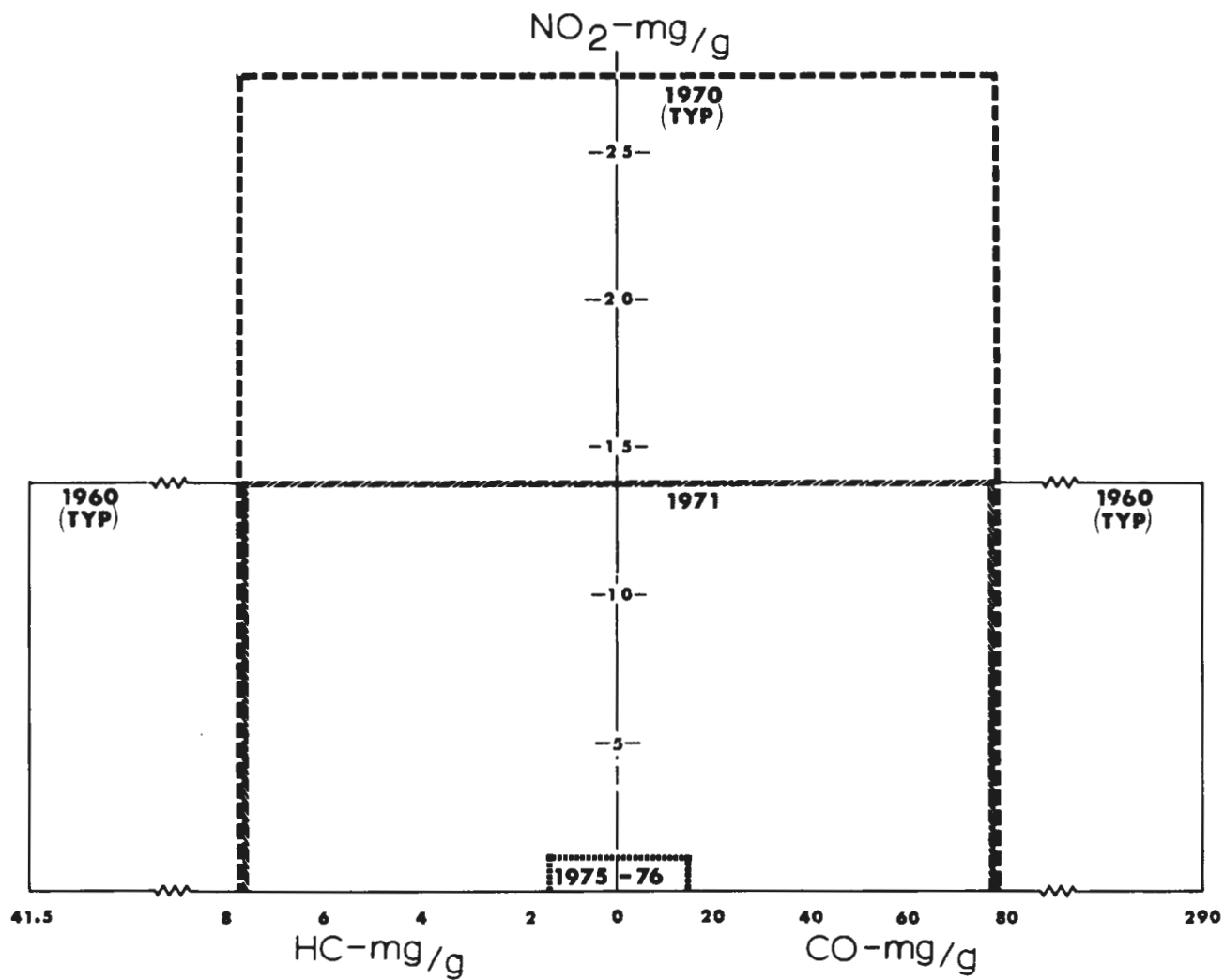
The next figure "Important Accomplishments", indicates that the 100 to 1 turndown ratio was established; fast transient response with low emissions and the demonstrated low volume and cost potential, along with the better 1976 emission goals.

The next figure indicates the packaging constraints and vapor generator boundary conditions imposed on a unit to be built and demonstrated for the EPA Rankine cycle engine demonstration program. The heat release was increased to 2½ million BTU/hr, turndown ratio was established at 40 to 1 instead of 100 to 1; the packaging volume was 24 x 24 x 20 inches and the total weight was not to exceed 175 pounds. The parasitic power including combustor fan and fuel accessories could not exceed 2½ electrical horsepower. The startup time was 15 seconds or less. The next figure (Fig. 11) shows the concept of the combustor/vapor generator with the vehicular packaging constraints. A radial fan was used with the rotating cup integrally mounted on the fan. The primary air enters a swirler and passes over the lip of the cup.



The combustor is seen to be about 20 inches in diameter and about 7 inches in axial length. The spray angle of 180 degrees from the cup allows the construction of a large diameter, relatively short combustor. The parasitic power required for an arrangement of this type to produce the 1500 pounds of steam per hour is inversely as a cube of the diameter. Thus, maximum advantage is taken of the desirable features of the rotating cup atomizer to achieve a relatively large diameter, short combustor. You will remember the numbers presented by Mr. Burtz of Steam Powers Systems this morning where, I believe, the weight was 835 pounds to deliver 3000 pounds of steam per hour at 1000 psia and 850<sup>o</sup>F compared with the 1500 pounds an hour at 1000 psi and 1000<sup>o</sup>F weighing only 175 pounds. It is therefore obvious that a very compact unit can be developed employing advanced combustor/vapor generator technologies. The emission levels for H/C is shown on the next slide (Fig. 12) and indicated to be well below the limit over the 3.5 to 135 pounds of fuel per hour. CO on the next figure (Fig. 13) is likewise shown to be well below the allowable limits. NO<sub>2</sub> also is shown to be well below the limits as shown on the next slide (Fig. 14). The two curves indicate a transition between no air going into the secondary ports up to about 70 pounds of fuel per hour to air going into the primary and secondary ports above 70 pounds per hour. The principal reason for introducing air into the secondary ports at fuel flows above 70 pounds is to limit the pressure drop across the combustor to 5 inches of water; thereby limiting the parasitic power required for combustor operation. The integrated control unit will operate well below the NO<sub>2</sub> line over the power range from 135 to 3.5 pounds per hour fuel flow, thus assuring a Rankine cycle combustor which can meet the 1976 emission goals.

This unit has been combined with a compact monotube vapor generator (Fig. 15) and is operating in the test stands at Solar establishing the conditions for automatic control. Packages shown are sufficient to fit into a 1972 automobile and we at Solar are very excited about the possibility of their being demonstrated in the near future. Liaison work is in progress with the systems contractors who are establishing vehicular requirements for application of the Rankine cycle units for automobiles. We at Solar are very privileged to be working with EPA on this most worthwhile project and despite some of the previous comments made by some of the authors today, we believe that they are doing an excellent job with a most difficult task and should receive support from all of us. Thank you.



∞ Figure 1. Comparing Typical Light Duty Vehicle Emission Levels to 1975-76 Allowables

---

## PERFORMANCE GOALS - RANKINE CYCLE AUTO ENGINE COMBUSTOR

- HEAT RELEASE -  $2 \times 10^6$  TO  $2 \times 10^4$  BTU/HR IN  $1.33 \overline{\text{FT}}^3$  MAX
- FUEL - DIESEL NO. 1; JET A OR KEROSENE
- EMISSIONS LESS THAN 1975-76 LEVELS ARE 1 TO 100% POWER CHANGE IN 2 SECONDS OR STEADY STATE
- PARASITIC POWER LOSSES LESS THAN 2 HP W/O VAPORIZER
- START TO FULL POWER IN 3 SECONDS OR LESS

Figure 2. Performance Goals – Rankine Cycle Auto Engine Combustor

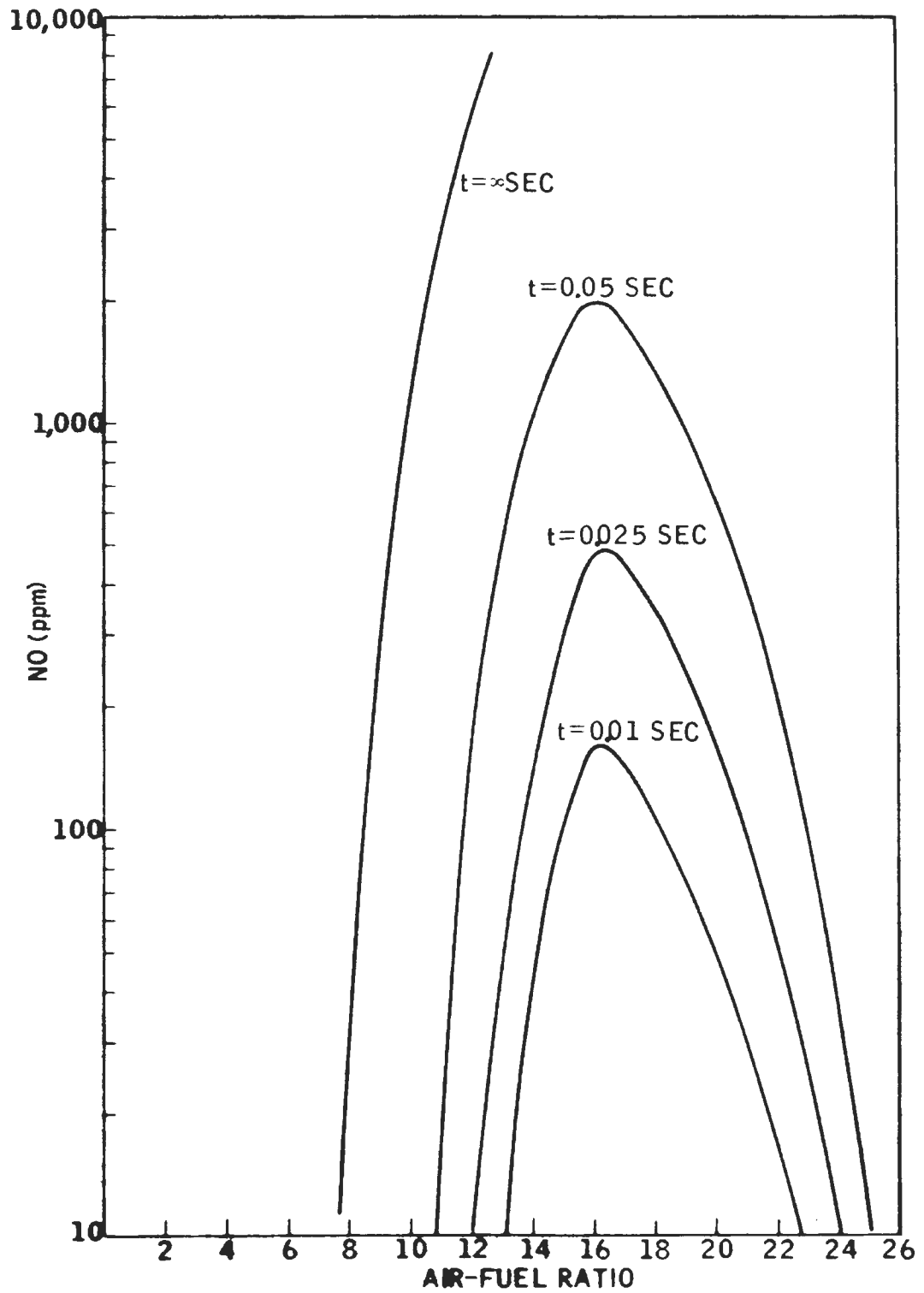


Figure 3. Nitric Oxide as a Function of Air-Fuel Ratio

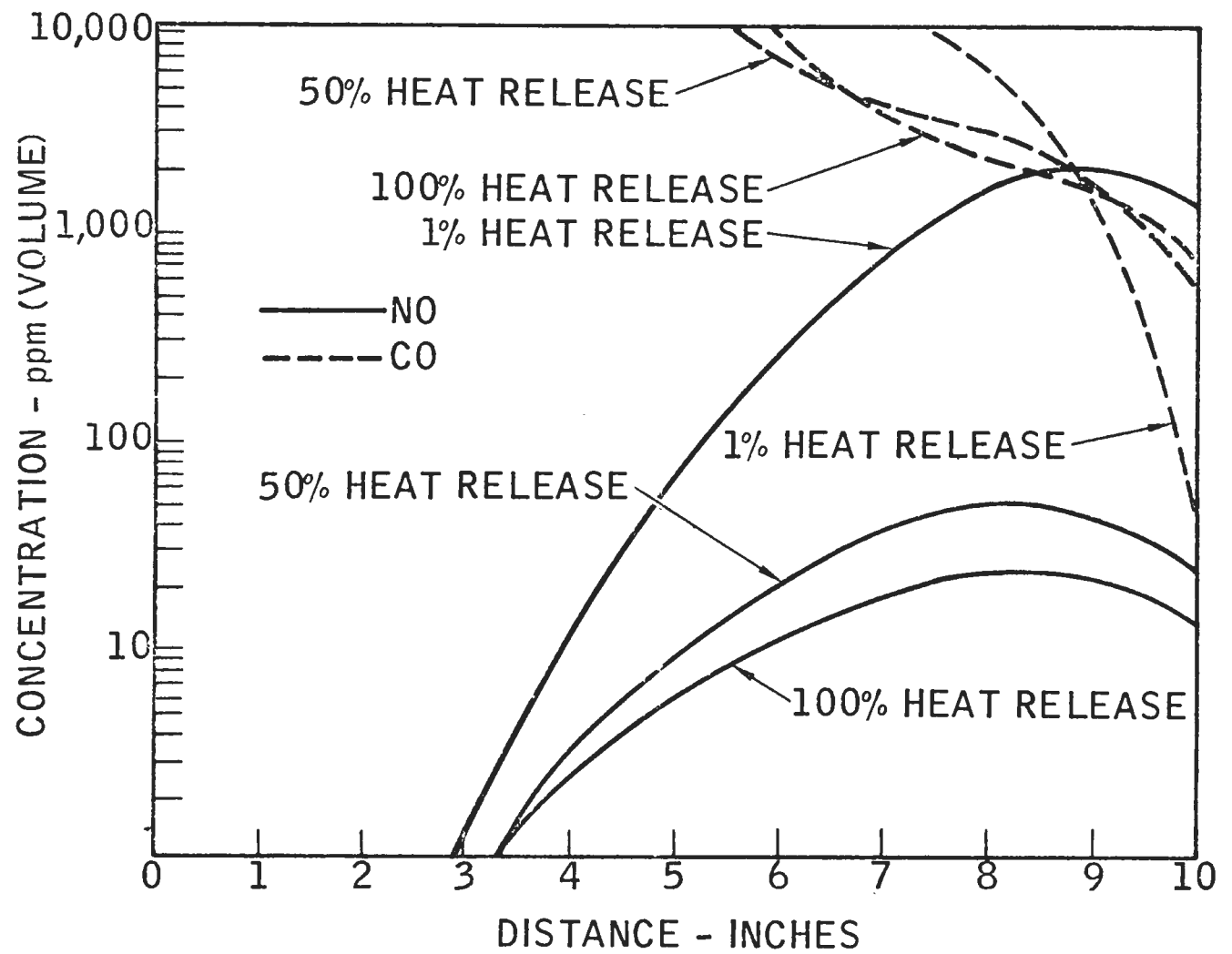


Figure 4. NO and CO Formation Along Trial Combustor

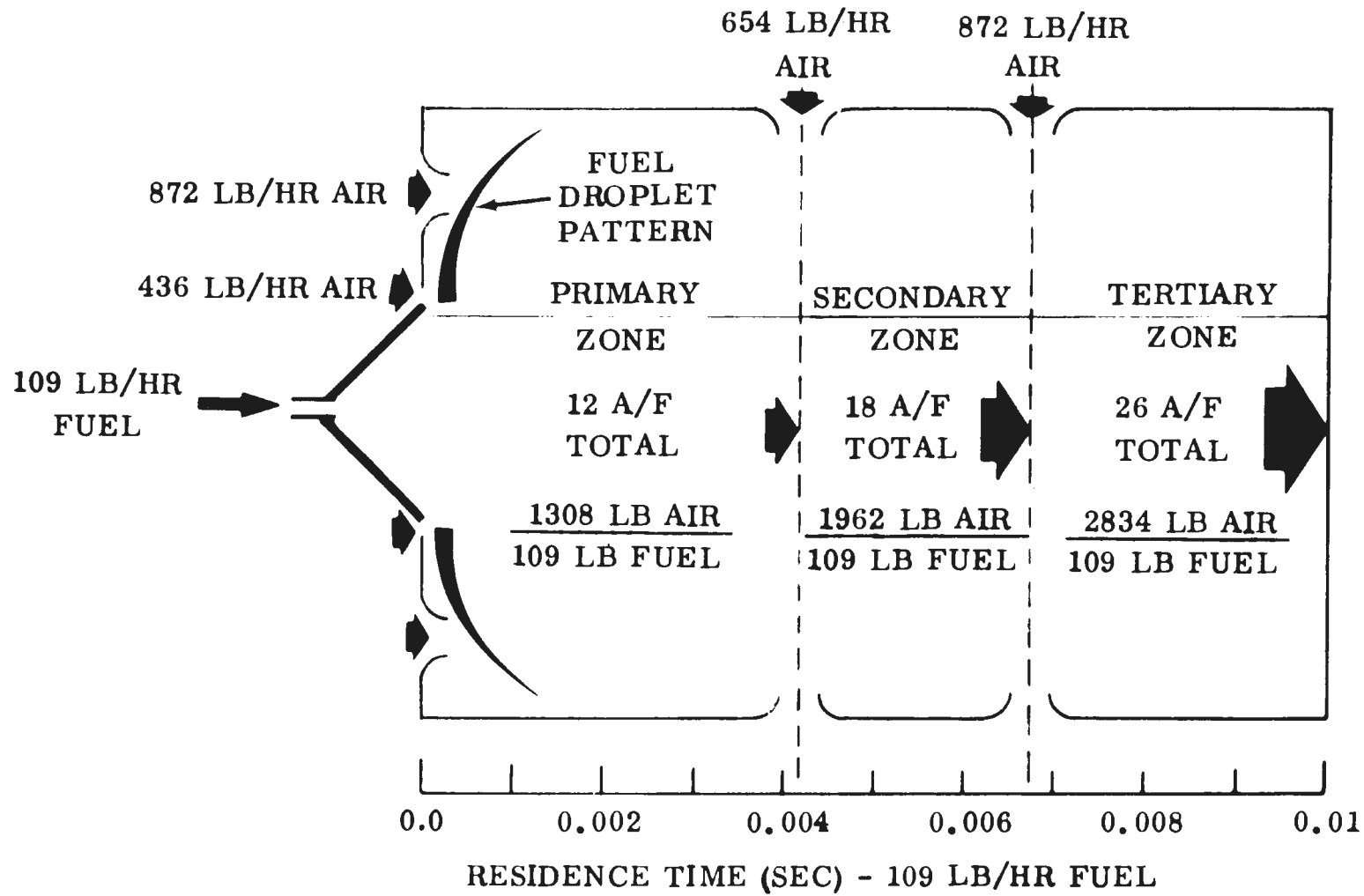


Figure 5. Solar-Low Emissions—Controlled Zone—Combustor

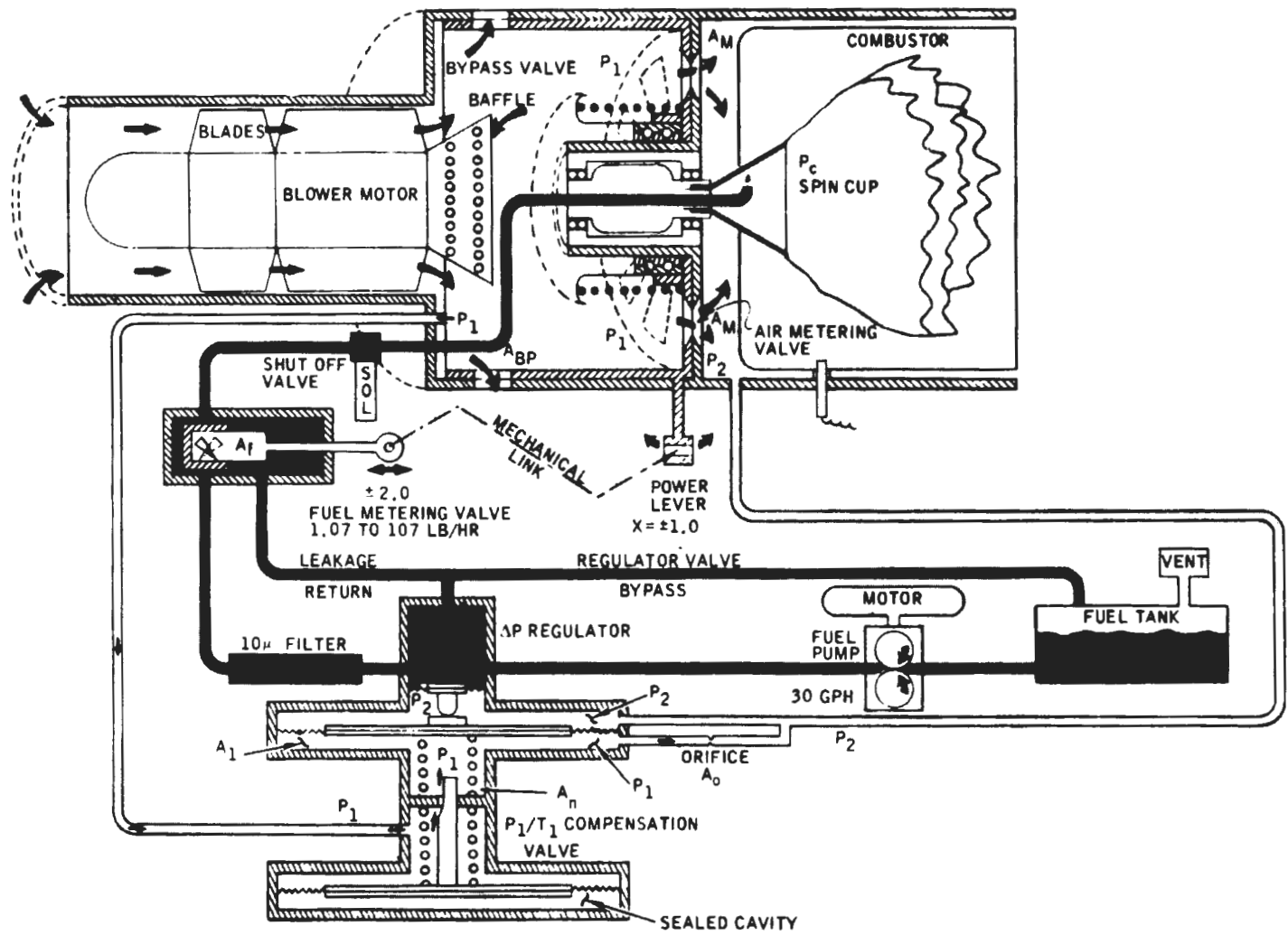
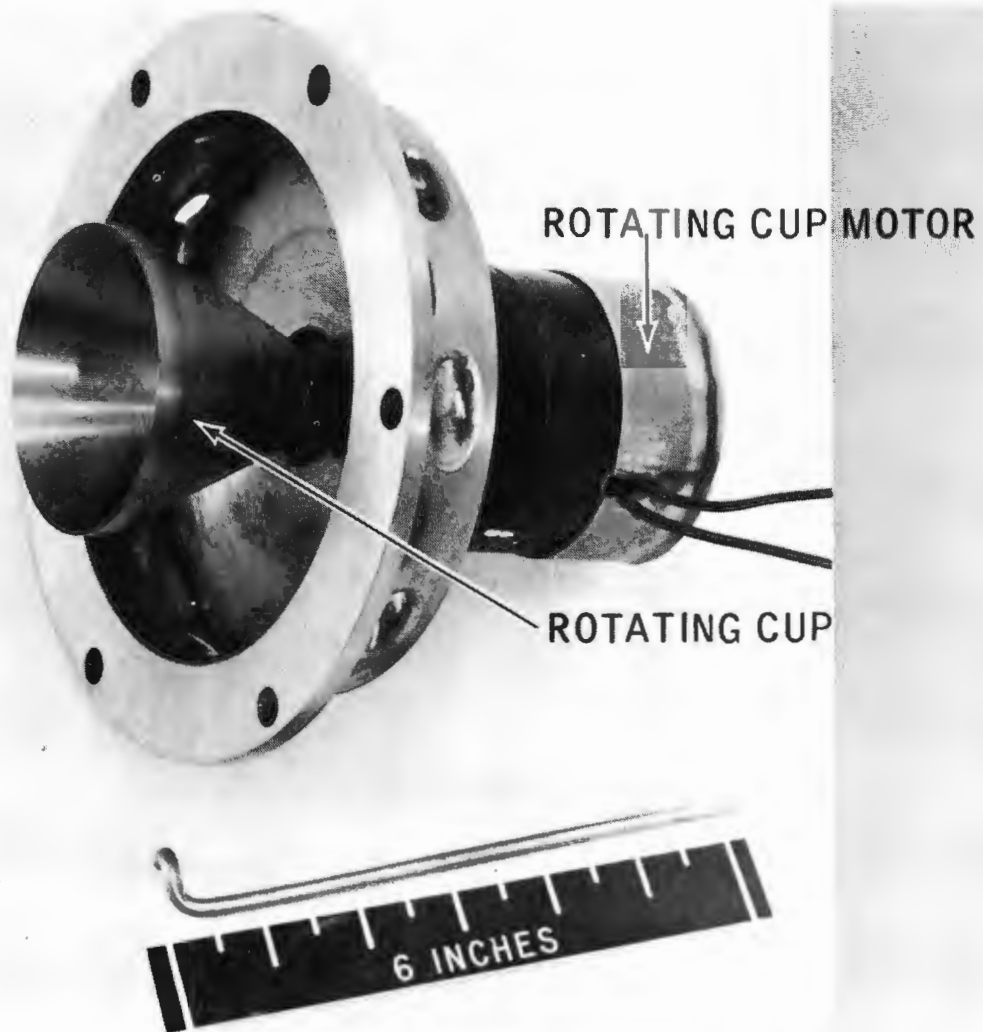
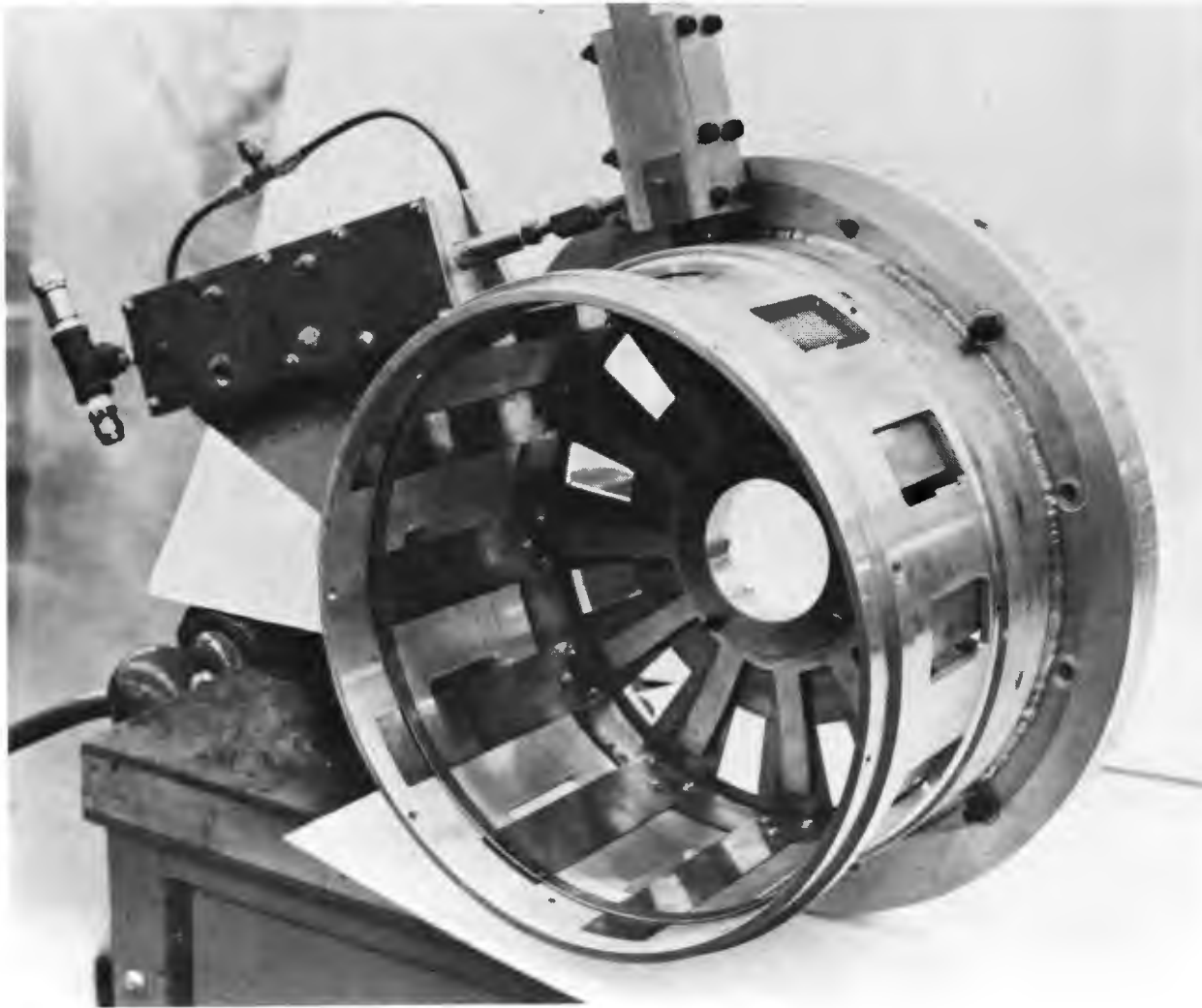


Figure 6. System Schematic



**Figure 7. Demonstration of Rotating Cup Fuel Atomizer**





**Figure 9. Air and Fuel Metering Valves**

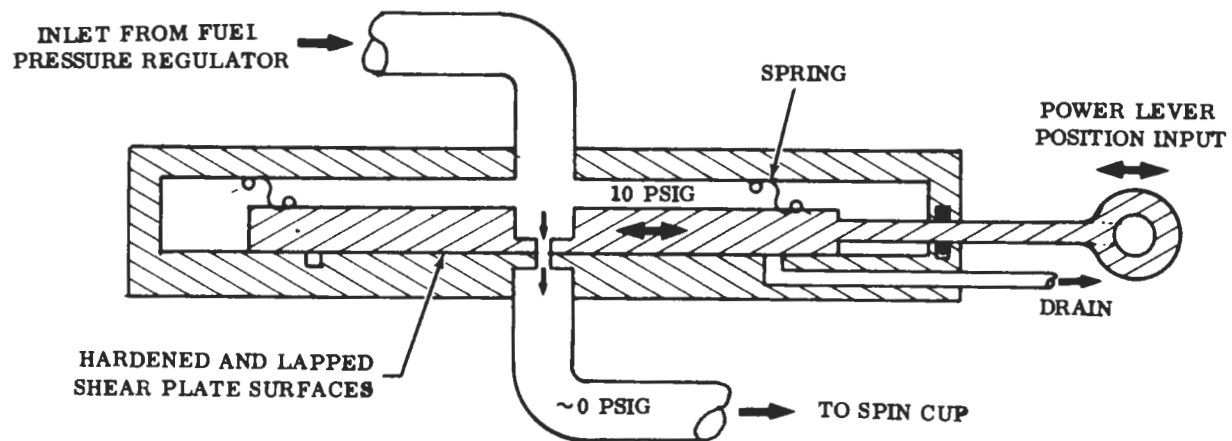
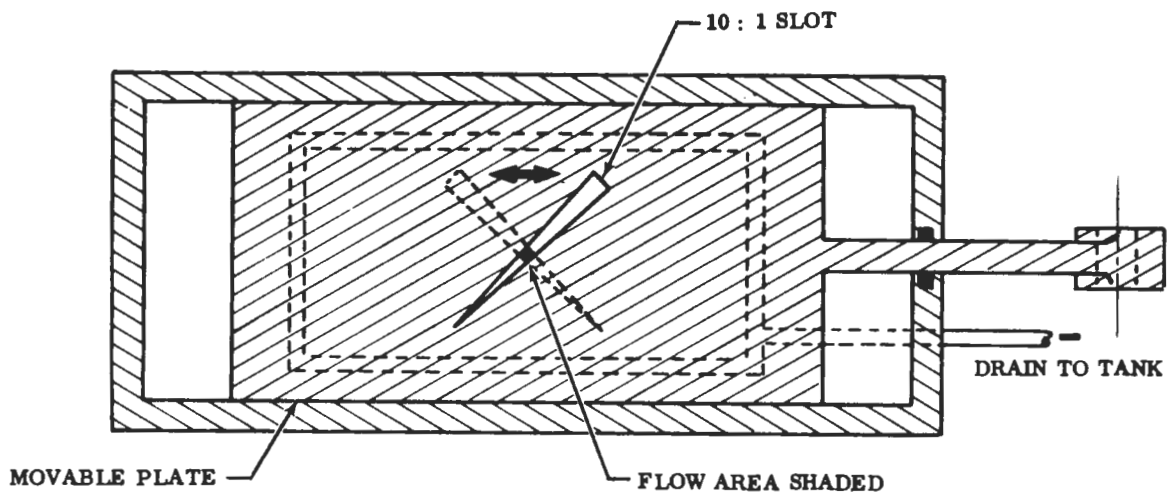


Figure 8. Fuel Metering Valve – 100 to 1 Concept

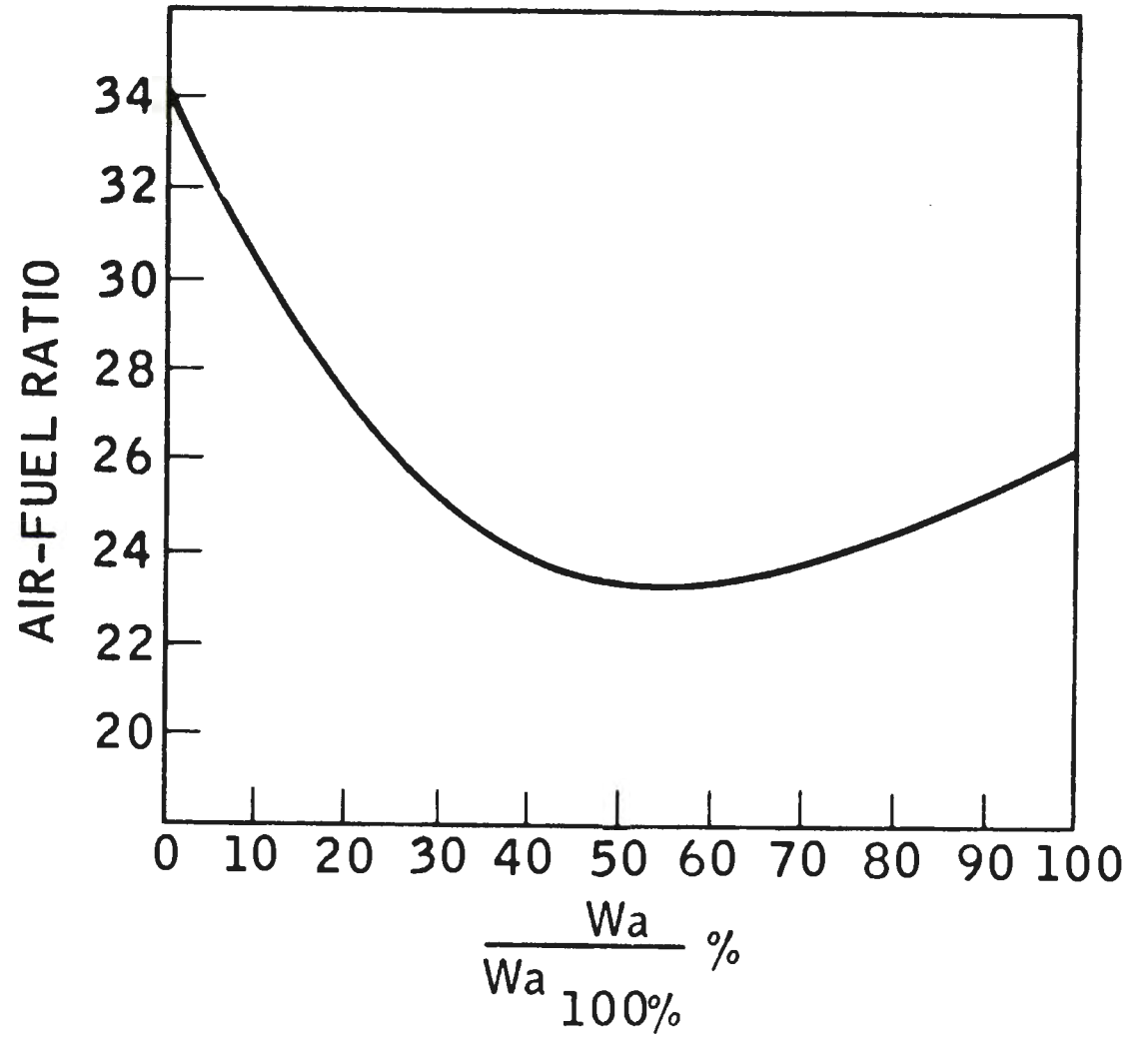
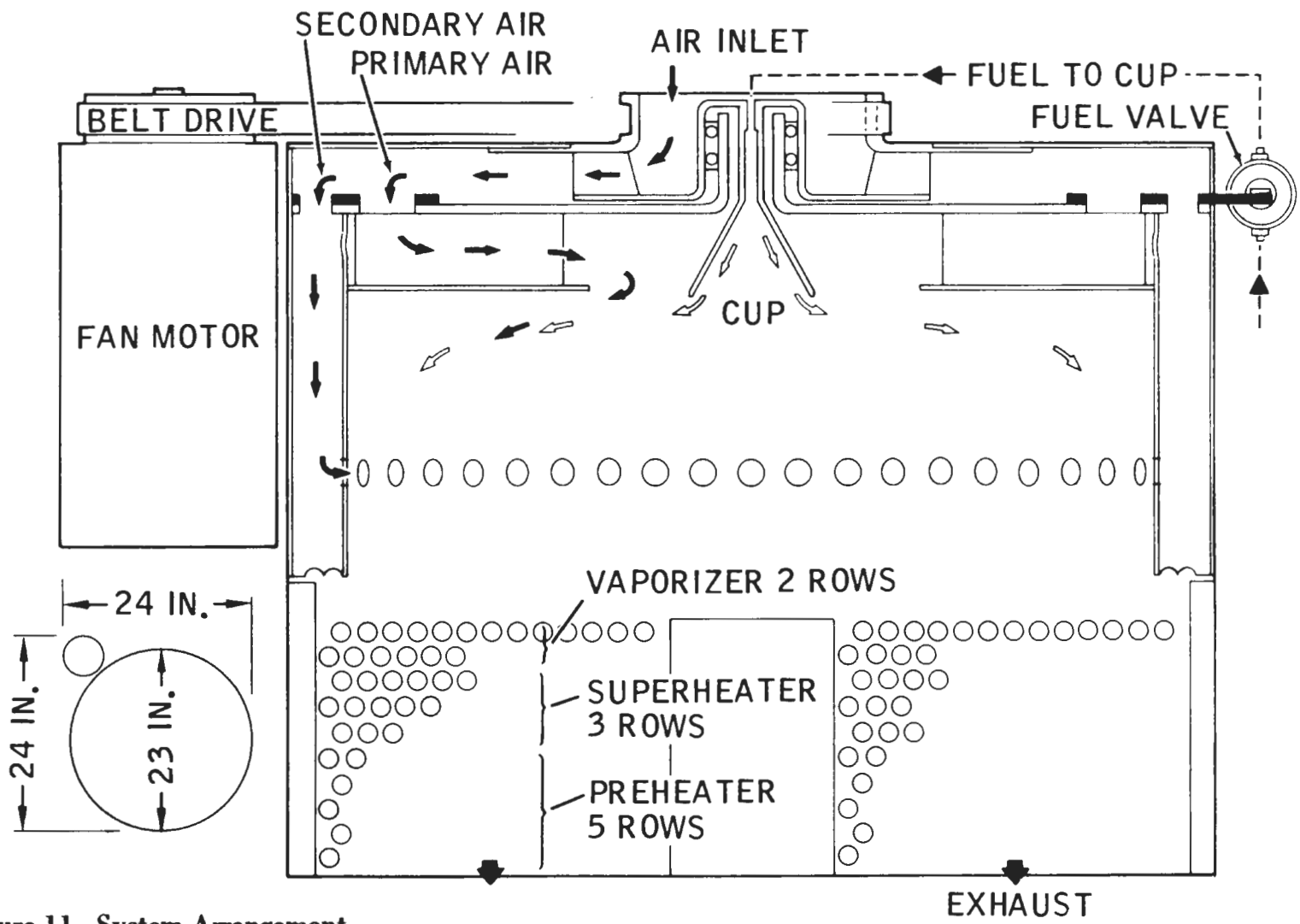


Figure 10. Air-Fuel Ratio for Minimum Emissions vs. Air Flow



78 Figure 11. System Arrangement

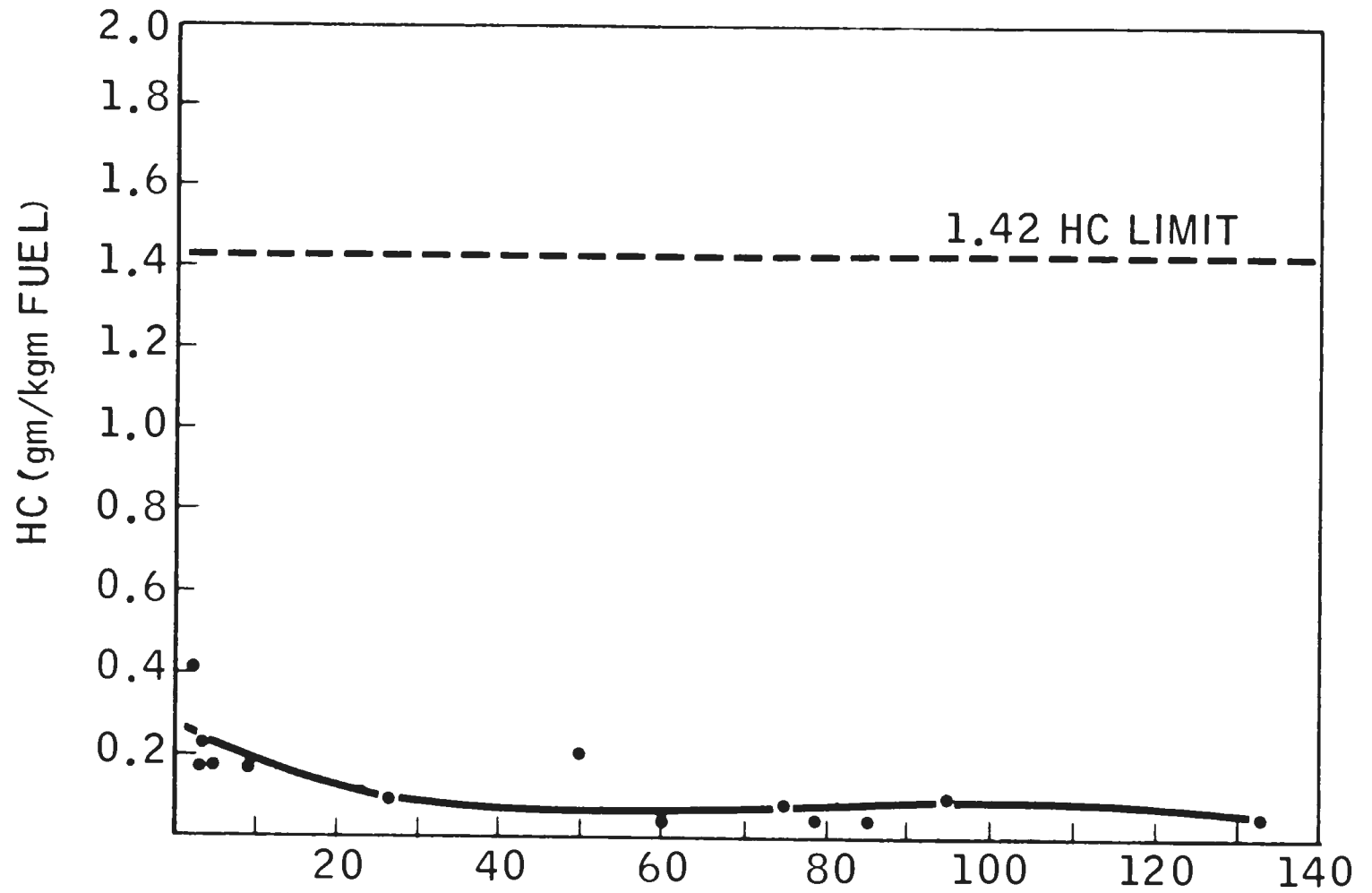
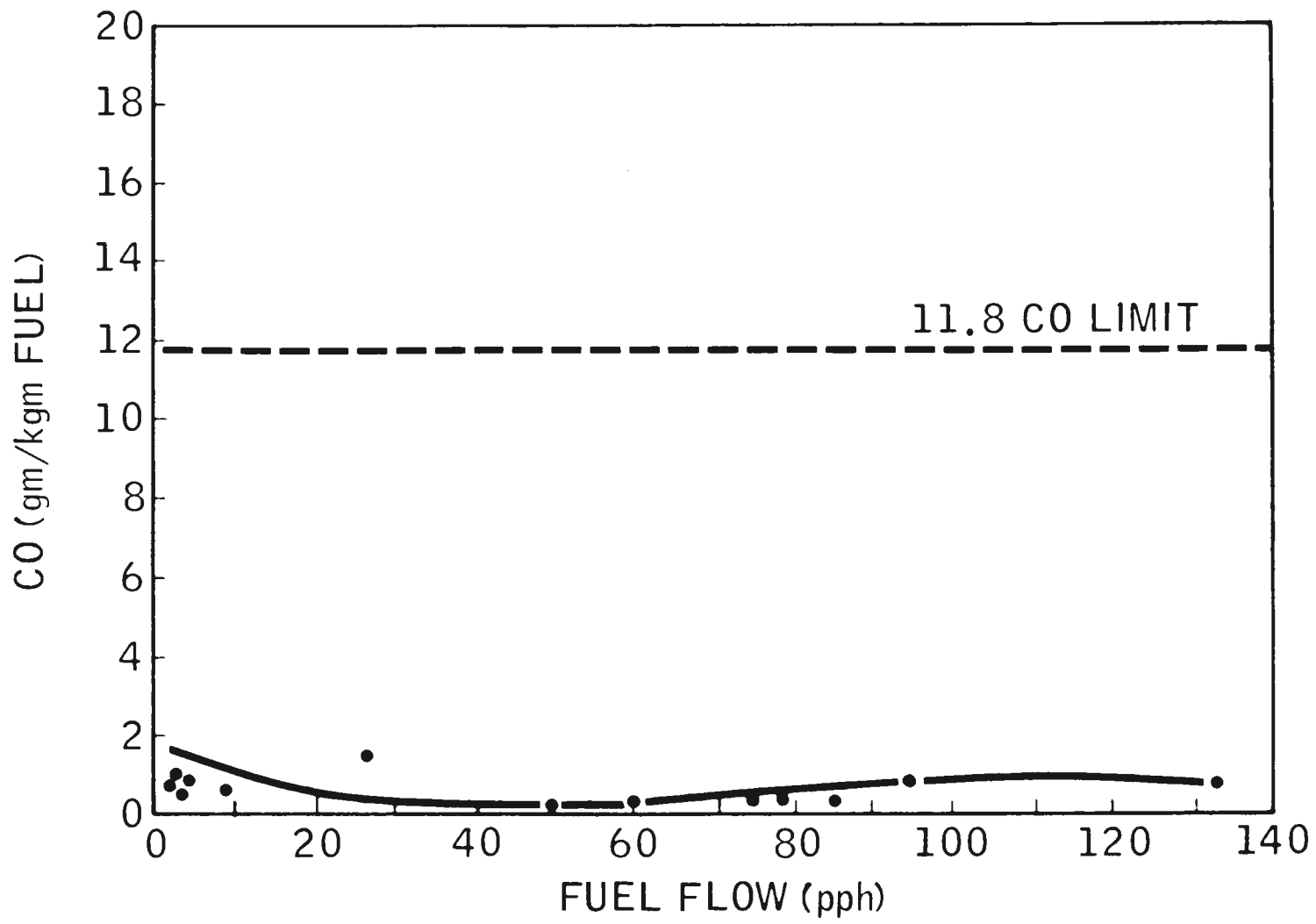


Figure 12. Emissions of HC



80 Figure 13. Emissions of CO

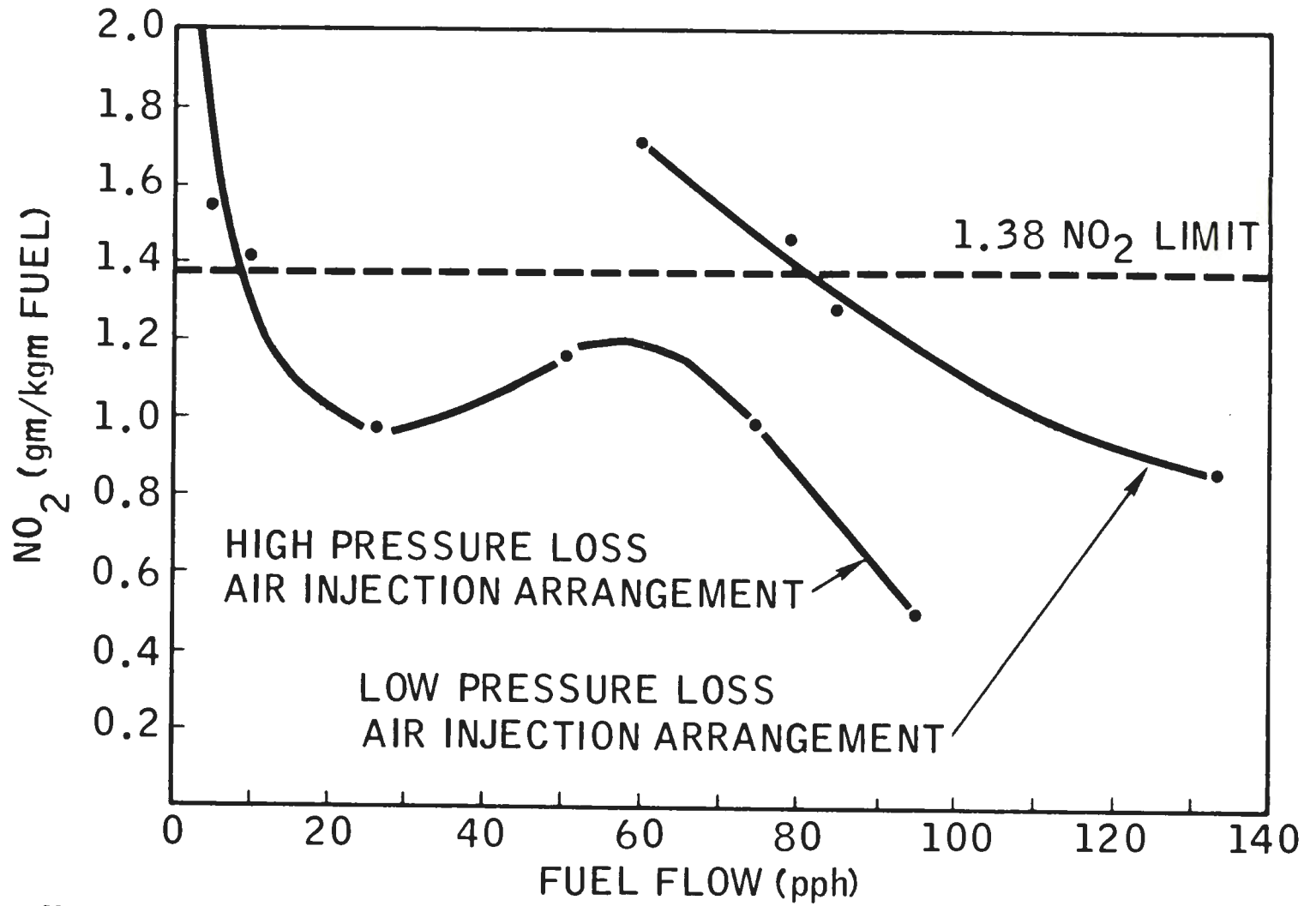
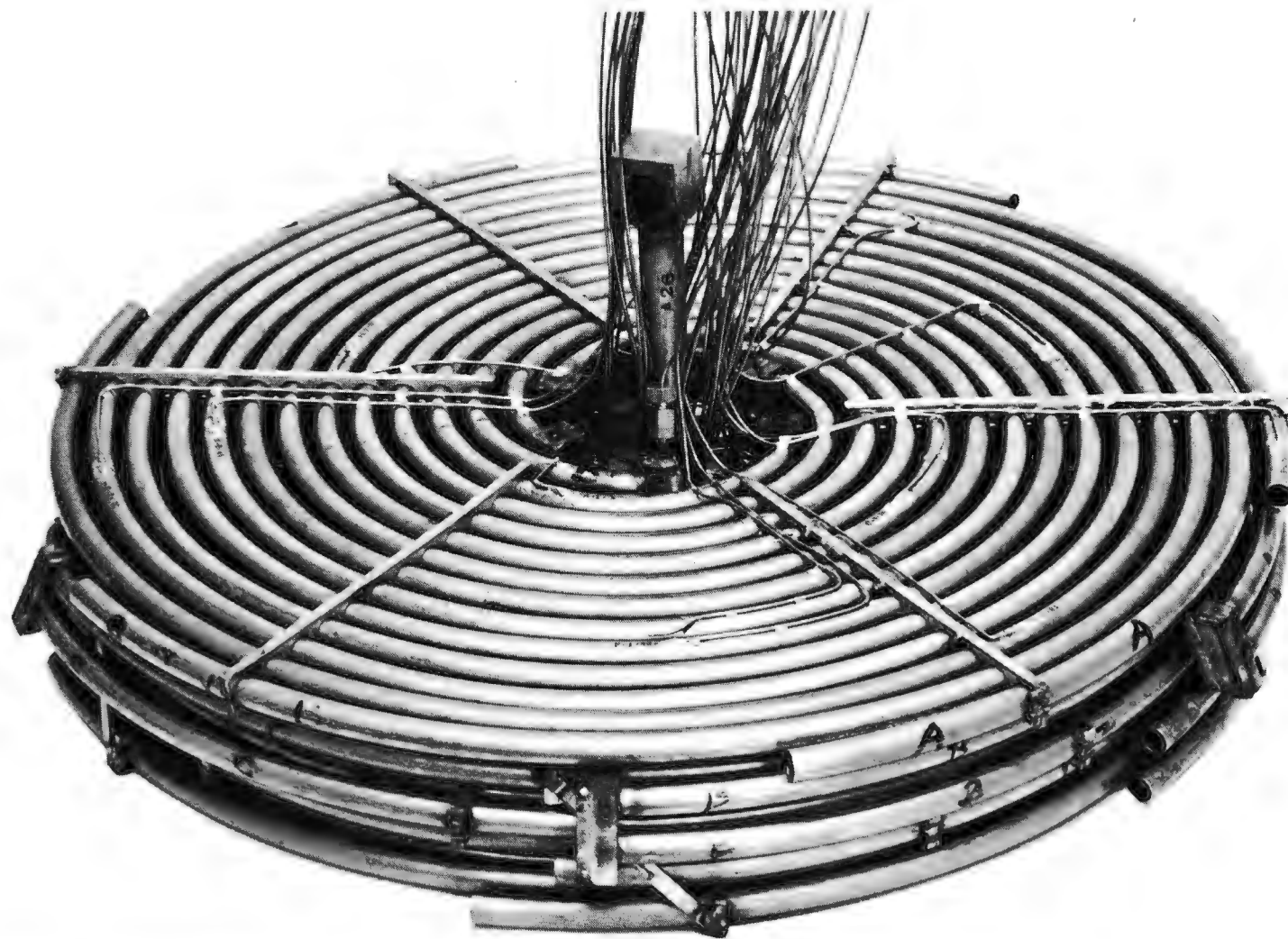


Figure 14. Emissions on NO<sub>2</sub>



82 **Figure 15. Instrumented Superheater of Monotube Vapor Generator**



*C. Carroll Carter, Assistant Administrator for Public Affairs,  
Urban Mass Transportation Administration,  
U.S. Department of Transportation*

Our work with the California Legislature is just part of our bus propulsion system development program. Our final speaker will speak about other work we are doing in the Rankine engine field. So, it's now a pleasure to introduce to you the Vice-President of Ground Transportation Program and Requirements at LTV in Dallas, Dr. Walter Hesse.

### **Vought Aeronautics Steam Bus**

*Dr. Walter J. Hesse, Vice President,  
Transportation Programs, Vought Aeronautics Company,  
LTV Aerospace Corporation, Dallas Texas*

Thank you very much Carroll. Let me first say, it's a pleasure to be here. You know, we don't have the dirty air that was advertised earlier by California. Texas is pretty clean, and we want to keep it that way and that is one of the strong reasons that we are involved in this particular program. Another item should be noted. It has come to my attention that our very able project director in all of these programs, Chuck Daniels, has his wedding anniversary today and part of his present to his wife was a ride on the steam bus.

A lot of the material that I had intended to present in some detail has already been covered by generalities and systems diagrams on the Rankine Cycle, so I will not repeat the information.

I do want to point out that our company has a number of ground transportation programs, and the ECE project that we're doing for the Dallas Transit System in terms of a grant from DOT, enjoys the same project status that the others do, even though the total funding is less. We're one of those companies in aerospace that determined, a few years ago, to move into a new field, and ground transportation was selected as the one big target. Recently, we received a significant contract with the Dallas-Fort Worth Airport Board for the new airport that is now under construction. This program will produce an automatic bus system, with multi-vehicles, multi-switches, multi-stations for both people and cargo. We are busy working on it, and very proud to have that contract. We're also very busy with another contract, with UMTA, the

TACV Program. We're doing the engineering design of that vehicle and hope to be a participant in the Phase II which takes place next year. The third contract activity is the subject of my address today. We're also a bidder on the vehicle of the Washington Subway System. I give you this brief background to show that we're very serious about the ground transportation business. We're attacking it on a broad scale – that's how we view our particular program on the steam bus activity.

As the prior speaker, Bill Lear, was reciting his company's activities looking at various types of prime movers and working fluids, it reminded me of what we did. We started about three years ago on our own funds and looked at different cycles, many different working fluids, different types of prime movers, including expanders, reciprocators and gear-type positive displacements, to turbines, etc. We concluded with the system that I will describe, and we will have our bus running sometime next spring. We have, what I would describe, as a very advanced-type technology system, both in forms of cycle and the working fluid. We have a turbine drive including a regenerator (which is different, at least from what I have heard today from previous systems). For a working fluid we are using toluol. I don't want to get in a debate about the relative merits of various working fluids with the previous speaker. The test results, when they come out, will justify one or the other of us. We think with proper design, our fluid is perfectly safe and will do the job more efficiently. In keeping with "fluid names" we want to give a name for our working fluid. The boss on our project and General Manager of the Dallas Transit System, is Mr. Wilson Driggs – a very able task master. He wouldn't let us go to work until he was sure that we had a very successful oriented program. So we are going to call our working fluid in honor of him. It's either going to be "Wilsoniam", or "Driggsium".

The D.O.T. code name for our project is TEX-MTD-2, and it stands for Texas Mass Transit/Demonstration-2. Our program is relatively small in total dollars because we were able to use a small bus with a low-powered engine. The grant to the Dallas Transit System is over a half million dollars. They in turn have subcontracted to us. We have a principal key subcontractor that does almost all the hardware on the propulsion system, that's Sunstrand.

Phase I of our program which started this past spring, is to build and install an organic Rankine Cycle engine in a 25-passenger bus. It turned out that Sunstrand had hardware components that would match this bus and give us the same power weight performance that the current large city bus does. We will conduct an operational check-out and emissions measurements, and will have a very limited transit evaluation in Phase I.

The bus, a 25-passenger vehicle manufactured by Highway Products, was procured a few months ago. Since that time it has undergone the emission tests, run by EPA. The actual cycle was taken from bus routes in the Detroit area and included the various route types that run some eight miles in about thirty minutes duration. The emission tests were repeated over and over

again so as to obtain a good set of data on the ICE engine, and then next spring we'll run the same cycle of operations with the ECE engine installed.

DTS, our project boss in this program, installs the engine in the bus and later conducts a very brief transit evaluation. Our main job is total systems integration and technical monitoring.

Sunstrand, again the key subcontractor for the propulsion system, has the overall responsibility for propulsion systems definition, component design, and bench tests. That activity is currently underway, and they will do the operational check at a later date.

As I mentioned before, the bus is manufactured by Highway Products, and there are a good number of these throughout the country. The power plant, as it is purchased today, is 400 cubic-inch Chrysler V-8 engine, very much over-powered for what is normally power weight ratios of large buses, and it has the Chrysler three-speed automatic transmission which we will continue to use in conjunction with the ECE engine. Now our power plant will generate net shaft horsepower, after auxiliary power deductions, of 88 horsepower, and the key thing there is that power level gives us approximately the same performance as a large GM bus with a current diesel engine. So, we will have a comparison pretty much in real terms of thrust or power-weight ratio of the large size vehicle.

Figure 1 shows the back end of the bus with its existing power plant. You see the fan on the left side that cools the radiator. We'll take the same compartment and install most of the ECE engine; in fact, everything except the condenser, which will be installed on the roof. Figure 2 shows to scale, the ECE components and how they will be rigged to set in the same compartment. The burner-heater is in red and the regenerator is in blue. Its principal purpose is to take the working fluid in liquid state and pass it through the regenerator or heat exchanger where it picks up some of the heat of the working fluid as it exhausts from the turbine. It increases the cycle efficiency. Now in Dallas, our streets are pretty warm, so we prefer to get that condenser up above the bus where it is in a cooler environment. An additional reason is to reduce the amount of hot air that might be exhausted around the street level and pedestrians. This particular installation, being a technical feasibility demonstration, is not very attractive; however, in later true prototype installations, the condenser would be installed more attractively or even inconspicuously.

The next figure presents our Rankine Cycle diagram. I want to dwell on this a little because it shows some differences from the prior system discussed as well as how we work the system. Fuel, in this case — propane, is supplied through the valving system to the heater. The working fluid, toluol passes through the heater and will operate at peak pressures and temperatures of about 700 psi and 700°F. It is a supercritical regime. It comes out of the heater at those conditions and goes over through the valving system and then the admission control, before it goes into the turbine. This control circuitry is all integrated and worked from the accelerator pedal on the bus. The

turbine exhaust then goes into the regenerator where the liquid is heated up partially before it goes back into the burner. From the regenerator, the gaseous working fluid goes into the roof condenser system and is condensed, and then comes down to the feed pump.

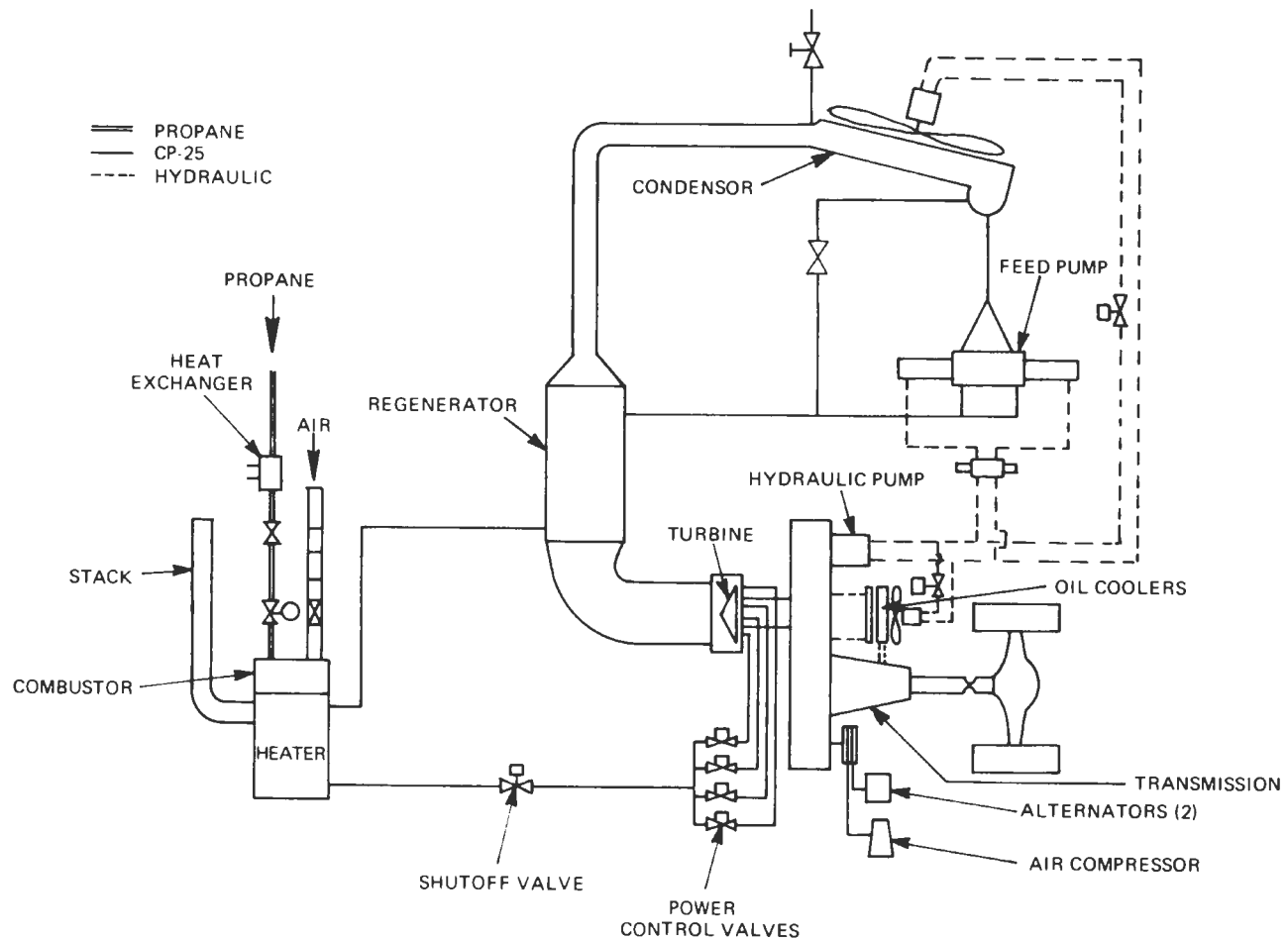
There is some new development work in this feed pump which is, in itself, interesting. The gearbox is new work and is attached to the existing transmission in the bus. Hydraulic pumps are attached to the gearbox to supply power to the condenser fan. In essence, the cycle is the same as you have seen before by previous speakers except we have the addition of the regenerator system. We are using propane gas, which is different, and a different type of feed pump.

The next figure shows prior related ECE experience of Sunstrand. I think it's appropriate to make note of this chart because Sunstrand has done considerable work in the field of organic propulsion systems. You see here four such systems. Shown is a fairly large, 100 KW unit, a 40 KW, and some units smaller in size, down to 6 KW. The total running time, roughly in all of these systems is about 7000 hours. These systems use different working fluids; these are fluorinated hydrocarbons.

The next figure shows some of the key milestones that I think are pertinent. We've just finished the test of exhaust pollution with the conventional engine. The installation is scheduled for February-March of 1972, and a brief evaluation will be conducted in April and May. We'll get data from this system that will (1) give the efficiency, (2) give the pollution measurements, and (3) demonstrate what kind of performance is to be obtained on the road. But the next step should be one that integrates the engine in a better form, with the total bus for service test operation.

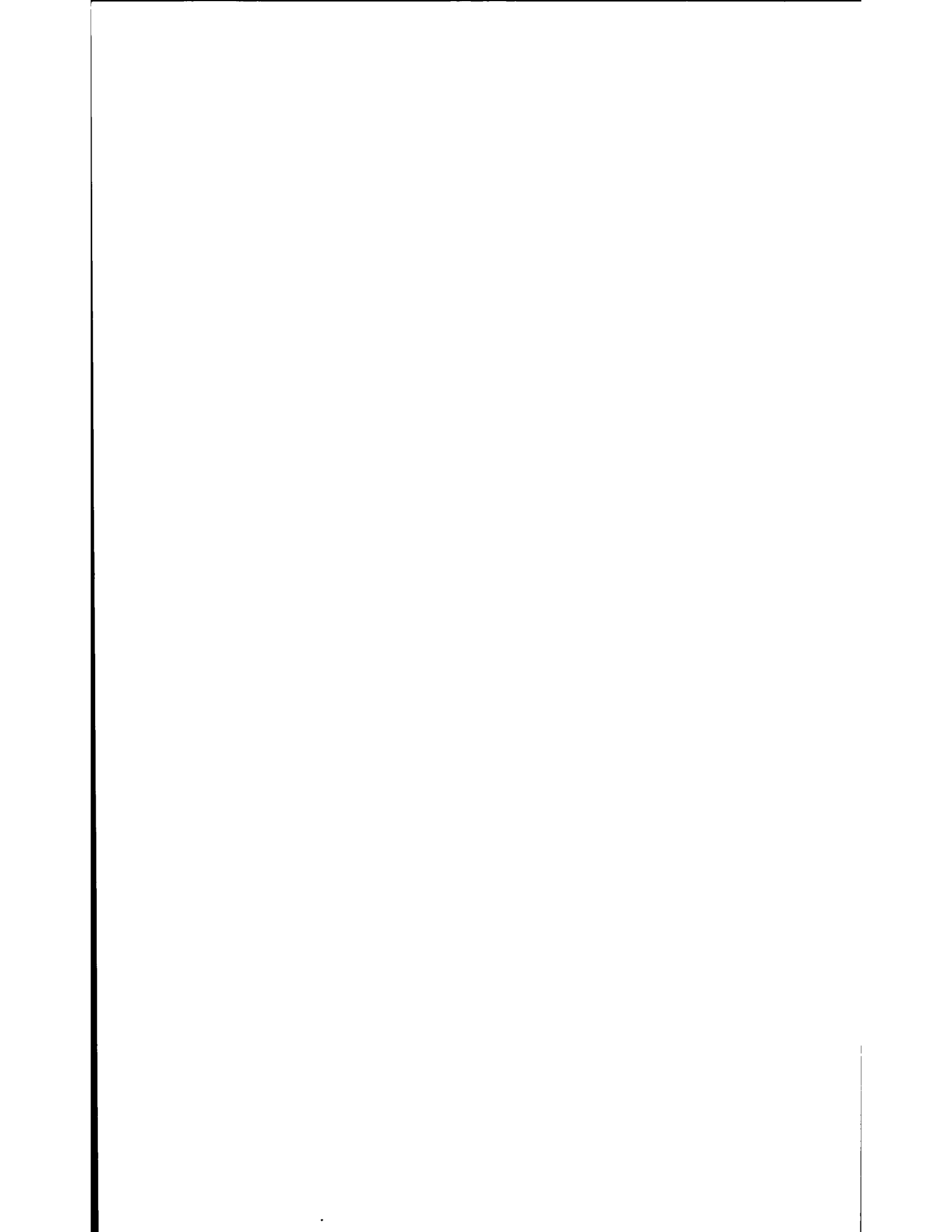
These are the test runs that were done. As I said before, they confirm roughly to about eight miles and a 30-minute run. They were done a number of times, as you can see on this particular chart. This will be repeated afterwards with the ECE engine so we will have a direct comparison of pollution levels between ICE and ECE.

And that gentlemen, outlines briefly the program we have in Dallas. I thank you.



ORC BUS ENGINE SCHEMATIC

Figure 1. System Schematic in LTV/Sunstrand Demonstration Bus.



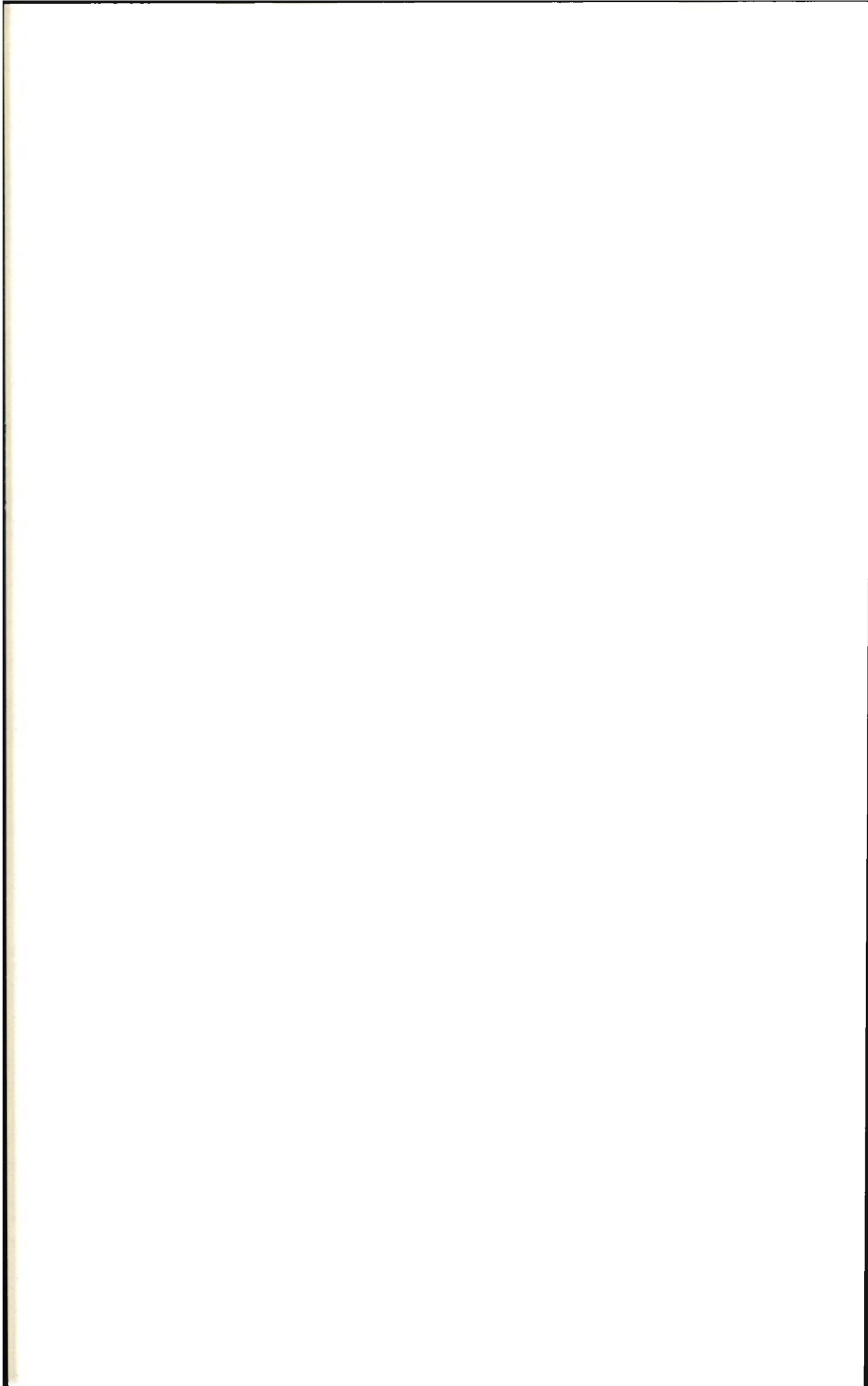


**Figure 2. Actual Installation in LTV/Sunstrand Demonstration Bus (June 1972)**

Vertical line on the left side of the page.

Vertical line on the right side of the page.





PRINTED ON RECYCLED PAPER

