

ENERGY STORAGE PROPULSION SYSTEM FOR RAPID TRANSIT CARS

System Design and Equipment Description



AiResearch Manufacturing Company



Metropolitan Transportation Authority

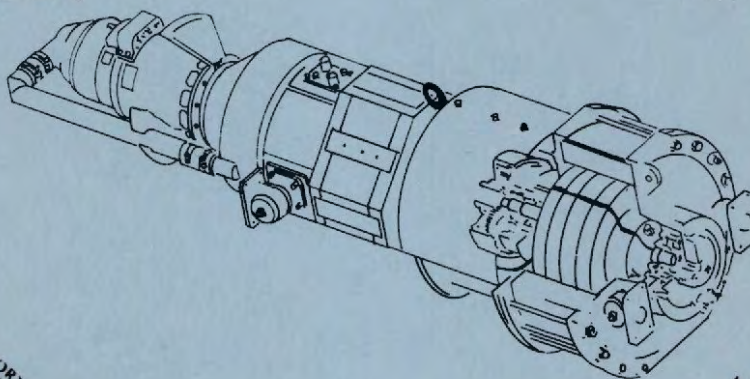

Urban Mass Transportation Administration



New York State Department of Transportation

TECHNICAL REPORT SEPTEMBER 1975

Prepared By
Metropolitan Transportation Authority
1700 Broadway
New York, N.Y. 10019

Prepared For

U.S. Department of Transportation
Urban Mass Transportation Administration
Office of Research and Development
Washington, D.C. 20590

N.Y. State Department of Transportation
Development Division
1220 Washington Ave.
Albany, N.Y. 12232

F
25
R37
975

NOTICE

This document is disseminated under the sponsorship of the Department of Transportation in the interest of information exchange. The United States Government assumes no liability for its contents or use thereof.

The United States Government does not endorse products or manufacturers. Trade or manufacturers' names appear herein solely because they are considered essential to the object of this report.

The preparation of this report has been financed in part through a grant from the United States Department of Transportation, Urban Mass Transportation Administration, under the Urban Mass Transportation Act of 1964, as amended.

1. Report No. UMTA-NY-06-0006-75-1	2. Government Accession No.	3. Recipient's Catalog No. S.C.R.T.D. LIBRARY	
4. Title and Subtitle Energy Storage Propulsion System for Rapid Transit Cars: System Design and Equipment Description		5. Report Date September 1975	6. Performing Organization Code
7. Author(s) Donald Raskin and Ronald T. Yutko		8. Performing Organization Report No.	
9. Performing Organization Name and Address Metropolitan Transportation Authority 1700 Broadway New York, N.Y. 10019		10. Work Unit No. (TRAINS) NY-06-0006	11. Contract or Grant No.
12. Sponsoring Agency Name and Address Urban Mass Transportation Administration Office of Research and Development 2100 Second Street, S.W. Washington, D.C. 20590		13. Type of Report and Period Covered Interim Technical Report	
15. Supplementary Notes Also sponsored by: N.Y. State Department of Transportation 1220 Washington Avenue Albany, New York 12232		and AiResearch Manufacturing Co. The Garrett Corporation 2525 West 190th Street Torrance, California 90509	
16. Abstract <p>When a transit rail car accelerates, it draws energy from a wayside electric power source; when it decelerates, the car must rid itself of this energy. Conventional rail cars dissipate this energy in the form of heat. This report describes a transit car propulsion system which will save much of this presently wasted energy by storing the car's kinetic energy in flywheels which are mounted below the car floor. The stored energy is then available for the subsequent acceleration of the car. Thus a significant reduction in energy usage is expected, along with a resultant reduction in subway tunnel heating. This energy storage propulsion system has been installed on two New York City subway cars and will be subjected to an extensive series of tests. This report discusses the background and design approach and describes the technical features of the Energy Storage propulsion system. The system was developed by The Garrett Corporation, under contract from New York State Metropolitan Transportation Authority (MTA). The development and test program is sponsored by the Urban Mass Transportation Administration, New York State Department of Transportation, Garrett and MTA.</p>			
17. Key Words Energy Storage, Flywheel, Mass Transit, Rail Transportation, Traction Motors (DC), Propulsion (DC), Energy Conservation		18. Distribution Statement Document is available to the public through the National Technical Information Service, Springfield, Virginia 22161	
19. Security Classif. (of this report) Unclassified	20. Security Classif. (of this page) Unclassified	21. No. of Pages	22. Price

08893

TF
925
.R37
1975



Frontispiece. Garrett technicians installing Energy Storage Unit beneath NYCTA R-32 Car

Preface

In 1971 the New York State Metropolitan Transportation Authority (MTA) was awarded grant contracts from the U.S. Department of Transportation's Urban Mass Transportation Administration and the New York State Department of Transportation to develop and test a rapid transit car propulsion system which would reduce electrical energy consumption. This system, called Energy Storage, stores for re-use the energy which is normally dissipated as heat when a car is decelerated. The contract called for the testing of this system on two existing New York City Transit Authority subway cars (type R-32).

In early 1972, MTA awarded a contract to the AiResearch Manufacturing Company of California (a Division of The Garrett Corporation) to develop, install and test the Energy Storage Propulsion System. An extensive program of testing and evaluation is to be carried out under the direction of MTA, in accordance with the terms of its grant contracts.

This report discusses the background, design approach and technical features of the Energy Storage System.

Contents

	Page
Introduction	6
Background	
Benefits	
The Energy Storage Project	
System Design	8
Description of Energy Flow	
Energy Storage System Description	
Equipment	15
General Design Requirements	
Equipment List	
Energy Storage Unit	
a. Design development	
b. Flywheel motor	
c. Gear unit	
d. Flywheel unit	
e. Alternator	
f. ESU mounting arrangement	
g. ESU protective sensors	
Simplified System Schematic	
Traction Motors	
Chopper	
Input Filter	
Smoothing Inductor	
Power Control Unit	
Auxiliary Control Unit	
Electronic Control Unit	
Appendix A	32
System Function and Operation	
Appendix B	37-46
Performance Curves—Conventional R-32 and Energy Storage Cars	

Introduction

Background:

During the 1960's the demand for electric power in the United States grew at a much higher rate than did the ability of electric utility companies to supply additional generating capacity. As a result, the Country experienced periodic blackouts and "brownouts" (voltage reductions). Because these difficulties were particularly severe in New York City, there was especially strong motivation to reduce the high power demand on the local electric utility. Since the subway system in New York City is the largest single user of electric power and, most importantly, because the peak demand for subway power coincides with the city-wide peak demand period, there was a great need to reduce energy consumption by the subways. This reduction in consumption would also be beneficial to the subway operation, itself, by lowering power costs by a modest, yet significant amount.

In the 1970's, however, the power problem changed drastically from a shortage of generating capacity to a shortage of the energy sources, themselves. It thus became greatly important to conserve energy so that:

- 1) Large operating cost savings could be made.
- 2) As little as possible of scarce energy resources would be expended.
- 3) A favorable effect on the U.S. balance of trade with foreign countries would be achieved through reduced petroleum imports.

With regard to the first item above, it should be noted that the total cost for electric power used for operating subway cars in New York rose from \$36 million in 1971 to \$78 million in fiscal 1975.

It was in 1970, between the two stages of the energy shortage problem, that plans were made to develop, test and demonstrate a new transit car propulsion system that held promise for sizable energy savings. The system, called Energy Storage, uses a set of rotating discs (flywheels) to store on-board the transit car that energy which conventional cars waste during braking cycles. The stored energy is re-used during the next acceleration of the car.

Benefits:

The primary result of equipping a car with the Energy Storage (ES) propulsion system is that the car uses less energy in its operation than a conventional car does. Moreover, since it uses less energy it also generates less waste heat energy. Furthermore, because the flywheel supplies much of the energy during acceleration, there is a smaller surge of current drawn from the third rail during the acceleration and as a result the voltage level on the third rail is more nearly constant. As a consequence of

these three features, the Energy Storage propulsion system has the following benefits:

I. Reduction in Energy Consumption

- A. Reduced energy costs (Reductions in propulsion energy by more than 40% are possible in theory)
- B. Reduced energy demands on electric utility companies
- C. Ancillary benefits in the Environment, in the conservation of national resources, and in favor of the national balance of payments

II. Lower Waste Heat

- A. Cooler tunnels and stations, resulting in a more pleasant environment for passengers and employees and in a cooler ambient for the underfloor equipment
- B. Reductions in requirements for air conditioning of cars and stations

III. Improved Stability of Third Rail Voltage

- A. Greater reliability and life of control circuits
- B. Capability of higher car acceleration rates on an existing electrification
- C. Reduction in the required power rating for electrical substations of subway systems which are in the design stage

In addition to the above, the fact that energy is stored on-board the car enables an ES car to operate on its own power during certain emergencies (e.g., when third rail power fails under conditions in which the motorman is allowed to proceed to the next station to discharge passengers).

There are additional benefits which result from the particular equipment used on the ES cars.

Primarily,

1. The chopper, which is used for propulsion control, is more energy efficient than conventional control equipment
2. The separately-excited traction motors provide an inherent spin-slide protection for the car
3. There is more dynamic braking than in a conventional car (because of the use of separately-excited traction motors) which results in lower friction brake shoe wear and higher wheel life.

The Energy Storage Project:

The equipment to be described in this report evolved from discussions which began in 1965 between representatives of The Garrett Corporation (AirResearch Manufacturing Company of California), Metropolitan Transportation Authority (MTA), and New York City Transit Authority (NYCTA). The discussions started as an exploration to find significant applications in the public transportation field for Garrett's expertise in high speed rotating machinery and for its developing interest in electric propulsion equipment.

The interaction between the high technology manufacturer and the operators of a major transit system brought the proposed design through many evolutionary stages. Thus, for example, the original Garrett concept of large flywheel on each car which would eliminate the need for third rail contact, except at periodic recharging stations, became one with a smaller wheel used for storage of only one stop's energy for immediate re-use on the next acceleration. With the evolution of the basic concept, the flywheel changed from the large wheel mounted with a vertical rotational axis into two small units rotating along fore-and-aft axes.

With the definition of the hardware to a point which seemed practical to both the manufacturer and the user, an application was made to the Urban Mass Transportation Administration (UMTA) of the United States Department of Transportation and to the New York State Department of Transportation for funds to carry out development and testing of the equipment. These funds were granted to MTA and a contract was signed by Garrett and MTA in January 1972.

In order to evaluate the capabilities of the system, Energy Storage (ES) propulsion equipment was installed by Garrett under two NYCTA subway cars (Type R-32, built in 1965), in place of the conventional propulsion equipment. Initial testing of the two ES cars was performed on UMTA's Rail Transit Test Track at the Transportation Test Center in Pueblo, Colorado. Extensive testing of the cars is underway on the NYCTA, under the direction of MTA, and is to be followed by a reliability and energy efficiency trial of the cars in revenue service on several routes of the New York City Transit System.

This report provides a description of the Energy Storage equipment and discusses the development of the design. The report, which was written by MTA, describes engineering work performed in nearly all cases by Garrett. The results of the testing of the ES components and subsystems and of the completed cars will be presented in a separate report to be published subsequent to the completion of the test program.

System Design

Description of Energy Flow:

One of the aspects most characteristic of transit car operations—as distinguished from other types of railroading—is the large number of starts and stops. A typical run in New York City for example, involves 38 station stops in a total run length of 23.5 miles. There are numerous additional accelerations and decelerations because of speed and traffic restrictions. A theoretical analysis of energy flow throughout an entire run is laborious. Nevertheless, an understanding of the basic phenomena is actually simple, since the run can be viewed as a composite of pieces each consisting of an acceleration, a period of level speed operation, and a deceleration. One of these pieces is shown in Figure 1.

By referring to Figure 1, the energy flow in this idealized transit run segment can be traced. In the portion A-B, the car accelerates and electrical energy is drawn from the third rail by the propulsion system. This energy is used to overcome losses (e.g., bearing friction and air resistance). It is also used to increase the kinetic energy of the car. (The kinetic energy is equal to one-half of the car mass times the square of its velocity.) During the segment B-C, the velocity is constant; therefore, the kinetic energy is constant. During this segment, a relatively small amount of energy is drawn to overcome the rolling resistance and air drag of the car. Note that by the fact that the car is moving, it "possesses" energy equal to $\frac{1}{2}MV^2$. During segment C-D, the car comes to a stop. Since it is now stationary, its kinetic energy is zero. Therefore, its previous kinetic energy must have been dissipated in some manner (because of the Law of Conservation of

Energy). Normally, this dissipation is done by transforming the kinetic energy into heat energy in brake grids or in the brake shoes and wheel treads. In segment D-E no energy is drawn for propulsion while the car sits in the station.

Thus energy is drawn to overcome losses and to create kinetic energy. Clearly the energy that is used to overcome friction is lost. However, that which has become kinetic energy is recoverable in principle. In fact, the present practice of dissipating kinetic energy by creating heat is not only wasteful but is a nuisance to the subway environment, as well.

The fraction of the total propulsion energy that is used in creating kinetic energy can be quite considerable in transit operations. The fractional amount depends on the number of stops in the route, their spacing, and the car's top speed. However, in a high speed operation on a route with closely-spaced stops this fraction can be in excess of 60%.

Energy Storage System Description

The Energy Storage System seeks to absorb this kinetic energy by spinning up a set of heavy discs (flywheels), converting the car's kinetic energy into flywheel kinetic energy. (The kinetic energy of a flywheel is proportional to the square of its rotational speed.)

The energy transfer is done electrically. When the car stops, its traction motors operate as generators (as in conventional dynamic braking) to supply current to another motor which is geared to each flywheel. The flywheel motor is thus accelerated to store the braking energy in the flywheels. When it

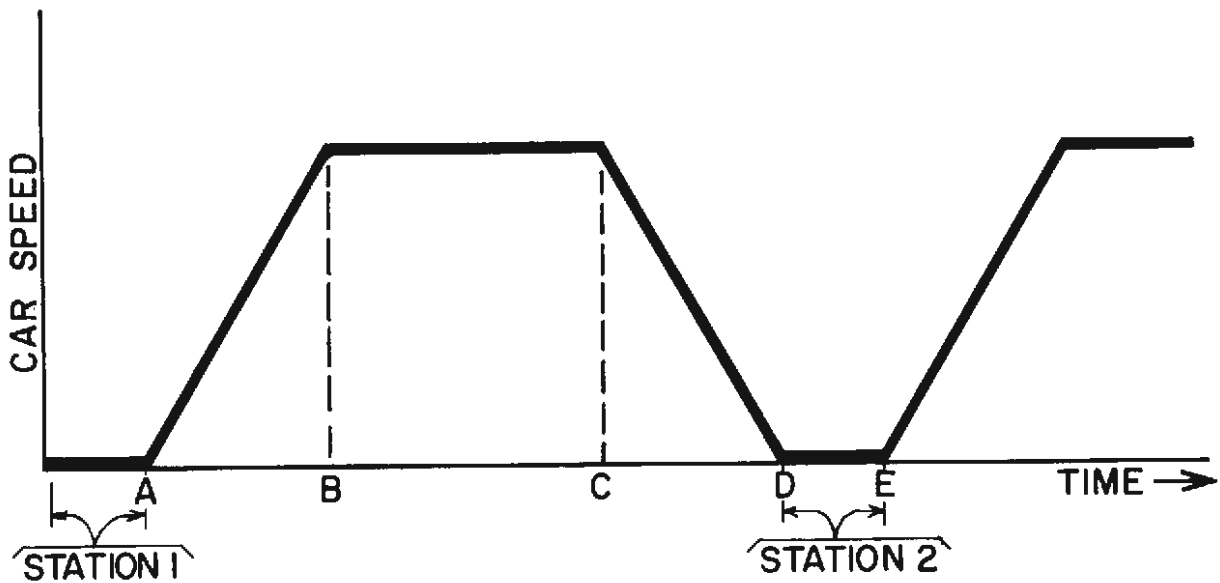

Fig. 1 Idealized Velocity Profile for Transit Car.

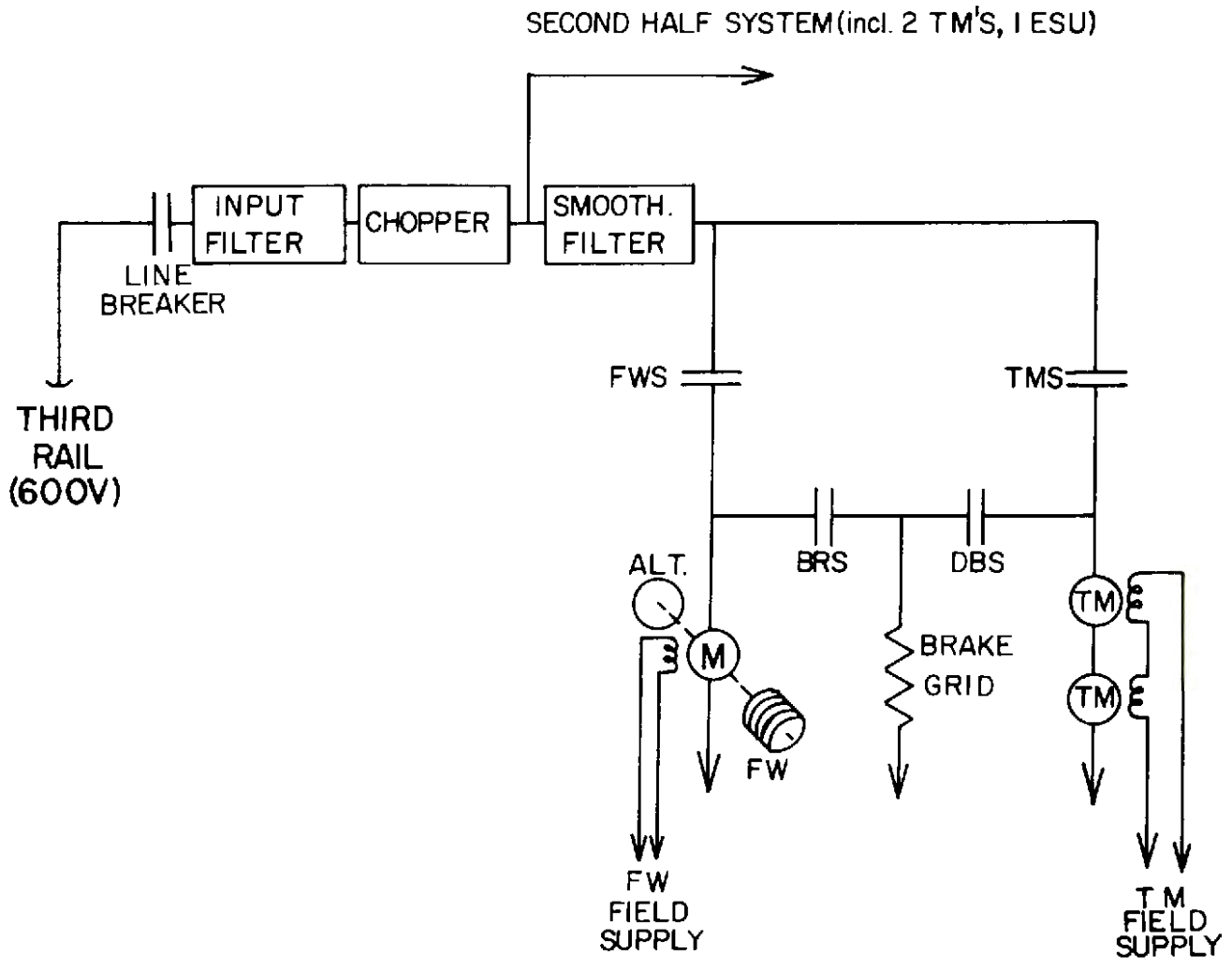

Figure 1. Power Distribution Diagram

Fig. 2 Power Distribution Diagram

is time for the car to accelerate, the spinning inertia of the flywheel turns the flywheel motor which acts as a generator, supplying current to the traction motors to propel the car. Thus, the flywheel and the traction motors alternate in opposing roles:

During an acceleration, the flywheel motors act as generators for the traction motors.

During a deceleration, the traction motors act as generators to accelerate the flywheel motors.

Each carset of ES equipment consists of two flywheel-and-motor sets (called Energy Storage Units or ESU's), four traction motors (with each truckset of two motors permanently wired in series), one chopper, and assorted control and signal conditioning equipment. Both flywheel motors and traction motors are of the separately-excited type. That is, the current for the motor fields is supplied from a source which is independent of the armature current. This independence allows the field windings to be designed to operate at relatively low voltage and current levels. Thus the field strengths and the resulting back emf's of the motors are easily controlled by low power solid state circuits.

The ES components are interconnected as shown in Fig. 2. The flywheel units can be started up by closing the flywheel start contact (FWS) and using the chopper to gradually increase the voltage across the flywheel motor armature. The flywheel motor field power is supplied initially from the car batteries; when the ESU is spinning at a high enough speed to produce output on the shaft-mounted alternator, the motor fields are supplied by a variable voltage controller fed by the alternator. Once started, the flywheel motor is always operated above its base speed. This allows the ESU to serve as a variable voltage power source (during car acceleration) or as a variable impedance power acceptor (during car deceleration) by simply controlling the motor field currents.

With the ESU spinning at approximately its top speed, the car is ready for acceleration. The chopper is turned off and the traction motor switch (TMS) is closed. The flywheel motor field current is increased, thus bringing up the voltage applied to the traction motors (TM) and moving the car. The characteristics of the main propulsion elements during an acceleration are shown in Figure 3, where the relevant currents and voltages are plotted against the car speed. It should be noted that the curves displayed in Figure 3-5 are somewhat idealized in order to simplify the discussion of the ES system.

As the flywheel motor field current (curve f) increases, so does the voltage applied to the traction motors (curve c). The traction motors are operated in a constant current (constant torque) mode up to base speed, with essentially all of the current being supplied by the ESU (curves a and e). Since the ESU's are supplying power to propel the car, the speed of the flywheels decreases (curve d).

When the car reaches the base speed of the traction motors (19 mph on a 580 V line), the traction motor fields are decreased (curve b). This results in a tractive effort profile roughly approximating that of a conventional R-32 (as required for the testing program). The ESU continues to supply current to the traction motors as the flywheel motor field current is increased further.

Losses are made up for by supplying current to the system through the chopper from the third rail. These losses will consist of the car running losses already discussed, as well as any losses within the Energy Storage System (i.e. losses in transfer of energy between ESU and traction motors and losses within the ESU, itself). The current through the traction motor armatures, then, will be the sum of the flywheel armature current and the chopper current. Note, however, that since the chopper current (curve g) is used for make-up of losses it is not only greatly reduced in magnitude but is essentially level during the whole acceleration cycle. This feature, called power averaging, leads to the third set of benefits listed in the Introduction.

In curve (d) it will be noted that the flywheel speed does not decrease below 70% of flywheel top speed. This is so that the ESU operates above the base speed of the flywheel motor during all car movements. In fact, the flywheel speed is kept on a schedule related to car speed (Fig. 4). This adherence to a schedule ensures that the ESU is always able to absorb as much of the available kinetic energy of the car as is possible and to supply as much acceleration power as is required, as well. Since the available kinetic energy is proportional to the total weight of the vehicle (including passengers), the schedule is modified by a signal from the load weight transducer on the car.

In braking, the chopper is locked "off" (so that it acts, in essence, as a blocking diode) and the system allows the voltage generated by the traction motor to rise. Simplified curves for a full service brake from 55 mph are shown in Fig. 5. Characteristics of the ES system are plotted against car speed decreasing from 55 mph to zero.

The voltage generated by the two traction motors in series rises to 750V at 45 mph and remains con-

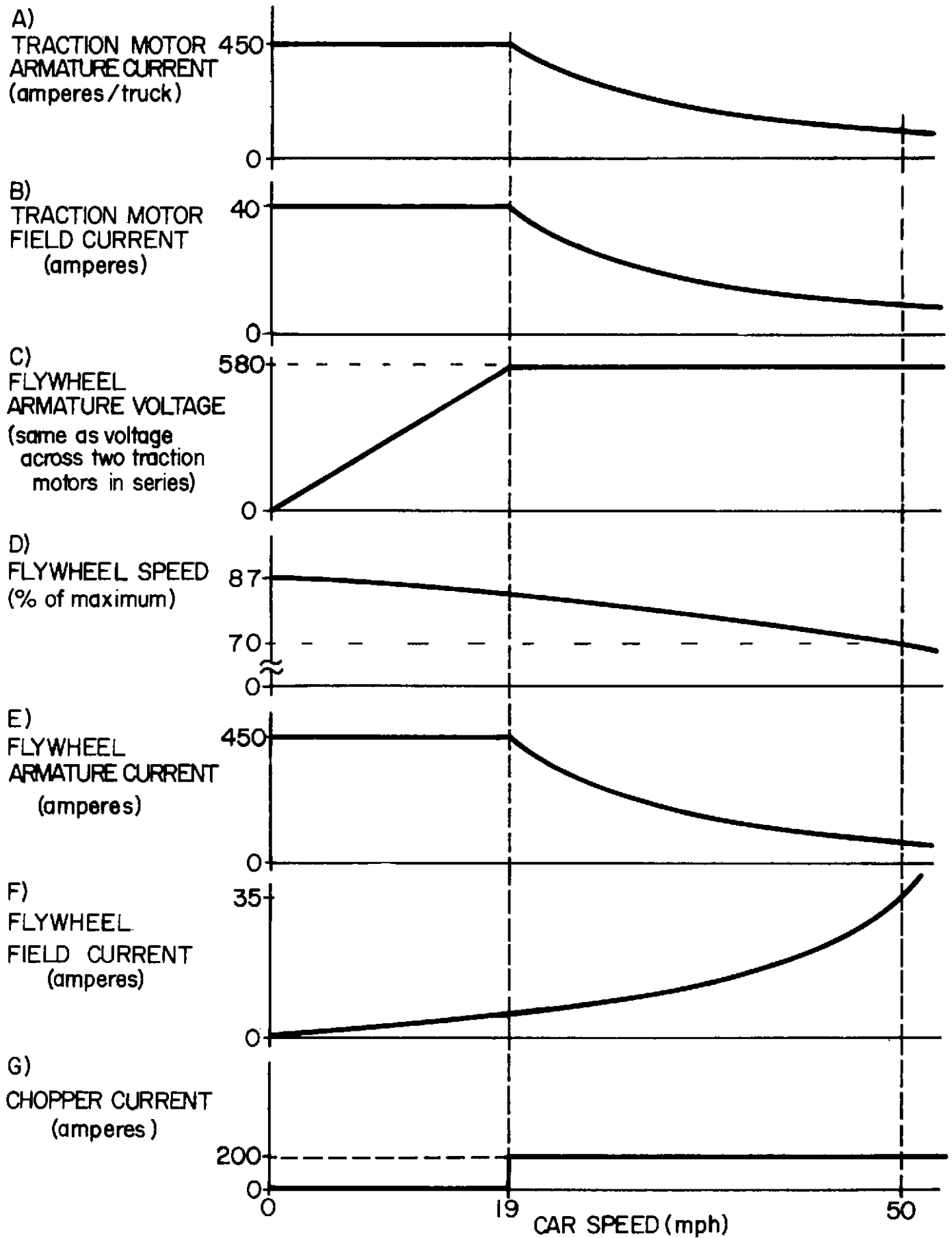

Fig. 3 Energy Storage Car Acceleration Characteristics (empty car)

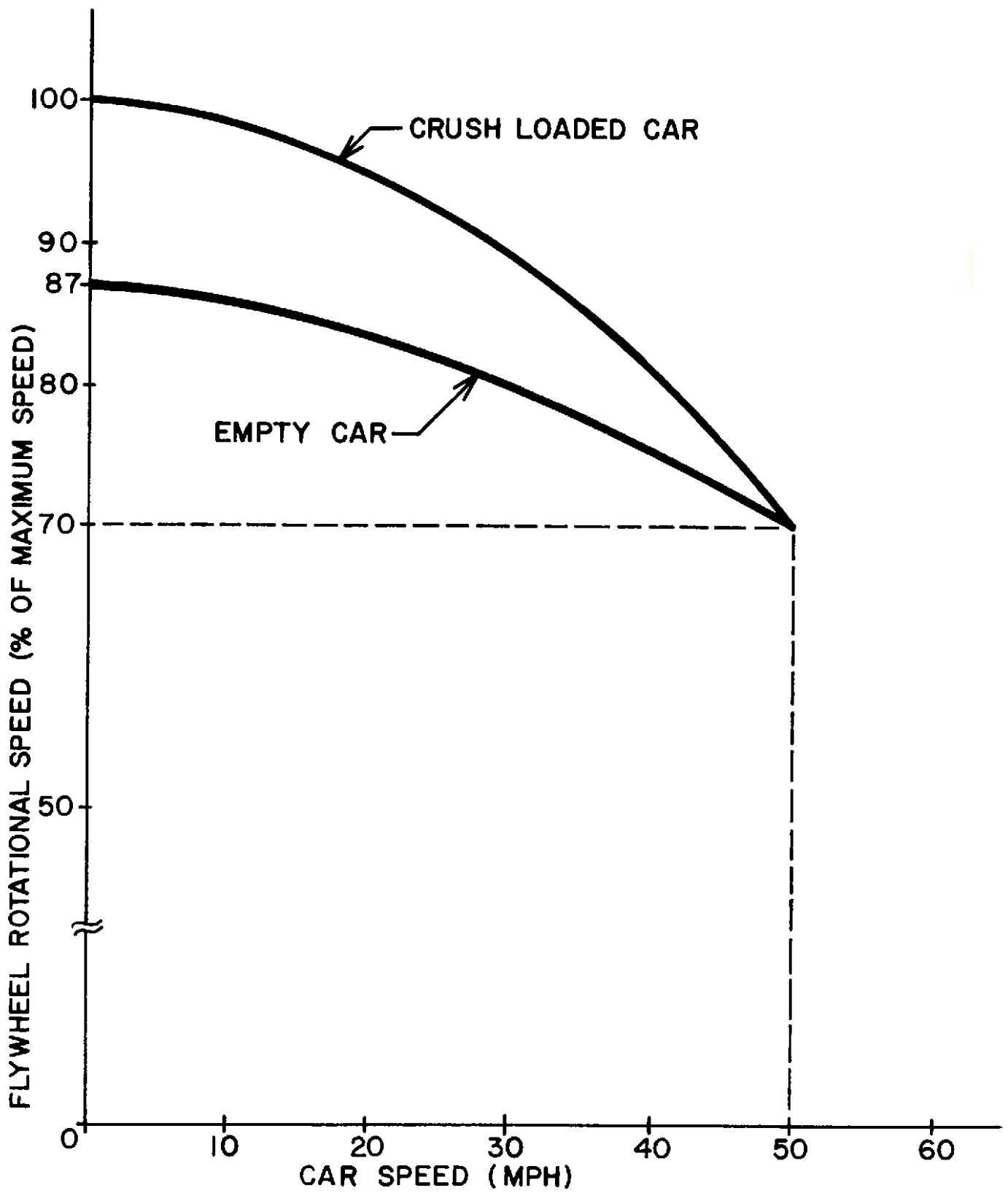

Fig. 4 Flywheel Speed Schedule

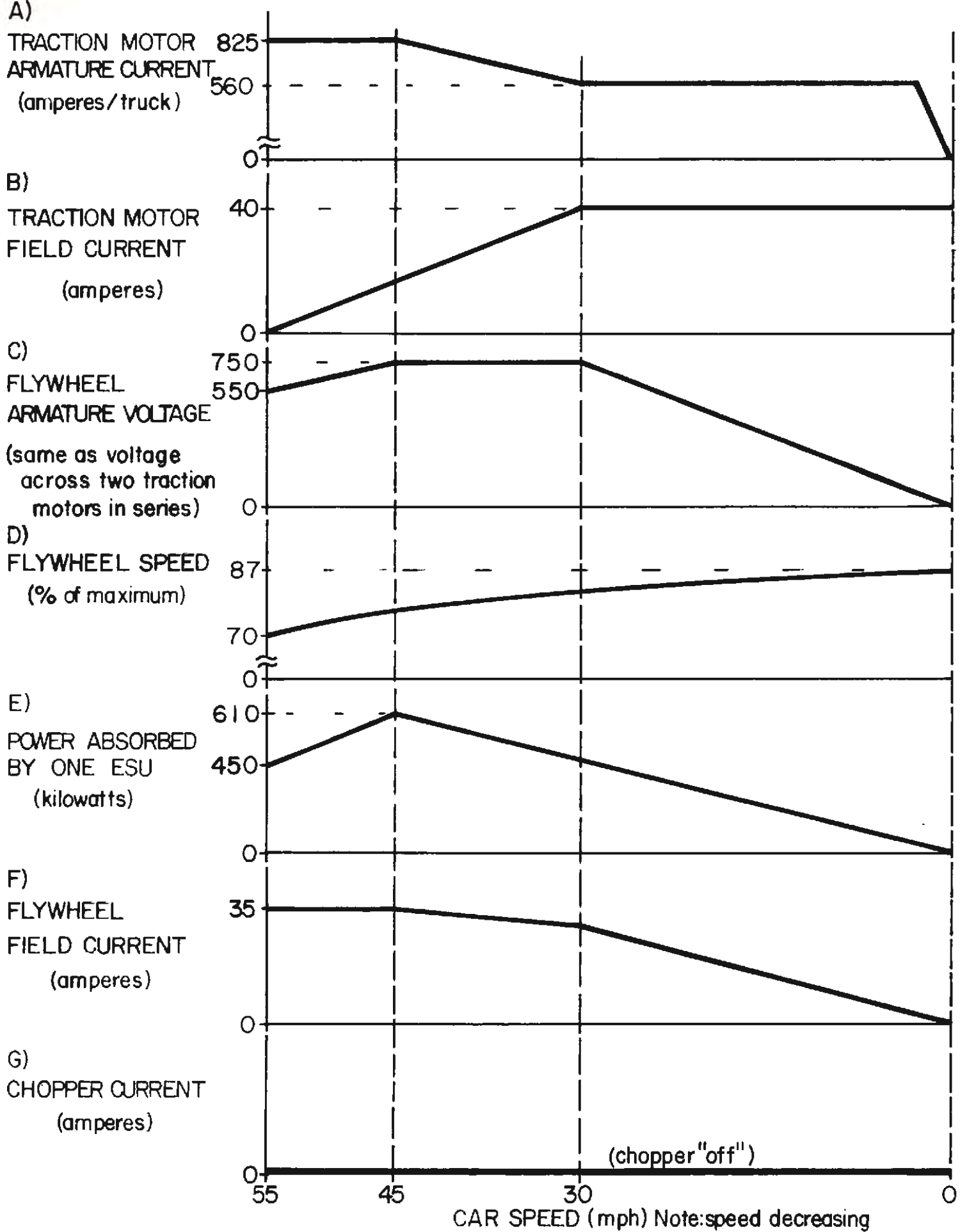

Fig. 5 Full Service Brake (empty car)

stant until 30 mph. (Note that the "base speed" of the traction motors at 750V corresponds to a car speed of 30 mph.) The system connection requires that all of the current generated by the traction motors flows into the flywheel motor (except as described in the following paragraph). The power generated rises from 300 kw/motor at 45 mph before decreasing linearly with speed.

Despite the maintenance of a flywheel speed schedule, there will be conditions under which the ESU is not able to absorb the full braking energy without exceeding its maximum speed. For example, the flywheel schedule assumes the car to be on level track. If, in fact, the car is on a downgrade, the braking energy will be greater than the schedule allows (because gravity is adding energy to the system). Under these conditions, the excess energy is dissipated in the dynamic brake grids in a manner similar to that of conventional dynamically braked cars. This function is performed by opening the TMS contactor when the ESU has attained its top speed and closing the DBS contactor (see Figure 2).

At the end of a day the flywheel can be shut down by dumping the stored energy into the brake grids after opening FWS and closing BRS.

* * *

It must be pointed out that the ES system as described in this section will maximize the power averaging feature. This can be seen by noting curve g of Figure 3 which shows a very flat absorption of power from the third rail. In order to provide this high degree of power averaging, the flywheels have to be maintained at sufficiently high speeds to supply the remainder of the power during acceleration.

On the other hand, the higher the flywheel schedule speeds are, the larger will be the flywheel running losses. Thus power averaging must be weighed against the energy consumption penalty it carries. In the actual system a balance is achieved which sacrifices some of the power averaging capabilities for net energy conservation advantages. Operating curves of the actual ES car system will be published in the subsequent ES project report which will summarize the testing.

Equipment

General Design Requirements

The design of all of the Energy Storage equipment was constrained by four major requirements:

1. *Conservative mechanical and electrical design*

Since the testing of this novel propulsion system is to take place on a passenger-carrying transit system, every effort was made to ensure the security of riders and employees. This concern led to many subsidiary requirements, such as

- a) Materials used in the flywheels should be conventional, well-understood ones. The use of state-of-the-art materials and advanced flywheel configurations in a transit application was felt to be premature. There should be a considerable factor of safety in the flywheel stress levels.
- b) The flywheels should be "contained" in the sense that if there should be a failure of a disc, no parts should be ejected from the ESU.
- c) There should be no possibility for power to flow from the ESU or from the input filter back to the third rail. This is to protect from shock hazards shop personnel and track crews which may be working on a nominally "dead" section of third rail.
- d) No chopper-induced fluctuations or harmonics should be emitted to the wayside by the car. This is to prevent interference with the signal system.

2. *Space limitations*

The ES equipment had to be packaged and mounted on the car in such a way as to (a) conform to the NYCTA equipment clearance outline and (b) not interfere with passenger or crew space.

3. *Adaptation of existing car*

The test bed for the ES equipment is the NYCTA R-32 car. These cars are of stainless steel construction and are 60-ft long (Figure 6). They operate on Division B of the NYCTA (IND-BMT lines). All of the propulsion equipment including controls and motors, but not including gear units and motor couplings was removed from the car. Brake equipment, motor-generator and batteries were left essentially unaltered. All of the ES equipment had to be designed to be applied to these cars.

An additional design constraint resulted from the fact that the cars are to be restored to their original state (i.e., with conventional propulsion equipment) at the completion of the test program.

4. *Conventional car operation*

Since the primary purpose of the test of the ES equipment is to determine its energy efficiency relative to conventional propulsion equipment, the

performance levels of the ES car are matched to the conventional R-32. In particular, acceleration and braking rates are made to conform with the standard cars so that when the two ES cars operate in train with conventional cars, neither type of equipment is pulling or pushing the other.

Of course, the motorman's controls on the ES cars are identical to the conventional R-32 and the response to trainline commands (as well as the generation of trainline signals if the ES cars are at the head end) is identical.

Because of the concern for direct comparability between the ES cars and other R-32's, no additional modifications to the car—such as air conditioning or re-styling—were permitted.

Equipment List

In order to refit the two R-32 cars with the hardware necessary for Energy Storage capability, the equipment listed in Table I was removed from or installed in the underfloor area.

The total net weight differential between the standard R-32 and the Energy Storage Car is an increase of 10,754 pounds. The majority of this additional weight is accounted for by the two Energy Storage Units. These units are prototype models designed with the major emphasis on conservatism rather than streamlining or weight reduction. Significant weight reduction should be possible on any future production units.

Energy Storage Units

a. *Design development*

The maximum amount of energy which must be stored in the ESU's on a car is equal to the kinetic energy of that car at top speed and under crush load. For the ES car the top speed is 50 mph and the crush weight is 100,000 lb. Thus the maximum energy to be stored is 8.4 million ft-lb or 3.2 kw-hr per car.

The flywheel motor must be designed to handle this amount of energy during the time it takes to stop the car. The characteristics of the motor chosen for the job by Garrett are such that two ESU's per car are required, each absorbing half of the car's braking energy.

In order to be able to control the power flow in and out of the ESU by simply varying the flywheel motor field current, the flywheel motor must operate above its base speed. The base speed of the motor is determined by the applied voltage (600v line in car acceleration, 750v in deceleration). Operation of the motor chosen by Garrett above its base speed at 600V results in the ESU being maintained in the

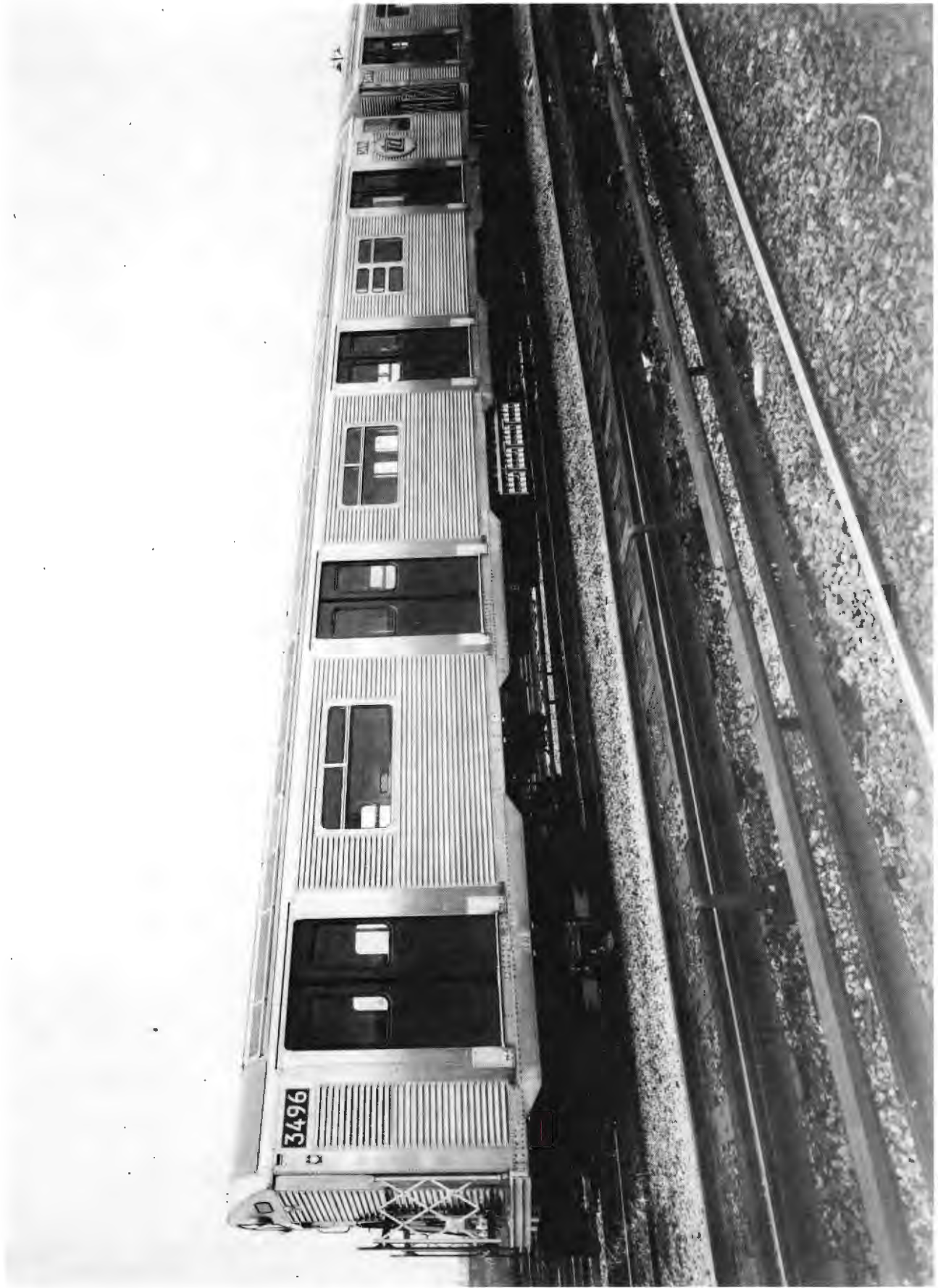

Fig. 6 New York City Transit Authority R-32 Car

TABLE 1. Equipment lists for conversion of R-32 car.

Conventional R-32 equipment removed from each car:

Item	Quantity/Car	Weight of Individual Component
1) Control Unit (cam controller)	1	1230 lb
2) Resistor (dynamic brake)	2	569
3) Traction Motor	4	1600
4) Brackets and Cables	—	150
Total removed weight—		8918 lb/car

Energy Storage equipment added to each car:

Item	Quantity/Car	Weight of Individual Component
1) Energy Storage Unit		
a) No. 1 unit, with alternator	1	4985 lb
b) No. 2 unit, without alternator	1	4705
2) Power Control Unit	1	1020
3) Auxiliary Control Unit	1	565
4) Electronic Control Unit	1	100
5) Smoothing Inductor	1	350
6) Input Inductor	1	100
7) Chopper	1	385
8) Traction Motor	4	1440
9) Brake Resistor	2	96
10) Fan and Duct	1	120
11) 60 Cycle M-G	1	190
12) Support Brackets	—	1100
13) Cabling	—	100
Total added weight—		19.672 lb/car

speed range of 70 to 100 percent of maximum speed. In summary, each of the two flywheels must absorb half of 3.2 kw-hr when they are run up from 70% to full maximum speed. Since the energy contained in a flywheel is proportional to the square of its rotational speed, the storage requirement can be calculated as follows:

$$(\text{Energy} - 100\% \text{ speed}) \times \left(1 - \left(\frac{70}{100}\right)^2\right) = \frac{3.2}{2} \text{ kw-hr}$$

Thus the energy stored in each ESU at 100% speed is, coincidentally, 3.2 kw-hr.

Once the energy and rotational speed requirements have been determined, the weight (strictly speaking, the moment of inertia) of the flywheel assembly, itself, is established. It remains only to determine the detailed shape of the flywheel.

The underfloor space limitation determines the maximum diameter of the ESU. This forces the choice of a flywheel disc cross-section that is "space efficient" and eliminates the use of the most "weight efficient" shape, a pure hyperbolic disc. Furthermore the need to harden the entire thickness of the steel disc limits the thickness of each disc. An additional limitation on section thickness is imposed to permit thorough X-ray inspection of the discs.

The requirement of complete containment of the rotating flywheels puts further limitations on the design of the discs. Containment is provided by surrounding the circumference of the rotating assembly with a ring-shaped shield. This shield

must be designed to absorb the flywheel fragments under the worst type of fly-apart. This "worst case" is a failure of a flywheel into three equal-sized pie wedges (tri-hub burst). The thickness of the containment ring can be kept within practical dimensions by making the flywheel out of several relatively thin discs, which are coupled together in such a way as to be independent with regard to fracture. If the flywheel consists of several discs, the containment ring has to be designed to absorb the energy of only one disc if it should fail (provided, of course, that the discs are assembled in such a way as to prevent multi-disc fly-aparts).

The limitations on flywheel diameter and thickness and the desire to limit the size and weight of the containment ring (without sacrificing conservative design) led to a multi-disc flywheel. As mentioned, these considerations favor an assembly of many thin discs. Since the present ESU design represents the first application of flywheels to transit cars, it was decided to use a very conventional method for assembling the discs together. This method puts a practical upper limit on the number of discs. Thus it was determined that the flywheel in each ESU should be an assembly of four discs.

Each ESU consists of a motor, a gear unit to multiply the motor shaft speeds up to the proper range for flywheel operation, and a flywheel assembly surrounded by a containment ring. One of the two ESU's on each car has, in addition, an alternator

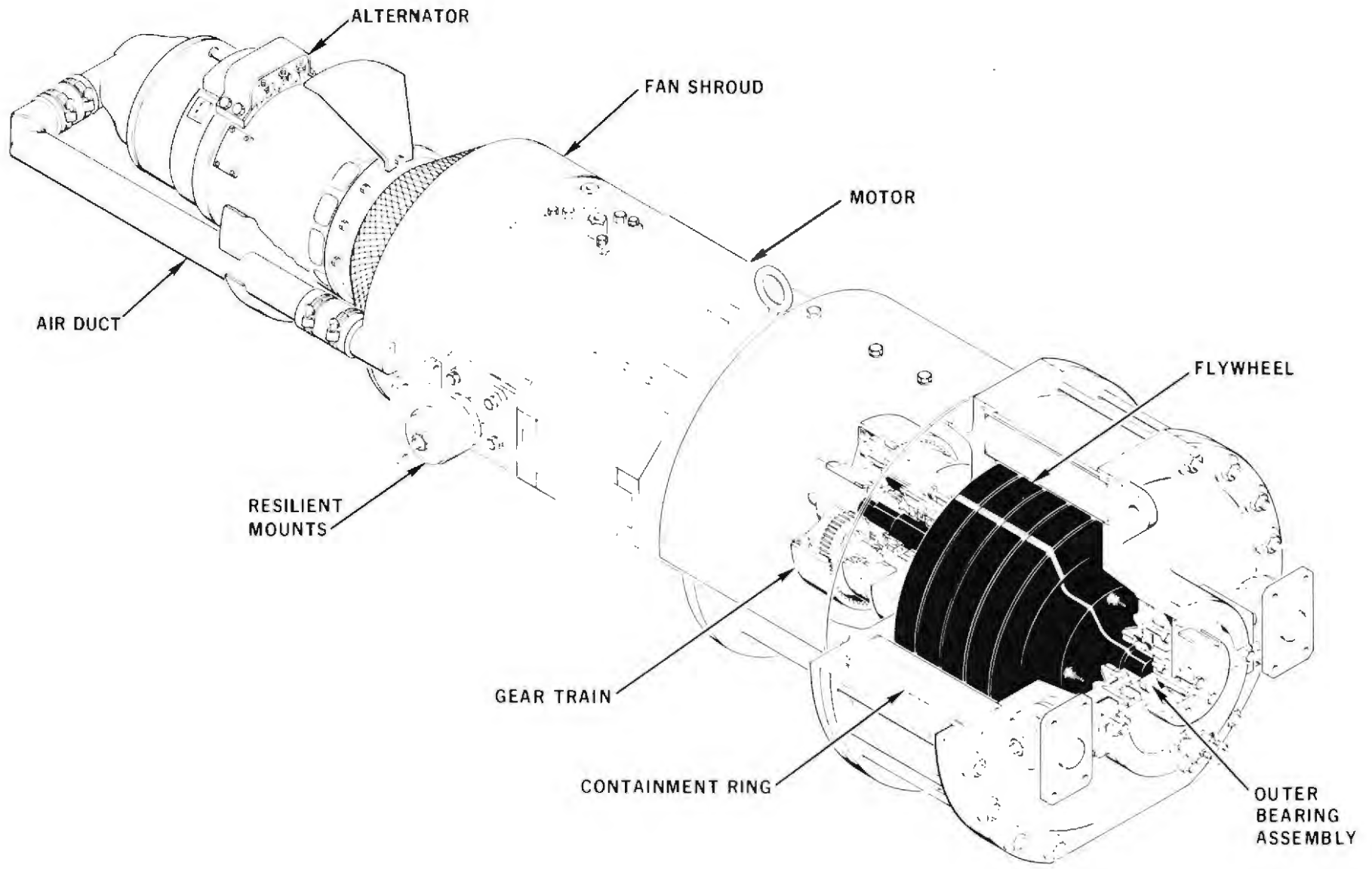

Fig. 7 Energy Storage Unit

mounted on the motor shaft. The alternator generates AC power for the variable voltage field power supplies.

Figure 7 shows an ESU in cross section. The separate parts of the ESU are described in the following sections.

b. Flywheel motor

As has been mentioned previously, the flywheel is driven by a separately-excited motor. Electrically the flywheel motor is identical to the traction motor used on the UMTA State-of-the-Art Cars (SOAC). It is a laminated-frame, fully compensated motor which is cooled by a shaft-mounted fan.

The maximum speed of the motor is 4200 RPM and it is rated at 430 Amps and 750 Volts.

Additional details of the motor design are contained in the report titled *State-of-the-Art Car Development Program, Vol. 1: Design, Fabrication and Test*, pp. 29-33 (NTIS No. PB 235-703).

c. Gear unit

The 4200 RPM maximum motor shaft speed is multiplied by a 3.33:1 gear unit to produce a flywheel maximum speed of 14,000 RPM. The unit is shown in Figure 8. It consists of a sun gear mounted on the flywheel shaft, surrounded by three planetary gears. The flywheel motor transmits power to and receives power from the unit through a ring gear which engages the outer teeth of the planets.

The unit is oil lubricated. The pump which forces the oil into the bearing areas is geared to one of the planets. This gerotor type pump also supplies oil to the flywheel bearings and in addition provides a vacuum of approximately 1/2 psi in the flywheel chamber.

The lubricating oil is cooled by being pumped through a long, finned-tube heat exchanger, which is mounted on the outside of the gear unit housing. The heat exchanger is in the flow path of the cooling air from the flywheel motor. An oil filter is mounted outside of the gear unit.

d. Flywheel unit

The flywheel is an assembly of four steel discs, mated to each other with curvic couplings, and attached to two endcap-shafts with a ring of six tie-bolts (Figure 9). The rotor is surrounded by a

3.5" thick steel containment ring which can rotate tangentially to absorb energy from a flywheel fragment.

The design of the containment ring follows from four major considerations:

- 1) The containment ring material is selected by the piercing requirement for a one-third element of a single disc.
- 2) The volume of containment material is based on the total translational kinetic energy of the three elements of a single disc which has burst.
- 3) A tri-hub burst analysis method is then used to establish that the selected volume, thickness, and containment material are adequate.
- 4) The containment ring structure is free to rotate so that any angular momentum transferred goes into spinning the ring rather than applying a sudden torque to the ESU support elements.

The material chosen for the containment ring is 9310 steel, AMS 6260, with a core hardness of RC 28-40 and a case hardness of RC 54-58 (case depth range 0.060-0.075"). The required minimum containment ring thickness was determined to be 3.48", based on this material's minimum strain energy density of 20.4×10^3 in-lb/cu. in. at a temperature of 250°F. The length of the ring is 11.8".

The strain energy capacity in the containment ring in the hoop direction was determined to be 5.20×10^6 foot-pounds at 250 °F. This is approximately 2.5 times the kinetic energy generated by the failure of a 150 pound flywheel disc at 14,280 RPM (102% of top speed).

A four disc flywheel rotor made of vacuum melt alloy steel was chosen because of the design and manufacturing considerations already described. The ability of a flywheel to store kinetic energy is dependent on the shape, the weight, and the square of the rotational velocity of the disc chosen ($E = \frac{1}{2}I\omega^2$). Of course, the maximum allowable rotational velocity of the disc is dependent upon the tensile strength of the material. Because of its high strength, Class I (vacuum melt) 4340 alloy steel, heat treated to RC 42-44, was chosen. Table 2 describes the material properties of the steel used for the flywheel disc.

Table 2. Properties of the flywheel material.

Properties	At Room Temperature			At 300 F		
	F tensile ultimate (ksi)	F tensile yield (ksi)	e (%)	F tensile ultimate (ksi)	F tensile yield (ksi)	e (%)
Hardness (RC)						
42	194	171	10	188	156	10
44	208	183	10	202	167	10



Flywheel Housing

Oil Cooler

Flywheel Shaft

Oil Filter

Oil-Vacuum Pump

Fig. 8 Flywheel Gear Unit

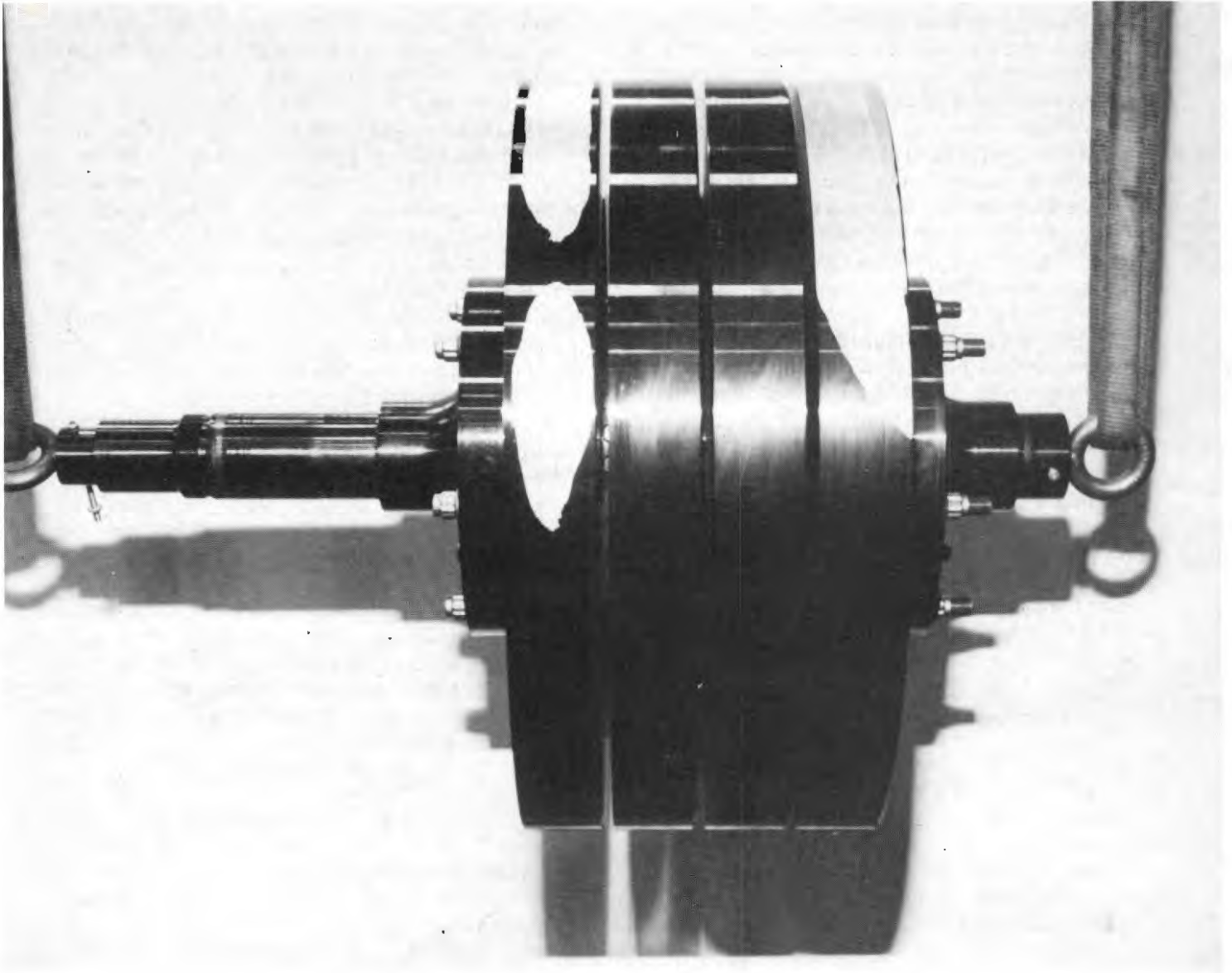

Fig. 9 Energy Storage Unit Rotor

The containment ring requirement limited the maximum diameter of the actual flywheel discs to 20 inches, after rotational clearance and assembly features such as housing flanges are considered. The width of the individual discs was determined by the manufacturing parameters imposed by hardening and inspection. The 4340 alloy steel cannot be conventionally heat-treated and through-hardened in sections larger than 2 inches thick, and a disc thicker than 2 inches cannot be quality-inspected by X-ray methods. Since both of the above methods were considered desirable to the manufacture of the flywheel, a 2-inch maximum thickness was imposed on the individual discs.

The most "space efficient" disc profile was determined to be a modified hyperbolic design described as a "modified constant stress" disc. The disc is slightly tapered in a hyperbolic shape from the centerline to the tie-bolt holes, and from the tie-bolt holes to the circumference of the disc the taper is reversed (see Figure 10). The arrangement produces a disc that maintains a constant stress level from the centerline to the tie-bolt holes, and a decrease in stress from the bolt holes to the radius. The thinned section below the bolt holes is at a slightly higher stress level, as can be seen in Figure 10. The weight of each disc is 150 lb.

Using the information summarized in Figure 10, it was possible to determine the factors of safety and fatigue life of the flywheel discs. Location B, being the highest principal stress area, was used in the factor of safety calculations. Yield and ultimate factors of safety are evaluated as follows:

$$\frac{\text{Minimum yield strength at } 300^\circ\text{F}}{\text{Maximum operating stress at } 300^\circ\text{F}} = \frac{156 \text{ ksi}}{75 \text{ ksi}} = 2.1$$

$$\frac{\text{Minimum ultimate strength at } 300^\circ\text{F}}{\text{Maximum operating stress at } 300^\circ\text{F}} = \frac{188 \text{ ksi}}{75 \text{ ksi}} = 2.5$$

Because a stress concentration of two exists at the center of the tie-bolt hole, this location (Figure 10, point A) was considered as the most critical area of the disc in terms of a fatigue analysis. A summary of the analysis is found in Table 3.

The daily start-stop duty cycles and the station-to-station operational cycles were combined, and from this it was predicted that a flywheel disc will not experience initiation of fatigue cracking during the normal operating cycles within a period of 35 years.

Creep was not a significant criterion for the disc material selection because the maximum temperature experienced during normal operation was determined to be 300°F, and at this relatively low temperature, the disc will not suffer any creep damage in 35 years of operation.

The burst speed of the disc at normal operating conditions was calculated to be between 24,900 and 25,800 RPM (approximately 180 percent of the maximum rated speed of 14,000 RPM). The analysis indicates that the disc will not burst in the event of a vacuum pump failure because the metal temperature will not exceed 390°F.

The flywheel disc was also investigated from the point of view of Fracture Mechanics. The analysis approach assumed the existence of an initial crack-like defect in a most undesirable location and orientation such that it would not be detected by either ultrasonic or magnetic particle inspection. Since any surface crack larger than 0.030 inches deep by 0.050 inches long would be screened out by the 100 percent disc inspection procedures previously mentioned, the maximum possible undetected crack is limited to the 0.030 by 0.050 inch size. Fatigue testing was performed on a disc specimen by the California State University at Long Beach, and from this testing it was predicted that if such a crack was present, it would grow to a size of 0.148 inches by 0.328 inches at the end of one year of revenue service. This crack growth results from cyclic loading as follows:

- 1) 365 start-stop cycles of daily operation
- 2) 88,600 station-to-station cycles of minimum-to-maximum speed operation
- 3) Operating time of 2920 hours (assumed 8 hours per day)

Table 3. Flywheel disc fatigue analysis.

Cycles	Rotor Speed Change	Nominal Stress Change	Required Cycles (in 35 yrs. of operation)	Predicted Cycles to Failure at 300°F
Everyday Start-Stop Duty Cycles	0-14,000 RPM	7-58 ksi	1.28 x 10 ⁶	9 x 10 ⁶
Station-Station Operational Cycles	9800-14,000 RPM	28.4-58 ksi	3.1 x 10 ⁶	23 x 10 ⁶

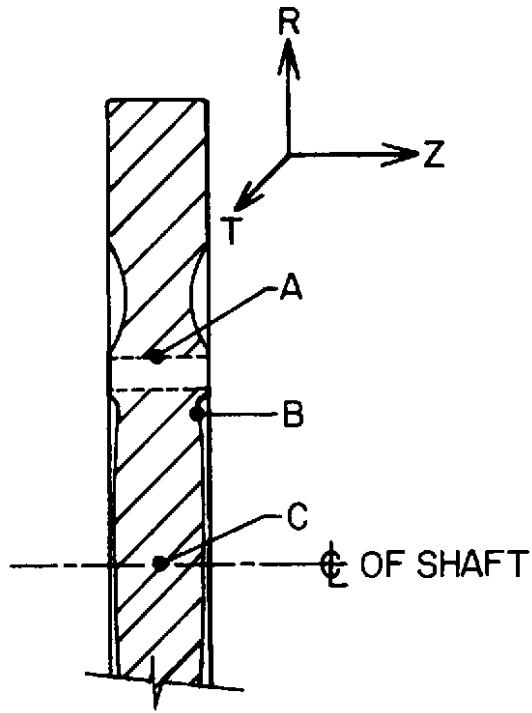

STRESS LOCATION	NOMINAL STRESS LEVELS (ksi)				
	TANGENTIAL	RADIAL	AXIAL	PRINCIPAL ₍₂₎	VON MESES
A(I)	58	57	-8	58	64
B	69	75	7	75	67
C	64	64	-1	64	65

NOTE: 1 - $K_f = 2.0$ (stress concentration)
 2 - IN PLANE R-Z

Fig. 10 Flywheel Disc Stress Chart

At the end of one year of operation, a previously undetected (and fatigue-grown) crack would not cause a sudden failure in an overspeed condition, provided that the overspeed does not exceed 16,500 RPM (118% of maximum speed). The system is protected against such a high speed by several redundant levels of precautionary system monitors. When the annual inspection of the discs is performed, such a fatigue-grown crack would be plainly evident.

The cases of surface cracks existing in other locations were investigated as well, but in each of these cases it was determined that the margin of safety was even greater.

Four discs are mated together with curvic couplings to form the flywheel. This coupling configuration provides torque transmission between discs and allows the discs to grow radially. The primary feature of the coupling is that any growth of the discs will be in such a manner as to maintain the axial alignment and, consequently, the balance of the assembly. The number of discs was chosen to be four, because use of curvic couplings in an assembly of a larger number would have been unwieldy.

The disc assembly is held together by six tie-bolts. During assembly, the bolts are held in an 11,500 lb tensile pre-load by the use of a hydraulic fixture. The nuts are then made snug against the endcaps. This procedure allows a precise determination of the stress in the bolts, which would not have been possible if the pre-load had been applied by torquing the nuts.

The flywheel assembly is supported by two roller bearings pressed onto the endcap-shafts at a separation distance of 19¼". The nominal vertical load on each bearing is 1500 to 1800 lb (1260 lb for maximum gyroscopic load, 370 lb for weight (1G) and ± 185 lb (½ G) for dynamic loading). The roller bearings have a rated maximum design load of 2900 lb for 3000 hr at 14,000 RPM. In addition, two pre-loaded ball bearings opposing each other are utilized for thrust loadings up to a shock value of 15G's.

The flywheel cavity is maintained at a vacuum of approximately ½ psi. Operating the flywheel in a vacuum allows for a large reduction in the windage losses and, hence in the heating of the enclosed, rotating discs. The vacuum is produced by a combination lubrication-vacuum geroter pump mounted in the gear train housing, using carbon face seals within the flywheel cavity. The flywheel assembly (with endcap-shafts) weighs 750 lb and the containment ring weighs 800 lb. The maximum diameter of the flywheel assembly is 19.8". The inner diameter of the containment ring is 20.2"; providing

a clearance of 0.2" (in radius) between rotary and stationary portions.

e. Alternator

An alternator is mounted on one of the two Energy Storage Units of each car. This unit supplies 230 VAC to the traction and flywheel motor fields after the speed of the flywheel has reached 2000 RPM. (At speeds below 2000 RPM, e.g. during flywheel startup, the motor field excitation is supplied by the car battery.) The alternator is rated at 90 KVA and is fused for a 300 amp maximum output.

The frequency of the alternator is variable since it is dependent upon the speed of the flywheel motor. The alternator is a commercial unit originally designed for operation at 6000 RPM with 400 Hz output. When used in the ES application, the output varies between 200-280 Hz due to a rotational speed range of 3000-4200 RPM.

The Energy Storage System includes the standard R-32 car battery and motor-generator (MG) set. However, since the ES control circuits draw more power than do the standard R-32 controls, a rectified low voltage output from the alternator is used to supplement the battery system. Nevertheless, the principal loads for the ESU alternator are the field supplies for the traction and flywheel motors and the 60 Hz motor alternator. (The 60 Hz motor alternator is a 115 volt, 60 Hz power supply required for the operation of the capacitor and chopper cooling fans.)

f. ESU mounting arrangement

The entire Energy Storage Unit is mounted under the car with its rotational axis in the fore-and-aft direction. The unit is supported by two separate support structures; one at the flywheel end of the assembly, and the other at the motor end (the ES alternator is cantilever-mounted from the motor). The two support structures are welded assemblies made from rolled ASTM A7 steel angle sections which are bolted to reinforced weldments on the two center sills of the R-32 cars. Attachment of the ES unit to the supports is accomplished by the use of four resilient motor mounts on the unit. The mounts are positioned on the horizontal plane through the rotational axis of the ESU and are fastened to each mounting plate on the support structure by four bolts. However, the vertical shear stress created by the weight of the ESU is carried by a 3" diameter boss protruding from each ESU mounting plate. These shear members fit into mating indentations in the support structure pads. In this way, the four bolts on each mount are not subject to the shear stresses of the ESU, and can be considered to be in tension only, serving to main-

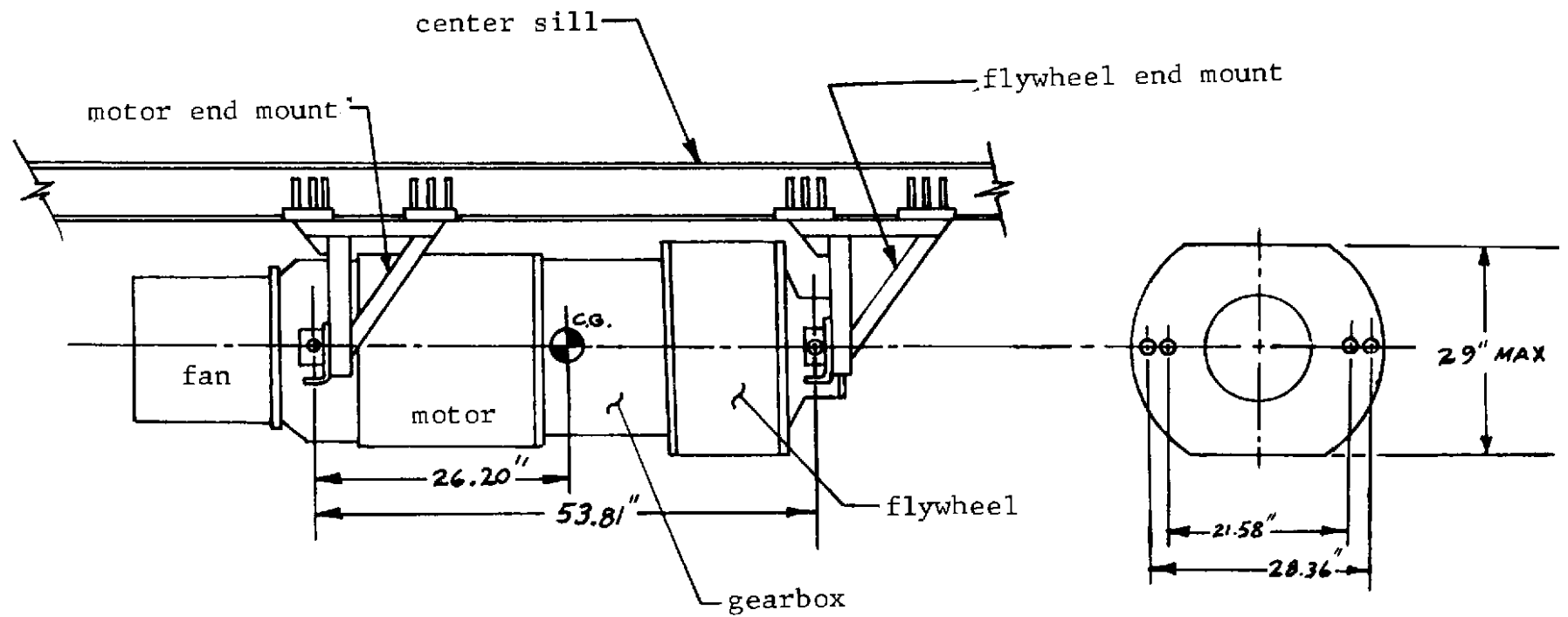

Fig. 11 Energy Storage Unit attached, by two support structures, to the two car body center sills.

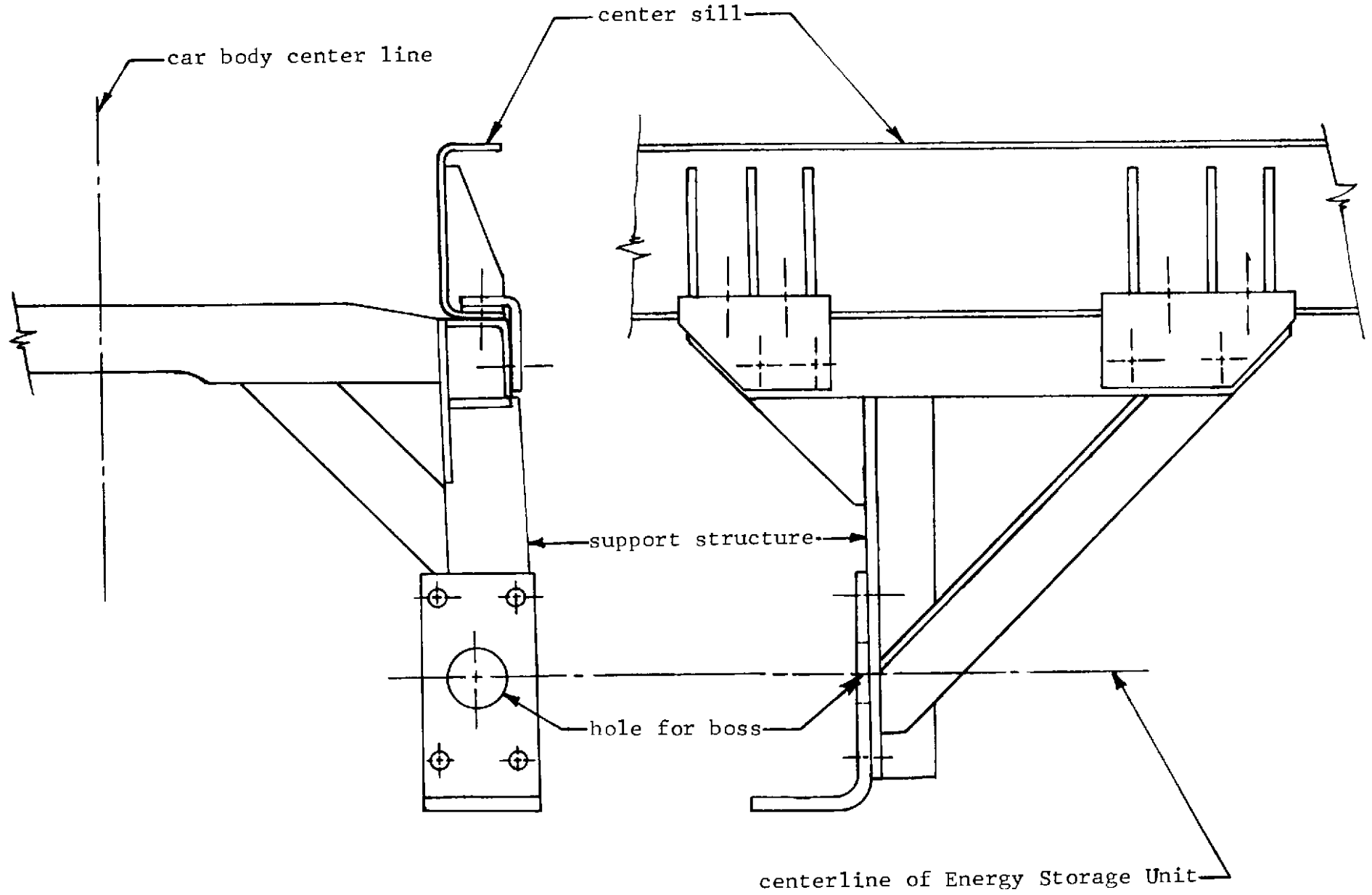

Fig. 12 ESU Support Structure motor end

tain engagement of the ESU mounts against the support structure (see Fig. 11, 12). The energy storage units with and without alternator weigh 5000 and 4700 pounds, respectively.

The structure was designed to withstand the following loadings without exceeding 50% of yield:

Limit Loads: 2.0G longitudinal
 1.0G lateral
 1.26G vertical-total

Fatigue Loads: $\pm 0.5G$ lateral
 $1 \pm 0.5G$ vertical

In addition, the support structure is designed to withstand, without failure, a shock loading of 10G in any direction without breaking loose, and a vibratory load of two million cycles.

The calculated loads that would cause yielding in any one member of the support structure were determined to be 6.1G vertical, 3.8G lateral, or 11.6G longitudinal (based on an alternator-equipped ESU).

g. ESU protective sensors

Several monitoring pickups are located in the gear train housing in order to ensure satisfactory flywheel operation. A thermocouple sensor monitors the oil temperature to ensure that it does not exceed 300° F during flywheel operation. A magnetic chip detector monitors the oil supply for metal particles, thereby checking for a possible failure condition. The low oil pressure trip ensures that the bearings are not starved for lubricant (this sensor is set at a minimum pressure limit of 40 psi). The actual speed of the flywheel assembly is monitored by two overspeed sensors, each totally independent of the other, with either capable of initiating a system shut-down in the event of an overspeed condition. In order to protect against a faulty signal from a defective sensor, both speed sensor outputs are compared and an error of more than 2 percent will shut down the Energy Storage Unit.

In order to ensure that the ESU does not overheat from windage losses, the vacuum of the flywheel housing is monitored by two low vacuum sensors. One pressure switch is set at 24 inches Hg of increasing vacuum to prevent high-speed flywheel operation during the start-up sequence; the second vacuum sensor is activated at 28 inches of Hg and indicates normal flywheel cavity vacuum. In the event of a loss of vacuum, the increase in the operating temperature of the lubricant will reach a maximum temperature level of approximately 390° F, which is within the safe operating range for the flywheel unit. Thus, a loss of vacuum will not result in sufficient flywheel overheating to cause a disc failure.

A vibration sensor on each ESU will cause a propulsion shutdown of the car if excessive motions of the unit occur. This sensor can be reset manually only after an inspection of the ESU.

The arrangement of the underfloor equipment is shown in Figure 13.

Simplified System Schematic

At this point a closer look at the system electrical schematic is in order. Figure 14 provides additional details of the interconnection of the 600V equipment.

When required, power from the third rail flows through the previously existing (R-32) shoes and knife switch. Voltage spikes that may be received from the third rail are limited and dissipated by the overvoltage suppressor (OVS). The OVS consists of a spark gap, a blowout coil and a non-linear resistor. The unit limits voltage levels to less than 2400V.

A blocking diode (VBR) is placed in the 600V circuit just downstream of the overvoltage suppressor. The VBR, which consists of three diodes in parallel, serves to protect against discharge of the input filter capacitor into the third rail. The VBR also ensures that the third rail shoes will not be "live" when the car is not in contact with the third rail. Each of the three VBR diodes is rated at 300 Amps, with a peak-inverse-voltage of 1800V.

An input filter is placed in the circuit for three purposes. First, the filter protects the chopper components from line transients. Second, the filter capacitor stores electrical energy so that the chopper can supply appropriately narrow pulses of power. Third, the filter protects wayside signals from waveforms that might be generated by the chopper and which might otherwise interfere with track circuits. The details of the filter will be described in a subsequent section.

The chopper supplies a controllable voltage level from the third rail to the flywheel and traction motors. Power is allowed to pass through the chopper in very short pulses, with thyristor "switches" very rapidly starting and stopping the flow. Depending on the ratio of the chopper "on" time to the amount of time between the start of each successive pulse, a direct-current average value is applied to the motors, and the motors respond as if an undulating DC voltage were applied to the terminals (the shape of the chopper output being smoothed by an inductor). In this manner, the 600 volt third rail supply can be employed without the use of high current conductors or energy-dissipating resistances.

The "commutation circuit" serves to turn the voltage pulse off after the appropriate amount of time. The freewheel diode enables current to flow

EVEN NUMBERED CAR

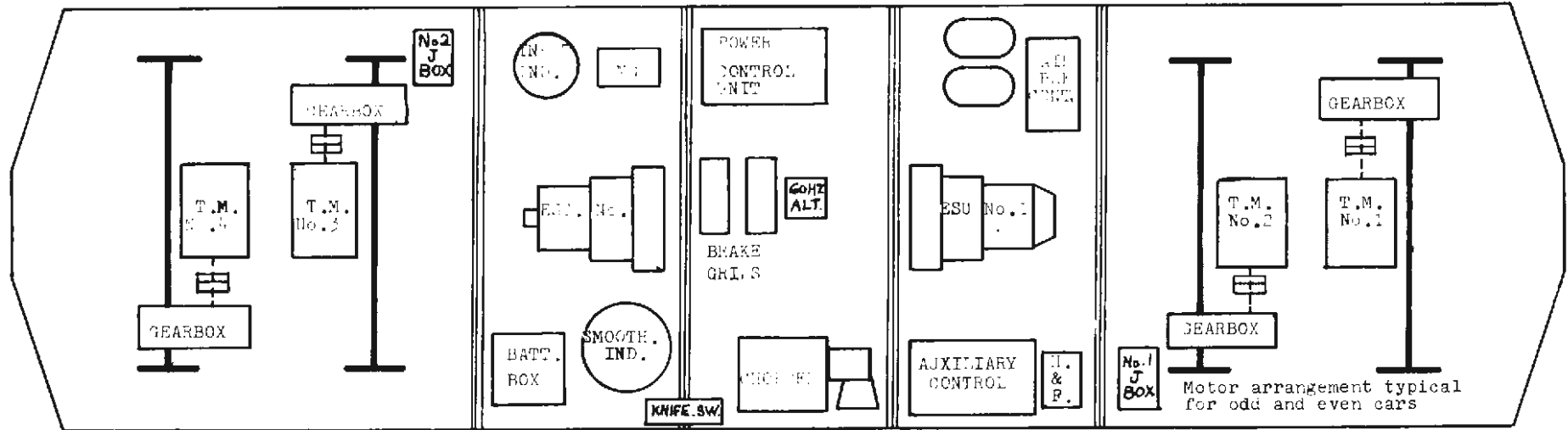

No. 2 END

TRUCK No. 2

TRUCK No. 1

No. 1 END

ODD NUMBERED CAR

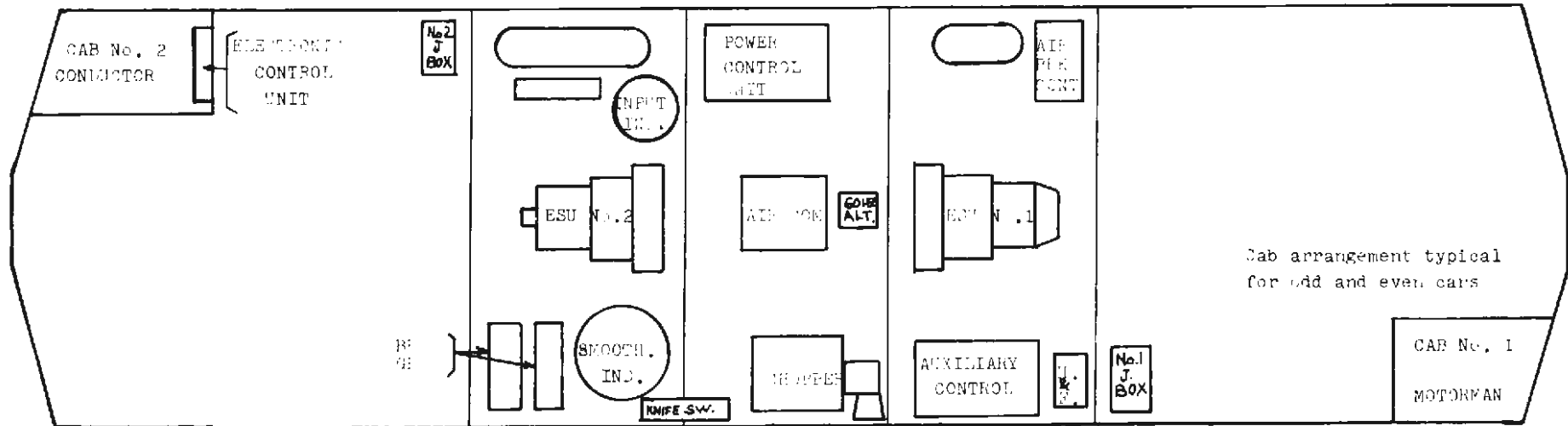

Fig. 13 Underfloor Equipment Layout

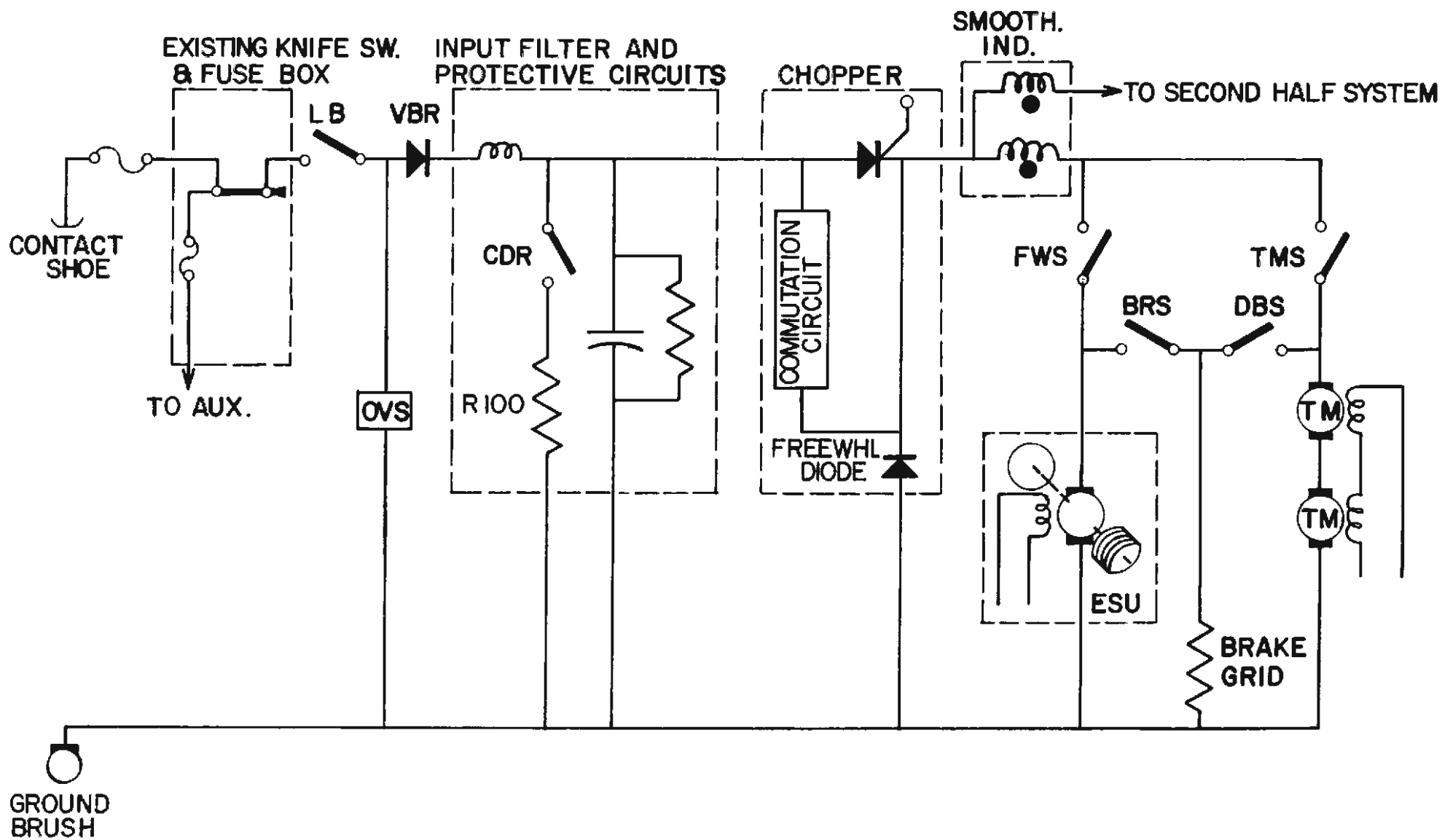

Fig. 14 Energy Storage System (simplified schematic)

through the ES equipment during the "off" portion of each chopper period. Further details on the chopper will be given in a subsequent section.

In Appendix A, a thorough run-through of the system operation (prepared by Garrett) is presented. A functional schematic drawing is included.

Traction Motors

The Energy Storage Car traction motors are very similar in design to the flywheel motors. The traction motors are also self-ventilated, separately-excited, undulating current type, but have a lower overall rating than the flywheel motors.

The characteristics of the traction motors are as follows:

- 1) Nominal voltage 290V
- 2) 1-hr. rating (@ 375 V, 1970 RPM, 305 Amp armature current and full field) 125hp (93kw)
- 3) Maximum operating speed 3940RPM
- 4) Overspeed test 4420RPM
- 5) Insulation type Class 200
- 6) Dielectric insulation strength of armature to frame 2700V
- 7) Maximum voltage during dynamic braking 375V
- 8) Maximum current undulation ratio at maximum current (I peak/I avg.) 1.2

Each traction motor weighs approximately 1450 pounds and is sized to permit installation in the NYCTA truck using the standard R-32 gear box and motor coupling.

A major benefit derived from the use of separately-excited DC traction motors is the inherent anti-slip/slide characteristic. Because the field current is not in series with the armature current, the torque of a slipping motor will drop very rapidly, thus providing built-in protection against spins and slides.

Chopper

As has already been mentioned, the chopper serves as a stepless, essentially lossless DC voltage transformer. The chopper built by Garrett for the ES cars is similar in principal to that used on UMTA's State-of-the-Art cars (SOAC) and on the MTA/UMTA Gas Turbine/Electric commuter cars.

The operation of the chopper is described in detail in Volume I of the SOAC Final Report (pp 60-67).* The ES and SOAC choppers are compared in Table 4.

The prime difference between the SOAC and ES choppers is in their power rating. Since the ES system requires a chopper only for make-up of losses and, in particular, since the bulk of the acceleration power comes from the flywheel rather than through the chopper, the ES chopper can be relatively small.

The chopper is mounted under the car floor. It is cooled by a fan which is powered by the 115V-60Hz alternator. The power components are mounted in heat sink modules which slide out when required for maintenance.

Input Filter

The primary components of the input filter are an inductor and a capacitor.

The input inductor is a convection-cooled air core reactor insulated to class H standards and rated at 3.0 mH and 400 Amps RMS. The unit is annular in shape with a 20-inch outer diameter and weighs approximately 100 pounds. There is one input inductor mounted under each car.

The input capacitor bank consists of eight parallel strings of five cylindrical liquid electrolytic capacitors. The individual capacitors are rated at 6000 uf and 300V. Each capacitor is bridged by a bleed resistor; each parallel string is fused.

Considerable care was given to the question of how to avoid shock hazards due to discharge of the electrical energy built-up on the capacitor. In addition to the bleed resistors (discharge time equals 20 minutes in the absence of any other protection) and the blocking diode VBR, there is a capacitor discharge circuit which can dissipate the charge to a tolerable level in 4 seconds. When the car is not receiving line voltage (as sensed by a potential relay upstream of the VBR) the capacitor discharge relay (CDR) contact closes and a 100-ohm resistor is placed across the capacitor to drain off the charge and remove potentially harmful voltage levels. The closure of the CDR is delayed by approximately one

TABLE 4. Comparison of characteristics of Energy Storage Car and State-of-the-Art Car Choppers

	ES	SOAC
Power rating	750 kw	1350 kw
Number of thyristors: Main	6	12
Commutating	2	6
Number of diodes: Commutating	2	2
Freewheel	2	4
Number of modules (drawers)	2	4
Weight	400 lb	975 lb
Dimensions (L x W x H)	51 x 35 x 14"	51 x 37 x 23.5"

*Available for purchase from the National Technical Information Service (NTIS No. PB235-703).

second to avoid undesired discharges while traversing third rail gaps.

Smoothing Inductor

The smoothing inductor is an air core device functioning to limit the undulation of the flywheel and traction motor currents to an acceptable level (the commutation of the chopper causes large pulses to be present in the motor input unless a smoothing circuit is employed). The device is 35 inches in diameter, 14 inches high and weighs approximately 350 pounds. The inductor is constructed as two parallel windings (one coil for each half-car system). Each winding is rated at 3.0 mH and 400 Amps RMS.

Power Control Unit

The power control unit is an enclosure mounted under the car floor that contains the high voltage controls and the 600 volt contactors for the traction equipment. The unit houses the line switch, the input filter capacitor, and the overvoltage suppressor.

The power control unit also contains the overcurrent relays. These seven relays monitor the motor and line currents and de-energize the fields of the motors if the normal control in the chopper system fails to limit the current. This is accomplished by the overcurrent energizing the relays, tripping the line and motor contactors, and thereby de-energizing the motor fields. In addition, a differential current relay is placed in the line voltage loop to monitor and compare the positive line current and the negative (return) current. If a 50 Amp differential occurs in either the drive or brake mode, the differential current relay will trip the line and motor contactors and, simultaneously, de-energize the fields of the motors through the quick shut-down relay. After the ground fault condition is removed, the relays can be reset from the car cab.

In summary, the power control unit contains the following items:

- 1) brake resistor switch (BRS)
- 2) capacitor modules
- 3) dynamic brake switch (DBS)
- 4) differential current relay
- 5) flywheel motor switch (FWS)
- 6) line breaker (LB)
- 7) overcurrent relay
- 8) overvoltage suppressor (OVS)
- 9) quick shutdown relay (QSDR)
- 10) reverse voltage rectifier (VBR)
- 11) traction motor switch (TMS)
- 12) voltage transducers
- 13) capacitor discharge relay (CDR)
- 14) capacitor bank cooling fans

Auxiliary Control Unit

The auxiliary control unit is mounted under the car floor and houses most of the trainline interface devices, such as the emergency relay, brake rate transducer, and (on the even-numbered car only) the motor-generator contactor. In addition, certain flywheel-associated devices such as the flywheel alternator relay, the flywheel start relay, and the chopper and capacitor cooling fan relays are enclosed within the auxiliary control unit. The phase delay rectifiers for both the flywheel and traction motor fields are also contained within this unit. The phase delay rectifiers are circuits operated from the 230 volt AC, 3-phase output of the flywheel alternator, and are utilized to supply controllable field currents to the traction and flywheel motors.

The auxiliary control unit is 83" long, 30" wide, 22" high and weighs 565 pounds. The unit is accessible from the side of the car.

Electronic Control Unit

The electronic control unit (ECU) is mounted in the conductor's cab of each Energy Storage Car, and serves the combined functions of chopper and motor field control, Energy Storage system logic, and system protection. Specifically, the ECU controls the traction and flywheel motor field currents and voltages, as well as the chopper pulse width and duty cycle frequency. In addition, the operation of the various R-32 contactors and switches are controlled by the ECU.

The logic function of the electronic control unit monitors car weight and car speed and determines the speed of the flywheel in relation to the flywheel speed schedule. The logic required to simulate the performance of a standard R-32 car is programmed into the ECU for operational capability with the NYCTA fleet. All of the system sensors, such as vacuum, speed, and temperature, are monitored by the ECU and their inputs are used to effect a flywheel shut-down in the event of a fault signal. Limiters are employed to share the current between flywheels and to equalize the power transmitted to the traction motors for acceleration.

The ES propulsion system has an intrinsically stepless, analog type of control, but it must operate in train with cam controlled cars which receive propulsion commands from a three-notch master controller. Thus, the ES car must take the propulsion command signal from the three (digital) trainlines and translate the signal into an equivalent (analog) tractive effort profile. This translation is performed by the ECU.

Curves of tractive effort and traction motor current in the three modes of car operation (switching, series and parallel) are given in Appendix B.

Appendix A

System Function and Operation*

General

The functional aspects of the system are described from the car operator's point of view.

Flywheel Startup

To explain how the equipment functions, the following description assumes that the car is being put into operation from a completely de-energized condition. Component names, abbreviations, etc., refer to E.S.C. Wiring Diagram, AiResearch drawing No. 543124 included in this Appendix.

To energize the electrical systems, all of the cab mounted circuit breakers should be closed, as in a conventional R-32 car. The only additional step is to close the Flywheel Run Switch in each cab of both cars. This will then cause the electronic controls to begin the startup sequence of the flywheels. The receipt of this command signal is acknowledged by the Flywheel Vacuum Warning-Light illuminating.

When the flywheel run command is received by the electronic control unit (ECU), a relay within the ECU energizes the logic power supplies. If there has not been a quick shutdown (QSD) during previous car operation, internal commands will be generated to first close the flywheel start relays 1 and 2 (FSR1 and FSR2) in the auxiliary control unit (ACU) and then the linebreaker (LB) located in the power control unit (PCU). The flywheel armatures will also be connected to the chopper by closing flywheel switches 1 and 2 (FWS1, 2). If the system was previously in the QSD mode, it will be indicated by the QSD light in each car cab. It is then necessary to momentarily close the Reset switch of the normal car controls.

When the flywheel start relays are closed, battery current is applied to the fields of the flywheel motors but is limited by series resistors R110 and R111. The linebreaker (LB) is allowed to close only if the following conditions are satisfactory:

- (a) Linebreaker overload trip has been reset since the last trip
- (b) The potential relay (PTR) is energized by 3rd rail voltage of at least 400 volts
- (c) The QSD relay has been reset since the last trip

The above 3 conditions are imposed on the linebreaker by the 3 contactors in series with the LB coil.

When LB closes, the input filter is then charged through the voltage blocking rectifiers (VBR1, 2 and 3). The step charging of the series LC circuit will tend to charge the capacitor bank CM1 to CM8

to a voltage higher than the 3rd rail voltage. However, this does not endanger any of the connected equipment. The capacitor bank voltage is monitored by the ECU by means of the voltage divider VX1. If the level of voltage is satisfactory (400V to 700V) the chopper will be commanded to regulate the current to the two flywheel armatures to a constant 700 amps. At this instant, the flywheel motor fields are excited by battery current and the chopper begins to supply armature current. The resulting torque accelerates the flywheels.

The next event in the startup sequence is the closure of flywheel pressure switches (FPI) on both flywheel units. This switch closes at approximately 24 in. Hg vacuum. The action of FPI is used to indicate the proper operation of the flywheel vacuum pumps. When the start sequence is initiated by the ECU, a timer circuit is also energized that will shut down the system by means of the QSD circuit if the following signals are not received before a 180 second time interval elapses.

- (a) Flywheel pressure switch (FPI) closes at 24" Hg vacuum pressure
- (b) Oil pressure switch, opens at 40 psig
- (c) Flywheel speed signals are all present
- (d) Flywheel speed signals from one flywheel match within ± 2 percent

At approximately 2000 rpm the flywheel alternator regulators become effective and raises the alternator output voltages to 230 volts line-to-line. This voltage then energizes the control equipment cooling fans through the TI transformer, rectifier TRI, and the 60 Hz motor alternator. The proper operation of these components is indicated to the ECU by means of the cooling fan relay (CFR) closing a contact switch in series with the TR2 output. The proper operation of TR2 is indicated by the flywheel alternator relay (FAR). When CFR and FAR are both energized, the 32 volt output at TR2 indicates to the ECU that the flywheel alternator and 60 Hz MA are operating properly.

When the ECU receives the above signals, the flywheel motor speed is then raised to the 3000 RPM idle condition when the driving controls are off.

The system will then remain in this condition until a direction command is received from the conventional trainlines. For the low speed region, the field of the flywheel motors is set to the full value by the alternator-driven field supplies and the chopper is used to regulate the armature current. When the flywheel motor voltage is approximately equal to the line voltage, the chopper is gated full on (100

*Prepared by AiResearch Manufacturing Co. of California, a Division of The Garrett Corporation

percent conduction) and speed control is then accomplished by means of field current regulation.

Traction Motor Operation During Car Acceleration

When the operator selects a direction on the conventional reverser, the flywheel speed is commanded to increase to a level determined by the load weight transducer (LW). When the master controller is moved to a power position (switching, series or parallel), the following sequence will occur:

- (a) The chopper will be commutated off and the flywheel fields will be reduced to zero in order to produce zero armature volts on the flywheel motors. The Traction Motor Switches 1 and 2 (TMS1 and 2) will then be closed and the traction motor fields will be set to the full value.
- (b) In order to energize the traction motor armatures, the flywheel field is used to regulate traction motor armature current to a value determined by the ECU on the basis of car speed and tractive effort required to match the performance of conventional R-32's.

The energy required to accelerate the car will be taken initially from the flywheel. As the flywheel speed drops below the speed program, the chopper will be turned on and chopper current will be regulated in proportion to the error in flywheel speed.

As the car speed increases, the chopper conduction angle will increase to maintain the commanded current level. As the chopper reaches 100 percent conduction, the control of traction armature current is transferred to the traction motor fields. The flywheel fields are then used to regulate flywheel speed according to the speed program.

Change of Mode

Whenever the operator changes the setting of the master controller, the change of traction armature current programs will occur as a jerk-limited system output. If the master controller is moved to the off position, the traction system will be commanded to maintain essentially zero armature current. The flywheel control continues to follow the flywheel speed program which is a function of car speed and car weight. If the flywheel speeds are below the schedule, energy will continue to be added from the 3rd rail. If the flywheel speeds are above the schedule, no energy will be added and the auxiliary loads will gradually decrease flywheel speed.

Braking Mode

Whenever the operator selects the braking mode by moving the brake handle into the service braking region, the traction armature current will be regulated to a command received through the Dynamic Brake Rate Transducer (DBRT) that is proportional to the straight air pipe pressure. When the braking effort is greater than 60 percent of the commanded value and the motor current is greater than approximately 60 A/car, the Lock Out Magnet (LOM) will be energized.

During the braking mode, all energy regenerated by the traction motors is used to increase the speed of the flywheels. For virtually all of the normal operating conditions, this does not produce an over-speed condition of the flywheel. However, during a rare case where a heavily loaded car is held in the braking mode on a downgrade, the regenerated energy may cause the flywheel to approach the maximum speed condition. If this occurs, the flywheel speed controls will override the traction controls and cause a jerk-limited reduction of braking effort. When the armature currents are essentially zero, the TMS1 and 2 switches will be opened and the Dynamic Brake Resistor Switches (BRS1 and 2) will be closed. The armature current will then be raised to the commanded value and the excess braking energy will be dissipated in the dynamic brake grids. This mode will continue until the car is brought to a stop or the operator commands a return to the drive mode.

Station Stop Mode

Whenever the car reaches a stopped condition, as measured by the traction motor speed sensor, the traction motor current is commanded to zero and the TMS1 and 2 switches will be opened. If necessary, the chopper will then be energized and energy added to the flywheel to return it to the speed determined by the load weigh transducer. If a significant load change is made during the station stop, the flywheel system will modify the scheduled speed accordingly. The actual flywheel speed will adjust itself to the new schedule value, either in the station or shortly after leaving the station.

If the operator removes the direction command, the flywheel speed schedule will be reduced to approximately 70 percent of maximum value.

During all of the above operating modes, the electronic control unit (ECU) is continually monitoring all armature and field currents as well as limiting the armature voltages. The digital portion of the control responds to mode command changes by

reducing system output on jerk-limited rates and then making the appropriate changes in the main switch positions. The actual position of the switches is used to verify the circuit arrangement prior to releasing the current and voltage commands for a jerk-limited application of system output.

Third Rail Safety Provisions

Due to the energy storage capability of these cars, certain components have been used to prevent the input filter from being a hazard to operating and maintenance personnel.

A voltage blocking rectifier (VBR1-VBR3) is located between the shoes and the capacitor bank to prevent the third rail shoes from being energized after the car brakes contact with the third rail. The very small amount of rectifier leakage current will be absorbed by the various sensing networks that are on the third rail side of the rectifier.

A capacitor discharge relay (CDR) and resistor (R100) are located across the capacitor bank to eliminate any hazard to personnel opening the equipment boxes. The normally open contacts of CDR are closed when both the linebreaker (LB) and potential relay (PTR) have been de-energized for approximately one second. The time delay is used to prevent operation at the discharge circuit when third rail contact is lost only momentarily. After the time delay has elapsed, R100 will discharge the capacitor bank to less than 50 volts in approximately 4 seconds.

Fault Modes

There are a number of devices located throughout the electric and electronic circuitry whose function is to sense a component fault or failure and to cause rapid shut off of the total propulsion and flywheel system. This quick shutdown (QSD) circuitry then prevents further operation until a reset command has been received from the train operator. Each cab panel incorporates a red light indicating that the QSD circuit has been activated.

In the power circuit, there are seven overcurrent relays that monitor the bus currents. If the current amplitudes become excessive, the relays then close a contact switch that energizes the trip coil of the quick shutdown relay (QSDR), which in turn de-energizes the linebreaker coil. The differential current relay (DI) will respond to a 50A difference in current between the positive input lead and the negative return lead. This function is included to protect the system from ground faults. When the QSDR is tripped, the coil current to all power contactors other than the brake resistor switches (BRS1, BRS2) is also removed. These actions isolate the system from the third rail and all motors from each other.

Whenever the Electronic Control Unit receives a QSD signal, it energizes the BRS1 and BRS2 switches as well as the FSR1 and FSR2 switches. These switches apply current from the battery to the flywheel drive motor fields which will then generate the available voltage across the brake resistor. This braking function reduces the flywheel speed to approximately 50 percent in 4 minutes. At the end of this period, the battery field circuit is completely de-energized.

In addition to the above fault sensing devices, the following transducers are used to monitor the operating conditions of each flywheel unit:

- (a) *Oil Pressure Switch*—This switch becomes activated at 40 psig, decreasing pressure, causing a system QSD.
- (b) *Oil Temperature Switch*—This switch is activated at 300°F, causing a system QSD.
- (c) *Vacuum Switch No. 1*—This switch is activated at 24 in. Hg (increasing vacuum) causing a system QSD if deactivated while running at high-speed. It prevents high-speed operation during startup.
- (d) *Vacuum Switch No. 2*—This switch is activated at 28 in. Hg (increasing vacuum) indicating normal flywheel cavity vacuum when activated. If deactivated while running, this switch will illuminate the FW Vacuum Light in each cab panel.
- (e) *Outboard Bearing Oil Pressure Switch*—This switch becomes activated at 10 psig, decreasing, causing a system QSD.
- (f) *Flywheel Speed Sensor*—This device generates a pulse waveform whose frequency is proportional to the speed of the flywheel shaft. There are two sensors on each flywheel whose outputs are used by the ECU to monitor the speed of the flywheels. The ECU determines when an overspeed condition exists and will cause a system QSD. To protect against faulty speed transducers, the outputs of the two sensors of each flywheel are compared such that if an error of more than approximately one percent occurs, the system will be shut down.
- (g) *Flywheel Vibration Sensor*—This unit, which is mounted on a plate welded to each ESU, is a snap-action switch which is actuated at approximately 4.5G. The switch is used directly in the QSD circuit so that actuation of the switch causes a QSD signal to be generated. The unit is intended to protect the system against bearing or rotor failure and will respond uniformly to vibrations in the range 0-18,000 RPM.

To enable startup of the flywheel system, it is necessary to override the inputs from the oil pressure and vacuum transducers. This is done for a fixed period only. If all inputs are not satisfactory after 180 seconds, the system will be shut down.

A manual input, in addition to the above automatic functions, is also required from the cab-mounted flywheel trainline switches to allow the startup sequence to begin. If a Flywheel Run Switch is manually opened while the flywheels and car are being operated, a QSD type shutdown will be initiated.

Within the Electronic Control Unit (ECU) there are also miscellaneous functions that can initiate a QSD. These functions include:

- (a) Loss of low voltage power supply
- (b) Chopper overcurrent
- (c) Chopper overtemperature
- (d) Motor bus overvoltage
- (e) Steady state unbalance of armature currents

Appendix B

Performance Curves —
Conventional R-32 and Energy Storage Cars

1. R-32 Resistance Curves (Davis formula)
2. R-32 Performance—Switching Mode
3. R-32 Performance—Series Mode
4. R-32 Performance—Parallel Mode
5. ES Car Resistance Curves (Davis formula)
6. ES Car Armature Current Programs
7. ES Car Performance—Switching Mode
8. ES Car Performance—Series Mode
9. ES Car Performance—Parallel Mode

R32 PerformanceSwitching Mode

Rail Voltage = 600v
 Wheel Diameter = 32 3/8"
 Gear Ratio = 7.235:1

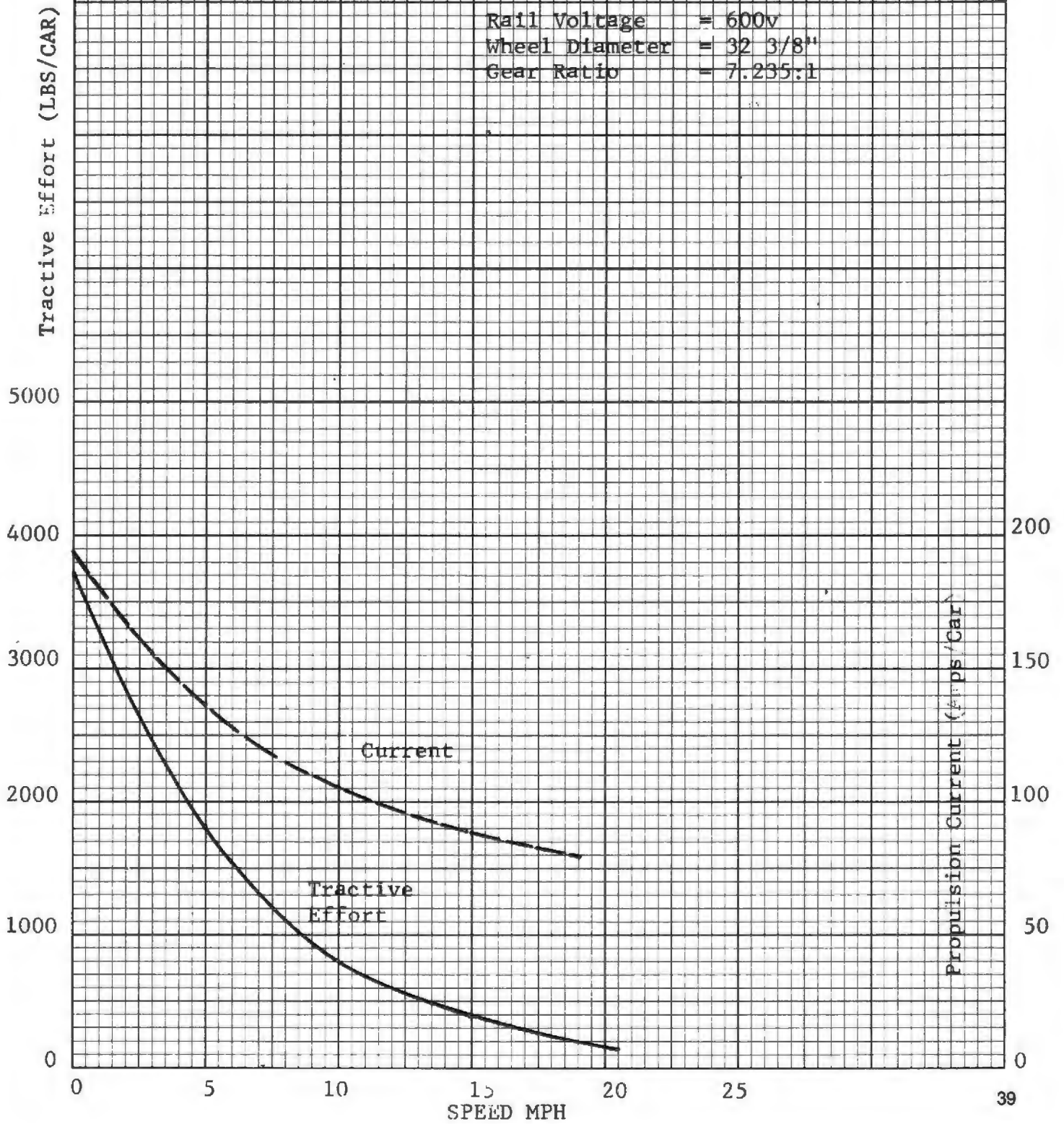

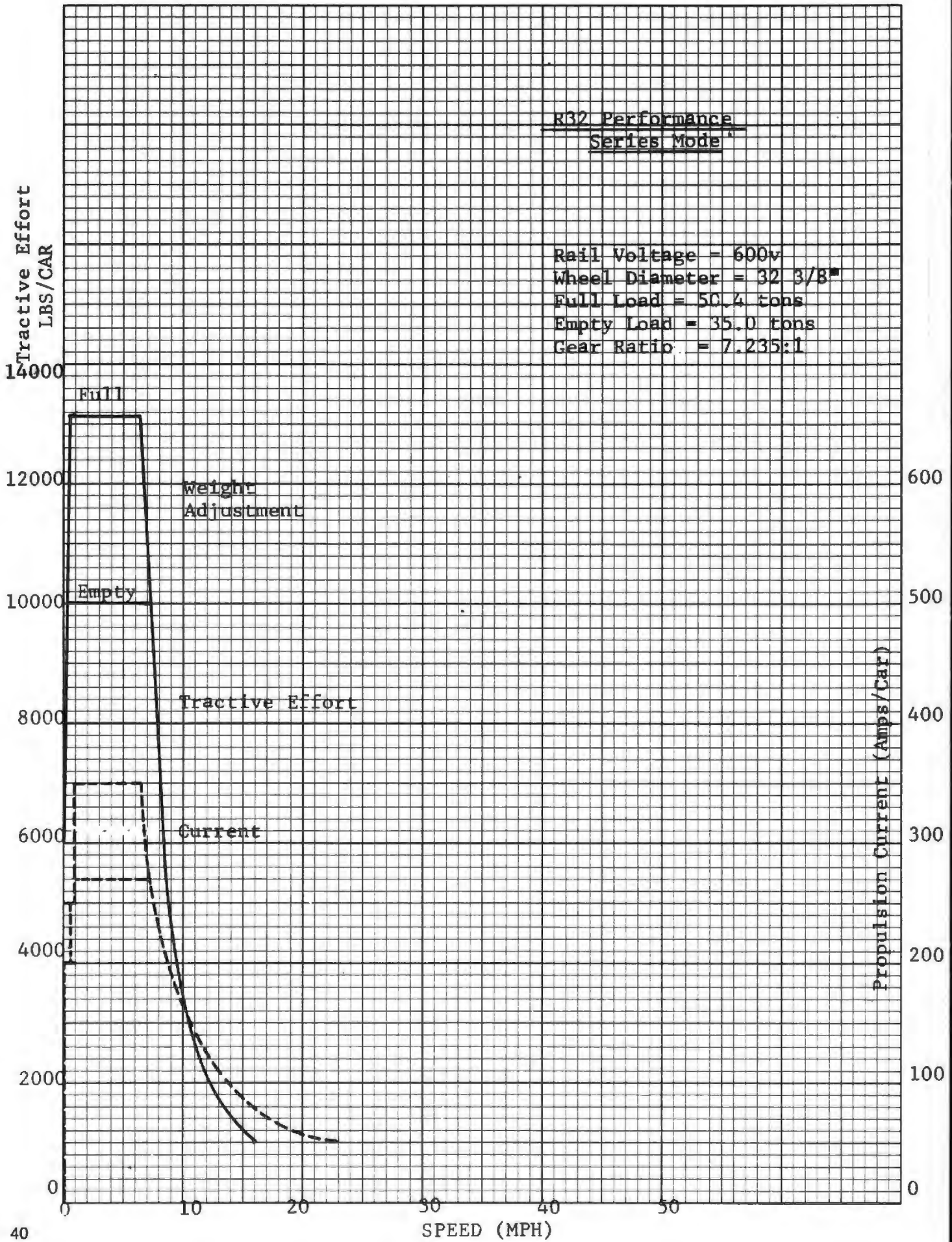

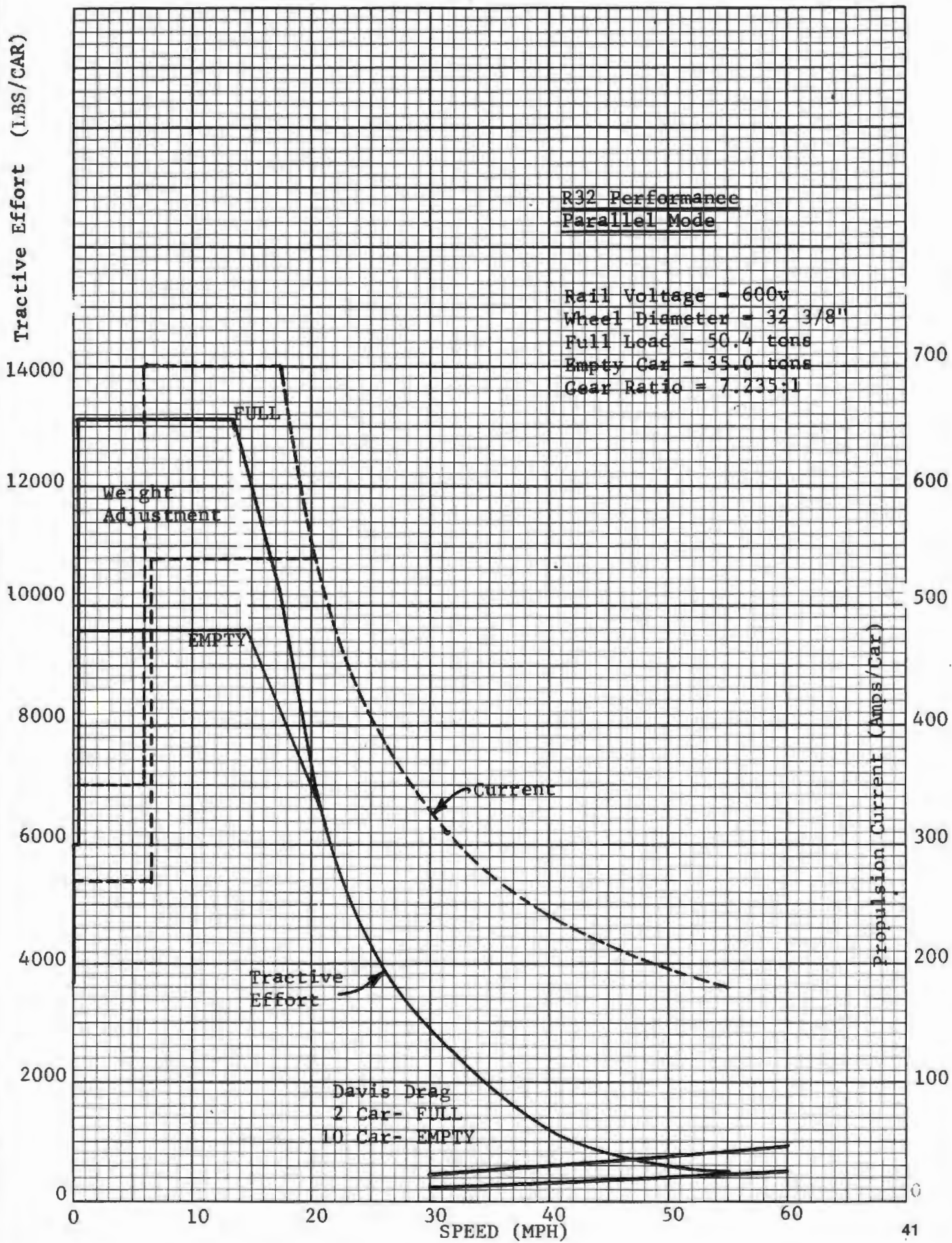

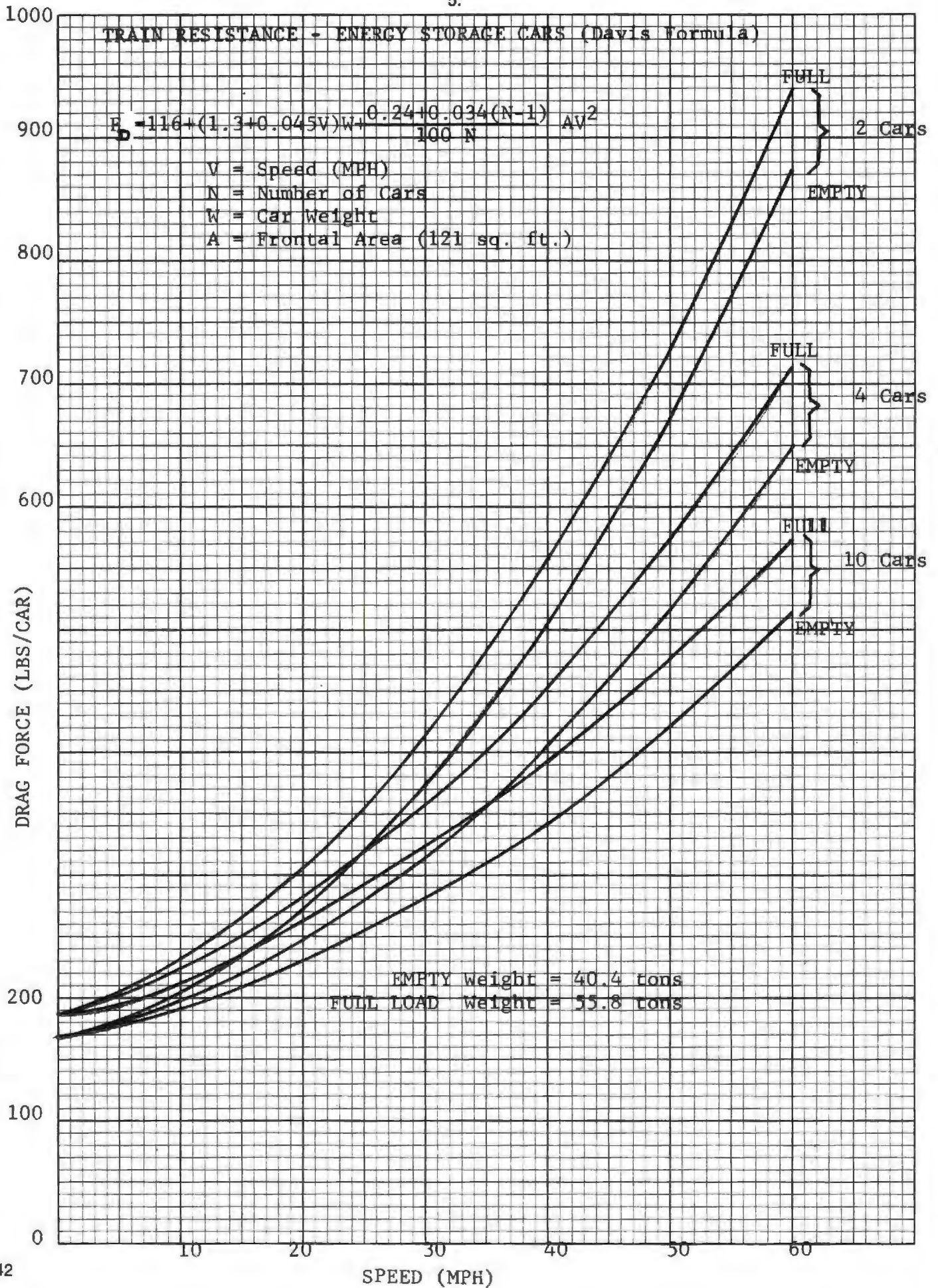

ENERGY STORAGE CAR
ARMATURE CURRENT
PROGRAMS

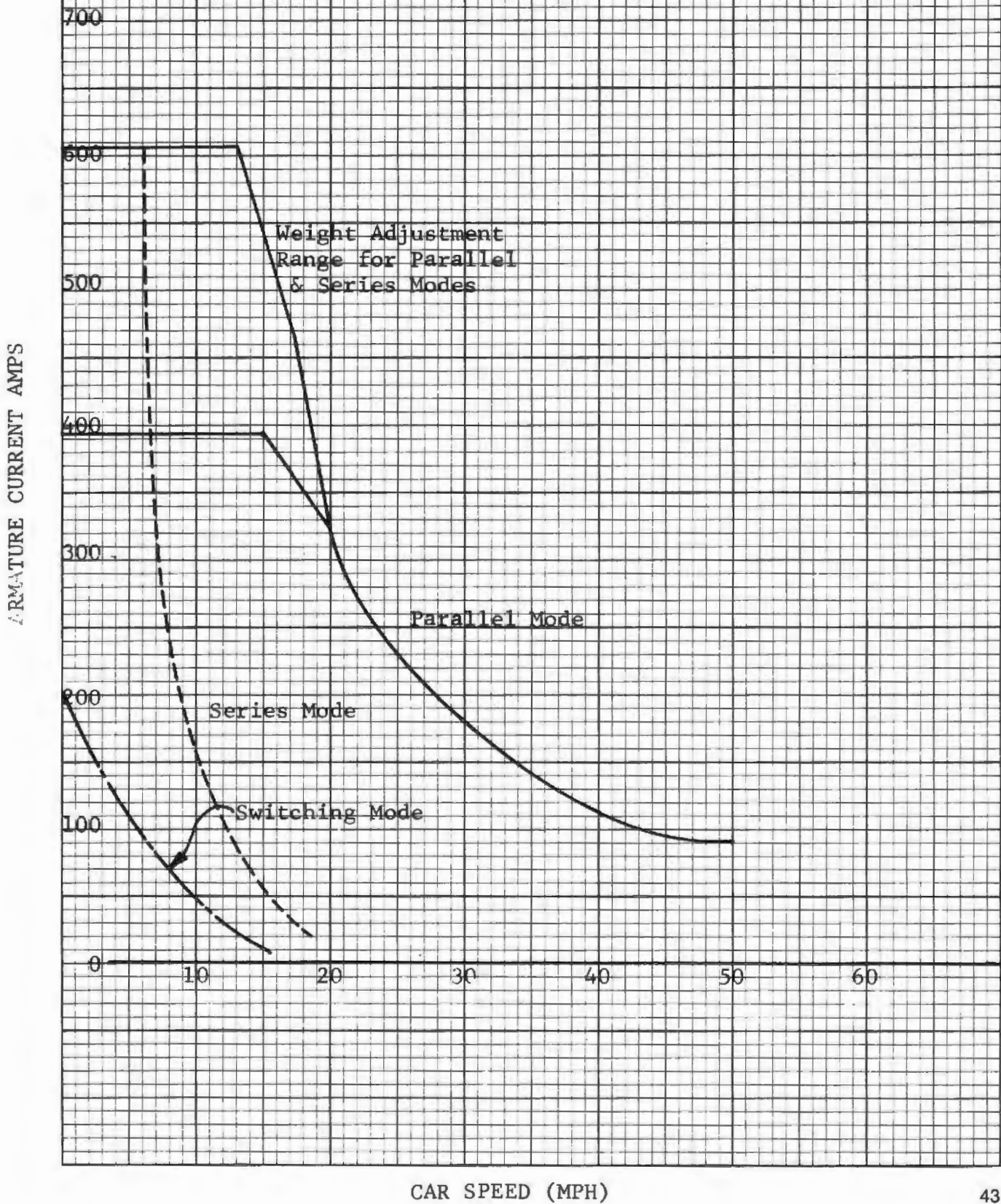

ENERGY STORAGE CARS
PERFORMANCE

Switching Mode

Rail Voltage = 600v

Wheel Diameter = 32 3/8"

Gear Ratio = 7.235:1

TRACTIVE EFFORT (LBS/CAR)

5000

4000

3000

2000

1000

0

0

5

10

15

20

25

speed (mph)

