

REPORT NO. UMTA-MA-06-0025-75-5

**SOAC
STATE-OF-THE-ART CAR
ENGINEERING TESTS AT
DEPARTMENT OF TRANSPORTATION
HIGH SPEED GROUND TEST CENTER**

**Volume V: Structural, Voltage, and
Radio Frequency Interference Tests**

George W. Neat
Raymond Oren
Editors



SEPTEMBER 1975
REPRINT
FINAL REPORT

DOCUMENT IS AVAILABLE TO THE PUBLIC
THROUGH THE NATIONAL TECHNICAL
INFORMATION SERVICE, SPRINGFIELD,
VIRGINIA 22161

TF
455
.963
v.5
c.1

Prepared for
U.S. DEPARTMENT OF TRANSPORTATION
URBAN MASS TRANSPORTATION ADMINISTRATION
Office of Research and Development
Washington DC 20590

NOTICE

This document is disseminated under the sponsorship of the Department of Transportation in the interest of information exchange. The United States Government assumes no liability for its contents or use thereof.

1. Report No. UMTA-MA-06-0025-75-5		2. Government Accession No. PB-244 751 PB-244 746-SET		3. Recipient's Catalog No.	
4. Title and Subtitle SOAC - STATE-OF-THE-ART CAR ENGINEERING TESTS AT DEPARTMENT OF TRANSPORTA- TION HIGH SPEED GROUND TEST CENTER Volume V: Structural, Voltage, and Radio Frequency Interference Tests				5. Report Date Reprint, September 1975	
				6. Performing Organization Code	
7. Author(s) George W. Neat, Raymond Oren, Editors				8. Performing Organization Report No. DOT-TSC-UMTA--74-16.V	
9. Performing Organization Name and Address Boeing Vertol Company* Philadelphia PA 19142				10. Work Unit No. UM604/R6730	
				11. Contract or Grant No. DOT-TSC-580	
12. Sponsoring Agency Name and Address U.S. Department of Transportation Urban Mass Transportation Administration Office of Research and Development Washington DC 20590				13. Type of Report and Period Covered Final Report April to July 1973	
				14. Sponsoring Agency Code	
15. Supplementary Notes *Under Contract to:				U.S. Department of Transportation Transportation Systems Center Kendall Square Cambridge MA 02142	
16. Abstract This six-volume report presents the technical methodology, data samples, and results of tests conducted on the SOAC on the Rail Transit Test Track at the High Speed Ground Test Center in Pueblo, Colorado during the period April to July 1973. The UMTA-sponsored Urban Rail Supporting Technology Program, for which TSC is Systems Manager, emphasizes three major development task areas: facilities, technology and test program. Test program development comprises three sub-areas: vehicle testing, ways and structures testing and track geometry measurement. The objective of the SOAC program is to demonstrate the current state of the art in rail rapid transit vehicle technology, with passenger convenience and operating efficiency as primary goals. The objectives of the Engineering Test program are to provide a set of SOAC engineering data and to further develop the methodology for providing transit vehicle comparisons. These objectives were met with the presentation of the test results in this report and the incorporation of the refinement of the testing methodology into the General Vehicle Test Plan, GSP-064. In this series, Vol. I contains a description of the SOAC test program and vehicle, and a summary of the test results; Vol. II, Performance Test data; Vol. III, Ride Quality Test data; Vol. IV, Noise Test data; Vol. V, Structural, Voltage, and Radio Frequency Interference Test data; and Vol. VI, a description of the Instrumentation System used for performance, ride quality and structural testing.					
17. Key Words Rail Transit Vehicle Testing			18. Distribution Statement DOCUMENT IS AVAILABLE TO THE PUBLIC THROUGH THE NATIONAL TECHNICAL INFORMATION SERVICE, SPRINGFIELD, VIRGINIA 22161		
19. Security Classif. (of this report) Unclassified		20. Security Classif. (of this page) Unclassified		21. No. of Pages 88	22. Price Vol.V: \$4.75 Set: \$28.00

01754

TF
455
.S63
v.5
c.1

PREFACE

This test report, presenting the results of engineering tests on the State-of-the-Art Cars (SOAC), derives from the efforts of two agencies of the U.S. Department of Transportation: the Rail Programs Branch of the Urban Mass Transportation Administration's Office of Research and Development and the Transportation Systems Center.

The report is presented in six volumes. Volume I is a description of the program and a summary of the test results. Volumes II through V are organized to technical disciplines as follows: Volume II, Performance; Volume III, Ride Quality; Volume IV, Noise; and this volume, Volume V, Structures, Voltage, and Radio Frequency Interference. Volume VI contains a description of the SOAC Instrumentation System used for Performance, Ride Quality, and Structural Testing.

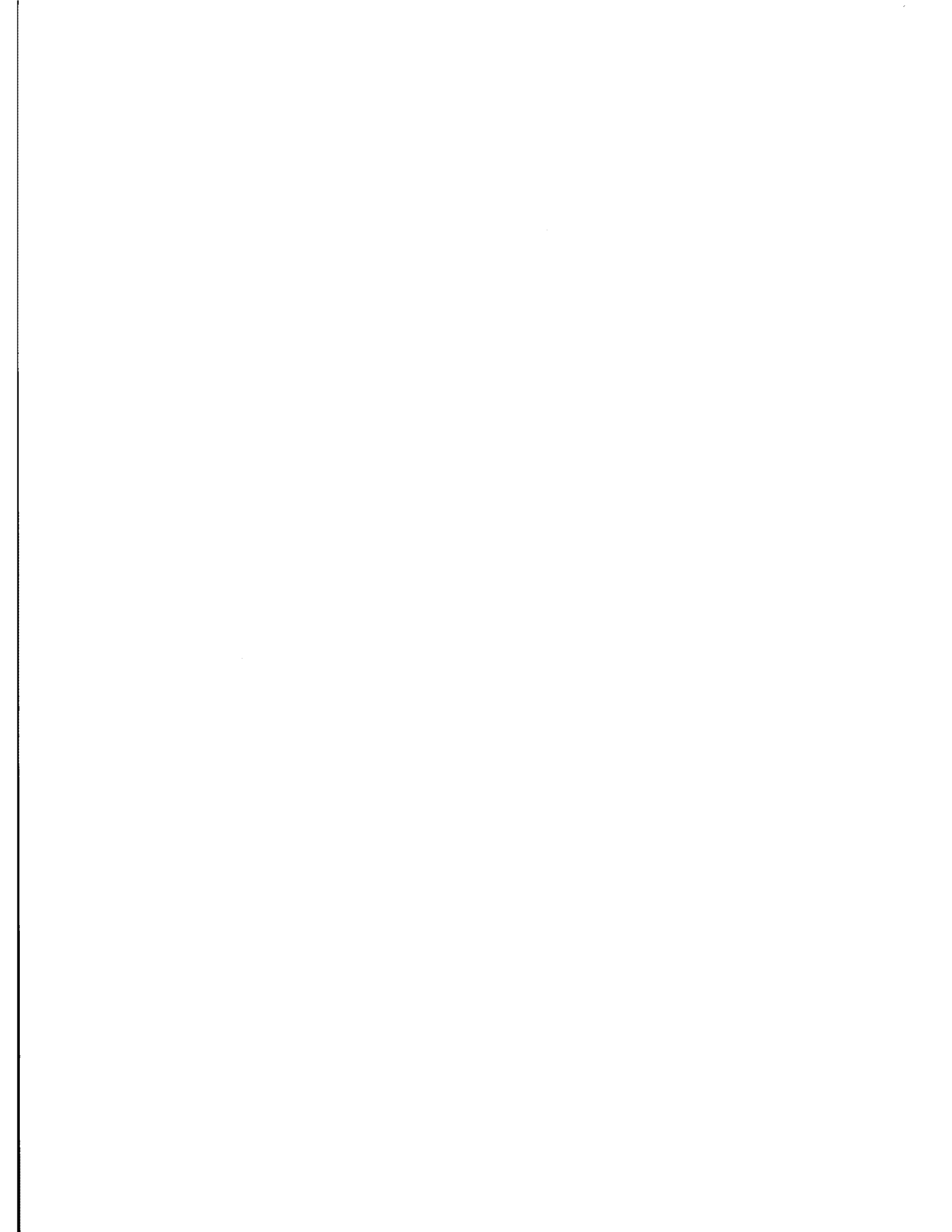

TABLE OF CONTENTS

<u>Section</u>		<u>Page</u>
1	STRUCTURE	1-1
	1.1 Summary	1-1
	1.2 Test Description	1-1
	1.3 Instrumentation	1-5
	1.4 Test Procedures	1-6
	1.5 Test Data and Analysis	1-7
2	VOLTAGE TRANSIENTS AND SPIKES	2-1
	2.1 Summary	2-1
	2.2 Test Description	2-2
	2.3 Instrumentation	2-2
	2.4 Test Procedures	2-3
	2.4.1 General	2-3
	2.4.2 Detailed Procedures	2-3
	2.5 Test Data	2-6
	2.5.1 Photographic Data	2-6
	2.5.2 Interpretation of Voltage Transients and Spikes	2-14
3	RADIO FREQUENCY INTERFERENCE	3-1
	3.1 Summary	3-1
	3.2 Test Description	3-2
	3.3 Instrumentation	3-2
	3.4 Test Procedures	3-3
	3.5 Data	3-5
APPENDIX	: DATA ACQUISITION SYSTEM FOR VOLTAGE TRANSIENTS AND SPIKES	A-1
REFERENCES	R-1

LIST OF ILLUSTRATIONS

<u>Figure</u>		<u>Page</u>
1-1	SOAC Truck Assembly	1-4
1-2	Sample Data Record	1-8
1-3	Upper Truck Frame Strain Levels as a Function of Track Sections	1-10
1-4	Forward Axle Right-Hand Chevron Vertical Displacement as a Function of Speed	1-11
1-5	Forward Axle Right-Hand Chevron Lateral Displacement as a Function of Speed	1-12
1-6	Upper Truck Frame Strain Levels as a Function of Speed	1-13
1-7	Forward Axle Right-Hand Chevron Vertical Displacement as a Function of Weight	1-14
1-8	Forward Axle Right-Hand Chevron Lateral Displacement as a Function of Weight	1-15
1-9	Upper Truck Frame Strain Levels as a Function of Weight	1-16
2-1	North Rail Gap Transient	2-7
2-2	Representative Transients in North Turn	2-7
2-3	Noise Near Locomotive Generator	2-8
2-4	Acceleration Observations on West Side of Track	2-8
2-5	Gradual Decrease in Power on South Side of Track	2-9
2-6	Observations in the South Switch Area	2-9
2-7	Representative Transients (Instrumented Car Being Pulled)	2-10
2-8	Minor Decrease of Power (Instrumented Car Pulling)	2-10

<u>Figure</u>		<u>Page</u>
2-9	Observations at the South Rail Gap (Instrumented Car Pulling)	2-11
2-10	Train Passing South Rail Gap (Trackside Measurement)	2-11
2-11	Representative Transient During an Observed Arc (Trackside Measurement)	2-12
2-12	Train Passing Instrumentation Unit at 80 MPH (Trackside Measurement).	2-12
2-13	Train Located Outside Instrumented Track Section (Trackside Measurement)	2-13
2-14	Transient Events, Maximum Amplitude (Observed) Duration Distribution (All Conditions; Instru- mentation on Board; 5481.0-Second Test Duration)	2-15
2-15	Transient Events, Maximum Amplitude (Observed) Duration Distribution (All Conditions; Instru- mentation Trackside; 1050.0-Second Test Duration)	2-16
2-16	Transient Events, Maximum Amplitude (Observed) Duration Distribution (Morning Run; Both Cars Energized; 2384.5-Second Test Duration)	2-17
2-17	Transient Events, Maximum Amplitude (Observed) Duration Distribution (Morning Run; Instrumented Car Pulling; 1729.5-Second Test Duration)	2-18
2-18	Transient Events, Maximum Amplitude (Observed) Duration Distribution (Morning Run; Instrumented Car Being Pulled; 1367.0-Second Test Duration)	2-19
2-19	Transient Events, Maximum Amplitude (Observed) Duration Distribution (Afternoon Trackside Run; Car in Area or Passing Test Site; 769.5-Second Test Duration)	2-20
2-20	Transient Events, Maximum Amplitude (Observed) Duration Distribution (Afternoon Trackside Run; Car Out of Area; 280.5-Second Test Duration)	2-21
2-21	Spike Voltage (Observed) Distribution (Morning Total Envelope; 5481.0-Second Test Duration)	2-22
2-22	Spike Voltage (Observed) Distribution (After- noon Total Envelope; Trackside Results; 1050.0- Second Test Duration)	2-23

<u>Figure</u>		<u>Page</u>
2-23	Spike Voltage (Observed) Distribution (Both Cars Pulling; 2384.5-Second Test Duration) . . .	2-24
2-24	Spike Voltage (Observed) Distribution (Instrumented Car Pulling; 1729.5-Second Test Duration)	2-25
2-25	Spike Voltage (Observed) Distribution (Instrumented Car Being Pulled; 1367.0-Second Test Duration)	2-27
2-26	Spike Voltage (Observed) Distribution (Track-side; Car in Area or Passing; 769.5-Second Test Duration)	2-28
2-27	Spike Voltage (Observed) Distribution (Track-side; Car Out of Area; 280.5-Second Test Duration).	2-29
2-28	Probability Density of Line Voltage (Experimental)	2-30
3-1	Electromagnetic Field Test Data	3-7
A-1	General Block Diagram for Rapid Transient Recording System Voltage Transients and Spikes .	A-2
A-2	Transient and Spike Input Probe Circuit	A-3
A-3	Spike Probe and Cable Response	A-4
A-4	Spike Probe and Cable Response	A-4
A-5	Transient Signal Amplifier "A" Circuit	A-6
A-6	Transient Signal Amplifiers "B" and "C"	A-7
A-7	Transient Signal Amplifier "D" Circuit	A-8
A-8	Transient Unit Signal Response	A-9
A-9	Spike Voltage Detector Circuit	A-12
A-10	Wide Band Spike Amplifier Circuit	A-13
A-11	Spike Probe, Cable and Amplifier Response . . .	A-14
A-12	General Flow Chart for "SUBWAY 1" Program (Main Computer Analysis Program)	A-16

<u>Figure</u>		<u>Page</u>
A-13	General Flow Chart for "SUBWAY 2" Computer Program	A-17
A-14	Application of the Transient Algorithm to a Simulated Transient Event	A-19

LIST OF TABLES

<u>Table</u>		<u>Page</u>
1-1	Summary of Structural Test Points	1-2
1-2	SOAC Structural Instrumentation System Test Parameters	1-5
3-1	SOAC Radiated Emission Tests (Data Sheet 1) . . .	3-4
3-2	SOAC Radiated Emission Tests (Data Sheet 2) . . .	3-6
A-1	Voltage Bands for the Transient Event Analysis .	A-10

Section 1

STRUCTURE

1.1 SUMMARY

Test Sequence

Test runs 122, 123 and 125: steel wheels
Test runs 137 and 138: resilient wheels

Test Procedure

No procedure number has yet been assigned.

Objective

To develop a methodology for structurally evaluating railcar trucks, to obtain a set of data on the SOAC, and to examine the loads being induced in the SOAC trucks.

Status

The methodology developed consists of tracing the major load paths through a railcar truck by measuring selected displacements and strain levels. The SOAC Test Car was instrumented to provide this information and the data set obtained as summarized in Table 1-1. Data has been collected at 90,000, 105,000 and 113,000 pounds at five different speeds for the six track sections on the UMTA Rail Transit Test Track.

1.2 TEST DESCRIPTION

The purpose for examining the structural integrity of railcar trucks is to determine if strain levels exist within the assembly which are significant with respect to their effect on the useful life of the component. Present technology in truck designs is based largely on static conditions; components are designed to a static set of conditions and healthy safety factors are added. Very little is known about the dynamic conditions of the completed assembly, and very little data is available on the loads induced in a railcar truck under normal operating

TABLE 1-1. SUMMARY OF STRUCTURAL TEST POINTS

Track Section	Weight (1000 lb)	Speed (mph)				
		20	35	50	60	80
I	90	x	x	x	x	x
	105	x	x	x	x	-
	113	x	x	x	x	x
II	90	x	x	x	x	x
	105	x	x	x	x	x
	113	x	x	x	x	x
III	90	x	x	x	x	x
	105	x	x	x	x	x
	113	x	x	x	x	x
IV	90	x	x	x	x	x
	105	x	x	x	x	x
	113	x	x	x	x	x
V	90	x	x	x	x	x
	105	x	x	x	x	x
	113	x	x	x	x	-
VI	90	x	x	x	x	x
	105	x	x	x	x	x
	113	x	x	x	x	x
North Gap Switch	90	-	-	-	-	-
	105	x	x	-	-	x
	113	-	-	-	-	-
Army Depot Switch	90	-	-	-	-	-
	105	x	x	-	-	x
	113	-	-	-	-	-

conditions. A description of this loading is required to predict the useful life of the system and to determine the operating design safety margins.

On the running rail interface side, loads are induced into the SOAC trucks from the axles through the chevrons (① on Figure 1-1). These are determinable by measuring the deflections of the chevrons while the vehicle is operating. The deflections may be converted to loads through a statically determined relationship of deflection as load characteristic for the chevron. For the SOAC chevrons this is a temperature dependent linear relationship of 7500 pounds per inch. (See Reference 1.) During the SOAC testing, the chevron temperature was monitored to assure that it remained within a tolerance band which validated the above relationship.

On the carbody interface side, loads are induced into the SOAC truck assembly through the airsprings, the damper assemblies, and the bolster anchor rods. Main loads are induced through the airsprings. The static loads are determined by the vehicle weight. This can be converted to air pressure in the airspring. Changes in airspring volume, which occur only by vertical deflections, reflect changes in pressure and therefore, load changes. The loads induced through the airspring are determinable by measuring the airspring deflections.

The damper assemblies function is to dampen the rate of change of loads between the trucks and the carbody. The damper rod connecting link (② on Figure 1-1) is a convenient path and was instrumented for the SOAC tests. The two vertical and two lateral connecting links were strain gaged and calibrated at the Garrett-AiResearch facility.

Longitudinal forces are induced into the truck by the vehicle acceleration, through the axles and through the Bolster Anchor Rod Assemblies. The SOAC Bolster Anchor Rod Assembly is a rod and tube assembly and does not lend itself to instrumentation by strain gaging. The method used was a deflection measurement which could be correlated to longitudinal acceleration to determine load. This correlation need be done only once at a known vehicle weight.

In addition to sensing the loads induced into the truck assembly two points were selected to monitor the loads within the truck frame. Static load tests completed during the SOAC design cycle defined the load paths within the truck frame. (See Reference 1.) Two of the highest stress level locations were selected to be monitored

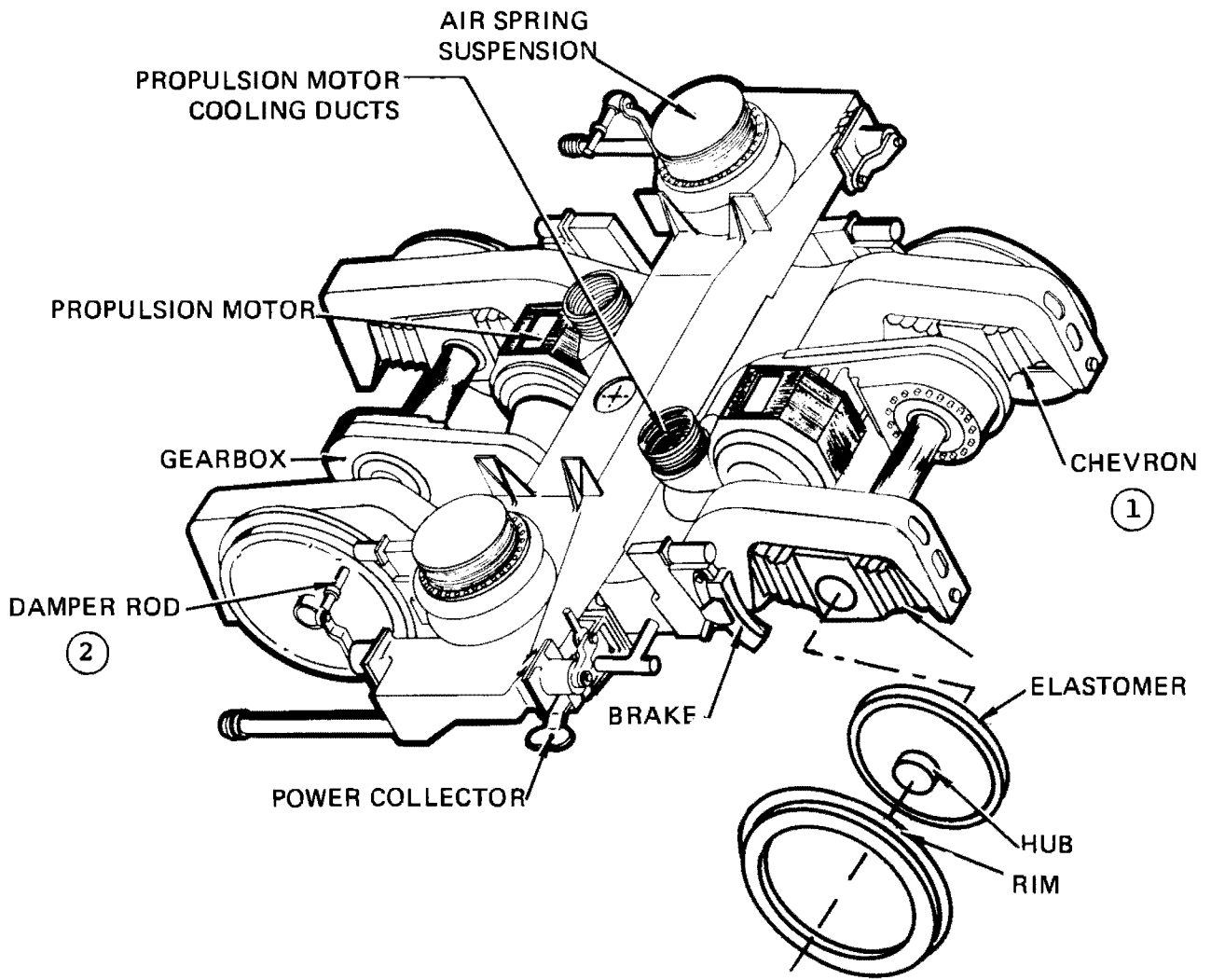

Figure 1-1. SOAC Truck Assembly

during this test. These locations were strain gaged and AC coupled in order that only the alternating loads could be examined.

1.3 INSTRUMENTATION

The complete description of the SOAC Structural Instrumentation system is described in Volume VI of this report. Table 1-2 is the structural parameter list.

In the initial specification for the SOAC Instrumentation system, the displacement measurements were to be accomplished by linear variable differential transformers. These sensors provide a linear voltage signal versus displacement. However, the delivery times for these items were not compatible with the delivery schedule of the instrumentation system and linear potentiometers were selected as an alternate system. This system is the standard method used in the industry and has proven adequate for measurement of displacement on a per test basis. The delicate nature of the sensors, however, has caused the loss of some data points. The evaluation of this technique of displacement measurement over an extended time period remains to be determined.

TABLE 1-2. SOAC STRUCTURAL INSTRUMENTATION SYSTEM TEST PARAMETERS

Channel	Parameter	Range
<u>Forward Truck</u>		
1	LH airspring vertical displacement	±1.0 in. (1)
2	RH airspring vertical displacement	±1.0 in. (1)
3	LH airspring lateral displacement	±1.0 in. (1)
4	RH airspring lateral displacement	±1.0 in. (1)
5	LH vertical damper load	±1500 lb (3)
6	RH vertical damper load	±1500 lb (3)
7	LH lateral damper load	±1500 lb (3)
8	RH lateral damper load	±1500 lb (3)
9	RH bolster anchor rod displacement	±1.0 in.
10	LH bolster anchor rod displacement	±1.0 in.
11	RH fwd chevron vertical displacement	±1.1 in. (2)
12	LH fwd chevron vertical displacement	-0.3 in.
13	RH aft chevron vertical displacement	-0.3 in.
14	LH aft chevron vertical displacement	-0.3 in.
15	RH fwd chevron lateral displacement	±1.00 in.
16	RH aft chevron lateral displacement	±1.00 in.
17	Truck frame strain gage absolute	0-10,000 psi
18	Truck frame strain gage absolute	0-10,000 psi
19	Temperature of RH fwd chevron	

TABLE 1-2. Continued

Channel	Parameter	Range
<u>Aft Truck</u>		
20	RH fwd chevron vertical displacement	±1.1 in. (2) -0.3 in.
21	RH fwd chevron lateral displacement	±1.0 in.

NOTES

- (1) Tolerance of leveling system must be added.
- 2) Estimated deflection from car empty weight. Positive deflection corresponds to an increase weight.
- (3) For calibration use ±1000 lb.

1.4 TEST PROCEDURES

- a. Ballast the car to the test weights.
- b. Calibrate the instrumentation. A constant oscillograph trace deflection at a selected standard voltage is obtained for each circuit.
- c. After the instrumentation is calibrated, the car is operated around the test track at one of the test speeds of 20, 35, 50, 60 or 80 mph. When the car is approaching the selected track section at the required speed, the tape recorders are started. The recorder event marker is used at the appropriate point. A record of 15 to 20 seconds duration is obtained.
- d. A log of the data recorded is made showing run number, speed, event marker position on the track, and the time of day.
- e. The tape recorded data is continuously played back through an oscillograph, operating at the paper speeds required to verify frequencies and amplitudes. The run number, test speed, position on the track and any deficiencies are noted on the oscillograph paper.
- f. After completion of the initial speed run the oscillograph records are reviewed and deficiencies are corrected.

- g. Steps 3 through 5 are repeated for each speed and test location listed in the test plan.
- h. The post-test calibration is performed.

1.5 TEST DATA AND ANALYSIS

The structural stress data parameters were recorded on analog tapes and played back through an oscillograph to obtain strip charts. A listing of all structural data records taken on SOAC at the HSGTC is presented in Table 1-1.

A sample data record is presented in Figure 1-2. Plots of maximum alternating stress, lateral displacement and vertical displacement versus velocity, car weight and track section are shown in Figures 1-3 through 1-9.

Figure 1-2 presents oscillograph data record strip charts showing eight channels of structural data plus longitudinal acceleration and car speed. This is a five second record (No. 1034, Run 123) at 50 mph, track station 315 (Section III) at a car weight of 113,000 lbs.

Figure 1-3 shows the maximum alternating stress measured on the forward truck upper frame for the six different track, fastener, tie and ballast combinations. Track Section III (jointed rail, wooden ties, stone ballast) produced the highest stress loads, but it should be noted that the scale is large and the significance of the difference between 850 psi and 1100 psi is considered to be negligible. This frame does, however, demonstrate the effectiveness of the strain gage instrumentation.

Figures 1-4 through 1-6 show the variation of maximum attenuating stress, chevron lateral displacement, and vertical displacement with car velocity for three different car weights. Stress generally increases with velocity (Figure 1-6) as would be expected. Both the 105,000 lb and 113,000 lb weights show a peak alternating stress at 60 mph, with the 105,000 lb weight showing the greatest response at this speed. Maximum alternating chevron displacements show a dip from 20 to 35 mph and then generally increase with speed. Figure 1-4 also shows the increased response for the 105,000 lb weight at the higher speeds, though higher at 80 mph than 60 mph.

Figures 1-7 through 1-9 show the same three parameters plotted versus car weight for speeds of 35, 50 and 80 mph. Figure 1-7 shows maximum alternating vertical chevron displacements peaking at 105,000 lbs for all three speeds. Figure 1-8 shows the lateral chevron displacements

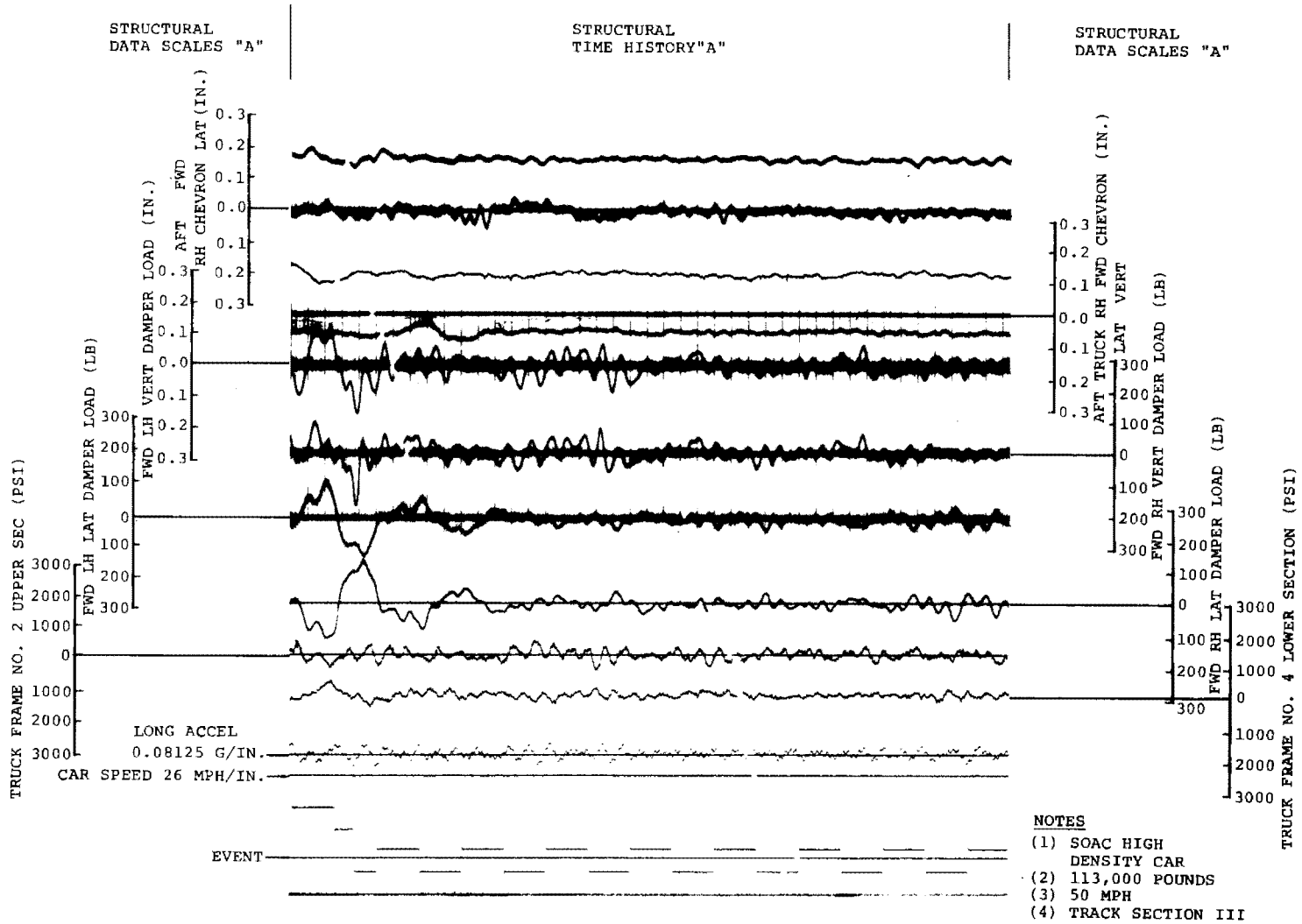

Figure 1-2. Sample Data Record (Sheet 1 of 2)

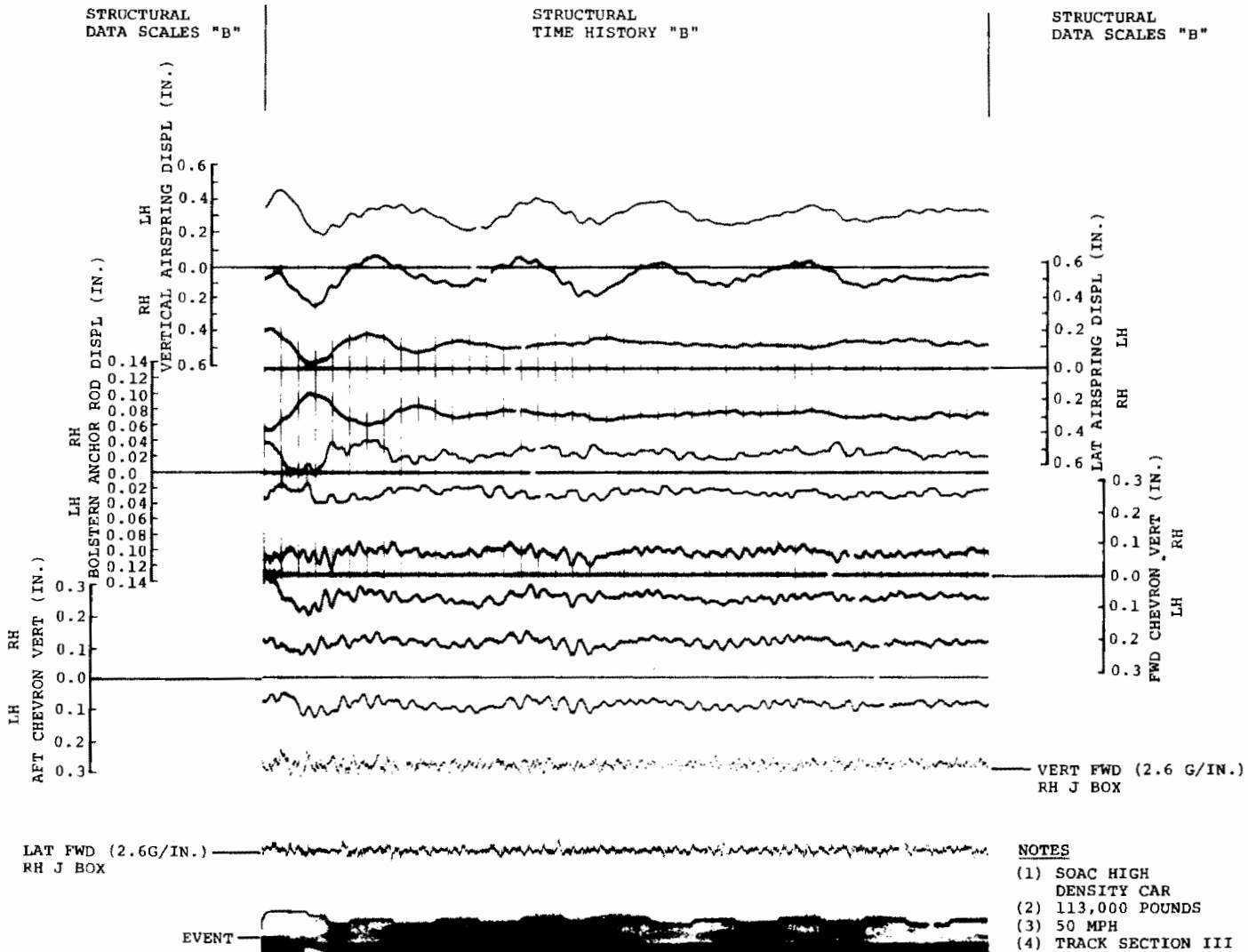

Figure 1-2. Sample Data Record (Sheet 2 of 2)

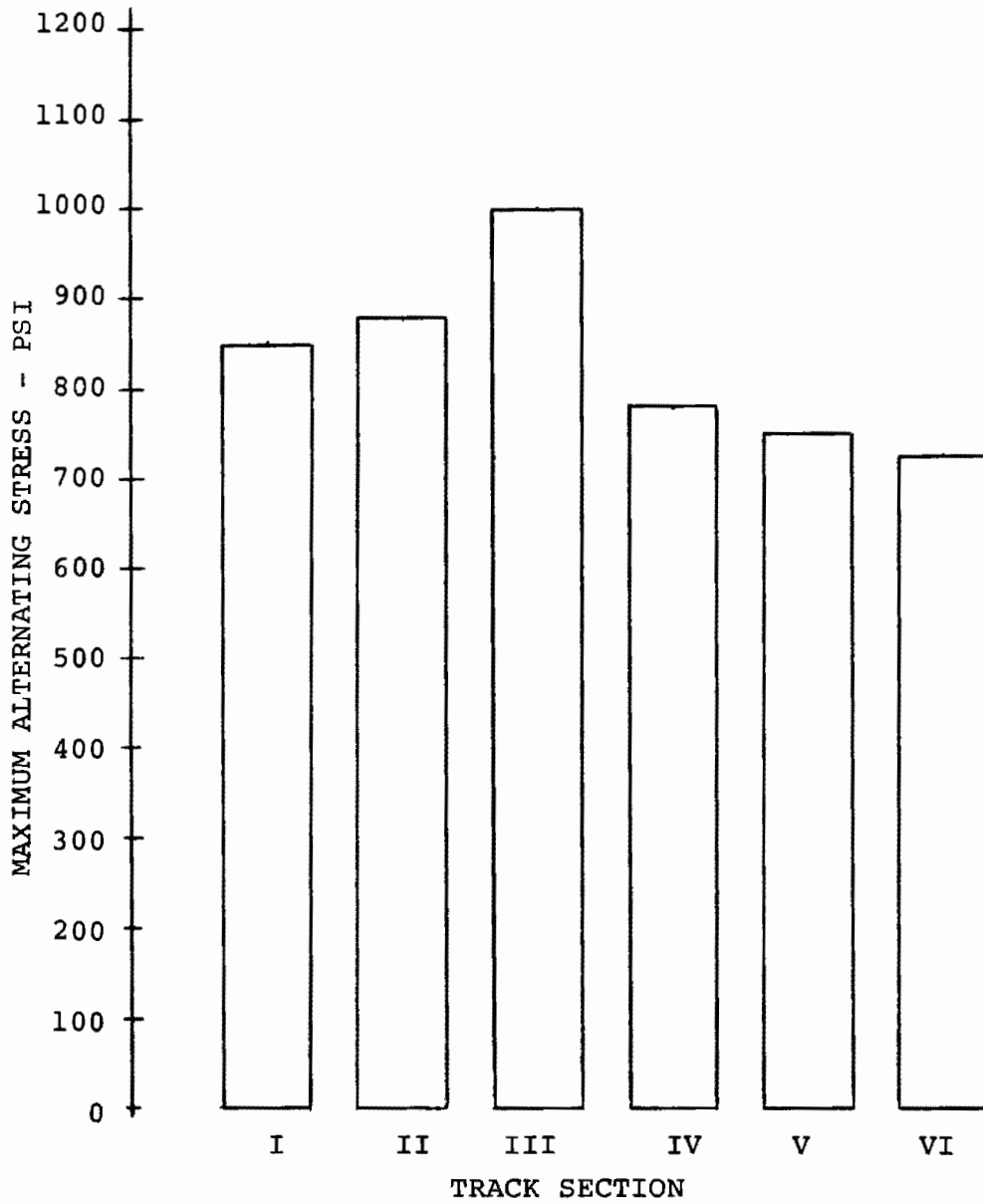

Figure 1-3. Upper Truck Frame Strain Levels as a Function of Track Sections

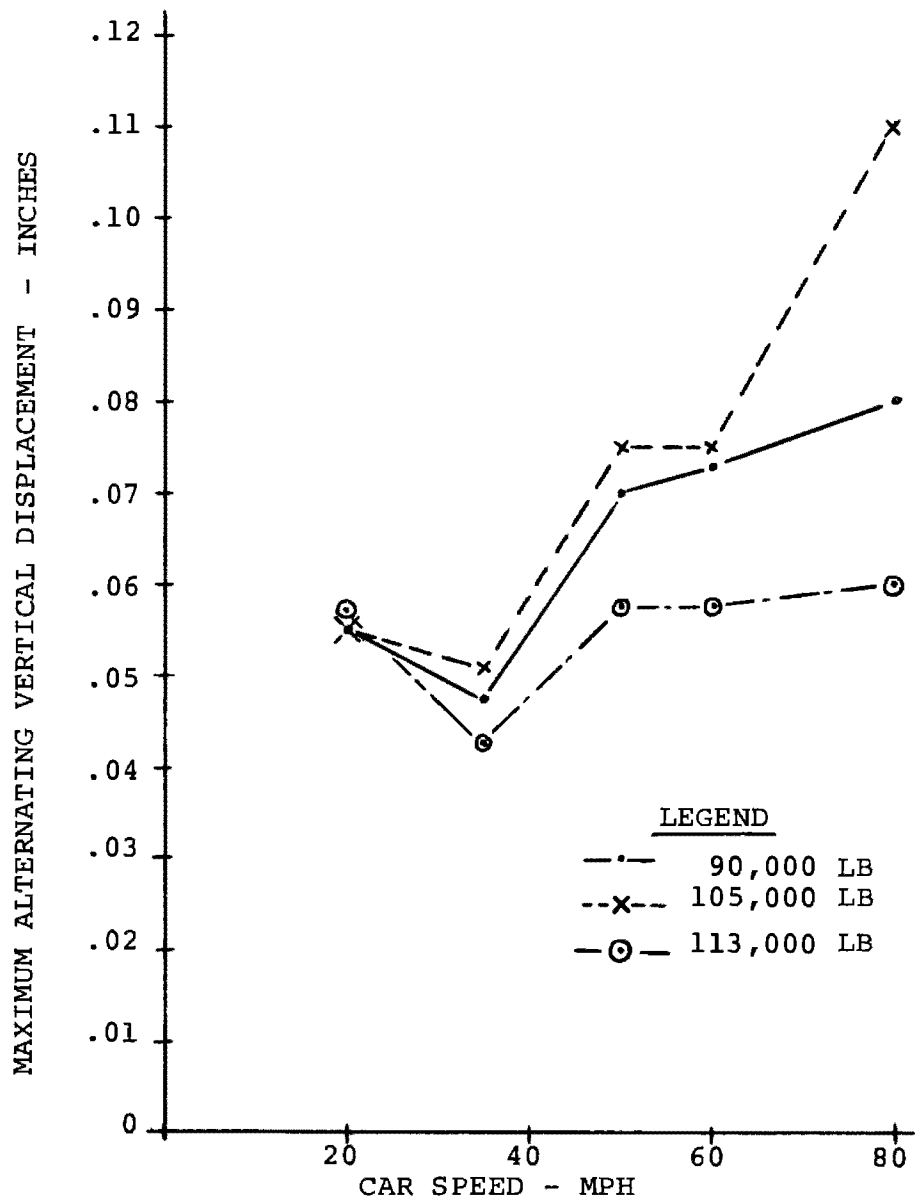

Figure 1-4. Forward Axle Right-Hand Chevron Vertical Displacement as a Function of Speed

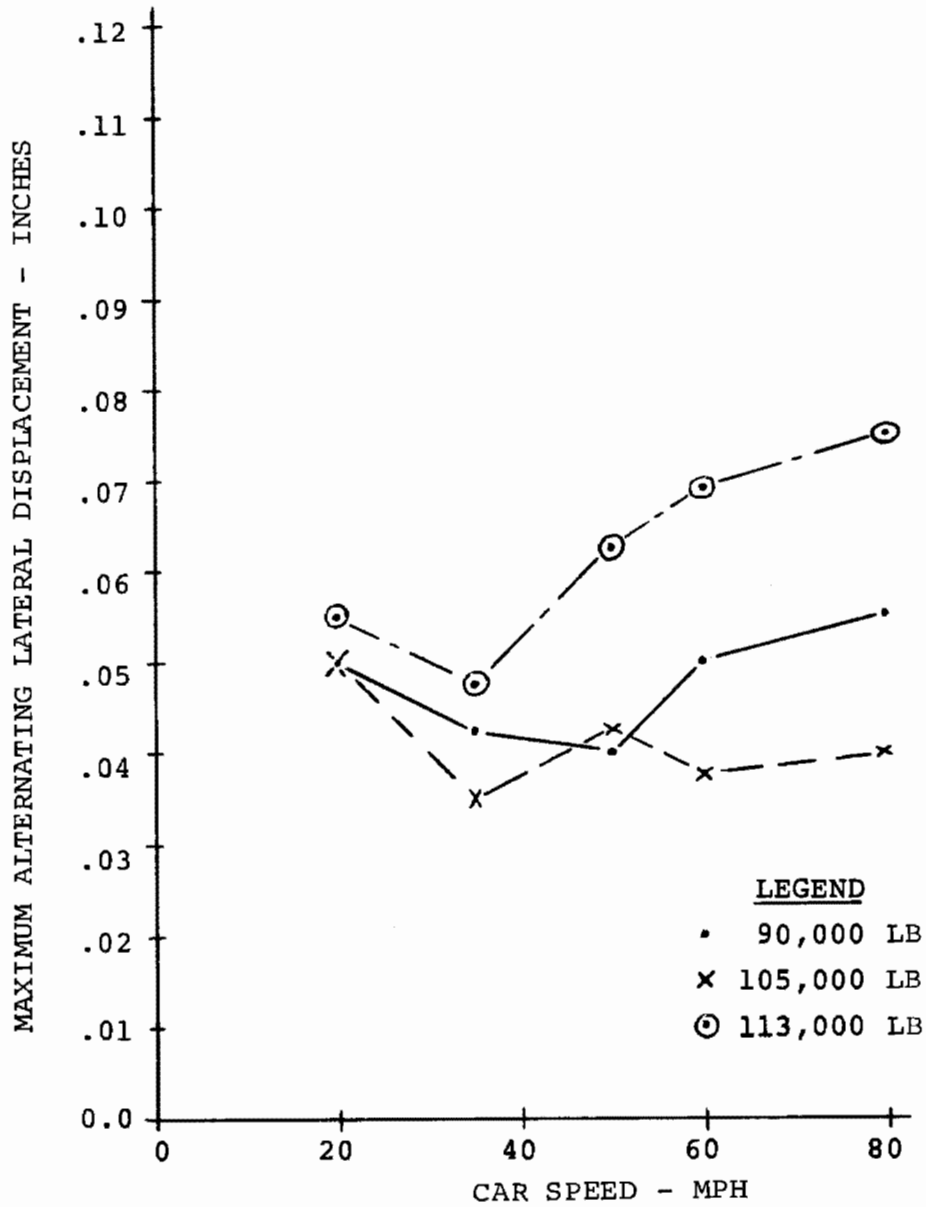

Figure 1-5. Forward Axle Right-Hand Chevron Lateral Displacement as a Function of Speed

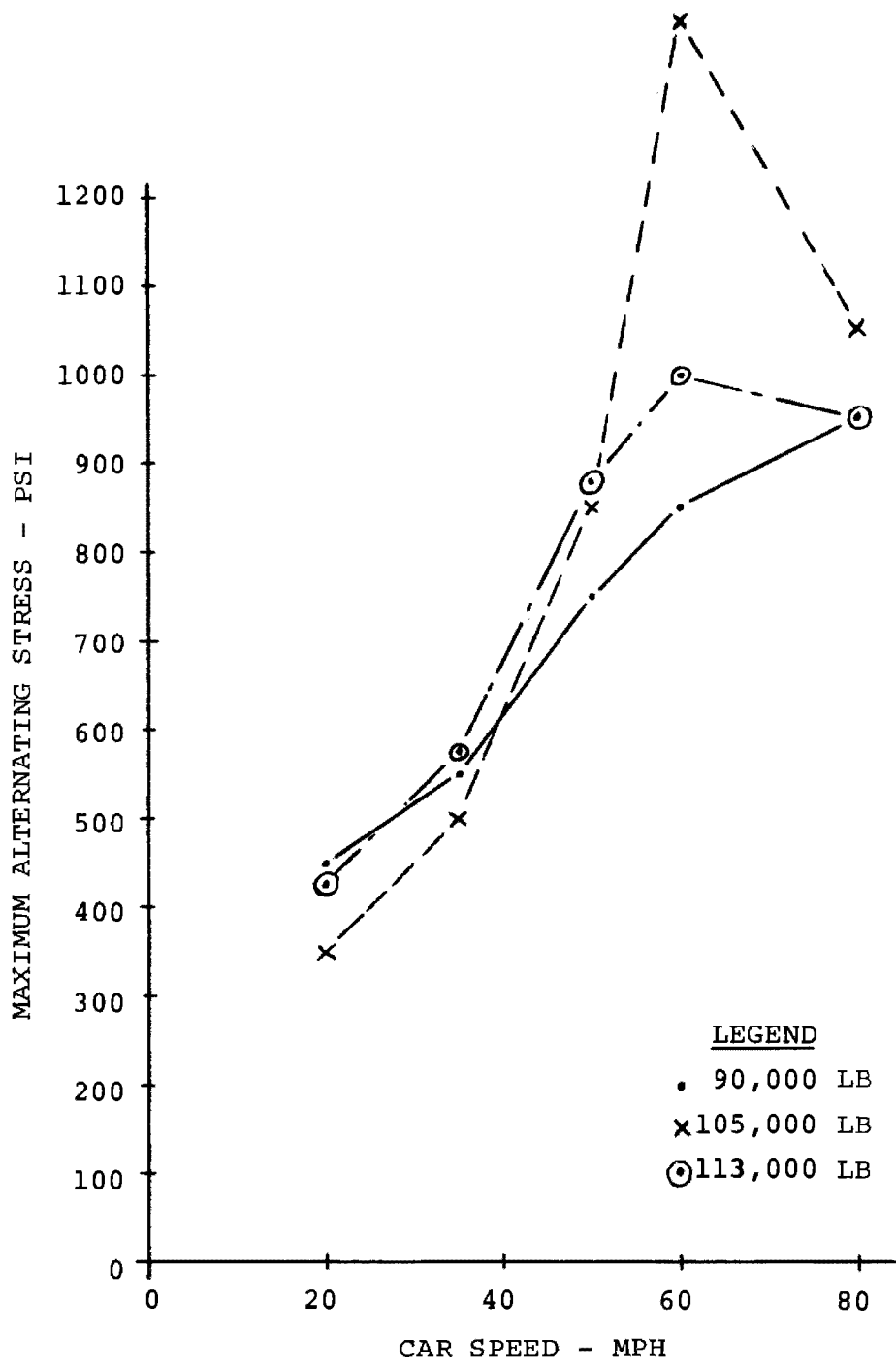

Figure 1-6. Upper Truck Frame Strain Levels as a Function of Speed

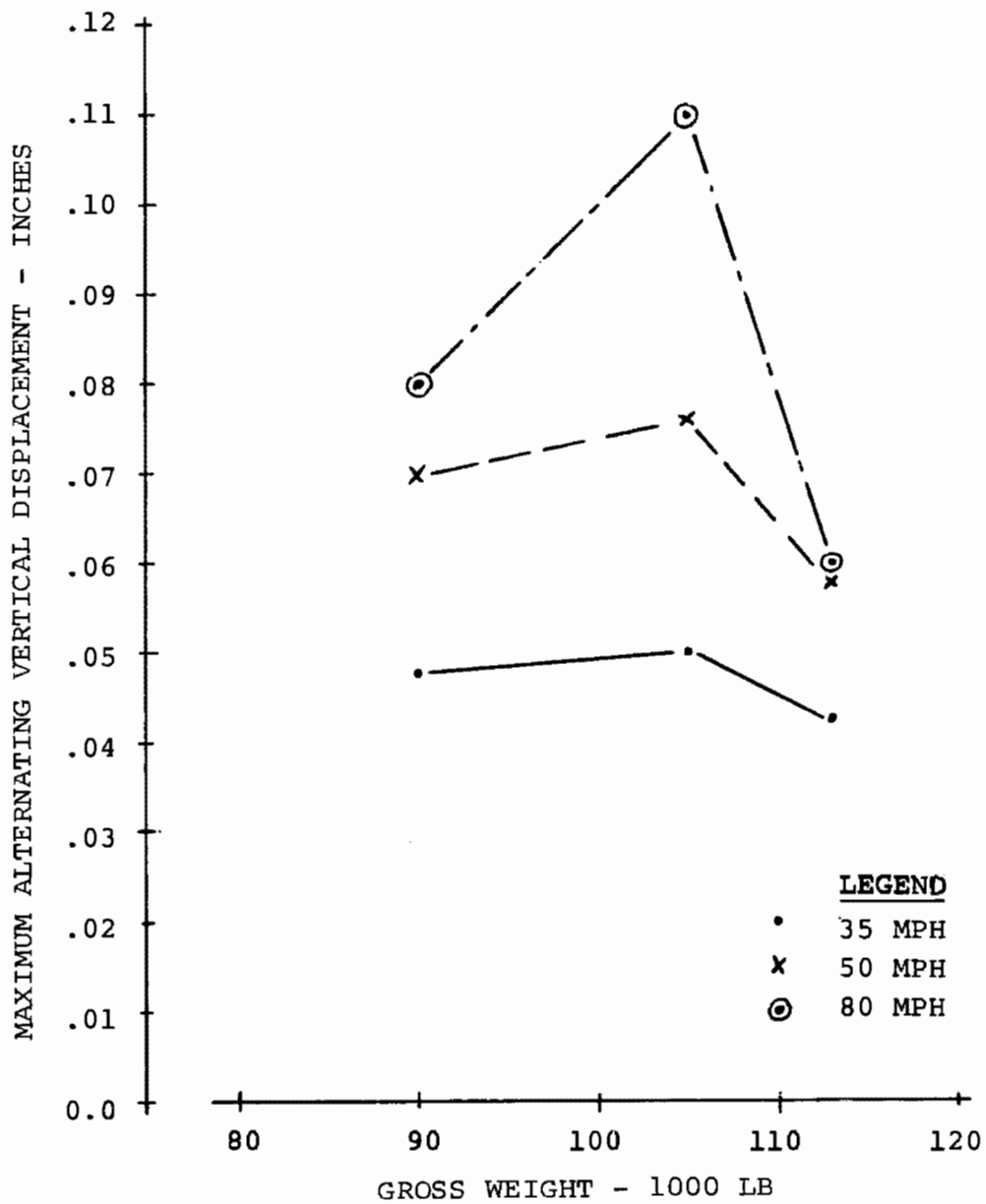

Figure 1-7. Forward Axle Right-Hand Chevron Vertical Displacement as a Function of Weight

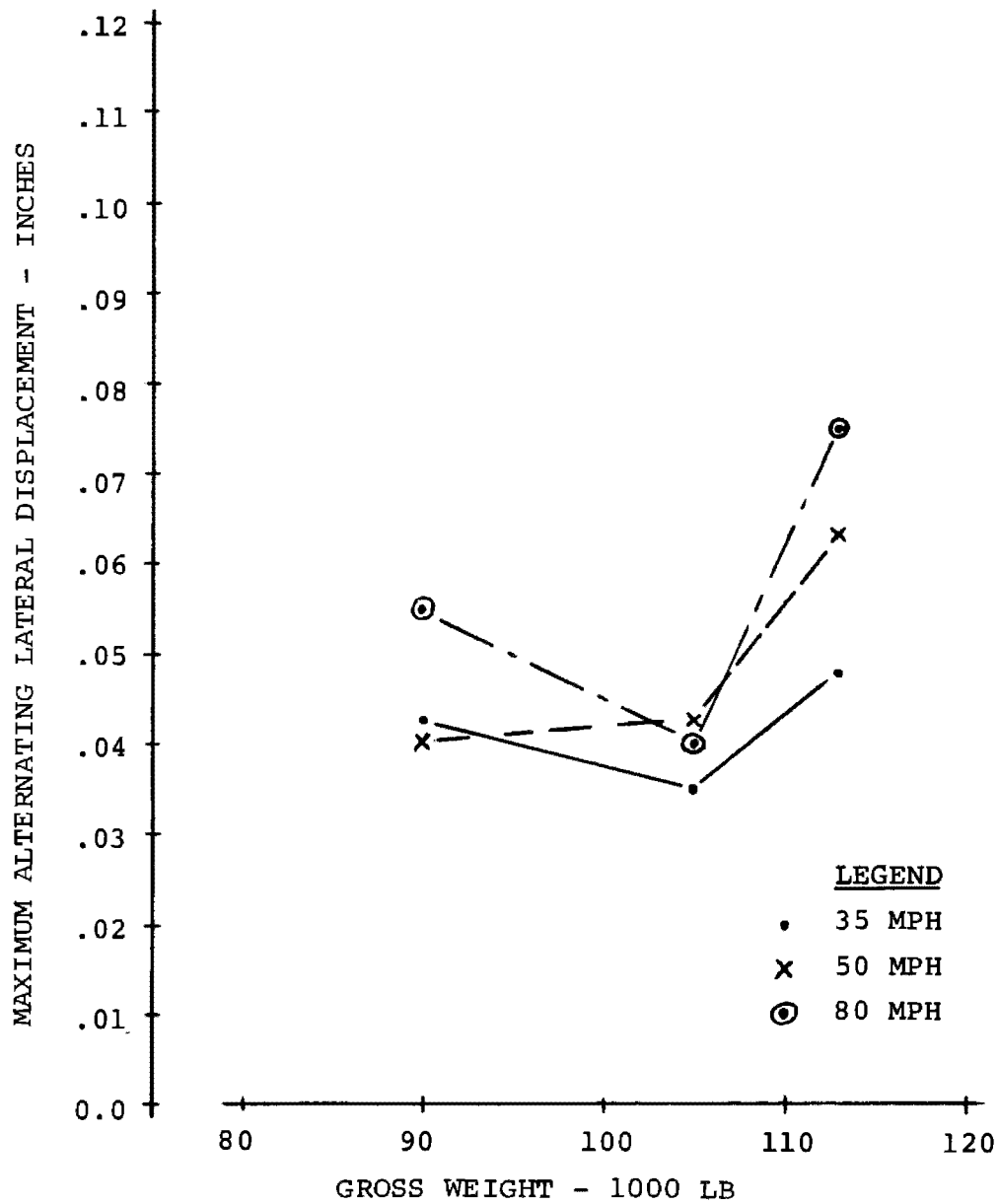

Figure 1-8. Forward Axle Right-Hand Chevron Lateral Displacement as a Function of Weight

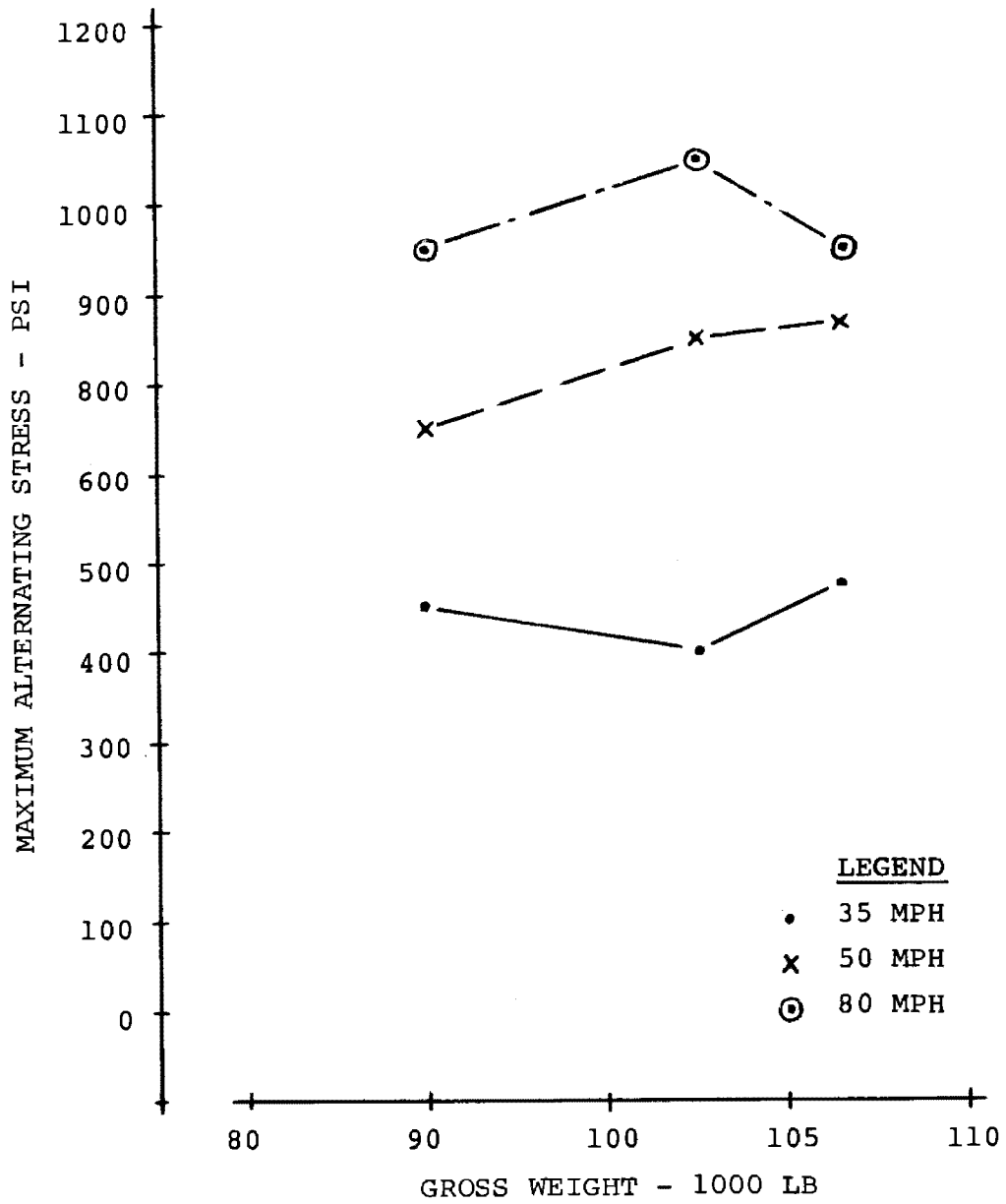
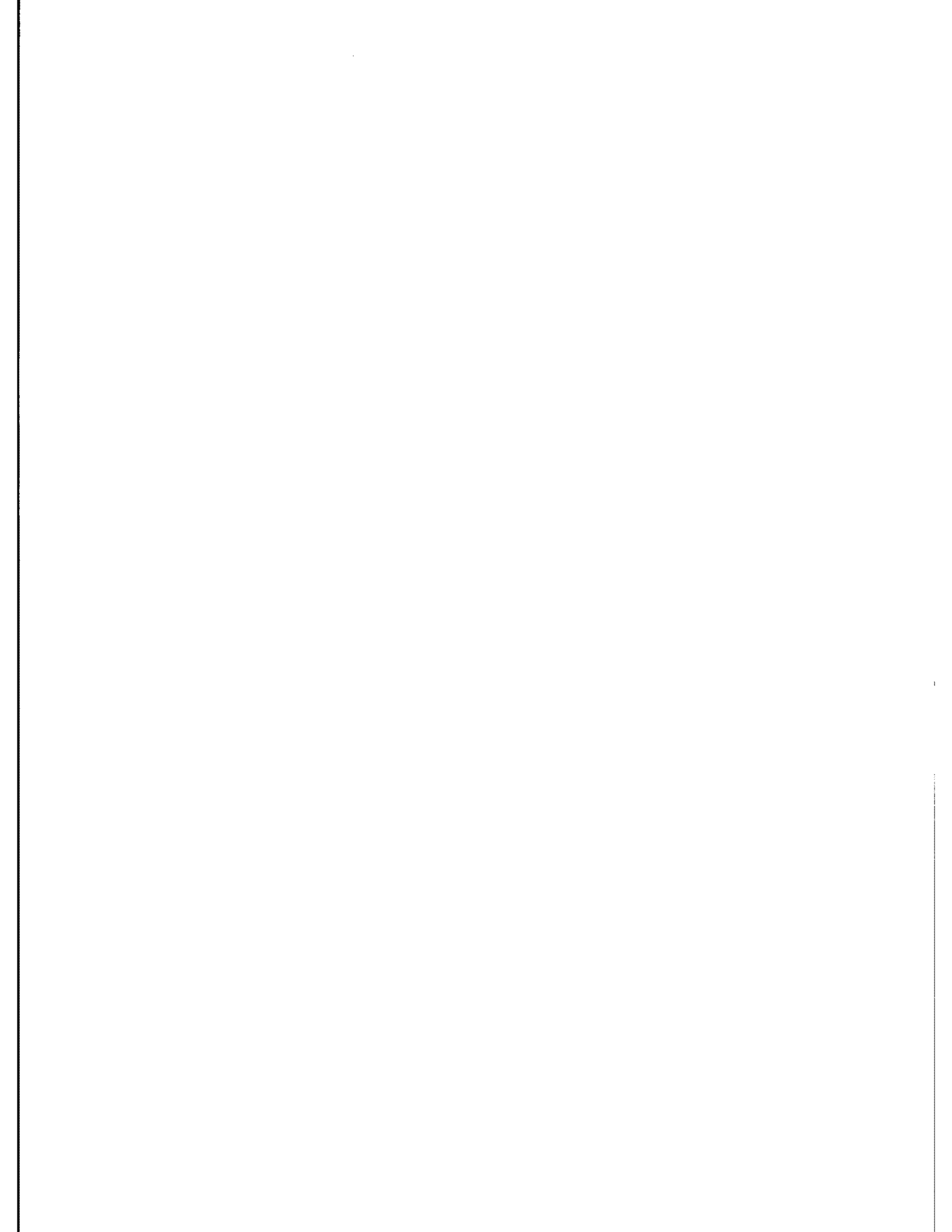

Figure 1-9. Upper Truck Frame Strain Levels as a Function of Weight

to be just the opposite of the vertical, reaching their minimum at 105,000 lbs and maximum at 113,000 lbs. Figure 1-9 shows very little gross weight effect on maximum alternating truck frame stress. The increased stress levels at 105,000 lbs are noticed here only slightly at 80 mph because the 60 mph condition is not plotted.



Section 2

VOLTAGE TRANSIENTS AND SPIKES

2.1 SUMMARY

Test Sequence

Testing was complete on April 18, 1973.

Test Procedures

No baseline procedure number has yet been assigned.

Objective

The purpose of this test was to obtain voltage transient and spike data on the SOAC vehicle while at the HSGTC in order to determine SOAC characteristics.

Status

The measurements and data reduction have been completed. The results of the transient and spike analysis are significantly affected by the relatively high positive spike noise of the locomotive power generator and the short rail gaps at the Pueblo test site. No long duration rail gap transients (where voltage applied to the car decreases to zero) or negative spikes were observed. Also, all positive spikes measured did not exceed +1600 volts. This is in contradistinction to the results of the transit property tests as described in Reference 2, where higher positive and negative voltage spikes were observed. It is believed that the reason for these significant differences is to be found in the different nature of the power supply, power distribution and car equipment of the Pueblo Test Site, compared to the nature of the previously investigated installations.

Unless stated otherwise, the theoretical aspects and basic test methods as outlined in Reference 2 continue to apply.

2.2 TEST DESCRIPTION

Tests were performed at the High Speed Ground Test Facility of the Department of Transportation near Pueblo, Colorado, as an extension of the previous Field Investigation of Voltage Transients and Spikes in 6000 vdc Subway Systems (Reference 2). These tests were conducted on a two-car train consisting of SOAC cars. The tests were performed on April 17, 1973.

2.3 INSTRUMENTATION

The instrumentation equipment installed was identical with one previously used and is described in Appendix A. It was installed in one car, hereafter, called the Instrumentation Car. The current measurement unit was installed such that a positive car current was indicated by a negative voltage supplied to the Ampex AR 200 analog recording system. The spike voltage levels for the spike voltage detection were set for the following voltages:

- +800, +1000, +1300, +1900, +2200, +2500
- -700, -1000, -1300, -1600, -2200, -2500

The analog data tapes were reproduced at University of Missouri-Columbia, Department of Electrical Engineering, by a Bell & Howell Model V3360 Tape Unit supplied by Rental Electronic Inc. Analog to Digital conversion (ADC) was performed using the UMC Systems Engineering Laboratories (SEL) 840 a process control computer. The resulting digital data tapes were further processed by the University of Missouri-Columbia Computer Network IBM 370-165 computer.

The computer programs used were the same as described in Reference 2 except that the following changes were made:

- The digital tape read routine was changed to use standard FORTRAN statements.
- A subroutine RSHIFT was written to translate data recorded by an Ampex Analog Recorder and reproduced by a standard IRIG Analog tape unit.
- A routine was added to determine a line voltage estimate for each record segment.
- A correction routine was added to partially compensate for a current polarity reversal which occurred when the current reproduce system saturated. This routine would normally not be required.

2.4 TEST PROCEDURES

2.4.1 General

The tests simulated normal subway operation with respect to speed, acceleration and deceleration, and braking. The simulation schedule was supplied by Boeing and included speeds from 0 to 80 mph and acceleration and deceleration in the vicinity of the base speed of 30 mph. The car system consisted of a two-car train. The test track is described in Volume I of this report.

2.4.2 Detailed Procedures

Configuration A

- Voltage measurement instrumentation (VMI) installed on high-density car
- Low-density car powered, high-density car dead

Configuration B

- VMI installed on high-density car
- High-density car powered; low-density car dead

Configuration C

- VMI installed on high-density car
- Both cars powered

Configuration D

- VMI installed on third rail at DOT-001 location
- Two-car train, both cars powered

The following tests (I through VI) will be applied to configurations A, B, and C. Tests VII, VIII and IX will be applied to configuration D.

Test I

- a. Proceed to start of level tangent track (location 300 CW or location 340 CCW).
- b. Start recorder; provide record number.

- c. Initiate maximum acceleration and maintain setting until 80 mph is reached.
- d. Stop recorder.

Test II

- a. Proceed to starting location at 80 mph.
- b. Start recorder; provide record number.
- c. At starting location, initiate full-service brake.
- d. When vehicle stops, stop recorder.

Test III

- a. Proceed to starting location and stop.
- b. Start recorder; provide record number.
- c. Initiate maximum acceleration.
- d. When speed reaches 40 mph, rapidly initiate full-service brake.
- e. When speed reaches 20 mph, rapidly initiate full acceleration.
- f. Repeat cycle two additional times.
- g. Stop recorder.

Test IV

- a. Proceed to North Rail Gap and stop.
- b. Start recorder; provide record number.
- c. Accelerate through North Rail Gap at maximum acceleration and at or slightly above 35 mph.
- d. Stop recorder when through the gap.

Test V

- a. Proceed towards the North Rail Gap at approximately 45 mph.
- b. Start recorder, provide record number.

- c. Initiate Full-Service Brake such that the cars will pass through the gap at full dynamic brake at approximately 35 mph.
- d. When through the gap, stop recorder.

Test VI

- a. Operate the car around the transit loop at approximately 45 mph.
- b. Start recorder; provide record number.
- c. Open and reclose the main line breaker.
- d. Reset the propulsion system.
- e. Repeat cycle two times.
- f. Stop recorder.

Test VII

- a. Stop SOAC train some distance from DOT-001.
- b. Start recorder; provide record number.
- c. Initiate full acceleration, so that SOAC will pass the DOT-001 at maximum acceleration at approximately 35 to 40 mph.
- d. Maintain acceleration until well past DOT-001 location.
- e. Stop recorder.
- f. Stop vehicle

Test VIII

- a. Maintain a speed approximately 45-50 mph until near DOT-001 location.
- b. Start recorder; provide record number.
- c. Initiate full-service brake such that the SOAC train will pass DOT-001 at maximum dynamic brake at approximately 35 mph.
- d. When well past DOT-001 or at full stop, stop recorder.

Test IX

- a. Approach DOT-001 location at 80 mph.
- b. Start recorder; provide record number 1.
- c. Maintain 80 mph for a full loop of the transit track.
- d. Provide event marks for VMI recorder based on SOAC location and record on the subsequent page.

2.5 TEST DATA

2.5.1 Photographic Data

Photographs showing typical events (Figures 2-1 through 2-13) were taken from the analog tapes.

Figures 2-1 through 2-6 apply to tests with both cars of the two-car train energized.

Figure 2-7 shows an oscillogram with the instrumentation car being pulled by the other car. In Figures 2-8 and 2-9 only the instrumentation car is being energized, with the other car being pushed. Figures 2-9 through 2-13 apply to trackside measurements. The trackside measurements were taken approximately 0.5 mile north of the locomotive and station area in an attempt to eliminate the line voltage noise associated with the locomotive power supply. However, considerable noise still appears in these pictures.

Figure 2-9 shows the same track locations as Figure 6 except that only the instrumentation car is energized. The polarity reversal of the reproduced current signal is faintly observable below the voltage trace.

Figure 2-10 shows a trackside voltage measurement was possible at this location. The voltage signal shows some switching transients and the noise voltage from the locomotive.

Figure 2-11 shows the trackside voltage measurement during an arcing condition with the cars about 0.5 mile north of the measurement point.

Figure 2-12 shows the trackside voltage as the cars pass the measurement point at 80 mph.

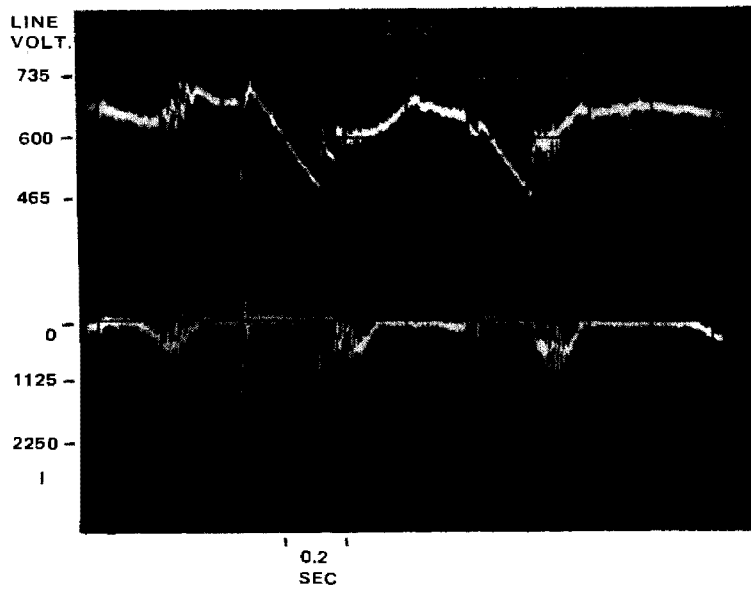

Figure 2-1. North Rail Gap Transient

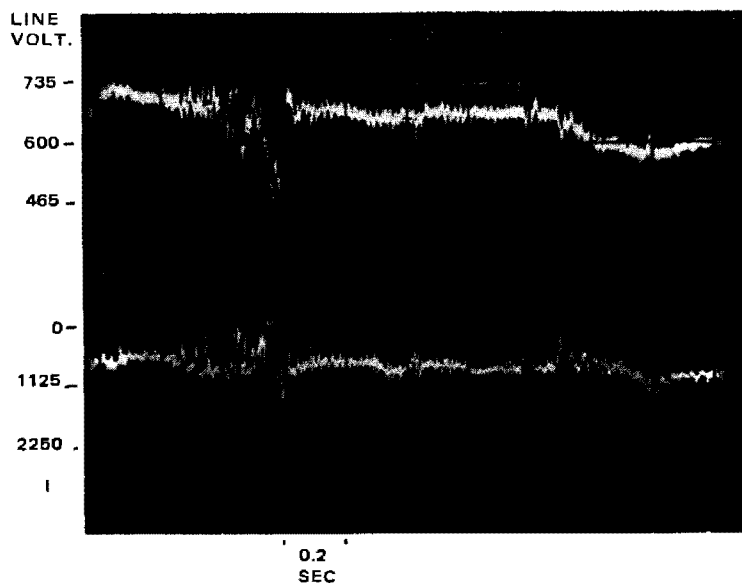

Figure 2-2. Representative Transients in North Turn

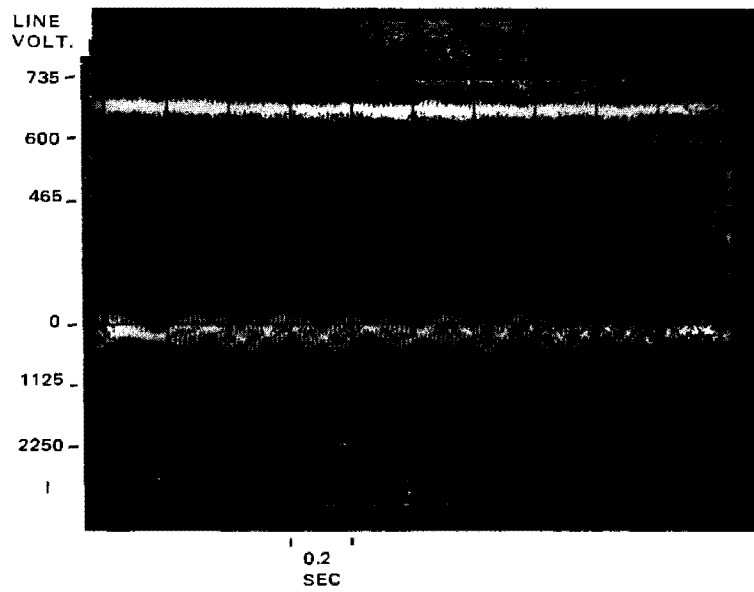

Figure 2-3. Noise Near Locomotive Generator

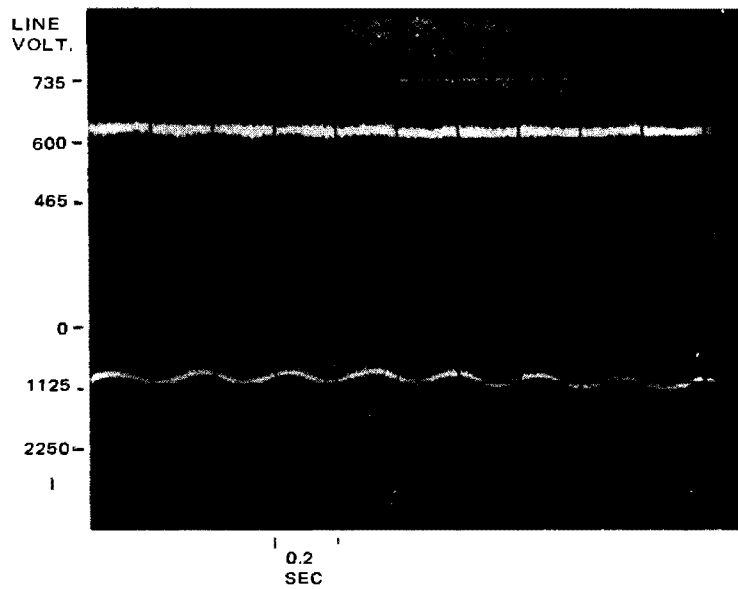

Figure 2-4. Acceleration Observations on West Side of Track

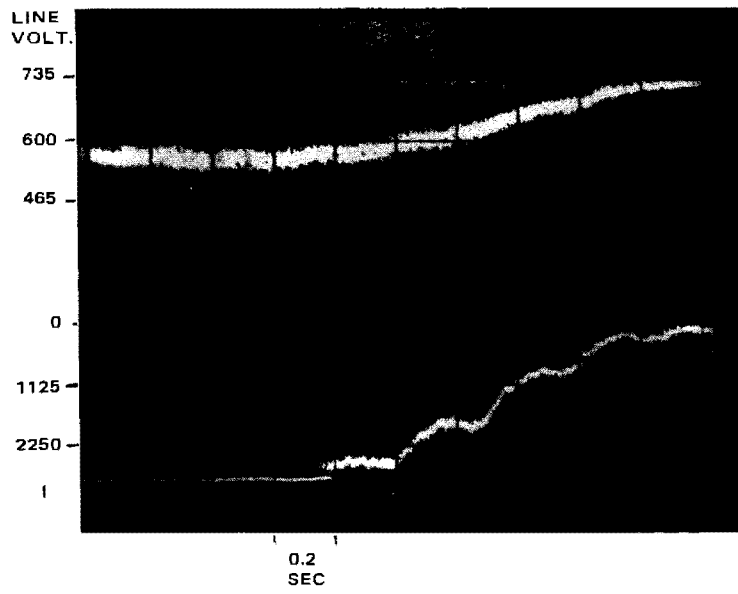

Figure 2-5. Gradual Decrease in Power on South Side of Track

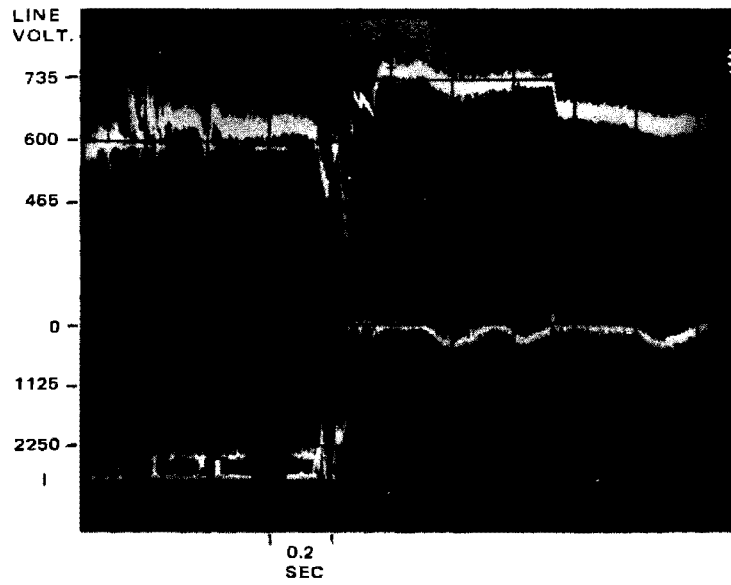

Figure 2-6. Observations in the South Switch Area

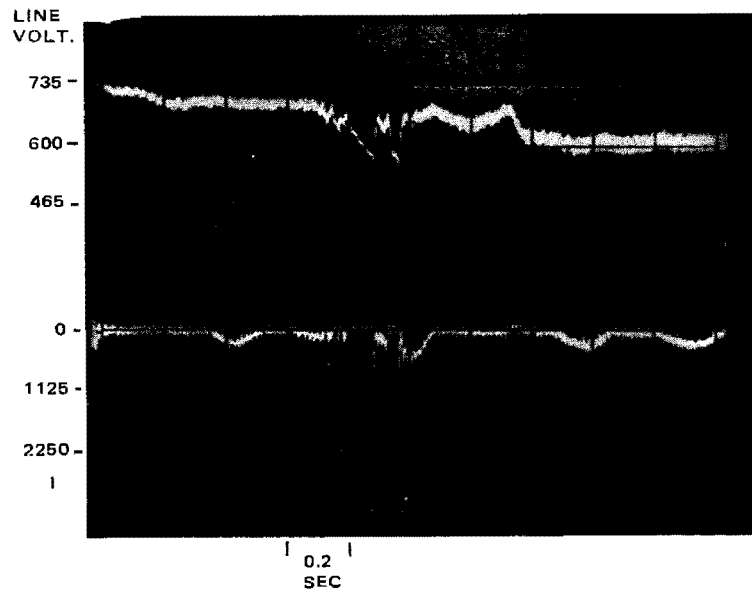

Figure 2-7. Representative Transients (Instrumented Car Being Pulled)

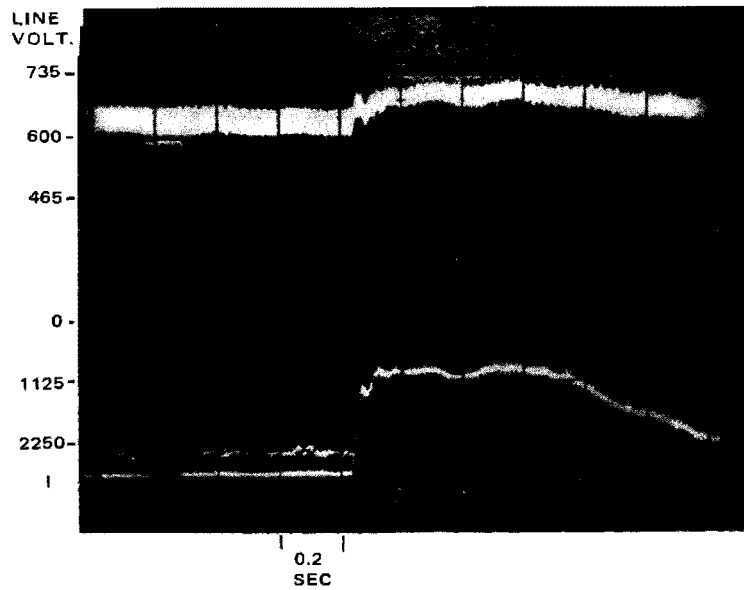

Figure 2-8. Minor Decrease of Power (Instrumented Car Pulling)

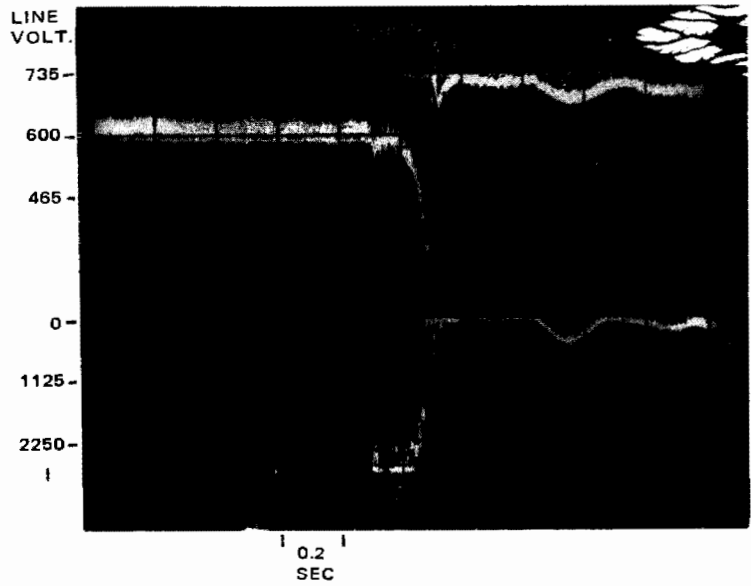

Figure 2-9. Observations at the South Rail Gap (Instrumented Car Pulling)

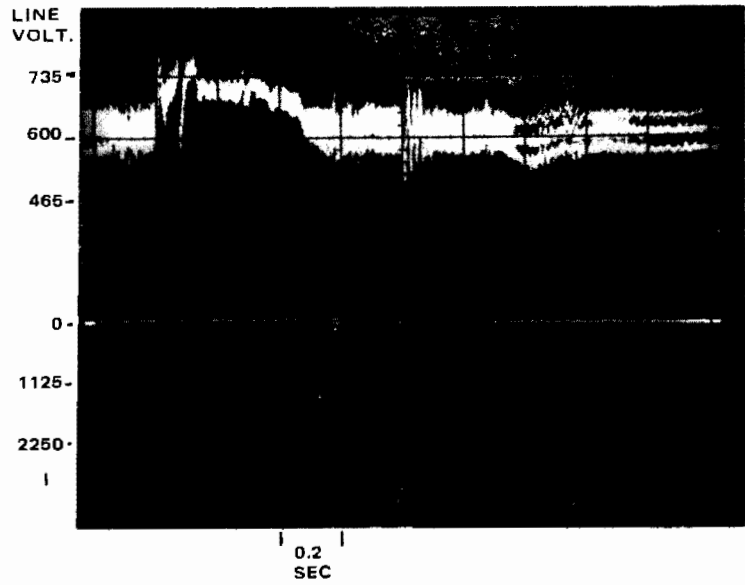

Figure 2-10. Train Passing South Rail Gap (Trackside Measurement)

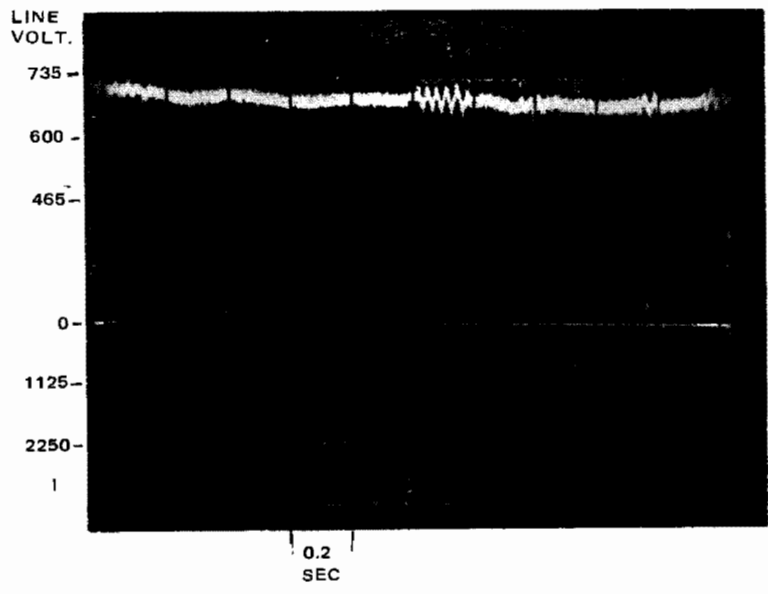

Figure 2-11. Representative Transient During an Observed Arc (Trackside Measurement)

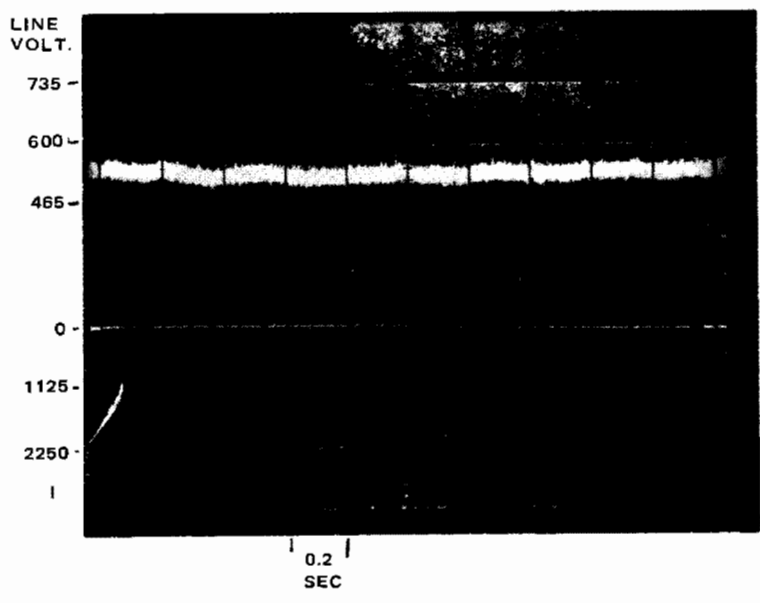

Figure 2-12. Train Passing Instrumentation Unit at 80 MPH (Trackside Measurement)

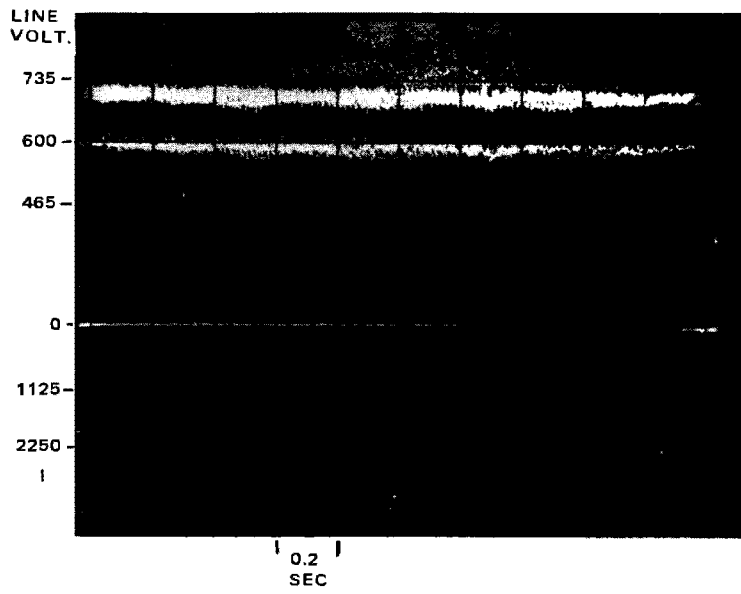

Figure 2-13. Train Located Outside Instrumented Track Section (Trackside Measurement)

Figure 2-13 shows the trackside voltage when the cars were on the opposite side of the track. In this case the cars are probably disconnected from the locomotive power source which supplied this voltage measurement.

2.5.2 Interpretation of Voltage Transient and Spikes

The test results are summarized in Figures 2-14 through 2-28.

Figures 2-14 and 2-15 summarize the transient event test results for instrumentation located in the car and the instrumentation located at the trackside location test runs. Figure 2-14 indicates relatively short transient events for voltage transients dropping below +550 volts compared with Reference 2. This result may be due to the limited number of rail gaps and their relatively short length at the Pueblo test site. It appeared that the rail gaps were of insufficient length to allow both third rail shoes to be disconnected simultaneously from the power sources. No plausible theory is being proposed for the long transients below +520 volts for the trackside data shown in Figure 2-15.

Figures 2-16, 2-17 and 2-18 show the duration of observed voltage transients for the test conditions with: (1) both cars energized, (2) instrument car pulling, and (3) instrument car being pulled. The three results are very similar. Some longer high voltage transients did occur with both cars pulling.

Figures 2-19 and 2-20 show the duration of observed transients measured at the trackside location. Figure 2-19 is almost identical with Figure 2-15, indicating that most of the transients on the third rail occur when the cars are near the measurement point.

The spike voltage test results, Figures 2-21 through 2-27, are obscured by the noise signals produced by the locomotive generator (see Figure 2-3). Thus the observed spikes which were confined to the voltage bands between +800 and +1600 volts, might be considered as short, high voltage transients. Two significant facts are observed. First, no negative spikes were observed. Second, the Pueblo test facility as it is presently configured presents a large number of medium amplitude positive spikes (or short transients) for testing 600-volt traction control systems.

Figures 2-23 and 2-24 are very similar. In both cases the instrument car was pulling. During these conditions, the observed currents were relatively large.

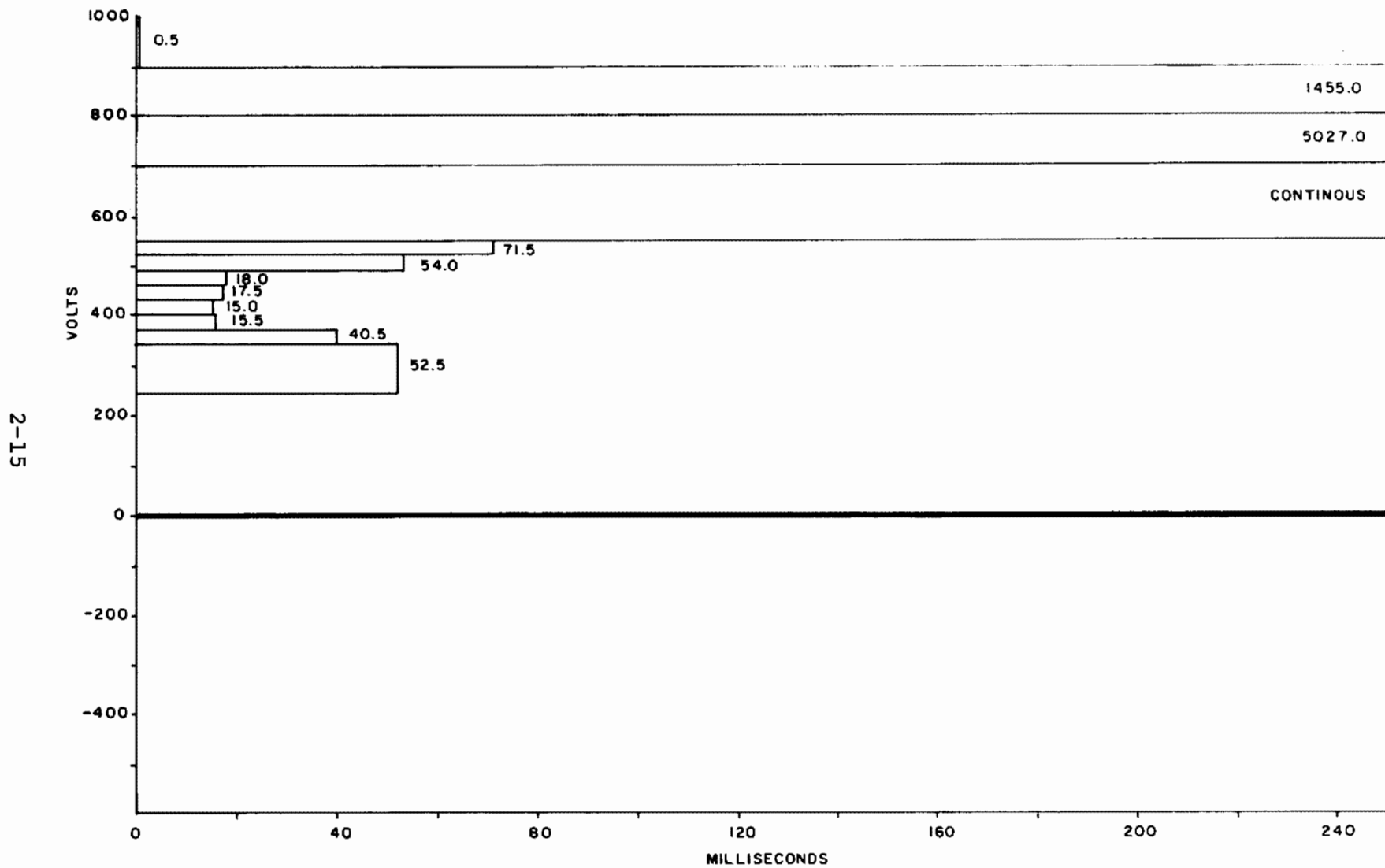

Figure 2-14. Transient Events, Maximum Amplitude (Observed) Duration Distribution (All Conditions; Instrumentation on Board; 5481.0-Second Test Duration)

2-16

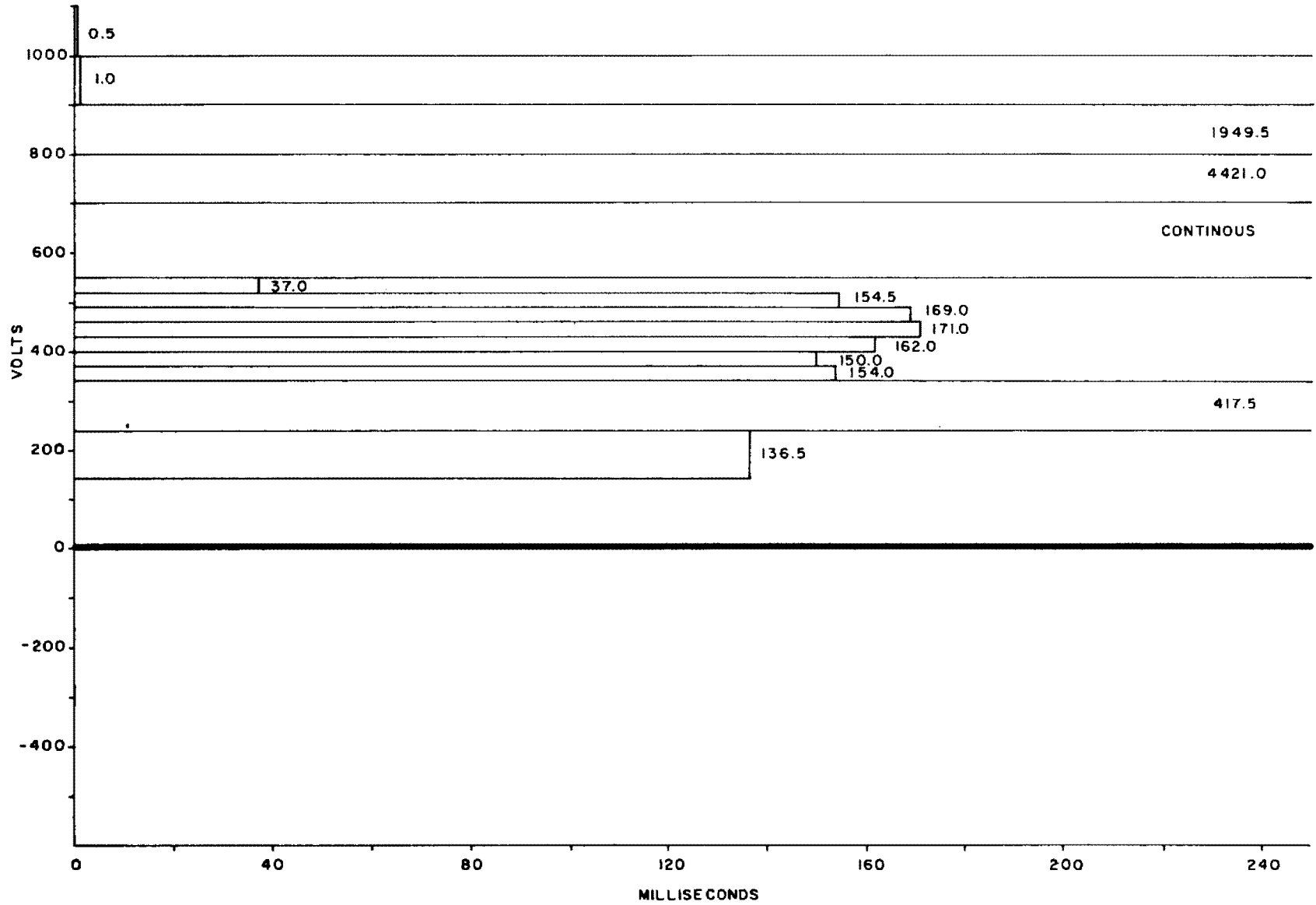

Figure 2-15. Transient Events, Maximum Amplitude (Observed) Duration Distribution (All Conditions; Instrumentation Trackside; 1050.0-Second Test Duration)

2-17

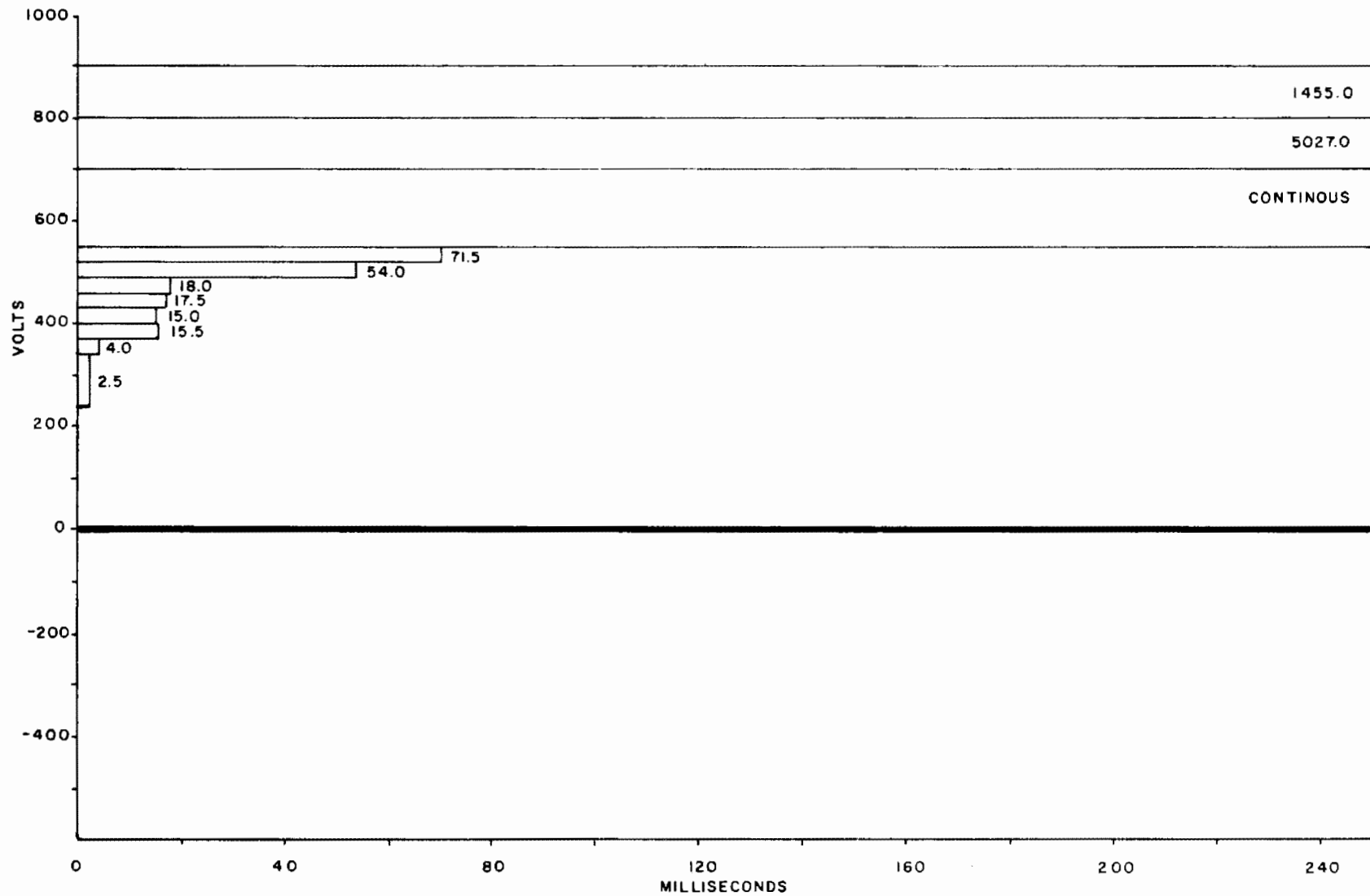

Figure 2-16. Transient Events, Maximum Amplitude (Observed) Duration Distribution (Morning Run; Both Cars Energized; 2384.5-Second Test Duration)

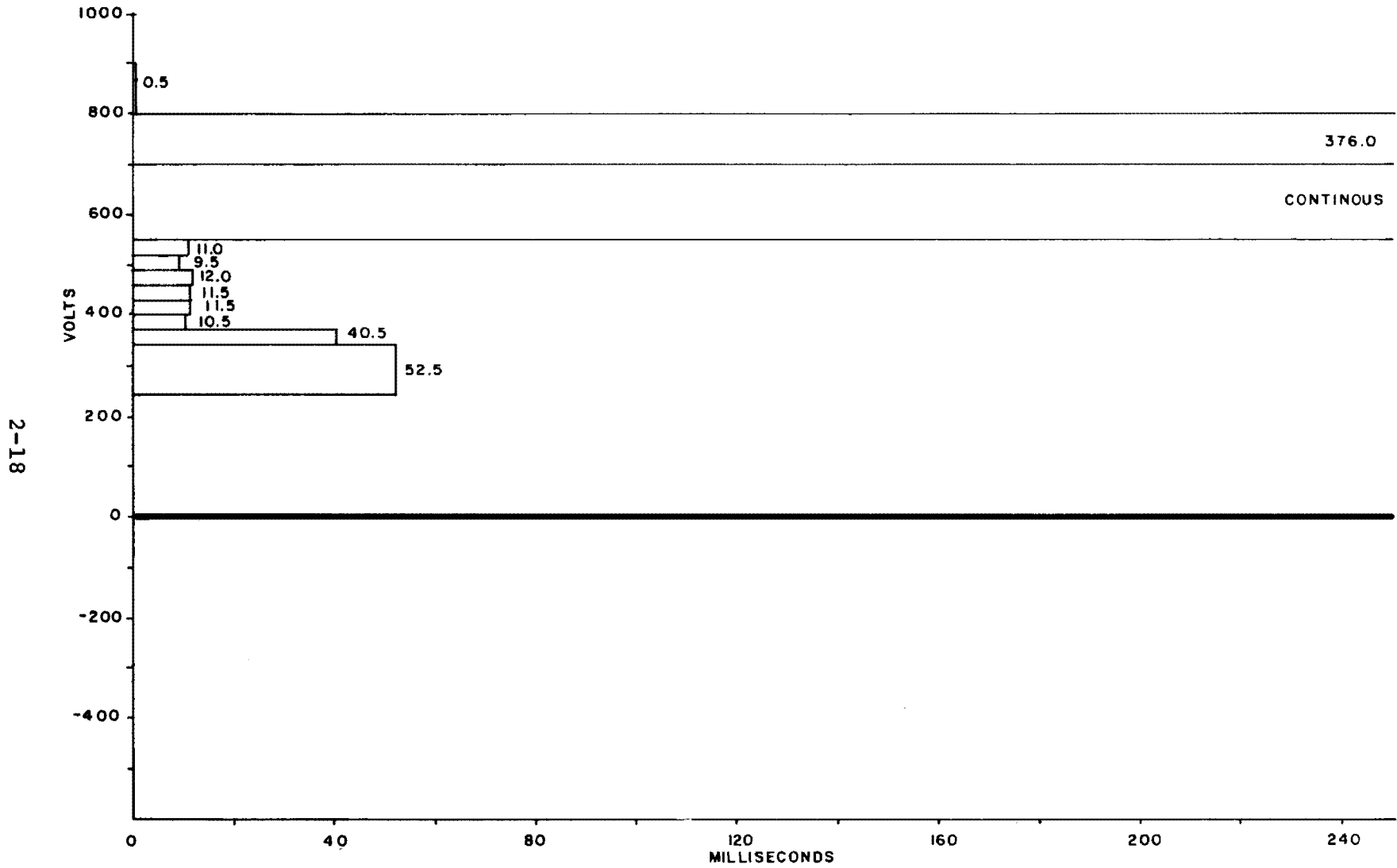

Figure 2-17. Transient Events, Maximum Amplitude (Observed) Duration Distribution (Morning Run; Instrumented Car Pulling; 1729.5-Second Test Duration)

2-19

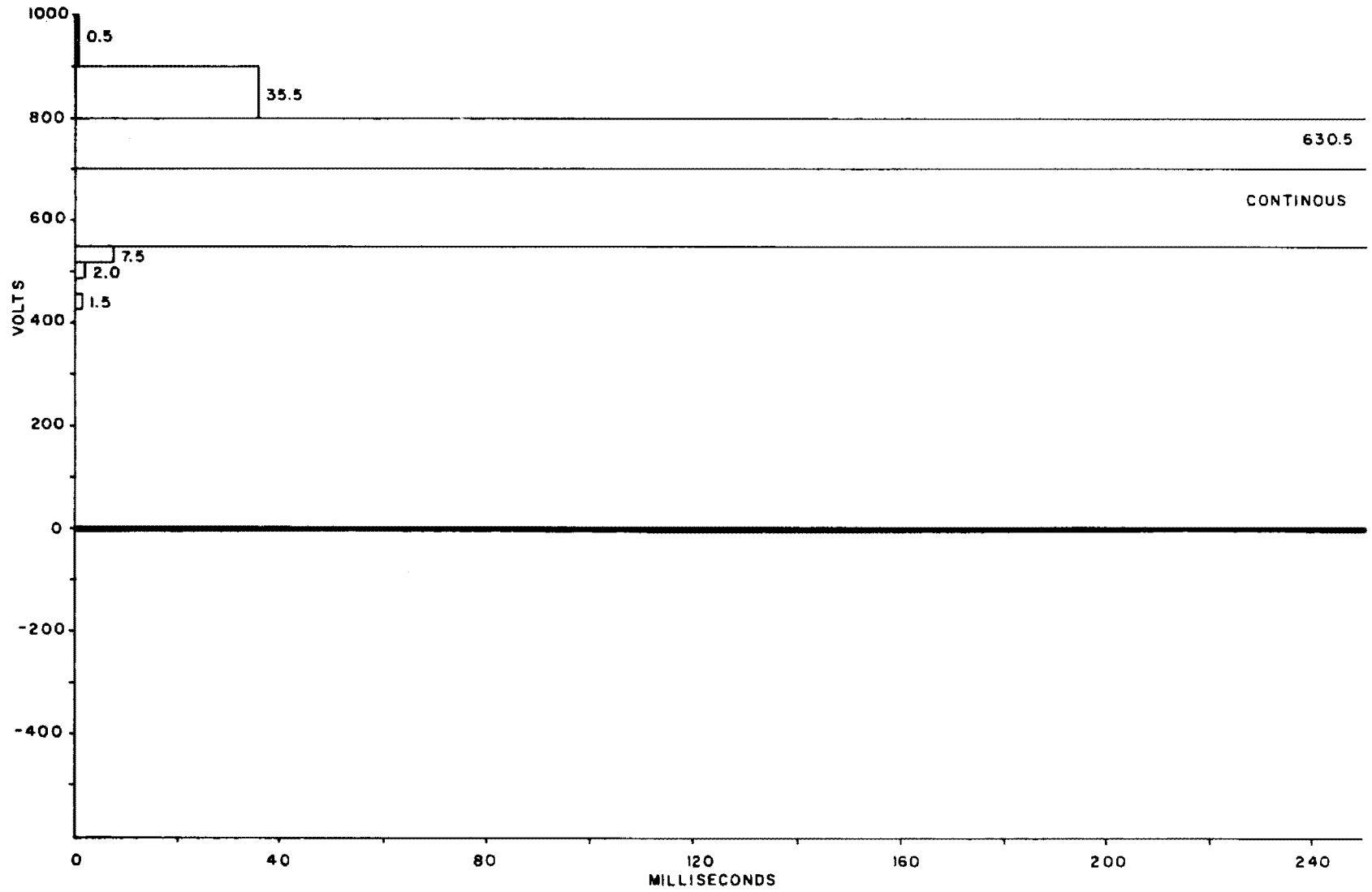

Figure 2-18. Transient Events, Maximum Amplitude (Observed) Duration Distribution (Morning Run; Instrumented Car Being Pulled; 1367.0-Second Test Duration)

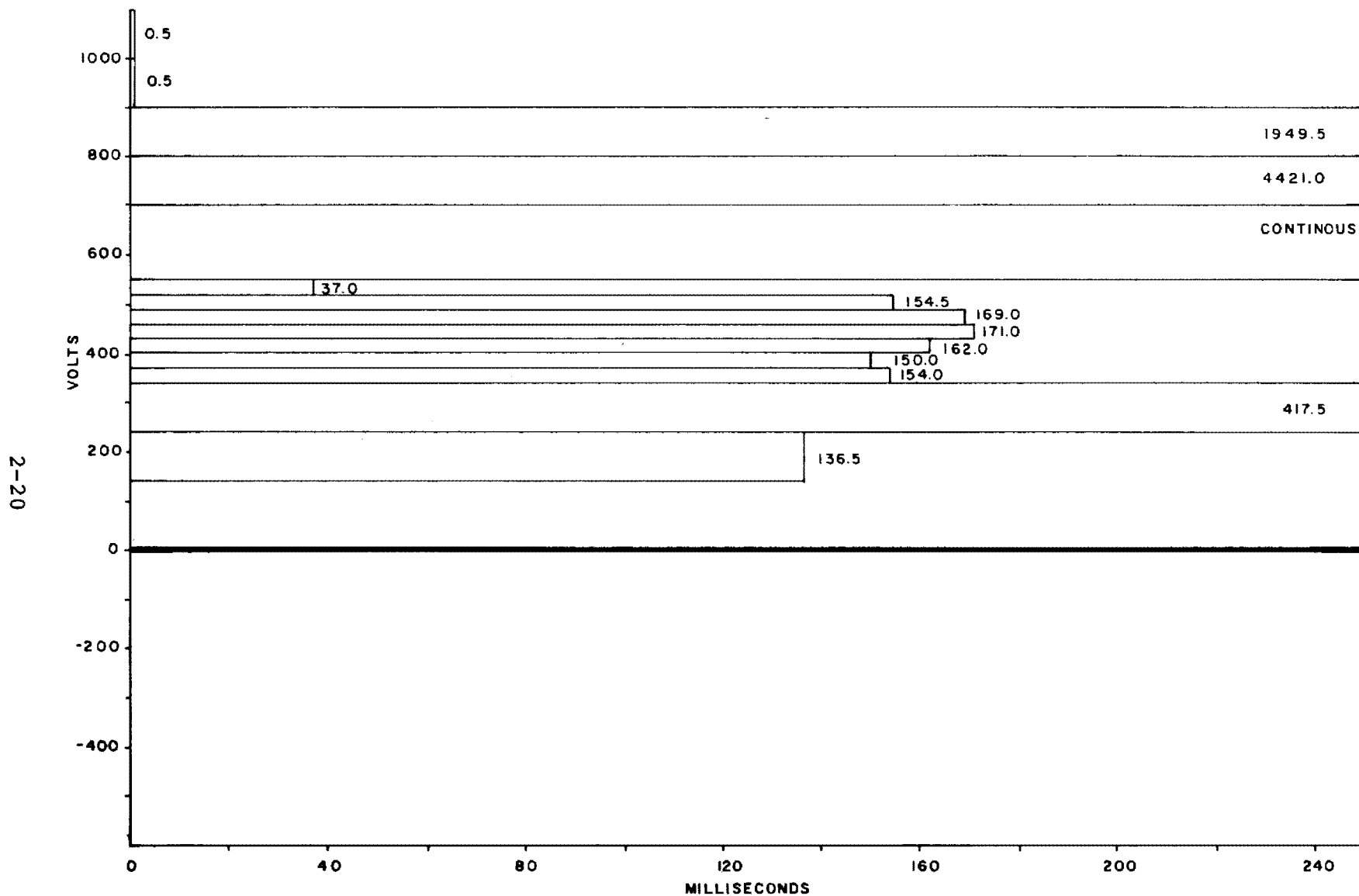

Figure 2-19. Transient Events, Maximum Amplitude (Observed) Duration Distribution (Afternoon Trackside Run; Car in Area or Passing Test Site; 769.5-Second Test Duration)

2-21

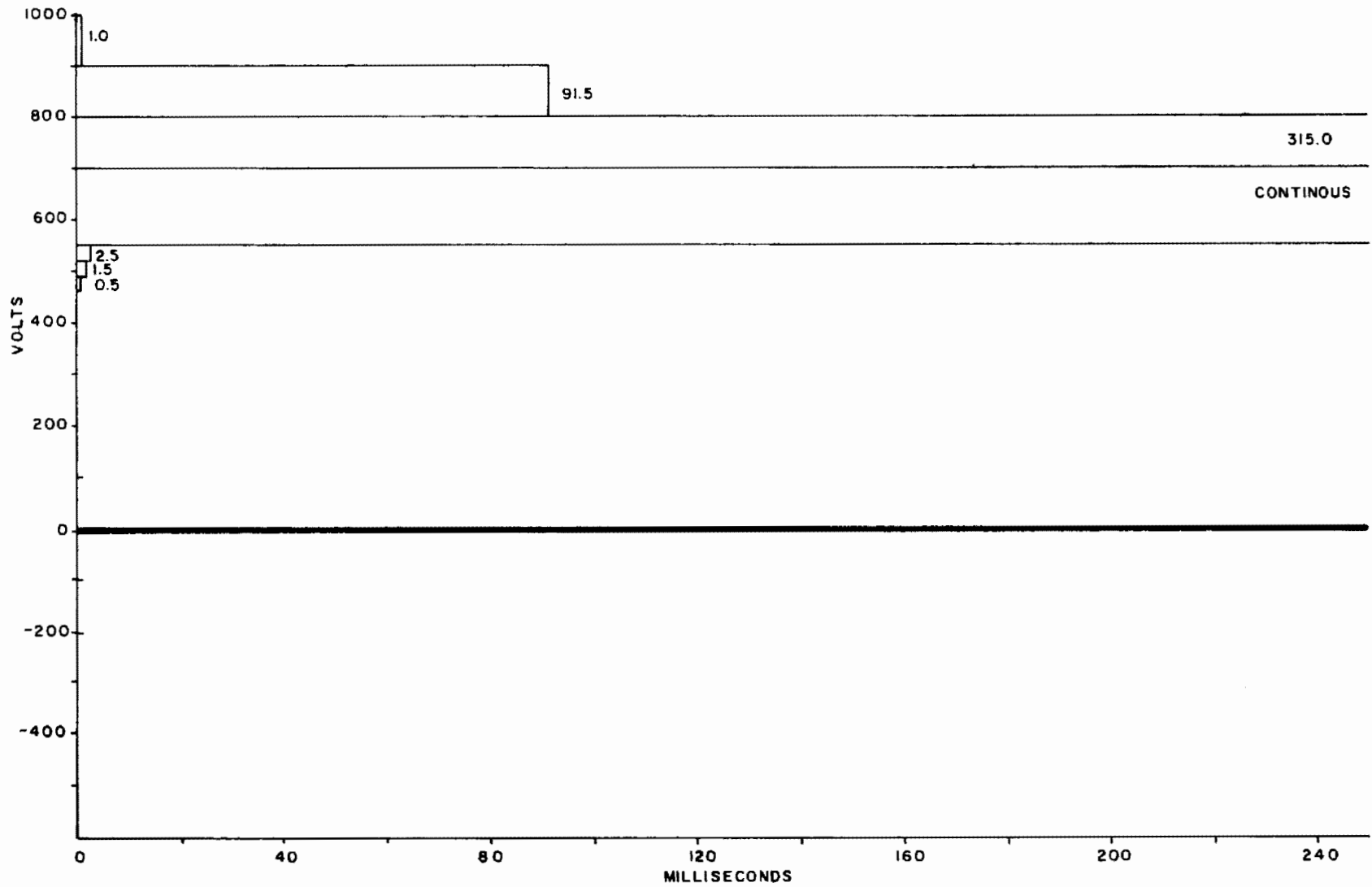

Figure 2-20. Transient Events, Maximum Amplitude (Observed) Duration Distribution (Afternoon Trackside Run; Car Out of Area; 280.5-Second Test Duration)

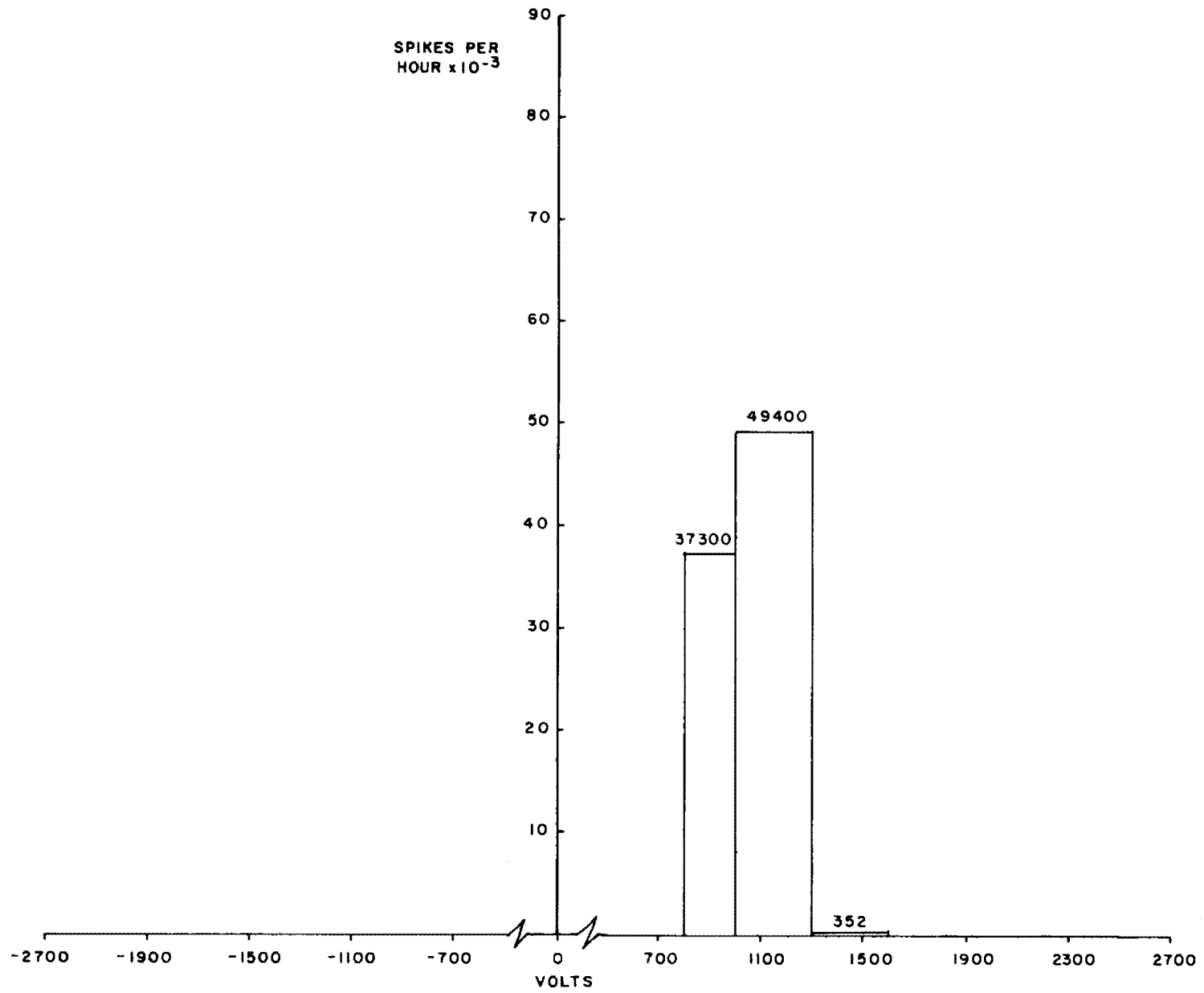

Figure 2-21. Spike Voltage (Observed) Distribution (Morning Total Envelope; 5481.0-Second Test Duration)

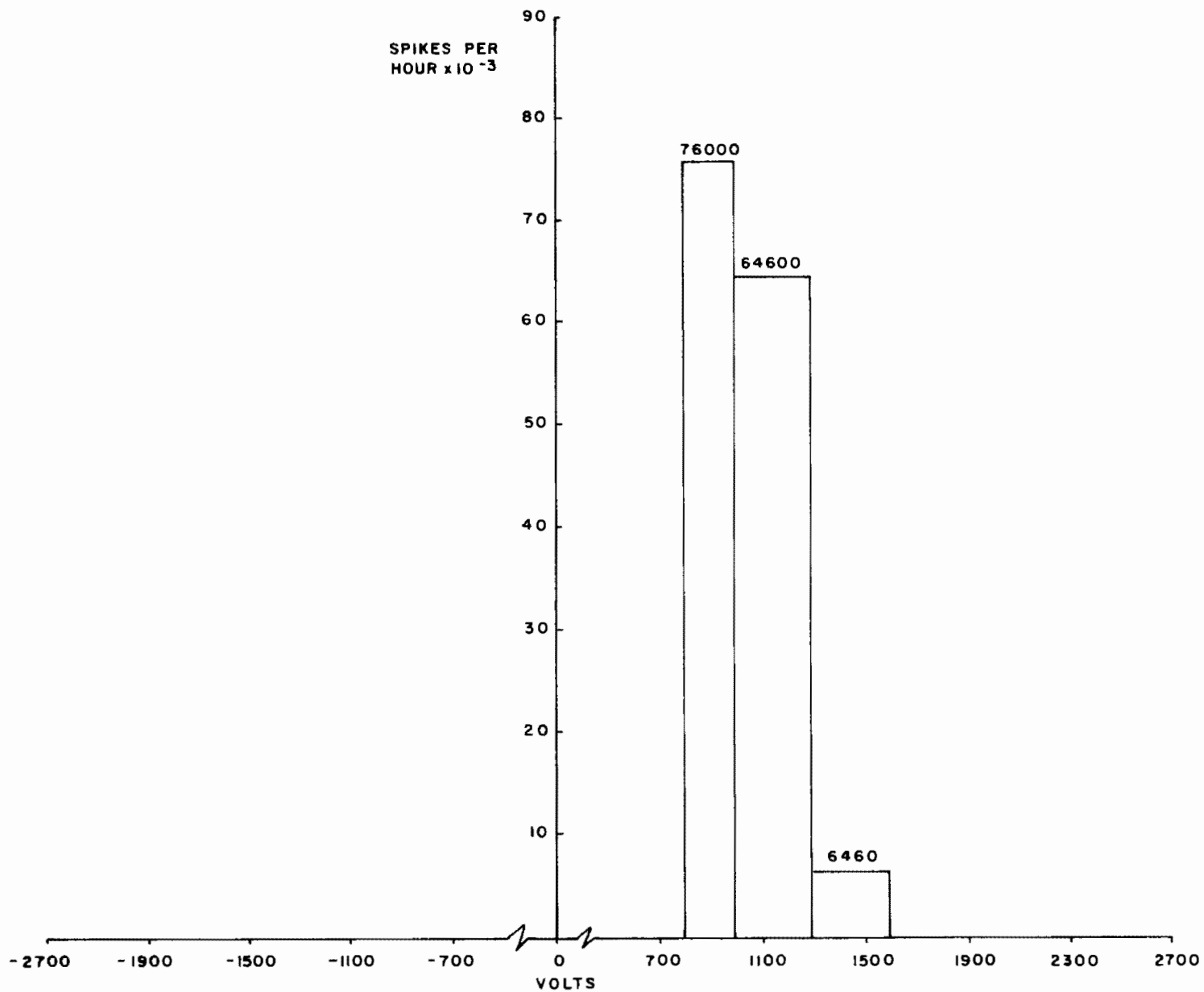

Figure 2-22. Spike Voltage (Observed) Distribution (Afternoon Total Envelope; Trackside Results; 1050.0-Second Test Duration)

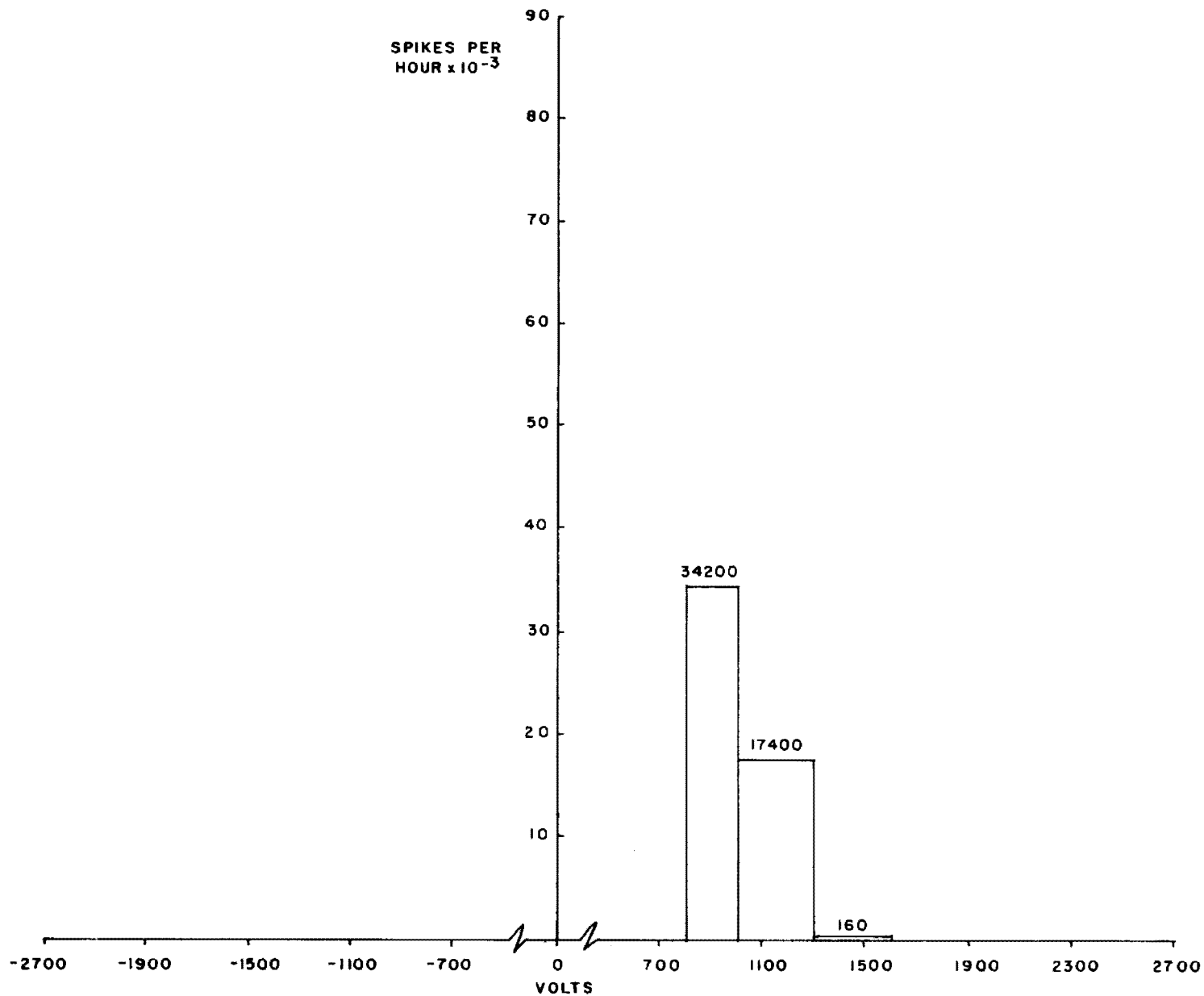

Figure 2-23. Spike Voltage (Observed) Distribution (Both Cars Pulling; 2384.5-Second Test Duration)

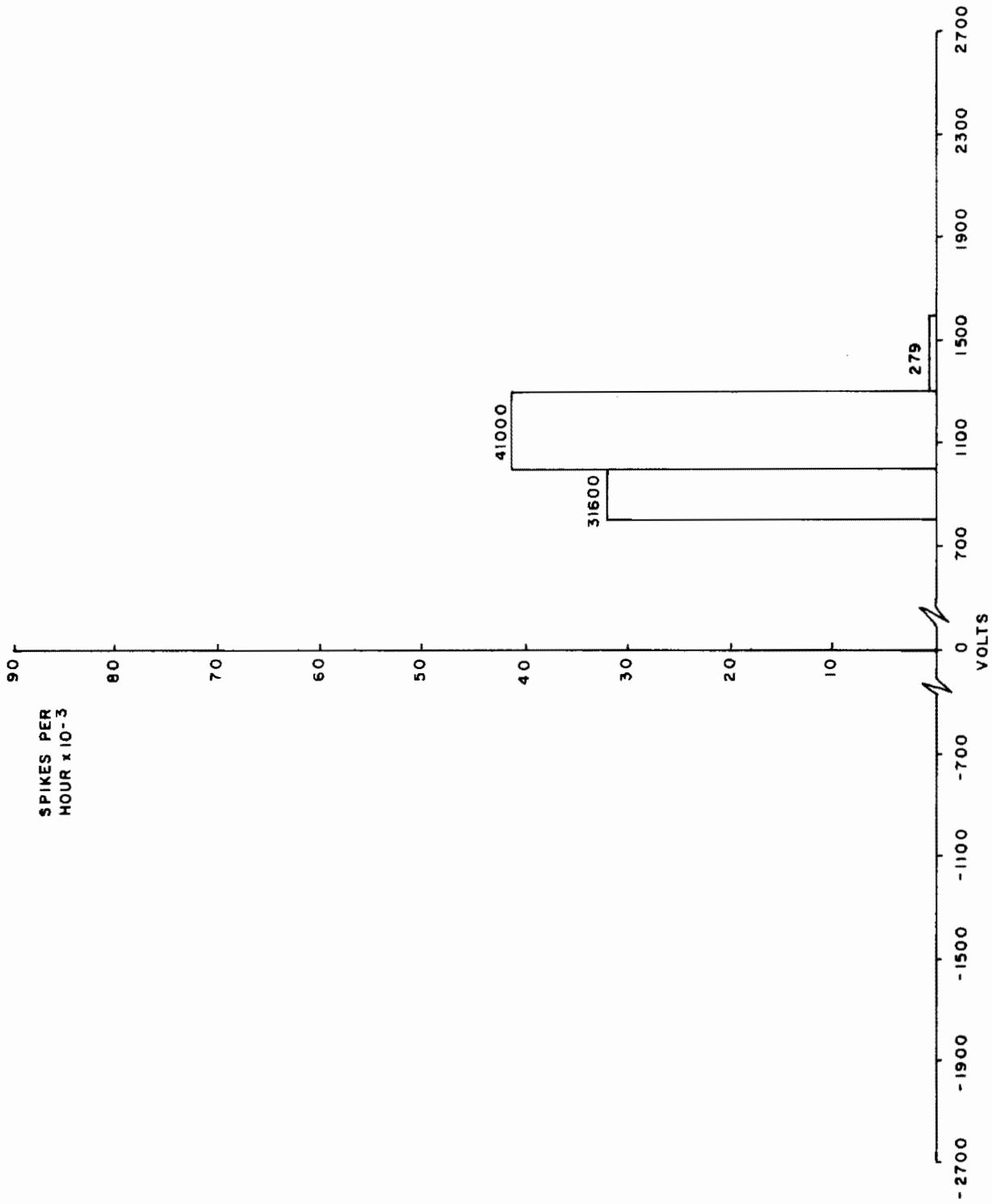

Figure 2-24. Spike Voltage (Observed) Distribution (Instrumented Car Pulling; 1729.5-Second Test Duration)

Figures 2-25 through 2-27 are also similar. In these cases the instrument car was not pulling or the data was taken from trackside measurements. During both conditions, the observed currents were relatively small.

Figure 2-28 shows experimental probability density curves which are very similar to those described in Reference 2.

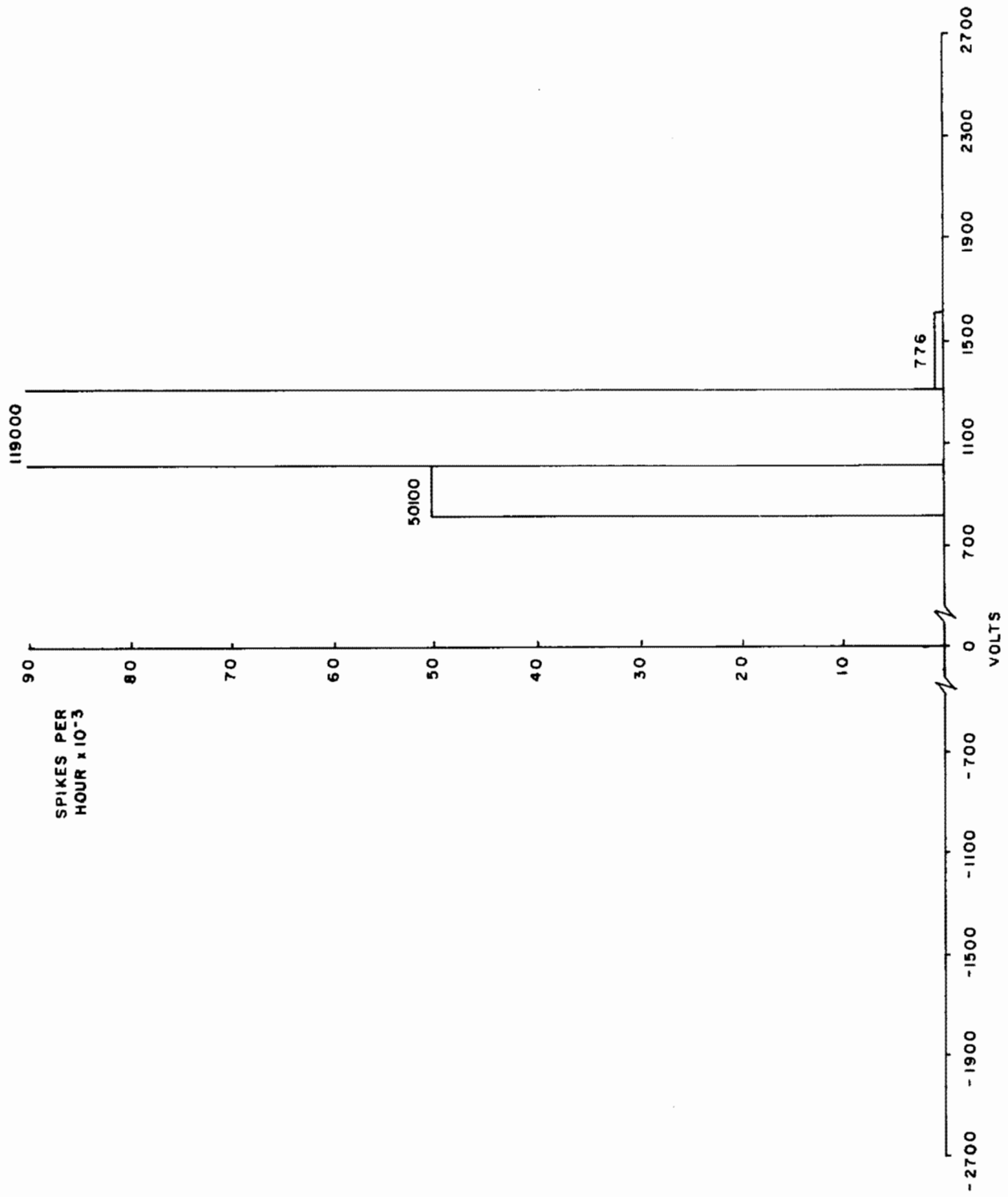

Figure 2-25. Spike Voltage (Observed) Distribution (Instrumented Car Being Pulled; 1367.0-Second Test Duration)

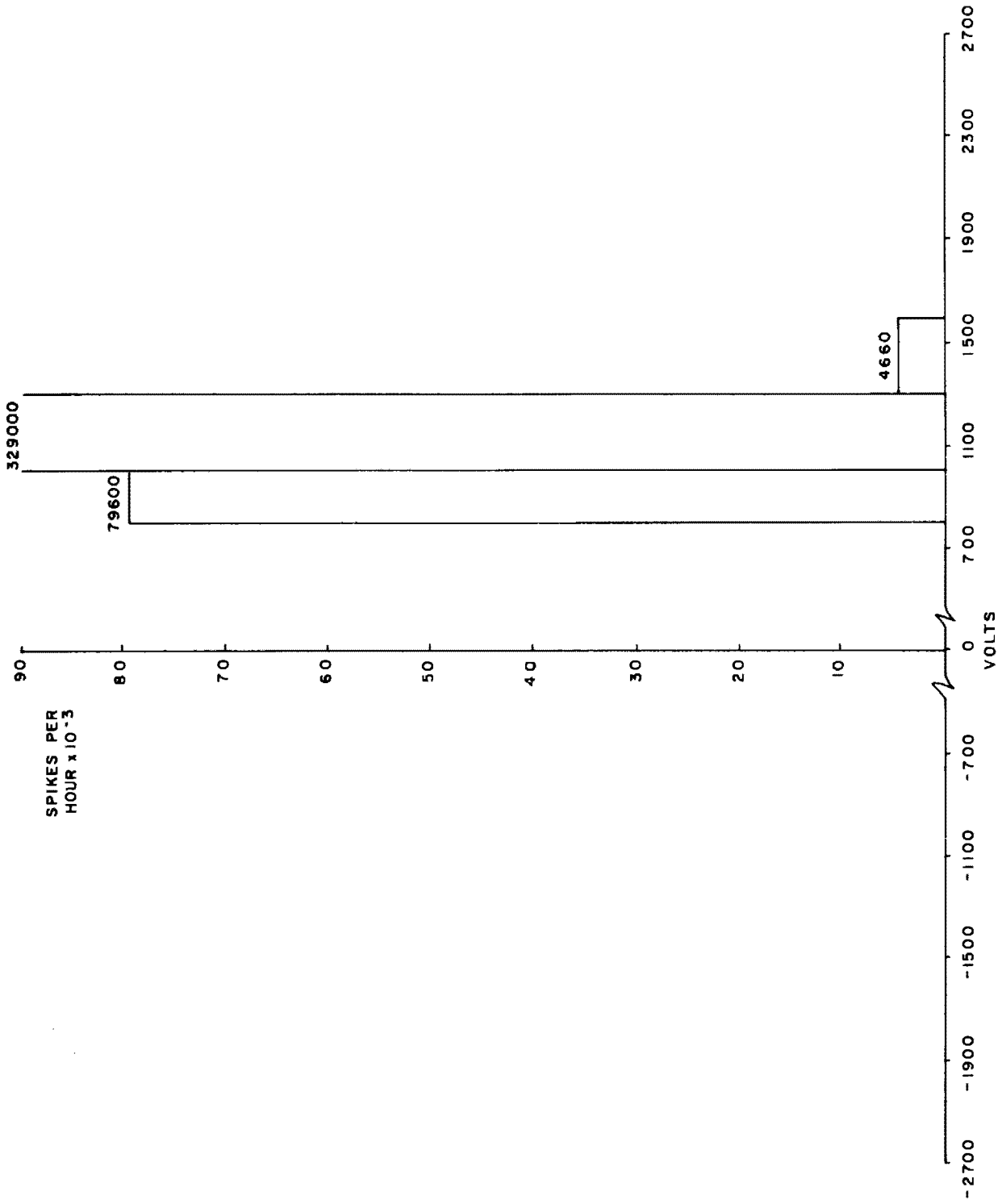

Figure 2--26. Spike Voltage (Observed) Distribution (Trackside; Car in Area or Passing; 769.5-Second Test Duration)

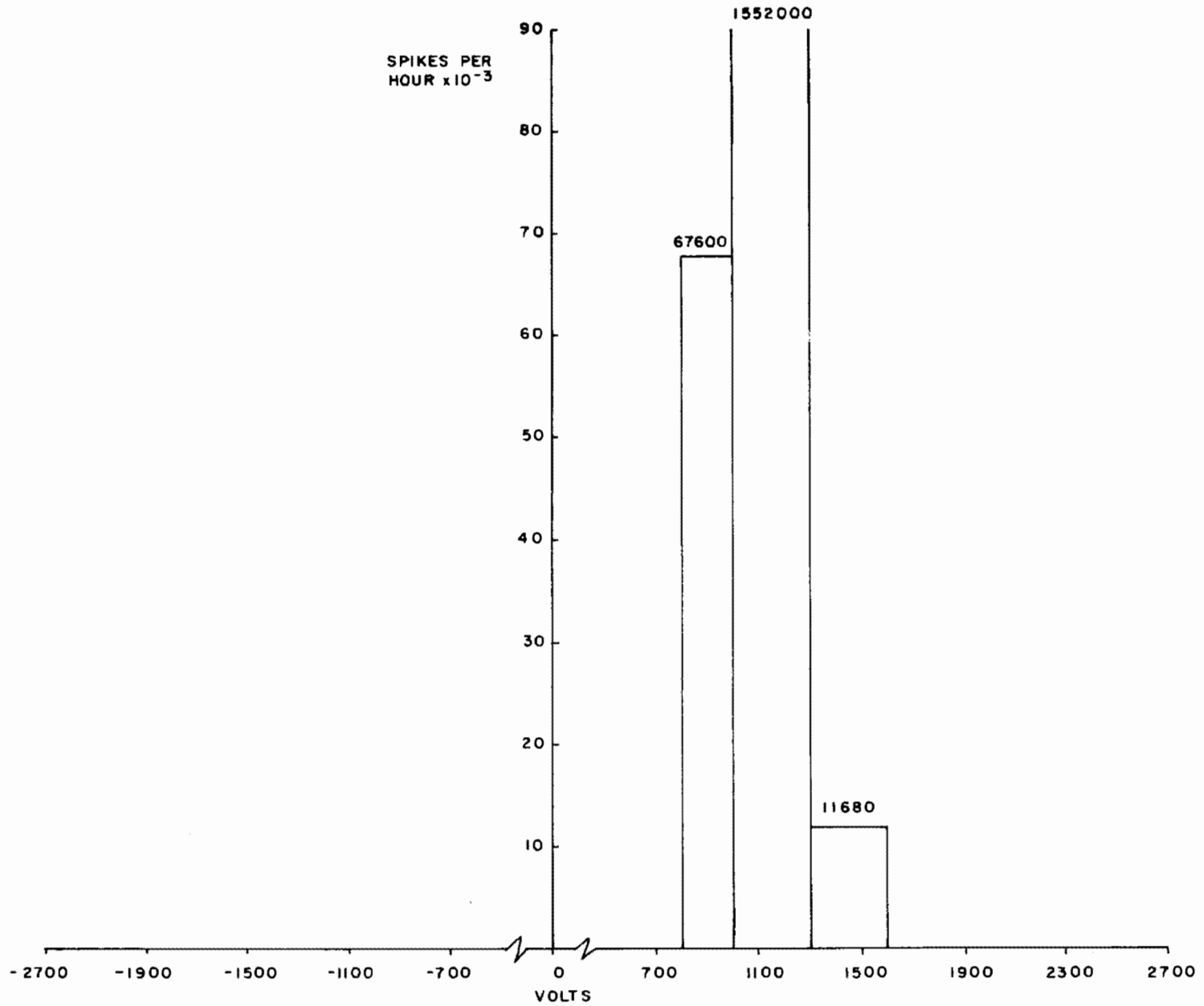
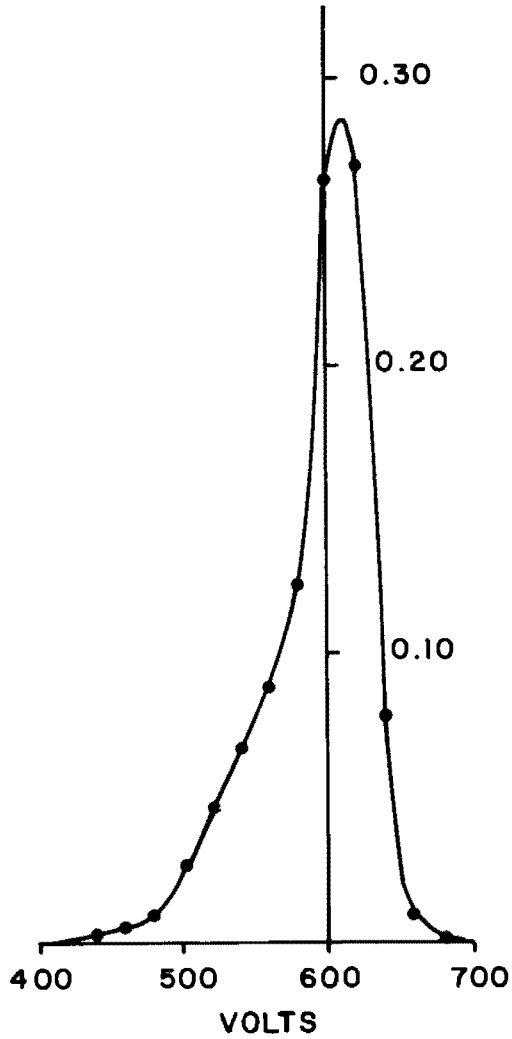

Figure 2-27. Spike Voltage (Observed) Distribution (Trackside; Car Out of Area; 280.5-Second Test Duration)

PUEBLO
MORNING ON CAR RUN



PUEBLO
AFTERNOON TRACKSIDE RUN

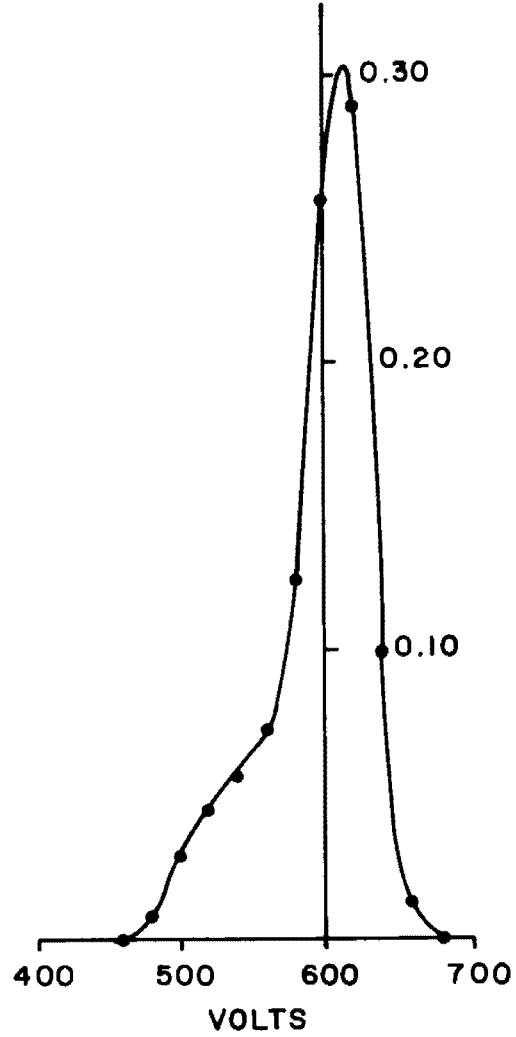

Figure 2-28. Probability Density of Line Voltage (Experimental)

Section 3

RADIO FREQUENCY INTERFERENCE

3.1 SUMMARY

Test Sequence

Runs were completed in April 1973.

Test Procedure

No baseline number has yet been assigned.

Objective

To measure the broadband radiated electromagnetic emissions from a rapid transit train consisting of two State-of-the-Art Cars coupled together and functioning as a unit. Measurements of internal emission levels were secured to identify sources of significant electromagnetic emission. Wayside emission data were obtained for comparison with the radio frequency interference goals established for SOAC.

Status

The tests took place on April 2 and 3, 1973, and comprised a series of measurements using Radio Interference Field Intensity (RIFI) meters with appropriate antennas.

Internal ambient electric field intensity measurements were made with all SOAC systems off, for reference, then repeated to assess the emission characteristics of the SOAC systems in operation. Wayside tests were performed under ambient conditions and with the SOAC train in all operating modes: acceleration above and below base speed, constant speed, and braking. More than 150 SOAC passbys were involved.

Raw and corrected measurements are provided on Data Sheets 1 and 2, respectively. A field-intensity-versus-frequency graph of worst-case wayside measurements compared to the SOAC RFI goals is also provided. No

significant sources of broadband radiation were identified during the internal tests on the SOAC, and the SOAC demonstrated complete conformance to the wayside radiated interference emission goals.

3.2 TEST DESCRIPTION

The RFI test program for the SOAC was basically identical to that developed for the Bay Area Rapid Transit District vehicle in September, 1971. (See Reference 3.)

The SOAC test program comprised three tasks:

- Measure the ambient electromagnetic noise levels, and select low-ambient-field-intensity frequencies as test points; there should be about four test points per decade.
- Measure emissions inside the vehicle with all systems in operation; identify any frequencies at which significant electromagnetic noise peaks are present and add these frequencies to the test points; locate the source(s) of emissions on the vehicle.
- Measure the ambient field intensity for each test point at the wayside station, then repeat the same measurement procedures with the vehicle running past the test station under each of the various test conditions.

3.3 INSTRUMENTATION

During testing inside the SOAC vehicle, a Stoddart Model IM-37/PRM-1A meter with a 41-inch rod antenna was used for measurements in the range of 150 KHz to 30 MHz. A Stoddart Model IM-88/URM-47 meter, with a range of 20 MHz to 400 MHz, was used for the higher frequency measurements. A tripod-mounted biconical antenna, per MIL-STD-461A, was used in conjunction with the IM-88/URM-47 for frequencies up to 200 MHz. Measurements at 400 MHz were made using a 10-inch hand-held dipole antenna. Based on the referenced BART test results, which indicated that horizontally polarized interference levels exceed vertically polarized levels at all frequencies above 30 MHz, all SOAC measurements were conducted with the biconical and dipole antennas in horizontal orientation.

The same instrumentation was utilized, with one exception, for the wayside electromagnetic emission tests. After about 25 percent of the wayside measurements had been completed, the tripod-mounted biconical antenna was blown

over in a gust of wind and damaged beyond use. A 21-inch dipole was substituted on the tripod for the remaining tests.

3.4 TEST PROCEDURE

The instrumentation was first set up inside one of the SOAC cars. All SOAC systems and third rail power were de-energized, and a complete scan of the frequency range (150 KHz to 400 MHz) was performed for the purpose of selecting those frequencies at which noise intensity would be monitored throughout the remaining tests. Four frequencies per decade were selected against a criterion of avoiding frequencies with a high ambient electromagnetic noise level (such as the broadcast frequency of a local station).

A second frequency scan was performed with the same test equipment after all SOAC systems had been turned on, in order to identify any emission frequencies (noise peaks) for later investigation during radiated emission tests with the instrumentation located external to the vehicle. There were none.

The bulk of the testing comprised radiated emission measurements conducted with the instrumentation in a stationary wayside location, adjacent to the tracks, while the SOAC train passed by. The instrumentation was situated on a small hill inside the HSGTC transit loop, within a gentle curve. The tracks passed the test location in a southwest/northeast direction, with a slight uphill grade in the northeast direction. The antennas were located 100 feet from the tracks and approximately at the level of the top of the SOAC cars (12 feet above track grade near Track Station 80). Electric field intensity measurements were recorded at each of the test frequencies and under each test condition, while the SOAC train passed through a zone approximately 300 feet long directly in front of the antenna locations. The test conditions comprised the following: running at constant speeds of 20, 40 and 80 miles per hour, acceleration at maximum rate, and service braking at maximum rate. An additional set of similar measurements was performed at certain of the test frequencies under conditions of maximum acceleration below base speed (20 miles per hour). All emission readings for these conditions were below or equal to readings recorded during operation at constant speeds, as shown on Data Sheet 1 (Table 3-1).

TABLE 3-1. SOAC RADIATED EMISSION TESTS (DATA SHEET 1)

Freq (MC)	Ambient (dB)	All Systems On (dB)	Outside Ambient (dB)	20 MPH (dB)		40 MPH (dB)		80 MPH (dB)		Accel. (dB)		Decel. (dB)	
				N	S	N	S	N	S	N	S	N	S
0.16	91	96	91	<96	<96	<96	<96	<96	<96	<96	<96	<96	<96
0.31	92	95	91	<91	<91	<91	<91	<91	<91	<91	<91	<91	<91
0.6	90	94	87	77	77	77	77	79	79	79	79	79	79
1.0	94	92	72	65	65	72	73	73	73	73	69	69	69
2	94	97	72	71	72	73	73	75	77	76	75	76	77
4	81	86	66	70	74	76	77	78	76	77	77	75	75
8	86	94	71	70	73	72	72	71	76	74	73	77	75
16	84	83	62	73	71	76	75	72	73	74	76	71	79
32	43	52	47	43	42	44	43	42	43	42	49	47	47
60	54	61	39	35	35	44	38	^c 36	^c 33	^c 36	^c 34	40	36
120	52	53	30	33	36	37	33	^c 38	^c 33	^c 31	^c 34	40	38
200	22	31	35*	34*	34*	36*	33*	^c 38	^c 37	^c 31*	^c 35*	36*	36*
400	48	48	32	32	32	32	32	32	32	35	35	31	31

NOTES

1. All dB units are dB μ V/MHz
2. Very high noise signal at approximately 195 MHz (ambient)
3. (*) Readings at 205 MHz
4. (c) 21-inch dipole antenna
5. Recorded levels at 0.16 and 0.31 MHz as <96 and <91 dB are ambient levels of DC to AC power converter

3.5 DATA

Measurements were recorded manually using the format shown on Data Sheet 1. These raw data are, in fact, voltage measurements derived from the RIFI meters and are in units of dB μ V/MHz. Applicable antenna factors (units of dB/m) were used to convert the raw measurements to electric field intensity readings. The corrected readings are shown on Data Sheet 2 (Table 3-2), in units of dB μ V/M/MHz, corresponding to those of the SOAC RFI goals.

The highest value of wayside emission recorded at each frequency is plotted in Figure 3-1, as a composite with the SOAC RFI goals. Although readings at 32 MHz exceed specification limits by 2 dB, it should be noted that the ambient level also exceeded the limit by the same amount. Furthermore, it should be observed that normally accepted tolerance for this type of test data are plus or minus 3 dB. Therefore, the readings at 32 MHz must be interpreted as complying with the SOAC goals.

TABLE 3-2. SOAC RADIATED EMISSION TESTS (DATA SHEET 2)

Freq MC	Antenna Corr. Factor (dB)	Corr. Ambient (dB)	Correction 20 MPH (dB)		Correction 40 MPH (dB)		Correction 80 MPH (dB)		Correction Accel. (dB)		Correction Decel. (dB)		Spec Limit (dB)
			N	S	N	S	N	S	N	S	N	S	
0.16	6	97	<102	<102	<102	<102	<102	<102	<102	<102	<102	<102	109
0.31	6	97	<97	<97	<97	<97	<97	<97	<97	<97	<97	<97	106
0.6	6	93	83	83	83	83	85	85	85	85	85	85	102
1.0	6	78	71	71	78	79	79	79	79	75	75	75	100
2	6	78	77	78	79	79	81	83	82	81	82	83	97
4	6	72	76	80	82	83	84	82	83	83	81	81	93
8	6	77	76	79	78	78	77	82	80	79	83	81	91
16	6	68	79	77	82	81	83	79	80	82	77	79	87
32	13	60	56	55	57	56	55	56	55	58	60	60	58
60	9 +5 ^c	48	44	44	53	47	49	49	58	52	49	45	58
120	16 -6 ^c	46	49	52	53	49	43	46	47	43	56	54	68
200	17 -2 ^c	52	51	51	53	50	49	49	51	47	51	51	68
400	0	32	32	32	32	32	32	32	35	35	31	31	68

NOTES

1. All dB units are dB μ V/MHz
2. Antenna correction factors for c above were obtained as follows:

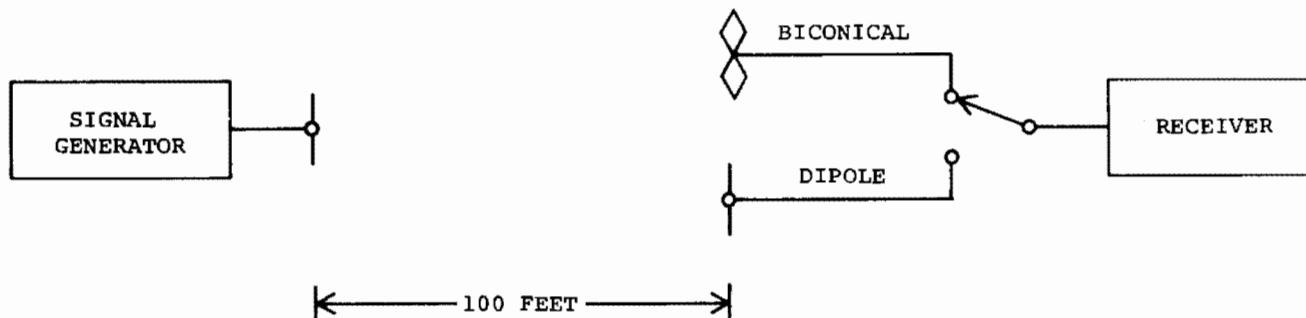

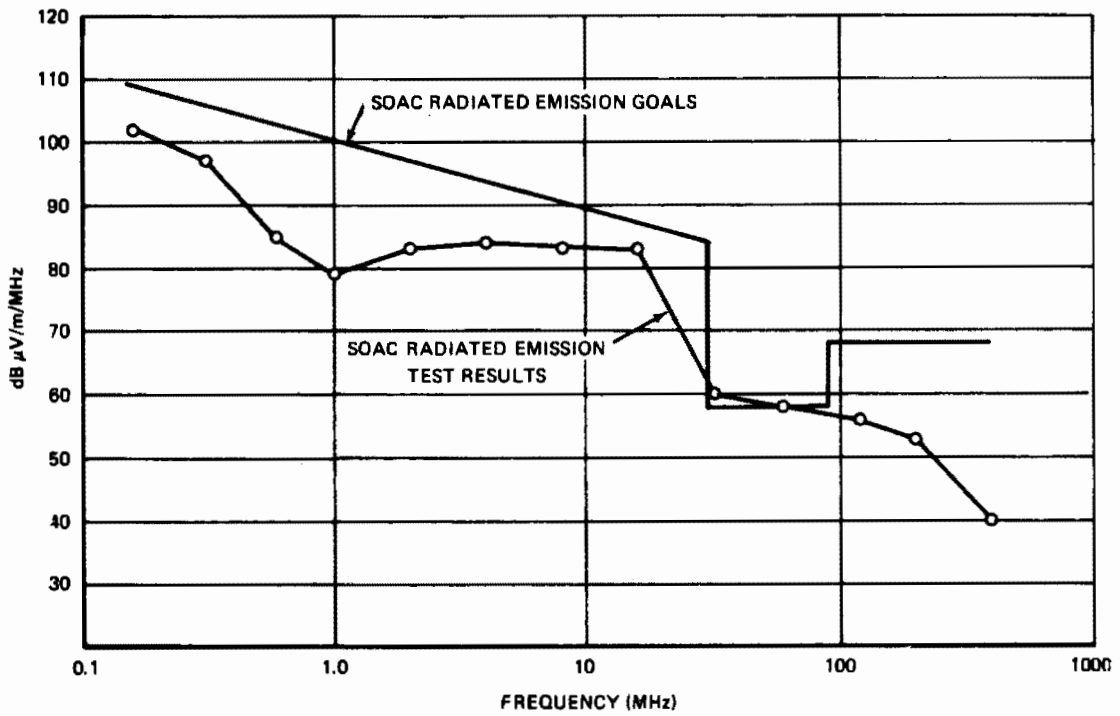
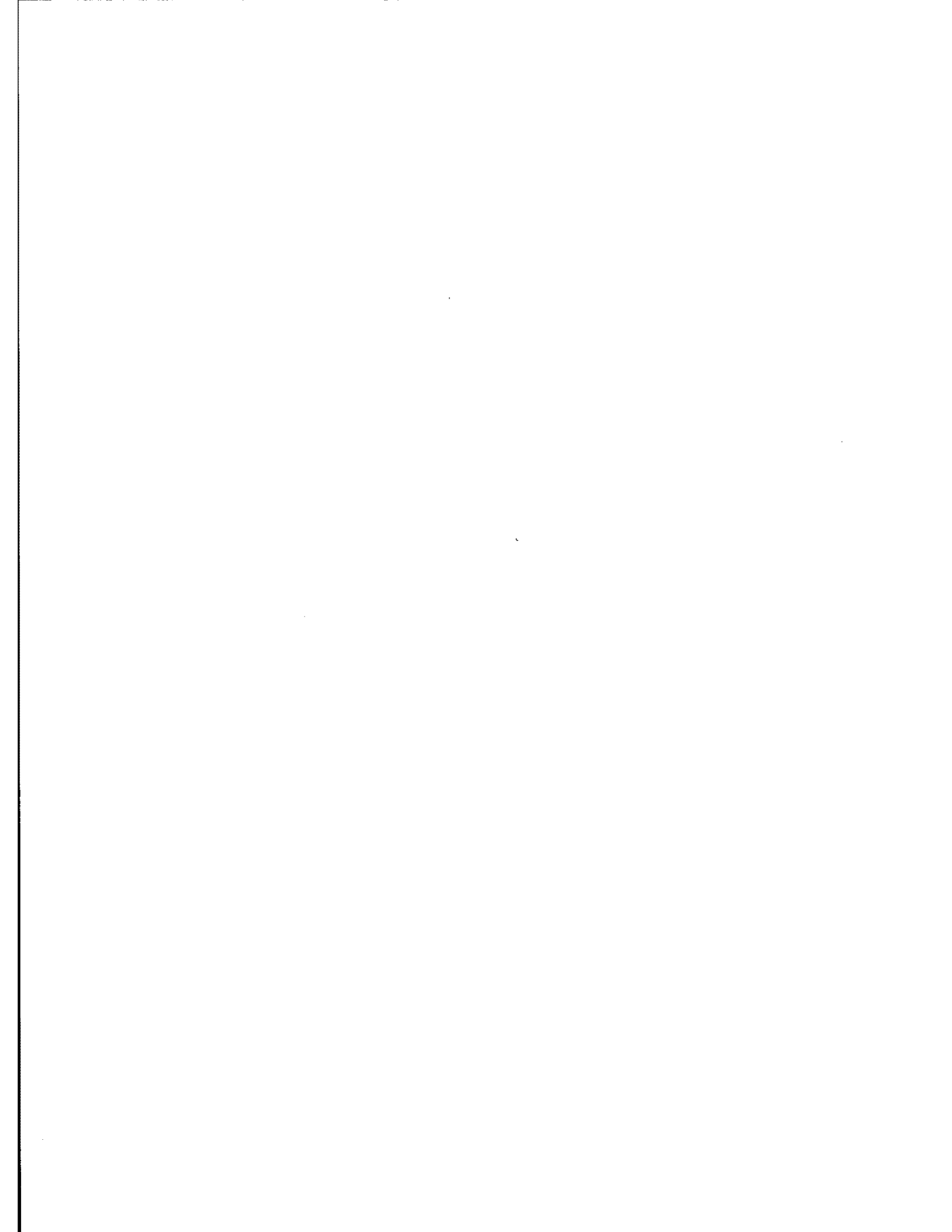

Figure 3-1. Electromagnetic Field Test Data



Appendix

DATA ACQUISITION SYSTEM FOR VOLTAGE TRANSIENTS AND SPIKES

The following description is adapted from INVESTIGATION OF VOLTAGE TRANSIENTS AND SPIKES IN DIRECT CURRENT RAPID TRANSIT SYSTEMS (Reference 2). It is included in this report as an indication of the measurement system used during the SOAC Engineering Test Program. The reader is directed to the cited report for a complete description of the Voltage and Transient Measurement System.

INSTRUMENTATION DESCRIPTION

Line voltage transients and spikes, car currents and wheel RPM were recorded using the Rapid Transit Recording System shown in Figure A-1. The principle component of the system was an Ampex AR-200 Flight Instrumentation Recorder. The recorder is capable of withstanding 15g impact shocks along any axis without loss of recording. The recorder was operated in the extended FM frequency response mode to achieve a band width of DC to 1250 PZ at 3 3/4 ips tape speed. The data tapes were 1 inch x 3600 feet x 1 mil, Ampex type 746-57311. The capacity of each tape at 3 3/4 ips is 3 hours, 12 minutes.

The signal ground was connected to the car chassis at only one point near the knife switch box. The probes were connected to a terminal on the knife switch. The Power Pack contained transformers which effectively isolated the battery supply bus-ground from the signal ground.

1. Spike and Transient Signal Probes (STSP)

The Spike and Transient Signal Probes are shown in Figure A-2. Both probes had identical components but were not used interchangeably during the tests. The 59 B/U coax cable was properly terminated to avoid high-frequency reflections which can produce major distortions in transient and spike signals. Figures A-3 and A-4 illustrate the small amount of reflection voltage ripple which has a negligible effect on spike peak voltage measurements and transient signal reproductions. Shunt resistor R10 (Figure A-2) is a safety load for the probe voltage divider circuit which limits the output voltage to 100 volts when the output BNC connector is disconnected. The

A-2

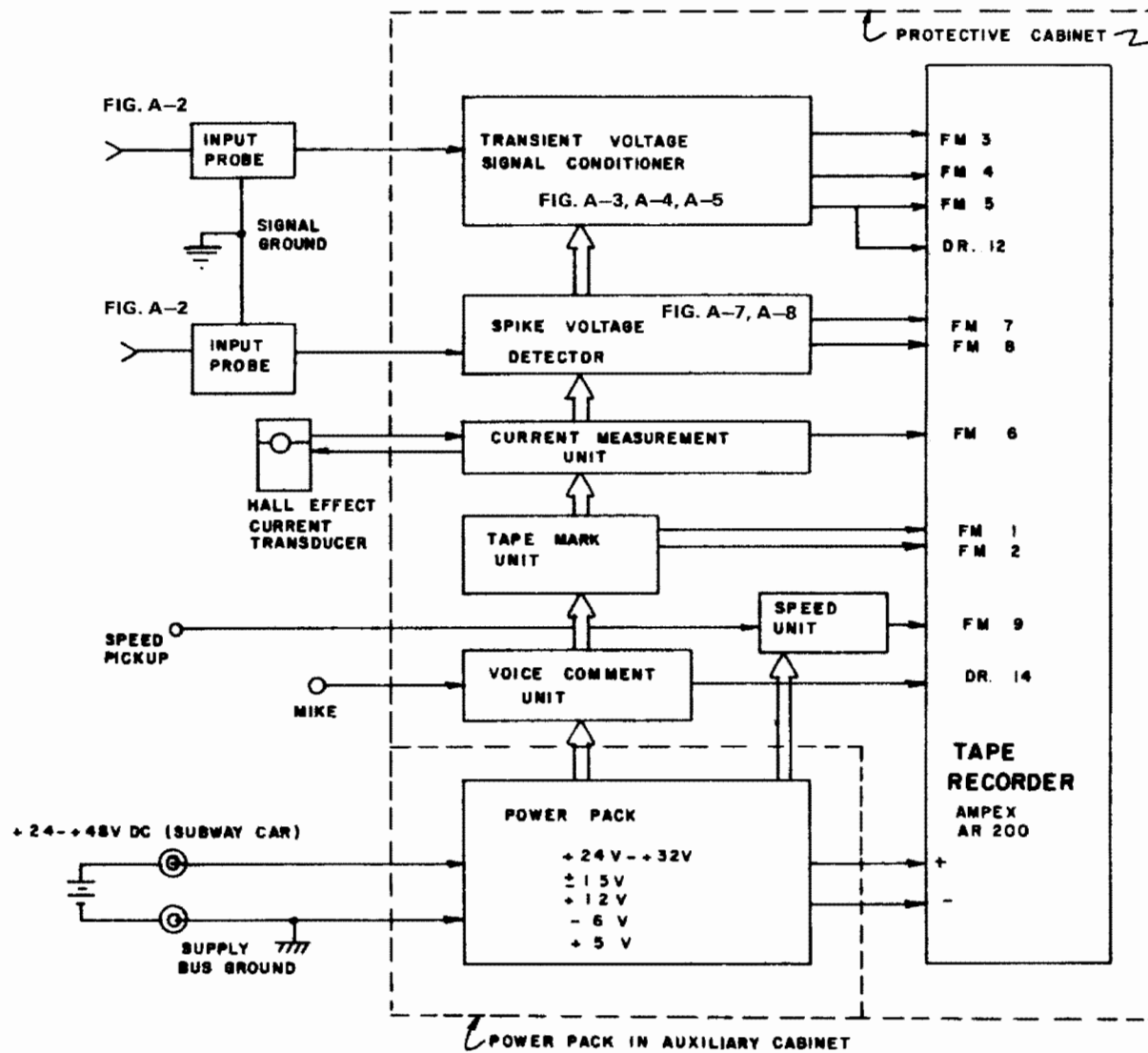
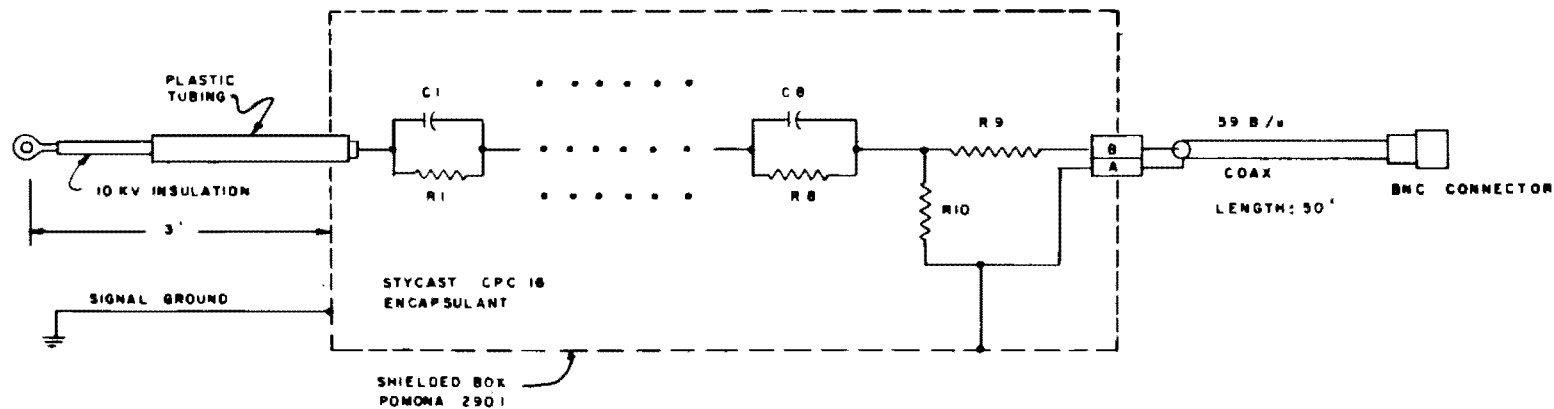

Figure A-1. General Block Diagram for Rapid Transient Recording System Voltage Transients and Spikes



A-3

TRANSIENT AND SPIKE INPUT PROBES PARTS LIST	
R1, R2, R3, R4	304 K ohm, ½ watt, ±1% Metal Film
R5, R6, R7, R8	
R9	75 ohm, ½ watt, ±1% Carbon
R10	499 K ohm, ½ watt, ±1% Metal Film
C1, C2, C3, C4	22 pf, 1000 volt, matched set
C5, C6, C7, C8	

Figure A-2. Transient and Spike Input Probe Circuit

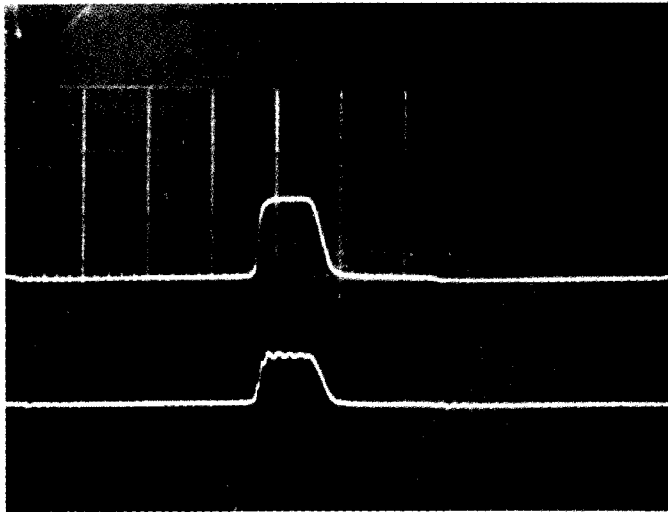

SCALE

UPPER TRACE: INPUT, VERT.
100 V/CM;

LOWER TRACE: OUTPUT, VERT.
0.1 V/CM;

HORIZ. 2 μ S/CM.

Figure A-3. Spike Probe and Cable Response

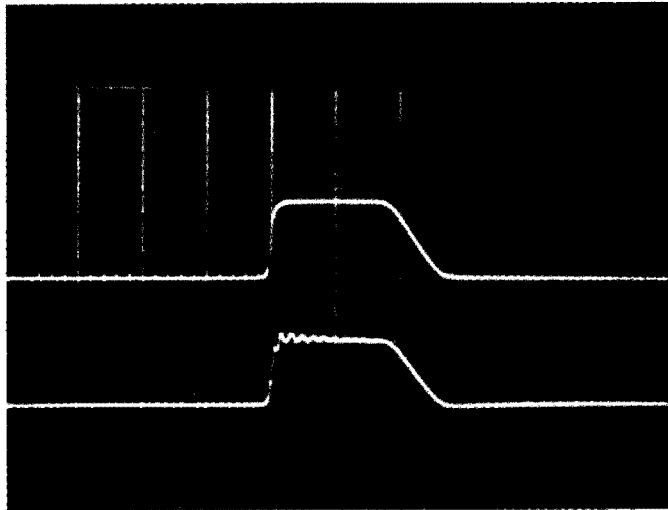

SCALE

UPPER TRACE: INPUT, VERT.
100 V/CM.

LOWER TRACE: OUTPUT, VERT.
0.1 V/CM.

HORIZ. 2 μ S/CM.

Figure A-4. Spike Probe and Cable Response

primary load for the spike voltage divider is located in the Operator Control Panel Unit. For the transient signal the primary load is located on the transient signal Amplifier "A" card, Figure A-5.

The probes were tested for insulation breakdown with 500 V_{AC} (RMS) equivalent to 7100 V_{DC} (spike).

2. Transient Signal Amplifier

The Transient Signal Amplifier A, shown in Figure A-5, provides the load for the Transient Signal Probe and zero suppression for a nominal +600v input signal. The nominal amplifier input voltage for a +600v probe voltage is +1.4 volts. The nominal signal gain for the amplifier is x(-1.4). The combined response of the probe, cable and amplifier A is $V_A = (600 - V_{in})/300$.

Transient Signal Amplifiers B, C, and D are shown in Figures A-6 and A-7. These amplifiers provide three sensitivity ranges of the line transient voltage signals for the input to the AR 200 recorder. The gains for amplifiers B, C, and D are X(-1.5), x(-0.5) and x(9.2) respectively. The combined response of the Transient probe, cable amplifiers A, B, C and D are:

$$V_B = (V_{in} - 600)/200$$

$$V_C = (V_{in} - 600)/600$$

$$V_D = (V_{in} - 600)/1500$$

These equations represent the nominal response of the transient recording system. For data analysis the response to measured calibration signals were used. The frequency response of amplifiers A, B, C and D is DC - 50 KHZ which is considerably above the recording capabilities of the AR 200 recorder at 3-3/4 ips Tape speed. Figure A-8 shows the response of the transient probe and amplifiers A and C to a 1000 V(RMS) AC 60 Hz sine wave.

3. Spike Voltage Detector (SVD)

The DC-1250 Hz response of the FM recording system and the 20KHz response of the direct recording system are insufficient to record voltage spikes which could have durations ranging from 2 to 100 μ s. (microseconds). The Spike Voltage Detector detects the existence of a spike in a given voltage band (see Table A-1) and generates a corresponding 1.5 ms. code signal which can be recorded and reproduced on the FM tape channel. In addition, mechanical counters, one for each voltage band, provide immediate reading and serve as a backup for the FM

SIGNAL INPUT

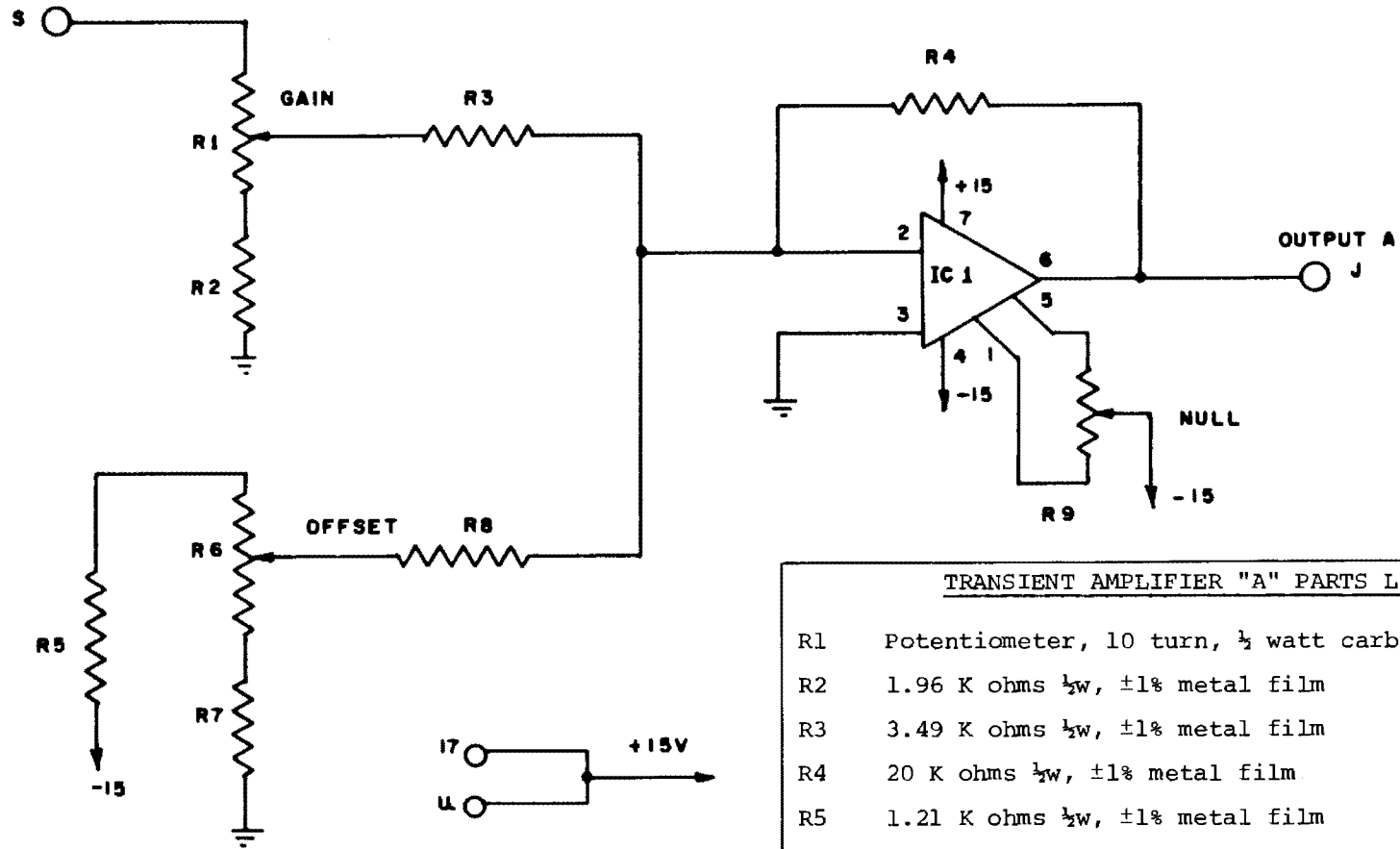

A-6

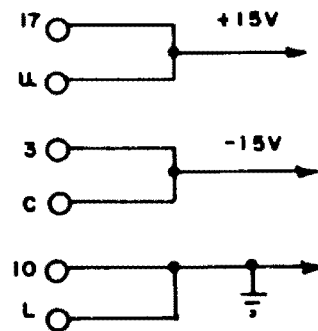

TRANSIENT AMPLIFIER "A" PARTS LIST

R1	Potentiometer, 10 turn, ½ watt carbon, 5K ohms, ±5%
R2	1.96 K ohms ½w, ±1% metal film
R3	3.49 K ohms ½w, ±1% metal film
R4	20 K ohms ½w, ±1% metal film
R5	1.21 K ohms ½w, ±1% metal film
R6	Potentiometer, 10 turn, ½ watt carbon, 500 ohms, ±5%
R7	200 ohms ½w, ±1% metal film
R8	40.2 K ohms ½w, ±1%, metal film
R9	Potentiometer, 10 turns, ½ watt carbon, 20K ohms, ±5%
IC-1	Integrated Circuit Operational Amplifier Signetics Type N5-741

Figure A-5. Transient Signal Amplifier "A" Circuit

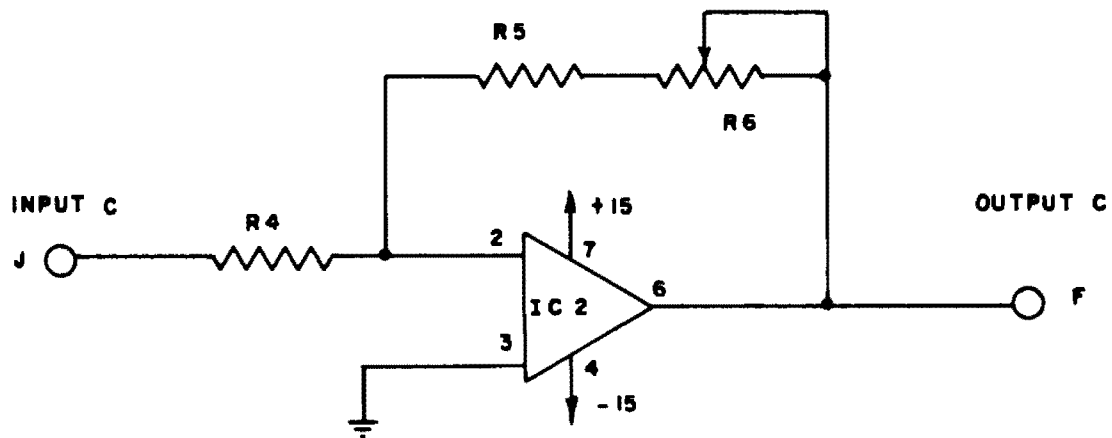
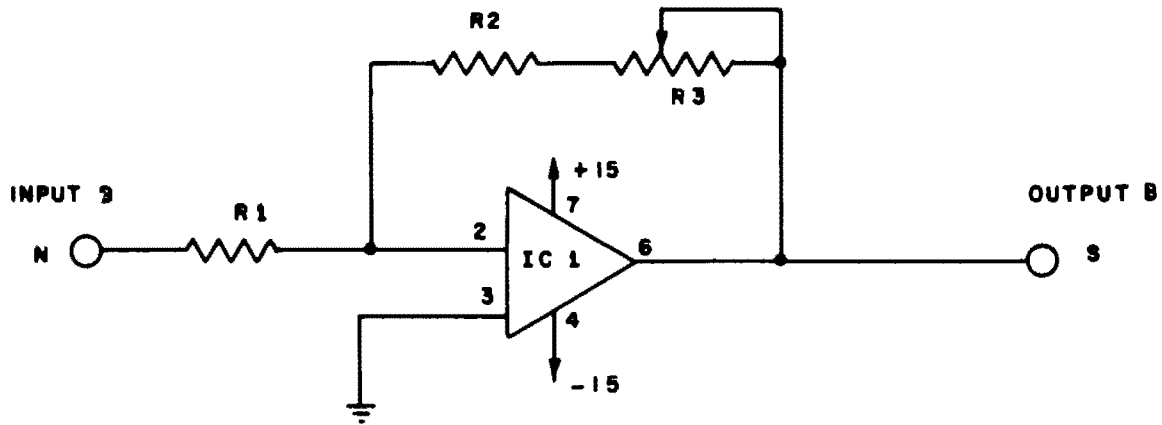

TRANSIENT SIGNAL AMPLIFIERS "B" AND "C" PARTS LIST

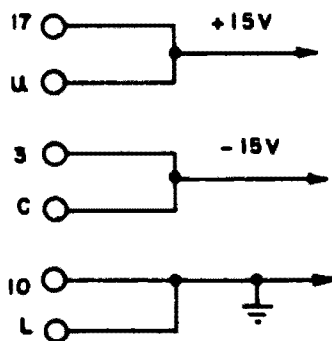

R1	4.02 K ohms, ±1% metal film
R2	5.11 K ohms, ±1% metal film
R3	Potentiometer, 10 turn, ½ watt carbon, 2 K ohms, ±5%
R4	12K ohms, ±1% metal film
R5	5.11K ohms, ±1% metal film
R6	Potentiometer, 10 turns, ½ watt carbon, 2K ohms, ±5%
IC-1,	Integrated Circuit Operational Amplifier
IC-2	Signetics N5-741

Figure A-6. Transient Signal Amplifiers "B" and "C"

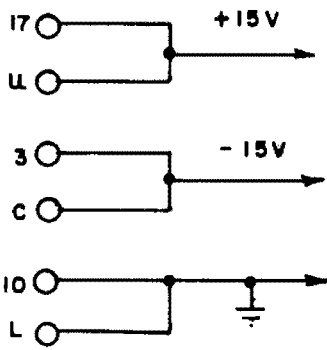
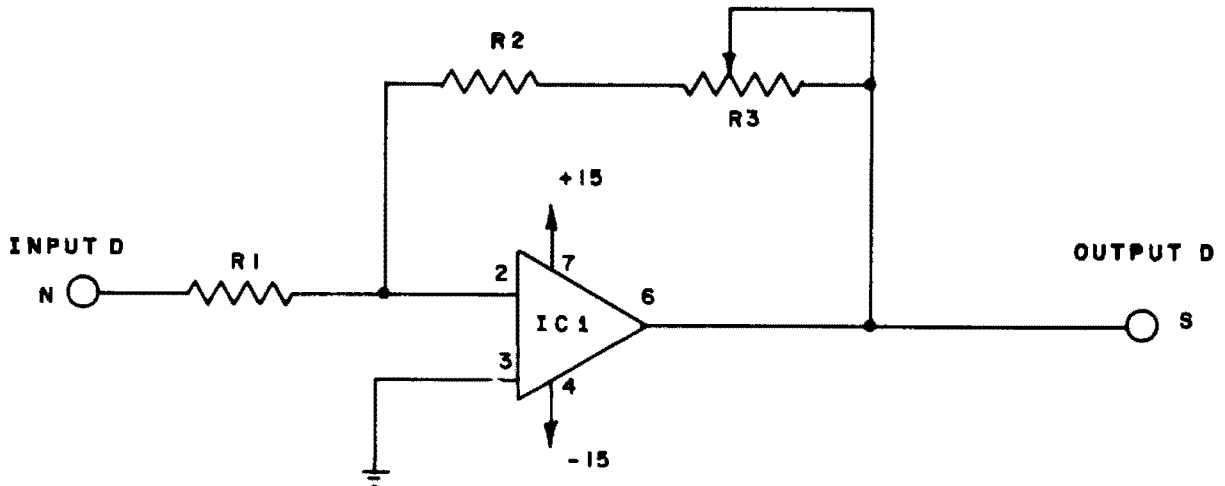

<u>TRANSIENT SIGNAL AMPLIFIER "D" PARTS LIST</u>	
R1	60.4 K ohms, ±1%, metal film
R2	10.5 K ohms, ±1%, metal film
R3	Potentiometer, 10 turn, ½ watt carbon, 5 K ohms
IC-1	Integrated Circuit Operational Amplifier Signetics N5-741

Figure A-7. Transient Signal Amplifier "D" Circuit

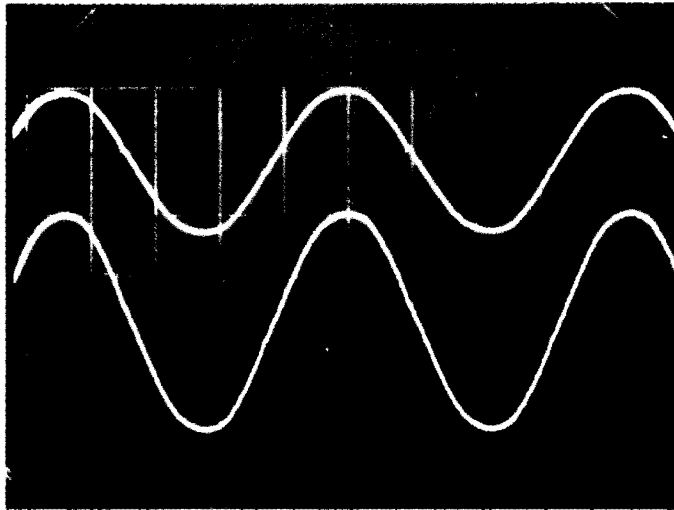

INPUT: 1000 VAC, 60 HZ.
UPPER TRACE: RESPONSE OF PROBE
AND CABLE
VERT. SCALE 2V/CM.
LOWER TRACE: RESPONSE OF AMPLI-
FIER C
VERT. SCALE, 1V/CM.
HORIZ. SCALE, 4 MS./CM.

Figure A-8. Transient Unit Signal Response

TABLE A-1. VOLTAGE BANDS FOR THE TRANSIENT EVENT ANALYSIS

Positive Event Voltage Bands

700 to 800 volts
800 to 900 volts
900 to 1000 volts
1000 to 1100 volts
1100 to 1200 volts
1200 to 1300 volts
1300 to 1400 volts
1 00 to 1500 volts
1500 to 1600 volts
1600 to 1800 volts
1800 to 2000 volts
2000 to 3000 volts

Negative Event Voltage Bands

550 to 520 volts
520 to 490 volts
490 to 460 volts
460 to 430 volts
430 to 400 volts
400 to 370 volts
370 to 340 volts
340 to 240 volts
240 to 140 volts
140 to 40 volts
40 to -40 volts
-40 to -140 volts
-140 to -240 volts
-240 to -340 volts
-340 to -440 volts
-440 to -1800 volts

tape system. A block diagram of the SVD is shown in Figure A-9. Two separate identical sections are provided, one for positive and one for negative spikes. The two sections enable other spikes of opposite polarity to be detected, if they occur during the 1.5 ms (milliseconds) output code signal period.

4. Wide Band Spike Amplifier (WBSA)

The Wide Band Spike Amplifier is shown in Figure A-10. The nominal input voltage to the amplifier for a 1000 volt spike signal is 1 volt. The amplifier divides the signal into its positive and negative parts. This division is necessary to limit the maximum differential input voltage applied to the Voltage Discriminator Units to $\pm 5V$. This limit allows spike magnitudes of at least 5000 volts without instrumentation damage. Figure A-11 shows the input from the spike probe and cable to the WBSA for a 6000 V_{ac} , 60 Hz input signal. A small amount of distortion is observed near zero volts. This distortion also appears in the two amplifier outputs and its effect is compensated by the calibration procedure.

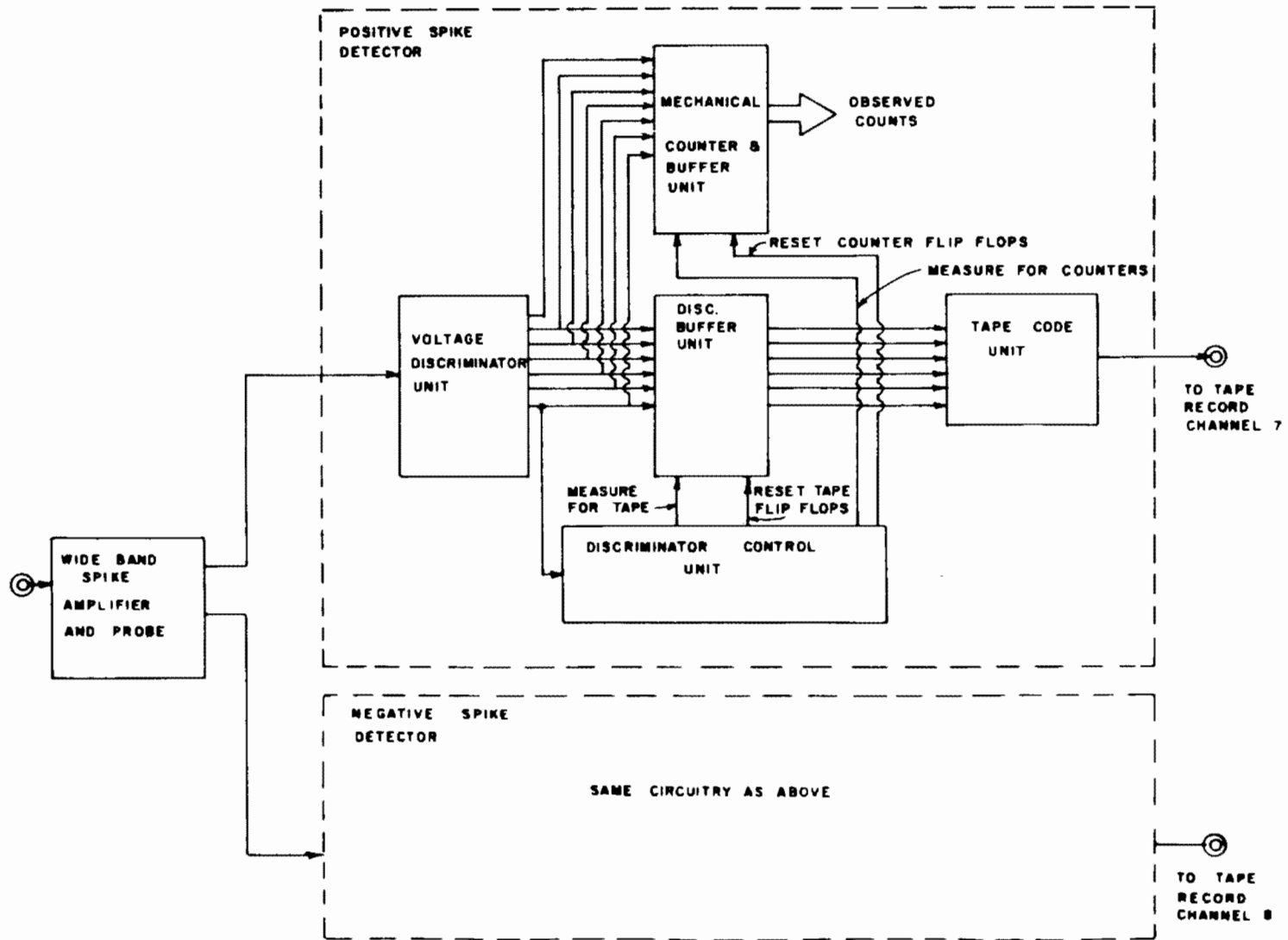
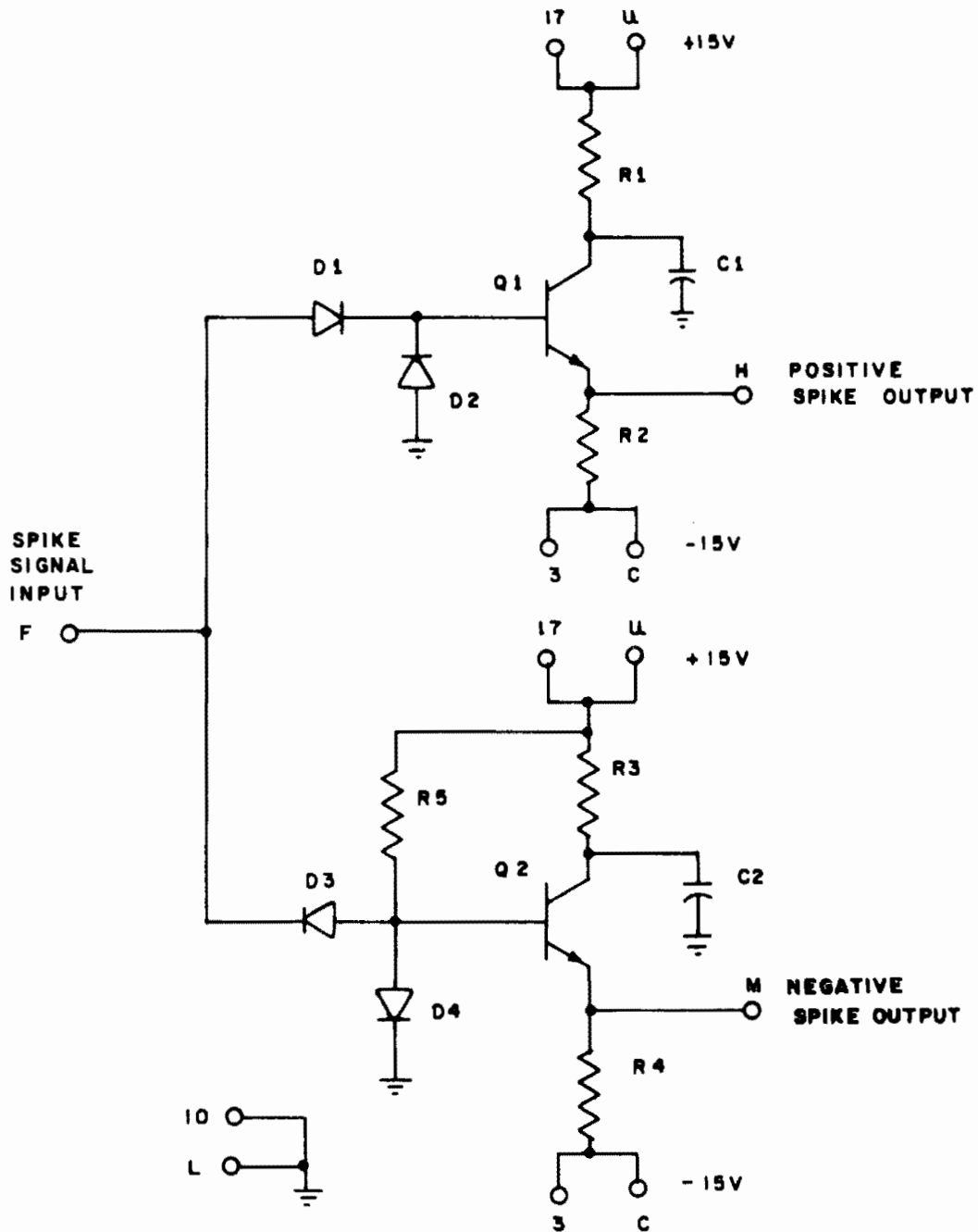

Figure A-9. Spike Voltage Detector Circuit



WIDE BAND SPIKE AMPLIFIER PARTS LIST

D1, D2, D3, D4	IN472 Texas Instrument Diodes
R1, R3	680 ohm 1 w, $\pm 10\%$ carbon
R2, R4	2.2 K ohm $\frac{1}{2}$ w, $\pm 10\%$ carbon
C1, C2	.01 MFD. 100 volt, $\pm 10\%$, Polyester
Q1, Q2	2N1613 (heat sinks attached)

Figure A-10. Wide Band Spike Amplifier Circuit

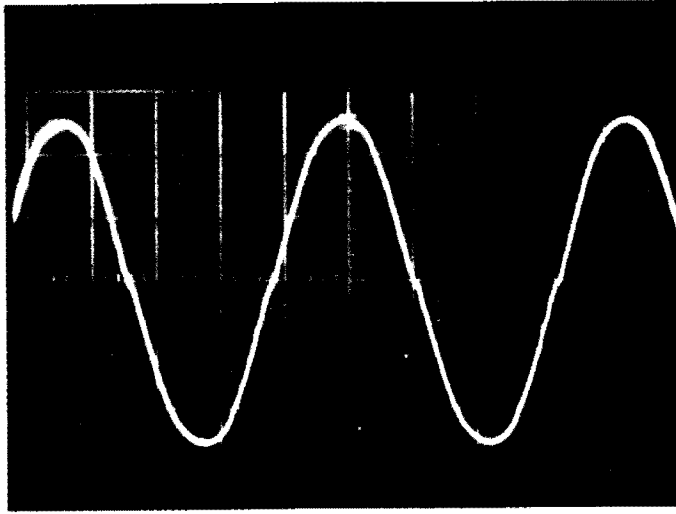

INPUT: 6000 VAC, 60 HZ.
SCALE: VERT. 2V/CM.
HORIZ. 4 MS./CM.

Figure A-11. Spike Probe, Cable and Amplifier Response

COMPUTER PROGRAM

Computer processing was performed on the University of Missouri-Columbia (UMC) Systems Engineering Laboratories (SEL) 840A process control computer and an IBM 360/50 data processor, belonging to the UMC College of Engineering.

1. Summary Description

The ADC computer program on the SEL 840A computer converted all data channels in one pass of a data tape and combined the data for 500 sample points into one tape block on a digital magnetic tape (total block time 0.250 seconds). The program was double buffered so that A to D conversion continued during block write time. The A to D converter had a resolution of 10 bits and sign (11 bits total) and utilized a simultaneous sample-hold multiplexer. The ADC computer program is proprietary to the UMC Department of Electrical Engineering for use with the SEL 840A computer.

The digital magnetic tape data were processed using the UMC College of Engineering Computer IBM 360-50 and Computer Program SUBWAY 1 (Figure A-12). This program produces a result listing and card output for each record in the run.

Computer Program SUBWAY 2 (Figure A-13) further summarizes the card outputs from SUBWAY 1 for a group (e.g., rush hour) of records.

Program SUBWAY 1 processes the data in each record as follows:

1. It performs transient event detection and analysis.
2. It accumulates spike counts in each spike voltage band.
3. It calculates the voltage experimental probability density (or voltage amplitude histogram).
4. It calculates the current experimental probability density (or current histogram).
5. It determines the maximum and minimum currents during transient events.
6. It records currents during spikes.
7. It determines the record length.

Program SUBWAY 2 summarizes the results of process items 1, 2, 3 and 7 for the record group.

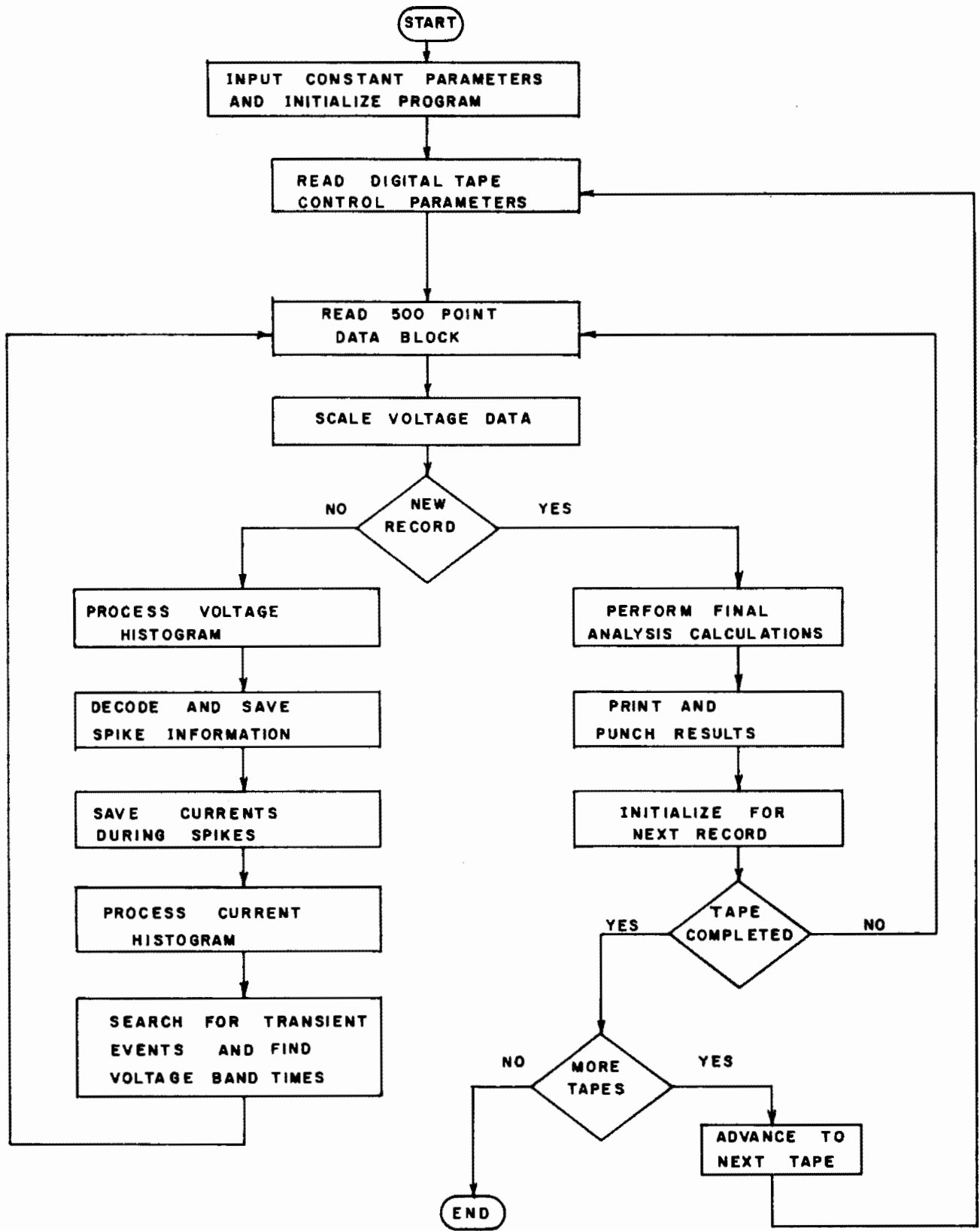

Figure A-12. General Flow Chart for "SUBWAY 1" Program (Main Computer Analysis Program)

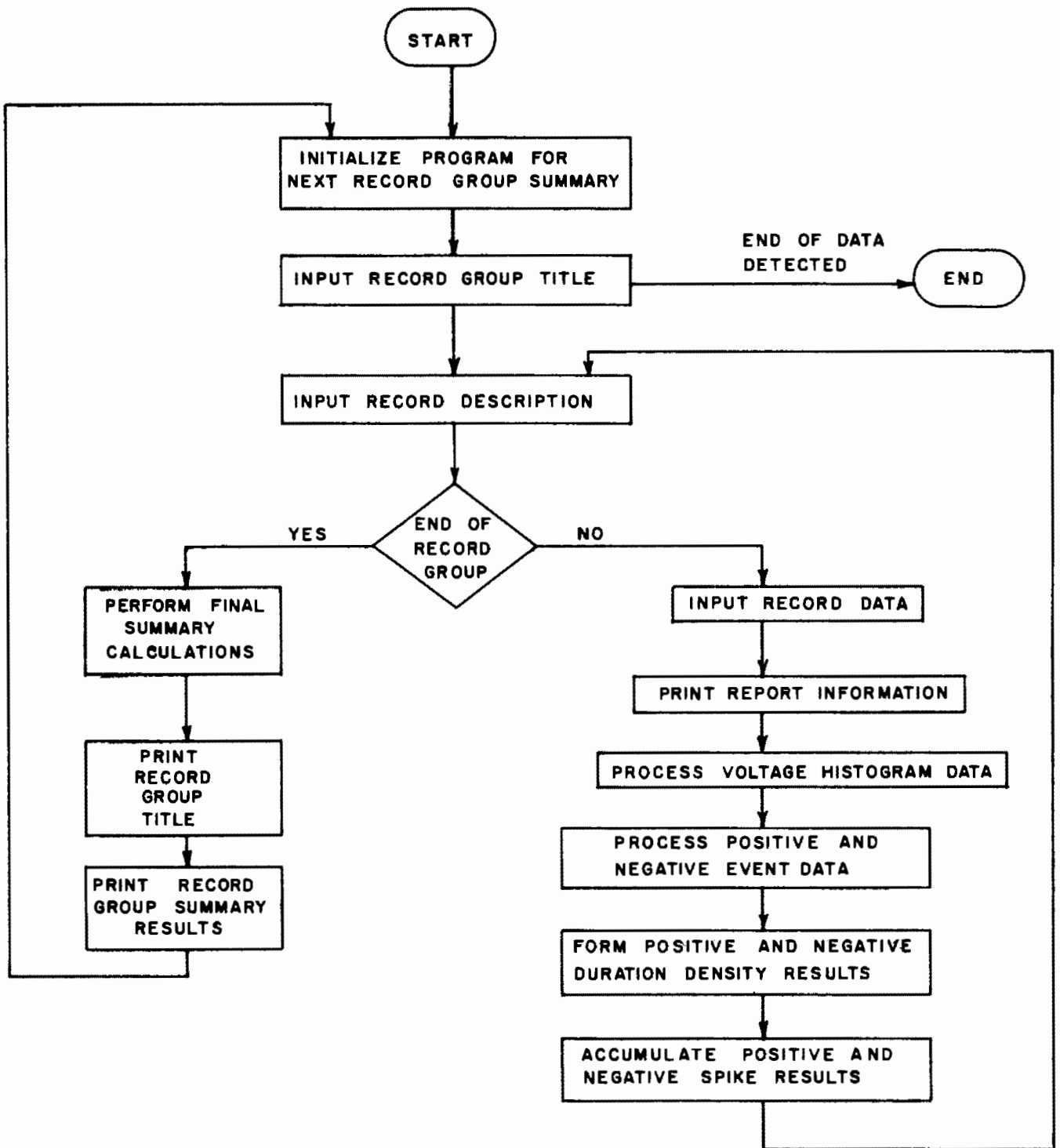

Figure A-13. General Flow Chart for "SUBWAY 2" Computer Program

Voltage Transients

For the program SUBWAY 1, a "Positive Event" was defined as an excursion of the 600V line voltage above 700 volts. A "Negative Event" was defined as a deviation of the 600V line voltage below 550 volts. Program SUBWAY 1 also determines the maximum time for which any of the transient events in the record remains in a specified voltage band. This time interval is calculated from the sample points per band and is referred to as the "voltage band time" or "band time". An illustration of this process for a simulated negative event is shown in Figure A-14. A list of the voltage bands used in the transient event analysis is given in Table A-1.

Group summary results for the transient event analysis were obtained by program SUBWAY 2 and are shown in the transient plots. The voltage band between +550 and +700V is a region of assumed continuous operation in which no transient event calculations were made. It should be noted that the voltage band between -40V and +40V is also a region of continuous operation even if during some tests no transient events were observed in this band. When the time scale was insufficient to display the total voltage band time, the band time (milliseconds) was entered at the right hand margin of the transient plots.

Programs SUBWAY 1 and SUBWAY 2 also evaluate the experimental probability density of the excursions from the nominal 600V line voltage (transient voltage signals). Density values indicate the probability that a particular line voltage occurs within the 20 voltage bands.

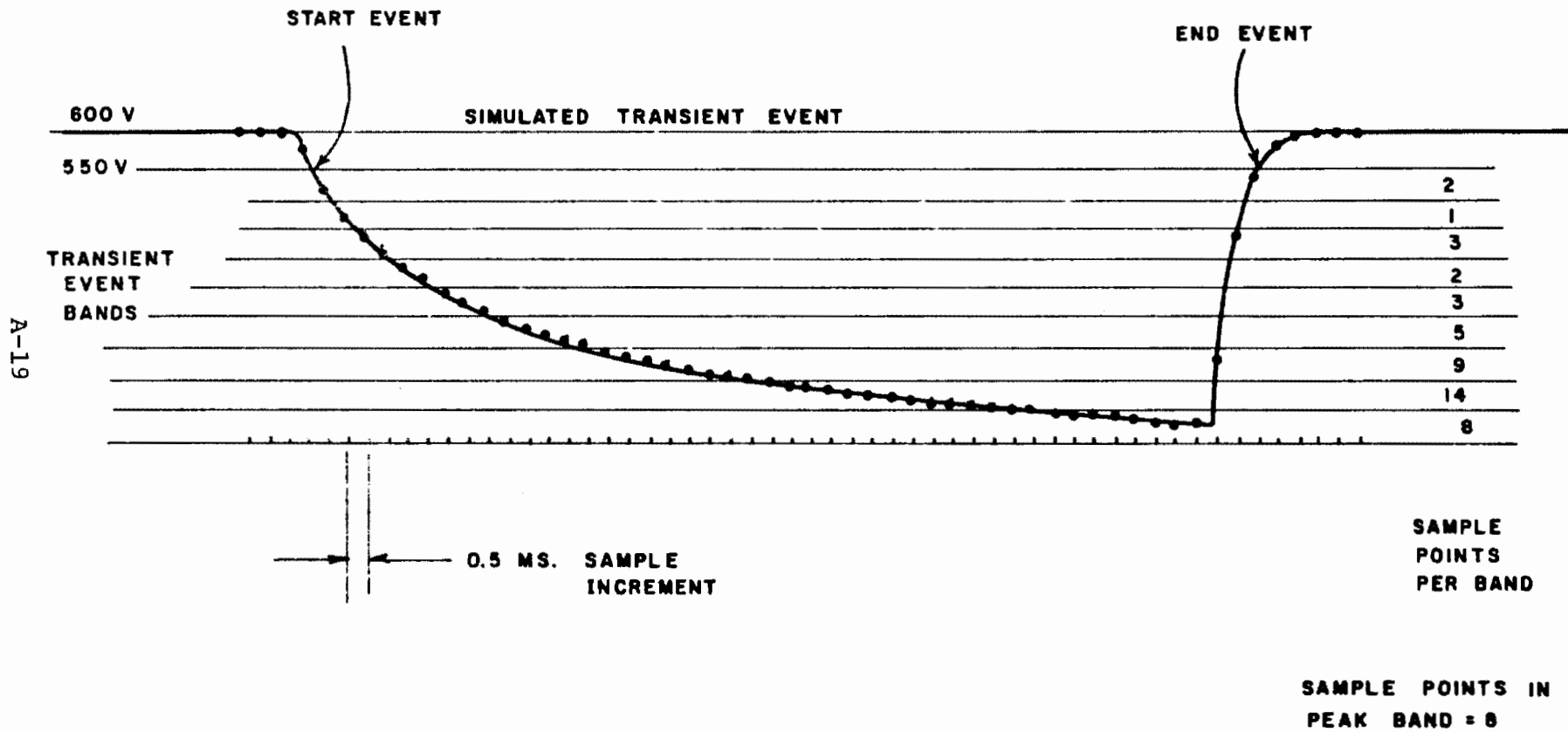
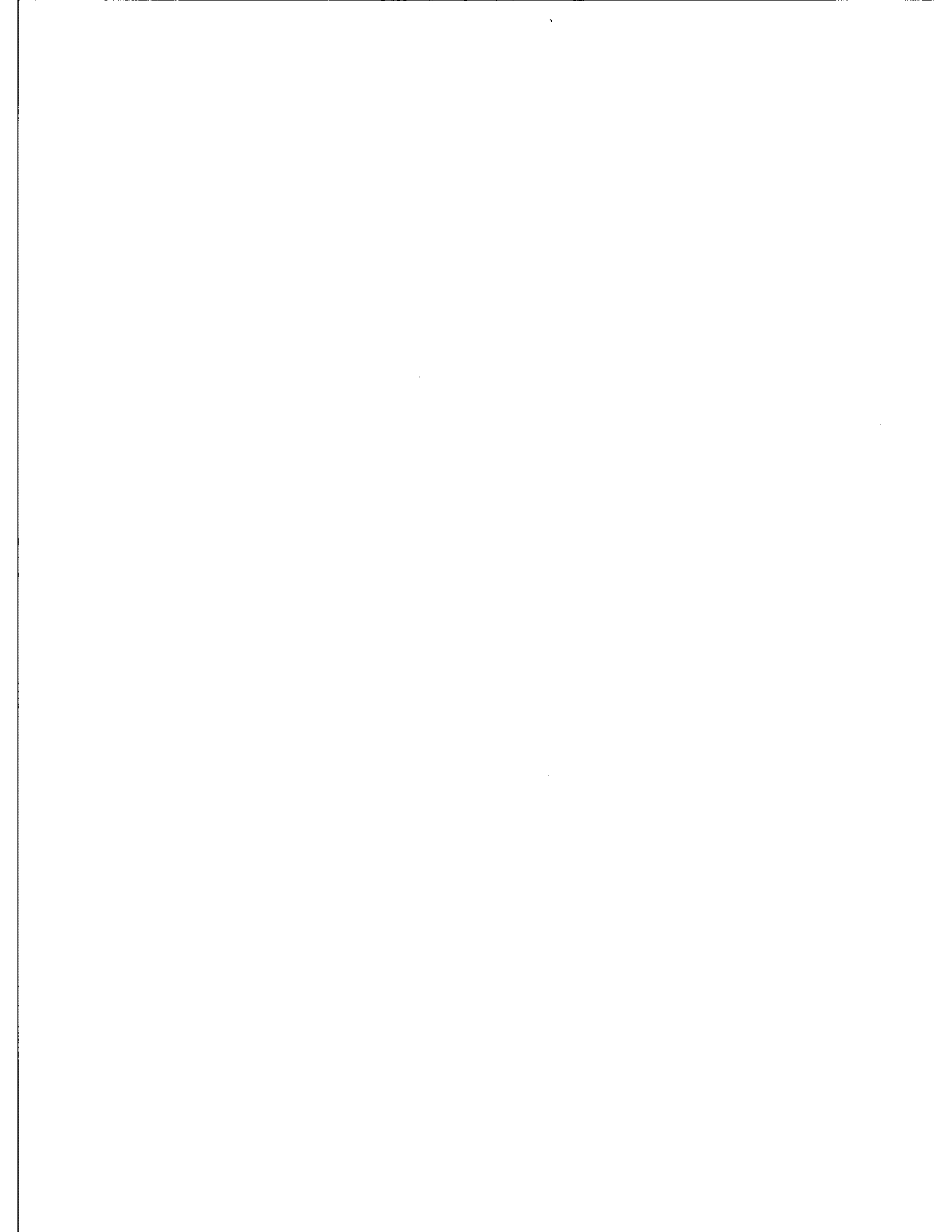

Figure A-14. Application of the Transient Algorithm to a Simulated Transient Event



REFERENCES

1. SOAC FINAL TEST REPORT, D174-10024-1, Boeing Vertol Company, Philadelphia, Pa., October 1973
2. INVESTIGATION OF VOLTAGE TRANSIENTS AND SPIKES IN DIRECT CURRENT RAPID TRANSIT SYSTEMS, Final Report, IT-06-0026-73-3, UMTA, June 1973.
3. ELECTROMAGNETIC INTERFERENCE ON BART VEHICLE NO. 107, Final Test Report, Contract No. 2Z4602, Electromagnetic Filter Company, Inc., September 28, 1971.

