

Report No. FHWA-RD-76-26

# GROUTING IN SOILS

S.C.R.T.D. LIBRARY

Vol. 1. A STATE-OF-THE-ART REPORT

Joe Herndon, Tom Lenahan



June 1976  
Final Report



THIS DOCUMENT IS AVAILABLE TO THE PUBLIC  
THROUGH THE NATIONAL TECHNICAL INFORMATION  
SERVICE, SPRINGFIELD, VIRGINIA 22161

Prepared for  
FEDERAL HIGHWAY ADMINISTRATION  
Offices of Research & Development  
Washington, D.C. 20590

### NOTICE

This document is disseminated under the sponsorship of the Department of Transportation in the interest of information exchange. The United States Government assumes no liability for its contents or their use.

The contents of this report reflect the views of Halliburton Services - Duncan, Oklahoma, which is responsible for the facts and the accuracy of the data presented herein. The contents do not necessarily reflect the official views or policy of the Department of Transportation. This report does not constitute a standard, specification, or regulation.

The United States Government does not endorse products or manufacturers. Trade or manufacturers' names appear herein only because they are considered essential to the object of this document.

### FHWA DISTRIBUTION

Sufficient copies of this report are being distributed by FHWA Bulletin to provide two copies to each regional office, one copy to each division office, and two copies to each State highway department. Direct distribution is being made to the division offices.

|   |  |  |           |
|---|--|--|-----------|
| 1. Report No.<br>FHWA-RD-76-26  | 2. Government Accession No.                          | 3. Recipient's Catalog No.   |           |
| 4. Title and Subtitle<br>GROUTING IN SOILS<br>VOL. 1 - A STATE-OF-THE-ART REPORT  |  | 5. Report Date<br>June 1976  |           |
|   |  | 6. Performing Organization Code  |           |
| 7. Author(s)<br>Joe Herndon, Tom Lenahan  |  | 8. Performing Organization Report No.  |           |
| 9. Performing Organization Name and Address<br>Halliburton Services<br>P. O. Drawer 1431<br>Duncan, OK. 73533   |  | 10. Work Unit No. (TRAIS)  |           |
|   |  | 11. Contract or Grant No.<br>DOT-FH-11-8517  |           |
| 12. Sponsoring Agency Name and Address<br>Offices of Research and Development<br>Federal Highway Administration<br>U.S. Department of Transportation<br>Washington, D.C. 20590  |  | 13. Type of Report and Period Covered<br>Final Report  |           |
|   |  | 14. Sponsoring Agency Code   |           |
| 15. Supplementary Notes<br>FHWA Contract Manager: J. R. Sallberg (HRS-11)   |  |  |           |
| 16. Abstract<br><p>This report summarizes present grouting technology applicable to soils. It includes all aspects of grouting, from theory to present practices; from the history of grouting to recommendations for improved techniques. The information was obtained from published and unpublished reports, job inspections, interviews of grouting specialists in both the United States and Europe, and the writers' past experience.</p> <p>A companion report, Volume 2 (FHWA-RD-76-27) is entitled "Design and Operations Manual."</p> |  |  |           |
| 17. Key Words<br>Foundation construction, soil grouting, water control, grouts, grout techniques injection, contracts.  |  | 18. Distribution Statement<br>No restrictions. This document is available through the National Technical Information Service, Springfield, Virginia 22161. |           |
| 19. Security Classif. (of this report)<br>Unclassified  | 20. Security Classif. (of this page)<br>Unclassified | 21. No. of Pages<br>303  | 22. Price |

## PREFACE

Volume 1 of this two-volume report presents the current state-of-the-art on all aspects of grouting from theory to field practices. Particular applications are given for cut-and-cover construction and soft ground tunneling. Conclusions are drawn, and recommendations are made for improvements in the grouting field. Also included in this volume are:

- (1) A summary of the patents applicable to grouting.
- (2) A list of grouting specialists, and material and equipment suppliers.
- (3) A bibliography of publications on grouting.
- (4) Unpublished case histories of grouting jobs.

This report is based on information from four sources: interviews with companies in the grouting or construction business, inspections of grouting jobs, reviews of the literature, and personal experiences of the writers. Information for the report was difficult to obtain because of the scarcity of case histories on soil grouting. Contract documents do not normally require a written report, so very few detailed records have been kept on grouting jobs by either construction companies or engineering firms. Documentation on successful jobs is generally limited to that used by the grouting companies in their advertising brochures, papers published by grouting personnel and a few unpublished reports. On European jobs, pressure and flow rate charts are made during the grout injection and given to the owner to document the grouting work; however, reports are not usually written about the grouting job.

01015

TA  
434  
.H37  
v.1

## ACKNOWLEDGEMENTS

The authors acknowledge with gratitude the assistance given by the following in the preparation of this report:

To Dr. R. L. Handy of Iowa State University for his contributions to the sections dealing with grouting theory and his review and helpful comments on the entire report.

To Mr. J. R. Sallberg, Contract Manager for the Federal Highway Administration, Department of Transportation, for his helpful suggestions and constructive criticism throughout the entire study.

To Mr. Carl Bock, Bechtel Associates, Washington, D. C., for his review of the reports and his pertinent comments and suggestions.

To Mrs. Clara Bishop of Halliburton Services for her assistance in the accumulation of literature and her patience and endurance in typing of the report.

And, to all the following people who cooperated in the study by giving time for interviews or furnishing materials for the report.

American Cyanamid Company - Wayne, New Jersey  
William J. Clarke

Antwerpse Bouwwerken Verbeeck, Antwerp, Belgium  
Luc Adriaenssen

Bechtel Associates - Washington, D. C.  
Frank C. Waram  
Jim Daley  
Jim McDermott

The Cementation Company, Ltd. - Croydon, Surrey, England  
Peter Jessop  
John Hislam  
Dr. R. A. Scott

Cementation Research, Ltd. - Rickmansworth, Herts, England  
F. H. Hughes  
Tom Hutchinson  
Mike Ling

Dames and Moore - Chicago, Illinois  
Dr. Pete Conroy  
Dr. Charles Heidengren

ECI - Soletanche, Inc. - Pittsburgh, Pennsylvania  
David J. D'Appolonia

E.N.E.L. (Italian National Electric) - Rome, Italy  
Dr. Capozza

Foundation Sciences, Inc. - Portland, Oregon  
Donald J. Dodds

Fruin-Collon Corporation - Washington, D. C.  
Ron Bills  
George Williamson

Geosonda - Rome, Italy  
Claudio Soccodato  
Lucio Diamanti

Geotecna - Milan, Italy  
Dr. Nicola Allaria  
Dr. Meisina

Geron Restoration Corporation - Saratoga Springs, New York  
Norman Wagner

Grow Tunnelers - New York, New York  
Paul DeMarco  
Henry Jacoby  
George Fox

Harza Engineering Company - Chicago, Illinois  
Keith Willey  
Dr. Ray LaRusso  
Svanti Hjertberg

Hayward Baker Grouting Company - Odenton, Maryland  
Wallace H. Baker

Horn Construction Company, Merrick, L.I., New York  
Burton Kassap  
Steve Pirrelli

Hunt Process Company - Santa Fe Springs, California  
Slade Rathbun

I.C.O.S. - Milan, Italy  
Dr. Nicolai Jurina  
Mr. Bellini

Intrusion Prepakt Company - Cleveland, Ohio  
Paul Smith  
Bruce Lamberton

Iowa State University - Ames, Iowa  
Dr. R. L. Handy

METRO - Amsterdam, Netherlands

METRO - Hamburg, Germany  
Rudolph Stoppenbrink

METRO - Hanover, Germany  
Frederick Weiss

Metropolitana Milanese s.p.s. - Milan, Italy  
Antonio Salvini

Nederhorst Grondtechniek - Gouda, Netherlands  
K. F. Brons

Parsons, Brinkerhoff, Quade & Douglas  
Peter VanderSloot - St. Louis, Missouri  
Tom Kuesel - New York, New York  
Dr. Birger Schmidt - New York, New York

Penetryn System, Inc. - Latham, New York  
Ed Stringham  
A. B. Colthorp

PRE-METRO M.I.V.A., Antwerpen, Belgium  
L. DeRoy

Pressure Grout Company - Daly City, California  
Ed Graf

Raymond International, Inc. - Cherry Hill, New Jersey  
Joe P. Welsh

S.A.R.A. (Societa Autostrada Romane e Abruzzisi), L'Aquila, Italy  
Dr. Castellano  
Sr. Marini

Soil Mechanics, Ltd. - Bracknell, Berkshire, England  
Kristin Moller  
Dr. B. O. Skipp

Soletanche Entreprise - Lyon, France  
Philippe Mahler  
Jean Pierre Banachau

Soletanche Entreprise - Paris, France  
Guy LeSciellour  
Jacque Levallois

Soletanche Laboratory - Montereau, France  
Dr. C. Caron

SWIBO - Vienna, Austria  
Jacques Gardes  
Bernard Tarralle

TAMS Consulting Engineers - New York, New York

Terra-Chem, Inc. - Dayton, New Jersey  
Herbert L. Parsons

Terrafreeze Corporation - Lorton, Virginia  
Bernd Braun

U-Bahn - Vienna, Austria  
Dipl. Ing. Walter Hinkel

Warner Engineering Services - Los Angeles, California  
James Warner



TABLE OF CONTENTS

|   |      |
|---|------|
| Documentation Page - - - - -                                  | i    |
| Preface- - - - -  | ii   |
| Acknowledgements - - - - -                                    | iii  |
| Table of Contents- - - - -                                    | vii  |
| List of Figures - - - - -                                     | xi   |
| List of Tables - - - - -                                      | xiii |
| List of Symbols- - - - -                                      | xiv  |
| <br>  |      |
| 1. INTRODUCTION - - - - -                                     | 1    |
| 2. GROUTING PRACTICES - - - - -                               | 3    |
| A. Grouting Fundamentals- - - - -                             |      |
| B. Grouting Theory (For True Solution Grouts) - - - - -       | 3    |
| 1. Physical Characteristics of Fluids - - - - -               | 5    |
| 2. Fluid Pressure Under Static Conditions - - - - -           | 5    |
| a. Variations of Pressure with<br>Depth in a Liquid - - - - - | 5    |
| 3. Pressure Measurement - - - - -                             | 6    |
| a. Pressure Measurement Devices - - - - -                     | 7    |
| 4. Flow of Water Under Pressure - - - - -                     | 7    |
| a. Fluid in Motion- - - - -                                   | 7    |
| b. Rate of Flow - - - - -                                     | 8    |
| c. Energy Equation- - - - -                                   | 9    |
| d. Friction Loss in Pipes and Fittings- - - - -               | 11   |
| 5. Flow Through Soils - - - - -                               | 12   |
| a. Flow of Water- - - - -                                     | 12   |
| b. Flow of Viscous Grouts - - - - -                           | 12   |
| C. History of Grouting- - - - -                               | 14   |
| D. Current Practices- - - - -                                 | 19   |
| E. Evaluation of Current Grouting Practices - - - - -         | 26   |
| <br>  |      |
| 3. GROUTING APPLICATIONS- - - - -                             | 28   |
| A. Waterstop- - - - -   | 28   |
| 1. Dam Foundations- - - - -                                   | 28   |
| 2. Cut-and-Cover- - - - -                                     | 29   |
| 3. Tunnel Boring- - - - -                                     | 33   |
| 4. Remedial Grouting- - - - -                                 | 34   |
| 5. Slurry Trench- - - - -                                     | 34   |

|    |  |    |
|----|--|----|
| B. | Strengthen Natural Soil Deposits-  | 34 |
| 1. | Under Footings and Foundations-  | 34 |
| 2. | For Tunnel Excavation -  | 36 |
| 3. | In Cut-and-Cover-  | 40 |
| C. | Compaction Grouting -  | 41 |
| D. | Tieback Anchorages-  | 41 |
| E. | Backpacking Tunnel Liners -  | 45 |
| F. | Alternate Use of Freezing -  | 45 |
| 4. | SITE INVESTIGATION AND SOIL TESTING-   | 48 |
| A. | Drilling and Sampling-   | 49 |
| B. | Soil Properties Affecting Grouting -   | 49 |
| 1. | Permeability -   | 50 |
| a. | Permeameter Tests for Permeability -   | 50 |
| b. | In Situ Tests for Permeability -   | 52 |
| 2. | Porosity -   | 55 |
| 3. | Particle Size Distribution -   | 56 |
| 4. | Pore Size Distribution -   | 59 |
| a. | Mercury Injection Method -   | 60 |
| b. | Errors in Assumptions-   | 62 |
| c. | Analysis of Groutability Related to Soil Pore<br>Size and Grout Particle Size- | 63 |
| d. | Grouting Pressure and Seepage Forces -   | 64 |
| C. | Geographical and Geological Data -   | 64 |
| 5. | GROUT MATERIAL SELECTION -   | 66 |
| A. | General Considerations -   | 66 |
| B. | Choice of Applicable Grout Groups-   | 66 |
| C. | Grout Properties -   | 72 |
| 1. | Viscosity Characteristics-   | 72 |
| 2. | Setting Time -   | 76 |
| 3. | Strength -   | 77 |
| a. | Strength Theory-   | 80 |
| b. | Strength Tests of Grout Material -   | 83 |
| 4. | Water Tightness-   | 84 |
| 5. | Stability or Permanence-   | 84 |
| 6. | Toxicity -   | 85 |
| D. | Grout Testing - Laboratory and Field -   | 85 |
| 6. | GROUT EQUIPMENT-   | 86 |
| A. | Drilling and Driving Equipment -   | 86 |
| B. | Mixing and Pumping Equipment -   | 86 |
| 1. | Handling of Materials-   | 86 |
| 2. | Grout Mixing and Pumping -   | 88 |
| a. | Cement Type Grout-   | 88 |
| b. | Chemical Grouts-   | 88 |
| C. | Injection Piping -   | 91 |
| 1. | Drive Points -   | 93 |
| 2. | Pipe in Boreholes-   | 94 |

|    |  |     |
|----|--|-----|
| 3. | Tube à Manchette and Stabilator - - - - -                                    | 95  |
| 4. | Other Types of Injection Pipes- - - - -                                      | 95  |
| D. | Monitoring Equipment- - - - -  | 98  |
| 7. | GROUT INJECTION PRINCIPLES - - - - -   | 99  |
| A. | Theoretical Considerations- - - - -  | 99  |
| 1. | Mathematical Theory - - - - -  | 99  |
| a. | Water Saturated Soils - - - - -  | 99  |
| b. | Injection from Slotted Pipe or<br>Tube à Manchette - - - - -                 | 106 |
| c. | Effect of Dry Soils - - - - -  | 107 |
| d. | Non-Newtonian Grouts and the Limiting Sphere- - - - -                        | 108 |
| 2. | Theory of In Situ Stress Modification by Grouting - - - - -                  | 113 |
| a. | Grouting Pressure to Induce Shear Failure - - - - -                          | 117 |
| b. | Grouting Pressure Against Walls - - - - -                                    | 119 |
| c. | Grouting Pressure in Tunneling- - - - -                                      | 122 |
| d. | Landslides- - - - -  | 123 |
| e. | Foundation Grouting - - - - -  | 123 |
| B. | Practical Aspects - - - - -  | 123 |
| 1. | Grout Penetration - - - - -  | 123 |
| 2. | Grid Patterns - - - - -  | 125 |
| 3. | Job Planning- - - - -  | 128 |
| C. | Injection Quality Control - - - - -  | 130 |
| D. | Safety and Environmental Considerations - - - - -                            | 130 |
| 8. | FIELD TESTS OF GROUTED SOILS - - - - -                                       | 132 |
| A. | Introduction- - - - -  | 132 |
| B. | Current Practices - - - - -  | 132 |
| 1. | Sampling and Laboratory Testing - - - - -                                    | 132 |
| 2. | Permeability Testing- - - - -  | 134 |
| 3. | In Situ Strength Tests- - - - -  | 134 |
| a. | Pressuremeter - - - - -  | 134 |
| b. | Borehole Shear Test - - - - -  | 137 |
| c. | Goodman Jack- - - - -  | 139 |
| 4. | Relation of Test Information to Unconfined<br>Compressive Strength - - - - - | 140 |
| 5. | Performance Evaluation- - - - -  | 141 |
| C. | New Concepts- - - - -  | 141 |
| 9. | SLURRY TRENCH AND DIAPHRAGM WALL CONSTRUCTION- - - - -                       | 143 |
| A. | Current Practices - - - - -  | 143 |
| 1. | Steel Beam and Concrete Panel Wall- - - - -                                  | 145 |
| 2. | Jointed-End Panels- - - - -  | 146 |
| 3. | Precast Concrete Panels - - - - -  | 146 |
| 4. | Other Excavation Methods- - - - -  | 147 |
| B. | Engineering Characteristics of Trench Slurry- - - - -                        | 148 |
| C. | Specification and Cost Data - - - - -  | 152 |

|     |   |     |
|-----|---|-----|
| 10. | CONTRACT DOCUMENTS AND SPECIFICATIONS - - - - -           | 154 |
|     | A. Current United States Contracting Practices - - - - -  | 154 |
|     | B. Current European Contracting Practices- - - - -        | 155 |
|     | C. Contractual Problems with Grouting Contractors - - - - | 156 |
| 11. | SUMMARY AND EVALUATION- - - - -                           | 158 |
| 12. | CONCLUSIONS - - - - -                                     | 163 |
| 13. | RECOMMENDATIONS - - - - -                                 | 167 |
| 14. | REFERENCES- - - - -                                       | 169 |
| 15. | APPENDIX- - - - -   | 175 |
|     | A. Glossary of Terms - - - - -                            | 176 |
|     | B. Bibliography- - - - -                                  | 180 |
|     | C. Case Histories- - - - -                                | 201 |
|     | D. Testing Information - - - - -                          | 241 |
|     | 1. In Situ Permeability Test Procedure - - - - -          | 241 |
|     | 2. Laboratory Grout Distribution Tests - - - - -          | 245 |
|     | E. Sample Specifications - - - - -                        | 250 |
|     | F. Applicable Patents- - - - -                            | 259 |
|     | G. Grouting Specialists- - - - -                          | 277 |
|     | H. Chemical Grouting Material Suppliers- - - - -          | 282 |
|     | I. Grouting Equipment Suppliers- - - - -                  | 283 |
|     | J. Bentonite Suppliers - - - - -                          | 284 |
|     | K. Current Research in Grouting Technology - - - - -      | 285 |

LIST OF FIGURES

| <u>Figure</u> |  | <u>Page</u> |
|---------------|--|-------------|
| 1             | Typical Grouting Job - - - - -   | 4           |
| 2             | Pressure in a Fluid- - - - -   | 6           |
| 3             | Velocity Profile - - - - -   | 8           |
| 4             | Energy Gradient - - - - -  | 10          |
| 5             | Temperature Effects on Viscosity of Water- - - - -                                     | 13          |
| 6             | Diagram of Joosten Grouting Process- - - - -   | 16          |
| 7             | Schematic of Job Layout- - - - -   | 18          |
| 8             | Slurry Trench, Diaphragm Wall and Grouting on French Job -                             | 20          |
| 9             | Dual Piston Type Grouting Pumps and Mixing Tanks - - - - -                             | 20          |
| 10            | Small Grouting Job in Cut-and-Cover Construction - - - - -                             | 23          |
| 11            | Grouting to Consolidate Sand Behind Wood Lagging - - - - -                             | 23          |
| 12            | Large Grouting Job Site and Equipment- - - - -   | 24          |
| 13            | Van Mounted Grout Pumps- - - - -   | 24          |
| 14            | Packer Element and Connector Tubing Used In Europe - - - -                             | 25          |
| 15            | Machine for Placing Packer Element and Connector Tubing- -                             | 25          |
| 16            | Grouting Tubes in Place for Grout Injection- - - - -                                   | 26          |
| 17            | New Style French Grout Curtain - - - - -   | 29          |
| 18            | Cut-and-Cover Grouting for Metro System in France- - - - -                             | 30          |
| 19            | Strength Curve of Special Grout Used with Prefabricated<br>Wall Installation - - - - - | 31          |
| 20            | Prefabricated Concrete Diaphragm Wall Construction - - - -                             | 32          |
| 21            | Grout Curtain Protecting Bridge Piers- - - - -   | 33          |
| 22            | Grouting Under Footing of British Hospital - - - - -                                   | 35          |
| 23            | Hamburg (Germany) Subway Grouting- - - - -   | 37          |
| 24            | Munich Germany Expressway Grouting - - - - -   | 38          |
| 25            | Grouting from Galleries in Paris Metro System- - - - -                                 | 39          |
| 26            | Running Ground Encountered in Tunneling- - - - -                                       | 40          |
| 27            | Schematic of Compaction Grouting to Level Tank - - - - -                               | 42          |
| 28            | Open Cut Construction with Both Strut Bracing and<br>Tieback Anchorages- - - - -       | 43          |
| 29            | Placing Tieback Anchor in Sheet Steel Wall - - - - -                                   | 44          |
| 30            | Typical Detail of Earth Tieback Anchor - - - - -                                       | 44          |
| 31            | Alternative Refrigeration Approaches - - - - -   | 46          |
| 32            | Falling Head Permeameter - - - - -   | 51          |
| 33            | Particle Size Distribution Curve - - - - -   | 58          |
| 34            | Correlation of Effective Diameter and Permeability - - - -                             | 59          |
| 35            | Pore-Size Distribution Curves for Loess Soil - - - - -                                 | 61          |
| 36            | Sheet Piling on Obstruction Missed in Site Investigation -                             | 64          |
| 37            | Soil Limits for Grout Injectability- - - - -   | 71          |
| 38            | Soil and Grout Materials Grain-Size Curves - - - - -                                   | 73          |
| 39            | Limits of Groutability of Sands by Particulate Grouts- - -                             | 74          |
| 40            | Viscosities of Various Grouts- - - - -   | 75          |
| 41            | Cement Consistometer - - - - -   | 76          |
| 42            | Compressive Strength of Various Grouts - - - - -                                       | 76          |
| 43            | Soil Strength Characteristics- - - - -   | 81          |
| 44            | Drilling Machine on Grout Job in France- - - - -                                       | 87          |

| <u>Figure</u>   | <u>Page</u> |
|---|-------------|
| 45 Batch Plant for Large Grouting Operation- - - - -  | 87          |
| 46 Progressive Cavity Type Grouting Pump - - - - -  | 89          |
| 47 Cutaway View of Progressive Cavity Pump - - - - -  | 89          |
| 48 Dual Pump Grouting Unit - - - - -  | 90          |
| 49 Trailer Mounted Grout Pumps - - - - -  | 91          |
| 50 Electronic Console for Grout Pump Automation- - - - -  | 92          |
| 51 Grout Pumps and Mixing Tanks in Van Unit- - - - -  | 92          |
| 52 Recording Gauges and Pump Controls in Grouting Trailer- - -                                  | 93          |
| 53 Pump Open Drive Point for Grout Injection - - - - -  | 94          |
| 54 Tube à Manchette- - - - -  | 96          |
| 55 Operational Principle of Tube à Manchette - - - - -  | 96          |
| 56 Stabilator Valve Tube - - - - -  | 97          |
| 57 Schematic of Grout Principle- - - - -  | 100         |
| 58 Newtonian vs. Plastic Flow- - - - -  | 109         |
| 59 Force Affecting Flow of a Fluid Element in a Cylindrical<br>Tube of Diameter D - - - - -     | 110         |
| 60 Comparison of Shearing Stress and Velocity of Newtonian<br>and Bingham Plastic Flow- - - - - | 111         |
| 61 Pore Pressure Effect on Stress - - - - -   | 114         |
| 62 Relation Between Principal Shearing and Normal Stress- - -                                   | 115         |
| 63 Effect of Grouting Pore Pressure on Effective Stresses - -                                   | 116         |
| 64 Soil Pressures on a Retaining Wall - - - - -   | 120         |
| 65 Grout Volume Required to Fill Radially Around Grout Point-                                   | 125         |
| 66 Typical Grid Pattern for Waterstop Application - - - - -                                     | 126         |
| 67 Typical Grouted Section for Strengthening Soil - - - - -                                     | 127         |
| 68 Schematic of Grouting for Metro System in Hanover, Germany                                   | 127         |
| 69 Soil Grouting for Metro System in Hanover, Germany - - -                                     | 128         |
| 70 Schematic Drawing of Pressure Meter Equipment- - - - -                                       | 135         |
| 71 Typical Results of a Pressuremeter Test- - - - -   | 135         |
| 72 Iowa Bore-Hole Direct Shear Test Device- - - - -   | 138         |
| 73 Goodman Jack for Borehole Testing - Soft Rock- - - - -                                       | 139         |
| 74 Clamshell Bucket Crane Used for Slurry Trench Construction                                   | 144         |
| 75 Slurry Trench and Diaphragm Wall Construction- - - - -                                       | 145         |
| 76 Alternate Methods for Sealing Diaphragm Wall Panels- - -                                     | 146         |
| 77 Effect of Mixing on Hydration of Slurry (5% Bentonite) - -                                   | 151         |
| 78 Gel Strength for Bentonite - - - - -   | 152         |
| C-1 Grouting Operation in Progress - - - - -  | 207         |
| C-2 Connection Between Station and Tunnel Through<br>Grouted Soil- - - - -                      | 208         |
| C-3 Grouting Setup for Bridge Support- - - - -  | 210         |
| C-4 Tunnel Alignment Showing Intersected Chimney - - - - -                                      | 213         |
| C-5 Grout Point Locations in Chimney Section - - - - -  | 215         |
| C-6 Grid Pattern and Grouted Areas - - - - -  | 217         |
| C-7 Schematic Equipment Layout - - - - -  | 218         |
| C-8 Schematic of Grouting for Sewer Support- - - - -  | 220         |
| C-9 Washington Grouting Site - - - - -  | 220         |
| C-10 Typical Excavation Under Grouted Area- - - - -   | 221         |
| C-11 Clay Encountered in Tunnel Excavation- - - - -   | 221         |
| C-12 Detail of Grout Pipe Installation and Seal - - - - -                                       | 223         |
| C-13 Grout Injection Pumps and Flowmeters - - - - -   | 224         |

| <u>Figure</u> |   | <u>Page</u> |
|---------------|---|-------------|
| C-14          | Schematic - Pumping System- - - - -                       | 226         |
| C-15          | Schematic - Grouting Manifold - - - - -                   | 227         |
| C-16          | View of Grouting Area on Dam- - - - -                     | 229         |
| C-17          | Grouting Site - - - - -                                   | 237         |
| C-18          | Grout Distribution Manifold - - - - -                     | 237         |
| C-19          | Grouting Toward Portal Opening- - - - -                   | 239         |
| C-20          | Tunnel Portal Opening - - - - -                           | 239         |
| C-21          | Grouted Soil at Tunnel Face - - - - -                     | 240         |
| C-22          | Sample of Grouted Soil- - - - -                           | 240         |
| D-1           | Piezometer Installations (Schematic)- - - - -             | 242         |
| D-2           | Piezometer Test - Falling Head - - - - -                  | 243         |
| D-3           | Typical Field Time-Lag Curve- - - - -                     | 244         |
| D-4           | Equipment for Laboratory Grout Distribution Test- - - - - | 245         |
| D-5           | Test Probe Layout - - - - -                               | 246         |

LIST OF TABLES

| <u>Table</u> |  | <u>Page</u> |
|--------------|--|-------------|
| 1            | Loss Coefficients for Valves and Fittings - - - - -  | 12          |
| 2            | Injectability of Main Types of Grout- - - - -  | 21          |
| 3            | Typical Mechanical Analysis of Soil - - - - -  | 57          |
| 4            | Examples of Calculated A/C Ratios - - - - -  | 62          |
| 5            | Cost Comparisons of Grout - - - - -  | 68          |
| 6            | Properties of Currently Used Grouts - - - - -  | 69          |
| 7            | Test of Grout Materials in Sand - - - - -  | 79          |
| 8            | Relationship Between Failure Grouting Pressure and Effective<br>Overburden Pressure- - - - - | 119         |
| 9            | Limiting Soil Penetration for Cement Grouts - - - - -  | 124         |
| 10           | Bentonite Slurry Properties - - - - -  | 149         |
| 11           | Bentonite Limiting Properties - - - - -  | 150         |
| 12           | Summary of Grouting Operations Applicable to Tunnel<br>Construction - - - - -                | 159         |
| 13           | Evaluation of Grouting Operations in Tunneling- - - - -                                      | 161         |
| C-1          | Test Boring Reports by Raymond Beneath Walt Whitman<br>Bridge Overpass- - - - -              | 212         |
| C-2          | Hole Drilling Schedule- - - - -  | 231         |
| C-3          | Flow Rate Test- - - - -  | 232         |
| C-4          | Immersion Test- - - - -  | 232         |
| C-5          | Visual Inspection Test- - - - -  | 233         |
| C-6          | Tests of Grouted Area of Dam- - - - -  | 234         |

## LIST OF SYMBOLS

- A - cross sectional area of flow  
a - area of standpipe  
 $\gamma$  - unit weight (or density) of soil  
 $\gamma_d$  - dry unit weight of soil  
 $\gamma_m$  - wet unit weight of soil  
 $\gamma_s$  - saturated unit weight of soil  
 $\gamma_g$  - unit weight of grout  
 $\gamma_w$  - unit weight of water  
C - constant of integration  
 $C_u$  - uniformity coefficient  
c - soil cohesion  
D - pore diameter of soil  
 $D_o$  - diameter of borehole  
d - diameter  
E - pressuremeter modulus  
e - void ratio  
G - specific gravity  
g - acceleration of gravity  
h - head of water  
 $h_o$  - initial head of water  
 $h_1$  - final head of water at time, t  
 $h_r$  - hydraulic head  
 $h_w$  - depth of water table below ground surface  
 $I_r$  - rigidity index



$i$  - hydraulic gradient  
 $i_y$  - minimum hydraulic gradient  
 $i_v$  - vertical hydraulic gradient  
 $K$  - dimensionless loss coefficient  
 $K'$  - Rankin stress ratio  
 $K_0$  - coefficient of earth pressure at rest  
 $k$  - coefficient of permeability  
 $k_g$  - coefficient of permeability for grout  
 $k_h$  - horizontal permeability coefficient  
 $\theta$  - velocity factor  
 $L$  - length  
 $M$  - mass  
 $\mu$  - coefficient of viscosity, or absolute viscosity  
 $N$  - ratio of grout viscosity to water viscosity  
 $n$  - soil porosity  
 $P$  - soil pressure force on retaining wall  
 $P_f$  - end pressure of elastic stress range of pressuremeter  
 $P_g$  - grouted soil pressure force on retaining wall  
 $P_\ell$  - limit or maximum pressure of soil using pressuremeter  
 $P_o$  - In situ horizontal stress  
 $P_p$  - grouting pore pressure  
 $Q$  - gravity of flow  
 $q_u$  - unconfined compressive strength of soil  
 $r$  - radial distance of grout penetration  
 $r_o$  - internal radius of pipe or casing  
 $S$  - sinking distance of grout in soil

$\sigma$  - total soil stress  
 $\sigma'$  - effective intergranular stress  
 $\sigma''$  - effective stress due to buoyancy  
 $\sigma_1$  - major principal soil stress  
 $\sigma_3$  - minor principal soil stress  
 $\sigma_1''$  - major principal soil stress less hydrostatic pore pressure  
 $\sigma_3''$  - minor principal soil stress less hydrostatic pore pressure  
 $\sigma_s''$  - soil shearing stress  
 $\tau$  - soil shearing stress at failure  
 $\tau_f$  - yield stress  
 $\tau_y$  - basic time lag in groundwater observations  
 $t$  - time  
 $t_i$  - tensile strength between soil grains  
 $t_s$  - grout set time  
 $\phi$  - angle of internal soil friction  
 $u$  - soil pore pressure  
 $\Delta u$  - grout pumping pressure  
 $V$  - volume  
 $V_e$  - volume of void space  
 $V_s$  - volume of solid particles  
 $V_r$  - radial flow velocity  
 $V_1$  - Poisson's ratio  
 $W$  - weight

## 1. INTRODUCTION

The construction of open trenches or tunnels for mass transit or highway systems has increased steadily in recent years. Many problems are encountered as excavations are made; among these are the intrusion of water, and the movement of the adjacent ground into the excavation. Grouting is one technique which can be used to help solve these problems. Grouting is the injection of a fluid material into the voids of the soil formation to stop or reduce water movement, or to consolidate and strengthen the soil.

Grouting technology has not advanced to the status of a science, but remains as an art. This is due in a large measure to the secrecy which has surrounded the process for many years. Grouting specialists have been reluctant to share their techniques and grout material compositions with others. As a result, construction contractors are dependent upon the grouting specialists to recommend proper procedures and specific grouts when their services were needed.

In the United States, grouting is generally done on an emergency basis when water intrusion or running ground is encountered during construction. Remedial grouting is also used in Europe, but other types of grouting are used extensively and are frequently included in the original construction plans.

On the other hand, European grouting organizations are normally large companies with complete foundation design and construction capabilities. Each company is capable of performing grouting, constructing slurry walls, installing tieback anchors or dewatering. Some are also qualified to conduct site investigations and drive piling. It is not uncommon for European companies to be involved in all aspects of foundation work from the inception to the construction. Most of these companies have proprietary grout materials, developed by their own research laboratories, and are very open and communicative about their pumping equipment, downhole piping or accessories, techniques and job data.

The technology for grouting in rock has been well developed in the United States and is generally well documented by papers and technical manuals (1)\*. However, information on grouting in soils has not been readily available. This situation has been slowly improving over the past 15 years, due largely to the emphasis placed on soil grouting by the Geotechnical Division of the American Society of Civil Engineers. Even with this emphasis, however, most of the significant literature available on soil grouting has been produced by European grouting specialists.

---

\* Underlined numbers in parentheses identify references listed by like numbers in Chapter 14, beginning on page 169.

There are two general soil grouting procedures: fracture grouting and permeation grouting. Fracture grouting employs an injection pressure considerably higher than the overburden pressure for the purpose of opening cracks or channels in the soil deposit. The grout then flows along these channels throughout the soil and subsequently sets. This process not only forms lenses of grout but also can produce ground heave or lift; the grout also tends to follow any buried items, such as utility pipes, as it seeks channels of flow through more open soil layers. This type is not widely used.

Permeation grouting is aimed at filling the voids in the soil deposit with the grout fluid, displacing the water from the soil pores if necessary. The range of soils for this type grouting depends on the grout viscosity, but generally ranges in coarse sands or gravel for cement grouts; and soils up through fine sands are usually groutable with some type of chemical grout. A low injection pressure is used to prevent movement of the soil or creation of a fracture. The grout will then set at a selected time to bind the soil particles into a solid mass. This report is concerned mainly with permeation grouting.

This report summarizes present knowledge in grouting technology applicable to soils. It also forms a basis for future improvements in grouting materials, equipment and techniques. This report includes recommendations for checking a completed grout treatment for quality and effectiveness of the grouting, and provides recommendations for further research to improve soil grouting.

This report includes sections on all aspects of grouting design and operational procedures in soil deposits, including the following:

- a. Grouting fundamentals, history and current practices.
- b. Grouting applications as waterstop barriers and for soil strengthening.
- c. Site investigation and determination of subsurface soil characteristics.
- d. Theory of grout injection and distribution.
- e. Grout material properties and their selection.
- f. Grouting equipment.
- g. Field testing of grouted soil.
- h. Grouting contracts and specifications.
- i. Slurry trench and diaphragm wall construction.
- j. Soil tieback anchors.
- k. Backpacking of tunnel liners.

The Appendix includes a bibliography, case histories, test procedures, sample specifications, patents pertaining to soil grouting, a list of grouting specialists, material suppliers and equipment suppliers, current grouting research, and a glossary of terms.

## 2. GROUTING PRACTICES

### A. Grouting Fundamentals

Grouting is a process in which a liquid is forced under pressure into the voids of soils, where the liquid will, in time, solidify by physical or chemical action. The injection of grout into the soil voids is used to block water movement, or to increase the strength of the treated material. Grouting is applicable mainly to cohesionless soils that are relatively permeable.

The first step is a thorough site investigation to reveal soil structure and permeability. This information is essential to determine groutability, the best grout fluid and the applicable technique for the job.

Grouting is normally accomplished by placing pipes in the ground, either vertically on a grid pattern or at varying angles to obtain the desired distribution, and injecting a fluid into the soil through the pipes at a pressure below the overburden pressure to fill the soil voids over a given area. Various grouts are available, including particulate types like cement or clay slurries and various types of chemical grouts. Chemical grouts can be designed to set quickly in the presence of flowing water or to set more slowly to allow greater penetration into the soil. Figure 1 shows a typical grouting job.

On-site facilities are necessary to provide sufficient storage capacity for grout components, as well as equipment for mixing the grout and injecting it into the ground. Special pipes include rods which are driven into the ground, and plastic pipe with slots or holes which are grouted into boreholes for placing the grout at the desired levels. Provisions must be made to measure the flow of the grout into each pipe and the pressure at the point of injection.

Grouting is limited to relatively pervious soils and to situations where the cost will not be a prohibitive factor. It is also limited to applications where the required strength is within the capability of the grout fluids available.

### B. Grouting Theory (For Solution Type Grouts)

There are basic laws of fluid flow which relate to grouting. One definition of fluids is based upon its action under various types of stress. Fluids possess elastic properties only under compression. Application of infinitesimal shear or tension results in continual distortion. As a result, pressure imposed on a fluid at rest will be transmitted undiminished to all other points in the fluid (2).

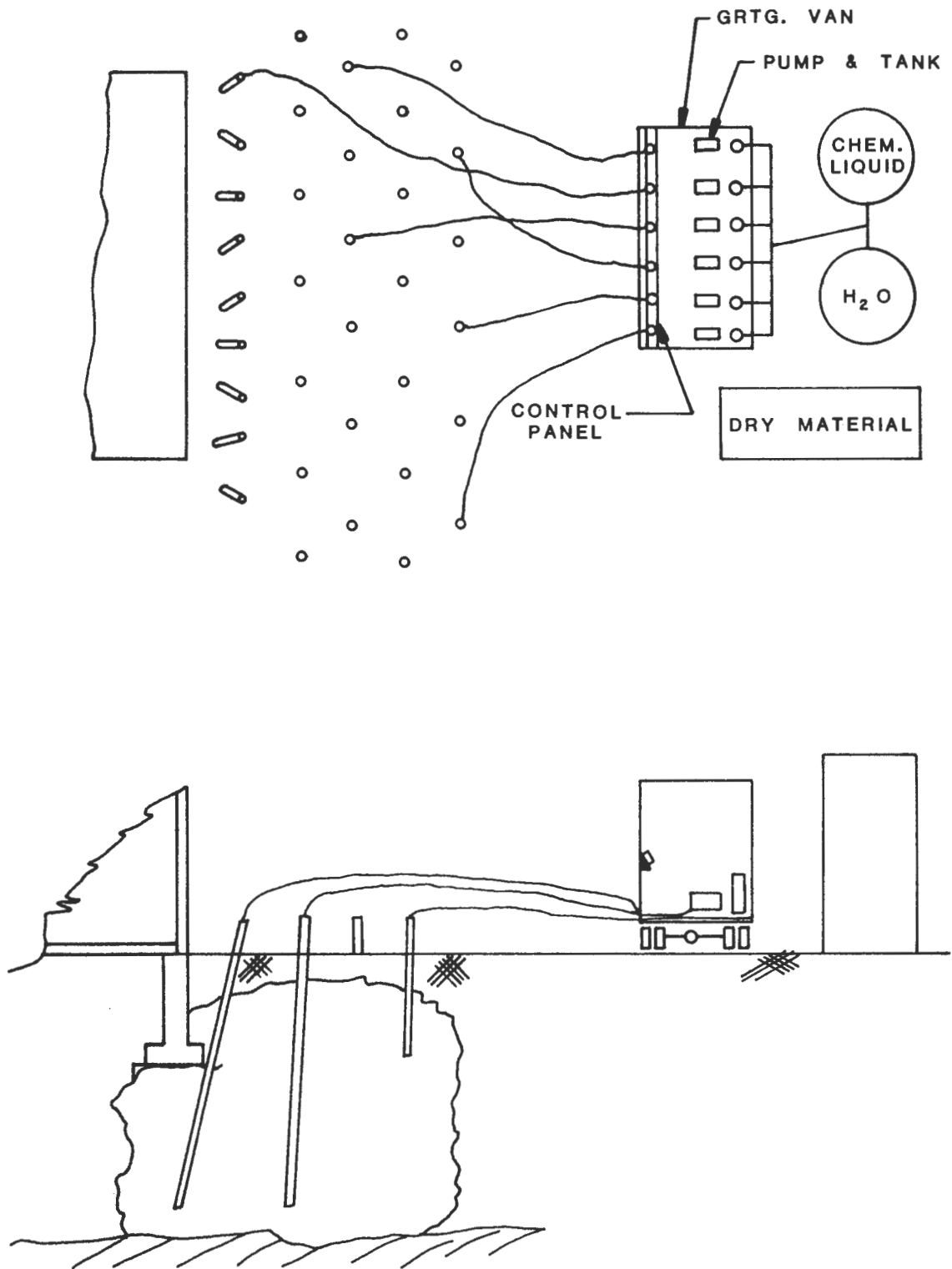

Figure 1. Typical grouting job.

## 1. Physical Characteristics of Fluids

The basic physical characteristics of a fluid are its unit weight, viscosity, and surface tension. All of these characteristics depend upon the molecular structure of the fluid. Unit weight ( $\gamma$ ) is the weight per unit volume, or

$$\gamma = \frac{W}{V} \quad (1)$$

Specific gravity is the ratio of unit weight of the fluid to the unit weight of pure water. These properties all vary with temperature, so the temperature must be given when these properties are used in calculations.

Viscosity, the resistance of a fluid to flow, is due fundamentally to cohesion and interaction between fluid molecules. As flow occurs these effects appear as a shearing stress between the moving layers of fluid. For nonturbulent flow, this stress has been found to be proportional to the rate of change of velocity perpendicular to the direction of flow. The constant of proportionality is known as the coefficient of viscosity.

The apparent effects of tension which occur on the free surface of a fluid depend fundamentally upon the relative strength of the intermolecular cohesive and adhesive forces. When adhesion is the predominant force, the liquid will wet a solid surface with which it is in contact and rise at the point of contact; if the cohesion predominates, the liquid surface will be depressed at the point of contact. For example, water rises in a capillary tube and mercury is depressed at the point of contact. For tube diameters of one-half inch or more, capillary action is negligible, but when the diameter is small, as in the pores of fine grained soils, the capillary rise can be several feet.

## 2. Fluid Pressure Under Static Conditions

Before considering problems of fluids in motion, certain properties of static fluids should be understood. Fluid statics is concerned with fluid in which there is no relative motion between fluid particles. If no relative motion exists between fluid particles, viscosity can have no effect, and exact solutions to problems may be obtained by analytical methods without the aid of experimentation.

### a. Variations of Pressure with Depth in a Liquid

The fundamental equation of fluid statics relates pressure, density, and vertical distance in a fluid. This equation may be derived readily by considering the equilibrium of a typical unit element of fluid having cross-sectional area  $A$  and length  $L$ , inclined to the vertical at an angle  $\alpha$ , as shown in Figure 2. If the pressure at point  $M$  is denoted by  $P_1$ , the force on that end will be  $P_1A$ . Similarly the force on end  $N$  will be  $P_2A$ . Similarly the force on end  $N$  will be  $P_2A$ . The weight of the volume

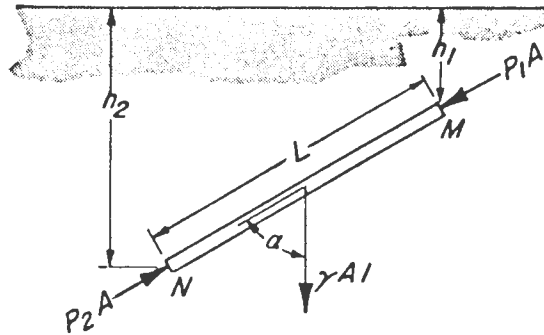

Figure 2. Pressure in a fluid.

of liquid is  $\gamma AL$ , where  $\gamma$  is the density of the fluid. Since the element is in equilibrium, the forces acting on it in any direction must be zero. Summing the forces along the MN axis, the forces perpendicular to the length  $L$  have no effect, since they cancel each other. The following equation is obtained

$$P_1A - P_2A + \gamma AL \cos \alpha = 0 \quad (2)$$

As  $L \cos \alpha = h_2 - h_1$ , it follows that

$$P_2 - P_1 = \gamma(h_2 - h_1) \quad (3)$$

Since a liquid is a substance which will continue to deform as long as any shearing stress exists in it, there can be no shear in a liquid at rest. By letting  $P_1$  and  $h_1$  be zero, and omitting the subscripts 2, we get

$$P = \gamma h \quad (4)$$

### 3. Pressure Measurement

Pressures are measured and quoted in two different systems, one relative (gage) and the other absolute. If the measure shows pressure above absolute zero, it is called absolute pressure; that is, it includes the pressure exerted by the weight of the atmosphere. If the measure shows pressure either above or below atmospheric pressure, it is called gage pressure. This term is used because almost all pressure gages of any type register zero when open to the atmosphere, and when in use register only the difference between the pressure of the fluid to which they are connected and that of the surrounding air.

The atmospheric pressure is also called the barometric pressure. Barometric or atmospheric pressure varies with altitude, and, at any given place, with time and weather conditions. Usually barometric pressure appears on both sides of an equation, and one negates the other. Thus the value of the atmospheric pressure is of no significance when dealing with liquids, and most pressures are recorded as gage pressure.



#### a. Pressure Measurement Devices

The Bourdon pressure gage and the mercury barometer are the usual devices for measuring gage and absolute pressures, respectively. A gage similar to the barometer is a piezometer. A piezometer is a very simple device for measuring moderate liquid pressures. It consists of a tube open to the atmosphere in which the liquid can rise freely without overflowing. The pressure acting on the top of the column is atmospheric, and on the bottom, the pressure of the system; therefore, the height of the liquid column times the liquid density is the gage pressure per equation 4. A piezometer should have a tube larger than one-half inch in diameter to minimize capillary error. Connections should be made perpendicular to flowing fluids, and the tube should not project into the flowing liquid. The pneumatic type of the no-flow piezometer is being used increasingly for construction control.

#### 4. Flow of Water Under Pressure

##### a. Fluid in Motion

Fluid flow may be steady or unsteady, laminar or turbulent. Steady flow occurs in a system when none of the variables involved changes with time; if any variable changes with time, the condition of unsteady flow exists. For example, in a pipe leading from a large reservoir of fixed surface elevation, unsteady flow exists while the outlet valve is being adjusted. When the valve opening is fixed, steady flow occurs. Under the former condition, the pressures, velocities, etc., vary with time; in the latter case, they do not. During grouting, problems caused by unsteady flow occur only when valves are being opened or closed.

If fine threadlike streams of colored liquid are injected into a large glass tube through which water is flowing at a low velocity, the colored liquid will be visible as straight parallel lines throughout the length of the tube. As the velocity of the water is increased, the lines first become wavy, then break down into numerous vortices beyond which the color becomes uniformly diffused.

The first type of flow is known as laminar, streamline or viscous flow. The significance of these terms is that the fluid appears to move by sliding laminations of infinitesimal thickness relative to adjacent layers; that the particles move in definite and observable paths or streamlines; and also that the flow is characteristic of a viscous fluid.

The second type of flow, where the color is uniformly diffused, is known as turbulent flow; the individual particles move in erratic paths. A distinguishing characteristic of turbulent flow is its irregularity. There is no definite frequency, as in wave action, and no observable pattern, as in the case of eddies. Thus, a rigid mathematical treatment of turbulent flow is impossible, so statistical means of evaluation must be applied.

### b. Rate of Flow

The quantity of fluid flowing per unit of time across any section is called the discharge, or rate of flow. The rate of flow may be flow may be expressed in any units suitable.

In the ideal case of a frictionless laminar flow in a straight channel, all particles move in parallel lines with equal velocities. The rate of discharge,  $Q$ , would be obtained by multiplying this uniform velocity,  $V$ , by the area of the cross section,  $A$ , of the flowing fluid, perpendicular to the direction of flow.

$$Q = AV \quad (5)$$

In the flow of a real fluid the velocity adjacent to the wall will be zero; it will increase very rapidly within a short distance from the wall and produce a velocity profile such as is shown in Figure 3. If the flow is laminar, there is merely the velocity profile to consider; but if the flow is turbulent, not only will the velocity vary across the section, but, at any one point, it will fluctuate with time.

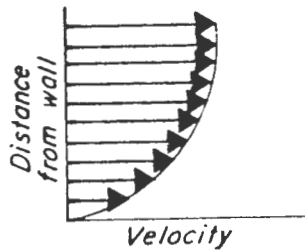

Figure 3. Velocity profile

The rate of flow  $Q$  in these instances may be calculated with laminar flow equation by calculating an apparent average velocity  $V$  for all particles.

The law of continuity is an obvious statement that in steady flow without storage, what goes in at the upstream section must come out at the downstream section, so that

$$\gamma_1 A_1 V_1 = \gamma_2 A_2 V_2 \quad (6)$$

For a liquid,  $\gamma_1$  will be equal to  $\gamma_2$  and

$$A_1 V_1 = A_2 V_2, \text{ or } Q \text{ is constant} \quad (7)$$

### c. Energy Equation

A body of mass,  $m$ , and velocity,  $V$ , possesses kinetic energy equal to  $mV^2/2$ . Since weight equals mass times the acceleration of gravity, the kinetic energy expressed in terms of weight is  $WV^2/2g$ , or simply  $V^2/2g$  per unit weight.

In the flow of a real fluid the velocities of different particles will usually not be the same, so it is convenient to use the mean velocity,  $V$ , and a factor,  $\theta$ , such that for the entire section, the true average value is

$$\text{Kinetic energy per unit weight} = \theta(V^2/2g) \quad (8)$$

The greater the variation of velocity across the section, the larger will be the value of  $\theta$ . For laminar flow in a circular pipe,  $\theta = 2$ ; for turbulent flow in pipes  $\theta$  ranges from 1.0 to 1.15; but for normal cases it is usually between 1.03 and 1.06.

In some instances it is very desirable to use the proper value of  $\theta$ , but in many cases the error in disregarding it is negligible. As precise values of  $\theta$  are seldom known, it is customary to omit it and assume that the kinetic energy is  $V^2/2g$  per unit weight of fluid.

The laws of mechanics show that the potential energy of a weight  $W$  at a vertical distance  $z$  above datum is (relative to the datum)  $Wz$  ft-lb. If the weight is considered in units of one pound, the potential energy =  $z$  ft-lb/lb and  $E$  is the energy of the liquid associated with its temperature. The energy contained in each pound of fluid may therefore be expressed as  $(E + V^2/2g + z)$  ft-lb/lb.

The work done on a fluid within an area by a weight of fluid entering the area would equal the work done by the fluid in an area on the fluid leaving the area. It can be derived that  $P/\gamma$  is generally treated as the "pressure energy" of the flow. The energy equation thus becomes

$$\frac{P}{\gamma} + \frac{V^2}{2g} + z = \text{Constant} \quad (9)$$

The equation imposes another mathematical condition upon flow in a streamtube. It has already been shown (for a fluid of constant density) that the product of cross-sectional area and velocity is always constant along a streamtube. From the energy equation, it becomes evident that the sum of the three terms involving pressure, velocity, and elevation will also be constant at every point along the streamtube. This is known as the Bernoulli equation.

Examination of the terms of equation 9 reveals that  $p/\gamma$  and  $z$  are respectively the pressure and potential heads, and hence may be visualized as vertical distances. Pitot's experiments showed the

"velocity head",  $V^2/2g$ , to be a vertical distance which could be measured by placing a small open tube in the flow with its open end upstream. Thus the energy equation may be visualized for liquids as in Figure 4, the sum of the terms being the constant distance between the horizontal (and therefore parallel) datum plane and the "total head line" or "energy line" (E.L.). The "pressure grade line" or "hydraulic grade line" (H.G.L.) drawn through the tops of the piezometer columns gives a picture of pressure variation in the flow:

- (1) its distance from the centerline of the streamtube is a direct measure of the pressure in the flow, and
- (2) its distance below the energy line is proportional to the square of the velocity. Complete familiarity with these lines is essential because of their wide use in engineering practice and their great utility in problem solutions.

The energy equation gives further aid in the interpretation of streamline diagrams; equation 9 indicates that when velocity increases, the sum of the pressure and potential head must decrease.

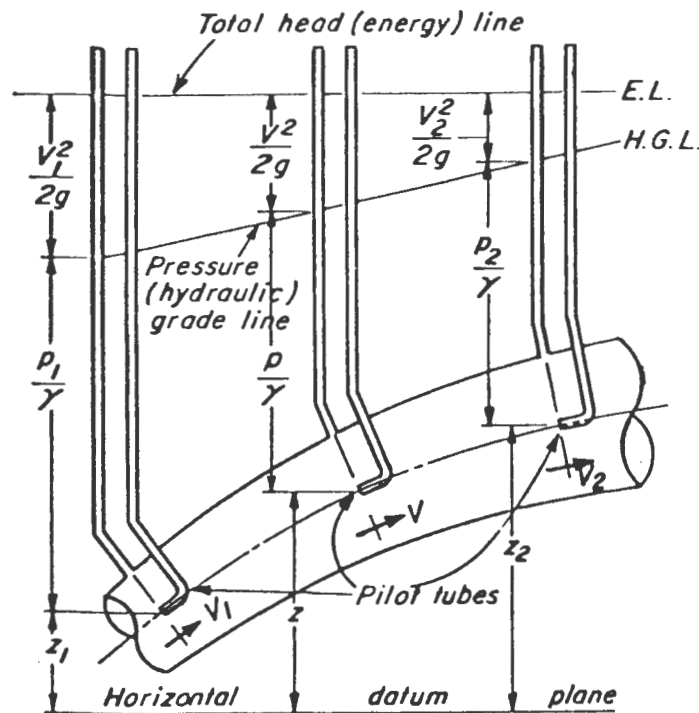

Figure 4. Energy gradient.

In the usual streamline diagram, the potential head varies little, allowing the approximate general statement: "where velocity is high, pressure is low." Regions of closely spaced streamlines have been shown to be regions of relatively high velocity; the energy equation indicates that these are also regions of relatively low pressure.

#### d. Friction Loss in Pipes and Fittings

As a real fluid passes through a pipe, some mechanical energy is degraded into unavailable energy; there is a so-called "friction loss" or a "head loss" due to friction or viscosity of the fluid and the turbulent motion. No energy is actually destroyed. Some energy, however, is transformed into a form which is not available for maintaining the flow; thus, from the point of view of the flow, it is "lost". This loss is present in grouting piping systems and can affect the actual grouting pressure since friction opposes flow. Let  $h$  represent this lost head. Then the general energy equation can be written as

$$-h = (p_2 - p_1) / \gamma + (V_2 - V_1) / (2g + z_2 - z_1) \quad (10)$$

or

$$h = (p_1 - p_2) / \gamma + (V_1^2 - V_2^2) / 2g + (z_1 - z_2) \quad (11)$$

Each term in equations 10 and 11 is expressed in units of mechanical energy per unit weight of fluid flowing. The lost energy,  $h$ , can be stated in terms of foot-pounds per pound of fluid, or simply feet, or some other net unit of length.

If the area of the pipe is constant, then by equation 7,  $V_1 = V_2$ . In this case, the pressure grade line is parallel to the energy grade line, or

$$h = \frac{P_1}{\gamma} + Z_1 - \frac{P_2}{\gamma} + Z_2 \quad (12)$$

The head loss due to fittings is frequently expressed as  $K(V/2g)$ , where  $K$  is a dimensionless loss coefficient and  $V$  is some characteristic velocity. Reliable head loss coefficients for many shapes of fittings have not been fully measured at the present time. So, real difficulties are encountered in trying to correlate experimental data, particularly measurements with different types of fluids. The values given in this section are to be regarded as approximations, because they are based on limited experimental results.

Values for  $K$  in the equation below are shown in Table 1:

$$\text{Head loss} = K \frac{V^2}{2g} \quad (13)$$

Table 1 - Loss coefficients for valves and fittings.

| Valve or Fitting       | K    | Valve or Fitting   | K    |
|------------------------|------|--------------------|------|
| Globe valve, wide open | 10.0 | Return bend        | 2.2  |
| Angle valve, wide open | 5.0  | Standard tee       | 1.8  |
| Gate valve, wide open  | 0.19 | Standard elbow     | 0.9  |
| Gate valve, 1/4 closed | 1.15 | Medium sweep elbow | 0.75 |
| Gate valve, 1/2 closed | 5.6  | Long sweep elbow   | 0.60 |
| Gate valve, 3/4 closed | 24.0 | 45-degree elbow    | 0.42 |

Source: The Crane Company

These data emphasize the need to obtain pressure readings at the point of injection into the ground to provide the most accurate reading possible.

#### 5. Flow Through Soils

##### a. Flow of Water

The law for flow through soils is named after Darcy who demonstrated experimentally that the rate of flow is proportional to the gradient. Darcy's law is written

$$Q = kiA \quad (14)$$

or

$$Q/A = V = ki$$

The area A in these equations is the total cross-sectional areas of solid mass across which flow Q occurs. In equation 14, the term k is Darcy's coefficient of permeability, which herein is called simply the permeability. This coefficient, which is the only permeability coefficient in common use in soil mechanics, is best defined as the constant of proportionality between the superficial velocity V and the gradient i, so k has the dimensional units of a velocity. The most commonly used unit for this coefficient in soil testing is cm/sec, or meters/sec.

##### b. Flow of Viscous Grouts

Viscosity is the term used to describe the nature of a liquid to flow easily like water (low viscosity), or sluggishly like heavy oil (high viscosity). Viscosity is due to the fundamental cohesion and interaction between fluid molecules. As flow occurs, these effects appear as a shearing stress between thin moving layers.

Viscosity has been found to be proportional to the rate of change of velocity in respect to depth for laminar flows. The coefficient of viscosity is the constant of proportionality in the relationship mentioned above.

The dimensions of viscosity are lb-sec/ft<sup>2</sup>; the metric counterpart is dyne sec/cm<sup>2</sup>, which has been given the special name of poises after Poiseuille who did some of the first work on viscosity. A centipoise is simply 1/100th of a poise. Water at 68°F has a viscosity of one centipoise.

Viscosity varies inversely with temperature. From calculations made by an equation developed by Bingham and Jackson (65), the decrease in viscosity caused by an increase in temperature is shown in Figure 5. In a viscous liquid the cohesive force between molecules is the primary property which controls viscosity. As the temperature of a liquid increases, the intermolecular bond decreases with a resulting decrease in the coefficient of viscosity  $\mu$ .

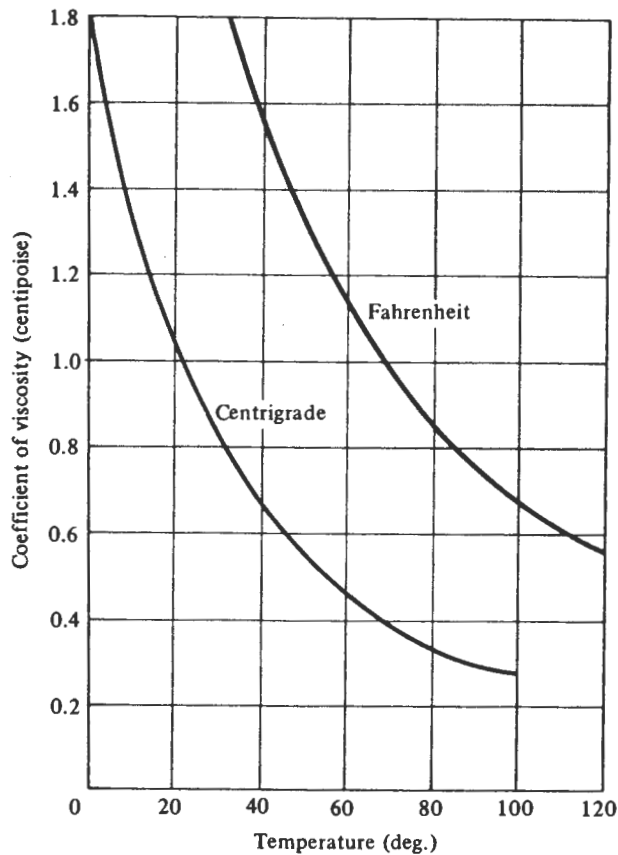

Figure 5. Temperature effects on viscosity of water (32).

The viscosity of the water or fluid permeating the soil has an effect on the coefficient of permeability. If there is a difference between the viscosity of the water used to obtain the soil permeability coefficient originally and that of the grout, Cambefort (66) sets forth the following relationship which can be used to determine the permeability coefficient with the grout:

$$\frac{k_g}{k} = \frac{\mu}{\mu_g}$$

where

$k_g$  = soil permeability coefficient  
using grout with a viscosity  $\mu_g$

$k$  = soil permeability coefficient  
using water with a viscosity  $\mu$

or

$$k_g = \frac{k\mu}{\mu_g} \quad (15)$$

The observed behavior of liquids under conditions of viscous flow can be explained by the hypothesis that the liquid moves in the form of concentric cylinders or shells, sliding one within the other like sections of a telescope.

The flow rate for this condition is described by

$$Q = NkiA \quad (16)$$

where

$N$  = viscosity ratio

$k$  = coefficient of permeability

$i$  = hydraulic gradient

$A$  = total cross-sectional area  
where flow  $Q$  occurs

### C. History of Grouting

Grouting was first invented and used in 1802 by French engineer, Charles Berigny, who called it the Injection Process (3). He used slurries of clay and hydraulic lime, which were forced into subaqueous formations with a simple hand-operated pump to stop water flow. In 1876, portland cement was injected beneath a dam in England under gravity head to seal fissured rock that was leaking. Between 1880 and 1905 a group of mining engineers in the coal fields of Northern France and Belgium introduced injections of portland cement grout as an aid in



shaft sinking through fissured, water-bearing rock. They developed high pressure pumps and made improvements in the mixing and injection of grout, which remain the basis of much of the modern practice of rock grouting.

The most difficult problems of water intrusion in shaft sinking are not found in the rock portions, but in permeable overburden deposits which overlie the rock. Attempts were made to grout these cohesionless soils with portland cement. This succeeded in the open, coarse-grained sediments, but failed in the fine-grained, dense sediments of low permeability.

As the operators found that portland cement slurries would not penetrate the finer sand grains to achieve water shutoff, they added more water to the mixture to make it more fluid. This increased fluidity, but still did not permit the grout to permeate the sand because solid particles still in suspension were too large to enter the pore spaces in the sand deposits to effect water shutoff. Since successful treatment of soils with wide ranges of porosity is very desirable, the search continued for a liquid grout that had no solids in suspension, had a low viscosity and had the ability to set at a predetermined time.

As early as 1887, a patent was granted to Jeziorsky for injection of soils by sodium silicate with a two-shot process (4). The two-shot process consisted of injecting one chemical solution down a pipe to the desired depth, then following with an injection of another chemical which reacted with the first one to form a gel. This gel in the soil pores prevented the passage of water from the formation. A single-shot process patent was issued in 1909 for using a mixture of a diluted sodium silicate and a dilute acid as a grout material. This grout became a gel which could be used only for waterproofing. Additional patents were issued through the following years as attempts were made to improve these two processes.

The greatest improvement in the two-shot process was developed by Dr. Hugo Joosten, a Dutch engineer, and a patent was issued to him in 1926. By using sodium silicate for one solution, a precipitate of insoluble silica gel is obtained by the chemical reaction with a calcium chloride solution. This process has been used for sand consolidation since its introduction, yet it has inherent drawbacks. A close network of injection holes is required in order to obtain good penetration since the two solutions react immediately when they meet.

The process of silicate gel formation is not completely understood, so it is impossible to state exactly how sodium silicate reacts with soils (5). However, sodium silicate can be used in soil stabilization mainly because it reacts with soluble calcium salts in water solutions to form insoluble gelatinous calcium silicates, and hydrated calcium silicates are cementing agents.

The sodium silicate most commonly used is a solution known as

waterglass which has a silica/alkali ratio of about 3.22 and is sold at a density of about 41° Baume at 68°F or a specific gravity of 1.394. The reaction obtained in the Joosten process using this silicate with calcium chloride would be:

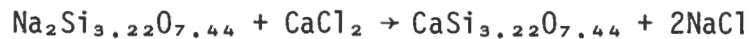

Using a sodium metasilicate with calcium chloride would give:

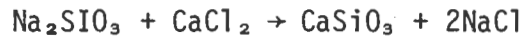

In either case, a complex metal hydroxide silica gel is formed. The early uses of silicate grouts using the Joosten grouting process were for consolidation of sands in mine shafts and around footings, foundations, and piers.

The Guttman process is a similar two-shot process which differs from the Joosten process only in the reduction of the viscosity of the sodium silicate before injection by the use of a suitable salt solution. This permits the grouting of finer-grained soil than the Joosten process.

Figure 6 is a diagram of these two-shot processes which form a precipitate in the soil. Drawings (a) and (b) show the injection of the silicate component as the pipe is driven by stages into the ground. Drawings (c) and (d) show the stage injection of the catalyst component (calcium chloride or a similar material) as the pipe is withdrawn from the soil.

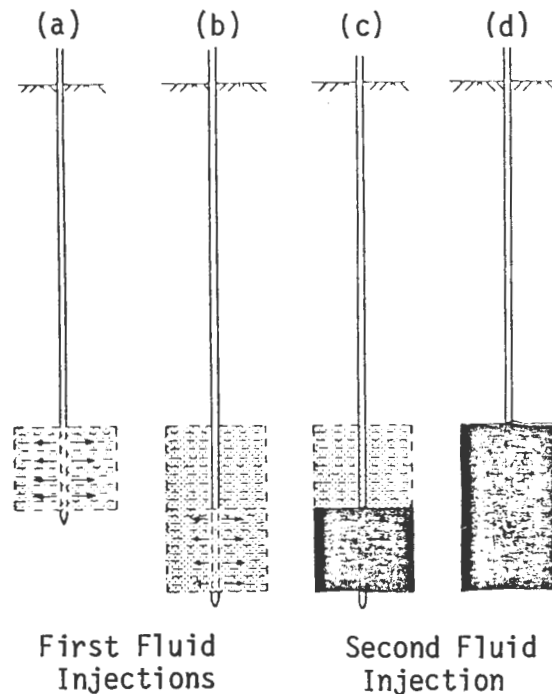

Figure 6. Diagram of Joosten grouting process.

Because of the large influx of people to urban areas, underground transportation systems were built in increasing numbers. This normally was done by open cut construction, except in areas where the route was in built-up areas which could not be destroyed. In these areas, tunnels of large diameter were bored. The relative closeness to the surface many times placed this construction in cohesionless soils, usually below the water table. Unsupported soils and water influx created serious construction problems of ground support.

The need to stabilize foundation soils accelerated the development and refinement of chemical grouts, since the particle grouts could not permeate the finer soils to bind the particles together as needed for consolidation.

About 1952 American Cyanamid Company developed a chemical grouting material called AM-9, which is composed of a mixture of acrylamide and one of its methyl derivatives. This water soluble grout material has a very low viscosity (1-2 cp) which it retains until gellation occurs. It is widely used now, particularly for waterproofing applications. This grout can be mixed and injected in a single pipe since the set time can be controlled within limits as desired.

In 1957, a process was developed by a European grouting firm, Soletanche Entreprise, in which a pure or diluted silicate was combined with an organic ester and various additives to produce a new grout material. Time of gellation could be controlled to permit one-shot injection. This development provided a material of relatively low viscosity which produced enough strength to consolidate cohesionless soils under structures, as well as to permit excavation without water or soil intrusion. Better mixing was provided than in the two-shot procedure, and this permitted the injection pipes to be placed farther apart.

Other grout materials have been discovered through continual research. Among these are lignochromes or lignin based materials, phenolformaldehyde and various resins and combinations thereof.

The original injection tubes were simply pipes with the lower end covered to prevent soil from entering and plugging the pipe as it was driven into the soil; when the pipe was driven to desired depth, the end covering was ejected by pumping water or grout and the injection of grout was then begun. This system, although now more highly developed, is still used for placement of grout down to depths of 50 to 60 feet.

Figure 7 shows a schematic diagram of the equipment setup for a grouting job which might be typical of that followed by many grouting companies.

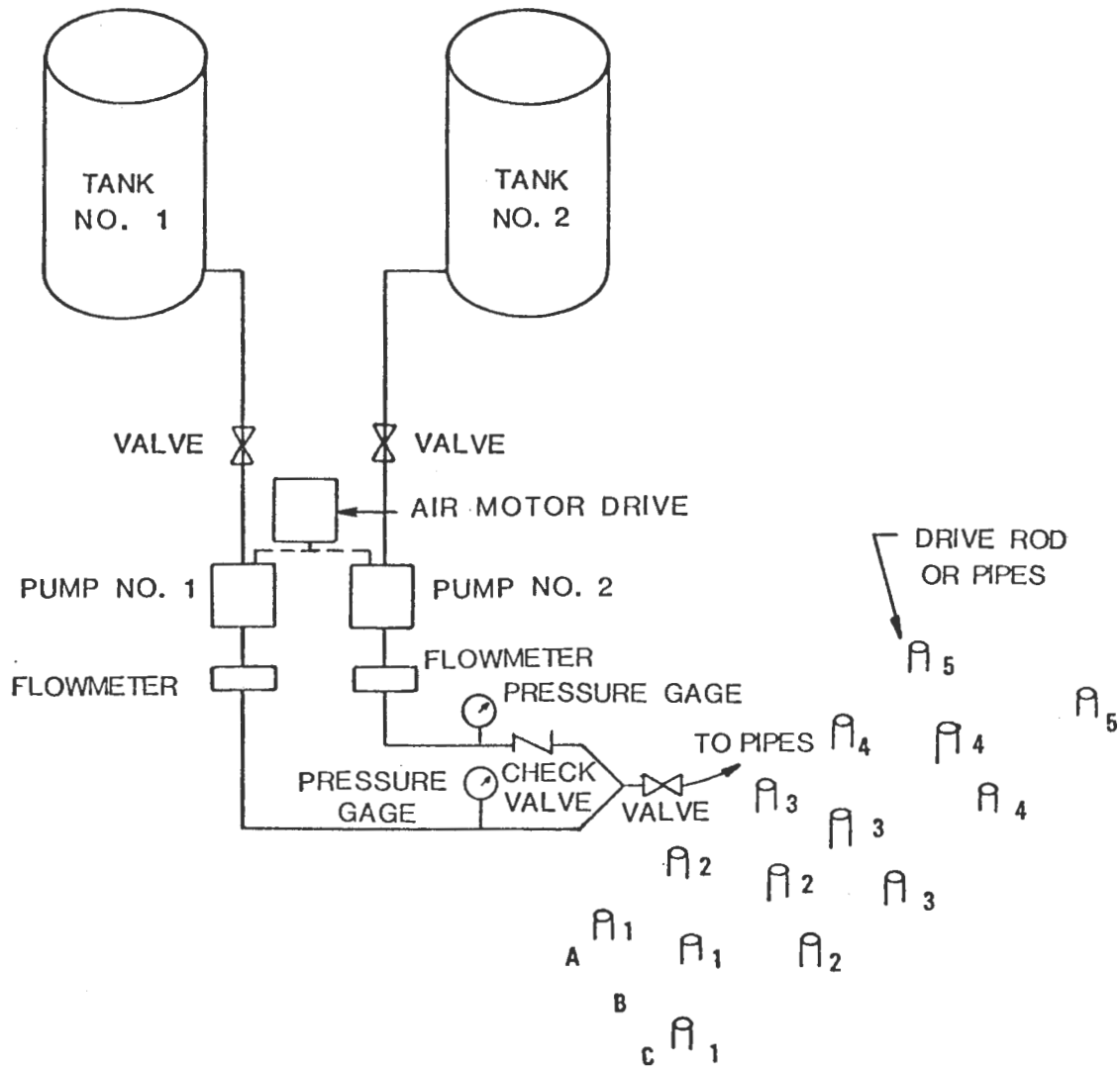

Figure 7. Schematic of job layout.

#### D. Current Practices

Generally, the practices of grouting companies are basically similar in the objectives for grouting and in the techniques used; differences in the operations are found in the mixing and injection systems and in the grouts used. These areas of practice will be discussed in this section.

The objectives of grouting are mainly to stop running ground or water leakage, to consolidate soil so it will stand up during excavation, to strengthen granular soil under foundations, and to level slabs or structures. The objectives and accomplishments of grouting have been accepted by construction companies and Metro system management in Europe to the extent that it is common practice to include grouting as a part of the construction procedure. This is not true in the United States, where grouting companies are generally called to a job when running ground or water intrusion halts construction process.

When grouting is included in a project, the American way is to write some type of specification which must be followed by the contractor. In Europe, the grouting company is given the opportunity of proposing how they would conduct the work to achieve the aim of the owner, and then quote a cost for that work. This might include several types of water or ground control, all of which could be done by the same company. This could include dewatering, slurry trenches, diaphragm walls, tieback anchors or grouting. Figure 8 shows cut-and-cover construction for a Metro system in a French city where one grouting company has built slurry trenches and diaphragm walls. Subsequently, they grouted extensively between the walls to waterproof and strengthen the soil below the proposed tunnel structure to prevent water intrusion when excavation is made between the diaphragm walls.

Techniques used in Europe are generally similar to those used by American grouting contractors. The grout is mixed and injected through pipes driven into the ground or plastic pipes lightly grouted into drilled holes. Permeation type grouting is used in most cases; the amount of grout injected is usually 30-35% of the soil volume, although one European company frequently uses as much as 50% grout. One variation in technique, found in both the United States and Europe, is the use of cement or cement-bentonite grouts ahead of the chemical grouts to fill the larger voids, thereby reducing the amount required of the more expensive chemical grout. Some companies do this as standard practice in an effort to reduce the cost; others use cement only if the soil investigation shows that the permeability is high enough to permit its use for permeation grouting. This would be in coarse sand or ground with a permeability greater than  $10^{-2}$  m/s, according to Table 2.

The mixing and injection systems vary considerably, both here and abroad. A commonly used system includes a piston type, air operated pump with separate mixing tanks. Figure 9 shows a dual pump so constructed that two streams can be moved in equal volumes in a two-stream



Figure 8. Slurry trench, diaphragm wall and grouting on French job.



Figure 9. Dual piston type grouting pumps and mixing tanks.

Table 2. Injectability of main types of grouts (63).

| Ground Nature             | Coarse Sand and Gravel   | Medium to Fine Sands  | Clayey Sand, Silts       |
|---------------------------|--|---|--------------------------|
| Characteristics of Ground | $d_{10} > 0.5\text{mm}$  | $0.02\text{mm} < d_{10} < 0.5\text{mm}$   | $d_{10} < 0.02\text{mm}$ |
|                           | $S < 100\text{cm}^{-1}$  | $100\text{cm}^{-1} < S < 1000\text{cm}^{-1}$  | $S > 1000\text{cm}^{-1}$ |
|                           | $K > 10^{-3}\text{m/s}$  | $10^{-4}\text{m/s} < K < 10^{-3}\text{m/s}$   | $K < 10^{-5}\text{m/s}$  |
| Nature of Grout           | Bingham Type Suspension  | Collodial Solution  | True Solution            |
| Strengthening             | <i>Neat Cement</i><br><br>( $K > 10^{-2}\text{m/s}$ )<br>Grout with air entraining agent | <i>Joosten</i><br><br>( $K > 10^{-4}\text{m/s}$ )<br>High strength gel with organic reagent | <i>Resins</i>            |
| Reduce Permeability       | <i>Clay Cement</i><br><br>Grout with air entraining agent<br>Clay based gel              | <i>Gel</i><br><br>Lignochrome   | <i>Resin</i><br><br>AM-9 |

grout system. Figure 10 shows the setup for a grouting job to consolidate running sand, with the pumps located in a cut-and-cover construction site on the Virginia coast. Injection is made by a hand-held manifold through holes drilled in the wood lagging walls as shown in Figure 11.

Larger jobs involve the use of storage tanks for the grout components, track drills for drilling holes to place slotted plastic pipe, and a larger trailer or portable building to house the pumps and related equipment. Figure 12 shows such equipment on a site in Washington, D.C. Figure 13 shows the trailer interior with the electric-powered, progressive cavity type pumps driven through a gear box to provide proportionate delivery of the grout components. Flow meters display the volume of grout injected by each pump.

The European grouting companies have more sophisticated systems for their grouting operations than their American counterparts. Each company seems to have different styles of pumps, varying from small gear type to larger piston pump, but all are mounted in trailers or in portable buildings which are moved from job to job. Pumps are driven by air motors or electric motors.

Injection is accomplished by American contractors primarily through drive rods or plastic pipe set in boreholes. Most European companies use the tube-a-manchette system invented by Soletanche Entreprise, which now seems to be readily available to all companies. In addition, one Dutch grouting company uses a single tube-a-manchette element at a desired depth connected to the surface by a small, flexible plastic tube as shown in Figure 14. Six elements can be placed at one time on a spacing of one meter (3.28 feet), using a special machine which holds the plastic tubes inside steel pipes for placement. Figure 15 shows the machine placing the six elements on a job near Amsterdam, Holland. Withdrawal of the steel pipes leaves only the plastic tubing extending above the ground ready for grouting as shown in Figure 16. This is used to place a single grout layer about one meter thick.

The grouting companies of Europe have their own research laboratories to perform research on grouting materials and processes. As a result, these companies use a variety of grouting materials. The predominate base component is sodium silicate, but the reactant used with the silicate varies between companies. The American companies primarily use grout materials which have been developed by the chemical manufacturers. Silicate type grout has the largest usage, primarily due to its lower cost and availability, but significant amounts of AM-9 polymeric water gel, formaldehyde and lignin based grouts, are also used. A detailed discussion of the grout materials is given in Chapter 5.





Figure 10. Small grouting job in cut-and-cover construction.



Figure 11. Grouting to consolidate sand behind wood lagging.



Figure 12. Large grouting job site and equipment.

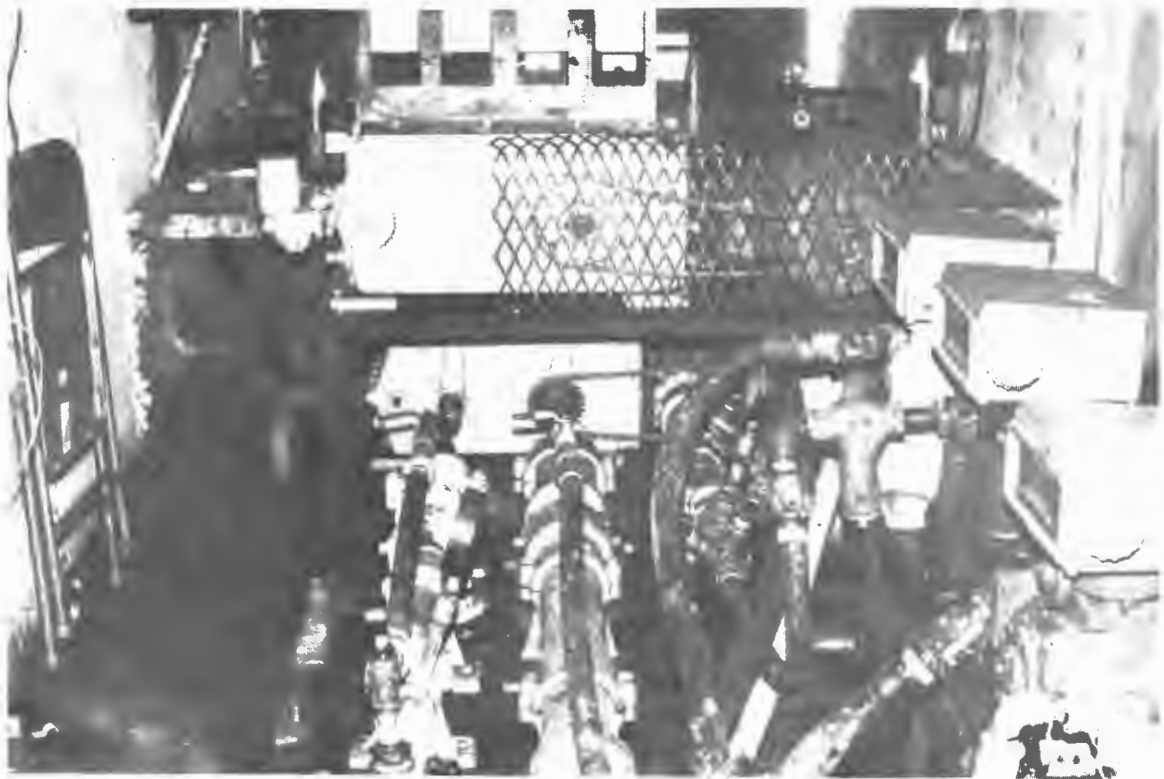

Figure 13. Van mounted grout pumps.



Figure 14. Packer element and connector tubing used in Europe.

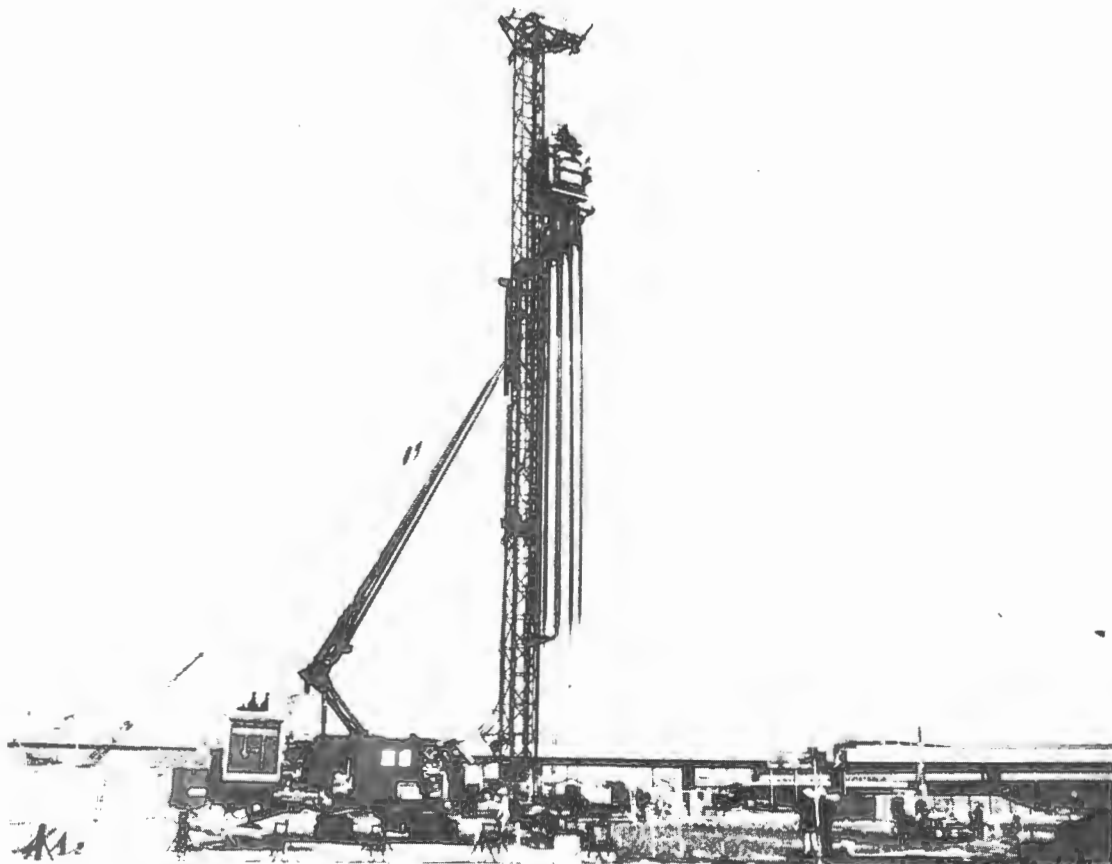

Figure 15. Machine for placing packer element and connector tubing.



Figure 16. Grouting tubes in place for grout injection.

#### E. Evaluation of Current Grouting Practices

Grouting is used only occasionally in the United States, but it is used very extensively in Europe. The American companies are small firms with limited capability and equipment, while the European companies are complete foundation specialists with research laboratories and personnel capable in many disciplines. The European companies began about 40 years ago when construction of dams became widespread through Europe and Asia. When the governments initiated this work, they looked for private companies to conduct foundation investigations. This brought about the development of the foundation company in Europe with diversified capabilities, including grouting. During the past 15 years, urban transportation work increased so the companies applied their expertise to the tunneling operations inherent in the construction of Metro systems. Grouting was considered a valuable stabilization method for open cuts and tunneling, so it was given primary consideration in planning of the Metro systems. The private companies were used extensively to help in the planning work for the systems. This resulted in the larger, diversified companies in existence today.

In contrast, in the United States, the expertise for this type of work was developed by government agencies, such as the Corps of Engineers, Bureau of Reclamation, etc., who built their own organizations to perform the grouting work on dams. Consequently, when the

work began on a large scale for underground transportation, there were no grouting companies with complete foundation design and construction capabilities. There was very little incentive for the development of such organizations, since grouting was not given consideration as a method for construction and its use was limited to emergency situations.

In the United States, fixed price contracts are the general practice for construction projects. With this practice, it is essential that the prospective bidders be told the exact conditions of the soil where a tunnel or excavation is to be made, especially if grouting applications are involved. Since the site investigation many times is not thorough, it becomes very difficult to write a specification setting forth end conditions. In addition, there are no economical means for determining soil conditions after grouting. Therefore, the few specifications that have been written usually specify a compressive strength for the grouted soil and the guide lines for conducting the grouting. Confirming the results has been very hard, and usually is attempted by drilling a few boreholes at random across the grouted area.

In contrast, European practice is to send out a "tender" to prospective contractors for a particular construction job, for example some portion of a Metro (subway) system. The owners permit the foundation companies to make a proposal on their method to accomplish the job. Many contracts are then made by negotiation with the company submitting the most satisfactory proposal for the job.

Generally the payment for jobs in Europe is made on the basis of square meters of surface grouted or cubic meters of soils grouted, while in the U.S. payment is usually based on gallons of grout pumped. The European companies furnish a recorded chart of pressure and flow rate information on each hole grouted, using a grout material which has known strength qualities. From the owner's standpoint, this seems to be a satisfactory way to handle the grouting. Costs are presently (1975) on the order of \$150.00 to \$200.00 per cubic meter of soil grouted in European Metro systems, as compared to about \$130.00 per cubic meter in the United States.

### 3. GROUTING APPLICATIONS

Grouting has been used successfully in the earth to stop groundwater flow, to strengthen soil deposits, for compaction or mud jacking, for tieback anchor grouting and in backpacking of tunnel liners.

#### A. Waterstop

The use of grout to prevent water movement is the oldest usage for grout. Water movement is stopped or greatly reduced by making a section of soil relatively impermeable with grout across the area of the water flow.

##### 1. Dam Foundations

The use of portland cement grout curtains in foundations of dams has been well documented in literature pertaining to rock grouting. This application has generally been successful over the past 50 to 60 years in stopping or greatly reducing water movement through fissures and cracks of the rock foundations. The use of cement grouting for dams and related applications in rock is well documented in manuals published by the Corps of Engineers (1a,b,c), the Bureau of Reclamation (1f) and the Departments of the Army and Air Force (1d). Therefore, further discussion will be limited to grouting in soil formations.

In recent years, dams have been constructed on beds of alluvial soils. Portland cement grouts were still used for grout curtains where the alluvium was coarse enough to permit the grout to penetrate. Chemical grouts (usually silicate type), and clay grout were used for the finer sand layers. A number of jobs using cement, clay and/or chemical grouts are described by R. Chadeisson (6) for dams in Algeria, Germany, Canada, France and Hong Kong. The permeability of the grout curtain underlying the future Mattmark Dam in Switzerland was reduced using cement and chemical grouts (7). Soil deposits as deep as 100 meters (328 feet) were grouted in four stages. Clay-cement and bentonite grouts were used for the first three stages, reducing the overall permeability to  $10^{-4}$  cm/sec. A fourth grouting stage using an aluminate-sodium silicate grout further reduced the permeability of the grout curtain to  $6 \times 10^{-5}$  cm/sec.

A unique method of placing a grout curtain was devised by a French contractor, Etudes et Travaux de Foundation (67). A row of steel piles is driven into the ground by a pile hammer. As the eighth pile is driven, a pile extractor begins pulling the first pile placed. Each pile contains a grout tube inside the flange. As the pile is removed, cement grout is pumped into the void left by the pile. The result is a solid cement curtain with the shape of the piles as shown in Figure 17. This method has been successfully used in the placement of a curtain through a highly permeable gravel bed under earth-fill dikes near the Danube River in Germany.

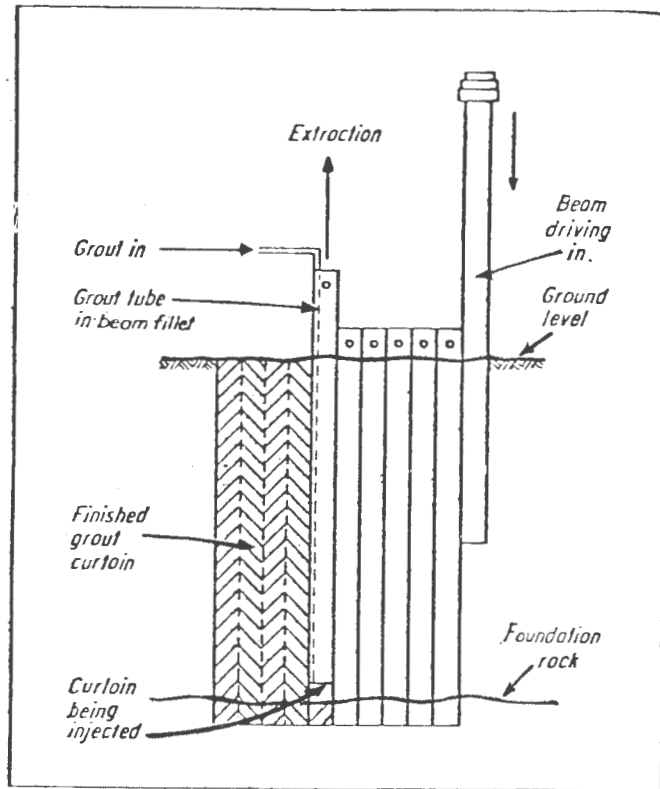

Figure 17. Pile-type cement grout curtain,  
source: ENR, April 25, 1963

## 2. Cut-and-Cover

Cut-and-cover tunnel construction is being used where surface conditions permit for Metro underground systems both in the United States and Europe. Very little grouting has been done for water control during cut-and-cover construction in the United States. On the other hand, the cut-and-cover construction for a Metro system now being built in Lyon, France utilizes diaphragm walls and sheet steel piling, with grouting performed between the walls prior to excavation to prevent the water from entering the excavation (see Figure 18). For this job, the volume of soil from 8m to 16-1/2m (26.25 to 54.14 feet) below ground level is grouted between the diaphragm walls using cement and chemical grouts. The drawing in Figure 18 shows the details for this job.

A type of diaphragm wall now being used by one company in European installations is the prefabricated panel called "Panosol" (68). With this system, the slurry used to fill and hold open the trench contains portland cement and a retarder additive with the bentonite to obtain a set after several days. Figure 19 shows how the grout strength must increase with time to satisfy the following requirements:

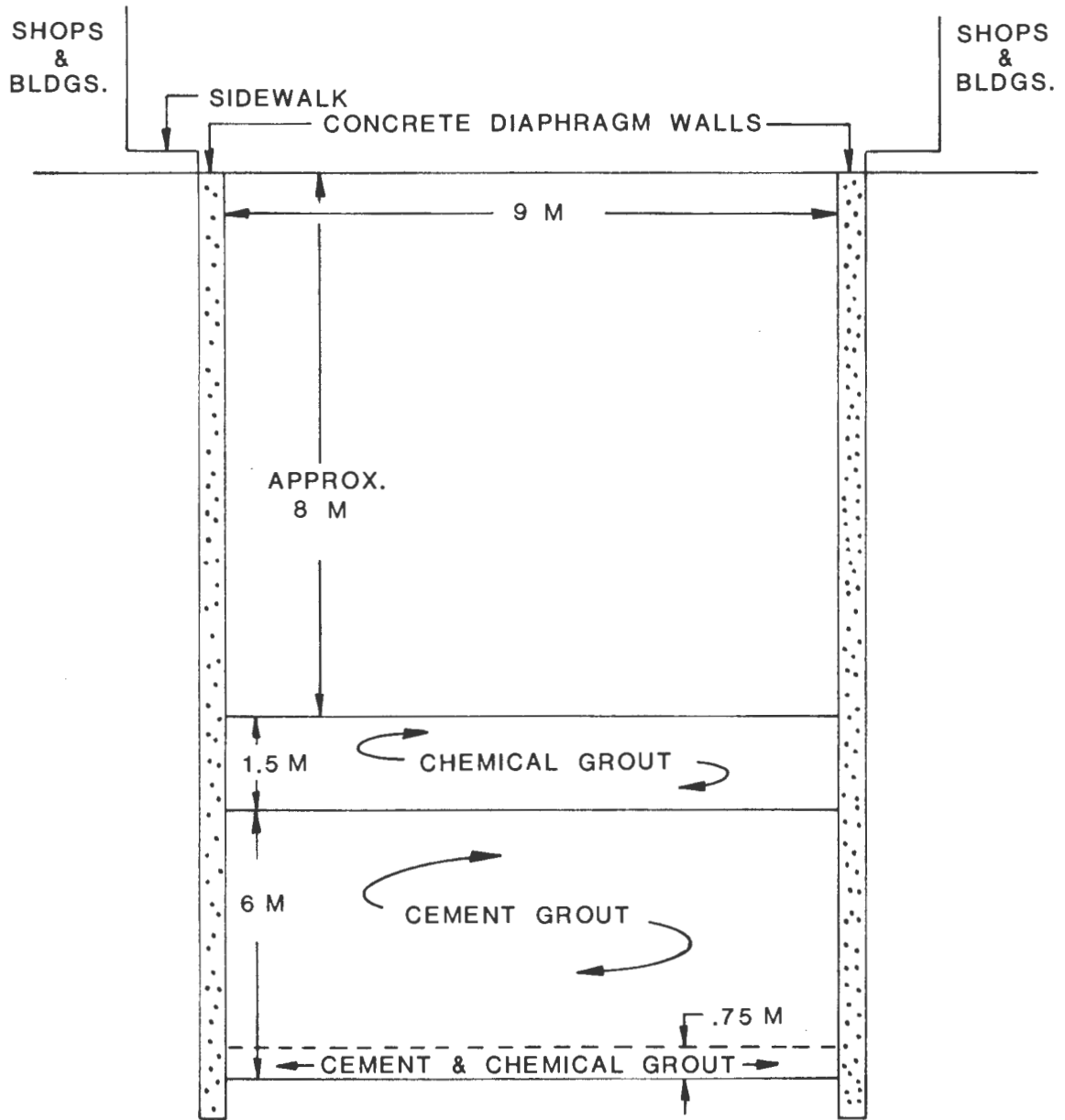

Figure 18. Cut-and-cover grouting for Metro system in France, source: Soletanche Enterprise - Paris, France



- (a) Remain fluid during excavation and placement of wall elements.
- (b) Acquire sufficient resistance in several days to permit excavation of area beside installed wall.
- (c) Permit grout removal from inside of wall after excavation.
- (d) Obtain final strength equivalent to soil strength.

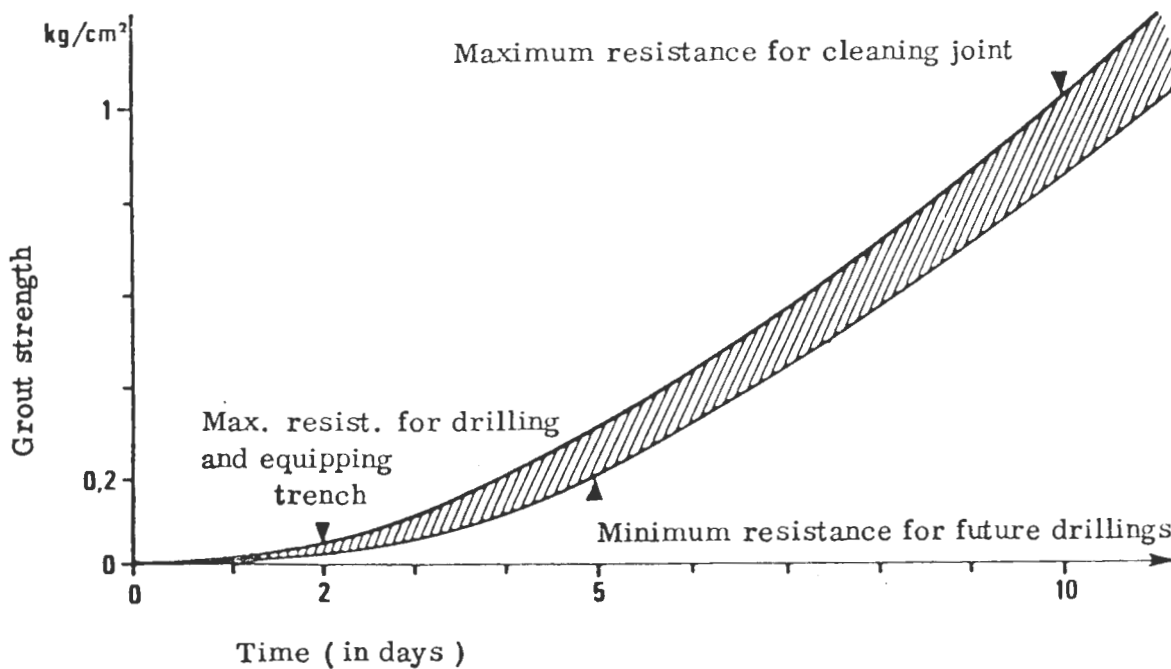
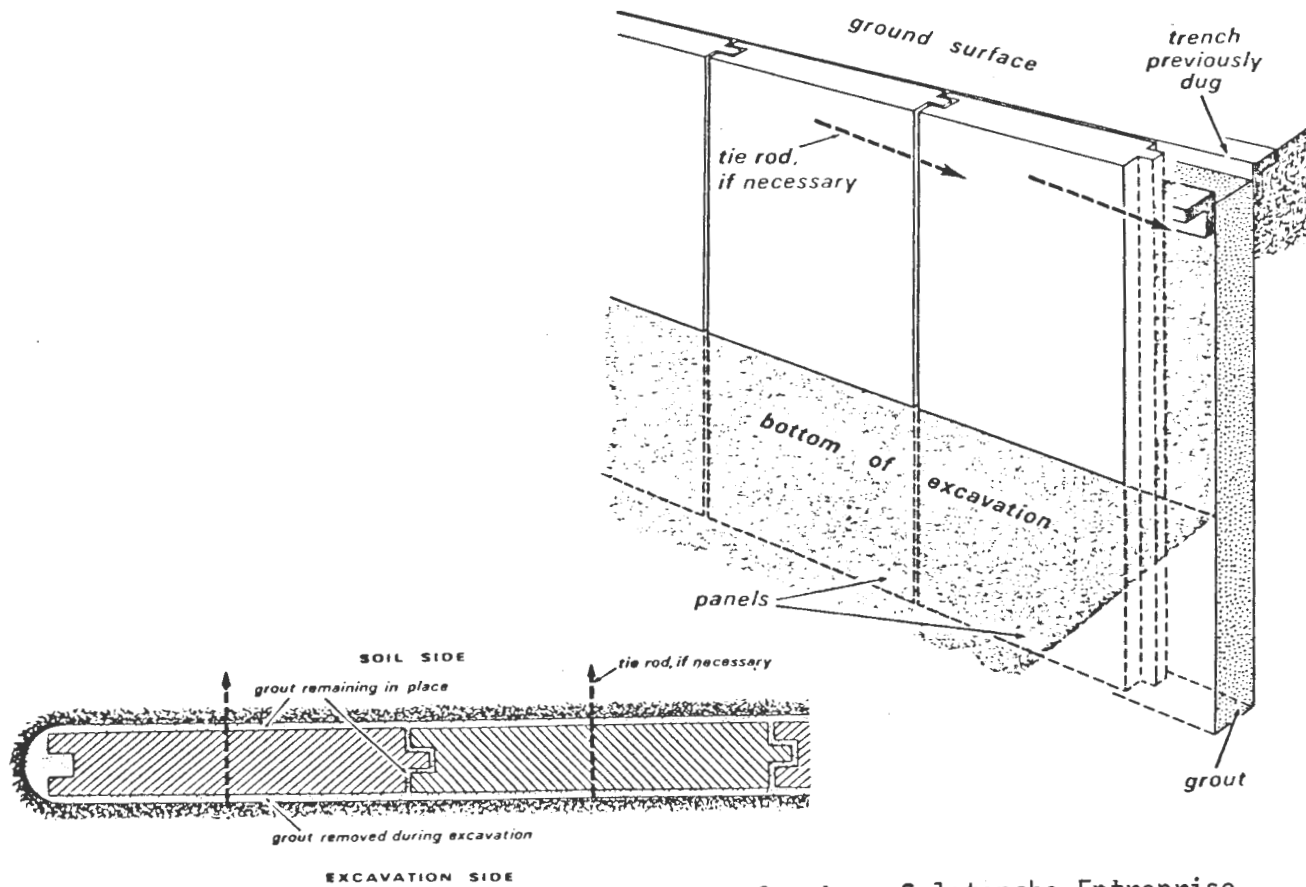

Figure 19. Strength curve of special grout used with prefabricated wall installations (68).

The prefabricated wall elements of reinforced concrete are made in several shapes and appearances. These may include tongue and groove, as shown in Figure 20, or T-shaped or H-shaped beams with slabs between. The grout in the trench fills the joint between the wall elements to provide the necessary seal.



Courtesy Soletanche Entreprise

Figure 20. Prefabricated concrete diaphragm wall construction.

On a job for a Metro station in Holland, chemical grouting was performed on a 1m (3.28 ft) thick section at a depth of about 9 to 10 meters (29.5 to 32.8 feet) using a special one-element packer (see Figures 14, 15 and 16). When this area is excavated, a thickness of sand sufficient to hold the hydrostatic head of groundwater is left over the grouted section.

### 3. Tunnel Boring

One application for grouting in tunneling is in reducing the permeability of water-bearing sand so that the tunnel can be excavated using compressed air with lower air pressure (8). Another application was in construction of a trunk storm sewer which required manholes extending down through a water-bearing sand. Entrance of water into the tunnels was prohibited by grouting the sand around the manhole as the lining was sunk into place through the sand (9).

In the Paris transit system, the tunnel crossing the Seine river used immersed caissons. A grout curtain was constructed prior to immersion from a floating barge to prevent the sand underlying the piers of the Neuilly Bridge from flowing into the excavation for the caissons (10). This is shown in Figure 21.

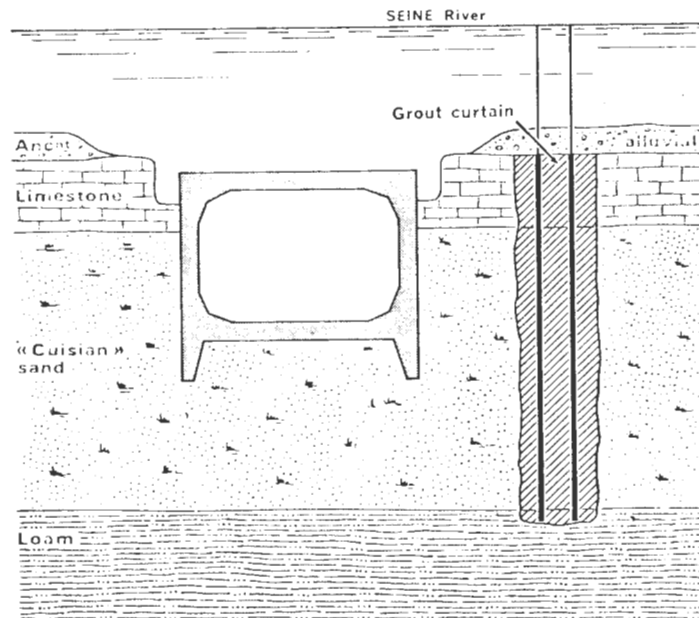

Figure 21. Grout curtain protecting bridge piers (10).

#### 4. Remedial Grouting

Remedial grouting is that performed on completed structures when leakage occurs. A common application is repairs to leaking earthen dams. On a dam in Illinois, seepage through the downstream toe of the dam was blocked by a chemical grout, then sealed using cement and bentonite grout (11). An Oklahoma dam was grouted with chemical grout to reduce water leakage through the earthen dam. A case history of this dam is included as Exhibit G, Section C of the Appendix. Leakage into metal or concrete structures through joints, bolt holes or cracks can also be repaired using chemical grout injection. This is fairly common for concrete tunnels and mine shafts. Underground missile tunnels of corrugated steel have also been repaired with chemical grouting after welding and sealing compounds had failed (12).

#### 5. Slurry Trench

A slurry trench is a narrow trench which is filled with a bentonite slurry as it is excavated to stabilize the walls of the trench. The slurry trench can also be used to prevent migration of groundwater in conjunction with applications discussed above. A successful job has been done southwest of Memphis, Tennessee by using a slurry trench as a grout curtain. Slurry was replaced in the trench with a dense, impermeable clay soil, which was packed in place to form a waterstop barrier. This resulted in an estimated saving of \$1 million by permitting dry excavation for a large pumping station. The slurry trench and diaphragm wall system is widely used in Europe, particularly in underground construction next to existing structures.

#### B. Strengthen Natural Soil Deposits

This application involves permeation of the soil voids with a grout material to replace the air or water, cementing the particles together to give increased compressive strength. It has been used in construction of subways in built-up urban areas to: (a) strengthen soil formations under buildings adjacent to the excavated areas, (b) to solidify soil for tunneling support, (c) to strengthen foundation soil under bridge piers and (d) to prevent loss of ground during excavation of tunnels or other areas. This type of grouting has been and is being used in most of the Metro (subway) systems in Europe, and it is now being used on an increasing scale in the United States and other countries constructing underground transit systems.

##### 1. Under Footings and Foundations

Grouting to strengthen soil deposits under footings and foundations is normally accomplished by setting injection pipes from the surface at an angle to reach the soil under the building foundation or bridge footings. One such job was performed in Cleveland, Ohio to strengthen the soil under two bank buildings so the soil could be completely excavated between the buildings without any damage to either structure. A silicate

type chemical grout was injected into the soil under the footings of the two structures. This permitted excavation to extend as much as eleven feet below the footings of the two bank buildings without any movement of either structure. The soil was solidified sufficiently to be used as forms for the concrete foundations of the new buildings (13). Another example of strengthening the soil under an existing footing is shown in Figure 22, where the soil was consolidated under the footings of a hospital in London to prevent settling when nearby excavation was made (14).

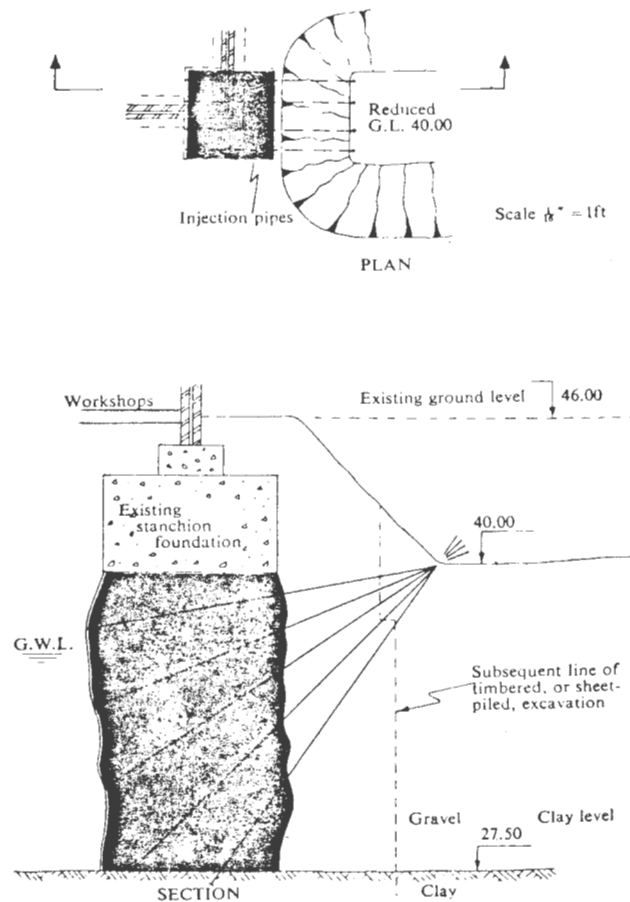

Courtesy Soil Mechanics, Ltd.

Figure 22. Grouting under footing of British hospital.

Soil around a large sewer line was grouted with cement grout followed by chemical grout. This was done to provide support for the line as two tunnels of the Washington, D.C. Metro system was bored under the line. This job is detailed as Case History E in Section C of the Appendix.

Grouting under footings for strengthening the soil is very prevalent

on the continent of Europe. The writers observed extensive grouting for a Metro system in Hanover, Germany. A silicate type chemical grout was being used under building foundations located adjacent to and above the proposed tunnel of the Metro system to prevent any settlement of buildings during tunnel excavation.

## 2. For Tunnel Excavation

Perhaps the most common use of grouting on a larger scale is the consolidation of soil to prevent running ground or water intrusion during tunnel or shaft excavation. Grout is injected either from the ground surface, from a gallery (pilot tunnel) or into the face of the tunnel within the excavation.

In New York City, chemical grouting with formaldehyde and acrylamide types was used in the construction of a large sewer interceptor tunnel because mixed face conditions (interlayered permeable and impermeable soils) were indicated in preliminary surveys. This conditions would permit water and ground intrusion where permeable layers were encountered. The use of compressed air would have been expensive and inconvenient, so grouting was selected as the construction method. Initial grouting was done from the tunnel face using acrylamide. Subsequent grouting was done from the surface ahead of the face with formaldehyde grout to achieve a successful job(15).

Grouting was selected as the most feasible solution in the construction of eight junction corridors between four tunnels into an underground station located under the Hamburg, Germany, State Railways Central Station. The soil was consolidated and strengthened from the excavated tunnels so that the corridors could be excavated by hand under the roof of treated ground without any major difficulties (16). Figure 23 shows this grouting procedure.

Another soil strengthening application reported was grouting for the underground railway in Munich, Germany (16). The purpose was to strengthen the soil and to reduce the permeability in water-bearing sand and gravel to permit excavation with automatic shield under reduced air pressure. As shown in the upper portion of Figure 24, most of the grouting took place from cellars of the buildings above. A bentonite cement grout was used first to fill the larger voids; then, a silicate base grout was injected to fill the smaller voids. Grout holes were also drilled through the invert canal or from working shafts to complete the job, as shown in the lower view looking into the tunnels.

During construction of the Auber Station in the Paris Transit System, grouting was the key method of construction rather than an auxiliary process of remedial grouting (10). To accomplish the grouting properly, three work tunnels were constructed parallel to the Auber Station to perform the grouting from underground. A top gallery was constructed first, then the side areas of the station were grouted to permit dry excavation of the other two working galleries and to obtain a seal of side walls for the main tunnel as shown in Figure 25(a).

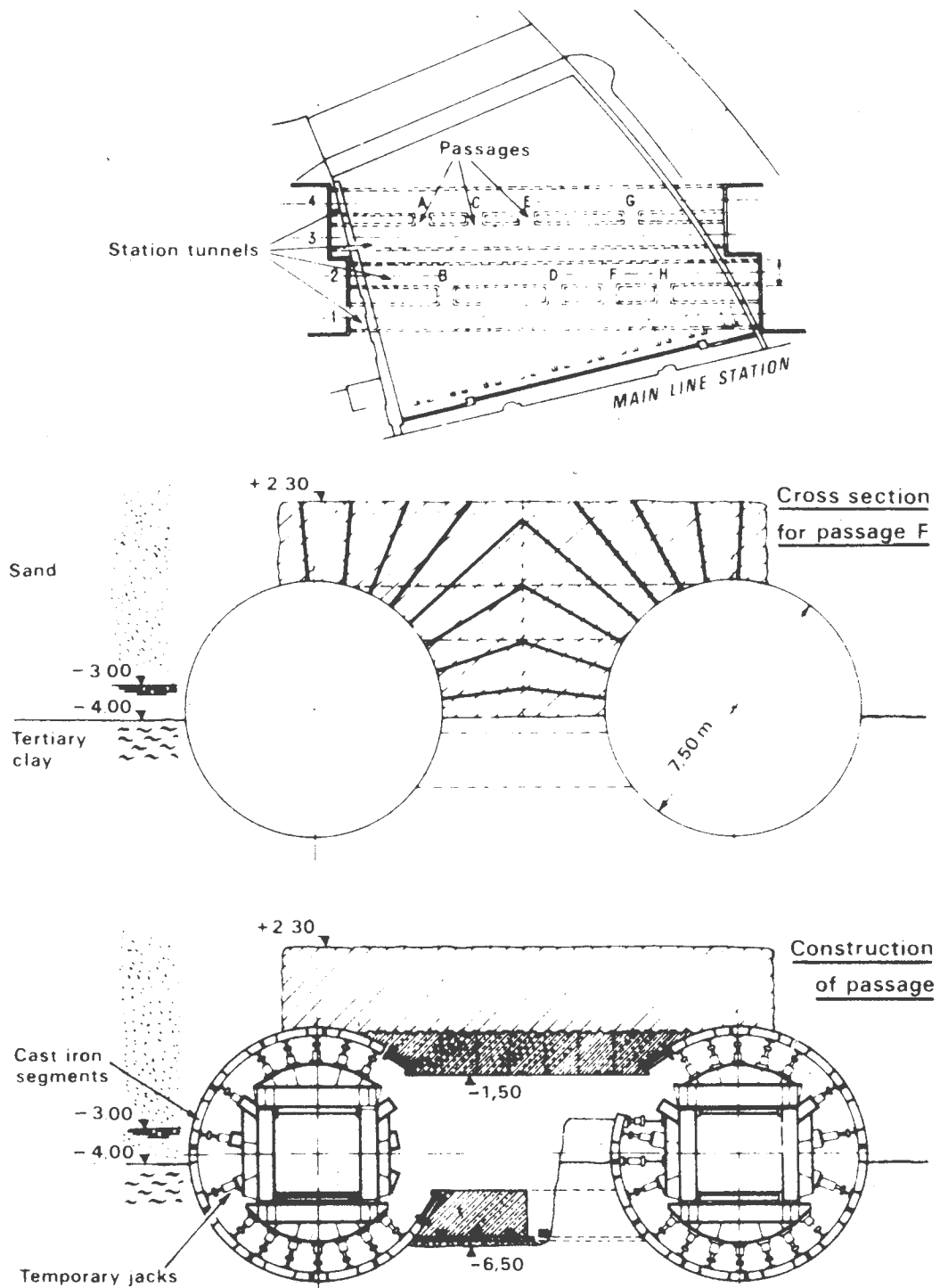

Figure 23. Hamburg (Germany) subway grouting (16).

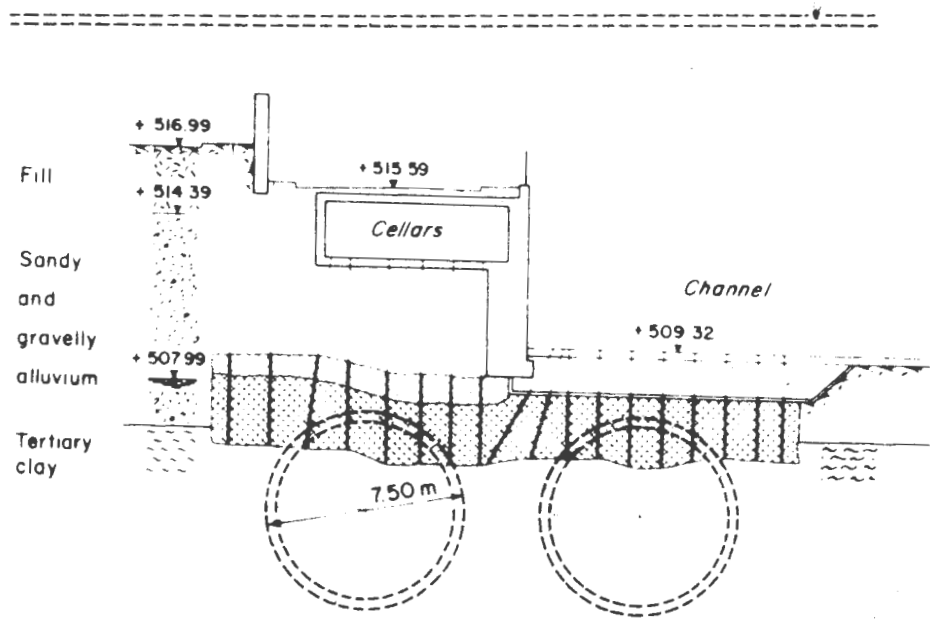
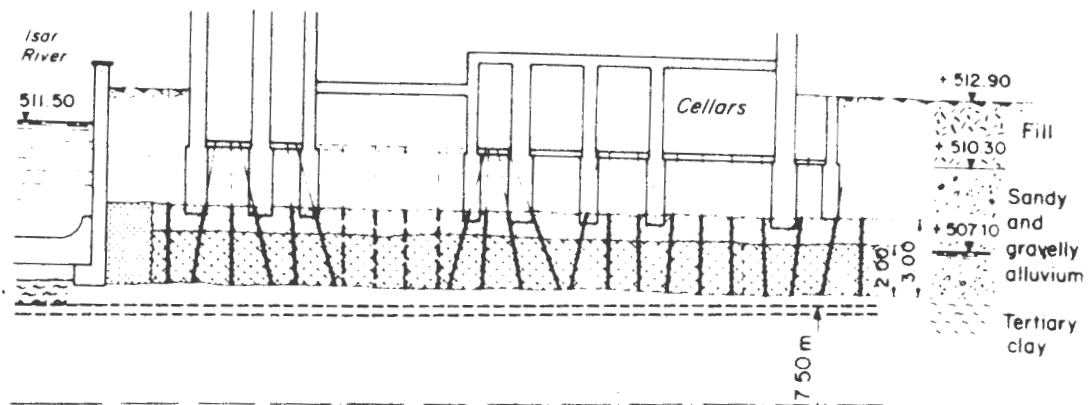
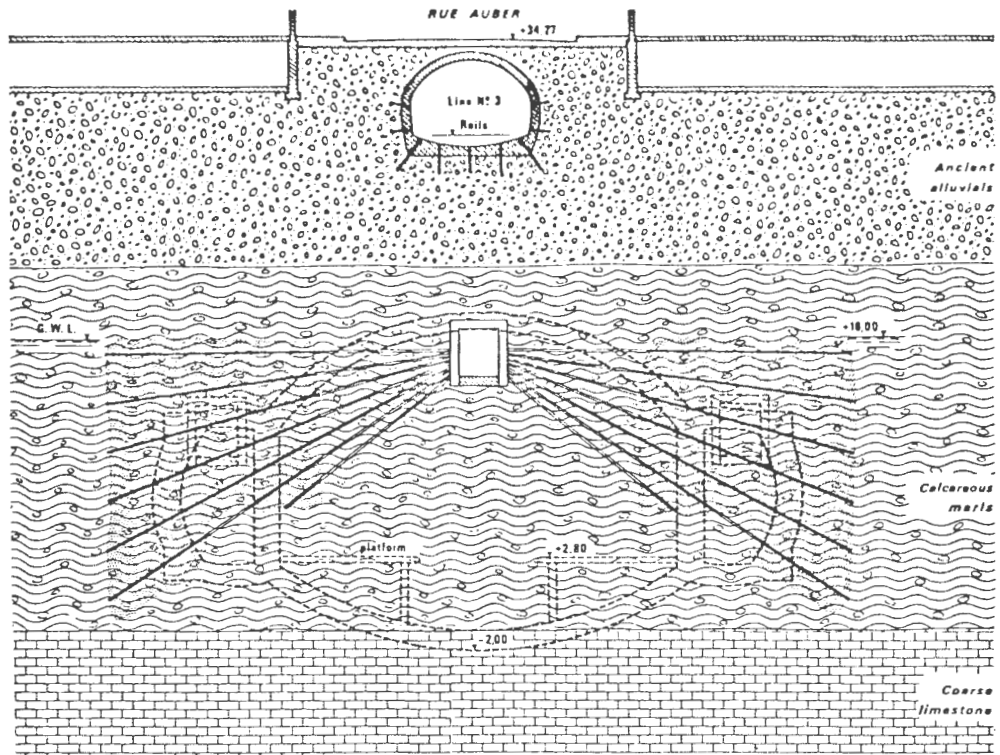
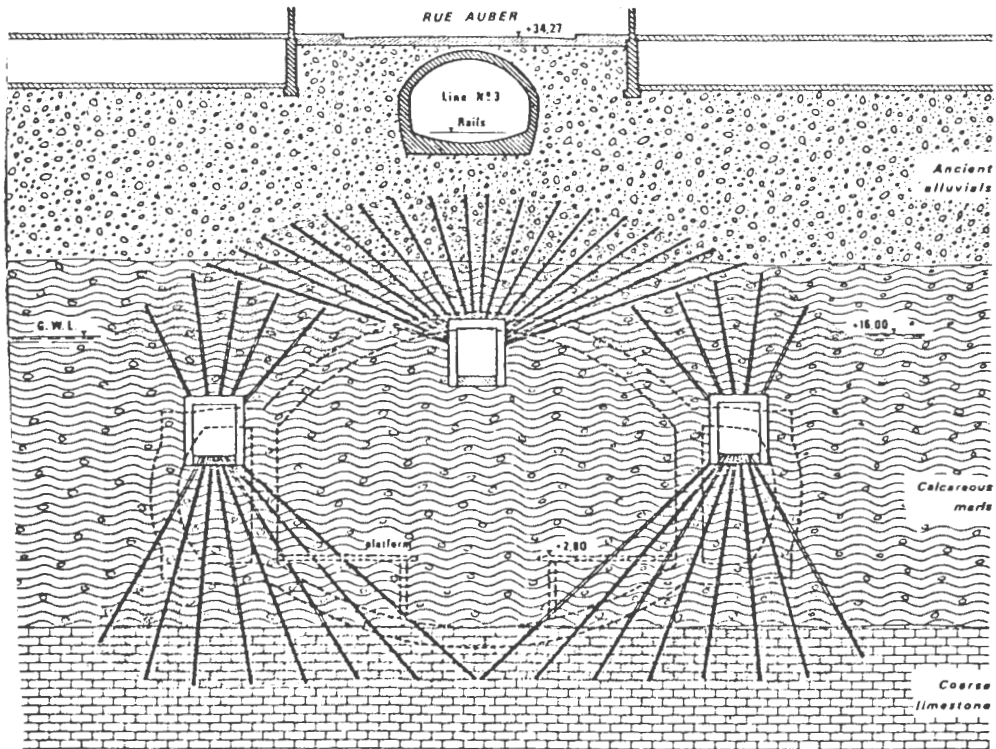

Figure 24. Munich (Germany) expressway grouting (16).





(a)



(b) From Soletanche Entreprise

Figure 25. Grouting from galleries in Paris Metro system.

Grouting was then used to seal the floor, the lower part of the side wall area, and the soils surrounding the arch of the station. This treatment was made from all three galleries as shown in Figure 25(b). The successful operation here was important because the station was located under historical buildings which could not be disturbed.

While excavating a tunnel on the Washington Metro system near RFK Stadium, cohesionless sand and gravel were encountered which produced a running face and ground settlement as shown in Figure 26. A grouting program using silicate base chemical grout was initiated to stabilize the face from the surface before excavation. Grouting was successful in consolidating the soil to allow excavation without further loss of ground. A detailed report is given as Exhibit H in Section C of the Appendix.

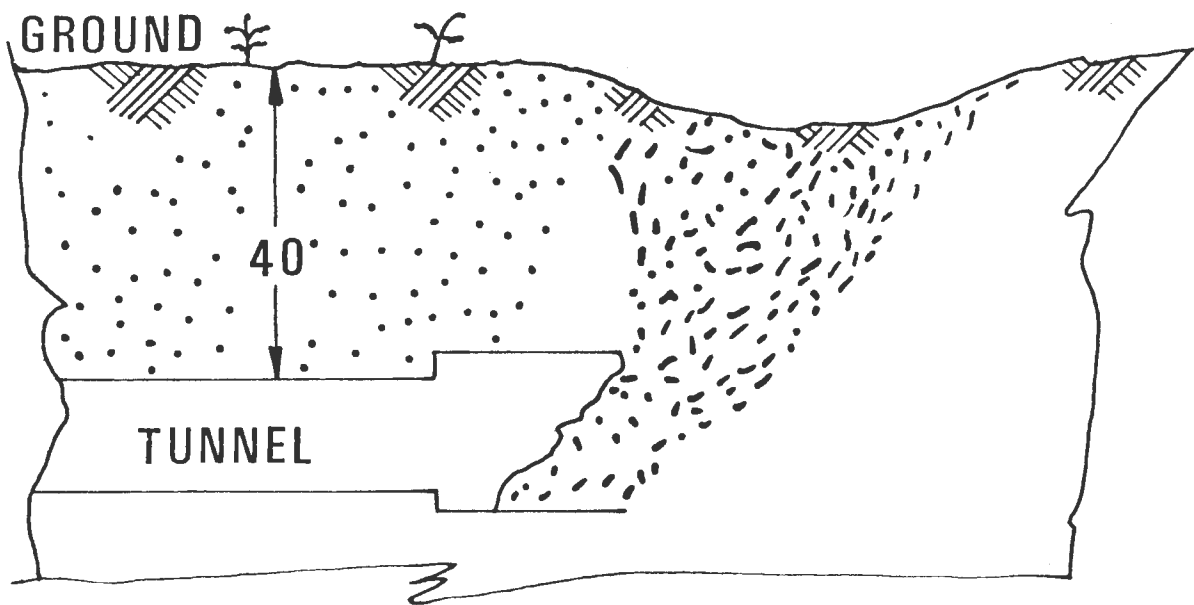

Figure 26. Running ground encountered in tunneling.

### 3. In Cut-and-Cover

A major use of grouting and slurry trench construction in cut-and-cover construction is for water shutoff. In Lyon, France, grout was used to strengthen the soil to withstand the hydrostatic head below the excavated portion between the diaphragm walls. Details were given in Section A.2 on pages 29 and 30.

### C. Compaction Grouting

Compaction grouting, in contrast to permeation type grouting, consists of intruding a mass of viscous cement grout into the soil to fill voids and to compact the soil by pressure (17). The process is most often used to compact fine grained soils and to raise structures which have settled (18). Its use below 20 to 30 feet (6 to 9 meters) is not economically feasible; nor is it effective in near-surface soils where the overlying restraint is small. Compaction grouting is used to stabilize soil under residences and light buildings; it has also been used to level concrete slabs and pavements, to raise tanks and structures which have settled, and to level machinery bases to stop vibration. It has also been used under footings of structures which have been built on uncompacted fill. Caution must be observed to prevent excessive uplift of structures, or when grouting in an area where underground pipes may have been ruptured by excessive settlement.

A heavy compressor in a northeastern industrial firm was vibrating so badly that the plant operation was endangered by rupturing lines. The voids beneath the compressor base were filled with cement grout, and the soil was compacted to provide more resistance against vibration. The subsequent reduction in vibration was 90% and the movement was no longer visible (19).

A large storage tank in the Midwest area had settled, but it was lifted back to near normal conditions by compaction grouting (20). Grout holes were drilled around the periphery of the tank, and viscous grout was injected through vertical pipes as shown in Figure 27 to form a wall of grout around the circumference of the tank. The grouting to level the tank was then made through pipes at a 30-degree angle to place the grout inside the grout wall and under the tank as shown in the lower drawing of Figure 27.

### D. Tieback Anchorages

The use of tieback anchors is widespread both in Europe and in the United States. The technology is well defined through many published papers (see Bibliography), and there are many competent companies who design and install tieback anchors. These anchors are installed in both rock and soil to provide lateral support for walls used in ground support walls. In the United States, ground support by soldier beam and wood lagging walls are most common and anchors are used in some cases. Anchors are also used with sheet steel piling and concrete diaphragm walls. Figure 28 shows a soldier beam and lagging wall where part of the wall is supported with tieback anchors. The tieback anchor system provides an open, uncluttered work site.

In open cut construction in Europe, concrete diaphragm walls are used extensively, and sheet steel piling is used to some extent. Tiebacks are used with both types of walls. The grout used in the tieback

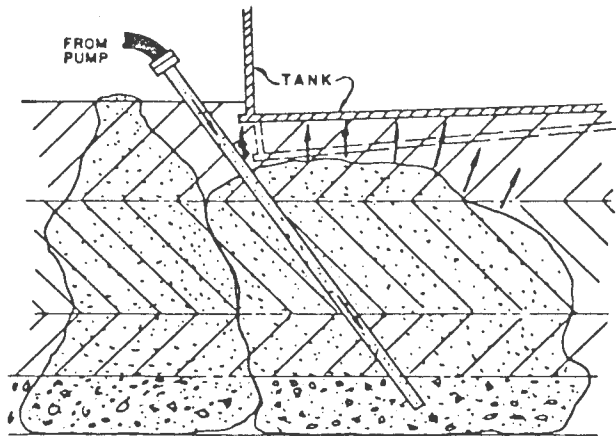
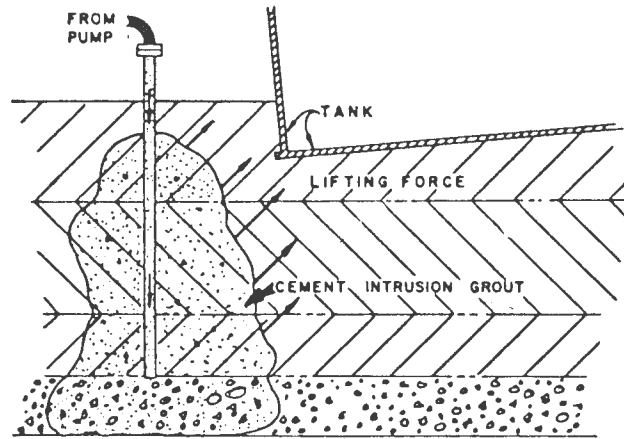

Figure 27. Schematic of compaction grouting to level tank (20).



Figure 28. Open cut construction with both strut bracing and tieback anchorages.

anchorage is generally conventional portland cement grout. Figure 29 shows workmen placing an anchor in a sheet steel wall on a cut-and-cover construction job in Lyon, France.

Prestressed rods or cables are normally used as tiebacks. The location of the grouted anchor zone is dependent upon the soil properties. A theoretical "failure plane" will extend up from the bottom of the wall at an angle of  $30^\circ$  to  $35^\circ$  with the vertical (see Figure 30). The grouted anchorage must be beyond this "failure plane" to be considered in a safe location. The length of tieback which passes through the theoretically nonbearing soil is greased or wrapped with plastic to prevent bond with the surrounding soil when the anchorage section is grouted. Figure 30 gives a typical detail of an earth anchor tieback which uses a steel rod for the stress member (21). Holes are normally drilled about  $20^\circ$  to  $30^\circ$  below horizontal. Bore size varies according to the soil and may be from 3-inch diameter (7.5cm) for granular soils to 12-inch diameter (30cm) in cohesive soils. The length of the grouted section is calculated for the desired load; in some cases the section to be grouted is enlarged by underreaming or postgrouting to provide greater holding strength. Design load per anchor varies from 50 kips to 100 kips in the United States. Anchors are normally stressed to a proof load, then backed off to the design or working load (22). Detailed information



Figure 29. Placing tieback in sheet steel wall.

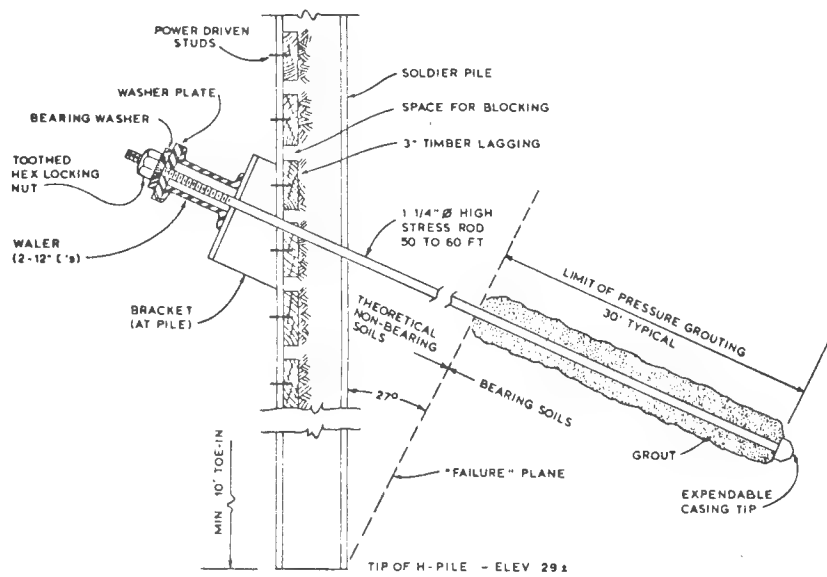

Figure 30. Typical detail of earth tieback anchor (21).

is given in Report No. FHWA-RD-75-130, April 1, 1976 by Goldberg-Zoino and Associates, Newton Upper Falls, Massachusetts.

Costs for using tieback anchors are higher than for using struts. However, the anchors can be made permanent, and they provide an open work area between the walls.

#### E. Backpacking Tunnel Liners

Backpack grouting in modern tunnel construction refers to filling the annular space between a tunnel bore and the tunnel lining (or rings) with portland cement. The tunnel bore is somewhat larger than the outside diameter of the tunnel lining. After excavation of about four feet (1.22 m), or the length of one ring of lining, the lining is put into place. The rings (about 1 meter long) are erected by bolting the sections together and to the last ring installed. Ring grouting is started immediately after the ring is in place. Most of the rings are iron or steel and contain plugged holes around the periphery through which grout can be injected. Grouting is accomplished using a sand, cement and water slurry. The composition used recently on a job in Brazil was about 63% sand, 21% cement and 16% water.

Backpack grouting is accomplished as quickly as possible after ring placement to fill the space behind the ring before the soil can fall into the space and cause settlement on the surface. Grouting injection is begun at the bottom and progresses up the sides to the top. Injection points are moved up as the grout appears in the hole next higher up the side, or as it leaks into the tail of the shield. Pump pressure is kept as low as possible to move the grout without danger of fracture. A final grouting stage is done after grouting to top of ring using a neat cement grout with one part of cement to one part of water by weight.

The grout should be mixed and ready for use as each liner section is erected. The setting time should not be any longer than necessary to mix and place the cement. On a tunnel for the Sao Paulo, Brazil subway, a cycle time for machine tunneling to advance, erect and grout a one meter ring was 2 hours and 10 minutes.

#### F. Alternate Use of Freezing

Freezing of ground for mining and construction applications has been in use for over a century. It is adaptable to any size, shape or depth of excavation and the same equipment can be used in each application. It is best suited for use in soft ground for excavations deeper than 7 meters (23 feet). Excellent reviews of frozen ground construction techniques have been presented by Khakimov (23), Sanger (24), and Shuster (25).

Freezing will probably be used increasingly in the Soviet Union. It is used in Europe also, but only to a small degree in the United States. It is expensive and is usually a last resort. There are only one or two companies in this country that have the equipment and capabilities to perform freezing operations. One company has two 100-ton refrigeration units, driven by electric motors, which they use in their work.

Figure 31 shows five basic alternate freezing approaches. All of these approaches consist of a primary source of refrigeration and secondary distribution system to circulate the coolant or refrigerant in the ground.

The freezing approach used on most projects today is the Primary Plant and Pumped Loop Secondary Coolant System. This system uses a conventional one- or two-stage ammonia or freon refrigeration plant. Its distribution system typically consists of an insulated coolant supply manifold, a number of parallel connected freezing elements in the ground with inner supply and outer return lines and an insulated manifold.

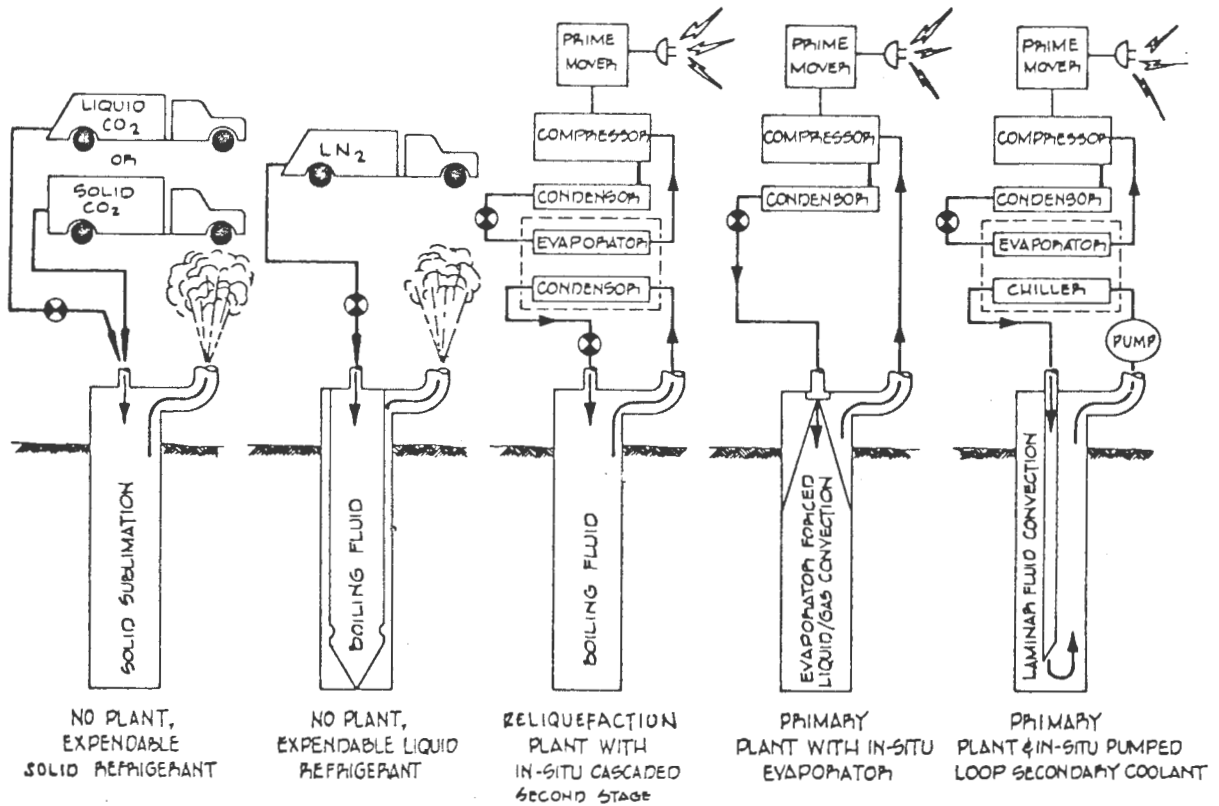

Figure 31. Alternative refrigeration approaches (25).



Control of the freezing process is done by monitoring ground temperatures at critical locations. It is necessary that the ground be kept at preselected temperatures, since all properties of frozen soil are strongly temperature-dependent. Flowing groundwater can also be a problem, so freezing under such conditions requires greater care and higher costs.

The cost for freezing ranges from approximately \$8.00 to \$20.00 per square foot of frozen wall; a weekly charge is also made for the time it remains frozen. If the construction time exceeds six months, this approach will probably not be competitive with other methods.

At this time, the general physics related to ground freezing is reasonably well understood, and approximate analytic methods are available for necessary design calculations in the references cited by Sanger and Shuster.

## 4. SITE INVESTIGATION AND SOILS TESTING

The site investigation for a grouting operation should be as thorough as necessary to furnish a basis for determining groutability and selecting the type of grout material applicable. Information on soil structure, permeability and groundwater conditions is very important.

This investigation should have top priority, because this phase yields the information on which the grouting plans are based. Yet, the available literature reveals that this is a neglected area in planning for a grouting job or other underground construction.

According to Peck, Hendron and Mohraz (26) . . . "One of the outstanding shortcomings in the state-of-the-art of soft ground tunneling at the present time is the manner in which subsurface information is obtained, presented, made available to bidders and related to the contract documents. The engineer or owner, fearing claims, is strongly tempted to place no conclusions regarding the behavior of the soil in the contract documents, although he and his advisors are probably the only ones having the time and facilities to make an adequate assessment of the subsurface conditions. The bidders, on the other hand, are tempted to be optimistic to enhance their likelihood of being the lowest bidder, and to look for every apparent deviation, significant or otherwise, from the conditions they say they have assumed on the basis of the contract documents. This mutually antagonistic relationship is unhappily growing worse and threatens to overshadow many of the technical improvements that potentially decrease the cost of tunneling." This quotation is equally applicable to the grouting aspect of the tunneling program. Frequently, grouting is required because of unforeseen problems encountered in the tunnel construction. If the site investigation for the tunnel had been conducted in a thorough manner, problem soil conditions could have been anticipated and the contractor could have planned remedial measures. If grouting was necessary, time and expense would be saved in beginning the remedial grouting operation.

A recent study for the Federal Highway Administration on subsurface investigation (27) points out that tunnel designers want to know the ground type, the structural defects, the physical and engineering properties, and the groundwater conditions. This information is also necessary for the design engineer should grouting be considered as part of the initial design planning.

The above study also considers the feasibility of using acoustic methods to explore a site from long horizontal holes drilled through the entire site area. If additional research now in progress to further develop this technique is successful, this method would be very valuable in more accurately determining the soil conditions throughout a given area.

There are three fields of interest when conducting a site investigation where grouting might be involved in the proposed construction. These are: drilling and sampling, soil properties affecting grouting, including laboratory and field testing, and geographical and geological data.

#### A. Drilling and Sampling

Drilling of boreholes and recovery of soil samples are the most common parts of a site investigation. Often the investigation consists only of a few boreholes across the site. The holes are generally spaced too far apart. Then it is assumed that the strata between the holes are consistent. This is especially not true in alluvial deposits where pockets and lenses of sand and clay are commonplace. In such instances, the assumptions are incorrect and gaps have been left in the investigation information.

Unlike site investigations for highways, where the soil is generally cohesive and samples are from shallow depths, site investigation for construction or grouting of tunnels requires deep samples, often from cohesionless soils. It is virtually impossible to recover a sample of undisturbed cohesionless soil without using very sophisticated samplers; therefore, samples of soil which are recovered must be recompacted in the test apparatus for laboratory testing.

A Swedish piston sampler, using metal foil which unrolls and enclosed the sample, has been successfully employed in Europe to obtain samples in soft soil up to 60 feet (18.3m) in length (28). The Delft (Holland) Soil Mechanics Laboratory (29) developed a continuous sampler, which encloses a 66mm sample in a waterproof nylon stocking up to 20 meters (66 ft.) in length. This sampler has been used successfully in sampling interbedded layers of peat, clay and sand without disturbance. Sampling can begin at any depth. For deeper tunneling, only that depth which is of interest can be sampled. Neither of these two samplers have been used to any great extent in the United States.

Even under conditions where the sample is disturbed and then recompacted for determination of permeability, simple laboratory testing should be done to determine the feasibility of grouting prior to conducting the more costly field tests.

#### B. Soil Properties Affecting Grouting

When grouting is considered as a solution to a problem in cohesionless soils, it is necessary to know certain properties of the soils in order to answer the following questions:

1. Is the soil groutable?
2. If groutable, what type of grout can be used?
3. What success can be anticipated if grouted?

The soil properties that must be determined in any site investigation are:

1. Permeability
2. Porosity
3. Particle-size distribution
4. Pore-size distribution
5. Chemical properties

### 1. Permeability

Permeability is that property of a soil which allows the flow of a fluid through it. This consideration is important since the grout fluid must flow into the voids of the soil to replace air or water. The permeability of the soil also indicates the groutability and the general type of grout that might be used for any particular soil, especially in terms of viscosity requirements. The permeability may be estimated from the gradation of the soil or determined by laboratory tests on samples of undisturbed soil or recompacted soil to approximate in situ conditions, or from in situ tests at the site.

#### a. Permeameter Tests for Permeability:

Computations of permeability are based on Darcy's law, which states that in laminar flow the velocity of percolation is directly proportional to the hydraulic gradient (or the ratio of the drop of head to the length of the soil layer). In other words, the quantity of water flowing through a given cross-sectional area of soil is equal to the hydraulic gradient multiplied by a constant called the coefficient of permeability. Equation 14 (given in Chapter 2) is expressed as:

$$Q = Aki$$

where

Q = volume of flow per unit time,  
cfd or cc/min

A = cross-sectional area of flowing  
water, sq ft or sq cm

k = coefficient of permeability

i = hydraulic gradient

The cross-sectional area A is the area of the soil including both solids and void spaces. Since the water actually flows only through the void spaces, the velocity  $k_i$  in equation 14 is a fictitious velocity at which the water would have to flow through the whole area A in order to give the quantity of water Q which actually passes through the soil.

The coefficient of permeability  $k$  has the dimensions of a velocity, i.e., distance divided by time. Normally this is expressed in cm/sec.

For the most part, permeability tests and evaluations relate the permeability of soil to water, or sometimes to air. For fluids other than water, the permeability coefficient  $k$  for water must be multiplied by the ratio of viscosity of water to that of the fluid. This is expressed in equation 15 (Chapter 2) as:

$$k_g = \frac{k\mu}{\mu_g}$$

The coefficient of permeability can be determined by either a constant-head or falling-head permeability test. The constant head test can be performed in accordance with ASTM D 2434-68, Standard Method of Test for Permeability of Granular Soils (Constant Head). The quantity of water flowing through the soil specimen is measured for a given time while the head is kept constant. This test is used principally for coarse-grained soils with  $k$  values greater than  $10^{-4}$ cm/sec and is limited to disturbed granular soils containing not more than 10% soil passing the 200 sieve.

The falling head test is useful for fine-grained soils (fine sands to fat clays) with  $k$  values less than  $10^{-4}$ cm/sec. There is no ASTM test established, but it is conducted in the same manner as the constant head test, except that the head of water is not maintained constant but is permitted to fall within the upper part of the specimen container or in a standpipe directly connected to the sample (30). An illustration of this test principle is shown in Figure 32.

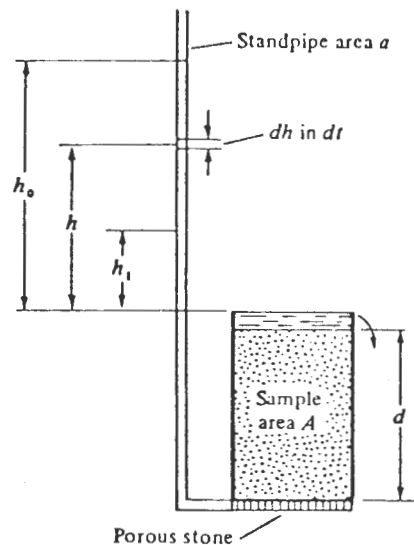

Figure 32. Falling head permeameter (32).

In the conduct of the test, water passing through the soil sample causes water in the standpipe to drop from  $h_0$  to  $h_1$ , in a measured period of time,  $t$ . The head on the sample at any time  $t$  between the start and finish is  $h$ ; and, in any increment of time  $dt$ , there is a decrease in head equal to  $dh$ . From these facts, the following relationships may be written:

$$k \frac{hA}{d} = -a \frac{dh}{dt}$$

Then

$$k \frac{A}{d} \int_0^{t_1} dt = -a \int_{h_0}^{h_1} \frac{dh}{h}$$

from which

$$k = \frac{ad}{At_1} \left[ \log_e \frac{h_0}{h_1} \right] \quad (17)$$

where

- $a$  = standpipe area, sq cm
- $d$  = length of sample, cm
- $A$  = area of sample, sq cm
- $t_1$  = time for drop in head, sec
- $h_0$  = initial head, cm
- $h_1$  = final head after time  $t$ , cm

The weak point in laboratory determination of permeability is the difficulty of ensuring that the amount of compaction and the structure of the soil sample in the permeameter is representative of that to be grouted in the ground. These samples, when recompacted for laboratory tests, will also approximate the conditions of the sediments in place. It is almost impossible to recover samples without altering the state of stress, the structure, the density and the moisture, as well as losing some of the finer material.

Therefore, the laboratory samples will usually produce different flow rates and permeabilities than the same tests conducted in situ. It is good practice, however, to collect these samples and perform laboratory tests to obtain an indication of the permeability before going to the additional expense of in situ testing. If the laboratory tests give a permeability of less than  $10^{-5}$  cm/sec, the groutability of the soil is questionable.

#### b. In Situ Tests for Permeability

Permeability obtained by in situ testing provides a value which is based on a more nearly unaltered soil structure. This test can determine

groutability, help establish the type of grouting material to be used, and find the injection rates to aid in establishing a set time for the grout.

Current practice of grouting companies in the United States does not usually include in situ permeability measurements. Perhaps this is because most site investigations are made by soil engineering companies during the feasibility study, and sufficient money is not included in a grouting subcontract to perform the in situ testing. However, the site investigations in Europe are often performed by the same company that will do the grouting; so they have more freedom to conduct the site investigation as they desire. This arrangement enables the company to get the specific information needed for both designing and conducting the grouting.

Either constant-head or falling-head field permeability tests can be performed in boreholes. The constant head tests may be conducted either with open end casing or with a packer. In these tests, water is pumped at a constant pressure into a hole drilled into the stratum to be investigated. With open-end casing, tests are conducted with casing set in the hole down to the test stratum. Pump rates and fluid volume are measured for a given time and the permeability calculated from the data obtained. In the packer test, data can be obtained in a similar manner on each stratum as the hole is drilled by inserting an air inflatable packer, since the hole will probably not stand open without casing for later tests. These tests are detailed in the Appendix of Volume 2, Design and Operation Manual, FHWA-RD-76-27.

For constant head, open-end tests, the coefficient of permeability can be calculated by equation 18, which is based on electrical analogy experiments (64):

$$k = \frac{Q}{5.5r_oH} \quad (18)$$

where

k = coefficient of permeability  
 Q = volume of flow per unit of time  
 r<sub>o</sub> = internal radius of the casing  
 H = differential head causing flow,  
 that is, the difference in head  
 between water inside and outside  
 the well casing.

This equation assumes radial flow, and may be applied where the formation thickness is 10D<sub>o</sub> or more, using any consistent units. When packers are used, the equations are:

$$k = \frac{Q}{2\pi LH} \ln \frac{2L}{D_o}, \text{ for } L \geq 5D_o \quad (19a)$$

$$\frac{Q}{2LH} \sinh \frac{L}{D_o}, \text{ for } 5D_o > L \geq \frac{1}{2}D_o \quad (19b)$$

where

L = length of hole tested  
D<sub>o</sub> = diameter of the hole (other symbols  
are as above)  
ln = natural logarithm  
sinh<sup>-1</sup> = arc hyperbolic sine

Example A: An NX (3-3/16" I.D.) casing is open at the end at 20 feet depth. The groundwater table is at 5 feet depth. Upon application of 10 psi pressure at the ground surface, Q = 10 gal/min. Find k.

Solution:

$$H = 5' + 10 \frac{1b}{\text{in}^2} \times \frac{144 \text{ in}^2}{1 \text{ ft}^2} \times \frac{1 \text{ ft}^3}{62.4 \text{ lb}}$$
$$= 5' + 23.1 = 28.1 \text{ ft of head.}$$

From equation 18:

$$k = \frac{10 \text{ gal/min}}{5.5(1.594 \text{ in}) (28.1 \text{ ft})} \times \frac{12 \text{ in}}{1 \text{ ft}} \times \frac{1 \text{ ft}^3}{7.48 \text{ gal}}$$
$$= 0.065 \text{ ft/min}$$
$$= 0.033 \text{ cm/sec}$$

Example B: An 8' length of NW borehole (3-5/8" in diameter) is isolated by packers and tested with H = 10 ft., Q = 50 gal/min. Find k.

Solution: Since L > 5D, equation 19a applies.

$$k = \frac{50 \text{ gal/min}}{2\pi(8 \text{ ft}) (10 \text{ ft})} \ln \frac{240 \text{ in}}{3.62 \text{ in}} \times \frac{1 \text{ ft}^3}{7.48 \text{ gal}}$$
$$= 3.57 \text{ ft/min}$$
$$= 1.81 \text{ cm/sec}$$

The falling head test employs a piezometer installed in a borehole for the purpose of measuring the rate of the falling water level against time. This method is an economical one which can be used in a wide range of soil types. A piezometer also serves the additional function of measuring the excess hydrostatic pressures during the field operations (69).

The relation for a falling-head open-end piezometer is:



$$k = \frac{\pi d^2}{11 D_o (t_2 - t_1)} \ln \frac{H_1}{H_2} \quad (20)$$

where  $d$  = diameter of the standpipe  
 $D_o$  = diameter of the intake hole  
 $t_1$  and  $t_2$  = times for respective heads  $H_1$  and  $H_2$

Example: An AX casing (I.D. = 2.0 in) is left open-ended at 30 feet depth, and the water table equilibrates at 25 feet depth. The casing then is filled with water, and the water level drops 12 feet in 2 hours. Find  $k$ .

Solution: In this case  $D_o = d = 2.0$  inches

$H_1 = 25$  ft;  $H_2 = 25 - 12 = 13$  feet

$$\begin{aligned} k &= \frac{\pi (2 \text{ in})^2}{11 (2 \text{ in}) (2 \text{ hours})} \ln \frac{25 \text{ ft}}{13 \text{ ft}} \\ &= 0.187 \text{ in/hour} \\ &= 0.0079 \text{ cm/min or } 1.316 \times 10^{-4} \text{ cm/sec} \end{aligned}$$

## 2. Porosity:

The relative amount of void matter in a soil may be expressed conveniently by means of either the void ratio or porosity. The void ratio is the ratio of the volume of voids to the volume of solids. The porosity is the ratio of the volume of voids to the total volume of the soil. Porosity is usually expressed as a percentage rather than as an abstract ratio. In either case, the ratio refers to the total amount of void space, without regard to the amount of moisture or air contained in the voids or pores.

These relationships may be expressed by simple formulas as follows:

$$\text{the void ratio, } e = \frac{V_e}{V_s} \quad (21)$$

where  $V_e$  = volume of void space and  
 $V_s$  = volume of solid particles and

$$\text{the porosity, (in percent) } n = \frac{V_e}{V} \times 100$$

$$\text{where } V = \text{total volume of soil} \quad (22)$$

The volume of voids and volume of solids of a soil are determined from the bulk dry unit weight  $\gamma_d$  and the specific gravity  $G$  of the soil mineral grains. In the case of saturated soils, the volume of voids and solids can be determined from the saturated unit weight  $\gamma_s$  and the water

content in pounds per cubic foot  $W_w$ , both being readily determined by nuclear moisture-density gages.

For dry soil:

$$V_s = \frac{\gamma_d}{G\gamma_w} \quad (23)$$

where  $\gamma_w$  = unit weight of water (1 gm/cm<sup>3</sup>, 62.4 lb/ft<sup>3</sup>)

$$V_e = 1 - V_s \quad (24)$$

For saturated soil:

$$V_e = \frac{W_w}{T_w} \quad (25)$$

where  $\gamma_w$  is as above

$$V_s = 1 - V_e \quad (26)$$

In the first method the specific gravity  $G$  can be measured, or may be assumed to be 2.65 for ordinary sands or 2.70 for clays.

The porosity is helpful in determining the amount of grout fluid which would be required to completely fill the void space in the mass of soil to be grouted. Laboratory tests can be made for porosity, but the value obtained must be considered an approximation since the soil structure has been altered or destroyed in the sample. Tests conducted by Beard and Weyl (31) in 1972 indicated that the porosity varied between dry-loose sand and wet-packed sand, and varied with the sorting. Average wet-packed porosity ranged from 42.5 percent for extremely well-sorted sand to 27.9 percent for very poorly sorted sand.

Grouting firms generally use a porosity value of about 33% when planning a grouting job. Some European grouting firms, however, assume a figure over 50%; consequently, they inject more grout than the voids can hold, resulting in the use of excessive grout and possible ground heave.

### 3. Particle Size Distribution

Mechanical analysis of a soil sample is the process of separating a soil into particle size groups, including both the sieve analysis of the coarser grains and the measurement of settling velocity of the fine grains. This analysis can be expressed as the percentage of total weight of dry soil particles which falls in each size class, namely, gravel, sand, silt-size, clay-size and colloidal-size.

Another method of expressing the grading of the soil is to give the percentage of total weight of dry soil particles, which is finer than each of a series of stated diameters from the smallest size up through the maximum size of particle contained in the soil. Table 3 gives an illustration of the latter method (32). The sieve analysis is made in accordance with ASTM Method D 422.

---

Table 3  
Typical Mechanical Analysis of Soil (32)

| Sieve Number<br>or<br>Dia. of Grain (mm) | Percent Finer<br>or Passing<br>by Weight |
|--|--|
| No. 4 (4.76)                             | 100                                      |
| No. 10 (2.00)                            | 96                                       |
| No. 20 (0.84)                            | 92                                       |
| No. 40 (0.42)                            | 89                                       |
| No. 60 (0.25)                            | 82                                       |
| No. 100 (0.147)                          | 78                                       |
| No. 200 (0.074)                          | 65                                       |
| (0.025)                                  | 52                                       |
| (0.010)                                  | 31                                       |
| (0.005)                                  | 21                                       |
| (0.002)                                  | 13                                       |
| (0.001)                                  | 8  |

---

Soil gradation may be represented by a particle size distribution curve. Such a curve is plotted in Figure 33 for the soil analysis in Table 3 (32).

The particle-size distribution curve is an excellent way to describe a soil. The median grain size ( $D_{50}$ ) is defined as the size where 50% of the soil by weight is finer and 50% is coarser. This median describes an average particle size, but does not delineate the range in particle sizes. A measure proposed many years ago by Hazen to describe filter sand is the effective size,  $D_{10}$ , or the maximum diameter of the smallest 10%, by weight, of the soil particles. The uniformity coefficient ( $C_u$ ) is the quotient obtained by dividing the maximum diameter of the smallest 60% by weight, of the soil particles by the effective size, or

$$C_u = \frac{D_{60}}{D_{10}} \quad (27)$$

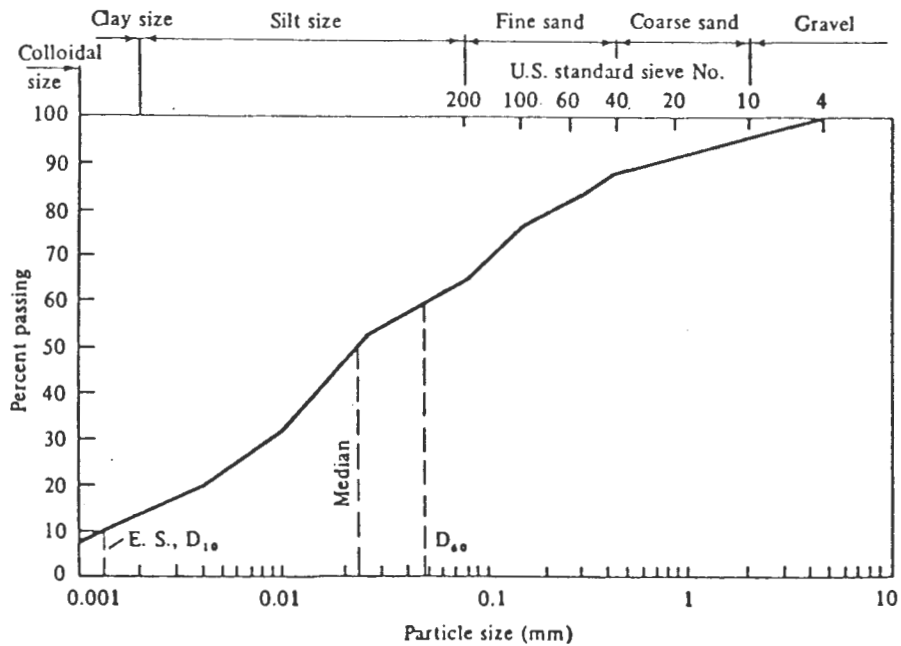

Figure 33. Particle-size distribution curve (32).

In Figure 33, the uniformity coefficient would be:

$$C_u = \frac{0.049}{0.0012} = 41$$

A low uniformity coefficient indicates a soil in which the grains are fairly uniform in size. A high value indicates that the size of grains is distributed over a wide range. For example, a wind-blown silt deposit may have a uniformity coefficient of around 10 to 20, while a well-graded sand may range as high as 200-300.

A low value of effective size ( $D_{10}$ ) indicates that the soil contains a relatively large amount of fine material. A higher value indicates a smaller percentage of fines.

A "rule of thumb" which has been applied to chemical grouting is that if the grain size is such that more than 20% passes the 200 sieve, the chance of successfully permeating the soil with any grout is negligible (33).

Figure 34 shows the relationship between the effective size,  $D_{10}$ , of the soil sample to permeability coefficient and types of soil.

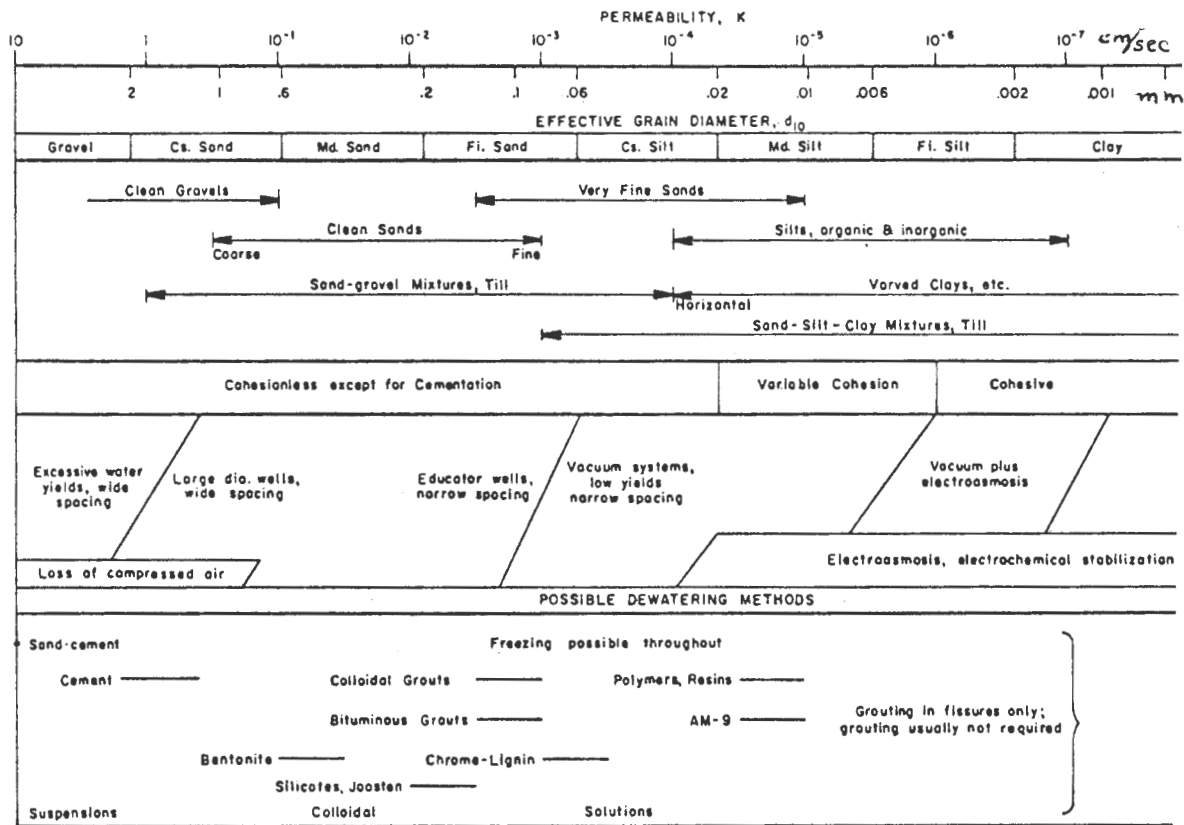

Figure 34. Correlation of effective diameter and permeability (54).

There is also a relationship between the particle size of the soil to be grouted and the particle size of particulate type grouts. The effects of this relationship on groutability will be discussed further in Chapter 5, Grout Material Selection.

#### 4. Pore Size Distribution

A more direct measure of soil groutability might be its total porosity plus the pore size distribution. Equipment has become available recently to measure the distribution of pore sizes in a soil with speed and precision; however, correlations to groutability have not yet been attempted. Nevertheless, useful relationships should exist, and a better knowledge of actual pore sizes would lead to a more intelligent selection of grout and grouting technique.

### a. Mercury Injection Method

Current pore size measurement techniques utilize mercury as a penetrating liquid because it is nonwetting and external pressure is needed to force it into soil pores. The amount forced usually is determined volumetrically.

The relation between required pressure for injection and the pore size is the simple capillary rise (or depression) shown graphically below and in equation 28.

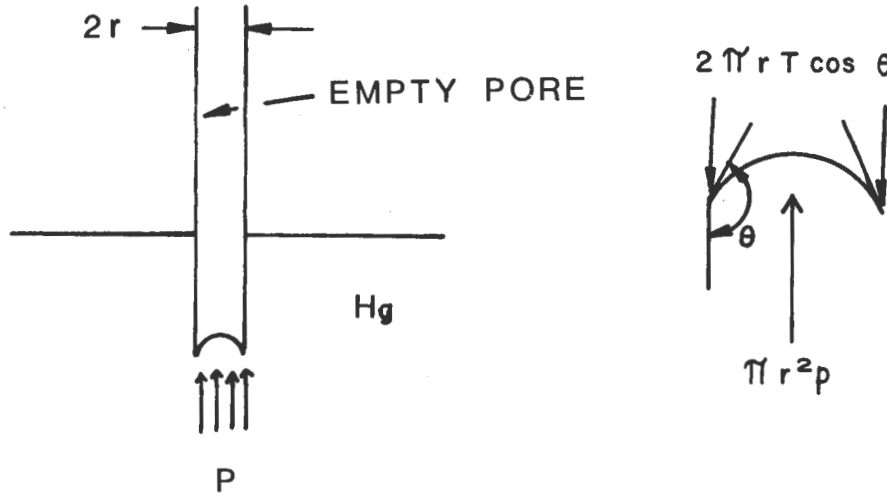

The force opposing injection into a circular cross-section capillary is the circumference times the liquid surface tension  $T$  times the cosine of the wetting angle  $\theta$ . For injection to occur, this must be equalled by external applied pressure  $P$  times the capillary cross-sectional area:

$$-2 \pi r T \cos \theta = \pi r^2 P$$

or

$$r = \frac{2 T \cos \theta}{P} \quad (28)$$

where  $r$  is the capillary radius. The negative sign is needed because  $\cos \theta$  is negative when  $\theta > 90^\circ$ . Measurements of  $\theta$  for mercury against a variety of materials gives a range of about  $112-142^\circ$ ; a value of  $130^\circ$  is commonly used in the calculation.  $T$  has been determined as 474 dyne/cm at  $25^\circ\text{C}$ .

Substitution gives:

$$r = \frac{609}{P} \quad (28a)$$

where  $r$  is the capillary radius in centimeters and  $P$  is the applied

pressure in dynes/cm<sup>2</sup>. Converting to pore diameter,  $d$ , in micrometers, ( $\mu\text{m}$ ) with pressure expressed in psia:

$$d = \frac{176.8}{p} \quad (28b)$$

The minimum pressure which may be read is about 0.5 to 1 psi, giving a maximum measurable pore diameter of about 350  $\mu\text{m}$ , or 0.35mm. Porosimeters are available with maximum pressure ratings of 1000 to 50,000 psi, giving respective minimum pore diameters of 0.18 to 0.0035 $\mu\text{m}$ , the lower pressure instruments being least expensive. Only 177 psi is required to carry a determination down to 1 micron diameter pores.

The testing method involves vacuum evacuation to obtain initially clear voids, then equilibration at any desired pressure or pressures. A complete pore size distribution requires about 4 hours, which is less than the time required for a conventional particle-size analysis. However, only one sample can be tested at a time.

Representative pore-size distribution curves are shown in Figure 35 for a loess (silt) soil compacted to several void ratios (34). (The natural void ratio was  $e = 0.975$ ). Modal (or most common) diameters are indicated by steepest portions in the pore size distribution curves. These curves vary from 10 $\mu\text{m}$  for the least dense to 3 $\mu\text{m}$  for the most dense degree of compaction, illustrating the variability in pore size distributions even with a constant particle-size distribution.

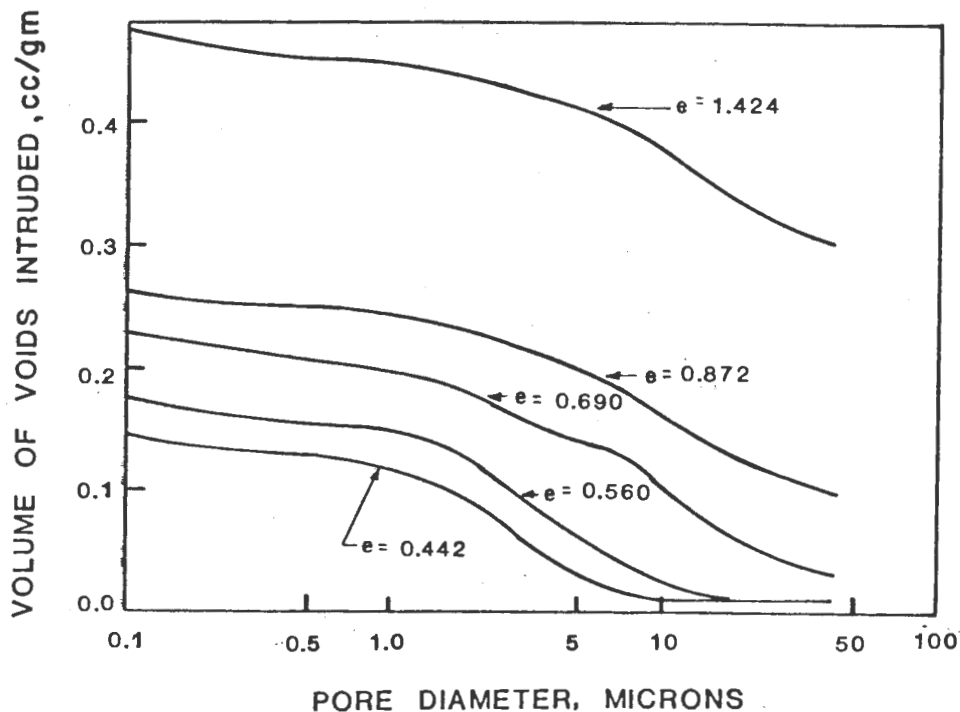

Figure 35. Pore-size distribution curves for a loess soil (34).

### b. Errors in Assumptions

The first unrealistic assumption for the derivation of equation 28 is that soil pores are not actually circular. Departures from a circle increase the wetting surface and resistance to penetration, and decrease the pressurized area. A more general expression for equation 28 is:

$$\frac{A}{C} = \frac{T \cos \theta}{P} \quad (29)$$

where A is the cross-sectional area and C is the circumference of the capillary. A few examples of calculated A/C ratios are given in Table 4. It can be noticed that the error from this assumption appears to be relatively unimportant if the pore radius is defined as a minimum radius.

---

Table 4  
Examples of Calculated A/C Ratios

| <u>Figure</u>   | <u>a</u><br><u>A/C</u> | <u>Minimum Radius</u> | <u>a/b</u> |
|-----------------|------------------------|-----------------------|------------|
| Circle          | r/2                    | r                     | 0.5        |
| Square          | d/4                    | d/2                   | 0.5        |
| Equil. Triangle | $\frac{b\sqrt{3}}{12}$ | $\frac{b\sqrt{3}}{6}$ | 0.5        |

---

Secondly, soil pores are not uniform in diameter throughout the soil, so many of the smaller pores are inaccessible at a prescribed calculated pressure. This has been termed the "ink bottle" effect. When pressure is raised, the pores may be filled, biasing the determined pore data to finer sizes; or, the pores may remain inaccessible, reducing the determined total pore volume. This type of error is fundamental to any injection method since the liquid (mercury) of necessity must not wet the soil, whereas many grouts do.

In a static or nearly static situation a wetting fluid will be drawn into empty soil pores, filling the "ink bottles" from the bottom; thus mercury injection could underestimate grout "take" for low viscosity chemical grouts. On the other hand, pores filled with water already are wetted with a very low wetting angle, and many grouts probably will not displace water by surface tension (i.e., surface free energy) effects. Thus the "ink bottles" probably exist for grout as well as for mercury,



and the error may be small. The importance of this error has not been evaluated. The "ink bottles" may be investigated by depressuring and measuring mercury ejection.

c. Analysis of Groutability Related to Soil Pore Size and Grout Particle Size

One problem not yet resolved is the maximum allowable grout particle size for a particular pore size distribution, since penetration is not through a single opening, but through a long series of alternate widening and narrowing pores radiating outward into soil. Even if the minimum opening is twice the largest grout particle size, there is a likelihood that somewhere along the crooked trail two particles will arrive at a constriction simultaneously, blocking the passage against further entry of grout. This probability of blockage is probably an inverse function of the grout penetration distance as  $1/r$  -- that is, grout extending twice as far into soil will encounter twice the number of restrictions and have only one-half the chance of getting through. On the other hand, radial outward penetration also increases the number of routes available, probably as a function of the sphere surface area or  $r^2$ , which will be much faster than the opposing factor  $1/r$ . Thus, soon after pumping begins, the soil either should accept a particle grout or it should not.

For rock fissures a maximum particle-to-crack width of 3 has been found realistic. This appears reasonable, based on a greatly diminished probability that four particles will arrive simultaneously in such a way as to bridge the opening strongly enough to resist dislodgement. An analogy may be drawn to rush-hour traffic in a city, and the probability of stoppage is greatest where traffic is heaviest, and diminishes greatly as alternate routes become available and traffic becomes diluted.

A "rule-of-thumb" for grouting with particulate grouts states that the soil pore should be three times the grout particle diameter. This will allow for grout flow in the pore with little likelihood of bridging occurring. However, a more exact theory based on probabilities may be developed by assuming the number of constrictions per unit length is a function of soil particle size. Then probability of penetration,  $P$ , becomes a function of the following:

$$P = f \frac{1}{r}, r^2, D/d, d, C$$

where  $r$  = grout penetration distance, cm  
 $D$  = pore diameter, cm  
 $d$  = particle diameter, cm  
 $C$  = grout concentration, cu cm

and  $1/r$  and  $d$  relate to number of constrictions in the grout path,  $r^2$  relates to number of paths available, and  $D/d$  and  $C$  relate to probability of blocking at a particular constriction. These terms should be rearranged to give dimensionless ratios for investigation in the laboratory. Other variables, such as pumping pressure and zeta potential of grout and of soil, may be pertinent and should be included in such a study.

#### d. Grouting Pressure and Seepage Forces

A question arises whether soil structure may be lost and pores reduced by grouting pressure, or more specifically by the grouting pressure gradient, since a large decrease in pressure over a short distance in effect transfers the residual pumping force to a small volume of soil. For example, pore clogging and a loss of permeability will increase the pressure gradient in the clogging soil until the pressure transfer may be large enough to collapse the structure of the soil and make it virtually impermeable. A similar effect exists with nonparticulate grout, except in this case, the force applied to the soil is seepage force caused by friction of the grout flowing through the soil pores. The effects of such transfer of grouting pressure to the soil is discussed further in Chapter 7 of this report.

#### C. Geographical and Geological Data

There are many sources of information for site investigations, particularly in built-up urban areas (35). Residents of the area are available for questioning regarding the site. Files from city or county offices sometimes yield valuable information, such as photographs or maps of the site from past years. Contour maps from government offices, such as Soil Conservation, may prove helpful. Geological maps should be obtained from local or state offices to give the soil layers in detail. The importance of this phase was shown by an occurrence in a cut-and-cover job while sheet piling was used. Some of the piling would not drive to desired depth as can be noted in Figure 36.



Figure 36. Sheet piling on obstruction missed in site investigation.

Subsequent investigation of city files revealed that foundations of earlier buildings were still in place some distance below the surface, and these were the objects stopping the sheet piling. The boreholes used in the site investigation had missed these footings; however, a study of city maps initially would have revealed the footings before a decision was made to use the sheet piling.

This phase will also show whether grouting can be done from the surface or whether other approaches must be used. Locations of buried utilities will have a bearing on this decision, since a pattern of injection pipes from the surface would probably damage the utilities.

## 5. GROUT MATERIAL SELECTION

### A. General Considerations

Einstein and Schnitter (7) have summarized the steps recommended for the selection of a grout for a particular operation. These steps are:

- (1) Soil investigation to include permeability, particle size distribution, flow characteristics of groundwater and any other limiting conditions for grouting.
- (2) Choice of a group of grouts which seem applicable.
- (3) Determination of grout properties using laboratory tests if needed.
- (4) Conducting laboratory tests to examine the properties of grout interacting with the soil, such as injectability, permeability reduction and unconfined compressive strength.
- (5) Field tests of one or more grouts to determine in situ injectability, set time in ground, permeability reduction and any unexpected conditions.

The first step has been considered in the preceding chapter. The remaining steps will be discussed in this chapter.

### B. Choice of Applicable Grout Groups

The two main types of grouts are:

- (1) Particulate or non-Newtonian grouts containing particles in suspension, such as cement or clay.
- (2) True solution or Newtonian fluids, such as some chemical grouts.

A Newtonian fluid is defined as a fluid which, in laminar flow, exhibits a pressure drop directly proportional to flow rate. Laminar flow occurs at low flow rates and is characterized as being smooth or streamlined in nature. When pressure drop is directly proportional to flow rate, doubling the flow rate will double the pressure drop. Water, refined oils, sugar solutions and organic solvents are examples of Newtonian fluids. These have definite measurable viscosities.

A non-Newtonian fluid is one which, in laminar flow, exhibits a

pressure drop that is not directly proportional to flow rate. That is, doubling the flow rate does not double the pressure drop. Pressure drop can be larger or smaller than the proportionate value. True viscosity of these fluids is not measurable.

Some grouting contractors use a combination of particulate (non-Newtonian) grouts and chemical grouts in order to reduce the overall costs of the grout. Either a cement or cement/bentonite grout could be used first to fill large voids or pore space, and then the low viscosity, more expensive chemical grout would be injected to fill the remaining voids. Other grouting specialists use cement only if the permeability is  $10^{-1}$  cm/sec or greater.

Chemical grouts that are in common usage are based on sodium silicate, acrylamide, polyphenolic and urea-formaldehyde, lignins and resins. The silicate base grouts are the most widely used. They are composed of water diluted solution with varying percentages of sodium silicate mixed with a reagent to produce a gel. Increasing the percentage of silicate increases the strength obtained in the soil, but also increases the viscosity of the grout.

Sodium silicate is alkaline, so an acidic reactant is used to form colloidal silica which aggregates to form a gel. Acid-forming materials, which have been used either on jobs or experimentally, include chlorine, ammonium salts, bisulfates, bicarbonates, sulfur dioxide and sodium silicofluoride. Reaction also occurs with salts of some metals, such as calcium, magnesium, aluminum, zinc, lead, titanium and copper. Many grouting companies have developed the reactant which they use with silicate to form their grout; therefore, most silicate grout are proprietary, and the grout composition is secret.

Acrylic based grouts are water solutions of two organic chemicals and a reactant that produce a stiff gel when set. Cost is relatively high, but viscosity is almost as low as water, so it can be used in soils with very low permeability. The material is toxic to the skin, and safety precautions need to be observed in handling the material both dry and mixed. It should not be used if the grout or the grouted soil will contact a fresh water supply.

Polyphenolic formaldehyde based grouts are liquids of low viscosity which set to give high strengths. Cost is moderate. The material cannot be used safely in closed areas because of toxic fumes emitted.

Lignin based grouts are composed of water-base lignin liquor with an acid reagent that produces a medium strength comparable to acrylamides. The cost is low and viscosity is around 8 to 10 centipoises. Materials are sometimes hard to obtain and handle, except in powder form which is available in Europe.

The cost is a definite factor to apply to selection of grout. The cost of various grouts in relation to the cost of portland cement grout is given in Table 5. The actual cost of a grout delivered to the job site should be used for comparative purposes if at all possible.

TABLE 5  
Cost Comparisons of Grout

| <u>Type of Grout</u>    | <u>Basic Cost Figure</u> |
|-------------------------|--------------------------|
| Portland Cement         | 1.0                      |
| Silicate Base - 15%     | 1.3                      |
| Lignin Base             | 1.65                     |
| Silicate Base - 30%     | 2.2                      |
| Silicate Base - 40%     | 2.9                      |
| Urea-formaldehyde Resin | 6.0                      |
| Acrylamide (AM-9)       | 7.0                      |

The in-place cost for soil grouted with cement grout is approximately \$13.50 to \$35.00 per cubic yard of soil grouted. The cost per cubic yard using chemical grout is from \$40.00 to \$190.00. The cost in Europe ranges from \$150.00 to \$200.00 per cubic meter with chemical grout.

The known grouts are listed in Table 6. This information is a compilation from various papers and brochures showing a comparison of some significant properties of the grouts. This table may be helpful as a guide in tentatively selecting the type of grout or a general grout group, or for selecting a grouting company who might use their proprietary grout materials to perform the grouting job. Some grouting companies also sell their grouts to construction companies who wish to perform their own work under the direction of a grouting specialist furnished by the grouting company.

Table 6. Properties of currently used grouts.

| <u>GROUT MATERIAL</u>              | <u>CATALYST MATERIAL</u>                | <u>UNCONFINED COMPRESSIVE STRENGTH (PSI) OF GROUTED SOIL</u> | <u>VISCOSITY (CENTIPOISE)</u> | <u>SETTING TIME MINUTES</u> | <u>TOXICANT*</u> | <u>POLLUTANT**</u> |
|------------------------------------|---|--|-------------------------------|-----------------------------|------------------|--------------------|
| <u>SILICATE BASE</u>               |   |  |                               |                             |                  |                    |
| LOW CONCENTRATION                  | BICARBONATE                             | 10-50  | 1.5                           | 0.1 - 300                   | NO               | NO                 |
| LOW CONCENTRATION                  | HALLIBURTON CO. MATERIAL                | 10-50  | 1.5                           | 5 - 300                     | NO               | NO                 |
| LOW TO HIGH CONCENTRATION          | SIROC - DIAMOND SHAMROCK CHEMICAL CO.   | 10-500   | 4-40                          | 5 - 300                     | NO               | NO                 |
| LOW TO HIGH CONCENTRATION          | CHLORIDE - JOOSTEN PROCESS              | 10-1000  | 30-50                         | 0                           | NO               | NO                 |
| LOW TO HIGH CONCENTRATION          | ETHYL ACETATE SOLETANCHE & HALLIBURTON  | 10-500   | 4-40                          | 5 - 300                     | NO               | NO                 |
| LOW TO HIGH CONCENTRATION          | RHONE-PROGIL 600                        | -  | -                             | -                           | -                | -                  |
| LOW TO HIGH CONCENTRATION          | GELOC-3 H. BAKER CO.                    | 10-500   | 4-25                          | 2 - 200                     | NO               | NO                 |
| LOW TO HIGH CONCENTRATION          | GELOC - 3X                              | 10-250   | 4-25                          | 0.5 - 120                   | NO               | NO                 |
| <u>LIGNIN BASE</u>                 |   |  |                               |                             |                  |                    |
| BLOX-ALL                           | HALLIBURTON CO. MATERIAL                | 5-90   | 8-15                          | 3 - 90                      | YES              | YES                |
| TDM                                | CEMENTATION CO. MATERIAL                | 50-500   | 2-4                           | 5 - 120                     | YES              | YES                |
| TERRA-FIRMA                        | INTRUSION CO. MATERIAL                  | 10-50  | 2-5                           | 10 - 300                    | YES              | YES                |
| LIGNOSOL                           | LIGNOSOL CO. MATERIAL                   | 10-50  | 50                            | 10 - 1000                   | YES              | YES                |
| <u>ACRYLAMIDE BASE</u>             |   |  |                               |                             |                  |                    |
| AM-9 ***                           | DMAPN and AMMONIUM or SODIUM PERSULFATE | 50-500   | 1.2 - 1.6                     | 0.1 - 1000                  | YES              | YES                |
| <u>FORMALDEHYDE BASE</u>           |   |  |                               |                             |                  |                    |
| UREA-FORMALDEHYDE                  | HALLIBURTON CO. MATERIAL                | OVER 1000  | 10                            | 4 - 60                      | YES              | YES                |
| UREA-FORMALDEHYDE                  | AMERICAN CYANAMID CO. MATERIAL          | OVER 500   | 13                            | 1 - 60                      | YES              | YES                |
| RESORCINOL FORMAL-DEHYDE           | CEMENTATION CO. MATERIAL                | OVER 500   | 3.5                           | —                           | YES              | YES                |
| TANNIN - PARA-FORMALDEHYDE         | BORDEN COMPANY MQ-8                     |  |                               |                             |                  |                    |
| GEOSEAL MQ-4 & MQ-5                | BORDEN COMPANY MATERIAL                 |  |                               |                             |                  |                    |
| <u>UNSATURATED FATTY ACID BASE</u> |   |  |                               |                             |                  |                    |
| POLYTHIXON FRD                     | CEMENTATION CO. MATERIAL                | OVER 500   | 10 - 80                       | 25 - 360                    | NO               | NO                 |

\* - A material which must be handled using safety precautions and/or protective clothing.  
 \*\* - Pollutant to fresh water supplies contacted.  
 \*\*\* - Also available from grouting companies under trade names of PWG or Injectite-Q.

Resin grouts of polyester or epoxy base are used in applications where extremely high strength is desired. One such grout is a furan resin, furfuryl alcohol dissolved in a nonaqueous solution, which is hardened by the addition of an acid. These grouts are generally high in viscosity, and are used in repair grouting of concrete structures or other similar applications. Total quantity used of this type grout is small.

The ideal grouting system is a single Newtonian fluid with the lowest possible viscosity, a controlled setting time and an appreciable gel strength of indefinite performance. Cost is a dominate factor, but should include not only the materials but also the mixing and injection.

Dempsey and Moller (8) list twelve aspects which should be considered in grout selection by the grouter who must meet a performance specifications:

- a. The reliability and completeness of the soils information available.
- b. The most practical method of introducing grout into the ground.
- c. The degree of permanence required of the grout.
- d. The possible effects on existing structures of ground movement as a result of grouting.
- e. The degree of saturation of the soil to be injected or the possibility of groundwater movement.
- f. The chemical composition of the groundwater and/or soil which might inhibit the reaction of the grout constituents or which might be aggressive to the set grout.
- g. The risk and effect of grout drying out upon exposure.
- h. The extent of the treatment and the spacing of injection points in order to produce the desired effect of impermeability or imparted strength.
- i. The toxicity of the products of the reaction and their possible effect on groundwater or underground operations.



- j. The working environment in which the grouting materials have to be stored, mixed and injected, should any of them be toxic.
- k. The justification and economics of providing intensive supervision for the more sophisticated processes.
- l. The availability of grouting materials in time both to begin and to sustain an operation where the total requirements are difficult to access.

Figure 37 gives the limits for various types of chemical grouts which can be used in different soil. Selection of grout types can be made based on the soil properties found in the site investigation.

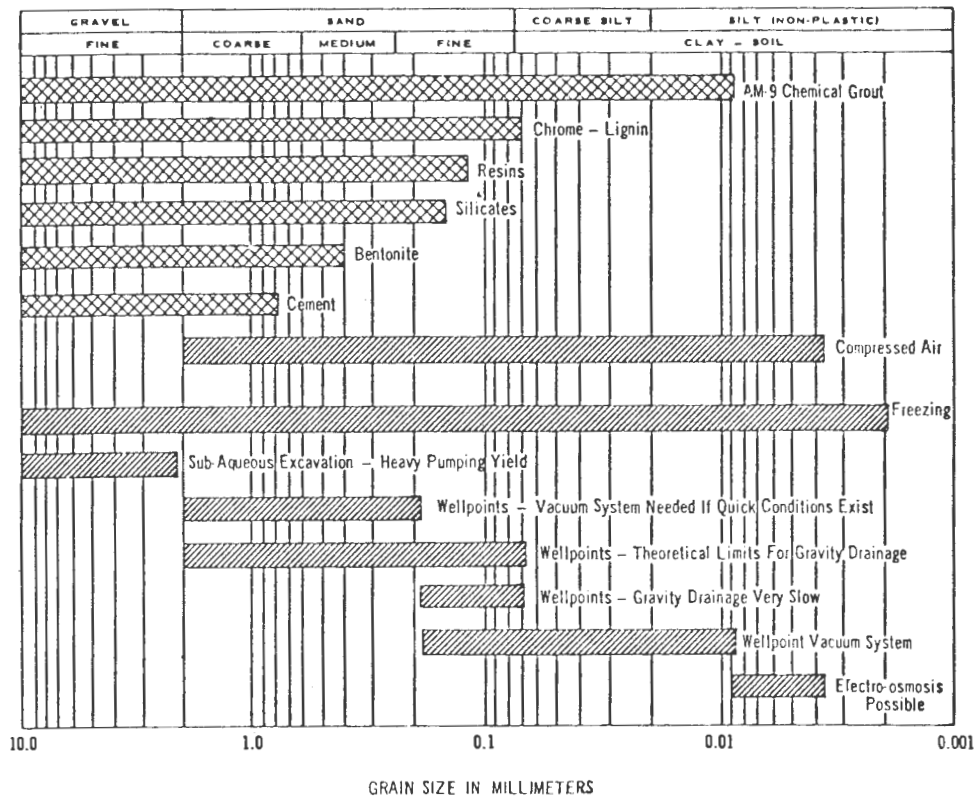

Figure 37. Soil limits for grout injectivity (11).

### C. Grout Properties

The grout properties of available grouts should be considered when selecting grouts. Since it is possible that a particulate grout may be used in preliminary grouting, these will be discussed as well as the chemical grouts. The important properties to consider are viscosity characteristics, setting times, strength of grout and grouted soil, water tightness, stability or permanence and toxicity.

#### 1. Viscosity Characteristics

In considering a particulate grout material, it is important that the particles of the grout material be substantially smaller than the pores between the soil particles. In order to penetrate a formation at a reasonable pressure and flow rate, the size of the largest suspended particles in the grout cannot be greater than about one-third the size of the pores. Generally, pores are about one-fifth as large as the grains. For soil consisting predominately of one grain size, grout particles should be less than one-tenth of the soil particle mean size. This rule does not apply to true solution chemical grouts, where the viscosity can be measured. It would be applicable to particulate type grouts, such as cement or clay grouts. Figure 38 shows limiting grain sizes of materials that can be successfully grouted by particulate grouts. These data are based on experience and testing and should be used only as a general guide (1d).

Another way of expressing the relationship between the particle size of the grout and the grain size of the soil to be grouted is by the groutability ratio, GR.

$$GR = \frac{D_{15}}{D_{85}}$$

where

$D_{15}$  = the 15% size of the soil to be grouted (fifteen percent of the soil has finer grain sizes).

and

$D_{85}$  = the 85% size of the grout particles, where 85% of the grout material is finer.

Based on tests by the Corps of Engineers (36), the limits of groutability based on the GR value are shown in the graph on Figure 39. The right end of each bar represents the sand-grout ratio for the finest sand proven groutable while the left end represents the sand-grout ratio for the coarsest sand proven not groutable. Since tests reported were limited to two grouting

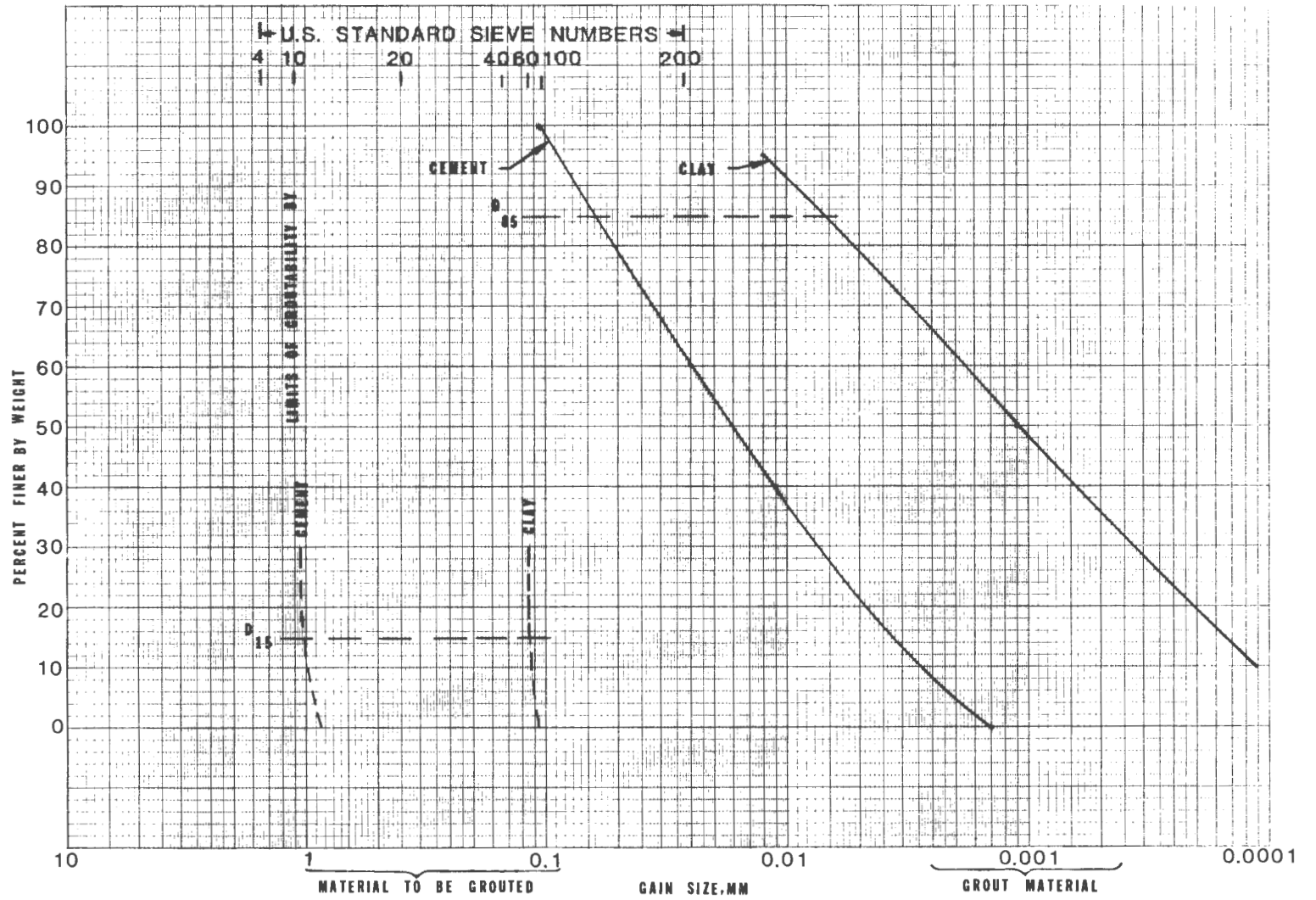
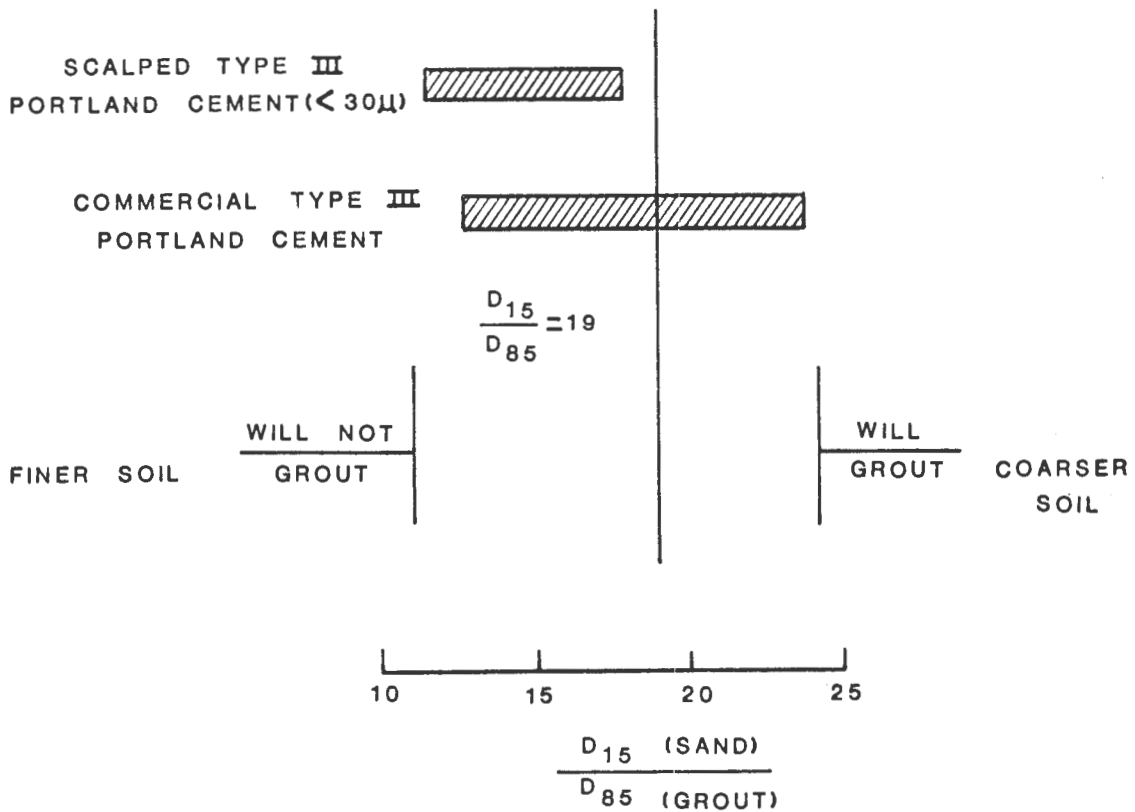

Figure 38. Soil and grout material grain-size curves (1d).

agents, determination of this grouting criterion is based on successful penetration of the permeameter specimens only.

It can also be noted that the cement grouts tested would not penetrate a sand having a sand-grout particle diameter ratio less than 11, but that each cement grout tested would penetrate materials with sand-grout ratios greater than 24. Therefore, these values may be considered as criteria for determining groutability. However, the data tend to indicate that a minimum practical limiting grout ratio for portland cement grouts should be somewhere in the vicinity of 19.



Courtesy of Corps of Engineers

Figure 39. Limits of groutability of sands by particulate grouts.

It is difficult to use particulate grouts for permeation grouting in soils finer than very coarse sand without the possibility of either plugging the soil face or creating a fracture. This fact limits the use of cement grouts to soils with permeability greater than  $10^{-1}$  cm/sec and clay grouts to soils with permeability greater than  $10^{-2}$  cm/sec.

The viscosity of the chemical grouts varies with the percentage of solids in solution. This is shown graphically in Figure 40 for several chemical grouts and a bentonite grout (37). The wide band on each curve indicates the concentration primarily used in field operations. Since only the AM-9 is a true solution, the viscosities given for the other grouts must be considered as an apparent viscosity because they contain minute particles in suspension. However, it does give some idea of the effect on viscosity by increasing the concentration of a grout.

In addition, all of the grouts except AM-9 gradually increase in viscosity with time after mixing until gelation takes place. The AM-9 grout remains a constant viscosity, then increases suddenly in viscosity as it sets.

Increases in temperature will reduce the viscosity only a very small amount, so comparisons shown in Figure 40 would not change appreciably by temperature variation.

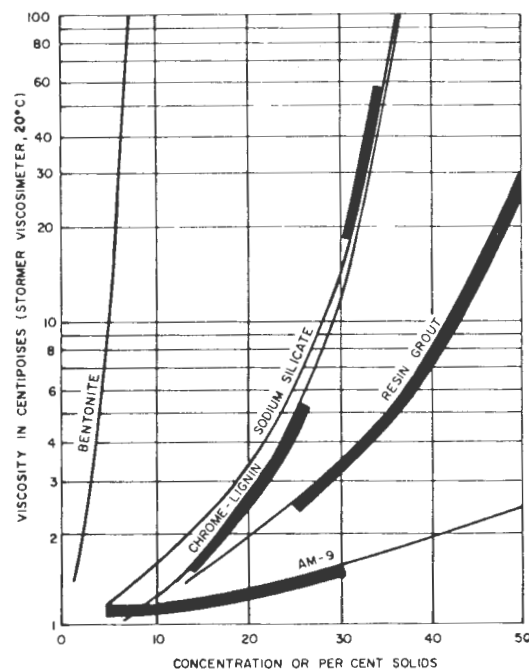

Figure 40. Viscosities of Various Grouts (11).

## 2. Setting Time

The setting time, sometimes called gel time or the induction period, is that time between the addition of the catalysts and the formation of a gel (38). With cement grouts, it is the time required to harden, or thicken to a point of immobility.

The basic cement grout is a portland cement grout, and the water ratio can range from less than 1:1 to as thin as 20:1. Bentonite can be used to provide increased volume at less cost. Percentages up to 8 percent are common. Other chemicals can be added to accelerate the setting. Sand is sometimes added when filling large openings.

Setting time, or the time to harden, is a matter of hours; this characteristic is generally the same as thickening time. Thickening time is a terminology used in oil well grouting for the time required for a cement slurry of a given composition to reach a consistency of 100 units of consistency (Uc), determined by methods outlined in American Petroleum Institute standard RP 10B. A unit of consistency is a standard value of measurement relating torque equivalent to degrees of firmness of the cement slurry. Thickening time for a portland cement grout with a 0.5:1 water-cement ratio is about 4 hours at an ambient temperature of 80° F. Pumpability of this grout would be about 70% of the thickening time, or approximately 3 hours. As the water-cement ratio is increased, thickening time and pumpability will increase proportionally.

Thickening time is measured in the laboratory by a consistometer. Figure 41 shows a picture of the device. A sliding wire bridge gives a voltage reading which is calibrated to relate to units of consistency.

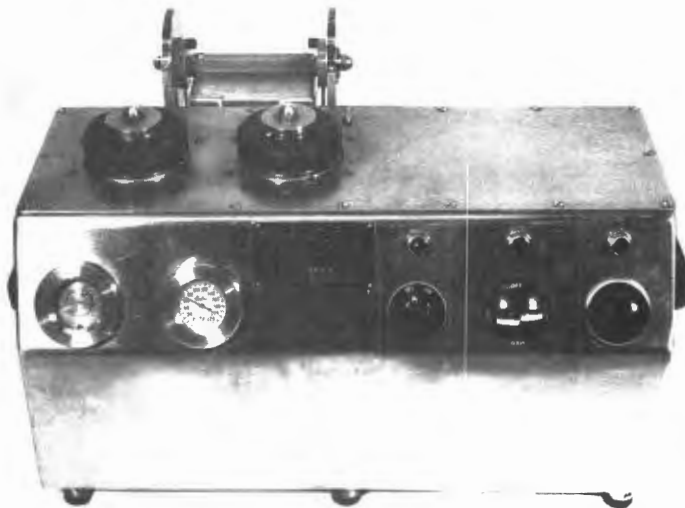

Figure 41. Cement Consistometer  
Courtesy of Halliburton Services

The setting time or gel time of most chemical grouts can be varied from a few minutes to an hour or longer. Some can be compounded to give only a few seconds setting time. Variations in the amount of catalyst or reactant added, or variations in the concentration of the primary constituent, affect the setting time. An increase in the temperature of the grout, or the use of accelerators, decreases the set time.

Setting time also depends to some degree on the process used. When the Joosten (two-shot) process is used, setting time is almost instantaneous. When a one-solution batch type is used, a setting time of less than 20 minutes is not recommended in order to insure placing the grout before setting occurs. A short setting time (1 to 20 mins) can best be obtained using a two-stream process.

The choice of a setting time depends on several factors. Prime factors are:

- a. The volume of grout to be injected
- b. The soil permeability
- c. The porosity of the soil, and
- d. The rate of groundwater flow

The grout should be injected at a pressure below fracturing pressure. The set time must be long enough to permit the required amount of grout to penetrate to the selected radius. This time will be governed by the soil permeability for the selected grout.

When pumping into flowing groundwater, the grout should be injected at a rate equal to or greater than that of the flowing water to prevent excessive dilution or total loss of grout. Setting time should be made as short as possible so that the grout will set while injecting, thus forcing the grout into other channels or pore spaces to give coverage over the desired area. It is difficult to use cement grouts in formations with rapidly flowing water, unless special accelerators are used.

### 3. Strength

The prevalent means of measuring the strength of grout is by unconfined compressive strength tests on mixtures of grout and soil. However, there is not standard procedure for this test with cohesionless soil, so the values given in the literature for different grout formulations must be recognized as approximate values. To be meaningful, the soil composition used for the tests must be the same, and the sample composition and curing must be uniform from one test to another.

Most grouting companies conduct their own tests on the grouts used, and their operations are based on this information. The soil used in most cases is specified as a medium fine-grain sand. Both angular and round grain sands are used. Some companies on the European continent use a medium fine-grain sand known as Fontainebleau sand for the test samples.

Wide ranges of unconfined compressive strength values are reported in various papers referenced in this study. Values are given for a particular grout without reference to grout concentration or composition. For example, acrylamide grout (AM-9) is shown in one source at 70 psi (4.92 kgs/cm<sup>2</sup>) for 10% concentration, and in another table, it is listed at 50 to 500 psi (3.52 to 35.2 kgs/cm<sup>2</sup>). Similar variations are obtained on other grouts also.

These discrepancies can be obtained on the same grout by a difference in test procedure or soil sample preparation. If the grouted samples to be tested are kept wet in order to be more representative, a much lower strength value would be obtained than a test on the same sample when permitted to dry before testing. In short, published data on strength properties are generally not suitable for comparison because of a lack of uniformity in test specimen preparation, soil used, curing time and environment, and method of testing (39).

The lack of a standard test procedure is certainly an important factor in the variety of results published for the strength of grouted soil. In the tests described by Warner (39), the sample was made by pouring sand into the mixed grout and forming a test cube. In a discussion of this paper by Fawcett (40), the experience of a 12-year research program is cited to show that the best procedure for producing a grouted sample is to inject the grout into a soil sample which has been compacted to a reasonable facimile of actual soil conditions.

Skipp and Renner reported (41) extensive tests using three grout materials in closely graded coarse and medium sands. Using these controlled tests, with samples kept wet until the unconfined compressive strength was measure, values were obtained as shown in Table 7. Even under well controlled test conditions, a range of values was obtained for some grouts. These are, in general, much lower than reported in most of the literature; but values are probably more representative of actual strengths. The strengths are consistently higher in medium sands than in coarse sands.



**TABLE 7**  
**Tests of Grout Materials in Sand**

| Test                   | Coarse Sand |                                 |                   |                                 |             |                                 | Medium Sand |                                 |                 |                                 |
|------------------------|-------------|---------------------------------|-------------------|---------------------------------|-------------|---------------------------------|-------------|---------------------------------|-----------------|---------------------------------|
|                        | Silicate    |                                 | Urea-Formaldehyde |                                 | Polyester   |                                 | Silicate    |                                 | Polyester Resin |                                 |
|                        | Stress      | Relative Density Range Per Cent | Stress            | Relative Density Range Per Cent | Stress      | Relative Density Range Per Cent | Stress      | Relative Density Range Per Cent | Stress          | Relative Density Range Per Cent |
| Unconfined Compression | 130-290     | 58-97                           | 7.0-27            | 41.5-67                         | 3,260-3,530 | 40-57                           | 245-280     | 50-92                           | 4,075-4,760     | 78-99                           |
| Tensile                | 14-46       | 52-95                           | 1.2-10.4          | 61.7-74                         | —           | —                               | 25-63       | 50.93                           | —               | —                               |

The graph shown in Figure 42 gives a good comparison of unconfined compressive strengths for cement and several chemical grouts; these grouts were injected into a sample of medium-fine, wet, compacted sand and cured wet in tests reported by Diamond Shamrock Corporation (13).

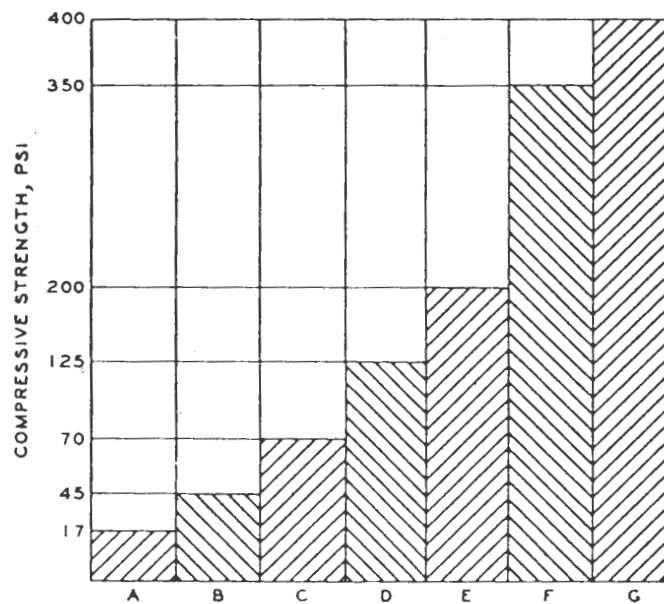

GROUT CODE

- A - CHROME-LIGNIN 17%
- B - CHROME-LIGNIN 25%
- C - ACRYLAMIDE 10%
- D - 40% SILICATE
- E - 50% SILICATE
- F - 60% SILICATE
- G - CEMENT (LIME MODIFIED)

Figure 42. Compressive strength of various grouts

This graph also shows that increased concentration of the basic grout component gives a similar increase of strength in the grouted sample. When the grout is to be used only to reduce permeability, the strength becomes less important and must only be sufficient to withstand the hydrostatic water head.

a. Strength Theory

A better understanding of the strength-giving properties of grout can be obtained by understanding the sources of strength in soil. One of these sources is grain-to-grain sliding friction which, in accord with Amonton's Laws of friction, is proportional to stress applied normal to the shearing plane, illustrated in Figure 43 (a). In this relationship the shearing strength  $\tau_f$  relates to the normal stress  $\sigma$  as

$$\tau_f = \sigma \tan \phi_s$$

where  $\tan \phi_s$  is the coefficient of sliding friction.

Strength increases more rapidly with normal stress in a dense sand than in a loose sand. The added strength, shown in Figure 43 (b), may be considerable as it reflects the degree of grain interlocking which must be overcome before the soil can shear. The "unlocking" occurs by grains sliding up and over one another, causing a measurable dilatancy or volume expansion of the soil. The greater the amount of dilatancy required for soil to shear, the stronger the soil. Also, since expansion represents work against the normal stress  $\sigma$ , the higher the normal stress the larger the dilational component of the shearing resistance. This means that the effect of interlocking is additive to that of sliding friction. An excellent analogy is two sheets of sandpaper placed face-to-face under pressure; in order to slide one over the other, they must slightly move apart, meaning work against the applied pressure. Since the two components of strength ordinarily are measured together,  $\phi$  is designated the angle of internal friction, to include both frictional and dilatancy components, and  $\tan \phi$  is the coefficient of internal friction.

The separate contributions of friction and dilatancy to shearing strength may be quite important for evaluating effects of grouting, particularly if filling of soil pores with solids means that the pore spaces no longer can be distorted to accommodate moving grains. The net effect would be a considerable increase in dilatancy and internal friction, even with no cementation whatsoever. Unfortunately triaxial test data are not readily available for soil samples before and after grouting, but it appears likely that  $\phi$  could be raised from about  $26^\circ$  for in situ, loose-sand soils to as high as  $45^\circ$  to  $55^\circ$ , thereby doubling or tripling their strength (indicated by  $\tan \phi$ ) at any particular normal stress with no contribution from cementation of the grout.

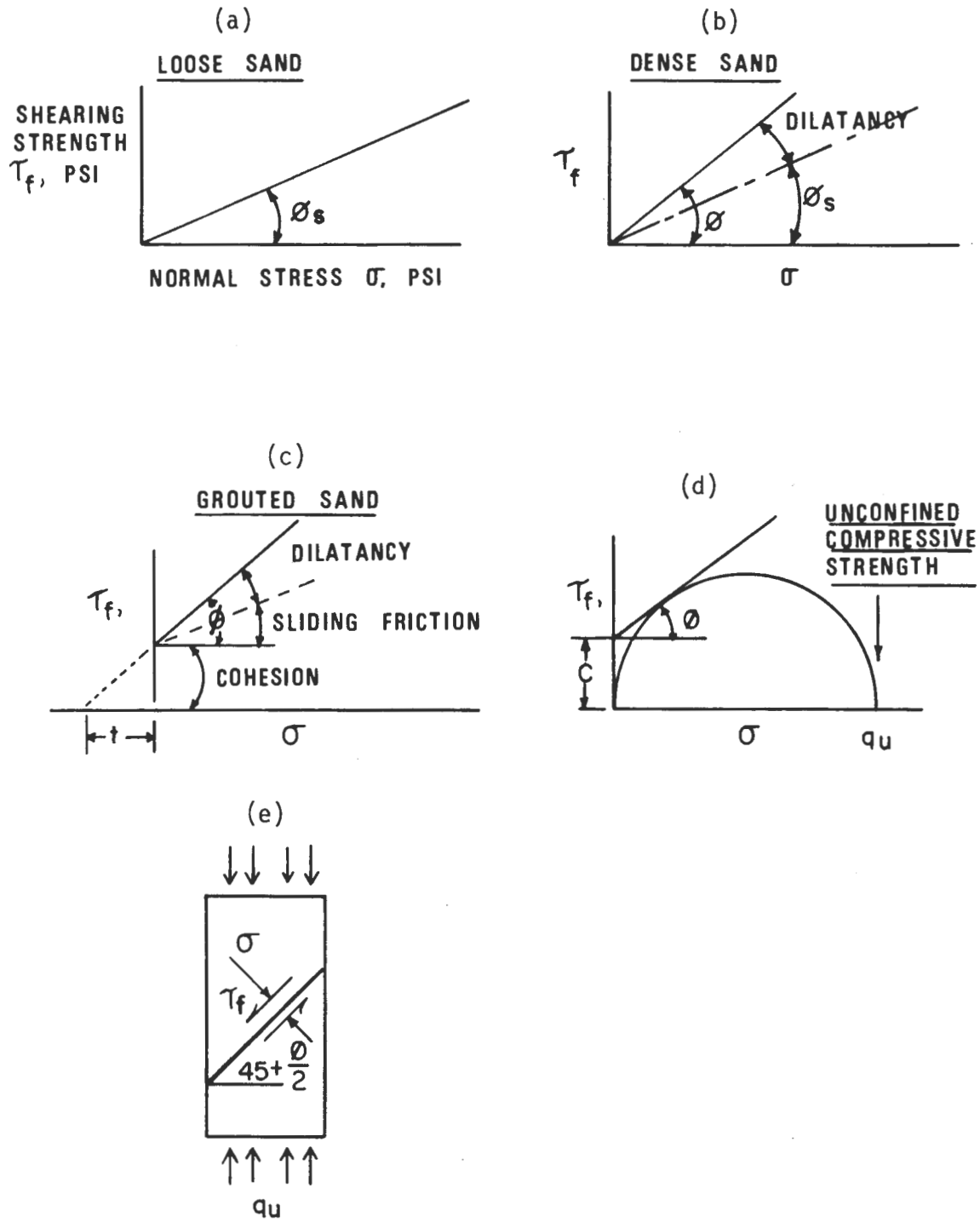

Figure 43. Soil strength characteristics.

A third contributor to soil strength is cohesion  $c$ , shown in Figure 43 (c), or shearing strength at zero applied normal stress. Cohesion exists in clay soils as a result of consolidation or drying, and represents an inherited or intrinsic tension  $t_i$  between soil grains. Cohesion also is generated by cementing agents, such as portland cement or silicate grouts, with  $t_i$  representing average tensile strength of the bonds. (Measured tensile strengths will be less than the indicated  $t_i$  because of stress concentrations and progressive failure).

The relation between cohesion  $c$ , friction angle  $\phi$ , and unconfined compressive strength  $q_u$  is shown in Figure 43 (d), where the arc represents a Mohr circle drawn through  $\sigma = 0$  and tangent to the failure envelope. From this it can be shown that

$$q_u = \frac{2c \cos \phi}{1 - \sin \phi} \quad (30)$$

The unconfined strength is particularly sensitive to cohesion  $c$ , since if  $c = 0$ ,  $q_u = 0$ , regardless of the value of  $\phi$ . However,  $q_u$  may be increased several fold by increased  $\phi$ , the explanation being that even in the unconfined test a component of the load is exerted as normal stress against the shearing plane, shown in Figure 43 (e). The theoretical ratio  $\frac{q_u}{c}$  for different friction angles is given as follows:

| $\phi^\circ$ | $\frac{q_u}{c}$ |
|--------------|-----------------|
| 0            | 2.00            |
| 10           | 2.38            |
| 20           | 2.86            |
| 30           | 3.46            |
| 40           | 4.29            |
| 50           | 5.49            |
| 60           | 7.46            |

Thus increasing  $\phi$  from  $20^\circ$  to  $50^\circ$  will increase the unconfined compressive strength ratio from 2.86 to 5.49, even with no contribution from cementation.

The influence of increased friction angles by grouting should be several times more important in the field than is indicated by the effect on unconfined compressive strength, because of higher pressure existing in soils in situ. These pressures act against potential shearing planes, so any increased frictional response along these planes will greatly increase the shearing strength. The amount of this increase is shown by the well-known Coulomb equation.

$$\tau_f = c + \sigma \tan \phi \quad (31)$$

where  $\tau_f$  = shearing stress at failure  
 $c$  = cohesion  
 $\sigma$  = normal stress on the shearing plane  
 $\phi$  = angle of internal friction

As an example, consider the overburden pressure at a depth of 40 feet (12.2 m) under soil weighing 120 pcf (1922.4 kgs/cu m), with the water table at the ground surface. The buoyant unit weight is then 120-62.4 = 57.6 pcf (92.5 kgs/cu m), 62.4 being the unit weight of water. At 40 feet (12.2 m) depth,  $\sigma$  in the vertical direction is 40 x 57.6 = 2304 psf (11250 kgs/sq.m). If cohesion is zero, grouting which changes only the friction angle  $\phi$  from 20° to 50° will increase shearing resistance on a horizontal plane from

$$\tau_f = 0 + 2304 \tan 20^\circ = 839 \text{ psf}$$

to

$$\tau_f = 0 + 2304 \tan 50^\circ = 2746 \text{ psf, or}$$

by a factor of 3.3. Thus for design purposes, it would appear that  $c$  and  $\phi$  should be separably determined on the grouted soil. This may be done by laboratory direct shear or triaxial testing; methods of such determination in situ are discussed in Chapter 8.

If grouting pressure substantially relieves soil grain-to-grain contact pressures, grain-to-grain sliding friction may be reduced and substituted by grout-to-soil sliding friction. In cohesionless soils with relatively high permeability, the effect of grout-to-soil sliding friction would be minimal. The extent of this reduction in sliding friction will depend on the extent of dissipation of grouting pressure prior to setting. If the grout sets too quickly and traps excess pore pressure, the grout-to-soil sliding friction may become a major factor to consider.

#### b. Strength Tests of Grout Material

Laboratory testing and evaluation to obtain grout strengths of the gel formed by the grout have been made by at least one grouting company. A cone-type, grease penetrometer (Precision Scientific Instrument Company Senior Model Universal Type), with a 200-gram weight for cone assembly, was used in the tests.

Tests were conducted in accordance with ASTM Test D217-68 on an acrylamide grout, using grout concentrations from 4% to 10%.

The values obtained showed that this could be an approach to determine strengths and solids concentration of various gels. Once a standard is established for this test, results could possibly be related to compressive strength of given soils in standardized tests. Values thus obtained might be meaningful enough to use in specifications for grouting jobs.

#### 4. Water Tightness

Water tightness is the ability of the grout to prevent passage of water through the gelled grout. A grout must be impermeable, or possess almost zero penetration to be successful in water shutoff applications or strengthening. This quality should be determined by the manufacturer for any grout and be a part of the specification for the grout, rather than having to be determined by the user of the grout.

The grout should also not be subject to syneresis, which is the progressive exudation of water from a gel with time after the set of the gel (37). This phenomenon will change the permeability of grouted soil to some degree in a period of time, corresponding to the concentration of the gel. This should also be given in the manufacturer's grouting specifications.

#### 5. Stability or Permanence

The stability of a grout during mixing is controlled in one-solution grouts by the use of additives to prevent premature reaction. In the Joosten process and the two-stream method, it is necessary to keep the two components separate until the reaction is desired.

The stability over a long term, or the permanence of the grout in the soil, may be important depending on the purpose for the grouting. In cases where permeability reduction of water shutoff is desired for a limited time, permanence is not a factor. In strengthening applications or for permanent water stoppage, permanence would be desirable.

Silicate grout can be permanent or limited, depending on the distribution and the process used. In a commonly used one-shot formulation, the result is a nonpermanent gel which can be used as a temporary aid in construction (42). The other grout types are considered permanent.

Some grouts, such as organic aqueous monomers, are permanent and stable, but tend to shrink upon drying or when not in contact with water. However, the gel swells back to its original volume upon contact with water.

## 6. Toxicity

The toxicity of grout is becoming more important because of the emphasis today on safety and pollution. Many of the chemical grouts are toxic to the skin, while some have vapors which are injurious to the lungs. The silicate grouts are generally not toxic. Grouts which require special precautions for handling are generally so identified by the manufacturer.

In most cases, the toxicity comes from the reactant or activator used with the basic component. Sodium dichromate, used as an activator with chrome lignin grout, can cause ulcerous sores which are difficult to heal (42), so the use of gloves and goggles are required. The AM-9 basic chemical is neurotoxic by skin contact, inhalation or swallowing. The liquid catalyst used with AM-9 is slightly caustic and mildly toxic. It is necessary to wear gloves and goggles while working with these grouts.

Other than silicate grouts, most chemical grouts are pollutants for fresh water. These grouts cannot be used when grouting on a dam or where a water supply might be contacted by the grout. In European operations, inspectors from the government check on jobs to insure that no pollutant grout ever comes in contact with ground-water.

### D. Grout Testing - Laboratory and Field

Laboratory tests should be made on the tentatively selected grouts by flowing the grout through a wetted, recompacted soil sample until set occurs. Injectability and pressure can be observed during this test. After the grout sets, the sample should be kept moist until unconfined compressive strength tests can be made. It is possible to make permeability measurements before and after grouting the sample, prior to the compressive strength test.

If possible, field tests should be made at the grouting site by pumping water and then grout. Such tests will substantiate laboratory tests and also indicate more accurately the pumping rates, pressure required, effect of flowing groundwater on grout, etc. These tests should determine the grout to be selected for the job.

## 6. GROUT EQUIPMENT

The equipment needed to perform a grouting operation includes:

- (a) Drilling or Driving Equipment
- (b) Mixing and Proportioning Equipment
- (c) Pumping Equipment
- (d) Injection Piping
- (e) Monitoring Equipment

This equipment is normally furnished by the grouting company. Some items (such as drilling equipment) are rented or leased by the smaller companies as it is required. Most larger grouting companies, especially in Europe, own their equipment, and some even build their drilling or pipe placement machinery, pumps and equipment.

### A. Drilling and Driving Equipment

Driving equipment is used to drive grout pipes (lances) into the ground for grouting at shallow depths. The driver can be some type of mechanical or hand-held hammer. A modified jack hammer is sometimes used to drive the grout pipe into the ground. A track drill can be utilized also for this purpose. The power source is normally air. One United States company uses a hydraulic hammer of their own design which delivers 7,000 blows per minute.

If the grouting is to be performed as the grout pipe is withdrawn from the total depth, some type of pulling device must be used which will permit the pipe to be pulled slowly in short stages. There does not seem to be any equipment specifically made for this purpose, so most operators use "chain booms" on a hydraulic lift. This does not afford a smooth operation, since it causes the pipe to jump several feet as the pull overcomes the friction of the pipe in the ground.

Drilling equipment includes small rotary drill rigs, track drills and special hydraulic drilling machines. A typical drill is shown on a field site in Figure 44. Much of the grouting is conducted through plastic pipes grouted in the drilled holes. All the grouting jobs visited in Europe were performed with this technique except one where vibration was used to sink special small elements to a desired depth.

### B. Mixing and Pumping Equipment

#### 1. Handling of Materials

Cement, bentonite and powdered chemical grout materials are normally furnished in sacks or cartons. For large jobs, the materials are available in bulk and are stored in large tanks at the job site. Dry materials are moved from the storage tanks to the mixing tank using screw conveyors.



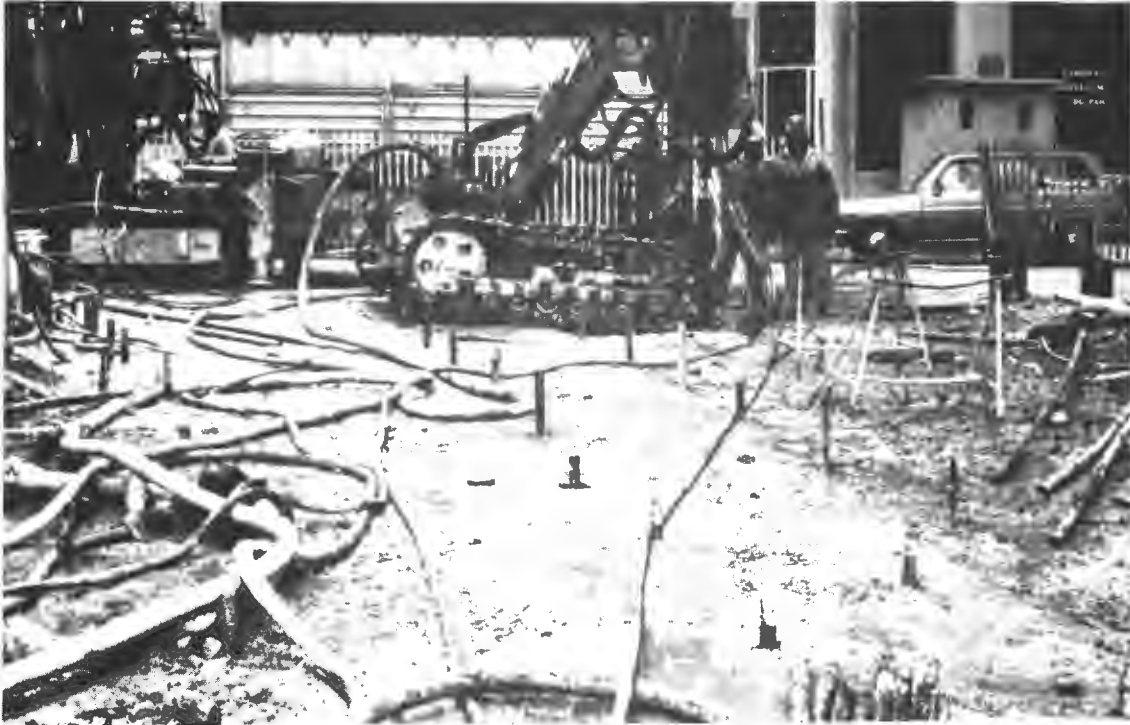

Figure 44. Drilling machine on grout job in France.



Figure 45. Batch plant for large grouting operation.

A batch plant with a tank for each material is shown in Figure 45. On this job in France, the material was mixed in tanks located in the metal buildings and pumped to the injection pumps near the grout pipes in an excavation as shown in Figure 49.

Liquid materials are stored in tanks also, and are moved with a proportioning pump to the holding tanks located adjacent to the injection pumps. Most European grouting companies now have this equipment automated so that proper amounts are fed to the pumps and mixing tanks by setting the desired amounts on a control panel.

## 2. Grout Mixing and Pumping

### a. Cement Type Grout

Cement mixing equipment, which has been used for years in mixing cement for grouting of dams, consists of a tank containing paddles or some type of mixing and stirring mechanism; these paddles may be operated by an air motor or other power source. Mixer sizes vary from one or two cubic foot capacity up to 25 or 30 cubic feet, depending on the job requirements. Usually the grout plant includes a holding tank where the cement grout slurry is agitated while waiting for use. Water-cement ratios are kept high initially (about 3 to 5) to prevent clogging the pores, then more cement is added as the injection pressure indicates the feasibility.

Cement grouts (or bentonite) can be pumped satisfactorily with either piston-type, positive-displacement pumps or progressive cavity pumps. Accurate pressure gauges are required, and these should be rated for the pressure range expected for the job. A water meter should be used to permit control of the water-cement ratio. Figure 46 shows a skid-mounted, progressive cavity pump with a hopper to receive cement slurry from the mixer or holding tank. This type pump has a steel helical rotor turning within a flexible double-thread helical stator, as shown in the cutaway drawing (Figure 47). The meshing helical surfaces push the fluid ahead with uniform movement and low turbulence. These pumps also are satisfactory for pumping chemical grouts.

### b. Chemical Grouts

Mixing tanks for the chemical grouts must be constructed of materials not affected by the chemicals being used for the grout. The acrylamide grouts must be mixed in tanks of plastic, aluminum or stainless steel. Since most of the chemicals go into solution readily, minimal mixing action is required. The tank might contain mechanical paddles driven by an air motor, but stirring could be done with a wooden paddle for small batches. For jobs using large quantities of grout, large tanks with some type of stirring or blending device would be required.

Chemicals and water must be proportioned accurately. Some companies that supply grout components will furnish prepackaged and color-coded chemicals to make mixing as simple as possible.

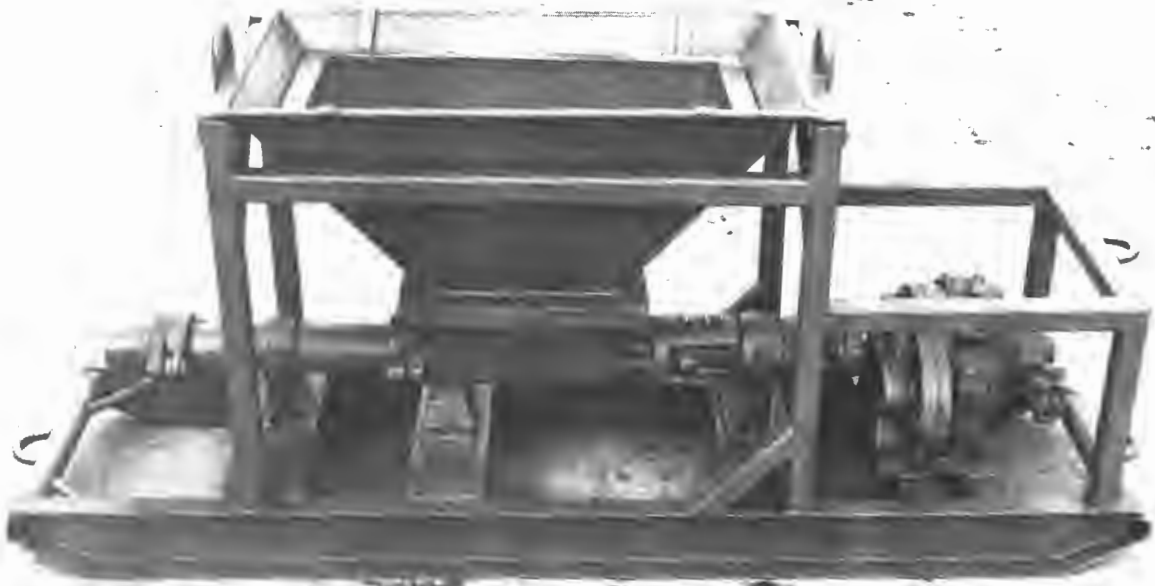

Figure 46. Progressive cavity type grouting pump.

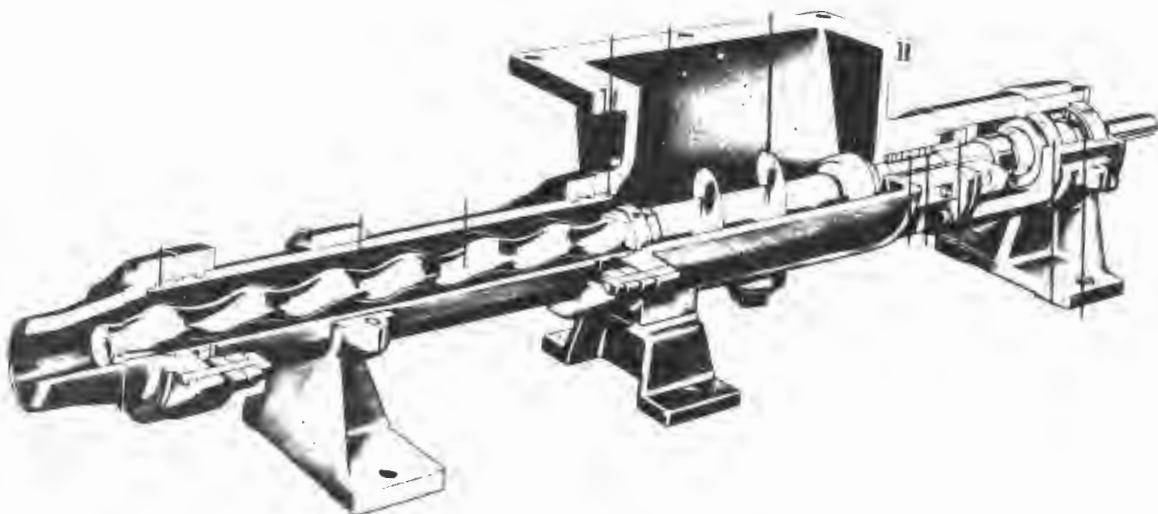

Figure 47. Cutaway view of progressive cavity pump.

Progressive cavity pumps or piston type pumps are preferred for chemical grouting. Many of these are driven by an air motor, but a gasoline or diesel engine may be used if the pump is outside or in a well ventilated area. An air motor is a rotary vane type motor powered by compressed air. Horsepower ratings up to 15 HP can be obtained. The motor is explosion-proof and can be used anywhere there is a source of air.

Figure 48 shows two grouting units; each unit has two triplex plunger pumps driven by a small diesel engine. Each of these units will handle two fluids in equal volumes, so they are ideal for use with two-stream grouting.

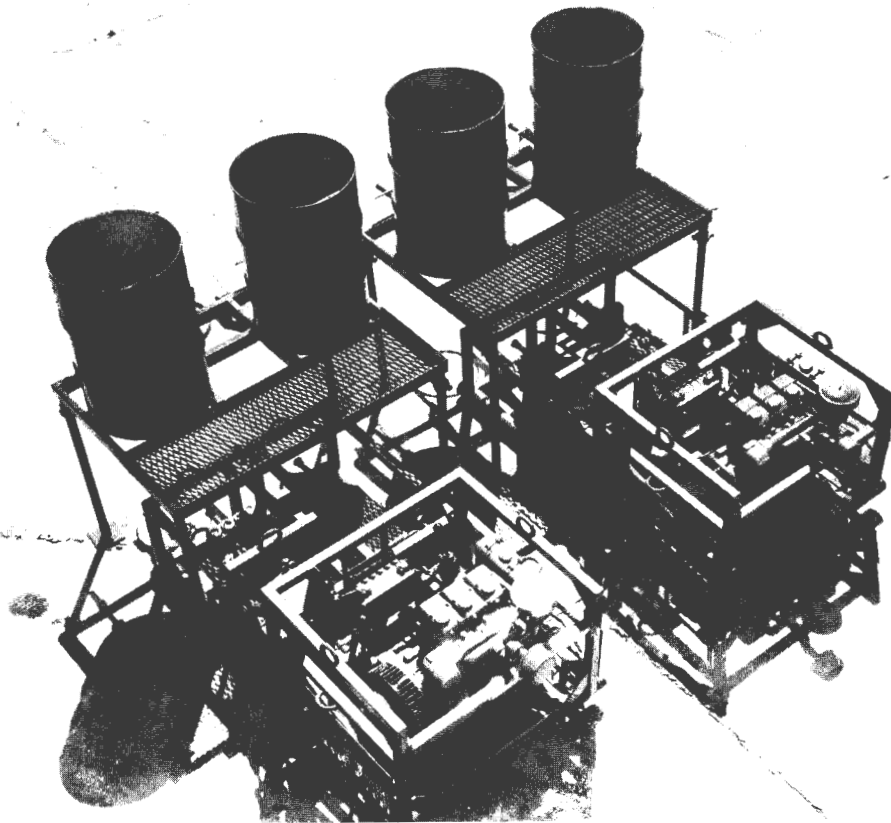

Figure 48. Dual pump grouting unit.

The mixing and pumping equipment used by the large European grouting companies is largely automated to provide more efficient operation. They use a large number of pumps (six to eight), but each pump injects into only one pipe. Figure 49 is a pump trailer pumping grout into the floor of an excavation between sheet steel piling on a job in France. The grout is mixed and fed from the batch plant shown in Figure 45. These pumps are double-acting, positive displacement type driven by air motors.

Another contractor used a "pump house" adjoining his batch plant, which was set up on a job for a Metro system in France. The materials

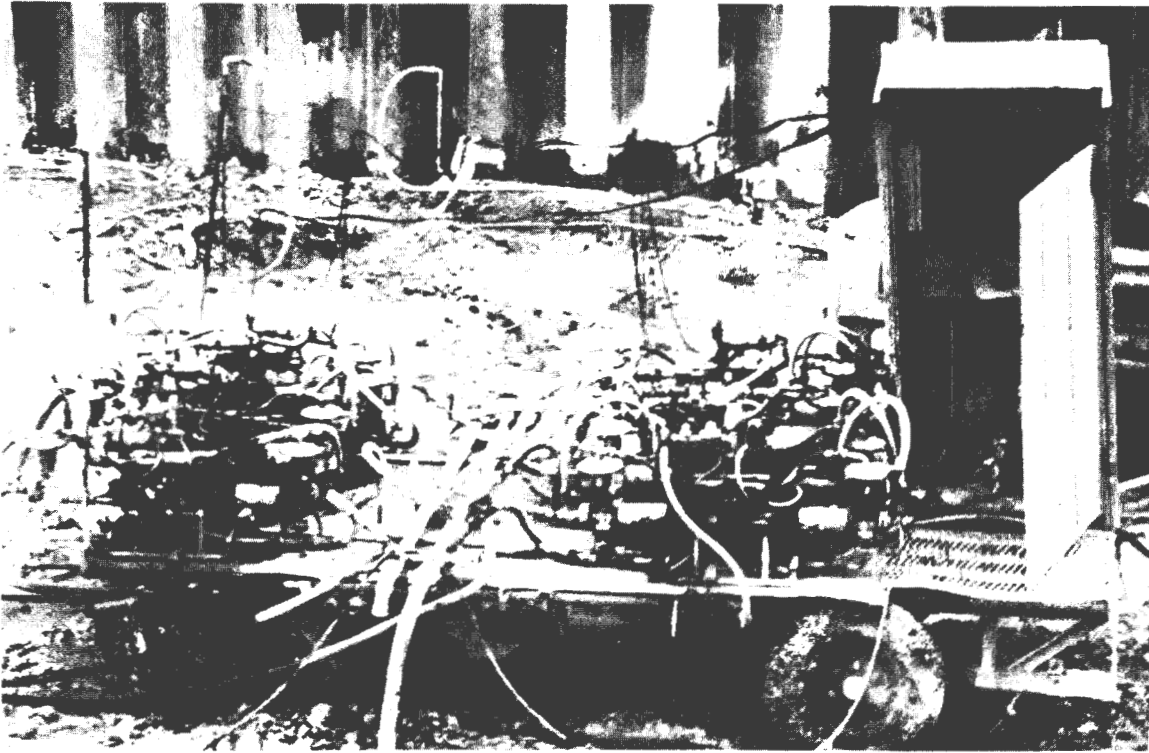

Figure 49. Trailer mounted grout pumps.

were automatically fed to the mixing tanks by using an electronic console. The pumps were then programmed from another console shown in Figure 50. This console controls each pump to inject the required amount and then stop.

Figure 51 shows the interior of a grouting trailer of a Dutch contractor. Each pump, operated by an electric motor, is mounted above the chemical mixing tank. Eight of these mixing-pumping systems are included in the trailer. Recording gauges and control switches for the pumps are mounted on the opposite wall of the van type trailer and shown in Figure 52.

### C. Injection Piping

In general practice, the grout is injected into the soil through grout pipes placed in the ground. There are several common methods being used. These methods are:

- (1) Drive Points
- (2) Pipe in Boreholes
- (3) Tube à Manchette and Stabilator
- (4) Other types



Figure 50. Electronic console for grout pump automation.



Figure 51. Grout pumps and mixing tanks in van unit.



Figure 52. Recording gauges and pump controls in grouting trailer.

### 1. Drive Points

For work at shallow depths, where pressure must be kept to minimum values to prevent lifting the ground surface, injection can be made through small size injection tubes driven into the ground with some sort of hammering device. This is perhaps the most widely used method in the United States. Special tools are available for this type of injection. Figure 53 shows one such tools with a retained point which can be opened for grouting at the desired depth by lifting the rod slightly.

This tool has many good features. It is threaded to fit standard EW Drill Rod so that additional rods can be added as the tool is driven to the desired depth. A hammer head and a combination pulling-pumping had are available that fit into the upper threaded end of the tool. The same tool is also available with an expendable pump-out point for use when a full opening is desired for more viscous grouts. A pointed end permits the tool to be driven into the ground without becoming plugged in the process. The tight fit of the tool in the ground seals it to the soil, insuring that the grout is injected into the strata to be treated. Injection can be made in stages as the tool is driven in, or as it is being withdrawn after it has been driven to the full depth to be grouted.

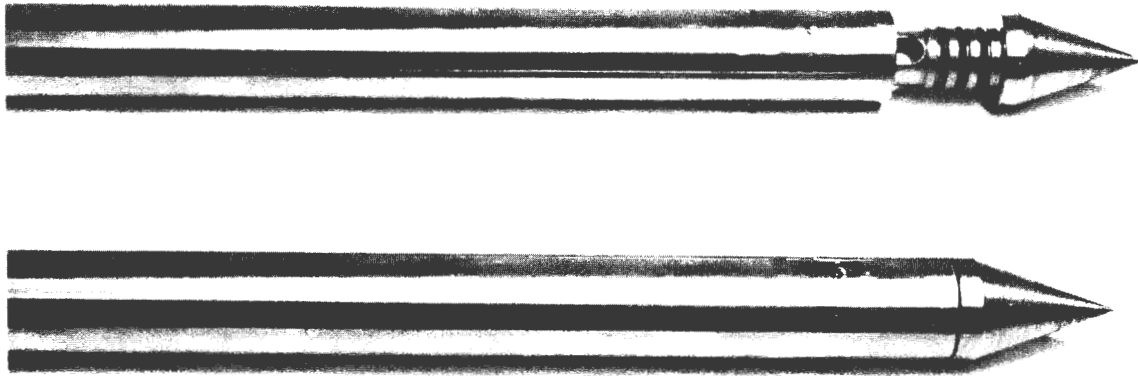

Figure 53. Pump open drive point for grout injection.

The use of this type of tool is limited to shallow depths and to loose or soft soil. Most companies will not use this type of tool below 50 to 60 feet. Driving and pulling equipment must be available to use with this tool.

## 2. Pipe in Boreholes

This method requires injection boreholes to be drilled to the deepest point of grouting. The borehole is then cased and the drilling mud, a bentonite slurry used during drilling, is removed. The injection pipe, with an air inflatable packer on the end, is lowered into the casing. The casing is then raised to the upper side of the strata to be grouted and the packer set in the lower end of the casing. The lowest zone is then grouted. The casing and injection pipe are then raised together to the upper edge of the next zone and injection is made again.

An alternate method is sometimes used when the soil is very permeable. As the borehole is advanced, drilling is stopped at desired intervals, the drill pipe is lifted slightly and the grout is injected without using a packer. This method is not applicable unless the grout can be injected into the soil using only the head of the grout column to place the grout, so it would not be used very often.



Another alternate method would be to place plastic pipe containing holes or slots into the borehole and contain it with a gravel pack around the perforated section and a light grout above the gravel to seal off the hole. Injection would then be made into the pipe with the grout moving through the perforations. This method does not permit selective grouting nor give the operator control over the grout placement.

### 3. Tube á Manchette and Stabilator

A third method is the use of specially made plastic injection pipe containing holes covered with a flexible restraining sleeve which expands under grout pressure to allow the grout to flow out into the soil. One such pipe, called "Tube á Manchette", is an invention of Soletanche Entreprise, a French grouting firm. Figure 54 shows the principle of this pipe system. A threaded plastic pipe section about 12 inches (30 cm) long contains a ring of four holes of about one-half inch (1.27 cm) diameter in the center, covered by a rubber sleeve on the outside. Any desired number of these sections can be screwed on the end of a pipe to cover the area desired to grout.

Figure 55 shows the steps in the grouting process using this system. The tube a manchette piping is placed in the completed cased borehole (Figure 55-2). The casing is then withdrawn (Figure 55-3) and a clay cement slurry known as "sleeve grout" is poured or pumped into the void left around the tube a manchette piping.

Then a small diameter grouting pipe, fitted with opposing cup-type or ring-type packers, is lowered into the outer sleeve (Figure 55-4). Grout injection is made selectively through the grout pipe between the packers. Pumping the grout expands the rubber manchette and forces the grout to fracture through the weak sleeve grout to permeate the sand strata. The grout tube can be moved as desired to place the packer section opposite the formation to be treated. Most European companies use this grouting system.

A similar system was developed by Stabilator, a Swedish firm. It has been used in Europe and is now being used by some companies in the United States. This system uses a drill bit inside a steel extension tube which acts as casing for the hole being drilled. When the hole has been drilled to the desired depth, the ring drill bit is knocked off and the drilling rod withdrawn, leaving the outer tubing in place. This outer tubing contains apertures in milled slots which are covered with leaf springs to act as one-way valves. This arrangement is shown in Figure 56. Grouting is accomplished through an injection tube with double packers similar to the tube á manchette system.

### 4. Other Types of Injection Pipes

The only other type of injection piping that the writers found in use is that of the single-element tube á manchette used by a Dutch company. This system was explained in an earlier chapter and shown in

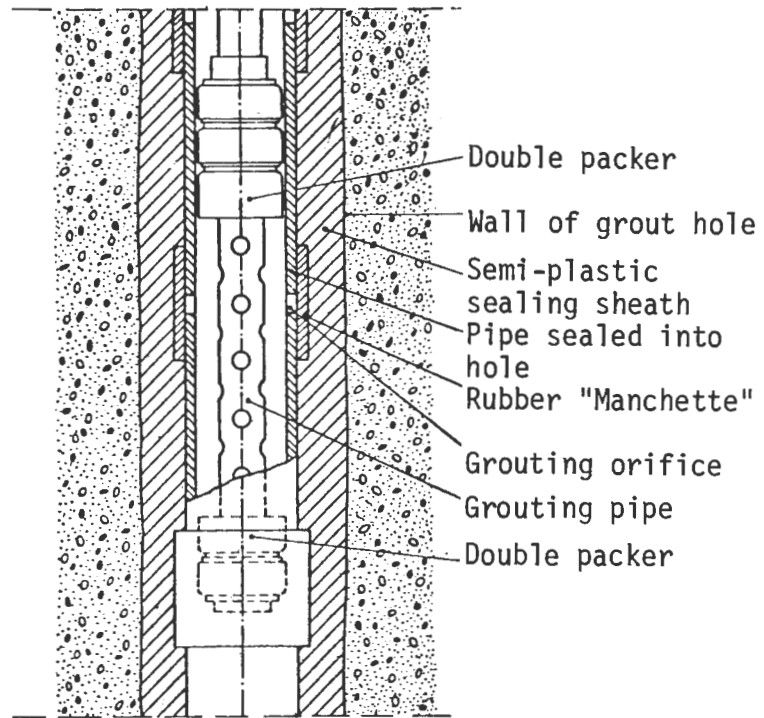

From Soletanche Entreprise.

Figure 54. Tube à Manchette

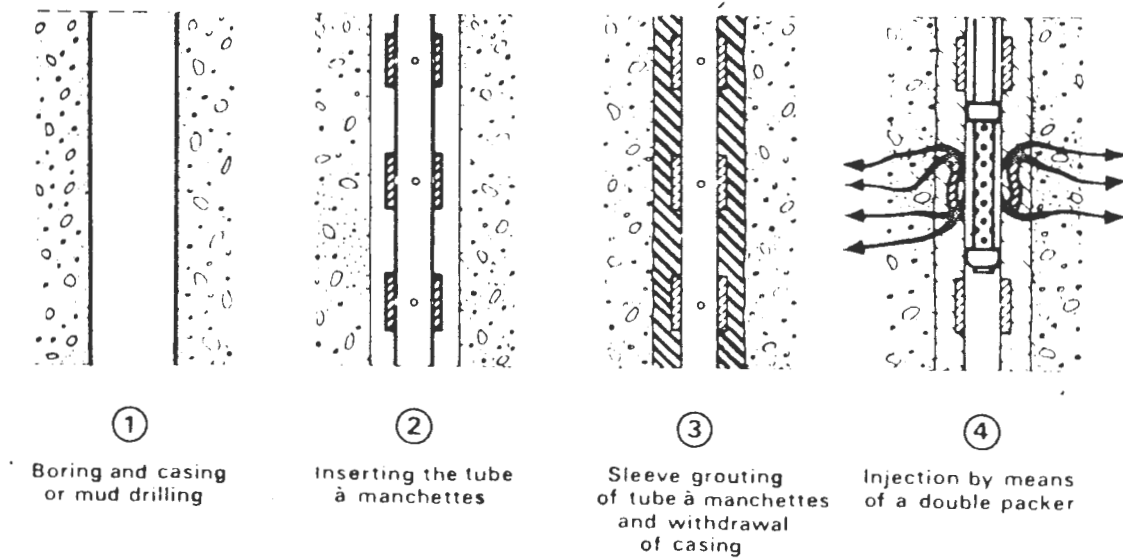

From Soletanche Entreprise.

Figure 55. Operational principle of Tube à Manchette

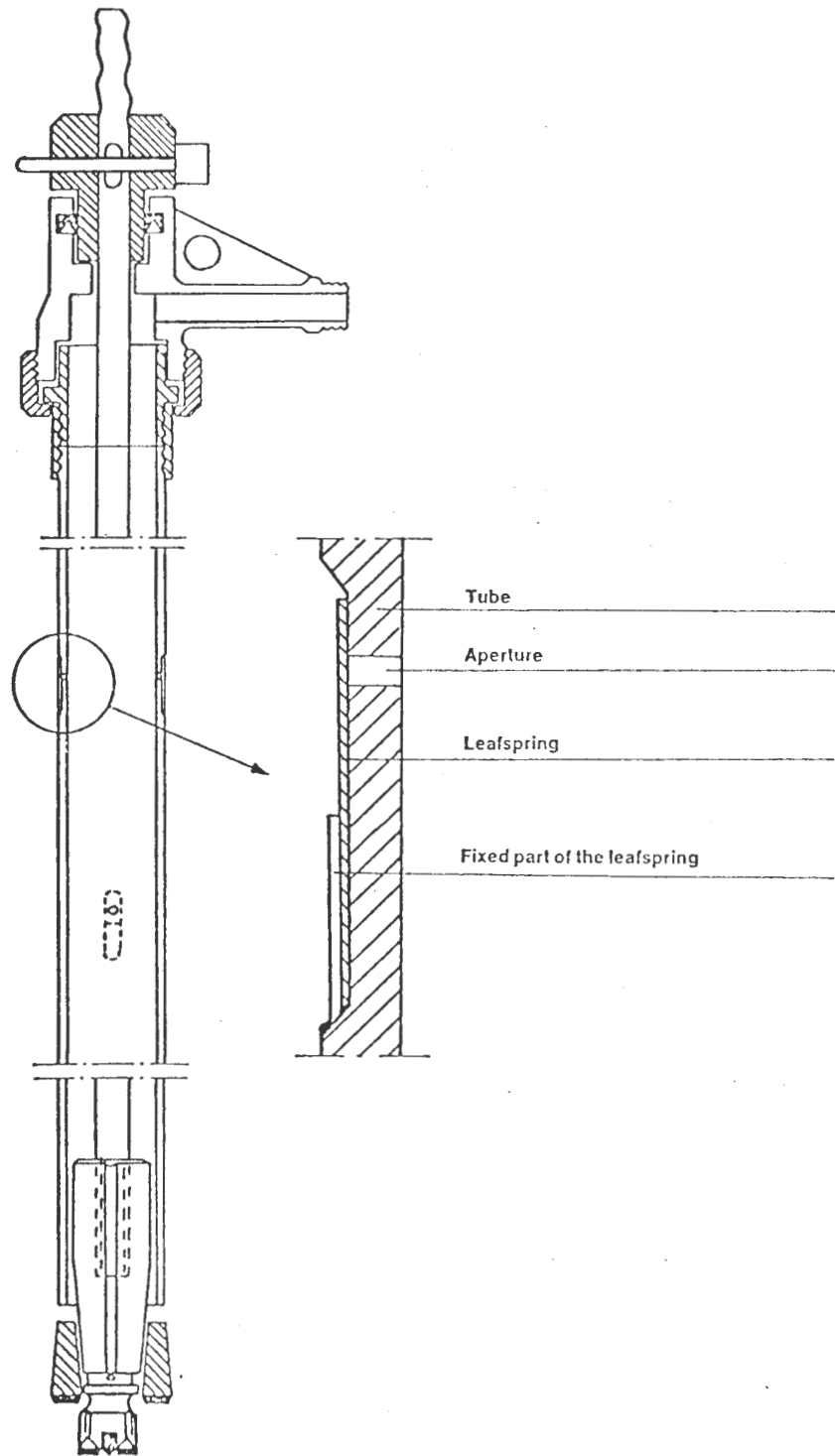

Courtesy - Stabilator, Stockholm Sweden

Figure 56. Stabilator valve tube.

Figures 14, 15 and 16. Its use is limited to applications where grouting is to be done at one specified depth for a thickness of approximately one meter.

#### D. Monitoring Equipment

Monitoring is an important part of the grouting operation. During the mixing of the grout, the grout components must be controlled to provide exact proportions of each in the final grout mix. This is done by a proportioning pump or by flow meters on the line from each pump (see Figure 13). Some grouting companies have the pumps electrically controlled to pump only the desired amount and then stop. Dry components are weighed or prepackaged to give accurate proportions.

The grout injection pressure can be monitored by visual or recording gauges that can be observed by the pump operator. Flow meters on the grout pump discharge lines, or a calibrated tank on the suction side, can be used to determine the amount of grout injected in each hole.

The monitoring equipment is normally a part of the equipment furnished by the grouting company.

## 7. GROUT INJECTION PRINCIPLES

Grouting procedures are based largely on past experience. Injection theory, based upon idealized soil conditions, is helpful in planning for grouting, but present grouting practices are usually based upon operations which have been successful in the past.

### A. Theoretical Considerations

For a typical grouting situation, pipes are placed into the formation to be grouted from either the ground surface, a tunnel or a gallery. Pipes are normally placed in a grid pattern. The distance between pipes must be such that the grout can travel at least half of the distance between pipes in order to place grout completely throughout the soil before the set occurs in the grout. The grout injection rate through the pores of the soil is dependent upon soil permeability, grout viscosity and grout shear strength. The permeability is measured with water and corrected for the viscosity of the grout. In the case of Newtonian (true fluid) grouts, the permeation of the grout is controlled by grout viscosity for any given soil permeability. The particulate (non-Newtonian) type grout has its flow controlled in the early stages by viscosity, but in the later stages by the grout shear strength.

#### 1. Mathematical Theory

Equations based on flow theory can be helpful in preliminary studies of a grouting problem. However, the simplifying assumptions used in deriving such equations generally preclude their use for anything but this purpose. The properties of a zone to be grouted may be appreciably altered by the placement of injection pipes or by previous adjacent grouting (38). The soil particle distribution is disturbed, which affects flow characteristics and permeability. Also, it is possible that the grout characteristics may change as it becomes contaminated by passage through the soil pores, either by dilution from groundwater or by suspended fines picked up from the soil.

Considerable theoretical background exists for the analysis of seepage into wells. Grouting practice is essentially a special case where pumping is into rather than out of a formation, and most important for the analysis, flow normally occurs at single injection points rather than along a hole axis through a slotted screen or well liner. Neglecting the force of gravity, flow therefore is radial in three dimensions, and the shape of the grouted mass approximates a sphere with the tip of the grout pipe at the center.

##### a. Water Saturated Soils

From the equation for volume of a sphere, the volume of soil permeated by grout is:

$$V = \frac{4}{3} \pi r^3 \quad (32)$$

where  $r$  is the maximum radial penetration away from the tip of the pipe (see Figure 57). The grout volume equals the volume of soil voids,  $V_g = nV$  where  $n$  is the soil porosity expressed as a fraction. The grout volume also equals the pumping time,  $t$ , multiplied by the average grout take  $Q$  in cfm. Substituting,

$$nV = Qt = n \frac{4}{3} \pi r^3 \quad (33)$$

$$r = 0.620 \sqrt[3]{\frac{Qt}{n}} \quad (34)$$

where

$r$  = radial distance of grout penetration,  
cm (feet)\*

$Q$  = average rate of grout take,  $\text{cm}^3$  ( $\text{ft}^3$ )/min

$t$  = pumping time or gelation time,  
minutes

$n$  = porosity of the soil expressed as  
as a fraction

\* English units are given in parenthesis.

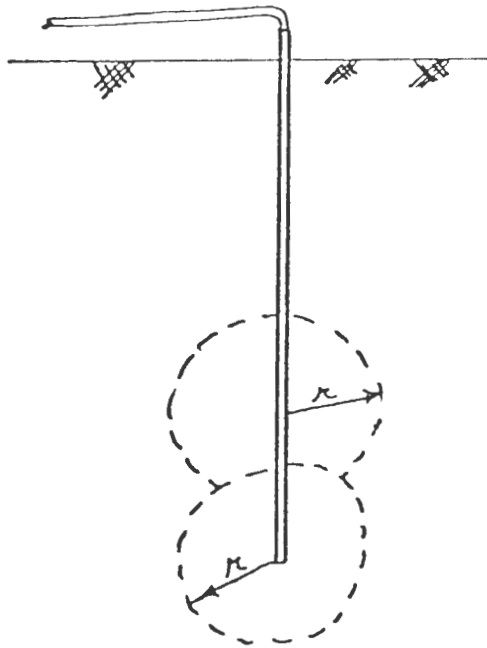

Figure 57. Schematic of grout principle.

For Newtonian fluids, the Darcy Law for flow rate  $Q$  gives

$$Qt = tAk_g i \quad (35)$$

where  $k_g$  is the permeability coefficient of the soil for grout. The soil area  $A$  at any instant is the surface of the penetration sphere,  $A = 4\pi r^2$ , and the average hydraulic gradient  $i$  is

$$i = \frac{h}{r} \quad (36)$$

where  $h$  is the head difference in feet of water. By equating  $Qt$  in equations 33 and 35, substituting for  $A$  and  $i$ , and solving for  $t$ ,

$$t = \frac{n}{3k_g h} r^2$$

As previously shown, the permeability coefficient  $k_g$  is related to that for water by the ratio of respective viscosities:

$$k_g = \frac{k}{N}, \text{ and}$$

$$t = \frac{nN}{3kh} r^2 \quad (37)$$

where

- $t$  = time, minutes
- $n$  = soil porosity
- $N$  = ratio of viscosity of grout to that of water
- $k$  = soil coefficient of permeability, cm/min (ft/min)
- $h$  = hydraulic head, cm(ft) of water
- $r$  = radius of the grouted soil mass, cm(ft)

While the above equation, attributed to Maag, is a relatively simple expression of the effects of viscosity, permeability, grouting pressure and radial distribution on grouting time, its use is not recommended for reasons illustrated later. One reason is that it ignores resistance of water outside of the grout penetration sphere, and therefore would probably underestimate the time  $t$  except in dry soils. More importantly, it assumes that  $i$  is constant along a radius, which according to equation 36 means that the grouting pressure should increase linearly with the grouting sphere radius. This is not necessarily true.

In order to take these additional factors into account, the grouting flow rate  $Q$  at the surface of a grouted soil sphere of radius  $r$  is

$$Q = 4\pi r^2 V_r \quad (38)$$

where  $V_r$  is the radial flow velocity or "flux" across a unit area of soil.

The Darcy Law written in differential form for a unit area is

$$V_r = -k \frac{\partial h}{\partial r}$$

where the partial differential  $-\frac{\partial h}{\partial r}$  represents the hydraulic gradient or head loss per unit of length, at any particular radius. Substituting for  $V_r$  in equation 38,

$$Q = -4\pi r^2 k \frac{\partial h}{\partial r}$$

integration gives

$$h_r = \frac{Q}{4\pi k} \frac{1}{r} + C$$

That is, hydraulic head ( $h_r$ ) is inverse to radial distance  $r$  from the grouting pipe. If the pipe radius is  $r_0$ , then  $h_r = h$  when  $r = r_0$ , from which the constant of integration  $C$  is

$$C = h - \frac{Q}{4\pi k r_0}$$

and

$$h_r = \frac{Q}{4\pi k} \left( \frac{1}{r} - \frac{1}{r_0} \right) + h \quad (39)$$

Equation 39 is applied both inside and outside the grout sphere of radius  $r$ .

$$\text{Inside, } h_r = \frac{QN}{4\pi k} \left( \frac{1}{r} - \frac{1}{r_0} \right) + h \quad (40)$$

$$\text{Outside, } -h_r = \frac{Q}{4\pi k} \left( \frac{1}{r_n} - \frac{1}{r} \right) \quad (41)$$

where  $r_n$  is the radius of the sphere of influence, beyond which the hydraulic gradient is unchanged. A physical picture of this is obtained by considering that within this radius the injection volume is compensated by raising of the water table. If  $r_n$  is large,  $\frac{1}{r_n} = 0$ .

Equation (41) then becomes

$$h_r = \frac{Q}{4\pi k} \frac{1}{r} \quad (41a)$$

Combination of equations 40 and 41a and solving for  $h$  gives



$$h = \frac{Q}{4\pi k} \left[ \frac{N}{r_0} - \frac{N-1}{r} \right] \quad (42)$$

where

$h$  = grouting pressure at the tip of the pipe,  
cm (ft) of water

$Q$  = flow rate,  $\text{cm}^3/\text{min}$  ( $\text{ft}^3/\text{min}$ )

$k$  = soil coefficient of permeability,  
 $\text{cm}/\text{min}$  ( $\text{ft}/\text{min}$ )

$N$  = ratio of grout viscosity to that  
of water

$r_0$  = radius of the grout pipe, cm (ft)

$r$  = radius of the grout (sphere), cm (ft)

This equation was first developed by Raffle and Greenwood (43). Note that if the viscosity ratio  $N = 1$ ,

$$h = \frac{Q}{4\pi k r_0} \quad (42a)$$

That is, for a constant flow rate  $Q$  the pressure  $h$  is constant regardless of the grout penetration distance  $r$  and depends only on pipe radius  $r_0$  and soil permeability  $k$ . If the grout is more viscous than water, i.e.,  $N > 1$ , equation 42 states that for a constant flow rate the pressure must increase with increasing grout penetration.

The maximum pressure as  $r$  becomes very large is:

$$h = \frac{QN}{4\pi k r_0} \quad (42b)$$

The above equations still do not show the time required for grout to reach a particular radius. In this case the rate of change in radius  $\frac{dr}{dt}$  is a function of radial fluid flow rate  $V_r$  and fractional soil porosity,  $n$ :

$$\frac{dr}{dt} = \frac{V_r}{n}$$

Substitution for  $V_r$  from equation 38 gives

$$\frac{dr}{dt} = \frac{Q}{4\pi r^2 n}$$

The quantity  $\frac{Q}{4\pi}$  may be substituted from equation 42

$$\frac{dr}{dt} = \frac{hk}{n} \left[ r^{2N} \left( \frac{1}{r_0} - \frac{1}{r} \right) + r \right]^{-1} \quad (43)$$

Rearranging and integrating gives

$$hkt = \left[ \frac{N}{3} \frac{r^3}{r_0} + \frac{N+1}{2} r^2 + r \right] + C$$

The integration constant may be evaluated by noting that when  $t = 0$ ,  $r = r_0$ . Then

$$\frac{hkt}{n} = \frac{N}{3} \left( \frac{r^3}{r_0} - r_0^2 \right) - \frac{N-1}{2} \left( r^2 - r_0^2 \right)$$

which is somewhat more conveniently expressed

$$t = \frac{nr_0^2}{hk} \left[ \frac{N}{3} \left[ \left( \frac{r}{r_0} \right)^3 - 1 \right] - \frac{N-1}{2} \left[ \left( \frac{r}{r_0} \right)^2 - 1 \right] \right] \quad (44)$$

A simpler equation results if at time  $t = 0$  the grout radius is assumed to be 0. Then  $C = 0$  and

$$t = \frac{nr_0^2}{hk} \left[ \frac{N}{3} \left( \frac{r}{r_0} \right)^3 - \frac{N-1}{2} \left( \frac{r}{r_0} \right)^2 \right] \quad (44a)$$

where symbols are as listed for equations 37 and 42.

The three equations for grouting time arranged in order from most to least accurate are 44, 44a and 37. Since the equation simplicity is inverse to this order, some comparative results are presented as follows: (Equations 44 and 44a are solved by  $r$  by trial and error):

Example 1 - Case History - Exhibit A - BART Tunnel grouting.

$$\begin{aligned} t &= 0.5 \text{ minute (gel time)} \\ n &= 0.41 \\ r_0 &= 1 \text{ in.} = 0.0833 \text{ ft.} \\ h &= 50 \text{ psi} = 7200 \text{ psf} = 115.4 \text{ feet} \\ &\quad \text{of water (assumed)} \\ k &= 0.2 \text{ cm/sec} = 0.39 \text{ ft/min (assumed)} \\ N &= 5.2 \text{ for chemical grout} \end{aligned}$$

Solutions arranged from most accurate to least accurate are as follows:

| <u>Equations</u> | <u>r, ft</u> | <u>Q, ft<sup>3</sup>/min</u> | <u>Qt, ft<sup>3</sup></u> |
|------------------|--------------|------------------------------|---------------------------|
| 44 and 42        | 1.42         | 9.5                          | 4.8                       |
| 44a and 42       | 1.42         | 9.5                          | 4.8                       |
| 37 and 34        | 5.63         | 614                          | 307                       |

As anticipated, equation 37 overpredicts the grouted radius in this example by a factor of 4 while the grout volume is overestimated by a factor of 65. Use of equation 44a in lieu of 44 did not change results, and the grout quantities indicated by equations 34 and 42 are fairly compatible if the same sphere radius is used. In this particular example, drilling showed the sand to be consolidated to a depth of about 1.5 feet per shot, so grouting was continued at 1.5 feet increments to about 6 feet.

In some instances, including the example given above, grouting is performed through a surface such as a wall or tunnel lining, and the distribution thus approximates a hemisphere rather than a sphere. In this case the time-penetration relationships of equations 44 and 44a are unchanged, but the grout volume is reduced one-half.

Example 2 - Case History - Exhibit D - Pregrouting for tunnels, Pontiac, Michigan.

t = 10 min (assumed)  
n = 0.25  
r = 0.75 in = 0.0625 ft  
h<sup>0</sup> = 40 psi = 92.3 ft water  
k = 0.05 cm/min = 0.00164 ft/min (assumed)  
N = 2 for silicate grout

Solutions are as follows:

| <u>Equations</u> | <u>r, ft</u> | <u>Q, ft<sup>3</sup>/min</u> | <u>Qt, ft<sup>3</sup></u> |
|------------------|--------------|------------------------------|---------------------------|
| 44 and 42        | 0.844        | 0.0617                       | 0.617                     |
| 44a and 42       | 0.844        | 0.0617                       | 0.617                     |
| 37 and 34        | 3.01         | 2.86                         | 28.6                      |

Again, equation 37 seems to overestimate grout penetration and amount. Equations 44a and 34 are recommended for general use. Actual radius used was 1.5 feet, so the theoretical approach probably can best be used as a guide for planning of a job.

Analytical treatments are perhaps most useful for predicting the effects of modifications in practice. For example, what are the effects of increased grouting pressure, or increased radius of the grouting pipe?

Example 3 - Same as Example 2, but (a) with twice the pressure, or 184.6 ft water; or (b) with twice the pipe radius, r<sub>0</sub> = 1.5 in = 0.125 feet.

Solutions utilizing equation 44a for radius and equation 34 for amounts are as follows:

| <u>Grouting Spec.</u> | <u>r, ft</u> | <u>Q, ft<sup>3</sup>/min</u> | <u>Qt, ft<sup>3</sup></u> |
|-----------------------|--------------|------------------------------|---------------------------|
| Original              | 0.844        | 0.0631                       | 0.631                     |
| h x 2                 | 1.059        | 0.125                        | 1.25                      |
| r <sub>0</sub> x 2    | 1.075        | 0.130                        | 1.30                      |

It can be seen that either modified procedure should increase the grout radius about 25% and approximately double the "take" for the same pumping time.

b. Injection from Slotted Pipe or Tube à Manchette

Example 3 shows that the grouting rate could be approximately doubled by either doubling the pumping pressure or the radius of the grout pipe; however, allowable pumping pressure is limited by overburden pressure, and larger holes cost more to drill. The same effect of increasing the flow rate by increasing the area of the soil-grout interface can be achieved by grouting a short length of the hole, viz, either by raising the grout pipe prior to injection or by using a slotted pipe or packer injection device. This principle is widely recognized in well practice, where theoretical treatments show that radial two-dimensional horizontal flow to a slotted pipe is far more efficient than spherical flow to an open end. For a short exposed length L the exposed area is:

Sidehole exposure only:  $A = 2 r_0 L$

Sidehole + end hemisphere:

$$A = 2\pi r_0 L + 2\pi r_0^2$$

Dividing by the area used for derivation of the above equations,  $2\pi r_0^2$  gives a correction factor for  $r_0$ :

Sidehole: multiply  $r_0$  by  $\frac{L}{r_0}$

Sidehole + end: multiply  $r_0$  by  $\left(\frac{L}{r_0} + 1\right)$

Example 4: Same as Example 2, but with injection through Tube à Manchette one diameter long (Fig. 55), or with open drive point (Fig. 53) open one diameter, or with grouting pipe raised one diameter prior to injection.

| <u>Method</u>    | <u>Effective r<sub>0</sub>, ft</u> | <u>r, ft</u> | <u>Q ft<sup>3</sup>/min</u> | <u>Qt, ft<sup>3</sup></u> |
|------------------|------------------------------------|--------------|-----------------------------|---------------------------|
| Tip Injection    | 0.0625                             | 0.844        | 0.0631                      | 0.0631                    |
| Tube à Manchette | 0.125                              | 1.075        | 0.130                       | 1.30                      |
| Drive Point      | 0.125                              | 1.075        | 0.130                       | 1.30                      |
| Retracted Point  | 0.1875                             | 1.243        | 0.201                       | 2.01                      |

It can be seen that any of these other methods increase the flow rate Q two to three times, increasing r or decreasing time t for a given grout penetration in a given time. The drive point and retracted tip calculations assume no caving of the hole.

In summary, grouting equations such as 44a and 34 provide a valuable insight into grouting practices which have been arrived at more or less by trial. Equation 44a requires a trial-and-error solution for grouting radius r; usually in practice a radius is assumed based on prior experience. Equation 37, while simple and not requiring a trial-and-error solution, is quite inaccurate and should not be used.

c. Effect of Dry Soils

Grouting of dry soils means equation 40 can be applied directly except that  $h_r = 0$ . Equation 43 becomes

$$\frac{dr}{dt} = \frac{hk}{n} \left[ r^2 N \left( \frac{1}{r_0} - \frac{1}{r} \right) \right]^{-1} \tag{45}$$

and if  $r = 0$  at  $t = 0$

$$t = \frac{nr_0^2}{nk} \left[ \frac{N}{3} \left( \frac{r}{r_0} \right)^3 - \frac{N}{2} \left( \frac{r}{r_0} \right)^2 \right] \tag{46}$$

where symbols are as before.

Example 5. Same as example 2, but with grouting into dry soil. Solving gives:

| <u>Condition</u> | <u>r, ft</u> | <u>Q, ft<sup>3</sup>/min</u> | <u>Qt, ft<sup>3</sup></u> |
|------------------|--------------|------------------------------|---------------------------|
| Saturated        | 0.844        | 0.0631                       | 0.631                     |
| Dry              | 0.860        | 0.0667                       | 0.667                     |

The difference is relatively minor. Another factor is that the loss of buoyancy will cause greater sinking of the grout. The vertical hydraulic gradient on a bulb of grout due to gravity is the head loss per unit elevation:

$$\begin{aligned} \text{Dry Soil, } i_v &= G \\ \text{Submerged Soil, } i_v &= G - 1 \end{aligned}$$

where G is the specific gravity of the grout. Note that if  $G = 1$  the gradient in dry soil is 1.0, and in submerged soil 0; in the latter case no gravity flow will occur. The relative importance of gravitational head can be seen by comparison to typical values of  $\frac{h}{r}$  - - the gravitational head is relatively small, so the effect of gravity is negligible over short

times. If however, setting is delayed for a long time, gravity will pull the grout downward in accord with the Darcy relationship. The distance of sinking  $S$  is velocity times time, or with other symbols as above,

$$\text{Dry soil: } S = \frac{k}{N} tG \quad (47)$$

Saturated soil: Neglecting the viscous resistance of water displaced,

$$S = \frac{k}{N} t(G-1) \quad (48)$$

Example 6. Same as example 2, but  $G = 1.2$  and  $t = 5$  hours.

$$\text{Dry: } S = \frac{0.00164}{2} (300) (1.2) = 0.30 \text{ ft}$$

$$\text{Saturated: } S = \frac{0.00164}{2} (300) (0.2) = 0.05 \text{ ft}$$

Thus, even with a prolonged setting time, grout sinking would be small or negligible.

#### d. Non-Newtonian Grouts and the Limiting Sphere

The above considerations apply to ideally viscous grouts, that is, where shearing stress is proportional to the rate of shear. Many common grouting materials also exhibit a threshold or yield stress (or minimum shearing stress) to cause flow, above which the flow rate and shearing stress again become proportional, as shown in Figure 58. A yield stress dictates the maximum distance of penetration, since a minimum pressure is necessary to drive the flow, and pressure decreases with increasing surface area of the penetration sphere.

In ideal Newtonian flow, Figure 58, Curve A, the rate of shear is proportional to shearing stress,  $\tau$ :

$$\text{Newtonian: } \frac{dv_x}{dy} = - \frac{\tau}{\mu}, \quad (49)$$

$\mu$  being the viscosity. For ideal plastic flow, curves B and C of Figure 58, the rate of shear is proportional to shearing stress in excess of the yield stress,  $\tau_y$ :

$$\text{Plastic: } \frac{dv_x}{dy} = - \frac{\tau - \tau_y}{\mu} \quad (50)$$

Curves B and C of Figure 58 are drawn to illustrate the phenomenon of thixotropy, characteristic of many grouts, and especially those containing bentonite. Setting time allows particles gradually to become oriented for optimum exercise of electrical attractions, such that the grout thickens as indicated by an increase in yield stress. Stirring temporarily disrupts the bonds, renewing the fluidity. A practical implication would be if pumping stops for a few minutes during injection of a thixotropic grout, it may be difficult or impossible to start again with out exceeding established maximum pressure.

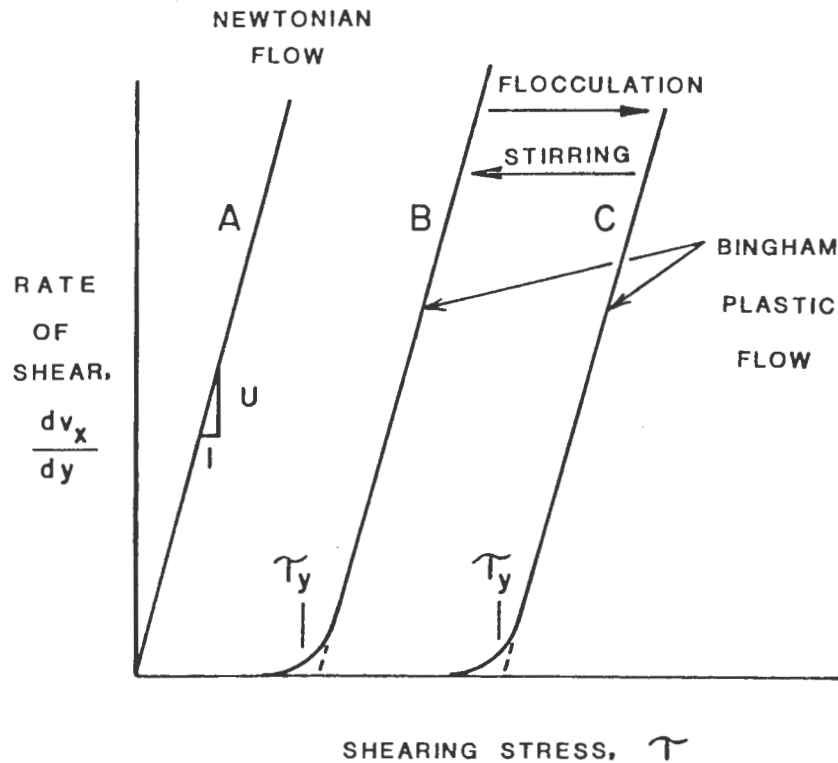

Figure 58. Newtonian vs. plastic flow.

Figure 59 illustrates how the Hagen-Poiseuille derivation for laminar flow through a cylindrical tube equates driving pressure  $\gamma dh$  times circular cross-sectional area  $\pi y^2$ , with resisting shear stress  $\tau$  times cylindrical area  $2\pi y dx$ :

$$\pi y^2 dh = 2\pi y \tau dx$$

where  $\gamma =$  unit weight of water, so

$$\tau = \frac{y}{2} \frac{dh}{dx} \quad (51)$$

Therefore, shearing stress is zero at the middle of the tube ( $y = 0$ ) and varies directly as the distance from the center, increasing to a maximum at the boundary.

Substitution of  $y = \frac{D}{2}$  where  $D$  is the pore diameter gives

$$\tau_{\max} = \frac{D}{4} \frac{\gamma dh}{dx} \quad (52)$$

at the surface of the pore. For the case of plastic flow  $\tau$  must exceed the yield stress  $\tau_y$ , from which

$$\left(\frac{dh}{dx}\right)_{\min} = i_y = \frac{4\tau_y}{qD} \quad (53)$$

where  $i_y$  = minimum hydraulic gradient for flow  
 $\tau_y$  = yield stress  
 $D$  = pore diameter

That is, flow will cease when the hydraulic gradient falls below a value dictated by the grout yield stress and the soil pore diameter. In spherical or radial injection, the hydraulic gradient decreases with increasing penetration distance; hence, grout having a yield stress also will have a limited penetration into soil or rock pores. The same is true for drilling mud in wells, where low penetration is an advantage.

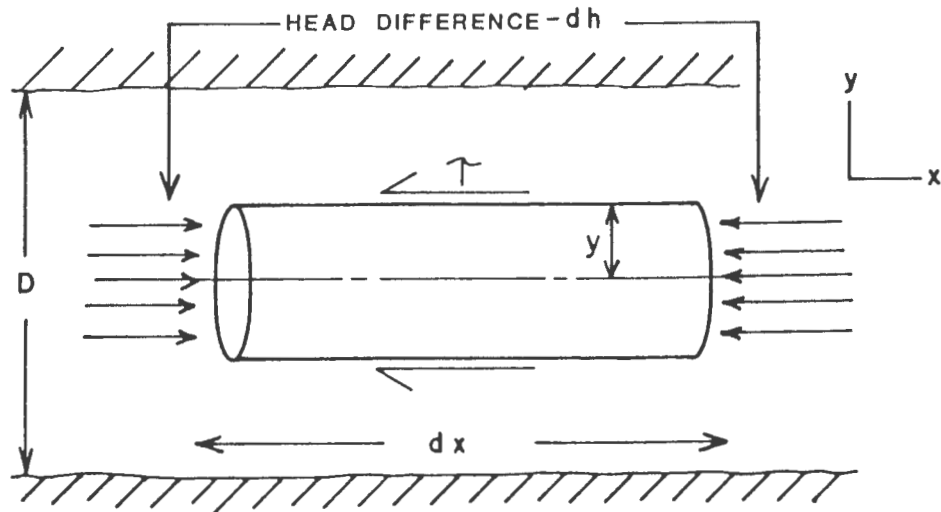

Figure 59. Force affecting flow of a fluid element in a cylindrical tube of diameter  $D$ .

The effect of a yield stress on flow velocity is illustrated by a general consideration of the forces in Figure 59. If the yield stress is zero, i.e., the fluid is Newtonian, the variation of  $\tau$  across a circular capillary is shown in Figure 60(a) corresponding to equation 51. Toward the center of the capillary, the shearing stress reduces linearly to zero. The same relation applies if the fluid exhibits a Bingham yield stress, except that in the center of the tube where  $\tau < \tau_y$ , the mass will behave as a plastic surrounded by a liquid shield, as in Figure 60(b).



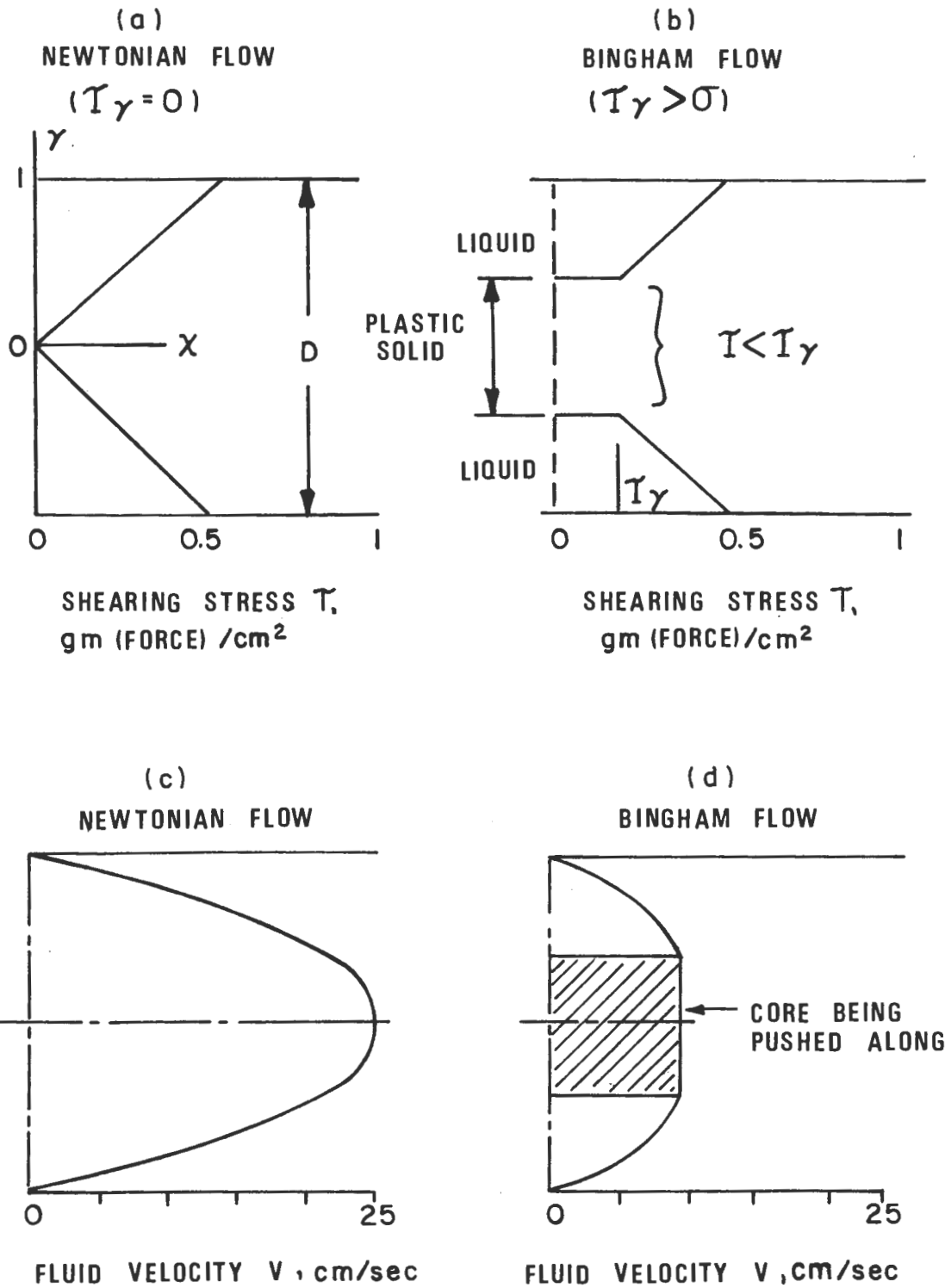

Figure 60. Comparison of shearing stress and velocity.

The existence of a solid core being transported does not change the relation of equation 51 outside of the core, but inside  $\tau$  will be zero.

The flow velocity  $v$  in the tube (Figure 60) is obtained by combining equations 49 and 51 and integrating with respect to  $y$ . For Newtonian fluids,

$$v = \frac{\gamma_w}{4\mu} \frac{dh}{dx} \left[ \left( \frac{D}{2} \right)^2 - y^2 \right] \quad (54)$$

This is the equation of a parabola, shown in Figure 60(c) for water under a unit hydraulic gradient ( $\gamma_w = 1 \text{ gm/cm}^3$ ,  $\mu = 0.01 \text{ gm/cm-sec}$ ,  $dh/dx = 1$ ).

A similar combination of equations 50 and 51 for fluids with a yield stress gives

$$v = \frac{\gamma_w}{4\mu} \frac{dh}{dx} \left[ \left( \frac{D^2}{2} \right) - y^2 \right] - \frac{\tau_y}{\mu} \left( \frac{D}{2} - y \right) \quad (55)$$

or

$$v = \frac{1}{\mu} \left( \frac{D}{2} - y \right) \left[ \frac{\gamma_w}{4} \left( \frac{D}{2} + y \right) \frac{dh}{dx} - \tau_y \right] \quad (56)$$

A graph for a fluid similar in other respects to water but with a yield stress  $\tau_y = 0.2 \text{ gm (force)/cm}^2$  is shown in Figure 60(d). The above function is discontinuous at  $\tau = \tau_y$ ; which means from equation 51 that it applies only when

$$y > \frac{2\tau_y}{\gamma} \div \frac{dh}{dx}$$

As can be seen from the graphs of Figure 60, the yield stress of a fluid tends to:

- (1) Reduce injection velocity
- (2) Give a central core of plastic material supported and pushed along in a surrounding liquid
- (3) Present a maximum injection distance for a particular pore size, because of the decrease in hydraulic gradient with radial or spherical penetration

The exact prediction of penetration rate and maximum radius is not a simple matter since they depend on the hydraulic gradient at the grout front. This could be found from flow rate if the Darcy law were valid. However, as shown by equation 55 and its discontinuity, flow velocity is not simply a constant times the hydraulic gradient  $dh/dx$ ; in the peripheral

ring, the gradient is partly utilized to overcome the yield stress while the core is carried in nonviscous flow. A valid theoretical equation could be developed, but has not been. A further complicating factor is thixotrophy, commonly present in non-Newtonian grouts, which would allow gradually stiffening core material to act as a stoppage in channel restrictions.

## 2. Theory of In Situ Stress Modification by Grouting

Pressure grouting changes existing stresses in soils and fractured rocks to the extent that their stability may be affected prior to grout setting. For example, grouting adjacent to a basement, retaining wall or other rigid substructure may temporarily or permanently increase lateral load on the structure. Grouting tends to equalize in situ compressive stresses and relieve shearing stresses; this may be an advantage prior to excavation or tunneling, or may be a disadvantage where shearing stress is required for stability, as in an active landslide.

Modification of in situ stresses by grouting occurs in three ways:

(1) Seepage Forces. These represent frictional restraint to the flow of grout, and therefore exist only during actual grout flow. Stresses should relax immediately as pumping stops, when a small reverse force and flow may even occur due to (a) compressibility of pore air or, (b) rebound of an expanded soil structure. Seepage forces are temporary; they are also directional, opposing the flow direction and thus extending radially from the grout pipe, and they are distributed throughout the affected soil. Seepage forces tend to compact affected soil and decrease permeability and flow, as already discussed, but otherwise they probably are not of major significance.

(2) Hydrostatic Pressure. Grouting of unsaturated soils introduces a hydrostatic head by filling the pores with a fluid. This can be quite significant if it occurs in soils normally unsaturated, as behind retaining walls. Grouting of saturated soils increases hydrostatic head only moderately, by raising the head or by the grout being heavier than water.

(3) Pore Pressure. Hydrostatic pressure in excess of that from the standing head will build up during grout pumping, and can be relieved only by escape flow. If the escape is impeded by low permeability or by setting of peripheral grout, pore pressures may remain intact while the grout sets, and remain as a permanent modification of in situ stress.

The relation between total pore pressure and intergranular stress is shown in Figure 61. When intergranular stress is expressed on a gross area basis, pore pressure subtracts to give "effective stress":

$$\sigma' = \sigma - u \quad (57)$$

where  $\sigma'$  is effective intergranular stress  
 $\sigma$  is total stress  
 $u$  is pore pressure

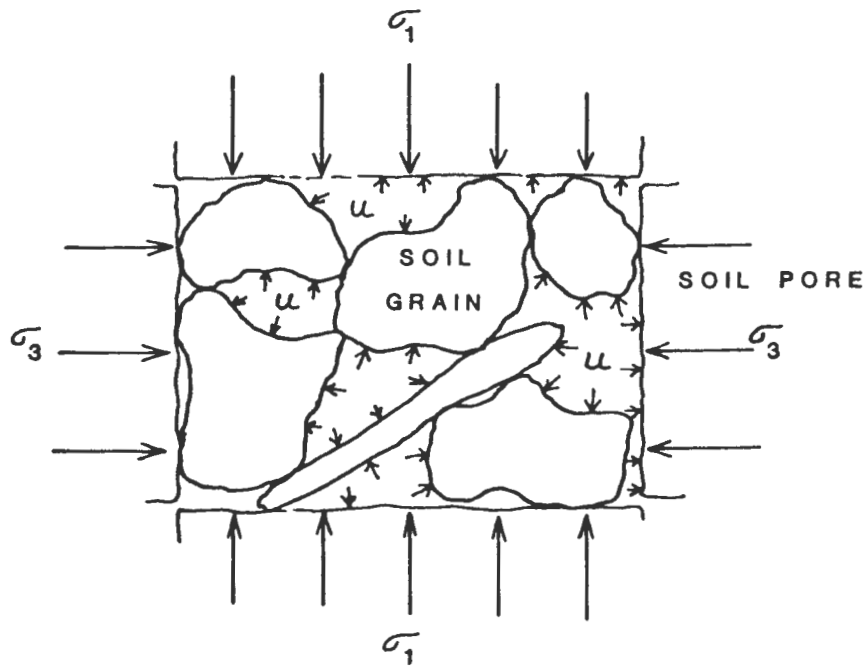

Figure 61. Pore pressure effect on stress.

After the grout sets, the residual pore pressure is frozen as a grout-to-soil grain pressure, and it is no longer truly hydrostatic since the pore material then can sustain unequal compressive stresses and shearing stress. That is, after setting,  $u$  becomes a matrix stress which is part of and not differentiated from the total stresses  $\sigma_1$ ,  $\sigma_3$ , etc. The pore pressure prior to setting is the major concern.

A careful distinction is necessary between pore pressure arising from hydrostatic head and that due to grout pumping. For example, raising the hydrostatic head pore pressure by submergence increases the total stress as well as the pore pressure, leaving the effective stress unchanged. Therefore, soils at the bottom of the sea, although under a very high stress and pore pressure, remain soft and unconsolidated, since the effective stress is the same whether under deep submergence or under shallow submergence. In contrast, since raising the pore pressure by grouting causes no proportionate increase in confining stress ( $\sigma_1$  and  $\sigma_3$  in Figure 61), the effective stress is reduced. The discussion will include the following symbols:

- $u$  = total pore pressure
- $\Delta u$  = that part of  $u$  derived from grout pumping pressure
- $\sigma$  = total stress
- $\sigma'$  = net effective stress
- $\sigma'' = \sigma - (u - \Delta u)$  = effective stress due to buoyancy and exclusive of pumping pressure.

Stresses in a solid can be defined in terms of three principal stresses, designated  $\sigma_1$ ,  $\sigma_2$ , and  $\sigma_3$ , acting on three mutually perpendicular planes that are devoid of shearing stresses. The maximum and minimum (designated major and minor) principal stresses  $\sigma_1$  and  $\sigma_3$  plotted on an abscissa, with their difference used as the diameter of a circle, Figure 62, allows a graphical evaluation of shearing and compressive stresses on any plane in the solid. Mohr failure theory says that when the circle is large enough to contact a failure envelope, the material will fail in shear along a plane at a direction  $\theta$  with the major principal plane. The values of shearing and normal stress  $\tau_f$  and  $\sigma_n$  on this plane are as shown.

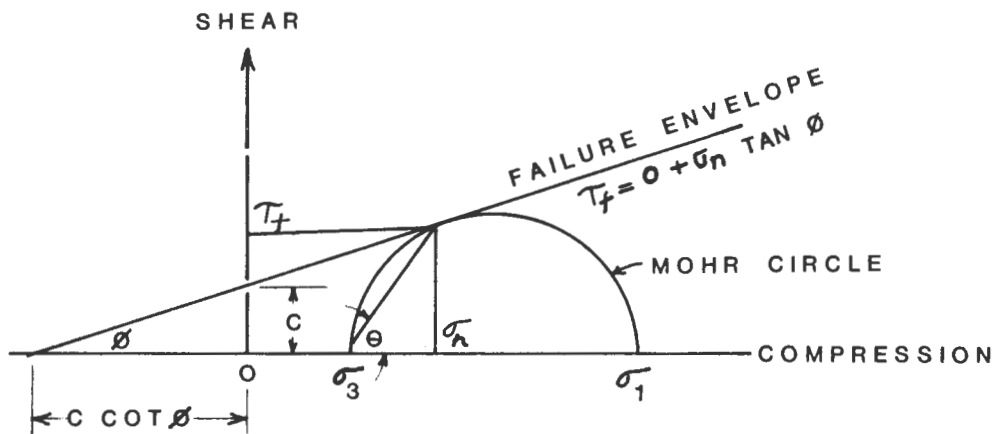
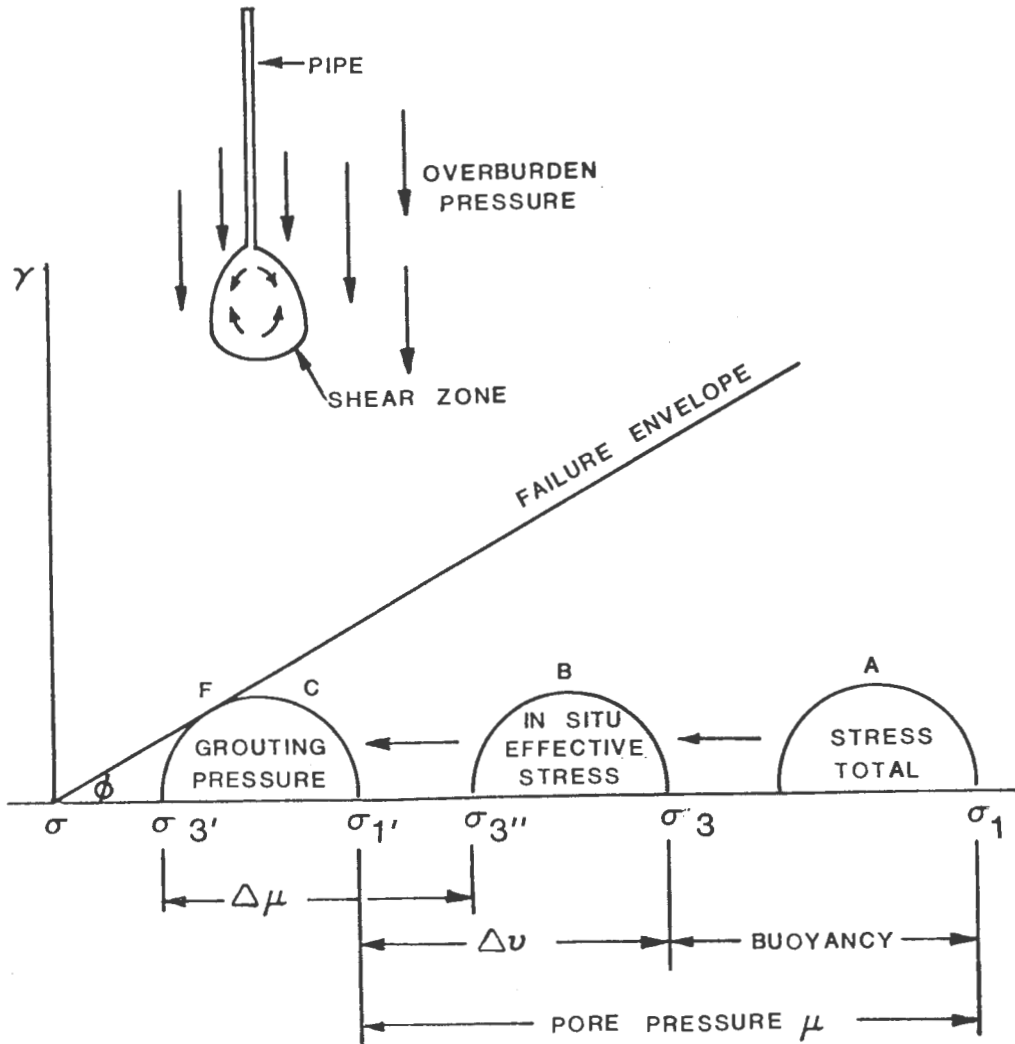

Figure 62. Relation between principal shearing and normal stresses.

The effect of a grouting pore pressure  $\Delta u$  on effective stresses is shown in Figure 63. Since  $u$  subtracts from all compressive stresses, the effect of a high water table is to shift the Mohr circle to the left, as from position A to position B in the figure. If the additional grouting pressure  $\Delta u$  is large enough (position C), failure will occur, which in confined soil implies only a readjustment of internal stress as the affected soil shears and compresses in response to the major principal stress. This is a departure from the conventional theory for measurement of horizontal in situ stress by hydraulic fracturing, where it is assumed that failure is in tension along vertical planes (46). The zone of soil most affected should be below the grout pipe, where downward seepage forces combine with soil pressure to give the largest principal stress. Shearing of granular soils often involves an increase in volume (dilatancy), in which case pores will minutely expand, accept more grout, and reduce the grouting pressure. Alternately in loose materials shearing may decrease the volume, sealing against further entry of grout, increasing pressure and tending to create a void around the grout pipe. In both cases, the change in soil structure should change the failure envelope

such that either less or more pressure will be needed to sustain the failure; thus, a sudden pressure change may be a clue that failure is occurring. It should be noted that efforts to increase grouting pore pressure beyond the point of failure will enlarge the failure zone or cavern, with potentially dangerous consequences, particularly in shallow grouting.



Note: Grouting pressure  $\Delta u$  theoretically may induce soil shear failure. Inset shows overburden pressure (arrows), and hypothetical failure zone and shear directions.

Figure 63. Effect of grouting pore pressure effective stresses.

a. Grouting Pressure to Induce Shear Failure

The relationships of Figure 63 can be used to predict grouting pressure sufficient to induce soil shear failure. Under ordinary conditions the major principal stress  $\sigma_1$  is vertical and the result of overburden pressure. Therefore at depth  $h$ ,

$$\sigma_1 = \gamma h \quad (58)$$

where  $\gamma$  is the soil unit weight. In soil below a water table the effective stress is reduced by hydrostatic pore pressure

$$\sigma_1'' = \gamma h - \gamma_w (h - h_w) \quad (58a)$$

where  $\gamma_w$  is the density of water and  $h_w$  is the depth of the water table below the ground surface. A grouting pressure  $\Delta u$  further decreases the effective stress, and in Figure 63 can be seen

$$\begin{aligned} \sigma_1' &= \sigma_1'' - \Delta u \text{ and} \\ \sigma_3' &= \sigma_3'' - \Delta u \end{aligned} \quad (59)$$

Figure 63 is for a cohesionless soil, which means for the failure condition the Rankine stress ratio  $K'$  of lateral pressure to vertical pressure is:

$$K' = \frac{\sigma_3'}{\sigma_1'} = \frac{1 - \sin \phi}{1 + \sin \phi} \quad (60)$$

Substituting from equation 59,

$$K' = \frac{\sigma_3'' - \Delta u}{\sigma_1'' - \Delta u} = \frac{1 - \sin \phi}{1 + \sin \phi} \quad (60a)$$

which may be solved for  $\Delta u$ :

$$\Delta u = \frac{\sigma_3'' (1 + \sin \phi) - \sigma_1'' (1 - \sin \phi)}{2 \sin \phi} \quad (61)$$

Thus the grouting pressure to cause failure depends in part on the in situ effective horizontal stress  $\sigma_3''$ , which usually is not known. In the special case where horizontal stress equals vertical stress,  $\sigma_3'' = \sigma_1''$ , equation 61 reduces to

$$\Delta u = \sigma_1'' \quad (61a)$$

per usual grouting practice. However,  $\sigma_3''$  usually is less than  $\sigma_1''$ , particularly in geologically recent soils that are normally consolidated; that is, the horizontal stress has developed as a consequence of consolidation under the existing overburden pressure. The ratio  $\sigma_3''/\sigma_1''$  is commonly designated  $K_0$ , the coefficient of earth pressure at rest.

Substituting  $\sigma_3'' = K_o \sigma_1''$  in equation 61,

$$\Delta u = \sigma_1'' \frac{K_o(1 + \sin\phi) - 1 + \sin\phi}{2 \sin\phi} \quad (62)$$

An empirical equation by Jaky for  $K_o$  of normally consolidated soils is

$$\frac{\sigma_3''}{\sigma_1''} = K_o = 1 - \sin\phi \quad (63)$$

Substituting,

$$\Delta u = \sigma_1'' \left( \frac{1 - \sin\phi}{2} \right) \quad (64)$$

In the case of cohesive soils the failure envelope is shifted to the left by an amount  $c \cot \phi$  (Fig. 62), indicating an additional pore pressure in this amount. The general equation for normally consolidated soils with or without cohesion is therefore

$$\Delta u = \sigma_1'' \frac{1 - \sin\phi}{2} + c \cot \phi \quad (65)$$

where

$\Delta u$  = grout pressure which allows soil shear failure  
 $\sigma_1''$  = overburden pressure less buoyancy  
 $\phi$  = soil angle of internal friction  
 $c$  = soil cohesion

Example 1: An alluvial soil has  $\gamma = 130$  pcf,  $\phi = 30^\circ$ ,  $c = 4$  psi. Find the grouting pressure to cause shear failure at a depth of 80 feet, the water table being 10 feet below the ground surface.

Solution: Using equation 58a,

$$\sigma_1'' = 130(80) - 62.4(80-10) = 6032 \text{ psf}$$

Assuming normal consolidation, using formula 65,

$$\begin{aligned} \Delta u &= 6032 \left( \frac{1 - \sin 30}{2} \right) + 4(144) \cot 30 \\ &= 1508 + 998 = 2506 \text{ psf} = 17.4 \text{ psi} \end{aligned}$$

Note that despite the contribution from soil cohesion this is considerably less than the overburden pressure  $\sigma_1''$ , and is in fact less than the calculated  $\sigma_3''$  (equation 63):  $\sigma_3'' = \sigma_1'' (1 - \sin\phi) = 6032(0.5) = 3016$  psf.

In summary, grouting pressure, through development of soil pore pressure, may initiate shear failure of soil under its own weight, even when the pumping pressure is considerably less than the overburden stress reduced for buoyancy. In normally consolidated cohesionless soils,



the relationship between failure grouting pressure and effective overburden pressure is approximated by  $1/2 (1 - \sin\phi)$ , with values as follows:

| Table 8. Relationship Between Failure Grouting Pressure and Effective Overburden Pressure |                |      |      |      |      |      |      |      |        |        |        |
|---|----------------|------|------|------|------|------|------|------|--------|--------|--------|
|   | $\phi^\circ =$ | 0    | 5    | 10   | 15   | 20   | 25   | 30   | 35     | 40     | 45     |
| $\frac{\Delta u}{\sigma_1} = \frac{1 - \sin\phi}{2}$                                      | =              | 0.50 | 0.46 | 0.41 | 0.37 | 0.33 | 0.29 | 0.25 | (0.21) | (0.18) | (0.15) |

This relation introduces an apparent anomaly: the higher the internal friction angle the lower the grouting pressure necessary to induce failure. It is true that in normally consolidated soils, high friction angles result in low lateral confining pressures. However,  $\phi$  values in excess of about  $30^\circ$  probably are a result of overconsolidation, where the  $\Delta u/\sigma_1$  ratio may approach 1.0. The analysis does indicate that shear failure must routinely occur during common grouting practice of normally consolidated (i.e. soft or loose) soils, and therefore must relate to injection of grout in these soils. However, it should be emphasized that this has not been verified by laboratory or field test data.

#### b. Grouting Pressure Against Walls

Grouting seldom is attempted behind a retaining wall other than soldier beam and lagging because of the unevaluated pressure effect on the wall. For instance, let us assume that soil behind an existing wall is to receive a surcharge loading of sufficient magnitude that the wall will fail if not given additional support, as by buttresses or tiebacks. A possible solution might be to grout the soil behind the wall to increase the soil strength sufficiently to carry the surcharge without additionally loading the wall. But how will the grouting process itself affect stability of the wall?

Example 2: A 20-foot wall retains soil with  $\gamma_m = 120$  pcf,  $c = 0$ ,  $\phi = 25^\circ$ , under drained conditions. The grouting pressure will not exceed one-half the present overburden pressure.

Solution: (1) Calculated pressure distributions are shown in Figure 64. Prior to grouting (47), the force on the wall (see Figure 64a) is:

$$P = \frac{1}{2} \gamma_m H^2 K' - 2 c H \sqrt{K'} \quad (66)$$

where

$$K' = \frac{1 - \sin\phi}{1 + \sin\phi}$$

$\gamma_m$  = wet unit weight of soil

H = height of wall

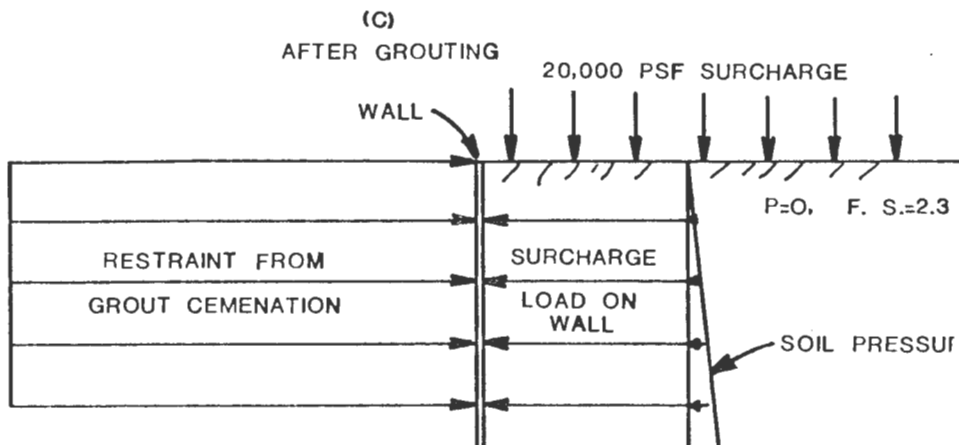
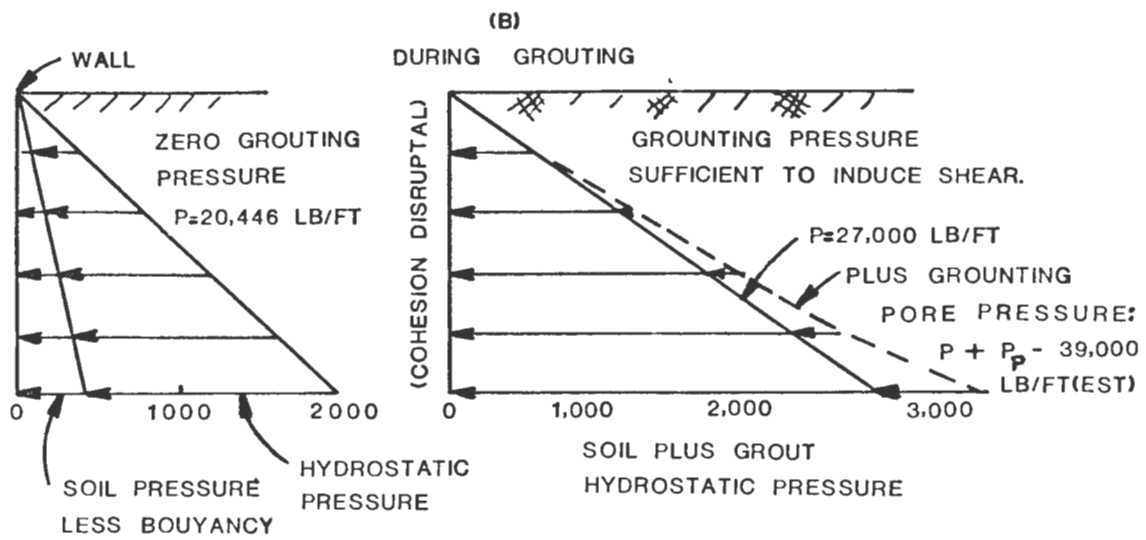
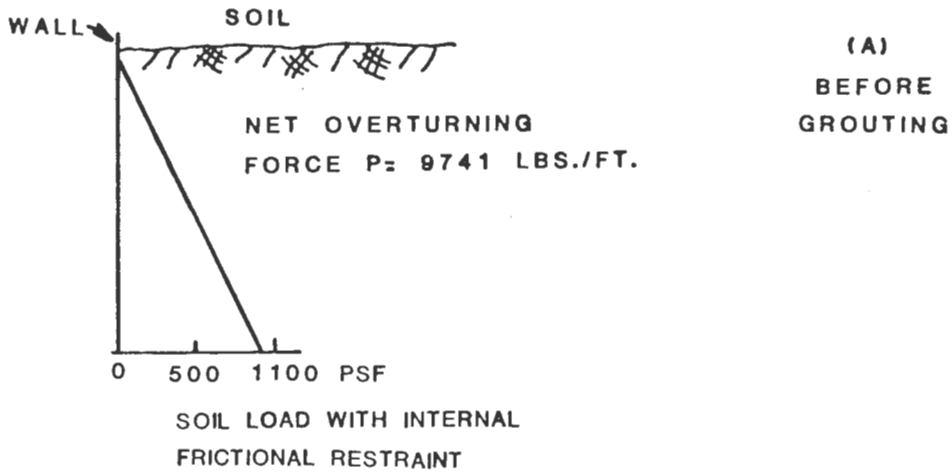

Figure 64. Soil pressures on a retaining wall.

Substituting,

$$P = \frac{1}{2}(120)(20)^2(0.406) - 0 = 9741 \text{ lb/ft}$$

(2) Saturation of the soil with grout will introduce hydrostatic pressure on the wall, varying from zero at the ground surface to  $\gamma_g H$  at depth  $H$ ,  $\gamma_g$  being the density of the grout. The total hydrostatic force is the average pressure times the height of the wall:

$$P_g = \frac{1}{2} \gamma_g H^2 \quad (67)$$

Partly offsetting this is reduced soil pressure on the wall due to buoyancy, so  $\gamma_m$  in equation 66 is replaced by  $(\gamma_m - \gamma_g)$ . Thus for the submerged case, equation 66 becomes

$$P_g = \frac{1}{2} (\gamma_m - \gamma_g) H^2 K' - 2cH\sqrt{K'} + \frac{1}{2} \gamma_g H^2 \quad (68)$$

If  $\gamma_g = 80$  pcf and the soil density after grouting is 135 pcf,

$$\begin{aligned} P_g &= \frac{1}{2} (135 - 80) (20)^2 (0.406) - 0 + \frac{1}{2} (80) (20)^2 \\ &= 4446 - 0 + 16,000 \\ &= 20,446 \text{ lb/ft} \end{aligned}$$

This pressure distribution is shown at the left in Fig. 64b. It represents a theoretical minimum exerted wall pressure, and is not appreciably different from what would occur if the soil were saturated with water ( $\gamma_g = 62.4$  pcf).

(3) The grout pressure to cause soil shear failure using equation 65 is:

$$\Delta u = \sigma_1'' \left( \frac{1 - \sin 25}{2} \right) + 0 = 0.289 \sigma_1''$$

If the grouting pressure equals  $0.5 \sigma_1$  the soil will be in shear, separating soil grains and thereby decreasing  $\phi$  to 0 and increasing  $K'$  to 1.0, and disrupting soil cohesion. From equation 66 with  $K' = 1$  and  $c = 0$ ,

$$P_g = \frac{1}{2} (135) (20)^2(1) - 0 = 27,000 \text{ lb/ft}$$

from soil plus grout hydrostatic pressure on the wall. This represents a practical minimum, shown to the right in Figure 64b. (note that when the soil is shearing, grout hydrostatic pressure is not separable from soil pressure and is not added).

(4) The grouting pressure  $\Delta u$  puts an additional force on the wall, and one that is less well defined because of dissipation when pumping stops. If pumping continues until setting, the pressure may remain. The maximum force therefore is defined by an equation for grouting pore pressure,  $P_p$ , analogous to equation 67.

$$P_p = \frac{\Delta u}{2} H^2 C_u \quad (69)$$

where  $C_u$  is a pressure dissipation coefficient. The maximum grouting pressure may increase with depth; in this example  $\Delta u = \frac{1}{2} \sigma_1$ , giving

$$P_p = \frac{1}{4} \sigma_1 H^2 C_u$$

where  $\sigma_1 = \gamma H$ . Then

$$\begin{aligned} P_p &= \frac{1}{4} \gamma H^3 C_u = \frac{1}{4} (120)(20)^3 C_u \\ &= 240,000 C_u \text{ lb/ft} \end{aligned}$$

The coefficient  $C_u$  would be minimized through proper grouting procedures, i.e., grouting first close to the wall and then farther back, and stopping pumping sufficiently prior to set to allow dissipation of pore pressure. Figure 64-b assumes  $C_u = 0.05$ . Note also that the grout pumping pressure is concentrated at the base of the wall, giving lower overturning movement.

In summary, the minimum additional force on the wall from grouting is 27,000 lb/ft; the maximum with full activation of grouting pressure is  $240,000 + 27,000 = 267,000$  lb/ft, an increase almost by a factor of 10, but this would not occur if procedures are designed to dissipate grouting pore pressure prior to set.

Example 3: After grouting, the soil has  $\phi = 30^\circ$ ,  $c = 100$  psi and  $\gamma_s = 135$ pcf. A surface surcharge load of 20,000 psf is planned. What is the final force on the wall?

Solution: If  $q_s$  is the surcharge load, the additional pressure is  $q_s K$ , and the additional force  $q_s KH$ . Adding to equation 66,

$$\begin{aligned} P &= \frac{1}{2} \gamma_s H^2 K - 2cH \sqrt{K} + q_s KH \quad (70) \\ &= 9000 - 332,550 + 133,300 = -190,220 \end{aligned}$$

or in effect  $P = 0$ . For comparison, equation 70 solved for the soil without grouting gives  $P = 9741 - 10,193 + 162,340 = 161,890$  lb/ft. The factor of safety with grouting is: F.S. = resisting force  $\div$  acting force =  $332,500 \div (9000 + 133,330) = 2.3$  for zero pressure on the wall.

### c. Grouting Pressure in Tunneling

The theoretical analysis suggests that grouting soil or rock prior to tunneling could have beneficial effect on stress distribution, in addition to strengthening loose materials and sealing off water. The main advantage would be in heavily overconsolidated soils or in rocks subjected to tectonic stresses such that the in situ horizontal stress exceeds the

vertical stress. Equation 61 still applies, except that  $\sigma_1$  is horizontal and  $\sigma_3$  vertical. Although the horizontal stress is seldom known with any precision, a grouting pressure equal to the overburden pressure should allow relief of excessive horizontal stresses where they exist. The advantage would be a reduction of horizontal residual stress which tends to cause lateral closure during tunneling or drilling operations, and subsequent wall spalling and rockbursts (48).

#### d. Landslides

In contrast to foundation grouting, active landslides represent a delicate balance between downslope components of soil weight plus ground-water seepage, versus resisting shearing stresses in soil along the failure zone. Any reduction of a critical shearing stresses by grouting pressure thus will speed up movement and could precipitate a disaster. Grouting, if attempted at all, must be at a low pressure and with fast-acting chemicals. Preferred methods are to control water through use of drains, wells or electroosmosis, or the use of dry water-reacting chemical such as quicklime(49).

#### e. Foundation Grouting

Grouting pressure conceivably could cause temporary failure of soils under existing foundations, although such occurrences have not been reported because of the time and care required and the sequential nature of grouting operations. Furthermore, remedial grouting can be performed to correct differential settlements or vibrations, or in anticipation of heavier loading, without significantly affecting an existing high factor of safety against shear failure. The grouting of an underdesigned foundation, which did not take into account a high water table, could become a critical operation; however, with normal operational care, failure would be unlikely after some grout has been placed and allowed to set.

### B. Practical Aspects

#### 1. Grout Penetration

Most grouting specialists base their grouting procedures and planning on their prior experiences and on the soil properties. The grout used is generally one which they have used successfully and in which they have confidence. Since the permeation of the chemical grout is controlled by its viscosity and the permeability of the soil deposit, the grouting specialist can have a general idea of the setting time needed to reach a desired radius of penetration from the injection point.

If a non-Newtonian, particulate grout having shear strength is pumped under constant pressure into the soil, the opposing drag, due to the corresponding shear stress acting at the growing area of the surface wetted by the grout, ultimately becomes equal to the whole of the applied

pressure so that none is available to maintain the viscous flow. In other words, grout slurries of ordinary portland cement and water can reach a point during injection when the pressure must be increased in order to keep the grout moving. Since the pressure should not exceed the overburden pressure, there is a limit of penetration for the particulate grout.

Table 9 gives calculated values of the limiting penetration radius for soils with permeability of 1,  $10^{-1}$  and  $10^{-2}$  cm/sec at an injection head of 100 feet (30.48m) (43). For cement grouts, the calculation cannot profitably be considered for less than  $k = 1$  cm/sec (open gravel) because permeation is thereafter limited by the direct blockage of voids by the larger particles of cement.

| Shear Strength<br>(dynes/cm <sup>2</sup> ) | Limiting Penetration for 100 ft<br>of Injection Head (feet) |                                 |                                 | Corresponding<br>Water/Cement<br>Ratio for O.P.<br>Cement |
|--|---|---------------------------------|---------------------------------|---|
|  | Permeability, cm/sec  |                                 |                                 |   |
|  | <u><math>k = 1</math></u>                                   | <u><math>k = 10^{-1}</math></u> | <u><math>k = 10^{-2}</math></u> |   |
| 67.6                                       | 14.1  | 4.68                            | 1.7                             | 0.4   |
| 25.6                                       |   | 11.73                           | 3.9                             | 0.5   |
| 6.6  |   |                                 | 14.3                            | 0.66  |

When using clay (bentonite) type grouts, the initial rates of shear involved in mixing and pumping the grout may reduce the shear strength to as low as 2 dynes/cm<sup>2</sup> at the time of injection; therefore the grout begins to penetrate the soil at a rate determined by the effective grout viscosity. When the penetration reaches the point that the rate of shear falls considerably, the grout shear strength increases rapidly and the penetration then becomes dependent on shear strength similar to that shown for cement in Table 9.

The amount of grout to be used can be found by using the graph in Figure 65. This is true for any type of grout used, but it would not be correct if the grout is injected at a pressure which causes fracture of the soil formation. As fractures occur, so many channels become excessive and the operator cannot know where the grout is being placed.

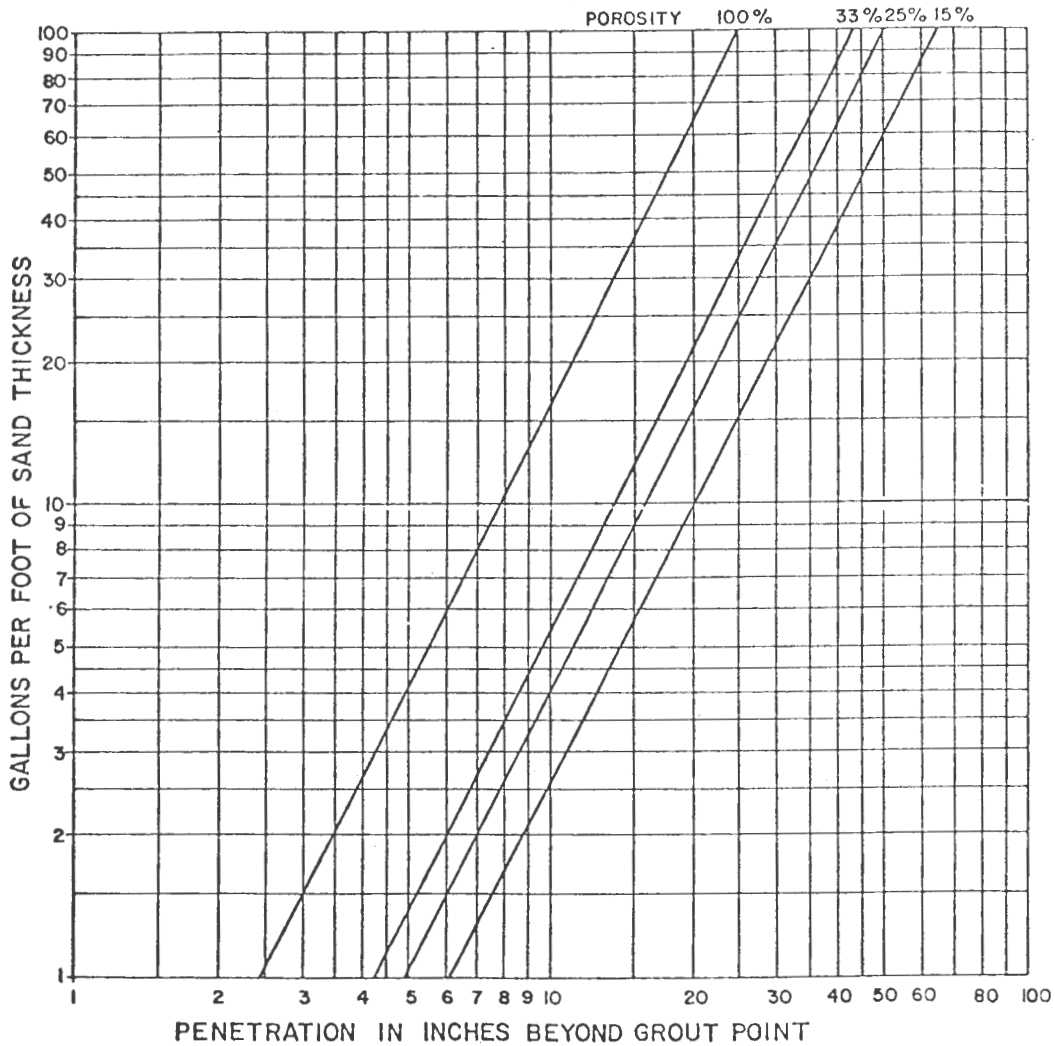

Figure 65. Grout volume required to fill pore space radially around grout point.

## 2. Grid Patterns

The pattern for the grout injection is planned so the area to be grouted is completely covered. The grid pattern is normally based on data obtained from preliminary work and the purpose desired to be accomplished. Effective spacing of the injection points is governed by the type of grout to be used, grout viscosity, soil permeability, injection pressure and rate of grout take. Spacing radius can be determined by use of equation 34. The grouting is usually done from the surface if conditions permit; but it can be performed from cellars, from shafts, or from within

a tunnel excavation. A typical grid pattern for a waterstop application is shown in Figure 66.

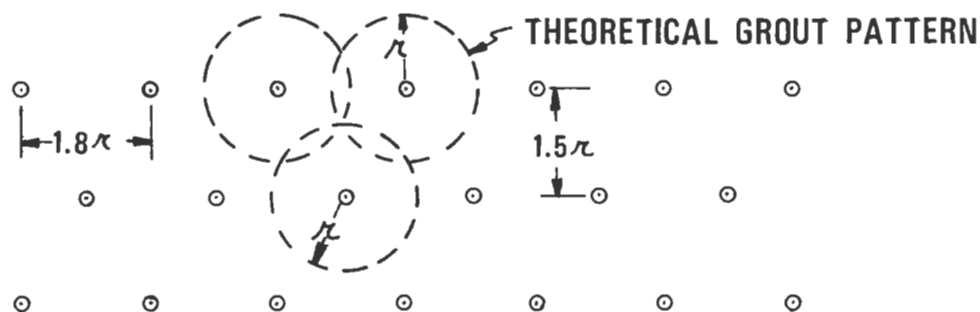

Figure 66. Typical grid pattern for waterstop application.

Tests by Karol (38) have shown that a single row is not sufficient to give overlapping in the soil between holes. Therefore, by the use of two rows, or three rows with the center row offset as shown above, the grout will intermingle to give complete coverage.

Grout is normally injected into alternate pipes in row 1 for the length of the row (#1, #3, etc.), then pipes in Row 1 between the odd-numbered pipes are used for injection. Grout injection then is made in the second row of pipes, following the same procedure as used in Row 1. If three rows are used, injection is made in row 3 after row 1; then injection is made in successive holes in row 2 to fill the voids left between the grout placed on rows 1 and 3.

Figure 67 is an elevation view of the grout pipe spacing used to cover the desired width on a portion of the Vienna subway. Treatment was made both from ground surface and from cellars.

The grouting in the downtown section of the Metro system in Hanover, Germany was done radially from shafts sunk at intervals along the proposed route of the tunnel, as shown in Figure 68. From these shafts, grouting was performed under the streets and adjacent buildings to strengthen the soil to prevent settlement when the tunnel is excavated below the building. Alternate pipes were used for injection, then the remaining pipes were used. In courtyards behind buildings, grout pipes were placed from the surface as shown in Figure 69 to supplement the radial grouting from the shaft. No apparent grid pattern was used, but pipes were placed both vertically and angularly to fill in spots not covered from the shaft. A Tube à Manchette system of grout pipes was used with a silicate type chemical grout.



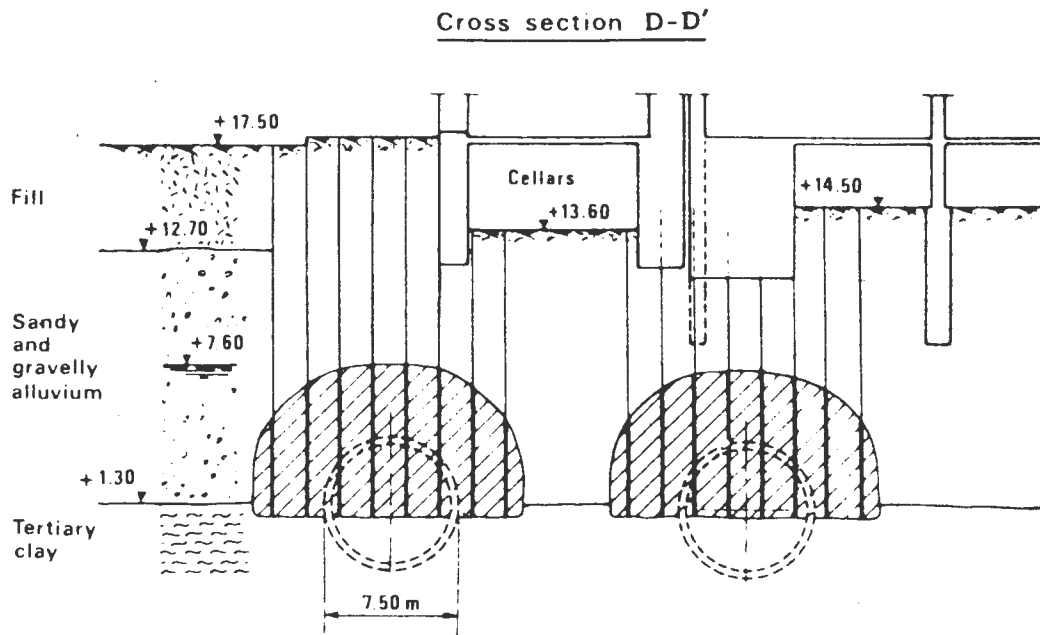

Figure 67. Typical grouted section for strengthening soil.

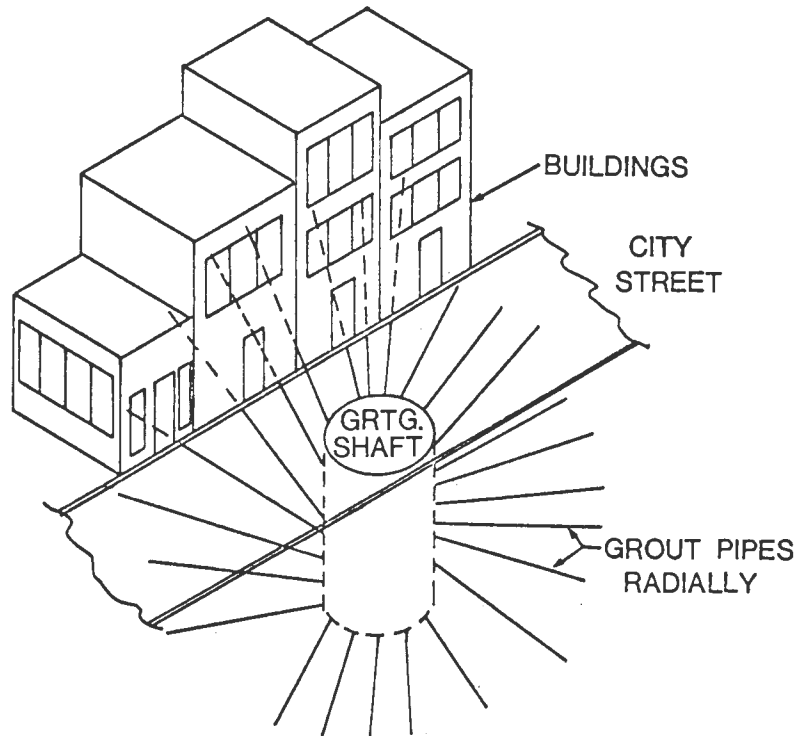

Figure 68. Schematic of grouting for Metro system in Hanover, Germany



Figure 69. Soil grouting for Metro system in Hanover, Germany.

### 3. Job Planning

Most of the grouting specialists interviewed seem to think that cement grout should be used ahead of chemical grout if the soil permeability permits. This procedure uses the cement grout to fill any large voids or pore spaces before the chemical grout is injected to fill the smaller remaining voids; thus, the use of the more expensive chemical grout is minimized. In actual field operations, the pressure required to inject the cement grout often becomes higher than overburden pressure and fractures the formation, thereby placing stringers of cement grout throughout the sand rather than permeating the voids in the sand formation. If there are utility pipes in the area which have voids or loose soil around them, the grout will seek this path after fracturing the soil, and will continue to flow along such path until set occurs. In the case of a chemical grout, this would involve a large quantity of grout if pumping were continuous.

A grouting specialist will generally follow the same injection procedure for all of the jobs performed, whether the end result will be for water shutoff, soil consolidation or soil strengthening. The difference would relate to the grout selected for the job. Theoretically, a weaker grout can be used if only water control through soil impermeability is involved. This concept is generally followed.

The placement of a grout curtain across an area to prevent water movement is accomplished by injection in boreholes or through drive pipes. When injection is performed on a grid pattern, a curtain of sufficient width can normally be obtained using three rows of injection holes with the center row offset so holes are centered between holes in the adjacent rows. The length of the curtain must be sufficient to reach across the path of water movement and deep enough to reach an impervious layer.

In dam construction, grout curtains are used extensively for water cutoff walls. Many of these are in rock or coarse alluvial soil where cement grout or a combined cement-clay grout can be utilized; but the use of chemical grouts in the alluvial soils is becoming more common, especially after injection of cement grout. Grout curtains can also be used to prevent water flow into an excavation for tunnel or cut-and-cover construction. Water intrusion into an excavation causes "quick" conditions, resulting in lowering the water table which could cause subsidence of ground or settlement of adjacent buildings.

Although grouting is useful for water control in underground construction, most grouting in this type of construction is used to consolidate or strengthen soil. For this type job, site conditions will determine the location from which the injections can be made. It is generally better to drill the holes and perform the injection from the ground surface, but this is not always possible. Less desirable conditions for mixing and pumping the grout may be a factor for increased costs or for longer grout set time.

Pumping tests on the site should be made to determine rate of injection. Water, or a tentatively selected grout, may be used for the test. As a "rule of thumb," the pumping rate which can be maintained with water at about one-half of the allowable pumping pressure (one psi per foot of overburden is normal) should be used. This would allow a safety factor for injecting the more viscous grout during the job.

The time in minutes required to perform the injection in each hole can be determined by the volume of grout required per foot of sand consolidated (from Figure 65) multiplied by the depth of sand to be treated then divided by the injection rate in gallons per minute. More precisely, this is:

$$\text{(Per Hole) } t, \text{ minutes} = \frac{\text{Grout (gals/ft)} \times \text{depth of sand (ft)}}{\text{Inj. Rate (gal/min)}} \quad (71)$$

The grout set time  $t_s$  can also be determined by dividing volume of grout per foot (from Figure 65) by the pump rate, then multiplying by 0.5, or

$$\text{set time, } t_s = \frac{\text{Grout (gal/ft)}}{\text{Inj. Rate (gal/min)}} \times 0.5 \quad (72)$$

The constant (0.5) is used so that the grout will begin to set when half of the volume has been injected, thus forcing the grout to distribute itself over a wide area rather than following the first part of the grout

into the more open pore spaces. If flowing water is present, the multiplier constant should be reduced drastically, perhaps to 0.1 or less, to let the grout set before it can be washed out of the formation to be grouted.

### C. Injection Quality Control:

The quality of the grout operation is equally as important as the quantity injected and techniques used. Quality control measures must be used to insure that the grout is correctly mixed and properly injected into the required areas at the correct pressures and rates. Since the entire end results are underground, the degree of success cannot be known exactly until after the grouting is completed and some type of test or excavation is made in the grouted area.

Control of the grout during the job involves constant monitoring of the grout components, injection pressures and quantity injected as a function of time. As a rule of thumb, the injection pressure should not exceed the pressure exerted by the weight of soil, which is equal to approximately one psi for each foot of the overburden. Excessive pressure in the soil will cause uplift of the ground above the point of injection by accumulation of lenses of grout, and damage to structures at the surface could result. Some means of checking the soil permeability before and after the grout treatment should be established. Soil strength should also be determined before and after grouting if it is possible to do so. Records should be kept during the entire field operation, showing all data pertaining to each phase of the job.

Most of the European grouting companies use houses or vans with complete recording equipment for a permanent record of flow rates and pressures (see Figures 50, 51 and 52). Pumps are automated to pump only the preset volume of grout at each level of injection. Charts of flow rate and pressure are furnished by the grouting specialists to the owner as a part of his permanent file. The basis for the owner accepting the grouting as satisfactory is the similarity to past grouting performance. Where the grout system does not include recorders, accurate records should be kept to document the grouting and provide a basis for better evaluation of future grouting.

### D. Safety and Environmental Considerations

Safety of the workmen is of prime importance. Visitors and neighborhood residents should also be included when considering safety measures.

There are a number of problems that could be present when using chemical grouts. These include:

1. Dust of the powdered chemicals which are toxic to the skin or when breathed.
2. Fumes from the liquid mixtures for the grout.

3. Liquid mixtures of grout components which are toxic to skin.
4. Contamination of groundwater by discoloration or poisoning.
5. Mixing of chemicals in dry state rather than being dissolved in water, which can cause explosion.

Protective clothing and gloves should be worn at all times, since most of the chemical grouts have some components which are toxic to the skin. Face masks should be available for workmen who must work in closed areas where fumes from grouts may be breathed. Protective headgear should be available for all workmen, as well as visitors at the site. Safety glasses should also be available for workmen and visitors in areas where grout is being injected to provide eye protection.

Environmental impact should be considered before grouting is used. This is particularly true of chemical grouts which may be toxic and affect groundwater or impounded supplies of drinking water. The effect of the ground level uplift due to grouting with excessive pressures should be considered and limits of uplift established which would be satisfactory. Arrangements for disposal of excess grout should be made before the operation begins.

## 8. FIELD TESTS OF GROUTED SOILS

### A. Introduction

Field testing of grouted soils is not common practice among the grouting specialists or construction companies. The usual procedure for checking results of grouting is to use safeguards during the actual grouting rather than make subsequent tests in the soil. For instance, surface structures are monitored for rise during grouting underneath the foundations, and grout is closely checked for quantity and injection pressure during the job.

Some type of field test is needed, however, that would show if the grout permeated the soil as desired and provided the required strength. It would be helpful to the design engineers or owners if such tests could be related to unconfined compressive tests made on grouted soil samples before the grouting job. Knowledge of the grouting results before excavation could also prevent encountering unexpected trouble from water intrusion during construction.

### B. Current Practices

In European underground construction, grouting is established as a dependable, efficient operation; the owners are satisfied that the guarantee by the contractor and the recorded data from grouting job substantiate the results. The contractors rely greatly on the injection data and previous grouting experience for obtaining satisfactory results. In some instances for water stop grouting, some leakage after grouting is acceptable, so such criteria is established prior to the grouting.

In the United States, contractors are usually told how much grout to inject; sometimes they are given a desired soil compressive strength to obtain after grouting, but there are usually no tests conducted to check results. When contractors make tests, they will probably use one of the following methods:

#### 1. Sampling and Laboratory Testing

As previously indicated in Chapter 7, soil strength may be considered to be comprised of two components - cohesion  $c$  which reflects the shearing strength with no confinement, and internal friction represented by an angle  $\phi$ , which describes the additional strength resulting from confinement. Presently, the only widely accepted methods to evaluate these parameters involve sampling and laboratory triaxial or direct shear testing.

Much attention has been directed towards obtaining relatively undisturbed samples of soft clay soils by means of hydraulically pushing any of a variety of sampling tubes. Simplest and most

common in the United States is the Shelby tube, which is essentially a sharpened thin-walled steel cylinder. Piston samplers represent a modification in which a piston on top of the sample pulls a partial vacuum as the tube is pushed, thereby reducing accumulated side friction by pulling the sample into the tube. The Swedish foil sampler and the Dutch sampler, developed by the Delft Soil Mechanics Laboratory, further reduce side friction by simultaneously encasing the sample in unrolling foil or in nylon mesh, respectively, as the sampling progresses. These methods are available for sampling low-strength grouted soils, but they will probably be unsatisfactory for stronger soils or those containing gravel.

Granular soils in their natural state present an even more difficult sampling problem than clays, because sands compact during sampling and then fall apart when removed from the sampler. Furthermore, gravel or coarser particles in the soil increase disturbance and may damage the sampler. A common expedient in the United States is the relatively thick-walled Gow or "split spoon" sampler used in a Standard Penetration Test (SPT) (ASTM D 1587-67). The sampler is driven by a 140 pound (63.5 kg) hammer falling 30 inches (76.2 cm), and the number of blows recorded for each 6 inches (15.24 cm) of penetration. Samples are used only for identifications, the relative density being indicated by the blow count. In cohesionless soils a correlation has been obtained to friction angle  $\phi$  and may be defended on the basis that both  $\phi$  and the blow count depend on relative density, i.e., compactability. However, in grouted soils the pores should be filled solid, so the "relative density" is 100% - that is, the ideal grouted soil is not compactable. Furthermore, it usually has cohesion. Therefore, the SPT or similar less standardized tests, such as drive cones, are useful mainly to detect extent of grouting, and not to evaluate strength of the grouted soil. Drive tests do have a function if there is doubt whether grout stayed where intended, or if it may have digressed through a thin, highly permeable layer or if it may have been washed out by flowing groundwater.

Another means which would probably work well in grouted soil is to obtain a "core" using a mobile rotary drilling rig with a "core barrel." This core barrel is a hollow stem auger which is drilled into the soil by rotary action, trapping the soil within the barrel.

The most positive means for obtaining a sample would be to sink or drill a large hole with supported walls, so that an individual could be lowered from the surface to obtain a sample of the grouted soil.

Any samples obtained through any of the above methods would then be laboratory tested for unconfined compressive strength.

## 2. Permeability Testing

A method sometimes employed is the measurement of in situ permeability reduction obtained by the grouting. This test should be conducted before the grouting as outlined in Chapter 4, Section B, of this report, using either constant head or falling head test, and then repeated after grouting. The comparison will indicate the effectiveness of the grouting. A reduction of permeability from an initial value of  $10^{-1}$  cm/sec or greater to a final value of  $10^{-5}$  cm/sec or less might be ample for water shutoff and even possibly for strengthening. A decrease in permeability gives an indication of strength increase.

## 3. In Situ Strength Tests

The difficulty in sampling grouted soils indicates a greater reliance on in situ tests. The four most common methods recently listed by Schmertmann (50) are the previously mentioned SPT, the Menard pressuremeter, Dutch (static) cone test, and vane shear test. A fifth method believed to hold sufficient promise is the Iowa Borehole Shear Test (BST). Of these, only the pressuremeter and BST appear to be applicable to grouted soils.

a. Pressuremeter. The pressuremeter test involves inflating a rubber membrane inside a borehole and measuring the volume expansion as a function of applied fluid pressure (44). The test can be performed in a standard EX, AX or NX borehole. This equipment, shown schematically in Figure 70, consists of a combination volumeter-manometer connected to a cylindrical borehole expansion device. This probe is constructed of a steel tube surrounded by two flexible rubber membranes, the interior membrane forming the measuring cell and the exterior membrane providing the guard cells at the two ends of the probe (45). The guard cell is activated by gas pressure and is used to reduce end effects on the measuring cell to provide an essentially two-dimensional condition. The measuring cell is pressurized with water which is kept at a slightly higher pressure than the guard cell to insure that it is always pressing against the borehole wall. Two concentric tubes connect the volumeter to the probe. An adapter connects the probe to a standard drill rod for lowering and raising the probe within the borehole.

After lowering the probe to the desired depth, pressure is applied to the borehole wall by inflating the rubber membranes. The volumeter-manometer accurately measures the radial expansion under each pressure increment. Testing can be performed swiftly and economically during the drilling operation. During the early part of the test the soil is assumed to behave elastically. In soils, further expansion initiates plastic shear failure, which starts when applied pressure equals the original horizontal pressure plus the soil cohesion.



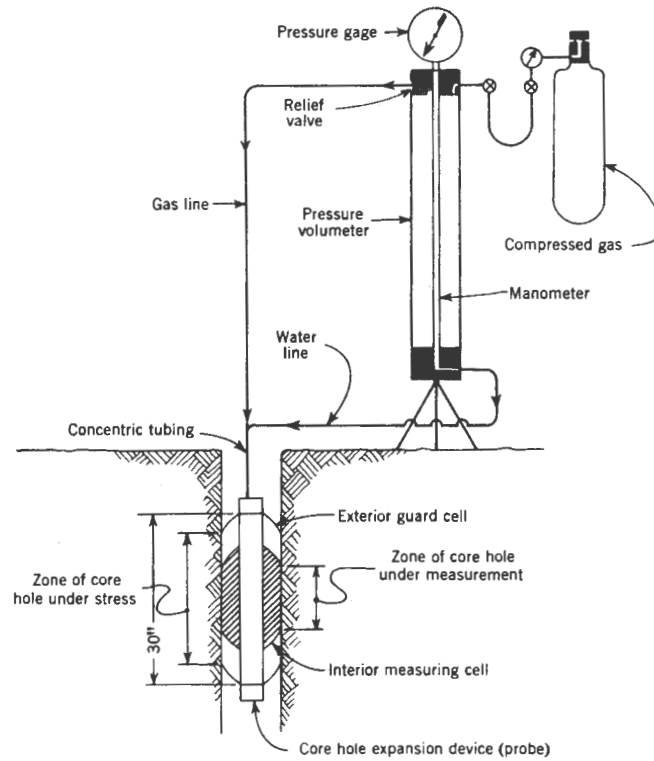

Figure 70. Schematic drawing of pressuremeter equipment (45).

A typical pressuremeter test result is shown in Figure 71. The beginning pressure ( $P_0$ ) and end pressure ( $P_f$ ) of the elastic stress range, and the limit or failure pressure ( $P_l$ ) are indicated. The  $P_0$  value approximates the at-rest pressure.

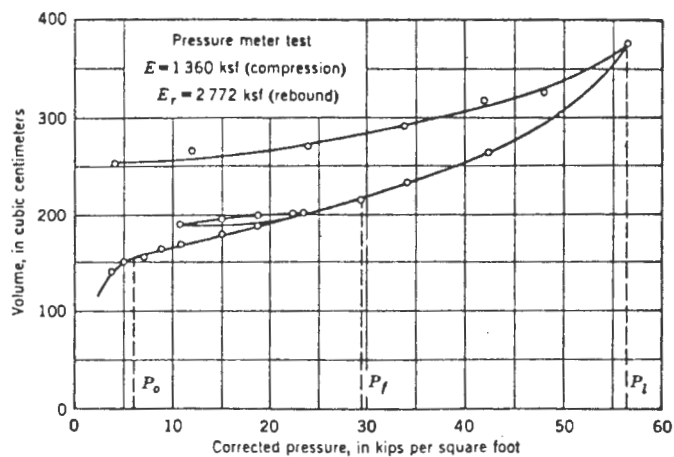

Figure 71. Typical results of a pressuremeter (45).

The interpretation of pressuremeter data involves evaluating the in situ horizontal stress  $P_0$  from the data plot, and then evaluating either cohesion  $c$  assuming  $\phi = 0$ , or friction angle  $\phi$  assuming  $c = 0$ . Cohesion may be obtained from a semi-empirical equation

$$\frac{q_u}{2} = c_u = \frac{P_\ell - P_0}{5.5} \quad (73)$$

where

$q_u$  = unconfined compressive strength

$c_u$  = undrained cohesion

$P_\ell$  = limit (maximum pressure) of pressuremeter

$P_0$  = in situ horizontal stress of soil

$P_0$  is roughly determined from the pressure-volume curve, and strongly influences the calculation of  $c_u$ . Correlations to data from other tests are somewhat erratic, the pressuremeter  $c_u$  usually being too high and thus on the unsafe side for design. Sensitivity to hole disturbance recently led to introduction of self-boring pressuremeters (51), but the latter probably could not be used with grouted soils because cuttings must be carried up through the core of the instrument.

The evaluation of  $\phi$  from pressuremeter data has been even more challenging, in part because of strong dependence on horizontal stress. One method is to assume various horizontal stresses and by trial-and-error solution evaluate the minimum  $\phi$  (52). The appropriate equations are

$$P_\ell = P_0 (1 + \sin \phi) (I_r \sec \phi)^{\sin \phi / (1 + \sin \phi)} \quad (74)$$

where

$$\text{rigidity index } I_r = \frac{E}{2(1 + \nu_1)(c_u + P_0 \tan \phi)}$$

and

$\nu_1$  = Poisson's ratio

$E$  = Pressuremeter modulus

$$2\nu(1 + \nu_1) \frac{\Delta P}{\Delta V}$$

$\nu$  = initial volume

$\Delta P / \Delta V$  = slope of the pressure-volume curve

$c$  = cohesion

A computer is needed for solution, and cohesion should be independently measured or assumed to be zero.

Most grouted soils have considerable internal friction as well as cohesion. Thus at its present stage of development the pressure-meter may be used to estimate one or the other (usually  $c$ ), but not both. A major problem appears to be dependence of the data on initial in situ stress, which is changed by grouting. Furthermore, tensile failure of the grouted soil may mask the already weak determination of  $P_0$ .

This test was used in Washington, D. C. on a large grouting job performed for the purpose of strengthening the material under highway I-95 at 7th Street. The soil materials were sediments with some relatively large gravel particles in them. When the membrane was inflated, apparently single point contact pressures were obtained on these particles; the membrane was ruptured, so that no meaningful readings were obtained. However, this tool has been demonstrated under adverse conditions using the elements inside of split casing. This permits the casing to expand under the pressure of the rubber packers without significant resistance, and it protects the tool from sharp gravel in the soil.

b. Borehole Shear Test. The borehole shear device developed at Iowa State University involves expanding opposed serrated plates to engage soil in opposite sides of a smooth borehole, and then pulling to induce shear in the soil. The expanding shear head is shown in Figure 72. Both the expansion and pulling forces are monitored. The nominal normal and shearing stresses,  $\sigma_n$  and  $\tau$ , are obtained by dividing the measured forces by appropriate plate areas. A plot of maximum shearing stress versus applied normal stress gives a Mohr-Coulomb type linear failure envelope with slope  $\phi$  and ordinate intercept  $c$ . The test is essentially a drained test except in saturated heavy clays, where it may be undrained. It can be performed in any sand or clay soil with or without drilling mud to hold the hole open (70).

Limitations of the BST are:

1. If gravel content exceeds about 10% it may be impossible to secure a smooth hole.
2. Cohesion exceeding about 10 psi ( $0.703 \text{ kgs/cm}^2$ ) will keep the plate teeth from seating. In this case  $\phi$  will be too high and  $c$  too low (usually zero), but the envelope will remain below the true failure envelope and is thus on the safe side.
3. Drainage conditions are inferred from the data, and by retesting with different consolidation times.

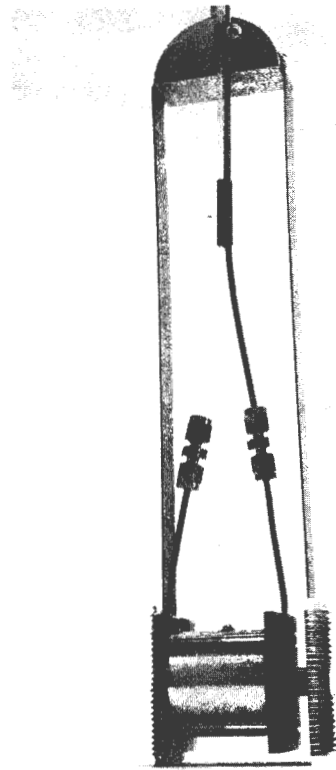
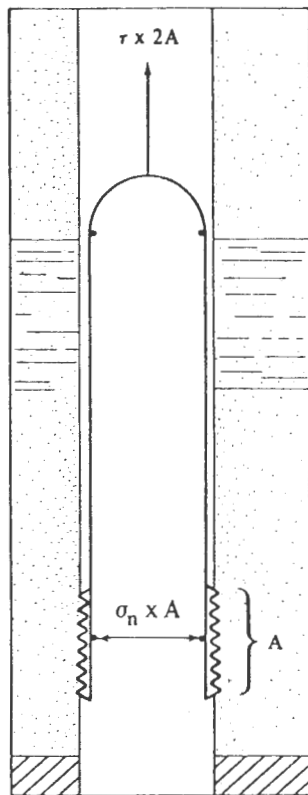

Figure 72. Borehole shear device (32).

Advantages of the BST are:

1. It is the most rapid method available for independent evaluation of  $c$  and  $\phi$ , a complete test usually requiring 30 minutes.
2. Data are reduced and plotted while the test is being conducted, enabling immediate value judgements and retesting if necessary.
3. Its use is not limited to either clays or sands; it tests either alone or both combined in mixtures.
4. It is not sensitive to hole disturbance provided the drained, sheared soil has higher strength than the undisturbed soil and therefore adheres to the shear plates. Successive tests at higher normal stresses are performed without relocating the instrument, a technique known as stage testing.

The major limitation of the BST for grouted soils is that a moderate cohesion will prevent plate seating. However, the borehole shear principle recently has been extended to development of a rock borehole shear tester (RBST), enabling cohesions exceeding 1000 psi (70.3 kgs/cm<sup>2</sup>) to be measured. In this case stage testing is not used, the instrument being removed from the hole, cleaned and rotated for successive failure points. However, rocks such as coal and shale that are too soft to sample are successfully tested, avoiding the problem of bias toward the unsafe side due to recovery and testing of only the strongest cores. Siltstone, sandstone, limestone and concrete also may be tested, the limitation being that shearing stress cannot exceed 7000 psi (492 kgs/cm<sup>2</sup>), corresponding to an unconfined compressive strength in excess of 14,000 psi (984 kgs/cm<sup>2</sup>). The instrument is being developed at Iowa State University for the U. S. Bureau of Mines.

c. Goodman Jack. The Goodman Jack is another tool used in evaluating or measuring rock properties. One model is designed for soft rock. This tool is a hydraulic jack with curved bearing plates for use in a 3-inch (76.2 mm) diameter borehole. The plates are forced against the wall of the borehole by hydraulic pistons, and the borehole deformation is measured accurately by two self-contained Linear Variable Differential Transformers (53).

This tool could possibly be used to measure the strength of grouted soil. Field trials should be conducted.

The tool for soft rock and the indicator used with the tool are shown in Figure 73.

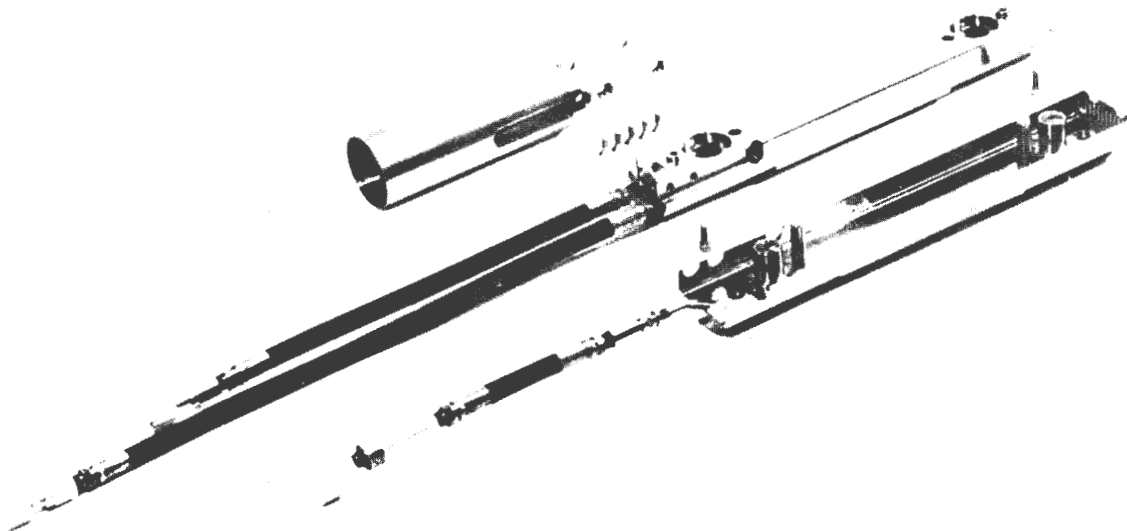

Figure 73. Goodman jack for borehole testing soft rock model

#### 4. Relation of Test Information to Unconfined Compressive Strength

Most concrete or rock cores are tested in unconfined compression, the maximum axial load divided by the cross-sectional area being the unconfined compressive strength,  $q_u$ . If the friction angle  $\phi$  is zero, it may be shown that  $q_u = 2c$ ,  $c$  being cohesion. In most instances  $\phi$  is not zero, and there is frictional resistance along the failure plane, which is inclined. For uniform confinement effects from end friction, the minimum height-to-diameter ratio for a valid test is usually standardized at 2.0. The theoretical shear plane inclination (Figure 43 (e)) in a vertical load test is  $45^\circ + \phi/2$  with horizontal, so  $\phi$  may be estimated by measuring the failure angle. The relations between  $q_u$ ,  $\phi$  and  $c$  are as follows:

$$q_u = \frac{2c \cos \phi}{1 - \sin \phi} = 2c \cot \left(45 - \frac{\phi}{2}\right) \quad (76)$$

$$c = \frac{q_u (1 - \sin \phi)}{2 \cos \phi} = \frac{q_u}{2} \tan \left(45 - \frac{\phi}{2}\right) \quad (77)$$

Although the unconfined compressive strength greatly underestimates reliable design strength when the soil is confined, it is useful for predicting stability of unsupported tunnel walls or excavations.

Example 1: A 4-inch diameter core 8 inches long is loaded axially to failure which occurs when the load is 9000 lb. The break angle is measured and found to be  $55^\circ$ . Find  $q_u$ ,  $c$  and  $\phi$ .

Solution:

$$a) \quad q_u = 9000 \text{ lb} \div \pi (2 \text{ in})^2 = \underline{716 \text{ psi}}$$

$$b) \quad 55^\circ = 45^\circ + \phi/2$$

$$\phi = \underline{20^\circ}$$

$$c) \quad c = \frac{716}{2} \tan (45-10) = \underline{251 \text{ psi}} \quad (\text{Using Equation 77})$$

Example 2: A RBST gives  $c = 1500$  psi and  $\phi = 32^\circ$ . Estimate  $q_u$  and the maximum depth for an unsupported tunnel wall with stress concentration of 2 and an additional factor of safety of 2.

Solution:

$$a) \quad q_u = 2 (1500) \cot (45 - 16) \quad (\text{Using Equation 76})$$

$$= \underline{5410 \text{ psi}} = \underline{779,000 \text{ psf}}$$

b) Assuming the overburden density  $\gamma$  is 150 pcf,

$$h\gamma = \frac{779,000}{2 \times 2} = 150h$$

$$h = \underline{1300 \text{ ft.}}$$

(This does not preclude buckling failure of walls, which would be analyzed as thin columns.)

#### 5. Performance Evaluation

Satisfactory performance of the treated soil deposit and/or the protected structure under stress is the most important criterion of a successful treatment. The most common way of evaluating the grout treatment is to proceed cautiously with construction and observe carefully for any signs of failure or grout deficiency.

Adequate performance of the grouted soil is the ultimate test as to the value of the grouting, and many times this is the only criterion used. When the grouted soil does not perform as expected, the additional remedial work is likely to be very costly and time consuming. Performance methods can be risky, especially for strength grouting. The consequences of ineffective grouting might be irreparable.

#### C. New Concepts

Improved methods for evaluating the adequacy of the grout treatment are needed; in particular, field methods are desired that can be conducted in place. Samples for controlled laboratory testing are difficult to obtain, and facilities for testing are not always available.

Two problems which must be solved for evaluation of grouting success prior to performance are (a) is there proper distribution of the grout in the soil? and (b) have the pertinent soil properties been obtained? As indicated above, progress is being made on the latter problem by measurement of soil properties in situ; both the pressuremeter and borehole shear techniques appear promising for strength evaluations. On the other hand, indirect determination of the distribution of grout in soil has had only moderate attention.

Two types of geophysical tests are available and commonly used for remote determination of soil changes with depth; these are seismic refraction and electrical resistivity. The resistivity methods are more sensitive to changes in soil pore fluid, and thus could be used to monitor distribution during grouting. The seismic methods are more responsive to changes in soil strength and elasticity, and thus should perform well after grouting. The seismic refraction methods have a disadvantage in not penetrating below a hard layer;

thus the depth to the top of a grouted formation might be determined.

The feasibility of using resistivity measurements to determine the progress of grouting has been confirmed in small-scale laboratory tests which show a marked change in soil resistivity upon grouting. The information and data on these tests are included in Section D-2 of the Appendix. Further development of the necessary hardware and testing in full scale field operations is recommended.



## 9. SLURRY TRENCH AND DIAPHRAGM WALL CONSTRUCTION

A slurry trench is generally defined, in the United States, as a narrow trench, excavated under a bentonite slurry and later back-filled with spoils or selected materials, from clays to gravels (55). The slurry trench provides a temporary barrier to the movement of water through the soil. The bentonite slurry exerts a hydrostatic force against the walls of the trench in excess of the groundwater pressure, thus providing temporary support for the vertical trench walls.

The bentonite used in the slurry is an ultrafine clay, of which the principal mineral constituent is sodium montmorillonite. The slurry is a colloidal suspension of bentonite in water, with thixotropic properties forming a gel structure of sufficient consistency to hold large particles in suspension. A "filter cake" of tightly packed bentonite molecules is formed on the wall of the excavated trench or hole as the slurry tends to permeate the adjacent soil. This cake then acts as a water-tight membrane to maintain the differential pressure at the interface.

A slurry wall (called a diaphragm wall in Europe) is essentially a slurry trench excavated under bentonite slurry and back-filled with concrete and steel reinforcement. The concrete displaces the bentonite slurry to form a concrete wall. A diaphragm wall is sometimes constructed using precast concrete elements placed in a slurry trench. In this construction, cement is added to the bentonite slurry so that the slurry provides a seal at the section joints of the precast elements.

Slurry walls were first constructed in Italy in 1948 when patents were obtained by I.C.O.S. of Milan, Italy. This system was used in other European countries by 1954, and applications were made on most continents by 1962, when it reached the United States. The technology has improved so rapidly that technical solutions which could not be foreseen 25 years ago are commonplace today.

The purpose of the diaphragm wall is to provide rigid walls for supporting the sides of excavated sections of earth. Diaphragm walls are more rigid than sheet pile walls or soldier beam and lagging walls. They can be built in a variety of sizes and shapes. Work can be performed adjacent to existing buildings without disturbing their foundation support. This method minimizes disruption to traffic in urban areas and reduces the need to relocate and resupport utilities; it also eliminates noisy driving equipment necessary for piling.

### A. Current Practices

The design and construction of slurry trenches and diaphragm

walls has grown into a science; the use of this type of construction has spread throughout Europe and is becoming more common in the United States. Diaphragm walls are being used to support the ground adjacent to excavation, and in the construction of many European metro systems. The reinforced concrete walls range in thickness from 18 inches to 60 inches; they are cast in sections not exceeding 25 feet in length.

Several methods are used for constructing diaphragm walls. The most common method employs a clamshell bucket to excavate a narrow trench in sections around the desired area. The alignment of the trench is controlled by two concrete guide walls on either side of the trench. These guide walls and the special, narrow clamshell bucket hanging from the weighted arm of a large crane can be seen in Figure 74, a Metro system job in France. These clamshells can be hydraulically or mechanically operated, and the bucket is either cable-suspended or controlled with a Kelly bar.



Figure 74. Clamshell bucket crane used for slurry trench construction

As the trench is dug, bentonite slurry is pumped into the trench to replace the excavated material. The level of the bentonite slurry must be maintained at least 2 feet (61 cm) higher than the highest level of ground water, and the weight of the slurry must be kept consistently greater than that of the groundwater to insure a positive static pressure on the walls of the excavation. The slurry is often circulated back to a desanding plant during excavation to control the slurry weight; suspended particles are removed as the slurry passes over a screen in the system.

Several methods are used to construct a diaphragm wall. These include: (1) steel beam and cast concrete panel, (2) jointed-end panels, and (3) precast concrete panels.

### 1. Steel Beam and Concrete Panel Wall

After the slurry trench (or a portion thereof) is finished, wide flange steel beams of sufficient width to fit across the trench are installed at selected intervals to form panel joints as shown in Figure 75.

A prefabricated cage of reinforcing steel is placed in the panel section. Concrete is then placed by the tremie method to displace the bentonite slurry. Figure 75 shows a completed concrete wall panel, a panel being constructed, and a section of slurry trench excavation (56).

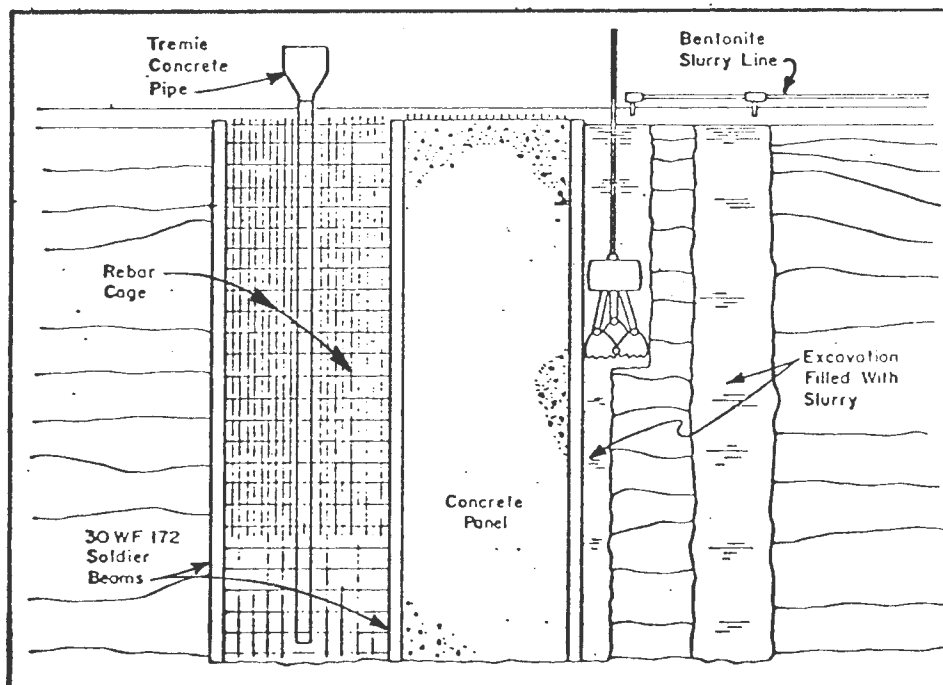

Figure 75. Slurry trench and diaphragm wall construction (56).

## 2. Jointed-End Panels

In this type of construction, a large pipe is placed at each end of the initial wall section to form a concave joint at each end. In subsequent sections, a pipe is only needed at one end.

When the concrete is placed and begins to set, the end pipes are slowly withdrawn to form a semicircular joint at each end of the panel. This approach has been modified by Soletanche Entreprises of France as shown in Figure 76 to provide a more impervious joint. Single or double key joints are placed in line with the panel joint, then removed before concrete sets to form a vertical cavity. When the concrete hardens sufficiently, the joint can be grouted through the cavity. A water-stop joint can also be used in lieu of key-tube and grouting (57).

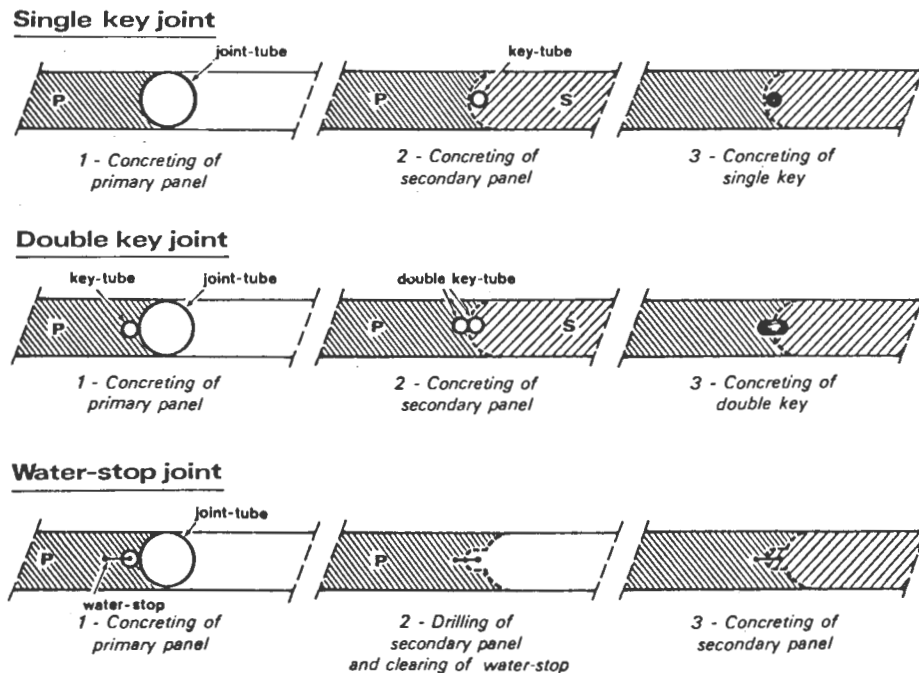

Figure 76. Alternate methods for sealing diaphragm wall panels (57).

## 3. Precast Concrete Panels

Another type of construction for diaphragm walls using slurry trenches is the use of precast concrete wall panels. These panels are placed in the slurry trench and fitted together to form the wall. A number of distinct advantages are claimed over the cast-in-situ-type wall (58). These are:

- a. The general appearance is superior. No cutting back of irregular wall surface is required and the finished surface is even and clean.

- b. The shape of the diaphragm can be tailored to form an integral part of the final structure, satisfying technical and economic considerations.
- c. Improved concrete quality and accuracy in placing reinforcement give considerable savings on materials; prefabricated diaphragms are generally 30% thinner than cast-in-place designs.
- d. The prefabricated diaphragm can be built and installed in the ground to finer tolerances, and wall openings can be more accurately positioned.
- e. Watertightness at the joints and in the wall itself is better than with conventional diaphragm walls.

The Prefasif system, developed by the Entreprise Bachy of Paris, France, uses panels about 2 meters (6.56 ft.) wide; these are locked together by a special device at the lower end which lines them up with adjacent panels. A double female joint left between panels is subsequently regouted, with a waterstop inserted if desired. The bentonite slurry is replaced with a sealing grout just prior to insertions of the precast Prefasif panels.

A similar system, called Panosol, was developed by Soletanche Entreprise of Paris. This system has a tongue and groove type joint to line up the panels. It is also available with T-beam joints between wall sections. The seal between the panels is obtained from special slurry remaining in the trench. A slurry of bentonite and cement is used during excavation of the trench, and that portion not displaced by the wall sections is left in the trench to harden. The grout fills any voids in the joint between adjoining panels, and between the precast wall and the soil.

#### 4. Other Excavation Methods

Another type of trenching machine used for digging slurry trenches is the special trenching machine developed by E.L.S.E. in Italy in 1958. This machine consists of a trenching shovel traveling on a mobile vertical mast which runs on a fixed mast at the forward end of a large structural frame. The bare frame moves on rails laid on the ground and operates by electrically powered winches.

Two other methods are sometimes used. One method performs excavation with percussion tools. This technique is used in very hard soil which might be strewn with boulders; the excavation starts by drilling primary holes with bentonite slurry and then concreting by the tremie method. Then a tool is used to chop out the area between the concreted holes. This method is slow and more expensive than the clamshell method; however, it is the only

method which can be used for trenches to depths in excess of 200 feet (61 m). The other method involves drilling a series of holes at short intervals, then excavating the material between the holes using some type of a clamshell rig.

## B. Engineering Characteristics of Trench Slurry

The use of bentonite slurry in the drilling of oil wells has been standard procedure for many years. There has been much research on this technique to develop materials for use under the extreme temperatures and pressure requirements of deep drilling. Companies exist in the petroleum service area whose sole business is manufacturing and supplying the materials, and supervising their mixing and applications. This is possible because the quantities used are so large, and the use is so critical. However, the requirements for slurry trench construction are much less exacting because the use is at ambient temperatures and normally at depths less than 200 feet (61 m). It is necessary that the bentonite slurry used in trenches and drilled holes accomplish the following (59):

- a. Support the excavation by exerting hydrostatic pressure on its walls,
- b. remain in the excavation, and not flow into the soil, and
- c. suspend detritus to avoid sludgy layers building up at the excavation base.

In addition, these slurries must allow for

- d. clean displacement by concrete, with no subsequent interference with the bond between reinforcement and set concrete,
- e. screening or hydrocycloning to remove detritus and enable recycling, and
- f. easy pumping.

The most important properties of bentonite for use in the slurry trenches are defined in Tables 10 and 11.

Tests have shown (59) that the bentonite concentration should be over 4-1/2% to obtain low fluid loss for proper support of the excavation and proper sealing of the wall. This would be a good rule to observe in the use of bentonite for slurry trenches.

Table 10. Bentonite Slurry Properties

| Property  | Definition   | Current Test Method   |
|---|--|---|
| Concentration   | Kg of bentonite per 100 kg water   | —   |
| Density   | Mass of given volume of slurry   | Mud balance (e.g. by Baroid)  |
| Plastic Viscosity<br>Apparent Viscosity<br>Yield Stress | For a slurry (behaving as a Bingham body) under shearing conditions:<br>Shear stress = $T + V_p S$<br>where<br>T = yield stress<br>$V_p$ = plastic viscosity<br>S = shear rate<br>Apparent viscosity = shear stress/shear rate and is dependent upon shear rate for a Bingham body | Fann Viscometer   |
| Marsh Cone Viscosity                                    | Time for fixed volume of slurry to drain from a standard cone  | Standard Marsh cone as used by drilling companies   |
| 10-Minute Gel Strength                                  | Shear strength attained by the slurry after quiescent period of 10 minutes. (Slurry violently sheared before starting)   | Fann Viscometer<br>Falling tube shear-ometer. (Note: these two measurements give answers which commonly differ by up to a factor of 2.) |
| pH  | Logarithm of the reciprocal of the hydrogen ion concentration  | pH meter, pH papers can give unreliable results   |
| Sand Content  | Percentage of sand greater than 200 mesh in suspension   | API sand content test (basically 200 mesh screen)   |
| Fluid Loss  | Volume of fluid lost in set time of slurry when filtered at set pressure through standard filter medium  | Standard fluid loss apparatus as used by drilling companies - (600 cm mud, 100 lb/in <sup>2</sup> 30 min. filter paper)                 |
| Filter Cake Thickness                                   | Thickness of filter cake built up under standard conditions.   | Measure filter cake buildup in fluid loss test  |

Table 11. Bentonite Limiting Properties (59).

|                          | Bentonite concentration | Density  | Plastic viscosity                                  | Apparent viscosity      | Marsh cone viscosity                | Yield strength                                      | 10 min gel strength (Fann) | pH                                      | Fluid loss  | Sand content                  |        |  |               |
|--------------------------|-------------------------|--|--|-------------------------|-------------------------------------|---|----------------------------|---|---|-------------------------------|--------|--|---------------|
| Excavation support       | > 4½%<br>§ 13           | > 1.034 g/cm³<br>§ 16                                  |  | Not a primary parameter | Regarded only as a qualitative test | Regarded as less important than 10 min gel strength | > 36 dyn/cm²<br>§ 15       |   | Results can be deceptive, with present type of test | > 1%<br>§ 14                  |        |  |               |
| Excavation sealing       | > 4½%<br>§ 19           |  |  |                         |                                     |   |                            |   |   |                               |        |  |               |
| Detritus suspension      | > 4%<br>§ 25            |  |  |                         |                                     |   |                            | > 25 dyn/cm²<br>§ 25                    |   |                               |        |  |               |
| Displacement by concrete | < 15%                   | < 1.3 g/cm³<br>(requires further verification)<br>§ 28 | < 20 cP<br>(requires further verification)<br>§ 28 |                         |                                     |   |                            |   |   | < 11.7<br>§ 37                |        |  | < 35%         |
| Physical cleaning        |                         | < 1.21 g/cm³<br>§ 35                                   |  |                         |                                     |   |                            |   |   |                               |        |  | < 25%<br>§ 35 |
| Pumping                  |                         |  |  |                         |                                     |   |                            | > 25 dyn/cm² § 40<br>< 200 dyn/cm² § 41 |   |                               |        |  |               |
| Limits                   | > 4½%<br>< 15%          | > 1.034 g/cm³<br>< 1.21 g/cm³                          | < 20 cP  |                         |                                     |   |                            |   |   | > 36 dyn/cm²<br>< 200 dyn/cm² | < 11.7 |  |               |



The fluid loss (or filtration) and wall-building characteristics of the slurry are measured by means of a filter press using the standard API (American Petroleum Institute) 30-minute test. These filter presses are standard, and are available from Fann Instrument Corporation, Houston, Texas or from one of the oil field mud companies.

The initial mixing of the water and bentonite is very important. Bentonite prepared with a high shear mixer has more complete hydration and a much faster rate of hydration, as well as a higher final shear strength, than that prepared with an anchor stirrer. This is shown graphically in Figure 77. A measure of the degree of hydration is the 10-minute gel strength of the slurry. This can be measured with a Fann viscometer when the slurry is mixed. Figure 78 shows gel strength for various concentrations of bentonite (60)

Viscosity can be measured during excavation with a Marsh funnel to determine the need for adding either water or bentonite to the slurry. The density can be measured using a standard mud balance.

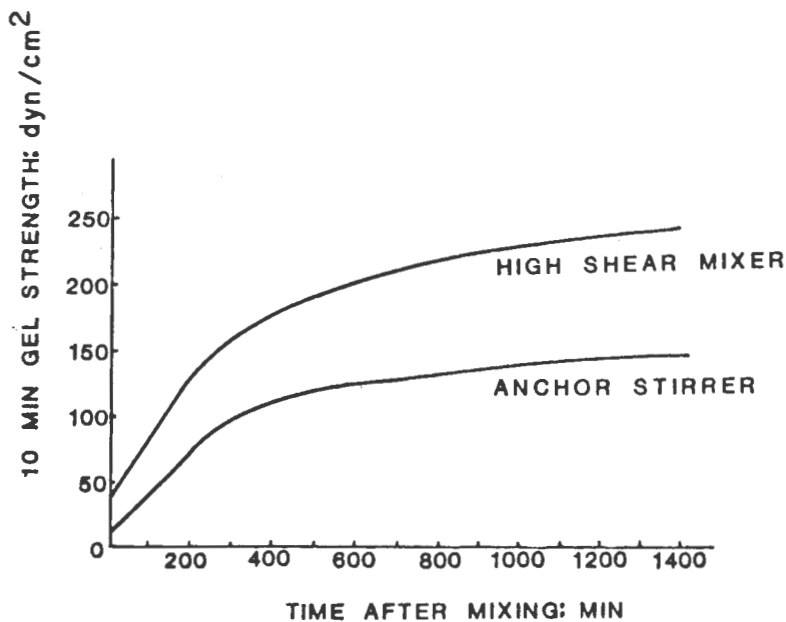

Figure 77. Effect of mixing on hydration of slurry (5% bentonite) (59).

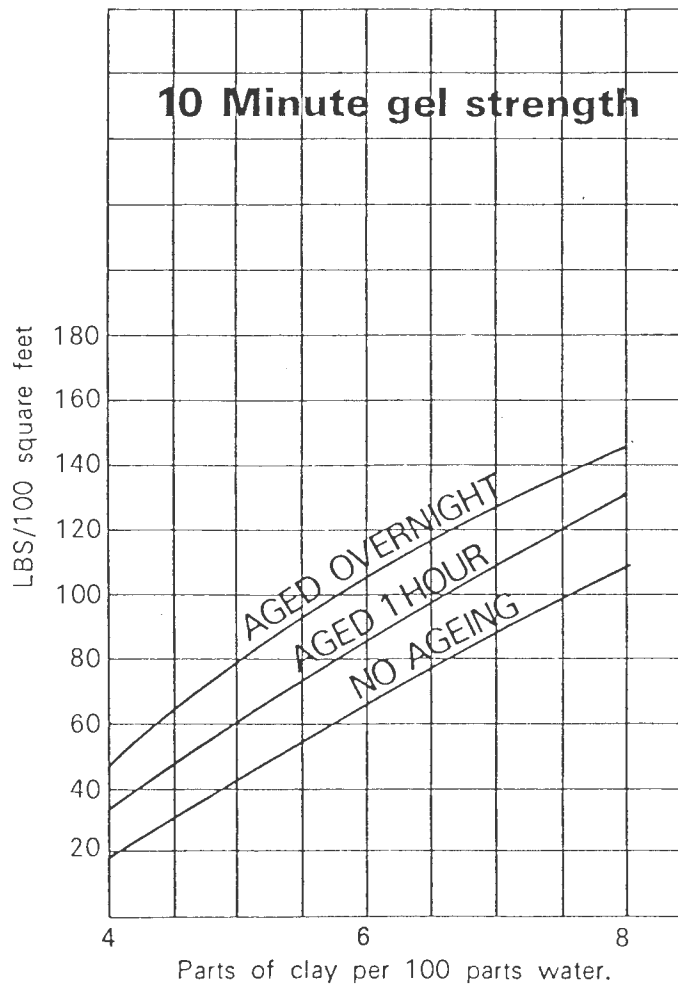

Figure 78. Gel strength for bentonite (60).

### C. Specification and Cost Data

A sample specification for diaphragm walls has been published by one of the large European foundation companies. This specification is included in Section E of the Appendix.

The cost of a slurry wall is very dependent on local conditions, such as the soil profile, the labor market and the degree of urbanization at the site; but cost is less dependent on wall thickness and the quantity of reinforcing steel required. The local conditions must be carefully analyzed from job to job.

The costs in the following paragraph were developed by Tamaro in a 1970 paper (55). Allowance should be made for cost increases since 1970.

A 70 foot (21.34 m) deep wall, 30 inches (76.2 cm) thick and containing 15 pounds per square foot (73.23 kgs/sq m) of reinforcing

steel, can be constructed in granular or cohesive soils, without obstructions, using clamshell equipment at a cost between \$10.00 and \$20.00 per square foot. The same wall, constructed in a formation of till, boulder strata or weathered rock requiring percussion equipment would cost between \$30.00 and \$50.00 per square foot. A premium of 10% of the base cost should be added for each 50 feet (15.24 m) of additional depth below the initial 70 feet (21.34 m) of depth.

## 10. CONTRACT DOCUMENTS AND SPECIFICATIONS

One area of particular interest and concern to grouting contractors is the contractual arrangement for construction work. There is a marked difference between practices in the United States and in Europe; this difference was pointed out in interviews with contractors in both countries and in a recent study of contracting for underground construction for the National Science Foundation (61).

### A. Current United States Contracting Practices

Public agencies, both federal and state, and private owners almost invariably issue contract documents that include detailed plans and specifications, often prepared by engineering organizations. Public agencies usually issue these to all contractors who express an interest in the job as a result of public notices. In the private sector, however, bidders are usually prequalified. Their qualifications to perform the work are investigated and approved before the bidding documents are issued to them.

The plans and specifications are prepared either by engineers directly employed by the owner (normally the situation with public agencies engaged in a substantial and continuing program of construction), or by an engineering organization engaged by the owner for this purpose. The owner's staff engineers or the engineering organization will arrange for subsurface investigations, analysis of the results, and preparation of designs, plans and specifications, cost estimates, and performance-time schedules for construction. Staff engineers or separate engineering organizations will be employed to perform management and administrative functions on behalf of owner. These tasks will be in connection with construction performance and the evaluation and determination of the validity of contractor claims for additional money or time for performance.

In the invitation to bid, notification is given of the form of contract that will be awarded; this is usually a firm-fixed-price contract. Technical plans or drawings and contract documents are included.

Public agencies will require that sealed bids be submitted, accompanied by a bid bond or cash deposit to guarantee execution of the contract documents by the successful bidder. In the private sector, however, bid bonds are seldom required.

All bids are publicly opened by public agencies at the time and date specified in the invitation. At that time, bid prices are announced with the engineer's estimate, and the bids are immediately made available for inspection by the public. Private owners very seldom open bids publicly, publish the engineer's estimate, or make bids available for public inspection.

All public agencies and most private owners require that the bid be responsive to the invitation, i.e., that it must not be qualified or restricted concerning quality, quantity, price, or time for performance of the work. After bid opening, the lower bidder must satisfy the owner, if he has not already done so, that he is responsible. This means that he has a satisfactory record of performance of like work, and the management capability, financial strength, and equipment availability to assure timely performance of the job as specified.

Award by public agencies is made to that responsible bidder who submits the lowest responsive bid. Private owners are not bound by any such legal requirements concerning acceptability of bids.

On award of public agency contract, the contractor must furnish performance and payment bonds in the amounts called for in the invitation to bid. Private owners will normally make no such requirement if they have prequalified and preselected bidders for invitation to bid.

## B. Current European Contracting Practices

In European countries, contracting practices vary from one country to another and even within a country. To some extent, however, certain practices prevail within all countries.

Consulting engineers are used in England in the same manner as in the United States, i.e., in the planning of projects and in preparation of contract documents. In other European countries, the owners normally prepare drawings and specifications and supervise the construction with their own engineering staff.

Potential contractors are prequalified, i.e., the qualifications and experience of their management personnel, their financial capacity, equipment availability, and their past record of work performance and claims submissions are investigated. Owners are particularly interested in a potential contractor's past record of arbitration and court litigation. Contractors found to have satisfactory records in these areas are then placed on a list of qualified bidders.

Contractors are preselected for invitation to bid by a two-step procedure. First, they are placed on a prequalified list. Second, a specific number of contractors are selected from the list to receive an invitation to bid; however, all on the list may be invited.

Bidders are, in general, permitted and even invited to submit an alternative design for the job, provided that they fulfill the following requirements:

- (1.) A bid is submitted for performance of the job

as advertised, so that the owner will have a comparable basis for evaluating all bid received.

- (2.) Any alternative proposed must be accompanied by detailed plans and specifications, together with the bidder's written justification for adoption of the alternative. The bidder must also include a bid price schedule covering the alternative submitted, and must be prepared to support his prices for an alternative with his detailed cost estimate.

Although the attachment of qualifications and restrictions on the bid is discouraged and may be prohibited by the owner, contractors are, as a practical matter, allowed to attach such qualifications on the bid which affect one or more of the following factors: quality, quantity, price, or time of performance. Although the owner has the option of rejecting any qualified bid, he will negotiate with such a bidder and with others whose bids are close to the estimate. Following such negotiations he will award the contract on the basis of the best price for the job as modified by an alternatives and qualifications that he has accepted.

Bids are, in general, opened privately, and negotiations may then be conducted with the apparent low bidder and with other close bidders, covering bid prices, alternatives, and qualifications on bids. This particular procedure represents a radical difference from contracting practice in the United States, except for jobs awarded by some private owners.

Contractors are reluctant to resort to arbitration and especially to court litigation, because this usually results in their removal from the list of qualified contractors. In any event, the contractor who resorts to such means for collecting on claims acquires the reputation of being a "hard head".

In one of the countries visited, subsurface conditions are generally thoroughly investigated by owners. The results of this investigation, including interpretations of the basic data, are furnished to bidders more frequently than they are in the United States. The practice varies greatly, however, from country to country and even within a country. Owners generally assume the risk concerning changed subsurface conditions.

### C. Contractual Problems with Grouting Contractors

For the United States, the grouting contractor is generally a subcontractor to the general contractor, often for a fixed fee. Since the general contractor is usually awarded a firm-fixed-price contract, he essentially becomes the owner of the project until it is completed and delivered to the ultimate owner. For that reason,

the public agency contracting officer or private owner will deal only with the general contractor. The grouting contractor, working under the general contractor, does not usually have anyone who is interested in his work or its success. If he decides to make changes in his grouting program (which are necessary many times due to unexpected conditions encountered), the general contractor will not adjust his contract to permit any changes resulting in additional charges. This poses a difficult problem for the grouting contractor who must redesign his grouting program during the course of the job, and possibly not be paid for additional costs encountered.

There are times when ground conditions with flowing water and/or running sand are encountered which halt normal construction progress. This unforeseen development is not covered by a fixed-price contract, so the general contractor must seek approval for additional funds to complete the job without losing money. This proves difficult, but the contractor is reluctant to proceed without this approval. As a consequence, many jobs are delayed while arbitration and litigation take place.

Sometimes the general contractor will employ a grouting contractor for a trial grouting operation, but the scope is usually insufficient to accomplish a satisfactory solution or prove the feasibility of such approach. However, this gives the general contractor better grounds to obtain additional funds for changed site conditions and obtain relief from his fixed-price contract.

Meanwhile, the grouting contractor is not free to negotiate a contract for a procedure which would probably alleviate the problem. This is one factor that has kept grouting from becoming a useful technology in underground construction practices.

In Europe, this situation does not normally exist. On many of the European Metro systems, their engineers design the system and include grouting as part of the original contract. In such cases, negotiations are made directly with the grouting company. Moreover, when grouting work is indicated in underground construction because of problems encountered, the Metro system personnel still deal directly with the grouting contractor. This procedure provides a more responsive situation than exists in the United States.

Owners and contractors appear to work more as a team in Europe than they do in the United States. They are both reluctant to force a dispute to resolution by arbitration, and contractors who propose alternatives have an incentive to make them work. The owners who accept the alternatives also have a concern in the success of such work. Mutual interest is a key in successful relationships.

## 11. SUMMARY AND EVALUATION

General systems analyses of the entire grouting operation, primarily in cohesionless soils, have shown that there are some distinct differences in grouting performed in the United States and that performed in Europe. These differences seem most pronounced in the size of the jobs, the basic injection techniques, the pumping and mixing equipment, the site investigation and contractual arrangements.

In the United States, most of the jobs are small and are performed on an emergency basis. Grout is normally injected through open end or slotted pipe into all the layers adjacent that will accept the grout. Many times one pump is used to inject the grout into a number of pipes simultaneously. The site investigation has already been performed without consideration for grouting, so information often is meager.

In European operations, many of the jobs involve grouting large sections of Metro systems as a part of the original planning. Grout is injected selectively into one layer at a time using the tube a manchette pipe system. Pumping and mixing equipment are in batteries of six to eight units, housed in a small shed or trailer, and automated so that each pump injects grout into one pipe and shuts off automatically at the proper volume. These companies perform their own site investigation in many instances.

The various aspects of soil grouting in cut-and-cover or soft ground tunneling have been discussed in preceding sections of the report. However, each aspect relating to tunneling will be examined again for the purpose of determining the needs for, the consequences of, and the prospects for improvements. The areas to be examined will be: (1) grout curtains for cut-and-cover; (2) waterstop barriers for cut-and-cover or tunnels; (3) remedial grouting; (4) strengthening soil under structures above tunnels; (5) consolidating soil for tunnel excavation; (6) slurry trenches and diaphragm walls; and (7) backpacking tunnel liners.

Table 12 gives information on the seven areas listed above. Included are the materials required, the grouting procedure, the monitoring required during grouting, the testing necessary after grouting, and the results of each type of grouting.

Table 13 shows the need for improvement, the consequences of improvement, the prospects for improvement and the approaches to improvement for the seven areas of grouting.

Equipment is badly needed to monitor the distribution of the grout throughout the soil during injection. Such equipment could be used to optimize the use of grout and materially reduce the cost



TABLE 12 - SUMMARY OF GROUTING OPERATIONS APPLICABLE TO TUNNEL CONSTRUCTION

| Operation | Type of Grouting                                  | Material Required                                  | Procedure Used - (Operations)   | Monitoring Required  | Subsequent Testing Required   | Result of Grouting   |
|-----------|---|--|---|--|---|--|
| A         | Grout Curtain for Cut-and-Cover                   | Cement and/or Silicate Grout                       | Grid Pattern - Normally 3 rows of holes. Inject through drive points or Tube a Manchette.   | Surveillance of Excavation for water inflow. Quantity of grout pumped. Grout pressure.   | None if sufficient site investigation is made.  | Gives permanent water-block for excavation area.   |
| B         | Waterstop Barrier for Cut-and-Cover or Tunnel     | Chemical Grout for Water Stopping                  | Random pattern of grout holes to apply grout where water is located, or grid pattern can be used.   | Same as A.   | Same as A.  | Same as A. Also used to reduce permeability to permit use of compressed air at lower pressures.  |
| C         | Remedial Grouting                                 | Usually quick-setting chemical grout               | Varies according to problem. Can be performed with hand-held grout points by injecting grout around points of leakage, or could be done by pipes in grid pattern.                                 | Daily check after completion of the grouting.  | None. Visual check is usually sufficient.   | 1. Permits construction to continue.<br>2. Strengthens soil<br>3. Stops localized water leaks  |
| D         | Strengthening Soil Under Structures Above Tunnels | Cement, High-Strength Chemical Grout               | Grout pipes placed from surface at angle to reach under foundations, or holes drilled radially from shaft.  | 1. Constant check on buildings or soil for heave or uplift.<br>2. Grout pumped per hole at each level and grout pressure.  | 1. Cores to obtain samples for test strength or<br>2. Permeability tests in situ before & after grouting. | 1. Prevents surface settlement when mining.<br>2. Prevents water or soil from entering tunnel.   |
| E         | Consolidating Soil for Tunnel Excavation          | Chemical grout, medium strength                    | Can be injected by pipes from surface or into face from within tunnel   | 1. Measurement of grout pumped into each pipe at each location.<br>2. Grout pressure.  | None since soil is excavated soon after injection.  | 1. Prevents surface settlement when mining.<br>2. Prevents water or soil from entering tunnel.   |
| F         | Slurry Trenches and Diaphragm Walls               | Bentonite cement slurries, reinforcing steel bars. | Slurry trenches filled with bentonite slurry, then reinforcing steel cages are placed in trench and concrete replaces the bentonite slurry. Some precast walls used now in lieu of cast-in-place. | 1. Bentonite slurry level in trench was to be kept within 2 feet of surface.<br>2. Density must be kept between 1.034 and 1.25/cm <sup>3</sup> .<br>3. Gel strength must be kept between 50 and 200 degrees/cm <sup>2</sup> .<br>4. Bentonite concentration must be over 4-1/2%. | Tests on slurry for density, pH, 10-min. gel strength.  | 1. Provides protection from groundwater intrusion.<br>2. Completed wall provides support and may be used as part of permanent structure. |
| G         | Backpacking Tunnel Liners                         | Concrete   | Pump behind each section as it is bolted in place.  | Monitor upper holes as grouting is done from lower holes.  | Squeeze grout as test for complete grouting.  | Keeps soil from caving in and creating surface settlement.   |
| H         | Tiebacks  | Portland Cement                                    | Pump grout into anchor hole.  | Pressure and quantity of grout.  | Pressure Tested with anchor tool  | Holds anchor in place.   |

of grouting. In the present method, a large percentage of the grout goes beyond the limits of the theoretical area desired to be consolidated and is wasted.

Another need is the development of tools for obtaining the in situ unconfined compressive strength (or shear strength) of the soil after it has been grouted.

Further research is needed to determine if the strength of a grout material can be found by testing the grout in a gelled condition in the laboratory, and then relating this strength in some manner to unconfined compressive strength in a standard soil material. This test might also be used to evaluate the amount of grout concentration required for a specific job application. This could result in a less expensive grout, since the solids used to gain concentration are the expensive ingredient of the grout. There is also still a need for further improvement in the basic grouting materials, so study should proceed along this line to develop a less expensive grout.

Different approaches can also be taken to the grouting operation. In certain areas of the world, two different material injections are made during grouting; portland cement grout is injected throughout the area to fill the larger voids with an inexpensive grout, followed by an injection of chemical grout to fill the finer voids. This technique might be changed by having a better grout fluid that would obtain the desired results in all the pore spaces, and the time and cost of making two individual grouting passes across an area could be effectively reduced.

The area of grid patterns and injection pipes might be improved. Where grout rods are driven into the ground as injection pipes, better and more efficient driving and pulling equipment are needed. The current equipment used is simply adapted to this application from its normal use, so that efficiency is usually sacrificed for expediency. The track drill and jack hammer used to drive the rods in the ground turn counterclockwise while moving up and down; therefore, these tools tend to rotate the pipe in the direction that unscrews the joints. A paving hammer is also used, it is somewhat better because it does not rotate while it reciprocates. Equipment used to withdraw the pipe could be improved, here again, equipment now in use are simply modifications of equipment designed for other purposes.

The development of grout for backpacking tunnel liners might take a new approach to the type of material used. Current practice is to use a grout material which solidifies and fills the void space around the ring, so a portland cement slurry has usually been utilized. A new grout might not necessarily be required to solidify, as the sediments surrounding it are not cemented together; therefore, this grout (or filler) might only be composed of solids

TABLE 13 - EVALUATION OF GROUTING OPERATIONS IN TUNNELING

| Operation  | Need for Improvement  | Consequences of Improvement   | Prospects for Improvement   | Approaches to Improvement  |
|--|---|---|---|--|
| A - Grout Curtain  | <ol style="list-style-type: none"> <li>1. Need means of knowing grout distribution pattern.</li> <li>2. Need lower cost grout material.</li> <li>3. Need more efficient means of setting grid pattern pipes.</li> <li>4. In U.S., better injection pipes are needed.</li> </ol> | <ol style="list-style-type: none"> <li>1. Help establish most efficient grid patterns; could possibly get by on less boreholes.</li> <li>2. Cheaper operation</li> <li>3. Equipment developed to set pipes quicker or with better technique.</li> <li>4. Better pipes would give more controlled placement of grout.</li> </ol> | <ol style="list-style-type: none"> <li>1. Some research has been done on checking grout distribution. More tests could follow.</li> <li>2. Interest is growing in finding a new material</li> <li>3. No plans are being made for equipment improvement.</li> <li>4. U.S. could follow European pattern on injection pipes.</li> </ol> | <ol style="list-style-type: none"> <li>1. Recommendation to be made for further research on checking grout distribution.</li> <li>2. Current research being done on establishing standard test and developing less expensive grout on DOT contract.</li> </ol> |
| B - Waterstop Barriers for Tunnels or Cut-and-Cover Construction | Same as A Above   | Same as A Above   | Same as A Above   | Same as A Above  |
| C - Remedial Grouting  | <ol style="list-style-type: none"> <li>1. Main improvement would be in area of costs so process can be done cheaper</li> <li>2. Same as 1 under A.</li> </ol>   | Make grouting more attractive to general contractors.   | DOT study in progress on improved or less expensive grout.  | DOT study in progress to develop cheaper grout.  |
| D - Strengthening Soil Under Structures Above Tunnels            | <ol style="list-style-type: none"> <li>1. Need new high-strength grout of low viscosity and medium cost.</li> </ol>   | <ol style="list-style-type: none"> <li>1. Would make this method more competitive with underpinning.</li> <li>2. Could help control amount of grout used.</li> </ol>  | <ol style="list-style-type: none"> <li>1. No prospects known</li> <li>2. Fair</li> </ol>  | <ol style="list-style-type: none"> <li>1. Possible Research Contract from Federal or Private Sources</li> <li>2. Possible Government Research Project.</li> </ol>  |
| E - Consolidating Soil for Tunnel Excavation                     | Need medium strength, low viscosity, low cost grout.  | Make this method more economical.   | See C, Above.   | Research Contract by DOT so new grout will be available to everyone.   |
| F - Slurry Trenches and Diaphragm Walls                          | <p style="text-align: center;"><u>Bentonite Slurry:</u></p> <ol style="list-style-type: none"> <li>1. Properties of fluid loss.</li> <li>2. Possible replacement with polymers.</li> </ol>  | <ol style="list-style-type: none"> <li>1. Possibly better filter cake.</li> <li>2. Polymers would be biodegradable and would not be an environmental hazard.</li> </ol>   | Depends on research in petroleum drilling industry.   | Contact mud companies regarding existing information on data on polymers which have been listed.   |
| G - Backpacking Tunnel Liners                                    | Need to develop new material and technique  | Speed up operation - fill void before soil can settle.  | Depends on interest by tunneling constructors.  | Conduct a research contract to study this phase and make recommendations based on pilot studies. Possible demonstration project.   |
| H - Tiebacks   | <ol style="list-style-type: none"> <li>1. Faster setting grout with high strength and low cost.</li> </ol>  | Speed up operation to reduce costs.   | Nothing being done now.   | Development of new grout by company in tieback business.   |

which are the same character as the surrounding sediments. A slurry of water and solids could be placed in the annulus between the liner and the in situ sediments, thus filling this void quickly and completely to reduce settlement. This type of filler might be suitable for injection into each individual liner section as it is placed. Placing portland cement grout into each individual liner section presents many problems, as this grout slurry cannot be maintained for a very long period of time without setting. Generally the void is not filled behind each individual liner section as it is put in place, but two or more sections are grouted at one time.

Hutchinson et al (59) have recommended improvements to the slurry trench and diaphragm wall construction procedures. These improvements involve further research to improve the fluid loss properties of bentonite slurry for use in slurry trenches, and to develop a method for on-site analysis of the slurry properties. Other questions that should be answered include the effects of sand in the slurry to aid in filter cake formation in gravel formations, the effects of cement contamination upon the slurry properties and the problems of the slurry displacement by the concrete. An area which also should be investigated is the use of polymers to replace the bentonite slurry. Considerable work is being done by the oil field service companies on polymers, since they are not toxic and are biodegradable in nature.

Research should also be done on the concrete used for the diaphragm wall to provide better watertightness and continuity across panels (62), as well as techniques and cement compositions required for placing the concrete in narrow, deep trenches.

## 12. CONCLUSIONS

This study of current grouting practices in the United States and Europe has highlighted several areas from which a number of conclusions are warranted. These are as follows:

1. Site investigation procedures are well established using conventional methods for determining grain size and permeability in laboratory tests with soil samples. It is very difficult to recover samples of undisturbed cohesionless soil, so most samples are disturbed and must be recompacted before testing. This gives a wide variation in test results. Tests are standardized for obtaining in situ permeability, but these tests are not used very often in a site investigation.
2. Site investigations in the United States are normally the responsibility of consulting engineer companies who engage soil specialists to conduct the investigation. In England, consulting engineers who have complete soils and foundation analysis capabilities within their organizations are used for the planning and site investigation. Elsewhere in Europe, the grouting companies are capable and qualified to conduct the site investigation, and often are engaged to do so. These investigations are usually more thorough than in America because they are conducted with grouting in mind as a possible construction method.
3. The amount of money allotted for site investigation in the average United States construction project is usually a very small percentage of the total cost, so the number of test borings is kept to a minimum. It is assumed that the soil layers remain constant across the area, but this is often not true.
4. Other than obtaining samples or checking permeability, there are normally no in situ tests conducted in the site investigation which are repeated after grouting to determine the results of the grouting. Some in situ testing devices have been used in cohesive soils, but it is not known whether these tools would be applicable to cohesionless soils or to consolidated cohesionless soils after grouting.
5. Grouting is seldom included in the initial specifications for construction work in the United States; rather, conventional methods for cut-and-cover or soft ground tunneling, such as soldier beam and lagging, dewatering, underpinning, and compressed air excavation,

are usually specified, and grouting is used only in emergency situations. In European operations, grouting is given initial consideration in many underground construction projects for such purposes as: (1) stabilizing soil for simplified excavation of tunnels; (2) strengthening soil under buildings or utilities in place of underpinning; (3) waterproofing areas between sheet steel or concrete diaphragm walls; or (4) installation of slurry trenches in cut-and-cover construction.

6. Grout materials are available in a wide variety of strengths, viscosities and cost, but most are relatively expensive. Selection of proper grout can be made to fit the job purpose after a site investigation has disclosed the soil is groutable and the soil properties are determined.
7. In the construction or grouting business, there are no standard tests of cement grout to determine setting time or pumping time. There are tests in the oil well grouting field which could be applicable, such as thickening time and pumpability tests which are normally made on a laboratory consistometer.
8. Tests are not normally conducted on chemical grouts to determine physical properties, except when injected into soil samples. There is an ASTM test for unconfined compressive strength in cohesive soil, but there is no standard test for cohesionless soil or for such soil recompacted and grouted.
9. Many of the chemical grouts being used are toxic in some manner, and a few grouts are now prohibited from use by environmental authorities in some European countries.
10. There are mathematical approaches for planning of grouting operations; but most grouting specialists agree that the theoretical considerations are useful only in preliminary planning, so usually the grout plans are based largely on their past experience.
11. Several injection techniques are presently used successfully in grouting. The procedures can be designed to use methods best suited for a particular job. This also holds true for mixing and pumping equipment, but the common practice is for the grouting company to use the equipment which they have been using on past jobs.
12. Most of the grouting companies in Europe use a special injection pipe in boreholes to provide selective

grouting. Special packers are used on an inner pipe to straddle sleeve-covered, pre-drilled holes in the outer plastic pipe. This is an excellent grouting tool, but the United States companies have used this type of equipment very little.

13. European grouting companies operate from sophisticated grouting houses or vans. Their jobs are controlled by automated mixing and injection pumps, and flow rate and injection pressures are recorded during a job to substantiate grouting progress. The United States grouting firms do not possess such equipment, nor do they develop detailed records of their operations.
14. Standard field procedure for a grouting operation in the United States seems to be the injection of as much grout in as short a time as possible. Such procedure reduces labor and equipment costs, but tends to overrun the amount of grout needed. Undoubtedly this is done because the pay item for the grouting contractor is usually based on the amount of grout injected, and a guaranteed job is not required. In contrast, many European grouting firms are paid on the basis of soil grouted, and definite results are specified to be achieved.
15. There is no method available to determine grout distribution during the grouting operation. There are only a few methods now practiced to check the results of a grouting operation. Performance is determined when excavation is made through the grouted area. Laboratory examination of cores before and after a job is sometimes used to determine effectiveness of grouting. Reduction of existing water flow can be measured to find results. Settlement or rise of nearby buildings is another guide in evaluating the grouting results.
16. The use of bentonite slurries for temporary ground support in trenches and boreholes is common practice with some construction companies, but there is insufficient information about the action of the slurry in this application. Slurry trenches have been used extensively in Europe, but have been used only recently in the United States to any degree. This method will probably be used increasingly through the next few years as more engineers become aware of its advantages and companies acquire the equipment to perform the operation.
17. Tieback anchorages are a standard practice used by many companies, particularly in Europe. The technology has been well documented in publications, and usage of this tieback system seems to be growing in the United States.

18. Ground support by freezing in excavation of cohesionless soils is not used very much. It is a system that can be used for any shape configuration; but the technology is centered in only a few companies, and the work is relatively expensive compared to grouting or other means of support.
19. Contractural arrangements in the United States differ significantly from those in Europe. European practices are much more flexible, and they permit private companies to share their expertise in planning of the construction work. This is never allowed in the United States contracts; companies must submit to strict specifications which have long been outdated in more progressive, underground construction practices.
20. The grouting or backpacking for tunnel lining has not varied from portland cement grout. Improvements might be made in this application, or grout material used to provide lower costs or more efficiency.



## 13. RECOMMENDATIONS

The following recommendations are made as a result of this study:

1. Efforts should continue through workshops and conferences to further educate designers, engineers and constructors concerned with underground construction on the necessity of a thorough site investigation procedure. Ground conditions should be determined specifically enough to permit a realistic consideration of all methods of construction, including grouting.
2. A demonstration project should be initiated to test the Menard Pressuremeter, the Iowa Bore-Hole Direct Shear Test Device, and the Goodman Jack in cohesionless soils before and after grouting with various chemical grouts to attempt to determine a relationship to the unconfined compressive strength. It is also recommended that other known methods be investigated to accomplish this aim.
3. The Delft (Holland) Soil Mechanics Laboratory Soil Sampler should be tested in the same demonstration project to determine the feasibility of its use to obtain undisturbed samples in the cohesionless soil before and after grouting.
4. A standard test should be adopted for cement grout setting time and pumpability for use in coarse sand or gravel, possibly patterned after API tests used in oil well grouting work.
5. A standard laboratory test procedure should be established for obtaining unconfined compressive strength of grouted samples of cohesionless soil. A standard for preparation of the sample should also be a part of the procedure.
6. A method should be developed to determine the distribution of grout during the grouting operation. This is an aspect of grouting which would find immediate use in all countries. It could conceivably lower the grouting costs appreciably, since knowing the grout distribution pattern would result in using less grout.
7. A study should be made of other materials which might be substituted for cement in backpacking of tunnel

liners, in order that backpacking could be done immediately after each liner section has been set during the tunneling operation. A water slurry of various sands or pulverized fly ash should be investigated.

8. The methods and techniques for ground excavation by freezing should be compiled from many sources into one volume as a guide for conducting satisfactory freezing operations.
9. Efforts should be initiated by U. S. Government agencies to modify existing laws to change the contractual arrangements, so that the grouting contractor can negotiate directly with the contracting officer or owner, rather than being forced to have the general contractor act as his agent. This will give increased flexibility to working systems, and result in savings through contractor incentives to submit alternate proposals at a time in the bidding process when these alternatives may be reflected in the contract specifications.

## 14. REFERENCES

1. Rock Grouting References
  - a. Engineer Manual EM 1110-2-3501, Foundation Grouting: Planning, Department of Army, Office of Chief of Engineers.
  - b. Engineer Manual EM 1110-2-3502, Foundation Grouting: Equipment, Department of Army, Office of Chief of Engineers.
  - c. Engineer Manual EM 1110-2-3503, Foundation Grouting: Field Technique and Inspection, Department of Army, Office of Chief of Engineers.
  - d. TM 5-818-6 and AFM 88-32, Grouting Methods and Equipment, Departments of Army and Air Force, February 1970.
  - e. Bibliography of Cement Grouting, Journal of Soil Mech. and Foundations Division, ASCE, SM4, July 1963.
  - f. U.S. Department of Interior, Bureau of Reclamation, TM 646, "Pressure Grouting," June 1957.
2. Grouting Inspector's Manual, The Metropolitan Sanitary District of Greater Chicago, July 1975.
3. Ischy, E. and Glossop, R., "An Introduction to Alluvial Grouting," Institute of Civil Engineers, 1962, Paper No. 6598.
4. Caron, C., "The Development of Grouts for Injection of Fine Sands," Proceedings of the Symposium on Grouts and Drilling Muds in Engineering Practice, Butterworths, London, May, 1963.
5. Hurley, Claude H. and Thornburn, Thomas H., "Sodium Silicate Stabilization of Soils - a Review of the Literature," VILV-ENG-71-2007, University of Illinois, Urbana, Ill., February 1971.
6. Chadeisson, R., "Results of Injections in Cohesionless Soils," The Consulting Engineer, October, November and December 1963.
7. Einstein, Herbert H. and Schnitter, Gerold, "Selection of Chemical Grout for Mattmark Dam," ASCE Journal S. M. and F. Div., SM6, November 1970.
8. Dempsey, J. A. and Moller, K., "Grouting in Ground Engineering," Ground Engineering, The Institute of Civil Engineers, 1970.

9. "Chemical Grout Seals Shafts Through Wet Sand," Construction Methods and Equipment, May 1962.
10. Janin, J. and LeSciellour, Guy, "Chemical Grouting for Paris Rapid Transit Tunnels," ASCE, Journal of the Construction Division, Vol. 96, C01, June 1970.
11. "AM-9 Chemical Grout," American Cyanamid Company, 1965.
12. "Three Uses of Chemical Grout Show Versatility," Engineering News-Record, May 31, 1962.
13. "SIROC Grout Technical Manual," Diamond Alkali Co., Cleveland, Ohio, 1962, (Distributed by Soiltech Department, Raymond International Inc., Pennsauken, N.J.).
14. "Chemical Consolidation in Civil Engineering Practice," Geotechnical Pamphlet No. 7, Soil Mechanics, Ltd., 1969.
15. Anderson, E. Roy and McCusker, T. G., "Chemical Consolidation in a Mixed Face Tunnel," Proceedings, First North American Rapid Excavation and Tunneling Conference, Chapter 21, 1972.
16. Haffen, Marcel and Janin, Jean, "Grouting Cohesionless Water-Bearing Soils in City Tunnels," Proceedings, First North American Rapid Excavation and Tunneling Conference, Chapter 85, 1972.
17. Brown, D. R. and Warner, James, "Compaction Grouting," Journal of Soil Mechanics and Foundations Div. ASCE, Vol. 99, SM8, August 1973.
18. Warner, James and Brown, D. R., "Planning and Performing Compaction Grouting," ASCE, Journal of Geotechnical Engineering Division, Vol. 100, GT6, June 1974.
19. Special Report No. 103, Intrusion Prepakt, Inc., Cleveland, Ohio, 1972.
20. Mincheff, E. E., "How to Stabilize and Level a Tank That is Settling," Fifth Annual Meeting, API Division of Transportation, Philadelphia, Pennsylvania.
21. Dietrich, M., Chase, B., and Teul, W., "Tieback System Permits Uncluttered Site," Foundation Facts, Raymond International, Vol. VII, No. 1, 1971.
22. Nelson, James C., "Earth Tie-Backs Support Excavation 112 Feet Deep," Civil Engineering, November 1973, p. 40.

23. Khakimov, K. R., "Artificial Freezing of Soils - Theory and Practice," Israel Program for Scientific Translations, Jerusalem, 1966.
24. Sanger, F. J., "Ground Freezing in Construction," Journal of Soil Mechanics and Foundations, ASCE, Vol. 94, SMT, January 1968.
25. Shuster, John A., "Controlled Freezing for Temporary Ground Support," Proceedings, North American Rapid Excavation and Tunneling Conference, Vol. 2, Chapter 49, Chicago, 1972.
26. Peck, R. B., Hendron, A. J., Jr., and Mohraz, B., "State of the Art of Soft Ground Tunneling," Proceedings, First North American Rapid Excavation and Tunneling Conference, AIME, 1972, p. 259.
27. "Improved Subsurface Investigation for Highway Tunnel Design and Construction," Vol. 1, Ash, T. L., Russel, B. E. and Rommel, R. R., FHWA-RD-74-29, May 1974.
28. Kjellman, W., Kallstenius, T., and Wagner, O., "Soil Sampler with Metal Foils," Proc. Royal Swedish Geotech. Inst. No. 1, 77 pp., 1950.
29. Brochure, Delft Soil Mechanics Laboratory, 1974, Stieltjesweg 2, P. O. Box 69, Delft, Holland.
30. "Laboratory Soils Testing," EM 1110-2-1906, Office of the Chief of Engineers, November 1970.
31. "Influence of Texture on Porosity and Permeability of Unconsolidated Sand," Beard, D. C. and Weyl, P. K., The American Association of Petroleum Geologists Bulletin, V. 57, No. 2, February 1973, p. 349-369.
32. Soil Engineering, Third Edition, Spangler, M. G. and Handy, R. L., Intex Educational Publications, 1973.
33. Welsh, Joseph P., "Soil Solidification," Open Cut Construction Seminar, Metropolitan Section, Construction Group, ASCE, New York, New York, February 3, 1975.
34. Badger, W. W. and Lohnes, R. A., "Pore Structure of Friable Loess," Highway Research Record No. 429: 14-23, 1973.
35. Dumbleton, M. J., "Some Sources of Information for Site Investigations," Ground Engineering, Vol. 7, No. 3, May 1974.

36. "Grouting of Foundation Sands and Gravels," Technical Memorandum No. 3-408, Corps of Engineers, Vicksburg, Miss., June 1955.
37. Chemical Grout Field Manual, Third Edition, April, 1966, Cyanamid International, Wayne, New Jersey.
38. Soils and Soil Engineering, R. H. Karol, Prentice-Hall, 1960.
39. Warner, James, "Strength Properties of Chemically Solidified Soils," Journal of Soil Mechanics and Foundation Division, ASCE, Vol. 98, SM-11, November 1972.
40. Fawcett, David F., Journal of Soil Mechanics and Foundation Division, ASCE, Vol. 99, SM8, August 1973, pp. 638-39.
41. Skipp, B. O. and Renner, L., "The Improvement of the Mechanical Properties of Sand," Grouts and Drilling Muds in Engineering Practice, Butterworths, London, 1963.
42. Cunningham, L. J., "The Use of Chemicals in Mine Grouting," Sixty-third Annual Meeting, Canadian Institute of Mining and Metallurgy, March 1961.
43. Raffle, J. F. and Greenwood, D. A., "The Relation Between the Rheological Characteristics of Grouts and Their Capacity to Permeate Soil," Proceedings of the Fifth International Conference on Soil Mechanics and Foundation Engineering, 1961.
44. Calhoun, Max L., "Pressure-meter Field Testing of Soils," Civil Engineering, July 1969, pp. 71-74.
45. Dixon, Schaefer J., and Jones, Walter V., "Soft Rock Exploration and Pressure Equipment," Civil Engineering, October 1968, p. 34.
46. Massargoh, K. R., Holtz, R. D., Holm, G. G. and Fredriksson, A., "Measurement of Horizontal In Situ Stresses," ASCE Proc. of Conference on In Situ Measurement of Soil Properties, pp. 266-286, 1975.
47. Lambe, T. W. and Whitman, R. V., Soil Mechanics, New York, Wiley and Sons, 1969.
48. Coates, D. F., Rock Mechanics Principles, Ottawa, Canada, Information Canada, Mines Branch Monograph 874, Rev. 1970.
49. Handy, R. L. and Williams, W. W., "Chemical Stabilization of an Active Landslide," ASCE Civil Engineering, Vol. 37, No. 8, pp. 62-65, 1967.
50. Schmertmann, ASCE Proc. of Conf. on In Situ Measurement of Soil Properties, June 1-4, 1975, Vol. II.

51. Amer, S., Baguelin, F., Jezeguel, J. F. and LeMahartc, A.,  
"In Situ Shear Resistance of Clays," ASCE Proc. of Conference  
on In Situ Measurement of Soil Properties, Vol. 1, pp 22-24,  
June 1 - 4, 1975.
52. Winter, Ernest and Rodriguez, Alvaro, "Evaluation of Preconsolidation  
and Friction Angle in Soils Using the Pressuremeter," ASCE  
Proc. of Conference on In Situ Measurement of Soil Properties,  
Vol. 1, pp. 523-535, June 1 - 4, 1975.
53. Brochure, "Goodman Jack," Slope Indicator Company, 3686 Albion  
Place North, Seattle, Washington 98103, July 1975.
54. Exploration for Soft Ground Tunnels - A New Approach," Schmidt,  
Birger, from study for UMTA, DOT/TSC-654, 1974.
55. Tamaro, George, "Concrete and Slurry Walls Using Slurry Trench  
Construction," Soil Mechanics and Foundation Engineers  
Conference, University of Minn. 1972.
56. Galler, Sol, "Slurry Wall Technique Expedites Subway Construction,"  
Public Works Magazine, August 1973.
57. Brochure, "Cast-in-Situ Diaphragm Wall," Soletanche, Paris, France.
58. Francs, E. Colas Des, "Prefasif Prefabricated Diaphragm Walls,"  
Conference on Diaphragm Walls and Anchorages, September  
18-20, 1974, London, England.
59. Hutchinson, M. T., Daw, G. P., Shotton, P. G. and James, A. N.,  
"The Properties of Bentonite Slurries Used in Diaphragm  
Walling and Their Control," Conference on Diaphragm Walls  
and Anchorages, September 18-20, 1974, London, England.
60. "Bentonite for Civil Engineering," Streetley Minerals Group, Berk  
Mineral Products Division, Basing View, Basingstroke, Hanks,  
England.
61. "Better Contracting for Underground Construction," U.S. National  
Committee on Tunneling, National Academy of Sciences, Washington,  
D.C. PB 236-973.
62. "Some Practical Aspects of Diaphragm Wall Construction," Fuchsberger,  
M., Conference on Diaphragm Walls and Anchorages, September,  
18-20, 1974, London, England.
63. Glossop, R., "The Rise of Geotechnology and its Influence in  
Engineering Practice," Geotechnique, V. 18, 105-150,  
March 1968.

64. Earth Manual, U.S. Department of Interior, Bureau of Reclamation, 2nd Edition, U.S. Government Printing Office, Washington, D.C., 1974.
65. Bing and Jackson, Bureau of Standards Bulletin 14, 75 (1918).
66. Cambefort, Henri, "Inyección de Suelos," Ediciones Omega, S.A., Casanova, 220 - Barcelona, Spain, 1968.
67. "The French Have a Way with Grout Curtains," Engineering News-Record, April 25, 1963, pp. 32-33.
68. "PANASOL" Prefabricated Retaining Walls, Brochure, Soletanche Entreprise, 7 Rue de Logelbach, Paris
69. "Time Lag and Soil Permeability in Groundwater Observations, Bulletin No. 36, Waterways Experiment Station, Corps of Engineers, Vicksburg, Mississippi, April 1951.
70. Wineland, John D., "Borehole Shear Device," ASCE Proc. of Conf. on In Situ Measurement of Soil Properties, Vol. I, pp. 511-522, June 1 - 4, 1975.



## 15. APPENDIX

- A. Glossary of Terms
- B. Bibliography
- C. Case Histories
- D. Testing Information
  - 1. In Situ Permeability Test Procedure
  - 2. Laboratory Grout Distribution Tests
- E. Sample Specifications
- F. Applicable Patents
- G. Grouting Specialists
- H. Grouting Material Suppliers
- I. Grouting Equipment Suppliers
- J. Bentonite Suppliers
- K. Current Research in Grouting Technology

## A. GLOSSARY OF TERMS

Activator - Catalyst or hardner, reactant - the chemical solution which causes a mixture to gel or set when mixed with the base solution.

Alluvium - Clay silt, sand gravel or other rock materials transported by flowing water and deposited in comparatively recent geologic time as sorted or semisorted sediments, in riverbeds, estuaries and flood plains, on lake shores and in fans at the base of mounting slopes.

Backpack Grouting - The filling with grout of the annular space between the permanent tunnel lining support and the soil.

Bentonite - A montmorillonite-type clay formed by the alternation of volcanic ash which swells in the presence of water.

Catalyst - See Activator.

Coefficient of Permeability - The rate of discharge of water under laminar flow conditions through a unit cross-sectional area of a porous medium under a unit hydraulic gradient and standard temperature conditions.

Changed Conditions or Differing Site Conditions - Subsurface or latent physical condition at the site differing materially from those indicated in a contract; or nature, differing materially from those ordinarily encountered and generally recognized as inherent in work of the character provided for in the contract, which conditions can bring about an equitable adjustment to modify the contract.

Compaction Grouting - Intruding a mass of viscous cement grout into cohesionless soil to fill voids and to compact the soil by pressure. If performed in cohesive soil this is known as Compensation or Displacement grouting.

Consolidate, Consolidation, Grouting or Solidify - Terms applied to the binding together of soil particles into a mass of soil, such as occurs in permeation grouting (see permeation grouting).

Cut-and-Cover Tunneling - A process of installing a structure below ground by excavating an area of sufficient width, constructing the permanent structure at the bottom of the excavation, and then restoring the ground surface over the structure.

Deformability - A measure of the elasticity or stress deformation characteristics of the grout in the interstitial spaces as the earth mass moves.

Diaphragm Walls - The construction of a vertical, continuous concrete wall, cast in situ or made of precast concrete panels, in a narrow trench filled with bentonite slurry to form a structural retaining wall.

Fracturing, Fracturing Treatment or Fracture Grouting - Grouting performed using an injection pressure considerably higher than the overburden pressure, which opens cracks or channels in the soil deposit. The grout then fills these channels and forms lenses.

Free Water (Groundwater) - Water that is free to move through a soil mass under the influence of gravity.

Gel Time - See Setting Time.

Groundwater Table (Free Water Elevation) - Elevations at which the pressure in the water is zero with respect to the atmospheric pressure.

Grout - A suspended cement or clay slurry or a chemical solution that can be poured or forced into the openings between soil or rock particles to solidify or to change the physical characteristics of the material.

Groutability - The ability of soil to allow grout to be forced into the interstitial spaces between the particles.

Groutability Ratio - The ratio of the 15 percent size of the formation particles to be grouted to the 85 percent size of the grout particles (suspension-type grout). This ratio should be greater than 19 if the grout is to successfully penetrate the formation.

Grout "Take" - The measured quantity of grout injected into a unit volume of formation or soils.

Hydrostatic Head - The pressure in the pore water under static conditions; the product of the unit weight of the liquid and the difference in elevation between the given point and the free water elevation.

Injectability - See Groutability

Joosten Grouting - The earliest of the chemical grout processes, originating in 1925. In this process, a sodium silicate solution is pumped into the soil as a grout pipe is advanced downward. The pipe is then flushed with water, and calcium chloride is pumped in as the pipe is retracted. A precipitate forms upon contact between the two solutions.

Mixed Face - The face of a tunnel which consists of soil and hard rock.

Mud Jacking - A process in which a hole is bored through a concrete slab which has subsided and a water-soil cement slurry is pumped under the slab to fill voids, raise the slab and support the slab.

Mohr Circle - A graphical representation of the stresses acting on the various planes at a given point.

Newtonian Fluid - A true solution which tends to exhibit constant viscosity at all rates of shear.

Non-Newtonian Fluid - Not a true fluid which exhibits increasing viscosity at higher rates of shear.

Perched Water Table - A water table usually of limited area maintained above the normal free water elevation by the presence of an intervening relatively impervious confining stratum.

Permeability - See Coefficient of Permeability

Permeation Grouting - Replacing the water or air in the voids of the soil mass with a grout fluid at a low injection pressure to prevent creation of a fracture, permitting the grout to set at a given time to bind the soil particles into a soil mass.

Porosity - The ratio of the volume of the voids or pores to the total volume of the soil.

Proprietary - Made and marketed by one having the exclusive right to manufacture and sell; privately owned and managed.

Pumpability - A measure of the properties of a fluid or slurry grout to be pumped.

Reactant - See Activator

Resin - A synthetic addition or condensation polymerization substance or natural substance of high molecular weight, which under heat, pressure, or chemical treatment becomes a solid.

Setting Time - A term defining the hardening time of Portland Cement or the gel time for a chemical grout.

Slurry - Suspension of cement or clays in water or a mixture of both.

Slurry Wall - See Diaphragm Wall

Slurry Trench - A relatively narrow trench which is usually dug with a clamshell while the excavated portion is kept filled with a bentonite slurry to stabilize the walls of the trench.

Syneresis - When freshly prepared sodium silicate gel is placed in a closed glass container, a significant amount of water can be observed being extruded by the gel. This is the phenomenon of syneresis.

Toxicant - A poisonous agent.

True Solution - One in which the components are 100% soluble in the base solution

Tube a' Manchette - A plastic tube (pipe) of approximately 1 1/2" inside diameter, perforated with rings of 4 small holes at intervals of about 12 inches. Each ring of perforations is enclosed by a short rubber sleeve fitting tightly around the pipe so as to act as a one-way valve when used with an inner pipe containing packing elements which isolate a hole for injection of grout.

Tunnel Face - The principal frontal surface presenting the greatest area, such as the face of a pile of material, the point at which material is being mined.

Unconfined Compressive Strength - The load per unit area at which an unconfined prismatic or cylindrical specimen of material will fail in a simple compression test.

Void Ratio - The ratio of the volume of void space to the volume of solid particles in a given soil mass.

Water-Cement Ratio - The ratio by weight of water to the total dry solids in a cement slurry.

Water Intrusion - The flowing of water into unwanted areas, such as trenches and tunnels.

## B. Bibliography

### GROUTING IN SOILS

- Allen, R. H. and Galpin, J. W., "An Example of Controlled Pregrouting in Shaft Sinking," AIMME, Technical Publication No. 2427, February 1948.
- "AM-9 Chemical Grout," Technical Data, 1965, American Cyanamid Company, Wayne, New Jersey.
- Amer, S., Baguelin, F., Jezeguel, J. F. and LeMahartc, A., "In Situ Shear Resistance of Clays," ASCE Proceedings of Conference on In Situ Measurement of Soil Properties, Vol. 1, pp. 22-24, June 1 - 4, 1975.
- Anderson, E. Roy and McCusker, T. G., "Chemical Consolidation in a Mixed Face Tunnel," 1st North American Rapid Excavation and Tunneling Conference Proceedings, 1972, Chapter 21.
- Annett, S. R., "Chemical and Physical Aspects of Grouting Potash Mine Shafts," Canadian Min. and Met. Bulletin 62, pp 715-21, July 1969.
- "Applications Prove Chemical Grout Useful," Diamond Alkali's Siroc, Chemical and Engineering News 43: pp. 46-7, July 19, 1965.
- Ash, T. L.; Russel, B. E., Rommel, R. R., "Improved Subsurface Investigation for Highway Tunnel Design and Construction," Volume 1, FHWA-RD-74-29, May 1974.
- Badger, W. W. and Lohnes, R. A., "Pore Structure of Friable Loess," Highway Research Record No. 429: 14-23, 1973.
- Beard, D. C. and Weyl, P. K., Influence of Texture on Porosity and Permeability of Unconsolidated Sand," The American Association of Petroleum Geologists Bulletin, Vol. 57, No. 2, February 1973.
- Behre, M. C., "Chemical Grout Stops Water in Dump Fill with 70% Voids," Civil Engineer, 32: pp. 44-6, September 1962.
- "Bentonite for Civil Engineering," Streetley Minerals Group, Berk Minerals Products Division, Basing View, Basingstroke, Hanks, England.
- "Better Contracting for Underground Construction," U.S. National Committee on Tunneling, National Academy of Sciences, Washington, D.C. PB 236973, November 1974.
- Bing and Jackson, Bureau of Standards Bulletin 14, 75 (1918).
- "Bibliography on Chemical Grouting," ASCE, Journal, Soil Mechanics and Foundations Division, Vol. 92, No. SM6, November 1966.

- Brockett, R. W., "Survey of Modern Grouts and Grouting," Structural Engineer, No. 5, Vol. 52, Page A5, May 1974.
- Brown, D. R. and Warner, James, "Compaction Grouting," Journal of Soil Mechanics and Foundations Division ASCE, Vol. 99, SM8, August 1973.
- "Building Sites Stabilized with Grout," Engineering News-Record, V. 134, No. 2, pp. 68-9, January 11, 1945.
- Burmister, D. M., "Physical, Stress Strain and Strength Responses of Granular Soils," ASTM Special Publication No. 322, 1962.
- Calhoun, Max L., "Pressure-Meter Field Testing of Soils," Civil Engineering, July 1969, pp. 71-74.
- Cambeport, Henri, Inyección de Suelos," Ediciones Omega, S.A., Casanova, 220 - Barcelona, Spain, 1968. (Spanish Edition). Also available in French. No English edition.
- Cambeport, H. and Caron, C., "The Leaching of Sodium Silicate Gels," Proceedings of the 4th International Conference of Soil Mechanics and Foundation Engineering.
- Campbell, Chester W., "Chemicals Seal Foundation for New York Building," Civil Engineering, October 1957.
- Caron, C., "Development of Grouts for the Injection of Fine Sands," Grouts and Drilling Muds in Engineering Practice, Butterworths, London, 1963, pp. 136-141.
- Caron, C., Delisle, J. P. and Godden, W. H., "Resin Grouting with Special Reference to the Treatment of the Silty Fine Sand of the Woolwich and Reading Beds at the New Blackwell Tunnel," Grouts and Drilling Muds in Engineering Practice, Butterworths, London, 1963, pp. 142-145.
- Chadeisson, R., "Results of Injections in Cohesionless Soils," Consulting Engineer, London, V. 24, No. 4, pp. 425-428, October 1963; No. 5, pp. 547-522, November 1963; No. 6, pp. 652-653, December 1963.
- "Chemical Consolidation in Civil Engineering Practice," Geotechnical Pamphlet No. 7, Soil Mechanics Ltd., 1961.
- Chemical Grout Field Manual, 3rd Edition, Engineering Chemicals Research Center, American Cyanamid, Wayne, New Jersey, April 1966.
- "Chemical Grout Prevents Water Inflow," Coal Age, V. 67, p. 112, September 1962.
- "Chemical Grout Seals Shafts Through Wet Sand," Construction Methods and Equipment, May 1962.

- "Chemical Grout Technique Solves Meramec Shaft Sinking Problem," Engineering and Mining Journal, V. 160, pp. 107-9, November 1959.
- "Chemical Grouting; Progress Report of the Task Committee on Chemical Grouting," ASCE Soil Mechanics and Foundations Division Journal, Vol. 83, No. SM4, Paper 1426, November 1957.
- "Chemicals Solidify Beach Sand," Southwest Builder and Contractor, May 14, 1965.
- "Chemject to Prevent Seepage into Underground Structures," Chemject Corporation, 3521 N. Cicero Avenue, Chicago, Illinois
- Coates, D. F., "Rock Mechanics Principles," Ottawa, Canada, Information Canada, Mines Branch Monograph 874, Rev. 1970.
- Compton, A. J., "An Introduction to Alluvial Grouting," Structural Engineer, V. 52, No. 5, p. A-13, May 1974.
- Corps of Engineers EM 1110-2-3501, "Foundation Grouting: Planning," July 1966.
- Corps of Engineers, EM 1110-2-3503, "Foundation Grouting: Field Technique and Inspection," August 1963.
- Corps of Engineers, EM 1110-2-3502, "Foundation Grouting - Equipment," April 1949.
- Corps of Engineers, EM 1110-2-3504, "Chemical Grouting," May 1973.
- Corps of Engineers, TM 3-408, "Grouting of Foundation Sands and Gravels," June 1955.
- Crawhall, J. S., "Tunneling a Water-Bearing Fault by Cementation," Engineering News-Record, May 30, 1929, p. 874.
- Cunningham, L. J., "Use of Chemicals in Mine Grouting," Canadian Mining and Metals Bulletin 55:480-3, July 1962.
- "Cut-and-Cover Tunneling Techniques," Vol. 1, Report No. FHWA-RP-73-40, February 1973.
- "Cyanaloc 62 Chemical Grout," Explosives and Mining Chemicals Department, American Cyanamid Company, October 1962.
- Delft Soil Mechanics Laboratory, Brochure, 1974, Stieltjesweg 2, P. O. Box 69, Delft, Holland.
- Dempsey, J. A. and Moller, K., Grouting in Ground Engineering, Institute of Civil Engineers, London, 1970.



- Department of the Army, Office of the Chief of Engineers, EM 1110-2-1906, "Laboratory Soils Testing," November 1960.
- Department of the Army and Air Force, TM 5-818-6, AFM 88-32, "Grouting Methods and Equipment," February 1970.
- Dixon, Schaefer J., and Jones, Walter V., "Soft Rock Exploration and Pressure Equipment," Civil Engineering, October 1968, p. 34.
- Dorion, G. H. and others, "Permeability of Sand Stabilized with Chemical Grout," ASTM Bulletin, December 1960, p. 34-5.
- "Driving a Difficult Tunnel in Soft Ground," Engineering News-Record, pp. 507-13, April 1935.
- Dumbleton, M. J., "Some Sources of Information for Site Investigations," Ground Engineering, Vol. 7, No. 3, May 1974.
- Earth Manual, U.S. Department of Interior, Bureau of Reclamation, 2nd Edition, U.S. Government Printing Office, Washington, D.C. 1974.
- Einstein, H. A. and Schnitter, G., "Selection of Chemical Grout for Mattmark Dam," Proceedings of Soil Mechanics and Foundation Div., Vol. 96, SM6, pp. 2007-2023, November 1970.
- Elston, J. P. and Kravetz, G. A., "Discussion of Field Experiences with Chemical Grouting," by M. Polivka and L. P. Witte and J. P. Gnaedinger, ASCE Soil Mechanics and Foundation Div. Journal, Vol. 83, No. SM4, Part 1, Paper 1430, November 1957.
- EM-1110-2-3501, Corps of Engineers, "Foundation Grouting: Planning," July 1966.
- EM-1110-2-3502, Corps of Engineers, "Foundation Grouting: Equipment," April 1949.
- EM 1110-2-3503, Corps of Engineers, "Foundation Grouting: Field Technique and Inspection," August 1963.
- EM 1110-2-3504, Corps of Engineers, "Chemical Grouting," May 1973.
- "Engineering Properties of Three Sand-Gel Systems," Final Report No. 121, Mass. Institute of Tech., Cambridge, Mass., August 1961.
- Fawcett, David F., Journal of Soil Mechanics and Foundation Division, ASCE, Vol. 99, SM8, August 1973, pp. 638-639.

- Fern, K. A., "Application of Polymerization Techniques to the Solution of Grouting Problems," Grouts and Drilling Muds in Engineering Practice, Butterworths, London, pp. 146-149, 1963.
- Flatau, A. S., Brockett, R. W., Brown, J. V., "Grouts and Grouting - A Survey of Materials and Practice," Civil Engineering and Public Works Review, July 1973.
- "French Have a Way with Grout Curtains," Engineering News-Record, April 25, 1963.
- Glossop, R., "A Classification of Geotechnical Processes," Geotechnique, London, 2, 1, March 12, 1950.
- Glossop, R., "The 8th Rankine Lecture, The Rise of Geotechnology and its Influence on Engineering Practice," Geotechnique, V. 18, March 1968.
- Glossop, R., "The Invention and Development of Injection Processes," Part I - 1802-1850, Geotechnique, V. 10, No. 3, Sept. 1961: Part II - 1850-1860, Geotechnique, V. 11, No. 4, Dec. 1961.
- Glossop, R., "The Rise of Geotechnology and its Influence in Engineering Practice," Geotechnique, V. 18, p. 105-150, March 1968.
- Gnaedinger, J. P., "Symposium on Grouting: Grouting to Prevent Vibration of Machinery," ASCE, Soil Mechanics and Foundations Division Journal, Vol. 87, No. SM2, April 1961.
- Golder, H. Q. and Gass, A. A., "Field Tests for Determining Permeability of Soil Strata," ASTM Special Technical Publication No. 322, 1962.
- Golder, H. Q. and Harding, J. J. B. and Sefton Jenkins, R. A., "An Unusual Case of Underpinning and Strutting for a Deep Excavation Adjacent to Existing Buildings," Proceedings of the 5th International Conference of Soil Mechanics and Foundation Engineers, 2, p. 413, 1961.
- "Goodman Jack," Brochure, Slope Indicator Company, 3686 Albion Place North, Seattle, Washington 98103, July 1975.
- Graham, J. R. and Karpoff, K. P., "Chemical Grouting Investigations on Navajo Sandstone, Glen Canyon Dam, Colorado River Storage Project," Lab Report No. C-1064, Conc. and Struc. Branch, U.S. Bureau of Reclamation, Denver, Colorado, October 1963.
- Graham, J. R., "Chemical Grouting of Soil and Rock," For Presentation at 1967 Earth Control and Investigations Course and Concrete Control Course, U.S. Bureau of Reclamation, Denver, Colorado.
- Granton, I.C. and Frazer, H. J., "Systematic Packing of Spheres with Particular Relation to Porosity and Permeability," Journal of Geology, Vol. 43, No. 8, 1935.

Greenwood, D. A. and Raffle, J. F., "Formulation and Application of Grouts Containing Clay," Grouts and Drilling Muds in Engineering Practice, Butterworths, London, pp. 127-130, 1963.

"Grout Curtain Seals Excavation," Engineering News-Record, November 28, 1968.

"Grout Selection: A New Classification System," by I. C. Hilton, Civil Engineering (London), September 1967.

"Grouting with Bentonite," Concrete, V. 44, No. 7, p. 28, July 1936.

"Grouting in Dry Sands," American Cyanamid Company, Princeton, New Jersey, October 2, 1962.

Grouting Inspector's Manual, The Metropolitan Sanitary District of Greater Chicago, July 1975.

Grouting Methods and Equipment, TM 5-818-6, AFM 88-32, February 1970.

"Grouting - River Tunnel in England Made Dry by Grouting," Engineering News-Record, March 21, 1932, p. 430.

"Grouting Design and Practice," Consulting Engineer (London) October 1969.

"Grouting-Pumping Equipment," Eric Heaton, Mining in Canada, November 1968.

Grouts and Drilling Muds in Engineering Practice, Butterworths, London, 1963. (Symposium - British National Society of International Society of Soil Mechanics and Foundation Engineering of the Institute of Civil Engineers).

"Grouts and Grouting Materials, Applications and Plant," Civil Engineering and Public Works Review, London, July 1973.

"Guide Specifications for Chemical Grouts," Journal of Soil Mechanics and Foundation Division, Vol. 94, SM2, March 1968.

Haffen, M. and Janin, J., "Grouting Cohesionless Water-Bearing Soils in City Tunnels," Proceedings, First North American Rapid Excavation and Tunneling Conference, Chapter 85, 1972.

Handy, R. L. and Williams, W. W., "Chemical Stabilization of an Active Landslide," ASCE Civil Engineering, Vol. 37, No. 8, pp. 62-65, 1967.

Heaton, Eric, "Grouting," Mining in Canada, Feb., Mar., June, Nov., Dec., 1968 and March 1969 (Series of 6 Articles)

Hegarty, A., "Chemical Grouting," Mining Magazine, p. 20-23, July 1960.

- "Herculox Resin Grout," Technical Data Sheet PGS-0003, Halliburton Services, Duncan, Oklahoma.
- Hilton, I. C., "Grout Selection: A New Classification System," Civil Engineering, September 1967 (London).
- Hower, W. and others, "Fluid Grout for Water Control," Petroleum Engineer 39: B 26-9, June 1958.
- Hurley, Claude H. and Thornburn, Thomas H., "Sodium Silicate Stabilization of Soils - A Review of the Literature," VILV-ENG-71-2007, University of Illinois, Urbana, Illinois, February 1971.
- Hvorslev, M. J., "Time Lag and Soil Permeability in Groundwater Observations," Bulletin No. 36, Waterways Experiment Station, Corps of Engineers, U.S. Army, Washington, D.C. April 1951.
- Imako, Minoru, "Chemical Grouting Material of the Sodium Silicate, Sodium Aluminate System," Tokyo University, Chemical Abstract V. 46, April - July 1952.
- "Injectrol® G Silicate Grout," Halliburton Services Technical Data Sheet PGS-0036.
- Intrusion Prepakt, Inc., Cleveland, Ohio, Special Report No. 102.
- Ischy, E. and Glossop, R., "An Introduction to Alluvial Grouting," Institute of Civil Engineers, Paper No. 6598.
- Janin, Jean and LeSciellour, Guy, "Chemical Grouting for Paris Rapid Transit Tunnels," Journal of Construction Division, ASCE, Vol. 96, June 1970.
- "Japanese Tackle Water to Drive Record Tunnel," Engineering News-Record, pp. 16-17, April 4, 1974.
- Jones, Chester W., "The Permeability and Settlement of Laboratory Specimens and Sand-Gravel Mixtures," Symposium on Permeability of Soils, ASTM Special Publication No. 163, June 1954.
- Jones, G. K., "Chemistry and Flow Properties of Bentonite Grouts," Grouts and Drilling Muds in Engineering Practice, Butterworths, London, p. 22-28, 1963.
- Joosten, J. H., "The Joosten Process," Chemical Soil Solidification Company, 7650 S. Laflin Street, Chicago, Illinois 60629.
- Karol, R. H., "AM-9 Admixture for Cement," American Cyanamid Company, Wayne, New Jersey, January 1961.

- Karol, R. H., "Chemical Grouting Technology," Journal SM & F Div. SMI, Vol. 94, January 1968.
- Karol, R. H., "Chemical Grouts and Field Grouting," American Cyanamid Company, 1963.
- Karol, R. H., "Field Tests for Evaluating the Effectiveness of a Grouting Operation," American Cyanamid Company, 1960.
- Karol, R. H., "Gel Extrusion from Grout Holes," American Cyanamid Company, Princeton, New Jersey, February 1963.
- Karol, R. H., "Grout Curtains-Short Gel Times in Flowing Ground Water," American Cyanamid Company, 1961.
- Karol, R. H., "Grouted Cutoff Malpaso Dam, Chiapos, Mexico," American Cyanamid Company, May 1963.
- Karol, R. H., "Grout Viscosities," American Cyanamid Company, Princeton, New Jersey, March 1963.
- Karol, R. H., "Physical Properties of Chemical Grouts," American Cyanamid Company, November 1963.
- Karol, R. H., "Pumping Equipment for Chemical Grout," American Cyanamid Company, Princeton, New Jersey.
- Karol, R. H., "Short Gel Times with Long Pumping Times," American Cyanamid Company, Princeton, New Jersey, April 1961.
- Karol, R. H., Soils and Soil Engineering, Prentice-Hall, 1960.
- Karol, R. H. and Swift, A. M., "Symposium on Grouting: Grouting in Flowing Water and Stratified Deposits," ASCE, Soil Mechanics and Foundations Division Journal, Vol. 87, No. SM2, pp. 125-145, April 1961.
- King, J. C. and Bush, E. G. W., "Symposium on Grouting: Grouting of Granular Materials," American Society of Civil Engineers Proc., Vol. 87, SM2, No. 27911:1-32, April 1961.
- Kjellman, W., Kallstenius, T., and Wagner, O., "Soil Sampler with Metal Foils," Proc. Royal Swedish Geotech. Inst. No. 1, 77 pp., 1950.
- Kravetz, G. A., "The Use of Clay in Pressure Grouting," Proceedings ASCE, Vol. 84, No. SM1, February 1958.
- Kutzner, C. and Ruppel, G., "Chemical Soil Stabilization for Tunneling Under the Main Station in Cologne, as Part of the Underground Railway Construction," Strasse-Bruck Tunnel 22, November 8, 1970, p. 202.

- "Laboratory Soils Testing," EM 1110-2-1906, Office of the Chief of Engineers, U.S. Army Corps of Engineers, November 1970.
- Lambe, T. W., "Chemical Injection Processes," Annual Meeting ASCE, New York, October 1954.
- Lambe, T. W., "Effect of Polymers on Soil Properties," Proceedings, 3rd International Conference on Soil Mechanics and Foundation Engineering, Switzerland, August 1953.
- Lambe, T. W. and Whitman, R. V., Soil Mechanics, New York, Wiley and Sons, 1969.
- Lamberton, Bruce A., "Discussion of Strength Properties of Chemically Solidified Soils," Journal of Soil Mechanics and Foundation Div. ASCE, SM8, August 1973.
- Lancaster-Jones, P. F. F. and Gillott, C. A., "The Grouted Cutoff Curtain," Proc. of Inst. of C. E. (London) V. 14, October 1959.
- Leonard, J. T., "Grouting, Clay-Based and Chemical," Engineer, 211: 864-6, May 26, 1961.
- Leonard, M. W. and Dempsey, J. H., "Clays for Clay Grouting," Grouts and Drilling Muds in Engineering Practice, Butterworths, London, pp. 119-126, May 1963.
- Leonard, M. W. and Moeller, K., "Grouting for Support, with Particular Reference to the Use of Some Chemical Grouts," Grouts and Drilling Muds in Engineering Practice, p. 156-163, Butterworths, London, May 1963.
- Maillard, R. and Serota, S., "Screen Grouting of Alluvium by the E. T. F. Process," Grouts and Drilling Muds in Engineering Practice, pp. 75-79, Butterworths, London, May 1963.
- Marsland, A. and Loudon, A. G., "The Flow Properties and Yield Gradients of Bentonite Grouts in Sands and Capillaries," Grouts and Drilling Muds in Engineering Practice, p. 15-21, Butterworths, London, May 1963.
- Massargoh, Holtz, Holm and Fredricksson, "Measurement of Horizontal In Situ Stresses," ASCE Proc. of Conf. on In Situ Measurement of Soil Properties, pp. 266-286, 1975.
- Mayer, A., "Modern Grouting Techniques," Grouts and Drilling Muds in Engineering Practice, p. 7-9, Butterworths, London, May 1963.
- Mincheff, E. E., "How to Stabilize and Level a Tank that is Settling," Fifth Annual Meeting, API Division of Transportation, Proc., Philadelphia, Pennsylvania.

- Minear, V. L., "Use and Technique of Pressure Grouting in the Construction Industry," AIMME, Paper 2427, February 1948.
- Mitchell, L. K., "In-Place Treatment of Foundation Soils," Journal of Soil Mechanics and Foundation Division ASCE, Vol. 96, SMT, p. 73-110, January 1970.
- Morgenstern, N. R. and Vaughan, P. R., "Some Observations on Allowable Grouting Pressures," Proceedings of the Conference on Grouts and Drilling Muds in Engineering Practice, pp. 36-42, Butterworths, London, May 1963.
- Mott, B. H., "Solidifying Mines and Shaft Areas by Pressure Grouting," AIMME Technical Publication 2427, February 1948.
- Neelands, R. J. and James, A. N., "Formulations and Selection of Chemical Grouts and Typical Examples of their Field Use," Grouts and Drilling Muds in Engineering Practice, Butterworths, London, pp. 150-155, 1963.
- Neumann, H. and Wilkins, L. S., "Soil Solidification by Chemical Injection," Civil Engineering and Public Works Review, p. 635, June 1972.
- "New Chemical Grouting Processes," U.S. Waterways Experiment Station Bulletin (Soil Mechanics) V. 1, No. 9, p. 8, October 1, 1973.
- Numata, M. Maruyasha, T., and Kurosaki, "New Methods of Chemical Grouting to Solidify Loose Ground," Japan Society of C.E. No. 12, February 1952.
- "PANASOL" - Prefabricated Retaining Walls, Brochure, Soletanche Entreprise, 7 Rue de Logelbach, Paris.
- "Paris Subway is Built in Grout Casing," Engineering News-Record, January 1, 1970, p. 2.
- Peck, R. B., Hendron, A. J., Jr. and Mohraz, B., "State of the Art of Soft Ground Tunneling," Proceedings, 1st North American Rapid Excavation and Tunneling Conference AIME, 1972.
- Perrott, W. E., "British Practice for Grouting Granular Soils," Journal, American Society of Civil Engineers, SM6, 1965.
- Perrott, W. E. and Lancaster-Jones, P. F. F., "Case Records of Cement Grouting," Grouts and Drilling Muds in Engineering Practice, pp. 80-84, Butterworths, London, 1963.

- Polivka, M., Witte, L. P. and Gnaedinger, J. P., "Field Experience with Chemical Grouting," Journal, ASCE Soil Mechanics and Foundations Engineering Division, Vol. 83, No. SM2, Paper 1204, April 1957.
- "Pressure Grouting," U.S. Department of Interior, Bureau of Reclamation, TM-646, June 1957.
- "PWG® Chemical Grout," Technical Data Sheet PGS-0006, Halliburton Services, Duncan, Oklahoma 73533.
- Raffle, J. F. and Greenwood, D. A., "The Relation Between the Rheological Characteristics of Grouts and Their Capacity to Permeate Soil," Proceedings of the 5th International Conference on Soil Mechanics and Foundation Engineers, 2, 789, 1961.
- Riedel, C. M., "Chemical Soil Solidification in Foundation-Water Control and Tunnel Work," Sixth Annual Conference on Soils Mechanics and Foundation Engineering, University of Minnesota, Minneapolis, Minnesota, pp. 37-44, 1958.
- Riedel, C. M., "Chemical Soil Solidification Work in Construction and Emergencies," Proceedings of the Conference on Soil Stabilization, Massachusetts Institute of Technology, Cambridge, Mass. June 18-20, 1952, pp. 68-80.
- "Rockmakers," Architectural and Engineering News, March 1959.
- Schiffman, R. L. and Wilson, C. R., "The Mechanical Behavior of Chemically Treated Granular Soils," ASTM 58, 1958.
- Schmertmann, ASCE Proc. of Conference on In Situ Measurement of Soil Properties, June 1-4, 1973, Vol. 2.
- Scott, R. A., "Fundamental Considerations Governing the Permeability of Grouts and their Ultimate Resistance to Displacement," Grouts and Drilling Muds in Engineering Practice, pp. 10-14, Butterworths, London, 1963.
- "Shaft Sinking with Chemical Grout - Monktonhall Coal Mines," Coal Age, 66:72, September 1961.
- "SIROC Grout Technical Manual," Diamond Alkali Company, Cleveland, Ohio, 1964.
- Skempton, A. W. and Cattin, P., "A Full-Scale Alluvial Grouting Test at the Site of Mangla Dam," Grouts and Drilling Muds in Engineering Practice, pp. 131-135, Butterworths, London, 1963.
- Skipp, B. O. and Renner, L., "The Improvement of the Mechanical Properties of Sand," Grouts and Drilling Muds in Engineering Practice, pp. 29-35, Butterworths, London, 1963.



- "Sodium Silicate Stabilization of Soils - A Review of the Literature," by Hurley, Claude H. and Thornburn, Thomas, University of Illinois, Soil Mechanics Laboratory, Department of Civil Engineering and State of Illinois, Division of Highways, U.S. Department of Transportation, February 1971.
- "Soil Limits for Grout Injectivity," Graph - Halliburton Services, Duncan, Oklahoma 73533.
- "Soft Ground Tunnel Gives Jersey Sewer Contractor Hard Time," Engineering News-Record, September 29, 1966, pp. 26-28.
- Spangler, M. G. and Handy, R. L., Soil Engineering, Third Edition, Intex Educational Publications, 1973.
- "Soluble Silicates, Properties and Applications," Bulletin 17-1, Philadelphia Quartz Company, 1964.
- "Special Chemical Grout Helps Driving Tunnel at Hunterston Nuclear Power Station," Civil Engineering and Public Works Review, London, July 1973.
- "Surface Grouting Stabilizes Cut," Engineering News-Record, September 12, 1963, 171:51.
- "T.D.M. Process," The Cementation Company Ltd., Ground Engineering Division, London.
- "Terra Firma Chemical Grout, a Precatalyzed Lino-Sulfonate," Concrete Chemicals Company, Cleveland, Ohio.
- Thatcher, John H., "A Difficult Foundation Problem Solved with the Aid of Soil Solidification," Transactions of the New York Academy of Sciences, Sec. 2, Vol 27, No. 2, pp. 203-209.
- "Three Uses of Chemical Grout Show Versatility," Engineering News-Record, May 31, 1962, p. 168-70.
- "Time Lag and Soil Permeability in Groundwater Observations," Bulletin No. 36, Waterways Experiment Station, Corps of Engineers, Vicksburg, Mississippi, April 1951.
- TM-3-408, "Grouting of Foundation Sands and Gravels," Corps of Engineers, June 1955.
- TM 5-818-6, AFM 88-32, "Grouting Methods and Equipment," Department of the Army and Air Force, February 1970.
- "Tough Tunnel Bows to Chemical Grouting Baltimore's Susquehanna Water Tunnel," Engineering News-Record 168: 32-4, March 29, 1962.

Tschebotarioff, G. P., Soil Mechanics, Foundations and Earth Structures, McGraw Hill, New York, New York.

"Underground Mining: Ground Support: Grout Available to Suit Any Application," Engineering and Mining Journal, 167: 432, June 1966.

U.S. Department of the Interior, Bureau of Reclamation, TM 646, "Pressure Grouting," June 1957.

Vanoi, Dr. Ing. Diego, "Some Results in Freeway Tunneling by Means of Grouting Technique," Tunnel Symposium, Japan Society of Civil Engineers, 1970.

Warner, James, "Strength Properties of Chemically Solidified Soils," ASCE, Journal Soil Mechanics and Foundation Div., SM-11, November 1972.

Warner, James and Brown, D. R., "Planning and Performing Compaction Grouting," Journal of Geotechnical Engineering Division, ASCE, Vol. 100, No. GT-6, June 1974.

Wineland, John D., "Borehole Shear Device," ASCE Proc. of Conf. on In Situ Measurement of Soil Properties, Vol. 1, pp. 511-522, June 1 - 4, 1975.

Winter, Ernest and Rodriguez, Alvaro, "Evaluation of Preconsolidation and Friction Angle in Soils Using the Pressuremeter," ASCE Proc. of Conference on In Situ Measurement of Soil Properties, Vol. 1, pp. 22-24, June 1 - 4, 1975.

Welsh, Joseph P., "Soil Solidification," Metropolitan Section, Proc. Construction Group, ASCE, New York, New York, February 3, 1975.

Wright, R. E., "Chemical Grouting with Silicate-Bicarbonate and Silicate Aluminate Mixtures," Chemical Grout Symposium, Engineer's Club of San Francisco, Philadelphia Quartz Company of California, January 24, 1964.

## SLURRY TRENCHES AND BOREHOLE STABILIZATION

- Barla, G. and Mascardi, C., "High Anchored Wall in Genoa," Conference on Diaphragm Walls and Anchorages, Session IV, September 18-20, 1974, London.
- Beard, D. C. and Weyl, P. K., "Influence of Texture on Porosity and Permeability of Unconsolidated Sand," The American Association of Petroleum Geologists Bulletin, V. 57, No. 2, February 1973, p. 349-369.
- Behrendt, J., "The Slurry Trench Wall Construction Method Used in Underground Railway Construction in Cologne," Bauingenieur, 45, 204, p. 121, 1970.
- "Bentonite for Civil Engineering," Streetley Minerals Group, Berk Mineral Products Division, Baginstroke, Hanks.
- "Bentonite Slurry Stabilizes Trench and Keeps Groundwater Out," Engineering News-Record, February 11, 1960, p. 42.
- Boyes, R. G. H., Structural and Cut-Off Diaphragm Walls, Halsted Press, Wiley, New York 10016.
- "Cast-in-Situ Diaphragm Wall," Brochure, Soletanche, Paris, France.
- Cooke, P. W., "Up-to-Date Techniques with Drilling Mud," Grouts and Drilling Muds in Engineering Practice, Butterworths, London, 1963.
- "Concrete Displaces Slurry for Deep Perimeter Wall of Trade Center," Contractors and Engineers Magazine, February 1968, p. 26.
- Corbett, B. O. and Stroid, M. A., "Temporary Retaining Wall Constructed by Berlinoise System at Centre Beaubourg, Paris," Conference on Diaphragm Walls and Anchorages, Session 3, Paper 13, September 18-20, 1974, London.
- Ebor, Gais, "First Construction of Tunnel Sections with a Supporting Arch Between Slurry Trench Walls in the Building of the Rapid Transit System in Munich," Eisenbahngig, Vol. 21, p. 268, 1970.
- Elson, W. K., "An Experimental Investigation of the Stability of Slurry Trenches," Geotechnique, Vol. 18, No. 1, p. 37, 1968.
- Fehlmann, H. B., "The Application of Thixotropic Liquids Based on Bentonite for Subsoil Treatment," Proceedings of the 5th International Conference on Soil Mechanics and Foundation Engineering, 2, p. 765, 1971.

- Flatau, A. S., Brockett, R. W. and Brown, J. V., "Grouts and Grouting - A Survey of Materials and Practice," Civil Engineering and Public Works Review, London, July 1973.
- Fleming, W. G. K., Fuchsberger, M., Kipps, O., and Sliwinski, Z., "Diaphragm Wall Specification," Conference on Diaphragm Walls and Anchorages, Session 7, Paper 26, Sept. 18-20, 1974, London.
- Francs, E. Colas Des, "Prefasif Prefabricated Diaphragm Walls," Conference on Diaphragm Walls and Anchorages, September 18-20, 1974, Session 3, Paper 11, London.
- Fuchsberger, M., "Some Practical Aspects of Diaphragm Construction," Conference on Diaphragm Walls and Anchorages, September 18 - 20, 1974, London.
- Galler, Sol, "Slurry Wall Technique Expedites Subway Construction," Public Works Magazine, August 1973.
- Germachlnig, C. and Mathian, J., "Diaphragm Walls as Temporary Cutoff Walls at Sites of the Rhone," Travaux, Vol. 52, No. 428, 1970.
- Gerwick, Ben C., "Slurry Trench Techniques for Diaphragm Walls in Deep Foundation Construction," Civil Engineering, December 1967.
- Hetherington, H. A., "Drilling Muds for Mineral Drilling and Water Well Construction," Grouts and Drilling Muds in Engineering Practice, Butterworths, London, 1963.
- Hodgson, F. T., "Design and Construction of a Diaphragm Wall at Victoria Street, London," Conference on Diaphragm Walls and Anchorages, Session 2, Paper 7, September 18 - 20, 1974, London.
- Hutchinson, M. T., Daw, G. P., Shotton, P. G. and James, A. N., "The Properties of Bentonite Slurries Used in Diaphragm Walling and Their Control," Conference on Diaphragm Walls and Anchorages, September 18 - 20, 1974, London.
- "I.C.O.S. Company in the Underground Works," I.C.O.S., 1968.
- LaRusso, R. S., "Wanapum Development Slurry Trench and Grouted Cutoff," Grouts and Drilling Muds in Engineering Practice, Butterworths, London, 1963.
- "Leap-Frog Driving of Soldier Piles Cuts Slurry Trench Job Cost," Construction Methods, July 1968.

- Leonard, M. S. M., "Precast Diaphragm Walls Used for the Motorway, Paris," Conference on Diaphragm Walls and Anchorages, Session 3, Paper 12, September 18 - 20, 1974, London.
- Lorenz, H., "Utilization of a Thixotropic Fluid in Trench Cutting and the Sinking of Caissons," Grouts and Drilling Muds in Engineering Practice, Butterworths, London, 1968.
- Marker, H., "The Use of Slurry Trench Wall Construction Method," Schweizerische Bauzeitung, Vol. 88, No. 33, 1970, p. 735.
- McKinney, J. R. and Gray, G. R., "The Use of Drilling Mud in Large Diameter Construction Borings," Grouts and Drilling Muds in Engineering Practice, Butterworths, London, 1963, p. 218.
- Nash, J. K. T. L. and Jones, G. K., "The Support of Trenches Using Fluid Mud," Grouts and Drilling Muds in Engineering Practice, Butterworths, London, 1963, p. 177.
- Sadler, N. A. and Dominioni, G. C., "Underground Structural Concrete Walls," Grouts and Drilling Muds in Engineering Practice, Butterworths, London, 1963, p. 177.
- Saxena, S. K., "Measured Performance of a Rigid Concrete Wall at the World Trade Center," Conference on Diaphragm Walls and Anchorages, Session 4, Paper 14, September 18 - 20, 1974, London.
- Schmidt, Birger, "Exploration for Soft Ground Tunnels - A New Approach," Study for UMTA - DOT/TSC-654, 1974.
- Sliwinski, Z., Fleming, W. G. K., "Practical Considerations Affecting the Construction of Diaphragm Walls," Conference on Diaphragm Walls and Anchorages, September 18 - 20, 1974, London.
- "Slurry Trench Cutoff Wall Pierces Landslide Debris to Keep Site Dry," Engineering News-Record, November 13, 1975.
- "Special Rigs Go Through Rock and Wood to Form Slurry Trench," Construction Methods, July 1967.
- Spoor, Michael F., "Definition by Remote Sensing and the Chemical Grouting of Subsidence Areas," U.S. Army Engineer District, Huntington, West Virginia, Corps-Wide Geology, Soils and Drilling Meeting, October 1 - 4, 1974, Dallas, Texas.
- Tamaro, George, "Concrete and Slurry Walls Using Slurry Trench Construction," Soil Mechanics and Foundation Engineers Conference, University of Minn., 1972

Thon, J. G. and Harlan, R. C., "Slurry Walls for BART Civil Center Construction," Soil Mechanics and Foundation Division, ASCE, Journal, Paper 8361, September 1971, p. 1317.

Verder, C., "Excavation of Trenches in the Presence of Bentonite Suspension for the Construction of Impermeable and Load-Bearing Diaphragms," Grouts and Drilling Muds in Engineering Practice, Butterworths, London, 1963.

"Vibrating Beam Injects Thin Cutoff Walls," Engineering News-Record, November 27, 1973, p. 19.

Xanthakos, Petros P., "Underground Construction," National Education Seminar, University of Illinois, April 1974.

#### FREEZING

Bookreiev, D. A., Waterproofing and Drainage of Defense and Non-Defense Structures, Government Publication of Construction Literature, Moscow, 1943.

Brace, J. H., "Freezing as an Aid to Excavation in Unstable Material," Transactions, ASCE, Vol. 52, 1904.

Braun, Bernd, "Ground Freezing for Tunneling in Water-Bearing Soil at Dortmund, Germany," Tunnels and Tunneling, January 1972.

Bubbers, B. L., "Tunneling on the Brixton Extension of the Victoria Line," Tunnels and Tunneling, July 1971, p. 235.

"Construction Freezing," Terrafreeze Corporation, Lorton, Virginia 22079.

"Contractor Employs Deep Freeze," Mobay Chemical Company Builder News.

Cross, B., "Liquid Gas Freezes Bad Soil," Construction Methods and Equipment, New York, July 1964.

"Deep Freeze to Keep Shaft in Dry," Engineering News-Record, September 3, 1959, p. 25.

Dumont-Villares, A., "Underpinning the Companhia Paulista des Seguros Building, Sao Paulo," Geotechnique, London, March 1956.

- Ellis, D. R. and McConnell, J., "The Use of the Freezing Process in the Construction of a Pumping Station and Storm-Water Overflow at Fleetwood, Lancashire," Proceedings, Institute of Civil Engineers, London, February 1959.
- Endo, K., "Artificial Soil Freezing Method for Subway Construction," Civil Engineering in Japan, 1969, p. 103.
- Follenfant, H. G. and others, "Escalator Tunnel Victoria Line," Journal Institute of Civil Engineers, 1969, Paper 7270S
- "Freezing Makes Shaft Sinking Easier," Construction Methods and Equipment, New York, October 1954.
- Gail, Charles P., "Tunnel Driven Using Subsurface Freezing," Civil Engineering, May 1972, p. 37.
- Hashemi, Hadit and Slipecevich, Cedomir M., "Effect of Seepage Stream on Artificial Soil Freezing," Journal Soil Mechanics and Foundation Division, ASCE, SM3, March 1973.
- "Ice Wall Protects Shaft Excavation," American City, New York, April 1960.
- "Investigation of Description, Classification and Strength Properties of Frozen Soils," Vols. 1 and 2, Report 8, Frost Effects Laboratory, U.S. Army Corps of Engineers, Hanover, N. H., 1952.
- Kersten, Myles S., "Thermal Properties of Soils," University of Minnesota Bulletin 28, Vol. 52, No. 21, June 1, 1949.
- Khakimov, K. R., "Artificial Freezing of Soils - Theory and Practice," Israel Program for Scientific Translations, U.S. Department of the Interior, Washington, D.C., 1966.
- Latz, J. E., "Freezing Method Solves Problem in Carlsbad, New Mexico Shaft," Mining Engineering, October 1952.
- Low, G. J., "Soil Freezing to Reconstruct a Railway Tunnel," Journal of the Construction Division, ASCE, Vol. 86, No. C03, Paper 2639, November 1960.
- Sanger, F. J., "Ground Freezing in Construction," Journal of Soil Mechanics and Foundation Engineering, ASCE, Vol. 99, No. SM1, January 1968.

- Sayles, F. H., "Studies in the Creep of Frozen Soils," Technical Report 190, U.S. Army Cold Regions Research And Engineering Laboratory, Hanover, New Hampshire, 1967.
- "Shaft Sinking Can be a Chilling Experience," Engineering News-Record, August 9, 1962.
- Shuster, John A., "Controlled Freezing for Temporary Ground Support," First North American Rapid Excavation and Tunneling Conference, 1972, Chapter 49.
- Silinsh, J., "Freezing Keeps Shaft Dry and Holds Dirt in Place," Construction Methods and Equipment, January 1960.
- Smith, G. R., "Freezing Solidifies Tunnel Shaft Site," Construction Methods and Equipment, October 1962.
- Stewart, G. C., Gildersleeve, W. K., Janpole, S. and Connolly, J. E., "Freezing Aids Shaft Sinking," Civil Engineering ASCE, April 1963.
- "Swedes Quick-Freeze 39-Foot Tunnel Section," Engineering News-Record, October 29, 1970.
- Tsytovich, N. A. and Khakimov, K. R., "Ground Freezing Applied to Mining and Construction," Proceedings - 5th International Conference on Soil Mechanics and Foundations, Paris, 1961.
- Vialov, S. S., "Rheological Properties and Bearing Capacity of Frozen Soils," Translation No. 74, U.S. Army Cold Regions Research and Engineering Laboratory, Hanover, N. H., 1965.

#### TIEBACK ANCHORAGES

- "Anchors Hold Down Tunnel Sealed in Steel," Engineering News-Record, June 9, 1960, p. 29.
- "Batter Piles Brace Sheet piling Around Building Excavation," Engineering News-Record, March 11, 1965, p. 26.
- Booth, W. S., "Tiebacks in Soil for Unobstructed Deep Excavation," Civil Engineering, September, 1966, p. 46.
- "Bulkhead Tied Back to Soft Soil," Construction Methods, October 1967, p. 112.



- Dietrich, M., Chase, B., and Teul, W., "Tieback System Permits Uncluttered Site," Foundation Facts, Raymond International Vol. 7.
- Hanna, T. H. and Matallana, G. A., "The Behavior of Tied-Back Retaining Walls," Canadian Geotechnical Journal, 1970.
- Jones, N. C. and Kerkhoff, G. O., "Belled Caissons Anchor Walls as Michigan Remodels an Expressway," Engineering News-Record, May 11, 1961, p. 28.
- Kastnor, R. and Lareal, P., "Experimental Excavation of Length 50m Supported by Strutted Cast Diaphragm Walls: An Analysis of Stress Distribution in the Struts," Conference on Diaphragm Walls and Anchorages, September 18 - 20, 1974, London.
- Littlejohn, G. S., "Soil Anchors," Proceedings, Conference on Ground Engineering, London, June 1970.
- Littlejohn, G. S. and McFarlane, I. M., "A Case History Study of Multi-Tied Diaphragm Walls, Conference on Diaphragm Walls and Anchorages, September 18-20, 1974, London.
- "Long Buried Tiebacks Leave Cofferdam Unobstructed," Construction Methods and Equipment, May 1966.
- Mansur, Charles, "Tieback Sheeted Excavations," Construction Excavations University of Wisconsin, April 30, 1971.
- Meissner, H., "The Anchorage of Retaining Walls and Little Deformation," Bauingenieur, Vol. 45, No. 9, 1970.
- Nelson, James C., "Earth Tiebacks Support Excavation 112 Feet Deep," Civil Engineering, November 1973.
- Ostermayer, H., "Construction Carrying Behavior and Creep Characteristics of Ground Anchors," Conference on Diaphragm Walls and Anchorages, September 18 - 20, 1974, London.
- Reichenback, K., "Tieback Anchoring of Excavation Walls During Building of Underground Railway Lines 7 and 9," Strasse, Brucke, Tunnel, Berlin 23, No. 1, 1971, p. 18.

Shannon, William L. and Strazer, Robert J., "Tied-Back Excavation Wall for Seattle Bank," Civil Engineering, March 1970, p. 62.

"Soil Anchored Tie-Backs Aid Deep Excavation," Engineering News-Record, August 10, 1967, p. 34.

Wasser, Thomas D. and Darragh, Robert D., "Tiebacks for Bank of America Excavation Wall," Civil Engineering, March 1970, p. 65.

### C. CASE HISTORIES

Exhibit A - Tunnel Grouting - Bart System - San Francisco, California

Exhibit B - Chemical Grouting Beneath the Walt Whitman Bridge, Philadelphia, Pennsylvania

Exhibit C - Grouting a Vehicular Tunnel in Alaska

Exhibit D - Pregrouting for Tunnels under 26 Railroad Tracks, Pontiac, Michigan

Exhibit E - Grouting for Sewer Line Support Near Metro Tunnel, Washington, D. C.

Exhibit F - Grouting Overpass Piers on Route of Metro System, Washington, D. C.

Exhibit G - Grout Curtain on Earthen Dam - Public Service Company of Oklahoma Reservoir #3, Washita, Oklahoma

Exhibit H - Soil Consolidation for Tunnel Excavation, Washington, D. C.

Exhibit I - Chemical Soil Stabilization for Florida Power Corporation - Unit No. 3 - Crystal River

## EXHIBIT A

### CASE HISTORY

#### TUNNEL GROUTING - BART SYSTEM SAN FRANCISCO, CALIFORNIA

##### 1. Statement of Problem

Many times, the first contact to a grouting contractor from a tunneling contractor occurs when a problem is encountered with unconsolidated sand or water in large quantities. In this particular situation, the tunnel was being driven under air 90 feet below street level to a connection with the Civic Center Station of the Bay Area Rapid Transit (BART) system in San Francisco, California. Upon reaching the station, the tunnel would normally have been tied to the wall in a relatively simple operation since the air kept the water under control. However, when the tunnel was nearly at the station, it was necessary to stop driving the tunnel, fill the head of the shield full of cement, take the air off the tunnel and cease operating because the concrete station wall had not yet been constructed.

After the wall was built, the tunneling contractor was notified to finish the tunnel and connect it to the station wall. He was told that the traffic on the busy intersection of Market Street and Civic Center could not be stopped or detoured, so he would have to perform his work without the use of the surface area above the tunnel. He was also prohibited from using the normal procedure of dewatering the sand above the tunnel, since it might cause severe settlement problems on the buildings above. The formation was thought to be water saturated sand from 10 feet to 90 feet, or a head of 80 feet of water in an unconsolidated sand.

The tunnel contractor was required to complete the tunnel and connect it to the concrete wall of the station. If the sand was wet and unconsolidated as suspected, it would not be possible to open a hole in the concrete wall and mine the sand for the tunnel unless some remedial procedures were taken. The tunneling contractor then contacted Halliburton Services in January 1969 to see if it might be feasible to consolidate the sand sufficiently by grouting to permit opening the wall. This approach seemed to be feasible.

##### 2. Site Investigation

###### a. Site Examination

A visit was made to the San Francisco site by Halliburton grouting specialists and the problem viewed from inside the tunnel and from inside the station. The possible location for

grouting equipment in the station area appeared to be satisfactory.

b. Formation Sampling

A sample of the ground water leaking into the tunnel was obtained, but it was not possible to obtain samples of the formation behind the concrete station wall because the tunnel contractor felt it would be too expensive. Since it was thought that the sand from inside the station was the same as behind the wall, it was decided that formation sand samples would be obtained from the inside of the concrete slurry wall being excavated at that time. The excavation had reached a depth of about 46 feet below street level, so a formation sample was taken at that point. When the excavation reached the tunnel level at a 90 foot depth, a sample was also secured at that depth.

c. Soil and Subsurface Analysis

Initial laboratory tests were made to analyze the soil samples from the site. These were fine sand with a porosity of about 40% and a permeability of about  $10^{-3}$  cm/sec.

The grout tentatively selected was Herculox, a urea-formaldehyde chemical grout, which provided good strength characteristics. Re-compacted samples were grouted with the Herculox grout at the expected site temperature of 65°F. An unconfined compressive strength of 666 psi was obtained as an average of three tests. This was considered sufficient to support the expected overburden and water head when the grouted soil was mined.

3. Planning for the Grouting Operation

a. Job Planning

It was agreed that the grouting crew would come from personnel of the tunnel contractor and that Halliburton would furnish a grouting engineer to direct the grouting operation. Equipment, materials and chemical grout would be furnished by the grouting contractor. This included mixing and pumping equipment, miscellaneous valves, glands and grout injection pipes, as well as driving heads and pulling mechanism for the grout pipes. Pumps to be used were dual triplex plunger type positive displacement units made of non-corrosive materials.

The grouting was planned to be accomplished through a series of holes approximately in line with the circumference of the tunnel bore and in the center portion of the tunnel area. Grouting nipples 2 inches in diameter would be grouted into a hole drilled 18 inches deep in the 2 foot concrete wall and 2 inch full opening valves

would be placed on the nipples. The hole would then be completed through the other 6 inches of the wall. The grouting through the 2 inch nipples would be accomplished by extending the proper length grout pipe through a packoff gland in the valve into the sand to be grouted, then pumping a predetermined amount of chemical grout each foot as the grout pipe was withdrawn.

The grouting plan was then presented to the tunnel contractor, who agreed with the procedures as outlined.

b. Cost Estimate

The cost arrangement for this job as set forth below was also agreeable to the tunnel contractor.

1. Mobilization and Demobilization - Lump Sum.
2. Grouting Engineer - Fixed daily fee for each 8-hour shift or fraction thereof.
3. Grout mixing and pumping equipment with all hoses - Fixed daily fee for each 8-hour shift or fraction thereof. Payment to be per calendar day if on location not in use.
4. Chemical Grout - Fixed price/gallon for each gallon mixed.
5. Miscellaneous valves, packoff glands, grout pipes, driving and pulling mechanism - Lump Sum.

4. Performing the Grouting Job

Nine months had been required to complete all the preliminary work on this grouting operation. The tunnel contractor then proceeded to drill the holes and grout all the 2 inch grout nipples in the concrete station wall in accordance with the plan submitted. Three months later, equipment and grouting chemicals were shipped to the site and the grouting engineer was ready to start the job.

Grout pipes were driven into the formation initially to a depth of 6 feet through the grout nipples. Two or three holes were used to place grout through the rods. Predetermined amounts were pumped at one foot intervals while the grout pipe was withdrawn. Results were checked at this point because no exploratory investigation had been made prior to the job in the actual formation. It was found that the sand had not been consolidated properly and water flowed freely out of the open valves. This indicated that flowing water must be washing the grout away before it set. Since there was apparently flowing water present in the formation to be excavated, changes now had to be made in the grout

material and procedure to meet the unexpected conditions encountered behind the station wall.

As a result of this initial grouting, the Halliburton Chemical Laboratory formulated a grout material with a setting time of 20 to 30 seconds at the ground water temperature of 65°F to use to combat the flowing water. Due to the fast set, the grouting procedure had to be altered since the grout would probably set up in the pipes or grout the pipe in the sand using the planned procedure.

The grouting engineer decided to grout directly through the 2 inch pipe nipples into the sand and pump until an increase in pump pressure indicated that the grout had set. This procedure was tried through one pipe nipple. By drilling through the pipe into the grouted sand, it was found that the sand had been consolidated to a depth of about 18 inches. Grout was then pumped through the same pipe to consolidate the sand further. This technique was followed through each nipple in the concrete wall until the sand was consolidated to a distance of 5 to 6 feet from the station wall. The grout used in this operation was the Herculox grout, which provided high strength for the portion that was to be mined out to make the tunnel connection to the station wall. Figure C-1 shows the grouting operation in process.

The final step in the grouting operation was to grout the sand for approximately 25 additional feet to shut off any other water. This was accomplished using Injectrol® silicate grout, a less expensive gel type grout. It was pumped through the grout pipes as attempted in the initial part of the job. This grouting was successful because the flowing water had been stopped by the initial grouting of the sand next to the station wall. Total grouting time was 3 weeks.

The tunnel contractor then cut a hole in the station wall, mined out the consolidated sand and made the connection between the tunnel lining and the concrete station wall. Figure C-2 shows the hole through the concrete wall, and the consolidated dry sand behind it. Through the shield, which will be removed, the tunnel lining is visible.

## 5. Conclusions

1. A common difficulty found on most grouting jobs is the problem of obtaining prejob information on the condition of the formation to be grouted. In an effort to save money, no opening was made into the sand behind the station wall to find actual conditions before grouting started. The conditions found when grouting started were not what was expected, resulting in a delay and a reassessment before grouting could be completed. With

equipment and personnel on the site, this was an expensive delay.

2. It is essential to have a thorough on-site investigation with sufficient sampling to determine grouting feasibility. It would be preferable if permeability determinations and pumping data could be obtained in situ rather than by retrieving samples, since it is almost impossible to repack a sample to match the original formation characteristics.



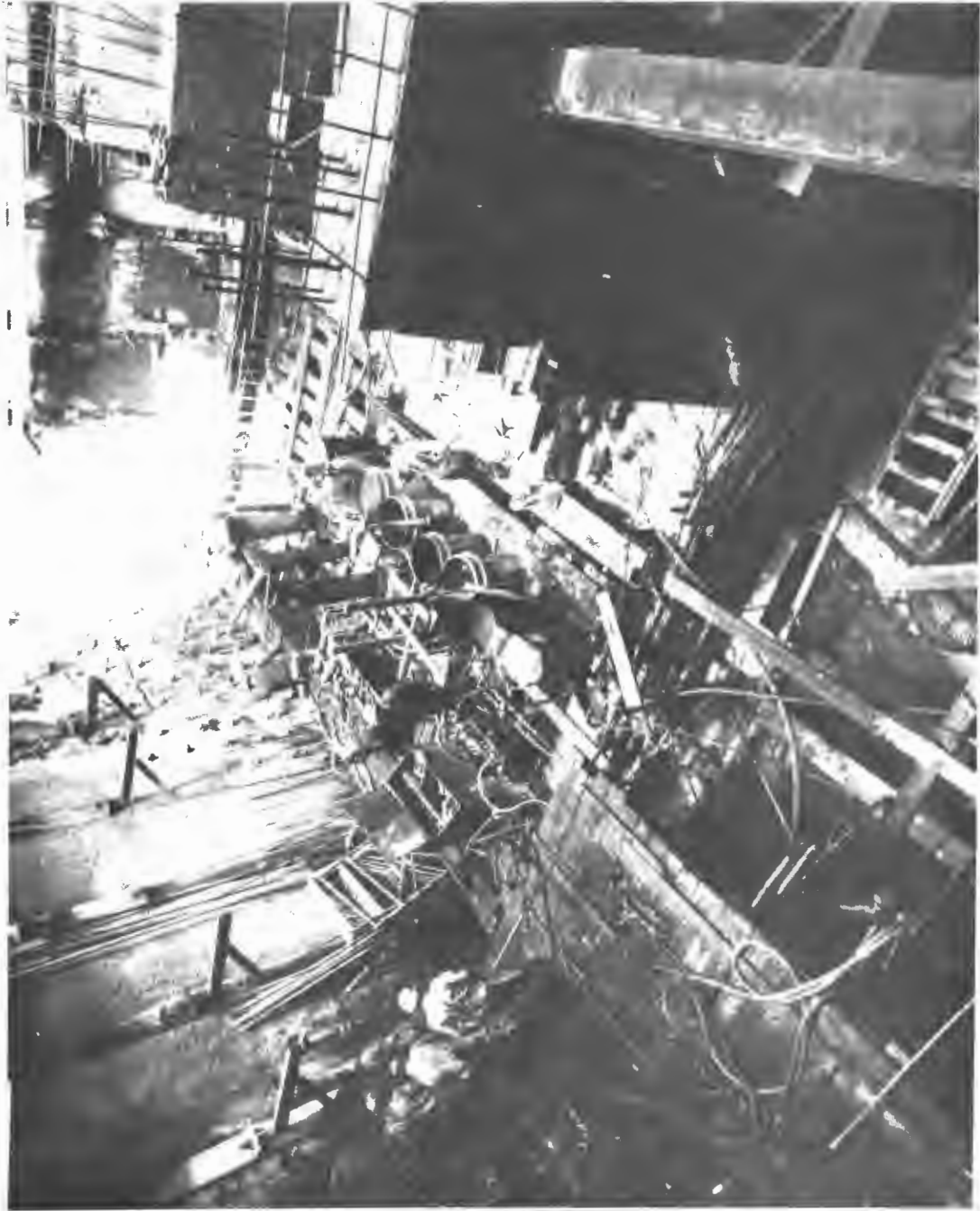

Figure C-1. Grouting operation in progress.



Figure C-2. Connection between station and tunnel through grouted soil.

## EXHIBIT B

### CASE HISTORY

#### CHEMICAL GROUTING BENEATH THE WALT WHITMAN BRIDGE PHILADELPHIA, PENNSYLVANIA

##### 1. General

The joint venture of Kuljian-DeLeuw Cather in designing the Philadelphia Broad Street Subway Extension encountered a problem as the proposed cut and cover subway excavation was extremely close to the pile supported East Pier of the Walt Whitman Bridge approach. Figure C-3 shows the proximity of the reinforced concrete box of the subway, and indicates the three rows of piles supporting the pier. Upon reviewing the soil data, the engineers wrote a broad specification for the chemical grouting of the granular soil around the piles in order to protect the pier during excavation and from the future vibration of subway traffic.

Peter Kiewit and Sons Company was successful bidder on this \$17,000,000 subway project. They retained the soils consulting firm of Woodward-Clyde and Associates of Philadelphia to determine the most effective method and type of grout to utilize.

##### 2. Job Information

Peter Kiewit's subcontract for the chemical grouting gave the project engineer for the grouting firm the responsibility of determining the grouting pattern, material, mix, etc. Due to the fine grained nature of the soil, it was elected to utilize Terranier "C" Chemical Grout, a product of ITT Rayonier, which had relative high strength, low viscosity, and is economical. As the borings indicated some difficulty would be experienced in conventional grouting techniques, it was elected to utilize the Stabilator Valve Tubing Method of grouting. Extensive experience in this system had been obtained when this method was introduced to the U. S. in grouting beneath the Florida Power Company's Nuclear Reactor at Crystal River, Florida. At this site, nearly 500,000 gallons of Siroc, Siroc Cement and Terranier was injected to depths of 90 feet. Basically, the Stabilator System utilizes lightweight casing which has spring valves built into it on strategic centers. The casing is installed by using an Atlas Copco Crawler drill. Drilling bits are used and the casing attached to the drilling bit along with the casing knockoff bit. When the desired depth is reached, the casing bit is knocked off, the drilling rods extracted, and the casing is then ready for grouting. A double packer is installed and the pump pressure forces the spring valve open, thus grouting the strata required. This drilling technique was developed in Sweden and has worked extremely well in glacial till and other

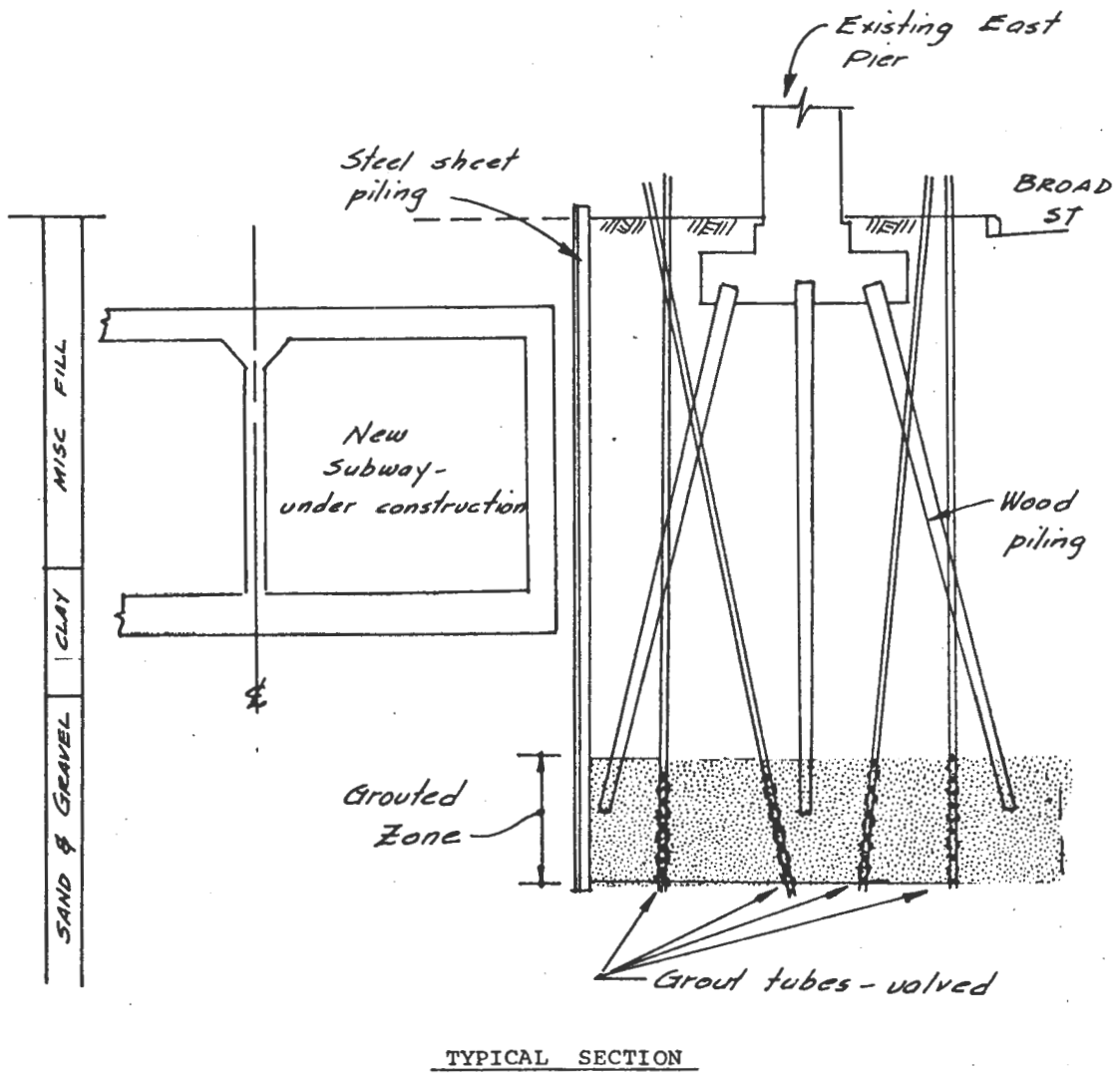

Figure C-3. Grouting setup for bridge support.

similar soils which are normally a driller's nightmare.

It was elected to utilize a grout pipe spacing of 5 feet on center, and in order to encompass the soil around the piles, five rows were required in one direction and 23 rows in the other direction. A depth of grouting four feet beneath the deepest piles and three feet above the tip of the shallowest pile was utilized.

Grouting equipment consisted primarily of a mixing and pumping tank for the Terranier Chemical Grout and the catalyst, and two chemical grout pumps. Terranier Chemical Grout reacts with formaldehyde to form a permanent irreversible gel. This chemical reaction takes place within 24 hours in normal temperature conditions. In order to speed the gel time up, a metal salt, Sodium Dichromate is used, thereby allowing the gel time to be controlled from instant set to any desired time requirement.

A study of the soil profile indicated that above the zone to be grouted there was a silty clay stratum impervious to chemical grout and the control of the grout travel from the bottom was accomplished by injecting through the bottom valve a double volume of chemical grout.

The basic pumping procedure utilized was to pump the two rows on either side of the pier with a predetermined volume of chemical grout having a gel time beneath 5 and 15 minutes. This in effect created a double cutoff wall and the interior row was then pumped to refusal.

### 3. Job Results and Conclusions

In order to analyze the results of the chemical grouting prior to excavation, borings were taken as shown in Table C-1. A marked increase was noted in the blow count. Also, prior to grouting, running sand stratas were encountered; these were not observed after grouting. Further, a marked increase in the cohesion of the sand was observed along with a decrease in the permeability of the soil.

It can be concluded that this chemical grouting operation was highly successful and will prevent any future movement of this pile supported pier from construction activity, the adjacent excavating or from the anticipated subway vibrations.

The grouting contractor for the job was the SOILTECH Department of Raymond International, Inc.

Table C-1  
 Test Boring Reports by Raymond Beneath Walt Whitman Bridge Overpass  
 Philadelphia, Pennsylvania

| Depth,<br>Feet | General<br>Description                     | STANDARD PENETRATION BLOW COUNT |                   |                    |                   |
|----------------|--|---------------------------------|-------------------|--------------------|-------------------|
|                |  | Location #1                     |                   | Location #2        |                   |
|                |  | Before<br>Grouting              | After<br>Grouting | Before<br>Grouting | After<br>Grouting |
| 5              | Miscellaneous Fill                         | 23/1"                           |                   | 17                 |                   |
| 6              |  |                                 | 16                |                    |                   |
| 7              |  |                                 |                   |                    |                   |
| 8              |  | 3                               | 4                 | 13                 |                   |
| 9              |  |                                 |                   |                    |                   |
| 10             |  |                                 |                   |                    |                   |
| 11             |  | 15                              | 16                | 2                  |                   |
| 12             |  |                                 |                   |                    |                   |
| 13             |  |                                 |                   |                    |                   |
| 14             |  |                                 |                   |                    |                   |
| 15             | 3  | 9                               | 9                 |                    |                   |
| 16             |  |                                 |                   |                    |                   |
| 17             |  |                                 |                   |                    |                   |
| 18             |  |                                 |                   |                    |                   |
| 19             |  |                                 |                   |                    |                   |
| 20             | Firm silty clay with<br>decayed vegetation |                                 |                   |                    |                   |
| 21             |  | 10                              | 7                 | 14                 | 21                |
| 22             |  |                                 |                   |                    |                   |
| 23             |  |                                 |                   |                    | 58                |
| 24             |  |                                 |                   |                    | 59                |
| 25             |  | 30                              | 33                | 27                 | 37                |
| 26             |  |                                 |                   |                    | 139               |
| 27             |  | 36                              |                   |                    |                   |
| 28             |  |                                 | 100/2"            |                    | 55                |
| 29             |  |                                 |                   | 30                 |                   |
| 30             |  |                                 |                   | 100/3"             |                   |
| 31             |  |                                 |                   |                    |                   |
| 32             |  |                                 |                   |                    |                   |
| 33             |  |                                 |                   |                    |                   |
| 34             |  |                                 |                   |                    |                   |
| 35             |  |                                 |                   |                    |                   |
| 36             | Dense gravelly sand                        |                                 |                   |                    |                   |
| 37             |  | 64                              |                   | 28                 |                   |
| 38             |  |                                 |                   |                    |                   |
| 39             |  |                                 |                   |                    |                   |
| 40             |  |                                 |                   | 48                 |                   |
| 41             |  |                                 |                   |                    |                   |
| 42             |  |                                 |                   |                    |                   |
| 43             |  | 46                              |                   | 38                 |                   |
| 44             |  |                                 |                   |                    |                   |
| 45             |  | 52                              |                   | 20                 |                   |

EXHIBIT C

CASE HISTORY

GROUTING A VEHICULAR TUNNEL IN ALASKA

1. General

The tunnel in this instance is the Keystone Tunnel on the Richardson Highway near Valdez, Alaska. The tunnel is 600 feet long and was originally 12 feet wide with one-lane traffic. In 1950-52 the tunnel was widened to about 20 feet to accommodate two lanes of traffic. The tunnel is basically through rock, but near the north end a "chimney" of unconsolidated alluvium was intersected as shown in Figure C-4. This chimney section, about 20 feet in length, was supported by timber cribbing which covered about 90 feet of the tunnel.

In 1972, the Alaskan Highway Department authorized a feasibility study to determine if grouting could be employed to stop water leakage into the tunnel and consolidate the alluvium to relieve the load on the timber cribbing.

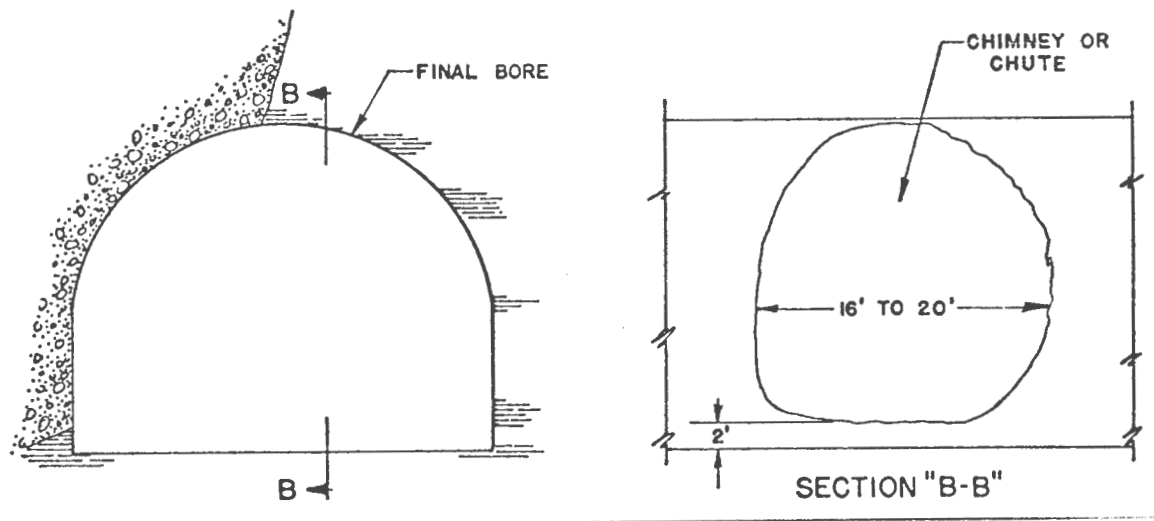

Figure C-4. Tunnel enlargement showing intersected chimney

## 2. Discussion of Feasibility Study

Two problems were pointed out in the feasibility study. These problems were:

- a. The rock section of the tunnel was leaking water in several areas. Two major leak points created a traffic hazard and a maintenance problem.
- b. The unconsolidated chimney section of the tunnel was placing excessive loading on the timber cribbing to cause deflection and also was leaking badly.

The study concluded that the leaking rock section could be grouted to control the water and that the unconsolidated alluvium could be stabilized with chemical grout to ease the load on the timber cribbing. It was also recommended that the grouting be done during the thaw time so results could be evident.

## 3. Job Discussion

The rock grouting portion of the job will not be discussed since it is not pertinent to soils grouting.

The grout material used was Halliburton's PWG<sup>®</sup> acrylamide grout (AM-9) in a 20% mixture. The grout was placed through drive type E-Rod grout points with a pump-open point.

Preparation for the grouting was made by cutting 2-1/4 inch diameter holes in the wooden cribbing on a 2 to 3 foot grid pattern as shown in Figure C-5. The drive rod grout points were driven 15 feet deep into the sand using a modified track drill. The point was opened and 100 gallons of grout was pumped into the sand with a small air-driven dual plunger pump. Pressure at maximum depth was kept below 60 psi at grout point and at 30 psi from 10 feet depth to surface.

After each injection of 100 gallons of grout, the drive rod was pulled 6 inches toward the surface and injection made again. This procedure was repeated until the drive rod was retrieved from the sand. The set time for the grout was one to two minutes. Injections were made in each row on holes 1 and 3, then holes 2 and 4, etc., until the area was completely grouted. The grouting was done in 1974.



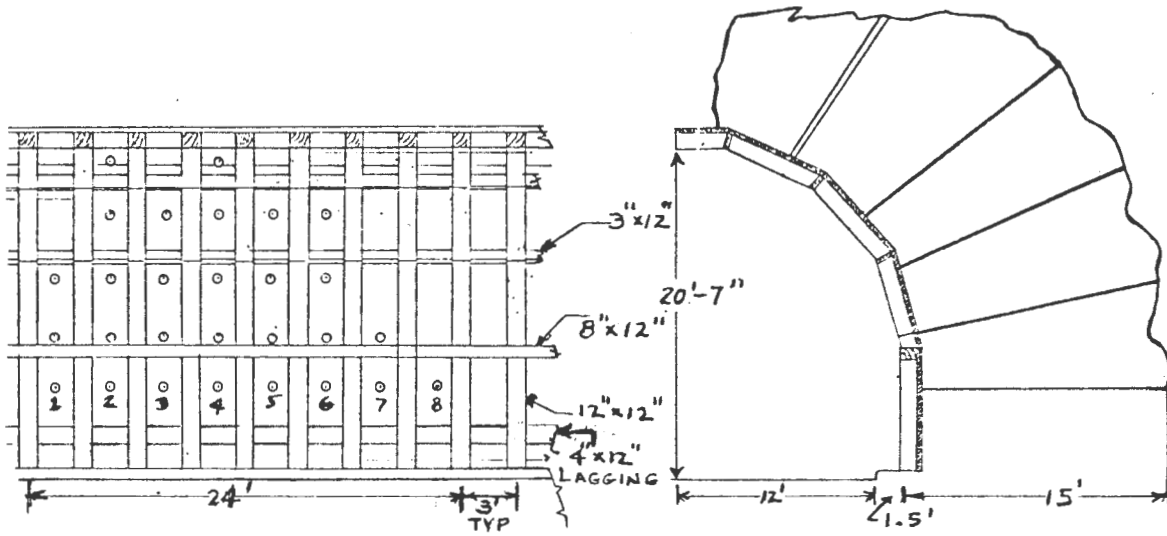

Figure C-5. Grout point locations in chimney section

#### 4. Results

The chimney section of alluvium was consolidated to a thickness of 15 to 16 feet thick for 25 or 26 feet in length. The samples of grouted alluvium from this area showed a compressive strength of over 100 psi. Followup reports show that the consolidated section is supporting the overburden and has eliminated the leakage in that section.

## EXHIBIT D

### CASE HISTORY

#### PREGROUTING FOR TUNNELS UNDER 26 RAILROAD TRACKS PONTIAC, MICHIGAN

##### 1. General

The need arose to bore a 14 foot diameter and a 4 foot diameter sewer tunnel 300 feet in length under 26 tracks in the Grand Trunk rail yard at Pontiac, Michigan. It was required that the work be done without stopping rail traffic in the rail yard. The contractor, Greenfield Construction Company of Livonia, Michigan, investigated the possibility of pregrouting the area for excavation of the tunnels to provide support for the rail traffic above during the tunnel excavation.

Core samples indicated that the formations down to a depth of 12 feet had a high permeability and below this the permeability was lower, but still sufficiently high to permit the use of a chemical grout for soil consolidation. The porosity varied from 28% at the upper edge of the grouted square to 22% at the bottom.

##### 2. Job Procedure

When Halliburton Services was approached as the grouting contractor, they suggested that the large tunnel be pregrouted only around the circumference and the interior be left unconsolidated. This would accomplish the purpose at much less expense. The smaller tunnel would be completely grouted.

The grid pattern used and the grouted areas are shown in Figure C-6. The grout used was Halliburton's Injectrol® G silicate grout. It was injected through E-Rod drive grout points. The grout points were driven to 32 feet in depth, then injection was made at each foot for the lower three feet and repeated on 18 more feet for the outer two rows in the grid pattern. The three interior rows in the pattern were then injected at depths of 11 to 15 feet on one foot intervals. The small tunnel was injected at each foot over the 8 foot depth. Injection started with the grout at a low 2 cp viscosity. The rod was moved one foot when the pressure rose to approximately 40 psi.

The equipment for the job is shown in the schematic drawing, Figure C-7. The square tanks represent large mixing and holding tanks. The small circular tanks marked "A" and "B" represent the 55 gallon tanks by each pump where the two fluid components are pumped into the ground in equal volumes and mixed together as they go into the drive rod grout point.

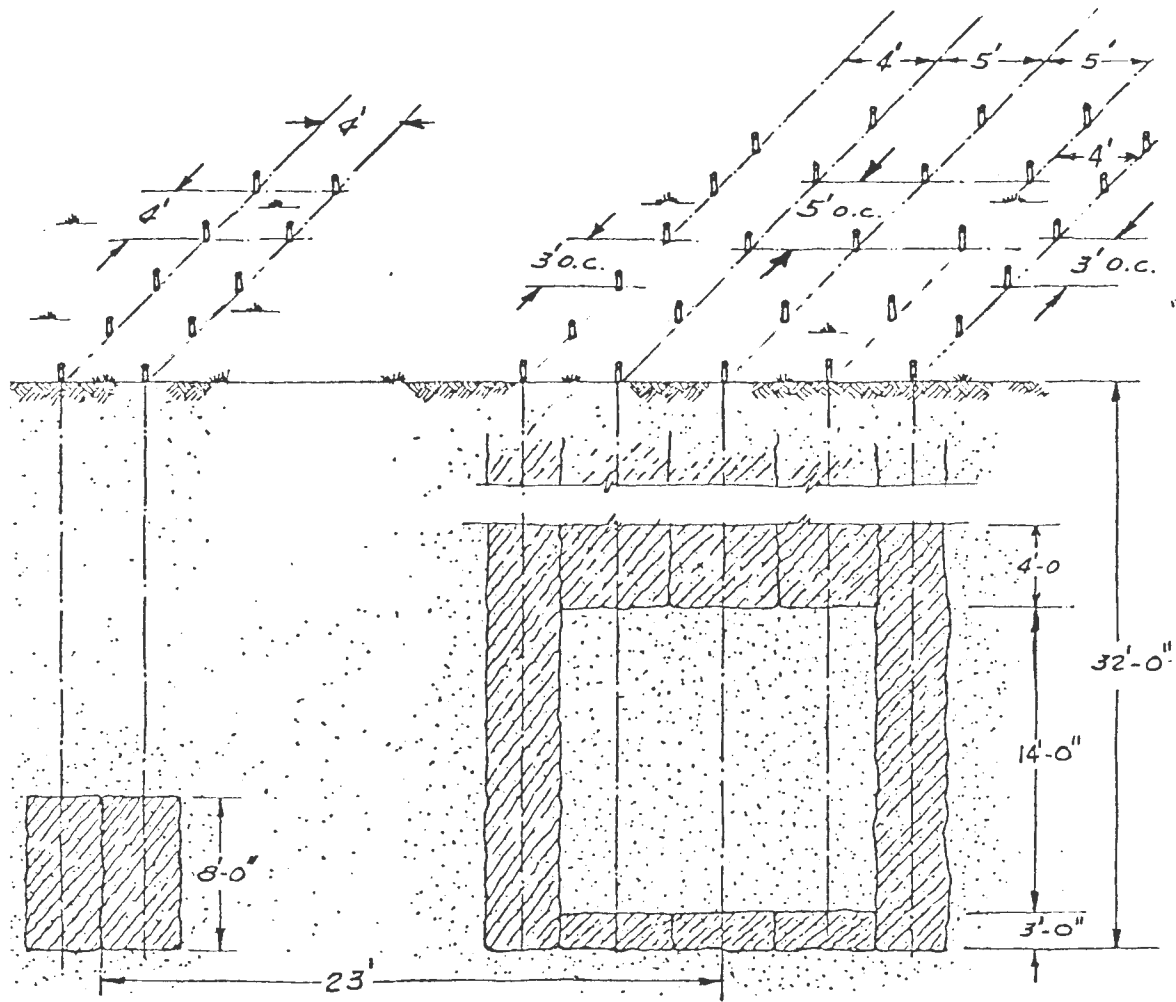

Figure C-6. Grid pattern and grouted areas

The entire job consumed about 100,000 gallons of Injectrol G grout. Had the large tunnel area been completely grouted, it would have required an additional 71,000 gallons of grout.

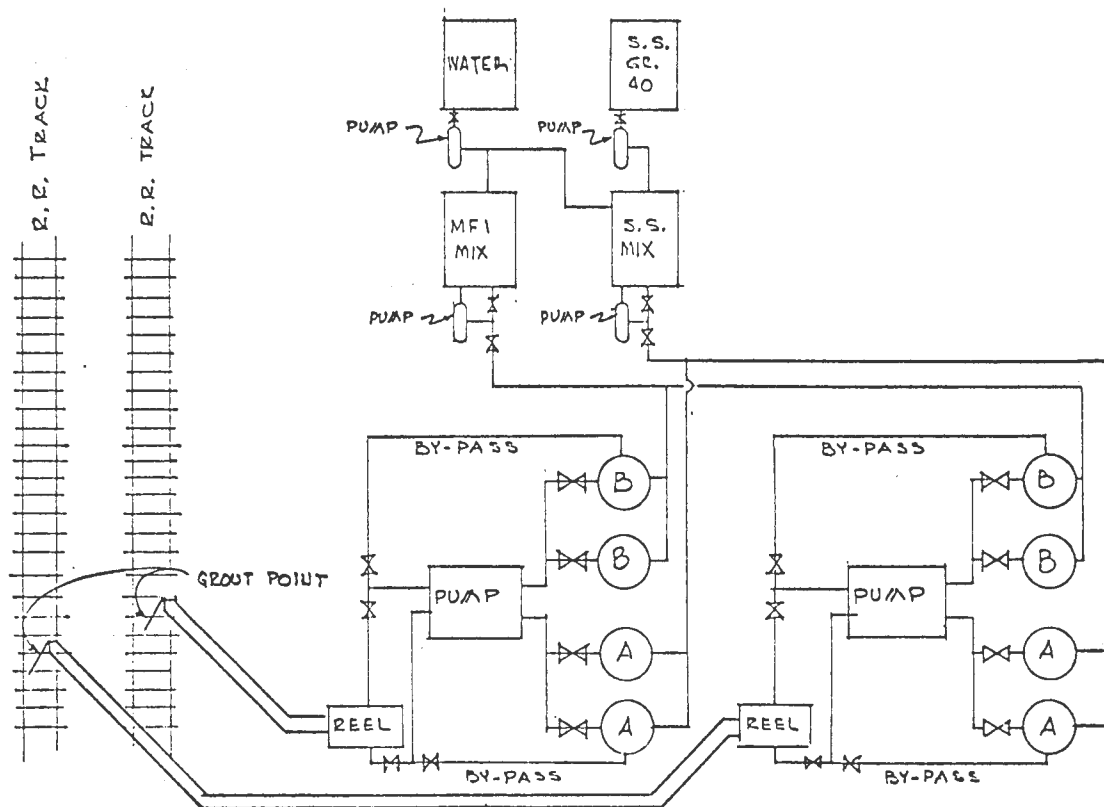

Figure C-7. Schematic equipment layout

### 3. Results

After the completion of the grouting, the large tunnel was mined successfully. It was necessary to grout certain parts of the tunnel area again as work proceeded. An additional 10,000 gallons were used for this purpose.

The small tunnel was bored successfully without any further grouting.

No settlement was noticed in the railroad tracks during the mining process.

## EXHIBIT E

### CASE HISTORY

#### GROUTING FOR SEWER LINE SUPPORT NEAR METRO TUNNEL WASHINGTON, D.C.

##### 1. General

A large sewer line called the New Jersey Sewer passes over a section where twin tunnels of the Metro System in Washington, D.C. are to be located. This is in the Mall area at 7th Street N.W. The general construction contractor was Dravo Construction Company. E.C.I. - Soletanche of Pittsburgh, Pennsylvania made the investigation and recommendations for the grouting operation and furnished supervisors to help Dravo mix the grouting materials.

##### 2. Grouting Procedure

Two 16 foot diameter shafts located 45 feet each side of the sewer were dug to a depth of 15 feet. The grout holes were drilled from each shaft to a location under the sewer pipe in sufficient width to give substantial support over the tunnel section. A schematic of this is shown in Figure C-8. The site showing the two shafts is seen in Figure C-9.

The pump rate used for the grouting was 1.5 gpm (300 liters/hr.) over an 8 hour shift. The initial grouting was with bentonite cement. After 2,200 cubic feet of this slurry had been injected, the balance of the grouting was conducted using silicate grout. Twelve thousand cubic feet of silicate grout was injected into the sand. The grouting was done over a three month period.

##### 3. Results

The first one of the two Metro tunnels was bored under the sewer line in August 1974. During the boring operation under and in the vicinity of the sewer line, no sand was encountered. All the excavation was in clay. A few stringers of cement were the only visible evidence of the grouting. Figure C-10 shows the tunneling in process at the site. Figure C-11 is a closeup showing the large pieces of clay encountered in the tunnel boring.

The second tunnel was also found to be entirely in the clay. This shows that a more thorough investigation over the site could possibly have shown that the grouting was not necessary, resulting in a saving of thousands of dollars. The effect of grout on the sands above the tunnel was not determined.

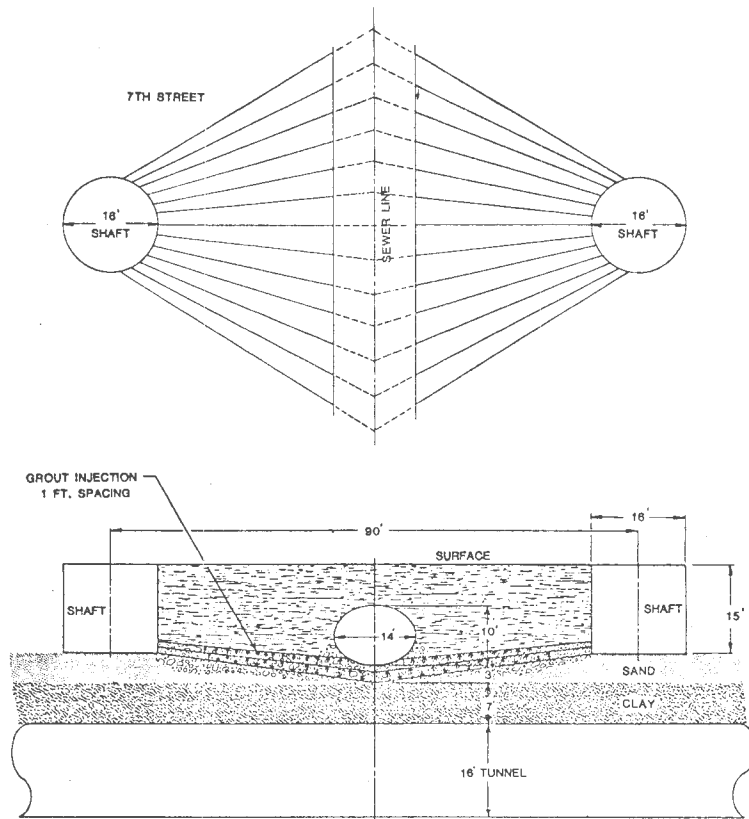

Figure C-8. Schematic of grouting for sewer support.

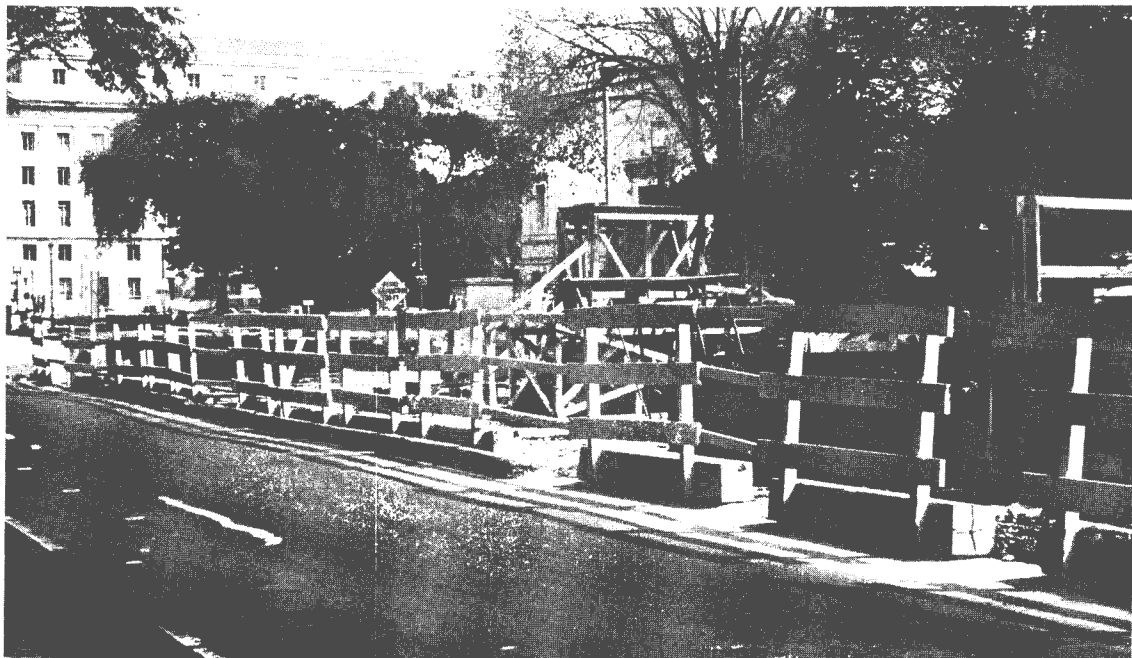

Figure C-9. Washington grouting site.



Figure C-10. Typical excavation under gouted area.



Figure C-11. Clay encountered in tunnel excavation.

## EXHIBIT F

### CASE HISTORY

#### GROUTING OVERPASS PIERS ON ROUTE OF METRO SYSTEM WASHINGTON, D.C.

##### 1. General

Two tubes of the Metro system are to pass under the bridge piers of the 7th Street overpass of I-95. The engineers did not want any loss of support during excavation to cause settlement of Interstate Highway I-95 or of the piers which support the overpass. The grouting was completed and tunnels have been bored. The grouting contractor was Hayward Baker Company.

##### 2. Job Information

The work was done where 7th Street passes on grade over I-95. There is a column on each side of I-95 and in the median which supports the overpass bridge, with I-95 being four-lane in each direction. The subway tunnel was excavated under 7th Street and passed underneath the three piers and I-95.

The grouted section extends 20 feet beyond the two extreme piers on the outside of I-95 and the complete section under the highway. It includes approximately the total width of I-95 plus 40 feet to take care of the outside dimensions.

The grouting pattern at the highway level called for drilling the hole approximately 17 feet deep with a stabilator-type drill. The casing was carried down as the hole was made with the drill rod and the eccentric bit extending beneath the casing. After the total depth was reached, the bit was knocked off and a 1-1/2 inch polyethylene pipe with slots sawed in the bottom 7-1/2 feet was placed inside this 3-1/2 inch casing. After this plastic pipe was placed, the annulus between this pipe and the casing was filled with ordinary masonry sand up 7-1/2 feet. Then the casing was pulled to this 7-1/2 foot level, and cement grout mixed with sodium silicate was placed in the annulus from the 7-1/2 foot level to surface. The casing was then withdrawn before the grout set. All grout pipes were set in this manner. (See Figure C-12).

Grouting was done on the surface of the highway with the holes drilled on a 7 foot grid pattern. All of the holes in the area of the underpass were drilled and grouted; then the 5 spot hole pattern was drilled on the inside of the 7 foot pattern and secondarily grouted. The idea was for the original holes to give solidification and reduce permeability and the inside pattern hole to then completely fill the voids and solidify the material.



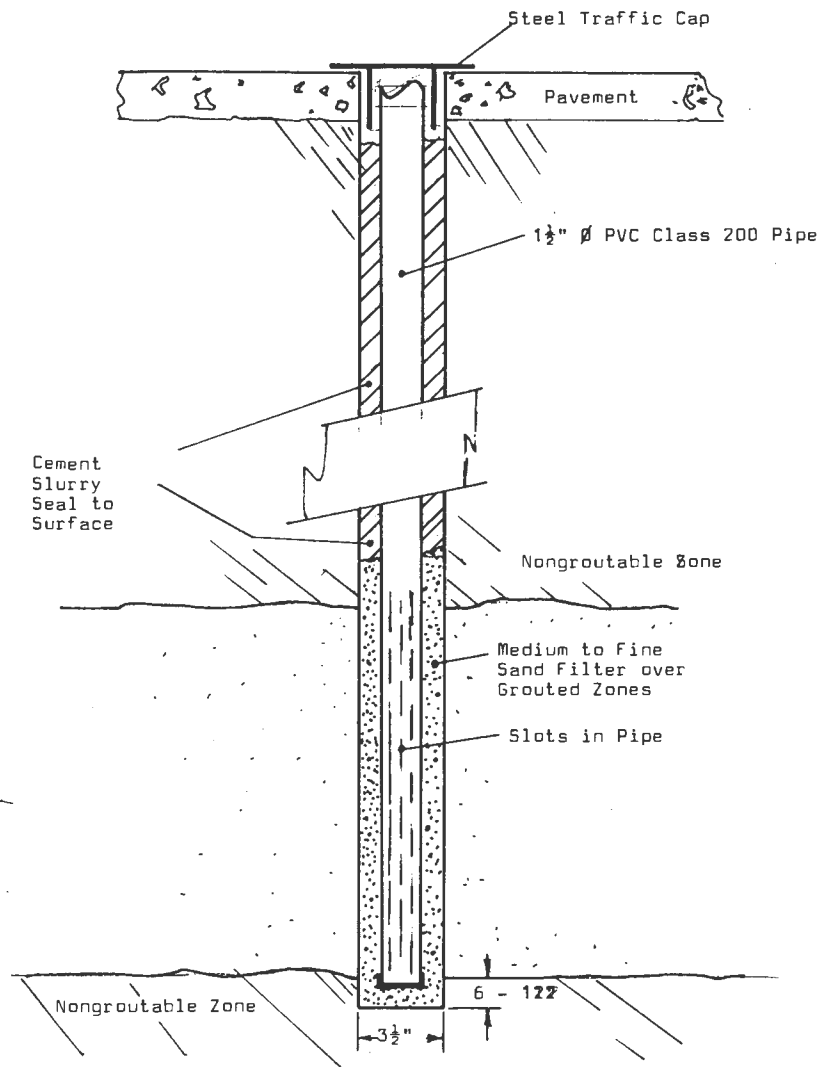

Figure C-12. Detail of grout pipe installation and seal.

The grouted section was approximately 3-1/2 feet each side of the crest line of the tunnel; i.e., the material 3-1/2 feet above the top of the tunnel and 3-1/2 feet into the tunnel will be grouted throughout the length of this section.

The grout hoses were fastened to the top of the grout pipe and approximately 900 to 1000 gallons of grout were injected in this pipe and forced out through the sawed slots in an attempt to distribute grout throughout the sand and consolidate the sand.

The chemical grout solution was a sodium silicate base with organic reactants, modified with oxidizers. The grouting contractor had storage tanks on the surface in a vacant lot on the 7th Street elevation where he stored the basic materials. None of the materials were premixed. One 4 inch Moyno pump was connected to the fresh water line. Another Moyno pump the same size was connected to the sodium silicate storage tank.

The pumps had individual water meters in order to control the volume injected, but approximately equal volumes are pumped. The pumps and meter are shown in Figure C-13.

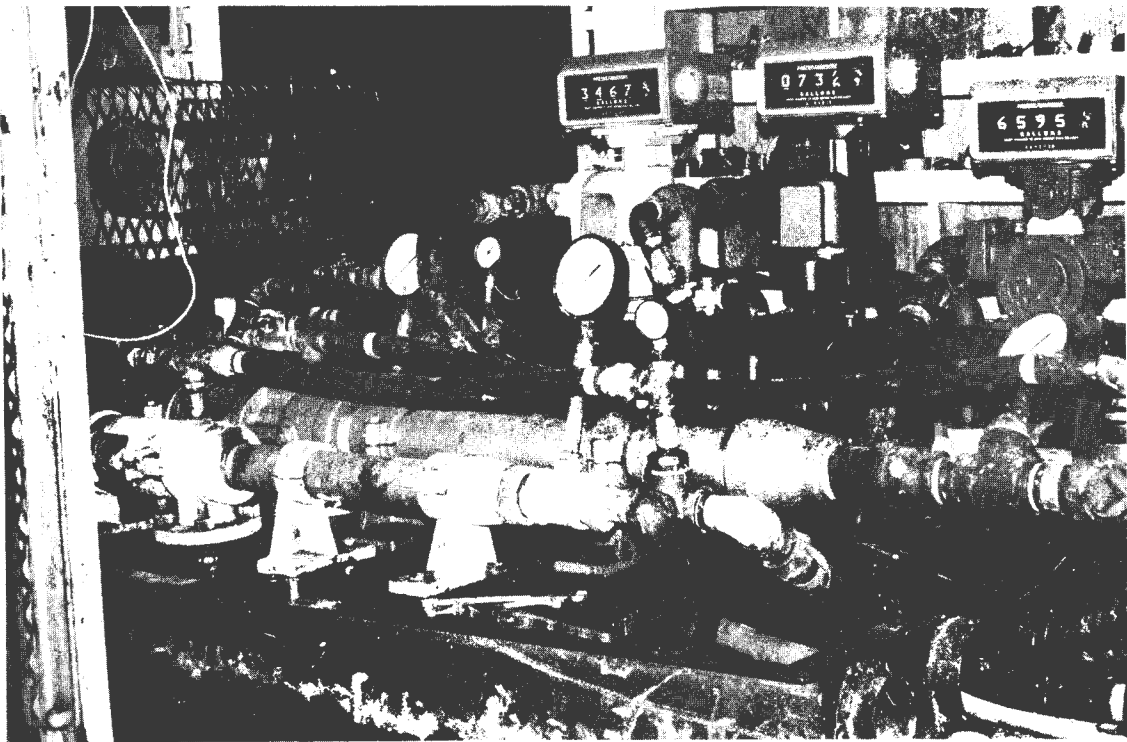

Figure C-13. Grout injection pumps and flowmeters

A schematic of the pump layout is shown in Figure C-14. The water and the sodium silicate were brought into one line. Adjacent to that was a 2-1/2 or 3 inch Moyno pump which was tied into the reactant material. This was ethyl acetate and formamide\*, which were mixed together and then pumped. Adjacent to that was a 1-1/2 inch Moyno pump which was piped to the peroxyde oxydizer solution. This Moyno pumped the peroxyde into the flow stream of ethyl acetate and formamide solution and mixed them together. The discharge from these pumps and the discharge from the water-silicate pumps came together in a 2 inch rubber hose further down the line. This then became one solution which was pumped across and down to the underpass to a manifold with 8 connections, as shown in Figure C-15. This manifold had flowmeters on each line with a one inch hose leading out to be connected to groutpipes in the holes. They attempted to get 60 to 80 gallons per minute of total flow with 6 or 8 gallons per minute going into each of the individual grout holes.

The maximum injection pressure at the grouthead of each of the individual grout pipes was 25 pounds per square inch, but very few of the grout holes showed much indication of pressure buildup, so apparently the material was going readily into the sand.

During a period of grouting near the ground surface, grout was observed on the surface around the curb and in the service manholes of the underpass. This was not noticed, however, during the majority of the grouting operation. After the primary holes on the injection pattern were grouted, about 80% of the secondary holes showed indication of reduced permeability as they took smaller amounts of grout and the pressure rose quickly during grouting.

Attempts were made to determine the strength of the grouted soil using a Menard pressuremeter, but results were inconclusive. A 36-inch diameter hole was drilled through the grouted section to the top of the clay. The wall "stood up" without casing or other support, so that the section could be observed from a ladder. It was found that the grout had consolidated the soil, but samples large enough for testing were not obtained.

Two 20-foot diameter tunnels have been dug, but both were under the grouted area in cohesive soil. Two additional tunnels are being dug at this writing, which will pass through the grouted area and very close to the overpass piers.

---

\* Patented process by Hayward Baker Company.

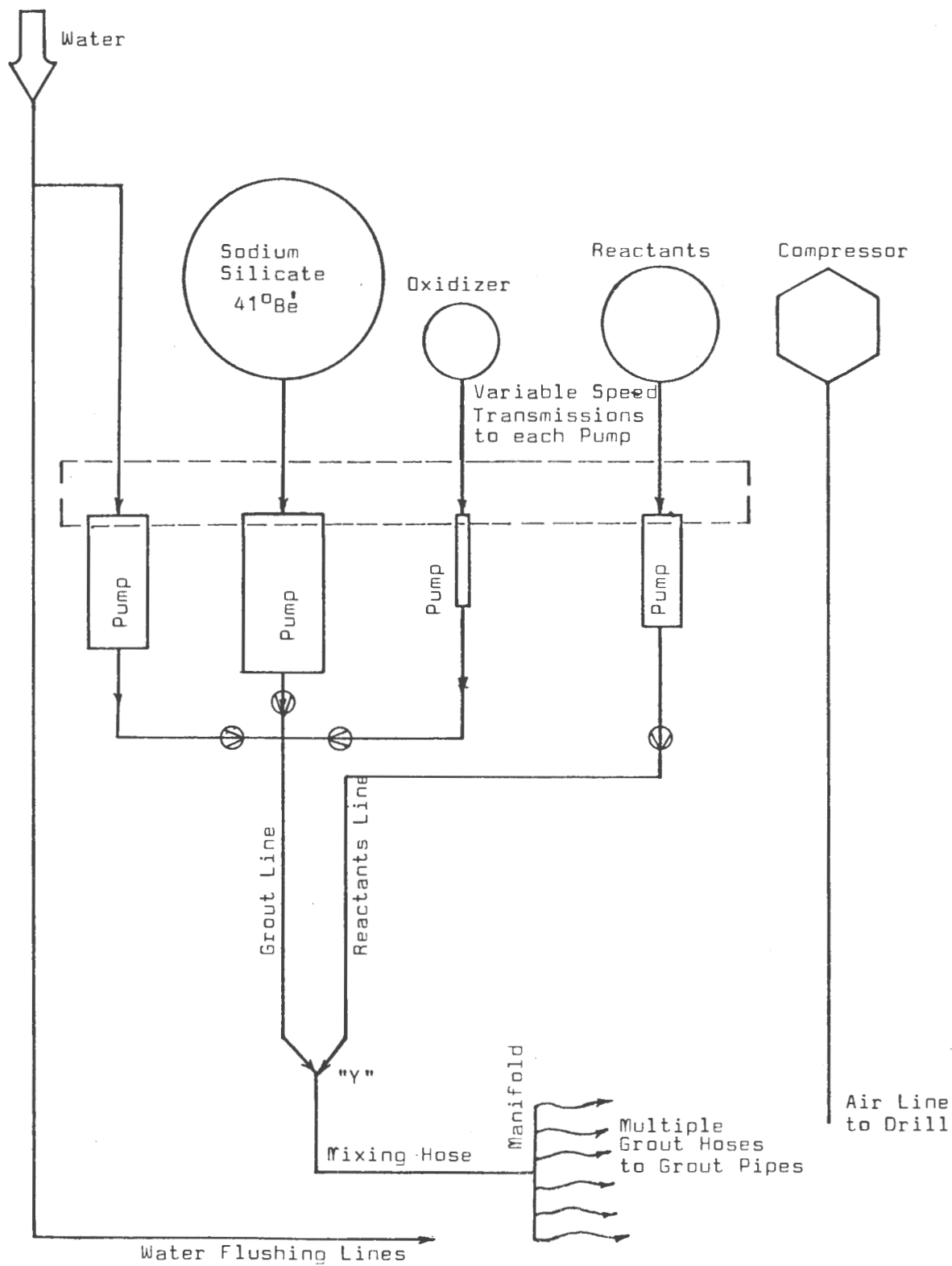

Figure C-14. Schematic - pumping system.

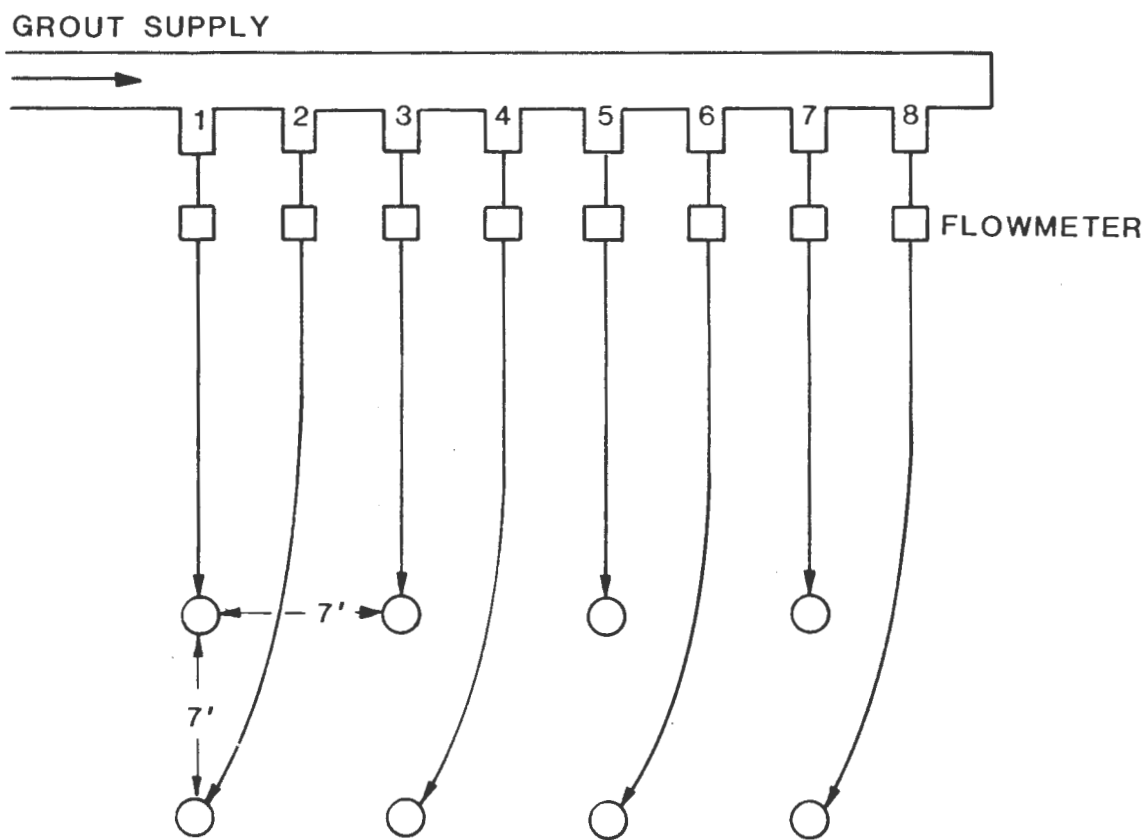

Figure C-15. Schematic - grouting manifold.

EXHIBIT G

CASE HISTORY

GROUT CURTAIN ON EARTHEN DAM  
PUBLIC SERVICE COMPANY OF OKLAHOMA RESERVOIR #13  
WASHITA, OKLAHOMA

1. General

An earthen dam was constructed in 1956-1957 across Leeper Creek. The natural grade of the terrain at the center line of the dam ranges from 1220 feet to 1275 feet. The top of the dam is at 1310 feet, with water level at 1280 feet. The length of the dam is approximately 2000 feet.

Leakage below the dam created swampy conditions on adjoining property, and also aroused fears that "piping" might jeopardize the integrity of the structure. A clay blanket, applied to the upstream side of the dam, resulted in reduced leakage at the west end, but appeared to have little effect on the leakage near the creek bed.

Test borings and data from drawdown pumping tests indicated that the entire area immediately under the dam fill from about 100 to 150 feet east of the creek bed and west for a distance of about 900 feet, consists of quicksand and stratified layers of permeable sandstone and sand, saturated with water which is migrating to the meadow immediately downstream from the dam.

It was concluded that two conditions existed:

- a. A considerable volume of water from the reservoir was flowing through the 20 to 30 foot thick formation immediately below the compacted fill forming the dam.
- b. The formation immediately beneath the dam fill was unstable, with poor bearing capacity to support the weight of the dam fill material.

2. Grouting Operations

Based on the boring and drawdown test data, a series of grout holes were drilled from a road made on the upstream slope of the dam at 1292 feet elevation, in a straight line on the inner slope of the dam, about 12 feet above the water line. The holes were drilled 5 feet apart, starting at a point 420 feet west of the east end of the dam, for 260 feet to a point 680 feet from the east end of the dam. Each hole was drilled to a depth of approximately 20 feet below the elevation of the dam fill material. Each hole was cased with two inch pipe to bottom, and grouted in place. This layout is shown in Figure C-16.



DETAIL OF GROUT AND TEST HOLES

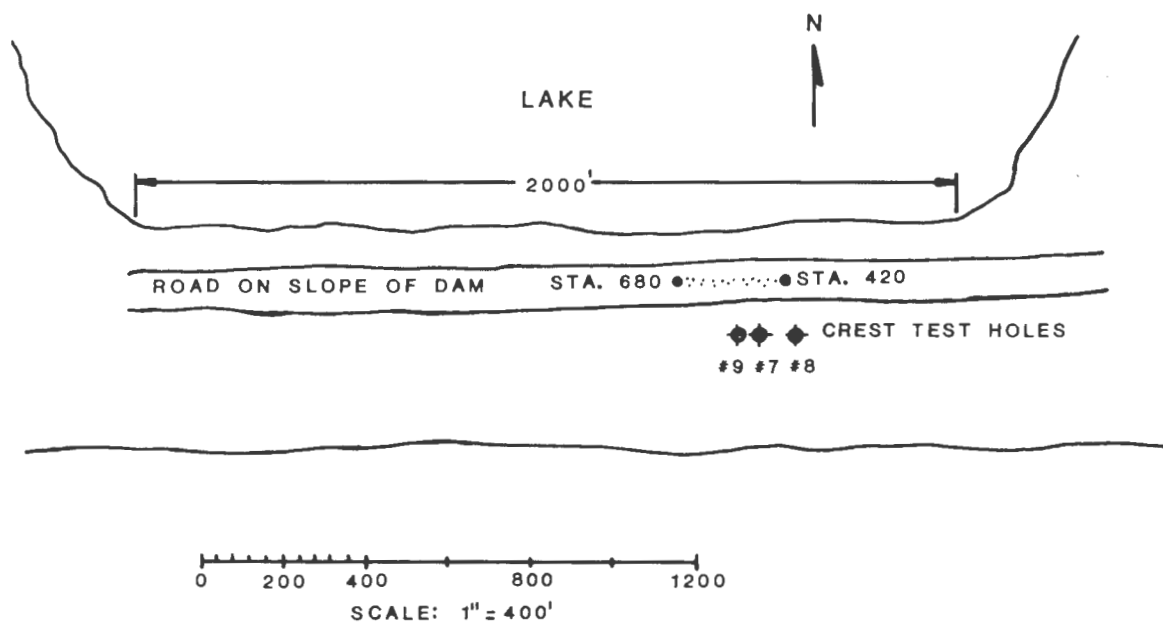

Figure C-16. View of grouting area on dam.

Grouting was accomplished with Injectrol® G silicate grout with a set time of 30 minutes. Each hole was grouted in five-foot stages, starting at the upper stage and working down. The upper stage was the interval immediately below the dam fill. The pipe interval in each five-foot stage was perforated first before grouting with one perforation per foot, for a total of five perforations per stage. Each of the top three stages were grouted with 250 gallons of Injectrol G grout and each bottom stage with 300 gallons.

The general pattern of grouting was to grout alternate holes (10' O.C.) one day, and the intervening holes the next day.

The holes east of the center of the treatment area were grouted during the first eleven work days, and the holes west of center during the last eight work days.

The highest initial pump pressure during the job was 60 psig in the first stage in hole number 475. The lowest pump pressure recorded was 10 psig. Average pump rate was approximately 10 gpm.

Grouting equipment used included one mixing unit, one van, one AC pump unit and one hose reel.

The maximum number of personnel on the job at any time were 2 engineers, one grout operator and four helpers.

After mixing and pumping 1,000 gallons of Injectrol G silicate grout the first day, an average of 3,080 gallons per day was injected during the remaining 18 work days. A total of 56,650 gallons of grout was used.

Treatment depth varied from 40 to 60 feet (elevation 1252' to 1232') at east holes and 65 to 92 feet in center portion back to 54 to 74 feet at west end of treatment area. This variation followed the profile of the dam taken 90 feet upstream from center line of dam.

### 3. Job Results

An investigation was undertaken about four months later to determine the effectiveness of the grouting job done during September 1968.

Nine 4-1/2 inch holes were drilled for the field testing. A two-inch pipe, with the lower ten feet slotted and covered with screen wire, was put into the hole. The intervals tested in each hole were (1) a ten-foot interval above the grouted interval, (2) the upper ten-foot grouted interval (3) the lower ten-foot grouted interval, and (4) a ten-foot interval immediately below the grouted intervals.



The depth and location of the test holes are tabulated in Table C-2 below. The term "Station No." refers to the distance of the hole in feet west of the east end of the dam.

TABLE C-2  
HOLE DRILLING SCHEDULE

| <u>Hole No.</u> | <u>Station No.</u> | <u>Total Depth</u> | <u>Note On Depth</u> |
|-----------------|--------------------|--------------------|----------------------|
| 1               | 572.0              | 93                 | 1                    |
| 2               | 627.0              | 90                 | 1                    |
| 3               | 517.5              | 82                 | 1                    |
| 4               | 542.5              | 86                 | 1                    |
| 5               | 557.5              | 91                 | 1                    |
| 6               | 612.5              | 60                 | 1                    |
| 7               | 465.0              | 100                | 2                    |
| 8               | 390.0              | 80                 | 2                    |
| 9               | 540.0              | 97                 | 2                    |

Note 1 - From road for grout curtain -  
Elevation 1292'

Note 2 - From crest of dam -  
Elevation 1310'

Holes 1 and 2 in line with the grout holes were drilled with mud and left standing full while other holes were drilled and tests made. Cores were taken in Hole number 1 (Station 572) from 61 feet to 93 feet and in Hole number 2 (Station 627) from 58 feet to 90 feet. Holes were 2 feet from one grout hole.

Compressive strength tests were made of two cores taken from Hole number 1 which was grouted from 67-87 feet. A core 7/8-inch in diameter and 1-1/2 inches long was taken from 61 feet depth. It showed a strength of 2.44 psi or 351 psf. A core 3/4-inch in diameter and 1-1/2 inches long taken at 67-1/2 feet showed a strength of 31.7 psi or 4564 psf. The marked difference in strength indicates that the grouting increased the strength greatly.

This conclusion is confirmed by the flow tests made through two cores from the same locations as shown in Table C-3 and from water immersion tests shown in Table C-4.

TABLE C-3  
FLOW RATE TEST

| Station No. | Depth (Ft) | Core Size     |             | Fluid Flow cc/min | Differential Pressure psig |
|-------------|------------|---------------|-------------|-------------------|----------------------------|
|             |            | Diameter (In) | Length (In) |                   |                            |
| 572         | 61         | 3/4           | 1 1/4       | 2.16              | 2                          |
| 572         | 67 1/2     | 3/4           | 1           | 0                 | 800*                       |

\*The Hassler Sleeve, rubber core holder, burst and damaged the core.

TABLE C-4  
IMMERSION TEST

| Station No. | Depth (Ft) | Sample Weight Approximately | Physical State Before Immersion | Physical State After Immersion |
|-------------|------------|-----------------------------|---------------------------------|--------------------------------|
| 572         | 61         | 200 grams                   | One piece                       | Loose sand                     |
| 572         | 67 1/2     | 150 grams                   | One piece                       | One piece                      |

The cores from above the grouted section were unconsolidated as expected. The cores in the upper and lower parts of the grouted section were consolidated in Station No. 572, but the center section was unconsolidated. This indicated that the grout from adjoining holes did not completely overlap, leaving a portion unconsolidated. The same explanation was true for the center and lower part of Station No. 627. This indicated that the holes should have been closer together or more grout injected through each hole. The visual tests shown in Table C-5 also confirmed the above explanation.

Tests were then made in Holes 7, 8 and 9 on the top of the dam using an electric probe to measure the depth of water in the hole. These holes were downstream from the grout curtain.

Hole number 7 (Station 465) was drilled with air to a depth of 100 feet, but a satisfactory test could not be obtained due to plugging of the pipe with flowing sand.

TABLE C-5  
VISUAL INSPECTION TEST

| Station No. | Depth (Ft) | Section Grouted | Length of Core Recovered (In)                     | Appearance  |
|-------------|------------|-----------------|---|---|
| 572         | 61         | 67' - 87'       | 10  | Unconsolidated                                    |
| 572         | 67½        |                 | 11  | Consolidated                                      |
| 572         | 72         |                 | 14  | Unconsolidated                                    |
| 572         | 87         |                 | 15½   | Consolidated                                      |
| 572         | 93         |                 | 14  | Top partially consolidated, bottom unconsolidated |
| 627         | 58         | 64½ - 84½       |   |   |
| 627         | 58         |                 | 11  | Consolidated                                      |
| 627         | 64½        |                 | 13½   | Consolidated                                      |
| 627         | 74         |                 | 15  | Partially consolidated                            |
| 627         | 87½        |                 | 12  | Unconsolidated                                    |
| 627         | 90         | 12½             | Top partially consolidated, bottom unconsolidated |   |

Hole number 8 (Station 390) was drilled with air 30 feet east of the east end of the grout curtain to a depth of 80 feet. Water was being blown out at about 59 gpm at the 80 foot depth. The head of water built up 30 feet in 15 minutes to an elevation of 1260 feet.

Hole number 9 (Station 540) was drilled with air to a depth of 97 feet. The two-inch pipe was hung at 90 feet, but water head build-up was measured at 62 feet (elevation 1248 feet) in one hour and 52 feet (elevation 1258 feet) in 2 hours.

Holes 3 through 6 were drilled halfway between grout holes and 2-1/2 feet towards the downstream side of the dam. Table C-2 shows hole location by station number and depth of hole. The hole was 4-1/2 inches in diameter. Testing was accomplished in the following manner: The hole was drilled to the top of grouted section and tests made in the lower 10-foot section. Then the hole was drilled 10 feet into the grouted section and tested again. The hole was drilled another 10 feet into the grouted section and tested and then drilled 10 feet below the grouted section and tested again.

The test was conducted using the air bubble method. In this test, a 3/4-inch flexible hose was lowered inside the 2-inch pipe through a packing at the surface, blowing the water or mud from the hole as it was lowered. Air continued to blow the hole free of

water until only a mist was obtained. The air flow was then reduced until it was very low. The air line at surface was connected to a continual source of air and a strip-chart pressure recorder which recorded the air pressure. As the water began to fill the hole, the pressure of the air had to increase in order to overcome the water head. This pressure can be read on the recorder as a function of time to obtain the head of water in the hole.

Results of tests made in Holes 3 through 6 by air bubble method are shown in Table C-6. It can be noted that the tests do indicate that the grouting was successful in reducing or eliminating the water flow in the area grouted.

TABLE C-6  
TESTS OF GROUTED AREA OF DAM

| Hole No. | Station No. | Total Depth (Ft) | Grouted Interval Depth (Ft)   | Test Interval (Ft) | 30-Minute Fillup (Ft-Water) |
|----------|-------------|------------------|---|--------------------|-----------------------------|
| 3        | 517.5       | 82               | 52 - 72   | 0 - 52             | 0                           |
|          |             |                  |   | 52 - 62            | 0                           |
|          |             |                  |   | 62 - 72            | 0                           |
|          |             |                  |   | 72 - 82            | 0                           |
| 4        | 542.5       | 86               | 56 - 77   | 0 - 56             | 0                           |
|          |             |                  |   | 56 - 66            | 0                           |
|          |             |                  |   | 66 - 76            | 0                           |
|          |             |                  |   | 76 - 86            | 20                          |
| 5        | 557.5       | 91               | 63 - 83   | 0 - 61.5           | 0                           |
|          |             |                  |   | 61.5 - 71.5        | 0                           |
|          |             |                  |   | 71.5 - 81.5        | 44*                         |
|          |             |                  |   | 81.5 - 91.0        | 0                           |
| 6        | 612.5       | 60               | Air drilled. Moisture at 60' prevented further drilling. Moisture had migrated from nearby holes. |                    |                             |

\*Fell to 35 feet in next 30 minutes

#### 4. Conclusions

Although the grout curtain was not placed all the way across the dam, it did span the center portion over the existing creek bed. This grout curtain of Injectrol® G silicate grout reduced the flow of water through the dam over 90% in the area of the grout curtain.

Some sections of the grout curtain show to be unconsolidated. This is probably due to the grout from adjoining holes not overlapping, leaving gaps through which water can leak. Only one row of

grout holes was used. Completely sealing the leakage would require another row of holes or injection of more grout in the present holes. It is doubtful if the additional results would justify the expense.

Hole number 8 drilled to the east of the grout curtain at Station 390 indicated that a flow of water was still going through the dam around the east end of the grout curtain, but sufficient grouting was done to prevent damage to the dam.

## EXHIBIT H

### CASE HISTORY

#### SOIL CONSOLIDATION FOR TUNNEL EXCAVATION WASHINGTON, D.C. METRO SYSTEM

##### 1. General

This grouting was done by the Hayward Baker Company with the same materials and technique used on the I-95 overpass grouting reported in Case History F.

##### 2. Job Information

This work was in connection with the mining of a tunnel for the Washington Metro located near RFK Stadium. The construction company had encountered sand and gravel along with an inflow of water. This was causing the face to "run", which resulted in an extension to the surface of the ground where settlement occurred. To stop this condition, grouting was considered and selected for the application.

The procedure for grouting was the same as used for the grouting under the piers of the 7th Street overpass on I-95. The holes were drilled and cased on ten-foot centers on a three-row grid pattern to a depth varying from 50 to 60 feet. A 1-1/2-inch plastic pipe, with the lower ten-foot section slotted at given intervals, was placed inside the casing and the lower ten feet surrounded with small gravel. The casing was then pulled up ten feet to the top of the sand. A light grout of cement and silicate was placed around the annulus from the sand pack to the surface, and then the casing was withdrawn from the hole before the grout set.

Figure C-17 shows the site above the tunnel, looking in the direction of the tunnel. The face of the tunnel is behind and below the observer. Three rows of plastic injection pipes are in the center of the picture. The two drilling rigs, a small mixer for the sleeve grout, and the grouting trailer are evident in the foreground.

Figure C-18 shows the grout distribution manifold. The large pipe on the left brings the grout to the manifold. The grout can be divided among the 6 smaller pipes of the manifold, where a line from each has a hose going to one of the plastic injection pipes set in the ground. Pressure gauges on each line were used to try to equalize the flow through all lines and indicate the actual injection pressure at the surface. There are valves on each line so the number of lines actually connected and being used can vary from one to six. Apparently five lines were being used at the time the picture was made. Flow indicators were also used on each line.



Figure C-17. Grouting site.

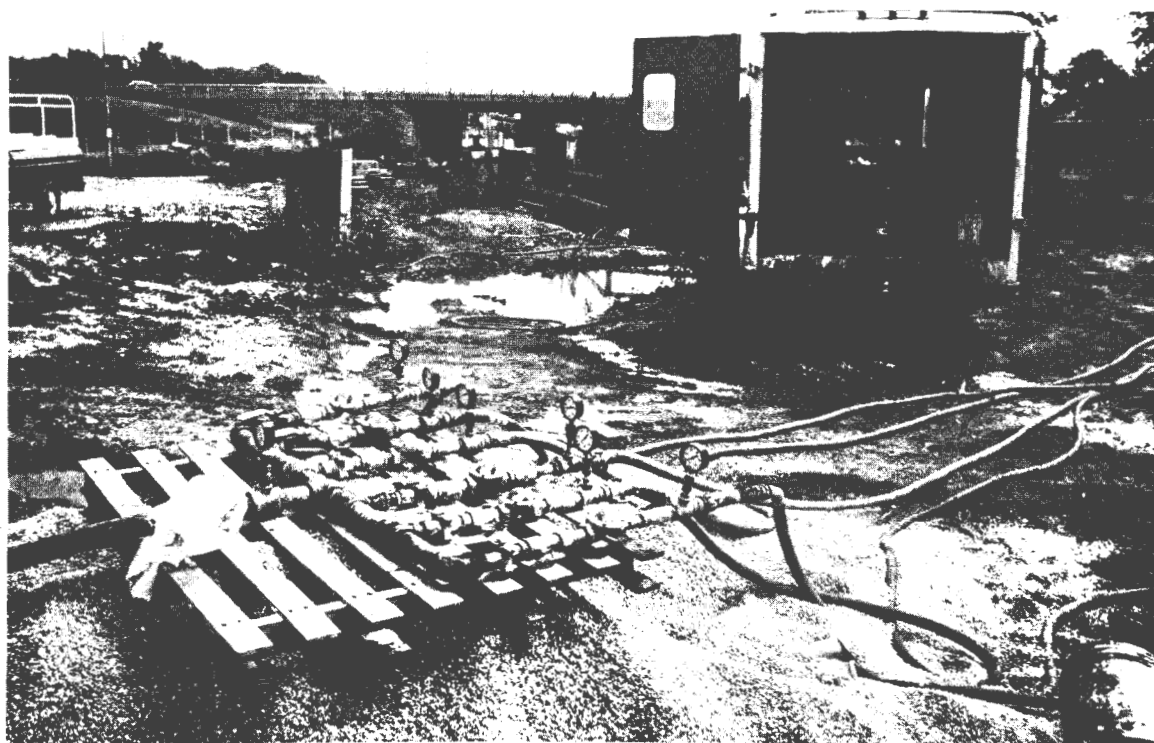

Figure C-18. Grout distribution manifold.

Figure C-19 shows grouting operations approaching the open cut section of the tunnel. The tunnel is progressing toward the large portal opening supported with soldier beam and lagging walls. Figure C-20 is the lower portion of the portal. Groundwater, along with grout fluid, can be seen in the lower left issuing through the wall as the grout fills the pores in the sand to be mined.

Figure C-21 is a view of the sediments at the face of the tunnel beneath the shield. The soil was very stable and dry. The consolidation seemed to be uniformly distributed, and mining was accomplished without any further problems.

Figure C-22 is a photograph of a sample of consolidated material taken from the face of the tunnel during mining. This sample was kept in an air-tight plastic sack to prevent drying. Two test pieces were obtained from the large sample. The unconfined compressive strengths of the samples were 32 psi and 44 psi, or an average of 38 psi. The presence of the large gravel and a wide range of particle size tends to make the compressive strength lower than if the soil were finely graded.

The silicate in the grout probably varied from 45 to 50 percent of the grout fluid, and the contractor injected about 30 percent by volume of chemical grout to the volume of the sand being grouted.

### 3. Results

The first tunnel was mined behind the grouting. The soil was stabilized sufficiently to permit excavation without further loss of sand, so the contractor decided to reduce the silicate concentration to about half of that used in the first tunnel. The second tunnel was grouted using about 25% sodium silicate concentration, and it was then mined out without any trouble.

When trouble was encountered with running ground, the tunnel contractor was able to dig only 30 feet of tunnel in 30 days. After grouting, the tunnel was dug at the rate of 30 feet per day.





Figure C-19. Grouting toward portal opening



Figure C-20. Tunnel portal opening.



Figure C-21. Grouted soil at tunnel face.



Figure C-22. Sample of grouted soil.

## D. Testing Information

### 1. In Situ Permeability Test Procedure

An in situ test procedure using a piezometer is an economical method which can be used in a wide range of soil types. This procedure is based on work by the Corps of Engineers (Hvorslev, M. L., Ref. 69) and by William G. Weber, Jr. ("In Situ Permeabilities for Determining Rates of Consolidation," State of California, Transportation Agency, Department of Public Works, Division of Highways, Highway Research Board Meeting, January 1968).

The test is performed using non-metallic, porous tube type piezometers. The piezometers consist of the porous stone permeameter with or without sand filter, placed in the soil mass. The permeameter is normally 1-1/2 inches in diameter and either 1 or 2 feet long. A 1/2 inch plastic tube is connected to the porous stone and extends vertically to the ground surface. A schematic of the piezometer installation is shown in Figure D-1. The test is normally conducted using the open type system, however, it can be conducted using the closed type system.

In conducting the test using the open piezometer system, the water level in the plastic tubing is lowered about 5 feet. This is accomplished by means of a hand vacuum pump connected to a 1/4 inch plastic tube placed inside the 1/2 inch plastic tubing. The end of the 1/4 inch plastic tubing is at the depth of the desired lowering of the water level. The depth to the water level is then measured at various time intervals, see Figure D-2. The pressure head at a given time interval is then divided by the amount of the total reduction in head. The time interval is plotted against the logarithm of the head ratio. A typical example of the field data are shown in Figure D-3. From these data the basic time lag, the time for  $H/H_0$  to equal 0.37, is determined.

It may be noted that these time lag curves do not always form a straight line through the zero time where  $H/H_0$  equals 1.00. This is primarily due to air in the soil or piezometer system. By lowering the water level in the 1/2 inch plastic tubing, the pressure is reduced and the air expands, partially escaping. This is one of the reasons for the use of the rising head test instead of the falling head test, where water is introduced into the system to increase the head. The correction for the air is made by parallel shifting the straight line portion so as to pass through the zero time where  $H/H_0$  equals 1.00. This parallel shifting of the curve assumes that the air has not affected the volume of water passing through the porous stone, which is only approximately true when small amounts of air are present. This restricts the use of this test to saturated soil.

These time lag curves are the basis for calculating the permeability of the soil surrounding the piezometer. There are three physical dimensions that are required to be known to calculate the

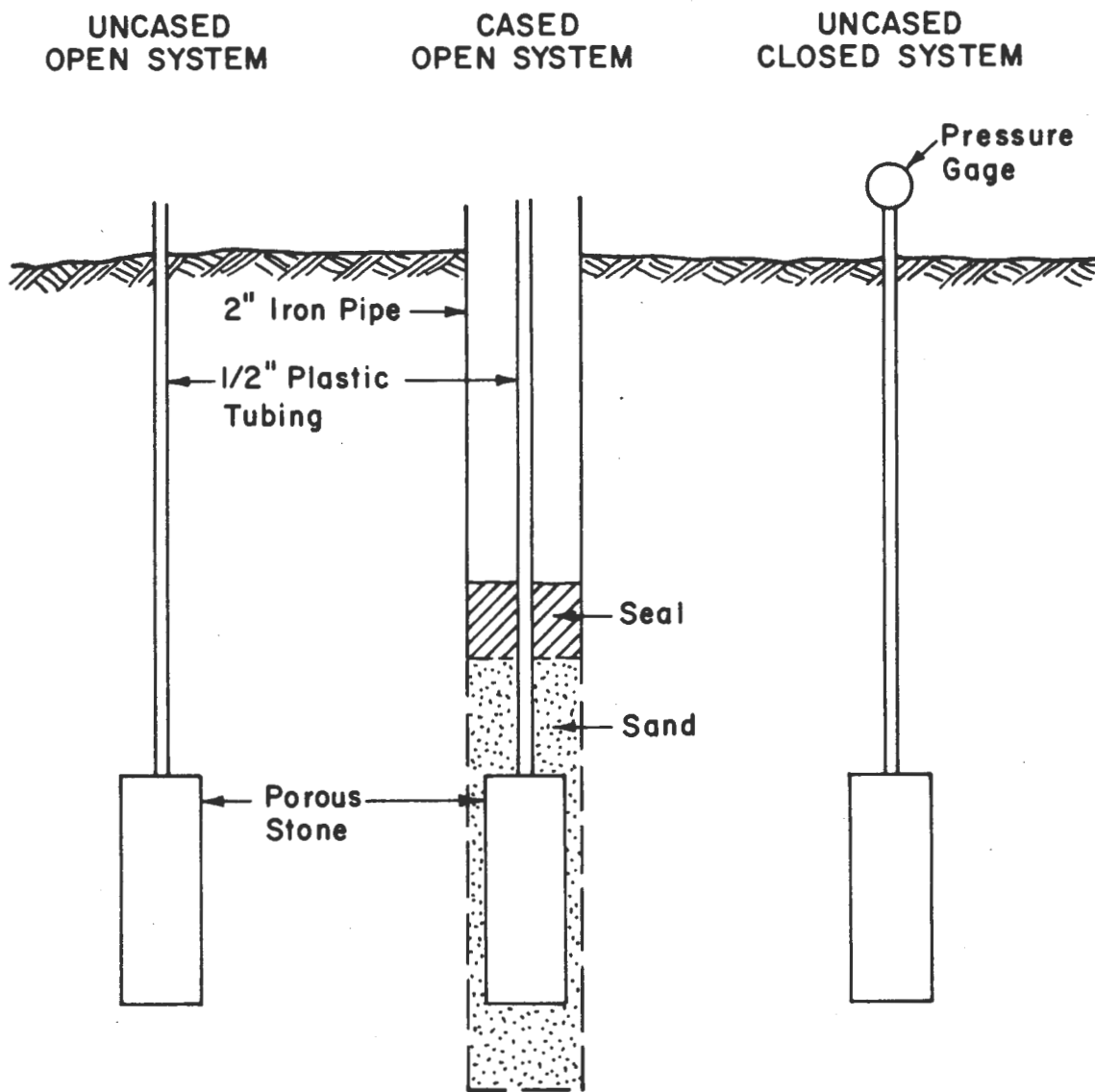

Figure D-1. Piezometer installations (schematic).

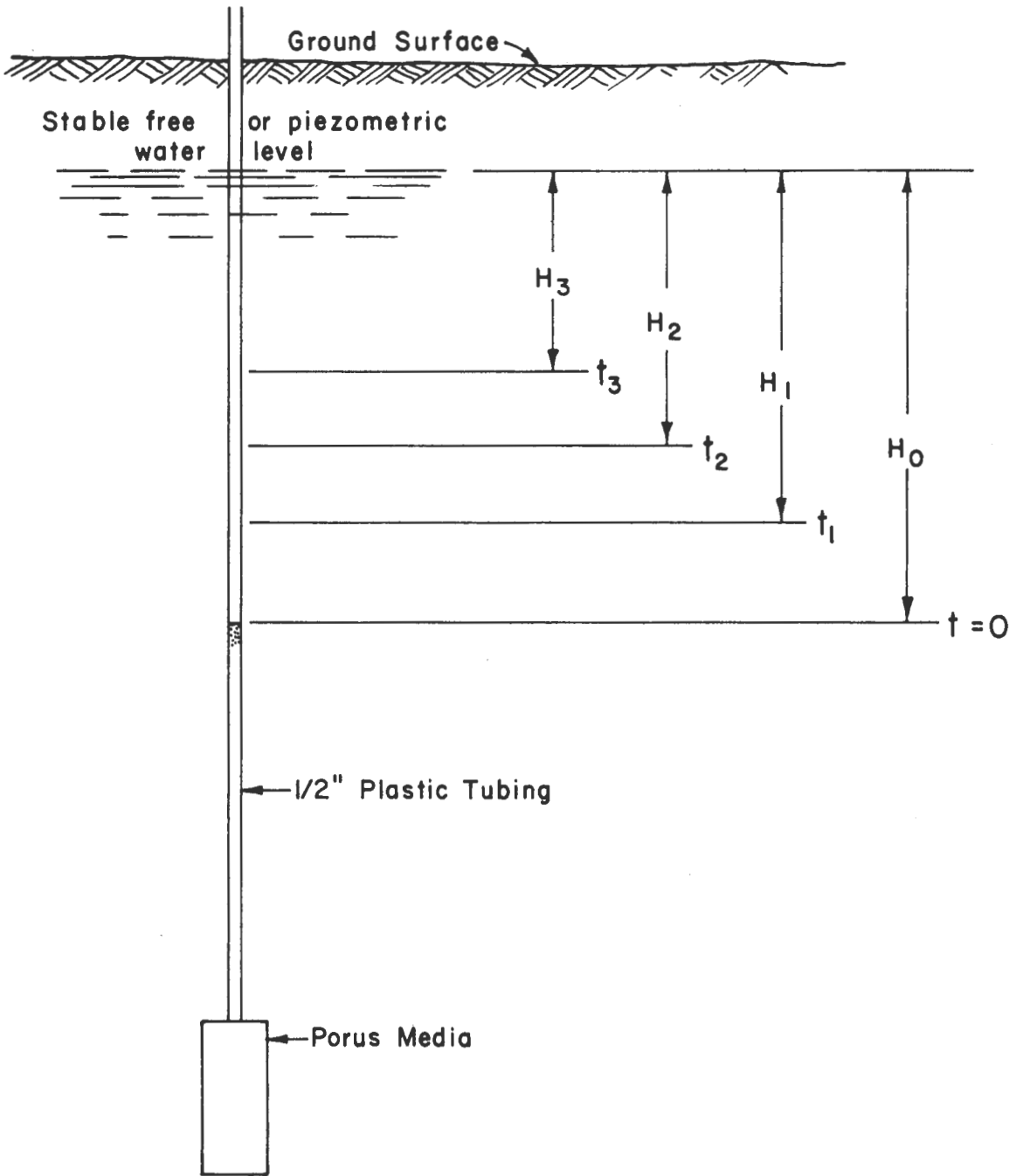

Figure D-2. Piezometer test - falling head.

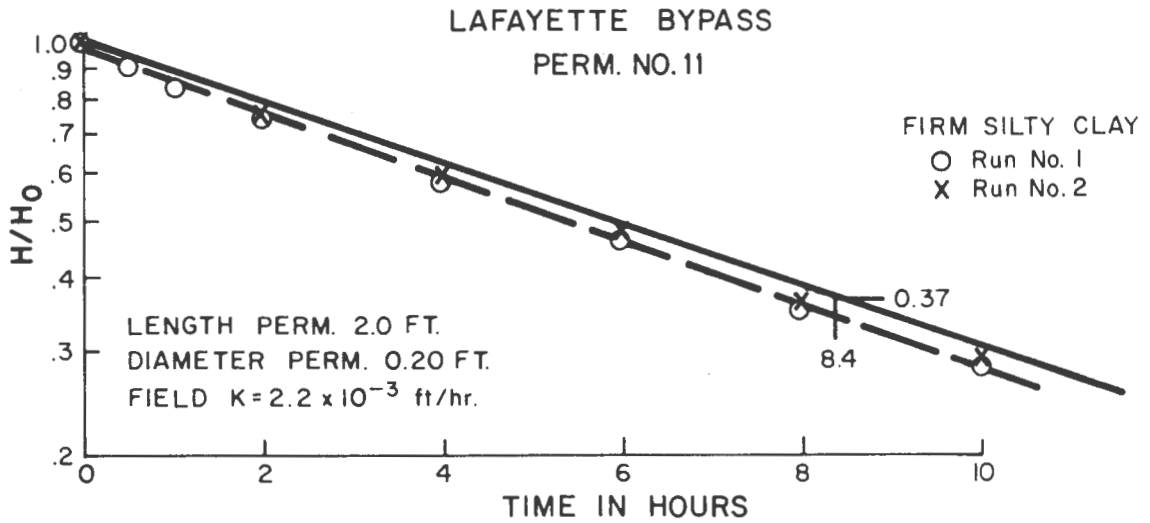

Figure D-3. Typical field time lag curve.

permeability: the length of the permeameter, the diameter of the permeameter, and the diameter of the stand pipe. These variables can all be measured with reasonable accuracy. Using the following equation, the permeability can be calculated.

$$k_h = \frac{a^2 \ln \left( \frac{mL}{d} + \sqrt{1 + \left( \frac{mL}{d} \right)^2} \right)}{8 L T} \quad (78)$$

Where:

- $k_h$  = Permeability in the horizontal direction
- $a$  = Area of standpipe
- $L$  = Length of permeameter
- $d$  = Diameter of permeameter
- $\ln$  = Natural logarithm
- $m$  = Square root of the ratio of horizontal to vertical permeabilities  
(assume  $m = 1$  for 1st approximation)
- $T$  = Basic Time Lag

## 2. Laboratory Grout Distribution Tests

Tests were conducted in the laboratories of Halliburton Services, Duncan, Oklahoma to attempt to determine if the distribution of grout could be monitored during the injection. A test box containing saturated medium fine sand was used for the tests. A single grout injection pipe was placed in the center of the box as shown in Figure D-4.

The grout distribution was traced by electrical surface measurements in the laboratory. At least three "four-electrode" systems were used in the tests. Each four-electrode system is comprised of two current electrodes between the grout hole and the current electrode. Figure D-5 shows the layout of four of the four-electrode systems. A fracture was simulated by placing a thin layer of coarse sand in the test box. An acrylamide grout mixed with 10% salt water was injected. The grout followed the "fracture", and the resistivity measurements indicated the direction the grout traveled.

A later test indicated that the first part of the injection followed the simulated fracture; then, after filling the fracture, the grout spread out fairly evenly across the test box. Observations after the set grout was dug out corroborated this.

A patent covering this monitoring technique is attached.



Figure D-4. Equipment for laboratory grout distribution test.

### 4 ELECTRODE SYSTEM PLACEMENT

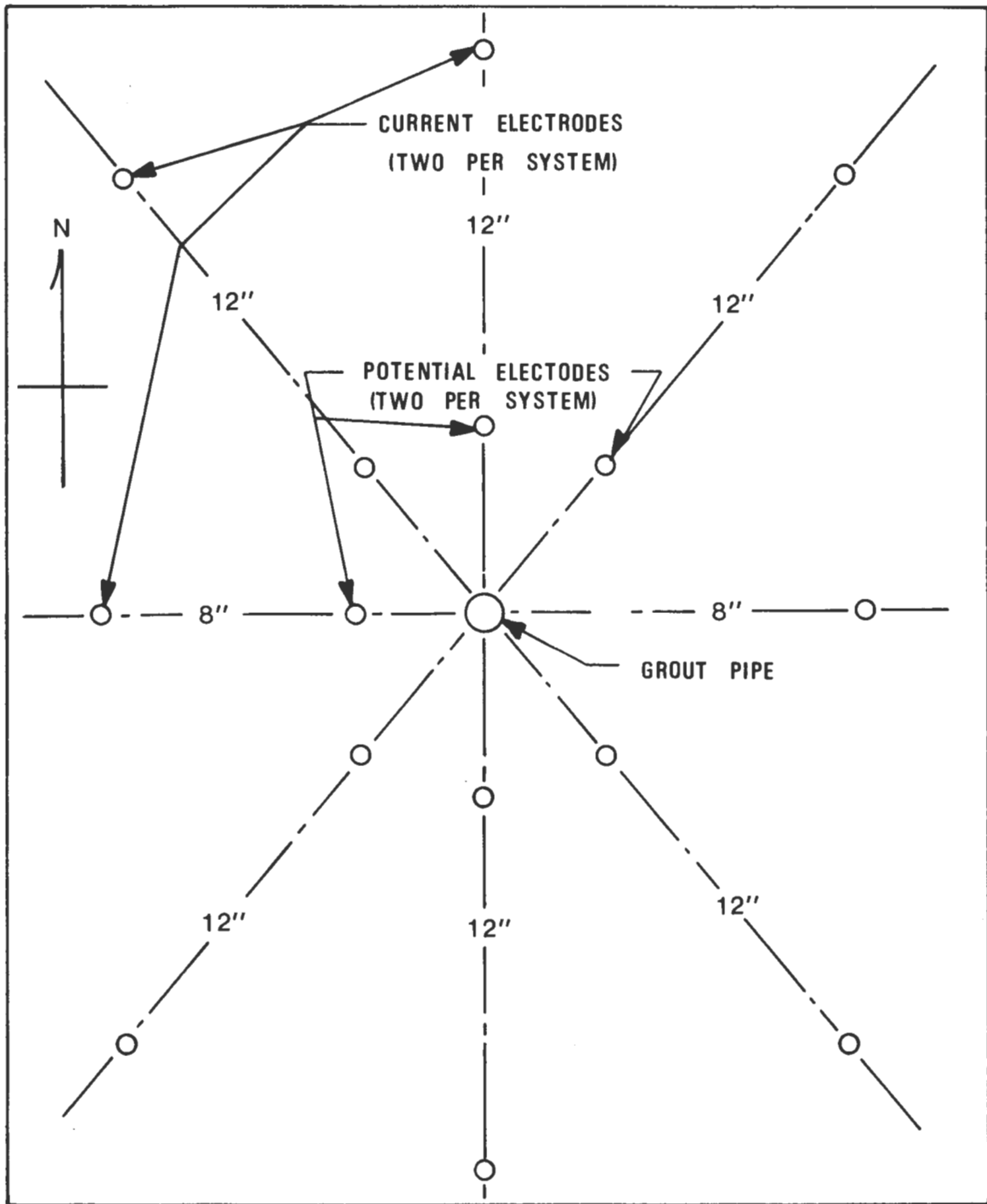

Figure D-5. Test probe layout.



May 9, 1967

C. D. McDOULETT ET AL  
METHOD OF TRACING GROUT IN EARTH FORMATIONS BY MEASURING  
POTENTIAL DIFFERENCES IN THE EARTH BEFORE AND  
AFTER INTRODUCTION OF THE GROUT  
Filed July 9, 1964

3,319,158

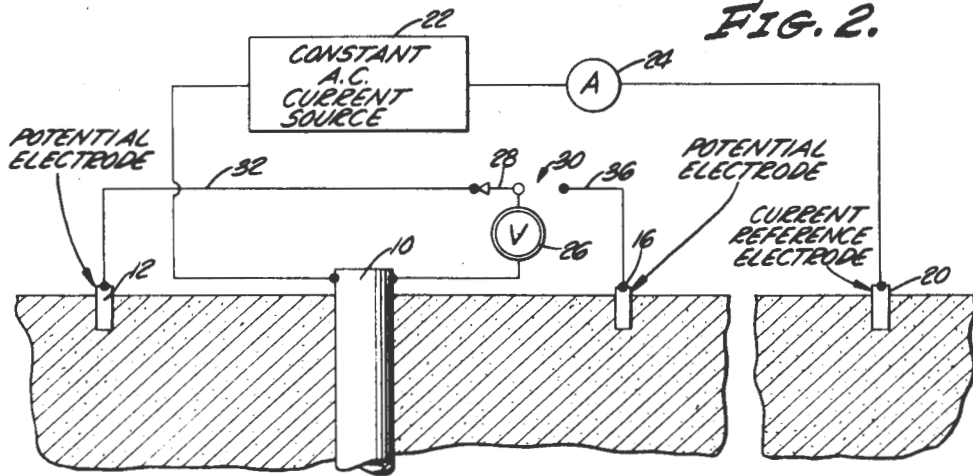

FIG. 2.

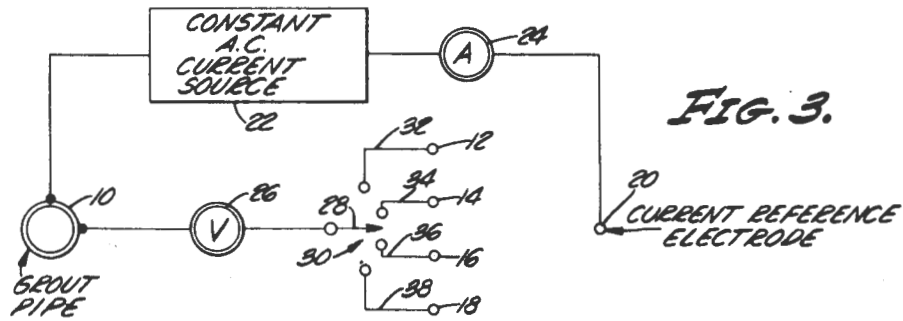

FIG. 3.

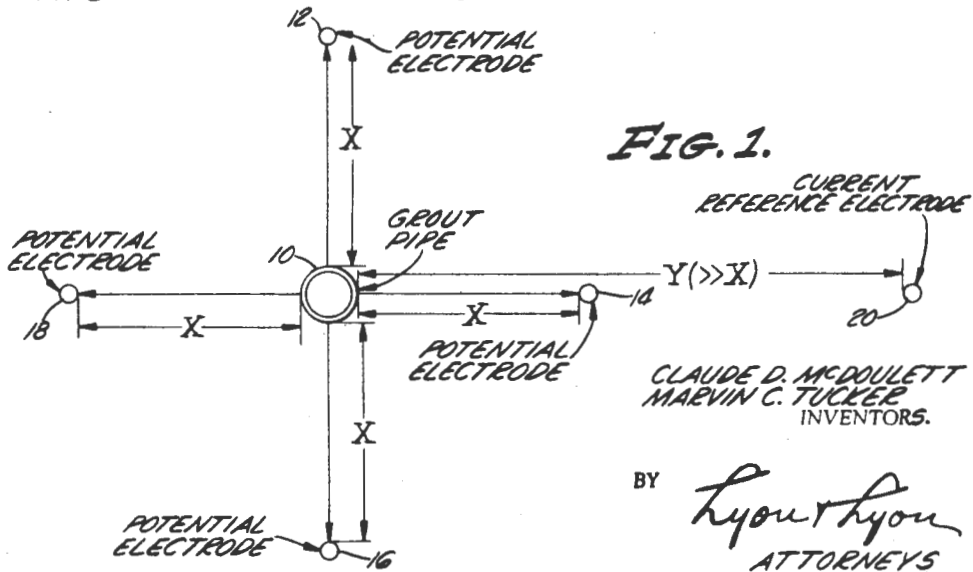

FIG. 1.

CLAUDE D. McDOULETT  
MARVIN C. TUCKER  
INVENTORS.

BY  
*Lyon Lyon*  
ATTORNEYS

1

3,319,158

**METHOD OF TRACING GROUT IN EARTH FORMATIONS BY MEASURING POTENTIAL DIFFERENCES IN THE EARTH BEFORE AND AFTER INTRODUCTION OF THE GROUT**

Claude D. McDoulett and Marvin C. Tucker, Duncan, Okla., assignors to Halliburton Company, Duncan, Okla., a corporation of Delaware

Filed July 9, 1964, Ser. No. 381,473

3 Claims. (Cl. 324-9)

This invention relates to a method and system for determining the distribution of grout around an injection well.

When injecting grout through a pipe into an earth formation, it is desirable to trace the relative distribution of grout around the pipe while it is being injected into the formation. Various methods of grout tracing and electrical systems for carrying them out have been proposed. The most common such system presently in use consists of a plurality of four electrode systems distributed about the grout hole in a predetermined pattern. Each of the four electrode systems comprises a pair of current electrodes spaced relatively distant from the grout hole on opposite sides thereof and a pair of potential electrodes aligned with the current electrodes and the grout hole and positioned considerably closer to the grout hole than the current electrodes.

A constant A.C. current is supplied to the current electrodes and an A.C. millivolt meter is connected to the potential electrodes. Generally, three such four-electrode systems are required to adequately cover the 360° around the grout pipe. Such a system requires sixteen lead cables and electrodes, and satisfactory operation is obtained only by spacing the current electrodes at least forty feet from the grout pipe.

Since it is often necessary to carry out a grouting operation within narrow confines, a conventional four-electrode system is frequently not usable, at least in its most accurate manner. Moreover, it is often difficult, as well as uneconomical, to transport the number of cables of the length required to the site of the grouting operation. It has also been found that the sensitivity of the four-electrode system is quite low and requires a substantial resistivity contrast between the grout and the formation fluid before meaningful results can be obtained.

It is therefore an object of the present invention to provide a system for tracing the distribution of grout around a grouting hole that requires less equipment and can be set up in a smaller area than has heretofore been possible.

It is also an object of the present invention to provide such a system in which only one electrode need be spaced a substantial distance from the grout hole and in which the grout pipe itself is used as an electrode.

It is another object of the present invention to provide such a system which is extremely sensitive and which permits the use of grout having a resistivity relatively close to that of the formation fluid.

It is a still further object of the present invention to provide an improved method for tracing the distribution of grout around a grout hole.

These and other objects and advantages of the present invention will become more apparent upon reference to the accompanying description and drawings in which:

FIGURE 1 is a diagrammatic plan view showing the disposition of the electrodes of the system of the present invention;

FIGURE 2 is a diagrammatic representation of the system of the present invention; and

FIGURE 3 is a schematic diagram of the electrical system of the present invention.

Referring now to FIGURE 1, a grout pipe 10 is shown

2

surrounded by a plurality of electrodes 12, 14, 16 and 18 which serve as potential electrodes in the system of the present invention. These electrodes are preferably angularly spaced at 90° intervals around the grout pipe and are spaced from the grout pipe by a distance X. A further electrode 20 is spaced from the grout pipe 10 by a distance Y which is much greater than the distance X. The electrode 20 serves as a current reference electrode in the circuit while the grout pipe 10 itself serves as the common potential and current electrode of the system.

As can be seen in FIGURES 2 and 3, the grout pipe 10 is connected to one terminal of a source 22 of constant A.C. current. The other terminal of the source 22 is connected through an ammeter 24 to the current reference electrode 20. The grout pipe 10 is also connected to one terminal of a millivolt meter 26, the other terminal of which may be connected to any of the potential electrodes 12, 14, 16 and 18 by means of the movable arm 28 of a switch 30 which selectively engages contacts coupled by cables 32, 34, 36 and 38 to the potential electrodes.

After the system has been set up, an A.C. current controlled at a predetermined constant value is applied to the combination current and potential reference electrode 10 and the current reference electrode 20 and passed through the earth formation between them. The current in the formation creates a potential difference between the electrode 10 and the potential electrodes 12, 14, 16 and 18 spaced around the electrode or grout pipe 10.

By means of the switch 30, base readings are obtained and recorded from each of the four electrodes 12, 14, 16 and 18 prior to injecting grout into the zone to be consolidated. In most cases, the grout will be more conductive than the formation fluid and in such cases the millivolt readings between the electrodes as indicated by the millivolt meter 26 will decrease as the grout displaces the formation fluid in the zone being consolidated. Since these readings are taken between the grout pipe in the center of the system and the potential electrode spaced equally around it, the change in readings per pair of electrodes will indicate the direction and magnitude of travel of the grout. This signal can be read and recorded manually or can be continuously recorded by a series of suitable recorders.

In a test of the system described above, the potential electrodes 12, 14, 16 and 18 were spaced 8 ft. from the grout pipe 10 and the current reference electrode 20 was spaced 160 ft. from the grout pipe. Before the grout injection was begun, a constant A.C. current of 1 amp was passed through the formation between the electrodes 10 and 20 and the potentials at the various electrodes 12, 14, 16 and 18 were measured at 305, 300, 310 and 310 millivolts, respectively. The formation fluid was determined to have a resistivity of 5 ohm-meters and the grout, which was of the type disclosed in assignee's copending application Ser. No. 187,951, filed Apr. 16, 1962, now Patent No. 3,223,163, was determined to have a resistivity of 1.58 ohm-meters. The grout injection depth was 35.6 ft. to 39.0 ft. It was determined theoretically before the grout was injected that 60 gallons of grout would be necessary to form a consolidated cylinder 4.5 ft. in diameter through the sand in the formation.

After the sixty gallons of grout were injected, the potential at electrode 12 had been reduced to 292 millivolts, at electrode 14 to 282 millivolts, at electrode 16 to 297 millivolts and at electrode 18 to 298 millivolts. The total change was thus 56 millivolts with 23.2 percent occurring at electrode 12, 32.2 percent occurring at electrode 14, 23.2 percent occurring at electrode 16 and 21.4 percent at electrode 18. From these values it can be calculated that the grout extends 2.1 ft. from grout pipe 10 towards potential electrode 12, 2.56 ft. towards potential electrode

3

12, 2.18 ft. towards potential electrode 16, and 2.08 ft. towards potential electrode 18.

From the foregoing description, it can be seen that a system and method have been provided for tracing the distribution of grout around a grout injection pipe. The system permits the use of fewer components than has heretofore been possible and provides a higher sensitivity, thus allowing the use of a grout having a resistivity relatively close to that of the formation fluid.

While the system has been described solely in terms of determining grout distribution, it should be obvious to those skilled in the art that it could also be used to determine the extent of other changes in resistivity taking place about a given reference electrode, or to determine the distribution of other substances, for example, a fracturing fluid, introduced into an earth formation. It should also be obvious that more or less potential electrodes may be used if circumstances warrant.

The invention may be embodied in other specific forms not departing from the spirit or central characteristics thereof. The present embodiment is therefore to be considered in all respects as illustrative and not restrictive, the scope of the invention being indicated by the appended claims rather than by the foregoing description, and all changes which come within the meaning and range of equivalency of the claims are therefore intended to be embraced therein.

We claim:

1. A method of determining the distribution of a substance introduced into an earth formation having a resistivity different from that of said substance, comprising: passing a constant current through said earth formation between the point of substance introduction and a point remote from said introduction point, measuring the potential difference between said introduction point and a point much closer to said introduction point than to said remote point, introducing said substance into the earth formation, and again measuring the potential difference between said introduction point and said closer point.

2. A method of determining the distribution of a substance introduced into an earth formation having a resistivity different from that of said substance, comprising:

4

passing a constant alternating current through said earth formation between the point of substance introduction and a point remote from said introduction point, measuring the potential difference between said introduction point and each of a plurality of other points spaced around said introduction point and positioned much closer to said introduction point than to said remote point, introducing said substance into the earth formation, and again measuring the potential difference between said introduction point and said spaced points.

3. A method for tracing the distribution of grout introduced through a grout pipe into an earth formation having a resistivity different from that of the earth formation, comprising: passing a constant alternating current through said earth formation between said grout pipe and a point remote from said grout pipe, measuring the potential difference between said grout pipe and each of a plurality of points equally spaced from said grout pipe and covering 360° around said grout pipe, said spaced points being positioned much closer to said grout pipe than to said remote point, introducing a known amount of grout into said formation through said pipe, and again measuring the potential difference between said grout pipe and said spaced points, the change in voltage between said second readings and said first readings indicating the distance the grout has traveled through said formation toward each of said spaced points.

References Cited by the Examiner

UNITED STATES PATENTS

|           |         |          |        |   |
|-----------|---------|----------|--------|---|
| 2,181,601 | 11/1939 | Jakosky  | 324—1  | X |
| 2,192,404 | 3/1940  | Jakosky  | 324—64 | X |
| 2,211,124 | 8/1940  | Jakosky  | 324—1  | X |
| 2,440,693 | 5/1948  | Lee      | 324—1  |   |
| 2,459,196 | 1/1949  | Stewart  | 324—1  |   |
| 2,575,349 | 11/1951 | Lee      | 324—1  |   |
| 2,625,374 | 1/1953  | Neuman   | 324—10 | X |
| 3,134,941 | 5/1964  | Norelius | 324—1  |   |

WALTER L. CARLSON, *Primary Examiner.*

G. R. STRECKER, *Assistant Examiner.*

### E. Sample Specifications

A copy of the specifications for the 1975 grouting job at 7th Street and I-95 in Washington, D. C. is attached. Specifications for grouting are not widely used in the United States, so this sample is included for information purposes only. Suggested specifications are included in a separate design manual, FHWA-RD-76-27.

The technology of slurry trenches and diaphragm walls is much more advanced than that of grouting, so specifications are considered standard. One such specification is attached.

## 1. SAMPLE SPECIFICATION OF GROUTING JOB

(Courtesy of Parsons, Brinkerhoff,  
Quade and Douglas, New York,  
New York.)

### Grout

Grout shall be non-shrinking, conforming to the requirements of Section \_\_\_\_.

### 7th Street Bridge Over Route I-95

#### Description

The Contractor shall protect the 7th Street Bridge over Route I-95 and maintain it safe for public use during the life of the Contract, as shown on the contract drawings and as described herein.

The program shall consist of:

a) Solidification by chemical grouting of the underlying soil situated between the bridge foundations and the proposed tunnels.

The grouting program shall be capable of producing from the groutable soil mass, a solidified soil material having an average compressive strength of 100 psi.

b) Erecting, maintaining and removing a system of adjustable temporary supports to permit continuous use of the bridge, should settlements develop as a result of the tunnel construction.

The grouting program must be acceptably completed, and the temporary support system must be in place complete and ready for operation, before tunnel construction will be permitted to approach closer than 200 feet to the nearest abutment of the bridge.

Approval by the engineer of any equipment, materials or methods, shall in no way relieve the Contractor of his responsibilities for supporting and protecting the structure from damage.

#### Pre-Construction Inspection

In accordance with Section 2, Special Conditions, pre-construction inspection of structures will be performed by the Authority. The Contractor shall have a representative present when the inspection of this structure is being made.

#### Limitations of Operations

The Contractor's attention is directed to traffic restrictions and limitations affecting his operations, as established by

the District of Columbia Department of Highways and Traffic and which are shown on the contract drawings.

### Grouting Program

It is the intent of this program to produce the greatest possible uniformity and cohesion of the soil within the designated areas shown on the contract drawings.

The locations and spacing of grout holes and grouting sequence, as shown on the contract drawings, are suggested patterns. The Contractor may revise this pattern. He shall submit full details of his proposed grouting program for attaining the required results, to the Engineer for approval. Grouting pressure shall not exceed 25 psi.

Details shall include descriptions of:

- a) Geometric layout of grouting pattern
- b) Equipment
- c) Materials
- d) Mixing - capability for closely controlling the mix ratio during grouting
- e) Pumping - capability for closely controlling the pumping rate during grouting
- f) Gel time - maximum gel time shall be two (2) hours
- g) Proposed grouting pressures

Should the above mentioned criteria and the uniformity and strength requirements not be met, the Contractor shall modify his program accordingly.

### Materials

Grout base material, reactant and catalyst, and their concentrations, shall be selected to bring about the greatest strength possible to the grouted soil material, compatible with the existing soil conditions. An average compressive strength of the grouted soil of 100 psi is required. Reduction of the soil permeability is a secondary consideration. Because of the strength requirements, certain types of chemical grout based on acrylamide, will not be acceptable. The Engineer reserves the right to reject the use of low base material concentrations. Grout shall be adapted to a "one-shot" process.

Grout-in-place shall be chemically stable within the time frame of tunnel construction.

Water used for grout shall be clean and contain no chemicals deleterious in any way to the gelling and strength development of the grout. The Contractor shall certify to this in writing.

Dye tracers shall be added to the grout solution. The Contractor shall certify that the proposed dye will not adversely influence the gelling and strength development of the grout.

Grout materials shall be stored and handled in accordance with the recommendations of the manufacturer.

### Grouting

The grouting program shall be under the continuous, direct supervision of personnel who shall have had previous experience and be qualified in the application of chemical grout for soil strengthening purposes.

The geometric layout of the holes, shown on the contract drawings, are intended to indicate the desired extent of the solidified soil mass. It is not intended to illustrate an acceptable grout pattern. The Contractor shall develop the layout of the grout holes, the order in which the holes are to be placed and grouted, and the vertical dimension and sequence of grouting the lifts for each hole. The maximum spacing of holes longitudinally along the abutments or pier, shall be 4'-0".

Grout holes shall not be drilled through the bridge footings.

Should the Contractor plan to use cased grout holes, he shall not install the casings by jetting methods.

### Record Keeping

The Contractor shall maintain complete records of his grouting operations. Such records shall contain the following minimum information:

- a) Hole number as identified on the Contractor's approved plan
- b) Time and date of initiation and completion of grouting for each hole
- c) Slope of battered grout holes
- d) Deepest penetration of grout pipe
- e) Grout mix ratio
- f) Concentrations of base material and reactant

- g) Pumping pressure at various depths of grouting
- h) Rate of grout take
- i) Gel time as measured on sample from sample cock between mixing chamber and grout pipe

Items "e" through "i" shall be recorded every time the chemical content of the grout and the pumping pressure are changed.

#### Temporary Support System

The Contractor shall be responsible for maintaining the bridge structure in a safe condition at all times, including the repair of any and all damage to the structure, including bridge approach slabs.

The Contractor shall install, maintain and operate a system for temporarily supporting the bridge superstructure to permit its continued safe use by the public. The system shall provide for vertical adjustment by jacking methods, at each area of support for each stringer. Upon completion of the Contract, the system shall be removed.

The support system is shown on the Contract Drawings. The Contractor shall submit for approval by the Engineer and the D.C. Department of Highways and Traffic, complete details of the temporary support system, including the jacking system and its operation. Details shall include the reinforcement of stringers to resist jacking loads and temporary support reactions. Approval by the D. C. Department of Highways and Traffic and the Engineer, shall not relieve the Contractor of his full responsibility under the Contract. The D. C. Department of Highways and Traffic, the Engineer, and the Authority, have no responsibility.

Tie rods joining the bridge approach slabs to the bridge abutments, shall be installed as shown on the Contract Drawings.



## 2. STANDARD SPECIFICATIONS FOR ICOS WALLS

(Courtesy of ICOS Corporation  
of America, New York, New  
York)

### Method of Construction

The Contractor shall construct the solid reinforced concrete wall where shown on the Contract Drawings by the bentonite slurry trench process to the end result that the perimeter wall shall be watertight (except only that moisture will be permitted to ooze out slowly in small drops through fine pores or to emerge like stains of sweat) and free from voids or segregation of materials. Where the term "watertight" is used in the Specifications, it shall be defined as in the preceding sentence.

### Location, Depth and Width

The ICOS wall shall begin near the existing ground surface at the elevation and location as shown on the Contract Drawings and shall extend down through the underlying materials to the depth required by the Contract Drawings or as directed by the Engineer. The minimum thickness of the ICOS wall shall be \_\_\_\_\_ feet. At any given point on the wall the inside surface of the wall as construction shall not vary in a direction normal to the plane of the wall by more than six inches, in addition to the tolerance specified below for vertical alignment, from the theoretical surface, based on the dimensions shown on the Contract Drawing. Where the inside surface of the wall has variations greater than that specified above, the wall variations shall be finished to conform to the tolerance above specified by chipping, grinding or by applying cement grout.

### Vertical Alignment

The wall shall be placed straight and the maximum variations of the plane of the wall, at any one point on it's inside face, from the vertical shown on the Contract Drawing shall be 1% of it's height.

### General Requirements for Excavation

Excavation for the ICOS wall shall be performed to the depths and widths required by the Specification and Contract Drawings. Excavation with respect to payment, shall include the removal of all natural materials encountered in excavating and consistent with the information provided by soil borings and other contract documents. Any man made obstruction and or any sub-soil condition varying considerably from what could ordinarily be expected, will be removed on a Time and Material basis, or by applying different unit prices. Excavation shall include a careful clearing of the bottom of the trench,

done by appropriate methods, prior to the placing of the concrete. If material is excavated below the bottom line of the wall, the Contractor shall fill the excess volume with concrete of the same class as that for which the excavation was made at his own expense. The excavation shall be kept open for construction of the ICOS wall by using bentonite slurry. The Contractor shall maintain the stability of the excavated trench at all times for its full depth. The Contractor shall control and supervise the use of the bentonite slurry continuously to maintain the excavated trench. Under no circumstances the level of the bentonite slurry shall be allowed to drop more than three feet below the level of the working platform. An adequate reserve of bentonite slurry and pumping equipment shall be provided in order to maintain the excavated trench at all times. Excavation adjacent to and around existing buildings, foundations, structures, and utilities which are to remain in place shall be performed without damage to or movement of same or the contents thereof and without movement of loss or undermining of ground.

#### Characteristics of Bentonite Powder

Composition: The bentonite shall be the high swelling Wyoming type sodium base bentonite consisting mainly of the clay mineral montmorillonite.

Purity: Montmorillonite content: 90% minimum  
Native sediments: 10% maximum

Chemical Composition: Sodium montmorillonite: 60% minimum  
Calcium and magnesium montmorillonite: 40% maximum

Viscosity: A fully hydrated slurry containing 6% bentonite solids (as received basis) when mixed with 94% distilled or deionized water shall achieve a viscosity of 15.0 centipoises minimum as measured by a Fann Viscometer or Stormer Viscosimeter.

Gelation: A fully hydrated slurry containing 6% bentonite solids, as prepared for viscosity determination, shall have a gelation value of 5 pounds per 100 square feet minimum as measured by a Fann or Stormer instrument.

Fluid Loss: A fully hydrated slurry containing 6% bentonite solids, as prepared for viscosity determination, shall lose no more than 16.5 ccs of fluid when subjected to a pressure of 100 psi for 30 minutes in a cell fitted with a 9.0 cm. Whatman No. 50 filter paper.

Sizing: Pulverized bentonite shall be ground to a fineness such that 80% minimum passes a USS 200 mesh screen in dry form.

#### Characteristics of Bentonite Slurry

Composition: The bentonite slurry shall consist of a uniform mixture of high swelling sodium base bentonite in water.

Density: The bentonite slurry shall weigh a minimum of 64.0 pounds per cubic foot, at a solids content of 6%.

Consistency: The bentonite slurry, at the point of mixing and before discharge to the reserve tank shall have a consistency of 15 centipoises minimum as measured by a Fann Viscometer or Stormer Viscosimeter.

Gelation: The bentonite slurry at the point of mixing and before discharge to the reserve tank shall have a gelation value of minimum 5 pounds per 100 square feet as measured by a Fann or Stormer instrument.

Marsh Funnel: Bentonite slurry achieving a flow rate of 60 minimum through a Marsh Funnel - one quart in, one quart out - is acceptable.

Fluid Loss: Bentonite slurry at the point of discharge to the reserve tank shall lose no more than 16.5 ml of fluid when subjected to filtration pressure of 100 psi for 30 minutes through a 9.0 cm Whatman No. 50 filter paper.

PH: The PH of bentonite slurry shall be at least 8.

#### Mixing and Circulating the Bentonite Slurry

All slurry for use in the trench shall be mixed in a batch or continuous mixer adjacent to the trench. No slurry is to be made in the trench. Mixing of water and bentonite shall be done by cyclone pumps or by other approved methods and shall continue until bentonite particles are fully hydrated and the resulting slurry appears homogeneous. The Contractor can vary the characteristics lower than that specified above. The Contractor will be allowed to recirculate and reuse bentonite slurry, if he so chooses, but he shall be responsible at all times for the quality of the slurry and shall avoid at all times contamination of the same. Bentonite slurry shall not carry more than 10% of solids in suspension when recirculated.

### Joints in ICOS Wall

The wall will be constructed in continuous sections whose length shall not exceed 30 feet which will be from now on referred to as "panels". The joining of wall panels shall be accomplished by use of pipes of suitable diameter at the panel ends, to be extracted subsequent to the setting of the concrete, or by other approved means. The joints between panels shall be watertight.

### Concrete for ICOS Walls

Concrete for ICOS walls shall be designed for a strength of \_\_\_\_\_ PSI with a slump of eight inches minimum. Maximum size of the aggregates should not exceed 3/4 of an inch. Additives of any nature should not be used except with written approval of the Engineer.

### Placing of Concrete

Concrete shall be placed in the slurry filled trench by the tremie method in such a manner that the concrete displaces the slurry and mixing of concrete and slurry does not occur. The concrete shall be placed by a metal hopper and a sectional tremie pipe with watertight connections of sufficiently large diameter as to permit a free flow of concrete. At the commencement of the pouring the tremie pipe shall be lowered to touch the bottom of the excavation and then raised approximately six inches. The discharge end of the tremie pipe shall be kept continuously submerged in the concrete for the duration of the pour, which should continue without interruptions until the concrete has been brought to the required elevation.

### Reinforcement

Reinforcement shall accurately conform in size and position to the requirements of the Contract Drawing and of the approved Shop Drawings. Bars shall be placed in a reinforced cage and wired or secured together in such a way as to provide a cage of sufficient rigidity to resist distortion. The reinforcing cage shall be lifted by approved methods and shall be suspended in the trench during placement of concrete in a manner to prevent distortion of the reinforcement and to avoid contact between the rods and the soil at the bottom of the trench. Appropriate spacing devices shall be used to keep the reinforcement away from the surface of the trench and to guarantee a minimum cover of two inches of concrete.

F. PATENTS PERTAINING TO GROUTING SOILS  
FOR WATER SHUTOFF OR CONSOLIDATION

Key: E = Equipment  
M = Material  
P = Process

| <u>Patent No.</u> | <u>Description</u>  |
|-------------------|---|
| 829,664           | <u>Process of Solidifying Earthly Ground - N. Mehner -</u><br>(August 28, 1906) - Injection of a mineral substance in liquid condition, melted gypsum alone or with other material (chloride of magnesium) only example given. (P)  |
| 1,421,706         | <u>Process of Excluding Water from Oil and Gas Wells - Ronald Van Auken Mills (July 4, 1922) -</u> This patent covers the process of introducing into wells, porous sands, or other porous rocks or rock-forming materials, one or more soluble chemical reagents, either as solids, liquids, gases or muds, dry or in aqueous or other solutions, free or in containers; and under necessary pressure that is practical, so that the said reagent or reagents come in contact with and react chemically with each other, react with the rock wall materials of the well, or with the dissolved constituents of natural waters or other solutions in the wells and interstices of porous rock in such manner as to cause chemical and physical precipitation in the wells and rock interstices.<br><br>Mills lists seven examples of his reaction as follows:<br>(1) sodium silicate with calcium chloride, (2) sodium silicate with magnesium chloride, (3) sodium silicate with hydrochloric acid, (4) sodium carbonate or sodium bicarbonate with calcium chloride, (5) sodium sulphate with barium chloride, (6) calcium sulfate with sodium silicate, (7) calcium oxide, with sodium silicate. (P,M) |
| 1,815,876         | <u>Process of Chemically Solidifying Earth - Michael Muller -</u><br>(July 21, 1931) - Muller's process consists of first saturating the earth with silicic acid-containing substances and then applying chlorine gas. The result is silicic acid, which combines with the quartz-containing constituents of the earth. (M)   |
| 1,820,722         | <u>Process of Solidifying Layers of Ground and Similar Masses -</u><br><u>Carl Zemlin - (August 25, 1931) -</u> This patent covers the use of a single uniform chemical solution which reacts with the soil to bring about the solidification. The only example which Zemlin gives and the only claim which he has covers the use of injecting hydrofluoric acid to react with the silica in the soil. This reaction gives silica fluoride,   |

| <u>Patent No.</u>    | <u>Description</u>   |
|----------------------|--|
| 1,820,722<br>Cont'd. | which in turn continues to act on the earth salts and acids to set silica free again and tends to cement together the solid particles of soil. (M)   |
| 1,827,238            | <u>Process of Solidifying Permeable Rock, Loosely Spread Masses or Building Structures</u> - Hugo Joosten (October 13, 1931 - This patent covers the injection of silicic acid-containing materials, followed by the injection of a gas which reacts with said materials to form silicic acid, which gels in situ from the nascent state and thus integrates the treated mass. The only gas suggested is carbon dioxide. Joosten also claims the injection of gel-forming chemicals followed by a gas. (M)   |
| 2,075,244            | <u>Process for Solidifying Earth</u> - Jan Van Hulst (March 30, 1937)<br>This patent has three features - in any application any one of any combination of these features may be used. The first feature is to place in the ground a quantity of coarse material such as gravel, gravel stone, stone chippings, or rock aggregate around the place where the injection fluid is to be introduced. This is supposed to aid penetration.<br><br>The second feature covers a process consisting of introducing an aqueous dispersion of a bituminous substance such as asphalt and causing this dispersion to coagulate at a desired place by suitably controlling the stability of the dispersion. The stability is controlled by adding to the dispersion coagulation-promoting agents such as electrolytes.<br><br>The third feature of this patent considers using a mixture of an aqueous bitumen dispersion with a finely divided colloidal substance such as various types of clays (bentonite, refractory, potter's fullers earth), water glass, silicic acid gel, diatomaceous earth, Cassel earth and other substances containing humic acids, gelatine, glue, etc. (M,P) |
| 2,081.541            | <u>Process for Solidifying Soils</u> - Hugo Joosten (May 25, 1937)<br>Joosten uses the injection of a single concentrated solution containing the silicic acid sol in an unstable or labile state. For this purpose the composition specifically described is that which is formed from a concentrated solution of an alkali silicate by first adding a suitable precipitating metal salt solution, particularly such as that of soluble zinc salts (for example zinc chloride or sulphate), and then bringing the precipitate thus obtained again to solution by adding ammonia or substances containing ammonia, or by previously admixing such ammonia and thereby preventing the formation of the precipitate. The Joosten Process consists of first injecting this unstable gel simultaneously  |

| <u>Patent No.</u> | <u>Description</u>   |
|-------------------|--|
| 2,081,541         | with the introduction of the material which reacts with the ammonia or expells it, or followed by the introduction of a material which releases the ammonia. He suggests a number of chemicals for expelling the ammonia, such as hydrochloric acid, acid salts such as sodium bicarbonate or bisulphate, copper salts, iron salts, etc. The main gas he suggests is carbonic acid gas. A mixture of air and carbon dioxide is carbonia acid gas. Joosten also covers the subsequent introduction of a highly concentrated solution of calcium chloride. (P)   |
| 2,131,338         | <u>Consolidation of Porous Materials</u> - James G. Vail - (September 27, 1938) - This patent covers a process consisting of impregnation with an unstable silicious colloidal liquid having an alkaline reaction in the state in incipient gel formation, and the said liquid is allowed to set in situ. Control of the time of setting can be accomplished by dilution or control of pH, for example. The best mixture reported consists of a solution of sodium silicate containing not substantially less than two mols of silica to one mol of sodium oxide with a solution of sodium aluminate, the concentration of said solutions being adjusted to produce, upon admixture, an unstable dilute liquor setting to a full volume alkaline gel within a period of the order of thirty minutes. (M) |
| 2,146,480         | <u>Process of Shutting off Water or Other Extraneous Fluid in Oil Wells</u> - H. T. Kennedy - (February 7, 1939) - Injection of a material which is hydrolyzed upon contact with water to form an insoluble solid matter. Examples: metal salt, salt of antimony, arsenic, bismuth, tin and iron, antimony trichloride. (M)  |
| 2,152,307         | John J. Grebe (to Dow Chemical Corporation) [March 28, 1939] An alkali phosphate and a water-soluble soap, the latter in excess, are introduced to plug the pores of water strata in a well. The treating solution may be forced into the pores by a hydrostatic head of oil. (M)  |
| 2,152,308         | John J. Grebe (March 28, 1939) - A water-soluble aluminate and a water-soluble soap, the latter in excess, are introduced into wells to plug the pores of water strata.[To Dow Chemical Corporation]   |
| 2,156,220         | T. H. Dunn (to Stanolind Oil and Gas Co.) [April 25, 1939] A solution of magnesium salt, and after it a solution of an alkaline hydroxide, are forced into water-bearing strata of a well, and excess pressure is held on the system sufficiently long for the chemicals to react and plug the pores with voluminous precipitate of magnesium hydroxide.(M)  |

| <u>Patent No.</u> | <u>Description</u>   |
|-------------------|--|
| 2,169,458         | F. A. Bent, A. G. Loomis, and H. C. Lawton (to Shell Dev. Co.) [August 15, 1939] - Metal alcoholates are introduced into wells to form water-insoluble hydroxide precipitates for sealing off gas and water formations. Slowly hydrolyzing alcoholates are preferred, e.g., aluminum secondary emyl alcoholate and the aluminum alcoholate of ethylene glycol.(M)  |
| 2,176,266         | <u>Process for Solidifying Permeable Masses</u> - T. G. Malmberg (October 17, 1939) - A water soluble alkali silicate grouting fluid is described which contains a water soluble acid salt of a weak acid to provide a controllable gel time. Specific salts claimed are sodium bicarbonate, sodium tetraborate and sodium bisulfite. Specific mixture claimed is composed of 100 parts by volume of a sodium bicarbonate solution containing 66 grams of bicarbonate per liter and 125 parts by volume of sodium silicate of specific gravity 1.21. (M) |
| 2,197,843         | <u>Process of Impermeabilizing, Tightening, or Consolidating Grounds and Other Earthy and Stony Masses and Structures</u><br>G. H. Van Leeuwen - (April 23, 1940) - This process consists of injecting a substance which is capable of swelling through a solvating agent, the particles of which substance are coated with a substance repelling the solvating agent, the swelling of said particles being effected in the mass under treatment by attracting or adsorbing or combining with or wetting by the said solvating agent.                    |

Where the solvating agent consists of water or an aqueous solution of dispersion, the swelling substance may comprise such things as colloidal clays, hydroxides of polyvalent metals, silicic acid, aluminates or other salts capable of swelling with water or of forming liquid crystals, and such organic colloids as polyaccharides such as cellulose or starch, gum arabic, agar-agar, lipoides, proteins such as casein and albumen, organic dyestuffs and the like. Wherever the solvate consists of organic liquids such as oil, hydrocarbons, chlorinated hydrocarbons, alcohols, carbon disulfide, and the like, the swelling substance may comprise, for example, rubber, balata, shellac, drying oil polymerization products, factis, nitrocellulose, acetyl cellulose, soaps and the like which are termed oleophile colloids.

The substances repelling the solvating agent, such as water, which are used in combination with the hydrophile colloids, are particularly oils, such as mineral oils, oil fractions and residues, tar oils and the like. Such repellent substances are called hydrophobic. In the case of the solvating agents consisting of organic liquids, such as oils, which are used in conjunction with the oleophile colloids, the



| <u>Patent No.</u>      | <u>Description</u>   |
|------------------------|--|
| 2,197,843<br>(cont'd.) | substance repelling the solvating agent may be an oleophobic substance, in most cases water or an aqueous liquid. Van Leeuwen gives a number of examples of injection fluids.  |
| 2,227,653              | <u>Process of Stanching and Consolidating Porous Masses - Charles Langer - (January 7, 1941) - This patent covers the injection of a single solution consisting of water glass and a reactive agent comprising an acid and a strong coagulant. The existing pH of the sodium silicate is decreased by the addition of an acid in order to obtain a weaker alkaline solution. By further adding a suitable salt of a heavy metal (iron, copper, lead, zinc and the like) as an electrolyte, the latter solution is destroyed and coagulates to a gel. By decreasing the pH value the sodium silicate solution becomes more sensitive and the coagulation to a gel in the ground or other mass being treated may be produced at any time desired by means of a correspondingly accurate quantity of electrolyte. The particular chemicals which appear to be the best, since the author specified these, are sodium silicate, hydrochloric acid and copper sulphate. (M)</u> |
| 2,236,147              | W. B. Lerch, C. H. Mathis, and E. J. Gatchell (to Phillips Petroleum Co.) - [March 25, 1941] - Formations in wells are plugged by introducing a liquid gel-forming material comprising a mixture of one part sodium silicate diluted with one part of a water solution containing 3-1/2 parts hydrochloric acid and 19 parts of sodium bisulfate solution. The acid and bisulfate delay the premature setting of the gel until the solution has penetrated the formation where it reacts with salts and acids to form gel which later solidifies. (M)  |
| 2,238,930              | L. C. Chamberlain and H. A. Robinson (to Dow Chemical Co.) [April 22, 1941] - The invention relates to methods of reducing the permeability of earth or rock formations with the formation of a plugging deposit within certain strata penetrated by the bore, thus preventing infiltration of water by introducing into the formation a water-miscible solution of a stabilizing agent (salts of organic acids) and then a nonaqueous water-miscible solution of a metal salt capable of forming a precipitate of a basic compound by reaction with an aqueous alkaline material. The stabilizing agent whereby the precipitation of the basic compounds is delayed in the water-bearing stratum and substantially prevented in the other gas-bearing stratum. (M,P)  |
| 2,252,271              | C. H. Mathis (to Phillips Petroleum Co.) - [August 12, 1941] A method of sealing cracks or porous formations by injection  |

| <u>Patent No.</u>   | <u>Description</u>  |
|---------------------|---|
| 2,252,271<br>Cont'd | of a resin-forming liquid is claimed, which is particularly suitable for plugging limestone and dolomitic materials due to its nonacid character. This particular resin is formed from an ester of a dicarboxylic acid and a polyhydric alcohol, condensed or copolymerized with or without a vinyl derivative, using benzoyl peroxide as a catalyst. The amount of catalyst added controls the time of setting of the fluid to a solid resin after it is placed in the porous formation. Being a nonacid, carbon dioxide which might otherwise be evolved in a reaction with the limestone, cannot impair the effectiveness of plug formation. (M)   |
| 2,258,829           | <u>Method of Ground Fixation with Bitumens</u> - J. Van Den Berge and F. Dijkstra (to Shell Development Co.) - Hand blown asphaltic bitumens are dissolved in an aliphatic solvent, e.g., kerosene, naphtha, and injected into the formation where it is allowed to gel. Solvent should contain less than 20% aromatic hydrocarbons. (M)  |
| 2,265,962           | F. A. Bent and A. G. Loomis (to Shell Development Co.) - [December 9, 1941] - A process for selectively plugging water formations in an oil well is claimed. The plugging agent is an ester of silicon which hydrolyzes upon contact with water in the formation to deposit silica and complex silicon compounds. The rate of hydrolysis is controllable by changing the pH of the treating solution, and/or by selection of the particular ester, or its concentration. One of the many possible compounds of this class is ethyl-ortho-silicate. (M,P)  |
| 2,270,006           | H. T. Kennedy (to Gulf Research and Development Co.) - [January 13, 1942] - In a method of sealing porous water-bearing strata by injecting a compound which forms a plug upon contact with water, the plugging agent used is one which takes considerable time to set, and the initiation of setting is variably controlled by addition of an accelerator. The sealing agents suggested are compounds of polyvalent metals carrying at least one OR group, where R stands for an alkyl or aryl radical. Examples are zinc ethylate $Zn(OC_2H_4)_2$ , aluminum triphenolate $Al(OC_6H_4)_3$ , and tri-chlorostannic ethylate $SnCl_3OC_2H_4$ . Accelerators may be silicon tetra chloride, or metal chlorides which form acid upon going into solution, such as $FeCl_3$ , $CuCl_2$ . (M) |
| 2,281,810           | <u>Earth Consolidation</u> - J. B. Stone and A. J. Teplitz - [May 5, 1942] - This patent covers a method wherein pervious earth formations are injected with an acid organic-silicate sol in a state of incipient gellation and adapted to set to a gel after an interval of time. The gel time of the  |

| <u>Patent No.</u>   | <u>Description</u>  |
|---------------------|---|
| 2,281,810<br>Cont'd | sol is controlled by the adjustment of the acidity by incorporation in the sol of a polybasic acid. Enough polybasic acid is used to delay the setting of the soil in the presence of calcium carbonate to between 1/4 of an hour and 2 hours. The sol claimed is one comprised of methyl silicate mixed with water. The polybasic acids mentioned are acids of phosphorus, oxalic acid, and citric acid. (M)   |
| 2,294,294           | <u>Treatment of Wells</u> (to Dow Chemical Co.) - [August 25, 1942]<br>This patent covers the injection of a material which by polymerization, addition or condensation, forms in situ a synthetic resin. (M)   |
| 2,307,843           | C. H. Mathis and Carl Rampaced (to Phillips Petroleum Co.) [January 12, 1943] - Plugging of formations in wells is performed using a resin-forming liquid prepared by mixing water, thiourea, and furfural, allowing the mixture to undergo partial condensation in the presence of hydrochloric acid added as a catalyst, then adding an alkali sufficient to reduce the pH to between 5.5 and 6.5, and finally placing the mixture in the formation where further condensation to a solid resin will occur. Setting time may be controlled by the amount of HCl used. Resins prepared in this way are particularly suited for use in limestone when otherwise a reaction with excess acid would occur, producing gaseous products which would impair the strength and sealing qualities of the set resin. (M) |
| 2,321,761           | C. H. Mathis and Carl Rampaced (to Phillips Petroleum Co.) [June 15, 1943] - A synthetic resin suitable for use in wells and particularly in limestone strata (where strong acids cannot be used) comprises a mixture of furfural, a urethane, and a hydrochloric acid catalyst to control the time of setting. As the mixture has a pH of about 7, limestone formations will not be attacked by it. (M)  |
| 2,323,928           | Abraham B. Miller (to Hercules Powder Co.) - [July 13, 1943]<br>Substantially petroleum-hydrocarbon insoluble pine wood resin is used as a soil stabilization agent, alone or in conjunction with other stabilizers such as $\text{CaCl}_2$ . The amount used may be between 0.12 and 10 percent and preferably is between 0.25 and 2.5 percent. (M)  |
| 2,323,929           | Abraham B. Miller (to Hercules Powder Co.) - [July 13, 1943]<br>A method of stabilizing soils by incorporating 0.2 to 10 percent of a substantially hydrocarbon insoluble pine wood resin as an aqueous suspension formed by mixing the resin with dilute alkali and saponifying a minor porportion of the resin. (M)   |

| <u>Patent No.</u> | <u>Description</u>  |
|-------------------|---|
| 2,330,145         | H. A. Reimers (to Dow Chemical Co.) - [September 21, 1943]<br>A sealing composition for well formations is claimed comprising 8 to 16 percent by weight of sodium silicate and 4.7 to 20.5 percent sulfuric acid. By varying the ratios of these components in a water solution a great deal of control is possible in the time required for setting to a firm gel. An extensive table is given showing, for different temperatures and compositions of the mixture, the minutes duration of a pumpable state and the final set strength in grams. By reference to this table it should be possible to choose the composition best suited to a given well condition (M).  |
| 2,332,822         | Milton Williams (to Standard Oil Development Co.)<br>[October 26, 1943] - Plugging agents for shutting off water strata in oil wells, which are readily removable by acidizing, are disclosed and claimed. The preferred agents are mixtures of arsenates or phosphates with salts of aluminum, calcium, cobalt, chromium, copper, iron, magnesium, manganese, or zinc. These precipitate as gels, which are readily soluble. A chart is given of setting time vs. temperatures for various mixtures of chromium acetate and disodium arsenate, and for mixtures of chromium acetate and disodium phosphate. The feature of acid removability should reduce the hazards usually associated with the use of gel forming materials in that if oil production is accidentally shut off it can be restored. (M) |
| 2,345,611         | W. B. Lerch, C. H. Mathis, and E. J. Gatchell (to Phillips Petroleum Co.) - [April 4, 1944] - Claims are asserted to the use of aldehyde-urea synthetic resins for plugging off water formations in wells. A preferred composition comprises thiourea and furfural with concentrated HCl as a catalyst in sufficient quantity to delay the time of set of the mixture until it is in place in the formation to be plugged. (M)  |
| 2,349,181         | W. B. Lerch, C. H. Mathis, and E. J. Gatchell (to Phillips Petroleum Co.) - [May 16, 1944] - A liquid resin-forming mixture of furfural and thiourea is claimed as a substitute for cement slurry in cementing casing. The setting time is controlled by varying the amount of hydrochloric acid used as a setting catalyst, and a filler may be added to provide bulk without greatly adding to the material cost. Bentonite, wood fiber, fine sand, carbon black and other similar nonreactive materials are disclosed as fillers. A relatively inexpensive resin disclosed but not claimed comprises furfural, caustic oil (a waste product from caustic washing of cracked distillate) catalyst, and filler. (M)  |

| <u>Patent No.</u> | <u>Description</u>   |
|-------------------|--|
| 2,403,643         | <u>Method of and Apparatus for Introducing Grout into Subsoil</u><br>G. L. Dresser (July 9, 1946) - A grout pipe, consisting of two concentric pipes, which allows the grout pipe to be jetted into the soil by washing the soil to the surface through the annulus. The grouting slurry is pumped after the appearance of the returning wash water indicates that clays, fines, etc., have been washed out of the hole. Grout pipe is maintained in place, forming a piling after the grout has set. (E)  |
| 2,439,833         | Cary R. Wagner (to Phillips Petroleum Co.) - [April 20, 1948]<br>A formation may be plugged off to water flow by injecting an aqueous solution of sodium carboxymethyl cellulose and a sufficient amount of a salt to produce a water insoluble precipitate. The precipitate may be removed by treating with one of the strong bases. (M)  |
| 2,485,527         | P. H. Cardwell (to Dow Chemical Co.) - [October 18, 1949]<br>Permeable formations penetrated by a well bore are plugged by injecting a mixture of two partial condensation products. One is the partial reaction product of an aldehyde with an alkylated phenol. The other is the partial reaction product of an aldehyde, a phenol, and a polyhydroxy benzene selected from the group consisting of phloroglucinol and resorcinol. The mixture reacts rapidly at normal well temperatures with little shrinkage to form a solid plug in the permeable formation. (M) |
| 2,618,570         | <u>Process for Preparing a Grouting Fluid</u> - W. C. Blackburn (November 18, 1942) - Fifty volumes of tetraethyl ortho silicate, 30 volumes of 95 percent ethyl alcohol, one volume of water. Let stand 24 hours (to hydrolyze some of the silicate) then mix with aqueous alkaline solution. (M)   |
| 2,651,619         | DeMello, Hauser and Lambe (September 8, 1952) - Acrylate of polyvalent metal and catalyst system. (M)  |
| 2,670,048         | <u>Method of Sealing Porous Formations</u> - Paul L. Menaul (February 23, 1954) - Patent covers injection dispersion of acrylic resin in hydrocarbon followed by injection anionic fluid to coagulate or precipitate resin. (M)  |
| 2,706,688         | <u>Asphalt Emulsion</u> - H. J. Sommer, R. L. Griffin (April 19, 1955) - An asphalt emulsion for grouting soil to stabilize it and render it impermeable to water. Emulsion contains a discontinuous asphalt phase and a continuous aqueous sodium silicate phase which also contains an emulsifying agent. The type of emulsifying agent is determined by the acidity or basicity of its asphalt. The emulsion remains stable   |

| <u>Patent No.</u>    | <u>Description</u>  |
|----------------------|---|
| 2,706,688<br>Cont'd. | at pH = 11.3. Reducing pH causes coagulation of the emulsion. The degree of pH reduction results in reduction in coagulation time. (M)  |
| 2,801,985            | <u>Soil Stabilization</u> - R. W. Roth - (August 6, 1957) - Grouting solution comprised of AM-955 (95% acrylamide, 5% N, N <sup>1</sup> - Methylenebisacrylamide), a redox catalyst (peracids and their salts), and nitrilotrispropionamide, dissolved in water (M)   |
| 2,860,489            | <u>Grouting or Sealing Apparatus</u> - L. E. Townsend, (November 18, 1958) - A grouting packer, with packing elements expanded against open hole walls by hydraulic pressure, provided by piston arrangement. (E)   |
| 2,940,729            | <u>Control System for Soil Stabilizer Polymerization</u> - David H. Rakowitz - (June 14, 1960) - Ferrocyanides and ferricyanides used as gelatin inhibitor in acrylamide polymer (AM-955) grouting fluid. The cyanides provide a means for predictably delaying gelation. (M,P)   |
| 2,947,146            | <u>Sealing Method for Underground Cavities</u> - R. L. Loofbourow (August 2, 1960) - Walls of underground excavations are sealed by applying sealant to walls and forcing it into the surface by increasing air pressure in the excavation.(P)  |
| 3,012,405            | <u>Method and Composition for Strengthening Loose Grounds</u> - C. Caron (to Societe dite: Solentanche (S.A.R.L.) - Paris) [December 12, 1961] - A water soluble alkali metal silicate grouting fluid is gelled by the addition of a hydrolyzable ester such as ethyl acetate. A surfactant such as isopropyl formate is added to form a stable emulsion of the ester and the silicate. Increasing the concentration of isopropyl formate speeds the gel time. (M)  |
| 3,021,298            | <u>Soil Stabilization with a Composition Containing an Acrylamide, a Bisacrylamide, and Aluminum and Acrylate Ions</u> - D. H. Rakowitz (to American Cyanamid Co.) [February 13, 1962] A grouting solution comprised of an acrylamide, a bisacrylamide, aluminum or chromium sulfate or nitrate. Cross-linking agents such as N, N <sup>1</sup> methylene bisacrylamide are also employed. A redox catalyst system is composed of a water soluble peroxy compound and a reducing compound together with nitrilotrispropionamide. Insolubilization is accomplished by cross-linking three covalent bonds and three covalent bonds and three ionic bonds. The set material stabilizes the soil and renders it impermeable to water. (M) |

| <u>Patent No.</u> | <u>Description</u>  |
|-------------------|---|
| 3,053,675         | <u>Process of and Material for Treating Loose Porous Soil</u> - S. J. Rehmar, N. L. Liver (to Intrusion Prepakt, Inc.) [September 11, 1962] - A grouting fluid comprised of a water-soluble lignin sulfonate, inorganic hexavalent chromium salt and an acid salt such as aluminum sulfate. The grouting fluid is injected into sandy soil, allowed to gel, whereupon the soil is subsequently grouted with a slurry such as cement. (M)  |
| 3,091,936         | <u>Resinous Composition</u> - L. A. Lundberg, J. C. Schlegel, J. E. Carpenter (to American Cyanamid Co.) - [June 4, 1963] A polyester resin is described that is employed to bond formations together, to prevent rock falls from the roofs of mines. The composition is designed to cure rapidly at low temperatures, and is comprised of the polyester resin, an inhibitor, for example phenol or monoalkyl phenols, a promoter consisting of a fatty acid cobalt salt together with a tertiary monoamine and a stabilizer consisting of a resin-soluble copper salt and a compound containing a basic imino group and salts thereof. (M) |
| 3,108,441         | <u>Process for Sealing Soils</u> - C. E. Watson (to California Research Corporation) - [October 29, 1963]. A wax emulsion, containing a surfactant, is used to establish a water-impermeable layer in soil. Wax particles are 0.1 to 2.5 microns in size. Wax concentration is from .05% to 2.0% by weight. The choice of surfactant type, i.e., cationic, nonionic or anionic, is determined by soil type and seepage rate before treatment. (M)   |
| 3,127,705         | <u>Water Leakage Inhibiting Masonry Treatment</u> - H. L. Hoover [April 7, 1964] - Water soluble polymeric acrylic acid material or water soluble metallic salts thereof are injected into the soil in the vicinity of a subgrade masonry wall. The ground water carries the material to the leaking masonry wall, where it reacts with insolubilizing alkaline earth metal ions present in the masonry structure, forming a water-insoluble, impermeable film on the masonry surface. (M)  |
| 3,166.132         | <u>Grouting Tool</u> - T. P. Lenahan, B. J. Bradley, A. H. Limbaugh (to Halliburton Company) - [January 19, 1965] - A grouting tool is described which allows lateral ejection of grouting fluid along its entire length after it has been driven to a desired depth. The tool is initially driven with the aid of a jet of water through a nozzle at the bottom end of the tool. A removable tube is retrieved from the tool, exposing longitudinal slots in the body of the tool. The nozzle is then shut off with a ball dropped into the tube,  |

| <u>Patent No.</u> | <u>Description</u>   |
|-------------------|--|
| 3,166,132         | after which the grouting fluid is pumped into the tool and through the longitudinal slots. (E)   |
| 3,202,214         | <u>Preparation and Use of Sodium Silicate Gels</u> - H. C. McLaughlin (to Halliburton Company) - [August 24, 1964] Improved gelling agents for silicate grouting fluids are described. One type includes agents which undergo the Cannizzaro reaction in the presence of sodium silicate solution. Included in this group are the aldehydes having no hydrogen atom on the alpha carbon, such as formaldehyde, glyoxal, benzaldehyde, furfural and trimethylacetaldehyde. Another group of gelling agents are those that undergo an oxidizing reaction to form organic acids. For example, methanol, formaldehyde, glycerin, ethylene glycol, glucose, sucrose, furfural and glyoxal. The oxidizing agent used to effect the reaction to form the organic acids may be peroxides, persulfates, perborates and hydrogen peroxide. The particular advantage with these gelling agents is that a time delay occurs before a sufficient amount of gelling agent is formed to cause gelation. This delay allows placement of the grouting fluid for a considerable distance through the soil. (M) |
| 3,208,226         | <u>Process for Stabilizing Soil</u> - J. J. Flovey (to American Cyanamid Co.) [September 28, 1965] - An aqueous solution of ureaformaldehyde resins, containing an acidic catalyst, is injected into soil, where it is allowed to harden. The resultant soil is stabilized and water-impermeable. Acidic catalysts that may be used include inorganic acids such as hydrochloric, sulfuric, nitric, phosphoric, acetic, chloroacetic, trichloroacetic, or acid salts such as ammonium bisulfate, sodium bisulfate, ammonium chloride, ammonium nitrate, or organic acids such as oxalic, maleic, paratoluene sulfonic, or other acidic materials such as aniline hydrochloride and the like. (M)   |
| 3,221,505         | <u>Grouting Method</u> - R. J. Goodwin, F. L. Becker (to Gulf Research & Development Co.) - [December 7, 1965] - A water-permeable soil is rendered impermeable by injecting a water miscible non-aqueous fluid, e.g., alcohol, to displace the water from the area to be grouted to another drilled hole. While pressure is maintained on the holes to prevent invasion of dewatered area, a gaseous agent, e.g., silicon tetrafluoride, is injected into the soil. The gas flows to the boundaries of the dewatered zone, where it reacts with the groundwater, generating a precipitate which plugs the pore spaces in the soil, and prevents the migration of fluids. (M,P)  |



| <u>Patent No.</u> | <u>Description</u>  |
|-------------------|---|
| 3,223,163         | <u>Composition and Method for Stabilization of Soil</u> - R. R. Koch, J. Ramos, H. C. McLaughlin - (to Halliburton Company) - [December 14, 1965] - Finely divided fillers, e.g., silica flour, gilsonite, asphaltic pyrobitumens, barite, talc, bauxite, scoria, are used to allow controlled placement of various grouting fluids. Particle size of the fillers range from 10 to 180 microns, allowing controlled fluid loss from fissures and vugs to the pore spaces in permeable soil masses. Grouting fluid types are chrome-lignin, acrylamide and alkali metal silicates. (M)   |
| 3,243,962         | <u>Method and Apparatus for Treating Soil</u> - G. R. Ratliff, (April 5, 1966) - A grouting tool is described, which contains a plurality of valved ports along its length. By manipulation the ports can be selectively opened or closed, controlling the point in the grout hole at which grouting fluid is injected into the soil. (E)   |
| 3,280,196         | <u>Hydraulic Grouting Packer</u> - B. Q. Barrington (to Halliburton Company) - [October 25, 1966] - Packer is equipped with an inflatable sleeve, operated by the pressure of the grouting fluid being pumped. (E)  |
| 3,293,864         | <u>Method and Apparatus for Impregnating Masses of Material</u> - H. H. Hagius, W. W. Brown (to Halliburton Company) - [December 27, 1966] - A controlled method for injecting grouting fluid into earthen material such as water-saturated backfill adjacent a foundation wall. The grout pipe is inserted and sealed through a flexible barrier wall. Excess water is pumped out of the backfill material. Compressed air is then injected, forcing the groundwater away from the wall, whereupon the grouting fluid is injected and pressure maintained until the fluid has set. (E,P)   |
| 3,294,563         | <u>Silicate Grout</u> - D. R. Williams (to Cementation Co., Ltd, London) - [December 27, 1966] - An alkali-metal silicate grouting fluid containing a metal complex and a sequestering agent which results in a slow release of metal ions. The metal ions react with the silicate to form water-insoluble gels. Preferred sequestering agents are oxalic and citric acids. The metals are those capable of forming hydroxylated ions in a pH range of 4 to 11, and include barium, magnesium, calcium, strontium, titanium, aluminum, thorium, zirconium, chromium, molybdenum, manganese, iron, nickel, tin, lead and zinc. (M) |
| 3,306,756         | <u>Composition and Method for Stabilizing Soil</u> - G. A. Miller (to Diamond Alkali) - [February 28, 1967] - The gelation of an alkali-metal silicate grouting fluid is accelerated by the addition of compounds including carboxylic acids,   |

| <u>Patent No.</u>    | <u>Description</u>  |
|----------------------|---|
| 3,306,756<br>Cont'd. | esters of carboxylic acids, ketones, alcohols, linear aldehydes (other than formaldehyde), cyclic polymers of the lower alkyl aldehydes and dioxane. (M)  |
| 3,324,665            | <u>Method of Stabilizing Piles</u> - T. J. Robichaux, S. G. Gibbs, R. M. Jorda - (June 13, 1967) - [to Shell Oil Co.] - A thermo-setting resin is pumped into loose soil through holes in a pile, resulting in the soil and pile becoming a unified, load-bearing structure. Preferred resins are of the epoxy type, which includes epoxidized esters of unsaturated monohydric alcohols and polycarboxylic acids, epoxidized esters of unsaturated alcohols and unsaturated carboxylic acids, polyethylenically unsaturated polycarboxylic acids. Curing agents include polyamides and polyamines. (M)   |
| 3,332,245            | <u>Method for Injecting the Components of a Phenoplastic Resin into Slightly Watertight Grounds</u> - C. Caron (to Solentanche, Paris) - [July 25, 1967] - Components of a phenolic resin are injected into loose soil, where they react to form a hard resin, solidifying the ground and rendering it impermeable. The resin components include resorcinol, water, formaldehyde and ammonium persulfate and optionally ammonia and sodium bicarbonate. The monomer solution has a viscosity of 3 centipoises. For very rapid polymerization, the diluted phenolic is pumped separately from the catalyst solutions, which is added by a metering pump at the point of injection. Without catalyst, the mixture polymerizes only after weeks. The pump time is adjusted by the amount of catalyst added. The solution remains stable to pH of 6, but polymerizes when taken to the acid or alkaline side. (M) |
| 3,334,689            | <u>Method of Stabilizing or Sealing Earth Formations</u> - H. C. McLaughlin (to Halliburton Company) - [August 8, 1967] A grouting solution with low initial viscosity capable of forming a stiff tough gel, with controllable gel times. Typical formulation includes acrylamide, triallyl phosphate, dimethylaminopropionitrile, disodium phosphate duohydrate, potassium ferricyanide, ammonium persulfate. Gel times are controlled by varying the amount of potassium ferricyanide. (M)  |
| 3,335,018            | <u>Composition and Method for Stabilizing Soil</u> - C. E. Peeler, A. D. Bergman, D. J. Olix (to Diamond Alkali) - [August 8, 1967] - A grouting slurry is described containing an alkali-metal silicate, amide, hydraulic cement and a reactive salt. Advantages claimed are no shrinkage upon curing and no cracking. (M)   |

| <u>Patent No.</u> | <u>Description</u>   |
|-------------------|--|
| 3,374,934         | Soil Stabilization and Grouting Method - J. Ramos and R. F. Rensvold (to Halliburton Company) - [March 26, 1968] - Attapulгите and asbestos are described as more efficient suspending agents for inert fillers (such as silica flour) in grouting slurries. (M)   |
| 3,391,542         | <u>Process for Grouting with a Tri-Component Chemical Grouting Composition</u> - F. W. Herrick, R. I. Brandstrom (to Rayonier, Inc.) - [July 9, 1968] - A grouting fluid is described, composed of a formaldehyde-reactive, water soluble, alkaline polyphenolic derivative of coniferous bark or a tannin of the catechin or condensed type, formaldehyde and a soluble salt of chromium iron or aluminum. Control of the gel time is governed by the concentration of the metallic salt, and can be regulated from a few seconds to several hours.(M)  |
| 3,416,604         | <u>Epoxy Resin Grouting Fluid and Method for Stabilizing Earth Formations</u> - Roger F. Rensvold (to Halliburton Company) - [December 17, 1968] - A grouting fluid comprised of an epoxy resin and an alkylamine wherein each alkyl group is a tertiary alkyl group containing from about 4 to about 8 carbon atoms used in stabilizing and sealing earth formations. Solid fillers, e.g., silica flour may be added. (M)   |
| 3,417,567         | <u>Soil Stabilization</u> - E. Higashimura, M. Ishii, Y. Ishikawa- (to Mitsubishi Rayon Co., Tokyo) - [December 24, 1968] - An aqueous grouting fluid, a typical representative being comprised of calcium acrylate, a reaction product of glycerine and methyl acrylate, and hydroxyethylacrylate. Glycidyl acrylate, acrylamide, tetraethylene glycol mono-acrylate glycidylacrylate can be used in alternative modifications. Gel times are controlled by a catalyst system which may contain ammonium persulfate, dimethylaminopropionitrile, sodium thiosulfate. The gelled material is water insoluble and resistant to syneresis. (M) |
| 3,421,585         | <u>Grouting, Plugging and Consolidation Method</u> - L. H. Eilers, C. F. Parks (to Dow Chemical Co.) - [January 14, 1969] - An aqueous gelable grouting composition comprised of a water-soluble polymer (acrylamide) a hydrogen ion source (hydrochloric acid), a water-soluble sodium silicate, capable of changing from a water-thin fluid to a stiff gel. Control of gel time is established by acid concentration, while control of gel strength is a function of sodium silicate content.  |
| 3,490,933         | <u>Grouting Composition</u> - L. E. Van Blaricom, H. R. Deweyert, N. H. Smith (to ITT Rayonier Corp.) - [January 20, 1970] See U.S. Africa Patent 68/1381  |

| <u>Patent No.</u> | <u>Description</u>   |
|-------------------|--|
| 3,604,213         | <u>Chemical Grouting Proportioning Pumping Method and Apparatus</u><br>H. L. Parsons - (September 14, 1971) - The hydraulic flow from a hydraulic pump is divided to drive two rotary hydraulic motors, each in turn driving a rotary pump. The outlet line of each motor is equipped with a valve to control the pump rate. (E)   |
| 3,660,984         | <u>Stabilizing Soils</u> - A. R. Anderson (to J. J. Packo) - [May 9, 1972] - Unstable and permeable soils are stabilized or solidified by injecting a fluid composed of a metal alkyl, a metal alkyl hydride or a metal alkyl halide and a liquid or solid compound of a tetravalent metal such as silicon, titanium, zirconium or hafnium. A preferred mixture is 20% diethyl zine with 80% tetraethoxysilane. The mixture reacts with the moisture in the soil, the rate of reaction proportional to the amount of water present. (M)  |
| 3,686,872         | <u>Soil Grouting Process</u> - A. J. Whitworth, S. Y. Tung, E. A. Hajto (August 29, 1972) - A grouting fluid consisting of an alkaline aqueous, low viscosity, gel-forming solution containing a polyphenolic vegetable tannin extract, an aldehyde and a gelling agent. Control of the gelling rate is achieved by the type and dispersible in alkaline aqueous media, and are compounds of silicon, vanadium, molybdenum, manganese, titanium, copper, zinc and zirconium. Typical specific materials cited are sodium metasilicate, sodium metasilicate nonahydrate, potassium silicates, ammonium fluorilicate, vanadium pentoxide, potassium permanganate, cupric sulfate, zinc chloride and zirconium nitrate. Sodium silicates and vanadium peroxide are preferred. (M) |
| 3,695,356         | <u>Plugging Off Sources of Water in Oil Reservoirs</u> - P. A. Argabright, C. T. Presley, H. C. Bixel (to Marathon Oil Company) - [October 3, 1972] - Aqueous solutions of isocyanuric salts are injected into the water-bearing formations, where they hydrolyze to form plugging precipitates. The rate of precipitation is controlled by varying the pH. (M)  |
| 3,696,622         | <u>A Method of Soil Stabilization and Leakage Prevention</u> - W. Tohma, T. Murata, N. Nahamura, A. Kudo (to Sumitomo Durez Co., Ltd., Tokyo) - [October 10, 1972] - Soil stabilization and sealing is accomplished with a resin composition comprised of a water soluble, strongly alkaline liquid phenol-formaldehyde resin. The gelation control agent is a lactone containing urea, a urea derivative and a basic or neutral salt. (M)   |

Patent No.

Description

- 3,719,050 Soil Stabilization Method - H. Asao, T. Hihara, S. Endo, C. Furuya, K. Sano (to Toho Chemical Industry, Ltd., Tokyo)- [March 6, 1973] - Soil is stabilized by injecting a polyurethane polymer, which solidifies upon reacting with water. The reaction time is shortened by the addition of an acidic material. Example of accelerator is m-tolylenediamine. Example of a retarder is p-nitrobenzoyl chloride. (M)
- 3,802,203 High Pressure Jet-Grouting Method - Y. Ichise, A. Yamakado, S. Takano (to Y. Ichise) - [April 9, 1974] - A grouting tool designed to inject water, grouting fluid and compressed air into a formation. Three coaxial jets at right angles to the axis of the tool are used to inject the compressed air and the grouting fluid. The outer coaxial jet is for compressed air, while the two inner coaxial jets are for a two-component grouting fluid. A single component grouting fluid may also be used with the tool. The tool is also equipped with a water jet in line with the long axis of the tool, fitted with a ball check valve. This jet is used to drive the tool to the desired depth. By jetting the grouting fluid while the tool is slowly raised, a curtain wall 7-18 mm thick is formed, about 70 mm long. By rotating the tool, a horizontal "panel" or barrier is formed. The pressure required for the grouting fluid is 50 to 1000 kg/cm<sup>2</sup>, whereupon the velocity of the fluid through the jets is 100-450 m/sec. Below a pressure of 50 kg/cm<sup>2</sup>, the cutting effect of the jet is not obtained. The air pressure may range from 3-7 kg/cm<sup>2</sup>. (E,P)

## FOREIGN PATENTS

| <u>Patent No.</u>                 | <u>Description</u>  |
|-----------------------------------|---|
| 68/1381<br>(See USP<br>3,490,933) | <u>Grouting Composition</u> - (Union of South Africa) - L. E. Van Blaricom, H. R. Deweyert, N. H. Smith (to Rayonier, Inc.) - [July 12, 1967] - An aqueous gel forming composition comprising an aqueous solution containing 25-45% sulfonated polyphenolic material extracted from coniferous tree bark and quebracho wood, 5-40% water soluble dichromate and 5-25% borax, with a pH of 8-10.5. The borax is added as a retarder to control the gel time. (M)                             |
| 222,316                           | <u>Method for the Stabilization of Soils</u> - (Australia) - R. W. Roth (to American Cyanamid) - [June 23, 1959] - An aqueous grouting fluid containing a bisacrylamide, acrylamide and the catalyst system comprising varying proportions of nitrilotrospropioramide retarder and a pexory catalyst.   |
| 385,751                           | John J. Grebe and S. M. Stoesser (to Dow Chemical Co.) - [December 19, 1939 - Canada] - Porous well formations are plugged with a water-insoluble viscid material and a water-soluble organic solvent, e.g., hardwood pitch and acetone. (M)  |
| 441,622                           | <u>Method of Stabilization of Mountain Layers</u> - Hugo Joosten (March 9, 1927 - Germany) - The patent covers a method of stabilization of quartz-containing earth based on the reaction of silicic acid-containing material and soluble salts or acids, with or without filling materials. The reaction produces silicic acid in situ, which improves the stability of the mass. (M)  |
| 849,712                           | N. V. DeBataafsche Pet. Mij. (November 30, 1939 - France) Water-bearing formations in a well are plugged up by treatment with a fluosilicate and an alkali, e.g., with a fluosilicate of Ca, Mg, Pb, Fe, aniline, diphenylamine, and others, and an alkali, such as NH <sub>4</sub> OH, NaOH, KOH. A number of products precipitate, including some by interaction with natural brine components. As equivalents of fluosilicates, the fluotitanates and a few analogues are disclosed. (M) |

G. LIST OF GROUTING SPECIALISTS

Grouting Specialists in the United States

Alabama Waterproofing Company, Inc.  
P. O. Box 692 - Route 18  
Birmingham, Alabama 35210  
Attn: Will Max Harden

Hayward Baker Company  
1875 Mayfield Road  
Odenton, Maryland 21113  
Attn: Wallace H. Baker, President

Chemgrout Incorporated  
805 East 31st Street  
LaGrange Park, Illinois 60525  
Attn: Doring Dahl, President

Chemical Soil Solidification Company, Inc.  
1728 Broadway  
Hewlett, Long Island 11557  
Attn: Martin Riedel, President

Chemical Soil Solidification Company, Inc.  
7650 South Laflin Street  
Chicago, Illinois

Dean Jones Contractor  
410 Opal Street  
Clinton, Oklahoma 73601  
Attn: Dean Jones, President

Eastern Gunitite Company  
240 Rock Hill Road  
Bala Cynwyd, Pennsylvania 19004  
Attn: P. A. Heaver, President

Foundation Sciences, Inc.  
Cascade Building  
Portland, Oregon 97200  
Attn: Ken Dodds, President

Geologic Associates, Inc.  
Reynolds Road  
Franklin, Tennessee 37064  
Attn: Raymond T. Throckmorton, Jr., President

Geron Restoration Company  
7 Wells Street  
Saratoga, New York 12866  
Attn: Gerald Benoit, President

Halliburton Services  
P. O. Drawer 1431  
Duncan, Oklahoma 73533  
Attn: Tom Lenahan, Grouting Consultant

Halliburton Services  
Nine Parkway Center - Suite 275  
Pittsburgh, Pennsylvania 15220  
Attn: Lloyd Wantland, Superintendent

Hunt Process Company, Inc.  
P. O. Box 2111  
Santa Fe Springs, California 90670  
Attn: Slade Rathbun, Manager

Intrusion Prepakt Company  
13224 Shaker Square  
Cleveland, Ohio 44120  
Attn: Bruce Lamberton, Vice President

Northern Systems, Inc.  
20702 Aurora Road  
Cleveland, Ohio 44146  
Attn: Ray Tartabini, President

Penetryn Systems, Inc.  
424 Old Niskayuna Road  
Latham, New York 12110  
Attn: Ed Stringham, President



Pressure Grout Company  
1680 Bryant Street  
Daly City, California 94015  
Attn: Ed Graf, President

Raymond International, Inc.  
Soiltech Department  
6825 Westfield Avenue  
Pennsauken, New Jersey 08110  
Attn: Joe Welsh, Manager

SOLINC  
Soletanche and Rodio, Inc.  
6849 Old Dominion Drive  
McLean, Virginia 22101  
Attn: Gilbert R. Tallard, General Manager

Terra-Chem, Inc.  
P. O. Box 46  
George's Road  
Dayton, New Jersey 08810  
Attn: Herbert L. Parsons, President

Warner Engineering Services  
2905 Allesandro Street  
Los Angeles, California 90039  
Attn: James Warner, President

Core Drilling - Grouting Specialists

Boyles Brothers Drilling Company  
P. O. Box 58  
Salt Lake City, Utah 84110  
Attn: F. E. Sainsbury, Vice President

Continental Drilling Company  
2810 North Figueroa Street  
Los Angeles, California 90065  
Attn: Richard O. Theis, President

Robert P. Jones Drilling Company  
3512 North 36th Street  
Boise, Idaho 83703  
Attn: Robert P. Jones, President

W. J. Mott Contractor Inc.  
817 - 8th Avenue  
Huntington, West Virginia 25701  
Attn: William H. Mott  
F. C. Stump

Pennsylvania Drilling Company  
1205 Chartiers Avenue  
Pittsburgh, Pennsylvania 15220  
Attn: Thomas B. Sturges, Vice President

Freezing

Terrfreeze Corporation  
8551 Backlick Road  
Lorton, Virginia 22079  
Attn: John Schuster, Manager

Grouting Specialists in Europe

Soil Mechanics, Ltd.  
Foundation House  
Eastern Road  
Bracknell, Berkshire, England

Ing. G. Rodio & c.s.p.A.  
Strada Pandina  
20077 Casalmalocco (Mi)  
Italy

Soletanche Entreprise  
7, rue de Logelback  
75017 Paris, France

Consonda  
Milan, Italy

Bachy  
Paris, France

ICOS  
via Luciano Manara, 1  
20122 Milano, Italy

Geosonda  
Via Girolamo da Capri, 1  
Roma, Italy

Keller Division  
Guest, Keen &  
Nettlefords, Ltd.  
Frankfort, Germany

Nederhorst Grondtechnik  
Postbus 177  
Gouda, Holland

SWIBO Ges. m.b.H.  
Kramergasse 3/6  
A-1010 Vienna, Austria

The Cementation Co., Ltd.  
Cementation House  
Mitcham Road  
Croydon, Surrey, England

## H. CHEMICAL GROUTING MATERIAL SUPPLIERS

American Cyanamid Company  
Industrial Chemicals & Plastics Division  
Wayne, New Jersey 07470  
Attn: William J. Clarke

Borden Chemical Company  
Division of Borden Company  
180 East Broad Street  
Columbus, Ohio 43215  
Attn: Charles E. Markhott

Diamond Shamrock Chemical Company  
Divisional Technical Center  
Paintesville, Ohio 44077  
Attn: W. T. Gooding, Manager

E. I. DuPont de Nemours  
Wilmington, Delaware

Philadelphia Quartz Company  
Public Ledger Building  
Independence Square  
Philadelphia, Pennsylvania 19106

3M Company  
Building 219-1  
3M Center  
St. Paul, Minnesota 55101  
Attn: John F. Evert

## I. GROUTING EQUIPMENT SUPPLIERS

---

| Company                                  | Type of Equipment   |
|--|---|
| Chem Grout<br>La Grange Park, Illinois   | Cement Slurry Equipment<br>Chemical Grout Equipment   |
| Gardner Denver<br>Quincy, Illinois       | High-Pressure Portland<br>Cement Pumps  |
| Halliburton Services<br>Duncan, Oklahoma | Low Volume, High Pressure<br>Chemical Pumps<br>Two-Stream Grout Manifold<br>Grout Drive Rods<br>Grout Packers |
| Kerr Pump Company<br>Ada, Oklahoma       | High-Pressure Chemical<br>Pumps   |
| Robins and Meyers<br>Springfield, Ohio   | Portland Cement and<br>Chemical Low-Pressure<br>Pumps   |

J. BENTONITE SUPPLIERS

| Company               | Location             | Tradename                       |
|-----------------------|----------------------|---------------------------------|
| American Colloid      | Chicago, Illinois    | Premium Gel                     |
| Barium Supply Company | Houston, Texas       | Basco Gel<br>Basco Double Yield |
| Baroid Division       | Houston, Texas       | Aquagel<br>Quick Gel            |
| Chemco, Inc.          | Harvey, Louisiana    | Chemco Gel                      |
| Gulf Coast Pre-Mix    | Lafayette, Louisiana | Pre-Mix Gel                     |
| IMCO Services         | Houston, Texas       | IMCO Gel<br>IMCO HYB            |
| Louisiana Mud         | Lafayette, Louisiana | Lamco Gel                       |
| Magcobar              | Houston, Texas       | Magcogel<br>Kwik-Thick          |
| MilChem               | Houston, Texas       | Mil-Gel                         |
| Wyo-Ben Products      | Billings, Montana    | Hydrogel                        |

## K. CURRENT RESEARCH IN GROUTING TECHNOLOGY

A summary of the ongoing research in the area of grouting was obtained from Smithsonian Science Information Exchange, Inc.

The following research was reported which was pertinent to soils grouting:

- a. "In Situ Improvement of the Properties of Soil by Grouting"

This project is a study of the effect of injections as a function of the nature of the soil and the equipment used. Both waterproofing and strengthening will be studied.

Sponsored by the French Government with work done by regional laboratories in France.

- b. "Compaction of Soil During Pressure Grouting"

This study aims at rationalizing the mechanisms controlling the process.

Work being done by Cementation Co., Ltd. in England.

One project was reported dealing with rock grouting. It deals with stopping water seepage in road tunnels by injection of chemicals into the rock. Work is being done in Oslo, Norway by the State Road Laboratory.

A research contract has been awarded by the Federal Highway Administration, Department of Transportation, for a study to conduct a comprehensive survey to find or develop improved chemical grout materials, which are lower in cost than present equivalent grouts and suitable for waterstop or strength increase in soils. Also included in the study is the development of a standard laboratory test for evaluating grouts.







