

Report No. DOT-TST 76T-23

S.C.R.T.D. LIBRARY

**THE GROUND MOVEMENTS RELATED TO  
BRACED EXCAVATION AND THEIR INFLUENCE  
ON ADJACENT BUILDINGS**



AUGUST 1976

FINAL REPORT

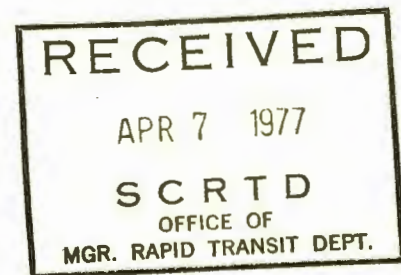

Prepared for

**U.S. Department of Transportation**  
OFFICE OF THE SECRETARY  
AND  
FEDERAL RAILROAD ADMINISTRATION  
Washington, D.C. 20590

TF  
230  
.076  
c.1

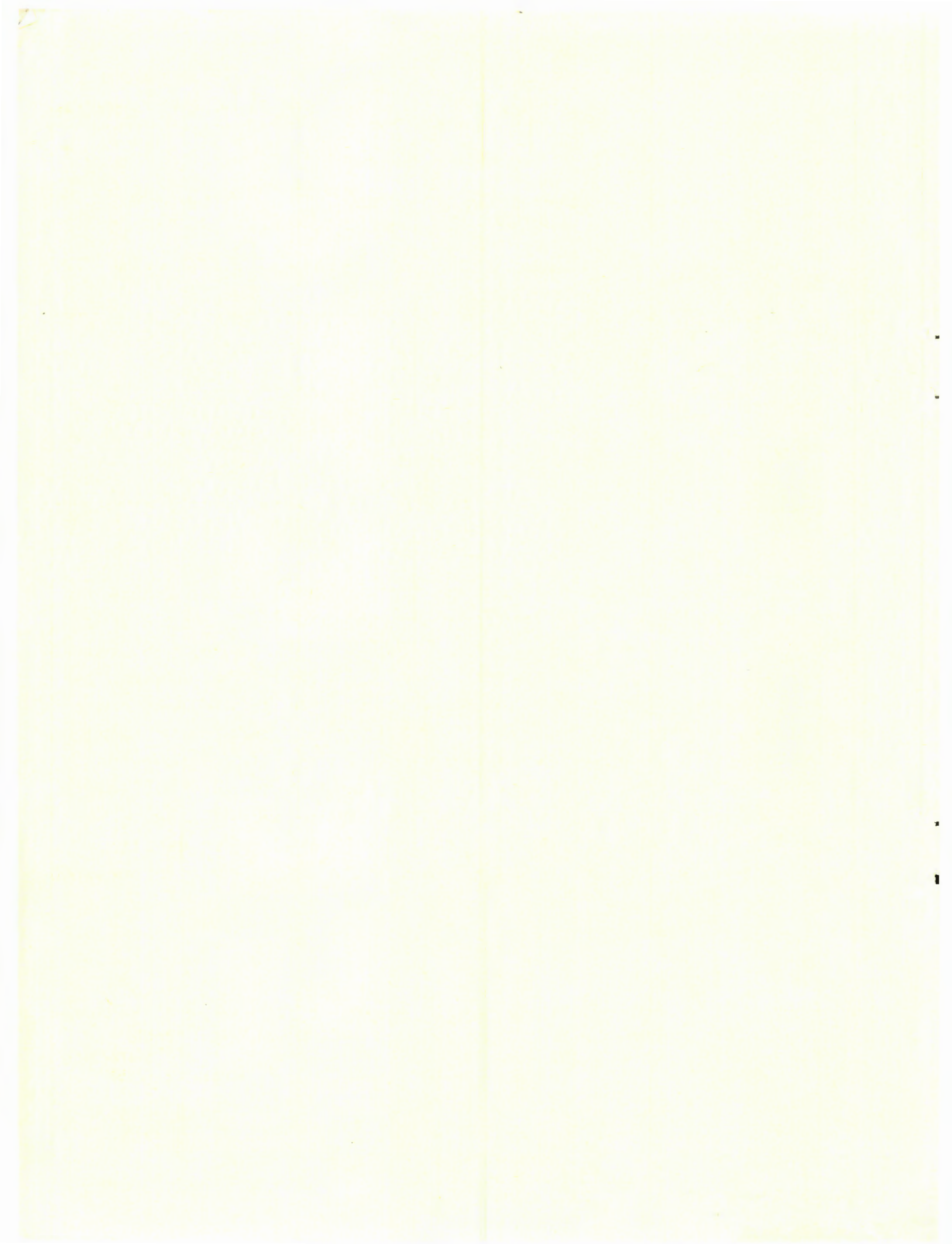

1. Report No. DOT-TST 76T-23	2. Government Accession No.	3. Recipient's Catalog No.	
4. Title and Subtitle The Ground Movements Related to Braced Excavation and Their Influence on Adjacent Buildings		5. Report Date August 1976	
		6. Performing Organization Code	
7. Author(s) T. D. O'Rourke, E. J. Cording, M. Boscardin		8. Performing Organization Report No. UILU-ENG-76-2023	
9. Performing Organization Name and Address Department of Civil Engineering University of Illinois at Urbana-Champaign Urbana, Illinois 61801		10. Work Unit No. (TRAIS)	
		11. Contract or Grant No. DOT FR 30022	
12. Sponsoring Agency Name and Address U.S. Department of Transportation Office of the Secretary, and Federal Railroad Administration Washington, D. C. 20590		13. Type of Report and Period Covered Final August 75 - August 76	
		14. Sponsoring Agency Code -	
15. Supplementary Notes			
16. Abstract This report summarizes the settlement and lateral displacement measurements associated with urban excavation projects in the dense sands and interbedded stiff clay of Washington, D. C. and the soft clay of Chicago. The ground movements caused by excavation in each area are discussed in light of the soil profile and construction techniques. The relationship between soil displacement and the damage caused to adjacent buildings is examined. Criteria for the onset of architectural damage are recommended for brick-bearing wall and frame structures subject to excavation movements. Brick-bearing wall structures are described, with special emphasis on the construction details related to building stability. Various modes of instability caused by differential ground movements are examined for brick-bearing wall structures. Case histories of building damage caused by adjacent excavation are presented.			
17. Key Words Excavation, Cut-and-Cover Construction, Soil Displacements, Bracing, Building Damage, Underpinning		18. Distribution Statement Document is available to the public through the National Technical Information Service, Springfield, Virginia 22151	
19. Security Classif. (of this report) Unclassified	20. Security Classif. (of this page) Unclassified	21. No. of Pages 137	22. Price

00962

TF  
230  
.076  
c.1

## PREFACE

This report was prepared in the Department of Civil Engineering at the University of Illinois at Urbana-Champaign. The work was sponsored by the Federal Railroad Administration, Department of Transportation through Contract No. DOT FR 30022. The work was performed under the technical direction of Mr. Russell K. MacFarland of the Office of the Secretary of Transportation. Mr. MacFarland has contributed to this work by virtue of his enthusiasm and continuing encouragement. The authors are grateful for his help.

The authors have been most fortunate in knowing dedicated, generous engineers whose assistance in obtaining field data and comments concerning the study have been invaluable. Special thanks is extended to Dr. Ralph Peck whose help at every level of this work is deeply appreciated. Special recognition is extended to Mr. Ted Maynard of the City of Chicago Bureau of Engineering whose great generosity and guidance in obtaining information not only has resulted in substantial data for the present report, but has contributed immensely to future studies in the area of urban construction. Messrs. Robert Evans, Graham Beck, and Carl Bock of Bechtel Associates, Inc. deserve a special note of gratitude for their help. Others who lent their efforts in obtaining field observations include Messrs. P. Dwiggin, M. Esrig, G. Fore, J. Gnaedinger, J. Gould, D. Hessong, J. Iturriaga, Y. Lacroix, R. Lukas, D. Marshall, W. Marshand, R. Mylar, J. Perez, L. Podell, M. Pugh, F. Slaght, A. Zimbrick, and F. Scotland.

Many University personnel contributed to this report. Mr. Jim Ulinski deserves special credit for his assistance in gathering field data and in summarizing technical information. Professor S. L. Paul has reviewed portions of the text and made useful comments throughout the course of the

study. Mr. H. H. MacPherson has helped in the collection of field measurements. The manuscript was typed by Mrs. Laura Hickman, Mrs. Mary Ann Speck and Miss Ruth Pembroke. Drafting of figures was performed by Mr. Ron Winburn, Ms. Ruth Ellen Cook, and Mr. Jim Gocking.

## TABLE OF CONTENTS

Chapter	Page
1. INTRODUCTION . . . . .	1-1
1.1 STATEMENT OF THE PROBLEM . . . . .	1-1
1.2 OBJECTIVES OF THE STUDY . . . . .	1-5
1.3 SCOPE . . . . .	1-6
2. GROUND MOVEMENTS ASSOCIATED WITH BRACED EXCAVATIONS . . . . .	2-1
2.1 INTRODUCTION . . . . .	2-1
2.2 GROUND MOVEMENTS RELATED TO BRACED EXCAVATION IN WASHINGTON, D.C. . . . .	2-3
2.2.1 SOIL CONDITIONS IN WASHINGTON, D.C. . . . .	2-3
2.2.2 SURFACE SETTLEMENT AND CONSTRUCTION METHOD . . . . .	2-5
2.2.3 LATERAL GROUND MOVEMENTS . . . . .	2-9
2.2.4 RELATIONSHIP BETWEEN LATERAL AND VERTICAL SURFACE MOVEMENT . . . . .	2-15
2.3 GROUND MOVEMENTS RELATED TO BRACED EXCAVATION IN CHICAGO . . . . .	2-19
2.3.1 SOIL CONDITIONS IN CHICAGO . . . . .	2-19
2.3.2 SURFACE SETTLEMENT AND CONSTRUCTION METHOD . . . . .	2-21
2.3.3 LATERAL GROUND MOVEMENTS . . . . .	2-33
2.3.4 THE RELATIONSHIP BETWEEN LATERAL AND VERTICAL SURFACE MOVEMENT . . . . .	2-33
2.4 SUMMARY . . . . .	2-40
3. ARCHITECTURAL DAMAGE TO BUILDINGS . . . . .	3-1
3.1 INTRODUCTION . . . . .	3-1
3.1.1 DEFINITIONS OF DAMAGE . . . . .	3-1
3.1.2 CORRELATION OF ARCHITECTURAL DAMAGE WITH DIFFERENTIAL MOVEMENTS . . . . .	3-1
3.2 BASIC CONSIDERATIONS OF ARCHITECTURAL DAMAGE . . . . .	3-5
3.2.1 PREVIOUS STUDIES OF ARCHITECTURAL DAMAGE . . . . .	3-5
3.2.2 NOTICEABLE DAMAGE . . . . .	3-9
3.2.3 TILTING OF BUILDINGS . . . . .	3-12
3.2.4 ADDITIONAL CONSIDERATIONS . . . . .	3-13
3.3 THRESHOLD OF NOTICEABLE DAMAGE . . . . .	3-16
3.3.1 ANALYSIS OF FIELD EVIDENCE . . . . .	3-16
3.3.2 ARCHITECTURAL DAMAGE RELATED TO UNDERPINNING . . . . .	3-17
3.3.3 ARCHITECTURAL DAMAGE RELATED TO MOVEMENTS CAUSED BY ADJACENT EXCAVATION . . . . .	3-19
3.3.4 COMPARISON OF FIELD EVIDENCE . . . . .	3-28
3.4 RELATIONSHIP BETWEEN ARCHITECTURAL DAMAGE AND BUILDING USE . . . . .	3-30

## Table of Contents (continued)

Chapter	Page
4. STRUCTURAL DAMAGE TO BRICK-BEARING WALL BUILDINGS . .	4-1
4.1 INTRODUCTION . . . . .	4-1
4.2 DESCRIPTION OF BRICK-BEARING WALL STRUCTURES . . . . .	4-1
4.3 MODES OF FAILURE . . . . .	4-8
4.3.1 BACKGROUND . . . . .	4-8
4.3.2 DIFFERENTIAL MOVEMENTS PERPENDICULAR TO THE BEARING WALLS . . . . .	4-11
4.3.3 DIFFERENTIAL MOVEMENTS PARALLEL TO THE BEARING WALLS . . . . .	4-16
4.4 FIELD OBSERVATIONS . . . . .	4-20
4.5 METHODS OF PROTECTION . . . . .	4-27
5. CONCLUSIONS . . . . .	5-1
5.1 GENERAL DISCUSSIONS . . . . .	5-1
5.2 GROUND MOVEMENTS ASSOCIATED WITH BRACED EXCAVATIONS . . . . .	5-2
5.3 ARCHITECTURAL DAMAGE TO BUILDINGS . . . . .	5-5
5.4 STRUCTURAL DAMAGE TO BRICK-BEARING WALL BUILDINGS . . . . .	5-6
REFERENCES . . . . .	R-1



## LIST OF FIGURES

Figure		Page
2.1	Soil Profile for Braced Excavations in Washington, D.C. . . . .	2-4
2.2	Summary of Settlements Adjacent to Braced Cuts in Washington, D.C. . . . .	2-6
2.3	Angular Distortion for Braced Cuts in Washington, D.C. . . . .	2-8
2.4	Lateral Distortion Corresponding to Stage 1: Excavation Before Installation of Braces . . . . .	2-11
2.5	Lateral Distortion Corresponding to Stage 2: Excavation to Subgrade . . . . .	2-11
2.6	Lateral Distortion Corresponding to Stage 3: Removal of Braces . . . . .	2-12
2.7	Soil Movements Related to Model Tests with Sand . . . . .	2-16
2.8	Ratio of Horizontal to Vertical Ground Movements for Model Tests and Excavations in Washington, D. C. . . . .	2-18
2.9	Soil Profile for Braced Excavations in Chicago . . . . .	2-20
2.10	Summary of Settlements Adjacent to Braced Cuts in Chicago . . . . .	2-22
2.11	Soil Displacements for Case 1 . . . . .	2-26
2.12	Soil Displacements for Case 1a . . . . .	2-26
2.13	Soil Displacements for Case 9 . . . . .	2-28
2.14	Wall Movement Associated with Lateral Displacements of Caissons . . . . .	2-28
2.15	Soil Displacements for Case 7 . . . . .	2-31
2.16	Angular Distortion for Braced Cuts in Chicago . . . . .	2-31
2.17	Summary of Lateral Displacements Adjacent to Braced Cuts in Chicago . . . . .	2-34
2.18	Ratios of Horizontal to Vertical Ground Movement for Case 1 . . . . .	2-34
2.19	Ratios of Horizontal to Vertical Ground Movement for Case 2 . . . . .	2-36

Figure		Page
2.20	Ratios of Horizontal to Vertical Ground Movement for Case 3 . . . . .	2-36
2.21	Ratios of Horizontal to Vertical Ground Movements for Case 4 . . . . .	2-37
2.22	Ratios of Horizontal to Vertical Ground Movements for Case 10 . . . . .	2-37
2.23	Relationship Between the Ratio of Horizontal to Vertical Ground Movement and the Coefficient of Deformation . . . . .	2-39
3.1	Building Deformation Caused by Settlement in Response to Opencutting . . . . .	3-3
3.2	Building Deformation Caused by Lateral Displacement in Response to Open Cutting . . . . .	3-3
3.3	Crack in a Hollow Block Wall Caused by Adjacent Excavation . . . . .	3-11
3.4	Crack in the Plaster Finish of a Hollow Block Wall Caused by Adjacent Excavation . . . . .	3-11
3.5	Plan View of a 10-Story, Concrete Frame Structure with Settlement Caused by Adjacent Excavations . . . . .	3-15
3.6	Field Evidence of Architectural Damage Related to Angular Distortion for the Underpinning of Structures . . . . .	3-18
3.7	Field Evidence of Architectural Damage Related to Angular Distortion for Structures Adjacent to Braced Excavations . . . . .	3-20
3.8	Architectural Damage to a 3-Story Brick-Bearing Wall Structure . . . . .	3-22
3.9	Architectural Damage to a 6-Story Steel Frame Structure . . . . .	3-24
3.10	Architectural Damage to a Row of Brick-Bearing Wall Structures . . . . .	3-25
3.11	Comparison of Field Evidence Related to Architectural Damage . . . . .	3-29
4.1	Typical Brick-Bearing Wall Structure . . . . .	4-2
4.2	Typical Masonry-Joist Connections . . . . .	4-5

Figure		Page
4.3	Typical Foundations for Brick-Bearing Wall Structures	4-7
4.4	Axes of Structural Response for Brick-Bearing Wall Structures . . . . .	4-10
4.5	Critical Bearing Condition for the Masonry-Joist Connection . . . . .	4-12
4.6	Translational and Rotational Components of the Differential Lateral Movement Between Bearing Walls . .	4-15
4.7	Typical Fracture Patterns Observed in Brick-Bearing Wall Structures Adjacent to Excavation . . . . .	4-18
4.8	Summary of Displacements Associated with a Braced Excavation Adjacent to a Chicago Rail Station . . . . .	4-21
4.9	Angular Distortion and Damage Associated with Tunneling Near Brick-Bearing Wall Structures . . . . .	4-24



## LIST OF TABLES

Table		Page
2.1	INFORMATION RELATING TO CHICAGO EXCAVATIONS . . . . .	2-23
2.2	ZONES OF ANGULAR AND LATERAL DISTORTION ASSOCIATED WITH BRACED EXCAVATIONS . . . . .	2-42
3.1	SUMMARY OF DAMAGE CRITERIA FOR INITIAL CRACKING IN BUILDINGS SUBJECT TO SETTLEMENT UNDER THEIR OWN WEIGHT . .	3-8
4.1	MINIMUM SAFE BEARING LENGTHS FOR JOISTS IN BRICK- BEARING WALL STRUCTURES . . . . .	4-14
4.2	DAMAGE RELATED TO BUILDING DISTORTION FOR BRICK- BEARING WALL STRUCTURES . . . . .	4-26



## LIST OF SYMBOLS

$C_D$	Coefficient of Deformation
$C_u$	Undrained Shear Strength
$d_H$	Horizontal Displacement
$d_L$	Lateral Displacement that Results in Minimum Bearing Length
$d_V$	Vertical Displacement
$H$	Height of Building
$L$	Deformed Building Length
$\ell$	Distance Between Two Points of Displacement
$\ell_B$	Minimum, Safe Bearing Length Under Allowable Loads
$N$	Standard Penetration, Blows/Ft
$\alpha$	Rigid Body Rotation
$\Delta$	Lateral Displacement
$\Delta/\ell$	Deflection Ratio
$\delta_H$	Lateral Distortion
$\delta_V$	Angular Distortion
$\theta$	Rotation of Bearing Wall





## CHAPTER 1

## INTRODUCTION

## 1.1 STATEMENT OF THE PROBLEM

The problem of relating ground displacement with building damage and of devising methods of protecting structures against the displacements caused by underground construction has long been a central concern of geotechnical engineering. Because this problem involves a wide range of considerations, combining elements of soil mechanics and structural engineering, its solution is best approached by considering various aspects of the problem separately. Correspondingly, the present report is developed in accordance with two fundamental considerations:

- 1) Describing the ground movements associated with braced excavations as a function of the soil profile and construction procedure.
- 2) Defining the limits of tolerable building distortion for structures subject to excavation movements.

Previous research and current needs are discussed briefly in light of these considerations under the following two headings:

Ground Movements Associated with Opencutting. The behavior of braced excavations has been reviewed by Peck (36) who has examined case histories of specific construction projects to integrate their behavior into the broader context of theory and design. Since Peck's state-of-the-art, the development and increased use of field instrumentation has resulted in many additional case studies where observations have called attention to the interrelationship between ground

movement and various parameters such as the soil properties, support stiffness, excavation technique, and ground water control (4,7,10,19,27,30,33,34,39,41,43). Because displacement is highly dependent on both the soil conditions and the construction procedure, there is immediate need to evaluate ground movement with special emphasis on the excavation technique and support methods. Attention needs to be directed to lateral ground movements, with concentration on their distribution behind the edge of the cut and their relationship with the deformation of the excavation wall. Furthermore, it would be beneficial to summarize soil movements in terms of strain as an expedient for relating the ground movements directly to building distortion.

Limits of Tolerable Building Distortion. To date, very little information is available that relates observed building damage with ground movements imposed by excavation. Although a general description of building damage in response to adjacent construction has been made by several researchers (5,20,41), detailed correlations of damage and ground movements are limited to a few instances where structural distortions caused by urban tunneling and by mining subsidence have been measured (5,21,26). It is important, therefore, that observations of building damage be combined with measured soil and building displacements to develop an empirical basis for evaluating the soil-structure interaction among several different soil and building types.

The work of defining limits for tolerable building distortion has been directed largely toward broad correlations of observed damage with differential building settlement. Based on a review of settlement histories, several researchers (3,16,40) have developed a statistical correspondence between building damage and measured differential settlement. In addition, theoretical

models have been formulated ( 6,38) that predict the onset of building damage by relating the deformed building shape caused by settlement with the critical tensile strain of concrete. These approaches to the problem of estimating building damage caused by adjacent opencutting and tunneling need improvement for several reasons:

1. The statistical correlations relate to buildings that settled primarily in response to consolidation under their own weight. Consequently, the settlements occurred over a relatively long period of time during which the building components could creep and thus adapt to load changes with minimal disturbance. By way of contrast, the movements caused by nearby excavation occur in a relatively short period of time, and correspondingly, building strains occur without the benefit of creep or long-term adjustments in the building loads.
2. The available criteria are based solely on settlement and do not include lateral displacement. Lateral displacements of substantial magnitude are caused by excavation and these movements contribute to tensile strains for which some structural elements -- such as masonry walls -- have a very low tolerance.
3. The damage criteria based on statistical correlation represent a broad simplification of building response. Especially with regard to judging potential instability, the criteria tend to obscure the influence of construction details that may be fundamentally important for setting limits on tolerable

building distortion. Consequently, the present criteria are not specific enough to account for the variety of structures encountered nor accommodate the detailed behavior of common building types. The study of tolerable and intolerable distortion needs to be organized with respect to both the use and the stability of specific types of structures.

4. The present criteria do not account for the relative stiffness between the structure and the soil. To estimate potential building damage, the engineer must make the tacit assumption that the building settles in compliance with the settlement profile. In certain instances this may be overly conservative. Buildings with stiff foundations, such as those with thick, reinforced mats or with deep, reinforced grade beams, tend to distribute differential movement throughout the structure such that the ground displacement is reflected in rigid body rotation as opposed to bending or shear distortion. Reductions in underpinning could be realized if the relative proportions of rigid body movement and angular distortion could be estimated for given combinations of structure and underlying soil.

In summary, the criteria for determining the limits of tolerable building distortion need reorganization when applied to the ground displacement generated by opencutting. Immediate savings in the cost of urban construction could be realized by improving the methods of evaluating structural response

to nearby excavation. Such improvements would allow for better decisions regarding the routing of transportation systems, excavation procedures, and underpinning.

## 1.2 OBJECTIVES OF THE STUDY

Field observations of ground displacements related to opencutting and their influence on adjacent buildings are organized according to three fundamental tasks:

1. To develop a basic inventory of ground movements associated with braced excavation, placing special emphasis on the soil type and method of construction. Soil displacements related to opencutting in both dense sands and soft clay are examined in order to represent a broad range of excavation behavior. Ground movements are summarized in terms of strain so that they can be directly related to building response.
2. To evaluate critical limits of distortion associated with the first appearance of cracks and separations in structures adjacent to braced excavation. This involves consideration of the influence of both vertical and lateral differential movement.
3. To closely examine brick-bearing wall structures and analyze the various modes of instability that are related to these buildings as a result of differential ground movement. In this manner, criteria for structural damage can be developed and zones adjacent to opencutting can be indexed according to their potential for serious damage.

### 1.3 SCOPE

In the following chapter, the soil displacements related to braced excavation in the dense sand and interbedded stiff clay deposits of Washington, D.C. and in the soft clay of Chicago are examined. The results of field measurements performed at several construction sites in each city are summarized to show typical vertical and lateral movements. Various aspects of the different construction methods are discussed. A relationship between lateral and vertical surface movement is developed as a function of the deformed shape of the excavation wall and the distance from the edge of the cut. Typical soil displacements are expressed in terms of strain and used to delineate characteristic zones of displacement related to opencutting.

In Chapter 3, architectural damage in structures adjacent to braced cuts is studied. Architectural damage refers to cracks and distortions, primarily of a cosmetic nature, that occur in building elements such as panel walls or floors. Previous research relating architectural damage with differential settlement is summarized and some of the problems of extending damage correlations to include a broad range of different building types are discussed. Correlations of architectural damage and differential movement are developed both for buildings that settled in response to underpinning and for buildings adjacent to excavation. Specific case histories of ground displacement and observed damage are discussed. On the basis of field observation, limiting values of distortion associated with architectural damage are recommended for brick-bearing wall and frame structures. The influence of architectural damage on the use of various building types is discussed.

In Chapter 4, brick-bearing wall structures are examined. A general description of this building type is provided with special emphasis on the structural details that are closely related to building stability. Various modes of building failure in response to differential ground movements are studied. Field observations of damage are summarized and combined with the results of the structural analysis to set limits for tolerable building distortion. Several different approaches to the protection of brick-bearing wall structures are discussed.





## CHAPTER 2

## GROUND MOVEMENTS ASSOCIATED WITH BRACED EXCAVATIONS

## 2.1 INTRODUCTION

In this chapter the soil movements associated with braced cuts are studied by concentrating on measurements and construction records of recent excavation in Washington, D. C. and Chicago. Opencutting in Washington, D. C. was performed in terrace deposits of dense sand and interbedded stiff clay. By way of contrast, opencutting in Chicago was performed in a prominent stratum of soft clay where base heave and squeezing ground developed large movements at the surrounding ground surface. By examining the ground displacements associated with both areas, a picture of excavation performance is developed that 1) shows typical patterns of movement for two distinct soil profiles whose material properties and engineering characteristics differ by a substantial margin, and 2) indicate the influence of various construction methods as they are applied to the particular soil conditions in each area. The combined study, then, serves to bracket a broad range of excavation behavior.

Ground movements can have serious repercussions on the stability of adjacent buildings, the operation of utilities, and the use of nearby streets. Correspondingly, the engineer should be able to judge the magnitude and distribution of ground movements to appraise the potential for damage and evaluate the need for protective measures. Especially with respect to buildings, judgments pertaining to their operation and possible failure must be developed within the context of strains that are imposed on various types of buildings.

For this reason, movements associated with the braced cuts in Washington, D. C. and Chicago are examined in terms of angular and lateral distortion. Angular distortion is defined as the differential settlement between two points divided by the distance separating them. In a similar fashion, lateral distortion is defined as the differential lateral displacement between two points divided by the distance separating them. Each parameter is a measure of the soil displacement in terms of strain and, hence, can be correlated directly with the response of adjacent structures to ground movement.

To develop a comprehensive picture of soil movement, the data from Washington, D. C. and Chicago are examined separately under four headings. First, the soil profile for each area is discussed and the important engineering properties of the profile are indicated. Secondly, the surface settlements and construction methods are examined. The settlements are expressed in dimensionless form and a comparative analysis of the data is made. Third, the lateral displacements are examined and related to the construction methods. Fourth, the relationship between the horizontal and vertical ground movements is studied and related to the construction procedure and corresponding displacements of the excavation wall. Finally, the various elements of the study are combined to delineate zones of typical ground movement. The zones are defined on the basis of angular and lateral distortion and are related to common construction methods for soil profiles similar to those of Washington, D. C. and Chicago.

## 2.2 GROUND MOVEMENTS RELATED TO BRACED EXCAVATION IN WASHINGTON, D. C.

### 2.2.1 SOIL CONDITIONS IN WASHINGTON, D. C.

Washington, D. C. is built on a series of terraces that flank the Potomac and Anacostia Rivers. These terraces were deposited during the Pleistocene Epoch in response to the alternating changes in sea level and volumes of runoff that were associated with the glacial and interglacial periods. The excavations summarized in this report were performed in either of two terraces in downtown Washington, known locally as the "25-ft" and the "50-ft" terraces.

A representative soil profile for the excavations under study is shown in Fig. 2.1. Typical values of undrained shear strength are listed for the cohesive soils and typical standard penetration rates are listed for the sandy materials. The Pleistocene terrace deposits tend to vary in composition with individual strata of sand or clay increasing and diminishing in thickness, depending on their location. The terrace soils are mostly slightly cohesive sands and gravel. A layer of stiff gray clay is shown at a depth of 25 ft (7.6 m), however this depth may vary from 10 to 30 ft (3.1 to 9.2 m). Clay lenses in the stratum of interbedded dense sand and stiff clay are typically 1 to 3 ft (0.3 to 1 m) thick. In this example, an unconformity is indicated at a depth of 70 ft (21.3 m) where the terrace deposits of Pleistocene age overlie Cretaceous hard clay. In some areas the hard clay is absent, and the terrace deposits rest directly on Cretaceous, clayey sands and gravel.

The water table, before subway construction, was located at two levels. A perched water table above the stiff gray clay was found at a depth of approximately 15 ft (4.6 m) below the street surface. The water table in the lower

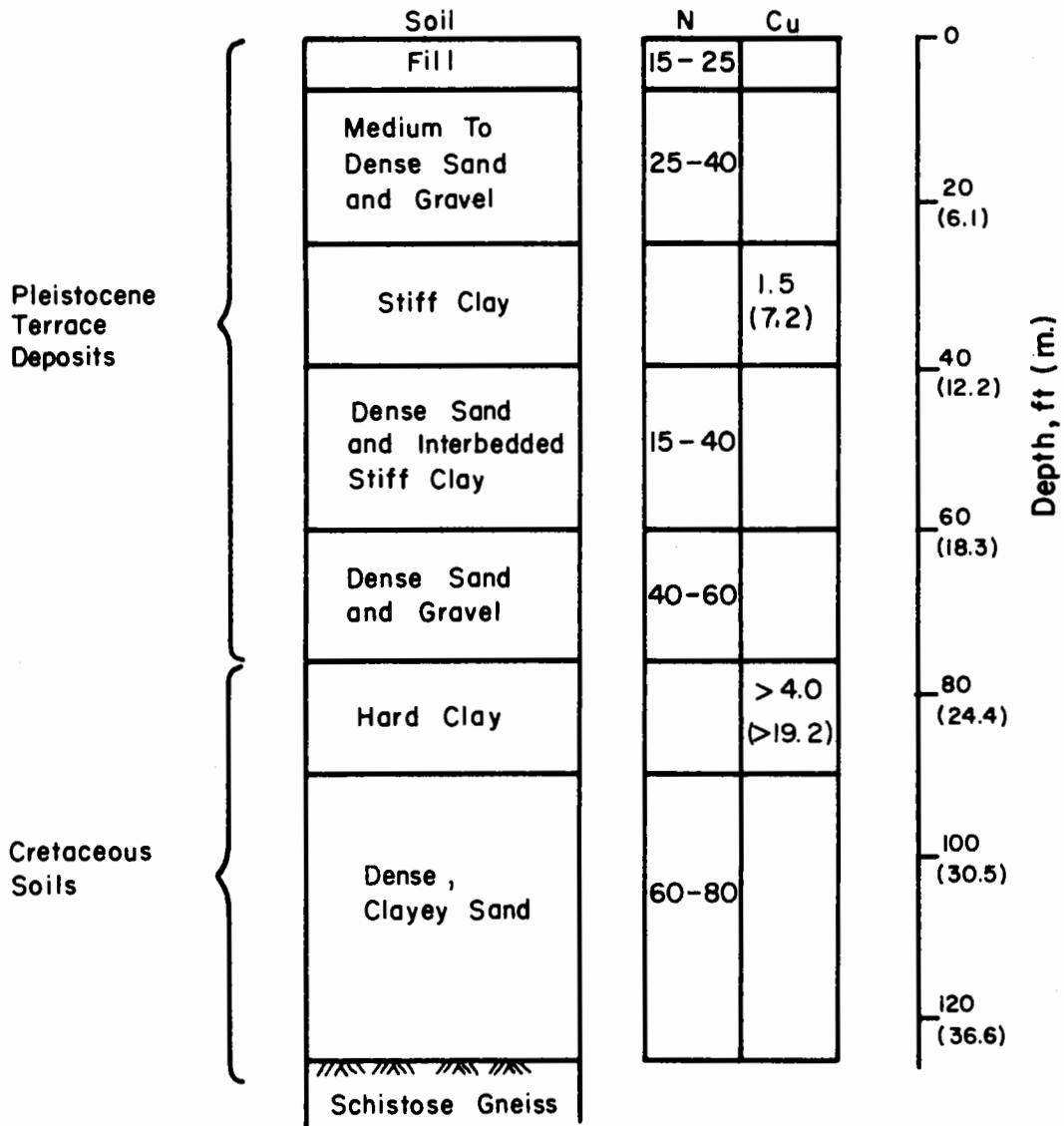

Symbols : N - Standard Penetration Resistance, Blows/ft  
 Cu - Undrained Shear Strength, KSF ( $P_0 \times 10^4$ )

Fig. 2.1 Soil Profile for Braced Excavations in Washington, D. C.

Pleistocene deposits was found at a depth of approximately 40 ft (12.2 m) below the street surface. During construction the granular soils of the Pleistocene and Cretaceous strata were dewatered below the subgrade of all braced cuts under study.

#### 2.2.2 SURFACE SETTLEMENT AND CONSTRUCTION METHOD

The surface settlements associated with 6 different sections of braced excavation are summarized according to the methods of construction and plotted in dimensionless form in Fig. 2.2. The settlement and distances are expressed as percentages of the maximum excavation depth. Each excavation is listed according to its location and prominent characteristics in a table that accompanies the data plot.

Previous research (34) has shown that ground movements generated by strut removal during subsurface construction can result in a 100 percent increase over the displacement caused by excavation to subgrade. Consequently, the total excavation history, including strut removal and backfilling, should be used as a baseline from which to judge the influence of soil movements on nearby structures. For this reason, the settlement data assembled in Fig. 2.2 represent both the initial and final stages of construction.

The construction procedure for each excavation was similar. The excavations were supported by cross-lot braces with vertical separations that averaged between 12 and 16 ft (3.7 and 4.9 m). The braced cuts were deepened approximately 20 to 25 ft (6.1 to 7.6 m) below the lowest, previously installed struts before installation of the next brace level. The excavation walls were

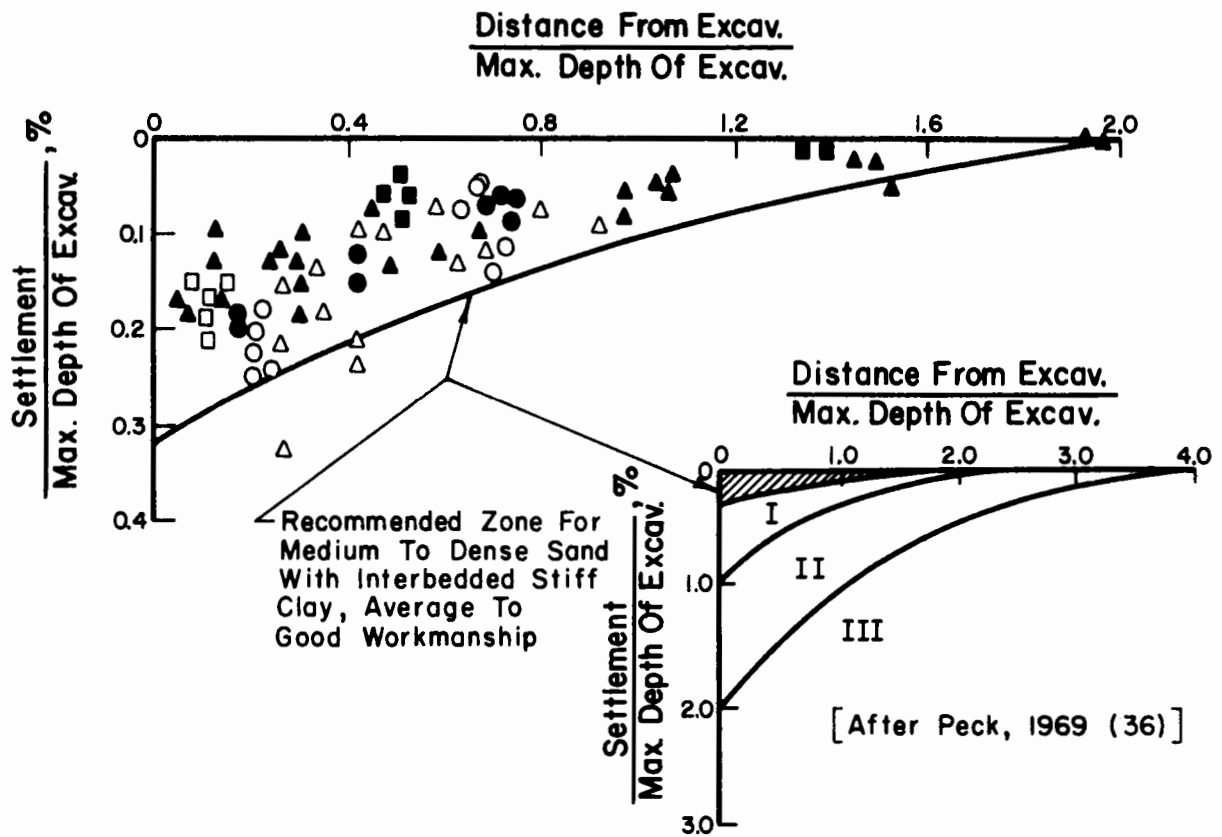

Case	Symbol	Location	Max. Depth, ft	Support
1	●	7 th & G St., N.W.	60	Soldier Pile-Lagging With Cross-Lot Struts For All Cases
2	○	9 th & G St., N.W.	60	
3	▲	11 th & G St., N.W.	55	
4	△	12 th & I St., N.W.	60	
5	■	7 th & G St., N.W.	80	
6	□	1 st & D St., S. E.	80	

Fig. 2.2 Summary of Settlements Adjacent to Braced Cuts in Washington, D. C.

composed of soldier piles, ranging in size from 14BP102 to 24WF120, on roughly 7 ft (2.1 m) centers with oak lagging installed between adjacent piles. Problems with running or sloughing soil were not encountered for the data indicated. Occasionally, local difficulty in controlling the ground water was experienced but the majority of opencutting was performed without substantial seepage and in soil that locally maintained its vertical face when exposed during lagging operations.

When compared with the settlements summarized by Peck (36) excavations in sand and soft to hard clay, the settlements shown in Fig. 2.2. are small. Expressed as a percentage of the maximum braced cut depth, they range from a value of 0.3 percent near the edge of excavation to values less than 0.1 percent at distances from the edge of excavation equal to or exceeding the maximum depth of the cut. Settlements reported in the literature for excavation in San Francisco (2,42), Los Angeles (28), Boston (27), and Minneapolis (25) that were extended through profiles of medium to dense sand and sand with interbedded stiff clay also fall within the same zone of settlement.

Figure 2.3 shows the angular distortion associated with braced cuts in Washington, D. C. plotted as a function of the dimensionless distance from the edge of excavation. The angular distortion was estimated by dividing the differential settlement of two points along a line perpendicular to the edge of excavation by the distance separating them. The dimensionless distance associated with each value of angular distortion was estimated as the distance from the edge of excavation to a point midway between the two points from which the differential settlement was computed. The values of angular distortion shown in Fig. 2.3 were derived from the settlement measurements associated

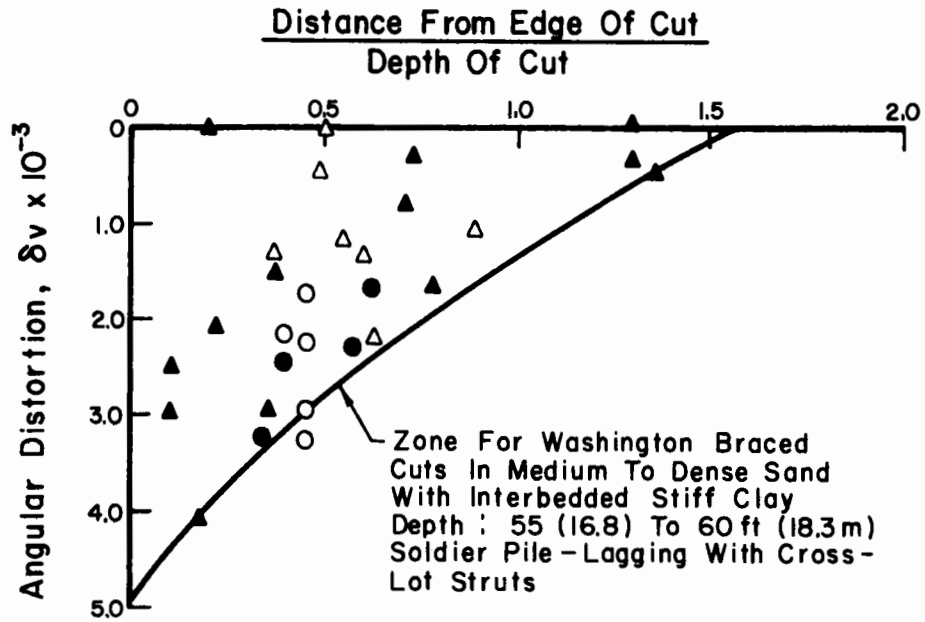

Case	Symbol	Max. Depth, ft (m)	Support
1	●	60 (18.3)	Soldier Pile- Lagging With Cross-Lot Struts For All Cases
2	○	60 (18.3)	
3	▲	55 (16.8)	
4	△	60 (18.3)	

Fig. 2.3 Angular Distortion for Braced Cuts in Washington, D. C.



with the excavations listed as Case 1 through 4 in Fig. 2.2. The angular distortion ranges from a maximum value of approximately  $5 \times 10^{-3}$  near the edge of excavation to a value slightly larger than  $1 \times 10^{-3}$  at a distance from the edge of excavation equal to the maximum depth of the cut.

### 2.2.3 LATERAL GROUND MOVEMENTS

Cut-and-cover subway construction can be visualized as occurring in three prominent stages. During each stage, construction methods and support application contribute to the ground displacement in a characteristic way.

These stages include:

1. Excavation before installation of braces.
2. Excavation to subgrade after upper braces installed.
3. Removal of braces and construction of the permanent structure.

Figures 2.4 through 2.6 trace the development of lateral soil movement as a function of the construction history for a cut-and-cover excavation in Washington, D. C. The excavation was 60 ft (18.3 m) deep and was supported by soldier pile and lagging walls with 5 levels of cross-lot struts. A detailed study of this excavation and others in Washington, D. C. has been performed by O'Rourke (34). The figures show the horizontal wall movements and lateral distortion in the retained soil for each of the construction stages listed above. The lateral distortion has been estimated from inclinometer measurements by dividing the differential lateral displacement between two points at a given elevation by the distance separating them and plotting the lateral distortion at the mid-point between the two measurements. The contour interval for lateral distortion has been chosen as  $0.5 \times 10^{-3}$ , which is the

critical tensile strain for concrete and masonry elements (38). The lateral strains estimated for this particular excavation compare favorably with inclinometer data from other excavations in Washington, D. C. The lateral movements and construction sequence are discussed as follows:

1. Excavation before installation of braces: Because time was required for the connecting of steel lacing between adjacent street beams, the excavation was advanced to a depth of 20 to 25 ft (6.1 to 7.6 m) before the street beams were shimmed against the walls of the cut. Hence, deformation of the wall occurred primarily as a cantilever-type movement. The lateral distortion indicated in Fig. 2.4 reflect this mode of deformation showing tensile strains that develop from the upper edge of the cut in a triangular pattern of contours that decrease in magnitude with depth and distance from the wall. Soil movements were measured at a distance from the edge of cut approximately equal to the depth of measured displacement at the excavation wall. This depth exceeds the depth of the excavation bottom by approximately 10 ft (3 m).

2. Excavation to subgrade after upper braces installed: As the upper braces were installed, the upper portion of the excavation wall was restrained from further lateral movement. In fact, preloading of the upper level struts resulted in a net decrease in the measured lateral movement near the top of the cut. The incremental distortion, plotted in Fig. 2.5, show that there was a recompression of the soil near the top of the excavation as referenced to the soil movement during stage 1 construction. In the deeper portions of the cut, the inward bulging of the excavation wall was associated with lateral tensile strains. These strains, shown in Fig. 2.5, emanate from a section of the wall

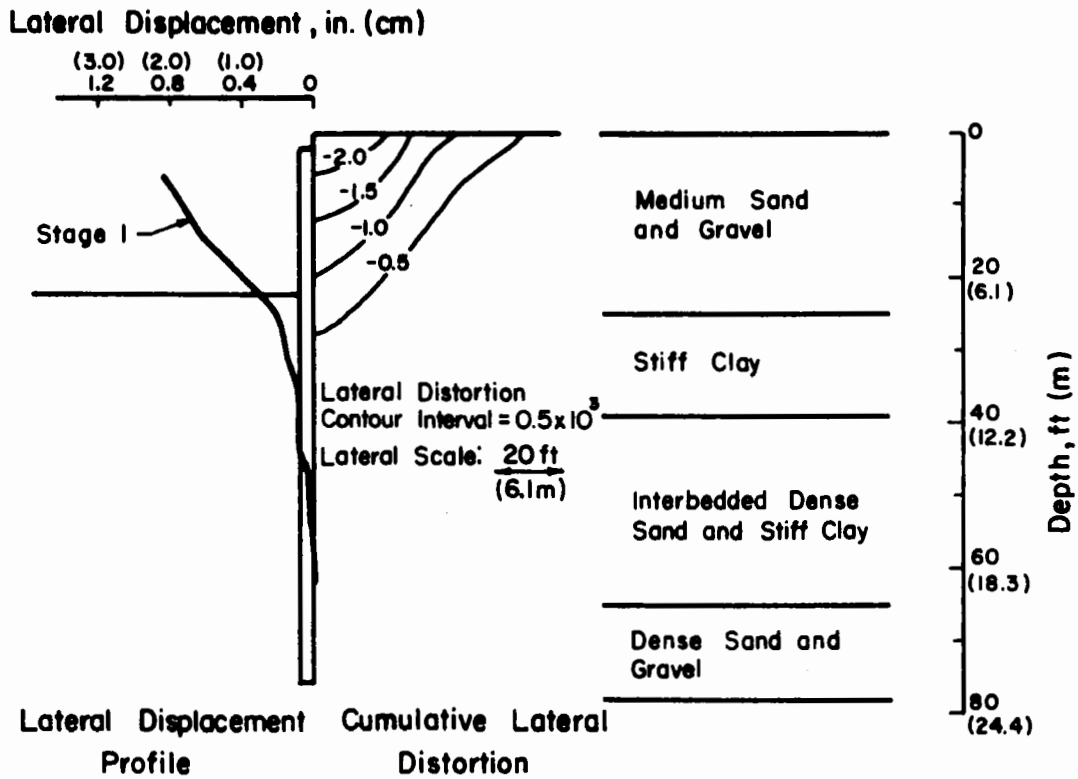

Fig. 2.4 Lateral Distortion Corresponding to Stage 1: Excavation Before Installation of Braces

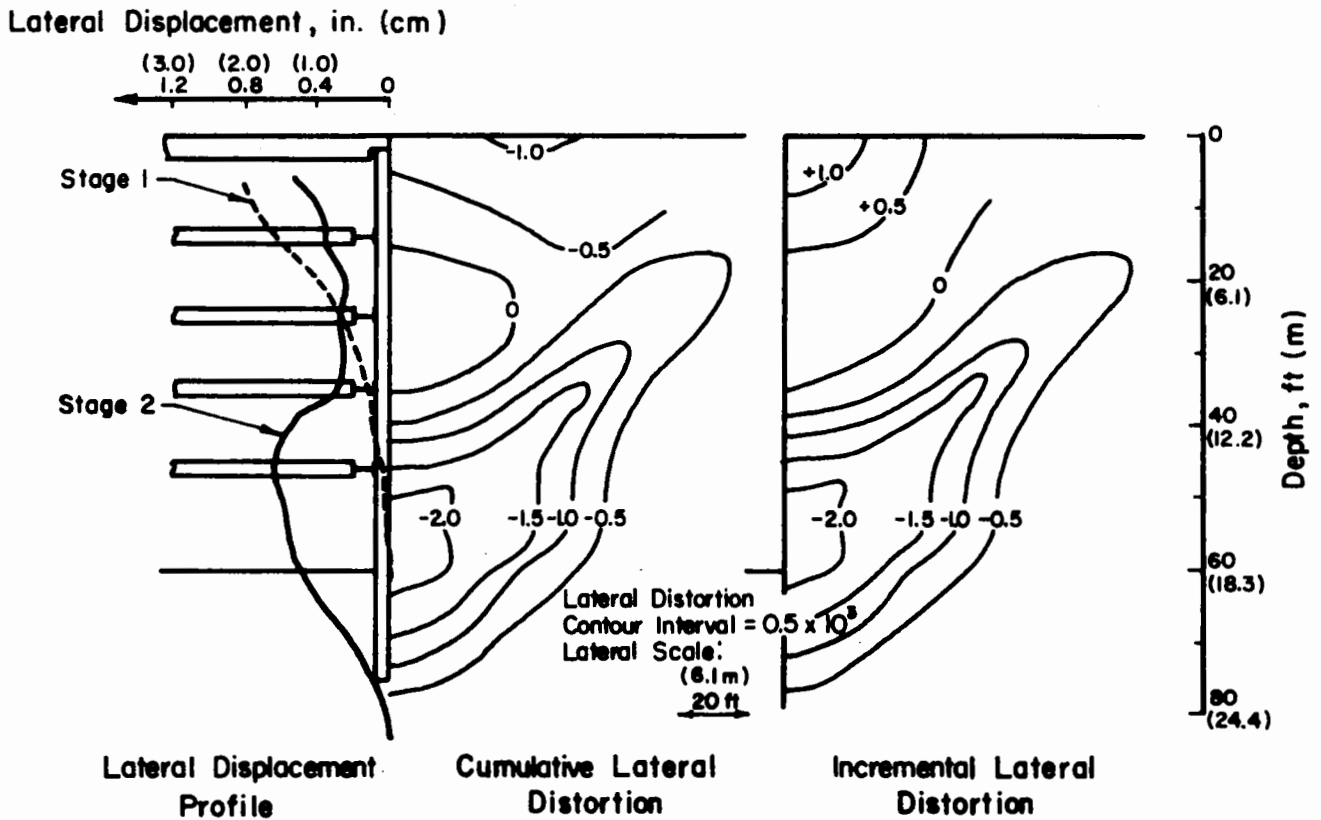

Fig. 2.5 Lateral Distortion Corresponding to Stage 2: Excavation to Subgrade

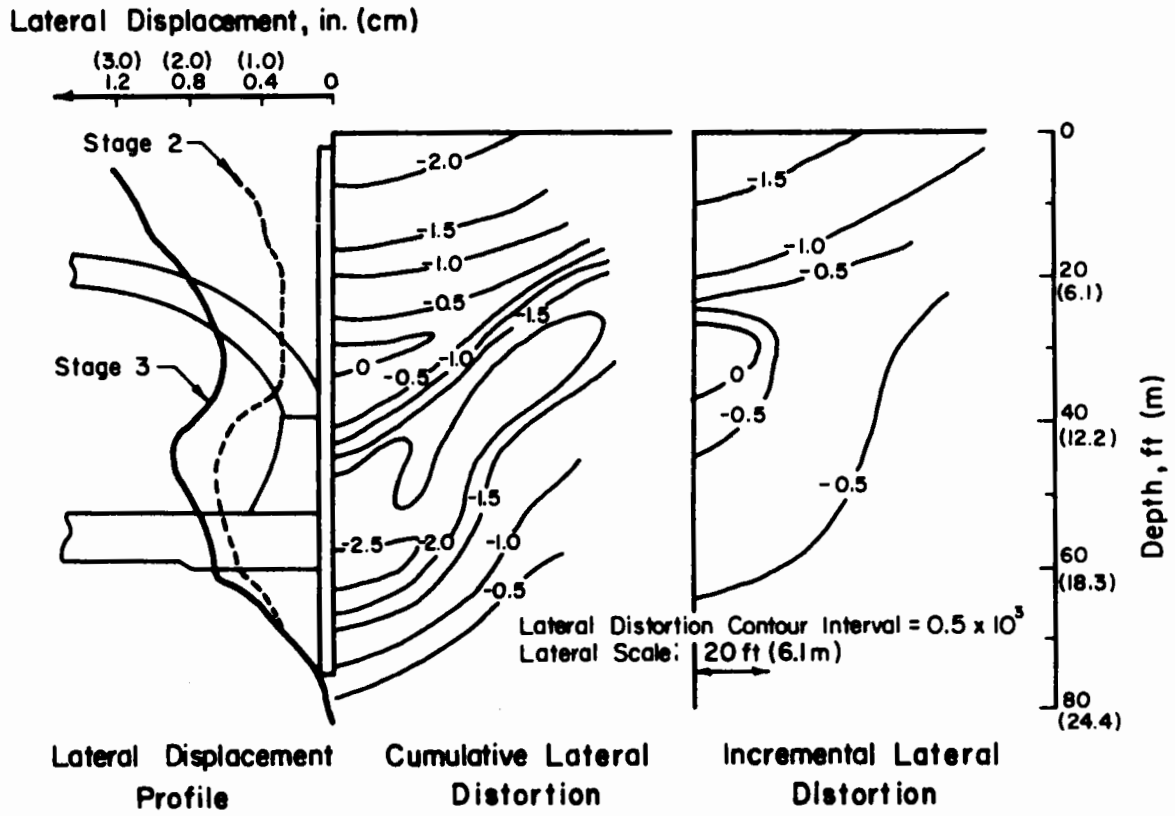

Fig. 2.6 Lateral Distortion Corresponding to Stage 3: Removal of Braces

near the bottom of excavation in contours that loop upward from their point of origin toward the ground surface at an angle of roughly  $45^\circ$  from the vertical. Near the excavation wall, lateral ground strains were measured at a depth of 1.20 times the maximum depth of excavation.

3. Removal of braces and construction of the permanent structure:

As the bottom braces were removed to build the underground structure, further inward bulging of the wall occurred at the lower levels of excavation. When the upper two brace levels were removed, the wall was supported in its lower portion by the subway structure and the corresponding movements resulted from a cantilever-type deformation of the wall. Consequently, the incremental strains are a composite of the soil distortions associated with inward bulging at depth and cantilever movement near the top of the wall. This is indicated in Fig. 2.6 where the plot of the incremental distortions, as referenced to the stage 2 construction, show incremental tensile strains concentrated near the bottom of the cut in a prominently curved pattern of contours as opposed to a nearly triangular pattern of contours at the upper portion of the cut. The increase in ground distortion at levels below the subway invert is very small.

The cumulative distortion shown in Fig. 2.6, is the sum contribution of strains developed in the three stages of construction. Two zones of distortion can be distinguished. Lateral tensile strain of over  $2.5 \times 10^{-3}$  is concentrated near the wall at the invert line of the subway structure. From this point lateral strains emanate in a looped pattern of contours that are directed upward toward the ground surface. This zone forms the lower boundary

of ground movement for the retained soil mass. Near the top of the cut the contours of lateral strain are inclined diagonally to the excavation wall and reflect the cantilever movements that have been concentrated at this level of the excavation. The lateral distortion at the ground surface is approximately  $2 \times 10^{-3}$  within a distance of 25 ft (7.6 m) from the edge of excavation. A notable point of deformation occurs at a depth of 30 ft (9.2 m) where the cumulative lateral distortion is zero. This apparent absence of strain reflects the characteristic S-shape of the wall displacements. The conspicuous indentation of the wall at this level derives from the high preloads (approximately 60 to 70 percent of the design load) that were jacked into the struts at this level. The struts were preloaded against the clay stratum and the resulting plastic deformation was not fully recovered when the struts were removed during stage 3 construction.

In summary, the lateral movements generated by opencutting are related directly to the mode of deformation at the excavation wall which, in turn, is related to the construction procedure. Three stages of construction (initial excavation before placement of braces, excavation to subgrade, and removal of struts) can be distinguished for cut-and-cover excavation that contribute to the ground displacements. The final displacement profile is a composite of the soil movements generated during each stage of construction and is composed essentially of two zones of lateral distortion. A deep-seated zone of lateral strain develops in response to inward bulging of the excavation wall and forms the lower boundary of the mobilized soil mass. An upper zone of lateral distortion develops in response to cantilever movement of the excavation wall and contributes directly to the surface strains within a distance of 20 to 30 ft (6.1 to 9.2 m) from the edge of the cut.

#### 2.2.4 RELATIONSHIP BETWEEN LATERAL AND VERTICAL SURFACE MOVEMENT

Since the soil displacement is related to the mode of deformation at the excavation wall, it seems reasonable to assume that a consistent relationship exists between the lateral and vertical soil movements, depending on the type of wall deformation. Hence, it would be beneficial to examine soil behavior under the influence of various wall distortions to gain an insight as to how the soil displacements are transmitted to the ground surface where buildings and other structures derive their support.

Figure 2.7 summarizes the results of two model tests that were performed by Milligan (31) at Cambridge University. In both tests a flexible, smooth wall was used in combination with dense sand (rounded, coarse quartz with initial void ratios of 0.54 and 0.55). Soil strains and displacements were measured by means of X-ray radiographs that were taken of lead shot embedded in the soil matrix. As the soil deformed, X-ray pictures provided a direct measure of soil strain by showing the relative displacements of lead shot. The ground movements are shown at a scale of 1.5 times the actual measured displacements. All dimensions, as well as the lateral wall movement, are expressed in dimensionless form as a function of the maximum excavation depth.

The wall deformations shown for the model tests are the results of a series of measurements taken at successively deeper excavation levels. For each stage of measured deformation, the patterns of soil movement remained unchanged and the magnitudes increased in proportion to the wall movements. Consequently, the final displacement vectors shown in Fig. 2.7 are representative of the movement patterns that developed for wall deformations as small as one-tenth those indicated.

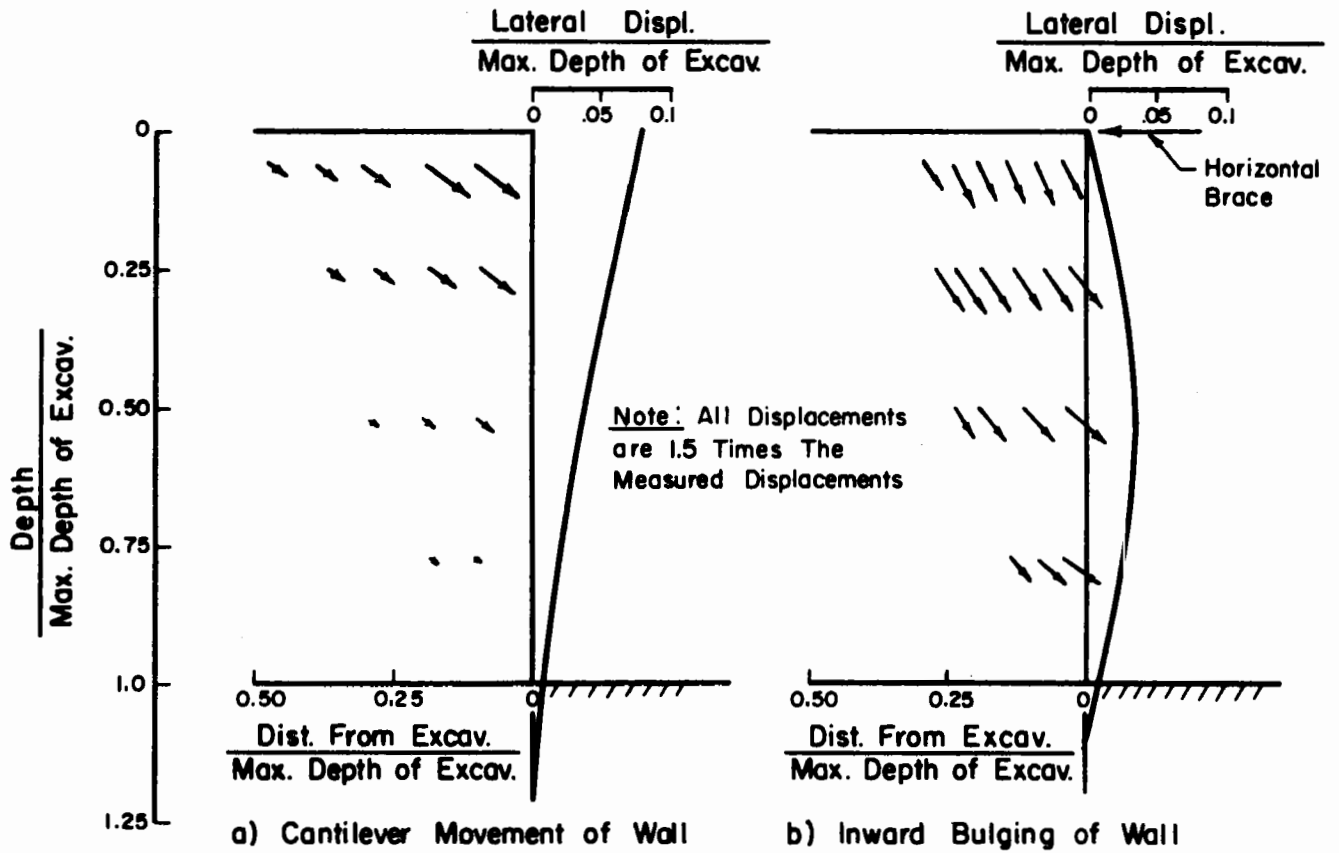

Fig. 2.7 Soil Movements Related to Model Tests with Sand



The different types of wall deformation are reflected in the pattern of soil movement. Near the ground surface, the vector displacements for the cantilever movement of the wall show a ratio of lateral to vertical displacement ranging between 1.3 and 1.5. By way of contrast, the vector displacements for the inward bulging of the wall show a more complicated pattern of orientation. Horizontal restraint at the upper level of excavation has limited the development of lateral movement at this elevation. Correspondingly, the ratio of lateral to vertical displacement near the ground surface ranges between 0.5 to 0.7.

Figure 2.8 summarizes the ratios of the horizontal to vertical surface movements that were measured for both the model tests and braced excavations in Washington, D. C. Ratios of horizontal to vertical displacement for the braced cuts were obtained from two different excavations. Settlement and inclinometer measurements, associated with the 60 ft (18.3 m) excavation described in the previous section, were combined to estimate ratios of surface movement within approximately 35 ft (10.7 m) of the edge of the cut. At greater distances from the excavation, precise optical leveling and tape extensometer readings near the column footings of a highrise apartment building were used. The apartment building is located within 40 ft (12.2 m) of a 60 ft (18.3 m) excavation. The ratios correspond to a time when the excavations had been deepened to subgrade and the bottom-level braces had been removed. Both excavations were characterized by a similar soil profile and construction procedure. The distances from the edge of excavation, within which the ratios of horizontal to vertical displacement were estimated, are expressed as a fraction of the maximum excavation depth.

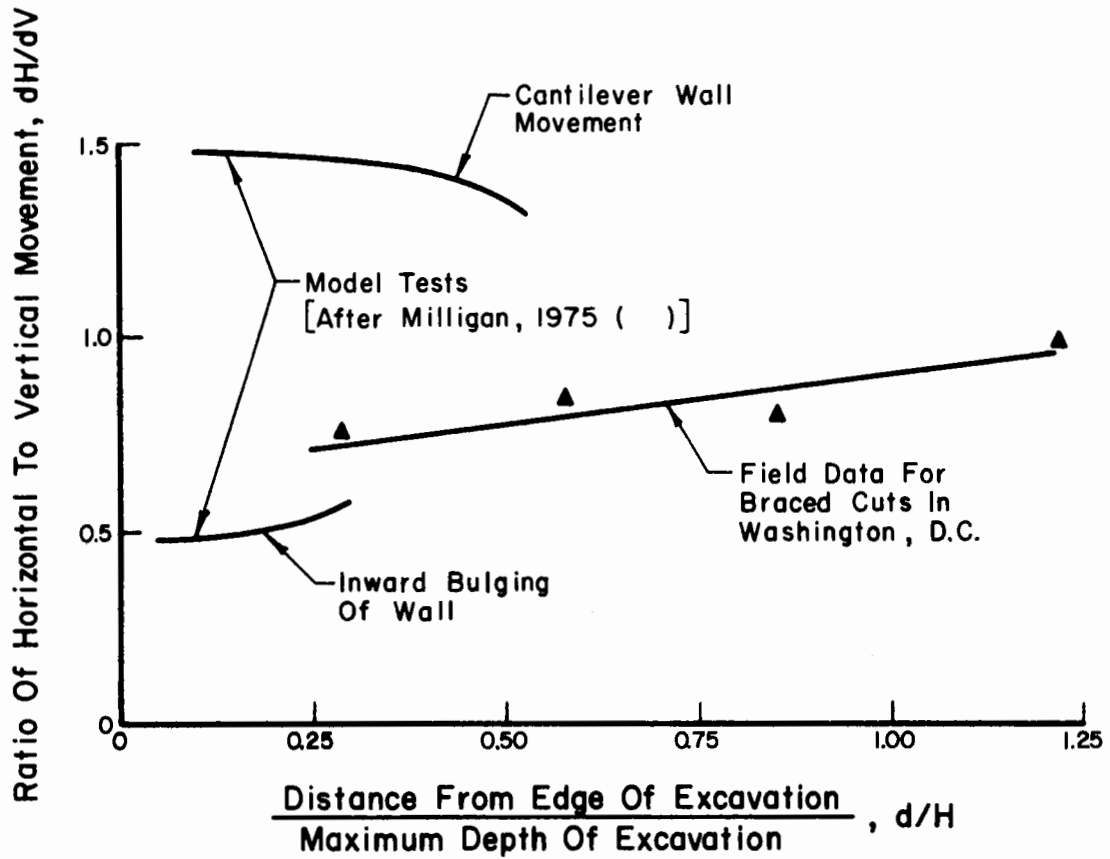

Fig. 2.8 Ratio of Horizontal to Vertical Ground Movements for Model Tests and Excavations in Washington, D. C.

The results of the model tests serve to bracket a range of surface displacement patterns that can be anticipated within the zone of plastic soil behavior. Within this framework the field data appear to represent a reasonable ratio of lateral to vertical displacement. The field data indicate that the ratio of horizontal to vertical movement increases with distance from the edge of excavation, ranging from the value of 0.7 at a distance of 0.25 the maximum excavation depth to nearly 1.0 at distances exceeding the maximum excavation depth.

## 2.3 GROUND MOVEMENTS RELATED TO BRACED EXCAVATION IN CHICAGO

### 2.3.1 SOIL CONDITIONS IN CHICAGO

The City of Chicago is founded on a series of till sheets that were deposited during the Pleistocene Epoch. Much of the downtown or "Loop" area of Chicago is underlain by a stratum of soft, compressible clay that was deposited as part of this glacial sequence. All the Chicago cuts studied in this report were extended into the soft clay and thus, their performance is indicative of the relatively large, plastic deformations that accompany excavation in this type of material.

Figure 2.9 shows a typical soil profile for downtown Chicago. Representative values of undrained shear strength are listed for the clays and typical standard penetration rates are listed for the granular soils. A notable stratum of soft clay occurs at a depth of approximately 15 ft (4.6 m) below the street surface. The soft clay grades into clay of medium consistency at a depth of approximately 40 ft (12.2 m), however the transition zone

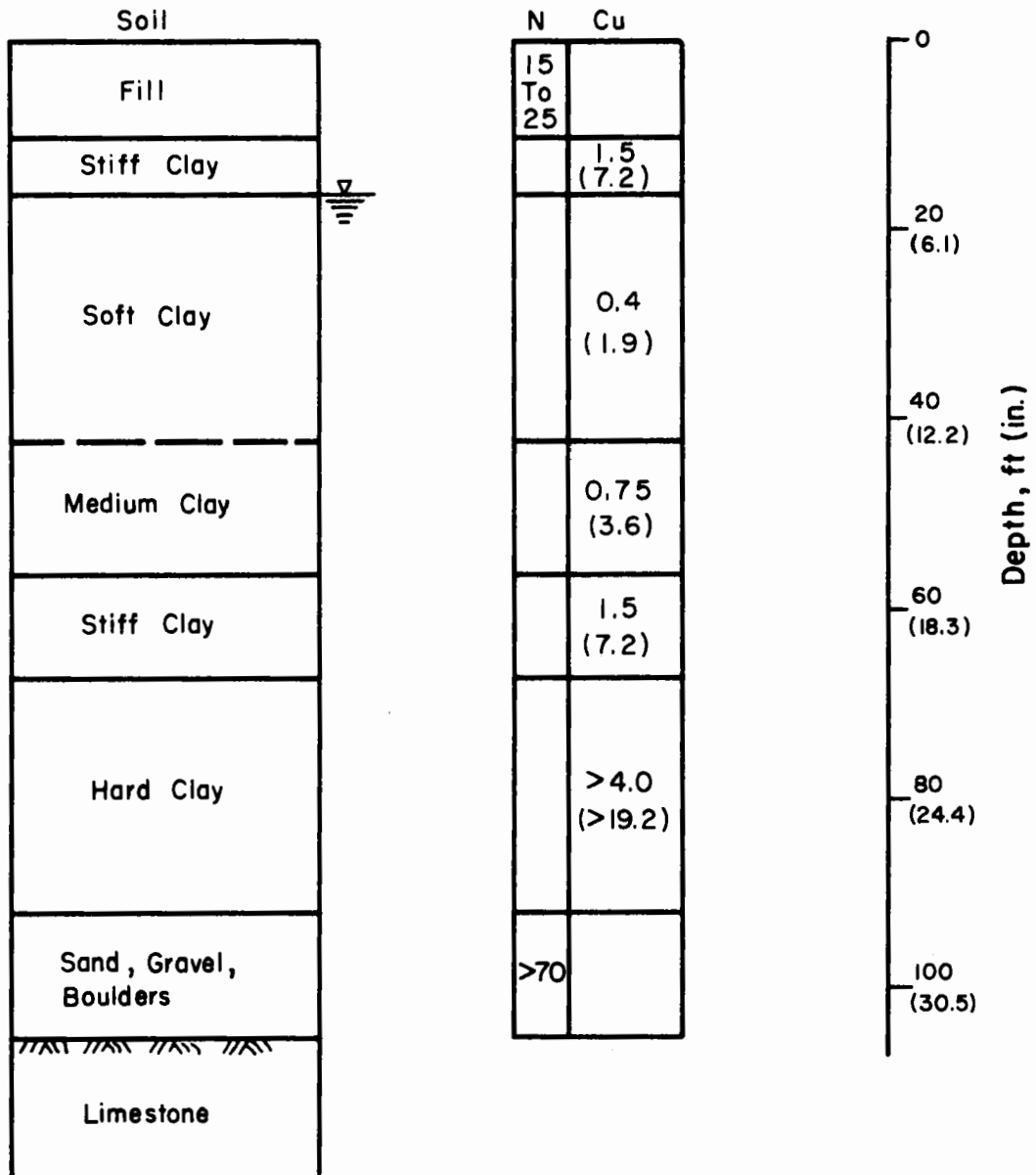

Symbols: N - Standard Penetration Resistance, Blows/ft  
 Cu- Undrained Shear Strength, KSF ( $P_o \times 10^4$ )

Fig. 2.9 Soil Profile for Braced Excavations in Chicago

may occur as much as 10 ft (3 m) higher or lower, depending on location. The soft clay is capped with a relatively thin layer of stiff, desiccated clay. A stratum of hard clay and silt, referred to as hardpan, occurs at a depth of approximately 65 ft (19.8 m). The depth of the limestone bedrock ranges from 95 to 110 ft (30 to 33.5 m). The water table is located at the top of the soft clay stratum.

### 2.3.2 SURFACE SETTLEMENT AND CONSTRUCTION METHOD

The surface settlements associated with 9 different braced excavations are summarized according to the methods of construction in Table 2.1 and plotted in dimensionless form in Fig. 2.10. The settlements and distances are expressed as percentages of the maximum excavation depth. The settlements represent the final stages of the excavation sequence and, as such, correlate with the removal of the upper level braces during construction of the basement walls. With the exception of minor variations in the thicknesses of individual strata, the soil profile associated with the summarized excavations is essentially constant. Consequently, Fig. 2.10 allows for a comparative analysis of the soil movements as a function of the support conditions and construction technique.

Three zones of ground displacement have been distinguished in Fig. 2.10 and related to the salient characteristics of construction. These zones approximate the three zones of settlement delineated by Peck (36) with the exception that the widths of the settlement zones are notably shorter than those indicated by Peck. As such, the settlements associated with the Chicago excavations are confined to areas that are comparatively nearer the edge of excavation. Peck's summary, however, includes data from braced excavation in

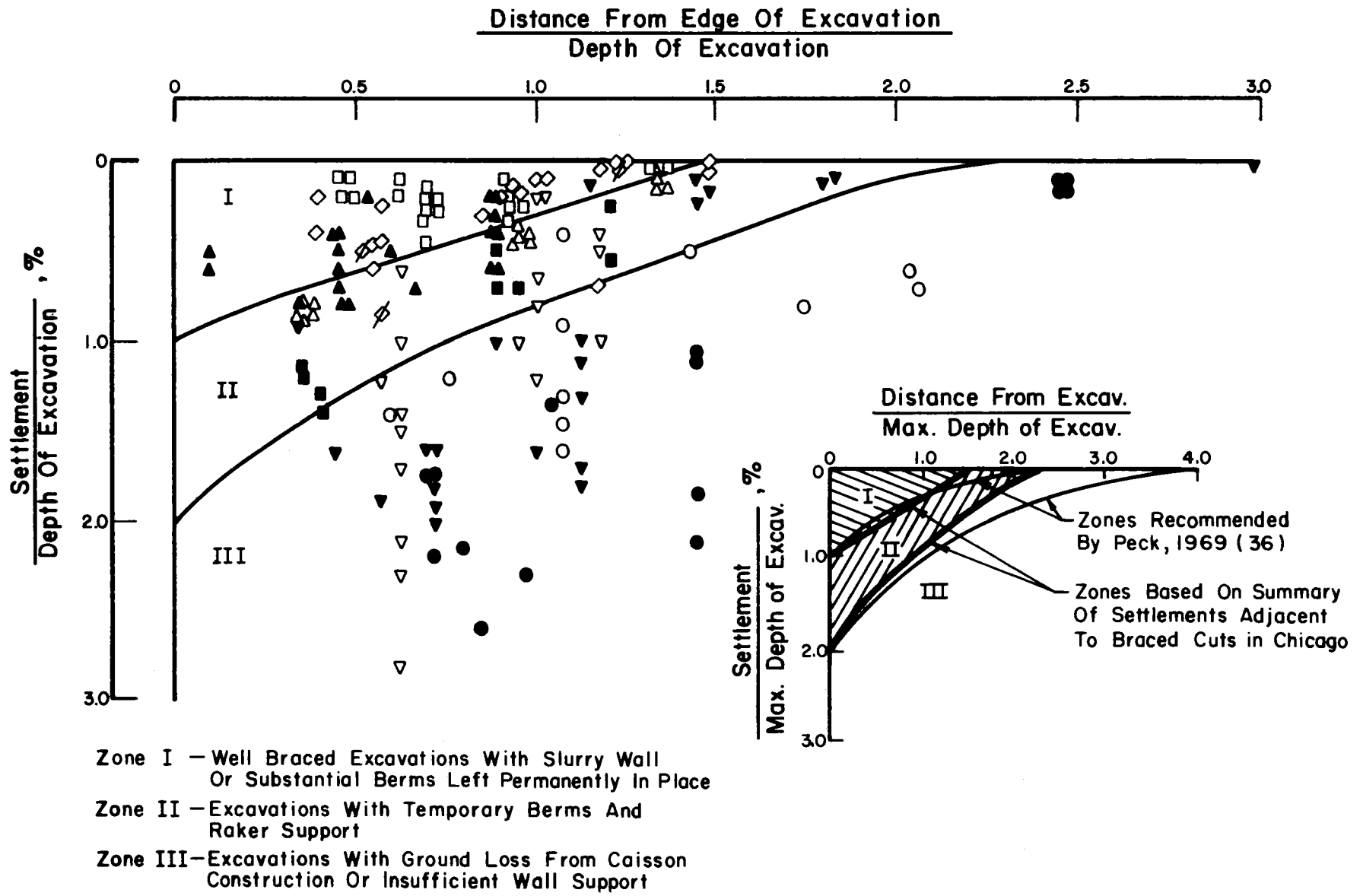

Fig. 2.10 Summary of Settlements Adjacent to Braced Cuts in Chicago

TABLE 2.1 INFORMATION RELATING TO CHICAGO EXCAVATIONS

Case	Symbol	Depth H, ft (m)	Wall	Support	Excavation Procedure	Special Characteristics
1	◇	44 (13.4)	14 BP 73 On 7 ft (2.1 m) Centers With Lagging	2 Upper Levels of Cross-Lot Struts, Bottom Level Rakers; Upper Levels Preloaded; 12 ft (3.7 m) Vert. Space	Excavate 14 ft (4.3 m) Below Previous Strut Excavate Center With Berm On Sides Of Cut	Permanent Berms Except Along South Wall Where Increased Settlement Occurred
1a	∅					Berms Removed And Bottom Level Rakers Installed
2	△	27 (8.2)	Sheet Pile MZ 27	3 Raker Levels; 8 ft (2.4 m) Vert Space, Preloaded	Excavate Center With Berms Adjoining The Wall	
3	□	44 (13.4)	30 in. (76.2 cm) Slurry Wall	Upper Level Tiebacks, Bottom Level Rakers; 16 ft (4.9 m) Vert. Space; Preloaded	Excavate 14 ft (4.3 m) Install Tiebacks Excavate Center With Berms	
4	▽	30 (9.2)	10 HP 42 On 5 ft (1.5 m) Centers With Lagging	2 Raker Levels; 10 ft (3 m) Vert. Space; Preloaded	Excavate Center With Berms Adjoining The Wall	Insufficient Wall Support Due To Delay In Raker Installation
5	○	26 (7.9)	30 in. (76.2 cm) Slurry Wall	1 Strut Level No Preload	Excavate 15 ft (4.6 m) Install Struts Excavate Center	Lost Ground Associated With Caisson Construction
6	●	28 (8.5)	21 WF 76 On 6.5 ft (2 m) Centers With Lagging	Cantilever Support With Some Rakers	Excavate 14 ft (4.3 m) Drill Caissons Excavate To Subgrade	Lost Ground Associated With Caisson Construction And Insufficient Wall Support
7	▼	45 (13.7)	30 in. (76.2 cm) Slurry Wall	3 Raker Levels; 11 ft (3.4 m) Vert. Space; Preloaded	Excavate Center With Berms Adjoining The Wall	Lost Ground Associated With Caisson Construction
8	▲	70 (21.3)	Sheet Pile MZ 38	6 Strut Levels; 10 ft (3 m) Vert. Space Preloaded	Excavate 12 ft (3.7 m) Below Previous Strut	
9	■	37 (11.3)	Sheet Pile MZ 38	3 Raker Levels; 10 ft (3 m) Vert. Space; No Preload	Excavate Center With Berms Adjoining The Walls	

Oslo (11) where the depth of soft clay beneath the excavation bottom was, in most instances, considerably larger than for the Chicago cuts.

The excavations summarized in Table 2.1 were braced cuts associated with deep basement construction. Typically, this type of opencutting is extended an initial 6 to 8 ft (1.8 to 2.4 m) to provide a working level from which drilled caissons are installed. The central portion of the excavation then is deepened to subgrade as berms are left in place against the excavation walls. Grade beams and basement slabs are constructed in the central area of the cut while wall support is provided by installing rakers between the completed foundation and sheeting line. Several levels of rakers may be required, depending on the depth of cut. As the temporary berms are removed in stages, successively deeper levels of rakers are installed.

Zone I includes settlement data associated with cases 1 and 3. In each case, the upper level supports were installed and preloaded before the central portion of excavation was deepened to subgrade. In case 1 substantial berms were left permanently in place along the north and west walls of the soldier pile lagging system. In case 3 the bottom levels of the slurry wall were supported by temporary berms until rakers were installed and preloaded.

Zone II includes settlement data related primarily to excavations with temporary berms and raker support. The excavation support includes soldier pile-lagging walls and sheet pile walls. Where rakers were preloaded and installed on small vertical spaces, as was the condition for case 2, settlements were restrained. Correspondingly, they plot near the upper portion of the zone.



The largest settlements measured for the Chicago excavations are shown in Zone III and are related either to ground loss from caisson construction or to insufficient support of the excavation wall. The data for cases 5 through 7 pertain to excavations where the drilled caissons were excavated without slurry. Consequently, squeezing ground caused by lack of restraint in the open holes, especially in the soft and medium clay strata, is responsible for part of the settlement. For case 7, additional lost ground during caisson installation can be attributed to excessive pumping of water and fines from the sand and gravel stratum overlying bedrock.

It is unlikely that the settlements associated with Zones I and II were influenced significantly by caisson construction. In these cases when drilled caissons were installed, they were excavated under guidelines that called for minimizing the hole dimensions with respect to the temporary casings and maintaining a bentonite slurry during drilling. In addition, inclinometer measurements for the excavations in question did not indicate deep ground movements during caisson construction.

A better understanding of the excavation procedure and associated ground movements can be obtained by examining the inclinometer measurements for several excavations that used different methods of wall support. Information of this nature is assembled in Figs. 2.11, 2.12, 2.13 and 2.15 where lateral displacements for each of several cuts are illustrated in combination with the soil profile and a scale representation of the excavation levels. Where possible, settlement profiles are shown in relation to the lateral wall movements. The dates corresponding to the soil displacements and levels of excavation are referenced to the beginning of caisson construction.

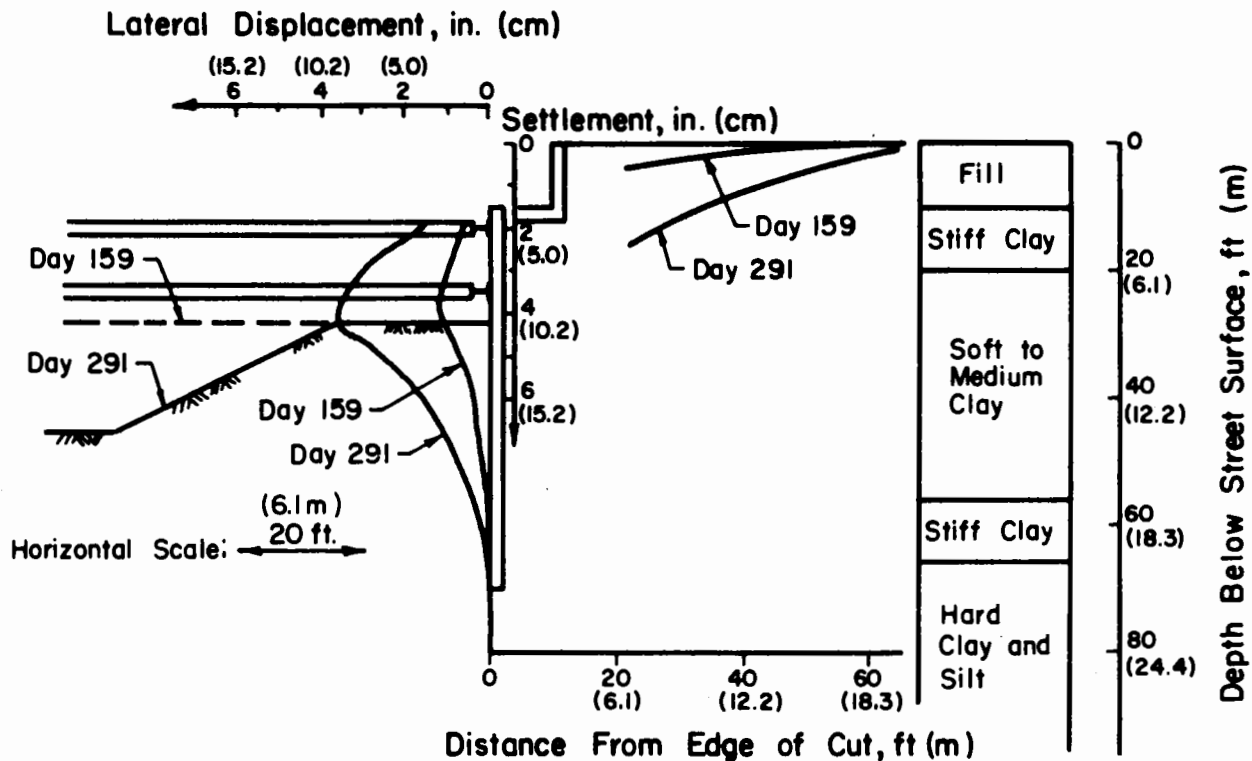

Fig. 2.11 Soil Displacements for Case 1

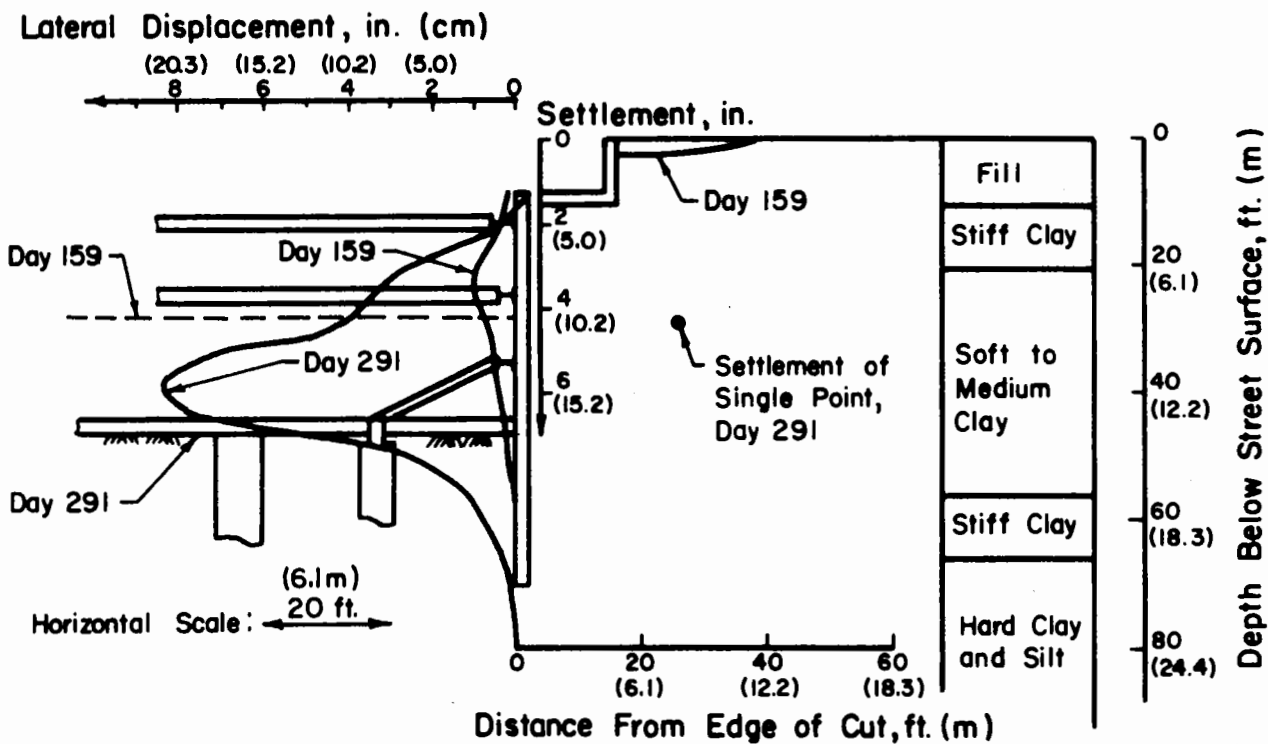

Fig. 2.12 Soil Displacements for Case 1a

Figures 2.11 and 2.12 show the lateral wall displacements associated with case 1 and case 1a, respectively. The wall of this excavation was composed of 14BP73 soldier piles on 7-ft (2.1-m) centers with wood lagging installed between adjacent soldier piles. The wall was supported in its upper levels by two tiers of cross-lot and diagonal struts that were preloaded to 50 percent of the design brace load. The central portion of the excavation was deepened to a subgrade level of 44 ft (13.4 m) below the surrounding street surface. Large berms were left in place against the north and east walls of the cut as shown in Fig. 2.11. The berms were approximately 25 ft (7.6 m) wide at the top and were sloped at an angle of roughly  $30^{\circ}$  from the horizontal. The lateral wall displacements and surface settlements before and after excavation of the central area of the cut are indicated in the figure. By way of contrast, Fig. 2.12 shows the lateral displacements for the south wall of the excavation where the berms were removed and replaced with raker supports. A comparison of the two figures indicates that the transfer of lateral restraint from berms to the raker system was relatively inefficient. Installation of the bottom rakers required that the berms be diminished to a size appropriate for insertion of the raker support. Excavation of this nature decreases the lateral restraint at the excavation wall as well as reduces the dead weight of soil acting to limit bottom heave. The reduction of berm support in combination with deformation and adjustment of the rakers contributed to the prominent inward bulging shown in Fig. 2.12. The increased displacement emphasizes the need for careful excavation of the soft clay in combination with prompt installation of stiff bracing.

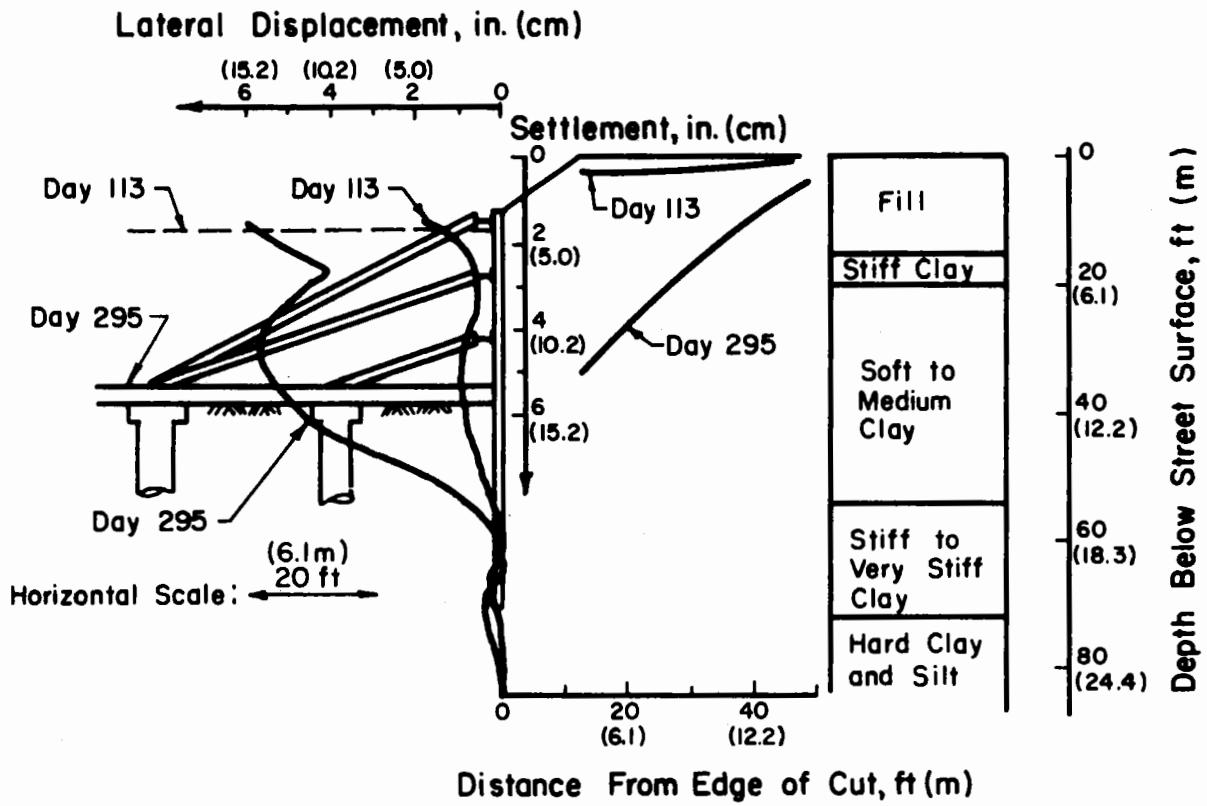

Fig. 2.13 Soil Displacements for Case 9

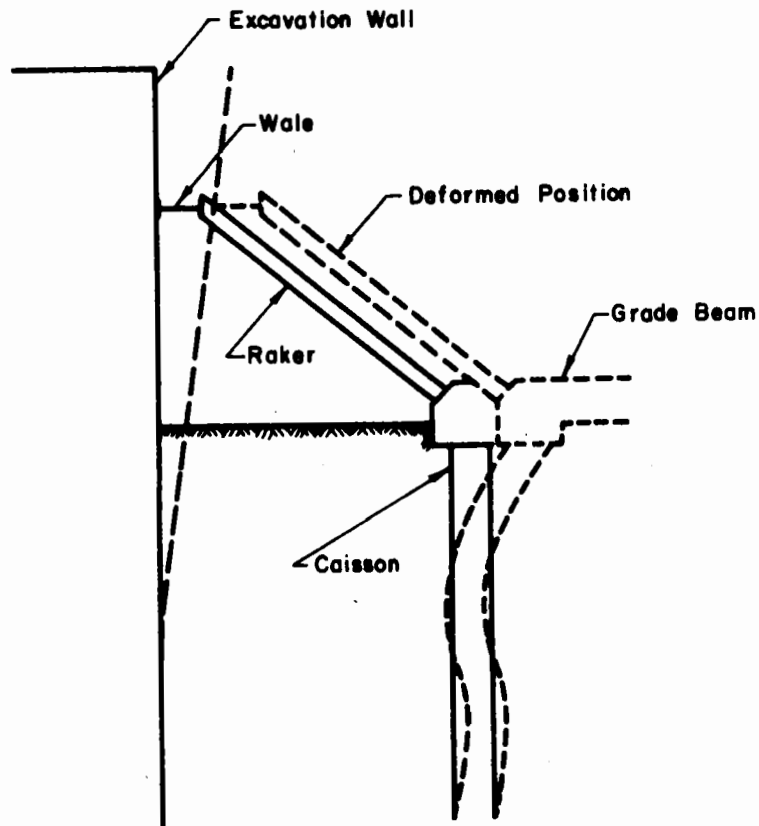

Fig. 2.14 Wall Movement Associated with Lateral Displacement of Caissons

Figure 2.13 shows the lateral wall displacements associated with case 9. The wall of this excavation was composed of MZ 38 sheet piles that were supported by three levels of rakers. The rakers were not preloaded during installation. Lateral movement and settlement profiles are shown for excavation levels corresponding to a depth of 13 and 37 ft (4 and 11.3 m). Most of the lateral displacement developed in the strata of soft to medium clay in a manner similar to the ground deformations shown in Fig. 2.12. As in Fig. 2.11, the volume of lateral wall movement is approximately equal to the volume of settlement behind the sheeting line. Substantial displacements occurred as both the excavation was deepened to subgrade and the temporary berms were removed during raker installation. Large increases in lateral deformations, ranging from 4 to 5 in. (10.2 to 12.7 cm), occurred at all raker levels as the excavation was extended into the soft and medium clays.

In this type of excavation the rakers transmit their loads to the completed portion of the foundation. Correspondingly, most of the earth pressures generated at the wall of the cut are balanced by 1) the lateral resistance of the caissons and 2) the adhesion between the bottom soils and the basement slabs. Commonly, the grade beams for a given foundation are constructed several weeks in advance of pouring the basement slabs. Since the grade beams are connected to the caissons, rakers that are braced against the grade beams transmit the greatest portion of their load to the caissons. The corresponding movement of the caissons and rakers is shown in an exaggerated form in Fig. 2.14. The elastic displacement of the caissons can be estimated with the aid of the dimensionless charts described by Davisson and Gill (9) and Davisson (8).

Estimates performed on this basis reveal that, if only 25 percent of the anticipated earth pressure for a 40-ft (12.2-m) cut in Chicago soils is transmitted to a grade beam connecting two caissons, lateral movements between 1 and 3 in. (2.5 and 7.6 cm) can develop for caisson diameters of 5 and 3.5 ft (1.5 and 1.1 m), respectively. Lateral movements of the caissons diminish the effective raker stiffness and cause displacement at the level of support on the excavation wall. Consequently, optimal bracing requires that raker installation be coordinated with the construction so that raker loads can be transmitted to a suitable foundation bearing. In addition, preloading the rakers increases the effective support stiffness by taking up the initial separations in the bracing line and promoting a flush contact between the caissons, grade beams, and basement slabs in the area of raker abutment.

Figure 2.15 shows the lateral wall displacements for case 7. The large ground movements, which occurred during caisson construction at this site have not been indicated in order to concentrate on the specific displacements that developed during opencutting. Hence, the lateral displacements have been referenced to a time after the completion of caisson construction and before excavation in the soft and medium clays. The excavation was supported by a 30-in. (76.2-cm)-thick, concrete slurry wall, restrained at three levels by rakers. The upper two raker levels were preloaded to 50 percent of the design load. The installation of the first level rakers occurred while substantial berms were in place. The installation of all raker levels corresponded closely with construction of the basement slabs in the areas of raker abutment so that a sound foundation bearing was provided. The wall displacements extend to a deeper level than those shown on Figs.

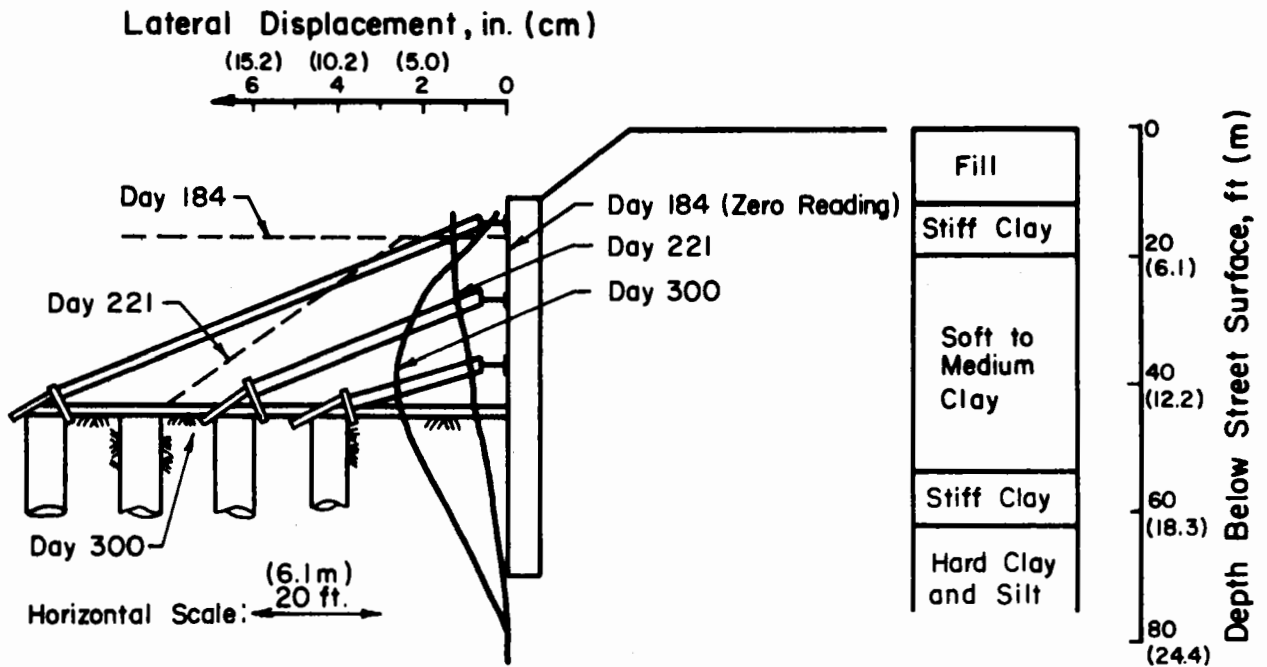

Fig. 2.15 Soil Displacements for Case 7

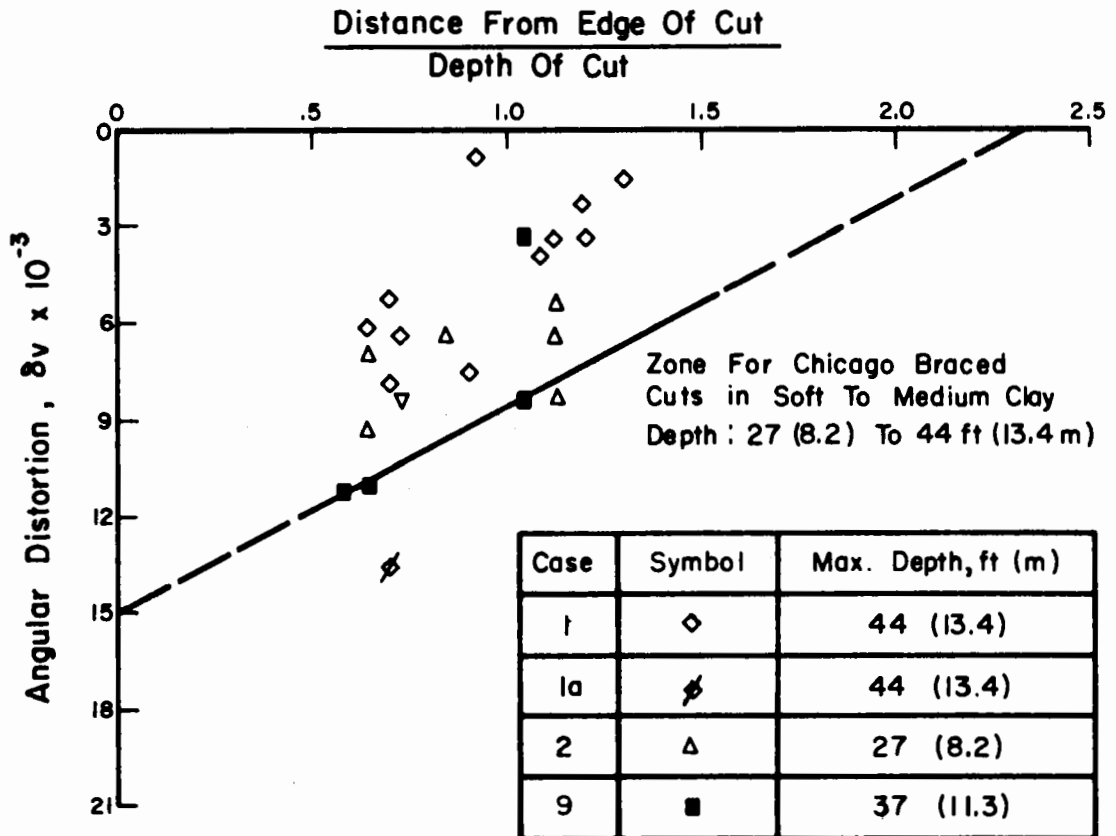

Fig. 2.16 Angular Distortion for Braced Cuts in Chicago

2.13 and 2.14, and reflect the nature of the concrete wall whose stiff section tended to transmit movement into the underlying soils. The volume of lost ground is approximately one-half that for the sheet pile excavation shown in Fig. 2.13 that used a similar scheme of raker support.

The volume of measured wall displacements for case 7 compares favorably with the volume of slurry wall movements for case 3 that have been summarized in detail by Gnaedinger, et al., (14). The relatively small volumes of movement associated with deep excavation in both these cases indicate that slurry walls, when used in combination with excavation control and careful installation of braces, can result in relatively small soil displacements.

Figure 2.16 shows the angular distortion associated with braced excavations in Chicago plotted as a function of the dimensionless distance from the edge of excavation. The angular distortion was estimated in a manner similar to the method used for the braced excavations in dense sand and interbedded stiff clay. The values of angular distortion shown in the figure are derived from the measurements associated with the excavations listed as cases 1, 1a, 2 and 9 in Table 2.2. Settlement profiles were available for these cases only. On the basis of the data indicated, there is no consistent relationship between excavation depth and angular distortion. Angular distortion appears to be smallest for case 1 where permanent berms were left in place. Ground loss associated with caisson construction was not significant for these excavations and thus, the angular distortions are related directly to opencutting. The recommended zone of angular distortion has been delineated on the basis of settlement data within a range of distances from 0.5 to 1.5 times the maximum depth of excavation.



### 2.3.3 LATERAL GROUND MOVEMENTS

The lateral surface movements associated with 4 different braced excavations are summarized in Fig. 2.17. These excavations represent the cases where both ground loss from caisson construction was not significant and lateral survey data were available. The lateral displacements and distances are expressed as percentages of the maximum excavation depth. The lack of sufficient excavation support is indicated by the relatively large movements associated with case 4. Because the data is limited, it is difficult to recommend zones of lateral movement. The estimated zone for good to average workmanship is based primarily on the data from cases 1 through 3 where the corresponding distances from excavation are concentrated between 0.30 and 0.75 times the maximum excavation depth.

### 2.3.4 THE RELATIONSHIP BETWEEN LATERAL AND VERTICAL SURFACE MOVEMENT

The relationship between lateral and vertical surface displacement is closely associated with the mode of deformation at the excavation wall. For excavation in sand, it has been shown that wall deformation related to cantilever movement and inward bulging each result in a characteristic ratio between the lateral and vertical surface displacement. In a similar fashion, it is useful to examine the ratio of lateral to vertical soil displacement for braced cuts in Chicago. If a characteristic ratio can be shown as a function of the wall deformation, then this relationship would form a basis for estimating the lateral distortions associated with opencutting where lateral displacement data is limited or nonexistent.

The relationship between horizontal and vertical ground movements has been studied for five braced cuts in Chicago. In all cases, ground loss

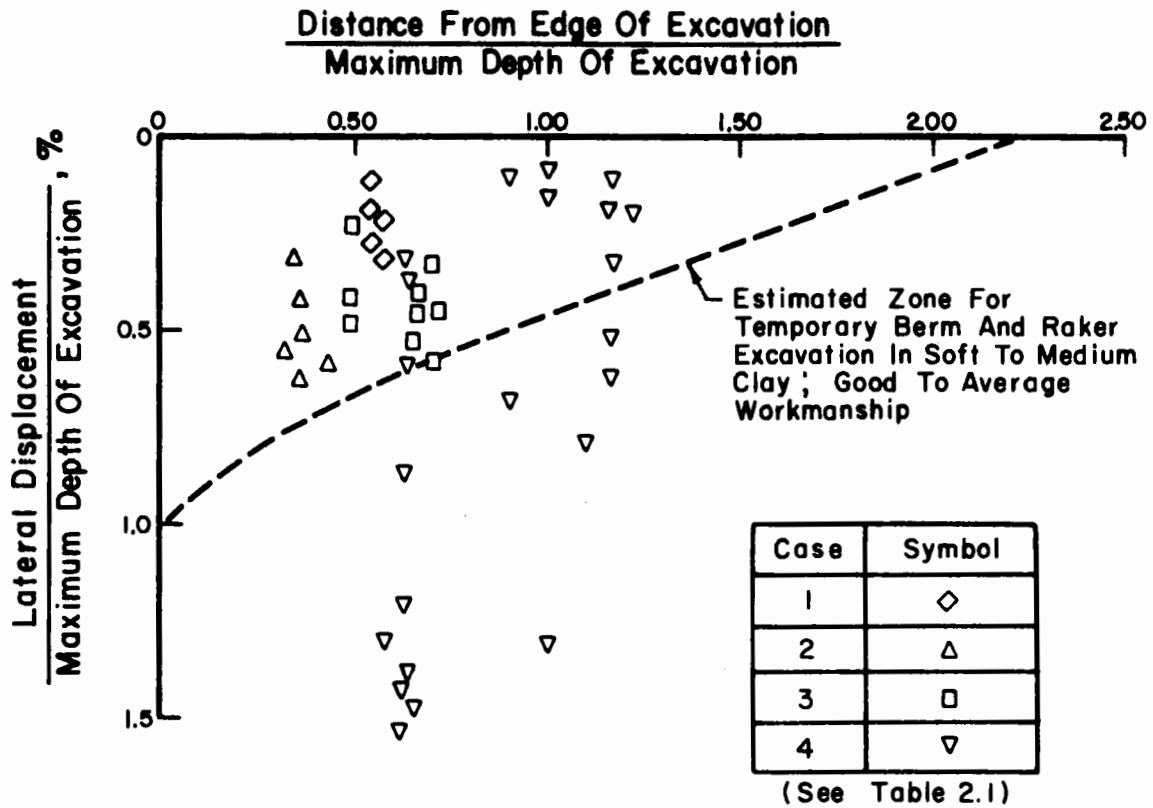

Fig. 2.17 Summary of Lateral Displacements Adjacent to Braced Cuts in Chicago

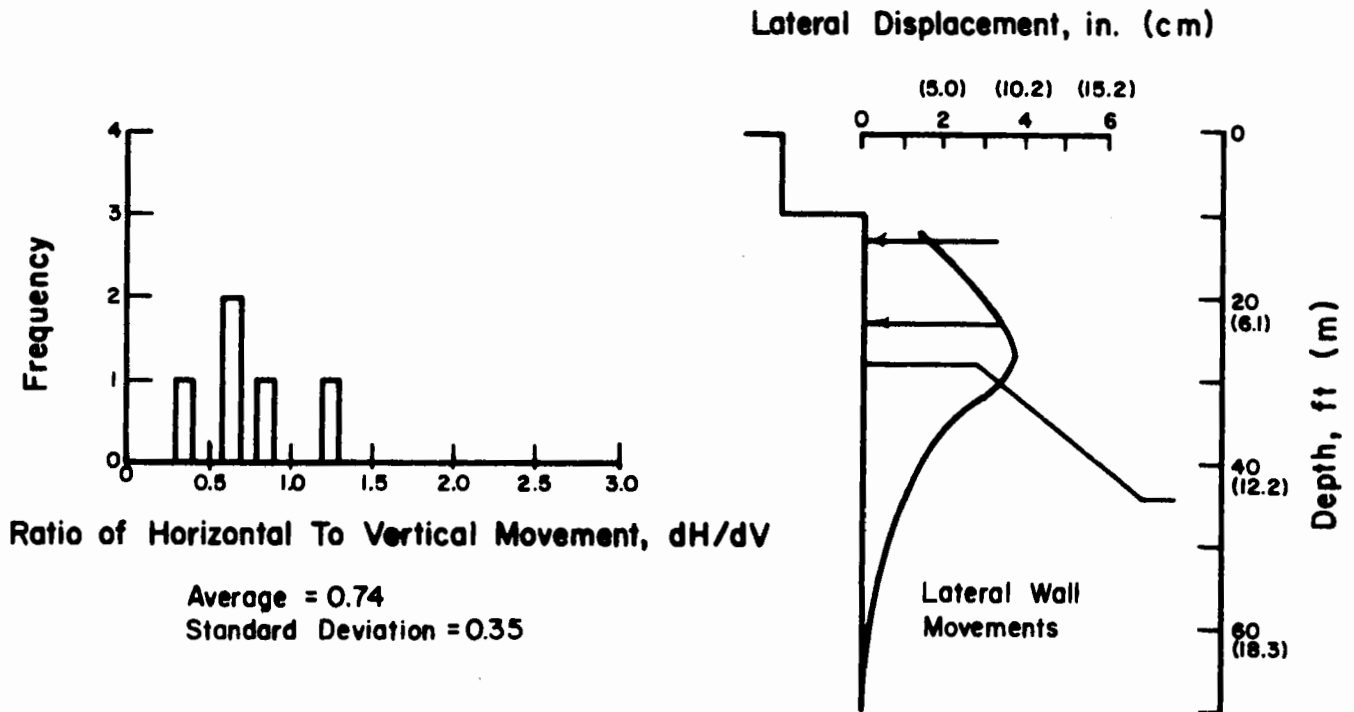

Fig. 2.18 Ratios of Horizontal to Vertical Ground Movement for Case 1

associated with caisson construction was not significant and hence, the data are representative of soil movements that are related directly to opencutting. All the data have been screened in accordance with two guidelines: 1) Each ratio of lateral to vertical displacement derives from the combined measurement of lateral movement and settlement at the same point, 2) Measurements equal to or less than 1/4 in. (0.6 m) have been neglected in order to minimize the influence of survey error on the computed ratio.

Information pertaining to the ratio of horizontal to vertical surface displacement is summarized in Figs. 2.18 through 2.22. Each figure provides a graphical representation of the data distribution in the form of a histogram. The average ratio of the horizontal to vertical displacement, as well as the standard deviation, is indicated. A lateral displacement profile is presented in each figure that shows the wall deformation corresponding to the ground movements from which the ratios of the horizontal and vertical ground displacement were calculated.

Figures 2.18 and 2.19 show that the average ratios of horizontal to vertical movement are 0.74 to 0.60 for cases 1 and 2, respectively. The lateral wall displacements for these excavations show substantial inward bulging and thus the low ratios reflect horizontal restraint in the upper levels of the excavation. By way of contrast, Fig. 2.20 shows an average ratio of horizontal to vertical movement of 1.68 for case 3 where cantilever deformation of the excavation wall is apparent. Figures 2.21 and 2.22 show prominent cantilever deformation with a slight inward bulging of the excavation walls for cases 4 and 10\*,

---

\* The excavation associated with Case 10 is not listed in Table 2.1, having been only partially completed at the time of writing this report.

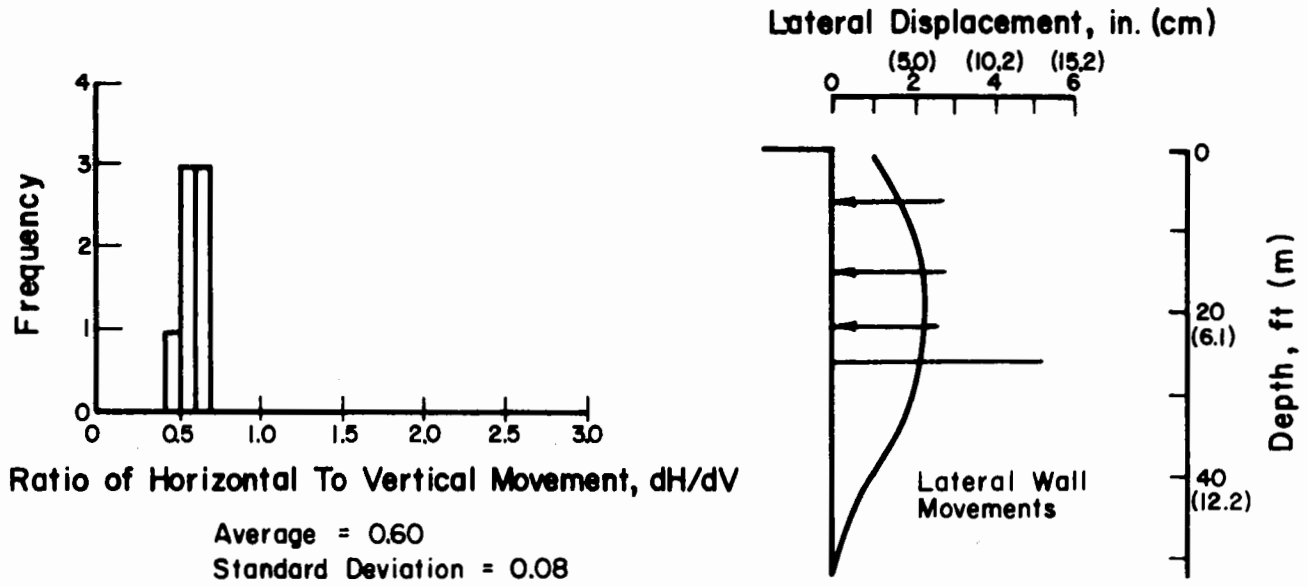

Fig. 2.19 Ratios of Horizontal to Vertical Ground Movement for Case 2

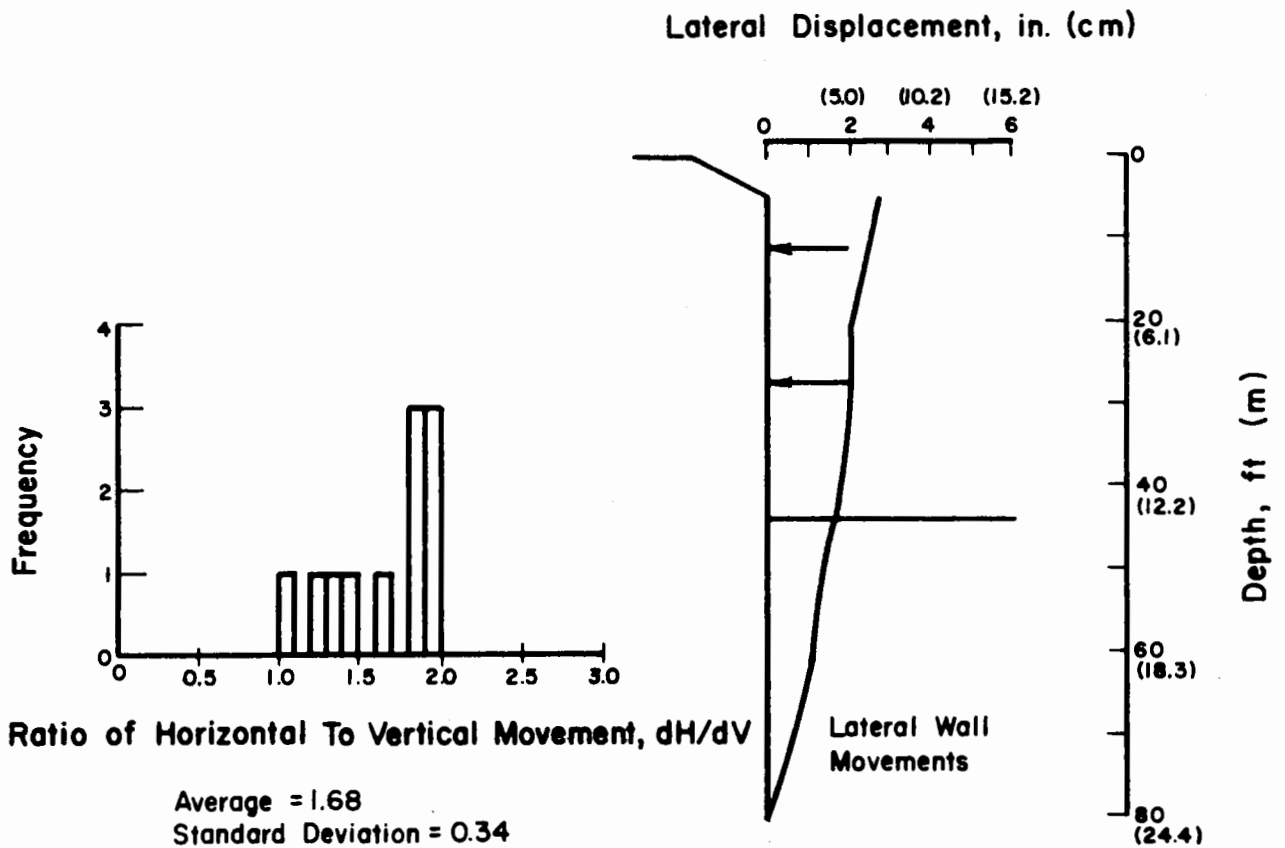

Fig. 2.20 Ratios of Horizontal to Vertical Ground Movement for Case 3

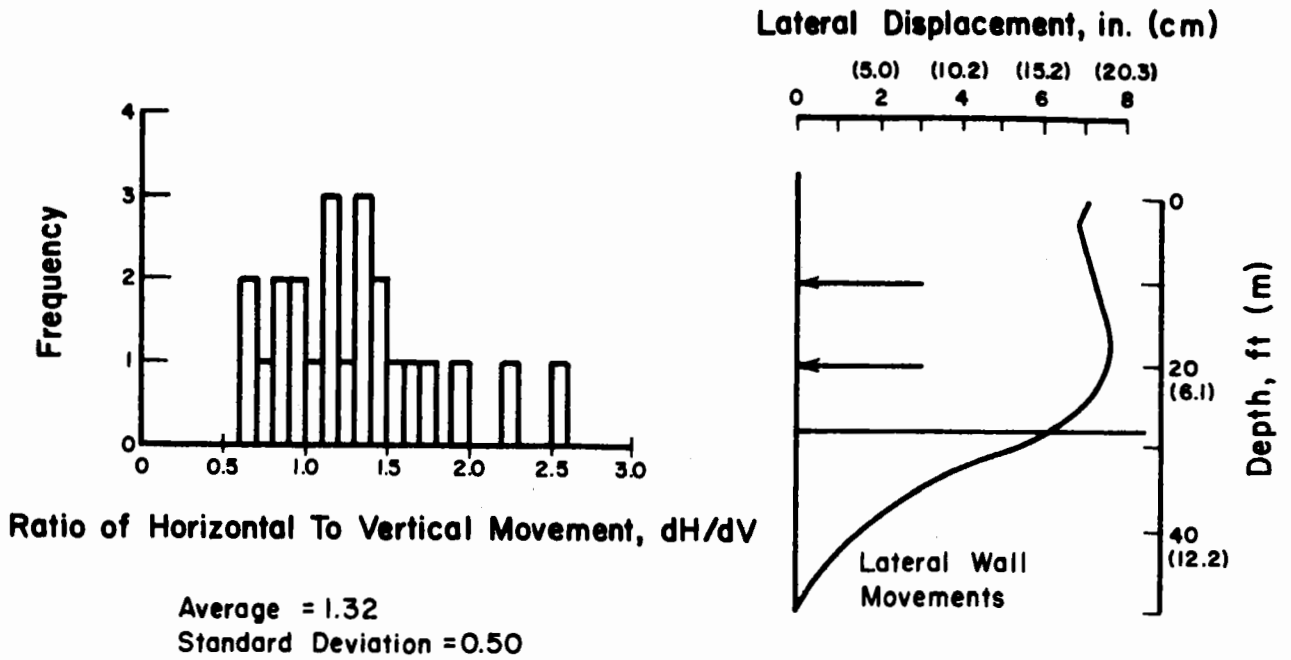

Fig. 2.21 Ratios of Horizontal to Vertical Ground Movement for Case 4

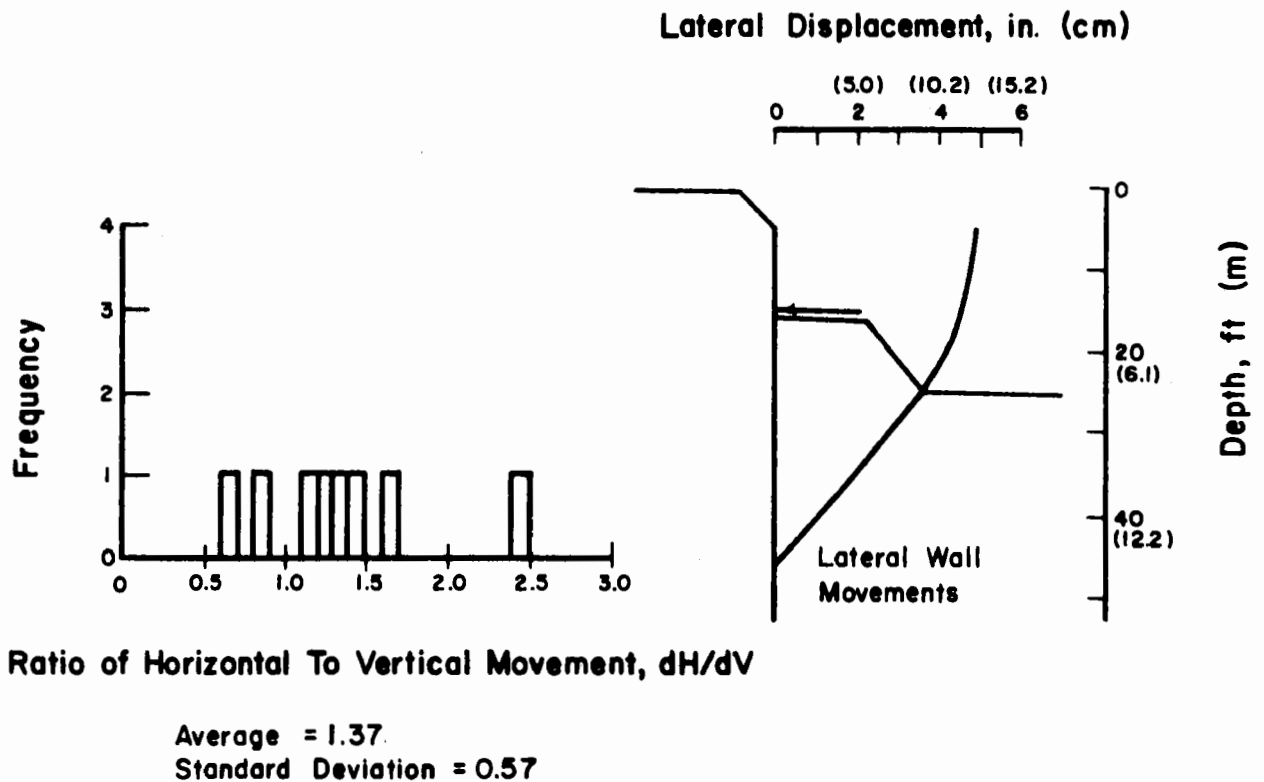

Fig. 2.22 Ratios of Horizontal to Vertical Ground Movement for Case 10

respectively. The ratios of horizontal to vertical displacement for these excavations range from 1.32 to 1.37 and reflect the combined influence of bulging and cantilever wall movements.

The information summarized in Figs. 2.18 through 2.22 related to surface measurements that were taken within a distance of .35 to 1.0 times the maximum excavation depth from the edge of the cut. The scatter of the data and the limited range of distances prevent the delineation of a clear relationship between the ratio of lateral to vertical movement and distance from the excavation.

To illustrate the influence of wall deformation on soil movements, a coefficient of deformation,  $C_D$ ; is defined in Fig. 2.23. The numerator of the term is a measure of the cantilever portion of wall movement and is expressed as the lateral displacement,  $\bar{\Delta}$ , at the top brace level. Correspondingly, the denominator is a measure of the inward bulging and is defined on the basis of the displacement,  $\Delta'$ , separating the point of maximum bulging from the line of rigid wall rotation. The coefficient of deformation indicates the relative amounts of cantilever movement and inward bulging that are developed at the excavation wall. Consequently, it can be related to the pattern of ground movement behind the sheeting line.

The average ratios of horizontal to vertical displacement for the five excavations, referenced in Figs. 2.18 through 2.22, are plotted as a function of the coefficient of deformation in Fig. 2.23. For values of the coefficient greater than 4 and less than 1, the ratio of lateral to vertical displacement

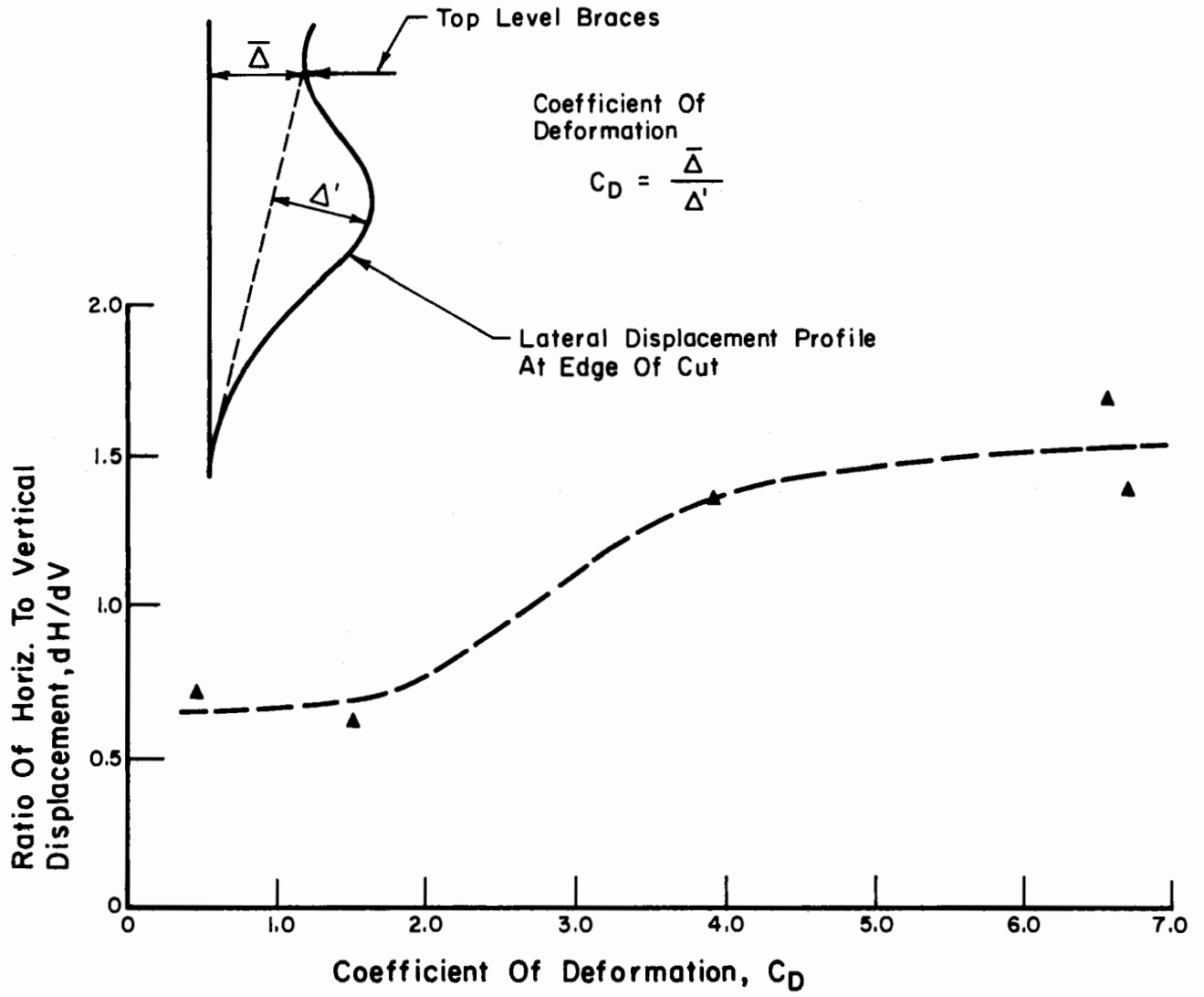

Fig. 2.23 Relationship Between the Ratio of Horizontal to Vertical Ground Movement and the Coefficient of Deformation

approaches 1.6 and 0.6, respectively. It should be emphasized that the coefficient of deformation is only a rough gaging of the wall distortion and will not be simple to apply to profiles of wall movement that have been influenced by high preloading of the braces. However, within the limits of interference from preloading, the coefficient of deformation can be a tool for relating the shape of the deformed wall with the pattern of surface displacements behind the sheeting line. In this way, the surface displacements can be related to the excavation method. For example, if the upper level supports are installed without adequate stiffness or berms are cut back substantially before raker installation, cantilever movements will predominate and lateral displacements will develop in excess of settlement. By way of contrast, if the upper level supports are installed early in the excavation program in such a manner that they have sufficient stiffness, lateral surface movements will be restrained to values less than those of the settlements.

#### 2.4 SUMMARY

The ground displacements associated with recent excavation in Washington, D. C. and Chicago have been examined in light of the soil profile and construction methods in each area. The typical surface settlements and lateral displacements for excavation in both cities have been summarized in dimensionless form as a percentage of the maximum excavation depth and in terms of angular and lateral distortion. The ratio of horizontal to vertical surface displacement has been examined and shown to be useful for two reasons: 1) the ratio of horizontal to vertical movement is related to the deformed



shape of the excavation wall and is diagnostic of certain excavation methods, 2) measurements of lateral movement are usually scarce and hence, typical ratios of horizontal to vertical surface movement can be used to estimate lateral displacement from settlement data.

On the basis of the assembled diagrams and corresponding information, zones of angular and lateral distortion associated with various excavation procedures are described in Table 2.2. Distances from the edge of excavation are expressed as a fraction of the maximum excavation depth. The values of angular and lateral distortion associated with excavation in dense sand and interbedded stiff clay have been determined from measurements related to opencutting in Washington, D. C. For these cuts, the ratio of horizontal to vertical surface movement was estimated as approximately 0.8 within a distance from the excavation equal to one-half the maximum excavation depth. The values of angular and lateral distortion associated with excavation in soft clay have been determined from measurements related to opencutting in Chicago. For these cuts, the ratio of horizontal to vertical surface movement was estimated as approximately 1.3 within a distance from the excavation equal to the maximum depth of excavation.

The difference between the ratios for cuts in dense sand and cuts in soft clay is primarily a function of the excavation technique. The maximum wall movements associated with excavation in Washington, D. C. occurred in the deepest portions of the cuts when the upper levels were restrained with cross-lot braces. By way of contrast, the temporary berm and raker construction used in the large building excavations of Chicago often resulted in substantial cantilever movement before the upper rakers were installed. This was

TABLE 2.2

ZONES OF ANGULAR AND LATERAL DISTORTION  
ASSOCIATED WITH BRACED EXCAVATIONS

Distance from edge of excavation Maximum depth of excavation	Excavation in dense sand and interbedded stiff clay; cross- lot struts; approximate depth: 60 ft (18.3 m)		Excavation in soft clay; temporary berm and raker support; approximate depth: 25 to 45 ft (7.6 to 13.7 m)	
	Angular Distortion, $\delta_V$ ( $\times 10^{-3}$ )	Lateral Distortion, $\delta_H$ ( $\times 10^{-3}$ )	Angular Distortion, $\delta_V$ ( $\times 10^{-3}$ )	Lateral Distortion, $\delta_H$ ( $\times 10^{-3}$ )
0 to 0.5	5 to 3	4.0 to 2.5	15 to 12	19.5 to 15.5
0.5 to 1.0	3 to 1.25	3 to 1.25	12 to 9	15.5 to 12.0
1.0 to 1.5	1.5 to 0	1.5 to 0	9 to 5	9 to 5
1.5 to 2.5			5 to 0	5 to 0

not always the case, however, as is evidenced by the ground movements related to cases 1 and 2 where the upper braces were installed early in the excavation program. Hence, the lateral distortions shown in Table 2.2 for cuts in soft clay could be decreased by 25 to 50 percent if the excavation is designed such that the wall will be braced adequately while substantial berms are still in place. Furthermore, slurry walls in combination with conscientious excavation and bracing have resulted in relatively small displacements. Field observations (10,19,41) suggest that the settlement profiles adjacent to slurry walls tend to be concave upward as opposed to the downward turning profiles shown by other excavation schemes, especially those using soldier piles and lagging (34,35). It seems reasonable, therefore, that the angular and lateral distortions indicated in Table 2.2 should be diminished if applied to a well braced, slurry wall system. At present, additional measurements and study are needed to develop a clear picture of the ground movements associated with slurry wall construction.

Angular distortion provides a measure of the change in shape or slope, of the settlement profile. The deformed shape of the ground surface can then be related, by direct analogy, to the deformed shape of a structure. However, the degree of correspondence between the slope of the ground surface and the deformed shape of the structure is a function of the geometry of the structure relative to the curved portion of the settlement profile and the stiffness of the structure relative to the stiffness of the foundation soil. In a similar manner, the lateral distortion is a measure of the lateral strains imposed on a given building. However, the degree to which the building reflects the imposed ground strains is a function of the stiffness of the building and of the forces mobilized between the building and the deforming soil. Although

angular and lateral distortions of the soil provide a first estimate of building deformation, judgments pertaining to structural response, especially potential instability, can be made only by studying the specific buildings. Consequently, it is useful to regard the values of angular and lateral distortion summarized in this chapter as the upper limits of strain imposed on a given structure, realizing that further examination of the structure may be required to determine its stiffness and construction details.

## CHAPTER 3

## ARCHITECTURAL DAMAGE TO BUILDINGS

## 3.1 INTRODUCTION

## 3.1.1 DEFINITIONS OF DAMAGE

Building damage generally is divided into two categories:

- 1) Architectural Damage, i.e., damage that pertains to the cracks or separations in panel walls, floors, and finishes.
- 2) Structural Damage, i.e., damage that relates to the cracks or distortions in primary support elements such as beams and columns.

Frequently, a further distinction is made on the basis of the building services. This type of damage, referred to as functional damage, pertains to damage that impairs the use of the structure.

The present chapter deals solely with architectural damage. In this chapter, architectural damage is studied by summarizing previous research, developing correlations between architectural damage and differential movement on the basis of field evidence, and discussing the influence of architectural damage on the use of various buildings.

## 3.1.2 CORRELATION OF ARCHITECTURAL DAMAGE WITH DIFFERENTIAL MOVEMENT

Two parameters are commonly used for developing correlations between architectural damage and differential settlement. These parameters are the angular distortion and the deflection ratio. As defined in the previous chapter, angular distortion,  $\delta_v$ , is the differential settlement between two points divided by the distance separating them. When related to building damage, angular distortion is commonly modified by subtracting

the rigid body tilt from the measured settlement. In this way the modified value is more representative of the deformed shape of the structure. The deflection ratio,  $\Delta/\ell$ , is defined as the maximum displacement,  $\Delta$ , relative to a straight line between two points divided by the distance,  $\ell$ , separating the points.

Both parameters are illustrated in Fig. 3.1 as they apply to the settlement of a building adjacent to excavation. The deformed shape of the building is exaggerated for purposes of illustration. The shape of the settlement profile is convex and is characterized by a slope that increases with diminishing distance from the excavation. Field data (34,35) indicate that this type of profile represents the general condition for many braced cuts.

In the figure, rigid body tilt is indicated by the angle,  $\alpha$ . Often, rigid body tilt is extremely difficult to estimate on the basis of settlement, especially settlement related to opencutting. In addition, the settlement profile associated with opencutting develops in stages as the excavation is carried to subgrade. Consequently, the building is subjected to a settlement wave that causes bending and shear distortion in the structure even though the final slope of the settlement profile may be constant. In most cases, the building dimension perpendicular to the edge of excavation is relatively large with respect to the length of the settlement profile. For the general case, therefore, the evaluation of angular distortion directly from differential settlement is a reasonable way to estimate the deformed shape of the building. Rigid body tilt, however, must be considered in certain applications, especially when judging the influence of settlement on stiff, narrow structures. In these cases, rigid rotations should be evaluated

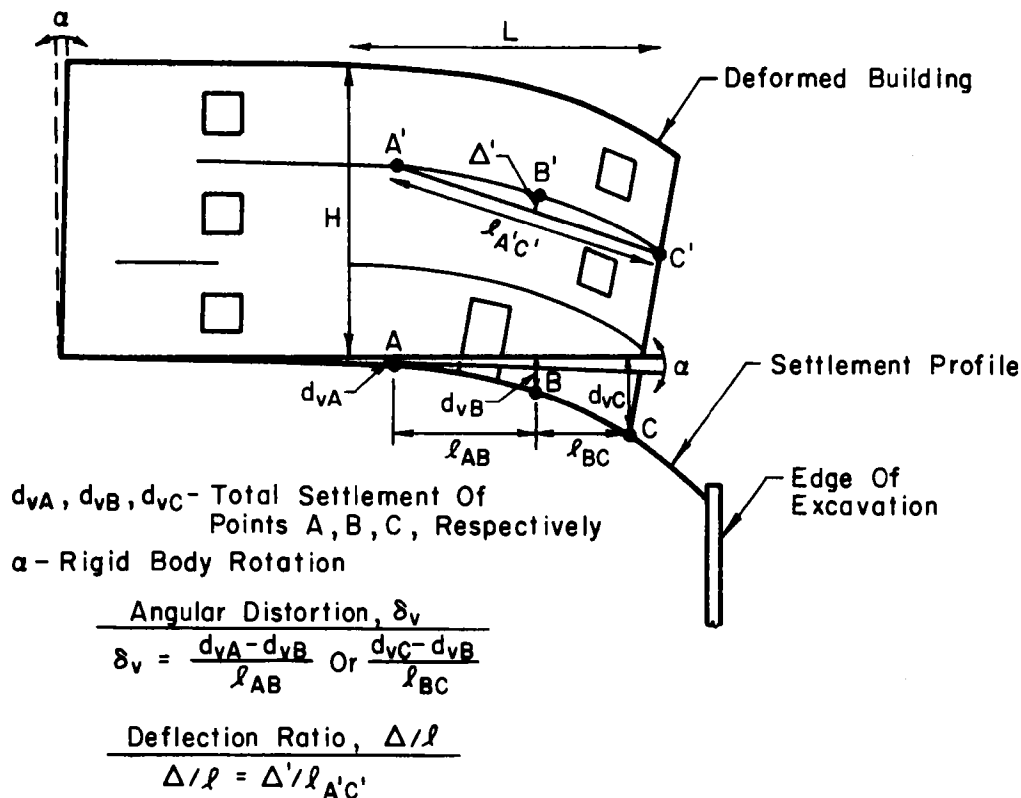

Fig. 3.1 Building Deformation Caused by Settlement in Response to Opencutting

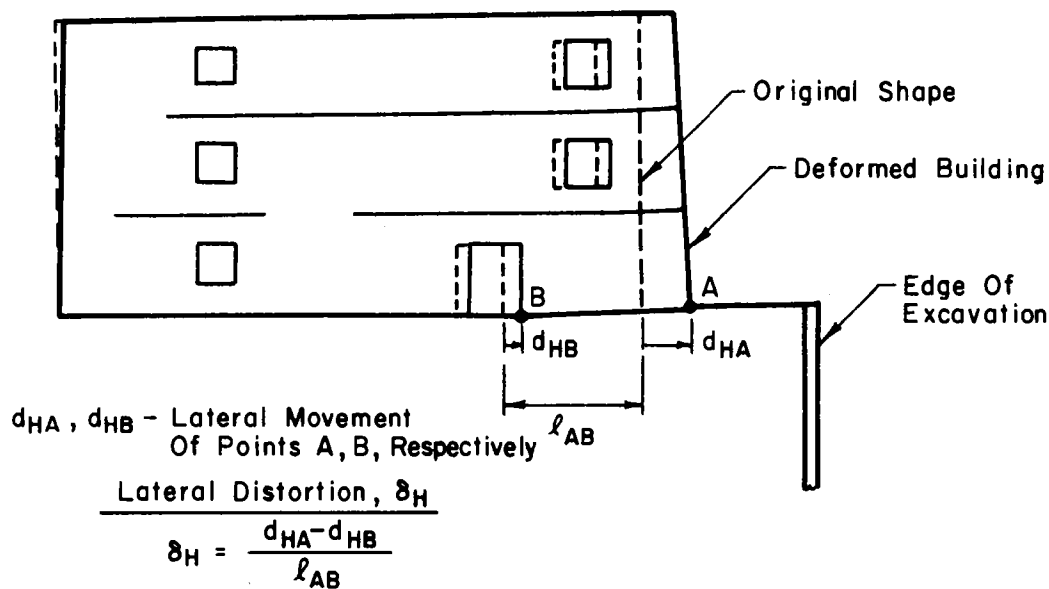

Fig. 3.2 Building Deformation Caused by Lateral Displacement in Response to Opencutting

from inclination measurements of the front and rear walls, in addition to settlement data.

No single expression for differential settlement is clearly the most expedient for correlation with damage. Both parameters possess advantages that make them useful for different applications. For example, the deflection ratio is advantageous in that: 1) it is closely related to the radius of curvature and, hence, a good indicator of bending deformation, and 2) it provides a direct measure of the deviation from uniform settlement and rigid body tilt. Polshin and Tokar (38) and Burland and Wroth (6) have used the deflection ratio as a convenient index for studying the damage sustained by continuous bearing walls that have settled over their full length. For a building adjacent to opencutting, however, the curved portion of the settlement profile frequently develops such that the ratio of the deformed building length to building height ( $L/H$ ) is approximately equal to or less than unity. Shear strain, for this geometric condition, contributes most prominently to the building deformation. Consequently, angular distortion is a useful parameter because it is directly related to shear strain. When applied to frame structures, angular distortion also provides a convenient means of relating the settlement of adjacent columns to the strains imposed in a structural bay. Furthermore, correlations based on angular distortion, by virtue of their simple definition, can be related to a broad range of field observations and compared directly with previous research.

In this chapter, both angular distortion and the deflection ratio are discussed in the context of previous criteria for architectural damage. Only angular distortion, however, is used for correlating observed damage with differential building settlement caused by adjacent excavation.



Buildings near braced cuts also are influenced by lateral displacements. As was indicated in the previous chapter, the lateral soil strains associated with opencutting can be large and can represent a substantial portion of the strain sustained by adjacent structures. Hence, it is important to judge the limits of building disturbance in light of the lateral ground distortion. Lateral distortion,  $\delta_H$ , is defined as the differential lateral movement between two points divided by the distance separating them. Figure 3.2 shows lateral distortion as it applies to the horizontal movement of a building adjacent to excavation. The deformed shape of the building is exaggerated for purposes of illustration.

## 3.2 BASIC CONSIDERATIONS OF ARCHITECTURAL DAMAGE

### 3.2.1 PREVIOUS STUDIES OF ARCHITECTURAL DAMAGE

Correlations between differential settlement and architectural damage have been the subject of extensive research. Various methods of analysis have been followed and different criteria for the first appearance of damage have been proposed. It is useful, therefore, to briefly summarize the results of previous research as a baseline from which to extend the study of architectural damage to buildings influenced by both vertical and lateral movement.

Essentially, two different methods of formulating damage criteria have been used: 1) Empirical correlations of architectural damage and differential settlement have been developed on a statistical basis by analyzing the settlement data for a large number of buildings, 2) Theoretical models have

been developed by considering the critical tensile strain for building materials and the ratio of the deformed length to height (L/H) of the structure. These different methods and the work performed by the major proponents of each are summarized under the following two headings:

Empirical Correlations: Skempton and MacDonald (40) reviewed the settlement histories of 98 buildings to set deformation criteria for damage to structures. The criteria indicate that cracks in panel walls of frame buildings or walls in load bearing wall structures are likely to occur if the angular distortion exceeds  $3.3 \times 10^{-3}$  (1/300). These criteria were corroborated by Grant, et al., (16) in a more recent study of the settlements associated with 95 additional buildings. Furthermore, Grant, et al., recommended a threshold for architectural damage on the basis of the deflection ratio. According to their study, cracks in panel walls of frame buildings and walls of load-bearing structures are likely to occur if the deflection ratio exceeds  $1.0 \times 10^{-3}$  (1/1000). The broad background, on which the empirical correlations are based, include data from many areas and a great variety of observations. Although they represent some instances of subjective judgment, they, nevertheless, correspond to a substantial body of field evidence and, most importantly, reflect the perceptions of those who used the buildings.

Theoretical Models: The theoretical models are based on two unifying concepts:

- 1) Damage occurs when the instantaneous increase in building strain exceeds the critical tensile strain of concrete or brick masonry. Critical tensile strain is defined as the strain at which local fracture becomes visible.

- 2) The strain imposed on a given building is related to the geometry of the building as expressed by the ratio of the deformed length to height of the structure (L/H).

Polshin and Tokar (38) were the first to formulate damage criteria on the basis of the above concepts. They developed an approximate theoretical relationship that predicted cracking in brick-bearing walls as a function of the critical tensile strain for brick masonry (0.05 percent), the deformed shape of the wall, and the ratio of the deformed length to height (L/H) of the wall. They compared their theoretical relationship with observations of several different structures. For  $L/H < 3$ , they specified limiting deflection ratios of  $0.3 \times 10^{-3}$  (1/3300) and  $0.4 \times 10^{-3}$  (1/2500) for buildings on sand and soft clay, respectively. In addition, they recommended an angular distortion of  $2.0 \times 10^{-3}$  (1/500) as a threshold value for the appearance of cracks associated with in-filled framed structures. Burland and Wroth (6) extended and refined the work of Polshin and Tokar by developing models that predicted the onset of cracking for both bending and shear-induced deformation. In addition, they called attention to hogging, i.e., convex curvature, which is the principal mode of building deformation caused by opencutting and tunneling. Their models show that, for deformation geometries similar to those of buildings adjoining braced cuts ( $L/H < 2$ ), cracks can occur in bearing wall structures at deflection ratios as low as  $0.4 \times 10^{-3}$  (1/2500).

The criteria for initial cracking in response to differential settlement are summarized in Table 3.1. These recommendations represent the range of critical values generally encountered and, hence, are indicative of the field observations and recommendations of others (6,15,17). For in-filled frames, the criteria for initial cracking are in general agreement. For

TABLE 3.1

SUMMARY OF DAMAGE CRITERIA FOR INITIAL CRACKING IN BUILDINGS  
SUBJECT TO SETTLEMENT UNDER THEIR OWN WEIGHT

Source	Deformation corresponding to initial cracking		
	In-filled frames	Load bearing walls	
	Angular distortion, $\delta_v$	Relative deflection, $\Delta/l$	Angular distortion, $\delta_v$
Field observations - Skempton & MacDonald (40)	$3.3 \times 10^{-3}$		$3.3 \times 10^{-3}$
Field observations - Grant, et al. (16)	$3.3 \times 10^{-3}$	$1.0 \times 10^{-3}$	$3.3 \times 10^{-3}$
Theoretical model and field observations - Polshin & Tokar (38)	$2.0 \times 10^{-3}$	$^{1}0.3$ to $0.4 \times 10^{-3}$	
Theoretical model - Burland & Wroth (6)		$^{2}0.4 \times 10^{-3}$	

<sup>1</sup> L/H < 3<sup>2</sup> L/H < 2

load-bearing walls, however, critical values of the deflection ratio are appreciably different. Deflection ratios based on consideration of critical tensile strain (Polshin and Tokar, Burland and Wroth) tend to support values almost three times lower than the values based on summaries of building settlement (Grant, et al.).

### 3.2.2 NOTICEABLE DAMAGE

Deformation exceeding the critical tensile strain may cause local fractures that are spotted through the use of careful and well-directed observation, but may not necessarily be noticed by building occupants. For example, Littlejohn (26) has reported on the initial cracking of brick walls subject to mining subsidence. Cracks were detected at a deflection ratio of  $0.16 \times 10^{-3}$  (1/6130) and a lateral strain in the brickwork of approximately  $0.25 \times 10^{-3}$ . However, the cracks were observed as part of a systematic surveillance program and were only 0.004 to 0.01 in. (0.10 to 0.26 mm) wide. In a similar manner, a building adjacent to deep opencutting was instrumented as part of a measurement program performed by the University of Illinois. In the area of instrumentation, a 9-in. (0.23-m) thick, reinforced concrete wall was monitored for signs of distress. Small cracks, less than 1/64 in. (0.4 mm) wide,

were first noticed in the upper portion of the wall at an angular distortion of  $0.3 \times 10^{-3}$  (1/3300) and a lateral strain of  $0.3 \times 10^{-3}$ . However, no cracks or separations were reported in other portions of the structure even though the majority of walls were finished with plaster and building personnel had been alerted to the possibility of such disturbance. Clearly, the criteria for architectural damage should reflect the dimensions at which cracks become noticeable, especially if applied to large excavation projects where movements associated with open-cutting and tunneling are inevitable.

The extent to which a crack becomes noticeable is a function of the surface on which the crack appears. This includes the location of the surface, its texture, and the ambient lighting. These characteristics can be illustrated by reference to Figs. 3.3 and 3.4, which are photographs of a crack that developed in an in-filled partition wall of a steel frame building. The building was located adjacent to a deep open cut where, in several structural bays, soil movements caused architectural damage similar to the crack shown in the figures. The partition wall was constructed of concrete hollow blocks that were finished with plaster on one side only. Figure 3.3 shows the crack, which was 1/32 in. (0.8 mm) wide, as it occurred on the unfinished side of the wall. The crack follows the mortar joints, where it is obscured by the texture of the concrete and delineation of the blocks. By way of contrast, Fig. 3.4 shows the crack as it occurred in the plaster finish on the opposite side of the wall. The crack reflects the stair-step pattern of the hollow blocks. Although it was still 1/32 in. (0.8 mm) wide, it is much more noticeable owing to the contrasting background and en-echelon pattern of propagation.

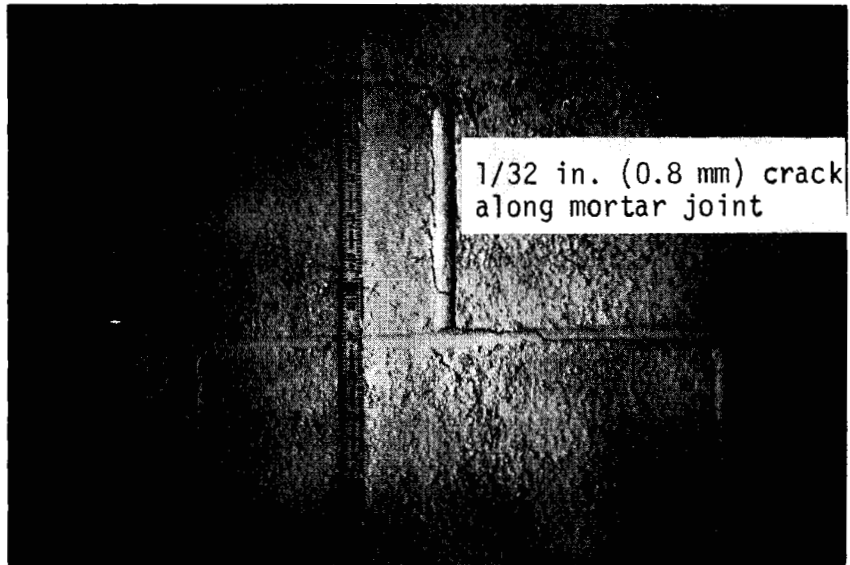

Fig. 3.3 Crack in a Hollow Block Wall  
Caused by Adjacent Excavation

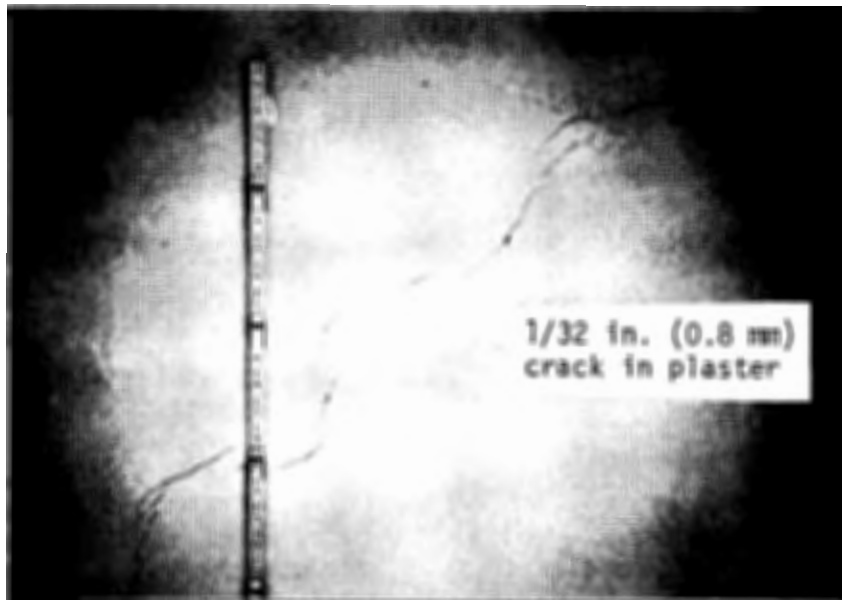

Fig. 3.4 Crack in the Plaster Finish of a  
Hollow Block Wall Caused by  
Adjacent Excavation

In this report architectural damage is distinguished as cracks in plaster walls that are equal to or greater in width than 1/64 in. (0.4 mm) and cracks in hollow block, brick, and rough concrete walls that are equal to or greater in width than 1/32 in. (0.8 mm). Separations in tile floors are assumed to be evident at widths of 1/16 in. (1.6 mm). On this basis, the correlations coincide with reasonable limits of visible disturbance and should represent a threshold where distortions are noticed and reported by building occupants.

### 3.2.3 TILTING OF BUILDINGS

Buildings subject to excavation movements often experience tilt, especially along the building line closest to the excavation. Visual effects associated with tilt may impose a limit on tolerable building distortion since movement out of plumb may become objectionable, even before cracks and distortions are noticed. It is very difficult to set criteria for objectionable tilt because tolerance for this type of displacement depends on the use of the building and the nature of its environment. Occasionally, brick-bearing wall structures contain facade walls that are as much as 2 and 3 in. (5.1 and 7.6 cm) out of plumb over a three to four story building height. These inclinations are tolerated by building occupants, who generally are not aware that floors are locally out of level or that there is an apparent lean to the building. For example, during construction of the Chicago subway, litigation was undertaken by store owners who claimed that adjacent excavation had caused tilting along their building fronts. Reference to a pre-construction survey, however, showed that the buildings had been previously out of plumb and that, in some



instances, ground movements had actually improved the verticality of the structures. Frequently, construction surveys of adjacent property only include optical leveling, whereas it would be advantageous to incorporate additional measurements of building inclination. Such measurements, which can be easily taken on corner structures by means of a transit, reference the building condition before construction and provide an ongoing measure of deformation against which complaints and potential problems can be evaluated.

A rigorous treatment of tilt would require measurements and discussion of building inclinations that are commonly accepted by the occupants in various neighborhoods and for various structures. In addition, serious scrutiny would have to be directed to tall buildings where relatively small inclinations tend to be emphasized by the great heights. This kind of study is outside the scope of this report and, correspondingly, special consideration of tilt is omitted from the treatment of architectural damage.

#### 3.2.4 ADDITIONAL CONSIDERATIONS

There are additional problems associated with developing criteria for architectural damage. For each structure, the limits of tolerable distortion are a function of the age and deterioration of the building. In fact, each building may be thought of as possessing a "strain memory" wherein the strains related to settlement under its own weight, structural modifications, nearby construction, and gradual deterioration with age are accumulated. Furthermore, a particular building may possess local areas of weakness where even small ground strains can be concentrated to cause observable damage. Kerisel (20) has commented that the most prominent separations that occur in

deformed structures often appear at the junction of two walls of different rigidities. This general aspect of building damage can be illustrated by reference to Fig. 3.5.

Figure 3.5 shows a plan view of a 10-story building with respect to the braced excavations that were performed on two sides of the structure. The building is composed of a reinforced concrete frame with two basement levels and a 4.5-ft (1.3-m) - thick reinforced concrete mat foundation. Prior to excavation, the building was underpinned either with continuous pit piers or pipe piles whose locations are shown by the shaded areas in the figure. Typical settlements, measured along the exterior walls of the building, are indicated. The maximum angular distortion, calculated on the basis of available settlement data, is  $0.8 \times 10^{-3}$  (1/1250). Although settlement of the structure was relatively small, conspicuous damage occurred in the form of cracks in plaster walls and fallen ceiling tiles. This damage was restricted to the area of the expansion joint located 110 ft (33.6 m) from the closest excavation. On the roof, separation of the expansion joint was reported to be 1/2 in. (1.3 cm) in excess of the joint separations on lower floors. The concentration of damage indicates that the building strains were transmitted to the area of the joint where lateral movement and rigid body rotation of the building were reflected in local cracks and separations.

Since the capacity of each building to tolerate strain is a function of its specific construction, previous strain history, age, and deterioration, the collection and summary of field data should not be regarded as setting definite limits on the appearance of architectural damage. Rather, correlations of observed damage and measured displacements specify a range wherein cracks and separations are most likely to occur and be noticed.

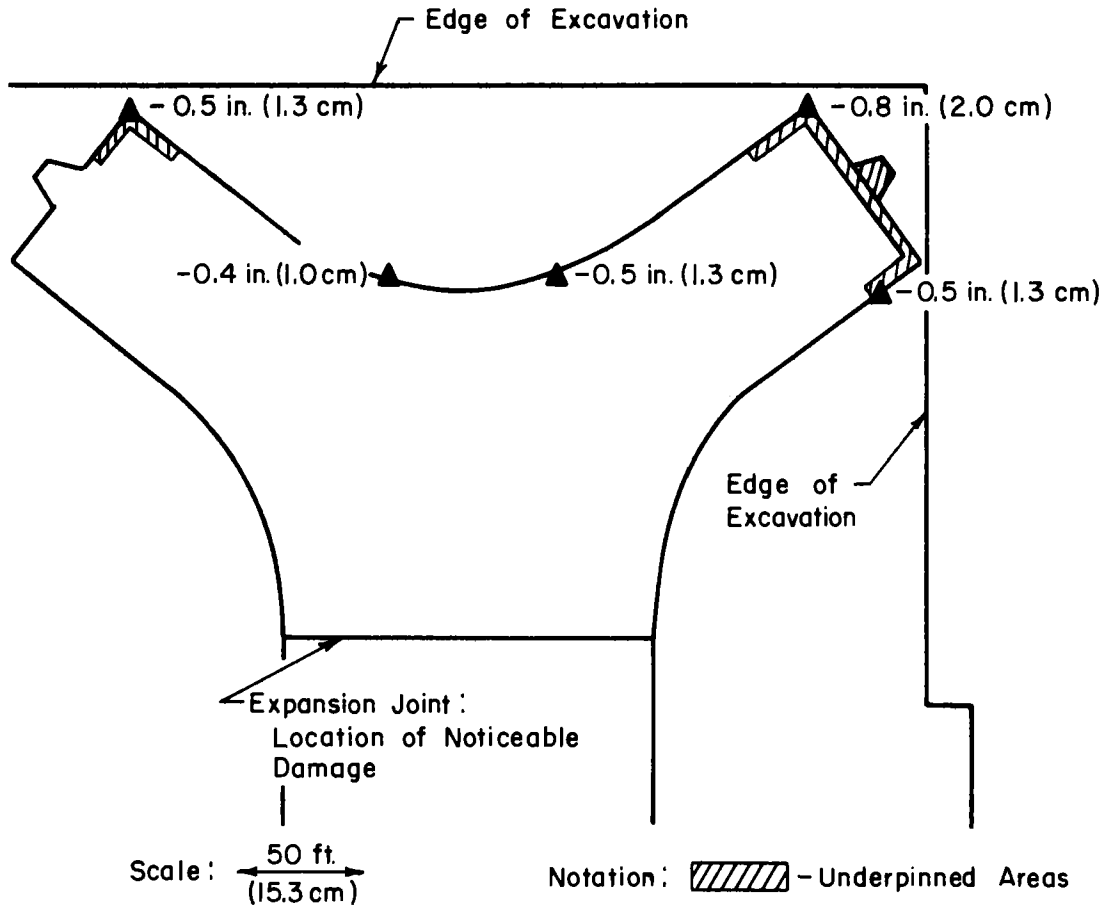

Fig. 3.5 Plan View of a 10-Story, Concrete Frame Structure with Settlement Caused by Adjacent Excavations

### 3.3 THRESHOLD OF NOTICEABLE DAMAGE

#### 3.3.1 ANALYSIS OF FIELD EVIDENCE

Building distortion related to braced excavation or tunneling is the result of both vertical and lateral ground movement. Any approach to distinguishing the limits of noticeable deformation must include treatment of both types of displacement. Unfortunately, very little information is available that relates observed building damage to measurements of lateral strain. Most construction surveys of surrounding property are performed by optical leveling. Hence, the field data available for correlation with observed damage is generally in the form of settlement measurements. Furthermore, lateral building strains are difficult to interpret. Because of the complex nature of building deformation, the measured separation of two points on a structure frequently cannot be corrected for the tensile or compressive strains related to bending.

In this section, the influence of lateral displacement will be evaluated on a comparative basis by examining the onset of noticeable damage as a function of both vertical movement alone and of combined vertical and lateral movement. Correspondingly, correlations of architectural damage with measured settlement are developed from two sources: 1) Settlement records and visual inspection associated with the underpinning of structures, and 2) Settlement records and visual inspection associated with the deformation of structures adjacent to open-cutting. In the former category, observed damage is not related to lateral displacement since underpinning results almost entirely in differential settlement. In the latter case, structural deformation results from both

vertical and lateral movements. Consequently, by comparing the two correlations, it is possible to judge how lateral displacement affects the threshold of noticeable damage.

The information used to develop correlations between architectural damage and angular distortion is in the form of direct evidence, that is, all observations of damage have been documented according to both location in the structure and the maximum angular distortion that was measured. The observations have been screened by comparing reported damage with preconstruction surveys. All the buildings included in the correlations have been inspected by the writers or their close associates.

### 3.3.2 ARCHITECTURAL DAMAGE RELATED TO UNDERPINNING

For buildings influenced by the excavation for and installation of underpinning, evidence concerning settlement damage and angular distortion is summarized in Fig. 3.6. Angular distortions pertaining to the differential settlement measurements at 30 locations and representing 9 brick-bearing wall and 3 frame structures have been plotted. Information related to each structure is summarized in the table that accompanies the figure. Because age provides a rough measure of deterioration, especially for brick-bearing wall structures, this information is also listed.

Only two instances of damage are indicated. In one case, a brick-bearing wall settled as the result of excavating an underpinning pit beneath it. The angular distortion, measured relative to the opposite bearing wall of the structure, was  $2.4 \times 10^{-3}$  (1/417). Several cracks and a sticking door were reported. In the other case, angular distortion of  $1.5 \times 10^{-3}$  (1/667) was measured in response to the settlement of an H-column during underpinning.

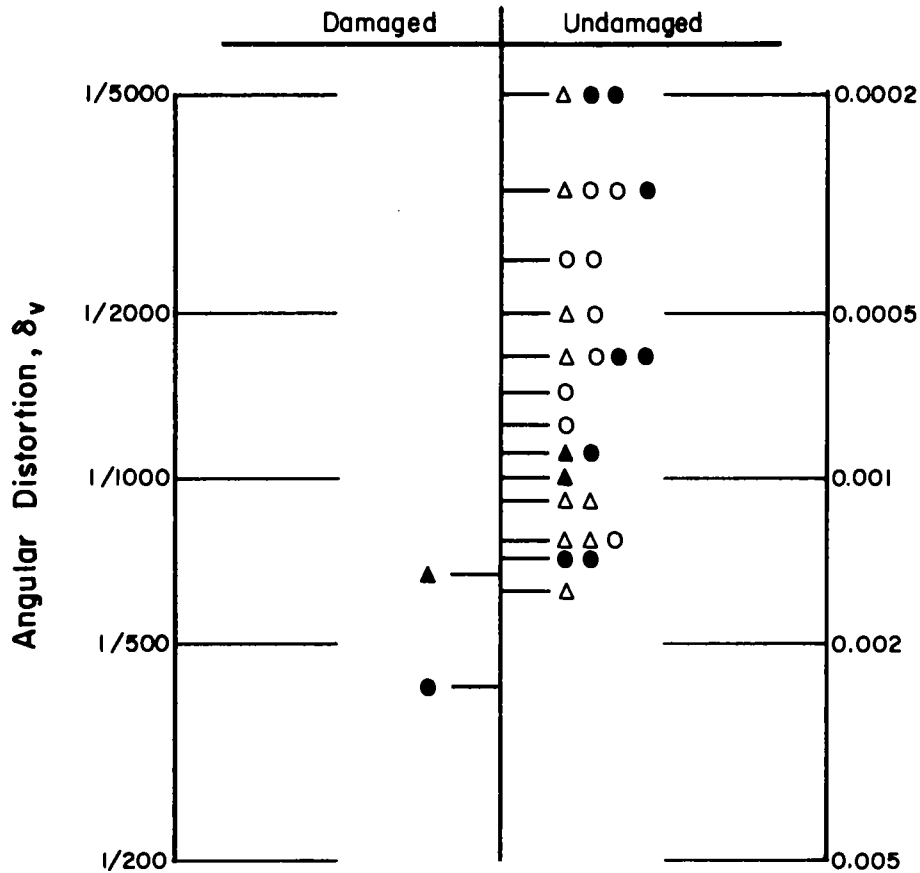

Symbol	Age	Description
●	50 To 80 Yrs.	2 - 4 Story Brick Bearing - Wall Structures With Timber Beams ; Rubble Foundations
▲	35 Yrs.	13 Story Steel Frame With Concrete Floors, Infilled Plaster Partition Walls ; Spread Footing Foundation
○	≈20 Yrs.	6 Story Steel Frame With In-Filled Hollow Block and Plaster Walls ; Spread Footing Foundation
Δ	45 Yrs.	10 Story Steel Frame With Concrete Floors and In-Filled Brick Walls ; Spread Footing Foundation 2 Basement Levels

Fig. 3.6 Field Evidence of Architectural Damage Related to Angular Distortion for the Underpinning of Structures

Cracks in plaster partition walls between the settled and an adjacent column were noticed as high as 8 stories above the level of underpinning.

On the basis of this limited data, it is difficult to set a threshold for the appearance of damage in response to underpinning settlements. The data, however, tend to support a relatively low threshold of critical distortion. In each case, the angular distortion associated with damage was smaller than the limiting value proposed by Skempton and MacDonald and Grant, et al. There are, at least, two reasons for this discrepancy. In the first place, underpinning was performed on relatively old structures that had settled in response to their own weight. The strains associated with settlement and age may have added to the strains sustained during underpinning to render an apparently low threshold for damage due to angular distortion. Secondly, the strains imposed during underpinning occur over a relatively short period of time without much benefit from creep or readjustment of building loads. When compared with correlations based on long term settlements accumulated during and after building construction, it seems reasonable that the short-term values would indicate lower limits for the onset of cracking.

### 3.3.3 ARCHITECTURAL DAMAGE RELATED TO MOVEMENTS CAUSED BY ADJACENT EXCAVATION

For buildings adjacent to deep opencutting, evidence concerning architectural damage and angular distortion is summarized in Fig. 3.7. The maximum, angular distortions pertaining to 9 brick-bearing wall and 5 frame structures have been plotted. One of the data points, pertaining to brick-bearing wall structures, represents a row of 5 commercial buildings that were

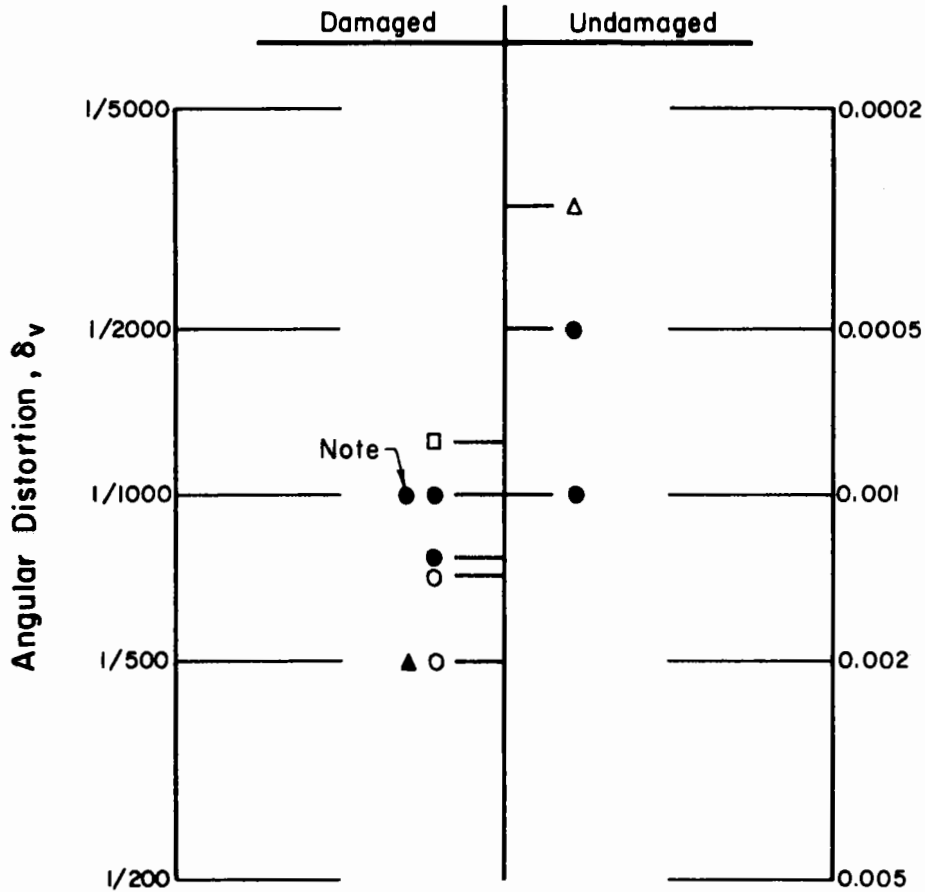

Symbol	Age	Description
●	50 To 80 Yrs.	2 - 4 Story Brick Bearing-Wall Structures With Timber Beams Mostly Rubble Foundations
▲	≈50Yrs.	6 Story Steel Frame With Brick In-Filled Walls; Spread Footing Foundation
○	> 50Yrs	9-10 Story Steel Frame With Brick Curtain Walls; Spread Footing Foundation
□	5 Yrs	10 Story Reinforced Concrete Frame; 4.5' ft. (1.4m) Thick Reinforced Concrete Mat Foundation; 2 Basement Levels
Δ	10 Yrs.	9 Story Reinforced Concrete Frame; Flat Slab Construction; Spread Footing Foundation

Note : Data Point Represents A Row Of 5 Buildings Interconnected With Common Bearing Walls

Fig. 3.7 Field Evidence of Architectural Damage Related to Angular Distortion for Structures Adjacent to Braced Excavations



interconnected by common party walls. Information related to each structure, including its age, is listed in the table that accompanies the figure.

A better understanding of the architectural damage caused by adjacent excavation can be obtained by studying the detailed observations and inclinometer measurements that exist for several of the cases. Information of this nature is assembled in Figs. 3.8, 3.9 and 3.10 where displacements and observed damage are indicated with respect to scale representations of the various structures.

Figure 3.8 shows a 3-story, brick-bearing wall structure that was located 50 ft (15.2 m) from the edge of a 60 ft (18.3 m) deep excavation. The soil profile at the site is composed primarily of dense sand with some interbedded stiff clay. As is common for many commercial buildings, an underground vault adjoins the structure. The vault extends 25 ft (7.6 m) from the edge of the cut. A 1/8 in. (0.32 cm) separation in the floor tiles of the display case was first noticed just after the bottom level braces had been removed from the excavation. Corresponding to this time, the surface settlements and the lateral displacement profiles at several distances from the edge of excavation are shown in the figure. The measured ground movements were taken at a location that was offset 20 ft (6.1 m) from the building front. An inspection of the building showed separations between the facade wall and all floors of the structure. These separations occurred at exactly the same location as the tile separation in the display case. No cracks were evident in the vault. Apparently, vertical and lateral soil movements were transmitted across the vault to the building facade. Although surface settlement at the building line was only 1/8 in. (0.32 cm), the disturbance had become large

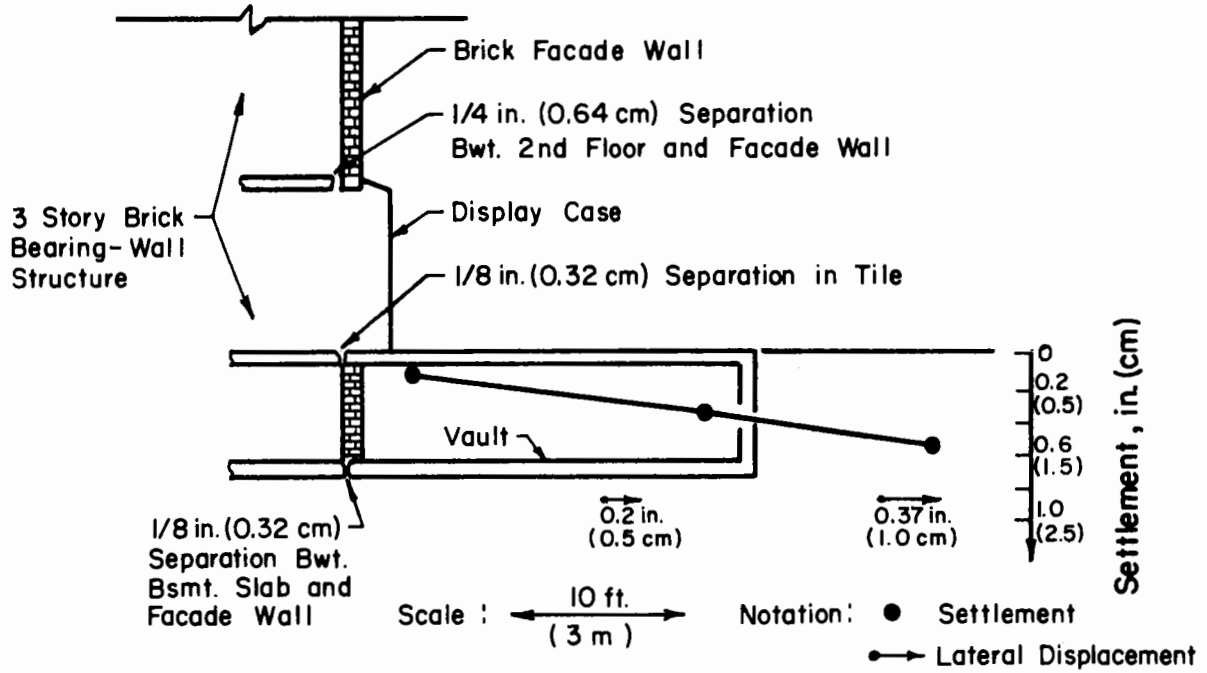

a) Detail of 3-story Building

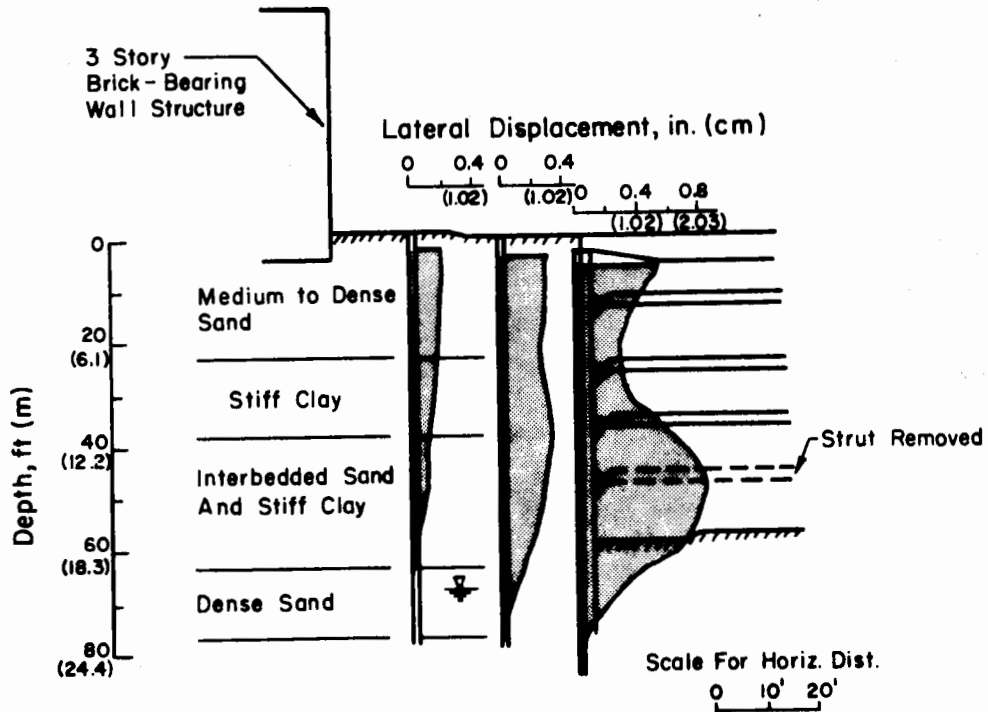

b) Lateral Displacement Profiles

Fig. 3.8 Architectural Damage to a 3-Story Brick-Bearing Wall Structure

enough to be noticed and reported by the building owner. Angular and lateral distortion along the vault were  $1.0 \times 10^{-3}$  (1/1000) and  $0.8 \times 10^{-3}$  (1/1250), respectively.

Figure 3.9 shows the first floor level of a 6-story, steel frame structure that was located 4 ft (1.2 m) from the edge of a 55 ft (16.8 m) deep excavation. The building contains one basement level and is supported on spread footings at a depth of approximately 12 ft (3.7 m) below the ground surface. The building was not underpinned. The soil profile at the site is composed primarily of dense sand and interbedded stiff clay. Settlement of the building and lateral displacements at the edge of excavation are shown corresponding to a time just after the bottom level braces were removed from the cut. During this time, 1/32 to 3/32 in. (0.8 to 2.4 mm) cracks formed along the mortar joints in a characteristic "saw-tooth" pattern. They were located in the second bay behind the front of the structure where maximum angular distortion was measured as  $2.0 \times 10^{-3}$  (1/500). The location and orientation of the cracks suggest that they were related to diagonal extension of the building frame. Lateral distortion of the ground surface is estimated as  $1.6 \times 10^{-3}$  (1/625). With time, additional cracks developed in the exterior walls between the four columns closest to the excavation. Because many of the interior building walls were covered with false paneling or display material, cracks were not apparent inside the structure.

Figure 3.10 shows a plan view of five brick-bearing wall structures with respect to an 80-ft (24.4-m) deep excavation that was located 12 ft (3.7 m) from the building line. The structures range in size from 2 to 4 stories and contain one basement level each. The soil profile is similar to the profile

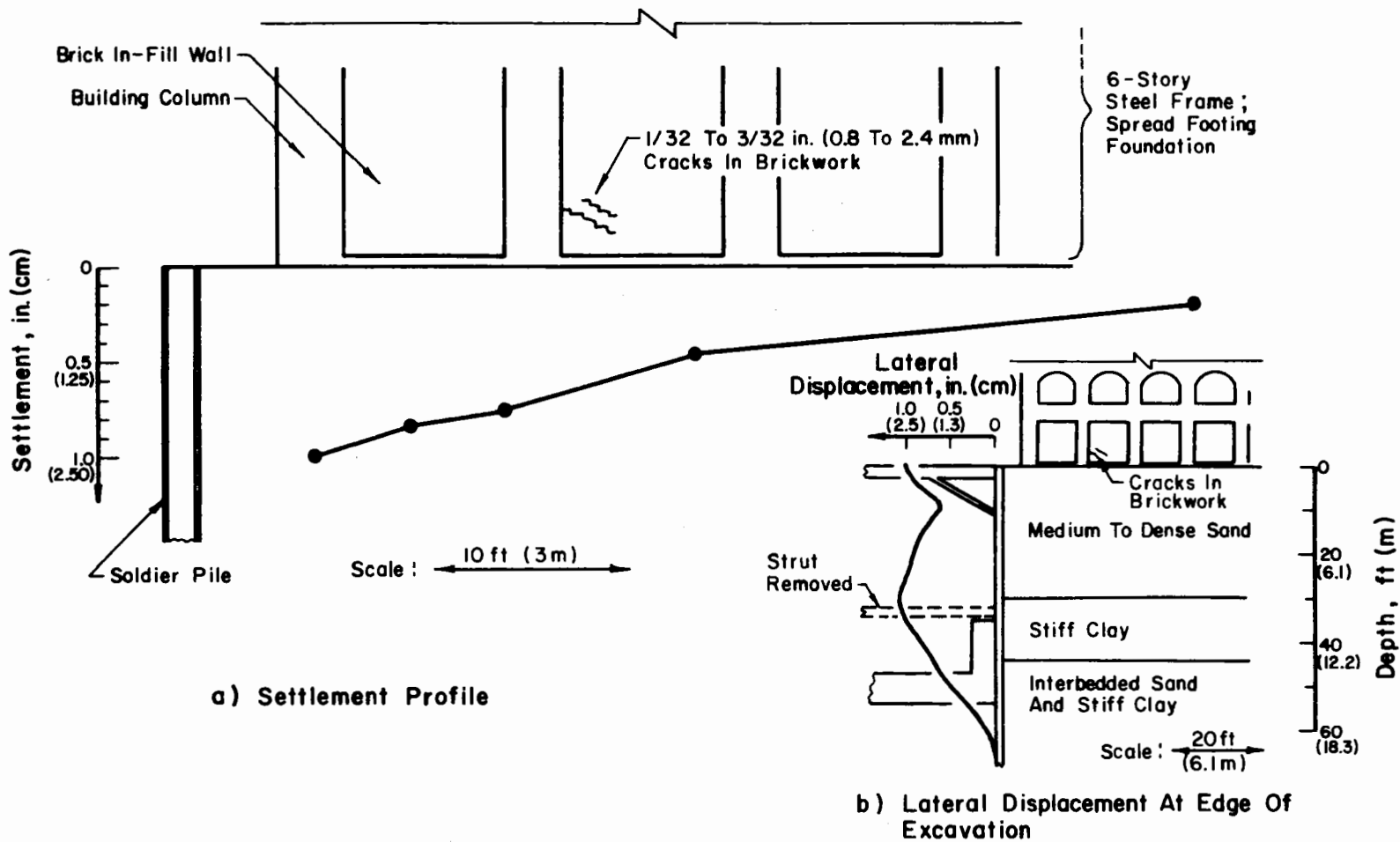
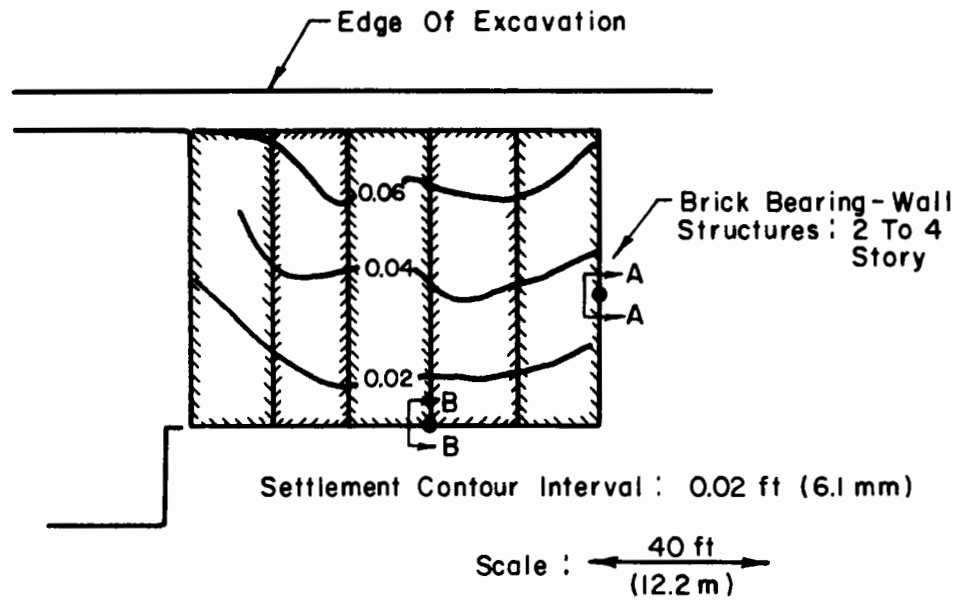

Fig. 3.9 Architectural Damage to a 6-Story Steel Frame Structure



a) Plan View Of Buildings

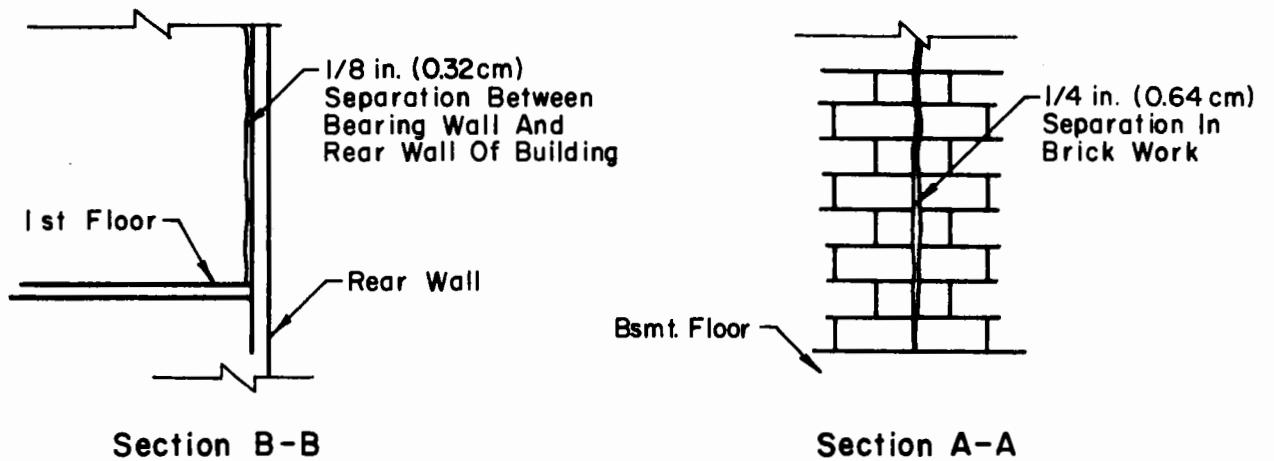

Fig. 3.10 Architectural Damage to a Row of Brick-Bearing Wall Structures

indicated in Fig. 3.8. All the structures were underpinned along the building line prior to excavation with jacked, pipe piles. The settlements associated with underpinning were mostly less than 3/8 in. (1.0 cm) and any related damage was confined to the area near the front of the structures. The settlements, corresponding to a time when the bottom three brace levels were removed from the cut, are shown in the form of settlement contours. In response to excavation the maximum angular distortion of the buildings is  $1.0 \times 10^{-3}$  (1/1000). Although the vertical movements were small, cracks and separations developed that were not noticed previously even though the buildings had been inspected before the beginning of construction and just after underpinning. Typical forms of architectural damage are indicated in the figure. Section A-A shows a 1/4 in. (0.64 cm) separation that developed in the bearing wall of the end structure at the basement level. The separation could be traced as a 1/8 to 1/4 in. (0.32 to 0.64 cm) crack in the exterior cladding of the structure at the first floor level. The separation apparently developed at the junction between two distinct sections of the wall. Section B-B shows a 1/8 in. (0.32 cm) crack that occurred between a bearing wall and rear facade wall at the first floor level. Similar cracks were observed in three other structures. The cracks increased in width in the upper stories of the buildings.

Although it is impossible to make a single, comprehensive judgment concerning these observations, several comments are offered to emphasize the salient features of the building and excavation behavior:

1. Architectural damage frequently occurred at areas of local weakness within a given structure. Ground strains, transmitted to zones of structural discontinuity, were evidenced

in cracks and separations at facade walls and between individual sections of bearing walls.

2. At the buildings under observation, ground movements were typical of the displacements associated with adequately braced, dewatered excavations in dense sand and interbedded stiff clay. Several of the brick-bearing wall structures were underpinned prior to excavation. Total settlement at the building wall adjacent to the excavation were approximately 3/4 in. (1.9 cm), of which 40% occurred during underpinning and 60% during excavation. Lateral displacements were estimated to be in the range of 1/4 to 3/4 in. (.6 to 1.9 cm). Although the settlement of these structures was small, architectural damage was observed and reported by the occupants. By way of contrast, a 6-story, steel frame structure was not underpinned even though it was located only 4 ft (1.2 m) from the edge of excavation. Although cracks were apparent in the external building wall, no damage was observed during inspection of the building interior nor reported by the occupants.
3. In one instance, ground strains were transmitted across an underground vault to cause local cracks and separations at the facade wall of an adjoining structure. Although underground vaults generally are not considered part of a given structure when determining the building line, the vaults, nevertheless, can transfer ground strains to the building and cause architectural damage.
4. The largest, cumulative movements correspond with strut removal during construction of the underground structure. Correspondingly, much of the observed damage occurred during

a time when the bottom level struts were removed from the excavations. Especially when removing the lower brace levels, deep-seated ground movements are generated that can influence adjacent buildings at a significant distance from the edge of excavation.

Judging from the data summarized in Fig. 3.7 and by reviewing the previous case histories, it seems reasonable to recommend an angular distortion of  $1.0 \times 10^{-3}$  (1/1000) as the threshold value for architectural damage to brick-bearing wall structures adjacent to braced excavations. Only one case of damage was reported for a lower angular distortion and this corresponds to an instance when cracks were concentrated near the expansion joint of the structure. This case has been discussed in the previous section (see Fig. 3.5). Information pertaining to frame structures is limited, but it appears that an angular distortion of  $1.3 \times 10^{-3}$  (1/750) could be used as a conservative lower bound for the first appearance of damage when these buildings are adjacent to open cuts.

#### 3.3.4 COMPARISON OF FIELD EVIDENCE

Figure 3.11 compares the evidence concerning architectural damage and angular distortion as it was developed for 1) the settlement of structures under their own weight, 2) settlement caused solely by underpinning, and 3) movements associated with adjacent excavation. The summary of evidence for structures that settled under their own weight represents the combined data of Skempton and MacDonald, and Grant, et al. The limiting value of angular distortion recommended for brick-bearing wall structures adjacent to open cutting is



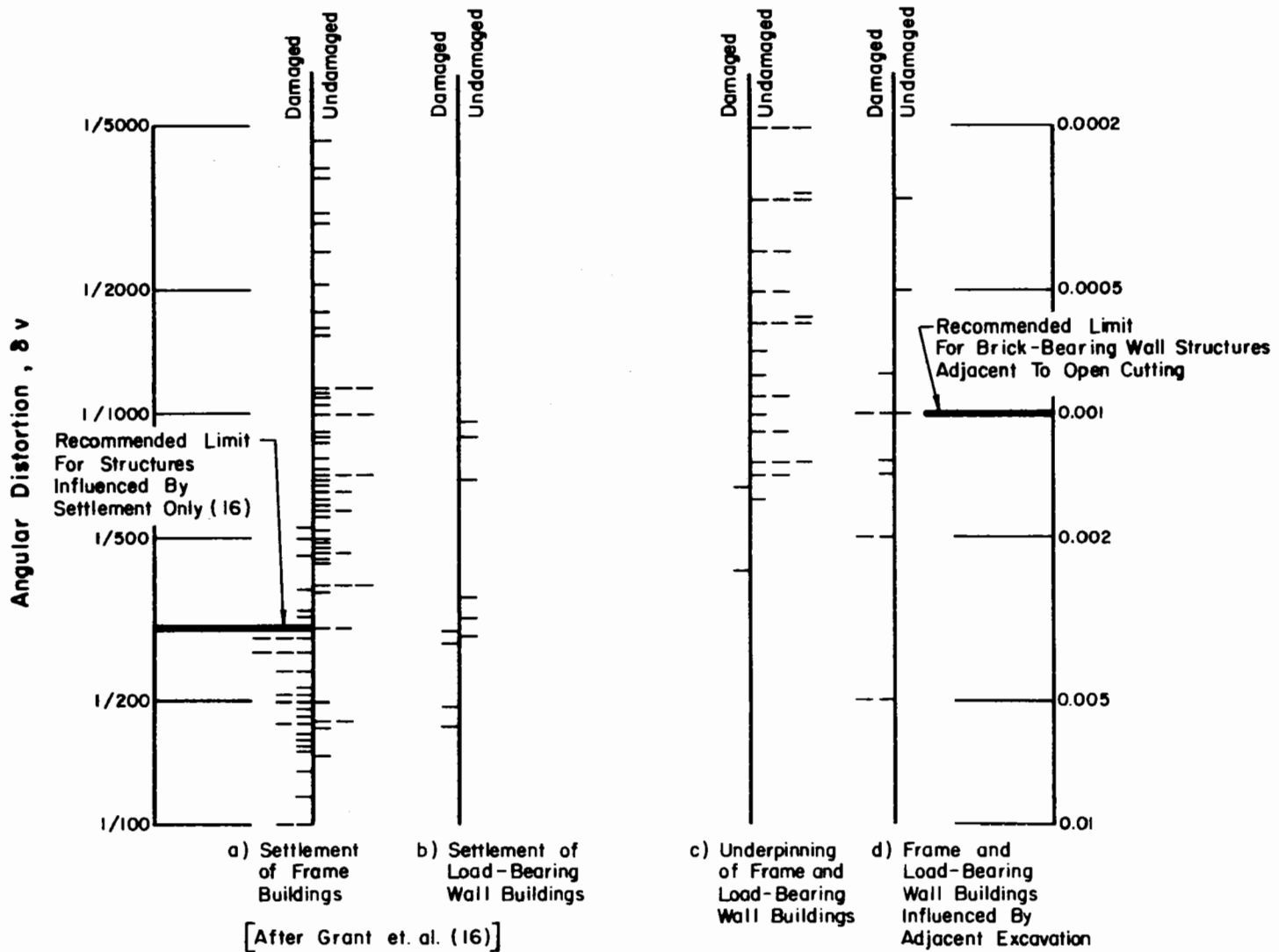

Fig. 3.11 Comparison of Field Evidence Related to Architectural Damage

approximately one-third the value proposed for the settlement of structures under their own weight. This difference in threshold deformation is primarily related to the lateral displacements that accompany braced excavation and to the fact that buildings adjacent to opencutting have invariably sustained some strains prior to excavation as a function of settlement under their own weight and deterioration with age.

#### 3.4 RELATIONSHIP BETWEEN ARCHITECTURAL DAMAGE AND BUILDING USE

Architectural damage does not imply that the stability of a given structure is compromised or even that its use is impaired. Architectural damage relates to cracks and separations of a cosmetic nature that may be displeasing for aesthetic or psychological reasons, but generally will not disrupt the building services nor endanger the occupants. Peck, et al., (37) have cautioned that architectural damage is not necessarily intolerable, especially when considered in light of the damage that can be expected from shrinkage, temperature changes, weathering and vibrations.

There are certain building types that are relatively insensitive to architectural damage. These include warehouses, garages, and many industrial buildings where the absence of partition walls limits the visible surface space and the nature of the environment tends to obscure the cracks, if they do appear. Although distortions may be noticed in other building types, they are not necessarily an inconvenience to building occupants. Minor cracks and separations in merchandizing stores, low income or rented housing, and office buildings are often disregarded or repaired in the course of normal maintenance.

There are, however, several building types in which architectural damage is likely to impair the building services or to result in local deterioration of the architectural fixtures. Most notable among these are hospitals, churches, and public galleries. Hospitals, of course, are expected to provide a suitable environment for therapy and surgical recovery. Under these circumstances, architectural damage is likely to interfere with the intended services and provoke complaints from patients and hospital personnel. Churches and public galleries often are constructed of monumental stone and masonry, and are provided with decorative lintels, cornices, and sculptural ornamentation. Cracks or separations that develop across these fixtures can lead to local collapse and, therefore, threaten valuable property and endanger the building visitors. In this instance, even inconspicuous cracks can become intolerable.

In summary, architectural damage related to adjacent excavation is likely to occur if angular distortion exceeds  $1.0 \times 10^{-3}$  (1/1000) for brick-bearing wall structures and  $1.3 \times 10^{-3}$  (1/750) for frame structures. Considering these low values, it is doubtful that many protective measures, especially underpinning, can be relied on to prevent the movements associated with minor cracks and separations. Consequently, excavations and related protective measures should not be designed on the basis of architectural damage except where such damage represents a clear impediment to the use of the building or to the safety of the building occupants. If ground movements are expected to cause architectural damage, the best approach to limiting building disturbance may be through close control of the excavation procedure or the use of rigid support techniques such as well-braced slurry-walls.



## 4. STRUCTURAL DAMAGE TO BRICK-BEARING WALL BUILDINGS

### 4.1 INTRODUCTION

Brick-bearing wall structures occupy a substantial portion of most urban areas. Consequently, deep excavations for transportation systems or building foundations are often made in close proximity to structures of this type. The ground movements associated with urban excavations are likely to affect the use and stability of these buildings, and for this reason, engineers and designers must be able to anticipate the building damage and recommend protective measures.

In general, the behavior of brick-bearing wall structures is poorly understood. Many range from 50 to 100 years in age and some date from the early 19th century. Consequently, a great number were constructed either before building codes were adopted or in compliance with a previous code. In addition, the unavoidable deterioration with age and wide variations in material composition restrict a rigorous structural analysis of these buildings. As a result, their behavior in response to ground movements must be estimated on the basis of general construction procedure, assumptions concerning material properties, and field observation.

### 4.2 DESCRIPTION OF BRICK-BEARING WALL STRUCTURES

Brick-bearing wall structures are used for both commercial and domestic purposes. The commercial units are generally from two to five stories high, while the domestic units, such as town houses, are two or three stories high. A typical brick-bearing wall structure is illustrated in Fig. 4.1, adjacent to

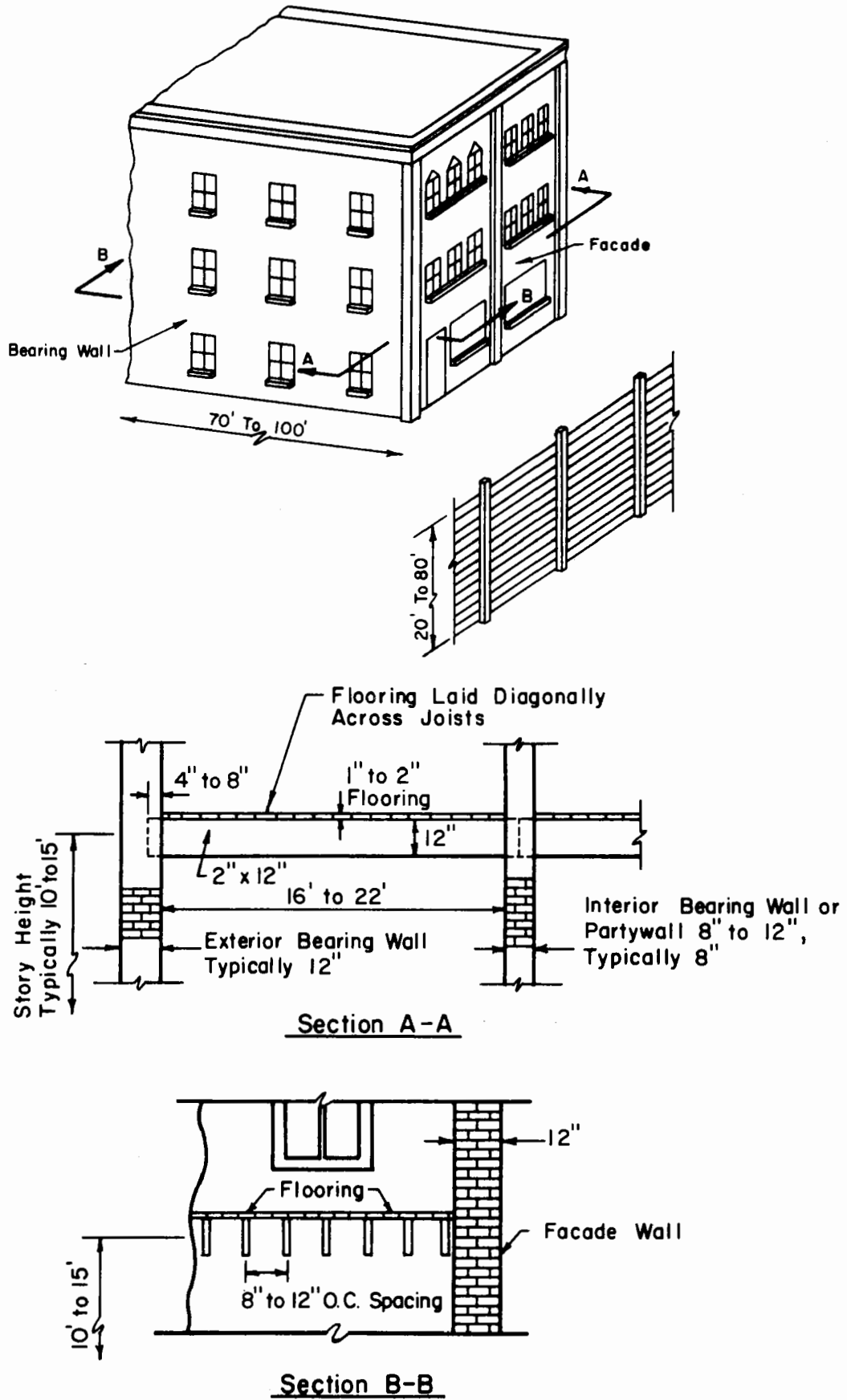

Fig. 4.1 Typical Brick-Bearing Wall Structure

a deep excavation. Included in the figure, are two cross-sections that show the major structural features for this type of building.

Section A-A provides a cross-sectional view of two adjacent brick-bearing walls. As indicated in the diagram, the exterior and interior walls are generally 12 and 8 in. (30.5 and 20.3 cm) thick, respectively, and are separated by distances that range between 16 and 22 ft (4.9 and 6.7 m). The building floors are supported by timber joists that are connected with the walls by means of end pockets in the masonry. The floor joists are commonly 2 in. (5.1 cm) wide by 12 in. (30.5 cm) deep, but may occasionally be larger in very old buildings where beams with dimensions as great as 6 in. (15.2 cm) wide and 12 in. (30.5 cm) deep are found. The bearing length in the masonry pockets is between 4 and 8 in. (10.2 and 20.3 cm). Section B-B shows a cross-sectional view oriented parallel to the bearing walls of the structure. The joists are spaced 8 to 12 in. (20.3 to 30.5 cm) on center. The largest joist spacings correspond to the shortest floor spans. Correspondingly, 12 in. (30.5 cm) spacings are found where the joist spans are 16 ft (4.9 m), whereas 8 in. (20.3 cm) spacings are found where the joist spans are 22 ft (6.7 m). The facade walls are self-supporting masonry units between adjacent bearing walls. They are typically 12 in. (30.5 cm) wide and may carry stone cladding and architectural accouterments.

The bearing walls of most masonry structures are oriented parallel to the long axis of the building. However, in many buildings the bearing walls are oriented in the opposite sense so that the joists span from front to rear and are supported by a series of short bearing walls traversing the structure at intervals of approximately 20 ft (6.1 m).

Two structural features deserve closer scrutiny. They are the masonry-joist connection and the building foundation. Both features are discussed under the following two headings.

Masonry-Joist Connection: There are three common types of masonry-joist connections: 1) simple end bearing, 2) end bearing anchored to the building wall, and 3) metal hangers. Typical cross-sections of these connections are illustrated in Figure 4.2. Simple end bearing is the most widely used type of connection; although the bearing length may be as large as 8 in. (20.3 cm) it is most commonly 4 in. (10.2 cm). When the bearing end of the joists are anchored to the building wall, the anchorage is generally provided by means of 18-in. (45.7-cm) long expansion bolts. The bolts are connected to metal bearing plates that help stabilize the exterior wall. The bearing plates are generally 8 in. by 8 in. (20.3 cm) square; however, they can often be found in the shape of stars and other ornamental figures. The anchor bolts are frequently located at 8 ft (2.4 m) intervals. It is important to note that the anchor bolts and bearing plates usually occur on only one wall because the other wall is usually not an exterior wall. Consequently, the anchored joist cannot be regarded as a structural tie between adjacent bearing walls. The third type of masonry joist connection is accomplished by means of a metal hanger. As shown in the figure, this is a Z-shaped steel unit with one leg, 4 in. (10.2 cm) or more long, embedded in the masonry wall with a ledge, formed by the other leg, to support the joist.

All of the connections described above have one common characteristic. They provide very little, if any, fixity at the ends of the joists. As indicated by the head-on view in Fig. 4.2, there is a space between the joist and



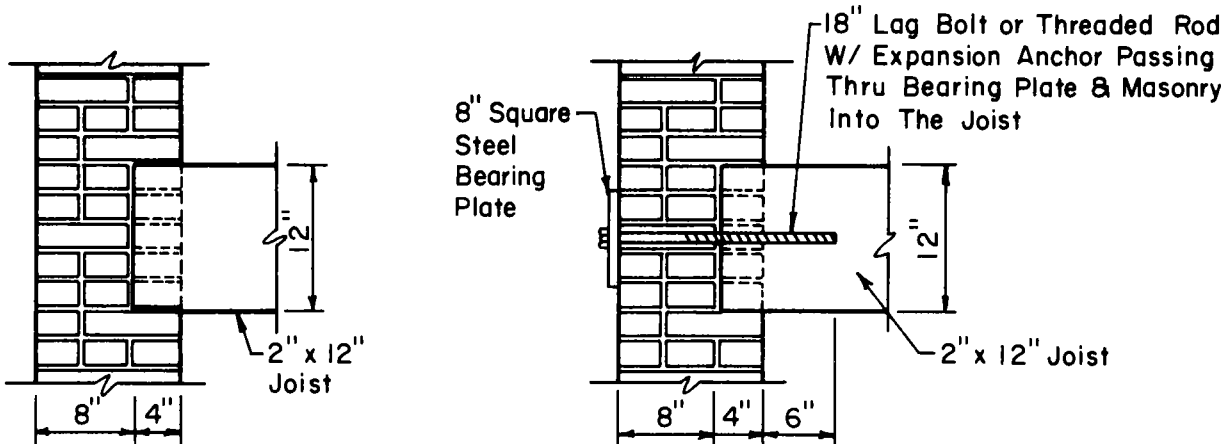

a) Simple End Bearing On Masonry

b) Simple End Bearing on Masonry W/ Bearing Plate And Bolt 8' O.C.

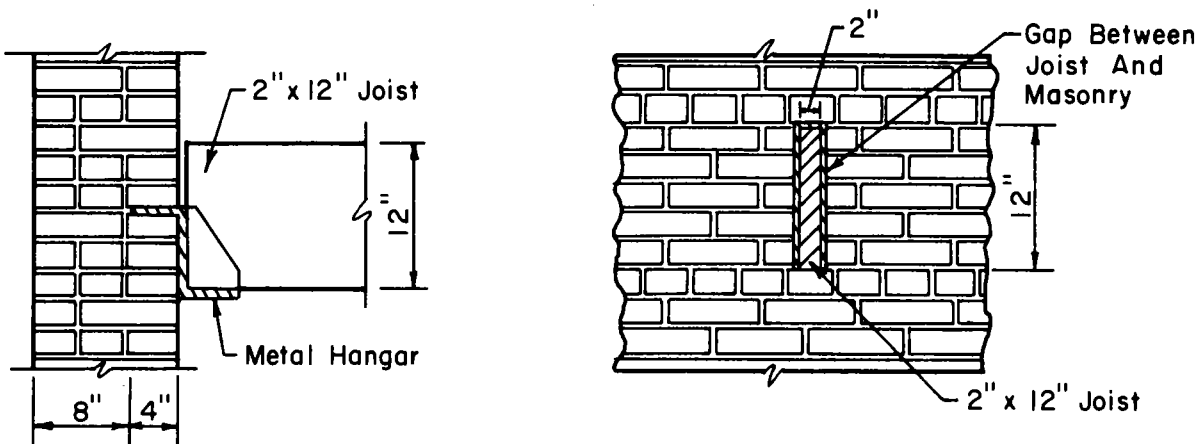

c) Metal Hangar

d) Head-On View of Joist in Masonry Pocket

Fig. 4.2 Typical Masonry - Joist Connections

masonry. This space results from shrinkage and deterioration at the joist-masonry interface. (In modern masonry buildings a space is intentionally left to insure a lack of connection; this is done as a safety precaution against wall collapse in the event of fire.) Consequently, there is almost no moment capacity at the ends of the joists. This condition is apparent in structures being demolished, where one may easily remove the joist from the masonry pocket by hand. From the sketch of the metal hanger it should be apparent that the joist rests on the hanger as if on a simple support. The few nails connecting the joist to the hanger provide stability during construction and have a negligible effect upon the fixity of the joint.

Building Foundations. The foundations for brick-bearing wall structures may be grouped into three categories: 1) walls that bear directly on the soil, 2) walls that are supported by rubble footings, and 3) walls that are supported by continuous concrete or reinforced concrete strip footings. Typical cross-sections of these foundations are illustrated in Fig. 4.3.

Many older structures derive their support from one of the first two types of foundations. Excavation of underpinning pits and redistribution of building loads during jacking and wedging can easily cause these foundations to loosen and crack. Frequently, if lime mortar had been used in the original construction, years of exposure to the generally damp basement environment will result in extensive deterioration along the joints of the brickwork. This condition further weakens the masonry and complicates the underpinning procedure.

In the more modern structures, the building walls are supported on continuous strip footings. These footings are often reinforced along their bottom portion and, thus, represent a condition more favorable for underpinning.

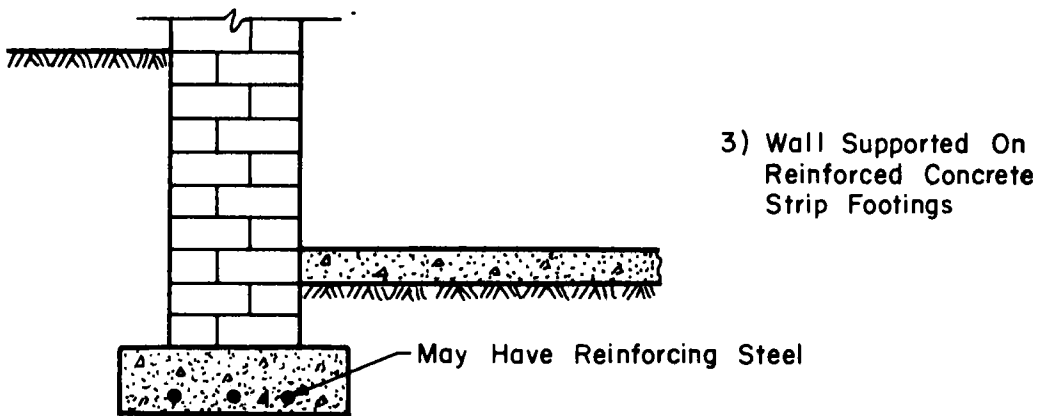
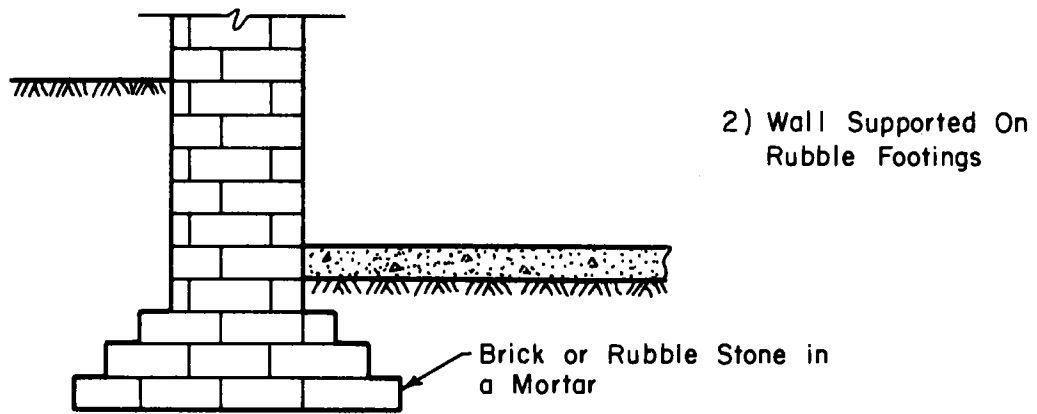
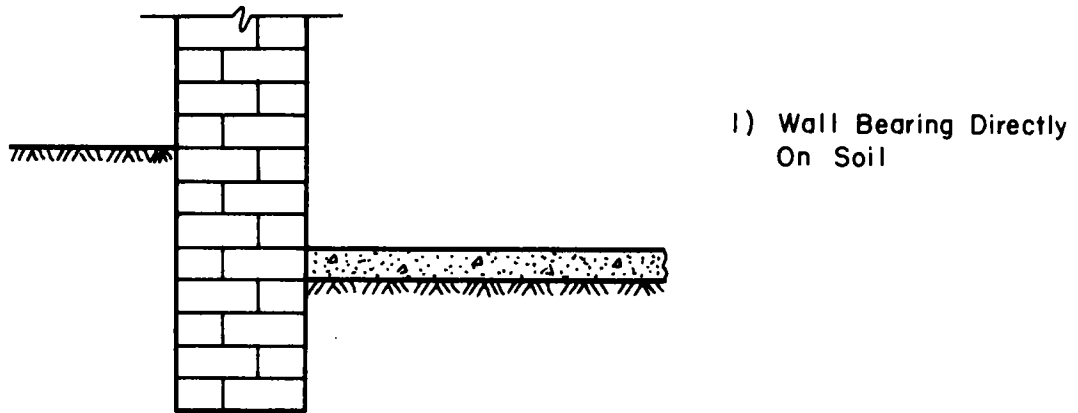

Fig. 4.3 Typical Foundations for Brick-Bearing Wall Structures

### 4.3 MODES OF FAILURE

#### 4.3.1 BACKGROUND

The brick-bearing wall structures in current use are associated with a great range of time periods. Consequently, the composition of these buildings can vary substantially with major differences resulting from variations in both the materials and standard practice that were employed at the time of construction. The type of brick chosen, as well as local variations in the quality control of brick production, lead to significant differences in the material properties of the masonry. Today, higher strength and stiffness are achieved through standardized control of the composition, kilning, and curing procedures for brick. The variation of brick strength as a function of the time period can be illustrated by comparing the test data of McBurney and Lovewell (29) with those of Monk (32). According to McBurney and Lovewell, the bricks produced in 1929 had a median strength of about 7000 psi (48.3 MPa), while the more recent investigation by Monk shows a median strength in excess of 10,500 psi (68.9 MPa). Many of the older structures were built with hardwood timbers (e.g., oak), whereas modern buildings use either softwood (typically fir) or steel-bar joists. Probably the most significant variations are related to the mortar. Old buildings were generally constructed with lime mortar, a 1:3 mixture of hydrated lime and sand that is characterized by low strength, modulus, and resistance to weathering. By way of contrast, buildings erected after 1900, are generally constructed with mortars containing substantial proportions of Portland cement in addition to sand and plasticizing agents (e.g., ASTM C270 Type M, S, N, and O mortars). When compared with lime

mortar, the Portland cement-based mortars have greater strengths, higher moduli, and more resistance to deterioration. Variations in the design and workmanship are more difficult to generalize; they are related to the standard practice and local building code during the time of construction, and were influenced greatly by the experience of the builder.

An important characteristic of brick-bearing wall structures is their anisotropy with respect to structural behavior. Each building can be visualized as having two prominent axes of structural response. One axis is aligned perpendicular to the bearing walls; the other axis is oriented parallel to the bearing walls. Both axes are shown in Fig. 4.4 as they apply to a structure that borders an open cut. The building is most sensitive when movements occur perpendicular to the bearing walls. Soil deformation in this direction causes relative displacement of the bearing walls that can result in the loss of floor support. This occurs because the joists are pulled out of the masonry pockets. Ground movements parallel to the bearing walls cause bending, shear, and direct tensile distortion of the bearing walls, but floor support in this case is affected only insofar as the strains result in local deterioration of the masonry-joist connections.

Although for most structures the bearing walls are oriented parallel to the long dimension of the building, this need not always be the case. As was mentioned previously, the bearing walls for some structures, especially those used for domestic purposes, are aligned parallel to the short dimension of the buildings. There is no general way to identify this type of construction other than by direct inspection. Consequently, brick-bearing wall structures near areas of anticipated excavation should be examined to determine the orientation of the bearing walls prior to construction.

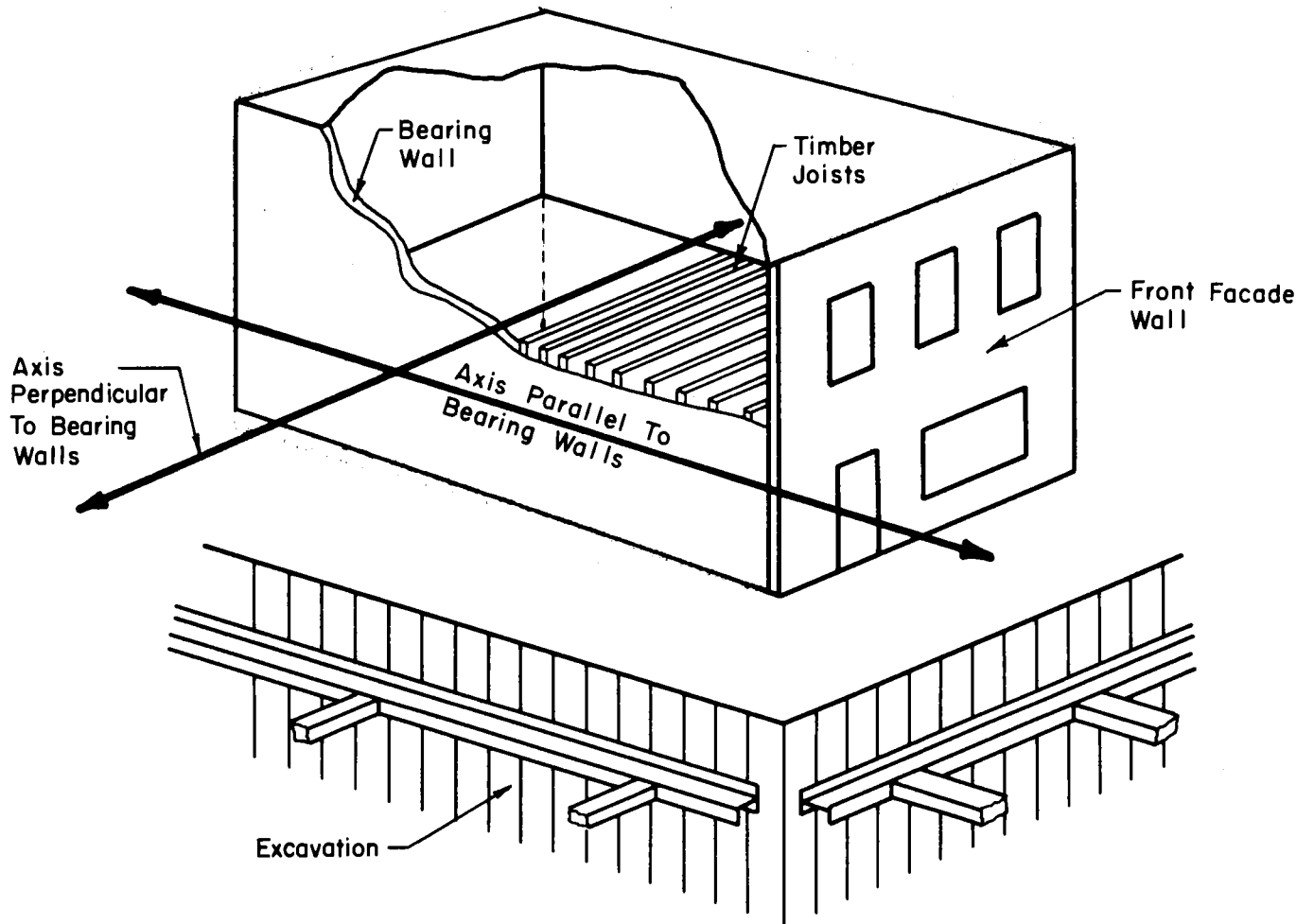

Fig. 4.4 Axes of Structural Response for Brick-Bearing Wall Structures

Since the behavior of brick-bearing wall structures is closely related to the two axes of structural response, these axes provide a convenient means of approaching the problems of building instability. In the following two sections the influence of relative ground movements on these buildings will be discussed according to each of the two axes.

#### 4.3.2 DIFFERENTIAL MOVEMENTS PERPENDICULAR TO THE BEARING WALLS

As was discussed in the previous section, there is little or no fixity of the floor beams at the masonry-joist connections. For this reason, bending moments in the beams will not be seriously affected for conditions of differential vertical movement.

The most critical feature with respect to building stability is the masonry-joist connection. Ground movements perpendicular to the bearing walls cause relative displacement of the walls which, in turn, diminishes the bearing area available for the joist. Figure 4.5 shows a condition of incipient failure. The wall has moved relative to the joist such that the bearing area has been reduced to the point where a bearing failure is imminent. The maximum tolerable movement is simply the lateral displacement,  $d_L$ , corresponding to a minimum bearing length,  $l_B$ , that is safe under an allowable load criterion. The minimum bearing length is a function of the compressive strength of the masonry. This strength can vary over a wide range of values depending on the age and material properties of the brick and mortar. Consequently, the critical aspect of this analysis is the choice of a strength parameter that represents a conservative, yet reasonable estimate of typical field conditions.

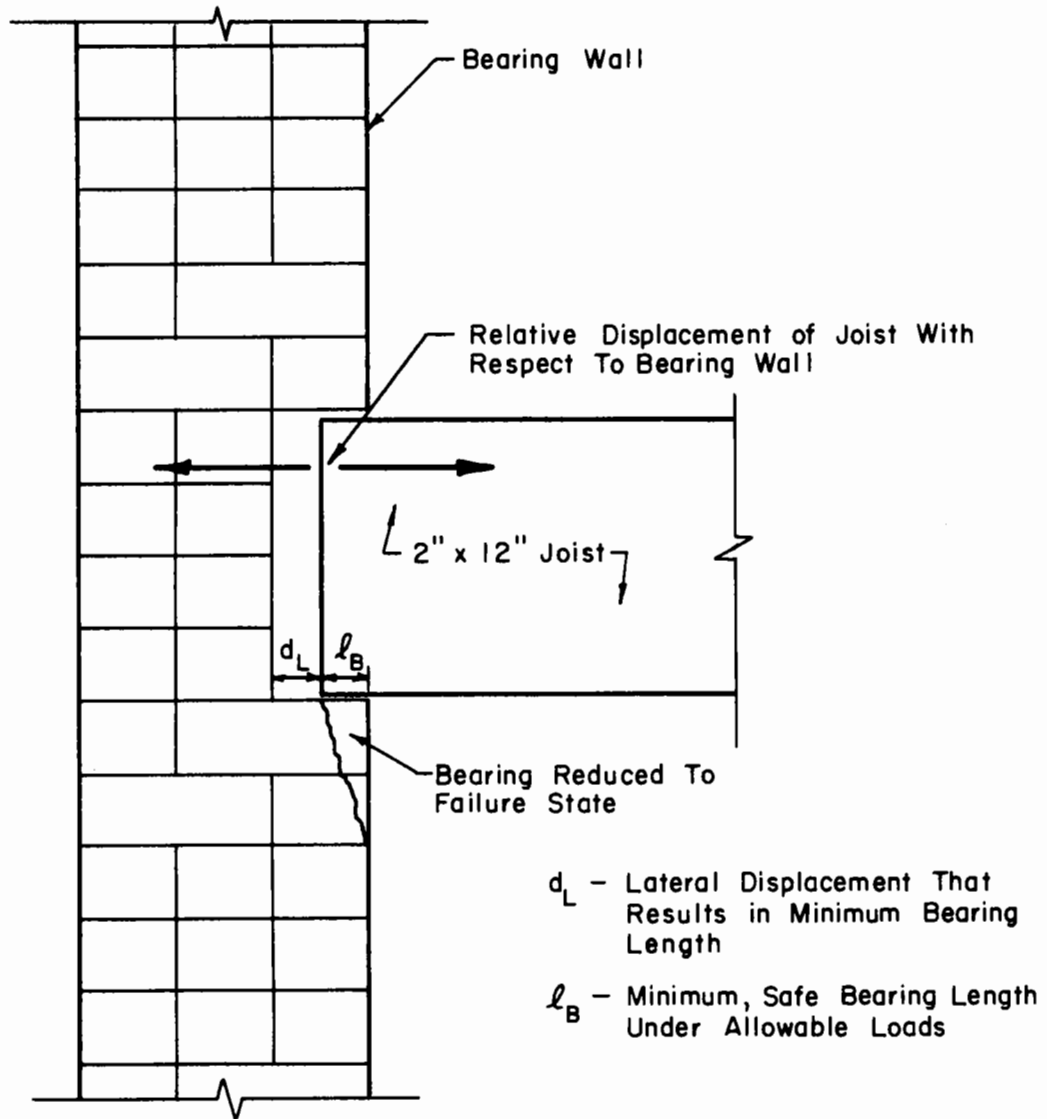

Fig. 4.5 Critical Bearing Condition for the Masonry - Joist Connection



Using the recommended loads published by the American Institute of Timber Construction (1), live loads are assumed to be 40 psi (0.002 MPa) for domestic units and 75 psi (0.004 MPa) for commercial structures. These loads, when combined with typical dead loads of 18 psf (0.001 MPa), result in a bearing load of 440 lbs (1957.1 N) and 625 lbs (2780 N) for domestic and commercial buildings, respectively. The bearing loads are based on a 22 ft (6.7 m) span and an 8 in. (20.3 cm) joist spacing for domestic units and a 20 ft (6.1 m) span and an 8 in. (20.3 cm) joist spacing for commercial structures. To obtain a cross section of masonry strengths, test data on the ultimate compressive strength from several sources (12,13) were evaluated in terms of allowable working stress. The allowable working stress was determined using the methods recommended in Gaylord and Gaylord (12). These methods introduce a factor of safety of 3.

Table 4.1 presents minimum safe bearing lengths for joists in brick-bearing wall structures using allowable working stresses. Required bearing lengths are shown for typical domestic and commercial buildings. Because lime mortar masonry is the weakest material, it represents the critical bearing condition in the field. Consequently, the average strengths of lime mortar masonry are used in this report to determine the minimal bearing lengths of the joists. This condition corresponds to maximum, safe lateral displacement between bearing walls of 2.3 to 2.8 in. (5.8 to 7.1 cm) for commercial and domestic units, respectively.

It is important to note that, although the joists of a particular structure may be bolted to one of the bearing walls (Section 4.2), these bolts are intended only to provide local support for the exterior wall. The bolts

TABLE 4.1  
 MINIMUM SAFE BEARING LENGTHS FOR JOISTS IN  
 BRICK-BEARING WALL STRUCTURES

Type of masonry	Required bearing length, in. (cm)	
	Domestic buildings	Commercial buildings
Lime mortar masonry <sup>a</sup> (lowest strength)	1.8 (4.57)	2.5 (6.35)
Lime mortar masonry <sup>a</sup> (highest strength)	0.9 (2.29)	1.3 (3.30)
Lime mortar masonry <sup>a</sup> (average strength)	1.2 (3.05)	1.7 (4.32)
Lowest class of modern cement mortar masonry <sup>b</sup>	1.0 (2.54)	1.4 (3.56)

<sup>a</sup>Based on data from Glanville and Barnett, 1934 (13).

<sup>b</sup>From Gaylord and Gaylord, 1968 (12).

do not represent a structural connection between bearing walls. Consequently, the joists will be free to slip laterally at the wall opposite the bolted, masonry-joist connections and loss of bearing can occur in the manner described above.

Differential lateral movement at the masonry-joist connection can occur as the result of two distinct forms of deformation: 1) direct lateral strain, and 2) differential rotation of the adjacent bearing walls. Fig. 4.6 shows both forms of deformation. Lateral strain between bearing walls causes relative translation of the walls and, as such, contributes directly to the loss of joist bearing. For cases where only lateral displacements influence the wall separation, lateral distortion ranging from  $9 \times 10^{-3}$  and  $10 \times 10^{-3}$  is sufficient to cause a critical condition of minimum floor bearing. However,

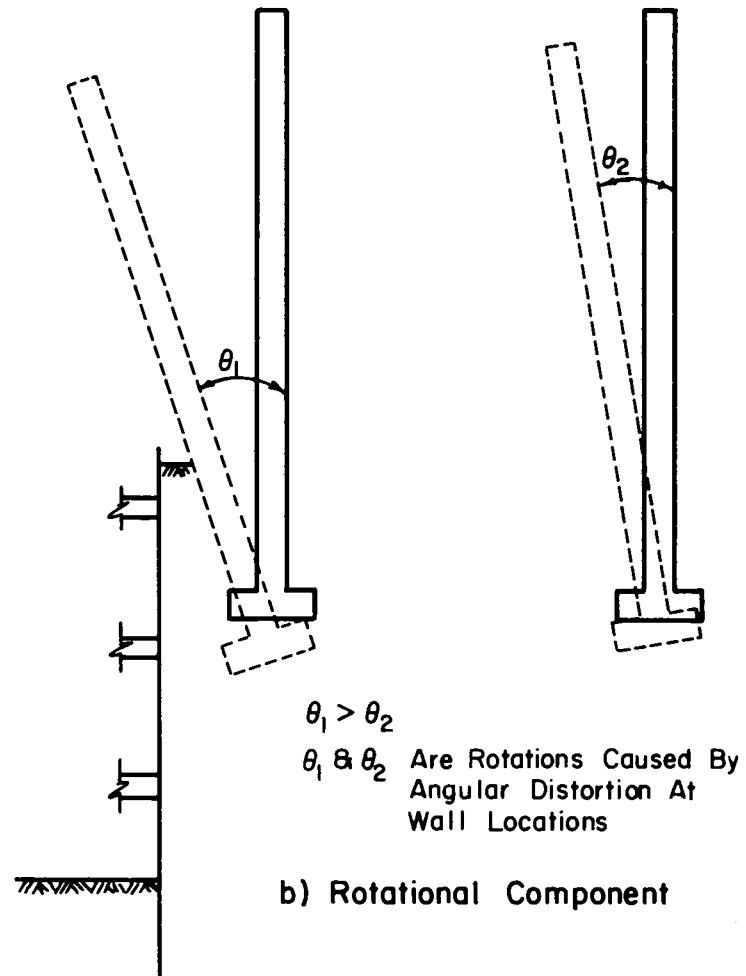
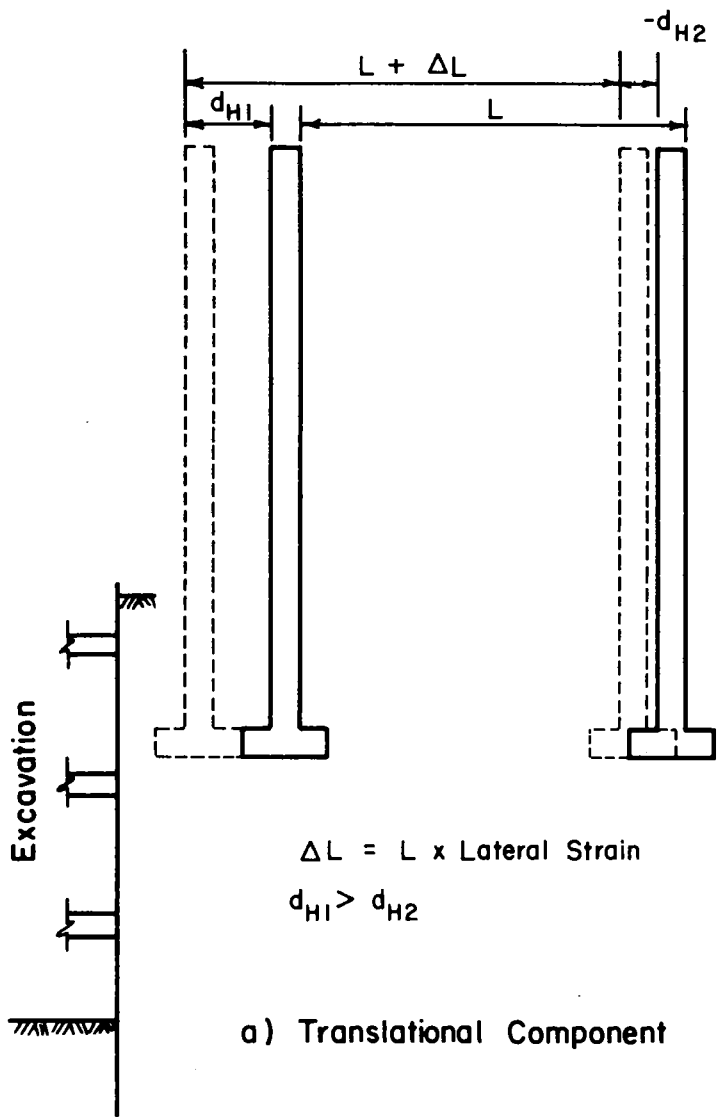

Fig. 4.6 Translational and Rotational Components of the Differential Lateral Movement Between Bearing Walls

differential rotation of the bearing walls also increases the wall separation. It is difficult to evaluate how angular ground distortion is translated into differential rotation of the bearing walls. The loss of joist bearing contributed by wall rotation will be a function of the stiffness of the bearing wall with respect to the restraining forces at the masonry-joist connections. More observational and analytical work are needed to understand this aspect of the building behavior. For the conservative assumption of rigid wall rotation, the maximum relative displacement of one wall with respect to the other will be proportional to the wall height. For a 5-story structure, a relative rotation of  $4 \times 10^{-3}$  radians could be sufficient to reduce the joist bearing to an unsafe condition in the upper story of the building.

#### 4.3.3 DIFFERENTIAL MOVEMENTS PARALLEL TO THE BEARING WALLS

Differential ground movements that occur parallel to bearing walls will cause several types of strain. For example, hogging (convex deformation) is generally associated with the settlement caused by opencutting. This type of deformation results in tensile strain in the upper portion of the structure and causes cracks that can develop without the benefit of boundary restraint. Because the ratio of the deformed length to height of the building (L/H) is frequently close to unity, shear strains contribute substantially to building distortion. Shear strains result in diagonal extension cracks that generally take form as a "saw-toothed" pattern of fractures along the mortar lines. These cracks are concentrated in areas of relatively low stiffness such as vertical window lines. In addition, lateral strains are transmitted directly to the walls by means of horizontal ground movement.

Several structures, which had been deformed by ground movements parallel to the bearing walls, were studied at urban construction sites in Washington, D. C. and New York City. In each case, cracks and separations developed in a similar manner. Figure 4.7 shows a typical fracture pattern associated with these buildings. Essentially, three types of cracks were observed:

1. Inclined cracks and separations at the mortar joints were concentrated near windows. This specific type of fracture was the largest and most extensively developed in all cases. Apparently, the cracks are related to tensile strains that develop in response to shear and lateral distortion. As the structure settles differentially, rectangular elements of the bearing wall tend to deform as illustrated in the diagram. The consequent diagonal extension strain is exhibited in the characteristic "saw-toothed" pattern of the crack.
2. Vertical and near vertical cracks occurred near the roofs of the buildings. These cracks extended through the bricks and along mortar joints. They were concentrated near the facade wall where angular distortions were largest. They were significantly less conspicuous than the diagonal, "saw-toothed" cracks.
3. Vertical and near vertical cracks occurred near the base of the building. These cracks generally extended from the ground surface to heights of 5 to 10 ft (1.5 to 3.0 m).

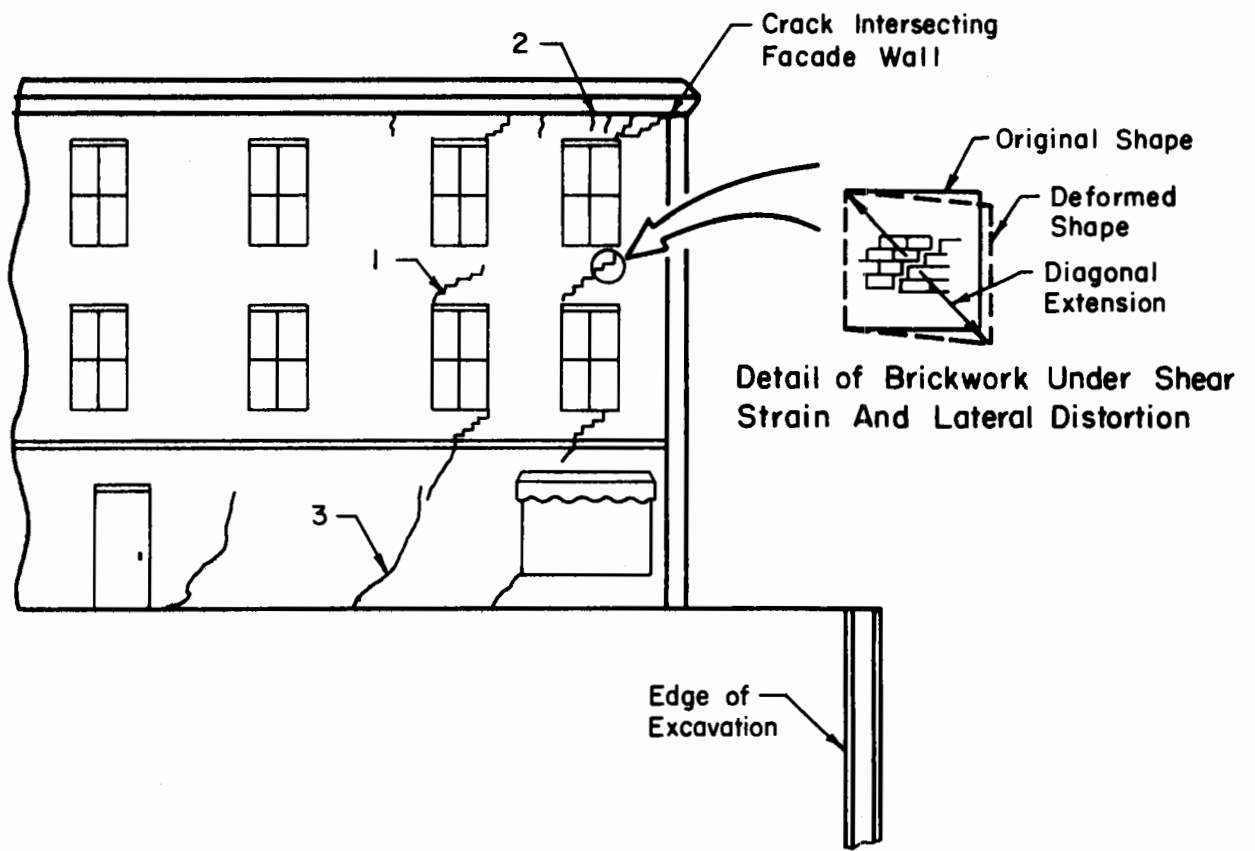

Fig. 4.7 Typical Fracture Patterns Observed in Brick-Bearing Wall Structures Adjacent to Excavation

Their general orientation and location suggest that they were influenced by lateral ground strain.

A stability analysis of brick-bearing walls subject to differential ground movement is precluded by uncertainties associated with the development of cracks and separations. For example, little is known about how far and in what direction cracks will propagate after their initial formation. In addition, the amount of movement that will concentrate across a given crack and the redistribution of building load throughout a fractured portion of the bearing wall are both dependent on the location of windows and other discontinuities, the specific pattern of the surface movements, and the variations of material properties within a particular masonry unit.

When diagonal extension cracks intersect the facade wall of the structure, spalling of stone cladding and collapse of architectural cornices can occur. Hence, the intersection of bearing wall cracks on the building facade and the corresponding deformation of the facade wall represent a potential hazard. It is difficult to set measurable limits for this type of damage. One approach to the problem is through previous experience. Redevelopment and building engineers in Washington, D. C. have adopted a rule of thumb with respect to brick-bearing wall structures. When facade walls for 3 to 5-story buildings are more than 6 in. (15.2 cm) out of plumb, the condition is considered serious enough to either reinforce the wall or demolish the structure. Assuming an initial verticality, this type of wall inclination would correspond to an angular distortion of approximately  $8.0 \times 10^{-3}$  in response to adjacent opening.

In summary, the limits of building stability are related to the minimal bearing area at the masonry-joint connection and the prevention of spalling

or local collapse at the facade wall of the structure. However, these conditions will be preceded by building distortions of smaller magnitude. Before structural failure can occur, the functional restraints associated with tilted floors and jammed doors may well exceed acceptable limits and necessitate remedial measures.

#### 4.4 FIELD OBSERVATIONS

In the previous sections of the Chapter the problem of defining limits for tolerable building distortion has been approached by examining the construction details associated with brick-bearing wall structures and by analyzing various modes of instability caused by differential ground movements. At this point, it would be helpful to study several cases where damage caused by excavation movement either threatened the stability of a structure or caused it to receive immediate repair owing to the corresponding inconvenience and disruption of building services.

Figure 4.8 summarizes the settlements and lateral displacements associated with a braced excavation that was performed adjacent to a rail station in Chicago. Displacement measurements and building observations were provided by Lacroix (23), who has reported on the wall movements and instrumentation techniques performed at other sections of this cut (22). The construction dates are referenced to the start of excavation.

As indicated in the figure, the most critical section of the building with respect to soil movement was located in the structural bay closest to the cut. Stability in this area was related to the masonry bearing provided for the floor slab. Hence, the stability was controlled by the differential lateral movement of adjacent bearing walls. Building plans indicated that the bearing



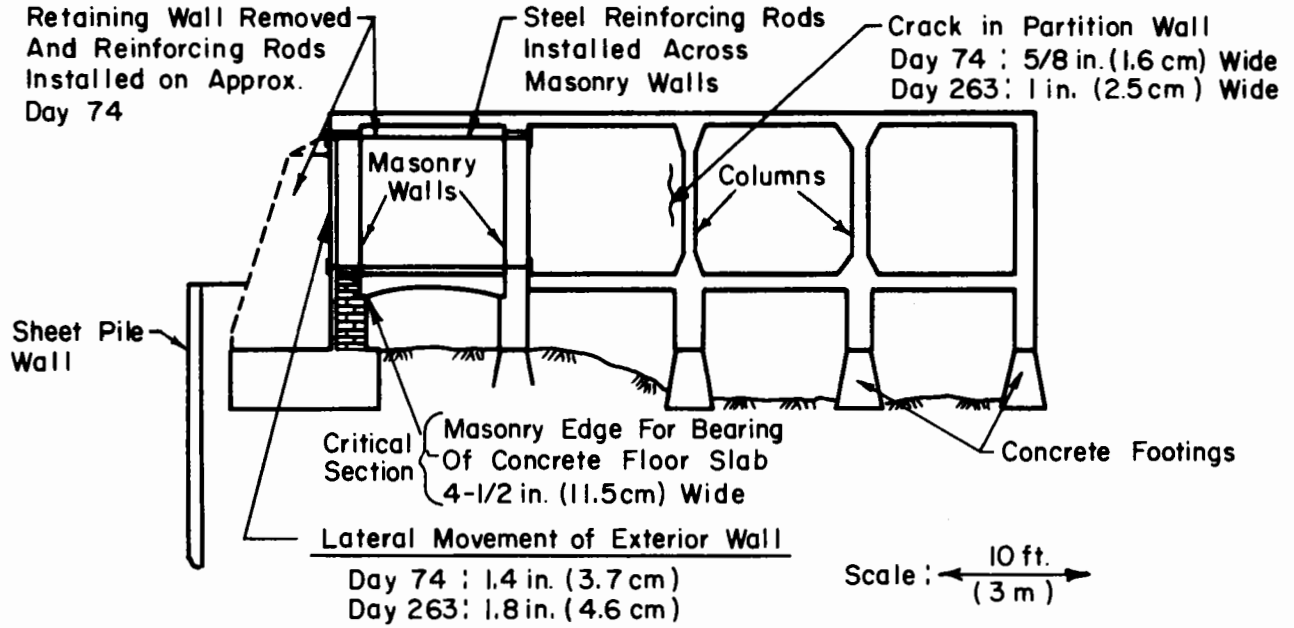

a) Detail of Rail Station

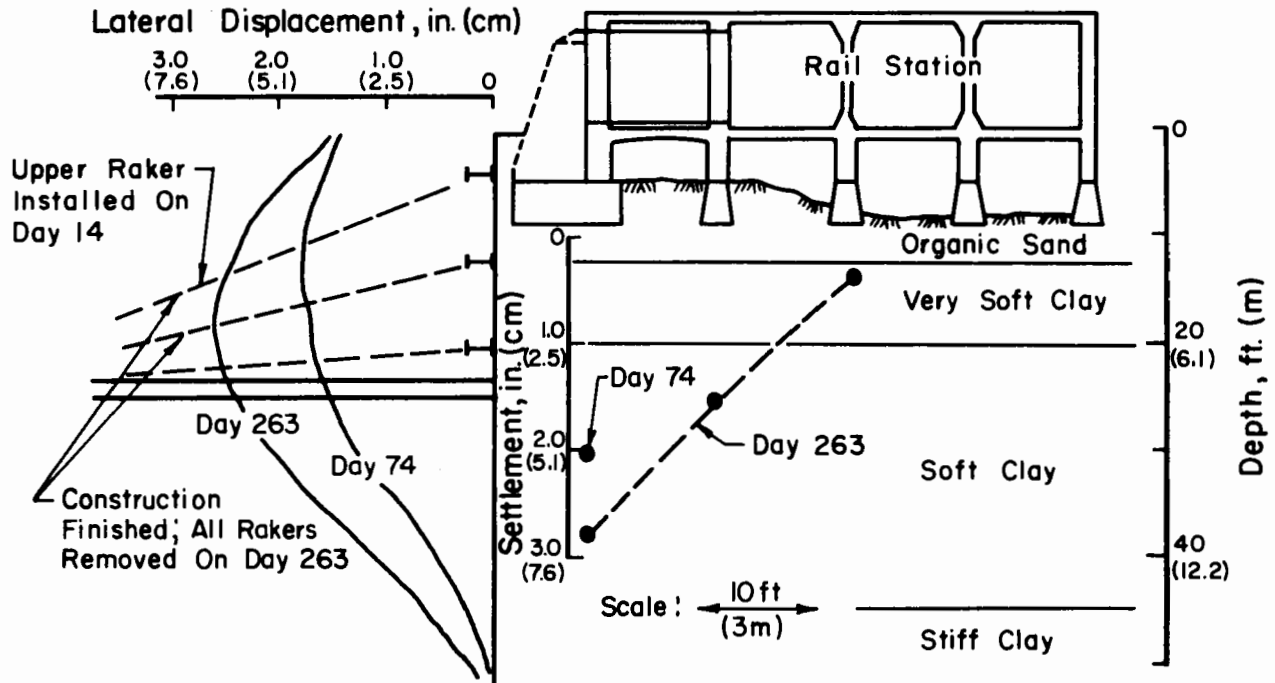

b) Vertical and Lateral Displacement Profile

Fig. 4.8 Summary of Displacements Associated with a Braced Excavation Adjacent to a Chicago Rail Station

length was originally 4.5 in. (11.4 cm). A lateral displacement of 2 in. (5.1 cm), for the wall closest to opencutting, was judged critical for reducing the bearing length to a minimum.

The maximum lateral displacement of the exterior wall was measured as 1.4 in. (3.6 cm) on Day 74. At this time, the maximum settlement of the exterior wall was approximately 2 in. (5.1 cm) and the maximum lateral displacement of the excavation wall was 1.8 in. (4.6 cm). At this point, remedial measures were undertaken to prevent collapse of the concrete floor slab. The retaining wall next to the structure was removed to decrease the dead load at the edge of excavation. In addition, steel tie-rods were installed between the two masonry walls closest to the excavation.

Measurements taken at the completion of the excavation (Day 263), after all rakers had been removed from the cut, show that inward movement of the excavation wall increased by nearly 1 in. (2.5 cm). Vertical and lateral displacements of the exterior station wall increased by 0.8 and 0.5 in. (2 and 1 cm), respectively. From Day 74 to Day 263, interior measurements showed that lateral displacement between the exterior bearing wall and the floor slab increased by only 1/16 in. (1.6 mm). During this time, additional measurements showed an incremental expansion of 3/8 in. (1 cm) in a vertical wall crack near the column line, 34 ft (10.4 m) from the edge of excavation. Apparently, the reinforcing rods had successfully tied the brick-bearing walls together such that lateral strains were transmitted into the adjacent structural bay.

Figure 4.8 shows the estimated settlement profile for the structure on Day 263. The maximum angular distortion sustained between the column line and bearing wall of the second structural bay is approximately  $8 \times 10^{-3}$ . Severe

cracking was apparent in this bay. Several cracks, ranging from 0.5 to 1.0 in. (1.3 to 2.5 cm) wide, were visible in the partition walls of this section.

Figure 4.9 shows a plan view of a tunnel that was excavated near a group of 2 and 3-story brick-bearing wall structures in Washington, D. C. Excavation of the tunnel was carried from points A to B, primarily through a stratum of soft, silty clay. Ground loss varied substantially, with a maximum centerline settlement at the ground surface of 4 in. (10 cm) occurring near the corner building closest to point B. A minimum, centerline settlement at the ground surface of 1.4 in. (3.7 cm) occurred near the corner building closest to point A.

Buildings located along the longitudinal path of tunneling were influenced by a settlement wave that was generated across the structures as the tunnel advanced and passed their specific locations. Consequently, the maximum angular distortion imposed on a given structure was a function of the time-history of movement. For this reason, the maximum angular distortions have been evaluated by reviewing the successive settlement profiles that were developed as the tunnel was driven along the building line.

Figure 4.9 shows the maximum angular distortions plotted with respect to their location along the building line. By comparing the observed damage at the store fronts with the locations and magnitudes of the maximum angular distortions, it is possible to evaluate how building damage is related to various intensities of deformation. Figure 4.9 shows that, for the structures near point A, a maximum angular distortion of  $2.8 \times 10^{-3}$  (1/357) corresponds to minor cracks and separations at the facade of the building. During tunneling, there were no complaints from the occupants of the structures in this vicinity. The

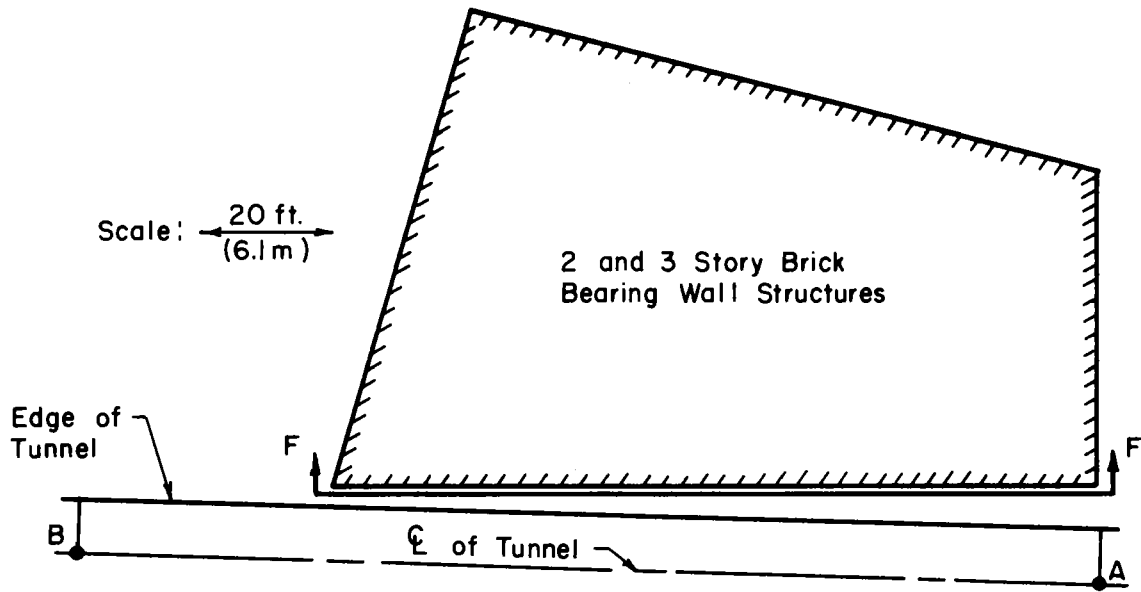

a) Plan View of Tunnel and Buildings Along Path of Tunnel

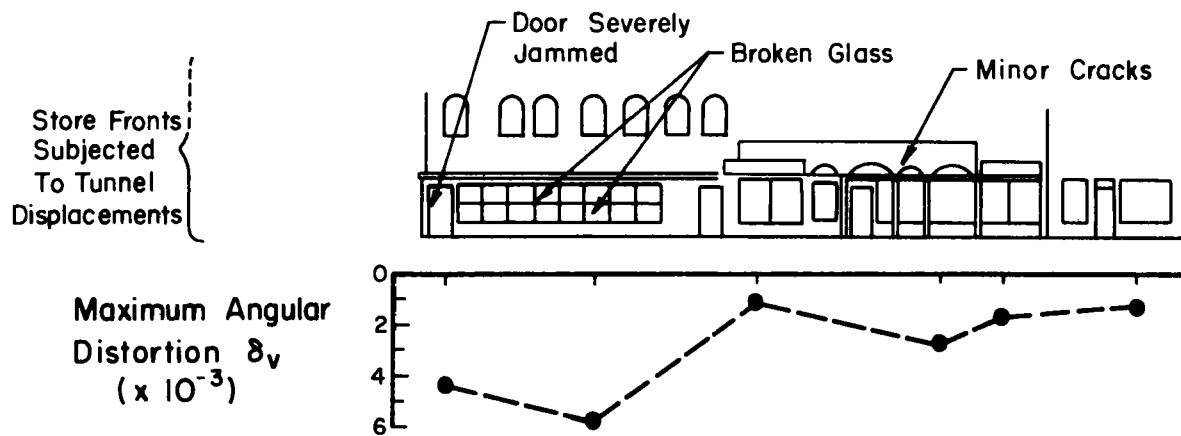

b) Profile of Store Fronts (Section F-F) With Maximum Angular Distortion and Location of Damage

Fig. 4.9 Angular Distortion and Damage Associated with Tunneling Near Brick-Bearing Wall Structures

structure closest to point B, however, experienced broken windows. Its entrance-way was distorted such that the contractor's assistance had to be obtained to close and lock the door. The maximum angular distortions for this structure ranged between  $4.5 \times 10^{-3}$  (1/220) and  $6.0 \times 10^{-3}$  (1/167).

Observations relating building damage with differential ground movements parallel to bearing walls were taken during recent opencutting through deposits of inorganic silt in New York City. The silt, locally known as "bull's liver", became extremely unstable when subjected to vertical cutting and construction vibrations. Ground loss, associated with this condition, resulted in substantial movements along the bearing walls of adjacent 2 to 5-story buildings. Unfortunately, settlement profiles were obtained on only a few corner structures. These measurements show angular distortion of approximately  $8 \times 10^{-3}$ . The facade wall of one corner structure was measured as much as 6.5 in. (16.5 cm) out of plumb over a 5-story height. Spalling of the sandstone cladding through the upper stories of several buildings was apparent. At one location, a sandstone block was dislodged from the building facade and fell to the sidewalk.

Field observations of damage and the descriptions of brick-bearing wall structures are combined in Table 4.2 to correlate building damage with different levels of structural deformation. Various forms of damage are described and related to specific ranges of angular and lateral distortion. Unless otherwise specified, it is assumed that the angular and lateral distortions at the ground surface are approximately of the same magnitude. Additional field observations should extend and refine this information. Special conditions may, at times, rule out the application of some of these

TABLE 4.2  
 DAMAGE RELATED TO BUILDING DISTORTION  
 FOR BRICK-BEARING WALL STRUCTURES

Description of damage	* Angular, $\delta_V$ , and lateral, $\delta_H$ , distortion at the ground surface
Threshold of architectural damage	$1.0 \times 10^{-3}$
Architectural damage; sticking doors; may be conspicuous concentrations of cracks; cracks and separations as large as 1/8 to 1/4 in. (0.3 to 0.6 cm) wide	$1.0 \times 10^{-3}$ to $3.0 \times 10^{-3}$
Damage is an inconvenience to building occupants; jammed doors and windows; broken window panes; building services may be restricted. Cracks and separations may be as large as 1/2 to 1 in. (1.3 to 2.5 cm) wide	$3.0 \times 10^{-3}$ to $7.0 \times 10^{-3}$
Spalling of stone cladding and possible collapse of cornices along the facade wall (differential movements parallel to brick-bearing walls)	$7.0 \times 10^{-3}$ to $8.0 \times 10^{-3}$

\*Note: angular and lateral distortion are assumed to be approximately equal.

values, as would be the case for an old structure whose facade walls are seriously out of plumb before the start of construction. Consequently, the table should serve as a guide so that estimates of potential damage can be made on a general basis with the understanding that, for individual cases, additional judgments may be required.

#### 4.5 METHODS OF PROTECTION

Structures adjacent to excavation are often protected by conventional underpinning techniques. These methods use jacked, pipe piles or hand excavated piers to transfer building loads to soil or rock beneath the zone of soil displacement caused by excavation. This type of protection is expensive and may interfere with building services. In addition, some settlement of the underpinned structures will occur for two reasons:

1. During installation movement develops in response to the excavation of working pits and the transfer of building load to the underpinning elements. The amount of settlement is related to the quality of the installation technique which, in turn, varies according to the foundation conditions, control of ground water, and workmanship. In Washington, D. C., settlements associated with the installation of underpinning are frequently 1/4 to 1/2 in. (0.6 to 1.3 cm), but may be higher for difficult conditions such as brick-bearing walls founded directly on soil or rubble stone footings.

2. After the underpinning elements are installed, settlement is caused by elastic compression of the piles in response to drag-down forces in the soil, additional settlement of the pile tips, and redistribution of buildings loads. In Washington, D. C., settlements of underpinned buildings are often 1/4 to 5/8 in. (0.6 to 1.6 cm), subsequent to underpinning.

Although conventional underpinning significantly reduces angular distortion and restrains the relative rotation of bearing walls, movements associated with underpinned structures are commonly of sufficient magnitude to result in architectural damage. Consequently, the primary advantage of conventional underpinning is not so much to eliminate cosmetic disturbance, but to improve building stability. For this reason, conventional underpinning can be particularly effective in soil where difficulties in controlling the ground water are anticipated. In this situation, local infiltration of fines, sloughing along the sheeting line, and upward seepage at the excavation bottom can result in erratic concentrations of ground loss. The sharp settlements, resulting from this condition can be bridged by the underpinning elements to prevent serious damage.

Large lateral displacements generally accompany large settlements especially where cantilever deformation of the excavation wall has been excessive. The relatively flexible underpinning elements do not restrict the lateral movement of the soil mass and, for this reason, severe deformation can occur even though the building has been reinforced against vertical displacement. For brick-bearing wall structures, lateral distortion of  $10 \times 10^{-3}$  could be sufficient to result in an unsafe bearing length of the floor joists.



Judgments related to the underpinning of brick-bearing wall structures should be made with consideration of the economics of individual cases. Very often, it will be difficult to justify the high expense of underpinning relatively inexpensive buildings. For these cases, attention should be directed to limiting the ground movements through controlled excavation procedure and the use of rigid support techniques, such as slurry walling.

Protective measures should always include an adequate monitoring program. Frequently, optical leveling of the adjacent building line is the only information regarding structural movement obtained for a given excavation project. The limited scope of this information does not allow for a clear judgment regarding building distortion and associated damage.

Settlement profiles of structures should be taken at several different locations along the excavation to provide a measure of the angular distortion sustained by surrounding buildings. Each settlement profile should include three or more points, spaced at separations of 15 to 20 ft (4.6 to 6.1 m) along the building line perpendicular to excavation. Inclination measurements of building walls closest to the excavation should be taken periodically in combination with visual inspection to detect spalling of stone cladding or deterioration of architectural accouterments. When large lateral movements are anticipated, lateral offset surveys should be performed on at least two lines behind the edge of excavation to determine horizontal ground strains. In all cases, initial readings should be obtained prior to underpinning and dewatering.

Monitoring programs that follow the guidelines listed above help in the evaluation of building damage, indicate potential hazards, and suggest remedial measures in case of large ground movements. A good set of initial measurements, especially with regard to wall inclination, helps to define the building conditions previous to construction and may be beneficial in the event of future legal claims.



## 5. CONCLUSIONS

### 5.1 GENERAL DISCUSSION

To predict building damage associated with braced excavation a knowledge of the ground movements that typically develop in different soil profiles for various construction techniques is required. Recent observations of excavation in Washington, D. C. and Chicago have been particularly helpful in this matter. Field measurements of settlement and lateral displacement in both cities emphasize the great difference of excavation behavior for cuts in dense sand and interbedded stiff clay as compared with cuts in soft clay. Particularly for excavation in soft clay, different construction procedures result in large variations of vertical and lateral displacement. Hence, an understanding of the various construction methods and their ramifications on the ground movement is imperative for evaluating the influence of excavation on surrounding buildings.

It is expedient to relate ground movements directly to building deformation. Ground movements expressed in terms of simple strain, either as angular or lateral distortion, are helpful in this regard. The degree to which a building reflects the imposed ground strain depends on the frequently complex interaction between the structure and soil. Values of angular and lateral ground distortion provide an upper limit of strain imposed on a given building that may be modified according to the stiffness of the structure, the forces mobilized between the structure and the soil, and the length of the structure relative to the extent of the settlement profile.

In this report information has been collected for three areas: typical ground movements and strains caused by excavation in both dense

sand and soft clay; architectural damage related to excavation movements for various building types; and potential modes of instability related to brick-bearing wall structures. Specific conclusions are summarized for each of these areas under the following three headings:

## 5.2 GROUND MOVEMENTS ASSOCIATED WITH BRACED EXCAVATIONS

1. The patterns of settlement associated with soldier pile and lagging excavation in the dense sands and interbedded stiff clay of Washington, D. C. show a remarkable similarity among several different construction sites. Expressed as a percentage of the excavation depth, the surface settlements were equal to or less than 0.3% near the edge of the cut and 0.05% at a distance equal to 1.5 times the excavation depth. The angular distortion for cuts between 55 and 60 ft (18.3 m) deep were equal to or less than approximately  $5 \times 10^{-3}$  near the edge of excavation to a value slightly larger than  $1 \times 10^{-3}$  at a distance behind the cut equal to the excavation depth.

2. Three distinct stages of ground movement can be distinguished for cut-and-cover subway construction. These include: 1) Excavation before placement of braces, 2) Excavation to subgrade after the upper braces are installed, and 3) Removal of braces, and construction of the permanent structure. During each stage, ground movements are related either to cantilever movement or inward bulging of the excavation wall. Visualizing the movements as the result of individual construction stages helps to explain the final distribution of ground movement and call attention to incremental soil strains that develop in the course of the construction history.

3. A comparative study of nine different excavations in the soft clay of Chicago indicates that substantial differences in ground movement result from variations in the construction procedure. For excavations using temporary berms and rakers, the soil displacement is closely related to the size of the berm during installation of the upper level rakers, the manner in which the berm is excavated in tandem with raker placement, and the vertical separation of brace levels. Observations show that early installation of the top level braces, before excavation of the central portion of the cut or while substantial berms are in place, is extremely helpful for controlling movement. The observations also indicate that large settlements can result from caisson excavation unless guidelines are adopted to control this aspect of the construction.

4. Angular distortions associated with berm and raker excavation in the Chicago soft clay have been summarized for several cases. Based on this information, angular distortion is equal to or less than  $11 \times 10^{-3}$  and  $5 \times 10^{-3}$  for distances behind the excavation of 0.5 and 1.5 times the maximum excavation depth, respectively.

5. Displacement of the excavation wall is partly a function of the bracing stiffness. When rakers are installed between the sheeting line and a caisson foundation, the bracing stiffness frequently depends on the lateral resistance of the caissons. Even for elastic displacements, lateral movement at the top of the caissons can be significant under the excavation support loads required for cuts in soft clay. Therefore, optimal bracing requires that raker installation be coordinated with the foundation construction. In this manner, the bracing stiffness can be

increased by transmitting individual raker loads among several caissons or to a combination of caissons and foundation slabs.

6. Field observations show that slurry walls, when used in combination with excavation control and careful installation of braces, can result in relatively small soil displacements. Although additional study is needed to develop a comprehensive picture of slurry wall behavior, their ability to restrain ground movements in soft clay represents an advantage over alternative support methods when building damage must be minimized.

7. Both model tests and field measurements for excavations in clay and sands and gravels show that the ratio of the horizontal to vertical ground movement varies according to the relative proportion of cantilever movement and inward bulging of the excavation wall. For wall deformation that is predominantly cantilever, the ratio of horizontal to vertical ground movement approaches a value of approximately 1.6 at distances behind the excavation of 0.5 to 1.5 the excavation depth. For wall deformation that occurs predominantly as inward bulging, the ratio of horizontal to vertical ground movement tends to a value of approximately 0.6. Using this information, surface displacements can be related to the excavation procedure. For example, if the upper level braces are installed and preloaded before the excavation is deepened substantially or while large berms are still in place, the lateral movements will be restrained to values less than those of the settlements. Conversely, if the upper level braces are installed without adequate stiffness or after the excavation has been deepened appreciably, lateral movements will develop in excess of the settlement. This condition can lead to excessive lateral strain, against which conventional underpinning techniques, such as pipe piles and continuous piers, offer little restraint.

### 5.3 ARCHITECTURAL DAMAGE TO BUILDINGS

1. For large excavation projects where movements associated with opencutting and tunneling are inevitable, architectural damage should reflect the dimensions at which cracks become noticeable to building occupants under general working and living conditions. For this reason, architectural damage is distinguished as cracks in plaster walls that are equal to or greater in width than 1/64 in. (0.4 mm) and cracks in hollow block, brick, and rough concrete walls that are equal to or greater in width than 1/32 in. (0.8 mm). Separations in tile floors are assumed to be evident at widths of 1/16 in. (1.6 mm).

2. Based on correlations of observed damage with measurements of building settlement in response to opencutting, the following criteria are proposed: 1) an angular distortion of  $1.0 \times 10^{-3}$  (1/1000) is recommended as the threshold value for architectural damage to brick-bearing wall structures adjacent to excavation. 2) An angular distortion of  $1.3 \times 10^{-3}$  (1/750) is recommended as a conservative lower bound for architectural damage to frame structures adjacent to excavation. It is realized that these recommendations are developed from observations on a limited number of buildings. Further observations, therefore, will be helpful to extend and refine the data from which these recommendations are derived.

3. The limiting value of angular distortion for architectural damage to brick-bearing wall structures adjacent to excavation is approximately one-third the value proposed by Skempton and MacDonald (40) and Grant et al (16) for the settlement of structures under their own

weight. This difference is primarily related to the lateral strains that accompany braced excavations, to the fact that buildings adjacent to open-cutting have invariably sustained some strains prior to excavation as a function of settlement under their own weight and deterioration with age, and to the fact that the distortions imposed on a structure during excavation occur rapidly.

4. Considering the low values of angular distortion associated with architectural damage, it is doubtful that many protective measures, especially underpinning, can be relied on to prevent the movements associated with minor cracks and separations.

#### 5.4 STRUCTURAL DAMAGE TO BRICK-BEARING WALL BUILDINGS

1. An important characteristic of brick-bearing wall structures is their anisotropy with respect to structural behavior. Each building can be visualized as having two axes of structural response. One axis is aligned perpendicular to the bearing walls; the other axis is oriented parallel to the bearing walls. Structural stability is most sensitive to ground movements perpendicular to the bearing walls. Soil displacement in this direction causes lateral movement of one wall with respect to the other that, in turn, leads to loss of the floor support.

2. For buildings constructed of lime mortar masonry, the minimum bearing lengths for floor beams at the masonry-joist connections are estimated to be 1.2 in. (3.0 cm) for domestic structures and 1.7 in. (4.3 cm) for commercial



structures. Because masonry-joist connections are typically 4 in. (10.1 cm) long, this corresponds to a maximum, safe lateral displacement between bearing walls of 2.3 in. (5.8 cm) and 2.8 in. (7.1 cm) for commercial and domestic units, respectively.

3. Differential lateral movement at the masonry-joist connection can occur as the result of two distinct forms of deformation: 1) direct lateral strain and 2) differential rotation of adjacent bearing walls. For cases where only lateral displacements influence the relative movement of bearing walls, lateral distortion of  $10 \times 10^{-3}$  can be sufficient to cause a critical condition of minimum joist bearing. The loss of joist bearing contributed by wall rotation is difficult to evaluate, and will be a function of the stiffness of the bearing wall with respect to the restraining forces at the masonry-joist connections. More observational and analytical work are needed to evaluate this aspect of building behavior.

4. Field observations indicate that diagonal extension cracks are the largest and most extensive fractures that occur in response to ground movements parallel to brick-bearing walls. When diagonal extension cracks intersect the facade wall of the structure, spalling of stone cladding and collapse of architectural accouterments can occur. Hence, the daylighting of bearing wall cracks on the building facade and the corresponding deformation of the facade wall represent a potential hazard. Field observations and guidelines used by building engineers indicate that this type of problem can occur in response to angular distortions of  $7.0 \times 10^{-3}$  to  $8.0 \times 10^{-3}$ .

5. Judgments related to the underpinning of brick-bearing wall structures should be made with consideration of the economics of individual cases. Very often, it will be difficult to justify the high expense of underpinning relatively inexpensive structures. For these cases, attention should be directed to limiting ground movements through controlled excavation procedure and the use of rigid support techniques, such as slurry walling.

6. An adequate monitoring program is important for protecting structures adjacent to excavation. Frequently, construction surveys of surrounding building lines provide information that is inadequate to evaluate the building distortions and associated damage. Settlement profiles of structures should be taken at several locations along the excavation to provide a measure of the angular distortion sustained by surrounding buildings. Inclination measurements of building walls closest to the excavation should be taken periodically in combination with visual inspection to detect spalling of stone cladding or deterioration of architectural counterments. When large lateral displacements are anticipated, lateral offset surveys should be performed on at least two lines behind the edge of excavation to determine horizontal ground strains. Monitoring programs that use these methods provide a sound basis for predicting potential hazards and for recommending remedial measures in case of damage. A good set of initial measurements, especially with regard to wall inclination, helps to define the building conditions previous to construction and may be beneficial in the event of future legal claims.

## REFERENCES

1. American Institute of Timber Construction, Timber Construction Manual, Sections 2 and 3, John Wiley and Sons, Inc., 1966.
2. Armento, W. J., "Cofferdam for BARTD Embarcadero Subway Station," Journ. of Soil Mech. and Found. Div., ASCE, Vol. 99, No. SM10, pp. 727-744, 1973.
3. Bjerrum, L., Discussion in Sect. VI, Proc. European Conf. on Soil Mech. and Found. Engr., Wiesbaden, Vol. II, pp. 135-137, 1963.
4. Bjerrum, L., C. T. Frimann Clausen, and T. M. Duncan, "Earth Pressures on Flexible Structures," State-of-the-Art Report, Proc. Eur. Conf. Soil Mech. Found. Engr., Madrid, Vol. 2, pp. 169-196, 1972.
5. Breth, H., and G. Chambosse, "Settlement Behavior of Buildings Above Subway Tunnels in Frankfurt Clay," Proc., Conf. on Settlement of Structures, pp. 329-336, 1975.
6. Burland, J. B., and C. P. Wroth, "Settlement of Buildings and Associated Damage," Proc., Conf. on Settlement of Structures, pp. 611-654, 1975.
7. Cunningham, J. A., and J. I. Fernandez, "Performance of Two Slurry Wall Systems in Chicago," Proc. ASCE Specialty Conf. on Perf. of Earth and Earth-Supported Structures, Purdue, Vol. I, Part 2, pp. 1425-1449, 1972.
8. Davisson, M. T., "Lateral Load Capacity of Piles," Pile Foundations, Highway Research Record 333, pp. 104-112, 1970.
9. Davisson, M. T., and H. L. Gill, "Laterally Loaded Piles in a Layered Soil System," Journ. of Soil Mech. and Found. Div., ASCE, Vol. 89, SM3, pp. 63-94, 1963.
10. Dibiagio, E., and J. A. Roti, "Earth Pressure Measurements on a Braced Slurry-Trench Wall in Soft Clay," Proc. Eur. Conf. Soil Mech. Found. Engr., Madrid, Vol. 1, pp. 473-483, 1972.
11. Flaate, K. W., "Stresses and Movements with Braced Cuts in Sand and Clay," Ph.D. Thesis, University of Illinois, 1966.
12. Gaylord, E. H., and C. N. Gaylord, "Structural Engineering Hand Book," Section 15, McGraw-Hill, Inc., 1968.
13. Glanville, W. H., and P. W. Barnett, "Mechanical Properties of Bricks and Brickwork Masonry," Great Britain Scientific and Industrial Research Dept., Building Research Board Special Report No. 22, London, 1934.

14. Gnaedinger, J. P., S. A. Gill, and P. A. Keim, "Performance of Tied-Back Excavation at Water Tower Place," Performance Monitoring for Geotechnical Construction, ASTM STP 584, pp. 78-99, 1975.
15. Gould, J. P., and J. D. Parsons, "Long Term Performance of Tall Buildings on New York City Varved Silt," Conference on Tall Building Foundations, Lehigh University, 1975.
16. Grant, R., J. T. Christian, and E. H. Vanmarcke, "Differential Settlement of Buildings," Journ., Geot. Engr. Div., ASCE, Vol. 100, GT9, pp. 973-991, 1974.
17. Horn, H. M., and T. W. Lambe, "Settlement of Buildings on the MIT Campus," Jour. of Soil Mech. and Found. Div., ASCE, Vol. 90, SM5, pp. 181-196, 1964.
18. Jackson, W. T., J. Y. Perez, and Y. Lacroix, "Foundation, Construction and Performance for a 34-Storey Building in St. Louis, Missouri," Geotechnique, Vol. 24, No. 1, pp. 63-90, 1974.
19. Jaworski, W. E., "An Evaluation of the Performance of a Braced Excavation," Ph.D. Thesis, Massachusetts Institute of Technology, 1973.
20. Kerisel, J., "Old Structures in Relation to Soil Conditions," Geotechnique, Vol. 25, No. 3, pp. 433-483, 1975.
21. King, H. J., and R. J. Orchard, "Ground Movement in the Exploitation of Coal Seams," Colliery Guardian, Vol. 198, pp. 471-477, 1959.
22. Lacroix, Y., "Observational Approach and Instrumentation for Construction on Compressible Soils," Utilization of Sites of Soft Foundations, Highway Research Record, No. 133, Washington, D. C., 1966.
23. Lacroix, Y., personal communication, 1976.
24. Lambe, T. W., L. A. Wolfskill, and I. H. Wong, "Measured Performance of Braced Excavation," Journ. of Soil Mech. and Found. Div., ASCE, Vol. 96, SM3, pp. 817-836, 1970.
25. Larson, M. L., W. R. Willette, H. C. Hall, and J. P. Gnaedinger, "A Case Study of a Soil Anchor Tied-Back System," Proc. ASCE Specialty Conf. on Perf. of Earth and Earth-Supported Structures, Purdue, Vol. 1, Part 2, pp. 1341-1366, 1972.
26. Littlejohn, G. S., "Observations of Brick Walls Subjected to Mining Subsidence," Proc., Conf. on Settlement of Structures, pp. 384-393, 1975.
27. Liu, T. K., and J. P. Dugan, "An Instrumented Tied-Back Deep Excavation," Proc. of ASCE Specialty Conf. on Perf. of Earth and Earth-Supported Structures, Vol. 1, Part 2, pp. 1323-1339, 1972.

28. Maljian, P. A., and J. F. Van Beveren, "Tied-Back Deep Excavations in Los Angeles Area," *Journ. of Constr. Div., ASCE*, Vol. 100, C03, pp. 337-356, 1974.
29. McBurney, J. W., and C. E. Lovewell, "Strength, Water Absorption, and Weather Resistance of Building Bricks Produced in the United States," *ASTM Proceedings of the Thirty-Sixth Annual Meeting*, Vol. 33, Part II, Technical Papers, 1954.
30. McRostie, G. C., K. N. Burn, and R. J. Mitchell, "The Performance of Tied-Back Sheet Piling in Clay," *Can. Geot. Journ.*, Vol. 9, No. 2, pp. 206-218, 1972.
31. Milligan, G. W. E., "The Behavior of Rigid and Flexible Retaining Walls in Sand," Ph.D. Thesis, Cambridge University, 1974.
32. Monk, C., "A Historical Survey and Analysis of the Compressive Strength of Brick Masonry," *Structural Clay Products Research Foundation, Research Report No. 12*, Geneva, Ill., 1967.
33. Murphy, D. J., G. W. Clough, and R. S. Woolworth, "Temporary Excavation in Varved Clay," *Journ. Geot. Engr. Div., ASCE*, Vol. 101, GT3, pp. 279-295, 1975.
34. O'Rourke, T. D., "A Study of Two Braced Excavations in Sands and Interbedded Stiff Clay," Ph.D. Thesis, University of Illinois, 1975.
35. Peck, R. B., "Earth-Pressure Measurements in Open Cuts, Chicago Subway," *Transactions, ASCE*, Vol. 108, pp. 1008-1036, 1943.
36. Peck, R. B., "Deep Excavations and Tunneling in Soft Ground," *Proc. 7th Int'l. Conf. on Soil Mech. and Found. Engr., Mexico City, State-of-the-Art Vol.*, pp. 225-290, 1969.
37. Peck, R. B., D. U. Deere, and J. L. Capacete, Discussion of building damage, *Proc. Institute of Civil Engineers*, Vol. 5, Part III, pp. 778-781, 1956.
38. Polshin, D. E., and R. A. Tokar, "Maximum Allowable Non-Uniform Settlement of Structures," *4th Int'l. Conf. on Soil Mech. and Found. Engr.*, Vol. 1, pp. 402-405, 1957.
39. Scott, J. D., N. E. Wilson, and G. E. Bauer, "Analysis and Performance of a Braced Cut in Sand with Large Deformations," *Can. Geot. Journ.*, Vol. 9, No. 4, pp. 384-406, 1972.
40. Skempton, A. W., and D. H. MacDonald, "The Allowable Settlement of Buildings," *Proceedings, Institute of Civil Engineers*, Vol. 5, Part III, pp. 727-784, 1956.

41. St. John, H. D., "Field and Theoretical Studies of the Behavior of Ground Around Deep Excavations in London Clay," Ph.D. Thesis, Cambridge University, 1975.
42. Thon, J. G., and R. C. Harlen, "Slurry Walls for BART Civic Center Subway Stations," Journ. Soil Mech. and Found. Div., ASCE, Vol. 97, SM9, pp. 1317-1334, 1971.
43. Wong, I. H., "Analysis of Braced Excavations, Ph.D. Thesis, Massachusetts Institute of Technology, 1971.