

S.C.R.T.D. LIBRARY

TRANSBUS SAFETY AND HUMAN FACTORS

Booz, Allen & Hamilton Inc.
Transportation Consulting Division
4330 East-West Highway
Bethesda, Maryland 20014

S.C.R.T.D. LIBRARY



SEPTEMBER 30, 1977

SUMMARY REPORT

Prepared for

DEPARTMENT OF TRANSPORTATION

Urban Mass Transportation Administration

Bus Projects Division

Washington, D. C. 20540

TL
232
.T78

TRANSBUS SAFETY AND HUMAN FACTORS

**Booz, Allen & Hamilton Inc.
Transportation Consulting Division
4330 East-West Highway
Bethesda, Maryland 20014**



SEPTEMBER 30, 1977

SUMMARY REPORT

Prepared for
DEPARTMENT OF TRANSPORTATION
Urban Mass Transportation Administration
Bus Projects Division
Washington, D. C. 20540

1. Report No.		2. Government Accession No.		3. Recipient's Catalog No.	
4. Title and Subtitle Transbus Safety & Human Factors				5. Report Date September 30, 1977	
				6. Performing Organization Code	
7. Author(s) Booz, Allen & Hamilton Inc.				8. Performing Organization Report No. TR 77-004	
9. Performing Organization Name and Address Booz, Allen & Hamilton Inc. Transportation Consulting Division 4330 East West Highway Bethesda, Maryland 20014				10. Work Unit No.	
				11. Contract or Grant No. DOT-UT-10008	
12. Sponsoring Agency Name and Address U.S. Department of Transportation Urban Mass Transportation Administration Washington, D.C.				13. Type of Report and Period Covered Summary Report 1971 to 1976	
				14. Sponsoring Agency Code	
15. Supplementary Notes					
16. Abstract This report describes the overall program of transit bus safety and human factors research that was conducted between 1971 and 1976 in support of the Transbus program. The report describes work efforts in the following areas: system safety analysis, passenger observations and human factors research, door studies, bus bumper and crash testing, bus seat safety, and interior design for passenger safety. The report references and summarizes previously published materials, but a number of additional working papers and technical briefings are presented as appendices to this report to more fully document these research efforts.					
17. Key Words Transit Bus, Transbus, Bus Passenger Safety, Elderly and Handicapped, Human Factors			18. Distribution Statement Document is available to the U.S. public through the National Technical Information Service, Springfield, Virginia 22161.		
19. Security Classif. (of this report) Unclassified		20. Security Classif. (of this page) Unclassified		21. No. of Pages 148	22. Price

T A B L E O F C O N T E N T S

	<u>Page Number</u>
1. OBJECTIVE	1
2. INTRODUCTION	1
a. The Scope of the Transbus Safety and Human Factors Effort	1
b. System Safety Analysis	1
c. Passenger Observations and Human Factors	2
d. Door Studies	2
e. Bumper and Crash Testing	2
f. Seat Safety	2
g. Interior Design Features	2
h. Coordination	2
i. System Safety Approach	2
j. Methodology	3
3. CHRONOLOGY OF THE TRANSBUS AND HUMAN FACTORS PROGRAM	3
a. Overview	3
b. Efforts in 1971	3
c. Efforts in 1972	6
d. Efforts in 1973	8
e. Efforts in 1974	11
f. Efforts in 1975	12
g. Efforts in 1976	13
h. Summary of Transbus Safety and Human Factors Program (1971-1976)	14
4. REFERENCES	15
APPENDIX A - Transit Bus Safety Report #1 - Bus Accident Data Analysis	
APPENDIX B - Observations of Passengers On-Board Current Buses	

APPENDIX C - Impact of Mass Transit on
Urban Traffic Safety

APPENDIX D - Improvements in the Safety of
Urban Transit Coaches

1. OBJECTIVE

The primary objective of this report is to summarize the work accomplished in the areas of transit bus safety and human factors research as part of the Transbus program. Transbus was the U.S. Department of Transportation, Urban Mass Transportation Administration's program, which supported the design, construction and testing of advanced, standard size (40 feet), prototype, urban transit buses. Since safety and human factors research was a major element of the work program from its outset in 1971, much valuable information has been generated in the form of reports, presentations, working papers and technical society papers. This report organizes this information in a logical program context and in a chronological sequence. The rationale for each work element is described. For the most part, the reader is referred to previously published materials, which present key results. In some instances, previously unpublished draft reports, working papers, and briefings are presented in appendices to complete the public record of the Transbus safety and human factors effort.

2. INTRODUCTION

a. The Scope of the Transbus Safety and Human Factors Effort. The Transbus safety and human factors effort has been one of the most extensive activities of its type in the history of urban transit bus design. The effort, which took place from mid-1971 through 1976, involved six general task areas as follows:

- . System safety analysis
- . Passenger observations and human factors
- . Door studies
- . Bumper and crash testing
- . Seat safety
- . Interior features.

b. System Safety Analysis. The integrating task that tied together the safety and human factors program was the system safety analysis task. The basic approach used was that of system safety engineering. The task began with an analysis of bus accidents and bus accident costs. This identified key problem areas requiring solutions during the program by design, testing, and evaluation of the transit bus prototypes.

c. Passenger Observations and Human Factors. The second major task area involved observations and human factors research. This effort supplemented the system safety analysis work by obtaining in-service data from extensive observations and human factors test results related to safety.

d. Door Studies. The next task, door studies, involved both studies of the efficiency of boarding and alighting with various door widths/floor heights and also the safety parameters of doors to be required in future specifications.

e. Bumper and Crash Testing. The fourth task involved the crashworthiness and body structural aspects of transit bus safety. In particular, testing of new energy-absorbing bumpers and full-scale bus crash testing was performed.

f. Seat Safety. The fifth task involved transit bus seats, the design of seats both for comfort and for excellent crashworthiness and survivability. The program included a HYGE sled/seat test and evaluation effort that compared current transit bus seats to the new cantilever design seat concepts proposed for Transbus.

g. Interior Design Features. The sixth task involved all aspects of interior safety and human factors design including grab rails, stanchions, padding, and basic studies of passenger movement within transit buses under potential accident situations.

h. Coordination. The program included coordination of the Transbus safety effort with research at the National Highway Traffic Safety Administration, which is responsible for safety standards for all new motor vehicles manufactured and sold in the United States. In addition, numerous periodic review sessions were held with representatives of the transit industry and public interest groups, such as those representing the elderly and handicapped.

i. System Safety Approach. A systems safety engineering approach guided the Transbus safety effort. The safety and human factors effort was based on a comprehensive bus accident data analysis and actual passenger observations/human factors tests, not on *a priori* judgments about key bus safety and human factors issues. The planning of the key work elements began after the initial data had been assembled and analyzed. A cost benefit approach

to improved transit bus design for safety, which focused on key high payoff areas, was developed.

j. Methodology. Over 90 transit bus accident types were analyzed in terms of frequency of occurrence and claims cost per incident. The design safety improvement payoff function was defined as follows:

$$\text{Payoff} = \left[\begin{array}{l} (\% \text{ potential reduction} \\ \text{in accident expense} \\ \text{due to bus redesign}) \end{array} \times \begin{array}{l} (\text{Current life-} \\ \text{cycle accident} \\ \text{expense}) \end{array} \right] - \begin{array}{l} (\text{Life-cycle} \\ \text{cost of bus} \\ \text{redesign}) \end{array}$$

Current life-cycle accident expense was defined as the product of bus accident frequency and average cost for each accident type. Accident frequency data were commonly available from most transit bus properties. A major accomplishment of the accident analysis was the gathering of related traffic and passenger safety claims costs associated with various accident types. By placing both frequency and cost within a fault tree analysis structure, it was possible to delineate high potential payoff areas. Some of these areas could be treated by transit bus design; others could not. These latter areas depended primarily on operational factors that were beyond the control of a bus designer. The Transbus program focused on those specific aspects of transit bus design that could improve overall bus safety. The Transbus safety and human factors effort generated a number of reports and presentations which it is believed are of benefit to the safety community in general and to transit safety practitioners in particular. The following section describes in chronological order the key events of the effort, key findings, and the documents that were developed.

3. CHRONOLOGY OF THE TRANSBUS SAFETY AND HUMAN FACTORS PROGRAM

a. Overview. Figure 1 describes the six major tasks and indicates that 23 related documents were generated. Each document is referenced by a number within the triangle that marks the completion date of the document. These numbers are keyed to Table 1.

b. Efforts in 1971. Work in the transit bus safety area began shortly after the award of the Bus Technology Program contract to Booz, Allen Applied Research in the

FIGURE 1
 TRANSBUS SAFETY AND HUMAN FACTORS
 EFFORTS SCHEDULE

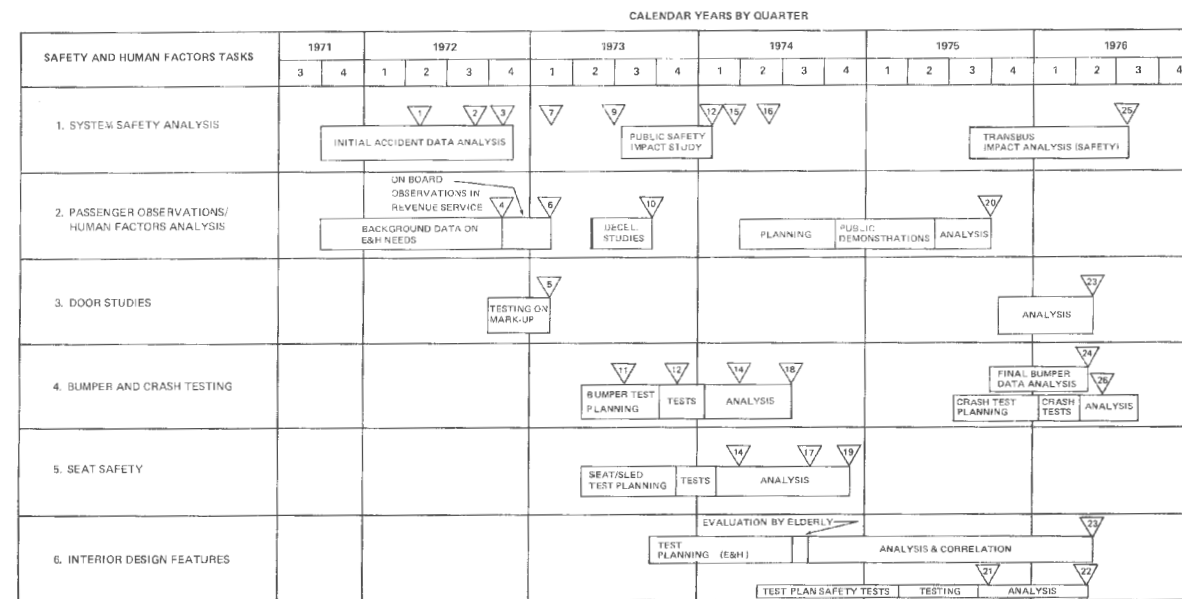

Table 1
Major Documents Referenced in Figure 1
(For detailed reference listing see "Section 4: References")

1. "Transit Bus Safety, Interim Report 1"
2. Transit Bus Safety, Report #1 - Bus Accident Data Analysis
3. "Transit Bus Safety, Interim Report 2"
4. Report on the Design Guidelines Meeting for the Elderly and Handicapped in the Transbus Program
5. Transbus Boarding and Alighting Studies, Forty-Inch Front Door
6. "Observations of Passengers On-Board Current Buses"
7. "Transbus—Current Development in Urban Bus Design"
8. Bus Passenger Seating and Crash Protection—Implications for the UMTA Transbus Program
9. "Transbus Safety Analysis and Public Demonstration Program"
10. Urban Buses Acceleration and Deceleration Studies
11. The Benefits of Energy Absorbing Bumpers for Transit Buses
12. "Benefits of Energy Absorbing Bumpers for Transit Buses"
13. "Impact of Mass Transit on Urban Traffic Safety"
14. "Transbus Bumper and Seat Test Results"
15. "Maintainability and Safety of Transit Buses"
16. "Interior Design for Passenger Safety"
17. Transbus Seat Test Results
18. "The Benefits of Energy Absorbing Bumpers for Transit Buses"
19. "Safety Considerations in Design of New Transit Bus Seats"
20. Transbus Public Testing and Evaluation Program
21. "Cause and Prevention of On-Board Accidents"
22. Bus Interior Design for Improved Safety
23. Human Factors Evaluation of Transbus by the Elderly
24. Energy Absorbing Bumpers for Transit Buses
25. Transbus Operational, Passenger, and Cost Impacts
26. Transbus Structural Crash Test Report

summer of 1971. In a parallel effort, Simpson & Curtin developed a specification for a new 40-foot transit bus. During these early stages of the program, an extensive literature search was conducted to collect existing information on transit bus safety. Numerous meetings were held with suppliers, manufacturers and operators of transit vehicles to obtain their ideas as to the direction of the safety and human factors effort. One of the key goals of the overall Transbus program was improving comfort, convenience, and safety of the passenger.

It was clear, following the initial literature review, that most of the existing data on transit bus safety was available only from the transit properties. In most cases, local transit authorities are not required to report in detail their accident information to a higher authority. This situation is not typical of many other transportation modes. Rensselaer Research Corporation was given a sub-contract to collect bus accident data from various transit properties during the fall of 1971. This data collection effort involved visits to two properties and correspondence with up to 20 properties. Detailed accident and claims cost data were obtained from ten properties. In late 1971, at about the time that procurement documents were being sent to potential Transbus prototype manufacturers, Booz, Allen Applied Research began an intensive bus accident analysis effort. This analysis involved the survey of safety reports published by the American Transit Association (ATA) and in-depth analysis of the accident data files from six major properties.

c. Efforts in 1972. By April 1972 a fault tree framework has been constructed which allowed the display of the various types of transit bus accidents along with their frequency and cost. By the end of April, Interim Report 1 on bus safety was presented to the Urban Mass Transportation Safety Administration (UMTA), the National Highway Traffic Safety Administration (NHTSA), and representatives of the Office of the Secretary of Transportation. During May of 1972, Rensselaer continued the safety data collection effort with specific emphasis on passenger accidents on-board the bus. Also, data were collected that allowed the estimation of bus accident severity as a function of the portion of the bus damaged in the traffic accident. Rensselaer presented this information to Booz, Allen Applied Research in June of 1972. During the initial year of the Transbus program, extensive coordination occurred between Booz, Allen and representatives of the elderly and handicapped communities.

Starting as early as October of 1971, a decision had been made to include in the prototype Transbus designs assist devices that would allow an individual in a wheelchair to board a transit bus. This decision was made to determine the technical feasibility of such devices. It became very evident, however, from the data being collected that the problem of dealing with the needs of the elderly and handicapped went far beyond merely providing access for an individual in a wheelchair. A large percentage of transit riders are ambulatory handicapped. They suffer from a wide variety of mobility limitations. It was clear from the analysis of on-board accidents that these limitations resulted in safety problems. Human factors design aspects of transit bus vehicle interiors clearly deserved close attention in the Transbus program. For this reason, the safety and human factors programs became closely interrelated in the area of on-board safety.

During June of 1972, an overall program implementation plan was completed for the Transbus program. This plan included the basic framework for the Transbus safety and human factors effort. Many of the key tests and analysis needs had been defined at that point. In August of 1972, Interim Report 2 on bus safety was presented to the ATA Bus Technology Committee and drafts were given to each of the three bus manufacturers, who had been selected to build the Transbus prototypes. This additional information on bus safety and human factors was intended to aid the manufacturers in identifying and solving safety problems in their respective design efforts. In July and August of 1972, meetings were held with each of the three Transbus manufacturers to review in detail the findings of Booz, Allen's safety and human factors analysis effort. In August, meetings were held with UMTA and NHTSA to review in detail the Transbus performance specifications and to correlate those specifications with present and future standards of NHTSA. By the end of August, a comprehensive draft report, Transit Bus Safety Report #1 - Bus Accident Data Analysis, was completed. This report is contained in its entirety as Appendix A of this report.

After an extensive preliminary screening and background data research on the needs of the elderly and the handicapped, Booz, Allen organized a design guideline seminar to address the specific needs of the elderly and handicapped in the design of Transbus. This seminar was held on October 18, 1972 at Booz, Allen Applied Research with a selected cross section of opinion represented among 15 invited experts. During this one-day meeting, 15 pages of detailed design

guidelines were developed for meeting the needs of the elderly and handicapped on the Transbus program. The design guidelines report was developed from the proceedings of the meeting and distributed to Transbus manufacturers. The three Transbus manufacturers each had one representative in attendance at the design guideline meeting.

During 1972, it became apparent that additional data relating to actual passenger behavior on-board transit buses were required. Therefore, detailed on-board observation of bus passengers was conducted. These on-board observations began in October of 1972 and continued into early 1973.

d. Efforts in 1973. In early 1973, Booz, Allen Applied Research prepared a working paper presentation, "Observations of Passengers On-Board Current Buses," which summarizes this research effort. In parallel with on-board observations of the behavior of over 1,000 passengers in actual revenue service, Booz, Allen conducted studies of boarding and alighting behavior using the initial American Motors Transbus mock-up at Delta Display's facility in Detroit. These tests were conducted in November of 1972 and preliminary results were presented to the ATA Bus Technology Committee in December of that year. The data gathered in on-board observations of passengers in six cities were analyzed and presented in early 1973 to the ATA Bus Technology Committee and the three Transbus manufacturers. Appendix B contains a copy of this presentation.

During the early phases of the bus design effort, each of the Transbus manufacturers developed preliminary designs for handicapped devices that would allow people in wheelchairs to board and use transit buses. These designs were to be implemented on prototype bus No. 3 from each manufacturer. Each manufacturer was using as baseline material the report on design guidelines for the elderly and handicapped developed at the October 1972 seminar. A meeting was held in December 1972 between UMTA and Booz, Allen to summarize efforts to date related to designs for the handicapped. It was concluded that Booz, Allen should begin close coordination of these design efforts with the President's Committee for Employment of the Handicapped to obtain their input on the detailed designs being developed. In January 1973, Booz, Allen met with the technical representatives of the President's Committee. At that meeting Rohr Industries presented a number of wheelchair access concepts. In early 1973, it was decided that each manufacturer should build a different access device concept.

General Motors was to build a wheelchair lift device. American Motors was to build a level entry platform device, which would require a curbside platform. Rohr Industries was to incorporate an innovative ramp in conjunction with a kneeling feature on their low floor bus design. The basic concepts for the wheelchair access devices, which later appeared on the Transbuses and in public service demonstrations in 1974 and 1975, were thus established at the beginning of 1973.

With the initial collection of safety and human factors data available in the United States complete, Booz, Allen established contact with the British Leyland in England to open technical communications channels related to safety and human factors efforts that had been conducted during the development of the British "National Bus" design. The foundation for the technical exchange of information occurred in January 1973 when a Booz, Allen representative visited British Leyland, the Manchester, England Bus Company, and London Transport. This exchange, which continued throughout the Transbus program, was highly valuable to bus designers both in the United States and the United Kingdom.

In January 1973, a technical paper describing the Transbus program and the prototype coaches was presented to the annual meeting of the Society of Automotive Engineers. This was the first public exposure of the Transbus program to the technical community.

In March of 1973, planning for the Transbus seat test program and energy-absorbing bumper test program was well underway. Discussions were held with members of General Motors Research Center staff to obtain their experience in the crash testing of buses and in seat designs for survivability. Discussions were also held with representatives of Durwin Severy, Inc. of Los Angeles to review the UCLA school-bus crash data collected during the late 1960's in a test series conducted for NHTSA. Contacts were also established with British Leyland as part of the continuing technical exchange, and British Leyland provided some data on their safety seat development program. In February 1973, a meeting was held with NHTSA to discuss the proposed rule-making action on bus seats.

A rough draft of the energy-absorbing bumper test plan was submitted to UMTA in March of 1973. Also, a test plan for sled testing to simulate high-speed crashes in relation to an evaluation of Transbus cantilevered seats was presented

in early May. A draft copy of the Transbus seat test plan was reviewed with National Seating Company, with Flexible Bus Company, with General Motors, and with the American Seating Company in April of 1973. In May of 1973, the bumper test procedure was completed, and the bumper test IFB was released for bid the second week in June. In May of 1973, Booz, Allen attended a meeting with UMTA and NHTSA to discuss the safety analysis effort on Transbus and the implications related to bus seat safety rulemaking actions.

In May of 1973, Booz, Allen began a second series of on-board observations on transit buses. This series was directed at obtaining data on typical deceleration rates of transit buses. A decelerometer was constructed and used on ten bus trips in the Washington, D.C. area to measure peak deceleration rates. This data was to form a baseline for on-board safety testing, which would occur at a later date. In July, work began on an analysis of transit bus safety in relation to other urban transit modes. Statistics for all types of urban travel were collected. The major objective of this effort was to define the effect of modal shifts to or away from transit buses on public safety.

In July of 1973 the requests for bids for both the Transbus seat tests and performance tests were released. Also in July a report projecting potential savings from energy-absorbing bumpers was completed using data obtained previously from transit properties. The analysis employed Insurance Institute for Highway Safety automobile crash damage data. Work was begun in July of 1973 to establish a detailed plan for human factors testing on Transbus.

Early October of 1973, bumper and performance test contracts were awarded to Dynamic Science Division of Ultrasystems in Phoenix, Arizona. The Transbus seat test subcontract was awarded to the Calspan Corporation in Buffalo, New York. In response to a request from UMTA, Booz, Allen conducted carbon monoxide readings on-board Chicago Transit Authority buses in August of 1973. The data obtained indicated that carbon monoxide levels on-board current buses do not constitute a health hazard. In December of 1973, Transbus bumper testing began at Dynamic Science. Also, The Benefits of Energy-Absorbing Bumpers for Transit Buses, report TR73-013, was submitted to UMTA. The Transbus seat test program began at Calspan Corporation in November of 1973. In that same month, the Transbus safety test program was reviewed in detail with visitors from British Leyland, and technical information was obtained

on safety testing they had conducted. By the end of 1973, Transbus bumper testing had been completed by Dynamic Science.

e. Efforts in 1974. Transbus seat testing was completed by Calspan in January of 1974. Also in January, Booz, Allen completed a draft report, "Impact of Mass Transit on Urban Traffic Safety," which is presented as Appendix C to this report. This report was reviewed with UMTA. The results of the Transbus safety analysis effort and preliminary data on bus maintainability collected from 16 bus properties was presented to the annual reliability/maintainability symposium sponsored by the Institute of Electrical and Electronic Engineers in January 1974. This was the first exposure of Transbus safety work to the technical community. In February of 1974, the first Transbus prototype vehicles from General Motors and Rohr were delivered to the Dynamic Science test track in Phoenix, Arizona. In March, an ATA meeting was held at the Dynamic Science facility to introduce the Transbus prototypes. At this same meeting, a review of preliminary results of the Transbus safety tests on bumpers and seats was presented to the ATA Bus Technology Committee. In March of 1974, Booz, Allen, accompanied by a representative of NHTSA, visited Calspan to review the results of the seat testing and to assess the severity of any particular seat safety problems. This review was to aid NHTSA in the final formulation of the pending bus seat safety standard.

In May of 1974, the Transbus human factors test plans were reviewed with Dr. Patrick Ruffles-Smith. Dr. Ruffles-Smith was the program manager of all Transportation and Road Research Laboratory (TRRL) testing conducted in the United Kingdom on safety, human factors, and the needs of the elderly and handicapped on transit buses. His comments related to the Transbus human factors testing program plan and were very valuable in finalizing the plan. Also in May of 1974, Booz, Allen presented the results of its analysis of on-board accidents to the ATA Safety Committee.

In June of 1974, coordination with senior citizens groups in Phoenix, Arizona began with the objective of planning for the human factors evaluation of Transbus by the elderly. In July of that year, meetings were held with representatives of American Association of Retired Persons and the Phoenix Park Department to obtain a suitable selection of test subjects and a test facility for the human factors evaluation. During the final week in August of 1974, an extensive human factors test program was

conducted in Phoenix using 33 senior citizens as test subjects. The prototype bus No. 2 from each Transbus manufacturer and a baseline current "New Look" transit bus were used as test articles. This testing program was the first time that the Transbus prototypes had been shown to the public outside of the Phoenix test track.

A detailed description of this test program entitled, "Human Factors Evaluation of Transbus by the Elderly," was presented in Transbus document TR 76-002, published in May of 1976. While the final publication of results was delayed for nearly 2 years, data collecting during the testing on human subjects was used throughout the final portion of the Transbus program in numerous evaluations. The human factors evaluation by the elderly used many of the techniques developed by British Leyland, but also tested for other areas of importance, such as night vision, the capacity of various buses, boarding and alighting speed, and door safety. In the door safety area, Leyland again contributed technical information, which they had collected on their door safety test program.

In August of 1974, a representative of Booz, Allen attended the conference on transit management sponsored by the National Research Board in Kerrville, Texas and informally presented the results of the transit bus safety analysis effort with particular emphasis on cost savings possible in transit safety. In September, initial data obtained from the Transbus human factors testing was relayed to manufacturers of the Transbus prototypes. Each of the three manufacturers was requested to include certain safety-related design changes in the interior of the No. 3 prototype prior to delivery in October for the Transbus demonstration program. These design changes primarily involved seat design and the addition of grab rails in certain areas of the bus. Most of these changes were made on the vehicles prior to the demonstration, indicating the very rapid response on the part of the manufacturers to data developed in the Transbus program. In October, preliminary bumper test results were presented to the transit section at the annual meeting of the National Safety Council in Chicago, Illinois.

Public demonstrations of the Transbuses began in November of 1974 in Miami, Florida. The demonstration planning for these efforts had begun at the very beginning of the program and many safety and human factors related items were included in the program. In particular, opinions related to safety from transit authorities and drivers

were solicited as part of the demonstration program. Also included in the demonstration program were special one-day demonstrations for the handicapped in each city. This was possible because Transbus No. 3 prototypes, which were being demonstrated, each included a wheelchair access device. Demonstration activities occupied the central focus of the Transbus program throughout the winter of 1974 and into the early spring of 1975. In December, the results of the Transbus seat test program were presented to the 18th Stapp Car Crash Conference in Ann Arbor, Michigan.

f. Efforts in 1975. Survey information was gathered from the more than 10,000 persons who viewed the Transbuses at various demonstration locations in the 4 cities and rode on the vehicles in actual revenue service demonstrations. Demonstrations were complete in April of 1975 and the Transbus Public Testing and Evaluation Program report was published in September of that year. This report contains a chapter on the demonstrations of the handicapped assist devices in each of the 4 cities.

As early as October of 1974, Booz, Allen conducted trial tests involving an assessment of on-board safety on transit buses. These trial tests involved the use of a human test subject and the use of Transbus prototypes to simulate accident situations. Results of these tests were reported to transit sections of the National Safety Council Convention in October of 1975 and detailed test plans were developed for the final test series to be conducted later. This series of on-board accident tests was viewed as being too hazardous and, therefore, was not conducted as part of the evaluation of Transbus by the elderly.

Work began in August of 1975 to pull together all Transbus evaluation information into a report. A substantial portion of this report dealt with the results of the safety and human factors effort and related these results to potential safety claims cost savings in transit properties using Transbus. This report was originally reviewed in presentation format in October of 1975 at the New Orleans meeting of the American Public Transit Association. A series of reviews with a special subcommittee of the Bus Technology Committee continued throughout the winter of 1975 and early into 1976.

g. Efforts in 1976. The final report on Transbus evaluation information entitled, Transbus Operational Passenger and Cost Impacts, was published in July of 1976. Preliminary drafts of this report were introduced as

evidence at public hearings on Transbus held by the Department of Transportation in May of 1976. In early 1976, the final Transbus crash test program plan was reviewed with NHTSA. The testing contract was awarded the Calspan Corporation to conduct crash testing of the Transbus prototypes. The program was completed in April 1976, and the final crash test report was submitted by Calspan in May 1976. Results indicate that crash testing has verified many of the previous findings from component testing, both seats and bumpers, and demonstrated the superior safety and crashworthiness of Transbus. The Transbus bumpers performed as anticipated in the full-scale crash tests, based on data from the bumper test program conducted earlier at Dynamic Science. The test indicated performance consistent with the bus body repair cost savings projections prepared earlier. High speed front end crash testing, involving automobiles striking head-on into the Transbus prototypes at 56 mph, yielded results that indicate that the Transbus seat test program profile and seat test program results are consistent with what is to be expected in extremely severe crashes of transit buses. Thus, crash testing with the full Transbus vehicle has verified the test program and test results obtained in the Transbus seat and bumper test programs more than 2 years earlier. Side impact crash tests involving automobiles striking the sides of buses at 25 mph indicate significant improvements in bus damage susceptibility and repairability as projected from the engineering data.

h. Summary of Transbus Safety and Human Factors Program (1971-1976). In summary, the Transbus human factors and safety program has employed a comprehensive systems analysis approach to transit bus safety involving analysis, testing, and demonstration. While the program results have primarily been focused on the design, development, and evaluation of Transbus prototypes, much of the information gained has been disseminated to other agencies such as NHTSA and to the technical safety research community, both here and abroad. Because most of the literature that has been developed as part of this overall effort has not been published either in technical journals or in Transbus program reports, the appendices to this report contain significant findings that may be of interest to the research community. While some of this material may be outdated by more recent Transbus reports, it is included in this report so that a comprehensive overview of the overall Transbus safety effort can be obtained. In particular, Appendix D of this report contains a summary report—"Improvements in the Safety of Urban Transit Coaches"—

presented by John F. Wing, the Booz, Allen Transbus program manager, on July 11, 1977 at the 5th International Congress on Automotive Safety.

4. REFERENCES

This section contains a comprehensive listing of major publications related to the Transbus safety program. Most of these publications are generally available as Transbus program documents. Those which are not, and are significant, are presented in the appendix of this report.

APPENDIX A

TRANSIT BUS SAFETY REPORT #1 - BUS ACCIDENT

DATA ANALYSIS (DRAFT REPORT)

This report contains the results of a comprehensive analysis of transit bus accidents in the 1969-1970 time period. The report was a key reference document throughout the Transbus Program for design trade-offs related to safety. Fault tree analysis techniques were employed to structure accident statistics in terms of both frequency and average claims costs of various types of accidents. The results of the fault tree analysis provided safety design priorities for the Transbus program based upon the life cycle costs of claims expenses by accident type.

The report remained a draft working paper and was never published as an official program report. Copies were provided to key program participants, UMTA, NHTSA and the Transbus manufacturers on an informal basis.

TRANSIT BUS SAFETY
REPORT #1 - BUS
ACCIDENT DATA ANALYSIS

for

Urban Mass Transportation Administration

September 29, 1972



BOOZ • ALLEN APPLIED RESEARCH INC.

WASHINGTON
CHICAGO
LOS ANGELES

T A B L E O F C O N T E N T S

	<u>Page Number</u>
I. PREFACE	1
II. RESULTS AND CONCLUSIONS	3
1. Introduction and Accident Cost Summary	3
2. Bus/Other Vehicle Accidents	8
3. Passenger Injuries	9
4. Bus Repair Costs	12
5. Pedestrian Accidents	15
6. Bus Hits Fixed Object Accidents	18
III. METHODOLOGY	19
APPENDIX A: FAULT TREES	
APPENDIX B: REFERENCES	

I N D E X O F F I G U R E S
A N D T A B L E S

<u>Figure</u>		<u>Page Number</u>
Figure 1	Fatal Accident Involvement Rate - 1969	4
Figure 2	Operating Cost Breakdown	6
Figure 3	Safety in Relation to Other Vehicle Costs	6
Figure 4	Accident Costs to Bus Company	7
Figure 5	Accident Frequency	13
Figure 6	Bus Repair Cost	14
Figure 7	Scenarios of New York State Fatal Accidents (1969)	17
Figure 8	Accident Rates, 1966 - 1969	20
Figure 9	Accident Trends 1950 - 1969	20
Figure 10	Urban Versus Rural Accidents	21
Figure 11	The Ten Key Accidents	24
Figure A-1	Definition of Fault Tree Symbols	A-2
 <u>Tables</u>		
Table 1	Comparison of Urban Bus Accidents Involving Personal Injury	5
Table 2	On-Board Accidents	11a, b, c

I. PREFACE

This report describes the results of a study of transit bus accidents conducted by Booz, Allen Applied Research, Inc. The primary objective of the study was to provide background information to support the design of a new 40-foot urban bus, Transbus. This new vehicle is being developed under contract number DOT-UT-10003 from the Urban Mass Transportation Administration (UMTA), as part of the overall UMTA Bus Technology Program to revitalize the transit industry.

The Transbus vehicle, which is being developed competitively to the prototype stage by three subcontractors, will have a number of attributes directed at improving transit speed, passenger comfort, safety, environmental impact, and operating economies.

Safety has been identified as a key attribute of the new Transbus vehicle. Early in the program, as Booz, Allen was developing the detailed performance requirements for Transbus, it became apparent that the type of background data required to form the basis for safety related design analyses were not available. Therefore, a detailed analysis of the current transit industry operating experience in the safety area was undertaken. The results of this analysis are presented in this report and will serve as design guidelines for prototype Transbus manufacturers.

This effort to date represents but a first step in the overall safety program for Transbus. Subsequent steps include:

- . Development of vehicle conceptual designs reflecting substantial potential improvements in passenger safety and accident cost reduction
- . Detailed design and fabrication of prototype buses guided by safety design guidelines

- . Safety verification testing of prototype buses at proving grounds and in public service demonstrations
- . The development of a procurement specification for future 40-foot bus purchases based upon proven safety benefits.

As the Transbus program continues, Booz, Allen Applied Research, Inc. will prepare reports describing the results of this continuing safety effort.

This report was prepared by James A. Mateyka, who also directed the data gathering effort. Much of the data presented in this report was collected by Mr. Charles McKenna of the Rennselaer Research Corporation under subcontract from Booz, Allen. The author wishes to express his appreciation to the American Transit Association, the New York State Department of Motor Vehicles and the ten transit properties which actively participated in this effort.

II. RESULTS AND CONCLUSIONS

1. INTRODUCTION AND ACCIDENT COST SUMMARY

The urban transit bus is an extremely safe transportation mode choice. We estimate that in 1969, only 15 of the over 5 billion passenger trips by transit bus ended in passenger fatalities. In terms of fatal accident involvements, it is not the bus passenger, but rather the pedestrian and the automobile occupant who are more typically the victim. This is clear from the following fatality estimates for 1969:

- . 15 bus occupant fatalities
- . 135 pedestrian fatalities
- . 70 other vehicle occupant fatalities

- . 220 fatalities in accidents involving urban transit buses.

As a consequence, on a vehicle mileage basis, commercial buses (transit and intercity) have a relatively high fatal accident involvement rate, second only to motorcycles, motor bikes and motor scooters. See Figure 1 which is based on data from the National Safety Council. (1)*

Paradoxically, the data developed in this study for personal injuries associated with urban bus accidents yields the opposite trend. Bus passenger accidents are much more frequent than bus-pedestrian accidents. As shown in Table 1, however, pedestrian accidents are typically much more severe when measured in terms of average claims costs to the bus property:

* Numbers in parenthesis refer to references at the end of this paper.

FIGURE 1
Fatal Accident
Involvement Rate - 1969

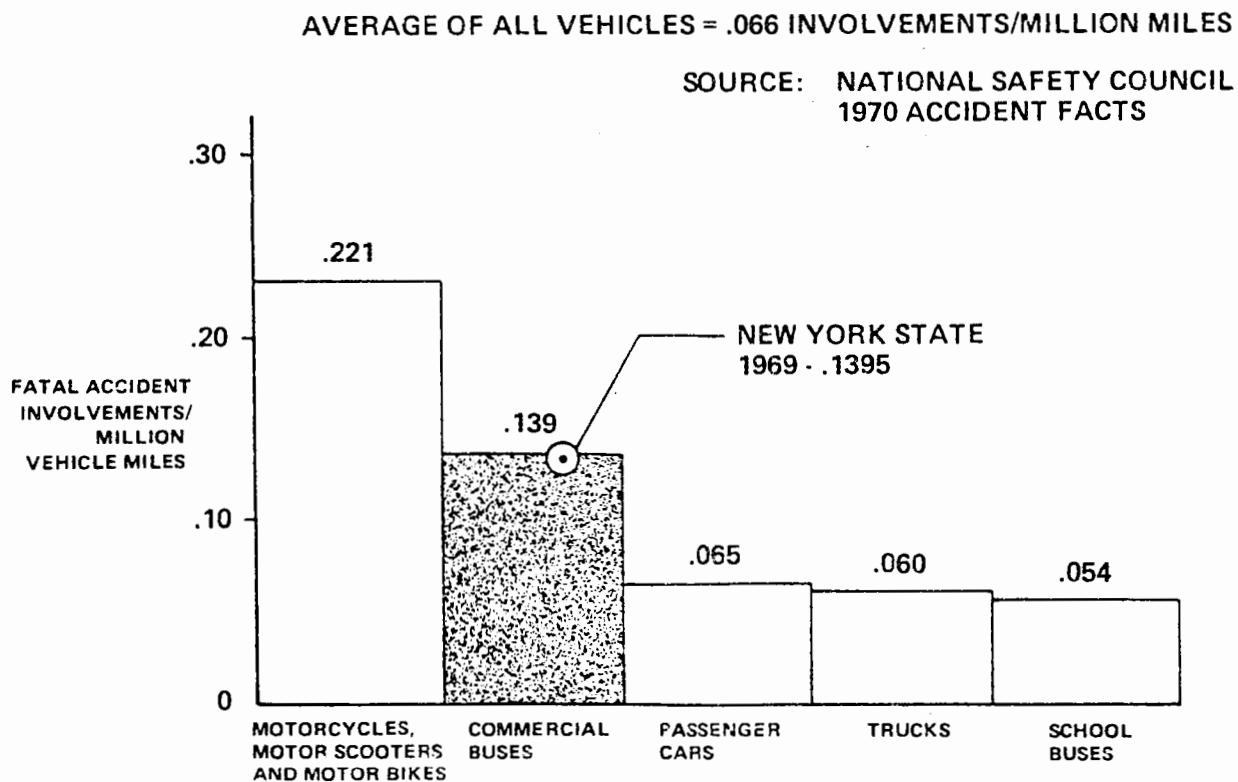

TABLE 1
Comparison of Urban Bus Accidents
Involving Personal Injury

Type of Accident	Number of Injury Causing Accidents, 1969	Average Claims Costs, \$
Passenger Accident	35,700	\$ 241.63
Pedestrian Accident	2,100	\$1,143.56

The cost of transit bus accidents to urban transit operations in 1969 was approximately \$50 million, or about 4 percent of total operating costs. This represents a severe burden on financially declining urban transit properties and represents but a fraction of the total social cost of bus accidents.

Figure 2 puts the cost of accident claims and insurance in perspective with other operating costs. (2) In Figure 3, the 4¢/mile safety related cost (accident claims and insurance) is shown to exceed the combined costs of fuel, oil, and tires. (2) Over the 500,000 mile life of a typical transit bus accident costs are equal to about one-half of the initial price of the vehicle. These cost summary statistics strongly indicate that a safer bus holds the promise of significant operating cost reductions for the transit industry. Also, given the current program of Federal Capital Assistance grants for the purchase of new buses, these operating cost reductions could be obtained with reduced capital investment requirements if a safer bus design were available.

In line with the primary objective of this analysis, that of providing guidelines for the safer design of the new 40-foot urban bus, the results are presented in terms of accident costs per 500,000 vehicle miles. In this form, the data presented is most useful to the design engineer who must constantly trade-off the cost of innovative safety features against the potential safety benefits.

FIGURE 2
Operating Cost Breakdown

<u>¢/MILE</u>		<u>ITEM</u>
41.7	—	DRIVER'S WAGES
15.0	—	MAINTENANCE
15.0	—	G&A, TAXES, AND ADVERTISING
9.0	—	DEPRECIATION
8.3	—	OTHER TRANSPORTATION (FUEL, OIL, AND SUPERVISION)
4.0	—	ACCIDENT CLAIMS AND INSURANCE
<u>93.0</u>		

SOURCE: AVERAGE OF THE 16 LARGEST PUBLIC BUS OPERATIONS
IN 1970

FIGURE 3
Safety in Relation
to Other Vehicle Costs

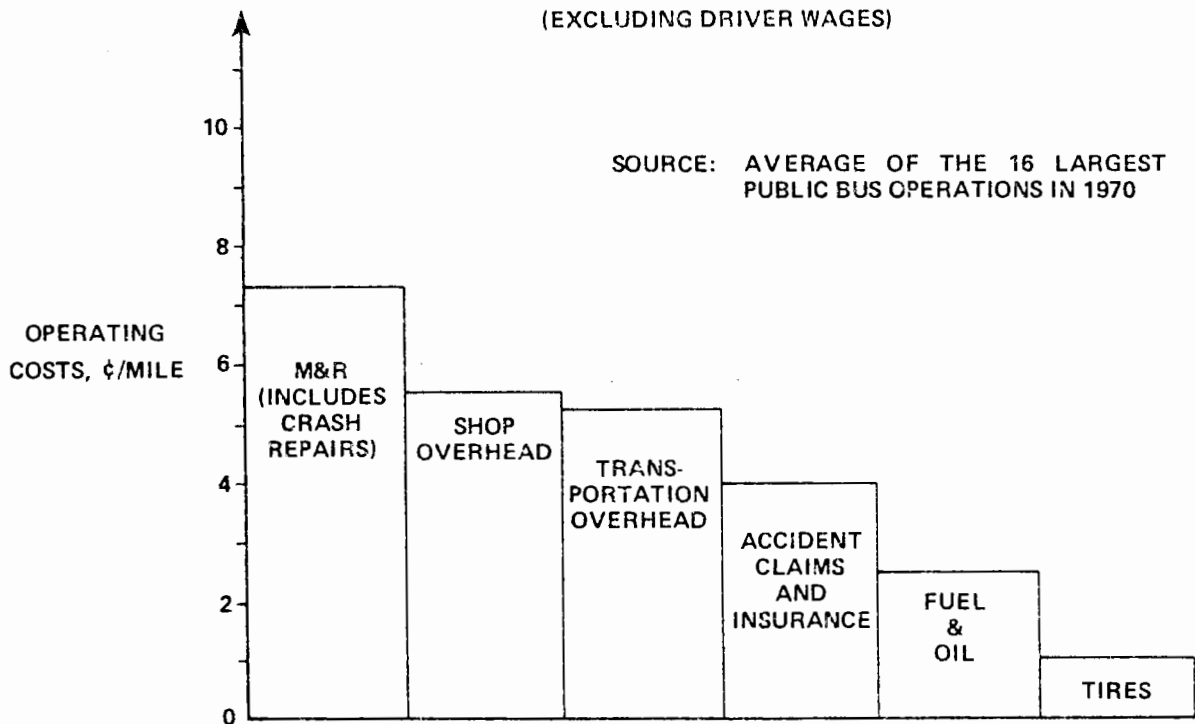
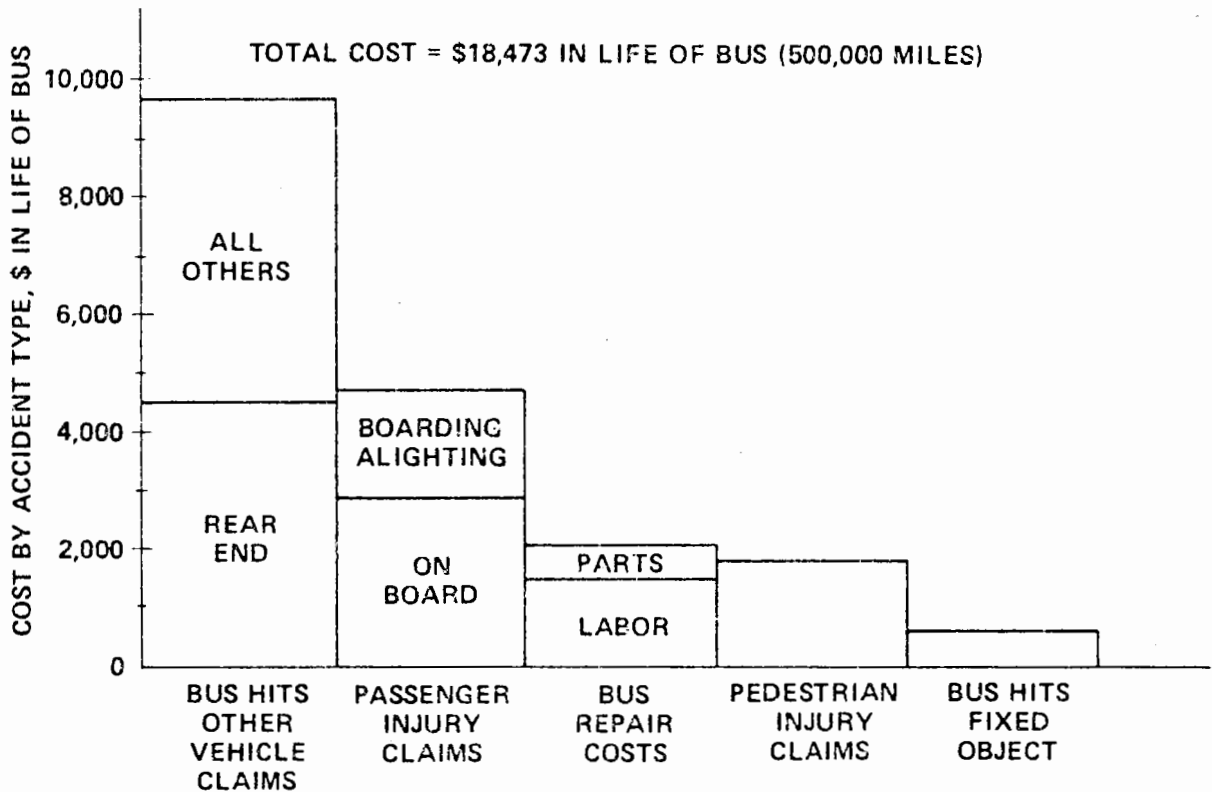

Figure 4 presents a summary of the results of this analysis. Bus property costs are shown for various types of accidents for an assumed 500,000 mile life of a typical transit bus. The costs which total \$18,473 include:

- . Claims paid in accidents involving other motor vehicles
- . Claims paid in passenger accidents
- . Bus repair costs for all accident related damage
- . Claims paid in accidents involving pedestrians
- . Claims paid in accidents in which the bus hit a fixed object.

A discussion of each of these five accident categories is presented later in this report.

FIGURE 4
Accident Costs to Bus Company



It can be argued that defining costs in this manner over-emphasizes the financial burden on bus properties, but does not yield a comprehensive picture of the national impact of transit bus accidents. Pain and suffering, lost time, and expenses for extended medical care and rehabilitation are not included. A recent study of compensation for motor vehicle crash losses performed by the Department of Transportation indicates that claims payments often represent but a fraction of the total social cost. (3) Thus, the cost data presented in Figure 4 is conservative, but the breakdown into relative cost categories is sufficient to provide guidance for the new 40-foot bus design. An attempt to measure total social cost would involve a massive data gathering and analysis effort which is far beyond the scope of this effort. A very detailed breakdown of accident statistics, including accident frequency, average cost, and total cost is given in Appendix A in a fault tree format. These fault trees represent, by far, the most comprehensive analysis of transit bus accidents available.

2. BUS/OTHER VEHICLE ACCIDENTS

Results: It is apparent from Figure 4 that accidents with other motor vehicles are the dominant cost category. By far, the dominant type of other vehicle accidents, in terms of accident frequencies and total costs, is the rear end accident. In this type of accident the bus strikes the rear of an automobile in traffic. The average claim for the rear end type accident (\$644.75) indicates a 10 mph impact speed. This impact speed estimate is based upon automobile collision damage repair costs developed in low speed barrier crash experiments. (4) Based upon detailed data given in the fault trees in Appendix A, the 10 mph impact speed appears to be typical for accidents involving the front of the bus striking automobiles in traffic. Typical claims costs of accidents involving the front of the bus are as follows:

- . C = \$645: Bus hits the rear of automobile
- . C = \$521: Bus hits the right side of automobile at an intersection
- . C = \$921: Bus hits the left side of automobile at an intersection.

Claims cost data for other types of bus/automobile accidents indicate a second somewhat less important class in terms of total costs. This class of accidents involves the side of the bus. The severity of accidents of this type measured in average accident cost is as follows:

- . C = \$197: Bus/automobile sideswipe accident
- . C = \$151: Bus turning at intersection: bus usually turning right hits vehicle on right
- . C = \$291: Other vehicle (automobile) passing; vehicle usually passing on the left
- . C = \$165: Bus passing other vehicle (automobile); bus usually passing on the right.

Conclusions: The information gathered, strongly indicates that an energy absorbing front bumper offers substantial potential cost benefits. Such a bumper should be designed to include the front corners of the bus. The design objective should be to reduce damage (claims costs) to the automobile in crashes involving impact speeds of 10 mph. In addition, the accident cost data indicates that energy absorbing bus sidewall structures and rub rail designs which reduce damage to automobiles in sideswipe accidents offer substantial safety benefits. In this case, the design objective involves accidents which currently cause automobile damage of about \$200. Design considerations involving reduced bus damage will be discussed later.

3. PASSENGER INJURIES

Results: As shown in Figure 4, the second largest cost category involves passenger injury claims. Passenger accidents, while on board, are more costly to the bus company than those associated with passenger boarding and alighting. To obtain an in-depth analysis of on-board accident types in sufficient detail to be of use for design trade-offs, data were obtained in addition to the in-depth statistics collected from individual bus properties.

The results of four special surveys of the on-board accident problem were obtained. These surveys were conducted by:

- . The National Safety Council (5)
- . Transit Casualty Company (6)
- . A West Coast bus property (7)
- . A Midwestern bus property. (7)

In addition, the Rensselaer Research Corporation conducted a case-by-case search through the personal injury records of one West Coast and one East Coast bus property. The data compiled from these sources were remarkably consistent in terms of the types and frequencies of on-board accidents, despite the fact that the surveys spanned a time period of nearly two decades. Table 2, given below reflects a synthesis of these data. The percentages given in Table 2 refer to accident occurrences not claims costs. Note that 56 percent of all on-board accidents occur when the bus decelerates. Bus drivers indicated that about one-half of these passenger accidents resulted from decelerations which were aimed at traffic accident avoidance. Table 2 indicates that most people were standing or walking (typically to the rear) just prior to the accident. The data strongly indicates that the area of prime concern in interior design should be forward of the first cross seat. Table 2 also illustrates that injured passengers typically do not use available assist devices. The demography of injured passengers indicates that elderly females are most likely to be involved in on-board accidents.

Table 2 also indicates that most injuries result from falls to the floor, rather than striking an object within the bus. Thus, the average cost of an on-board accident is only \$262.50. Table 2 indicates that the victim of an on-board bus accident is typically older, weaker, smaller and more frail than the average American.

As shown in Figure 4, boarding and alighting accidents involve somewhat lower claims expenses than on-board accidents. The most important types of boarding and alighting accidents fall into two classes:

- . Door related accidents (total claims costs equal \$823 in the life of the bus)
- . Alighting accidents (total claims costs equal \$742 in the life of the bus).

TABLE 2
On-Board Accidents

BUS MOTION AT TIME OF ACCIDENT

- 56% DECELERATING
- 21% NORMAL OPERATION
- 16% ACCELERATING
- 7% TURNING

PASSENGER AT TIME OF ACCIDENT

- 46% STANDING
- 30% SITTING
- 17% WALKING
- 7% UNKNOWN

PASSENGER LOCATION

- 39% FORWARD OF FIRST CROSS SEAT
- 32% FIRST CROSS SEAT TO REAR DOOR
- 25% BEHIND REAR DOOR

TABLE 2
On-Board Accidents (Continued)

PASSENGER USE OF ASSIST DEVICES

- 28% YES
- 72% NO

WHICH DEVICE USED?

- 34% STANCHION
- 51% SEAT HANDLE
- 5% OVERHEAD BAR

WAS PASSENGER CARRYING OBJECT?

- 54% YES
- 46% NO

WHAT WAS OBJECT CARRIED?

- 47% PACKAGE
- 33% PURSE
- 14% UMBRELLA
- 6% CHILD

TABLE 2
On-Board Accidents (Continued)

HOW INJURED?

- 61% FELL TO FLOOR
- 17% HIT SEAT
- 12% HIT STANCHION
(USUALLY FRONT RIGHT STANCHION)
- 9% HIT FAREBOX
- 3% HIT DRIVER PARTITION

SEX OF INJURED PASSENGER

- 82% FEMALE
- 18% MALE

AGE GROUP OF INJURED PASSENGER

- 53% OVER 50
- 47% UNDER 50
- 18% OVER 65

Boarding accidents are less than half as frequent as alighting accidents and are substantially less severe (\$30 in the life of the bus). This indicates that it is more dangerous to fall down the stairs rather than up the stairs, as one would expect.

Door related accidents are more severe in terms of average claims cost/accident than alighting accidents (\$301.90 compared to \$146.70). About twice as many door related accidents involve the front door as the rear door. Passengers are equally likely to be caught in the front door in the act of boarding as they are in the act of alighting.

Conclusions: The information gathered on passenger accidents indicates that improved assist devices should offer potential safety benefits. However, the low rate of assist device usage and the relatively low grasping strength of the typical on-board accident victim indicates that assist device design alone is not the answer. Whole body support and compartmentalization appears to be required for many weaker passengers. The data clearly indicates that the following interior hazards must be reduced or eliminated:

- . Unpadded seat backs with hazardous assist rails
- . Hazardous stanchions in the front of the bus
- . Unprotected fare box
- . Hard unpadded floor.

It is highly likely that these improvements would provide substantial safety benefits. A systems approach to interior design is required to trade-off the costs and benefits of specific interior features.

4. BUS REPAIR COSTS

Results: In Figure 4, the costs of repairing accident damage on a typical urban transit bus is \$1,958 for a 500,000 mile life. This is only about 20 percent of claims costs for damage to the other vehicle. Thus, the major accident costs do not involve the bus, but rather the other vehicle, typically an automobile.

Bus repair costs are far from insignificant. Repairs are very labor intensive, with 71 percent of bus repair costs involving labor. Escalating labor costs will tend to increase the relative economic importance of bus damage, unless body design substantially reduces the current labor intensive nature of bus repairs.

In Figure 5, results are presented from an analysis of the maintenance records of a major West Coast bus property. (7) This figure indicates that the right side and left rear corner of the bus are most frequently damaged.

FIGURE 5
Accident Frequency

F= NUMBER OF ACCIDENTS IN THE
LIFE OF THE BUS (500,000 MILES)

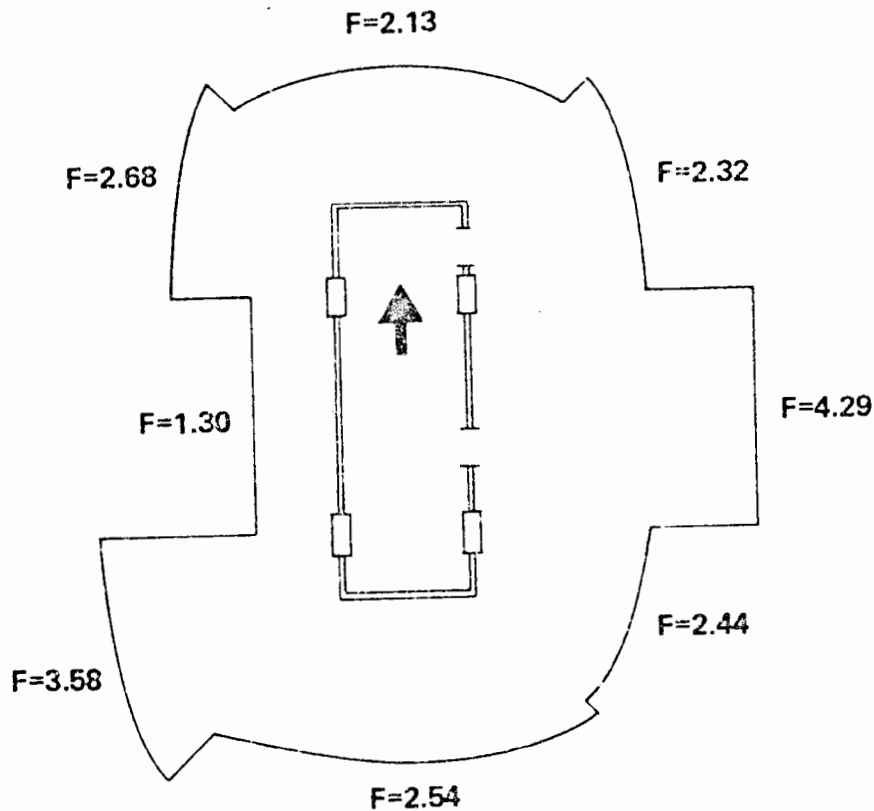
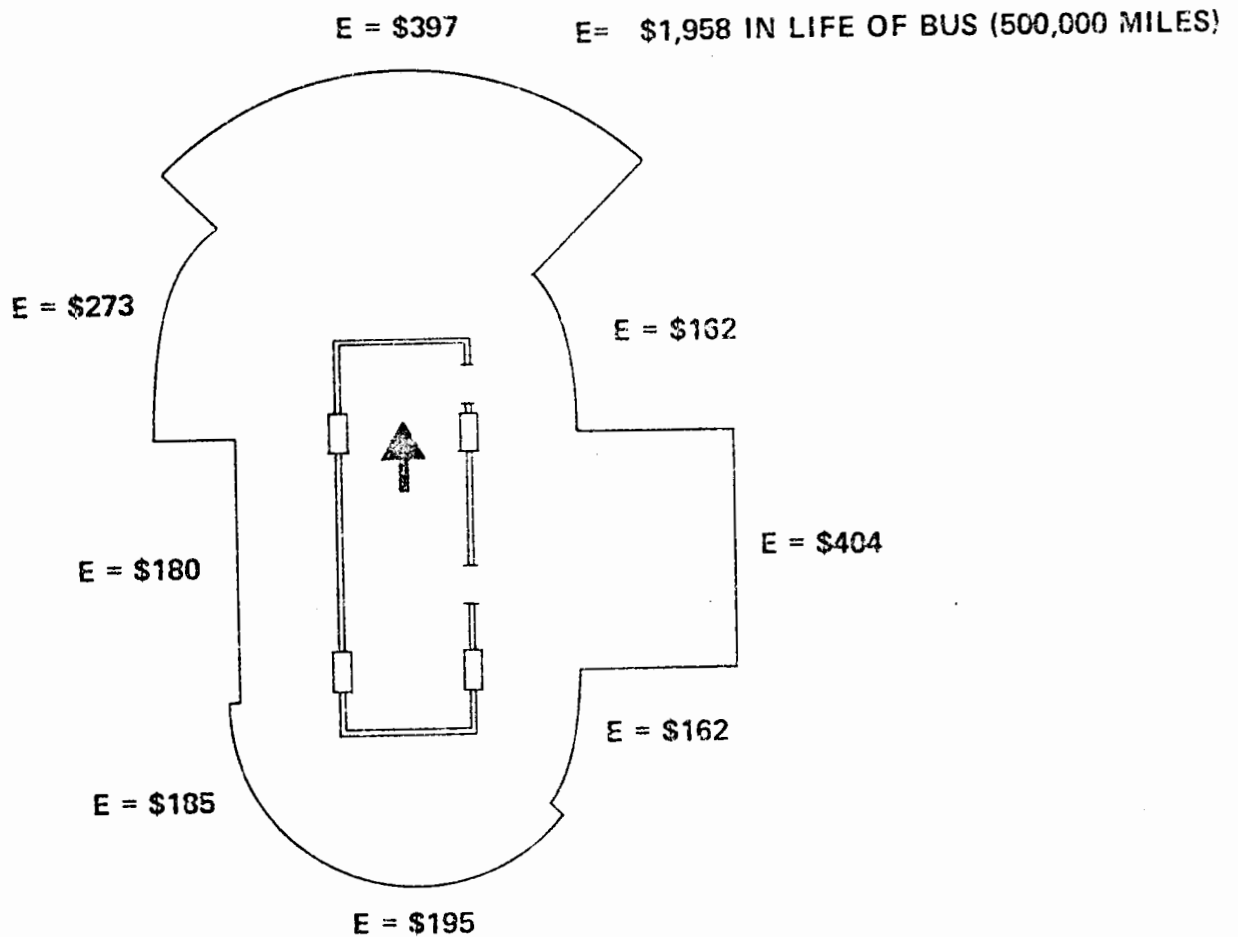

Figure 6 presents the total bus repair costs broken into sectors. Note that repair costs are highest for the right side and the front of the bus. This data is consistent with traffic accident data, which indicated that the front of the bus was involved in the most severe accidents. The high cost of repairing the right side of the bus is related to the high frequency of accidents in that section of the bus. The costs of repairing the left front corner of the bus are also shown to be quite high. The average cost of bus accident repairs by sector can be obtained by dividing the expense (E), given in Figure 6, by the frequency (F), given in Figure 5. Average bus repair costs range from \$52 (left rear corner) to \$187 (front).

FIGURE 6
Bus Repair Cost



Conclusions: Bus damage repair costs can be sharply reduced if the currently excessive labor requirements are reduced in the new 40-foot bus body design. An energy absorbing front end designed to eliminate bus damage in low speed crashes, (average repair cost of \$200) would offer substantial cost benefits. To be truly effective such a bumper should "wrap around" the front corners.

5. PEDESTRIAN ACCIDENTS

In Figure 4, pedestrian accidents are shown to account for \$1,669 in claims payments in the life of the typical transit bus. Bus/pedestrian accidents often involve rather severe consequences as might be expected given the 200:1 mass ratio involved. The average pedestrian accident involves a \$1,143.56 claims payment by the bus property.

As mentioned earlier, pedestrians are the most common victim in fatal accidents involving urban transit buses. As shown in Figure 1, the fatal accident involvement rate of commercial buses is relatively high on a vehicle mileage basis. In 1969, as shown on the figure, New York State reported a fatal accident involvement rate for commercial buses which was almost precisely the national average. Thus New York, which has the largest number of commercial bus registrations of any state was selected as a source of detailed data regarding fatal bus accidents.

In 1969, the fatal bus accident experience in New York State was as follows:

- . 44 fatal accident involvements
 - 50 fatalities
 - 45 injuries in fatal accidents

- . Fatality group
 - 33 pedestrians
 - 17 automobile occupants
 - 0 bus occupants

- . Type of bus involved
- 26 urban transit bus
- 4 intercity bus
- 4 school bus

These data, which were obtained from the New York State Department of Motor Vehicles by the Rensselaer Research Corporation, are a striking example of pedestrian hazards related to urban transit bus operation.

In Figure 7, the scenarios of fatal pedestrian accidents are broken down in a fault tree format. While 21 pedestrians were killed when struck by the front of the bus, a surprising 12 deaths involved the right rear section of the bus. The five deaths, which resulted from people holding on to the right side of the bus, all involved males between the ages of 10 and 15 years. The seven people who were killed by slipping under the right rear wheels fell into two groups:

- . Children under 10 years of age
- . Females over 50 years of age.

A breakdown of the actions prior to slipping under the rear wheels is as follows:

- . 3 - discharged passengers
- . 2 - trying to catch bus: bus pulled out
- . 2 - swept under bus turning right.

Conclusions: To reduce pedestrian injuries and deaths, it is essential that the front of the new 40-foot bus have no sharp edge or protrusions. Energy absorption characteristics for pedestrian impacts should be incorporated in the front end design. Since the bus to pedestrian mass ratio is roughly 200:1, even fairly low speed impacts will result in fairly severe pedestrian injury. Without a fundamental study of the dynamics of bus/pedestrian impact, it is not clear what features in the design of the front end of the bus are most effective in reducing passenger injury. In a recent theoretical study, the Cornell Aeronautical Laboratory has established that above impact

FIGURE 7
 Scenarios of New York State
 Fatal Accidents (1969)

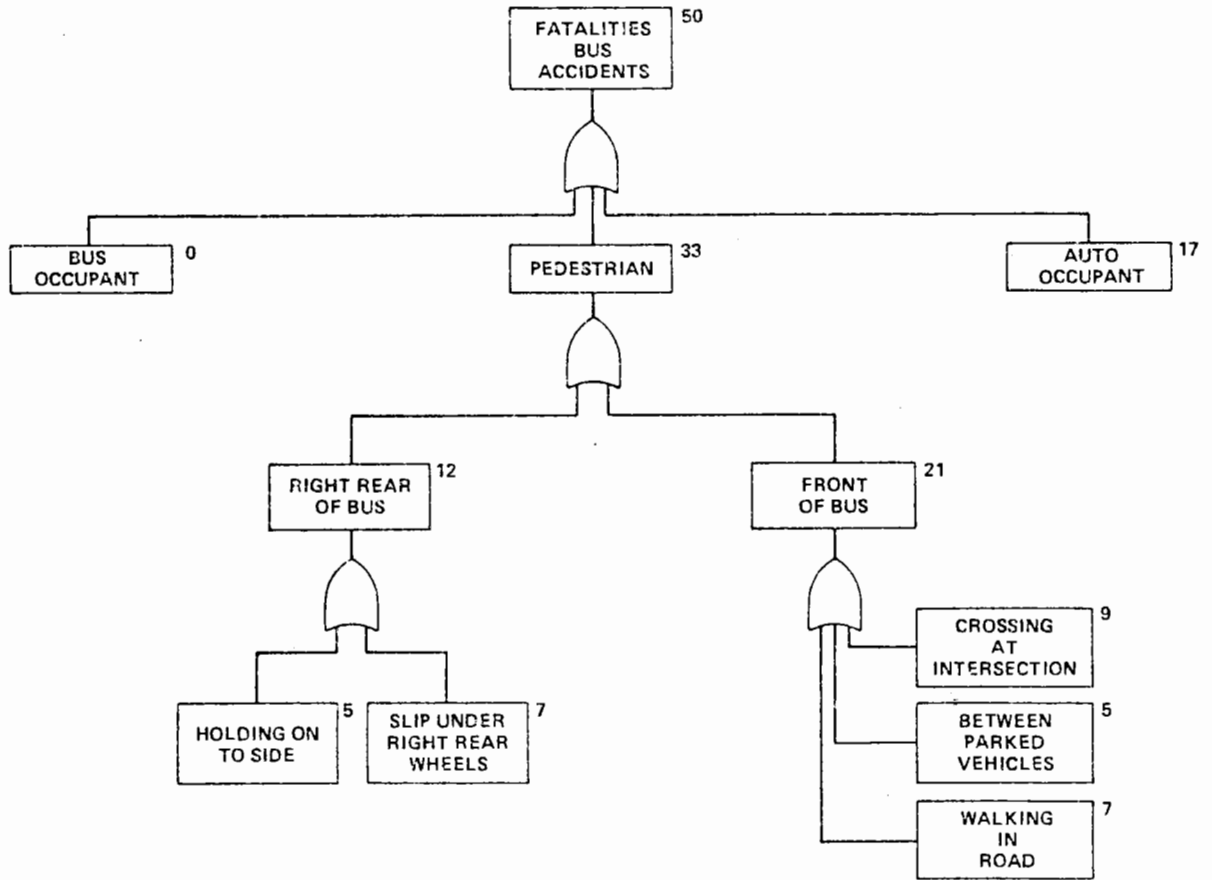

speeds of 15 mph, automobile/pedestrian impacts are unalterably fatal. (8) Since a bus weighs nearly 10 times as much as an automobile, fatal impact speeds are likely to be somewhat lower. The Cornell results also demonstrate that beyond a certain point it is the secondary impact with the ground rather than the initial vehicle impact which may be most damaging to the pedestrian.

The relatively high percentage of fatal bus accidents could be eliminated by the following design steps:

- . Eliminate all potential protuberances on the new bus that would allow a person on foot or on a bicycle to cling to the vehicle
- . Eliminate the possibility of people being crushed by the right rear wheels.

Improved driver vision of the right side of the bus may also be helpful in reducing pedestrian accidents in the rear wheel area.

6. BUS HITS FIXED OBJECT ACCIDENTS

Results: This type of accident involves \$477 in claims costs in the life of the bus, and occurs most frequently when the bus is turning. The swept area of a vehicle the size of a bus is substantial.

Conclusions: While driver training and improved right side visibility may help to reduce such accidents, rub rails and energy absorption built into the side of the bus should offer some benefits.

III. METHODOLOGY

This study was divided into two phases:

- . Data Collection
- . Data Analysis

Data was collected initially to ascertain whether transit bus safety improvement should be an important aspect of the Transbus program. Initial data collected from the available literature indicated that:

- . Urban bus accident rates were high relative to other motor vehicles on a mileage basis, see Figure 8. (1)
- . Bus accident rates were increasing while those of other fleet vehicles were decreasing or stable, see Figure 9. (1)
- . Urban traffic congestion appeared to be particularly deleterious to bus safety, see Figure 10. (1, 9)

The American Transit Association was visited and cooperated fully with this effort. New York State Department of Motor Vehicles was contacted and supplied a computer sorted print-out of bus accidents involving fatalities in 1969. Individual cases were pulled and analyzed by Rensselaer Research Corporation. An initial analysis of Transbus program safety objectives indicated that the data required for this analysis must involve both accident frequency and claims cost data, to a level of depth that was not commonly tabulated by a majority of transit properties.

A total of 10 properties were selected based upon geographical distribution. Initial contacts were made and guarantees were given regarding the confidentiality of the data. Very good data was obtained from seven of the properties contacted. Subsequent analysis efforts employed data from only six properties to achieve a representative sample in terms of the following characteristics:

FIGURE 8
Accident Rates, 1966 - 1969

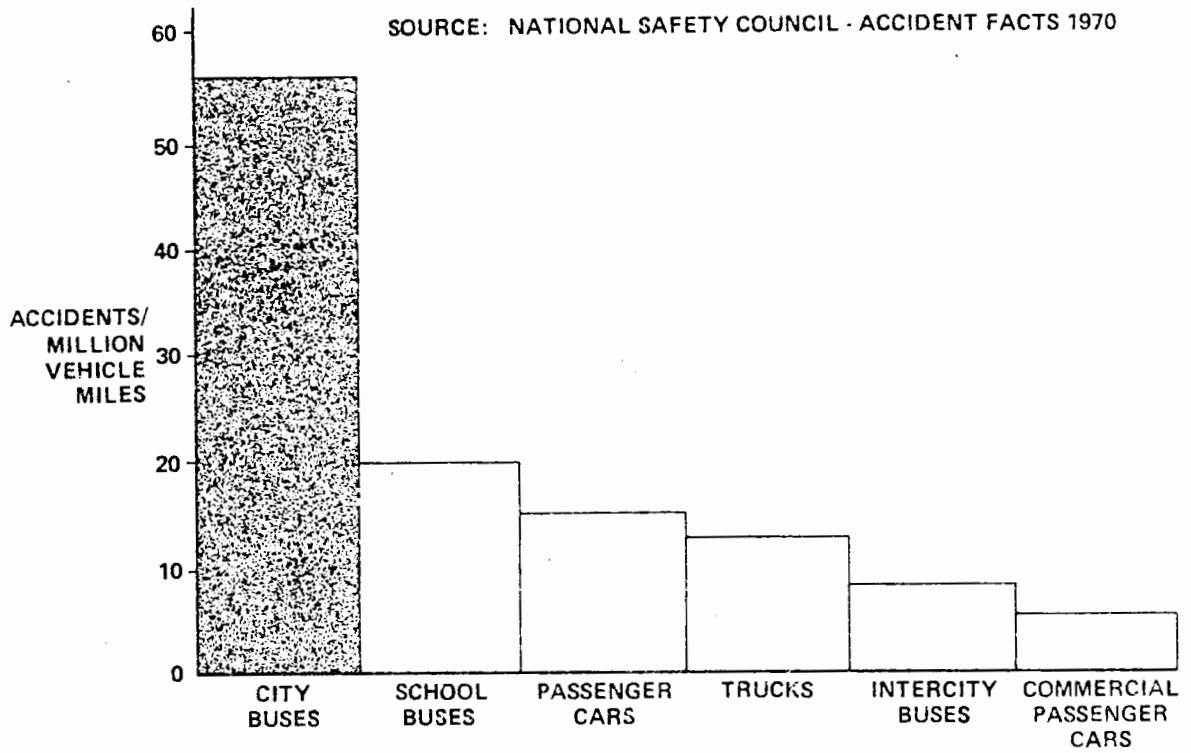

FIGURE 9
Accident Trends 1950 - 1969

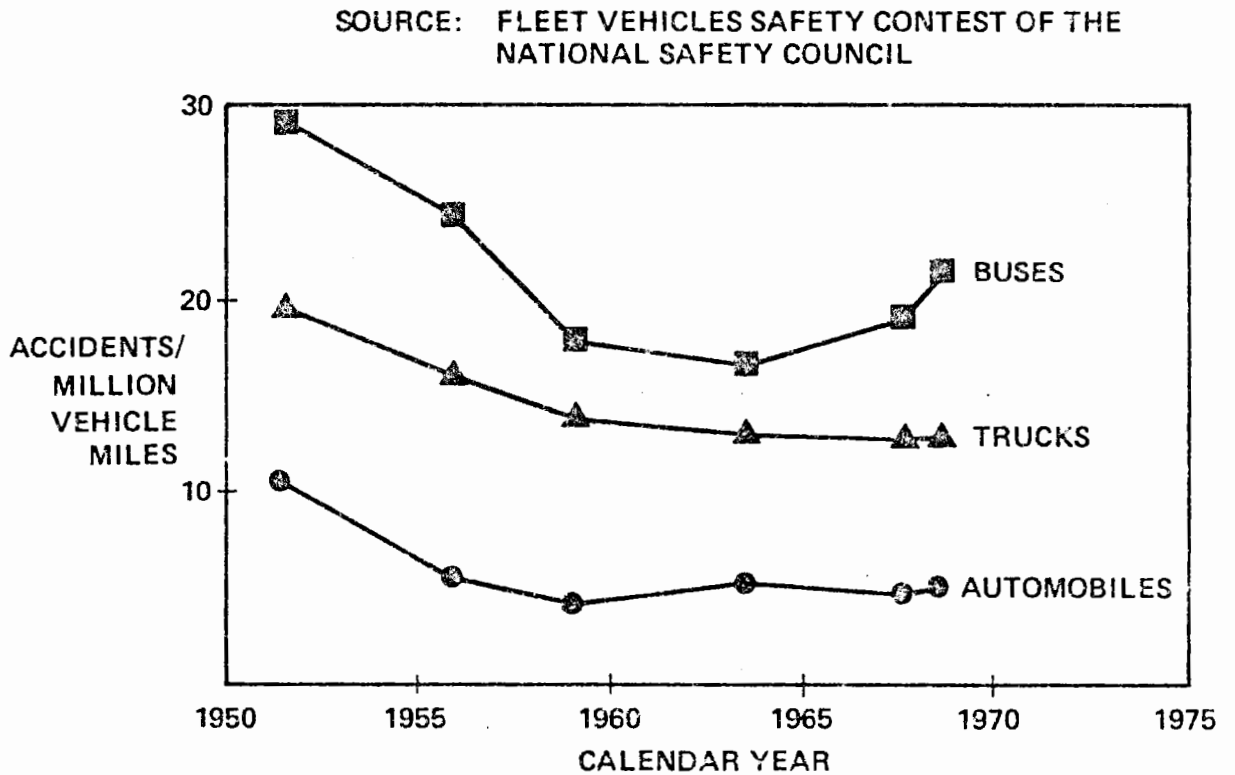
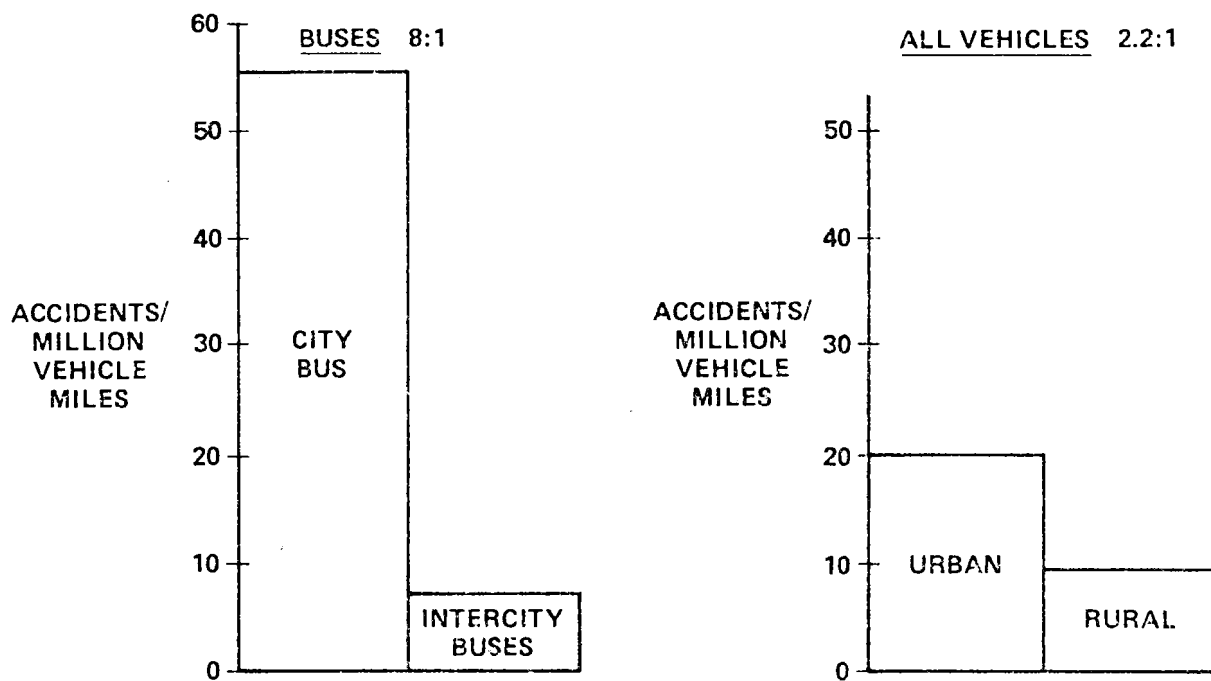

FIGURE 10
Urban Versus Rural Accidents



- SOURCES:
- NATIONAL SAFETY COUNCIL – ACCIDENT FACTS 1970
 - U.S. DEPARTMENT OF TRANSPORTATION, FEDERAL HIGHWAY ADMINISTRATION, BUREAU OF PUBLIC ROADS - HIGHWAY STATISTICS, 1969

- . Location of bus properties:
 - 2 Eastern
 - 2 Middle America
 - 2 Western
- . 8 percent of the total U. S. urban population
- . 18 percent of U. S. transit bus passengers
- . 16 percent of U. S. transit bus mileage.

All data presented are for the base year of 1969-1970. The mean value of safety related costs for the properties selected is within 3 percent of the national transit average. Safety related costs include claims payments and overhead costs associated with insurance and staff expenses. The bulk of this data gathering effort was carried out by Rensselaer Research Corporation (RRC). After a preliminary analysis of the data from the selected bus properties, a series of special data requirements became apparent:

- . On-board accident details
- . Bus damage and repair cost details.

To obtain this data Rensselaer Research Corporation personnel spent two weeks at two major bus properties (one on each coast). With the assistance of transit property personnel, case by case data was taken to fulfill the data requirements with regard to bus damage and on-board accident details. This completed the data gathering effort.

The analysis of the data involved the use of fault tree techniques to classify an accident structure. Factors relating to accident frequency, average accident cost, and bus life cost were associated with each accident type described in the fault tree. The complete fault tree is given in Appendix A, along with a discussion of the symbols employed and details of the numerical technique employed to analyze the data. This discussion has been placed in the appendix so that it can stand alone.

Figure 11 summarizes the results of the analysis in tabular form. The 10 key bus accidents are rank ordered according to the claims cost involved for the 500,000 mile life of the vehicle. Accident type number 7 is a subclass of type 5, and is therefore not included in the total. Only nine accident types account for 74 percent of all claims costs.

Figure 11 is present here by way of summary. Detailed results are given in Appendix A, in a fault tree format.

FIGURE 11
The Ten Key Accidents

<u>TYPE</u>	<u>CLAIMS + OVERHEAD</u>
1. BUS HITS REAR OF OTHER VEHICLE	\$ 4,308
2. PASSENGER ON-BOARD BUS DECELERATING	\$ 1,878
3. HITS PEDESTRIAN	\$ 1,669
4. RIGHT ANGLE:INTERSECT.	\$ 1,120
5. BUS TURNING	\$ 1,092
6. HITS PARKED CAR	\$ 1,054
7. BUS TURNING RIGHT	(\$896)
8. SIDESWIPE	\$ 852
9. INJURED BY DOOR	\$ 823
10. INJURED WHILE ALIGHTING	\$ 742
TOTAL	\$12,538 = 74%

APPENDIX A FAULT TREES





In this Appendix the fault tree is employed as a logic structure to display bus accident data. The symbols are employed in Figure A-1. Note that the number within the triangles are references to fault tree page numbers. The number in the triangle at the top of the page indicates the page from which the top event or accident has come. The numbers in the triangles in the middle of the page refer to the number of the page containing a continuation of the event or accident type.

Each event or accident type is characterized by five numbers defined as follows:

- . F_S - The frequency of the type of accident based on the six property sample: accidents/500,000 bus miles
- . F_N - The estimated frequency of the type of accident developed from national statistics: accidents/500,000 bus miles
- . C_S - The average claims costs of the type of accident based on the 6 property sample: dollars
- . E_S - The total claims cost expense of the type of accident based on the 6 property sample (500,000 miles assumed as bus life): dollars
- . E_N - The estimated total safety cost of the type of accident developed from national statistics, including overhead and insurance costs (500,000 miles assumed as bus life): dollars.

The methods employed to develop these numbers will be described in detail below. The following indices characterize the 6 bus property data base:

FIGURE A-1
Definition of Fault Tree Symbols

<u>SYMBOL</u>	<u>SYMBOL DESCRIPTION</u>
	An event, in this case a bus accident type
	An "OR" gate: This indicates that any of the events below the gate will lead to the event above the gate
	An "AND" gate: This indicates that all of the events below the gate must occur for the event above the gate to occur
	An internal symbol: Number inside the triangle references another page in the fault tree
	No further development

- . Population served - 12.3 million
- . Total transit bus passengers - 891 million trips
- . Total transit bus mileage - 221 million miles

This compares to national indices for 1970 which are as follows: (10)

- . Urban population - approximately 150 million
- . Total transit bus passengers - 5,034 million trips
- . Total transit bus mileage - 1,409 million miles.

In averaging the data from the six properties the data were not weighted by any considerations such as number of passengers carried or mileage. A straight average was employed. For each property in the sample the following equation held for each accident type:

$$E_i = F_i \times C_i$$

The averaging process to obtain E_S and F_S was as follows:

$$E_S = \left(\sum_{i=1}^n E_i \right) / n$$

$$C_S = \left(\sum_{i=1}^n C_i \right) / n$$

$$F_S = \left(\sum_{i=1}^n F_i \right) / n$$

Where n is the number of bus properties in the sample, in this case n=6.

Thus, in the fault trees, the following is true:

$$E_S \neq F_S \times C_S$$

To check the validity of the sample, two additional numbers were generated, E_n and F_n . National data obtained from accident statistics and financial reports to the American Transit Association was used to fill in the top level categories in the fault tree. (11, 12) The percentage split of accident frequency and expense at each "OR"

gate was calculated based upon the 6 property sample. Although the relative levels of accident frequencies and expenses varied from property to property, the percentage splits were remarkably consistent.

The top level national statistics were then apportioned down through the fault trees. Note that, in general, the frequency numbers F_S and F_n check rather well. The national expense E_n is consistently higher than E_S . This is because related insurance and overhead costs associated with accidents are included in the national expense category E_n . In this way a more realistic expense number by accident type was generated.

The application of this methodology displays the utility of fault trees in logical structuring of a problem and extending the available data. Good agreement was obtained between sample results (F_S) and national projections (F_n).

The fault trees that follow are numbered 1 to 21 to provide a consistent cross reference. The cross reference format is employed to condense the rather large tree into the required 8-1/2" x 11" format.

FAULT TREES

NOTE: The following pages are numbered from 1 to 21 for the purpose of providing fault tree cross-references.

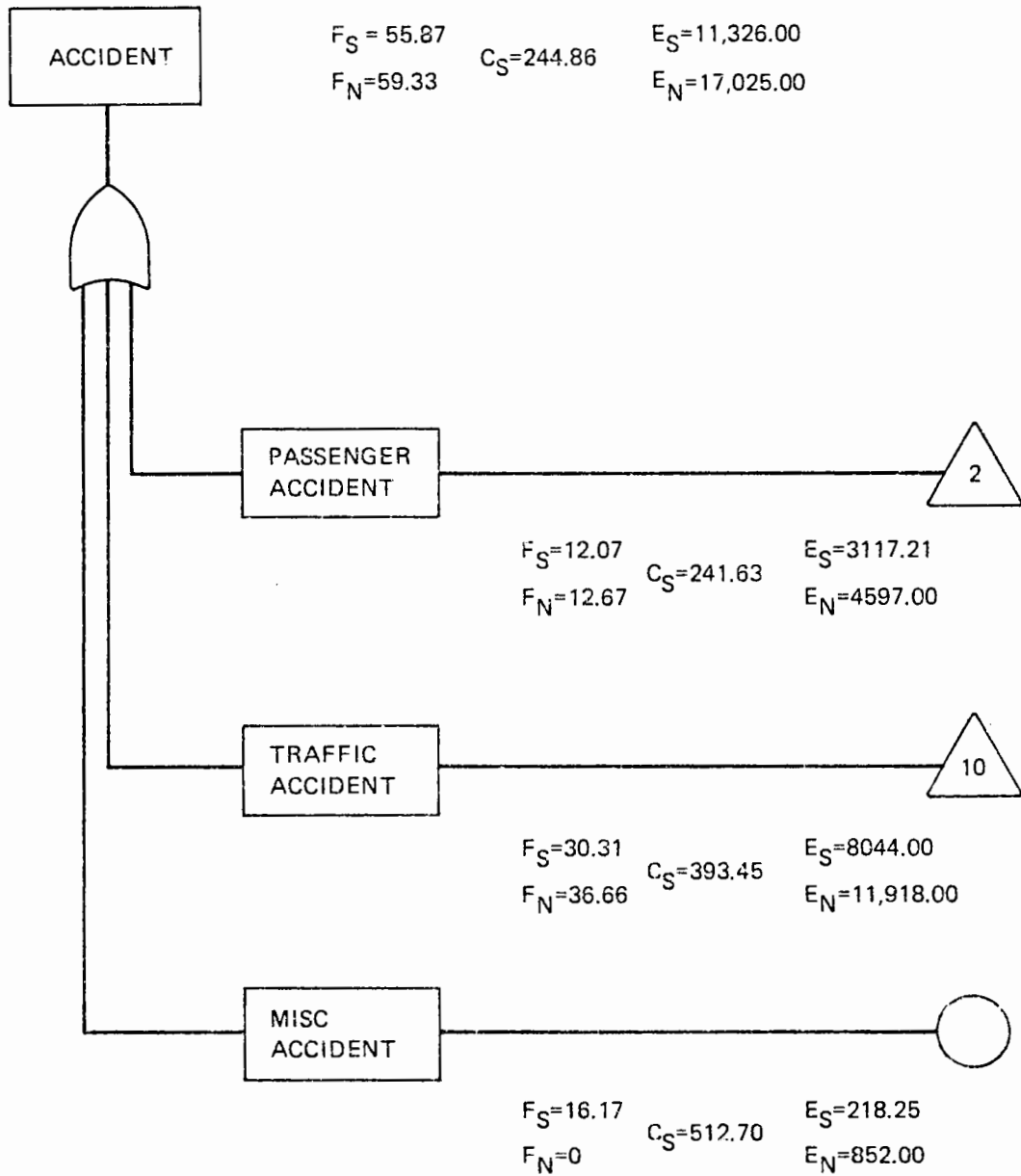

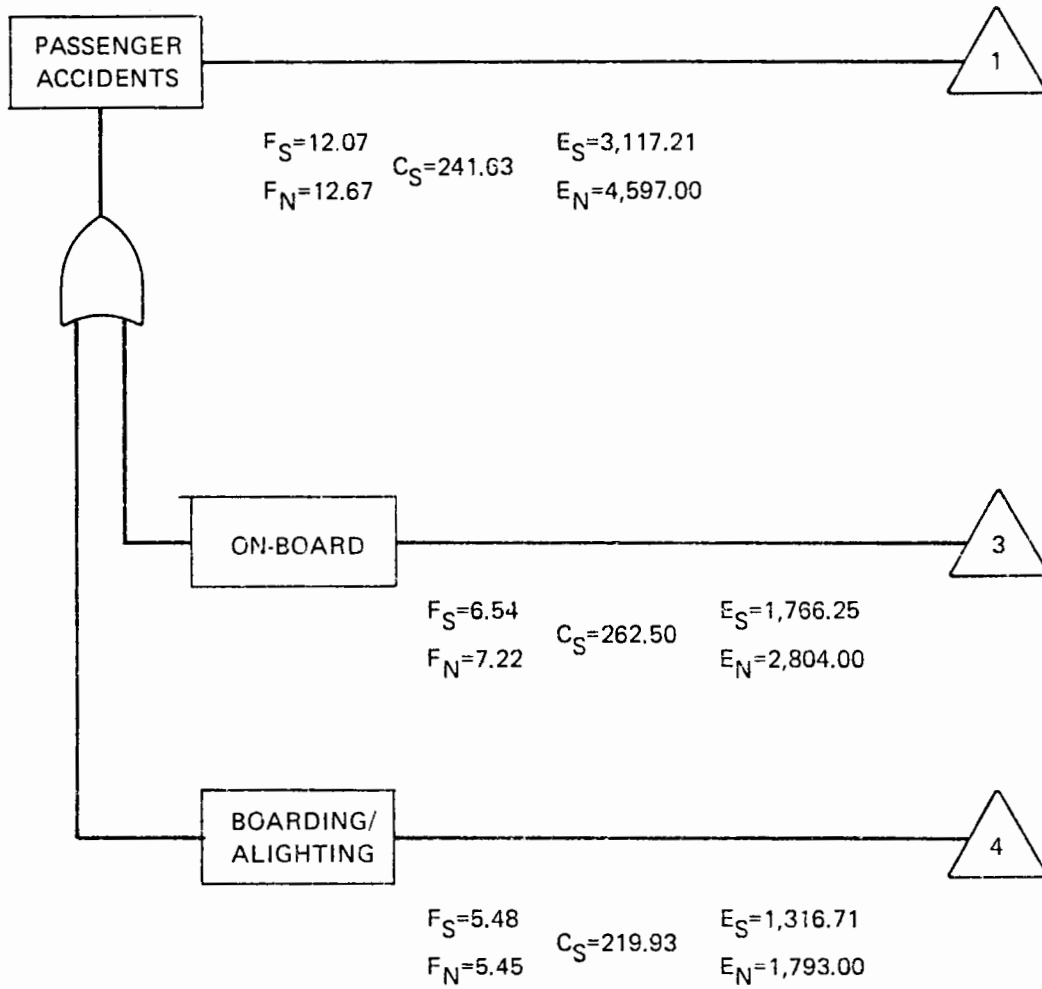

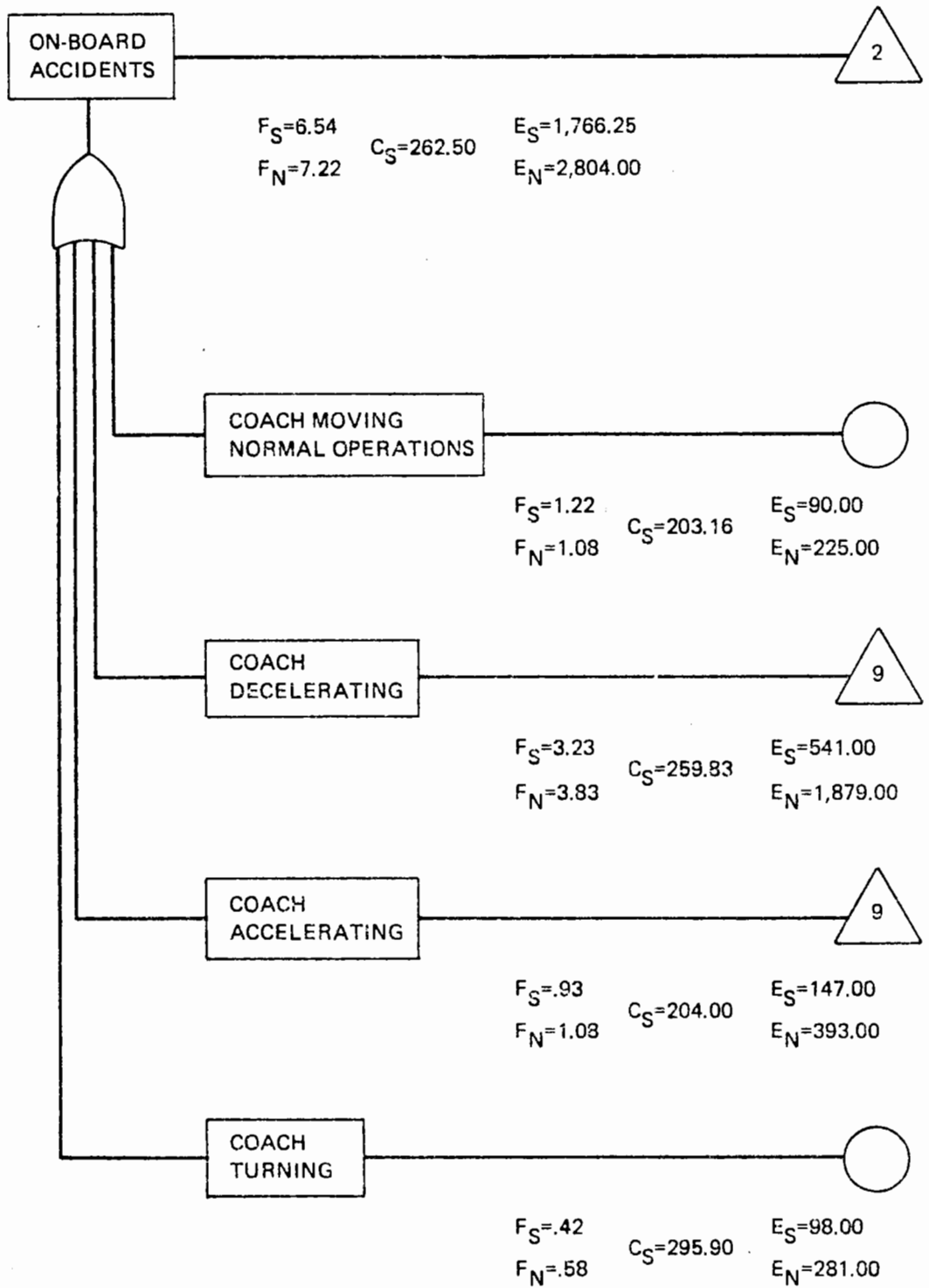

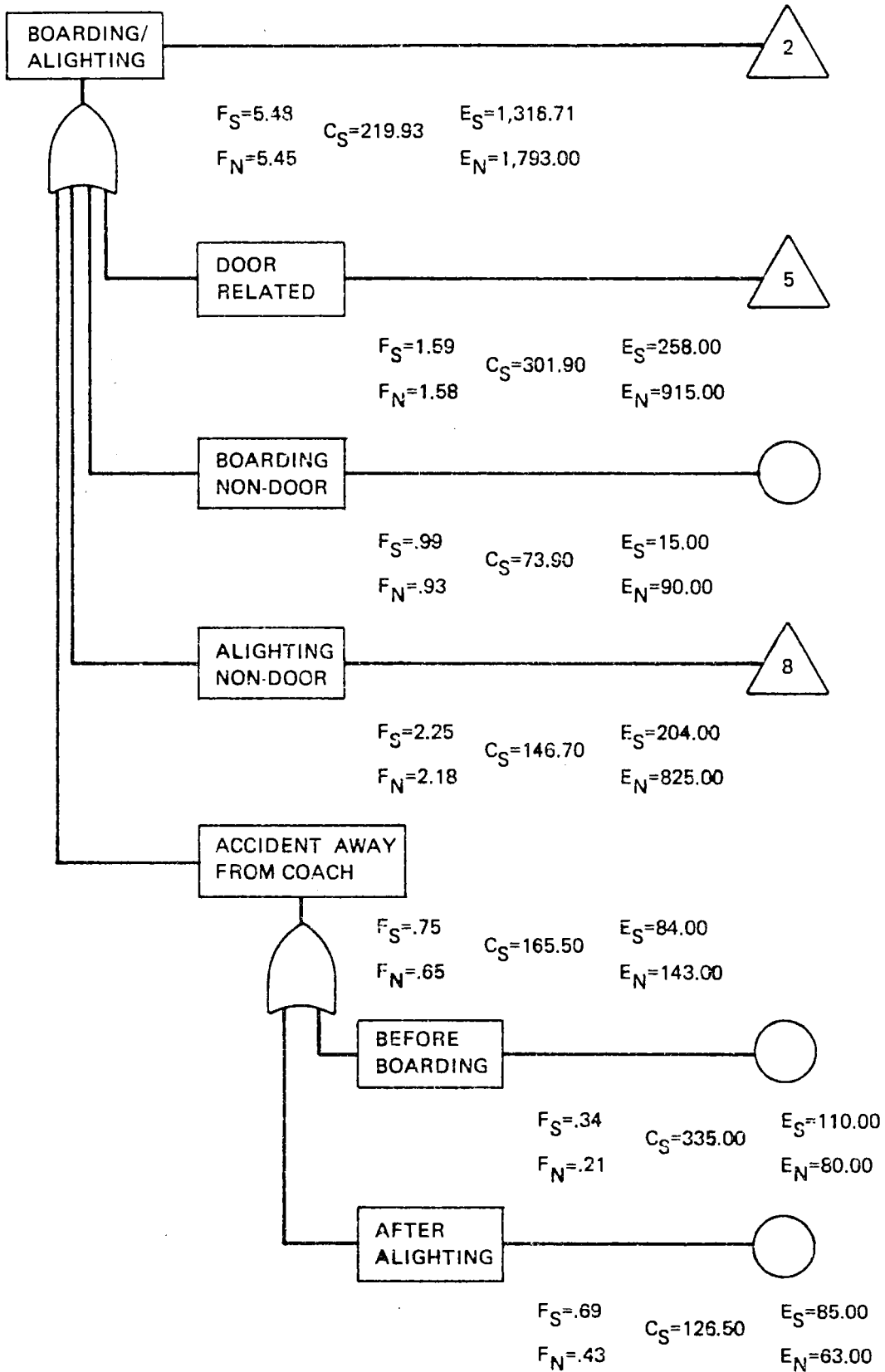

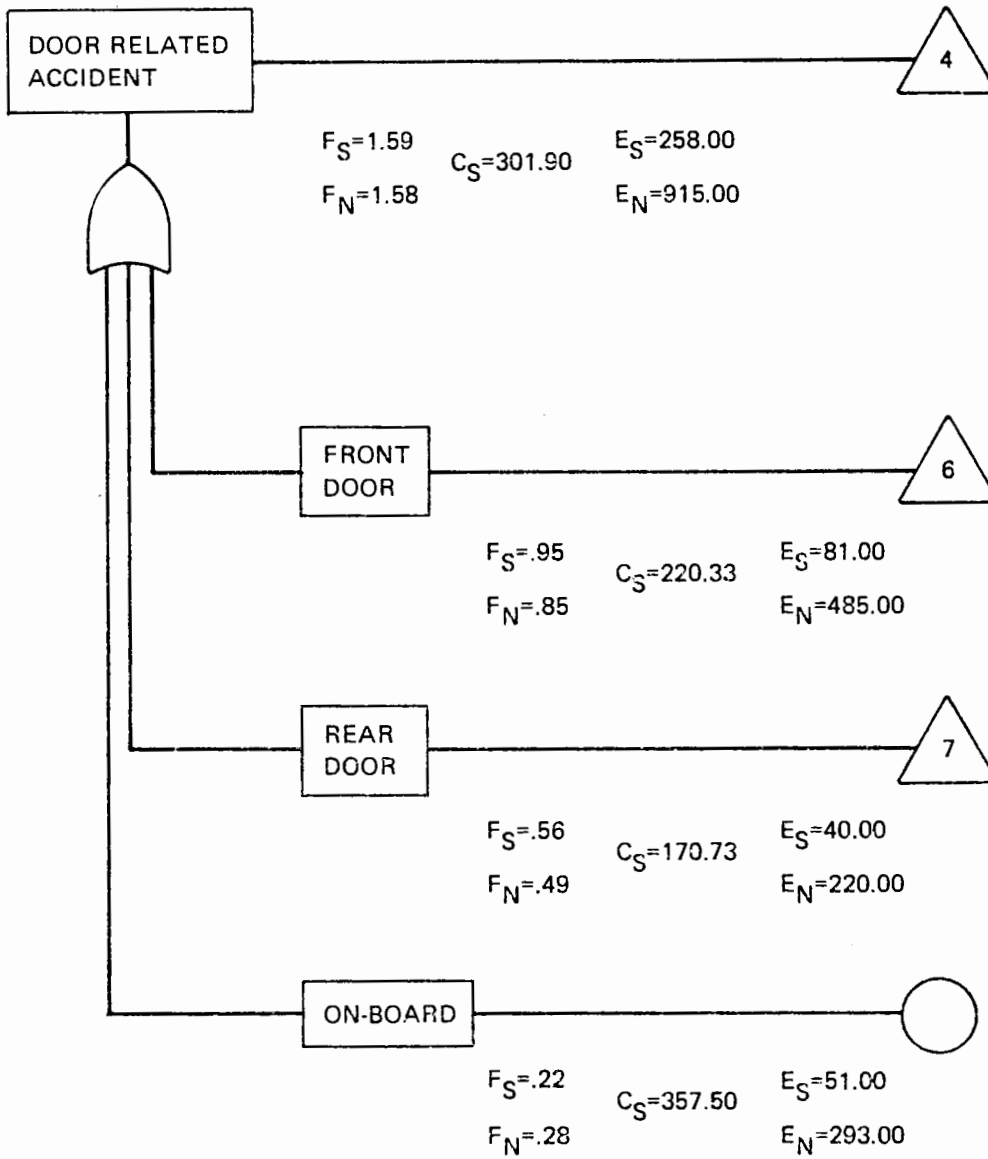

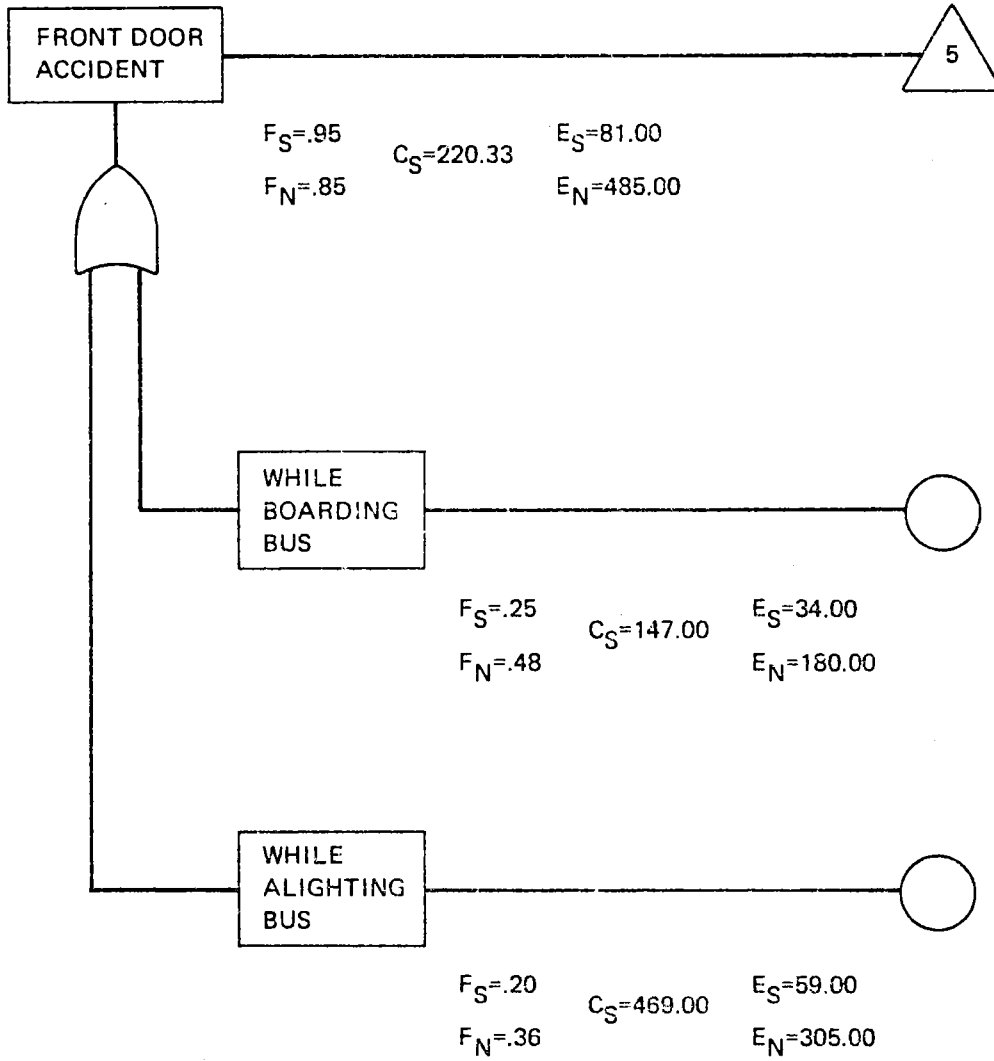

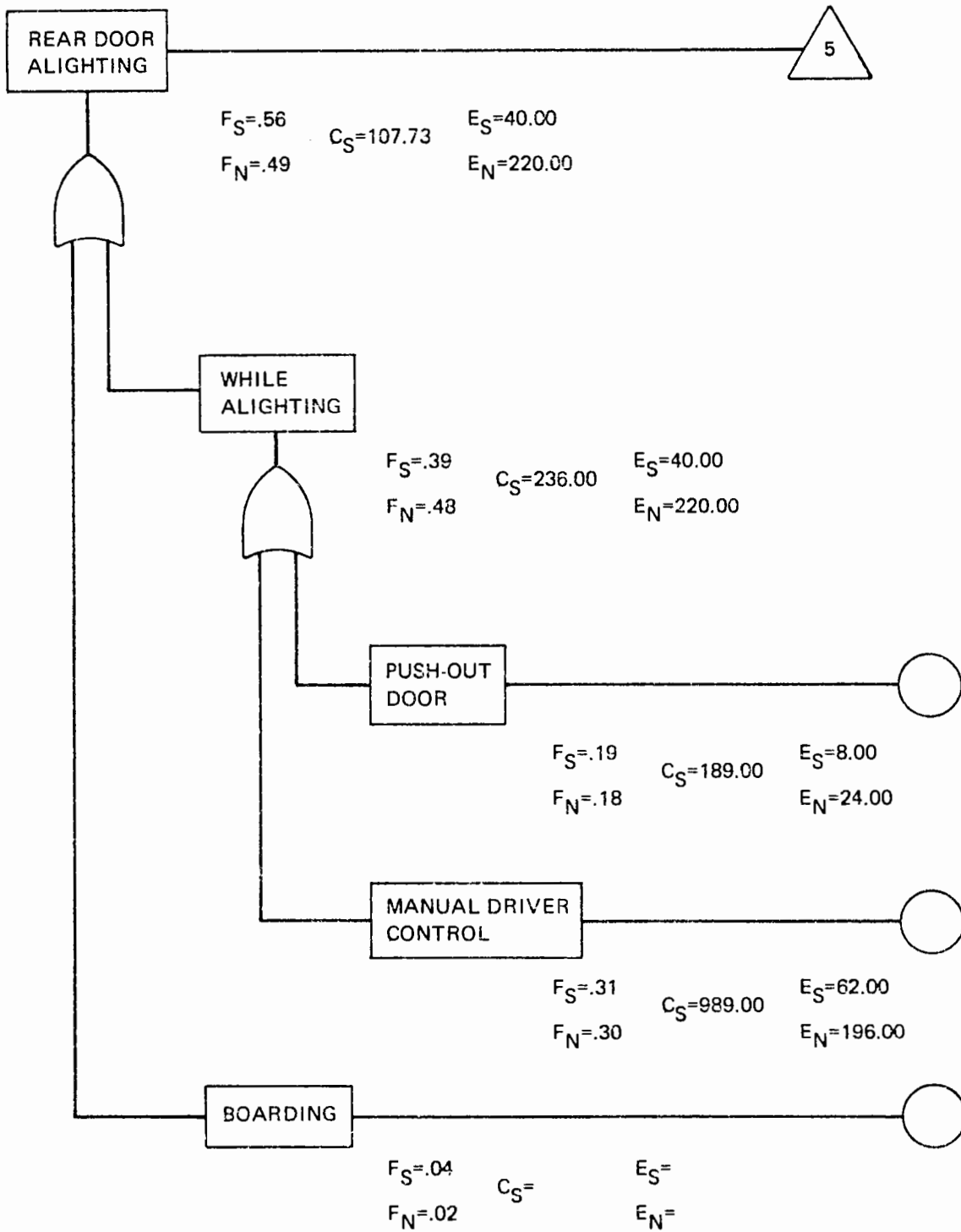

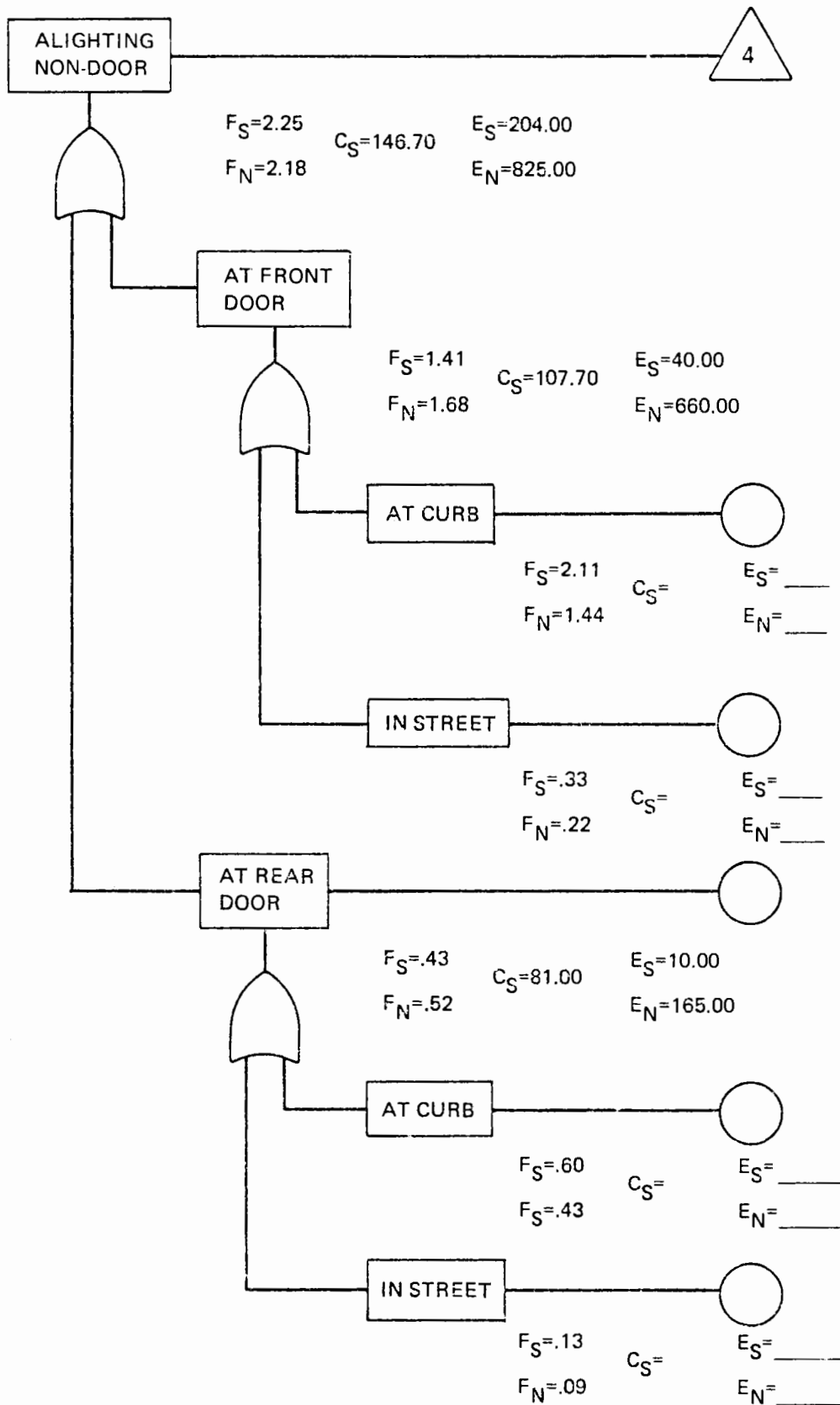

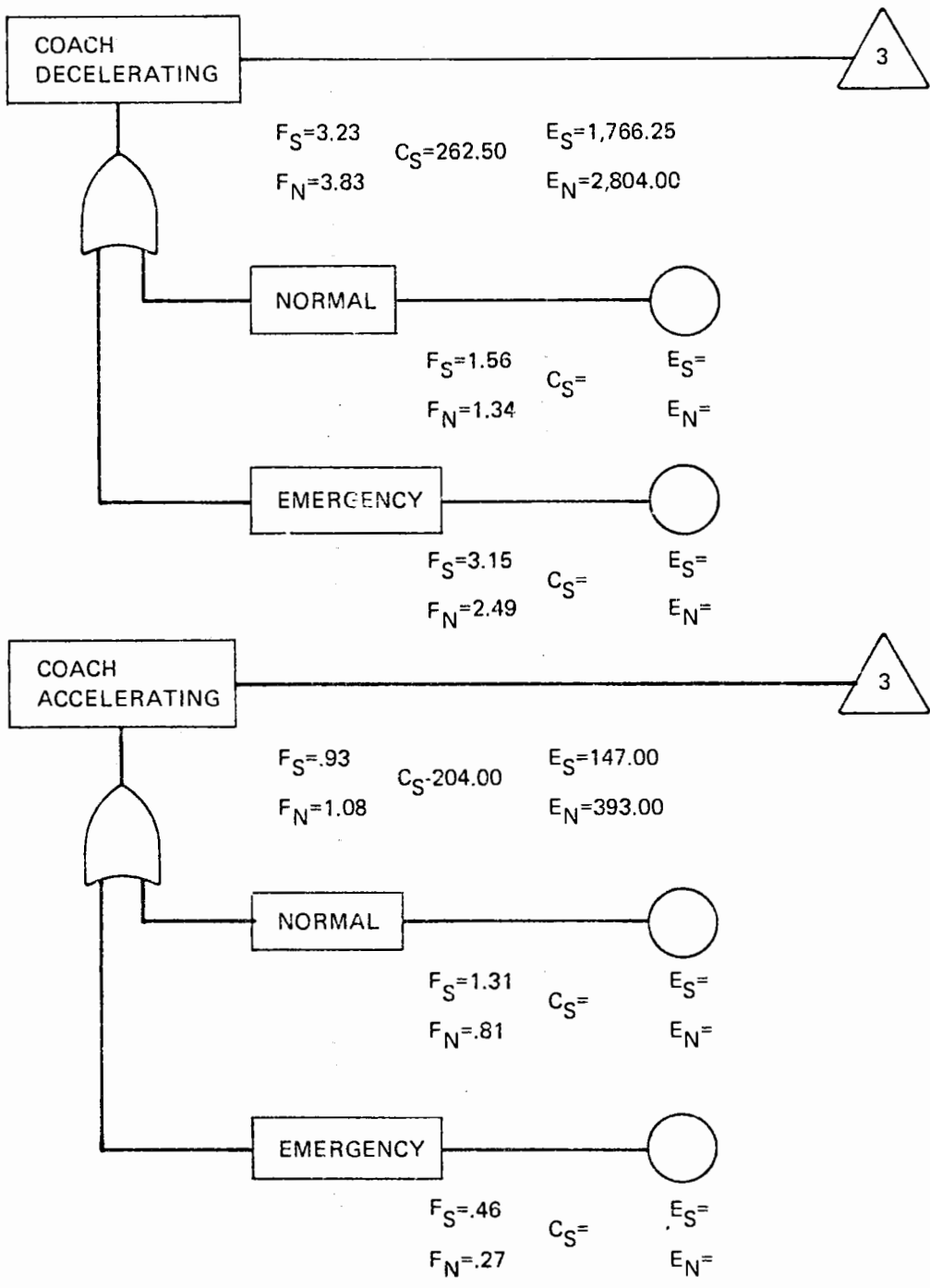

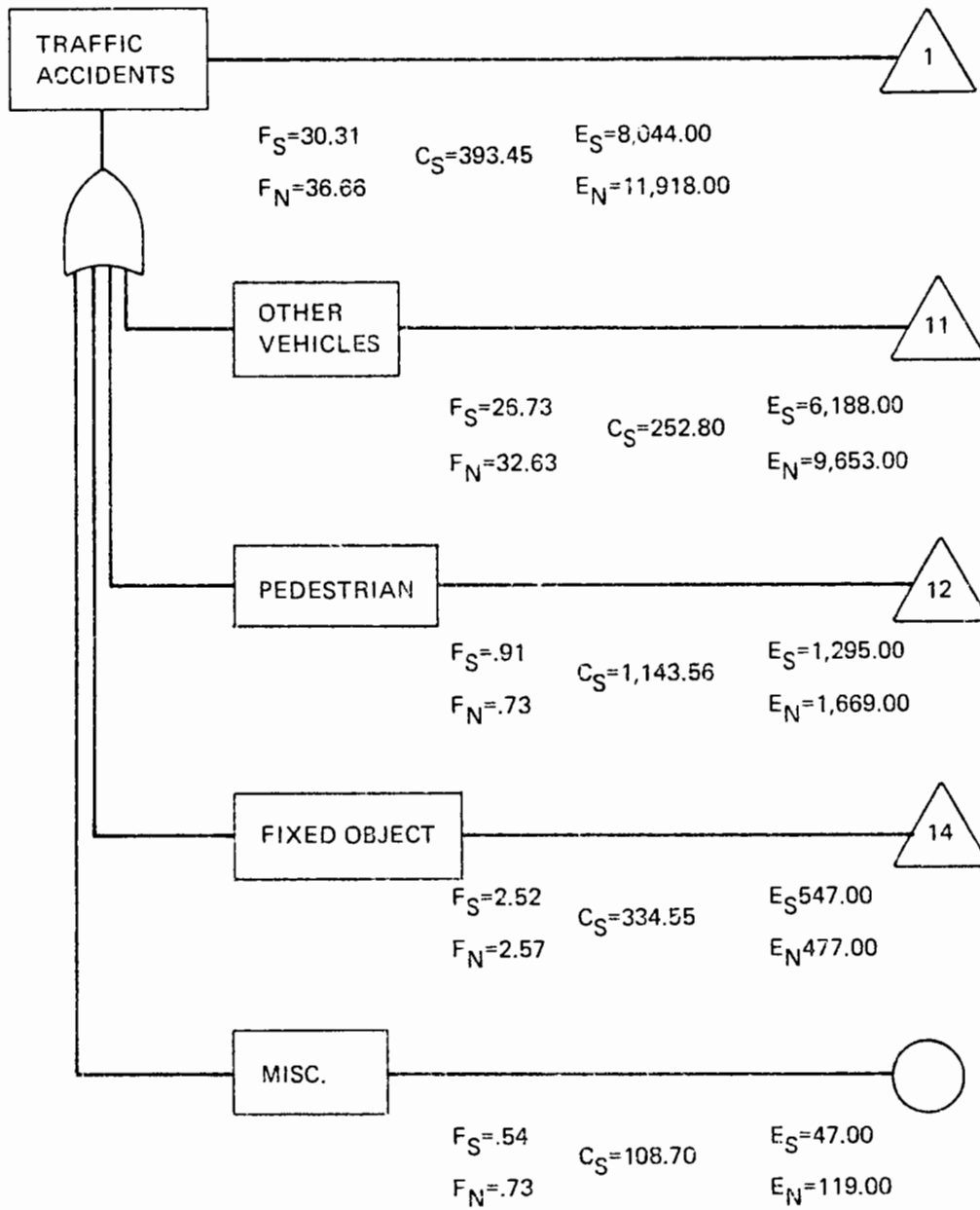

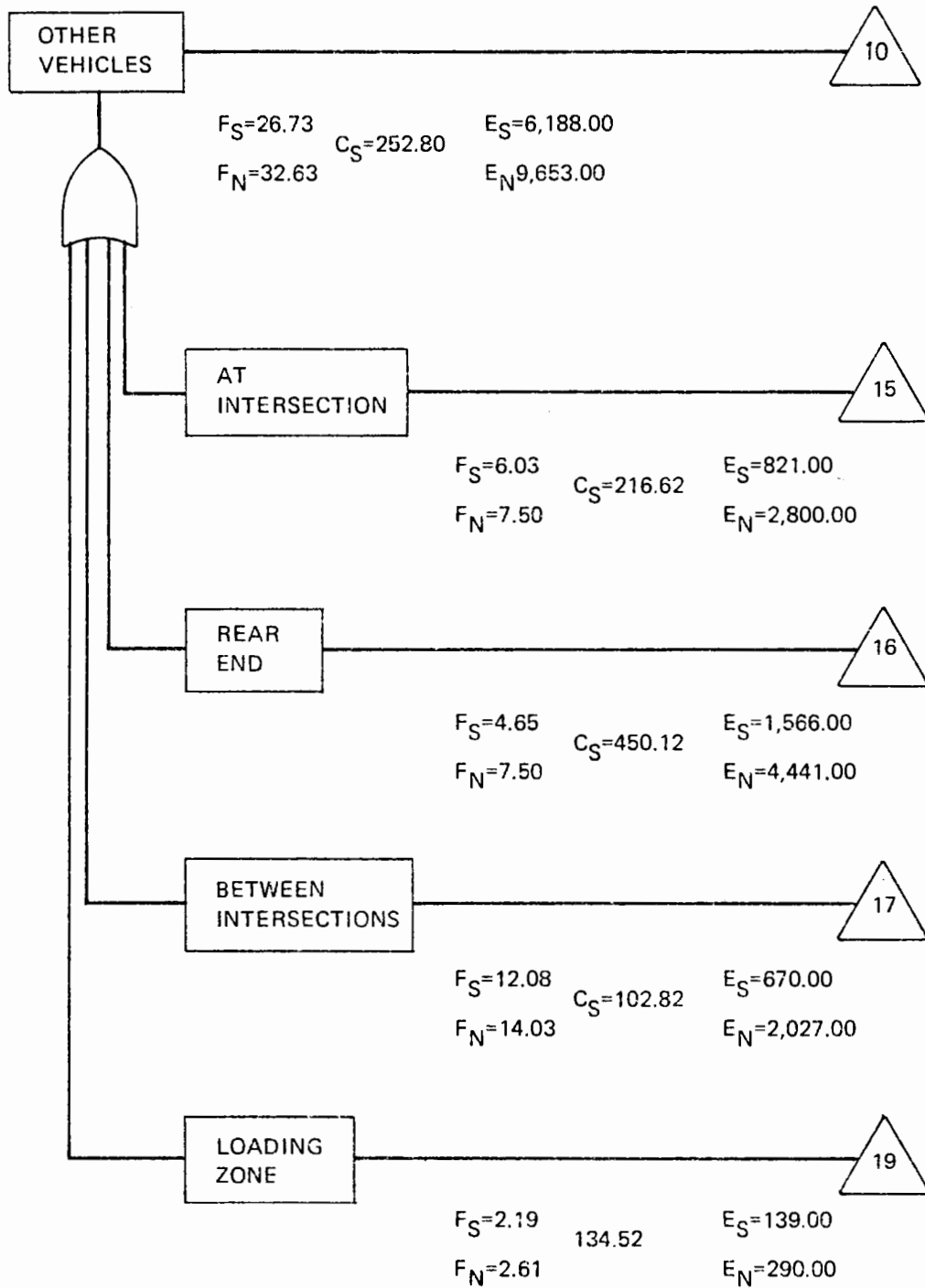

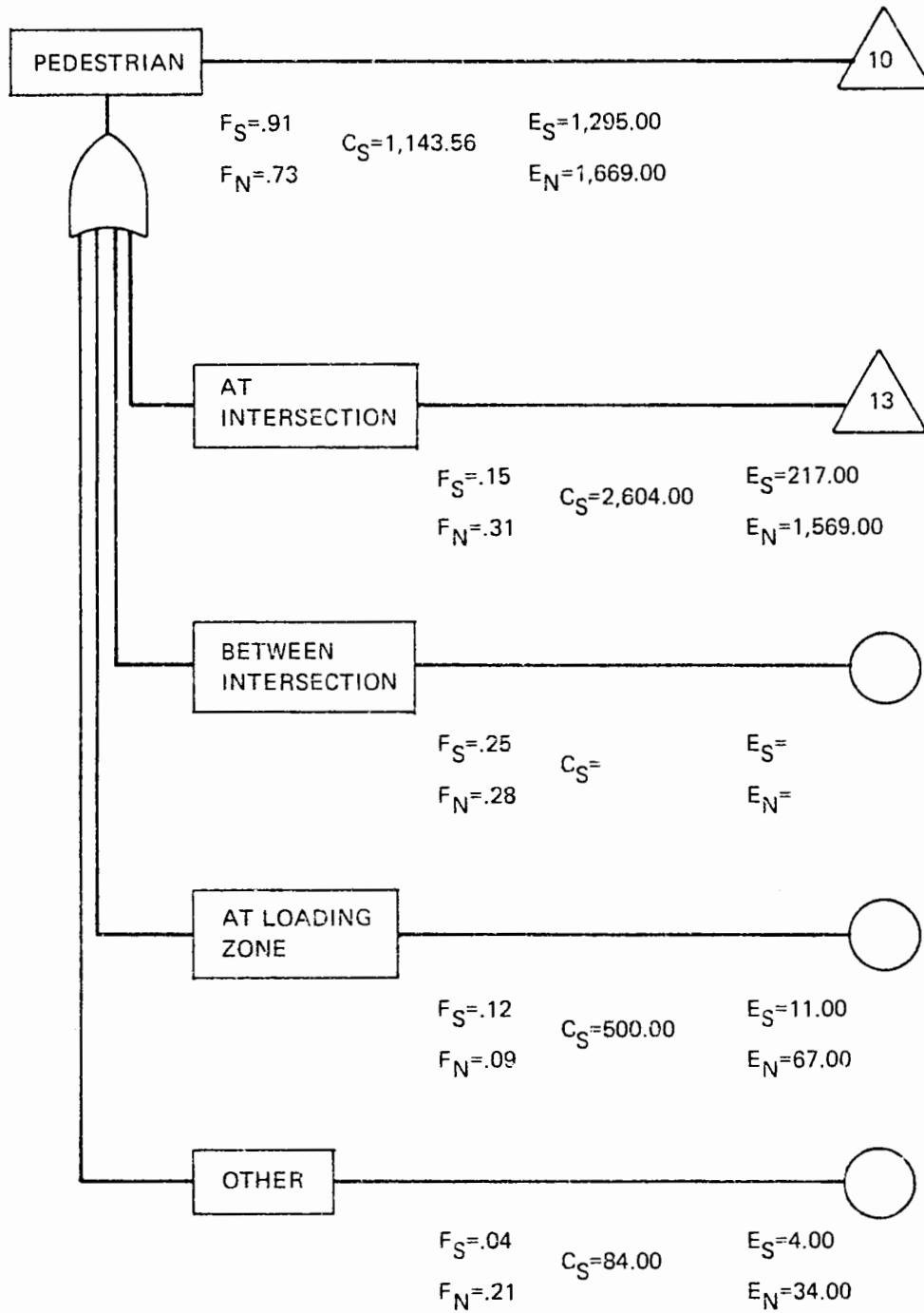

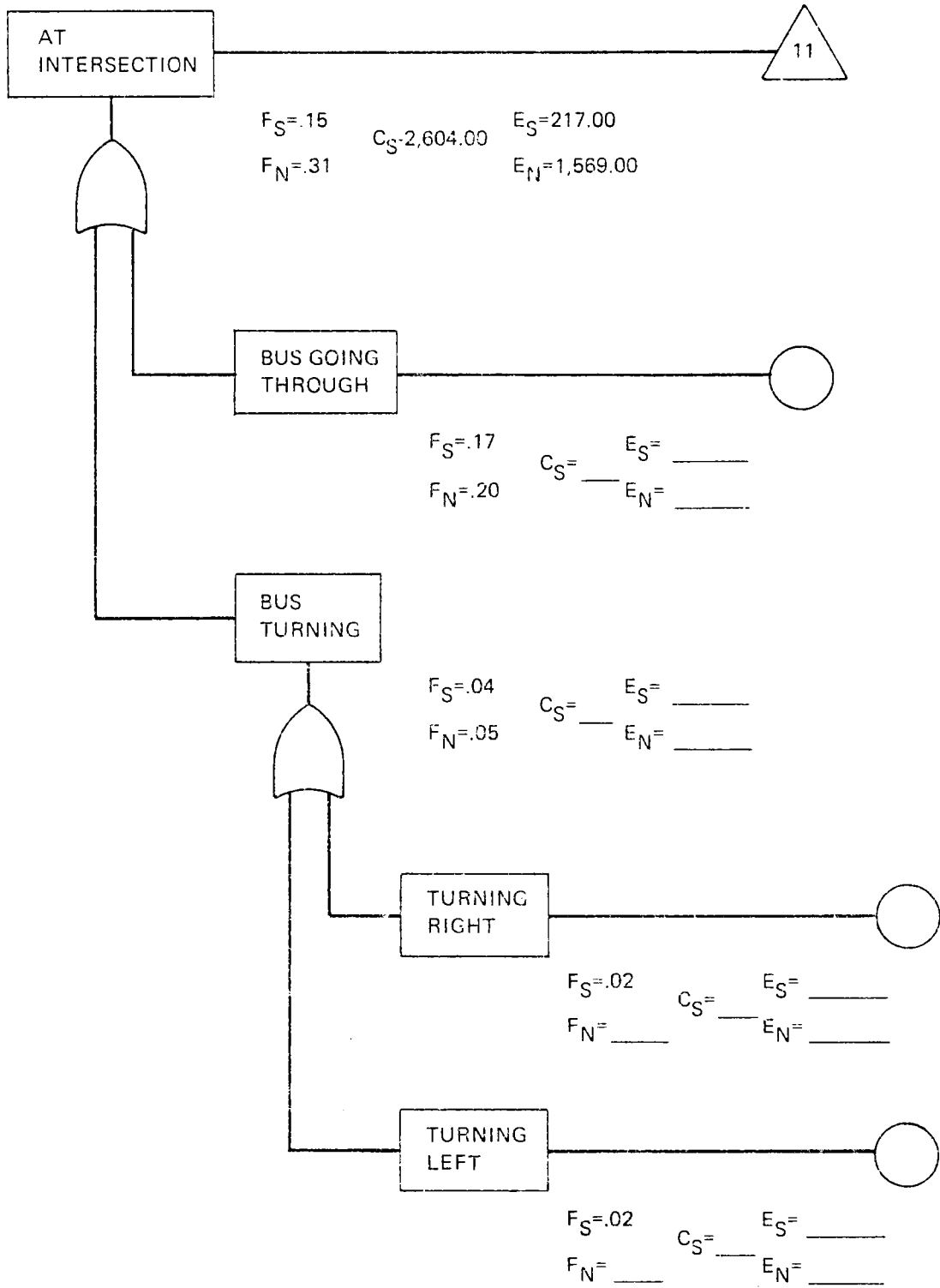

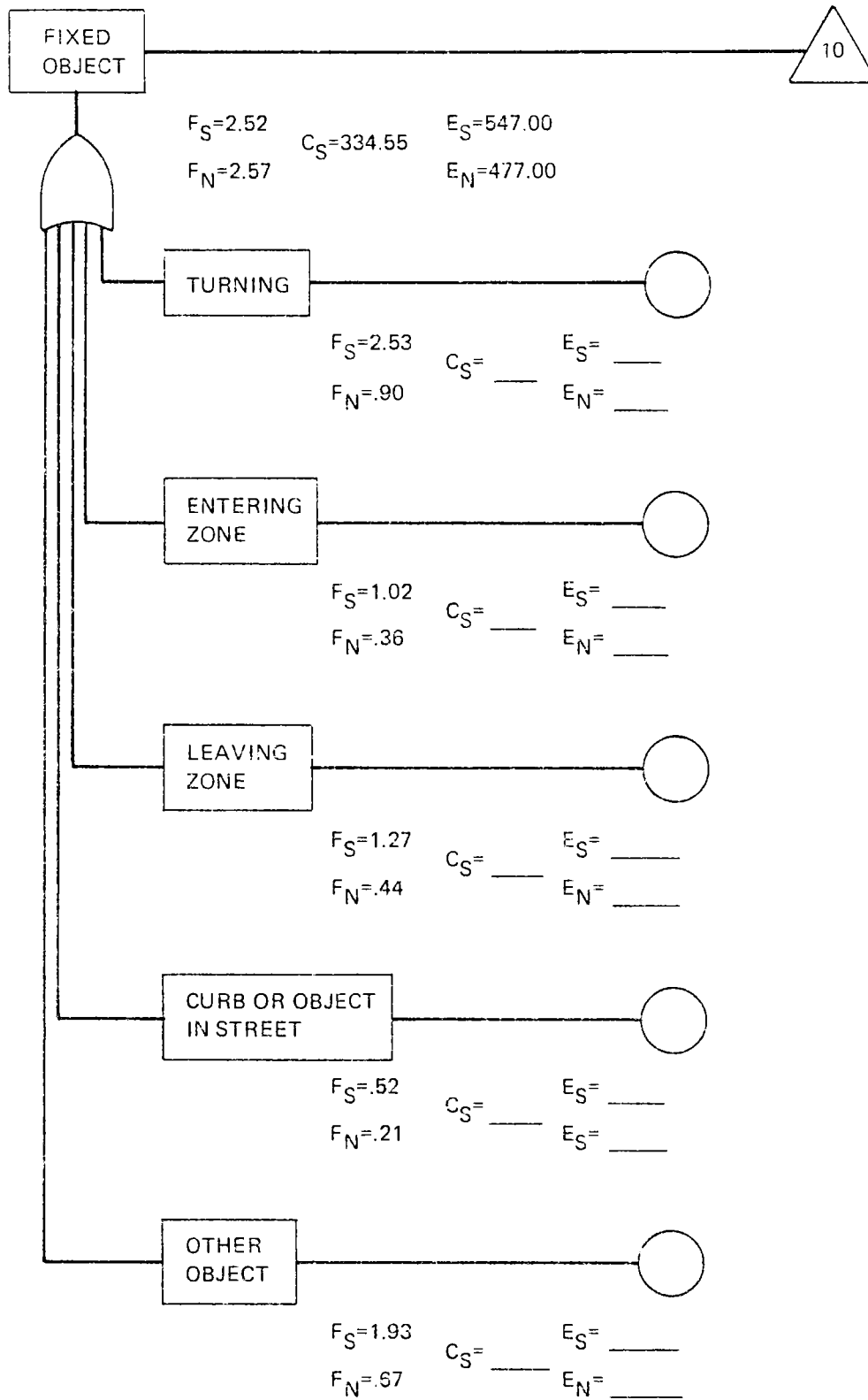

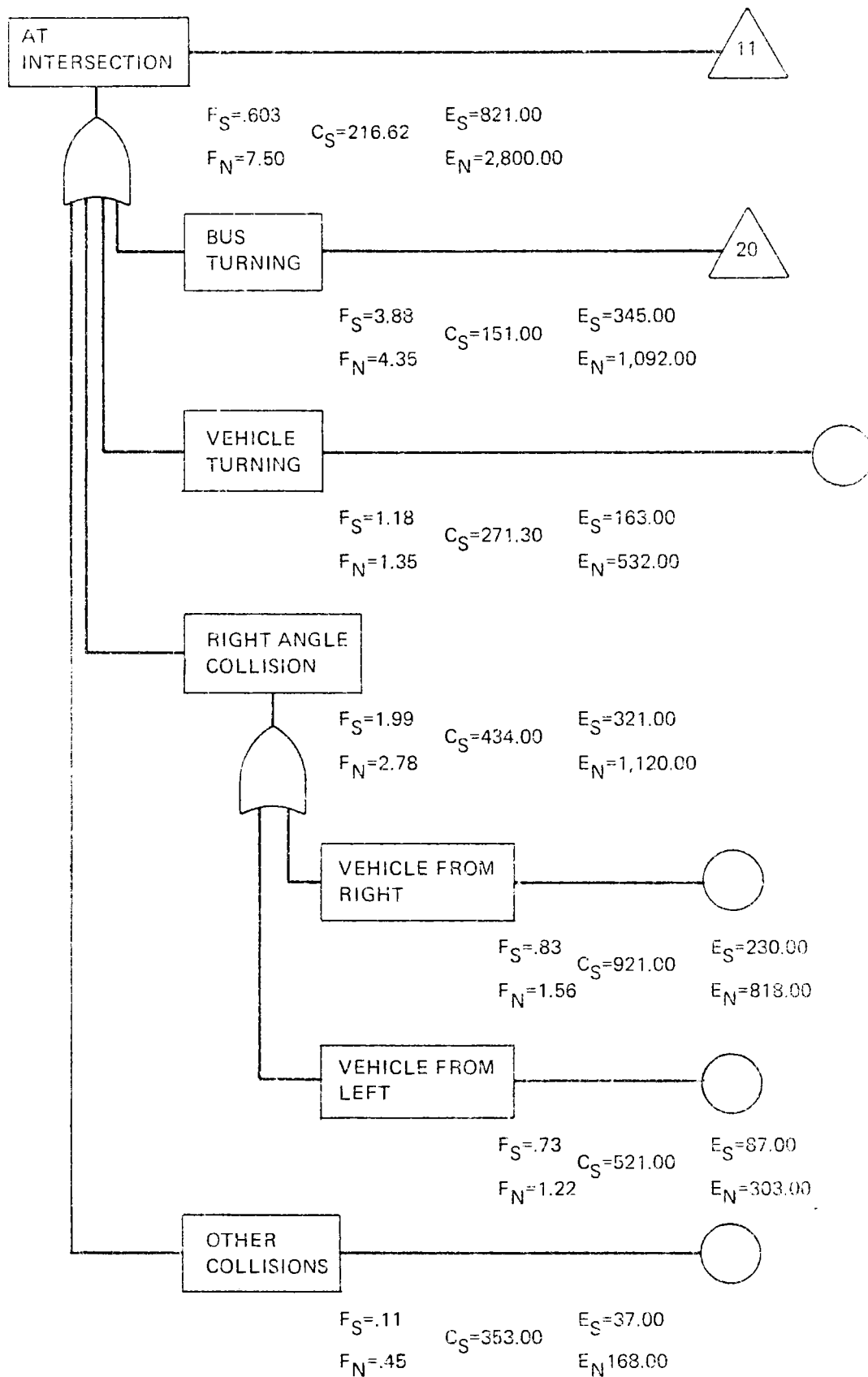

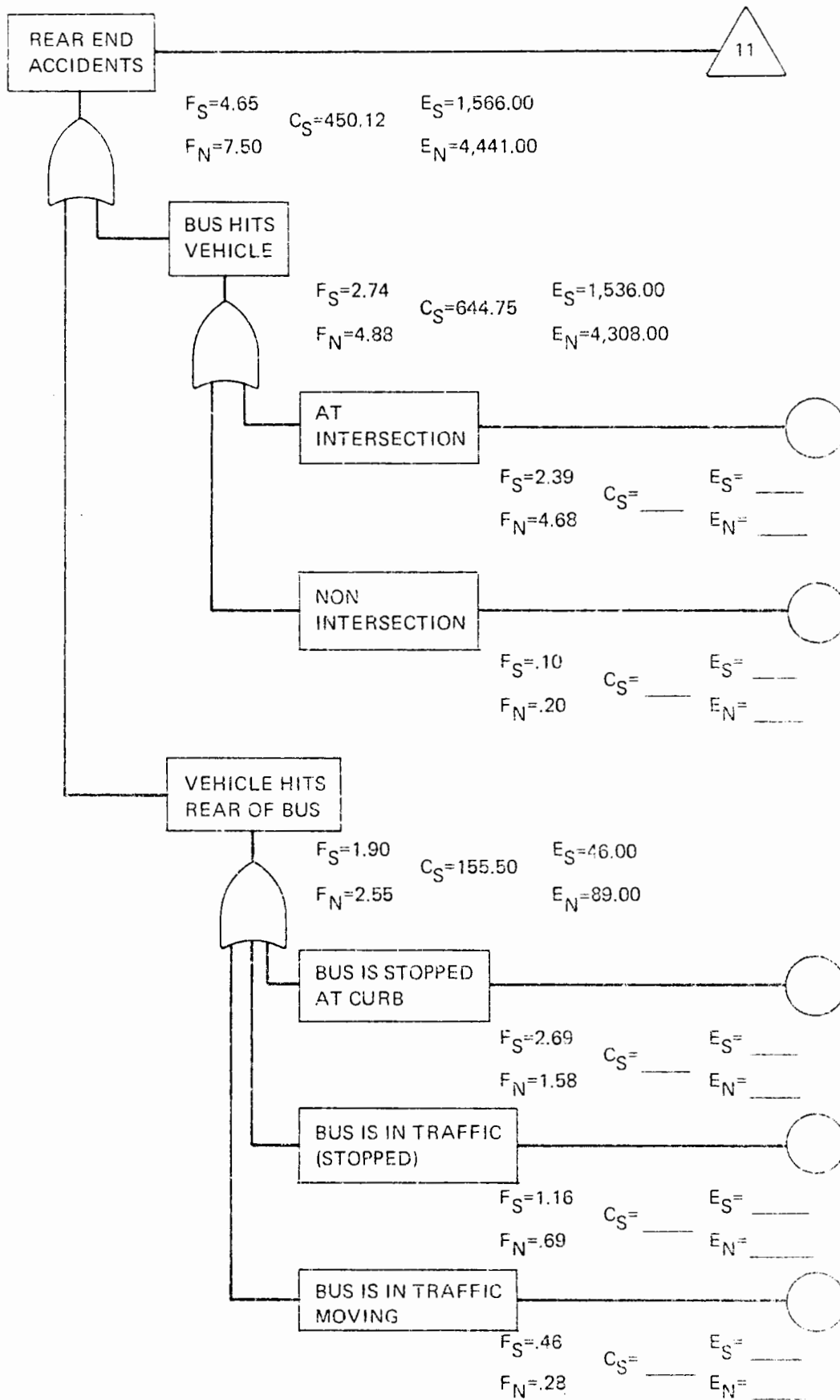

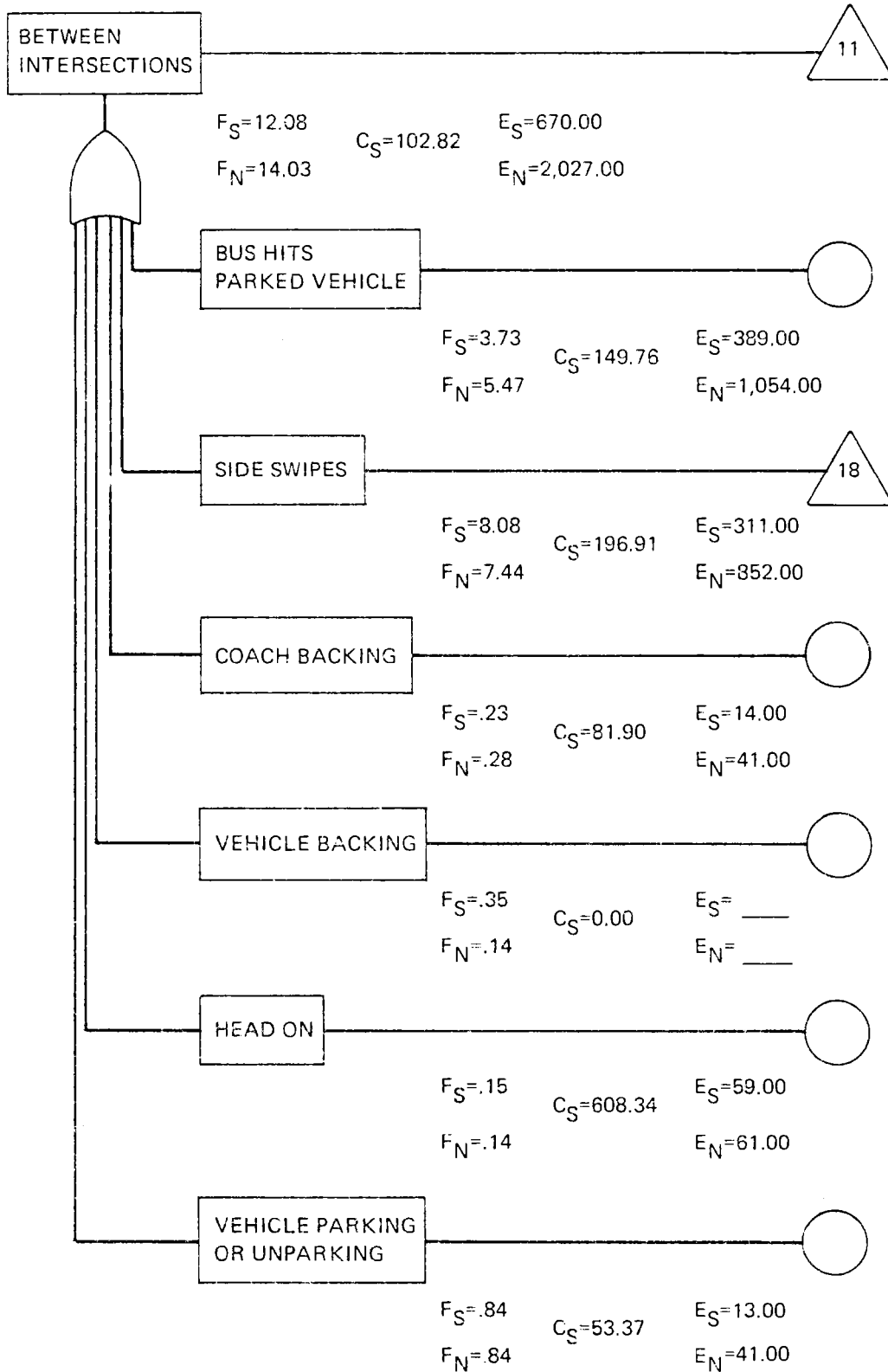

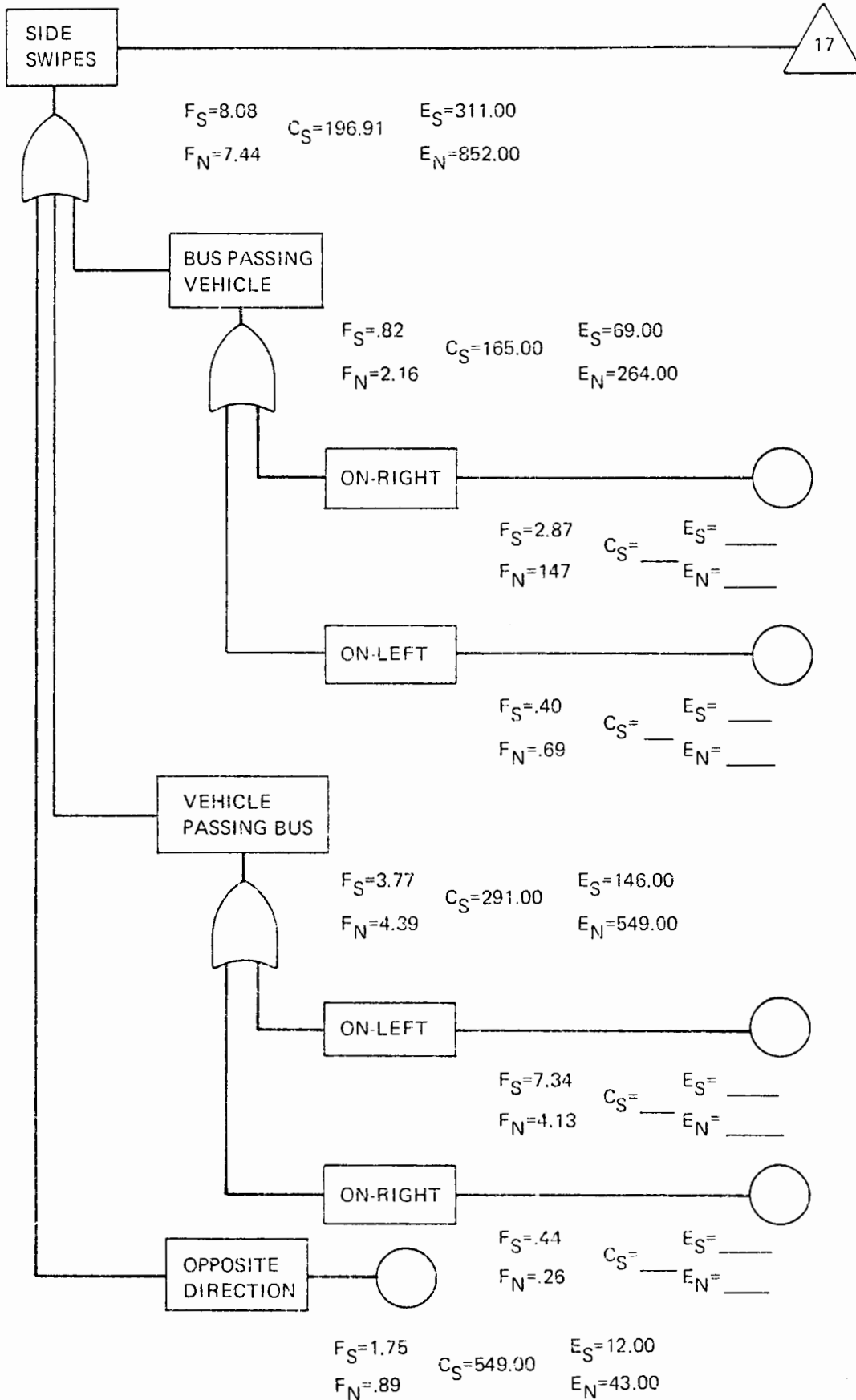

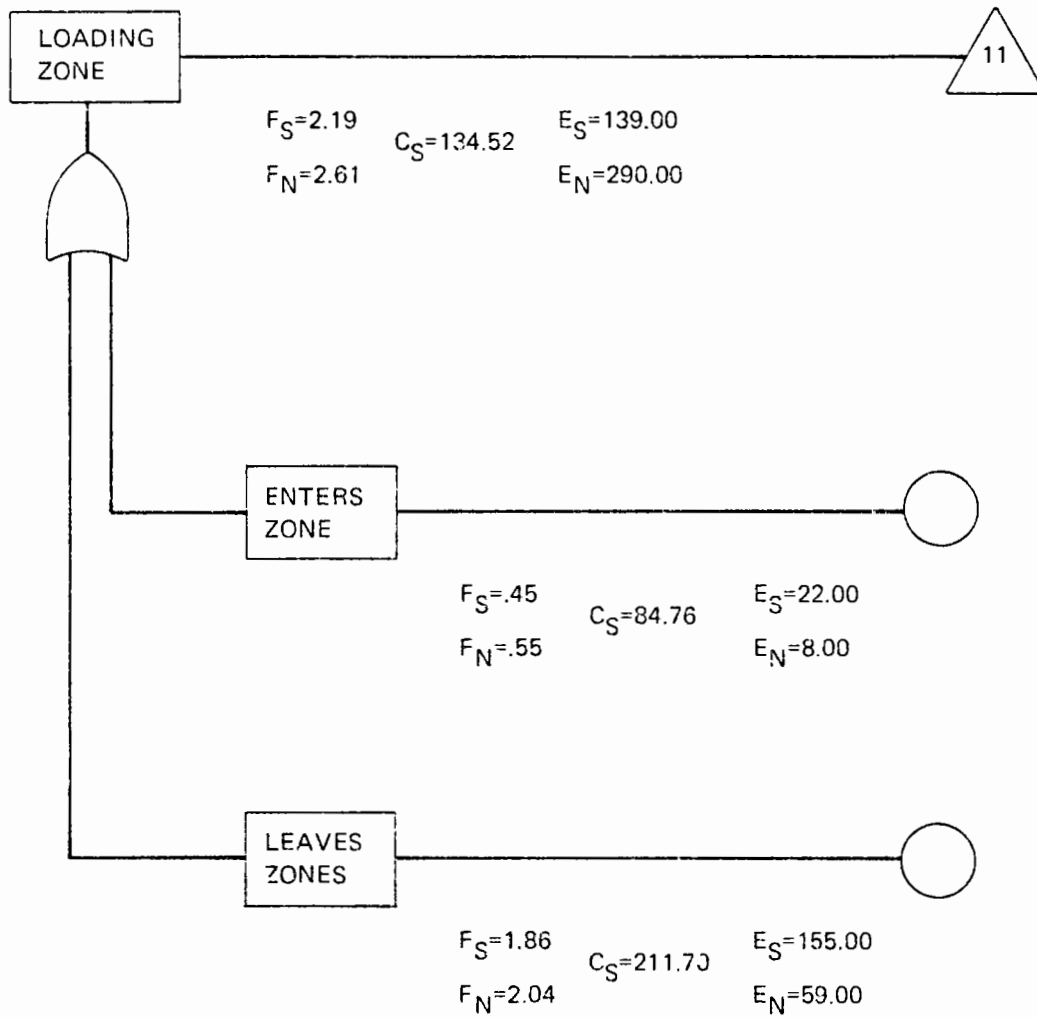

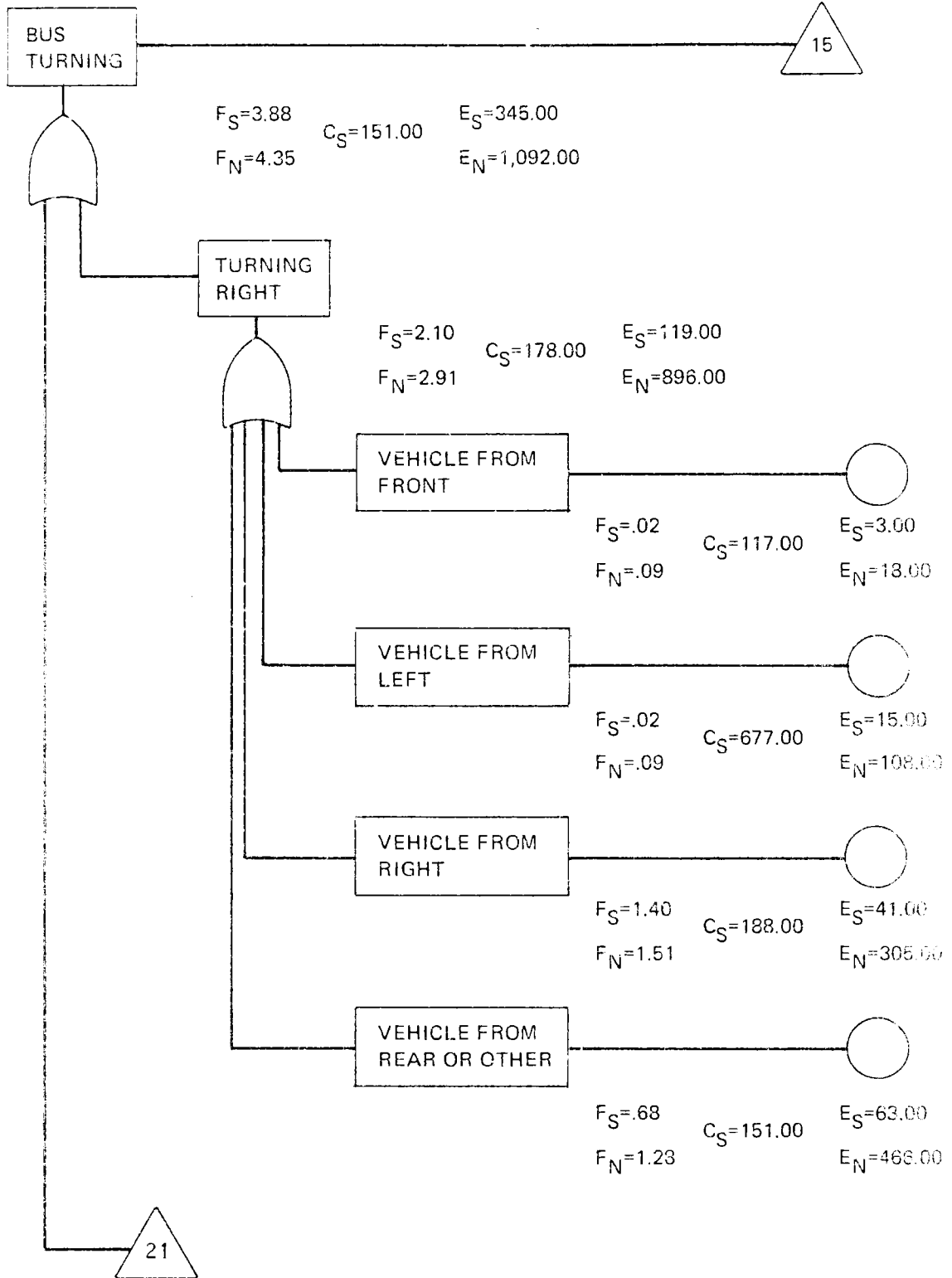

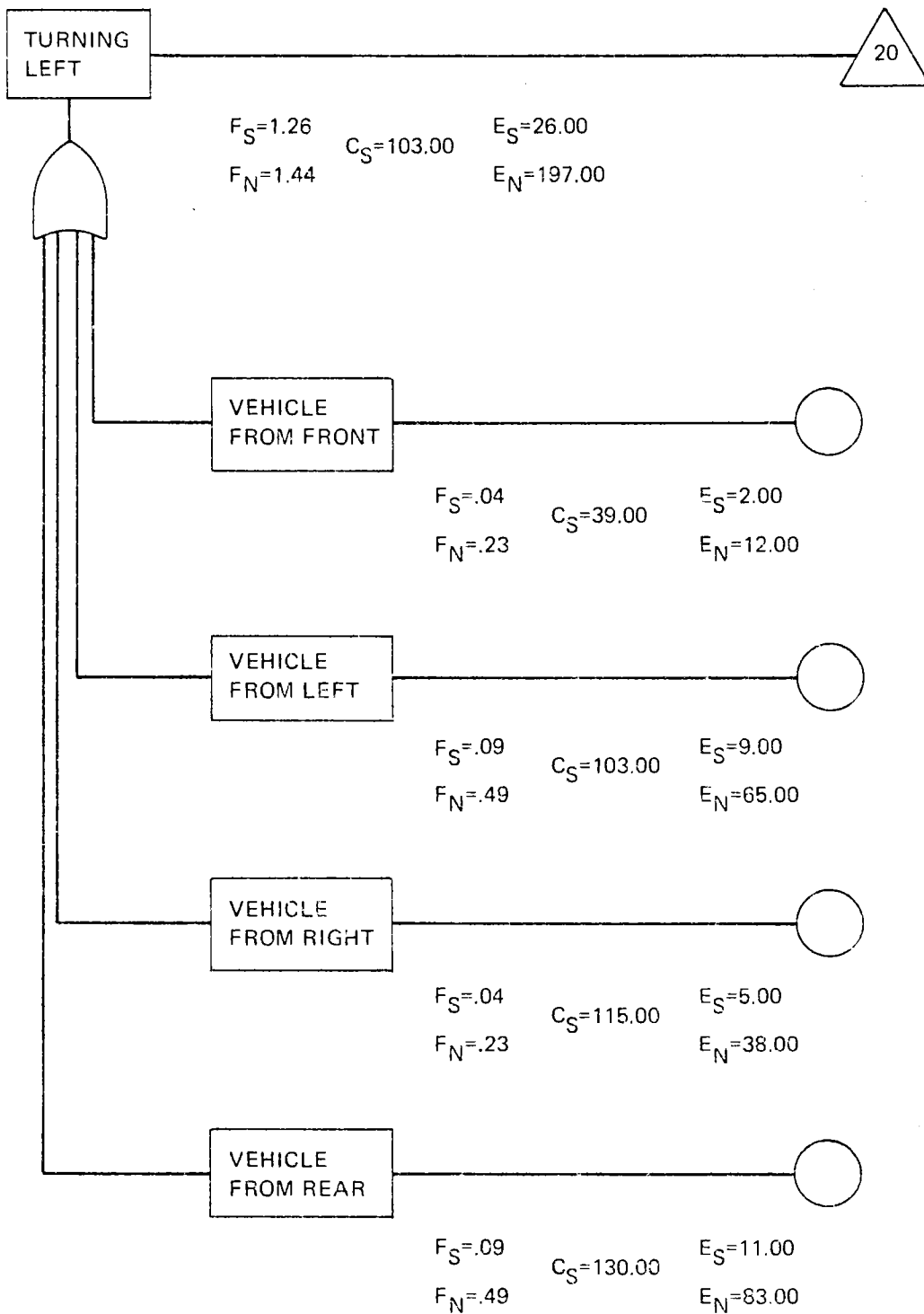

APPENDIX B
REFERENCES

APPENDIX B: REFERENCES

1. National Safety Council, "Accident Facts - 1970 Edition," Chicago, Illinois, 1970.
2. Simpson & Curtin and Booz, Allen Applied Research, Inc., "Life Cycle Cost Evaluations of Proposals Submitted in Response to RFP S(BTP) -71-0001 - Bus Technology Program," January, 1972. (Available from Booz, Allen Applied Research, Inc., Bethesda, Maryland.
3. John A. Volpe, "Motor Vehicle Crash Losses and Their Compensation in the United States," A Report to the Congress and the President, March, 1971, U. S. Department of Transportation, Washington, D. C.
4. Dr. William Haddon, Jr. Testimony before the House Committee on House bill (HR-9641), the automobile damageability bill, 1971.
5. National Safety Council, Transit Section, Motor Transportation Department, "Results of Survey of Passenger Accidents," Howard Baker, Chairman, Projects and Research Committee.
6. M. G. Bullock, "On Board Accidents," Mass Transportation, May, 1957.
7. Data gathered from specific bus properties was obtained on a confidential basis, therefore specific source references can not be quoted.
8. Paul M. Culkowski, et al, "Research in Impact Protection for Pedestrians and Cyclists," Cornell Aeronautical Laboratory, Inc., for the National Highway Traffic Safety Administration, Washington, D. C., May, 1971 (Contract No. FH-11-6955: PB 201-260).

9. U. S. Department of Transportation, Federal Highway Administration, Bureau of Public Roads, "Highway Statistics 1969," available from the superintendent of Documents, U. S. Government Printing Office, Washington, D. C.
10. American Transit Association, "'70 - '71 Transit Fact Book," Washington, D. C.
11. American Transit Association, "1970 Transit Operating Report," Washington, D. C.
12. American Transit Association, "ATA Accident Data Exchange - Report No. 62," Washington, D. C., March, 1971.

APPENDIX B

OBSERVATIONS OF PASSENGERS

ON-BOARD CURRENT BUSES

This report was prepared in presentation format and reviewed with UMTA, APTA and the Transbus manufacturers. It presents basic human factors data derived from observations of over 650 bus passengers in 6 cities. The basic information obtained on boarding/alighting times, reasons for delays at stops, on-board passenger movement, use of passenger assists, door preferences and seating preferences were employed to guide Transbus design efforts related to passenger accommodations.

This report remained a draft working paper and was a key reference document upon which portions of the Transbus human factors effort were based.

OBSERVATIONS OF PASSENGERS ON-BOARD CURRENT BUSES

INTERIM REPORT

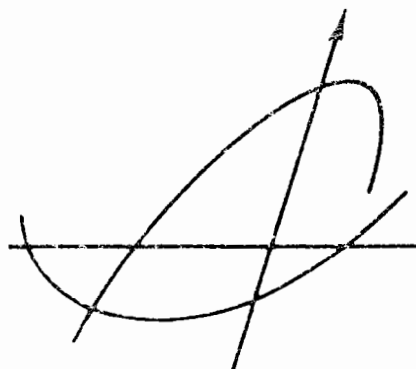

BOOZ, ALLEN APPLIED RESEARCH

JANUARY 31, 1973

PRESENTATION OUTLINE

- 1. OBJECTIVES**
- 2. METHODOLOGY**
- 3. DATA BASE**
- 4. QUANTITATIVE RESULTS**
- 5. INTERIM CONCLUSIONS**
- 6. PLANS FOR FUTURE WORK**

1. OBJECTIVES

- (1) IMMEDIATE: OBTAIN DATA TO AID THE INTERIOR DESIGN ON TRANSBUS
 - PASSENGER CHARACTERISTICS (SEX, AGE)
 - PASSENGER PREFERENCES (ASSISTS, SEATS, AND EXIT DOORS)
 - FACTORS INFLUENCING STOP TIME
- (2) LONG RANGE: USE DATA BASE TO SUPPORT THE TRANSBUS PROGRAM
 - TESTING ON MOCK-UPS
 - PLANNING HUMAN FACTORS EVALUATION
 - PLANNING PUBLIC DEMONSTRATIONS

1. OBJECTIVES (CONT'D)

(3) SPECIFIC ANSWERS TO QUESTIONS

- STOP TIME AS A FUNCTION OF THE NUMBER OF PASSENGERS
- DELAYS WHICH INCREASE STOP TIME
- PASSENGER POSITION WHEN BUS STARTS OR STOPS
- USE OF PASSENGER ASSISTS
- ALIGHTING VIA FRONT OR REAR DOOR
- SEATING PREFERENCES

2. METHODOLOGY

- INITIAL BUS RIDES TO DEVELOP DATA GATHERING FORMS AND TECHNIQUES
- DATA GATHERING
 - SELECT ROUTE/OBTAIN SCHEDULE
 - BOARD BUS AND FILL IN SEATING CHART
 - OBSERVE AND RECORD ACTIONS OF EACH PASSENGER BOARDING OR ALIGHTING
- DATA ANALYSIS
 - AVERAGE AND NORMALIZE DATA
 - PLOT SUSPECTED RELATIONSHIPS
 - INVESTIGATE SPECIAL PROBLEMS

3. DATA BASE

- OBSERVED APPROXIMATELY 1000 PASSENGERS BOARDING/ALIGHTING
- FIVE ARTERIAL ROUTES (TWO DOORS)
 - SAN DIEGO TO CHULA VISTA (7%)
 - WEST 25TH STREET, CLEVELAND (10%)
 - CONNECTICUT AVE., WASHINGTON, D.C. (28%)
 - CHARLES STREET, BALTIMORE (23%)
 - WOODWARD AVE, DETROIT (32%)
- SUBURBAN ROUTES (ONE DOOR)
 - SAN DIEGO
 - MARYLAND SUBURBS OF WASHINGTON, D.C.

3. DATA BASE (CONT'D)

- ONLY DATA FROM ARTERIAL ROUTES ARE PRESENTED IN THIS REPORT
 - 302 PASSENGERS BOARDING
 - 362 PASSENGERS ALIGHTING
- BASIC DATA RECORDED ON FORM
 - AGE GROUP
 - SEX
 - ASSISTS EMPLOYED
 - POSITION AT START-UP/STOP
 - TOTAL STOP TIME
 - NUMBER BOARDING AND ALIGHTING BY DOOR
 - COMMENTS ON SAFETY PROBLEMS, DELAYS, ETC.

ARTERIAL ROUTE PASSENGER CHARACTERISTICS VS NATIONAL POPULATION CHARACTERISTICS

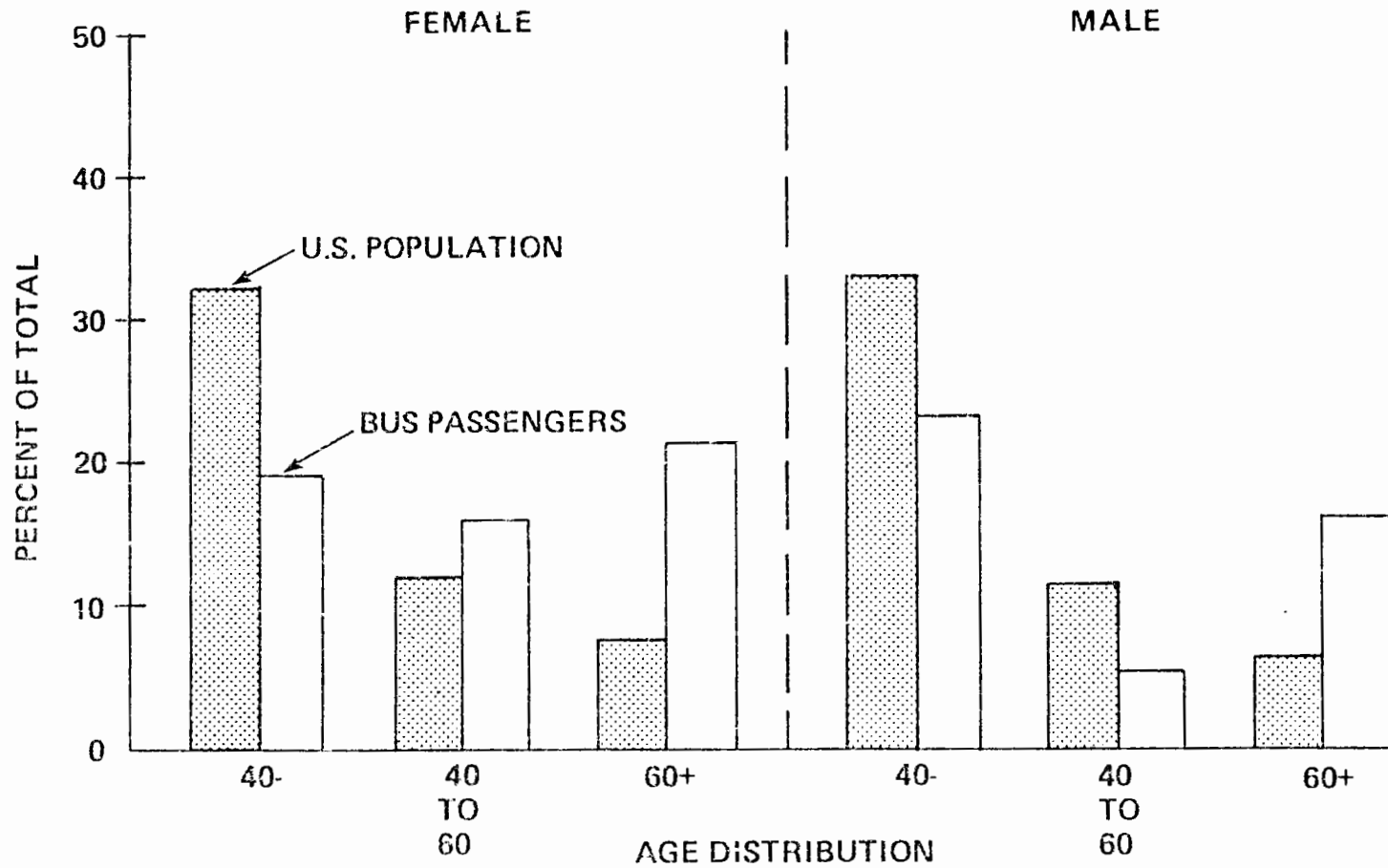

4. QUANTITATIVE RESULTS

STOP TIME VS. NUMBER OF BOARDING PASSENGERS

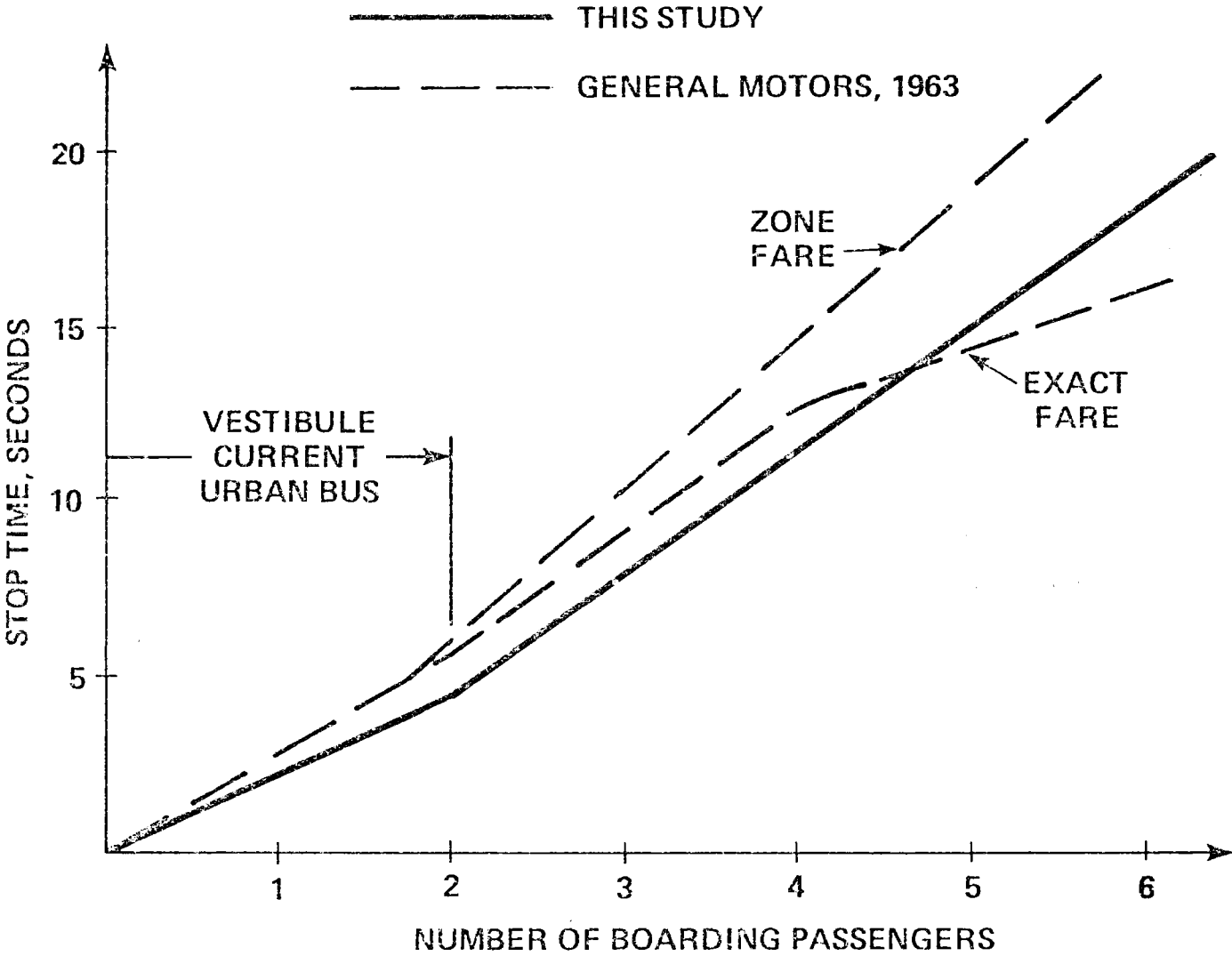

DELAYS WHICH INCREASE STOP TIME

● ASKING INFORMATION	43%	(13.5 SECONDS)
● EXIT VIA FRONT	31%	(4.0 SECONDS)
● ELDERLY AND HANDICAPPED	18%	(3.4 SECONDS)
● UNKNOWN	5%	(4.5 SECONDS)
● CARRYING PACKAGES	3%	(5.0 SECONDS)

**NOTE: DELAY DUE TO TRAFFIC CONGESTION,
TRAFFIC SIGNALS, ETC. NOT INCLUDED.
PASSENGER DELAYS OCCUR AT ONE HALF
OF THE STOP WHERE PEOPLE BOARDED THE BUS.**

POSITION OF BOARDING PASSENGERS WHEN BUS BEGINS TO MOVE

- **38% ARE SEATED**
- **36% ARE AT FAREBOX**
- **13% ARE WALKING TO THE REAR, BUT FORWARD OF FORWARD-FACING SEATS**
- **11% WALKING TO REAR DOWN THE AISLE**
- **2% IN FRONT STEPWELL**

POSITION OF ALIGHTING PASSENGERS WHEN BUS STOPS

- **34% AT REAR DOOR**
- **21% IN REAR STEPWELL**
- **26% AT FAREBOX**
- **7% OPPOSITE FRONT INWARD FACING SEATS**
- **6% IN FRONT STEPWELL**
- **4% IN SEATS**
- **2% IN AISLE IN MIDDLE OF BUS**

PASSENGER ASSIST USAGE BY BOARDING PASSENGERS

●	DRIVER'S STANCHION	26%
●	LEFT SEATS	25%
●	SECOND STANCHION ON DRIVER'S SIDE	20%
●	RIGHT SEATS	12%
●	DOOR STANCHION	7%
●	SECOND STANCHION ON DOOR SIDE	5%
●	OVERHEAD	5%

PASSENGER ASSIST USAGE BY ALIGHTING PASSENGERS

• DOOR STANCHION	28%
• POLE AT REAR DOOR	24%
• SECOND STANCHION ON DOOR SIDE	11%
• DRIVER'S STANCHION	10%
• RIGHT SEATS	10%
• LEFT SEATS	7%
• OVERHEAD	6%
• SECOND STANCHION ON DRIVER'S SIDE	4%

USE OF ASSISTS BY AGE AND SEX

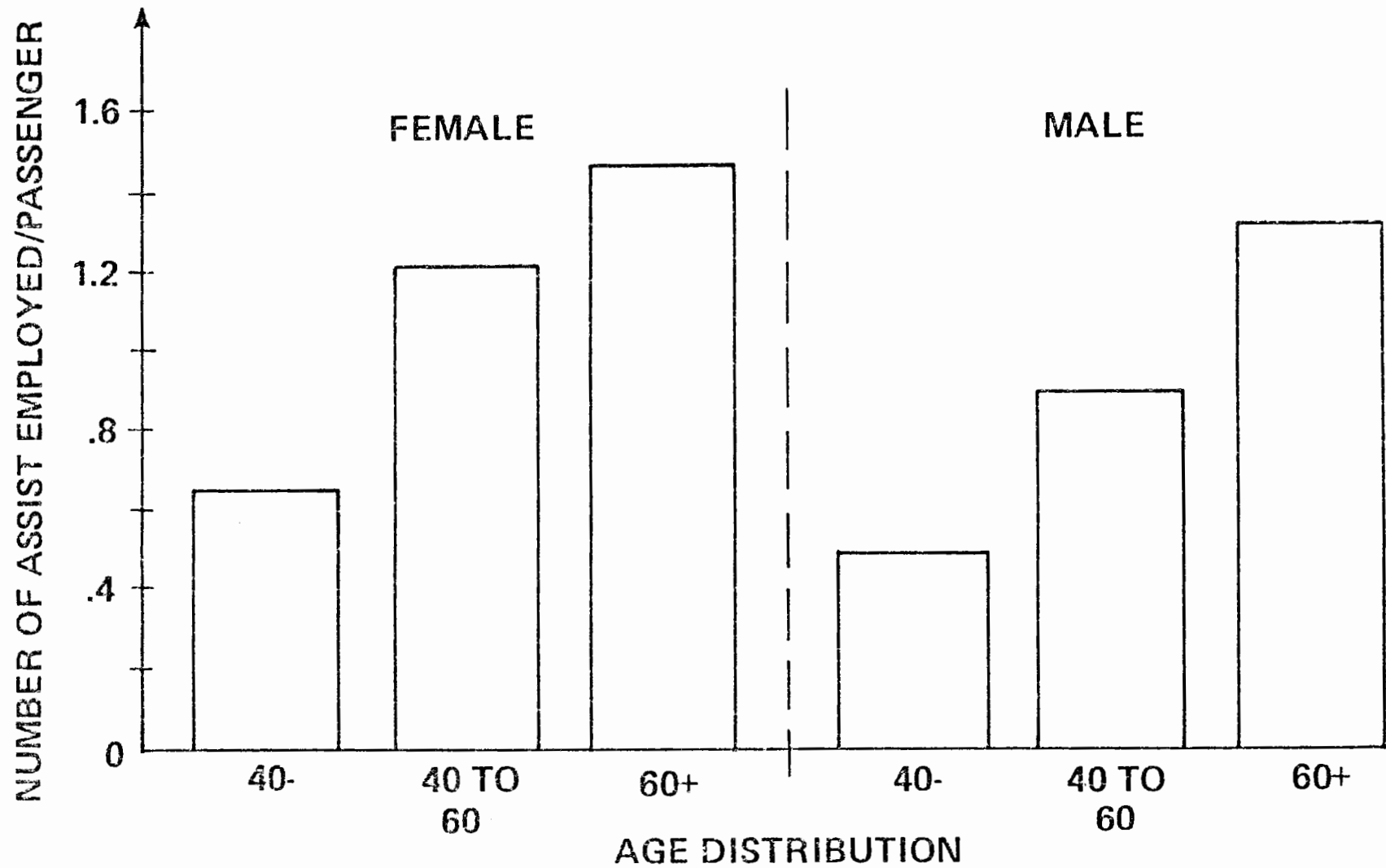

SUMMARY COMMENTS ON ASSIST USAGE

- **GIVEN THE OPTION ALL PASSENGERS WILL EMPLOY VERTICAL STANCHIONS (SAN DIEGO)**
- **OVERHEAD RAIL IS RARELY USED**
 - **NORMALLY ONLY 50TH% + MALES**
 - **OR BY STANDEES IN AISLE**
- **ASSIST DEVICES SHOULD PROVIDE ADEQUATE SUPPORT AT EACH STEP DOWN THE BUS**

DOOR EMPLOYED TO EXIT BUS

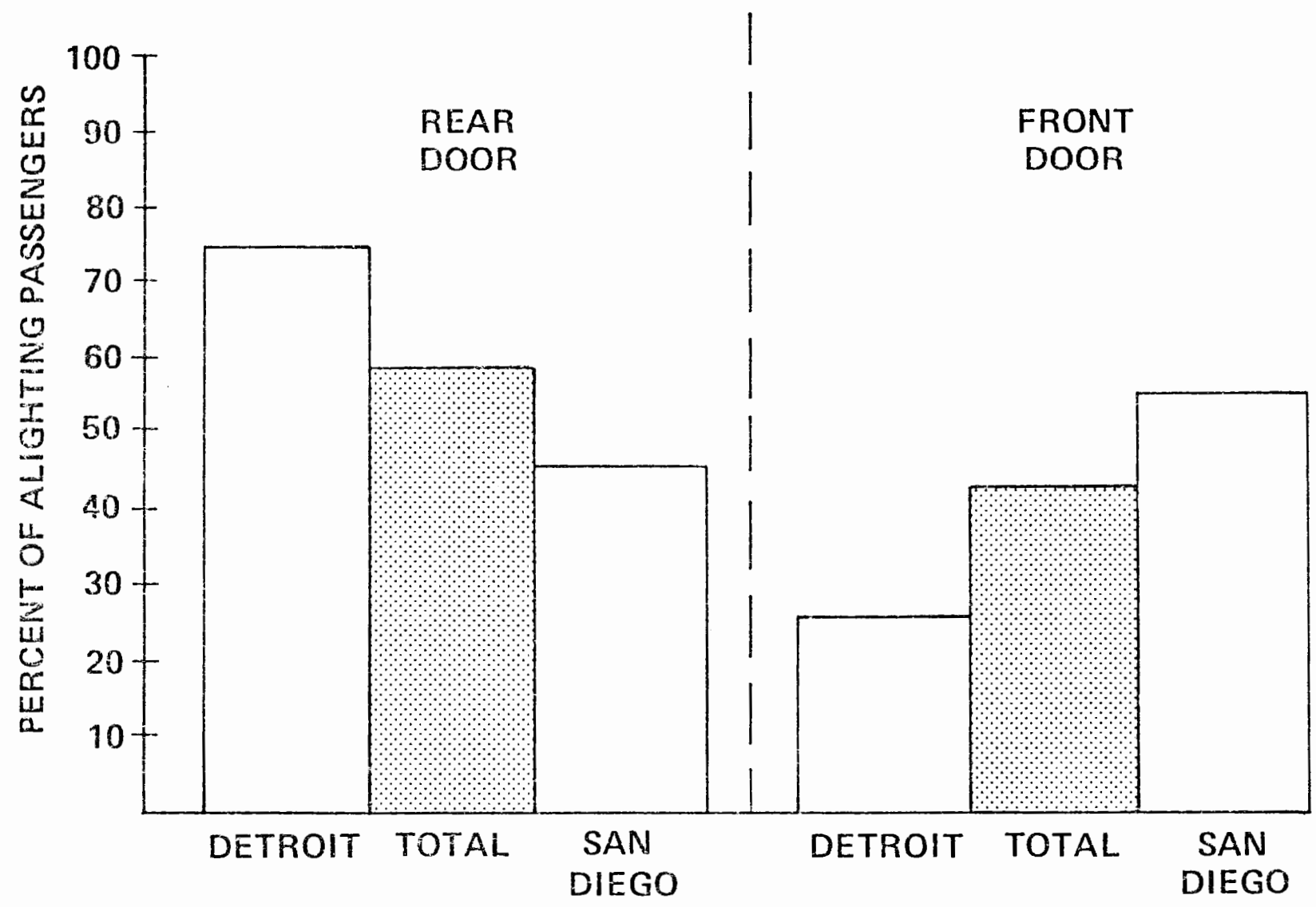

SEAT PREFERENCES: ALL PASSENGERS

- **EMPTY BUS: UNOCCUPIED FRONT FACING SEATS FORWARD OF REAR DOOR**
- **10 PEOPLE ON BUS: FRONT LONGITUDINAL SEATS**
- **20 TO 25 PEOPLE ON BUS: THE REMAINING "PRIVATE" SEAT**
- **ALL SEATS OCCUPIED: SIT WITH LEAST THREATENING PASSENGER**
- **NEARLY FULL: REAR AND REAR LONGITUDINAL SEATS LAST**

SEAT PREFERENCES: SPECIAL GROUPS

ELDERLY PASSENGERS

- **FRONT LONGITUDINAL SEATS**
- **FORWARD FACING NEAR FRONT**
- **OTHER SEATS**

YOUNG MALES

- **SIMILAR TO OTHERS, BUT SHOW PREFERENCE FOR SEATS IN EXTREME REAR CORNERS.**

GENERAL CONCLUSIONS: SEAT SELECTION

PRIVACY, PERSONAL SAFETY, AND FEAR OF MISSING STOP ARE FACTORS WHICH MOTIVATE SEAT SELECTION.

5. INTERIM CONCLUSIONS

- NARROW FRONT DOOR AND TWO PERSON VESTIBULE REDUCES SPEED OF TRANSIT
- PASSENGER INFORMATION SYSTEM IMPROVEMENT WILL REDUCE BOARDING DELAYS
- SEAT SELECTION INDICATES THAT PRIVACY IS KEY FACTOR
- MONITORING OF COACH INTERIOR BY DRIVER IS EXCELLENT
- ASSIST DEVICES IN FRONT OF BUS MUST BE IMPROVED AND OVERHEAD RAIL REPLACED

6. PLANS FOR FUTURE WORK

- **DETAILED RESULTS OF THIS ANALYSIS REPORTED BY THE END OF FEBRUARY, 1973**
- **STOP TIME DATA USED TO DEVELOP A "SPEED OF TRANSIT" EVALUATION METHOD**
- **SPECIAL STUDY OF PROBLEMS OF THE ELDERLY**
- **DEVELOP PLANS FOR HUMAN FACTORS AND HANDICAPPED TESTS ON MOCK-UPS**
- **DEVELOP HUMAN FACTORS TEST PLAN FOR PROVING GROUNDS TESTING OF PROTOTYPES**
- **DEVELOP DATA GATHERING REQUIREMENTS FOR PUBLIC DEMONSTRATIONS**

APPENDIX C

IMPACT OF MASS TRANSIT

ON URBAN TRAFFIC SAFETY

This report employed internal research conducted by Booz, Allen as a baseline for projecting alternative scenarios of future public transit ridership. It projected the potential national safety benefits of increased transit ridership for these scenarios. The report also presents information on the relative risk of travel on various transportation modes. The report clearly shows that the national safety benefits of shifting urban trips to mass transit are substantial, even if the safety of the mass transit systems, i.e., buses and rail rapid transit systems, remains at the current level.

IMPACT OF MASS TRANSIT ON URBAN TRAFFIC SAFETY

DECEMBER 6, 1973

FOR
DEPARTMENT OF TRANSPORTATION
URBAN MASS TRANSPORTATION ADMINISTRATION

BY
BOOZ, ALLEN APPLIED RESEARCH

BOOZ ALLEN & HAMILTON



OBJECTIVE OF INVESTIGATION

TO ASSESS THE IMPACT OF INCREASED PUBLIC TRANSIT RIDERSHIP, ESPECIALLY TRANSIT BUS RIDERSHIP, ON URBAN TRAFFIC SAFETY

METHOD OF ANALYSIS

A 1990 PROJECTION OF THE ALTERNATIVE FUTURES OF URBAN TRAFFIC SAFETY FOR THREE ASSUMPTIONS ABOUT TECHNICAL AND POLICY DEVELOPMENTS IN MASS TRANSIT.

- I. CONTINUATION OF PRESENT TRENDS**
- II. INCREASED USE OF PRESENT MODES**
- III. INCREASED USE OF PRESENT MODES AND EFFECTIVE USE OF SELECTED NEW MODES**

1970 PUBLIC RIDERSHIP AND PROJECTED 1990 PUBLIC TRANSIT RIDERSHIP

MODE	BILLIONS OF URBAN TRIPS	PERCENT OF TRIPS
	<u>1970</u>	
PUBLIC TRANSIT	5.93	7.7
AUTOMOBILE	71.0	92.3
TOTAL	76.93	100.0
	<u>1990 - I</u>	
PUBLIC TRANSIT	3.7	2.3
AUTOMOBILE	158.0	97.7
TOTAL	161.7	100.0
	<u>1990 - II</u>	
PUBLIC TRANSIT	14.73	9.1
AUTOMOBILE	147.29	90.9
TOTAL	162.02	100.0
	<u>1990 - III</u>	
PUBLIC TRANSIT	38.5	20.4
AUTOMOBILE	150.5	79.6
TOTAL	189.0	100.0

PROJECTION METHODOLOGY

THE PROJECTIONS WERE MADE FOR THE 119 METROPOLITAN AREAS WITH A CENTRAL CITY POPULATION OF 100,000 AND OVER IN 1960

ASSUMED: 1970 TRAFFIC SAFETY RECORD OF CURRENT TRANSPORTATION MODES

PROJECTED INDEPENDENTLY: THE TRAFFIC SAFETY RECORD OF EACH MODE FOR EACH ASSUMPTION

PROJECTION METHODOLOGY

(CONTINUED)

DEVELOPED: A BUS MULTIPLE REGRESSION MODEL TO PROJECT TRANSIT BUS AND DEMAND RESPONSIVE BUS ACCIDENTS, FATALITIES, AND INJURIES

NUMBER OF BUS ACCIDENTS IN CENTRAL CITY OR SUBURB
($R = .9828$, $F < .001$) = $60.39 + (47.82)$ (MILLIONS OF VEHICLE MILES OPERATED) + (11.15) (MILLIONS OF PASSENGERS CARRIED)

DEVELOPED: A MOTOR VEHICLE MULTIPLE REGRESSION MODEL TO DERIVE AUTOMOBILE ACCIDENTS, FATALITIES AND INJURIES

NUMBER OF MOTOR VEHICLE FATALITIES IN A CENTRAL CITY OR SUBURB
($R = .9858$, $F < .001$) = $1.37 + (.0011)$ (CITY SIZE) + $(.093)$ (CITY AREA)

RISK OF FATALITY BY
TRANSPORTATION MODE

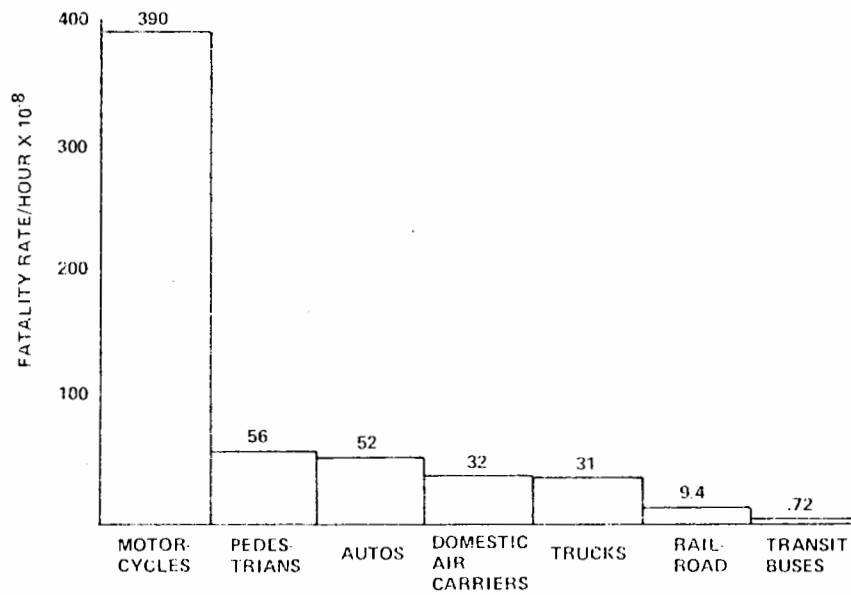

RISK OF INJURY BY
TRANSPORTATION MODE

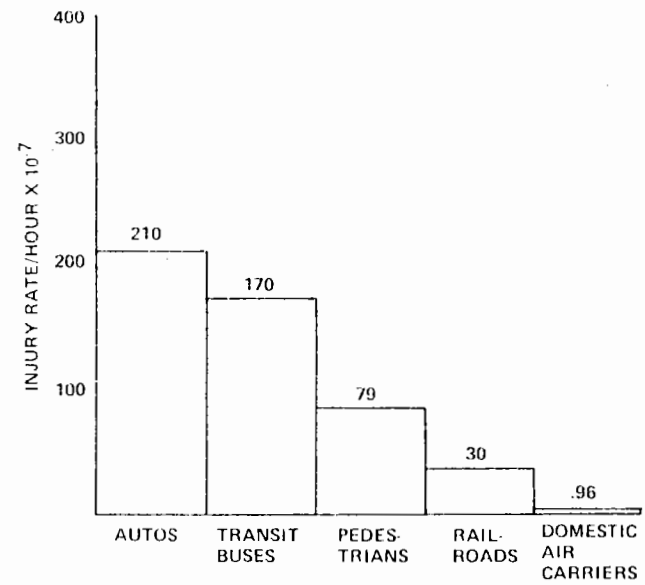

IMPACT OF PUBLIC TRANSIT RIDERSHIP ON URBAN TRAFFIC SAFETY

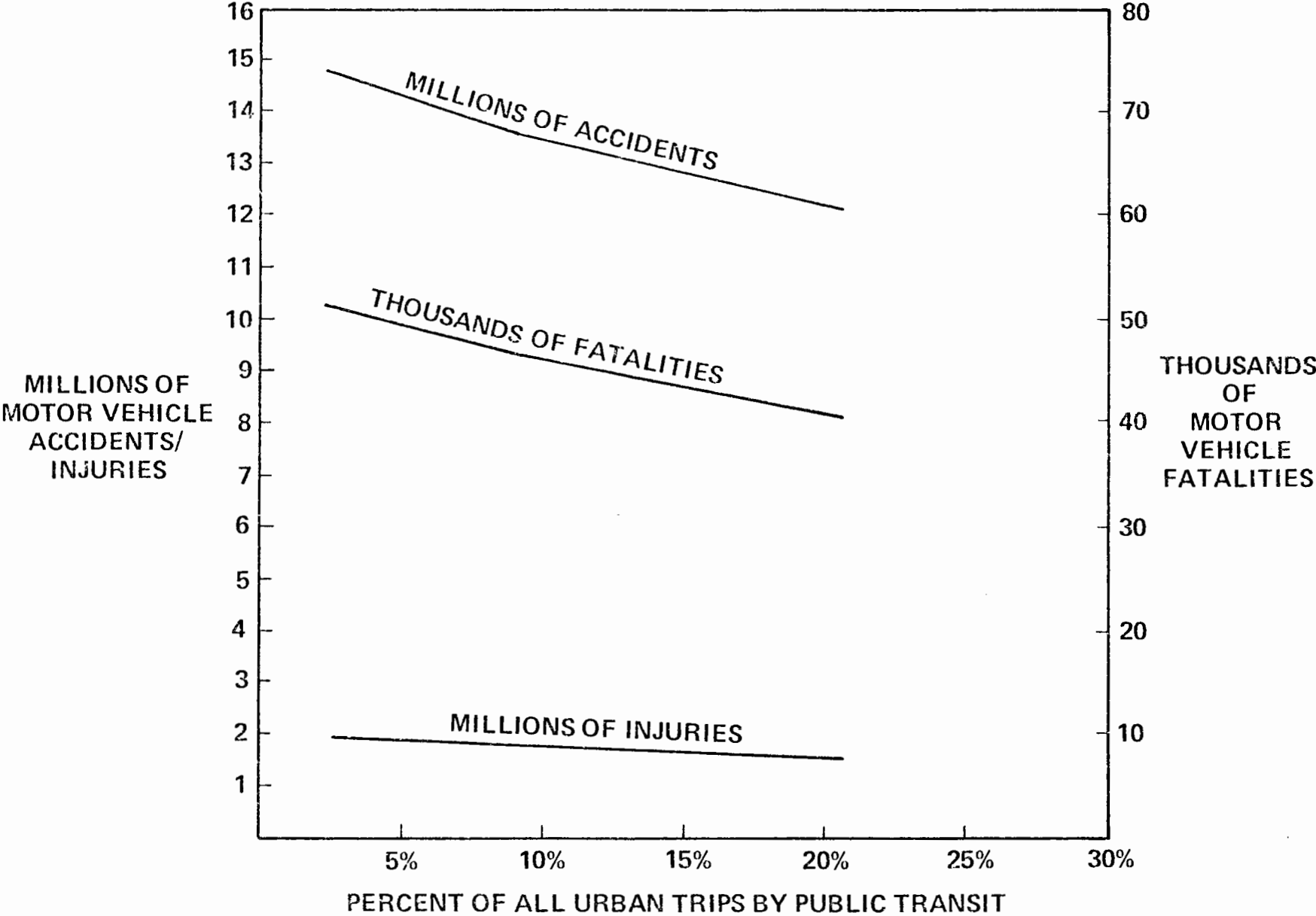

PERCENT REDUCTION IN ACCIDENTS, FATALITIES AND INJURIES

ASSUMPTION	ACCIDENTS	FATALITIES	INJURIES
1990 - II	8.5%	8.9%	6.6%
1990 - III	19.1%	20.7%	13.8%

CONCLUSION: FOR EACH 5% INCREASE IN PUBLIC TRANSIT RIDERSHIP, THERE IS A 5.3% DECREASE IN ACCIDENTS, 5.7% DECREASE IN FATALITIES, AND 3.8% DECREASE IN INJURIES

IMPLICATIONS

- INCREASING PUBLIC TRANSIT RIDERSHIP HAS SUBSTANTIAL TRAFFIC SAFETY BENEFITS
- MASS TRANSIT HAS ITS LEAST IMPACT IN REDUCING INJURIES

ACCORDING TO THE NATIONAL HIGHWAY TRAFFIC SAFETY ADMINISTRATION, 60% OF THE COSTS OF MOTOR VEHICLE ACCIDENTS IN 1971 WAS ACCOUNTED FOR BY INJURIES

THE RISK OF INJURY TO TRANSIT BUS PASSENGERS IS ALMOST AS HIGH AS THE RISK OF INJURY TO AUTOMOBILE OCCUPANTS

IN ASSUMPTIONS TWO AND THREE, OVER 50% OF PUBLIC TRANSIT RIDERSHIP WAS PROJECTED TO BE BY TRANSIT BUS

- IN ORDER TO FURTHER INCREASE THE IMPACT OF PUBLIC TRANSIT RIDERSHIP ON URBAN TRAFFIC SAFETY, THE RISK OF INJURY ON TRANSIT BUSES NEEDS TO BE REDUCED

APPENDIX D

IMPROVEMENTS IN THE SAFETY

OF URBAN TRANSIT COACHES

This recent technical paper by John F. Wing, the Booz, Allen program manager for the Transbus program, summarizes key safety accomplishments of the program. Particular emphasis is placed on bumper, seat and full scale crash test results. An appendix to the report contains material related to safety from the final Transbus specifications.

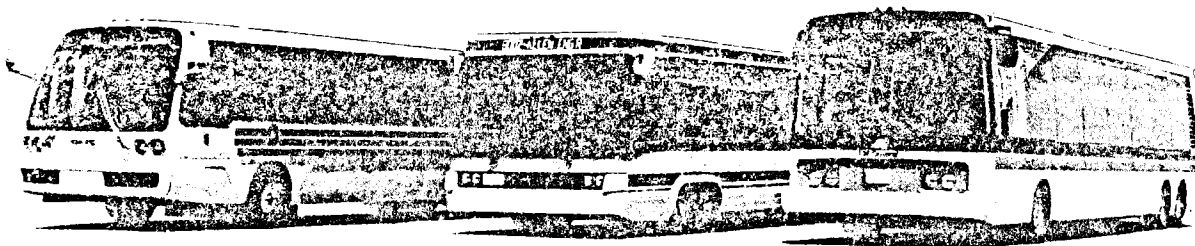

IMPROVEMENTS IN THE SAFETY OF URBAN TRANSIT COACHES

John F. Wing

Booz, Allen & Hamilton Inc.

PRESENTED TO

**FIFTH INTERNATIONAL CONGRESS ON
AUTOMOTIVE SAFETY**

**National Motor Vehicle Safety Advisory Council
U. S. Department of Transportation**

July 11, 1977

IMPROVEMENTS IN THE SAFETY OF URBAN TRANSIT COACHES

**John F. Wing
Booz, Allen & Hamilton Inc.**

**PRESENTED TO
FIFTH INTERNATIONAL CONGRESS ON
AUTOMOTIVE SAFETY
CAMBRIDGE, MASS.**

**National Motor Vehicle Safety Advisory Council
U. S. Department of Transportation**

July 11, 1977

IMPROVEMENTS IN THE SAFETY OF URBAN TRANSIT COACHES

John F. Wing
Booz, Allen & Hamilton Inc.

ABSTRACT

The Transbus program, sponsored by the Urban Mass Transportation Administration, is a research, development, and demonstration project to develop improved, safer buses. This paper describes the analyses, tests, and resulting specifications for safety features which have evolved from the project. Body crashworthiness, bumpers, low floor, seats, and passenger-assist improvements and tests are discussed. Savings in accident costs of as much as \$5,000 during the life of a typical transit bus are projected.

INTRODUCTION

The Urban Mass Transportation Administration does not have legislated authority over safety aspects of the design and operations of buses. However, through its research, development, and demonstration programs and through its approval of capital assistance for purchase of new buses, it can exert a powerful influence for improving passenger and pedestrian safety in urban buses.

The Transbus program is a \$28-million research, development, and demonstration program sponsored by the Urban Mass Transportation Administration of the U.S. Department of Transportation (Ref 1). The prime contractor on this program is Booz, Allen & Hamilton with technical assistance and evaluation provided, where necessary, by the American Public Transit Association. The program led to the development and manufacture of prototype buses by AM General, GMC Truck and Coach Division, and Rohr Industries.

One of the principal objectives of the program is to improve transit coach safety through:

- . Analysis of current safety problems
- . Development and test of improved components and bus features
- . Preparation of standard specifications for future safer vehicles.

ANALYSIS OF TRANSIT COACH SAFETY

The transit bus safety analysis conducted in the Transbus program is the first comprehensive study of this problem (Ref. 2). It was conducted using a fault tree safety analysis technique. Accident frequency and severity data were tabulated for 92 different types of bus accidents from a sample of approximately one-fifth of the U.S. transit industry.

All accident types were considered in the analysis, not just those related to component failures. The analysis also included not only precrash considerations, but also crash and post-crash problems associated with transit bus accidents. Because the goal of the analysis was to provide bus designers with safety design targets against which to trade off other design considerations, the methodology focused on economic considerations of safety. The key output factor was the total life-cycle cost of various types of bus accidents. This factor was obtained by multiplying the frequency of certain types of bus accidents by an average cost for that type of accident.

The analysis indicated that 69 percent of all accident claims costs are associated with traffic accidents and 5 percent were other types. The costs of all claims and bus damage repair in the life cycle of a typical transit bus were found to be \$19,324, that is, 40 percent of the vehicle purchase price. Accident claims and insurance costs were found to be 3 to 4 percent of total life-cycle costs in 1969-70. By 1975, however, these costs had risen to 4.5 to 5.5 percent.

Figure 1 summarizes the results for 1969-70 in terms of accident expense during the life of a transit bus. Each major category of claims and repair costs represented in Figure 1 is discussed below.

Bus and Other Vehicles

Accidents involving other motor vehicles are the dominant cost category. A single accident type, that is, a bus striking the rear of another vehicle, accounts for nearly half of all accident expenses. An in-depth analysis of a total of 26 rear-end accidents from one West Coast and one East Coast bus operator indicated that 80 percent occurred at impact velocities of 8.25 miles (13.2 kilometers) per hour or less. The results of this analysis were sufficient to justify the need for an energy-absorbing front bumper of the Transbus.

A major class of accidents in the "all others" category shown in Figure 1 are those involving the side of the bus, usually the curb side. In these cases, average claims costs for automobile damage were approximately \$200, indicating a relatively low-impact velocity in these "sideswipe" accidents. As a result of this finding, one of the Transbus prototypes were especially designed to absorb this impact in lower sidewall areas.

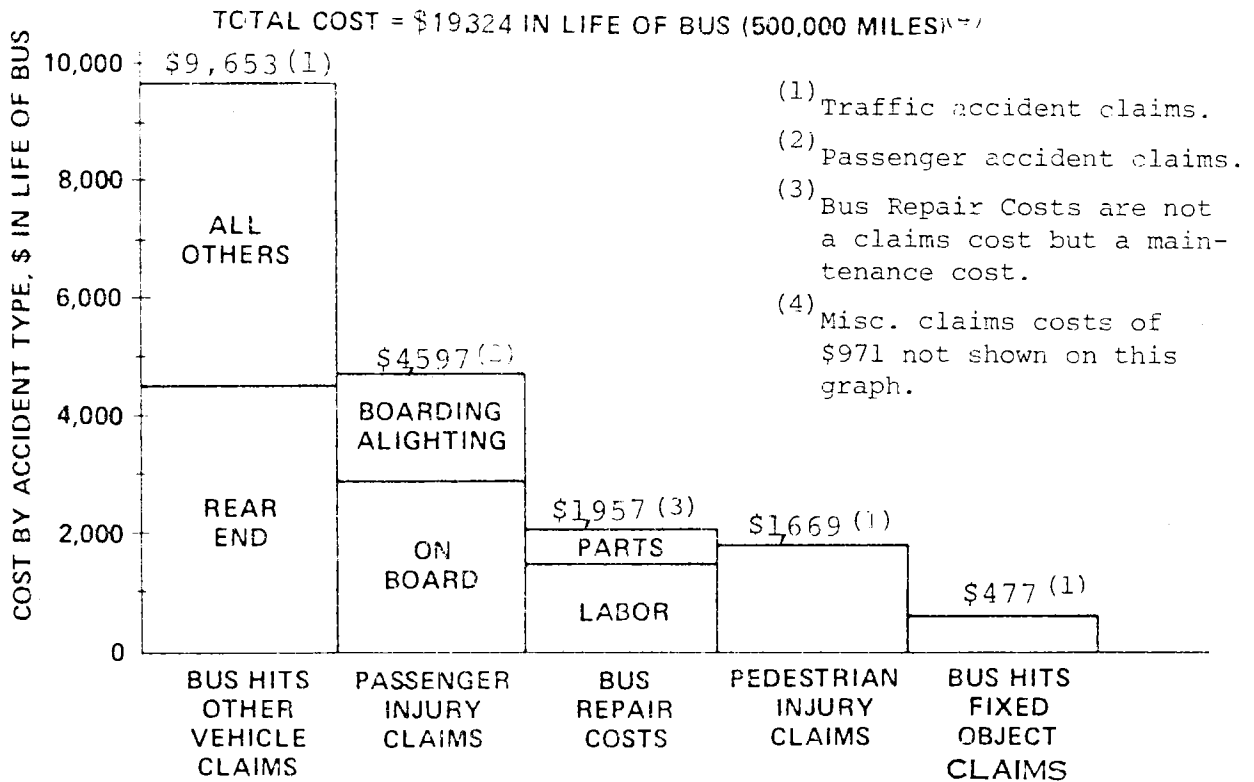

Figure 1. Accident Costs to Bus Company

These special designs included fiberglass lower side panels mounted to the body through elastomeric springs.

Passenger Injuries

As shown in Figure 1, onboard accidents account for the majority of passenger accident expenses. The precise nature of these accidents and the design innovations tested on Transbus prototypes to reduce their frequency and severity are discussed in detail in References 3 and 7. Other passenger accident expenses involve boarding (especially door-related) and alighting accidents.

The Transbus design has a number of features to reduce door-related accidents, such as sensitive edges on rear doors, wider doors, and reduced closing forces. A key safety feature of the Transbus design is reduction in floor height from the 34 inches typical of current transit buses to less than 22 inches.

Accident-Related Bus Repairs

As shown in Figure 1, the cost of repairing bus damage is about 20 percent of the claims costs for damage to the other vehicle. These data were obtained by a review of the maintenance records of a West Coast bus operator who segregated accident repairs from other body work. Perhaps the most important finding is that labor costs account for 71 percent of all bus body accident repair costs. Based on labor rate projections, this percentage will continue to increase. Therefore, the Transbus bodies were designed with repairability as a primary consideration.

Pedestrian Accidents

Claims for pedestrian accidents totalled nearly \$1,700 during the life of a typical bus. Individual bus/pedestrian accidents often involve severe consequences. The Transbus has several design features to reduce the frequency and severity of pedestrian injury. These features are soft, smooth, energy-absorbing bumpers with up to 1.5 inches (3.81 centimeters) of urethane coating; the absence of sharp protrusions on the front of the bus; and a large front windshield allowing excellent driver vision. Small rear tires and lower body skirts tend to prevent pedestrians falling under rear tires.

Improved operational safety in such areas as driver training, and the location of bus stops, may also be very effective in reducing pedestrian accidents and claims costs.

TESTS OF TRANSBUS PROTOTYPES

The testing program for Transbus coach and component safety effectiveness included bumpers, seats, full vehicle crash, and interior. Other tests not specifically aimed at safety were performance, endurance, and revenue demonstration.

Bumper Tests

Five bumper systems were tested (Ref. 4). These were:

- . AM General Transbus. A pneumatic energy-absorbing bumper cast from an elastomeric compound developed by the Firestone Tire and Rubber Company.
- . General Motors Truck and Coach Division Transbus. An aluminum bumper covered by an urethane and spring-mounted to the vehicle structure.
- . Rohr Industries Transbus. A steel bumper covered with polycarbonate and mounted to the vehicle structure with shock-absorbing cylinders supplied by the Menasco Manufacturing Company.

- . GMC Production Bus Bumper. The GMC production bumper is a rigid bumper, consisting of a steel faceplate supported by two leaf springs.
- . Energy Absorption System (EAS) Water Bumper. The EAS water bumper is an impact-cushioning bumper and consists of seven specially designed water-filled vinyl modules with four (each) plastic release plugs mounted on a flexible beam. During impact, the plastic release plugs pop up, allowing water to escape through pressure-regulating orifices. This action absorbs a significant amount of the impact energy, considerably lessening the severity of the crash.

In addition, two new energy-absorbing bumpers, TRANSAFE and HELP, developed after the Transbus prototypes were designed, were also evaluated:

- . The TRANSAFE Bumper. This bumper, recently developed by EAS, is a foam-type energy-absorbing bumper cast from a polyurethane composition. Three energy-absorbing modules are mechanically attached to a high-strength fiberglass-reinforced plastic backup beam.
- . HELP Bumpers (Pneumatic and Semi-Pneumatic). These two High Energy Level Pneumatic (HELP) bumpers, recently developed by Firestone Tire and Rubber Company, are an improved design of the pneumatic bumper used on the AMG Transbus.

The test and evaluation program for these bumper systems included:

- . The performance testing of the three Transbus bumper systems, the water system, and the standard current coach bumper employing test procedures similar to those of Federal Motor Vehicle Safety Standard 215 (FMVSS-215) for automotive bumpers.
- . In-service evaluations of the maintenance characteristics of the Transbus bumpers by maintenance personnel of four U.S. transit operations under demonstration grants from the Urban Mass Transportation Administration as part of the Transbus public demonstration program.
- . A detailed analysis of the life-cycle costs and benefits of each Transbus bumper system and the other new design bumpers.
- . Crash tests at 10 and 55 mph.

The tests were conducted at the Dynamic Science Division of Ultrasystems and at Calspan Corporation, using pendulum strike systems and 4000 lb cars. A summary of the significant test results from the pendulum tests are shown in Table 1. The table indicates the speed of the 4000-pound impacting pendulum and the deflection of the test bumper for the test in which the bumper reached its energy absorption limit. The results for both direct front impacts and 30° corner impacts are shown. Information is presented regarding the content of permanent damage that resulted from impacting the bumper at its energy absorbing limit.

Table 1
Limit Performance of Bus Bumpers in Transbus Test Program

Bumper Type	Front		Corner		Permanent Damage
	m.p.h.	Inches	m.p.h.	Inches	
Current GMC	2.6	2-1/4	2.6	4-3/4	2-inch Deformation
Water Bumper	6.1	7	4.1	7	Lost Plugs
AM General (Air Bag)	7.0	5	6.0	6	Air Release Valve Leaks and 1-inch Deformation
General Motors (Free Mounted Spring)	7.5	6	4.6	6-1/4	Permanent Deformations of Up to 4-1/4 Inches
Rohr (Shock Absorbers)	6.5	3-1/2	6.1	4	1/2-inch Dimple in Top Edge

A more detailed presentation of test results is given in Reference 4, and an evaluation summary is given in Figure 2.

The significant recommendations resulting from the bumper tests and evaluation were:

- Impact-Absorbing Capability. The front bumper should provide impact protection from a 5-mph impact with a fixed flat barrier parallel to the longitudinal centerline of the coach. In addition, the bumper should protect the coach and a 4,000-pound, post-1973 American automobile from damage when the coach strikes the rear bumper of the automobile parallel to the longitudinal centerline of the coach at 6.5 mph, and up to a

Factors	AMT Transbus Pneumatic	GM Transbus Free Springs	Fahr Transbus Blaster Shock	RAS Water	FAV Folau (HILF/AFR)	Firestone Pneumatic (HELP)	Firestone Semi- Pneumatic (HELP)
1. Weight	264 lbs.	207 lbs.	187 lbs.	171 lbs. (filled)	170 lbs.	173.5 lbs.	159 lbs.
2. Support Requirements	15 PSI Air Supply	None	None	Water glycol	None	None	None
3. Maximum Capability (Fixed Barrier)							
. Front	6.4 mph	7.8 mph	6.8 mph	6.1 mph	7.0 mph	7.1 mph	7.6 mph
. Corner	7.0 mph	4.8 mph	6.1 mph	4.1 mph	4.9 mph	5.3 mph	5.6 mph
4. Life Expectancy	10 years	15 years	15 years	10 years	10 years	10 years	10 years
5. Readiness (Reset Feature)	Auto. refill if connected to coach air supply.	Automatic	Automatic	Manual refill	Automatic	Automatic	Automatic
6. Maintenance Requirement							
. Periodic	Valve/ plumbing inspection	None	None	Water ejector valves & water level	None	None	None
. Mst. Overhaul Time	3 hours	2 hours	5 hours	4 hours	2 hours	4 hours	3 hours
7. Problems							
. Vandalism Susceptibility	Punctures	Slashing of face cover	Slashing of face cover	Punctures	Slashing of face cover	Punctures	Punctures (minor problem)
. Other	Valves/ plumbing air leaks	Faceplate opening too large and dis- torts easily under minor impacts	Polycar- bonate cover cracks and falls off	Water ejector plugs eject under minor impacts	None	None	None
Safety - low Impact Attenuation	1 mph 72% 2 mph 70%	1 mph 22% 2 mph 71%	1 mph 20%* 2 mph 63%*	1 mph 59% 2 mph 91%	12 mph N/D 3 mph 74%	1 mph N/D 2 mph 42%	1 mph N/D 2 mph 59%
9. Aesthetic Features	Good	Good	Good	Poor	Good	Good	Good
10. Versatility for Rear Application	Practical	Not practical due to large center opening	Practical	Not practical too heavy & requires periodic maintenance	Practical	Practical	Practical
11. Approximate Initial GEM Cost	Not in production	Not in production	\$600 (102")	\$450 (102")	\$345 (102")	\$450 (102")	\$350 (102")

* Estimated.
N/D No Data

Figure 2. Summary Evaluation of Transit
Bus Bumpers

30° angle to the longitudinal centerline of the coach at 5.5 mph. The rear bumper should provide impact protection from a 2 mph impact with a fixed flat barrier parallel to the longitudinal centerline of the coach. In addition, the rear bumper should provide energy-absorbing capability to with-stand impacts by the striker (defined in FMVSS-215) loaded to 4,000 pounds at 4 mph, parallel, or up to a 30° angle, to the longitudinal centerline of the coach.

- . Rebound Characteristics. Bumpers should exhibit energy-attenuation capability of not less than 70 percent of the input kinetic energy (within the bumper's physical limitations) to minimize rebound which could contribute to serious secondary results.
- . Pedestrian Protection Characteristics. Bumpers should present a soft exterior for impact with objects at low speeds and exhibit substantial deflection (1.0 to 1.5 inches) before significant force build-up is encountered. This should be useful in protecting pedestrians and other objects during minor impacts.
- . Readiness Characteristics. Bumpers should be designed to provide immediate, automatic resetting. All bumpers tested, with the exception of the water bumper, currently have this feature.
- . Maintainability Characteristics. Bumpers should be designed to be nearly maintenance free, including periodic inspection and servicing. In addition, when maintenance action is required due to a severe impact, the failed bumper system should be restorable to usable condition within 4 hours of active repair time. This time includes removal from the bus, disassembly-replacement of failed component parts, reassembly, and replacement on the bus. Rear bumper attachment brackets should be designed for quick removal/replacement without special tools to minimize access time for engine maintenance requiring bumper removal.
- . Reliability Characteristics. The mean time between failure (excluding major impacts beyond those required by the Transbus Specification) should not be less than 100,000-revenue-miles. The life expectancy should be a minimum of 12 years and/or 500,000 miles of in-service use.
- . Safety Characteristics. The bumper physical exterior should be designed with a smooth, soft exterior surface without sharp protrusions and should incorporate wrap-

around features to provide maximum protection to corner panels of the bus. Rear bumpers should be designed to flare into the rear portion of the coach to prevent unauthorized riders from securing a toehold.

Seat Tests

Sixteen simulated crash tests were performed by Calspan Corporation on three Transbus prototype seat-sidewall configurations and one current production bus seat-sidewall configuration (Ref. 5). Since the Transbus seats were cantilevered from the sidewall in order to improve cleanability and reduce tripping hazards, a combined seat-sidewall fixture was used to obtain realistic test conditions. A baseline was established by testing a typical transit seat, an American Seating Model 6462. Four anthropomorphic dummies, varying in size from a 95th percentile male to a 6-year old child, were instrumented and used in each test.

Test conditions simulated a rear-end collision, panic braking, and 20 mph frontal crash into a rigid barrier. The tests were fully instrumented and conducted in accordance with Booz, Allen test specification No. TS-002.

The following sled test pulses were selected to simulate bus accidents:

- . A 0.75 ± 0.005 g pulse with a rise time of 0.3 sec simulating an emergency stop.
- . A 3.25 ± 0.25 g pulse peaking at 50 ms simulating a bus being struck from the rear by an automobile at about 30 mph.
- . A 10 ± 1 g pulse peaking at 50 ms simulating a bus striking a rigid barrier at about 20 mph.

The first two pulses were intended to produce seat loads in the range specified for normal use and, therefore, were expected to be nondestructive. By loading the seats dynamically in two directions, these tests evaluated whether Transbus manufacturers met the basic intent of the Transbus specification. The two low g pulses were used to uncover any undetected passenger hazards that might be present. These first two test pulses were considered to be typical of the low-speed accident environment characteristics of transit bus operations.

The final test was primarily a proof test of the cantilevered seat concept.

The seat test facility and pre-test configuration are shown in Figure 3. The results of the bus-into-barrier crash test simulation are summarized in Table 2.

Figure 3. Seat Test Facility, Including Dummy Seating Positions and Camera Locations

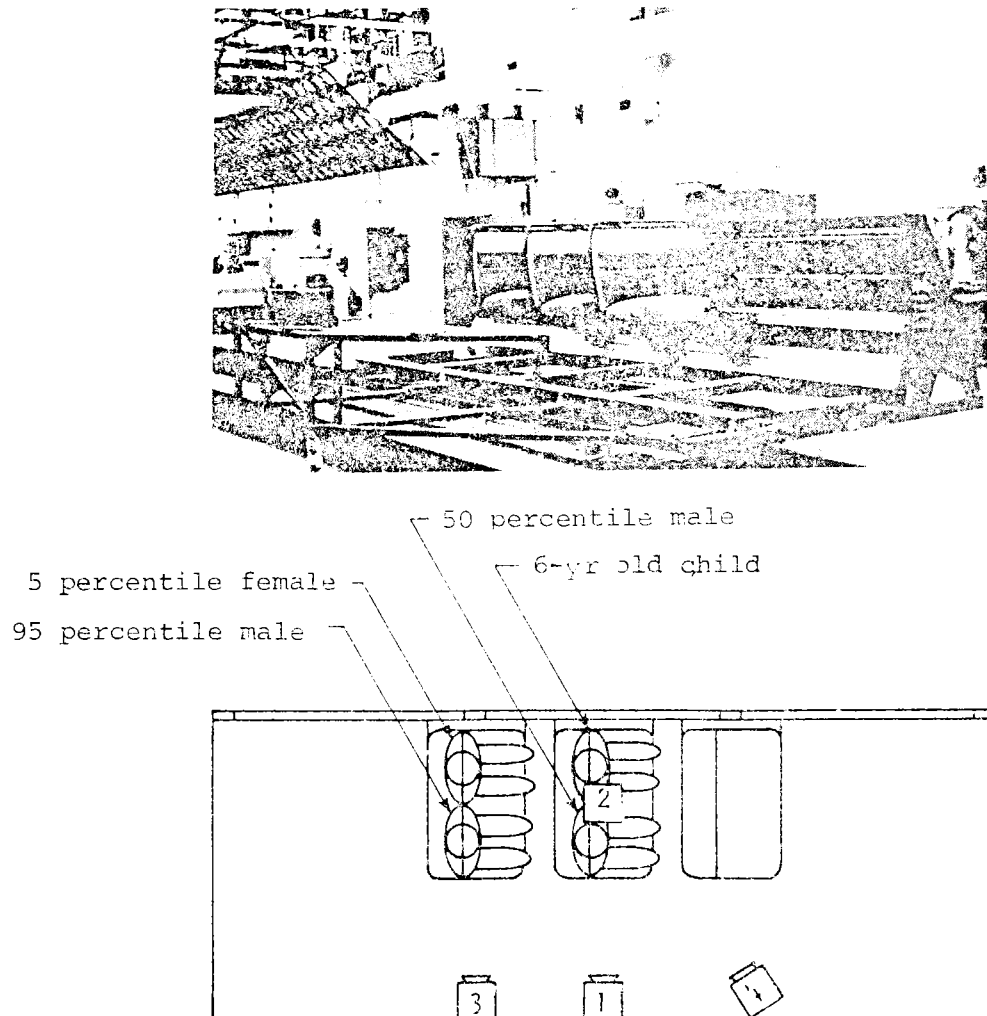

The following general conclusions can be drawn from the detailed test results for the Transbus seats:

- Passenger containment in severe bus crashes can be obtained with cantilevered seats.
- Structural cross-members near the top of the seat back used as passenger assists or to mount cantilevered seats to the wall must be heavily padded so that smaller persons may be protected from severe head impact hazards.
- Energy-absorbing grabrail/crashpads on transit bus seats can be designed to reduce substantially head impact severity, but sharp corners must be avoided.

Table 2
 Seat Test Results for Simulated
 Barrier Impact (Peak Sled Acceleration - 10.0 g's)

	Current Transit Bus	Composite Average of Three Transbuses*	Composite Best of Three Transbuses**
Sled peak, g	10.0	9.5	9.5
95th male			
Head, g	60	68 $\begin{pmatrix} +50 \\ -31 \end{pmatrix}$	37
Chest, g	50	36 $\begin{pmatrix} +9 \\ -15 \end{pmatrix}$	21
HSI†	380	228 $\begin{pmatrix} +152 \\ -113 \end{pmatrix}$	115
50th male			
Head, g	100	40 $\begin{pmatrix} +5 \\ -4 \end{pmatrix}$	36
Chest, g	35	50 $\begin{pmatrix} +17 \\ -22 \end{pmatrix}$	28
HSI	780	440 $\begin{pmatrix} +440 \\ -240 \end{pmatrix}$	200
5th female			
Head, g	50	98 $\begin{pmatrix} +52 \\ -35 \end{pmatrix}$	63
Chest, g	29	48 $\begin{pmatrix} +5 \\ -10 \end{pmatrix}$	38
HSI	240	420 $\begin{pmatrix} +380 \\ -240 \end{pmatrix}$	180
6-year-old child			
Head, g	70	106 $\begin{pmatrix} +94 \\ -48 \end{pmatrix}$	58
Chest, g	12	65 $\begin{pmatrix} +27 \\ -15 \end{pmatrix}$	50
HSI	660	757 $\begin{pmatrix} +943 \\ -557 \end{pmatrix}$	200

* Composite data are listed as an average of the three seats followed by the range about the average.

** Lowest value obtained on any of the three Transbus seat designs.

† The Head Severity Index (HSI) is defined as follows:

$$HSI = \int_{t_d}^{t_f} a^{2.5} dt$$

An HSI of 1000 is commonly assumed to indicate a possible fatality.

- . Retention of the passengers within the seat compartment and control of the trajectory of seat back impact and rebound are greatly enhanced if the seat back is designed to allow substantial knee penetration.
- . Overly rigid seat backs in the knee area can result in high femur loads and potentially unacceptable dummy rebound characteristics.

The Transbus testing was effective in that it uncovered design deficiencies in very severe crash simulations. None of the deficiencies was major. The fundamental result of the 10 g test sequence was the verification that cantilevered Transbus seats offered passenger containment superior to that found in present transit buses.

Reference 9 provides a more detailed description of test results. Actual test data are presented in Reference 5.

Crash Tests

The Calspan Corporation conducted structural crash testing of the GMC, Rohr, and AM General Transbus prototypes, and a GM standard production coach in accordance with Booz, Allen test specification No. TS-013.

The tests included three impact tests on each of the four buses (Ref. 6). In each test, the bus was stationary and the impact vehicles, 1973 Plymouth four-door sedans weighing over 4,025 pounds each, were towed into the buses at target speeds of 10, 25, and 56 mph for the bumper, side, and offset frontal impact tests, respectively. Data obtained during the crashes included acceleration of both the bus and impact vehicle and displacement time histories of the bumper and sidewall in the bumper and side impact tests. Both high-speed and standard speed motion pictures were taken, and structural damage and deformation examinations were made.

The principal conclusions drawn from those tests included the following:

- . The energy-absorbing bumpers demonstrated the ability to protect the Transbus prototypes from damage at typical traffic accident speeds (10 mph head-on impact of 4,000-pound automobile into the front of the bus).
- . Even relatively severe side impacts (automobile impacts at 25 mph) would not have presented significant hazards to bus passengers. In all but one Transbus, deformation of the sidewall at the impact zone was much less than 3 inches.

- . Transbus prototypes sustained relatively minimal damage in the 56-mph head-on collision with a 4,000-pound automobile, compared to the current standard production coach.
- . Instrument readings indicate that decelerations observed during the 56-mph head-on collision were less than half the conditions under which Transbus seats were tested in the laboratory.

In general, the tests demonstrated that very significant advances in structural integrity in crash situations had been achieved in the Transbus prototypes.

Interior Safety Tests

Other tests were conducted using human subjects to evaluate the safety and human factors aspects of interior arrangements, boarding and alighting, and passenger-assist devices.

Evaluation of these features was conducted by subjecting the test buses to rapid decelerations, a prime accident initiating factor, by sudden braking as test subjects were standing or walking in the aisles. The conclusions derived from these tests are summarized in Table 3. The tests are described in Reference 7.

TRANSBUS SAFETY SPECIFICATIONS

As a result of the Transbus tests, demonstrations, and evaluation, specifications were developed to improve safety in new transit coaches. These are included in Reference 8. Key safety elements are included in the Appendix to this paper.

CONCLUSIONS

The utility of the fault tree approach to categorizing and analyzing bus accident data was primarily in the insight provided for making design trade-offs. Because the results allowed the bus designer to estimate the life-cycle cost of various categories of accidents, it was possible to select those new bus features that provided the highest benefit-to-cost ratios. The use of claims and damage repair costs as a direct measure of accident severity does not provide an absolute measure of total social loss, but it is a good relative measure of the significance of various accident types.

These Transbus design concepts were evaluated in a comprehensive prototype vehicle and component test program. Based on the analysis and tests, it was projected that new features, such as lower skirt clearance, improved right-side mirror, curb lighting, energy-absorbing bumpers, and smooth front and rear body surfaces would reduce pedestrian fatalities associated with urban

Table 3
Key Interior Safety Features for Buses

<u>Safety Design Feature</u>	<u>Rationale</u>
Recessed Padded Farebox	Very hazardous impact area for standees and alighting passengers.
Energy-Absorbing Stanchions in Front of Bus	Hazardous impact for standees and alighting passengers.
Overhead Rail	People are accustomed to this assist; also valuable to the blind.
High Aisle-Side Seat-Back Rails	Provide support for passengers walking in aisle in case of rapid deceleration. (These are in lieu of a "forest" of vertical stanchions.)
Hand Rail and Barrier to Lean Against When Paying Fare	Necessary since fare collection actions may lead to loss of support and balance.
Staggered Assists (Vertical or Aisle-Side Seat-Back) Allowing Hand-Over-Hand Grasp While Walking Through the Bus	Open spaces where no support is provided; allow passengers to accelerate and then impact with interior surfaces. Large open spaces thus allow passengers to be moving at high speed prior to impact.
Energy-Absorbing Stanchions in Open Areas at Rear Door	Hazardous impact for standees and alighting passengers.
Adequate Interior Mirrors for Driver	Vision of standees and rear stepwell
Accessible Push-To-Stop Tape/Cord with "Stop Requested" Light	Give confidence that bus will stop and keep alighting passengers in seats.
Lower Interior Lighting Levels at Night	Make it possible to see stops at night through tinted windows; keep alighting passengers in seats until almost at stop.
Driver-To-Passenger Public Address	Give confidence to visually impaired passengers to stay in seats and suggest alighting by rear door for all passengers

buses by 20 percent. Design features in the interior of the bus, such as padded seat backs, improved seat back assists, assist rails in the doors, impact barriers at the fare box, lower floor height and steps, and wider doors also would substantially reduce passenger accidents.

The Transbus features likely to result in the greatest savings in accident-related expenses are the energy-absorbing bumpers and sidewalls. These features may decrease traffic accident claims costs by as much as 35 percent. In summary, it is estimated that the safety features on the Transbus prototypes could decrease operating expenses by about 1 cent per mile when compared to current buses. This is a 30 percent reduction in safety-related costs.

Several, but not all, of the safety features developed in the Transbus prototype program are being incorporated into the RTS-II design of General Motors and into the 870 design of Rohr-Flexible. The results indicated that the safety features designed into Transbus could account for a savings of as much as \$5,000 during the life of a typical transit bus. When the Department of Transportation authorizes the full Transbus design for capital assistance, it will have made a tremendous impact on transit coach safety.

REFERENCES

1. J.F. Wing, H.H. Buckel and J.A. Mateyka, Transbus. Current Developments in Urban Bus Design. Society of Automotive Engineers, Detroit, Mich., January 1973.
2. J.A. Mateyka, J.A. Talley, System Safety/Risk Analysis Techniques Applied to Motor Vehicles and Rapid Transit Systems. Journal of Safety Research, March 1977.
3. J.A. Mateyka, Maintainability and Safety of Transit Buses. Proceedings of the 1974 Annual Symposium on Reliability and Maintainability, Los Angeles, January 1974.
4. Energy Absorbing Bumpers for Transit Buses, Booz, Allen Applied Research, May 1976.
5. Transbus Seat Test, Calspan Corporation, July 1974.
6. Transbus Structural Crash Test Report, Calspan Corporation, May 1976.
7. Bus Interior Design for Improved Safety, Booz, Allen Applied Research, April 1976.
8. Transbus Procurement Requirements, Urban Mass Transportation Administration, June 1977.
9. J.A. Mateyka, Safety Considerations in Design of New Transit Bus Seats, Proceedings of the Eighteenth Stapp Car Crash Conference, Ann Arbor, Mich., December 1974.

APPENDIX

Excerpts from Transbus Procurement Requirements (8) Pertaining to Safety

2.1.1.5 Pedestrian Safety

Exterior protrusions greater than ½ inch and within 80 inches of the ground shall have a radius no less than the amount of the protrusion. The left side rearview mirror and required lights and reflectors are exempt from the protrusion requirement. Grilles, doors, bumpers and other features on the sides and rear of the coach shall be designed to minimize the ability of unauthorized riders to secure footholds or handholds.

2.1.2.9 Fire Protection

The passenger and engine compartments shall be separated by a bulkhead(s) which shall by incorporation of fireproof materials in its construction be a firewall. This firewall shall preclude or retard propagation of an engine compartment fire into the passenger compartment. Only necessary openings shall be allowed in the firewall, and these shall be fireproofed. Any passageways for the climate control system air shall be separated from the engine compartment by fireproof material. Piping through the bulkhead shall have copper, brass, or fireproof fittings sealed at the firewall with copper or steel piping on the forward side. Wiring may pass through the bulkhead only if connectors, conduits or other means are provided to prevent or retard fire propagation through the firewall. The conduit and bulkhead connectors shall be sealed with fireproof material at the firewall. Engine access panels in the firewall shall be fabricated of fireproof material and secured with fireproof fasteners. These panels, their fasteners, and the firewall shall be constructed and reinforced to minimize warping of the panels during a fire that will compromise the integrity of the firewall.

2.1.2.10 Crashworthiness

The coach body and roof structure shall withstand a static load equal to 150 percent of the curb weight evenly distributed on the roof with no more than a 6-inch reduction in any interior dimension. Windows shall remain in place and shall not open under such a load.

The coach shall withstand a 25-mph impact by a 4,000-pound, post-1973, American automobile at any point, excluding doorways, along either side of the coach with no more than 3 inches of permanent structural deformation at seated passenger hip height. This impact shall not result in sharp edges or protrusions in the coach interior.

Exterior panels below the rubrail and their supporting structural members shall withstand a static load of 2,000 pounds applied perpendicular to the coach anywhere below the rubrail by a pad no larger than 5 inches square. This load shall not result in deformation that prevents installation of new exterior panels to restore the original appearance of the coach.

2.1.5 FLOOR

2.1.5.1 Height

Height of the floor above the street shall be no more than 22 inches, measured at the centerline of the front door. The floor may be inclined only along the longitudinal axis of the coach. The floor incline shall be less than 1° of the horizontal. All floor measurements shall be with the coach at the design height and on a level surface.

2.1.6 STEPS AND STEPWELLS

2.1.6.1 Steps

A maximum of two steps shall be required for passenger ingress and egress. The step in each doorway shall be in a fixed location relative to the floor of the coach. At the front door, the first step up from street level shall not exceed 14 inches with the coach at the design height, and the second step riser height to coach floor level shall be no more than 8 inches. At the rear door, the interior step down from the floor level shall not exceed $9\frac{1}{2}$ inches, and the second step to street level shall not exceed 15 inches with the coach at the design height. Risers shall be continuous, flat, vertical planes across the entire width of the stepwell except for notches which may be required at either end to accommodate the opened doors. These notches shall not exceed 3 inches in depth and 3 inches in length. All corners shall have radii no less than $\frac{1}{8}$ inch to facilitate cleaning.

Step tread depth shall be no less than 12 inches and the plane of the step treads shall be parallel to the plane of the floor. Treads shall be covered with 5/16-inch, nonskid, ribbed, composition rubber material that shall remain effective in all weather conditions. Color of the tread covering shall match the vestibule flooring. The edge of the floor shall have no overhang at the step riser. The edge of the floor at the step riser and the end of the step tread shall have a bright, contrasting white band no less than 2 inches wide on the full width of the step. The color shall be permanently blended into the tread covering material.

- (1) *OPTION*: Yellow Step Edges. The colored bands on the edges of the steps shall be a bright yellow.

2.2.3.3 Passenger Interior Lighting

An overhead fluorescent lighting system shall provide general illumination in the passenger compartment and shall be controlled independent of the run switch. The system shall provide from 15 to 25 foot-candles of illumination on a 1-square-foot plane at an angle of 45° centered 33 inches above the floor and 24 inches in front of the seat back at each seating position. Floor surface in the vestibule and aisle shall be illuminated to no less than 10 foot-candles. Floor surface illumination in the vestibule may be reduced to no less than 2 foot-candles when the front door is closed. Fluorescent light fixtures shall be located above the side windows at or near the juncture of the coach ceiling and the side wall and may be provided over the rear door. Fluorescent lighting shall not be installed above the driver's side window and the front door. Lamp fixtures and lenses shall be fire-resistant and shall not drip flaming material onto seats or interior trim if burned. Advertising media located in this area shall be illuminated by back or direct lighting, although the interior lighting requirements shall be attained without advertising media installed. The fixtures shall be sealed to prevent accumulation of dust and insects but shall be easily openable on hinges for cleaning and service. The lenses shall be retained in a closed position by tamperproof devices with any fasteners being captive and requiring the same tool to open as other interior access panels. Power supplies shall be enclosed with fireproof material and shall be located at the individual light fixtures. Power supplies shall be inaudible with an operating frequency above 18,000 Hz. Interchangeability of fluorescent lamps, lenses, fixtures, and power supplies shall be maximized.

A stepwell lighting system shall be illuminated when the master switch is in RUN and NITE/RUN, except the front stepwell lamps which shall be extinguished when the doors are closed. The system shall provide no less than 2 foot-candles of illumination on the entry and exit step treads with the doors open. These lights shall be shielded to protect passengers' eyes from glare. Light fixtures shall be totally enclosed, splashproof, designed to provide ease of cleaning as well as lamp and housing removal, and shall not be easily removable by passengers. Stepwell lights shall be protected from damage caused by passengers kicking lenses or fixtures and shall not be a hazard to passengers.

2.3.2 PASSENGER SEATS

2.3.2.1 Arrangements

The coach shall be designed to accept four basic seating configurations with defined capacity and comfort. Selection shall be based on the type of service the coach is to provide. Available seating configurations and seat types are summarized in Figure II-7.

Passenger seats shall be arranged in a transverse, forward facing configuration, except at the wheel housings where seats may be arranged as appropriate with due regard for passenger access and comfort.

Seat pitch, the distance between any point of a seat and the corresponding point of the seat immediately forward or rearward, shall be a nominal 28 inches. Seating capacity with this arrangement shall be no less than 46 on standard length coaches and no less than 38 on coaches 35 feet in length including accommodation for one wheelchair passenger. Hip-to-knee room, measured from the front of one seat back cushion horizontally across the highest part of the seat cushion to the back of the seat immediately in front, shall be no less than 27 inches at all seating positions. Foot room, measured forward parallel to the floor from a point vertically below the front of the seat cushion, shall be no less than 14 inches. Seats immediately behind the wheel housings may have foot room reduced to 10 inches, measured to the first vertical barrier, provided the wheelhouse is sloped so that it may be used as a footrest. Fold-down seats may be used in the wheelchair parking area, however, all seating dimensions shall be maintained when the fold-down seats are occupied or when a wheelchair is parked in the designated area.

Each transverse, forward facing seat, except the rear seats, shall accommodate two adult passengers. Thickness of the transverse seat backs shall be minimized to increase passenger knee room and coach capacity. The area between the longitudinal seat backs and the attachment to the coach side walls shall be designed to prevent debris accumulation.

The aisle between the seats shall be no less than 20 inches wide at seated passenger hip height. Seat backs shall be shaped to increase this dimension to no less than 24 inches at standing passenger hip height. Coaches built to the 96-inch body width configuration shall have minimum aisle widths of 16 inches at seated passenger hip height and 20 inches at standing passenger hip height.

Section	Seating Alternative	Pitch (in)	Hip-to-Knee Room (min)	Coach Capacity* (min) 40'/35'
2.3.2.4	Standard Seats	28	27	46/38
2.3.2.4(1)	Padded Seats	30	28	44/36
2.3.2.4(2)	Cushioned Seats	32	29	42/35
2.3.2.1(1)	Perimeter Seating	NA	NA	41/35

*Includes accommodation for one wheelchair passenger

FIGURE II-7. SEATING ARRANGEMENT SUMMARY

- (1) *OPTION*: Perimeter Seating. All passenger seats shall face the interior of the coach with a seating capacity of 41 on standard length coaches and 35 on coaches 35 feet in length. Seating shall meet the requirements for longitudinal seats in Section 2.3.2.3 except that armrests shall be provided between every other seating position at the same location as the vertical passenger assists defined in Section 2.6.3.5. The seat width shall be no less than 17 inches not including the armrest width.

2.3.2.2 Dimensions

Seats for the various seating arrangements shall have the dimensions shown in Figure II-8. Transverse seats in coaches built to the 96-inch-wide body configuration shall have a minimum width of 34 inches.

- (1) *OPTION*: 34-inch Wide Seats. The transverse seats shall have a maximum width of 34 inches. This option may be specified with 102-inch wide coaches and the aisle width dimensions of Section 2.3.2.1 shall become 24 and 28 inches respectively.

2.3.2.3 Structure and Design

The passenger seat frame and its supporting structure shall be constructed and mounted so that space under the seat is maximized to increase wheelchair maneuvering room and is completely free of obstructions to facilitate cleaning. The structure shall be fully cantilevered from the side wall with sufficient strength for the intended service. The lowest part of the seat assembly that is within 12 inches of the aisle shall be at least 12 inches above the floor. The underside of the seat and the side wall shall be configured to prevent debris accumulation and the transition from the seat underside to the coach side wall to the floor cove radius shall be smooth. All transverse objects, including seat backs, modesty panels, and longitudinal seats, in front of forward facing seats shall not impart a compressive load in excess of 1,000 pounds onto the femur of passengers ranging in size from a 5th-percentile female to a 95th-percentile male during a 5g deceleration of the coach. Permanent deformation of the seat resulting from two 95th-percentile males striking the seat back during a 5g deceleration shall not exceed 2 inches, measured at the aisle side of the seat. Structural failure of any part of the seat or side wall shall not introduce a laceration hazard.

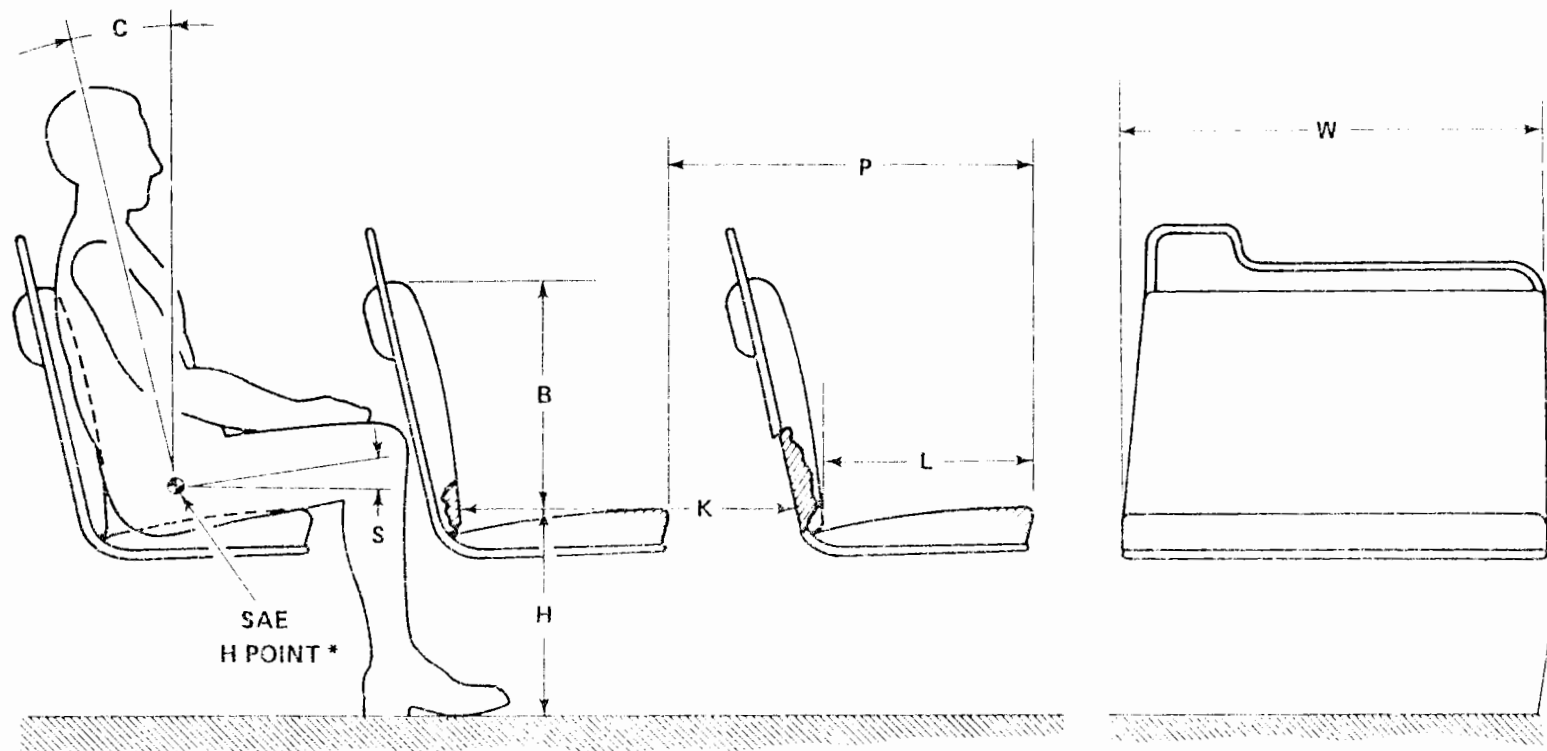

W	WIDTH	35 INCHES MINIMUM OR 34 INCHES MINIMUM ON 96-INCH WIDE COACH
L	LENGTH	17±1 INCHES
B	BACK HEIGHT	15 INCHES MINIMUM
H	SEAT HEIGHT	TRANSVERSE SEATS 17±1 INCHES, LONGITUDINAL SEATS 18±2 INCHES
S	SEAT CUSHION SLOPE	5° TO 11°
C	SEAT BACK SLOPE	8° TO 17°
K	HIP - TO - KNEE ROOM	27 INCHES MINIMUM
P	PITCH	28 INCHES NOMINAL

*Reference SAE Standard J826

FIGURE 11-8. SEATING DIMENSIONS AND STANDARD CONFIGURATION

The seat assembly shall withstand static vertical forces of 500 pounds applied to the top of the seat cushion in each seating position with less than ¼-inch permanent deformation in the seat or its mountings. The seat assembly shall withstand static horizontal forces of 500 pounds evenly distributed along the top of the seat back with less than ¼-inch permanent deformation in the seat or its mountings. The seat backs at the aisle position and at the window position shall withstand repeated impacts of two 40-pound sandbags without visible deterioration. One sandbag shall strike the front 40,000 times and the other sandbag shall strike the rear 40,000 times. Each sandbag shall be suspended on a 36-inch pendulum and shall strike the seat back 10,000 times each from distances of 6, 8, 10, and 12 inches. Seats at both seating positions shall withstand 4,000 vertical drops of a 40-pound sandbag without visible deterioration. The sandbag shall be dropped 1,000 times each from heights of 6, 8, 10, and 12 inches. Seat cushions shall withstand 100,000 randomly positioned 3½-inch drops of a squirming, 150-pound, smooth-surfaced, buttocks-shape striker with only minimal wear on the seat covering.

The back of each transverse seat shall incorporate a handhold no less than 7/8 inches in diameter for standees and seat access/egress. The handhold shall not be a safety hazard during severe decelerations. The handhold shall extend above the seat back near the aisle so that standees shall have a convenient vertical assist, no less than 4 inches long that may be grasped with the full hand. This handhold shall not cause a standee using this assist to interfere with a seated 50th-percentile male passenger. The handhold shall also be usable by a 5th-percentile female, as well as by larger passengers, to assist with seat access/egress for either transverse seating position. Armrests shall not be included in the design of transverse seats.

Longitudinal seats shall be of the same general design as transverse seats but without seat back handholds. Longitudinal seats may be mounted on the wheelhouses. Armrests shall be included on the ends of each set of longitudinal seats and shall be located from 7 to 9 inches above the seat cushion surface. The area between the armrest and the seat cushion shall be closed by a barrier or panel and shall be constructed and trimmed to complement the modesty panels. The top and sides of the armrests shall have a minimum width of 2 inches and shall be free from sharp protrusions that form a safety hazard.

Seat back handholds and armrests shall withstand static horizontal and vertical forces of 250 pounds applied anywhere along their length with less than ¼-inch permanent deformation. Seat back handholds and armrests shall withstand 25,000 impacts in each direction of a horizontal force of 125 pounds with less than ¼-inch permanent deformation and without visible deterioration.

2.3.2.4 Construction and Materials

Seat material of the standard configuration seat shall be fiberglass, polycarbonate, or nylon and shall be attached to the frame with tamperproof fasteners. Coloring shall be consistent throughout the seat material, with no exposed portion painted. All exposed metal of the standard seat structure shall be aluminum or stainless steel. The seat shall be contoured for individuality, lateral support, and maximum comfort and shall fit the framework to reduce exposed edges. The seat back thickness shall not exceed ½ inch in the knee room area. The seat forward of a seated passenger shall absorb energy in a severe crash by allowing the passenger's knees to deform the seat back in accordance with the requirements of Section 2.3.2.3. Complete seat assemblies shall be interchangeable to the extent practicable. Color and materials of the seats are defined in attachments to Part II: Technical Specifications.

- (1) *OPTION*: Padded Seats. Seating and interior trim shall have features to improve safety, comfort, and capacity. Transverse seats shall have a nominal seat pitch of 30 inches and a hip-to-knee room dimension no less than 28 inches at all seating positions. Seating capacity shall be no less than 44 on 40-foot-long coaches and no less than 36 on coaches built to the 35-foot-length option, including accommodation for one wheelchair passenger. Selected materials shall minimize damage from vandalism and shall reduce cleaning time. The seat shall be contoured for lateral support, individuality, and comfort to each individual passenger. The seat cushion and back shall be padded with neoprene foam, or material with equal properties, no less than ½-inch thick in seating areas and shall be covered with vinyl material. Seat covering materials shall be selected on the basis of durability, ease of maintenance, and pleasing texture and appearance.

The upper rear portion of the seat back, seat back handhold, and upper rear surface of the modesty panels located immediately forward of transverse seats shall be padded and/or constructed of energy absorbing materials. During a 5g deceleration the HIC number shall not exceed 400 for passengers ranging in size from a 6 year old child through a 95th-percentile male. The minimum radius of any part of the seat back, handhold, or modesty panel in the head or chest impact zone shall be a nominal ¼-inch. Color of the padding shall complement the balance of the coach interior and shall be consistent throughout the material. Seats, back cushions, and other pads shall be securely attached and shall be detachable by means of a simple release mechanism employing a special

tool so that they are easily removable by the maintenance staff but not by the passengers. To the extent practicable, seat cushions and pads shall be interchangeable throughout the coach. All materials and workmanship shall conform to SPI standards and specifications in tests for plastic foam. Materials shall have high resistance to tearing, flexing, and wetting. Color, fabrics, and patterns for seats and trim are defined in attachments to Part II: Technical Specifications.

- (2) *OPTION*: Cushioned Seats. Seating and interior trim shall have features to maximize safety, comfort, and capacity. Transverse seats shall have a nominal seat pitch of 32 inches with a hip-to-knee room dimension no less than 29 inches at all seating positions. Seating capacity of 40-foot-long coaches shall be no less than 42 and no less than 35 in coaches built to the 35-foot-length option, including accommodation for one wheelchair passenger. Selected materials shall minimize damage from vandalism and shall reduce cleaning time. The seat structure shall incorporate springing for the seat bottom. The seat cushion and back shall be padded with neoprene foam, or material with equal properties, no less than 2 inches thick in seating areas and shall be upholstered with vinyl and/or fabric materials. Springs and cushions shall be shaped for individuality, lateral support, and comfort. Upholstery materials shall be selected on the basis of durability, ease of maintenance, and pleasing texture and appearance. Upholstery of the driver's seat shall be the same material and color as the passenger seats.

Passenger head protection and the seat back handhold shall be built integrally into the seat, and padding shall be provided on modesty panels located immediately forward of transverse seats. Protection shall be afforded to passengers ranging in size from a 6-year-old child to a 95th-percentile male to prevent head injury of more than 400 HIC during a 5g deceleration. The minimum radius of equipment in any portion of the head or chest impact zone shall be a nominal ¼-inch. Armrests shall be padded with material that is the same as, or similar to, the seat back padding and handholds. Color of the padding shall complement the other interior materials. Seats, back cushions, and other pads shall be securely attached and shall be detachable by means of a simple release mechanism employing a special tool so that they are easily removable by the maintenance staff but not by the passengers. To the extent practicable, seat cushions and pads shall be interchangeable throughout the coach and the pad coloring shall be consistent throughout the materials. All material and workmanship shall conform to SPI standards and specifications in tests for plastic foam. The material shall have high resistance to tearing, flexing, and wetting. Colors, fabrics, and patterns for the seats and all interior trim is defined in attachments to Part II: Technical Specifications.

2.6.3 PASSENGER ASSISTS

2.6.3.1 General Requirements

Passenger assists in the form of full grip, vertical stanchions or handholds shall be provided for the safety of standees and for ingress/egress. Passenger assists shall be convenient in location, shape, and size for both the 95th-percentile male and the 5th-percentile female standee. Starting from the entrance door and moving anywhere in the coach and out the exit door, a vertical assist shall be provided either as the vertical portion of seat back assist (see Section 2.8.2.3) or as a separate item so that a 5th-percentile female passenger may easily move from one assist to another using one hand and the other without losing support. Excluding those mounted on the seats and doors, the assists shall be between 1¼ and 1½ inches in diameter or width with radii no less than ¼ inch and shall permit a full hand grip with no less than 1½ inches of knuckle clearance around the assist. A crash resulting in a 1-foot intrusion shall not produce sharp edges, loose rails, or other potentially dangerous conditions associated with a lack of structural integrity of the assist. Any joints in the assist structure shall be underneath supporting brackets and securely clamped to prevent passengers from moving or twisting the assists. All passenger assists shall be constructed of anodized aluminum or stainless steel, and shall withstand a force of 300 pounds applied over a 12-inch lineal dimension in any direction normal to the assist without permanent visible deformation. Brackets, clamps, screw heads, and other fasteners used on the passenger assists shall be flush with the surface and free of rough edges.

2.6.3.2 Front Doorway

Front doors shall be fitted with assists to provide continuous handrails on both sides of the entry stairway. The front door assists shall be no less than 2¼ inch in width and shall provide at least 1½ inches of knuckle clearance between the assists and their mountings. Assists shall extend as far outward as practicable, and shall be no more than 2 inches from the outside edge of the door jamb or opened door. The door mounted assists shall have a vertical portion that can be easily grasped by a 5th-percentile female boarding from street level. Door assists shall extend through the stairway parallel to the stair slope, 36 inches above the average step tread surface and shall be functionally continuous with the horizontal front passenger assist and the vertical assist on the front modesty panel.

2.6.3.3 Vestibule

The aisle side of the driver's barrier and the modesty panels shall be fitted with vertical passenger assists that are functionally continuous with the overhead assist and that extend to within 36 inches of the floor. These assists shall have sufficient clearance from the barrier to prevent inadvertent wedging of a passenger's arm. A horizontal passenger assist shall be located across the front of the coach and without restricting the vestibule space, shall provide support for a boarding passenger from the front door through the fare collection procedure. Passengers shall be able to lean against the assist for security while paying fares. The assist shall be no less than 36 inches above the floor or the average step tread surface. The assists at the front of the coach shall be arranged to permit a 5th-percentile female passenger to easily reach from the door assist, to the front assist, to vertical assists on the driver's barrier or front modesty panel. A barrier shall be provided across the front of the coach to prevent passengers from sustaining injuries on the fare collection device or windshield in the event of a sudden deceleration. This barrier shall extend from the horizontal assist to within 6 inches of the floor across the front of the vestibule, and shall be constructed to prevent injury to a passenger's head of more than 100 HIC in impacts of 10 mph.

2.6.3.4 Overhead

Except forward of the standee line and at the rear door, a continuous, full grip, overhead assist shall be provided. This assist shall be convenient to standees anywhere in the coach and shall be located over the center of the aisle seating position of the transverse seats. The assist shall be no less than 70 inches above the floor. Overhead assists shall simultaneously support 150 pounds on any 12-inch length. No more than 5 percent of the full grip feature shall be lost due to assist supports.

2.6.3.5 Longitudinal Seats

Longitudinal seats shall have vertical assists located between every other designated seating position. Assists shall extend from near the leading edge of the seat and shall be functionally continuous with the overhead assist. Assists shall be staggered across the aisle from each other and shall be no more than 52 inches apart.

2.6.3.6 Rear Doorway

Vertical assists that are functionally continuous with the overhead assist shall be provided at the aisle side of the transverse seat immediately forward of the rear door and on the aisle side of the rear door modesty panel. Rear doors shall be fitted with assists to provide continuous handrails on both sides of the exit stairway. The rear door assists shall be no less than 2 1/4 inch in width and shall provide at least 1 1/2 inches of knuckle clearance

between the assists and their mounting. A vertical portion of each assist shall be located within 2 inches of the outside edge of the door jamb or opened door and shall be at least 12 inches in length and centered 33 to 40 inches above the lower step tread. When the Passenger Controlled Rear Door Option 2.2.1.2(1) is selected the touch bars shall be the vertical portion of the door mounted assist and the touch bars shall be functionally continuous with the remainder of the door mounted assists. A 5th-percentile female shall be provided assists extending through the stairway parallel to the stair slope, 36 inches above the average step tread surface that are functionally continuous during the entire exiting process.

3.6.3 BUMPER SYSTEM

3.6.3.1 Location

Bumpers shall provide impact protection for the front and rear of the coach up to 26 inches above the ground. The bumpers shall wrap around the coach to the extent practicable without exceeding allowable coach width.

3.6.3.2 Front Bumper

No part of the coach, including the bumper, shall be damaged as a result of a 5-mph impact of the coach at curb weight with a fixed, flat barrier perpendicular to the coach's longitudinal centerline. The bumper shall protect the coach and a stationary 4000-pound, post-1973, American automobile from damage as a result of impacting at 6.5 mph into the rear bumper of the automobile parallel to the longitudinal centerline of the coach and at 5.5 mph into the rear bumper of the automobile at a 30° angle to the longitudinal centerline of the coach. The energy absorption system of the bumper shall be independent of every power system of the coach and shall not require service or maintenance in normal operation during the service life of the coach. The flexible portion of the bumper may increase the overall coach length specified in Section 1.5.1.1 by no more than 6 inches.

3.6.3.3 Rear Bumper

The rear bumper and its mounting shall provide impact protection to the coach at curb weight from a 2-mph impact with a fixed, flat barrier perpendicular to the longitudinal centerline of the coach. The rear bumper shall protect the coach, when impacted by

the striker defined in FMVSS #215 loaded to 4000 pounds, at 4 mph parallel to, or up to a 30° angle to, the longitudinal centerline of the coach. The rear bumper or bumper extensions shall be shaped to preclude unauthorized riders standing on the bumper and shall wrap around the coach to protect the engine compartment doors and radiator. The bumper extensions shall not hinder service and shall be faired into the coach body with no protrusion or sharp edges. The bumper shall be independent of all power systems of the coach and shall not require service or maintenance in normal operation during the service life of the coach. The flexible portion of the bumper may increase the overall coach length specified in Section 1.5.1.1 by no more than 6 inches.

1. Report No.		2. Government Accession No.		3. Recipient's Catalog No.	
4. Title and Subtitle Transbus Safety & Human Factors				5. Report Date September 30, 1977	
				6. Performing Organization Code	
7. Author(s) Booz, Allen & Hamilton Inc.				8. Performing Organization Report No. TR 77-004	
9. Performing Organization Name and Address Booz, Allen & Hamilton Inc. Transportation Consulting Division 4330 East West Highway Bethesda, Maryland 20014				10. Work Unit No.	
				11. Contract or Grant No. DOT-UT-10008	
				13. Type of Report and Period Covered Summary Report 1971 to 1976	
12. Sponsoring Agency Name and Address U.S. Department of Transportation Urban Mass Transportation Administration Washington, D.C.				14. Sponsoring Agency Code	
15. Supplementary Notes					
16. Abstract This report describes the overall program of transit bus safety and human factors research that was conducted between 1971 and 1976 in support of the Transbus program. The report describes work efforts in the following areas: system safety analysis, passenger observations and human factors research, door studies, bus bumper and crash testing, bus seat safety, and interior design for passenger safety. The report references and summarizes previously published materials, but a number of additional working papers and technical briefings are presented as appendices to this report to more fully document these research efforts.					
17. Key Words Transit Bus, Transbus, Bus Passenger Safety, Elderly and Handicapped, Human Factors			18. Distribution Statement Document is available to the U.S. public through the National Technical Information Service, Springfield, Virginia 22161.		
19. Security Classif. (of this report) Unclassified		20. Security Classif. (of this page) Unclassified		21. No. of Pages 148	22. Price

T A B L E O F C O N T E N T S

	<u>Page Number</u>
1. OBJECTIVE	1
2. INTRODUCTION	1
a. The Scope of the Transbus Safety and Human Factors Effort	1
b. System Safety Analysis	1
c. Passenger Observations and Human Factors	2
d. Door Studies	2
e. Bumper and Crash Testing	2
f. Seat Safety	2
g. Interior Design Features	2
h. Coordination	2
i. System Safety Approach	2
j. Methodology	3
3. CHRONOLOGY OF THE TRANSBUS AND HUMAN FACTORS PROGRAM	3
a. Overview	3
b. Efforts in 1971	3
c. Efforts in 1972	6
d. Efforts in 1973	8
e. Efforts in 1974	11
f. Efforts in 1975	12
g. Efforts in 1976	13
h. Summary of Transbus Safety and Human Factors Program (1971-1976)	14
4. REFERENCES	15
APPENDIX A - Transit Bus Safety Report #1 - Bus Accident Data Analysis	
APPENDIX B - Observations of Passengers On-Board Current Buses	

APPENDIX C - Impact of Mass Transit on
Urban Traffic Safety

APPENDIX D - Improvements in the Safety of
Urban Transit Coaches

1. OBJECTIVE

The primary objective of this report is to summarize the work accomplished in the areas of transit bus safety and human factors research as part of the Transbus program. Transbus was the U.S. Department of Transportation, Urban Mass Transportation Administration's program, which supported the design, construction and testing of advanced, standard size (40 feet), prototype, urban transit buses. Since safety and human factors research was a major element of the work program from its outset in 1971, much valuable information has been generated in the form of reports, presentations, working papers and technical society papers. This report organizes this information in a logical program context and in a chronological sequence. The rationale for each work element is described. For the most part, the reader is referred to previously published materials, which present key results. In some instances, previously unpublished draft reports, working papers, and briefings are presented in appendices to complete the public record of the Transbus safety and human factors effort.

2. INTRODUCTION

a. The Scope of the Transbus Safety and Human Factors Effort. The Transbus safety and human factors effort has been one of the most extensive activities of its type in the history of urban transit bus design. The effort, which took place from mid-1971 through 1976, involved six general task areas as follows:

- . System safety analysis
- . Passenger observations and human factors
- . Door studies
- . Bumper and crash testing
- . Seat safety
- . Interior features.

b. System Safety Analysis. The integrating task that tied together the safety and human factors program was the system safety analysis task. The basic approach used was that of system safety engineering. The task began with an analysis of bus accidents and bus accident costs. This identified key problem areas requiring solutions during the program by design, testing, and evaluation of the transit bus prototypes.

REFERENCES

1. "Transit Bus Safety, Interim Report 1," Booz, Allen Applied Research, Presentation to Urban Mass Transportation Administration, U.S. Department of Transportation, Contract DOT-UT-10008, April 26, 1972.
2. Transit Bus Safety Report #1 - Bus Accident Data Analysis, Booz, Allen Applied Research, TR72-006, September 29, 1972.
3. "Transit Bus Safety, Interim Report 2," Booz, Allen Applied Research, Presentation to Urban Mass Transportation Administration, U.S. Department of Transportation, Contract DOT-UT-10008, Fall 1972.
4. Report on the Design Guidelines Meeting for the Elderly and Handicapped in the Transbus Program, Booz, Allen Applied Research, TR72-001, October 1972.
5. Transbus Boarding and Alighting Studies, Forty-Inch Front Door, Booz, Allen Applied Research, TR73-001, January 31, 1973.
6. "Observations of Passengers On-Board Current Buses," Booz, Allen Applied Research, Interim Report Presentation to Urban Mass Transportation Administration, U.S. Department of Transportation, Contract DOT-UT-10008, January 31, 1973.
7. "Transbus - Current Development in Urban Bus Design," J.A. Mateyka, Paper Presented to the Annual Meeting of the Society of Automotive Engineers, Detroit, Michigan, January 1973.
8. "Bus Passenger Seating and Crash Protection (Docket No. 73-3, Notice 1) - Implications for the UMTA Transbus Program," Booz, Allen Applied Research, Presentation to Urban Mass Transportation Administration, U.S. Department of Transportation, Contract DOT-UT-10008, May 12, 1973.
9. "Transbus Safety Analysis and Public Demonstration Program," J.A. Mateyka, Booz, Allen Applied Research, Presentation to the American Transit Association Mid-Year Meeting, Mechanical Division Session, Denver, Colorado, June 6, 1973.

10. Urban Buses Acceleration and Deceleration Studies, Booz, Allen Applied Research, TR73-001, August 31, 1973.
11. The Benefits of Energy Absorbing Bumpers for Transit Buses, Booz, Allen Applied Research, TR73-013, November 1973.
12. "Benefits of Energy Absorbing Bumpers for Transit Buses," Booz, Allen Applied Research, Presentation to Urban Mass Transportation Administration, U.S. Department of Transportation, Contract DOT-UT-10008, December 6, 1973.
13. "Impact of Mass Transit on Urban Traffic Safety," Booz, Allen Applied Research, Presentation to Urban Mass Transportation Administration, U.S. Department of Transportation, Contract DOT-UT-10008, December 6, 1973.
14. "Transbus Bumper and Seat Test Results," J.A. Mateyka, Booz, Allen Applied Research, Presentation to the American Transit Association Bus Technology Committee, Phoenix, Arizona, March 28, 1974.
15. "Maintainability and Safety of Transit Buses," J.A. Mateyka, Booz, Allen Applied Research, Paper Presented at the 1974 Annual Reliability and Maintainability Symposium, Los Angeles, California, January 29-31, 1974.
16. "Interior Design for Passenger Safety," J.A. Mateyka, Booz, Allen Applied Research, Presentation to the American Transit Association, Mid-Year Meeting, Claims Division Session, Washington, D.C., May 21, 1974.
17. Transbus Seat Test Results, Booz, Allen Applied Research, TR74-004, August 1974.
18. "The Benefits of Energy Absorbing Bumpers for Transit Buses," J.A. Mateyka, Booz, Allen Applied Research, Paper Presented to the National Safety Congress and Exposition, Transit Section Meeting, Chicago, Illinois, October 2, 1974.
19. "Safety Considerations in Design of New Transit Bus Seats," J.A. Mateyka, Booz, Allen Applied Research, Paper Presented at The 18th Stapp Car Crash Conference, Ann Arbor, Michigan, December 4-6, 1974.
20. Transbus Public Testing and Evaluation Program, Simpson & Curtin, National Analysts, September 1975.

21. "Cause and Prevention of On-Board Accidents," J.A. Mateyka, Booz, Allen Applied Research, Paper Presented to the National Safety Congress and Exposition, Transit Section, Chicago, Illinois, October 1, 1975.
22. Bus Interior Design for Improved Safety, Booz, Allen Applied Research, TR76-001, April 30, 1976.
23. Human Factors Evaluation of Transbus by the Elderly, Booz, Allen Applied Research, TR76-002, May 28, 1976.
24. Energy Absorbing Bumpers for Transit Buses, Booz, Allen Applied Research, TR76-003, May 1976.
25. Transbus Operational, Passenger, and Cost Impacts, Booz, Allen Applied Research, Simpson and Curtin, TR75-002, July 7, 1976.
26. Transbus Structural Crash Test Report, Calspan Corporation, 2N-5875-V-1, May 1976.