

REPORT NO. UMTA- MA-06-0025-78-11

**NOISE ASSESSMENT OF THE SOUTHEASTERN PENNSYLVANIA
TRANSPORTATION AUTHORITY HEAVY RAIL TRANSIT SYSTEM**

R. Spenser
E. Hinterkeuser

The Boeing Vertol Company
P.O. Box 16858
Philadelphia, PA 19142



S.C.R.T.D. LIBRARY

OCTOBER 1978

INTERIM REPORT

DOCUMENT IS AVAILABLE TO THE U.S. PUBLIC
THROUGH THE NATIONAL TECHNICAL
INFORMATION SERVICE, SPRINGFIELD,
VIRGINIA 22161

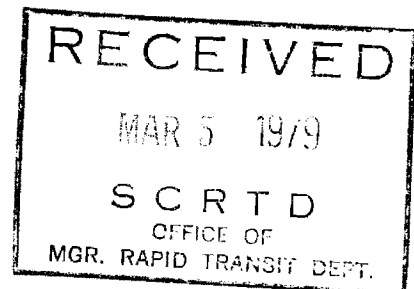

Prepared for

U.S. DEPARTMENT OF TRANSPORTATION
OFFICE OF TECHNOLOGY DEVELOPMENT AND DEPLOYMENT
Office of Rail and Construction Technology
Washington DC 20590

NOTICE

This document is disseminated under the sponsorship of the Department of Transportation in the interest of information exchange. The United States Government assumes no liability for its contents or use thereof.

NOTICE

The United States Government does not endorse products or manufacturers. Trade or manufacturers' names appear herein solely because they are considered essential to the object of this report.

1. Report No. UMTA-MA-06-0025-78-11		2. Government Accession No.		3. Recipient's Catalog No.	
4. Title and Subtitle Noise Assessment of the Southeastern Pennsylvania Transportation Authority Heavy Rail Transit System				5. Report Date October 1978	
				6. Performing Organization Code 8-2791	
7. Author(s) R. H. Spencer and E. G. Hinterkeuser				8. Performing Organization Report No. DOT-TSC-UMTA-78-46	
9. Performing Organization Name and Address The Boeing Vertol Company * P.O. Box 16858 Philadelphia, Pa. 19142				10. Work Unit No. (TRAINS) R9743/UM949	
				11. Contract or Grant No. DOT-TSC-850	
12. Sponsoring Agency Name and Address U.S. Department of Transportation Office of Technology Development and Deployment Office of Rail and Construction Technology 2100 Second Street S.W., Washington, D.C. 20590				13. Type of Report and Period Covered Interim Report October 1974 - July 1975	
				14. Sponsoring Agency Code UTD-30	
15. Supplementary Notes *Under contract to: U.S. Department of Transportation, Research and Special Programs Administration, Transportation Systems Center, Cambridge, Massachusetts 02142.					
16. Abstract <p>This report describes the noise climate on and near the Southeastern Pennsylvania Transportation Authority, (SEPTA), Broad Street Subway and Market-Frankford Elevated Line. It is one of a series of coordinated assessments sponsored by the Urban Mass Transportation Administration and technically administered through the Transportation Systems Center of the U.S. Department of Transportation. The two SEPTA urban rail transit lines have approximately 22.6 miles of two-way revenue track (of which 13.1 miles are in subway), and 53 stations. Noise level data are given for specific measurements made in cars, in stations and along the non-subway wayside at appropriate locations. Based on these measurements, in-car average maximum A-weighted sound levels, $L_A(\text{Max})$, range from 74 to 98 dBA and are estimated to be in the 75 to 89 dBA range for 94 percent of the SEPTA route. Wayside $L_A(\text{Max})$ levels, at 15m (50 ft) from the near track, range from 76 to 89 dBA, and are in the 85 to 89 dBA interval for 90 percent of the above ground route mileage. Station $L_A(\text{Max})$ levels range from 80 to 90 dBA with 61 percent of SEPTA stations in the 85 to 89 dBA interval, and 29 percent in the 95 to 99 dBA interval.</p> <p>The rationale for choice of measurement sites and the methodology for arriving at the summary noise distributions from the data are discussed explicitly. Measurement and analysis instrumentation and procedures are also described.</p>					
17. Key Words Noise, Rapid Transit, Transportation Noise, Measurement Methodology, Instrumentation, Data Analysis, Community Noise, Station Platform Noise, Vehicle Noise			18. Distribution Statement DOCUMENT IS AVAILABLE TO THE U.S. PUBLIC THROUGH THE NATIONAL TECHNICAL INFORMATION SERVICE, SPRINGFIELD, VIRGINIA 22161		
19. Security Classif. (of this report) Unclassified		20. Security Classif. (of this page) Unclassified		21. No. of Pages 352	22. Price

00989

TD
893
.T7
G64

PREFACE

This report has been prepared under the Urban Rail Noise Abatement Program being sponsored by the Urban Mass Transportation Administration's (UMTA's) Office of Rail and Construction Technology. The Noise Abatement Program is being managed at the Transportation Systems Center for UMTA. The objectives of the Noise Abatement Program are to assess noise produced by urban rail transit operations and to appraise methods and costs for reduction of such noise.

This report is one in a series of six noise assessment reports covering noise due to transit operations on seven rail transit systems in five U.S. cities. Consistent results of the six assessments were achieved through use of standardized noise measurement and data reduction procedures developed at TSC and tested on the Massachusetts Bay Transportation Authority (MBTA) in Boston. The assessment report for the MBTA was published in 1974 (Reference 1).

Physical differences among the transit systems, as well as differences in the technical orientations of the teams, and in funds available to the teams for measurement and analysis, led to some differences in report organization, technical depth and writing style. Therefore, to provide at least introductory consistency among the reports for the reader, the front material, including the introduction of each assessment report, has been edited at TSC. The organization and technical content of each report, however, are basically as originally written by the respective teams and are, together with the accuracy of the measurements, the responsibility of the authors.

This report has been prepared by the Boeing Vertol Company under contract DOT-TSC-850. Authors of the report were R. H. Spencer and E. G. Hinterkeuser. Technical Monitors for the program were Dr. E. G. Apgar and Dr. Robert Lotz. Liaison with the Southeastern Pennsylvania Transportation Authority was provided by Mr. John Nielson of SEPTA. Dr. Leonard Kurzweil of the Transportation Systems Center directed the final technical editing of the report.

METRIC CONVERSION FACTORS

Approximate Conversions to Metric Measures

Symbol	When You Know	Multiply by	To Find	Symbol
LENGTH				
in	inches	2.5	centimeters	cm
ft	feet	30	centimeters	cm
yd	yards	0.9	meters	m
mi	miles	1.6	kilometers	km
AREA				
in ²	square inches	6.5	square centimeters	cm ²
ft ²	square feet	0.09	square meters	m ²
yd ²	square yards	0.8	square meters	m ²
mi ²	square miles	2.6	square kilometers	km ²
	acres	0.4	hectares	ha
MASS (weight)				
oz	ounces	28	grams	g
lb	pounds	0.45	kilograms	kg
	short tons (2000 lb)	0.9	tonnes	t
VOLUME				
tsp	teaspoons	5	milliliters	ml
Tbsp	tablespoons	15	milliliters	ml
fl oz	fluid ounces	30	milliliters	ml
c	cups	0.24	liters	l
pt	pints	0.47	liters	l
qt	quarts	0.95	liters	l
gal	gallons	3.8	liters	l
ft ³	cubic feet	0.03	cubic meters	m ³
yd ³	cubic yards	0.76	cubic meters	m ³
TEMPERATURE (exact)				
	Fahrenheit temperature	5/9 (after subtracting 32)	Celsius temperature	°C

Approximate Conversions from Metric Measures

Symbol	When You Know	Multiply by	To Find	Symbol
LENGTH				
mm	millimeters	0.04	inches	in
cm	centimeters	0.4	inches	in
m	meters	3.3	feet	ft
m	meters	1.1	yards	yd
km	kilometers	0.6	miles	mi
AREA				
cm ²	square centimeters	0.16	square inches	in ²
m ²	square meters	1.2	square yards	yd ²
km ²	square kilometers	0.6	square miles	mi ²
ha	hectares (10,000 m ²)	2.5	acres	
MASS (weight)				
g	grams	0.035	ounces	oz
kg	kilograms	2.2	pounds	lb
t	tonnes (1000 kg)	1.1	short tons	
VOLUME				
ml	milliliters	0.03	fluid ounces	fl oz
l	liters	2.1	pints	pt
l	liters	1.06	quarts	qt
l	liters	0.26	gallons	gal
m ³	cubic meters	35	cubic feet	ft ³
m ³	cubic meters	1.3	cubic yards	yd ³
TEMPERATURE (exact)				
°C	Celsius temperature	9/5 (then add 32)	Fahrenheit temperature	

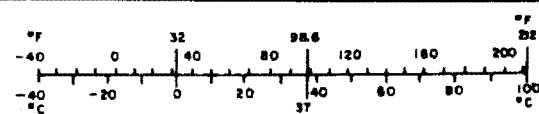
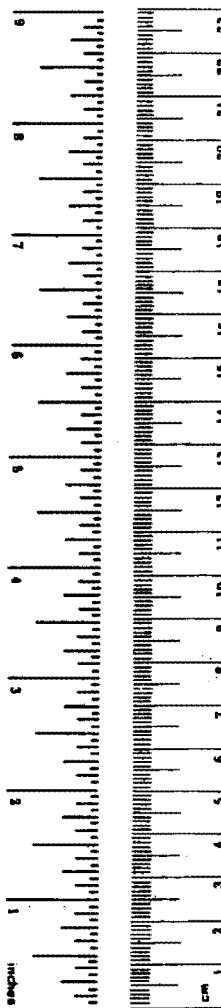

TABLE OF CONTENTS

	PAGE
LIST OF FIGURES	vii
LIST OF TABLES	xiv
LIST OF DEFINITIONS	xvi
1. SUMMARY	1-1
2. INTRODUCTION	2-1
2.1 Program Scope	
2.2 Reader's Guide to Report	
3. GENERAL MEASUREMENT METHODOLOGY	3-1
3.1 Community Noise	3-1
Sampling Strategy	
Conditions at Measurement Site	
Microphone Positions	
Measurement Procedure	
3.2 Station Noise	3-5
Sampling Strategy	
Conditions at Measurement Site	
Microphone Positions	
Measurement Procedure	
3.3 Vehicle Interior Noise	3-6
Sampling Strategy	
Conditions at Measurement Site	
Microphone Positions	
Measurement Procedure	
4. INSTRUMENTATION AND DATA ANALYSIS	4-1
4.1 Instrumentation	4-1
Data Requirements	
Data Acquisition System	
Equipment Calibrations	
4.2 Data Analysis	4-5
Graphic Level Recorder Calibration	
Individual Event Analysis	
Grouped Data Analysis	
Statistical Analysis	

TABLE OF CONTENTS

	PAGE
5. BROAD STREET SUBWAY - NOISE ASSESSMENT DATA	5-1
5.1 Description of Transit System	5-1
Routes and Service	
Roadbed	
Rail Vehicles	
Stations	
5.2 Noise Assessment Data	5-9
5.2.1 Wayside Community	5-13
5.2.2 Station Platform	5-41
5.2.3 Vehicle Interior	5-105
6. BROAD STREET SUBWAY - TRANSIT SYSTEM LINE SUMMARY	6-1
7. MARKET-FRANKFORD LINE - NOISE ASSESSMENT DATA	7-1
7.1 Description of Transit System	7-1
Routes and Service	
Roadbed	
Rail Vehicles	
Stations	
7.2 Noise Assessment Data	7-7
7.2.1 Wayside Community	7-11
7.2.2 Station Platform	7-59
7.2.3 Vehicle Interior	7-147
8. MARKET-FRANKFORD LINE - TRANSIT SYSTEM LINE SUMMARY	8-1
9. REFERENCES	9-1
 APPENDICES	
A. A STATISTICAL ANALYSIS OF SEPTA BROAD STREET SUBWAY STATION NOISE	A-1
B. REPORT OF INVENTIONS	B-1

LIST OF FIGURES

FIGURE		PAGE
4.1	Typical Data Acquisition System	4-2
4.2	Block Diagram of Noise Measurement Instrumentation	4-3
4.3	Data Analysis Equipment Schematic	4-6
4.4	Method of Determining L_{Amax} and T_5	4-8
4.5	Spectral Analysis Equipment	4-9
4.6	System Noise Level Averages & Characteristics - Analysis Equipment	4-13
5.1	SEPTA Broad Street Subway System Schematic	5-2
5.2	Broad Street Subway Car - 1928 Brill	5-5
5.3	Broad Street Subway Car - 1938 Pressed Steel	5-6
5.4	Ridge Avenue Spur Car - 1936 Brill	5-7
5.5	Wayside Measurements Location - 10th and Nedro (Fern Rock)	5-15
5.6	Statistical Distribution - Community - Fern Rock 25m Day	5-17
5.7	Statistical Distribution - Community - Fern Rock 25m Rush	5-18
5.8	Statistical Distribution - Community - Fern Rock 25m Evening	5-19
5.9	Statistical Distribution - Community - Fern Rock 25m Night	5-20
5.10	Statistical Distribution - Community - Fern Rock 60m Day	5-21
5.11	Statistical Distribution - Community - Fern Rock 120m Day	5-22
5.12	Typical Noise Time History - 10th and Nedro (Fern Rock)	5-23
5.13	Wayside Measurement Location - 11th Street and Nedro (Fern Rock)	5-25
5.14	Statistical Distribution - Community - 11th Street - 15m Day	5-27
5.15	Statistical Distribution - Community - 11th Street - 15m Rush	5-28
5.16	Statistical Distribution - Community - 11th Street - 15m Evening	5-29
5.17	Statistical Distribution - Community - 11th Street - 15m Night	5-30
5.18	Typical Time History - 11th and Nedro	5-31
5.19	Wayside Measurement Location - Broad and Wyoming	5-33
5.20	Statistical Distribution - Community - Broad and Wyoming - 7.5m Day	5-35
5.21	Statistical Distribution - Community - Broad and Wyoming - 7.5m Rush	5-36
5.22	Statistical Distribution - Community - Broad and Wyoming - 7.5m Evening	5-37
5.23	Statistical Distribution - Community - Broad and Wyoming - 7.5m Night	5-38

LIST OF FIGURES

FIGURE		PAGE
5.24	Typical Time History - Broad and Wyoming - Community	5-39
5.25	Station Platform - Fern Rock	5-43
5.26	Statistical Distribution - Station - Fern Rock - Day	5-45
5.27	Statistical Distribution - Station - Fern Rock - Rush	5-46
5.28	Statistical Distribution - Station - Fern Rock - Evening	5-47
5.29	Statistical Distribution - Station - Fern Rock - Night	5-48
5.30	Typical Time History - Fern Rock Station	5-49
5.31	Station Platform - Susquehanna-Dauphin	5-51
5.32	Statistical Distribution - Station - Susquehanna-Dauphin - Day	5-53
5.33	Statistical Distribution - Station - Susquehanna-Dauphin - Rush	5-54
5.34	Statistical Distribution - Station - Susquehanna-Dauphin - Night	5-55
5.35	Typical Time History - Susquehanna Dauphin	5-56
5.36	Station Platform - Spring Garden	5-59
5.37	Statistical Distribution - Station - Spring Garden - Day (Local Track)	5-61
5.38	Statistical Distribution - Station - Spring Garden - Rush (Local Track)	5-62
5.39	Statistical Distribution - Station - Spring Garden - Night (Local Track)	5-63
5.40	Typical Time History - Spring Garden - Local Track	5-64
5.41	Statistical Distribution - Station - Spring Garden - Day (Express Track)	5-65
5.42	Typical Time History - Spring Garden - Express Track	5-66
5.43	Station Platform - Spring Garden, Broad/Ridge Spur	5-69
5.44	Statistical Distribution - Station - Spring Garden (Broad/Ridge Spur)	5-71
5.45	Typical Time History - Spring Garden, Broad/Ridge Station	5-72
5.46	Station Platform - City Hall	5-75
5.47	Statistical Distribution - Station - City Hall - Day	5-77
5.48	Statistical Distribution - Station - City Hall - Rush	5-78
5.49	Statistical Distribution - Station - City Hall - Evening	5-79
5.50	Statistical Distribution - Station - City Hall - Night	5-80

LIST OF FIGURES

FIGURE		PAGE
5.51	Typical Time History - City Hall	5-81
5.52	Station Platform - Walnut-Locust	5-83
5.53	Statistical Distribution - Station - Walnut-Locust - Day	5-85
5.54	Statistical Distribution - Station - Walnut-Locust - Rush	5-86
5.55	Statistical Distribution - Station - Walnut-Locust - Evening	5-87
5.56	Statistical Distribution - Station - Walnut-Locust - Night	5-88
5.57	Typical Time History - Walnut-Locust Station	5-89
5.58	Station Platform - Snyder Avenue	5-91
5.59	Statistical Distribution - Station - Snyder Avenue - Day	5-93
5.60	Typical Time History - Snyder Avenue Station	5-94
5.61	Station Platform - Pattison Avenue	5-97
5.62	Statistical Distribution - Station - Pattison Avenue - Day	5-99
5.63	Statistical Distribution - Station - Pattison Avenue - Rush	5-100
5.64	Statistical Distribution - Station - Pattison Avenue - Evening	5-101
5.65	Statistical Distribution - Station - Pattison Avenue - Night	5-102
5.66	Typical Time History - Pattison Avenue Station	5-103
5.67	In Car Measurement Locations - SEPTA 1938 Brill Car	5-107
5.68	In Car Measurement Locations - SEPTA 1938 Pressed Steel Car	5-108
5.69	Statistical Distributions - In Car, Center of car Southbound	5-111
5.70	Statistical Distributions - In Car, Center of Car Northbound	5-112
5.71	Statistical Distributions - In Car, Operator's Booth Southbound	5-113
5.72	Statistical Distributions - In Car, Operator's Booth Northbound	5-114
5.73	Typical Time History - Center Car - 1938 Brill Car	5-115
6.1	Broad Street Subway - Track Construction Schematic	6-4
6.2	Station Platform Noise Environments	6-6
6.3	Summary of SEPTA Broad Street Subway Noise Environment	6-8
7.1	SEPTA Market-Frankford Line Schematic	7-2
7.2	1960 Series Budd Car	7-4
7.3	Wayside Measurement Location - 69th Street Terminal	7-13

LIST OF FIGURES

FIGURE		PAGE
7.4	Statistical Distribution - Community - 69th Street - 15m Day	7-15
7.5	Statistical Distribution - Community - 69th Street - 15m Rush	7-16
7.6	Statistical Distribution - Community - 69th Street - 15m Evening	7-17
7.7	Statistical Distribution - Community - 69th Street - 15m Night	7-18
7.8	Typical Time History - 69th Street Terminal - Wayside	7-19
7.9	Millbourne Wayside Measurement Site	7-21
7.10	Statistical Distribution - Community - Millbourne - 15m Day	7-23
7.11	Statistical Distribution - Community - Millbourne - 15m Rush	7-24
7.12	Statistical Distribution - Community - Millbourne - 15m Evening	7-25
7.13	Statistical Distribution - Community - Millbourne - 15m Night	7-26
7.14	Statistical Distribution - Community - Millbourne - 30m Day	7-27
7.15	Statistical Distribution - Community - Millbourne - 60m Day	7-28
7.16	Typical Time History - Millbourne Wayside	7-29
7.17	54th and Market Wayside Measurement Site	7-31
7.18	Statistical Distribution - Community - 54th and Market - 15m Day	7-33
7.19	Statistical Distribution - Community - 54th and Market - 15m Rush	7-34
7.20	Statistical Distribution - Community - 54th and Market - 15m Evening	7-35
7.21	Statistical Distribution - Community - 54th and Market - 15m Night	7-36
7.22	Statistical Distribution - Community - 54th and Market - 60m Day	7-37
7.23	Typical Time History - 54th and Market Wayside	7-38
7.24	York-Dauphin Wayside Measurement Site	7-41
7.25	Statistical Distribution - Community - York-Dauphin - 15m Day	7-43
7.26	Statistical Distribution - Community - York-Dauphin - 15m Rush	7-44
7.27	Statistical Distribution - Community - York-Dauphin - 15m Evening	7-45
7.28	Statistical Distribution - Community - York-Dauphin - 15m Night	7-46
7.29	Statistical Distribution - Community - York-Dauphin - 60m Day	7-47
7.30	Statistical Distribution - Community - York-Dauphin - 120m Day	7-48

LIST OF FIGURES

FIGURE		PAGE
7.31	Typical Time History - York-Dauphin Wayside	7-49
7.32	Somerset Wayside Measurement Site	7-51
7.33	Statistical Distribution - Community - Somerset - 15m Day	7-53
7.34	Statistical Distribution - Community - Somerset - 15m Rush	7-54
7.35	Statistical Distribution - Community - Somerset - 15m Evening	7-55
7.36	Statistical Distribution - Community - Somerset - 15m Night	7-56
7.37	Typical Time History - Somerset Wayside	7-57
7.38	69th Street Terminal Station Platform	7-63
7.39	Statistical Distribution - Station - 69th Street - Day	7-65
7.40	Statistical Distribution - Station - 69th Street - Rush	7-66
7.41	Statistical Distribution - Station - 69th Street - Evening	7-67
7.42	Statistical Distribution - Station - 69th Street - Night	7-68
7.43	Typical Time History - 69th Street Station	7-69
7.44	Millbourne Station Platform	7-71
7.45	Statistical Distribution - Station - Millbourne - Day	7-73
7.46	Statistical Distribution - Station - Millbourne - Rush	7-74
7.47	Statistical Distribution - Station - Millbourne - Evening	7-75
7.48	Statistical Distribution - Station - Millbourne - Night	7-76
7.49	Typical Time History - Millbourne Station	7-77
7.50	52nd Street Station Platform	7-79
7.51	Statistical Distribution - Station - 52nd Street - Day	7-81
7.52	Statistical Distribution - Station - 52nd Street - Rush	7-82
7.53	Statistical Distribution - Station - 52nd Street - Evening	7-83
7.54	Statistical Distribution - Station - 52nd Street - Night	7-84
7.55	Typical Time History - 52nd Street Station	7-85
7.56	40th Street Station Platform	7-87
7.57	Statistical Distribution - Station - 40th Street - Day	7-89
7.58	Typical Time History - 40th Street Station	7-90
7.59	34th Street Station Platform	7-93
7.60	Statistical Distribution - Station - 34th Street - Day	7-95
7.61	Typical Time History - 34th Street Station	7-96

LIST OF FIGURES

FIGURE		PAGE
7.62	30th Street Station Platform	7-99
7.63	Statistical Distribution - Station - 30th Street - Day	7-101
7.64	Statistical Distribution - Station - 30th Street - Rush	7-102
7.65	Statistical Distribution - Station - 30th Street - Evening	7-103
7.66	Statistical Distribution - Station - 30th Street - Night	7-104
7.67	Typical Time History - 30th Street Station	7-105
7.68	5th Street Station Platform	7-107
7.69	Statistical Distribution - Station - 5th Street - Day	7-109
7.70	Statistical Distribution - Station - 5th Street - Rush	7-110
7.71	Statistical Distribution - Station - 5th Street - Evening	7-111
7.72	Statistical Distribution - Station - 5th Street - Night	7-112
7.73	Typical Time History - 5th Street Station	7-113
7.74	2nd Street Station Platform	7-115
7.75	Statistical Distribution - Station - 2nd Street - Day	7-117
7.76	Typical Time History - 2nd Street Station	7-118
7.77	Berks Station Platform	7-121
7.78	Statistical Distribution - Station - Berks - Day	7-123
7.79	Statistical Distribution - Station - Berks - Rush	7-124
7.80	Typical Time History - Berks Station	7-125
7.81	York/Dauphin Station Platform	7-127
7.82	Statistical Distribution - Station - York/Dauphin - Day	7-129
7.83	Statistical Distribution - Station - York/Dauphin - Night	7-130
7.84	Typical Time History - York/Dauphin Station	7-131
7.85	Church Street Station Platform	7-133
7.86	Statistical Distribution - Station - Church Street - Day	7-135
7.87	Typical Time History - Church Street Station	7-136
7.88	Bridge Street Station Platform	7-139
7.89	Statistical Distribution - Station - Bridge Street - Day	7-141
7.90	Statistical Distribution - Station - Bridge Street - Rush	7-142
7.91	Statistical Distribution - Station - Bridge Street - Evening	7-143
7.92	Statistical Distribution - Station - Bridge Street - Night	7-144

LIST OF FIGURES

FIGURE		PAGE
7.93	Typical Time History - Bridge Street Station	7-145
7.94	SEPTA 1960 Budd Car Interior Measurement Locations	7-149
7.95	Statistical Distribution - Car Interior - Eastbound Single - Center	7-152
7.96	Statistical Distribution - Car Interior - Eastbound Single - Operator's Booth	7-153
7.97	Statistical Distribution - Car Interior - Westbound Single - Center	7-154
7.98	Statistical Distribution - Car Interior - Westbound Single - Operator's Booth	7-155
7.99	Statistical Distribution - Car Interior - Eastbound Double - Center	7-156
7.100	Statistical Distribution - Car Interior - Eastbound Double - Operator's Booth	7-157
7.101	Statistical Distribution - Car Interior - Westbound Double - Center	7-158
7.102	Statistical Distribution - Car Interior - Westbound Double - Operator's Booth	7-159
7.103	Typical Time Histories - Car Interior	7-160
8.1	Track Schematic - Market/Frankford Subway - Elevated	8-4
8.2	Summary of Noise Environment - Market/Frankford Line	8-7

	LIST OF TABLES	PAGE
1.1	Average Maximum A-Weighted Sound Level Distributions	1-2
3.1	Community Noise Survey Strategy	3-2
5.1	Broad Street Subway Station Configuration	5-4
5.2	Explanation of Measurement Result Summary Tables	5-10
5.3	Summary of Measurement Results - 10th and Nedro (Fern Rock) Community	5-16
5.4	Summary of Measurement Results - 11th and Nedro (Fern Rock) Community	5-26
5.5	Summary of Measurement Results - Broad and Wyoming	5-34
5.6	Station Selection Rationale	5-41
5.7	Summary of Measurement Results - Fern Rock Station	5-44
5.8	Summary of Measurement Results - Susquehanna-Dauphin Station	5-52
5.9	Summary of Measurement Results - Spring Garden Station	5-60
5.10	Summary of Measurement Results - Spring Garden Broad/Ridge Spur Station	5-70
5.11	Summary of Measurement Results - City Hall Station	5-76
5.12	Summary of Measurement Results - Walnut-Locust Station	5-84
5.13	Summary of Measurement Results - Snyder Avenue Station	5-92
5.14	Summary of Measurement Results - Pattison Avenue Station	5-98
5.15	Summary of Measurement Results - 1928 Brill Car/1938 Pressed Steel Interior	5-109
5.16	In Car Noise Plateau Levels -1928 Brill Car	5-110
6.1	Generalized Summary and Input for L_{dn} Calculations	6-2
6.2	Noise Measurement Summary Broad Street Subway	6-3
7.1	Station Configurations - Market/Frankford Line	7-5
7.2	Explanation of Measurement Result Summary Table	7-8
7.3	Summary of Measurement Results - 69th Street Community	7-14
7.4	Summary of Measurement Results - Millbourne Community	7-22
7.5	Summary of Measurement Results - 54th and Market Community	7-32
7.6	Summary of Measurement Results - York-Dauphin Community	7-42
7.7	Summary of Measurement Results - Somerset Community	7-52
7.8	Platform Selection Rationale	7-59
7.9	Summary of Measurement Results - 69th Street Station	7-64

LIST OF TABLES

		PAGE
7.10	Summary of Measurement Results - Millbourne Station	7-72
7.11	Summary of Measurement Results - 52nd Street Station	7-80
7.12	Summary of Measurement Results - 40th Street Station	7-88
7.13	Summary of Measurement Results - 34th Street Station	7-94
7.14	Summary of Measurement Results - 30th Street Station	7-100
7.15	Summary of Measurement Results - 5th Street Station	7-108
7.16	Summary of Measurement Results - 2nd Street Station	7-116
7.17	Summary of Measurement Results - Berks Street Station	7-122
7.18	Summary of Measurement Results - York/Dauphin Station	7-128
7.19	Summary of Measurement Results - Church Street Station	7-134
7.20	Summary of Measurement Results - Bridge Street Station	7-140
7.21	In Car Noise Plateau Levels - Budd Cars	7-150
7.22	Summary of Measurement Results - 1960 Budd Cars - Interior	7-151
8.1	Generalized Operation Summary and Input for Ldn Calculations	8-2
8.2	Noise Measurement Summary - Daytime	8-3
8.3	In Car noise Statistical Summary	8-6

LIST OF DEFINITIONS

L_A (Max) - Maximum A-weighted sound pressure level for a given noise event, measured in dBA.

AL_i - Instantaneous A-weighted sound pressure level for sample "i", measured in dBA.

L_{eq} - Equivalent Sound Level - in dBA.

$$L_{eq} = 10 \log \left[\frac{\sum_{i=1}^n \text{antilog} (AL_i/10)}{n} \right]$$

n - Number of samples of AL in a specified time period.

L_{dn} - Day-Night Equivalent Sound Level-in dBA.

$$L_{dn} = 10 \log \left[\frac{\sum_{i=1}^n 10^{(L_{eq}/10)} W_i \cdot T_i}{24} \right]$$

W_i - Time of day weighting factor

$$W_i (0700-2200) = 1$$

$$W_i (2200-0700) = 10$$

T_i - Time interval for "i"-th period

L_R - L_A (Max) + 10 log T_5 , in dBA

T_5 - Duration between the 5 dBA-down-from- L_A (Max) points measured in seconds

L_X - The A-weighted sound level equaled or exceeded X% of the time-in dBA.

SENEL - Single Event Noise Exposure Level, measured in dBA.

$$SENEL = 10 \log \left[\sum_{i=1}^n \text{antilog} (AL_i/10) \cdot \Delta t \right]$$

Δt - Effective duration of noise event, measured in seconds.

CNEL - Community Noise Equivalent Level-in dB.

$$CNEL = 10 \log \left[\frac{\sum_{i=1}^n W_i \cdot \text{antilog} (SENEL_n/10)}{86400} \right]$$

W'_i - Time of day weighting factor

$$W'_i (0700-1900) = 1$$

$$W'_i (1900-2200) = \sqrt{10}$$

$$W'_i (2200-0700) = 10$$

Hz - Frequency, measured in cycles per second

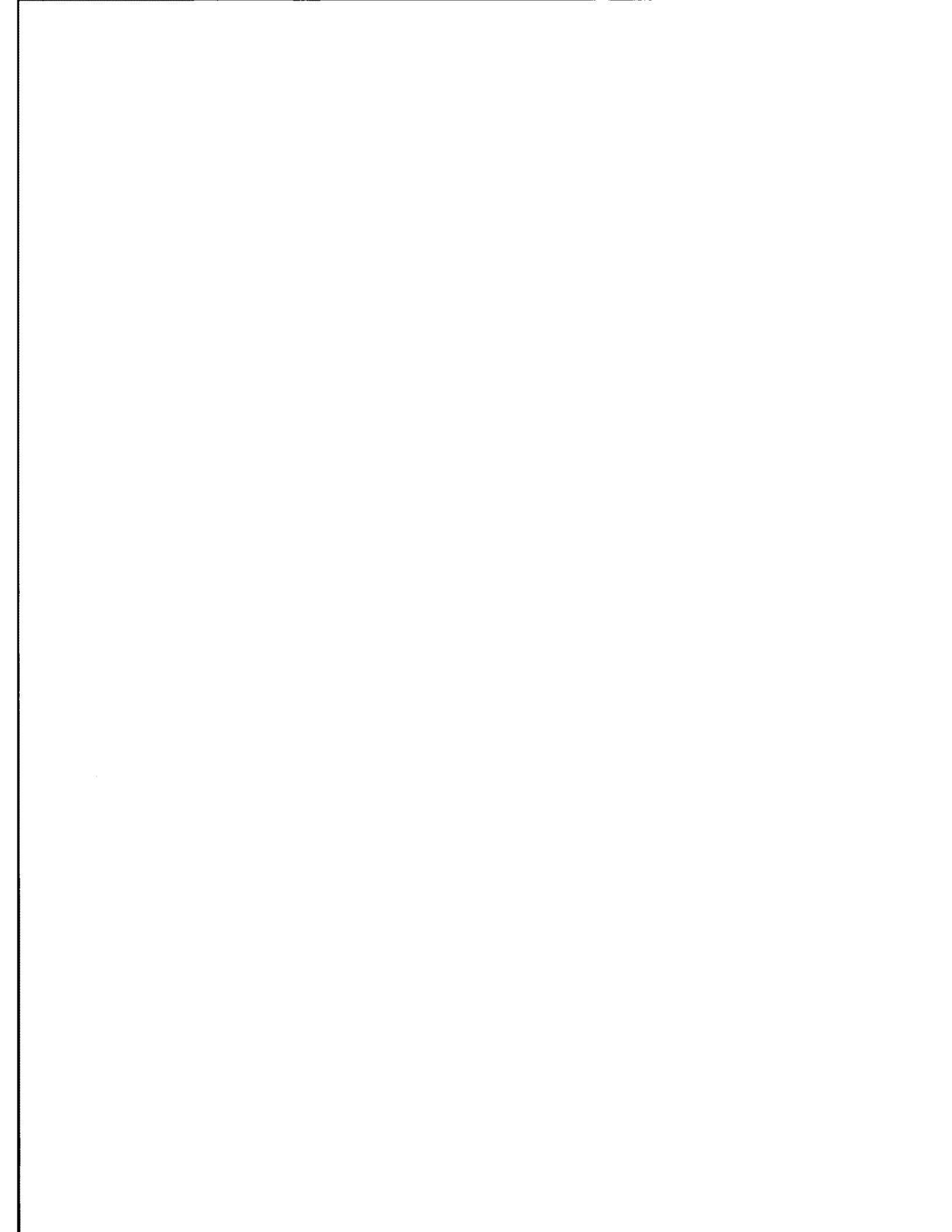

1. SUMMARY

The Urban Mass Transportation Administration is supporting a program under the technical administration of the Transportation Systems Center to determine the noise climate of the major rapid rail transit systems in the United States, and to assess the impact of that noise on patrons, employees and wayside communities. The results are to be used in determining approaches and associated costs to reach various selected noise abatement levels. The methodology, measurement techniques and analysis are common for all systems studied so that results can be compared. Noise assessment reports, covering each of the major rapid transit systems, are being issued as a series.

This report describes the two urban rail transit lines of the Southeastern Pennsylvania Transportation Authority (SEPTA), the Broad Street Subway and the Market-Frankford Elevated Line. The Broad Street Subway consists of approximately 9.8 miles of two-way revenue track of which 9.3 are subway, and 0.5 are at-grade trackage. The Market-Frankford Line consists of 12.7 miles of two-way revenue track of which 8.3 are elevated, 3.8 underground, and 0.6 at-grade trackage. The rail is jointed along all of both lines except for a small section of the Market-Frankford Line where new welded rail is being installed.

Rail vehicles in use on the Broad Street Subway were built in 1928 and 1938, and those in use on the Market-Frankford Line in 1960. There is no acoustical treatment of the cars.

Noise assessment was of three general types:

1. Community noise
2. Station noise
3. In-Car noise.

Conditions for each type of measurement were standardized as far as possible for supporting later analysis and for ensuring comparability of results with those of other systems. In addition to the acoustic data channels, one channel of a tape track was provided for comments by the measurement observer to assist in the later description or explanation of

the noise environment and phenomena.

Noise recordings were made with standardized instrumentation having a flat (unweighted) frequency response characteristic. Field calibration was performed during the data acquisition. In addition equipment was periodically calibrated using Class 2 NBS standards.

Detailed results are too extensive to show in this summary. However, the following estimates in dBA, were determined for the two urban rail lines of the SEPTA system (See Table 1.1).

TABLE 1.1 AVERAGE MAXIMUM A-WEIGHTED SOUND LEVEL DISTRIBUTIONS FOR THE BROAD ST. SUBWAY/MARKET FRANKFORD LINES

	MAXIMUM SOUND LEVELS (dBA)					
	70 to 74	75 to 79	80 to 84	85 to 89	90 to 94	95 to 99
Car Interior (Percent of Route Mileage)*	0/4	0/52	0/22	15/20	73/2	12/0
Wayside at 15m (50 ft) Distance (Percent of Above Ground Route Mileage)	0/0	100/6	0/2	0/90	0/0	0/2
Station Platform (Percent of Stations)	0/0	0/0	0/7	22/61	48/3	30/29

*Average of Single and Double Cars for Market-Frankford Line

2. INTRODUCTION

2.1 Program Scope

This report describes the noise climate of the Southeastern Pennsylvania Transportation Authority (SEPTA). The work is part of a noise assessment study by this contractor which included SEPTA, the Greater Cleveland Regional Transit Authority (RTA), formerly the Cleveland Transit System (CTS), the Port Authority Transit Corporation (PATCO), and the San Francisco Bay Area Rapid Transit (BART) System. Similar assessments have been undertaken by separate contractors of the Chicago Transit Authority (CTA), the New York City Transit Authority (NYCTA), and the Port Authority Trans-Hudson (PATH). The noise assessments for the BART, RTA, and PATCO systems, as well as for those systems considered by other contractors, are reported in other documents of this series.

This work was done as part of an Urban Mass Transportation Administration (UMTA) program to assess the noise produced by various U.S. urban rail transit operations and to appraise methods and costs for reduction of such noise. The characterization of the noise climate of each rail transit system, carried out in a uniform manner, provides data to assist in determining UMTA priorities and funding decisions. The noise assessment activity has three elements:

1. Noise climate assessment.
2. Consideration of abatement technique options.
3. Cost estimation for abatement to specified noise levels.

Specifically, this activity allows noise level comparisons (a) of systems, (b) of different types of equipment or track structure on the same system, and (c) before and after noise control actions. It also provides data pertinent to the establishment of possible regulatory actions to control noise levels.

The specific purpose of the work reported in this volume was to measure and otherwise describe the noise climate of the SEPTA system as well as to describe the measurement and analysis methodology used.

The noise climate and associated information includes descriptions of the various sources and paths of noise, and their relative contribution to the noise climate at the point of measurement.

Each of the two SEPTA lines was surveyed and classified by vehicle type, station type, roadbed construction type, and type of wayside land use. Representative measurement locations were then defined for each of these categories as well as for other locations with specified singularities (unique noise characteristics). This

approach, common to all assessments, is based on the noise assessment of the Massachusetts Bay Transportation Authority (MBTA), (Reference 1), which served as a pilot study for these later assessments. Consistency of results were achieved through the use of a standardized noise measurement and data reduction process. This process was successfully validated through "round robin" tests in which the assessment teams made simultaneous measurements of noise from Massachusetts Bay Transportation Authority trains and, without communication between teams, reported the resulting reduced data. The findings of all teams correlated well.

For the purposes of this assessment activity, it is adequate to measure a limited, but statistically sufficient number of vehicles, stations, and community sites, selected to cover the major construction and operating features of the system.

The present data describe the existing system noise climate and permits a first order estimate of abatement techniques and associated costs to satisfy reduced noise level criteria. When a preliminary investigation such as this reveals noise problems, and a decision is made to proceed with their solution, more detailed measurements and analyses must be made. Normally, this would include detailed diagnostic measurements to identify the dominant sources and paths for engineering design of site-specific noise control treatments.

2.2 Reader's Guide to Report

The general measurement methodology, including sampling strategy for measurement site selections, site conditions, microphone positions, and measurement procedures for community, station, and in-car noise assessments, are presented in Section 3. Details of the instrumentation and data analysis procedures are given in Section 4.

Sections 5 and 7 include an overview of the SEPTA system (Sections 5.1 and 7.1) followed by a detailed description of the measurement results. The principal findings for Sections 5 and 7 are summarized in Sections 6 and 8, respectively.

3. GENERAL MEASUREMENT METHODOLOGY

3.1 Community Noise

Sampling Strategy - The purpose of this survey was to determine noise levels in the wayside community caused by train operations as well as other community background noise. Measurements of noise in the community have been categorized as shown in Table 3.1 by source, path and receiver. In each case, the variable which affects either the physical noise during generation, propagation, or reception, or the response of the listener to that noise, have been itemized.

For each transit line in this study, the type of railcar used was typical of the system as was the rail type and quality. However, a wide variation in roadbed type, background noise, conditioning of residents to noise, and land usage was noted.

Except for areas where wheel screech, rail joint noise or other singularities prevailed, the sites were selected from operational characteristics of the transit systems. Thus, locations were chosen at the wayside where the trains were operating near normal full speed as well as decelerating and accelerating near stations.

Noise measurements considering all the variables shown in Table 3.1 would be not only costly and time-consuming, but also unnecessary to adequately describe the community noise. Site selection was based on the following parameters:

Type of Roadbed Support

- (1) Aerial Structure
- (2) At-grade
- (3) Underground
- (4) Other sites with singularities

Building Construction Type

- (1) Residential
- (2) Commercial

The measuring microphone or sound level meter for all types of transit structures was 1.6m (5.25 ft) above the ground. This was also the case near aerial structure. Previous measurement on BART* indicated that for the type of structure present on that system, no significant difference existed between noise levels at 1.5m (5 ft) above grade and 9.1m (29.9 ft) above grade, 15m (50 ft) from the near track centerline.

* S.L. Wolfe, H.J. Saurenman, P.Y.N Lee, "Noise Assessment of the Bay Area Rapid Transit System," UMTA-MA-06-0025-78-10, October 1978.

TABLE 3.1. COMMUNITY NOISE SURVEY STRATEGY

Sound Source Parameters

Car

Type, No. Cars, Wheel Quality, Truck Type

Rail Type

Jointed, Welded, Surface Roughness, Type of Fastener

Track Construction

Tangent, Curve

Sound Path Parameters

Roadbed Type

Open-cut (Concrete, Grassy), At-grade, Elevated
Structure (Steel, Concrete), Underground

Terrain Attenuation

Housing Density, Terrain Type

Sound Receiver Parameters

Background Noise

Time of Day (Waking/Sleeping)

Conditioning of Residents to Noise

Land Use

Residential, Commercial

Conditions at Measurement Site - The measurement site was chosen such that no obstacles were in the vicinity of the microphone to disturb the sound field. Meteorological conditions such as temperature and wind were noted and no measurements were made in winds above 7m/sec (23 ft/sec). Microphones were located no closer than 2m (6.6 ft) from any reflecting surface (other than the ground). Photographs of each measurement site were taken.

Microphone Positions - The basic distance for measurement of noise for all wayside measurements was 15m (50 ft) with alternate distances of 7.5m, 30m, 60m (25, 100 and 200 ft respectively) selected where the 15m distance was not achievable.

The microphone and windscreens were oriented vertically at a distance of 1.6m (5.25 ft) above local ground level for all measurements.

Measurement Procedure - Measurement procedures and practices as defined in International Standard ISO-3095-1975(E) in draft form at the time of the noise measurements, "Acoustics - Measurement of Noise Emitted by RAILSOUND VEHICLES," were used as a guide for the measurement program. A calibration tone was recorded on each tape track just prior to and immediately following the measurement program to insure that a valid sample of data had been obtained. A sound level meter also was employed frequently as a verification measurement system. Recorder gain settings were selected to provide optimum dynamic range coverage.

For each train passby, additional information such as vehicle identification number and wheel condition, or specific noise sources whether or not they were related to the transit train, was recorded. In general, 30-minute recordings were made at each microphone location four times during a normal day and included measurements during daytime off-peak service (10 a.m. to 2 p.m.), rush hour (4 p.m. to 6 p.m.), evening (7 p.m. to 10 p.m.), and night (11 p.m. to 4 a.m.) to obtain sufficient information to calculate day-night levels, L_{dn} .

It was also necessary to establish the number of train passbys required to be included in the data sample such that future reductions of system noise of 5 dBA or more could be detected and whether the reductions would be significant for a 95% confidence level. The methodology describing this investigation is presented in detail in Appendix A. In this appendix it has been shown that a sample size of 4 trains is adequate to detect a reduction in system noise level. Based on daytime headways of 6-7½ minutes between trains for each of the systems surveyed, a 30 minute recording interval was then selected for a sample. This was then standardized for each time period throughout the day. It was generally observed that during this period, six trains in each direction passed by the microphone location.

No attempt was made to operate the propulsion system with the car on jacks (spin test) to determine the contribution of motor and gearbox noise. This should be performed in any future study where noise reduction of an existing car is contemplated. Although a complete diagnostic study of the data was not performed, sufficient information was obtained to identify sources which contribute to the car signature in the community.

3.2 Station Noise

Sampling Strategy - Station platform noise measurements were intended to assess the noise environment to which the transit system patrons are exposed while entering and leaving trains at a station platform or while waiting for trains, and to determine the exposure of employees in ticket booths due to train passage. Measurements of noise in transit stations were categorized by station platform layout (i.e., center platform, side platform) and roadbed category (i.e., elevated, at-grade, underground, freeway median).

Conditions at Measurement Site - The microphone locations were chosen so that no permanent obstacles were present near the microphone. The platform locations selected were open visually and acoustically to all tracks at that station so that noise of all trains had some direct-incident waves arriving at the microphone. Except for rush-hour measurement periods, shielding at mid-platform locations by patrons was minimal. Meteorological conditions such as temperature and wind were noted and no measurements were made in winds above 7m/sec (23 ft/sec). Photographs of each measurement site were taken.

Microphone Positions - The noise measurement locations were 1.6m (5.25 ft) above the platform level in the middle of a stopped train and at the end of a stopped train at a distance of 2m (6.6 ft) or one-half the platform width, whichever was smaller, from the platform edge. The microphone was oriented vertically with a wind-screen attached.

Measurement Procedure - Procedures for measurement of noise levels on station platforms generally follow those outlined for community noise recordings. The 30 minute sampling time provided sufficient passings of trains to achieve statistical confidence levels as described in Appendix A.

3.3 Vehicle Interior Noise

Sampling Strategy - Measurements of noise within the transit vehicle were made to document the acoustic environment which patrons and operating personnel experience under typical service conditions. Continuous recordings were made in the second car of a multicar train during round trips. Microphone locations were selected to be representative of the locations of patrons and car operators; that is, a mid-car seated ear level position and an operator's ear level position within the cab area.

Cars selected for measurement were chosen as being typical examples of a specific car model to be surveyed. Cars with wheel flats were avoided when smoothed wheels were normally observed in operation.

Conditions at Measurement Site - Data were taken during non-rush hour conditions so that the area within 1m (3.3 ft) of the microphone was free of riders. This also improved the chances for obtaining data which was clear of conversation and other non-vehicle noise. No effort was made to correct for these sources. The car chosen for recording was free from unusual noise sources. General vehicle conditions and unusual conditions such as slowing for maintenance or construction personnel were noted.

Microphone Positions - The microphone was oriented vertically at the ear level of a seated passenger at a mid-car position 1.2m (4 ft) above the floor. In addition to a mid-car microphone position, noise data was recorded at the train operator's location and over a truck. To standardize with other program measurements, a windscreen was placed over the microphone. Variations in noise throughout the car both longitudinally and vertically were investigated using a sound level meter.

Measured or estimated speeds were reported on the tape at least once between adjacent stations. Each car in the train surveyed was identified by car number, and unusual conditions of any nature in the car were similarly reported.

Measurement Procedure - The procedure for recording vehicle interior noise levels was to calibrate the on-board microphones prior to data recording. Data records were then initiated at a station stop with doors open, and continuous records were taken over the travelled route. An auxiliary channel was used to voice-annotate the data with incidentals such as travel time, station stop, estimated speed, and track identification. At the end of the trip, with car doors open, the data recorder was stopped and the microphone recalibrated.

4. INSTRUMENTATION AND DATA ANALYSIS

4.1 Instrumentation

Data Requirements - The noise of the transit system was recorded on magnetic tape using a flat, or unweighted, frequency response characteristic. Flat response is important in order to avoid peak clipping and harmonic distortion of the recorded noise data. The monitoring meter of the tape recorder was set to fast/quasi-peak to avoid overload, such as might occur during wheel/rail impact noise at joints and crossovers.

Noise data has been summarized in tabular and graphic format in a standard manner so that comparisons may be made among measurements for each test condition or among different transit systems.

Data Acquisition System - The prime data acquisition systems (illustrated in Figures 4.1 and 4.2) consisted of Bruel and Kjaer one-half inch and one-inch microphone cartridges and cathode followers, either battery-powered or driven from a power supply integral to the magnetic tape recorders. These microphones, in addition to their normal protection grids, were fitted with wind-screens for both interior and exterior noise measurements. These were spherical, open cell foam covers.

The output of the microphones was tape recorded in the direct mode (amplitude modulation) on portable Kudelski tape recorders, either Nagra Model III for single-channel, or Nagra IV SJ for dual-channel data acquisition. The tape recorder was battery-operated and run at a tape speed covering the frequency range of interest.

To supplement laboratory calibrations, field equipment checks were made using Bruel and Kjaer Sound Level Calibrators for single frequency, single level calibrations. This was done prior to the start and after the completion of any measurements recorded on each tape reel with occasional in-between calibrations if the measurements extended over a period of hours on any one tape reel.

The data recorded on magnetic tape was also checked for fidelity by the simultaneous use of headsets on the output of the tape recorders while data was in the process of being recorded. Where this was not feasible (for example, when the acoustic environment was too high to aurally separate the headphone signal from the surrounding environment) the built-in loudspeaker of the tape

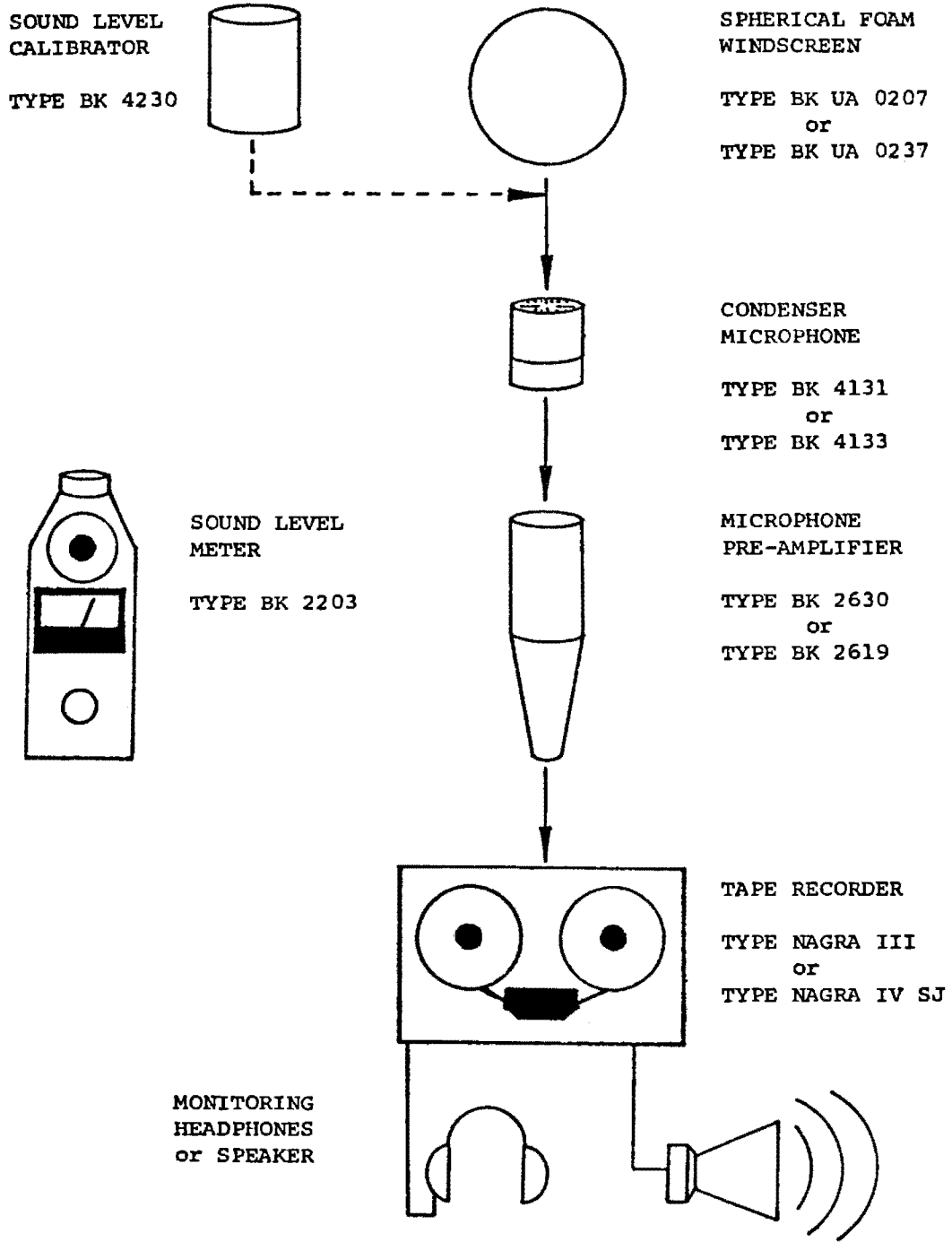

FIGURE 4.1. TYPICAL DATA ACQUISITION SYSTEM

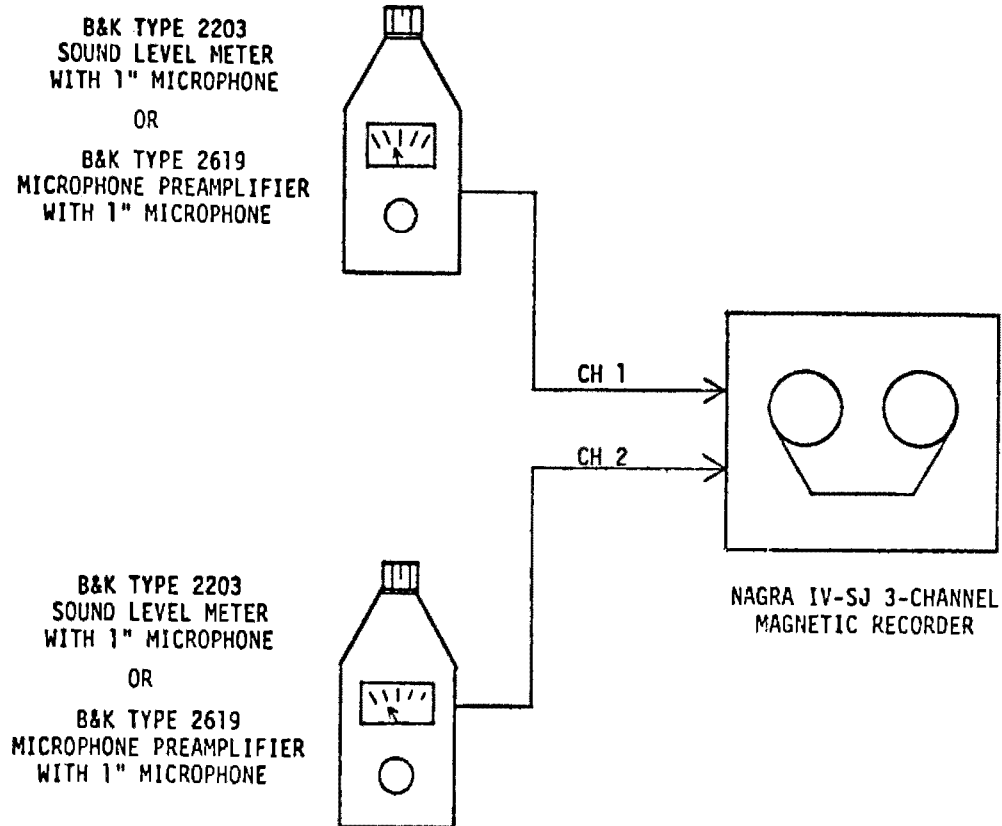

FIGURE 4.2. BLOCK DIAGRAM OF NOISE MEASUREMENT INSTRUMENTATION

recorder was used in a less noisy setting to verify the correctness and fidelity of the noise data, immediately after acquiring the data.

Tape recorder gain settings were optimized for maximum signal-to-noise ratio or dynamic range with the aid of a Bruel and Kjaer sound level meter Type 2203. This is a general purpose sound level meter with characteristics as specified by ANSI Standard S1.4-1971.

Equipment Calibrations - In addition to the field calibrations performed during the acquisition of the data, microphones, calibrators, tape recorders and analysis equipment were periodically laboratory calibrated using reference instruments and signal generators of the Class 2 type which are traceable to the National Bureau of Standards. In this data analysis, compensation has been included for the effects of using a foam windscreen and a microphone protection grid, corrections for random sound wave incidence for in-car and station platform noise data, and right-angle (90-degree) incidence for community noise data. The individual corrections for tape recorder frequency response and incidence angle relative to the microphone were summed as a function of frequency. These corrections were then applied to the analysis in terms of a weighting network with the same characteristic as the correction curve.

4.2 Data Analysis

Graphic Level Recorder Calibration - Since the data contained in this report will be compared with the acoustical environment of numerous other transit systems, it is important that the levels reported are correct on an absolute basis. It is also important because at some future time this data will form a baseline against which changes in system noise will be measured when improvements have been incorporated. An effort has therefore been made to ensure that the basic noise level data, reported in terms of sound level dBA, is reproducible. The average maximum levels of acoustic events are therefore desired from graphic level recorder traces simulating the "Slow" response of a sound level meter meeting ANSI S1.4-1971 Type 1 accuracy. Equivalence of graphic level recorder response to such a sound level meter accuracy was initially ensured by using the techniques described in a paper by Webster and Farinacci (Reference 2). Subsequently, an alternate and less time-consuming instrument calibration method was adopted when laboratory comparisons indicated that ordinary train and other environmental noises were accurately reproduced. This simpler method consisted of setting the potentiometer range control knob of the graphic level recorder to 40 dB, and the lower limiting frequency knob to 20 Hz. The writing speed knob was then adjusted to give a square corner trace to a 1000 Hz, 400 millivolt step input with the graphic level recorder baseline sensitivity adjusted to give a trace deflection at the 30 dB line on the 50 dB range paper. This test was then repeated at the 40 dB line. The final writing speed knob setting was chosen as the middle writing speed of those settings which met the square corner criterion. Transient noises also were correctly represented with errors not exceeding 2 to 3 dBA.

Individual Event Analysis - Typical acoustical events have been illustrated in a dBA time history format with calibrated amplitude and time axes on a strip-chart. These are annotated to illustrate special, as well as expected, acoustic events such as wheel squeal, door closings, etc.

Figure 4.3 illustrates the basic data reduction equipment in schematic form. Specifically, the typical events illustrated on the strip chart recordings are:

- Community Noise: Passby as a function of distance from track

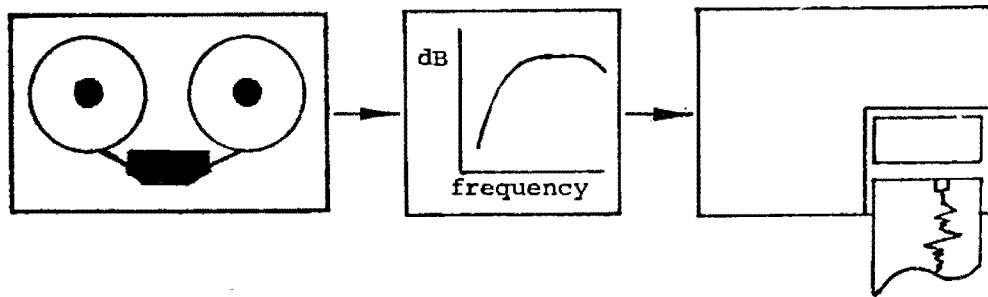

TAPE RECORDER
PLAYBACK

TYPE NAGRA III
or
TYPE NAGRA IV SJ

dB (A)
WEIGHTING
NETWORK

TYPE BK 2112
or
TYPE GR 1921

GRAPHIC LEVEL
RECORDER

TYPE BK 2305

FIGURE 4.3. DATA ANALYSIS EQUIPMENT SCHEMATIC FOR INDIVIDUAL EVENT ANALYSIS

- o Station Noise: Passby
 Train Arrival
 Train Departure
 Train Stopped

- o In-Car Noise: Acceleration
 Steady Speed
 Deceleration
 Special Noises

A-weighted time histories of the above types of noise events are used to determine both the Average Maximum Level $L_A(\text{Max})$ and the duration (T) in seconds of the noise event measured 5 dBA below the $L_A(\text{Max})$. The duration is then used to calculate L_R :

$$L_R = L_A(\text{Max}) + 10 \log T_5 \quad \text{dBA}$$

where:

$L_A(\text{Max})$ = maximum A-weighted sound level for a given noise event

T_5 = duration in seconds of the 5 dB-down points from $L_A(\text{Max})$

L_R is, in effect, an approximation to SENEL, the Single Event Noise Exposure Level used in computing the Community Noise Equivalent Level (CNEL). L_R was suggested by Schultz (Reference 3) and has been applied to urban rail transit vehicle noise as a measure of the total sound energy contained in a discrete noise event as measured at a standard receiver location. L_R has been applied to data measured as part of this program on station platforms and at community wayside locations. Figure 4.4 illustrates this method of determining L_R and also indicates the smoothed curve faired through fluctuating data.

Special noises noted may be specific to a particular site, illustrations of train squeal, pure tones from equipment, tunnel section, wheel impact at rail joints, turnouts and crossovers, car banging due to hunting, flange rubbing, etc. The equipment illustrated in Figure 4.5 was utilized for the documentation of singular spectral characteristics with either fixed bandwidth or fixed percentage bandwidth frequency analyzers.

Grouped Data Analysis - In order to assess the statistical significance and the level of confidence which can be expected from the results of this measurement program, a detailed statistical analysis was performed of the noise data encountered at one of

COMMUNITY
WAYSIDE

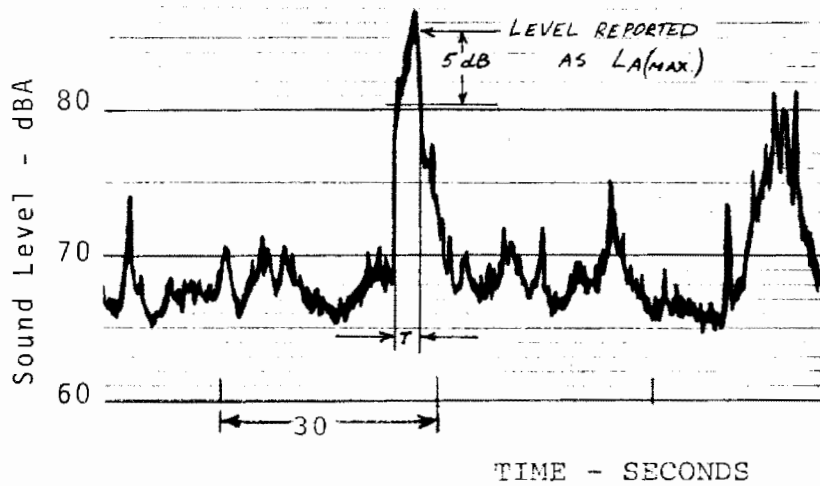

STATION
PLATFORM

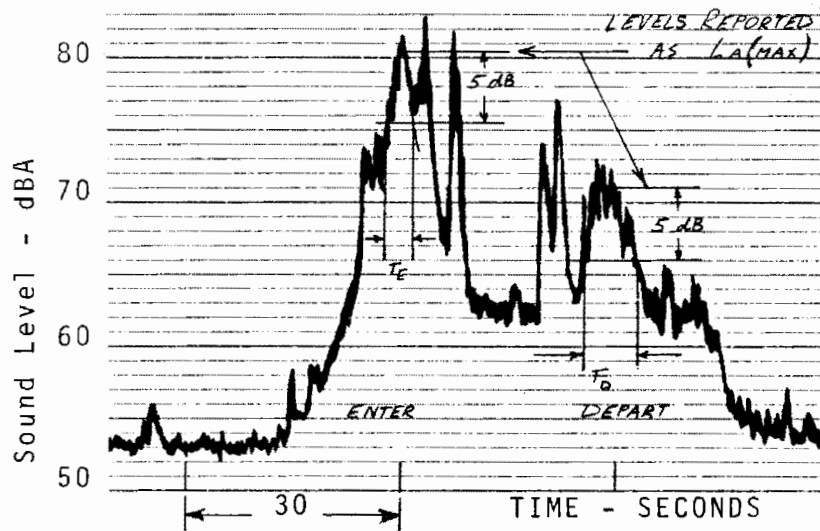

IN-CAR

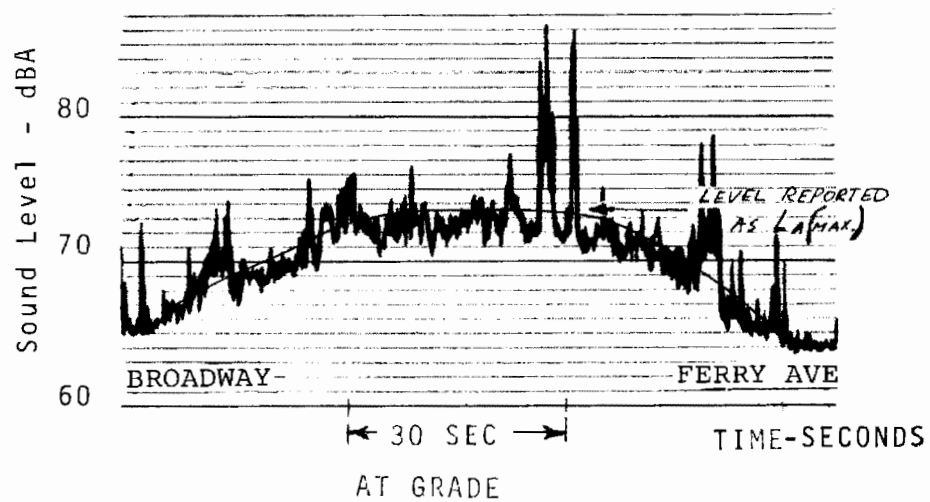

FIGURE 4.4. METHOD OF DETERMINING $L_A(\text{Max})$ AND T_5

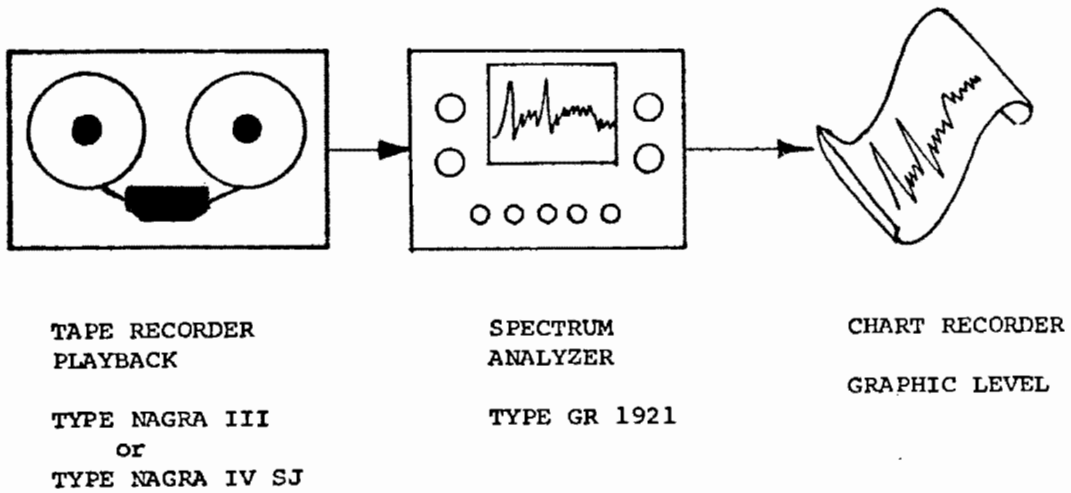

FIGURE 4-5. SPECTRAL ANALYSIS EQUIPMENT SCHEMATIC FOR SITE SPECIFIC NOISE SINGULARITIES

Philadelphia's subway station platforms. This analysis (detailed in Appendix A) established that in order for a future 5 dBA reduction in train noise level to be significant statistically with a 95-percent confidence level and detectable considering normal data scatter, a sample of from four to six train passbys was necessary. This criterion was generally met at all measuring locations and times of day with the exception of nighttime when reduced transit system activity did not permit a sufficient data sample. Based on the assumption that the noise of transit systems other than Philadelphia's have similar statistical properties, the statistical analysis further showed that a standard deviation of less than 2.2 dBA at a particular site indicates a sufficiently small data scatter permitting the detection of a 5 dBA reduction with 95-percent confidence.

The validity of the foregoing conclusions have been further demonstrated by comparing the average $L_A(\text{Max})$ platform noise levels for two SEPTA Broad Street Subway stations. In each case, the specific sites compared were for the two meter microphone positions adjacent to the local southbound tracks. Four-car trains were recorded during the daytime period at the Walnut-Locust and the Spring Garden Stations with the following results:

TRAIN OPERATING CONDITION	$L_A(\text{Max}) \sim \text{dBA}$	
	WALNUT-LOCUST	SPRING GARDEN
ARRIVING, NEAR TRACK	94	92
DEPARTING, NEAR TRACK	86*	92
ARRIVING, FAR TRACK	90	89
DEPARTING, FAR TRACK	88	90
AVERAGE MAXIMUM LEVEL	90	91

* low speed

With one exception, the corresponding noise events are within 2 dBA of each other. The exception is for noise levels of departing trains, operating on the near track at Walnut-Locust which differ by 6 dBA from the corresponding condition at Spring Garden. This reduction in level at Walnut-Locust can be attributed to slower train speeds since immediately south of Walnut-Locust the system changes from a four-track system to a two-track system.

Since both Walnut-Locust and Spring Garden are four-track, two center platform stations with the same architectural features at platform level, the close agreement among the measured noise levels confirms the validity of the detailed statistical analyses at the beginning of the measurement program. This analysis demonstrated the justification for sampling only one station of each type on the system.

The measurement summary tables included for each measurement site reported therefore list the standard deviation for L_A (Max) and L_R for each noise sample recorded. In addition, the cumulative amplitude distributions have been tabulated for L_{99} , L_{90} , L_{50} , L_{10} , and L_1 . The equivalent sound level, L_{eq} , and the Day-Night Level, L_{dn} (for wayside sites), are also presented for each measurement site documented.

The Equivalent Sound Level, L_{eq} , provides a single number measure of the time varying noise, not only of the transit vehicles, but all noise at a specific site. It has been calculated separately for each time period when noise was sampled. It also is used for calculating the Day-Night Levels. L_{eq} has been determined from the following expression:

$$L_{eq} = 10 \text{ Log } \frac{\sum_{i=1}^n \text{antilog } \frac{AL_i}{10}}{n}$$

where:

AL_i is the instantaneous A-level for sample i

n is the number of samples of AL in a specified time period

For the analysis, n was chosen based on a sampling rate of $r = 10/\text{second}$, where $n = rT$ and T is the sample time. Thus, for a 30-minute sample:

$$n = 10 \times 30 \times 60$$

$$n = 18000$$

The Day-Night Equivalent Sound Level (L_{dn}), like the Equivalent Sound Level (L_{eq}), was developed as a single number measure of community noise exposure, but unlike L_{eq} , L_{dn} adds corrections to nighttime noise to account for increased annoyance during the night hours. It has been included in this study to assess the total community noise and has significance in that the

transit system is a contributor to the total noise environment. In some instances, reduction of transit system noise would have to be accompanied by reductions in numerous other community noise sources to arrive at any substantial reduction in L_{dn} . The expression used for calculating L_{dn} is:

$$L_{dn} = 10 \log \left[\frac{\sum_{i=1}^n 10^{L_{eq}/10} \cdot W_i \cdot T_i}{24} \right]$$

where:

L_{eq} is determined as noted above for four time periods throughout the day

W_i is the weighting factor for nighttime annoyance

$$W_i (7 \text{ a.m.} - 10 \text{ p.m.}) = 1$$

$$W_i (10 \text{ p.m.} - 7 \text{ a.m.}) = 10$$

T_i is the time interval for i^{th} period

n is the number of weighted- L_{eq} periods throughout the day

Input for calculating L_{dn} for stations and communities is presented in a later section of this report.

Statistical Analysis - Characteristic noise profiles were also prepared in terms of cumulative sound level amplitude distribution plots and tabular summaries so that L_x statistics can be used to derive additional transit system noise attributes. Figure 4.6 illustrates the analysis equipment used to derive statistical and other environmental noise parameters such as L_{eq} and L_{dn} .

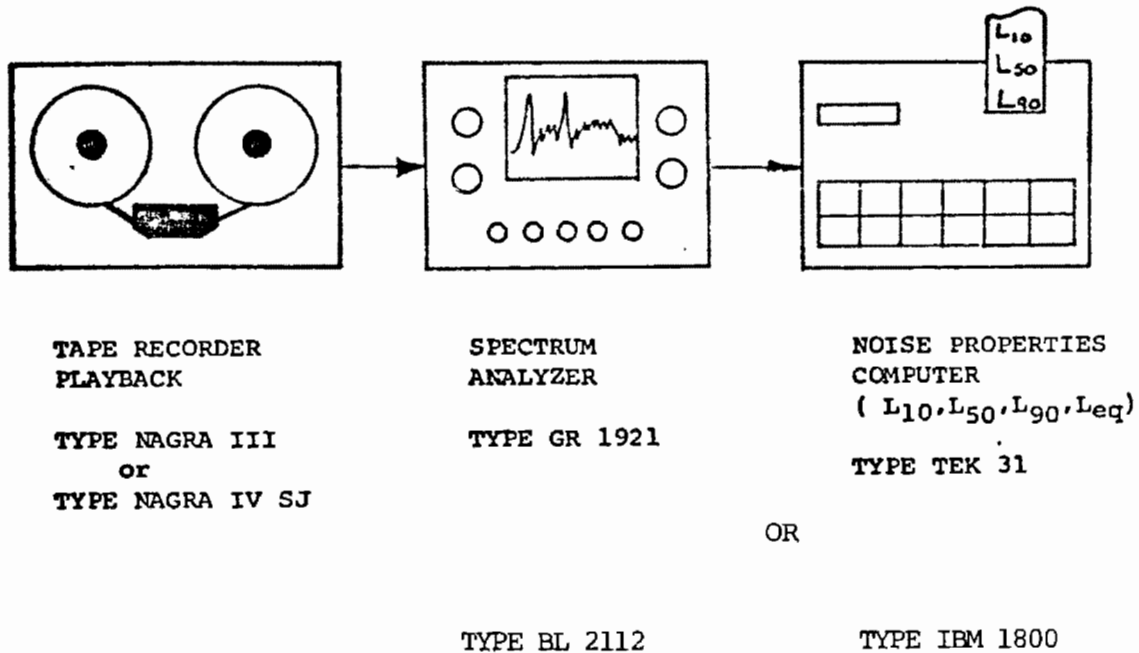
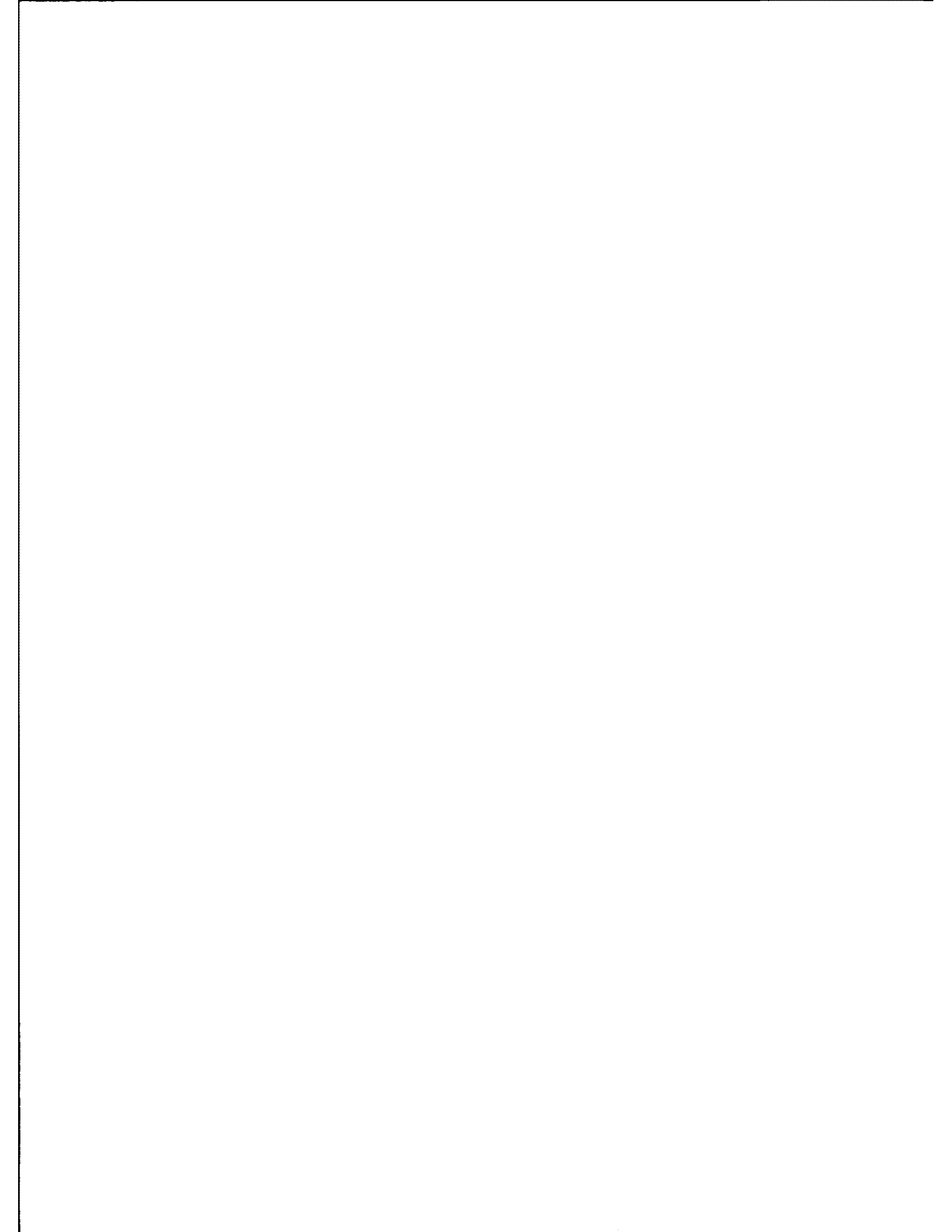

FIGURE 4.6. SYSTEM NOISE LEVEL AVERAGES AND CHARACTERISTICS - ANALYSIS EQUIPMENT



5. BROAD STREET SUBWAY - NOISE ASSESSMENT DATA

5.1 Description of Transit System

Routes and Service - The Broad Street system is a cut-and cover subway located directly under Broad Street with the southern terminal at Pattison Avenue and the northern terminal at Fern Rock Station, covering a distance of 9.8 miles (Figure 5.1). The Fern Rock terminal is the only station on the system which is on-grade. The subway was constructed in 1928 and operates a total of 225 cars. Ridge Avenue spur joins the system at the Fairmount Station and terminates at the Market-Frankford Line at Eighth Street, all underground. This spur, opened in 1936, originally extended across the Benjamin Franklin Bridge to the Broadway terminal in Camden. In 1969, the section between 8th and Market Streets in Philadelphia and Broadway in Camden became an integral part of the Delaware River Port Authority's Port Authority Transit Corporation (Lindenwold Line) and the Broad Street-Ridge Avenue spur was terminated at Eighth Street.

Roadbed - The entire Broad Street Subway system is underground except for the Fern Rock Station, which is on-grade. The roadbed in the underground section from Pattison Avenue to Snyder consists of jointed rail set on tie plates located on resilient pads on concrete roadbed. A drainage ditch covered by steel grating is located between the rails. Between Snyder Avenue and the on-grade section at Fern Rock, the rail is set on short wood ties set in concrete. Every fifth tie is a cross tie.

The on-grade section of track at Fern Rock is ballast and tie construction. The rail has bolted joints for the entire route. The rail surface is smooth with no corrugations observed, and only slight pitting was noted. Except for the tunnel ceiling at the City Hall Station, where perforated steel sheets are used, no noise control treatment is employed.

The Broad Street Line consists almost entirely of tangent track except at City Hall Station, where curved track routes the system around the City Hall Plaza, and also near Fern Rock, where the track turns east under Grange Avenue, leading to the terminal. In both instances, wheel screech occurs.

The underground track sections are ventilated directly to the atmosphere through vent shafts located along the sidewalk at street level. Except for periods of very low street noise, or when an observer stands directly on the grating at street level, subway system noise goes unnoticed in the community.

The Broad Street Line between Pattison Walnut-Locust Station is a two-track system. North of Walnut-Locust it is a four-track system, except between Erie and Olney where only two of the four tracks are in use.

Rail Vehicles - Figures 5.2, 5.3 and 5.4 illustrate the transit cars in use on the Broad Street system. 150 cars were built in 1928 and additional 50 constructed in 1938. The Bridge cars operate only on the Ridge Avenue spur. In the summer, the cars operate with windows as well as the doors between cars open for ventilation. Noise levels while running between stations for these conditions are generally between 90 dBA and 100 dBA.

Power pickup for the car is through a third-rail system entirely.

Stations - Station configurations, as listed in Table 5.1, consist of one center platform between two tracks (7), two center platforms between four tracks (8), and two side platforms outside four tracks (7). All station surfaces visible from the station platforms at underground locations are of hard masonry, or ceramic tile construction. The four-track, two-side platform stations are skip-stop stations for express trains which operate during peak hours. Cashier's booths are generally located one level above the station platform on a mezzanine level, although a limited number of stations do have the booth located at platform level.

The Pattison Avenue terminal is a two level, two track center platform station. Platform width is 40 ft compared with 20 ft (12,6m) for on-line center platform stations. The lower platform level is used only during periods required by the sports arena area which it serves.

Walnut-Locust is an interchange with the Port Authority Transit Corporation's Lindenwold Line which crosses above the Broad Street Line. Passengers exit overhead to mezzanine level and the PATCO Line, and one level above that to Broad Street.

The station at City Hall is an interchange with the Market-Frankford Line and the Subway-Surface Line (PCC cars). The Broad Street subway passes below both of the other systems.

Wheel screech is very evident at this station as the tracks curve around City Hall Plaza. Car operators also sound the horn in this location and the combined noise level may reach 100 dBA. A cashier's booth located one level above the tracks is exposed to this noise although it is occupied only during peak hours.

Fairmount is an interchange station with the Ridge Avenue spur which terminates at Eighth and Market Streets. The construction of the spur is generally similar to the Broad Street Line, but it is a two-track system except at Eighth Street where it single tracks into the terminal station. At Eighth Street, passengers can transfer to the Market-Frankford Line.

Susquehanna-Dauphin Station is a four-track two-side platform configuration typical of eight other stations on the system. Fern Rock Terminal is a two-track, center platform station located on-grade.

TABLE 5.1

BROAD STREET SUBWAY STATION CONFIGURATIONS

Two-Track, One Center Platform

*Pattison Avenue Terminal 88
Oregon
*Snyder 93
Tasker-Morris
Ellsworth-Federal
Lombard-South
*Fern Rock Terminal 86

Four-Track, Two Center Platforms

*Walnut-Locust 92
*City Hall 92
Race-Vine
*Spring Garden 95
Girard
North Philadelphia
Erie Avenue
Olney

Four-Track, Two Side Platforms

Fairmount
Columbia
*Susquehanna 98
Allegheny
Hunting Park
Wyoming
Logan

BROAD-RIDGE SPUR STATION CONFIGURATIONS

Single-Track, Side Platform

Eighth Street

Two-Track, Two Side Platforms

Vine
*Spring Garden 89
Fairmount

Four-Track, Two Side Platforms

Girard

* Survey station

CAR NUMBERS 1 TO 150

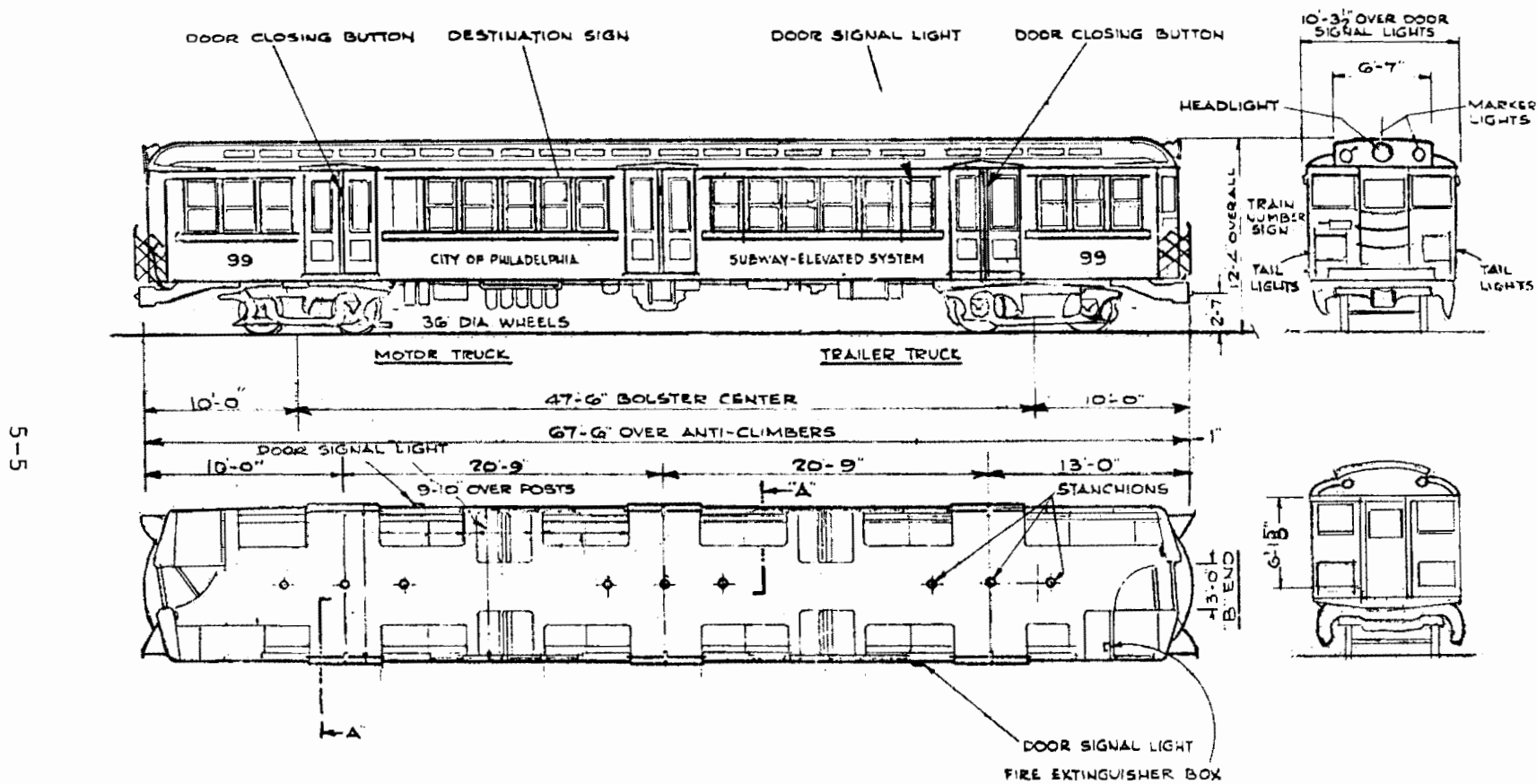

67 SEATED PASSENGERS

FIGURE 5.2 - NORTH BROAD STREET SUBWAY CAR — 1928 BRILL

CAR NUMBERS 151 TO 200

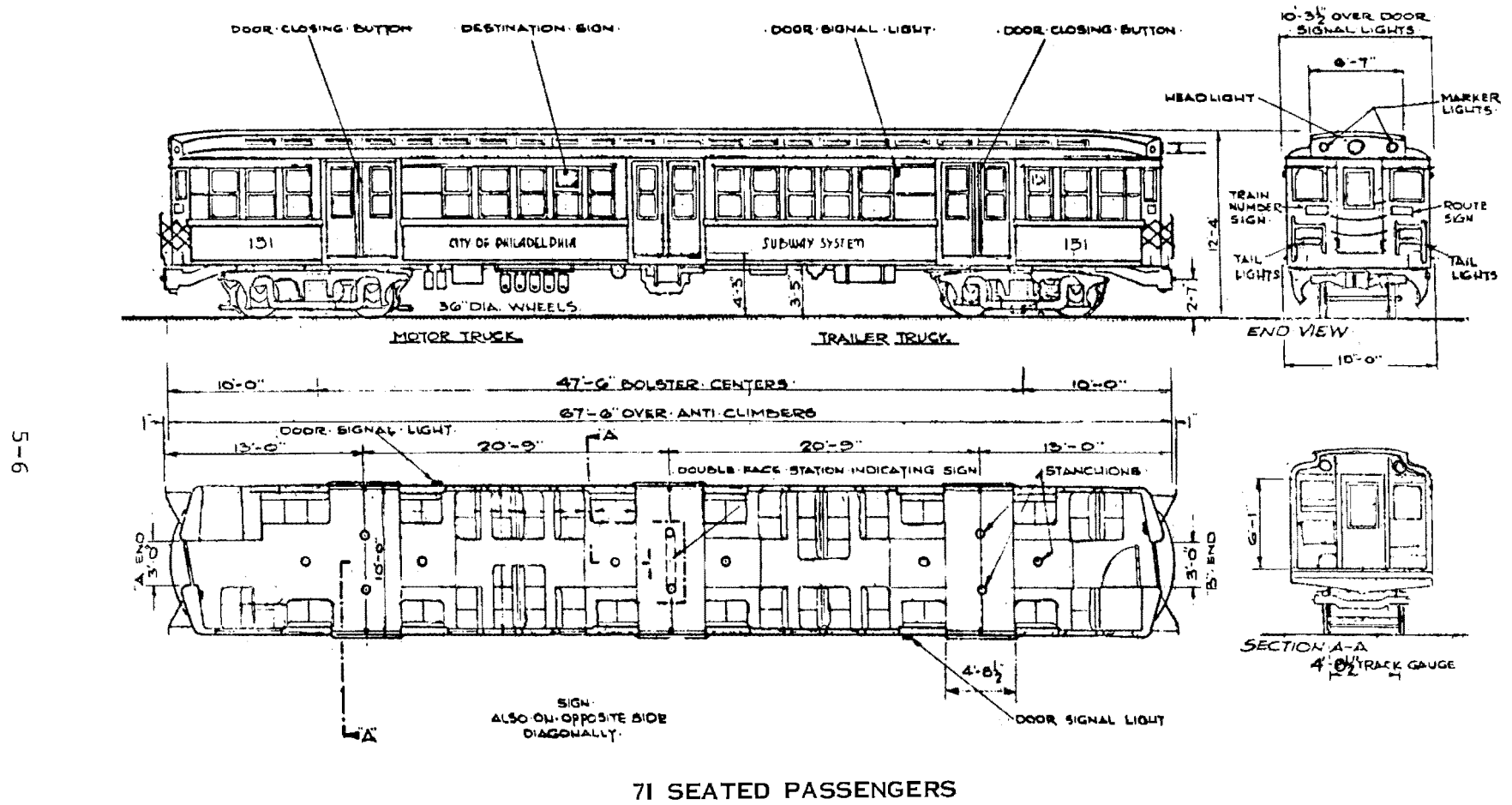
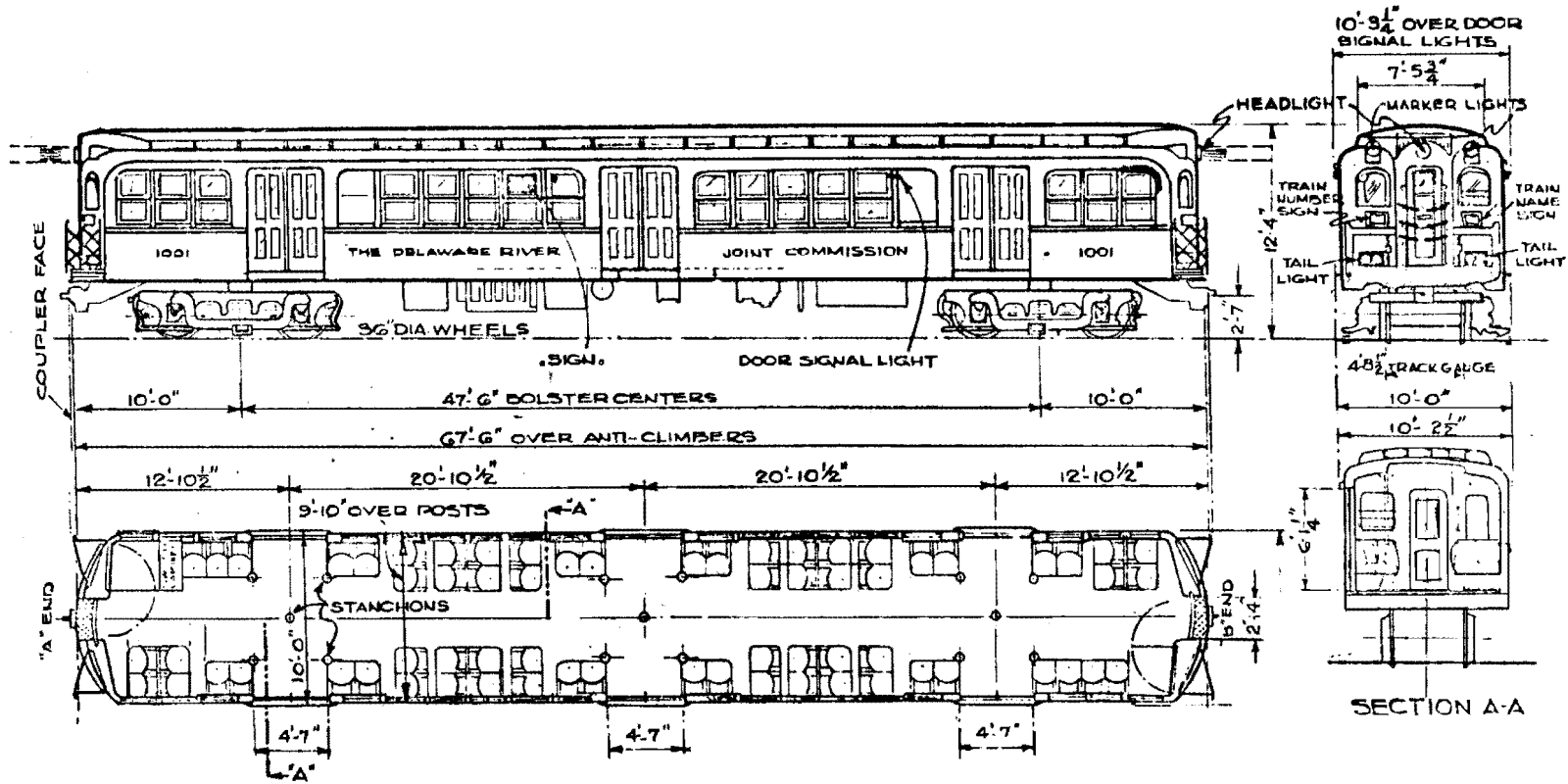

FIGURE 5.3 -SOUTH BROAD STREET SUBWAY CAR — 1938 PRESSED STEEL

CAR NUMBERS 1001 TO 1026

5-7/5-8



67 SEATED PASSENGERS

FIGURE 5.4 - RIDGE AVENUE SPUR (BRIDGE) SUBWAY CAR - 1936 BRILL



5.2 Noise Assessment Data

The environmental noise data of the transit system has been grouped for each measurement location with site descriptions and data on the noise survey results. After a general review of the test sites, whether they be community, station or car, and their relationship to the overall transit system geography, specific details are furnished for each site, including the following:

- a. A short description of the important features of the measurement site.
- b. A description of the noise climate identifying the major sources of noise at the location.
- c. Photograph of site including both microphones and tracks.
- d. Sketch of site showing location of both microphones and tracks.
- e. A summary table of the statistical measures of each noise sample (L_1 , L_{10} , L_{50} , L_{90} and L_{99} , L_{eq}), along with the average maximum levels of the train passbys on the near and far tracks. Also given in the table are the average level of L_R for the passbys on the near and far tracks.
- f. Statistical distribution curves for all 30 minute samples at each site.
- g. A sample strip chart trace including near and far track train passbys at the microphone closest to the track.

Table 5.2 is presented to describe the content of information in each summary table. An explanation of each column follows:

Column

- (1) The measurement period in 24 hours during which the noise sample was taken.
- (2) Distance of the microphone from the centerline of the nearest track.
- (3) Length of data sample, in minutes.

TABLE 5.2 . EXPLANATION FOR MEASUREMENT RESULT SUMMARY
 TABLES PRESENTED AT EACH SITE.

(1)	(2)	(3)	(4)	(5)	(6)	(7)	(8)	(9)	(10)					(11)
TIME	MIC POSITION	SAMPLE TIME	TRAIN CONDITIONS	UNITS	AVG MAX LEVEL		AVG LR		CUMULATIVE AMPLITUDE DISTRIBUTION					Leq
					NEAR	FAR	NEAR	FAR	L99	L90	L50	L10	L1	

Notes: a - Track
 b - Number of Trains - (e.g.: 4-2 means four 2-car trains)
 c - Standard Deviation of Level

(12) L_{dn} =

Column

- (4) Type of train operation during sample, i.e., Passby for community noise and Arrival or Departure for station noise.
- (5) Identification for the data presented.

N = Number of trains in sample - cars per train
(4-2 indicates four 2-car trains)

dBA = Averaged A-weighted sound levels, $L_A(\text{Max})$,
for number of trains noted (See Fig. 4.4)

S = Standard deviation of $L_A(\text{Max})$ or L_R
listed immediately above it.

$$S = \sqrt{\frac{\sum_{i=1}^N (x_i - \bar{x})^2}{N-1}}$$

where x_i = individual $L_A(\text{Max})$ or L_R
 \bar{x} = Mean value of $L_A(\text{Max})$ or L_R

- (6) $L_A(\text{Max})$ data for trains operating on near tracks.
- (7) $L_A(\text{Max})$ data for trains operating on far tracks.
- (8) L_R data for trains operating on near tracks.
- (9) L_R data for trains operating on far tracks.
- (10) Summary of cumulative amplitude distribution for data sample, dBA.
- (11) Equivalent Sound Level for sample of duration noted in Column (3) (See Section 4-2)
- (12) Day-Night Equivalent Sound Level for A-weighted noise level integrated over 24 hour period. Weightings are applied to the noise levels measured during the four time periods during the day. (See Section 4-2 and Table 6.1.)

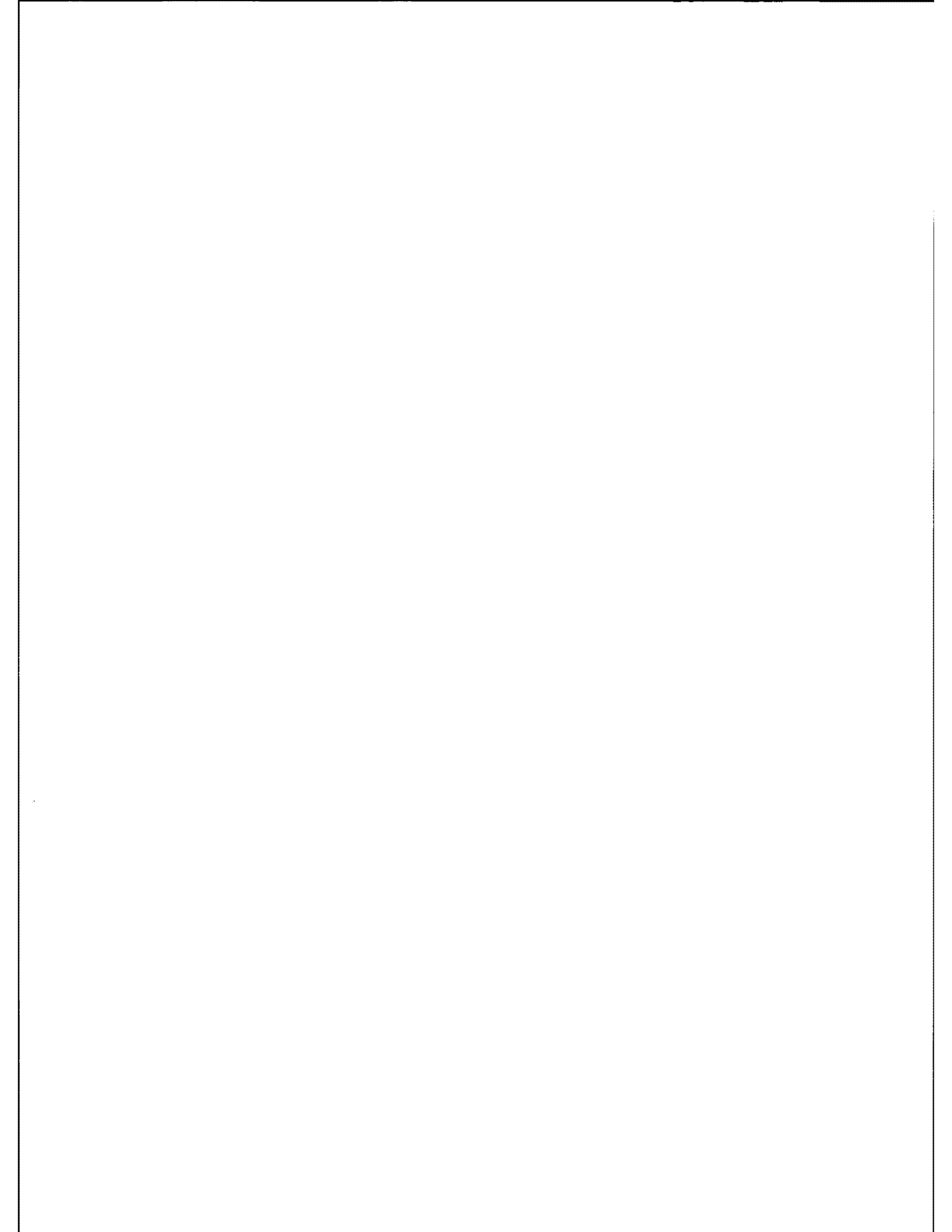

5.2.1 Wayside Community - Noise of the Broad Street Subway in the community above the subway system is essentially inaudible. That noise which does propagate through the station entrances and air vents is inaudible beyond a few feet of these areas as a result of the masking of street traffic.

At Fern Rock, however, some wheel screech is audible at street level and transit system traffic is audible in the surrounding community. Nedro Avenue which parallels the Fern Rock Station, is lined with houses which face the station area. The houses are within 25m of the tracks. One community noise survey location was on Nedro Avenue, 25m from the Fern Rock Station at Tenth Street.

10TH AND NEDRO - WAYSIDE

SITE DESCRIPTION (see Figure 5.5)

The 10th and Nedro site is located at-grade north of the Fern Rock Station. This station is the northern terminal for the subway. Trains leave for the run southbound on the same track which they enter the station.

Nedro Avenue is situated parallel to the tracks and the station platform, while 10th Street joins Nedro Avenue at right angles to the track, opposite the stopped trains. There is a small grade to both streets. The structures along both streets consist of single and multiple dwelling two-story private residences and apartments.

NOISE CLIMATE (see Table 5.3, Figures 5.6 - 5.12)

The noise climate at this site is primarily comprised of automobile traffic, and SEPTA buses which arrive, idle and depart the immediate vicinity of Fern Rock Station. Rail transit noise is largely inaudible because of the very slow speeds with which trains approach and depart the platform. Occasional yard impact noise arising from train make-up, automobile horns, and wheel/rail squeal are audible. Additional sounds come from pedestrian traffic associated with the station, and other community noise sources, such as an occasional barking dog.

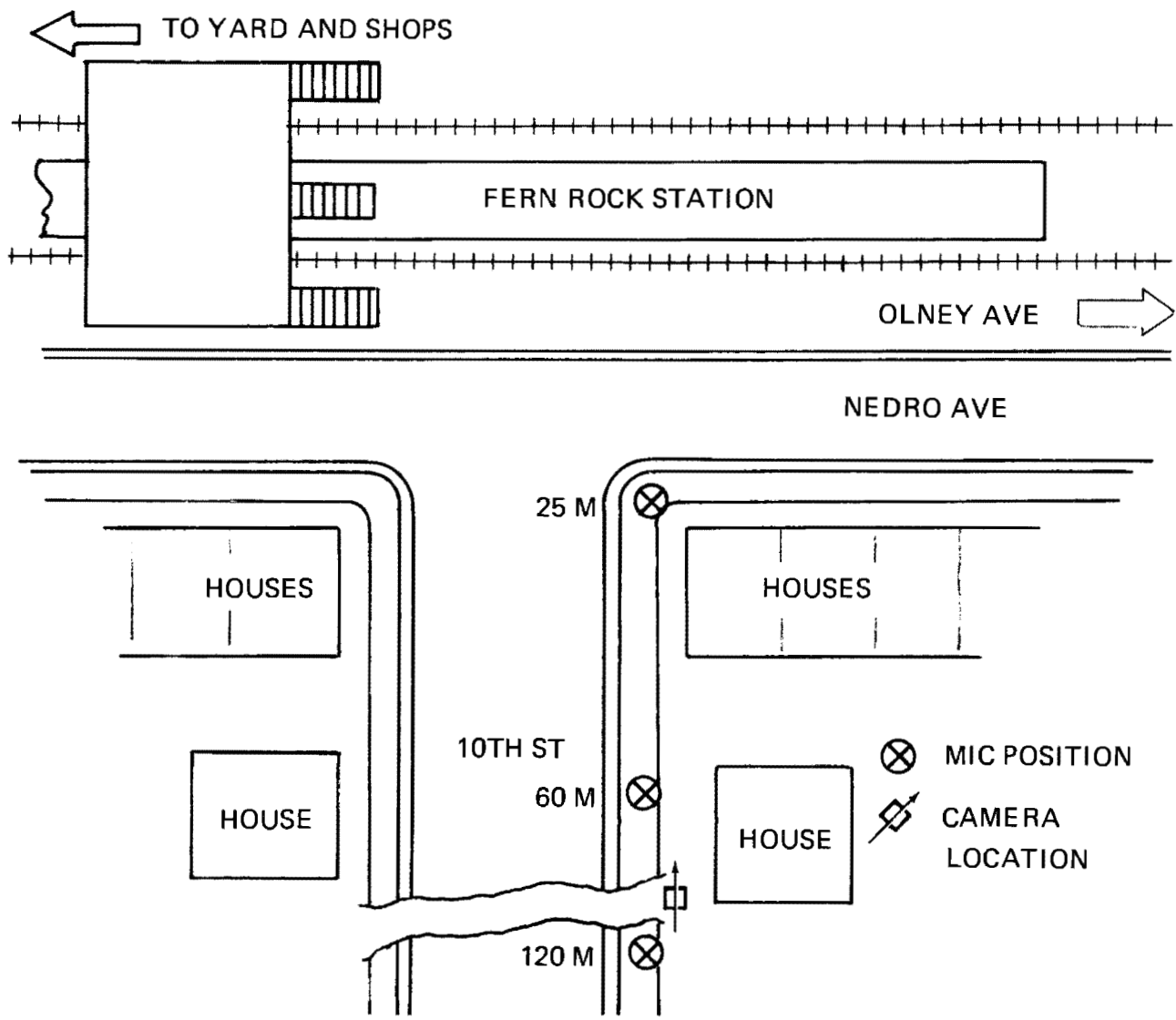

FIGURE 5.5 - WAYSIDE MEASUREMENT LOCATION, 10TH AND NEDRO FERN ROCK

TABLE 5.3. SUMMARY OF MEASUREMENT RESULTS FOR 10TH AND NEDRO, FERN ROCK, COMMUNITY

TIME	MIC POSITION	SAMPLE TIME	TRAIN CONDITIONS	UNITS	AVG MAX LEVEL		AVG LR		CUMULATIVE AMPLITUDE DISTRIBUTION					Leq
					NEAR	FAR	NEAR	FAR	L99	L90	L50	L10	L1	
					a) 1	3	1	3						
Day	25 m	30 min	Arrival	b) N	3-4	2-4	3-4	2-4	53	54	59	69	83	71
				dBA	72	70	82	81						
				c) S	1.04	2.47	1.37	0.07						
			Departure	N	3-4	2-4	2-4	2-4						
				dBA	70	75	79	81						
				S	1.26	0.35	0.07	2.69						
Rush	Arrival and Departure	dBA					55	59	65	72	82	70		
Evening		dBA					52	57	65	71	84	71		
Night		dBA					46	47	52	66	75	65		
Day	60m	15 min	Arrival and Departure	dBA					63	63	65	69	82	69
Day	120m	15 min		dBA					62	62	63	68	76	66
Notes: a - Track														
b - Number of Trains -(e.g.: 4-2 means four 2-car trains)														
c - Standard Deviation of Level														
L _{dn} = 76														

5-16

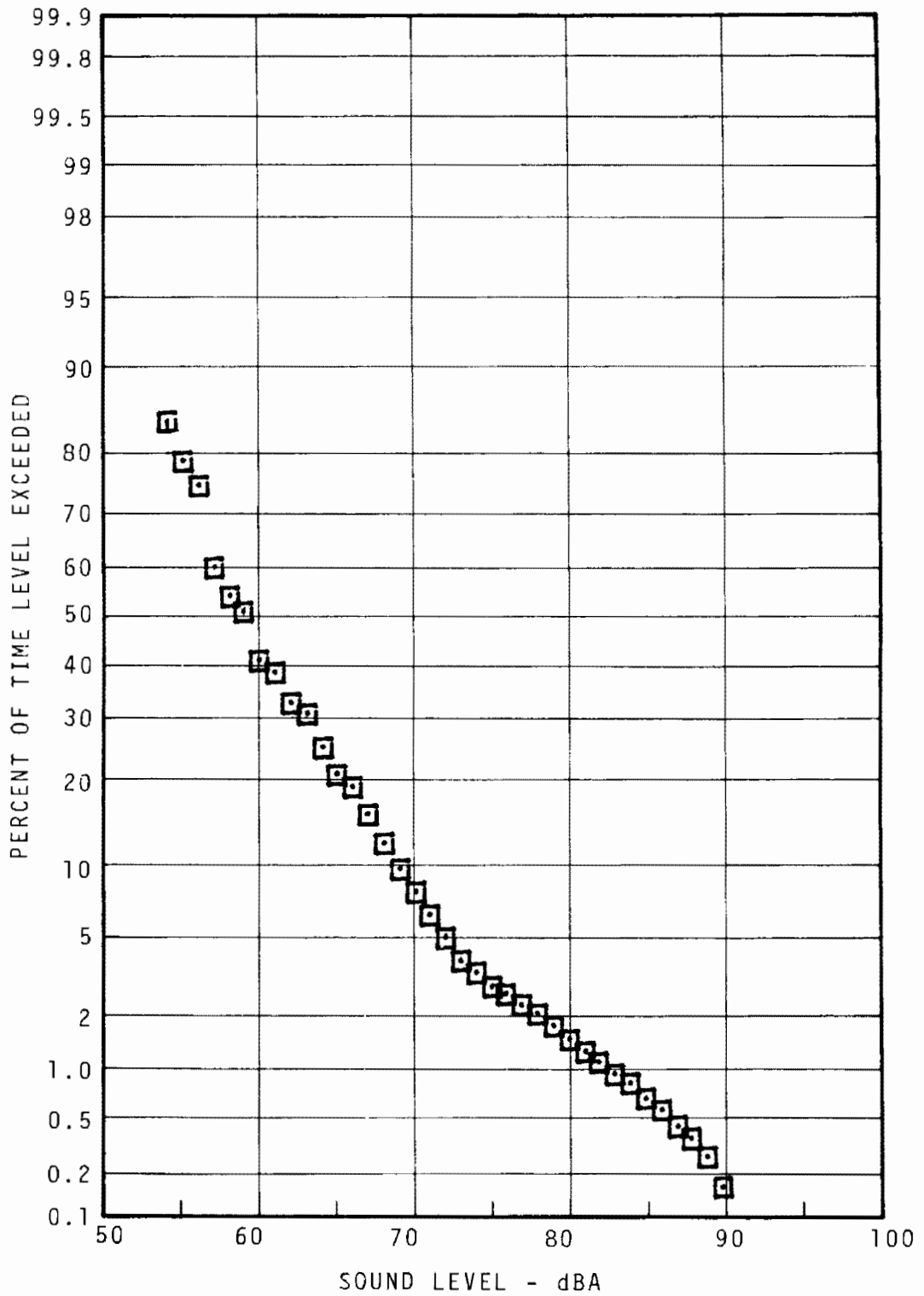

FIGURE 5.6 - 10th AND NEDRO, FERN ROCK COMMUNITY
 STATISTICAL DISTRIBUTION - 25M -
 DAYTIME

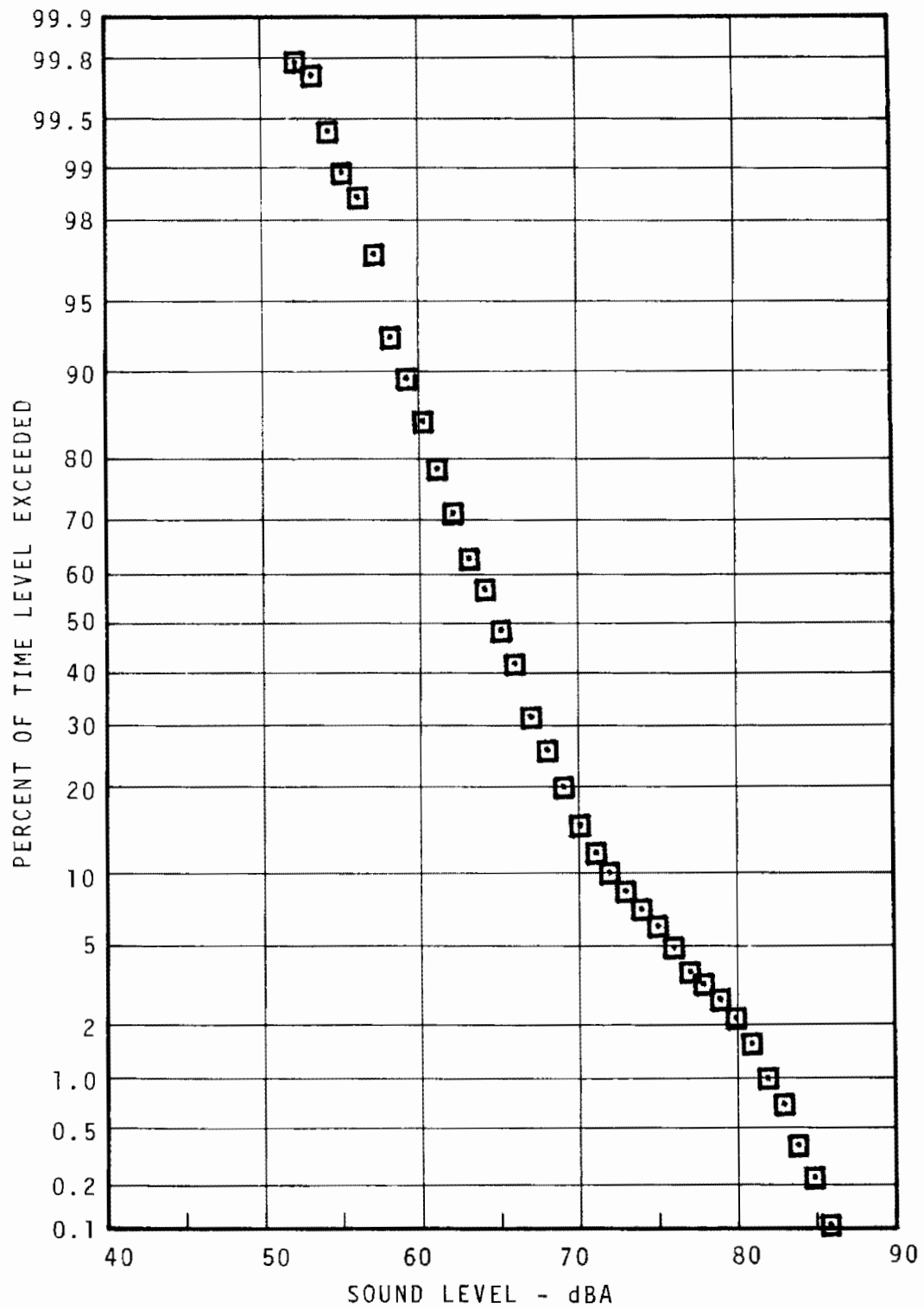

FIGURE 5.7 - 10th AND NEDRO, FERN ROCK COMMUNITY
 STATISTICAL DISTRIBUTION - 25M -
 RUSH HOUR

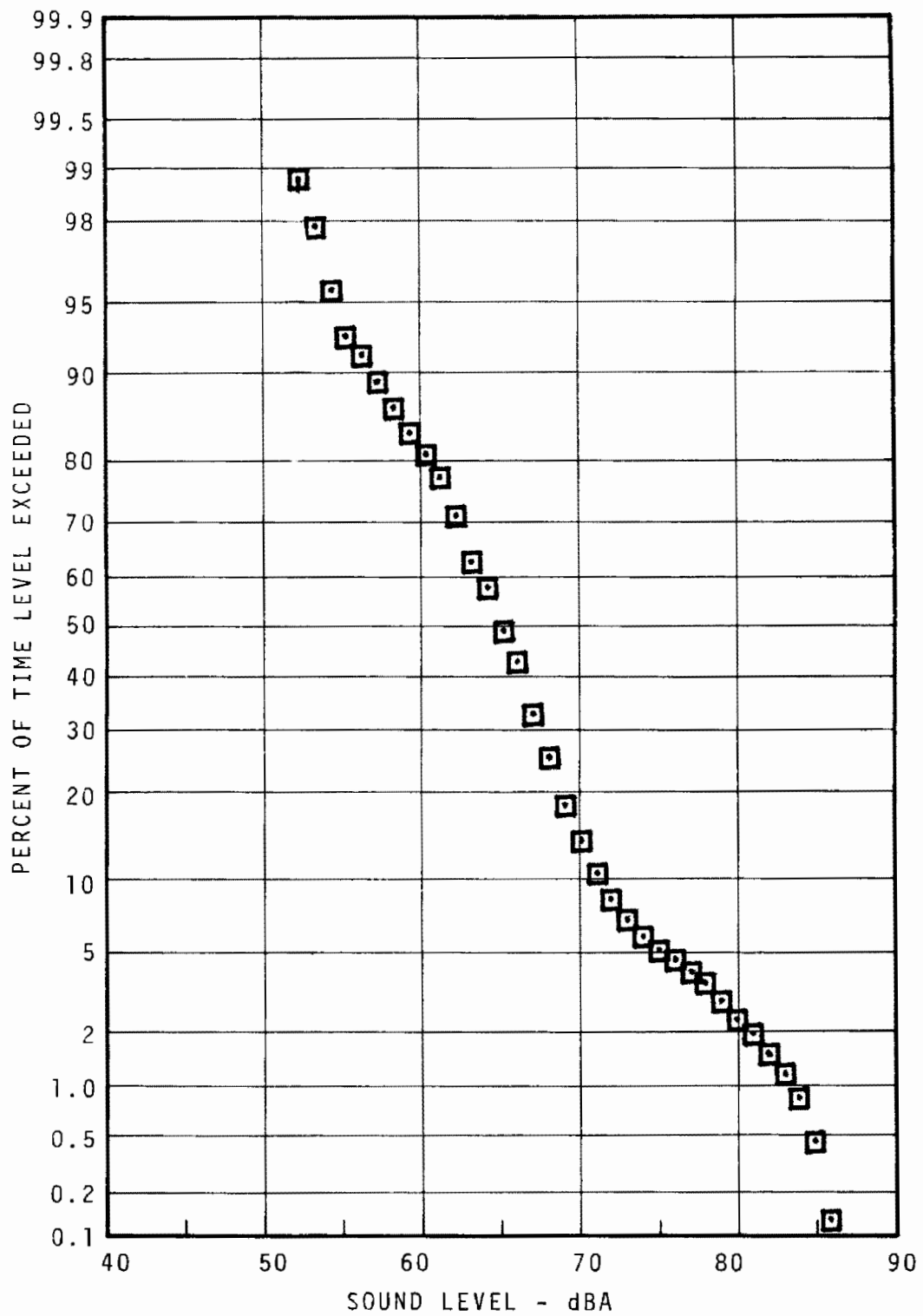

FIGURE 5.8 - 10th AND NEDRO, FERN ROCK COMMUNITY
 STATISTICAL DISTRIBUTION - 25M -
 EVENING

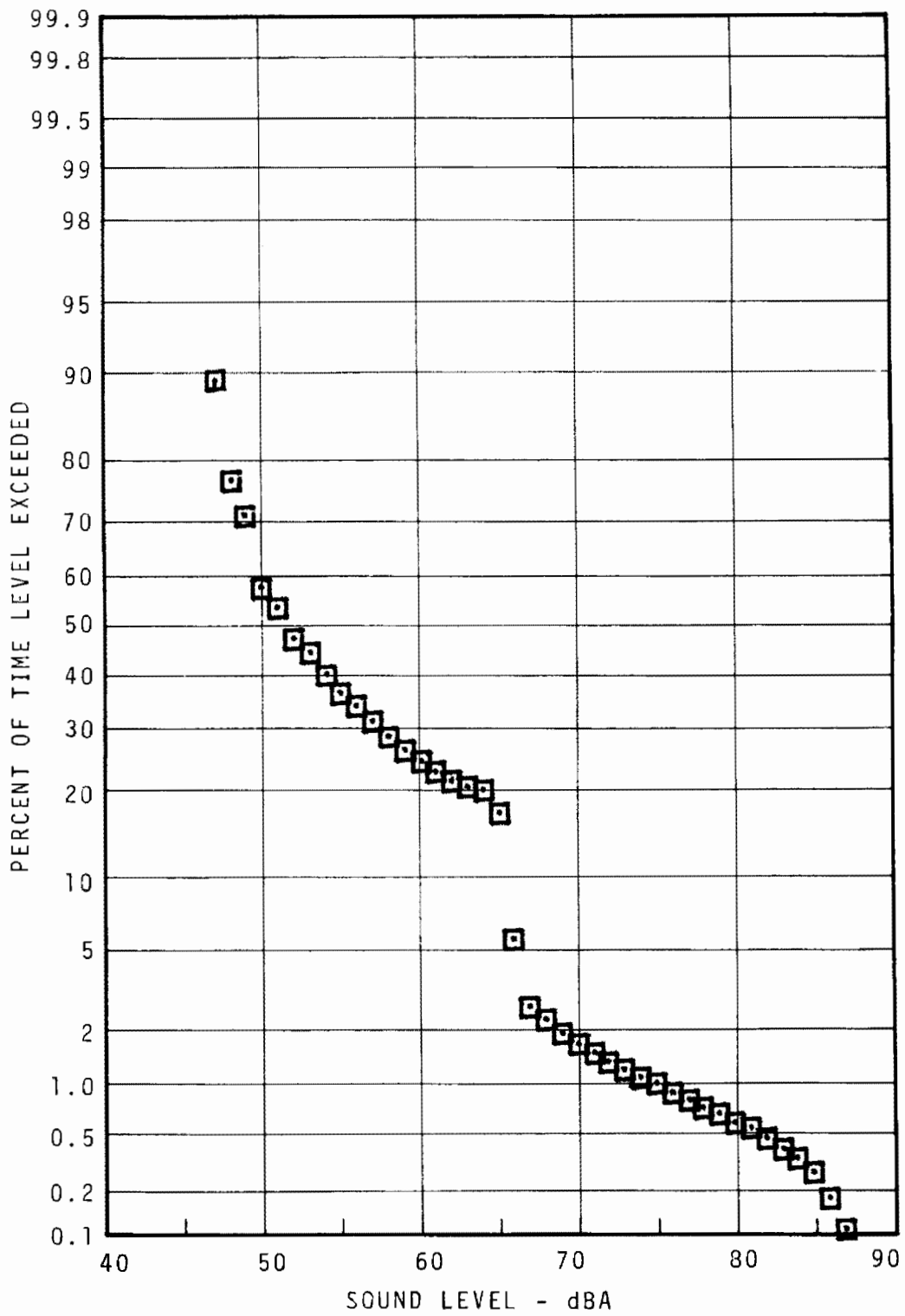

FIGURE 5.9 - 10th AND NEDRO, FERN ROCK COMMUNITY
 STATISTICAL DISTRIBUTION - 25M -
 NIGHT

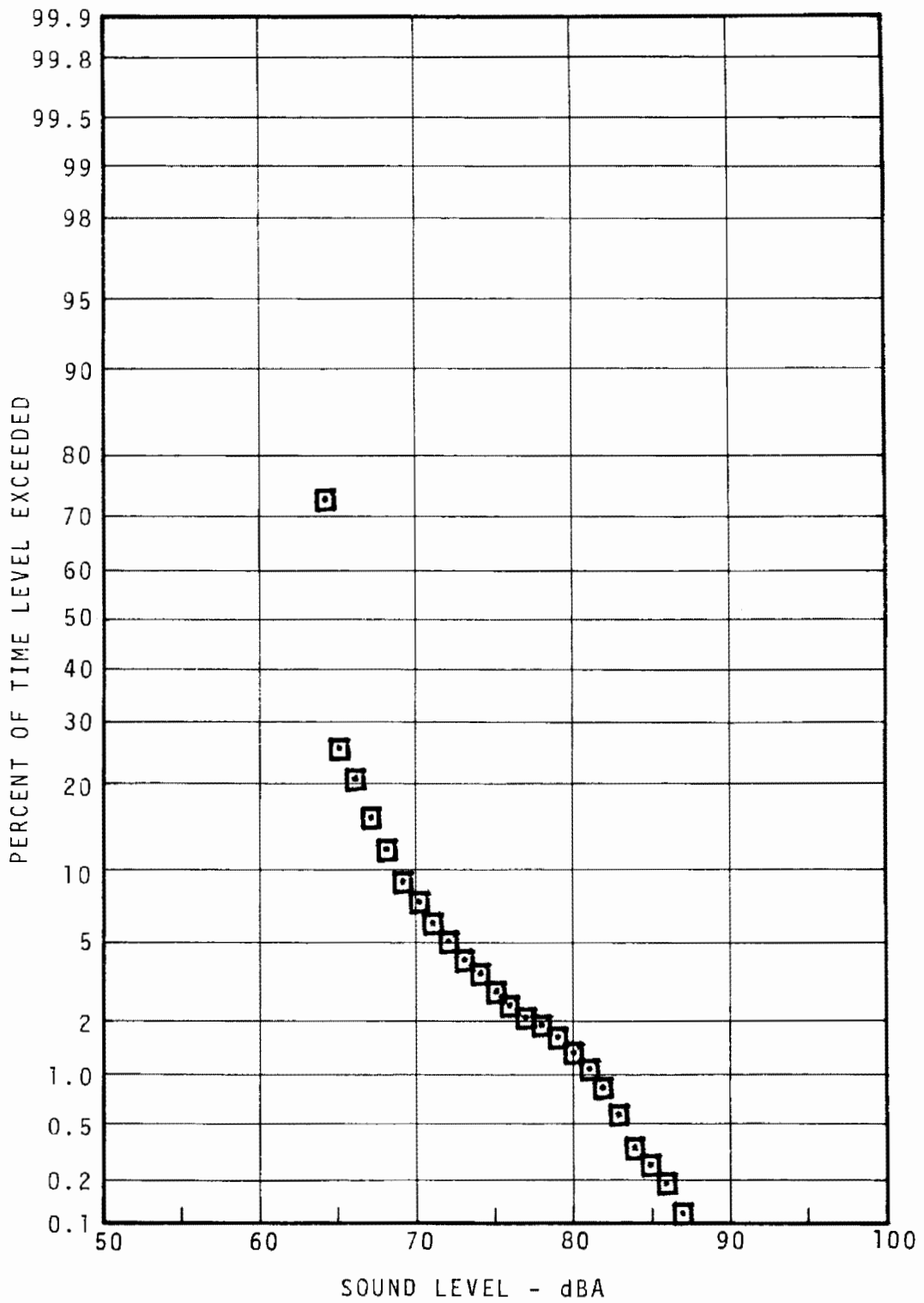

FIGURE 5.10 - 10th AND NEDRO, FERN ROCK COMMUNITY
 STATISTICAL DISTRIBUTION - 60M -
 DAYTIME

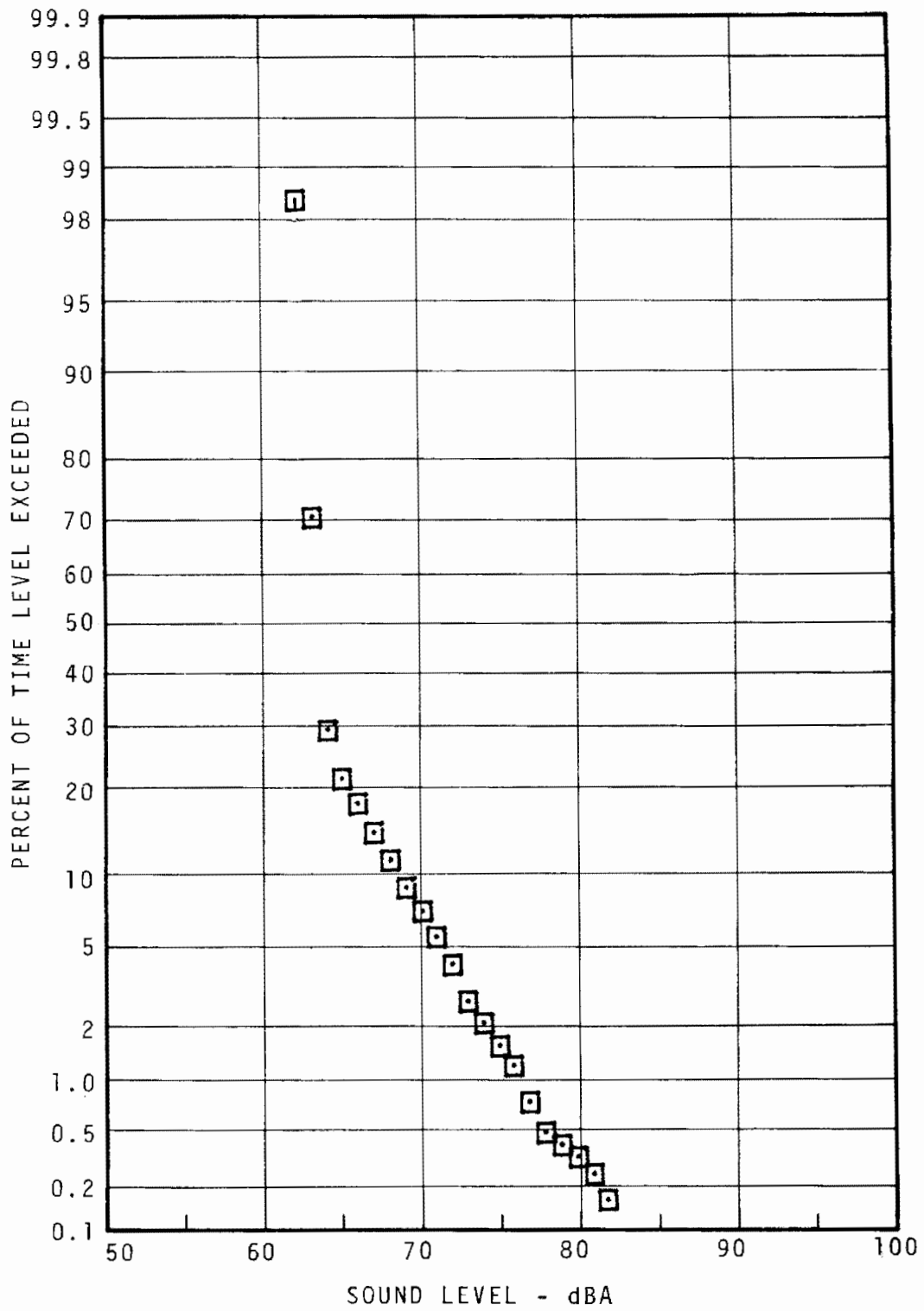

FIGURE 5.11 - 10TH AND NEDRO, FERN ROCK COMMUNITY
 STATISTICAL DISTRIBUTION - 120M -
 DAYTIME

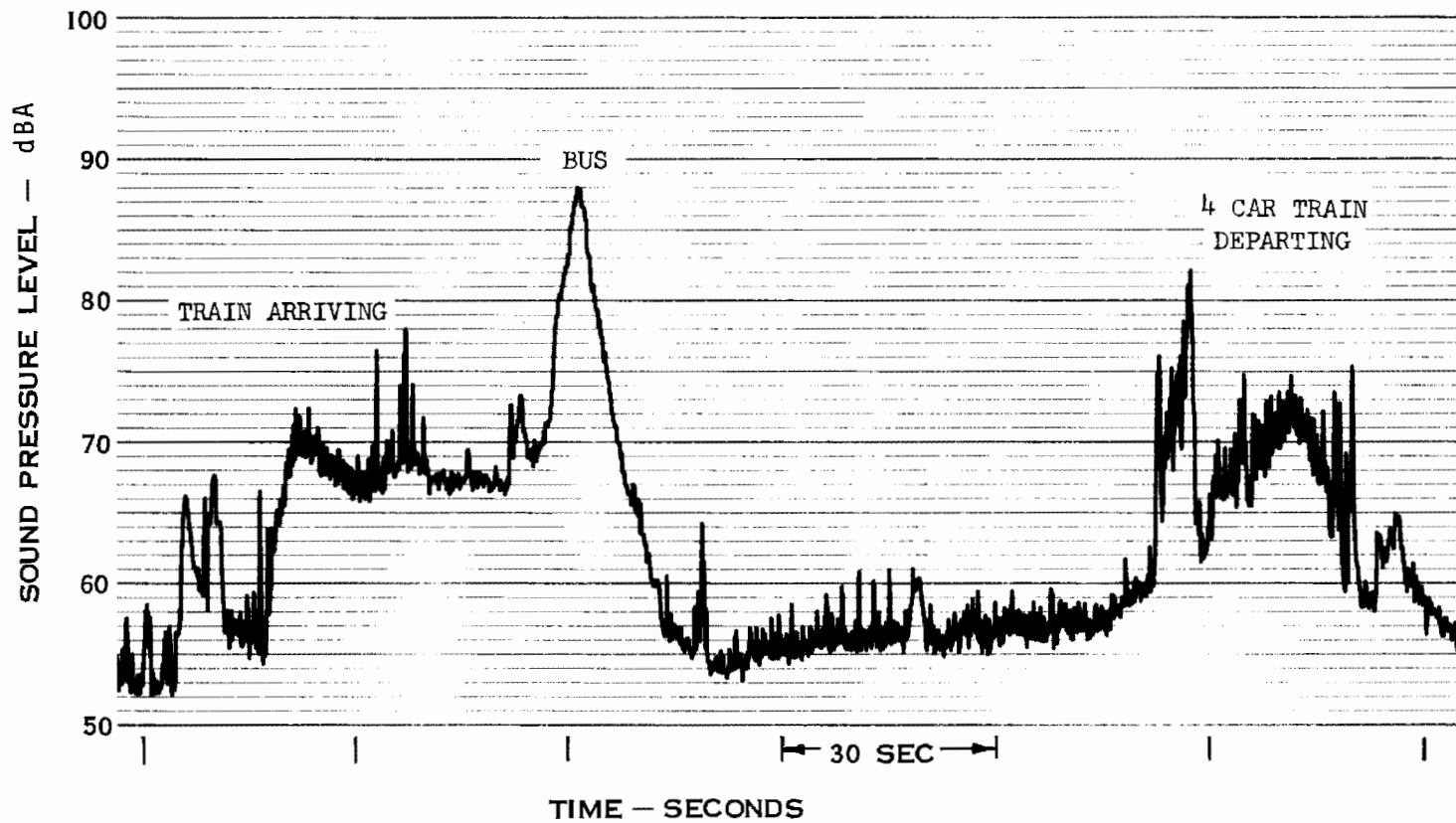

FIGURE 5.12-TYPICAL NOISE TIME HISTORY, 10TH & NEDRO St. COMMUNITY, 25 METERS SEPTA BROAD STREET LINE

11TH AND NEDRO - WAYSIDE

SITE DESCRIPTION (see Figure 5.13)

The wayside location at 11th and Nedro Streets is approximately two blocks southwest of the Fern Rock Station near the tunnel portal. The roadbed is approximately 10 ft below street grade at this location. SEPTA's Fern Rock shops are located on the south side of the tracks and the north side is a mixed commercial region. The residential housing in this area consists of two and three story stucco dwellings. Also located in the vicinity is an elementary school, a gas station, a number of small stores, and a bus stop.

NOISE CLIMATE (see Table 5.4, Figures 5.14 - 5.18)

The community noise climate at this location arises from the transit line operation, the Fern Rock yard and shops, buses idling and motor vehicle traffic on nearby streets. The background noise level at rush hour is 2 to 7 dBA greater than daytime and evening periods, whereas at night, the background is more than 10 dBA quieter than daytime levels.

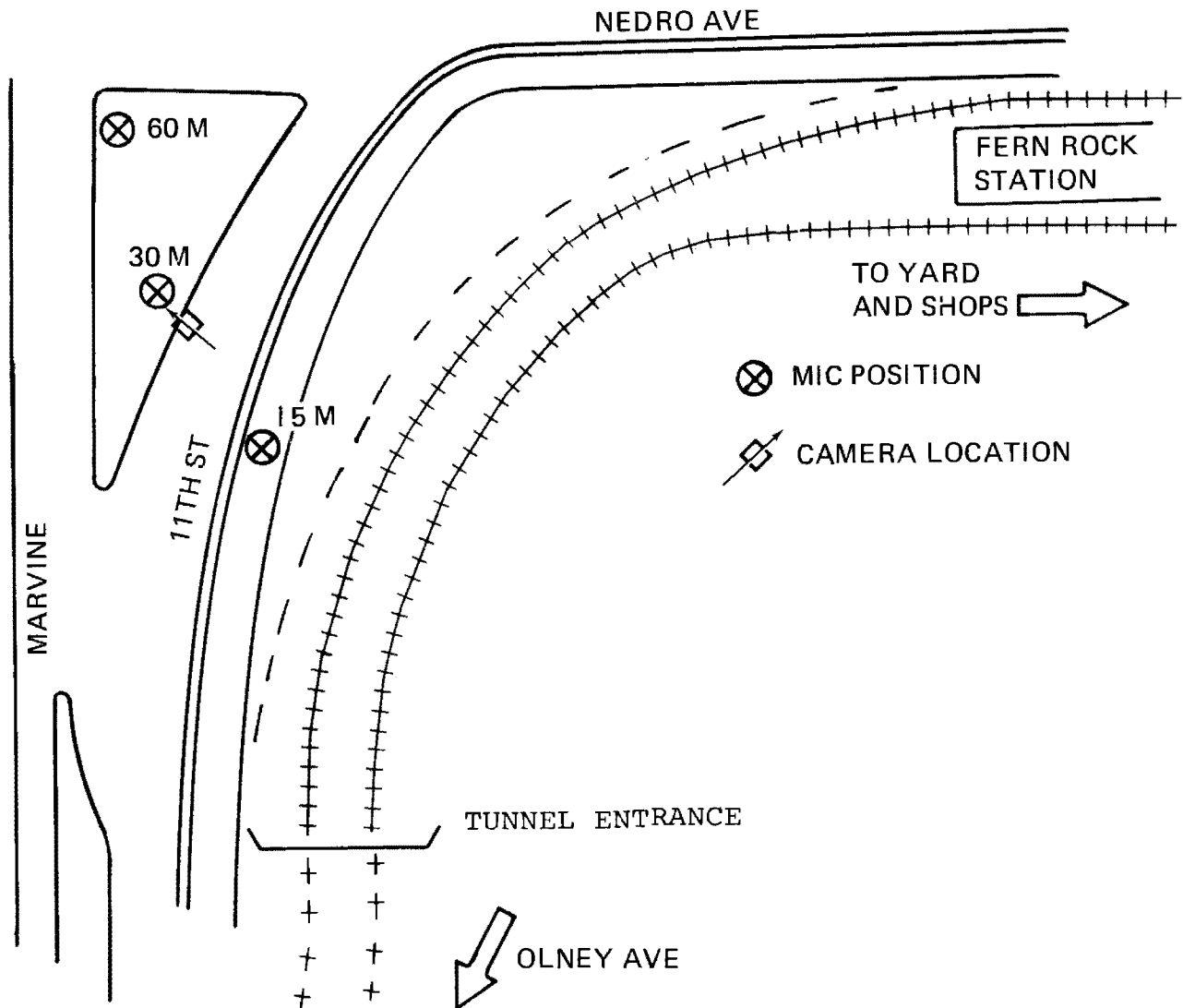

FIGURE 5.13 - WAYSIDE MEASUREMENT LOCATION, 11TH STREET, FERN ROCK

TABLE 5.4 - SUMMARY OF MEASUREMENT RESULTS FOR 11TH STREET, FERN ROCK, COMMUNITY

TIME	MIC POSITION	SAMPLE TIME	TRAIN CONDITIONS	UNITS	AVG MAX LEVEL			AVG L _R			CUMULATIVE AMPLITUDE DISTRIBUTION					L _{eq}
					Near	Far	From	Near	Far	From	L ₉₉	L ₉₀	L ₅₀	L ₁₀	L ₁	
					^a South	North	Yard	South	North	Yard						
Day	15 m	30 min	Pass-by	b) N	4-4	4-4	1-4	3-4	4-4	1-4	56	59	67	73	78	69
				dBA	77	75	76.5	84	87	87.1						
c) S				2.90	1.03	-	0.98	2.01	-	58	63	68	73	77		
dBA																
dBA															52	
Night	dBA							46	46	48	59	68	56			

Notes: a - Track
 b - Number of Trains -(e.g.: 4-2 means four 2-car trains)
 c - Standard Deviation of Level

L_{dn} = 74

5-26

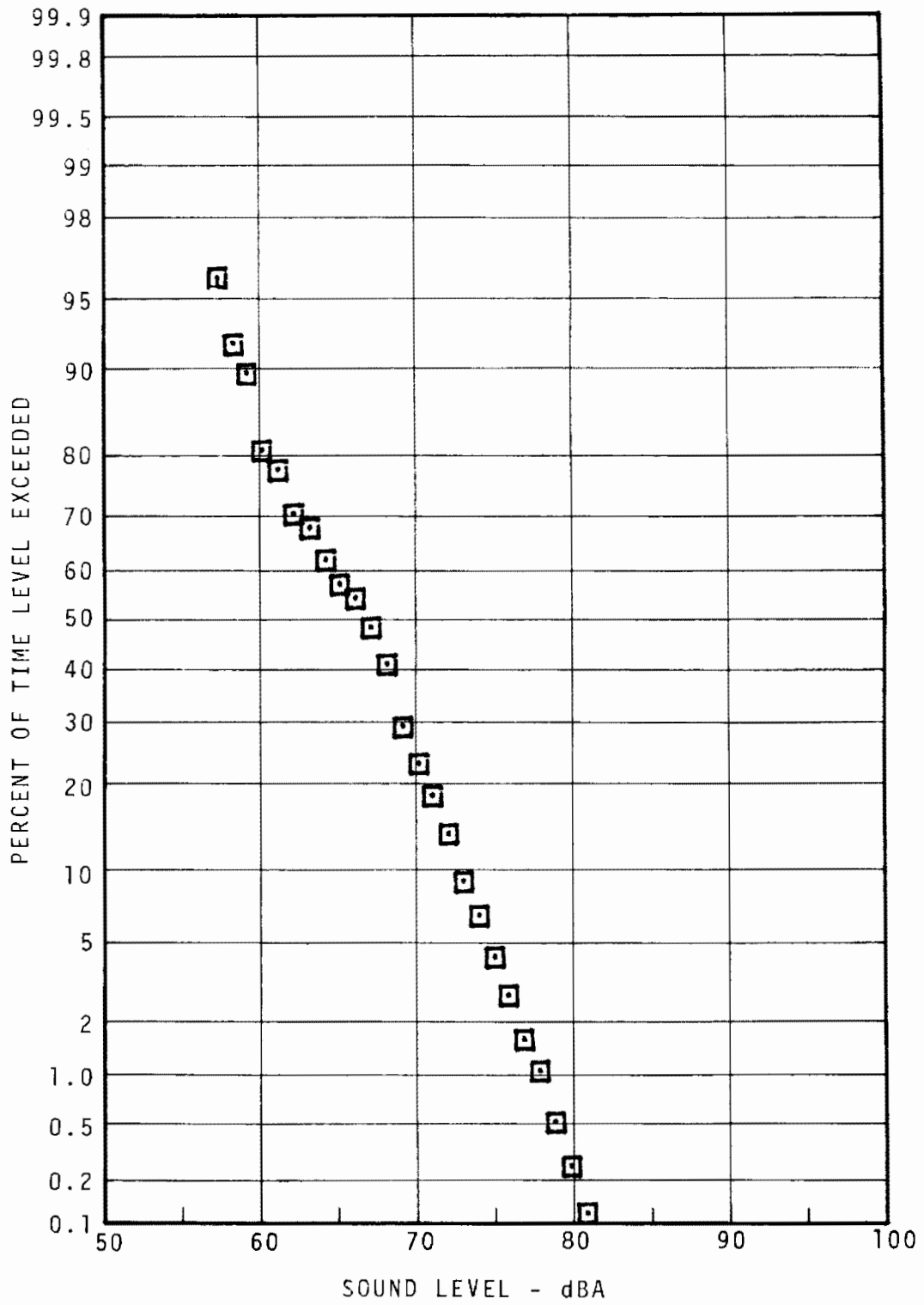

FIGURE 5.14 - 11th STREET, FERN ROCK COMMUNITY
 STATISTICAL DISTRIBUTION - 15M -
 DAYTIME

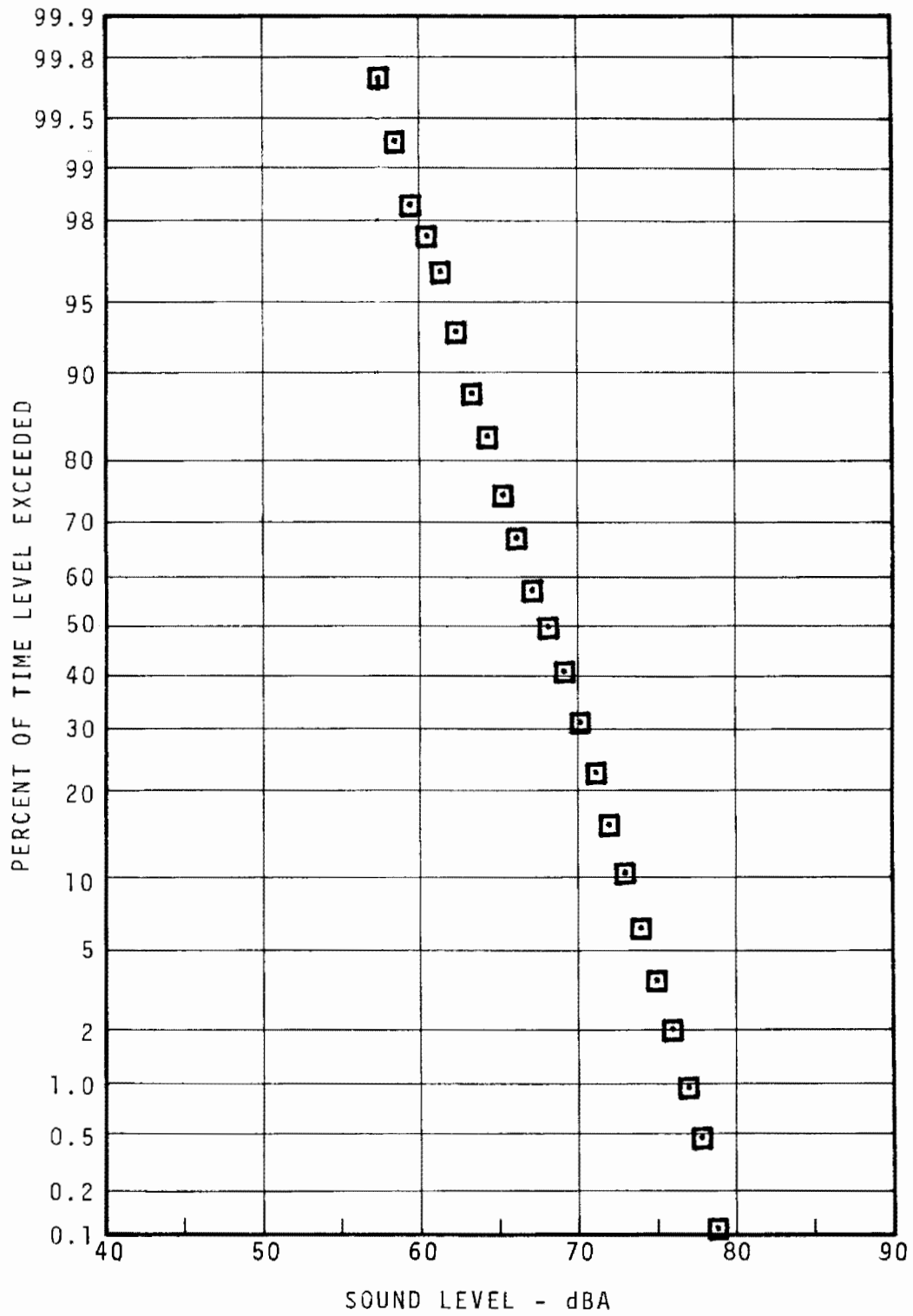

FIGURE 5.15 - 11th STREET, FERN ROCK COMMUNITY
 STATISTICAL DISTRIBUTION - 15M -
 RUSH HOUR

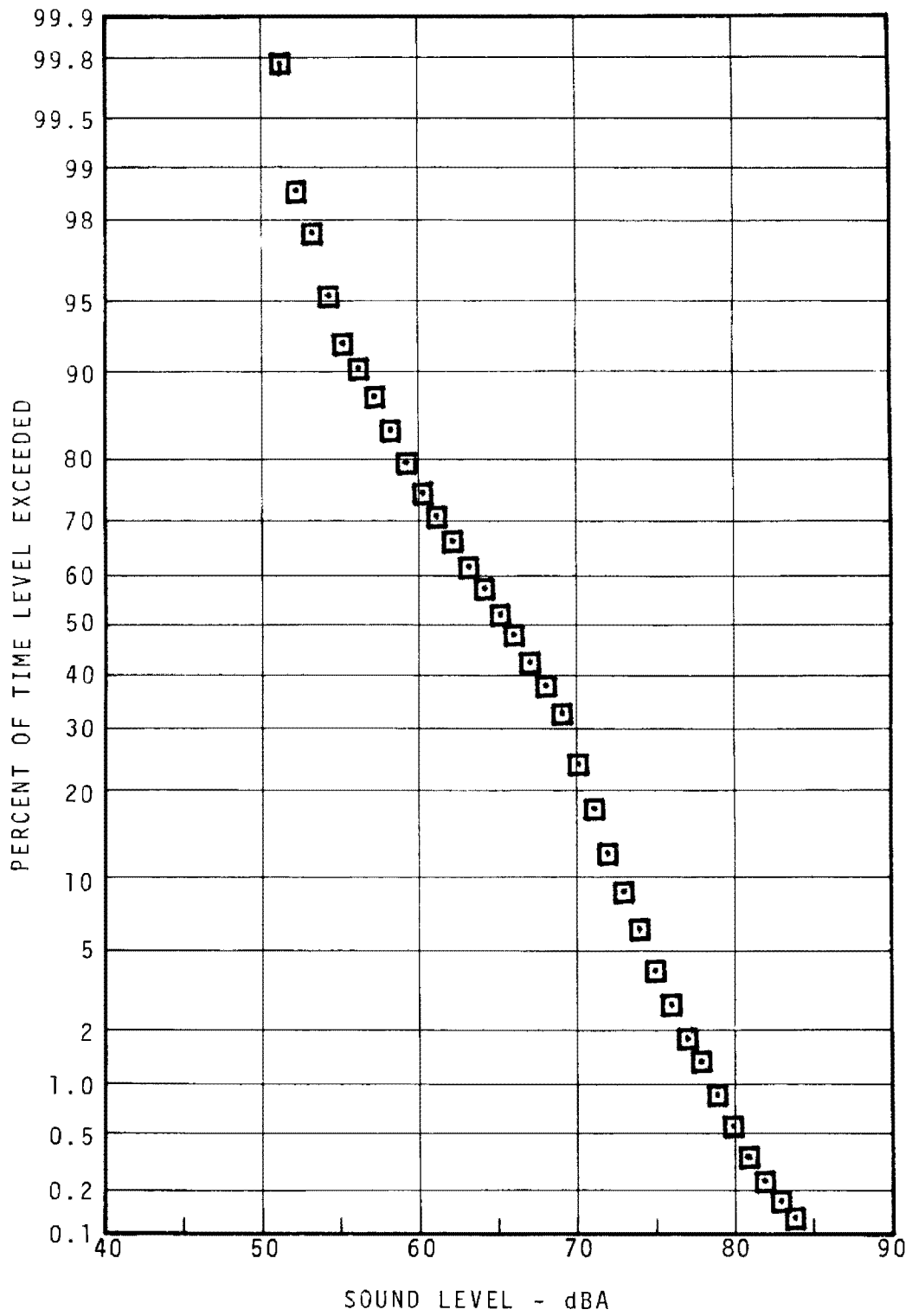

FIGURE 5.16 - 11th STREET, FERN ROCK COMMUNITY
 STATISTICAL DISTRIBUTION - 15M -
 EVENING

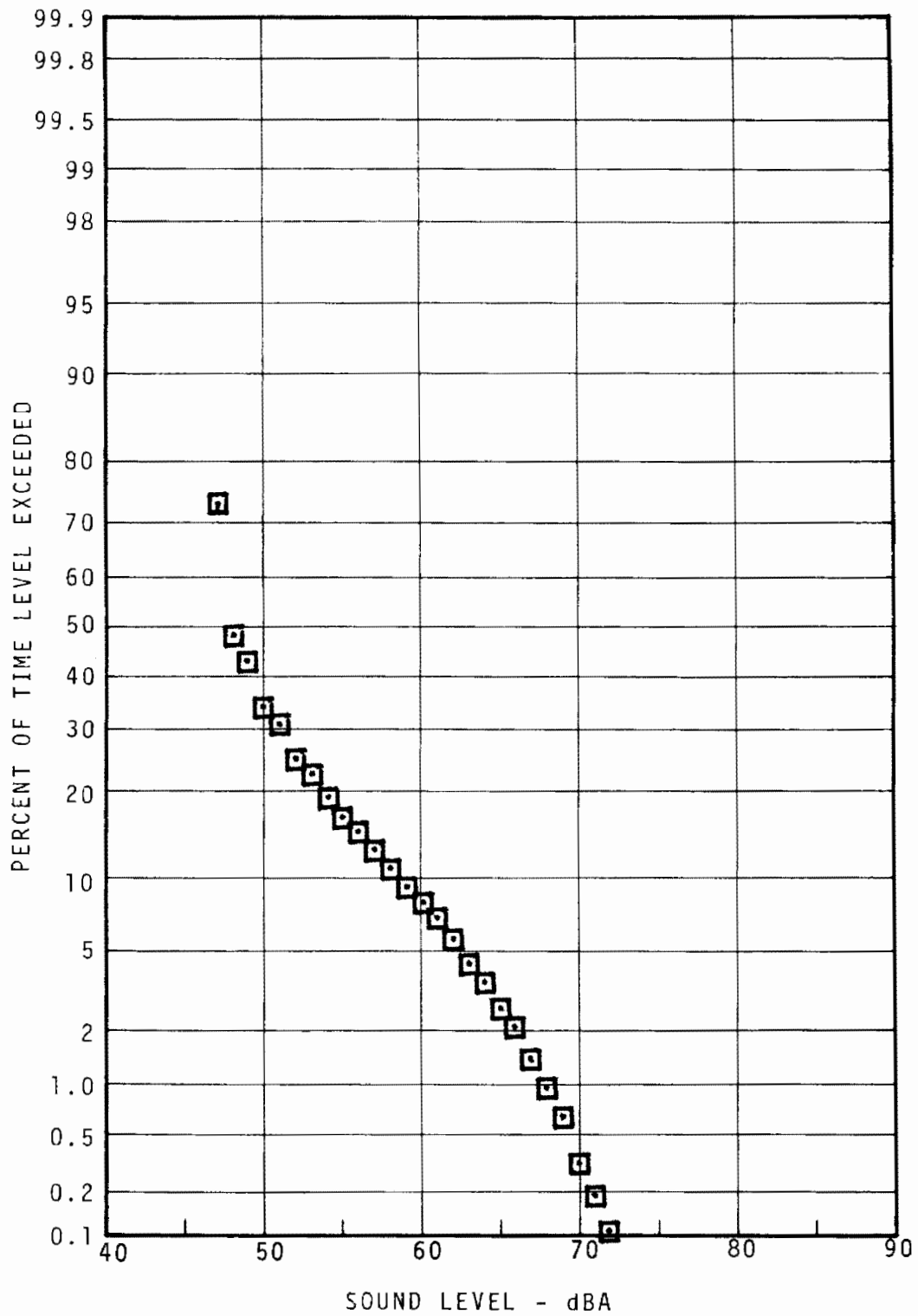

FIGURE 5.17 - 11th STREET, FERN ROCK COMMUNITY
 STATISTICAL DISTRIBUTION - 15 M -
 NIGHT

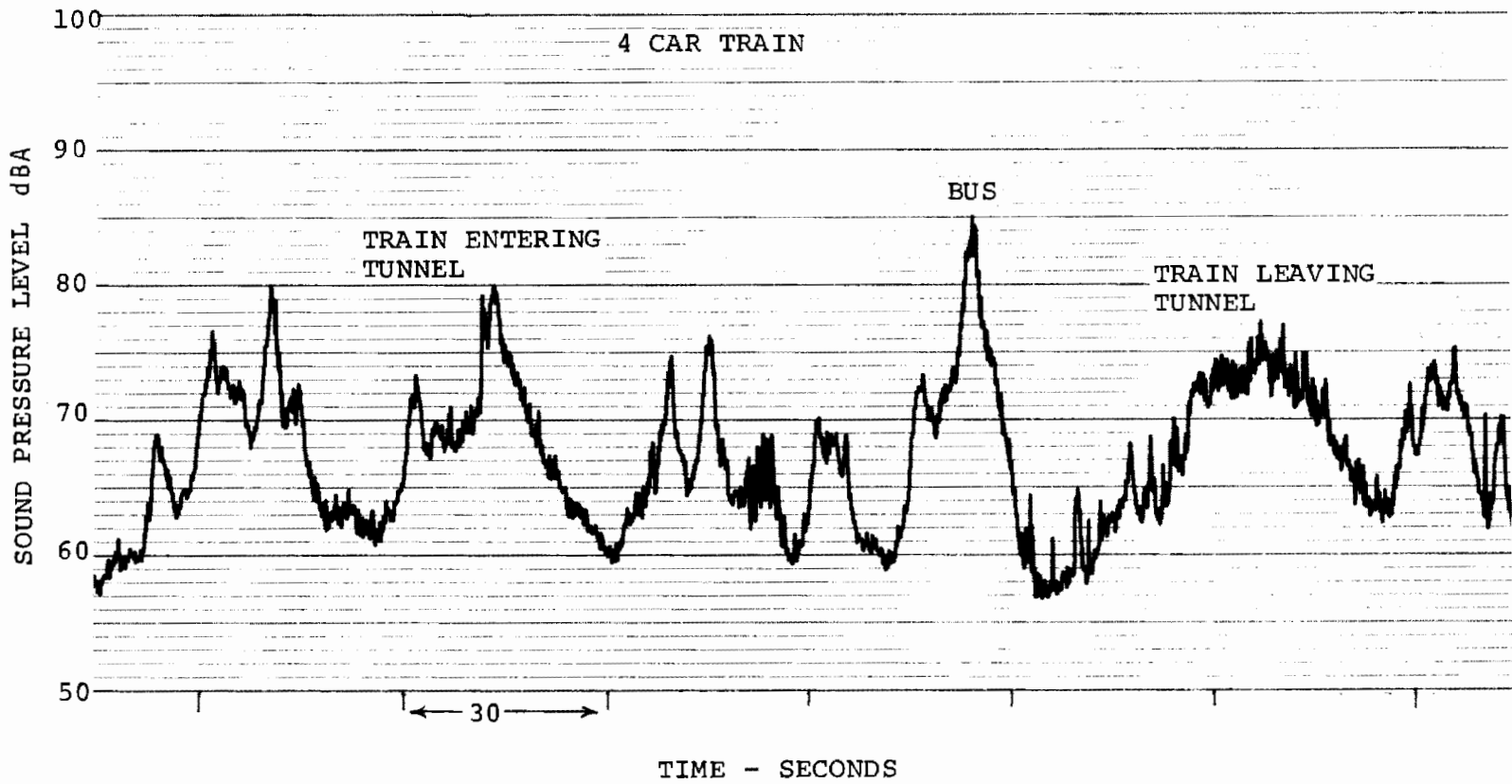

FIGURE 5.18 -TYPICAL TIME HISTORY, 11TH & NEDRO, WAYSIDE

BROAD AND WYOMING COMMUNITY

SITE DESCRIPTION (see Figure 5.19)

The measurement site is a mix of residential and business properties with the latter located primarily on Broad Street. An entrance to the subway is located on the southwest corner of the intersection and ventilation shafts are positioned at frequent intervals along the street side of the sidewalk. Broad Street (Pa. Rte. 611) is a major north-south thoroughfare in this vicinity and traffic is moderate-to-heavy. The subway operates directly below the street.

NOISE CLIMATE (see Table 5.5, Figures 5.20 - 5.24)

Although the subway is vented to the street, the shafts have several bends which serve to reduce the noise propagated to street level. Only in the occasional periods when there is no traffic on Broad Street (most frequently at night) can trains be heard near the vents. Noise levels (L_{99} through L_1) are within 6 dBA for daytime, rush hour and evening. For L_1 and $L_{0.1}$ the rush hour levels increase 15 dBA above daytime. At night, L_1 remains the same as for daytime, but L_{90} drops 13-17 dBA below all other times during the day.

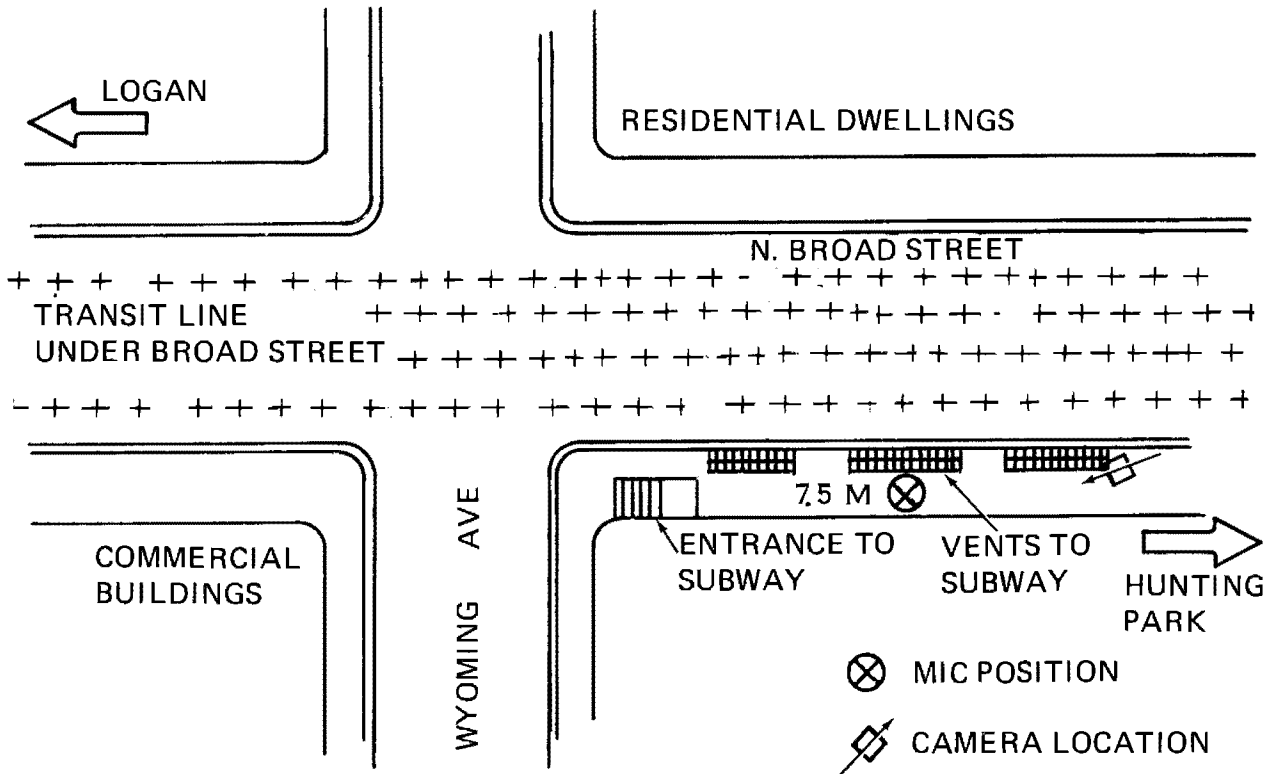
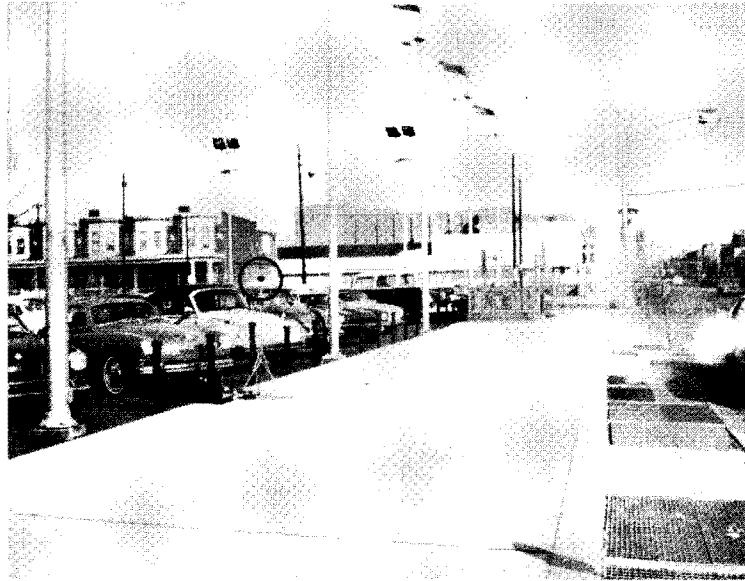

FIGURE 5.19 - WAYSIDE COMMUNITY MEASUREMENT LOCATION, BROAD AND WYOMING

TABLE 5.5- SUMMARY OF MEASUREMENT RESULTS FOR BROAD AND WYOMING, COMMUNITY

TIME	MIC POSITION	SAMPLE TIME	TRAIN CONDITIONS	UNITS	AVG MAX LEVEL		AVG LR		CUMULATIVE AMPLITUDE DISTRIBUTION					Leq	
					NEAR	FAR	NEAR	FAR	L99	L90	L50	L10	L1		
Day	7.5 m	30 min	Pass-by	dBA					60	63	69	75	82	72	
Rush				dBA					66	67	72	76	86	78	
Evening				dBA						64	65	71	76	81	74
Night				dBA						47	49	57	70	81	67
Notes: a - Track b - Number of Trains -(e.g. 4-2 means four 2-car trains) c - Standard Deviation of Level													L _{dn} - 79		

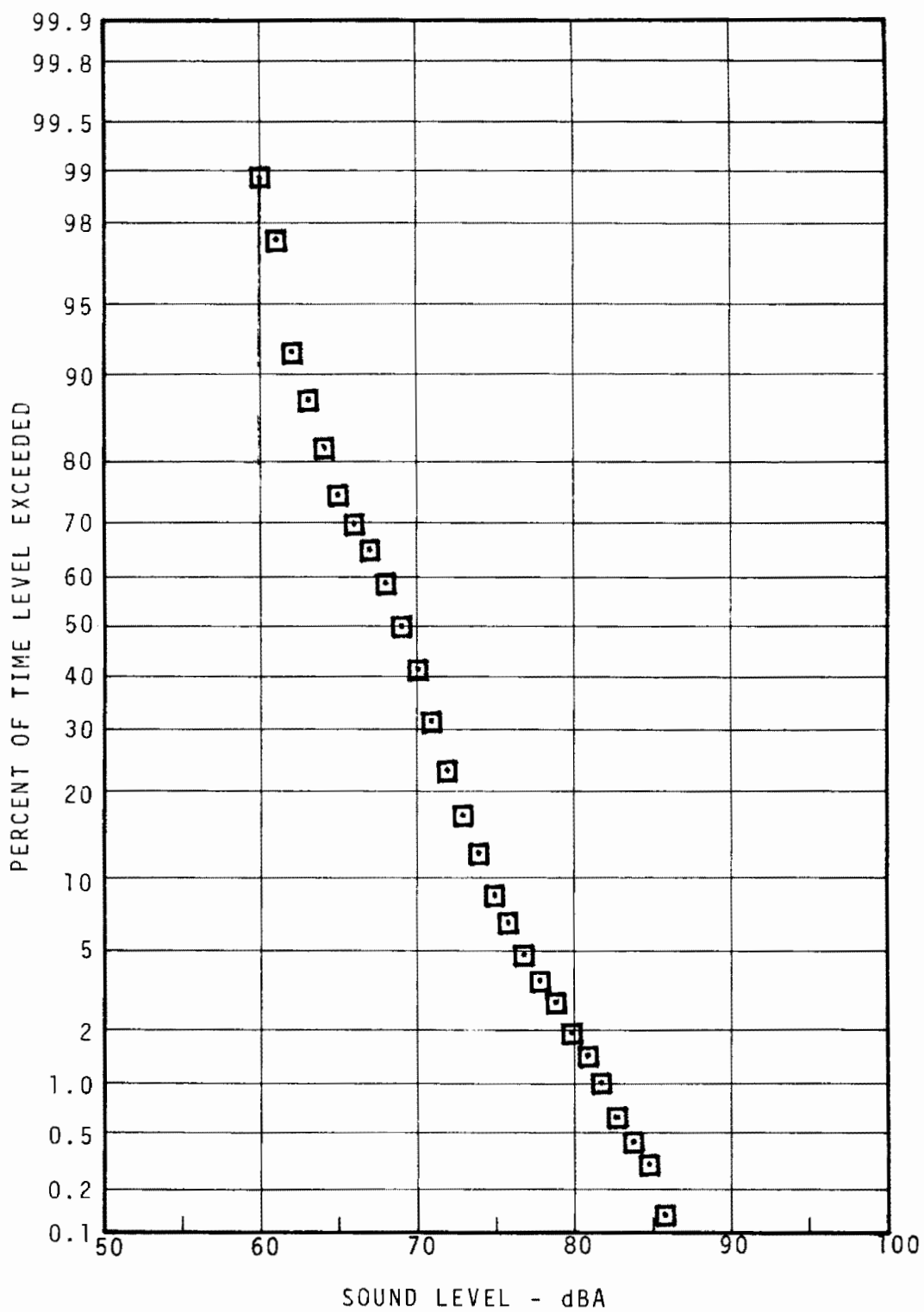

FIGURE 5.20 - BROAD AND WYOMING COMMUNITY STATISTICAL DISTRIBUTION -7.5M- DAYTIME

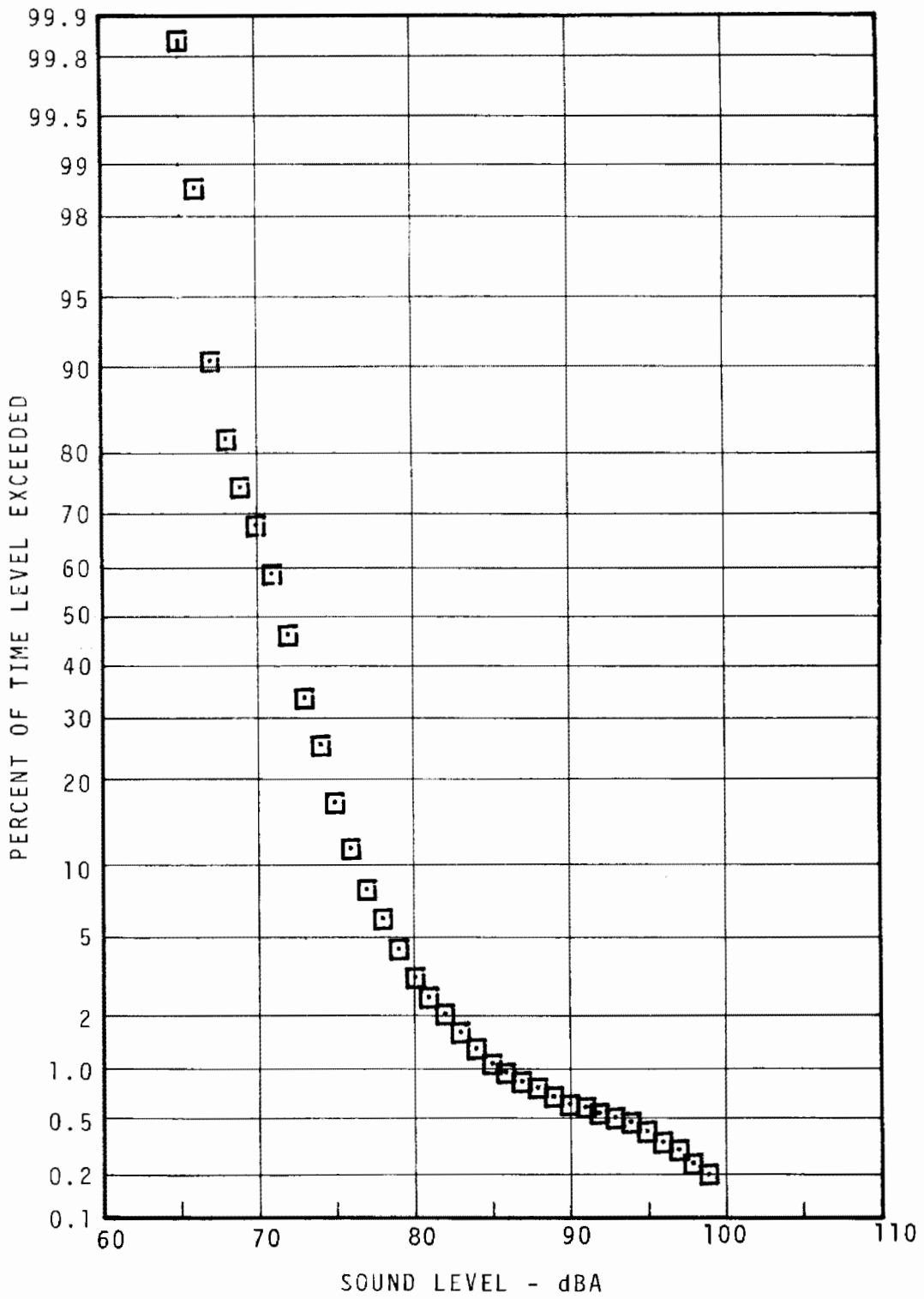

FIGURE 5.21 - BROAD AND WYOMING COMMUNITY STATISTICAL DISTRIBUTION -7.5M- RUSH HOUR

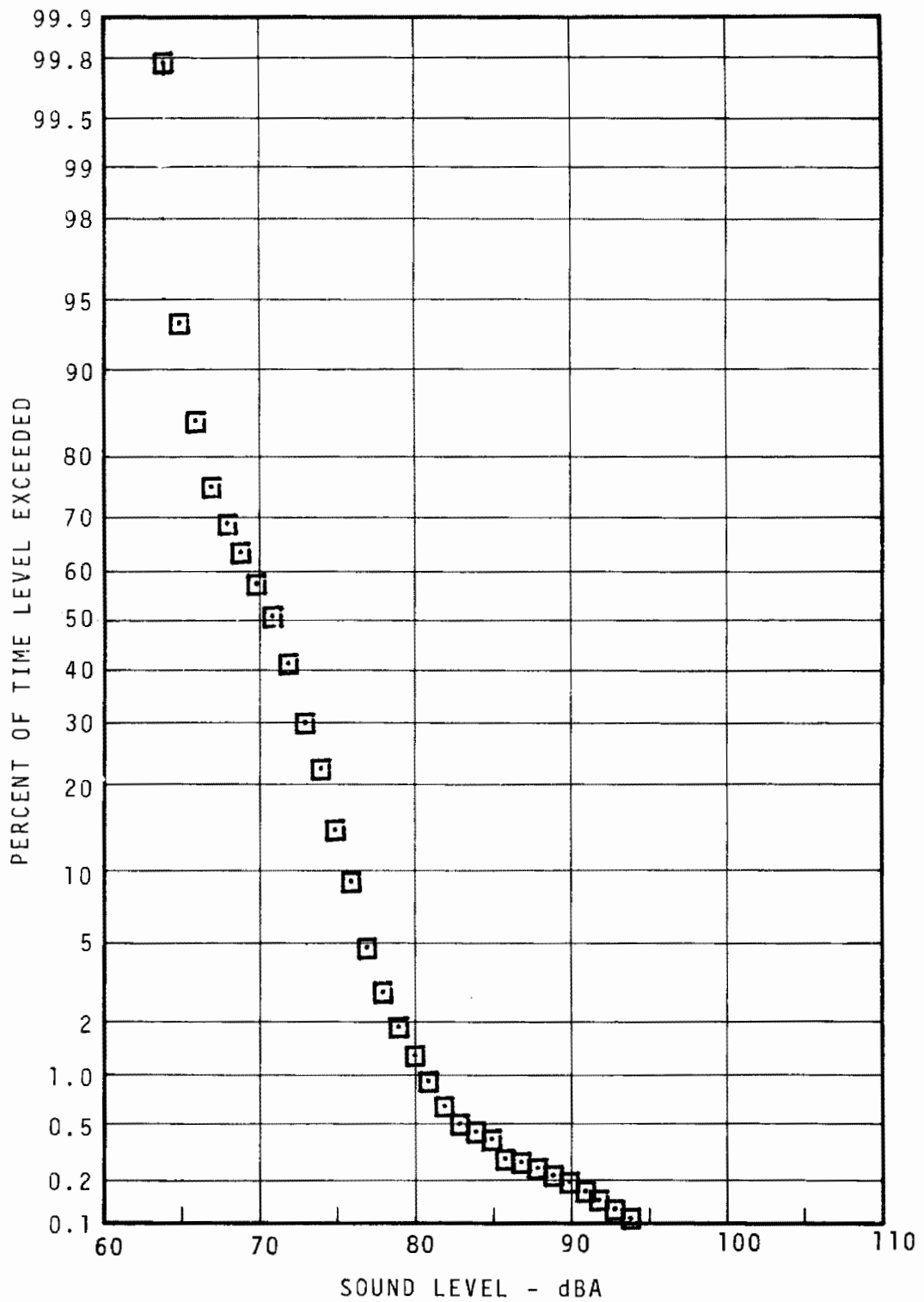

FIGURE 5.22 - BROAD AND WYOMING COMMUNITY STATISTICAL DISTRIBUTION -7.5M- EVENING

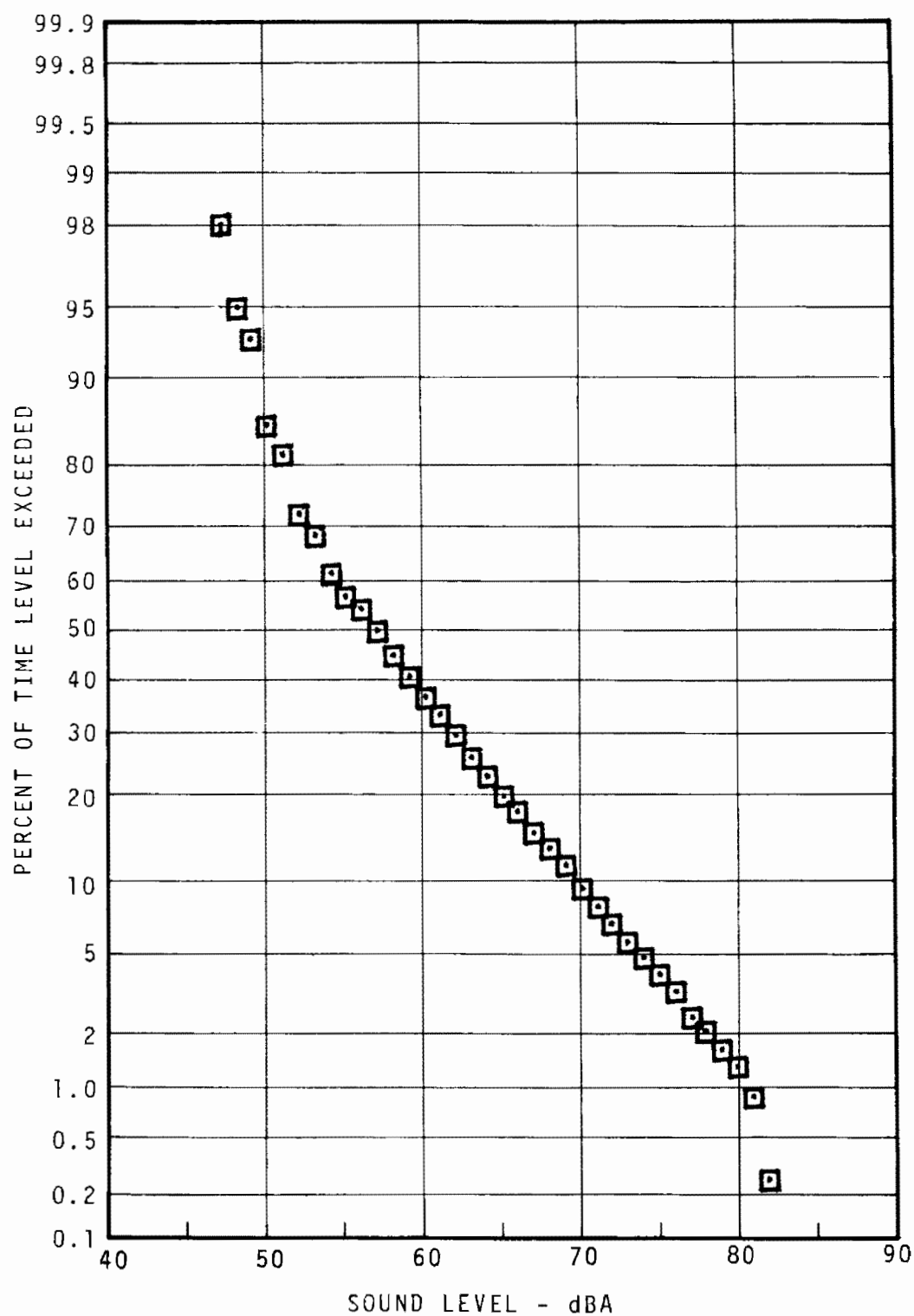

FIGURE 5.23 - BROAD AND WYOMING COMMUNITY STATISTICAL DISTRIBUTION -7.5M - NIGHT

5-39/5-40

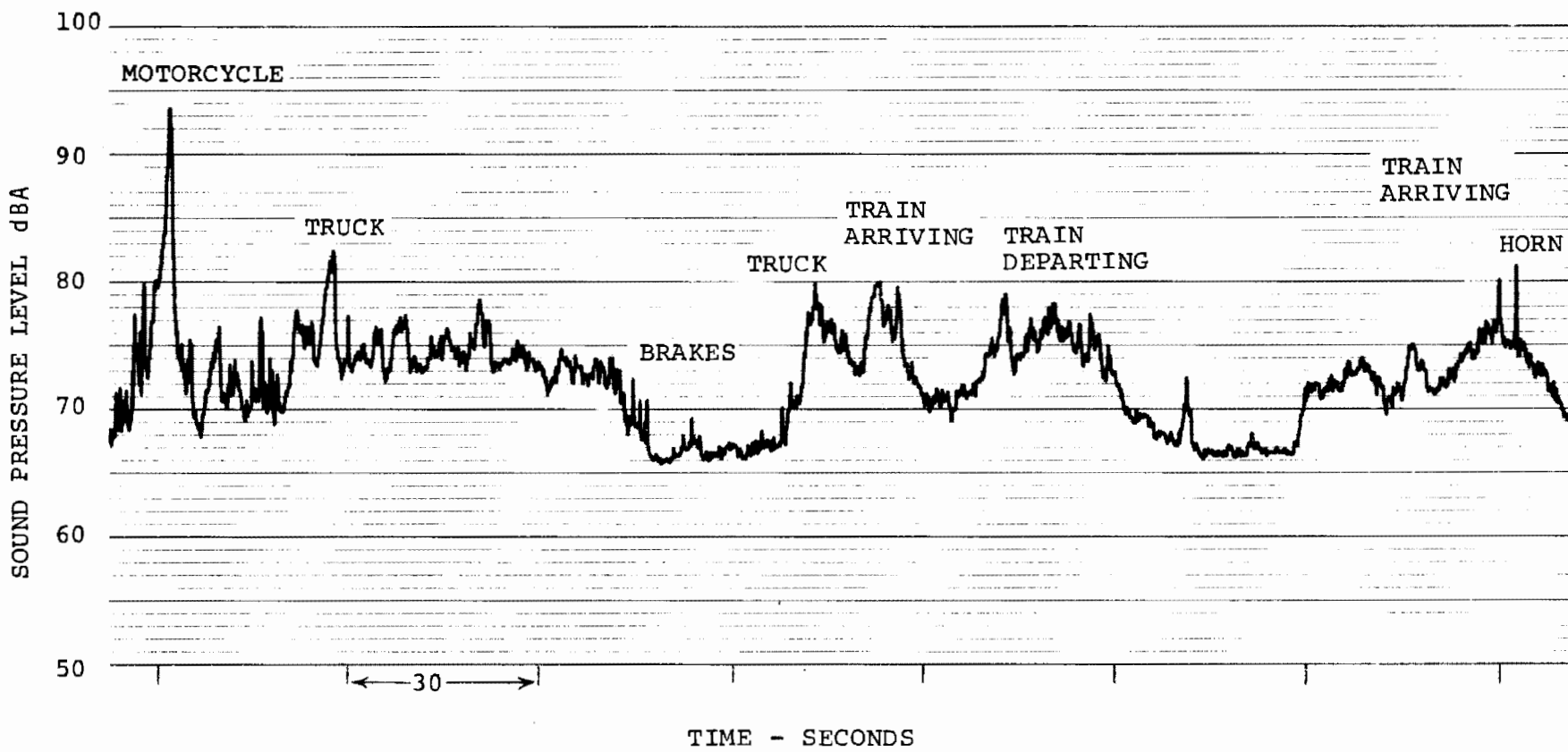
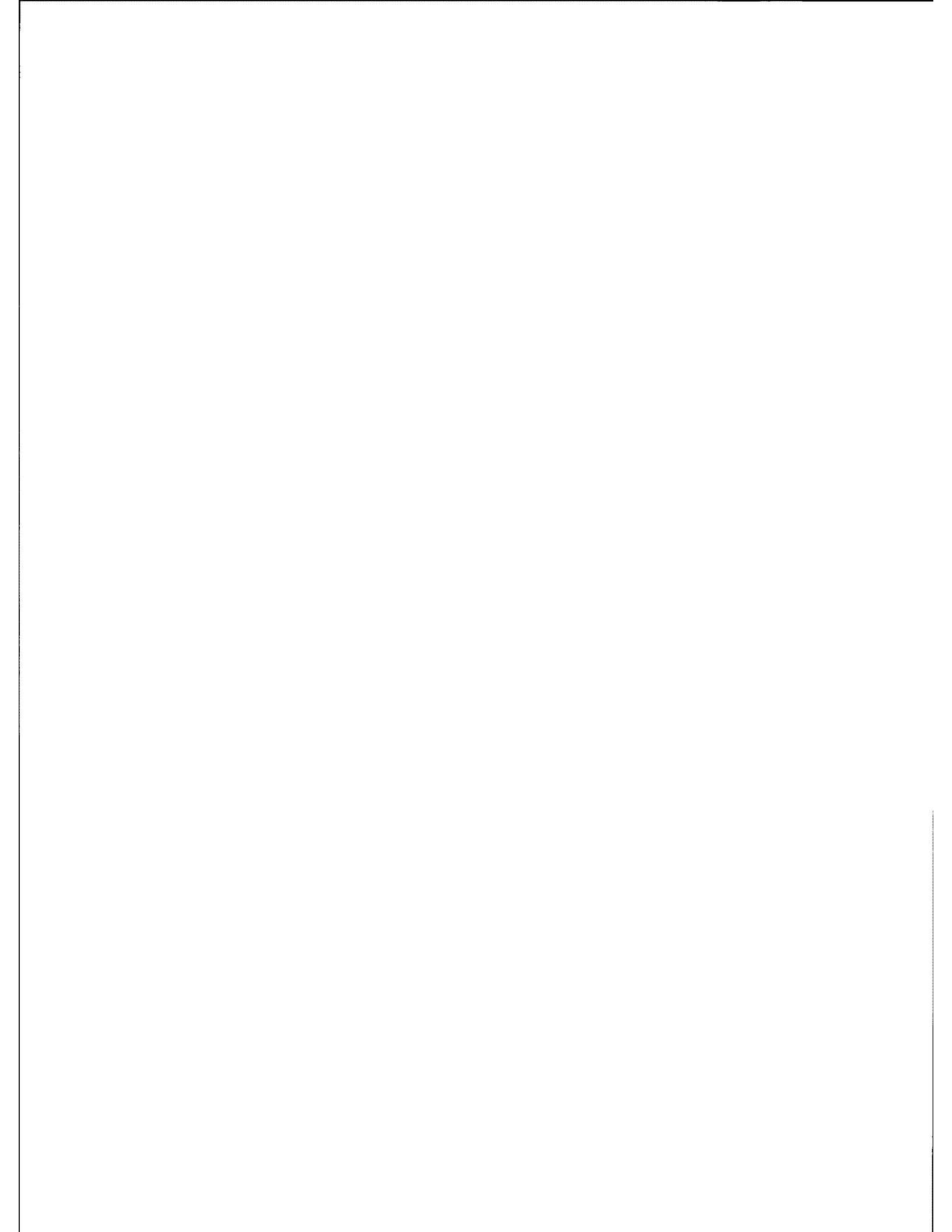

FIGURE 5.24 -TYPICAL TIME STUDY, BROAD & WYOMING, COMMUNITY



5.2.2 Station Platform

Station platform noise measurements were made for eight locations on the Broad Street Subway. Seven of these stations were on the main north-south line and one was on the Ridge Avenue spur. Two of the stations (Fern Rock and Pattison) were system terminals, four were 4-track on-line stations and two were 2-track on-line stations. Site selection was based on the rationale described in the following Table 5.6.

Table 5.6.

Station	Rationale
Fern Rock	An at-grade terminal. Car shops located here. Two tracks and center platform
Susquehanna-Dauphin	A typical skip-stop station. Four tracks and two side platforms.
Spring Garden	A four track, two center platform station.
Spring Garden (spur)	A two-track, two side platform station.
City Hall	A major interchange station with substantial patron activity. Four tracks and two center platforms.
Walnut-Locust	A typical all-stop station and an interchange with the PATCO Line. Four tracks and two center platforms.
Snyder	A two-track, center platform station.
Pattison	Underground terminal near Philadelphia sports complex. Major patron activity during sporting events. A new terminal. Two tracks and center platform.

FERN ROCK STATION

SITE DESCRIPTION (see Figure 5.25)

Fern Rock Station is the only station located on-grade. It consists of one center platform, bounded on each side by single tracks. Roadbed is of ballast and tie construction. Access to the platform from street level is achieved by an enclosed overhead walkway which also contains the cashier's booth.

The yard and shops for the Broad Street Line are located beyond the south side of the platform. A commuter parking lot is located between the station and the yard and shops. A bus depot is situated on Nedro Avenue on the north side of the station, approximately 10 ft. above rail level. The housing on Nedro Avenue is a mix of two- and three-story structures. On the south side of the platform, the yard and shops for the Broad Street Line extend, embracing a commuter parking lot access to which is by means of a driveway overpass over the tracks. On the opposite side of the station is a bus depot at street level, roughly 10 feet above the level of the rails. Nedro Avenue is a mix of two- and three-story stucco residential dwellings.

NOISE CLIMATE (see Table 5.7, Figures 5.26 - 5.30)

Maximum noise levels on the station platform are generated by arriving and departing trains. Ambient noise levels are low during the day, evening and night time hours but increase by 10 to 15 dBA during rush hour because of vehicular traffic on Nedro Avenue, as well as buses idling at the depot next to the station. Very audible at most times is the noise of the turnstiles adjacent to the cashier's booth as patrons enter. Other noises which propagate to the station platform originate within the yard and include trains sounding their horn entering and leaving the subway and wheel squeal generated on the approach tracks to the station.

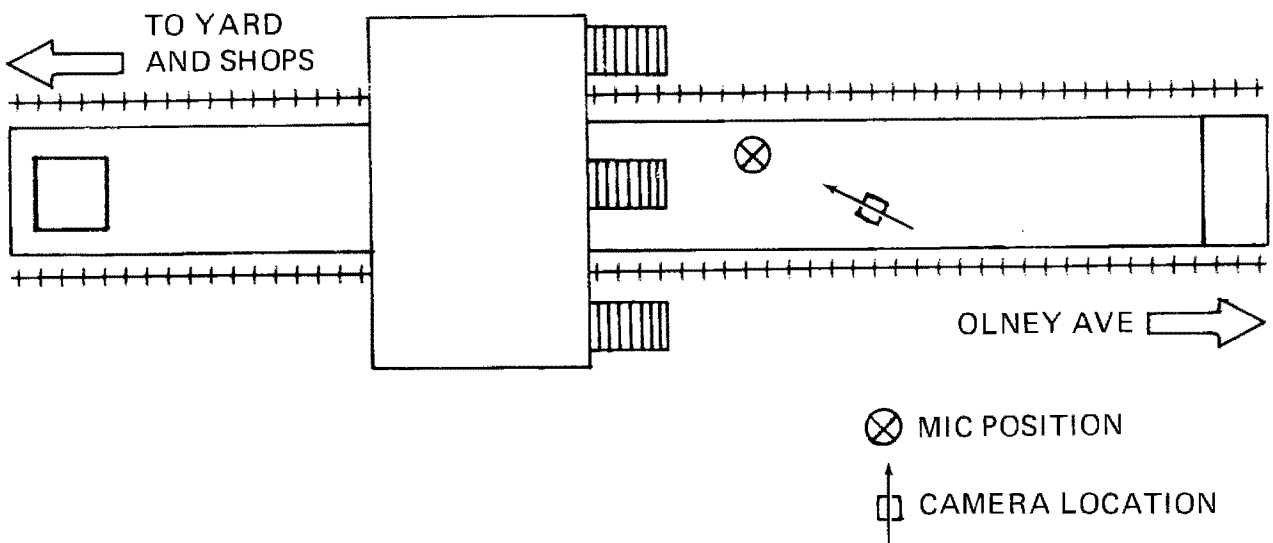

FIGURE 5.25 - FERN ROCK STATION PLATFORM - AT GRADE

TABLE 5.7-SUMMARY OF MEASUREMENT RESULTS FOR FERN ROCK STATION PLATFORM

TIME	MIC POSITION	SAMPLE TIME	TRAIN CONDITIONS	UNITS	AVG MAX LEVEL		AVG L _R		CUMULATIVE AMPLITUDE DISTRIBUTION					L _{eq}						
					NEAR	FAR	NEAR	FAR	L ₉₉	L ₉₀	L ₅₀	L ₁₀	L ₁							
					a) 3	1	3	1												
Day Rush Evening Night	Center of stopped train	30 min	Arrival	b) N	-	4-4	-	4-4	53	56	64	76	86	74						
				dBA		85		96												
				c) S		2.13		1.45												
			Departure	N	4-4	-	4-4	-												
				dBA	86		97													
				S	1.85		1.22													
			Arrival and departure	dBA											68	69	70	81	87	76
				dBA											53	54	58	71	83	70
				dBA											53	53	56	65	79	68

Notes: a - Track
b - Number of Trains -(e.g.: 4-2 means four 2-car trains)
c - Standard Deviation of Level

5-44

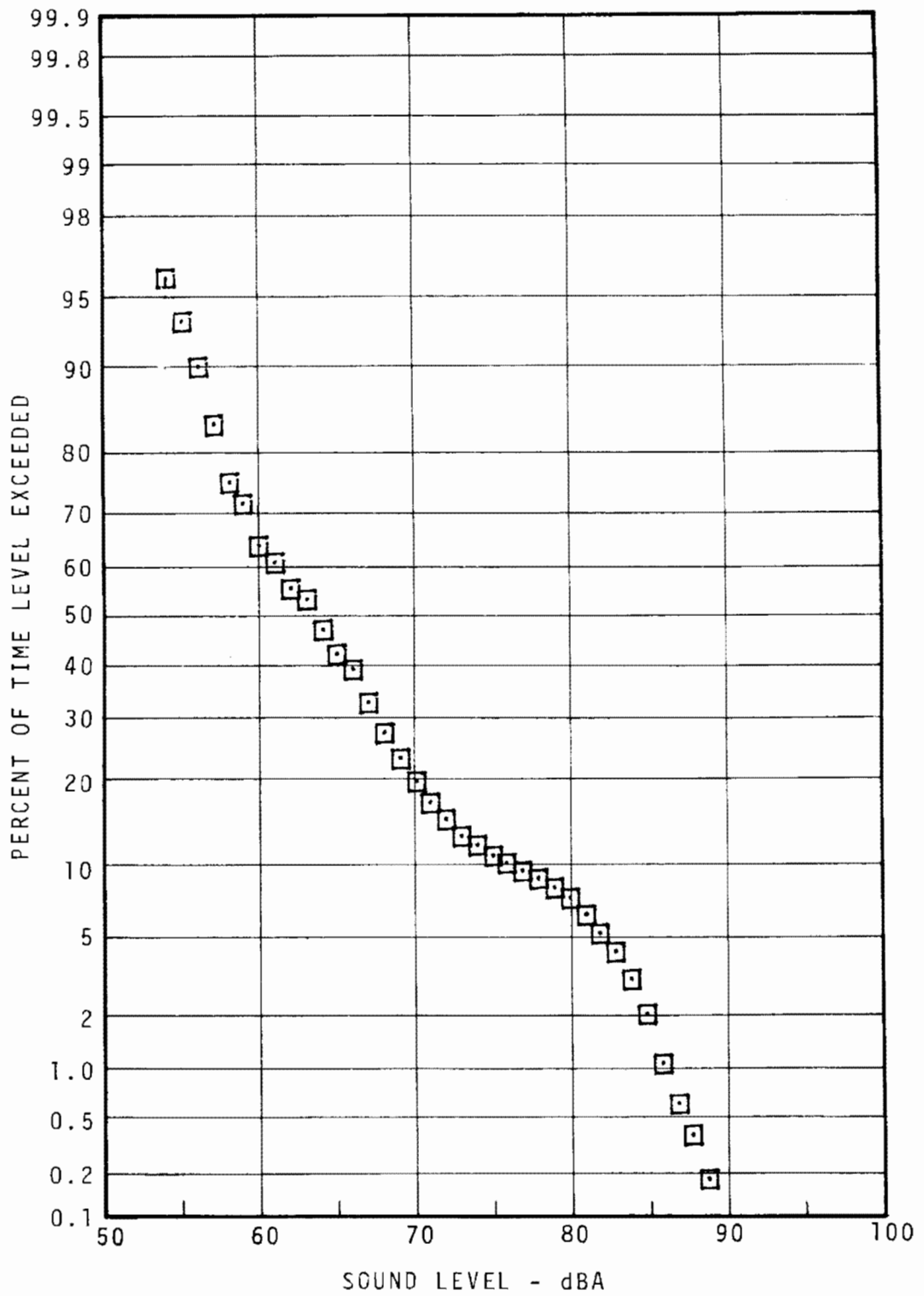

FIGURE 5.26 - FERN ROCK STATION PLATFORM
 STATISTICAL DISTRIBUTION
 DAYTIME

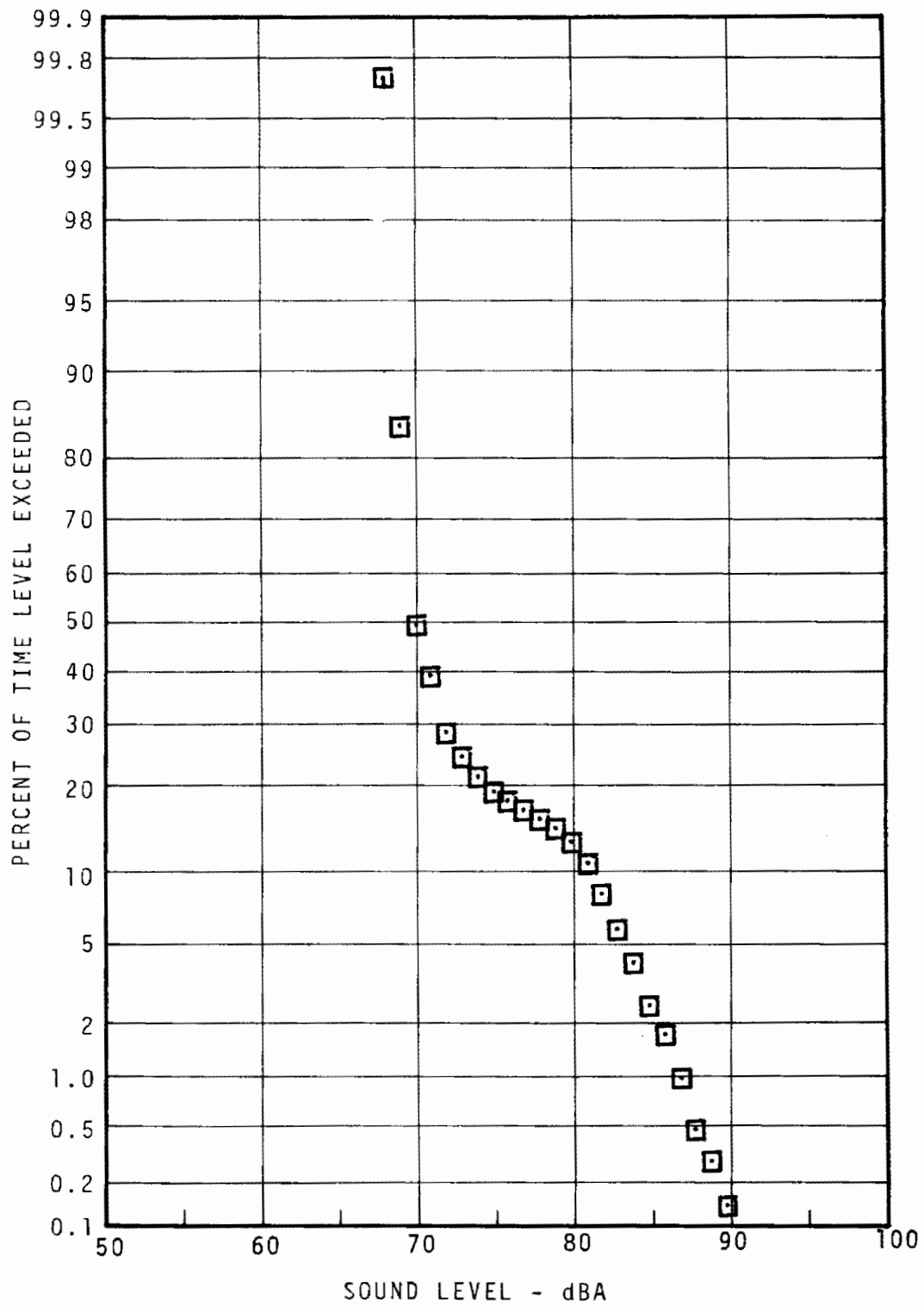

FIGURE 5.27 - FERN ROCK STATION PLATFORM
 STATISTICAL DISTRIBUTION
 RUSH HOUR

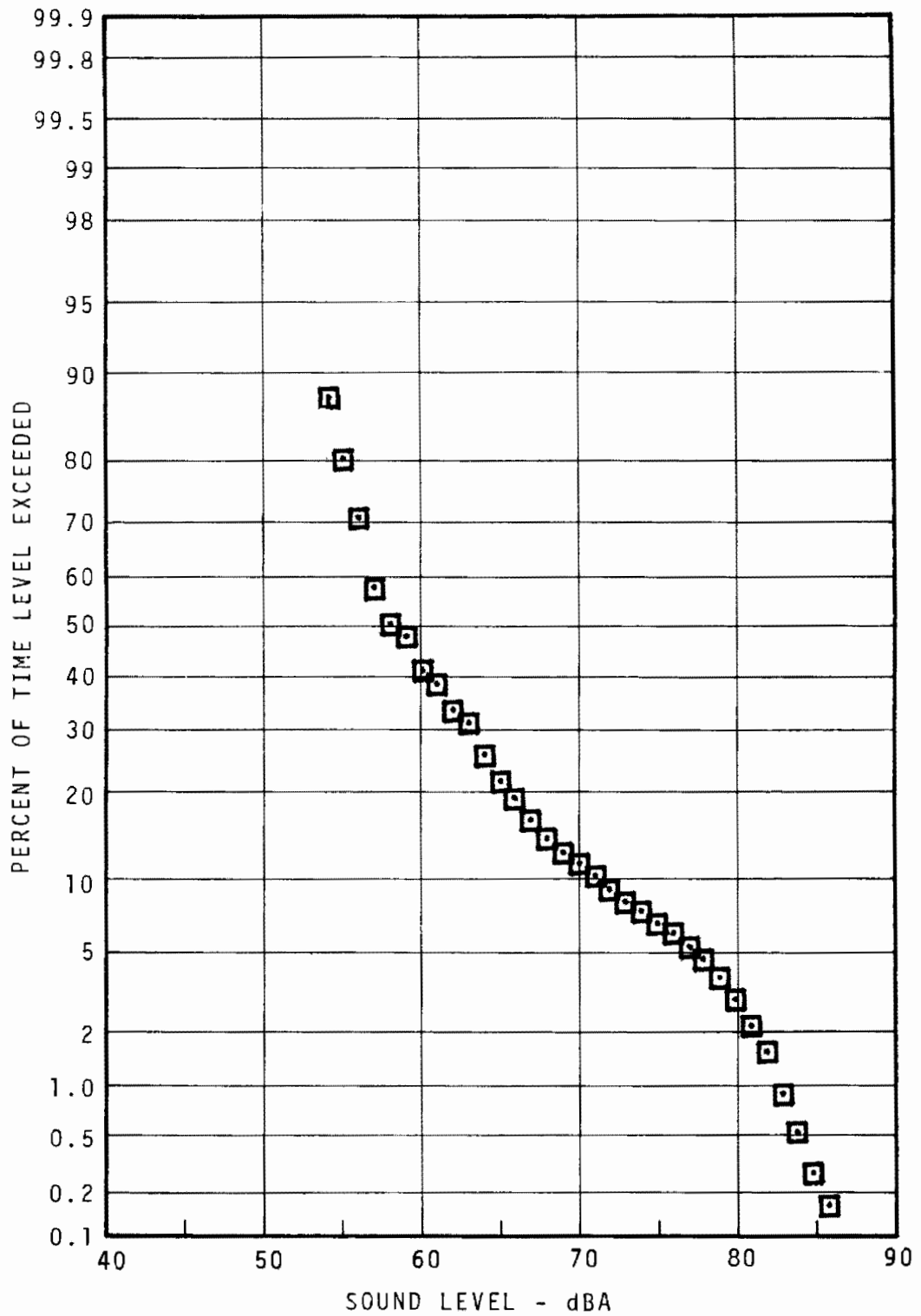

FIGURE 5.28 - FERN ROCK STATION PLATFORM
 STATISTICAL DISTRIBUTION
 EVENING

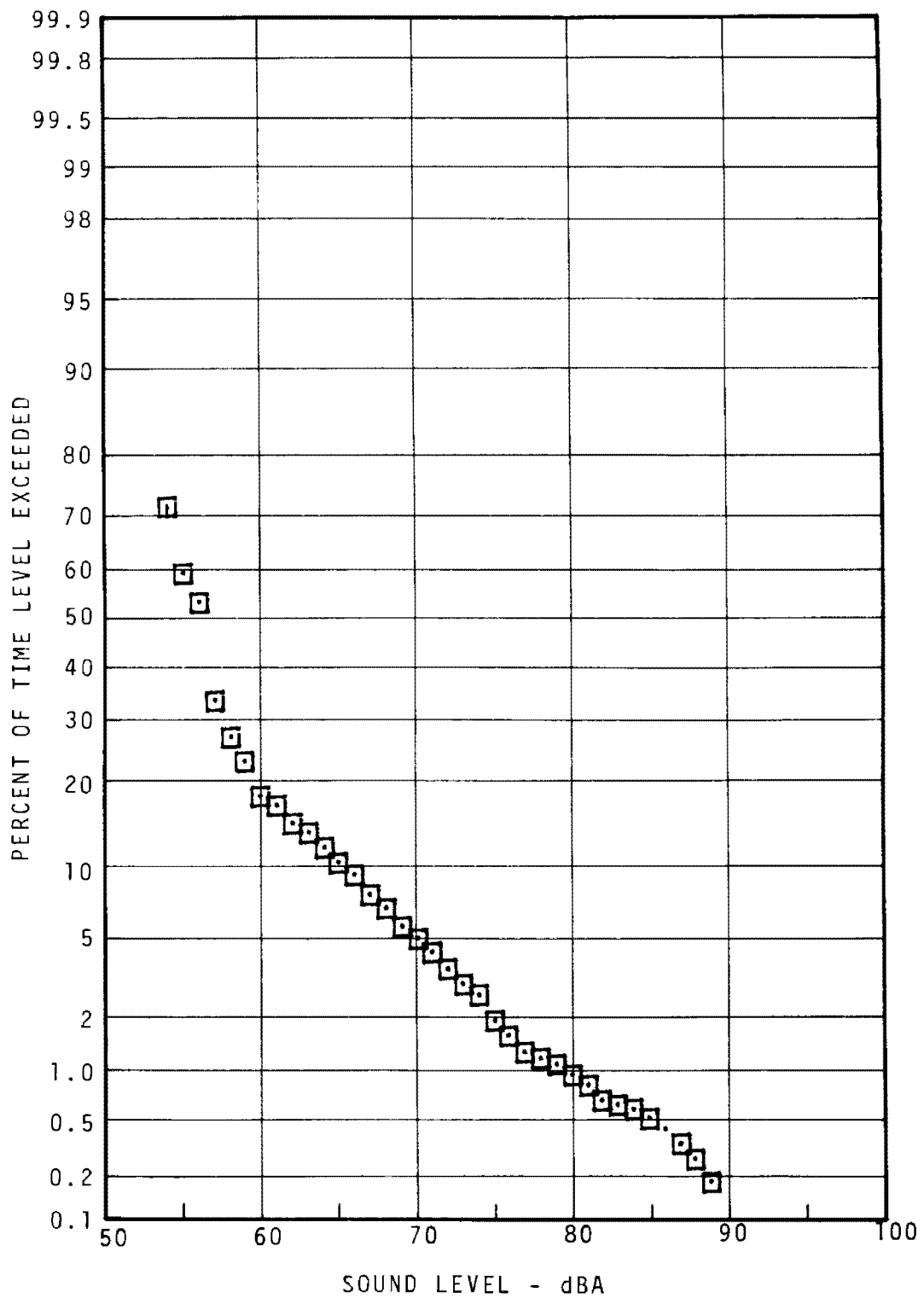

FIGURE 5.29 - FERN ROCK LOCATION PLATFORM
 STATISTICAL DISTRIBUTION
 NIGHT

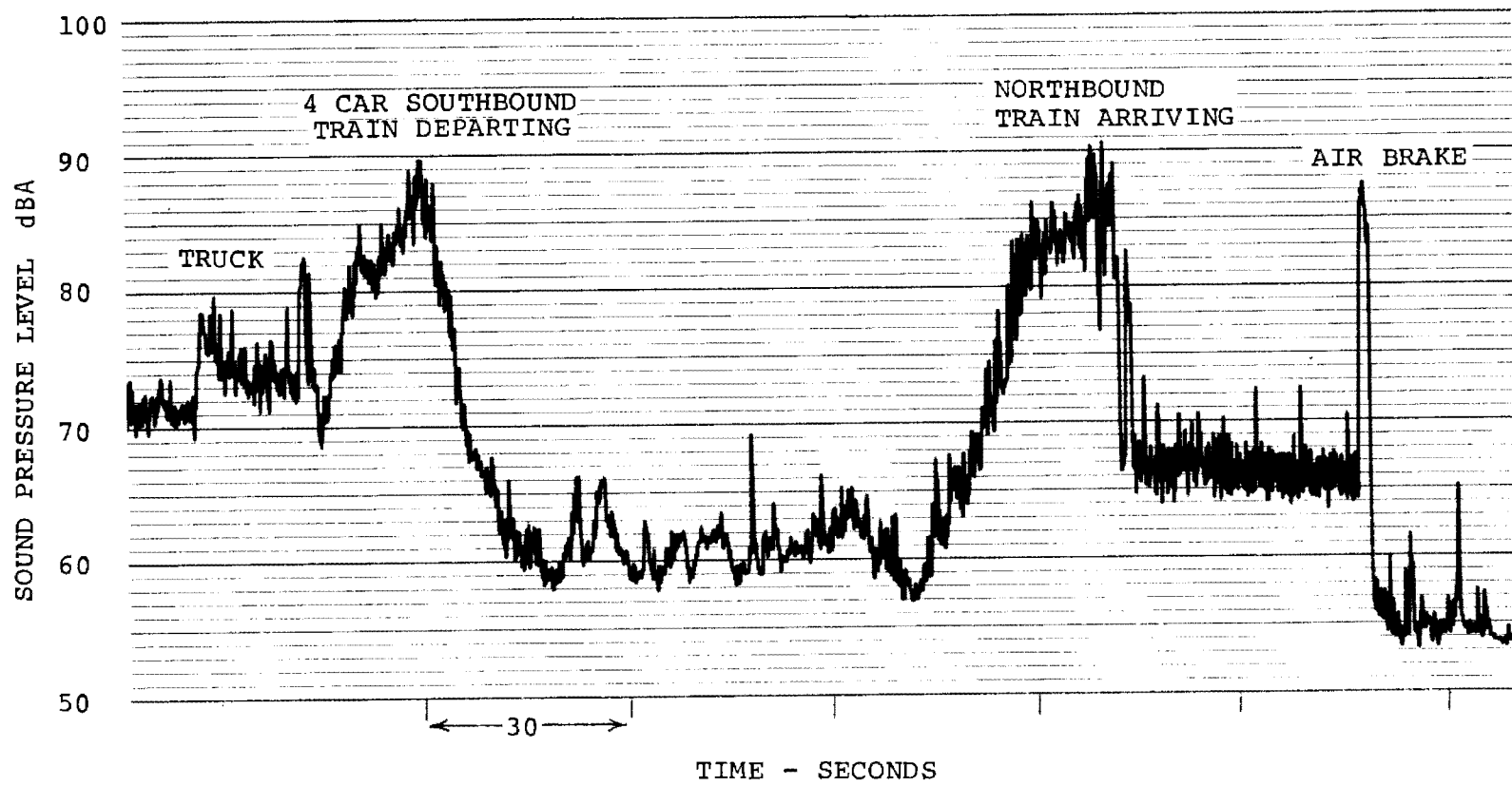

FIGURE 5.30 - TYPICAL TIME HISTORY, FERNROCK STATION

SUSQUEHANNA-DAUPHIN STATION

SITE DESCRIPTION (see Figure 5.31)

This station is a typical underground express skip-stop station with side platforms adjacent to the two outer local tracks. It is located between Dauphin Street and Susquehanna Avenue. Patrons enter from street level on either side of Broad Street to platform level, where the cashier's booth is located. The platforms are approximately 12 feet wide between the cashier's booth and the track. The platform floor is concrete, the walls are ceramic tile, and the cover consists of concrete beams with approximately five feet spacing.

NOISE CLIMATE (see Table 5.8, Figures 5.32 - 5.35)

When there are no trains in the vicinity of this station, the traffic noise from Broad Street can be heard at station platform level, by way of stairwells and air vents located north and south of the station. Trains can be heard approaching one to two stations distant, especially the express trains. Express trains generate higher noise levels than local trains as a result of their higher speed.



← COLUMBIA

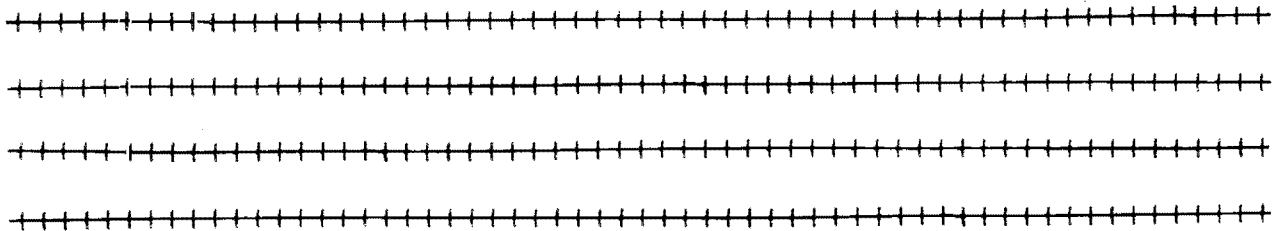
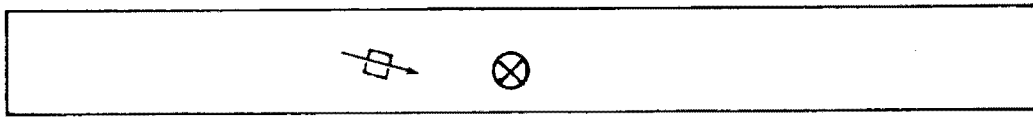

NORTH PHILA →

⊗ MIC POSITION

⊞ CAMERA LOCATION

FIGURE 5.31 - SUSQUEHANNA-DAUPHIN SUBWAY STATION PLATFORM

TABLE 5.8 SUMMARY OF MEASUREMENT RESULTS FOR SUSQUEHANNA - DAUPHIN STATION PLATFORM

TIME	MIC POSITION	SAMPLE TIME	TRAIN CONDITIONS	UNITS	AVG MAX LEVEL		AVG LR		CUMULATIVE AMPLITUDE DISTRIBUTION					Leq
					NEAR	FAR	NEAR	FAR	L99	L90	L50	L10	L1	
					a) South	North	South	North						
Day	Center of stopped train	30 min	Arrival	b) N	4-4	5-4	4-4	5-4	67	67	69	90	97	86
				dBA	97	96	107	105						
				c) S	0.85	0.87	0.76	0.90						
			Departure	N	4-4	5-4	4-4	5-4						
				dBA	100	97	109	107						
				S	2.80	1.34	2.82	1.10						
			Arrival	N	1-6		1-6							
				dBA	98		108							
				S	-		-							
			Departure	N	1-6		1-6							
				dBA	98.5		108							
				S	-		-							
Rush			Arrival and departure	dBA					76	76	77	93	106	93
Night			Arrival and departure	dBA					69	70	71	77	93	80

Notes: a - Track
b - Number of Trains -(e.g.: 4-2 means four 2-car trains)
c - Standard Deviation of Level

5-52

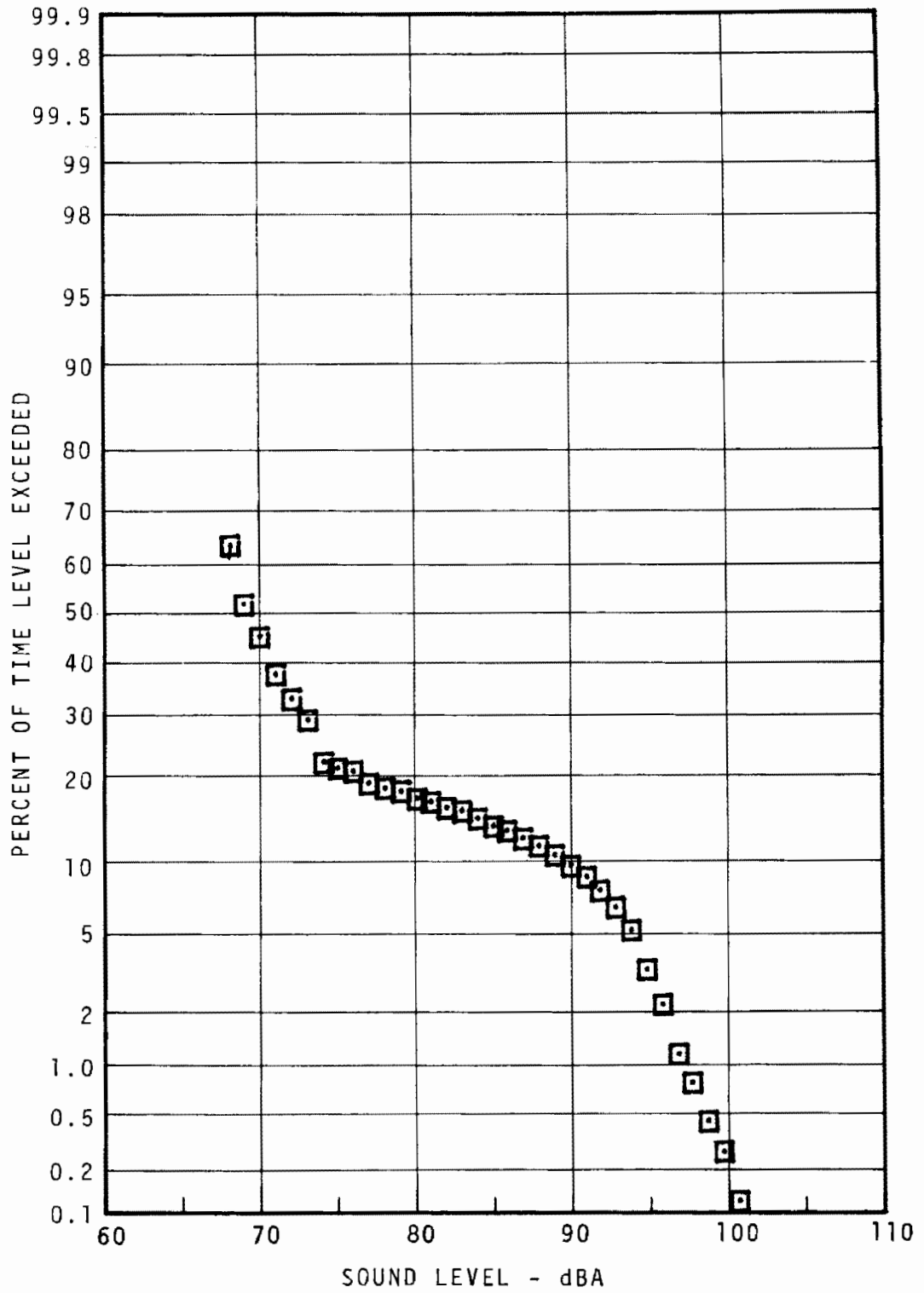

FIGURE 5.32. - SUSQUEHANNA-DAUPHIN STATION
 PLATFORM STATISTICAL DISTRIBUTION
 DAYTIME

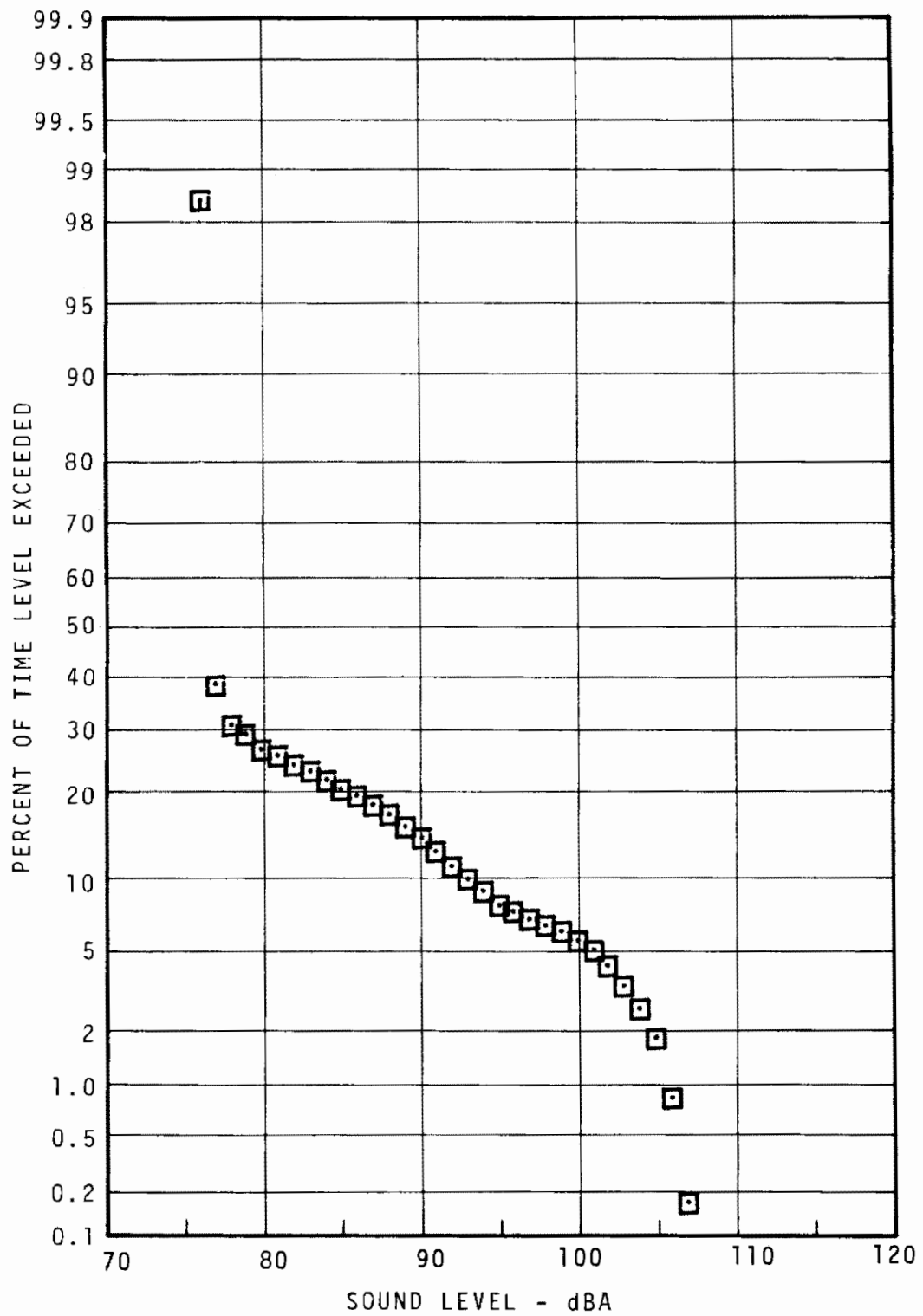

FIGURE 5.33 - SUSQUEHANNA-DAUPHIN STATION
 PLATFORM STATISTICAL DISTRIBUTION
 RUSH HOUR

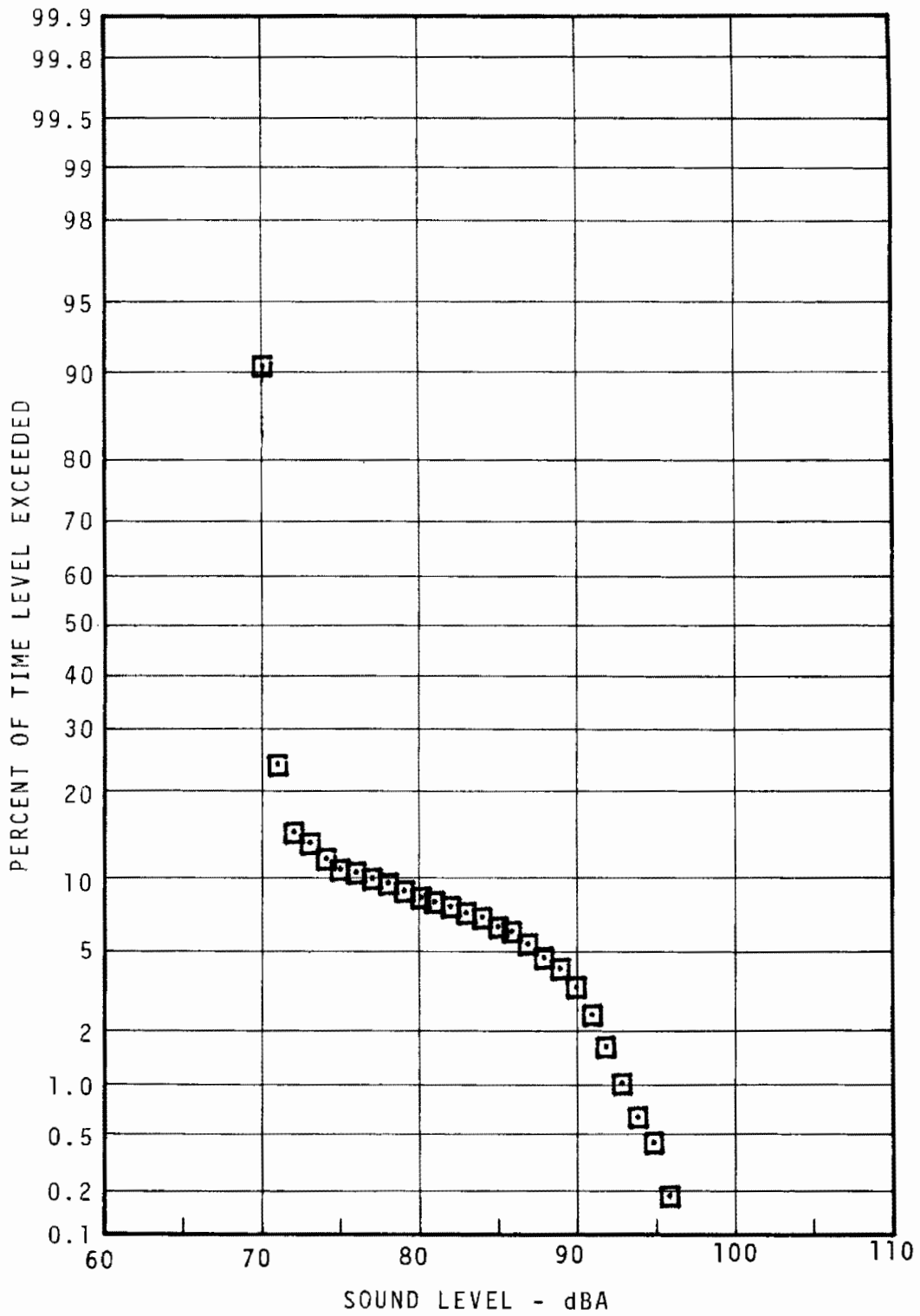

FIGURE 5.34 - SUSQUEHANNA-DAUPHIN STATION
 PLATFORM STATISTICAL DISTRIBUTION
 NIGHT

5-56/5-57

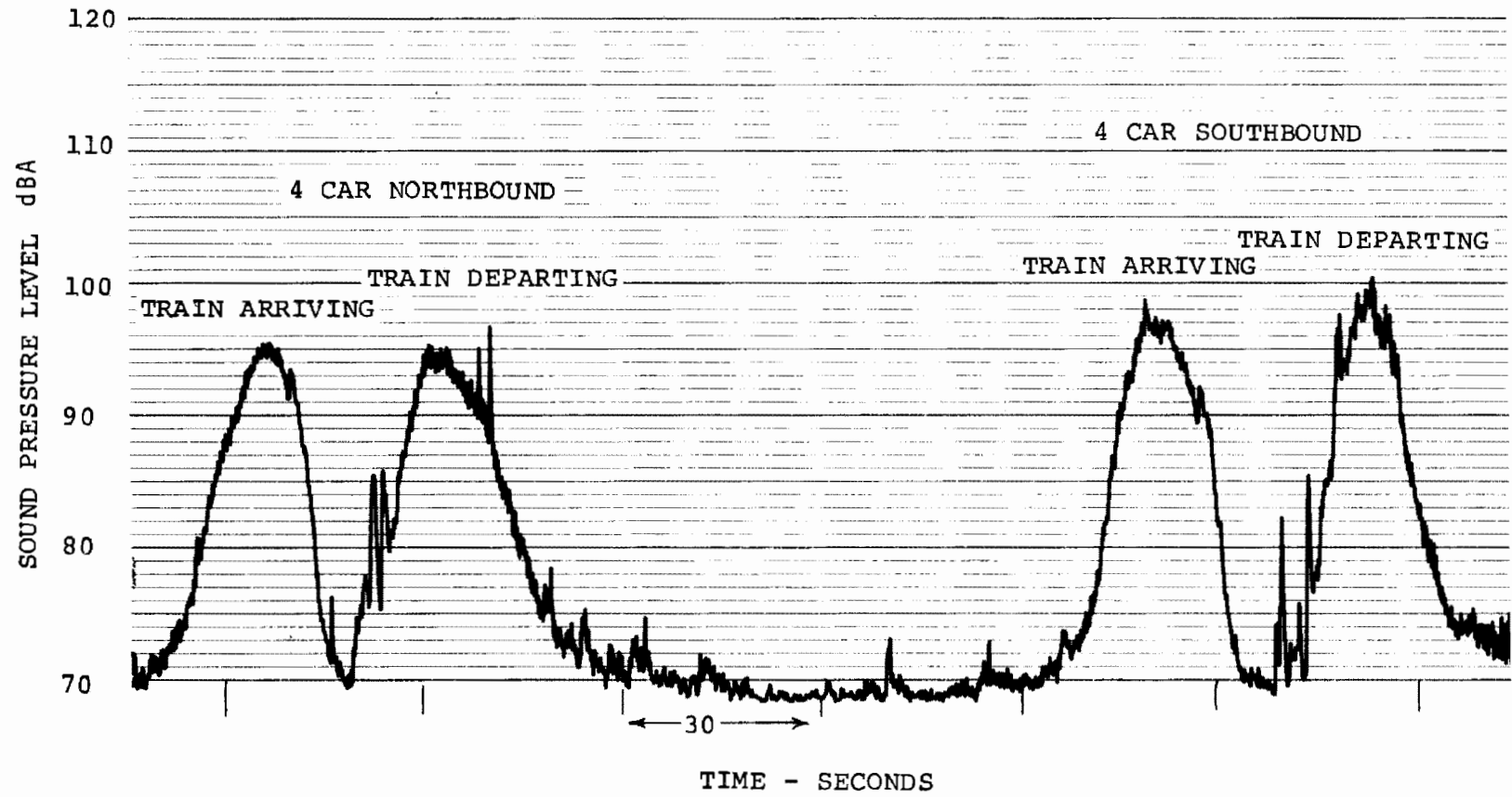
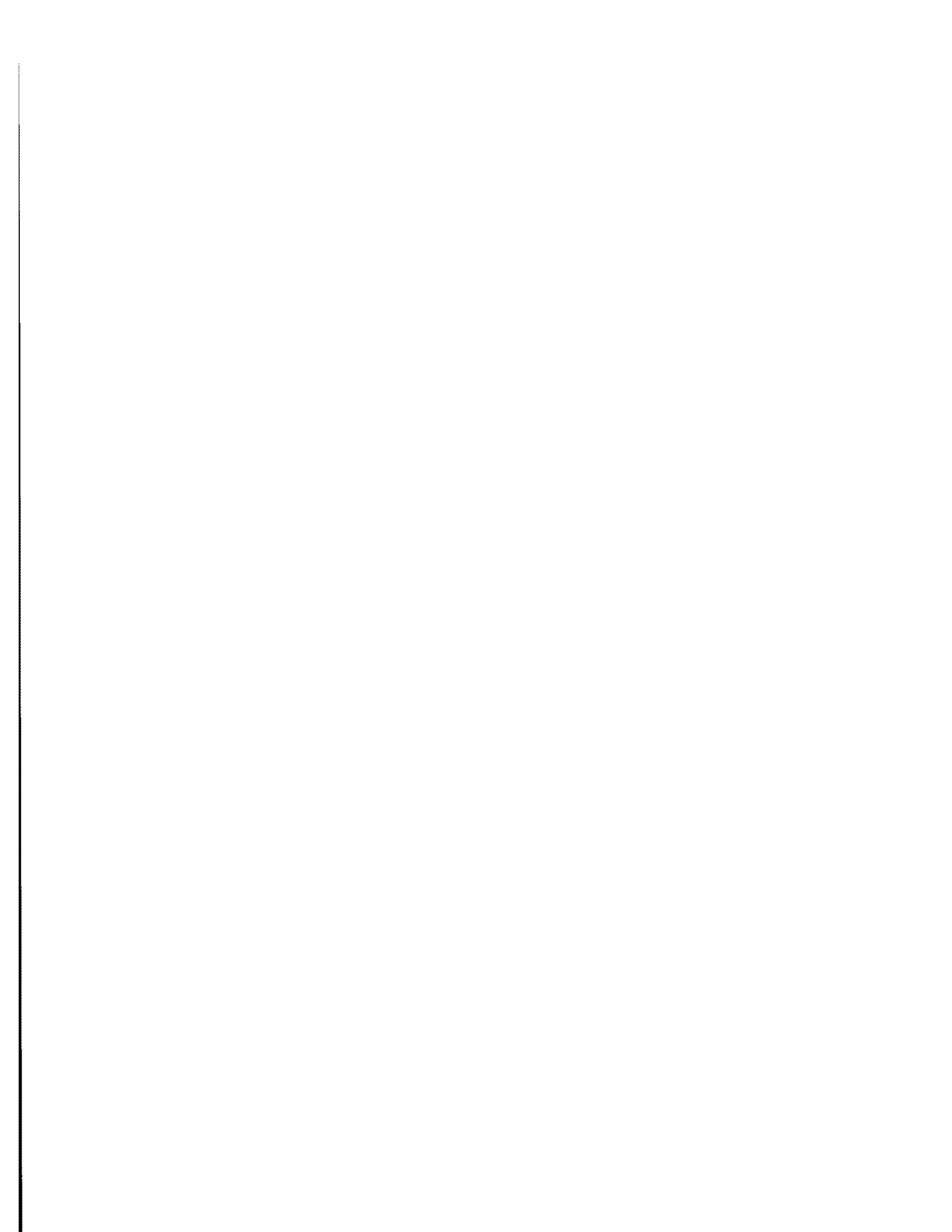

FIGURE 5.35 - TYPICAL TIME HISTORY, SUSQUEHANNA & DAUPHIN, STATION



SPRING GARDEN STATION

(BROAD STREET)

SITE DESCRIPTION (see Figure 5.36)

Spring Garden Station is a four track, two island platform station stop for both local and express trains. Local trains use outer tracks while express trains operate on the inner two tracks. Express tracks are straight, whereas local tracks curve outward from the center express tracks around the platforms. Station platforms are constructed of concrete as are the outer walls. Patrons reach street level by means of stairways on the two center island platforms.

NOISE CLIMATE (see Table 5.9, Figures 5.37 - 5.42)

The noise climate of the Spring Garden Station is characterized by the rumble of vehicular traffic from Broad Street, and of approaching and departing trains. When local trains approach the station from both north and south, a moderate amount of flange rubbing and some occasional squeal can be heard as trains negotiate the curve of the local tracks. North of the station a crossover produces impact noises.

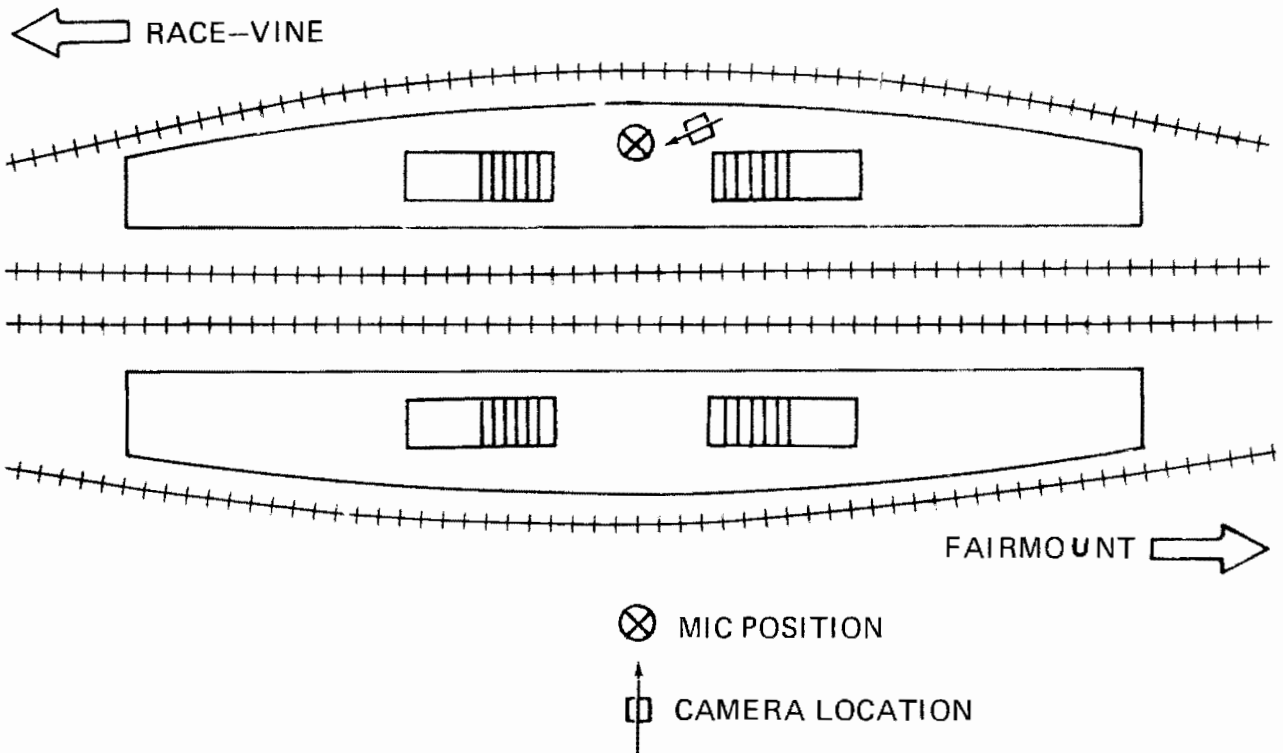

FIGURE 5.36 - SPRING GARDEN SUBWAY STATION PLATFORM

TABLE 5.9- SUMMARY OF MEASUREMENT RESULTS FOR SPRING GARDEN STATION PLATFORM

TIME	MIC POSITION	SAMPLE TIME	TRAIN CONDITIONS	UNITS	AVG MAX LEVEL		AVG L _R		CUMULATIVE AMPLITUDE DISTRIBUTION					Leq	
					NEAR	FAR	NEAR	FAR	L ₉₉	L ₉₀	L ₅₀	L ₁₀	L ₁		
					a) South	North	South	North							
Day	Center of stopped train 2 m from edge of local track	30 min	Arrival	b) N	5-4	5-4	5-4	3-4	56	57	62	84	92	80	
				dBA	92	89	101	99							
				c) S	1.04	3.91	1.10	3.42							
			Departure	N	5-4	5-4	4-4	5-4							
				dBA	92	90	101	101							
				S	2.00	0.91	1.86	0.67							
Day	Center of stopped train 2 m from edge of express track		30 min	Arrival	N	3-4	4-4	3-4	4-4	61	61	63	78	87	74
					dBA	94	94	104	104						
					S	1.21	4.62	0.90	4.35						
				Departure	N	3-4	4-4	3-4	4-4						
					dBA	99	93	108	103						
					S	1.18	1.4	1.25	1.03						
Arrival	N	1-6			1-6										
	dBA	96.8			106										
	S	-			-										
Departure	N	1-6			1-6										
	dBA	98.2			107.5										
	S	-			-										
Rush	2 m from local track	30 min	Arrival and departure	dBA					66	67	69	89	96	84	
Night				dBA					69	69	73	74	90	77	

Notes: a - Track
 b - Number of Trains -(e.g.: 4-2 means four 2-car trains)
 c - Standard Deviation of Level

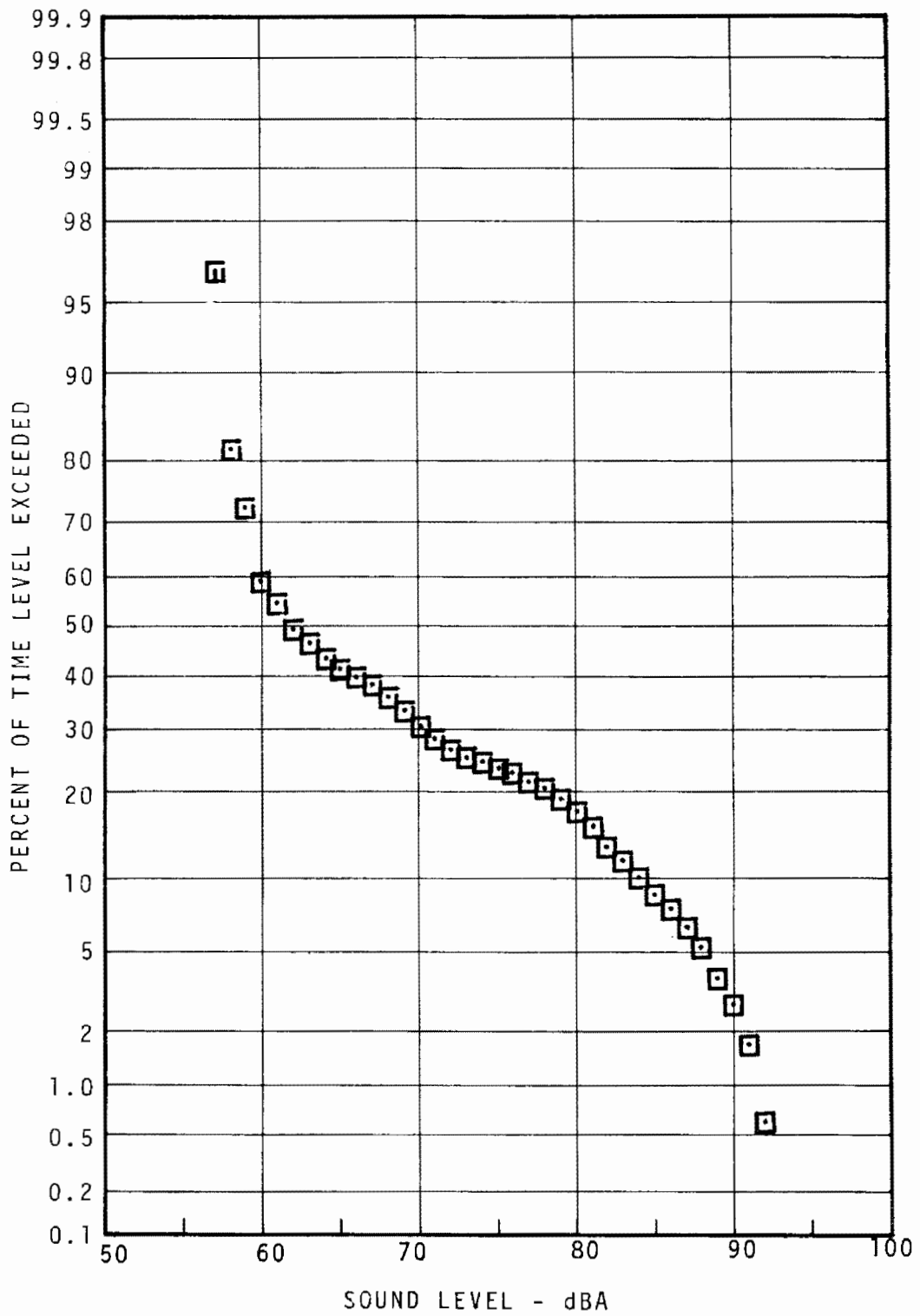

FIGURE 5.37 - SPRING GARDEN STATION
 PLATFORM STATISTICAL DISTRIBUTION
 DAYTIME - LOCAL TRACK SIDE

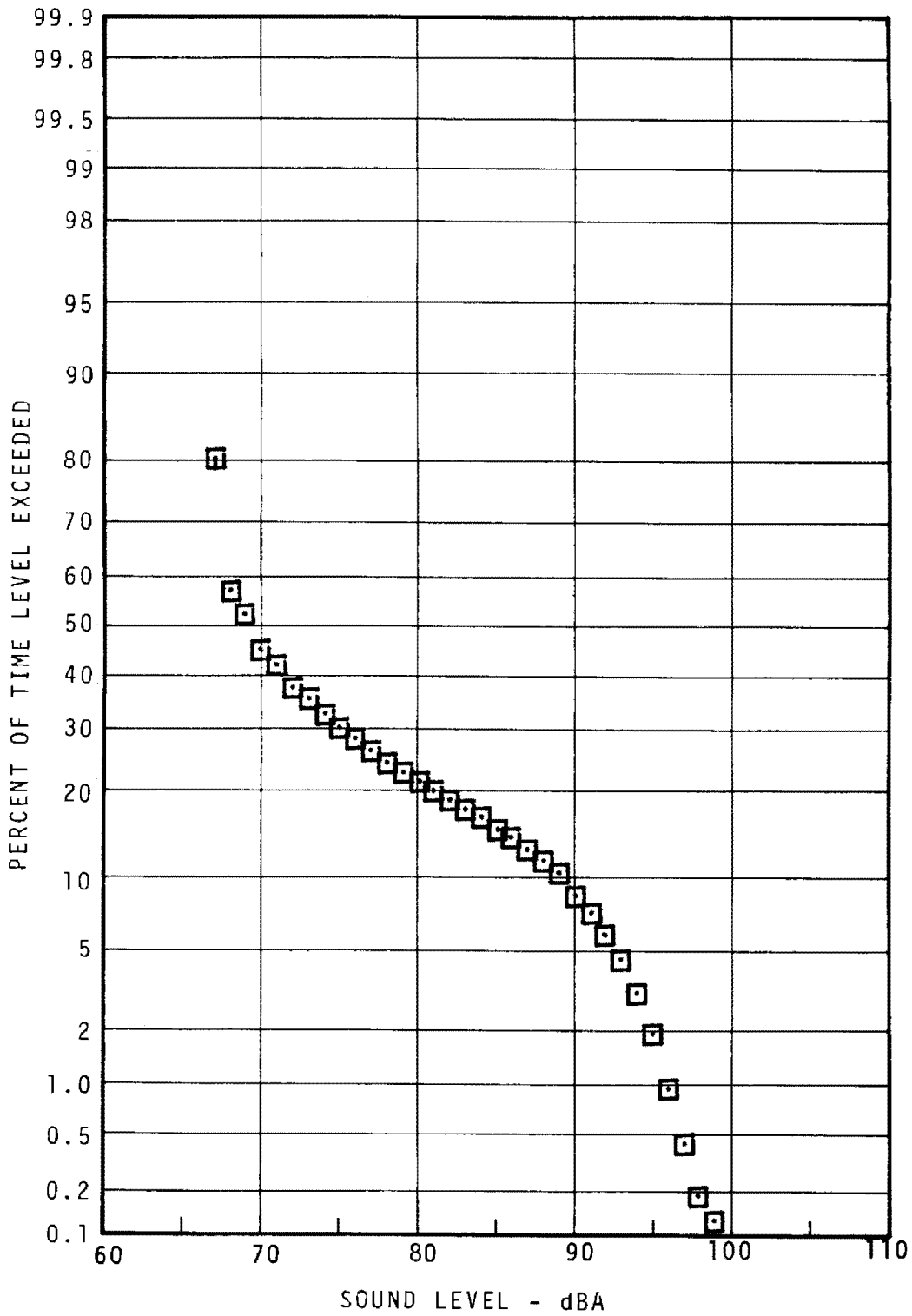

FIGURE 5.38 - SPRING GARDEN STATION
 PLATFORM STATISTICAL DISTRIBUTION -
 RUSH HOUR - LOCAL TRACK SIDE

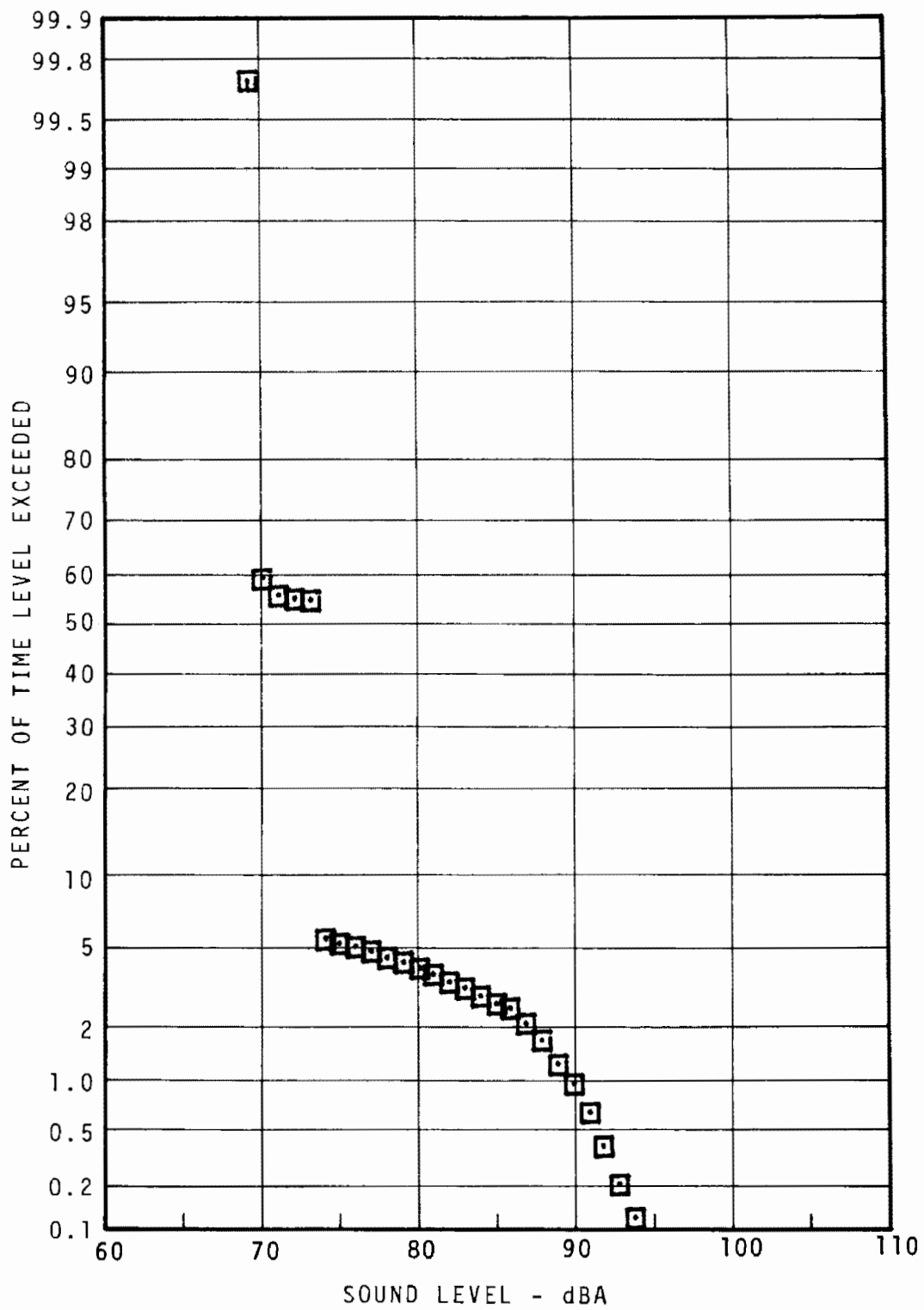

FIGURE 5.39 - SPRING GARDEN STATION
 PLATFORM STATISTICAL DISTRIBUTION -
 NIGHT - LOCAL TRACK SIDE

5-64

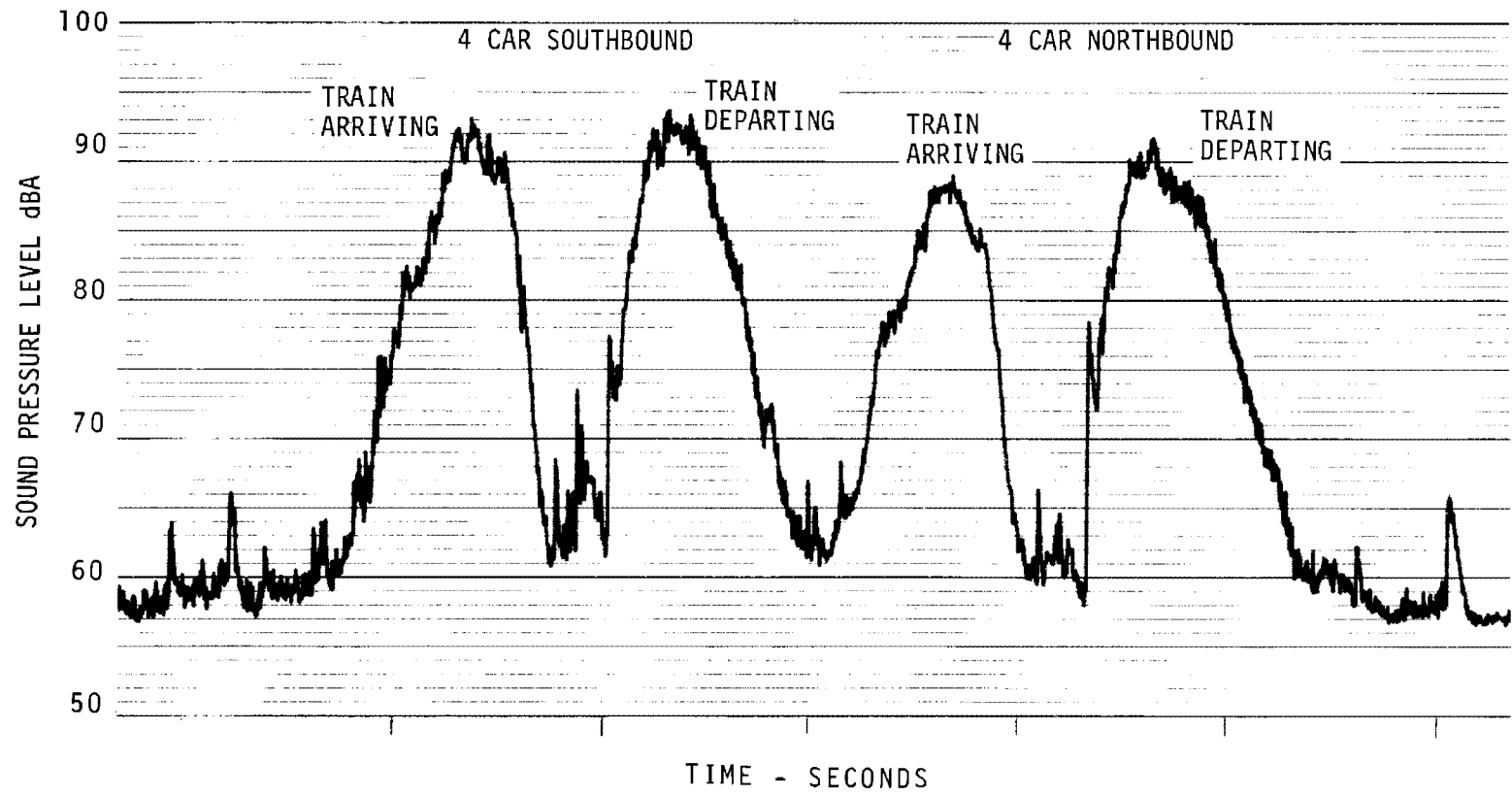

FIGURE 5.40 - TYPICAL TIME HISTORY, SPRING GARDEN STATION (BROAD) LOCAL TRACK

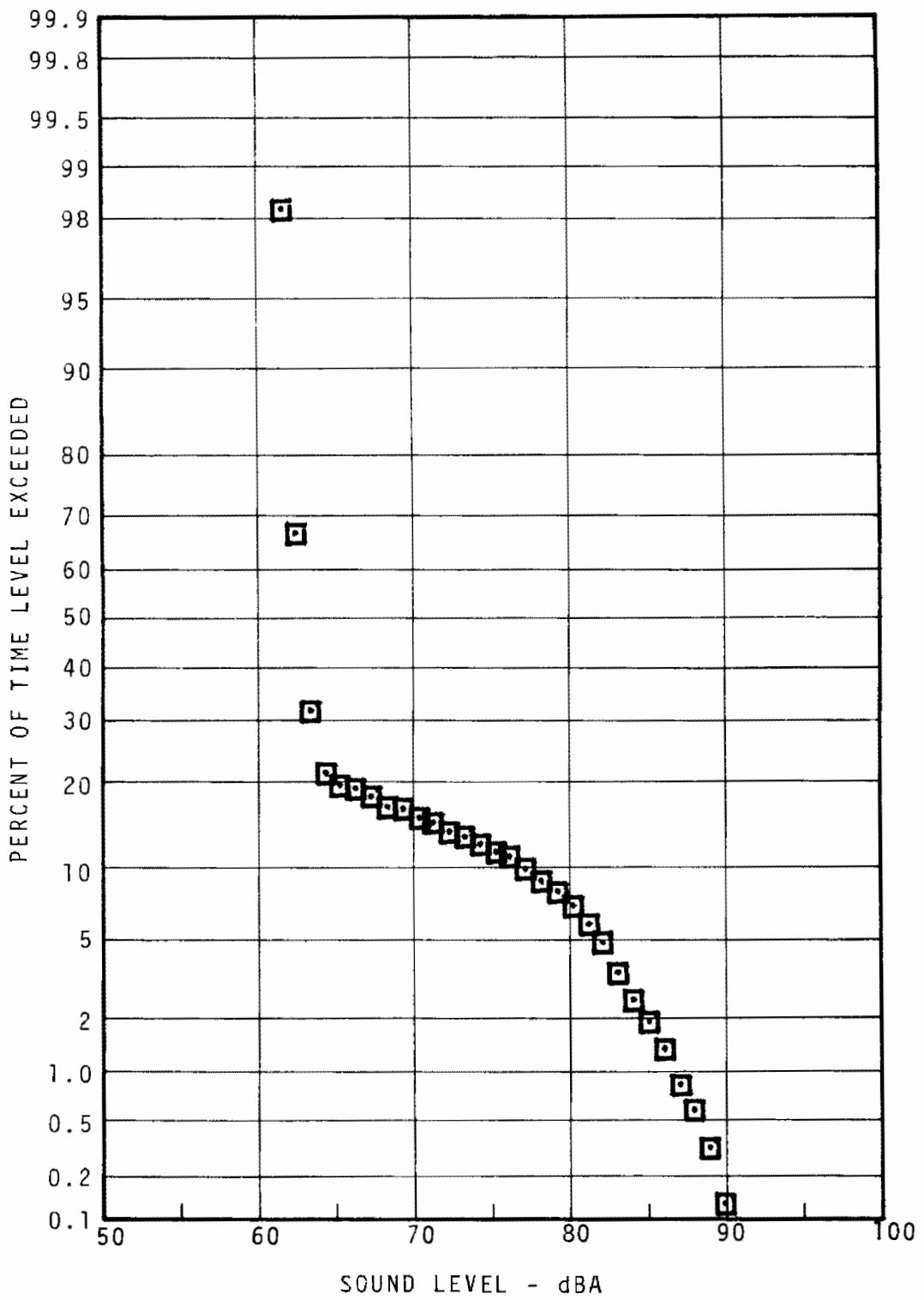

FIGURE 5.41 - SPRING GARDEN STATION
 PLATFORM STATISTICAL DISTRIBUTION
 DAYTIME - EXPRESS TRACK SIDE

5-66/5-67

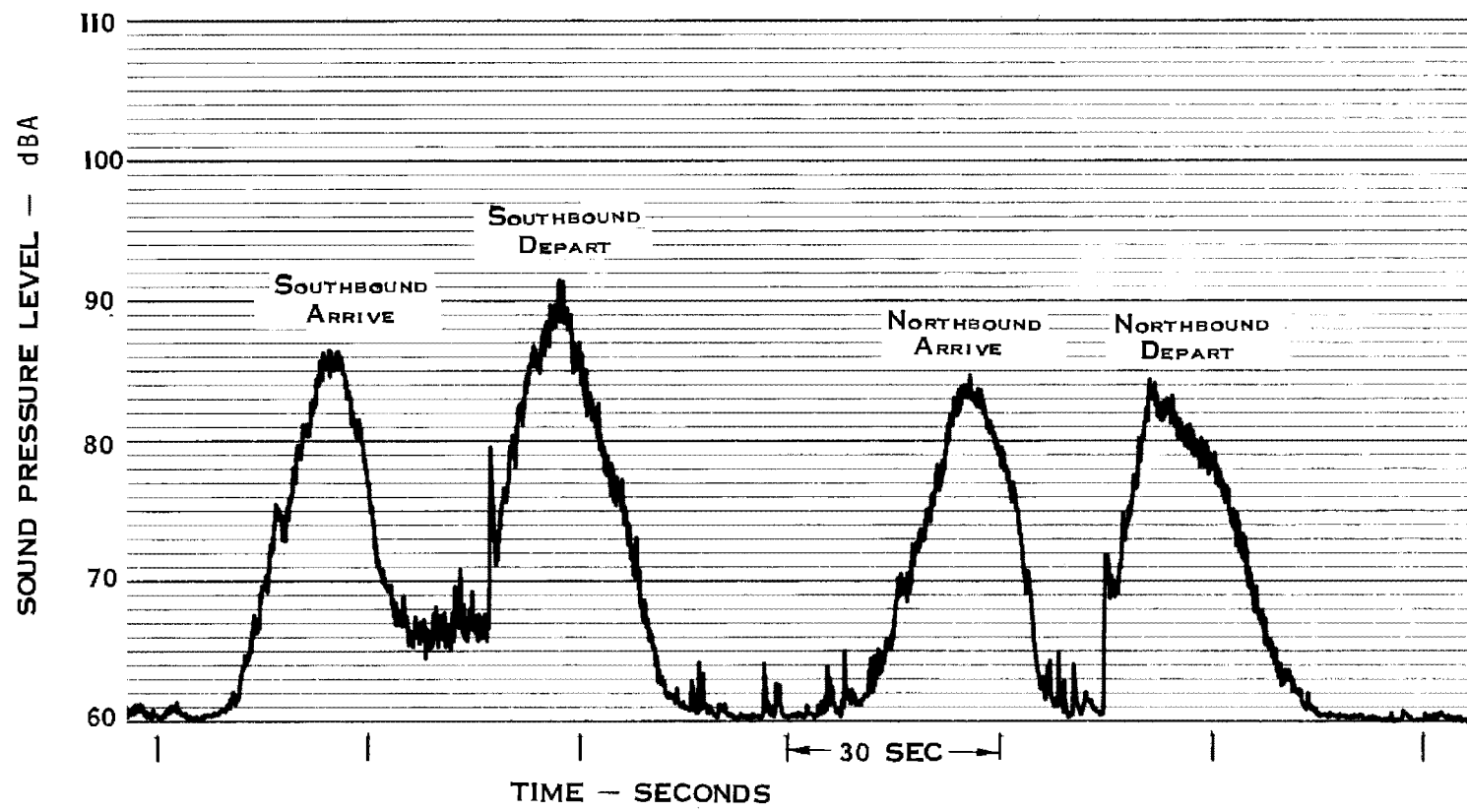
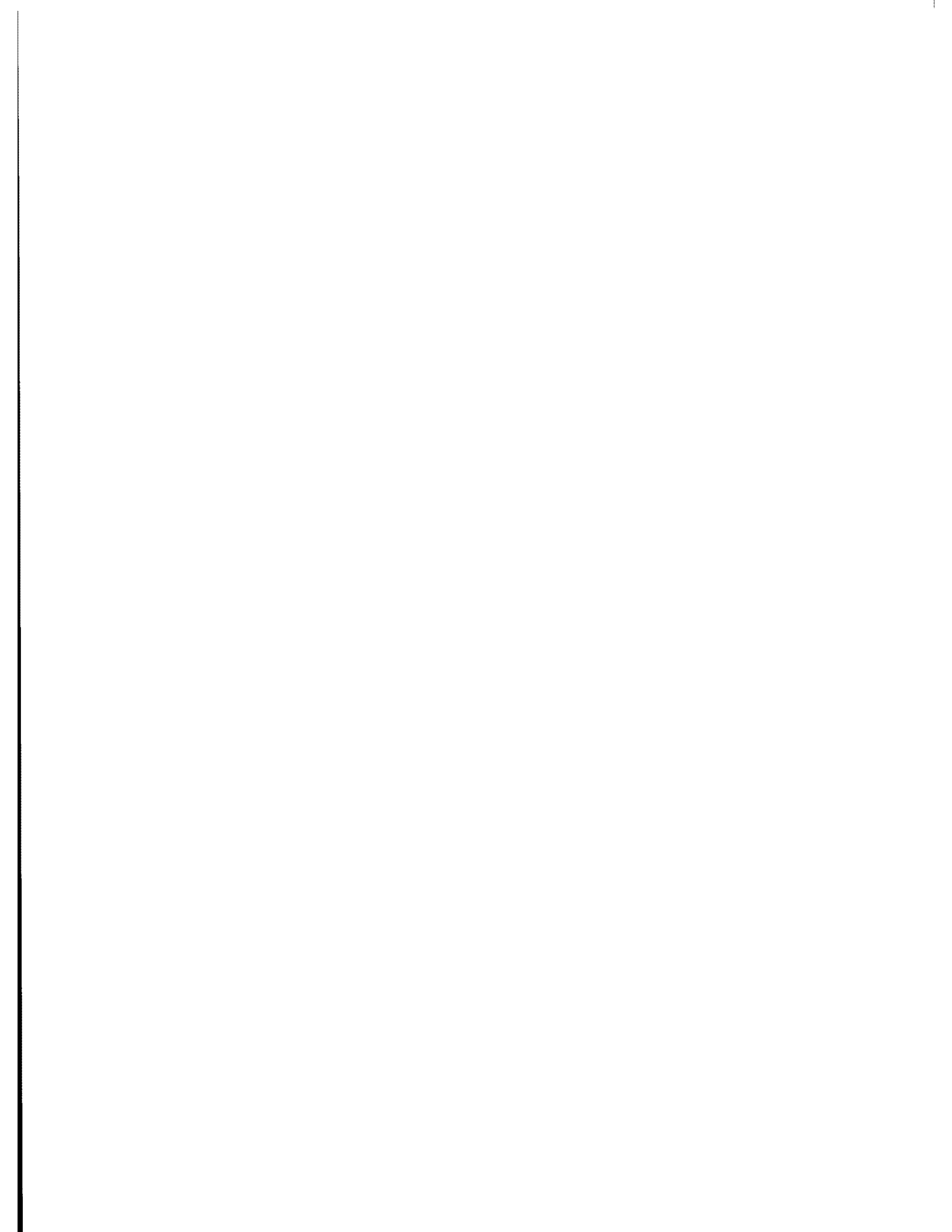

FIGURE 5.42 -TYPICAL TIME HISTORY SPRING GARDEN ST. STATION
CENTER PLATFORM (EXPRESS TRACK)



SPRING GARDEN STATION

(Ridge Spur)

SITE DESCRIPTION (see Figure 5.43)

This station is located on the Broad Ridge spur of the Broad Street Subway. The line extends from 8th Street to Fairmount Station on the north-south line. Local trains operate on this track exclusively. The station is a two track, two side platform type with a concrete floor. Between the tracks is a single row of supporting girders but the roadbed, walls and cover are of the same construction as the line south of City Hall.

NOISE CLIMATE (see Table 5.10, Figures 5.44 - 5.45)

Headway is normally three to five minutes longer than on the main north-south line. Much of the line is located at a lower level than the Broad Street system with the result that traffic noise from Ridge Avenue is less audible. Three- and four-car trains operate on the spur line and the cars used are of the same manufacture.

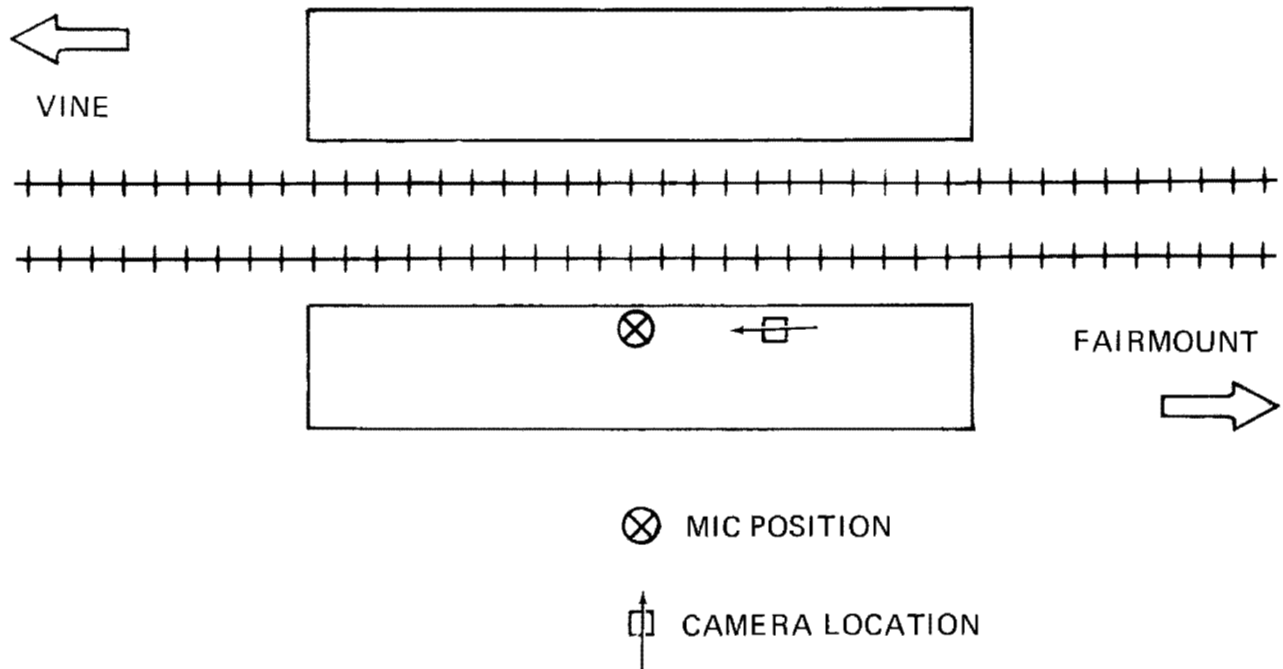

FIGURE 5.43. - SPRING GARDEN SUBWAY STATION - BROAD/RIDGE SPUR

TABLE 5.10 - SUMMARY OF MEASUREMENT RESULTS FOR SPRING GARDEN (BROAD/RIDGE SPUR) STATION PLATFORM

TIME	MIC POSITION	SAMPLE TIME	TRAIN CONDITIONS	UNITS	AVG MAX LEVEL		AVG L _R		CUMULATIVE AMPLITUDE DISTRIBUTION					Leq
					NEAR	FAR	NEAR	FAR	L ₉₉	L ₉₀	L ₅₀	L ₁₀	L ₁	
Rush	Center of stopped train	30 min	Arrival and departure	dB(A)					66	66	67	83	95	82

Notes: a - Track
b - Number of Trains -(e.g.: 4-2 means four 2-car trains)
c - Standard Deviation of Level

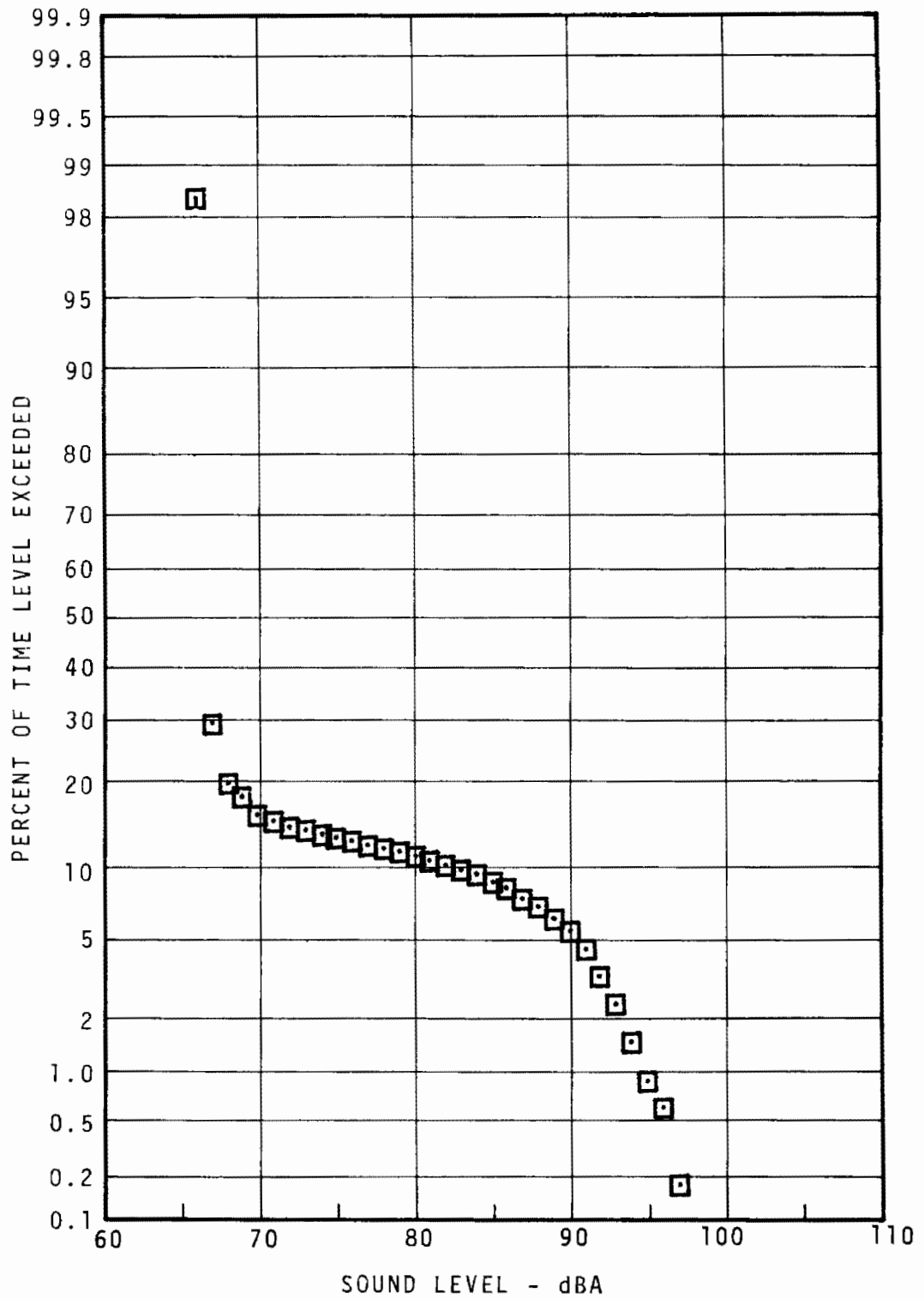

FIGURE 5.44 - SPRING GARDEN (BROAD/RIDGE SPUR)
STATION PLATFORM STATISTICAL DISTRIBUTION
RUSH HOUR

5-72/5-73

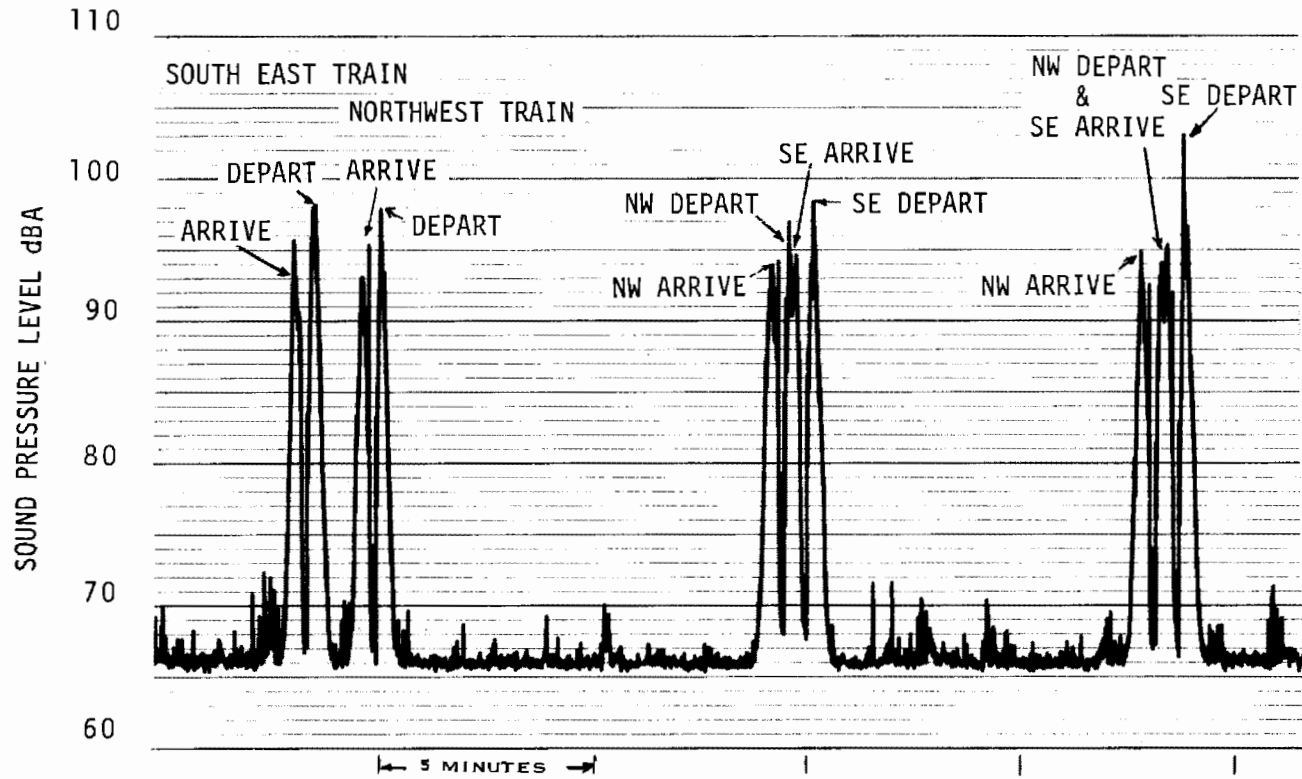
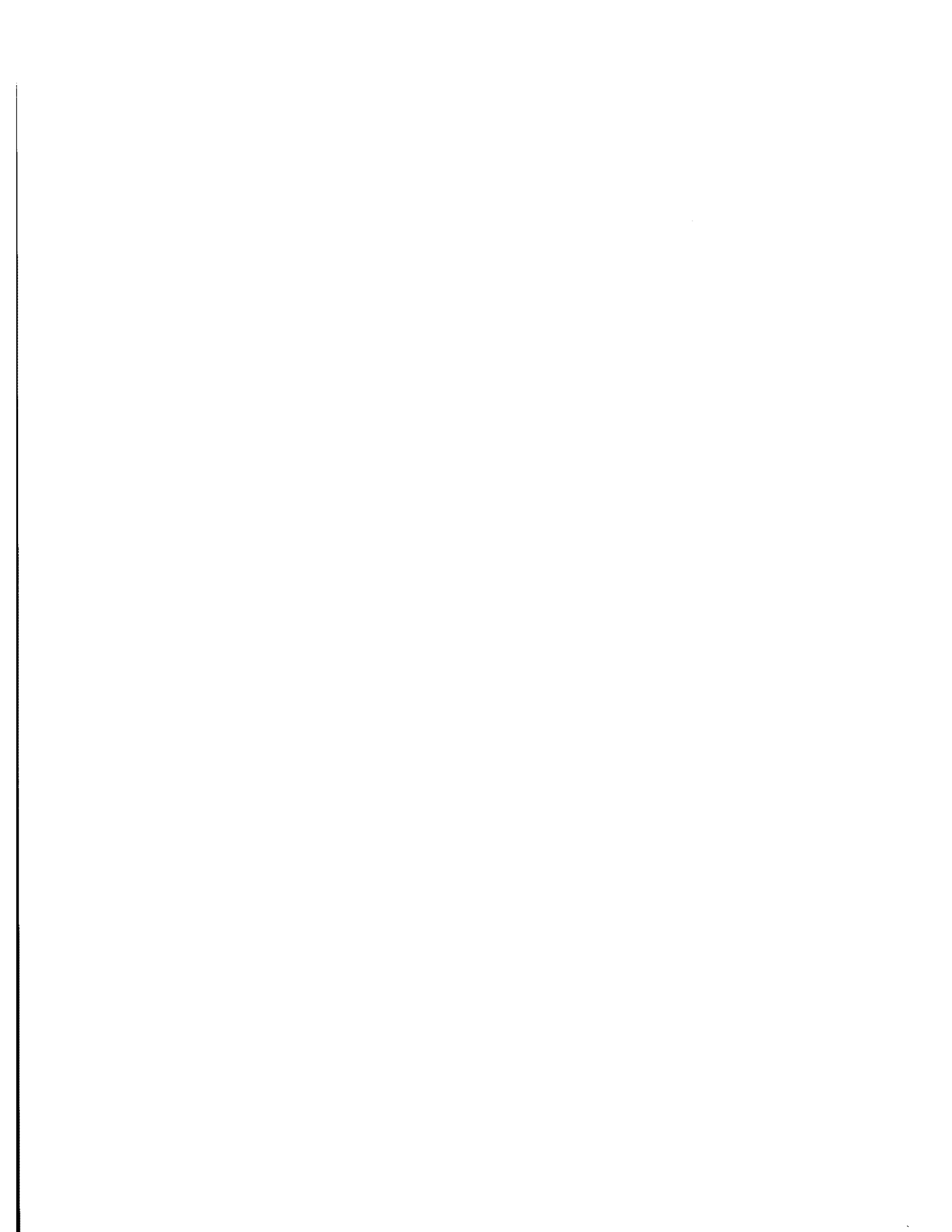

FIGURE 5.45 - TYPICAL TIME HISTORY, SPRING GARDEN STATION (RIDGE AVENUE STATION)



CITY HALL STATION

SITE DESCRIPTION (see Figure 5.46)

City Hall Station is a primary stop on the system with its location at the center of business in Philadelphia. This stop is the destination of a majority of passengers on the line. There is an interchange with the Market-Frankford subway as well as the subway-surface line (a light rail system which operates on-street and underground). The station is located under City Hall Plaza and connects with other transit lines by way of a large underground concourse system. The concourse also extends south to the next station on the Broad Street Line, Walnut-Locust.

The Broad Street Line is at the lowest level at the interchange, and is crossed by the Market-Frankford Line. There are two center platforms and four tracks. The land platforms are divided by walls covered with ceramic tile. These walls support the overhead structure and stairways. Cashier's booths are located one level above track level.

NOISE CLIMATE (see Table 5.11, Figures 5.47 - 5.51)

As cars approach to stop at the station, brake air is vented. Motormen sound the warning horn as trains approach the curve north of the station, where high amplitude wheel squeal is also generated. Wheel squeal and low frequency noise of trains negotiating crossovers south of the station is quite audible on the mezzanine above platform level. The noise arising from Market-Frankford trains and subway-surface cars overhead are also quite audible.



WALNUT
LOCUST
←

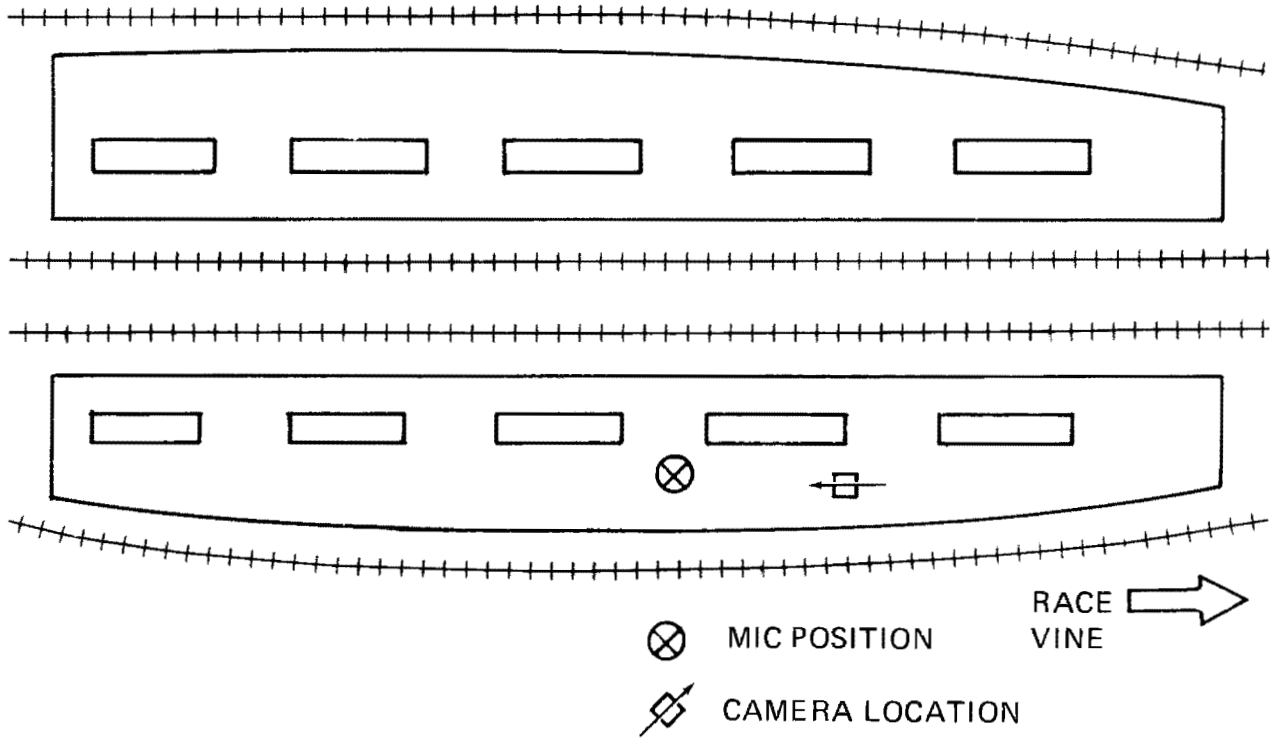

FIGURE 5.46 -CITY HALL SUBWAY STATION PLATFORM

TABLE 5.11-SUMMARY OF MEASUREMENT RESULTS FOR CITY HALL STATION PLATFORM

TIME	MIC POSITION	SAMPLE TIME	TRAIN CONDITIONS	UNITS	AVG MAX LEVEL		AVG L _R		CUMULATIVE AMPLITUDE DISTRIBUTION					Leq
					NEAR	FAR	NEAR	FAR	L ₉₉	L ₉₀	L ₅₀	L ₁₀	L ₁	
					^{a)} North	South	North	South						
Day	Center of stopped train	30 min	Arrival	^{b)} N	4-4	4-4	4-4	4-4	65	65	67	84	93	81
				dBA	94	73	104	87						
				^{c)} S	1.14	1.01	2.12	0.63						
			Departure	N	4-4	4-4	4-4	4-4						
				dBA	91	85	102	96						
				S	0.64	6.55	0.25	5.56						
Rush	2 m from edge of local track	Arrivals and departures	dBA					63	64	69	90	97	86	
Evening			dBA					56	58	61	83	91	79	
Night			dBA					66	66	67	71	89	75	

Notes: a - Track
 b - Number of Trains -(e.g.: 4-2 means four 2-car trains)
 c - Standard Deviation of Level

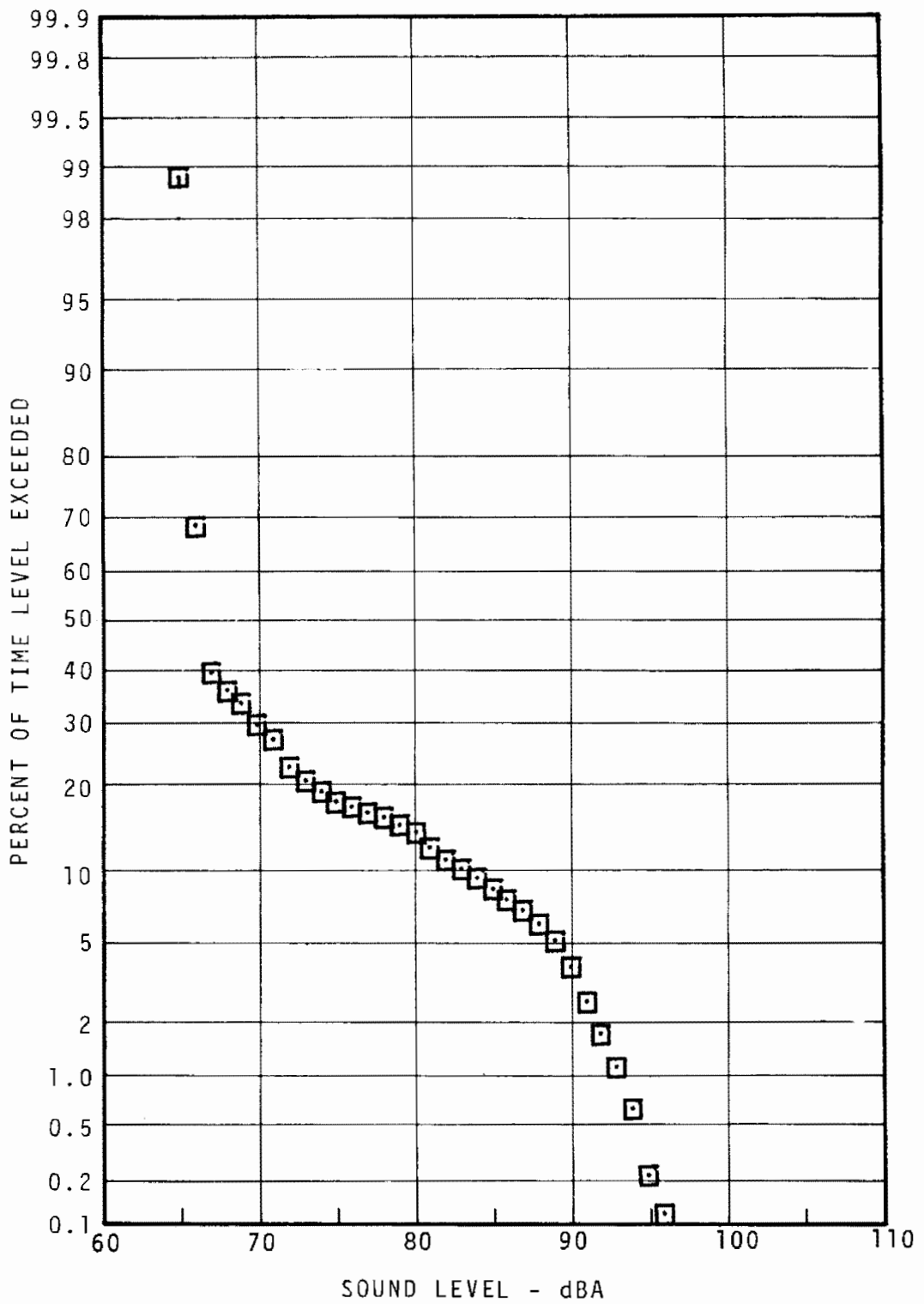

FIGURE 5.47 - CITY HALL STATION PLATFORM
 STATISTICAL DISTRIBUTION
 DAYTIME

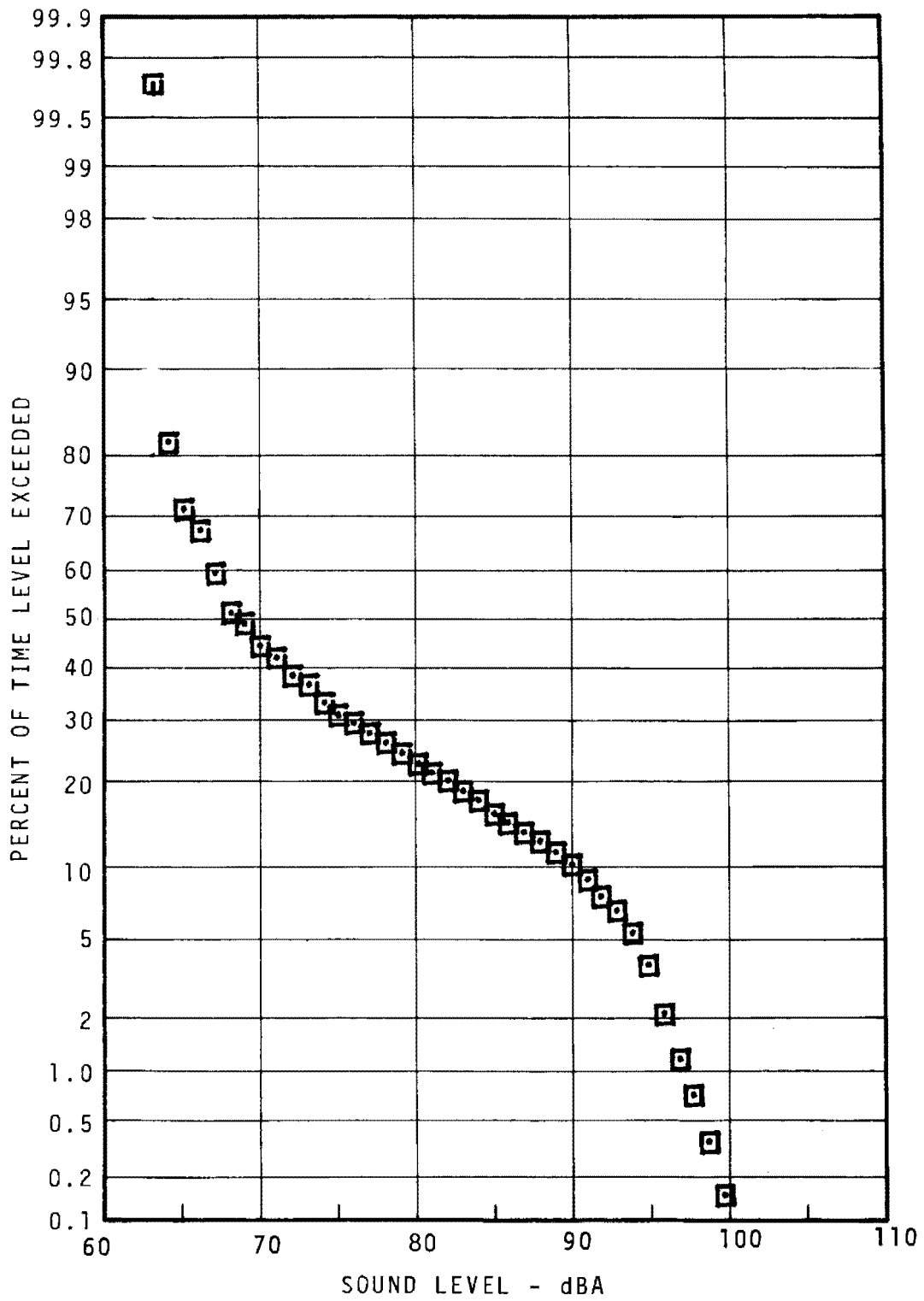

FIGURE 5.48 - CITY HALL STATION PLATFORM
 STATISTICAL DISTRIBUTION
 RUSH HOUR

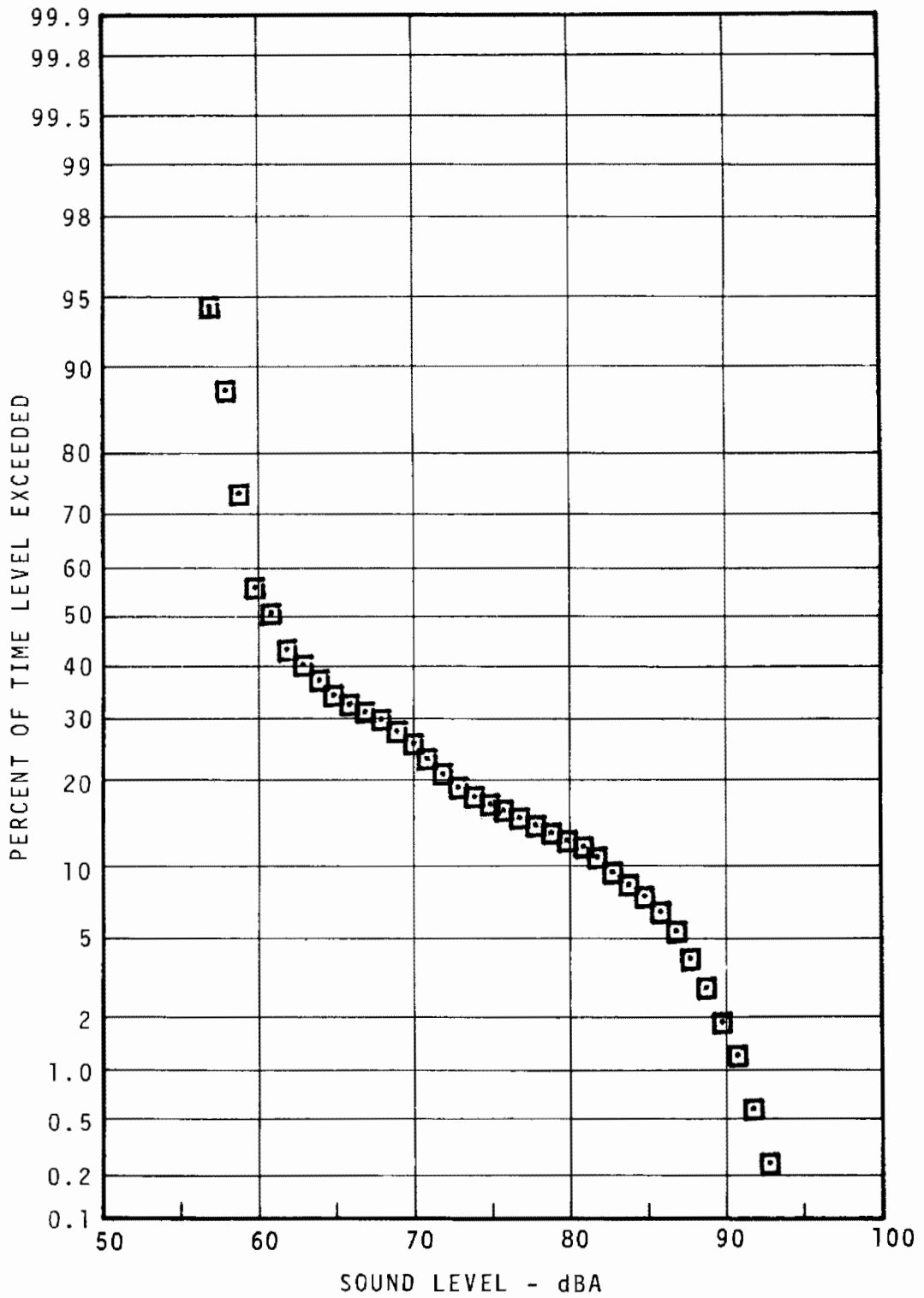

FIGURE 5.49 - CITY HALL STATION PLATFORM
 STATISTICAL DISTRIBUTION
 EVENING

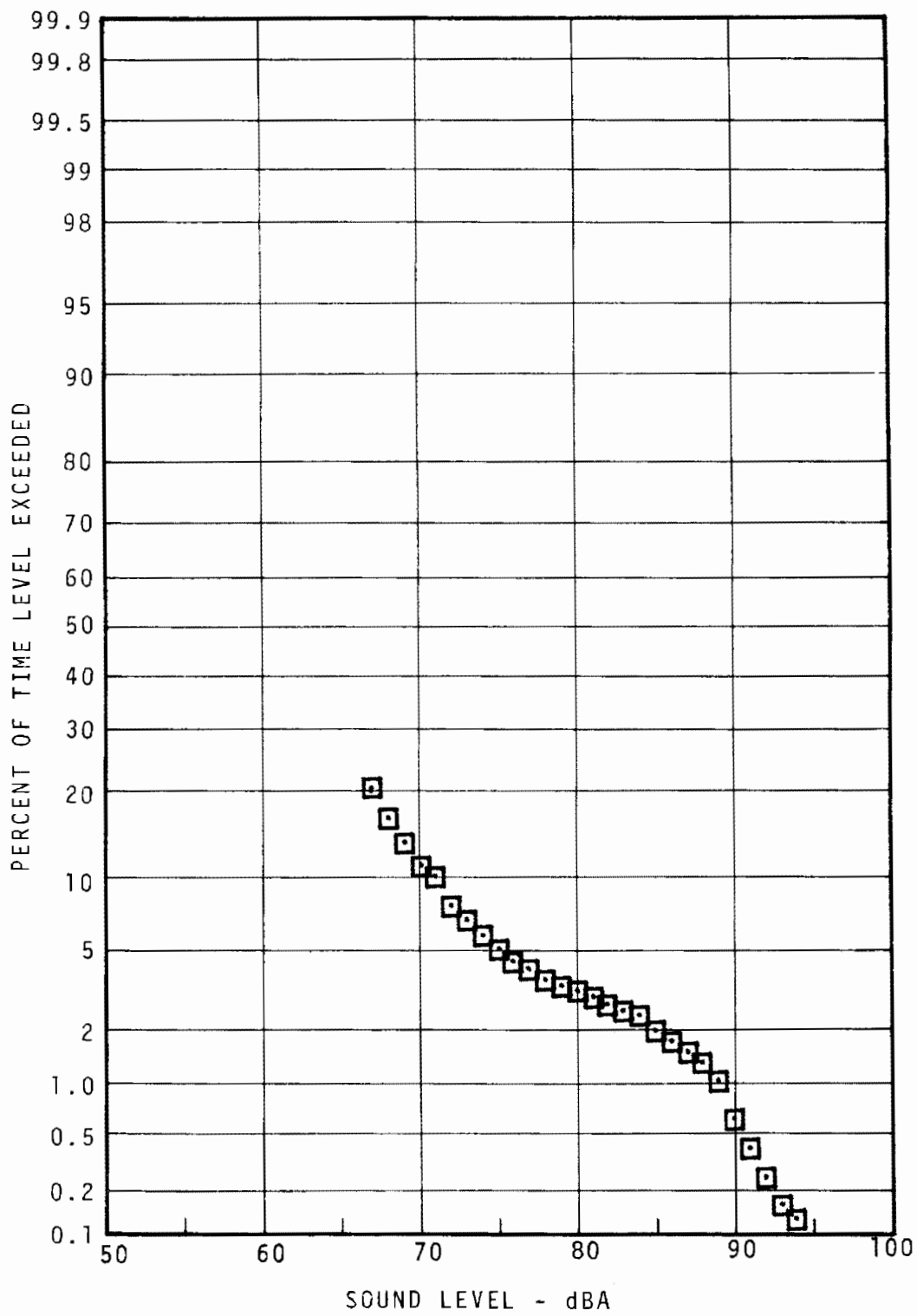

FIGURE 5.50 - CITY HALL STATION PLATFORM
 STATISTICAL DISTRIBUTION
 NIGHT

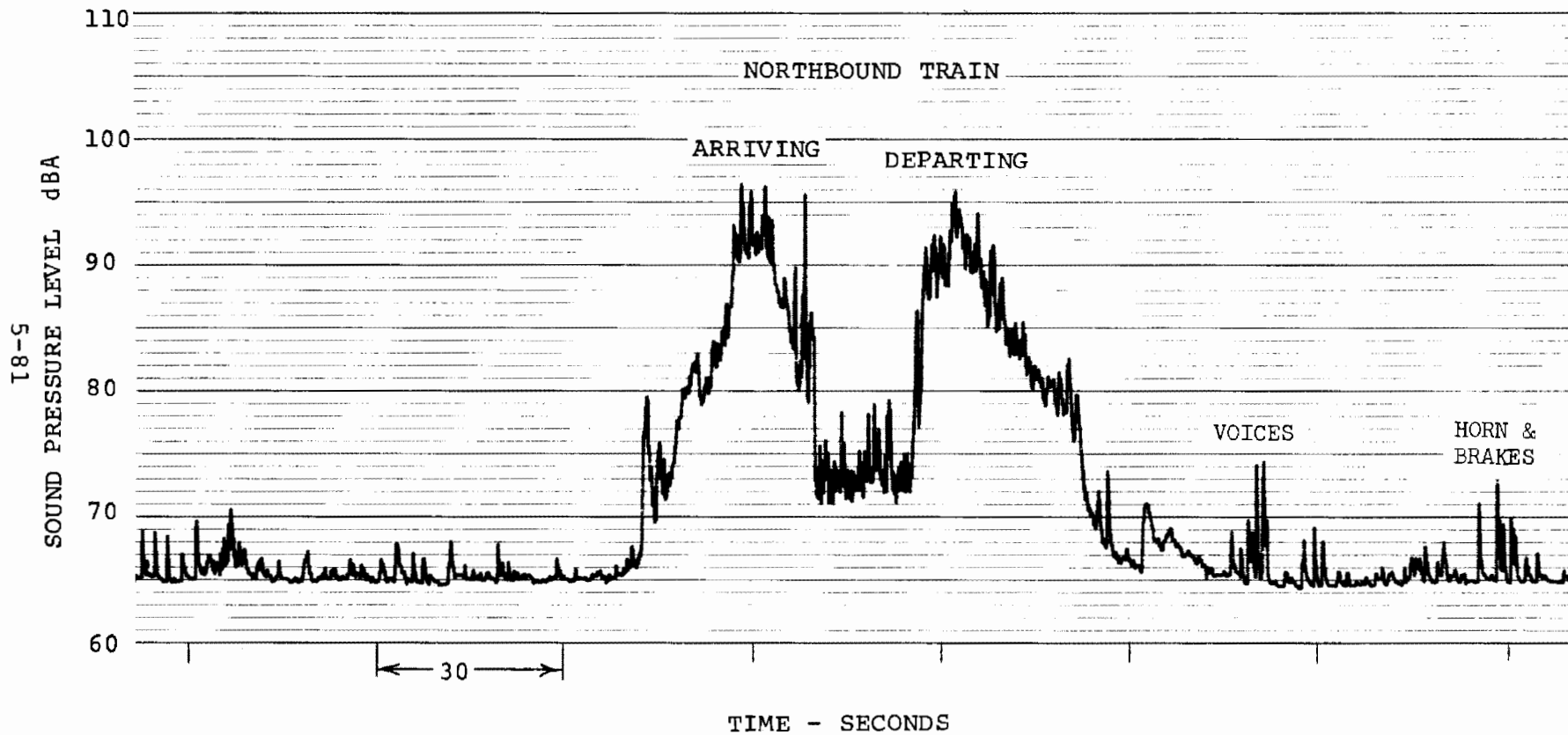

FIGURE 5.51 - TYPICAL TIME HISTORY, CITY HALL, STATION

WALNUT-LOCUST STATION

SITE DESCRIPTION (see Figure 5.52)

Walnut-Locust is a four-track, two island platform station. The roadbed consists of short ties set in concrete with every fifth tie a long tie. Rows of steel columns run along the platforms and between the center two tracks. The ceiling is boxed by concrete beams and the outside walls are scalloped concavely every two to three feet between vertical steel beams. Back-to-back stairways exit overhead where the cashier's booth is located. Walnut-Locust is an interchange station with the PATCO Line which crosses one level above the Broad Street Subway.

NOISE CLIMATE (see Table 5.12, Figures 5.53 - 5.57)

Both local and express trains stop at this station. There is some noise due to flange rubbing and occasional short-duration squeal as the trains negotiate the shallow curves of the outer two tracks. Also audible are impact noises from crossovers both north and south of the station. When no subway trains are nearby, vehicular traffic noises can be heard from the street two levels above. Also, there is occasional low frequency noise resulting from the PATCO system.

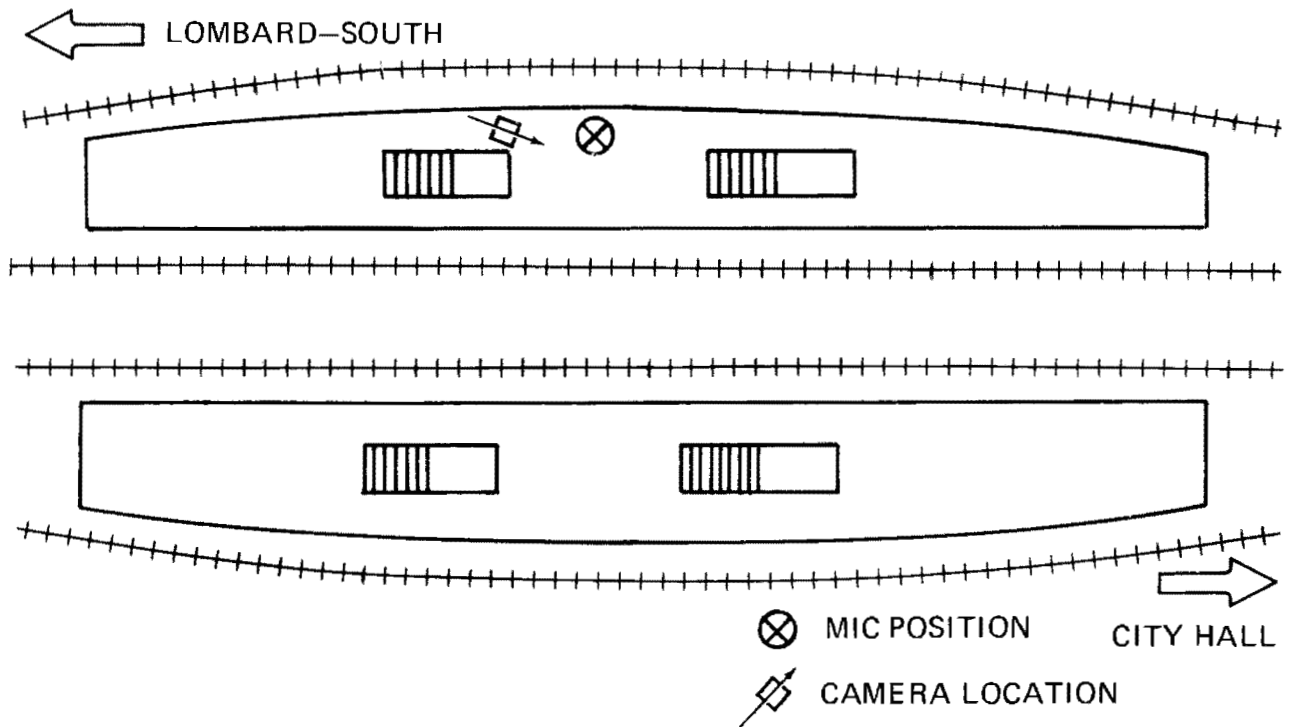
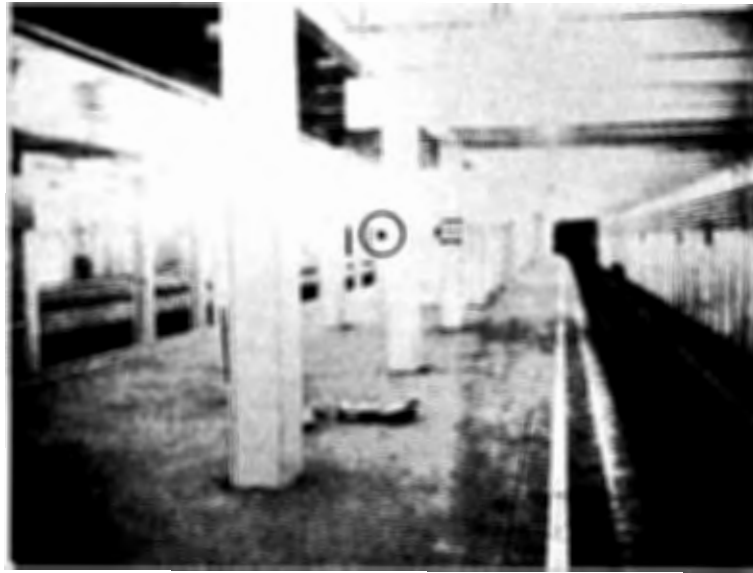

FIGURE 5.52 -WALNUT-LOCUST SUBWAY STATION PLATFORM

TABLE 5.12-SUMMARY OF MEASUREMENT RESULTS FOR WALNUT-LOCUST STATION PLATFORM

TIME	MIC POSITION	SAMPLE TIME	TRAIN CONDITIONS	UNITS	AVG MAX LEVEL		AVG LR		CUMULATIVE AMPLITUDE DISTRIBUTION					Leq
					NEAR	FAR	NEAR	FAR	L99	L90	L50	L10	L1	
					a) South	North	South	North						
Day	Center of stopped train 2 m from edge of local track	30 min	Arrival	b) N	1-4	3-4	1-4	3-4	56	57	59	85	91	79
				dBA	94	90	104	99						
				c) S	-	0.58	-	0.29						
			Departure	N	1-4	3-4	1-4	3-4						
				dBA	86	88	97	98						
				S	-	1.44	-	1.80						
			Arrival	N	3-6	1-6	3-6	1-6						
				dBA	92	90	102	100						
				S	2.09	-	1.00	-						
			Departure	N	3-6	1-6	3-6	1-6						
				dBA	90	89	101	100						
				S	1.32	-	0.76	-						
Rush	15 min	Arrivals and departure	dBA					63	64	70	92	98	87	
Evening			dBA					56	58	61	78	92	78	
Night			dBA					63	64	70	84	92	80	
Notes: a - Track b - Number of Trains -(e.g.: 4-2 means four 2-car trains) c - Standard Deviation of Level														

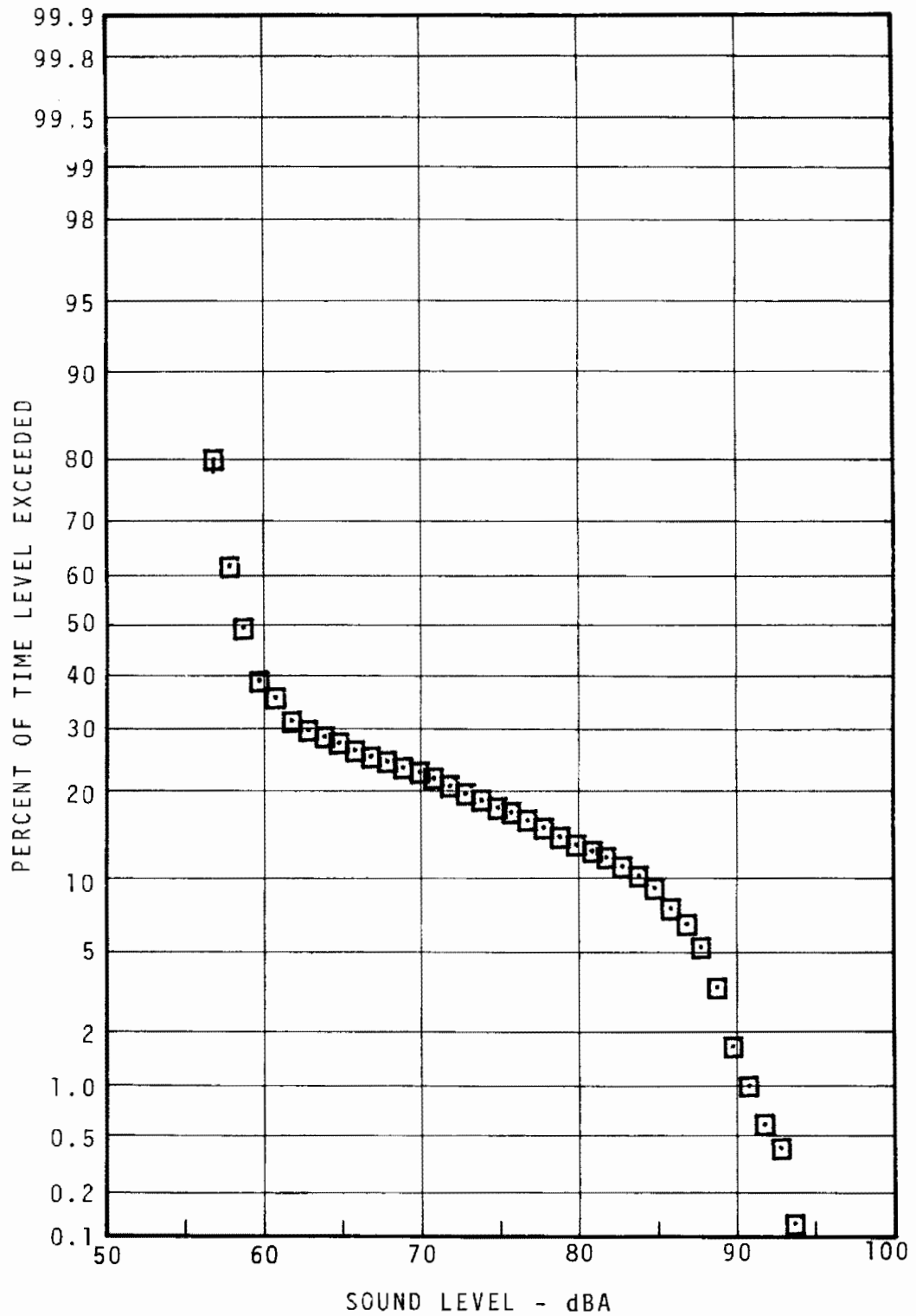

FIGURE 5.53 - WALNUT-LOCUST STATION PLATFORM
 STATISTICAL DISTRIBUTION
 DAYTIME

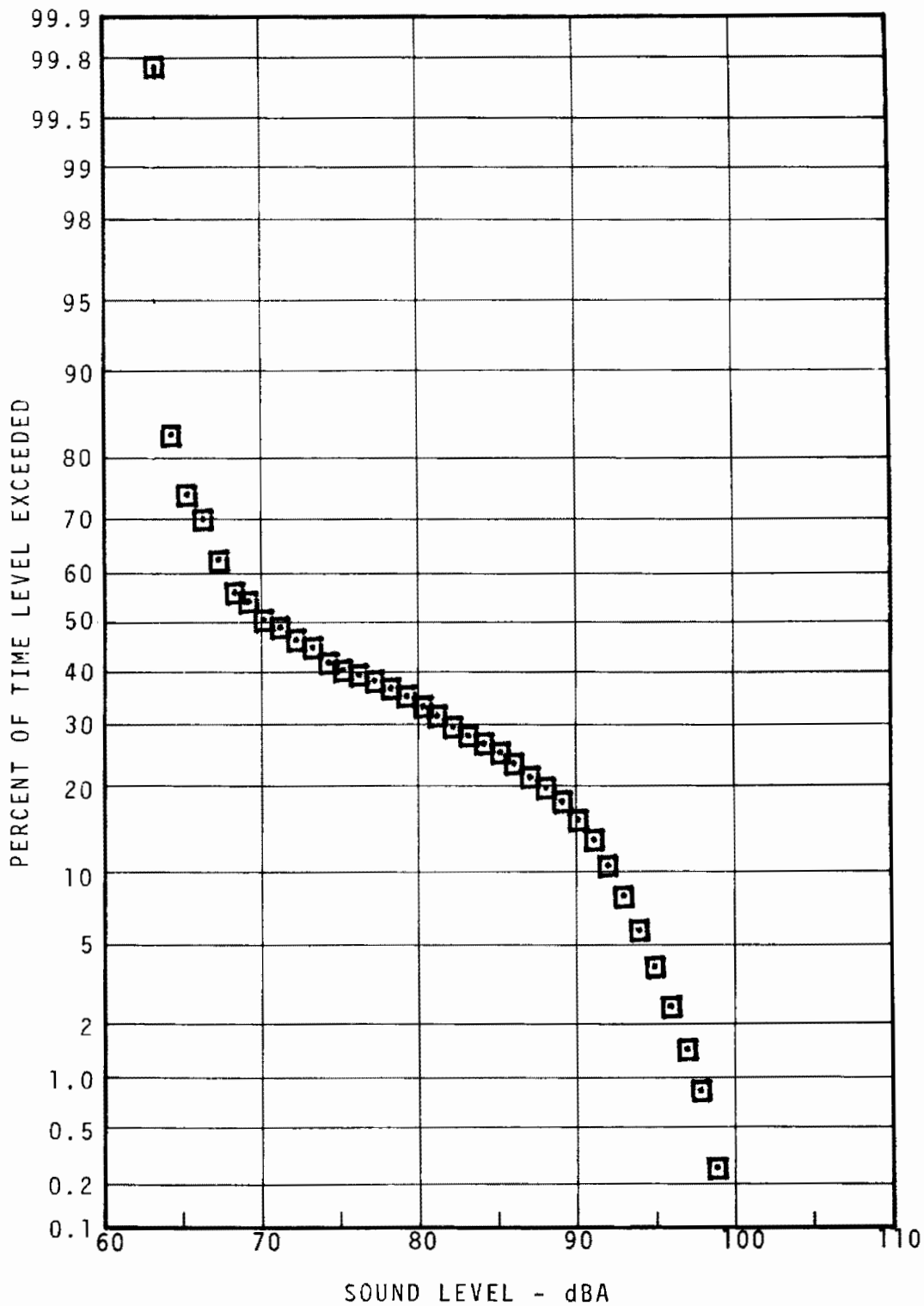

FIGURE 5.54 - WALNUT-LOCUST STATION PLATFORM
 STATISTICAL DISTRIBUTION
 RUSH HOUR

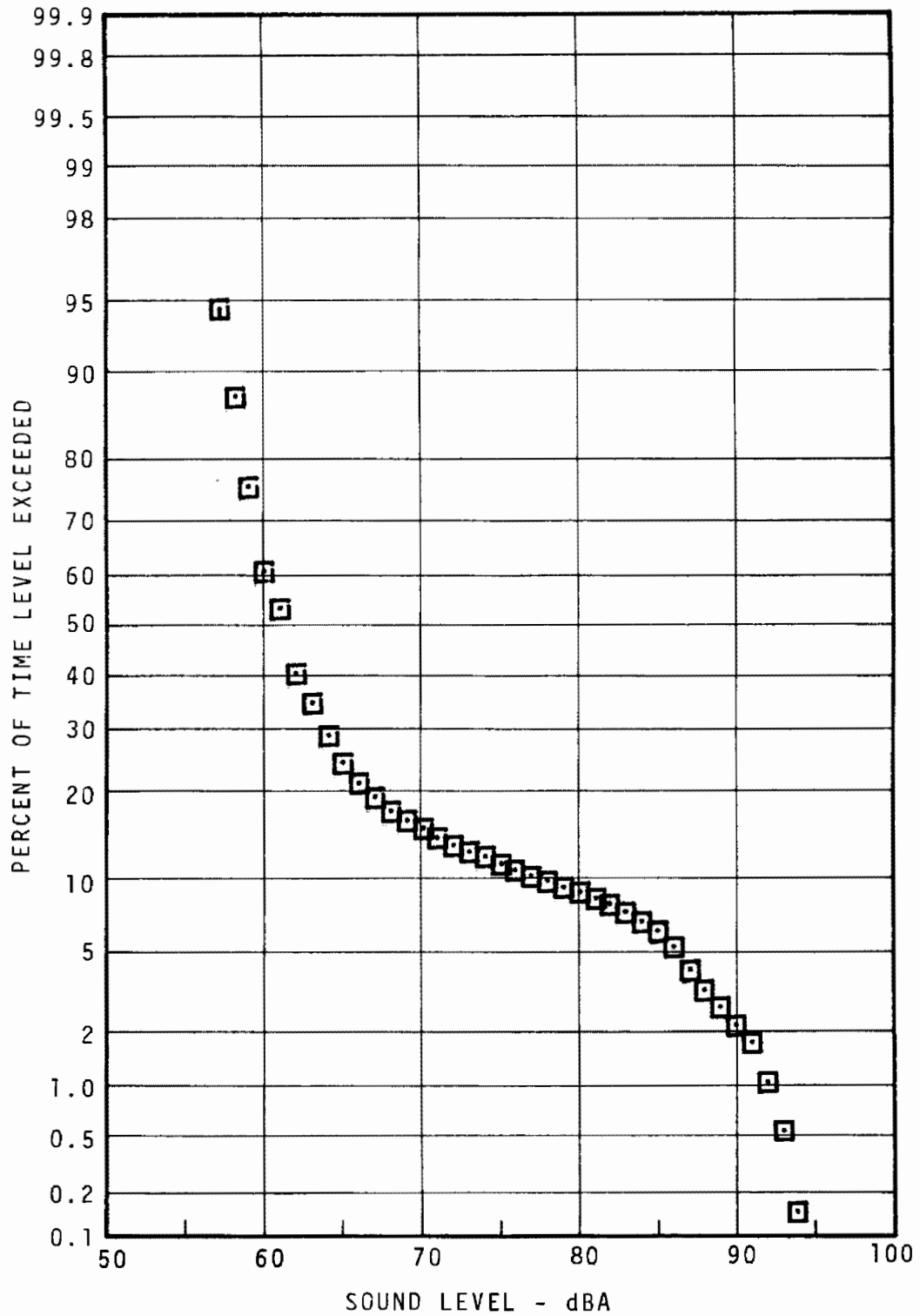

FIGURE 5.55 - WALNUT-LOCUST STATION PLATFORM
 STATISTICAL DISTRIBUTION
 EVENING

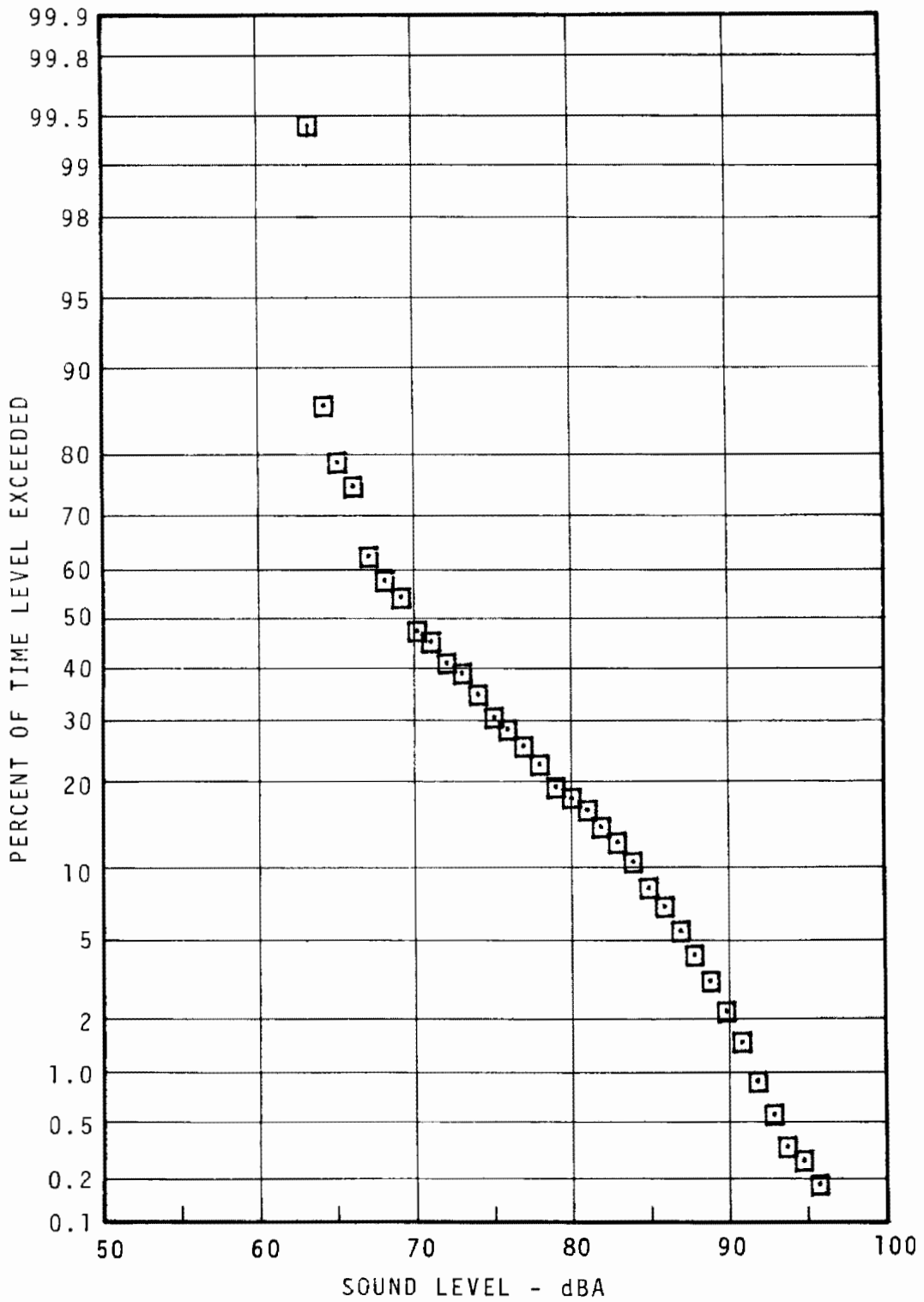

FIGURE 5.56 - WALNUT-LOCUST STATION PLATFORM
 STATISTICAL DISTRIBUTION
 NIGHT

68-5

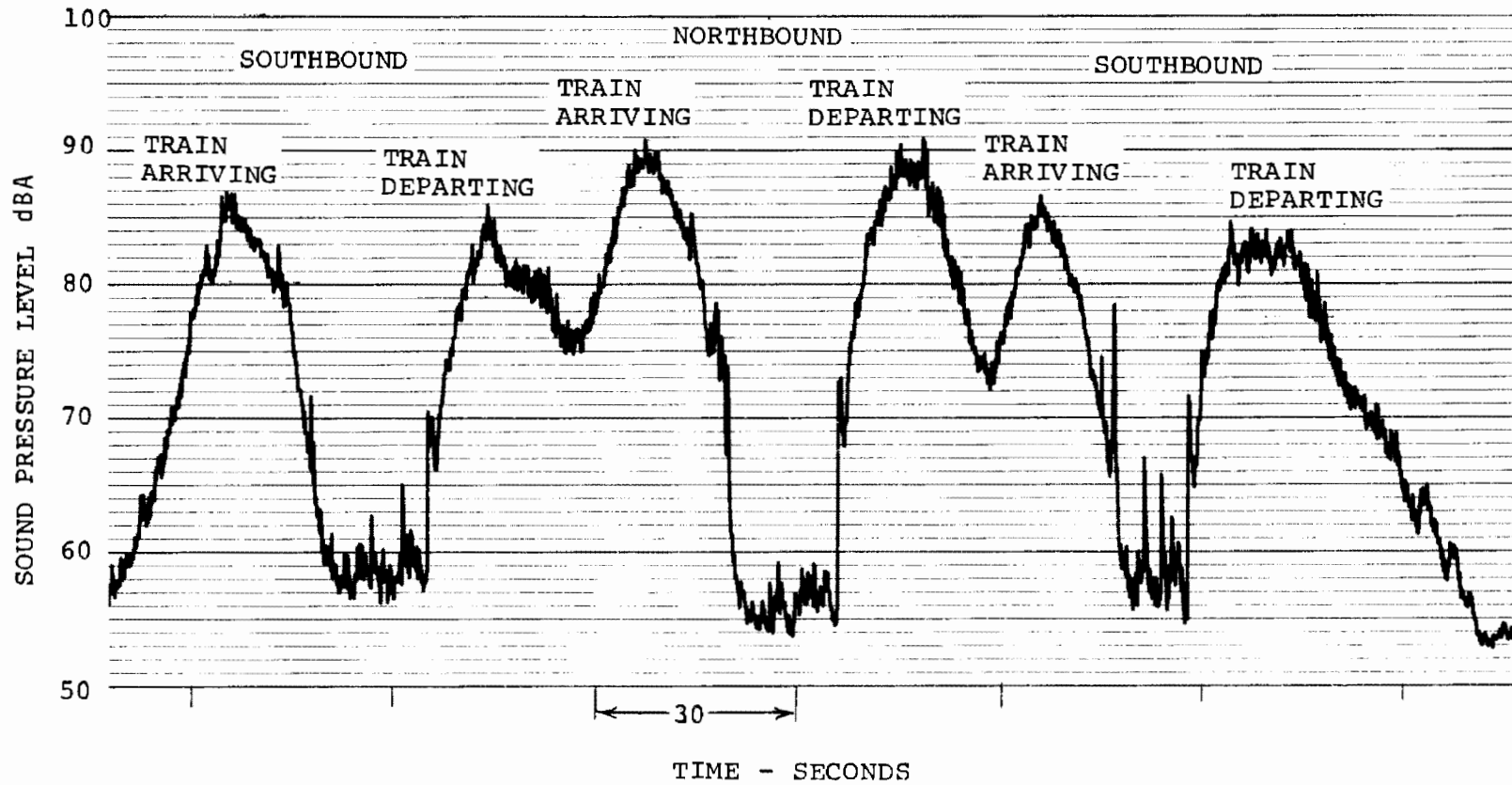

FIGURE 5.57 - TYPICAL TIME HISTORY, WALNUT-LOCUST STATION

SNYDER STATION

SITE DESCRIPTION (see Figure 5.58)

Snyder Avenue is a two-track, center platform station. The southbound track is tangent, whereas the northbound track curves around the center platform. Immediately north of the station towards Oregon Station, the tracks veer left and join the southbound tracks. A crossover is located just north of the station and because of this, trains approach from the north and leave northbound at a low speed. Patrons exit from the center platform, which is approximately four to five meters wide, using one of four stairways to an overhead mezzanine level. This mezzanine forms an underground concourse extending to City Hall, or passengers may exit one level above the concourse to street level. The station platform is concrete, concrete walls are scalloped, and this pattern repeats every two to three feet. The rail is set on wood ties which are embedded in concrete. Until 1973, when the system extension to Pattison Avenue was completed, Snyder was the southern terminal for the system.

NOISE CLIMATE (see Table 5.13, Figures 5.59 - 5.60)

The highest sound levels at this station stem from the impact noise due to the crossover just north of the station. Wheel squeal is also audible as trains negotiate this curve going north and south. Vehicle noise from Broad Street level is generally inaudible at platform level.

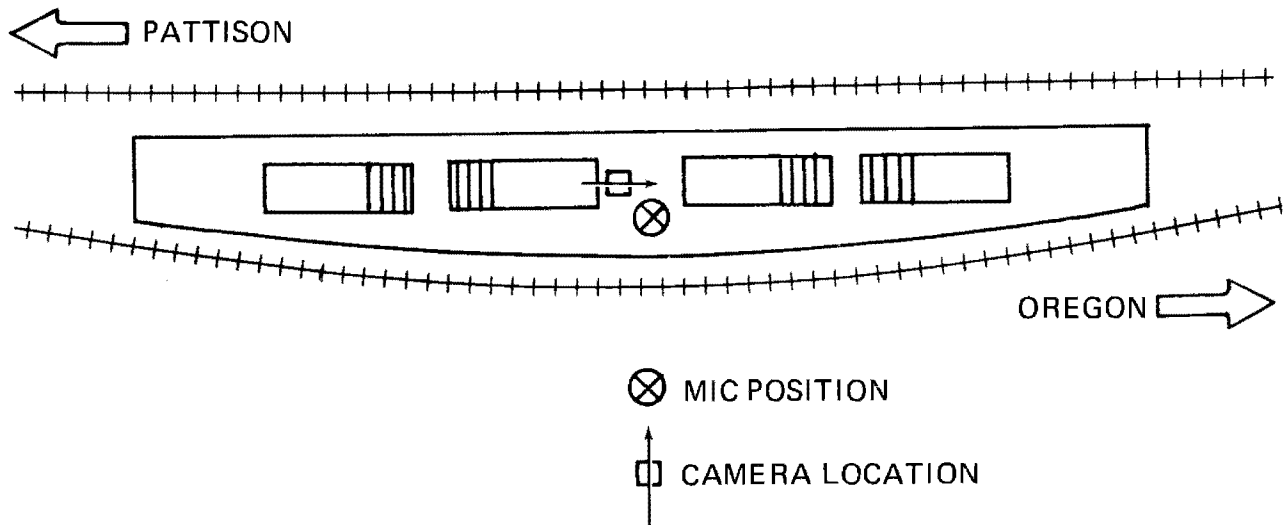

FIGURE 5.58 -SNYDER AVE. SUBWAY STATION PLATFORM

TABLE 5.13 - SUMMARY OF MEASUREMENT RESULTS FOR SNYDER AVE STATION PLATFORM

TIME	MIC POSITION	SAMPLE TIME	TRAIN CONDITIONS	UNITS	AVG MAX LEVEL		AVG LR		CUMULATIVE AMPLITUDE DISTRIBUTION					Leq
					NEAR	FAR	NEAR	FAR	L99	L90	L50	L10	L1	
					^{a)} North	South	North	South						
Day	Center of stopped train	30 min	Arrival	b) N	4-4	5-4	4-4	5-4	57	58	63	87	92	81
				dBA	94	91	103	101						
				c) S	0.41	1.08	1.02	0.75						
			Departure	N	4-4	5-4	4-4	5-4						
				dBA	92	94	102	104						
				S	1.26	0.82	0.97	0.90						

Notes: a - Track
b - Number of Trains -(e.g.: 4-2 means four 2-car trains)
c - Standard Deviation of Level

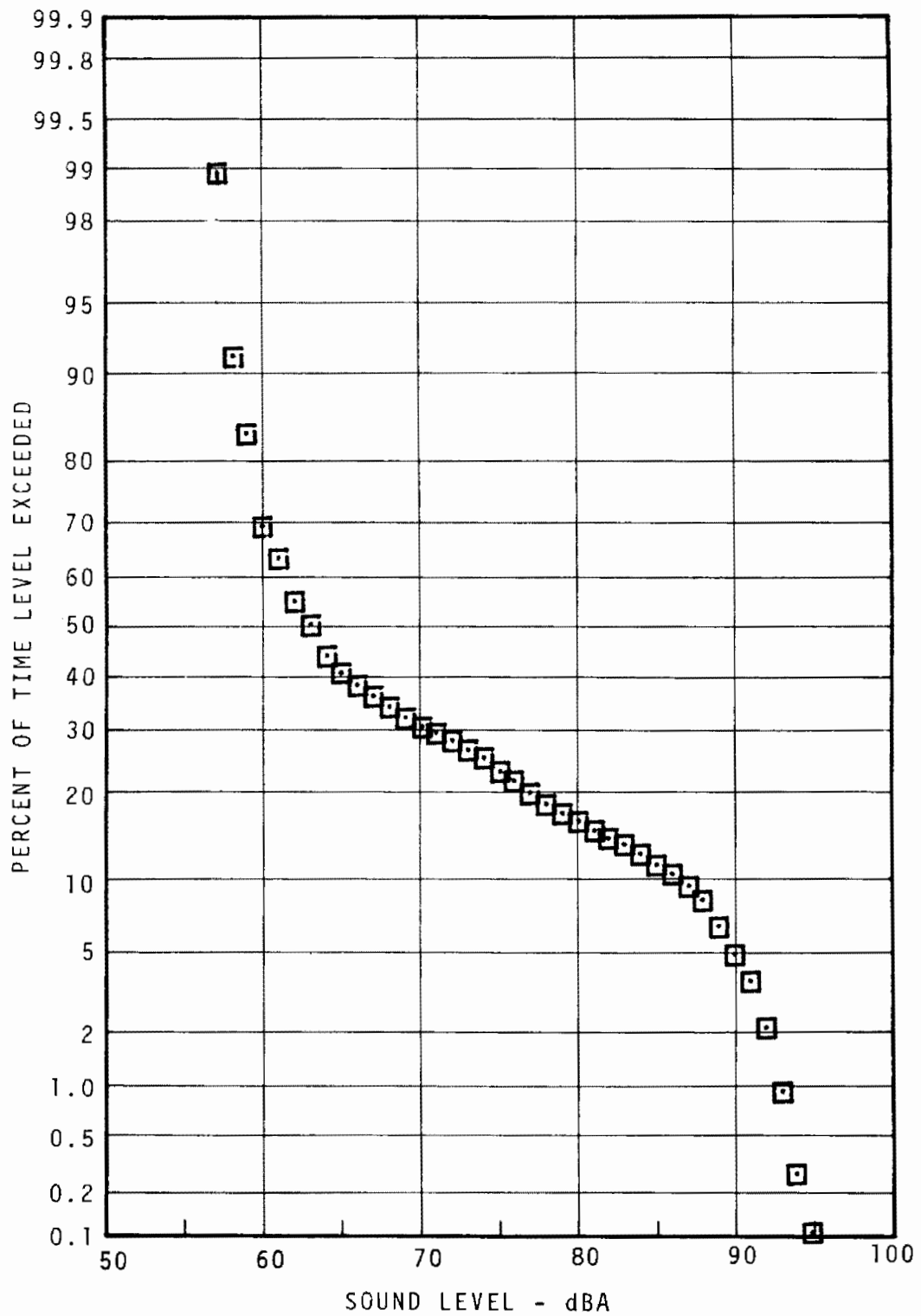

FIGURE 5.59 -SNYDER AVENUE STATION PLATFORM
 STATISTICAL DISTRIBUTION
 DAYTIME

5-94/5-95

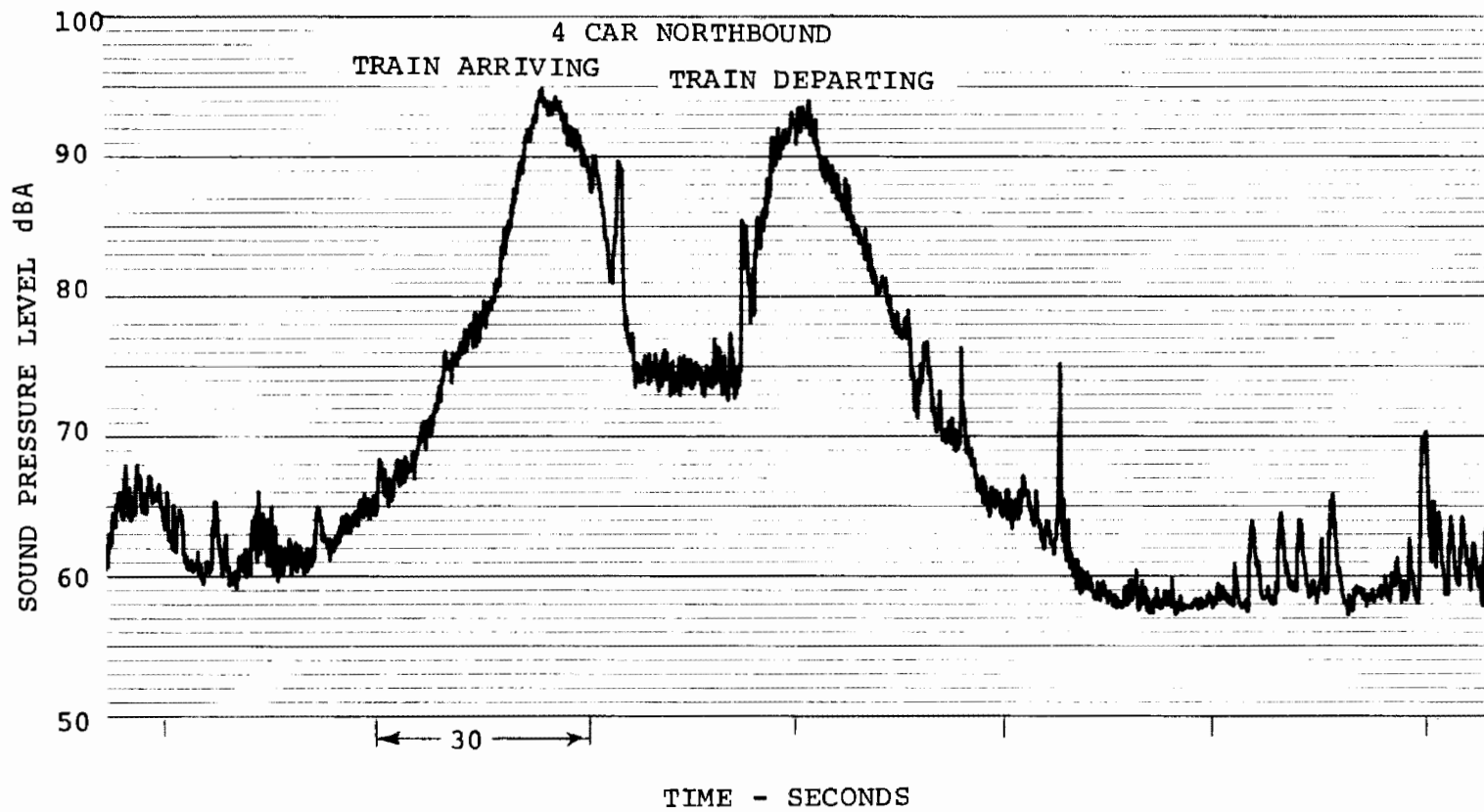
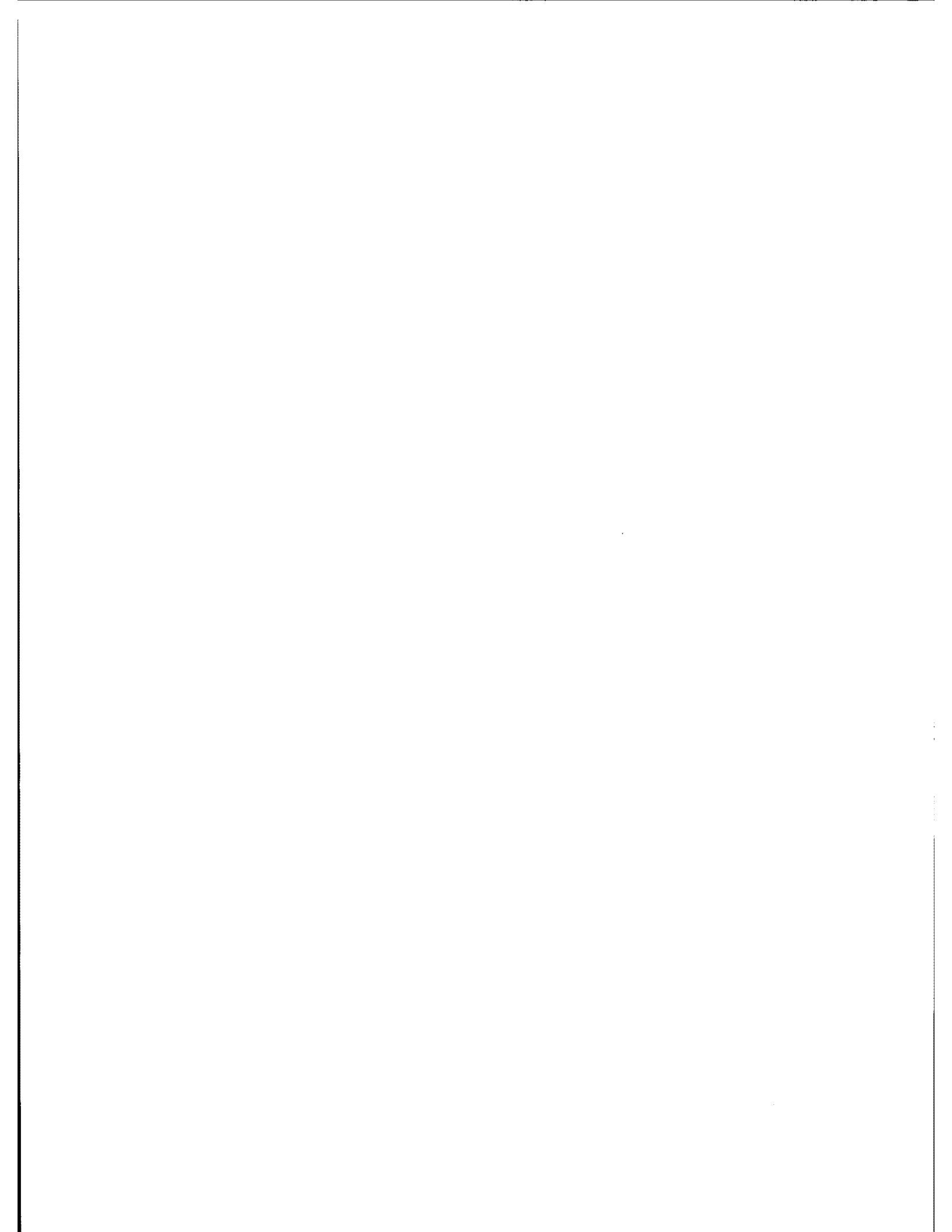

FIGURE 5.60 - TYPICAL TIME HISTORY, SNYDER & BROAD STATION



PATTISON AVENUE

SITE DESCRIPTION (see Figure 5.61)

The station at Pattison Avenue is the southern terminal for the Broad Street Subway. It is a bi-level station, with the upper level in regular use, and the lower level opened only during those times when demanded by sports events traffic. Each level consists of two tracks and a center platform about 70 ft. in width. The station platform is concrete and walls and ceiling are faced with ceramic tile.

Pattison and Oregon Stations were opened in 1973 when the system was extended from Snyder Avenue to serve the sports complex in Philadelphia. The stadiums include J. F. Kennedy and Veterans Memorial, as well as the Spectrum, an indoor arena.

NOISE CLIMATE (see Table 5.14, Figures 5.62 - 5.66)

Noise is generally lower than other stations since trains start and stop at lower speeds, where brake squeal is noted. Brake air release and air compressor noise is audible for standing trains. During periods when the air compressor is not operating the background noise is attributable to other-than-subway noise sources, such as turnstile and escalator noise. Occasionally, truck and bus noise from street level are audible at platform level.

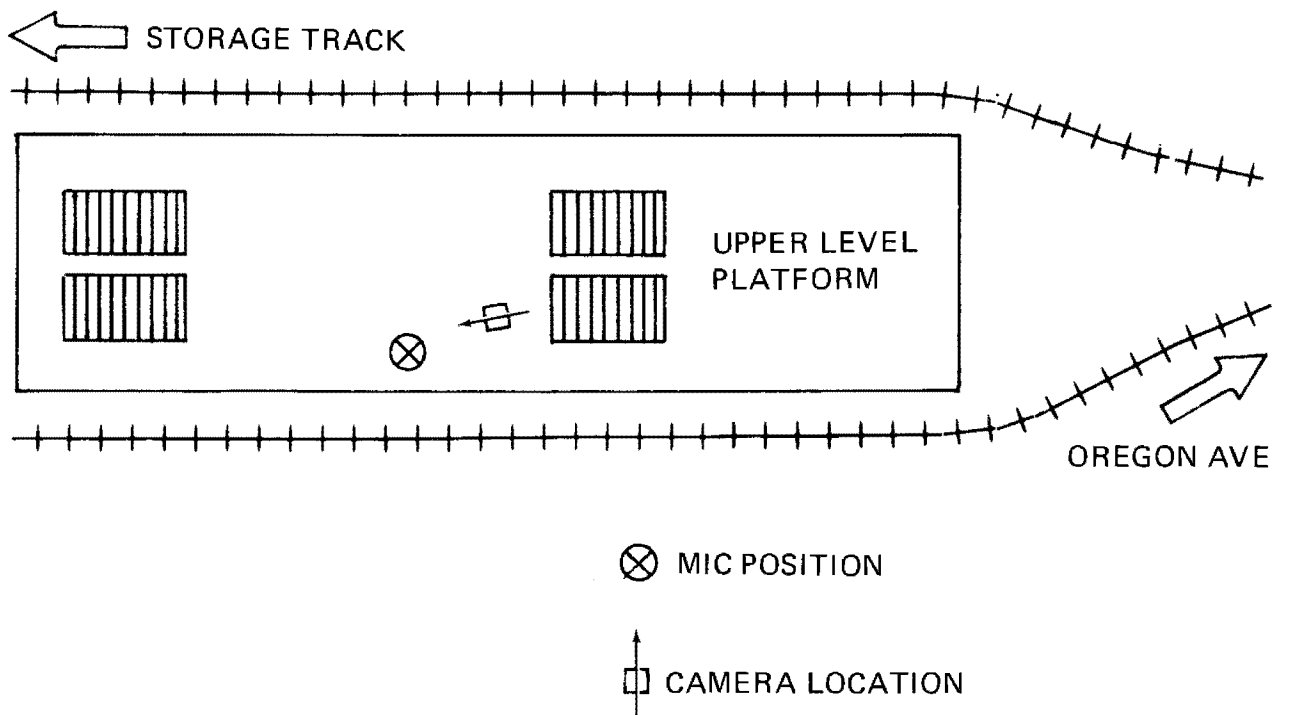

FIGURE 5.61- PATTISON AVE. SUBWAY STATION PLATFORM

TABLE 5.14-SUMMARY OF MEASUREMENT RESULTS FOR PATTISON AVE. STATION PLATFORM

TIME	MIC POSITION	SAMPLE TIME	TRAIN CONDITIONS	UNITS	AVG MAX LEVEL		AVG LR		CUMULATIVE AMPLITUDE DISTRIBUTION					Leq						
					NEAR	FAR	NEAR	FAR	L99	L90	L50	L10	L1							
					a) 4	5	4	5												
Day Rush Evening Night	Center of stopped train	30 min	Arrival	b) N	4-4	1-4	4-4	1-4	56	58	63	84	91	79						
				dBA	89	88	101	100												
				c) S	1.21	-	0.53	-												
			Departure	N	4-4	1-4	4-4	1-4												
				dBA	90	86	101	99												
				S	1.95	-	1.51	-												
			Arrival and departure	dBA											62	63	65	82	94	81
				dBA											57	58	62	78	91	78
				dBA											65	65	66	72	89	74

Notes: a - Track
 b - Number of Trains-(e.g.: 4-2 means four 2-car trains)
 c - Standard Deviation of Level

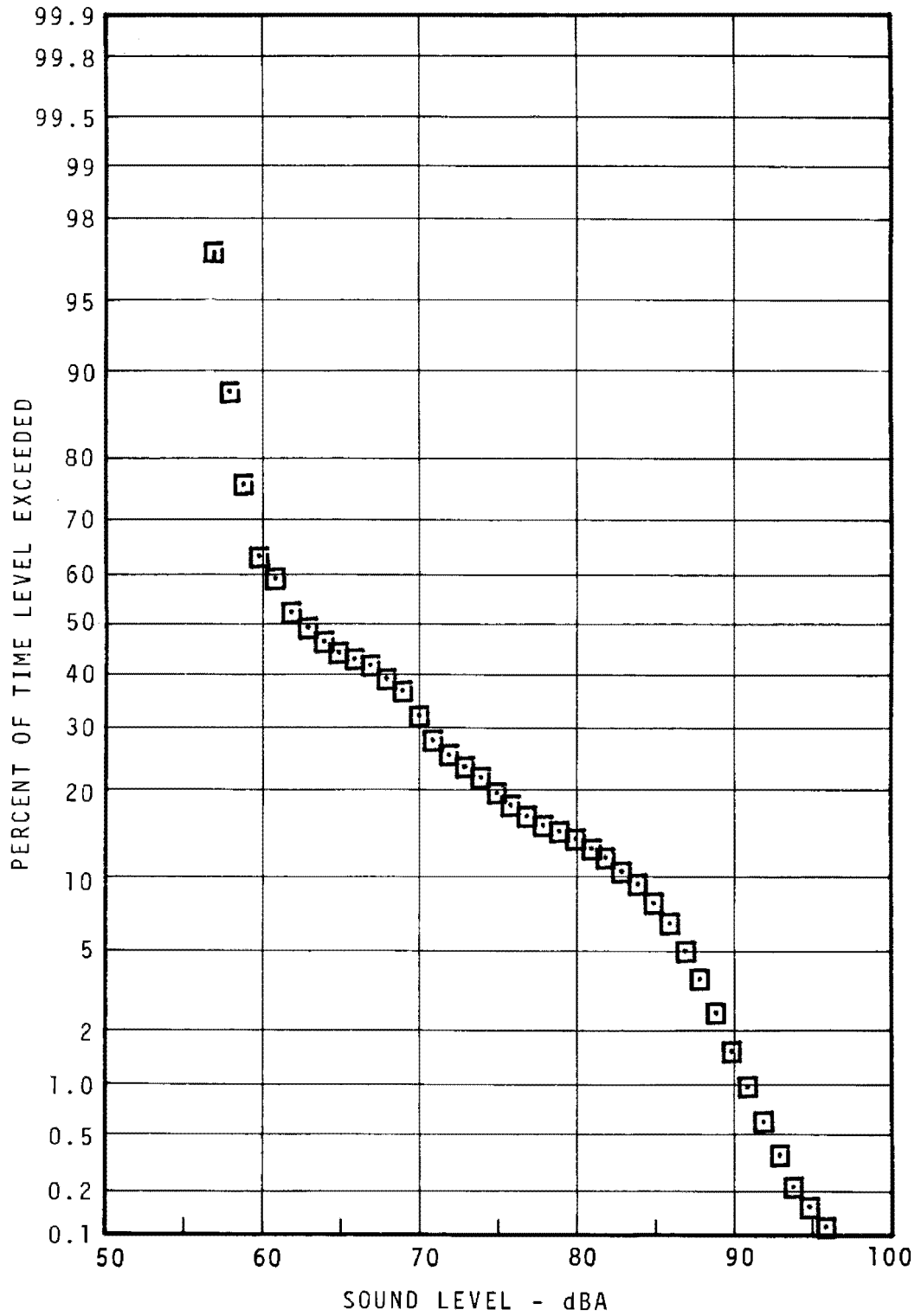

FIGURE 5.62 - PATTISON AVENUE STATION PLATFORM
 STATISTICAL DISTRIBUTION
 DAYTIME

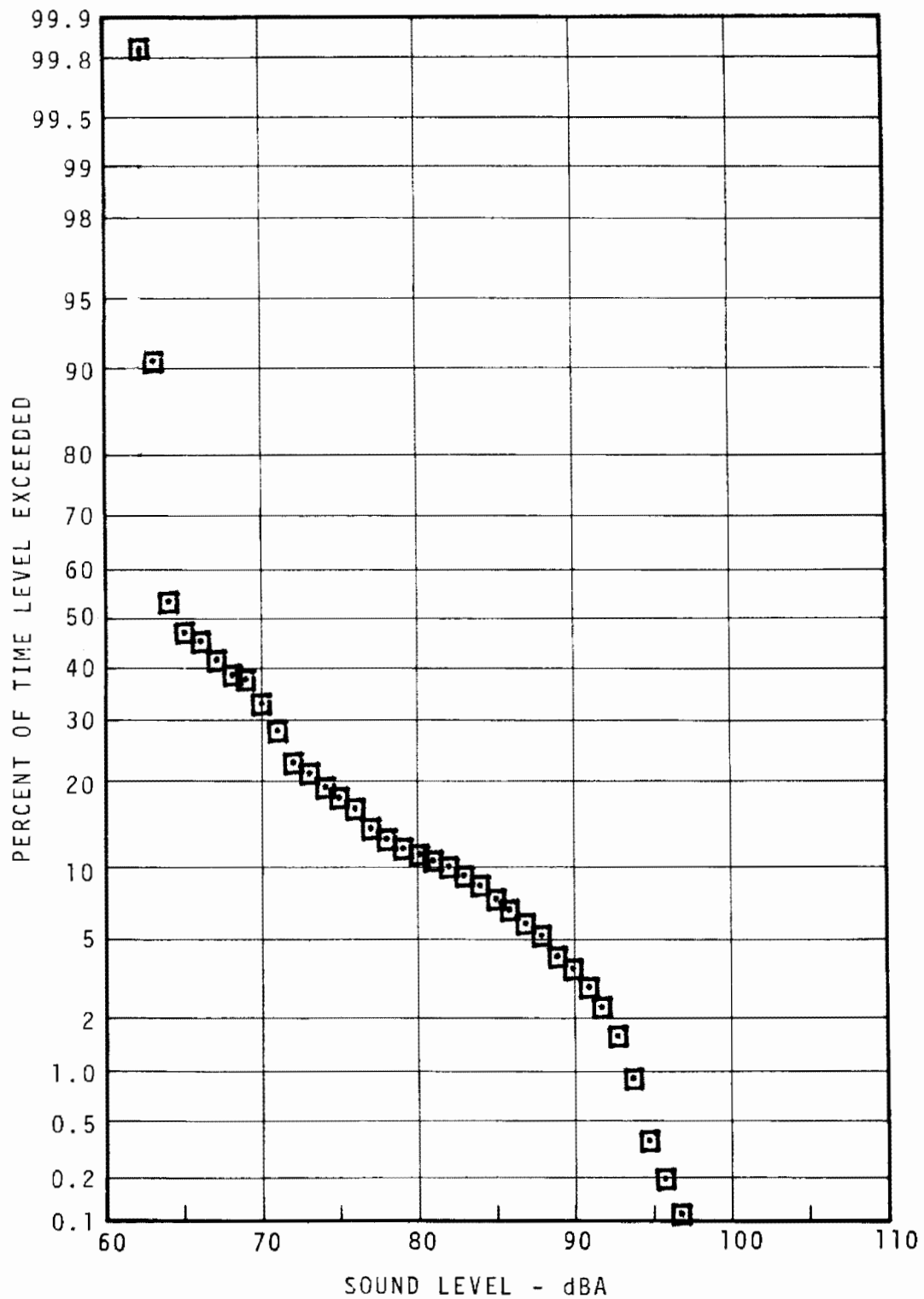

FIGURE 5.63 - PATTISON AVENUE STATION PLATFORM
 STATISTICAL DISTRIBUTION
 RUSH HOUR

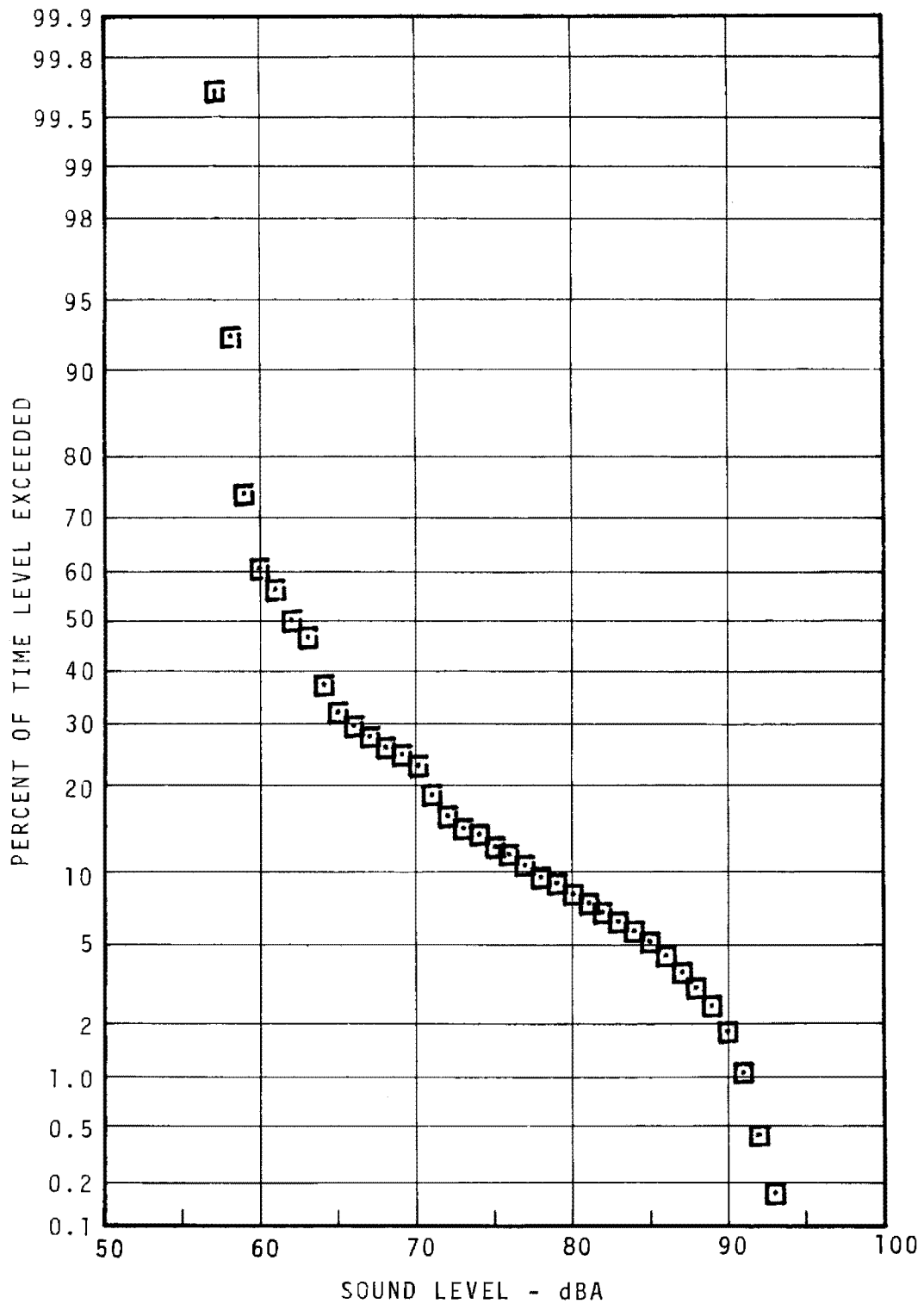

FIGURE 5.64 - PATTISON AVENUE STATION PLATFORM
 STATISTICAL DISTRIBUTION
 EVENING

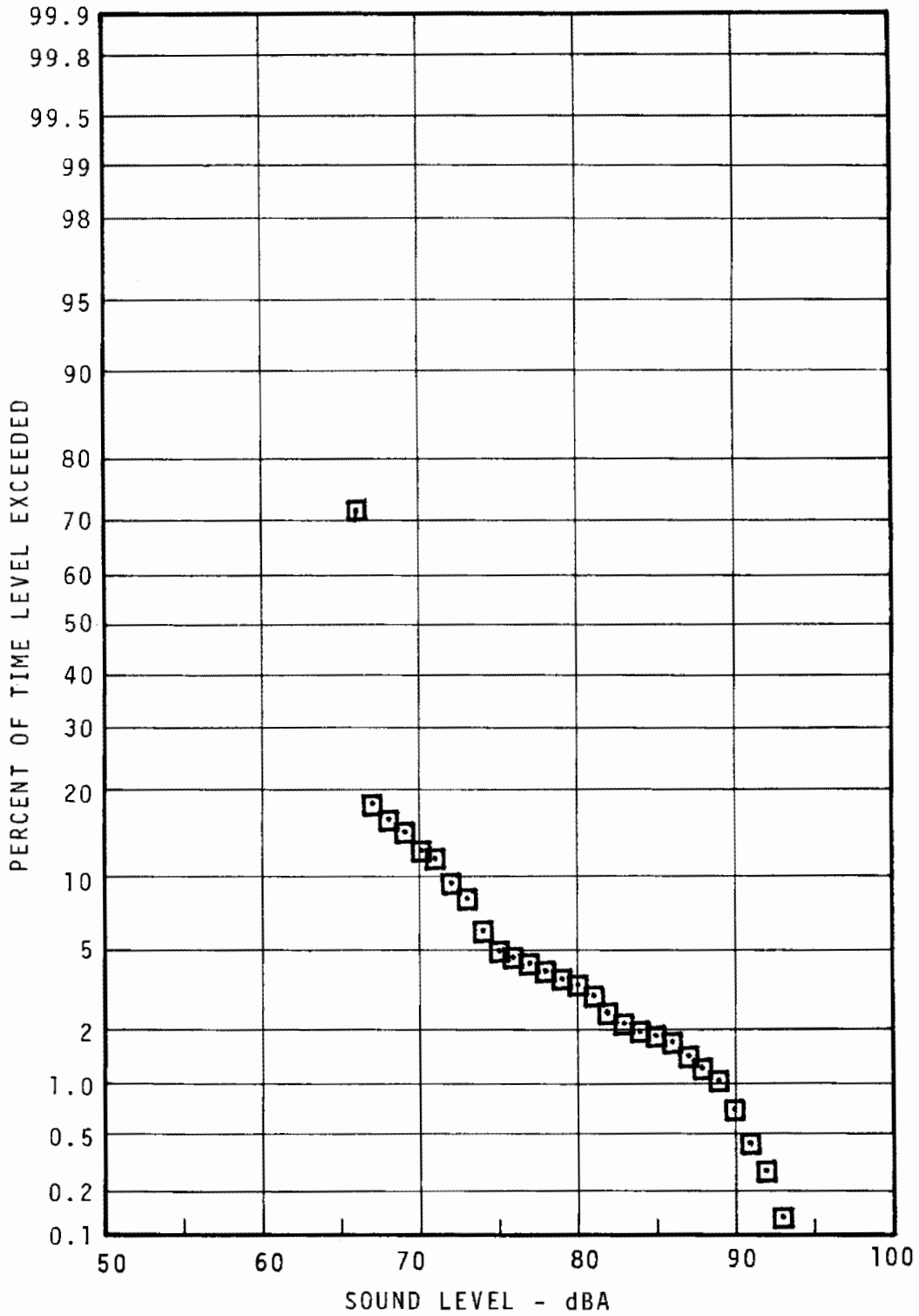

FIGURE 5.65 - PATTSION AVENUE STATION PLATFORM
 STATISTICAL DISTRIBUTION
 NIGHT

5-103/5-104

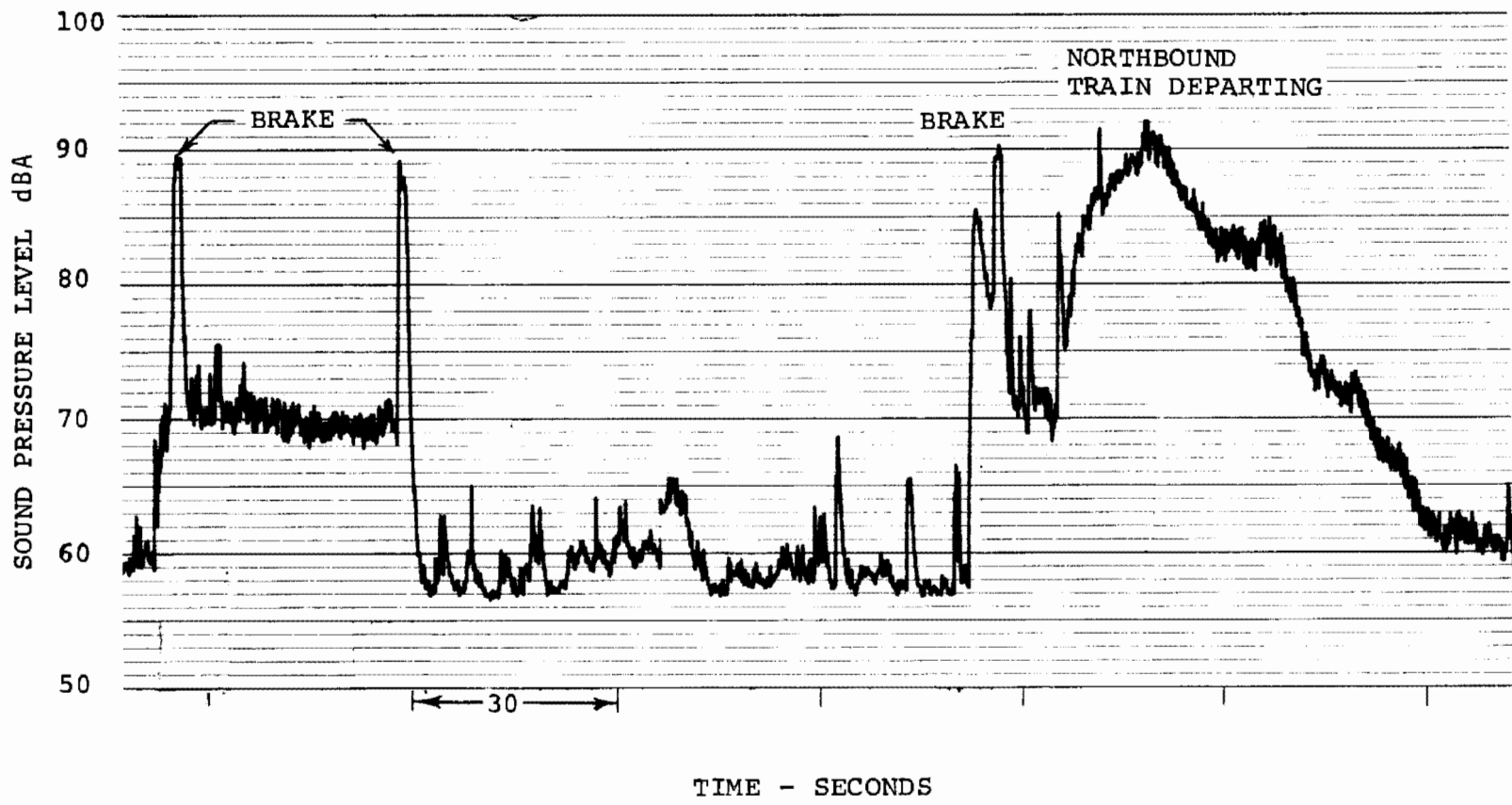
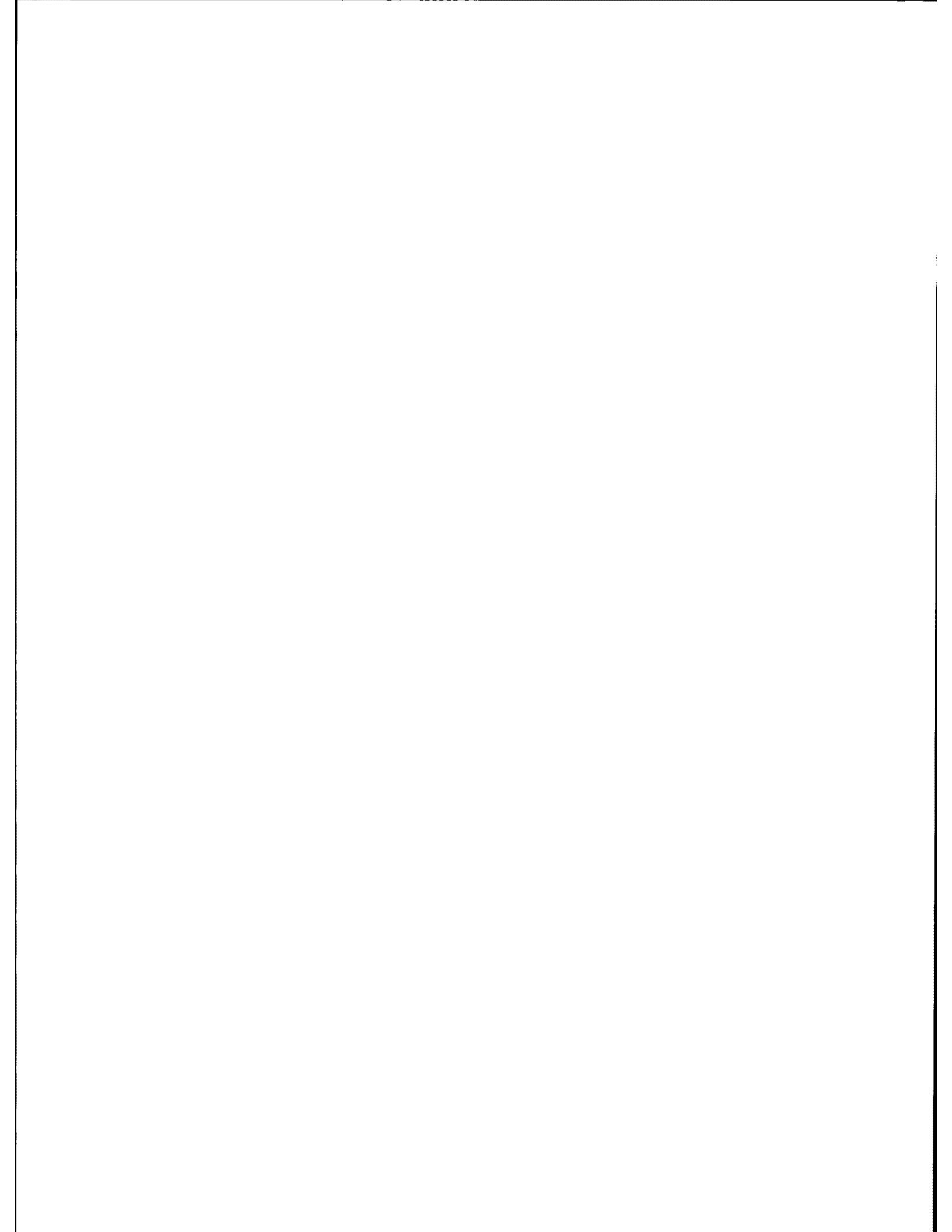

FIGURE 5.66 - TYPICAL TIME HISTORY, PATTISON AVE. STATION



5.2.3 Vehicle Interior

Both the 1928 Brill and 1938 Standard pressed steel cars were surveyed. Continuous recordings were made from terminal to terminal. Cars selected were typical of those in service and data was obtained for seated passenger and operator ear levels. A separate recording track was used to note site specific noise sources. Data was taken during off peak hours to avoid interference with normal operations, although the cars were in revenue service during the recordings.

NORTH BROAD-BRILL CAR INTERIOR

CAR DESCRIPTION (see Figures 5.67, 5.68)

These cars were built in 1928 by the Brill Company in Philadelphia and SEPTA operates 127 of them on the Broad Street Subway. The cars currently accommodate 67 seated passengers. The original additional seating capacity was reduced 30-40 years ago to provide increased passenger-carrying capacity. The cars have conductor booths at each end of the car. During the summer months, many windows and the doors between cars are open to admit additional ventilating air. There are two motors per car (one powered, one unpowered truck) with 210 hp and each car has tread brakes operated pneumatically or electrically. Car weight is 112,000 lbs., including a three-inch concrete floor in each car. Cars operate at an average speed of 17 miles per hour with a top speed of 45-50 mph and average headways of 3.5 minutes for express trains and 7.5 minutes for local trains during non-rush hours.

NOISE CLIMATE (see Table 5.15, Figures 5.64 - 5.73)

When the cars are stationary, the air compressor is audible during short periods when it cycles up. Brake air release is loud and lasts for about one second. The peak noise levels inside the car range between 90 and 100 dBA, the latter level occurs at top speed with the windows open. The source of this noise is both the propulsion system and wheel/rail noise, although the propulsion system appears to be the primary source. During periods of coasting, interior noise levels are substantially reduced over periods of acceleration.

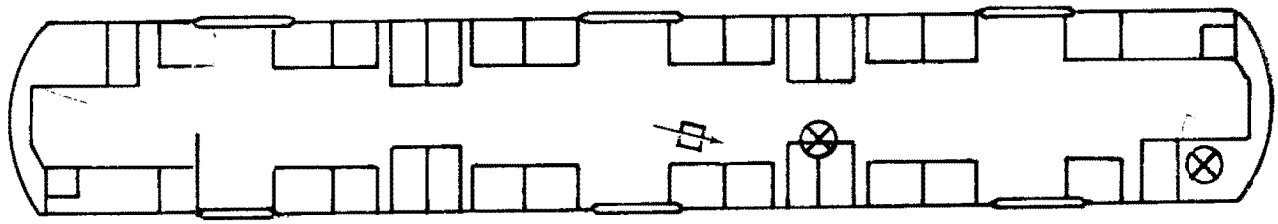

- ⊗ MIC POSITION
- ◻ CAMERA LOCATION

FIGURE 5.67 - IN-CAR MEASUREMENT LOCATIONS -SEPTA-1928
BRILL CAR

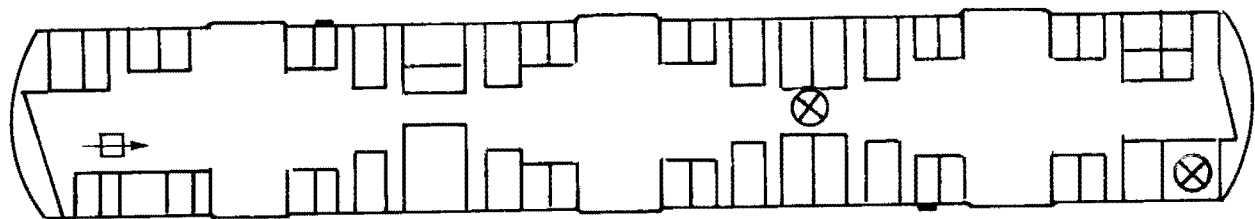

⊗ MIC. POSITION
⊘ CAMERA LOCATION

FIGURE 5.68 - IN-CAR MEASUREMENT LOCATIONS -
SEPTA 1938 PRESSED STEEL CAR

TABLE 5.15 - SUMMARY OF MEASUREMENT RESULTS FOR 1928 BRILL AND 1938 PRESSED STEEL CARS - INTERIOR NOISE LEVELS

CAR TYPE	MIC POSITION	SAMPLE TIME	TRAIN HEADING	UNITS	AVG MAX LEVEL		AVG LR		CUMULATIVE AMPLITUDE DISTRIBUTION					Leq
					NEAR	FAR	NEAR	FAR	L99	L90	L50	L10	L1	
Brill	Center	33 min	North	dBA					63	67	83	89	92	85
	Oper.			dBA					64	66	80	85	88	81
	Center	34 min	South	dBA					65	68	84	91	94	87
	Oper.			dBA					65	67	80	87	90	83

TABLE 5.16
 SEPTA BROAD ST. SUBWAY
 IN-CAR NOISE PLATEAU LEVELS
 1928 NORTH BROAD BRILL - MID CAR

STATION	NORTHBOUND L_A (Max) (dBA)	SOUTHBOUND L_A (Max) (dBA)	AVERAGE L_A (Max) (dBA)
Fern Rock	88.5	90	89
Olney	88	86.5	87
Logan	88.5	91	90
Wyoming	88.5	92.5	91
Hunting Park	88.5	89	89
Erie	89.5	92	91
Allegheny	90	91	91
N. Philadelphia	91.5	92.5	92
Susq.-Dauphin	90	90	90
Columbia	90.5	92	91
Girard	89.5	91.5	91
Fairmount	90.5	90.5	91
Spring Garden	89.5	90	90
Race-Vine	92	92	92
City Hall	92.5	92	92
Walnut-Locust	89	92	91
Lombard-South	92.5	95.5	94
Ellsw.-Federal	91	93.5	92
Tasker-Morris	89	92	91
Snyder	92.5	96.5	95
Oregon	94.5	95.5	95
Pattison			

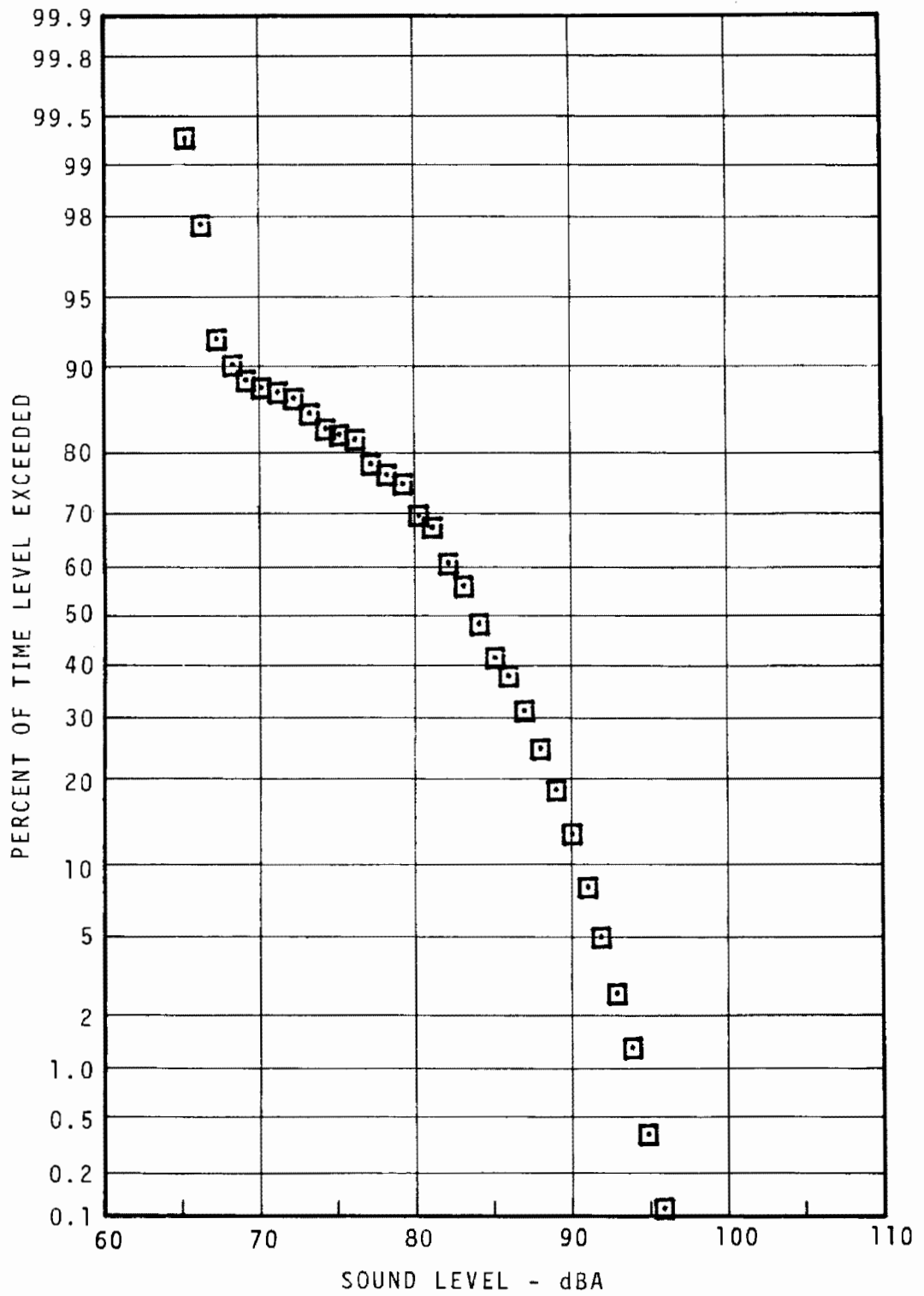

FIGURE 5.69 - 1928 BRILL IN-CAR (CENTER)
 STATISTICAL DISTRIBUTION
 FERN ROCK TO PATTISON AVENUE

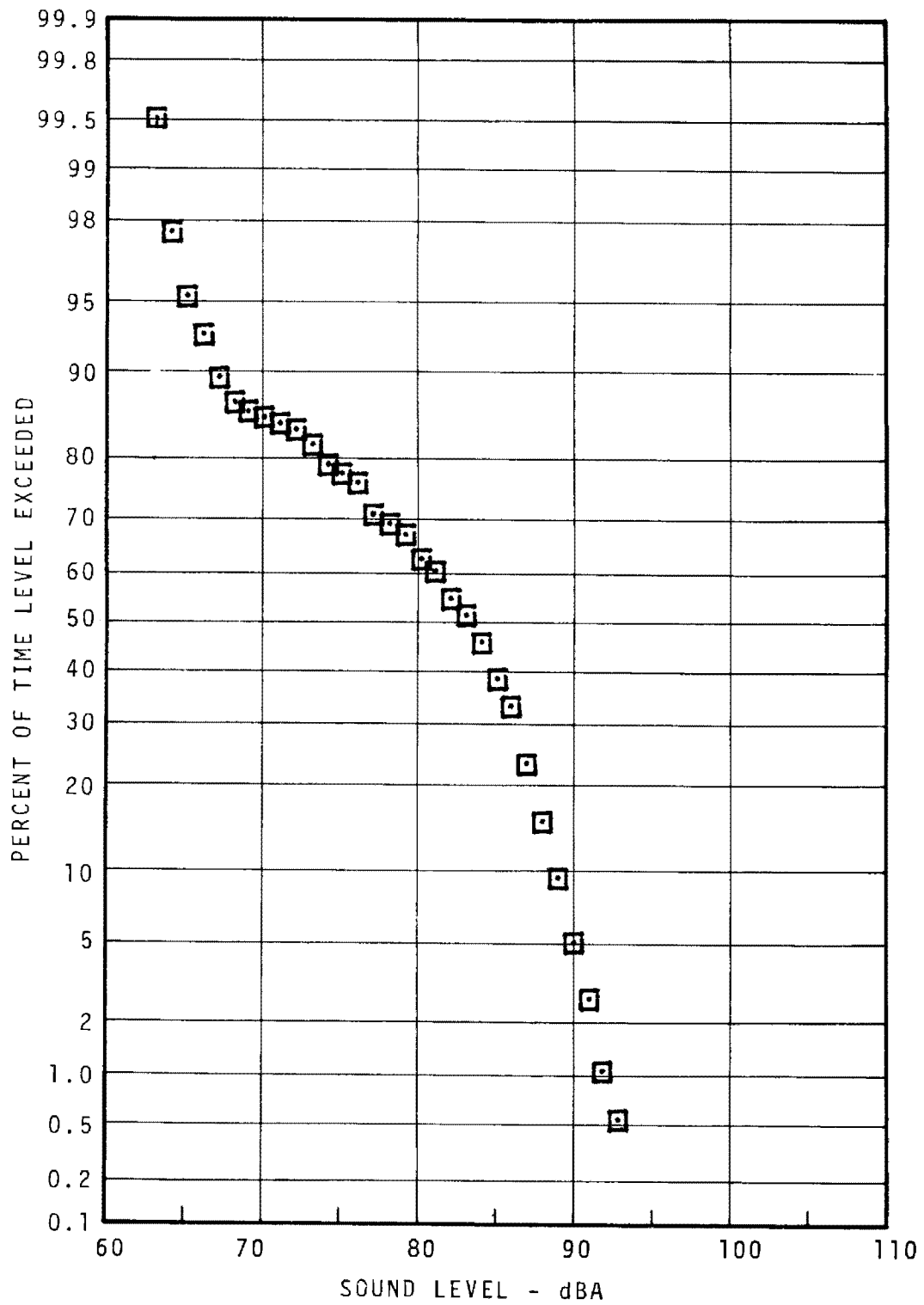

FIGURE 5.70 - 1928 BRILL IN-CAR (CENTER)
 STATISTICAL DISTRIBUTION
 PATTISON AVENUE TO FERN ROCK

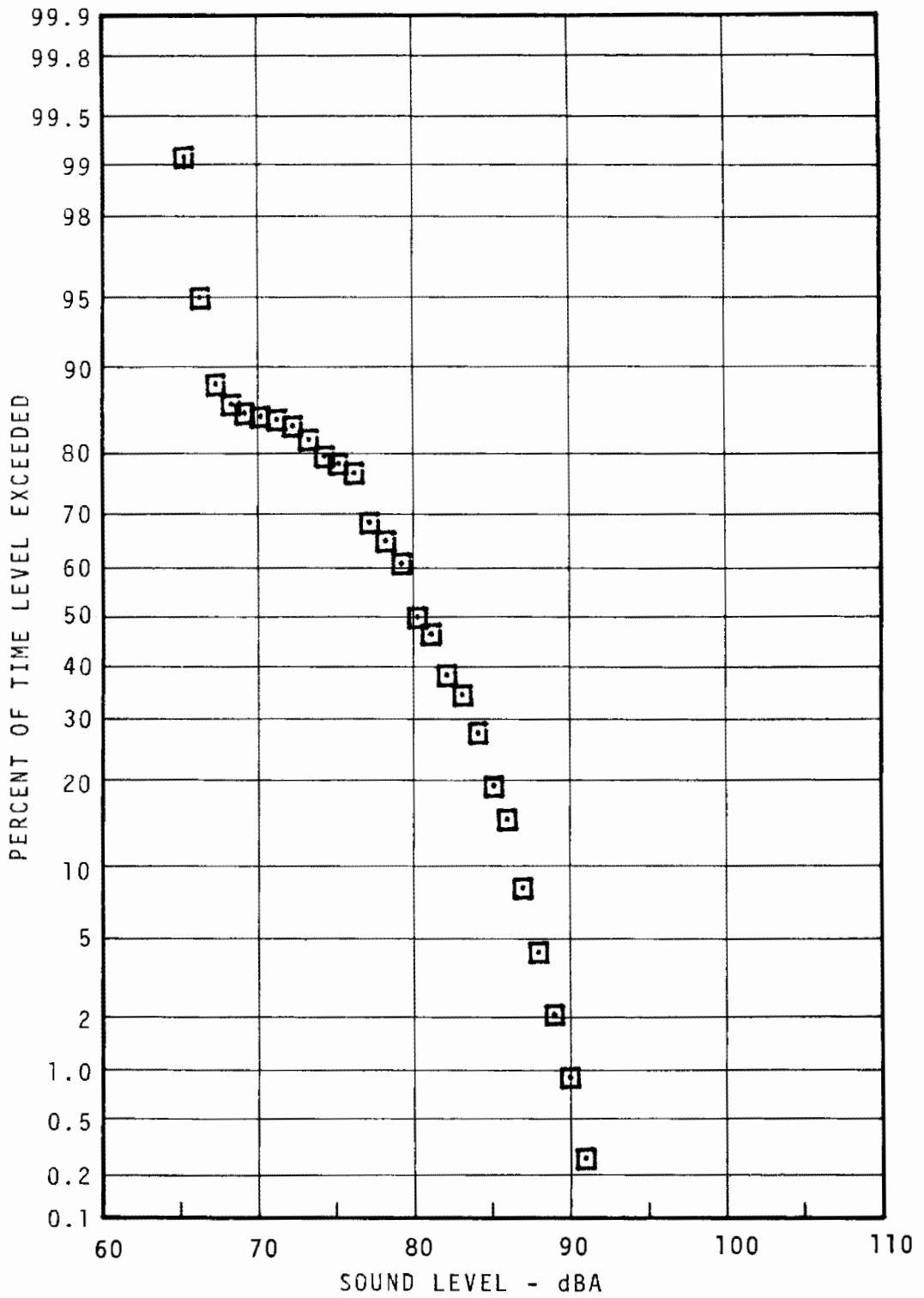

FIGURE 5.71 - 1928 BRILL IN-CAR (CONDUCTOR'S BOOTH)
 STATISTICAL DISTRIBUTION
 FERN ROCK TO PATTISON AVENUE

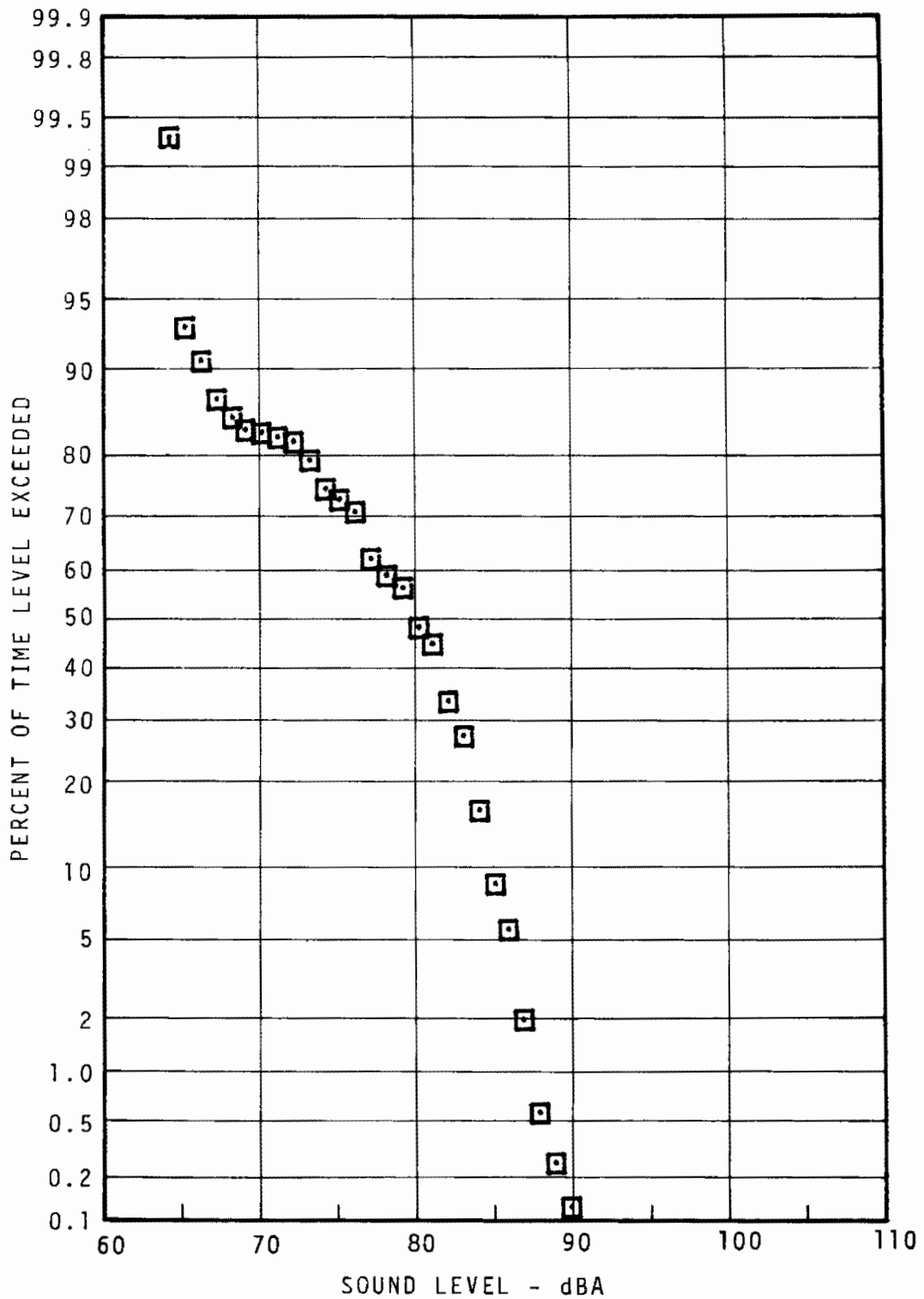

FIGURE 5.72 - 1928 BRILL IN-CAR (CONDUCTOR'S BOOTH)
 STATISTICAL DISTRIBUTION
 PATTISON AVENUE TO FERN ROCK

5-115/5-116

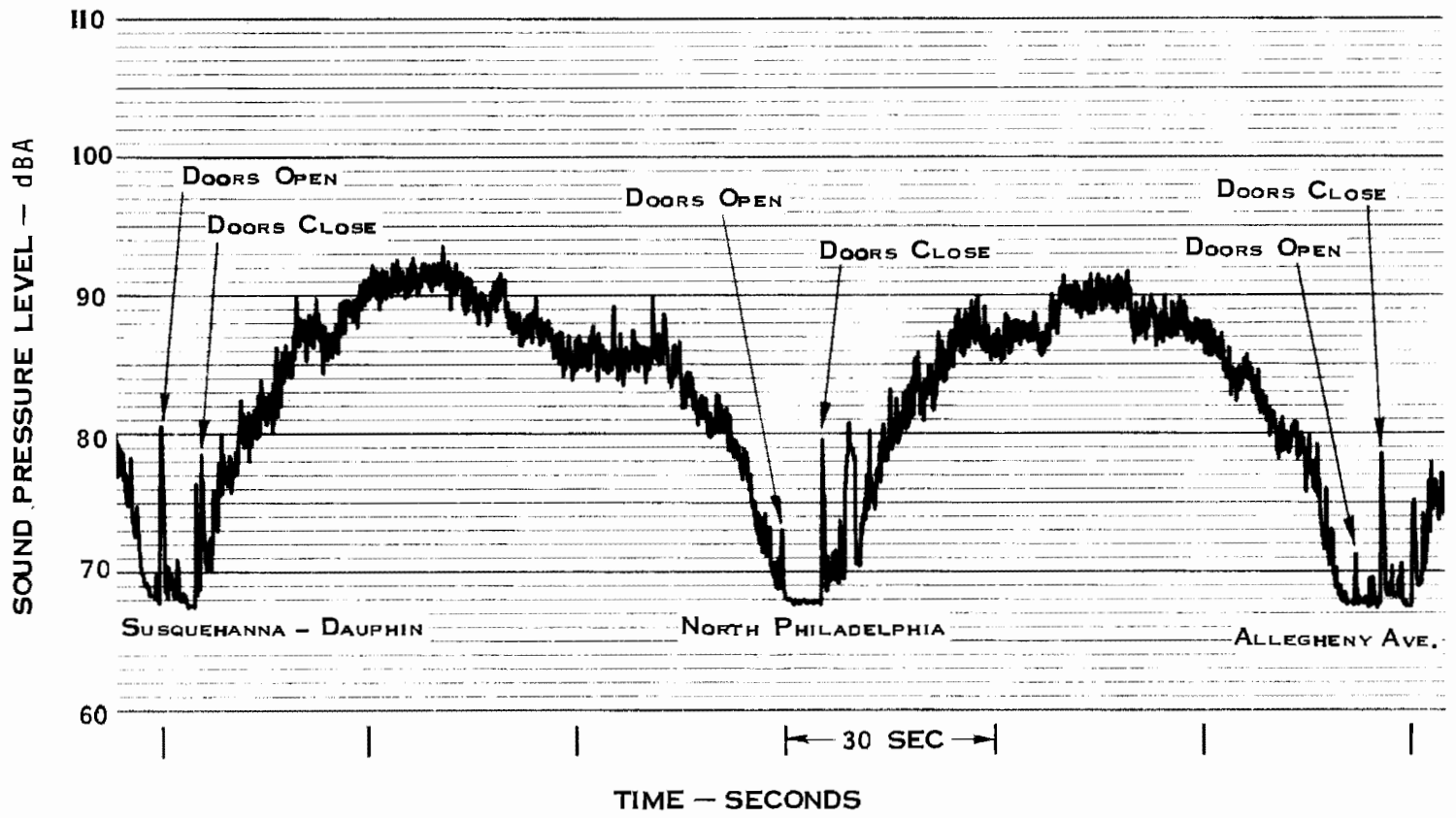
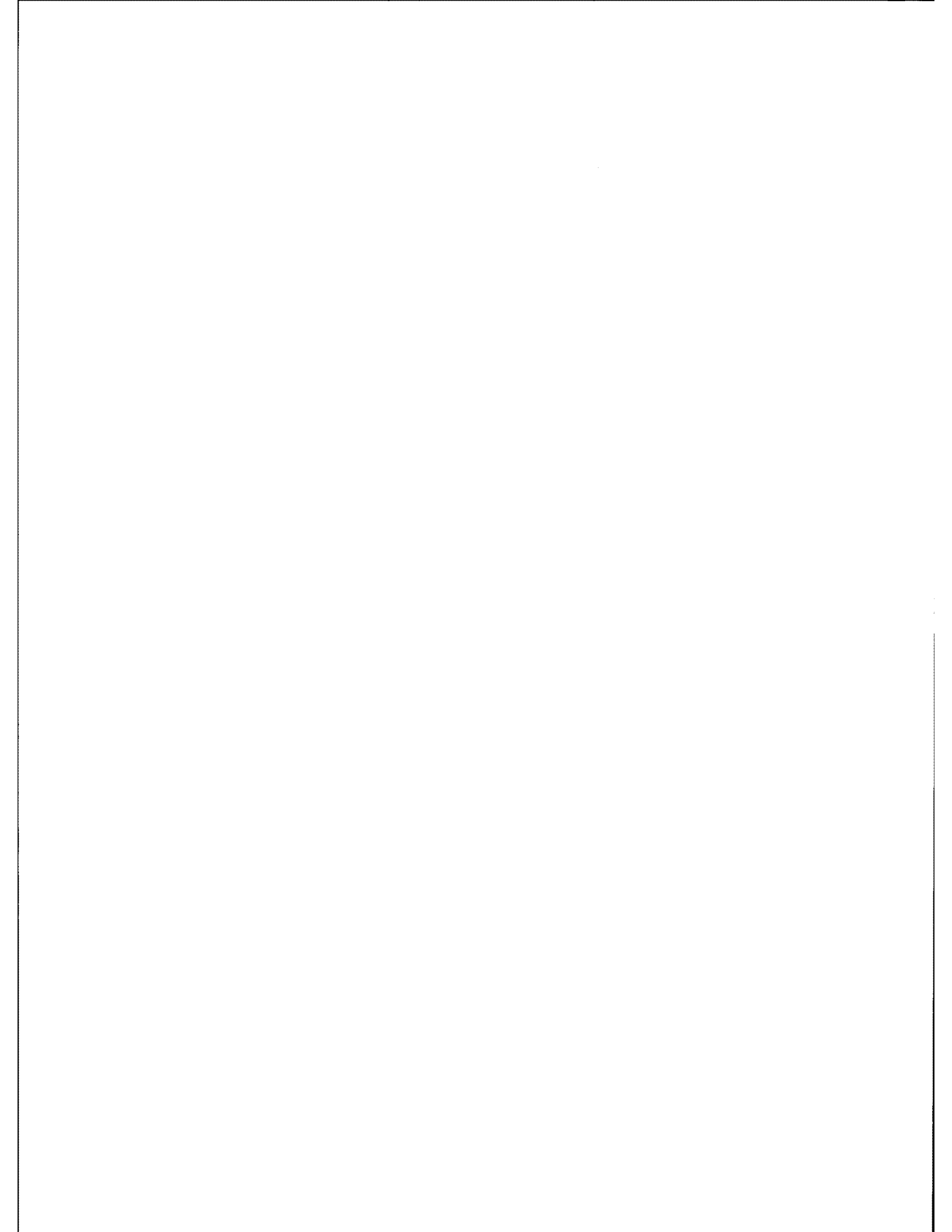

FIGURE 5.73-TIME HISTORY OF IN CAR NOISE ENVIRONMENT 1928 BRILL CAR
SEPTA BROAD STREET LINE - CENTER CAR



SEPTA - BROAD STREET SUMMARY

6. TRANSIT SYSTEM LINE SUMMARY

6.1 General

The data reported in Section 5 which was recorded for representative community, station platform and in-car locations is summarized for the entire Broad Street Line in the following tables and illustrations. General information regarding system operating factors (cars per train, headway, noise measurement periods, etc.) are presented in Table 6.1 to illustrate the rationale for selecting time intervals, or 'windows', when noise measurements were obtained. Although daytime measurements were used for illustration purposes in the tables, calculation of day-night levels have been based on daytime rush hour, evening and night time measurements. Other quantities used in the L_{dn} calculations have also been identified in Table 6.1.

Tables summarizing noise recorded at each community and station location selected for measurement have been included in Section 5. This information has been further generalized to provide an overview of the noise climate of the Broad Street Subway and this data is presented in Table 6.2. Wayside noise levels shown represent the average of the passby maximum levels. This is presented for both the near and far tracks as reported in Section 4. Wayside data is shown for the Fern Rock location only since all other stations on the system are located underground.

Station noise reported in Table 6.2 represents an average of the maximum level, $L_A(\text{Max})$, recorded for each train observed during the recorded interval. The maximum level may occur either for the arrival or departure of the train. In-car data shown represents the plateau level measured at a center car location during constant speed running between stations.

A summary of track construction for the Broad Street Line is presented in Figure 6.1.

6.2 Community Noise

The noise produced by the Broad Street Subway in the community is limited to the immediate Fern Rock Station area. Noise levels were measured at two locations in this area. The first site was directly across the street from the terminal station and levels represent the arrival and departure noise on tangent tracks. The second site was near the curve which joins the terminal platform with the line. These latter levels are wheel screech maximums of arriving

SEPTA BROAD STREET LINE

TABLE 6.1. GENERALIZED OPERATING SUMMARY AND INPUT FOR L_{dn} CALCULATION

TIME OF DAY	6	8	10	12	2	4	6	8	10	12	2	4
CARS/TRAIN	3	6	4	6	6	4	4	4	3	3		
HEADWAY, MIN	15	10	7½	7½	7½	7½	10	10	15	15	30	30
MEAS. WINDOW-SEPTA -PROGRAM	DAY	RUSH	DAY DAY	SCHOOL	RUSH RUSH	EVE EVE			OWL OWL			
WEIGHTING FACTOR, w_i	10	1	1	1	1	1	10	10	10	10	10	10

Period	Meas. L_{eq}	w_i	$\frac{T}{(hrs)}$
5-7	DAY	10	2
7-9:30	RUSH	1	2.5
9:30-4	DAY	1	6.5
4-6	RUSH	1	2
6-10	EVE	1	4
10-1	EVE	10	3
1-5	OWL	10	4

TABLE 6.2.

NOISE MEASUREMENT SUMMARY
SEPTA BROAD ST. SUBWAY
DAYTIME

STATION	INTER-STATION DISTANCE (MILES)	AVER. TIME BETWEEN STATIONS (MIN.)	TYPE ROADBED	TRACK CONSTRUCTION	NO. OF CARS PER TRAIN	WAYSIDE NOISE (15m) (dBA)		STATION PLATFORM NOISE (dBA)	IN-CAR NOISE, MID-CAR 1928 - NORTH BROAD BRILL - (dBA)
						NR	FR		
Fern Rock			At-grade	Wood tie & stone ballast	4	75	77	86	
	0.60	3				77	75		89
Olney			Underground	Wood ties in concrete					
	0.60	2							87
Logan									90
	0.40	1.5							
Wyoming									91
	0.45	1.5							
Hunting Park									89
	0.60	2							
Erie									91
	0.50	2							
Allegheny									91
	0.40	1							
N.Phila.									92
	0.55	2						98	
Susq.-Dauphin									90
	0.55	1							
Columbia									91
	0.50	2							
Girard									91
	0.30	1							
Fairmount									91
	0.25	1						91	
Spring Garden								91	
	0.35	1							90
Race-Vine									92
	0.45	2						93	
City Hall									92
	0.30	1						90	
Walnut-Locust									91
	0.30	2							
Lombard-South									94
	0.55	1							
Ellsw.-Federal									92
	0.45	1							
Tasker-Morris									91
	0.35	2							
Snyder				Rail on tie plate				93	
	0.50	2							95
Oregon									95
	0.80	2							
Pattison								88	
Fairmount*				Wood ties in concrete					
	0.35	1							
Spring Garden*								93	
	0.45	1.5							
Vine*									
	0.35	1							
8th Street*									

*Ridge spur stations

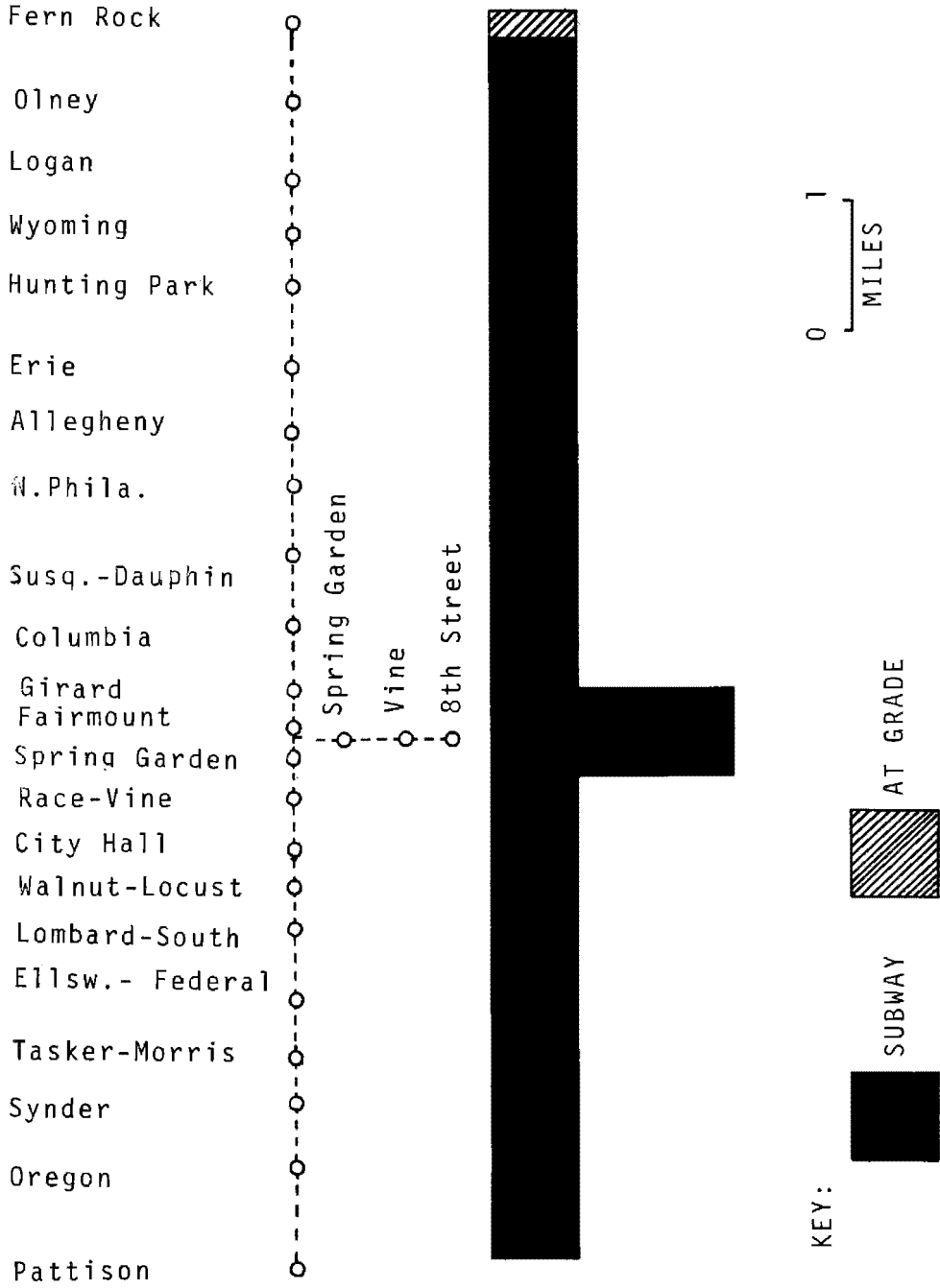

FIGURE 6.1. SEPTA BROAD STREET SUBWAY - TRACK CONSTRUCTION SCHEMATIC

and departing trains. Adjacent to the curve south of the station, noise levels are approximately 5 dB(A) higher than those measured near the terminal due to the generation of squeal at this site. Noise measurements also were made at street level over the station at Wyoming Avenue to establish the contribution of transit system noise in the community along the subway route.

Data analyzed from the Wyoming Avenue site showed that street level noise levels due to the trains are indistinguishable in the recorded samples of traffic and other community sources. This data therefore has not been included in the summary table. Observer comments verified these findings in that a passing train was inaudible at street level, with the possible exception of within a few meters of the vent shafts located on the adjacent sidewalks during night time measurements.

6.3 Station Noise

Lowest noise levels on the Broad Street Subway were measured at the terminals, with the at-grade station (Fern Rock) lower than Pattison Avenue by only 2 dBA. Underground on-line stations range from 90-98 dBA.

A comparison of the statistical distributions for Snyder Avenue Station on the Broad Street Line and for City Hall Station on the PATCO Line was made and is presented in Figure 6.2. These stations are structurally and architecturally similar and a comparison of noise levels with the same number of cars per train was thought to afford some insight into the effect of the transit vehicle on noise exposure in the station. Figure 6.2 does not illustrate any meaningful difference in the statistical quantities between L_{25} and L_1 , however, and the values for $L_A(\text{Max})$ for 6 car trains was 93 dBA at Snyder Avenue and 92-93 dBA at City Hall Station on the PATCO Line. The L_{25} to $L_{99.9}$ level difference on the PATCO system results from data taken at the site during rush hours in order to obtain the same number of cars per train as for Snyder Avenue on the Broad Street Line.

6.4 In-Car Noise

Noise levels in the Broad Street cars range between 97 and 106 dBA along the system. Car speeds north of Logan are somewhat lower due to crossovers both between Logan-Olney and Olney-Fern Rock, and interior noise levels are lower by 3-5 dBA as a result. From Logan south to Snyder Avenue, interior noise levels range between

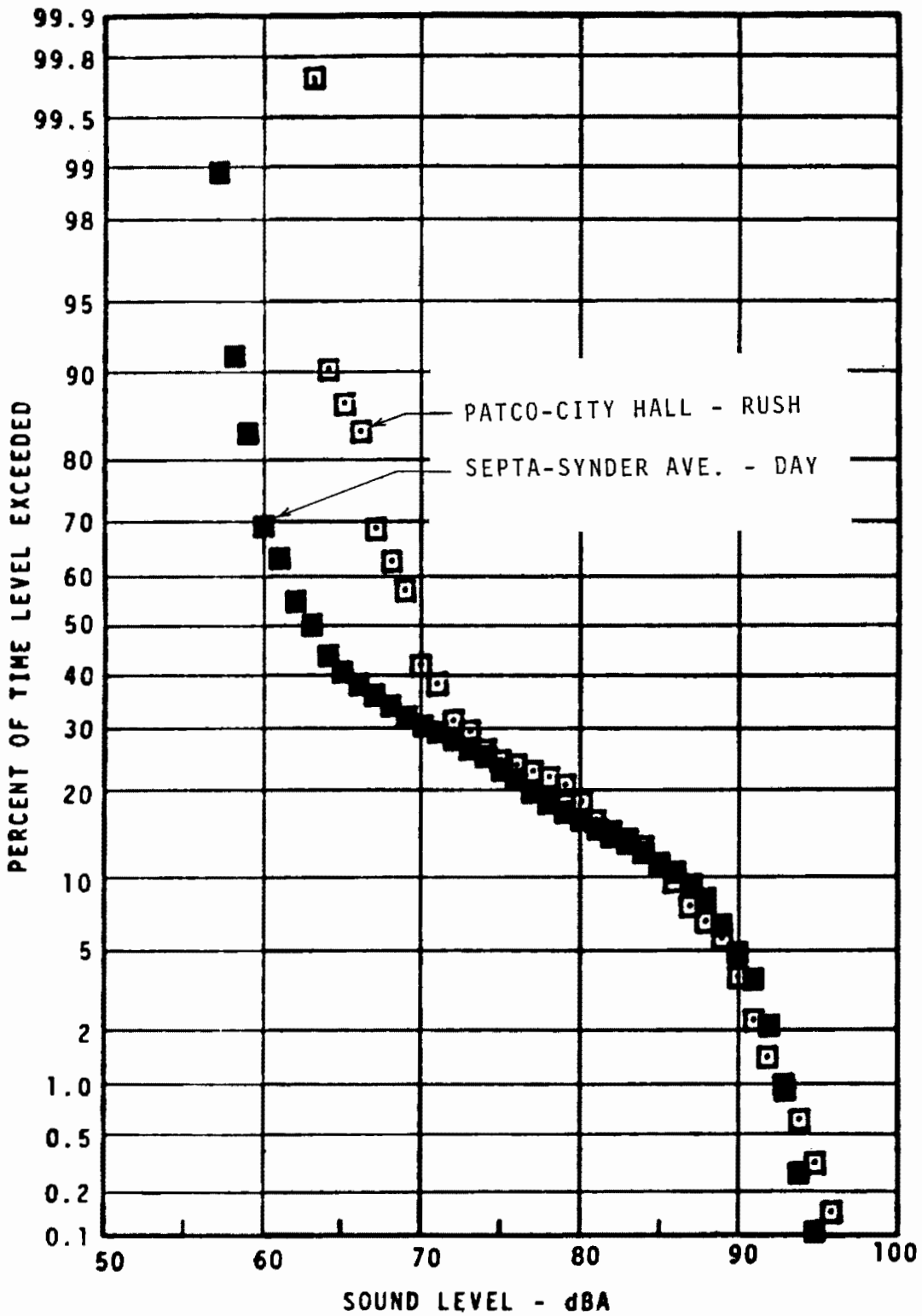

FIGURE 6.2. COMPARISON OF SEPTA AND PATCO UNDERGROUND STATION PLATFORM NOISE ENVIRONMENTS (FOUR CAR TRAINS)

99 and 104 dB(A). South of Snyder Avenue, interior plateau levels are 105-106 dB(A) resulting from straight, rather than scalloped, subway wall construction as well as a concrete dividing wall between north and southbound tracks in this same area.

6.5 Broad Street Subway Noise Summary

A graphic summary of community, station and in-car noise on the Broad Street Line is presented in Figure 6.3. The levels have been grouped into eight 5 dB(A) ranges of noise from 70-75, 75-80, 80-85, 85-90, 90-95, 95-100, 100-105, and 105-110 dBA. Wayside measurements were made at a distance of 15m from the near track, station noise was obtained at the center of a stopped train and in-car data was taken in the second car of a multicar train.

In-car noise levels are established primarily from the propulsion system, with wheel/rail noise audible when trains are not accelerating or maintaining speed. In-car data was taken with all windows closed, however, much of the year cars are operated with doors between cars and ventilators open, and undercar noise is little attenuated. At the higher speeds, communication in the car is not possible at normal voice levels. Wheel squeal is generated just north of City Hall Station as the trains negotiate curved track around City Hall Plaza and also near the tunnel portal of Fern Rock as the system tracks align with Nedro Avenue. A patron riding the system from terminal to terminal would experience noise plateau levels in the 85-90 dBA group 19 percent of the time, levels in the 90-95 dBA group 69 percent of the time and levels in the group 95-100 dBA 12 percent of the time. A patron's actual exposure is dependent on his specific commuting route of course, but if that route is between Snyder Avenue and Logan Stations the mean level of exposure for each station-to-station plateau is 91 dBA with a standard deviation of only 1.25 dBA.

Due to vehicle propulsion system noise and the reverberant characteristics of the subway stations, noise levels with trains entering and departing range between 88 and 98 dBA. The one station located at grade, Fern Rock, displays the lowest levels on the line, 86 dBA. The majority of the stations, 46 percent, have noise levels in the 90-95 dBA range with 23 percent in the group from 85-90, and 31 percent in the group from 95-100 dBA.

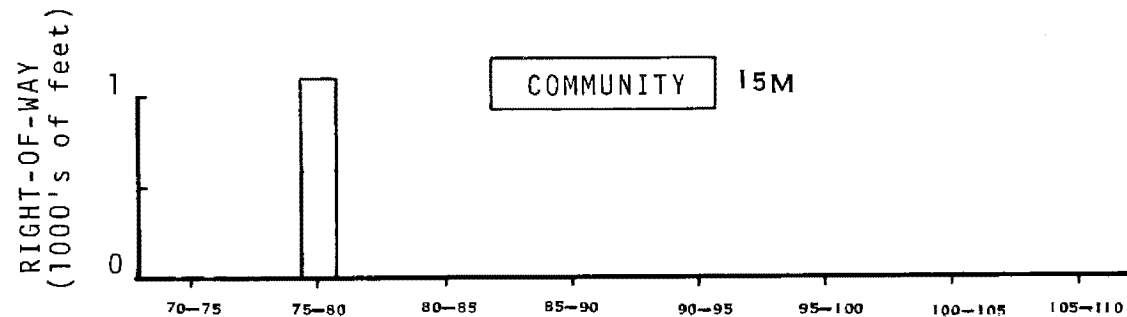
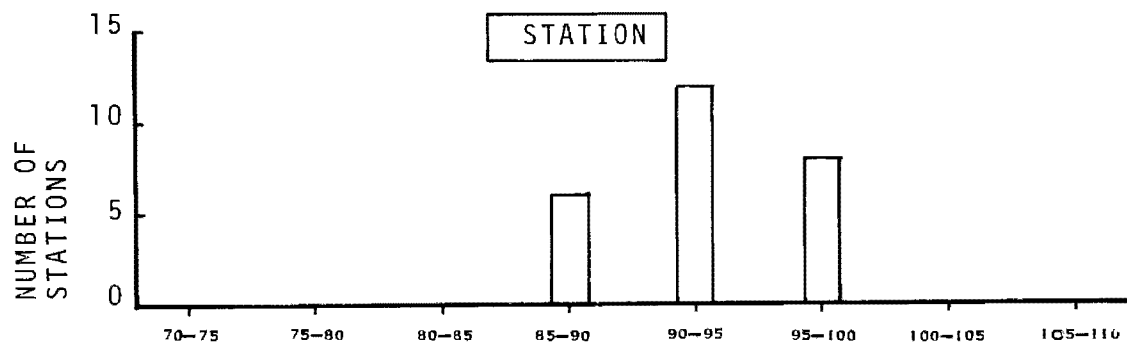
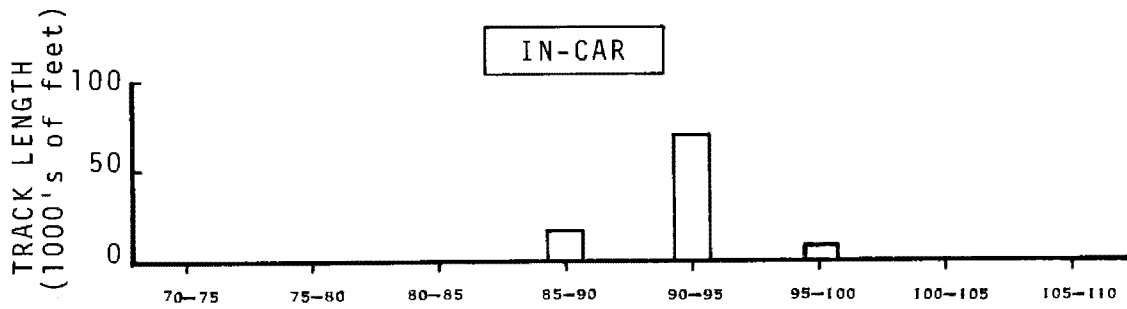

GROUPED SOUND LEVEL, $L_A(\text{Max})$ - dBA

NOTE: GROUPED SOUND LEVEL INTERVAL INCLUDES LOWER, BUT NOT UPPER ENDPOINT.

FIGURE 6.3 - SUMMARY OF SEPTA BROAD STREET SUBWAY NOISE ENVIRONMENT.

Community noise exposure is restricted to the vicinity of Fern Rock Station. In the immediate location of the station, community noise is in the 75-80 dBA group when the 15m noise is estimated. It is in this locale that most of the residential buildings are located. A few hundred meters from this site, community noise levels are also in the group from 75-80 dBA resulting from the generation of wheel squeal, but the distance to the nearest housing increases from 15m to more than twice this, tending to offset the increased level due to squeal. Elsewhere on the line, the noise of subway train operation is not a measurable quantity in the community.

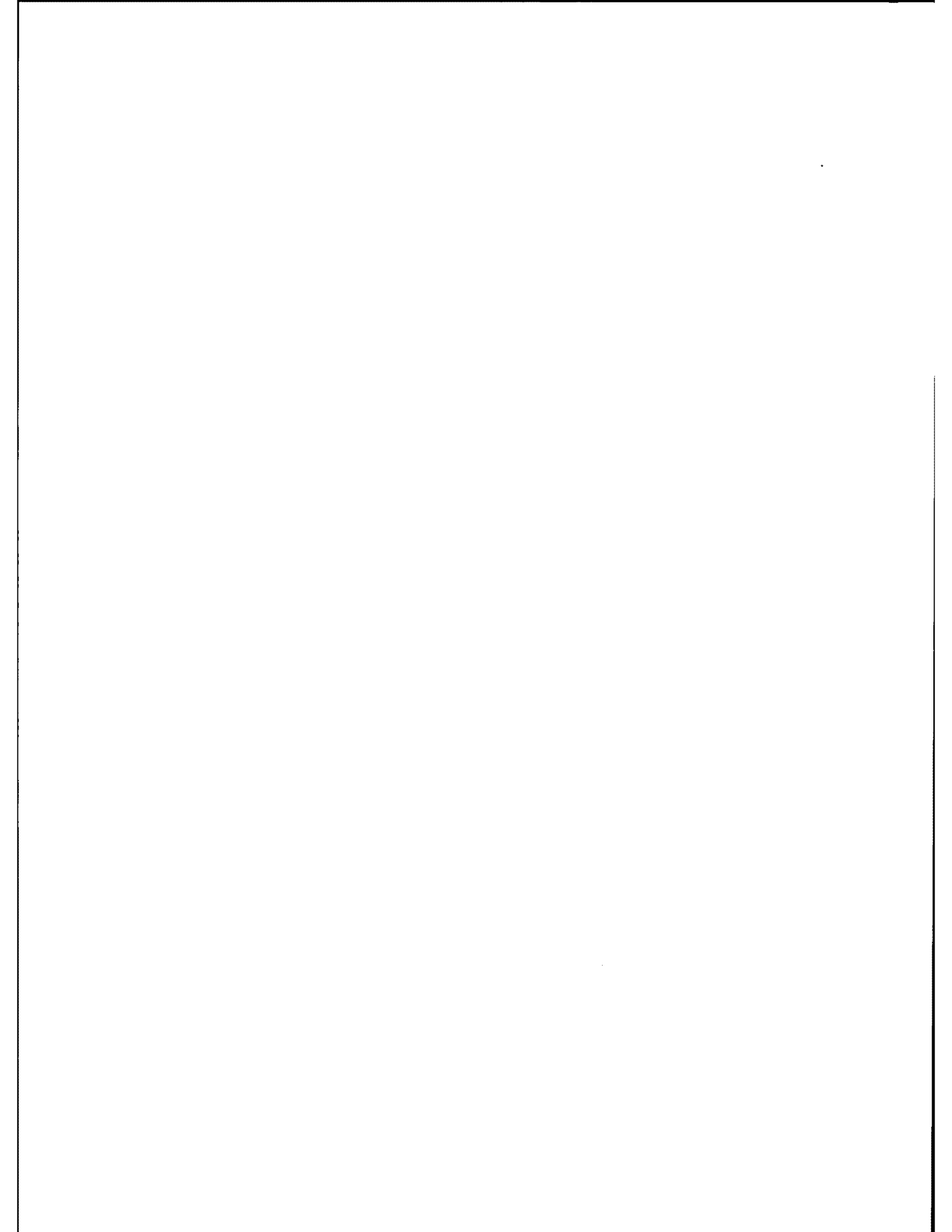

7. MARKET-FRANKFORD LINE - NOISE ASSESSMENT DATA

7.1 Description of Transit System

Routes and Service^{*} - The Market-Frankford subway elevated line operates over all three basic types of roadbed (elevated, subway and at-grade) for a total distance of 12.8 miles, extending from 69th Street in Upper Darby, Pa., just west of the Philadelphia county line, to the Frankford area in North Philadelphia as shown in Figure 7.1. Its route is along Market Street in West Philadelphia, through center city, to Front Street where it turns north. It then follows Front Street to Kensington Avenue (York-Dauphin Station) running in a northeast direction until it joins with Frankford Avenue. From there, it continues to Bridge Street terminal. Maintenance facilities for the transit vehicles are located at 69th Street.

The 69th Street area is a major business district near the Philadelphia line. Connections to all the major western suburban areas are available at the 69th Street Terminal by bus, light rail, or other high-speed rapid transit lines.

The region which the route serves in West Philadelphia is comprised of residential homes, as well as commercial and business establishments which front directly on Market Street. Center city, where the system is located underground, is the hub of commercial and business enterprise. The North Philadelphia segment is similar to West Philadelphia in that it serves a residential and commercial area, although there tends to be more housing and less commerce along this northern segment than is the case for west Philadelphia.

At 33rd Street, a route of the subway-surface system (light rail) parallels the Market-Frankford Line in the subway and continues to the 15th Street Station with intermediate stops at 30th, 22nd and 19th Streets.

The Market-Frankford system interchanges with the subway surface line only at 15th and 30th Street Stations, where passengers exit overhead and descend to grade level platforms on separate outside tracks. Noise levels of the PCC cars contribute substantially to the acoustical environment of the Market-Frankford patrons.

* Description is for system as it existed at the time of the noise measurements (1975). When the Delaware Expressway was constructed, the line was relocated to follow the expressway route, which curves westward approximately one block from Front Street. Here the track structure was integrated into the highway structure, but it returns to a separate steel elevated steel structure again just south of the Girard Station. North of Bridge-Pratt, the line descends to grade into a reversing loop.

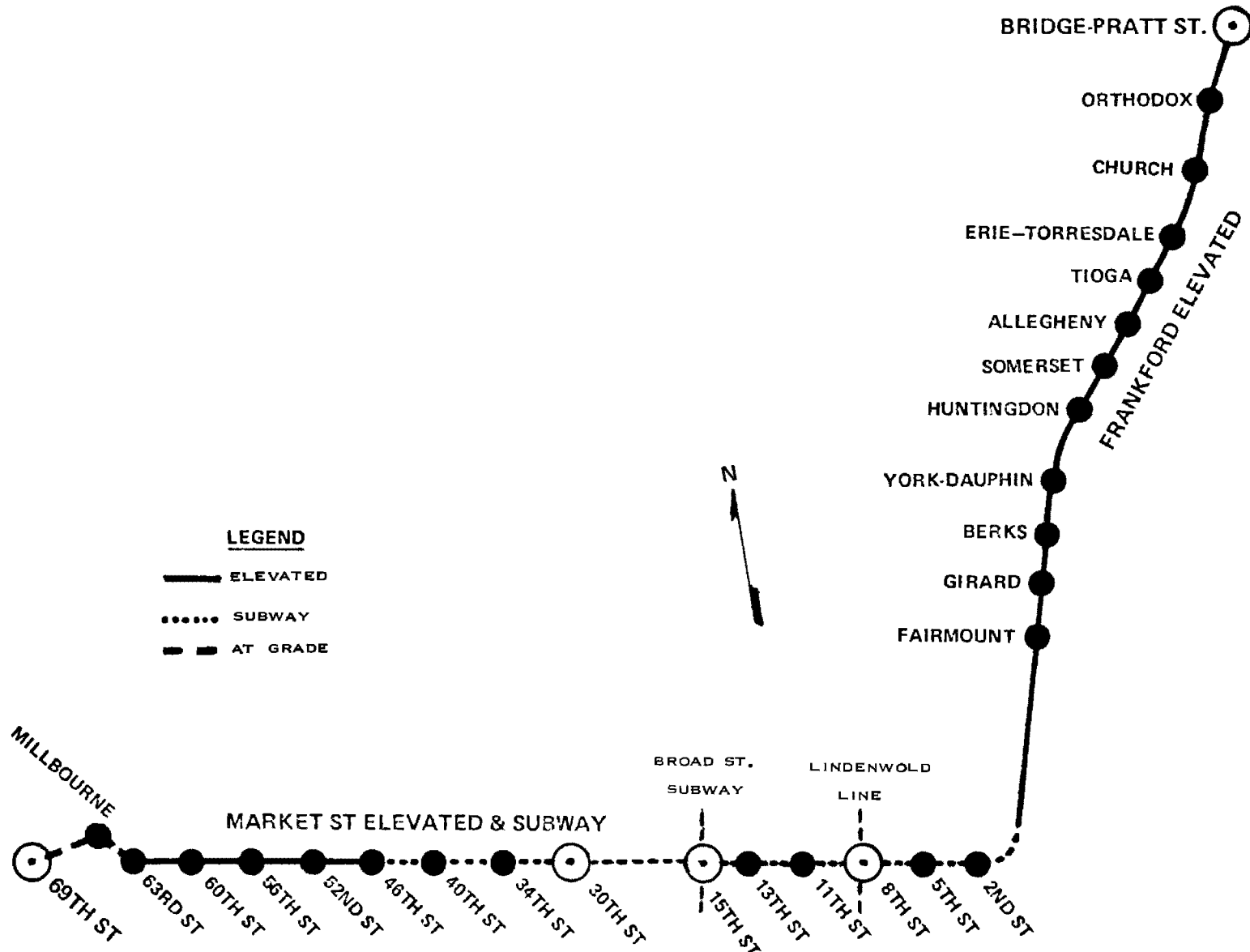

FIGURE 7.1 SEPTA MARKET - FRANKFORD SUBWAY ELEVATED SYSTEM SCHEMATIC

Roadbed - Inbound from the 69th Street Terminal, where the system is on-grade, the roadbed is ballast and tie construction for a distance of just over one-half mile. At this point, it becomes elevated above Market Street on steel structure where it continues to 46th Street Station. The structure over this segment of the route region supports a concrete sub-base on which ballast and tie roadbed is laid.

In some station areas, the roadbed consists of short wood ties set in concrete. Just east of 46th Street, the line descends into the subway, below Market Street, continuing under center city to Front Street where it makes a sharp turn northbound around a 200 ft radius curve. The roadbed in the tunnel consists of short wood ties in concrete. There are no tunnel ventilating shafts and patrons on subway station platforms feel an onrush of air due to train motion through the tunnel just prior to train arrival at the station.

At Front Street immediately north of Market, the line becomes elevated on steel structure and remains so to the Bridge-Pratt Terminal, which is also elevated on steel structure. The line goes on-grade into a reversing loop although most trains remain in the station area and are operated in the reverse direction for the return run to 69th Street.

There are numerous locations on the line where wheel screech is generated: the 69th Street reversing loop, entering and leaving the terminal, between the Milbourne and 63rd Street Stations, entering the subway east of 46th Street, north of 2nd Street, just prior to leaving the subway, north of York-Dauphin Station where the line joins Kensington Avenue and south of Church Street Station.

The rail is jointed along the entire route except for a section on the westbound tracks between 46th and 52nd Streets in West Philadelphia. As rail is replaced, new welded rail is being installed. Many joints in the existing rail are not aligned, or have large gaps and produce large amplitude impact noise.

Rail Vehicles - the transit cars in use on the Market-Frankford Line were built by Budd in 1960. These are shown in Figure 7.2. There are 273 cars of this type on the system. The cars are ventilated by overhead fans.

Speeds between stations are typically 45 mph, although trains accelerate to 55 mph descending under the Schuylkill River. Between 2nd and Bridge Streets, roadbed and elevated structure maintenance has reduced speeds between stations to 20 mph. This speed restriction will be in force until the extensive structural maintenance is completed. It has currently (1975) been in effect for a period of about one year. Power pickup is by outside third rail. Noise levels in the car typically are in the range of 80 to 90 dBA. There is no specific acoustical treatment of the cars other than the thermal insulation normally applied to the car body. One car (No. 635) had

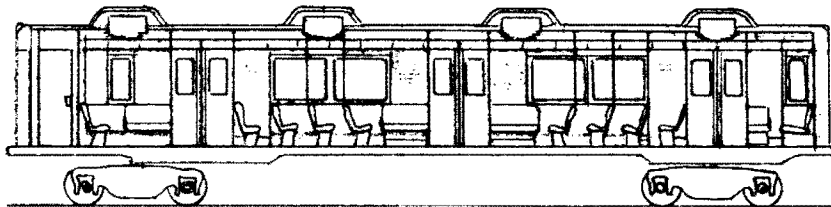

SECTION VIEW

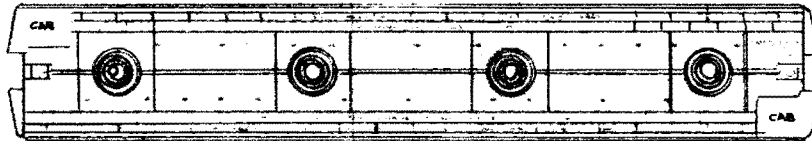

REFLECTED CEILING PLAN

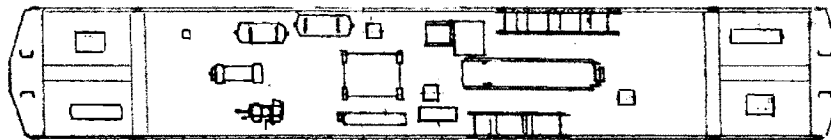

UNDERFLOOR EQUIPMENT PLAN

54 SEATED PASSENGERS

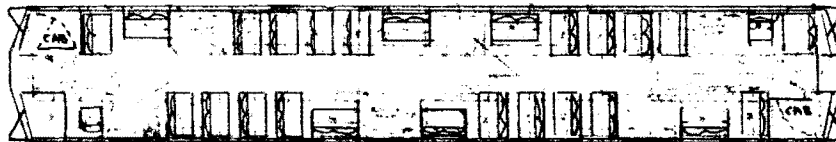

FLOOR PLAN (BUDD CAR NOS 1031 TO 1046)

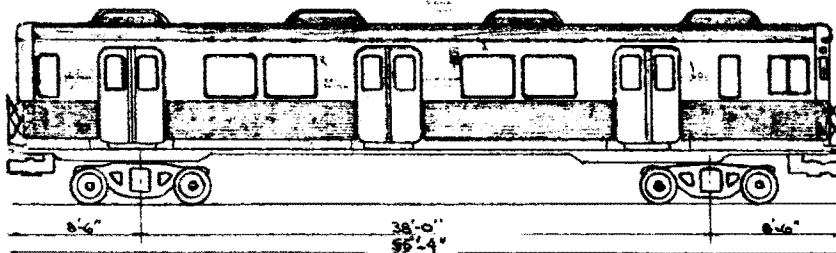

ELEVATED NEAR SIDE

FIGURE 7.2 - MARKET - FRANKFORD LINE 1960 SERIES BUDD CAR

Acousta Flex wheels for evaluation purposes. After about 40,000 miles, these were removed for refurbishing by the manufacturer and have been reinstalled. These wheels virtually eliminate the wheel screech normally generated by all steel wheels.

Stations - Table 7.1 lists the stations on the system by type.

At 69th Street Terminal, passengers exit on one side platform overhead to other connections within the terminal. Entering patrons board trains by way of the center platform.

Passengers at the only other on-grade station, Milbourne, enter and exit the station area from the cashier's booth on the eastbound platform. An overhead walkway is used for crossing to and from the westbound platform.

Elevated station platforms are entered from street level through a cashier's booth frequently located under the station on a crossover walkway but above street level. Passenger crossovers between platforms are either below track level, or in some instances north of 2nd Street above the tracks. Patrons are exposed to general community noise on these platforms in addition to the noise of the transit vehicles.

The underground stations are virtually all masonry in construction, consisting of large surface areas of concrete and ceramic tile. Fifteenth Street Station is an interchange with the Broad Street Subway and also the subway-surface system. Thirtieth Street also has a subway-surface station located on outboard tracks.

Patrons on the 2nd Street Station platform are exposed to wheel squeal as trains negotiate the 200 ft radius curve just north of the station. North of this curve the roadbed becomes elevated and, in most instances, the stations are similar in layout to the elevated stations in West Philadelphia.

TABLE 7.1. STATION CONFIGURATIONS - MARKET-FRANKFORD LINE

On-Grade	<ul style="list-style-type: none"> ● Three-track, one center, one side platform 69th Street Terminal ● Two-track, side platform Milbourne 																		
Elevated	<ul style="list-style-type: none"> ● Two-track, side platform <table border="0" style="margin-left: 20px;"> <tr> <td>63rd</td> <td>Fairmount</td> <td>Somerset</td> </tr> <tr> <td>60th</td> <td>Girard</td> <td>Allegheny</td> </tr> <tr> <td>56th</td> <td>Berks</td> <td>Tioga</td> </tr> <tr> <td>52nd</td> <td>York-Dauphin</td> <td>Erie-Torresdale</td> </tr> <tr> <td>46th</td> <td>Huntingdon</td> <td>Church</td> </tr> <tr> <td></td> <td></td> <td>Margaret-Orthodox</td> </tr> </table> ● Two-track, one center, one side platform Bridge-Pratt Terminal 	63rd	Fairmount	Somerset	60th	Girard	Allegheny	56th	Berks	Tioga	52nd	York-Dauphin	Erie-Torresdale	46th	Huntingdon	Church			Margaret-Orthodox
63rd	Fairmount	Somerset																	
60th	Girard	Allegheny																	
56th	Berks	Tioga																	
52nd	York-Dauphin	Erie-Torresdale																	
46th	Huntingdon	Church																	
		Margaret-Orthodox																	
Underground	<ul style="list-style-type: none"> ● Two-track, side platform <table border="0" style="margin-left: 20px;"> <tr> <td>40th</td> <td>11th</td> </tr> <tr> <td>15th*</td> <td>8th</td> </tr> <tr> <td>13th</td> <td>5th</td> </tr> <tr> <td></td> <td>2nd</td> </tr> </table> ● Two-track, center platform <table border="0" style="margin-left: 20px;"> <tr> <td>30th*</td> </tr> <tr> <td>34th</td> </tr> </table> 	40th	11th	15th*	8th	13th	5th		2nd	30th*	34th								
40th	11th																		
15th*	8th																		
13th	5th																		
	2nd																		
30th*																			
34th																			

*Also subway-surface line stations.

7.2 Noise Assessment Data

The environmental noise data of the transit system has been grouped for each measurement location with site descriptions and data on the noise survey results. After a general review of the test sites, whether they be community, station or car, and their relationship to the overall transit system geography, specific details are furnished for each site, including the following:

- a. A short description of the important features of the measurement site.
- b. A description of the noise climate identifying the major sources of noise at the location.
- c. Photographs of site including both microphones and tracks.
- d. Sketch of site showing location of both microphones and tracks.
- e. A summary table of the statistical measures of each noise sample (L_1 , L_{10} , L_{50} , L_{90} and L_{99} , L_{eq}), along with the average maximum levels of the train passbys on the near and far tracks. Also given in the table are the average level of L_R for the passbys on the near and far tracks.
- f. Statistical distribution curves for all 30 minute samples at each site.
- g. A sample strip chart trace including near and far track train passbys at the microphone closest to the track.

Table 7.2 is presented to describe the content of information in each summary table. An explanation of each column follows:

Column

- (1) The measurement period in 24 hours during which the noise sample was taken.
- (2) Distance of the microphone from the centerline of the nearest track.
- (3) Length of data sample, in minutes.
- (4) Type of train operation during sample, i.e., Passby for community noise and Arrival or Departure for station noise.

TABLE 7.2. EXPLANATION FOR MEASUREMENT RESULT SUMMARY
TABLES PRESENTED AT EACH SITE.

(1)	(2)	(3)	(4)	(5)	(6)	(7)	(8)	(9)	(10)					(11)
TIME	MIC POSITION	SAMPLE TIME	TRAIN CONDITIONS	UNITS	AVG MAX LEVEL		AVG LR		CUMULATIVE AMPLITUDE DISTRIBUTION					Leq
					NEAR	FAR	NEAR	FAR	L99	L90	L50	L10	L1	

Notes: a - Track
b - Number of Trains - (e.g.: 4-2 means four 2-car trains)
c - Standard Deviation of Level

(12) L_{dn} =

Column

(5) Identification for the data presented.

- N = Number of trains in sample - cars per train (4-2 indicates four 2-car trains).
- dBA = Averaged A-weighted sound levels, $L_A(\text{Max})$, for number of trains noted (see Figure 4.4).
- S = Standard deviation of $L_A(\text{Max})$ or L_R listed immediately above it.

$$S = \sqrt{\frac{\sum_{i=1}^N (x_i - \bar{x})^2}{N-1}}$$

where x_i = individual $L_A(\text{Max})$ or L_R
 \bar{x} = mean value of $L_A(\text{Max})$ or L_R

- (6) $L_A(\text{Max})$ data for trains operating on near tracks.
- (7) $L_A(\text{Max})$ data for trains operating on far tracks.
- (8) L_R data for trains operating on near tracks.
- (9) L_R data for trains operating on far tracks.
- (10) Summary of cumulative amplitude distribution for data sample, dBA.
- (11) Equivalent Sound Level for sample of duration noted in Column (3) (See Section 4-2).
- (12) Day-Night Equivalent Sound Level for A-weighted noise level integrated over 24 hour period. Weightings are applied to the noise levels measured during the four time periods during the day. (See Section 4-2 and Table 8.1.)

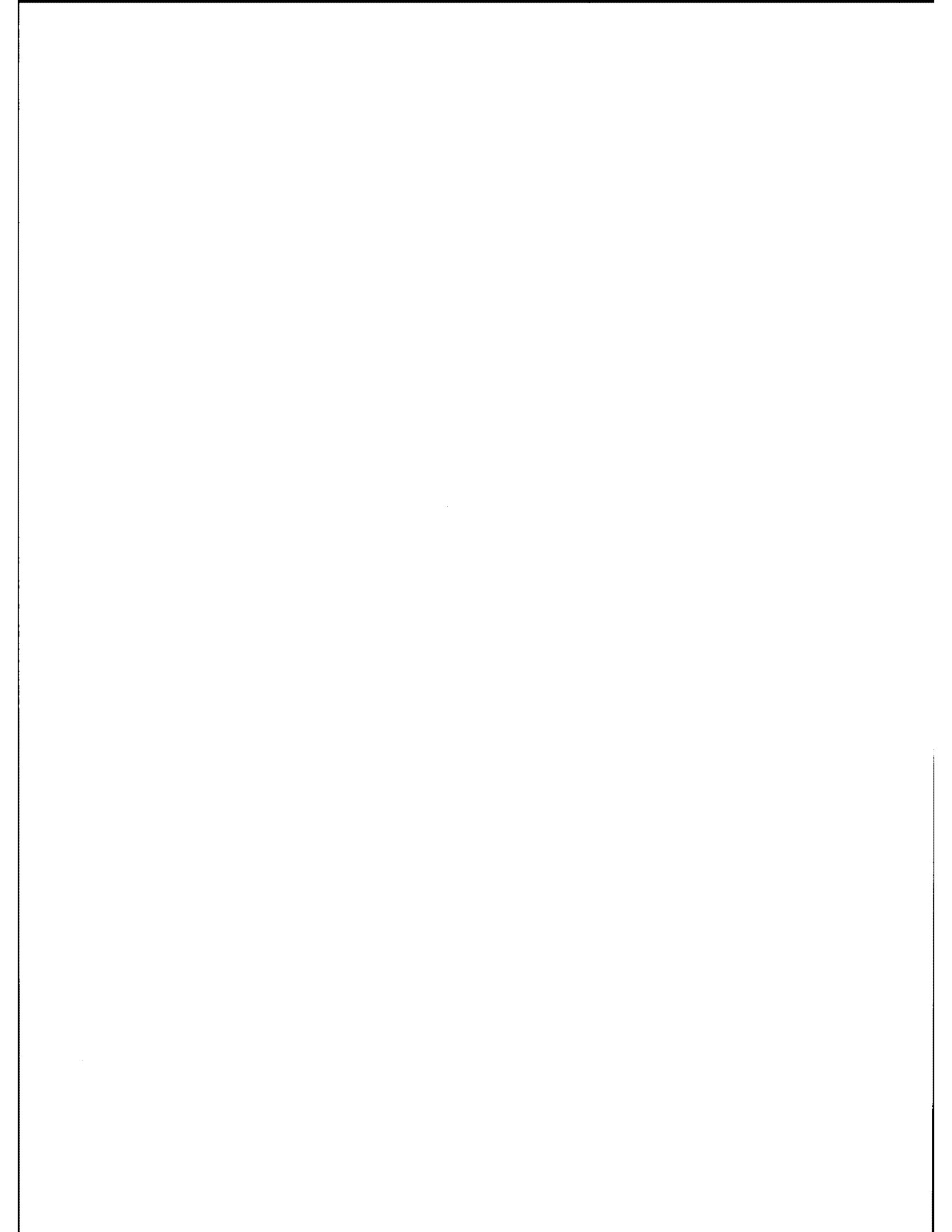

7.2.1 Wayside Community

Where the Market-Frankford Line is above ground, it contributes to the noise of the community, but this zone is generally limited to a distance of one block from the right of way. At 69th Street Terminal, wheel screech is generated while reversing trains negotiate a 140 ft radius curve. Several residential dwellings are located immediately across the street from the reversing loop. A measurement site was located nearby this location on Victory Avenue.

A second noise measurement site was located in the Millbourne community where screech is heard as the roadbed curves to join Market Street eastbound as the trains enter the elevated roadbed over this curved track.

A survey site also was located along Market Street between the 52nd and 56th Stations where high speed roar is predominant. This was in a combined residential-commercial area at the corner of 54th Street. 54th Street has no major auto or truck traffic.

Due to almost total masking of the transit system where it is located underground, no survey sites were selected in the community above this segment. This decision was based on an assessment of noise of SEPTA's Broad Street Line at the Wyoming Avenue community site (see page 5-29).

Immediately north of the York-Dauphin Station there is a short radius curve where the system leaves Front Street and joins Kensington Avenue. High screech levels are produced on this curve that are very audible along with horn signals which are sounded in this area. A measurement site was selected on York Street in a residential area near this curve, although the community under the elevated structure both on Front Street and Kensington Avenue consists of nearly all business and commercial property.

A fifth site, in a primarily residential neighborhood was selected along Frankford Avenue north of Somerset Station. Dwellings are generally closer to the elevated structure in this region than along Market Street in West Philadelphia. The specific location for this measurement site was on Hart Lane on the northwest side of the line between Somerset and Allegheny Stations.

69TH STREET TERMINAL WAYSIDE

SITE DESCRIPTION (see Figure 7.3)

Several twin homes face Victory Avenue adjacent to this noise measurement location near the 69th Street Terminal return loop. The site was directly across the street from a curve of 140 ft radius which, used to return trains to the outbound platform at the terminal. Traffic on Victory Avenue is generally light-to-moderate in volume and travels at 35-45 mph.

NOISE CLIMATE (see Table 7.3, Figures 7.4 - 7.8)

As the transit trains enter the return loop, the wheels begin to squeal. This continues with little diminishment until the train has cleared the loop. Traffic noise is also a predominant source of noise in the area, but it is of a broadband characteristic compared with the pure tones which the wheels emit. Other traffic noise is audible from several hundred feet south of the microphone location from the West Chester Pike-Garrett Road area. Occasionally, over-flying aircraft are audible.

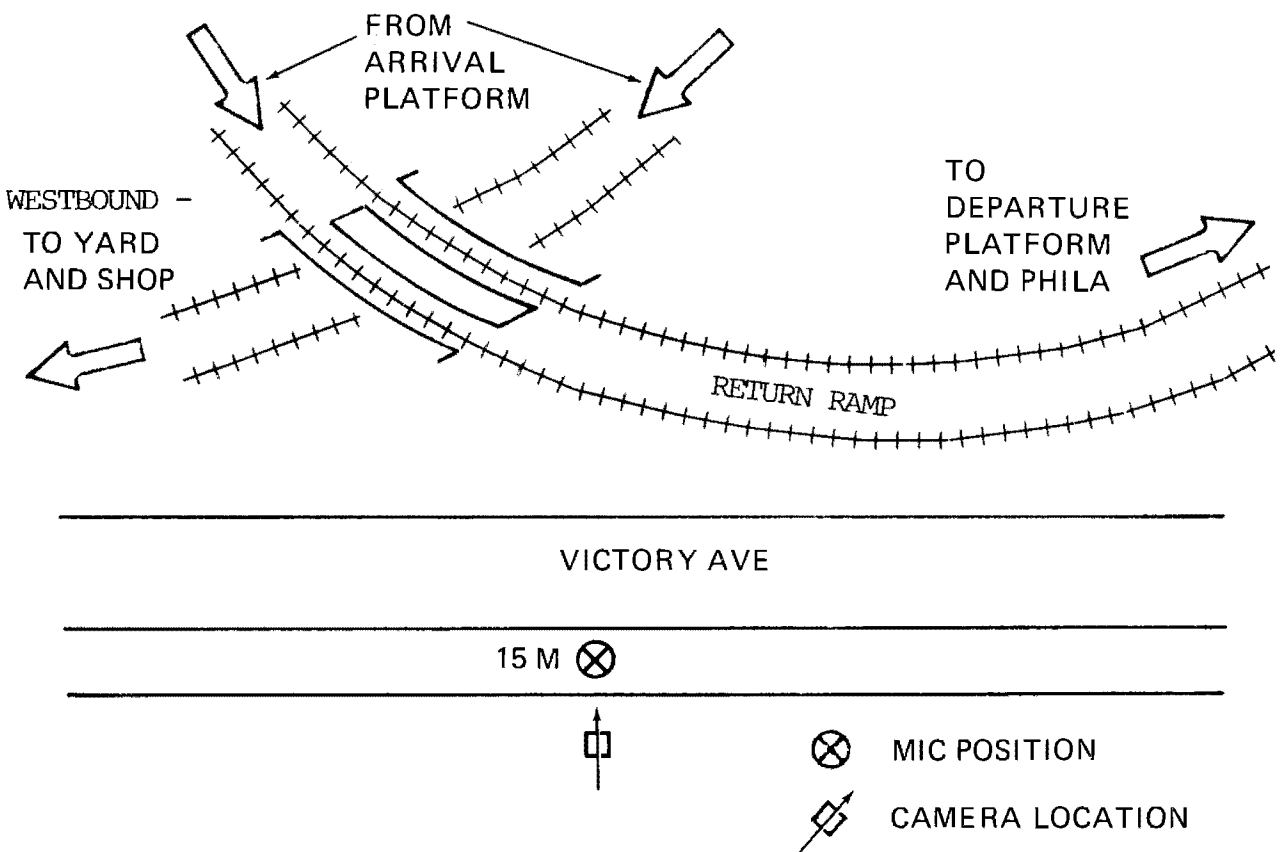
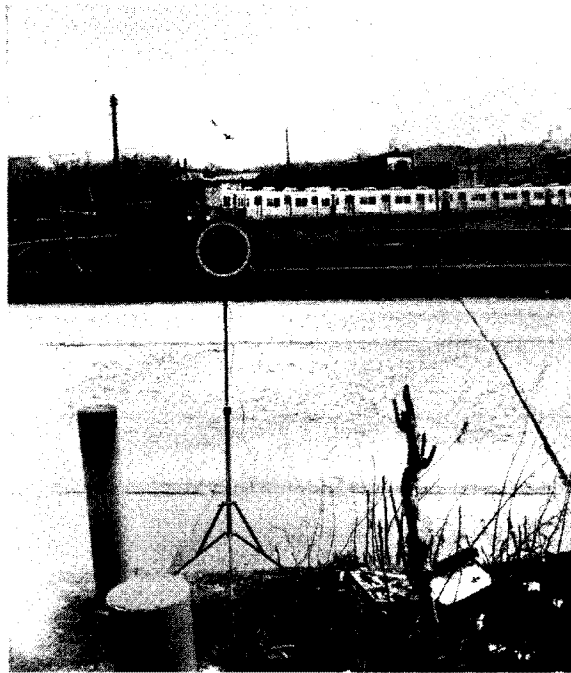

FIGURE 7.3 - WAYSIDE MEASUREMENT SITE, 69TH ST. TERMINAL ON GRADE

TABLE 7.3 - SUMMARY OF MEASUREMENT RESULTS FOR 69TH STREET COMMUNITY

TIME	MIC POSITION	SAMPLE TIME	TRAIN CONDITIONS	UNITS	AVG MAX LEVEL		AVG L _R		CUMULATIVE AMPLITUDE DISTRIBUTION					Leq
					a) O'SIDE TRACK	INSIDE TRACK	OUTSIDE TRACK	INSIDE TRACK	L ₉₉	L ₉₀	L ₅₀	L ₁₀	L ₁	
Day	15 m	30 min	Pass-by	b) N	4-6	1-6	4-6	1-6	58	60	68	78	91	78
				dBA	81	80	93	93						
				S	4.76	-	5.53	-						
					EAST BELOW RAMP	WEST BELOW RAMP	EAST BELOW RAMP	WEST BELOW RAMP						
				N	2-6	3-6	2-6	3-6						
				dBA	79	92	88	101						
				S	2.83	3.69	0.71	1.27						
Rush			dBA					65	68	74	83	93	81	
Evening			dBA					64	65	72	81	91	79	
Night			dBA					64	65	66	75	88	77	
Notes: a - Track b - Number of Trains - (e.g.: 4-2 means four 2-car trains) c - Standard Deviation of Level												L _{dn} = 84		

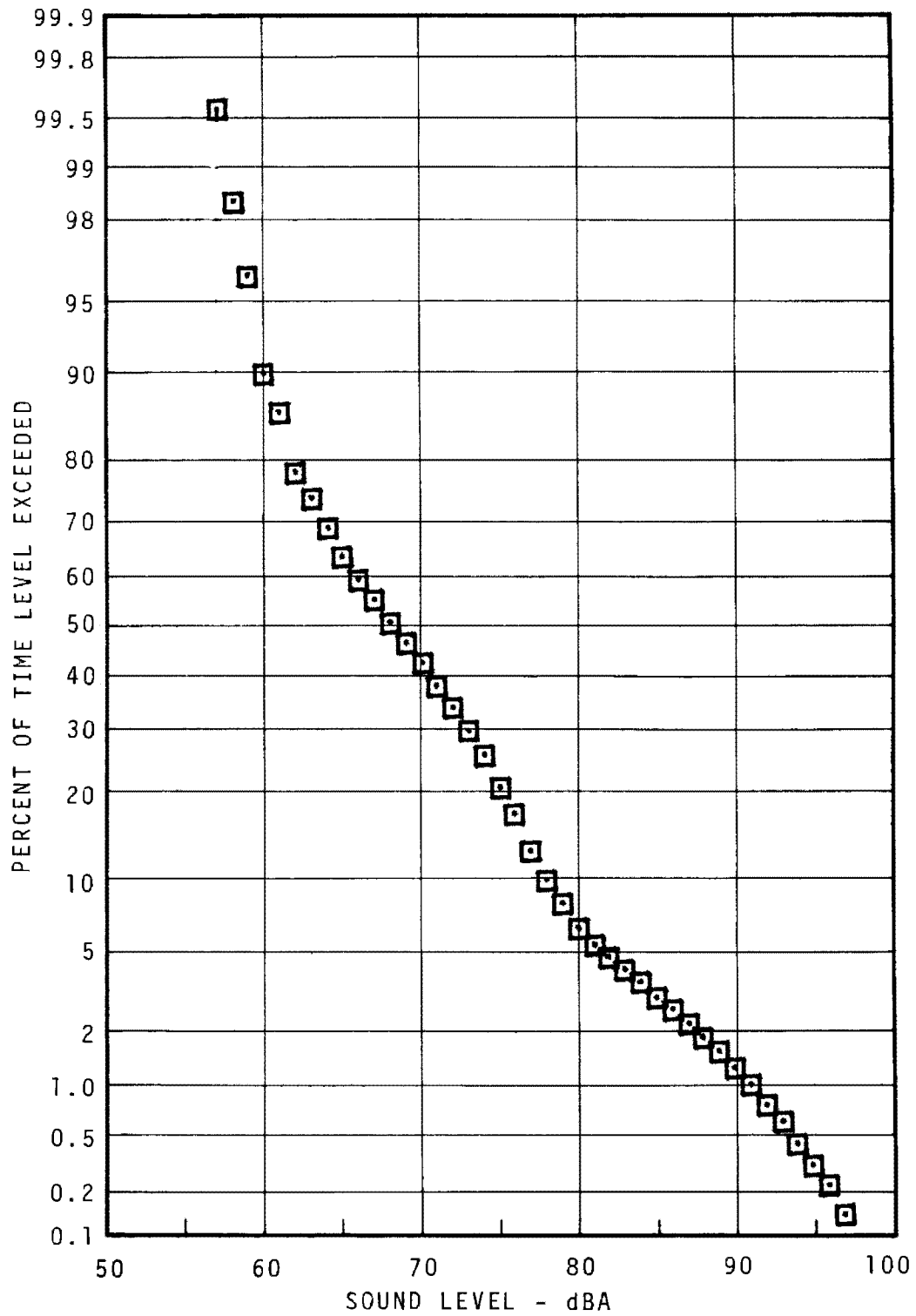

FIGURE 7.4 - 69TH ST. COMMUNITY STATISTICAL DISTRIBUTION - 15M - DAYTIME

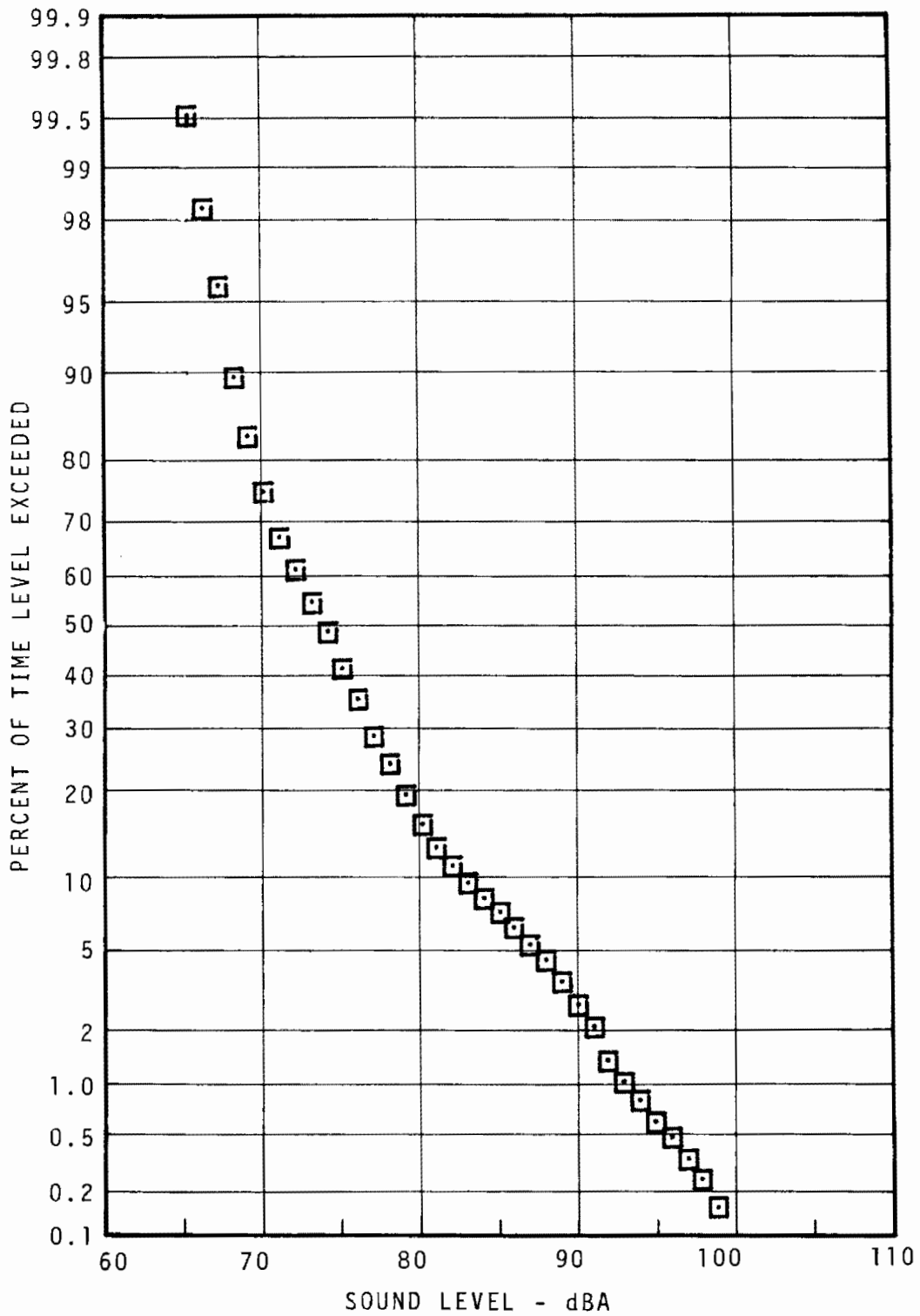

FIGURE 7.5 - 69TH ST. COMMUNITY STATISTICAL DISTRIBUTION -15M - RUSH HOUR

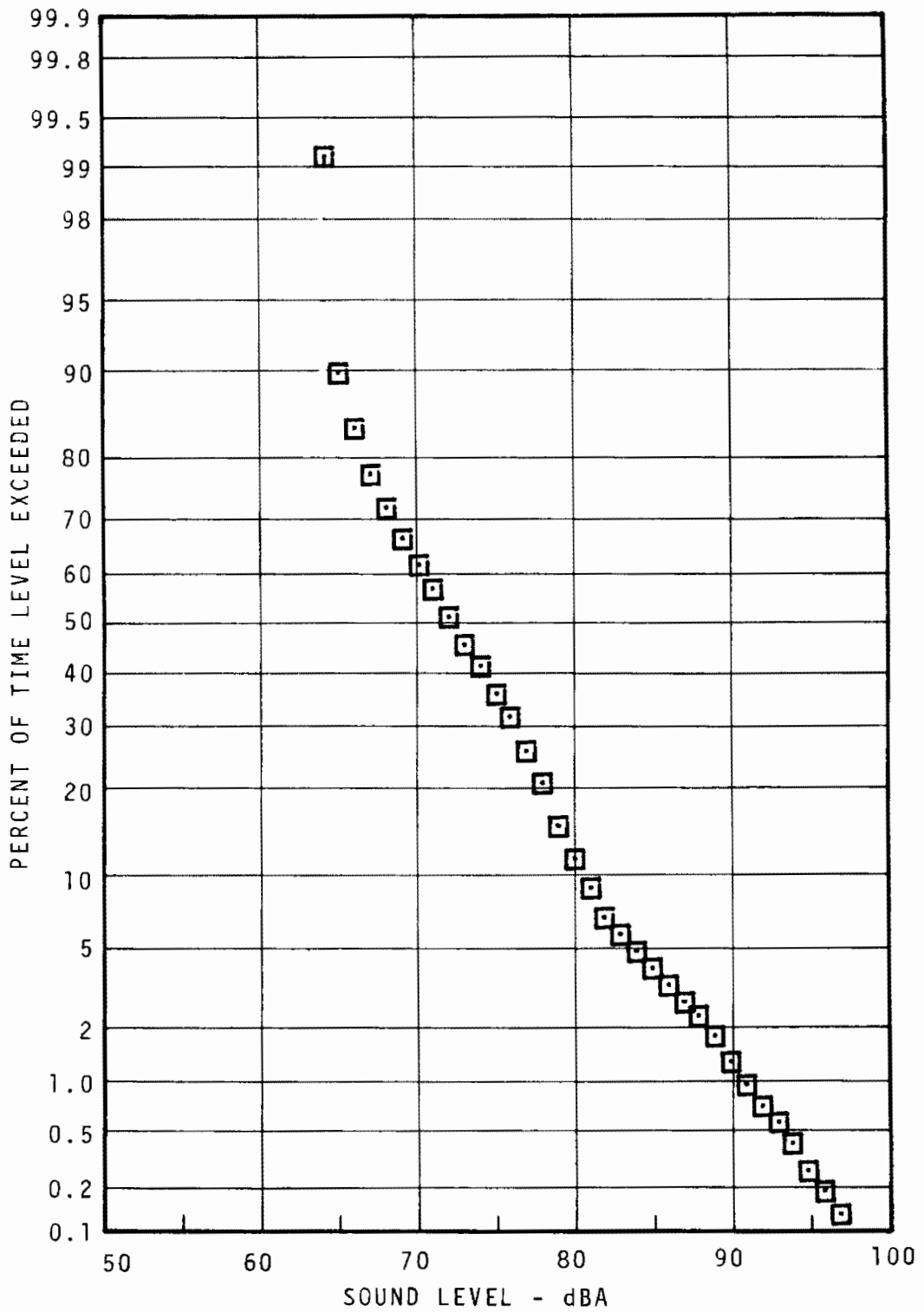

FIGURE 7.6 - 69TH ST. COMMUNITY STATISTICAL DISTRIBUTION - 15M - EVENING

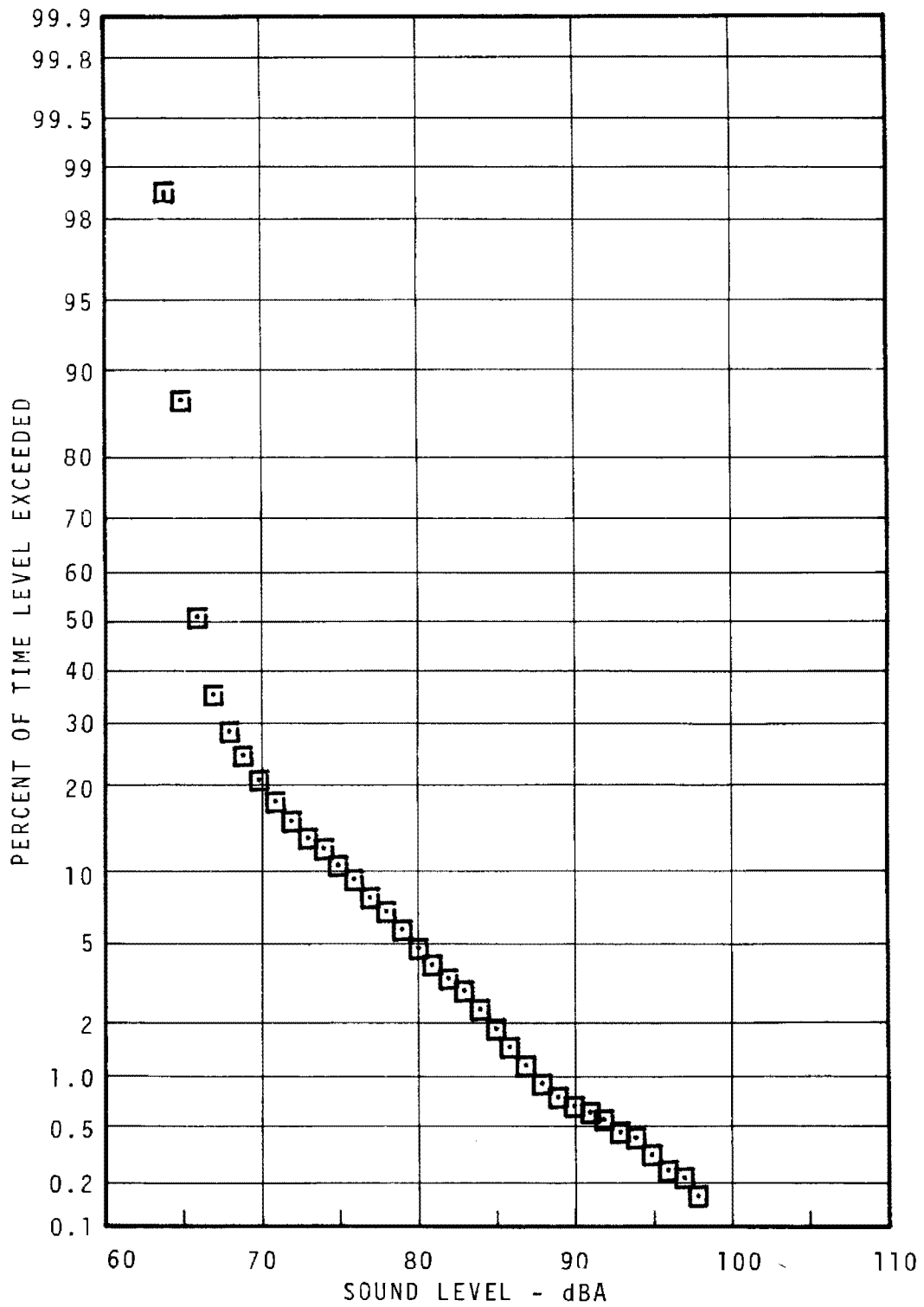

FIGURE 7.7- 69TH ST. COMMUNITY STATISTICAL DISTRIBUTION - 15M - NIGHT

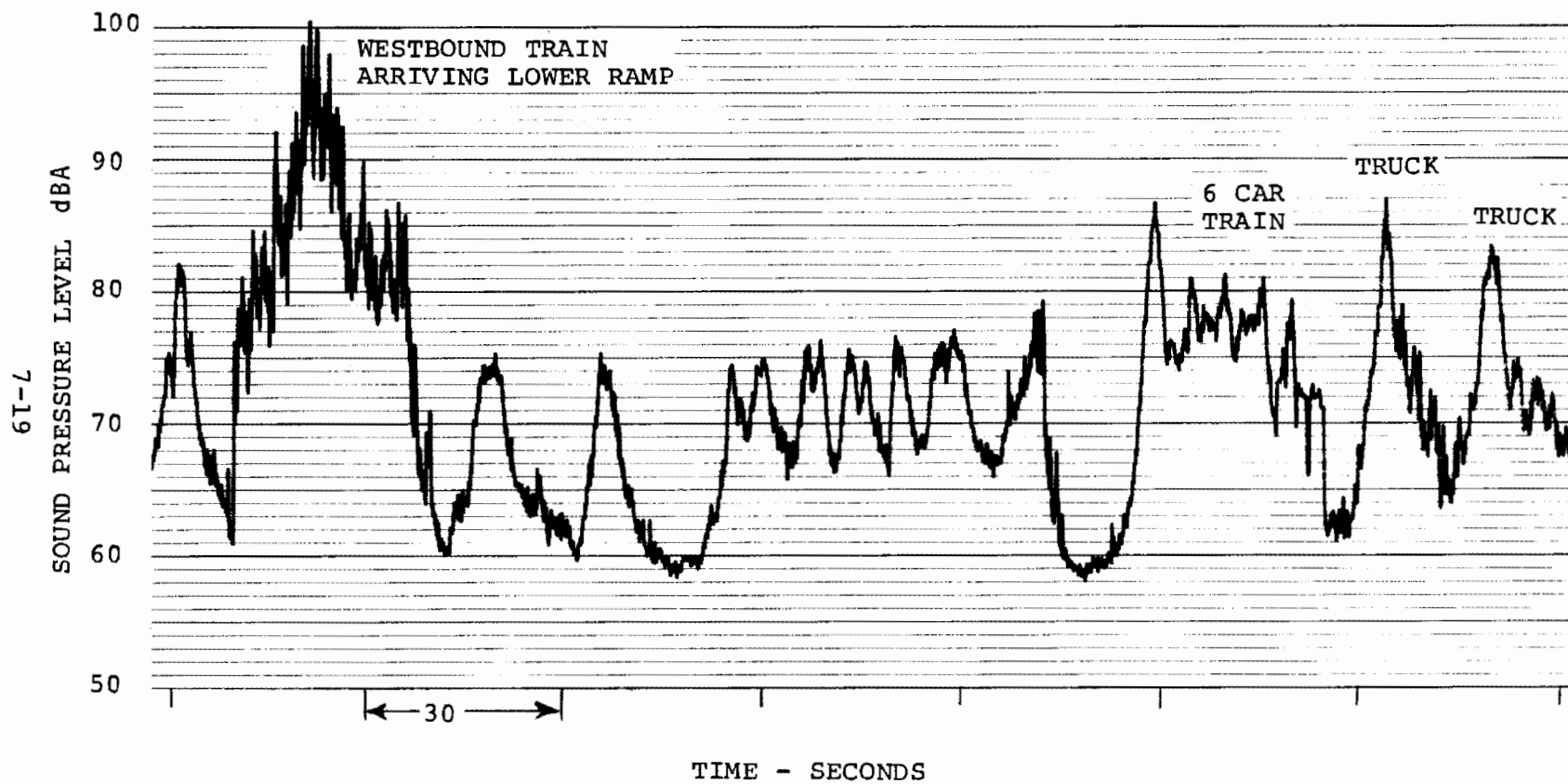

FIGURE 7.8 - TYPICAL TIME HISTORY, 69TH ST. TERMINAL, WAYSIDE

MILLBOURNE WAYSIDE

SITE DESCRIPTION (see Figure 7.9)

Millbourne is a small residential community situated between Philadelphia and Upper Darby, where the 69th Street Terminal is located. Park Street, the community location for noise measurements, is situated normal to the transit system. The track and roadbed are located on grade at this location. The Millbourne Station platform can be entered off Park Street which terminates at the SEPTA right-of-way. The far side of the Market-Frankford Line consists of a partly wooded area to the west and a parking lot to the east, both of which are 15 ft below grade. The tracks are approximately 5 ft below Park Street. The Millbourne Police Station is located across Park Street from the measurement site. Many homes on Park Street are two story twins.

NOISE CLIMATE (see Table 7.4, Figures 7.10 - 7.16)

Millbourne is a moderately quiet residential area in the region where the microphone was located. There is no through traffic on Park Street and an occasional automobile passes by at relatively low speed. The trains operate also at relatively low speeds arriving and departing at Millbourne. One block east of Park Street the system operates on elevated structure and the tracks curve at this point to align with Market Street. Wheel squeal is generated on this curve and is audible at the Park Street measurement site. The increase in L99 through L20 levels at night compared with daytime and evening levels, resulted from operations of a police radio nearby the site.

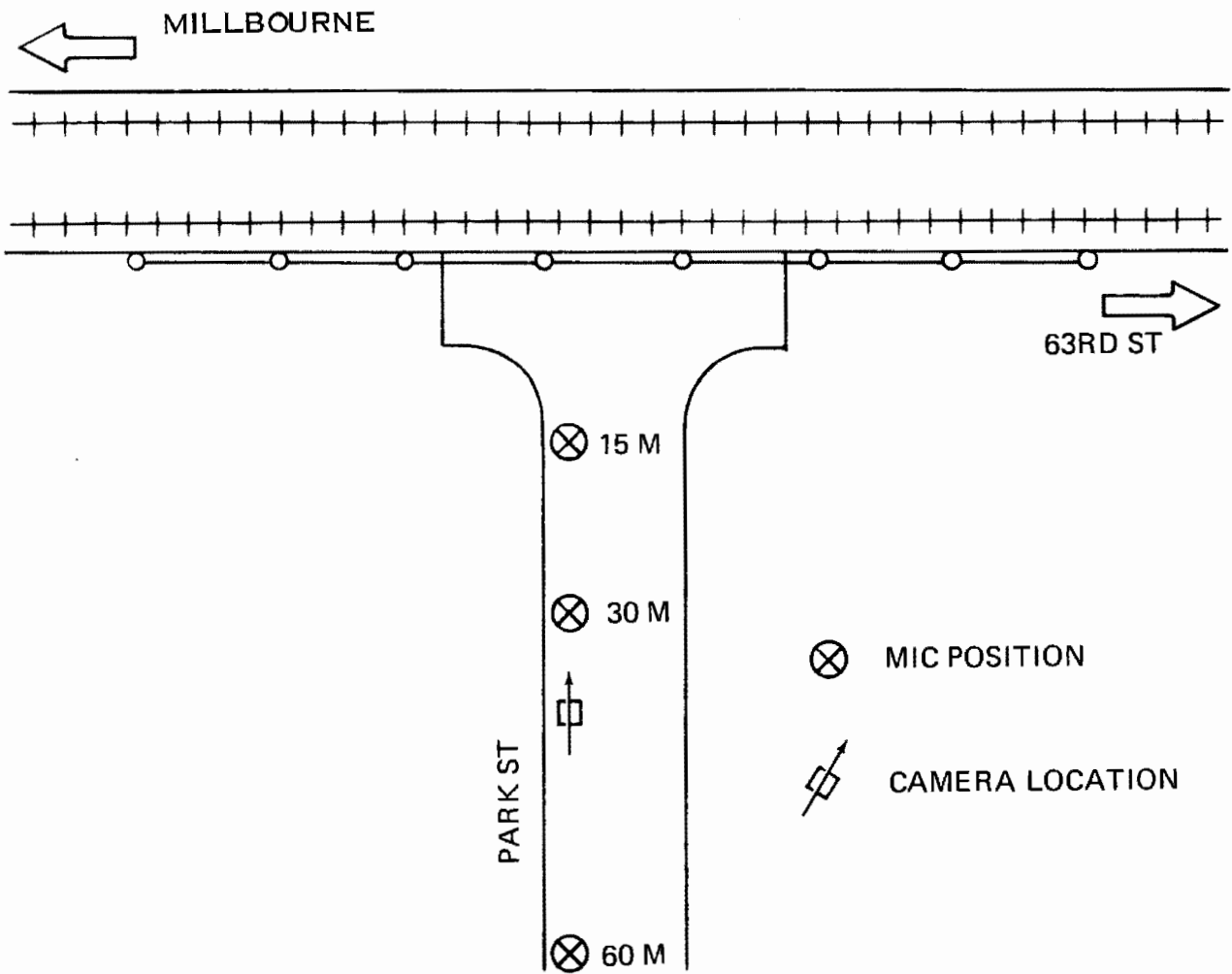
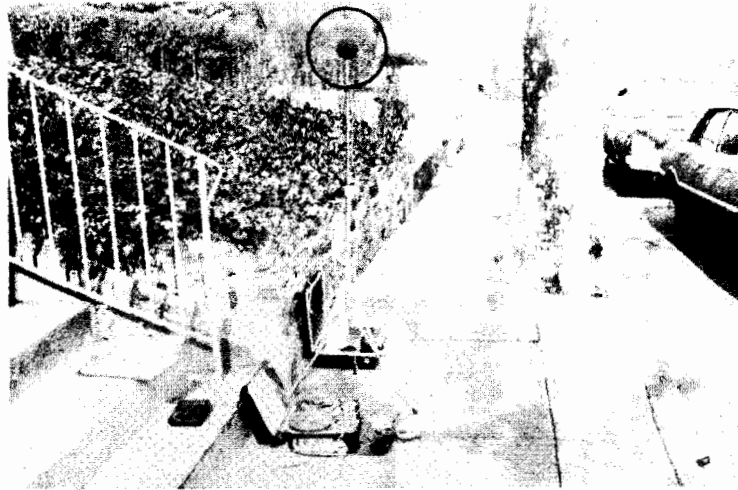

FIGURE 7.9 - WAYSIDE MEASUREMENT SITE, MILLBOURNE.
ON-GRADE

TABLE 7.4- SUMMARY OF MEASUREMENT RESULTS FOR MILLBOURNE COMMUNITY

TIME	MIC POSITION	SAMPLE TIME	TRAIN CONDITIONS	UNITS	AVG MAX LEVEL		AVG L _R		CUMULATIVE AMPLITUDE DISTRIBUTION					Leq
					NEAR	FAR	NEAR	FAR	L99	L90	L50	L10	L1	
Day	15 m	30 min	Pass-by	b) N	4-6	4-6	4-6	4-6	49	51	54	67	80	66
				dBA	78	73	89	95						
				S	1.71	2.84	1.45	2.30						
Day	30 m	15 min	Pass-by	dBA					50	52	57	66	75	63
Day	60 m	15 min	Pass-by	dBA					50	53	59	65	74	63
Rush	15 m	30 min	Pass-by	dBA					63	64	65	76	85	73
Evening	15 m	30 min	Pass-by	dBA					49	52	57	68	79	66
Night	15 m	30 min	Pass-by	dBA					61	61	62	64	73	63
Notes: a - Track b - Number of Trains - (e.g.: 4-2 means four 2-car trains) c - Standard Deviation of Level													L _{dn} = 72	

7-22

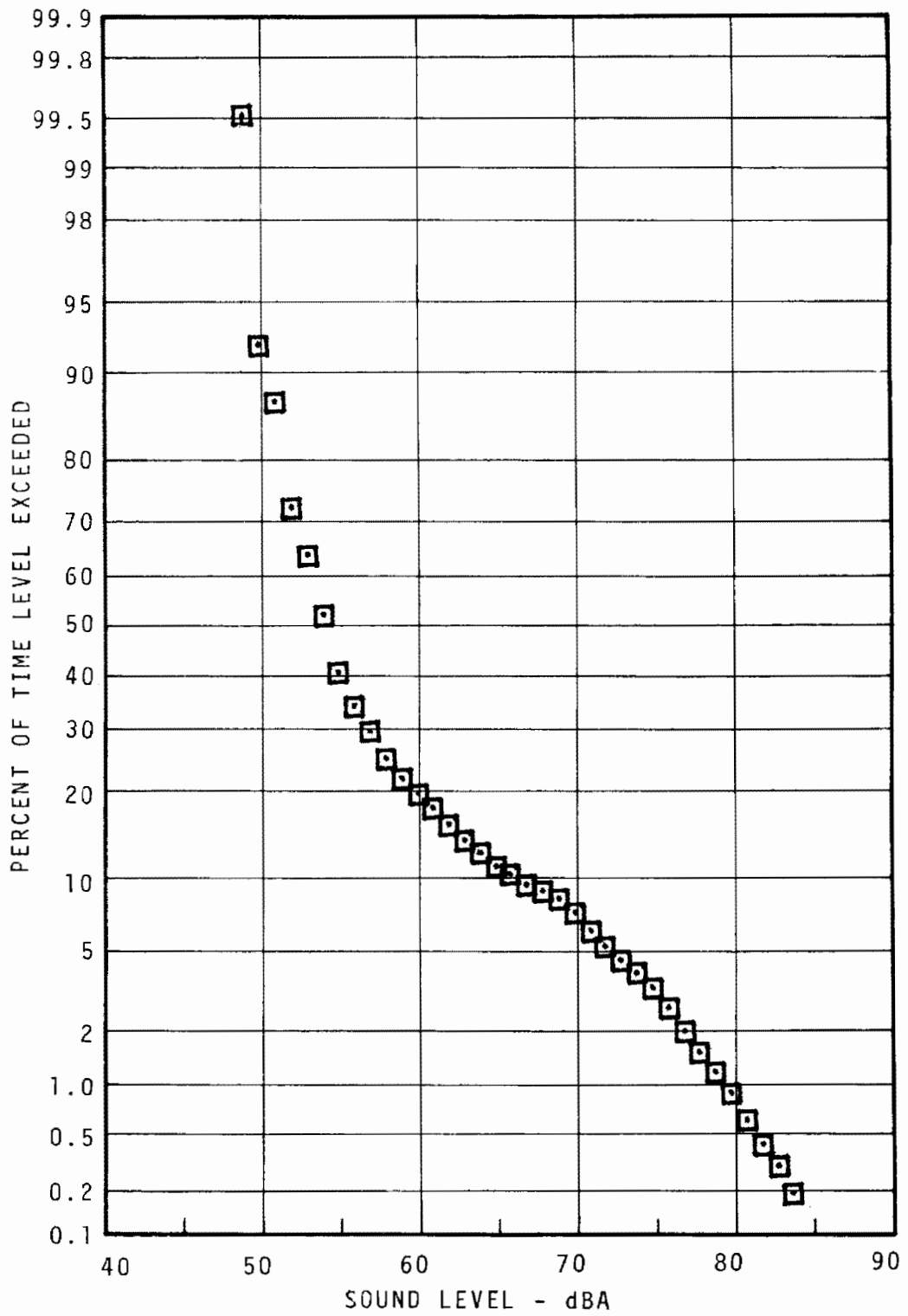

FIGURE 7.10 - MILLBOURNE COMMUNITY STATISTICAL DISTRIBUTION - 15M - DAYTIME

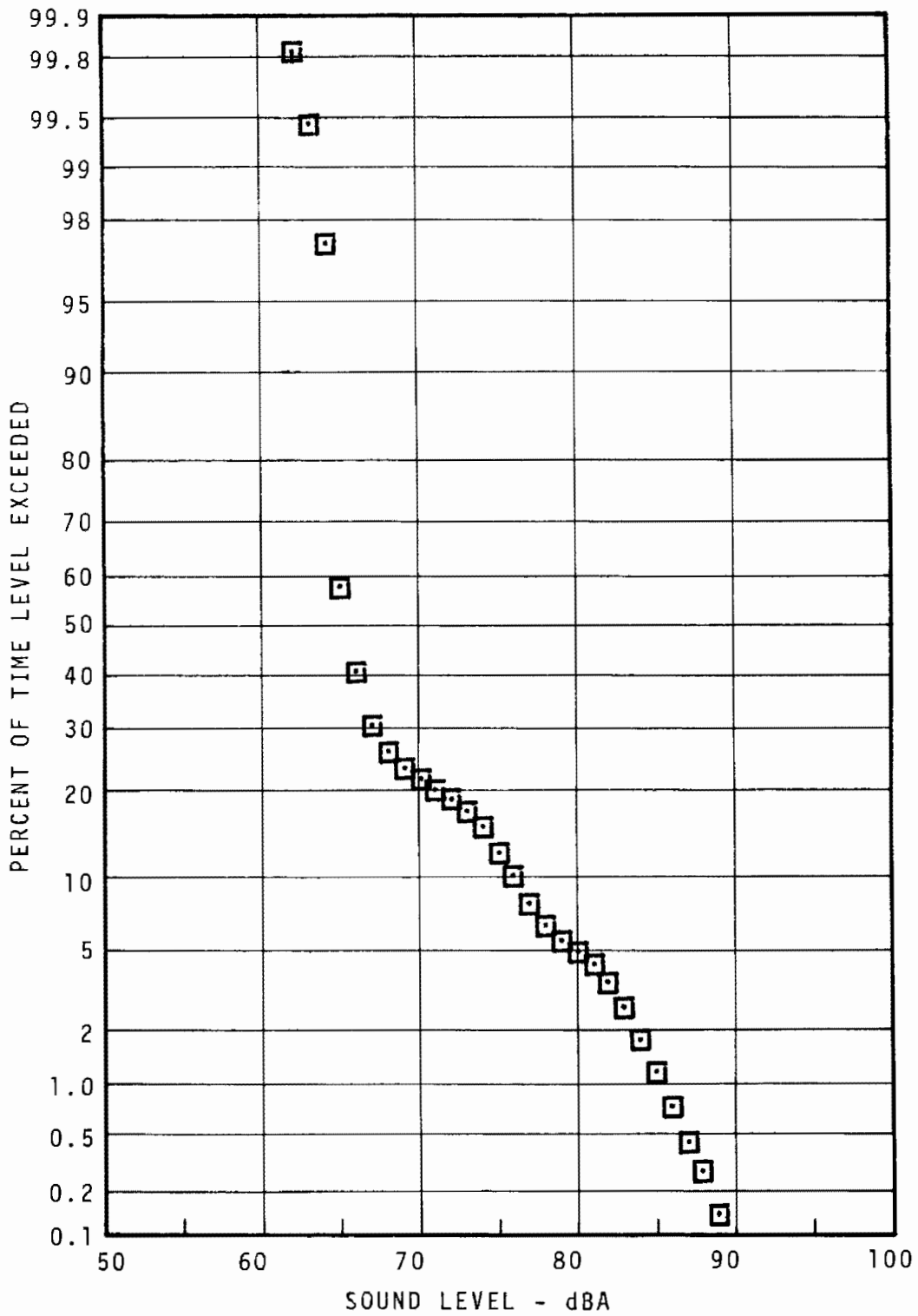

FIGURE 7.11 - MILLBOURNE COMMUNITY STATISTICAL DISTRIBUTION - 15M - RUSH HOUR

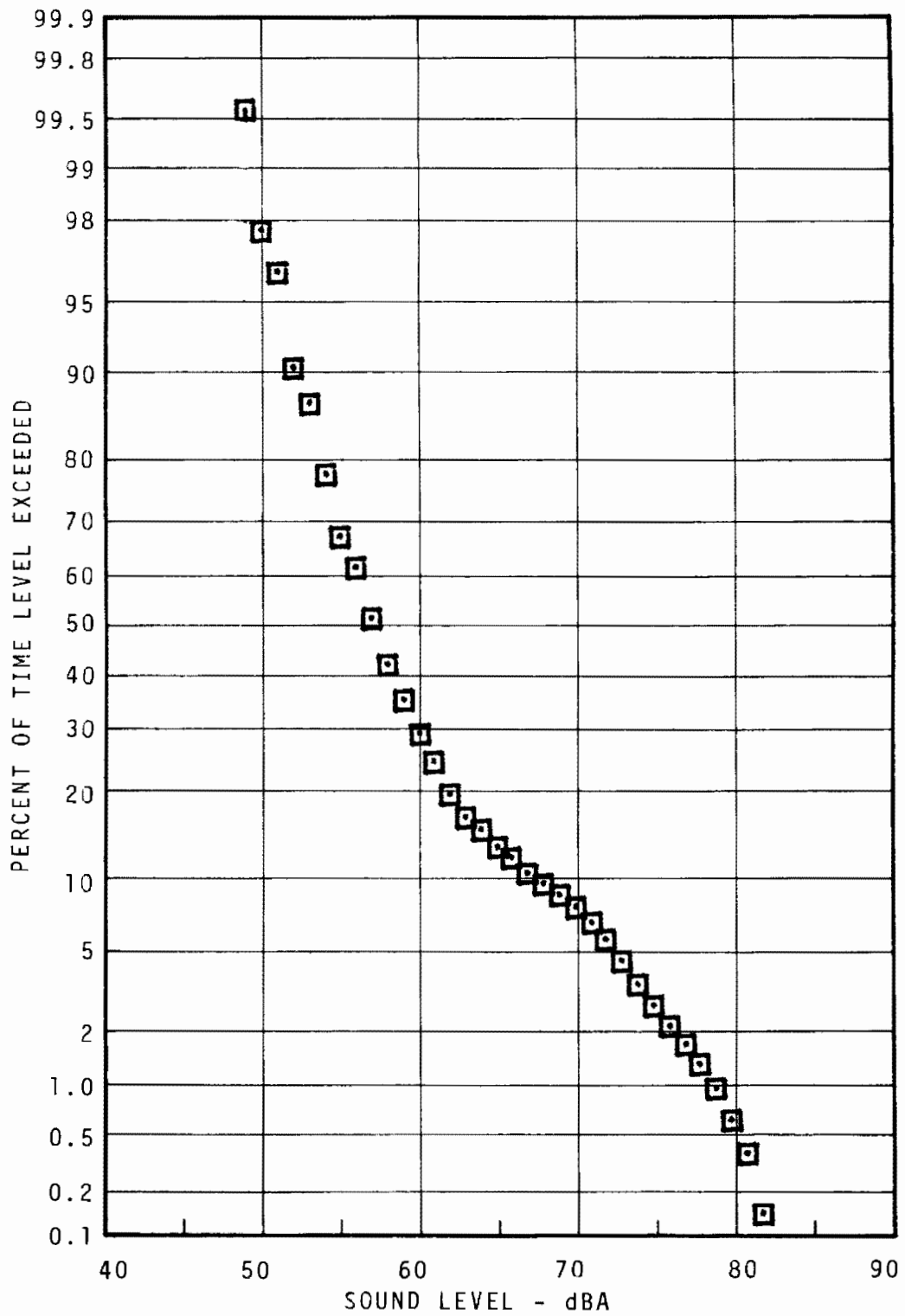

FIGURE 7.12 - MILLBOURNE COMMUNITY STATISTICAL DISTRIBUTION - 15M - EVENING

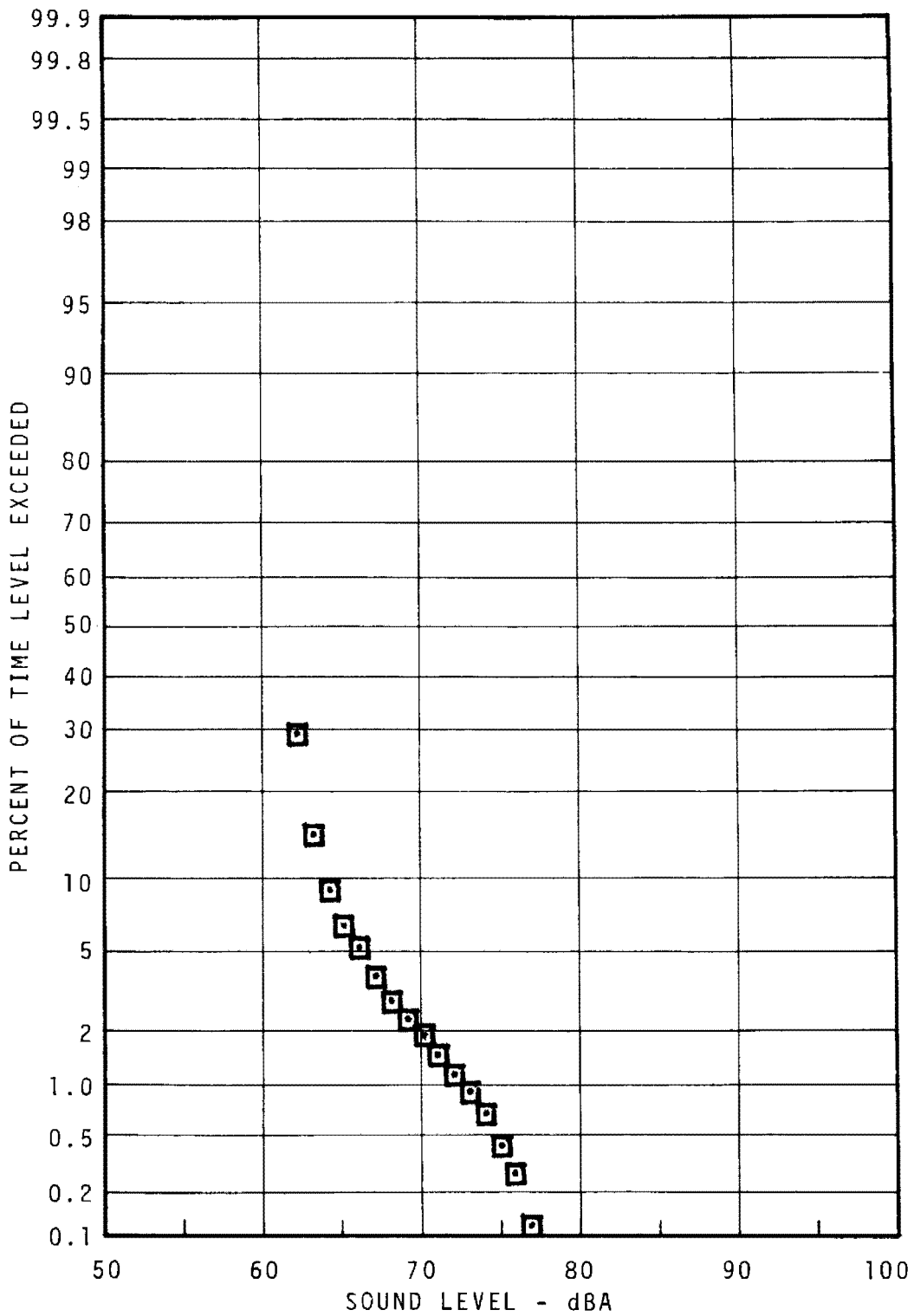

FIGURE 7.13 - MILLBOURNE COMMUNITY STATISTICAL DISTRIBUTION - 15M - NIGHT

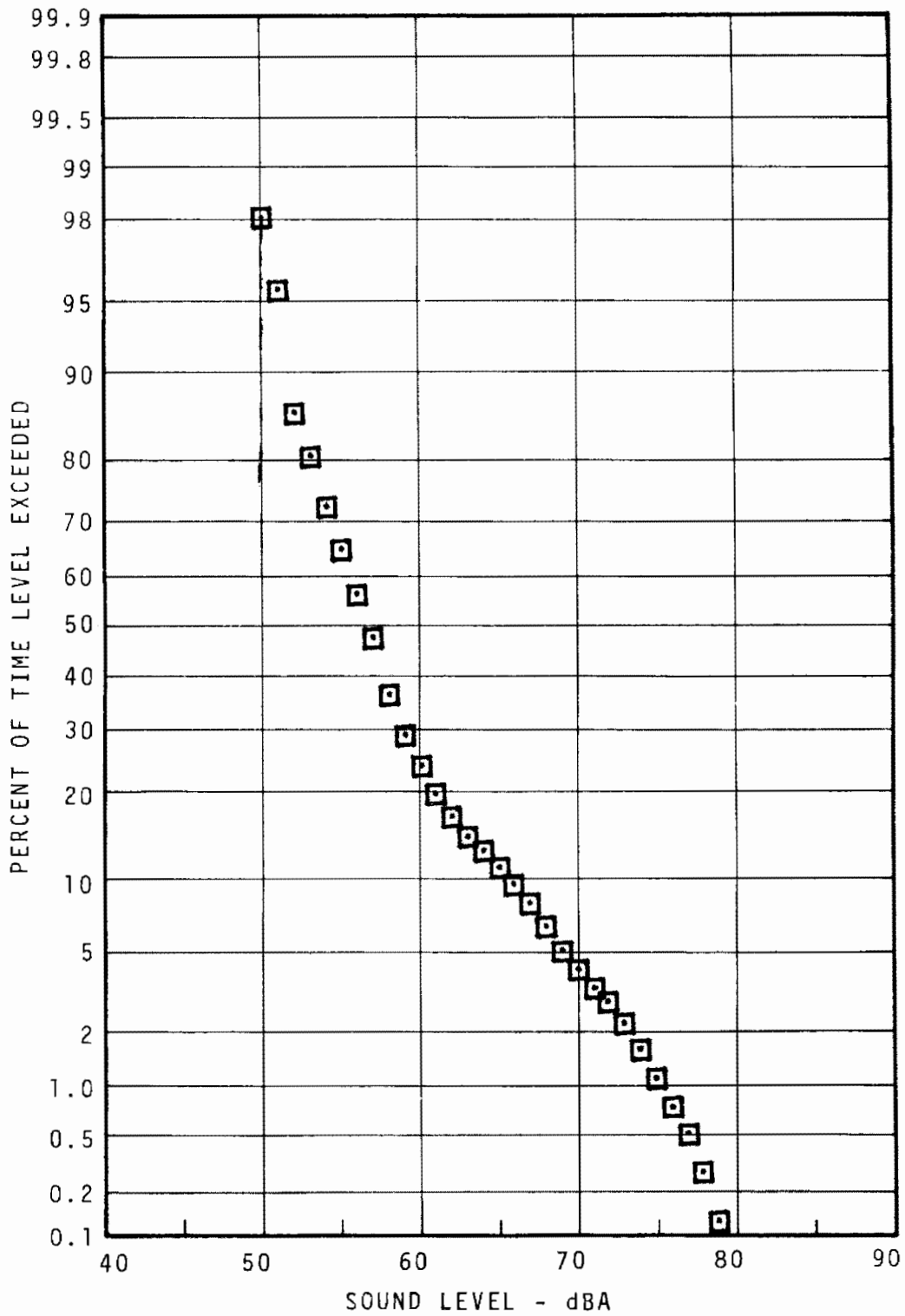

FIGURE 7.14 - MILLBOURNE COMMUNITY STATISTICAL DISTRIBUTION - 30M - DAYTIME

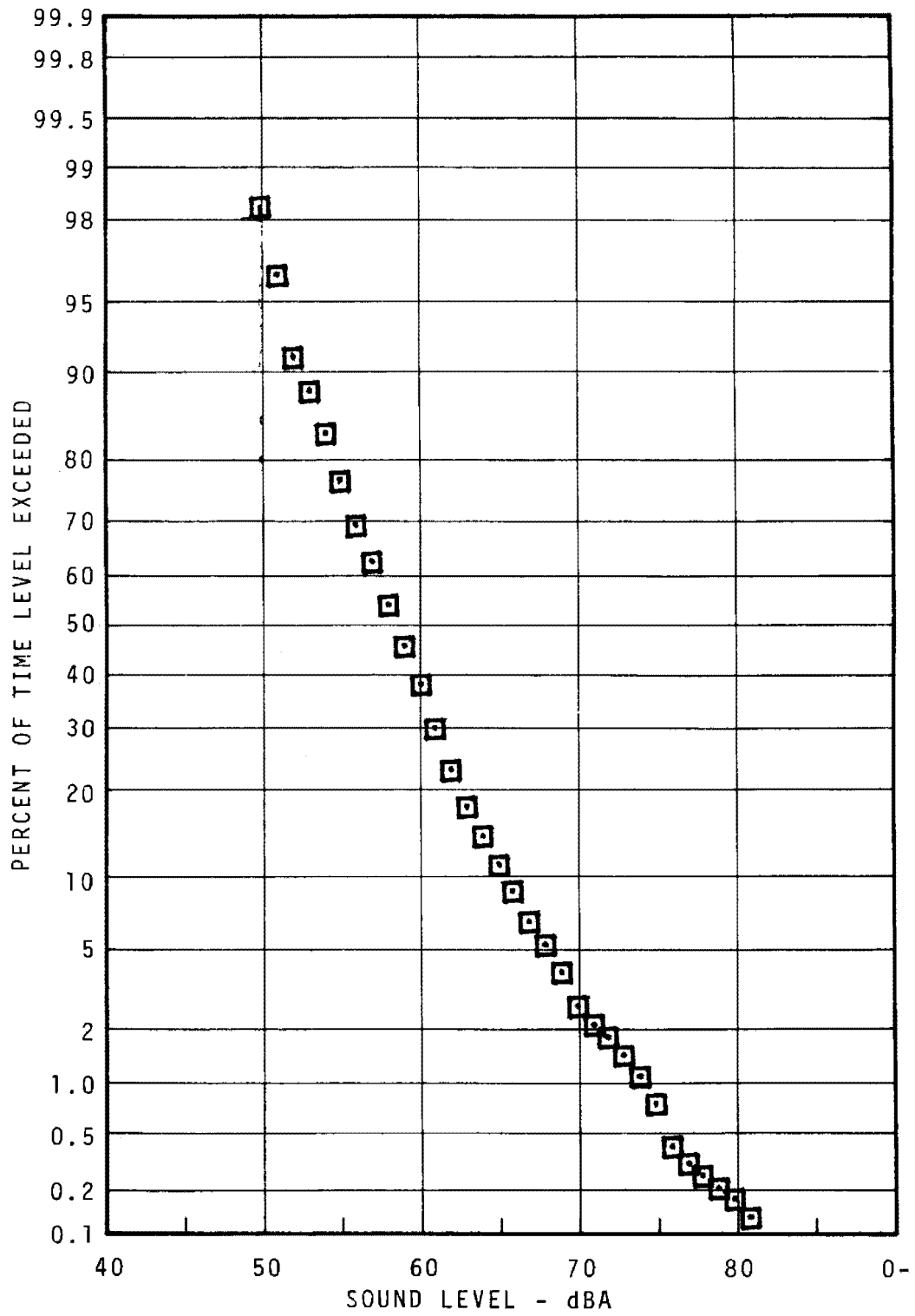

FIGURE 7.15 - MILLBOURNE COMMUNITY STATISTICAL DISTRIBUTION - 60M - DAYTIME

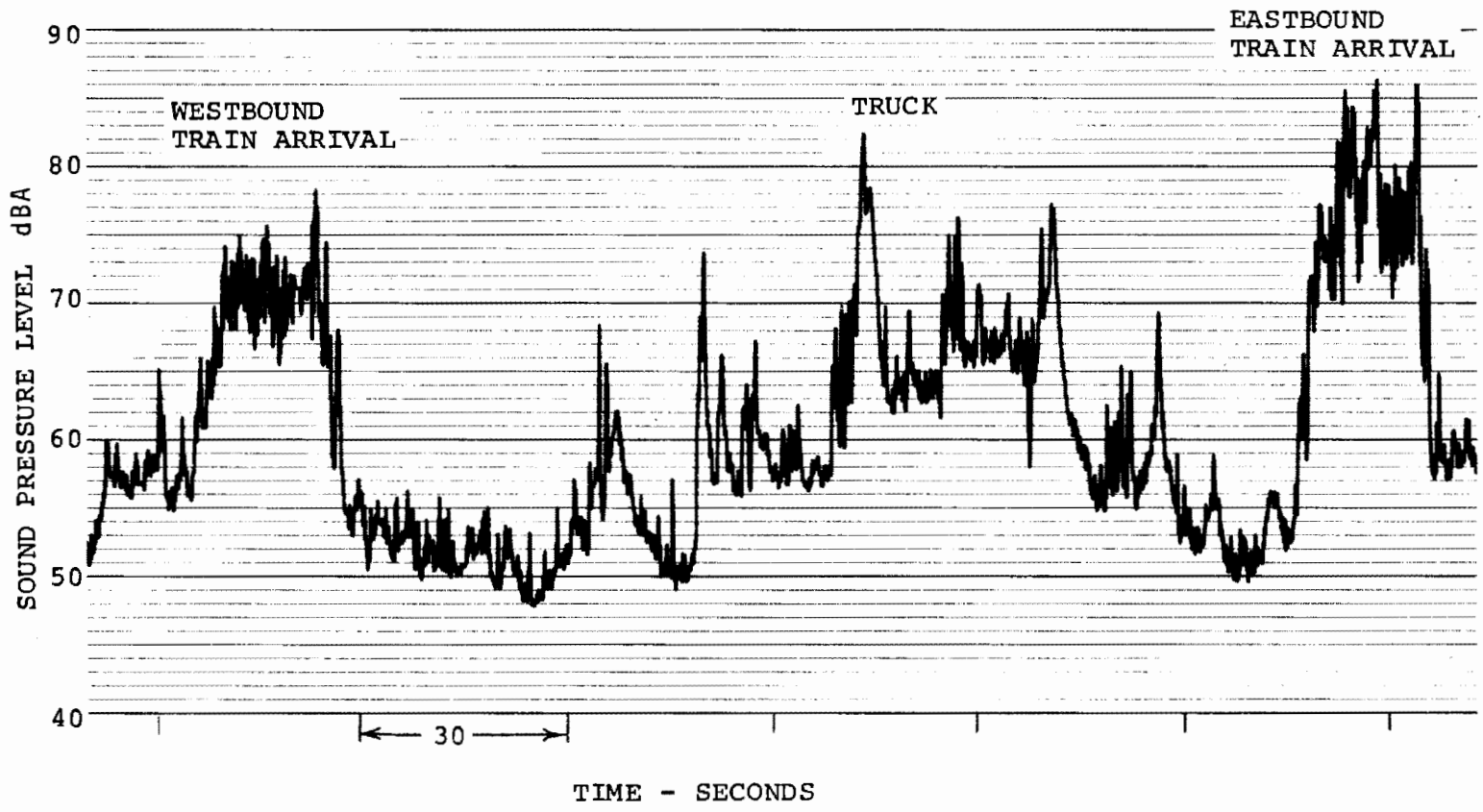

FIGURE 7.16 - TYPICAL TIME HISTORY, MILLBOURNE, WAYSIDE

54TH AND MARKET WAYSIDE

SITE DESCRIPTION (See Figure 7.17)

The Market-Frankford Line is elevated along Market Street at this location. The region is combined commercial and residential with Market Street having predominantly commercial establishments near the 52nd Street shopping district. The microphone was placed midway between the 52nd Street and 56th Street Stations. along 54th Street. Traffic on Market Street is moderate and 54th Street is not a major through street. Most housing in the area is of two story row construction.

NOISE CLIMATE (see Table 7.5, Figures 7.18 - 7.23)

The noise at this community site results primarily from motor vehicle traffic. Transit trains predominate when they pass by, however, barking dogs, sirens, loud radios and other noise sources of an active neighborhood all contribute to the acoustical climate at 54th and Market Streets.

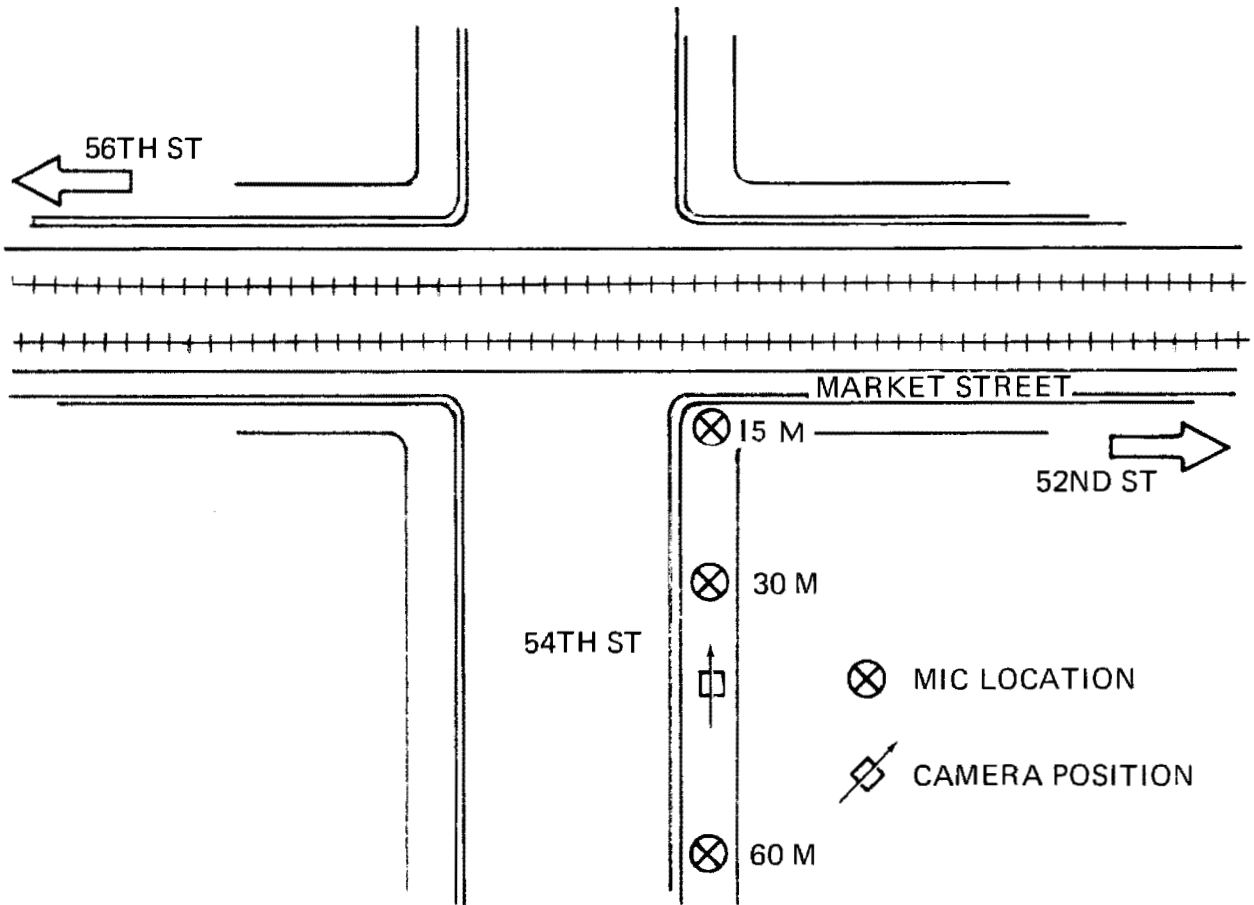

FIGURE 7.17 - WAYSIDE MEASUREMENT SITE, 54TH AND MARKET.
ELEVATED STEEL STRUCTURE

" TABLE 7.5 - SUMMARY OF MEASUREMENT RESULTS FOR 54TH & MARKET COMMUNITY

TIME	MIC POSITION	SAMPLE TIME	TRAIN CONDITIONS	UNITS	AVG MAX LEVEL		AVG L _R		CUMULATIVE AMPLITUDE DISTRIBUTION					L _{eq}
					NEAR	FAR	NEAR	FAR	L ₉₉	L ₉₀	L ₅₀	L ₁₀	L ₁	
Day	15 m	30 min	Pass-by	N	4-6	S-6	4-6	S-6	58	60	66	75	88	74
				dBA	89	84	96	92						
				S	2.13	2.49	1.29	2.17						
Day	30 m	15 min	Pass-by	dBA					57	58	63	71	82	67
Day	60 m	15 min	Pass-by	dBA					56	58	61	71	80	67
Rush	15 m	30 min	Pass-by	dBA					61	64	69	80	89	77
Evening	15 m	30 min	Pass-by	dBA					54	59	65	73	85	72
Night	15 m	30 min	Pass-by	dBA					53	54	56	64	77	66
Notes: a - Track													L _{dn} = 77	
b - Number of Trains - (e.g.: 4-2 means four 2-car trains)														
c - Standard Deviation of Level														

7-32

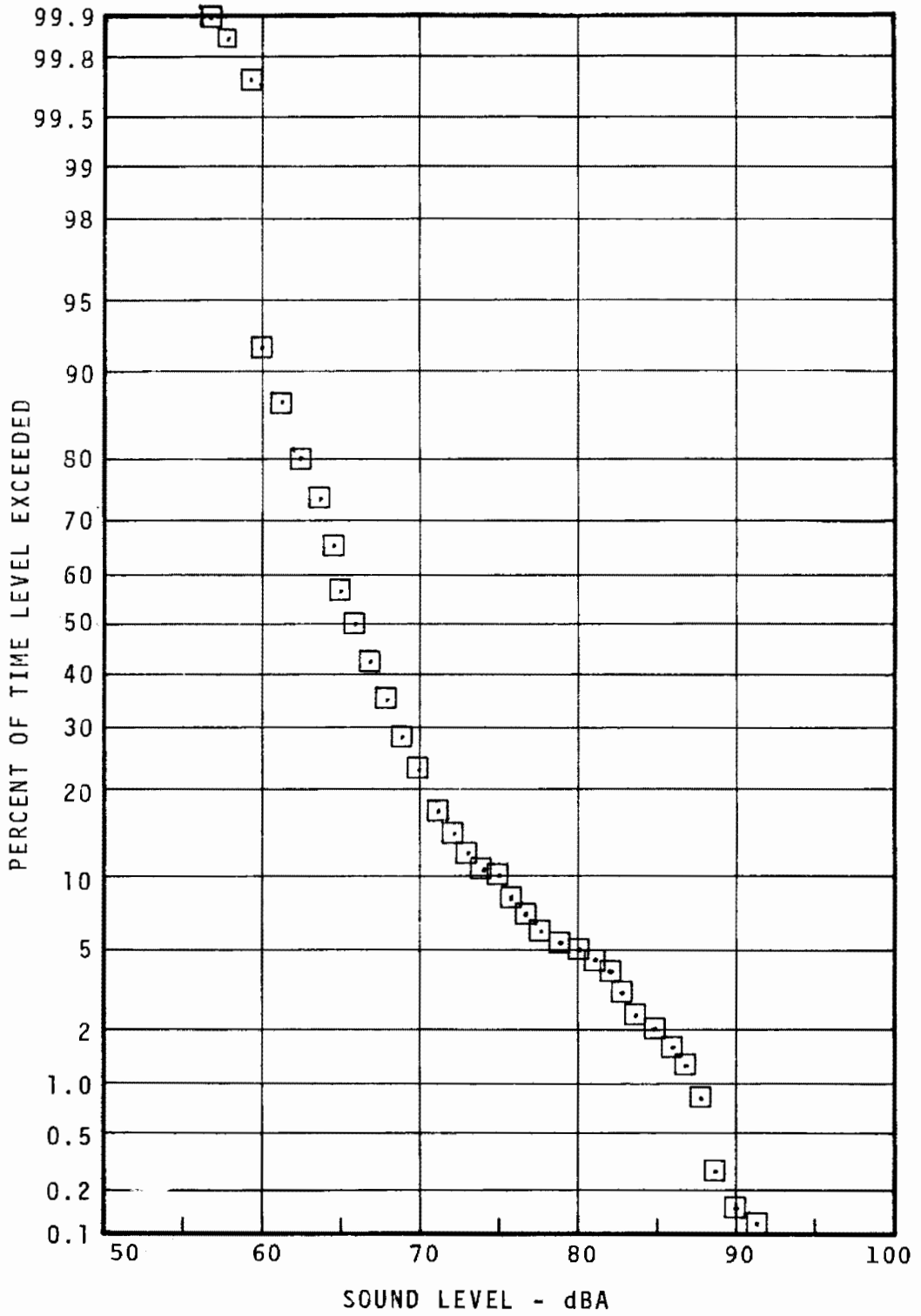

FIGURE 7.18 - 54TH AND MARKET COMMUNITY STATISTICAL DISTRIBUTION - 15M - DAYTIME

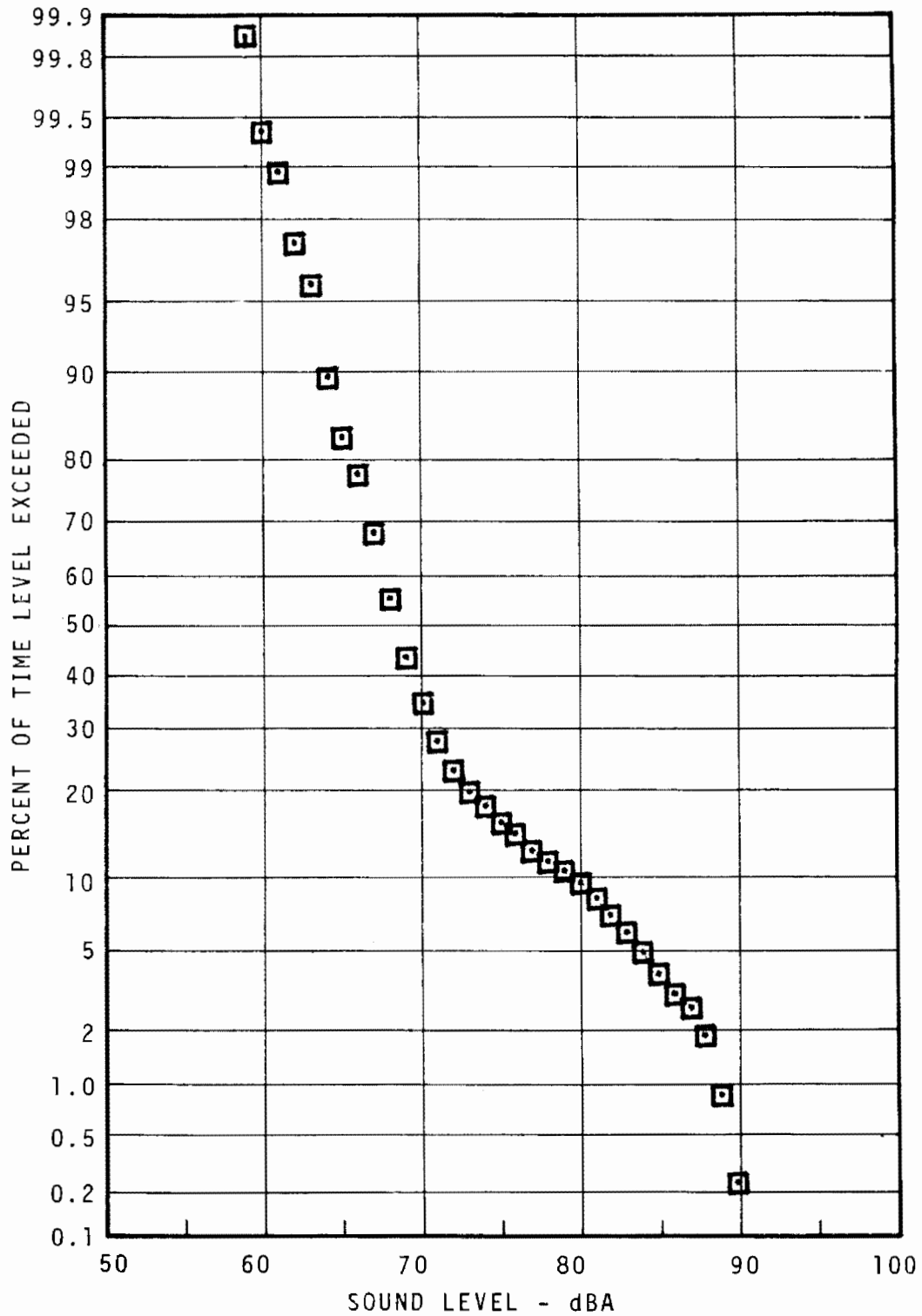

FIGURE 7.19 - 54TH AND MARKET COMMUNITY STATISTICAL DISTRIBUTION - 15M - RUSH HOUR

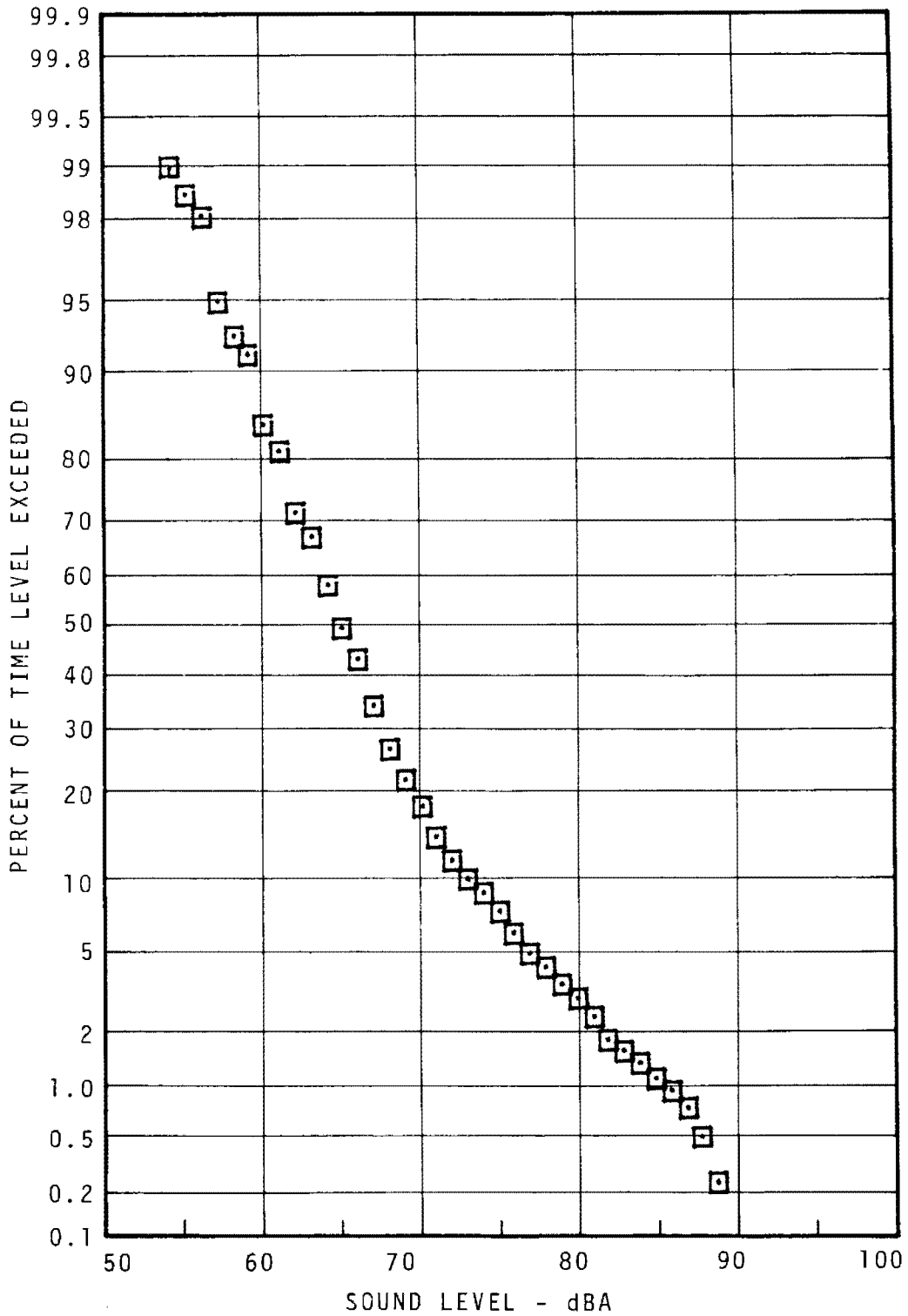

FIGURE 7.20 - 54TH AND MARKET COMMUNITY STATISTICAL DISTRIBUTION - 15M - EVENING

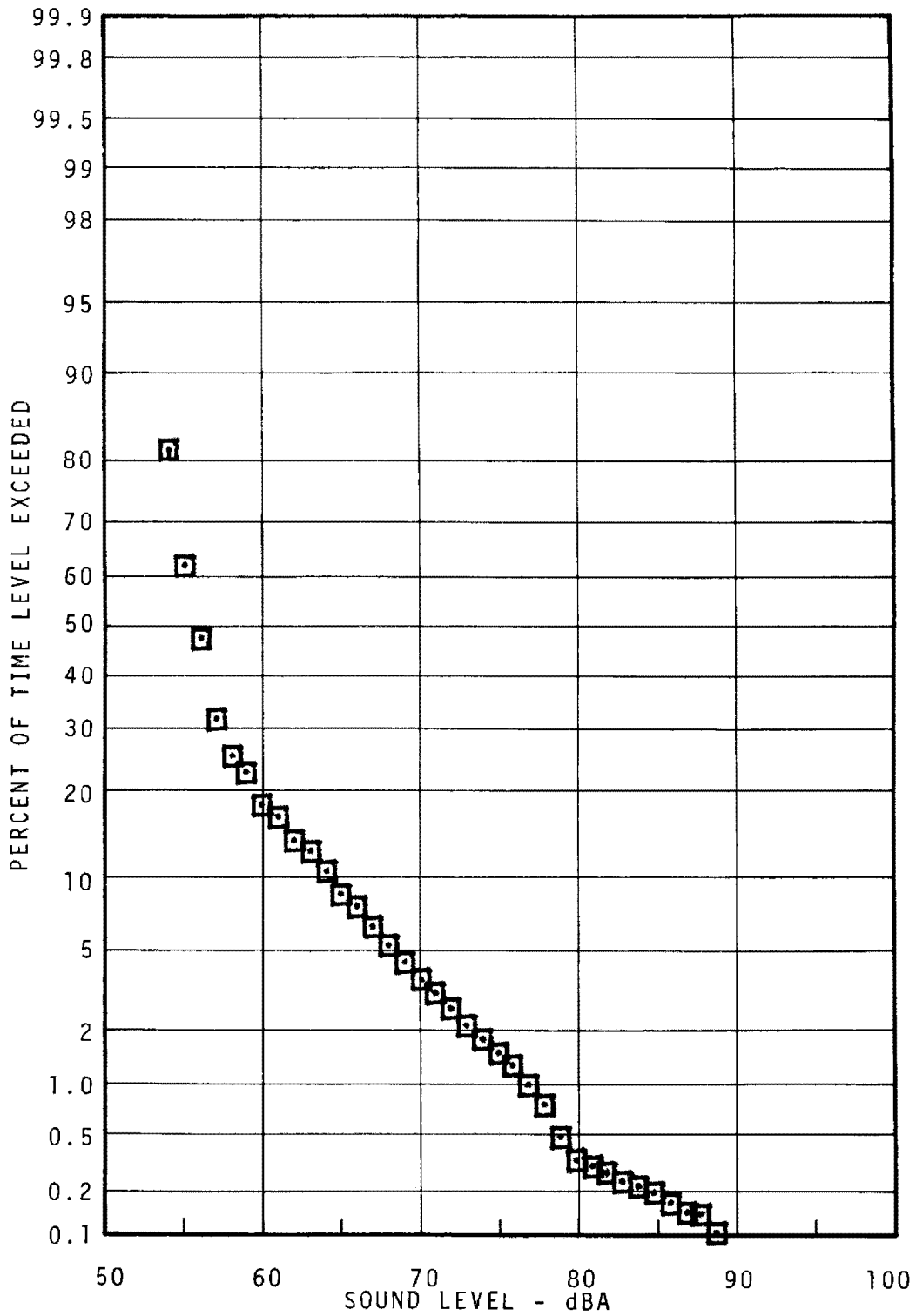

FIGURE 7.21 - 54TH AND MARKET COMMUNITY STATISTICAL DISTRIBUTION - 15M -NIGHT

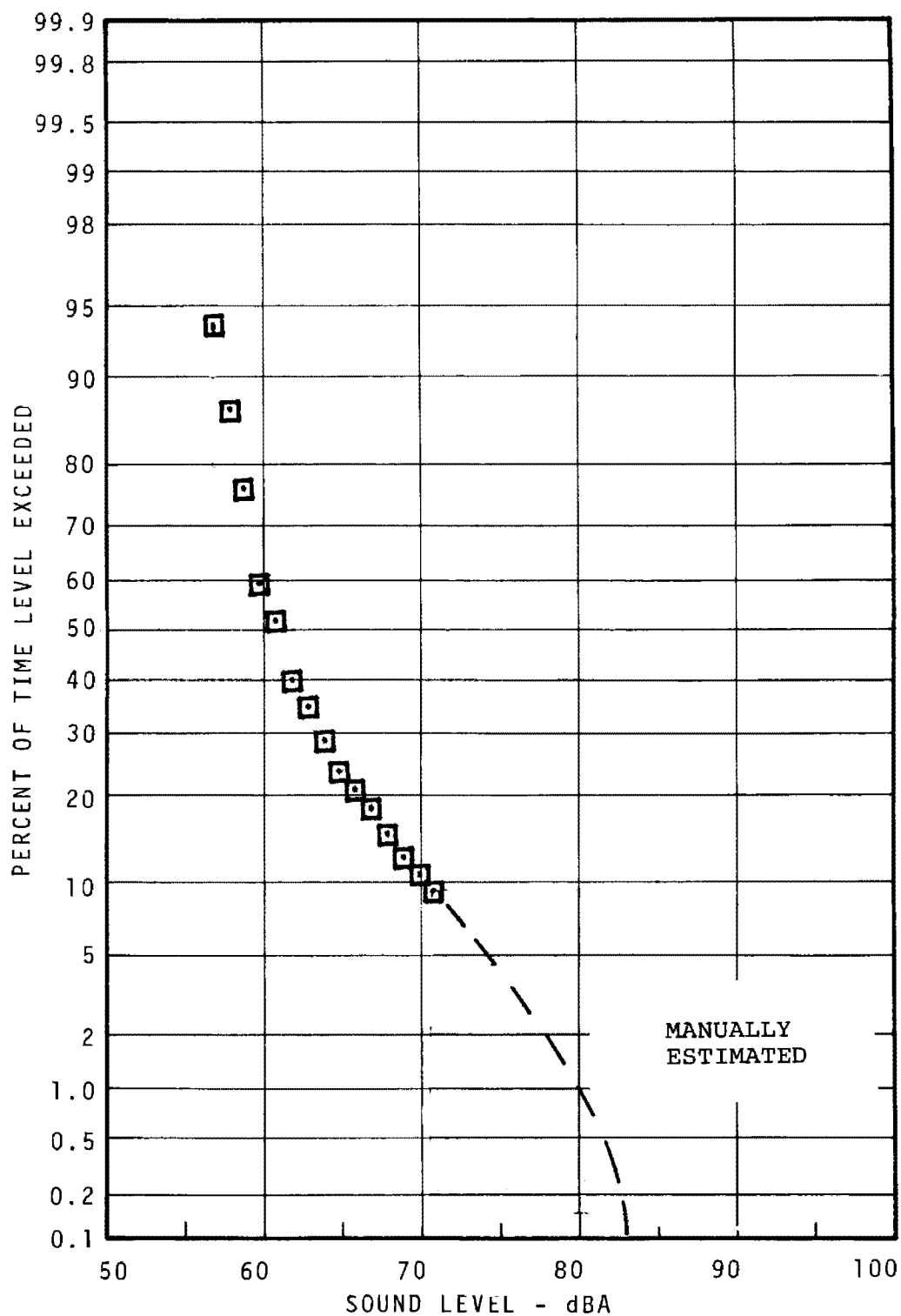

FIGURE 7.22 -54TH AND MARKET COMMUNITY STATISTICAL DISTRIBUTION - 60M - DAYTIME

7-38/7-39

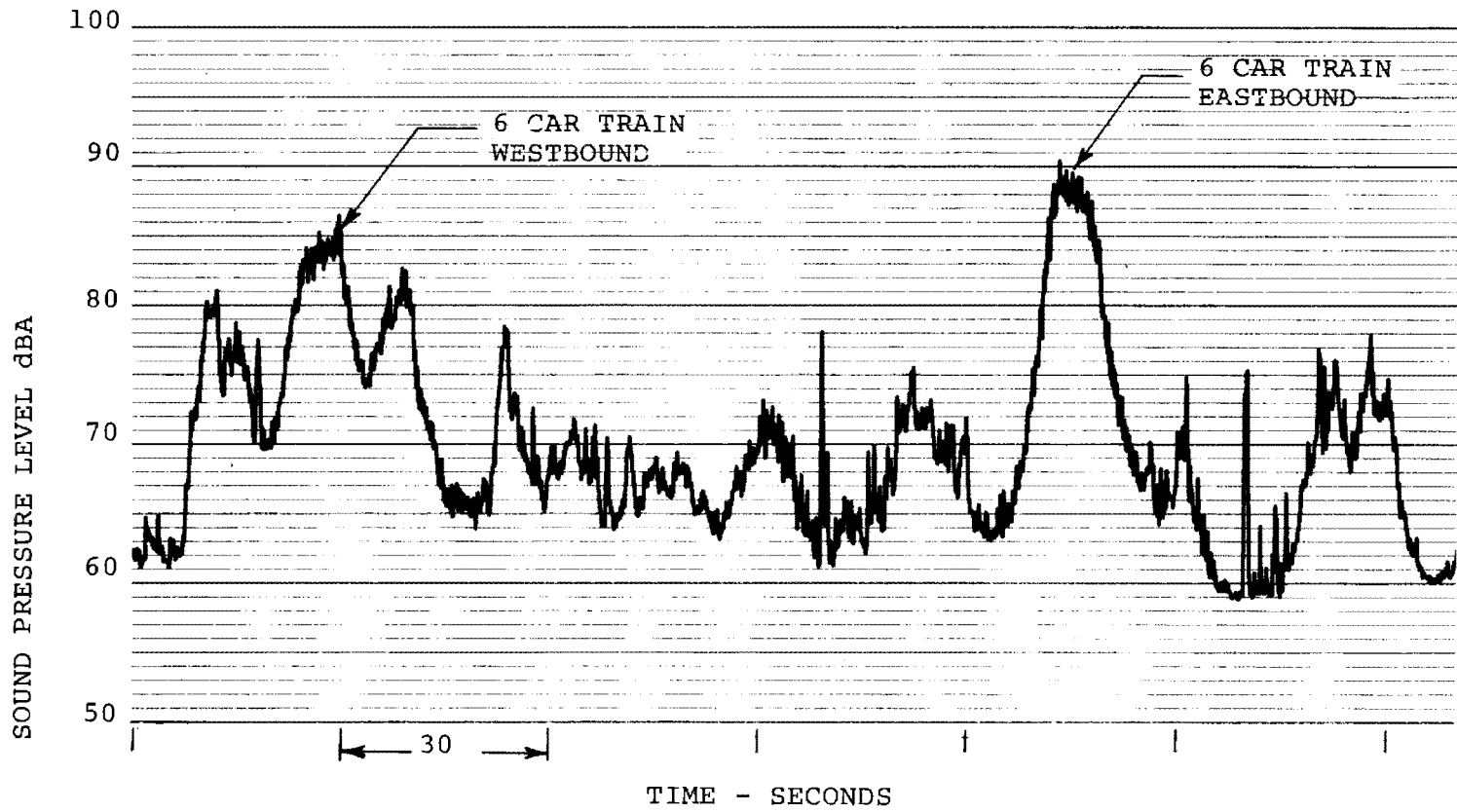
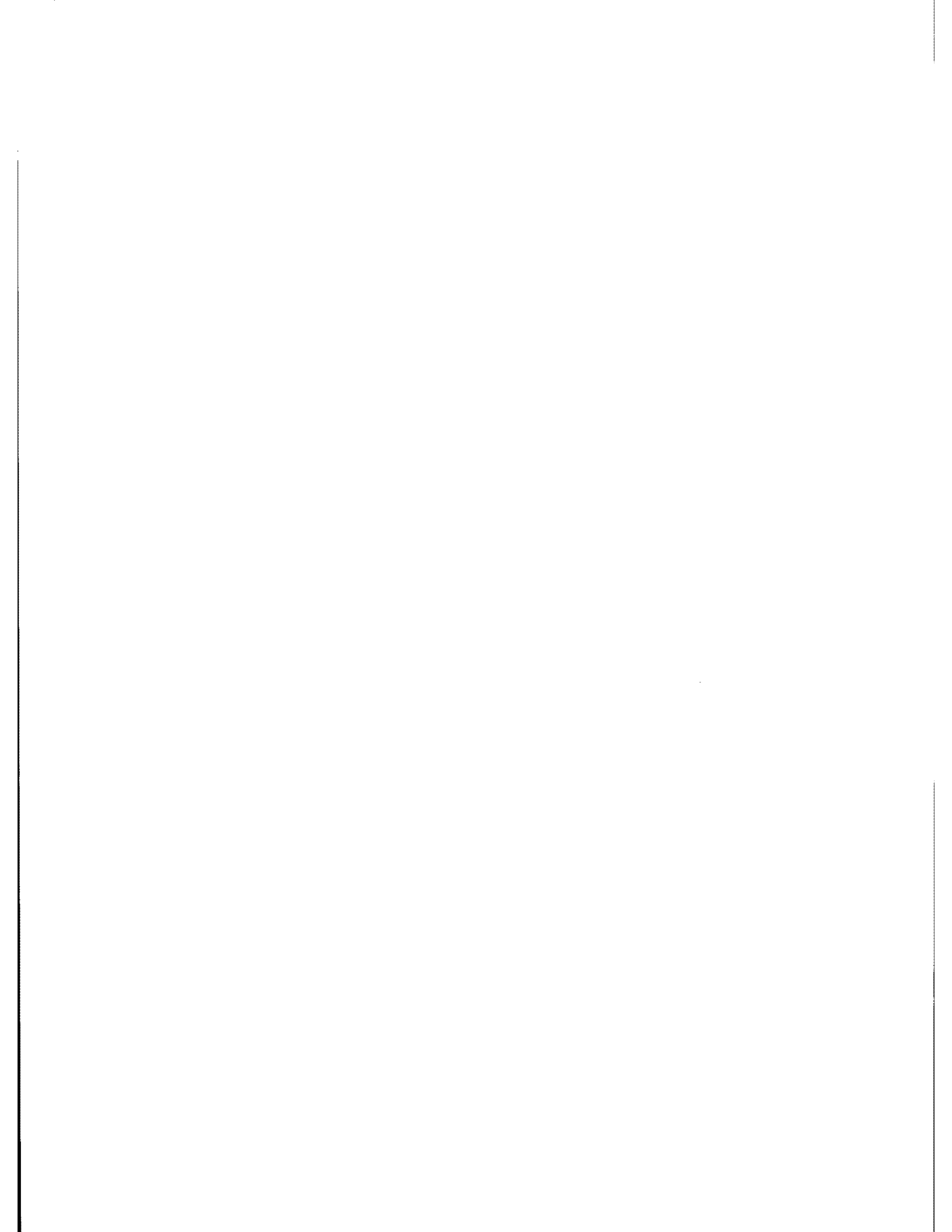

FIGURE 7.23 - TYPICAL NOISE TIMEHISTORY, 54TH AND MARKET COMMUNITY, 15M.



YORK/DAUPHIN WAYSIDE

SITE DESCRIPTION (see Figure 7.24)

The Market/Frankford Line is elevated on steel structure at this location and northbound it curves to the northeast, leaving Front Street and joining Kensington Avenue. The region is an active business/commercial area with a residential region occupying the locale behind the commercial properties that face Front and Kensington. Most housing in the area is of two story row construction.

NOISE CLIMATE (see Table 7.6, Figures 7.25 - 7.31)

Motor vehicle traffic noise is always present in this area. Trains passby on the curve at slow speeds, but car wheels emit high amplitude squeal which continues for approximately 10 seconds. As with other active areas in the city, sirens, motorcycles, children at play are all noise sources which contribute to the noise of the community.

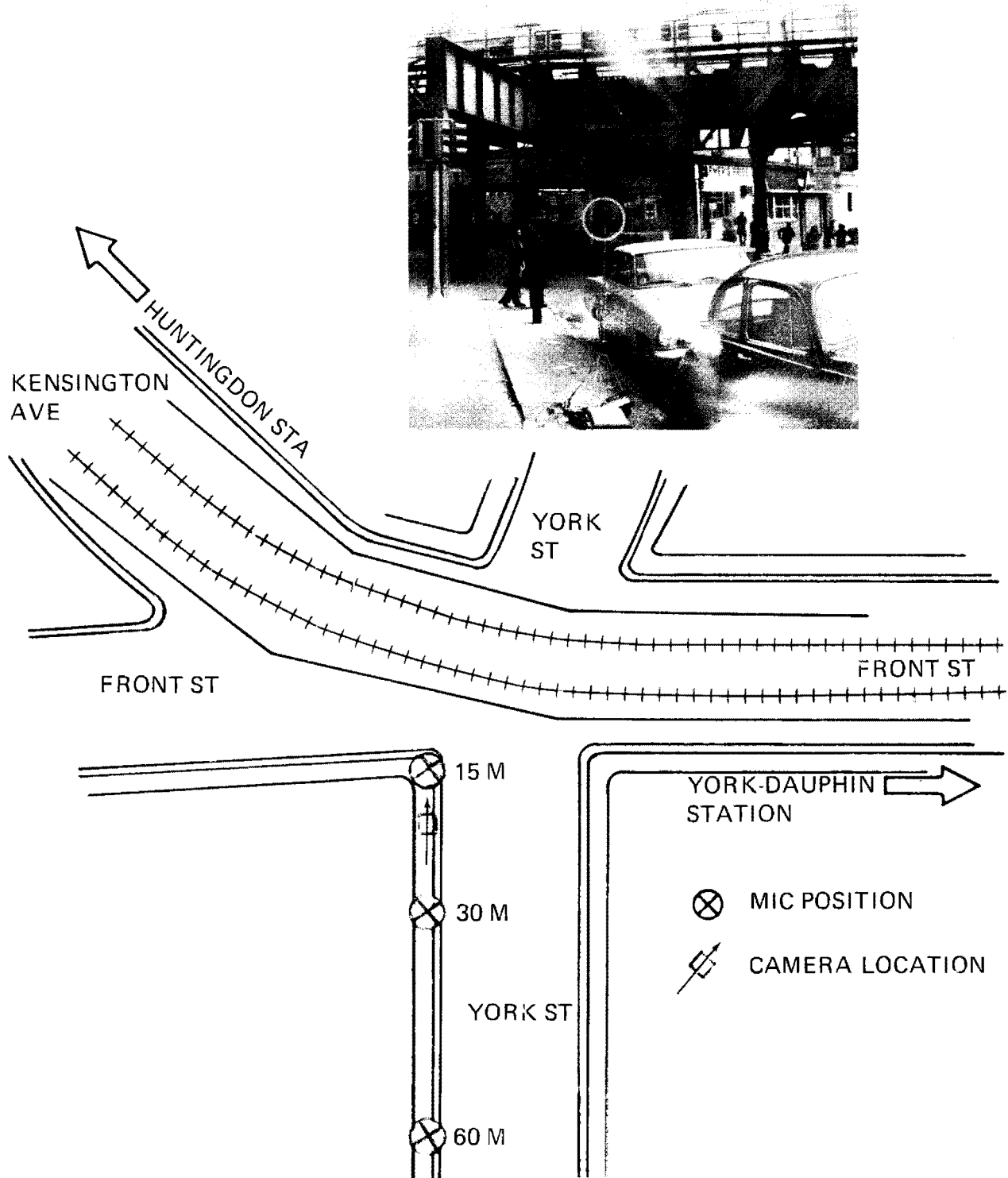

FIGURE 7.24 - WAYSIDE MEASUREMENT SITE, NEAR YORK-DAUPHIN STATION. ELEVATED STEEL STRUCTURE

TABLE 7.6 - SUMMARY OF MEASUREMENT RESULTS FOR YORK-DAUPHIN COMMUNITY

TIME	MIC POSITION	SAMPLE TIME	TRAIN CONDITIONS	UNITS	AVG MAX LEVEL		AVG LR		CUMULATIVE AMPLITUDE DISTRIBUTION					Leq
					NEAR	FAR	NEAR	FAR	L99	L90	L50	L10	L1	
Day	15 m	30 min	Pass-by	b)N	4-6	4-6	4-6	4-6	63	64	68	78	94	81
				dBA	98	90	106	100						
				S	3.28	1.70	2.41	0.80						
Day	60 m	15 min	Pass-by	dBA					62	63	65	72	84	71
Day	120 m	9 min	Pass-by	dBA					62	63	65	71	82	71
Rush	15 m	30 min	Pass-by	dBA					59	62	68	89	98	85
Evening	15 m	30 min	Pass-by	dBA					66	67	72	79	93	79
Night	15 m	30 min	Pass-by	dBA					53	54	59	64	84	71
Notes: a - Track													Ldn = 84	
b - Number of Trains - (e.g.: 4-2 means four 2-car trains)														
c - Standard Deviation of Level														

7-42

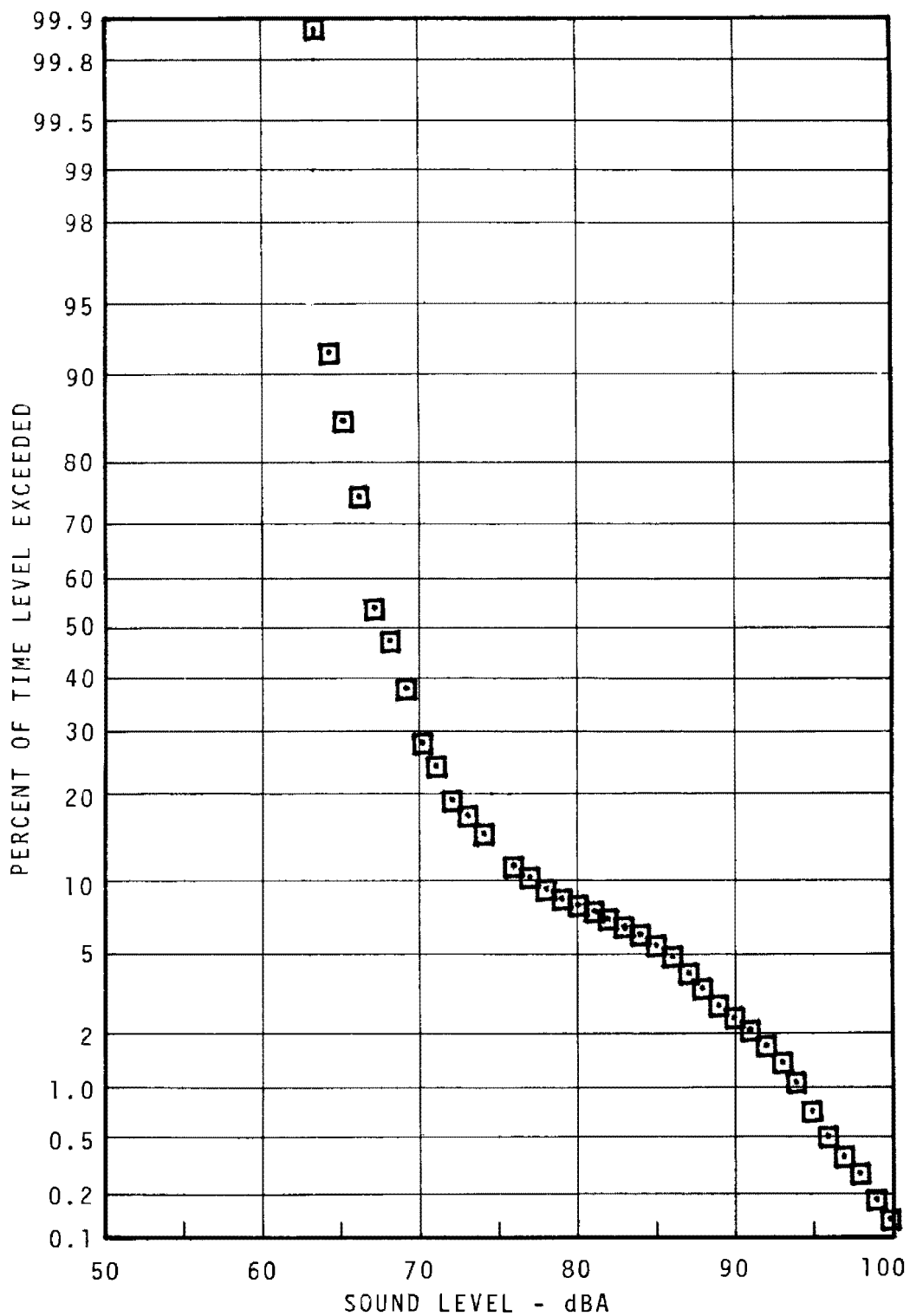

FIGURE 7.25 - YORK-DAUPHIN COMMUNITY STATISTICAL DISTRIBUTION - 15M - DAYTIME

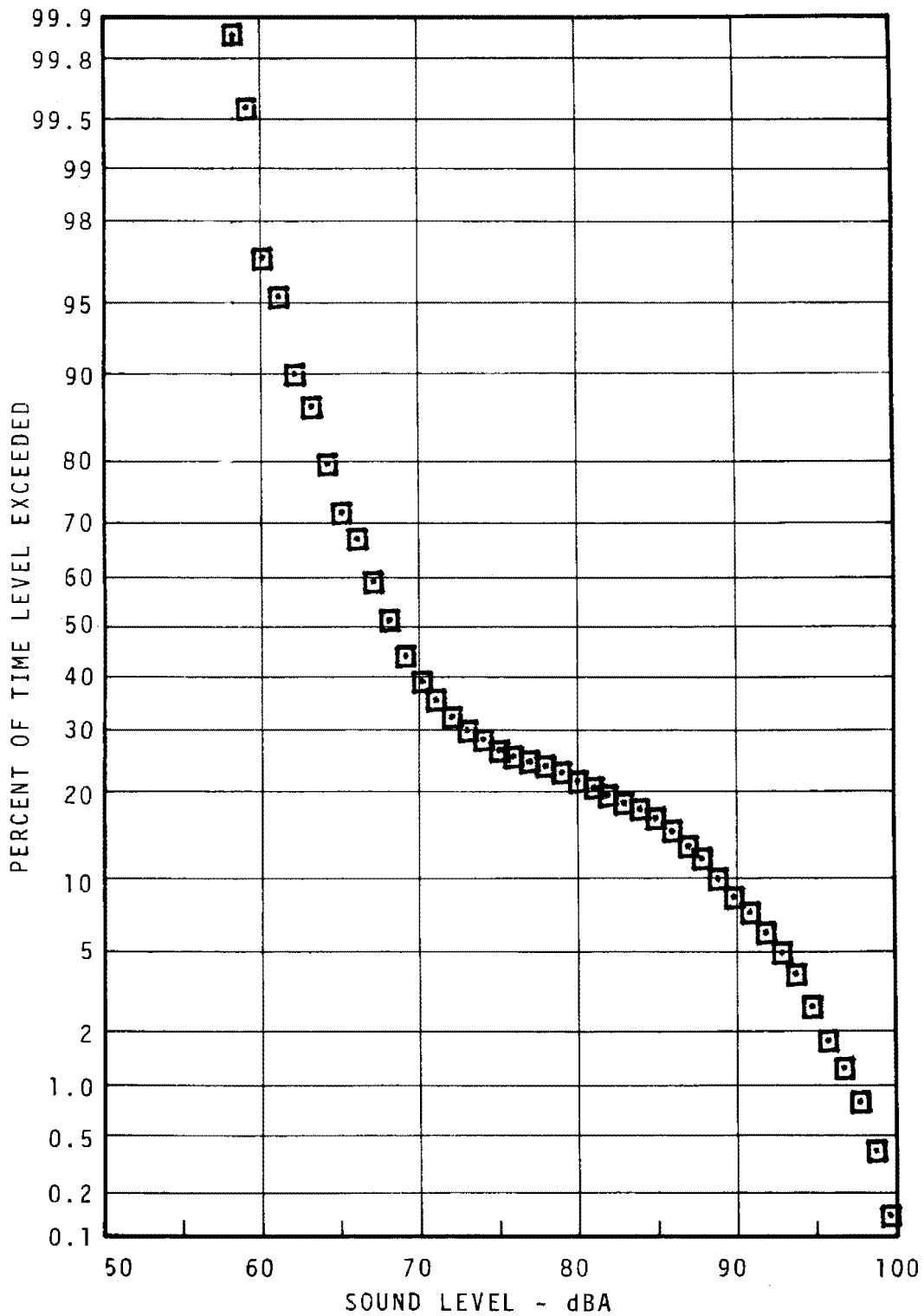

FIGURE 7.26 -YORK-DAUPHIN COMMUNITY STATISTICAL DISTRIBUTION - 15M - RUSH HOUR

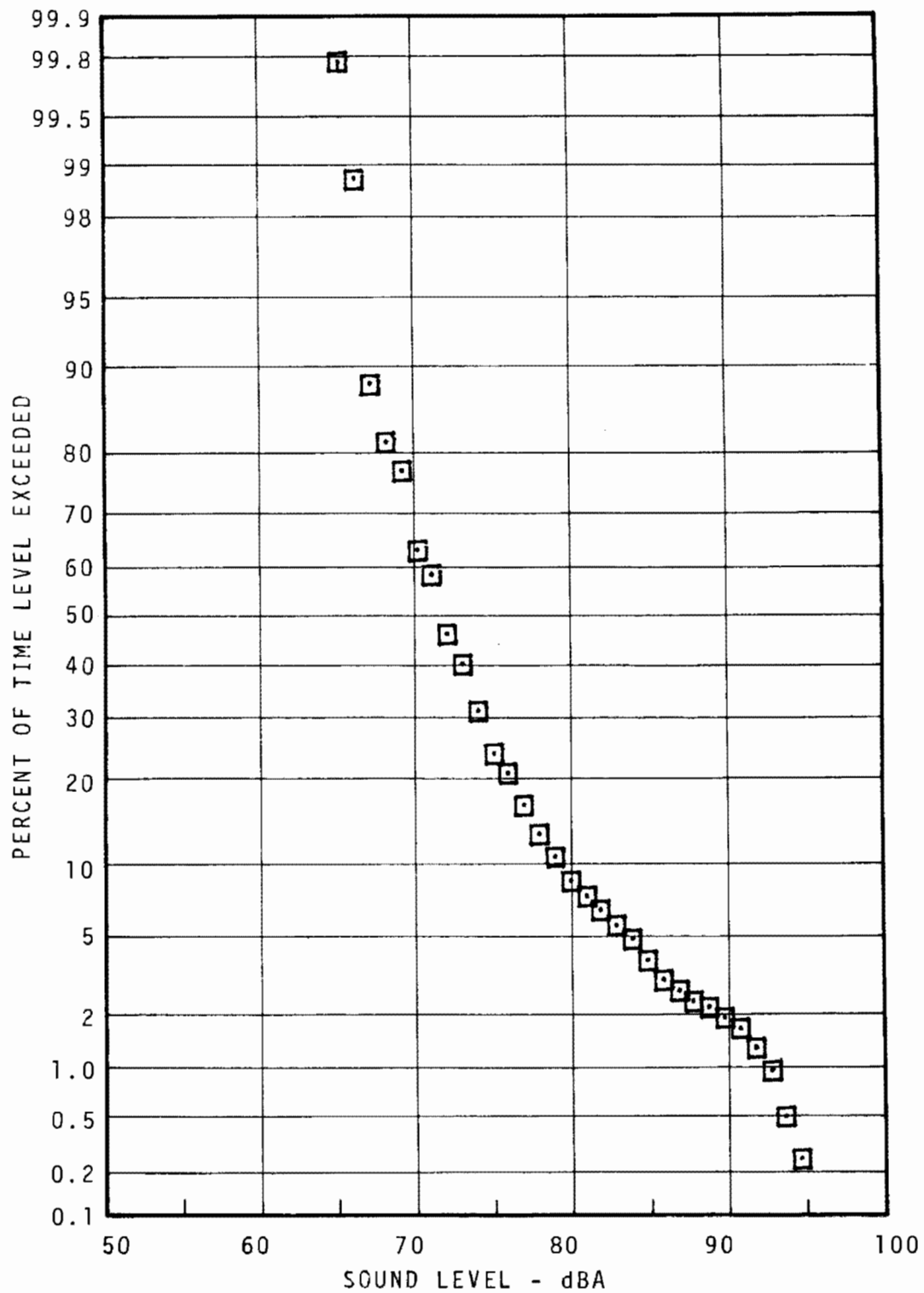

FIGURE 7.27 - YORK-DAUPHIN COMMUNITY STATISTICAL DISTRIBUTION - 15M - EVENING

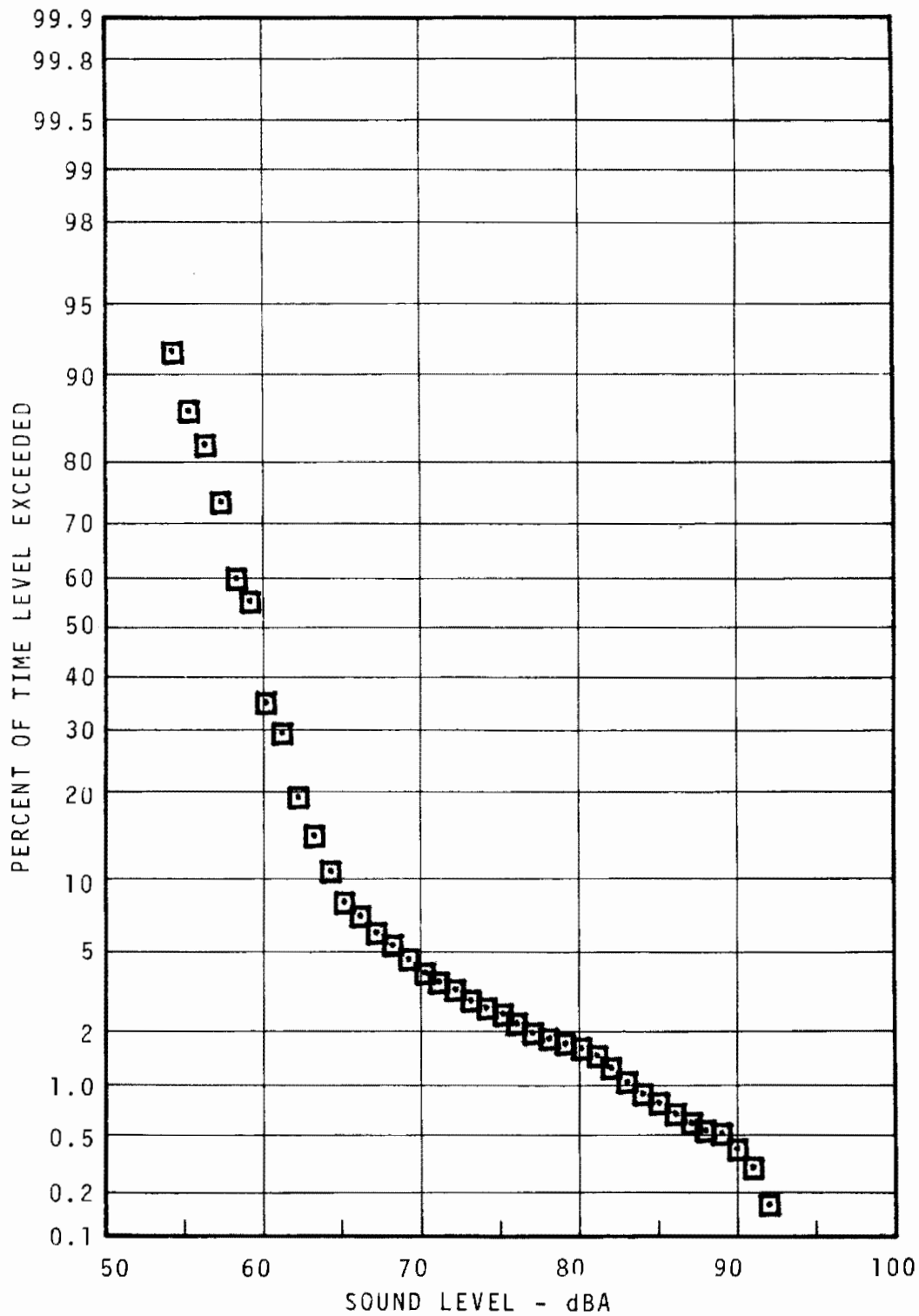

FIGURE 7.28 - YORK-DAUPHIN COMMUNITY STATISTICAL DISTRIBUTION - 15M - NIGHT

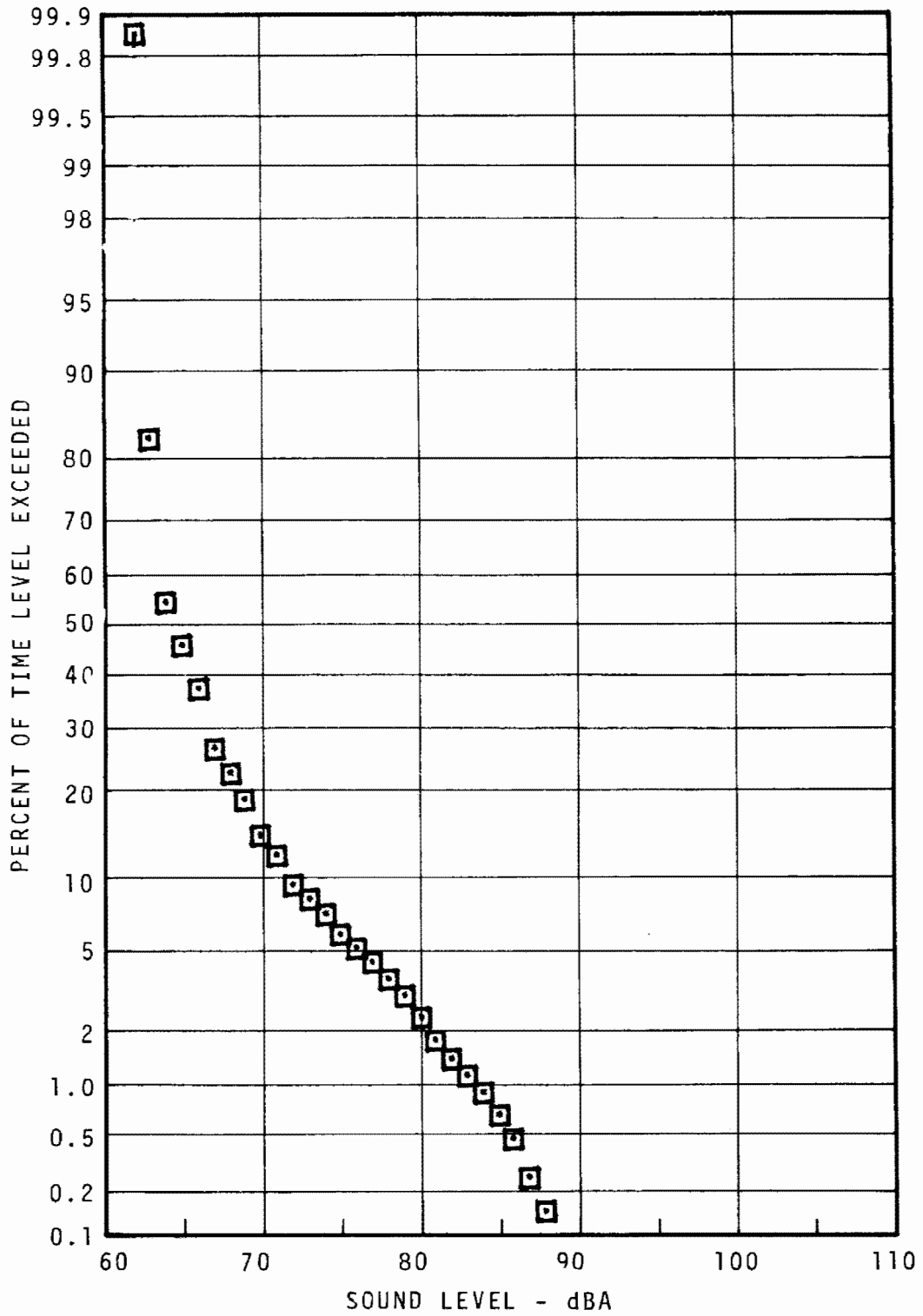

FIGURE 7.29 - YORK-DAUPHIN COMMUNITY STATISTICAL DISTRIBUTION - 60M - DAYTIME

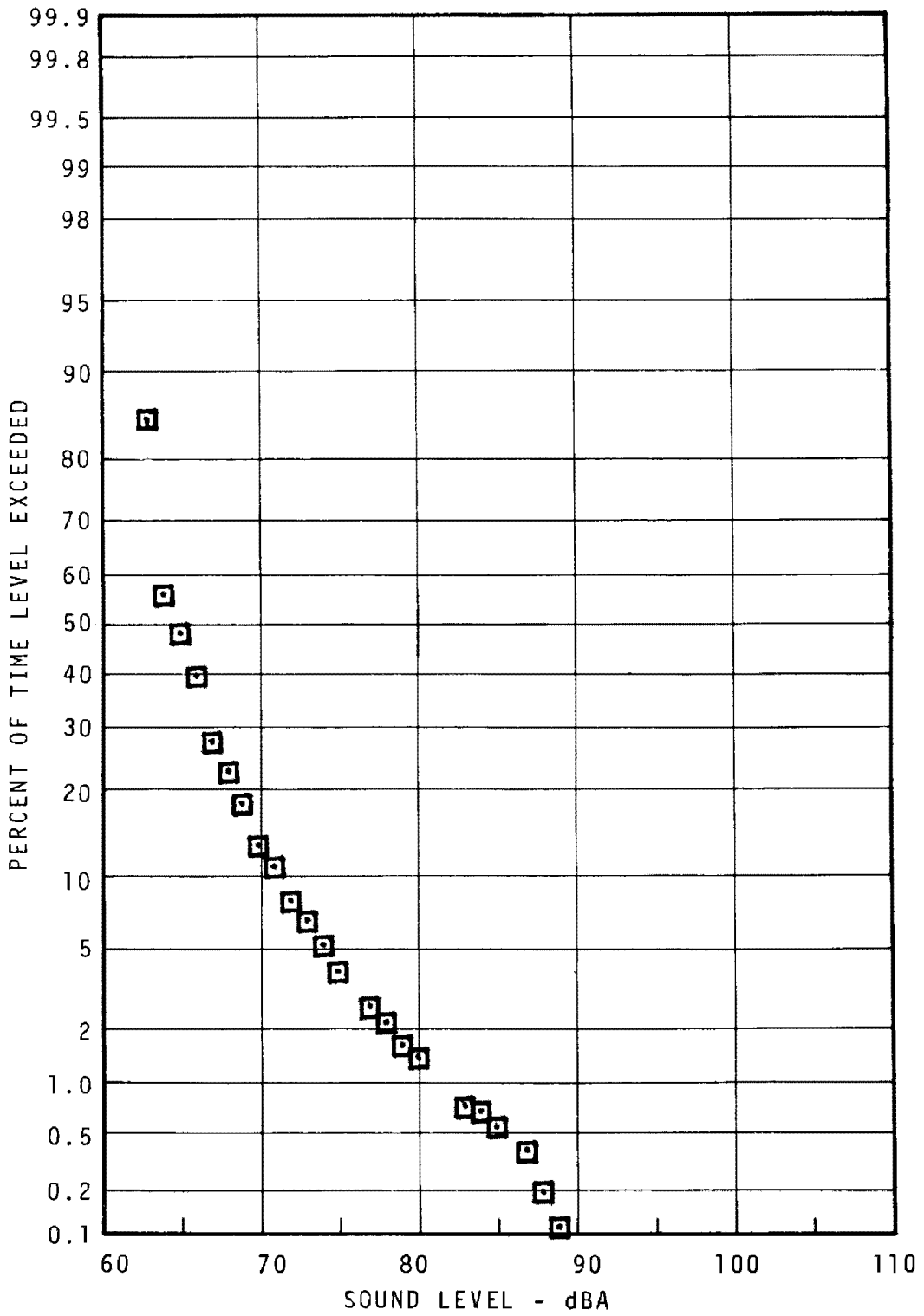

FIGURE 7.30 - YORK-DAUPHIN COMMUNITY STATISTICAL DISTRIBUTION - 120M - DAYTIME

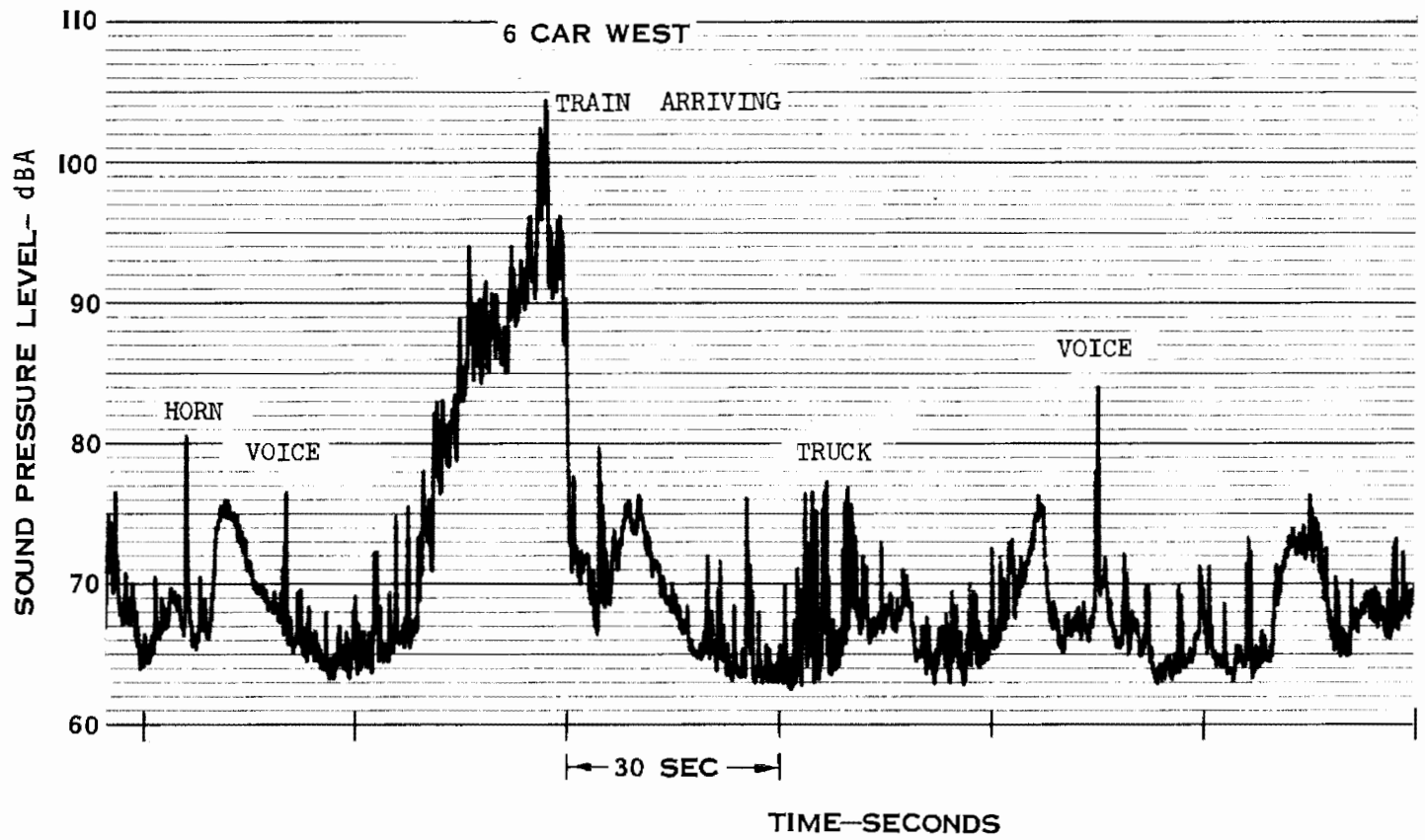

FIGURE 7.31-TYPICAL NOISE TIME HISTORY YORK-DAUPHIN COMMUNITY 15 METERS MARKET-FRANKFORD ELEVATED LINE

SOMERSET COMMUNITY

SITE DESCRIPTION (see Figure 7.32)

The Market-Frankford Line operates over elevated steel structure in this region. The location is predominantly residential with some business located along Kensington Avenue. Somerset Station is one block to the right (south) of Hart Lane, a residential street generally used by residents of the immediate area only. Kensington Avenue is a moderately busy thoroughfare in this locale. Most housing in the area is of two story row construction.

NOISE CLIMATE (see Table 7.7, Figures 7.33 - 7.37)

Traffic on Kensington Avenue is the general source of noise in this vicinity. Trains on the elevated structure are audible for a distance of one-to-two blocks from the right-of-way due to the lower background noise than at most other sites. There is not a large difference in the noise climate throughout the daytime, rush hour, evening and nighttime hours, with statistical levels within 5-6 dBA for all measurement periods. This results from the predominantly residential character of the neighborhood.

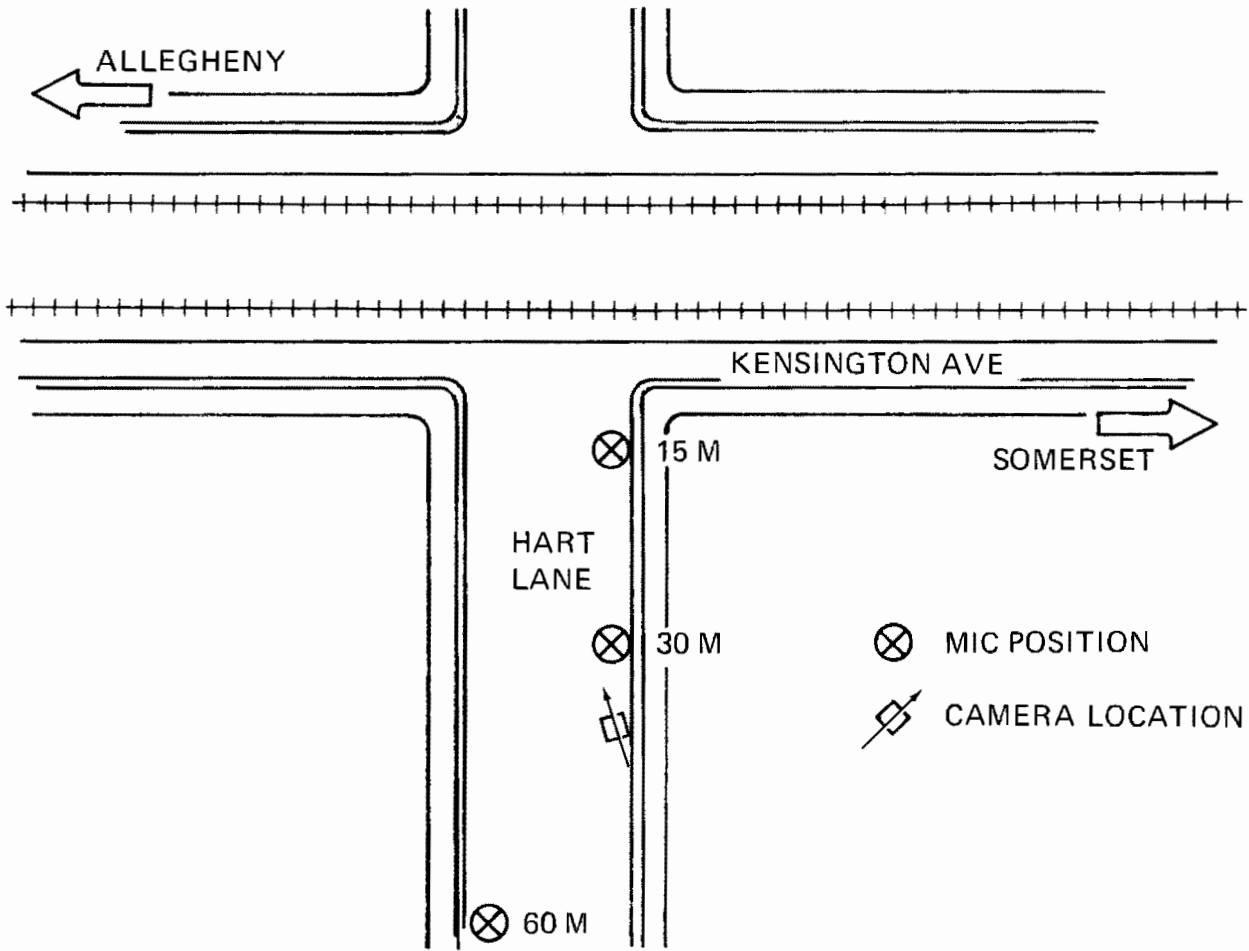

FIGURE 7.32 - WAYSIDE MEASUREMENT SITE, NEAR SOMERSET STATION. ELEVATED STEEL STRUCTURE

TABLE 7.7 - SUMMARY OF MEASUREMENT RESULTS FOR SOMERSET COMMUNITY

TIME	MIC POSITION	SAMPLE TIME	TRAIN CONDITIONS	UNITS	AVG MAX LEVEL		AVG LR		CUMULATIVE AMPLITUDE DISTRIBUTION					Leq
					NEAR	FAR	NEAR	FAR	L99	L90	L50	L10	L1	
Day	15 m	30 min	Pass-by	b) N	4-6	4-6	4-6	4-6	55	59	66	79	85	74
				dBA	86	80	96	92						
				S	1.26	1.32	1.08	1.04						
Rush	15 m	30 min	Pass-by	dBA					57	61	68	81	87	76
Evening	15 m	30 min	Pass-by	dBA					53	54	61	69	83	69
Night	15 m	30 min	Pass-by	dBA					53	53	56	66	77	65
Notes: a - Track b - Number of Trains - (e.g.: 4-2 means four 2-car trains) c - Standard Deviation of Level													Ldn = 77	

7-52

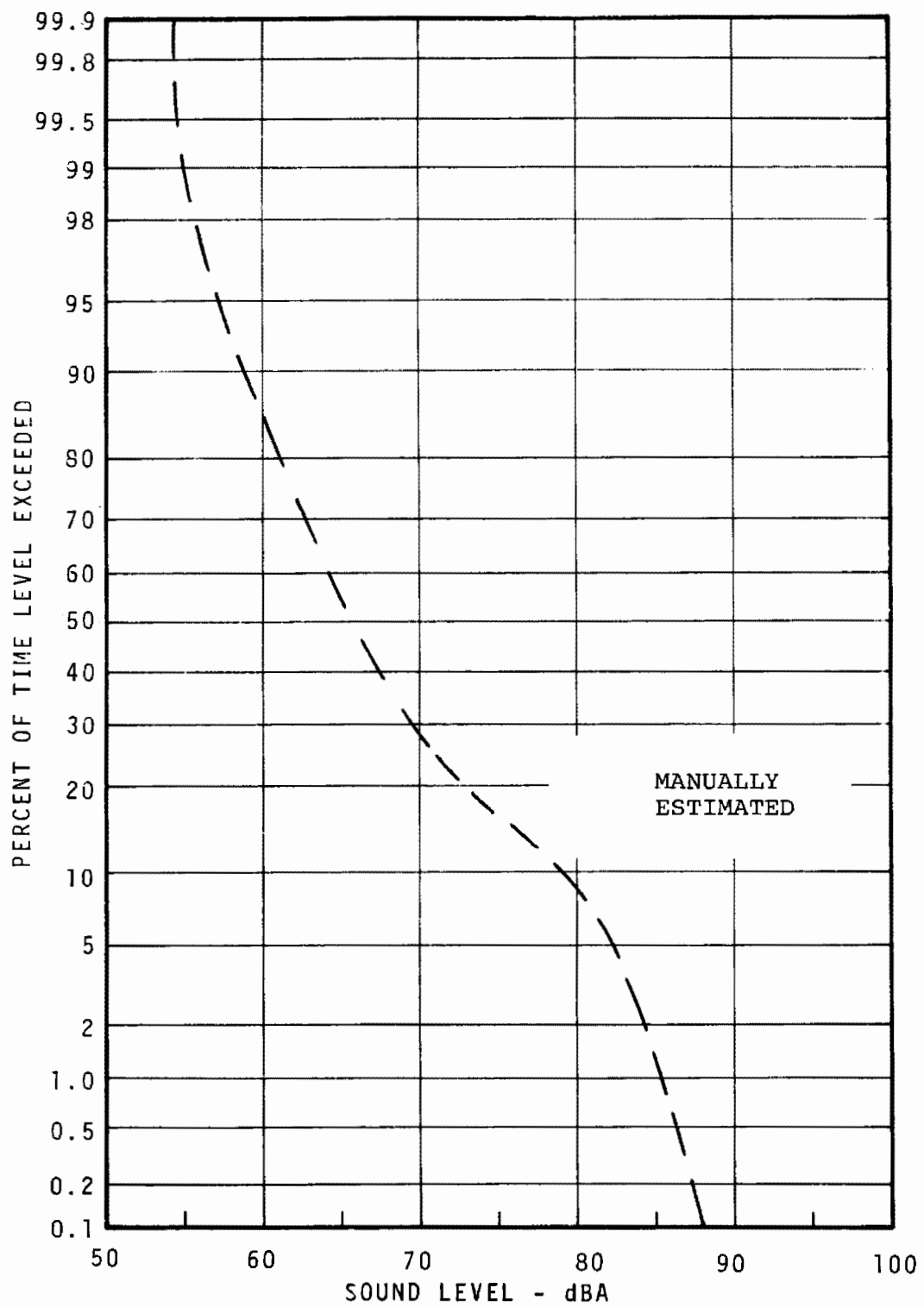

FIGURE 7.33 - SOMERSET COMMUNITY STATISTICAL DISTRIBUTION - 15M - DAYTIME

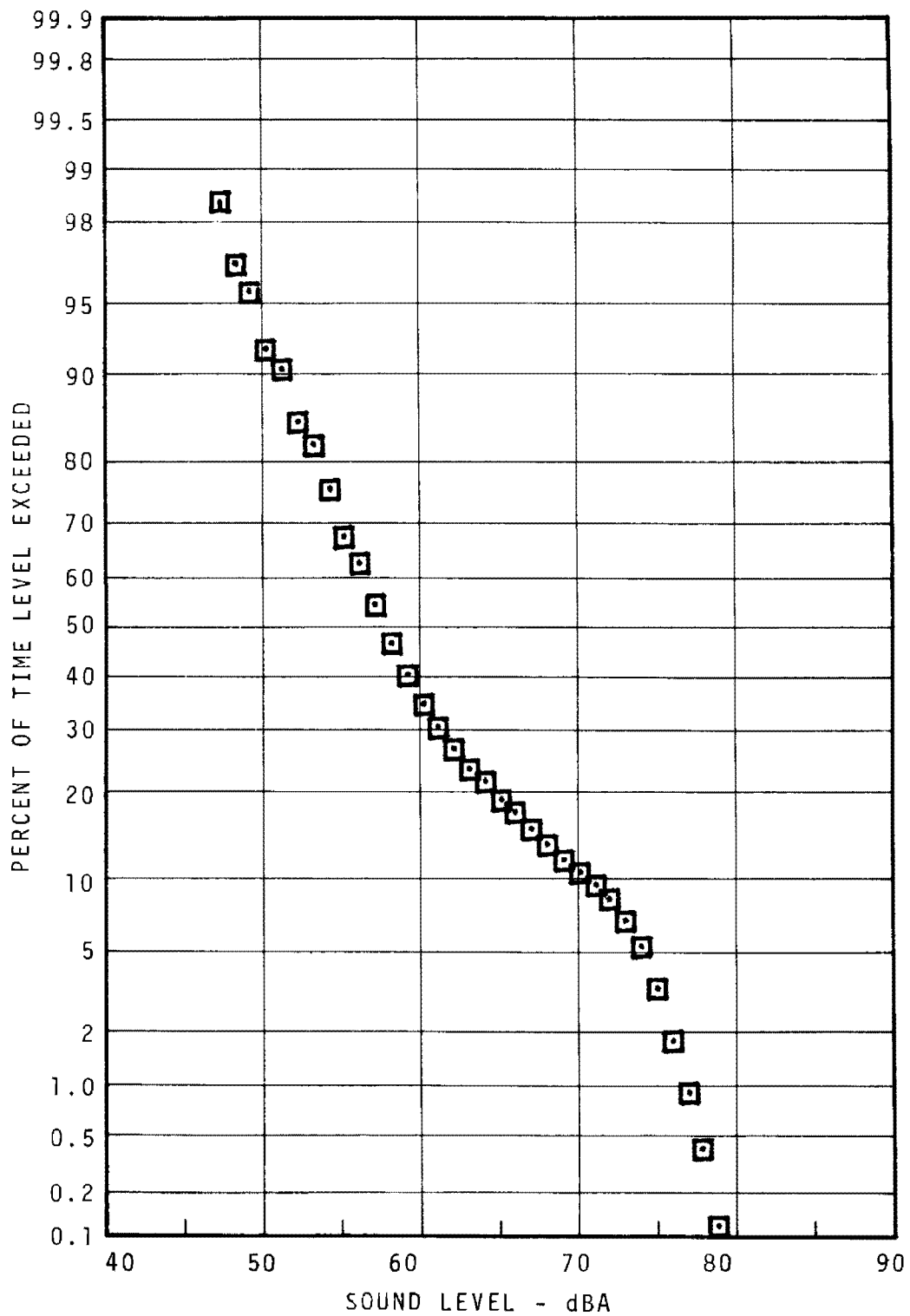

FIGURE 7.34 - SOMERSET COMMUNITY STATISTICAL DISTRIBUTION - 15M - RUSH HOUR

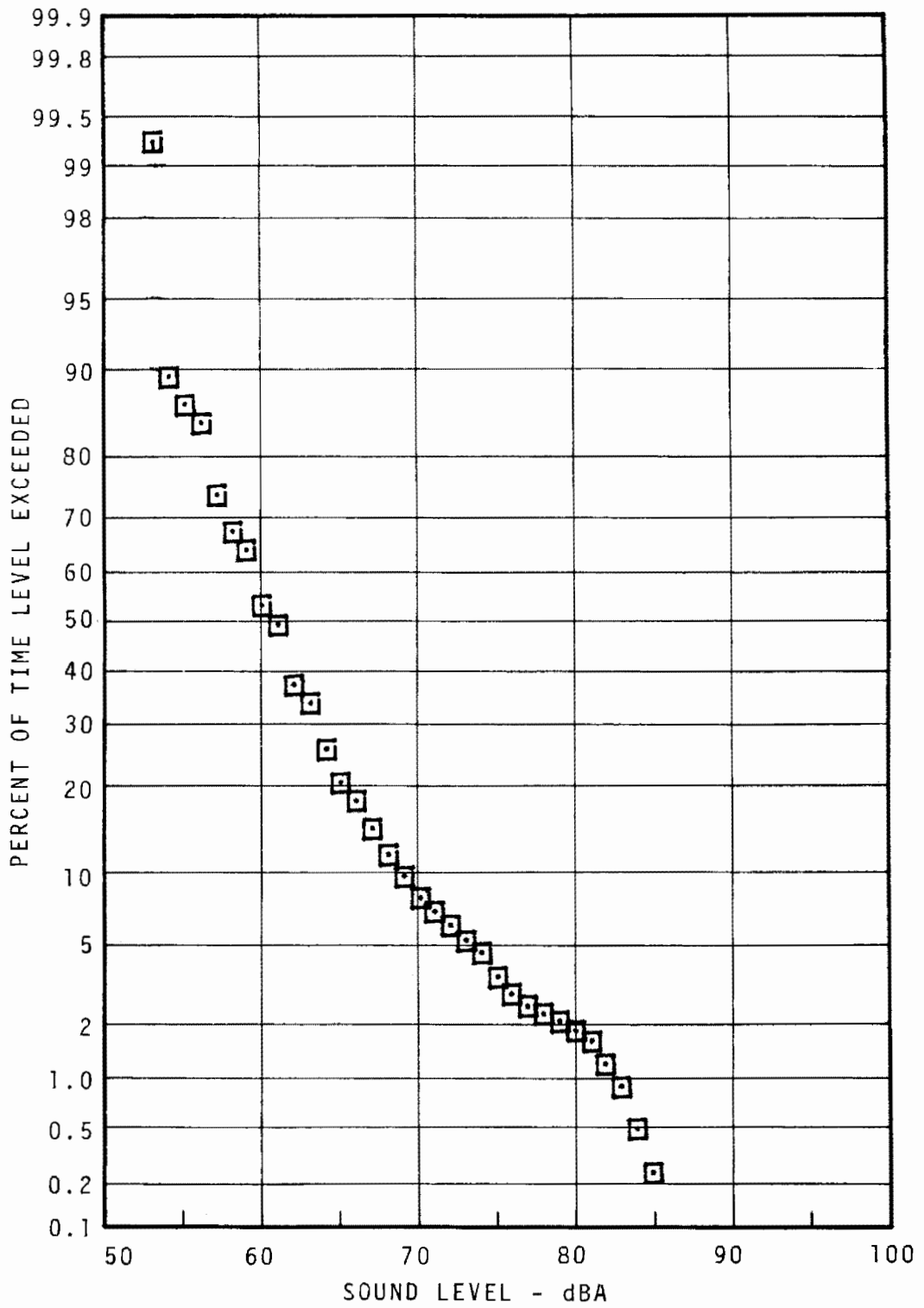

FIGURE 7.35 - SOMERSET COMMUNITY STATISTICAL DISTRIBUTION - 15M - EVENING

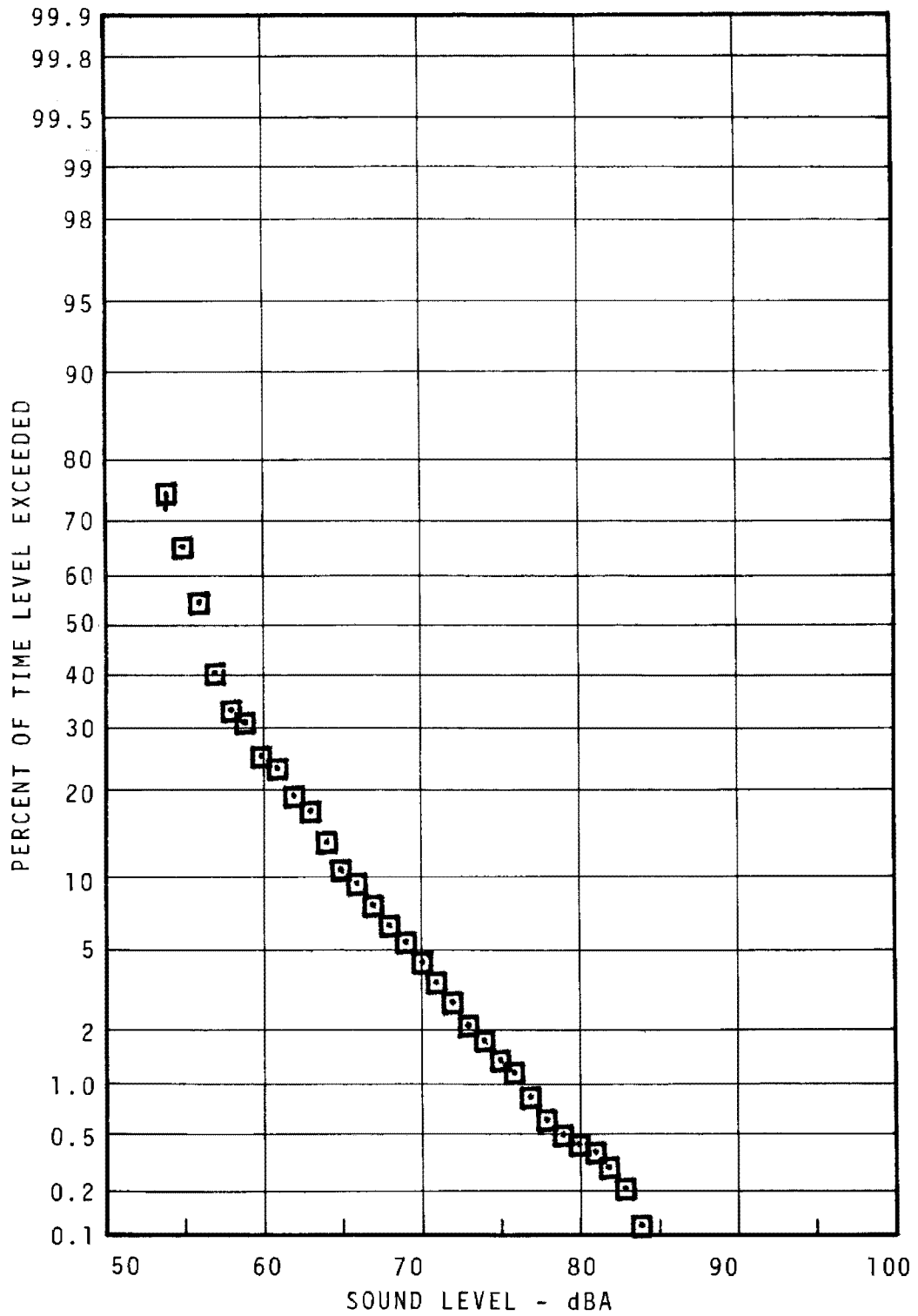

FIGURE 7.36 - SOMERSET COMMUNITY STATISTICAL DISTRIBUTION - 15M - NIGHT

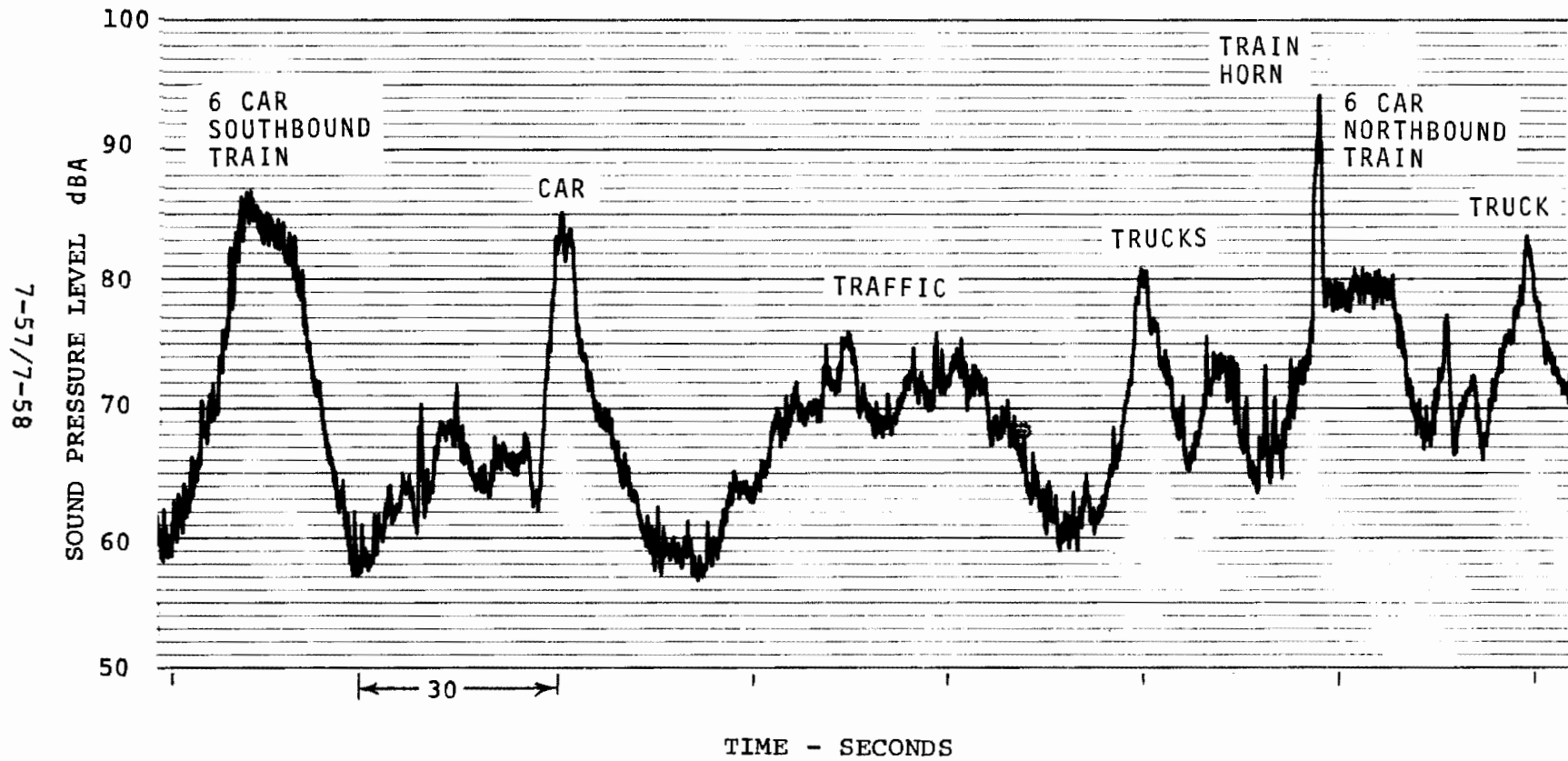
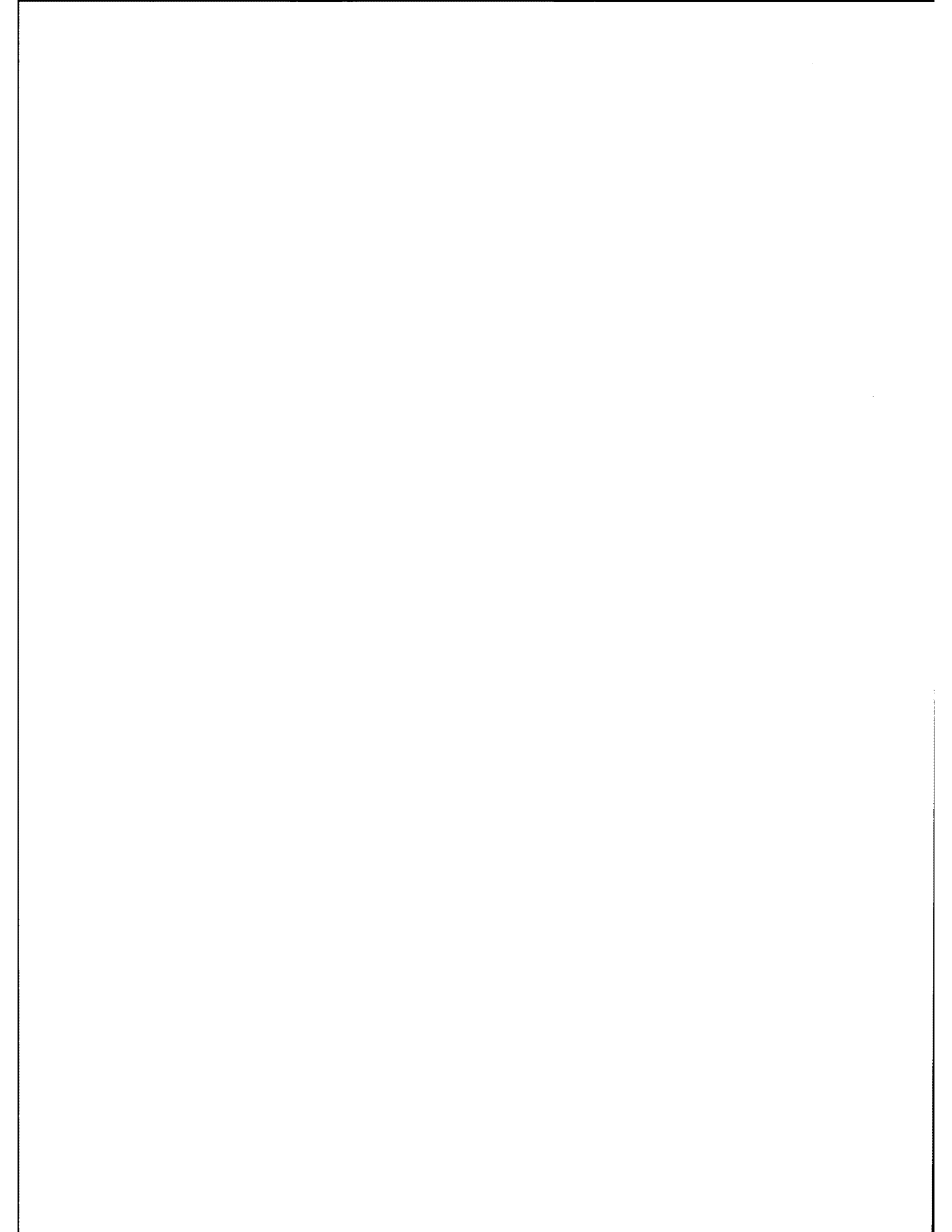

FIGURE 7.37 - TYPICAL TIME HISTORY, SOMMERSET COMMUNITY



7.2.2 Station Platform

Station platform noise measurements were made for twelve locations on the Market-Frankford subway elevated line. Two were system terminals - one at grade and the other on elevated steel structure. Two stations were located on-grade, five were on elevated steel structure and five in the subway. Of the five subway stations, two were of center platform configuration and three were side platforms. The elevated stations were all side platform, with the exception of the Bridge Street Terminal which was one center and one side platform. The two on-grade stations were comprised of one side platform location and the 69th Street Terminal which was one center and one side platform.

The specific selection rationale for each station is presented in Table 7.8.

TABLE 7.8. STATION SELECTION RATIONALE

STATION	RATIONALE
69th Street Terminal	The major terminal on the line. At-grade roadbed. Three tracks, one side platform, one center platform.
Millbourne	In a residential community near a screech-producing curve. Two tracks, side platforms, on-grade.
52nd Street	A typical elevated station. Located in a major business district of West Philadelphia. Two tracks, side platforms.
40th Street	Same as 2nd and 5th Street Stations except that patrons are exposed to auxiliary equipment noise.
34th Street	Similar in station and underground track construction as 30th Street Station, except for the absence of subway-surface car traffic. Also has auxiliary equipment noise.
30th Street	An underground station which interchanges with the subway-surface system. Two tracks, center platform. Subway-surface line has two outer tracks and side platform.
5th Street	Typical underground station with two tracks and two side platforms.
2nd Street	Same as 5th Street Station except that patrons here are exposed to squeal noise from the nearby 200 ft radius track curve.
Berks	A typical elevated station with two tracks and side platform. However, construction of elevated section is different than at 52nd Street.

TABLE 7.8. STATION SELECTION RATIONALE (CONTINUED)

STATION	RATIONALE
York-Dauphin	This station is of the same type construction as Berks and on the same type elevated structure. However, patrons on this station are exposed to wheel squeal from the curve just north of the station.
Church	Same station construction as Berks but different elevated structure.
Bridge-Pratt	The northern terminal on the system. Station platform is on elevated structure of the same type as Church Station. There are two tracks with one center and one side platform.

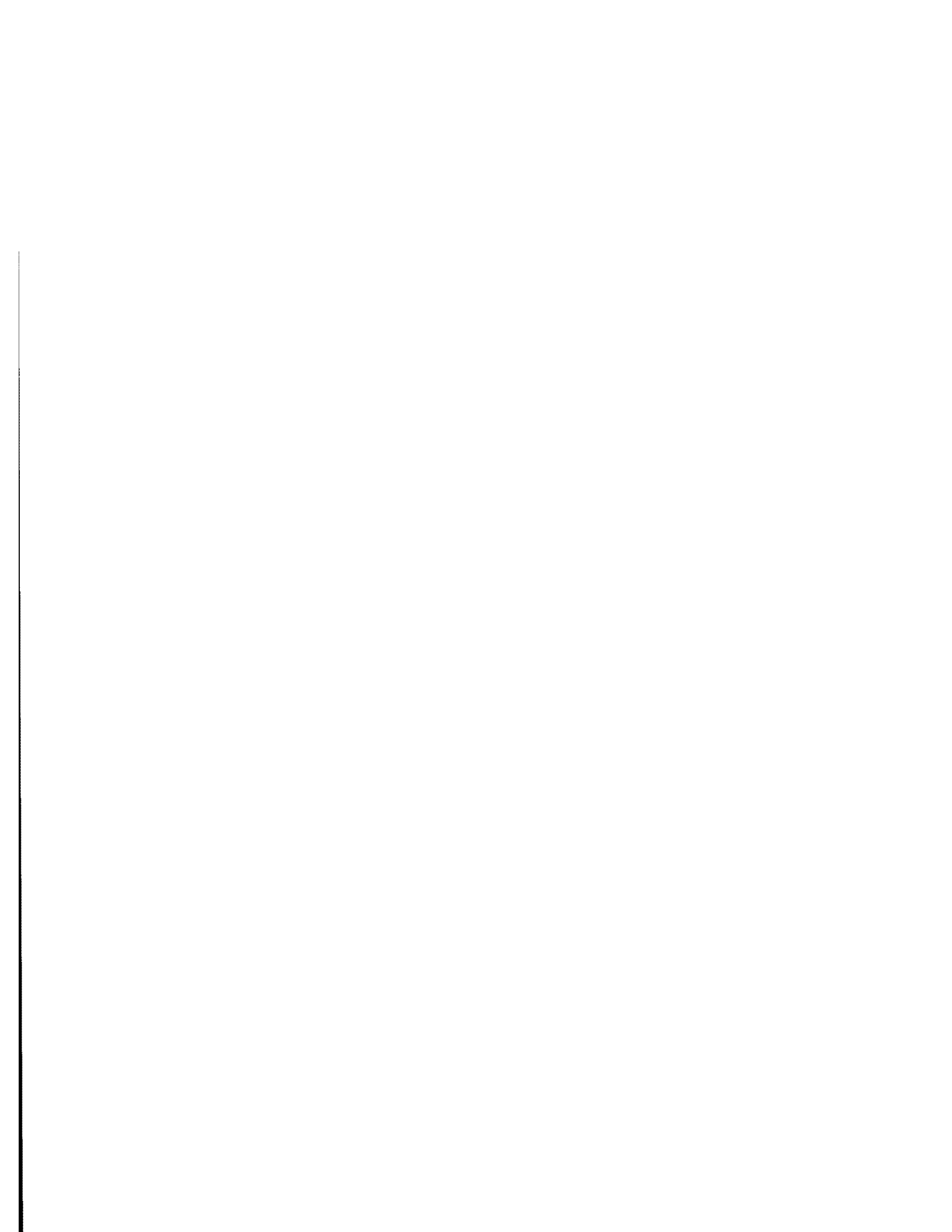

69TH STREET TERMINAL PLATFORM

SITE DESCRIPTION (see Figure 7.38)

The terminal at 69th Street is a three track, one side platform (for arriving trains) and one center platform (for departing trains) configuration. Connections to all the major western suburban areas are available at the terminal by bus, light rail or other high speed rapid transit lines. The track is on-grade at this station. Passengers arriving from the city exit on the south side platform, overhead to other connections within the terminal.

NOISE CLIMATE (see Table 7.9, Figures 7.39 - 7.43)

Wheel screech is audible on the station platform as trains arrive and depart the terminal area, both from the city and also from the return loop on the yard and shop side of the terminal. Undercar equipment noise of cars standing at the departure platform frequently establishes the background level. Occasionally, other transit vehicles are audible. Values of L_{eq} for night time and rush hours are separated by 17 dBA, indicative of the activity at this terminal during rush hour periods. Daytime and evening levels are similar and are midway between the night and rush hour extremes.

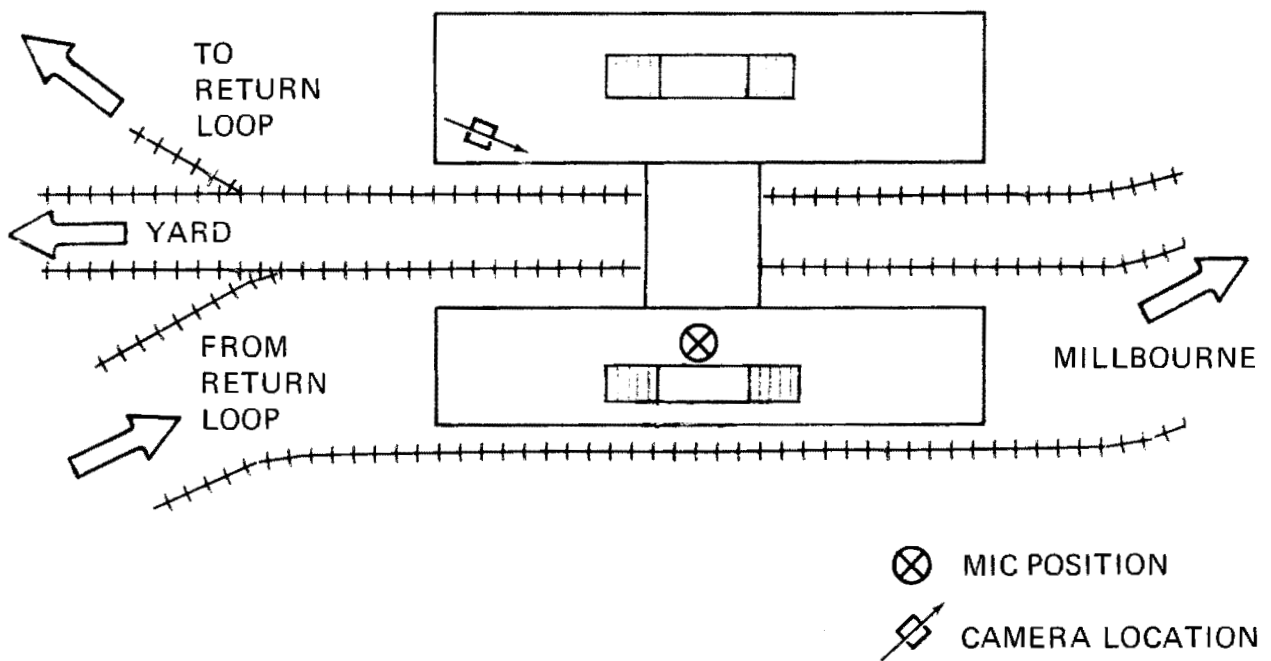

FIGURE 7.38 - 69TH STREET TERMINAL STATION PLATFORM.
ON GRADE

TABLE 7.9 - SUMMARY OF MEASUREMENT RESULTS FOR 69TH STREET STATION PLATFORM

TIME	MIC POSITION	SAMPLE TIME	TRAIN CONDITIONS	UNITS	AVG MAX LEVEL			AVG LR			CUMULATIVE AMPLITUDE DISTRIBUTION					Leq	
					a)	1	2	3	1	2	3	L99	L90	L50	L10		L1
Day	Center of Stopped Train	30 min	Arrival	b) N	3-6	3-6	2-6	3-6	3-6	2-6	65	71	76	82	87	79	
				dBA	87	86	86	95	95	93							
				c) S	1.53	1.44	0.71	0.50	0.35	2.69							
			Departure	N	4-6	4-6	2-6	4-6	4-6	2-6							
				dBA	86	86	83	94	95	93							
				S	1.70	2.00	0.35	1.73	1.76	0.99							
Rush	Center of Stopped Train	30 min	Arrival and Departure	dBA						71	75	82	91	96	88		
Evening	Center of Stopped Train	30 min		dBA							69	69	70	81	90	78	
Night	Center of Stopped Train	30 min		dBA							66	67	69	72	79	70	
Notes: a - Track b - Number of Trains - (e.g.: 4-2 means four 2-car trains) c - Standard Deviation of Level																	

7-64

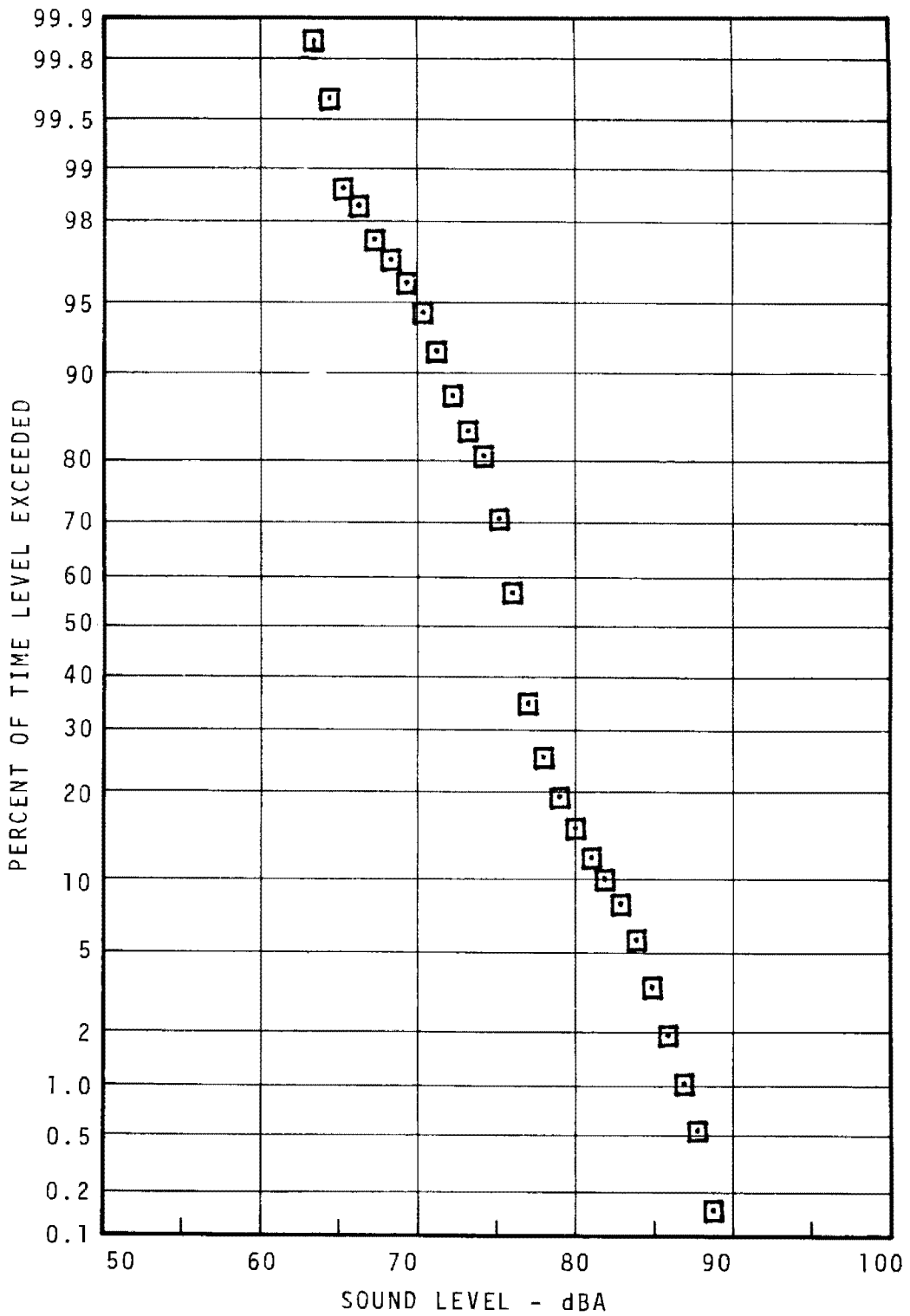

FIGURE 7.39 - 69TH ST. STATION PLATFORM STATISTICAL DISTRIBUTION - DAYTIME

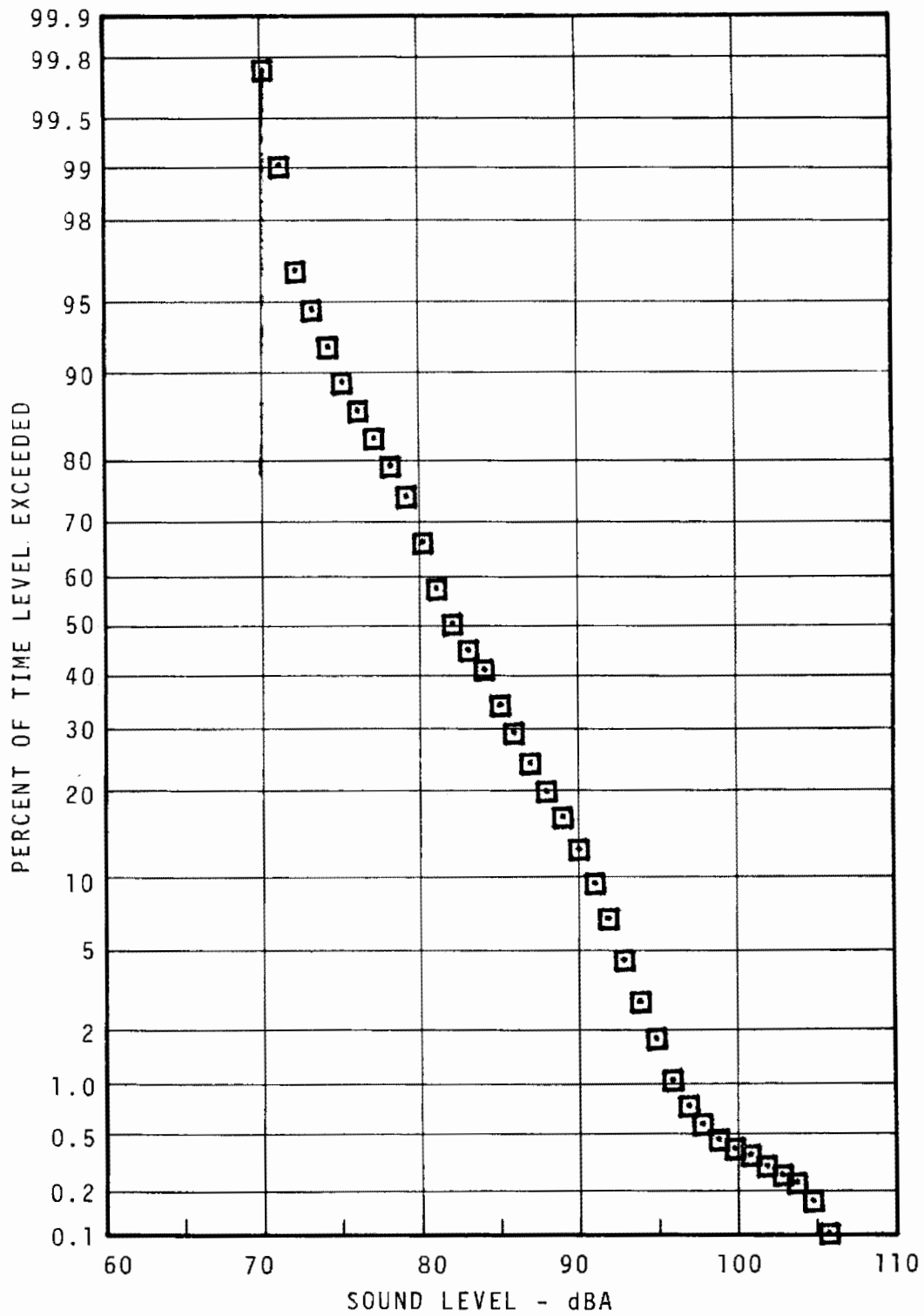

FIGURE 7.40 - 69TH ST. STATION PLATFORM
 STATISTICAL DISTRIBUTION -
 RUSH HOUR

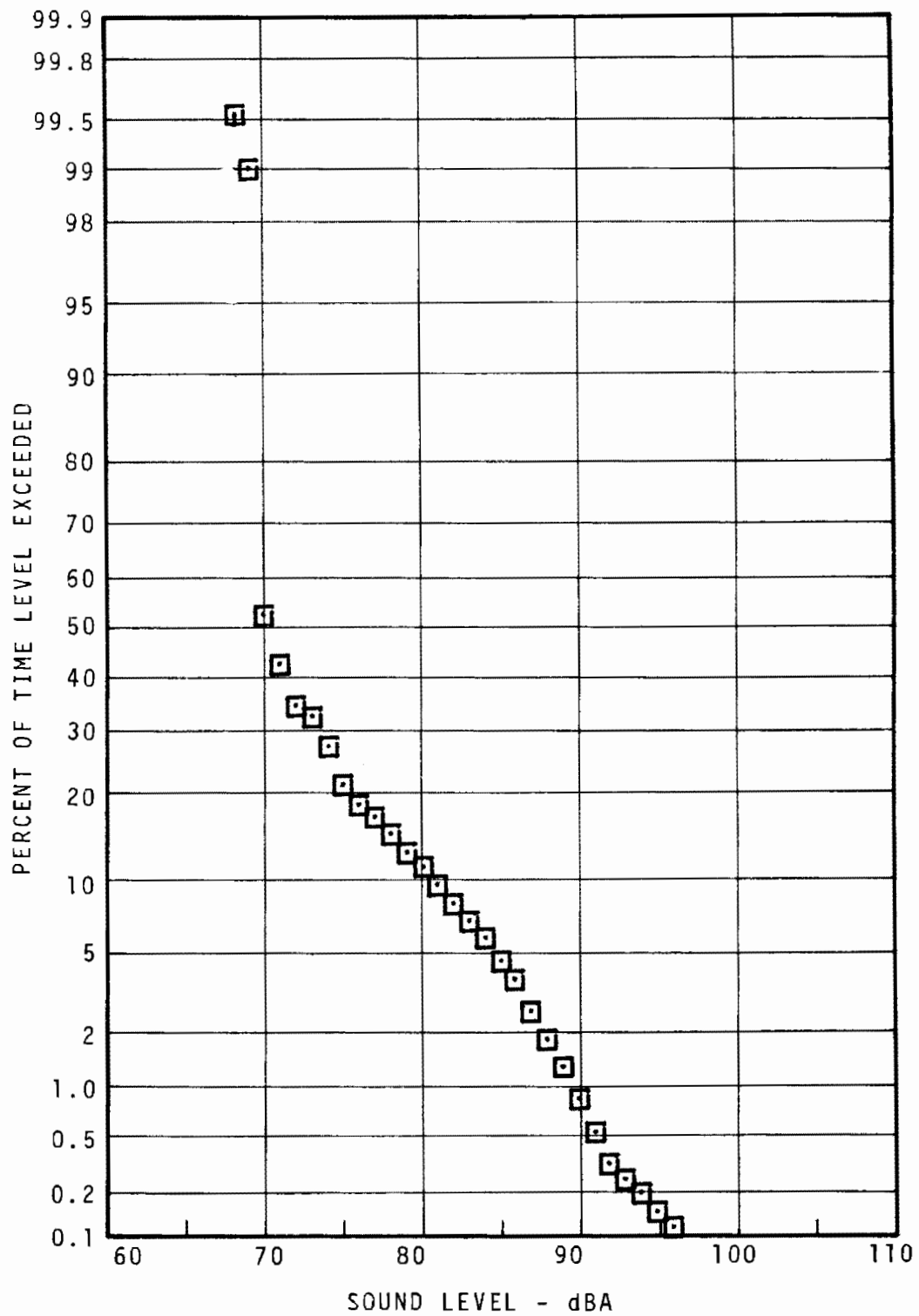

FIGURE 7.41 - 69TH ST. STATION PLATFORM
 STATISTICAL DISTRIBUTION -
 EVENING

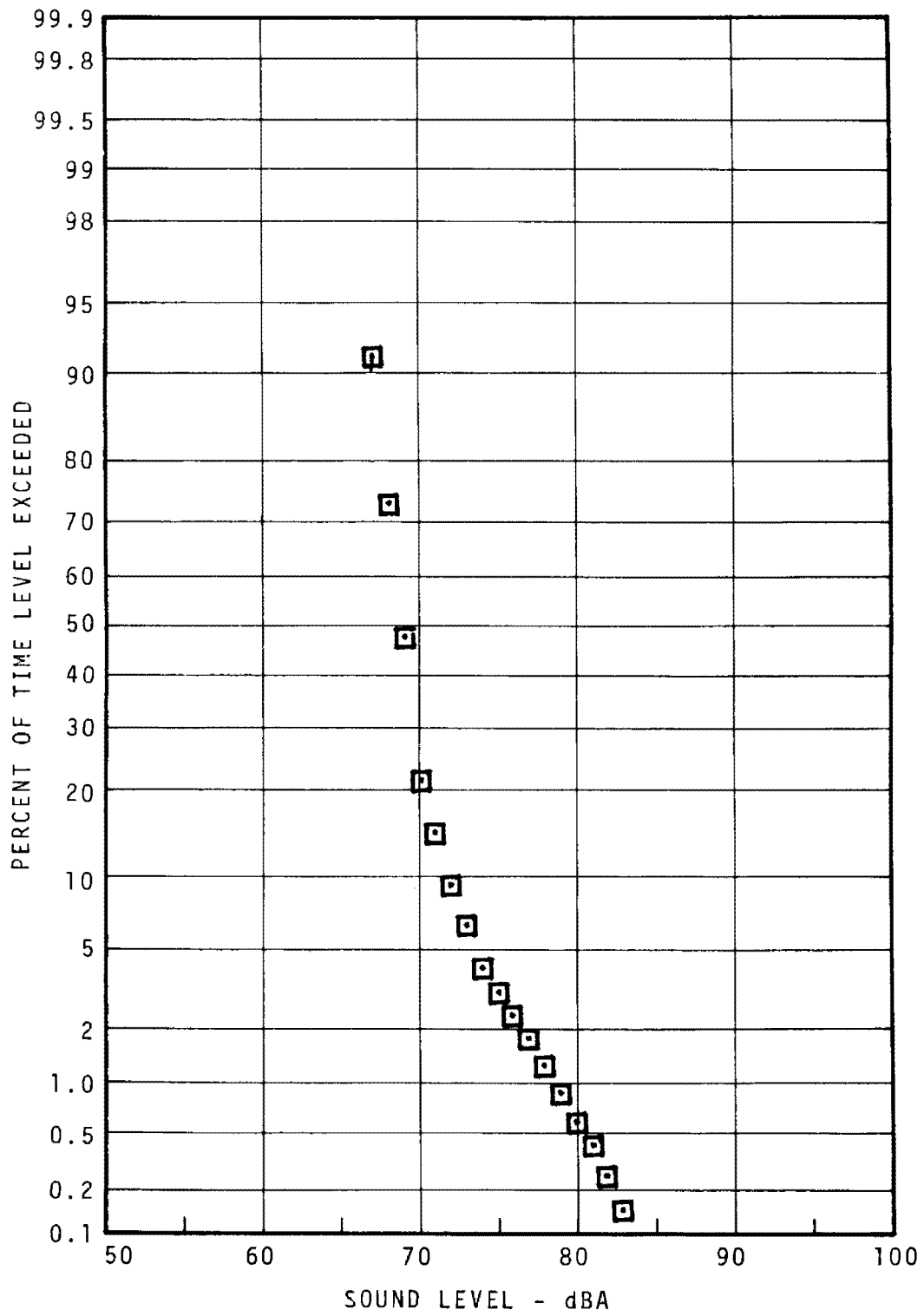

FIGURE 7.42 - 69TH ST. STATION PLATFORM
 STATISTICAL DISTRIBUTION -
 NIGHT

7-69

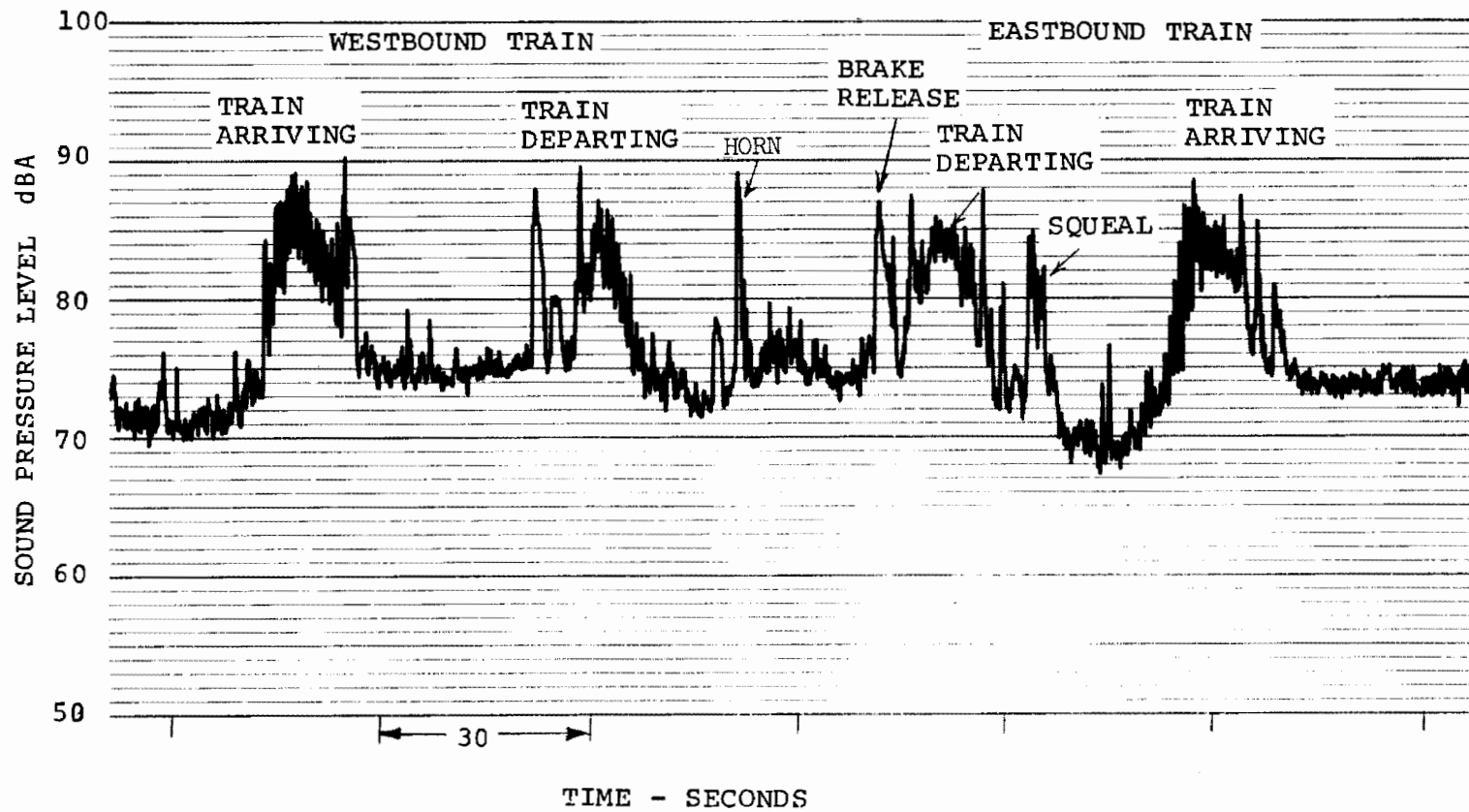

FIGURE 7.43 - TYPICAL TIME HISTORY, 69TH ST. STATION, DAYTIME

MILLBOURNE STATION PLATFORM

SITE DESCRIPTION (see Figure 7.44)

Millbourne Station is located on grade near the western end of the line. The south side of the right-of-way is above track grade and the north side below grade level. A walkway to nearby streets is located several feet below platform level on the south side of the track. The east and westbound platforms are connected by a single overhead walkway. East of the station the right-of-way becomes elevated on steel structure and forms an "S" curve to align with Market Street. West of the station, the line curves into the 69th Street Terminal area.

NOISE CLIMATE (see Table 7.10, Figures 7.45 - 7.49)

Trains approaching the station from both directions screech as they negotiate the curves, the westbound approach being the more noticeable. The noise arising from cars on a department store parking lot on the north side of the track, and traffic on Market Street also contribute to background levels. Measurements on the station platform were at the maximum width of the platform, 1.2m and the resulting levels were approximately 4 dBA higher than if measured at 2m. The number of trains during the rush hour sample was 25 compared with the nighttime sample of 7 trains. Both samples were 30 minutes in length and the latter included several passbys of a worktrain and a trash collection train.

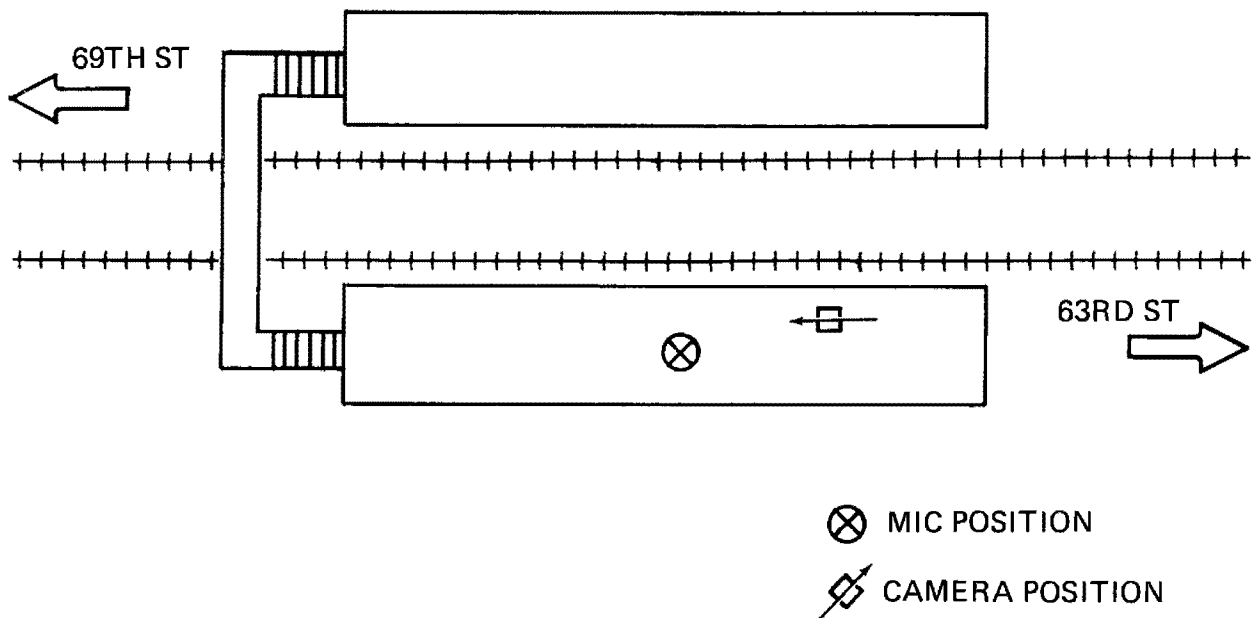

FIGURE 7.44 - MILLBOURNE STATION PLATFORM. ON GRADE

TABLE 7.10 - SUMMARY OF MEASUREMENT RESULTS FOR MILLBOURNE STATION PLATFORM

TIME	MIC POSITION	SAMPLE TIME	TRAIN CONDITIONS	UNITS	AVG MAX LEVEL		AVG L _R		CUMULATIVE AMPLITUDE DISTRIBUTION					L _{eq}
					NEAR	FAR	NEAR	FAR	L99	L90	L50	L10	L1	
Day	Center of Stopped Train	30 min	Arrival	b) N	4-6	4-6	4-6	4-6	48	49	50	69	79	67
				dBA	80	80	87	88						
				c) S	1.26	2.04	0.94	2.43						
			Departure	N	4-6	4-6	4-6	4-6						
				dBA	78	80	84	89						
				S	0.29	0.75	2.30	1.17						
Rush	1.2 m from Edge of Near Track	Arrival and Departure	dBA					66	66	69	88	95	83	
Evening			dBA					68	68	69	73	87	74	
Night			dBA					61	61	62	67	79	67	
Notes: a - Track b - Number of Trains - (e.g.: 4-2 means four 2-car trains) c - Standard Deviation of Level														

7-72

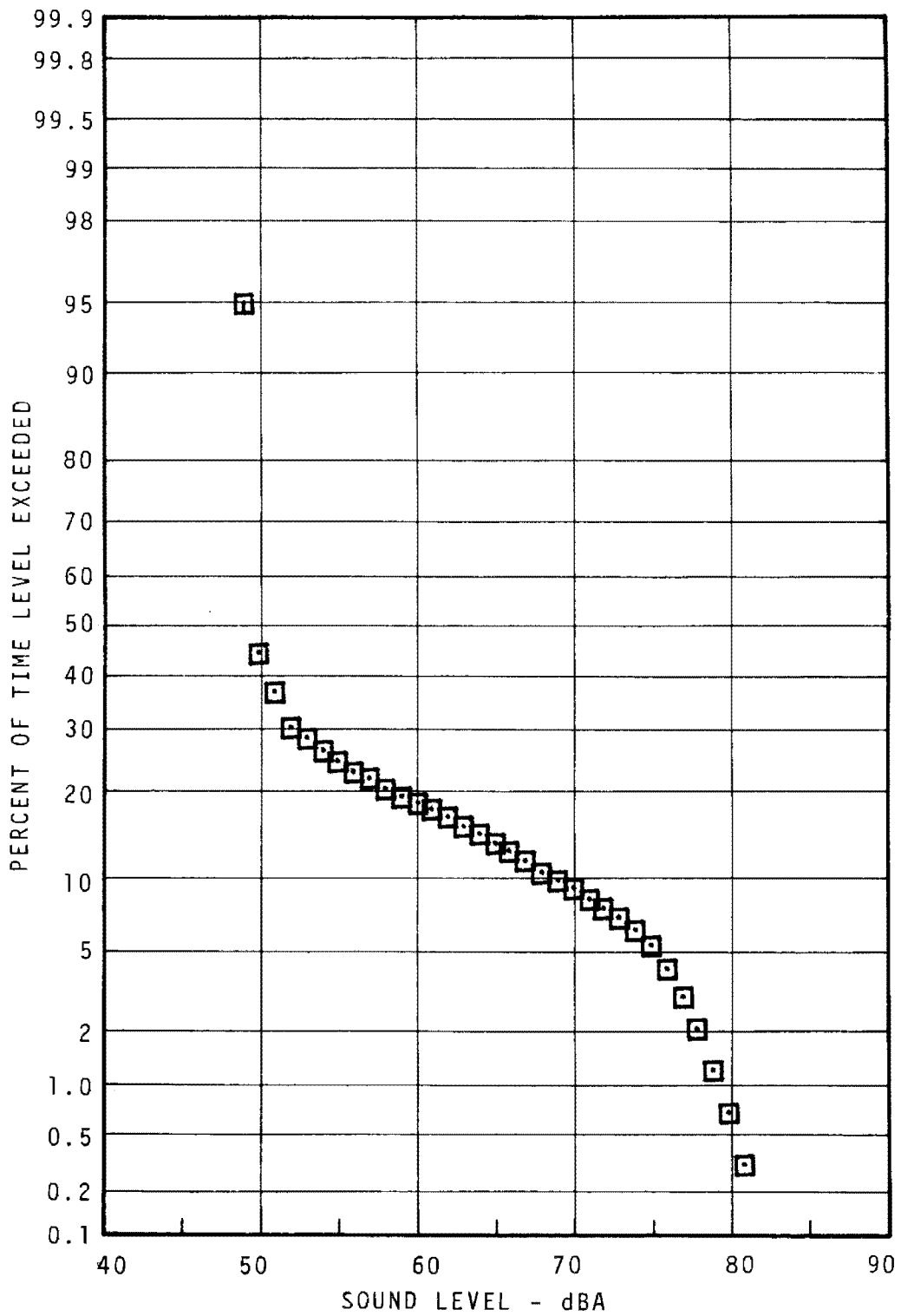

FIGURE 7.45 - MILLBOURNE STATION PLATFORM
 STATISTICAL DISTRIBUTION -
 DAYTIME

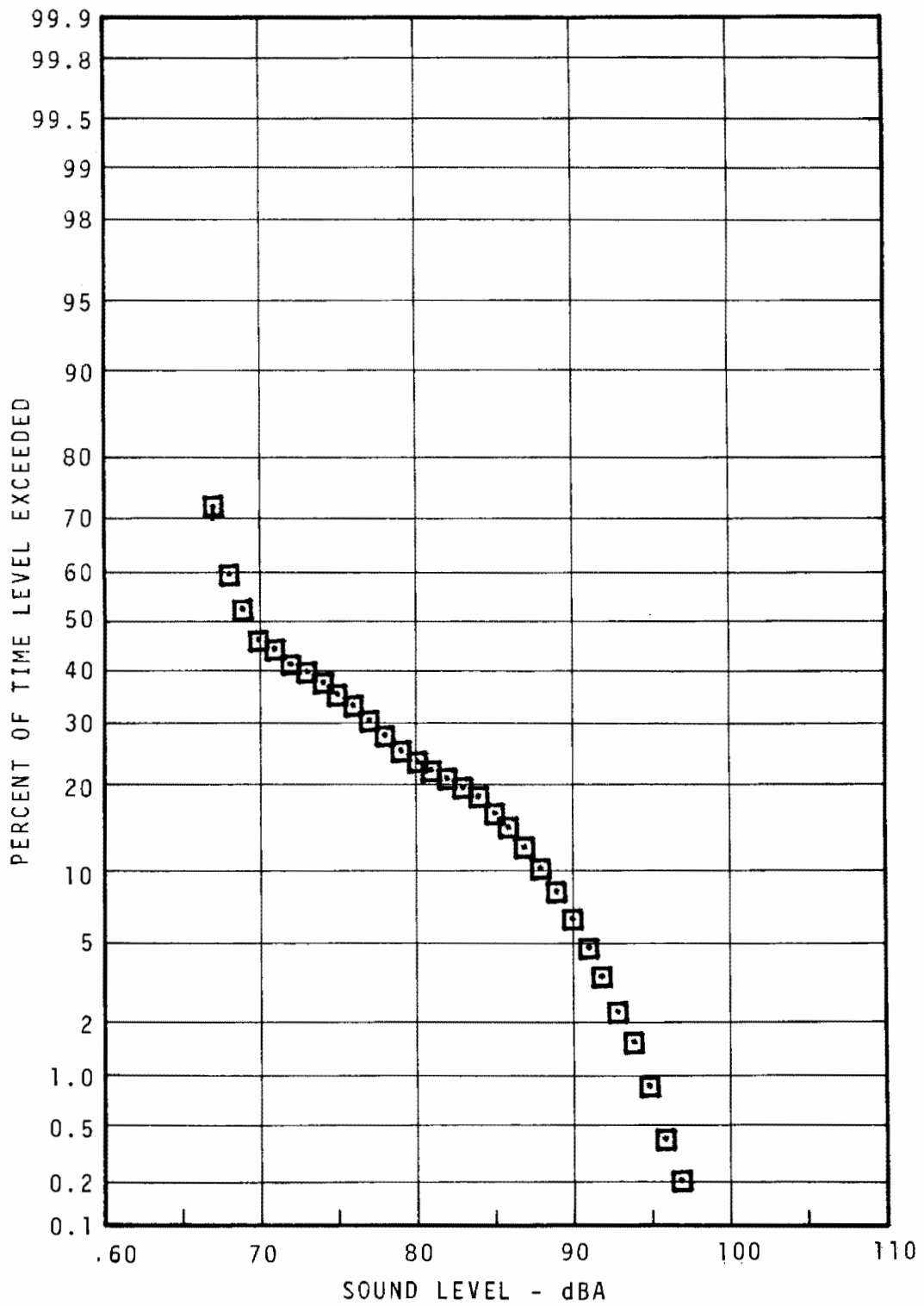

FIGURE 7.46 - MILLBOURNE STATION PLATFORM
 STATISTICAL DISTRIBUTION -
 RUSH HOUR

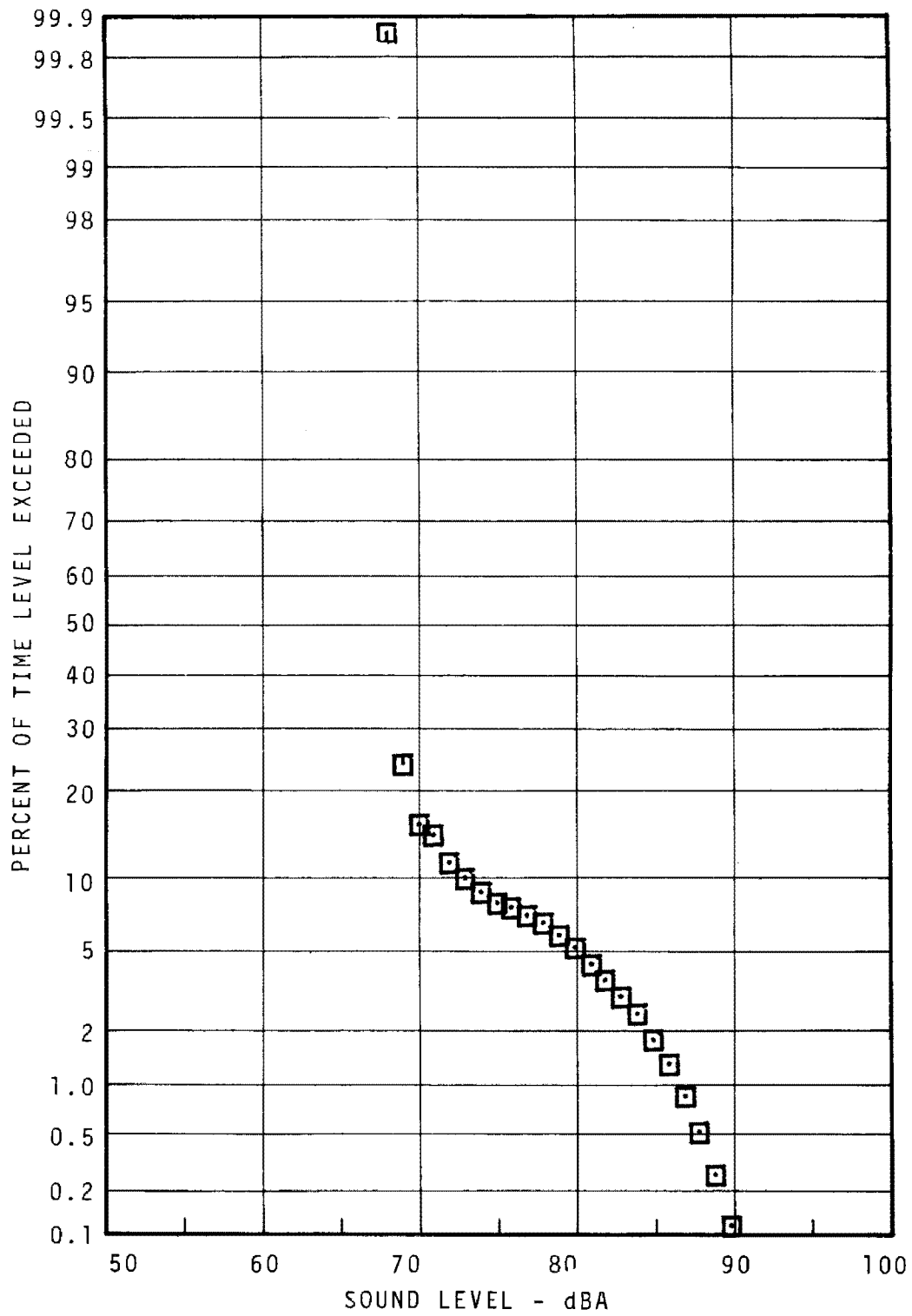

FIGURE 7.47 - MILLBOURNE STATION PLATFORM
 STATISTICAL DISTRIBUTION -
 EVENING

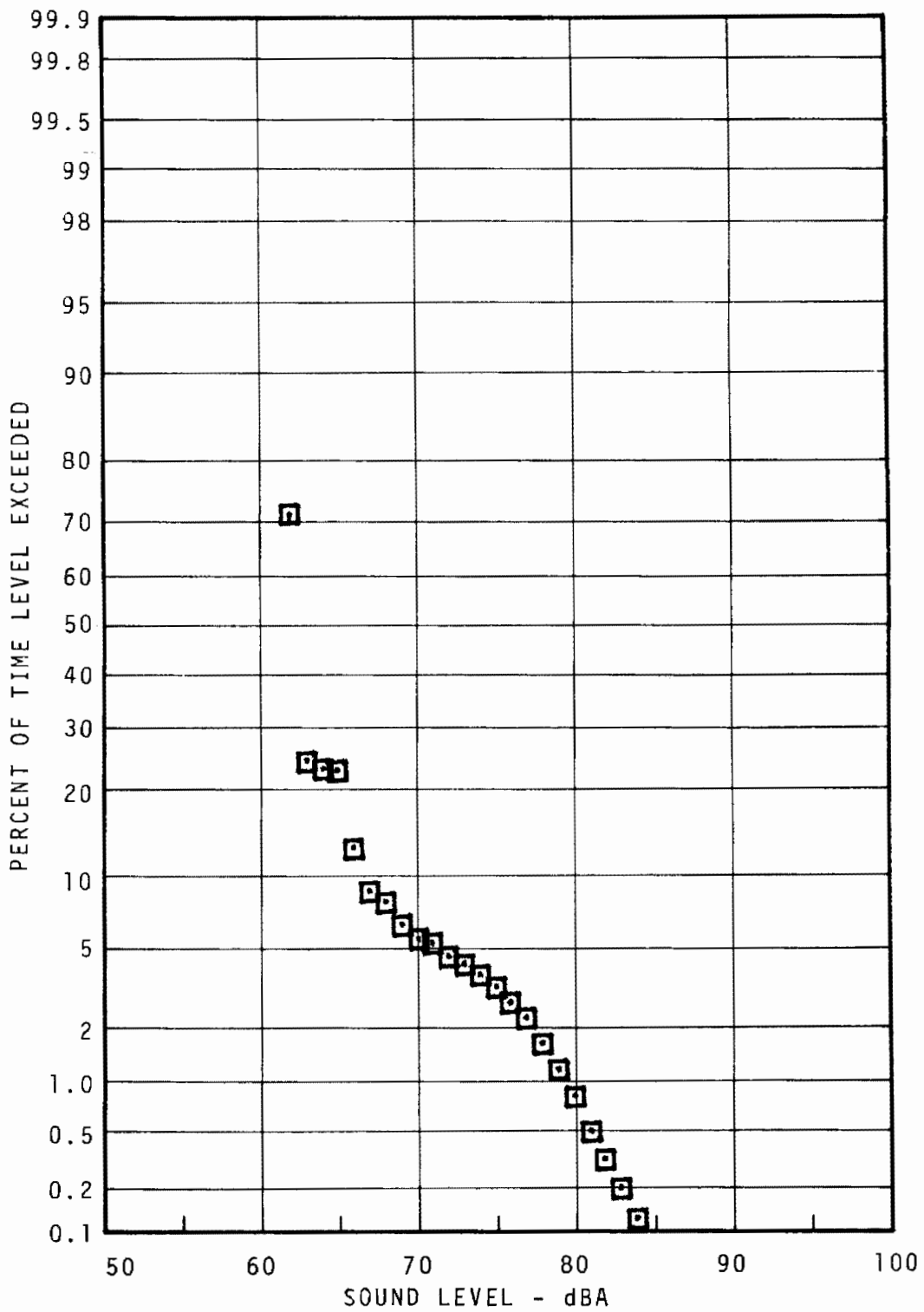

FIGURE 7.48 - MILLBOURNE STATION PLATFORM
 STATISTICAL DISTRIBUTION -
 NIGHT

7-77

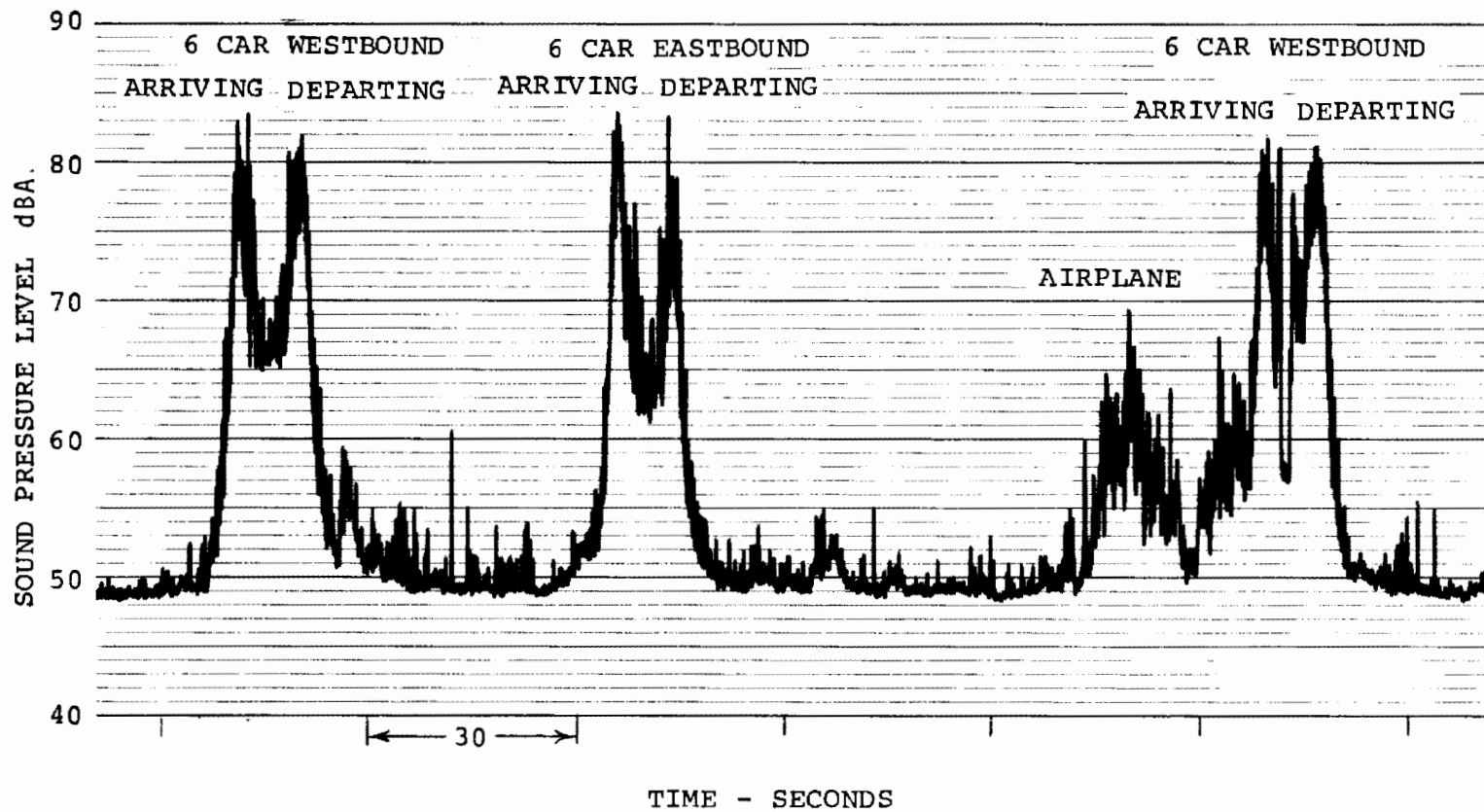

FIGURE 7.49 - TYPICAL TIME HISTORY, MILLBOURNE STATION

52ND STREET STATION PLATFORM

SITE DESCRIPTION (see Figure 7.50)

The station platform at 52nd Street is located above an active business-commercial region in West Philadelphia. The track is up grade westbound both approaching and departing from the station platform. Rail is welded on the westbound track from 46th Street to 52nd Street and jointed west of the station. On the eastbound track, rail is welded approaching the station and jointed east of the platform. Some rail gaps of 3/4 in. were noted and vertical misalignment is occasionally of the same magnitude. Entrance to and exit from the platform is near the center of the platform, and the cashier's booth is located on a crossover below station level, but above the street.

NOISE CLIMATE (see Table 7.11, Figures 7.51 - 7.55)

Where jointed rail exists, the impact noise which results is very noticeable. Even when other noise sources on the car become inaudible with distance, rail joint noise can be heard. With a train standing at the station, brake air compressor and door operation noise is audible, and propulsion system noise (gearbox) predominates as the car accelerates. Substantial traffic noise, sirens, loud public address systems and so forth, create the background noise heard at platform level.

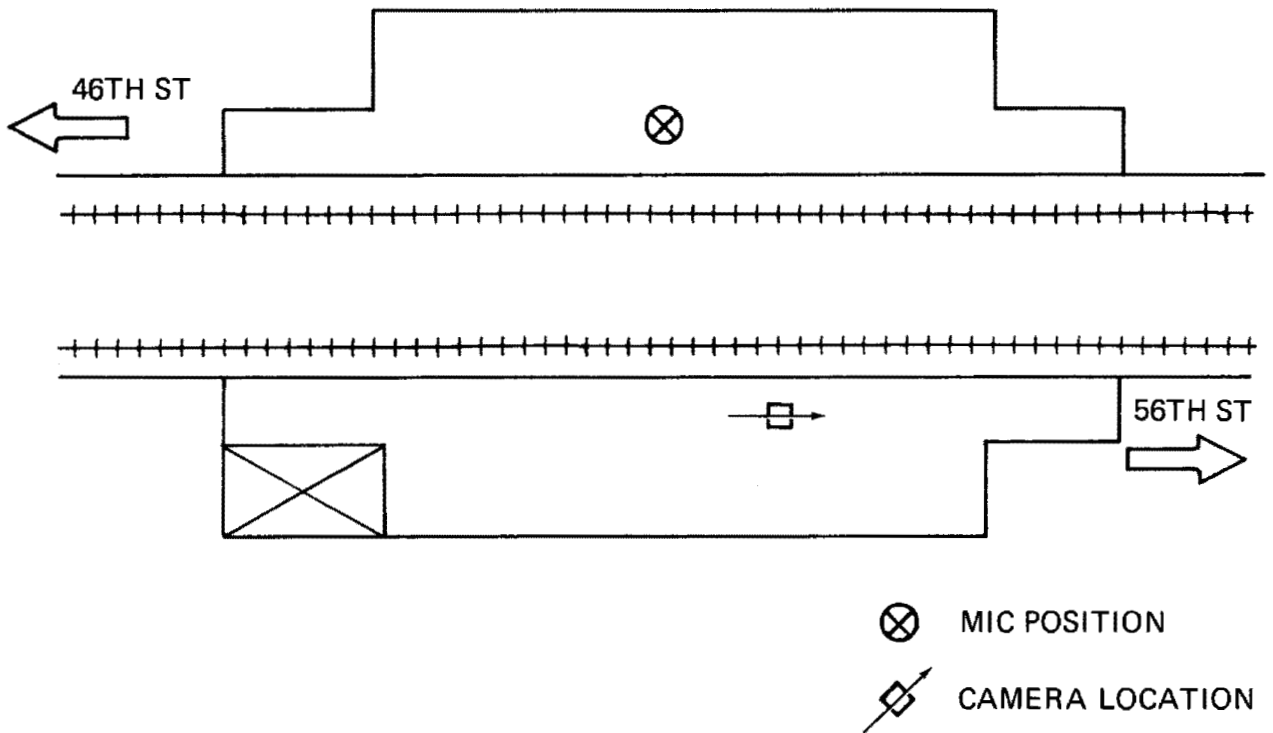

FIGURE 7.50 - 52ND ST. ELEVATED STATION PLATFORM

TABLE 7.11 - SUMMARY OF MEASUREMENT RESULTS FOR 52ND ST. STATION PLATFORM

TIME	MIC POSITION	SAMPLE TIME	TRAIN CONDITIONS	UNITS	AVG MAX LEVEL		AVG LR		CUMULATIVE AMPLITUDE DISTRIBUTION					Leq
					NEAR	FAR	NEAR	FAR	L99	L90	L50	L10	L1	
Day	Center of Stopped Train	30 min	Arrival	b) N	4-6	6-6	4-6	6-6	66	67	69	76	86	75
				dBa	87	86	95	94						
			Departure	c) S	1.44	2.14	1.72	1.04						
				N	4-6	6-6	4-6	6-6						
				dBa	86	85	94	93						
				S	2.10	2.60	1.76	1.95						
Rush	Arrival and Departure	dBa					61	63	70	82	88	77		
Evening		dBa					68	69	71	81	90	78		
Night		dBa					62	62	63	64	79	67		

Notes: a - Track
 b - Number of Trains - (e.g.: 4-2 means four 2-car trains)
 c - Standard Deviation of Level

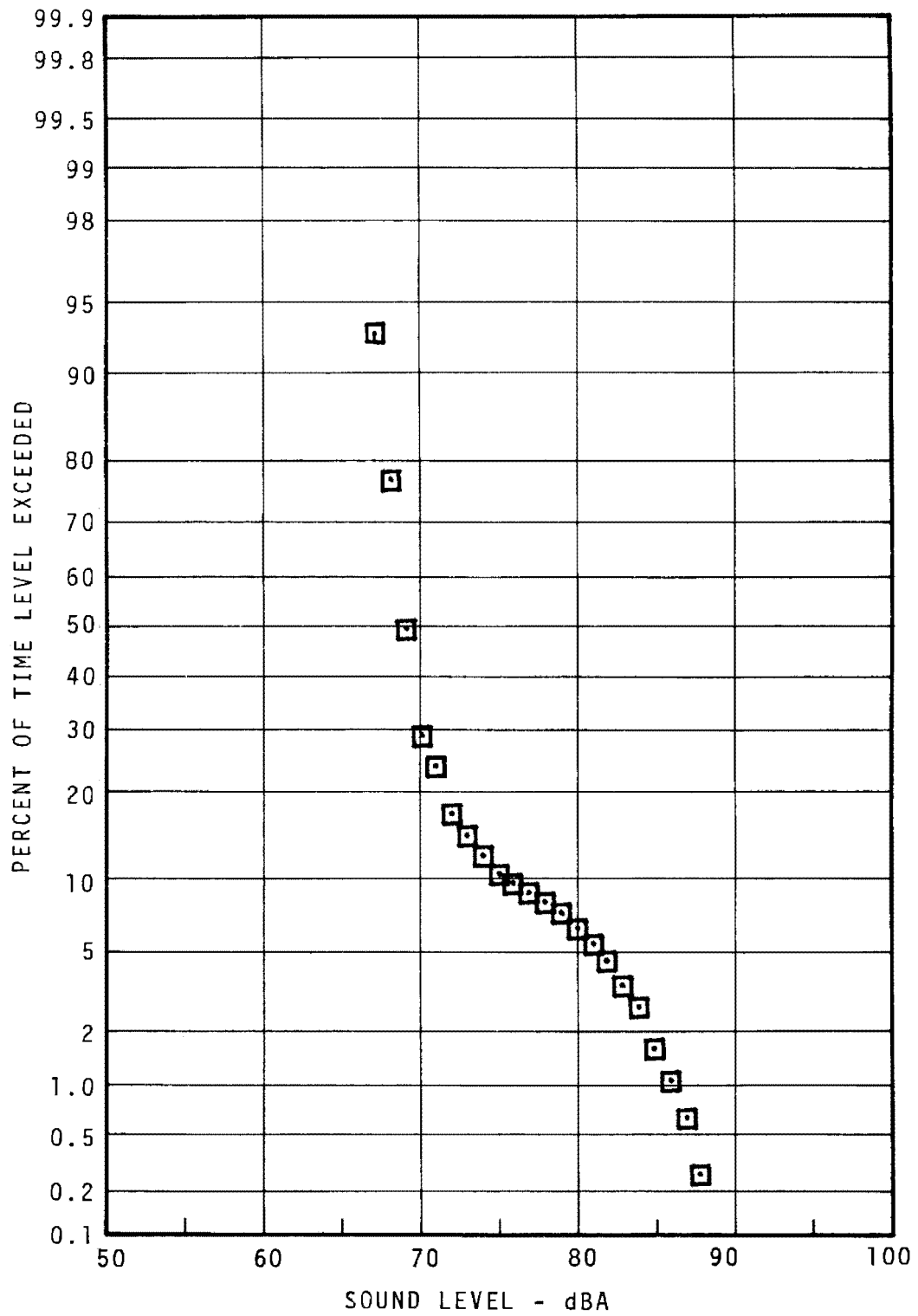

FIGURE 7.51 - 52ND STREET STATION PLATFORM
 STATISTICAL DISTRIBUTION -
 DAYTIME

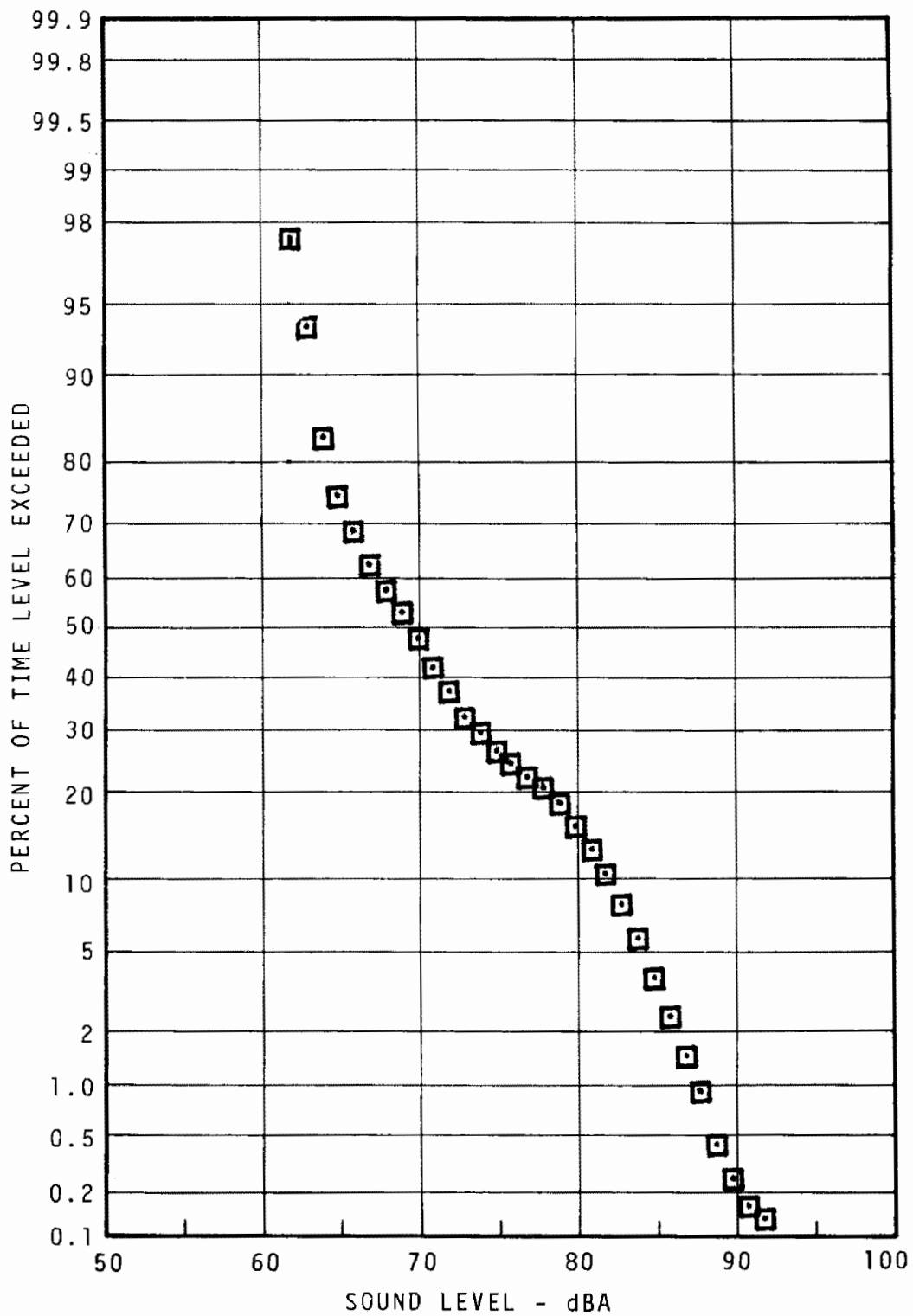

FIGURE 7.52 - 52ND STREET STATION PLATFORM
 STATISTICAL DISTRIBUTION -
 RUSH HOUR

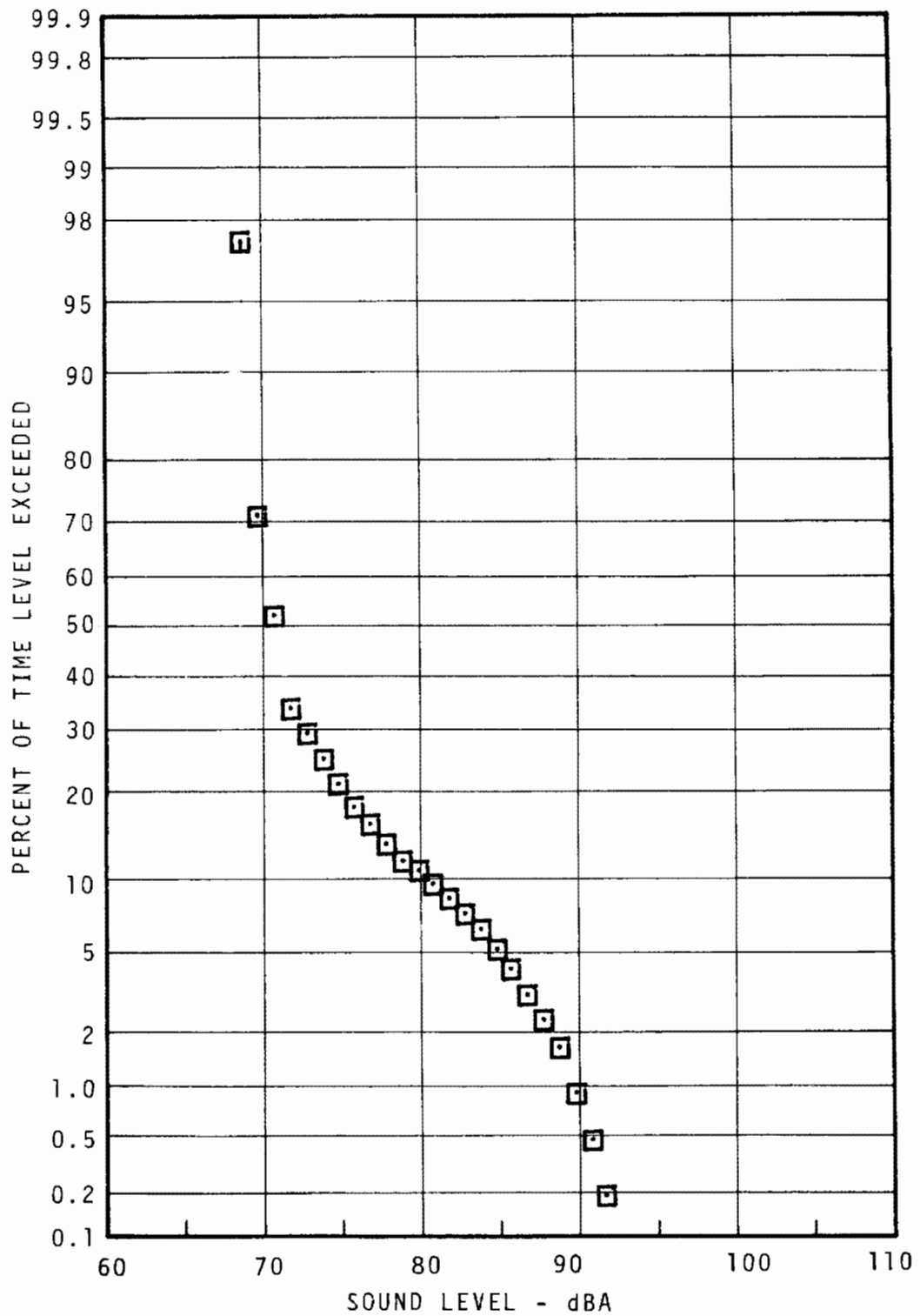

FIGURE 7.53 - 52ND STREET STATION PLATFORM
 STATISTICAL DISTRIBUTION -
 EVENING

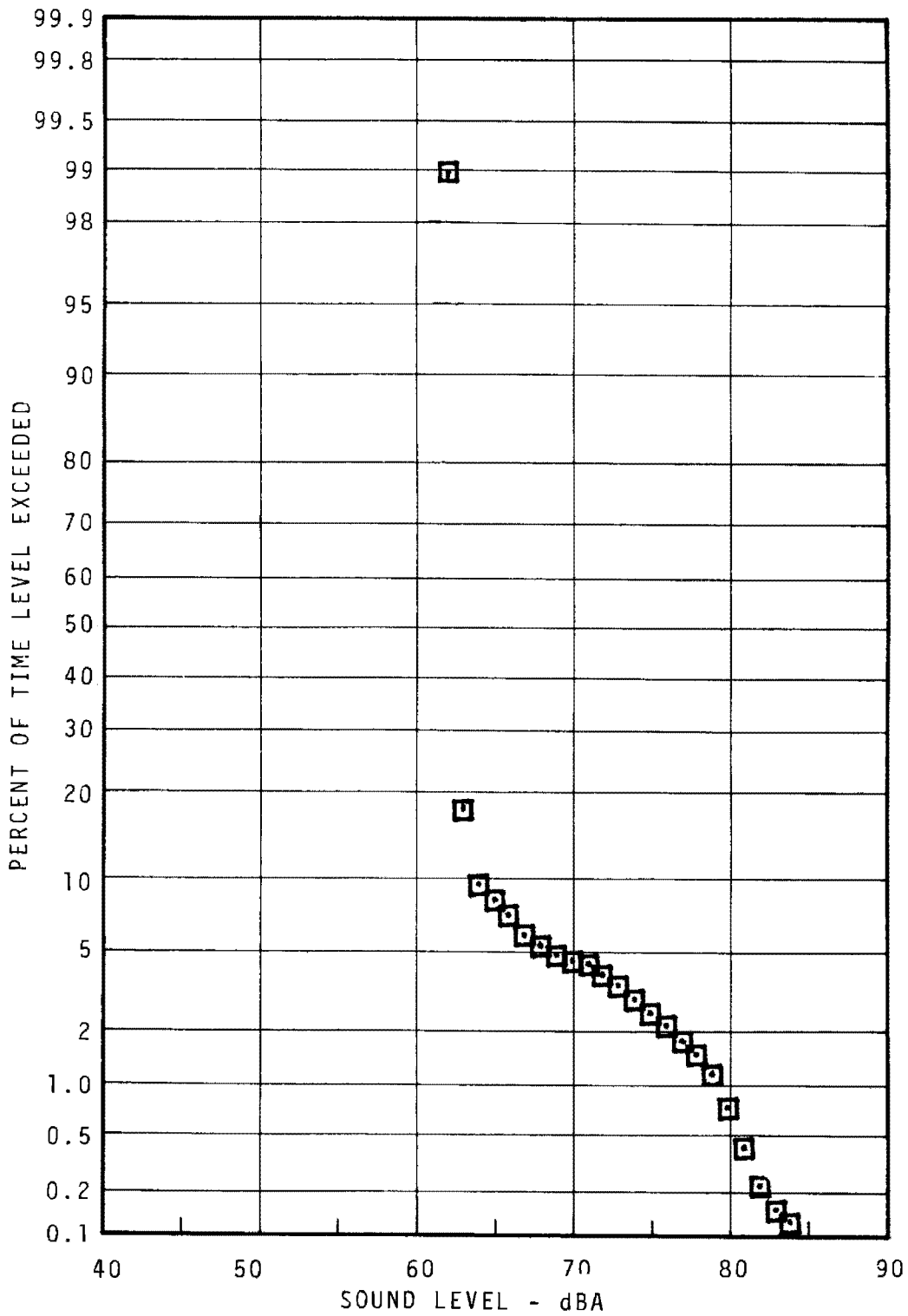

FIGURE 7.54 - 52ND STREET STATION PLATFORM
 STATISTICAL DISTRIBUTION -
 NIGHT

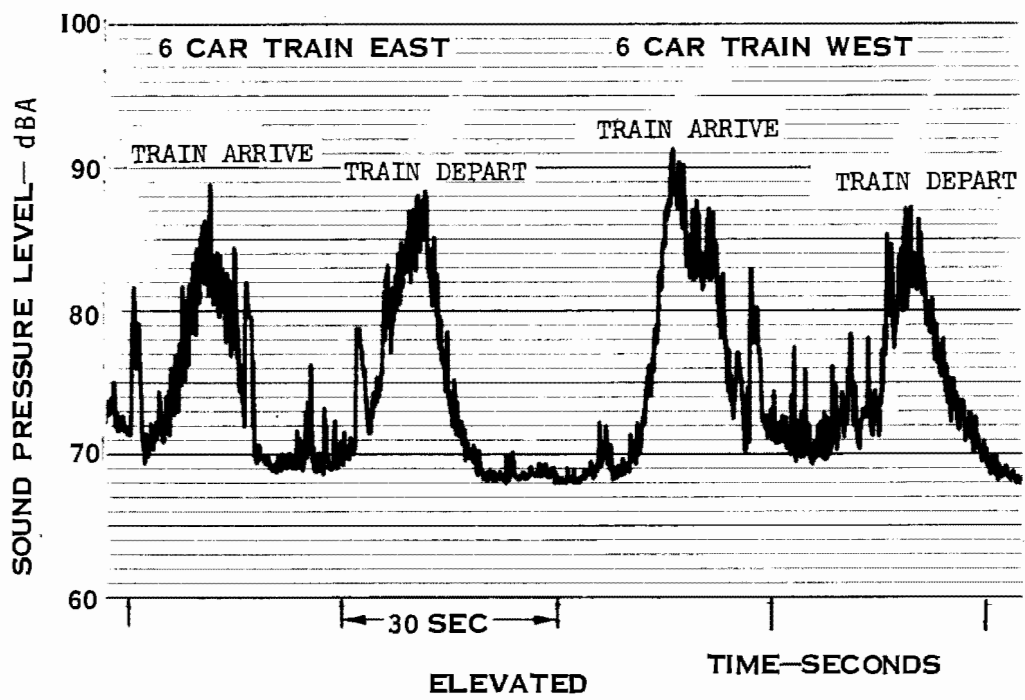

FIGURE 7.55—TYPICAL TIME HISTORY 52ND ST. STATION
 CENTER PLATFORM MARKET FRANKFORD ELEVATED LINE

40TH STREET STATION

SITE DESCRIPTION (see Figure 7.56)

40th Street is a two-track, side platform subway station. Unlike 30th Street and 34th Street, the cashier's booth is at track level and exit is obtained through side stairs directly to street level without a mezzanine.

NOISE CLIMATE (see Table 7.12, Figures 7.57 - 7.58)

The noise climate is essentially similar to other side platform stations located underground in the system. The L50 to L99 levels at 40th Street are approximately 3 dBA greater than those at 34th Street. Compared with 5th Street, 40th Street levels are similar except between L20 and L50 where the data at 5th Street is as much as 8 dBA greater.

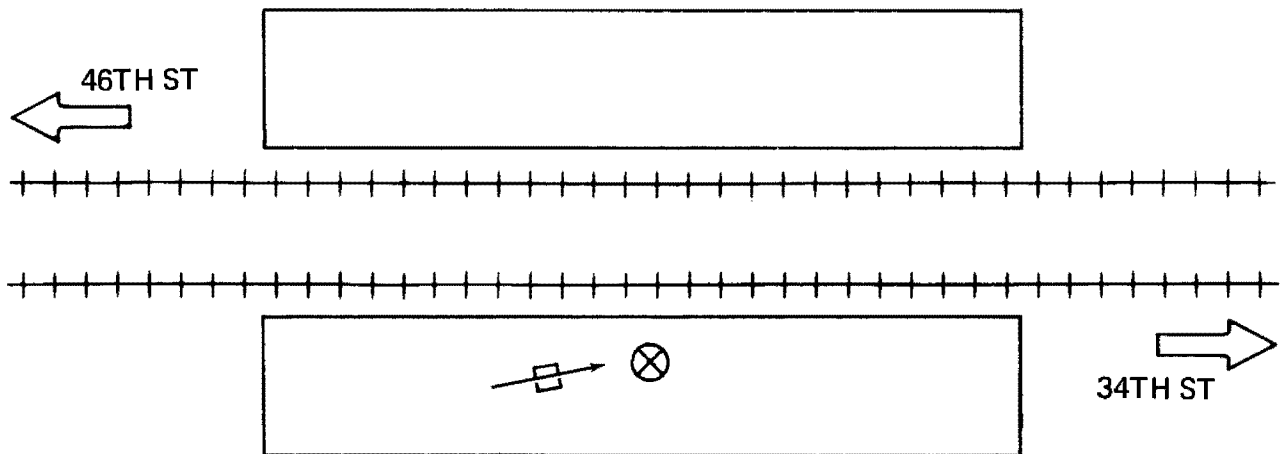

⊗ MIC POSITION

↗ CAMERA LOCATION

FIGURE 7.56 - 40TH ST. SUBWAY STATION PLATFORM

TABLE 7.12 - SUMMARY OF MEASUREMENT RESULTS FOR 40TH ST. STATION PLATFORM

TIME	MIC POSITION	SAMPLE TIME	TRAIN CONDITIONS	UNITS	AVG MAX LEVEL		AVG LR		CUMULATIVE AMPLITUDE DISTRIBUTION					Leq
					NEAR	FAR	NEAR	FAR	L99	L90	L50	L10	L1	
Day	Center of Stopped Train	30 min	Arrival	b) N	4-6	4-6	3-6	4-6	67	67	68	91	99	87
				dBa	100	96	108	106						
				c) S	1.19	3.12	0.81	2.43						
			Departure	N	4-6	4-6	4-6	4-6						
				dBa	92	100	103	108						
				S	0.96	1.55	1.32	1.08						
			Pass Through	N	1-6		1-6							
				dBa	104		111							
				S	-		-							

7-88

Notes: a - Track
 b - Number of Trains - (e.g.: 4-2 means four 2-car trains)
 c - Standard Deviation of Level

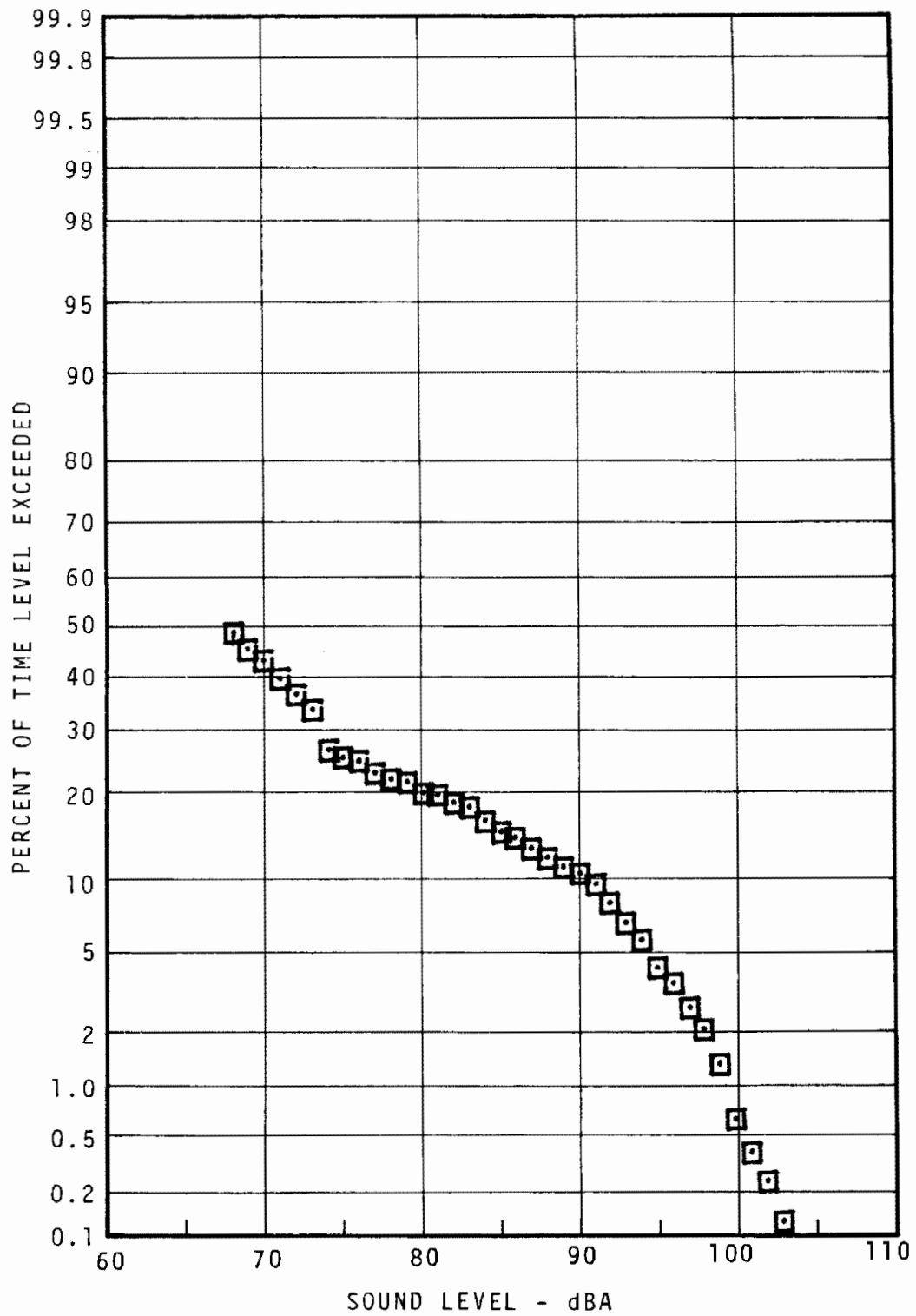

FIGURE 7.57 - 40TH STREET STATION PLATFORM
 STATISTICAL DISTRIBUTION -
 DAYTIME

7-90/7-91

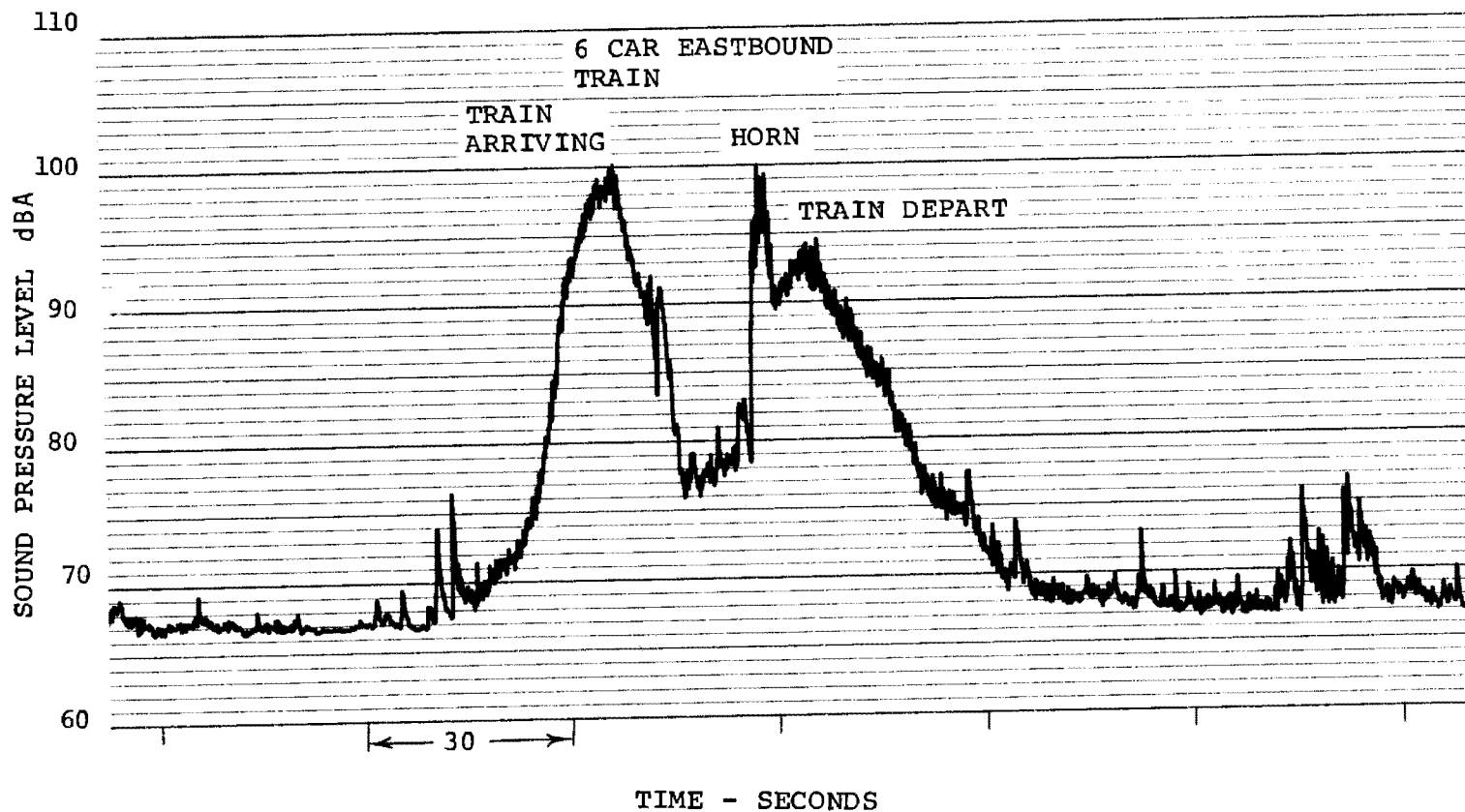
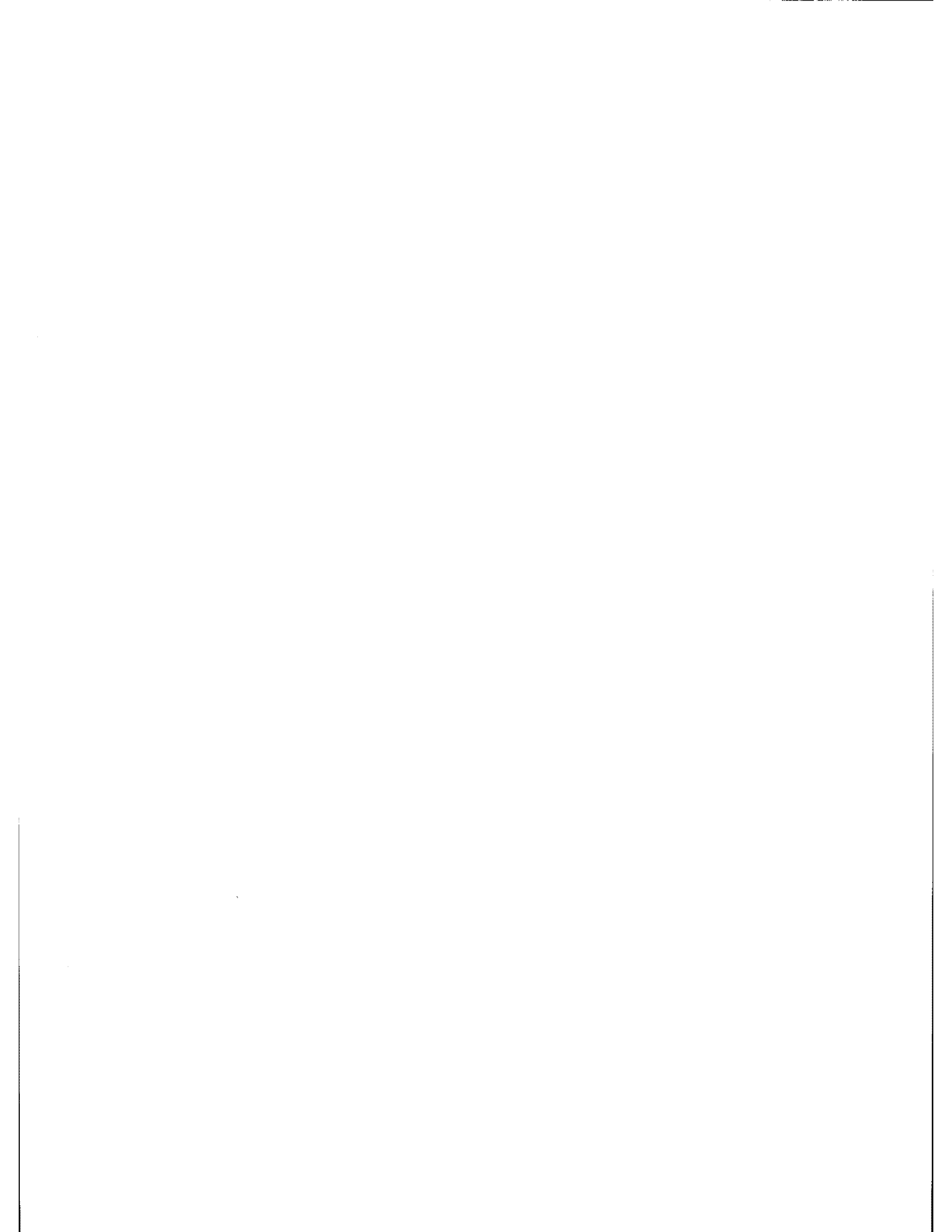

FIGURE 7.58 - TYPICAL TIME HISTORY, 40TH ST. STATION



34TH STREET STATION

SITE DESCRIPTION (see Figure 7.59)

The 34th Street Station is similar to 30th Street except that there is no interchange with the subway-surface system and a compressor is located at one end of the station platform.

NOISE CLIMATE (see Table 7.13, Figures 7.60 - 7.61)

As suggested by the differences noted above, the subway surface car noise is absent and a compressor is audible at the end of the station platform. Other noise characteristics at this station are similar.

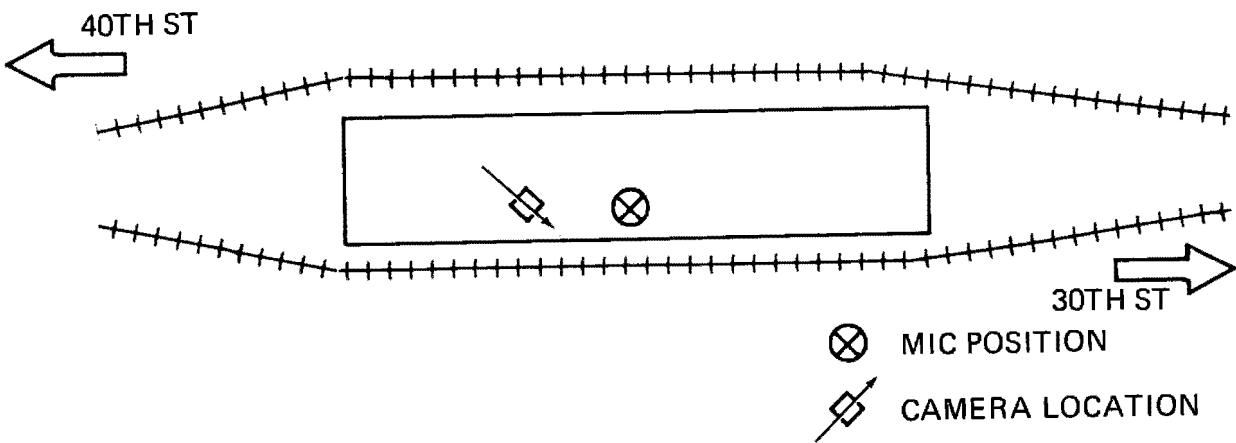
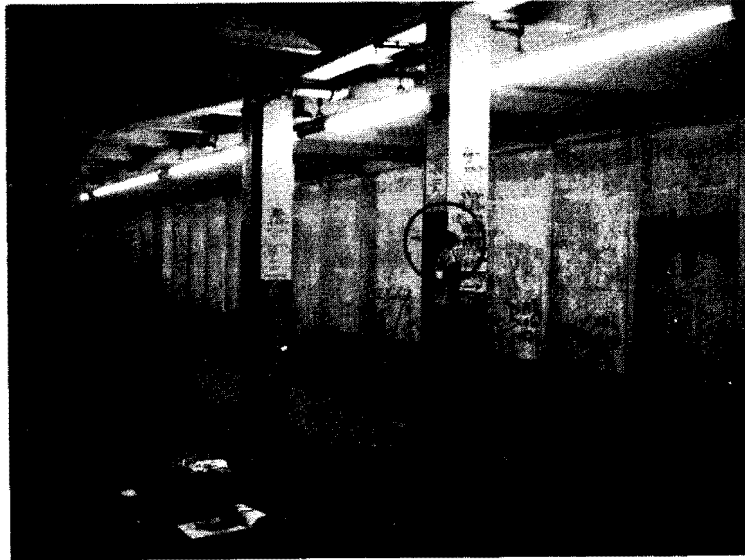

FIGURE 7.59 - 34TH ST. SUBWAY STATION PLATFORM

TABLE 7.13-SUMMARY OF MEASUREMENT RESULTS FOR 34TH ST. STATION PLATFORM

TIME	MIC POSITION	SAMPLE TIME	TRAIN CONDITIONS	UNITS	AVG MAX LEVEL		AVG L _R		CUMULATIVE AMPLITUDE DISTRIBUTION					Leq
					NEAR	FAR	NEAR	FAR	L99	L90	L50	L10	L1	
Day	Center of Stopped Train	30 min	Arrival	b) N	4-6	4-6	4-6	4-6	63	63	65	90	99	87
				dBa	99	97	108	106						
			Departure	c) S	1.65	2.35	1.22	1.47						
				N	4-6	4-6	4-6	4-6						
				dBa	98	99	107	108						
				S	2.38	1.04	2.21	1.24						
Notes: a - Track b - Number of Trains - (e.g.: 4-2 means four 2-car trains) c - Standard Deviation of Level														

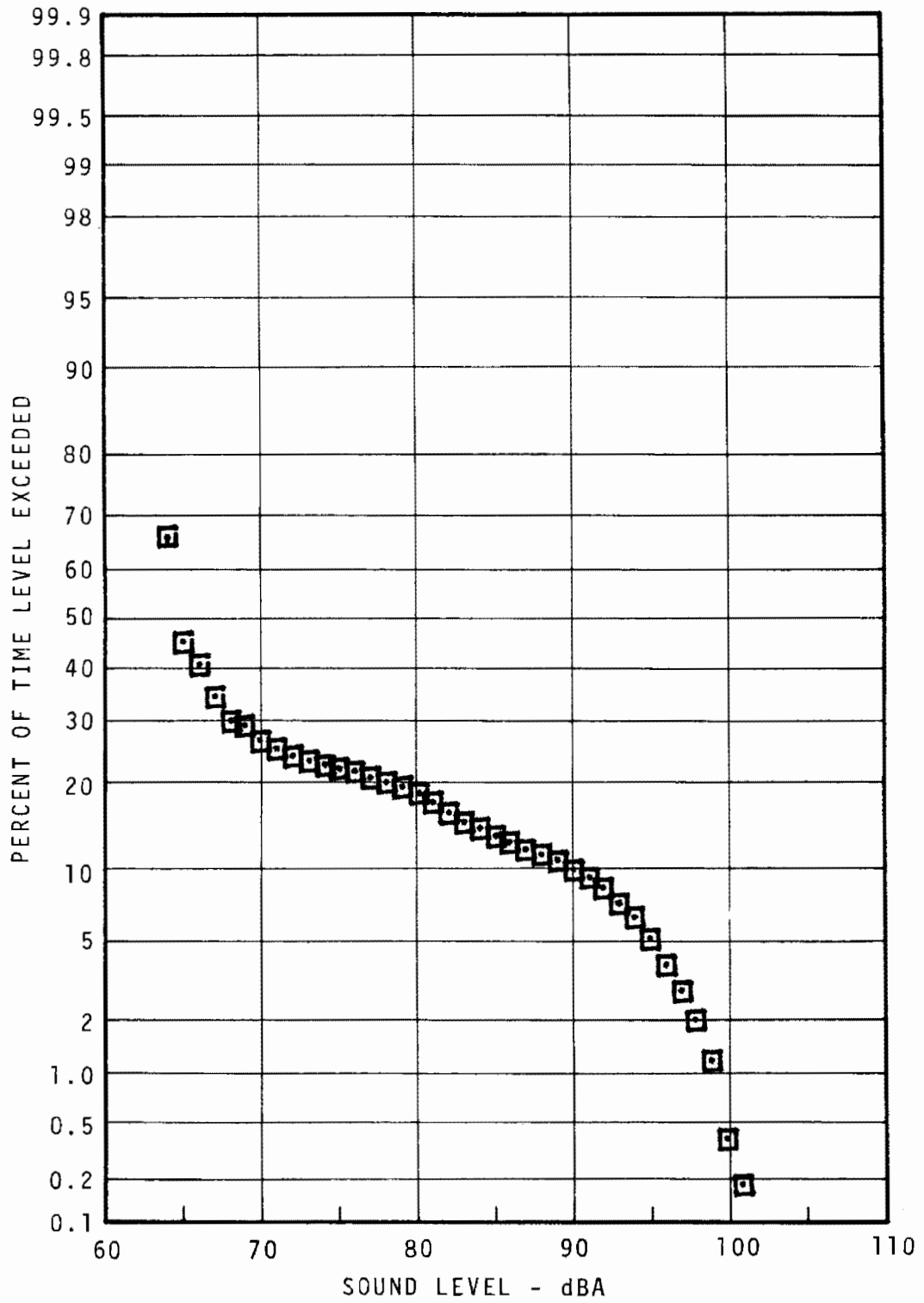

FIGURE 7.60 - 34TH STREET STATION PLATFORM
 STATISTICAL DISTRIBUTION -
 DAYTIME

7-96/7-97

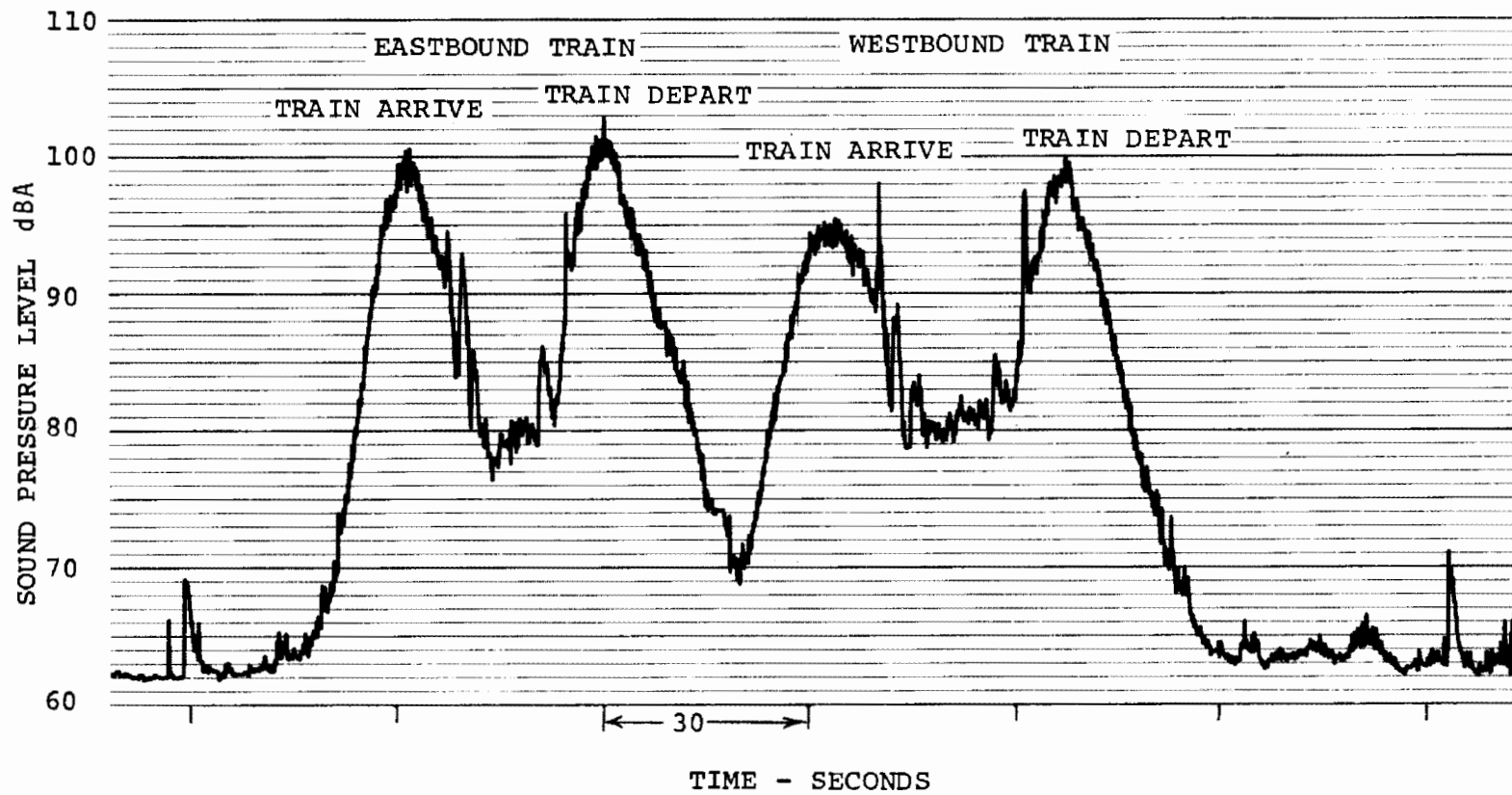
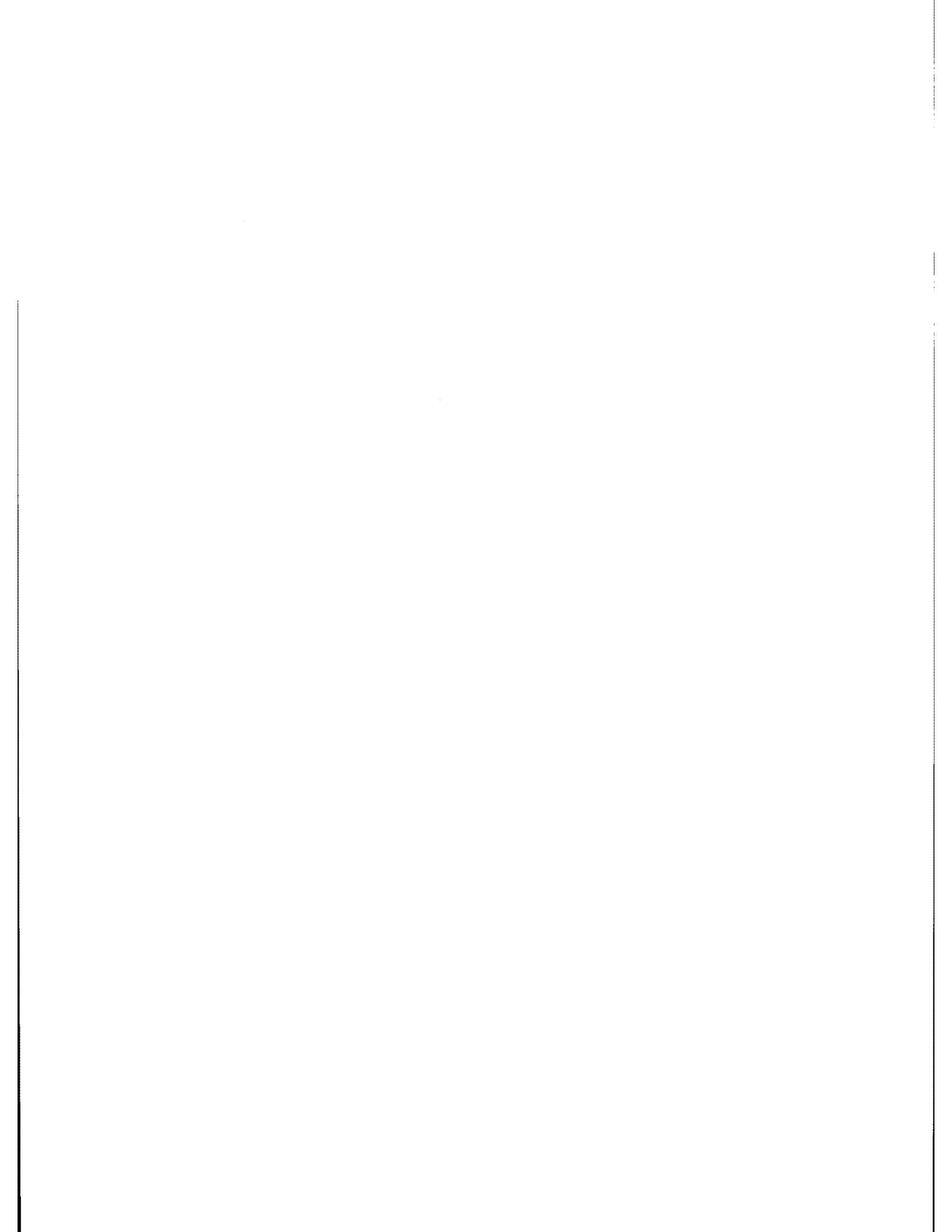

FIGURE 7.61 - TYPICAL TIME HISTORY, 34TH ST. STATION



30TH STREET STATION PLATFORM

SITE DESCRIPTION (see Figure 7.62)

30th Street is an island platform station and is an interchange station for subway-surface (PCC) cars as well as the Penn Central Railroad. The station platform level for the subway-surface cars is at rail level and connections between the two systems is by an overhead stairway. Above platform level is a mezzanine where the cashier's booth is located and entrance to the subway-surface system and exit to street level is obtained.

NOISE CLIMATE (see Table 7.14, Figures 7.63 - 7.67)

Noise levels at 30th Street Station have approximately the same values of $L_5 - L_{0.1}$ as other subway stations, but the statistical quantities between L_5 and L_{99} are frequently 10 dBA greater at 30th Street. The subway-surface operation at relatively high speeds into and out of the station is the major contributor to these higher levels. The PCC cars operate at frequent intervals at this location and passengers on the Market-Frankford platform are exposed to the passby noise of several PCC cars while waiting to board a Market-Frankford Line car. Overhead on the mezzanine, patrons are exposed to noise levels which are little attenuated over those at platform level, and reverberation times, while not measured, are relatively long.

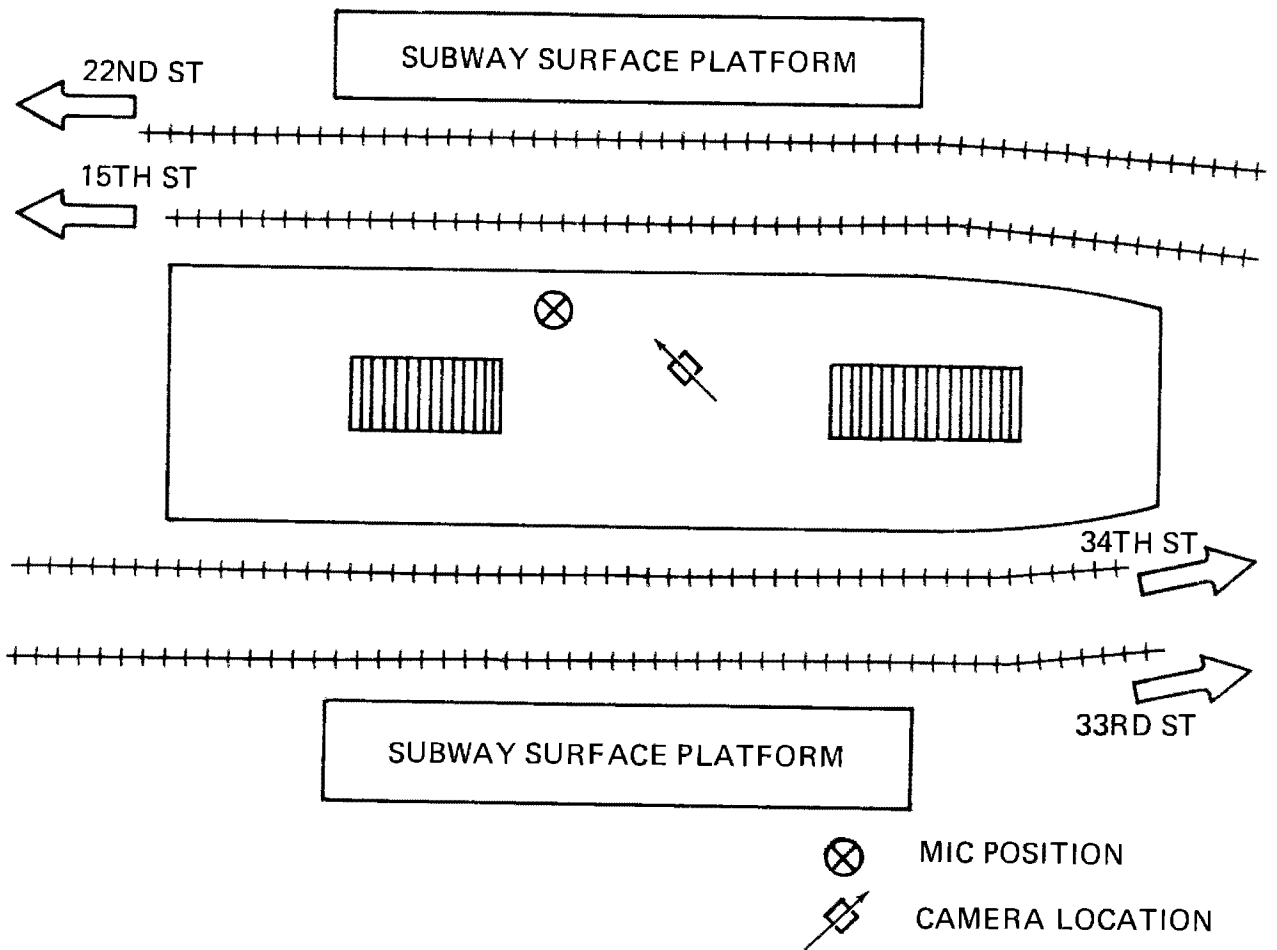

FIGURE 7.62 - 30TH ST. SUBWAY STATION PLATFORM

TABLE 7.14 - SUMMARY OF MEASUREMENT RESULTS FOR 30TH ST. STATION PLATFORM

TIME	MIC POSITION	SAMPLE TIME	TRAIN CONDITIONS	UNITS	AVG MAX LEVEL		AVG LR		CUMULATIVE AMPLITUDE DISTRIBUTION					Leq
					NEAR	FAR	NEAR	FAR	L99	L90	L50	L10	L1	
Day	Center of Stopped Train	30 min	Arrival	N	4-6	4-6	4-6	4-6	63	64	75	92	99	88
				dBa	99	100	108	109						
				S	3.33	1.78	2.24	1.93						
			Departure	N	2-6	2-6	2-6	2-6						
				dBa	93	94	104	104						
				S	1.41	3.18	1.27	0.92						
Rush	Arrival and Departure	dBa					66	74	84	91	94	87		
Evening		dBa					66	68	75	92	101	88		
Night		dBa					66	66	69	87	97	84		
Notes: a - Track b - Number of Trains - (e.g.: 4-2 means four 2-car trains) c - Standard Deviation of Level														

7-100

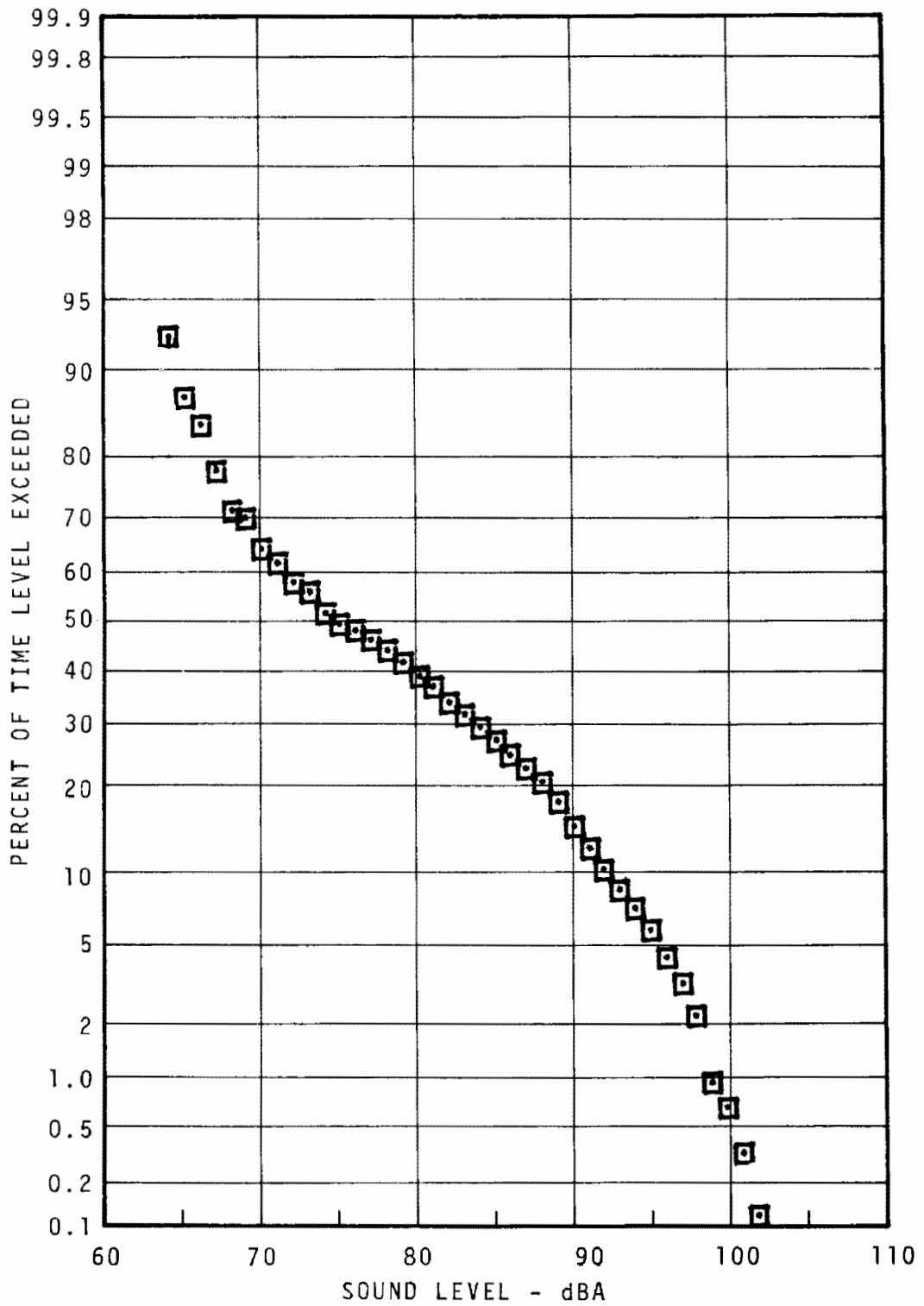

FIGURE 7.63 - 30TH STREET STATION PLATFORM
 STATISTICAL DISTRIBUTION -
 DAYTIME

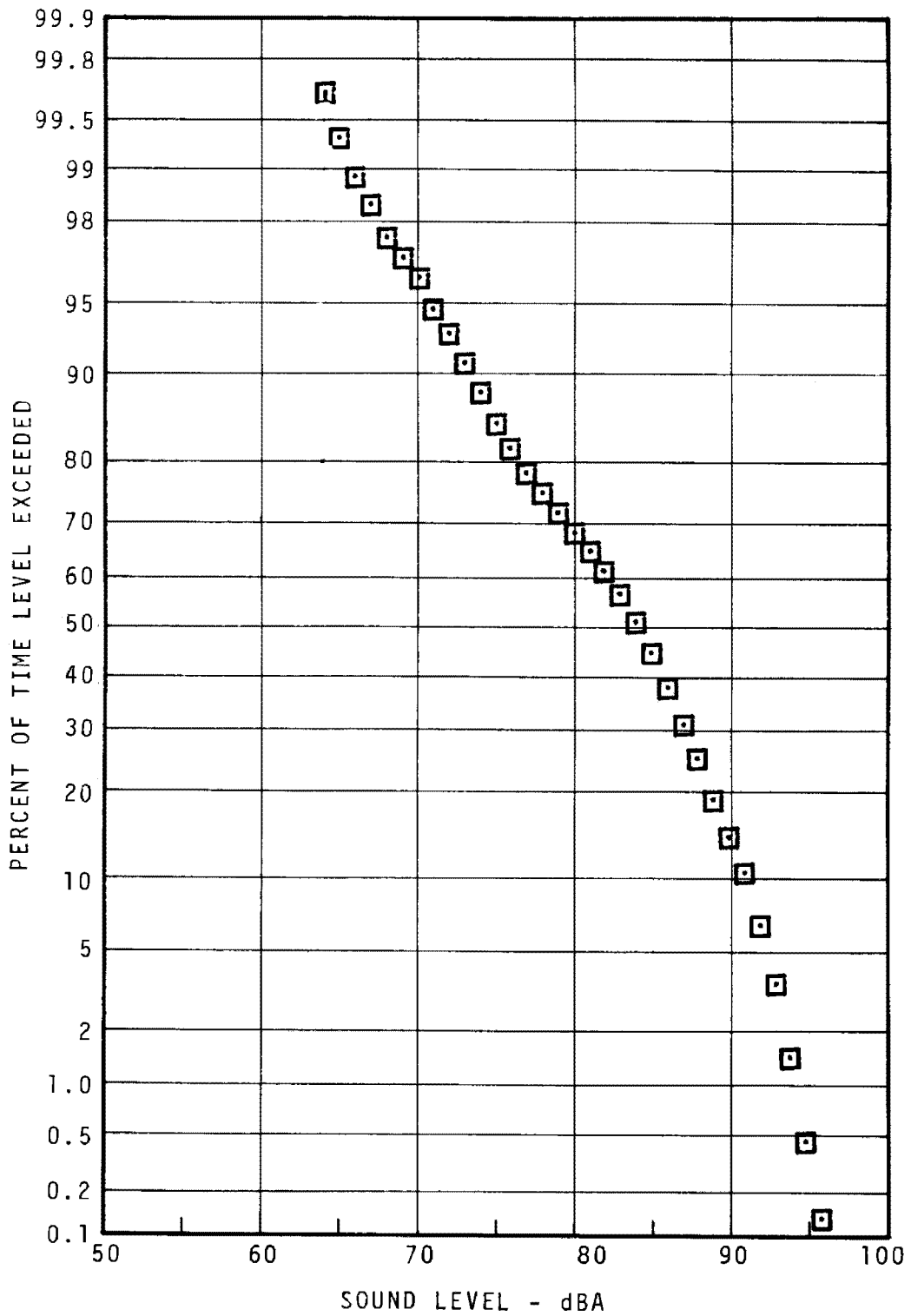

FIGURE 7.64 - 30TH STREET STATION PLATFORM
 STATISTICAL DISTRIBUTION -
 RUSH HOUR

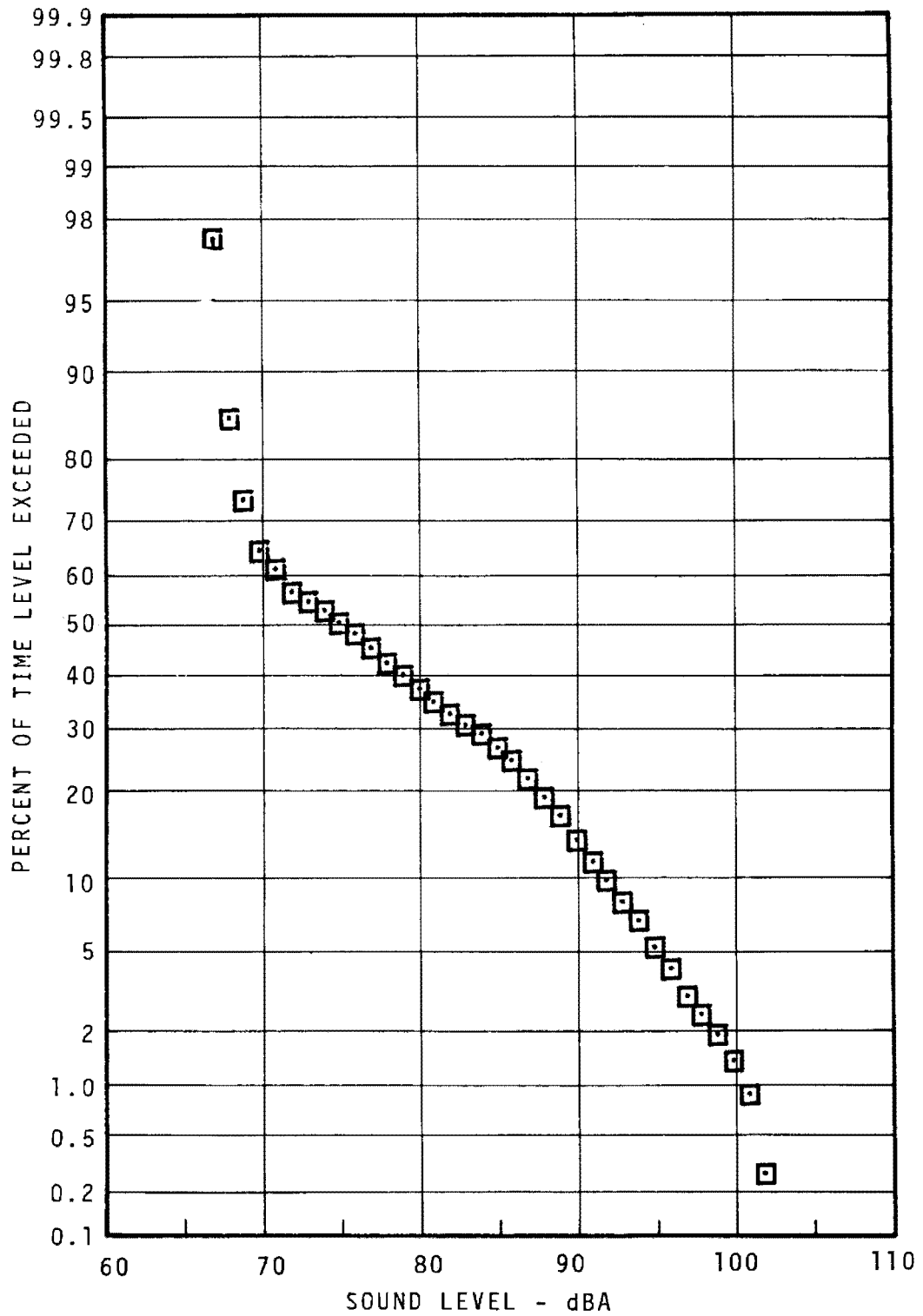

FIGURE 7.65 - 30TH STREET STATION PLATFORM
 STATISTICAL DISTRIBUTION -
 EVENING

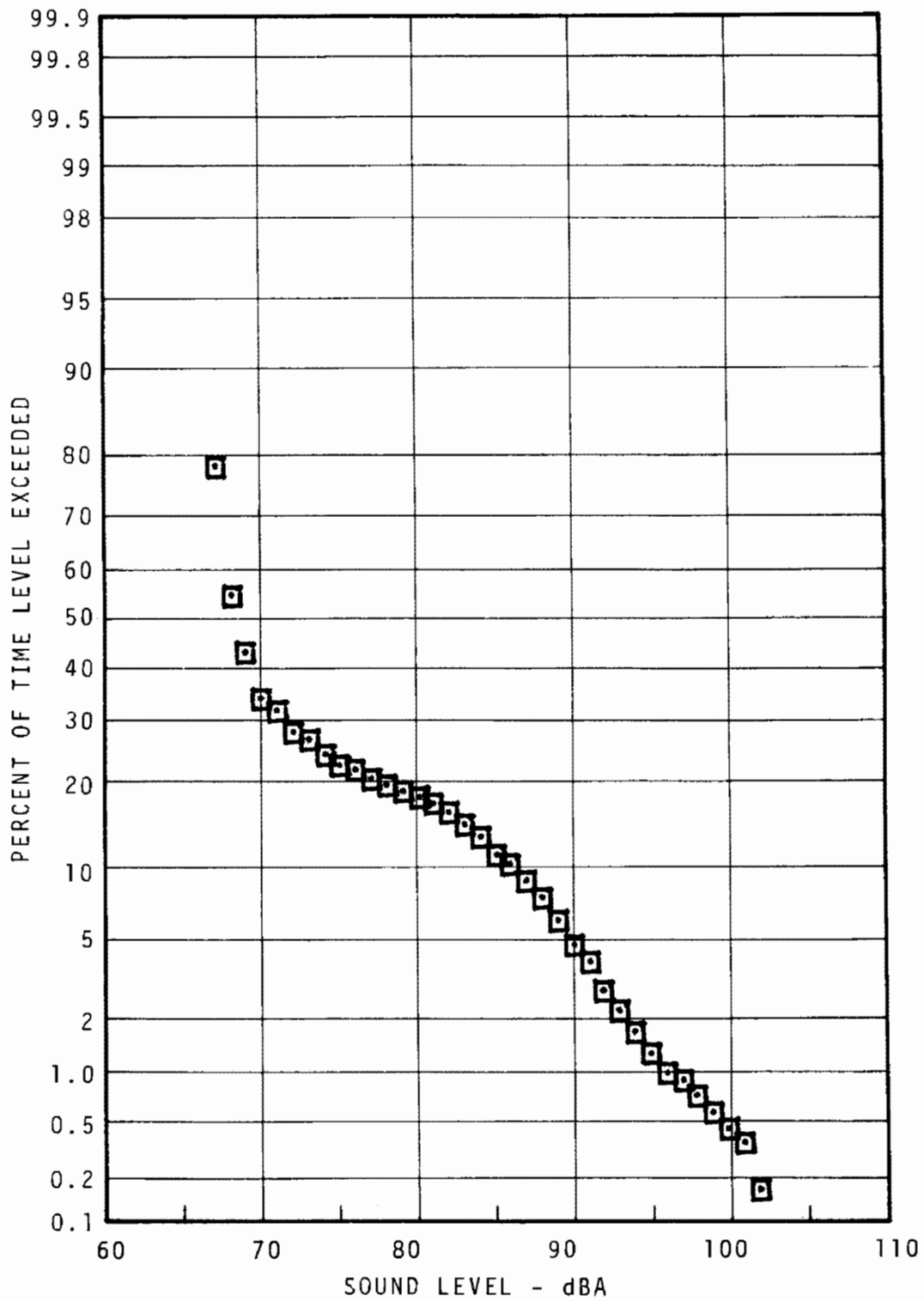

FIGURE 7.66 - 30TH STREET STATION PLATFORM
 STATISTICAL DISTRIBUTION -
 NIGHT

7-105

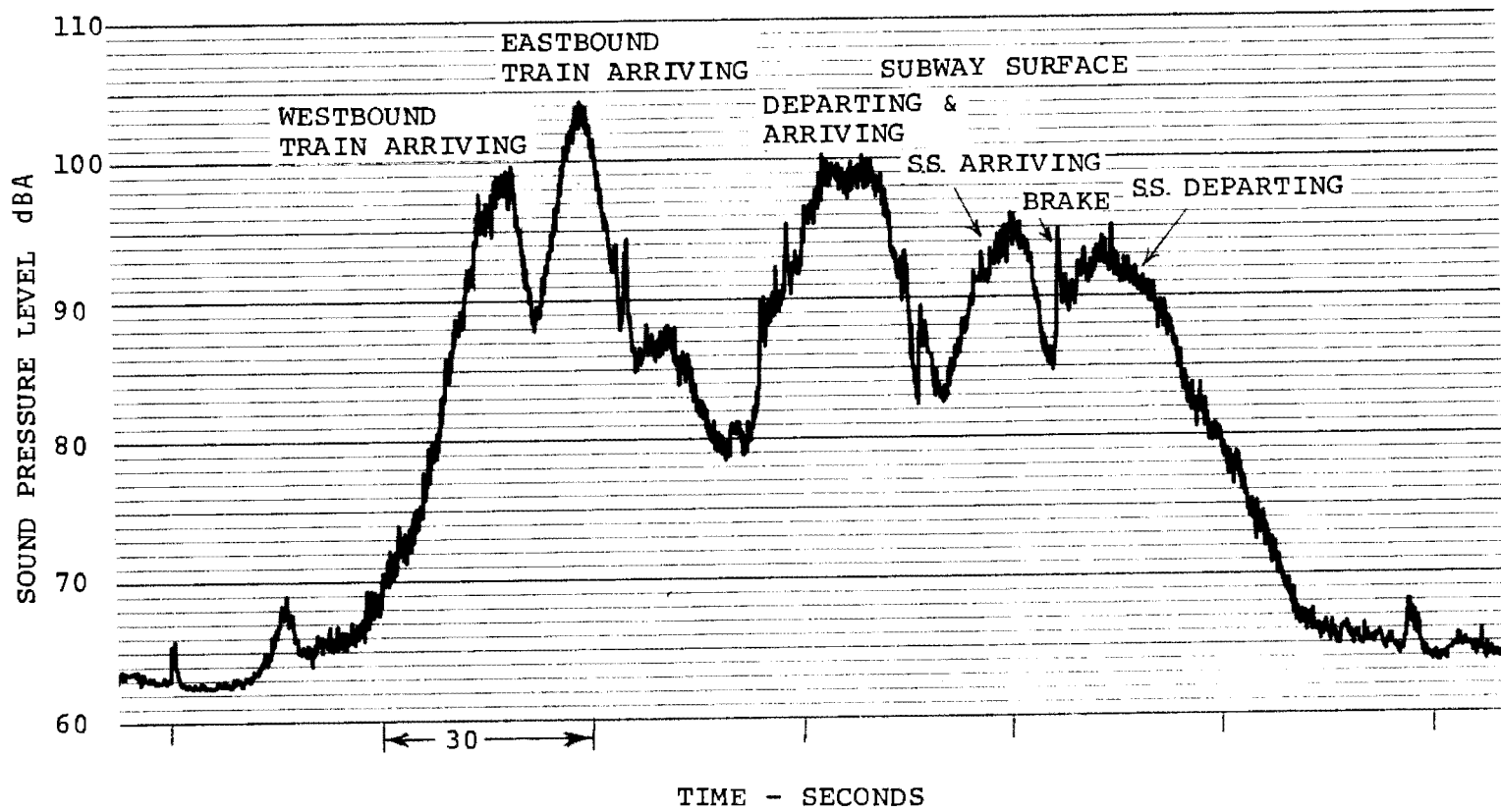

FIGURE 7.67 - TYPICAL TIME HISTORY, 30TH ST. STATION

5TH STREET STATION PLATFORM

SITE DESCRIPTION (see Figure 7.68)

The station at 5th Street is typical of many underground stations on the system, in that it is a two track side platform configuration. Construction of the station is all concrete. Passengers enter and exit at the center of the platform through revolving gates. East of 5th Street on the eastbound track only, the rail is welded to 2nd Street. Elsewhere the rail is jointed in the vicinity of the station.

NOISE CLIMATE (see Table 7.15, Figures 7.69 - 7.73)

Station construction creates long reverberation times. Wheel/rail noise, particularly impact noise due to rail joints, is noticeable as trains approach and depart at a distance and propulsion system noise contributes significantly when trains are in the immediate station area.

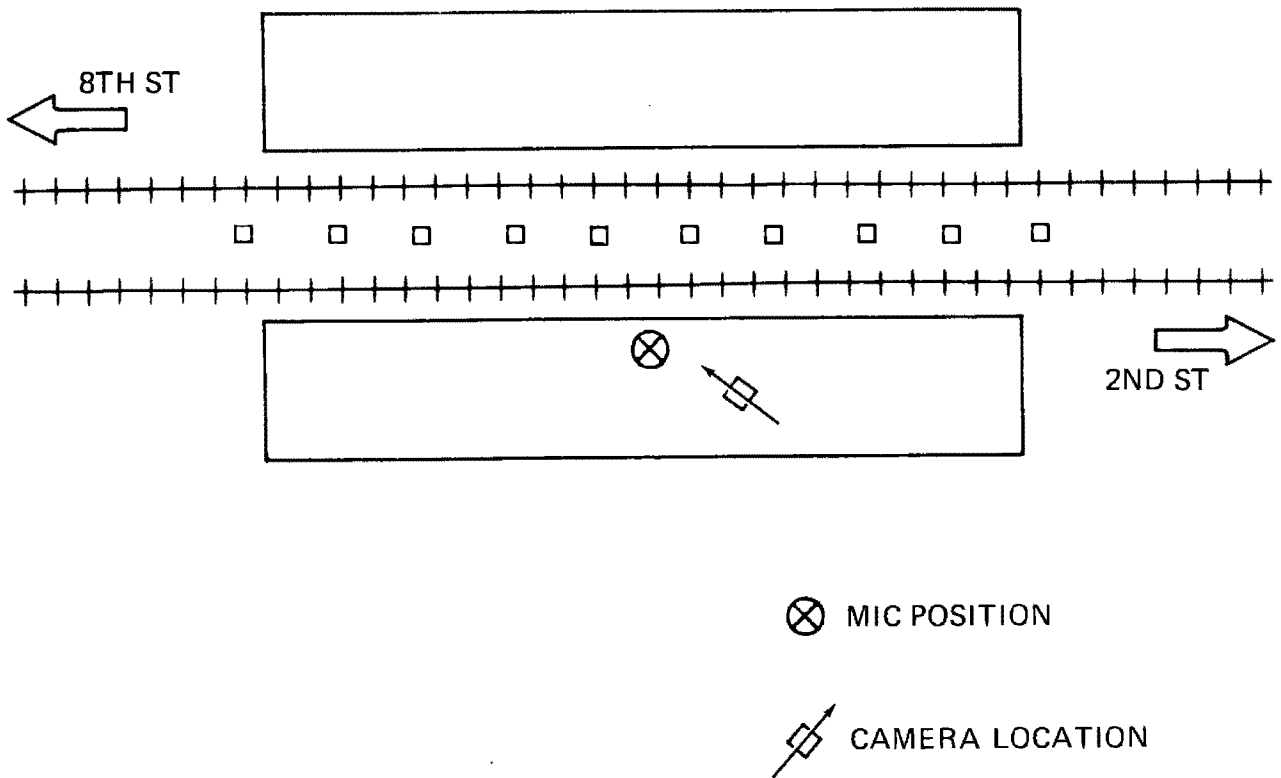

FIGURE 7.68 - 5TH ST. SUBWAY STATION PLATFORM

TABLE 7.15 - SUMMARY OF MEASUREMENT RESULTS FOR 5TH ST. STATION PLATFORM

TIME	MIC POSITION	SAMPLE TIME	TRAIN CONDITIONS	UNITS	AVG MAX LEVEL		AVG LR		CUMULATIVE AMPLITUDE DISTRIBUTION					Leq
					NEAR	FAR	NEAR	FAR	L99	L90	L50	L10	L1	
Day	Center of Stopped Train	30 min	Arrival	b) N	4-6	4-6	4-6	4-6	59	61	72	88	97	85
				dBa	97	98	106	106						
			Departure	c) S	0.87	1.32	0.42	1.19						
				N	4-6	4-6	4-6	4-6						
				dBa	94	99	103	108						
				S	1.31	2.14	1.22	1.48						
Rush	Arrival and Departure	dBa					59	62	71	89	94	83		
Evening		dBa					53	54	56	84	95	82		
Night		dBa					62	62	66	74	91	76		
Notes: a - Track b - Number of Trains - (e.g.: 4-2 means four 2-car trains) c - Standard Deviation of Level														

7-108

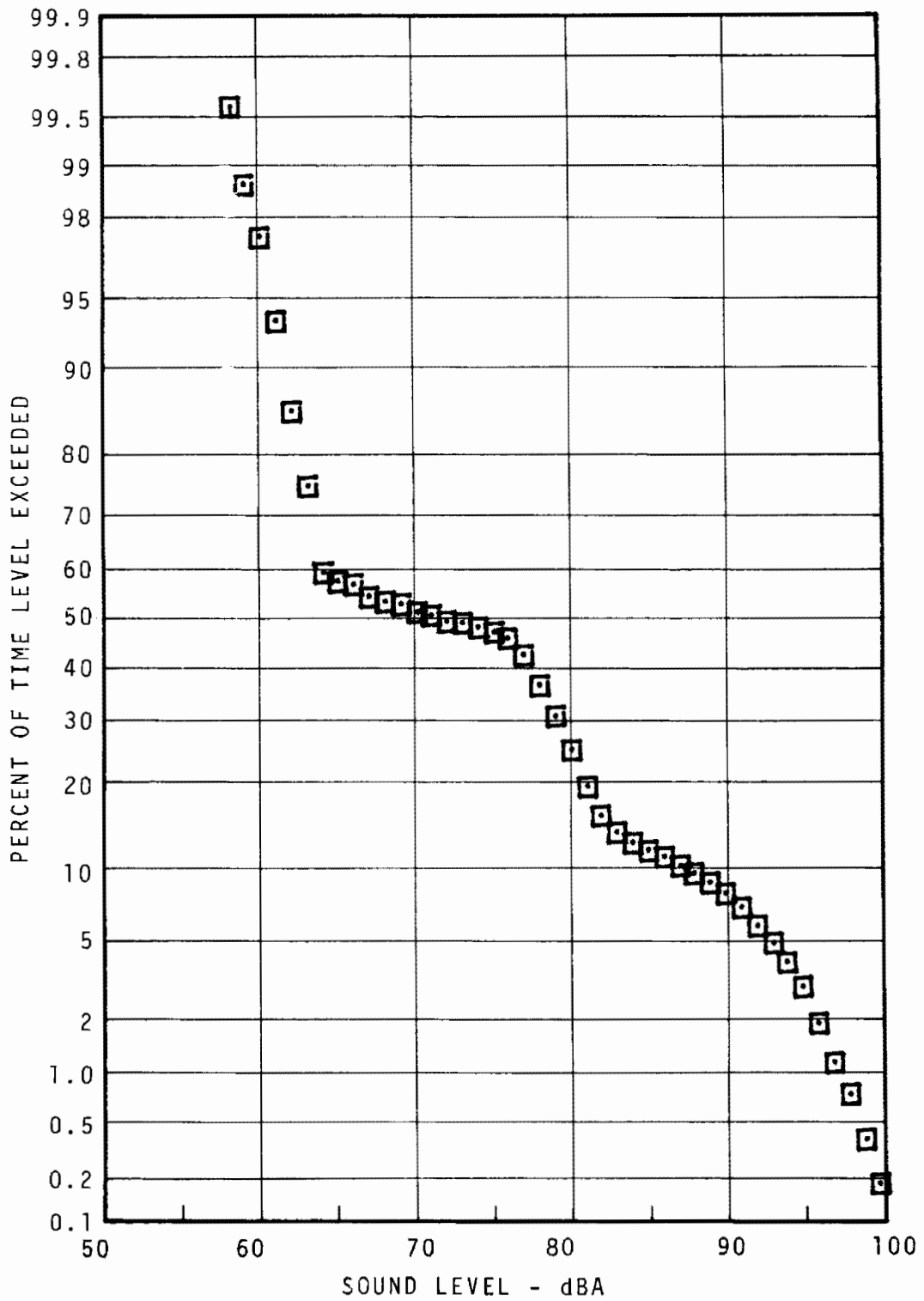

FIGURE 7.69 - 5TH STREET STATION PLATFORM
 STATISTICAL DISTRIBUTION -
 DAYTIME

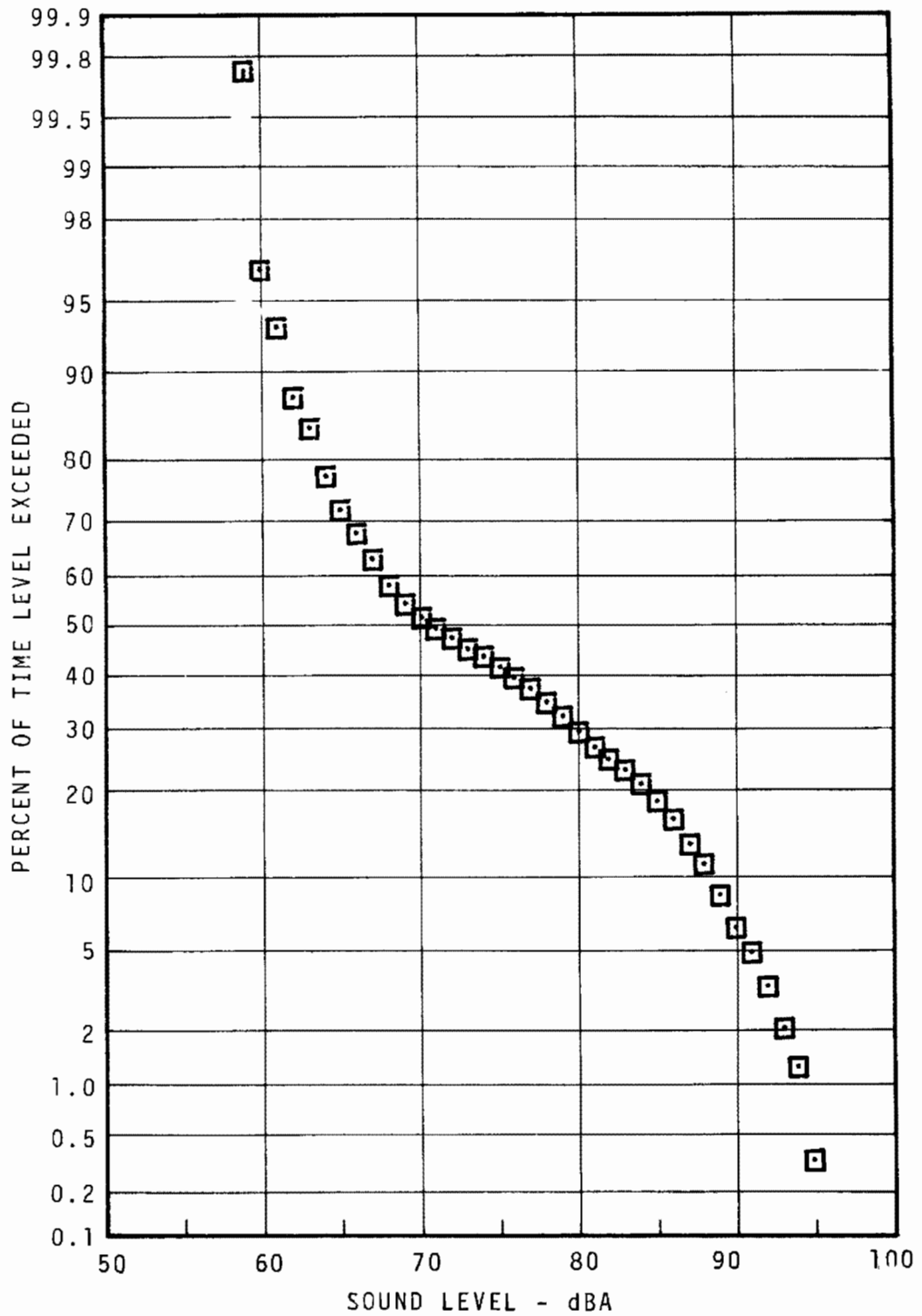

FIGURE 7.70 - 5TH STREET STATION PLATFORM
 STATISTICAL DISTRIBUTION -
 RUSH HOUR

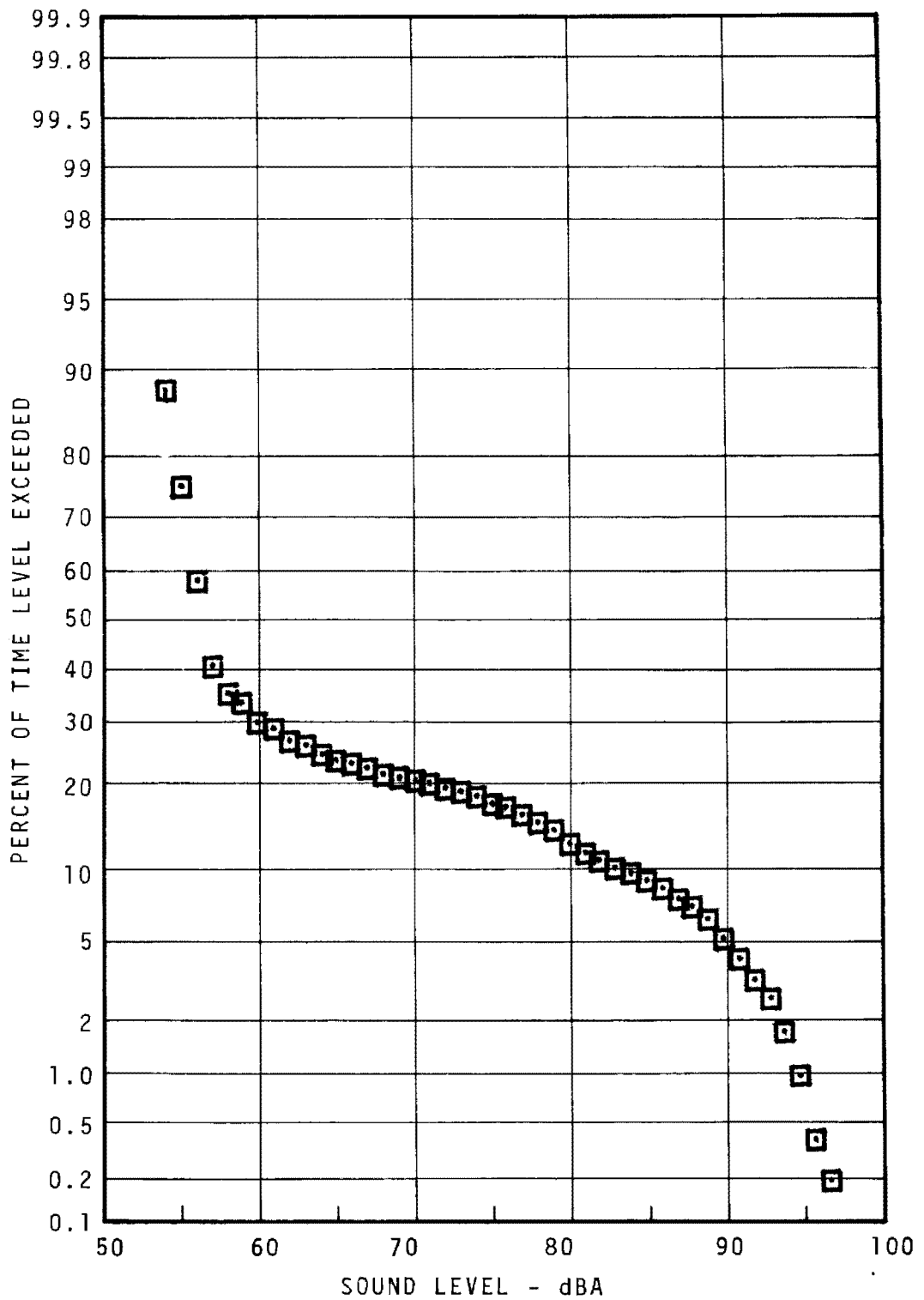

FIGURE 7.71 - 5TH STREET STATION PLATFORM
 STATISTICAL DISTRIBUTION -
 EVENING

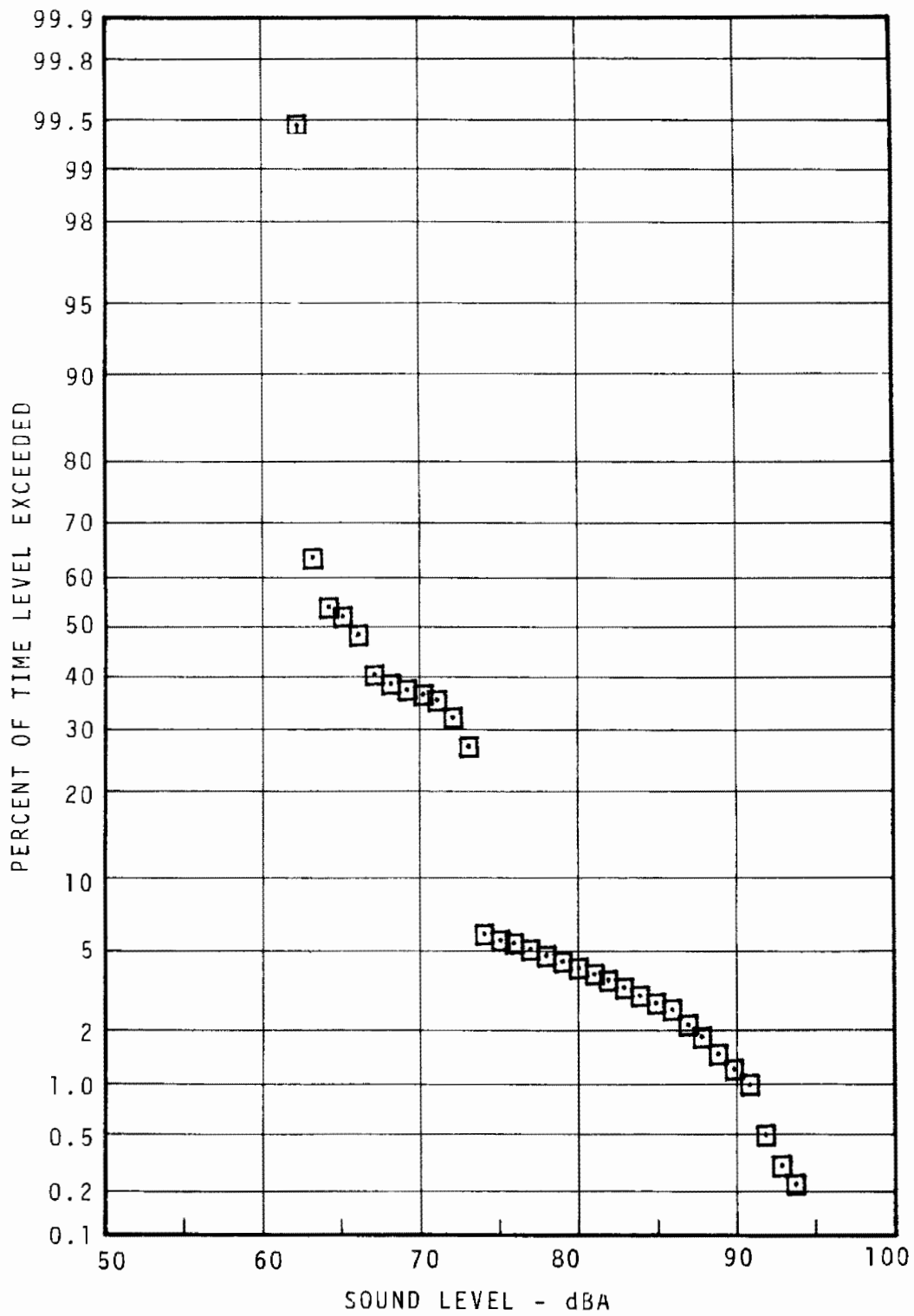

FIGURE 7.72 - 5TH STREET STATION PLATFORM
 STATISTICAL DISTRIBUTION -
 NIGHT

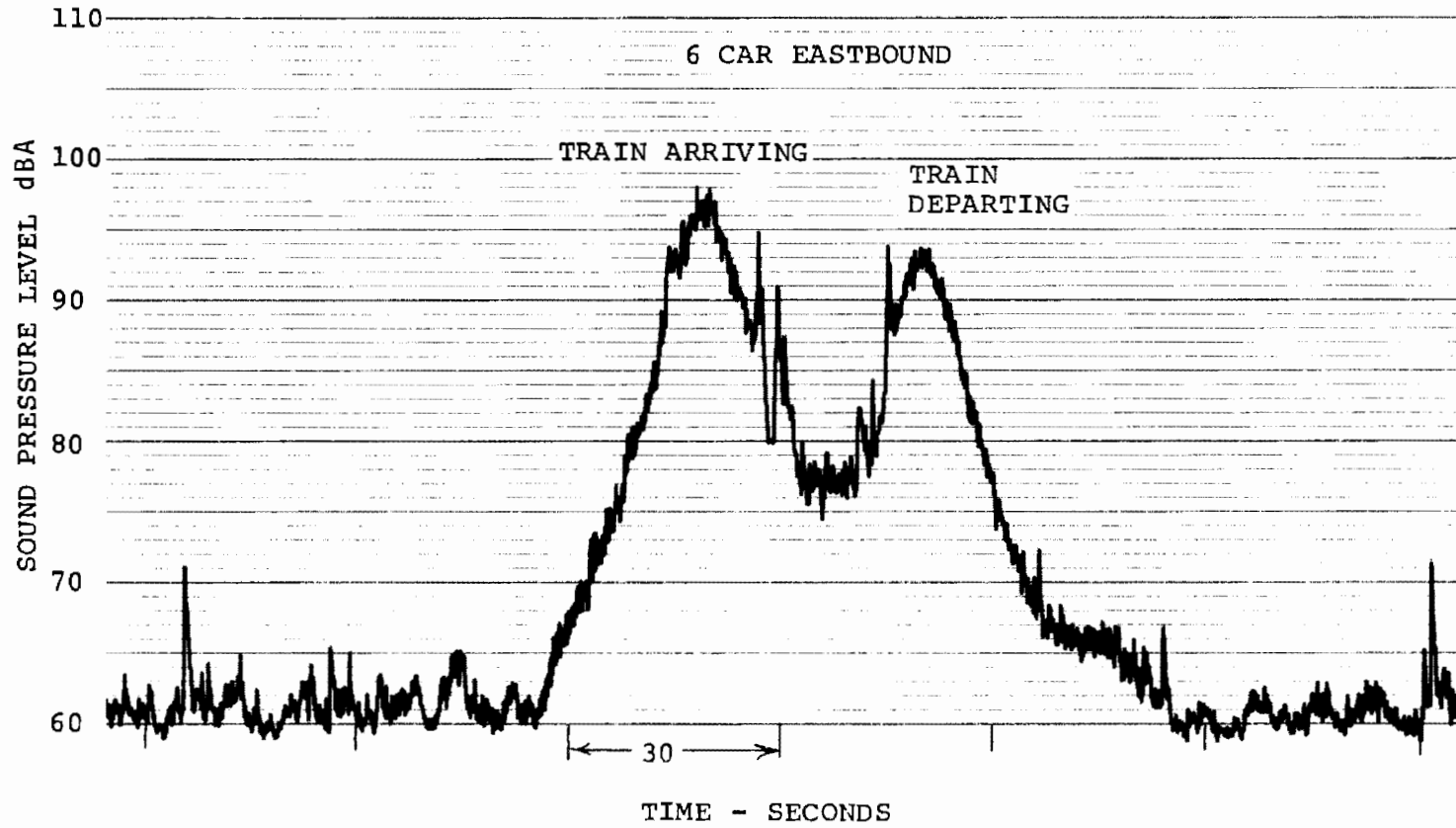

FIGURE 7.73 - TYPICAL TIME HISTORY, 5TH ST. STATION

2ND STREET STATION PLATFORM

SITE DESCRIPTION (see Figure 7.74)

At 2nd Street the station configuration is similar to that at 5th Street, but immediately north of the platform there is a 200 ft radius curve where the system joins Front Street. Wheel squeal generated on this curve can be heard at all platform locations at this station. During the noise survey period, this area was undergoing reconstruction and the tunnel cover was removed for several hundred feet east of the station platform, exposing the rail and track to weather and other outside environmental conditions. During peak hours northbound express trains do not stop at 2nd Street.

NOISE CLIMATE (see Table 7.16, Figures 7.75 - 7.76)

Trains entering the station on the westbound track and leaving the station on the eastbound track produce wheel squeal continuously for approximately a 30 second period. Nearly all of this noise is audible on the station platform. In addition, operators sound the horn prior to negotiating this curve.

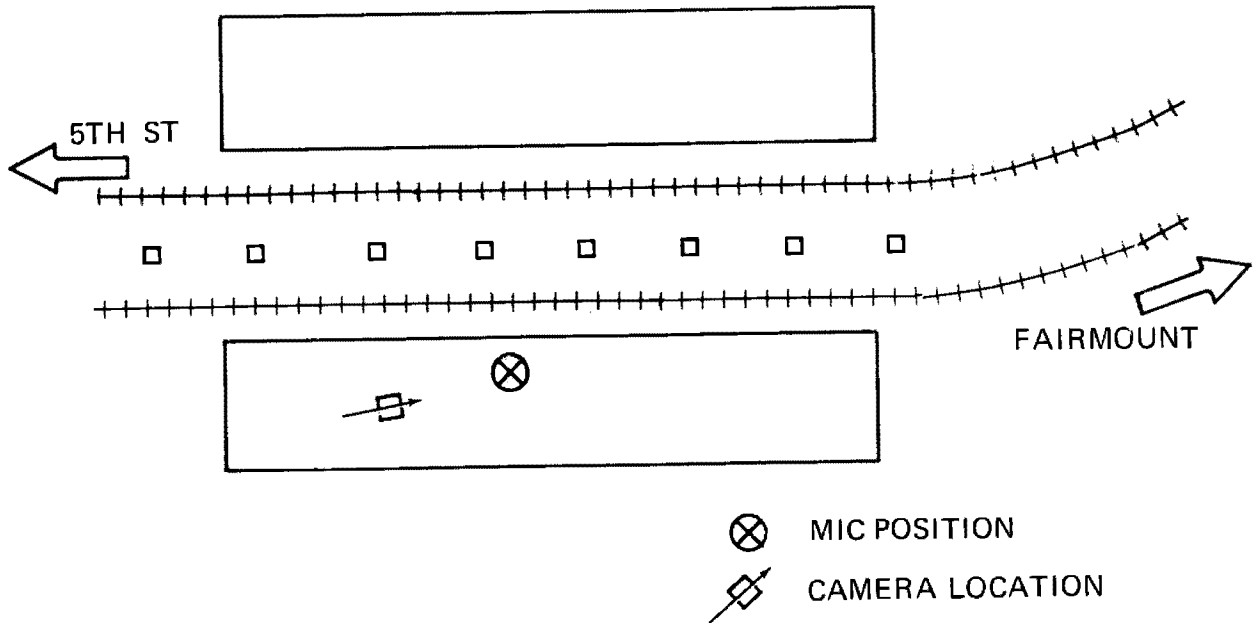

FIGURE 7.74.- 2ND ST. SUBWAY STATION PLATFORM

SUMMARY 7.16-SUMMARY OF MEASUREMENT RESULTS FOR 2ND ST. STATION PLATFORM

TIME	MIC POSITION	SAMPLE TIME	TRAIN CONDITIONS	UNITS	AVG MAX LEVEL		AVG L _R		CUMULATIVE AMPLITUDE DISTRIBUTION					Leq
					NEAR	FAR	NEAR	FAR	L99	L90	L50	L10	L1	
Day	Center of Stopped Train	30 min	Arrival	b) N	5-6	4-6	5-6	4-6	61	62	65	85	97	83
				dBA	97	90	106	99						
				c) S	2.33	2.53	2.10	1.27						
			Departure	N	5-6	4-6	5-6	4-6						
				dBA	87	97	97	106						
				S	0.65	1.55	0.97	0.99						
Notes: a - Track b - Number of Trains - (e.g.: 4-2 means four 2-car trains) c - Standard Deviation of Level														

7-116

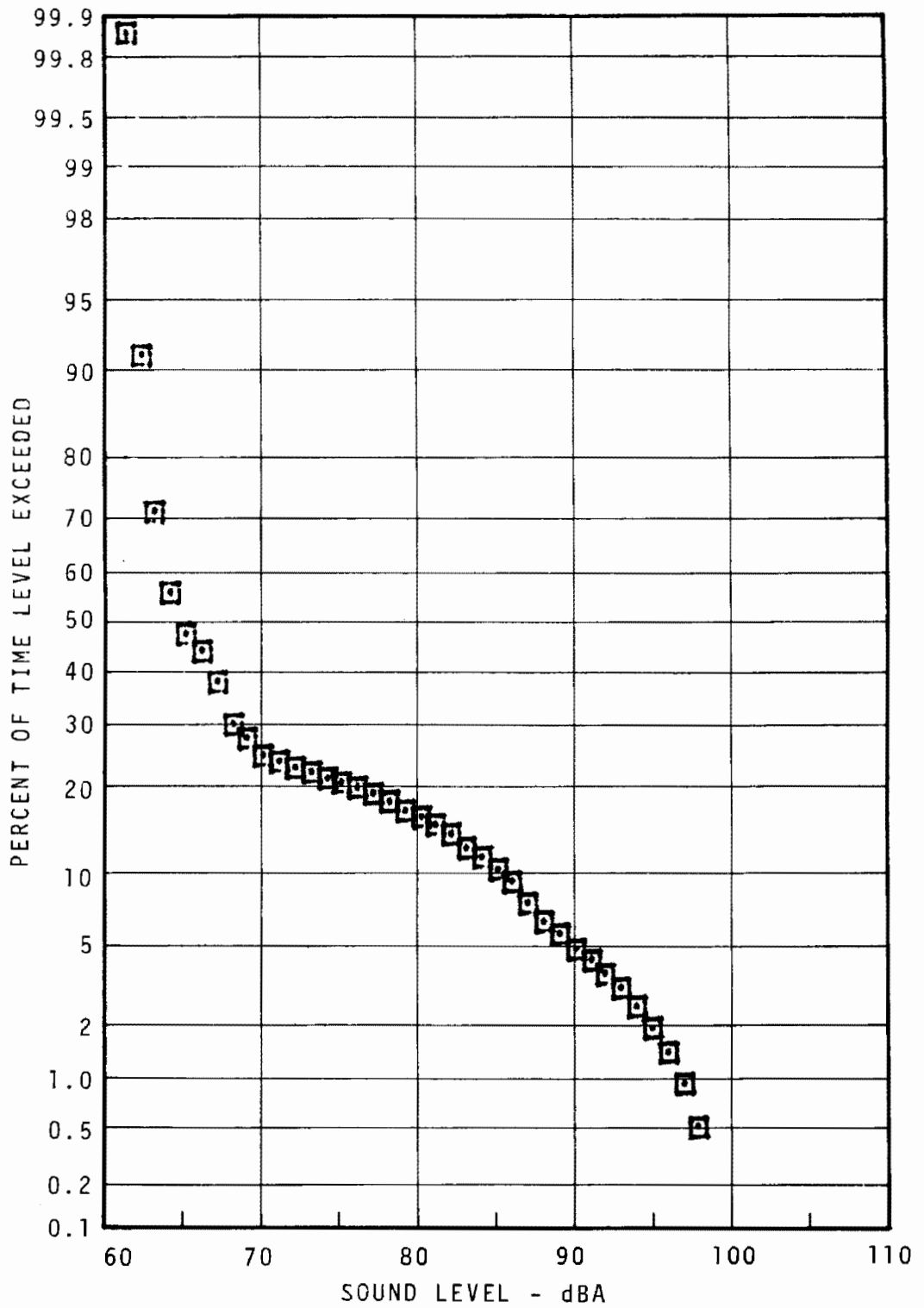

FIGURE 7.75 - 2ND STREET STATION PLATFORM
 STATISTICAL DISTRIBUTION -
 DAYTIME

7-118/811-7

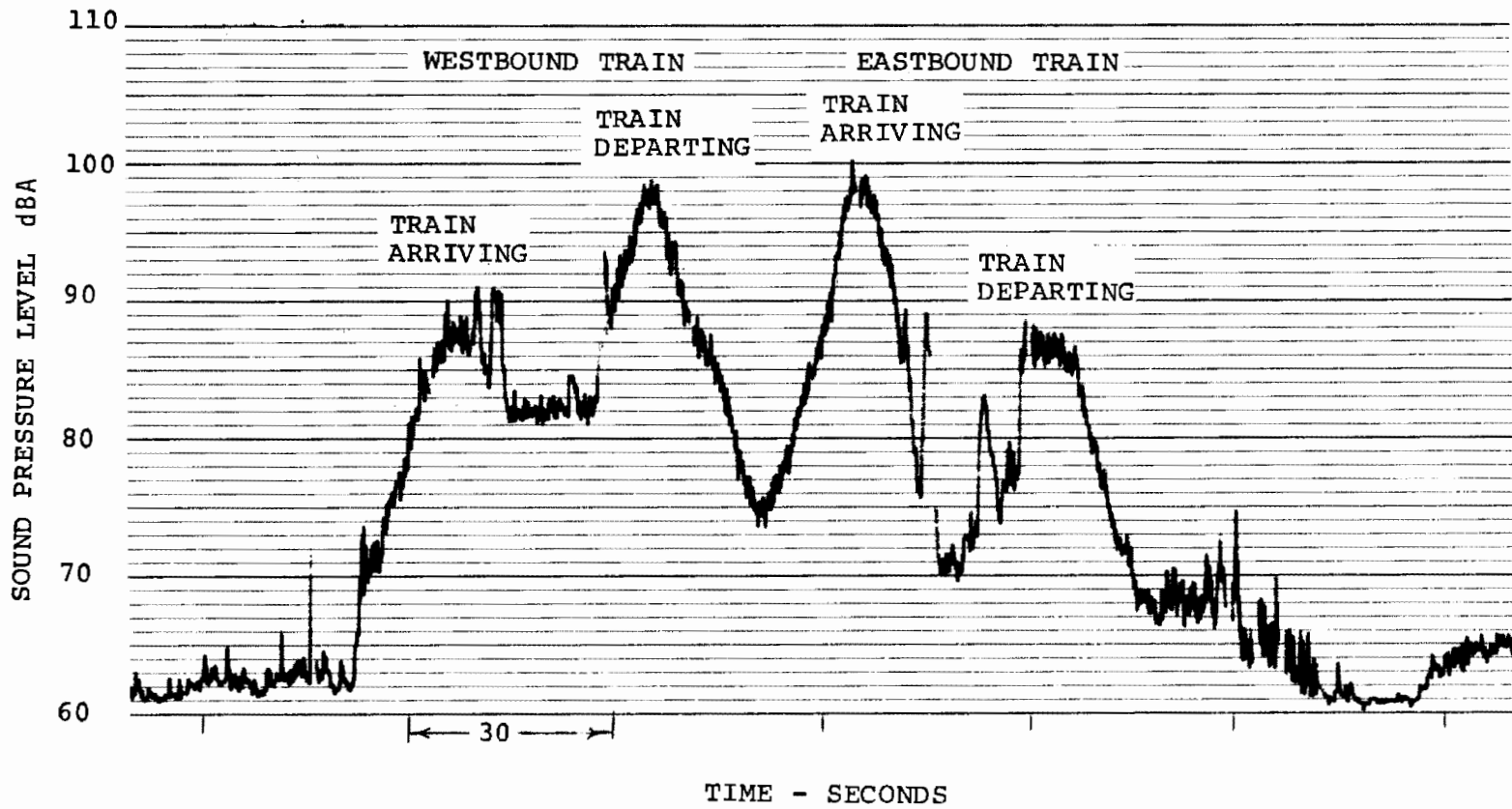
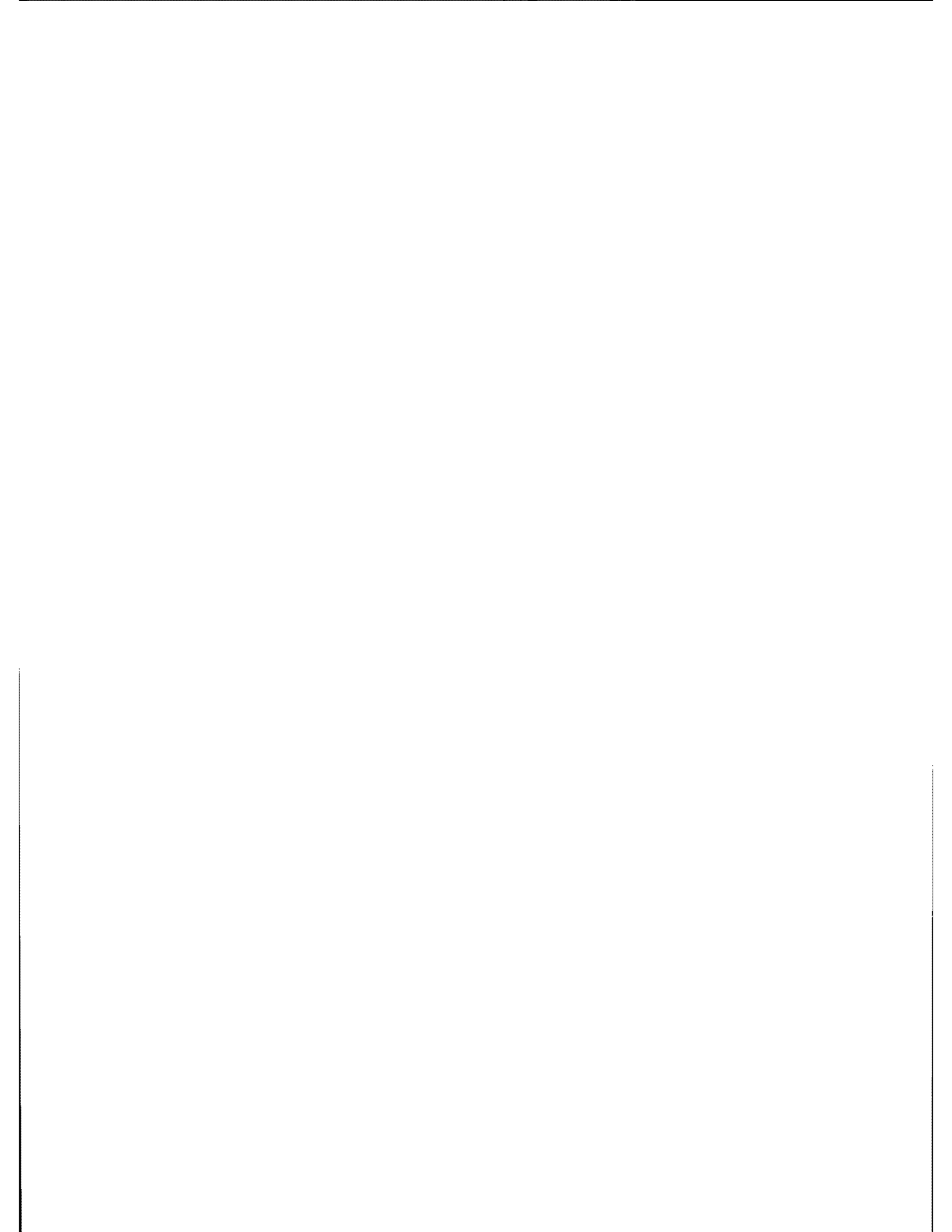

FIGURE 7.76 - TYPICAL TIME HISTORY 2ND ST. STATION



BERKS STATION PLATFORM

SITE DESCRIPTION (see Figure 7.77)

Berks station is a typical two track, side platform elevated station with construction which is somewhat different from that of 52nd Street in West Philadelphia. The general station layout, however, is in many respects similar to 52nd Street. Some exceptions to this are concrete station platforms at Berks compared with wooden planking at 52nd Street and a passenger overpass between platforms at Berks with an underpass at 52nd Street. In general, buildings at the wayside, including residential dwellings, are constructed in closer proximity to the right-of-way than is typical in West Philadelphia. During peak hours, northbound trains do not stop at Berks.

NOISE CLIMATE (see Table 7.17, Figures 7.78 - 7.80)

In many respects, the noise climate due to transit system operations is similar to 52nd Street. Background noise from vehicle traffic and other sources at street level is somewhat lower.

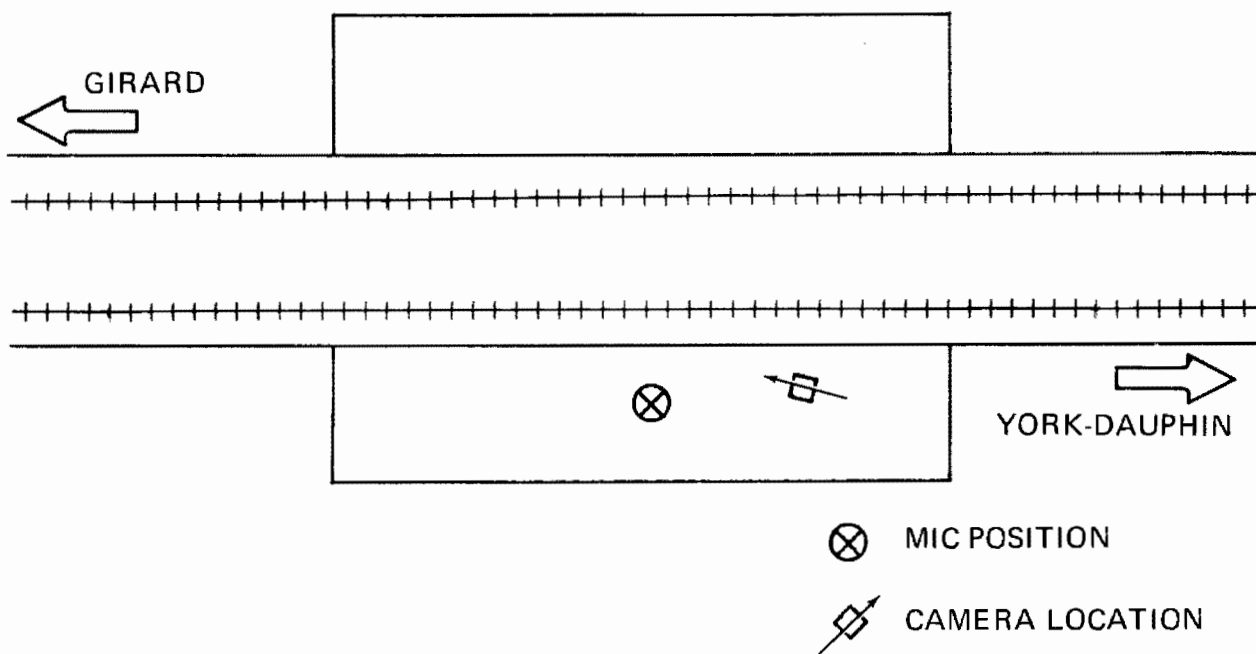

FIGURE 7.77 - BERKS ELEVATED STATION PLATFORM

TABLE 7.17 - SUMMARY OF MEASUREMENT RESULTS FOR BERKS STATION PLATFORM

TIME	MIC POSITION	SAMPLE TIME	TRAIN CONDITIONS	UNITS	AVG MAX LEVEL		AVG LR		CUMULATIVE AMPLITUDE DISTRIBUTION					Leq
					NEAR	FAR	NEAR	FAR	L99	L90	L50	L10	L1	
Day	Center of Stopped Train	30 min	Arrival	b) N	5-6	5-6	5-6	5-6	62	63	65	79	88	76
				dBA	88	90	97	98						
			Departure	c) S	3.72	3.34	2.28	2.82						
				N	5-6	5-6	5-6	5-6						
				dBA	84	84	92	93						
				S	5.16	1.27	5.87	1.53						
Rush		Arrival and Departure	dBA					64	66	71	87	96	84	

Notes: a - Track
 b - Number of Trains - (e.g.: 4-2 means four 2-car trains)
 c - Standard Deviation of Level

7-122

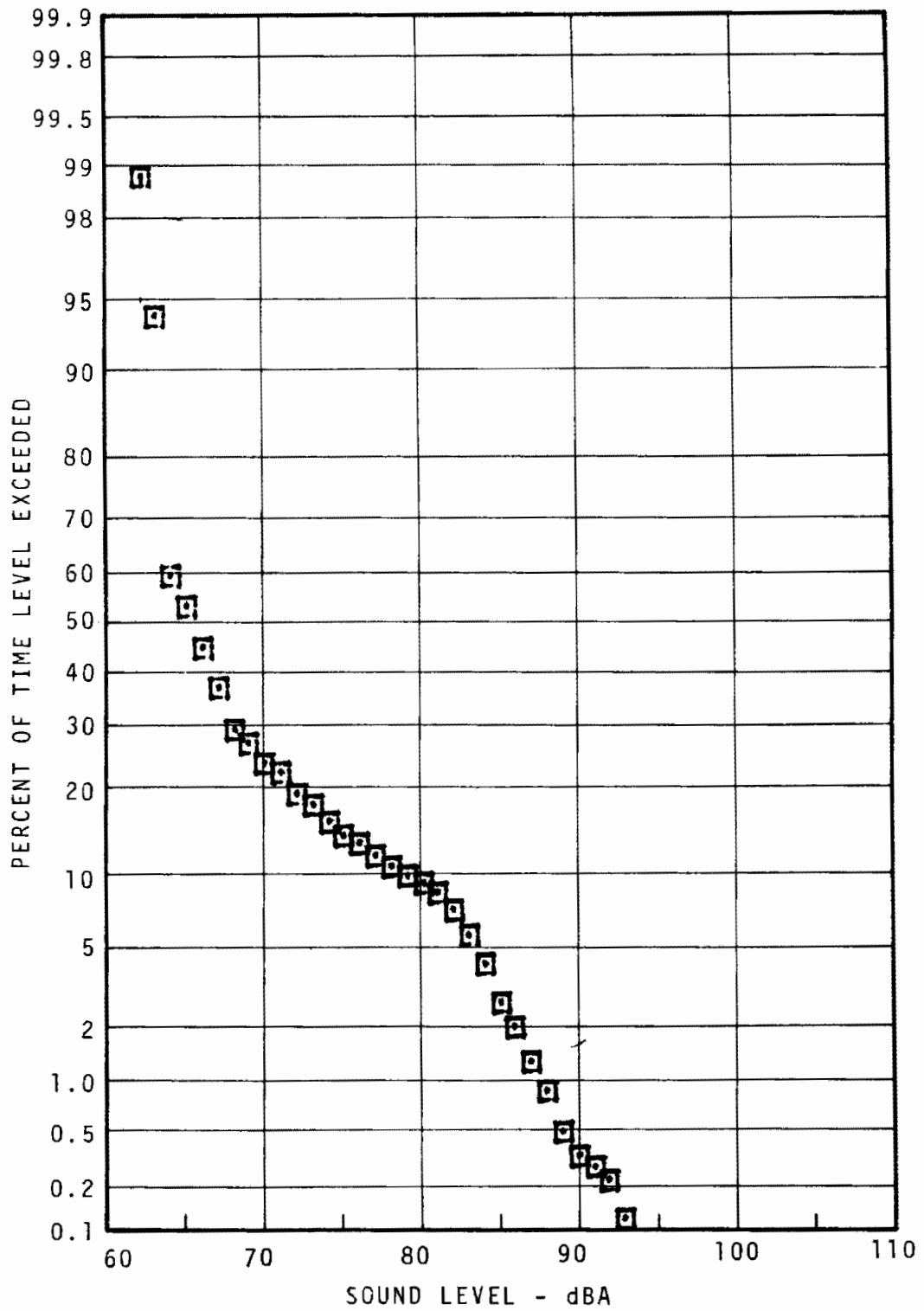

FIGURE 7.78 - BERKS STATION PLATFORM
 STATISTICAL DISTRIBUTION -
 DAYTIME

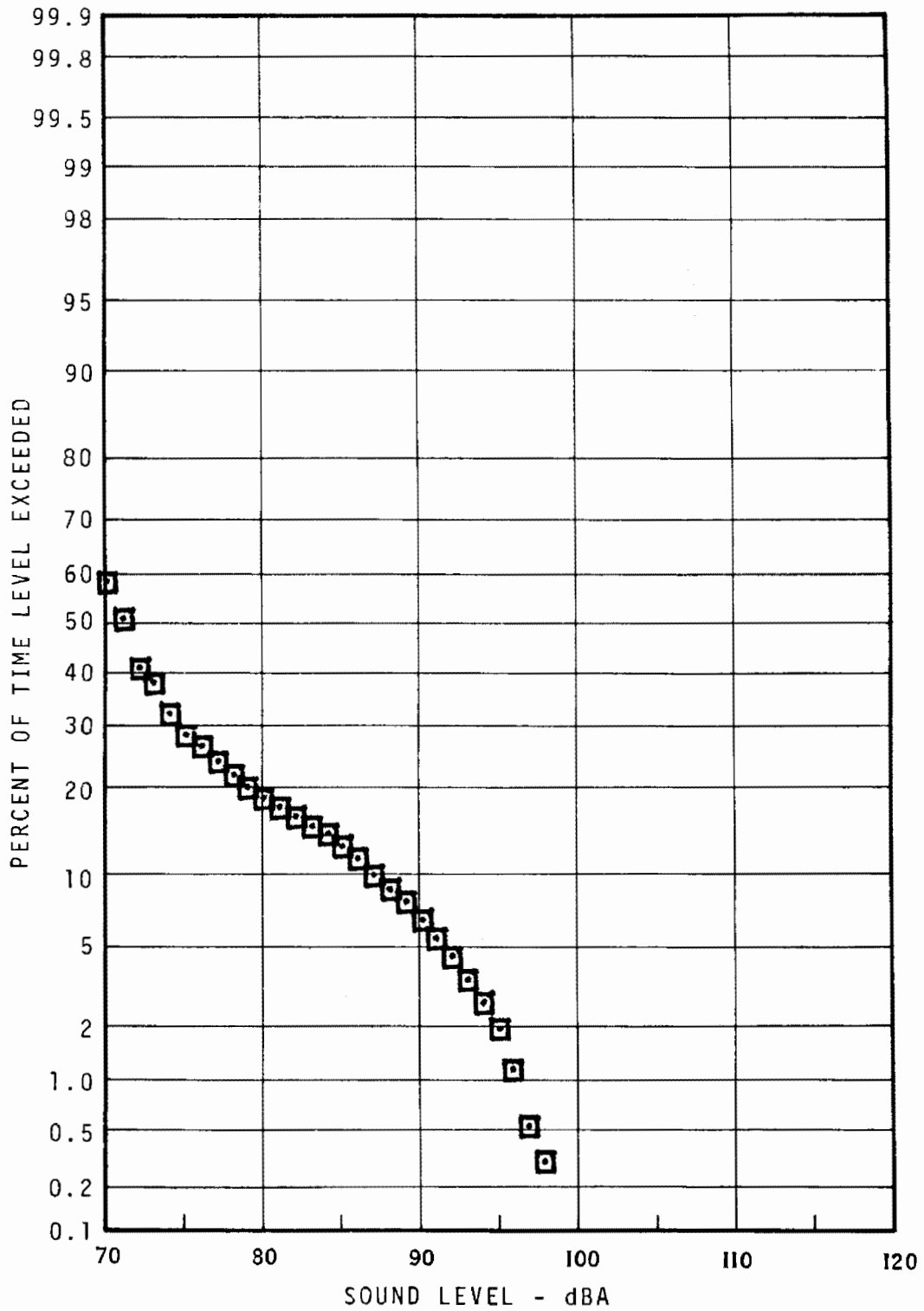

FIGURE 7.79 - BERKS STATION PLATFORM
 STATISTICAL DISTRIBUTION -
 RUSH HOUR

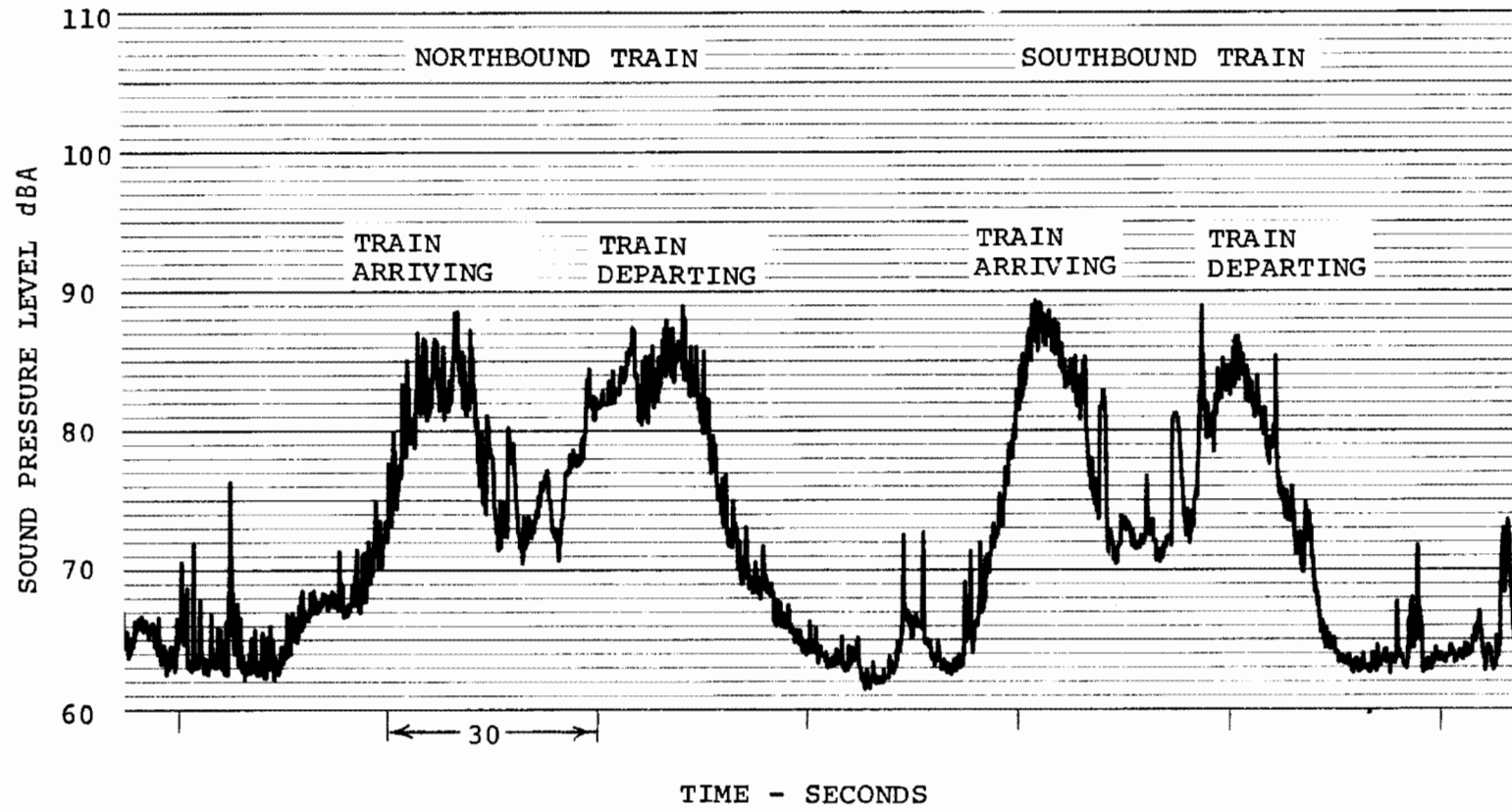

FIGURE 7.80 - TYPICAL TIME HISTORY, BERKS STATION

YORK-DAUPHIN STATION PLATFORM

SITE DESCRIPTION (see Figure 7.81)

York-Dauphin Station is similar in layout and construction to Berks, but immediately north of the station platform the system curves to align with Kensington Avenue. Trains negotiating this curve, both north and westbound generate strong wheel squeal. There are many two story houses in this area. During peak hours, westbound trains do not stop at this station. Front Street below the elevated structure is a busy commercial and business locality.

NOISE CLIMATE (see Table 7.18, Figures 7.82 - 7.84)

The squeal generated by trains on the curve is a notable difference in the noise climate at this station. Also different from Berks Station is the noise generated at street level. The York-Dauphin area displays higher noise levels due to the business and commercial properties in this area.

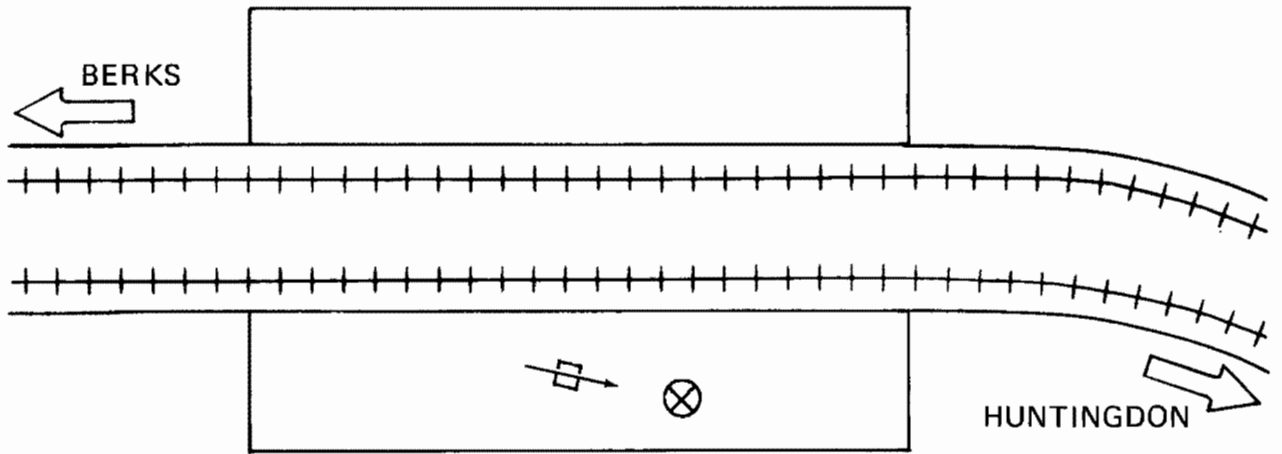
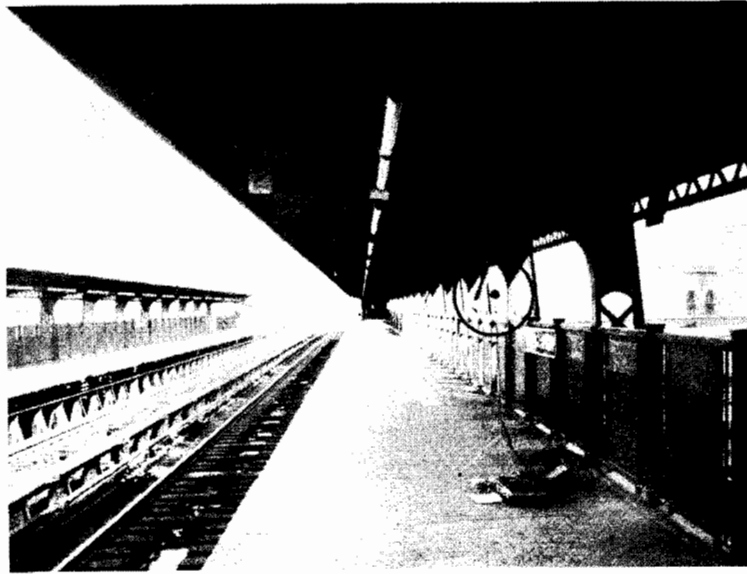

⊗ MIC POSITION

⊞ CAMERA LOCATION

FIGURE 7.81 - YORK-DAUPHIN ELEVATED STATION PLATFORM

TABLE 7.18 - SUMMARY OF MEASUREMENT RESULTS FOR YORK-DAUPHIN STATION PLATFORM

TIME	MIC POSITION	SAMPLE TIME	TRAIN CONDITIONS	UNITS	AVG MAX LEVEL		AVG LR		CUMULATIVE AMPLITUDE DISTRIBUTION					Leq
					FAR	NEAR	FAR	NEAR	L99	L90	L50	L10	L1	
Day	Center of Stopped Train	30 min	Arrival	b) N	5-6	4-6	5-6	4-6	70	71	72	79	89	78
				dBa	89	88	98	96						
			Departure	c) S	2.32	2.06	1.50	1.52						
				N	5-6	4-6	5-6	4-6						
				dBa	84	84	92	93						
				S	2.07	1.47	1.30	1.73						
Night		Arrival and Departure	dBa					56	57	60	70	100	76	

Notes: a - Track
 b - Number of Trains - (e.g.: 4-2 means four 2-car trains)
 c - Standard Deviation of Level

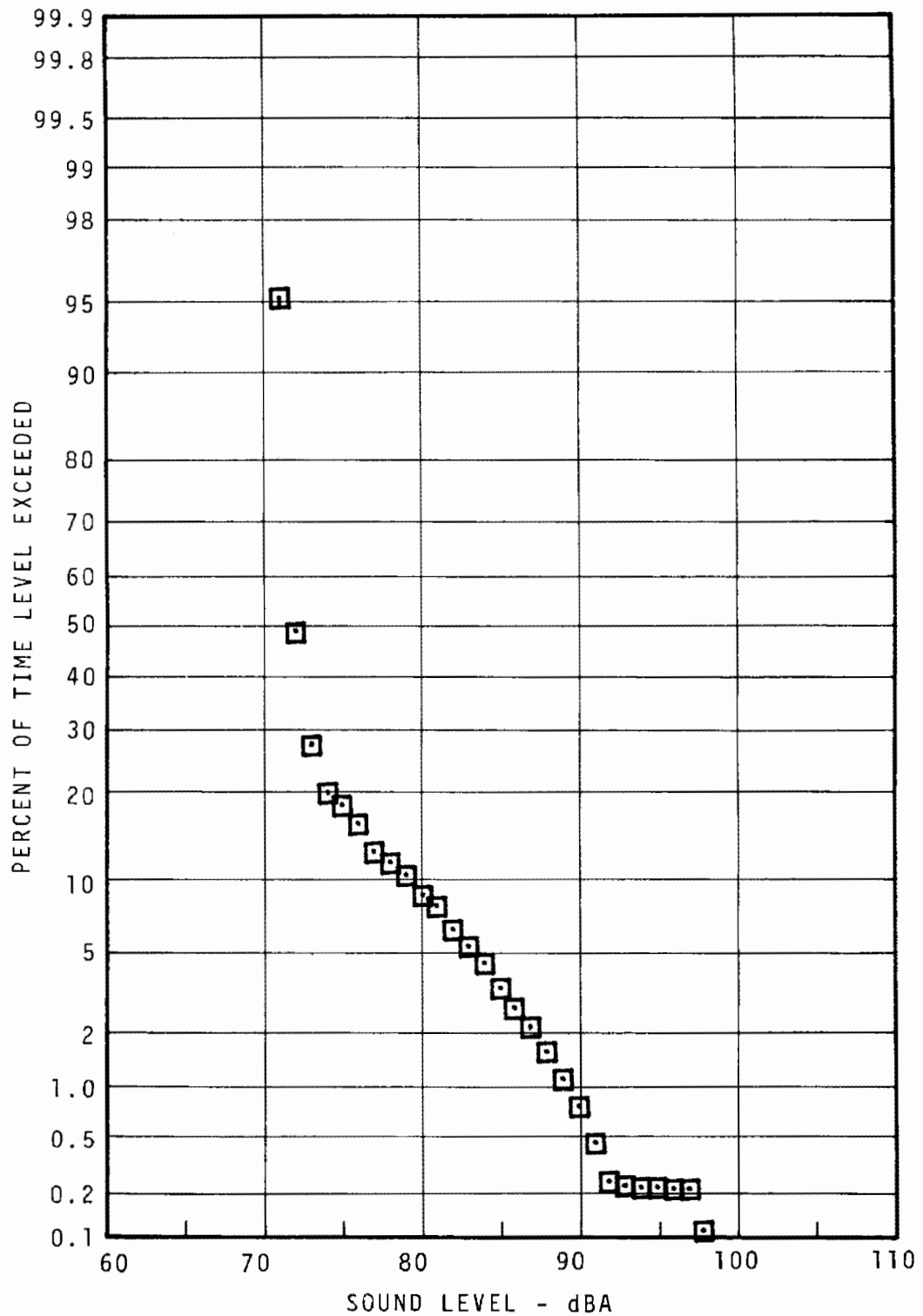

FIGURE 7.82 - YORK-DAUPHIN STATION PLATFORM
 STATISTICAL DISTRIBUTION -
 DAYTIME

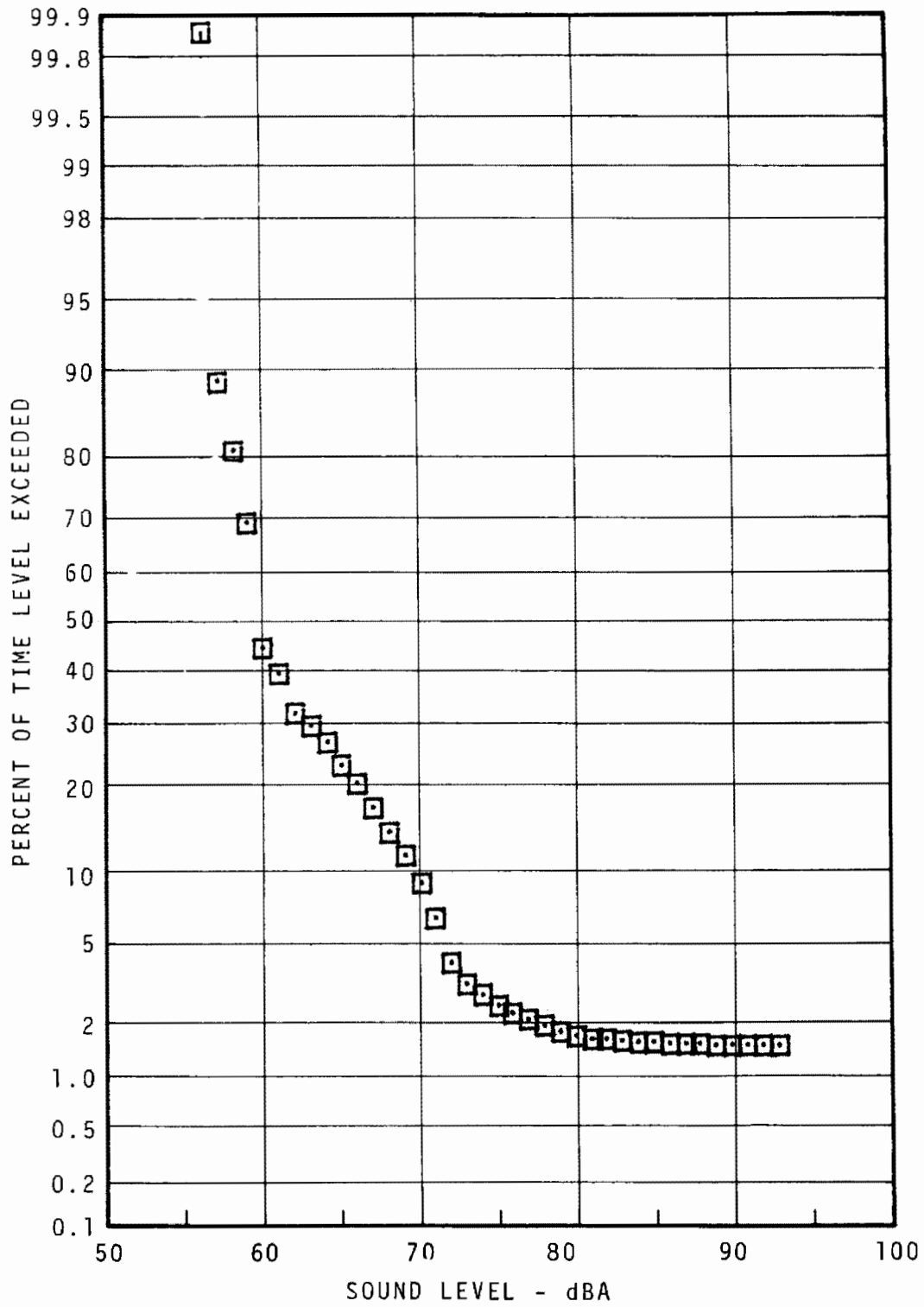

FIGURE 7.83 - YORK-DAUPHIN STATION PLATFORM
 STATISTICAL DISTRIBUTION -
 NIGHT

7-131

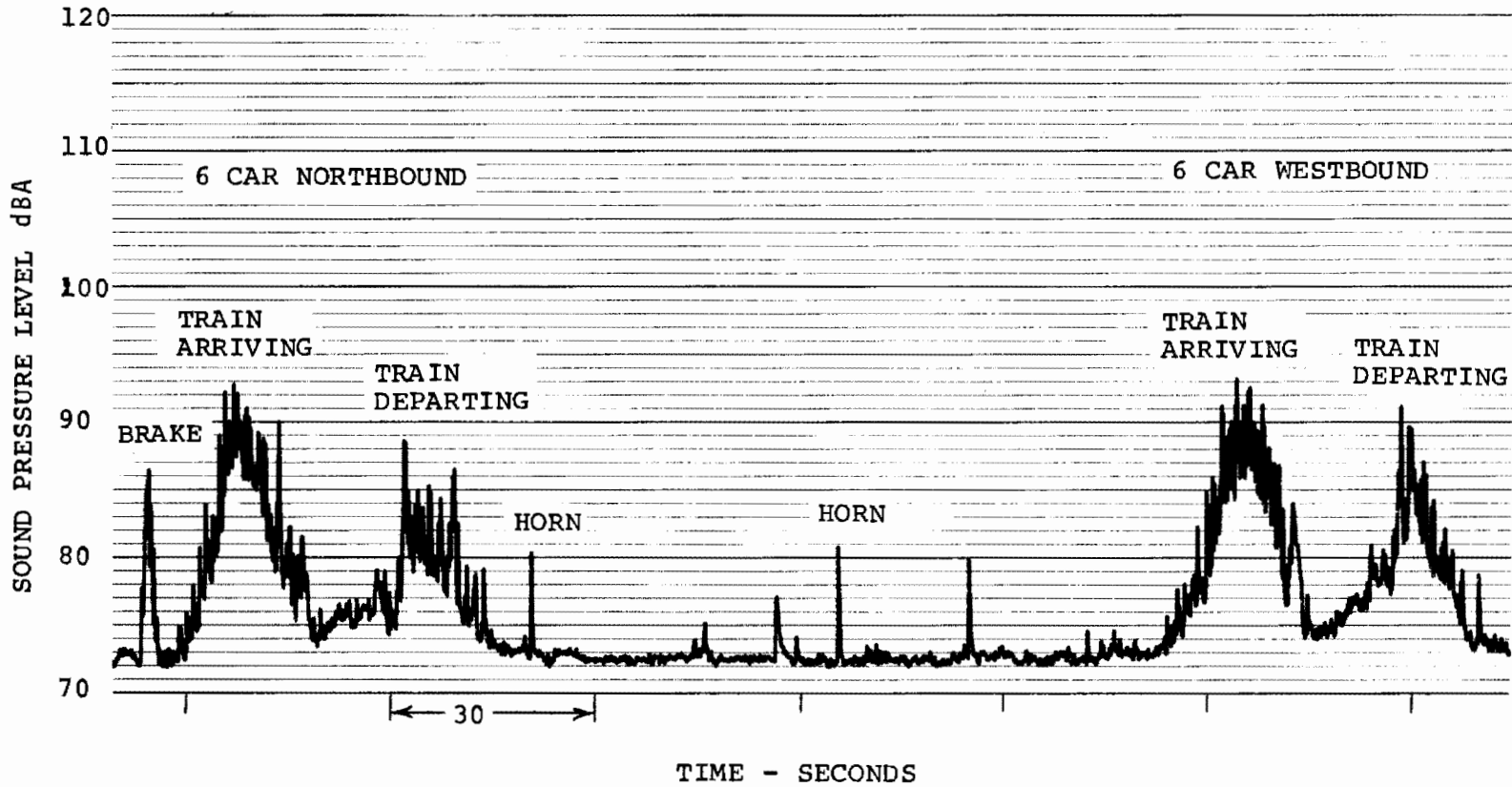

FIGURE 7.84 - TYPICAL TIME HISTORY, YORK-DAUPHIN STATION

CHURCH STREET STATION PLATFORM

SITE DESCRIPTION (see Figure 7.85)

Church Street is a two-track, side platform station with construction somewhat modified with respect to Berks. During peak hours "A" trains bypass this station and only "B" trains stop. Station platforms are concrete and the walls and roof structure are riveted steel plate and girders. Rail in the station vicinity is set in short concrete ties with every fifth tie a long cross tie. This station is also representative of the Margaret-Orthodox Station and both of them are elevated with respect to street level.

NOISE CLIMATE (see Table 7.19, Figures 7.86 - 7.87)

The noise climate of this transit station consists of the transit train noise together with vehicular noises from the street below. The latter in particular predominates during rush hours. Transit train noise is similar to that at Berks with the exception of an occasional nonstop express train. Aside from train and vehicular noises, an occasional dog barks in the adjacent neighborhood and church bells sound intermittently.

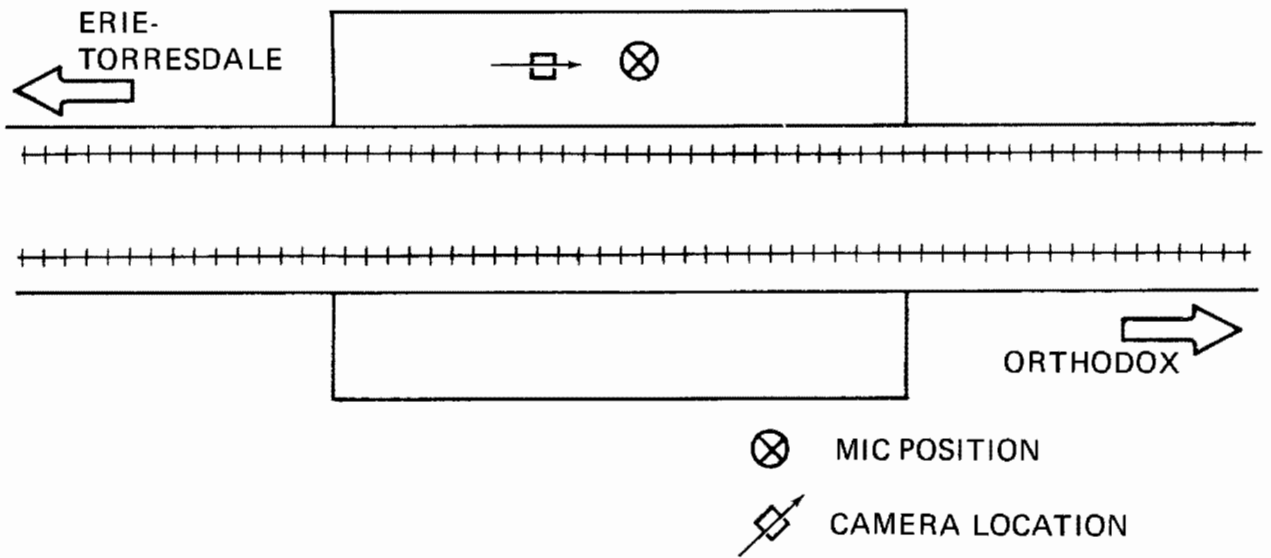

FIGURE 7.85 - CHURCH ST. ELEVATED STATION PLATFORM

TABLE 7.19 - SUMMARY OF MEASUREMENT RESULTS FOR CHURCH ST. STATION PLATFORM

TIME	MIC POSITION	SAMPLE TIME	TRAIN CONDITIONS	UNITS	AVG MAX LEVEL		AVG LR		CUMULATIVE AMPLITUDE DISTRIBUTION					Leq
					FAR	NEAR	FAR	NEAR	L99	L90	L50	L10	L1	
Day	Center of Stopped Train	30 min	Arrival	b) N	3-6	4-6	3-6	4-6	58	60	65	79	87	75
				dBA	85	86	94	94						
				c) S	2.18	2.55	2.99	2.15						
			Departure	N	3-6	3-6	3-6	3-6						
				dBA	85	85	93	94						
				S	1.80	1.80	2.14	1.15						
Notes: a - Track b - Number of Trains - (e.g.: 4-2 means four 2-car trains) c - Standard Deviation of Level														

7-134

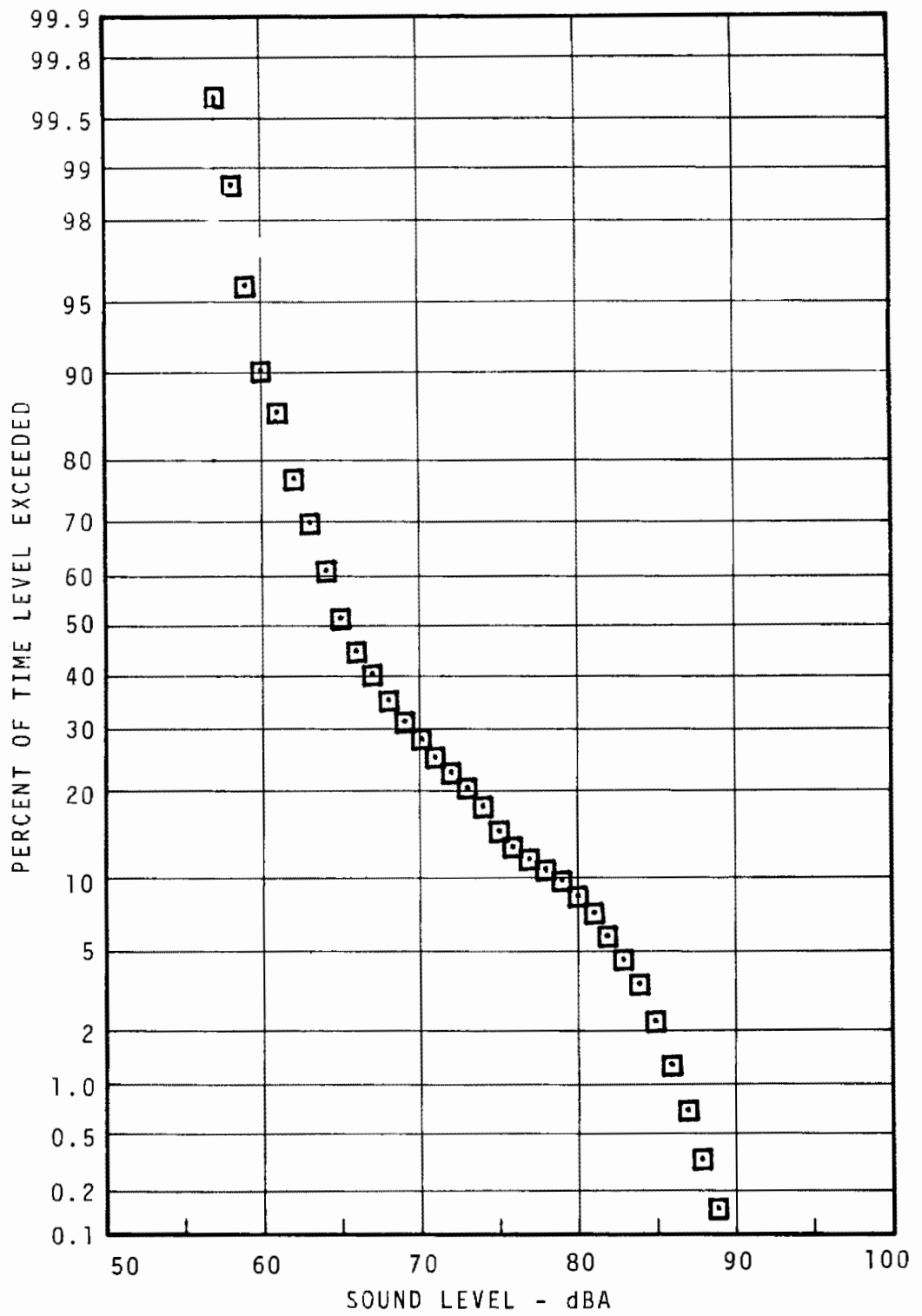

FIGURE 7.86 - CHURCH STREET STATION PLATFORM
 STATISTICAL DISTRIBUTION -
 DAYTIME

7-136/7-137

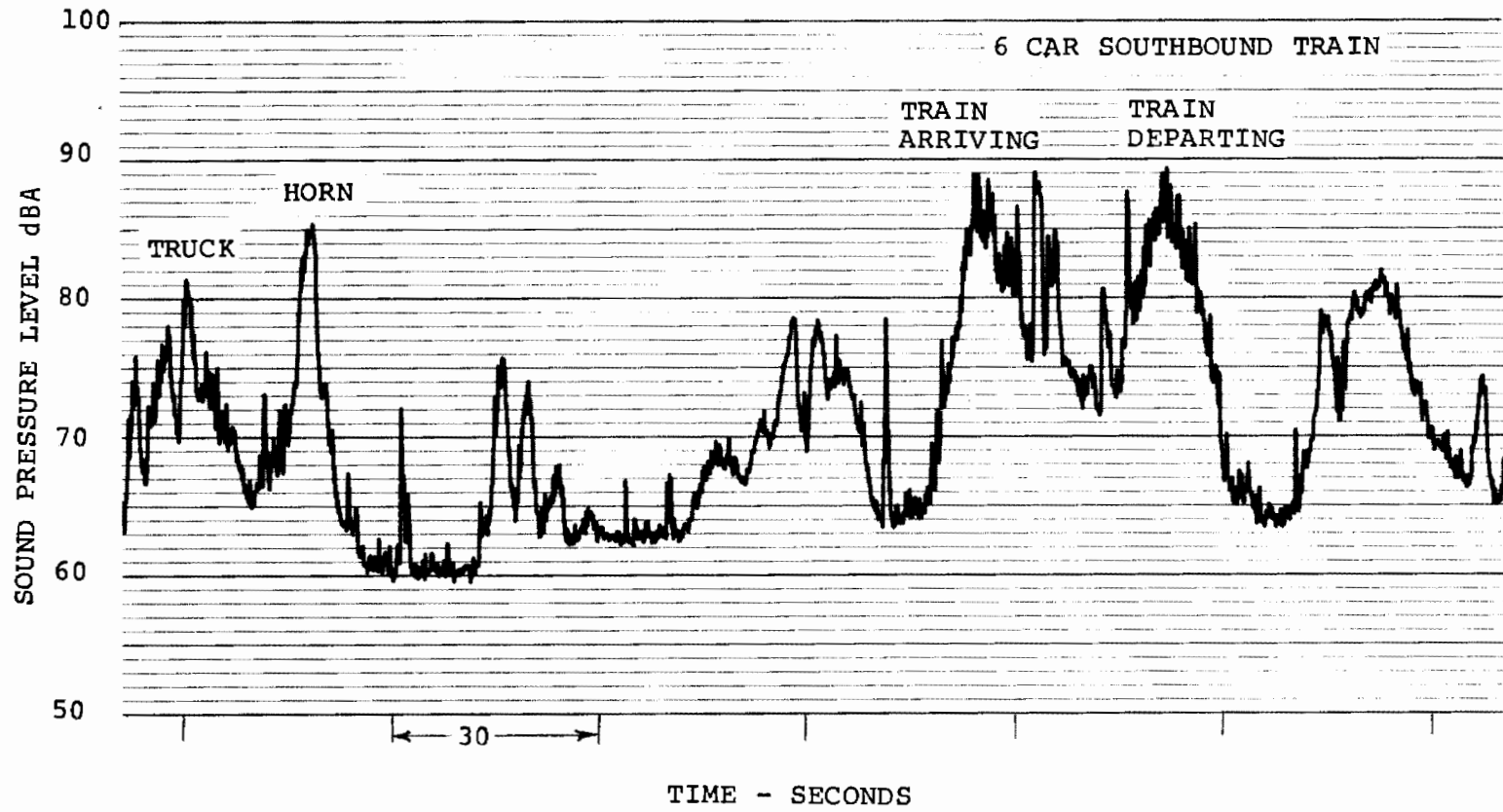
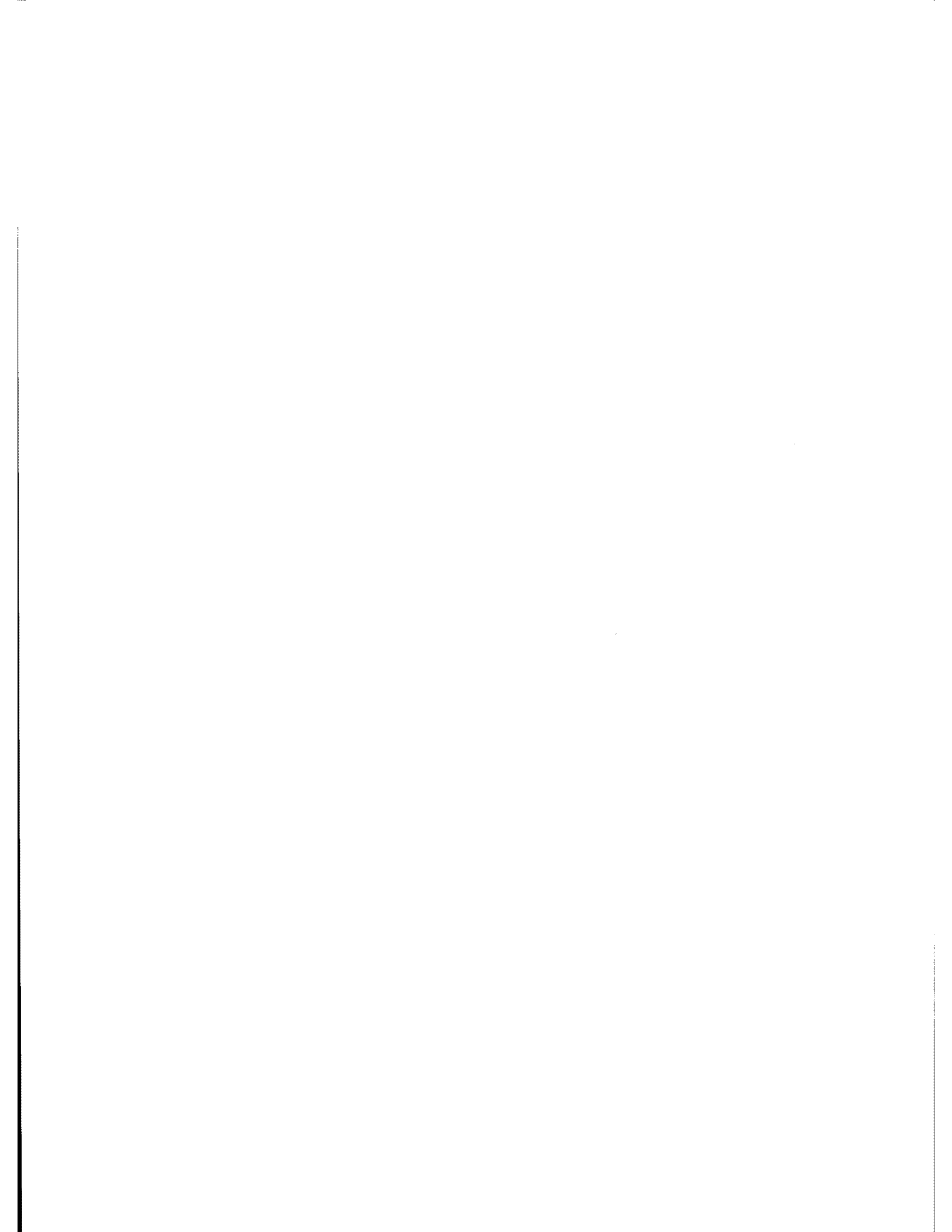

FIGURE 7.87 - TYPICAL TIME HISTORY, CHURCH ST. STATION



BRIDGE STREET TERMINAL STATION

SITE DESCRIPTION (see Figure 7.88)

Bridge Street Station consists of one island platform and one side platform with two tracks as shown in Figure 7.88. Trains enter and leave on both tracks without reversing, unlike the 69th Street Terminal. The side platform is used only during peak hours. When trains come off line at Bridge Street they continue north of the station to the yard area which is located on grade. Below the station on the west side is a bus terminal. A supermarket and other businesses are located on the east side. On the east side of the system, second floor housing lies within 15 ft of the transit line. Other business structures are built to within 2 ft of the steel supporting structure of the track.

NOISE CLIMATE (see Table 7.20, Figures 7.89 - 7.93)

Just west of the platform is a double crossover which produces high impact noise. Some insulated gaps also cause impact noise and there is a substantial noise and vibration level at the station when trains enter and leave. Background noise, in addition to standing trains, is generated by buses and street traffic.

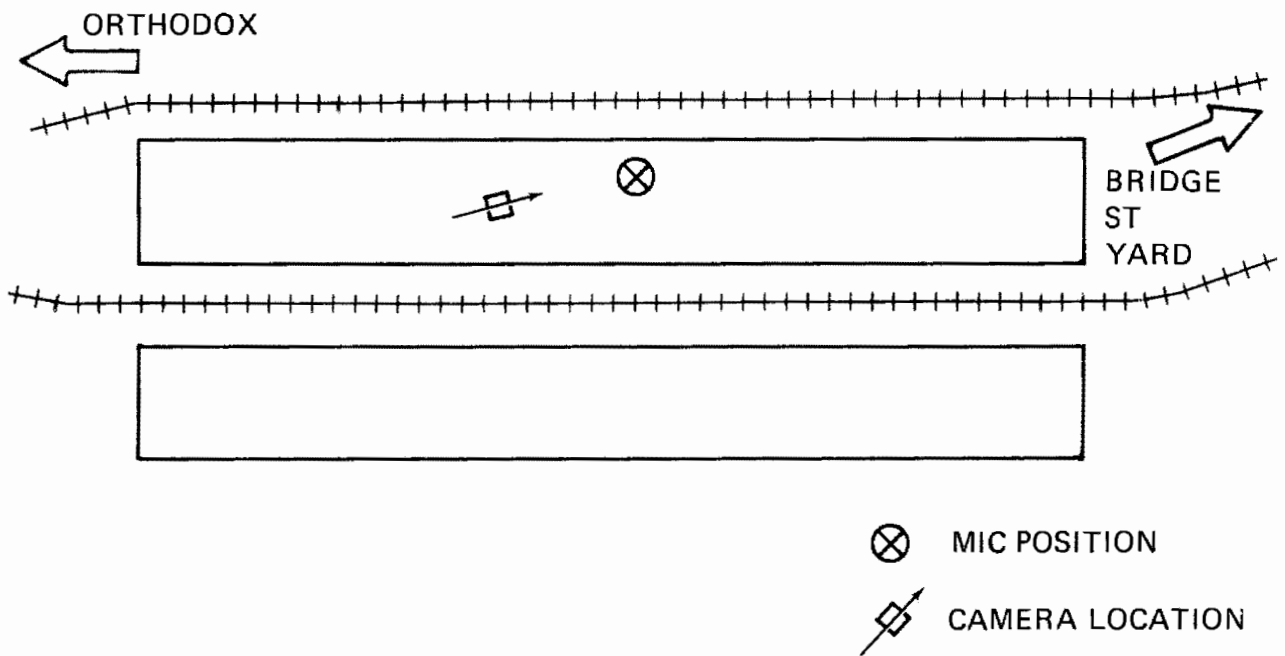
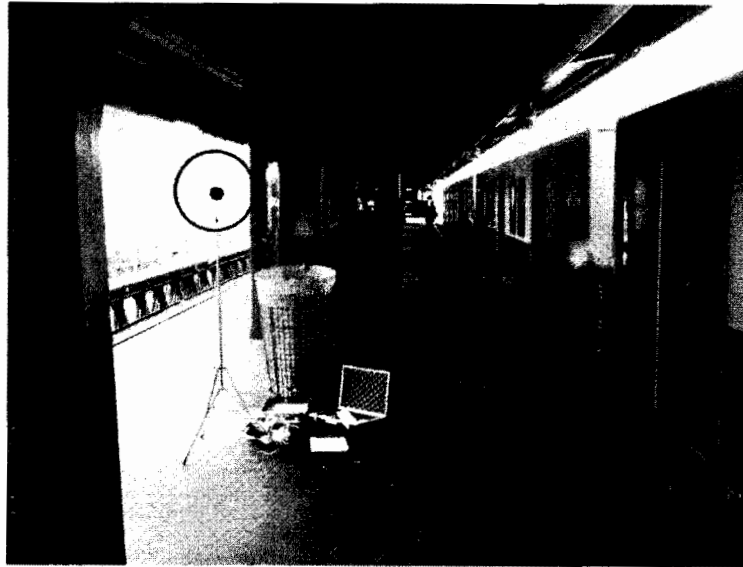

FIGURE 7.88 - BRIDGE ST. ELEVATED PLATFORM TERMINAL

TABLE 7.20 - SUMMARY OF MEASUREMENT RESULTS FOR BRIDGE ST. STATION

TIME	MIC POSITION	SAMPLE TIME	TRAIN CONDITIONS	UNITS	AVG MAX LEVEL		AVG L _R		CUMULATIVE AMPLITUDE DISTRIBUTION					L _{eq}	
					FAR	FAR	FAR	FAR	L ₉₉	L ₉₀	L ₅₀	L ₁₀	L ₁		
Day	Center of Stopped Train	30 min	Arrival	b) N	4-6		4-6		63	65	68	73	84	73	
				dBA	85		93								
				c) S	1.78		1.40								
			Departure	N		5-6		5-6							
				dBA		81		91							
				S		0.55		0.58							
Rush		Arrival and Departure	dBA					70	72	78	86	92	83		
Evening			dBA					61	63	66	72	87	74		
Night			dBA					69	70	72	74	85	75		

Notes: a - Track
 b - Number of Trains - (e.g.: 4-2 means four 2-car trains)
 c - Standard Deviation of Level

7-140

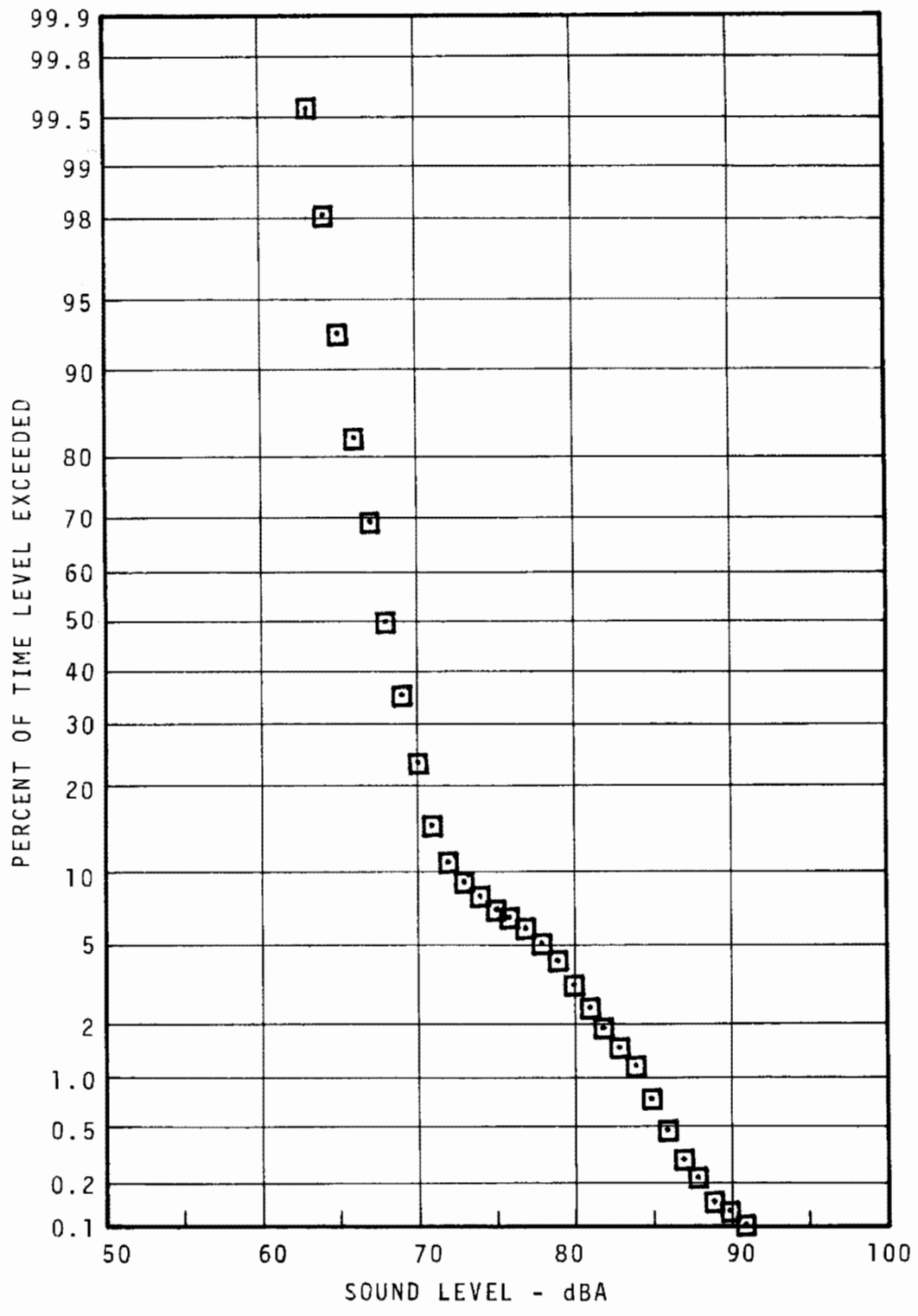

FIGURE 7.89 - BRIDGE STREET STATION PLATFORM
 STATISTICAL DISTRIBUTION -
 DAYTIME

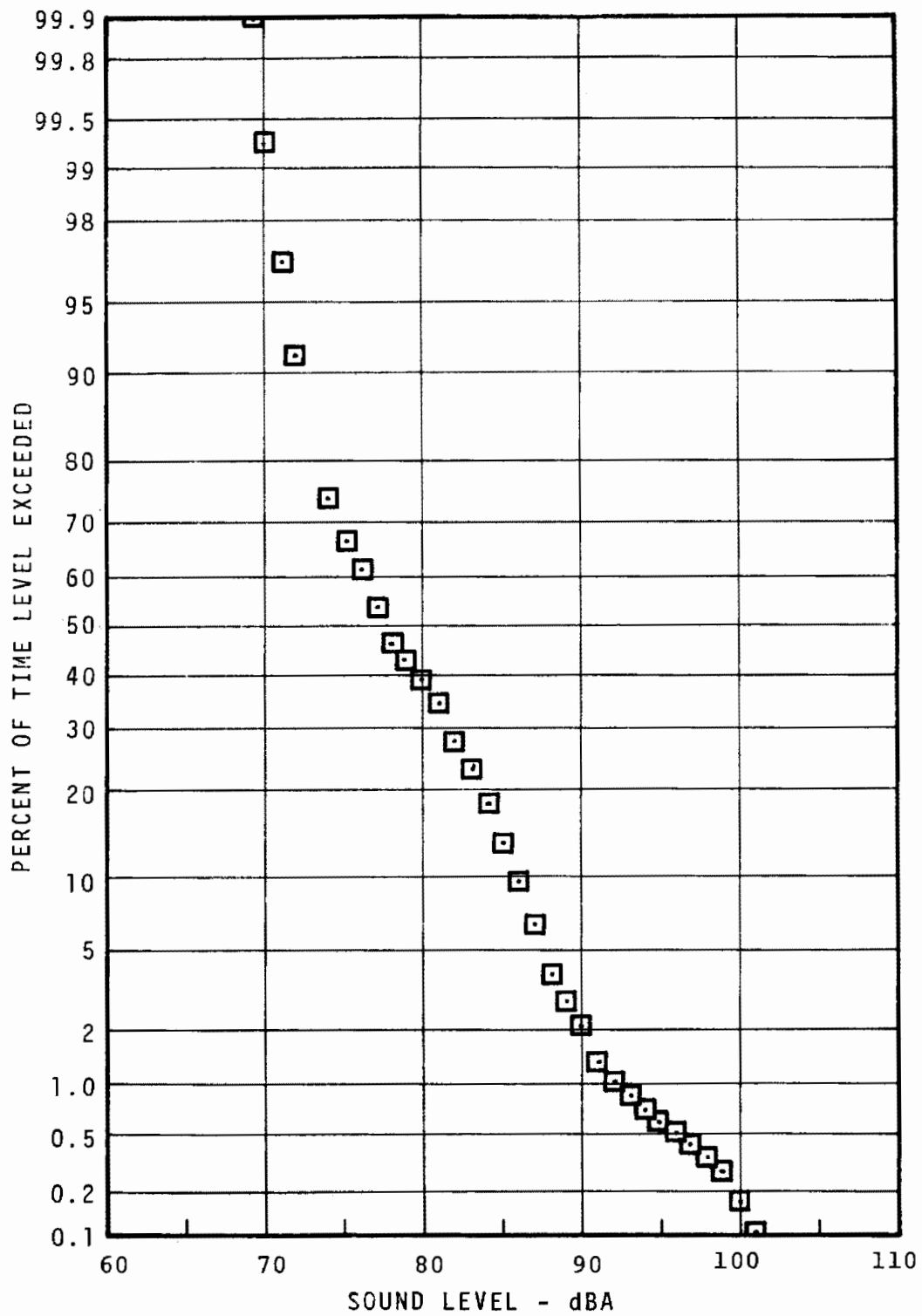

FIGURE 7.90 - BRIDGE STREET STATION PLATFORM
 STATISTICAL DISTRIBUTION -
 RUSH HOUR.

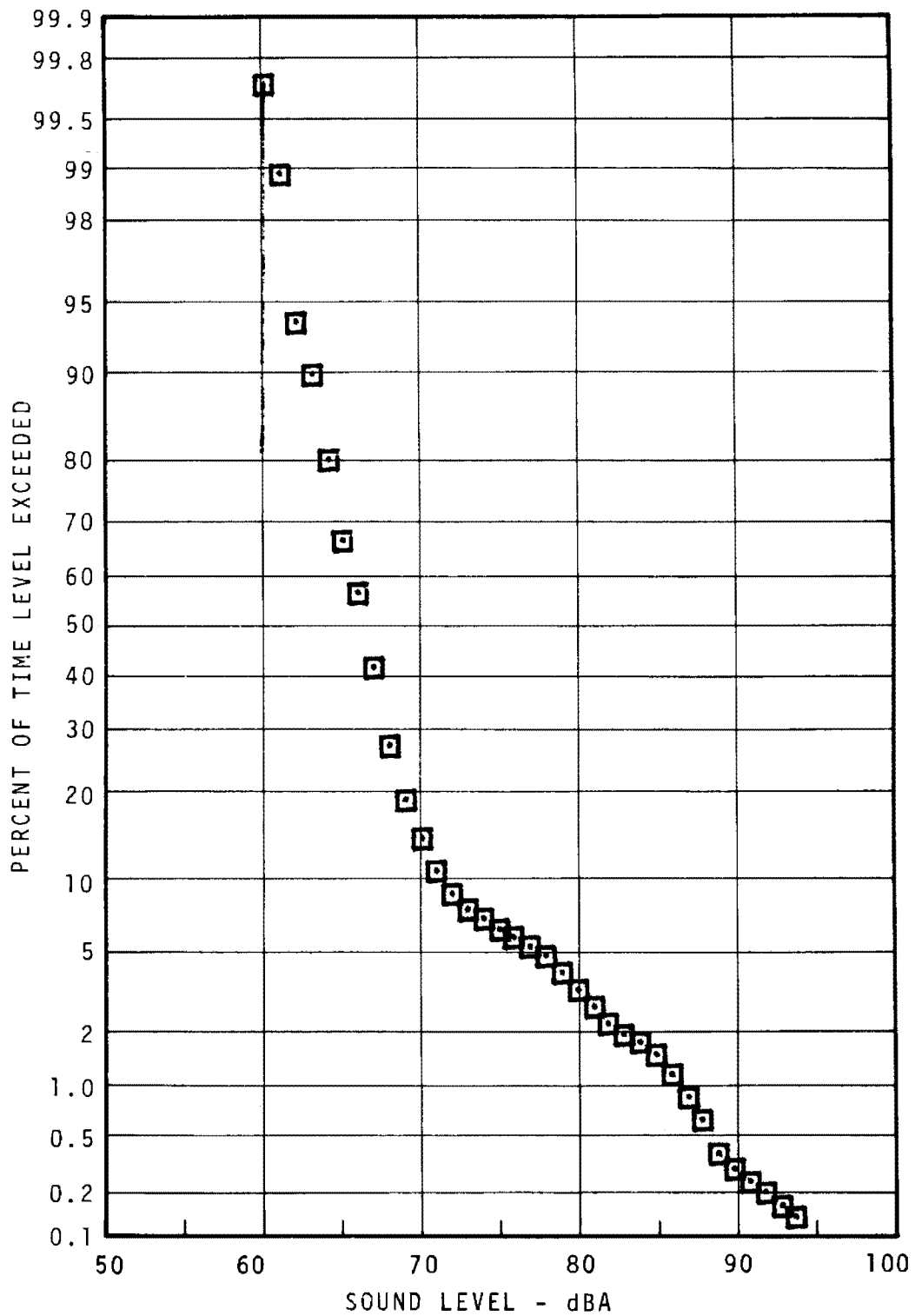

FIGURE 7.91 - BRIDGE STREET STATION PLATFORM
 STATISTICAL DISTRIBUTION -
 EVENING

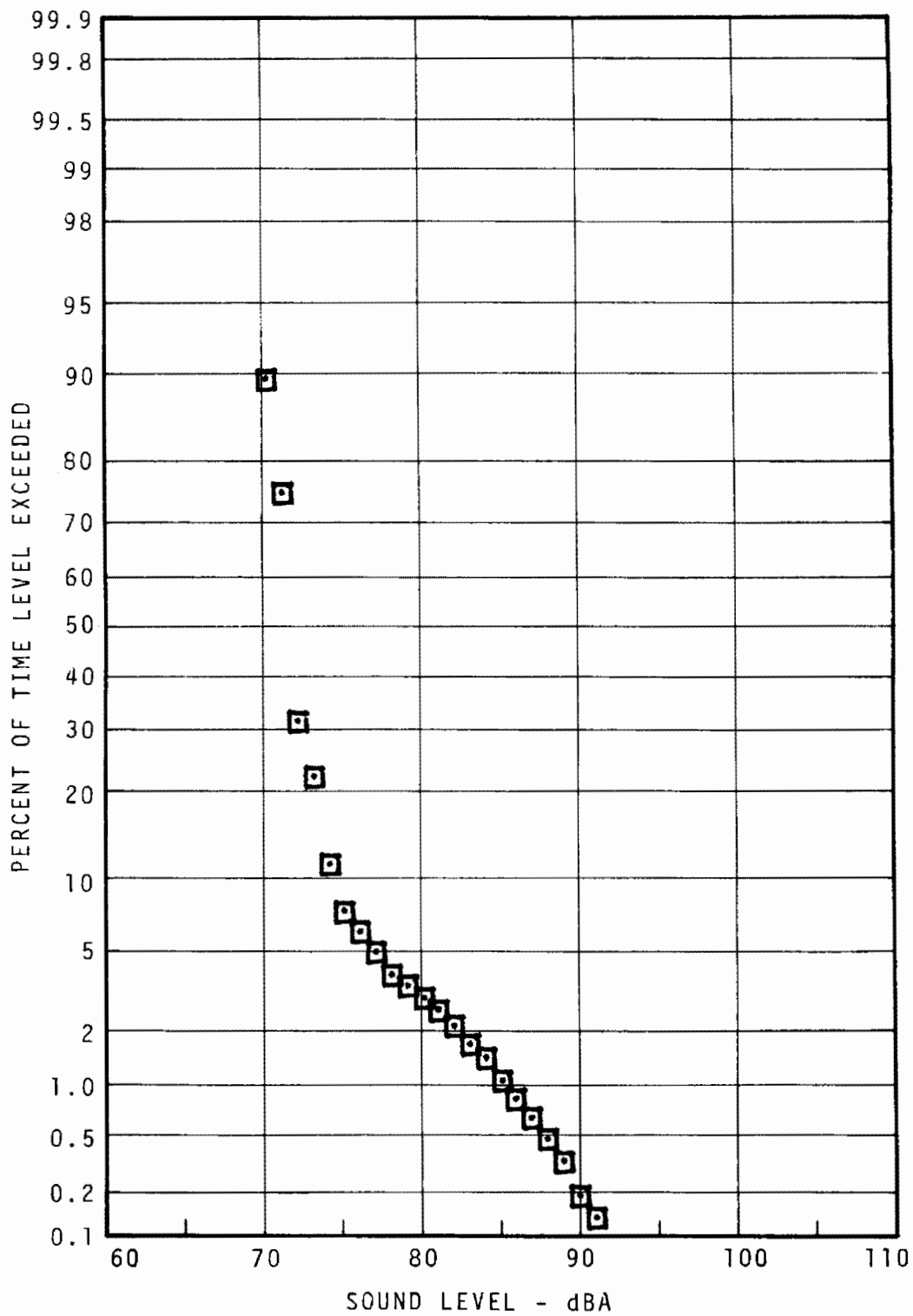

FIGURE 7.92 - BRIDGE STREET STATION PLATFORM
 STATISTICAL DISTRIBUTION -
 NIGHT

7-145/7-146

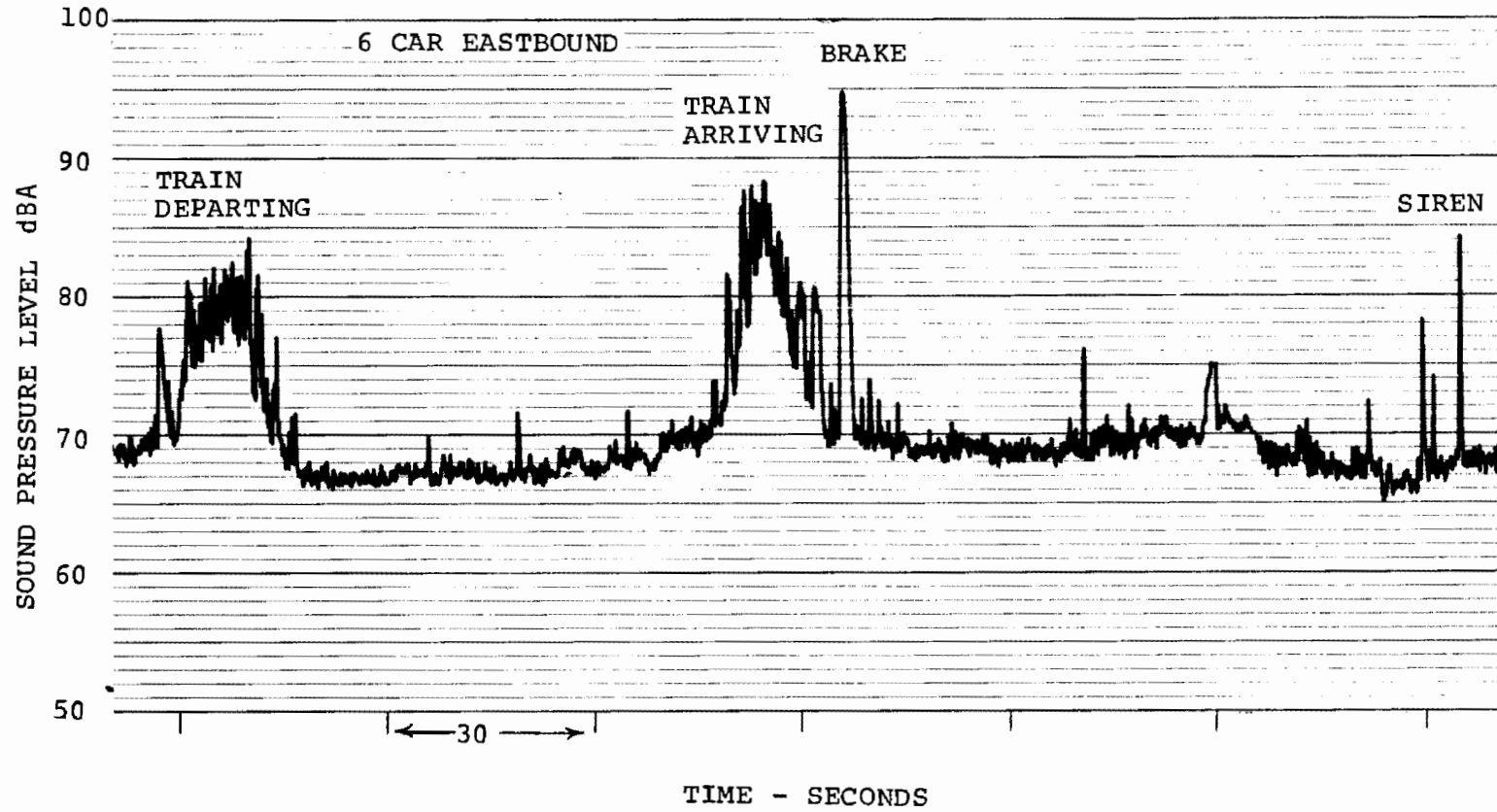
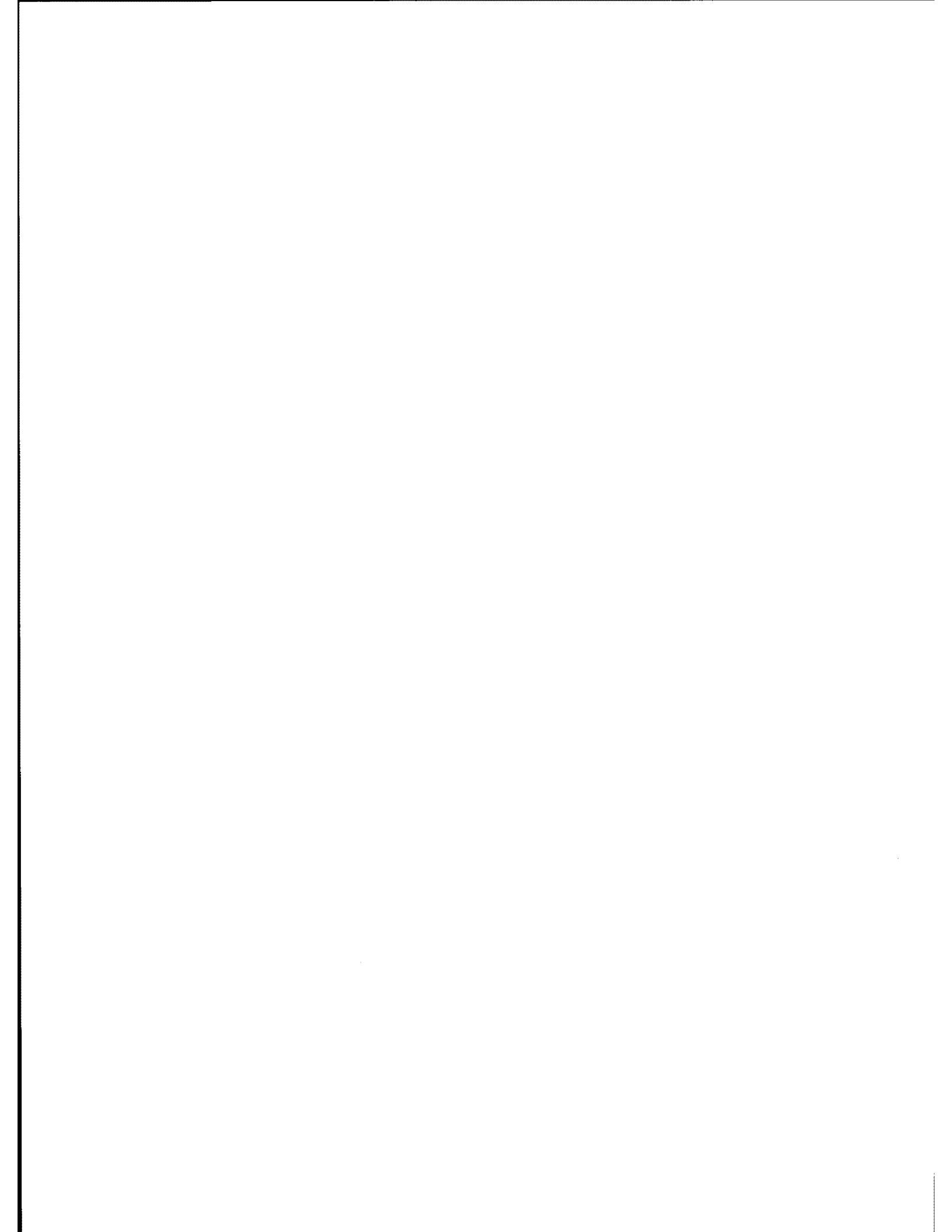

FIGURE 7.93 - TYPICAL TIME HISTORY, BRIDGE ST. STATION



7.2.3 Vehicle Interior

Continuous recordings were made in a 1960 Series Budd car for two separate round trips. Recordings were made in different cars for each round trip. A microphone was located at a mid-car seated, ear-level position and at an operator's station in the second car of a train. Voice annotation on a separate recording track noted specific noise sources and other information useful for interpreting the data.

1960 BUDD CAR INTERIOR

CAR DESCRIPTION (see Figure 7.94)

Measurements of in-car noise levels were made for two round trips in the Budd cars. On the northbound trips, data was taken in the second car of a six car train. For the return trip, the same car was utilized, but this car became the fifth car of the train. The number of passengers on the car during the measurement program remained generally constant at approximately 20. This number varied only slightly, with some passengers exiting, others boarding at each station. Measurements were made at the end of the morning rush hour, but before school hours began.

NOISE CLIMATE (see Tables 7.21, 7.22; Figures 7.95 - 9.103)

The brake air compressor is a predominant noise source on the car when it operates, and it sets up a very noticeable vibration level in the car. When the ventilation fans operate, they generate a broadband noise which sets the background level where the car is stopped.

As the train leaves the 69th Street Terminal, squeal is generated immediately beyond the station platform. Entering Millbourne Station, squeal is again generated, this time for a period of approximately one-half minute.

Leaving Millbourne, squeal is again generated negotiating the curve leading to the elevated structure. From this point until east of 46th Street Station, the predominate in-car noise sources are wheel/rail roar and impact. East of 46th Street the line "S" curves and descends into the subway with squeal, and the horn is sounded. The train accelerates to 40th Street where it then brakes hard. West of 30th Street Station, there is a crossover where substantial impact noise is generated. Leaving 30th Street the system descends under the Schuylkill River. From 33rd Street to City Hall a route of the subway-surface line parallels the Market-Frankford system on two outer tracks in the same subway. Just north of 2nd Street, the train generates perhaps the greatest amplitude squeal on the system as it negotiates the 200 ft (60m) radius curve within the tunnel, and the horn is sounded. North of this location, the system becomes elevated. During the measurement program, the elevated structure north of second street was undergoing repairs, and car speeds were restricted to 20 mph. North of the York-Dauphin platform, wheel squeal levels are very high. North of Allegheny Station the tracks rise to cross the Penn Central Railroad and impact noise is generated on the bridge. Low squeal levels are generated west of Church Street Station. Entering Bridge Street Terminal, substantial impact noise is generated as the train negotiates a double crossover. The return trip noise environment is essentially the reverse of that described for the northbound trip.

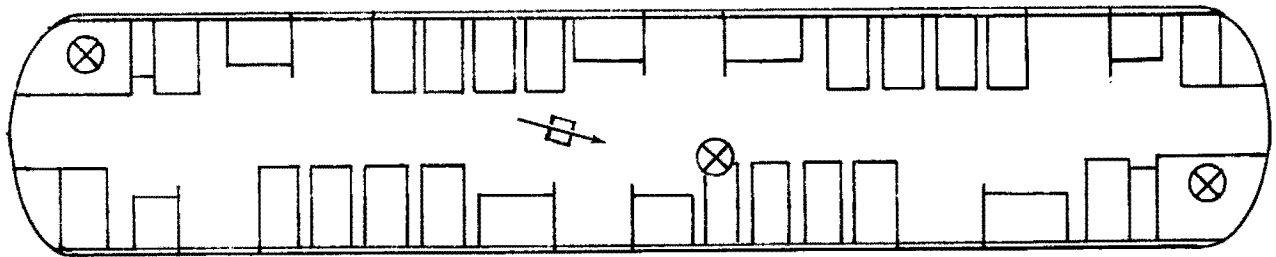
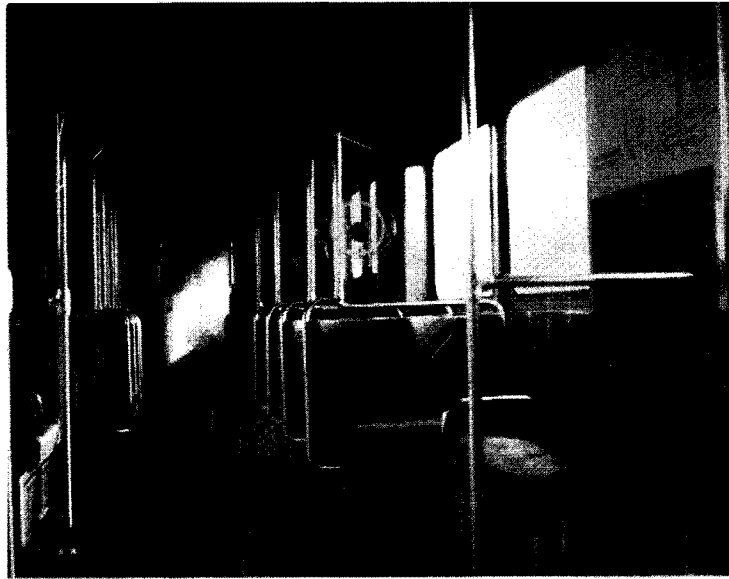

⊗ MIC POSITIONS

◻ CAMERA LOCATION

FIGURE 7.94 - IN-CAR MEASUREMENT LOCATIONS - SEPTA
1960 BUDD CAR

TABLE 7.21
SEPTA MARKET FRANKFORD LINE
IN-CAR NOISE PLATEAU LEVELS

STATION	BUDD CARS			DOUBLE CAR	
	SINGLE CAR - WESTBOUND L _A (Max) (dBA)	MID-CAR EASTBOUND L _A (Max) (dBA)	AVERAGE L _A (Max) (dBA)	EASTBOUND (MID CAR) L _A (Max) (dBA)	WESTBOUND (OP. BOOTH) L _A (Max) (dBA)
Bridge-Pratt	81.5	77	79	77	77
Orthodox	78.5	77.5	78	75	77.5
Church	78.5	75	77	76	78
Erie-Torresdale	80	77	79	77	77
Tioga	78	76.5	77	78	76.5
Allegheny	78	78.5	78	78.5	78
Somerset	80	77	79	77	76
Huntington	78	75	77	76	78
York-Dauphin	78.5	77.5	78	76	78
Berks	78	75.5	77	77	75.5
Girard	81.5	76.5	79	76	79
Fairmount	90	79.5	85	79.5	82
2nd Street	90	83.5	87	86	92
5th Street	88.5	88	88	90.5	93
8th Street	82.5	86	84	87.5	92
11th Street	85.5	81.5	83	79.5	87.5
13th Street	89	87	88	84	90.5
15th Street	88	85	87	84	91
30th Street	89.5	88.5	89	84.5	92
34th Street	88.5	88.5	89	85	93
40th Street	81.5	88	85	84	90
46th Street	83.5	83.5	84	81.5	81
52nd Street	83	81.5	82	78	82.5
56th Street	83.5	79.5	82	77.5	83.5
60th Street	78	80	79	78.5	81
63rd Street	77	76.5	77	80	76
Millbourne	82.5	77.5	80	74	79.5
69th Street					

TABLE 7.22 - . SUMMARY OF MEASUREMENT RESULTS FOR 1960 BUDD CARS - INTERIOR NOISE LEVELS

CAR TYPE	MIC POSITION	SAMPLE TIME	TRAIN HEADING	UNITS	AVG MAX LEVEL		AVG LR		CUMULATIVE AMPLITUDE DISTRIBUTION					Leq
					NEAR	FAR	NEAR	FAR	L99	L90	L50	L10	L1	
Single	Mid-Car	44 Min.	East	dBa					66	67	73	82	88	78
	Oper.			dBa					66	67	73	83	88	79
	Mid-Car	46 Min.	West	dBa					67	69	74	83	88	79
	Oper.			dBa					66	67	74	84	88	79
Double	Mid-Car	49 Min.	East	dBa					66	67	73	80	86	76
	Oper.			dBa					66	67	73	84	90	79
	Mid-Car	45 Min.	West	dBa					65	67	72	82	88	78
	Oper.			dBa					65	66	73	85	91	80

7-151

Single Car

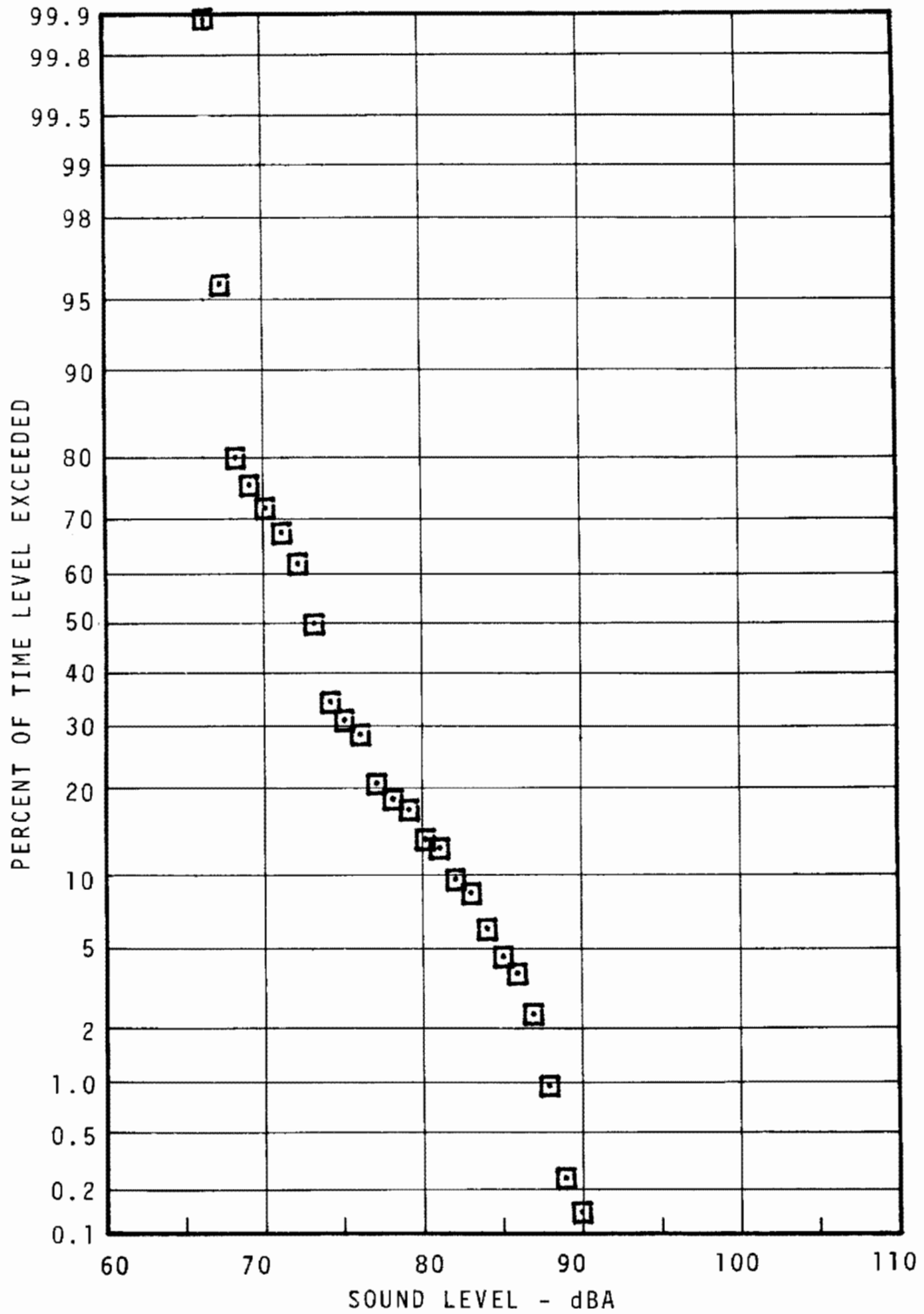

FIGURE 7.95 - 1960 BUDD IN-CAR (CENTER)
STATISTICAL DISTRIBUTION
69TH ST. TO BRIDGE ST.

Single Car

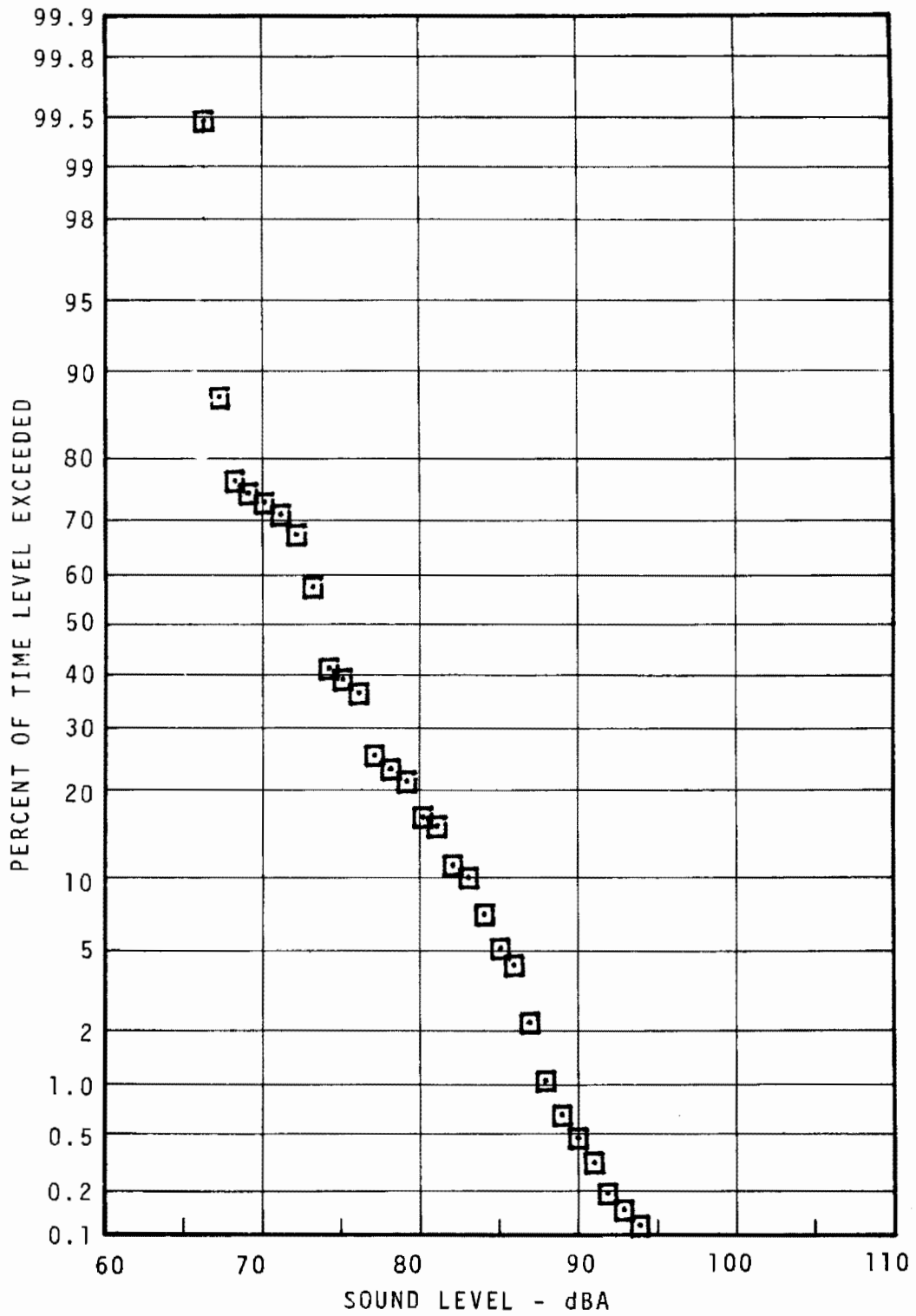

FIGURE 7.96 - 1960 BUDD IN-CAR (OPERATOR BOOTH)
STATISTICAL DISTRIBUTION -
69TH STREET TO BRIDGE ST.

Single Car

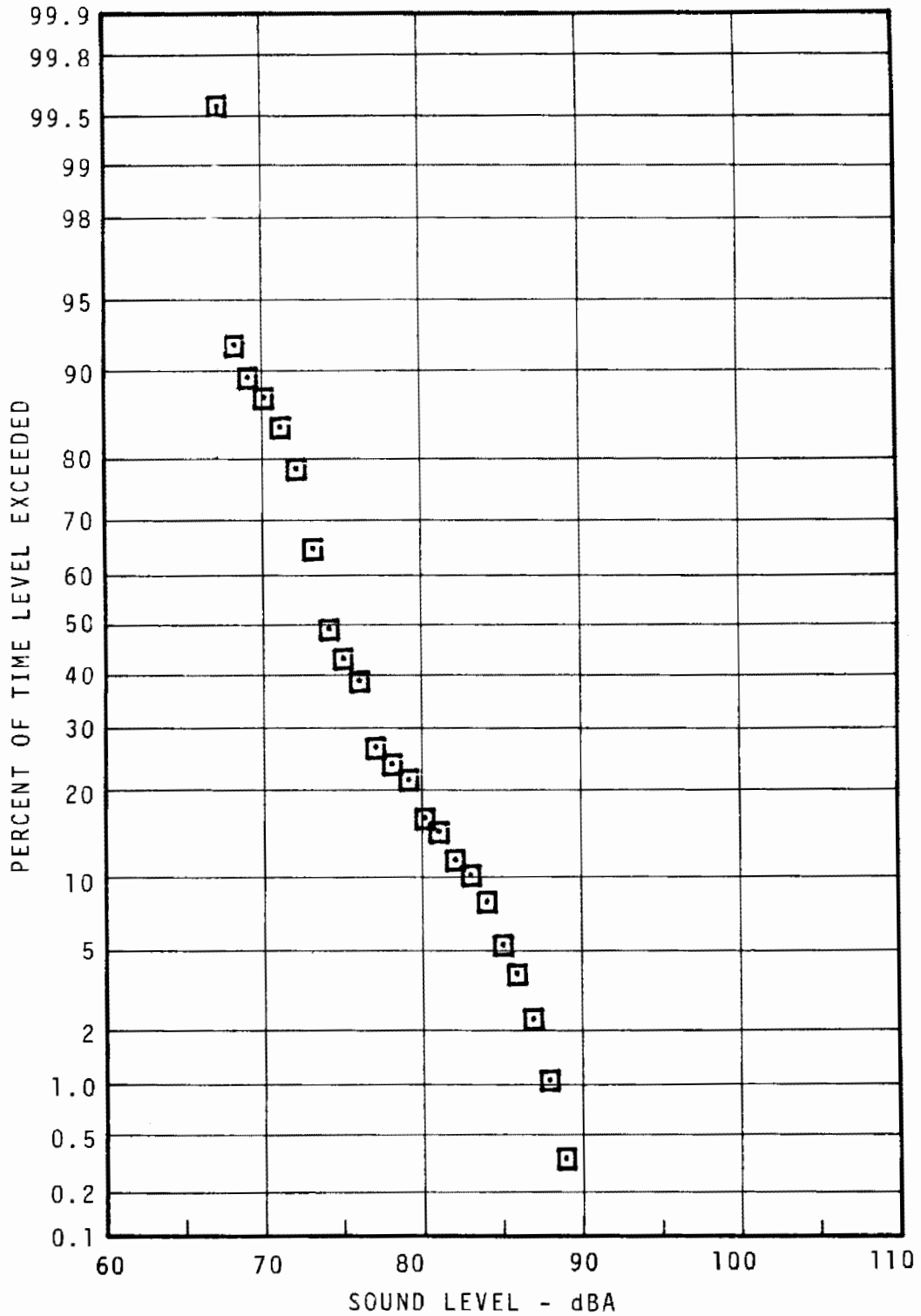

FIGURE 7.97 - 1960 BUDD IN-CAR (CENTER)
STATISTICAL DISTRIBUTION
BRIDGE STREET TO 69TH STREET

Single Car

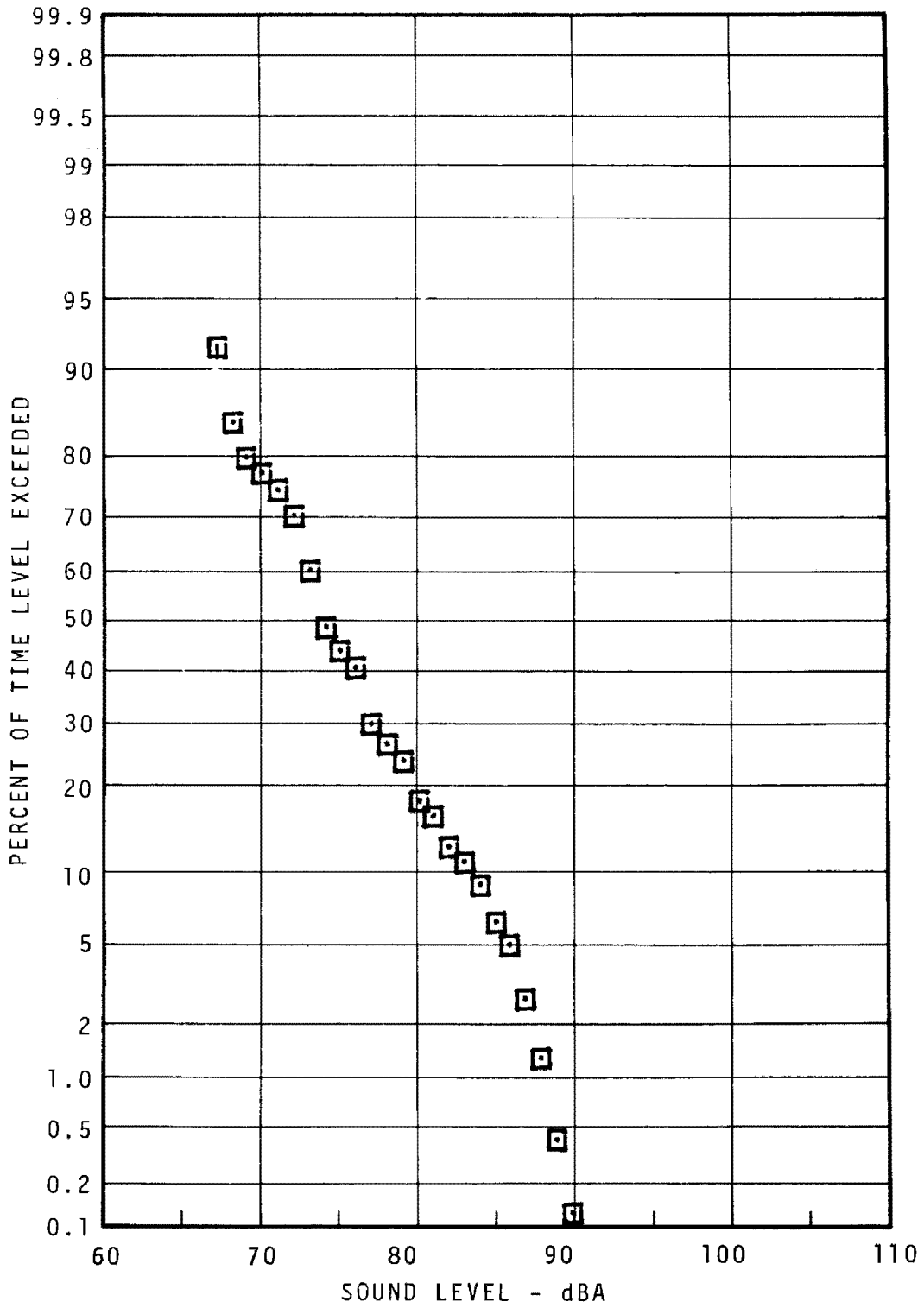

FIGURE 7.98 - 1960 BUDD IN-CAR (OPERATOR BOOTH)
STATISTICAL DISTRIBUTION -
BRIDGE STREET TO 69TH STREET

Double Car

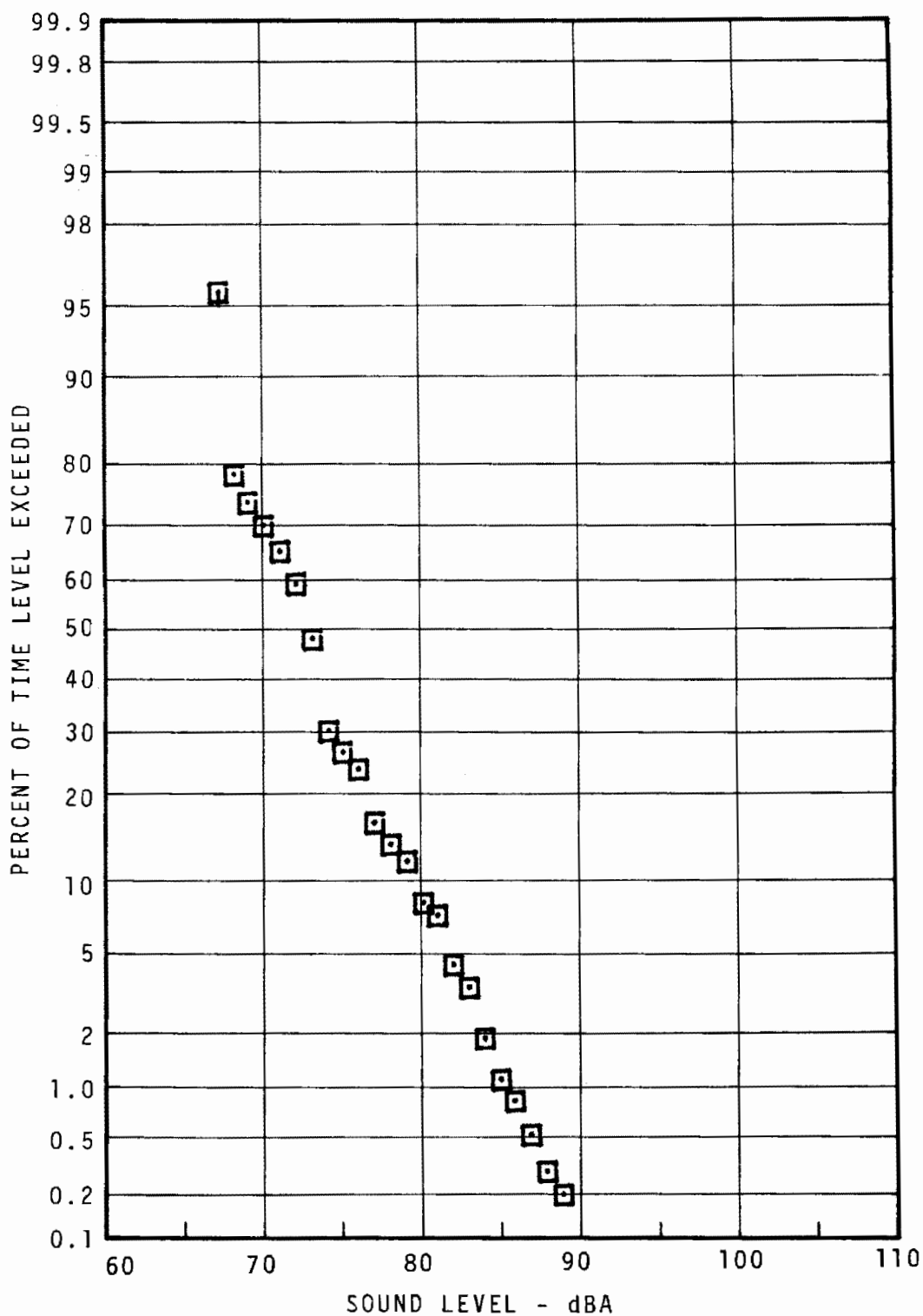

FIGURE 7.99 - 1960 BUDD IN-CAR (CENTER)
STATISTICAL DISTRIBUTION -
69TH STREET TO BRIDGE STREET

Double Car

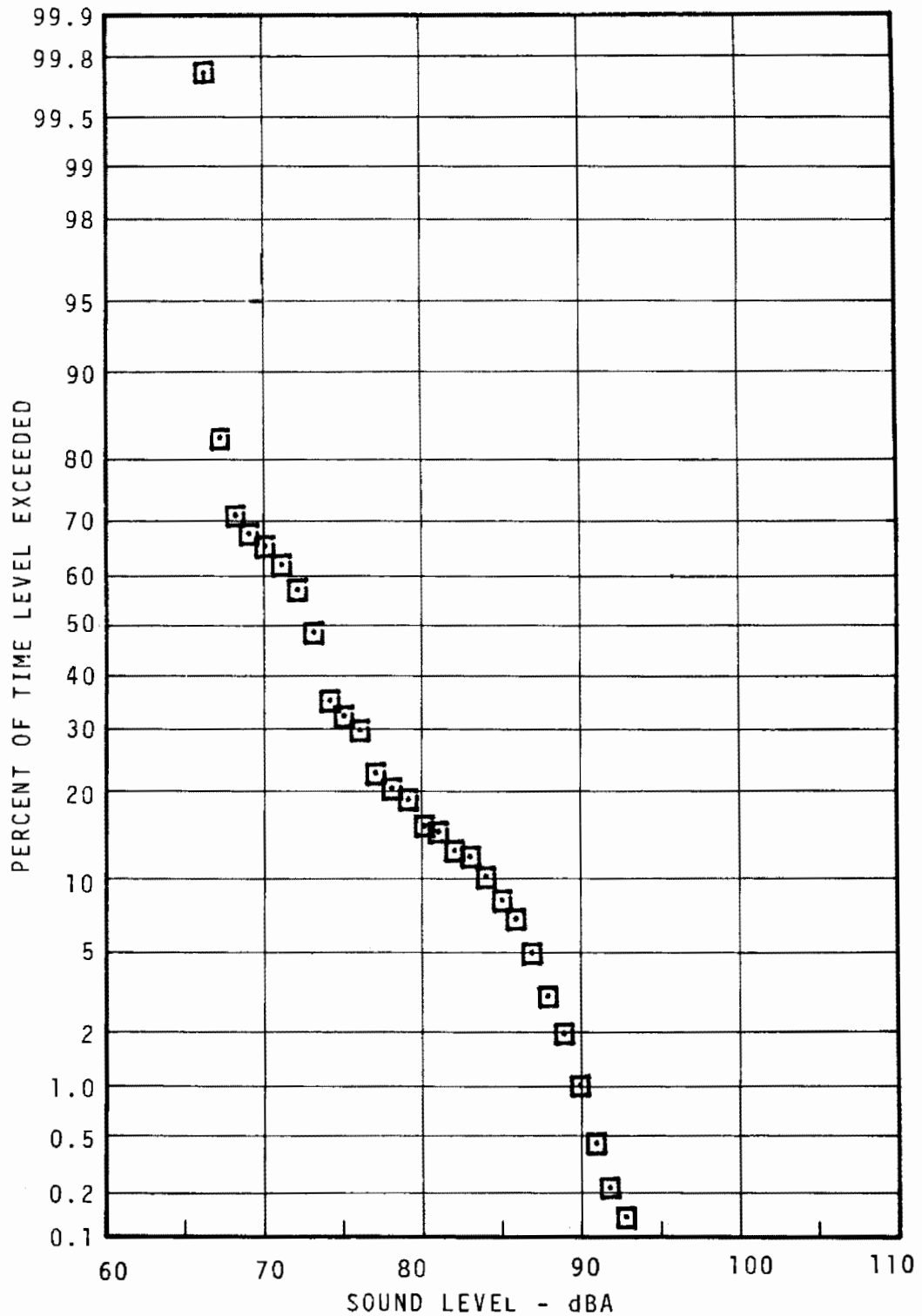

FIGURE 7.100 - 1960 BUDD IN-CAR (OPERATOR BOOTH)
STATISTICAL DISTRIBUTION -
69TH STREET TO BRIDGE ST.

Double Car

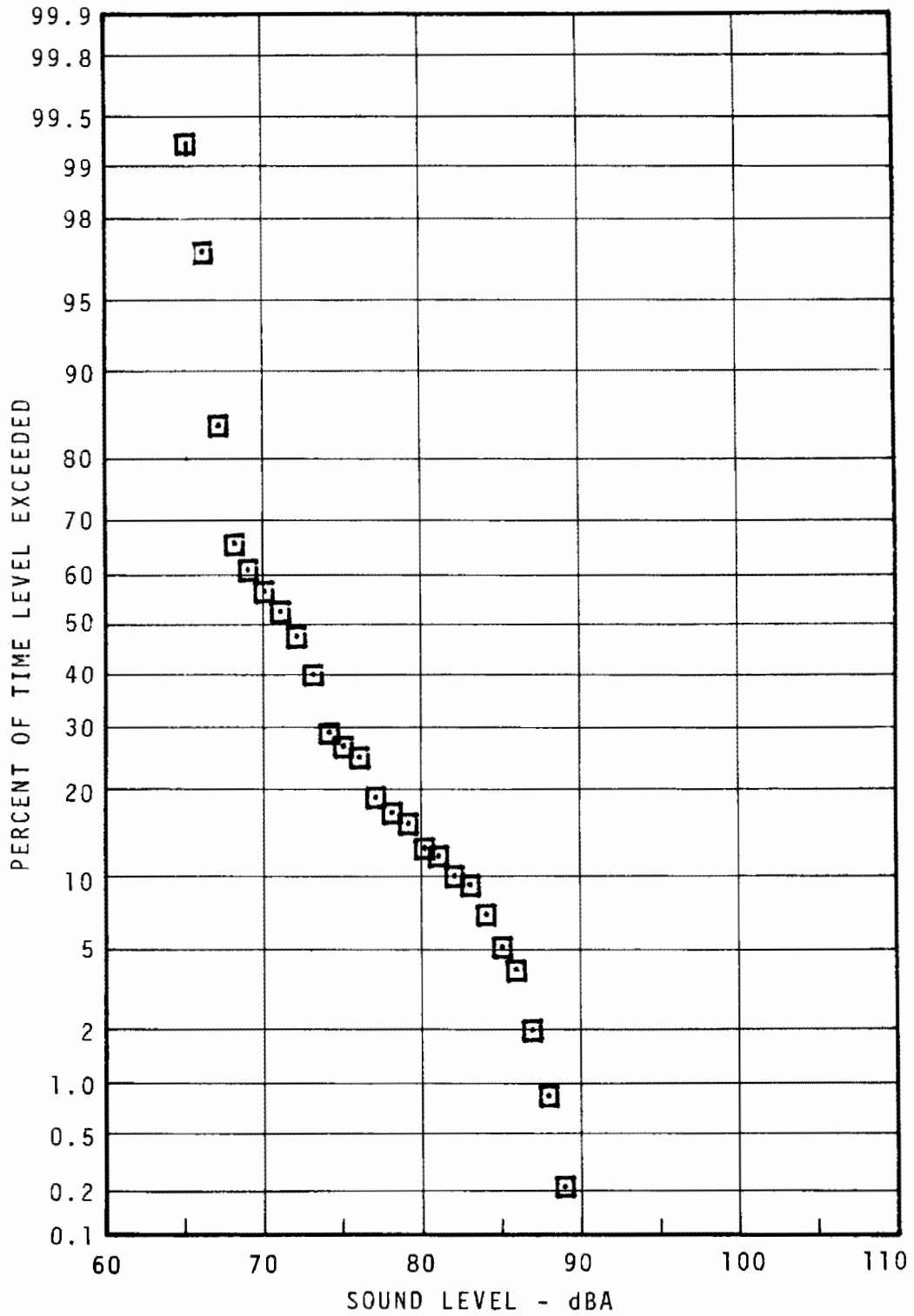

FIGURE 7.101 -1960 BUDD IN-CAR (CENTER)
STATISTICAL DISTRIBUTION -
BRIDGE STREET TO 69TH ST.

Double Car

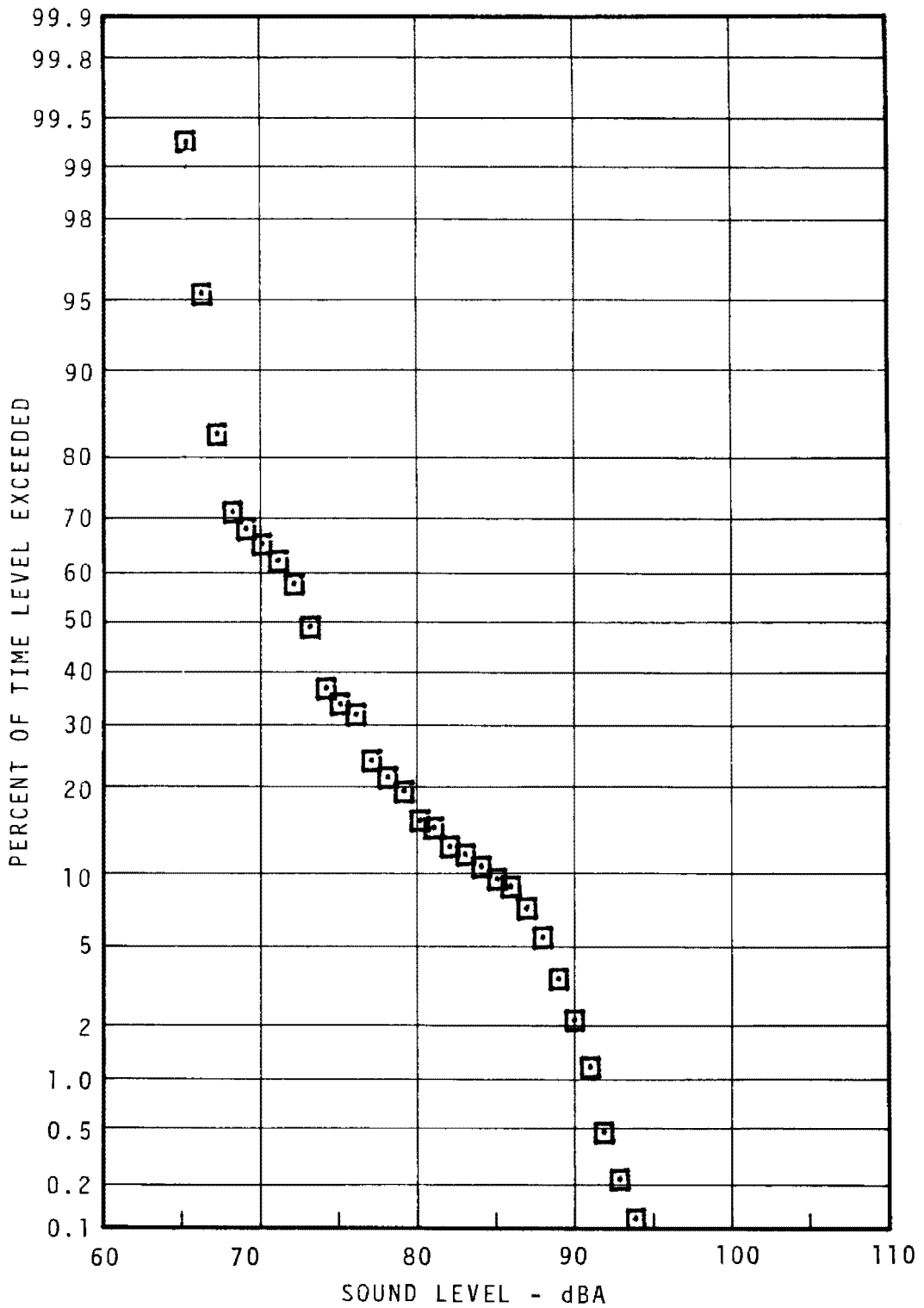

FIGURE 7.102 - 1960 BUDD IN-CAR (OPERATOR BOOTH)
STATISTICAL DISTRIBUTION -
BRIDGE STREET TO 69TH ST.

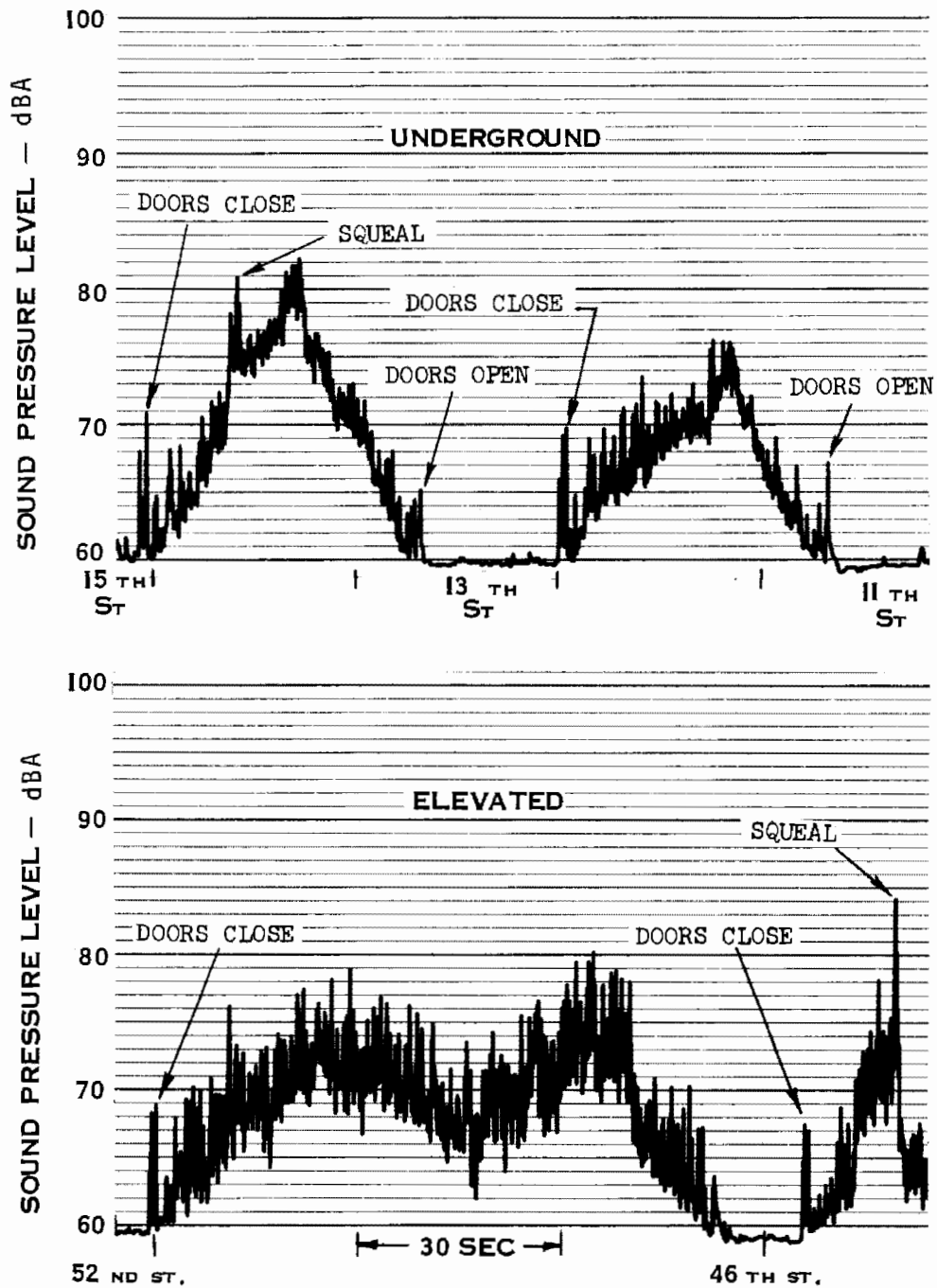

FIGURE 7.103 - TIME HISTORY OF IN CAR NOISE ENVIRONMENT
SEPTA MARKET-FRANKFORD ELEVATED LINE

SEPTA - MARKET/FRANKFORD LINE

8. TRANSIT SYSTEM LINE SUMMARY

8.1 General

The data reported in Section 7, recorded for representative community, station platform and in-car locations, is summarized for the Market Frankford Line in the following tables and illustrations. General information regarding system operating factors (cars per train, headway, noise measurement periods, etc.) are presented in Table 8.1 to illustrate the rationale for selecting time intervals, or "windows" when noise measurements were made. Calculation of day-night levels have been based on daytime, rush hour, evening and night time measurements. Quantities used for calculating L_{dn} have also been identified in Table 8.1.

Tables summarizing noise levels recorded at each community and station location selected for measurement were presented in Section 7. This information has been further generalized to provide an overview of the noise climate of the Market Frankford Subway-Elevated Line and this data is presented in Table 8.2. Wayside noise levels shown represent the average of the passby maximum levels. This is presented for both the near and far tracks as reported in Section 4. Data is shown for representative elevated structure and on-grade locations.

Station noise levels shown in Table 8.2 represent an average of the maximum level $L_A(\text{Max})$ recorded for each train observed during the recorded interval. This maximum level may occur either for the arrival or departure of the train. In-car data shown represent the plateau level between stations measured at a center car location.

A summary of track construction for the Market-Frankford Line is presented in Figure 8.1.

8.2 Community Noise

Noise levels were measured at three elevated structure locations; at Hart Lane between Huntingdon and Somerset, on York Street at York-Dauphin and at 54th Street between 52nd and 56th Street Stations. At the first two sites, the microphone was located nearest to the westbound track. Train speed at these two locations (as for the entire system north of 2nd Street) was restricted to 20 mph whereas speeds at the 54th Street site was estimated to be 45 mph. At 54th Street, the microphone was nearest the eastbound track. The effect of car speed on wayside noise can be estimated by comparing the two elevated steel tangent track locations, Hart Lane and 54th Street. The $L_A(\text{Max})$ levels at the former site are 2-3 dBA lower than at 54th Street due to the lower speeds (20 mph compared with 45 mph).

TABLE 8.1. GENERALIZED OPERATION SUMMARY AND INPUT FOR L_{dn} CALCULATION (see page 4-12)
SEPTA MARKET FRANKFORD LINE

TIME OF DAY	6	8	10	12	2	4	6	8	10	12	AM	2	4
CARS/TRAIN	6						4						
HEADWAY, MIN	7½	2½	7½	5	2½	7½	25						
MEAS. WINDOW-SEPTA -PROGRAM	DAY	RUSH	DAY		SCHOOL	RUSH	EVE		NIGHT				
WEIGHTING FACTOR, w_i	10		1						10				
	<u>Period</u>	<u>Meas. L_{eq}</u>	<u>w_i</u>	<u>T (hrs)</u>									
	5-7	DAY	10	2									
	7-9:30	RUSH	1	2.5									
	9:30-4	DAY	1	6.5									
	4-6	RUSH	1	2									
	6-10	EVE	1	4									
	10-10:30	EVE	10	0.5									
	10:30-5	NIGHT	10	6.5									

TABLE 8-2
 NOISE MEASUREMENT SUMMARY
 SEPTA MARKET-FRANKFORD LINE
 DAYTIME

STATION	INTER-STATION DISTANCE (MILES)	AVER. TIME BETWEEN STATIONS (MIN.)	TYPE ROADBED	TRACK CONSTRUCTION	NO. OF CARS PER TRAIN	WAYSIDE Noise (15m) (dBA)		STATION PLATFORM NOISE (dBA)	IN-CAR NOISE MID-CAR AVERAGE OF EAST & WESTBOUND TRIP	
						E	W		DOUBLE CAR (dBA)	SINGLE CAR (dBA)
Bridge-Pratt			Elevated	Ballast & Tie	6			83		
	0.60	1	↑	↑	↑				77	79
Orthodox	0.45	1							75	78
Church	0.50	1						85	76	77
Erie-Torr.	0.65	1.5							77	79
Tioga	0.45	1							78	77
Allegheny	0.60	2							79	78
Somerset	0.30	1				86	80		77	79
Huntington	0.35	1							76	77
York-Dauphin	0.45	1				90	98	86	76	78
Berks	0.70	2							77	77
Girard	0.50	1.5	↓	↓					76	79
Fairmount	0.95	3	Elevated	Ballast & Tie					80	85
2nd Street			Underground	Wood Ties in concrete				93		
	0.25	1	↑	↑					86	87
5th Street	0.25	1						97	91	88
8th Street	0.25	1							88	84
11th Street	0.15	.5							80	83
13th Street	0.25	.5							84	88
15th Street	1.00	3							84	87
30th Street	0.35	1						97	85	89
34th Street	0.55	1.5	↓	↓				98	85	89
40th Street	0.65	2	Underground	Wood Ties in concrete				98	84	85
46th Street	0.60	1.5	Elevated	Ballast & Tie					82	84
52nd Street	0.40	1	↑	↑				86	78	82
56th Street	0.40	1	↓	↓				89	84	82
60th Street	0.30	1	↓	↓					78	82
63rd Street	0.40	1	Elevated						79	79
Millbourne	0.40	1	On-grade			78	73	80	80	77
69th Street	0.40	1	On-grade	Ballast & Tie	6	80	81	86	74	80

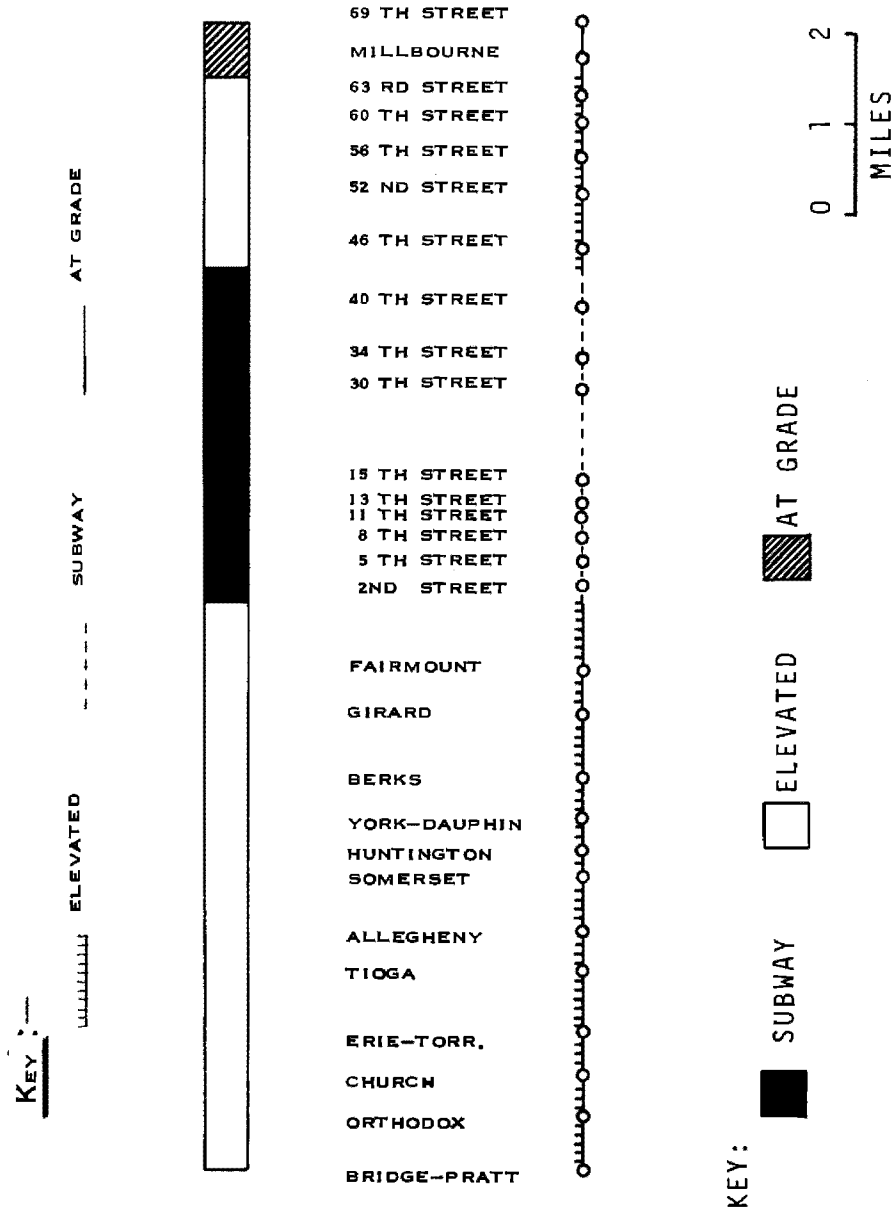

FIGURE 8.1 - SEPTA MARKET-FRANKFORD SUBWAY-ELEVATED TRACK SCHEMATIC

At the elevated structure location where wheel squeal predominates (York-Dauphin), L_A (Max) levels westbound average 9 dBA higher than the highest levels at 54th Street and 11 dB(A) higher than at Hart Lane (Somerset-Huntingdon). The community at Millbourne where the system operates on grade has a noise environment due to the transit system which is 5-10 dBA less than the communities adjacent to elevated structure. This is due in part to lower speeds and partly it is a result of the roadbed being located on-grade. At the on-grade squeal site near the 69th Street Terminal, transit system levels are set by wheel squeal as trains negotiate the return loop from the westbound to eastbound platforms. Unlike rolling noise durations during passby on tangent track, trains on the loop generate continuous squeal for relatively long periods, generally in excess of 1/2 minute at 2-1/2 minute intervals during rush hour and 7-1/2 minute intervals during daytime and evening hours.

8.3 Station Noise

Station platform noise levels generally can be grouped into two classifications - those above ground (80-87 dBA) and those in the subway (93-98 dBA). The on-line elevated stations are even more closely grouped between 85-87 dBA and the terminal stations range from 83-86. Millbourne, the only on-line, on-grade station, displayed the lowest station noise environment measured, 80 dBA, even though the microphone was located only one meter from the platform edge.

8.4 In-Car Noise

In-car noise levels can be grouped into three segments - (1) above-ground (elevated) north of 2nd Street, (2) underground from 2nd to 40th Street and (3) above ground (elevated and on-grade) west of 40th Street, and by type of car, either single or double. Speeds throughout segment (1) have been restricted to 20 mph due to construction and maintenance in that region. Table 8.3 presents a statistical summary of in-car noise on the line. Levels in the single car measured were 1-2 dBA higher than the double car. While no identification of wheel condition or speeds were made, it is likely that the minor reduction in double car levels over the single car results from the shared equipment arrangement between cars coupled as a married pair. In-car noise in the subway is 6-8 dBA higher than the elevated segments, and levels north of 2nd Street are approximately 2 dBA lower than the elevated segment west of 40th Street due to the noted speed restriction. In addition, the standard deviation (1σ) between plateau levels for segment (1) is approximately 1 dBA, whereas for the other two segments it is 2-3 dBA.

TABLE 8.3

IN-CAR NOISE STATISTICAL SUMMARY
MARKET - FRANKFORD LINE

Segment	Double Car		Single Car	
	\bar{x}	σ	\bar{x}	σ
(1) Bridge - 2nd (Elevated)	76.7	1.1	78.0	0.9
(2) 2nd - 40th (Subway)	84.7	3.3	86.5	2.1
(3) 40th - 69th (Elevated & On-Grade)	78.5	2.7	80.7	2.5

8.5 Market-Frankford Line Noise Summary

A graphic summary of community, station and in-car noise on the Market-Frankford Line is presented in Figure 8.2. Levels have been grouped into six 5 dBA ranges, 70-75, 75-80, 80-85, 85-90, 90-95, and 95-100 dBA. Wayside measurements were made at a distance of 15m (50 ft) from the near track, station noise recorded at the center of a stopped train and in-car data was taken in the second car of a multi-car train for two round trips.

In-car noise presented represents steady state plateau levels reached between stations. In the 1960 Budd cars, these levels are established primarily by wheel/rail noise, with propulsion system noise generally audible only during acceleration and deceleration. When trains are stopped, the noise of the air comfort blowers is audible. Substantial wheel squeal is generated leaving 69th Street, east of Millbourne, east of 46th Street, entering the subway portal, north of 2nd Street and north of York-Dauphin and near Church Station. In addition, there are several other locations where squeal is generated of a shorter duration or lower amplitude, generally between York-Dauphin and the Bridge Street Terminal. A patron riding the line from terminal to terminal would experience noise plateau levels in the 70-75 dBA group 4 percent of the time, from 75-80, 54 percent of the time, from 80-85, 28 percent of the time, from 85-90, 11 percent of the time and from 90-95, 3 percent of the time. Levels in the subway are from 6-8 dBA greater than elsewhere on the system.

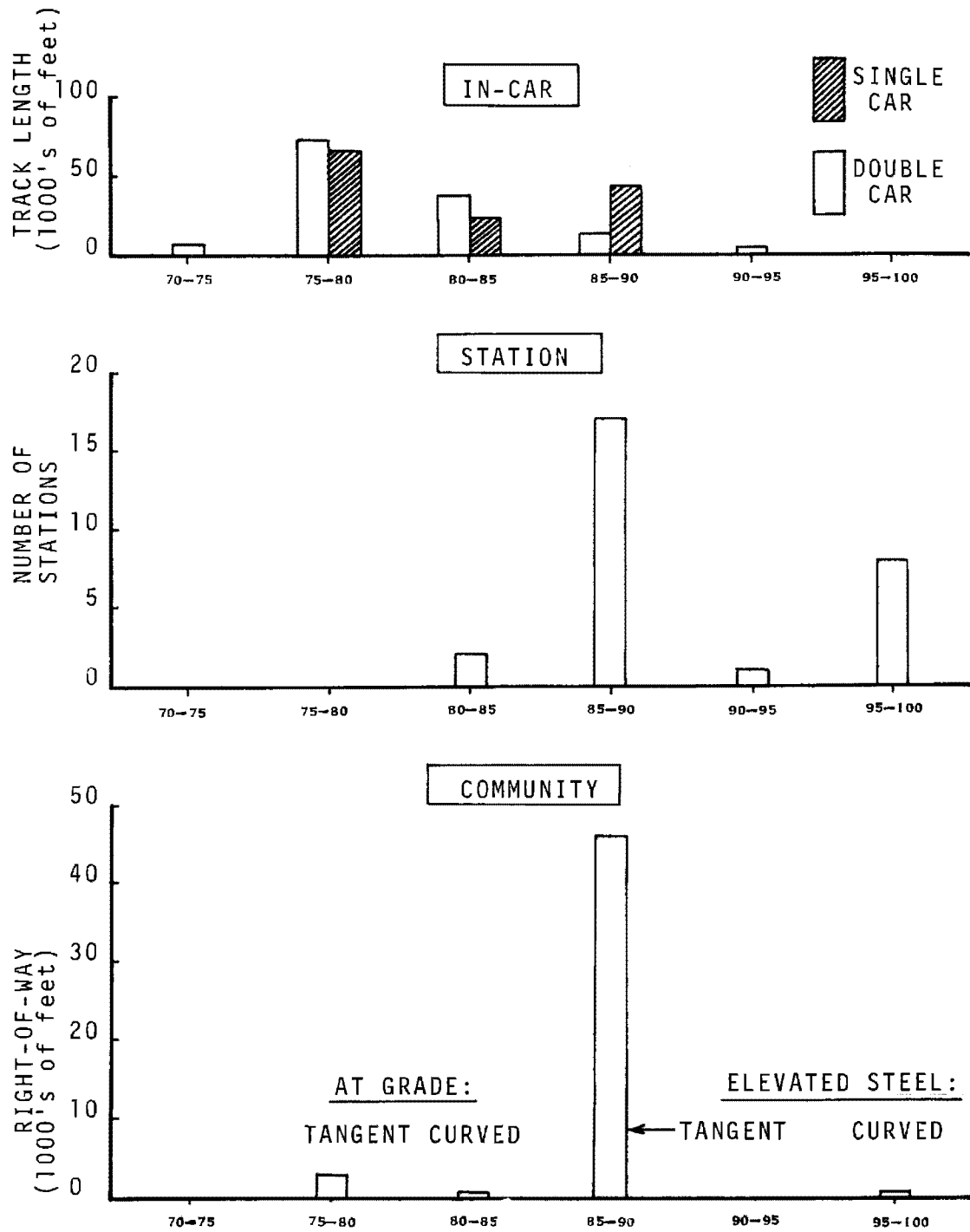

Grouped Sound Level, L_{max} - dBA

NOTE: Grouped Sound Level Interval Includes Lower, but not upper end point.

FIGURE 8.2 - SUMMARY OF SEPTA MARKET-FRANKFORD LINE NOISE ENVIRONMENT.

The majority of stations on the system (19) are located on elevated steel structure. Of these, 17 have a noise environment during train arrival or departure in the noise group from 85-90 dBA. The underground stations are exceed this level with eight of the nine subway stations ranking in the 95-100 dBA group. Two stations, Millbourne and Bridge Streets are within the 80-85 dBA group. Wheel/rail impact, roar and at some locations squeal, and propulsion system noise all contribute to the acoustical environment of a patron on the station platform.

Community noise levels on the system can be described almost entirely from measurements taken adjacent to elevated structure. Roadbed on the Market-Frankford Line is located on elevated structure over 62 percent of the route, with the subway portion representing 34 percent. The remaining 4 percent is on-grade. Data taken both in West Philadelphia (54th and Market) and North Philadelphia (Hart Lane) is in the 85-90 dBA interval, with the on-grade wayside levels occurring in the grouping from 75-80 dBA. The remaining groups illustrate squeal levels at the 69th Street Terminal return loop (80-85) and York-Dauphin curve on the elevated structure (95-100 dBA).

Where the roadbed is located in the subway, noise levels due to train operation are not measurable in the community.

9. REFERENCES

1. Kurzweil, L.G.; Lotz, R.; and Apgar, E.G.; "Noise Assessment and Abatement in Rapid Transit Systems"; Report No. UMTA-MA-06-0025-74-8; September 1974.
2. Webster, W.J. and Farinacci, J.W., "Use of Graphic Level Recorders as Indicating Instruments, Part 1: Meeting the Specifications of a Sound Level Meter", Bureau of Noise, New York State Department of Environmental Conservation, Albany, New York, 1974.
3. Shultz, T.J., "Development of an Acoustic Rating Scale for Assessing Annoyance Caused by Wheel/Rail Noise in Urban Mass Transit", Report No. UMTA-MA-06-0025-74-2, February 1974.

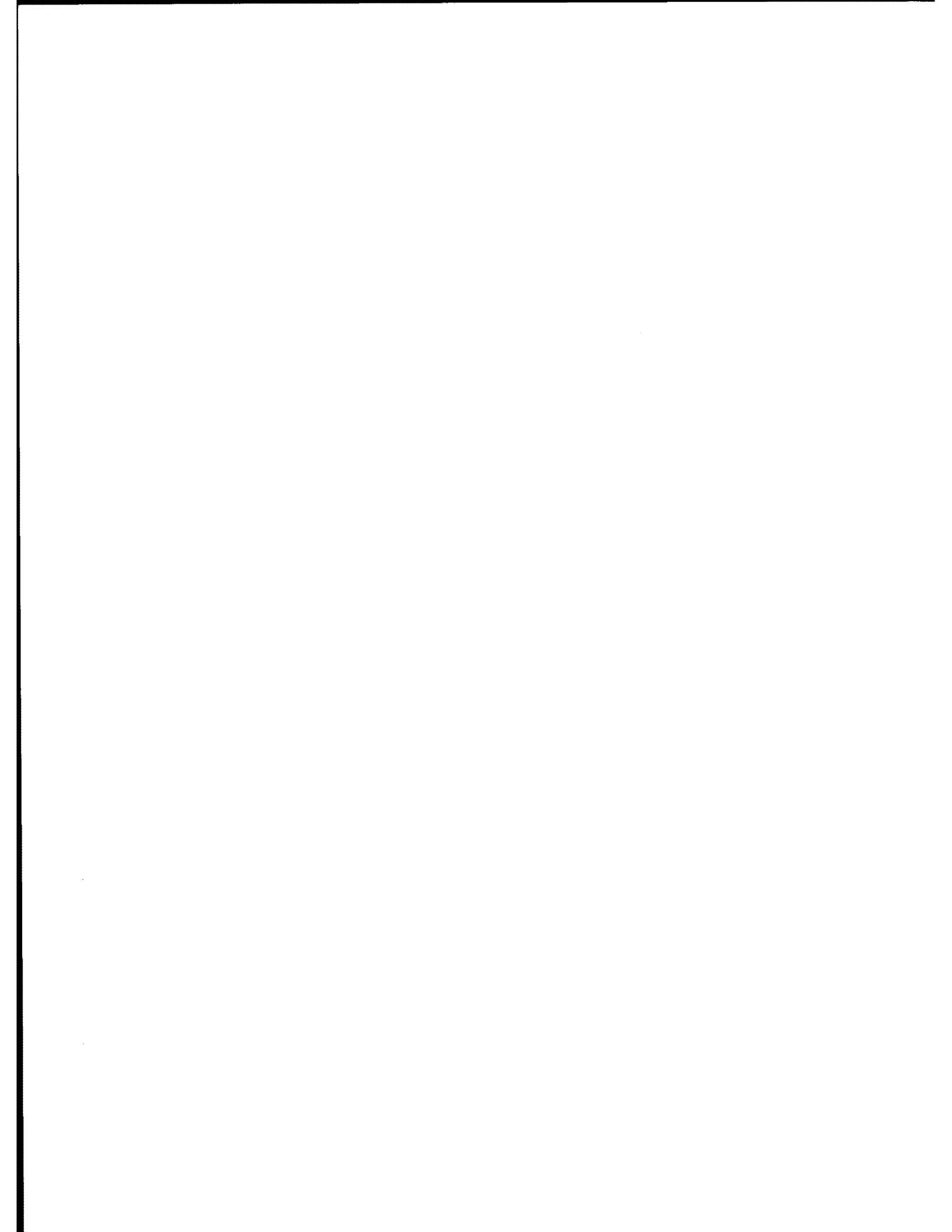

APPENDIX A

A STATISTICAL ANALYSIS
OF
SEPTA BROAD STREET SUBWAY STATION NOISE DATA

ASSESSMENT OF URBAN RAIL NOISE CLIMATES
AND
ABATEMENT OPTIONS
FOR
BART, CTS, PATCO AND SEPTA

Prepared by
L. Bukowski Doyle and R. H. Spencer
THE BOEING VERTOL COMPANY
for
DEPARTMENT OF TRANSPORTATION
Transportation Systems Center

CONTRACT DOT-TSC-850

STATISTICAL ANALYSIS OF STATION NOISE MEASUREMENTS

BACKGROUND AND PURPOSE

In sampling the noise climate for the rapid transit systems included in the Urban Rail Noise Assessment Program, it was necessary to establish the number of train passbys required for the data sample to determine whether future reductions of 5dBA or more in system noise could be detected and whether they would be significant for a 95% confidence level. For station noise, additional questions had to be addressed. For example, a transit system patron is exposed to arrival and departure noise and trains operating on near and far tracks and, in some instances, to express train passby noise. It was necessary to determine if all noise events were from the same population and therefore whether to be grouped or separated for the study. Data was sampled in an underground station on the SEPTA Broad Street Subway to investigate these questions. Snyder Avenue was considered typical of many stations on the system.

NOISE SURVEY

One channel of data was recorded on the Snyder Avenue Station northbound platform at the midpoint of a stopped train at standing patron ear level (1.6m above platform level, 2 meters from the platform edge). Six train passbys were recorded in each direction during a one-half hour continuous noise survey.

Time histories of A-weighted sound levels were produced on a B&K 2305 graphic level recorder, set as follows:

Potentiometer	50 dB
Potentiometer Range	50 dB
Lower Limiting Frequency	10 Hz
Writing Speed	200mm/sec.
Rectifier Response	rms
Paper Width	100mm

Peak levels for arriving and departing trains were read for both north- and southbound trains (Table 1).

TABLE I

PEAK A-WEIGHTED SOUND PRESSURE LEVELS - SNYDER AVE. STATION

	L _A (Max) - dBA			
	NORTHBOUND ARRIVAL	NORTHBOUND DEPARTURE	SOUTHBOUND ARRIVAL	SOUTHBOUND DEPARTURE
	96	-	101	-
	98	-	95	-
	94	97	97	101
	97	95	97	98
	96	96	100	106
	97	95	97	101
\bar{x}	96.3	95.8	97.8	101.5
s	1.4	0.96	2.2	3.3

Means (\bar{x}) and standard deviations (s) were calculated for the data samples as follows:

$$\bar{x} = \sum_{i=1}^n \frac{x_i}{n}$$

where n is the sample size and

$$s = \left[\sum_{i=1}^n \frac{(x_i - \bar{x})^2}{n-1} \right]^{1/2}$$

ANALYSIS OF DATA

Arrivals and departures for both north- and southbound trains were treated as separate events in order to determine whether the recorded samples were from the same population. Also, it was desired to establish with 95% confidence the number of events (passbys) required to ascertain that a future reduction in system noise of 5 dBA or more could be detected when measured by the same methods as those outlined (e.g., same sample size, microphone location, etc.).

The general relationship between mean, standard deviation and sample size for a 95% confidence envelope is known, but in order to establish the sample size it is necessary to secure information on \bar{x} and s for the station noise data after the system noise has been reduced. This, of course, is not a known value until it can be measured. However, it can be assumed that a 5 dBA reduction in the original levels could be achieved and that the standard deviation for the new data set would not differ substantially from the recorded baseline data. With these assumptions, Table II was established.

TABLE II

MEAN AND STANDARD DEVIATION OF PASSBY EVENTS

		ARRIVAL		DEPARTURE	
		BASELINE	HYPOTHESIZED	BASELINE	HYPOTHESIZED
NORTHBOUND TRAINS	\bar{x}	96.3	91.3	95.8	90.8
	s	1.4	1.4	0.96	0.96
	n	6	6	4	4
SOUTHBOUND TRAINS	\bar{x}	97.8	92.8	101.5	96.5
	s	2.2	2.2	3.3	3.3
	n	6	6	4	4

The statistical procedure of analysis of variance has shown that northbound arriving and departing trains and southbound arriving trains can be considered to be from the same population; southbound departing trains however, cannot be considered to be in this population. The difference is thought to result from higher train speeds for southbound departing trains.

The relationship of mean, standard deviation and sample size required to establish significant differences between two sets of data is shown in Figure 1. It is based on the sum of the sample standard deviations and the difference in the sample means. Furthermore, a 95% confidence envelope and equal sample sizes for both groups are assumed. Using the southbound arrival information as an illustration, the baseline data yields a mean of $\bar{x}_1 = 97.8$ and a standard deviation of $s_1 = 2.2$;

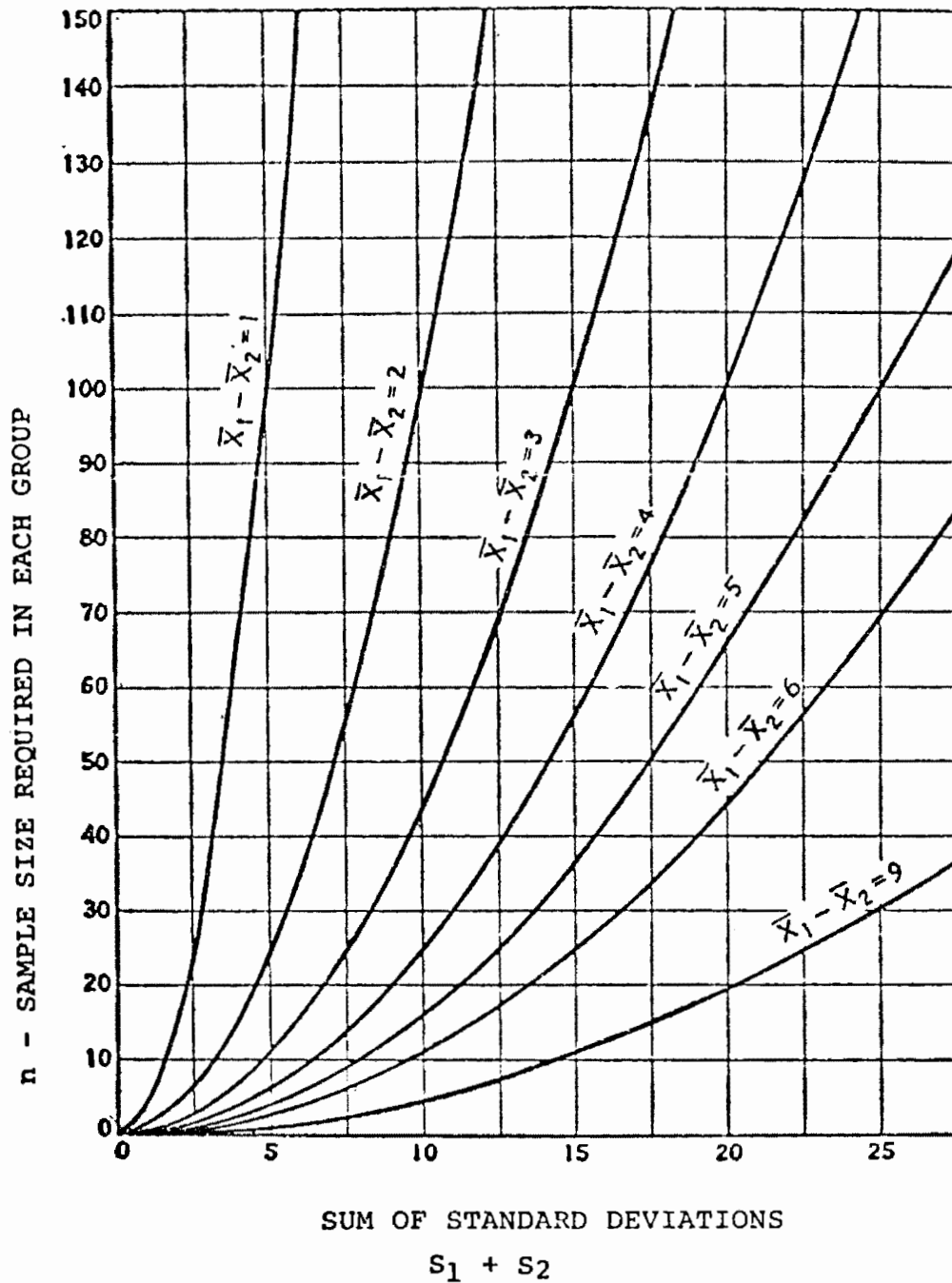

FROM L. R. HILL AND P.L. SCHMIDT "GRAPHICAL STATISTICS - AN ENGINEERING APPROACH," WESTINGHOUSE ENGR. MARCH 1950 AND MAY 1950.

FIGURE 1 - NUMBER OF TESTS REQUIRED TO ESTABLISH SIGNIFICANT DIFFERENCES BETWEEN TWO DATA SETS.

the hypothesized data has been reduced by 5 dBA, the minimum desired reduction in system noise, and the standard deviation has been retained at $s_2 = 2.2$. The sample size for both is $n = 6$.

$$s_1 + s_2 = 4.4 \quad \text{and}$$

$$\bar{x}_1 - \bar{x}_2 = 5$$

For this condition, 4 samples in each group are shown to be sufficient to detect a difference in the 2 sets of data (Figure 1). Table III presents the resulting sample sizes required for each set of data.

TABLE III
SAMPLE SIZE FOR STATION DATA

	NORTHBOUND		SOUTHBOUND	
	ARRIVAL	DEPARTURE	ARRIVAL	DEPARTURE
$\bar{x}_1 - \bar{x}_2$	5	5	5	5
$s_1 + s_2$	2.8	1.92	4.4	6.6
Reqd. Sample Size	3	1	4	6

STUDENT t TEST

To determine if significant differences could be detected in the two sets of data (baseline and hypothesized) the "Student t" test was utilized. The test involves the calculation of the standard deviation of the differences of means, where

$$t = \frac{\text{difference between the means}}{\text{standard deviation of the difference}}$$

If t exceeds certain tabulated values (see Ref. 1), it can be stated there is a difference between two sets of data. The t test assumes that both populations are normally distributed with differing means (μ_1 and μ_2), but similar standard deviations ($\sigma_1 = \sigma_2$). Sample parameters are used to test the population parameters.

A reduction in system noise by 5 dBA was tested as follows:

Test the hypothesis:

$$H_0: \mu_1 - \mu_2 = 5$$

vs $H_1: \mu_1 - \mu_2 > 5$

The critical region for the test is:

$$\frac{\bar{x}_1 - \bar{x}_2 - (\mu_1 - \mu_2)}{S_w \sqrt{\frac{1}{n_1} + \frac{1}{n_2}}} > t_{n_1+n_2-2; \alpha}$$

where, $S_w = \left[\frac{(n_1-1) s_1^2 + (n_2-1) s_2^2}{n_1+n_2-2} \right]^{1/2}$

and $\alpha = 0.05$ (i.e. 95% Confidence)

If the critical region is greater than the tabulated t value, the hypothesis must be rejected. From Table II and the baseline and hypothesized northbound arrival data:

<u>MEASURED BASELINE</u>	<u>HYPOTHESIZED DATA</u>
$\bar{x} = 96.3$	$x = 90.8^*$
$s_1 = 1.4$	$s_2 = 1.4$
$n_1 = 6$	$n_2 = 6$

*Chosen so that $\bar{x}_1 - \bar{x}_2 \neq 5$, otherwise leading to a trivial case.

Sample calculation: t-test

<u>MEASURED BASELINE</u>	<u>HYPOTHESIZED DATA</u>
$\bar{x}_1 = 96.3$	$\bar{x}_2 = 90.8$
$s_1 = 1.4$	$s_2 = 1.4$
$n_1 = 6$	$n_2 = 6$

$$S_w = \left[\frac{(n_1-1) s_1^2 + (n_2-1) s_2^2}{n_1 + n_2 - 2} \right]^{1/2}$$

$$= \left[\frac{(6-1)(1.4^2) + (6-1)(1.4)^2}{6+6-2} \right]^{1/2}$$

$$S_w = 1.4$$

From Ref 1; $t_{10}; 0.05 = 1.812$

$$\frac{96.3 - 90.8 - (5)}{1.4 \sqrt{1/6 + 1/6}} > 1.812$$

$$\frac{0.5}{1.4 (0.578)} > 1.812$$

however, $0.619 > 1.812$

Therefore, the first hypothesis, H_0 , may be accepted, i.e., the difference of the two means is equal to five.

The second hypothesis, H_1 , may be accepted when:

$$\frac{(\bar{x}_1 - \bar{x}_2) - 5}{1.4 (0.578)} > 1.812$$

or

$$\bar{x}_1 - \bar{x}_2 > (1.812) (1.4) (0.578) + 5$$

$$\bar{x}_1 - \bar{x}_2 > 6.47$$

CONFIDENCE INTERVALS

If \bar{x} and s^2 are the mean and variance of a sample of size n , and are from normally distributed data ($N(\mu, \sigma^2)$) where μ, σ^2 are unknown, then the confidence interval

$$\text{C.I.} = \left[\bar{x} \pm t_{n-1; \alpha/2} \frac{s}{\sqrt{n}} \right]$$

is a $100(1-\alpha)\%$ confidence interval for μ . Even though the data set may not be normally distributed, the expression can be applied for most cases.

Sample calculation: Confidence Interval

Using the peak northbound arrival data:

$$\begin{aligned} \text{C.I.} &= \left[\bar{x} \pm t_{n-1; \alpha/2} \frac{s}{\sqrt{n}} \right] \\ &= .05, 1 - \alpha = .95, \bar{x} = 96.3, s = 1.4, n = 6, \\ &\quad t_5; 0.025 = 2.571 \\ &= \left[96.3 \pm 2.571 \frac{1.4}{\sqrt{6}} \right] \\ &= 96.3 \pm 1.47 \end{aligned}$$

$$\text{C.I.} = 94.8 \text{ to } 97.8 \text{ dBA (95\% C.I. for } \mu \text{).}$$

RESULTS AND CONCLUSIONS

Based on the data sample recorded and the results shown in Table III, it appears that a sample size of $n = 6$ is adequate for the Snyder Avenue data, considered representative for the Broad Street Subway. This statistical procedure will be followed for the remaining systems to be measured, namely, the

Market-Frankford Line at SEPTA and for CTS. In each case a representative station will be selected for the data sample. Ideally, this procedure should be carried out for each type of station as well as for each community measurement. However, it is adequate to select representative locations for evaluations of required sample sizes.

Although the t test could not be evaluated using actual data for the improved system (no revisions to system noise have been made), the hypothesized data which was chosen such that $\bar{x} - \bar{x}_2 > 5$ indicates that a 5 dBA reduction in noise level in fact can be detected, assuming that the sample size and standard deviation remain the same.

Analysis of variance has shown that northbound arriving and departing trains and southbound arriving trains are from the same population and can be grouped. Southbound departure data if treated statistically would have to be grouped separately for this set of data.

Ref.1 - Holscher, Harry H., Simplified Statistical Analysis, Handbook of Methods, Examples and Tables; Cashners Books, Boston, Mass. 1971.

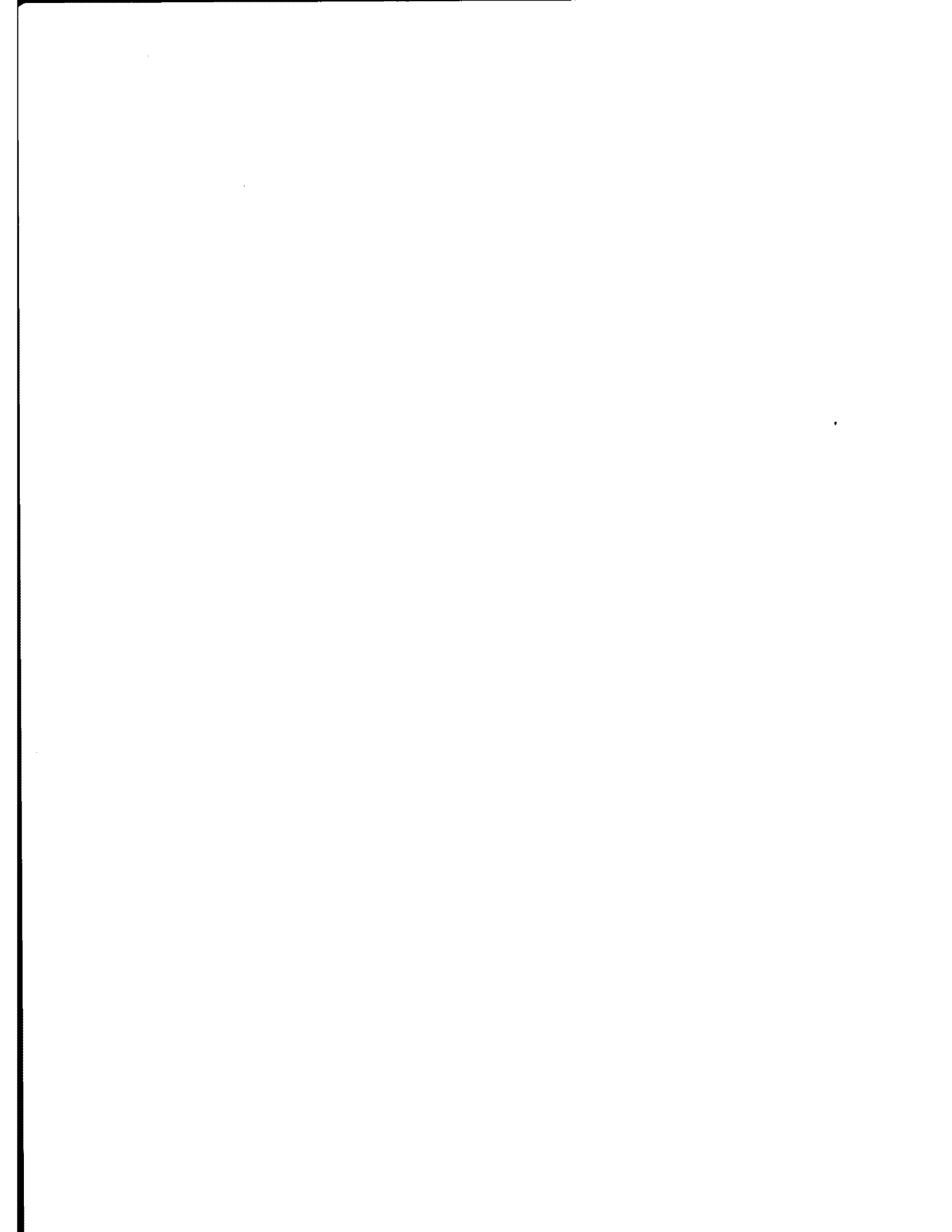

APPENDIX B
REPORT OF INVENTIONS

A detailed review of the work performed under this contract and the material contained in this report has not disclosed any discoveries or inventions. The work reported here represents a data base of noise measurements on a specific transit system, suitably extrapolated to all locations in and around the system as to provide an assessment of existing noise levels.

B-1/B-2

1