

S.C.R.T.D. LIBRARY

CASE STUDIES OF BUILDING BEHAVIOR IN RESPONSE TO ADJACENT EXCAVATION



APRIL 1979

FINAL REPORT

Prepared for

**U.S. Department of Transportation
OFFICE OF THE SECRETARY
AND**

**Urban Mass Transportation Administration
Office of Technology Development and Deployment
Washington, D.C. 20590**

This document is disseminated under the sponsorship of the Department of Transportation in the interest of information exchange. The United States Government and the University of Illinois assume no liability for its contents or use thereof.

1. Report No. UMTA-IL-06-0043-78-2	2. Government Accession No.	3. Recipient's Catalog No.	
4. Title and Subtitle Case Studies of Building Behavior in Response to Adjacent Excavation		5. Report Date October, 1978	
		6. Performing Organization Code	
7. Author(s) M. D. Boscardin, E. J. Cording, T. D. O'Rourke		8. Performing Organization Report No. UILU-ENG-78-2023	
9. Performing Organization Name and Address Department of Civil Engineering University of Illinois at Urbana-Champaign Urbana, Illinois 61801		10. Work Unit No. (TRAIS)	
		11. Contract or Grant No. DOT UT-80039	
12. Sponsoring Agency Name and Address U. S. Department of Transportation Office of Secretary and Urban Mass Transportation Administration		13. Type of Report and Period Covered Final Report Oct. 1976 - Oct. 1977	
		14. Sponsoring Agency Code	
15. Supplementary Notes			
16. Abstract <p>In this report, case histories of the distortion and damage to structures adjacent to tunnels and excavations are presented. Measurements of both ground movements and building response were made at two test sites in Washington, D.C., one a nine-story apartment building adjacent to a 60-ft-deep opencut and the other a pair of two-story brick-bearing wall structures near two 21-ft-diameter tunnels. The structures at the two test sites were instrumented to measure settlement and tilt of the bearing walls and foundations. Both lateral and diagonal displacements were measured with tape extensometers extending between column lines and bearing walls at various floor levels in the structures. From these data, the slope of the settlement trough could be separated into the components causing angular distortion and tilt of the structure. Lateral extension, shearing, or bending distortions could also be distinguished from the data.</p> <p>Additional data were gathered at other sites in Washington, D.C. and Chicago through construction records and field inspections. The ground surface settlement data, building response data, and the progress of the excavation are compared and related.</p>			
17. Key Words Settlements; Building Damage; Building Response; Adjacent Excavation		18. Distribution Statement Document is available to the public through the National Technical Information Service, Springfield, VA 22161	
19. Security Classif. (of this report) Unclassified	20. Security Classif. (of this page) Unclassified	21. No. of Pages 145	22. Price

09434

TF
220
.B67
c.2

ABSTRACT

In this report, case histories of the distortion and damage to structures adjacent to tunnels and excavations are presented. Measurements of both ground movements and building response were made at two test sites in Washington, D.C., one a nine-story apartment building adjacent to a 60-ft-deep opencut and the other a pair of two-story brick-bearing wall structures near two 21-ft-diameter tunnels. The structures at the two test sites were instrumented to measure settlement and tilt of the bearing walls and foundations. Both lateral and diagonal displacements were measured with tape extensometers extending between column lines and bearing walls at various floor levels in the structures. From these data, the slope of the settlement trough could be separated into the components causing angular distortion and tilt of the structure. Lateral extension, shearing, or bending distortions could also be distinguished from the data.

Additional data were gathered at other sites in Washington, D.C. and Chicago through construction records and field inspections. The ground surface settlement data, building response data, and the progress of the excavation are compared and related.

For the class of structures examined, the buildings tended to move with the ground and provided little resistance to the imposed foundation movements. However, variations in stiffness throughout some structures resulted in concentrations of damage and distortion at specific locations in the structure. Building damage in response to adjacent braced cut excavation typically results from approximately equal magnitudes of angular and lateral distortion, as was observed at the first test section, located in a reinforced concrete building adjacent to a 60 ft deep braced cut. However, for the tunnel settlement trough, the ratio of angular distortion to lateral extension strain varies throughout the width of the trough.

At the second test section, a brick-bearing wall structure was near the edge of the tunnel settlement trough, in the zone of "hogging" or convex curvature. It was subjected to lateral extension strains that increased in the upper floor levels due to the bending produced by the convex-shaped settlement profile beneath the building.

At the same test section, a brick bearing wall structure located nearer the center of the settlement trough, between the sagging and hogging portions, was subjected to final distortions that predominantly involved shearing displacements, with little to no lateral extension or bending in the upper stories. However, lateral extension and bending developed initially as the leading edge of the settlement wave impinged on the structure. As observed in our previous report, minor architectural damage to brick-bearing wall structures developed at angular distortions and also lateral extension strains of approximately $1/1000$. The hogging or convex portion of a settlement trough produces a condition where the lateral strains and angular distortions have an additive effect on the extension in the structure. In one particular case, damage was observed at angular distortions and lateral strains of $1/2000$ to $1/3000$.

The most useful relations between building damage and distortions can be established when both lateral strains and angular distortions are measured. However, some inferences on the lateral strains and distortions affecting structures can be made from the settlement slopes, if the settlement trough shape and the size and position of the structure with respect to the trough are known. The settlement slope is a most useful parameter when the width of the structure is of the same order or is greater than the $1/2$ width of the settlement trough.

PREFACE AND ACKNOWLEDGEMENTS

This report summarizes one year of field observations and data collection of the ground movements and resultant building distortion and damage in response to underground construction conducted by the Department of Civil Engineering, University of Illinois, for the Office of the Secretary, and Urban Mass Transportation Administration, U.S. Department of Transportation, under Contracts DOT-OS-70024 and DOT-UT-80039. The sponsor's technical representatives were Mr. Russell K. McFarland and Mr. Gilbert Butler.

Data from five structures adjacent to braced excavations and three structures adjacent to soil tunnels are summarized. The structural types include brick-bearing wall buildings, a concrete frame structure, and steel frame structures. Data for two of the cases were obtained from field instrumentation programs performed by University of Illinois personnel. Data for the remaining cases were gathered from construction records, published sources, and site inspections. The report summarizes and examines these data in light of previous field observations and analyses conducted by the University and others.

The collection of these case history and field data has involved the generous support and assistance of many individuals and groups. The support and assistance of the Washington Metropolitan Area Transit Authority and Mr. William S. Alldredge, Director of Construction, in allowing the University to conduct field observation programs on Metro tunnel projects is gratefully acknowledged. The cooperation and assistance of Mr. Carl Bock, Chief of Geotechnical Services, and Mr. Robert Evans, formerly Chief Soils Engineer, for Bechtel Associates, the Construction Manager for Metro, is gratefully acknowledged.

The assistance and cooperation of the Resident Engineer, Mr. Ted Brayman of Section G1, and his staff was invaluable and was greatly appreciated. The

cooperation of Mr. Glen Traylor of Traylor Brothers and his staff at Section G1 was also greatly appreciated.

Appreciation is extended to Mr. Ted Maynard of the City of Chicago Bureau of Engineering for his assistance and guidance in obtaining construction data for the case in Chicago. Others who lent their assistance in obtaining data include Don Hessong, Graham Beck, and the building owners and occupants.

Field observations for the Metro projects were made by H. H. MacPherson and M. D. Boscardin with the assistance of L. Lorig, J. W. Critchfield, J. G. Ulinski, C. P. Rodriguez, and B. Johnson.

TABLE OF CONTENTS

Chapter		Page
1.	INTRODUCTION	1-1
	1.1 GENERAL STATEMENT	1-1
	1.2 BACKGROUND.	1-3
	1.3 OBJECTIVES.	1-9
	1.4 SCOPE	1-10
2.	INSTRUMENTED TEST SECTION #1, A NINE-STORY APARTMENT BUILDING.	2-1
	2.1 INTRODUCTION.	2-1
	2.2 EXCAVATION SUPPORT AND CONSTRUCTION PROCEDURE.	2-1
	2.3 THE STRUCTURE	2-3
	2.4 OBSERVATION PROGRAM	2-7
	2.5 PRESENTATION AND DISCUSSION OF DATA	2-9
	2.5.1 SETTLEMENT MEASUREMENTS	2-9
	2.5.2 EXTENSOMETER MEASUREMENTS	2-16
	2.5.3 VISUAL INSPECTION	2-19
	2.5.4 INFLUENCE OF TEMPERATURE.	2-20
	2.6 CONCLUSIONS	2-23
3.	INTRUMENTED TEST SECTION #2 TWO-STORY BRICK-BEARING WALL BUILDINGS	3-1
	3.1 INTRODUCTION	3-1
	3.2 SOIL PROFILE	3-1
	3.3 EXCAVATION SUPPORT AND CONSTRUCTION PROCEDURE	3-1
	3.4 STRUCTURES.	3-5

Chapter		Page
3.5	OBSERVATION PROGRAM	3-6
3.5.1	MOVEMENT OF GROUND.	3-7
3.5.2	BUILDING DISTORTION.	3-8
3.5.3	VISUAL DAMAGE	3-8
3.6	GROUND SURFACE AND BUILDING SETTLEMENTS	3-13
3.7	MEASURED BUILDING DISTORTIONS	3-17
3.7.1	DISTORTION, BUILDINGS I AND II.	3-18
3.7.2	INITIAL DISTORTIONS, BUILDING I.	3-18
3.7.3	FINAL DISTORTIONS, BUILDING I.	3-23
3.7.4	FINAL DISTORTIONS, BUILDING II	3-24
3.8	VISIBLE EVIDENCE OF BUILDING DAMAGE	3-25
3.9	DETAILED MEASUREMENT DATA AND DISCUSSION.	3-32
3.9.1	SETTLEMENT.	3-32
3.9.2	TAPE EXTENSOMETERS.	3-32
3.9.3	PLUMB BOBS.	3-43
3.9.4	JOINTS AND SEPARATIONS.	3-43
4.	CASE HISTORIES FROM CONSTRUCTION RECORDS	4-1
4.1	INTRODUCTION.	4-1
4.2	CASE A.	4-1
4.3	CASE B.	4-8
4.4	CASE C.	4-9
4.5	CASE D.	4-11
4.6	CASE E.	4-16

Chapter	Page
4.7 CASE F.	4-18
4.8 SUMMARY	4-21
5. SUMMARY AND CONCLUSIONS.	5-1
5.1 GENERAL DISCUSSION.	5-1
5.2 CASE STUDY 1, CHAPTER 2	5-2
5.3 CASE STUDY 2, CHAPTER 3	5-3
5.4 CASE HISTORIES, CHAPTER 4	5-5
5.5 GENERAL CONCLUSIONS	5-7
APPENDIX A GROUND MOVEMENTS DUE TO UNDER GROUND CONSTRUCTION	A-1
A.1 MOVEMENTS DUE TO BRACED EXCAVATION.	A-1
A.2 MOVEMENTS DUE TO TUNNELING.	A-4
A.3 MOVEMENTS DUE TO MINING	A-5

LIST OF FIGURES

Figure		Page
1.1	BUILDING DEFORMATION CAUSED BY SETTLEMENT IN RESPONSE TO OPENCUTTING.	1-5
1.2	CRITERIA FOR TOLERABLE DISTORTION.	1-8
2.1	SOIL PROFILE AND EXCAVATION RELATIVE TO THE MONITORED APARTMENT BUILDING	2-2
2.2	PLAN VIEWS OF BASEMENT AND GROUND FLOOR OF THE 9-STORY APARTMENT BUILDINGS	2-5
2.3	SETTLEMENT PROFILES OF GROUND SURFACE AS RELATED TO CONSTRUCTION HISTORY	2-10
2.4	SUMMARY OF SETTLEMENTS ADJACENT TO THE BRACED EXCAVATION	2-11
2.5	ANGULAR DISTORTION FOR BRACED EXCAVATION	2-12
2.6	SETTLEMENT OF BUILDING COLUMNS	2-13
2.7	SETTLEMENT OF BASEMENT SLAB.	2-15
2.8	SECTIONS ILLUSTRATING TAPE EXTENSOMETER POINTS AND CUMULATIVE DISTORTION FROM 18 DEC 75 TO 2 DEC 76.	2-17
2.9	SKETCHES OF BUILDING DISTORTION BASED ON CUMULATIVE DISTORTION THROUGH 2 DECEMBER 76.	2-18
2.10	TAPE EXTENSOMETER MEASUREMENTS OF STRUCTURAL BAY DISTORTION AS A FUNCTION OF TEMPERATURE	2-21
2.11	FACTORS CONTRIBUTING TO FRAME DISTORTION	2-22
3.1	PROFILE SHOWING RELATIVE POSITIONS OF BUILDINGS I and II AND THE TUNNELS	3-2
3.2	PLAN VIEW OF TEST SITE SHOWING LOCATION OF GROUND SURFACE SETTLEMENT POINTS, EXTERIOR BUILDING SETTLEMENT POINTS AND PLUMB BOBS	3-3

Figure		Page
3.3	SOIL PROFILE AT TEST SITE	3-4
3.4	LOCATIONS OF TAPE EXTENSOMETER LINES AND CUMULATIVE DEFLECTION ALONG THE LINES	3-9
3.5	LOCATION OF TAPE EXTENSOMETER LINES AND INTERIOR SETTLEMENT POINTS IN THE BASEMENTS OF BUILDINGS I AND II	3-10
3.6	SKETCH OF PLUMB BOB AND DETAILS OF WEIGHT AND REFERENCE SCALES	3-11
3.7	SKETCH ILLUSTRATING BEAM PULLOUT MEASUREMENTS.	3-12
3.8	GROUND SURFACE SETTLEMENTS ALONG CENTERLINE OF INBOUND TUNNEL.	3-14
3.9	GROUND SURFACE SETTLEMENT PROFILE ALONG CROSS-SECTION AT STATION 307 + 90	3-14
3.10	GROUND SURFACE SETTLEMENT PROFILE ALONG CROSS-SECTION AT STATION 308 + 15	3-15
3.11	SETTLEMENT PROFILE ALONG TRANSVERSE CROSS-SECTION AT STATION 308 + 70	3-15
3.12	COMPARISON OF FINAL SETTLEMENTS OF THE BUILDING AND THE GROUND SURFACE	3-16
3.13	FINAL DISTORTED SHAPES OF THE FRONTS OF BUILDING I AND II	3-19
3.14	SETTLEMENT CONTOURS DUE TO TUNNEL EXCAVATION.	3-20
3.15	DISTORTED SHAPE OF THE BASEMENT NEAR THE FRONT OF BUILDING I, TUNNEL HEADING AT STA. 308 + 50.	3-21
3.16	PATTERN OF DIFFERENTIAL MOVEMENTS OF STRUCTURES IN DIFFERENT ZONES OF SETTLEMENT TROUGH CAUSED BY TUNNELING.	3-26
3.17	LOCATION OF CRACKS ON EXTERIOR OF BUILDING I.	3-28
3.18	CRACKS OBSERVED IN BASEMENT SLAB OF BUILDING I.	3-29
3.19	OPENING OF CRACKS IN RESPONSE TO TUNNEL EXCAVATION, BUILDING II.	3-30

Figure		Page
3.20	SETTLEMENT OF THE REAR FACADE WALLS OF BUILDINGS I AND II	3-33
3.21	SETTLEMENTS OF THE FRONT FACADE WALLS OF BUILDINGS I AND II.	3-33
3.22	SETTLEMENT OF SW BEARING WALL OF BUILDING I.	3-34
3.23	INTERIOR SETTLEMENTS OF BUILDING I, TRANSVERSE TO BUILDING AXIS	3-35
3.24	INTERIOR SETTLEMENTS OF BUILDING I, PARALLEL TO BUILDING AXIS	3-35
3.25	SUMMARY OF TAPE EXTENSOMETER MEASUREMENTS FOR VARIOUS LOCATIONS OF THE TUNNEL FACE	3-37 to 3-40
3.26	PLUMB BOB DATA SUMMARY	3-44
4.1	SETTLEMENT CONTOURS FOR CASE A	4-3
4.2	BUILDING SETTLEMENTS, CASES A AND B.	4-5
4.3	NORMALIZED SETTLEMENTS ADJACENT TO BRACED EXCAVATION.	4-6
4.4	ANGULAR DISTORTIONS OF BUILDINGS IN CASES A AND B	4-7
4.5	SETTLEMENT PROFILE PERPENDICULAR TO TUNNEL AXES, CASE C	4-12
4.6	BUILDING SETTLEMENT, CASE C.	4-13
4.7	CRACKING IN SIDE OF BUILDING, CASE D	4-15
4.8	CASE E, TWO BRICK WALLS.	4-17
4.9	CASE F, "EL" STRUCTURE	4-19
4.10	ANGULAR DISTORTION CRITERIA MODIFIED BY THE ADDITION OF THE CASE DISCUSSED IN THIS REPORT	4-24
A.1	DISTORTIONS DUE TO MINING, TUNNELING, AND BRACED EXCAVATION.	A-2

LIST OF TABLES

Table		Page
2.1	CHRONOLOGY OF EXCAVATION ADJACENT TO TEST AREA	2-4
3.1	CHANGE OF WIDTH OF INTERFACE JOINT	3-45
3.2	CHANGE IN BEARING OF JOINT ENDS.	3-45
4.1	SUMMARY OF CASE STUDIES.	4-22
5.1	DAMAGE RELATED TO BUILDING DISTORTION FOR BRICK - BEARING WALL STRUCTURES.	5-10
A.1	SUMMARY OF SETTLEMENT SLOPES AND LATERAL STRAINS.	A-3

CHAPTER 1

INTRODUCTION

1.1 GENERAL STATEMENT

A substantial portion of the cost of soft ground tunnels and braced excavations in urban environments is devoted to the protection and repair of adjacent structures and utilities. Often, the choice between cut-and-cover and tunnel construction is based on the potential ground movements associated with each method and the anticipated response of the nearby buildings to those ground movements. In some instances, the locations of tunnel routes and large braced excavations are selected to avoid large and/or sensitive structures.

Methods to reduce the effects of underground construction on nearby buildings and utilities may be divided into three categories: modification of construction techniques and equipment to reduce soil displacements; ground treatment in the form of grouting, dewatering, or freezing to reduce ground displacements; and underpinning and reinforcement of structures to isolate them from the ground displacements and to reduce the damaging distortions and strains in them. These methods tend to be expensive and some of them may have other disadvantages that require consideration. For example, the installation of underpinning involves excavation beneath the support elements of a building, which can cause some settlement and may result in damage to the buildings.

To develop a system that is compatible with surrounding structures as well as economical, the designer needs information that will permit him to:

- 1) Estimate the range of typical ground movements for various combinations of ground conditions and construction procedure. This includes estimating the risk of large collapse or very large ground movements.
- 2) Evaluate the response of nearby structures and utilities to the ground movements caused by underground construction. This forms a basis for judging potential damage, choosing adequate protection, and developing a system of observations and remedial measures.

In recent years there has been considerable effort devoted to field measurements (Peck, 1969; Hansmire and Cording, 1975; Jaworski, 1973) and analytical techniques (St. John, 1975; Wong, 1971) in order to show the patterns of movement associated with various soil types and construction procedures. However, studies of building or utility response to excavation-induced ground movements have been limited.

In some cases, the lack of information on ground movements and damage has resulted in overly conservative criteria that call for little or no movement in the vicinity of a utility or structure. Such criteria can result in the use of expensive protection measures where they are not needed. On the other hand the absence of information relating damage to movements can also cause significant problems to be overlooked, with the result that unanticipated damage may occur. For example, structures such as masonry buildings and structures supported on isolated footings are vulnerable to lateral strain. For these types of structures damage as a

result of horizontal ground displacement could be sustained even though the building had been underpinned for protection against vertical movement.

To improve predictions of building distortion and damage a better understanding of the relationship between ground movements and building response is required. To this end, well documented field studies are invaluable. As Burland et al. (1977) state:

"The importance of published comprehensive case records cannot be overstated. They provide the means of assessing the reliability of prediction methods, they give guidance to practitioners who are faced with the design of foundations and structures in similar circumstances, they can be used to develop an understanding of how structures interact with the ground and draw attention to weaknesses in design and construction; in short, well documented case studies provide the recorded precedents which are so valuable in developing the art of foundation engineering."

1.2 BACKGROUND

Building damage may be divided into three general categories:

- 1) Architectural Damage, i.e., damage affecting the appearance of structures, usually related to cracks or separations in panel walls, floors, and finishes. Cracks in plaster walls greater than 1/64 in. wide and cracks in masonry or rough concrete walls greater than 1/32 in. wide are considered to be representative of a threshold where damage is noticed and reported by building occupants.
- 2) Functional Damage, i.e., damage affecting the use of the structure, usually related to jammed doors and windows, cracking and falling plaster, tilting of walls and floors, and other damage that would require non-structural repair to return the building to its full service capacity.

- 3) Structural Damage, i.e., damage affecting the stability of the structure, usually related to cracks or distortions in primary support elements such as beams, columns, and load bearing walls.

The above categories are very broad with no clear cut limits, so that considerable overlap among the categories often occurs depending on the use of the structure. For example, architectural damage to a museum may also be considered functional damage. In contrast, the limit for functional damage of a warehouse may coincide with the limit for structural damage. In summary the use and the unique characteristics of a specific building must be considered in a discussion of damage with respect to that particular structure.

Two parameters commonly used for developing correlations between damage and differential settlement are the angular distortion and the deflection ratio (Fig. 1.1). Angular distortion, δ_v , is the differential settlement between two points divided by the distance separating them, assuming no tilting occurs. When related to building damage, angular distortion is commonly modified by subtracting the rigid body tilt, α , from the measured settlement. In this way the modified value is more representative of the deformed shape of the structure. The deflection ratio, Δ/ℓ , is defined as the maximum displacement, v , relative to a straight line between two points divided by a distance, ℓ , separating the points.

To date, the bulk of the investigative effort has been directed toward delineating the limits of tolerable distortion for structures settling in response to their self weight. Skempton and MacDonald (1956) put forth criteria for the limits of tolerable building distortions based upon field evidence from 98 case studies, 40 of which deal with structures

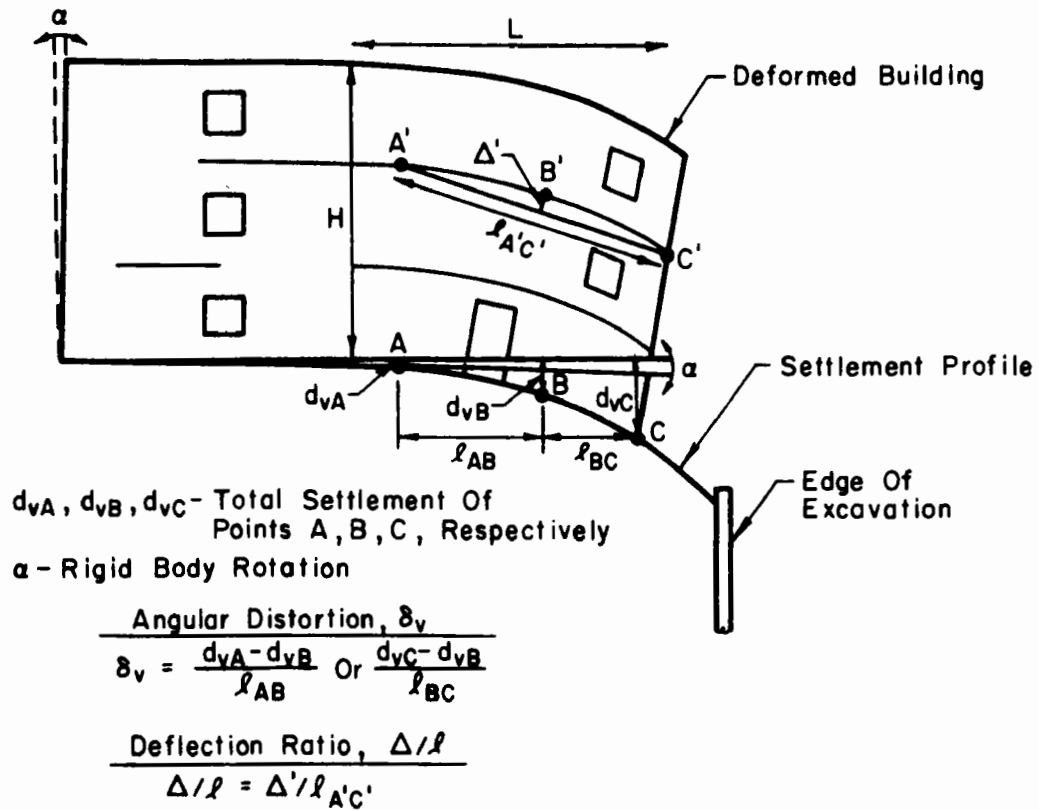

FIGURE 1.1 BUILDING DEFORMATION CAUSED BY SETTLEMENT IN RESPONSE TO OPENCUTTING

damaged as a consequence of settlements. Observed damage was correlated with angular distortion, and the following trends were noted. Angular distortions exceeding 1/150 were associated with structural damage, while angular distortions of about 1/300 were related to cracking in panel walls and load bearing walls. A limited study by Bjerrum (1963) corroborated the limits suggested by Skempton and MacDonald, and an angular distortion of 1/500 was suggested to be a suitable limit for buildings where cracking is not permissible. Grant et al. (1974), in a recent study of 95 buildings also agreed with the limits set by Skempton and MacDonald.

Meyerhof (1956) regarded framed panels and load-bearing brick walls separately. He suggested using limiting angular distortions of 1/250 for open frames, 1/500 for in-filled frames, and 1/1000 for load-bearing walls or continuous brick cladding. Meyerhof's recommendations agree closely with those of Polshin and Tokar (1957), who developed deflection ratio criteria, based on field observations and on analyses of building deflection assuming that the critical tensile strain, ϵ_{crit} , for the onset of cracking on brick masonry is 0.005. For brick masonry founded on hard clay or sand, limiting deflection ratios of 0.0003 and 0.0005 are suggested for buildings with deflected length to height ratios of less than 3 and greater than 5, respectively. For the same type of structures founded on plastic clay limit deflection ratios of 0.0004 and 0.0007 are proposed. In general, if the limits defined by Polshin and Tokar, and Meyerhof are not exceeded, the structure will have a low probability of developing cracks, whereas the levels recommended by Skempton and MacDonald represent thresholds where cracking and damage are quite probable.

Burland and Wroth (1975) extended deflection ratio work of Polshin and Tokar, and described the relationships between building strains and the ratio of the deformed length to height of a structure settling under its own weight. Burland and Wroth considered a hogging or convex deformation pattern in addition to the sagging or concave deformation profile. They noted that a hogging deformation can result from a number of causes, among which are mining subsidence, desiccation, subsidence due to tunneling, loss of support during underpinning, and movements around excavations.

More recently, studies relating building damage to shallow tunneling and opencutting have been published, Breth and Chambosse (1975); Littlejohn Kerisel (1975).

Recent investigations by the University of Illinois have been directed toward evaluating the behavior of structures subjected to ground movement induced by underground construction. O'Rourke et al. (1975) present data relating angular distortion to damage where the ground movement has been in response to deep open cutting. Adjacent to these cuts, the magnitude of the lateral strains were typically found to be of the same order as the magnitude of the angular distortions observed. Limiting angular distortions of 1×10^{-3} and 1.3×10^{-3} were proposed for architectural damage to brick-bearing wall structures and frame structures with masonry in-fill panels, respectively (Fig. 1.2). The observed crack patterns and the low magnitudes of settlement and angular distortion associated with damaged buildings adjacent to braced cuts implied that damage was at least in part related to the lateral ground movement. Therefore, any criteria for the limits of tolerable building distortion for structures influenced by excavation must consider the effects of horizontal straining induced in the structure.

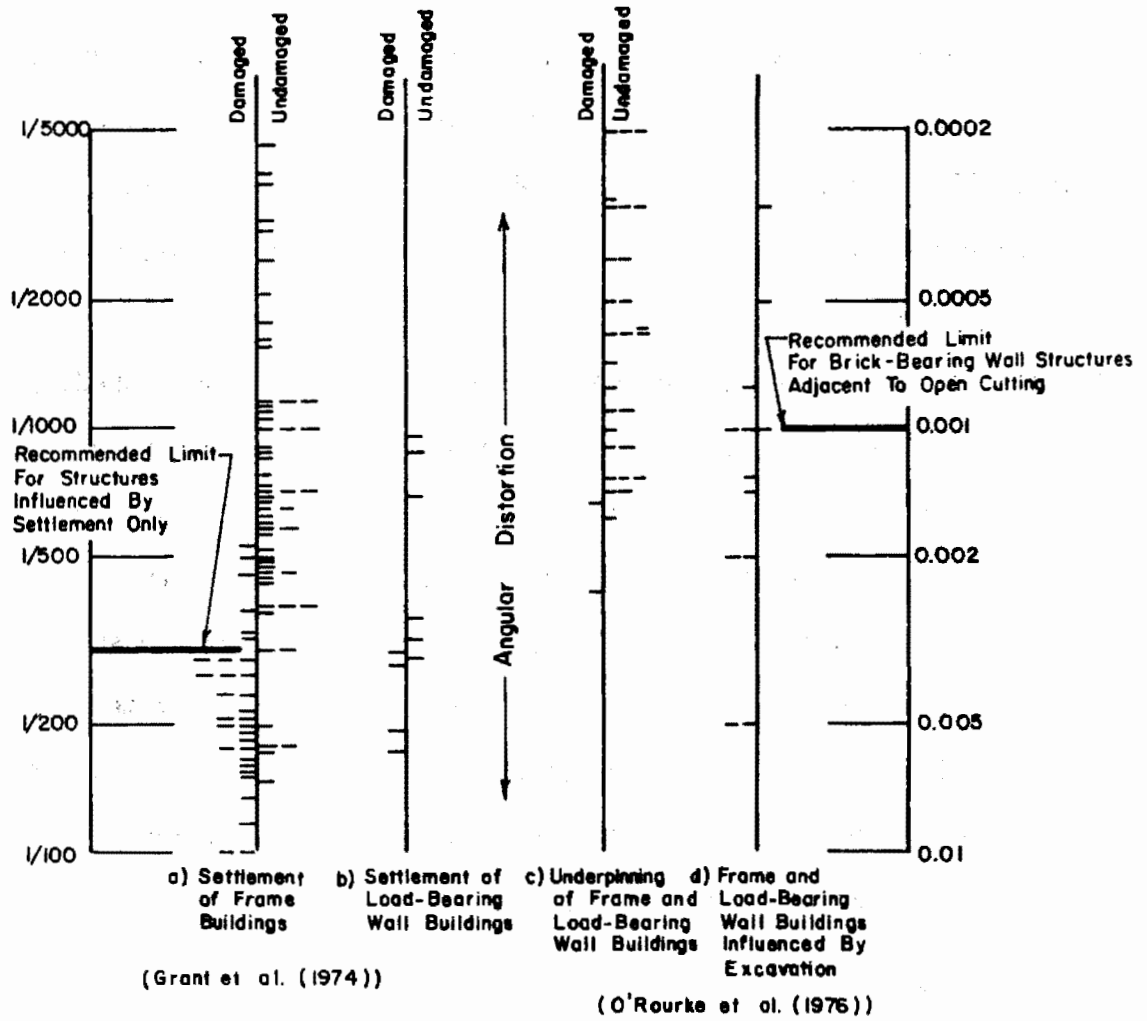

FIGURE 1.2 CRITERIA FOR TOLERABLE DISTORTION

In civil engineering works building damage is usually related to vertical movement by using angular distortion as a criterion. However, in mining subsidence cases, the angular distortions across a structure are small whereas the lateral strains are significant. Damage in response to mining subsidence in England has been correlated with the horizontal ground strain across the structure, Priest and Orchard (1958) and the National Coal Board of Britain (1975). Typically, it was found that most dwelling units could sustain horizontal ground strains up to 1.0×10^{-3} with little observable damage.

Before a rational criterion defining the limits of tolerable distortion for structures influenced by excavation can be developed, a number of variables must be investigated and their relationship to resultant damage understood. Among these variables are the type of structure, orientation of the structure, type of excavation and related pattern of ground movements, soil properties, the stiffness of the foundation and superstructure relative to the ground, and vertical and horizontal ground movements. Appendix A provides a brief synopsis of the typical ground movements and patterns of development associated with braced excavations, tunnels, and mines and related observations of building response.

1.3 OBJECTIVES

Previous studies included correlations of building damage with settlement, but often, no information was available on the structural distortions and strains throughout the structure. This study has concentrated on obtaining more complete information at a few selected sites where access could be gained for installing and reading extensometers, tiltmeters, strain gages, and interior settlement points. One of the major efforts

of the study was the development of procedures for measuring significant building behavior as nearby excavation or tunneling was carried out.

1.4 SCOPE

Data obtained from instrumented test sections, set up and monitored by the University of Illinois under contract with DOT, are presented and discussed in Chapters 2 and 3. The case studies deal with the response of structures influenced by excavations for the Washington, D. C. METRO system. The first case study investigates the response of a 9-story concrete apartment building located 38 ft (11 m) from the edge of a 60-ft- (18-m) deep open cut. The soil profile at this site consists of dense sands interbedded with stiff clays. The second case study reviews the behavior of a pair of two-story brick bearing wall structures in response to the excavation of two 21-ft (6.4 m) diameter tunnels with about 35 ft (10.7 m) of cover. The tunnels were driven through a hard fissured clay which is overlain by silty sand and gravel surficial deposits.

Chapter 4 contains summaries of six case studies developed from construction records and post-construction inspections. These cases include both bearing-wall structures and framed structures adjacent to tunnels and open excavations. The excavation-induced damage ranged from no discernable damage to severe structural damage. The cases are described in terms of the type of structure and foundation, type of excavation, distance from building to excavation, soil profile, settlement, angular distortion, observed or reported damage, and protective measures. These cases are added to the existing data to refine damage-distortion criteria and are evaluated in light of the instrumented test section results presented in Chapter 2 and 3.

Based upon these case studies the following topics are reviewed and discussed:

1. The settlement profiles of buildings that settle under their own weight tends to be concave or bowl-shaped. In contrast, settlement profiles that are convex or that exhibit reversals of curvature are often encountered in the vicinity of an excavation. The response of structures sustaining convex curvature (hogging) and reversals of curvature is investigated and discussed, as is the relationship between the progressive development of excavation-induced ground movements and the response of the affected structures.
2. Ground movements due to braced excavation and tunneling include a substantial lateral component of displacement as well as a vertical component of displacement. The susceptibility of structures to distortion and damage by each type of displacement is demonstrated by structures considered in this study.
3. The presence of a structure may alter the excavation-induced ground movements, or the settlement profile of the building may be less curved than the ground settlement profile depending on the stiffness of the structure. Structures to bridge or smooth out the ground surface settlement profile are described in the case studies.
4. The previous strain history of a structure, its physical condition, structural details, and structural type all affect its susceptibility to damage in response to excavation. The influence of these factors on magnitude of distortion required to cause damage are discussed.

CHAPTER 2
INSTRUMENTED TEST SECTION #1
A NINE-STORY APARTMENT BUILDING

2.1 INTRODUCTION

This first case history describes the behavior of a 9-story reinforced concrete apartment building 38 ft (11 m) from the edge of a braced excavation. The excavation was made during the construction of an underground subway station for the Washington, D.C., METRO by the cut and cover technique. The excavation is 60 ft (18.3 m) deep, 750 ft (229 m) long, and 70 ft (21.3 m) wide and extends through a profile of dense sands and gravels interbedded with stiff clays, see Figure 2.1.

2.2 EXCAVATION SUPPORT AND CONSTRUCTION PROCEDURE

The walls of the cut were supported by soldier piles and lagging with wales and cross lot bracing. The soldier piles, steel section W14 X 111 (360 mm deep x 166 kg/m), were drilled into place at approximately 7-ft (2.1 m) intervals. The soldier piles were anchored with 3500 psi (24 MPa) concrete below the subgrade level, whereas above the subgrade level they were encased in a lean concrete mixture. Their lengths ranged from 70 to 78 ft (21 to 24 m) and they extended 9 to 17 ft (2.7 to 5.2 m) below the subgrade level of the excavation. There were four levels of struts as shown in Figure 2.1. The top level of struts, the A-level, was used to support a platform upon which the construction vehicles were operated. At all levels the struts were spaced horizontally at 12 ft (3.7 m). Struts in

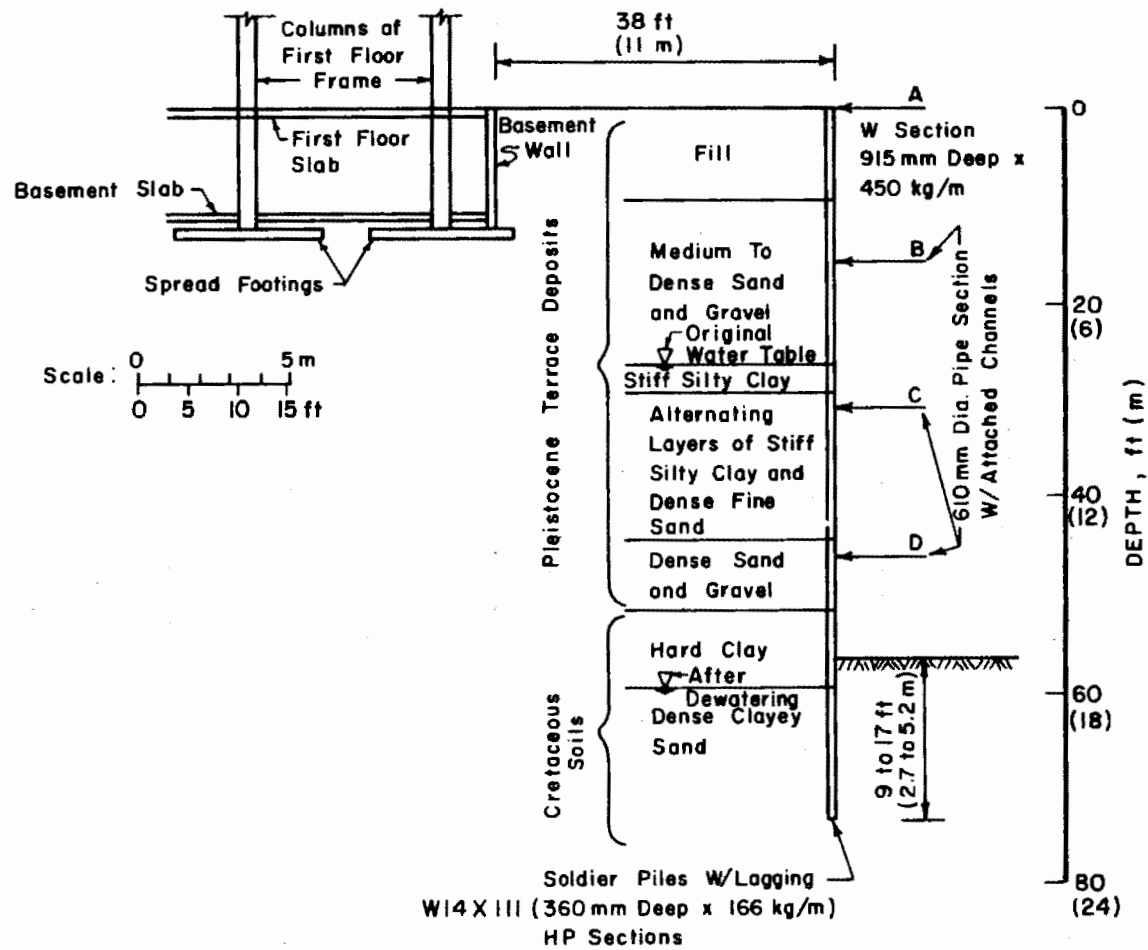

FIGURE 2.1 SOIL PROFILE AND EXCAVATION RELATIVE TO THE MONITORED APARTMENT BUILDING

the bottom three levels were preloaded to 50 percent of the design load at the time of installation. Prior to the installation of a particular strut level, the center of the cut was excavated 10 to 13 ft (3 to 4 m) below the strut level with 10-ft (3 m) high berms left at the sides. After the struts and wales were installed and preloaded the berms were excavated. Struts were removed as the station was constructed and the structural elements of the station became capable of supporting the excavation walls. The lowest level of struts, the D-Level, was removed in order to cast the upper arch. The B and A-levels of struts were removed during the backfilling operation.

Deep wells were used to dewater the site. In the vicinity of the monitored building, piezometers indicated a drawdown of approximately 33 ft (10 m) from the original water level. There were some problems with lesser drawdowns and related running ground, but this did not occur near the test area. A brief summary of the chronological sequence of the excavation is presented in Table 2.1.

2.3 THE STRUCTURE

The edge of the excavation was located approximately 38 ft (11 m) away from the 9-story apartment building. The dimensions of the structure were 56.3 x 158.3 ft (17.1 x 48.3 m) with the long dimension perpendicular to the excavation edge. The foundation for the structure was composed of 14.5 x 16-ft (4.4 x 4.8-m) spread footings located 14 ft (4.3 m) below the ground surface, as shown in Figures 2.1 and 2.2. The first story was predominately open with a small glass lobby in the center. Stories 2 through 9 were flat slab construction with the bottom of the second story resting on the heavy concrete frame of the first story. The first floor frame was composed of a series of large, extensively reinforced concrete

Table 2.1

Chronology of Excavation Adjacent to Test Area

<u>Date</u>	<u>Status of Excavation</u>
9-17-75	Dewatering Had Begun
12-18-75	Initial Measurements
1-15-76	Excavation Approximately 20 ft (6 m) Deep, and A-Level Struts in Place
2-19-76	Excavation Approximately 43 ft (13 m) Deep, and B and C-Level Struts in Place
3-7-76	Excavation to Subgrade, D-Level Struts in Place, and Preparing to Cast Invert
4-5-76	Invert Cast to Approximately 3 ft (1 m) Below D-Level Struts
5-5-76	D-Level Struts Removed, and Preparing to Cast Lower Arch
5-25-76	Lower Arch Section Cast to Approximately 3 ft (1 m) Below C-Level Struts
7-19-76	C-Level Struts Removed, and Preparing to Cast Upper Arch
8-6-76	Upper Arch Cast to Approximately 3 ft (1 m) Below B-Level Struts
12-2-76	Adjacent to Eastern Two-Thirds of the Building, B-Level Struts Removed and Backfilled to Within 12 ft. (3.5 m) of Top. Adjacent to Western Third of the Building, B-Level Struts Still in Place and No Backfill.

beams transverse to the building axis, parallel to the edge of the excavation. These were connected by a pair of longitudinal reinforced concrete beams. The transverse beams were 5.5 ft (1.7 m) wide and tapered from 6.5 to 5.5 ft (2 to 1.7 m) deep. They were located at about 18.5-ft (5.6 m) intervals and spanned approximately 42 ft (12.8 m). Each transverse beam was supported by two of the reinforced concrete columns, 2 x 3.3 ft (0.6 x 1.0 m) in cross-section, near the periphery of the structure. The longitudinal beams were 1.3 ft wide and 5.2 ft deep (0.4 x 1.6 m) and spanned from transverse beam to transverse beam. The two longitudinal beams were each 8 ft (2.4 m) from the longitudinal center line of the structure and continuous throughout the length of the structure. The concrete columns from the frame passed through the basement and rested directly upon spread footings which also supported the basement walls. Additional small columns were used in the basement to provide support for the first story concrete slab. These were founded upon 4-ft (1.2-m) square spread footings approximately 12 ft (3.6 m) deep. At each end of the structure there was a 7.7 x 14-ft (2.3 x 4.3-m) reinforced concrete tube, continuous throughout the height of the building, to the house stairways. Similarly, there was 7.7 x 14-ft (2.3 x 4.3-m) reinforced concrete tube for elevators near the center of the structure.

General criteria for protecting structures adjacent to open excavations had been established by the transit authority. A portion of the foundation of the structure was located in a zone where ground movements were expected to be discernable but not damaging to most buildings. In this zone major structures or very sensitive structures would be underpinned, but only where the possible damage would be irreparable or the expected cost of repair would exceed the cost of underpinning. As a consequence, the 9-story apartment building monitored was not underpinned and the opportunity for

observing distortion of the structure was available.

2.4 OBSERVATION PROGRAM

The observation program was two-fold and included 1) settlement surveys of both the ground surface and the building, and 2) tape extensometer and crack surveys of the structure. These data would then be used to correlate the distortion of the structure with both the status of the excavation and the accompanying ground movements. The following is a brief description of the observations made.

The exterior settlements measurements were made using an optical level and standard surveying rod with a plummet to aid in keeping the rod vertical. Figure 2.2 shows a plan view illustrating the location of the survey points. There were two settlement profiles of the ground surface, one to the east and the other to the west of the apartment building. Several of the points, west of the building, were 1-in. (25-mm) diameter steel rods driven to a depth of 3 ft (1 m), thus leaving the tops of the rods approximately level with the ground surface. The majority of the points were either cross-cuts or masonry nails established in the pavement surrounding the building. Several of the settlement points in the zone between the structure and the excavation were common to both the east and west profiles. Similarly, there were two settlement profiles on the structure itself. The settlement points were located at the northeast and northwest corners of the first floor slab of the building and first four columns of both the east and west column lines of the first floor frame. Both the ground surface and the building settlement points were referenced to a temporary bench mark located approximately 197 ft (60 m) from the edge of the excavation.

The interior survey program consisted of settlement observations of the basement slab, tape extensometer measurements between columns, and a crack survey. Settlement and tape extensometer surveys were conducted in a large empty room occupying the northwest quarter of the basement. The crack survey included observations in the basement, in the stairwell, and in the corridors and vacant rooms in the upper levels of the structure. The cracking was mapped and selected features were marked and measured for later comparisons. The basement slab settlement points were located as shown in Figure 2.2. The interior settlements were measured with an optical level and a standard surveying rod with a plummet. The interior reference point was located 132 ft (40 m) from the excavation. Differential settlement between the basement slab and the columns was measured to within $\pm 1/32$ in. (0.8 mm) using a graduated rule and a leveling system. The tape extensometer survey consisted of measurements between the bases of adjacent columns and along the diagonals between the top and bottom of adjacent columns. Figure 2.2 shows the locations for the tape extensometer measurements. The tape extensometer is composed of a steel tape, a calibrated tension spring and a dial indicator. A more complete description of the tape extensometer and its use is provided by Cording et al. (1975). The accuracy of the tape extensometer in detecting a change in the distance between reference points is $\pm .003$ in. (.1 mm) provided that a temperature correction is made for the thermal expansion of the steel tape. All extensometer readings were corrected for thermal expansion of the tape.

2.5 PRESENTATION AND DISCUSSION OF DATA

2.5.1 SETTLEMENT MEASUREMENTS

Settlement profiles of the ground surface to the east and west of the structure are shown in Figure 2.3. Ground movement was closely related to construction events. The settlement profiles became successively steeper and wider as the excavation progressed. The profiles show a pronounced increase in curvature within 50 ft (15 m) of the edge of the excavation.

Figure 2.4 shows a comparison of the settlements measured at the test site with those summarized by Peck (1969) and O'Rourke (1975). The measured settlements are small by comparison with the overall range of movements shown in Peck's summary. They are, however, typical of excavations in medium to dense sand with interbedded stiff clay and compare favorably with the settlements measured at similar cuts in Washington, D. C.

Figure 2.5 shows the angular distortion associated with the braced cut plotted as a function of the dimensionless distance from the edge of excavation. The angular distortion was estimated by dividing the differential settlement of two points along a line perpendicular to the edge of excavation by the distance separating them. The dimensionless distance from the edge of excavation was computed as the point midway between the two points from which the differential settlement was determined.

The exterior settlement survey on the building columns is presented in Figure 2.6. Comparison with Figure 2.3 reveals that the settlements of the columns are somewhat less than the settlements of the adjacent ground surface. This is to be expected because the column footings are

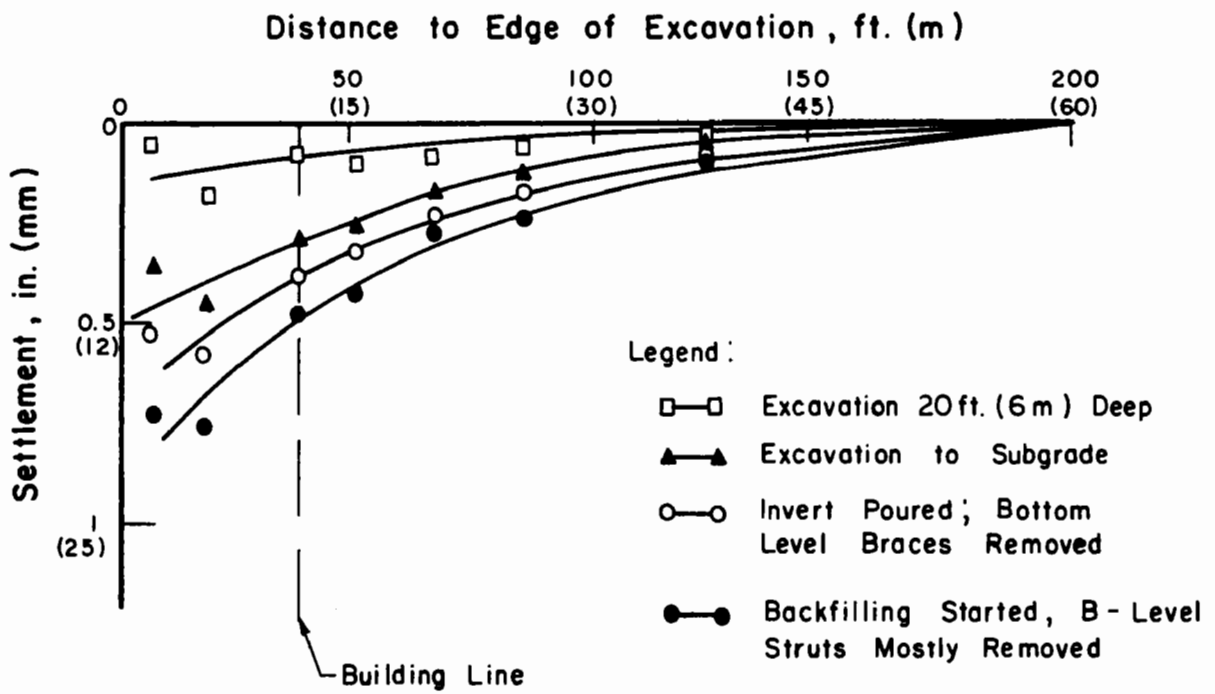

a) Settlement Profiles West of Building

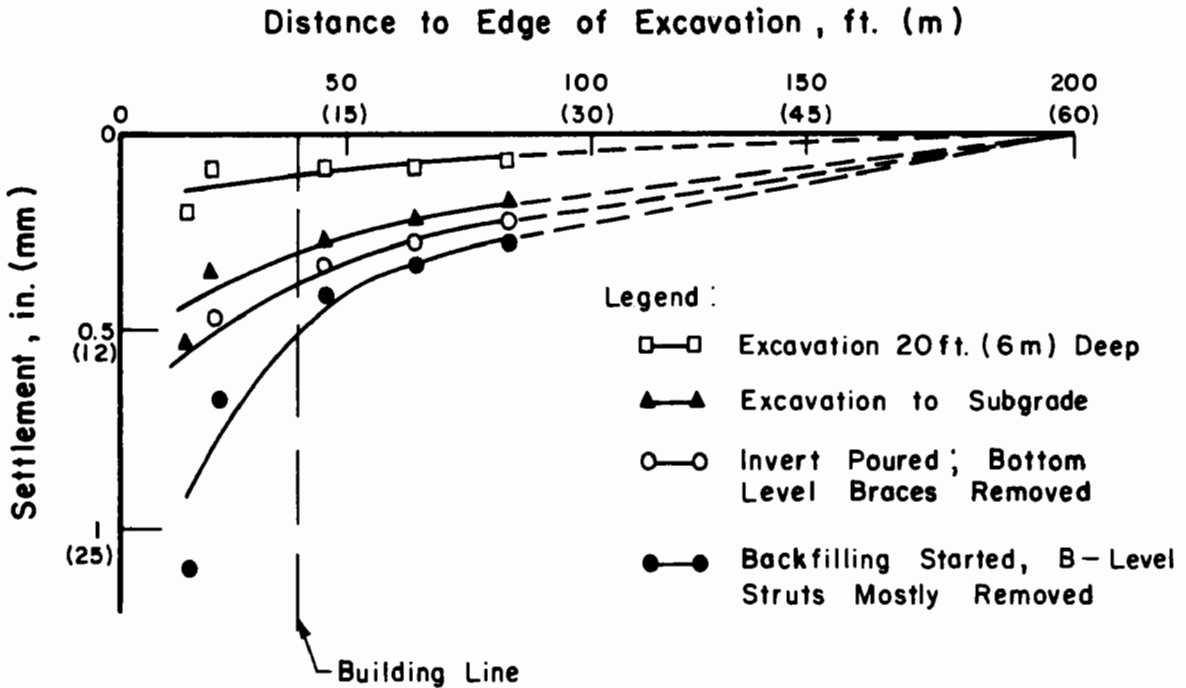

b) Settlement Profiles East of Building

FIGURE 2.3 SETTLEMENT PROFILES OF GROUND SURFACE AS RELATED TO CONSTRUCTION HISTORY

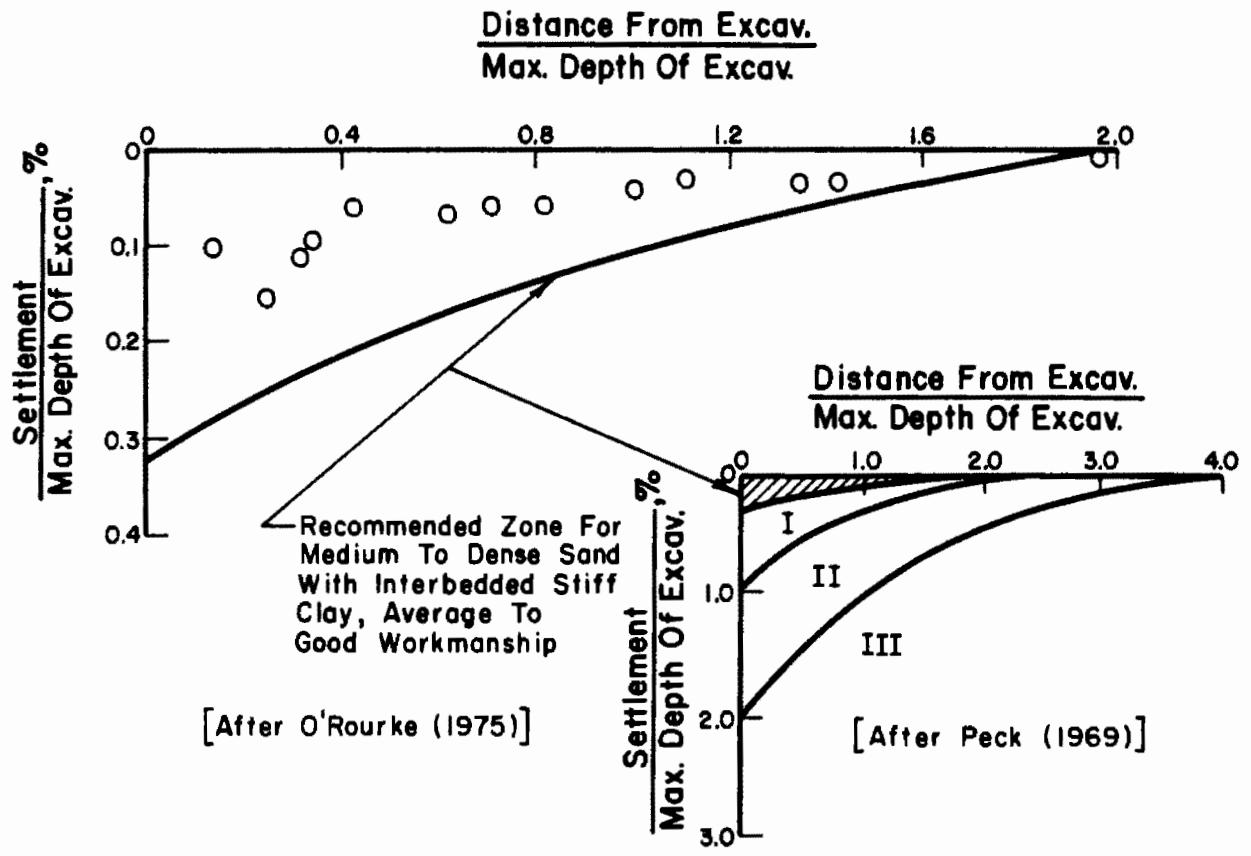
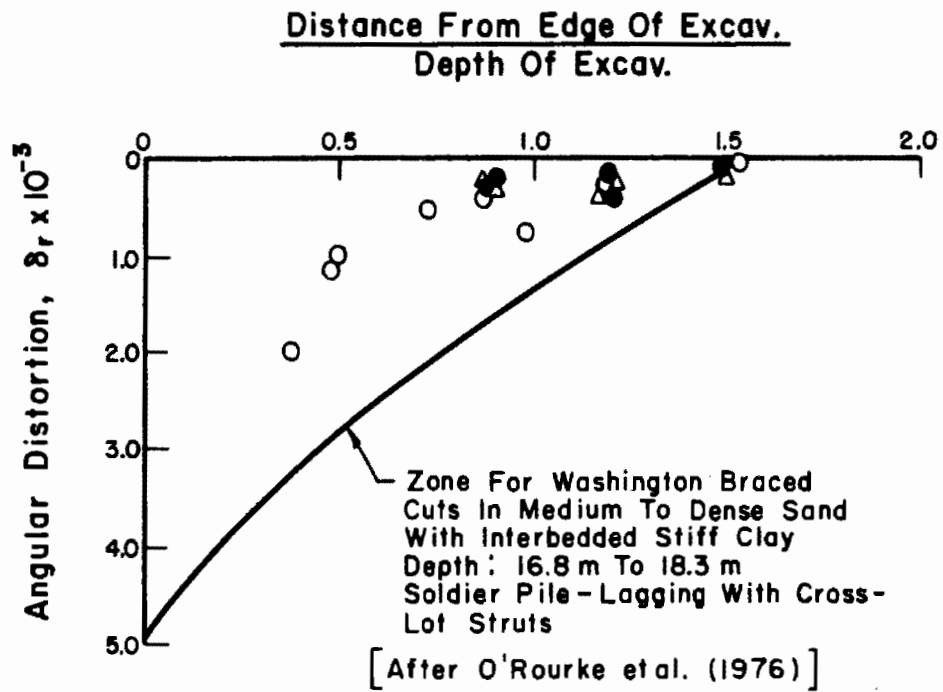
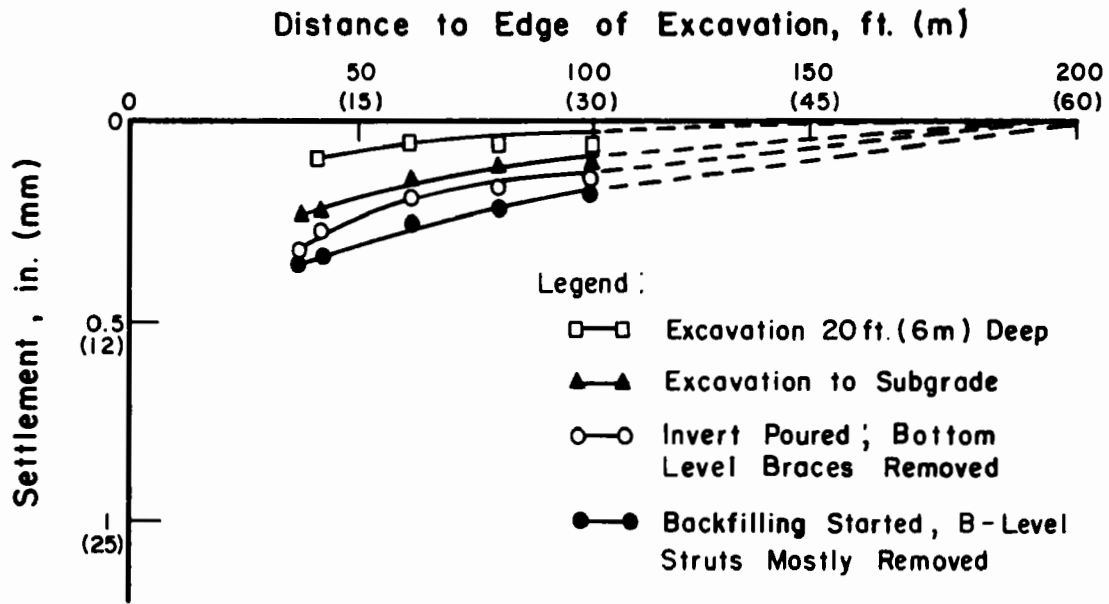

FIGURE 2.4 SUMMARY OF SETTLEMENTS ADJACENT TO THE BRACED EXCAVATION



- Estimated From Ground Surface Settlement Data
- Estimated From Column Settlement Data
- △ Estimated From Basement Slab Settlement Data

FIGURE 2.5 ANGULAR DISTORTION FOR BRACED EXCAVATION



a) Settlement Along West Column Line

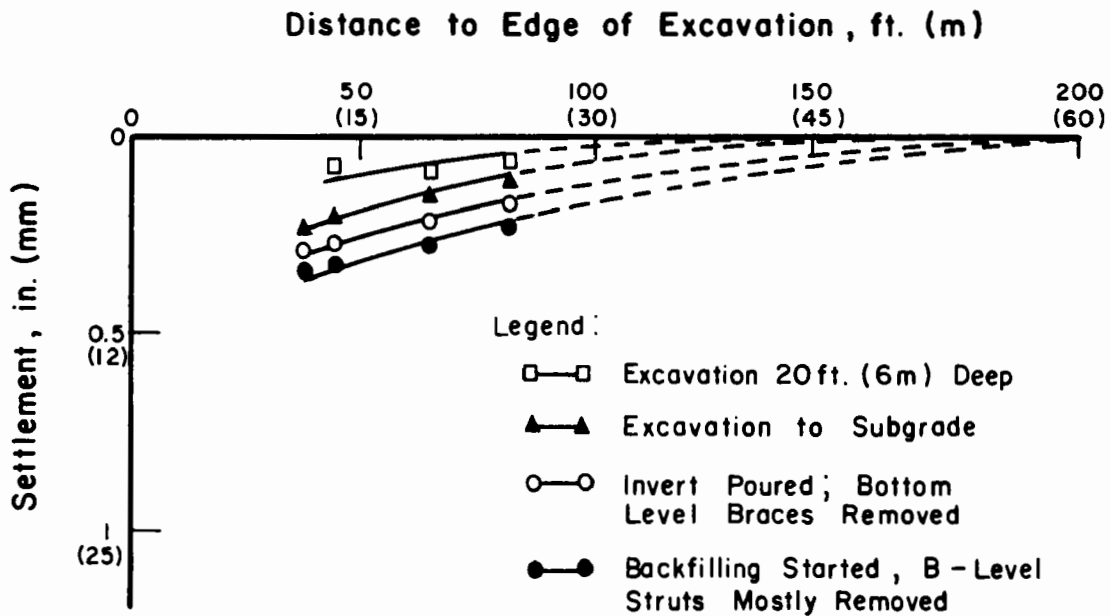

b) Settlement Along East Column Line

FIGURE 2.6 SETTLEMENT OF BUILDING COLUMNS

located approximately 13 ft (4 m) below the ground surface. In Figure 2.5 distortion estimates derived from the column settlement data are also plotted. The angular distortion experienced by the columns is approximately the same as the angular distortion derived from the ground surface settlement data.

The data from the interior settlement survey of the basement slab is presented in Figure 2.7. Initially, the basement slab settlements appeared to be 1/8 in. (3 to 4 mm) less than the ground surface settlements and the column settlements. Close inspection revealed that the reference point for the interior settlement had settled on the order of 1/16 to 1/8 in. (2 to 3 mm). Figure 2.7 has been adjusted to include the settlement of the reference points. It was expected that the basement slab would tend to move nearly the same as the column footings. Measurements of the settlement of the columns relative to the basement slab were made and no indication of relative movement was apparent. Data on angular distortion of the basement slab are presented in Figure 2.5. The angular distortion of the slab is approximately the same as the angular distortion data derived from both the ground surface settlement survey and the column settlement survey.

A comparison of the ground surface settlements presented in Figure 2.3 and the various stages of excavation shows that most of the total settlement occurred during the excavation and bracing phase of the project. However, a substantial portion of the total settlement, approximately 40 percent, occurred during station construction, strut removal, and backfilling phases of the work. Similar observations apply for the column settlements and the basement slab settlements shown in Figures 2.6 and 2.7. These observations corroborate previous measurements

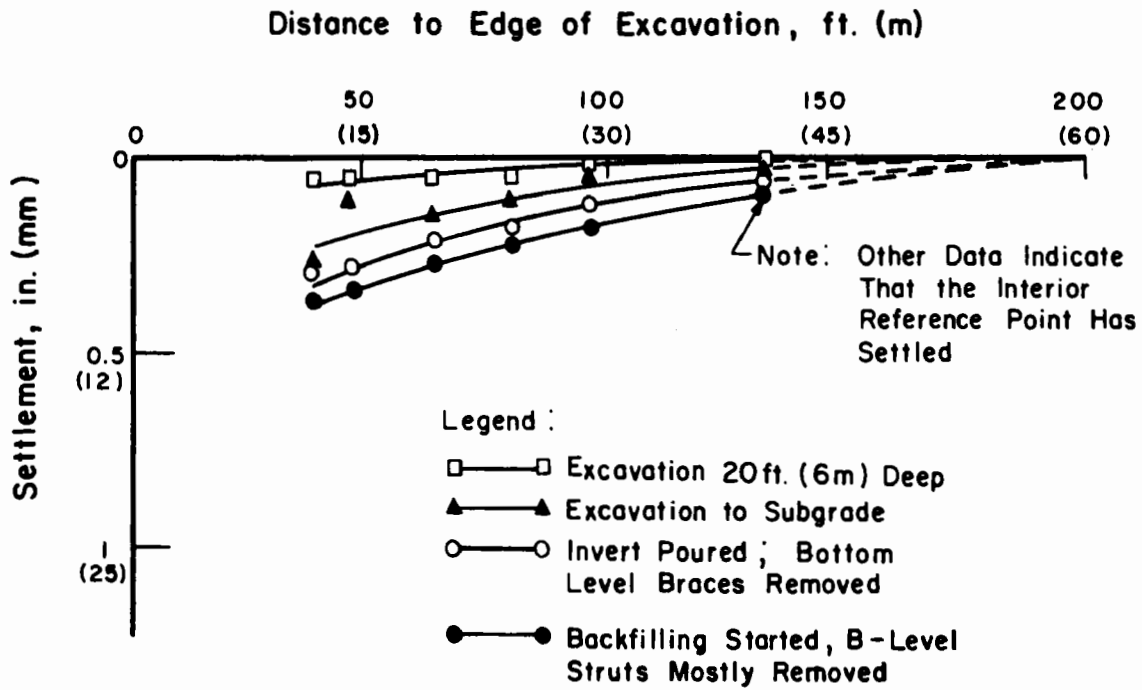

FIGURE 2.7 SETTLEMENT OF BASEMENT SLAB

at braced cuts in Washington, D. C. (O'Rourke, 1975) where inward movements in response to strut removal accounted for 40 to 45 percent of the total lateral movement of the excavation wall.

2.5.2 EXTENSOMETER MEASUREMENTS

Figure 2.8 shows the changes in the tape extensometer measurements that occurred from the time of the initial readings to the time corresponding to a partially backfilled condition and the removal of most B-level braces. The external building temperature and internal temperature of the structural bay under scrutiny were similar for the two sets of readings. Differential lateral extension at the bases of the columns was approximately 1/32 in. (1 mm). This horizontal extension correlates with diagonal extension and diagonal compression directed downward and upward, respectively, toward the columns nearest the excavation.

Figure 2.9 presents exaggerated views of the distorted building frame as observed along section C-H and C-I. The shape of the distorted structure has been developed from the extensometer and settlement measurements at the columns. It is evident that the building distortion is a function of relative displacement both vertically and horizontally. As shown in Figure 2.5, the angular distortion experienced by the structure is essentially the same as that determined for the ground surface. The horizontal strains calculated for each tape extensometer cross-section are approximately the same as the angular distortions. The similarity of horizontal and angular strains implies that, at the location of the building, horizontal ground movements were of nearly the same magnitude as the settlements.

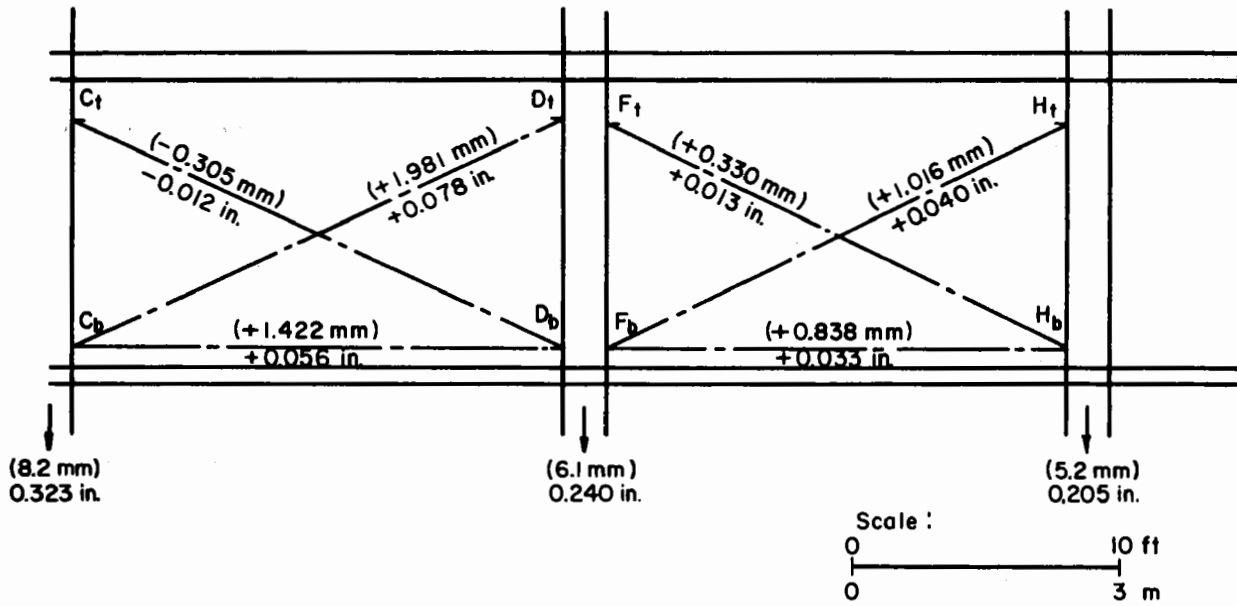

Section C-H

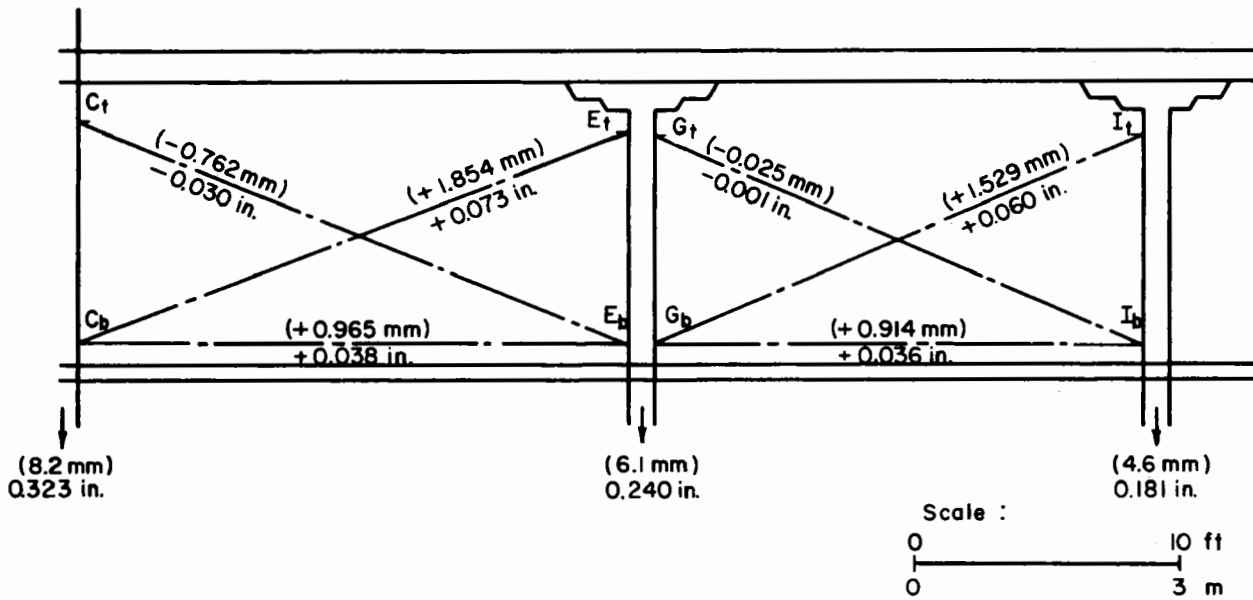

Section C-I

FIGURE 2.8 SECTIONS ILLUSTRATING TAPE EXTENSOMETER POINTS AND CUMULATIVE DISTORTION FROM 18 DEC 75 TO 2 DEC 76

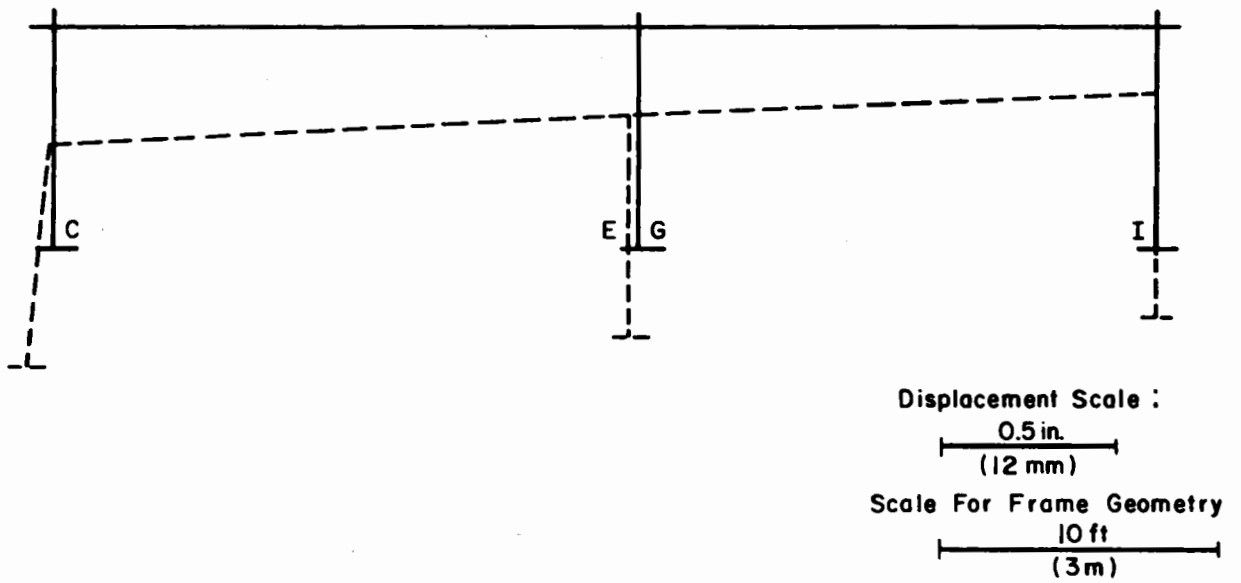

Section C-I

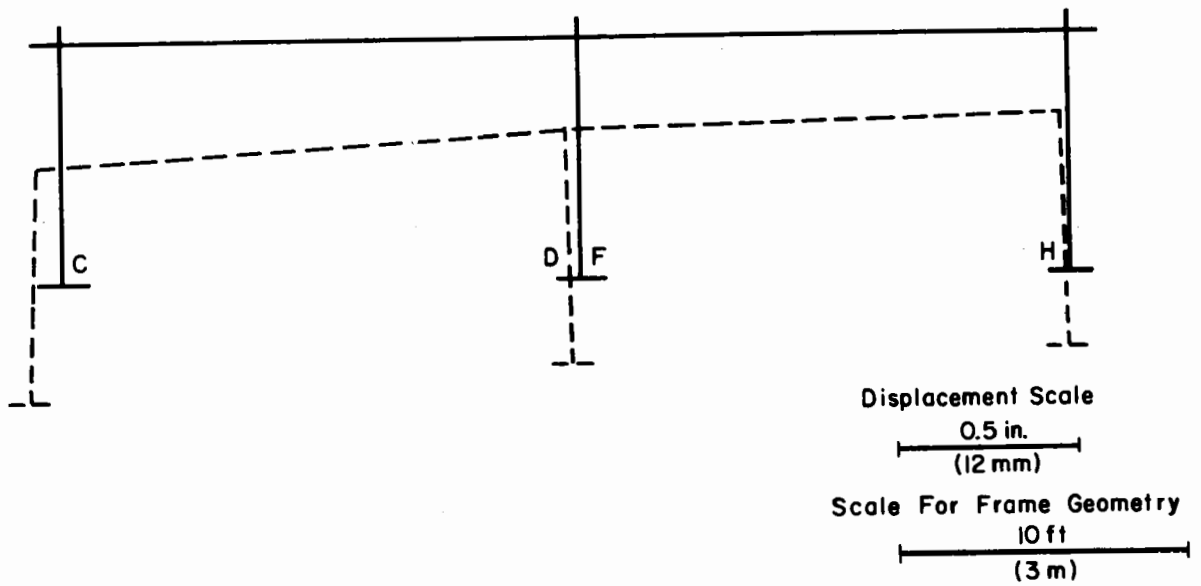

Section C- H

FIGURE 2.9 SKETCHES OF BUILDING DISTORTION BASED ON CUMULATIVE DISTORTION THROUGH 2 DECEMBER 76

For frame structures, the strain of the extension diagonal would be useful to describe the degree of distortion of the building. The diagonal extension strains for the bents nearest the excavation, C_b to D_t and C_b to E_t , are 0.033 % and 0.028 %, respectively. The diagonal extension strains for the bents farther from the excavation, F_b to H_t and G_b to I_t , are 0.018 % and 0.026 %, respectively. The bents shown in section C-I, Figure 2.2, have nearly equal diagonal extension strains. On the other hand, the diagonal extension strains for the bents shown in section C-H exhibit markedly different diagonal extension strains. These differences are caused by the three columns in section C-H being tied into the superstructure of the building, thus gaining added stiffness, whereas only the first column in section C-I is connected to the superstructure. The remaining two columns in section C-I are light columns that only support the first floor slab and do not extend and tie into the buildings frame.

2.5.3 VISUAL INSPECTION

The crack survey revealed that only minor cracking occurred during excavation and construction. Construction joints in the basement slab and at the basement slab-wall junction opened 1/64 to 1/32 in. (0.4 to 1.0 mm). This is in agreement with the lateral movements recorded in Figure 2.8. The observed cracking was concentrated in the area where the north basement wall and the north stairwell meet. The stairwell is much stiffer than the basement wall and it is integrally connected with the superstructure. Under such conditions, the area of the intersection of the wall and the stairwell would be quite susceptible to

cracking. The initial crack survey revealed pre-excavation cracks. Subsequent surveys indicated that these pre-existing cracks opened about 1/100 in. (0.3 mm) and some crack propagation, generally upward, had occurred. Several new hairline cracks also appeared in the area. The crack surveys of the stairwell and hallways did not reveal new or increased cracking. In addition, there were no reports of cracking in the apartments or other portions of the superstructure even though building personnel had been alerted as to the possibility of such distortion.

2.5.4 INFLUENCE OF TEMPERATURE

The data from the tape extensometer measurements are presented in Figure 2.10. Figures 2.2 and 2.8 illustrate the locations of these measurements. Figure 2.10 is a plot of the total change in the distances between reference points for the various dates of observation. Exterior and interior temperatures are noted.

In each bay, the diagonals directed upward toward the columns closest to the excavation (lines $D_b - D_t$, $E_b - C_t$, $H_b - F_t$, and $I_b - G_t$) show a significant extension during the summer months and a compression during the winter months and, in particular, to the movement determined from the final set of readings. Moreover, as the summer temperature increased, the extension of these diagonals increased significantly, whereas the measurements at the other extensometer lines showed only minor alterations. Clearly, the distortion of the building frame was influenced by temperature.

The influence of temperature is illustrated in Figure 2.11. For simplicity a single bay is shown and its distortions due to both

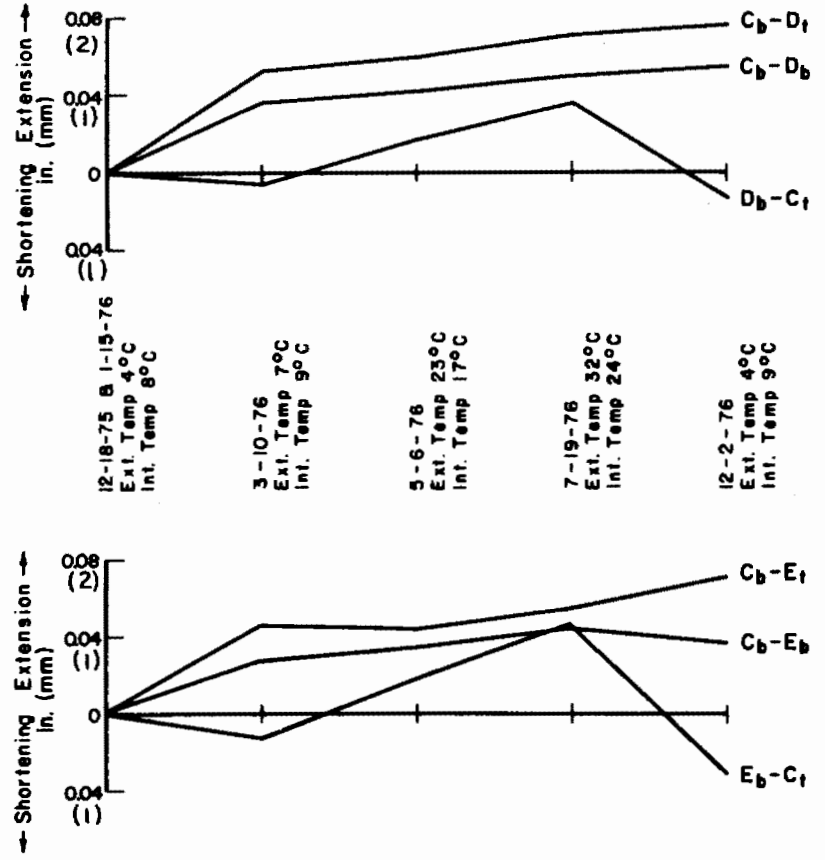
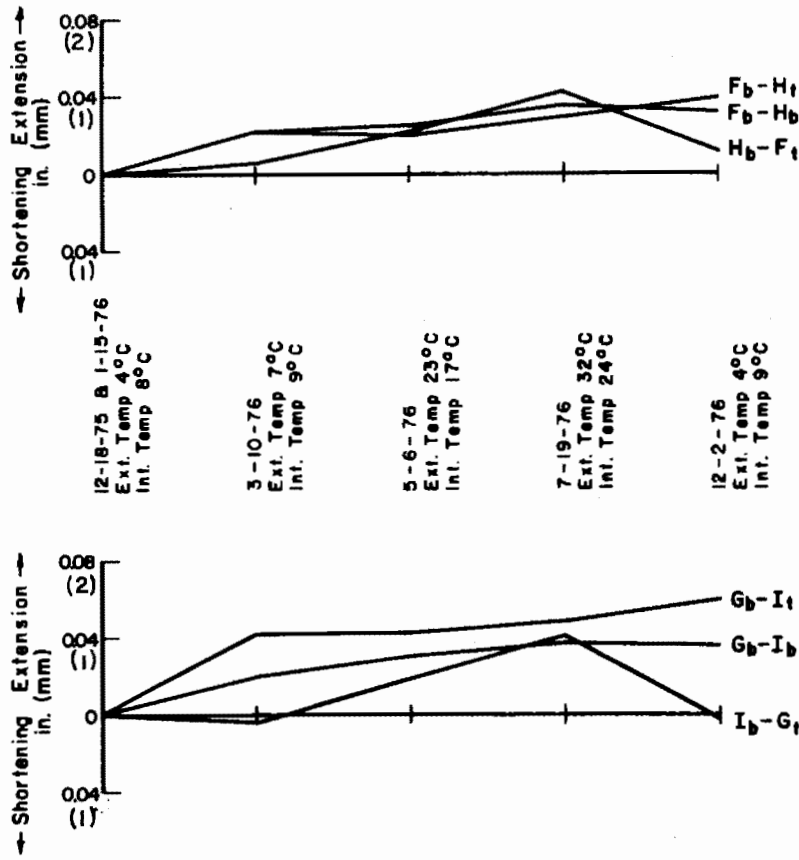
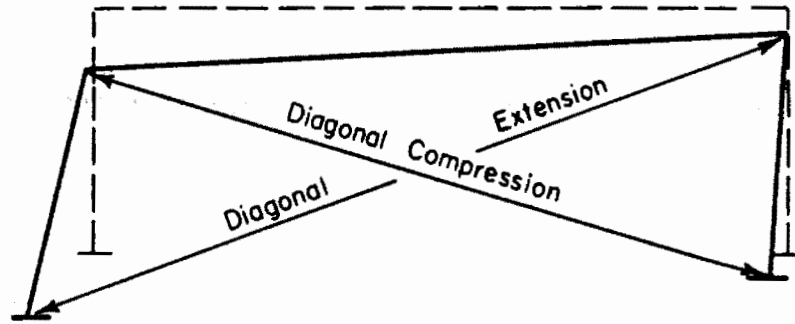
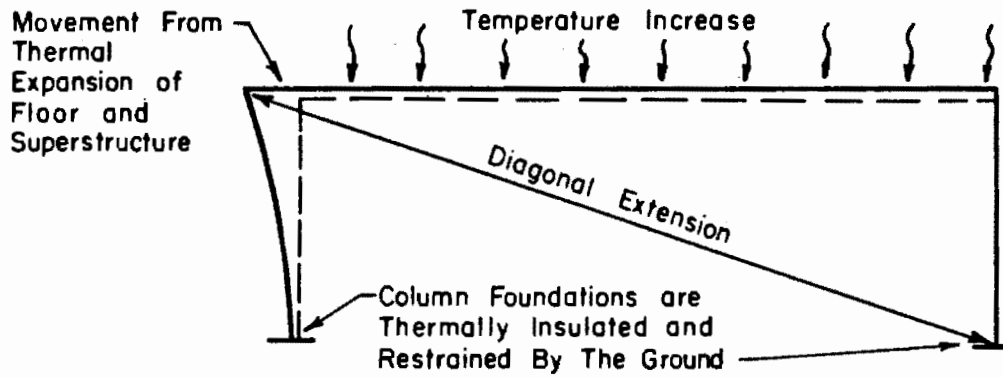

FIGURE 2.10 TAPE EXTENSOMETER MEASUREMENTS OF STRUCTURAL BAY DISTORTION AS A FUNCTION OF TEMPERATURE



a) Frame Distortion Caused By Differential Ground Movement



b) Frame Distortion Caused By Differential Thermal Expansion

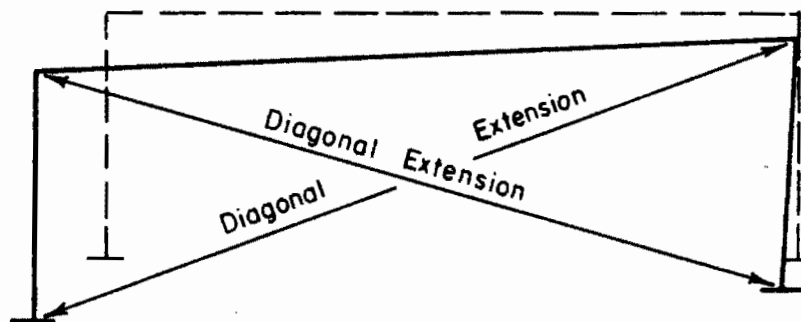

c) Frame Distortion Caused By Combined Differential Ground Movement and Thermal Expansion

FIGURE 2.11 FACTORS CONTRIBUTING TO FRAME DISTORTION

differential ground movement and thermal expansion are indicated separately. Thermal expansion of the first floor and superstructure causes additional separation at the tops of the columns, thus, extending the diagonal directed upward from the base of the interior column. Because the foundations of the columns are thermally insulated and restrained by the ground, the horizontal separation at the base of the frame remains constant. The average temperature change from the time of the zero readings until 19 July 1976 was approximately 72°F (22°C). If this increase of temperature caused a widening along the first floor line that was related to the coefficient of thermal expansion for concrete (6 micro-strains per F° or 9 micro-strains per C°), then the diagonal extension should have been approximately 0.04 in. (1 mm). This calculated value agrees with the measured increase. When the distortions caused by differential ground movements and thermal expansion are combined, the resulting deformation shows an extension of both diagonals.

In summary for the monitored building, the horizontal and diagonal tensile strains caused by thermal expansion were of the same magnitude as similar strains in the basement caused by ground movement from the 60 ft (18 m) deep excavation. Temperature contributes to building deformation and must be anticipated when planning a measurement program to assess structural response.

2.6 CONCLUSIONS

Reinforced concrete structures, such as the apartment building studied in this paper, are common place in many cities and thus are important when the design and engineering of deep, braced cuts are

considered. As such, measurements concerning the nature of building response to ground displacement are useful for evaluation of potential damage and judgements without protective measures. The results of the instrumentation program permit some conclusions that are pertinent to excavation planning and design:

1. The soil settlements adjacent to the 60 ft (18 m) deep cut were typical of the settlements measured in conjunction with other deep cuts in interbedded medium-dense sands and gravels and stiff clays.
2. The deformed shape of the 9-story building, which was located 38 ft (11 m) from the cut, conformed closely with the settlement profile, as is evidenced by the similarity of angular distortion measured at the ground surface and along the structure.
3. The building columns, which are founded on isolated footings, showed a differential lateral displacement of the same magnitude as the differential settlement. Consequently, the horizontal building strains were approximately equal to the angular distortion of the structure, both of which were approximately 0.2×10^{-3} to 0.3×10^{-3} .
4. Building damage was minimal, consisting of several hairline fractures and the 0.01 in. (0.3 mm) opening of pre-excavation cracks. This cosmetic damage was located near the intersection of a stairwell and a basement wall, an area of marked differential stiffness between building elements.
5. This case study also illustrates how the characteristic pattern of building distortion, diagonal extension and diagonal

compression, typically associated with differential settlement maybe altered by thermal expansion and/or contraction of the superstructure of the building. This behavior is especially significant when the structural elements are exposed to seasonal temperature fluctuations and small differential settlements. In this case study the initial observations were made during the winter. When subsequent observations were made during the summer, the diagonals that should have experienced contraction as a result of differential settlements were observed to have undergone extension. This behavior indicates that for small differential settlements thermal expansion can be as significant in causing building distortion as differential settlement.

CHAPTER 3
INSTRUMENTED TEST SECTION #2
TWO - STORY BRICK - BEARING WALL BUILDINGS

3.1 INTRODUCTION

This case history reviews the response of a pair of two-story brick-bearing wall structures to the excavation of two nearby subway tunnels. The tunnels are part of the Washington, D. C. METRO System, and are 20.8 ft (6.4 m) in diameter with a springline depth of 45 ft (13.7 m). The center to center tunnel spacing is 42 ft (12.8 m). Fig. 3.1 shows the relative positions of the structures and the tunnels in profile. As shown by the site plan, Fig. 3.2, the longitudinal axes of the buildings are skewed 22° from the tunnel axes.

3.2 SOIL PROFILE

The soil profile shown on Fig. 3.3, indicates that the test section is located near a transition from dense sands and gravels in river flood plain deposits to hard, clayey Cretaceous soils. Observations made at the tunnel heading during excavation beneath the test section indicated that the heading material was a hard red clay with occasional weathered and sandy zones near the tunnel crown. The clay material is hard and fissured with some slickensides present.

3.3 EXCAVATION SUPPORT AND CONSTRUCTION PROCEDURE

The tunnels were excavated using a Robbins articulated shield. The shield was 21.17 ft (6.45 m) long with an outside diameter of 20.83 ft (6.35 m). The excavation cycle consisted of: 1) shoving the shield forward into the soil with hydraulic jacks reacting against the temporary lining, and 2) raking the

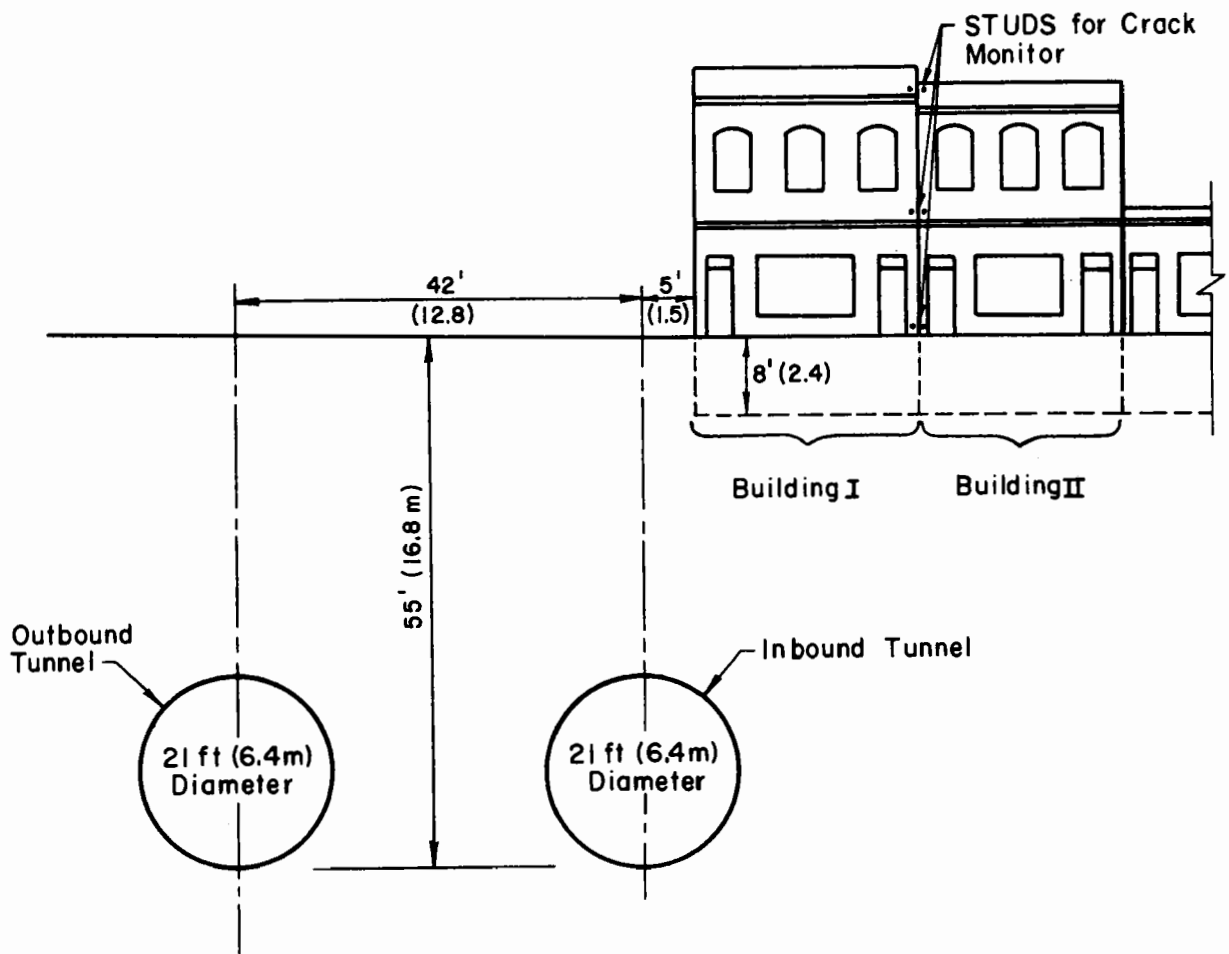

FIGURE 3.1 PROFILE SHOWING RELATIVE POSITIONS OF BUILDINGS I AND II AND THE TUNNELS

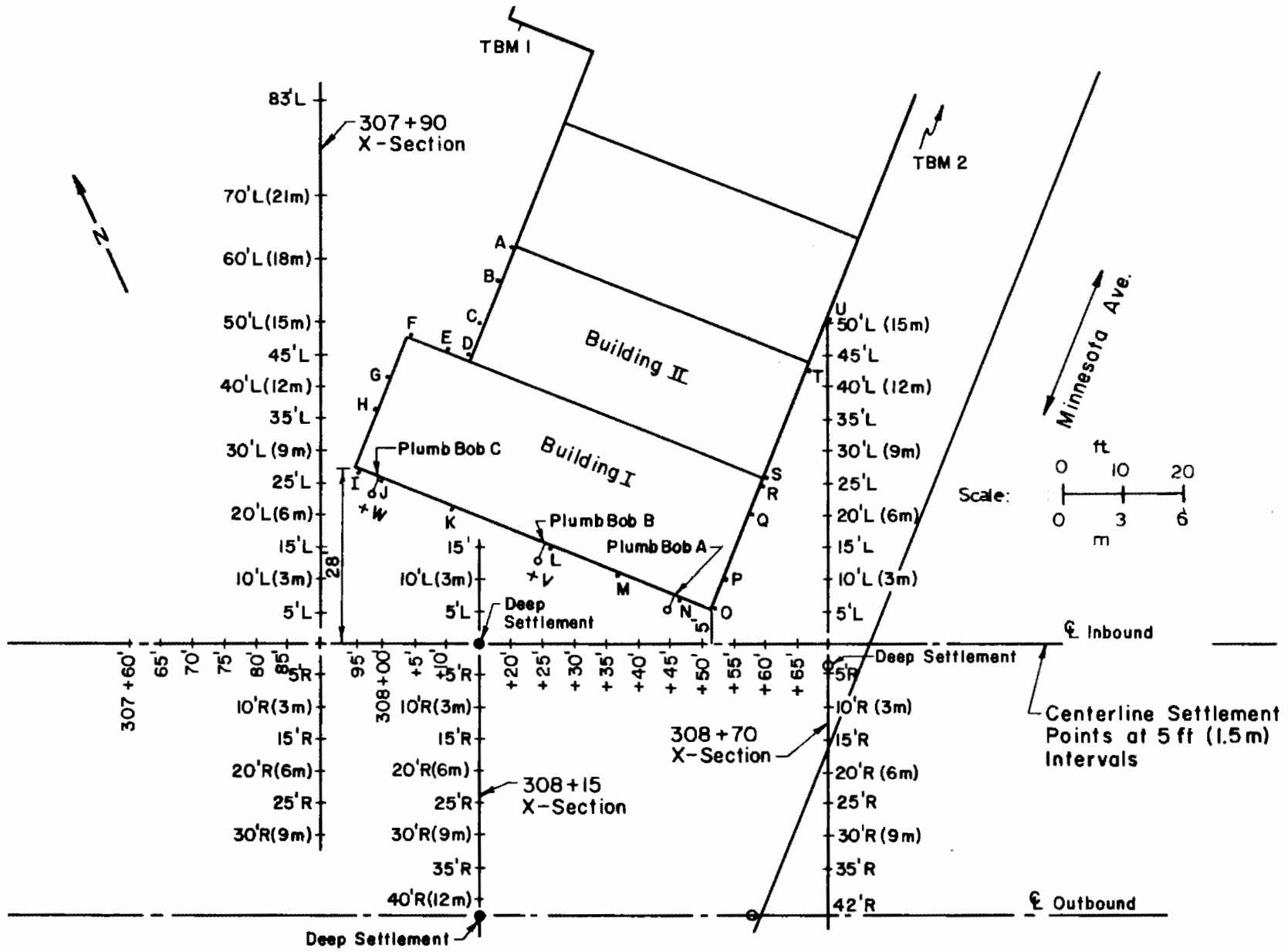

FIGURE 3.2 PLAN VIEW OF TEST SITE SHOWING LOCATIONS OF GROUND SURFACE SETTLEMENT POINTS, EXTERIOR BUILDING SETTLEMENT POINTS, AND PLUMB BOBS

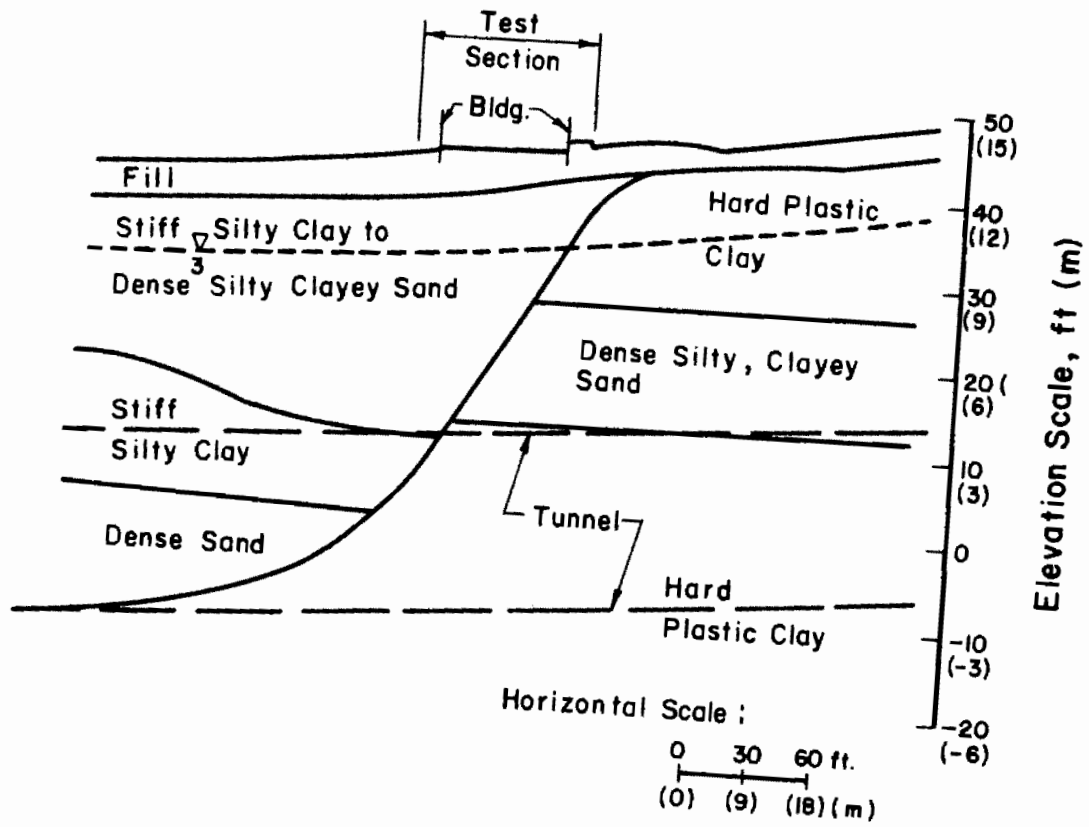

FIGURE 3.3 SOIL PROFILE AT TEST SITE

muck onto a conveyor belt with a hydraulically operated spade. The conveyor then carried the muck from the face into muck cars. A temporary lining consisting of steel ribs and timber lagging was assembled within the tailskin of the shield and then expanded as each rib cleared the tail. The ribs were four piece W6X25 sections and were spaced about 4 ft (1.2 m) center to center. The lagging consisted of 5 in. by 8 in. (127 mm by 203 mm) timbers, each 3.75 ft (1.1 m) long. The tunnel excavation and support system is described in detail by MacPherson, Critchfield, Hong, and Cording (1977).

3.4 THE STRUCTURES

The two brick masonry structures and their positions relative to the tunnels are illustrated in Fig. 3.1 and 3.2. The longitudinal axes of buildings are skewed approximately 22° from the tunnel axes with the corner of Building I 5 ft. (1.5 m) from the center line of the inbound tunnel. Because of their proximity to the tunnel excavations these structure were vacated for the duration of mining.

The two buildings are similar in construction. The bearing walls are parallel to the longitudinal axes of the buildings and composed of brick with lime mortar. There is no structural connection between the buildings. A steel beam, 8 I 18.4 (203 mm x 27 kg/m), supported by the facade walls and three equally spaced interior columns, extends along the length of each building, midway between the bearing walls. The timber floor joists, 2-by-10 in (51 by 254 mm) at 16 in. (0.4 m) intervals, span between the center beam and the bearing walls. The joist bearing at the masonry pockets was about 4 in (100 mm). The bearing walls and columns are supported by spread footings at depths ranging from 4 to 3 ft (1.2 to 2.4 m) below the ground level. Information about the

exact nature and size of the footings is not available. However, rubble type footings probably support both buildings. Based on type of construction, materials and present condition, the structures are estimated to be 80 to 90 years old. There appears to have been some renovation and restoration of the joists and front facade walls.

The bearing walls are 14 in. (0.35 m) thick at basement level and are reduced 1 in. (25.4 mm) in thickness for each story thereafter. The facade walls are 12-in. (300-mm) - thick brick masonry walls. The front facade walls are faced with one wythe, approximately 4 in. (102 mm), of cement mortar brick masonry backed by 8 in. (200 mm) of lime mortar brick masonry. The exposed lime mortar is generally soft and quite easily scraped from the joints of both the bearing and facade walls. In many instances there are gaps where the lime mortar has been eroded or has fallen from the joints. The exterior of the front facade walls has better mortar and presents a more competent appearance; the joints are tight and very hard with few cracks or gaps. The interior walls of Building I are either exposed brick or plaster over brick. Many cracks were present prior to the tunnel excavation which may have been related to previous settlement and to cyclic thermal and humidity changes. The interior walls of Building II were either brick or dry wall over brick with cracking prior to tunneling similar to that observed in Building I.

3.5 OBSERVATION PROGRAM

The observations may be divided into three categories:

- 1) Measurements of movement of the ground mass;
- 2) Distortion measurements of the building;
- 3) Inspection for visible evidence of building distortion (e.g. cracking, jammed doors, etc.).

The observations in each case were made before and after the tunneling operations as well as periodically during the tunnel excavation. The following is a brief description of the observations made.

3.5.1 MOVEMENT OF GROUND

The observations of the movements of ground mass were predominantly settlement measurements. However, the magnitude of the horizontal strain in the extension zone was estimated through observation and measurement of cracks parallel to the tunnel axes that developed in the sidewalks and pavement. The settlements were measured by precise surveys using an optical level and standard survey rod equipped with a plumbing device to insure verticality of the rod. The locations of the settlement observation points are shown in Fig. 3.2. There were three lines of settlement points perpendicular to the tunnel axes at Stations 307 + 90, 208 + 15, and 308 + 70 and a fourth line along the centerline of the inbound tunnel from Station 307 + 60 to Station 308 + 70. The settlement points for transverse sections 307 + 90 and 308 + 15 are 3-ft (1-m)-long steel rods 3/4 in. (19 mm) in diameter. The settlement points for transverse section 308 + 70 are cross cuts in the sidewalk and the pavement. Along the centerline of the inbound tunnel every fourth settlement point is a 3-ft (1 m) steel rod 3/4 in. (19 mm) in diameter. The remainder of the points are PK nails in the pavement. Three deep settlement points are also shown in Fig. 3.2. The anchorages for the deep settlement points are about 4 ft (1.3 m) above the crown of the tunnel. The bench marks were located 110 ft (33 m) and 140 ft (43 m) from the center of the inbound tunnel. Detailed descriptions of the ground movements may be found in MacPherson, Critchfield, Hong, and Cording. (1977)

3.5.2 BUILDING DISTORTION

Building distortion was monitored using the following five types of observations:

- 1) Interior bay distortion, determined by changes in horizontal and diagonal distances between elements of the bay, Fig. 3.4 and 3.5. Measurements were made using a tape extensometer having a sensitivity of ± 0.001 in. (0.03 mm) and a repeatability of ± 0.004 in. (0.1 mm).
- 2) Building settlement, based upon precise optical level surveys of exteriors of both buildings and the interior of the basement of Building I. The level-rod system had a repeatability of ± 0.04 in. (1 mm) and closure errors were on the order of ± 0.04 in. (1 mm).
- 3) Tilt of the south wall of Building I, measured using plumb bobs suspended from the roof, Fig. 3.6. Measurements were repeatable to ± 0.03 in. (0.8 mm).
- 4) Relative displacements between Building I and II, determined from changes in distance between pairs of studs attached on either side of the vertical joint forming the interface between the buildings. Measurements were made using a caliper with a sensitivity of ± 0.001 in. (0.03 mm). Repeatability was on the order of ± 0.01 in. (0.3 mm).
- 5) Change in bearing of floor joists, determined by measuring between a reference stud on the joist and the face of the wall, Fig. 3.7. A caliper with a sensitivity of ± 0.001 in. (0.03 mm) was used. The repeatability of the system was ± 0.01 in. (0.3 mm).

3.5.3 VISUAL DAMAGE

The third category of observations was inspection for visible evidence of building distortion. Detailed surveys noting the condition of building were made. Cracks were mapped and selected cracks were measured before and after tunnel excavation. Building elements which often prove quite sensitive to distortion were also inspected. These included doors, windows, column-beam junctions, and corner areas.

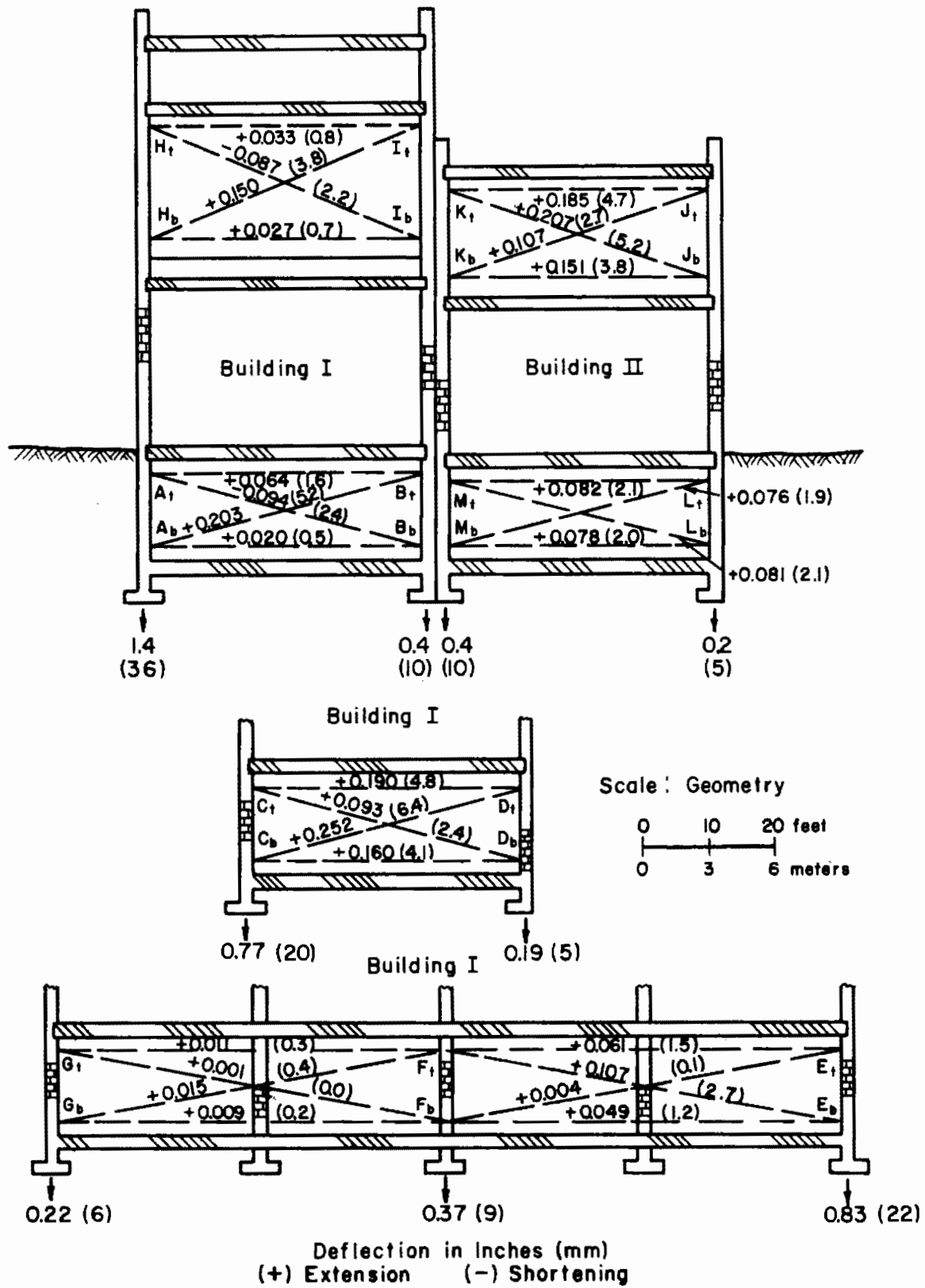

FIGURE 3.4 LOCATIONS OF TAPE EXTENSOMETER LINES AND CUMULATIVE DEFLECTIONS ALONG THE LINES

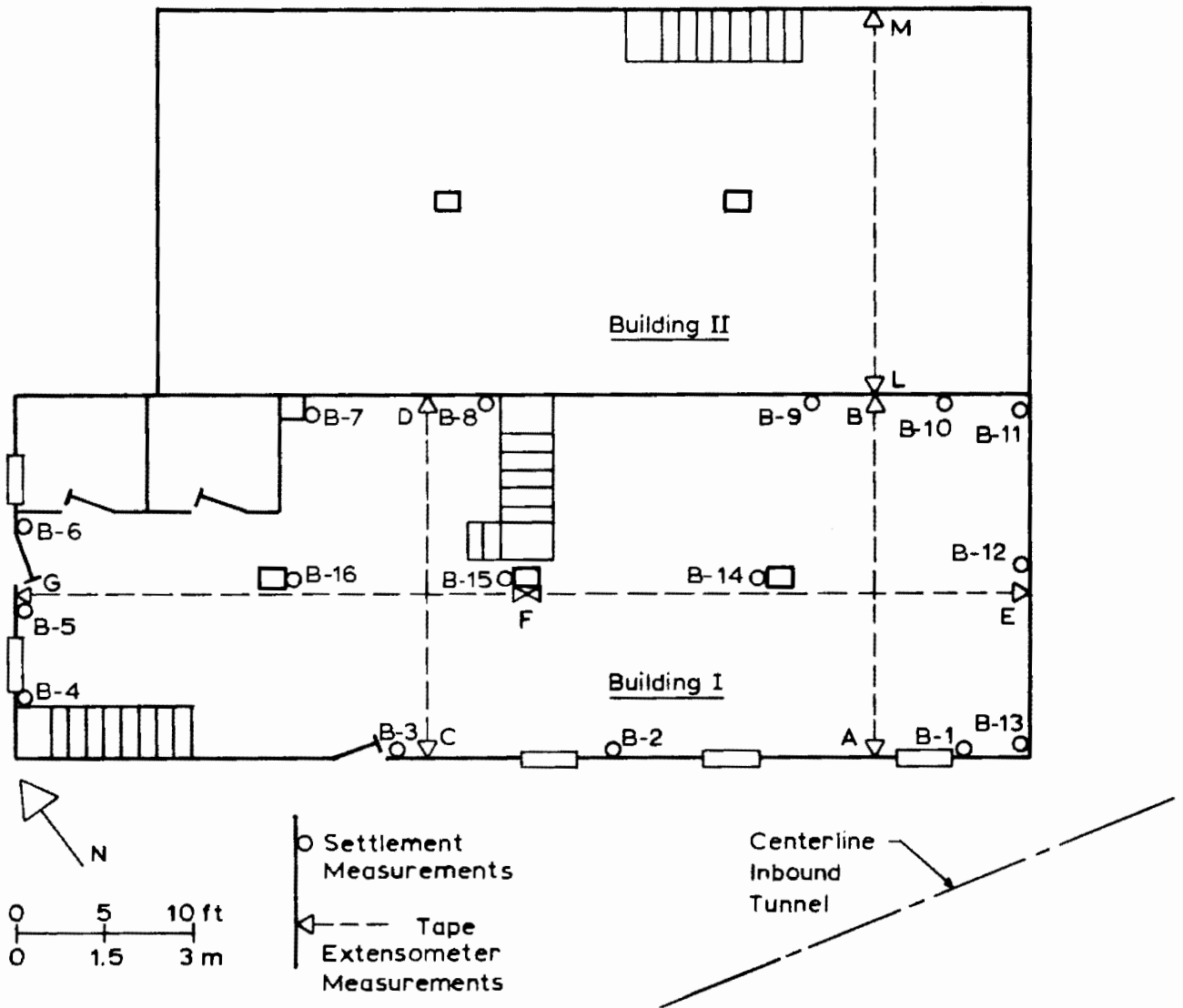

FIGURE 3.5 LOCATION OF TAPE EXTENSOMETER LINES AND INTERIOR SETTLEMENT POINTS IN THE BASEMENTS OF BUILDINGS I AND II.

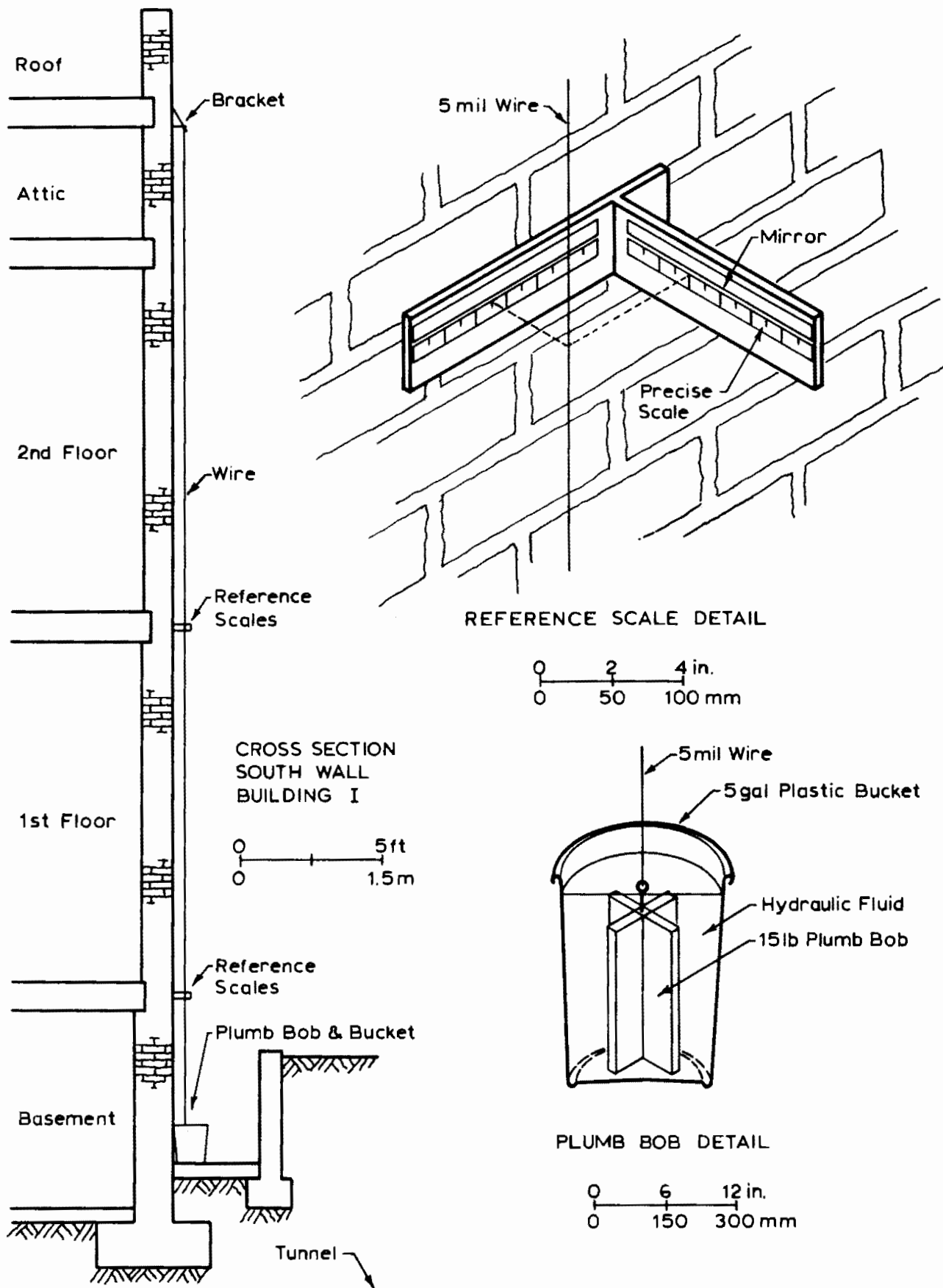

FIGURE 3.6 SKETCH OF PLUMB BOB AND DETAILS OF WEIGHT AND REFERENCE SCALES

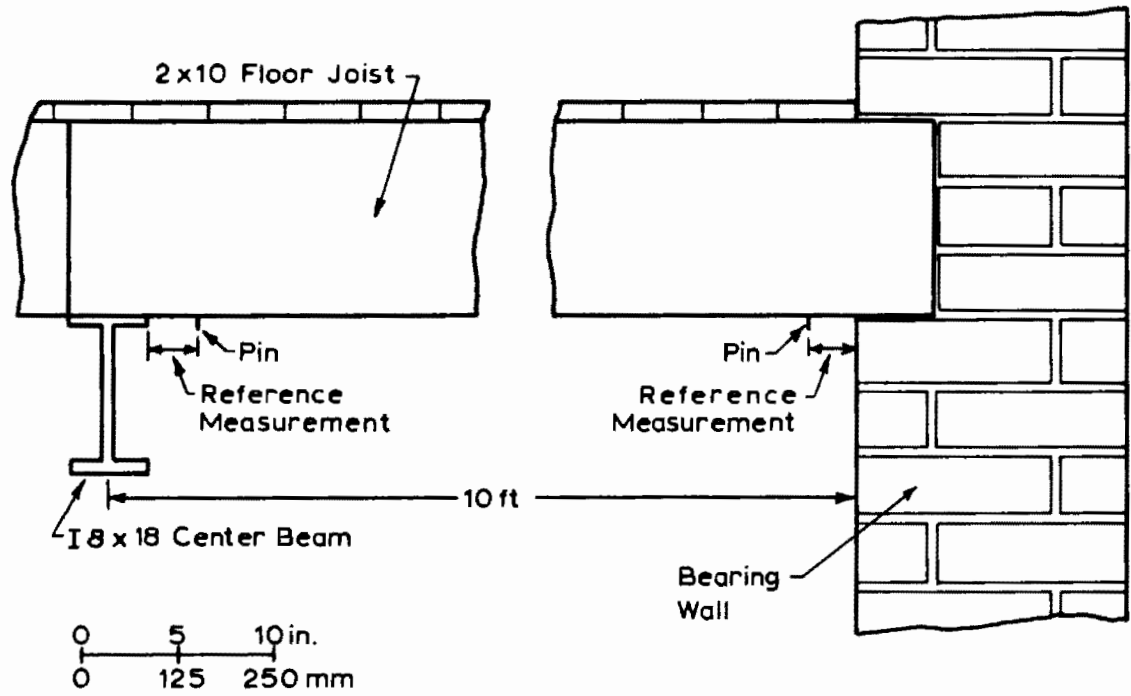

FIGURE 3.7 SKETCH ILLUSTRATING BEAM PULLOUT MEASUREMENTS

3.6 GROUND SURFACE AND BUILDING SETTLEMENTS

The settlement profiles of the ground surface presented in this section show the settlement due to the excavation of the inbound tunnel only. The excavation of the outbound tunnel, which was farther from the building, occurred first and was monitored by the contractor. Construction records indicate that less than 1/8 in. (3 mm) of settlement occurred in Building I, and that no evidence of building distress was observed due to excavation of the outbound tunnel.

The surface settlement pattern along the centerline of the inbound tunnel appears in Fig. 3.8. The four curves show the surface settlements associated with various positions of the tunnel heading during excavation. A comparison of Fig. 3.8 to Fig. 3.3 shows that more surface settlement occurred when tunneling through the sandy Pleistocene terrace deposits than when tunneling in the hard Cretaceous clay. Final surface settlements along the centerline range from nearly 4 in. (100 mm) to 1.5 in. (38 mm). Fig. 3.8 also indicates that the surface settlement preceded the tunnel heading by about 15 ft (4.6 m) and 25 ft (7.6 m) for tunneling in the Cretaceous clay and sandy terrace deposits, respectively. Approximately ten to fifteen percent of the total surface settlement occurred before the face of the excavation reached a given point. Forty to sixty percent of the total surface settlement appeared by the time the tail of the shield passed a given point. In addition, the sandy terrace material appeared to settle more than the hard clay material once the tail passed a point and the ribs and lagging were in place.

Surface settlements for the three transverse profiles appear in Fig. 3.9, 3.10, and 3.11. The surface settlement profile for each section is shown for several different stages of excavation. From the figures it is apparent that portions of the structures lie in the zone of lateral extension while

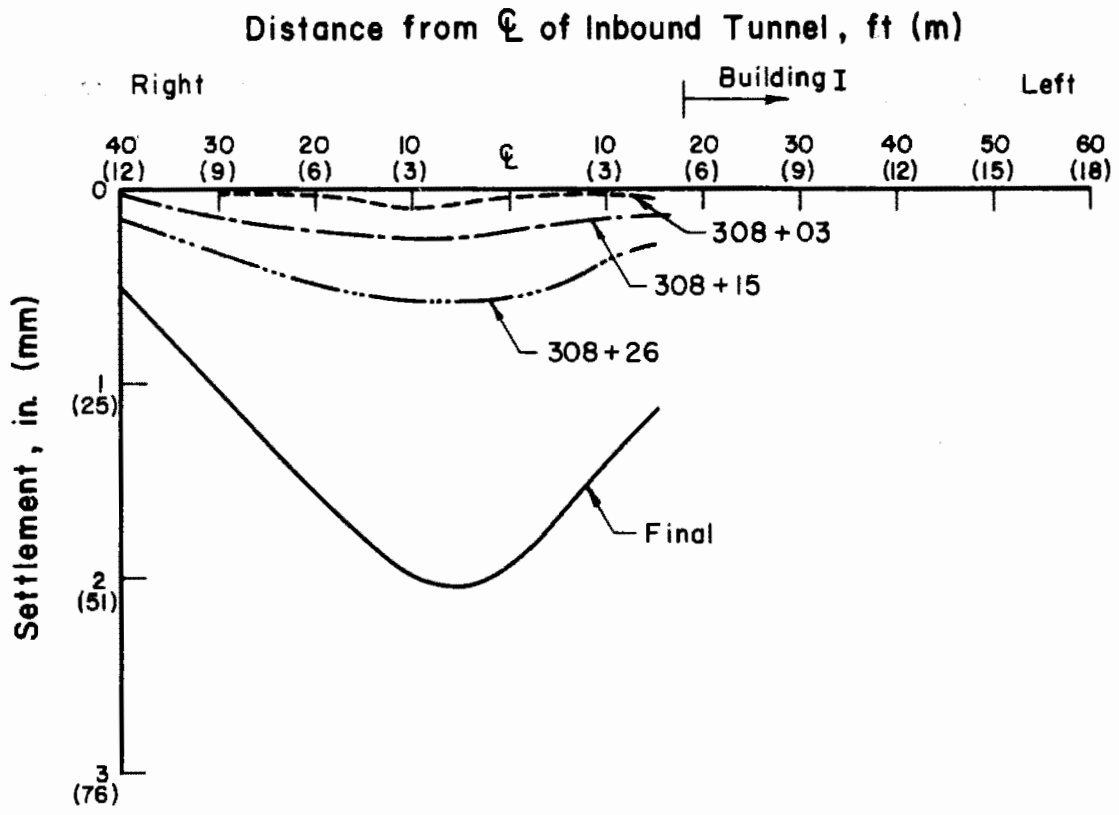

FIGURE 3.10 GROUND SURFACE SETTLEMENT PROFILE ALONG CROSS-SECTION AT STATION 308 + 15

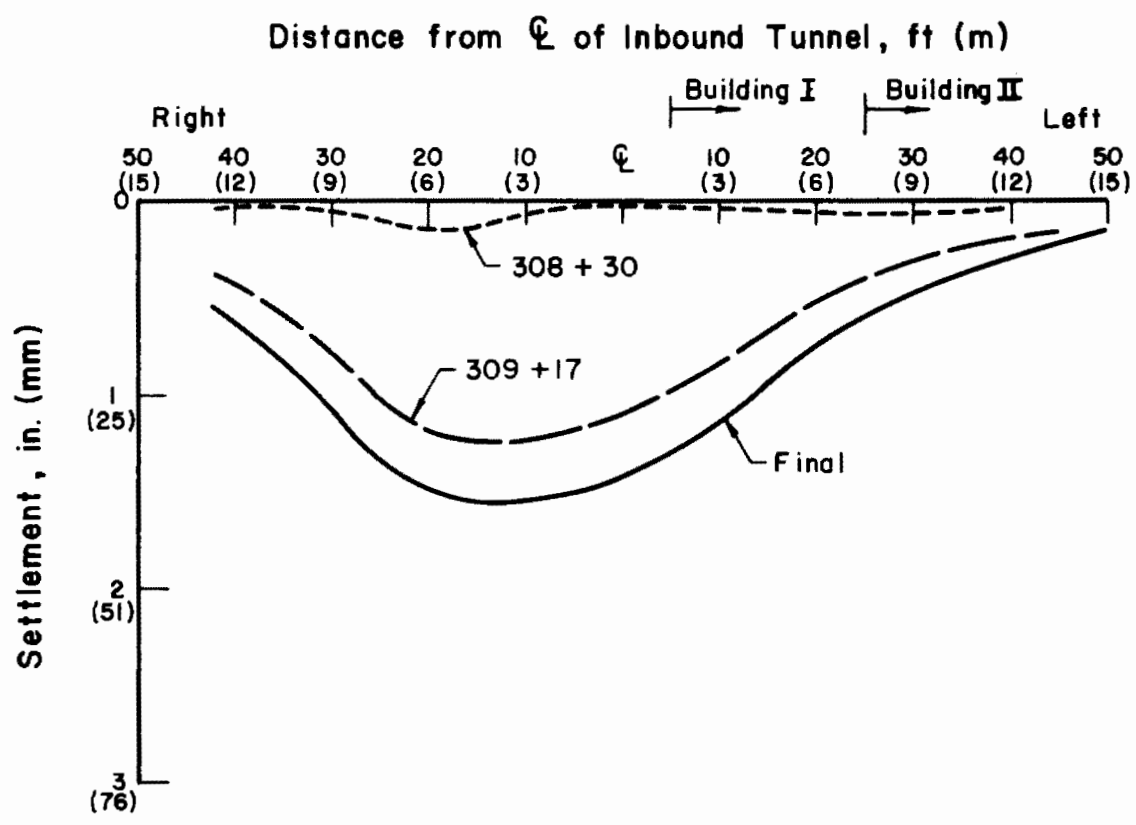

FIGURE 3.11 SETTLEMENT PROFILE ALONG TRANSVERSE CROSS-SECTION AT STATION 308 + 70

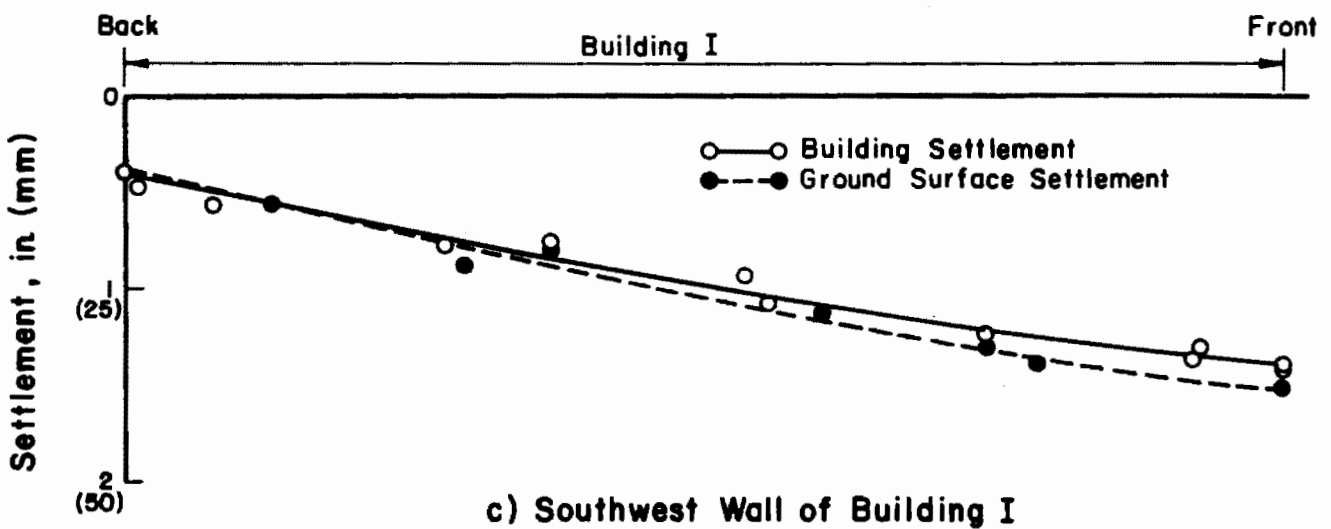
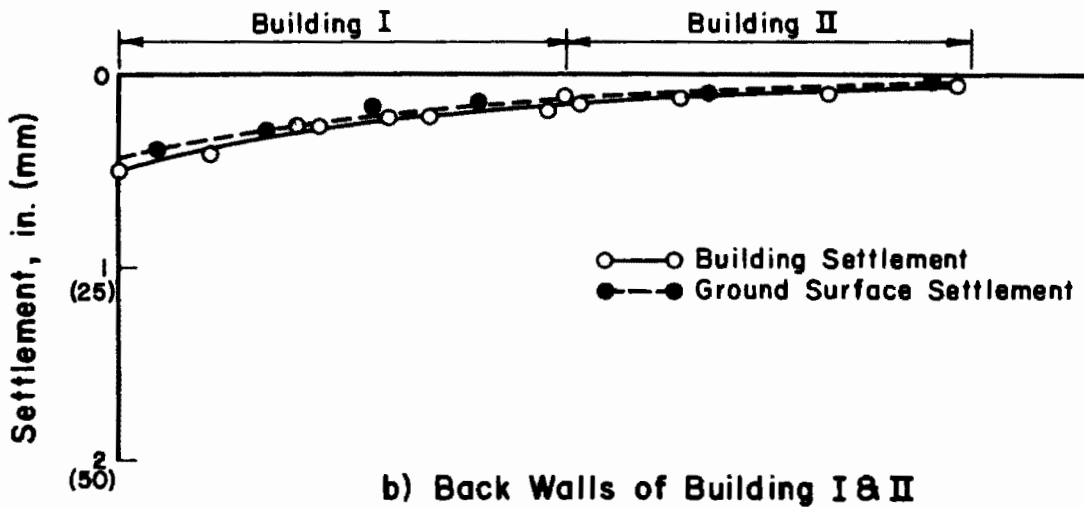
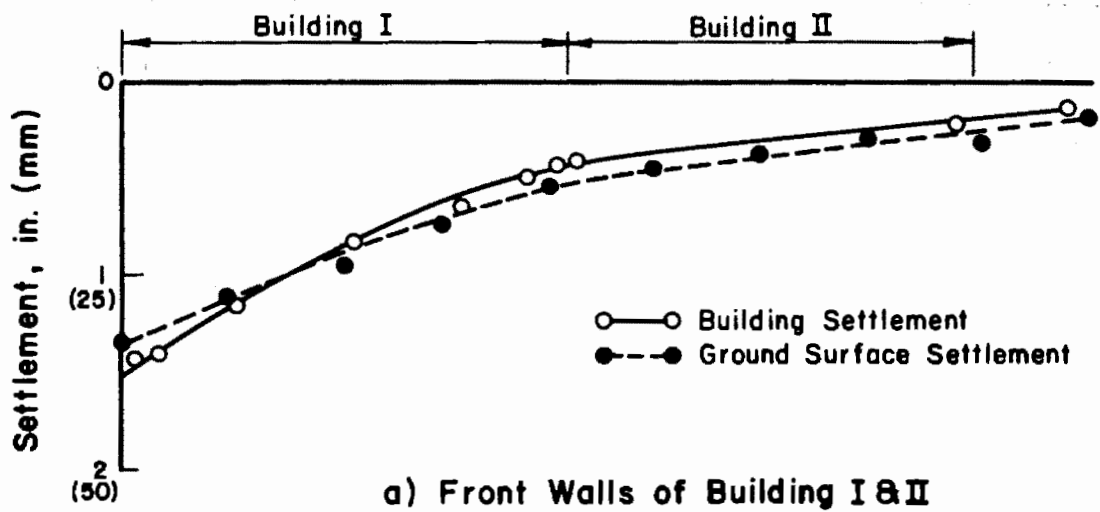

FIGURE 3.12 COMPARISON OF FINAL SETTLEMENTS OF THE BUILDING AND GROUND SURFACE

other portions lie in the zone of lateral compression. As the settlement profile developed and the settlement trough widened, a portion of Building I would initially be in the zone of lateral extension but later, after further development of the settlement trough, that portion of the structure would be in the zone of lateral compression. Thus, the tape extensometer measurements should show the effect of the development of the settlement trough. The same concept of extension and compression zones may be employed when considering lateral ground movements parallel to the tunnel axis. The settlement profile in the vicinity of the tunnel heading exhibits a reversal of curvature and a zone of maximum curvature similar to the transverse settlement profile of the trough. In effect, the buildings are subjected to two components of horizontal extension and compression, one transverse to the tunnel axis and one parallel to the tunnel axis. Evidence of the horizontal extension transverse to the tunnel axis appeared in the form of several new 1/32-in. (1.0- mm) - wide cracks, parallel to the tunnel, that formed in the sidewalks 20 to 40 feet from the tunnel centerline.

Small brick masonry structures supported on shallow footings are commonly observed to move with the ground and impose little restraint on the deformations of the soil. Comparisons of building settlements with ground surface settlements of this site are shown in Fig. 3.12. Clearly, there is little difference between the building and ground surface settlements. Therefore, the ground surface settlements may be employed as an indicator of the settlement of these structures and others similar to them to permit an evaluation of the potential for their damage as a result of underground construction.

3.7 MEASURED BUILDING DISTORTIONS

Fig. 3.13 presents an exaggerated sketch illustrating the final distorted configuration of Buildings I and II along a transverse cross-section

located near station 308 + 50. The sketch along with Fig. 3.4 summarizes the final settlement, tilt, tape extensometer, and crack width measurements gathered along this cross-section. The dimensions along the diagonals and the horizontals of the sketch indicate the strain along that line. Extension and compression strains are denoted positive and negative, respectively. The settlements and crack widths are in terms of inches (mm) and the rotations and slopes are specified as angles in radians.

3.7.1 DISTORTIONS, BUILDINGS I AND II

In the sketch summarizing the final observations, Fig. 3.13, the relative positions of Buildings I and II on the ground surface settlement profile should be noted. Building I is nearer the center of the settlement trough and predominantly in the zone of lateral compression. In this area vertical settlement dominates and the horizontal ground strains are very small. In contrast, Building II is near the edge of the settlement trough and is in the zone of lateral extension. Here, settlements and differential settlements are smaller than those found nearer the center of the settlement trough, and horizontal ground strains in this zone are significant. The horizontal tensile strains give rise to relative horizontal movements between points on the same order of magnitude as the differential settlement between the points. Settlement contours for the tunnel face at St. 308 + 25, representing an early stage of the settlement trough development, and the final settlements after mining are shown in Fig. 3.14a and 3.14b, respectively.

3.7.2 INITIAL DISTORTIONS, BUILDING I

During the early stages of the development of the settlement trough Building I was in the zone of lateral extension. Fig. 3.15 shows a distorted

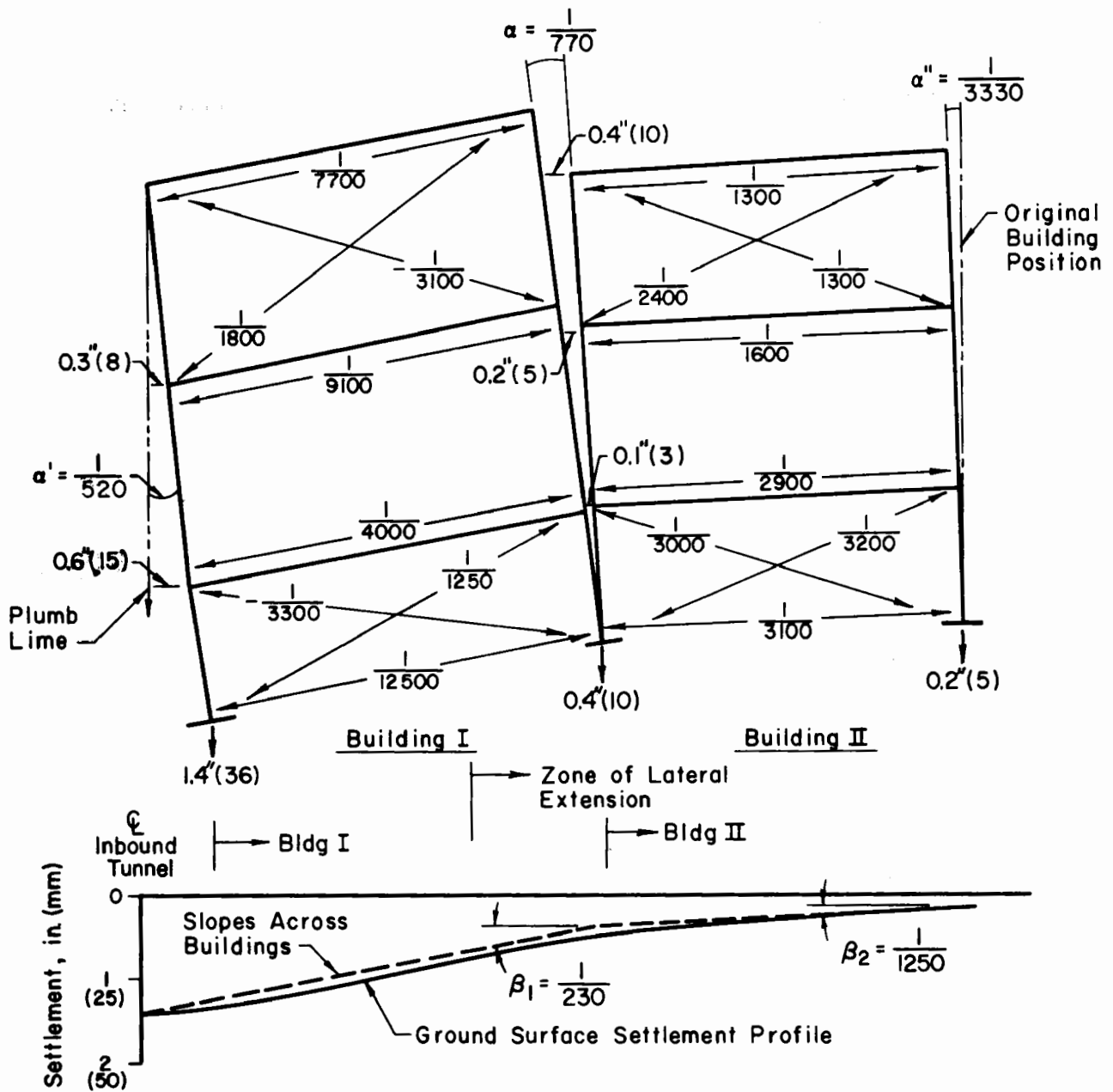

$\beta = \alpha + \delta_a$
 α = Rigid Body Rotation
 δ_a = Angular distortion between bearing walls

Building I
 $\beta_1 = 1/230$ (4.4×10^{-3})
 $\alpha' = 1/520$ (1.4×10^{-3})
 $\delta_{a1} = 1/410$ (2.4×10^{-3})

Building II
 $\beta_2 = 1/1250$ (0.8×10^{-3})
 $\alpha_2 = 1/3330$ (0.3×10^{-3})
 $\delta_{a2} = 1/2000$ (0.5×10^{-3})

Scales:

Geometry

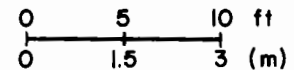

Displacement

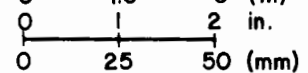

FIGURE 3.13. FINAL DISTORTED SHAPES OF THE FRONTS OF BUILDINGS I AND II

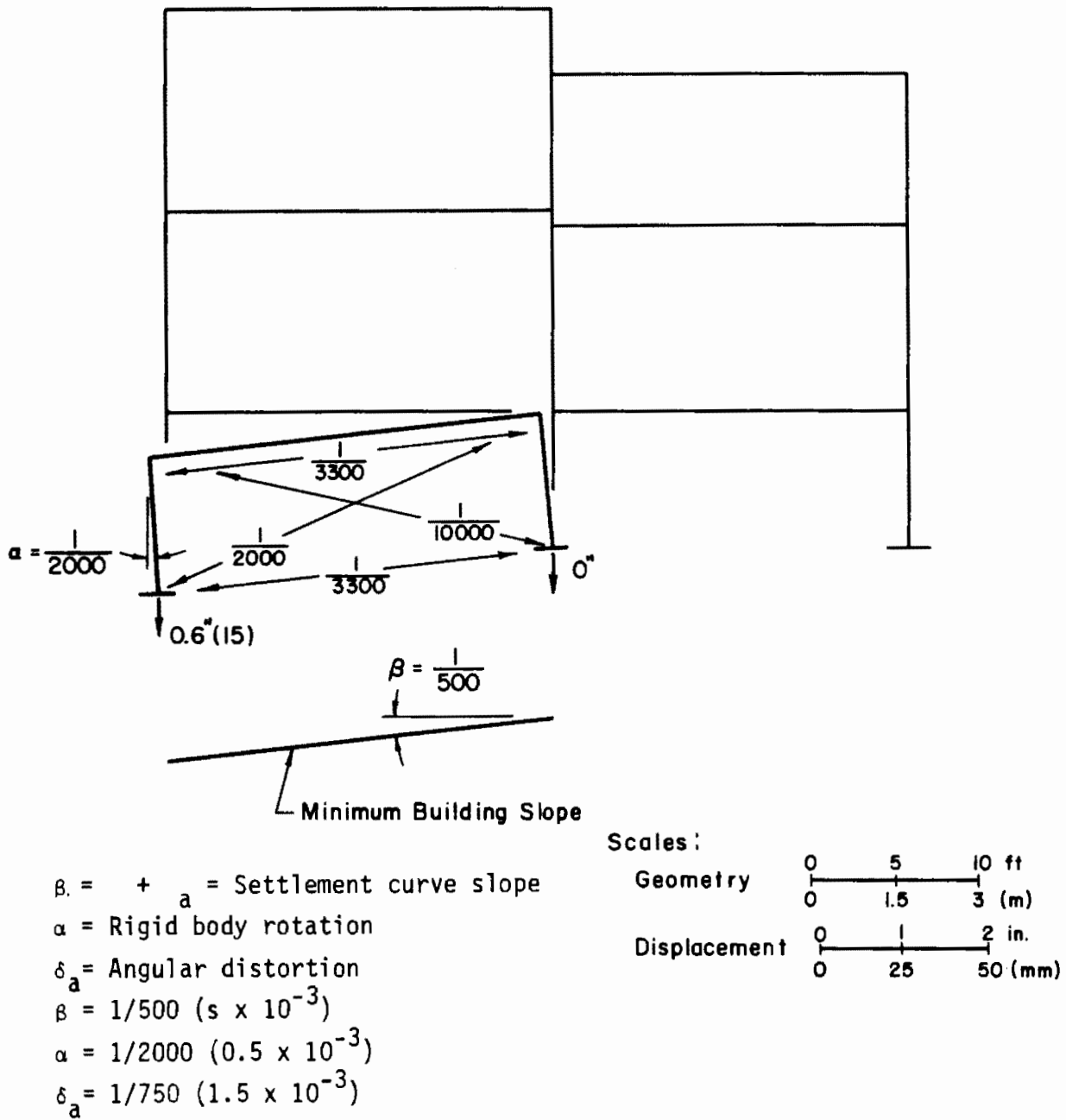

FIGURE 3.15 DISTORTED SHAPE OF THE BASEMENT NEAR THE FRONT OF BUILDING I, TUNNEL HEADING AT STA. 308 + 50

sketch of the basement of Building I along 308 + 50 cross-section at an early stage of development of the settlement trough when the face of the tunnel was approximately at Station 308 + 50. Settlement contours would be similar to those shown in Fig. 3.14a, but displaced about 25 ft (7 m) in the direction of tunnel advance. The differential settlement between the bearing walls was 0.6 in (15 mm) and the horizontal extension strain was 1/3300. Both diagonals were in extension as a result of the lateral extension of the ground, but the shear strains, derived from the differential settlements, caused a greater extension in one diagonal than the other. The rigid body rotation was about 1/2000, the slope of the building settlement profile, equivalent to the angular distortion plus rigid body rotation, equaled 2.0×10^{-3} (1/500), and the true angular distortion was 1.5×10^{-3} (1/750). Thus, during the early stages of the development of the settlement trough, the distortion of the structure had both horizontal and shear strain components, whereas, the final distortion of the structure appears dominated by the shear strain caused by differential settlement.

When the face of the tunnel was at Station 308 + 60 the front door of Building I became tightly jammed. The distortion of the door frame was sufficient to bind the door which had previously opened easily. Later, when the settlement trough was nearly fully developed, the door again worked normally. This one instance illustrates a situation where a portion of the structure experienced more severe angular distortion during the development of the settlement trough than the final measurements indicate. It is commonly observed that doors and windows that stick during tunneling may again function properly once the tunnel excavation has been completed. The above descriptions of the distortions and observation during the development of the settlement trough illustrate the manner in which correlations based upon the final angular distortion and slope of the building settlement profile may be misleading.

3.7.3 FINAL DISTORTIONS, BUILDING I

The final distorted shape of Building I is caused primarily by the differential settlements across the structure. The differential settlement between bearing walls is 1 in (25 mm) and causes a slope of 1/230 across the structure. The final relative horizontal movement between the bearing walls is slight. A horizontal extension strain of 1/12500 between the bearing walls at their base was recorded. The distortion caused by this combination of relative movements has primarily two components, a rigid body tilting and a shear or angular distortion of the building. The rigid body tilt of the structure is apparent from the plumb line measurements and from the opening of the joint between the two structures. The final plumb line measurements lead to a calculated rigid body rotation of 1/710. Shearing distortions are indicated by the strain measured along the diagonal tape extensometer lines. One diagonal of each pair exhibited extension whereas the other exhibited compression.

Due to the orientation of the building relative to the tunnel axis, the structure cuts across the settlement contours at an angle, Fig. 3.14b, and a torsion is induced in the structure. This angle of twist was approximately 0.15° over the 60-ft (18.3-m)-length of the structure. In this case the effect of the torsion on the building was slight. The amount of torsion induced was small and the lack of fixity of the structural connections between the wall and floor systems allowed this structure to tolerate this torsion with negligible deleterious effects.

The degree of shear deformation is commonly described in terms of angular distortion, a parameter often correlated with building behavior and damage. Typically the angular distortion of a structure is calculated by subtracting the rigid body rotation from the slope of the building settlement curve (O'Rourke et al., 1976). The final true angular distortion, δ_a , calculated

for Building I is 3.0×10^{-3} (1/330). However, the final angular distortion may not represent the maximum amount of distortion experienced by a structure during the development of the settlement trough. As the settlement trough develops localized distortions greater than the final angular distortion may develop and be followed by a reversal of the distortion pattern to result in a lesser final distortion. For this reason the slope of the building settlement curve may be a more appropriate parameter for correlating building behavior and damage in cases where detailed angular distortion measurements and time histories are not available.

3.7.4 FINAL DISTORTIONS, BUILDING II

The final distortions of Building II, shown in Fig. 3.13, illustrates the behavior of a structure in the zone of lateral extension. The differential settlement between the bearing walls is 0.2 in. (5 mm), causing of the building settlement curve to have a slope of 1/1250. The rigid body rotation of Building II is on the order of 1/3300 or less. Thus the differential settlements and the rigid body rotations of Building II are less than those of Building I. The final true angular distortion, δ_a , of Building II is about 1/2000. The horizontal tape extensometer measurements show lateral strains between the bearing walls ranging from 1/3100 in the basement to 1/1300 at the roof. Both diagonals of each set shown extension, the extension strains range from 1/3000 to 1/1300 for the basement and second story tape extensometer lines, respectively. The greater extension measured along the horizontal and diagonal tape extensometer lines higher up in the structure are caused by a relative rotation of the bearing walls. The bearing wall nearer the center of the settlement trough is on a steeper portion of the ground surface settlement curve and thus rotates more than the farther bearing wall. Again, the torsion about the longitudinal axis did not appear to have caused any distress in this building.

The above summary illustrates the general behavior of two similar structures located in different portions of the final settlement trough and the manner in which a developing settlement trough can distort a structure more and differently than the final measurements would indicate. Overall building response to settlement caused by an excavation involves three components; rigid body rotation, true angular distortion, and horizontal strain or distortion. The relative importance of each component varies depending on the position of the structure in the settlement trough and the stage of development of the settlement trough, as illustrated by Fig. 3.16.

3.8 VISIBLE EVIDENCE OF BUILDING DAMAGE

Visual inspections were made before, after, and at intervals during the tunnel excavation under the test site. The initial conditions of both Buildings I and II were quite poor. Extensive cracking was noted on the interiors and exteriors of both structures and the interior plaster walls were cracked and loosened at many locations. The initial state of each building was recorded through photographs, mapping of cracks, measurement of selected cracks, and written descriptions. Additional cracking and the increase in size of pre-existing cracks were noted during and after the tunnel excavation. When viewed in light of the very poor initial condition of both structures any damage caused by the tunnel excavation can only be termed as minor. However, if the same structures were in good repair and had been occupied, the same response would probably have caused more noticeable cracking.

In Building I new cracks and an increase in the width of existing cracks were found during and after the tunnel excavation. The areas where the cracking was noticed include the front and rear facade walls, the south bearing

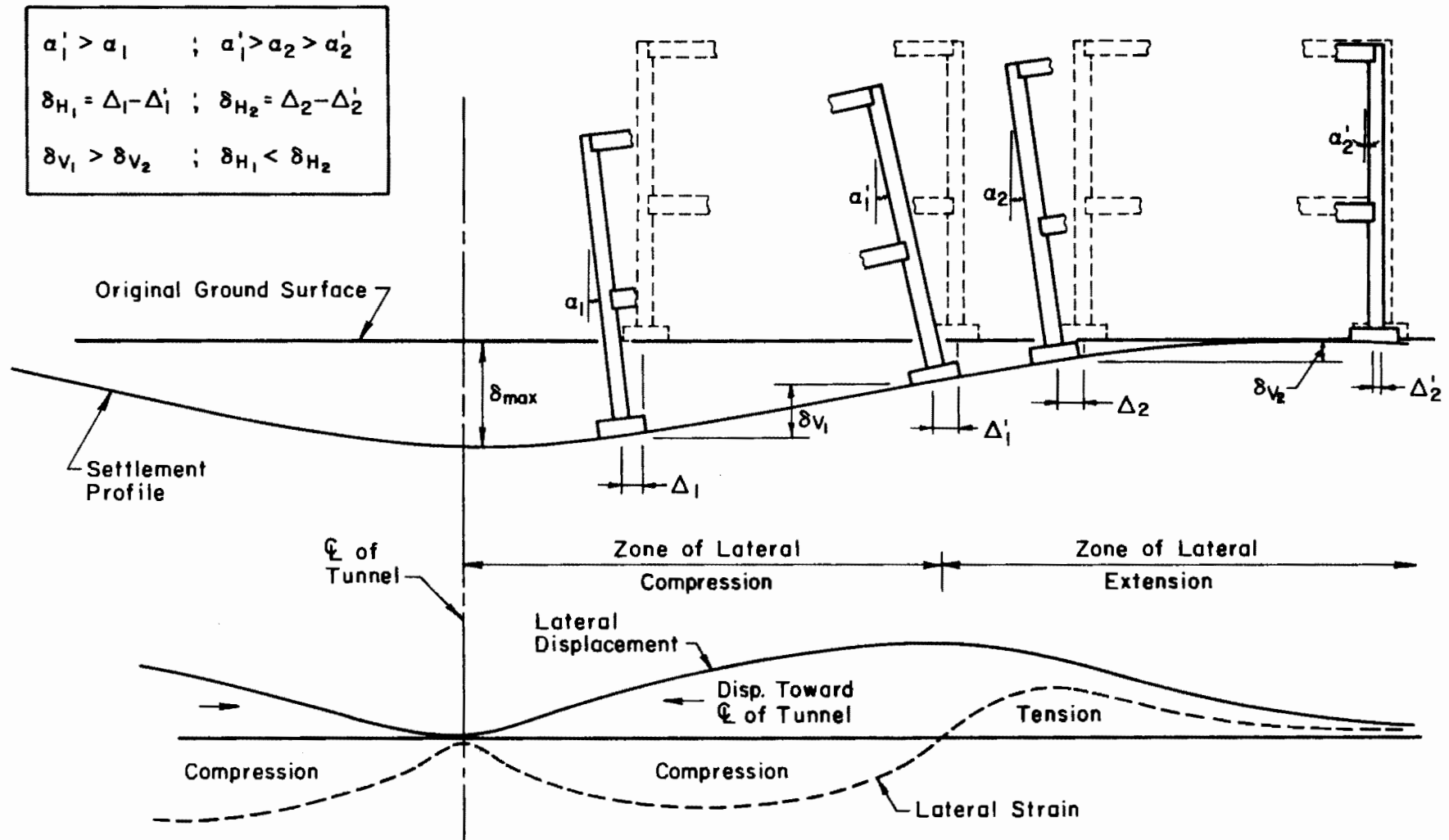

FIGURE 3.16 PATTERN OF DIFFERENTIAL MOVEMENTS OF STRUCTURES IN DIFFERENT ZONES OF THE SETTLEMENT TROUGH CAUSED BY TUNNELING

wall, and the basement slab. Examples of the cracking at these locations are shown in Fig. 3.17. The rear facade wall experienced a $1/64$ in. (0.4 mm) increase in the width of several of the existing cracks. An increase in crack size was also noted in the south bearing wall near front facade wall. Here a diagonal crack from the second story window down to the facade wall became clearly visible (Fig. 3.17b). In the front facade wall of Building I the cracks were concentrated around the doors at the first floor and the windows at the second floor (Fig. 3.17c). Cracks around the door nearest the excavation ranged from $1/32$ in. (0.8 mm) to $1/8$ in. (3 mm) at the bottom and top of the door, respectively. The door became jammed and difficult to open as a result of the tunnel-induced distortion. The door at the north end of the facade wall was surrounded by cracks about $1/32$ in (0.8 mm) wide. An increase in the widths of cracks on the front facade wall were also evident at the second floor where vertical cracks below the windows increased about $1/64$ in. (0.4 mm) in width. In the basement slab of Building I near the south bearing wall a new crack nearly 20 ft (6 m) long and $5/64$ in. (2 mm) wide appeared when the tunnel face was approximately at Station 308 + 30 (Fig. 3.18). The crack approximated the shape of the contours of settlement for this relative position of the tunnel face to the building. An increase of $1/32$ in. (1 mm) in the width of a pre-existing crack at the junction of the south bearing wall and the first floor ceiling was noted near the front of Building I. The tape extensometer data also indicated an increase of $1/32$ in. (1 mm) in the span between bearing walls at this location.

The cracking in Building II was concentrated around the corner of the south bearing wall and the front facade wall (Fig. 3.19). A pre-existing $1/16$ in. (1.6 mm) vertical crack between the bearing wall and the facade wall opened to $1/8$ in. (3 mm) in the basement to $1/4$ in. (6 mm) at the second floor.

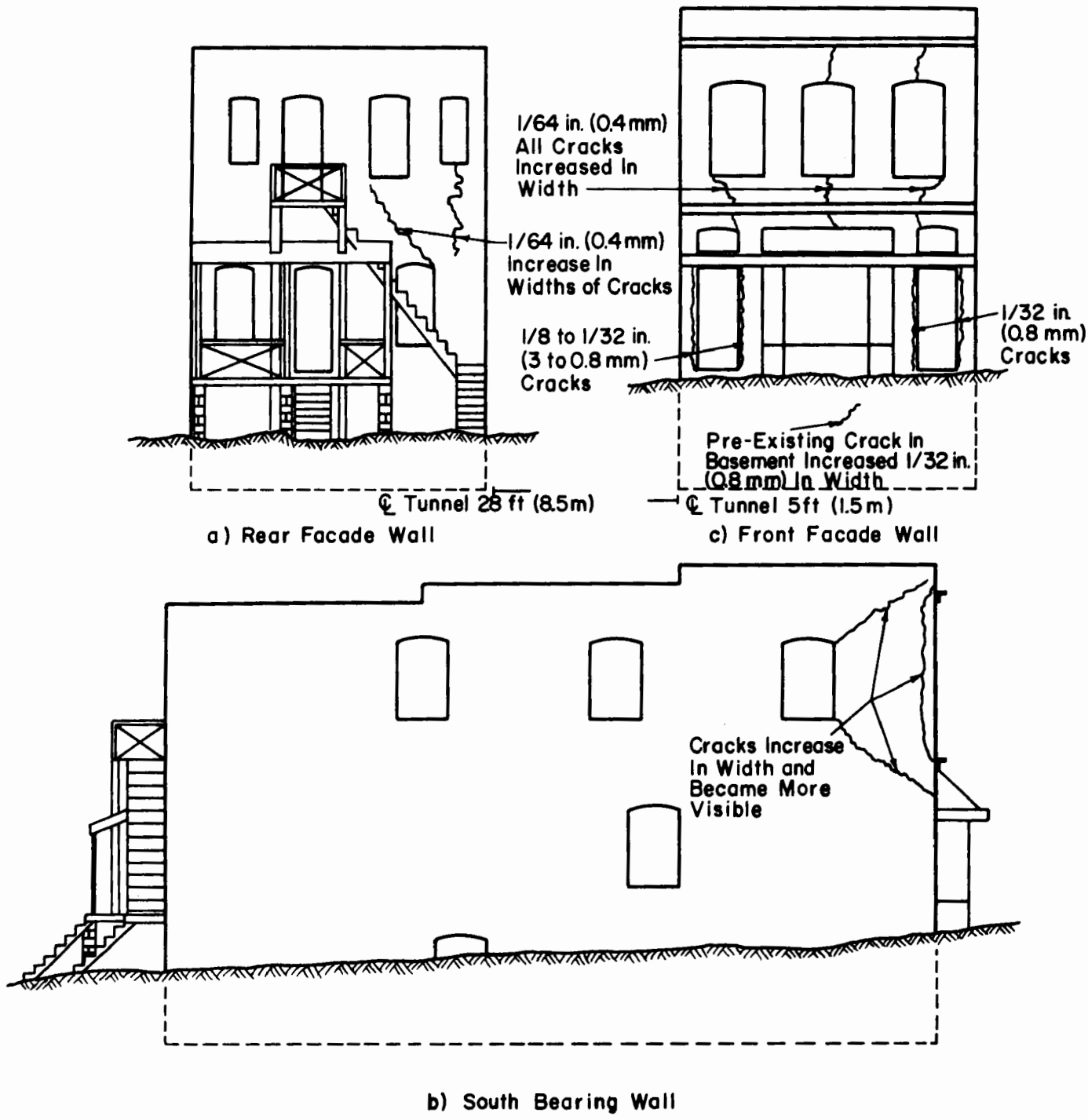

FIGURE 3.17 LOCATION OF CRACKS ON EXTERIOR OF BUILDING I

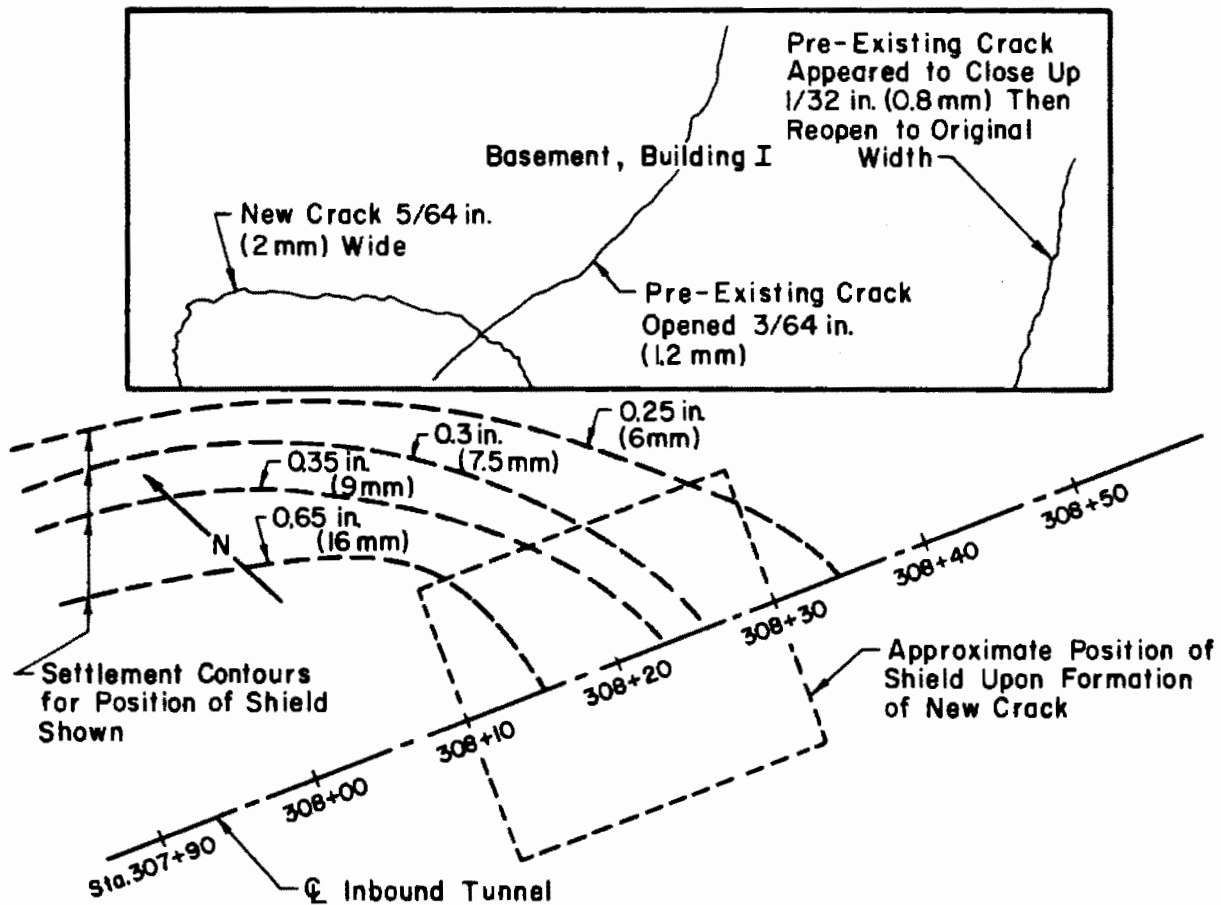

FIGURE 3.18 CRACKS OBSERVED IN BASEMENT SLAB OF BUILDING I

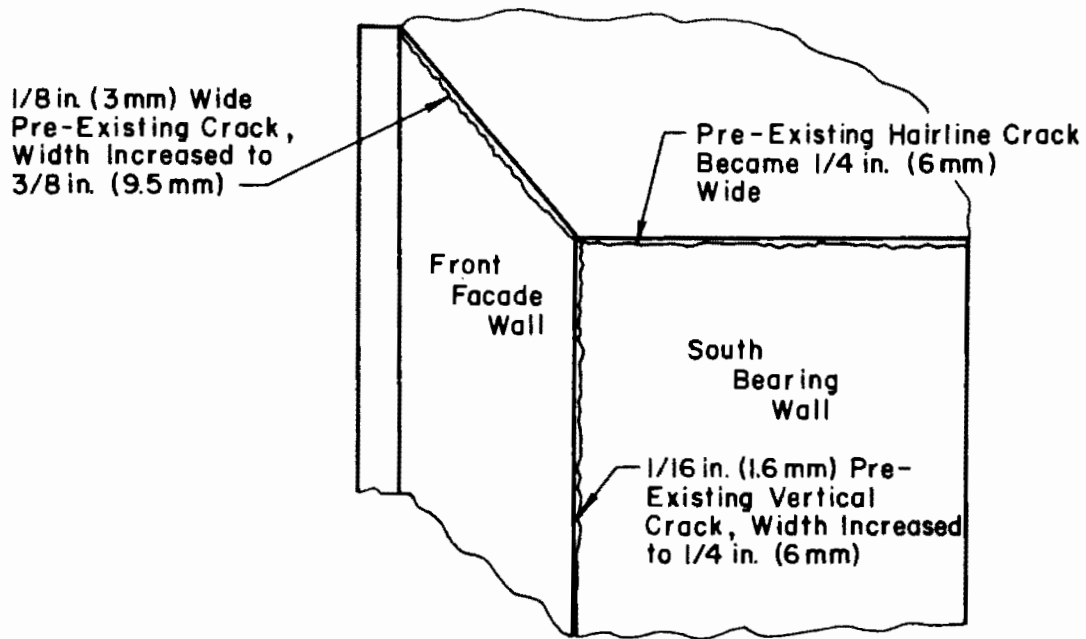
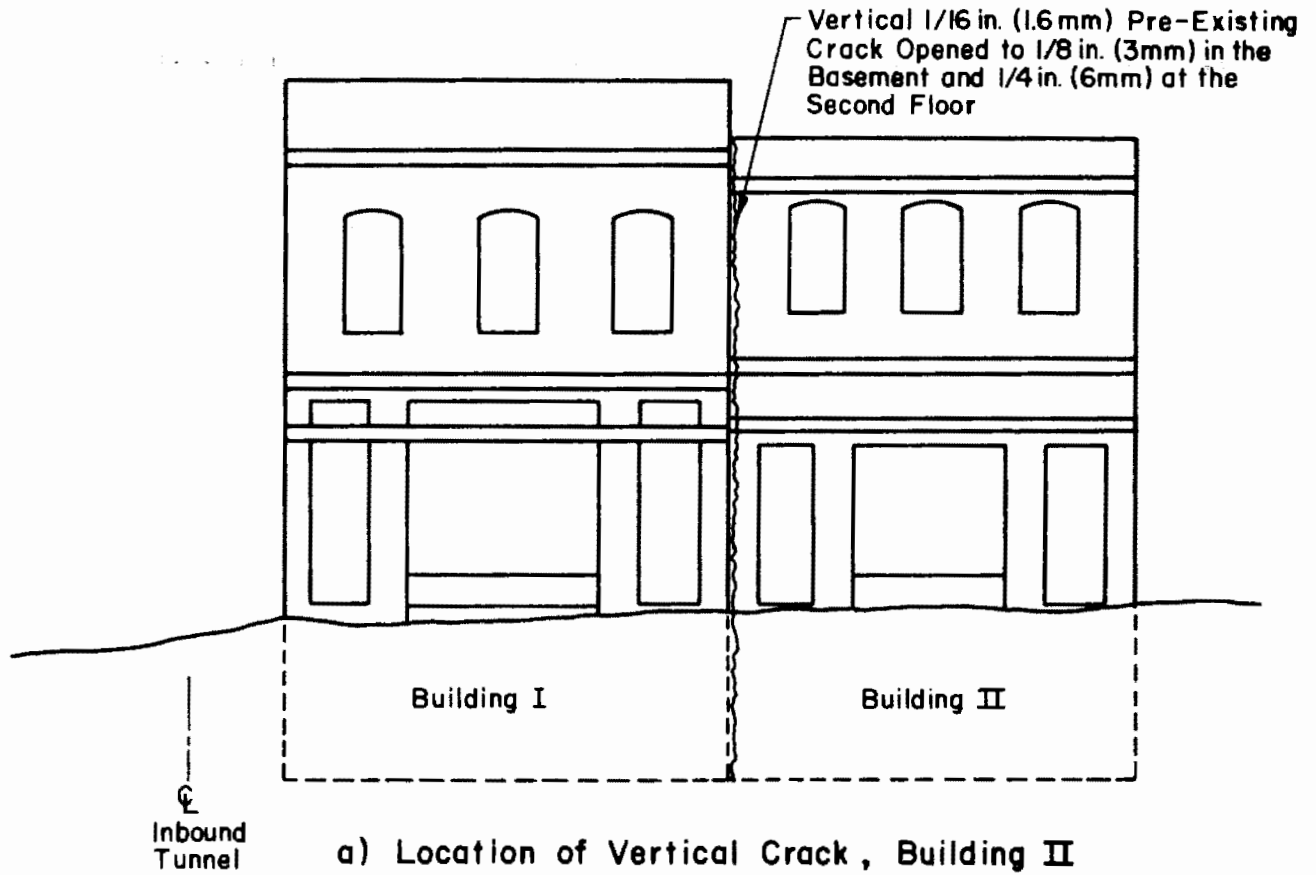

FIGURE 3.19 OPENING OF CRACKS IN RESPONSE TO TUNNEL EXCAVATION, BUILDING II

Daylight was visible through the crack at several locations. At the second story level the corner between the ceiling and the front facade wall formerly contained a crack 1/8 in. (3 mm) wide increased in width to 3/8 in. (9.5 mm). Also at the second story level the south bearing wall and ceiling corner near the front of the building contained a pre-existing hairline crack which grew to 1/4 in. (6 mm) in width. The tape extensometer data for Building II show that nearly all of the lateral extension experienced by the structure was concentrated in the widening of the few cracks described above.

It is evident that both Building I and Building II experienced some damage in response to the nearby tunnel excavation. However, considering the initial states of these structures the damage was relatively minor. O'Rourke et al. (1976) suggest 1.0×10^{-3} (1/1000) as a limiting angular distortion for the onset of noticeable damage for bearing wall structures influenced by adjacent excavation. Building I underwent a maximum angular distortion in the range of 3.0×10^{-3} to 4.0×10^{-3} (1/330 to 1/250). Building II experienced a maximum angular distortion on the order of 0.5×10^{-3} (1/2000). Thus, one would have expected to encounter damage in Building I and no damage in Building II. The fact that in Building II there were significant crack width increases may be explained as followed: the correlation suggested by O'Rourke et al. (1976) is based primarily upon observations of structures adjacent to open cuts where the lateral extension and the angular distortion contribute approximately equally to the distortion of the structure. In the case study described above, the excavation is a tunnel so there are specific zones where either the angular distortion or the lateral extension dominate in the distortion of the structures. Building I is in a zone where angular distortion is the primary mode of deformation and lateral extensions are small, whereas Building II is in a zone where lateral

extension is the dominant mode of distortion.

3.9 DETAILED MEASUREMENT DATA AND DISCUSSION

3.9.1 SETTLEMENTS

The results of the settlement surveys of the exteriors of the structures appear in Fig. 3.20, 3.21, and 3.22. Comparison of the building settlements with the ground surface settlements shown in Fig. 3.9, 3.10, 3.11, and 3.12 indicates that the buildings settled with the ground surface and little bridging occurred. The final settlement of Building I ranged from 1.4 in. (36 mm) to 0.14 in. (4 mm) and the final settlement of Building II ranged from 0.42 in. (11 mm) to less than 0.05 in. (1 mm).

Building settlement slopes calculated from the building settlement data range up to 4.4×10^{-3} (1/230 for Building I and 0.8×10^{-3} (1/1250) for Building II. If the rigid body tilt is subtracted, the true angular distortions calculated are 2.4×10^{-3} (1/410) and 0.5×10^{-3} (1/2000) for Buildings I and II, respectively. The practice of subtracting rigid body rotation before correlating behavior to angular distortion assumes that the tilt occurs simultaneously throughout the structure. This is not compatible with the pattern of development of a settlement profile.

A summary of the final settlement survey of the interior of the basement of Building I is shown in Fig. 3.23 and 3.24. The settlements measured agree with the settlement surveys along the exterior of the structures. The settlements range from 1.4 in. (35 mm) to 0.16 in. (4 mm). The maximum building settlement slope calculated from the interior settlement data is 4.8×10^{-3} (1/210).

3.9.2 TAPE EXTENSOMETERS

A summary of the final tape extensometer survey appears in Fig. 3.4. The exaggerated sketch of the distortion of the fronts of Buildings I and II

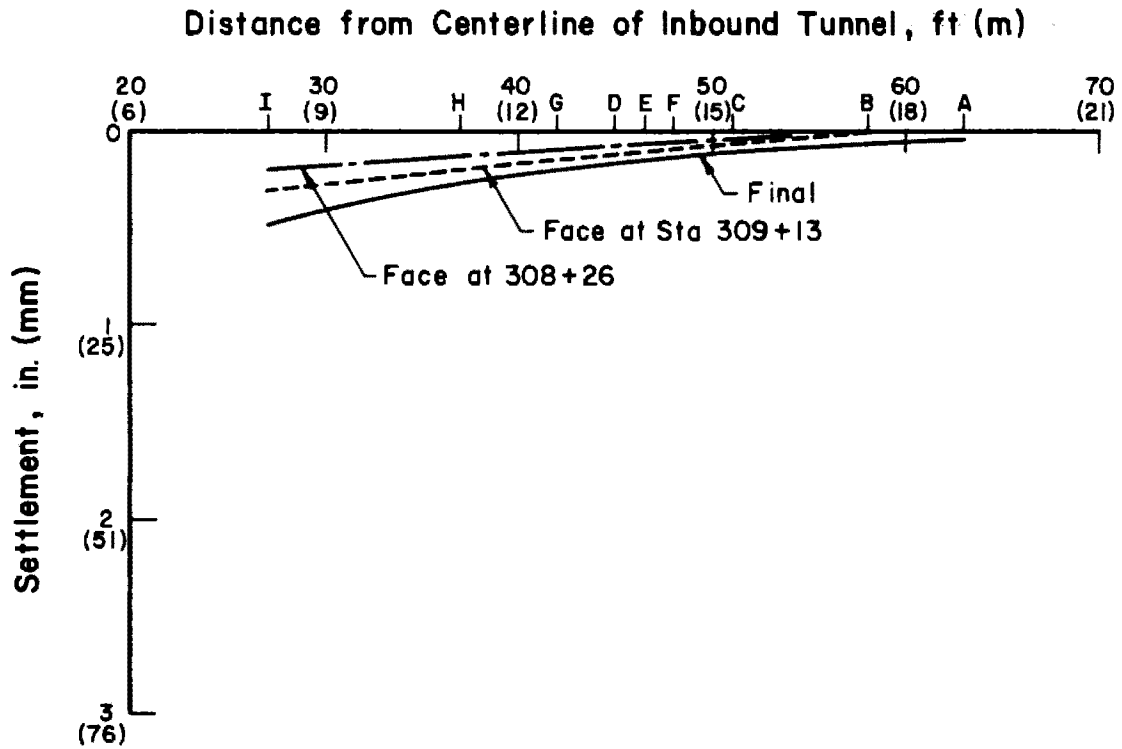

FIGURE 3.20 SETTLEMENT OF THE REAR FACADE WALLS OF BUILDINGS I AND II

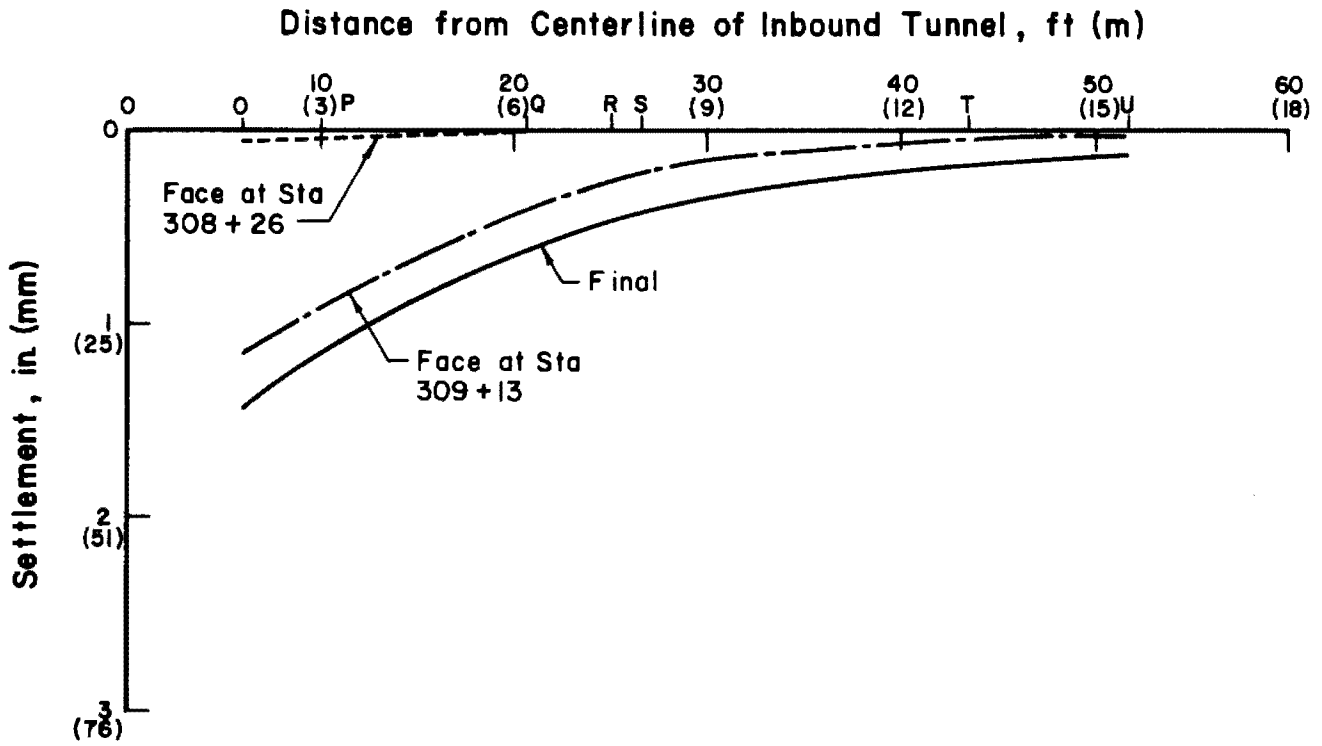

FIGURE 3.21 SETTLEMENTS OF THE FRONT FACADE WALLS OF BUILDINGS I AND II

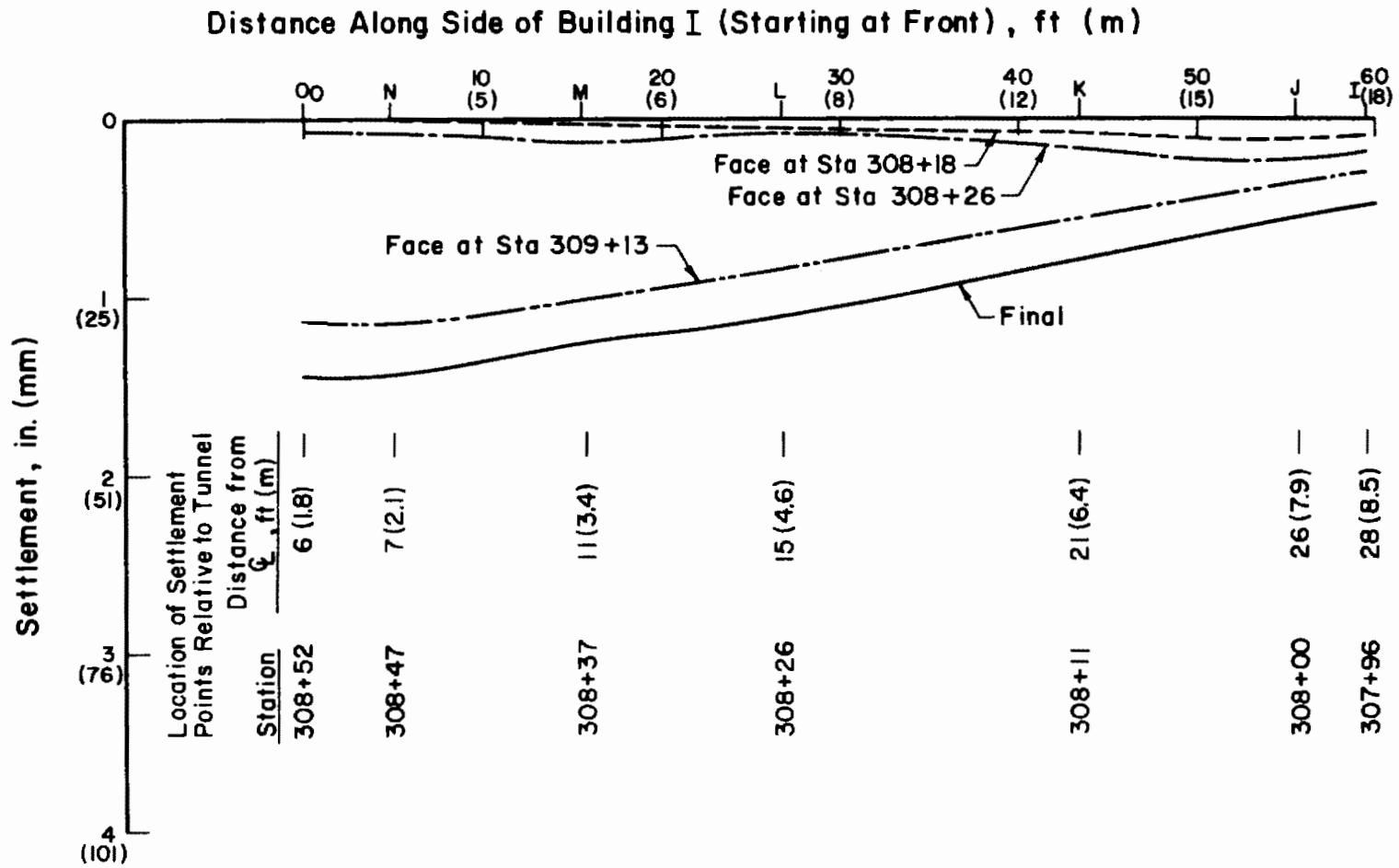

FIGURE 3.22 SETTLEMENT OF SW BEARING WALL OF BUILDING I

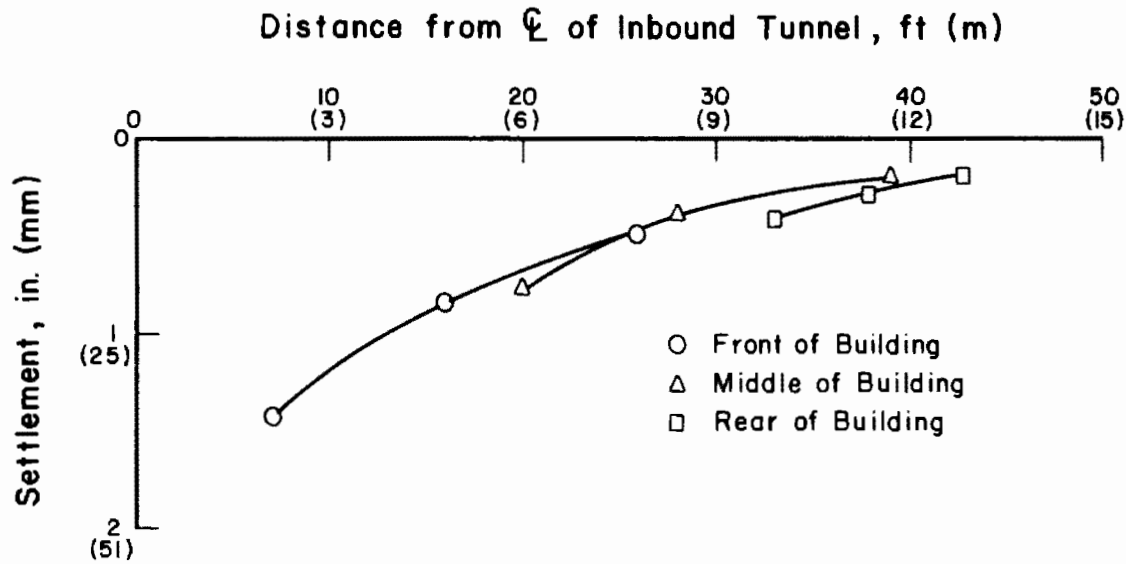

FIGURE 3.23 INTERIOR SETTLEMENTS OF BUILDING I, TRANSVERSE TO BUILDING AXIS

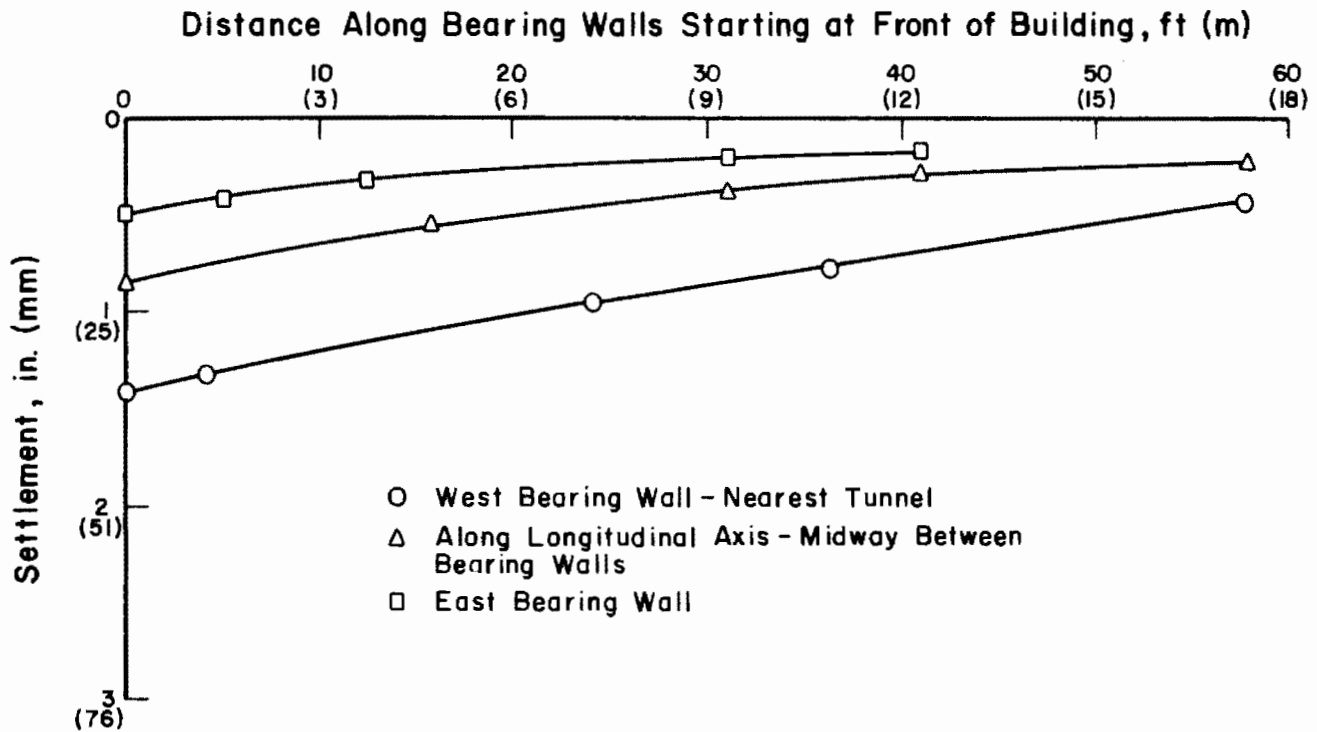

FIGURE 3.24. INTERIOR SETTLEMENTS OF BUILDING I, PARALLEL TO BUILDING AXIS

shown in Fig. 3.13 illustrates the rigid body rotation of the structure, as well as the horizontal and vertical components of building distortion. However, the final distortions of the structures only partially illustrates the overall building behavior in response to tunnel excavation. Fig. 3.25 presents data from each of the tape extensometer cross-sections for various stages of tunnel progress through the test site.

Tape extensometer lines A-B and H-I clearly demonstrate the extension of one diagonal and compression of the other, as well as the small relative horizontal displacement between the bearing walls of Building I in response to the tunnel excavation (Fig. 3.4 and 3.25).

The extension and compression diagonals are less obvious in tape extensometer cross-section C-D also located in Building I (Fig. 3.25). Since the axes of the building are skewed at an angle of 22° with respect to the tunnel axis, cross-section C-D is located farther from the centerline of the tunnel, in a zone where significant horizontal extension strain of the ground occurs. This results in a similar lateral extension of the building and extensions of both diagonals in cross-section C-D. However, one diagonal has a greater extension than the other as result of the differential settlement.

Cross-section J-K and L-M in Building II exhibit a different behavior than observed in Building I (Fig. 3.4 and 3.25). The magnitude of the horizontal strain is large and the differential settlements are small. Therefore, the lateral strains tend to dominate the relative displacements measured by the extensometers so that both extensometers undergo extension. The relative rotation of the bearing walls in Building II is apparent when the relative horizontal displacements between the walls at various levels are compared. As shown by Fig. 3.4, greater relative horizontal displacements occur at higher levels in the structure. Based upon the location of the various tape extensometer lines

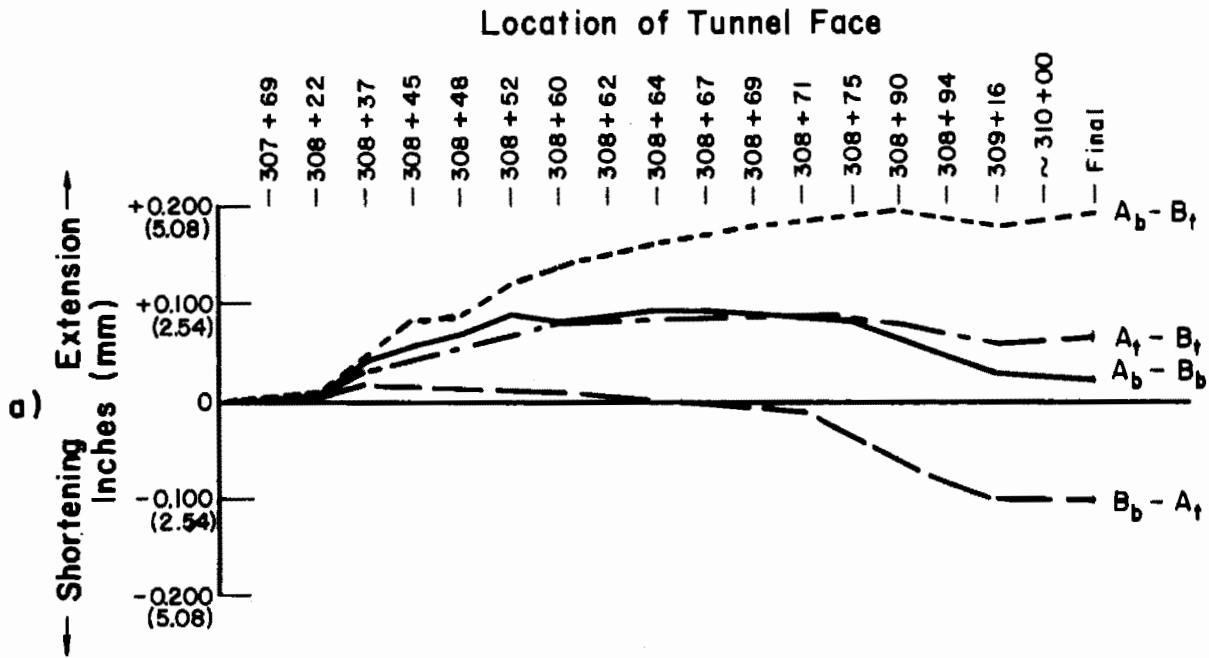

a) Tape Extensometer Line A-B

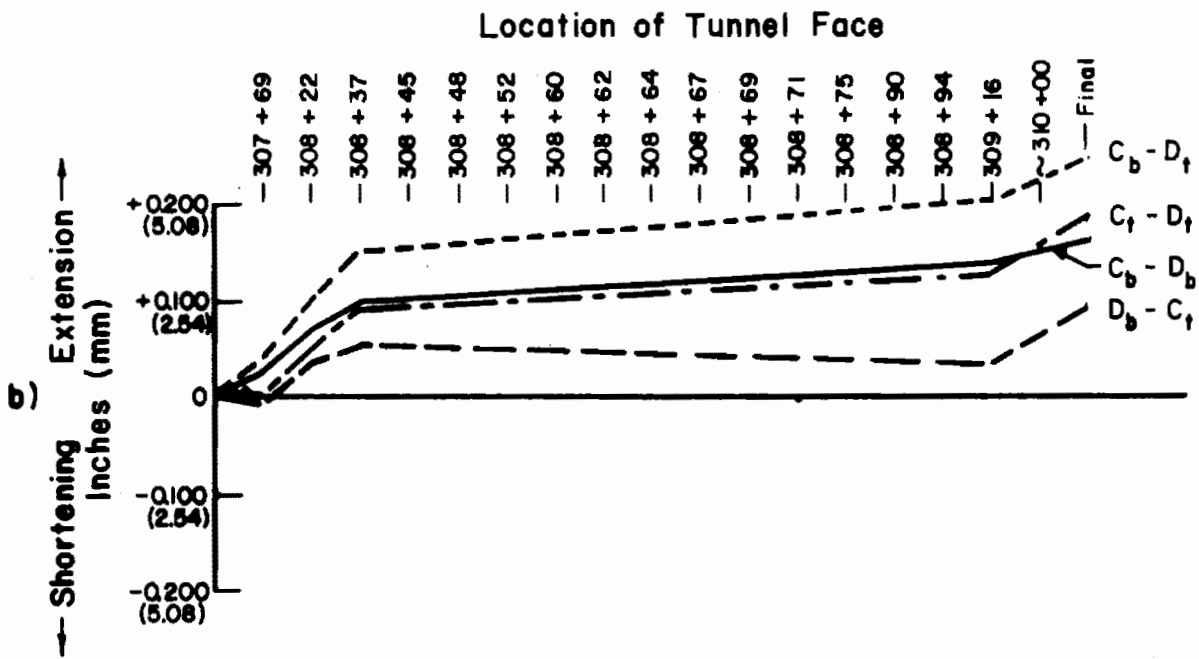

b) Tape Extensometer Line C-D

FIGURE 3.25 SUMMARY OF TAPE EXTENSOMETER MEASUREMENTS FOR VARIOUS LOCATIONS OF THE TUNNEL FACE

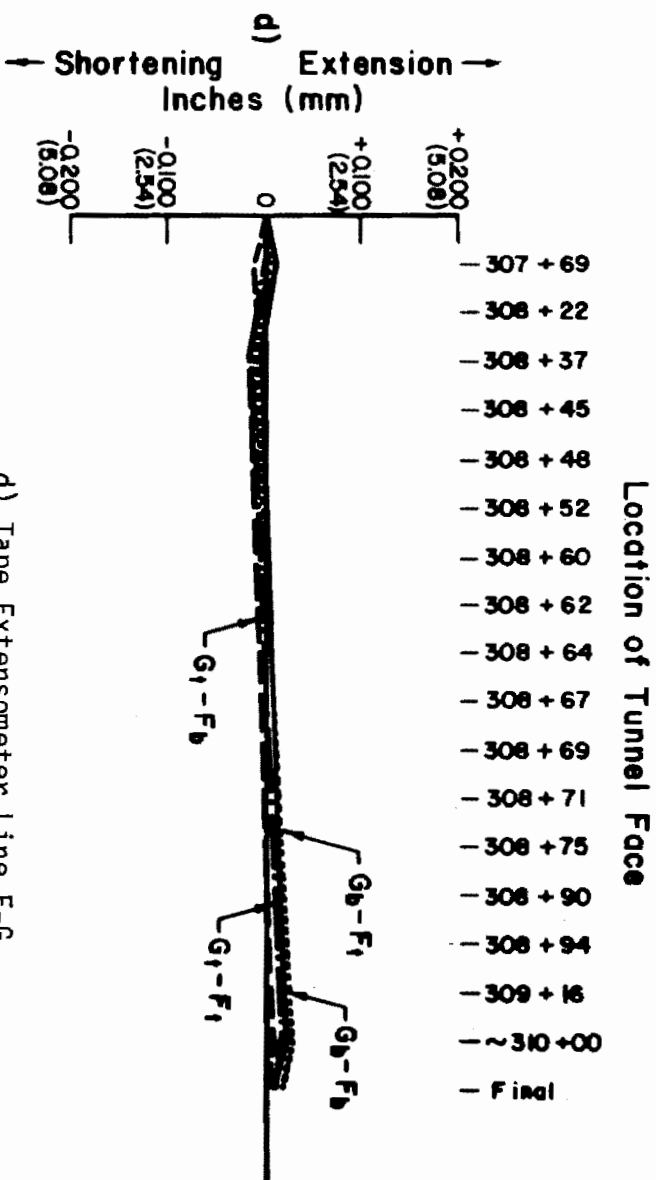
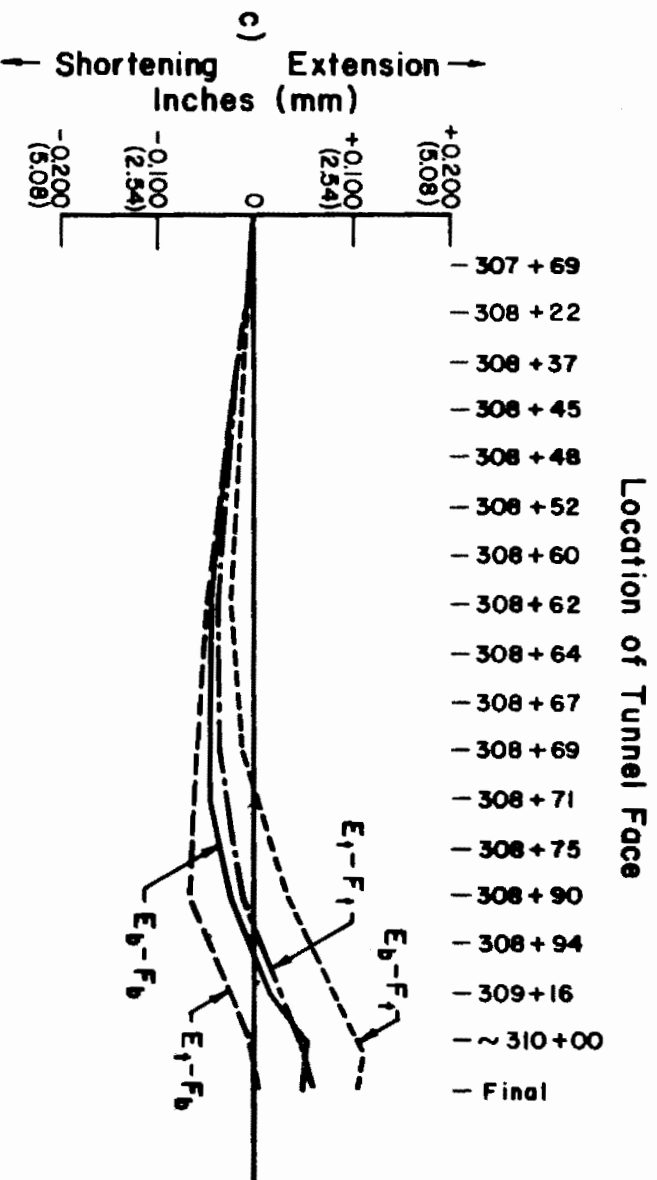
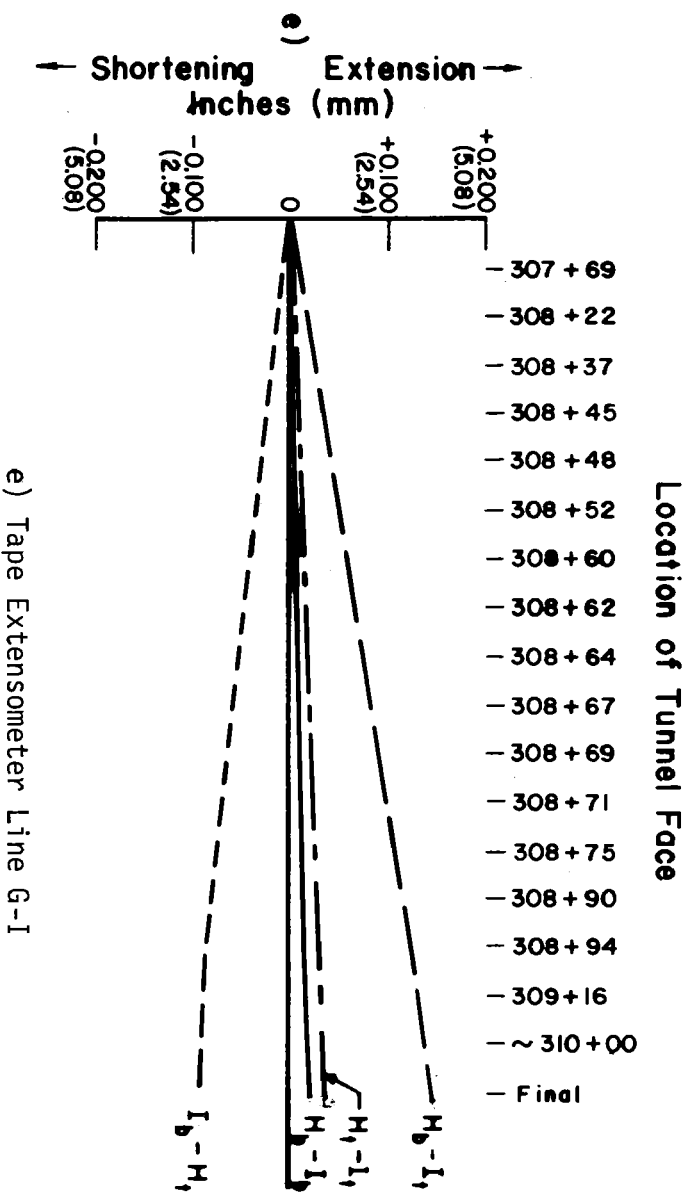
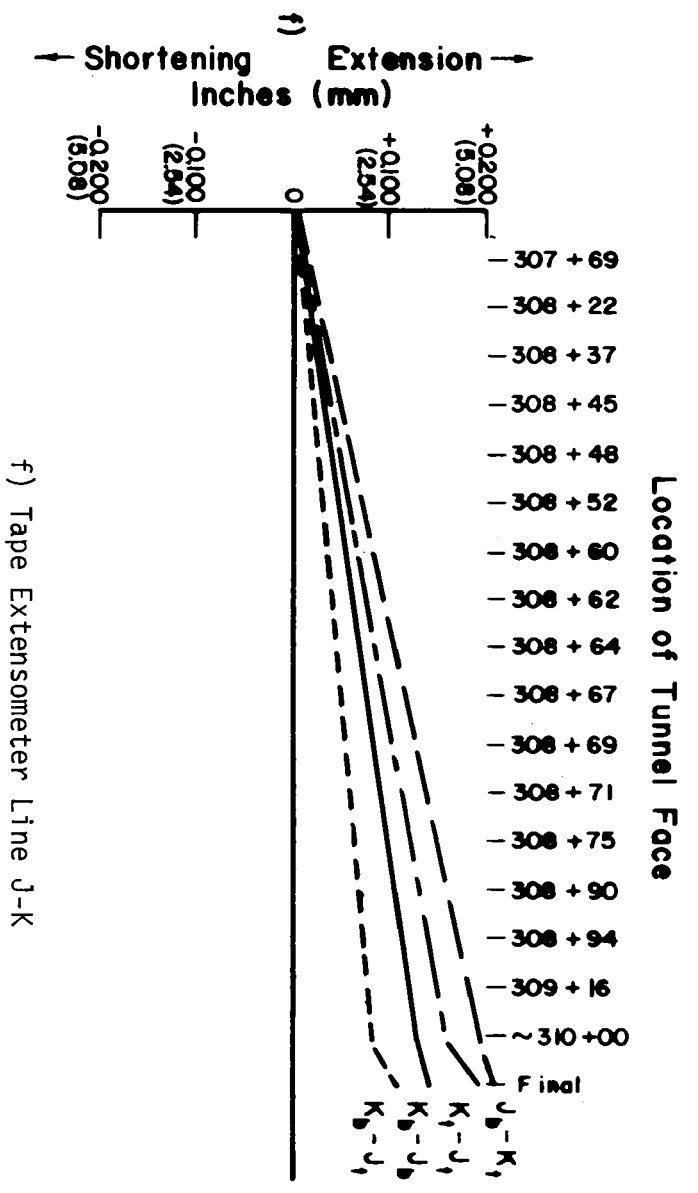

FIGURE 3.25 CONTINUED



e) Tape Extensometer Line G-I



f) Tape Extensometer Line J-K

FIGURE 3.25 CONTINUED

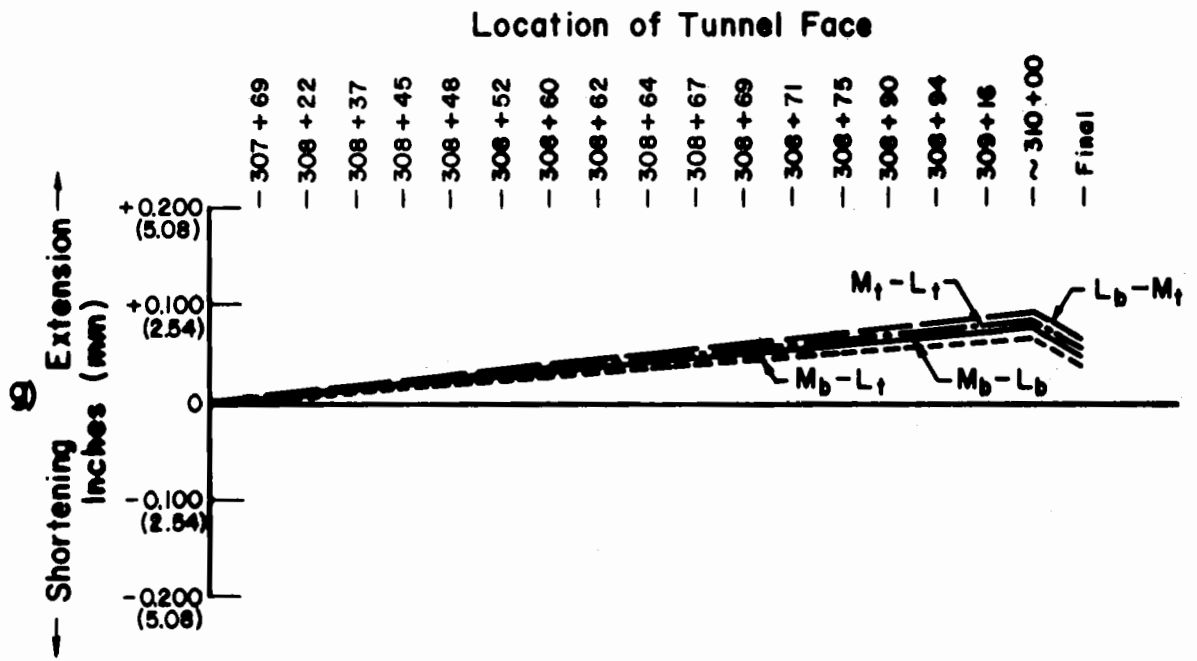

FIGURE 3.25 CONTINUED

relative to the settlement trough, such behavior as described above may be predicted and should be expected from knowledge of the types of ground movements associated with each of the zones of the settlement trough.

Tape extensometer lines A-B and H-I (Building I) are centered about 16 ft (4.9 m) from the centerline of the tunnel while lines L-M and J-K (Building II) are centered about 38 ft (11.6 m) from the tunnel centerline. Line C-D (Building I) occupies a position about 31 ft (9.4 m) from the tunnel centerline. Comparing these locations to the final settlement profiles in Fig. 3.9, 3.10, and 3.11 we find the following: lines A-B and H-I are primarily affected by the zone of lateral compression; line C-D is centered above the point of maximum curvature of the settlement trough where the horizontal extension strain maximizes yet, significant differential settlements still develop; and lines L-M and J-K are in the zone of lateral extension where differential settlements are slight. Also note that the south wall of Building II is located near the point of maximum curvature of the settlement profile. This causes it to rotate more towards the tunnel than the north wall of Building II.

Correlations may also be made with the tape extensometer measurements and the development of the settlement trough. For example, the plot in Fig. 3.25a of the tape extensometer measured displacements vs. location of the tunnel face illustrates the behavior of the structure at various stages of development of the settlement trough. Initially as the tunnel heading approaches the station of the cross-section being monitored, only the wall nearer the tunnel displaces to cause an increase in the distance between the bearing walls. During this early phase of the trough development the wall is in the zone of horizontal extension. The wall tilts, moves horizontally towards the tunnel, and settles slightly. As the tunnel heading passes by the station of the cross-section, the settlement trough widens and the wall is no longer in the zone of extension, but in the zone of compression. The horizontal movements are slight yet, the vertical move-

ments are significant. Later as the tunneling progresses the settlement trough continues to widen and the zone of extension begins to influence the next wall farther out and cause it to displace horizontally towards the tunnel. The horizontal distance between the two walls now decreases while the diagonals remain constant. The increase in differential settlement between the bearing walls compensates somewhat for the decrease in horizontal distance so the diagonals tend to remain the same length.

The tape extensometer lines designated E-F and F-G are located along the longitudinal axis of Building I, perpendicular to the tape extensometer lines described above. Through these tape extensometer lines the response of the structure to the settlement wave in the plane of the tunnel axis may be studied. In the vicinity of the tunnel heading the longitudinal ground surface settlement profile exhibits zones of lateral tension and compression, an inflection point, and a point of maximum curvature similar to the typical surface settlement profile perpendicular to the tunnel axis (Fig. 3.8). As the shield approaches a point, that point moves horizontally towards the shield in the zone of lateral extension. Once the shield passes the point in question, the absolute horizontal motion is reversed and the point once again moves towards the shield, but this time in the zone of lateral compression. Tape extensometer line E-F (Fig. 3.25 c) clearly illustrates this behavior. Tape extensometer line F-G (Fig. 3.25 d) faintly exhibits the same general behavior. Chronologically, the longitudinal span first tends to extend horizontally, then compress horizontally, and finally extend again. The net change in a span after passage of the shield varies depending upon the orientation of the span relative to the tunnel axis and the ground conditions. The net result of the horizontal measurements along both lines F-G and E-F is extension which can be attributed to the inclination of the building axis with respect to the tunnel axis and the direction in which the tunnel excavation proceeded.

3.9.3 PLUMB BOBS

The data from the plumb bob survey are summarized in Fig. 3.26. The resultant displacements of the top of the wall relative to its bottom at each of the plumb bob locations are shown as vectors for various stages of tunnel progress through the site. Both the distance of the wall from the centerline of the tunnel and the orientation of the wall with respect to the tunnel axis influences the tilt and its pattern of development. In this case the wall is oriented such that it cuts across the settlement trough so that the final tilt occurs both towards the tunnel axis and in a direction along the building wall towards the point where the wall is closest to the tunnel centerline (in this case in the direction of tunnel advance). The values of tilt perpendicular to the wall (almost perpendicular to the tunnel axis) are 1.4×10^{-3} , 0.6×10^{-3} , and 1.3×10^{-3} radians for plumb bobs A, B, and C, respectively. Slopes calculated from settlements along cross section perpendicular to the wall are 5.0×10^{-3} , 4.0×10^{-3} , and 3.2×10^{-3} and near plumb bobs A, B, and C, respectively, (Fig. 3.23). Thus, the inclination of the wall toward the tunnel is 1/3 to 1/4 of the slope of transverse building settlement profiles. The inclinations parallel to the wall (approximately in the direction of tunnel advance) are 1.4×10^{-3} , 1.2×10^{-3} and 1.3×10^{-3} for A, B, and C, respectively. The slope of the settlement profile along the wall is about 1.5×10^{-3} , Fig. 3.22. The inclination parallel to the plane of the wall is approximately the same as the slope of the building settlement profile along the wall.

3.9.4 JOINTS AND SEPARATIONS

Changes in the width of the joint forming the interface between Buildings I and II are summarized in Table 3.1. Initially the joint had a width of approximately 1/8 to 3/16 in. (3 to 5 mm). In response to the tunnel excavation the joint opened as shown in Fig. 3.13. A comparison of joint

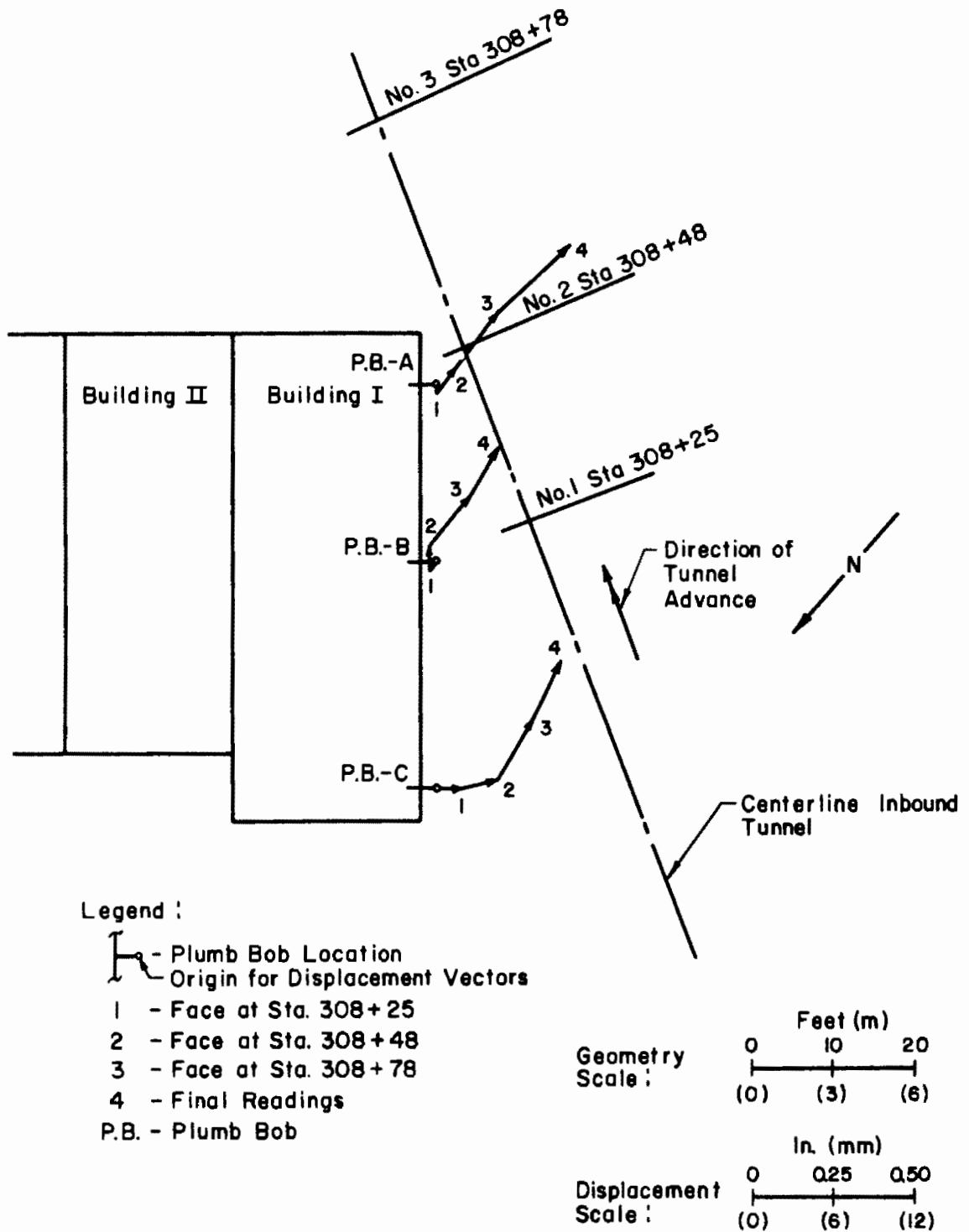

FIGURE 3.26 PLUMB BOB DATA SUMMARY
 (Vectors indicate the relative movement of the top of the wall with respect to the bottom for various stages of tunnel progress.)

TABLE 3.1
CHANGE OF WIDTH OF INTERFACE JOINT

<u>Location</u>	9 FEB 77 ^(a) <u>Δ in. (mm)</u>	26 FEB 77 ^(b) <u>Δ in. (mm)</u>
Top of second story	0.400 (10)	0.432 (11)
Top of first story	0.172 (4.4)	0.159 (4.0)
Top of Basement story	0.107 (2.7)	0.090 (2.3)

Note: (a) Face at Sta. 309+60
 (b) Final readings
 (c) Joint is along cross-section at Station 308+60,
 28 ft (8.5 m) from the tunnel centerline.

TABLE 3.2
CHANGE IN BEARING OF JOIST ENDS, in.(mm)

<u>Joist Location</u>	<u>South</u>	<u>S. Center</u>	<u>N. Center</u>	<u>North</u>	<u>Over All Change</u>
Joist 1	+ 103 (2.6)	- .065 (1.7)	+ .074 (1.9)	+ .014 (0.4)	+ .126 (3.2)
Joist 3	+ .052 (1.3)	- .012 (0.3)	+ .014 (0.4)	+ .022 (0.6)	+ .042 (1.1)
Joist 4	+ .056 (1.4)	+ .001 (.03)	- .007 (0.2)	- .003 (0.1)	+ .047 (1.2)
Joist 27	+ .132 (3.4)	+ .011 (0.3)	- .010 (0.3)	+ .036 (0.9)	+ .169 (4.3)

(+) - reduction in bearing.

(-) - increase in bearing.

Joist 1 is adjacent to front facade wall.

Joist 3 and 4 are near Tape extensometer line A-B.

Joist 27 is near Tape extensometer line C-D.

separation with the tape extensometer and plumb bob measurements at the front of the buildings, shows the measurements to be compatible with each other.

The movement of the first floor joists relative to their bearing was also monitored. The amount of increase or decrease of the bearing was measured using the system shown in Fig. 3.7. The changes in bearing of the four ends of each pair of joists observed are presented in Table 3.2. The overall changes indicated a decrease in bearing approximately corresponding to the lateral extension of the span (compare Table 3.2 and Fig. 3.4). However, the decrease in bearing was not uniformly shared among all four ends of a particular span. The ends bearing in masonry pockets tended to pull out when the span was in a state of extension, but when the span was being compressed, the corresponding increase in bearing was restricted to the ends on the central steel beam (Fig. 3.25 a and b). This behavior was probably influenced by: a) the roughness of the masonry bearing surface relative to the steel bearing surface, and b) the tendency for debris to collect in the void created between the end of the joist and the back of the masonry pocket, thus preventing the joist from slipping back into the masonry pocket.

CHAPTER 4

CASE HISTORIES FROM CONSTRUCTION RECORDS

4.1 INTRODUCTION

To supplement the information gathered at the two instrumented test sections described in Chapters 2 and 3, data were collected from past construction records and field inspection reports. From the investigation, the following six case histories were obtained. Five of the case studies are related to the behavior of structures adjacent to tunnels and open cuts excavated during subway construction. The sixth case study describes the influence of the open cut for the CNA Center in Chicago, Illinois, on one of the frames supporting the tracks of the Chicago Elevated Transit system, Cunningham and Fernandez (1972).

4.2 CASE A

5 1/2-story brick bearing wall structure 11 ft (3.5 m) from the edge of an open cut was the subject of this first case study. The cut was 60 ft (18 m) wide, 250 ft (76 m) long, and 55 ft (17 m) deep. Soldier piles with lagging and cross lot bracing provided the support for the walls of the excavation. The soil profile consisted of Pleistocene terrace deposits underlain by Cretaceous age soils. The terrace deposits consisted of 30 ft (9 m) of soft clays over stiff to medium stiff silty clays and clayey silts interbedded with dense fine to coarse sands with some gravel and boulders. The Cretaceous age deposits of hard silty clay interbedded with very dense fine to medium sands started at a depth of approximately 50 ft (15 m).

The structure had an irregular shape in plan but was roughly 65 ft (20 m) long and 30 ft (9 m) wide, (Figure 4.1). The walls were supported on strip footings of boulder and cobble rubble in a mortar matrix. The footings, located at a depth of 8.5 ft (2.6 m), were 14 in. (356 mm) thick and 3.5 ft (1.1 m) wide. The walls of the structure were lime mortar masonry; this was especially evident in the basement where the mortar in the joints was deteriorated and easily scraped out.

Prior to excavation of the open cut the front wall of the structure was underpinned as shown in Figure 4.1. Steel pipe piles 12 in. (305 mm) in diameter were spaced at 4-ft (1.2 m) intervals along the front wall of the building. The piles were jacked into the ground until the tips were at least 4 ft (1.2 m) below the bottom of the cut and each pile had achieved a minimum capacity of 60 tons (54,500 kg). Subsequent to installation, the underpinning piles were filled with concrete. Footings farther from the cut were not underpinned.

The installation of the jacking pits required excavation through a 5- to 8-ft (1.5-to 2.4-m)-thick layer of very soft, black organic clay. No settlement data were recorded during the underpinning, and the construction records contained no indication of any ground loss. However, the building owners reportedly observed some cracking of the basement wall during the underpinning operations that may have been related to ground loss. Complaints of vibrations and minor jolts were also registered by the building occupants during the underpinning operations.

There is no chronology available relating the sequence and degree of cracking in the structure with the status of the excavation. Thus, the following is a brief description of the damage observed subsequent to the

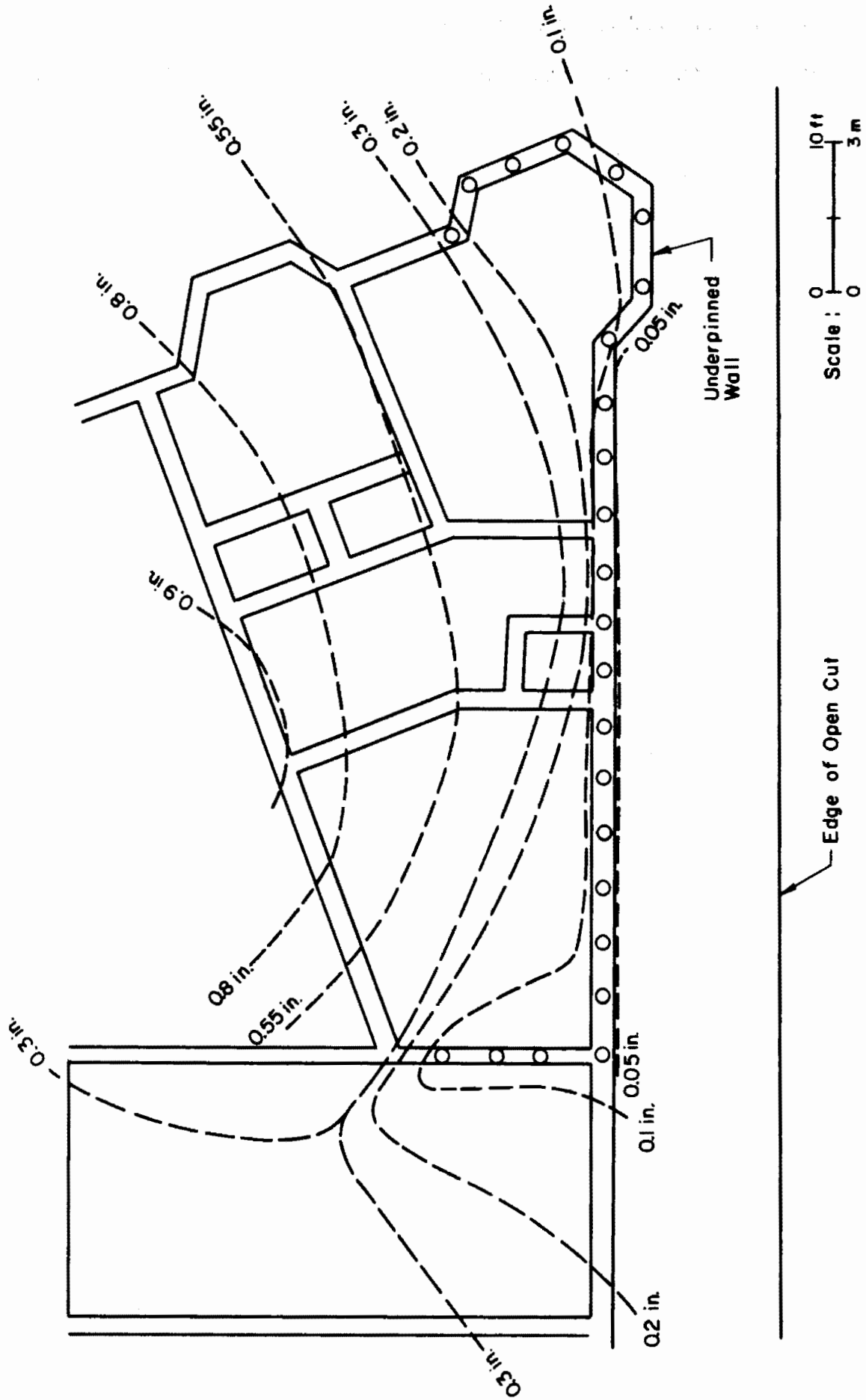

FIGURE 4.1 SETTLEMENT CONTOURS FOR CASE A

completion of all construction operations. Extensive cracking was noted on all floors; cracks ranged up to 1 and 2 in. (25 to 50 mm) in width. Door and window frames were severely distorted and repair was required to return the doors and windows to a functional state. The most severe damage occurred at the north end of the structure where steel channels were required to strap together and reinforce the 3rd, 4th, and 5th floors.

Settlement measurements taken on the building are shown in Figures 4.1, 4.2, and 4.3. It is evident that the underpinning supported the front wall of the building while the rear of the building, that was not underpinned, settled considerably as a result of the excavation. The underpinning acted to create large differential settlements over small distances, thus caused severe distortions in the structure. The angular distortions sustained by the building, based on settlement measurements at 8-to 15-ft (2.4-to 4.6-m)-intervals, are presented in Figure 4.4. There were many observations of angular distortion in the structure that exceeded 1×10^{-3} (1/1000), the limiting angular distortion for architectural damage to load bearing wall structures suggested by O'Rourke et al. (1976). Angular distortions of 1.8×10^{-3} (1/555) and 5.2×10^{-3} (1/190) were calculated for the north end of the structure along a line parallel to the edge of the excavation. Angular distortions ranging up to 8.0×10^{-3} (1/125) were calculated for the north end of the structure along a line perpendicular to the edge of the excavation.

Lateral movements perpendicular to the excavation line were measured at the north end of the structure. The reference points were set along the north wall of the building at the third story level, as a consequence, a good portion of the lateral movement observed is due to the relative rotations

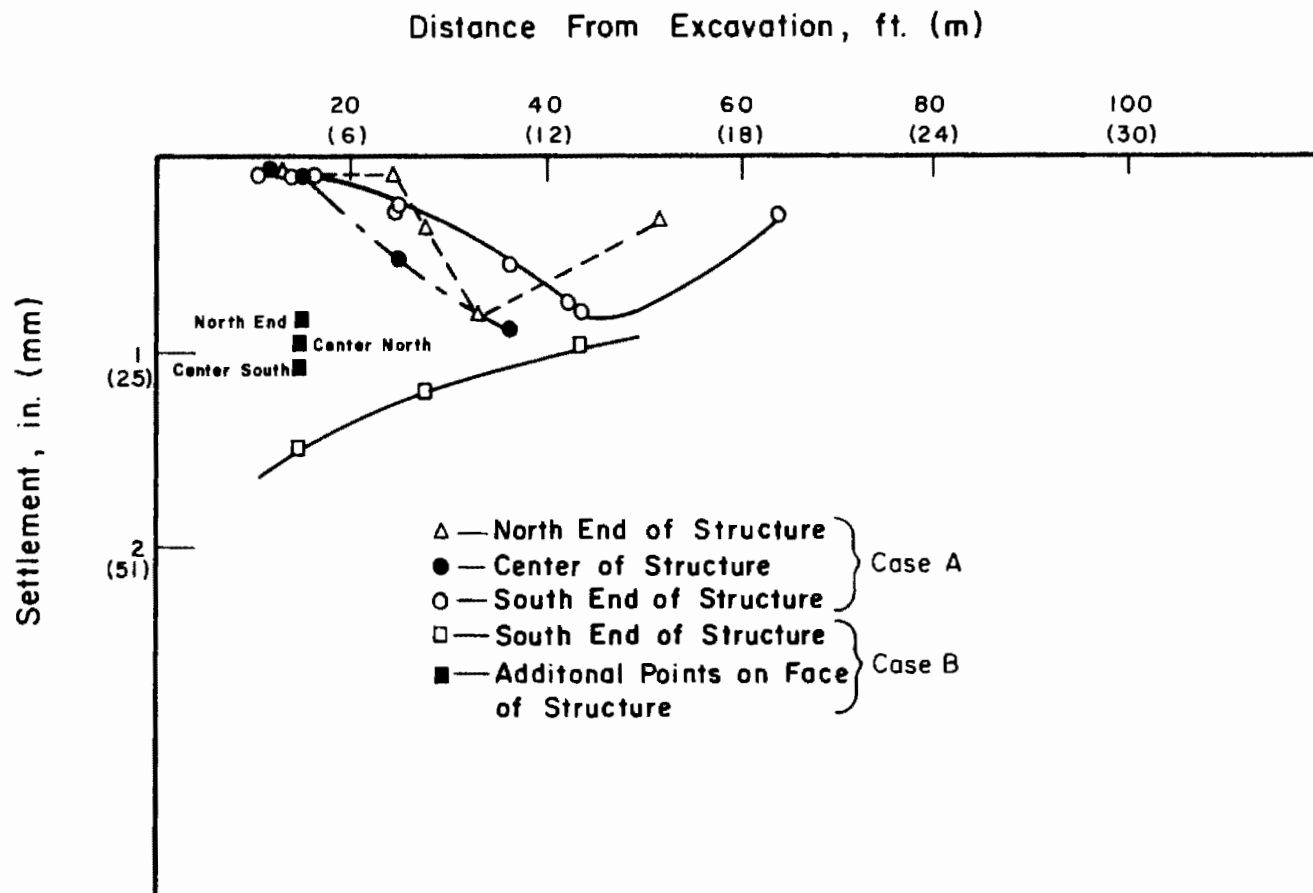

FIGURE 4.2 BUILDING SETTLEMENTS, CASES A AND B

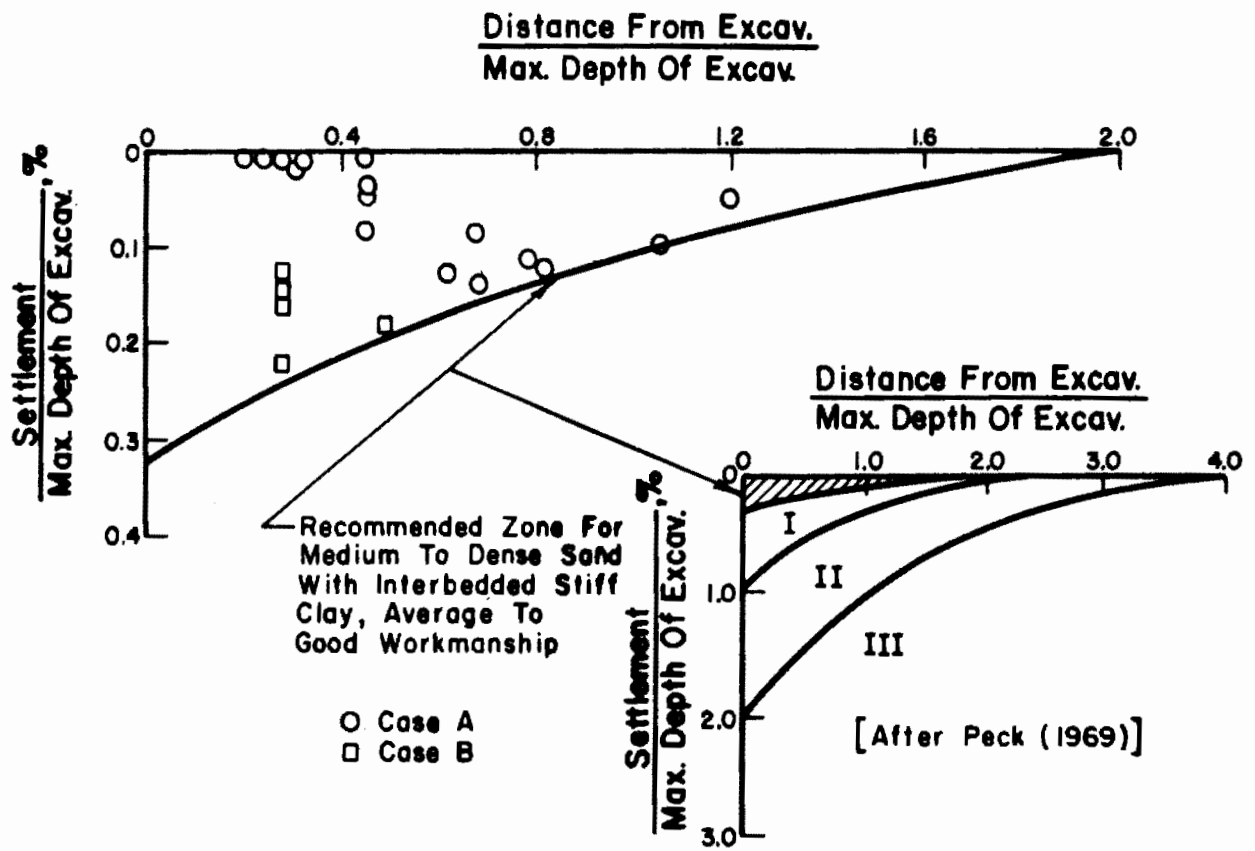

FIGURE 4.3 NORMALIZED SETTLEMENTS ADJACENT TO BRACED EXCAVATIONS

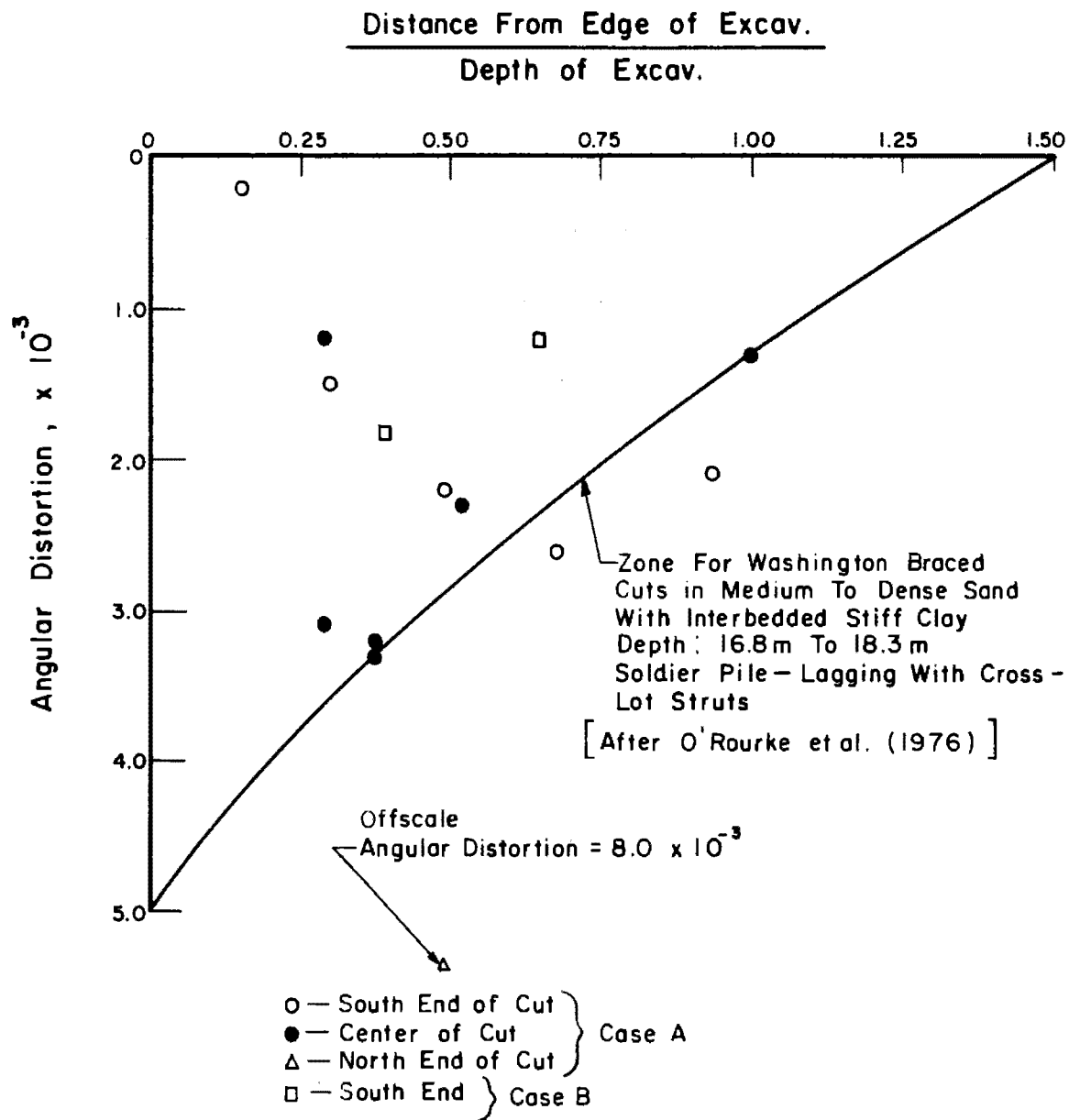

FIGURE 4.4 ANGULAR DISTORTIONS OF BUILDINGS IN CASES A AND B

in the building as well as any lateral displacement of the ground. These data serve to indicate that significant lateral distortion of the upper portions of the structure were taking place. The lateral compression strains calculated were 0.2×10^{-3} , 0.6×10^{-3} , and 1×10^{-3} at distances of 13.5 ft (4.1 m), 18.5 ft (5.6 m), and 23 ft (7.0 m) from the edge of the excavation, respectively.

4.3 CASE B

A 6-story steel frame structure adjacent to the same open excavation described in Case A provided the subject for this second case study. The front wall of the structure was located approximately 15 ft (4.6 m) from the edge of the excavation. The structures considered in Cases A and B were directly across the excavation from one another.

The structure was approximately 120 ft (37 m) by 125 ft (38 m) in plan. The columns were 8-in. (203-mm) by 8-in. (203-mm)-steel H-sections spaced at 23-ft (7-m) intervals parallel to the excavation and 18-ft (5.5-m) intervals perpendicular to the excavation. The beams were steel sections of unknown size. Masonry and plaster covered the steel framing. The infill walls were composed of brick masonry typically covered by paneling or display materials in the interior. The columns extended down through the basement and rested on spread footings, 17 ft (5.2 m) square and 20 ft (6 m) square for interior and exterior columns, respectively. The footings were 4-ft (1.2-m)-thick rubble footings or mortared brick fragments.

Prior to excavation of the open cut the first two column lines parallel to the excavation were underpinned. Each column footing was supported with four pipe piles jacked into place and filled with concrete. Pipe piles

with capacities of 40 and 65 tons (36,000 and 59,000 kg) were used under the interior and exterior columns, respectively. In all cases the pipe piles extend to a depth at least 4 ft (1.3 m) below the bottom of the open cut.

The following observations were made subsequent to the completion of construction. There was little to no damage observed in the structure. Some cracks were apparent in a stairwell at the northeast corner of the building, but little settlement data for this zone appeared in the construction records. Final settlement data and angular distortion data are presented in Figs. 4.2, 4.3, and 4.4. The angular distortions were based on settlements recorded at 14-ft (4.3-m)-intervals. The settlements were in the range of those typically found in buildings adjacent to excavations where no underpinning was employed. Settlement of the underpinning piles was approximately 1 to 1.5 in. (25 to 38 mm), whereas nearby points that were 20 ft (6 m) farther from the excavation and not underpinned settled about 1 in. (25 mm). This behavior of the underpinned portion of the structure may have been due to the downdrag of the soil on the piles causing them to elastically compress and/or to punch into the subsoil beneath the pile tips. The angular distortions calculated for the structure were in the range of 1.2×10^{-3} (1/830) to 1.8×10^{-3} (1/560). Thus, the structure was not damaged at angular distortions slightly larger than 1.3×10^{-3} (1/750), the recommended limit for damage to frame structures adjacent to excavation, O'Rourke et al, (1976).

4.4 CASE C

The behavior of a 3-story masonry structure in response to the excavation of two tunnels 37 ft (11 m) apart was investigated in this case

study. The centerline of the nearest tunnel came within 30 ft (9 m) of the building. Each tunnel was about 21 ft (6.4 m) in diameter and the springlines were about 62 ft (19 m) below the ground surface. Excavation of the tunnels was accomplished with a shield and support provided by steel ribs and timber lagging. The steel sets were installed after each 4-ft (1.2-m)-shove of the shield. The soil profile at this location consisted primarily of dense silty sands and gravels, Pleistocene terrace deposits.

The structure, 270 ft (82 m) by 205 ft (62 m) in plan, had a basement and 3 stories above ground. The long dimension of the building paralleled the tunnel axis. Concrete blocks with marble facing formed the 4-ft (1.2-m)-thick exterior walls. Brick masonry, typically 2.5 ft (0.76 m) thick, formed the walls and the plaster-covered barrel vaults and groined vaults. The barrel vaults provided the ceiling for 8-ft (2.4-m)-wide corridors parallel to the tunnels. Rows of rooms 16 ft (4.8 m) wide, ranging from 14 ft (4.3 m) to 28 ft (8.5 m) long, flanked the corridors. The groined vaults formed the ceilings for these rooms. Spread footings provided the foundation support for the walls. No underpinning was employed, however, the ground mass around the tunnels was stabilized through grouting operations when conditions warranted such action.

The building sustained extensive damage, the south end of the structure more so than the north end. Cracking appeared on all floors levels in both walls and ceilings and require major repairs. Large continuous cracks appeared in the crowns of the corridor barrel vaults due to horizontal extension on all three floors. Cracks in excess of 1/4 in. (6 mm) appeared and shoring to provide additional support for the barrel vaults was required. Cracking also occurred in the groined vaults and in the walls causing plaster

to spall from the masonry surfaces and rendering the entire side of the building nearest the tunnel unusable. The construction files indicated that problems with dewatering were encountered and many runs occurred in the sandy soil. This resulted in large local ground losses and erratic settlement patterns.

Measurements of the settlement of both the ground surface and the structure appear in Figs. 4.5 and 4.6. Street settlements in excess of 6 in. (152 mm) and building settlements ranging up to 1 in. (25 mm) developed. An angular distortion of 1.1×10^{-3} (1/910), was calculated for the north end of the structure. At the south end of the structure, where most of the damage was observed, angular distortions of 3.6×10^{-3} (1/280) and 7.2×10^{-3} (1/140) were calculated from building settlement data. The settlement points used in the angular distortion calculations were located at 10-ft (3-m)-intervals. In addition to building damage related to angular distortion, the structure appeared to have suffered distress from horizontal extension. The inflection point of the settlement profile, where horizontal extension strains are at a maximum, occurred just inside the front wall of the structure.

4.5 CASE D

The response of a 4-story brick bearing-wall structure to the excavation of a pair of tunnels, 20.8 ft (6.3 m) in diameter, through medium dense sands and gravels with occasional clay stringers and silty zones is discussed in this case study. The tunnels were parallel and 37 ft (11.2 m) apart, centerline to centerline, with the invert elevations about 58 ft (17.7 m) below the ground surface. The tunnels were driven using a shield,

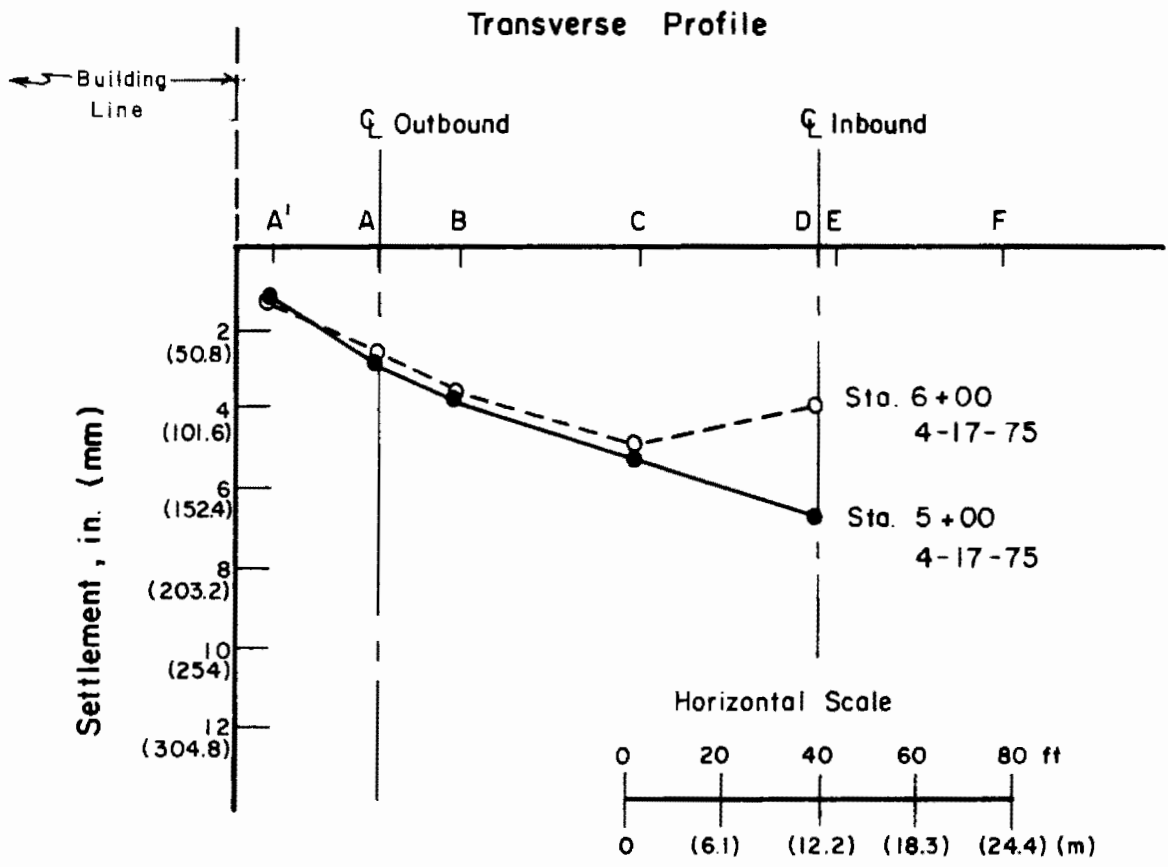

FIGURE 4.5 SETTLEMENT PROFILE PERPENDICULAR TO TUNNEL AXES, CASE C

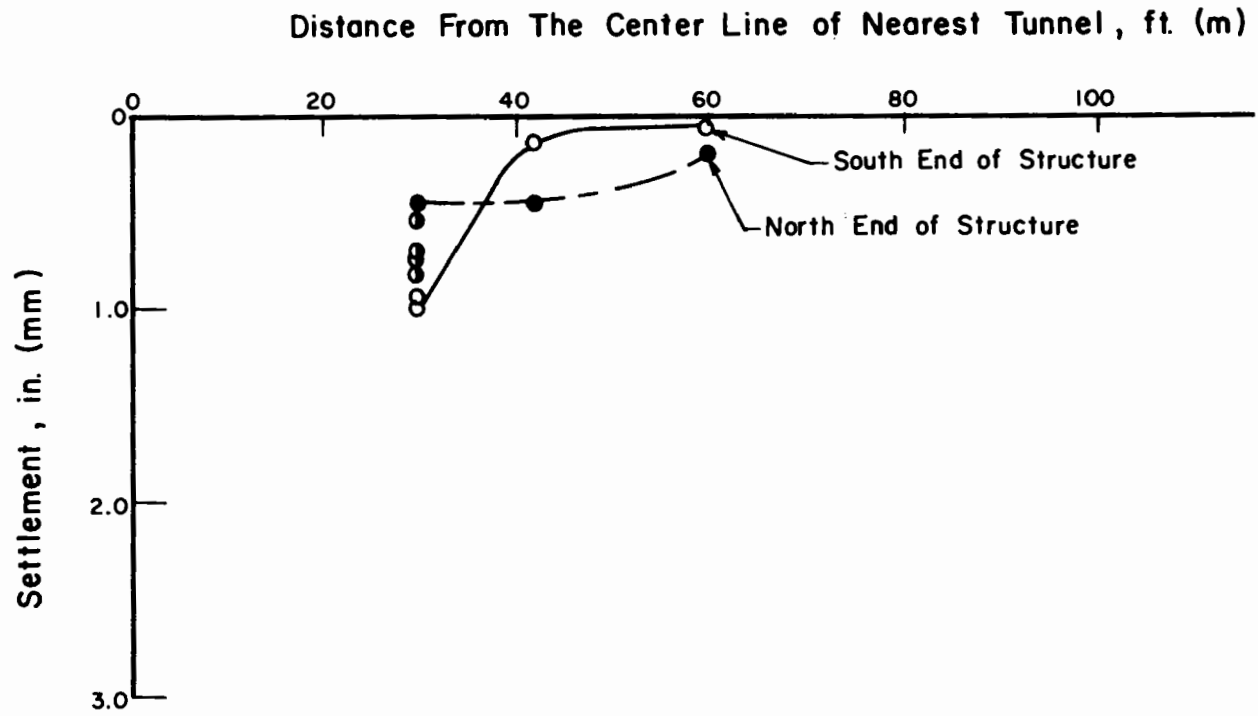

FIGURE 4.6 BUILDING SETTLEMENT, CASE C

and steel ribs and timber lagging were placed to provide the initial support. The steel sets were located at 4-ft (1.2-m)-intervals, corresponding to the length of shove used.

The building was on the order of 50 to 80 years old. It was 22 ft (6.7 m) by 60 ft (18 m) in plan and was located about 22 ft (6.7 m) from the edge of the excavation. The foundation for the structure was provided by rubble strip footings under the walls. The bearing walls were 16-in. (406-mm)-thick brick masonry, while the front facade wall was a 12-in. (304-mm)-thick brick wall clad with a veneer of architectural stone work. Prior to tunneling the building was abandoned and unused.

Damage to this structure was extensive and resulted in it being declared structurally unsound. Surface settlements over the centerline of the nearer tunnel were in excess of 10 in. (254 mm). The maximum settlement recorded was 2.8 in. (71 mm) at the front building line. Angular distortions of 17×10^{-3} (1/60) and 8.3×10^{-3} (1/120) were calculated from the settlement data along a line perpendicular to the tunnel axis. Angular distortions in excess of 5×10^{-3} (1/200) were calculated from settlements along the front of the structure, a line parallel to the axis of the tunnel.

Both bending cracks and diagonal cracks were readily visible in an exposed bearing wall, Fig. 4.7 . The diagonal cracking occurred near the front of the structure, within a distance from the excavation equal to H, the height of the building. The bending cracks occurred approximately at a distance H from the front of the building and near the top of the bearing wall. The windows in the bearing wall were also severely distorted, (Fig. 4.7). At the fourth floor it was noted that the facade wall had pulled away 1 in. (25 mm) or more from both the ceiling and the floor.

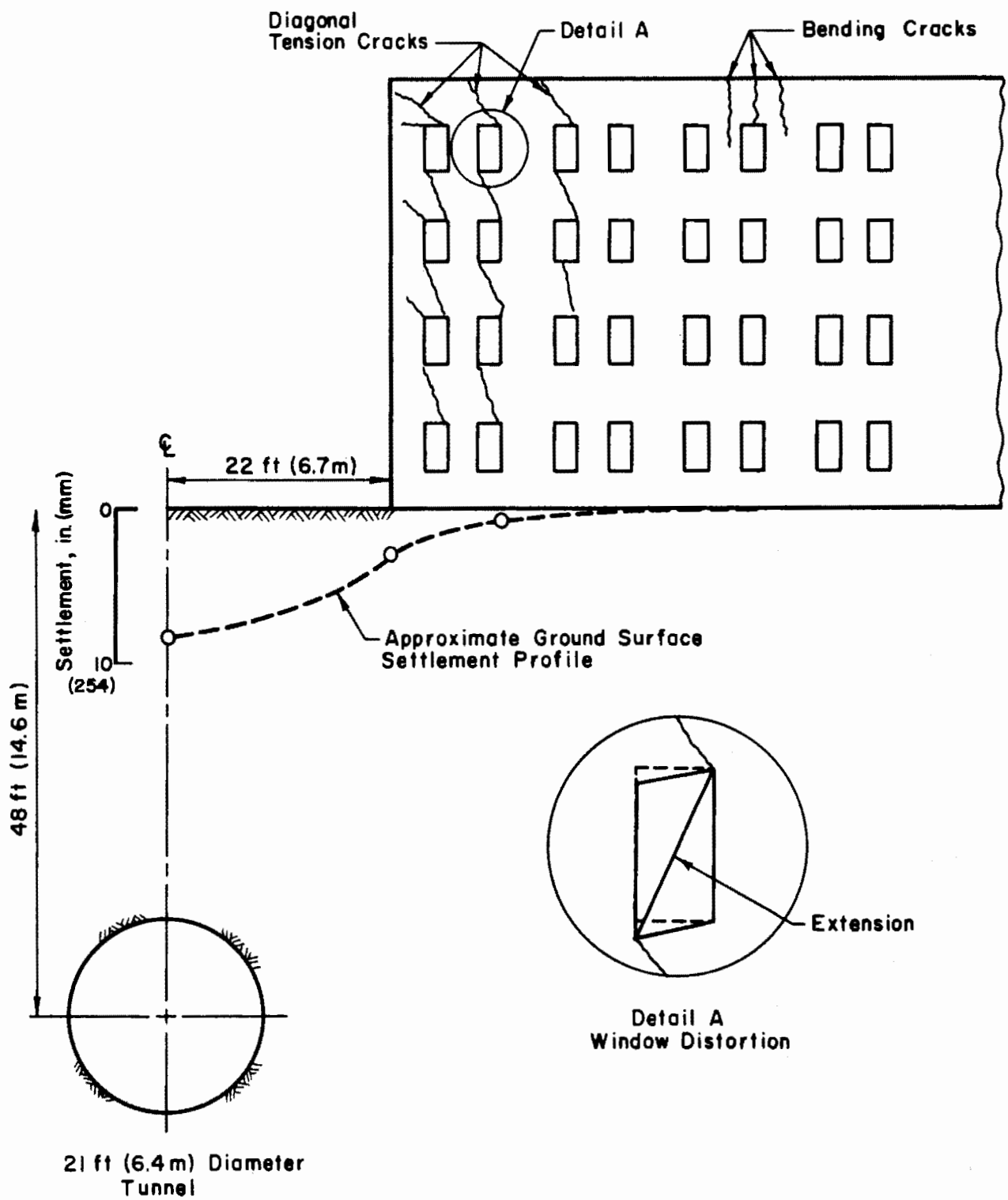

FIGURE 4.7 CRACKING IN SIDE OF BUILDING, CASE D.

From the exterior, the facade wall cladding appeared to be on the verge of buckling and separating from its support. During the tunnel excavation through the site two pieces of the architectural stone cornice fell from the facade. In the basement a 2-in. (50-mm)-wide vertical crack was observed in one bearing wall near the front facade wall.

Much of the problem associated with this combination of excavation and structure were reportedly due to the occurrence of large, localized runs at the face of the tunnel excavation. The runs tended to create erratic variations in the ground settlement which in turn caused severe distortions in the structure. This was the reason that the large angular distortions in the structure developed along a line parallel to the tunnel axis, as well as along a line perpendicular to the tunnel axis.

It is apparent that the angular distortions of the structure ($1/60$ to $1/200$) are in the range where significant structural damage is to be expected. The visual observations strongly suggest that a large reduction in the structural integrity of the building had occurred, sufficient in the eyes of the local authorities to warrant condemning the structure.

4.6 CASE E

Settlement and distortion were observed along two brick courtyard walls located next to a 60-ft (18-m)-deep open cut in dense sands interbedded with stiff clays, the same excavation described in Chapter 2 of this report (Figure 4.8). Both walls ran perpendicular to the edge of the open cut. One started 34 ft (10 m) from the edge of the excavation while the other began 47 ft (14 m) from the edge of the cut. The walls were 7.5 ft (2.3 m) high, 12 ft (3.7 m) long, and 8 in. (203 mm) thick. The foundations for the walls were concrete strip footings about 2.5 ft (0.8 m) below the ground surface.

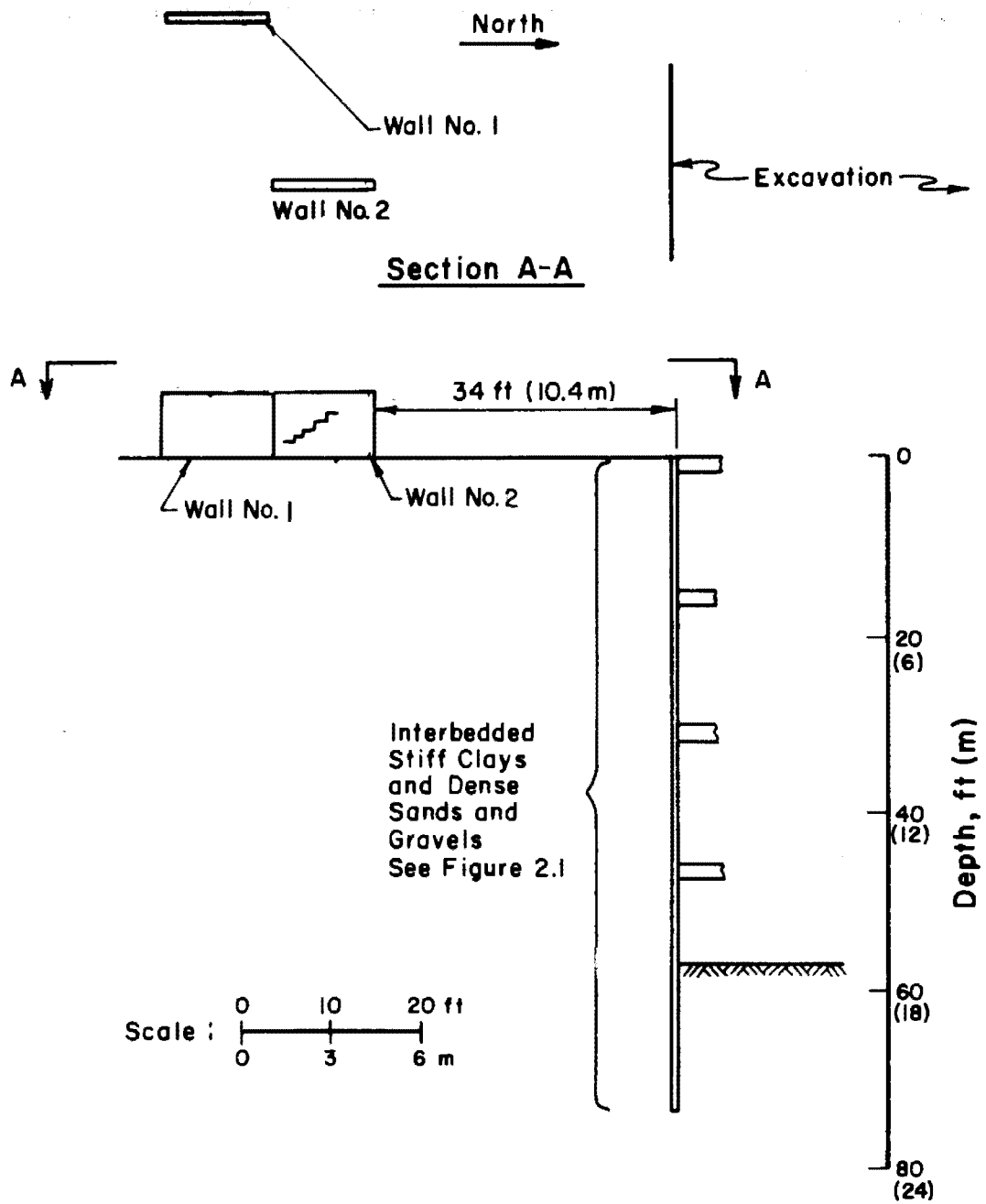
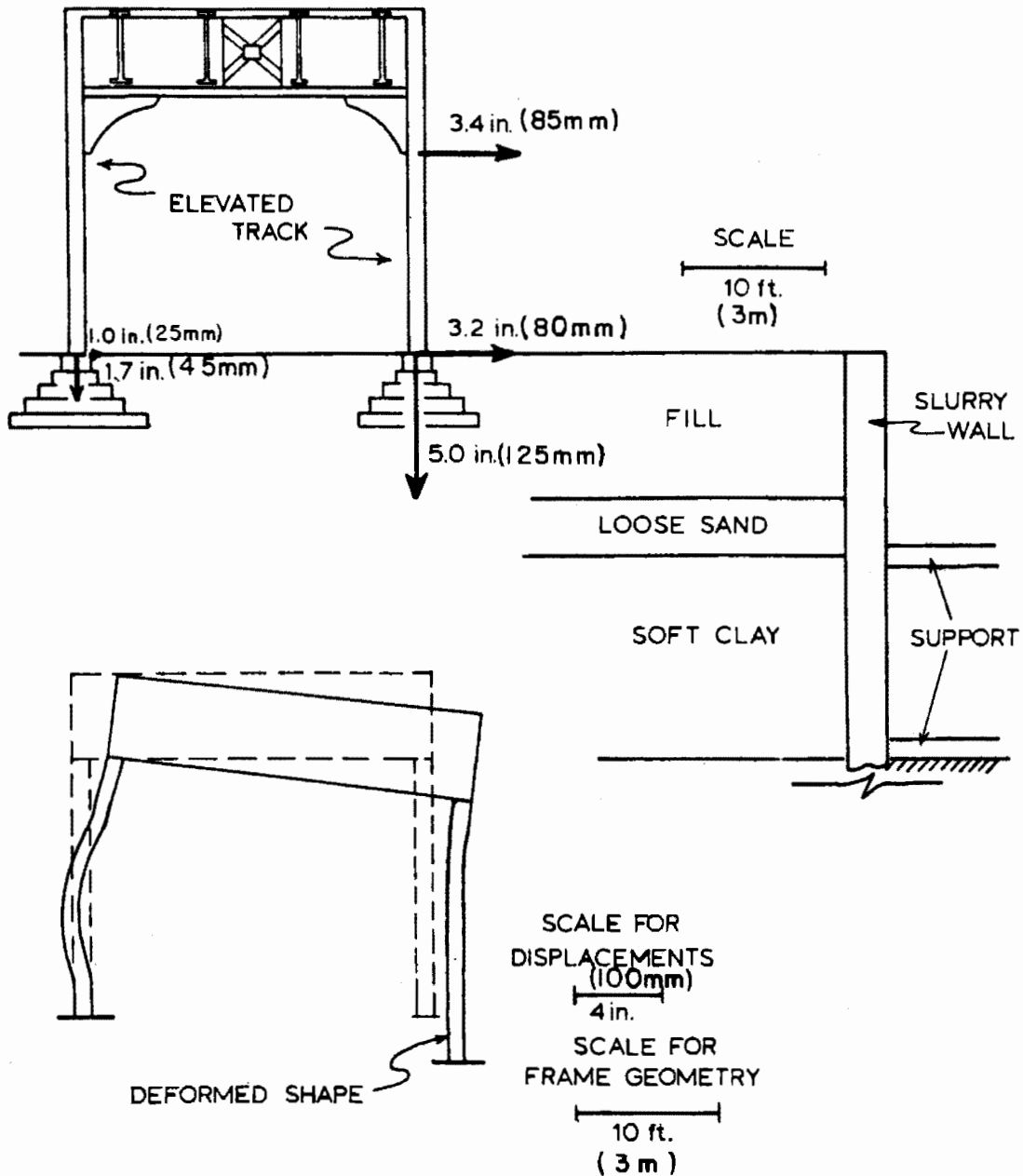

FIGURE 4.8 CASE E, TWO BRICK WALLS

The damage to the walls was negligible. The maximum settlement of the wall closest to the excavation was 0.75 in. (19 mm). Differential settlements on the order of 0.25 in. (6 mm) were observed between the ends of each wall. The relatively short length of the walls and a length to height ratio approximately equal to one resulted in most of the differential settlement causing a rigid body tilt of the walls towards the excavation. No evidence of angular distortion in either wall was apparent. The tilting caused separations at non-structural connections where the courtyard walls butted against the building walls. The separations ranged from 1/16 in. (1.6 mm) to 3/16 in. (4.8 mm), bottom to top. Some evidence of horizontal extension strain was noted. Several pre-existing vertical cracks widened approximately 1/16 in. (1.6 mm) and slip along pre-existing horizontal cracks was evident. The widening of cracks in the adjacent sidewalks provided additional evidence that the ground had undergone lateral extension.

4.7 CASE F

The effect of the CNA-Center excavation on one of the frames supporting the elevated rapid transit tracks in Chicago is reviewed in this case study (Figure 4.9). The excavation was supported by a slurry wall braced with rakers. It was 248 ft by 176 ft (75 m by 54 m) in plan and 28 ft (8.5 m) deep. The cut extended through fill and penetrated the medium-soft Chicago clays. The support frame for the tracks was a single steel bent supported on 8-ft (2.4-m)-square spread footings 5 ft (1.5 m) below grade. Each column of the frame was a built up section made up of two 15-in. (381-mm) channels and a 15-in. (381-mm)-deep I-beam. The transverse girder spanning between the two columns was a heavy built up section 60 in. (1500 mm) deep. The column



(Maynard & O'Rourke, 1977)

FIGURE 4.9 CASE F, "EL" STRUCTURE

nearer the excavation was 31 ft (9.4 m) from the slurry wall while the further column was 54 ft (16.5 m) from the slurry wall. The frame was approximately 24 ft (7.3 m) wide and 26 ft (7.9 m) high. Observations made at the site include both horizontal movements and vertical settlements.

The vertical settlement of the footing nearer the excavation was 5 in. (127 mm) while the vertical settlement of the further column footing was 1.75 in. (44 mm). A differential settlement of 3.25 in. (82 mm) resulted across the 24 ft (7.3 m) span of the frame, corresponding to a settlement slope of 11×10^{-3} (1/90) across the structure. After subtracting out the rigid body rotation, an angular distortion in the range of 5×10^{-3} (1/200) to 8×10^{-3} (1/125) remained. The horizontal movements in the vicinity of the frame were approximately 0.5 to 0.6 times the vertical settlements. The nearer column translated horizontally 3.1 in. (79 mm) towards the excavation while the further column moved 0.9 in. (23 mm) towards the cut. The differential horizontal movement of 2.2 in. (56 mm) between the columns resulted in a lateral extension in the structure of 7.6×10^{-3} .

No damage was observed in the frame. A STRUDL analysis of the frame using plan dimensions, the maximum design loadings, and the footing displacements indicated that the maximum stress in the frame was nearing the lower limit of the yield stress of the steel. Most of the stress was caused by the excavation related footing displacements. The Transit Authority cut and respliced the columns, as it is a CTA practice to relevel a frame once the differential settlement between columns reaches 3 in. (76 mm), Maynard and O'Rourke (1977).

4.8 SUMMARY

A summary of the Cases A through F is presented in Table 4.1. The cases described encompass a variety of the different types of structures and types of excavations typically encountered in urban areas. The six case studies illustrate many of the factors that must be considered when evaluating the anticipated response of structures adjacent to a proposed excavation and potential protective measures. Among these are: the pattern and magnitude of the vertical and horizontal ground movements; the type of structures; the size of the structures relative to the settlement profile; the extent of the underpinning; the loads imposed on the underpinning by soil movements in response to the excavation; and effect of horizontal straining of the structures. In cases A through D the structures are wide enough to extend beyond the settlement zone so that the rigid body rotations are small and the angular distortions of the structures are approximately the same as the slope of the building settlement curve.

Cases A through D illustrate responses of commercial and residential type structures to excavation-induced differential settlements and lateral extension strains. Cases A and B also show the influence of underpinning on building response. Cases E and F are simpler structures (brick walls and a steel frame) that clearly illustrate some of the individual components involved in structural response to excavation-induced ground movements.

The case histories presented show that the susceptibility of a building to structural damage depends on the structural characteristics of the building. For the masonry structures, excavation induced angular distortions in excess of 6.7×10^{-3} (1/150) resulted in significant structural damage, whereas structural damage did not occur for angular distortions less

TABLE 4.1
SUMMARY OF CASE STUDIES

CASE	STRUCTURE	FOUNDATION	DIST. TO EXCAVATION	EXCAVATION	SOIL	MAX. BLDG. SETTLEMENT	MAX. ANGULAR DISTORTION	DAMAGE	COMMENTS
A	5 1/2-story w/basement; Brick bearing wall 65x30 ft (20x9 m). Long axis and bearing walls parallel to edge of cut.	Rubble wall footings, front wall of building underpinned.	11 ft (3.5 m)	Open cut, 60 ft. (18 m) deep; soldier piles, lagging, and cross lot bracing.	Soft clay over interbedded stiff clays and dense sands.	0.9 in. (23 mm)	8×10^{-3} (1/125)	Severe Cracking, distorted windows and doors, some structural damage requiring reinforcement and shoring.	Underpinning of footings nearest the excavation prevented their settlement while footings farther from cut settled substantially causing severe distortion in the structure.
B	6-story w/basement; steel frame w/masonry in-fill walls 125x120 ft (37x38 m)	20-ft (6 m)-square spread footings under steel columns; 1st. two rows of columns underpinned.	15 ft (4.6 m)	Same as above	Same as above	1.5 in. (38 mm)	1.8×10^{-3} (1/560)	Negligible	Underpinning effectiveness questionable. Underpinned footings settled considerably during excavation.
C	3-story w/basement; vaulted masonry structure w/very thick walls and pillars. Barrel vaults parallel to tunnels.	Spread footings	30 ft (9 m) to \odot of the nearer tunnel	Twin tunnels 37 ft (22 m) apart; 21 ft (6.4 m) dia.; 62 ft (19 m) to springline. Rib and lagging temporary support.	Dense silty sands and gravels.	1 in. (25 mm)	7.2×10^{-3} (1/140)	Severe cracking of barrel vaults requiring shoring. Plaster falling from walls and ceilings.	Chemical grout used to stabilize running sands. Cracking still evident in zone where angular distortion equals 1.1×10^{-3} (1/910).
D	4-story w/basement; Brick bearing wall 22x60 ft (6.7 x 18 m). Long axis and bearing walls perpendicular to cut.	Rubble strip footings.	22 ft (6.7 m) to \odot of the nearer tunnel.	Twin tunnels 37 ft (11 m) apart 21 ft (6.4 m) dia. 48 ft (14 m) to springline. Rib and lagging temporary support.	Medium dense sands and gravels.	2.8 in. (71 mm)	12×10^{-3} (1/60)	Severe cracking and distortions. Structural damage, pieces of stone from facade loosening and falling.	Bending and diagonal tension cracks evident in bearing walls. Building was condemned.
E	2 brick walls; 7 1/2 ft x 12 ft. x 8 in (2.3 m x 3.7 m x 203 mm). Walls perpendicular to edge of cut.	Concrete strip footings.	34 ft (10 m)	Open cut 60 ft (18 m) deep soldier piles, lagging, and cross lot bracing.	Dense sands interbedded w/stiff clays.	0.75 in (19 mm)	0	Negligible, 1/16 in. (1.6 mm) widening of pre-existing cracks. 1/16 to 3/16 in. (1.6 to 4.8 mm) separations between adjacent building and walls due to wall rotation.	Walls rotated as rigid bodies and experienced little, if any, angular distortion.
F	Steel frame supporting elevated rapid transit tracks; 24 ft (7.3 m) wide 26 ft (7.9 m) high.	8 ft (2.4 m) Square spread footings.	31 ft (9.4 m)	Open cut 28 ft (8.5 m) deep. Slurry wall supported.	Fill over soft clay.	5 in. (127 mm)	6.6×10^{-3} (1/150)	No apparent damage. Analysis of frame and loads shows maximum stress in steel near yield.	Columns were cut, jacked, and spliced to relevel the columns when 5 in. (127 mm) displacement occurred.

than 2×10^{-3} (1/500) (Table 4.1 & Figure 4.10). These data are also in general agreement with the relationships between angular distortion and damage previously reported by Skempton and MacDonald (1956), and Bjerrum (1963). They indicate that for angular distortions greater than 6.7×10^{-3} (1/150) structural damage is to be expected for structures settling under their own weight. Our previous studies of brick bearing-wall structures adjacent to excavations have indicated that separations and cracks of 0.5 in. (12 mm) to 1 in. (25 mm) and minor structural damage may occur where the angular distortion sustained by the structure is in the range of 3×10^{-3} (1/300) to 6.7×10^{-3} (1/150). The steel frame for the elevated rapid transit line (Case F) sustained an angular distortion of 6.7×10^{-3} (1/150) with no apparent damage, yet a structural analysis indicated that prior to releveling the frame the maximum stress in the steel was approaching the lower limit of the yield stress for the steel. The steel frame structure with masonry in-fill (Case B) withstood an angular distortion of 1.8×10^{-3} (1/560) with no apparent cracking or damage due to adjacent excavation. Damage distortion relationships developed by O'Rourke et al. (1976) propose 1.3×10^{-3} (1/750) as the limiting angular distortion for frame structures with masonry in-fill panels where cracking and other architectural damage became noticeable. The in-filled frame structure of Case B may have been able to sustain an angular distortion greater than 1.3×10^{-3} (1/750) without apparent cracking because the finish of the in-fill walls was paneling, and consequently, not as sensitive to distortion as a plaster wall.

The following conclusions regarding underpinning may be drawn from Cases A and B:

- 1) It is difficult to protect a structure with underpinning against the small movements that can cause minor architectural damage.

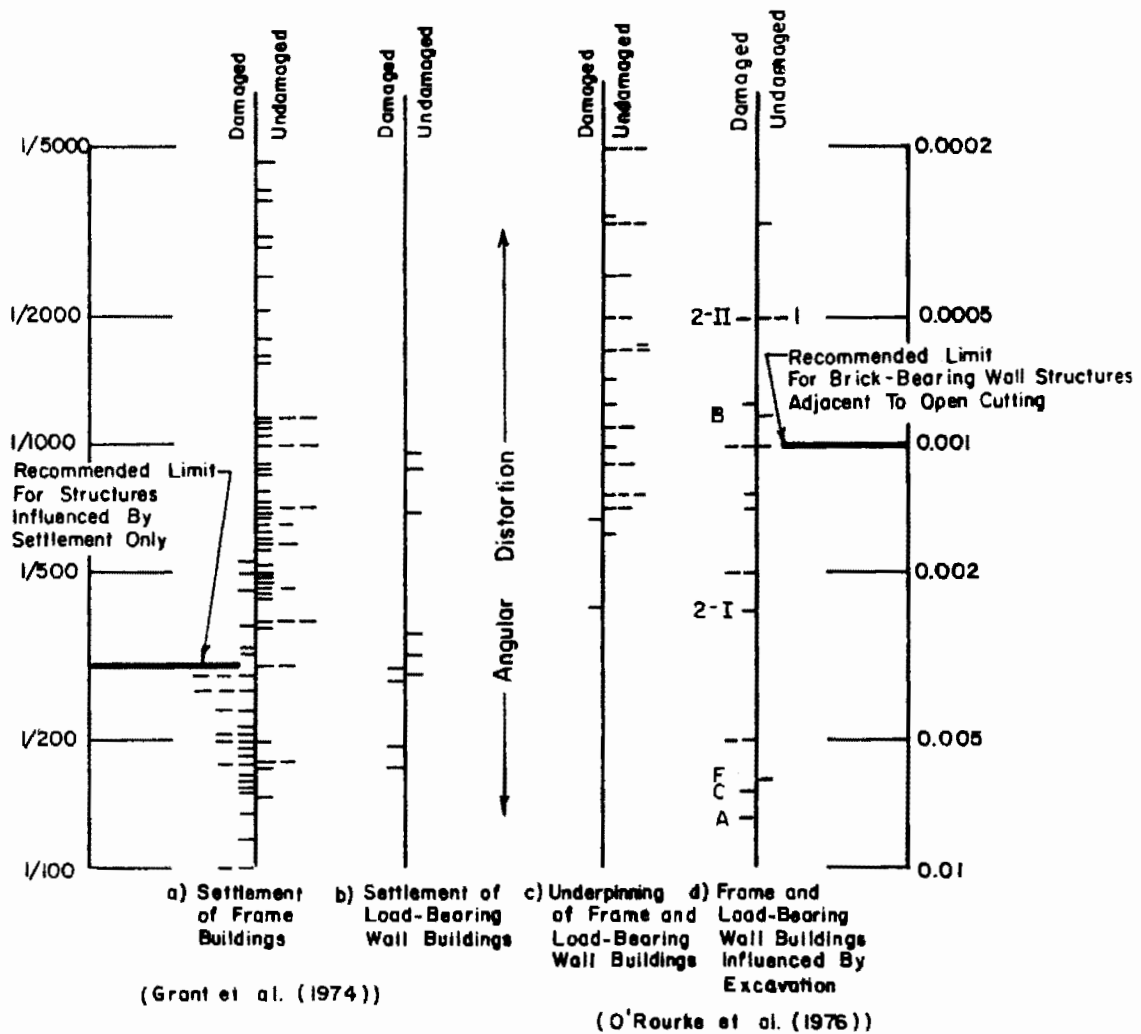

FIGURE 4.10 ANGULAR DISTORTION CRITERIA MODIFIED BY THE ADDITION OF THE CASES DISCUSSED IN THIS REPORT. (NOTE CASE D IS OFF THE SCALE)

- 2) Installation of the underpinning can result in cracking and damage to a structure.
- 3) If the underpinning does not support all portions of a structure likely to undergo significant settlement, severe and very damaging local distortions may be induced in the structure. These distortions may be more severe than those that would occur if no underpinning is employed.
- 4) The depth and construction procedure for underpinning should be such that settlements due to downdrag and tip disturbance are minimized.

Both Case E and F illustrate the horizontal extension component of distortion as well as the component attributable to vertical differential settlement. In the two brick walls, Case E, the lengths of the walls were sufficiently short with respect to the pattern of ground settlements that the differential settlement resulted almost entirely in rigid body tilting. Any cracking was primarily a result of lateral extension. The frame in Case F responded to the differential settlement pattern by both rigid body rotation and angular distortion. A comparison of Cases A, E and F illustrates the relation between the building width and the pattern of the settlement profile over the width of the building. When a settlement profile has developed under only part of a structure most of the response to differential settlements appears in the form of angular distortion. Correspondingly, when the building width is small relative to the width of the settlement profile, the building will tend to undergo rigid body tilting.

CHAPTER 5

SUMMARY AND CONCLUSIONS

5.1 GENERAL DISCUSSION

The cost of construction delays, litigation, repairs, and protective measures where structures are subjected to excavation-related distortions can be substantial. In order to make effective decisions for planning the excavation to minimize costs, delays, and damage, a better understanding of the response of structures to excavation-induced ground movements is required. This report presents data from two instrumented test sites (Chapters 2 and 3) and an additional six case histories (Chapter 4) to illustrate the behavior and response for a range of building and excavation situations. These data are used to corroborate and refine existing criteria relating ground movements and building distortion to damage.

Ground movement are the direct cause of building deformation. Thus, to effectively investigate the response of structures to adjacent excavation knowledge of the types of ground movements and the progressive development of the ground movements associated with the different types of excavations is necessary. A detailed discussion of the ground displacements caused by excavations is beyond the scope of this report, however, brief descriptions of the typical ground movements and progression of development of the movements for the three general classes of excavations considered (open cuts, tunnels, and mines) appear in Appendix A. Detailed discussion of the causes of ground movement due to tunneling are presented in other reports (Cording et al, 1976, MacPherson et al 1978).

5.2 SUMMARY OF CASE STUDY 1

Nine-story reinforced concrete structure located 38 ft (11m) from a 60-ft (18m)-deep cut (Chapter 2).

1. The soil settlements adjacent to the 60-ft (18-m)-deep cut were typical of the settlements measured for braced cuts in mixed profiles of dense sands and gravels and stiff clays.
2. The deformed shape of the 9-story building, which was located 38 ft (11 m) from the cut, conformed closely with the settlement profile, as shown by the similarity of angular distortion measured at the ground surface and along the structure.
3. The building columns, founded on isolated footings, sustained a differential lateral displacement of the same magnitude as the differential settlement. Consequently, the horizontal building strains were approximately equal in magnitude to the angular distortion of the structure, both of which were approximately 0.2×10^{-3} to 0.3×10^{-3} (1/5000 to 1/3000).
4. The horizontal and diagonal tensile strains in the basement, caused by ground movement from the 60-ft (18-m)-deep excavation, were of the same order of magnitude as strains caused by thermal expansion and contraction due to seasonal temperature changes.
5. Building damage was minimal, consisting of several hairline fractures and the 0.01 in. (0.3 mm) opening of pre-excavation cracks. This cosmetic damage was located near the intersection of a stairwell and a basement wall, an area of marked differential stiffness between building elements. The damage was considered to be below the level of significant architectural damage.

5.3 SUMMARY OF CASE STUDY 2

Pair of two-story brick bearing wall structures above and adjacent to two 21-ft-diameter tunnels in soil (Chapter 3).

1. The settlement trough that developed above the tunnels exhibited a typical concave shape, with a zone of lateral compression near the center of the trough and a convex shape (hogging) with lateral extension in the outer portions of the trough. The average slope of the settlement trough beneath Building I was $1/230$, with maximum settlements of 1.6 in. (41 mm) at the center of the trough and 1.4 in. (36 mm) at the nearest corner of the building.
2. The structures settled and strained laterally in compliance with the ground movements. The structures did not appear to restrain the ground movements to any significant extent.
3. Some of the distortions during the development of the settlement trough are larger than the final distortions recorded. This is illustrated in Building I where the final lateral extension, $1/12500$, was less than the lateral extension of $1/3300$ during settlement trough development. It was observed that doors that became jammed during tunnel excavation would work normally after the tunnel excavation was completed. Locally, angular distortions during development of the settlement trough may have been greater than the final distortions. Reversals of curvature are often induced in buildings as the settlement trough develops, and can cause greater distortions than the final distortions.
4. The longitudinal settlement wave preceding the tunnel excavation was similar in shape and magnitude to one-half of the transverse settlement trough. The wave is transient, and thus structures

near the centerline of the tunnel may experience reversals of curvature and horizontal movement. In this case, it is also apparent that distortions measured subsequent to the passage of the settlement wave are less than those sustained by the structure while under the influence of the longitudinal settlement wave.

5. The final modes of deformation of the structures were directly related to the position of the structures relative to the settlement trough. For Building I, located primarily within the concave or bowl-shaped portion of the settlement trough, the predominant mode of deformation was due to angular distortion. The building width was equal to approximately $1/3$ the half width, w , of the settlement trough so that there was a significant rigid body rotation ($1/520$) of the building. This resulted in an angular distortion of $1/410$, that was less than the average slope of the settlement trough beneath the building ($1/230$). Because the building was located between the concave (sagging) and convex (hogging) portions of the trough, lateral extension was small ($1/12500$) and most of the distortions were shearing distortions. For Building II, located on the convex, or hogging, portion of the settlement trough, lateral extension was significant in causing building deformation [angular distortion = 0.5×10^{-3} ($1/2000$); lateral extension $1/3100$]. The convex bending produced larger lateral extensions ($1/1300$) in the upper floor. Most of the lateral extension was concentrated in one crack parallel to and immediately adjacent to the bearing wall nearest the center of the excavation. Larger lateral strains developed in the upper floor because the joists and facade walls between the bearing walls provided very little resistance to bending.

6. Small lateral strains between the bearing walls were observed to change the bearing length of the joist.
7. Cracking and damage in Building I was minor. The cracking and crack widening that did occur, approximately 1/32 in. (0.8 mm) to 1/16 in. (1.6 mm), was not significant owing to the poor initial condition of the structure. The cracking at the front of Building I can be attributed primarily to the angular distortion (1/410) of the structure.
8. Cracking and damage in Building II was caused primarily by the lateral extension and convex bending. A pre-existing vertical crack between the bearing wall and the facade wall in width from the basement to roof. (The bearing wall was almost parallel to the tunnel line.) The crack widened to about 1/8 in. (3 mm) in the basement and 1/4 in. (6 mm) at the second floor. The increased width in the upper floors resulted from the convex bending (hogging) at the edge of the trough. Daylight was visible through the crack at several locations. Nearly all of the lateral extension strain across the building was concentrated in this one crack.

5.4 SUMMARY OF ADDITIONAL CASE HISTORIES, CHAPTER 4

Three masonry structures, three to five stories high, two small brick walls; a six-story steel frame structure with masonry in-fill panels; and an isolated steel frame with no in-fill adjacent to either tunnels or open cuts; as noted in Table 4.1.

1. A frame structure with in-fill panels was able to withstand more angular distortions before the onset of damage than load bearing wall structures.

2. Distortion criteria for the onset of damage was highly dependent on the architectural finish of the structure.
3. The horizontal component of distortion alone can cause major cracking.
4. Detachment and buckling of facade wall claddings became serious problems before distortions sufficient to impair the structural capacity of the bearing walls have developed (Case D).
5. Structures that were short relative to the settlement profile tended to tilt as rigid bodies. On the other hand, structures that were long with respect to the settlement profile generally respond to differential settlements with angular and lateral distortions because rigid body rotation is restrained (Case E vs. Case D).
6. A single steel frame with no in-fill walls was able to withstand angular distortions in the vicinity of 6.7×10^{-3} (1/150) without structural damage (Case F).
7. Cases A and B (Table 4.1) also illustrate the following points about underpinning.
 - a. It is difficult to protect a structure with underpinning against the small movements, particularly lateral movements, that can cause minor architectural damage.
 - b. Installation of the underpinning can cause some cracking damage to the structure.
 - c. If the underpinning does not support all portions of a structure likely to undergo significant settlement, severe and very damaging local distortions may be induced in the structure. These distortions may be more severe than those that would occur if no underpinning is employed.

- d. The depth and construction procedure for underpinning should be such that settlements due to downdrag and tip disturbance are minimized.

5.5 GENERAL CONCLUSIONS

1. The structures at the two test sites were instrumented to measure settlement and tilt of the bearing walls and foundations. Both lateral and diagonal displacements were measured with tape extensometers extending between column lines and bearing walls at various floor levels in the structures. From this data, the slope of the settlement trough could be separated into the components causing angular distortion and tilt of the structure. Lateral extension, shearing, or bending distortions could also be distinguished from the data.

For the class of structures examined, the building tended to move with the ground and provided little resistance to the imposed foundation movements. However, variations in stiffness throughout some structures resulted in concentrations of damage and distortion at specific locations in the structure. Cracks generally occur first at the intersection of elements with different relative stiffnesses.

2. Building damage in response to adjacent braced cut excavation typically results from approximately equal magnitudes of angular and lateral distortion, as was observed at the first test section, a reinforced concrete building adjacent to a 60 ft deep braced cut. However, for settlements over a tunnel, the ratio of angular distortion to lateral extension strain varies throughout the width of the trough, as was observed for the two brick bearing wall buildings at the second test section.

3. At the second test section, a brick-bearing wall structure (Building (II)) was near the edge of the tunnel settlement trough, in the zone of "hogging" or convex curvature. It was subjected to lateral extension strains that increased in the upper floor levels due to the bending produced by the convex-shaped settlement profile beneath the building.

At the same test section, a brick bearing wall structure located nearer the center of the settlement trough (Building I), between the sagging and hogging portions, was subjected to final distortions that predominantly involved shearing displacements, with little to no lateral extension or bending in the upper stories. However, some lateral extension and bending developed temporarily as the leading edge of the settlement wave impinged on the structure.

4. The most useful relations between building damage and distortions can be established when both lateral strains and angular distortions are measured. The behavior of Building II described in paragraph 6, below, illustrates the relative influences of lateral strain and angular distortion. Some inferences on the lateral strains and distortions affecting structures can be made using the settlement slope data alone, if the settlement trough shape and the size and position of the structure with respect to the trough are known. The average slope of the settlement trough is a most useful parameter for estimating potential damage when the width of the structure is of the same order of, or is greater than, the $1/2$ width, w , of the settlement trough.
5. In general, data from the case studies agree with results presented in our previous report (O'Rourke, et al. 1976) for the relation between angular distortion and the onset of architectural damage:

1.3×10^{-3} (1/750) for frame structures with masonry in-fill panels. In many of these cases, lateral extension strains were of approximately the same order as the angular distortions. Angular distortion criteria alone is not sufficient where lateral strains are large with respect to the angular distortion. The data are also in general agreement with the angular distortion criteria for the onset of structural damage set forth by Skempton and MacDonald (1956) and Bjerrum (1963); 6.7×10^{-3} (1/150). Refer to Table 5.1.

6. Polshin and Tokar (1957), and Burland and Wroth (1975), employing the concept of critical tensile strain in their analyses, concluded that the critical tensile strain was in the range of 0.5×10^{-3} (1/2000) to 0.75×10^{-3} (1/1333). Damage criteria from the Coal Board of Great Britain were developed for mining subsidence cases in which the lateral strains are the predominant cause of structural distortion during mining subsidence. Their criteria for the onset of damage are compatible with lateral extension strains on the order of 1/1000. The results of the observations on brick bearing-wall building II (Chapter 3) are consistent with the published data on lateral strains. Although angular distortion (1/2000), and lateral extension at ground level (1/3300) were less than the typically accepted levels of damage, the combination of the two distortions produced a lateral extension of 1/1300 in the upper floor, which concentrated at a single crack, 1/4 in. in width immediately adjacent to the bearing wall. Larger lateral strains developed in the upper floor because the joists and facade walls in the building provided very little resistance to lateral extension between the bearing walls. Other experience with bearing wall structures indicates that more restraint may be provided in the upper stories by the joists so that the bending

1. The maximum value of the angular distortion, δ_V , and lateral distortion, δ_H , at the ground surface, shall be limited to the values given in Table 5.1.

TABLE 5.1
DAMAGE RELATED TO BUILDING DISTORTION
FOR BRICK-BEARING WALL STRUCTURES

Description of damage	*Angular, δ_V , and lateral, δ_H , distortion at the ground surface
Threshold of architectural damage	1.0×10^{-3} (1:1000)
Architectural damage; sticking doors may be conspicuous concentrations of cracks; cracks and separations as large as 1/8 to 1/4 in. (0.3 to 0.6 cm) wide	1.0×10^{-3} to 3.0×10^{-3} (1:1000 - 1:300)
Damage is an inconvenience to building occupants; jammed doors and windows; broken window panes; building services may be restricted. Cracks and separations may be as large as 1/2 to 1 in. (1.3 to 2.5 cm) wide, possible instability of minor structural elements such as door lintels	3.0×10^{-3} to 7.0×10^{-3} (1:300 - 1:150)
Spalling of stone cladding and possible collapse of cornices along the facade wall (differential movements parallel to brick-bearing walls)	7.0×10^{-3} to 8.0×10^{-3}

*Note: angular and lateral distortion are assumed to be approximately equal.

strains are reduced. Bearing walls perpendicular to the tunnel axis would tend to allow less bending in the upper stories than was experienced in Building II, whose bearing walls were almost parallel to the tunnel.

REFERENCES

1. Bjerrum, L., Discussion in Sect. VI, Proc. European Conf. on Soil Mech. and Found. Engr., Wiesbaden, Vol. II, pp. 135-137, 1963.
2. Boscardin, M. and T. D. O'Rourke, "Building Response to Ground Movements Caused by an 18-Meter-Deep Excavation," Conference on Large Ground Movements, Cardiff, Wales, 1977.
3. Breth, H., and G. Chambosse, "Settlement Behavior of Buildings Above Subway Tunnels in Frankfurt Clay," Proc., Conf. on Settlement of Structures, pp. 329-336, 1975.
4. Burland, J. B., and C. P. Wroth, "Settlement of Buildings and Associated Damage," Proc., Conf. on Settlement of Structures, pp. 611-654, 1975.
5. Burland, J. B., B. B. Broms, and V.F.B. de Milo, "Behavior of Foundations and Structures," STATE-of-the-art-Report, Vol. II, 9th Int'l. Conf. on Soil Mech. and Found. Engr., Tokyo, pp. 495-546, 1977.
6. Cording, E. J., A. J. Hendron, Jr., W. H. Hansmire, J. W. Mahar, H. H. MacPherson, R. A. Jones, and T. D. O'Rourke - Methods for Geotechnical Observations and Instrumentation in Tunneling, Report for the National Science Foundation, Research Grant GI-33644X, (1975), December.
7. Cording, E. J. and T. D. O'Rourke, "Excavation, Ground Movements and Their Influence on Buildings," Session 40, ASCE Annual Convention, San Francisco, 1977.
8. Cunningham, J. A., and J. I. Fernandez, "Performance of Two Slurry Wall Systems in Chicago," Proc. ASCE Specialty Conf. on Perf. of Earth and Earth-Supported Structures, Purdue, Vol. I, Part 2, pp. 1425-1449, 1972.
9. Grant, R., J. T. Christian, and E. H. Vanmarcke, "Defferential Settlement of Buildings," Journ., Geot. Engr. Div., ASCE, Vol. 100, GT9, pp. 973-991, 1974.
10. Hansmire, W. H. and E. J. Cording, "Field Measurements of Ground Displacements About a Tunnel in Soil," National Technical Information Service, Springfield, Virginia, September 1975.
11. Jaworski, W. E., "An Evaluation of the Performance of a Braced Excavation," Ph.D. Thesis, Massachusetts Institute of Technology, 1973.
12. Kerisel, J., "Old Structures in Relation to Soil Conditions," Geotechnique, Vol. 25, No. 3, pp. 433-483, 1975.
13. Littlejohn, G. S., "Observations of Brick Walls Subjected to Mining Subsidence," Proc., Conf. on Settlement of Structures, pp. 384-393, 1975.

14. MacPherson, H. H., J. W. Critchfield, S. W. Hong, and E. J. Cording, "Settlements Around Tunnels in Soil: Three Case Histories," University of Illinois Report for U.S. Department of Transportation, UMTA-IL-06-0043-78-1, 1976.
15. Maynard, T. R. and T. D. O'Rourke, "Soil Movement Effect on Adjacent Public Facilities," ASCE Annual Convention, San Francisco, 1977.
16. Meyerhof, G. G., "Discussion on paper by A. W. Skempton and D. H. MacDonald," The allowable settlements of buildings, Proc. Inst. Civ. Engrs., Part II, Vol. 5, pp. 774, 1956.
17. O'Rourke, T. D., "A Study of Two Braced Excavations in Sands and Interbedded Stiff Clay," Ph.D. Thesis, University of Illinois, 1975.
18. O'Rourke, T. D., E. J. Cording, and M. Boscardin, "The Ground Movements Related to Braced Excavation and Their Influence on Adjacent Excavation," University of Illinois Report for U. S. Department of Transportation, DOT-TST-76T-22, 1976.
19. Peck, R. B., "Deep Excavation, and Tunneling in Soft Ground," Proc. 7th Int'l Conf. on Soil Mech. and Found. Engr., Mexico City, State-of-the-Art Vol., pp. 225-290, 1969.
20. Polshin, D. E., and R. A. Tokar, "Maximum Allowable Non-Uniform Settlement of Structures," 4th Int'l. Conf. on Soil Mech. and Found. Engr., Vol. 1, pp. 402-405, 1957.
21. Priest and Orchard, "Recent Subsidence Research," Transactions, Institution of Mining Engineers, Vol. 117, pp. 503-512, 1957-1958.
22. Skempton, A. W. and D. H. MacDonald, "The Allowable Settlement of Buildings," Proceedings, Institute of Civil Engineers, Vol. 5, Part III, pp. 727-784, 1956.
23. Subsidence Engineer's Handbook, National Coal Board Mining Department, London, 1975.
24. St. John, H. D., "Field and Theoretical Studies of the Behavior of Ground Around Deep Excavations in London Clay," Ph.D. Thesis, Cambridge University, 1975.
25. Wong, I. H., "Analysis of Braced Excavation, Ph.D. Thesis, Massachusetts Institute of Technology, 1971.

APPENDIX A

GROUND MOVEMENTS DUE TO UNDERGROUND CONSTRUCTION

To initiate a study of the behavior of structures adjacent to excavations knowledge of the general pattern and development of ground movements around an excavation is necessary. For purposes of discussion, excavations may be separated into three broad categories; braced excavations, tunnels, and mines. Each of these categories may be characterized by typical patterns and developments of the ground movements. The following are brief descriptions of the ground movements commonly encountered around braced excavations, tunnels, and mines.

A.1 MOVEMENTS DUE TO BRACED EXCAVATION

Ground movements around a braced cut are generally caused by lateral movement at the wall as the cut is excavated downward. A settlement wave tends to extend outward as the cut is deepened (Fig. A.1a). As a result, a structure may be progressively subjected to angular distortions equal to the maximum distortion as the settlement wave extends outward. However, if most of the movement develops near the bottom of the cut, such as when a soft layer having a high ratio of $\gamma H/S_u$ is encountered at depth, a structure that falls within the settlement slope will tilt and undergo an angular distortion less than the settlement slope. In one case, in a stiff fissured and slickensided clay, large displacements developed after the cut reached sub-grade, causing an abrupt offset at the ground surface at a distance from the wall of the cut approximately equal to the cut depth. Significant cracking occurred in houses straddling the offset, while structures closer to the cut settled, but were not distorted or damaged.

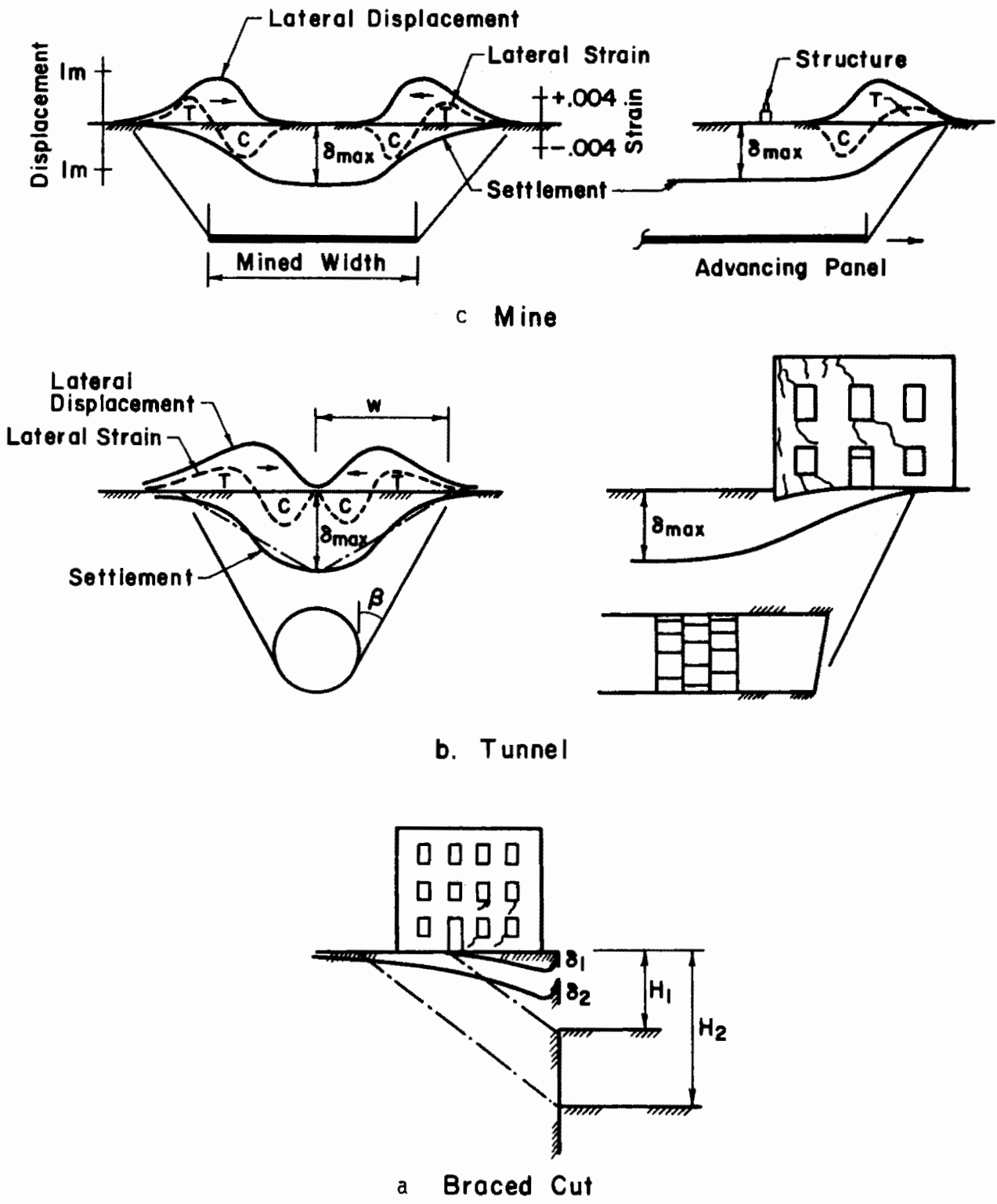

FIGURE A.1 DISTORTIONS DUE TO MINING, TUNNELING, AND BRACED EXCAVATION

TABLE A.1 SUMMARY OF SETTLEMENT SLOPES AND LATERAL STRAINS

	Distance From Edge of Excavation	Average Slope	Maximum Slope	Lateral Strain
Dense, sand and gravel, inter- bedded stiff clay	0 to 1H	δ_{\max}/H (1.5 to 3×10^{-3})	3 to 5×10^{-3}	$\delta_{\max}/2H$ to δ_{\max}/H (1.0 to 3×10^{-3})
	1H to 1.5H		0 to 1×10^{-3}	
Soft clay, Chicago Zone I	0 to 1.5H	$\delta_{\max}/1.5H$ (3 to 6×10^{-3})	9×10^{-3}	$\delta_{\max}/3H$ to δ_{\max}/H (3 to 9×10^{-3})
Zone II	0 to 1.5H	$\delta_{\max}/1.5H$ (6 to 12×10^{-3})	15×10^{-3}	6 to 18×10^{-3}
	1.5 to 2.5H		0 to 3×10^{-3}	

Table A.1 summarizes typical settlement slopes and lateral strains observed for braced excavations in dense sand and gravel and interbedded stiff clay in the Washington, D. C. area, and in soft clays in Chicago. (It should be noted that the settlement slopes and lateral strains for a given cut will be strongly dependent on the construction procedure and the effective wall and bracing stiffness. The depth excavated below strut levels, and the size of berms have a significant influence on ground movement).

At the ground surface at a distance of approximately 0.3 to 1.5H behind a braced cut, lateral displacements typically range from 0.5 to 1.5 times the vertical settlement. The ratio of lateral to vertical settlement tends to be lower for the bulging movements of a cut wall and higher for cantilever movements of a cut wall (O'Rourke, et al., 1976).

A.2 MOVEMENTS DUE TO TUNNELING

A single tunnel causes both a traveling wave in the longitudinal direction and a subsidence trough the transverse direction (Fig. A.1b). When the width of the structure is of the same order as the depth of the tunnel, the structure will be subject to angular distortions that are of approximately the same magnitude as the slope of the settlement trough. In this case, then, the settlement slopes can be related to damage.

Cording and Hansmire (1975) recommend that the average slopes of the settlement trough δ_{\max}/w , where w is the defined width of the trough, be used as an index to the damage over a tunnel. Breth and Chambosse (1975) observed the settlement of three five-story structures during driving of tunnels in Frankfurt. The slope of the building foundations depended on the position of the structure within the trough, but were typically of the

same order as or less than the average slope of the trough. They observed that concrete frame structures were not damaged for slopes flatter than 1:450. Kerisel (1975) suggests that old masonry structures are sensitive to the radius of curvature of the settlement trough. (Curvature would be inversely proportional to w^2/δ_{\max}). In general, local curvatures of the soil settlement trough are not as significant as the angular distortion, because of the ability of a structure to bridge or level out local small curvatures. Practically, curvature is difficult to measure accurately because of scatter in the settlement data and the relatively wide spacing of settlement points across the settlement trough.

Structures located near the edge of the settlement trough may undergo appreciable lateral strains as well as some angular distortion. Maximum separations may be observed in this area and may cause as much damage as occurs for a structure over the tunnel.

A.3 MOVEMENTS DUE TO MINING

Distortions due to mining subsidence, where deep long wall mining (full seam extraction) is carried out, provide an indication of behavior at a scale not observed in braced excavations because the depth of the mine and the width of the excavated seam is very large with respect to the width of a structure. Settlements may ultimately total several feet, and will cause the structure to tilt but will cause a very small change in slope across the structure, hence only small angular distortions (Fig. A.1a). The lateral strains, therefore, are the predominant factor influencing damage.

Damage has been correlated with the length of the structure times the lateral strain by Priest and Orchard (1958) and the National Coal Board of Britain (1975). It was observed that strains across larger structures

were concentrated at local weak areas of the structure, so that the wider the structure, the greater the sum of the strains and the potential compression or separation at a weakness.

Most dwelling houses, except long row houses, can absorb strains of 1.0 to 1.5×10^{-3} , and the damage is largely superficial -- such as cracking of plaster. With strains of 2.5 to 3.5×10^{-3} , serious structural damage can be caused even to isolated properties (The Mining Engineer, April, 1961). Priest and Orchard (1958) describe the effects of mining beneath a 14th century church. Mining sequences were controlled in order to keep lateral extension strains to less than 0.8×10^{-3} (1/1250) and compressive strains to less than 2×10^{-3} (1/500). Observed strains were at the levels anticipated and caused binding of a door, minor cracks in wall plaster in the transepts and between the stone floor slabs, and opening of a fracture to 1/8 in. and then closure within a period of three months.

Littlejohn (1975) observed that lateral strains of 0.25×10^{-3} (1/4000) due to mining subsidence caused visible cracks in a brick wall. However, the cracks were observed as part of a systematic surveillance program and were only 0.004 to 0.010 in. wide. Such cracks would not normally be noted by building occupants and therefore would represent an excessively severe criterion as a threshold for architectural damage. Ploshin and Tokar (1957) note a critical tensile strain of 0.5×10^{-3} as the limit for observable cracking of masonry and concrete walls.

