

~~Research~~
Library

The Status of
Advanced Propulsion Systems
for Urban Rail Vehicles



RECEIVED
AUG 1 1979
LIBRARY.

MAY 1979

Document is Available to the U. S. Public
Through The National Technical Information
Service, Springfield, Virginia 22161

Prepared for

U. S. Department of Transportation
Urban Mass Transportation Administration
Office of Technology Development & Deployment
Office of Rail and Construction Technology
Washington, D. C. 20590

F
55
N36
.1

RECEIVED
AUG 1 0 1979
LIBRARY.

NOTICE

This document is disseminated under the sponsorship of the Department of Transportation in the interest of information exchange. The United States Government assumes no liability for its contents or use thereof.

NOTICE

The United States Government does not endorse products or manufacturers. Trade or manufacturers' names appear herein solely because they are considered essential to the object of this report.

1. Report No. UMTA-VA-06-0053-79-1		2. Government Accession No.		3. Recipient's Catalog No.	
4. Title and Subtitle THE STATUS OF ADVANCED PROPULSION SYSTEMS FOR URBAN RAIL VEHICLES				5. Report Date May 1979	
				6. Performing Organization Code MTR-79W0022	
7. Author(s) V. D. Nene				8. Performing Organization Report No.	
9. Performing Organization Name and Address The MITRE Corporation 1820 Dolley Madison Boulevard McLean, Virginia 22101				10. Work Unit No. (TRAIS) VA-06-0053	
				11. Contract or Grant No. DOT-UT-9002	
12. Sponsoring Agency Name and Address U.S. Department of Transportation Urban Mass Transportation Administration 400 Seventh Street, S.W. Washington, D. C. 20590				13. Type of Report and Period Covered Final Technical Report Oct. 1978 - May 1978	
				14. Sponsoring Agency Code UTD-30	
15. Supplementary Notes					
16. Abstract <p>Rheostatic control of dc traction motors has been in use for several decades. With the advent of power electronics, however, more efficient alternate propulsion systems have been developed. These include chopper controls, ac drive with induction motors, systems using onboard energy storage and ac drive with tubular axle motors. Of these concepts, chopper controllers have been in regular revenue service for several years while others are still under prototype testing.</p> <p>This report describes in detail the status of all these propulsion systems. The performance characteristics, the significant advantages and disadvantages and the deployment of the hardware in revenue service for all these systems is discussed. The report concludes with a general description of alternate traction motors and power converters.</p> <p>This report is a technology review of advanced traction systems. It is based on information and data gathered from propulsion equipment suppliers in Europe, Japan, and the United States.</p>					
17. Key Words Propulsion Systems AC Drives Traction Systems Choppers Power Electronics Motors Urban Rail Vehicles			18. Distribution Statement Available to the Public through the National Technical Information Service, Springfield, Virginia 22161.		
19. Security Classif. (of this report) Unclassified		20. Security Classif. (of this page) Unclassified		21. No. of Pages 213	22. Price

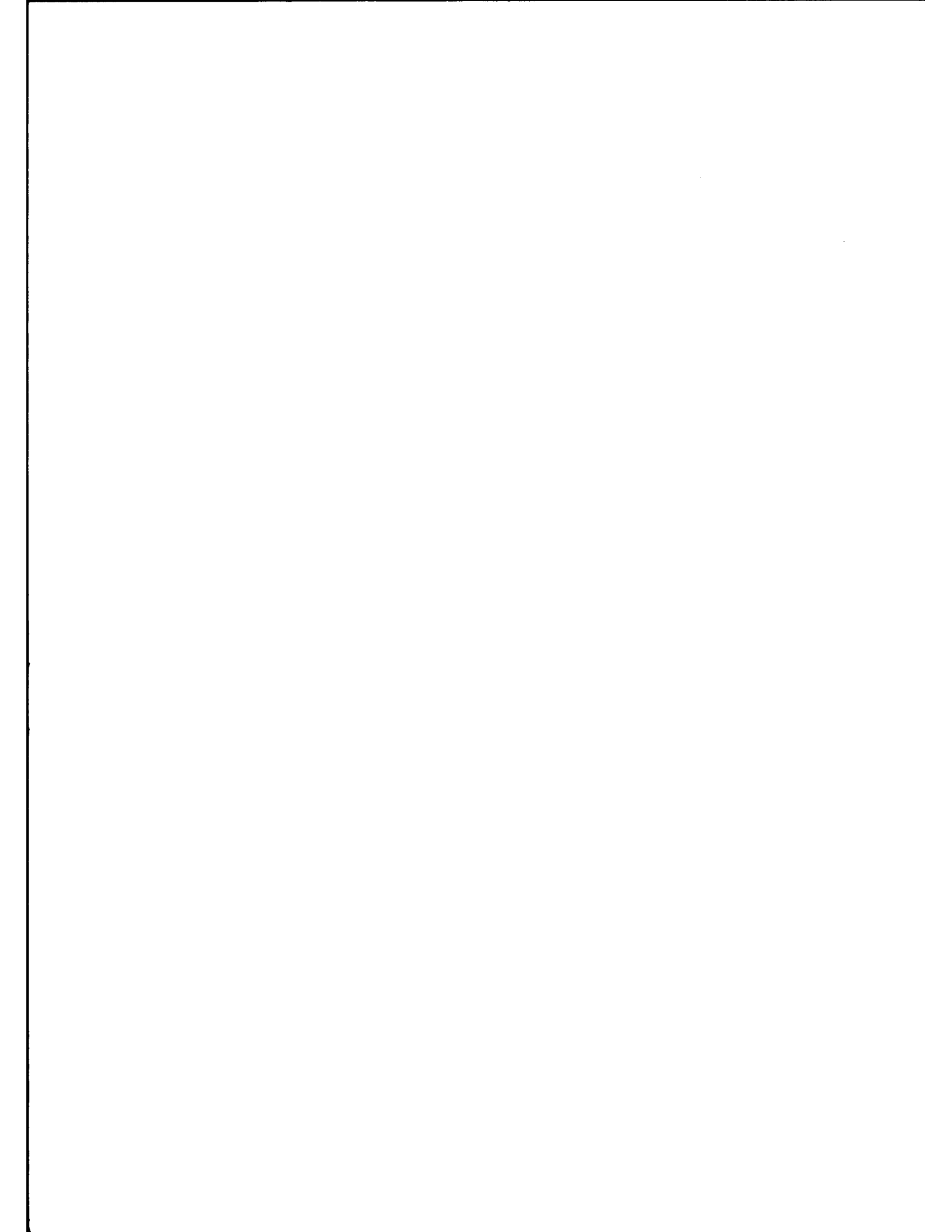

MITRE Technical Report
MTR-79W00022

The Status of Advanced Propulsion Systems for Urban Rail Vehicles

Interim Report

Vilas D. Nene

February 1979

Contract Sponsor: UMTA
Contract No.: DOT-UT 90002
Project No.: 12490
Dept. W-23

The MITRE Corporation
Metrek Division
1820 Dolley Madison Boulevard
McLean, Virginia 22102

01961

TF
455
.N36
c.1

ABSTRACT

Rheostatic control of dc traction motors has been in use for several decades. With the advent of power electronics, however, more efficient alternate propulsion systems have been developed. These include chopper controls, ac drive with induction motors, systems using onboard energy storage and ac drive with tubular axle motors. Of these concepts, chopper controllers have been in regular revenue service for several years while others are still under prototype testing. This interim report describes in detail the status of all these propulsion systems. The performance characteristics, the significant advantages and disadvantages and the deployment of the hardware in revenue service for all these systems is discussed. The report concludes with a general description of alternate traction motors and power converters. The final version of this report will include - similar assessment of the status of linear motor propulsion systems, monomotor and radial trucks and a summary of other propulsion activities in the area of high speed ground transportation.

ACKNOWLEDGEMENT

The author wishes to express his sincere thanks for the total access to the technical information extended to him by the following companies and organizations. He would also like to thank many of these organizations for the welcome extended to him during his visits and the long hours spent by their technical people during these visits.

These are: In the U.S. - GE, Westinghouse, and Garrett Corporation, NYCTA and BART. In Europe - ASEA (Sweden), Stromberg (Finland), BBC, Siemens and AEG (Germany), Alsthom (France), The French National Railways (SNCF), and the Railway Technical Center of the British Rail (U.K.). In Japan - Mitsubishi, Hitachi and Fuji Corporation.

Such a status report is clearly impossible without such cooperation.

The author also would like to thank Mr. H. Lee Tucker of the U.S. DOT/UMTA for his continued interest and support for this work.

Thanks are also due to Mr. Carl Swanson of the MITRE Corporation for carefully going through the manuscript and making very valuable suggestions.

TABLE OF CONTENTS

	<u>Page</u>
LIST OF ILLUSTRATIONS	vii
LIST OF TABLES	xiii
GLOSSARY	xiv
1.0 INTRODUCTION	1
2.0 PROPULSION EQUIPMENT WITH A CAM CONTROLLER	2
2.1 Starting and Motoring Operation	2
2.2 Braking Operation	4
2.3 Types of Cam Controllers	5
2.4 Energy Consumption	12
3.0 CHOPPER CONTROLLED PROPULSION EQUIPMENT	17
3.1 Operation of a Chopper Controller	18
3.2 Deployment of Chopper Controllers	21
3.3 Field Control of Traction Motors	32
3.4 Energy Savings by Regeneration	35
3.5 Advanced Cooling Methods	40
3.6 Use of a Microprocessor	45
4.0 AC DRIVES USING INDUCTION MOTORS	47
4.1 AC Drives for Locomotives	48
4.2 Urban Vehicles	53
4.3 Effect of Unequal Wheel Diameters	66
5.0 AN AC DRIVE WITH A SYNCHRONOUS MOTOR	70
5.1 A Self-Synchronous Propulsion System	70
5.2 Propulsion System Specifications	72
5.3 System Components	73
5.4 Test Results	77
5.5 A Locomotive Application	83
6.0 PROPULSION SYSTEM WITH ONBOARD ENERGY STORAGE	84
6.1 R-32 Energy Storage Car for NYCTA	86
6.2 ACT-1 Propulsion System	92
6.3 Improved Propulsion System for R-36 Cars of NYCTA	98
6.4 Noise and Vibrations	98
6.5 Additional Maintenance	98
6.6 Gyroscopic Effects	101

TABLE OF CONTENTS (concluded)

	<u>Page</u>
7.0 TUBULAR AXLE INDUCTION MOTOR	102
7.1 Motor Design	102
7.2 Inverter Design	103
8.0 CONCLUSIONS	109
LIST OF REFERENCES	113
APPENDIX I - DIFFERENT TYPES OF TRACTION MOTORS	119
APPENDIX II - POWER CONVERSION DEVICES	171

LIST OF ILLUSTRATIONS

<u>FIGURE NUMBER</u>		<u>PAGE</u>
1	Starting and Motoring Circuit	3
2	Braking Circuit	6
3	Load Sharing Between Two DC Generators	7
4	Typical Braking Characteristics	8
5	A Camshaft System	8
6	A Cam Controller	9
7	A Contactor	10
8	Typical Resistor Assembly	13
9	Energy Flow for Rheostatic Control	14
10	WMATA Car	15
11	Voltage Control by a Chopper	19
12	A Chopper Controller	20
13	BART Car	23
14	Subway Car of Type C9	24
15	A Thyristor Module	24
16	Complete Chopper Equipment	26
17	Articulated Tramcar	26
18	Trolleybus with Chopper Control	27
19	Wuppertal Suspension Railway	30
20	MF77 Cars of Paris Metro	30
21	Three-Coach Unit of Lyons Metro	31
22	Monomotor Truck - Lyons Metro	31

LIST OF ILLUSTRATIONS (continued)

<u>FIGURE NUMBER</u>		<u>PAGE</u>
23	Automatic Variable Field Control	33
24	Field Control by a Modified Shunt	36
25	Equivalent Circuits	37
26	Field Current Waveform	38
27	Field Weakening Ratio	38
28	Energy Flow for Regenerative Chopper	41
29	Freon Cooling Systems	43
30	Heat Transfer Characteristics	44
31	DE 2500 Locomotives with AC Drive	49
32	All Electric Locomotive with AC Drive	51
33	Dual Frequency Industrial Locomotive	51
34	Other Locomotives with AC Drive	52
35	Power Circuit of VL 80K	54
36	WABCO Propulsion System	55
37	Three Modes of Motor Operation	56
38	A Coach-Pair of Series M100	59
39	The Main Circuit of M100	59
40	Berlin Subway Vehicle with AC Drive	61
41	The Main Circuit Diagram	61
42	Twin Motor Unit of Squirrel Cage Traction Motors	64
43	AC Drive by Siemens	64
44	Pulsed Mode of Inverter Operation	68

LIST OF ILLUSTRATIONS (continued)

<u>FIGURE NUMBER</u>		<u>PAGE</u>
45	Effect of Unequal Wheel Diameters	68
46	System Block Diagram - Motoring Mode	71
47	Line Filter	74
48	Dual Inductor Assembly	74
49	Inverter Circuit	75
50	Capacitor Module Circuit Diagram	76
51	Cycloconverter Power Circuit	78
52	AC Traction Motor	78
53	Motoring/Braking Test Results	79
54	Torque-Speed Characteristics for Constant Inverter Frequencies	80
55	Comparison of Braking Performance	81
56	Use of Onboard Energy Storage	85
57	R-32 Energy Storage Unit	87
58	Propulsion System Schematic	88
59	Power Flow During a Typical Run	91
60	Energy Savings by Onboard Flywheel System	93
61	Typical Energy Flow of a Flywheel Car	94
62	ACT-1 Energy Storage Unit	96
63	ACT-1 Vehicle	97
64	ACT-1 Propulsion System Schematic	99
65	R-36 Propulsion System Schematic	99
66	ESU for R-36	100

LIST OF ILLUSTRATIONS (continued)

<u>FIGURE NUMBER</u>		<u>PAGE</u>
67	Speed Torque Characteristics	104
68	Partially Wound TAIM Primary and the Axle	104
69	Completed TAIM Primary	105
70	Squirrel Cage Secondary in the Hollow Axle	105
71	Completely Assembled TAIM	106
72	TAIM Mounted on a Vehicle	106
73	New TAIM Design	108
74	British Rail Research Vehicle	108
75	Essential Components of a DC Motor	120
76	DC Motor Schematic	121
77	Airgap Flux Distribution in a DC Machine	121
78	Current Reversal During Commutation	122
79	DC Motor with Interpoles and Compensating Windings	124
80	DC Motor Field Structure and Windings	125
81	Armature and Commutator of a DC Motor	126
82	The Brushgear	127
83	Methods of Field Excitation	128
84	Starting of a DC Motor	130
85	Speed Control of a DC Motor	131
86	Essential Components of an Induction Motor	135
87	A Squirrel Cage Rotor	136
88	Induction Motor Windings	139

LIST OF ILLUSTRATIONS (continued)

<u>FIGURE NUMBER</u>		<u>PAGE</u>
89	Equivalent Circuit	139
90	Torque and Current as a Function of Slip	141
91	Power Factor and Efficiency of Induction Motor	143
92	Speed Control for Traction Applications	145
93	Synchronous Motor Schematic	148
94	Synchronous Motor Phasor Diagrams	150
95	Use of Rotating Transformer/Rectifier	154
96	Synchronous Reluctance Motor	157
97	Vernier Motor	157
98	Doubly Slotted Structure of Vernier Motor	158
99	Homopolar Inductor Motor	162
100	Two Rotor Cores	163
101	Airgap Flux Density Distributions	164
102	Rice Motor	166
103	Lundell Motor	168
104	Operating Principle of a Chopper	173
105	Chopper Circuit and its Response	175
106	Different Modes of Chopper Operations	177
107	Chopper Commutation	177
108	Filter Response	178
109	Multi-Phase Chopper	179
110	Three Phase Bridge Rectifier	183

LIST OF ILLUSTRATIONS (continued)

<u>FIGURE NUMBER</u>		<u>PAGE</u>
111	Rectifier Operation for $\alpha = 30^\circ$	184
112	Rectifier Operation for $\alpha = 150^\circ$	185
113	Rectifier Output	186
114	Inverter Phasor Diagram	187
115	A Forced Commutated Single Phase Inverter	189
116	Currents During Commutation	189
117	Auxiliary Impulse-Commutated 3-Phase Inverter	191
118	Output Voltage, Line to Line of a Three-Phase Inverter	192
119	Use of a Single Inverter	194
120	Use of Multiple Inverters	195
121	Voltage Waveforms	197
122	Output Voltage with Four Added Commutations Per Half Cycle	197
123	Output Voltage for Different Phase Difference	201
124	Output Voltages with Many Commutations Per Half Cycle	204
125	Simplified Inverter Circuit	206
126	Two Quadrant Operation	209
127	Four Quadrant Operation	209
128	Cycloconverter Operation	210
129	Cycloconverter Waveforms	211
130	Three Phase Cycloconverter	213

LIST OF ILLUSTRATIONS (concluded)

<u>FIGURE NUMBER</u>		<u>PAGE</u>
131	Full Wave Three Phase Circuit	214

LIST OF TABLES

<u>TABLE NUMBER</u>		<u>PAGE</u>
I	Synchronous Machines	152
II	Synchronous Motors	169
III	Fundamental Amplitude Control by Varying α_1 and α_2	199
IV	Elimination of the Fifth and Seventh Harmonics	200
V	Multiple Inverter Control with Elimination of the Third and Fifth Harmonics	203

GLOSSARY

Acronyms

BART	Bay Area Rapid Transit, San Francisco, California
CTA	Chicago Transit Authority, Chicago, Illinois
GCRTA	Greater Cleveland Regional Transit Authority, Cleveland, Ohio
MARTA	Metropolitan Atlanta Rapid Transit Authority, Atlanta, Georgia
MBTA	Massachusetts Bay Transportation Authority, Boston, Massachusetts
MUNI	San Francisco Municipal Railway, San Francisco, California
NYCTA	New York City Transit Authority, New York, New York
RATP	Regie Autonome des Transports Parisiens, Paris France
SNCF	Societe Nationale Des Chemins de Fer, Paris, France
WMATA	Washington Metropolitan Area Transit Authority, Washington, D. C.

1.0 INTRODUCTION

This report summarizes the status of advanced propulsion concepts required for the ASDP Propulsion Assessment Study (Task 2, State-of-the-Art Assessment). The assessment covers the technical performance, reliability, maintainability, safety features and deployment status of traction systems using chopper controlled dc motors, three phase induction motors, self-synchronous motors, flywheel energy storage systems, and tubular axle motors.

DC series motors have been used as traction motors almost exclusively since the early days of electric propulsion of rail vehicles. This is because the torque-speed characteristic of the motor is extremely well-suited for traction applications and the speed can be controlled very easily by using series/parallel connections of several motors or by using external resistances. Inherent inefficiency of the rheostatic control and excessive maintenance costs for the commutator of the traction motor are the two major problems associated with this conventional traction technology. Recent advances in thyristor technology have made it possible to develop new efficient traction systems requiring less maintenance, with a reduction of overall life-cycle costs. Chopper control of dc motors and pulse-width modulated inverter control of induction motors are two examples. Other concepts include hybrid systems using flywheel energy storage, tubular axle motors, and ac self-synchronous motors. Thus, the technical problems that are of the greatest concern to rapid rail transit operators can be addressed by this existing technology, resulting in improvements that can be deployed to transit properties in the near term.

This report is a technology review of these advanced traction systems. It is based on information and data gathered from propulsion equipment suppliers in Europe, Japan and the U.S.

2.0 PROPULSION EQUIPMENT WITH A CAM CONTROLLER

Speed control of dc traction motors over a wide range essentially involves "armature control" for speeds below the base speed and "field control" for speeds above the base speed. The classical method is rheostatic control, accomplished by using external resistances in series with armature and in parallel with the field winding. By controlling these resistances, one can control both the armature current and the field current of the motor. In a transit car, armature control can also be achieved by series/parallel connections of the four traction motors on the car. With a cam controller, this rheostatic control is obtained by means of contactors actuated by a shaft. Although pneumatically operated cams were introduced as early as almost 60 years ago, cam control with an electric motor driven camshaft has been in use since early 1950's. (1-4)

2.1 Starting and Motoring Operation

The simplified circuit diagram of Figure 1 shows how the traction motors I-IV are controlled during starting and motoring operation. Contactors 6-19 are used to insert the appropriate resistances in the circuit. If the switches 1, 2, 3 and 6, 9 are closed, the four traction motors are in series and the starting resistance in the circuit is maximum. If, however, 1, 3, 4, 5 and 6, 9 are closed, the motors are in a series-parallel connection, where the motors I and II are in series with each other and they are in turn parallel to the series connection of the motors III and IV. After the starting resistors are shorted, this series-parallel connection is the final operating connection for motoring region. The field weakening is then achieved at high speeds by shunting the field as required by closing the appropriate contactor from contactors 12-19. It should be seen here that even a simple control as described above requires the use of several contactors.

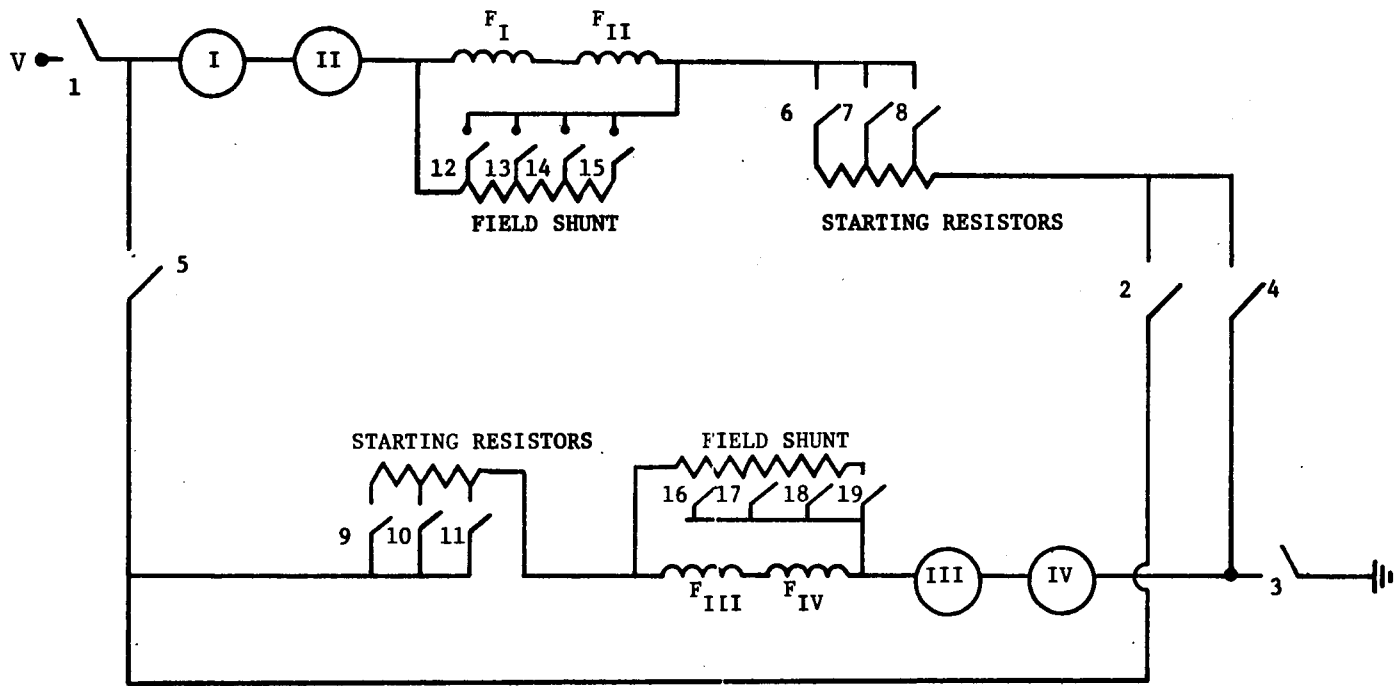

3

FIGURE 1
STARTING AND MOTORING CIRCUIT

2.2 Braking Operation

In general, two modes of braking operation are possible when the kinetic energy of the car is converted to electrical energy by using the traction motors as generators. In the regenerative braking mode electrical energy is in part returned to the source voltage; in a dynamic braking mode the electrical energy is dissipated in braking resistors. The following considerations, however, tend to limit the regeneration capability of rheostatic control:

- a. Voltage rise on the third rail: Whenever energy is fed back to the system, the traction motor has to generate voltages higher than the voltage of the third rail. The voltage difference required depends on the impedance between traction motor as a source and the wayside system as a sink of the energy being transferred. Because of the characteristics of the existing wayside and onboard equipment, the maximum voltage to which the system could be subjected during regeneration is severely limited.
- b. Stepped Control: The cam controller switches a finite number of resistances in and out of the armature and the field circuit as required. The control, therefore, is stepped and not smooth. Hence, the motor voltage cannot be continuously matched with the braking requirements.

Considering all the factors involved, use of regenerative braking with cam controllers cannot be economically justified for retrofitting existing transit systems or on new systems. One can, however, add static controllers to obtain regenerative braking of the traction motors on a cam controlled car. In such a system all the traction motors can be connected in series while their fields are separately excited to control the braking action. Braking is smooth because of the solid state control and it can be seen that it is no longer "cam controlled" in the true sense of the words. Such a system is, in fact, in use on commuter cars in Australia.

For dynamic braking, the traction motors operate as dc generators, converting the kinetic energy of the vehicle to electrical

energy that is dissipated in braking resistors. The braking force is controlled by controlling the braking resistor and by field shunting. Figure 2 shows such an operation. Here motors I and II are connected in series, and these in turn are connected in parallel to motors III and IV in series. Whenever two sources are connected in parallel to feed a load, the load sharing depends on the loading characteristics - the regulation of these sources. For example, Figure 3(a) shows two dc generators feeding power into the load. The V-I characteristics of these two generators are shown in Figure 3(b). For any load voltage V_L , the load on each generator can be obtained as shown in the figure. For dc generators, equal load sharing can be ensured by cross-connecting the field windings - the field winding of 1 being excited by the armature current of 2 and vice versa. Under these conditions, the V-I characteristic of each generator is controlled by the load on the other as shown in Figure 3(b) and the load current is shared equally between the two generators. This is precisely why the field windings in Figure 2 are cross-connected for dynamic braking. A set of typical braking force characteristics are shown in Figure 4.

2.3 Types of Cam Controllers

Figure 5 shows a simplified camshaft system with a camshaft driven by an electric motor through a gear box. The star wheel enables accurate and quick positioning of camshaft in each step. Further details of the cam controller are shown in Figure 6 and a contactor is shown in Figure 7.

Smoothness of control, response time and retrogression capability are some of the important characteristics of a cam controller. A cam control is essentially a stepped control and hence, smoothness of control is directly related to the number of steps or notches in the control. A large number of notches results in a longer camshaft. The

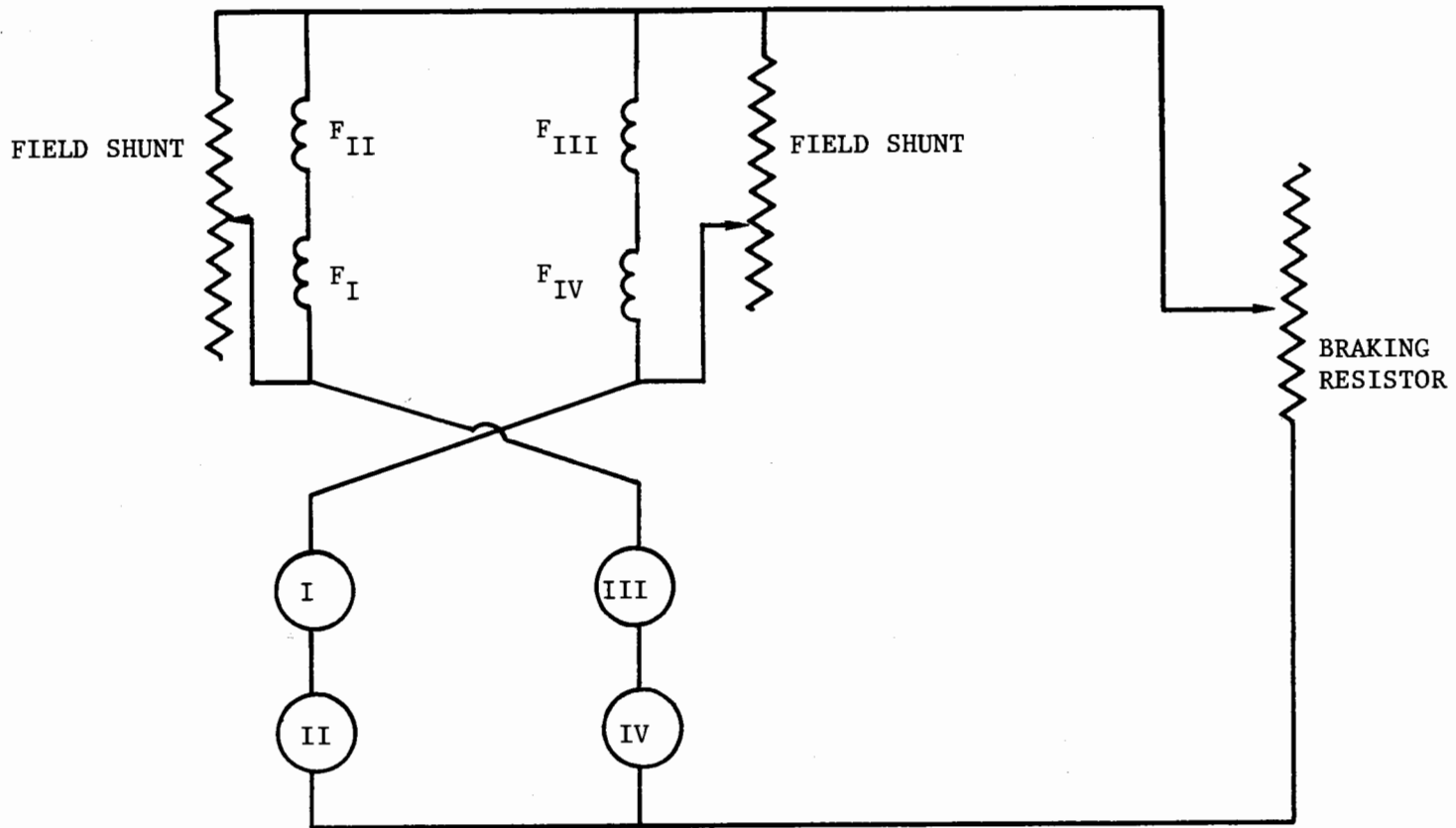

9

FIGURE 2
BRAKING CIRCUIT

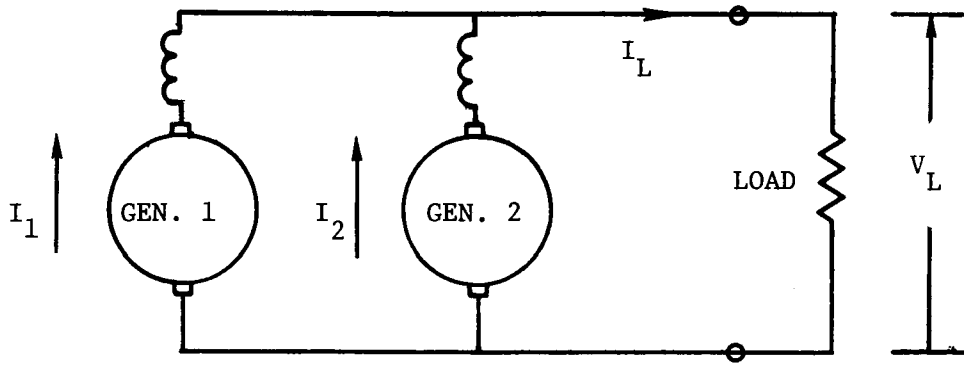

(a) Electrical Circuit

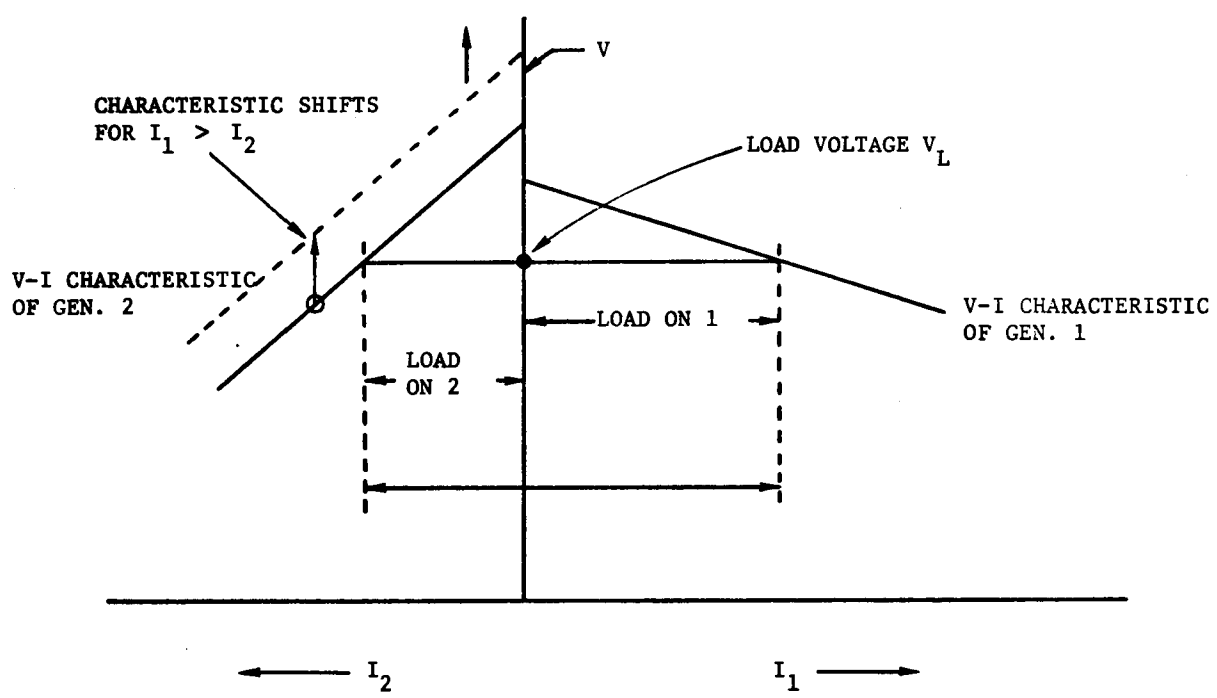

(b) Regulation Characteristics

FIGURE 3
LOAD SHARING BETWEEN TWO DC GENERATORS

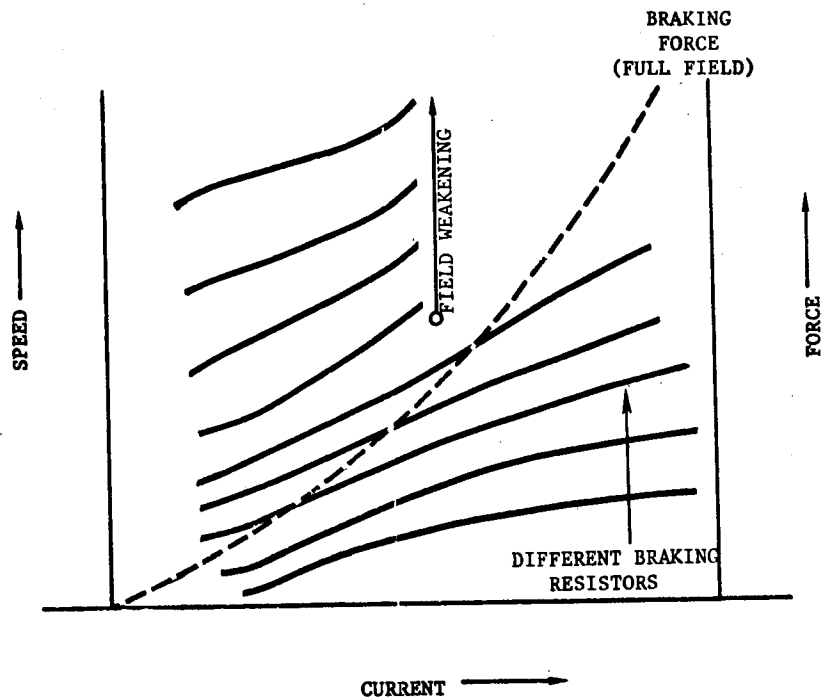

FIGURE 4
TYPICAL BRAKING CHARACTERISTICS

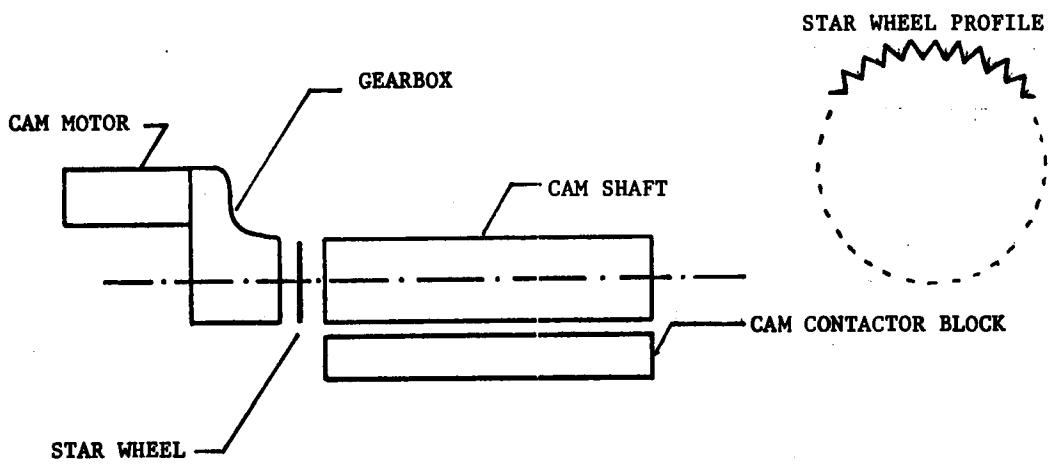

FIGURE 5
A CAMSHAFT SYSTEM

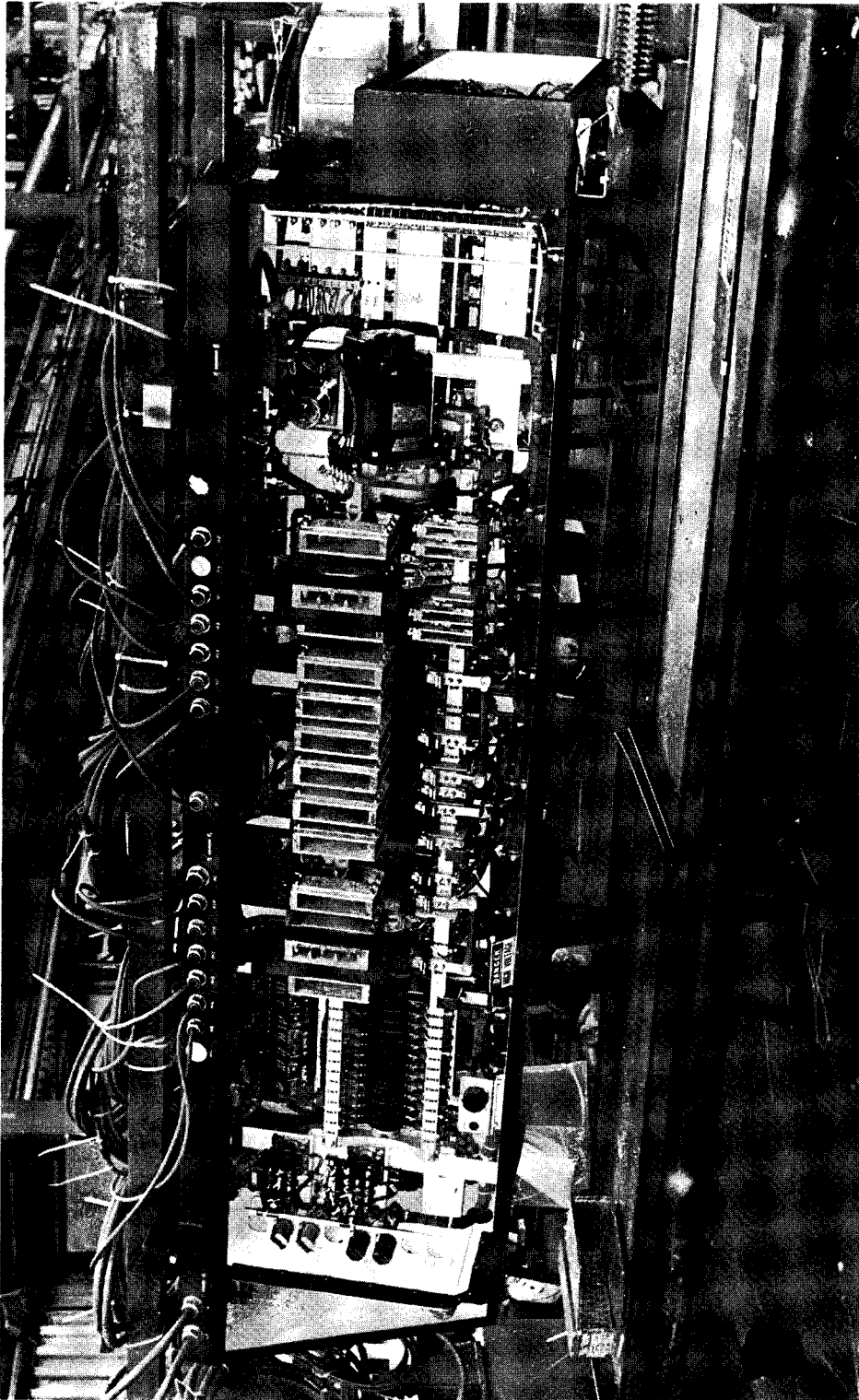
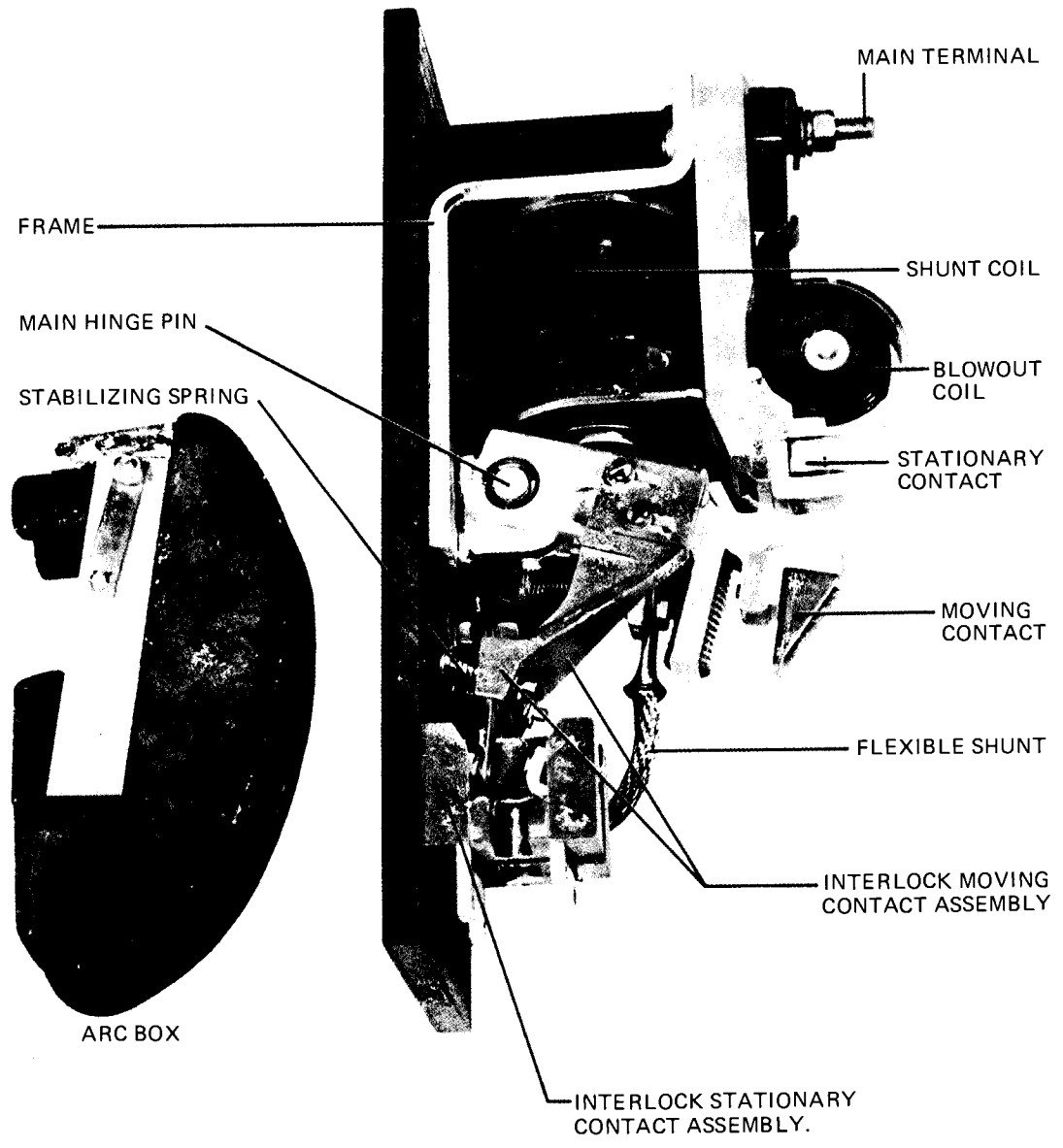

FIGURE 6
A CAM CONTROLLER



**FIGURE 7
A CONTACTOR**

response time of the controller is related to the speed with which circuit changeovers can be made. This response time can be reduced either by adding more contacts on the camshaft (this would increase its length) or by having a second motor driven cam. One camshaft can control only the resistors and the other shaft can control the contacts for circuit changeovers. Alternately one camshaft can control the motoring and the other can control the braking operation. In such a case, while the control is in motoring, the brake controller can be continuously "spotted," i.e., be ready with the required circuit connections depending on the vehicle speed. Another important characteristics of a cam controller is the possibility of retrogression. Earlier cam controllers achieved power modulation only by forward progression of the control. Any power reduction was possible only by opening the line switches or in some cases by momentarily inserting resistance before opening the line. New designs of cam controllers, however, make it possible to modulate power by either forward motion (progression) or by backward motion (retrogression) of the controller. With full retrogression, it is possible to get back to series motor connection from parallel connection and also have full field or weak field. With such a control it is necessary to equip all the main contractors with arc blow-out chutes.

The total propulsion system hardware includes several components which are not shown in Figures 1 and 2. For example, typical cam controlled propulsion equipment for transit vehicles will have following major components:

- a. Manual master controller.
- b. Four drive assemblies on each car, each consisting of a traction motor, gear unit, ground brush holder, speed sensors and other support hardware.
- c. Main controller on each car consisting of line switches, cam drive, contactors, relays, series-parallel controller, field shunt, power-brake controller, fuse box, limit relay, control logic, etc.

- d. Set of accelerating and dynamic braking resistors consisting of many tube assemblies as shown in Figure 8. Each tube shown in the figure could be 12-18 inches long.

It also has several other components such as a cooling system, air filters, a brake system and its mounting, etc.

2.4 Energy Consumption (5,6)

The typical rheostatic control of traction motors is very inefficient. All the energy which is required to accelerate a vehicle is lost. A certain amount is dissipated in starting resistors and the rest is stored as kinetic energy in the vehicle. This kinetic energy is then dissipated in braking resistors when the vehicle is brought to a stop. Also, the traction motor, the onboard auxiliaries, the substations and the third rail have electrical losses. The energy required to maintain the cruise speed of the vehicle is quite small compared to the total energy consumption. The actual dissipation of energy in the above components is highly dependent on the duty cycle and hence, it is difficult to quote a typical distribution. Figure 9 shows the results of a specific computer simulation of transit operations in the Northern Queens area of NYCTA⁽⁵⁾. One can get a fairly good idea of the relative share of different losses from this figure.

There are virtually thousands of transit and commuter cars around the world using cam controller propulsion equipment. In fact more than 1500 cars with such equipment were purchased by U.S. properties alone since 1972. These include 754 R-46 cars by NYCTA, New York (1972), 200 cars by WMATA, Washington D.C. (1973), 190 cars by CTA, Chicago (1974) and 190 cars by MBTA, Boston (1976). Figure 10 shows the WMATA car.

In conclusion, it can be said that the cam control is a very well proven technology and the control system is fairly simple. High

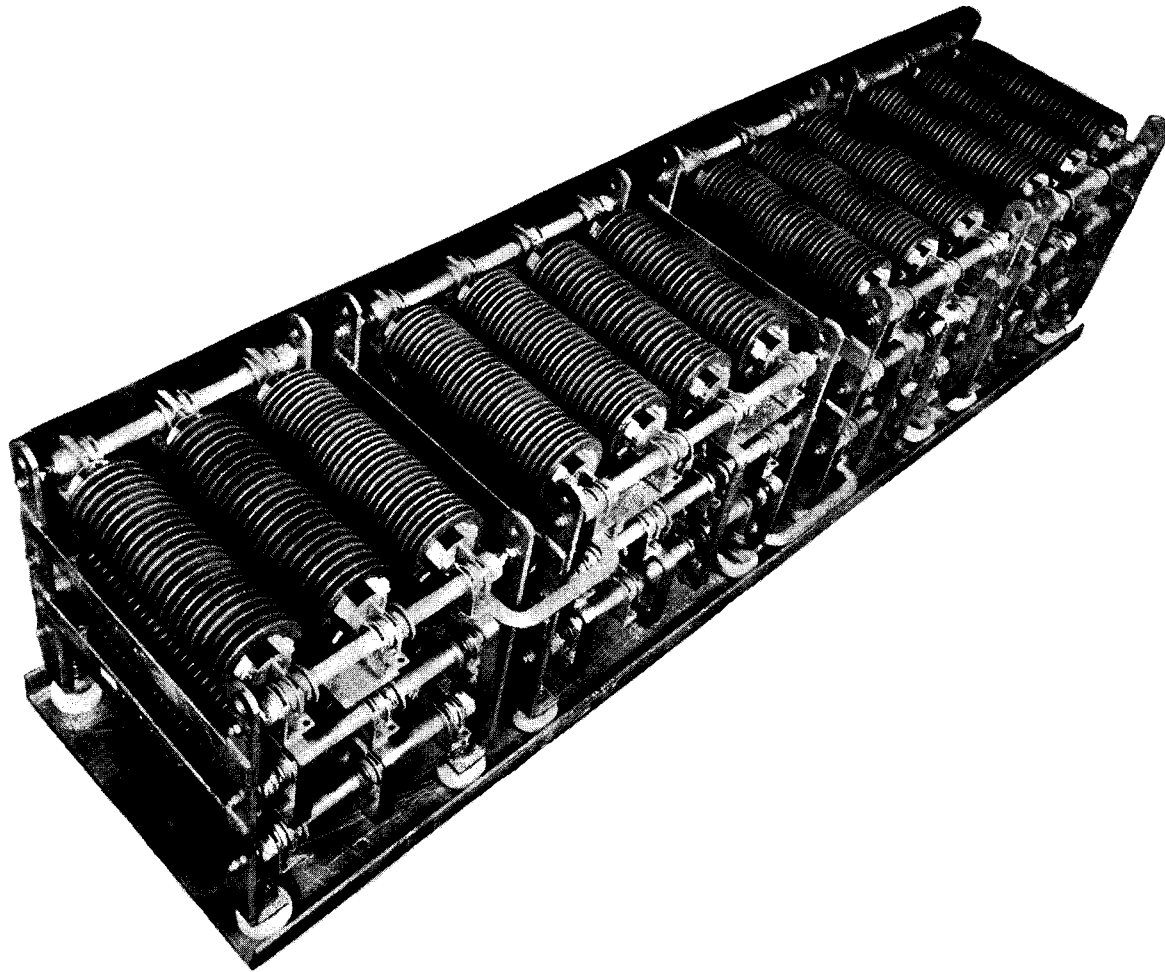

FIGURE 8
TYPICAL RESISTOR ASSEMBLY

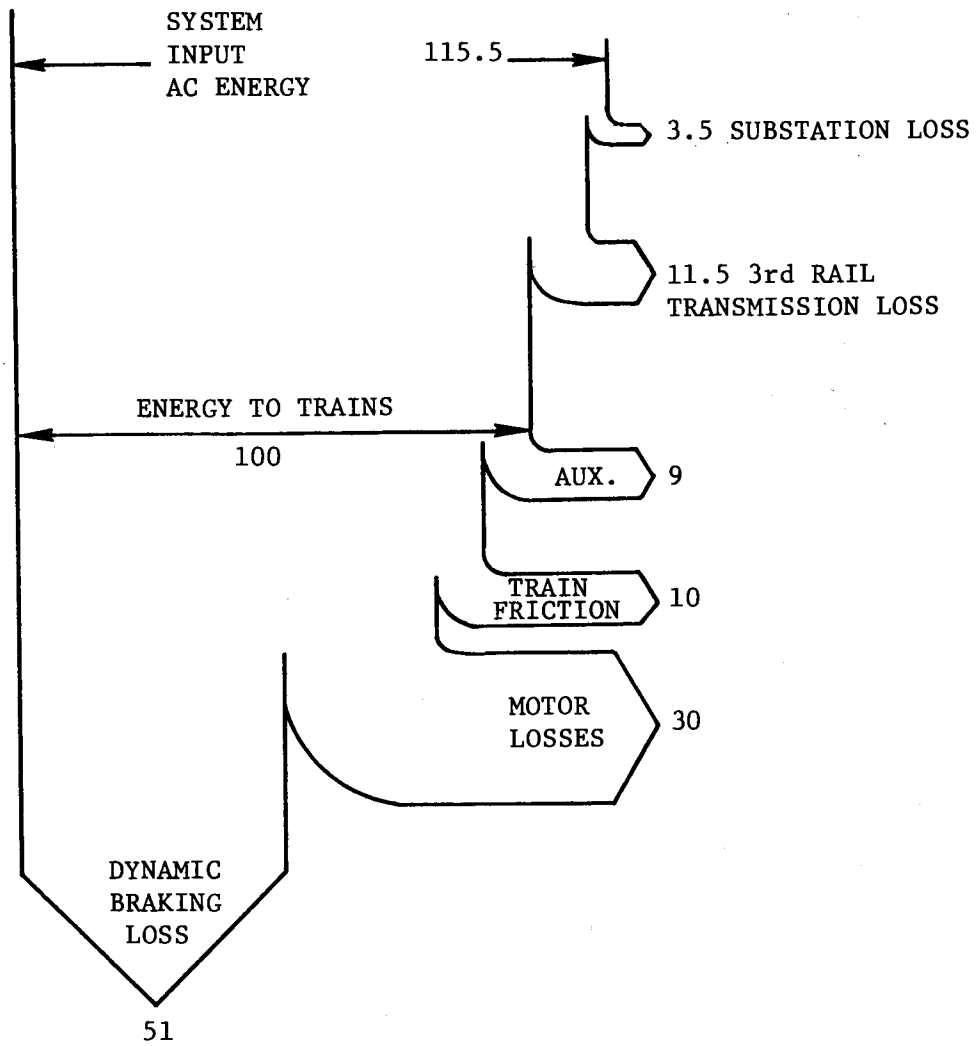
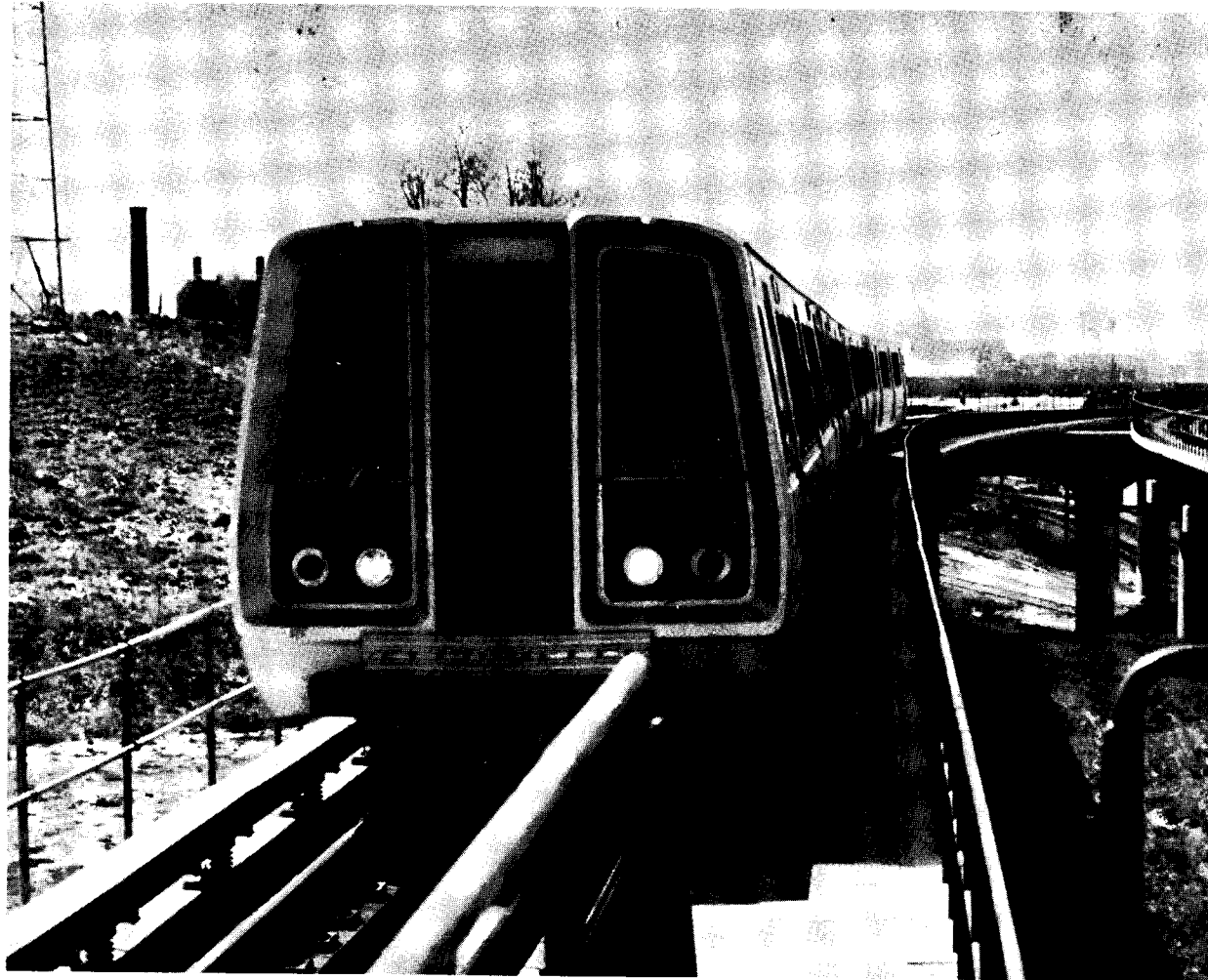

FIGURE 9
ENERGY FLOW FOR RHEOSTATIC CONTROL



**FIGURE 10
WMATA CAR**

energy consumption, maintenance and inspection (M&I) costs associated with the contactors, the control circuits and the dc traction motors, however, are the major disadvantages of such equipment.

3.0 CHOPPER CONTROLLED PROPULSION EQUIPMENT

The basic function of any propulsion control is to regulate the motoring and braking performance of the traction motors as required. A rheostatic controller regulates the voltage applied to the motor by using external resistances in series with the armature. A chopper control is another means of controlling the armature voltage of a dc traction motor while eliminating the relatively large control steps and resistor losses associated with rheostatic control. A chopper has three basic capabilities beyond the resistor control. First is the ability to regulate speed with a stepless control, thus eliminating the jerk associated with on-off control. The steady motor torque improves the vehicle performance when operating under automatic control and reduces slipping and sliding tendencies, permitting better utilization of adhesion. Secondly, the chopper control being a voltage control, the line current drawn is proportional to power rather than to torque as with a rheostatic control, resulting in load reduction during motoring. Finally is the ability to control regeneration and return part of the kinetic energy of the vehicle to the line during braking.

Since the early days of electric traction, it was realized that a variable voltage dc source can be used to efficiently control the speed of the dc traction motor. In fact, a similar system - the Ward Leonard System - was in common use to control large dc motors. However, for transit applications it was not possible to develop such a variable voltage dc source at a reasonable cost until after the development of high voltage power semiconductors in the middle 1960's. Also, since the energy crises of the 1970's, the cost of energy has risen, making it easier to justify the increased initial cost of equipment.

3.1 Operation of a Chopper Controller

A chopper essentially applies a continuous sequence of unidirectional voltage pulses (see Figure 11) to the load, the magnitude of the pulse being equal to that of the supply voltage. The average voltage output V_o (which is equal to $V \cdot t_{on}/T$) can be changed by changing t_{on} (pulse width modulation, PWM) or by changing T (frequency modulation) or by changing both. For transit application, however, PWM method is widely used because the frequency modulation can result in an undesired electromagnetic interference with the signalling and communication system. The operating characteristics of a chopper are discussed in detail in Appendix II.

Figure 12 shows a typical circuit for a basic chopper controlled propulsion equipment. There are several possible variations of a chopper control circuit and hence, this circuit is drawn to show only the major components. The chopper could be single phase or multi-phase, the number of motors per chopper could be different, and series motors with various field control schemes could be used. It shows separately excited motors, although the field control circuits are not shown. The propulsion system hardware also includes several other components such as line switches, contactors, control logic assembly, master controller, blower motor and its controls, heat shielding, and air filters which are not shown here.

When the switches 1, 2, 3 are closed the circuit operates in a motoring region. At start, the traction motors have no counter emf and hence, the starting current has to be controlled. Earlier chopper designs used variable chopping frequency to control the starting current. Such control involves a sweep-frequency operation for short intervals and can cause unacceptable electromagnetic interference with the signalling system. Newer chopper designs, therefore, either use stepped-frequency choppers or introduce a controlled resistor.

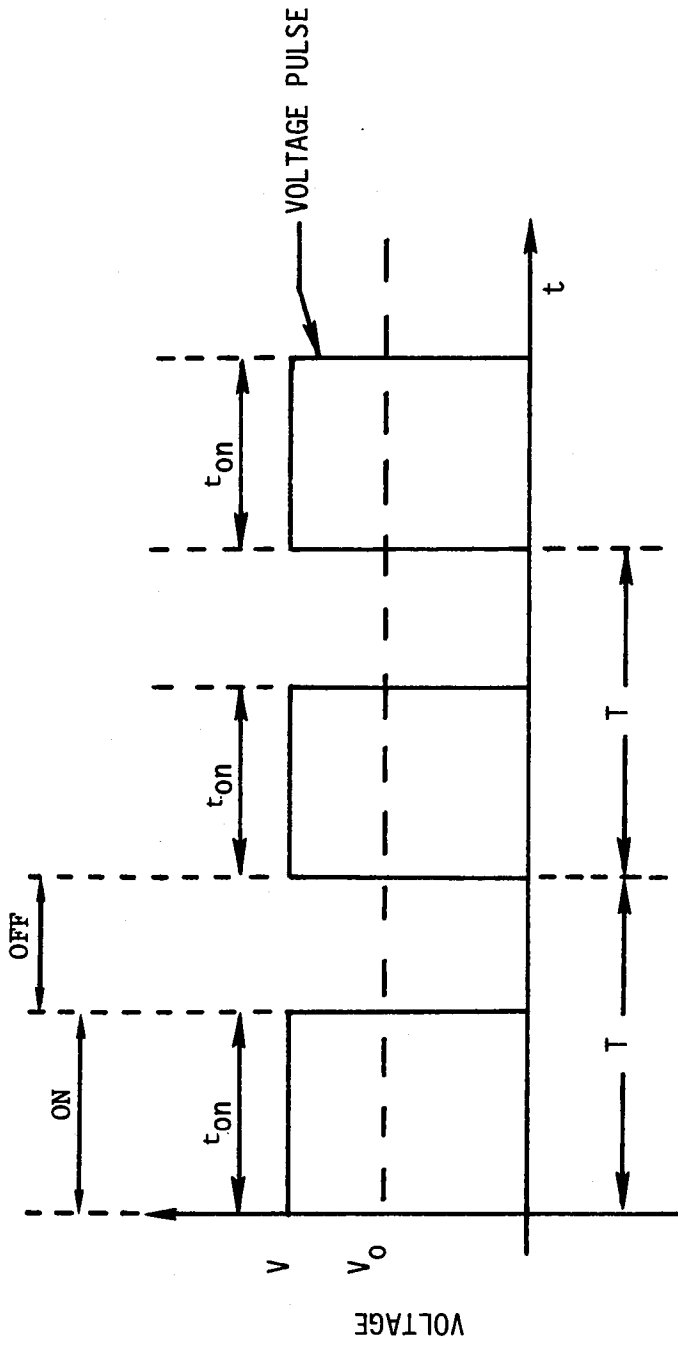

FIGURE 11
VOLTAGE CONTROL BY A CHOPPER

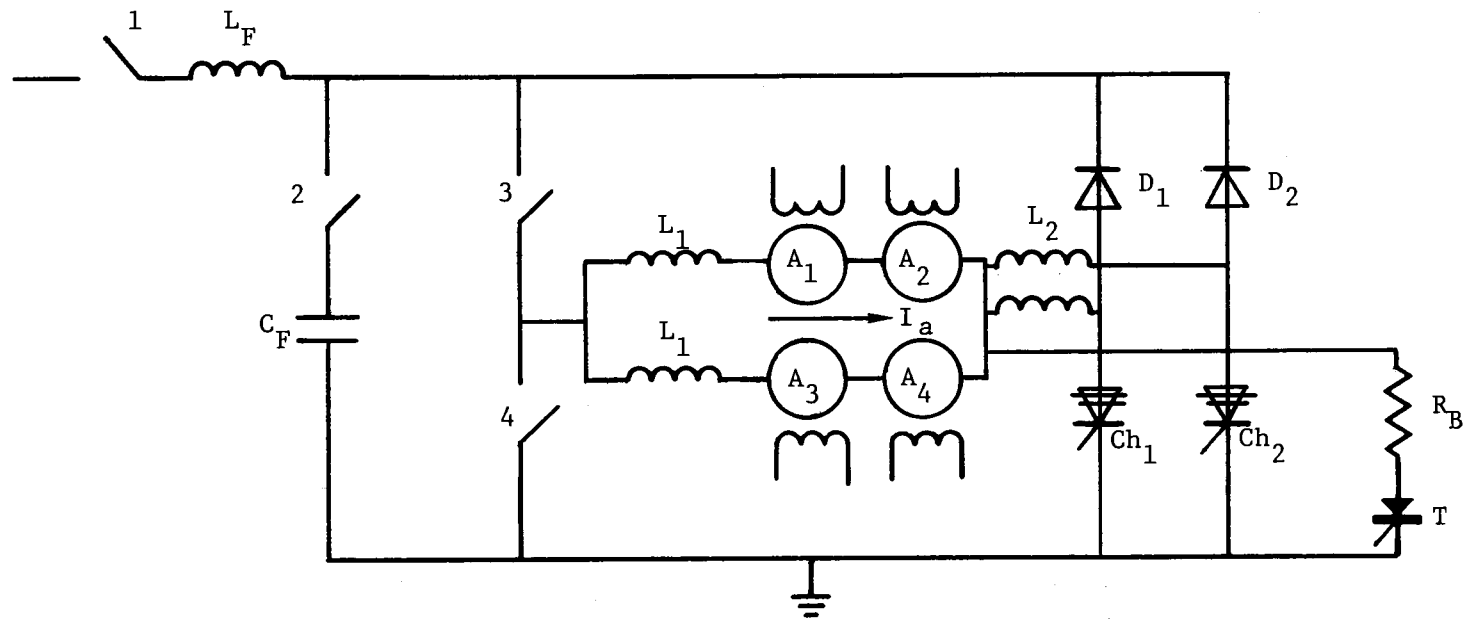

FIGURE 12
A CHOPPER CONTROLLER

in series during the start. Once the motors start and develop some counter emf, one can eliminate the resistor (or the variable frequency operation) and the motors can be directly controlled by choppers Ch_1 and Ch_2 . These choppers can be operated with a phase difference to give an effective multi-phase operation. Alternately one can use two separate choppers, each controlling two motors on a truck. The reactors L_1 and L_2 are used to improve load sharing between the motors and the choppers.

Under regenerative braking conditions, the switch 3 is opened and 4 is closed. The armature current I_a can now build up through a closed circuit - motors, choppers, and switch 4. After a sufficient current builds up, choppers can be turned off. The reactors in the circuit then tend to keep the armature current flowing, thereby feeding the current back to the line through the free wheeling diodes D_1 and D_2 . If the network cannot receive the current, it is directed to a braking resistor R_B by triggering the thyristor T.

3.2 Deployment of Chopper Controllers (7-22)

Chopper controlled transit equipment is being increasingly introduced around the world. In addition to heavy rail vehicles, it has also found application in light rail vehicles, street cars as well as buses.

On the North American continent, chopper equipment was first introduced on the BART (Bay Area Rapid Transit) system. Initially 250 cars (see Figure 13) were put in revenue service in 1972 and 200 cars were added during 1974-75 on the system. The cars registered over 120 million miles in the first five years of revenue service. This equipment was manufactured by Westinghouse Electric Corporation. Chopper controlled propulsion equipment made by Garrett Corporation was later introduced on the light rail system in Boston (MBTA) and

San Francisco (MUNI). Currently 275 of these propulsion units have been delivered to the car builder. General Electric Company is currently manufacturing chopper controlled propulsion equipment for revenue testing in Chicago (10 cars) and New York (2 cars). MARTA in Atlanta has ordered 100 cars for its new rapid transit system where revenue service is expected to start in July 1979. Propulsion equipment for these cars using chopper control is being produced by Garrett. Greater Cleveland Regional Transit Authority (GCRTA) has also ordered 48 chopper cars and its propulsion equipment will be made by Brown Boveri. Toronto Transit Commission (TTC) in Canada is buying 138 cars (chopper propulsion equipment by Garrett Corporation) of which about 90 have already been delivered and are in operation to date. Toronto will also be getting 200 light rail vehicles (CLRVs with chopper equipment by Garrett Corporation) over the next few years. Similarly Mexico City Metro has ordered 350 cars (using chopper equipment by Mitsubishi Electric, Japan) which will be delivered over the next few years. It can thus be seen that there are more than 1700 chopper controlled cars in operation or on order in North America.

ASEA supplied four car-pairs of C7 type⁽¹⁸⁾ with chopper control to Stockholm subway in 1973. Experience from revenue service has shown that up to 35 percent of the supplied energy can be saved depending on the line receptivity (ability of the line to receive the braking energy). Encouraged by this experience the Stockholm subway ordered additional 20 cars in 1976. These chopper controlled cars⁽¹⁹⁾ of type C9 are shown in Figure 14. These can provide high acceleration rates (1.3 m/s^2 , 0.13 g, 2.9 mphps) and the regenerative braking is available down to 2 km/h (1.25 mph). A typical thyristor module consisting of a main thyristor, an auxiliary thyristor and other relevant components is shown in Figure 15 and the complete chopper equipment for the car is shown in Figure 16. The chopper equipment package is roughly 5 feet wide and 11 feet long.

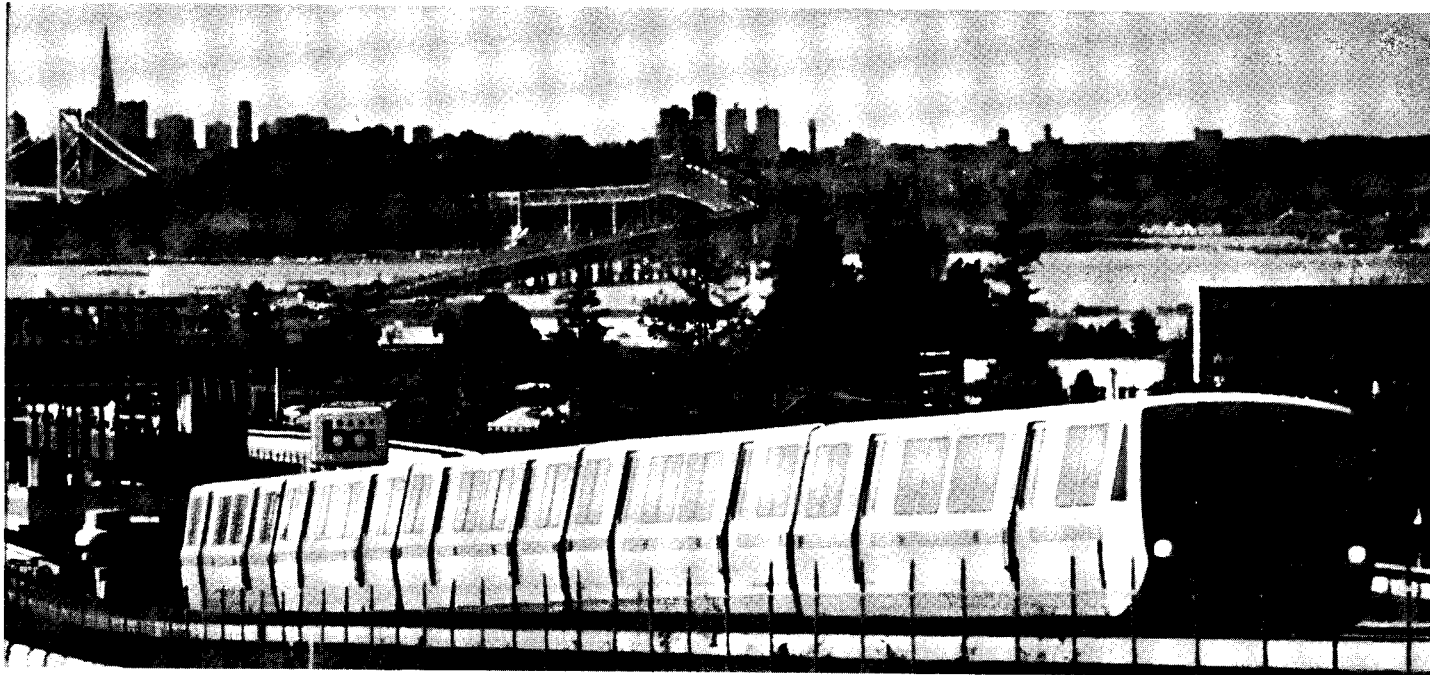

**FIGURE 13
BART CAR**

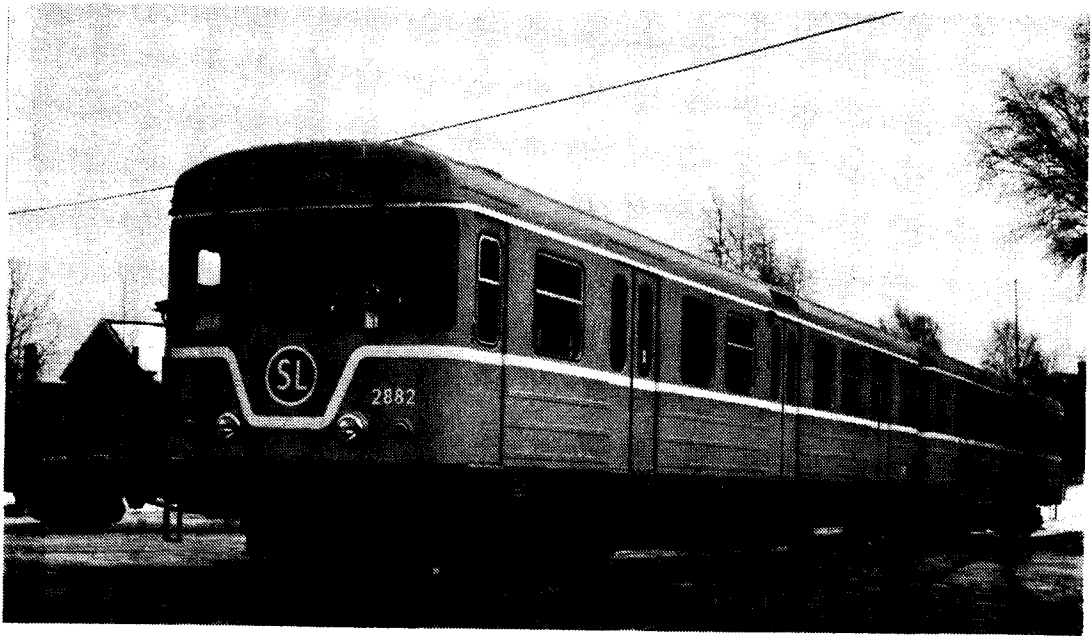

FIGURE 14
SUBWAY CAR OF TYPE C9

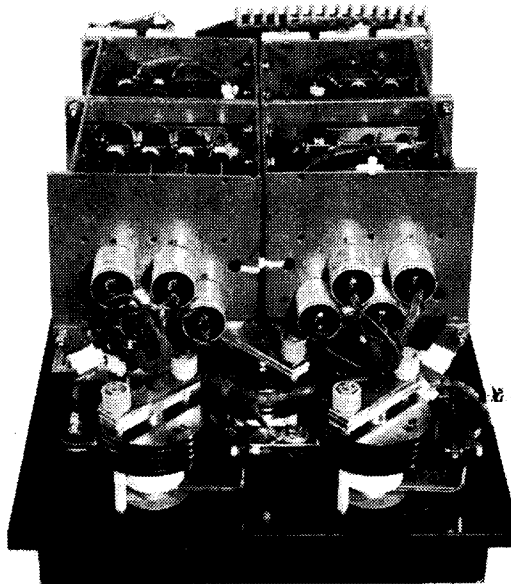

FIGURE 15
A THYRISTOR MODULE

Over the period of years, Stromberg Inc., of Finland, has made considerable advances in the field of chopper controlled as well as ac traction (induction traction motor supplied with a PWM inverter) equipment⁽²⁰⁾. During the years 1973-75, a total of 40 tram cars were supplied to the Helsinki City Transport. These were of articulated construction (see Figure 17), with the two-part body mounted on three trucks. The trucks at both ends have driven axles whereas the middle truck is a trailing truck. Each driven truck has one longitudinally mounted traction motor. For each tram car the two armatures are supplied by two choppers, whereas the two field windings are excited by only one chopper. The electrical dynamic braking is possible up to a low speed of 5 km/h. Some other characteristics of these trains are:

Weight	26 tonnes
Length	20 m
Max. speed	60 km/h
Supply voltage	600 V dc
Output, continuous	260 kW

Stromberg also supplied three coach pairs of type M1-6 to Helsinki Metro during 1971-72 for initial trials. These cars, with chopper controlled propulsion, were tested extensively. Around 1974, however, Stromberg offered a similar coach pair with ac traction and Helsinki Metro discontinued testing the chopper equipment after deciding to buy the new equipment. These cars are described later in Section 4.

Stromberg has also supplied one trolley bus shown in Figure 18, using a chopper controlled dc motor, to Winterthur Municipal Traffic Authority in Switzerland. This articulated trolley bus has a twin armature dc motor supplied by two choppers, and is currently under test to compare its performance with a similar bus having an ac drive.

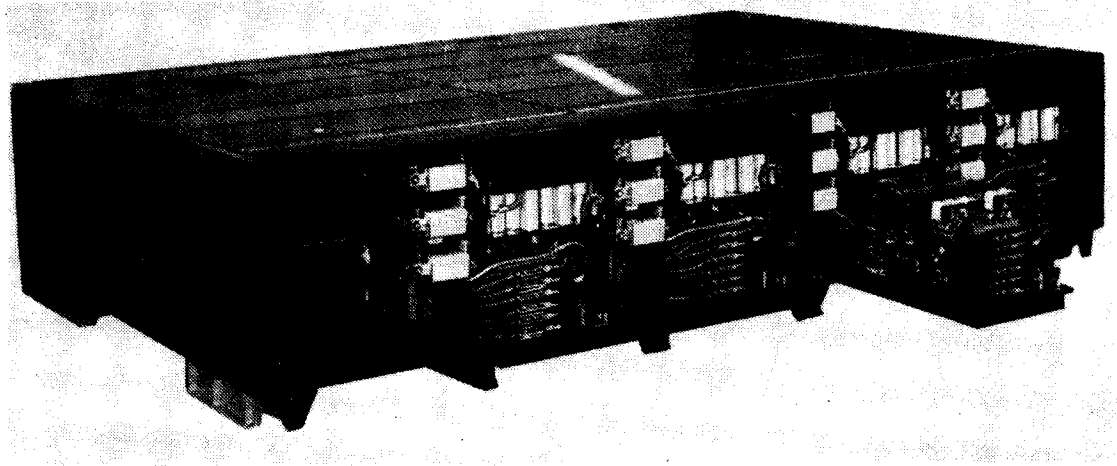

FIGURE 16
COMPLETE CHOPPER EQUIPMENT



FIGURE 17
ARTICULATED TRAMCAR

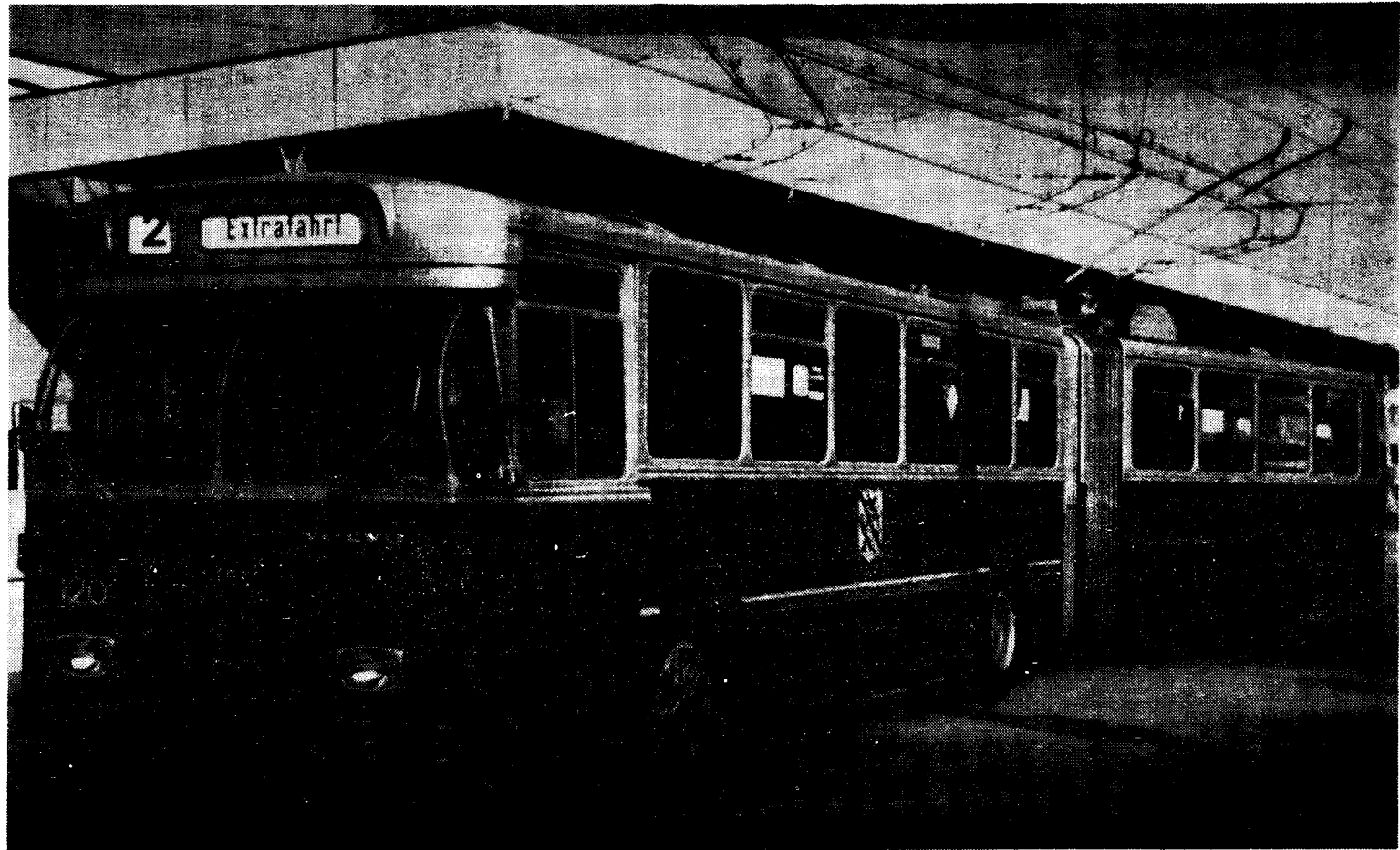

FIGURE 18
TROLLEYBUS WITH CHOPPER CONTROL

Brown Boveri, Siemens and AEG-Telefunken are the three German companies actively developing new propulsion equipment using dc and ac drives. Presently there are almost 200 cars with chopper control in revenue service in Germany.

AEG, in collaboration with Siemens, supplied 28 units to Wuppertal Suspension Railway-Monorail⁽²¹⁾ in 1973. As shown in Figure 19 this is a two-car unit powered by 4 series wound dc motors rated 50 kW at 1700 rpm with a maximum speed rating of 3850 rpm. In each car the two motors are connected in series and these in turn are connected in parallel so that there is only one chopper for all the four motors. Only dynamic braking is available.

The rapid transit streetcars made by AEG for Hanover are eight-axle articulated units with the two end trucks powered by individually chopper controlled dc traction motor rated at 218 kW at 1900 rpm. Regenerative braking is used depending on the line receptivity, if the voltage rises beyond allowable maximum dynamic braking is used. Currently 100 units of this type are in regular operation for speeds up to a maximum of 80 km/h. AEG has also supplied chopper controlled tram cars to the city of Melbourne, Australia.

For heavy rail vehicles, AEG and Siemens have supplied chopper controlled prototype equipment to Berlin and to the Munich Metro. This equipment is still in operation since the past several years.

BBC also manufactures chopper controlled traction equipment. Regenerative or dynamic braking is provided depending on the customer requirements. BBC has considered two ways of using the kinetic energy to heat the vehicle during braking. One way is to use dynamic braking and distribute the heat lost in the braking resistor through the heating system. This arrangement is very attractive where a new traction

system needs to be provided for an existing vehicle design. Another way is to return the braking energy back to the line and separately draw heating energy that can be better distributed by heating elements along the vehicle. Such a system is in fact under consideration for transit vehicles for Stuttgart area.

The Paris Metro (RATP) operating over 155 route miles, has more than 900 rubber-tired cars and more than 1400 rail cars. Recently RATP ordered 1000 new chopper controlled cars of MF 77 series shown in Figure 20. First two cars were completed in October 1977 and the first complete five-car trainset entered the service some time around April 1978 on Line 13 between St. Denis and Chantillon-Montrouge⁽²²⁾. By mid-1979 all the trains on this line are expected to be of MF 77 stock. Subsequent deliveries will be for Lines 7 and 8.

The metro system of Lyons will run three-coach rubber-tired MU equipment of Figure 21 with the possibility of adding a fourth coach to the consist. The vehicle has monomotor trucks as shown in Figure 22 and operates at a speed of 90 km/h. The braking energy cannot be returned to the line, especially in the early morning and late at night because the line is not receptive due to reduced traffic. This energy is then used to feed the auxiliary power system. The Marseilles Metro system is also expected to buy chopper controlled equipment for their next buy.

The Sao Paulo metro system in Brazil ordered its first set of 198 chopper controlled cars in 1972, which were delivered in 1975. The cars with traction equipment by Westinghouse have accumulated over 33 million miles of revenue service. Since then, this metro system has ordered 108 more carsets to be delivered over the two year period 1978-79. Over the same period, 270 carsets with chopper controlled propulsion system will be delivered by Westinghouse to Rio de Janeiro metro system in Brazil.

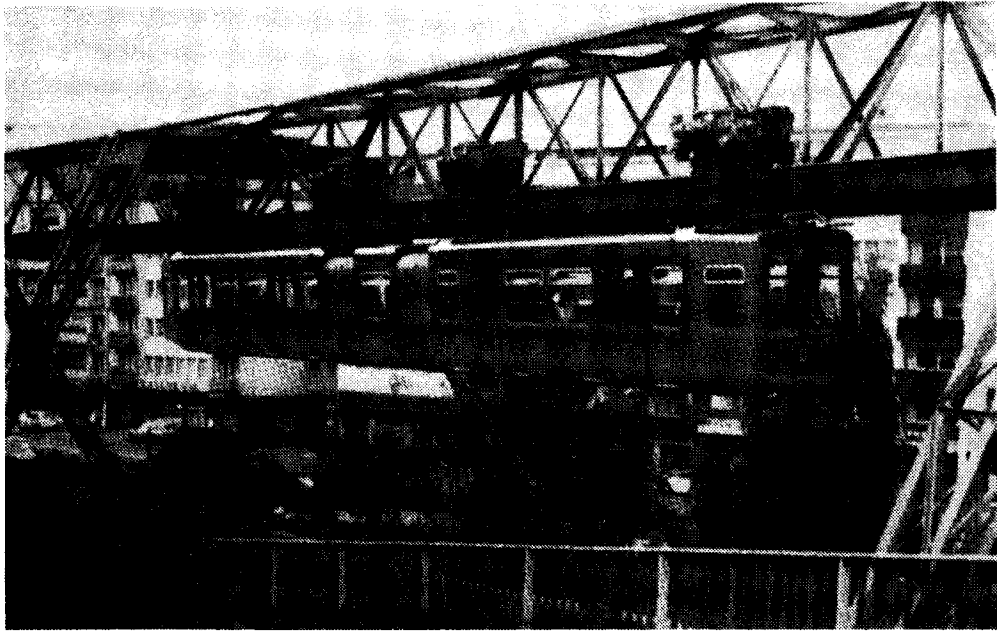

FIGURE 19
WUPPERTAL SUSPENSION RAILWAY



FIGURE 20
MF77 CARS OF PARIS METRO



FIGURE 21
THREE-COACH UNIT OF LYONS METRO

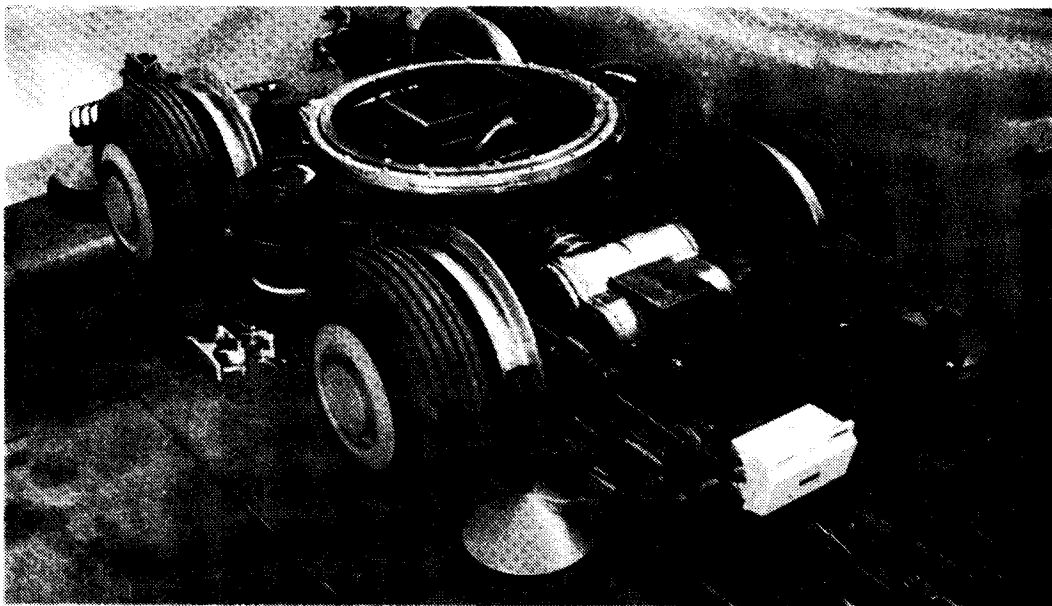
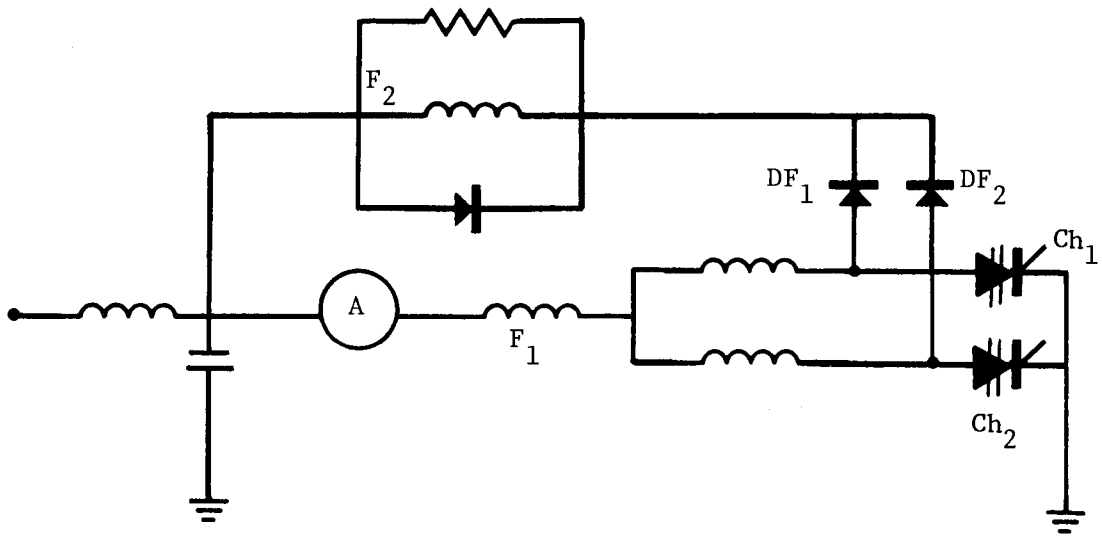

FIGURE 22
MONOMOTOR TRUCK - LYONS METRO

In Japan the first prototype chopper equipment was produced in the mid 1960's and several units were tested on Chiyoda, Ginza and Hibiya Lines of Teito Rapid Transit Authority, Tokyo. Since then choppers have been introduced on many transit systems such as in Tokyo, Osaka, Sapporo, Nagoya, Kyoto. Currently about 350 cars with chopper controllers by Mitsubishi Electric are in operation or on order in Japan. Considering equipment by other Japanese companies it can be estimated that there are probably more than 700 chopper cars in operation or on order there.

3.3 Field Control of Traction Motors

If separately excited traction motors are used, a separate chopper using thyristors or power transistors is usually used for field control. If, however, a series motor is used, the field weakening can be accomplished by using one of the several possible methods. One can use a simple series/parallel connection of field windings which gives a fixed 50% field weakening, or one can use shunt reactors in parallel with the field or one can use additional field windings. The time constant of the shunt reactor is usually adjusted such that there is a proper division of current between the reactor and the field even under transient and fault conditions. If an additional field winding is used, it can be connected in the interrupting circuit of the armature chopper to get a continuously varying field excitation for the motor^(23,24). The main power circuit for this system, known as Automatic Variable Field (AVF) system, is shown in Figure 23. The field winding is divided into two sections: one winding F_1 is connected in series with the armature, while the other winding F_2 is connected in series with the free wheeling diodes DF_1 and DF_2 for motoring operation. The two windings F_1 and F_2 are connected such that their fluxes are cumulative. As the speed increases, the conduction ratio of the chopper increases, thus reducing the "off" period. Since the field F_2 carries current during the "off" period, the effective field of the



MOTORING

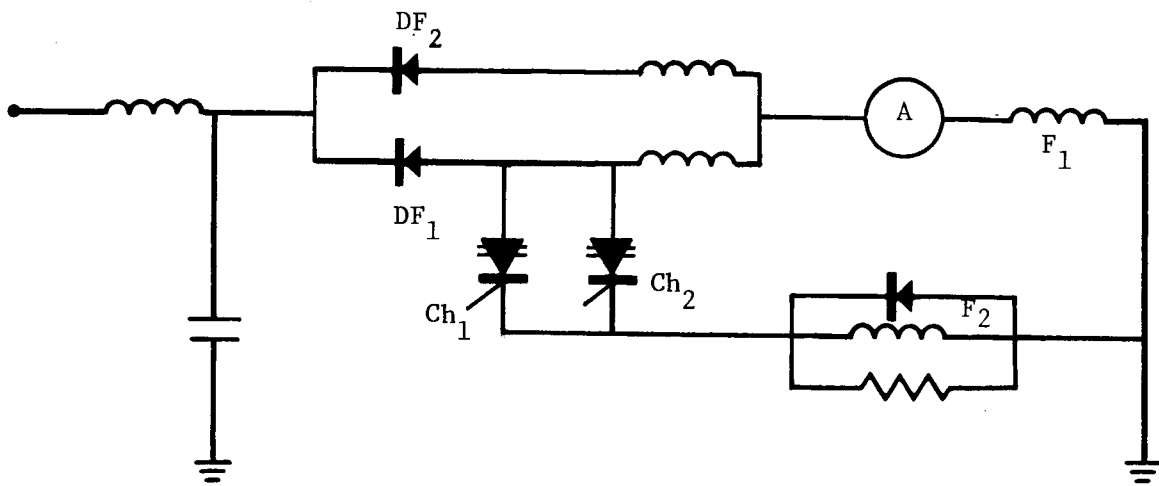

BRAKING

FIGURE 23
AUTOMATIC VARIABLE FIELD CONTROL

motor continuously decreases as the speed increases. During regenerative braking, the field F_2 is connected in series with the chopper. Hence, a weak field condition given mostly by the field winding F_1 is maintained in the high speed range because the conduction ratio is small. As the speed decreases, the conduction ratio of the chopper increases and hence, the current through F_2 and the resultant effective field increases. It should be noted here that the windings F_1 and F_2 are wound on the same core and are closely coupled. A voltage is therefore induced in F_2 by transformer action from F_1 and vice versa. This action can, however, be reduced to an acceptable level by connecting fields of several motors in series as well as by using an appropriate shunt across the field windings.

The first prototype unit using such an automatic variable field (AVM) control was tested by Mitsubishi Electric Corporation on the Yurakucho line of the Teito Rapid Transit Authority (Tokyo) in 1973. Since then production type equipment has been introduced on the Yurakucho line, on the Nankai Railway, and on the Tsurumai line of the Nagoya Municipal Railway. Similar equipment has also been selected by the Mexico City Transit Authority for its new order of 350 cars. In fact, by now, this AVF system is standard equipment on chopper controlled cars being marketed by Mitsubishi.

Such a method of automatic field control can generally improve the reliability and maintainability of the equipment because it reduces the part count by eliminating components such as field shunts and contactors. However, the motor design has to be related to the field weakening characteristics, resulting in a unique motor design for a given propulsion characteristics. In U.S. transit industry there is not much standardization and each property writes its own specifications for the propulsion system for its vehicles. Presently standard

lines of traction motors are used for several applications and any difference in propulsion system requirements is met by different controller designs. It is, therefore, not clear if the application of such an AVF system in U.S. can be economically justified at this time. With increasing standardization in U.S. transit industry, however, this type of field control would be of increasing value in the future.

Another method of automatic field weakening of a series traction motor can be illustrated with the help of Figure 24. A resistor is connected in shunt with the series field winding and the power is connected to a tap on this field shunt⁽²⁵⁾. If the reactor in series with the armature is sufficiently large, the armature current I_A is almost constant and one can obtain the equivalent circuits of Figure 25 for the operation during ON/OFF period for motoring/braking. The instantaneous field current is thus a function of K and the conduction ratio α . The field current wave forms are of the type shown in Figure 26 where the actual waveforms depend on the time constant $\tau = L_f / (R_f + R_s)$. The effective field weakening ratio is also a function of K and α as shown in Figure 27. At present Toshiba is developing such a system for traction applications.

There are several other possible methods of obtaining field control but a detailed discussion of these is beyond the scope of this work.

3.4 Energy Savings by Regeneration

During the vehicle braking, the traction motors are used in generating mode and convert the kinetic energy of the vehicle into electrical form. In dynamic braking this energy is dissipated in braking resistors while with regeneration at least a part of this energy is returned to the line. Such a regeneration is inherently

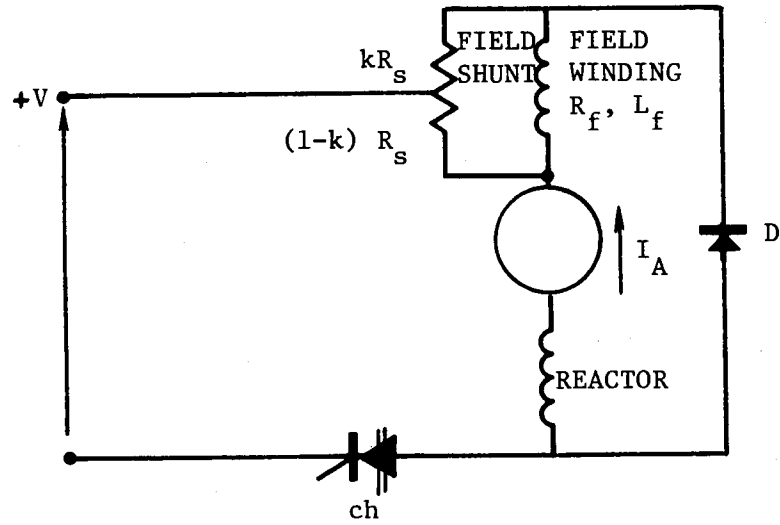

(a) MOTORING

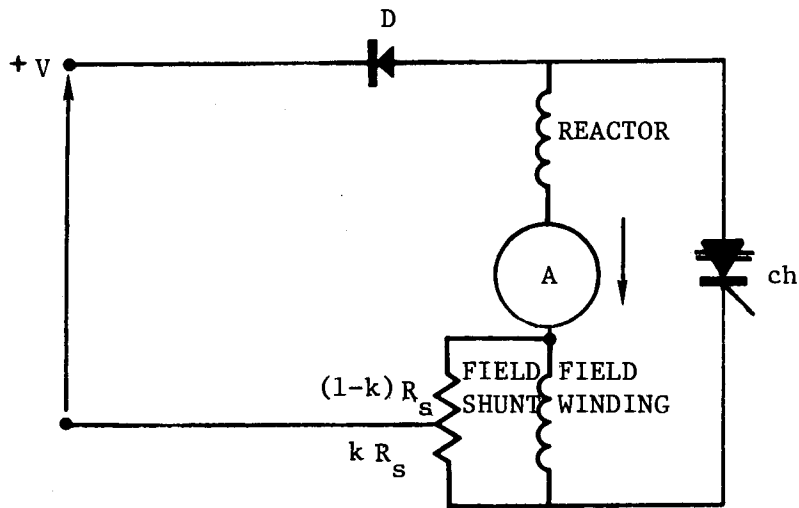

(b) BRAKING

FIGURE 24
FIELD CONTROL BY A MODIFIED SHUNT

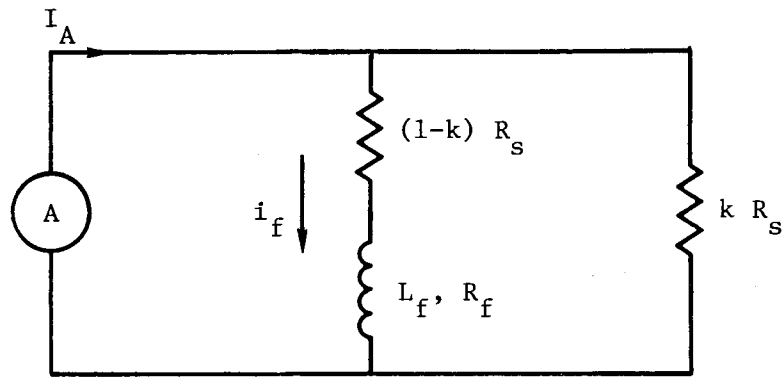

For ON period in motoring and OFF period in braking.

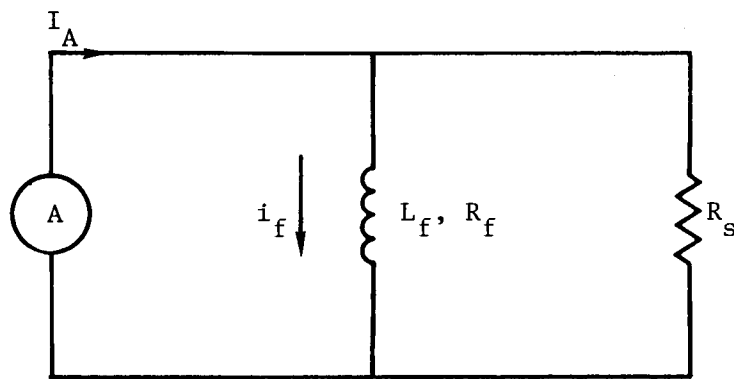

For OFF period in motoring and ON period in braking

FIGURE 25
EQUIVALENT CIRCUITS

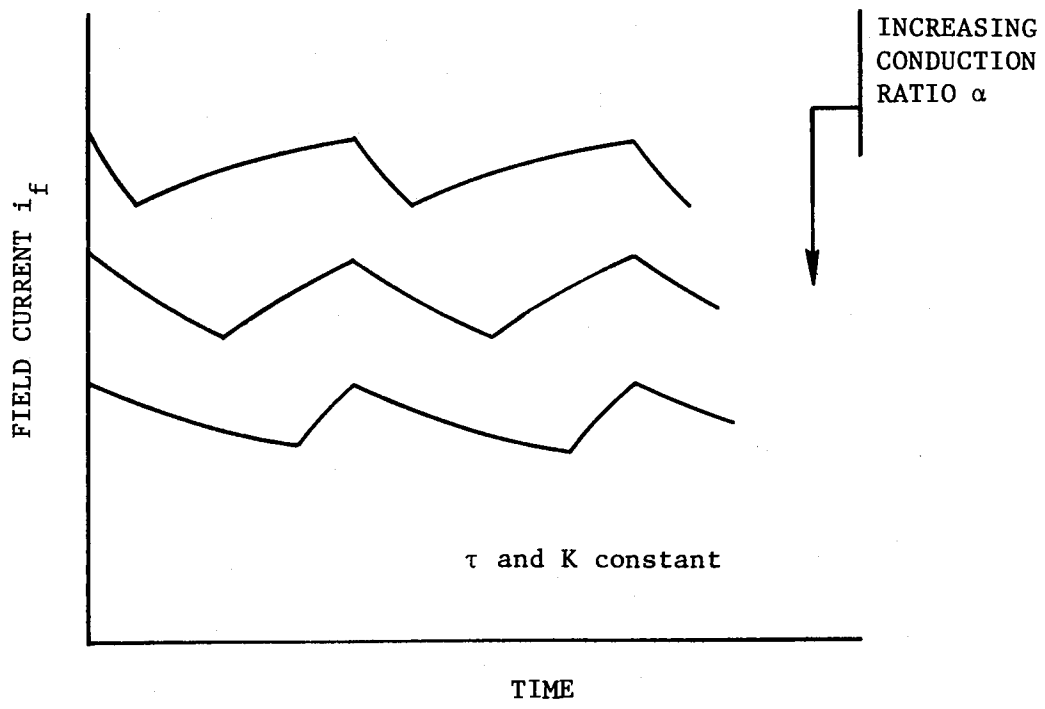

FIGURE 26
FIELD CURRENT WAVEFORM

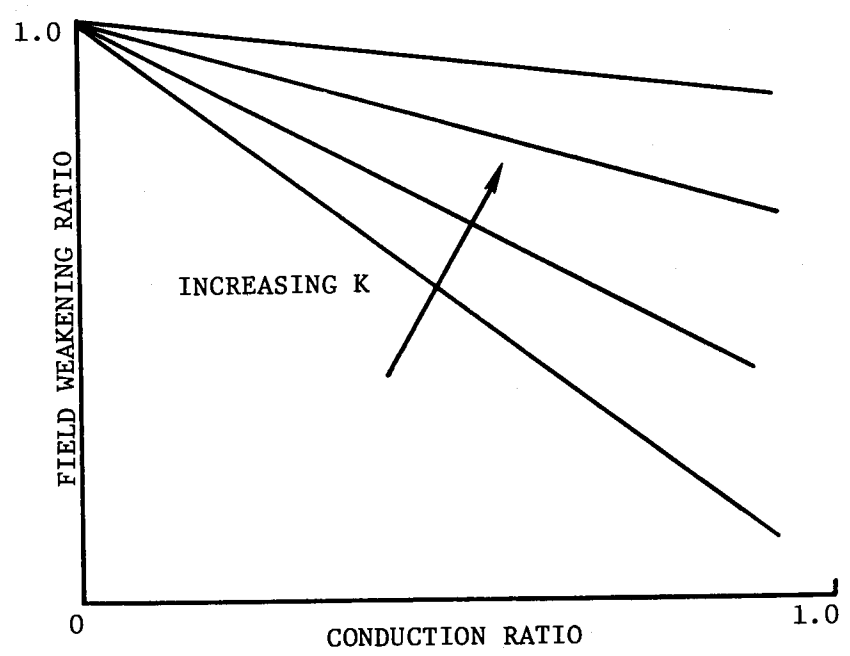

FIGURE 27
FIELD WEAKENING RATIO

possible with a chopper control. The magnitude of energy savings possible for practical application, however, is widely misunderstood, with numbers such as 50 percent energy savings often quoted. Although these savings are possible under the most favorable conditions, the actual energy savings are far below this figure.

There are several factors that limit the energy savings. The most important of these is the fact that the total energy available for regeneration is equal to the kinetic energy of the vehicle at the moment the braking begins. This is further reduced by the energy used in overcoming the train resistance and the losses of the motor and associated circuits. The second factor is that full regeneration may not be possible at high speeds when the motor voltage is higher than the line voltage. Depending on the braking requirements, it may be necessary to limit the current by external resistances and some energy may be inevitably lost during the process. The third key factor is related to the concept of line receptivity. This is a measure of how much energy made available by regeneration can be absorbed by the system. When the entire electrical system is considered, there is a constant instantaneous energy balance between the different sources and the sinks in the system. Line receptivity is thus a dynamic factor depending on several system conditions such as:

- Maximum voltage allowed onboard and on line
- Instantaneous power demand
- Substation characteristics
- Third rail impedance
- Regenerated power

All these factors vary widely and are almost never ideal at the same time. Moreover, the actual duration of braking when regeneration is possible and the duration of maximum power demand are very small compared to a typical vehicle run.

The actual energy saving possible on a typical rapid transit system is thus limited to the order of 20 percent. This estimate is also supported by the data obtained on the Sao Paulo Metro System in Brazil⁽²⁶⁾. In the year 1977 the specific energy consumption was reduced from about 4.2 kWh/car-km without regeneration to about 3.4 kWh/car-km with regeneration. Figure 28 shows the energy flow with a regenerative chopper car for the NYCTA system simulation⁽⁵⁾ used previously (see Figure 9). As mentioned earlier, the actual energy consumption in different components is highly dependent on the duty cycle and these results are presented here primarily for comparison.

3.5 Advanced Cooling Methods⁽²⁷⁾

Thyristors, transistors and other electronic components require cooling just as any other electrical apparatus. Oil cooling and forced air cooling with a blower are two of the most common methods of cooling choppers, inverters and other power electronic components. In forced air cooling, outside air is first filtered and then forced through the system, carrying heat away from heat sinks and other heat dissipating components. One could also use a closed cycle system where the same air is used again and again to cool the power electronics, thereby eliminating possible contamination by dust and other unwanted pollutants. However, for all such cooling systems, there are inevitable maintenance and other operating costs associated with the blower, the motor, the filter, etc.

Cooling systems using liquid freon offer great potential since large amounts of heat energy can be dissipated without the use of a pump. These systems were developed in the early 1970's for application in intercity passenger equipment, wayside substation equipment and general industrial equipment. In such a system, the heat generated by semi-conductors is transferred to a refrigerant - liquid freon R113 -

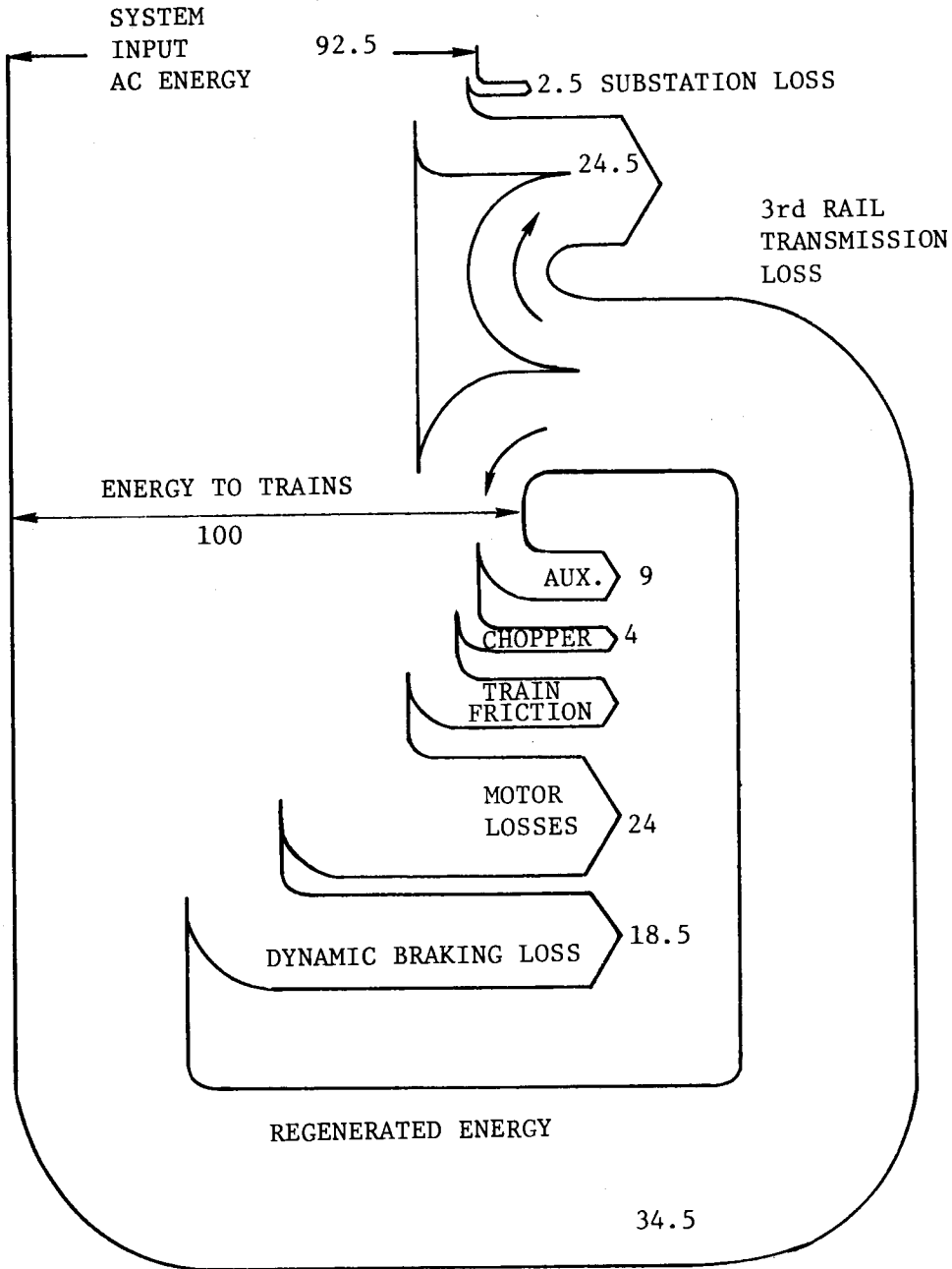
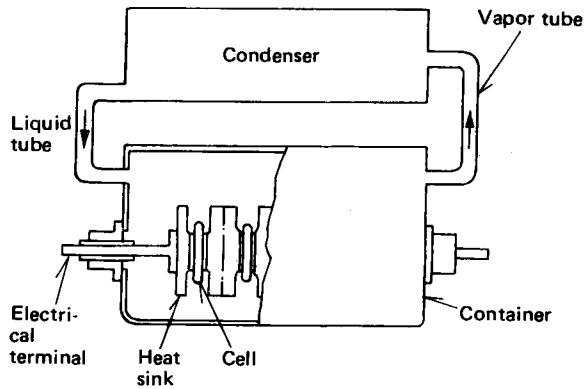

FIGURE 28
ENERGY FLOW FOR REGENERATIVE CHOPPER

causing it to boil. The vapor thus formed passes to a condenser, where it condenses and runs back under gravity to collect heat from the semiconductors. The entire circulation is natural and no pump is required. Two kinds of such systems are possible, as shown in Figure 29. In an immersed type, the solid state equipment is immersed in a bath of liquid freon and electrical connections are brought out through insulated airtight terminals. In the non-immersed type, the coolant flows from a reservoir through heat sinks and the solid state components are directly accessible without disconnecting the cooling system.

An effective cooling system is possible if the final temperature of the refrigerant gives adequate heat transfer characteristics of the heat sink within its permissible temperature range allowing for the temperature difference between the heat sink and the actual semiconductor junctions. The saturation or operating temperature of a two-phase cooling system - utilizing a fluid in its liquid and vapor form - is selected by considering the rate of heat generation and the cooling capacity of the condenser. The vapor pressure required within the system can then be obtained by knowing the properties of the fluid. In any cooling system, a final temperature is attained such that the heat generated by the equipment is equal to the heat dissipated by the condenser at that temperature.

The transfer of heat from the heat sink to the coolant requires that the surface of the heat sink be at a temperature somewhat greater (ΔT) than the saturation temperature of the liquid. The relationship between ΔT and the heat transfer rate is highly nonlinear, as shown in Figure 30. In the region B-C, nucleate boiling at the heat sink surface, small changes in ΔT create large changes in heat transfer rate and this region offers very effective, stable cooling. Operation at a greater ΔT is thermally unstable or less effective and hence avoided.



(a) Immersed Type

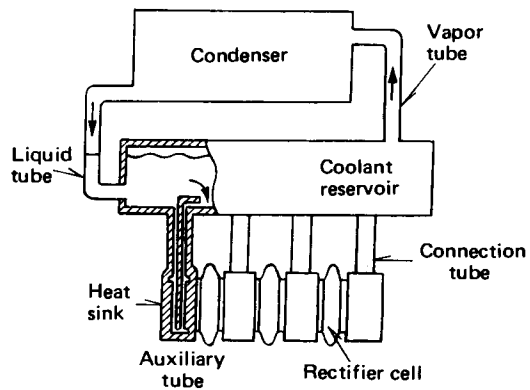

(b) Non-immersed Type

FIGURE 29
FREON COOLING SYSTEMS

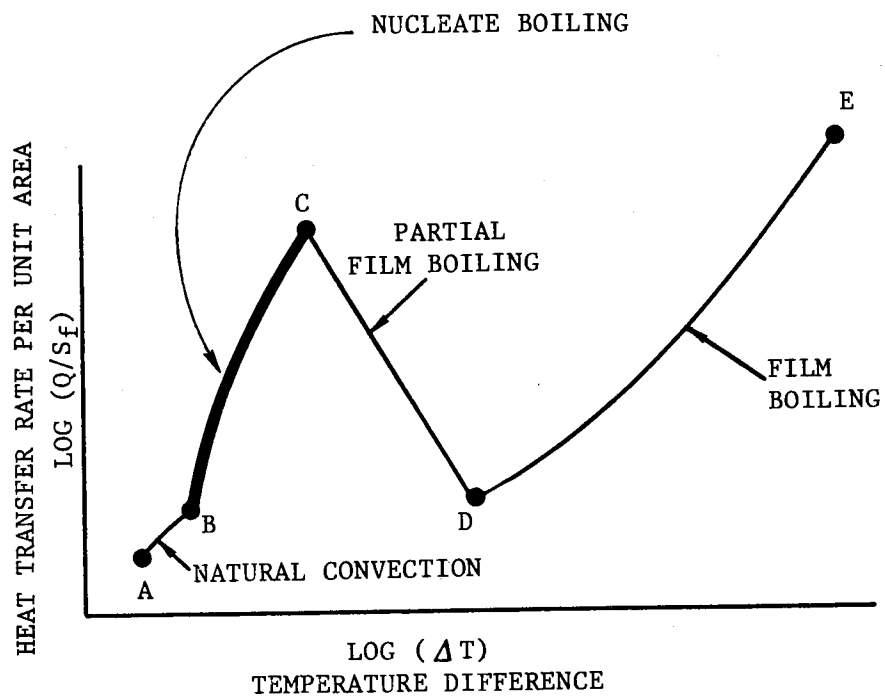

FIGURE 30
HEAT TRANSFER CHARACTERISTICS

Such a freon cooling system has been in use on the Shinkansen in Japan since 1972. As compared to forced air cooling, freon cooling of a 1000 kW rectifier would reduce its weight by almost 50 percent and the volume by more than 65 percent. The first prototype of such a system for urban rail vehicles was developed by Mitsubishi and was tested in non-revenue service on the Chiyoda line of Teito Rapid Transit Authority (Tokyo) in 1978. These tests were quite satisfactory and revenue testing may be undertaken this year. Alstom (France) is also developing a freon cooling system for application in transit vehicles for Paris, Lyons and Marseilles.

3.6 Use of a Microprocessor

Chopper control of traction motors was introduced almost a decade ago and improvements in the hardware have generally kept pace with the state-of-the-art in power electronics as well as solid state logic circuitry. Current chopper control circuits contain several analog devices such as operational amplifiers, transistors, resistors, capacitors and these are generally mounted on printed circuit boards. These control systems are becoming increasingly complex because additional functions - such as those required for diagnostics and testing for example - are being introduced for the system to perform.

A propulsion control system regulates the systems as commanded by the train line signals and by considering the status of all the components. It has to control the armature and the field of all the motors, limit the jerk, properly close and open the required contactors. It has to sense several variables such as the line voltage, vehicle speed and many others. In addition, it has to ensure the safety of all components and shut down the system if necessary. These control functions have to be designed individually for the specifications of each specific propulsion system. Along with increasing complexity, the reliability and maintainability requirements are also being

tightened and it is becoming more difficult to meet all these severe performance envelopes.

Under these complex requirements the use of a microprocessor in propulsion control can offer several potential benefits such as:

- a. Improved reliability - Several components such as auxilliary relays and interlocks of different switches could be eliminated with microprocessor logic. This would result in a reduction of the part count and hence in improved reliability and reduced weight of equipment.
- b. Hardware standardization - Standard hardware can be used for several applications with the microprocessor software providing the flexibility of design. This should have a system wide impact across the board such as reduced initial costs, improved reliability and maintainability, etc.
- c. Integration of diagnostic and test capability - In addition to control of propulsion, the microprocessor can provide continuous monitoring of the system performance and suggest an operator action in case of system malfunction. The same microprocessor can be used as a diagnostic tool during trouble shooting, thus eliminating the need for separate computer-based diagnostic equipment.

Such microprocessor controlled chopper equipment for transit cars has been developed and is currently marketed by Westinghouse Electric Corporation of the U.S. and by Mitsubishi Electric of Japan. After extensive development and testing in the laboratory environment, prototype hardware was installed and operated on a transit car at Sao Paul metro in revenue service. Based on the excellent results of these trials, such microprocessor logic is included in the chopper hardware for cars currently under manufacture for Rio de Janeiro metro. Mitsubishi Electric developed and tested prototype equipment with microprocessor control for a Dual Mode Bus and such an equipment has been developed for a transit car⁽²⁸⁾. This car will later be tested in revenue service.

4.0 AC DRIVES USING INDUCTION MOTORS

An induction motor offers several important advantages over the traditional dc traction motor. These are:

- For a given motor volume, more space is available for electromagnetic structure and hence the motor has a high volume and weight power density.
- There are no sliprings, commutator and brushgear to maintain.
- The motor can be operated at higher voltage and at higher speed because of the absence of a commutator.
- The regenerative braking is inherent and no contactors are required to change over from motoring to braking.
- The steep speed-torque characteristics tend to prevent wheel slip.
- For a given horsepower per axle, a small, light motor permits a simple truck design.

These inherent advantages of using a three phase squirrel-cage induction motor for traction were recognized long ago, but this application could not gain ground until adequate control equipment was available at an acceptable cost. The first research locomotive using induction traction motor was the "Brush Hawk" developed by Hawker Siddeley in 1965 but even then thyristor technology was not sufficiently advanced and the inverter control required over 300 thyristors per megawatt of traction power. Recent advances in thyristor technology have made it possible to reduce this number by a factor of over 10.

The concept of controlling the speed of an induction motor for traction application is discussed in detail in Appendix I and basic operation of different kinds of inverters are discussed in Appendix II. A brief history of ac drives for traction application will be given here.

4.1 AC Drives for Locomotives (29-37)

Brown Boveri teamed up with Henschel to produce the first of the three diesel electric prototypes of 2500 HP (hence the name DE 2500) using an ac/dc/ac transmission in 1971. It was a 1840 kW, 80 tonne, 140 km/h locomotive with Co-Co axle arrangement. The other two DC 2500s had similar ratings but one of them had Bo-Bo axle arrangement. These units, shown in Figure 31, have been extensively tested on the Swiss and German railway networks for different duties such as freight service, passenger service up to 140 km/h, and shunting service at speeds of 0-25 km/h. Two of these locomotives are in regular service now with the German Railways.

One of the locomotives has been converted for all electric operation by removing the diesel engine and the alternator and coupling it to a 4-axle pilot car carrying the line-side power conversion equipment such as the transformer, power converters, filters, etc. This unit of Figure 32 has been in operation since October 1974 and has the following technical data:

Transformer primary voltage	15 kV, 16 2/3 Hz, Single Phase
Transformer secondary voltage	2 x 648 V
DC Link voltage	1300 V
DC Link power, rated	1460 kW
Motor voltage	1015 V/phase
Power at wheels, rated	~1300 kW
Motor frequency, maximum	123 Hz
Weight of locomotive	80 tonnes
Weight of pilot car	54 tonnes
Maximum speed	140 km/h

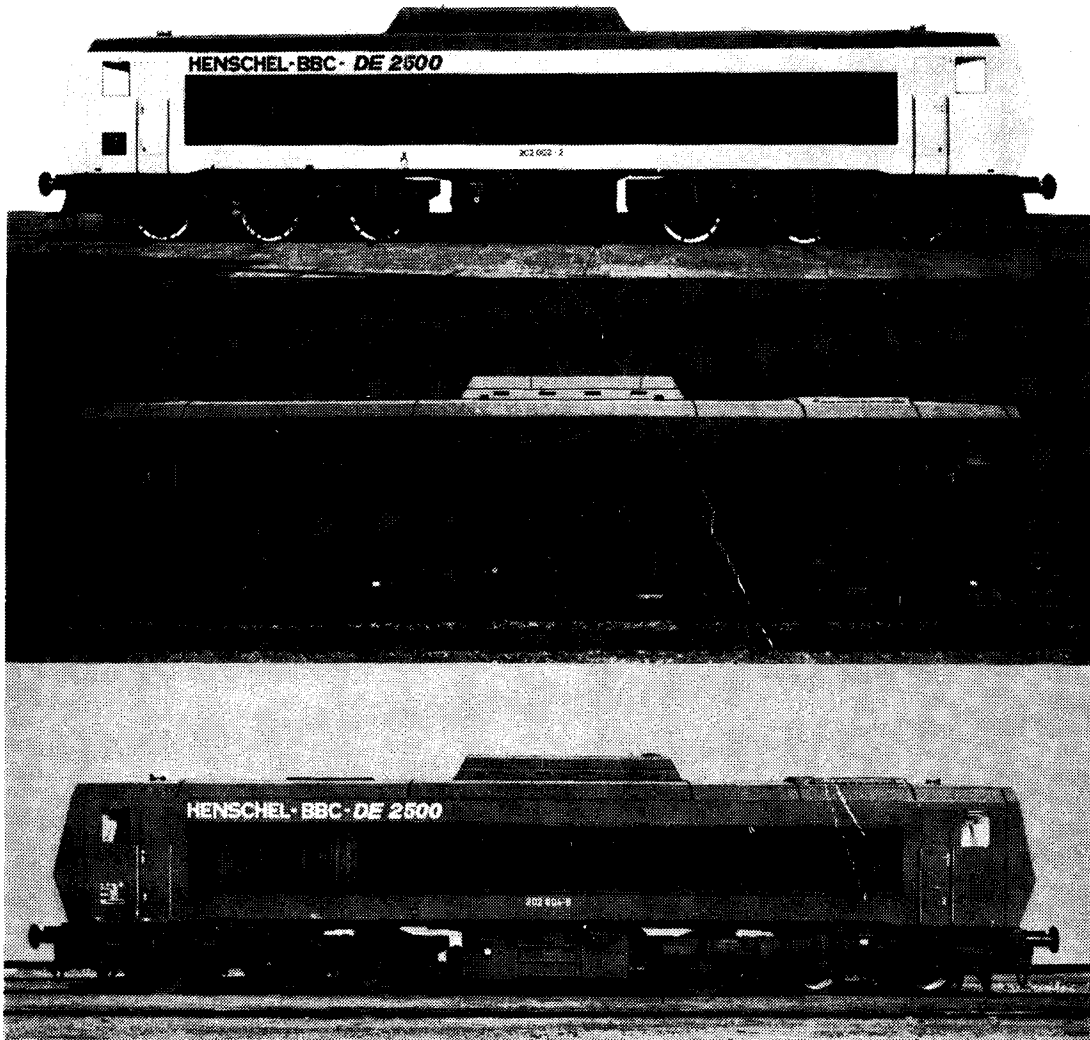

FIGURE 31
DE2500 LOCOMOTIVES WITH AC DRIVE

Brown Boveri has also supplied to Zechebahn and Hafenbetrieb Ruhr/Mitte AG (RAG) six dual frequency industrial locomotives of the type shown in Figure 33, having the following ratings:

Power, continuous	1.2 MW
Power, short time	1.5 MW
Line voltage	15 kV, Single Phase
Line frequency	15 2/3 Hz or 50 Hz
Maximum speed	60 km/h
Weight	88 tonnes
Axle arrangement	Bo-Bo

Other locomotives by BBC also use induction motors - some under development are Netherlands State Railway's test vehicle (1400 kW, 140 km/h, line voltage of 1500 Vdc, EDE 1000/500 industrial locomotives for 600 V dc or diesel power and rated at 100 kW, Am 6/6 freight and shunting locomotive of diesel-electric type as well as Ee 6/6 15 kV, 16 2/3 Hz electric locomotive for Swiss Federal Railways and E120 Series of 5.6 MW, 160 km/h locomotives for German Federal Railways. At present there are in all 37 units either in service or on order with induction motor drive. Some of these units are shown in Figure 34.

Russians have also been active in developing ac drives using induction motors. An experimental system for VL80 series eight-axle locomotive was built in 1968. The unit VL80K was one half locomotive⁽³⁵⁾ with 4 induction motors on 4 axles. Each motor had the following rating:

Power - 1.2 MW
Voltage - 1200 V/phase
Maximum Speed - 1960 rpm
Frequency - 0-132 Hz

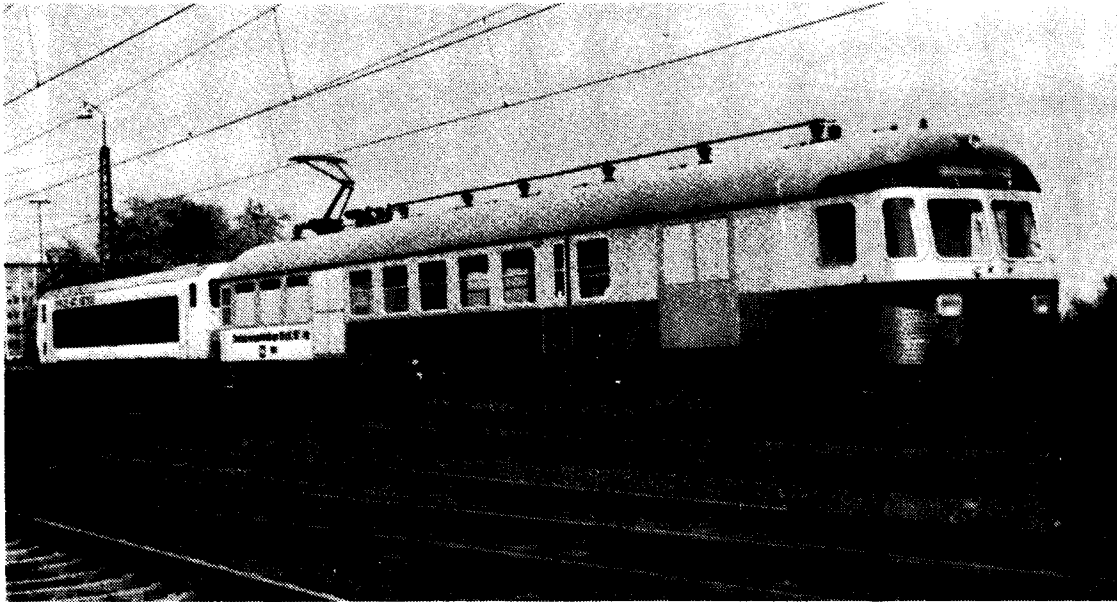

FIGURE 32
ALL ELECTRIC LOCOMOTIVE WITH AC DRIVE

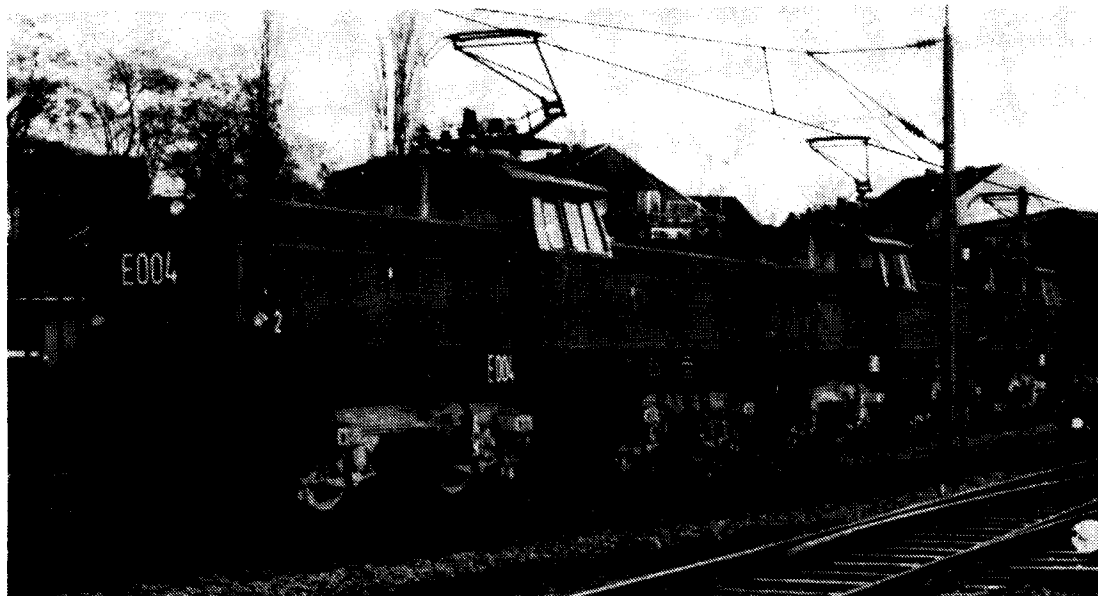

FIGURE 33
DUAL FREQUENCY INDUSTRIAL LOCOMOTIVE

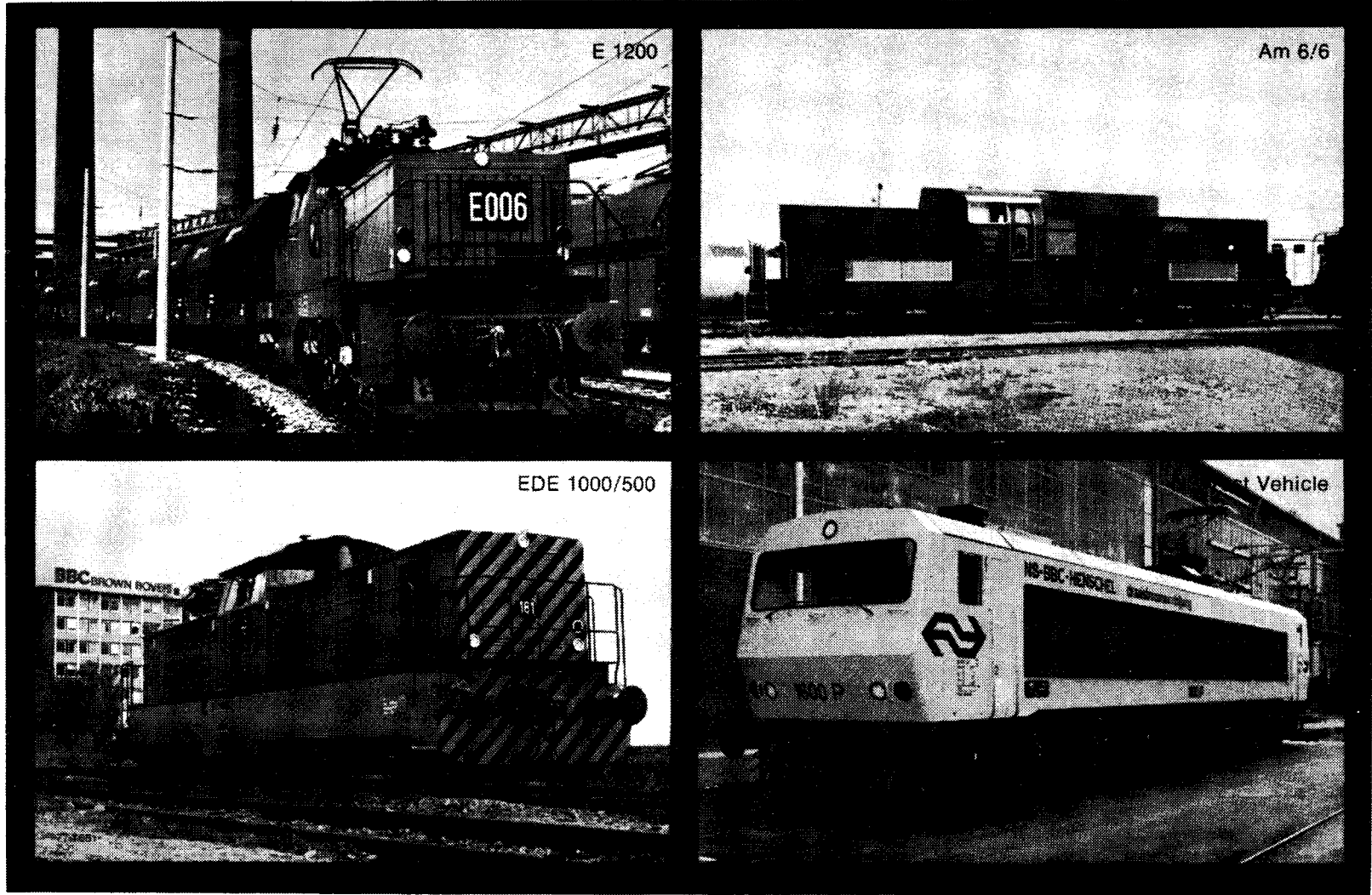

FIGURE 34
OTHER LOCOMOTIVES WITH AC DRIVE

The power circuit is shown in Figure 35. After initial investigations, the Russians are now developing a full 8-axle VL80a locomotive. The Russians have also awarded a contract to Stromberg of Helsinki, Finland, to independently develop a competing propulsion system for the same VL80a locomotive.

The National Railways of Finland, France and Italy are also working on the development of ac drives for traction. Stromberg is currently building a test locomotive for Finnish State Railways. It will be a 4-axle locomotive with 1.2 MW per axle and is expected to be completed by July 1979. The SNCF (France) conducted some experiments (1976) by putting a 500 kW induction motor on one axle of an old locomotive and supplying it from a 600 kVA inverter⁽³⁵⁾. A 1.2 MW drive using an induction motor is currently under development by SNCF. Italian State Railroads have built a shunting locomotive of Series E 323 using an ac drive. This 3-axle locomotive is driven by a 280 kW induction motor with a maximum speed of 3850 rpm at a frequency of 130 Hz.

4.2 Urban Vehicles

The first propulsion system using ac drive was tested on three rapid transit cars on the Cleveland Transit System in 1972. The propulsion equipment⁽³⁸⁾ was developed by WABCO. The major components of the system are shown in Figure 36. Two inverters supply all the four motors through a paralleling reactor. The motors were four pole motors with cast aluminum rotor and were self-ventilated. Each motor contained a pulse-type tachometer for obtaining a speed feed-back signal.

The three modes of motor operation in this WABCO system are shown in Figure 37. They are as follows:

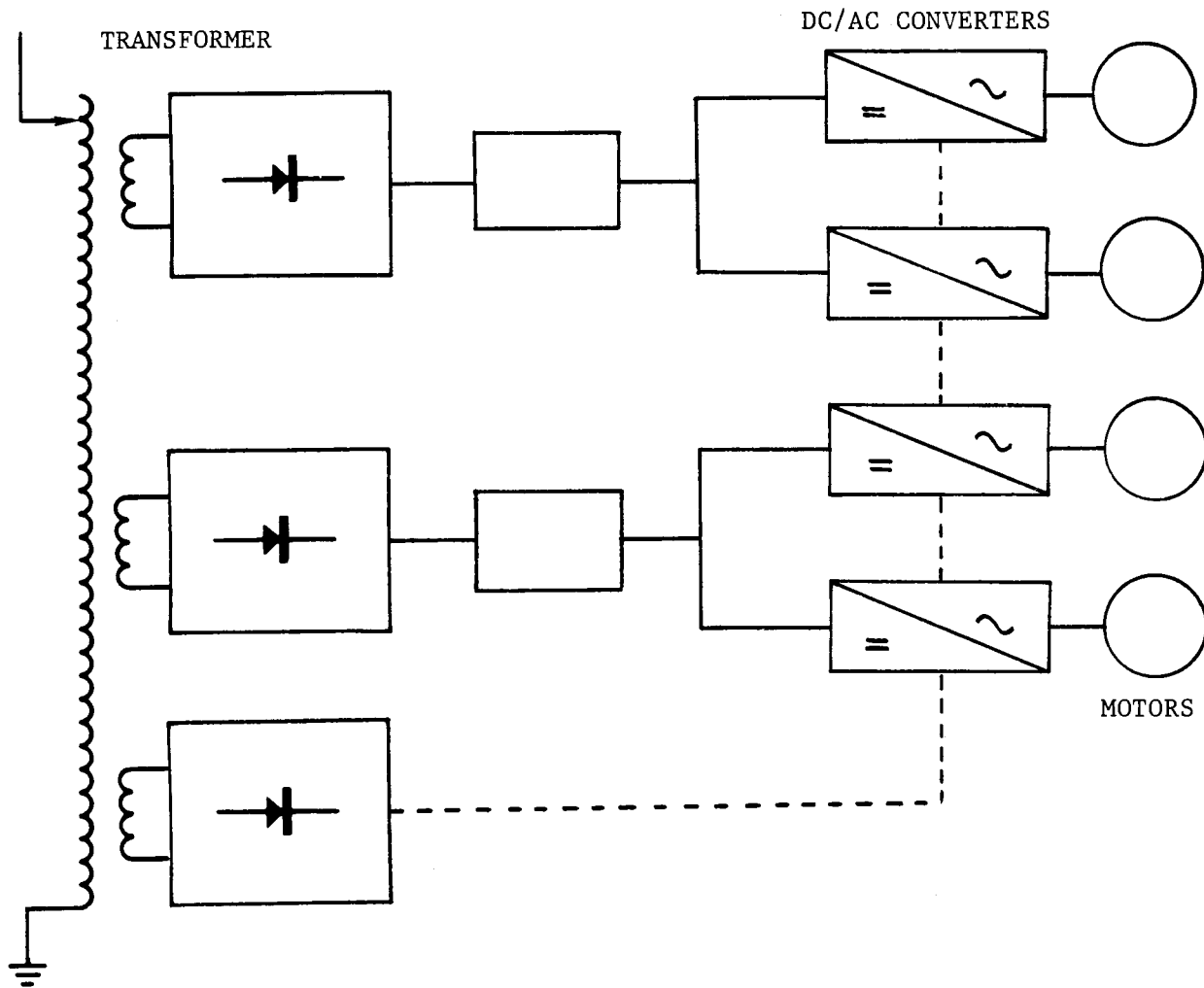

FIGURE 35
POWER CIRCUIT OF VL80K

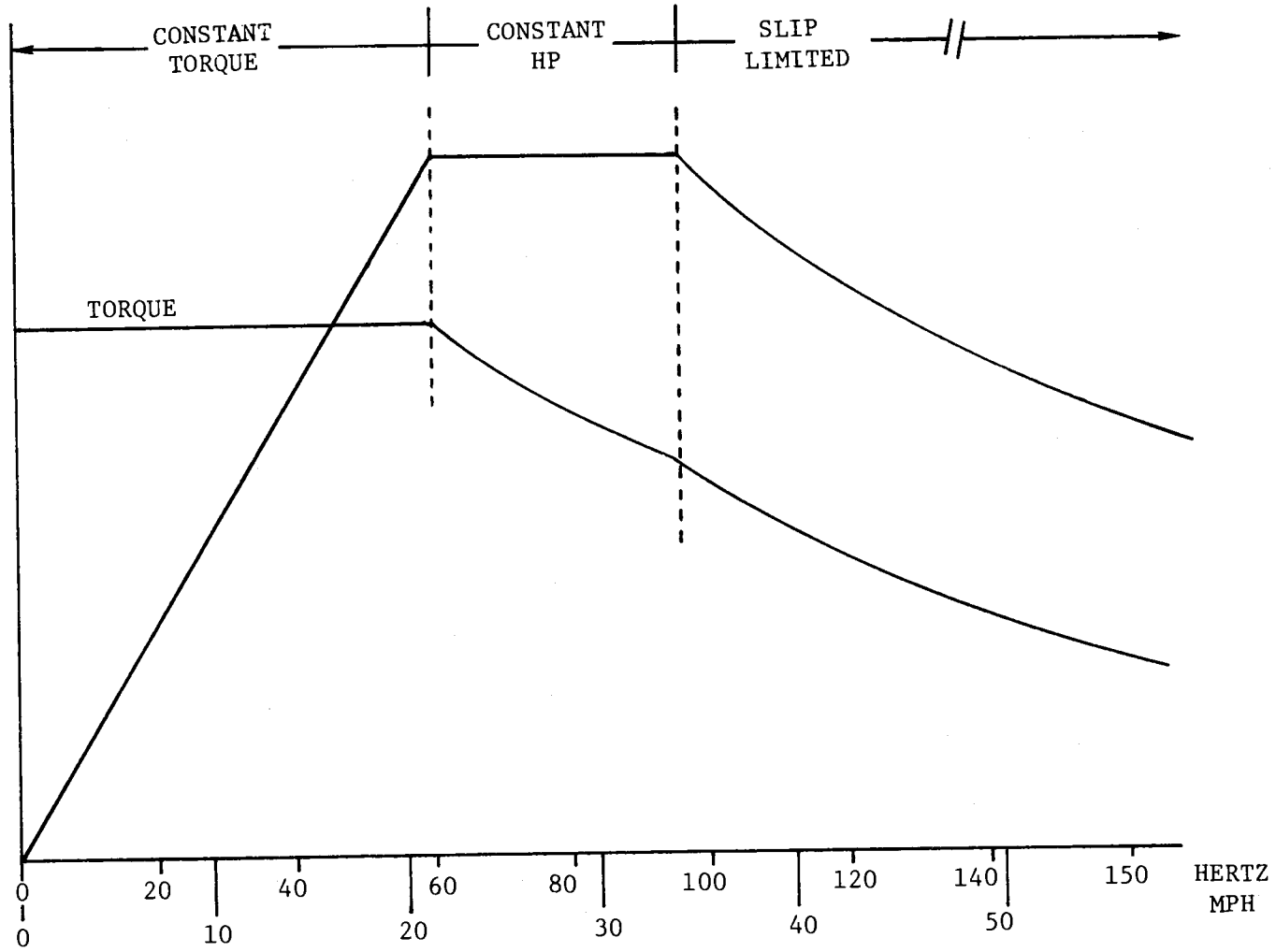

FIGURE 37
THREE MODES OF MOTOR OPERATION

- a. Constant torque - 1-60 Hz operation for 0-22 mph where the motor is operated at constant slip and constant airgap flux. This done by keeping the ratio V/f constant (after making an allowance for IR drop).
- b. Constant horsepower - At some frequency the inverter reaches a voltage limit and if the frequency is increased further, the airgap flux decreases in inverse proportion with the frequency. It is necessary to increase the operating slip to maintain the motor current. This is possible only for slips up to a maximum value which in this case was 3 percent. This operation was for 60-95 Hz and 22-35 mph.
- c. Slip limited - Once a maximum slip is reached at 95 Hz and 35 mph, the airgap flux, current, and hence the torque, are allowed to drop.

Regenerative braking was possible for speeds down to 5 mph and a voltage limiting circuit prevented the voltage from exceeding the prescribed maximum. The entire braking control was done without any contactors. In case of non-receptive line, friction braking was used to meet the requested braking rate. On the average, energy savings by regeneration amounted to 29% on the test car⁽³⁸⁾.

Each motor was rated at 110 kW with a maximum speed of 4500 rpm at 150 Hz. Each inverter was rated 350 kVA. Over a period of three years the three cars ran about 130,000 car-km. This test program demonstrated that an ac drive with induction motor can meet all the functional requirements for a rapid transit rail car with possibilities of regeneration.

As mentioned earlier, Stromberg had supplied three chopper controlled coach-pairs M1-6 to Helsinki Metro during 1971-72 for initial trials (construction of Helsinki Metro began in 1969 and the first line, 11 km long, between Kamppi and Puotinharju will be completed in 1981). Around 1974, however, Stromberg offered a similar coach-pair using induction motor drive⁽³⁹⁾. After careful deliberations

Helsinki Metro ordered three coach-pairs of series M100 of Figure 38 with an ac drive. Thus by mid-1976 Helsinki Metro was able to test both types of coach-pairs, one with the dc drive and the other with an ac drive. As a result of these trials, the Helsinki Metro chose ac induction motor drive for their transit cars and Stromberg is currently manufacturing 42 coach-pairs of series M100 for delivery over 1977-84.

In the ac induction motor drive, each truck of the train has two induction motors connected in parallel supplied by a PWM inverter as shown in Figure 39. Thus each coach-pair has 4 inverters and 8 traction motors. The wheel diameter is $800 \text{ mm} \pm 3 \text{ mm}$ and there is no slip control since the motors are in parallel and supplied with a common inverter. Some other characteristics of these sets are as follows:

Weight	31 tonnes/coach
Length	21.5 m/coach
Maximum speed	90 km/h
Supply voltage	750 V dc
Output, continuous	500 kW/coach
Motor weight/output	500 kg/125 kW
Motor speed, rated	1,990 rpm at 68 Hz

The inverter characteristics for M100 coach are:

Input voltage	750 V dc
Output voltage	560 V ac, 3 phase
Rated output	300 kVA
Frequency	0-130 Hz
Weight	660 kg
Dimensions	1,600 x 875 x 610 mm



FIGURE 38
A COACH-PAIR OF SERIES M100

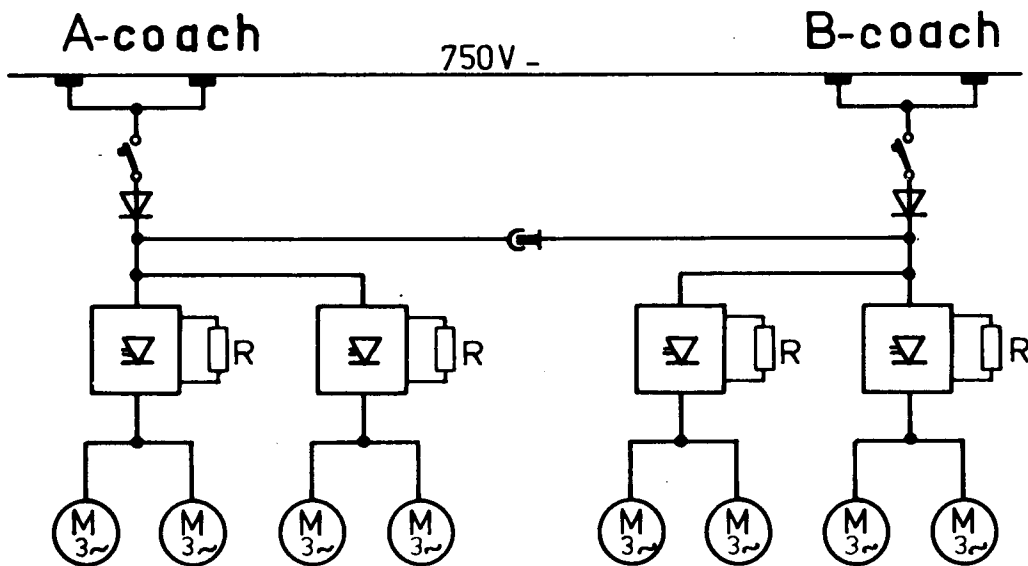

FIGURE 39
THE MAIN CIRCUIT OF M100

In 1977, Stromberg supplied a trolleybus using an inverter controlled induction motor to Winterthur Muncipal Traffic Authority in Switzerland⁽²⁰⁾. This articulated trolleybus has one induction motor driven by one inverter. Some of the characteristics of this bus are as follows:

Trolleybus

Length	17.8 m
Width	2.5 m
Weight	15 tonnes
Max. speed	60 km/h
Supply voltage	600 V dc
Brakes	eddy current and air brake

A similar trolley bus using ac drive and regenerative braking is currently under development for City of Helsinki and is scheduled to be tested beginning early this year.

AEG Telefunken, West Berlin is also developing ac drive systems using induction motors driven by PWM inverters for urban vehicles. Over the years they have investigated, and also tested in part, several alternate systems such as ac or dc supply, voltage or current drive, two quadrant or four quadrant controllers⁽⁴⁰⁾. From this experience, AEG has built a prototype urban vehicle of Figure 40 which is being tested at present under operating conditions on Berlin Metro (BVG)⁽⁴¹⁻⁴³⁾. This is a two car unit of F-76 series with an ac drive instead of a conventional camshaft controlled dc drive.

This two-car unit has eight induction motors driving eight axles and all these motors are connected in parallel controlled by a single inverter (see Figure 41). During braking extra resistances are

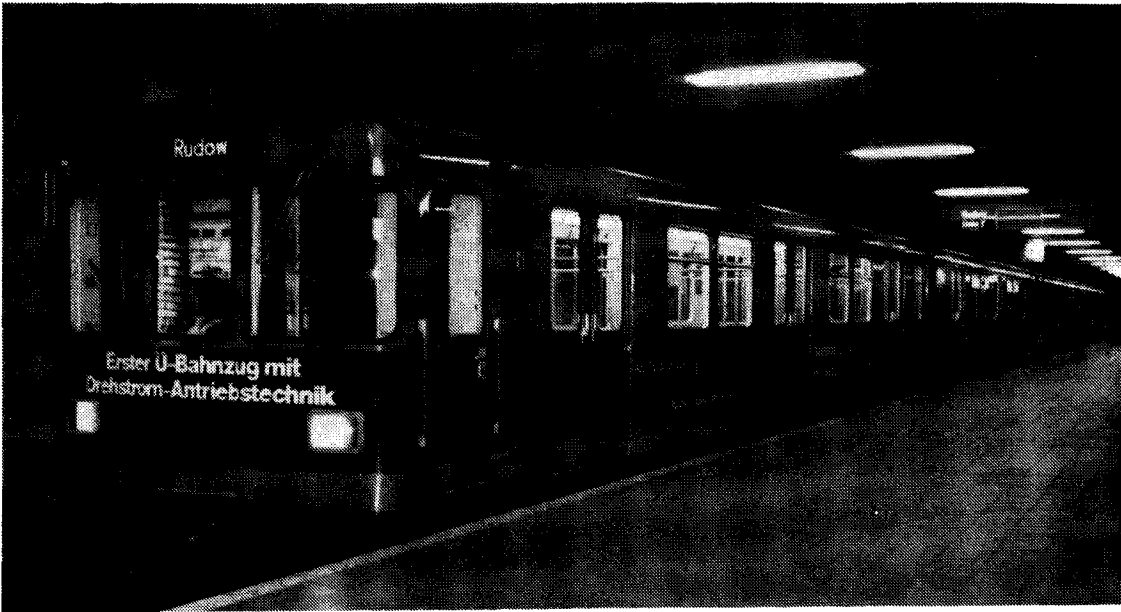

FIGURE 40
BERLIN SUBWAY VEHICLE WITH AC DRIVE

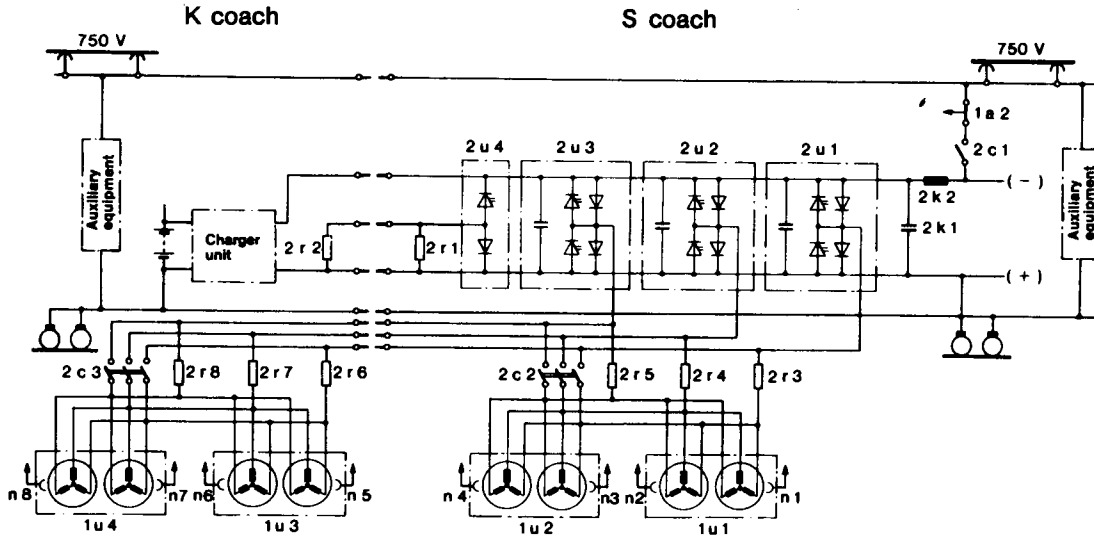

FIGURE 41
THE MAIN CIRCUIT DIAGRAM

connected in series with the motors so that the inverter needs only to be designed for motoring and not for the peak braking power. This inverter has a nominal rating of 775 kVA at 560 V and 940 kVA at a maximum allowable line voltage of 900 V. Each truck has a two-motor unit as shown in Figure 42 where each motor drives one of the two axles through a bevel gear. Both the axles are thus not rigidly coupled, allowing for larger differences in the wheel diameters in a truck. The motor is of a special high slip design to improve load sharing. After initial testing, this vehicle has been in regular service since January 1978 of Line 9 of BVG. The individual traction motor is rated as follows:

Power	70 kW
Current	92 A
Voltage	560 V
Frequency	60 Hz
Speed	1153 rpm
Weight of the twin motor	1035 kg

The Berlin Metro-BVG is currently buying camshaft control equipment for their F76 series and their next expansion is expected to be in 1982. AEG will probably sell 3-6 car pairs for a new pre-series some time around 1980 and they expect BVG to select ac traction for the next order.

BBC is also currently developing a new traction system using induction motor drive for Hamburg Transit Authority. This will be a three-coach articulated vehicle with four two-axle trucks. The three axles on each end are driven by a total of six induction traction motors and will be powered by two inverters one in each of the end-cars. A prototype is expected to be ready for the international exhibition in Hamburg 1979.

It should be noted here that all the systems described so far use a pulse-width-modulated (PWM) inverter to control the induction motor. Siemens (Germany), however, has selected a different approach to implementing an ac drive for traction^(44,45). A thyristor chopper is used to obtain a variable dc voltage which feeds a controlled-current-inverter (CCI) via a choke, as shown in Figure 43. The contactor S is closed for motoring operation and the CCI operates as a six-step inverter delivering 120° rectangular pulses of currents to the motor. For braking operation, the motor acts like a generator and CCI acts like a controlled rectifier. The direction of current through the inverter is the same but the voltage between the points P, Q reverses. The chopper is used to obtain braking action at any speed and any torque. This is done as follows: the chopper is switched on for some duration so that the terminals, P, Q are short-circuited via D_1 . The current in the loop - Chopper, L, CCI, Motor and D_1 - increases. Now the chopper is switched off and the current through L is continued by returning it to the line via D_1 and D_2 . If this current cannot be fed back for some reason it is diverted to a braking resistor R_B by firing the thyristor T. Regeneration is attempted once every chopper-cycle.

The six-step inverter creates unacceptable torque fluctuation at the motor shaft at low frequencies. This circuit can then be operated in a pulse-mode, where the current fed to the motor is chopped into pulses of varying width as shown in Figure 44. This can be done by triggering the thyristors in a sequence 1-2-(3-2)_{n-times} -3-(4-3)_{n-times} -4 . . . etc., instead of the usual sequence 1-2-3-4-5-6 (See Appendix II). For frequencies higher than say, 5-10 Hz, inverter is operated in a normal six-step, 120° conduction mode.

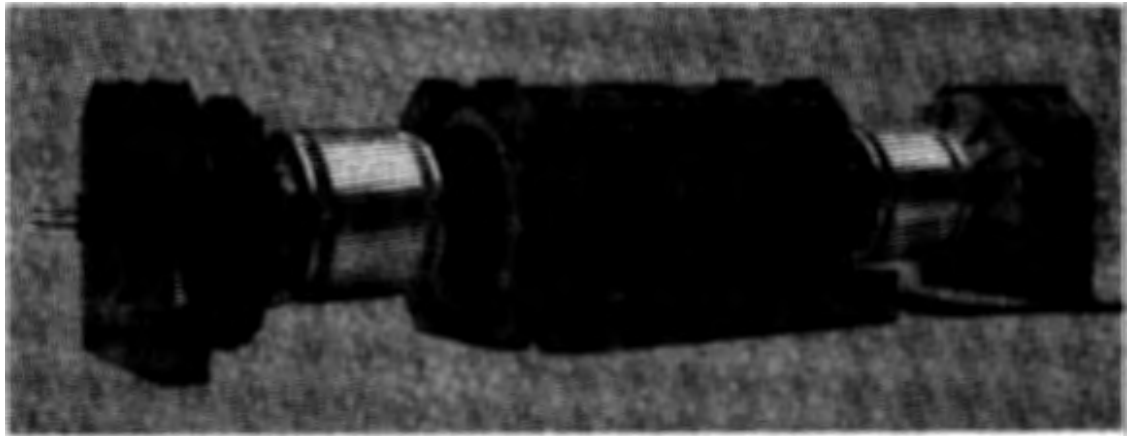

FIGURE 42
TWIN MOTOR UNIT OF SQUIRREL CAGE TRACTION MOTORS

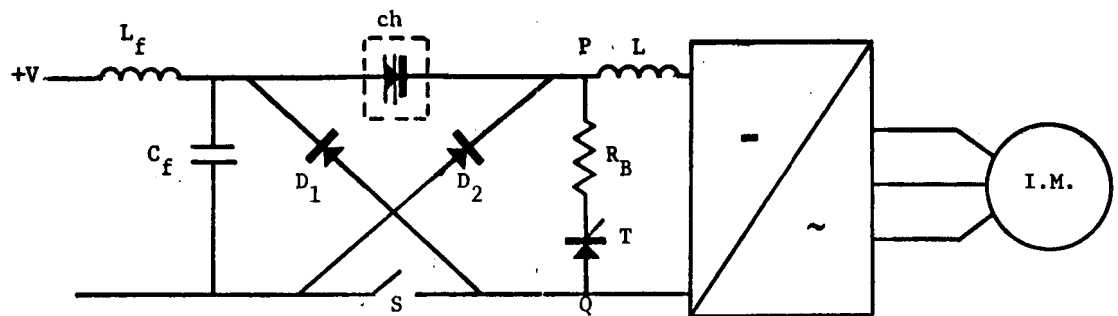

FIGURE 43
AC DRIVE BY SIEMENS

Siemens built a prototype of such a system for a street car for the City of Nurnberg in Germany. A street car has limited space and has quite severe braking requirements as compared to a vehicle on a dedicated right of way. This prototype is actually a modified four-axle trailer where only one truck was powered by a 185 kW induction motor driven by a 300 kVA, 0-120 Hz inverter. This car was put in revenue operations in August 1976 and since then a total of 8 cars are in revenue service in Nurnberg.

Siemens is also currently testing a prototype transit car on the Vienna Metro⁽⁴⁶⁾. This is a car-pair with each of the four trucks having an induction motor driving both the axles. The two motors on a car, rated 200 kW each, are fed from a common chopper-inverter circuit. The inverter is rated 625 kW or 900 kVA and operates over a frequency range of 0.2 - 140 Hz. As mentioned earlier, dynamic braking is used when the line is not receptive. The heat generated in the braking resistor is used to heat the vehicle in winter. In fact, priority can be given to dynamic braking when large amount of heat is required. The Vienna Metro has now ordered 50 such cars for future use.

AC drives for urban rail vehicles have also been under development in the U.S. and Japan^(47,48). The General Electric Company, Westinghouse Electric Corporation and Garrett Corporation in the U.S., all have developed such drives which have been extensively tested in their laboratories, but none of these drives have yet been tested on a transit car. AC drives have also been developed in Japan and first such drives are expected to be tested on a transit car within the next two years.

4.3 Effect of Unequal Wheel Diameters

Whenever more than one motor or generator is driving a common load, one needs to ensure that the load is shared by them equally. This problem has been discussed once earlier when braking of dc motors was considered. Similarly, the traction motors have to share the load during motoring. If the traction motors are identical, their speed-torque characteristics are identical, and for a given vehicle speed, the motors will be running at equal speeds if the wheel diameters are identical. Under these conditions load is equally shared by the motors. If, however, the wheel diameters are not identical, the motors will run at different speeds for a given vehicle speed. The dc traction motors are doubly excited motors and hence the load can be equalized at different speeds with the help of the field control. Hence, any variation between the wheel diameters does not have an appreciable impact on the load sharing of dc traction motors. Since wheel diameter is not critical, transit properties attempt to minimize the maintenance expenditures by not maintaining the wheel diameters to close tolerances. Also, in order to reduce the down time and improve the availability by promptly returning the equipment to service, many maintenance procedures call for unit exchange with a complete assembly - motor, gear unit, wheel axle - taken from the stock. Hence, wheel sets are frequently moved from unit to unit resulting in mixing of wheel sizes on a car. It is, therefore, not unreasonable to expect the wheel diameters to differ as much as 3 inches on a typical transit property.

At this stage one should remember that an induction motor is a singly excited machine and hence, if two or more motors are used in parallel, the load sharing is entirely dependent on the inherent characteristics of the motors. Hence, if one inverter is used to drive several motors in parallel on a transit car, and if the wheel

diameters are not identical, the motors will not share the load equally and this could pose a serious problem with large difference in wheel diameters.

Figure 45 shows a typical slip-torque characteristics of an induction motor. For a given vehicle speed, the motor driving the axle with large wheels will operate with lower speed. This means it will operate at higher slips while motoring and hence will draw more current and supply more torque. In braking region, however, the same motor will operate at lower slip and hence will be loaded lightly. So if motoring and braking periods are somewhat equal, the thermal load on all motors is not highly unbalanced, although the motors will need to have some additional thermal capacity. Furthermore, adhesion problems may result from mismatched wheel diameters. In motoring, the more highly loaded axle with larger wheels will tend to slip; in braking the more highly loaded axles with smaller wheels will tend to slide. In either case the actual slipping or sliding will be self-correcting, producing an intermittent rolling/slipping or sliding action. Any accelerated wear from this action will, over the long term, be self-correcting for slipping during motoring but worsen the situation for sliding during braking.

The sensitivity of load sharing to wheel diameters can be reduced if high slip motors are used because for these motors with higher rotor resistance, variation of torque for a given change in slip is smaller. These high slip motors are, however, inefficient and hence bigger and heavier.

European and Japanese transit properties maintain the wheel diameters to close tolerances - within 3-10 mms (< 1/2 inch). This is not done in the U.S. and, as mentioned earlier, very often differences as large as 3" are found. If ac traction is used in the U.S.,

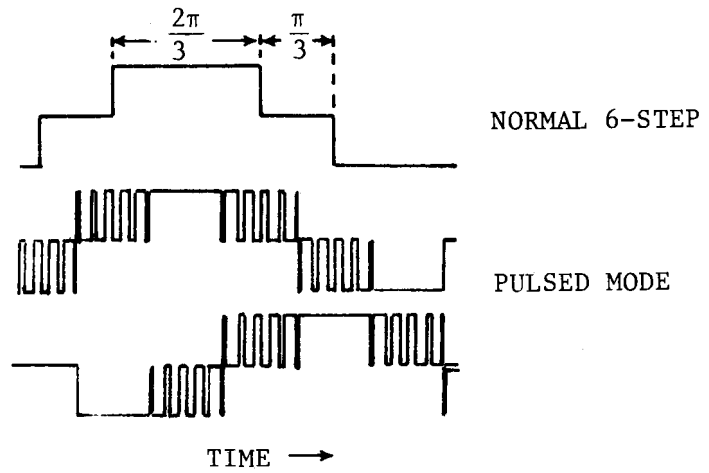

FIGURE 44
PULSED MODE OF INVERTER OPERATION

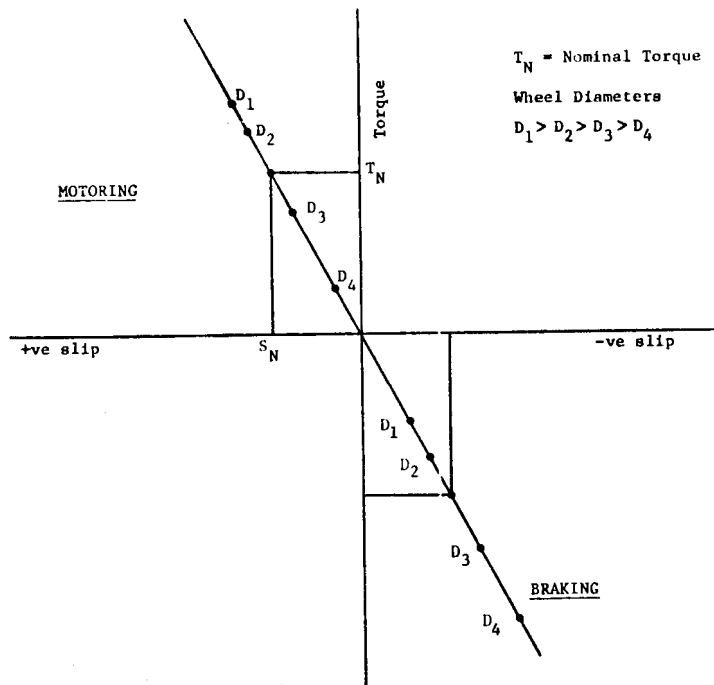

FIGURE 45
EFFECT OF UNEQUAL WHEEL DIAMETERS

it is generally agreed that the wheel diameters will have to be maintained much better than that - within say at least $3/4$ - $1\ 1/4$ inch. However, a final choice cannot be made until practical limit of adhesion considerations are experimentally determined.

5.0 AN AC DRIVE WITH A SYNCHRONOUS MOTOR

The synchronous motor can be advantageously used in place of the dc motor for various applications including vehicle traction. For variable speed applications, the synchronous motor has to be supplied from a variable voltage-variable frequency (VVVF) source. The speed of the motor can be controlled by varying the frequency, whereas the torque of the motor can be controlled by varying the airgap flux in the motor. The principle of such a control is very similar to that for an induction motor. However, doubly fed synchronous motors can operate at leading power factors when overexcited and this has enormous implications in the design of the inverters and/or cycloconverters used to control these motors. The different types of synchronous motors are discussed in Appendix I. The state of the art of such drives will be described here.

5.1 A Self-Synchronous Propulsion System

A development of a self-synchronous system was undertaken (October 1975) under the Advanced Subsystem Development Program (ASDP) sponsored by the DOT/UMTA. Delco Electronics was the contractor. This propulsion system⁽⁴⁹⁻⁵²⁾ is schematically shown in Figure 46. The 600 V dc supply is converted to a high frequency ac voltage with a frequency of 350-1200 Hz. This voltage is then converted to a low frequency ac by means of a cycloconverter. The output of the cycloconverter with a maximum frequency of 200 Hz, is directly connected to the stator of the motor. The rotor field winding of the motor is supplied from a rotating transformer and a rotating rectifier placed on the shaft of the motor. The primary of the rotating transformer is excited by a current transformer having its primary windings in series with the cycloconverter. With a rotor position feedback, the characteristics of such a system are almost identical with those of a dc series motor. The motor and the associated control are oil cooled to obtain high power density. Dynamic and/or regenerative braking is

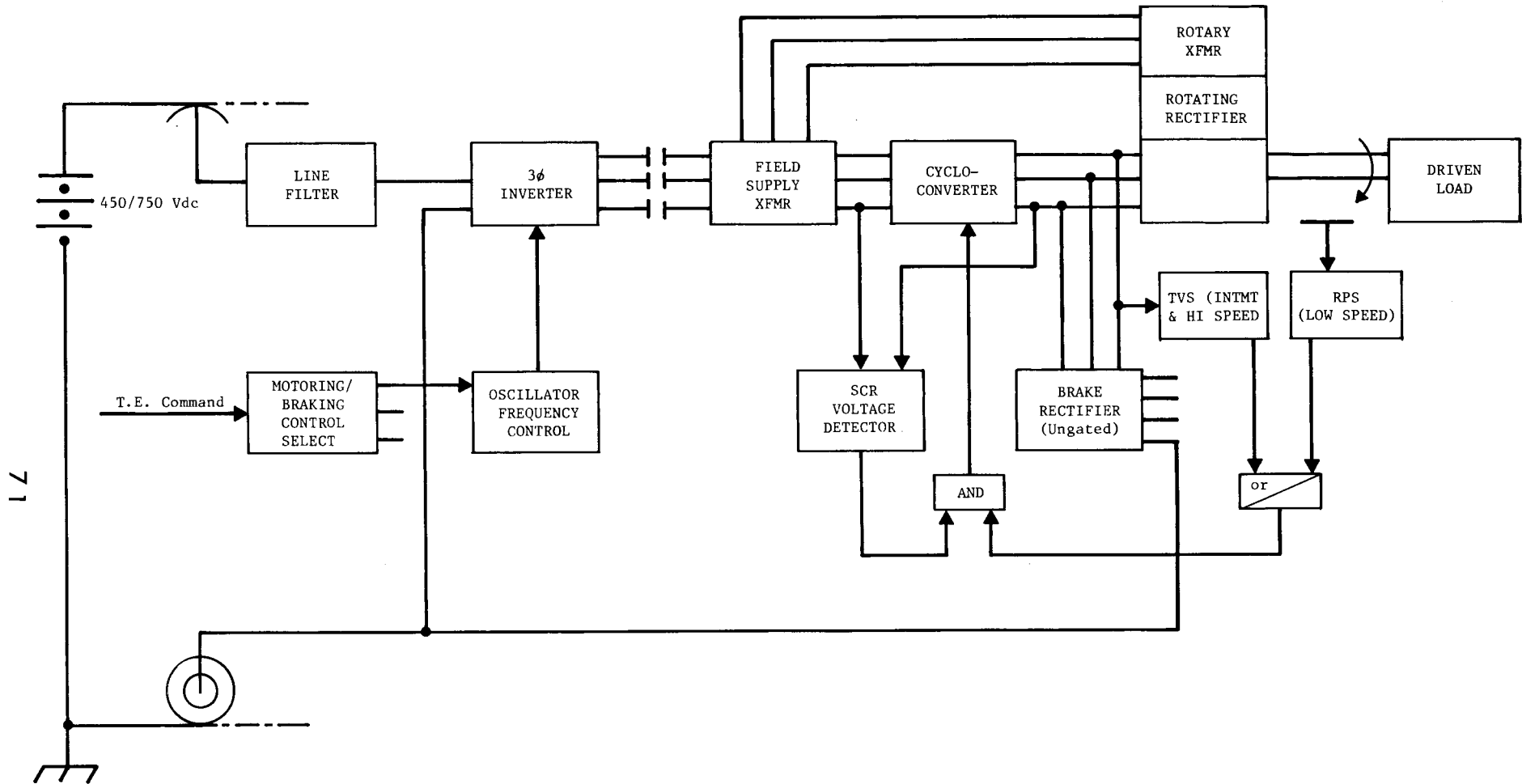

FIGURE 46
SYSTEM BLOCK DIAGRAM - MOTORING MODE

available and is controlled by means of a separate solid state converter and a two-stage braking resistor switched in and out by means of a thyristor.

5.2 Propulsion System Specifications

The propulsion system was designed to meet the following performance requirements: (50,51)

a. Transit Route Performance

- For the conditions of a nominal wheel diameter of 30" and no wind, the energy consumption for a round-trip over the synthetic test route at the Transportation Test Center shall not exceed 10.2 kWh/car-mile without regeneration. With regeneration to a fully receptive line, this consumption shall not exceed 6.4 kWh/car-mile.
- The total round trip time for the above 18.5 mile distance shall not exceed 39 minutes.

b. Discrete Performance Requirements

- The railcar shall be able to maintain a speed of 80 mph with a wheel diameter between 28-30 inches on a level tangent track without wind.
- The car shall maintain 80 mph intermittently on a level tangent track with a 15 mph headwind.
- The car shall maintain a speed of 70 mph on a 3 percent grade for a distance of 6000 feet.
- The car shall meet the following acceleration specification
 - 3.0 ± 0.2 mphps to 25 mph
 - travel 700 feet in 20 secs from stop
 - accelerate from 0 to 60 mph in less than 38 secs
- Dynamic braking alone should be capable of providing deceleration of $- 3.0 \pm 0.2$ mphps from 80 mph to 10 mph on level track without wind.
- Regenerative braking shall be available from 80 mph to 25 mph.
- Jerk rate shall not exceed 2 mphpsps

- The maximum capability of the cooling system shall be based on the following duty cycle repeated over a period of 30 minutes
 - a full power acceleration to 80 mph followed immediately by full dynamic braking to a full stop and a rest period of 20 secs.

5.3 System Components

The propulsion system consists of the following major components ⁽⁵¹⁾.

- **Line Filter:** The line filter consists of a dual inductor and two capacitor banks at the input of two power converters for the two drive systems per car as is shown in Figure 47. The nominal circuit constants for this filter are an inductance of 2.5 mH and a capacitance of 17600 μ F. This gives a resonant frequency of 25 Hz and a resonant impedance of 0.377 ohm. The damping resistor R is adjusted to give a damping of 0.4 with the motor drives de-energized. The dual inductor assembly, shown schematically in Figure 48, consists of two parallel windings on two separate E-cores which share a common I-section. The damping is obtained by putting a metal sheet in the air-gap. The material and the dimensions of this sheet were empirically determined to obtain a desired damping response.
- **Inverter:** The inverter is a series inverter as shown in Figure 49. The inductors are 150 μ H each with Q of 180 in free space at 1000 Hz. The capacitors are liquid cooled of a type developed for use by induction heating industry. Each of the capacitors contains two 20 μ F and two 40 μ F sections as shown in Figure 50(a). The equivalent circuit of this connection is shown in Figure 50(b). The 80 μ F segments are coupling capacitors whereas 40 μ F segments are commutating capacitors. The power semiconductors, inductors and capacitors are liquid cooled. Special low-loss design of the inverter yielded an efficiency of about 95 percent over a wide frequency range.
- **Cycloconverter:** The main power circuit of this cycloconverter is shown in Figure 51. At every instant one positive group of thyristors, say +A, and one negative group, say -B conduct the load current. Which particular thyristors in these groups are conducting depends on the instantaneous values of the voltages of lines X, Y and Z. The operation and characteristics of cycloconverters are explained in detail in Appendix II.

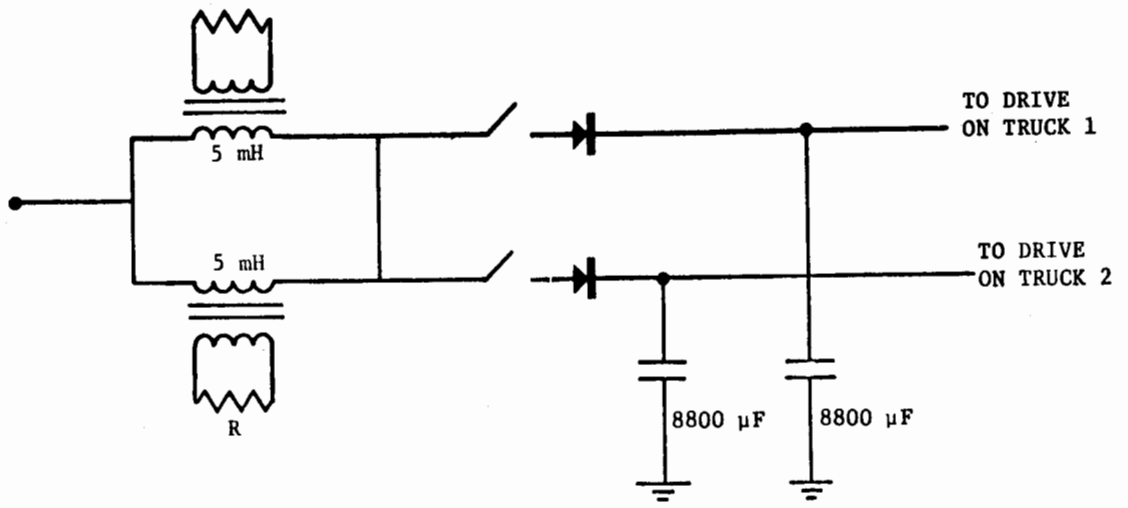

**FIGURE 47
LINE FILTER**

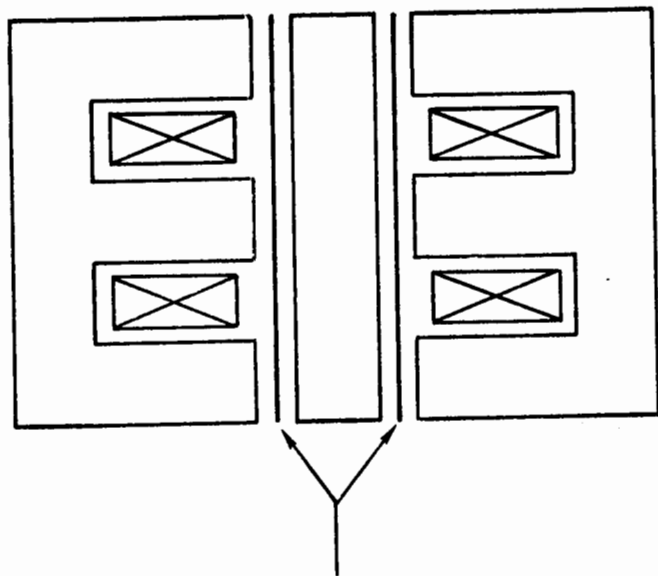

DAMPING METAL SHEET

**FIGURE 48
DUAL INDUCTOR ASSEMBLY**

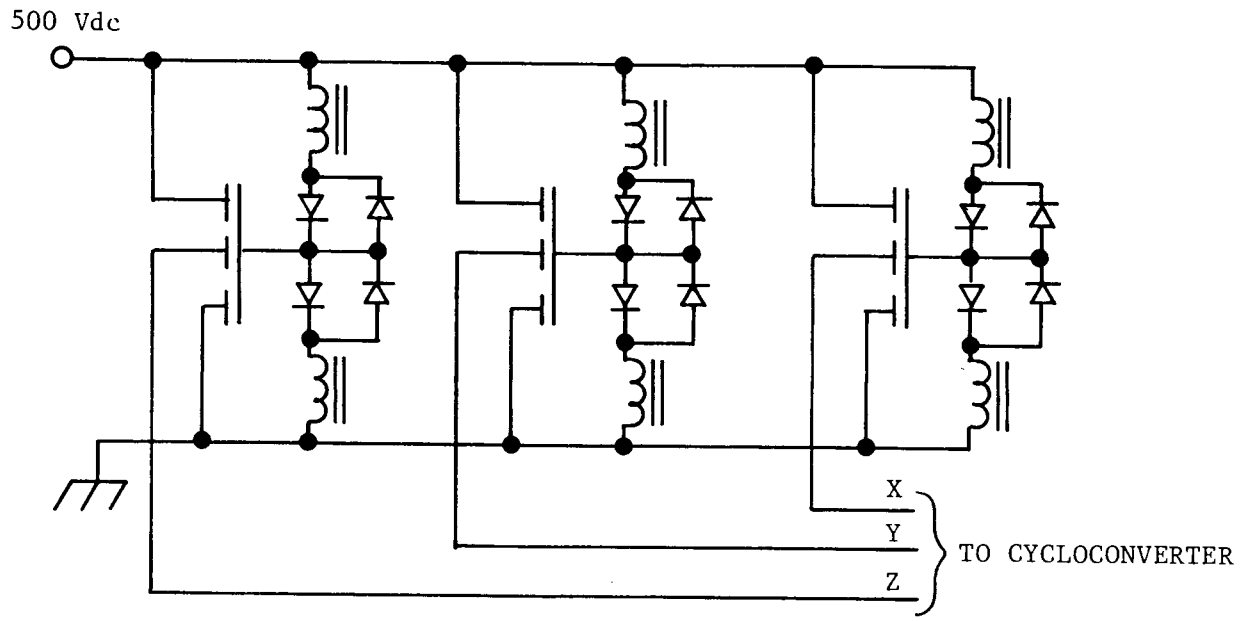

FIGURE 49
INVERTER CIRCUIT

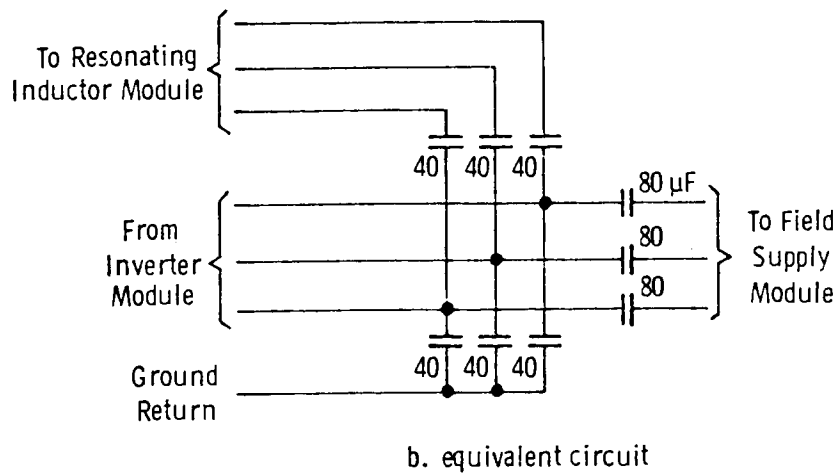
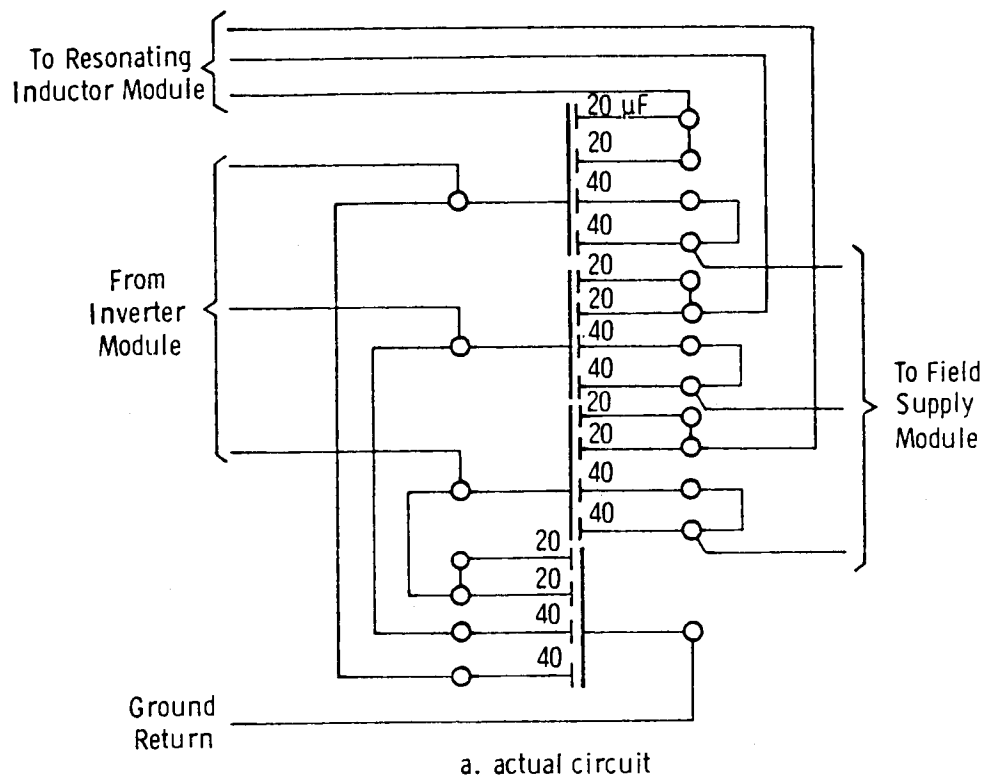

FIGURE 50
CAPACITOR MODULE CIRCUIT DIAGRAM

- Traction Motor: The traction motor (one per truck) is a brushless four-pole machine with forced convection liquid cooling. In motoring it can produce a torque of 1560 lb-ft for a speed range of 0-1646 rpm and it can deliver a constant horsepower of 489 hp (365 kW) for a speed range of 1646-5642 rpm. It carries a rotating transformer-rotating rectifier on its shaft for supplying the field winding. A rotor position sensor is installed in one end of the motor. The rotor position sensor is installed in one end of the motor. The rotor is a one-piece forging with four poles. Laminated pole heads are bolted on the forging to hold the prewound field coils in place. The pole head also carries damper bars. To cool the motor a fire resistant silicone oil is sprayed on the stator conductors, the end turns of the rotor windings, and the rotating transformer/rectifier. The coolant is collected in a sump at the bottom of the motor frame and is recycled back to cooling assembly. Figure 52 shows a sectional view of the motor. It is about 48 inches long and weighs 1905 lbs.

Extensive computer simulations of the performance of this propulsion system indicated that the system would in fact meet all the requirements.

5.4 Test Results

System level testing was performed using the total drive system. During the system level testing^(50,51), a large number of data points were obtained at gradually increasing power level. These results are illustrated in Figure 53. The torque-speed curves were also obtained for various inverter frequencies during dynamometer testing. These results are shown in Figure 54 where the torque discontinuity at a speed of 2000 rpm is due to a change of control technique. Dynamic braking performance was also obtained and compared with the predicted performance as shown in Figure 55. Here the experimental data obtained during component level testing and system level testing are compared with analytical predictions.

During the extensive system level testing - February 1977 to December 1977 - several unforeseen problems arose requiring extensive circuit reconfigurations. Some of the problems involved the motor and

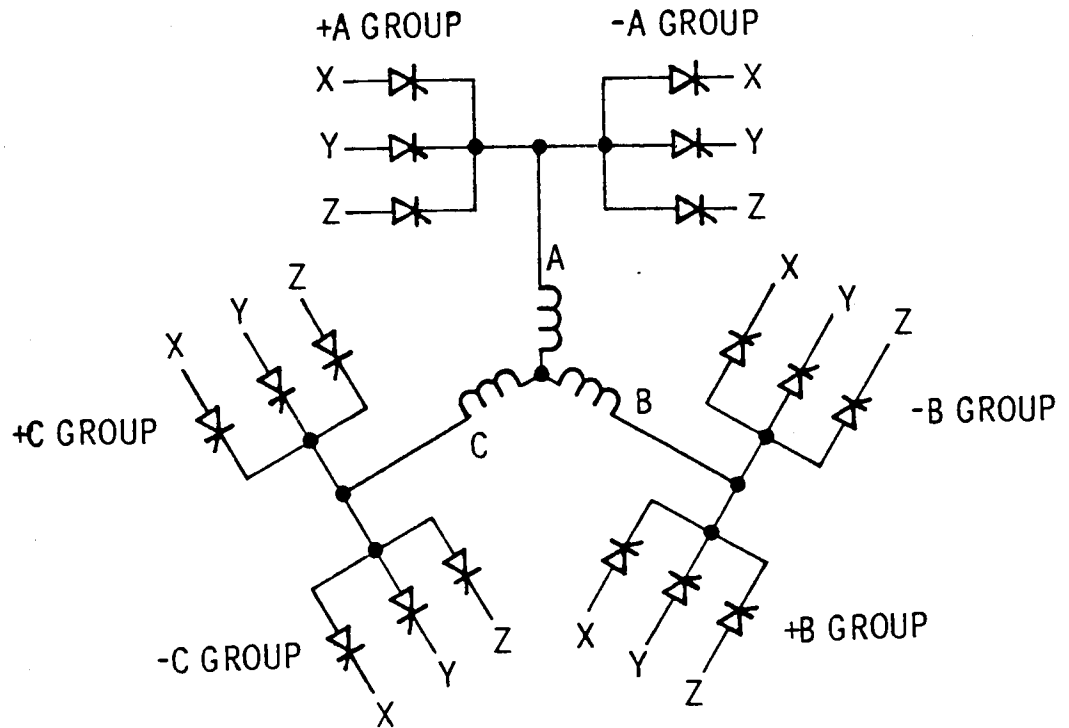

FIGURE 51
CYCLOCONVERTER POWER CIRCUIT

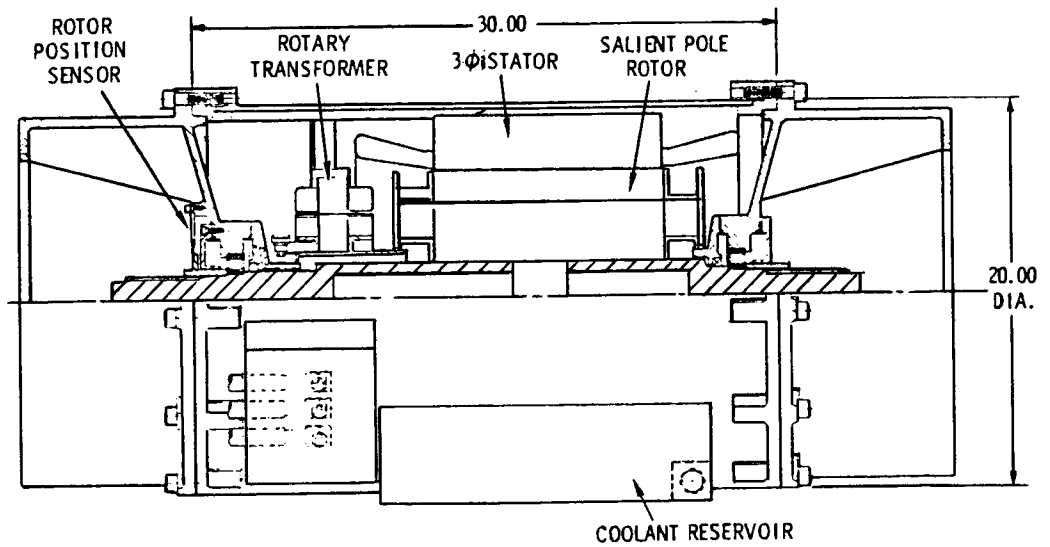

FIGURE 52
AC TRACTION MOTOR

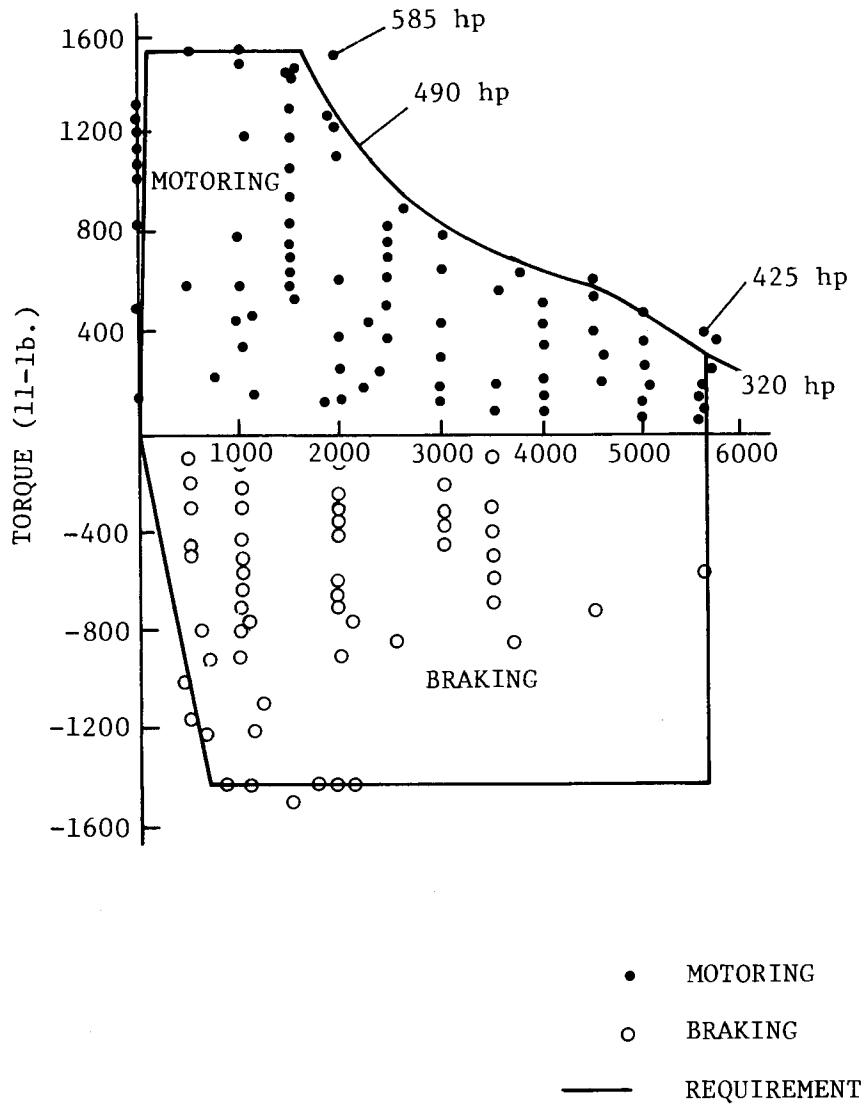

FIGURE 53
MOTORING/BRAKING TEST RESULTS

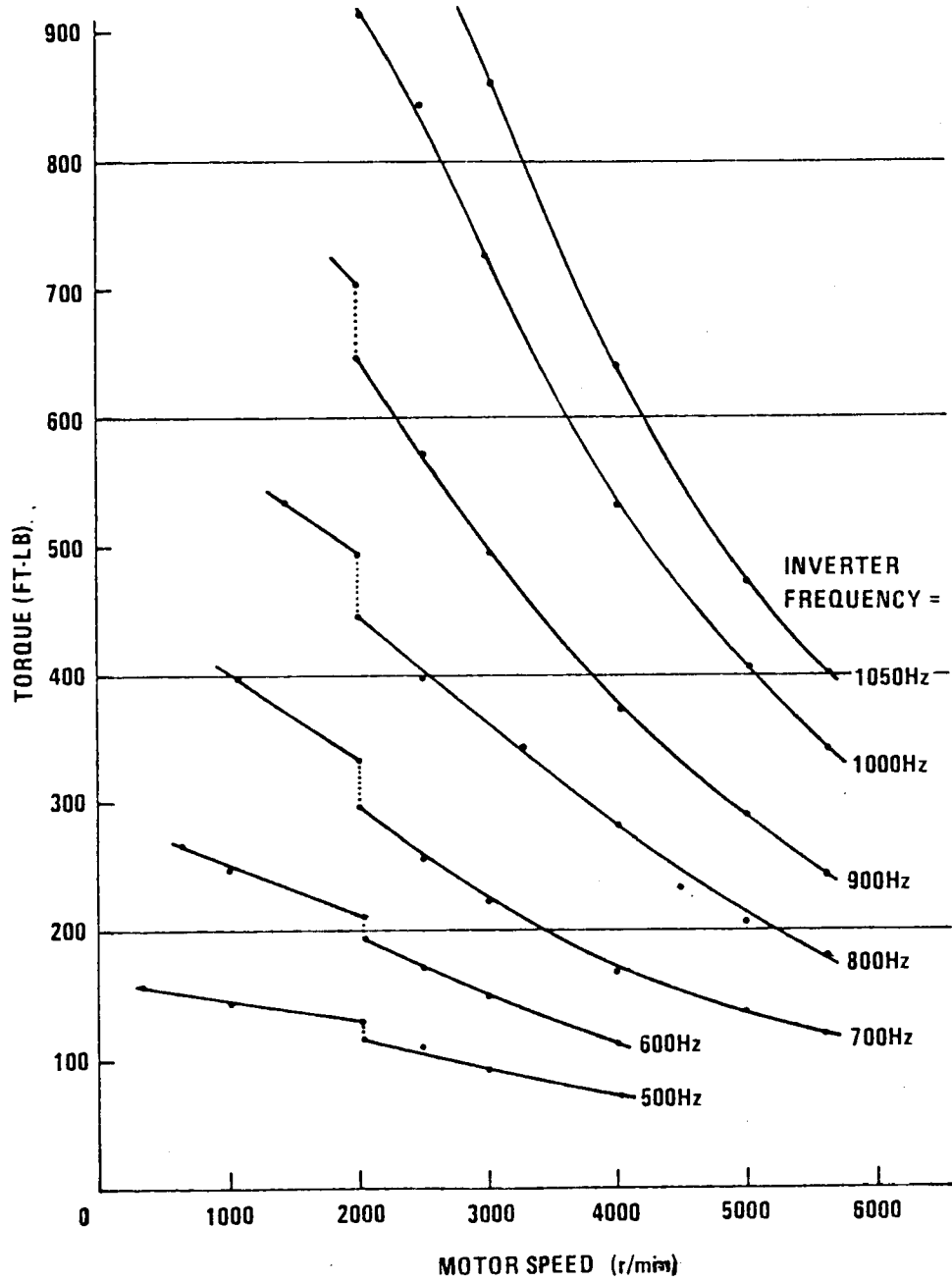

FIGURE 54
TORQUE-SPEED CHARACTERISTICS FOR CONSTANT
INVERTER FREQUENCIES

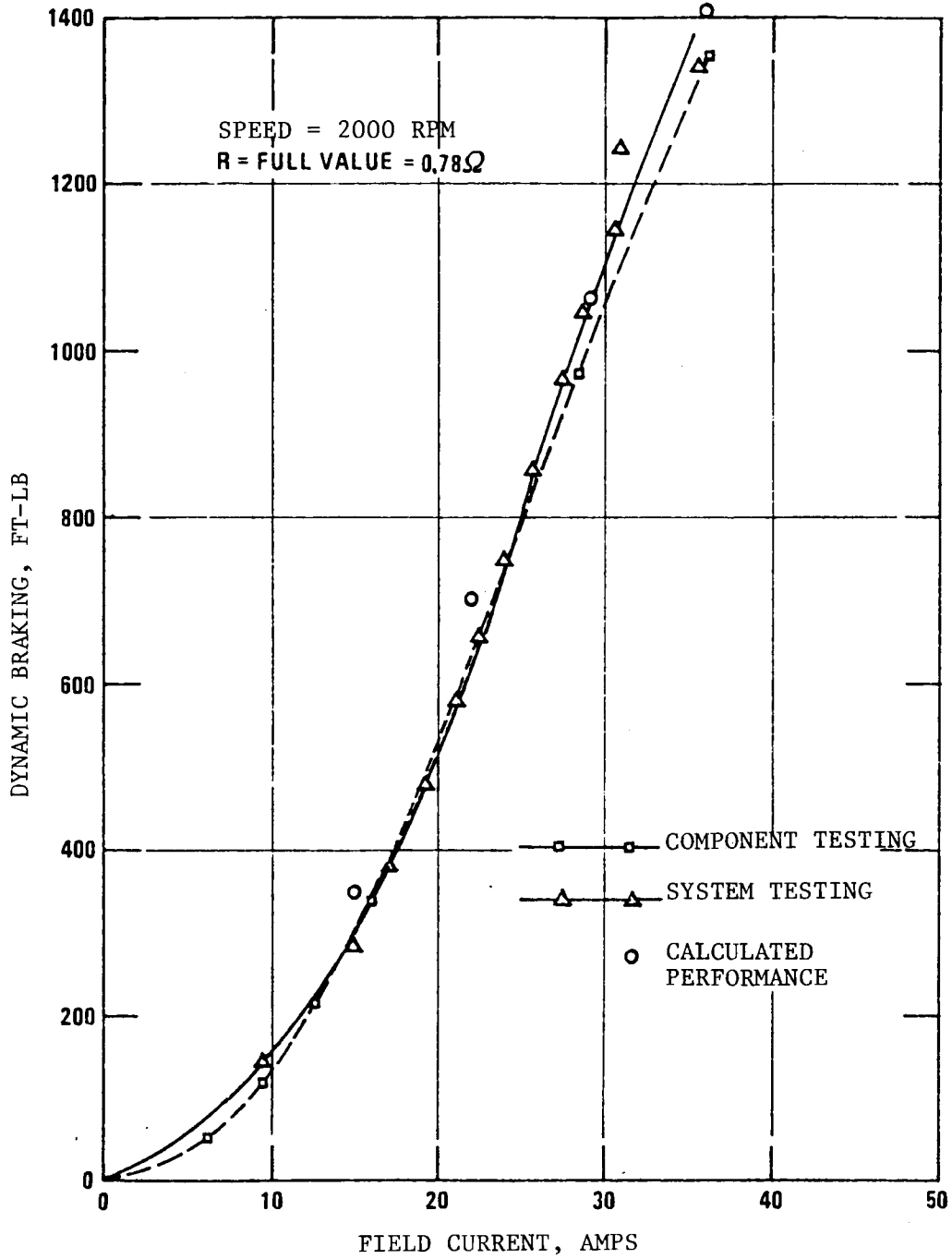

FIGURE 55
COMPARISON OF BRAKING PERFORMANCE

and some involved power converters and control electronics. The problems involving motor included Zener diode failures and other diode failures in rotating solid state equipment used for field supply and some minor problems with magnetic seals on bearings. The problems with power and control electronics included insufficient or weak gate drives, insufficient dv/dt and di/dt suppression, excessive noise in control circuits and some generic problems due to interaction between the inverter/cycloconverter and the motor. All of the above problem areas were studied and most problems were resolved by end of 1977. However, it was quite clear that substantial funding would be required to complete the full-scale development program. The potential market for such a propulsion system also appeared quite doubtful at the time. This development of the Self-Synchronous Propulsion System was therefore discontinued at the end of 1977.

The self-synchronous propulsion system used regenerative braking to reduce energy consumption and a brushless synchronous motor to reduce the high maintenance costs associated with dc traction motors. The system described in this section also used liquid cooling to obtain high power densities. The resulting propulsion system required several major new subsystems such as the inverter, the cycloconverter, the rotating transformer, the rotating rectifier, the oil cooling system, and complex electronic control systems. It is, therefore, doubtful that this system would have improved reliability or reduced maintenance. Hence, it does not appear to be a viable alternative to existing urban rail transit propulsion systems.

This is, of course, not to say that synchronous machines cannot be advantageously used for traction purposes. Other synchronous machines, such as a permanent magnet, a homopolar machine or a Lundell/Rice machine, might prove to be quite useful in spite of some possible problem areas. With the permanent magnet machine, field

weakening is difficult and the motor needs to be de-energized mechanically in case of a fault condition. The homopolar and Lundell/Rice machines have a high commutating reactance. Also, any synchronous machine would need an individual converter for control and may need special starting circuits. But in spite of these difficulties, use of synchronous motors would result in reduced inverter costs (inverters using natural-line or load - commutation are cheaper than those using forced commutation) and hence, a synchronous motor should still be considered as a viable alternative to a dc traction motor.

5.5 A Locomotive Application

In the area of locomotive propulsion, the Russians are developing a propulsion system using slip-ring type synchronous motors for their VL-80 locomotive. As mentioned earlier, an induction motor system is also being developed for this same VL-80 type locomotive. Because of the broad gauge rail system, the Russian locomotive trucks can accommodate synchronous motors, which are larger than equivalent induction motors. Also, the Russian solid state technology is not as advanced as that of the West and hence a possibility of reducing costs of power converters by using a synchronous motor is more significant in this context.

6.0 PROPULSION SYSTEM WITH ONBOARD ENERGY STORAGE

In the previous sections, the use of regenerative braking to return at least part of the kinetic energy of the vehicle to the line during braking was discussed. It was also pointed out that such regeneration is possible if, and only if, the line is "receptive" to this energy. The natural receptivity of a transit system depends on several factors, such as the characteristics of substations, traffic patterns, and the maximum allowable system voltage, all of which are in a constant state of flux. The analysis of regeneration has to be done essentially by obtaining the instantaneous energy balance on the whole system. Thus the line is more receptive during peak hours when one is more likely to find an accelerating train in the vicinity of a decelerating train. Examples given previously show that, in general, a typical transit system can be expected to regenerate 20-25 percent of the propulsion energy on a long-term basis.

The problem of line receptivity can be eliminated if energy storage capabilities can be provided on board the car, as shown in Figure 56. The kinetic energy of the vehicle can now be temporarily stored in the energy storage unit (ESU) during braking. This energy can then be used to accelerate the vehicle when required. Some amount of energy, however, is irretrievably lost in the process of effecting these energy flows to and from the ESU. But since there is no need to feed the vehicle kinetic energy back to the line, the resultant energy consumption by the vehicle for a run does not depend on the line receptivity.

In principle, any generic energy storage mechanism such as batteries, compressed air, or a flywheel can be used for such a system. In practice, however, the required storage capacity and the charge/discharge rates are high enough to preclude the use of the state-of-the-art batteries, and no major breakthroughs in battery

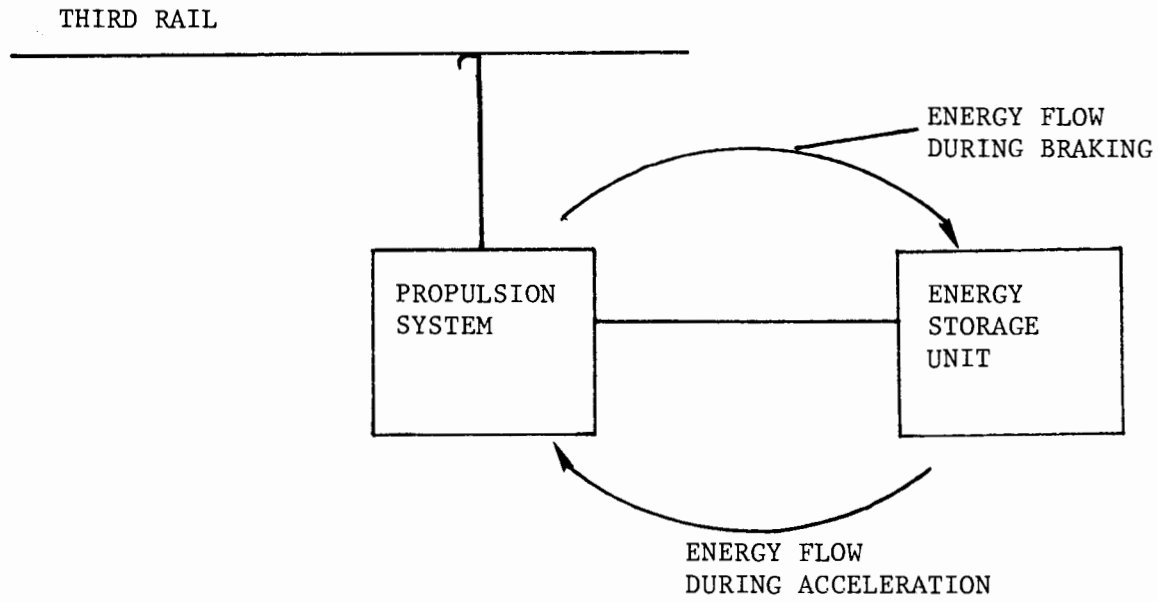

FIGURE 56
USE OF ONBOARD ENERGY STORAGE

technology are expected to occur in the near future. A compressed air system would be large and relatively inefficient. A flywheel coupled to a dc motor, on the other hand, is quite suitable for this application.

6.1 R-32 Energy Storage Car for NYCTA

The first prototype equipment using onboard flywheel storage was designed and built by Garrett and tested on two R-32 cars of NYCTA. These cars are 60 feet long and weigh 35 tons without passengers. These cars were modified with the following considerations:

- Only the hardware necessary to evaluate the effectiveness of the proposed propulsion system was replaced.
- Added equipment was packaged to conform to the NYCTA clearance envelope.
- Performance of the new propulsion system had to match that of the standard car in acceleration and braking, and
- The new system had to respond to the normal trainline commands.

The energy storage requirements were 3.2 kWh/car and the maximum charging rate was 1.3 MW/car. This capability was obtained by having two ESUs on each car. In practice a flywheel has to be able to store about twice the energy that is to be transferred back and forth. If a flywheel is operated over a speed range of 70-95 percent, about 40 percent of the maximum stored energy is transferable to and from the flywheel unit. Hence the R-32 flywheel units were rated at 3.2 kWh each at 100 percent speed and each car had two such flywheels. One such unit is shown in Figure 57. The incremental weight of this system was about 11,000 lbs.

Figure 58 shows the schematic of the total propulsion system. It has four separately excited traction motors used in two parallel groups, each having two motors in series. There are two ESUs, each

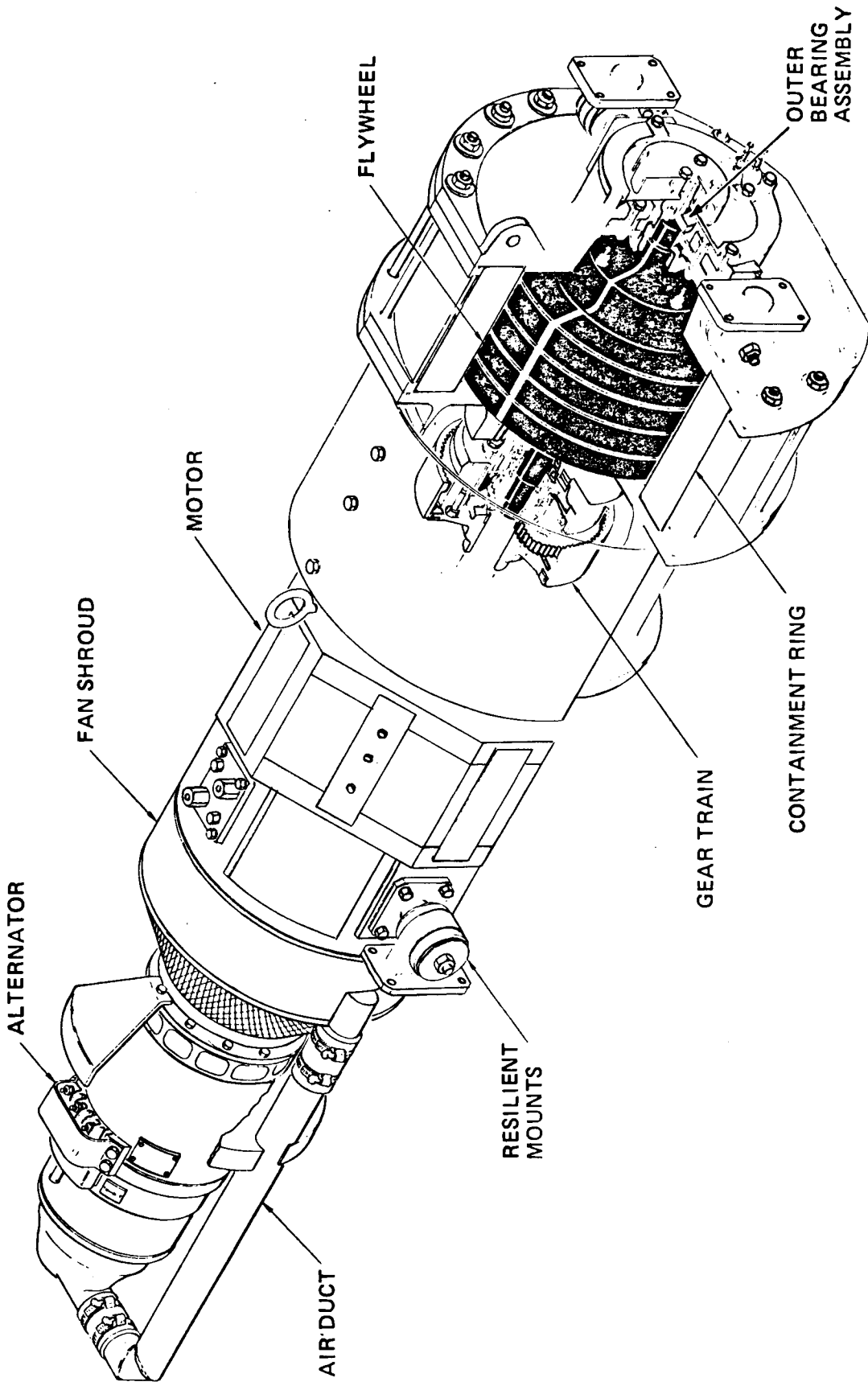
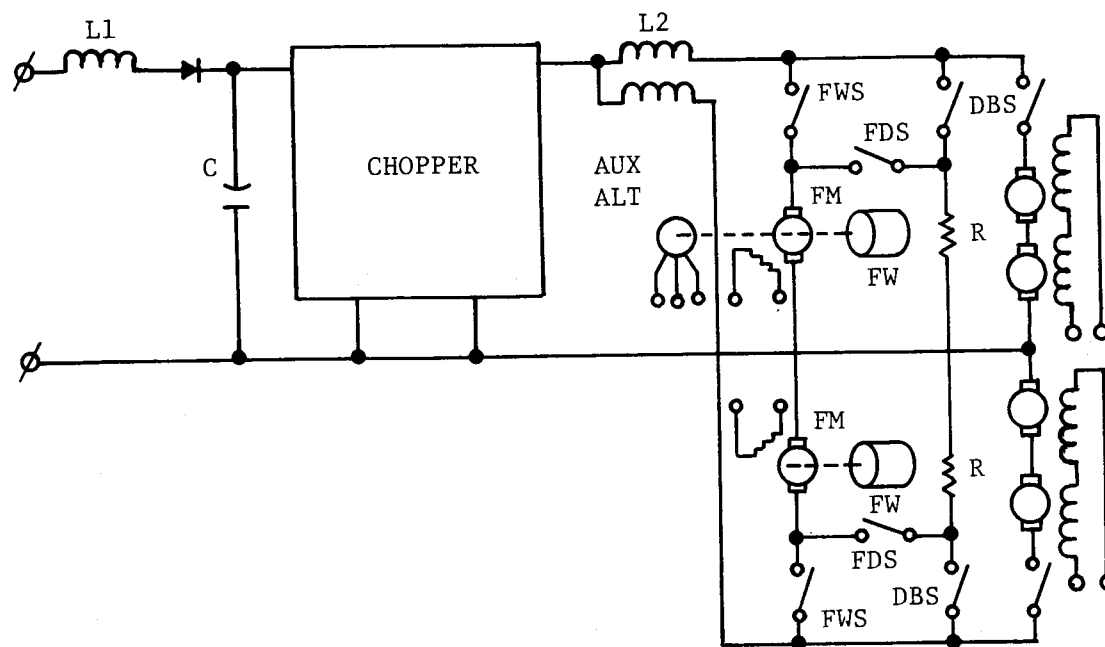

FIGURE 57
R-32 ENERGY STORAGE UNIT



DBS - DYNAMIC BRAKE SWITCH
 FDS - FLYWHEEL DUMP SWITCH
 FM - FLYWHEEL MOTOR
 FW - FLYWHEEL
 FWS - FLYWHEEL SWITCH

FIGURE 58
PROPULSION SYSTEM SCHEMATIC

consisting of a separately excited dc motor driving a flywheel through a gear train. An auxiliary alternator, mounted on one ESU, is used to supply the auxiliary loads including the field windings of the motor. The flywheel, made of four 2 inch thick steel discs, rotates at a speed of 10,000-14,000 rpm under normal operation in an evacuated (~0.5 psia) enclosure. The dc motor, rated at 650 kW at 3000 rpm, drives the flywheel through a gear ratio of 3.3:1, thus giving a maximum motor speed of 4250 rpm. The vacuum and lubricating oil pumps are also driven by the motor/flywheel. The entire unit is attached to the underframe of the car with rubber shock mounts.

The system operation can be described as follows. First, the flywheels are started up by feeding the flywheel dc motor armatures through the chopper while the fields are supplied through onboard batteries. The flywheels are charged up to an operating speed. At about 40 percent speed (~5600 rpm) the alternator can supply all the auxiliaries including the cooling fans. The system will remain in this condition until vehicle acceleration is commanded.

When the vehicle is required to accelerate, the traction motors are fully excited, the chopper is switched off and the traction motor armatures are fed from the flywheel dc machine working as a generator. The current through traction motors is controlled by controlling the field of the flywheel machine. This is identical to the classical Ward-Leonard control of a dc motor. The flywheel speed continues to drop and when it drops below a certain speed, the chopper is switched on again to maintain the required power. When the chopper conduction ratio reaches unity, the traction motors and the flywheel motor are controlled by field control.

Whenever a change in power is required it is obtained by taking in power from the flywheel and/or the line as required, while always maintaining the speed schedule for the flywheel.

The braking schedule of R-32 cars calls for a constant power braking (0.32 MW/motor) between speeds 55-45 mph and a constant force braking (~16,500 lbs. braking force for a vehicle of 112,000 lbs) between speeds 45-9 mph, thus giving a deceleration of about 3 mphps. At the start of braking, the flywheels are scheduled to be running at about 10,000 rpm (~70 percent). During braking, the kinetic energy of the vehicle is used to charge up the flywheel and they run at about 14,000 rpm (100 percent) at the end of the braking cycle, thus storing 1.6 kWh of energy each. Braking of lighter cars, or braking from lower speeds will cause less energy being stored in the flywheels. Sustained braking of heavy cars on a downgrade, however, will warrant the use of dynamic braking because the storage limit of the flywheel would otherwise be exceeded.

Whenever the vehicle is stopped, the flywheel continues to coast down and if its speed drops below a certain speed, the chopper is turned on to maintain its speed at the required level. The flywheels can be shut down rapidly through a resistance grid when required, such as at the end of the day.

A typical run between stations and the power flow are shown in Figure 59. It can be seen that in addition to energy savings, the peak power demanded from the line is reduced, resulting in improving the line regulation as well as reducing demand charges for power consumption.

Two converted R-32 cars were tested extensively at The Transportation Test Center and on different lines of NYCTA⁽⁵³⁾. These two cars were

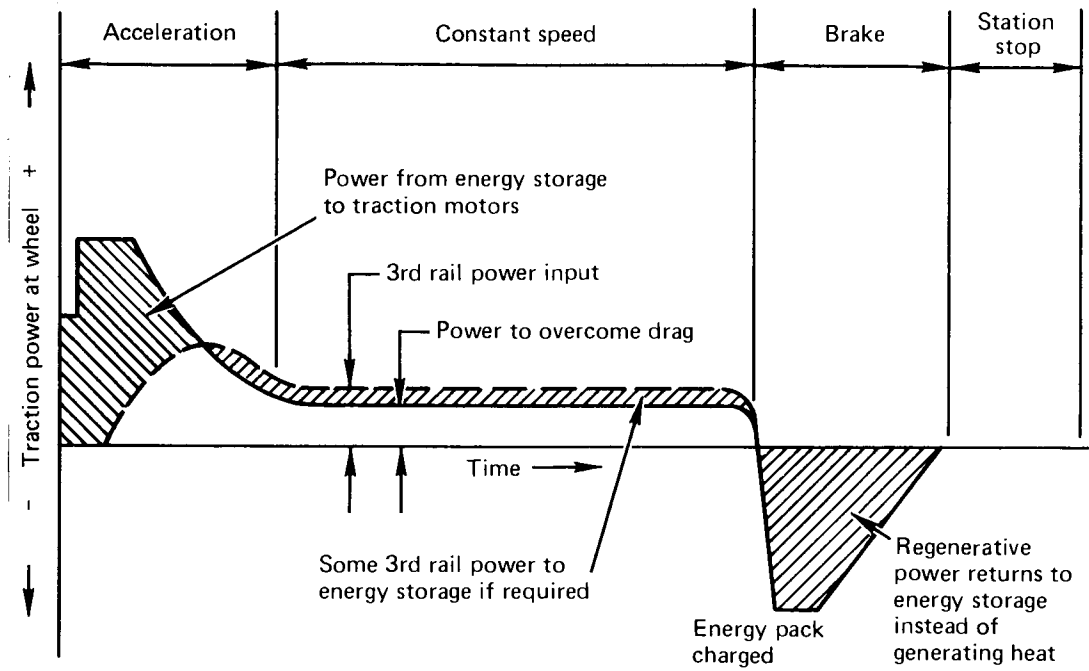

FIGURE 59
POWER FLOW DURING A TYPICAL RUN

testing for about one year under non-revenue operation and then, during a period of six months (February 1976 - August 1976), the cars accumulated about a total of 26,000 revenue miles on different lines. The energy savings demonstrated in comparison with the standard R-32 controlled cars are shown in Figure 60 for these lines.

In addition to the above testing, the energy consumption of propulsion using cam control, propulsion using chopper control with regenerative braking, and the above propulsion system was extensively analyzed with the help of a computer simulation of the NYCTA "A" line⁽⁵³⁾. Various parameters such as track curves and grades, speed restrictions, passenger loading and different duty cycles were considered. The "A" line consists of 76 stops over a total round trip of 47.23 miles at a schedule rate of 3 min/mile. The results of this simulation showed an average energy savings of 30 percent (from ~5 kWh/car-mile to ~3.5 kWh/car-mile) and a drop in the peak power demand of as much as 50 percent. A typical energy flow for the car with an ESU is shown in Figure 61. The actual numbers are, of course, a function of several variables and the numbers in the diagram are given for purposes of comparison with similar computations given in Figures 9 and 28 for cam and chopper control.

6.2 ACT-1 Propulsion System

The next generation of an onboard ESU was developed under the Advanced Concept Train (ACT-1) program of UMTA initiated in early 1972. This ESU was also developed by Garrett. Two cars with flywheel propulsion were built and have been undergoing tests at the Transportation Test Center since late 1977. Over a period of 15 months (October 1977 - December 1977) the cars have run a total of 23,500 miles including simulated revenue service for about 11,000 miles. The cars are about 75 feet long and weigh about 90,000 lbs when empty. The weight of the propulsion equipment (excluding the traction motors) is about

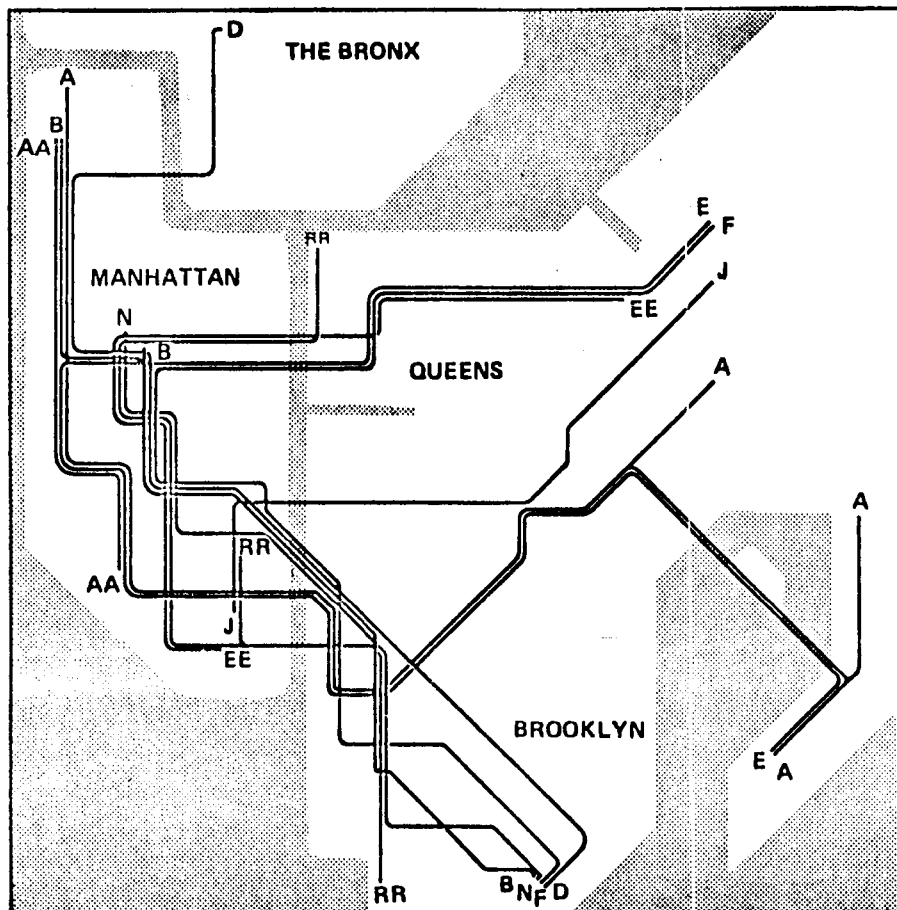

TEST SCHEDULE		
LINE	ENERGY SAVINGS	MILEAGE
A	32%	188
N	26%	92
E	31%	65
EE	31%	82
AA	38%	79
B	28%	210
D	27%	155
F	28%	162
RJ	24%	87
RR	28%	35

FIGURE 60
ENERGY SAVINGS BY ONBOARD FLYWHEEL SYSTEM

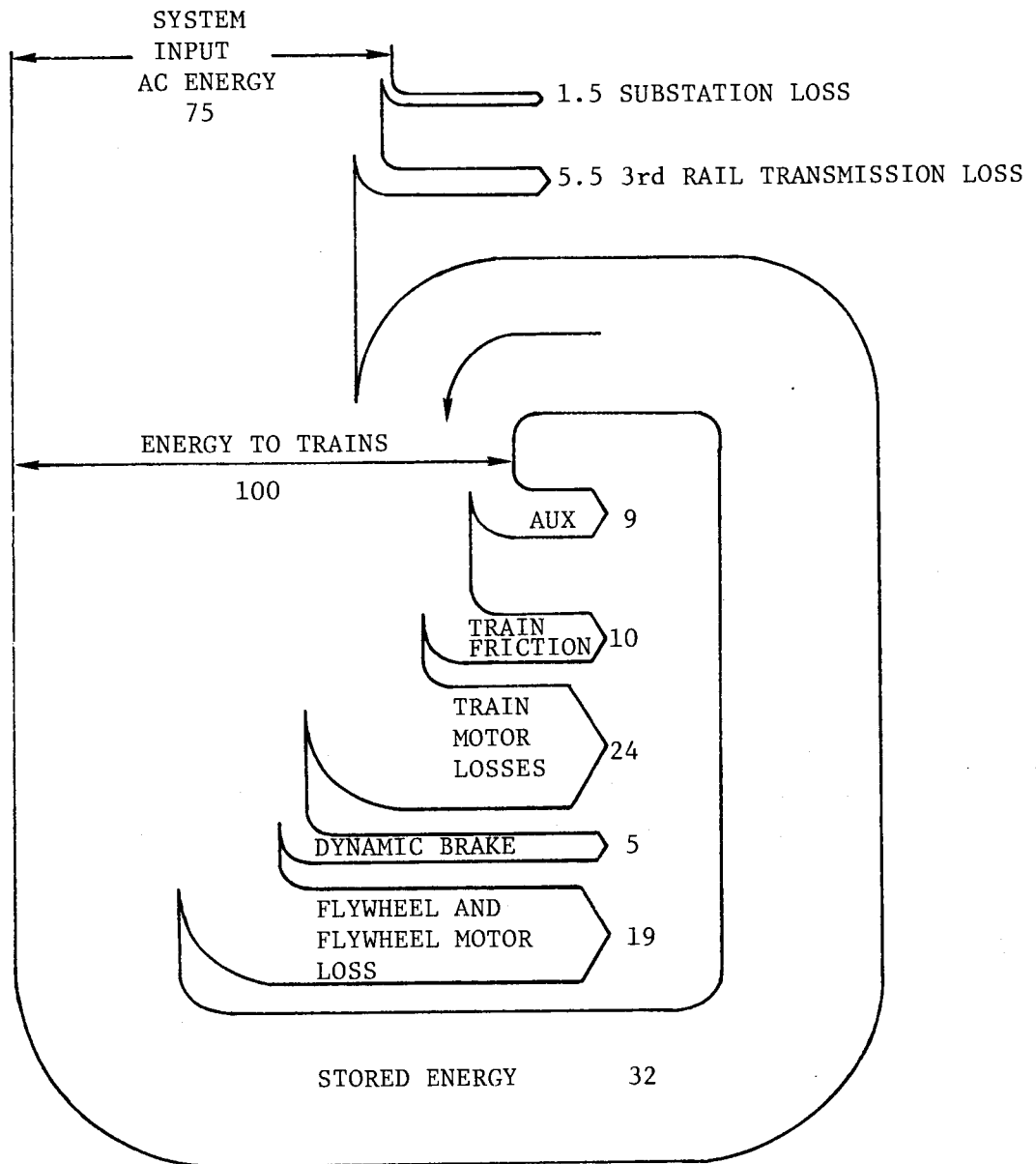

FIGURE 61
TYPICAL ENERGY FLOW OF A FLYWHEEL CAR

14,000 lbs. This includes about 6,000 lbs for the ESU motor and about 5,500 lbs for the flywheel and the gearbox. Each flywheel, made of 0.1 inch thick steel laminations, is rated 4.5 kWh and there are two such units in a car. Figures 62 and 63 show the ESU and the ACT-1 vehicle respectively.

Figure 64 shows the schematic of the propulsion system. There are only two traction motors per car because the vehicle uses mono-motor trucks. It can be seen that the chopper used in the other design has been eliminated. The flywheels are first started by drawing power from the third rail and supplying the field winding from the onboard batteries. The traction motors are started by supplying the armature current from the flywheel motors acting like generators. The flywheel acts as a prime mover and the field currents of the flywheel-generators are controlled to supply the required currents to the traction motors. The field windings of all the dc machines are supplied by an auxiliary alternator run by the flywheel itself. The system behaves like the classical Ward-Leonard system and has excellent control characteristics. The flywheel continues to decelerate as the vehicle accelerates and after a certain speed, the third rail supplies the cruising power to the motors. If under some operating condition, the flywheel speed drops below a predetermined value, the flywheel motors can be connected in series with the traction motors so that the flywheel can be brought up to desired speed.

During the vehicle braking, the traction motors operate as generators and drive the flywheel motors, thus storing the kinetic energy of the vehicle into the flywheel. If the flywheel speed reaches the rated maximum, the vehicle energy can be directed to a resistor bank for dissipation.

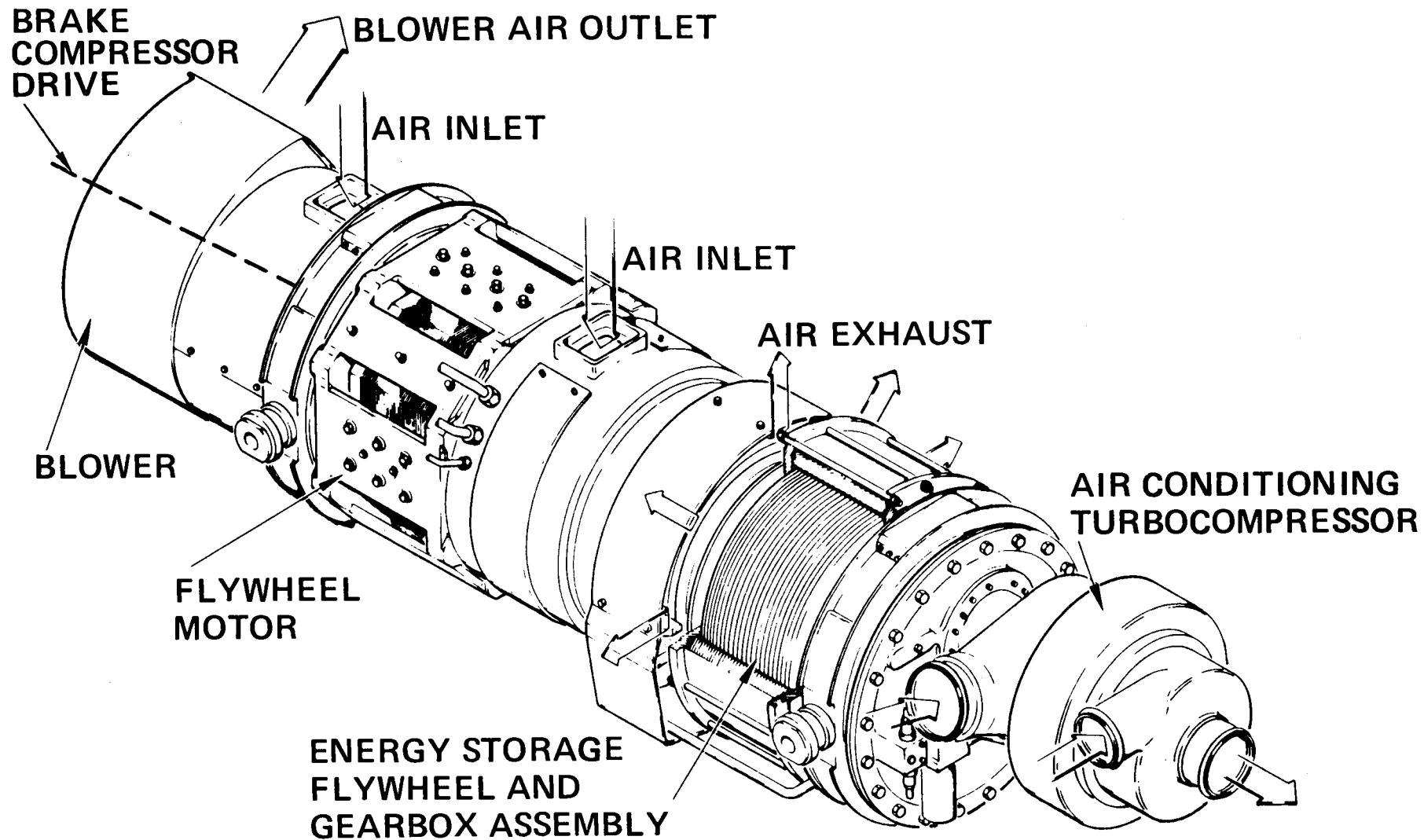

FIGURE 62
ACT-1 ENERGY STORAGE UNIT

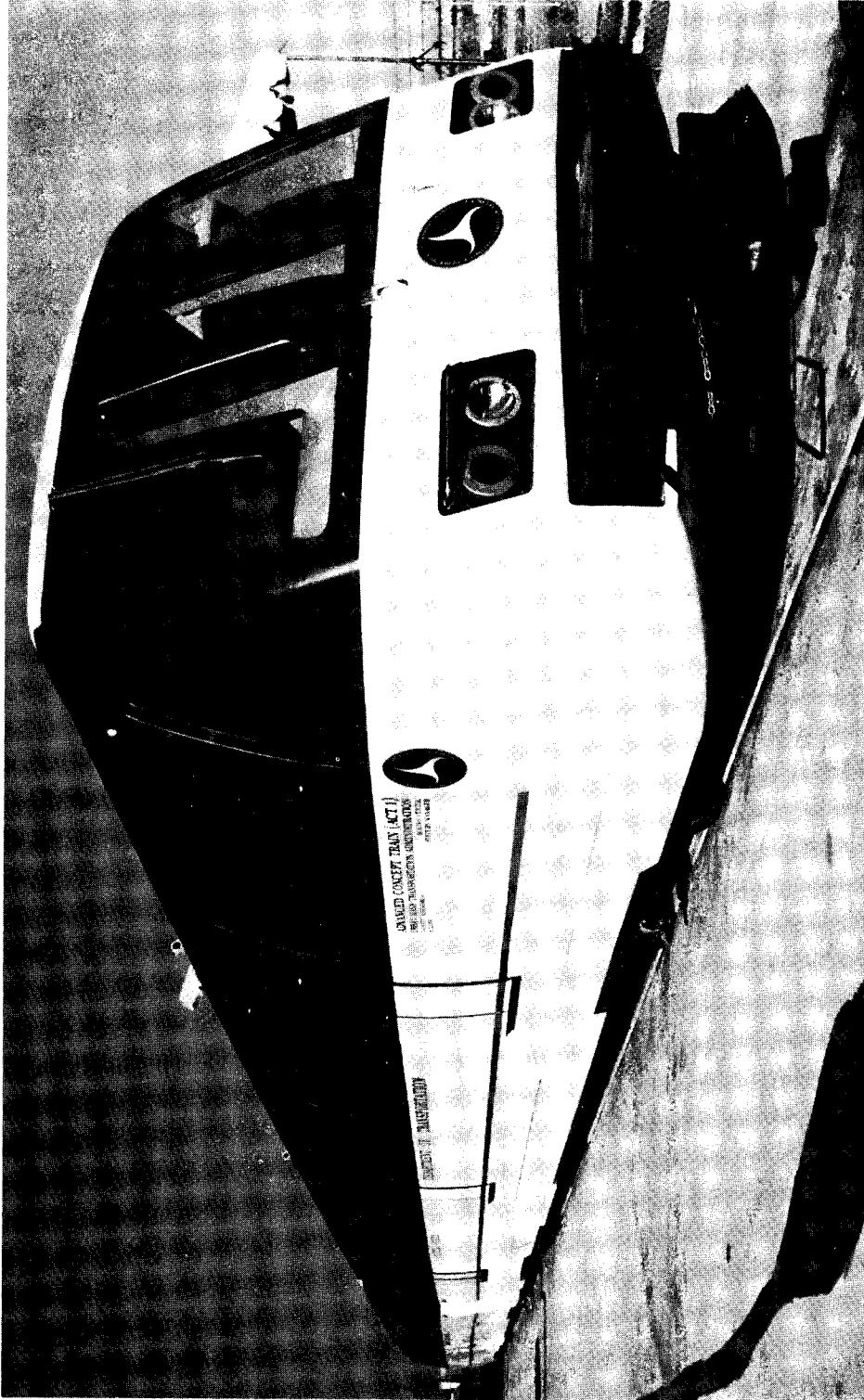

FIGURE 63
ACT-1 VEHICLE

6.3 Improved Propulsion System for R-36 Cars of NYCTA

An improved version of the ACT-1 flywheel propulsion system has been proposed by Garrett to NYCTA for a retrofit program on R-36 cars. This system, schematically shown in Figure 65, has only one flywheel unit per car. The car has bimotor trucks and hence there are four motors per car. The basic operation and the operating characteristics are similar to the ACT-1 system but the entire system has been redesigned so as to reduce the overall complexity. Figure 66 shows the new compact ESU unit for this system. A multiphase, 22-car deployment program of such an R-36 retrofit is expected to begin in the near future.

6.4 Noise and Vibrations

In spite of all the improvements to date, the noise and vibrations are still the undesirable characteristics of the onboard ESU system. The flywheel is rotating continuously and it is at peak speed in stations when it is fully charged at the end of braking schedule. In stations, therefore, a car with a flywheel is significantly noisy when compared to a car without a flywheel. For a car in motion, however, the increase in noise due to flywheel is insignificant. Similarly, the energy storage unit causes additional vibrations in a car that are especially noticeable in the vicinity of the storage unit. Although the noise and vibrations could possibly be reduced further, it has to be realized that this unit will always increase the noise and vibration levels in the car.

6.5 Additional Maintenance

The maintenance of dc traction motors - repair and replacement of brushgear, turning the commutators, rewinding of armatures, etc., - is one of the major components of the overall maintenance costs of transit cars. The required maintenance is so high that as many as 25 percent of traction motors are rewound every year on some transit

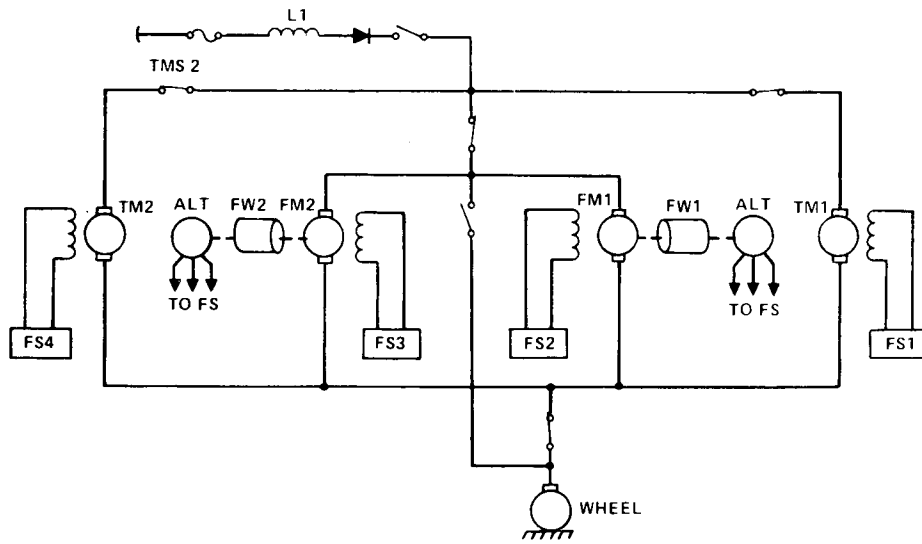

**FIGURE 64
ACT-1 PROPULSION SYSTEM SCHEMATIC**

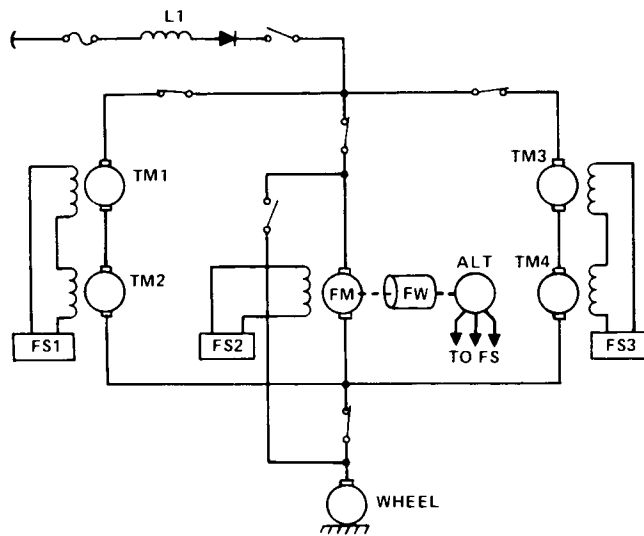

**FIGURE 65
R-36 PROPULSION SYSTEM SCHEMATIC**

100

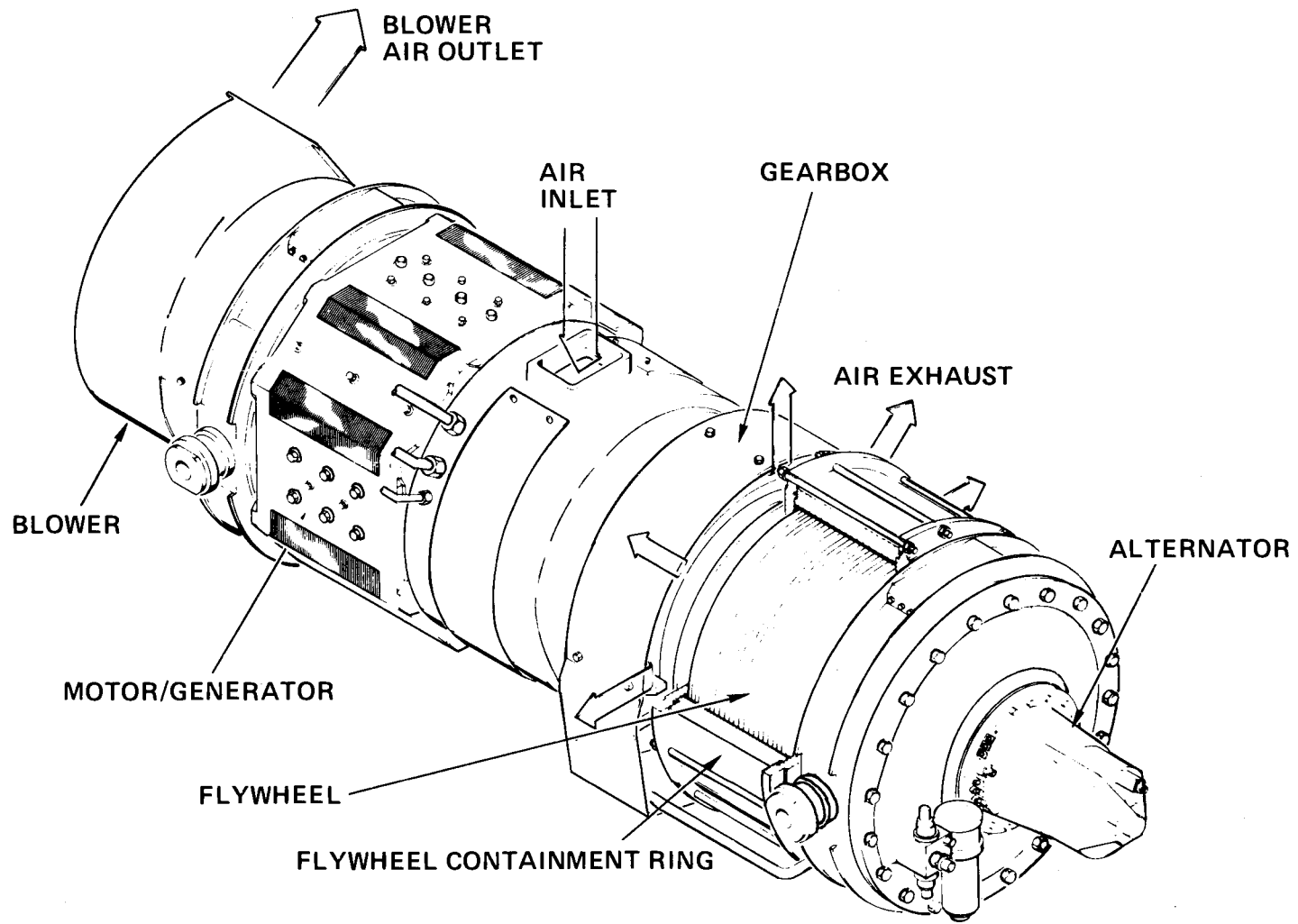

FIGURE 66
ESU FOR R-36

properties. In view of this, the addition of another dc motor to the propulsion system should be considered as a significant disadvantage. Moreover, other rotating equipment such as the flywheel, blower, and gear box require maintenance. It is not clear how the total maintenance costs of this system will compare with those of conventional cam and chopper controlled equipment. Any definite conclusion in this regard will have to wait until the necessary operating experience is obtained on a sizable fleet of cars with such a system.

6.6 Gyroscopic Effects⁽⁵⁵⁾

The flywheel is a rotating mass and hence exhibits a gyroscopic effect that must be considered while designing the energy storage unit. The energy storage unit is mounted on the car with the spin axis of the flywheel parallel to the longitudinal axis of the car. Additional forces are, therefore, produced when a car negotiates a curve or undergoes a pitch motion. For example, with the improved propulsion system using one ESU, it has been estimated that for a 50 ft car weighing about 100,000 lbs, an additional vertical force of about 684 lbs can be generated at each of the four ESU mounts when the car goes through a curve of 145 ft radius at a speed of 33 mph. This additional force is about 40 percent of the ESU weight at each mount. Similarly, if both ends of the car have a pitch motion of ± 6 inches at 1 cycle per second, the side loading on each mount is estimated to increase by about 500 lbs. All these additional forces are quite small compared to the total car weight and are not expected to have any noticeable effect on the car performance or the operating life of the components. However, when a single ESU is thus used, the effects of these forces on car body motion must be evaluated.

7.0 TUBULAR AXLE INDUCTION MOTOR

The British Railway Board's Railway Technical Center at Derby is developing a "Tubular Axle Induction Motor" (TAIM), which is basically an ac induction traction motor incorporated into the axle of a traction truck thus eliminating a gearbox. Although British Rail is interested in high speed operation (200 km/h), the motor concept could possibly be applied in rail transit systems.

7.1 Motor Design

The study of various design options for this type of motor began in 1974. A first test unit using a squirrel-cage rotor was built by adapting the design to the axle of the experimental Advanced Passenger Train (APT-E). Such an adaptation dictated the need for inner bearings for the stator support. The electromagnetic design of the motor also had to be compromised to some extent. A squirrel-cage design was chosen to get high efficiency and power factor and hence a lower inverter rating. The motor is of an inside-out construction so that a large airgap diameter and hence a large torque is possible for a given wheel diameter. The active length of the motor is 725 mm, leaving sufficient room for the endwindings and the inner bearings. The air-gap is 1 mm.

In an ac drive, the operating frequency should be kept low to reduce the reactive power requirements and hence the cost of the power conditioning equipment. This means that for a given speed of the motor, the number of poles has to be kept small. However, for a given airgap flux density, a lower pole number, i.e. a larger pole pitch, results in higher flux per pole and require thicker, heavier yoke. Thus, a TAIM has to satisfy these conflicting requirements. The experimental TAIM was a six-pole machine working with a maximum frequency of 75 Hz. The speed-torque characteristic of this motor is shown in Figure 67. The laboratory tests on this unit began in September 1976 and initial

track testing of similar experimental motor started in September 1977. The braking tests for the thermal performance of the motor were conducted for about three months early last year.

Figure 68 shows the partially wound primary winding and Figure 69 shows the completed primary with leads coming out at one end. The squirrel-cage secondary inside the hollow shaft can be seen in Figure 70. The completed TAIM is shown in Figure 71. Such a TAIM mounted on a vehicle can be seen on the left hand side of Figure 72.

Several other TAIMs are currently undergoing structural and electrical tests. Also a second generation design using solid-iron rotor and liquid-cooled stator windings is being tried out. In these new designs, the additional inner bearings have been eliminated and the stator is now self-supporting. The stator is also longer than before. These new designs have increased the power output by about 35% with weight penalty of only about 15%. This very simple new design is shown in Figure 73.

Currently a research vehicle unit is under fabrication at GEC-Traction at Manchester to continue the TAIM development. This vehicle is a 3-car unit with four conventional dc traction motors on one car, four axle-hung rotating induction motors on another car, and two TAIMs on a truck of the third car. The other two axles on the third car are free running. This unit schematically shown in Figure 74 is scheduled to be completed by March 1979 and a one year test program is expected to start by June 1979.

7.2 Inverter Design

Initially a six-step constant-current thyristor inverter was used to control the speed of the induction motor. The main advantage

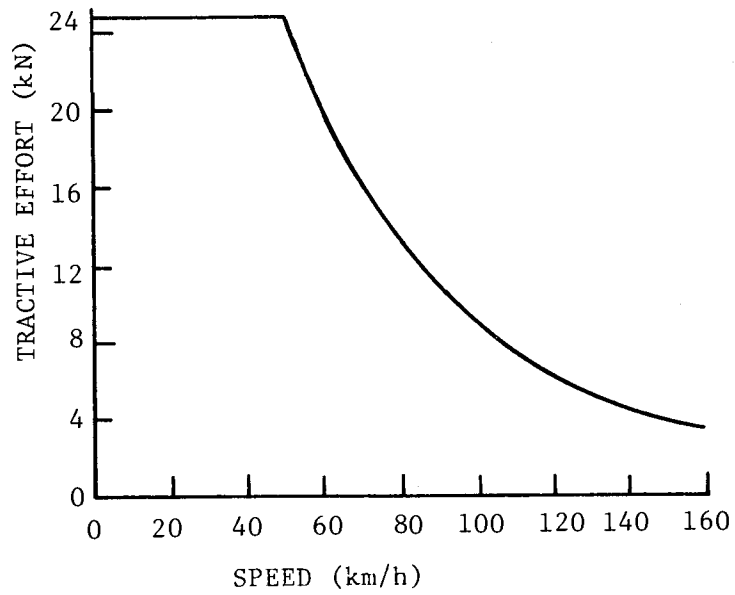

FIGURE 67
SPEED TORQUE CHARACTERISTICS

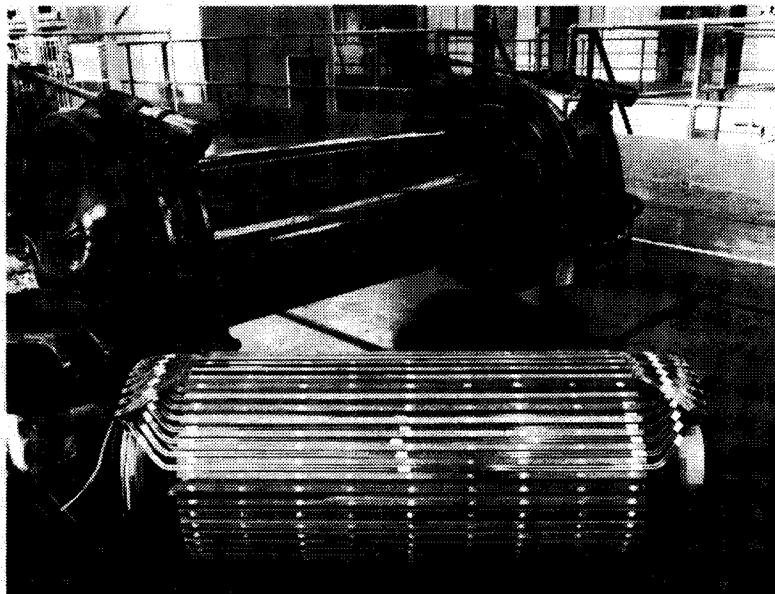

FIGURE 68
PARTIALLY WOUND TAIM PRIMARY AND THE AXLE

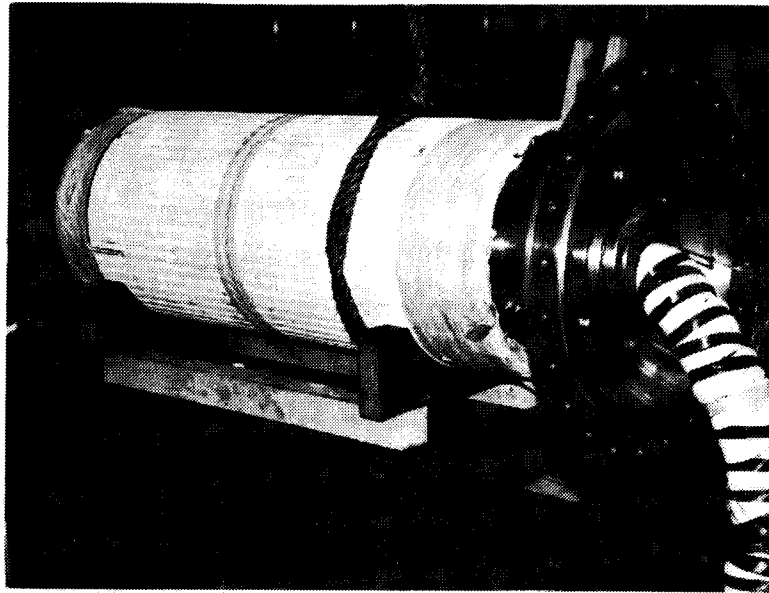

FIGURE 69
COMPLETED TAIM PRIMARY

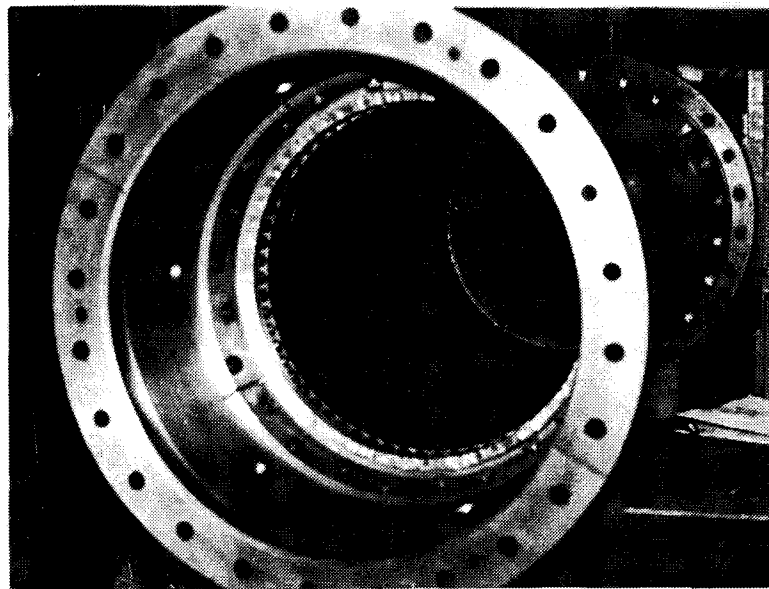
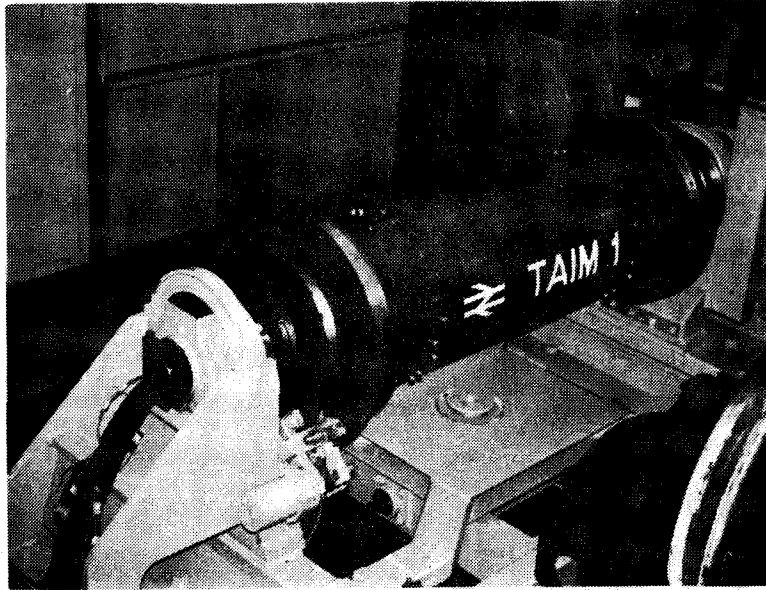

FIGURE 70
SQUIRREL CAGE SECONDARY IN THE HOLLOW AXLE



**FIGURE 71
COMPLETELY ASSEMBLED TAIM**



**FIGURE 72
TAIM MOUNTED ON A VEHICLE**

of this type of inverter is its low cost and simplicity, but it is not very suitable for systems requiring extensive low speed operation. Such an operation results in unacceptably high torque pulsations and high motor losses. PWM inverters can be used to alleviate this problem, but thyristor PWM inverters are quite expensive. British Rail firmly believes that with the on-going development of power transistors, PWM inverters using power transistors will be the induction motor controllers of the future. A 50 kVA PWM transistor inverter is presently operating at Derby and a full power inverter for supplying the TAIM is currently under development.

The tubular axle induction motor is a very interesting concept but its development will take several more years. Its suitability for propulsion of urban rail vehicles, therefore, cannot be evaluated at this time.

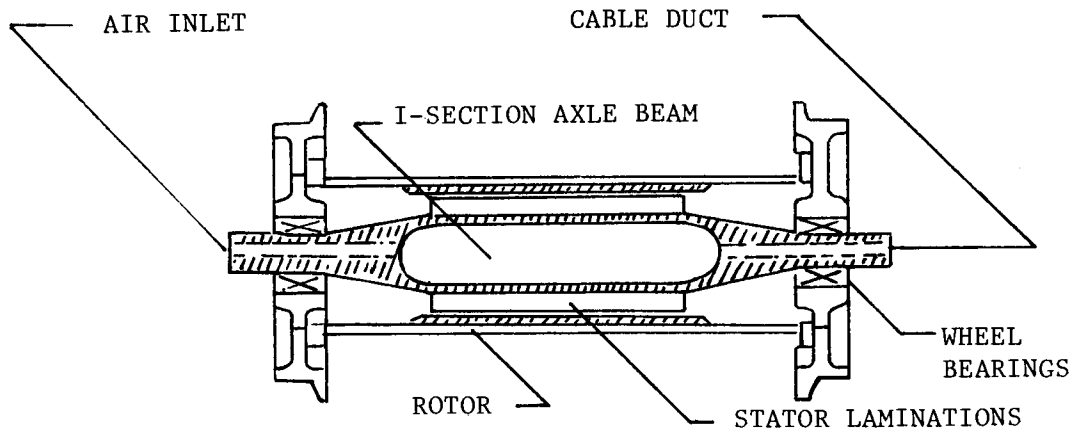

**FIGURE 73
NEW TAIM DESIGN**

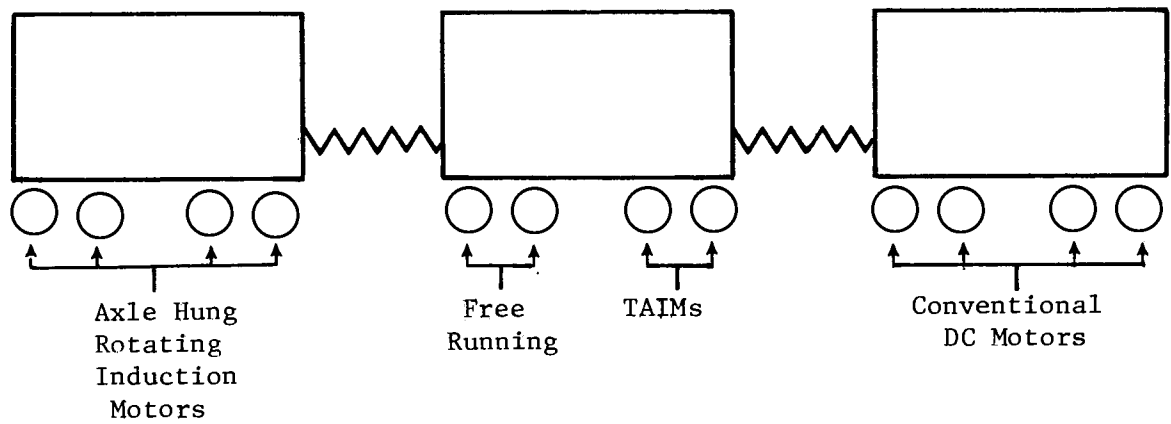

**FIGURE 74
BRITISH RAIL RESEARCH VEHICLE**

8.0 CONCLUSIONS

From this review of the state-of-the-art and on-going development of electric traction systems it is possible to draw the following conclusions:

AC Propulsion Using Induction Motors

AC propulsion systems using induction motors supplied by PWM inverters have completed prototype testing and are now in revenue service. Several locomotives are now in regular operation on the German and Swiss railway networks. Subway cars using ac drives are in revenue service in Berlin and Vienna, and they are undergoing pre-service testing in Helsinki.

At present, ac drives using induction motors are more expensive than the dc chopper systems for urban transit - by 0-20% depending on system characteristics such as line receptivity for braking energy, allowable wheel diameter variations and auxiliary power system design. It is expected, however, that with falling prices of solid state equipment as well as savings in traction motor maintenance, these ac drives can be offered at very competitive prices within the next 3-5 years. The future of ac drives will depend very much on the operating experience obtained by different transit properties running the prototype vehicles. There is no doubt that the equipment meets all the technical requirements but there is still some uncertainty about the failure rate and maintenance costs associated with the PWM or other type of inverter. If the prototype equipment performs as well as expected, the ac drives will become standard equipment beyond a period of about five years, at least in Germany. If ac drives are introduced in the U.S. in any appreciable numbers, it would probably be done in the late 1980's at the earliest.

DC Propulsion with Cam Control

DC drives with cam control (rheostatic control) are the classical traction systems for urban rail transit vehicles. The torque-

speed characteristic of the motor is well suited for transit applications and the speed of the motor is easily controlled. The cam controller is well proven technology and fairly simple. Alternative propulsion systems may be more advantageous in areas of maintenance costs, energy consumption (efficiency and regeneration) and smoothness of control.

The transit properties that have a big investment in conventional cam controlled equipment may consider that the efficiency resulting from limiting the number of types of equipment to be maintained outweigh the advantages of alternative propulsion systems. The NYCTA (New York) and CTA (Chicago) together operate more than 80 percent of the U.S. fleet of cars and thus represent a major share of this market. Both these properties are actively evaluating alternate propulsion systems. However, CTA has decided to buy rheostatic control equipment for its current order and if NYCTA buys any cars in the near future it will most probably opt for rheostatic control as well.

DC Propulsion with Chopper Control

Chopper control is a significant improvement over the conventional cam control, particularly in providing regenerative braking. The first prototype dc chopper systems were tested during the late 1960's, and they have now evolved into a proven reliable control technology. Street and subway cars with chopper control are in regular operation on transit lines in several European and North American cities.

It is likely that the dc chopper will be the system of choice for the next five years. The cost of energy has now increased to the point where the initial incremental cost for chopper control can generally be justified on a life-cycle cost basis. The future of chopper systems, however, is clearly linked with the pace of continued development and acceptance of ac drive systems using induction motors. Some transit properties, especially in Germany, believe that sufficient

data about the technical performance and the operating experience of ac drives will be available in the next 3-5 years. Therefore, they expect to continue to use cam controllers for a few more years and then introduce new drives.

AC Propulsion Using Synchronous Motors

The cost of solid state power conversion can be significantly reduced with the use of synchronous motors. This is because inexpensive line commutated inverters can be used by operating the synchronous motors at leading power factor. AC drives using synchronous motors, however, are not currently under active development anywhere and a major program of development of such a drive in the U.S. was discontinued over a year ago.

Since ac drives using synchronous motors are not currently under active development, it is unlikely that they would be considered competitive for a period of fifteen years or so. Drives using permanent magnet or other types of synchronous motors will, no doubt, be continually evaluated for possible development.

On-Board Energy Storage

A propulsion system using onboard energy storage has some very significant features such as regeneration even without any line receptivity and electronic control at lower power levels.

Onboard energy storage has the potential for improving traction system efficiency. Higher weight, increased noise and vibrations and possibly increased maintenance are some of the disadvantages of the system. The system, therefore, opens a number of important

"retrofit" options for application on the existing properties with old wayside equipment. Any final judgement on such possibilities will, of course, have to come after some operating experience is obtained on a sizable fleet of such cars.

Tubular Axle Induction Motor

The tubular axle induction motor is a very interesting and attractive concept for high speed transportation although its suitability for low speed urban vehicles has not been investigated in detail. Any judgement on the tubular axle induction motor concept can be made only after evaluating the results of operational testing and hence will have to wait for several more years.

LIST OF REFERENCES

1. "Electrical Equipment for Subway Cars with Rheostatic and Chopper Control," Pamphlet TB40-101E Edition 1 of Transport Division, ASEA, Sweden.
2. Gardner, A.L., "Propulsion and Automation Equipment for PATCO's Rapid Transit Cars," Trans. IEEE., Vol. IGA-7, No. 6, pp. 760-768, (1971).
3. "The Freiburg Eight-Axle Articulated Street Car - Electrical Equipment," Brochure V1/498E 05 73 of AEG-Telefunken, West Berlin.
4. "U-Bahn-Wagen Serie F76," Brochure N3/594/1177 of AEG Telefunken, West Berlin (in German).
5. "Optimization of Power Resources," Report No. IT-09-0023-TSC210 by Gibbs and Hill, Inc., New York.
6. "Energy Conservation in the New York Subway System," Report by School of Engineering and Applied Science of Columbia University, New York (1976).
7. Wagner, R., "Thyristor Chopper Controls for DC Traction Systems," Siemens Review, Vol. XLII, No. 1, pp. 39-43, (1975).
8. Wajima, K., et.al., "High-Speed Thyristors and Their Applications," Hitachi Review, Vol. 24, No. 6, pp. 259-67, (1975).
9. Tsuboi, T., et. al., "Newly Developed Thyristor Chopper Equipment for Electric Railcars," Trans. IEEE, Vol. IA-9, No. 3, pp. 294-301, (1973).
10. Kimura, K., et. al., "Chopper Control System for Electric Cars," Hitachi Review, Vol. 27, No. 2, pp. 77-84, (1978).
11. Sawa, K., et. al., "Thyristor Chopper Controller for Type 270 Electric Car," Fuji Electric Review, Vol. 19, No. 2. (1973).
12. Voss, U., "Electronic Controls for Rapid Transit," Brochure N3/578E 04 77 of AEG Telefunken, West Berlin.
13. Voss, U., "Chopper Technology for Rapid Transit," Brochure N3/589E/11 77 of AEG Telefunken, West Berlin.
14. Ashiya, M., et. al., "3000 V Chopper-Controlled Rail Cars for Spain's Renfe," Mitsubishi Electric Engineer, No. 3, pp. 1-6, (1977).

LIST OF REFERENCES (continued)

15. Kitaoka, T., et. al., "New Standard Thyristor Chopper Controlled Cars with Regenerative Braking," Mitsubishi Denki Engineer, No. 3, pp. 28-35, (1972).
16. Wagner, R., "Possibilities for Regenerative Braking on DC Traction Vehicles," Siemens Review, Vol. XL, No. 1, pp. 38-44, (1973).
17. "Thyristor Chopper Controllers for Rolling Stock," Brochure L 33489-A IT 7403 by Mitsubishi Electric Electric Corp., Tokyo, Japan.
18. "Thyristor Chopper Equipment in Subway Cars Class C7," Pamphlet TB 42-101E Edition 1 (1974) of Transport Division, ASEA, Sweden.
19. "Underground Coach Type C9 with Chopper Control for Stockholm," Brochure 7967-37E Edition 2 of Transport Division, ASES, Sweden.
20. "Electric Vehicles," Brochure 769 WW 15 77-04 of Stromberg Inc., Helsinki, Finland.
21. "Articulated Motor-Cars with Thyristor Control for the Wuppertal Suspension Railway," Brochure E4 Ref. 74/0070 of Siemens AG, Erlange, Germany.
22. "Paris Metro Cars set Design Standards for Series Aluminum Production," Railway Gazette International, pp. 469-475, December, 1977.
23. Ashiya, M., et. al., "Automatic Variable Field Chopper Control Equipment for Teito Rapid Transit Authority's Yurakucho Line," Mitsubishi Electric Engineer, No. 6, pp. 36-42, (1974).
24. Kitaoka, T., et. al., "Automatic Variable Field Chopper Control System for Electric Railcars," Trans. IEEE., Vol. IA-13, No. 1, pp. 18-25, (1977).
25. Jinzenji, T., and Kanzaki, T., "Modified Armature Choppers for DC Electric Coaches," Conf. Rec. of IEEE/IAS International Semiconductor Power Converter Conf., pp. 327-333, (1977).
26. Meister, J.M., "Regeneration Experience at the Sao Paulo Metro," Presented at APTA Rapid Transit Conference, Chicago, Illinois, June 1978.

LIST OF REFERENCES (continued)

27. Awano, T., "A Thyristor Chopper Controller with a Natural Cooling System," Mitsubishi Electric Advance, No. 6. pp. 5-7, (1978).
28. "A Thyristor Chopper Controller Applying a Microprocessor," Brochure HCN-Q1764 of Mitsubishi Electric, Tokyo, Japan.
29. "Asynchronous Motor Drive for Diesel Locomotives," Brochure DVK 40810E of Brown Boveri, Mannheim, Germany.
30. Hochbruck, Von H., and Korber, J., "Traktion mit Drehstromlocomotiven - Bedeutung für die Zukunft," Brochure DVK 70563D of Brown Boveri, Mannheim, Germany.
31. Körber, J., and Teich, O.W., "Three Phase Motors for Diesel and Electric Traction," Railway Gazette International, No. 2, pp. 64-71, (1975).
32. Körber, J., "Developing a 15 kV Single Phase Electric Locomotive with Three Phase Induction Motors," Railway Gazette International, No. 10, pp. 381-84, (1976).
33. Becker, Von E., and Gammert, R., "Drehstromversuchsfahrzeug De 2500 Mit Steuerwagen - Systemerprobung eines Drehstrmantriebes an 15 kV 16 2/3 Hz," Brochure D VK 60145 D of Brown Boveri, Mannheim, Germany.
34. Körber, Von J., "Drehstromtechnik für elektrische und dieselelektrische Triebfahrzeuge," Brochure D VK 60024 D of Brown Boveri, Mannheim, Germany.
35. Teich, Von W., "Drehstromantriebstechnik in Schienenfahrzeugen - Versuchseinheiten, Prototypen, Serien," Brochure D VK 70829 D of Brown Boveri, Mannheim, Germany.
36. Hochbruck, Von H., Kocher, E., Körber, J. and Teich, W., "Drehstromtechnik Mit Asynchronfahrmotoren - en neues Antriebssystem für Bahnen," Brochure D VK 50780 D of Brown Boveri, Mannheim, Germany.
37. Körber, J., "Die elektrische Lokomotive mit Kommutatorlosen Fahrmotoren," Brochure D VK 50756 D of Brown Boveri, Mannheim, Germany.
38. Cymbor, W.P., and Smith, R.D., "AC Propulsion Project - Single Car Performance," NTIS Report UMTA-OH-06-0006-73-3 (1973).

LIST OF REFERENCES (continued)

39. "Inverter Controlled AC Induction Motor Drives in Vehicles," Brochure 772 WW125 75-03 of Stromberg Inc., Helsinki, Finland.
40. Ciessow, G., Gölz, G., and Grumbrecht, P., "Three Phase AC Drive Systems for Traction Vehicles," AEG Telefunken Progress, Vol. 3, pp. 88-96 (1977).
41. "Drive Equipment with Three Phase Traction Motors for the Berlin Subway," Brochure N3/575E 05 77 of AEG-Telefunken, West Berlin.
42. Gölz, G., et. al., "Wirkungsweise Neuartiger Pulsstromrichter," Elektrotechnische Zeitschrift, Vol. 98, No. 5, pp. 346-49, (1977).
43. Kratz, G., "Der Drehstrom-Asynchronmotor als neuer Fahrmotor für die Berliner U-Bahn," Der Stadtverkehr Vol. 22, No. 2, pp. 83-87, (1977).
44. Rudiger, W., and Brunnecker, U., "Siemens Tests AC Motors on a Tramcar," Railway Gazette International, No. 6, pp. 228-229, (1976).
45. Meissen, W., and Sauer, H., "Drehstromantrieb für Schienenfahrzeuge am Gleich - und Wechselstrom -Fahrdraht," Eisenbahntechnische Rundschau Vol. 26, No. 7/8, pp. 445-52, (1977).
46. "DC Operated Double Unit with AC Three Phase Drives and Regenerative Brake of the Vienne Underground," Brochure E1, E4 78/3 of Siemens, Erlangen, Germany.
47. Plunkett, A.B., and Plette, D.L., "Inverter-Induction Motor Drive for Transit Cars." Trans. IEEE. Vol. IA-13, No. 1, pp. 26-37, (1977).
48. Mitsubishi, E., et. al., "Induction Motor Drive by High Frequency Pulse Width Modulation Inverter," Brochure HCN-Q1763 of Mitsubishi Electric, Tokyo, Japan.
49. Bourbeau, F.J., "Synchronous Motor Railcar Propulsion," Trans. IEEE, Vol. IA-13, No. 1, pp. 8-17, (1977).
50. "Self-Synchronous Propulsion System for Rapid Transit Railcars," Final Project Report, Vol. I, Report R78-14 by Delco Electronics, Santa Barbara, California (1978).
51. "Self Synchronous Propulsion System for Rapid Transit Railcars," Final Project Report, Vol. II, Report R78-14 by Delco Electronics, Santa Barbara, California (1978).

LIST OF REFERENCES (concluded)

52. Bourbeau, F.J., "Wide Speed Range Cycloconverter - AC Motor Drives Operating from Utility Frequency Power," Conf. Rec. of IEEE/IAS International Semiconductor Power Converter Conf., pp. 320-326, (1977).
53. Weinstein, C.H., "R-32 Energy Storage Propulsion System," Presented at IEEE Conf. on the Energy Crisis and Rail Transportation, New York, February 1976.
54. "Urban Rapid Rail Vehicle and Systems Program," NTIS Report No. UMTA-IT-06-0026-78-1, (1977).
55. "Energy Storage Propulsion System for New York City Transit Car," Report 77-14203-2 Addendum 3 of Garrett AiResearch Manufacturing Co., California (1977).

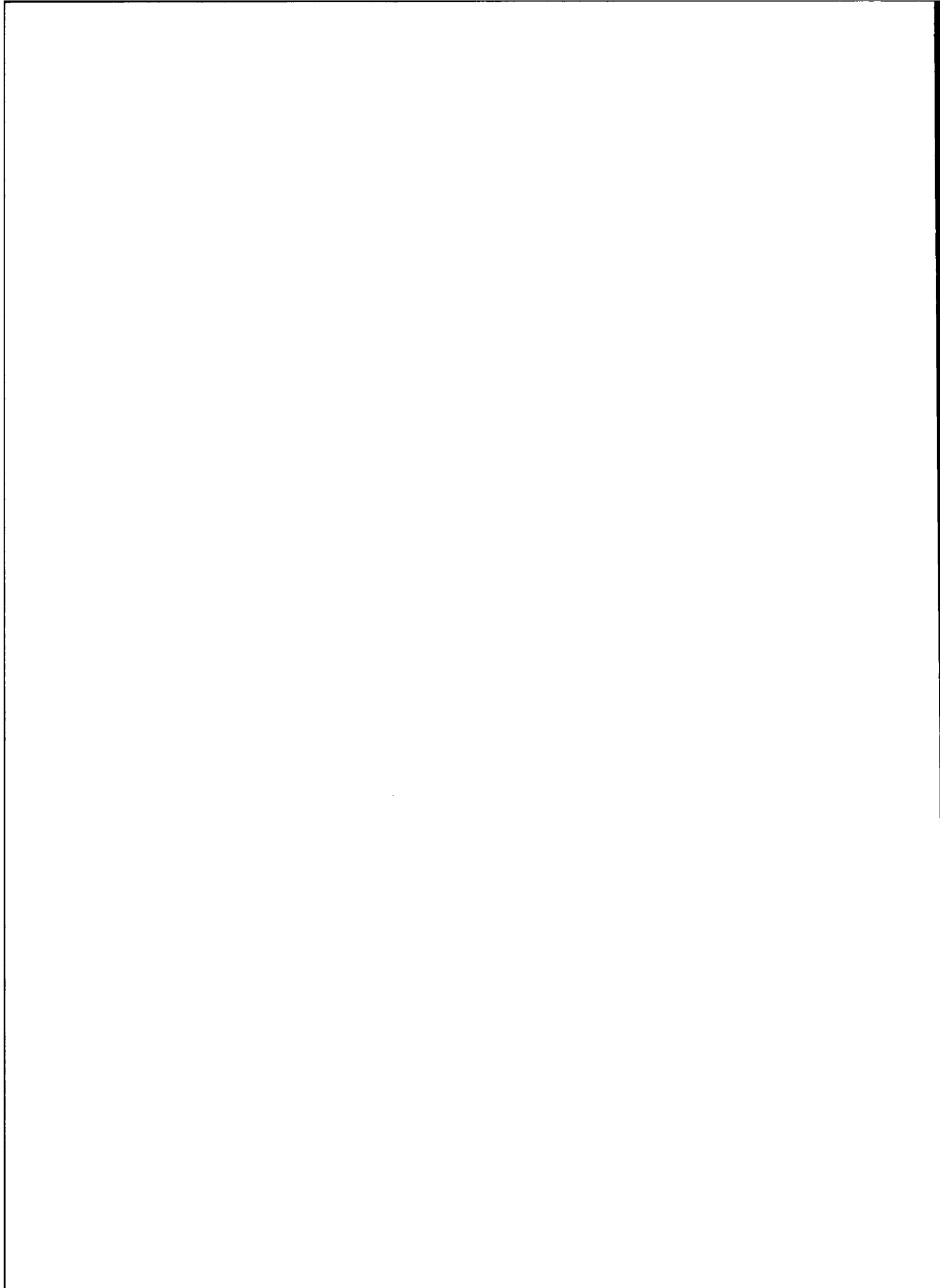

APPENDIX I

DIFFERENT TYPES OF TRACTION MOTORS

1.0 DC MOTOR

The essential components of a dc machine are shown in Figure 75 and the machine is schematically represented in Figure 76. As can be seen, the stator has salient poles excited by one or more field coils. The airgap flux distribution created by the field excitation is centered on the axis of the field pole, as shown in Figure 77. The armature of a dc machine is a winding that carries current through the brushes and the commutator. The current through an armature coil reverses as that coil goes under the brush, as shown in Figure 78. This current reversal is called commutation. The airgap flux distribution created by the armature current is centered on the brush-axis. Under normal operating conditions, the brushes are located on the interpolar axis - i.e., an axis displaced by 90 electrical degrees from the field axis. The armature reaction flux increases the flux under one pole-tip while decreasing the flux under the other pole-tip (also shown in Figure 77). For linear magnetic materials, therefore, the flux per pole is not affected by armature reaction. With saturation of the iron, however, there is a net resultant reduction of the flux per pole. In addition to this demagnetizing effect, the armature reaction also has an adverse effect on commutation. As shown in Figure 78, a coil undergoing commutation is in transition between two groups of armature coils. The current at the end of the commutation period must be equal and opposite to that at the beginning. For a short time during commutation, the armature coil is, in fact, short circuited by the brush. It can be said that generally the resultant voltage induced in this coil from different sources should be zero in order to achieve linear commutation of current through the coil. This is usually achieved by introducing an appropriate flux density in the interpolar region by means of small narrow poles located between the main poles.

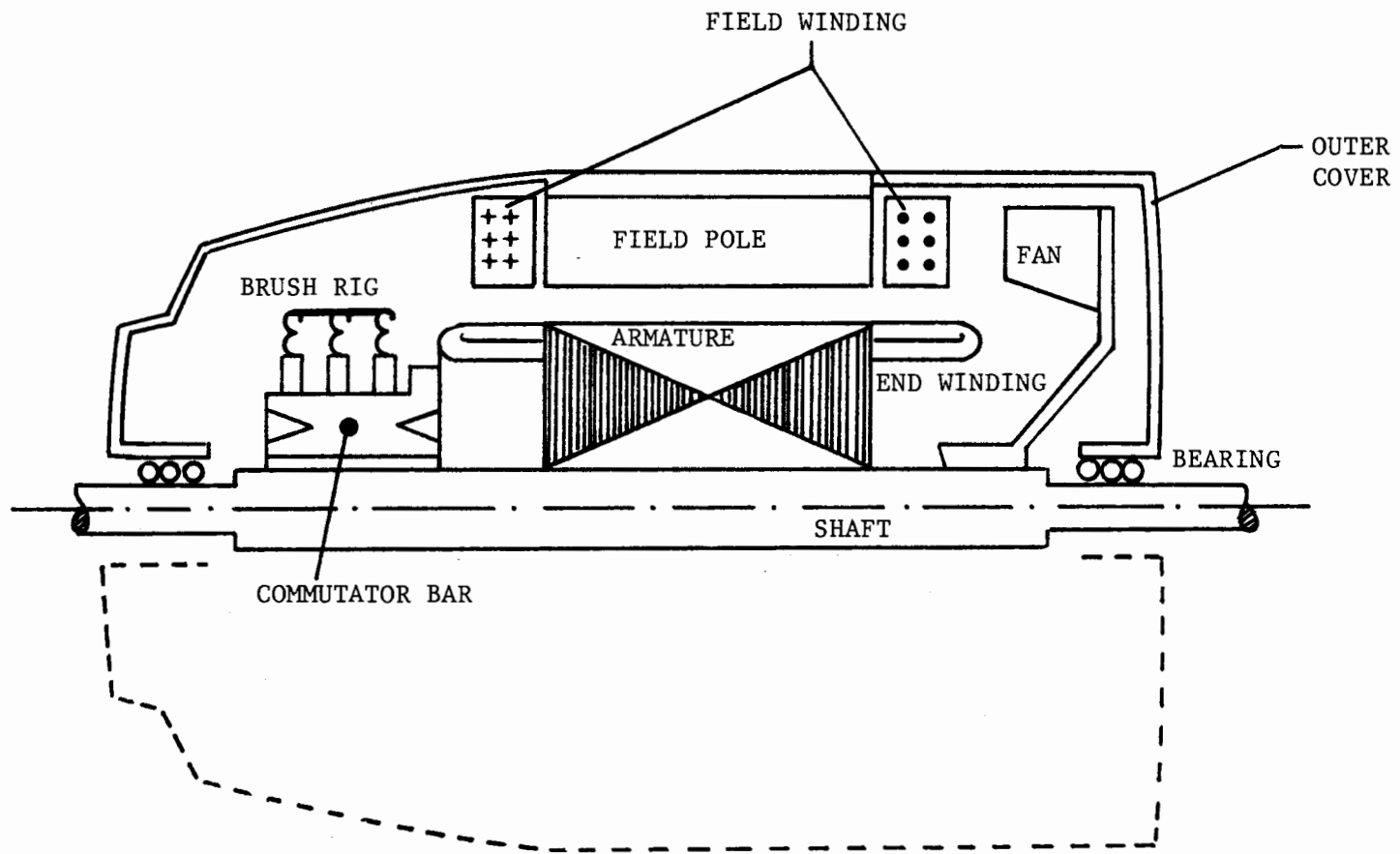
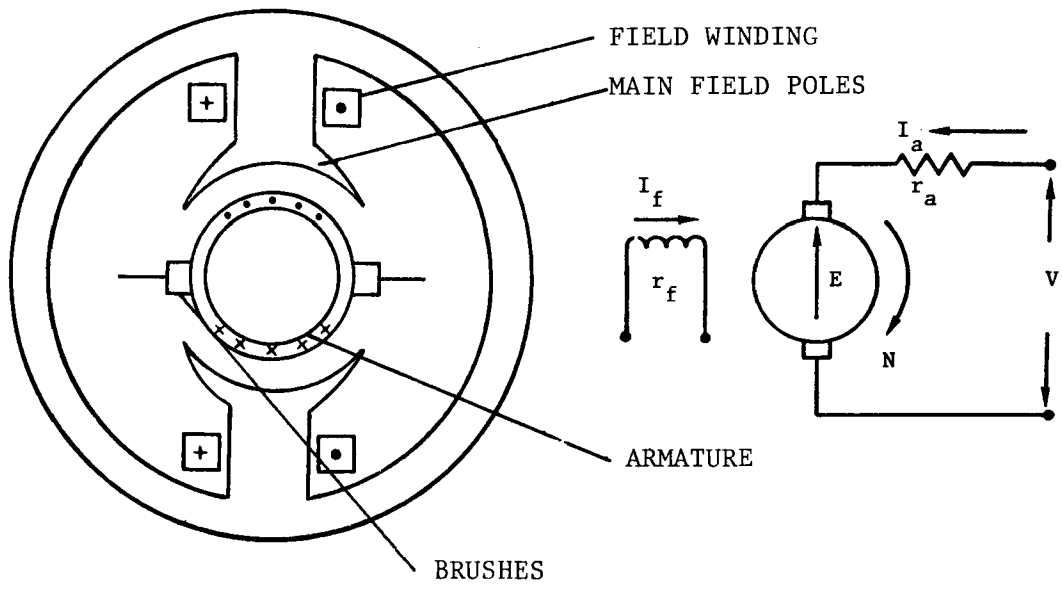
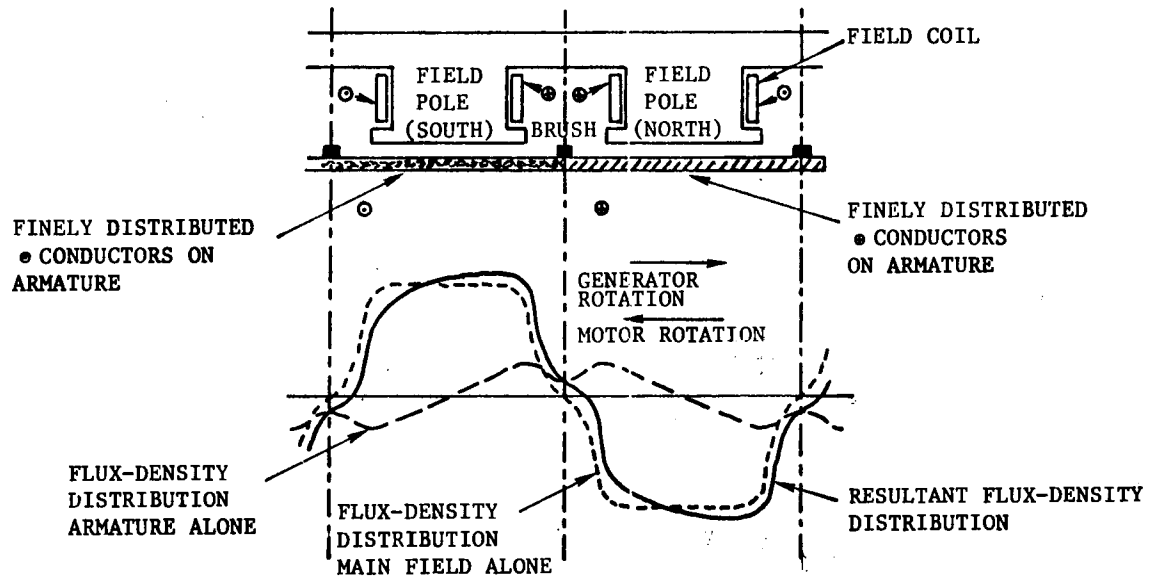

FIGURE 75
ESSENTIAL COMPONENTS OF A DC MOTOR



**FIGURE 76
DC MOTOR SCHEMATIC**



**FIGURE 77
AIRGAP FLUX DISTRIBUTION IN A DC MACHINE**

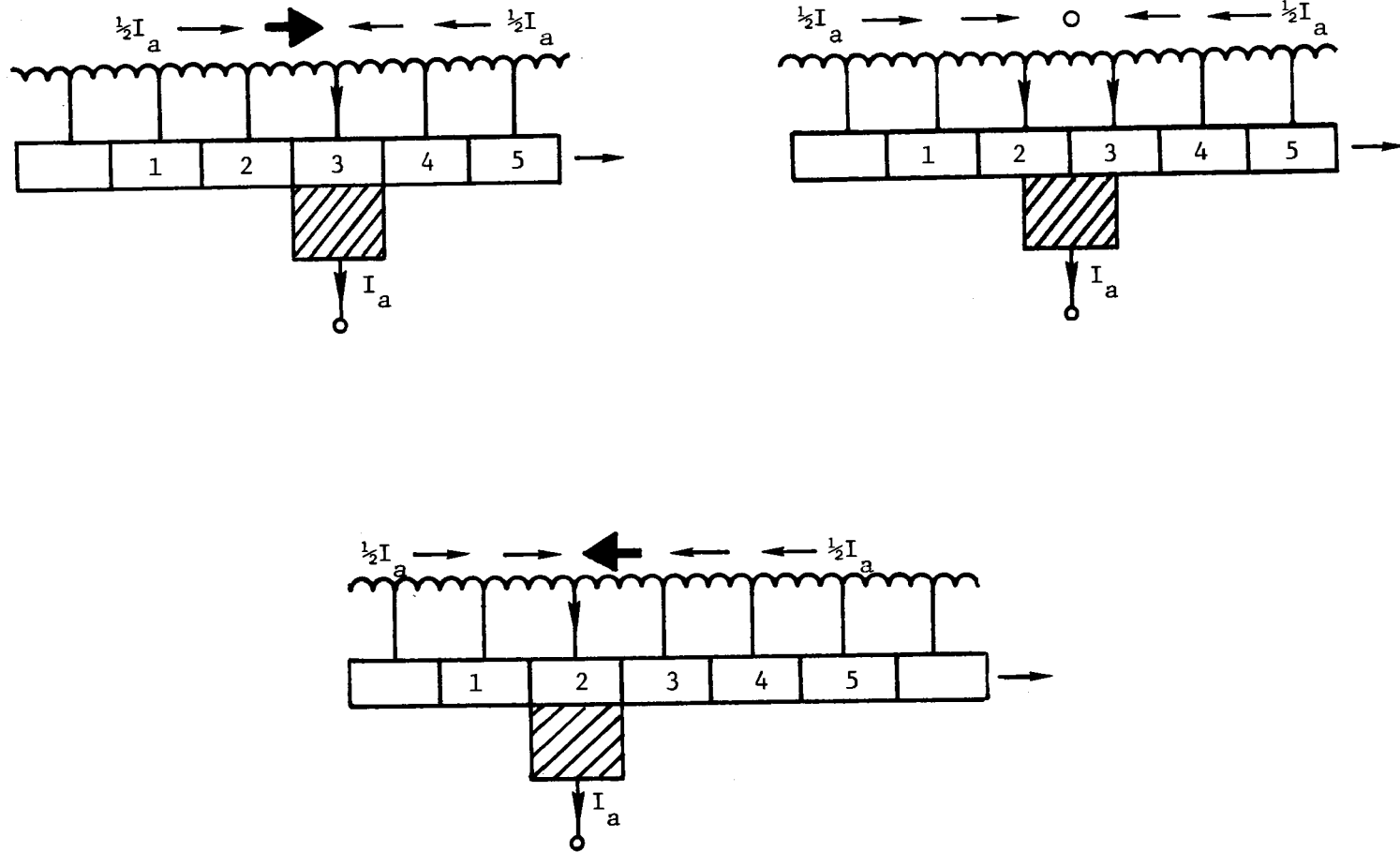

FIGURE 78
CURRENT REVERSAL DURING COMMUTATION

These auxiliary poles are called interpoles. The polarity of an interpole in a dc motor is that of the main pole just behind it.

For motors subjected to heavy overloads or rapidly changing loads or for motors operating under a weak field condition, the armature reaction is compensated by using poleface windings. These windings carry currents in a direction opposite to that of armature winding facing them. Such a winding is called a compensating winding. Figure 79 shows a dc machine having interpoles and compensating windings. Figure 80 shows the field structure and different windings in a dc motor. Figures 81 and 82 show the armature, the commutator and the brushgear.

In general, there are several ways to excite one or more field windings as shown in Figure 83. However, series excitation of the field winding is the most common method for traction application.

1.1 Operating Characteristics

The operating characteristics of a dc motor can be explained with the help of the following relationships:

$$V = E + I_a r_a$$

$$E = K_e \phi N$$

$$T = K_t \phi I_a$$

where

V - terminal voltage

E - armature back emf

I_a - armature current

r_a - armature resistance plus additional (series field or external) resistance, if any

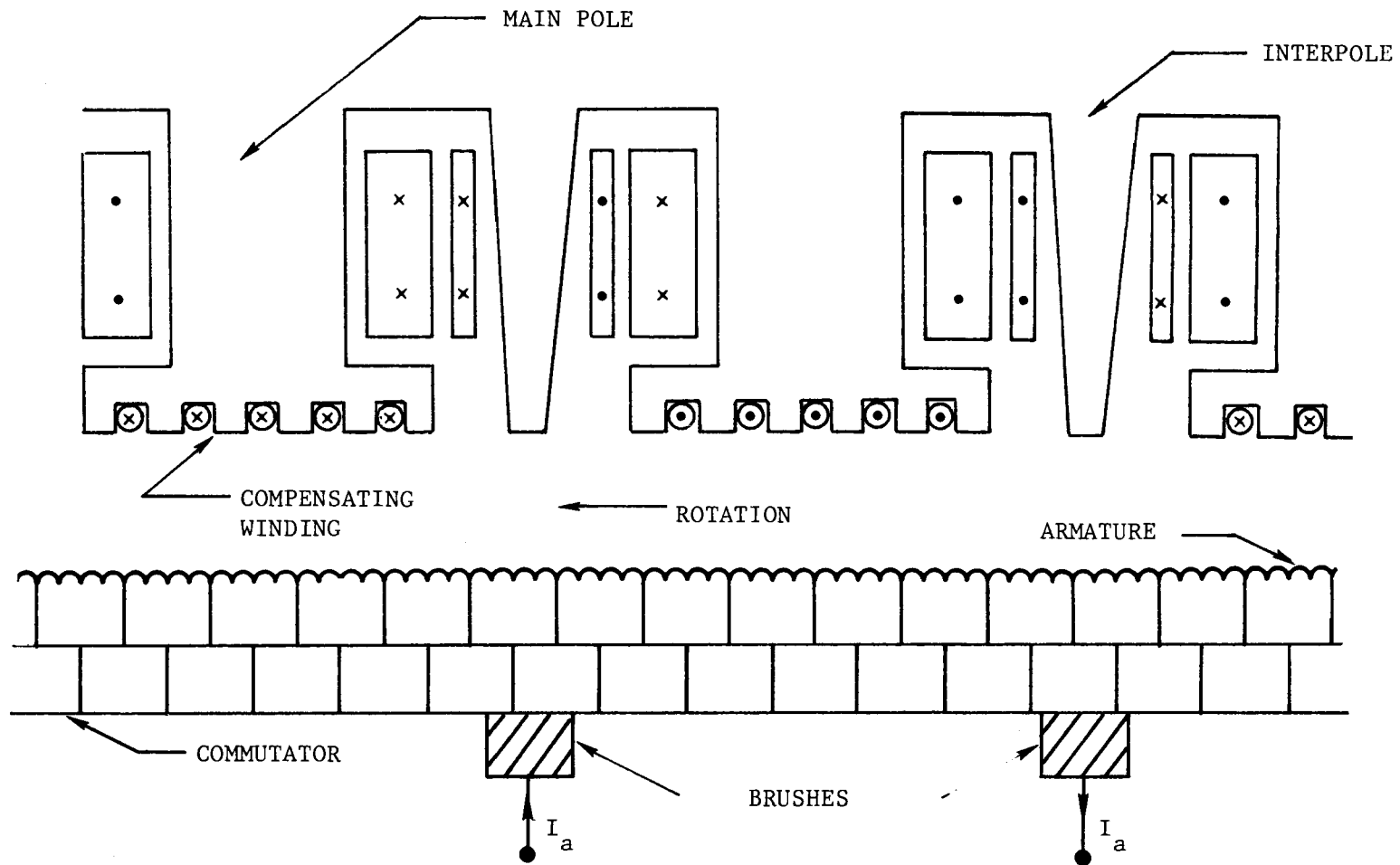

FIGURE 79
DC MOTOR WITH INTERPOLES AND COMPENSATING WINDINGS

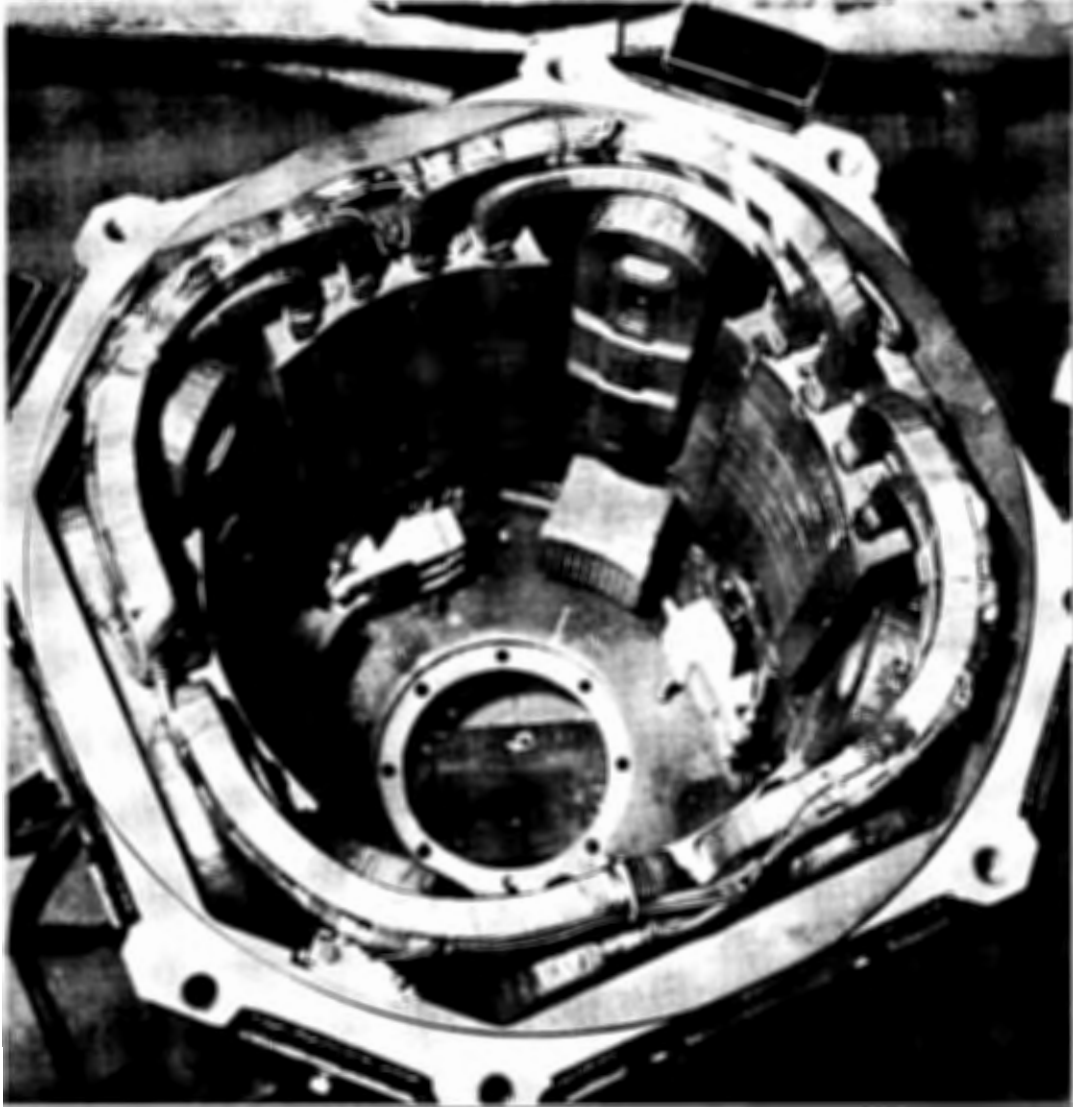

FIGURE 80
DC MOTOR FIELD STRUCTURE AND WINDINGS

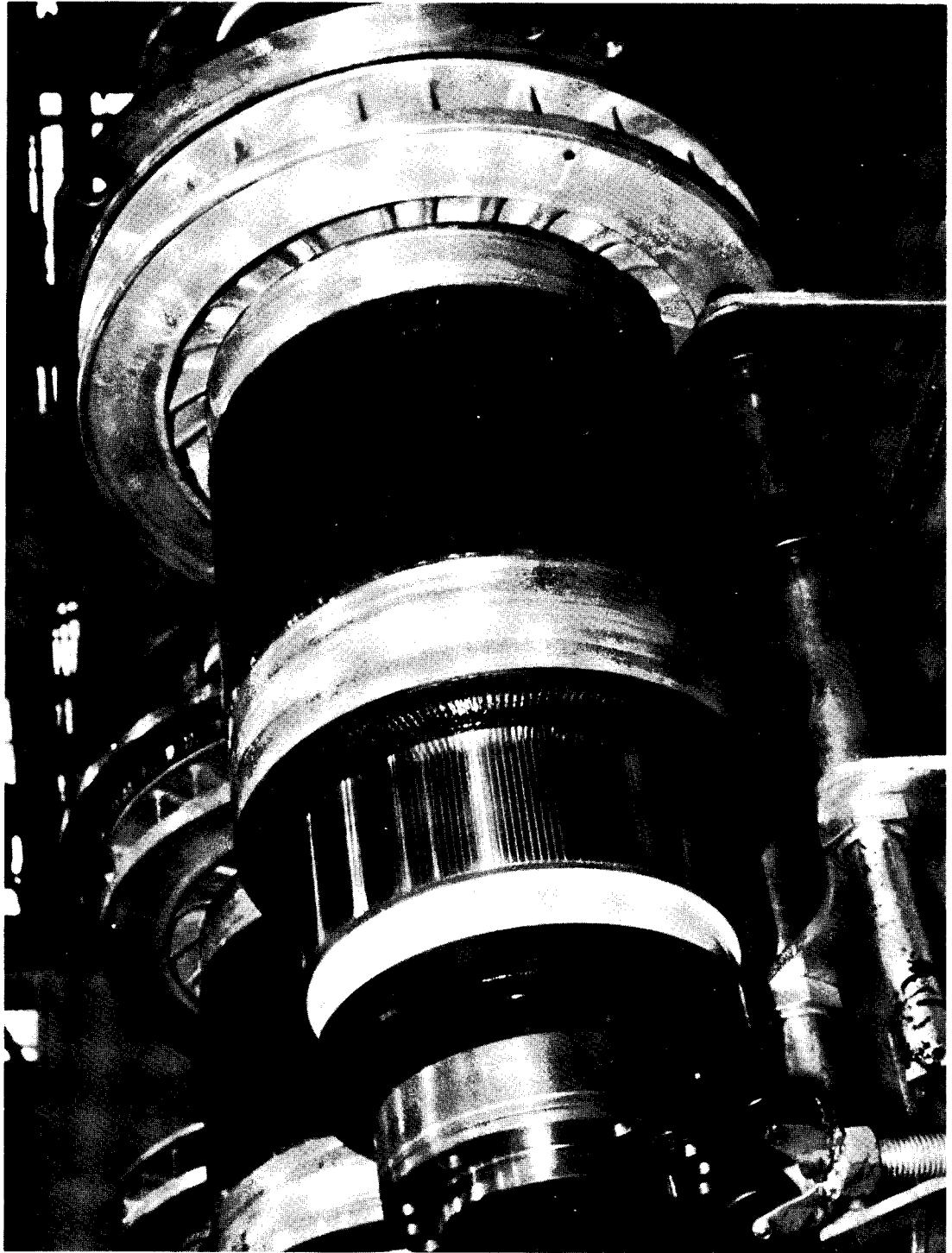

FIGURE 81
ARMATURE AND COMMUTATOR OF A DC MOTOR



FIGURE 82
THE BRUSHGEAR

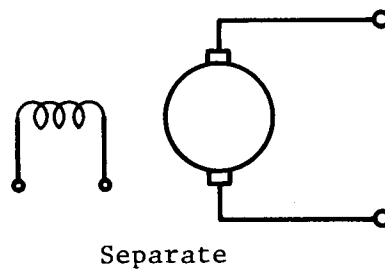
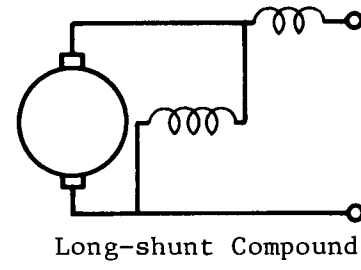
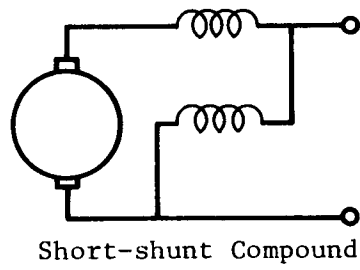
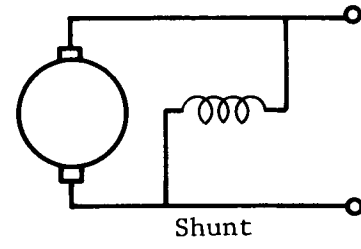
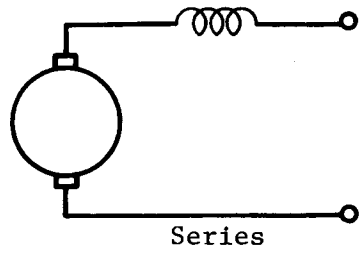

FIGURE 83
METHODS OF FIELD EXCITATION

ϕ - flux per pole
N - speed
T - electromagnetic torque
 K_e, K_t - constants

From these relationships one can obtain the speed of the motor as

$$N = \frac{V - I_a r_a}{K_e \cdot \phi}$$

Under steady state conditions, the motor operates at a speed where the electromagnetic torque generated by the motor equals the load torque. The speed of operation, therefore, can be controlled by controlling the armature (I_a) or the field (ϕ). Also, the back emf E is zero at start and hence the armature current I_a has to be limited either by reducing the voltage or by connecting external resistances in series with the armature and then cutting them out, manually or automatically, as the motor comes up to speed. Such a starting process is shown in Figure 84.

1.2 Speed Control of DC Motors

DC motors in general are very much adaptable to adjustable-speed application. In fact, easy control of the speed by several methods is one of the important reasons for their wide application in propulsion and in other industrial drives. The armature control and the field control are the two basic methods of speed control. The characteristics of these two control methods, shown in Figure 85, are as follows.

1.2.1 Armature Control

As the name suggests, this method involves a control of the armature circuit - reducing the armature voltage or inserting external resistances in the armature circuit. If more than one motor is to be

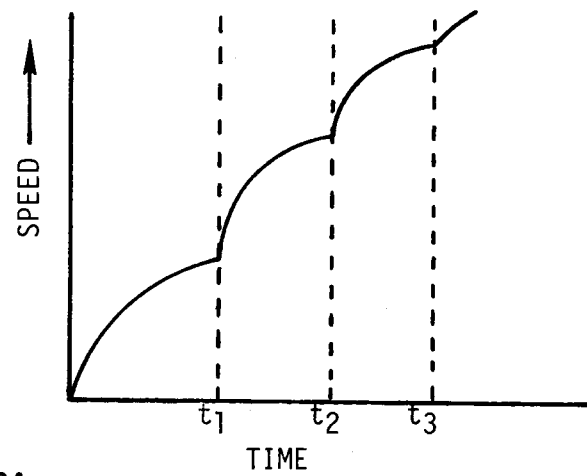
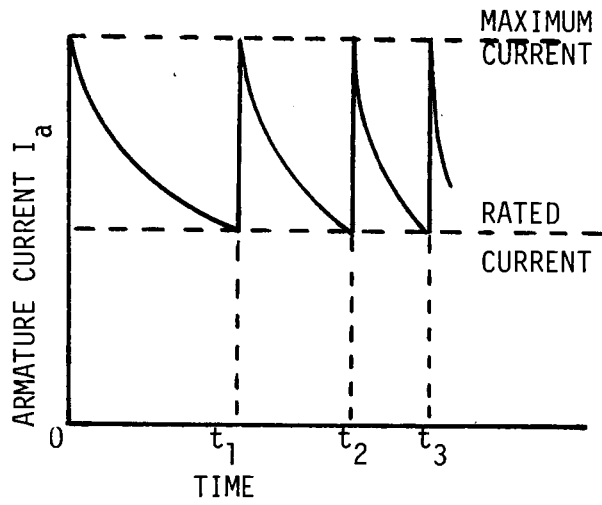
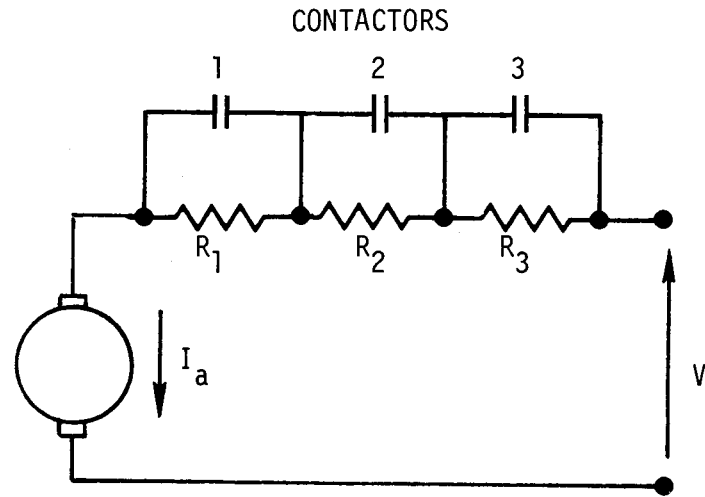

FIGURE 84
STARTING OF A DC MOTOR

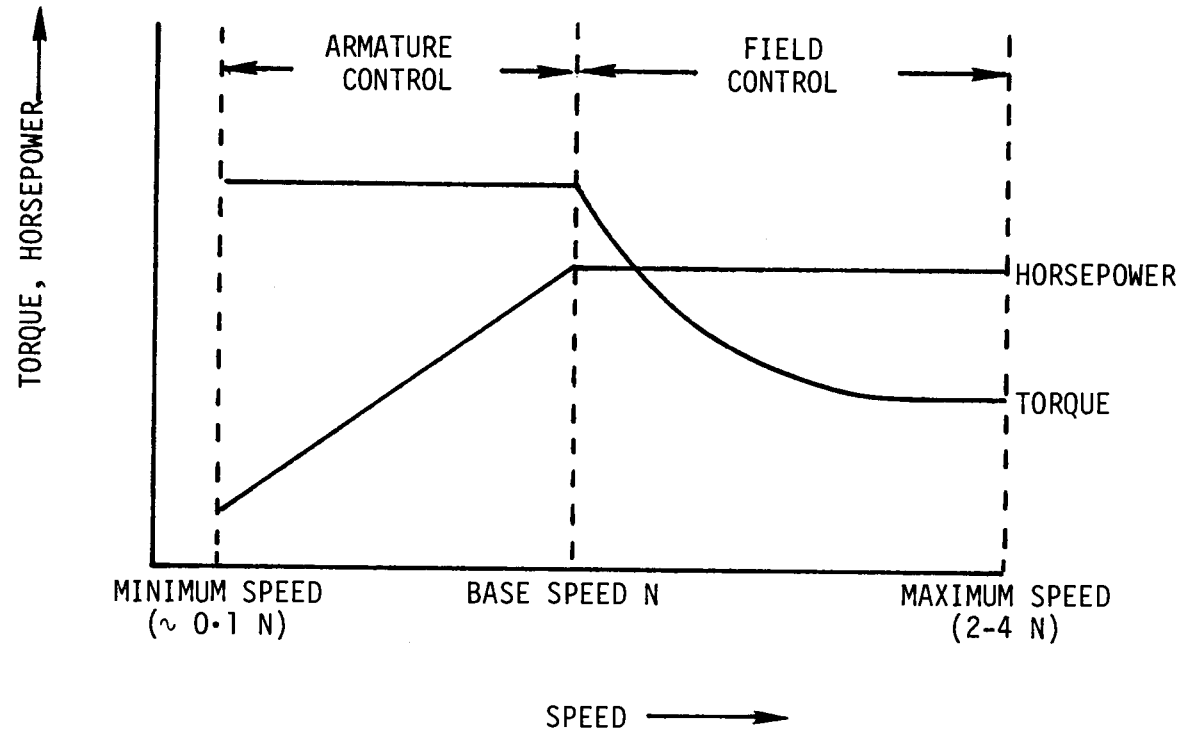

FIGURE 85
SPEED CONTROL OF A DC MOTOR

controlled, as in the case of propulsion of rail vehicles, armature voltage can be very easily controlled by using series or series/parallel connection of the traction motors. It could also be controlled by using a static controller such as a chopper. If the armature current and the airgap flux is held constant, the motor torque is constant. The speed can be controlled by controlling $(V - I_a r_a)$, thus giving a constant-torque, variable-horsepower operation. This method is used to control speeds lower than the base speed of the motor (the speed at normal armature voltage and full field condition).

1.2.2 Field Control

At speeds higher than the base speed, the terminal voltage and the armature current can be held constant and the speed can be controlled by controlling the flux per pole. If the flux ϕ per pole is reduced, the speed N increases. However, the torque T is also reduced, resulting in a constant-horsepower operation. Thus the field control results in a variable-torque, constant-horsepower operation. For conventional machines, the lower limit for reliable and stable operation is about 0.1 of the base speed, whereas the higher limit is about 4 times (preferably 2 times) the base speed. The lower limit is due to poor speed regulation at low speeds and the higher limit is due to the adverse effects of the armature reaction under weak field conditions.

1.3 Advantages and Disadvantages

The suitability of the dc motor for propulsion of a transit vehicle can be summarized as follows:

Advantages

- The speed-torque characteristic of a series motor is extremely well suited for traction application.
- Speed control can be easily implemented with the use of resistances and contactors
- Dynamic braking can be easily provided.

Disadvantages

- The presence of a commutator results in
 - lower volume and weight densities
 - a limited maximum operating voltage
 - high maintenance costs associated with the commutator and the brushgear.
- If rheostatic speed control is used, the large number of resistances and contactors require substantial maintenance.

2.0 THREE PHASE INDUCTION MOTOR

A three phase induction motor, as the name suggests, draws electrical power from a three phase source. The three phase primary windings are usually located on the stator. These distributed windings are placed in such a way that the axes of the three phase coils are displaced by 120 electrical degrees from each other around the stator periphery. The rotor carries either a three phase winding or a squirrel cage - conducting bars in slots along the rotor surface, short circuited on both ends by endrings. The rotor winding in a wound-rotor induction motor can be excited independently of the primary using sliprings connected to a three phase source, although they are usually short-circuited on themselves, with or without external resistances. For traction purposes, however, only squirrel cage motors are practical and hence this discussion is limited to such motors. The essential components of a squirrel cage motor are shown in Figure 86, and a squirrel cage rotor is shown in Figure 87.

2.1 Operation of the Motor

If the three phase windings schematically shown in Figure 88 of an induction motor are excited by a balanced three phase excitation, the three currents can be written as:

$$i_A = I_m \sin \omega t$$

$$i_B = I_m \sin \left(\omega t - \frac{2\pi}{3} \right)$$

$$i_C = I_m \sin \left(\omega t - \frac{4\pi}{3} \right)$$

where I_m is the amplitude of the phase current and ω ($=2\pi f$) is the supply frequency in radians per second. These currents create a magnetic flux density distribution in the airgap, which can be approximated as

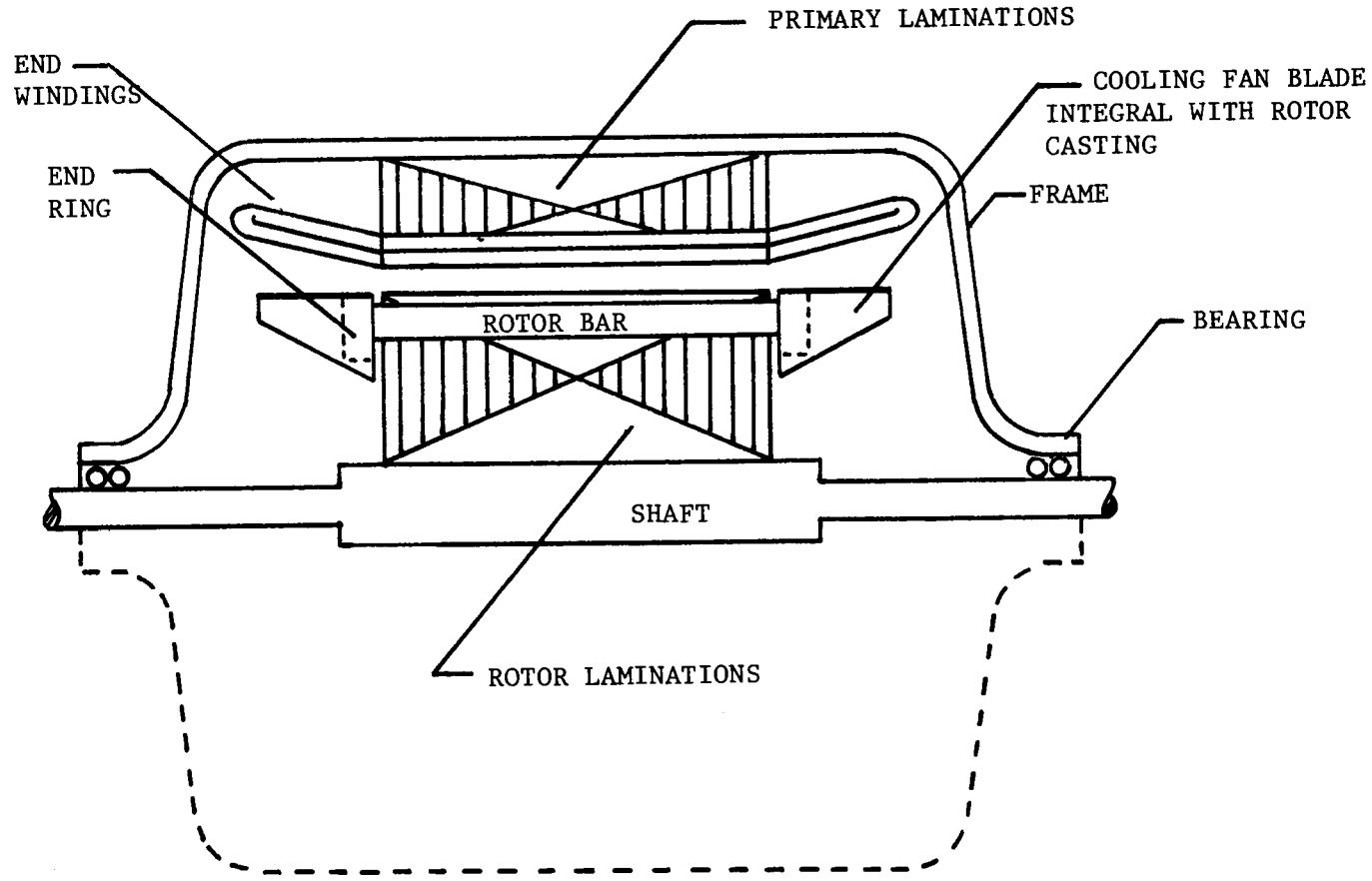

FIGURE 86
ESSENTIAL COMPONENTS OF AN INDUCTION MOTOR

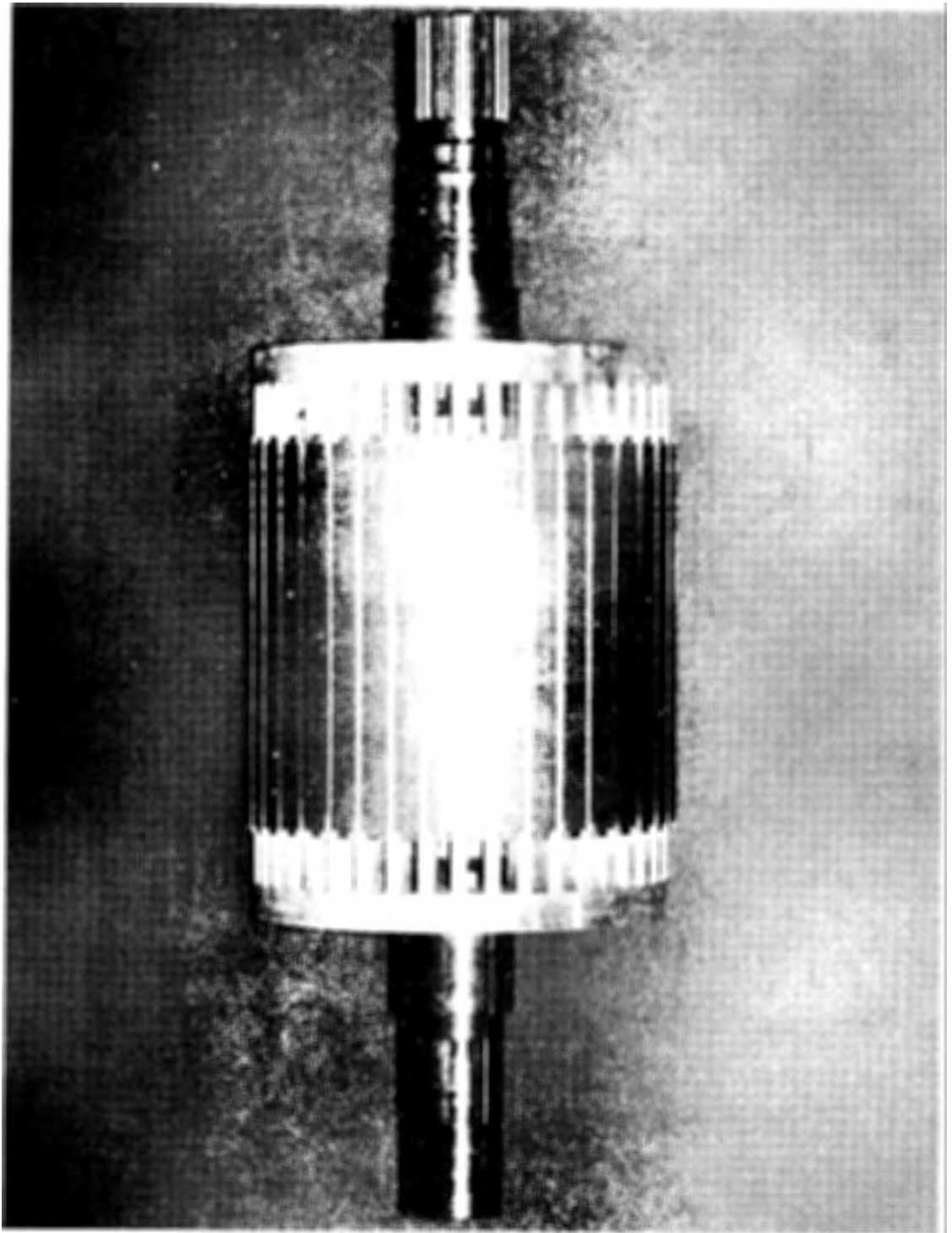

FIGURE 87
A SQUIRREL CAGE ROTOR

$$B(\theta, t) = B_m \sin(\omega t - \theta)$$

where $B(\theta, t)$ is the normal (radial) component of the flux density at a point θ electrical degrees from an arbitrary origin on stator periphery. It can be seen that the flux density varies sinusoidally in time with an amplitude B_m at a fixed position in the airgap, whereas at any particular instant in time the flux density is sinusoidally distributed in space. Also, a function of the form $f(\omega t - \theta)$ represents a traveling wave. Thus the airgap flux distribution can be seen as a rotating field, distributed sinusoidally in space, and rotating with an angular speed ω electrical radians/sec, determined by the supply frequency and known as synchronous speed.

If the rotor is rotating at an angular velocity of ω_r , the stator field moves past the rotor conductors with a relative velocity of $(\omega - \omega_r)$. Voltages of frequency $(\omega - \omega_r)$, also known as the slip frequency, are induced in rotor circuits and slip frequency currents flow in rotor circuits. The rotor circuit carries these currents by "induction" and hence the name "induction motor". The per unit slip of operation S is given by the equation

$$S = \frac{\omega - \omega_r}{\omega}$$

Thus, if S is known, the rotor speed can be obtained as

$$\omega_r = (1-S)\omega$$

The slip frequency currents flowing in rotor circuits create a magnetic field of their own. This rotor field, also approximately sinusoidally distributed in space, rotates at a speed of $S\omega$ with respect to the rotor circuits. Since the rotor itself is moving at a speed of $(1-S)\omega$

with respect to the stator frame, the rotational speed of the rotor field with respect to the stator frame can be computed as

$$\begin{aligned} & \text{Speed of the rotor field w.r.t. the stator} \\ &= \text{speed of the rotor field w.r.t. the rotor} \\ &+ \text{speed of the rotor w.r.t. the stator} \\ &= S\omega + (1-S)\omega \\ &= \omega \end{aligned}$$

One can thus see that the stator field and the rotor field are stationary with respect to each other, with both fields rotating at speed of ω in space, irrespective of the rotor speed. The angle between the axes of the stator field and the rotor field depends on the equivalent impedance of the rotor circuit. These two fields react to produce a steady electromagnetic torque. If the rotor were to rotate at synchronous speed, it would be stationary with respect to the stator field, and hence no current would be induced in the rotor and no torque could be produced.

2.2 Operating Characteristics

The operating characteristics of the motor can be explained with the help of an equivalent circuit shown in Figure 39. X_1 and X_2 are the leakage reactances per phase, R_1 and R_2 are the resistances of the primary and the secondary circuits per phase, and X_m is the magnetizing reactance per phase of the motor. S is the per unit slip of operation. For a constant voltage operation, the circuit equations can be solved to obtain I_1 , I_m and I_2 . The torque can then be obtained as

$$T = 3 I_2^2 \frac{R_2}{S}$$

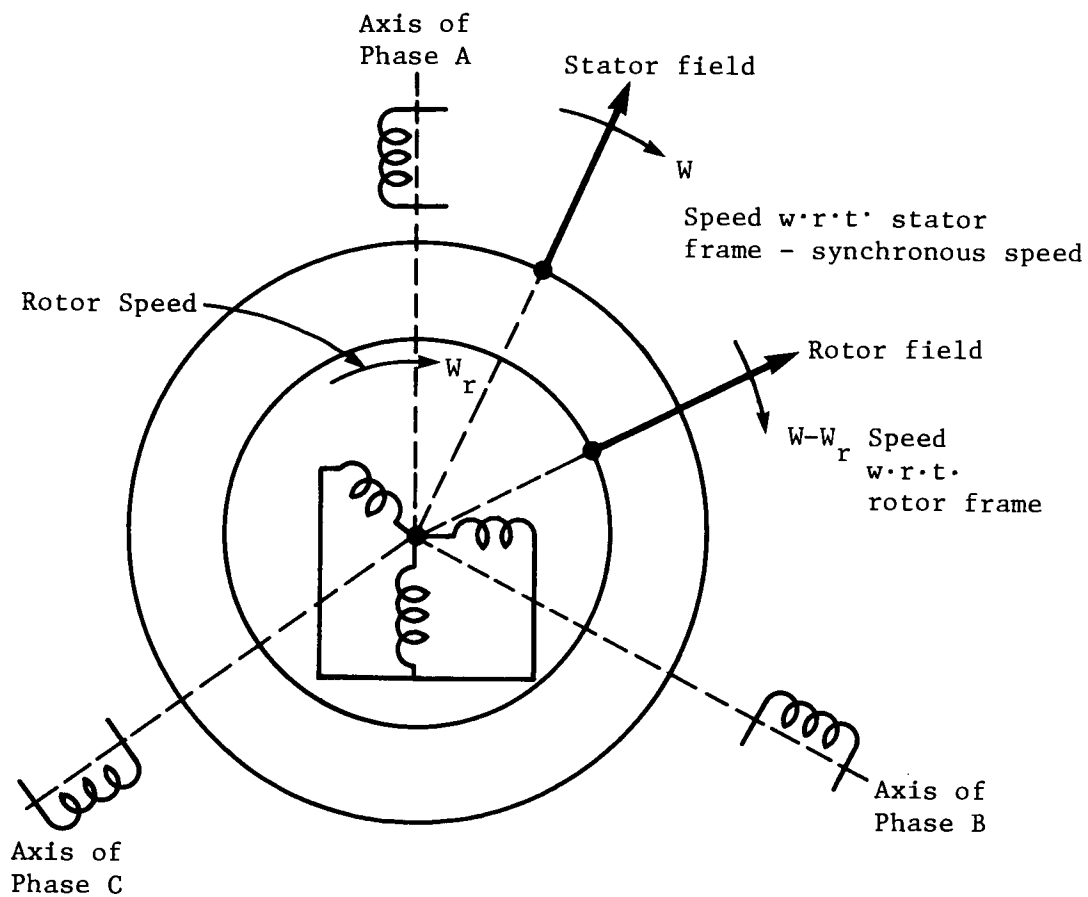

FIGURE 88
INDUCTION MOTOR WINDINGS

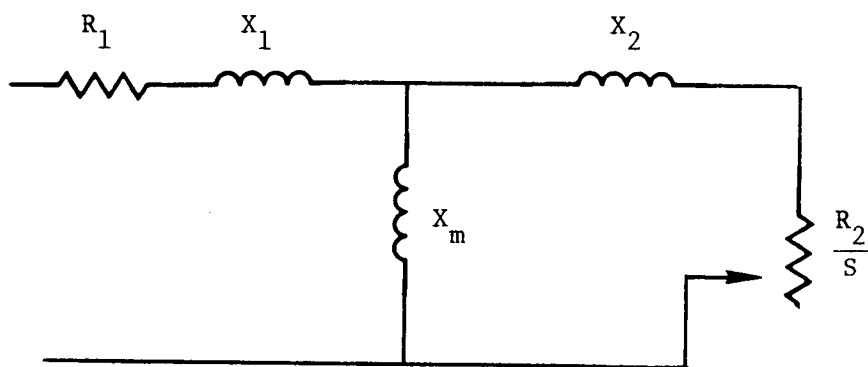

FIGURE 89
EQUIVALENT CIRCUIT

The torque and primary current variations with slip are shown in Figure 90. Certain characteristics of the motor operation are evident from this torque-speed curve.

For rotor speeds between zero and the synchronous speed, the torque and the speed are both positive, thus resulting in a motoring action. In this motoring region, the torque increases from its starting value with increasing speed, reaches a maximum called the pull-out torque, and rapidly drops to zero at synchronous speed. For a given load characteristics, the motor operates at a speed close to the synchronous speed ($\sim 95-99\%$), where the motor torque equals the load torque - at the point P for example. This operation is very stable because if the speed increases, the motor torque decreases and the motor decelerates. Similarly, if the speed decreases, the motor torque increases resulting in motor acceleration. It could also be shown that the operation at point Q is clearly unstable. Thus for a typical motor, the slip for the maximum torque could be in the range 0.1-0.2, and the normal full load slip could be in the range of 0.01-0.05 per unit, i.e. 1-5 percent. Thus an induction motor is essentially a constant speed motor.

When the rotor speed is more than the synchronous speed, i.e., for negative slip values, the torque produced is negative, becoming a braking torque. This mode of operation is regenerative braking. In this operation, the motor is driven by the load (a vehicle going down a grade, for example) and the kinetic energy of the load is converted to electrical energy that is fed back to the three phase source connected to the primary. Also, for negative rotor speeds - rotor speed in a direction opposite to that of the rotating field - the torque is still positive, thus opposing the rotor motion. This braking action is called "plugging". In this operation, the kinetic energy of the load and the rotor is wasted as heat in the rotor circuit. The primary winding continues to draw heavy current from the supply.

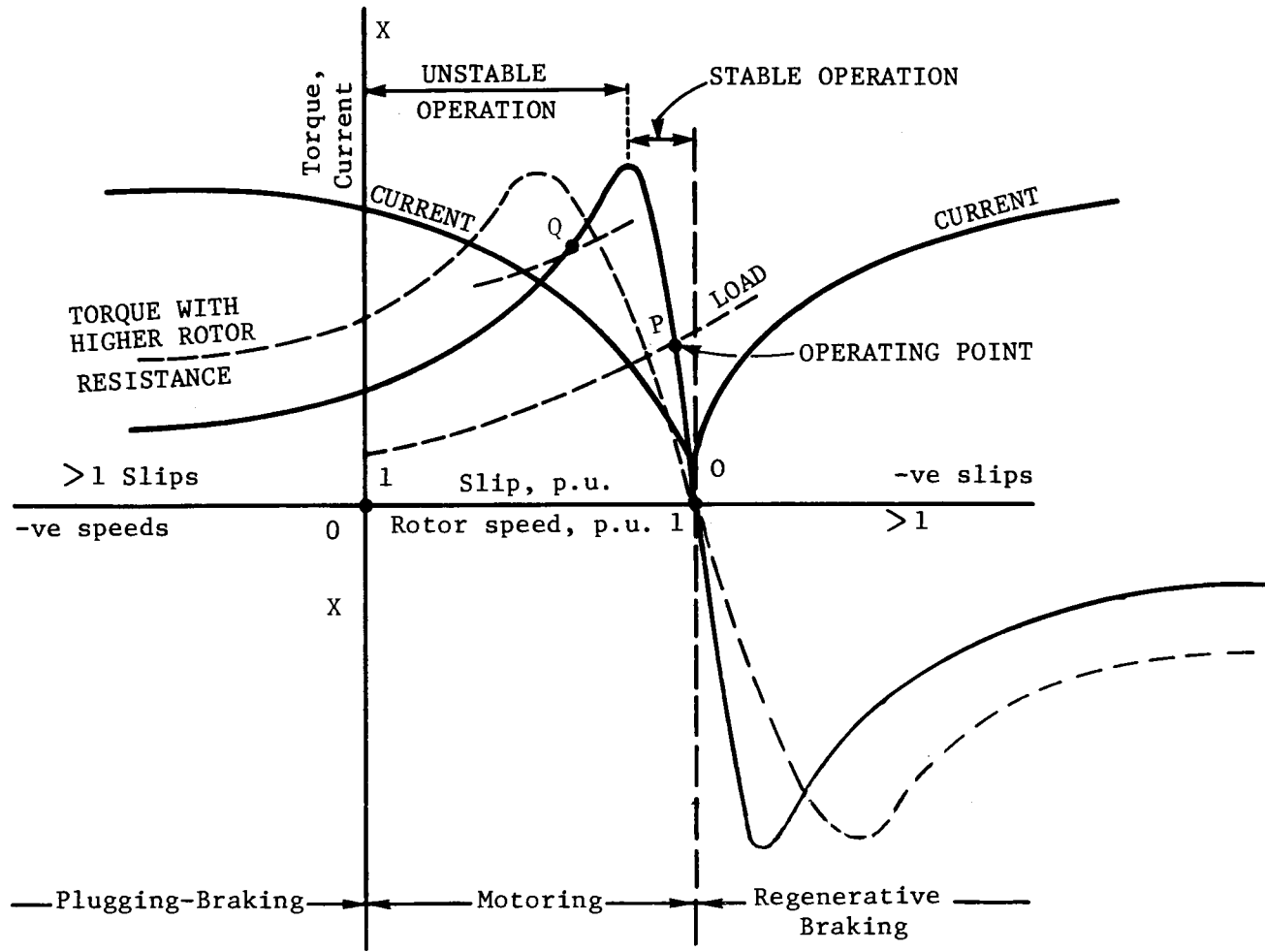

FIGURE 90
 TORQUE AND CURRENT AS A FUNCTION OF SLIP

The variations of the efficiency and the power factor of the motor with slip are shown in Figure 91. Copper losses in the stator and the rotor and iron losses in the stator core are the major loss components. Iron losses in the rotor core are usually small because the rotor carries slip frequency currents and fluxes. The power factor depends on the airgap and the leakage reactances of the primary and the secondary circuits.

2.3 Speed Control of Induction Motors

It can be seen from the very steep characteristics in the stable region of Figure 90, that the induction motor is basically suitable for a constant speed operation. The stable region can be extended by adding external resistances in the rotor circuit. However, this is possible only for a wound rotor motor and is clearly impossible for a squirrel cage motor. Also, the torque can be reduced by reducing the applied voltage. But any variable speed operation for a constant supply frequency is possible only at increased slip and hence at reduced efficiency. Hence, the most efficient method of speed control requires a variable voltage variable frequency (VVVF) supply where the speed can be controlled by changing the frequency and the torque can be controlled by changing the voltage.

The necessity of a VVVF source for efficiently controlling the speed of an induction motor was realized long ago, but it was not economically feasible before the introduction of power semiconductors. For small power applications and other applications where efficiency considerations were not important, voltage control methods using magnetic amplifiers, thyristors or series/parallel winding connections were developed. For restricted speed control, pole changing motors or pole amplitude modulation techniques were also developed. However, none of these methods are suitable for the control of vehicle propulsion.

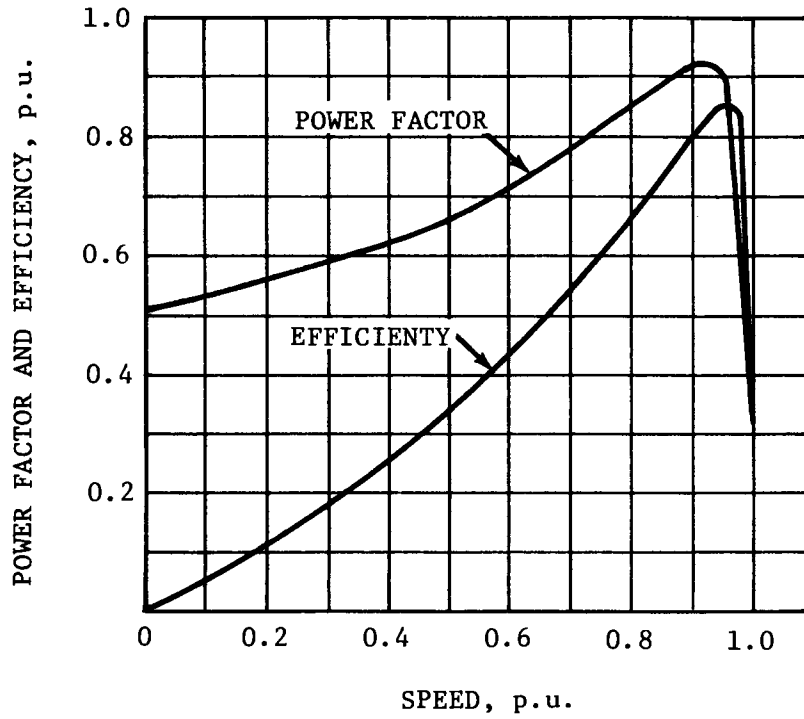

FIGURE 91
POWER FACTOR AND EFFICIENCY OF INDUCTION MOTOR

With a VVVF source, one can change the synchronous speed, and hence the operating speed of an induction motor, by simply changing the frequency of the source. The airgap flux of the motor can then be controlled by changing the source voltage or by changing the number of turns per phase in the motor, if possible. The operating principle of this method of speed control can be explained with the help of Figure 92. A typical torque-speed characteristic required for traction application is shown. The motor is operated with a constant flux and a constant current so that a constant torque is produced at all speeds up to the base speed. The airgap flux can almost be held constant by having a constant voltage/frequency ratio. Beyond the base speed, the voltage is held constant while frequency is increased. The airgap flux and thus the pull-out torque of the motor are reduced. A constant-current, constant-flux, constant-torque operation (Mode A) is possible up to higher speed for braking than for motoring. Hence, high braking torques are possible at high speeds.

It should be pointed out here that the induction motor can operate only at a lagging factor. This has an important impact on the design of the VVVF source. In general, it is possible to use either line commutated or forced commutated VVVF designs. The line commutated equipment is cheaper and has better fault characteristics than a forced commutated one. However, line commutation is possible only with leading power factor load. The induction motor, therefore, requires a forced commutated VVVF design. The static power converters are discussed in detail in Appendix B.

2.4 Advantages and Disadvantages

Suitability of the induction motor for propulsion of a transit vehicle can be summarized as follows:

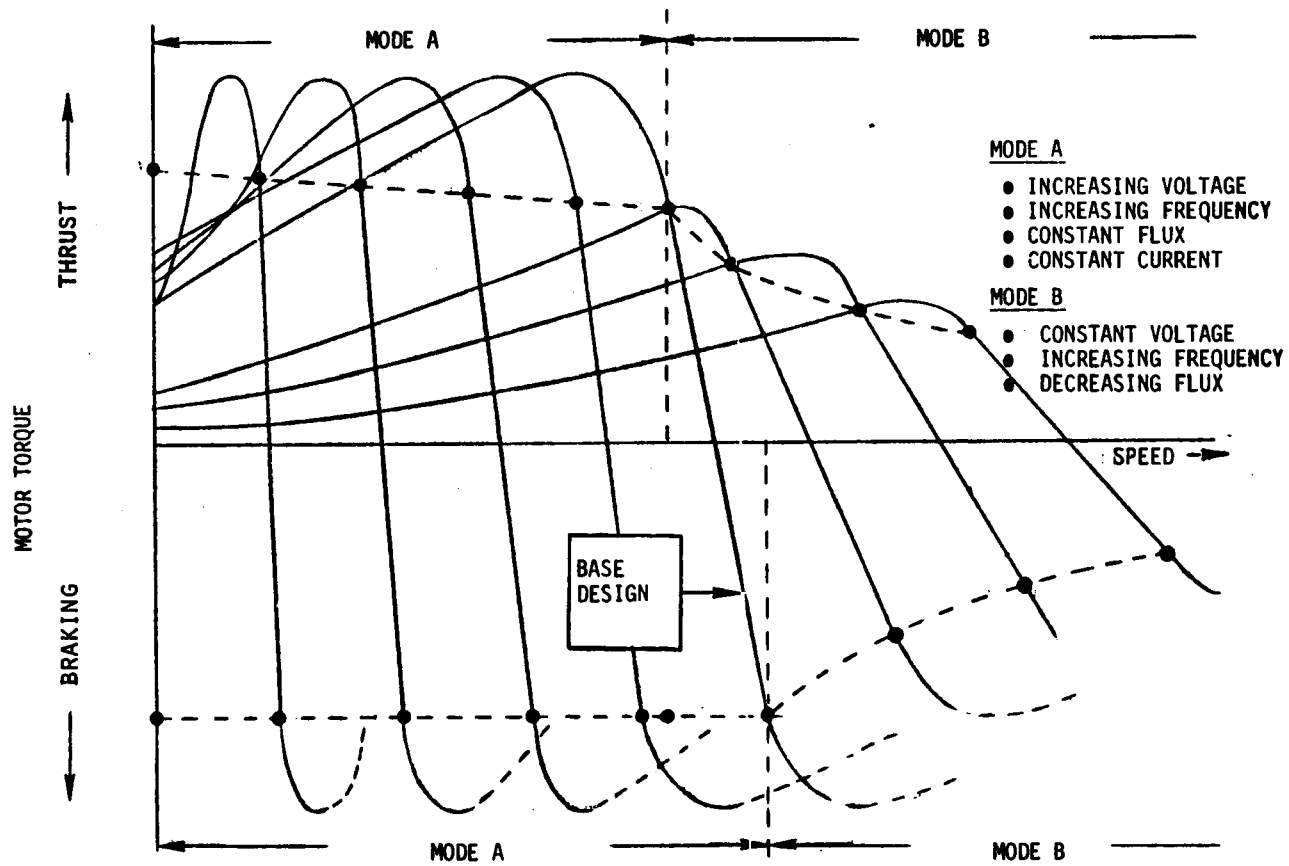

FIGURE 92
SPEED CONTROL FOR TRACTION APPLICATIONS

Advantages

- A very simple, rugged traction motor.
- High power density for weight and volume, and hence a light motor.
- High voltage and high speed operation is possible.
- Inherent tendency to control wheel slip.
- Regenerative braking without contactors
- Low initial and maintenance costs as compared to a dc motor.

Disadvantages

- Requires a variable-frequency, variable-voltage power source for speed control. This results in high initial cost for the total system at this time.
- If more than one motor are used in parallel, wheel diameters need to be maintained to close tolerances.

3.0 THREE PHASE SYNCHRONOUS MOTOR

The operating principle of different types of synchronous motors can best be explained with the help of a machine configuration shown in Figure 93. Consider a three phase stator winding similar to that of an induction motor. This winding, when excited, creates a rotating magnetic field. This field is sinusoidally distributed in space and rotates at a speed determined by the supply frequency. Also, consider a salient pole rotor structure having two axes of symmetry - the polar axis or direct axis d and the interpolar or quadrature axis q . Because of this saliency, the magnetic flux paths have different permeances in these two axes. The rotor is shown carrying a field winding. When excited with a direct current, it creates a magnetic field which is centered on the direct axis and is stationary with respect to the rotor surface. If this rotor rotates at the synchronous speed, the rotor field is then stationary with respect to the stator field and an electromagnetic torque is produced. A resultant average torque can be produced only at synchronous speed and hence these motors are called synchronous motors.

3.1 Operating Characteristics

The airgap flux produced by the currents in the armature (i.e., stator) winding is called the armature reaction. Since the analysis of this armature reaction involves the rotor saliency it can be done by resolving the armature reaction flux into components along the rotor d - q axes. The armature currents are also resolved into two components. The direct-axis component i_d causes an armature reaction centered on the direct axis, with a reactance X_d , called the direct axis synchronous reactance, associated with it. The quadrature axis component i_q causes the armature reaction to be centered on the quadrature axis, with a reactance X_q , called the quadrature axis synchronous reactance, associated with it. The component X_d is usually larger than X_q since the airgap under the direct axis is smaller than that under the quadrature axis.

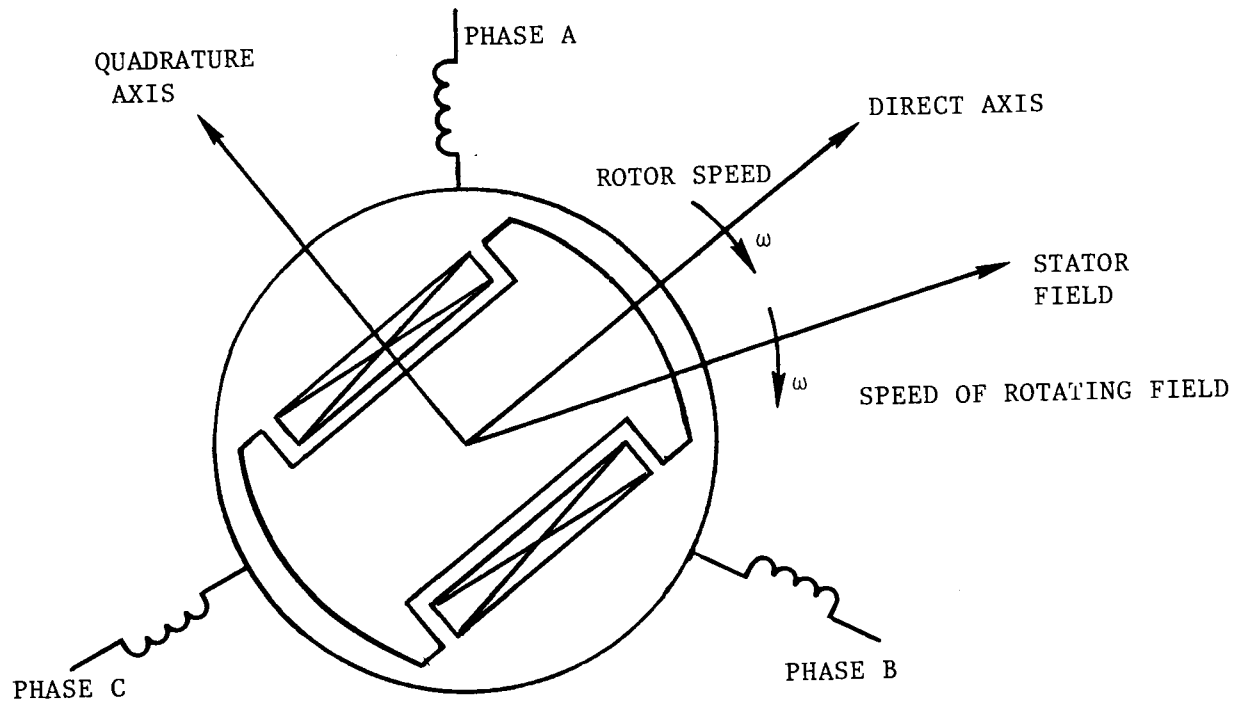

FIGURE 93
SYNCHRONOUS MOTOR SCHEMATIC

For a synchronous motor, the terminal voltage V_t and the excitation voltage E_f induced by the field winding are related as follows (the armature resistance is assumed to be zero):

$$E_f = V_t - j X_d I_d - j X_q I_q$$

This is a phasor equation that shows for a constant magnitude of the terminal voltage V_t and of the armature current I_a , the field excitation voltage E_f - actually the field current I_f - can be used to control the power factor of the motor. This is illustrated in Figure 94. The power factor angle ϕ between V_t and I_a as well as the power angle δ between E_f and V_t are both shown. An underexcited motor operates with a lagging power factor and an overexcited motor operates with a leading power factor. As mentioned earlier, less expensive thyristor power converter equipment can be used to control a leading power factor load.

The power developed by the motor can now be obtained with the help of the phasor diagram of Figure 94(b) as follows:

$$\begin{aligned} P &= I_d \cdot V_t \sin \delta + I_q V_t \cos \delta \\ &= \left(\frac{E_f - V_t \cos \delta}{X_d} \right) \cdot V_t \sin \delta + \left(\frac{V_t \sin \delta}{X_q} \right) V_t \cos \delta \\ &= \left(\frac{V_t E_f}{X_d} \right) \sin \delta + \frac{1}{2} V_t^2 \left(\frac{1}{X_q} - \frac{1}{X_d} \right) \sin 2\delta \end{aligned}$$

It should be seen here that the first term represents the power due to field excitation whereas the second term represents the power independent of excitation and due only to the rotor saliency - i.e. the power due to reluctance torque. The reluctance torque is produced because of the difference in reluctance under the direct and quadrature axes. The power expression can, therefore, be rewritten as:

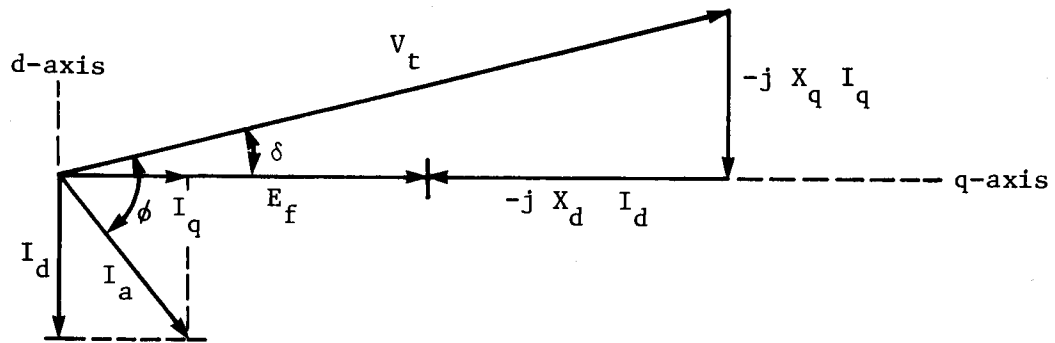

(a) Underexcited motor, lagging power factor

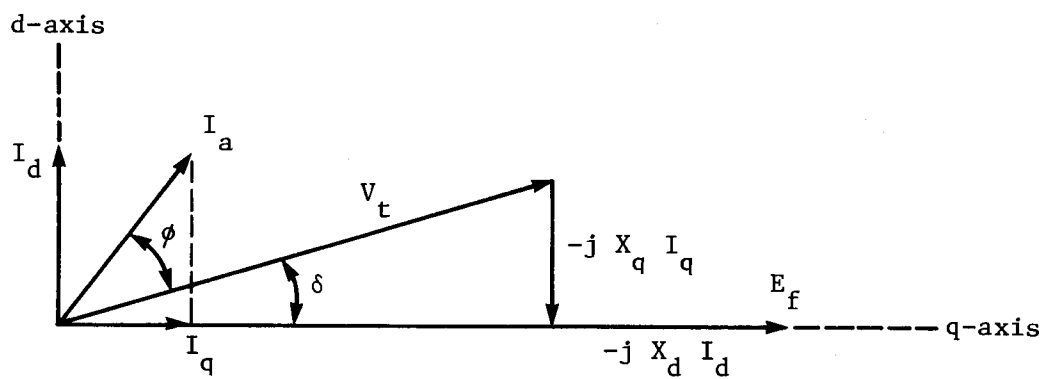

(b) Overexcited motor, leading power factor

FIGURE 94
SYNCHRONOUS MOTOR PHASOR DIAGRAMS

$$P = P_{fm} \sin \delta + P_{rm} \sin 2\delta$$

Where P_{fm} and P_{rm} represent the maximum values of the power due to the field excitation and reluctance variation respectively.

3.2 Types of Synchronous Motors

One can now visualize several types of synchronous motors based on whether both the field excitation torque and the reluctance torque are present, depending on the methods of rotor excitation. These types are listed below and also presented in Table I.

- Doubly excited motors (These motors have armature and field excitation and hence two torque components. Cylindrical construction has greatly reduced reluctance torque).
 - Permanent magnet excitation
 - Rotor field windings supplied through sliprings
 - Rotor field supplied through a rotating transformer
 - Homopolar inductor machine
 - Lundell/Rice machine
- Singly excited or reluctance motors (These motors have no field excitation and hence have only the reluctance torque).
 - Synchronous reluctance
 - Sub-synchronous reluctance motor, i.e., a Vernier motor

The above configurations will now be described.

3.2.1 Permanent Magnet Synchronous Motor

The principle of operation of this motor is the same as described earlier. However, the rotor magnetic field is created by using permanent magnets instead of electromagnets. The rotor excitation is thus contactless and hence there are no sliprings or brushes to wear. The field, however, cannot, be easily controlled. Hence, weak-field conditions cannot be easily achieved for traction applications. It should also be remembered that as long as the rotor is driven, the permanent magnet excitation will induce armature voltages and hence these motors cannot be deenergized. Thus, if the armature winding of a permanent magnet synchronous motor develops a fault, the motor can

TABLE I

SYNCHRONOUS MACHINES

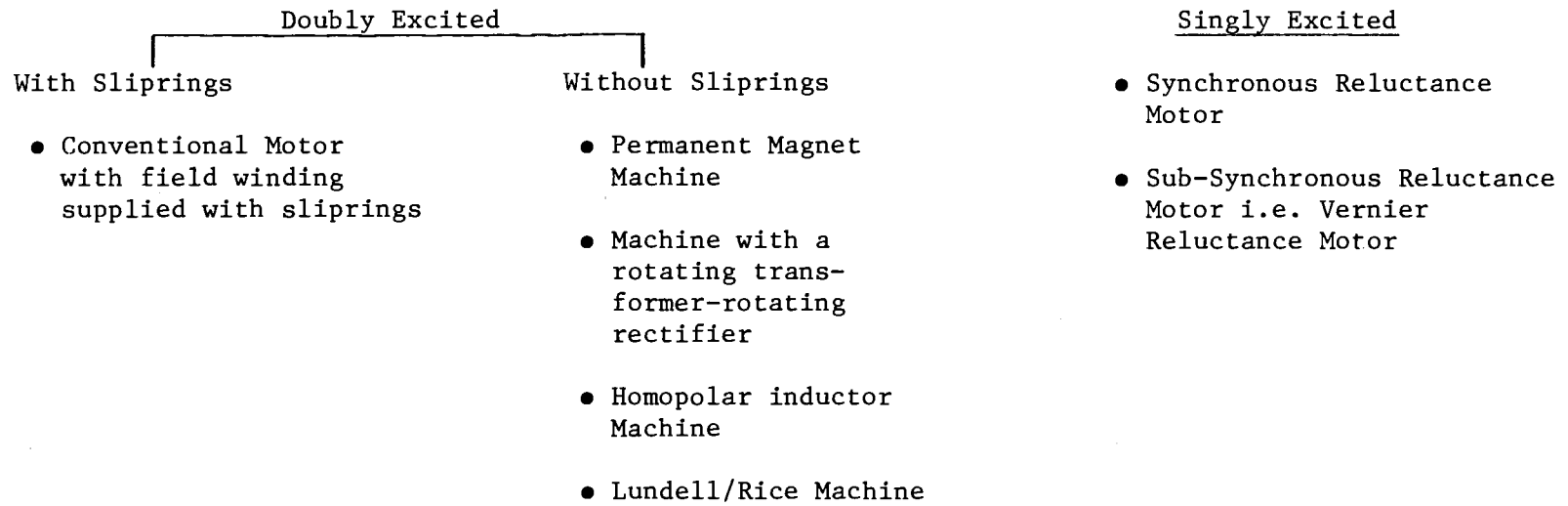

be burned out if the rotor is allowed to rotate, even if the motor is disconnected from its converter. In a multi-car vehicle consist, therefore, if one motor develops a fault, it has to be mechanically decoupled before the vehicle is moved.

With improved, inexpensive permanent magnet materials, these motors will, no doubt, be increasingly used for various applications.

3.2.2 Rotor Field Supplied Through Sliprings

This is the most common method of supplying field winding of a synchronous machine. The rotor winding terminals are brought out to two sliprings on the shaft and the dc field current is fed through a set of brushes. The field can then be controlled quite easily. The brushes, of course, need regular cleaning.

For application in rail propulsion, this motor has very little to offer. It is big and heavy compared to a squirrel-cage induction motor and it still has a brush-gear similar to a dc motor. Simple and cheap solid state converter circuits can, however, be used with a synchronous motor. In some countries, such as the Soviet Union for example, this could be an overriding consideration because the solid state technology is not as advanced. This can possibly explain their interest in continued development of a propulsion system using slip-ring synchronous motors for their VL80 type locomotive.

3.2.3 Rotor Field Supplied Through a Rotating Transformer

The rotor field can be supplied without sliprings (contactless) and can still be controlled if one uses a rotating transformer and rectifier equipment as shown in Figure 95. The shaft of the synchronous machine carries the secondary of a three phase transformer. The induced voltage in this winding is rectified by means of a rectifier circuit, also carried on the shaft. This rectified voltage is used directly to

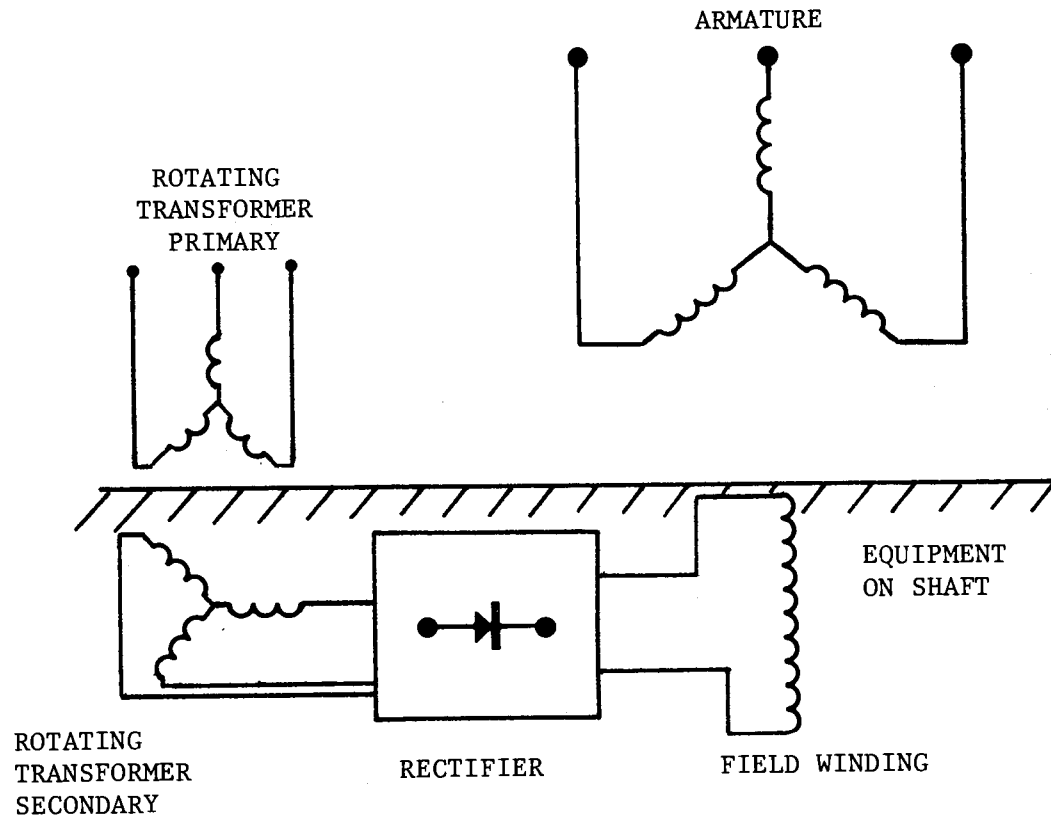

FIGURE 95
USE OF ROTATING TRANSFORMER/RECTIFIER

excite the rotor field. There is thus no contact between the stator and the rotor circuits and the energy to excite the field is obtained from the primary of the rotating transformer. Such systems are currently in use for several industrial applications.

A propulsion system for urban rail application using such a motor is described at greater length in Section 5 of this report.

3.2.4 Synchronous Reluctance Motor

This motor is a singly excited synchronous motor, wherein torque is generated because the airgap reluctance is a function of rotor position. The rotor carries no windings or permanent magnets but the airgap reluctance is different for the d-axis and the q-axis. A reluctance torque is, therefore, generated given by the second term of the power equation given previously. The essential features of the machine are shown in Figure 96.

It should be noted here that the reluctance distribution along the rotor periphery rotates at an angular velocity equal to the rotor velocity, i.e., when the rotor moves through an angle θ , the reluctance distribution also moves through an angle ϕ equal to θ . Thus the rotor rotates at synchronous speed, keeping the rotor flux stationary with respect to the stator flux.

The reluctance motor, being a singly excited device, cannot operate at a leading power factor and, in fact, has a very poor power factor. This motor is thus of little use in transportation applications. The rotor construction, however, is simple and rugged. This motor, therefore, is frequently used for applications in control circuits.

3.2.5 Vernier Reluctance Motor

A vernier reluctance motor is another singly excited machine in which a reluctance torque is generated because the airgap reluctance

is a function of the rotor position. However, in this machine, if the rotor moves through an angle θ , the configuration of the rotor causes the reluctance distribution to move through an angle ϕ , different from θ , but always a constant multiple of θ ($\phi = N \cdot \theta$) as shown in Figure 97. This means that the rotor field can rotate at synchronous speed, remaining stationary with respect to the stator field, if the rotor rotates at a sub-synchronous speed given by

$$\text{rotor speed} = \frac{1}{N} \cdot \text{synchronous speed}$$

The factor N depends on a particular design. For example, consider a doubly slotted structure as shown in Figure 98. Here the slot pitches are chosen such that

$$\frac{\lambda_s}{\lambda_r} = \frac{4}{3}$$

where λ_s and λ_r are the stator and the rotor slot pitch respectively. The maximum permeance (minimum reluctance) along the rotor periphery is obtained where the stator and the rotor teeth are opposite each other as shown. Now if the rotor is moved through half the stator slot pitch, the permeance/reluctance distribution moves through two stator slot pitches, as shown in Figure 98(b). This means that if the rotor field rotates at the synchronous speed, the rotor will rotate at 1/4th the synchronous speed.

For a vernier motor it can also be shown that the mechanical torque developed by the motor is N times the reluctance torque given previously, i.e.,

$$T_{\text{mech}} = N \cdot T_{\text{rel}}$$

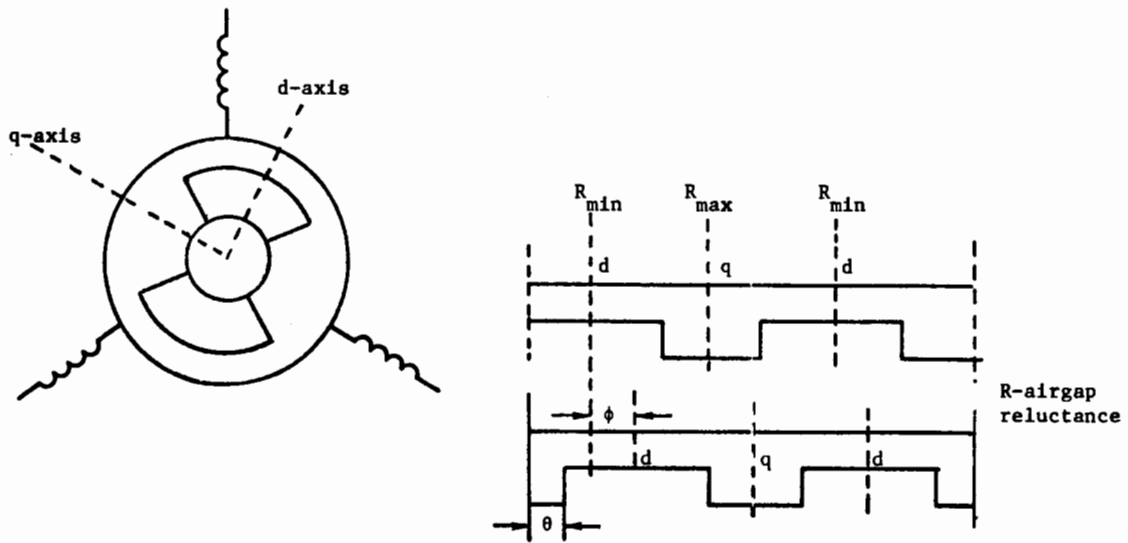

FIGURE 96
SYNCHRONOUS RELUCTANCE MOTOR

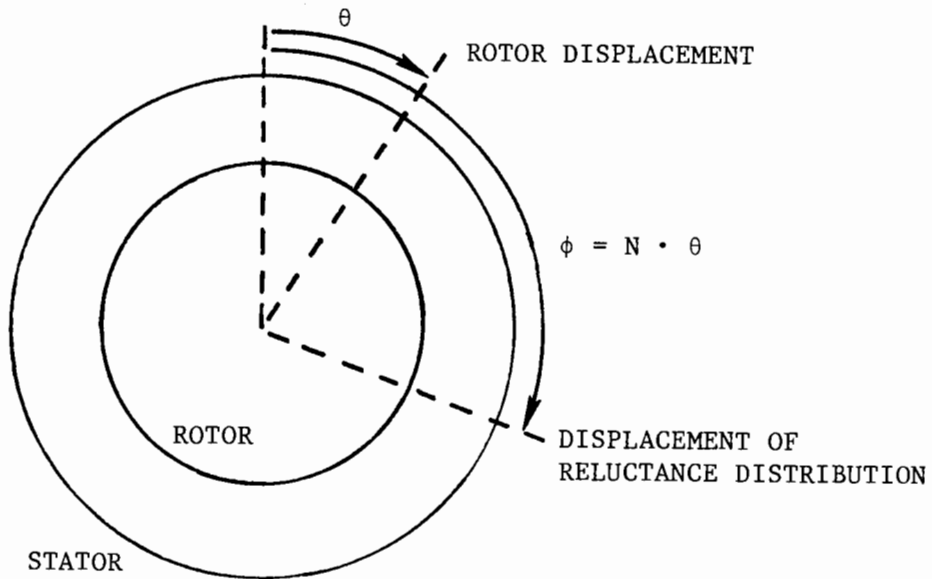

FIGURE 97
VERNIER MOTOR

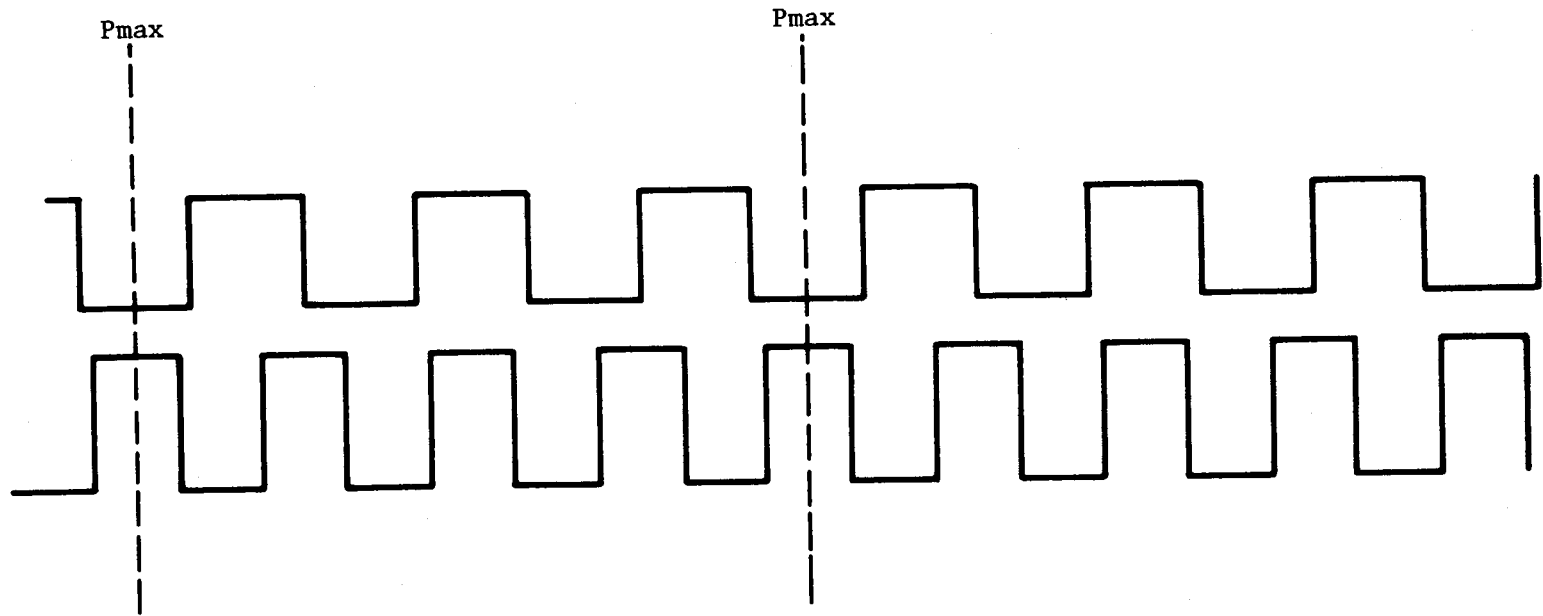

FIGURE 98(a)
DOUBLY SLOTTED STRUCTURE OF VERNIER MOTOR

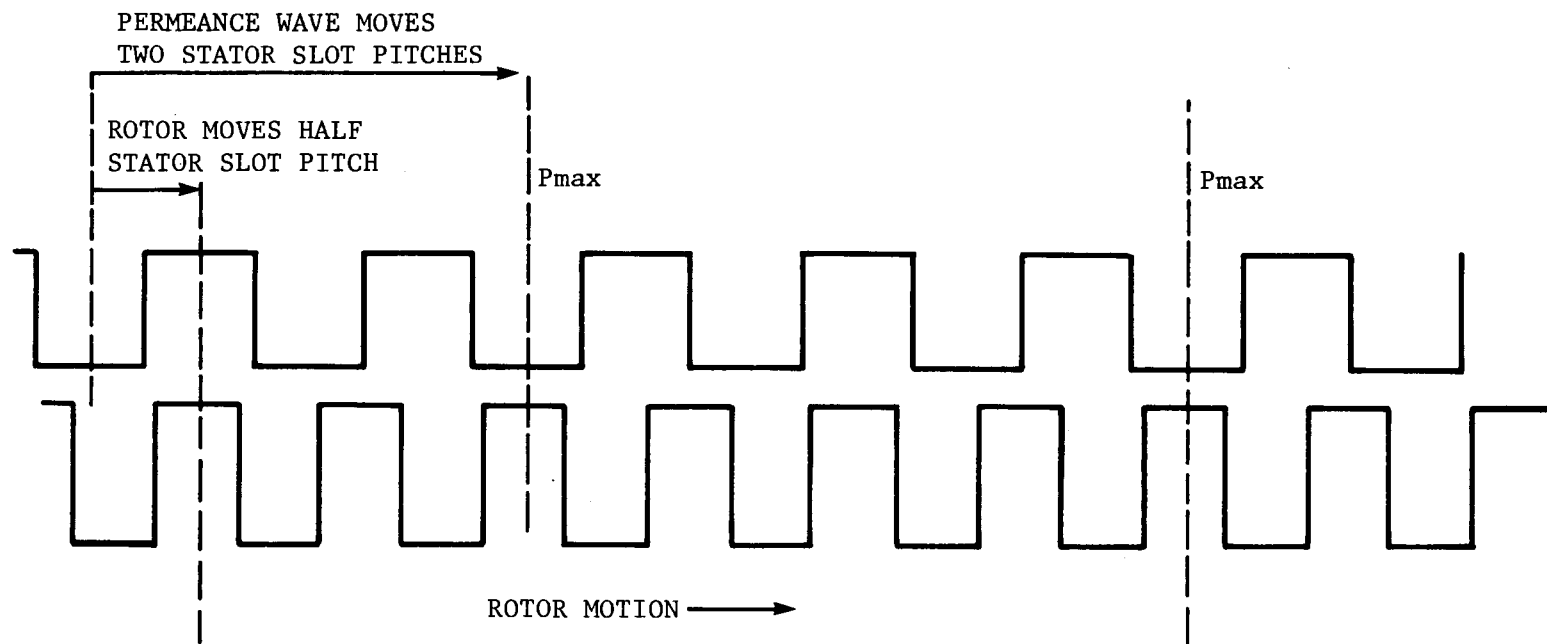

FIGURE 98(b)
DOUBLY SLOTTED STRUCTURE OF VERNIER MOTOR

Now, since

$$\text{rotor speed} = \frac{1}{N} \text{ synchronous speed}$$

the vernier motor behaves like a built-in electromagnetic reduction gear.

Experimental investigations on laboratory models have shown that slot shapes and slot combination need to be optimized for obtaining a higher power density, and even then the power factor is very poor. These motors also tend to be noisy because of the presence of a doubly slotted structure.

If such a motor is used for traction applications, it could possibly eliminate the need for a gear box and the motor could be directly built on the shaft. The power factor will, most probably, have to be improved by using static capacitors in order to reduce the inverter cost. Its suitability for urban rail systems can be evaluated only after a preliminary design of a total system including the motor and the converter.

3.2.6 Other Doubly Excited Configurations

We have so far seen three types of doubly excited synchronous motors. The permanent magnet motor cannot be easily operated under weak field conditions and for transit applications and it needs to be mechanically decoupled if fault conditions develop. The motor with sliprings has brush wear problems and a motor with a rotating transformer is quite a complex system. There are, however, some other configurations in which it is possible to create rotor field without bringing the field current into the rotor. In these configurations, the armature and the field winding are both on the stator and the field flux is made to go through rotor structure by developing special topologies. These will be described in this section. The reader should be cautioned here that these are basically 3-dimensional topologies

and only an attempt can be made to explain these with the help of some illustrations. The advantages and the limitations of these motors will be presented, but any detailed discussion is beyond the scope of this report.

3.2.6.1 Homopolar Inductor Motor

Consider a machine shown in Figure 99. It essentially consists of two rotor cores, and a common field winding. The salient poles of the rotor cores 1 and 2 are shown in Figure 100. It can be seen that the poles are shifted by a pole pitch. The flux density distributions along the airgap around the rotor cores is therefore as shown in Figure 101.

The field winding, when excited, creates an airgap flux distribution as follows:

- a) The flux enters the rotor on one side, say core 2, goes to core 1 through the central shaft, and returns to the yoke from core 1.
- b) Along the periphery of core 1 or core 2, the flux is all unidirectional, and hence the name, "homopolar motor". The flux distributions will depend on the topological constants such as the pole arc-to-pole pitch ratio, interpolar gap, etc.

The armature winding reacts with the sinusoidal component of the rotor field to create an electromagnetic torque. The homopolar machine is usually heavy because the magnetic structure has to handle the average field flux which does not contribute to the thrust. The alternating component of the airgap flux depends directly on the difference ($B_{\max} - B_{\min}$). The maximum flux density is, of course, limited by the saturation level and the minimum flux density depends on the leakage characteristics. The design of such machines is quite complex compared to say, an induction motor design, and one has to optimize the design considering various parameters such as the pole arc/pole pitch ratio, ac flux/average dc flux ratio, etc.

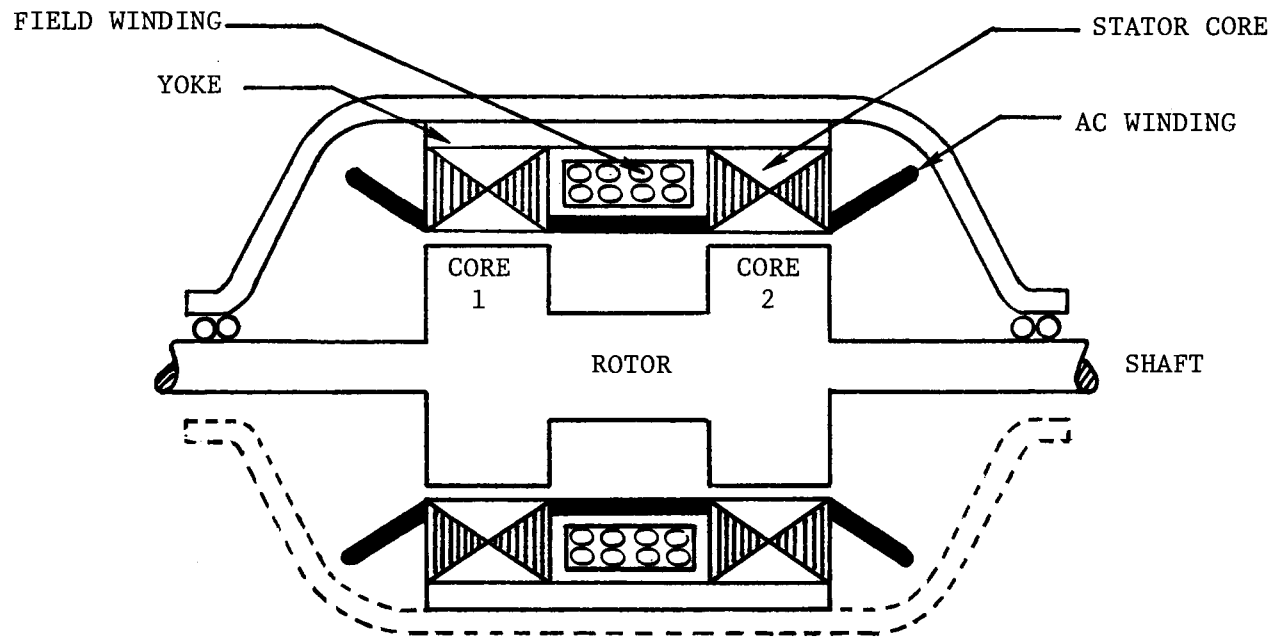

FIGURE 99
HOMOPOLAR INDUCTOR MOTOR

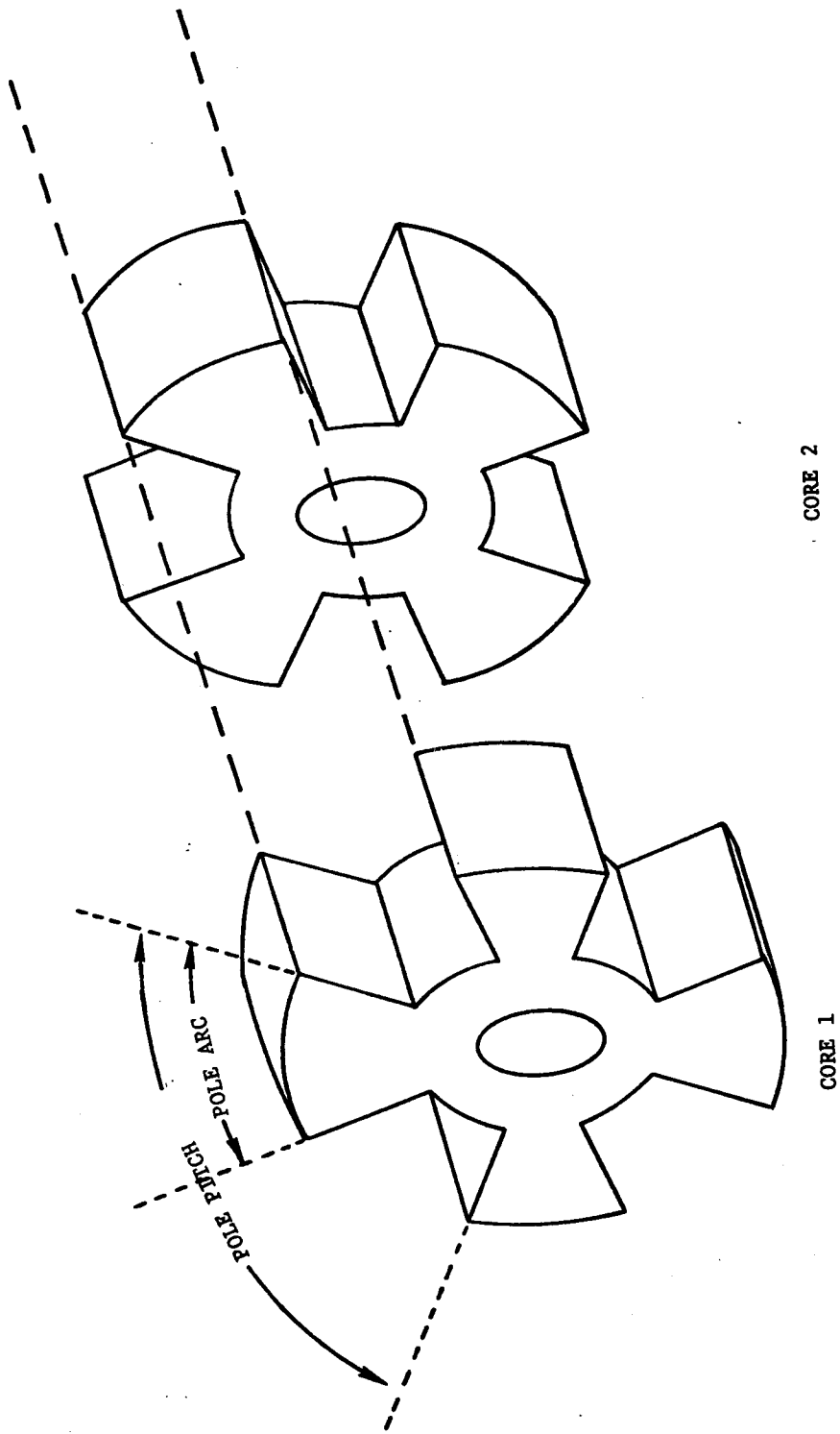

FIGURE 100
TWO ROTOR CORES

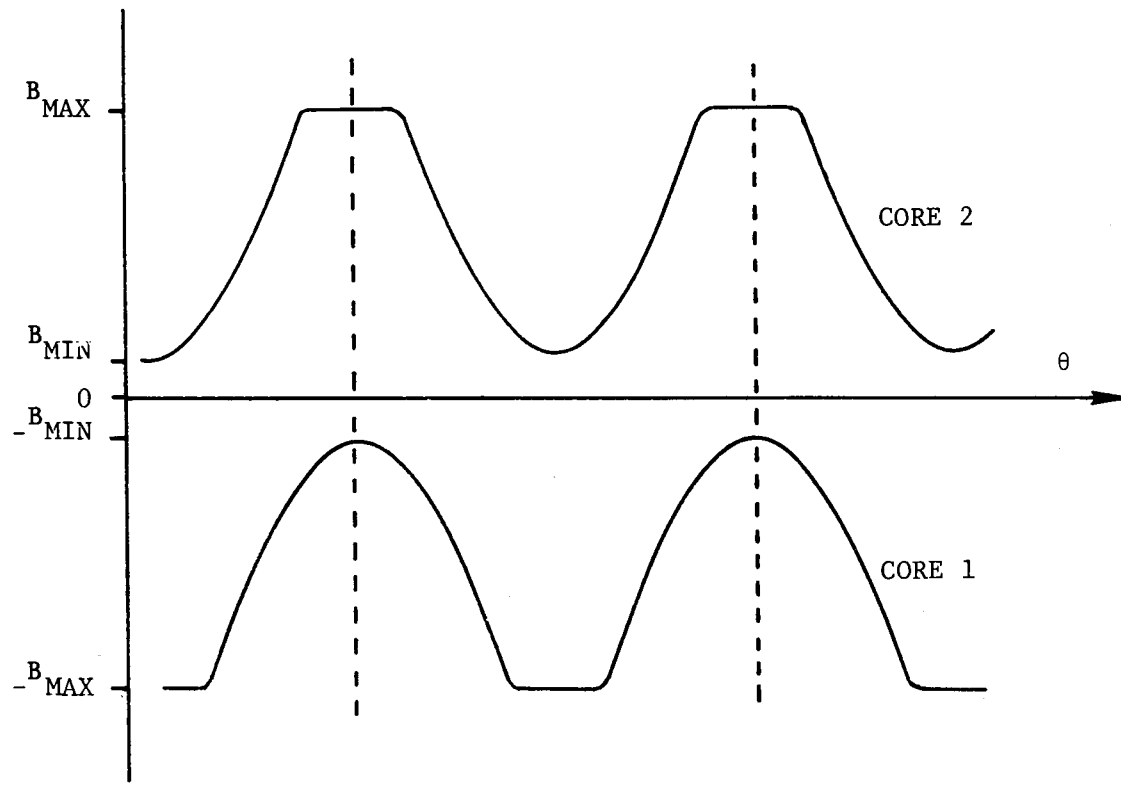

FIGURE 101
AIRGAP FLUX DENSITY DISTRIBUTIONS

As can be seen, this machine has a very simple, rugged rotor like a squirrel cage motor and it can also operate at a leading power factor. Large weight, volume and higher commutating reactance are some of the disadvantages of this motor. A high commutating reactance results in an expensive converter design. This commutating reactance could possibly be reduced by introducing some damping circuits to reduce the effects of high field leakage reactance.

In short, the homopolar inductor motor has some significant characteristics to make it a useful traction motor. However, there is a need to further evaluate motor designs for traction application before a judgement can be made on this issue.

3.2.6.2 Lundell/Rice Motor

These special motors are heteropolar synchronous machines where the armature and the field winding are placed in the stator and the rotor field is created by properly directing the field flux through the rotor structure. The rotor structures of these motors are quite complex, but there are no brushes or the sliprings to wear.

Consider for example a motor shown in Figure 102. It is commonly known as a Rice machine. The two windings, the magnetic and the non-magnetic parts of the structure are marked. One side of the rotor acts like a south pole and the other side like a north pole. The field flux path is as follows:

The yoke → the rotor on one side (right in Figure 102) → a rotor pole → the armature → the next rotor pole → the rotor on the other side (left in Figure 102) → back to the yoke.

The field flux thus covers four airgaps: two main airgaps between the armature and the field poles and two parasitic gaps between the yoke and the shaft. It should also be noted here that

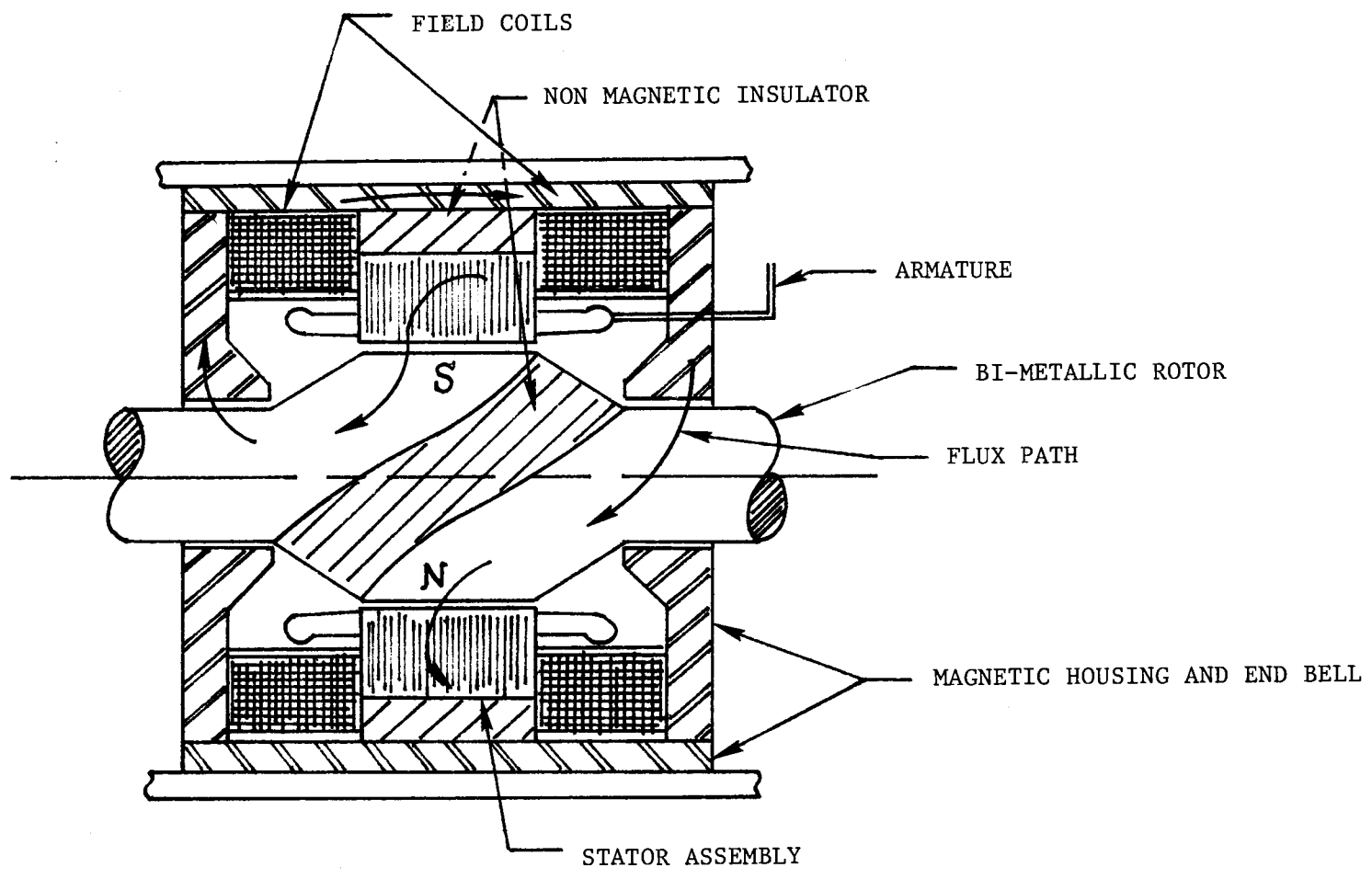

FIGURE 102
RICE MOTOR

the flux does not cross between the rotor poles but goes through the armature because the magnetic reluctance of the path through the armature is quite small compared to the gap between the rotor poles.

A second possible topology is shown in Figure 103. It is known as a Lundell machine. The field winding is fixed to the stator frame, but it is housed inside the rotor, thus shortening the path of the field flux. For a six-pole construction of Figure 103, the shaft and the three south poles form one structure and the three north poles are connected to the shaft with a non-magnetic separator. The north poles extend out and over the field winding. The flux path is as follows:

The yoke → a rotor north pole → the armature → the next south pole (on both sides) → the shaft → the yoke.

It should also be noted here that the field flux crosses two main airgaps and two parasitic airgaps as in the Rice motor described above. This Lundell motor cannot be designed for very high speeds because of the dynamics of the complex rotor structure. Also, because of the high leakage fluxes, it has high commutating reactance, thus needing expensive inverter. Here again, a damping circuit can possibly be introduced to reduce the commutating reactance.

The Lundell/Rice motor has several significant characteristics to make it a potentially useful traction motor. The suitability of these motors for rail propulsion, however, can be evaluated only after a total system design is worked out.

3.3 Advantages and Disadvantages

The suitability of different types of synchronous motors can be summarized as presented in Table II.

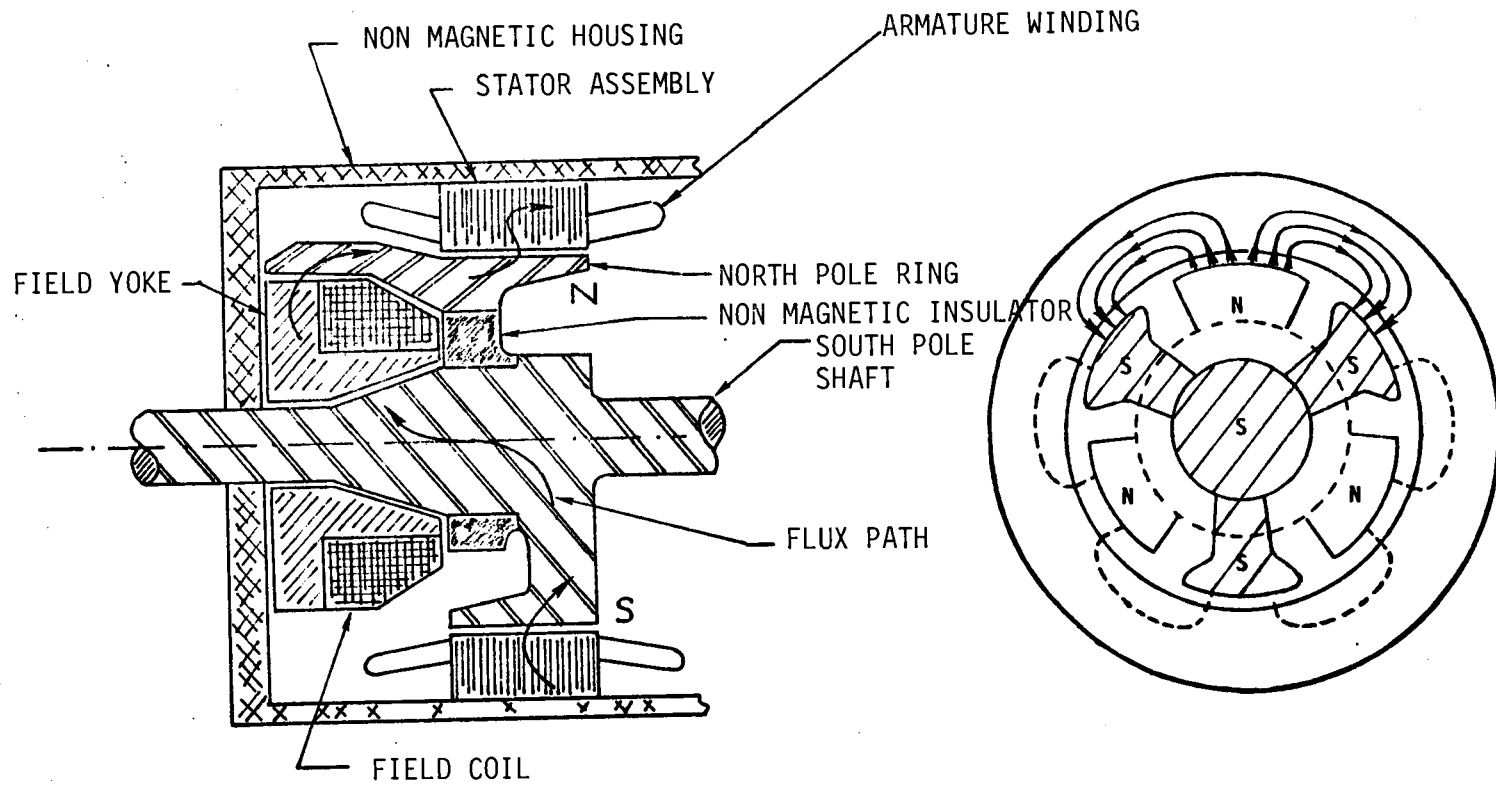

FIGURE 103
LUNDELL MOTOR

TABLE II

SYNCHRONOUS MOTORS

Doubly Excited

Singly Excited

Advantages

- Unity or leading power factor operation possible
- Cheap line commutated inverters can be used
- Motor-inverter optimization possible

Disadvantages

- Large, heavy, expensive motor
- One inverter per motor essential
- Special starting methods may be required

Advantages

- Gear may be eliminated by a vernier reluctance motor

Disadvantages

- Poor power factor
- Heavy motor

Disadvantages of Individual Types

- Permanent magnet motor
 - weak field conditions are difficult if not impossible
 - needs to be mechanically decoupled in case of a fault
- Slipring motor
 - brush wear & associated maintenance
- Motor with a rotary transformer
 - overall system complexity
- Inductor/Lundell/Rice motor
 - high commutating reactance



APPENDIX II

POWER CONVERSION DEVICES

1.0 STATIC CONVERTERS

The thyristor or semiconductor controlled rectifier (SCR) was developed in the late 1950's and became commercially available in 1960-61 in the ratings of approximately 200A and 1000V. Initially some difficulties were encountered in thyristor applications because the device itself was not fully understood. After these difficulties were surmounted, however, the thyristors gained wide acceptance very rapidly, and over the last decade, the growth of power electronics has been phenomenal. The earlier control components - thyratrons mercury-arc rectifiers, magnetic amplifiers, etc. - were superseded by thyristors and quickly became obsolete. Various types of solid state power converters were developed which could convert power from a fixed voltage dc or ac source to a variable-voltage, variable-frequency ac or variable-voltage dc power. Basically, a chopper is a dc-to-dc converter whereas an inverter is a dc-to-ac converter.

2.0 THE CHOPPER

The chopper is a dc-to-dc converter which varies the average value of the direct voltage applied to a load. In general, there are two classes of chopper circuits - a step-down chopper, where the load voltage is less than or equal to the supply voltage, and a step-up chopper, where the load voltage is equal to or more than the supply voltage. There are, of course, several types of chopper configurations in each of the above classes, depending on the commutation circuits used. Also, several choppers can be used to obtain a 4-quadrant circuit, i.e. circuit capable of reversal and regeneration.

The operating principle of a step-down chopper is shown in Figure 104. It shows that the chopper applies a continuous sequence of unidirectional voltage pulses to the load, the magnitude of the pulse being equal to that of the supply voltage. The width of the voltage pulse t_{on} and the period T of the pulses can be controlled by the chopper circuit.

Under ideal conditions

$$V_o = \frac{t_{on}}{T} \cdot V$$

and hence, the average load voltage V_o can be varied in the following ways:

- a. Pulse-width modulation, where t_{on} is changed while T is held constant.
- b. Frequency modulation, where t_{on} is held constant while T is changed.
- c. Combined pulse-width and frequency modulation.

In practice, the output voltage waveform of a chopper is different from the ideal one shown in Figure 104 but the essential characteristics of a chopper can be explained more easily with the idealized model.

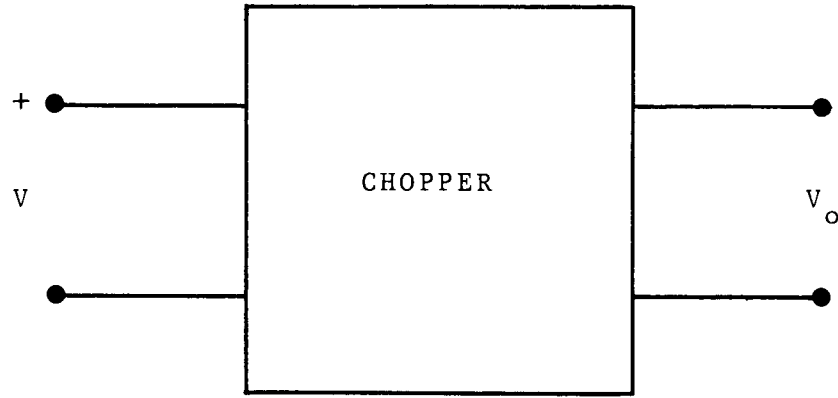

173

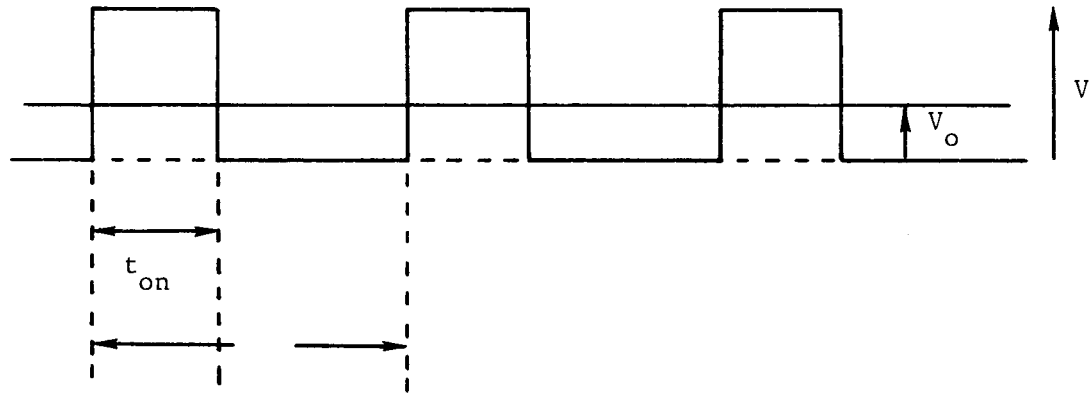

FIGURE 104
OPERATING PRINCIPLE OF A CHOPPER

2.1 Modes of Chopper Operation

Figure 105 shows a simplified chopper circuit where the auxiliary commutating circuits are not shown. T_1 and D_1 are the main thyristor and the free-wheeling diode respectively. Let the thyristor T_1 be switched on at $t=0$. The current i_o flows in the circuit and T_1 is switched off at $t=t_{on}$. The current i_o cannot be instantaneously brought to zero and the current continues to flow via the diode D_1 . The load current starts decaying and if the period T is long enough, i_o will be reduced to zero before T_1 is switched on again. The load current i_o is then discontinuous as shown in Figure 105(b). However, if the period T is not long enough, or if the time constant L/R of the load circuit is long, the current i_o will not be reduced to zero before T_1 is switched on again. The load current will thus build up until a steady state is reached and a continuous current results as shown in Figure 105(c). It can thus be seen that depending on the time constant L/R and the period T the current can be continuous or discontinuous.

For a given circuit, the boundary between the two types of operations can be obtained by solving the following equation:

$$\frac{V_o}{V} = \frac{e^{\left(\frac{t_{on}}{T} \cdot \frac{T}{\tau}\right) - 1}}{e^{T/\tau} - 1}$$

The solution of this equation is shown in Figure 106.

2.2 Chopper Commutation

So far it has been said that the thyristor T_1 is switched off at $t = t_{on}$ without saying how it is done. A thyristor can be switched off only by bringing the current through it to zero and holding it at zero for some time. In general, there are several ways a thyristor

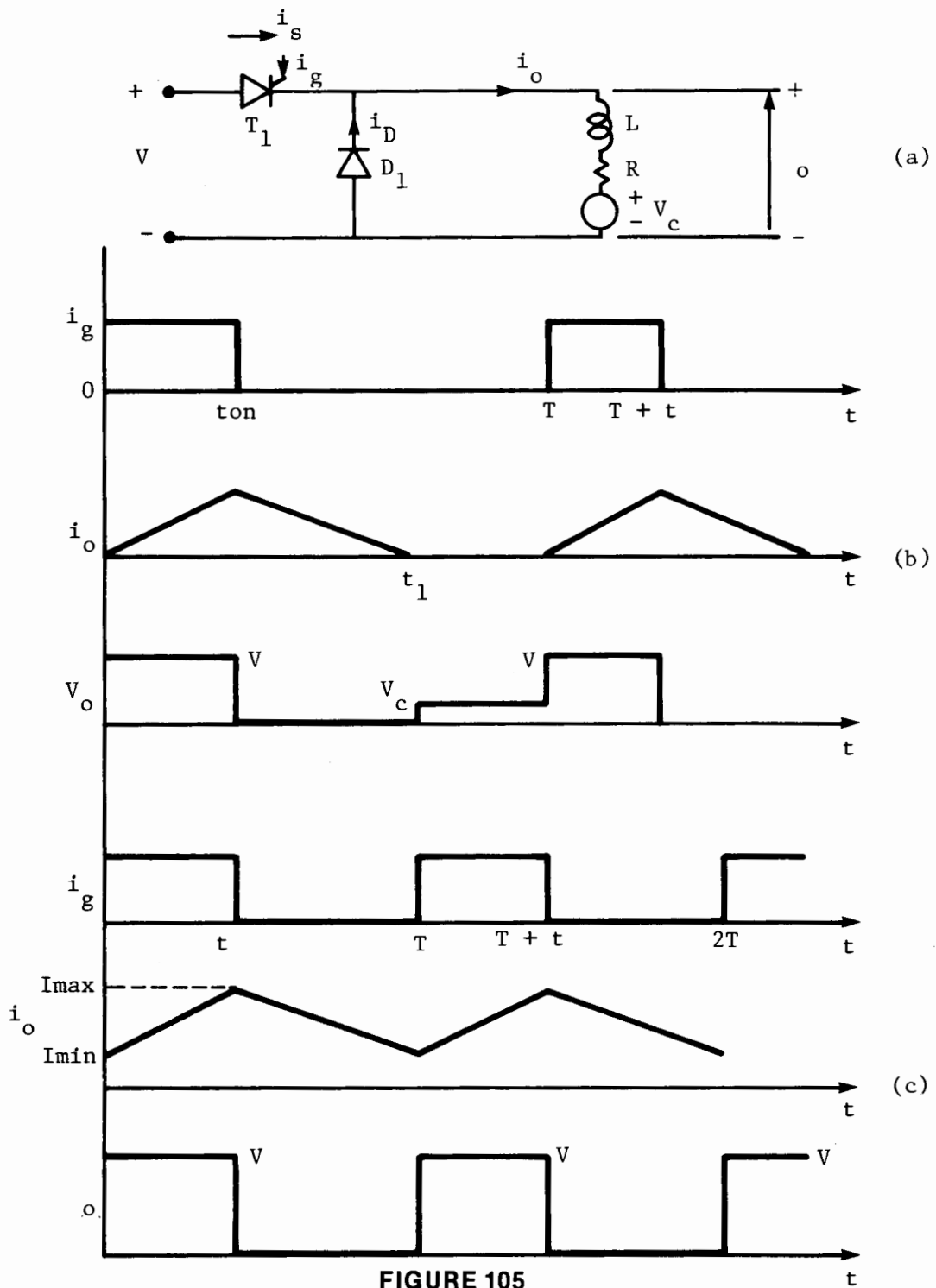

FIGURE 105
CHOPPER CIRCUIT AND ITS RESPONSE

can be switched off - a transfer of load current from one thyristor to another is called "commutation":

- The thyristor current goes through zero because of the voltage across it reverses (line commutation) or because the load current goes through zero with capacitive load (load commutation), and
- A current in a direction opposite to the load current is forced through a thyristor (forced commutation) by using auxiliary circuits.

These commutation methods will be discussed in detail later, but one method commonly used in chopper designs is explained in Figure 107. When T_1 is triggered on, the recharging thyristor T_3 is also switched on so that the commutating capacitor C reverses its polarity. So while T_1 is conducting, the capacitor C is charged with plate "a" having a positive potential. Now if the commutating thyristor T_2 is switched on, the capacitor C is connected in parallel with T_1 , and the load current is transferred from T_1 to T_2 . Also, the capacitor C gets charged in the opposite direction, with plate "b" being positive. T_2 then switches off and the free wheeling diode D_1 begins to conduct and the voltage across the load and the load reactor drops to zero. The main thyristor T_1 (and T_3) can be switched on again.

Although the load current in a chopper can be continuous because of load inductance and the free-wheeling diode, the current drawn from the supply is in the form of pulses of the duration of t_{on} . No current is drawn from the supply during the 'off' period. An L-C filter is usually used to smooth out the supply current. This is shown in Figure 108.

2.3 Multi-Phase Choppers

Several choppers can be used in parallel to feed a common load as shown in Figure 109. Such a circuit is commonly known as a multi-phase chopper. The voltage waveforms of a three phase arrangement are shown

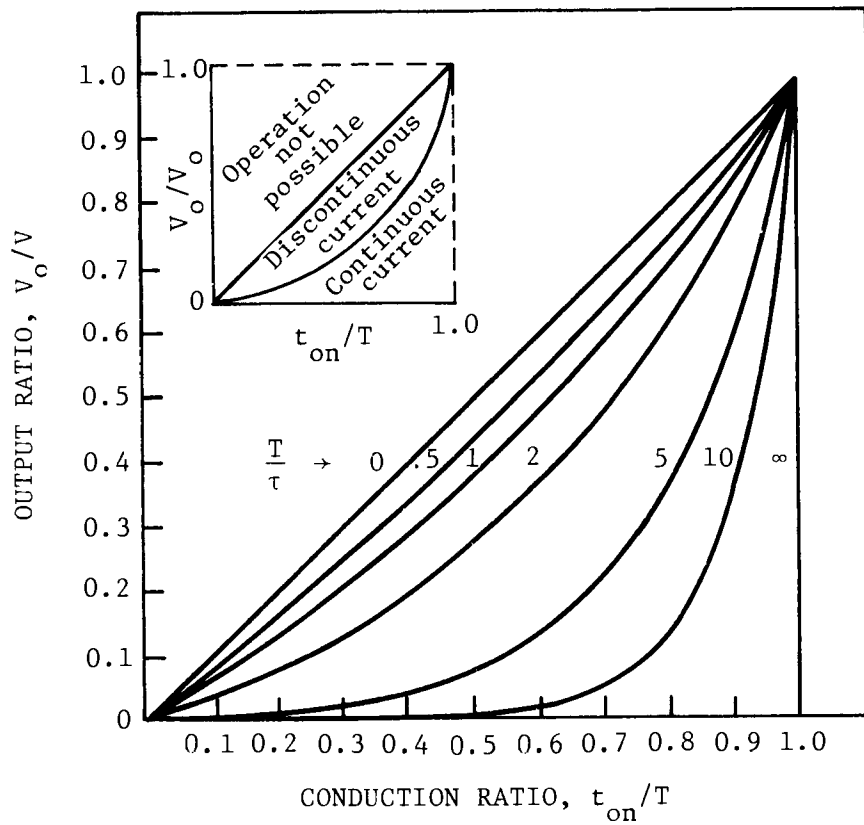

FIGURE 106
DIFFERENT MODES OF CHOPPER OPERATIONS

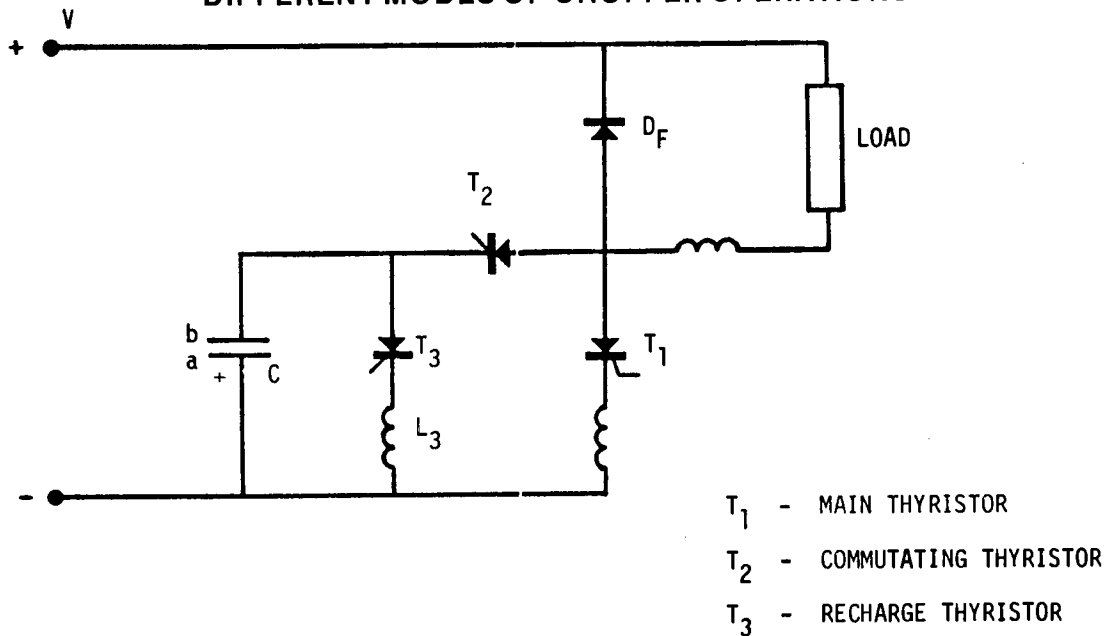

FIGURE 107
CHOPPER COMMUTATION

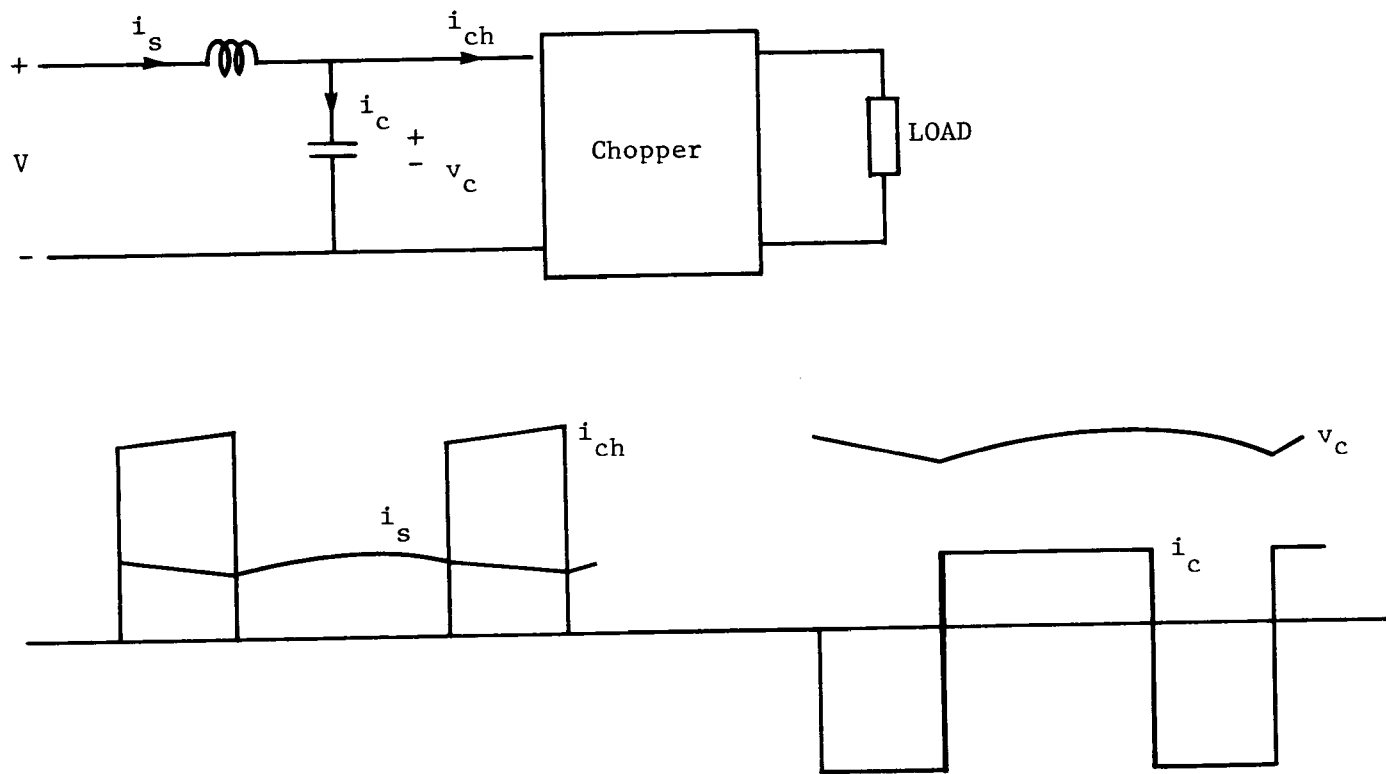

FIGURE 108
FILTER RESPONSE

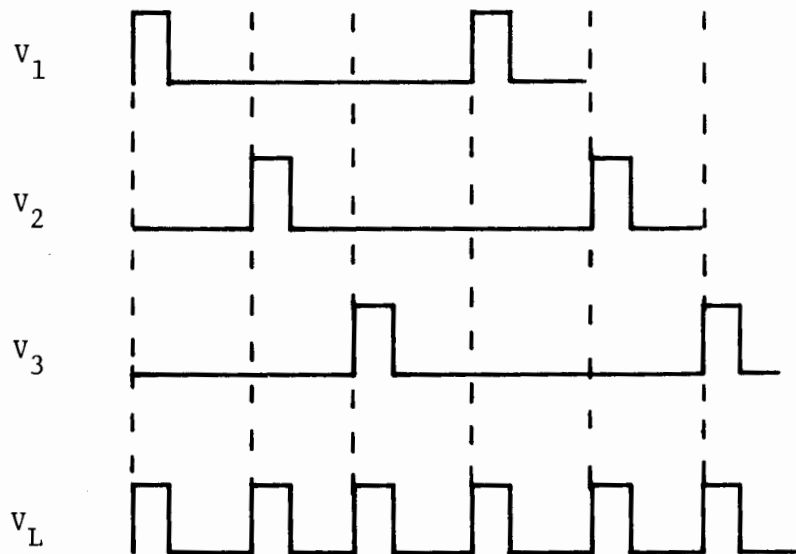
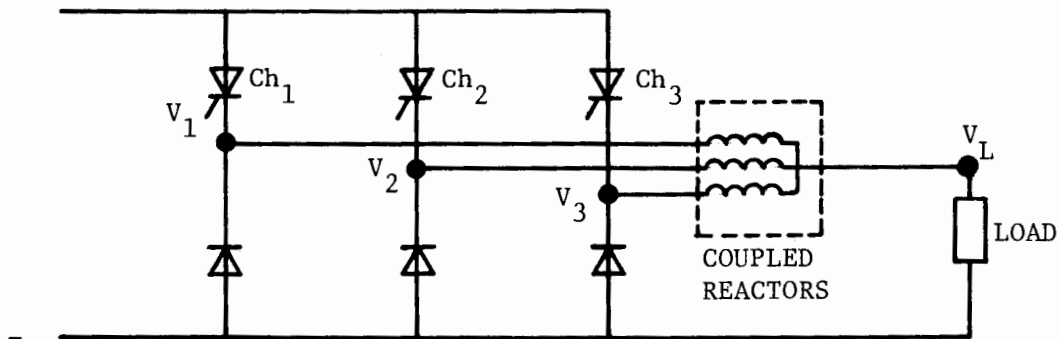

FIGURE 109
MULTI-PHASE CHOPPER

in the figure. The frequency of the load voltage can be seen to be three times the frequency of the individual chopper. Moreover, each chopper has to handle one third the load power. Also, the three reactors can be wound on a common iron core so that the fluxes due to the average current are cancelled out and hence, do not saturate the core. The harmonic content of the supply current can also be reduced by properly phasing the choppers with relation to each other. Two phase choppers are commonly employed for control of dc traction motors.

3.0 INVERTERS

It has been generally accepted that the most efficient method of speed control of ac drives is to use a variable-voltage, variable frequency (VVVF) ac supply to control the ac motor. With the advent of thyristors, it is now possible to convert power from a dc source to a VVVF ac power at reasonable costs. Inverters are a class of such circuits for dc-to-ac conversion. There are several types of inverters, and different types can be defined from several points of view. Depending on the method of thyristor commutation - transfer of load current from one thyristor to another - one can broadly consider three types of inverters:

- a. Line Commutated inverter: In this type of an inverter, the voltage across the thyristor reverses because of a presence of an ac line or a back-emf from the load. The thyristor, therefore, switches off when the current drops to zero. This is also called 'natural commutation' of a thyristor.
- b. Load Commutated inverter: Here the current through a thyristor drops to zero because of a natural tendency of the load current to drop to zero when excited by a dc source. A load with series inductances and capacitances having an oscillatory response, for example, can be controlled using a load commutated inverter. This is also called a 'natural commutation' of a thyristor.
- c. Forced Commutated inverter: Here, an auxiliary voltage source - usually a charged capacitor - is connected across a thyristor in such a way that the voltage across the thyristor reverses. The thyristor switches off and the load current can continue to flow through a free-wheeling diode connected across the load.

Out of these three types, the forced commutated and the line commutated inverters are quite suitable for ac drive control in a transit vehicle.

3.1 Line Commutated Inverter

The operation of a line commutated inverter can best be explained with the help of a 3-phase bridge rectifier circuit shown in Figure 110. Two thyristors - one odd numbered and one even numbered - conduct at a time for continuity of the load current. The instantaneous load voltage V_d depends on which thyristors are conducting. For example, if T_1 and T_2 are conducting, $V_d = V_{ac}$. The instantaneous and hence, the average output voltage can, therefore, be controlled by varying the thyristor triggering angle. Figures 111 and 112 show the operation of the circuit for two firing angles $\alpha = 30^\circ$ and $\alpha = 150^\circ$. For $\alpha = 30^\circ$, the average voltage is positive and for $\alpha = 150^\circ$ it is negative. It can be shown that for $\alpha = 90^\circ$, the average voltage is zero. Figure 113 shows the variation of the average voltage as a function of the firing angle α . It should be seen that for $\alpha < 90^\circ$, the power flow is from the ac circuit to the dc circuit and the circuit works like a rectifier. For $\alpha > 90^\circ$, however, V_d reverses and the power flows from the dc source to the ac source. This operation is called an inverter operation.

The voltage waveforms shown in Figures 111 and 112 assume an instantaneous commutation, i.e., the current transfers from one thyristor to another instantaneously. In practice, however, the commutation process is spaced over a finite time period, called the overlap period which depends on the commutating reactance of the circuit. The average output voltage is then less than that given by Figure 113.

It should be noted here that the commutation is achieved because of the ac line voltage and hence, the inverter is called the line commutated inverter. Also, the inverter operation results in a lagging current being drawn from the ac source although the inverter supplies real power to the ac source. This is quite clear from the phasor diagram drawn in Figure 114 for the inverter operation with $\alpha = 150^\circ$.

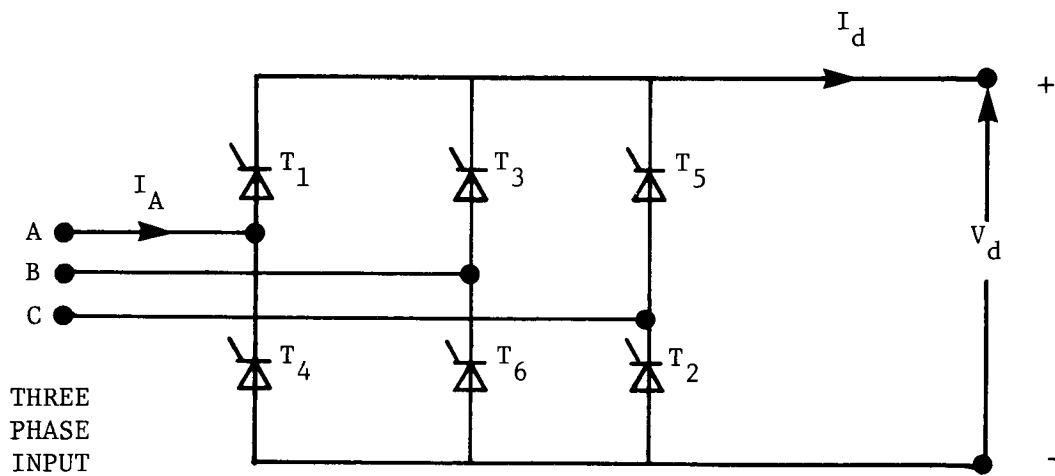

FIGURE 110
THREE PHASE BRIDGE RECTIFIER

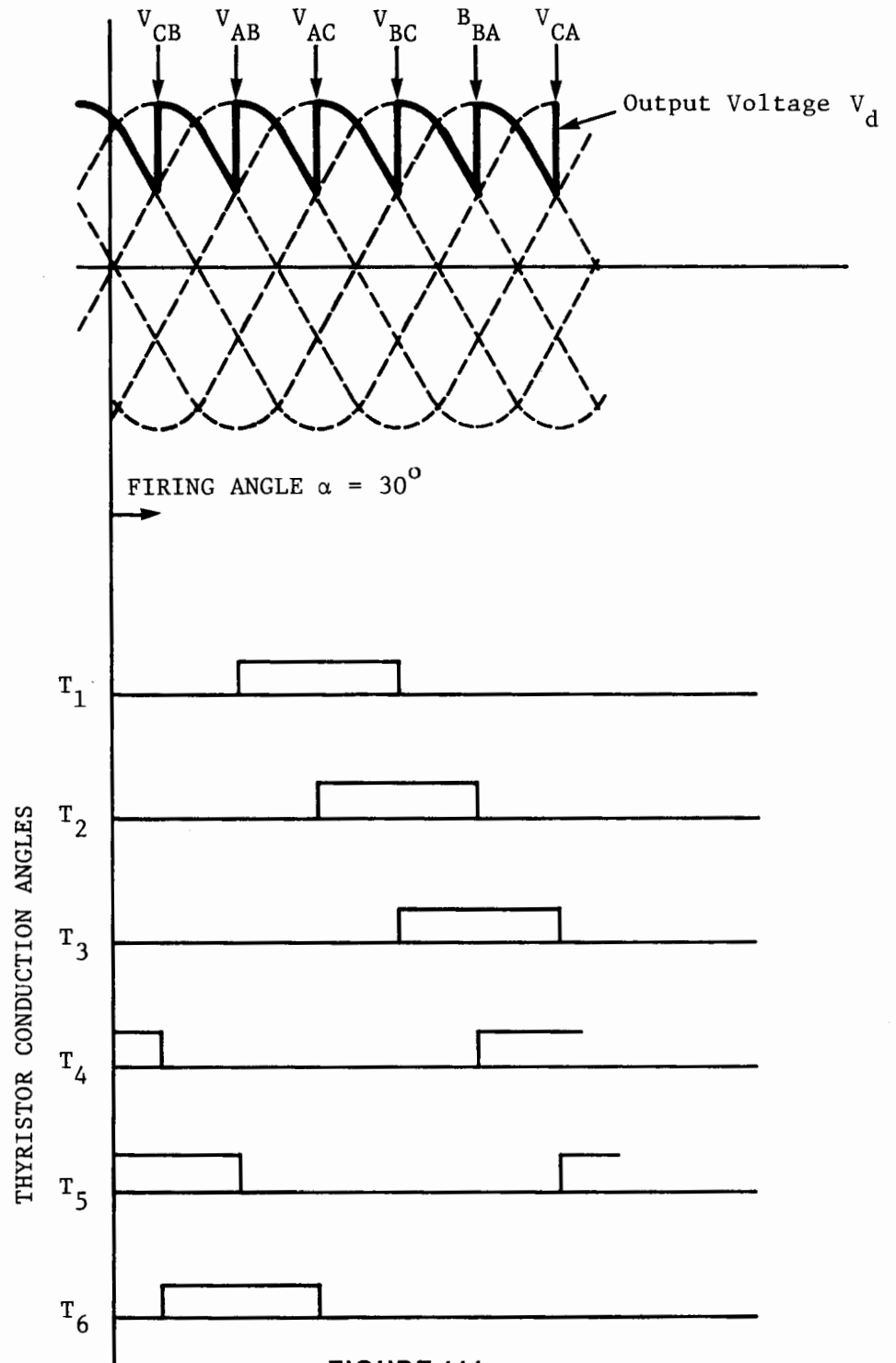

FIGURE 111
RECTIFIER OPERATION FOR $\alpha = 30^\circ$

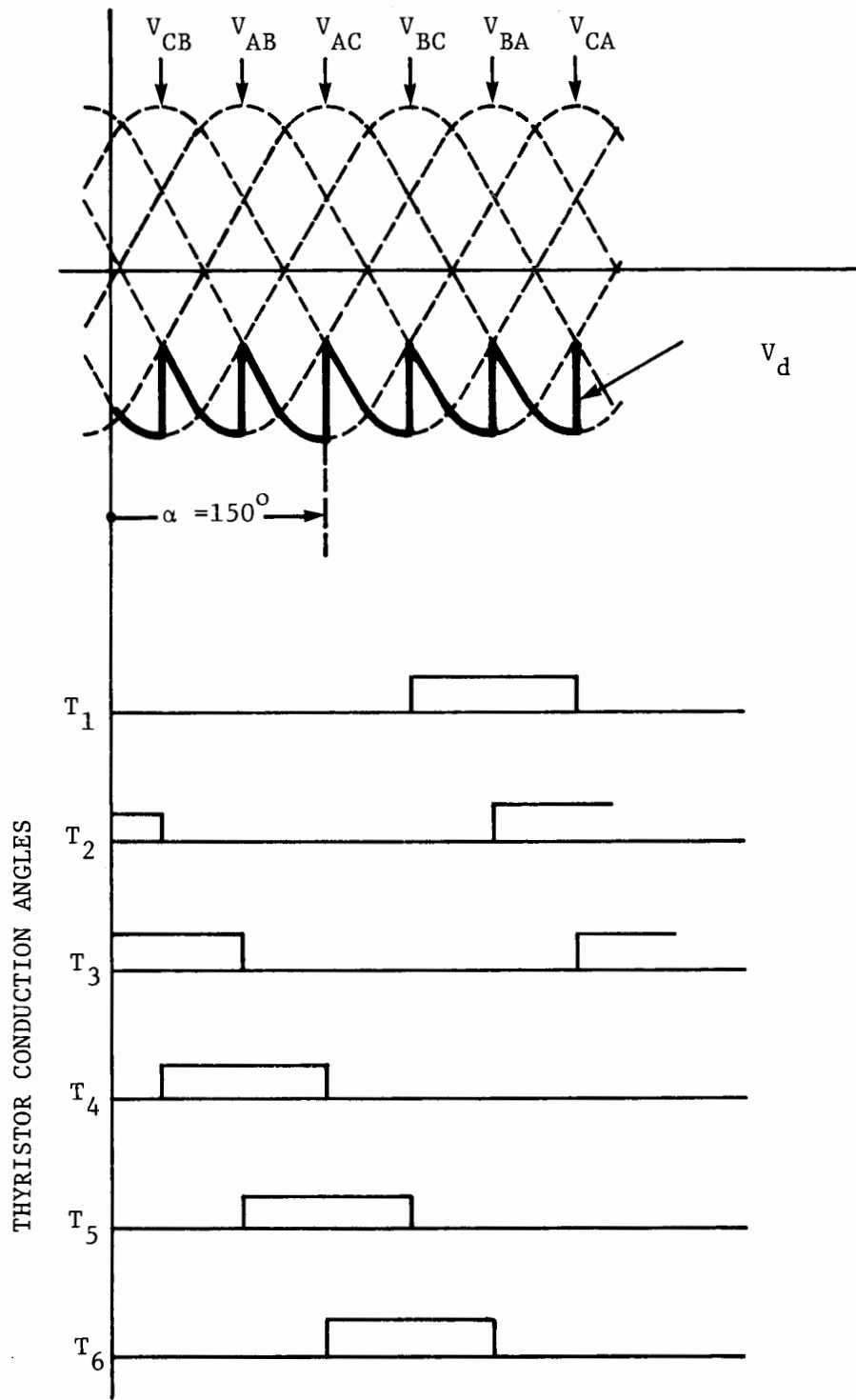
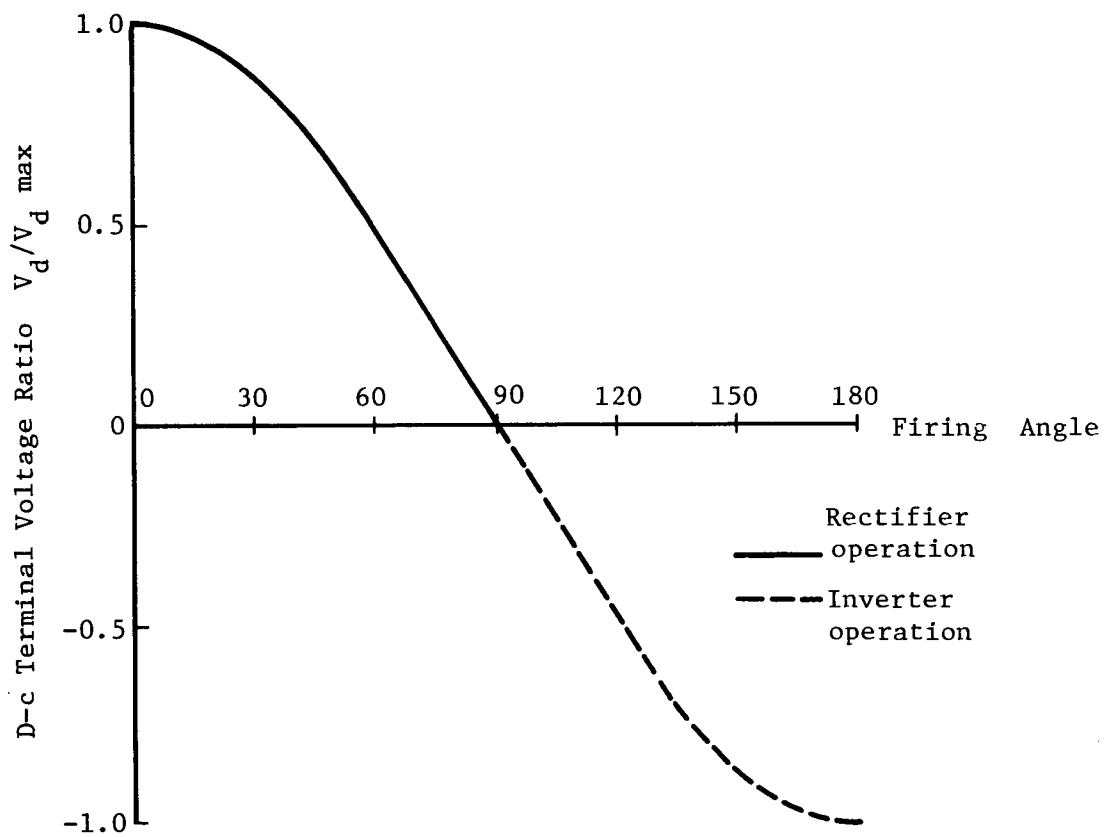
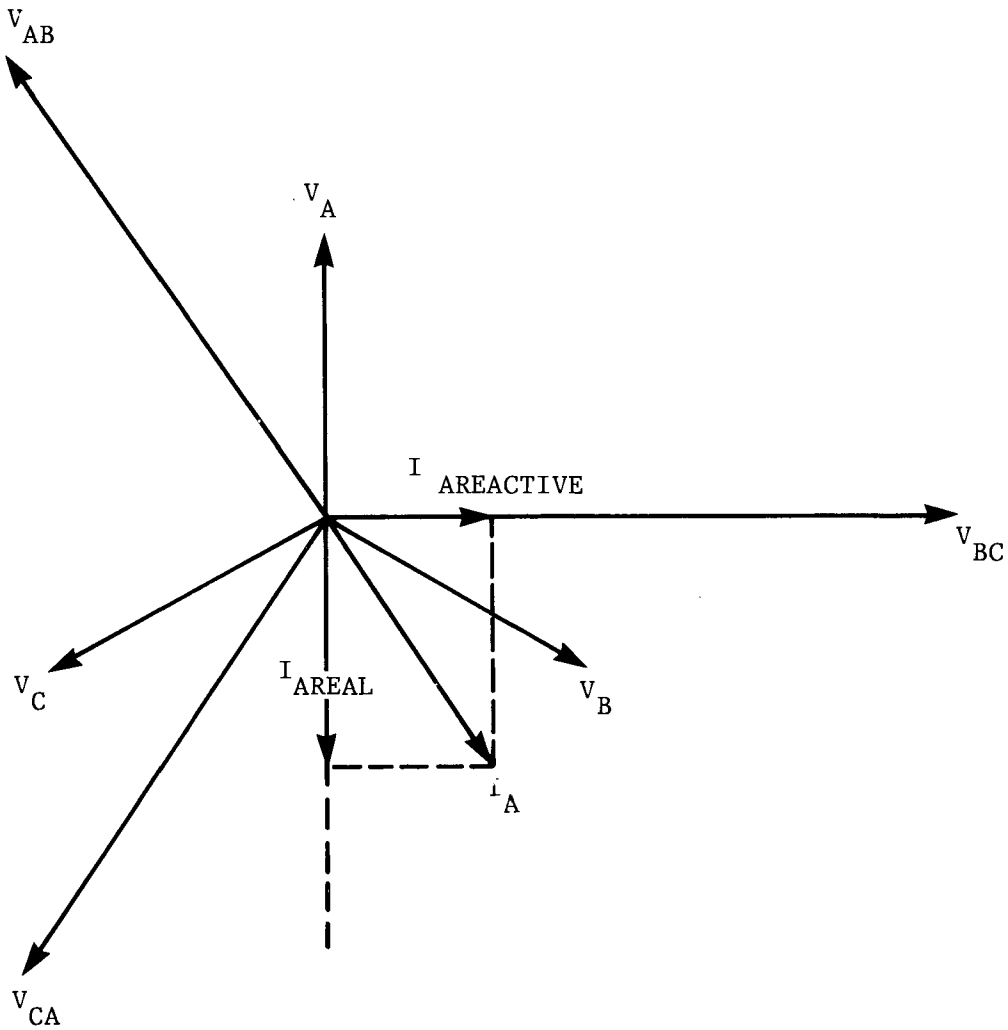

FIGURE 112
RECTIFIER OPERATION FOR $\alpha = 150^\circ$



**FIGURE 113
RECTIFIER OUTPUT**



$$\text{Power Supplied to AC} = \frac{3}{2} V_A I_{AREAL}$$

$$\text{Reactive power from AC} = \frac{3}{2} V_A I_{AREACTIVE}$$

FIGURE 114
INVERTER PHASOR DIAGRAM

This means that the ac load on the inverter must operate at a leading power factor. An overexcited synchronous motor, for instance, can be supplied by such a line commutated inverter.

3.2 Forced Commutated Inverter

A forced commutated inverter uses a charged capacitor to momentarily reverse the voltage across a conducting thyristor to switch it off. There are several ways to use such a forced commutation, and depending on the number of commutations required per cycle of the output voltage, the commutation circuit requirements differ. Moreover, the output voltage control and harmonic reduction requirements increase the general complexity of the inverter design. A discussion of all these inverters is clearly outside the scope of this work. However, the basic concepts and the inverter characteristics of one type of inverter are explained below.

3.2.1 Inverter Operation

Figure 115 shows a single phase inverter circuit which uses a center-tapped dc supply. Three phase and three phase bridge inverter circuits can be built from this basic circuit. The main thyristors T_1 and T_2 are switched on to conduct the load current during alternate half cycles of the ac output. For a reactive load, the feedback diodes D_1 and D_2 conduct for a part of each half cycle to return the reactive power from the load to the supply. The main thyristors are commutated by means of a commutation circuit of an inductance L , a capacitor C and the auxiliary thyristors T_{1A} and T_{2A} .

Let T_1 be assumed to conduct the load current and the capacitor C charged as shown in Figure 116. Now let T_{1A} be fired to commutate T_1 . The capacitor C now starts discharging and a current I_c flows through T_{1A} , C , L and the load as shown. This discharge current pulse builds up and thus the current I_1 through T_1 is reduced. When I_c

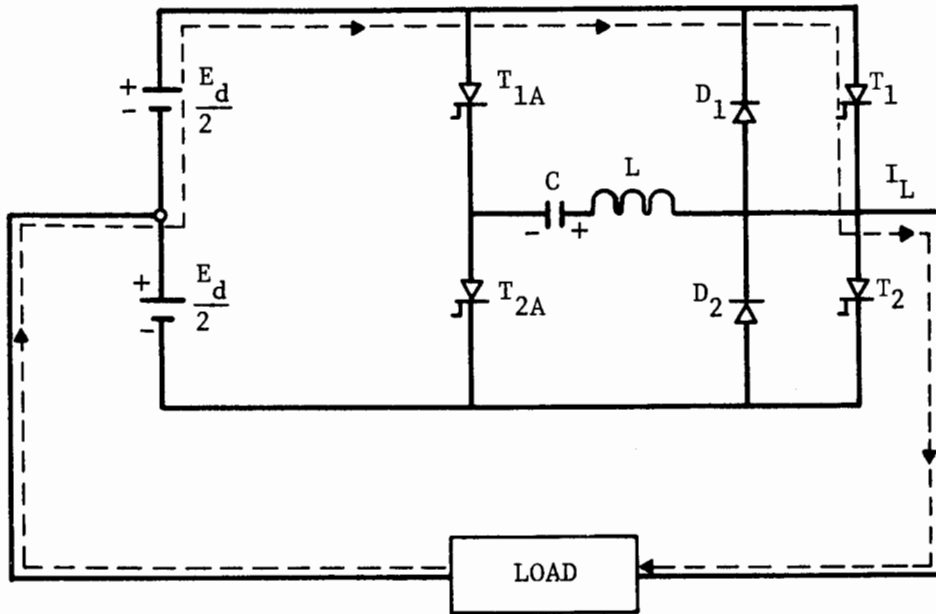

FIGURE 115
A FORCED COMMUTATED SINGLE PHASE INVERTER

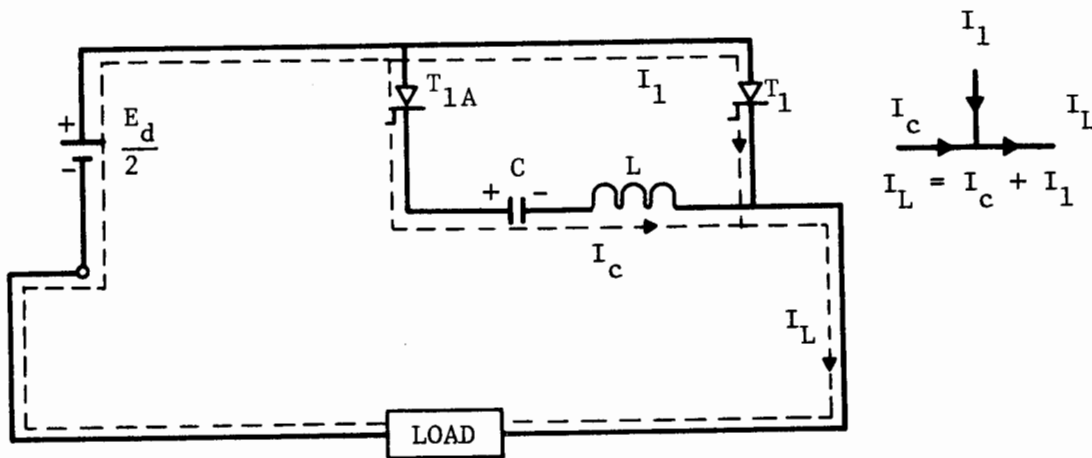

FIGURE 116
CURRENTS DURING COMMUTATION

equals I_L , I_1 is reduced to zero. Then any excess of I_C over I_L flows through the feedback diode D_1 . The voltage drop across D_1 when it conducts appears as a reverse voltage across T_1 and turns it off. After reaching a peak, I_C starts to decay and the capacitor is charged with polarity shown in Figure 116 (opposite to that shown in Figure 115). T_2 can now be switched on, and the load current is then reversed. The auxiliary thyristor T_{2A} can be fired when required to commutate T_2 . The load voltage is a square wave under all conditions of loading when the circuit is commutated only twice per output voltage cycle.

3.2.2 Three Phase Inverter Circuit

A three phase inverter circuit is shown in Figure 117. It can be seen that the dc source need not be center-tapped. The thyristors are triggered in the order 1-2-3-4-5-6. Depending on whether a thyristor conducts over 120 or 180 degrees in each output voltage cycle, two or three main thyristors conduct simultaneously. It should be remembered that at least two main thyristors have to conduct for the continuity of the load circuit. The output voltages for these operating conditions are shown in Figure 118. Because of the three wire system of three phase connections, the line current and the line voltage are free of triplen harmonics. With only two commutations per output voltage cycle, the ac output voltage can only be controlled by controlling the input voltage. For such an operation with varying input voltage, the commutation networks are connected to an auxiliary dc supply of fixed voltage so that the commutating capacitor charges to this fixed voltage irrespective of the input voltage.

3.2.3 Inverter Voltage Control

Most inverter applications require a means of voltage control. This control may be required because of variations in the dc source voltage, regulation within the inverter, or because it is desired to provide continuously variable voltage for the load. When the inverter

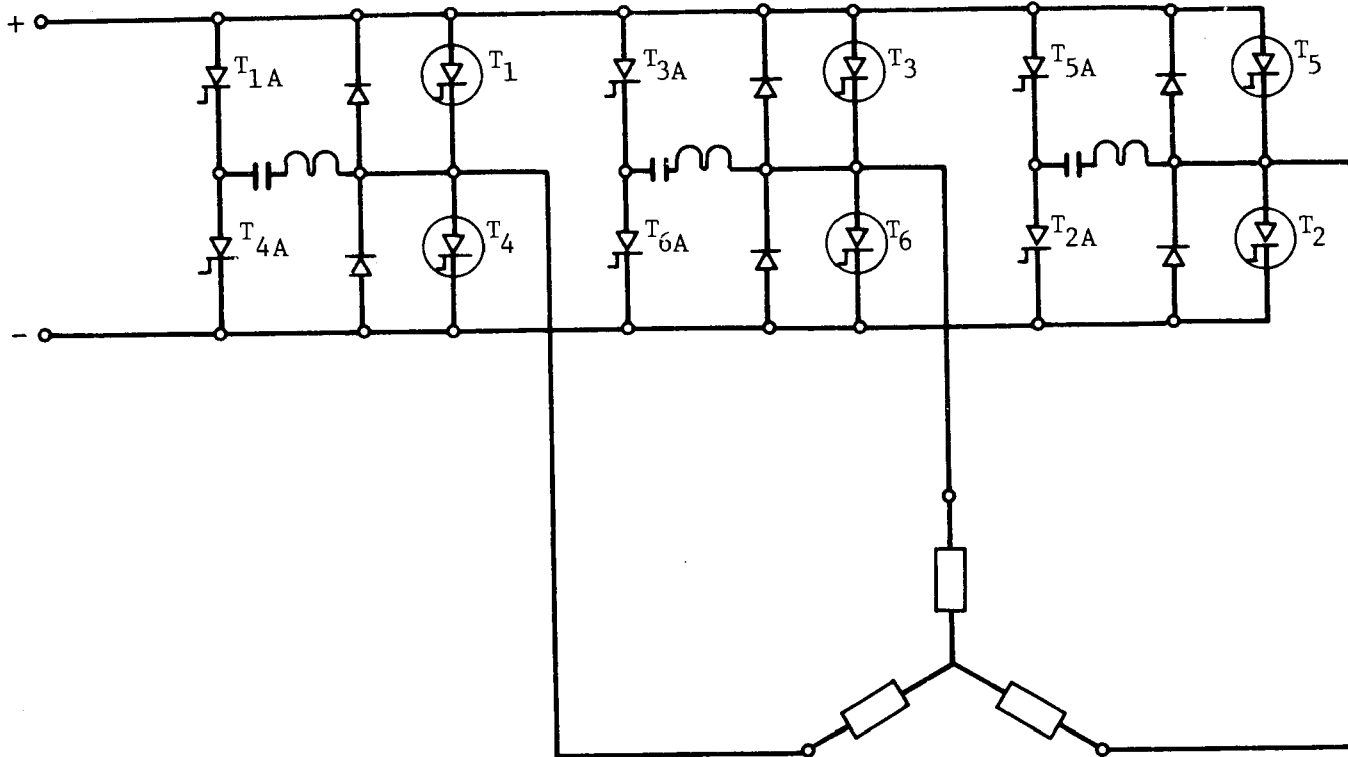
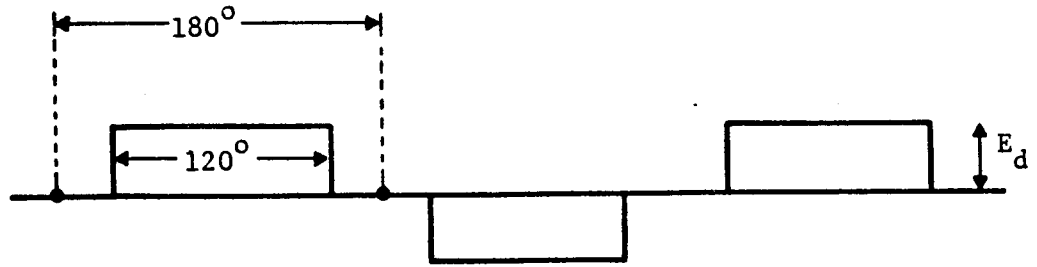
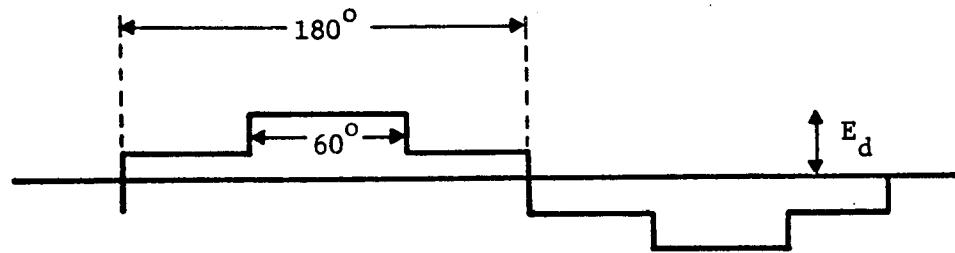

FIGURE 117
AUXILIARY IMPULSE-COMMUTATED 3-PHASE INVERTER



a) 120° CONDUCTION; 2 SCRs CONDUCT AT A TIME



b) 180° CONDUCTION; 3 SCRs CONDUCT AT A TIME

FIGURE 118
OUTPUT VOLTAGE, LINE TO LINE OF A THREE-PHASE INVERTER

is used as a variable frequency - variable voltage source for traction control, the harmonic content of the output voltage waveform has also to be controlled.

There are innumerable methods of inverter voltage control, each having many advantages and disadvantages. One can select a few of these for a specific application depending on the power rating, the range of voltage and frequency and the permissible harmonic content in the output voltage waveform. Finally, one particular scheme can then be chosen depending on how each of the above relates to the "total systems concept."

The methods of voltage control for traction application can be divided into two groups:

- a. Methods using one three-phase inverter as shown in Figure 119.
- b. Methods using multiple inverters as shown in Figure 120.

The circuit of Figure 119 can be operated in three different ways as:

- a. Variable input voltage; two commutations per cycle.
- b. Fixed input voltage; four added commutations per half cycle.
- c. Variable input voltage; four added commutations per half cycle.

The circuit of Figure 120 can also be operated in three different ways as fixed input voltage as:

- a. Four added commutations per half cycle.
- b. Many equi-spaced commutations per half cycle.
- c. Many "programmed" commutations per half cycle.

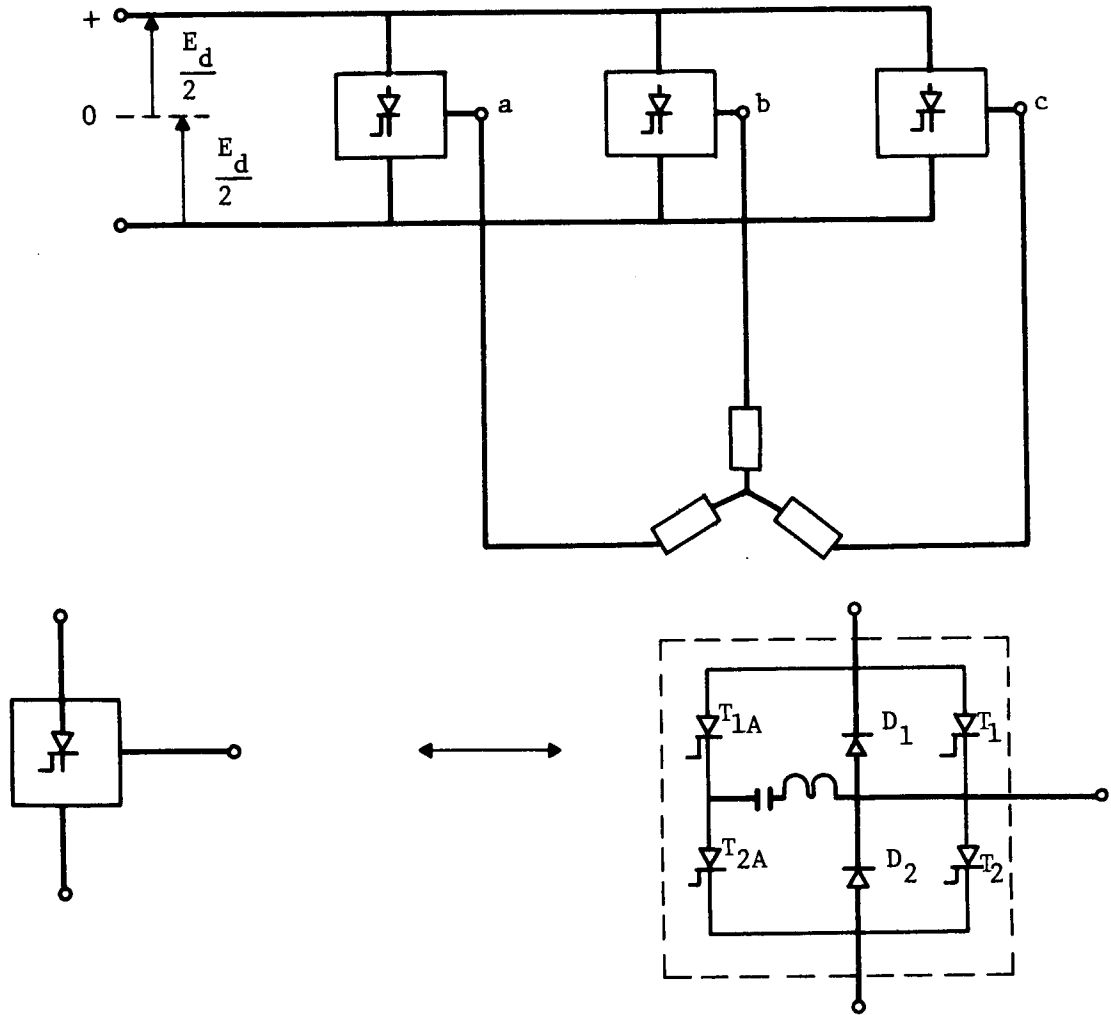

FIGURE 119
USE OF A SINGLE INVERTER

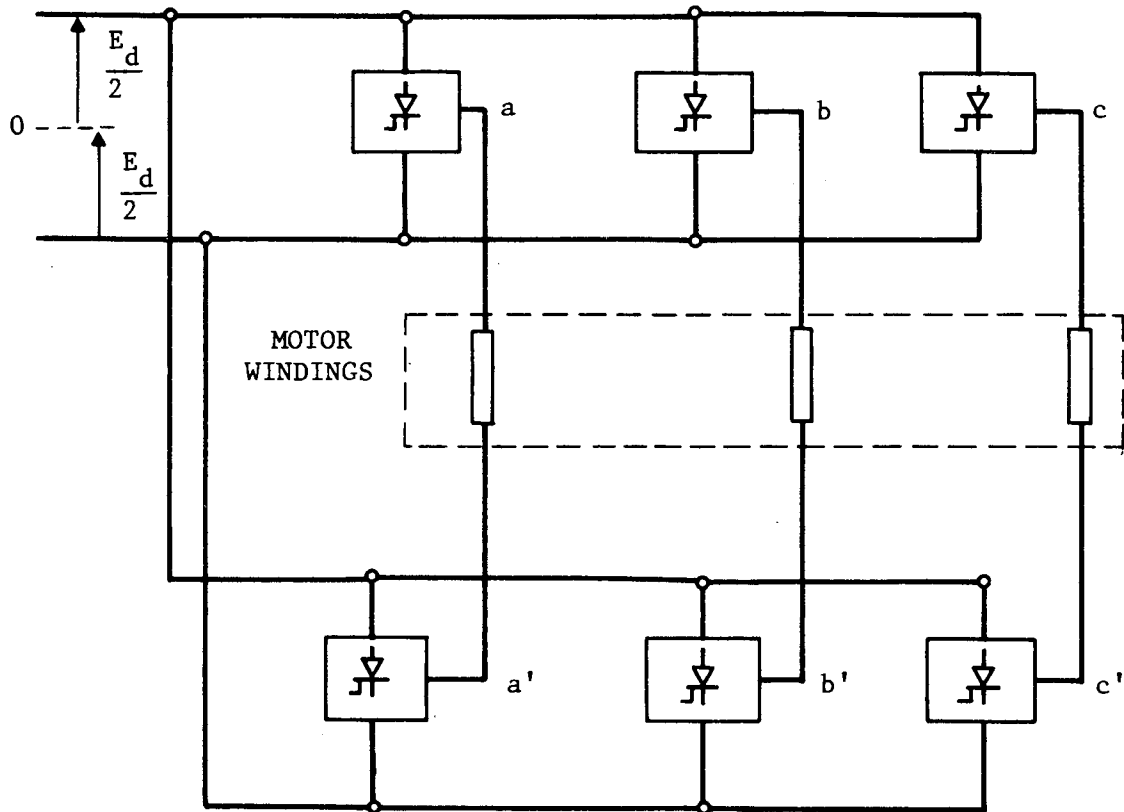

FIGURE 120
USE OF MULTIPLE INVERTERS

3.2.3.1 Input Voltage Control: Two Commutations per Cycle

When the circuit of Figure 119 is operated with two commutations per cycle, the instantaneous voltages of points a and b with reference to 0 can be drawn as in Figure 121. The resulting line voltage between a and b is also shown in the figure.

With proper referencing, the voltage V_{ab} can be written to be

$$V_{ab} = \sum_n V_n \sin n \omega t \quad n = 1, 5, 7, 11$$

where

$$V_n = \frac{2\sqrt{3} E_d}{n\pi}$$

It can be seen that the n^{th} harmonic content of the waveform relative to its fundamental is equal to $1/n$, i.e. the waveform contains 20% 5th harmonic, 14.3% of 7th harmonic, etc. Thus by varying E_d one can vary all these components. One way to vary E_d is by using a chopper in front of the inverter.

3.2.3.2 Inverter Operation with Four Added Commutations Per Half Cycle

The inverter of Figure 119 can be operated as shown in Figure 122 with four added commutations per half cycle. The harmonic components of the line voltage can easily be obtained as

$$V_n = \frac{2\sqrt{3} E_d}{n\pi} (1 - 2 \cos n\alpha_1 + 2 \cos n\alpha_2) \quad n = 1, 5, 7, 11$$

It can be seen that fundamental component V_1 can be varied either by keeping E_d constant and changing α_1 and α_2 , or by keeping α_1 and α_2 constant and changing E_d , say with a chopper. If E_d is constant it is always possible to eliminate one harmonic component while controlling

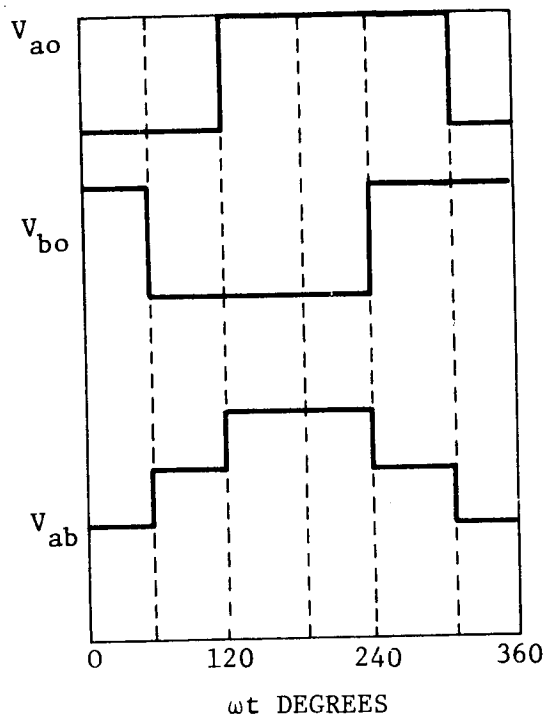

**FIGURE 121
VOLTAGE WAVEFORMS**

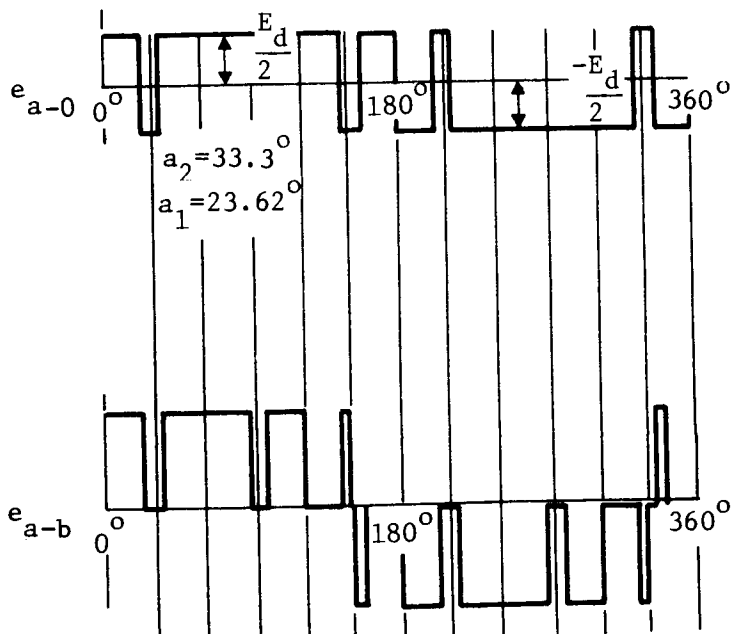

**FIGURE 122
OUTPUT VOLTAGE WITH FOUR ADDED COMMUTATIONS
PER HALF CYCLE**

the fundamental by varying α_1 and α_2 . For example, one can eliminate the fifth harmonic by ensuring

$$1 - 2 \cos 5\alpha_1 + 2 \cos 5\alpha_2 = 0$$

when varying α_1 and α_2 . Table III presents a set of such computations.

If, however, for any reason these harmonic components are unacceptable the circuit can be used with a varying input voltage. For such as operation α_1 and α_2 can be selected such that any two orders of harmonic are eliminated. For example, to eliminate 5th and 7th harmonic one can choose (approximately)

$$\alpha_1 = 16.25^\circ$$

$$\alpha_2 = 22.07^\circ$$

Table IV gives the harmonic components for such an operation.

3.2.3.3 Use of Multiple Inverters

When more than one inverters are used, it is always possible to operate the circuit at constant input voltage and to control the voltage delivered to the load. For instance, if both the inverters shown in Figure 120 are operated with four added commutations per half cycle as described in the earlier section, it is possible to control the output voltage by varying the phase shift between the individual outputs.

For a given phase shift ϕ (Figure 123), and the angles α_1 and α_2 , the line voltage harmonics can be obtained as

$$V_n = \frac{4E_d}{n\pi} (1 - 2 \cos n \alpha_1 + 2 \cos n \alpha_2) \cos \frac{n\phi}{2}$$

TABLE III
 FUNDAMENTAL AMPLITUDE CONTROL BY VARYING α_1 and α_2

α_1 deg	α_2 deg	$V_{1\max}/E_d$	HARMONIC COMPONENTS (PERCENT)			
			5	7	11	13
14.19	20.00	1.037	0.0	3.16	12.53	21.65
22.29	30.00	0.972	0.0	17.76	36.81	17.92
23.21	40.00	0.765	0.0	67.00	24.26	21.43
16.18	50.00	0.402	0.0	147.23	25.65	71.89
9.53	56.00	0.161	0.0	186.45	64.00	215.80
6.53	58.00	0.080	0.0	194.75	81.70	261.96

TABLE IV

ELIMINATION OF THE FIFTH AND SEVENTH HARMONICS

$$\alpha_1 = 16.25^\circ \quad \alpha_2 = 22.07^\circ$$

HARMONIC COMPONENTS
(PERCENT)

$V_{1 \max}/E_d$	V_5	V_7	V_{11}	V_{13}	V_{17}	V_{19}
1.029	0.005	0.007	20.30	27.13	17.09	4.33

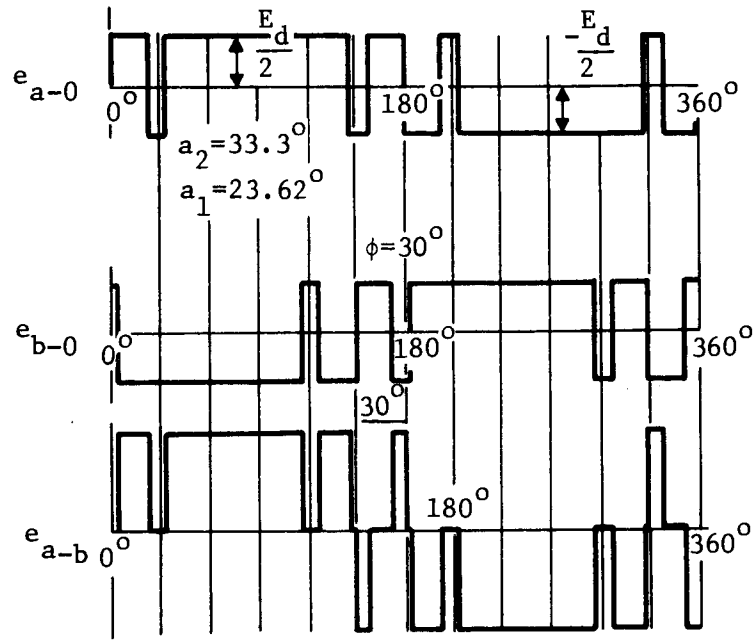

(a) $\phi = 30^\circ$

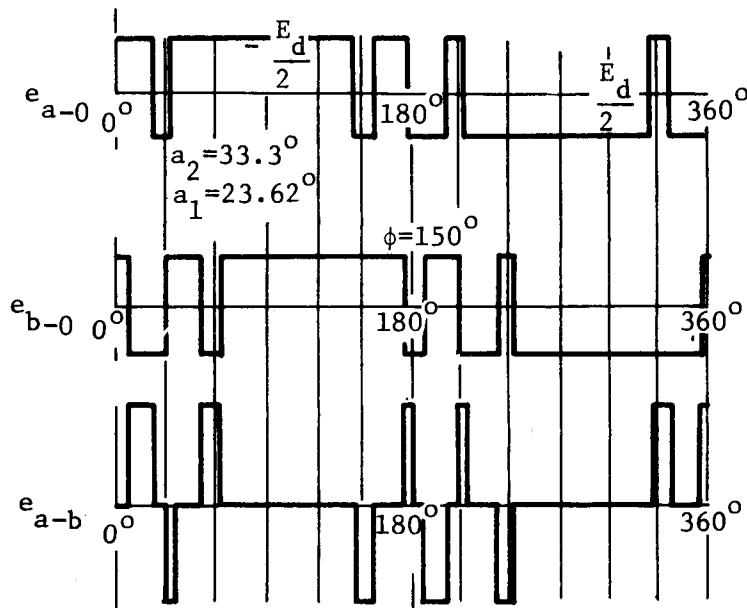

(b) $\phi = 150^\circ$

FIGURE 123
OUTPUT VOLTAGE FOR DIFFERENT PHASE DIFFERENCE

Again it can be seen that the angles α_1 and α_2 can be selected to eliminate any two required orders of harmonics and V_n can be varied by varying the phase shift ϕ . In many industrial applications where the load can be connected to the inverter through transformers, α_1 and α_2 can be selected to eliminate 5th and 7th harmonics and the third harmonic can be avoided with proper transformer connections. However, if the motor is directly connected to the inverter as in the case of vehicle propulsion, α_1 and α_2 should be chosen such that the third and the fifth harmonics are eliminated, i.e.

$$1 - 2 \cos 3 \alpha_1 + 2 \cos 3 \alpha_2 = 0$$

$$1 - 2 \cos 5 \alpha_1 + 2 \cos 5 \alpha_2 = 0$$

The approximate solution of these equations is

$$\alpha_1 = 23.62^\circ$$

$$\alpha_2 = 33.30^\circ$$

The fundamental amplitude and the harmonic components for these values of α_1 and α_2 are given in Table V for different values of the phase shift ϕ . It should be noted that at higher values of ϕ when the fundamental component is small, the harmonic components are excessive.

Another way to operate the circuit of Figure 119 is to have many commutations per half cycle. This day it is generally possible to eliminate all harmonics below the frequency of pulses occurring in the output voltage. Figure 124 shows two possible operations of this type. In Figure 124(a), a consecutive pulses have equal width and the voltage can be controlled by simultaneously varying the width of all pulses while maintaining the pulse frequency constant and

TABLE V

MULTIPLE INVERTER CONTROL WITH ELIMINATION OF THE THIRD AND FIFTH HARMONICS

HARMONIC COMPONENTS

(PERCENT)

ϕ degrees	$\frac{V_{1\max}}{E_d}$	3	5	7	9	11	13	15	17
0	1.068	0.015	0.065	29.52	48.68	36.20	3.51	19.95	16.07
30	1.032	0.011	0.017	7.91	35.60	36.20	3.51	14.60	4.31
60	0.925	0.0	0.065	29.52	0.00	36.20	3.51	0.0	16.07
90	0.756	0.015	0.065	29.52	48.68	36.20	3.51	19.95	16.07
120	0.534	0.030	0.065	29.52	97.35	36.20	3.51	39.90	16.07
150	0.277	0.042	0.24	110.17	132.98	36.20	3.51	54.50	60.00
180	0.0	0.0	0.0	0.0	0.0	0.0	0.0	0.0	0.0

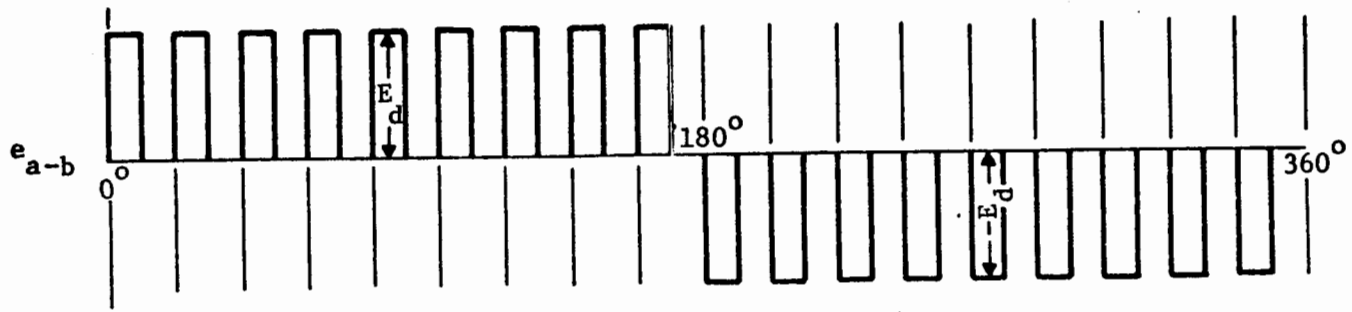

(a) PULSES OF EQUAL WIDTH

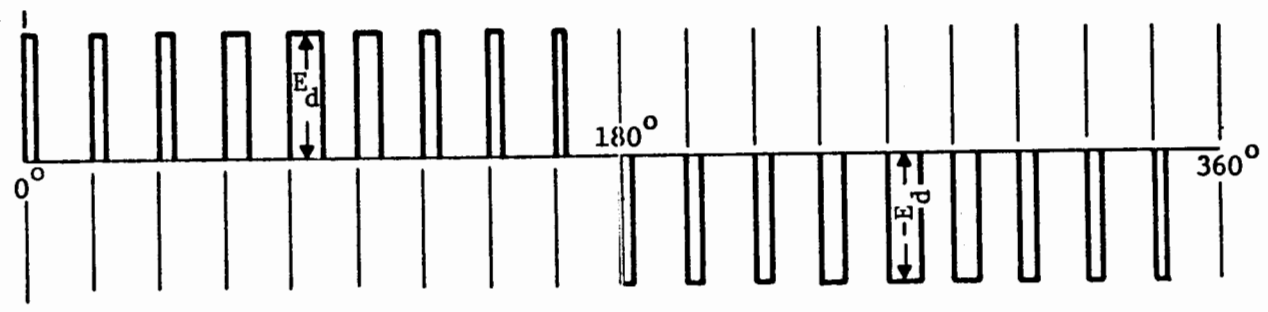

(b) PROGRAMMED COMMUTATION

FIGURE 124
OUTPUT VOLTAGES WITH MANY COMMUTATIONS
PER HALF CYCLE

synchronized to the output frequency. In Figure 124(b), the pulse widths of consecutive pulses vary in sinusoidal fashion. Here the voltage can be controlled by varying the width of all pulses while still retaining the sinusoidal relationship and the repetition rate of the pulses. This type of inverter is commonly known as a pulse-width-modulated i.e., a PWM inverter.

The PWM inverter is very widely used in the new generation of rail propulsion systems using induction traction motors as described earlier in Section 4.0.

3.3 Simplified Inverter Circuit

So far we have been discussing one type of inverter circuit which can be operated with several commutations per half cycle of the output voltage. Such a circuit requires auxiliary thyristors in commutation circuit. If, however, only a six-step, 120° conduction is required, a simple inverter circuit is possible as shown in Figure 125. The basic operation of the inverter is very similar to that of the earlier circuit. The commutation process is different and is explained below.

Let thyristors T_1 and T_2 be conducting and let the capacitor between thyristors T_1 and T_3 be charged with the polarity shown in Figure 125. Now if T_3 is switched on, T_1 gets reverse biased and is turned off. The load current continues to flow via T_3 and the capacitor until the capacitor is charged in the opposite direction. The current then flows through the diode in series with T_3 into the other line of the load. Blocking diodes are used in series with the thyristors so that capacitors do not discharge through the load continuously.

This circuit can be operated either from a current source - by using a large reactor in series - or from a voltage source - by using

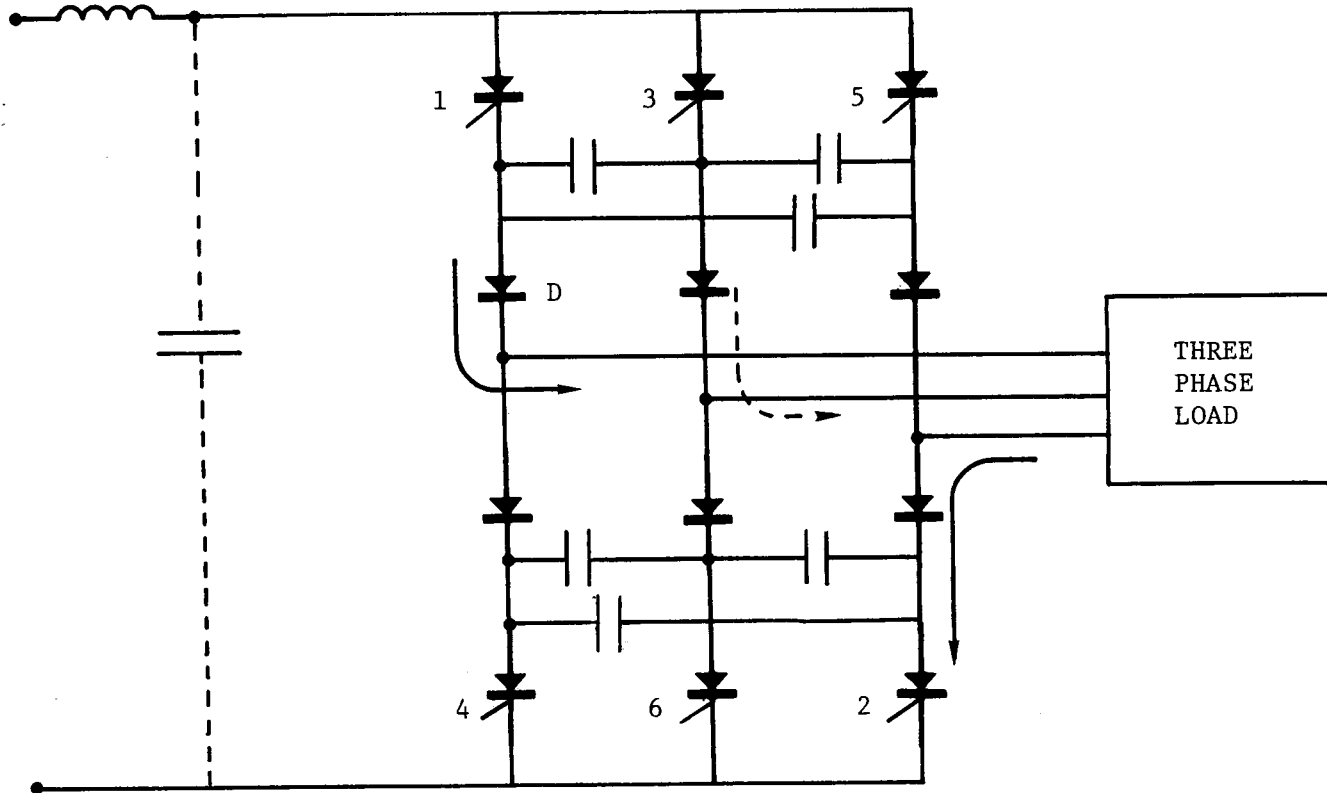

FIGURE 125
SIMPLIFIED INVERTER CIRCUIT

a large capacitor in parallel as shown in Figure 125. Several other inverter circuits are possible but a discussion of all these is clearly outside the scope of this work.

4.0 CYCLOCONVERTER

It has been explained earlier that a three-phase bridge rectifier circuit operates as a rectifier for firing angle $\alpha < 90^\circ$ whereas it works as an inverter for $\alpha > 90^\circ$. We have seen that this circuit can provide a continuously controllable dc voltage of either polarity, although the load current can only flow in one direction. Such an operation is a 2-quadrant operation (see Figure 126). It is possible to obtain a 4-quadrant operation by using two such converters as shown in Figure 127. Each converter can operate at a load voltage of either polarity and any direction of the load current can be obtained by using one converter at a time.

A cycloconverter is essentially a 4-quadrant converter whose firing angle is continuously changed to produce a continuously varying mean voltage level. By controlling the amplitude and the frequency of firing angle variation, the amplitude and the frequency of the output voltage can be controlled. A cycloconverter is thus ac-to-ac converter or a frequency converter.

A cycloconverter can supply power to a load of any power factor - leading or lagging. However, since each converter can carry a current only in one direction, the positive half cycle of the load current must be carried by the P-converter and the negative half cycle must be carried by the N-converter. Each converter will, of course, operate as a rectifier or an inverter as dictated by the load voltage. This is shown in Figure 128.

It should be noted here that the load voltage and the load current waveforms shown in Figure 128 represent the fundamental components of highly non-sinusoidal waveforms. The ideal waveform of an unfiltered output voltage is shown in Figure 129. It can be seen that the firing angle α of the circuit is a function of time and

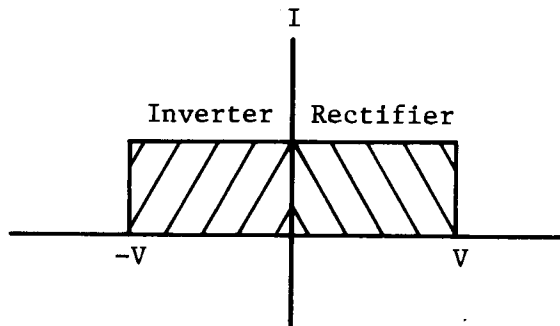

FIGURE 126
TWO QUADRANT OPERATION

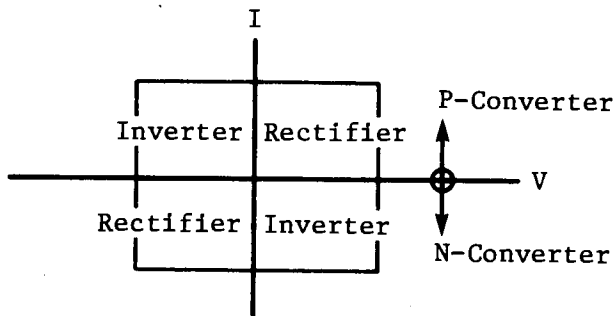
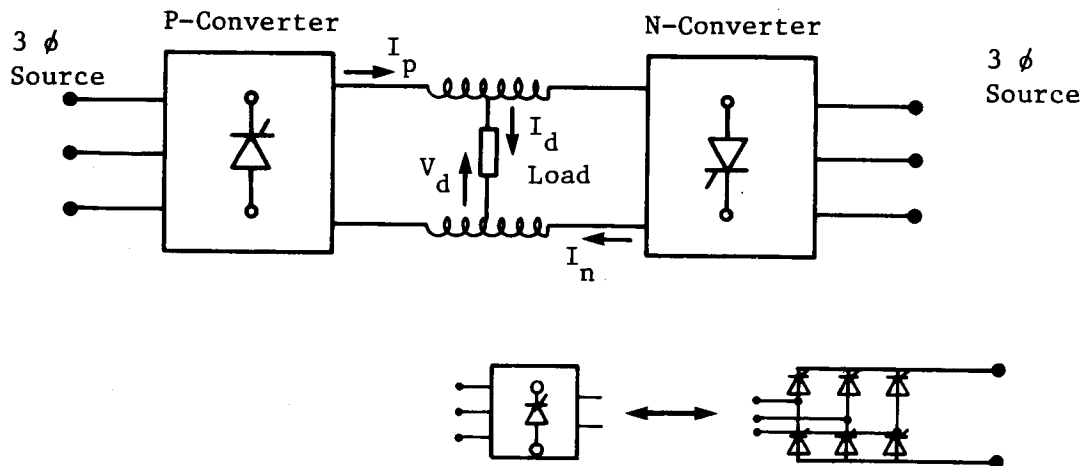
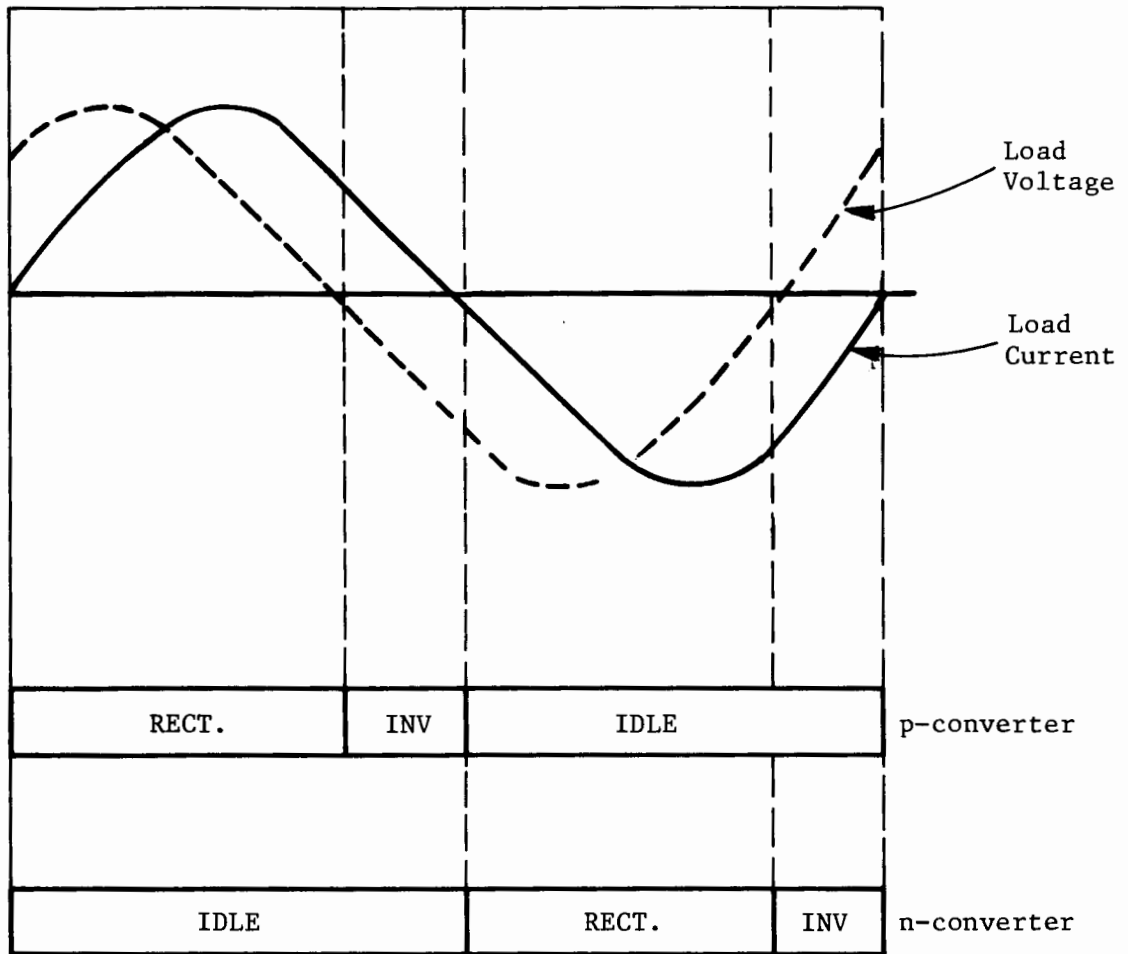

FIGURE 127
FOUR QUADRANT OPERATION



**FIGURE 128
CYCLOCONVERTER OPERATION**

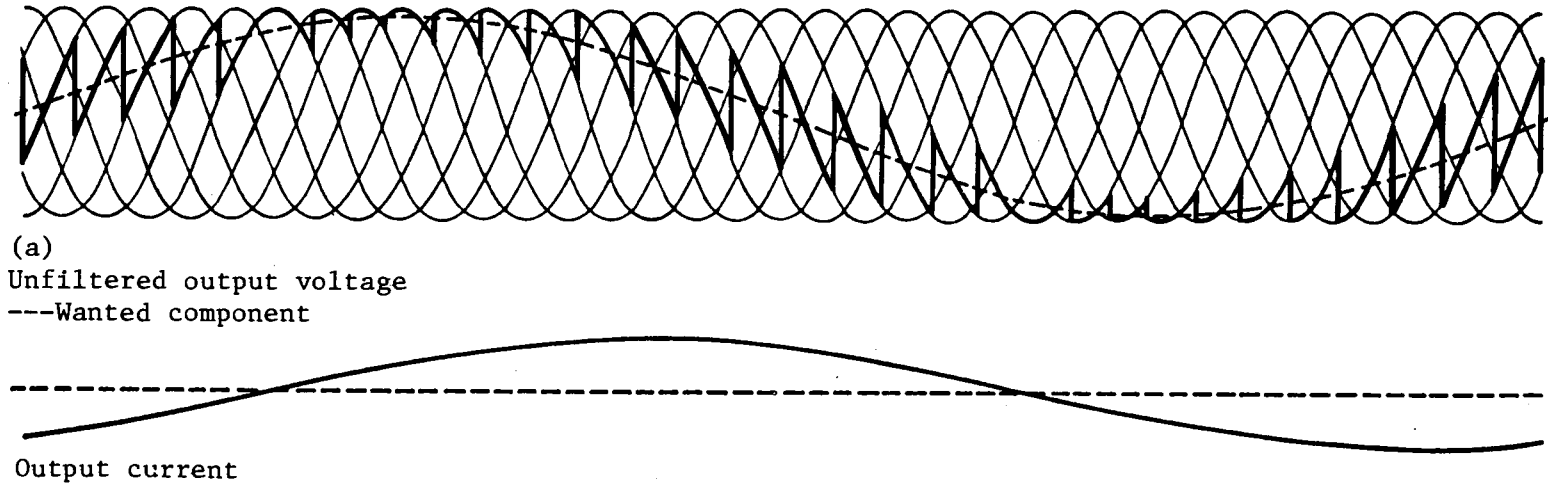

FIGURE 129
CYCLOCONVERTER WAVEFORMS

varies almost between 0° and 180° . It should also be remembered that these waveforms will be different if a finite commutation period is considered.

So far we have considered circuits where only one converter - P or N - is conducting at a time while the other is blocked. Such an operation is called a 'circulating current free' mode of operation. For some applications, however, a cycloconverter is operated such that both converters are operating at the same time. They are then controlled such that the firing angles α_P and α_N always add to 180° , i.e., $\alpha_P + \alpha_N = 180^\circ$. With such an operation, the instantaneous output voltages of the two converters are unequal, and hence a center-tapped reactor is introduced in the circuit (Figure 127) to limit the circulating current.

It is possible to build three phase cycloconverter circuits from the basic single phase circuit discussed above. One such circuit is shown in Figure 130. The thyristors are triggered such that at any instant of time, two thyristor groups such as say 1 and 2, feed current into the load. Out of the six thyristors in two groups, only two thyristors conduct at a time (ideal commutation) depending on the instantaneous line voltages. For large power applications, however, a full wave circuit shown in Figure 131 with 36 thyristors is used.

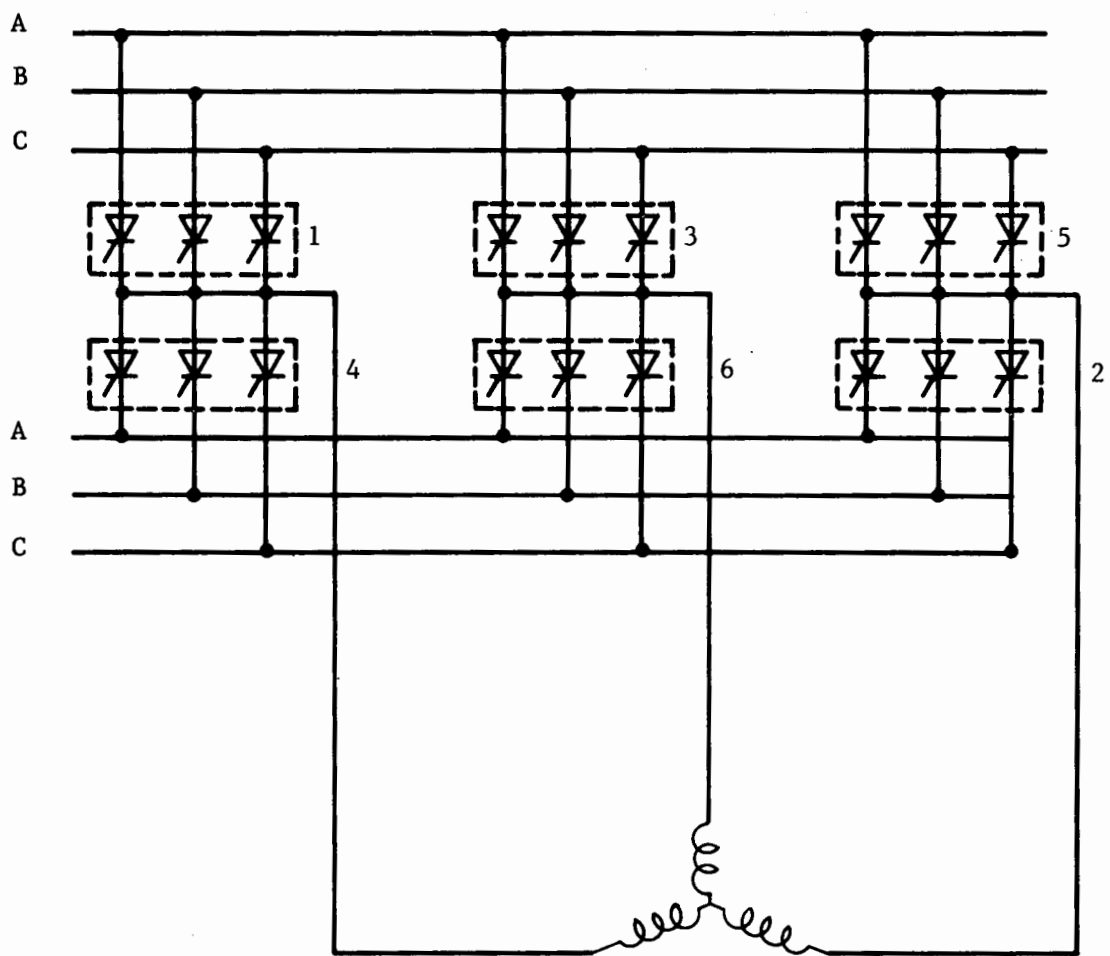

FIGURE 130
THREE PHASE CYCLOCONVERTER

3 PHASE INPUT

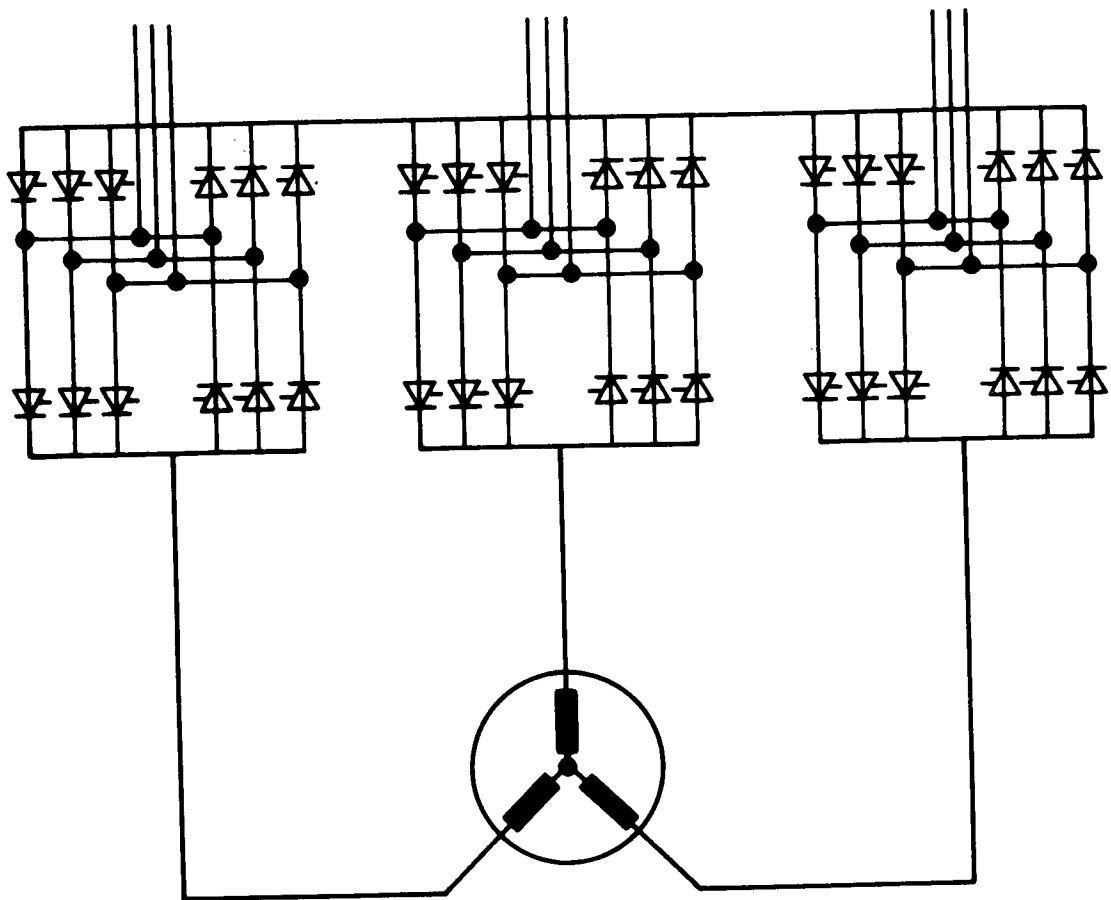

FIGURE 131
FULL WAVE THREE PHASE CIRCUIT