



U.S. Department
of Transportation

Urban Mass
Transportation
Administration

S.C.R.T.D. LIBRARY

Special Study of Precast Concrete Tunnel Liner Demonstration

Office of Technology
Development and Deployment
Office of Rail and Construction
Technology
Washington, D.C. 20590

Lexington Market Tunnels Baltimore, Maryland



APRIL 1980

FINAL REPORT

Report No.
UMTA-MD-06-0039-81-1

W.D. Wightman
S. Calabrese
E.L. Foster

UTD Corporation
8425 Frye Road
Alexandria,
Virginia 22309

Document is available to
the U.S. public through
the National Technical
Information Service,
Springfield, Virginia 22161

This document is disseminated under the sponsorship of the Department of Transportation in the interest of information exchange. The United States assumes no liability for its contents or use thereof.

The United States Government and the Metropolitan Atlanta Rapid Transit Authority do not endorse products or manufacturers. Trade or manufacturers' names appear herein solely because they are considered essential to the object of this report.

1. Report No. UMTA-MD-06-0039-81-1		2. Government Accession No.		3. Recipient's Catalog No.	
4. Title and Subtitle Special Study of Precast Concrete Tunnel Liner Demonstration, Lexington Market Tunnels, Baltimore, Maryland				5. Report Date April 30, 1980	
				6. Performing Organization Code	
7. Author(s) Wightman, W.D., Calabrese, S.J., and Foster, E.L. *				8. Performing Organization Report No.	
9. Performing Organization Name and Address Mass Transit Administration of Maryland 109 East Redwood Street Baltimore, Maryland 21202				10. Work Unit No. (TRAIS)	
				11. Contract or Grant No. 79-5764CP-2	
12. Sponsoring Agency Name and Address U.S. Department of Transportation Urban Mass Transportation Administration 400 Seventh Street, S.W. Washington, D. C. 20590				13. Type of Report and Period Covered Final	
				14. Sponsoring Agency Code	
15. Supplementary Notes * UTD Corporation 8425 Frye Road Alexandria, VA 22309					
16. Abstract A demonstration construction project was carried out for precast segmented concrete tunnel liner in the Lexington Market Section of the Baltimore Regional Rapid Transit System. In that project, twin tunnels, each approximately 1550 feet in length, were lined with concrete (outbound tunnel) and steel (inbound tunnel). Length, ground conditions, tunneling techniques, and crews were comparable for the two tunnels. The performance of the two liner systems was documented in considerable detail through a combination of instrumentation, record keeping, photography and personal observation. This performance and the program by which it was determined are described in detail in the report. The principal findings of the report are that the performance of the precast segmented concrete liner is comparable to that of segmented steel liner in all important respects. However, the concrete liner is more subject to damage and must therefore be installed with greater care. Both liners are capable of use beneath the groundwater table, and their sealing systems are capable of meeting minimum standards for leakage. Analysis of the costs of concrete vs. steel lined tunnels showed them to be nearly equal in short lengths (1550 lf ±), with the concrete having a cost advantage for longer lengths. Savings are predicted to be 15% or more for concrete vs. steel in lengths of 10,000 lf.					
17. Key Words Tunnel Liners Precast Segmented Concrete Tunnel Liners Soft Ground Tunneling Ground Control Compressed Air Tunneling			18. Distribution Statement Available to the public through the National Technical Information Service Springfield, Virginia 22161		
19. Security Classif. (of this report) Unclassified		20. Security Classif. (of this page) Unclassified		21. No. of Pages 248	22. Price

METRIC CONVERSION FACTORS

Approximate Conversions to Metric Measures

Symbol	When You Know	Multiply by	To Find	Symbol
LENGTH				
in	inches	*2.5	centimeters	cm
ft	feet	30	centimeters	cm
yd	yards	0.9	meters	m
mi	miles	1.6	kilometers	km
AREA				
in ²	square inches	6.5	square centimeters	cm ²
ft ²	square feet	0.09	square meters	m ²
yd ²	square yards	0.8	square meters	m ²
mi ²	square miles	2.6	square kilometers	km ²
	acres	0.4	hectares	ha
MASS (weight)				
oz	ounces	28	grams	g
lb	pounds	0.45	kilograms	kg
	short tons (2000 lb)	0.9	tonnes	t
VOLUME				
tsp	teaspoons	5	milliliters	ml
Tbsp	tablespoons	15	milliliters	ml
fl oz	fluid ounces	30	milliliters	ml
c	cups	0.24	liters	l
pt	pints	0.47	liters	l
qt	quarts	0.95	liters	l
gal	gallons	3.8	liters	l
ft ³	cubic feet	0.03	cubic meters	m ³
yd ³	cubic yards	0.76	cubic meters	m ³
TEMPERATURE (exact)				
°F	Fahrenheit temperature	5/9 (after subtracting 32)	Celsius temperature	°C

*1 in = 2.54 (exactly). For other exact conversions and more detailed tables, see NBS Misc. Publ. 286, Units of Weights and Measures, Price \$2.25, SD Catalog No. C13.10:286.

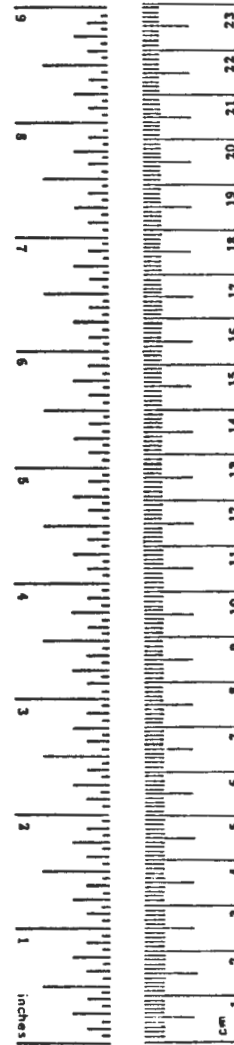

Approximate Conversions from Metric Measures

Symbol	When You Know	Multiply by	To Find	Symbol
LENGTH				
mm	millimeters	0.04	inches	in
cm	centimeters	0.4	inches	in
m	meters	3.3	feet	ft
m	meters	1.1	yards	yd
km	kilometers	0.6	miles	mi
AREA				
cm ²	square centimeters	0.16	square inches	in ²
m ²	square meters	1.2	square yards	yd ²
km ²	square kilometers	0.4	square miles	mi ²
ha	hectares (10,000 m ²)	2.5	acres	
MASS (weight)				
g	grams	0.035	ounces	oz
kg	kilograms	2.2	pounds	lb
t	tonnes (1000 kg)	1.1	short tons	
VOLUME				
ml	milliliters	0.03	fluid ounces	fl oz
l	liters	2.1	pints	pt
l	liters	1.06	quarts	qt
l	liters	0.26	gallons	gal
m ³	cubic meters	35	cubic feet	ft ³
m ³	cubic meters	1.3	cubic yards	yd ³
TEMPERATURE (exact)				
°C	Celsius temperature	9/5 (then add 32)	Fahrenheit temperature	

METRIC CONVERSION FACTORS

04759

TF
252
MS

FOREWORD

The work described in this report has been a cooperative undertaking by many people. Its successful completion is a tribute to their talents and their good will. Before presenting their findings, the authors wish to express their appreciation to each of those whose support helped to make our job easier. The following list, by organization, denotes those to whom special thanks is due.

Ralph M. Parsons Company

Mr. J.W. Maddox
Mr. Charles Brylla
Mr. Steve Kagay
Mr. Dave Shearer

MTA

Mr. Frank Hoppe

UMTA

Mr. Gilbert Butler

Traylor & Associates

Mr. Glen Traylor
Mr. Phil Stock

SOG Partners

Mr. John Dunncliff
Mr. William Beloff
Mr. Charles McNeilie
Mr. Richard Murdock
Mr. Bartlett W. Paulding, Jr.
Mr. Joe Engles
Dr. Ronald Heuer
Dr. Stanley Paul
Mr. Thomas J. Regan, Jr.

Parsons, Brinckerhoff, Quade & Douglas

Mr. Thomas Keussel

Daniel, Mann, Johnson & Mendenhall/Kaiser Engineers

Mr. Drupad Desai

Buchan Concrete Tunnel Segments, Ltd.

Mr. Gerald Levy
Mr. Charles Forrester
Mr. Harold Raffetto

Last, but by no means least, we wish to thank Mr. Paul Verdow, the Contracting Officer. He guided the project with a firm but understanding hand, which encouraged all concerned to do the best possible job.

The Authors

EXECUTIVE SUMMARY

During the period from the spring of 1976 through early 1980, a demonstration of precast segmented concrete tunnel liner was planned and implemented. The project was initiated and funded by the Urban Mass Transportation Administration (UMTA) of the U.S. Department of Transportation. Implementation was carried out jointly by UMTA and the Baltimore Regional Rapid Transit System (BRRTS), and was supervised by the Ralph M. Parsons Company, construction manager for BRRTS. Construction was done by Traylor and Associates, a joint venture consisting of Traylor Brothers, Morrison Knudsen Company, Inc., and Grow Tunneling. This study and report of findings were commissioned by UMTA to provide government and industry personnel with a comprehensive evaluation of precast segmented concrete liner for use in transit tunnels in the USA.

The demonstration site was the Lexington Market Section of BRRTS in Baltimore, MD. Twin tunnels, each about 1550 feet long, were constructed through waterbearing soils in a built up urban area. The tunnels passed near or beneath multi-story buildings and, at one location, crossed under the main tracks of the B and O Railroad with approximately 7 feet of soil between. Ground control and groundwater control were maintained by compressed air, supplemented as necessary by underpinning and grouting. By these means, surface settlements were limited and damage to structures was avoided.

Conclusions were to be drawn about the performance and cost of the precast segmented concrete liner by comparing it with a conventional segmented steel liner. In doing this, it was desired to maintain all conditions for the two liners as nearly identical as possible. This was accomplished by constructing one of the twin tunnels with concrete, the other with steel liner. The same crews were used for both and, with only minor differences in size and operating techniques, the (digger) shields were comparable. Because of the proximity of the tunnels to each other, ground conditions were similar as well. The tunnels were very nearly equal in length. These similarities helped to eliminate many of the uncertainties which might otherwise have existed for the conclusions drawn.

The findings of this study are that precast segmented concrete liner has the following characteristics as compared with segmented steel liner:

1. It performs equally well in supporting the ground when properly installed with adequate grouting of the annular void space.
2. The neoprene gasket sealing system, combined with secondary grouting where leakage has occurred (principally due to installation problems), is satisfactory and will seal against groundwater at least as severe as that encountered in the Lexington Market section.

3. Concrete segments are brittle and more subject to impact damage than their steel counterparts.

4. Suitable handling and installation techniques, including placing each ring in as nearly theoretical configuration as possible and grouting the voids from the tail shield rearwood make it possible to obtain full and satisfactory performance with respect to breakage.

5. The rates of installation of concrete vs. steel were found to be slightly lower (28'/day vs. 32'/day predicted), but the differences would be lower if equal segment lengths were employed.

6. Total adjusted direct costs per foot of tunnel in short (1550') lengths appear to be very nearly equal for concrete vs. steel (\$2445/lf vs \$2421/lf.) However, for longer lengths (10,000 ft), the tooling costs for concrete may be written off at a lower rate, and with allowances for this, plus other smaller differences, direct cost savings of 15% or more appear to be possible.

Based on these findings, it is concluded that precast segmented concrete tunnel liner is a viable, cost effective alternative to segmented steel liner in many applications.

One further conclusion may be drawn. This type of demonstration appears to be an excellent way to describe the characteristics of technical innovations, thereby expediting "mainlining" of those of sufficient merit into the industry. On this basis, it appears to be a cost effective adjunct to research and development.

TABLE OF CONTENTS

	<u>Page</u>
PART I. GENERAL PROJECT INFORMATION -----	1
1.0 Introduction -----	1
1.1 Background -----	1
1.2 Institution of the Demonstration Program -----	2
2.0 Special Observation Group (S.O.G.) Program and Approach -----	6
2.1 General Description of Project -----	6
2.2 The Special Observation Group (S.O.G.) Program -----	6
2.3 Implementation of the S.O.G. Program -----	10
2.4 Roles and Responsibilities of the Jobsite Participants --	14
3.0 Case History/Sequence of Events for Execution of Construction and Study Contracts -----	15
3.1 Pre-Construction Events -----	15
3.2 Construction -----	17
3.3 S.O.G. Program -----	23
4.0 Instrumentation Program -----	25
4.1 Scope of the Program -----	24
4.2 Geotechnical Instrumentation -----	25
4.3 Structural Instrumentation -----	37
4.4 Geometric Instrumentation -----	37
5.0 Geotechnical Setting -----	43
5.1 Geologic References in Bid Documents -----	43
5.2 General Geologic Description -----	43
5.3 Anticipated Subsurface Conditions Along the Tunnel Route	44
5.4 Actual Subsurface Conditions Encountered Along The Tunnel Route -----	48
PART II. TECHNICAL PERFORMANCE -----	74
6.0 Steel Plate Lined Tunnel -----	74
6.1 Design and Manufacture -----	74
6.2 Tunneling and Liner Erection Procedures -----	77
6.3 Production Analysis -- Steel Lined Tunnel -----	88
6.4 Geometric Data -----	93
6.5 Geotechnical Influences and Responses -----	96
6.6 Leakage and Sealing -----	109
6.7 Problems and Remedial Action -----	112
6.8 Comments -----	113

	<u>Page</u>
7.0 Precast Concrete Lined Tunnel -----	114
7.1 Design -----	114
7.2 Construction -----	116
7.3 Performance Analysis -----	138
7.4 Remedial Action -----	214
8.0 Conclusions of Performance Evaluation -----	218
8.1 Comparative Evaluation of Precast vs. Steel Liner -----	218
8.2 Findings for Improving Precast Performances -----	221
8.3 Limitations With Respect to Local Environment -----	222
PART III. TECHNICAL STUDY -- COST -----	224
9.0 Construction Cost Analysis -----	224
9.1 Direct Costs -----	225
9.2 Indirect Costs -----	232
10.0 Comparative Cost Analysis: The Steel and Precast Concrete Lined Tunnels -----	234
11.0 Cost Projections - Steel Vs. Precast Concrete Lined Tunnels Under Other Conditions -----	238
12.0 Conclusions of Cost Evaluations -----	241
12.1 Comparative Findings -----	241
12.2 Findings for Improving Precast Concrete Liner Costs -----	241
PART IV. SUMMARY OF STUDY FINDINGS -----	244
13.0 Summary of Performance and Cost Evaluations -----	244
13.1 Design Aspects -----	244
13.2 Fabrication Aspects -----	245
13.3 Installation Aspects -----	245
PART V. RECOMMENDATIONS FOR FUTURE STUDY -----	247
14.0 The 5-Year Study -----	247
15.0 Ongoing Study of Special Problems -----	248
REFERENCES -----	249
APPENDIX -----	A-1

LIST OF ILLUSTRATIONS

	<u>Page</u>
FIGURE 1. LOCATION DRAWING, LEXINGTON MARKET SECTION	7
FIGURE 2. GENERAL PROJECT PLAN	8
FIGURE 3. TUNNEL PROFILES	9
FIGURE 4. UNDERPINNING HECHT COMPANY GARAGE	18
FIGURE 5. UNDERPINNING HECHT COMPANY GARAGE	18
FIGURE 6. PROJECT AS-BUILT SCHEDULE	19
FIGURE 7. INSTALLATION OF SHIELD IN WORKSHAFT	21
FIGURE 8. AIRLOCK IN OUTBOUND PRECAST CONCRETE TUNNEL	21
FIGURE 9. TUNNELING OF CROSS PASSAGES	22
FIGURE 10. TUNNELING OF CROSS PASSAGES	22
FIGURE 11. CHECKING OUT IMBEDDED STRAIN GAGES IN CONTRACTOR'S YARD	24
FIGURE 12. SURFACE AND SUBSURFACE INSTRUMENTATION PLAN	27
FIGURE 13. SURFACE AND SUBSURFACE INSTRUMENTATION PLAN	28
FIGURE 14. SURFACE AND SUBSURFACE INSTRUMENTATION PLAN	29
FIGURE 15. SURFACE AND SUBSURFACE INSTRUMENTATION PLAN	30
FIGURE 16. SURFACE AND SUBSURFACE INSTRUMENTATION PLAN	31
FIGURE 17. SURFACE AND SUBSURFACE INSTRUMENTATION PLAN	32
FIGURE 18. SURFACE AND SUBSURFACE INSTRUMENTATION PLAN	33
FIGURE 19. SCHEMATIC OF SISTER BAR WATERPROOFING	38
FIGURE 20. EXTENSOMETER	39
FIGURE 21. DIAL CALIPER FOR JOINT MEASUREMENT	40
FIGURE 22. CONTOUR GAGE FOR JOINT OFFSET MEASUREMENT	40
FIGURE 23. LOCATION OF GEOMETRIC INSTRUMENTATION POINTS	42
FIGURE 24. OUTBOUND PROFILE	45
FIGURE 25. GEOLOGIC PROFILE AND JACKING PRESSURES, OUTBOUND TUNNEL	50
FIGURE 26. GEOLOGIC PROFILE AND JACKING PRESSURES, OUTBOUND TUNNEL	51
FIGURE 27. GEOLOGIC PROFILE AND JACKING PRESSURES, OUTBOUND TUNNEL	52
FIGURE 28. GEOLOGIC PROFILE AND JACKING PRESSURES, OUTBOUND TUNNEL	53
FIGURE 29. GEOLOGIC PROFILE AND JACKING PRESSURES, OUTBOUND TUNNEL	54
FIGURE 30. GEOLOGIC PROFILE AND JACKING PRESSURES, OUTBOUND TUNNEL	55
FIGURE 31. GEOLOGIC PROFILE AND JACKING PRESSURES, OUTBOUND TUNNEL	56
FIGURE 32. GEOLOGIC PROFILE AND JACKING PRESSURES, OUTBOUND TUNNEL	57
FIGURE 33. GEOLOGIC PROFILE AND JACKING PRESSURES, OUTBOUND TUNNEL	58
FIGURE 34. GEOLOGIC PROFILE AND JACKING PRESSURES, OUTBOUND TUNNEL	59
FIGURE 35. GEOLOGIC PROFILE AND JACKING PRESSURES, OUTBOUND TUNNEL	60
FIGURE 36. GEOLOGIC PROFILE AND JACKING PRESSURES, INBOUND TUNNEL	61
FIGURE 37. GEOLOGIC PROFILE AND JACKING PRESSURES, INBOUND TUNNEL	62

FIGURE 38.	GEOLOGIC PROFILE AND JACKING PRESSURES, INBOUND TUNNEL	63
FIGURE 39.	GEOLOGIC PROFILE AND JACKING PRESSURES, INBOUND TUNNEL	64
FIGURE 40.	GEOLOGIC PROFILE AND JACKING PRESSURES, INBOUND TUNNEL	65
FIGURE 41.	GEOLOGIC PROFILE AND JACKING PRESSURES, INBOUND TUNNEL	66
FIGURE 42.	GEOLOGIC PROFILE AND JACKING PRESSURES, INBOUND TUNNEL	67
FIGURE 43.	GEOLOGIC PROFILE AND JACKING PRESSURES, INBOUND TUNNEL	68
FIGURE 44.	GEOLOGIC PROFILE AND JACKING PRESSURES, INBOUND TUNNEL	69
FIGURE 45.	GEOLOGIC PROFILE AND JACKING PRESSURES, INBOUND TUNNEL	70
FIGURE 46.	GEOLOGIC PROFILE AND JACKING PRESSURES, INBOUND TUNNEL	71
FIGURE 47.	GEOLOGIC PROFILE AND JACKING PRESSURES, INBOUND TUNNEL	72
FIGURE 48.	FABRICATION AND CONSTRUCTION TOLERANCES	76
FIGURE 49.	TUNNELING MACHINE ASSEMBLY	78
FIGURE 50.	HYDRAULIC BREASTING DOORS IN USE	79
FIGURE 51.	AIRLOCK	80
FIGURE 52.	AIRLOCK	80
FIGURE 53.	GROUT BATCHING PLANT	81
FIGURE 54.	SHIELD AND REACTION RING ASSEMBLED FOR INITIAL SHOVE	82
FIGURE 55.	FALSE RINGS	83
FIGURE 56.	RING #273 ON INBOUND TUNNEL	84
FIGURE 57.	LASER CONTROL PLAN VIEW	85
FIGURE 58.	MUCK CAR BEING LIFTED UP THE SHAFT	87
FIGURE 59.	MUCK CAR BEING DUMPED INTO BIN	87
FIGURE 60.	SURFACE CONCRETING OPERATIONS	89
FIGURE 61.	TUNNEL CONCRETING OPERATIONS	89
FIGURE 62.	TUNNEL CONCRETING OPERATIONS	89
FIGURE 63.	PRODUCTION ANALYSIS -- STEEL	90 - 92
FIGURE 64.	TUNNELING PRODUCTION -- CUMULATIVE AVG ADVANCE RATES	94
FIGURE 65.	CUMULATIVE PRODUCTION EFFICIENCY RELATIONSHIPS	95
FIGURE 66.	INCLINOMETER-14 MOVEMENT PERPENDICULAR TO I.B. TUNNEL CENTERLINE	99
FIGURE 67.	PROPERTIES OF ERROR FUNCTION OR NORMAL PROBABILITY CURVE AS USED TO REPRESENT C/S OF SETTLEMENT TROUGH ABOVE TUNNEL	102
FIGURE 68.	SURFACE SETTLEMENT PROFILES	103
FIGURE 69.	SURFACE SETTLEMENT PROFILES	104
FIGURE 70.	CP. OF WIDTH OF SETTLEMENT TROUGH WITH PECK (1969)	106
FIGURE 71.	SURFACE SETTLEMENT PROFILES ALONG CENTERLINE	107
FIGURE 72.	PIEZOMETRIC DATA -- PZ-11, PZ-12, PZ-13	110
FIGURE 73.	SCHEMATIC OF JOINT SEALING SYSTEM FOR STEEL LINERS	111
FIGURE 74.	BOLTED PRECAST SEGMENTED CONCRETE LINER SEGMENT	115
FIGURE 75.	PRECAST SEGMENT AS DELIVERED	118

FIGURE 76.	ONE OF SEVERAL METHODS USED FOR LIFTING SEGMENTS	119
FIGURE 77.	STORAGE OF SEGMENTS IN CONSTRUCTION YARD	121
FIGURE 78.	SEGMENTS AT WORK SHAFT READY FOR INSTALLATION IN TUNNEL	121
FIGURE 79.	TAIL SEAL SCHEMATIC AND CROSS-SECTION	124
FIGURE 80.	PHOTO OF INSTALLED SEAL	124
FIGURE 81.	LIFTING SEGMENT WITH ERECTOR ARM	126
FIGURE 82.	ROTATING SEGMENT MANUALLY FOR INSTALLATION	126
FIGURE 83.	LIFTING SEGMENT INTO POSITION ON JIG RING	127
FIGURE 84.	SEGMENTS MOUNTED ON JIG RING AWAITING KEY SEGMENT	127
FIGURE 85.	INSTALLATION OF KEY SEGMENT	128
FIGURE 86.	PUSHING ASSEMBLED RING BACK TO CONNECT WITH PREVIOUS RING	128
FIGURE 87.	REMOVING KNOCK-OUT SEGMENTS AND BREASTING OFF	130
FIGURE 88.	DRIFT OPENING FOR CROSS-PASSAGE	130
FIGURE 89.	CROSS-PASSAGE EXCAVATION IN PROGRESS	130
FIGURE 90.	TEMPORARY BRACING DURING EXCAVATION OF CROSS-PASSAGE	131
FIGURE 91.	INTERSECTION OF CROSS-PASSAGE WITH PRECAST-LINED TUNNEL	131
FIGURE 92.	INTERSECTION WITH STEEL LINER	131
FIGURE 93.	PRODUCTION ANALYSIS -- CONCRETE	132 - 134
FIGURE 94.	ADVANCE RATE VS. TIME -- CONCRETE LINED TUNNEL	136
FIGURE 95.	PRODUCTION EFFICIENCY RELATIONSHIPS VS. TIME -- PRECAST CONCRETE TUNNEL	137
FIGURE 96.	SCHEMATIC OF PRECAST SEGMENTED CONCRETE LINER INSTALLATION	139
FIGURE 97.	SCHEMATIC CONFIGURATION OF LOADING	141
FIGURE 98.	CRITICAL POINTS ON LINEAR AXIS UNDER POSTULATED LOADING CONDITIONS	142
FIGURE 99.	EXTENSOMETER	144
FIGURE 100.	ANGULAR LOCATIONS OF EXTENSOMETER BALLS	145
FIGURE 101.	SCHEMATIC ARRANGEMENT OF BALL EXTENSOMETER MEASUREMENT SYSTEM	146
FIGURE 102.	POLAR DIAGRAM OF MEASURED RING CONFIGURATION	148
FIGURE 103.	TILT PLATE	149
FIGURE 104.	SCHEMATIC LAY-OUT SHOWING LOCATION OF CALIPER EXTENSOMETER PTS	151
FIGURE 105.	SCHEMATIC REPRESENTATION OF SEGMENT MOVEMENTS IN ONE RING	153
FIGURE 106.	DIFFERENTIAL POSITION OF PLANE OF RING	154
FIGURE 107.	PREDICTED POSITION AND SLOPE OF LINEAR AXIS	154
FIGURE 108.	POSITIONS OF SEGMENTS IN THE JACKING QUADRANTS AS A FUNCTION OF SHOVE POSITION	155
FIGURE 109.	SCHEMATIC DETAIL OF THRUST RING ASSEMBLY	158
FIGURE 110.	VARIATION OF SHOVE PRESSURES WITH TIME DURING SHOVE #471	159
FIGURE 111.	QUADRANT RAM LOADS (SINGLE RAM) CALCULATED FROM MEASURED HYDRAULIC PRESSURE	160 - 163

FIGURE 112.	STRUCTURAL INSTRUMENTATION LOCATION	164
FIGURE 113.	RING AND STRAIN GAGE CONFIGURATION AT TEST SECTION B	165
FIGURE 114.	COMPARISON OF SEGMENT LOADS W/RAM LOADS IN LEFT QUADRANT	168
FIGURE 115.	COMPARISON OF SEGMENT LOADS W/RAM LOADS IN RIGHT QUADRANT	169
FIGURE 116.	COMPARISON OF SEGMENT LOADS W/RAM LOADS IN TOP QUADRANT	170
FIGURE 117.	EXCESS OF RAM LOAD OVER SEGMENT LOAD IN LEFT, RT, TOP QUADRANTS	172
FIGURE 118.	RAM/SEGMENT LOAD DIFFERENTIAL AND RAM LOAD FOR STRAIN GAGES NUMBERS 12 AND 13, RING 470, AT 255°	174
FIGURE 119.	STRAIN GAGE FORCE LEVEL INDICATIONS	175
FIGURE 120.	SURFACE SETTLEMENT OUTBOUND TUNNEL ONLY, TEST SECTION A	179
FIGURE 121.	SOURCES OF LOST GROUND O.B. TUNNEL, MDS-17	181
FIGURE 122.	SOURCES OF LOST GROUND O.B. TUNNEL, MDS-21	182
FIGURE 123.	INCLINOMETER-12 MOVEMENT PERPENDICULAR TO O.B. TUNNEL CENTERLINE	184
FIGURE 124.	SEGMENTS IN TRANSPORT	186
FIGURE 125.	SEGMENTS DAMAGED DURING HANDLING	187
FIGURE 126.	DAMAGE CAUSED BY FORKLIFT	187
FIGURE 127.	CRACK AND SPALL CAUSED BY EXTRACTION	189
FIGURE 128.	SEVERE RING FRACTURING AT RINGS #447-451	190
FIGURE 129.	SEVERE RING FRACTURING AT RINGS #447-451	190
FIGURE 130.	FRACTURING OF RING #449	191
FIGURE 131.	FRACTURE OF RING #448	191
FIGURE 132.	EXPOSED REBAR IN RING #450	191
FIGURE 133.	LONGITUDINAL SEGMENT CRACK	193
FIGURE 134.	LONGITUDINAL SEGMENT CRACK	193
FIGURE 135.	SCHEMATIC REPRESENTATION OF LOCALIZED SEGMENT DAMAGE	194 - 196
FIGURE 136.	RING DAMAGE	198 - 203
FIGURE 137.	PRECAST LINER JOINT SEALING SYSTEM	206
FIGURE 138.	PRE-SEALING OF GASKET GROOVE	206
FIGURE 139.	SURFACE SETTLEMENT CENTERLINE, OUTBOUND TUNNEL	211
FIGURE 140.	SURFACE SETTLEMENT TROUGHS, OUTBOUND TUNNEL ONLY	212
FIGURE 141.	LOCATION OF REMOVED SEGMENTS	215
FIGURE 142.	GROUTING OF LEAKS IN OUTBOUND TUNNEL	216
FIGURE 143.	GROUTING OF LEAKS IN OUTBOUND TUNNEL	216
FIGURE 144.	TUNNEL PRODUCTION -- RINGS/DAY MOVING AVG OF 5 DAYS	219
FIGURE 145.	TUNNEL FOOTAGE PRODUCTION - L.F./DAY MOVING AVG OF 5 DAYS	220

LIST OF TABLES

	<u>Page</u>
TABLE 1. BID RESULTS	16
TABLE 2. CASTING YARD ACTIVITY	117
TABLE 3. MAXIMUM DOWNWARD MOVEMENTS, TEST SECTIONS A AND B	209
TABLE 4. THEORETICAL AS-BID DIRECT COSTS	226
TABLE 5. ACTUAL DIRECT COSTS OF TUNNELING OPERATIONS	228
TABLE 6. TYPICAL HEADING CREW -- PRECAST LINED TUNNEL	230
TABLE 7. TYPICAL SHAFT AND SURFACE SUPPORT CREW FOR DRIVING PRECAST LINED TUNNEL	231
TABLE 8. DIRECT COSTS PER TUNNEL FOOT INBOUND (STEEL) AND OUTBOUND (PRECAST) TUNNELS	235
TABLE 9. ADJUSTED DIRECT COSTS PER TUNNEL FOOT INBOUND (STEEL) AND OUTBOUND (PRECAST) TUNNELS	237

PART I. GENERAL PROJECT INFORMATION

1.0 INTRODUCTION

1.1 Background

Precast segmented concrete tunnel liners have been used in a number of countries throughout the world during the past 15 years. In early applications, the casting process was not well developed; manufacturing tolerances were excessive, and water leakage at the joints was common. Sealing was accomplished in some cases by casting a secondary lining in place inside the segmented liner. In others, gaskets and sealing compounds were employed with varying degrees of success.

As casting tolerances improved, and as the sealing problem became better understood, lining systems were developed which did not leak under a head of 15-20m of water. For example, a liner installed in a 6.2m diameter tunnel in Munich, West Germany had an "as-built" leakage of 0.3 liter/min/100m under a head of 16m of water. This was quickly reduced to zero using secondary sealing techniques. The Japanese have reported success with rubber gasket seals backed by supplementary caulking for a number of their tunnels in water bearing soils. The British also have had several successful installations, although their water conditions appear to have been somewhat less severe.

Thus, by 1975, precast segmented concrete tunnel liners had come of age. Worldwide use outside the USA had demonstrated their performance to be competitive with steel and other liner types, both in function and in cost.

Bolted precast segmented concrete liner was first considered for use in the USA in a transit tunnel of the BART system in San Francisco. The BART investigators concluded that the state of the art (in the early 1960's) did not provide sufficient confidence in the sealing capabilities of the liner system. It was expected to leak if used below the water table, and its cost was projected to be higher than that of steel. (Cost was influenced by secondary finishing operations required to achieve needed finished tolerances).

The conclusions reached by BART served to discourage consideration of precast concrete for other transit tunnels until 1973, when researchers at the U.S. Department of Transportation (USDOT) reexamined the BART findings and concluded that they were no longer valid, and the state of the art in concrete casting would now permit suitable manufacturing tolerances to be maintained. Sealing systems had been developed and used overseas which were capable of sealing against groundwater. Also, the price of steel had advanced to the point where

concrete was increasingly competitive. On the basis of these conclusions, the Urban Mass Transportation Administration (UMTA) began in 1974 to lay the groundwork for bringing bolted precast segmented concrete liners into the U.S. transportation system. A study was funded ⁽¹⁾, and the findings of that study confirmed the 1973 conclusions. A search was then undertaken to locate a suitable site for a liner demonstration. After considerable discussion, a site was found in the Baltimore Regional Rapid Transit System which met most of the basic requirements for a good demonstration. The decision to use the Lexington Market tunnel was further reinforced by the constructive support given to the innovation by Mr. Frank Hoppe, Director of Engineering and Construction for the Baltimore Region Rapid Transit Project (BRRTP), Mass Transit Administration (MTA), Maryland Department of Transportation (MDDOT).

Following the selection of a site, UMTA sponsored a conference in Baltimore during which technical discussions were presented covering all important aspects of bolted precast segmented concrete liners. Foreign authors described their systems, and U.S. authors discussed the problems to be overcome. One of the important recommendations coming from the conference was the suggestion that the length of the demonstration section be increased from its initially planned value of 500 feet to approximately 1500 feet. Although this increased the risk should the new liner encounter difficulties, it enhanced the value of the results obtained, since the contractor would have completed the learning curve before finishing the job. Once basic decisions were reached, detailed planning and design were initiated, and the demonstration program was off and running.

1.2 Institution of the Demonstration Program

1.2.1 Approach to Innovation

In 1972, the USDOT studied the problem of "mainlining" innovation into the tunneling industry. This showed the need for a new approach for the following reasons.

Engineers and designers are increasingly victimized by professional liability suits. Whenever a structure is found not to perform, for whatever reason, injured parties instinctively strike out, attempting to assign blame and recover damages. When involved in such an action, the engineer/designer's best defense is the statement: "I did it in precisely the same way that I and my professional compatriots have done it many times before". Obviously the individual

(1) Superscripts refer to numbered references in the Bibliography, Appendix A.

or organization who submits an innovative design has lost this line of defense. Risk is consequently increased by a large amount. As long as the engineer or designer is asked to function in such an environment, it is unrealistic to expect innovation to be a primary goal. Conversely, reward for innovative design is nearly equal to that for conventional design. Innovation for the engineer/design fraternity is thus an exercise in which the potential risk is out of all proportion to potential reward.

Contractors who undertake construction using innovative methods are in a similar predicament. If they have not previously used the method, "solid" data upon which to base a bid is lacking. Furthermore, if the job goes bad because of the innovation, the contractor risks losing money because he must complete construction and is liable for injuries to others for those occurrences to which the time honored "this is the way any qualified contractor would do the job" does not apply. Generally, too, an innovative approach does not realize its full potential on the first trial. If the bid takes account of these factors, it may not be competitive. Thus, the contractor has little to gain and much to lose by innovation.

The transit authority, which is subject to the wishes of local politicians and pressure groups, has a similarly difficult position. If innovation is introduced and is successful, local jurisdictions may save a small fraction of their 20% of total subway construction costs. For introductory innovation, the savings are likely to be miniscule. If, on the other hand, innovation fails, completion schedules may be thrown out of phase, third parties may be injured, and all sorts of possibilities exist for losses and claims. Within such a framework, an owner has little incentive to innovate.

In the final analysis, savings and other benefits will accrue from innovative methods only after they have come into general use. These benefits will be realized mainly by the federal government, which funds 80% of total costs, but usually subsequent to the first demonstration. Such benefits may more than offset the cost of an occasional failure. Thus, if innovation is to be introduced, the "feds" must be involved; take whatever risk is necessary to assure that other members of the metro partnership will participate; and conduct the demonstration in a way which will assure maximum acceptance by the industry.

There is one further complication. Most owners are required by law to accept the lowest responsible and responsive bid. As mentioned earlier, the contractor who makes prudence allowances for a bid on innovative work will often fail to be the lowest bidder. A way must be found to circumvent this requirement if innovation is to move forward.

The following approach was devised to enable the U.S. Department of Transportation to have a successful innovation program. When an innovation project has been selected, the USDOT will fund the necessary extra costs to have the innovative design prepared. Thus, two designs are prepared, one conventional and one innovative. Bids may then be solicited for construction by each method. A contractor may be considered non-responsive unless he bids on both, depending upon the bid approach. When the bids are in, the lowest "conventional" bid is compared to the lowest innovative bid. For the case where both methods must be bid and the bid for the innovative method does not exceed the bid for the conventional method by more than the amount USDOT has decided the demonstration is worth to them, the difference is funded by the USDOT. Thus, the work is accomplished for the lowest bid cost and within prescribed legal requirements. For the case where both alternatives must be bid without added funding, the marketplace determines which design is built.

USDOT may place other restrictions on the project, such as the requirement that independent observers have access to the jobsite and to records so that innovative methods may be properly evaluated. In addition, USDOT normally agrees to assume extraordinary risks, if these are judged to be present. Thus, it has been found possible to implement innovative technology and at the same time sustain the interests and legal requirements of all parties involved. The Lexington Market demonstration of precast segmented concrete tunnel liner was developed within such a framework.

1.2.2 Objectives of the Demonstration Program

The Lexington Market Demonstration Program has the following objectives:

1. To demonstrate the use of precast segmented concrete liner in a U.S. metro system.
2. To document the installation and use of precast liner so that industry will be fully informed about all factors related to its use.
3. To make such measurements and observations as are necessary to assess the performance of the liner system.
4. To make an economic analysis of the precast segmented concrete liner which will enable its cost to be compared with that of other lining systems.
5. To analyze faults and make recommendations for design improvements to be made in subsequent precast liners.

1.2.3 Involved Parties

The following parties participated in the manner described:

UMTA. The Urban Mass Transportation Administration of the U.S. Department of Transportation sponsored the demonstration program, making all necessary arrangements for federal involvement. This included procurement of the special design, paying differential costs between low bid and alternative designs, and sponsoring all necessary evaluation procedures.

BRRTS. The Baltimore Regional Rapid Transit System integrated the demonstration into its construction program and served as UMTA's "prime contractor" for getting the work done. Procurement of services and approval of work was handled through BRRTS and its supporting organizations.

DMJM/Kaiser Engineers. DMJM/KE serves as the general engineering consultant to BRRTS. In this capacity its staff supervised development of the liner design and was responsible for reviewing technical details.

Parsons, Brinckerhoff, Quade and Douglas. PBQD was the section designer for the Lexington Market Project. They developed the detailed design of the liner segments, selected the sealing system, and provided drawings and specifications for the project. As a part of their activities, PBQD supervised the preparation of a design review, which included laboratory testing of liner specimens at the University of Illinois.

Ralph M. Parsons Company. Parsons was the construction manager for BRRTS. In this capacity, it contracted for and administered the construction and S.O.G. programs. The Parsons' staff included the Resident Engineer, who provided project records and other types of support to the S.O.G. plus extensive support by Parsons' Geotechnical Services Group.

Traylor and Associates. A joint venture of Traylor Brothers, Inc., Morrison-Knudsen Company, Inc., and Grow Tunneling was the general contractor, responsible for construction of the Lexington Market Tunnels.

Buchan Concrete Tunnel Segments, Ltd. Buchan was responsible for manufacturing the concrete segments.

Special Observation Group. The S.O.G. consisted of a team led by UTD Corporation. Other team members included Goldberg, Zoino, Dunicliff and Associates; Geotechnical Engineers, Inc.; Mr. Thomas Regan, Jr. of Sverdrup and Purcel; and, Drs. Ronald Heuer and Stanley Paul of the University of Illinois. The function of the S.O.G. was to instrument the liner and adjacent ground, evaluate liner performance, and analyze the economics of the segmented liner construction process. The S.O.G. assignment included compilation of a list of potential design and installation improvements for future precast segmented concrete tunnel liner systems.

2.0 SPECIAL OBSERVATION GROUP (S.O.G.) PROGRAM AND APPROACH

2.1 General Description of Project

The Lexington Market section of the Baltimore Metro system was selected for demonstration of the use of precast segmented concrete tunnel liner. This section, shown in Figures 1 and 2, consists of twin tunnels, each about 1550 feet long, which form the connection between the Lexington Market Station on Eutaw Street and the Charles Center Station on Baltimore Street.

The tunnels were driven south from a workshaft on Eutaw Street, terminating in "Dead Headings" at the future Charles Center Station limits. The major portion of the alignment, about 1200 feet per tunnel, was designed on a horizontal curve of nominal 775 feet radius, starting at the workshaft. In addition, the plans called for a profile gradient of nearly 4%, downhill from the workshaft, leveling off to 0.35% for the last 400± feet of each tunnel. Figure 3 shows the design profiles.

The geologic profile indicated that the tunnel face would be in the interface region between residual soil and the overlying sedimentary deposits throughout much of its length. Dewatering was permitted for construction of the workshaft and for the first 275 feet of line tunnels. Beyond that, tunneling under compressed air was specified in order to minimize ground loss and subsequent surface settlement in the critical downtown area.

Other principal features of the project were the underpassing of a mainline railroad tunnel (B&O) and an eight-story parking garage (Hecht Company), by the subway tunnels. Since the clearance between the B&O tunnel and the new tunnel construction was only about 7 feet, special precautions were required to strengthen the surrounding soil by chemical grouting and to reinforce the B&O tunnel against structural damage. The Hecht Company garage required extensive underpinning before tunneling could begin, and both the garage and railroad structures were covered by careful monitoring programs for settlement and damage during construction.

2.2 The Special Observation Group (S.O.G.) Program

The fundamental objective of the demonstration program was to install precast segmented concrete tunnel liner as a substitute for conventional steel liner under similar conditions in which their relative performances could be compared. Making such a comparison required that the installation be carefully monitored as construction took place. The technical details of the system, including performance,

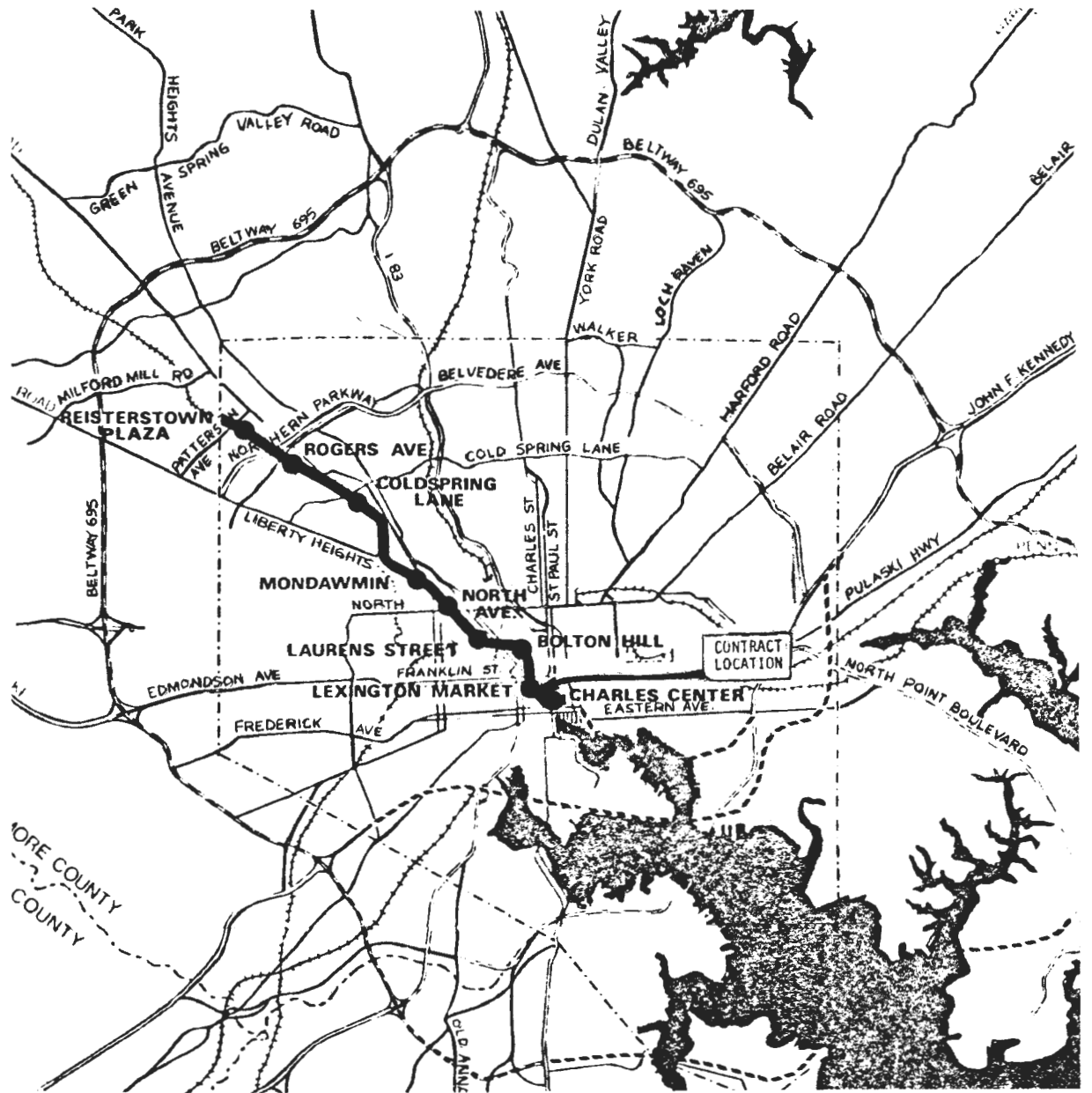

FIGURE 1. LOCATION DRAWING, LEXINGTON MARKET SECTION, BALTIMORE REGION RAPID TRANSIT PROJECT, BALTIMORE CITY, MD

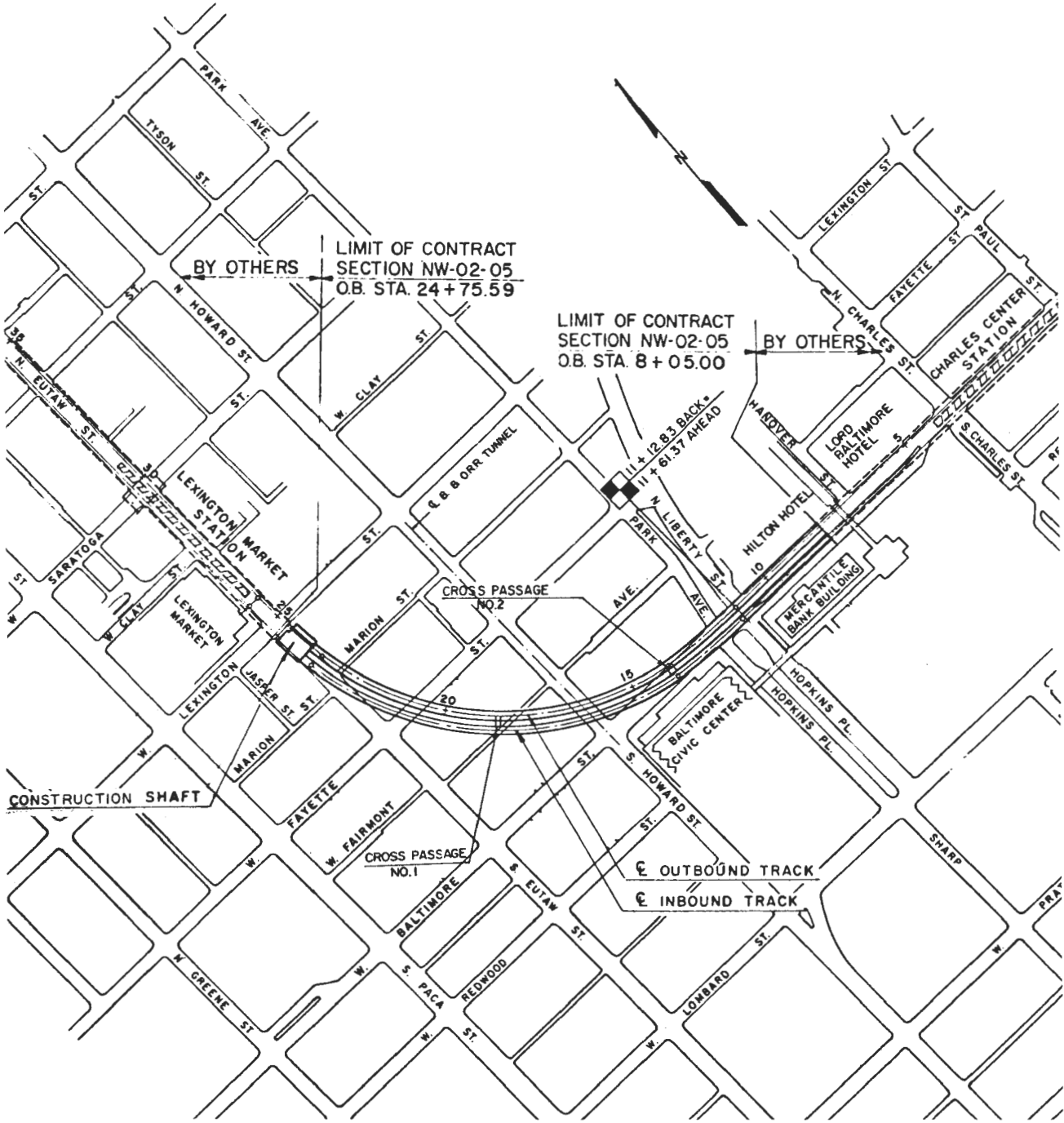

FIGURE 2. GENERAL PROJECT PLAN

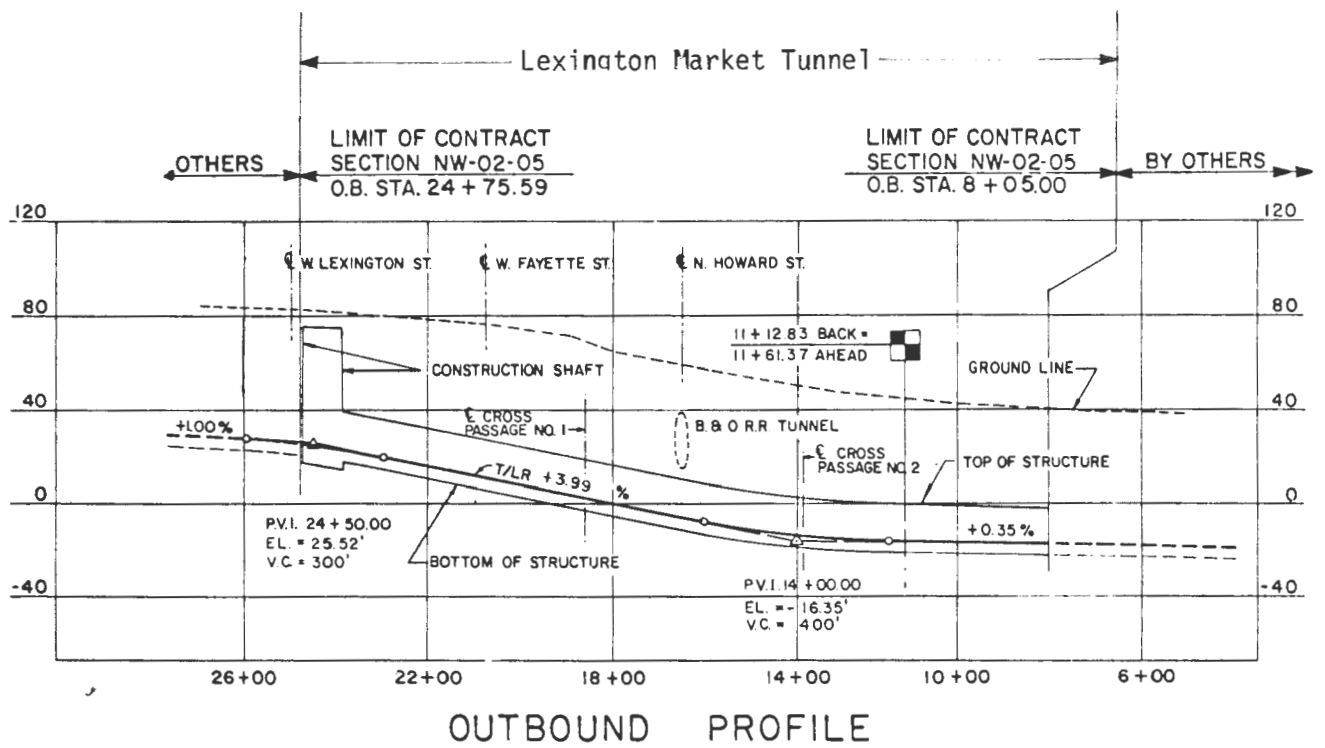
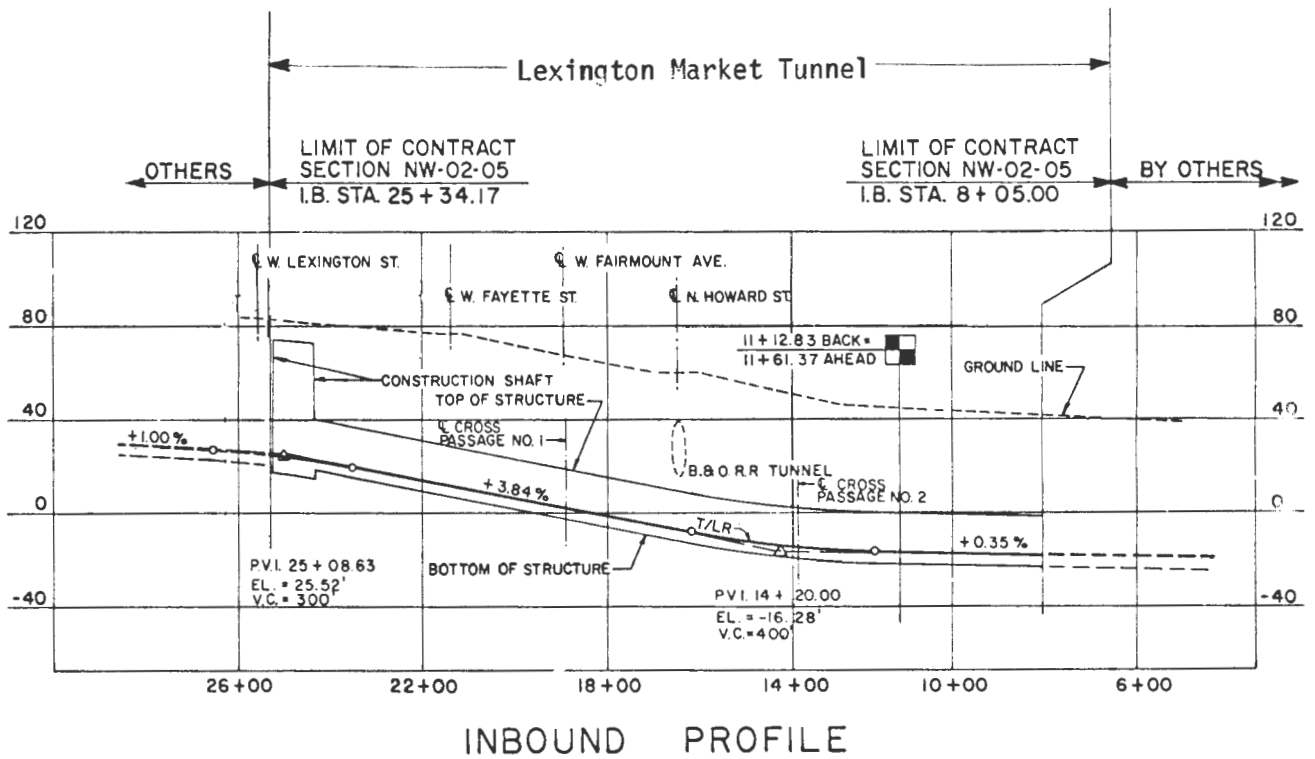

FIGURE 3 TUNNEL PROFILES

problems encountered, and costs were of primary interest. With information about these, comparisons could be made, and conclusions drawn about the feasibility of using precast segmented concrete liner in U.S. transit tunnels. The study was also expected to provide insight into the types of improvements which could be made in future systems, based on experience gained from the demonstration program.

The S.O.G. program was developed conceptually for implementation as part of the demonstration program. Its basic objective was to provide thorough documentation and evaluation of the precast segmented concrete liner from the standpoint of performance and cost. The evaluation would address three questions:

- (a) How do the performance and cost characteristics of the precast concrete liner, in place, compare with those of the steel liner, in place?
- (b) Based on this comparison, is it feasible to use precast segmented concrete liner in future transit work in the USA?
- (c) What recommendations can be made to future users about ways to improve the performance and/or cost aspects of precast liner?

A key element of the program was the requirement that an independent team of observers be employed for the evaluation. This team, the Special Observation Group (S.O.G.), would be responsible for developing a comprehensive program for achieving the study goals within guidelines established by the sponsor. Later, it would execute the program while construction was underway. Upon completion, it would prepare a report of findings.

2.3 Implementation of the S.O.G. Program

The bids received for the Lexington Market tunnel fell within the cost guidelines established by UMTA, and it was decided to proceed with a demonstration program for precast segmented concrete tunnel liner. Based on solicited technical and cost proposals, an S.O.G. team was selected, and a program developed to permit the thorough and systematic documentation of project data. All data was to be segregated into two general classifications:

- (1) Data related to technical or practical performance evaluations,
and
- (2) Data related to cost evaluations.

2.3.1 Performance Evaluations

2.3.1.1 Structural Performance of the Liner System

Evaluations of structural performance of the liner relate to its ability to provide a safe, durable and functional single shell support for a tunnel. The objectives for data gathering under this task were to:

- (1) Document the areas and degree of satisfactory performance of the precast liner, particularly as compared with steel liner;
- (2) Document the areas of unsatisfactory performance and determine the reasons for such problems; and
- (3) Provide a factual basis for optimization of precast segmented concrete liner performance in future use.

The first standard of structural performance to be investigated was the ability of the liner to withstand the loads to which it would be subjected during and after construction. During the design phase, segments of special configuration were tested in the laboratory to confirm the ability of the liner to support the theoretically predicted loads. Test results were helpful, but questions remained as to whether: (1) predicted loads were representative of field conditions; and (2) the properties of segments cast under laboratory conditions were representative of those of their production line counterparts. Also of interest were the deformation characteristics of the liner in-place. The latter influence such performance properties as train clearances, ground settlement, and segment-to-segment bolting requirements.

An instrumentation plan was developed to obtain the data necessary for the above evaluations. It included provisions for measuring strains in the segments under actual loading conditions during and after construction, and relative movements of the liner segments and joints. Plans made prior to establishment of the Special Observation Group called for six separate test sections, three in the precast tunnel and three in the steel lined tunnel. Practical considerations of time and budget required a subsequent reduction in scope from the initial plans. Since steel liner plate has been used as a tunnel support for many years, with well documented performance, the decision was made to concentrate resources on the precast concrete tunnel. Two sections of the concrete tunnel were selected for measuring deformations. These sections were continuously monitored during installation and for a considerable period thereafter, in order to develop liner performance data. The particulars of the special test sections are explained in more detail in later sections.

A second area of structural performance study was to be based on an investigation of any damage occurring in the precast liner. The program included means for detecting, documenting and analyzing liner damage and for factoring the results obtained into the relationships developed from the instrumented test sections.

The third performance area to be evaluated in the program was watertightness of the installed liner. Since the excavated soils were expected to be waterbearing to the extent that compressed air was required for tunneling, the environment provided an excellent setting in which to test the special water-sealing features of the liner system. Plans were made to isolate water inflows through the liner from the heading inflows as tunneling progressed and to quantify such inflows section by section throughout both tunnels.

In addition to the measurement and observation tasks outlined above, the program included provisions for documentation of methods and practices used in fabrication, handling and installation of the components of the liner system. This would permit the evaluation to separate effects related to the design itself and the materials employed from those related to workmanship, methods and/or techniques.

2.3.1.2 Geotechnical Engineering

An important aspect of precast liner performance was its influence on the ground surrounding the tunnel, particularly with regard to subsurface soil movement and surface settlement. Conversely, the influence of local geology on liner performance was of interest. Prior to construction, neither liner behavior nor the exact installation techniques which would finally be used had been fully defined. Likewise, soil behavior and the possible effects of surface settlement and/or hydrologic changes on adjacent urban structures had been examined theoretically, but were not known in any absolute sense.

The program included plans for monitoring geotechnical performance. A network of extensometers, inclinometers, and surface settlement survey points was set up along the tunnel alignment to measure ground movements. Piezometers were installed to monitor changes in groundwater conditions. To supplement the physical measurements, tunnel face (geological) logs were taken daily or more often, if needed. These provided background information about area geology which would not be available in any other way.

Geotechnical instrumentation was monitored periodically during normal construction. When the tunnel face passed the special test sections, measurement

frequency was increased, providing a nearly continuous record of both structural and geotechnical data during that period. This data was used when overall correlations of performance were being made.

2.3.1.3 Functional Performance

One of the very important topics to be addressed during the study was the question of practicality. This concerns, aside from the economic aspects, questions of the following types:

- (1) Does the U.S. precasting industry have the expertise and skills necessary for manufacturing the segments to the required specifications?
- (2) Does the U.S. tunneling industry have the technical skill and workmanship needed to install a precast liner system?
- (3) Can reasonable production rates be achieved?
- (4) Are storage areas and work space requirements for precast liner compatible with the urban environment?

The answers to these and other similar types of questions have an important bearing on the ability and willingness of the U.S. tunneling industry to accept segmented precast concrete liner.

2.3.2 Cost

In liners as in other construction activities, the bottom line is very important. Is this an equivalent product at lower overall cost? Is it a better product at a justifiable cost? Or is it economically infeasible? The demonstration program provided a unique opportunity to compare the relative costs of segmented steel and concrete under similar conditions. Length, cross section, geology, contractor personnel and many other factors were equivalent. Still, when the lining systems are applied to other geological conditions, with different contractors and different operating conditions their relative merits may shift. Thus, the results obtained are not expected to be representative of all possible cases. Rather, they have provided a good working knowledge of the variables which influence costs in these lining systems. Using data obtained about manpower requirements, production rates, equipment needs, material costs, etc., one should be able to extrapolate to other conditions with reasonable accuracy. The ability to do so is one of the important benefits gained from the demonstration program.

2.4 Roles and Responsibilities of the Jobsite Participants

There are a number of factors which make the conduct of an engineering investigation on a construction jobsite a difficult task. Chief among these is variability of basic objectives. The owner, represented by his construction manager, and the contractor are primarily interested in completing the work quickly and economically. Engineering investigators, on the other hand, are interested in obtaining information, some of which is available only at the expense of lost production. The conflicting objectives represented by these viewpoints can produce hard feelings and, in some instances, a lack of necessary cooperation.

The Lexington Market Demonstration Project was fortunate in the above respect. The sponsor, UMTA, working through the owner, BRRTS, established an equitable contracting arrangement for all parties involved. In this arrangement, the S.O.G. received a contract directly from Ralph M. Parsons Company, the Owner's construction manager. This made the S.O.G. responsible to one of the parties interested in time and cost of construction. This, combined with the construction background of S.O.G. personnel, helped to assure that no unnecessary delays would occur. It also gave Parsons, which would normally be interested only in quality and production, an interest in the outcome of the investigation. Thus, there were benefits for both parties in optimizing the S.O.G. program.

The General Contractor, Traylor and Associates, was provided with a contract which reimbursed it for assistance to the S.O.G. and for downtime caused by the S.O.G. program.

Early planning meetings between the jobsite participants established the roles of each and served to establish a rapport and mold a team effort which was maintained throughout the construction period.

The S.O.G. team had prime responsibility for planning study activities, for determining what data was necessary, for installing and monitoring technical instrumentation and for analyzing all data. The construction manager, in addition to coordinating the activities of the involved parties, supplied the S.O.G. with the day-to-day construction data collected by its inspectors. This eliminated redundancy of effort and reduced congestion in the work area as well, thereby promoting production efficiency. The contractor provided work and storage areas, equipment such as work platforms, and access as was necessary for the study team. In addition, he supplied advice and information about his operations which were of immeasurable value to the study.

3.0 CASE HISTORY/SEQUENCE OF EVENTS FOR EXECUTION OF CONSTRUCTION AND STUDY CONTRACTS

3.1 Pre-Construction Events

The circumstances and events which culminated in an agreement between UMTA and BRRTS to demonstrate precast liner in the Lexington Market Line have been described in a previous section. Once agreement was reached, the demonstration program got underway. In the spring of 1976, the section designer, PBO&D, was directed to prepare a design for the precast segmented concrete liner alternate. The design was completed, and advertisements for bids were issued on November 2, 1976. Bids were opened, after various postponements, on February 1, 1977.

During the period following the BRRTS/UMTA agreement and prior to bid advertisement, several features were added to the contract specifications. One of these was, of course, the structural design of the precast liner. Another was a set of clauses which prescribed the obligations of the contractor to the study program. These included information about the specific ways in which he was expected to assist and cooperate with the S.O.G. Also included were provisions for equitable reimbursement of his direct and/or delay costs related to the study.

The bid documents provide for two bidding alternates. The first specified the use of segmented steel liner in both the inbound and outbound tunnels. The second specified precast segmented concrete liner in the 1590 linear feet of inbound tunnel and segmented steel liner in the 1530 feet of outbound tunnel. All contractors were directed to bid on both alternatives, the basis for selection was contained in the bid documents. The differential costs which UMTA was willing to fund would be announced at bid opening.

Six sealed bids were received prior to the close of bidding at 2:00 pm on February 1, 1977. Prior to bid opening, an announcement was made by an UMTA representative outlining the basis for bid evaluation. He stated that UMTA had budgeted \$700,000.00 to support additional costs associated with the precast segmented concrete liner alternate. On this basis, if the lowest bid using the precast alternate did not exceed the lowest bid using the all-steel alternate by more than \$700,000.00, the precast bid would be selected for award of contract. Contractors were then given an opportunity to withdraw their bids before opening. None did.

Bid results are shown in Table 1. Traylor and Associates were the apparent low bidder for both alternates. Their price differential for the precast

TABLE 1. BID RESULTS

<u>BIDDER</u>	<u>TOTAL BID</u>	
	Alternate 1 (Steel)	Alternate 2 (Precast)
1. Traylor and Associates	\$17,448,570	\$17,514,970
2. McClean-Grove, Skanska	18,937,230	20,234,920
3. J. F. Shea Company	19,486,870	19,626,870
4. Fruin-Colnon, Horn, N&W Concrete	19,447,000	21,779,946
5. Perini Corporation	21,565,360	21,671,360
6. Peter Kiewit Sons'	21,839,946	22,651,756
Engineer's Estimate	21,202,327	21,896,005

vs. the all-steel alternate was \$66,400.00, which was well within UMTA's specified limit, making their bid acceptable for award of contract. Formal notice to proceed was given on August 25, 1977, and the precast segmented concrete liner demonstration got underway.

3.2 Construction

The basic construction approach was as follows. A main worksite would be located at Lexington and Eutaw Streets. On that site there would be a workshaft plus supporting facilities for muck and materials handling, equipment maintenance, and compressed air operations. The tunnels would be driven from the shaft, along a curve southward and eastward, terminating in a short tangent section at Charles Center Station on Baltimore Street.

It was planned to drive one tunnel at a time. The tunnel with segmented steel liner would be followed by the tunnel with precast segmented concrete liner. Both would be driven for 80% of their length under compressed air. Tunneling was complicated by the requirement to underpass the Hecht garage, which required extensive underpinning (see Figures 4 and 5), and the B and O railroad tunnel, where the soil required chemical grouting for reinforcement.

The sequence of events which occurred during construction is depicted in Figure 6. Following receipt of notice to proceed on August 25, 1977, site preparation began. The yard was laid out, fences installed, and utilities were relocated in the shaft excavation area. A dewatering system was installed with the capability of lowering the local water table to permit the first 275 feet of each tunnel to be excavated in free air. While this activity was in progress, chemical grout was applied to the soil at the B and O Railroad crossing.

Shaft construction began in mid-December with augering and setting of soldier piles. This activity was complicated by encroachment of the shaft on Eutaw Street, which could not be closed off for construction. A complex traffic diversion plan enabled the contractor to maintain continuous traffic flow on Eutaw Street while installing soldier piles and street decking. Excavation proceeded, under the decking, to final grade at a depth of 60± feet below ground level. Internal supports (wales, braces, lagging) were installed immediately behind the excavation. Finally, a concrete slab was placed, and shaft facilities were developed to support the tunneling operation.

Simultaneously with workshaft construction, the contractor carried out the grouting reinforcing and underpinning activities which would permit the tunnels

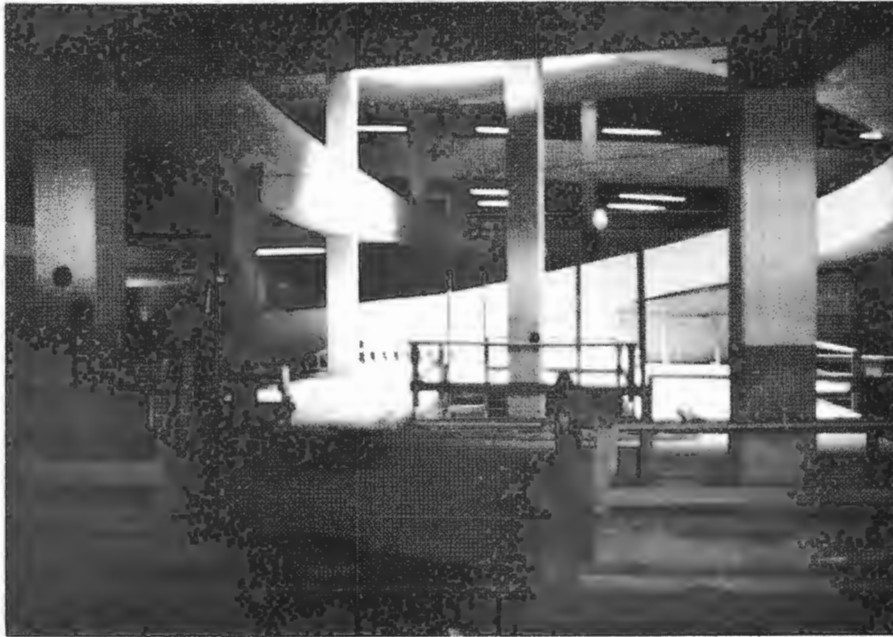

FIGURE 4.



FIGURE 5.

FIGURES 4 AND 5. UNDERPINNING HECHT COMPANY GARAGE

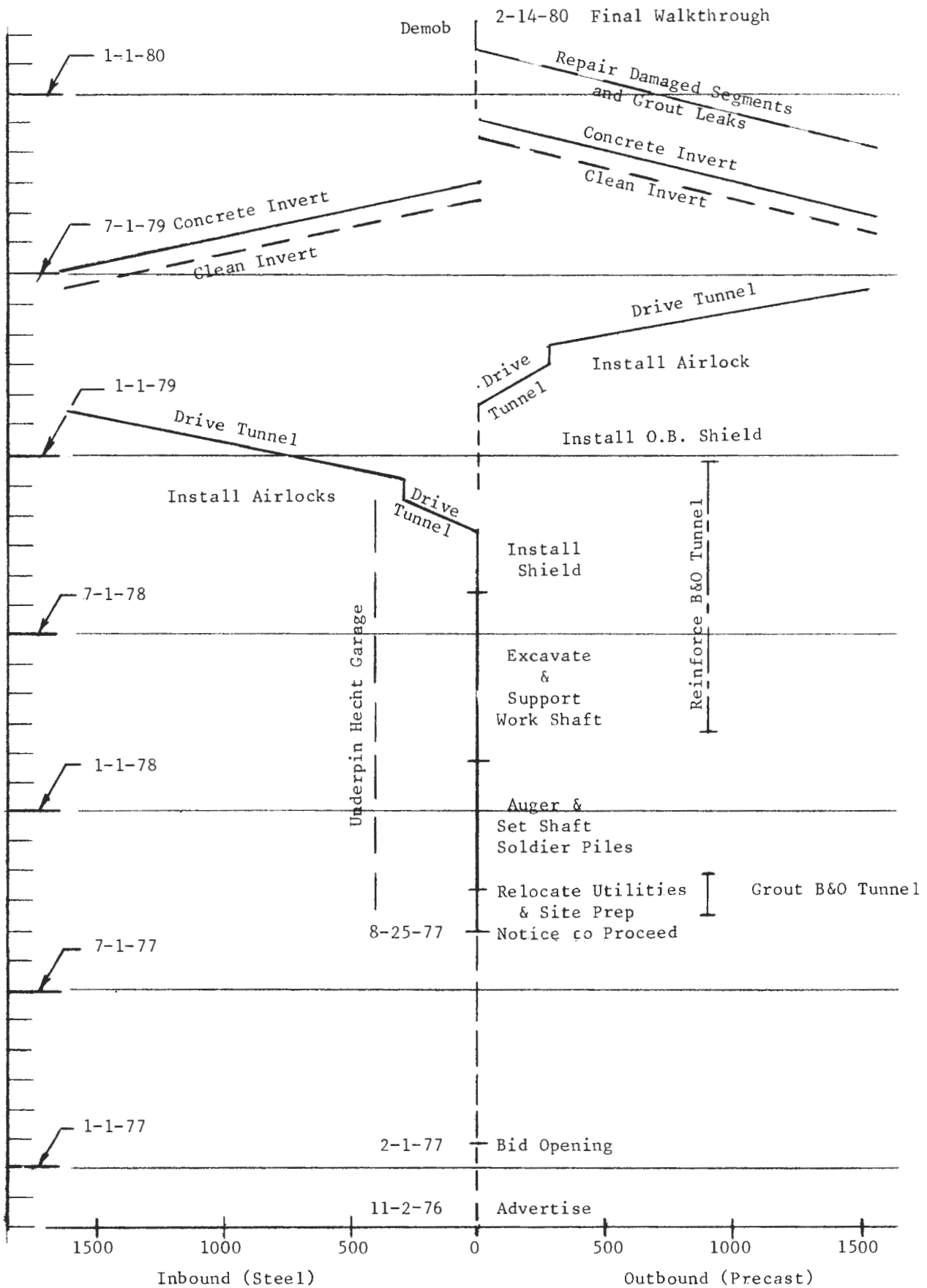

FIGURE 6. PROJECT AS-BUILT SCHEDULE

to underpass the railroad crossing and the multi-story Hecht Company garage. These were completed within a timeframe which permitted tunnel construction to proceed on schedule.

The inbound tunnel shield was received and installation began in August, 1978. It was of the digger type, equipped with erector arms designed for use with the steel liner. By October, 1978, the shield was in place and excavation of the inbound tunnel got underway. This proceeded for 275 feet under free air conditions. At that point, an air lock was installed and the compressed air system was brought on line. Pressures in the 4 to 12 psi range were used to control water inflows so that excavation could proceed. Construction of the remainder of the inbound tunnel resumed and continued until its completion in early February, 1979.

Approximately halfway into excavation of the inbound tunnel (Station 17 + 75), the shield encountered rock. The formation proved too hard for digger shield excavation. Tunnel construction was delayed for several days while drill and blast techniques were used to assist shield operations. Approximately 25 feet were excavated in this manner, after which ground geology again became compatible with shield operations, permitting the inbound tunnel to be completed without further incidents.

In the meantime the outbound shield arrived and its installation continued throughout most of the excavation activities in the inbound tunnel. Upon completion of the inbound tunnel, final touches were put on the shield for the outbound tunnel, readying it for startup in February, 1979. The second shield employed the same type of equipment and methods as its predecessor. Its outside diameter was slightly larger to allow for the increased thickness of the lining, and its erector arms were strengthened to enable it to handle the increased weight of the precast segments. Shield installation is shown in Figure 7.

The precast segments had been shipped from their point of manufacture in New Jersey to a staging area nearby the construction site. Here they were gasketed and prepared for transfer to the tunnel.

After startup in February 1979, the outbound tunnel was excavated to a length of approximately 275 feet. At that point, the compressed air lock was installed, the tunnel pressurized, and excavation completed. See Figure 8.

The next major activity was cleaning of the invert and placing of the concrete which would later serve as the base for rapid transit rails. This was done first in the steel lined inbound tunnel, followed by the precast concrete segment lined outbound tunnel. Simultaneously, cross passages between the two tunnels were excavated and lined with concrete. (See Figures 9 and 10)

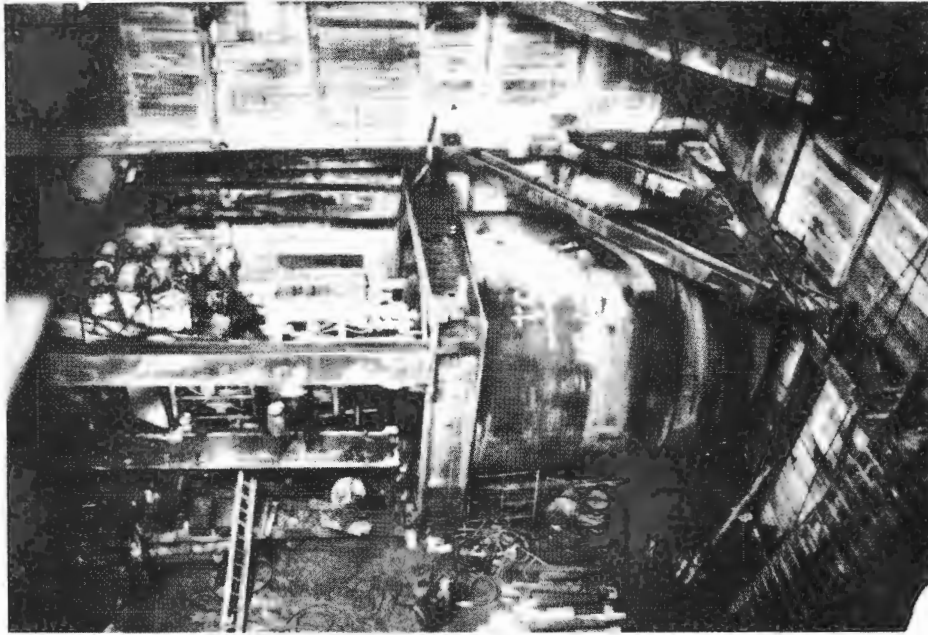

FIGURE 7. INSTALLATION OF SHIELD IN WORKSHAFT

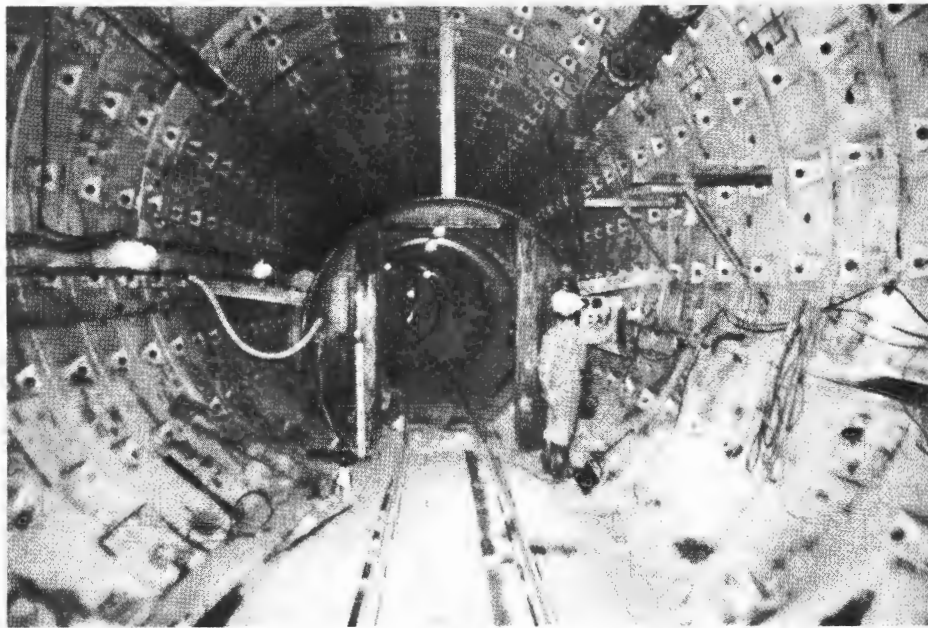

FIGURE 8. AIRLOCK IN OUTBOUND PRECAST CONCRETE TUNNEL

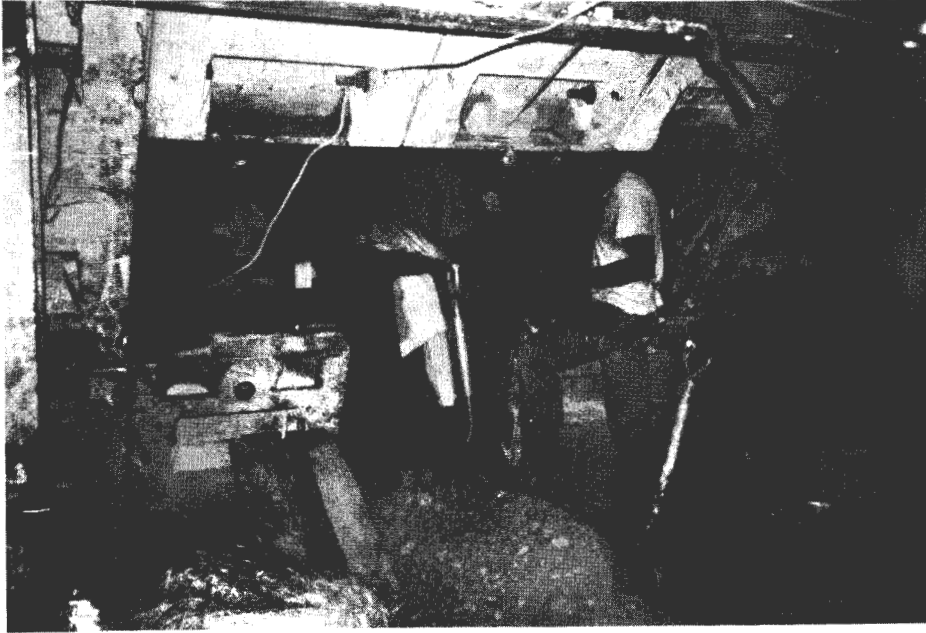

FIGURE 9.

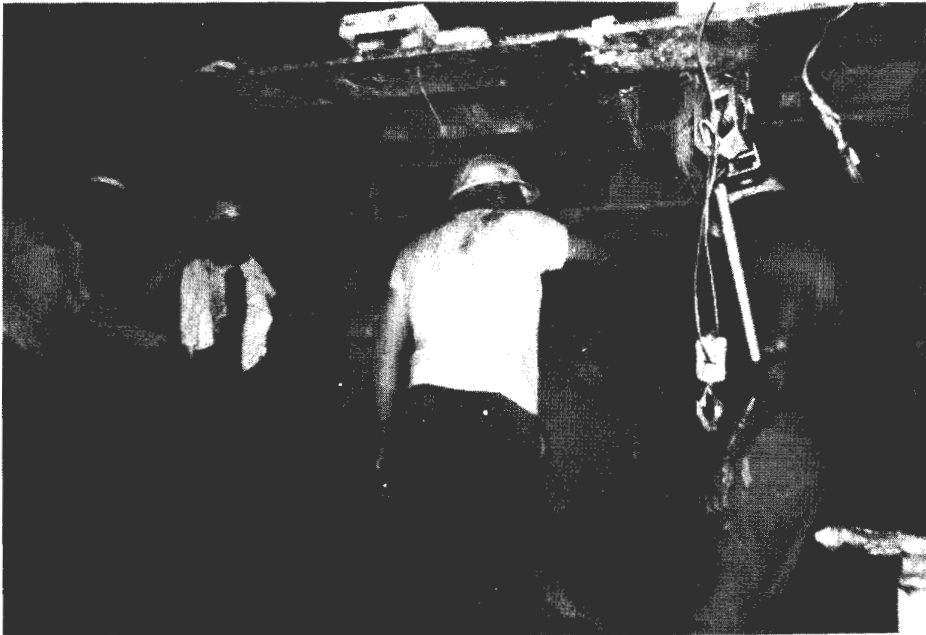

FIGURE 10.

FIGURES 9 AND 10. TUNNELING OF CROSS PASSAGES

Some segments had been damaged at installation. These were repaired, and chemical grouting was accomplished as necessary to waterproof the final installation. Upon completion of this task, the contractor demobilized and moved out. Final walkthrough occurred on February 14, 1980.

3.3 S.O.G. Program

The program of the Special Observation Group was initiated by contract in November 1978. In the proposal, and during subsequent negotiations, the general nature of the program had been agreed upon by the interested parties. However, detailed specifications for the instrumentation and the way in which it would be used were to be developed in an intensive 30-day study at the beginning of the S.O.G. program. In the 30-day study, the S.O.G. mapped out a detailed plan specifying the full scope of the measurements to be made, the responsibilities of each of the parties involved, and the schedule for preparation and use of the instrumentation. The findings were submitted and approved in December, 1978, and implementation began at once.

Two test sections were planned and instrumented. Test Section A, at Ring 200, Station 18+74±, was chosen as a preliminary exercise in which instrumentation would be tested and debugged, and initial liner performance data would be obtained. Test Section B, Rings 470, 471 and 472, Station 11+81±, was planned to provide complete and reliable data about all aspects of precast segmented concrete performance. Both test sections were instrumented to measure internal strains, (convertible to stresses), and gross segment deformations and movements under actual loading conditions in the tunnel. The data from them would be useable, it was hoped, to explain liner behavior elsewhere in the tunnel and to predict the performance of precast segmented concrete liner when used in other tunnels.

The S.O.G. fabricated sister bars, (see section 4.3), and installed them together with other instrumentation in concrete segments being fabricated at the precasting yard in New Jersey. This installation was completed on February 8, 1979. Later, the internally instrumented segments were shipped to the contractor's staging area in Baltimore, where surface instrumentation was added to them. (See Figure 11).

Measurement programs were carried out at both test sections. The work with Test Section 'A' provided only a limited amount of useful performance data. However, it was invaluable in enabling the S.O.G. to understand specific measurement problems and prepare for optimum employment of instrumentation at Test Section 'B'.

Test Section 'B' provided a large quantity of useful data, which was later reduced, analyzed, and used by S.O.G. investigators to describe liner performance.



FIGURE 11. CHECKING OUT IMBEDDED STRAIN GAGES IN CONTRACTOR'S YARD

S.O.G. gathering and analysis of data from Test Section 'B' continued from May 1979, when the section was first put in place, through January 1980, when final diametral measurements were made.

In addition to measurements made at the test sections, two other sources of information were employed by the S.O.G. One was data from the geotechnical instrumentation installed in the ground in the vicinity of the test sections and read by Parsons. This was obtained from observations whose frequency varied with the position of the tunnel face. Readings were taken frequently when the heading was in the vicinity of the ground instrumentation; less frequently when it had passed.

The second source of information was observations by S.O.G. staff members throughout construction. The visual observation program supplemented by written descriptions, provided a continuous record of geological conditions at the face. It also revealed special problem areas such as spalls and leaks. The visual and written observations were supported by a substantial photographic record taken in conjunction with them. Visual and photographic data, used in combination with numerical data from the test sections became a basis for the analytical activities of the S.O.G.

The S.O.G. program culminated in preparation of a report of findings submitted in April 1980.

4.0 INSTRUMENTATION PROGRAM

4.1 Scope of the Program

The Lexington Market Tunnel instrumentation program was developed to obtain data in the following areas of interest:

- Ground deformations
- Structural response to applied loads
- Post erection liner distortions

Ground deformations were monitored by the contractor and the construction manager, with some assistance from the S.O.G. during periods of intense data gathering. The data sources consisted of surface settlement points, single and multiple deep settlement points, inclinometers, and piezometers.

Structural responses to applied loads were monitored using strain gages inbedded in selected segments. These were oriented to provide information about longitudinal and circumferential strains, which would be translatable into stresses and the forces and moments which produced them.

Post erection liner distortions were measured in selected rings by means of several types of instruments capable of making geometric (linear and angular) measurements.

These will now be discussed under separate headings.

4.2 Geotechnical Instrumentation

4.2.1 General

A rather extensive geotechnical instrumentation program was undertaken for the Lexington Market Line. There were two reasons for the scope of this program. First, because it was decided by the tunnel designers that underpinning of only a limited number of structures adjacent to and directly over the tunnels would be undertaken (Hecht Company Garage and B&O Tunnel), very high quality workmanship was required of the contractor to limit the movement of the remaining potentially affected structures. The instrumentation was used during construction to assist the contractor in achieving efficient and careful construction procedures so that ground losses and deformations would be kept to a minimum.

Second, as part of the S.O.G. study, it was necessary to evaluate the geotechnical performance of the concrete-segment-lined tunnel in comparison to the adjacent steel-segment-lined tunnel and other similar tunnels described in the

literature. This, too, required the extensive use of geotechnical instrumentation. (The evaluation is given in Sections 6.5 and 7.3.2).

4.2.2 Location

The geotechnical instrumentation for the two tunnels included: 13 inclinometers, 23 multiple deep settlement points (MDS), 9 single deep settlement points (DS), approximately 408 surface settlement points located on lines parallel and perpendicular to the tunnel axis, and 11 piezometers. In addition 4 more inclinometers and 3 piezometers were located adjacent to the Lexington Market shaft and another inclinometer casing was mounted on the southern exterior wall of the Town Theatre. The planned location of these instruments is shown in Figures 12 through 18.

It will be noted that most of the instrumentation is concentrated at two locations: near the Lexington Market shaft at the start of each tunnel advance so that the contractor would be able to obtain data early in each of the tunnel drives to evaluate his techniques; and near Station 12+00 in the Test Section B area so that more detailed geotechnical response data could be obtained to incorporate into the precast concrete segment performance study.

4.2.3 Description of Instruments

The following is a brief description of the instruments used and the monitoring schedule that was followed:

4.2.3.1 Inclinometers

The 13 inclinometers located along the tunnel route were installed by the contractor prior to excavation. The inclinometer casings are 2.75 inches OD ABS plastic casings with telescoping couplings as manufactured by the Slope Indicator Company (SINCO). The casings were installed in grouted boreholes with the diametrically opposed instrument guide grooves in the casing oriented parallel and perpendicular to the tunnel centerlines. The casings are 73 to 79 feet deep from the ground surface, providing 8 to 11 feet of embedment below the adjacent tunnel invert.

The casings were installed approximately 1 to 4 feet from the nearest adjacent tunnel springline, as shown on Figures 12 to 18.

The inclinometer casings were monitored by the construction manager's personnel using two SINCO Model Number 50325 biaxial sensor probes and two SINCO Model Number 50308 magnetic tape readouts. The manufacturer reports that his inclinometer system has an accuracy of ± 0.3 inches per 100 feet of casing.

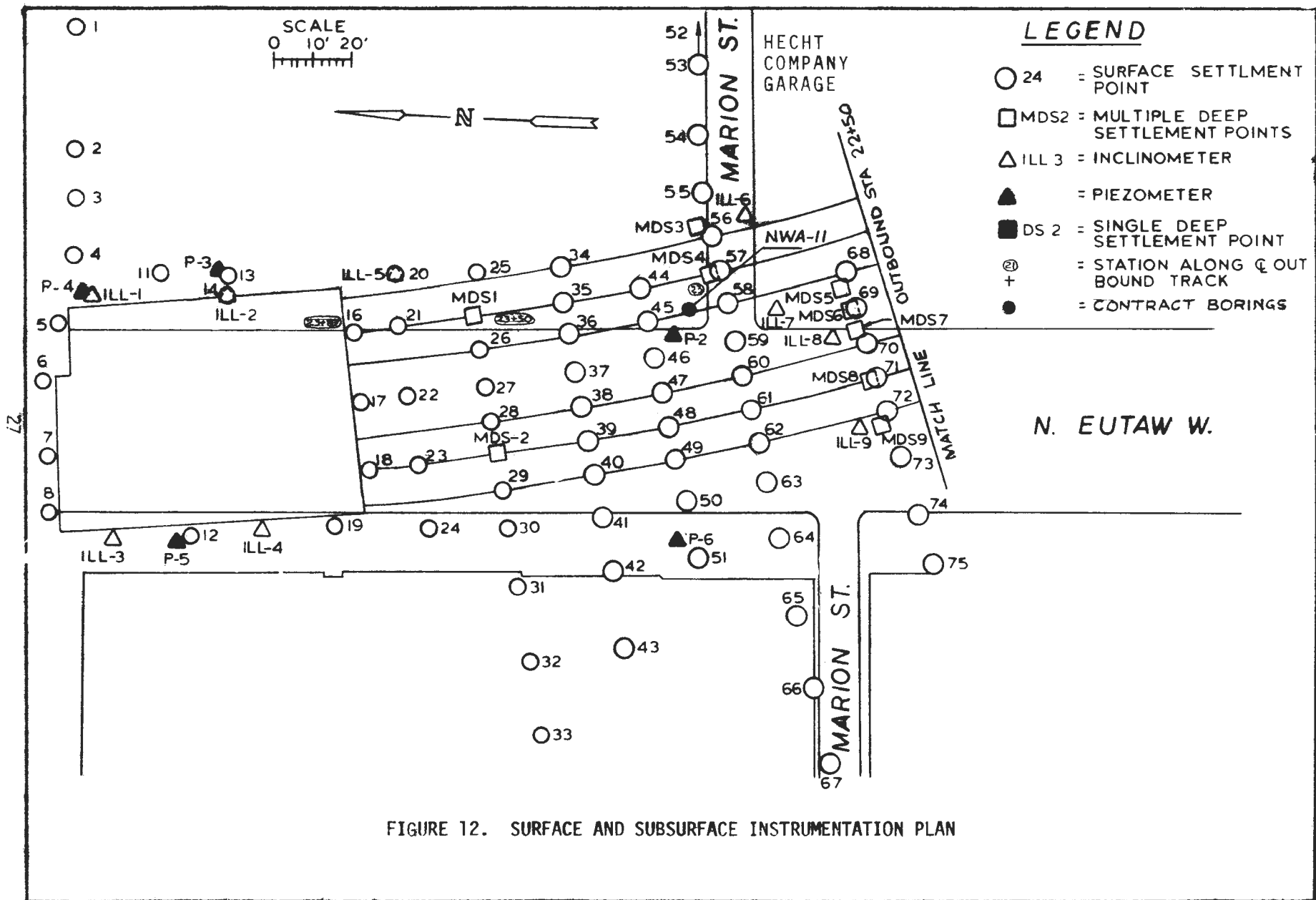

FIGURE 12. SURFACE AND SUBSURFACE INSTRUMENTATION PLAN

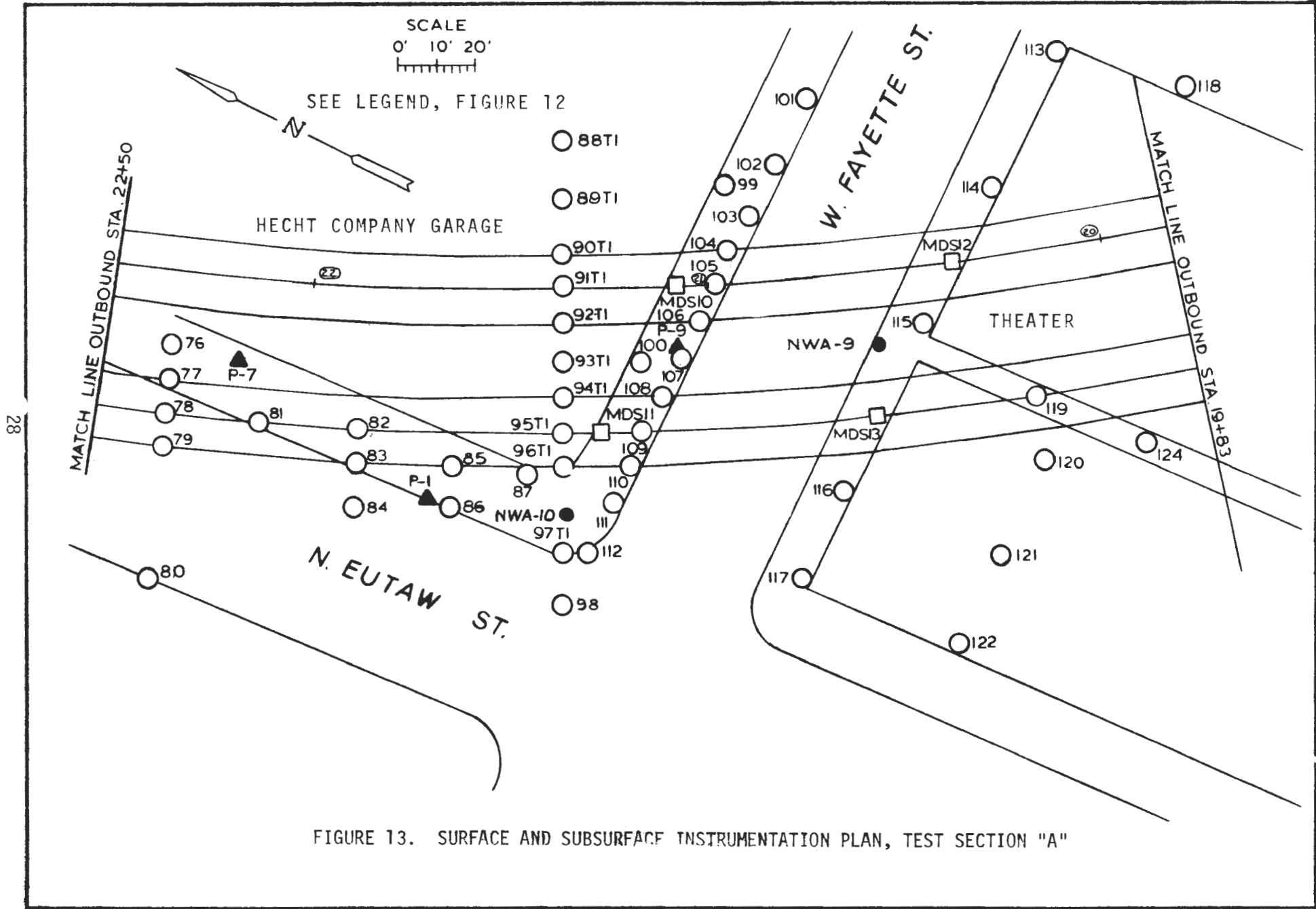

FIGURE 13. SURFACE AND SUBSURFACE INSTRUMENTATION PLAN, TEST SECTION "A"

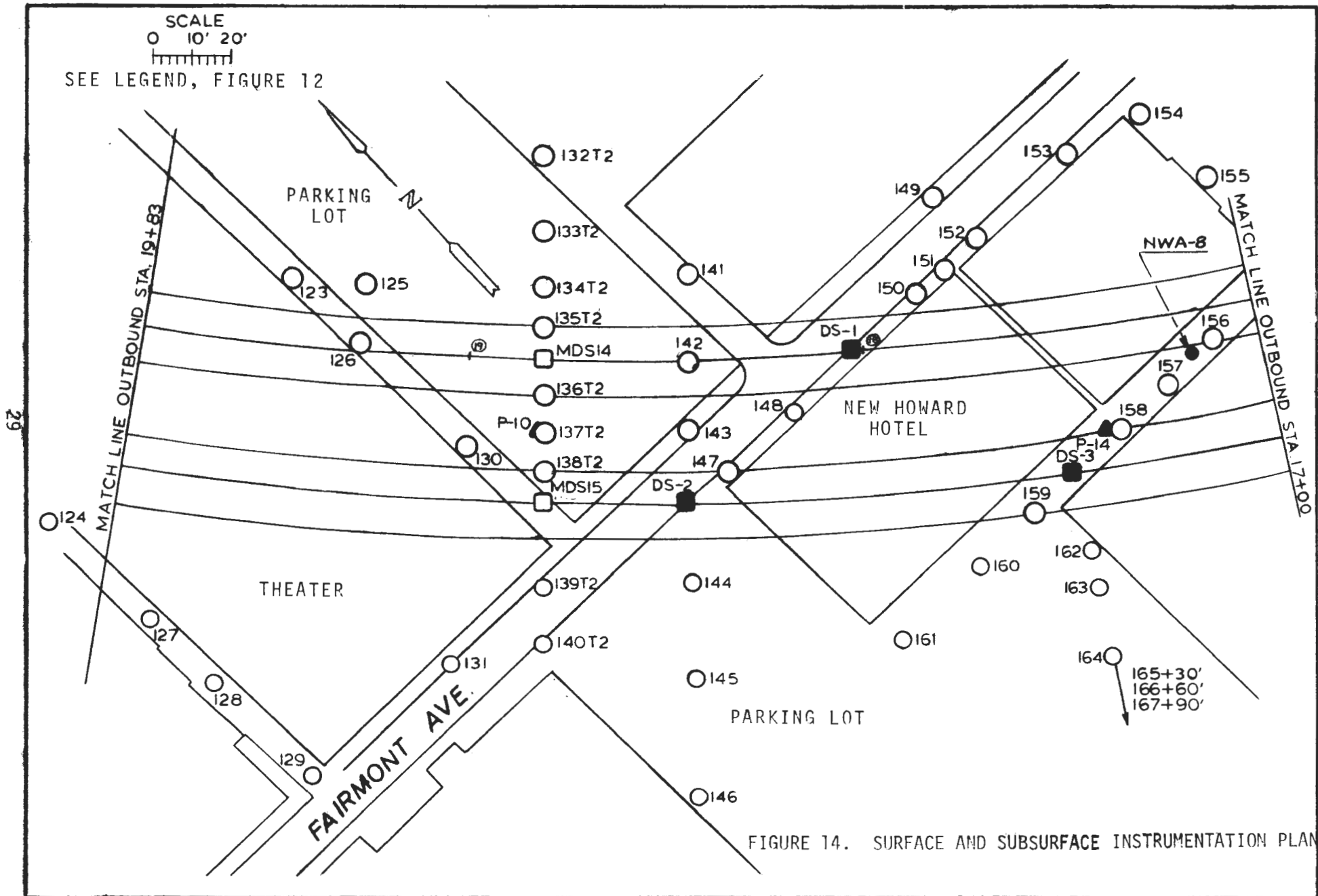
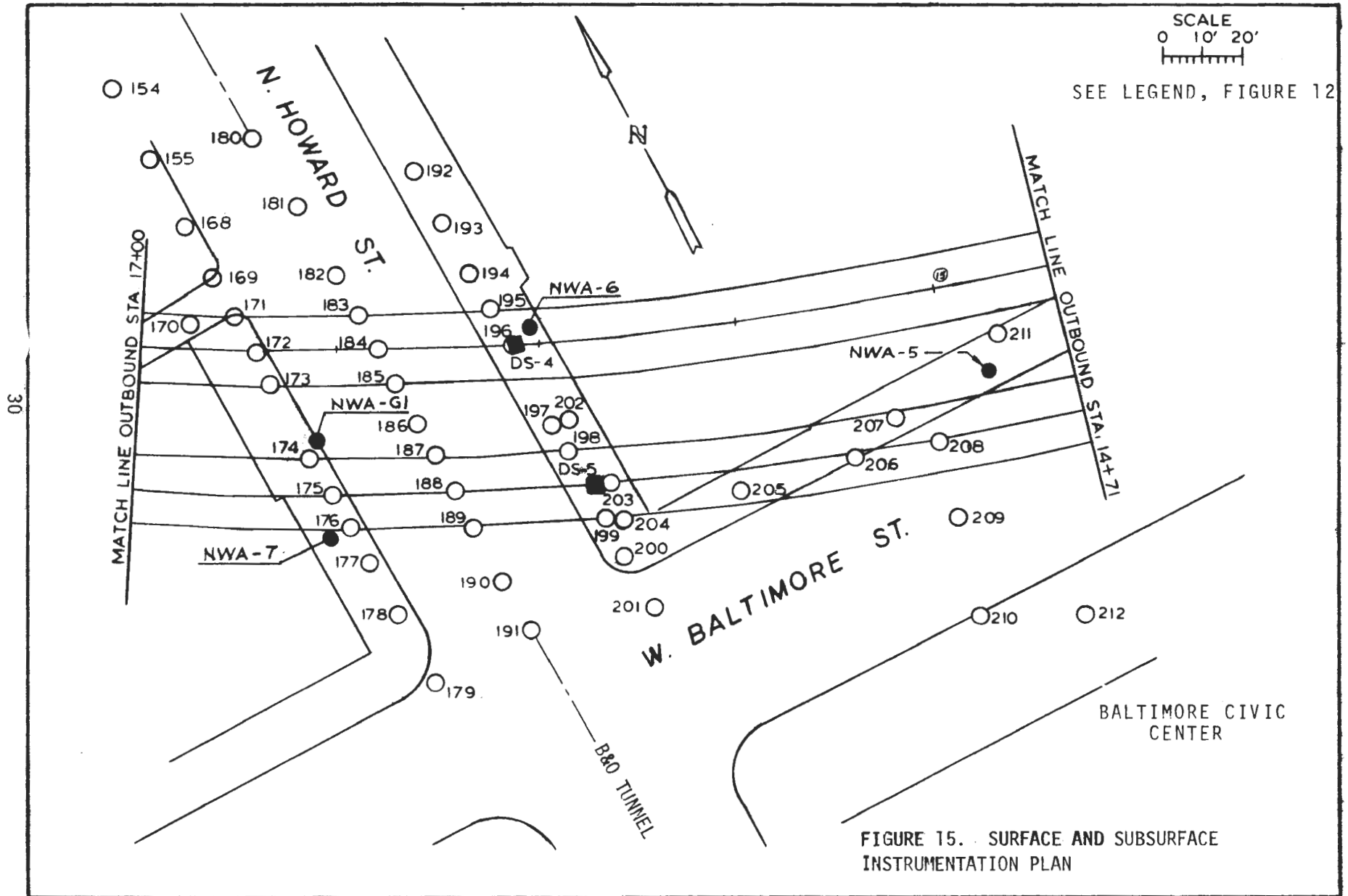
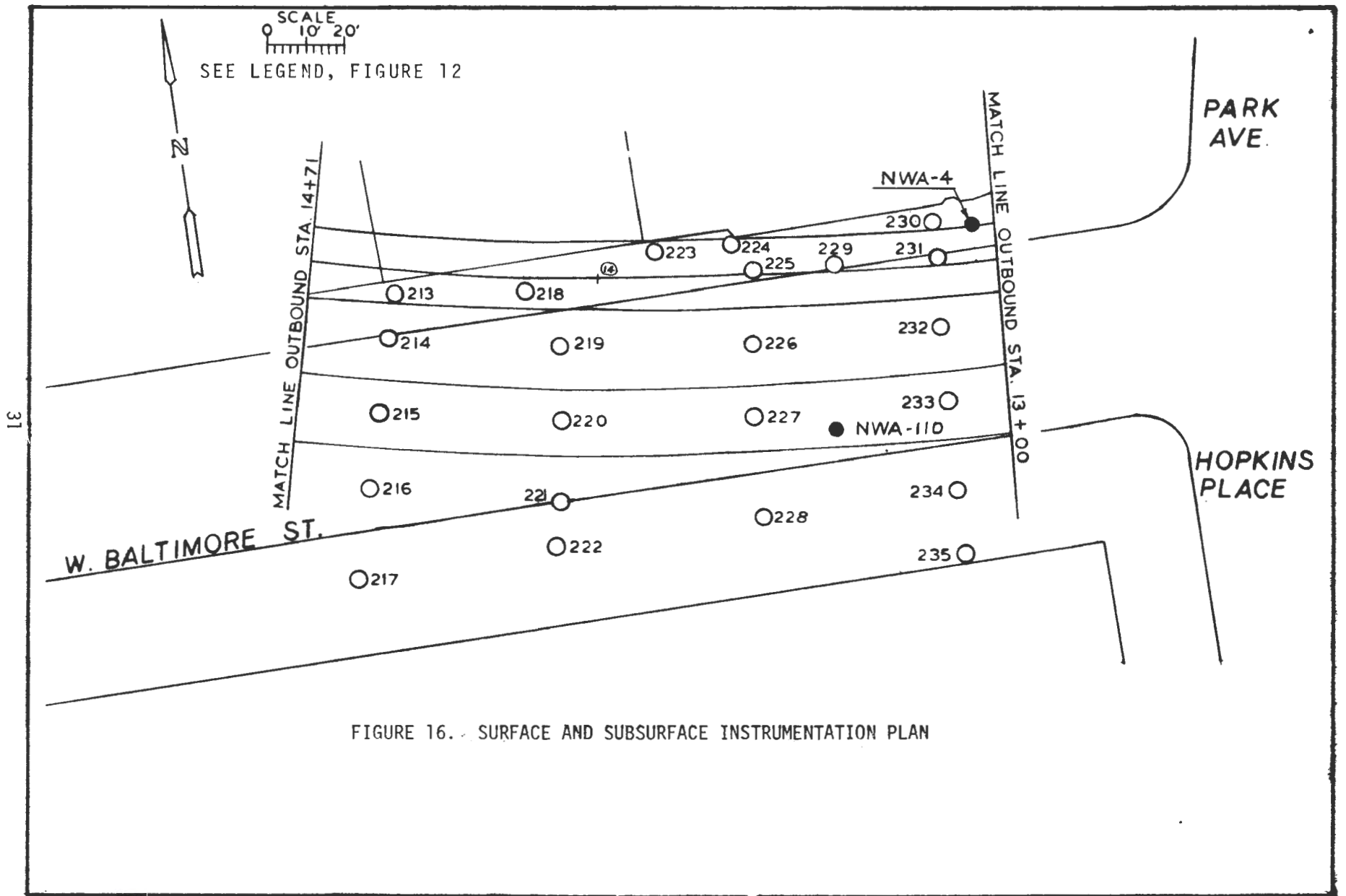

FIGURE 14. SURFACE AND SUBSURFACE INSTRUMENTATION PLAN





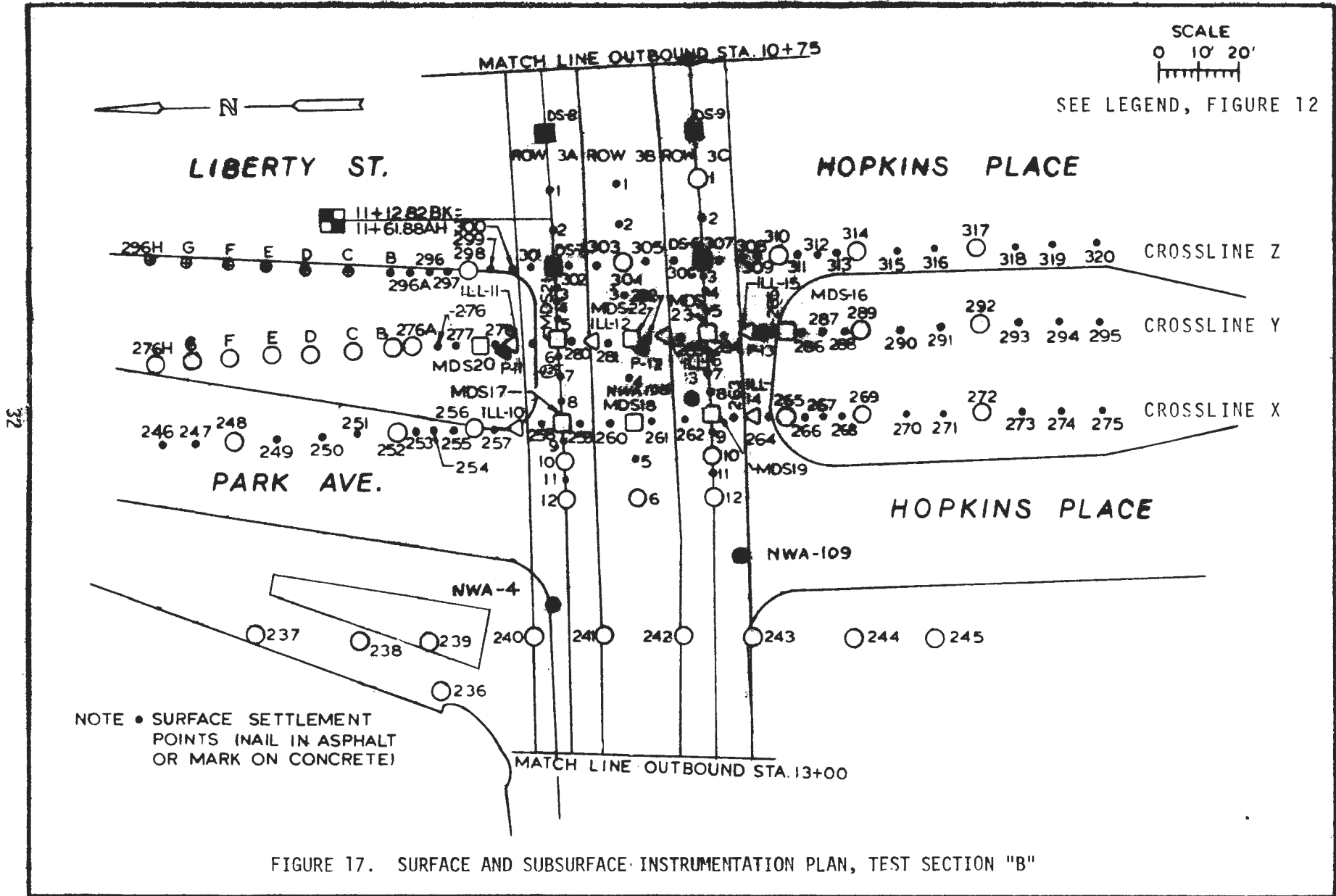

FIGURE 17. SURFACE AND SUBSURFACE INSTRUMENTATION PLAN, TEST SECTION "B"

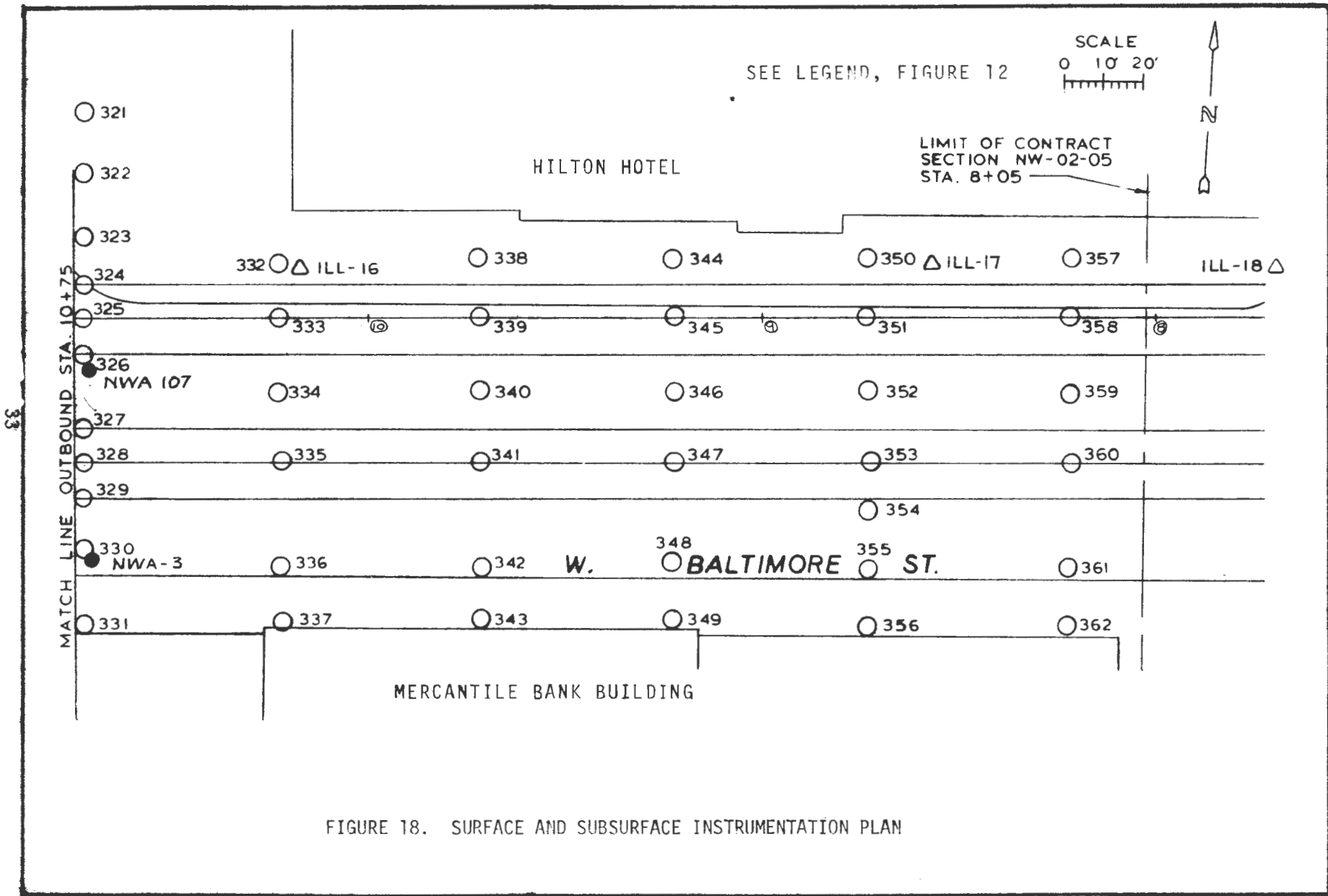

FIGURE 18. SURFACE AND SUBSURFACE INSTRUMENTATION PLAN

The deflections of both axes and the resultant total deflection were calculated from the data and plotted by use of a computer program. The schedule of readings usually consisted of measurements approximately two times a week when the instrument was within an area 100 feet ahead to 100 feet behind the face, regressing to periodic measurements made on an approximate monthly basis. The frequency of readings for each of the six inclinometers in Test Section B average about one set every two hours for the two shifts during approximately the five days the outbound (concrete) tunnel was advancing through a zone which extended 50 feet before to 100 feet beyond the instrument. Final measurements were obtained on these six inclinometers in November 1979, approximately 5-1/2 months after the passage of the outbound heading through Test Section B.

4.2.3.2 Multiple Deep Settlement Points

The 23 multiple deep settlement points (MDS) were installed by the contractor adjacent to the tunnels and above the tunnel centerlines. The MDS devices were four anchor, stainless steel rod type extensometers, Model Number 51886 as manufactured by SINCO. The anchors had hydraulically extended prongs which were expanded into the subsoil after installation of the assembly into the borehole. The boreholes were also continuously grouted to the ground surface with a weak bentonite-cement grout mixture. The reference heads were attached to steel casings installed to approximately 5 feet below the ground surface. The four anchors were assigned color designations according to depth. The deepest anchor was red followed by green, silver and white. For the instruments installed above the tunnel centerlines, the deepest anchor (red) was installed approximately 1.5 to 2 feet above the tunnel crowns, with the remaining three anchors at approximate 10 feet intervals above the red. For the instruments installed adjacent to the tunnels, the deepest anchor (red) was installed at the approximate spring line of the nearest tunnel with the second anchor (green) at about 2 feet above the crown and the remaining two anchors at 15 feet intervals above the green.

The MDS instruments were monitored by the construction manager's personnel using a depth micrometer to determine the change in distance from the top of each anchor rod relative to the reference head at the ground surface. Since the reference heads were attached to a short piece of surface casing, they were subject to near surface ground settlements. Therefore, the reference head elevations were determined using standard optical surveying

techniques each time an instrument was monitored. All reported anchor movements were adjusted for the reference head settlements which were detected. Since the total accuracy of a measuring system is controlled by its least accurate component (optical survey in this case), the anchor displacements are felt to be accurate to ± 0.1 inch, assuming good surveying technique. The monitoring schedule for each instrument consisted of approximately twice weekly readings when either tunnel face was in a zone of about 100 feet to either side of the instrument and monthly readings when the headings were outside this zone. The reading frequencies for MDS-16 through 23 in Test Section B were supplemented by approximately 11 readings per day during the 5-day period the advancing outbound tunnel was within a zone 50 feet before to 100 feet beyond Test Section B. Final measurements were made of all MDS's in November 1979, approximately 5 months after the completion of tunnel advance.

4.2.3.3 Single Deep Settlement Points

Nine (9) single deep settlement points (DS) were installed by the contractor over the tunnel centerlines. These points consisted of 1/2 inch diameter galvanized steel pipe within a 1 inch diameter galvanized steel guard tube. The inner reference pipe was driven approximately 2 feet below the bottom of the guard tube to anchor the tip into the soil. The tips of the reference pipes were approximately 20 feet below the ground surface.

The DS's were scheduled to be read by the construction manager's personnel, using standard optical surveying techniques. The originally planned monitoring frequency consisted of daily readings when the tunnel headings passed through a zone 50 feet before to 150 feet beyond the instrument locations, followed by weekly measurements for four weeks and then monthly measurements for the remainder of the project. However, due to a misunderstanding concerning the operation of the points, some of the survey elevation measurements were made on the guard tube rather than the inner reference pipe and, therefore, were invalid. Reliable measurements were obtained for all readings taken on DS-6, 7, 8 and 9 at a frequency of approximately 11 readings per day during the time the outbound heading was advancing through a zone 50 feet before to 100 feet beyond Test Section B; and for all other single deep settlement points after observation techniques were corrected. Final total settlement measurements were obtained for all nine points in November 1979, approximately 5 months after the completion of tunnel advance. These measurements are felt to be accurate to within ± 0.15 inches.

4.2.3.4 Surface Settlement Points

The surface settlement points were installed by the contractor and generally consisted of a 1 inch diameter steel pipe with a split-end driven approximately 2 feet below the bottom of the pavement surface. These shallow survey reference points were protected at the ground surface by a roadway box. The purpose of this type of surface installation was to eliminate the effects of rigid pavement bridging action that could occur as the underlying subsoils settled. A number of surface settlement points were installed in Test Section B consisting of P-K nails driven into the pavement. These points are indicated by a small x on Figures 12 to 18. It should be noted that settlement points 26A through H, which were reported as shallow points, were installed through the soil in a median planter which has a rigid concrete base. Therefore, these points will only reflect the change in elevation of the rigid concrete base.

The surface settlement points were monitored by the contractor's personnel using standard optical surveying techniques. The frequency of these measurements was similar to that originally proposed for the DS points and consisted of daily readings when the tunnel headings passed through a zone 50 feet before to 150 feet after the cross line of settlement points. These daily readings were followed by weekly readings for four weeks and then monthly readings until the end of tunnel excavation. These measurements are estimated to be accurate to within ± 0.15 inches.

4.2.3.5 Piezometers

A total of nine open standpipe piezometers were installed by the contractor before excavation of the shaft or tunnels. These piezometers consisted of 3 feet long by 1-3/4 inches OD well screen attached to 1-1/2 inches ID steel standpipe. This assembly was installed in a 3 inch minimum diameter borehole with the lower 8 feet containing the wellscreen backfilled with sand and the remainder of the borehole grouted to the ground surface. The previous sections of these piezometers are all located at approximately the invert elevation of the adjacent tunnel.

The piezometers were monitored by the contractor's personnel on a daily basis for the life of the construction project. An additional 2 to 3 readings per day were taken on PZ-11, 12 and 13 by members of the S.O.G. team during the 5 days the outbound tunnel heading was advancing within the Test Section B zone. Measurements were also made on these three piezometers in November 1979, approximately 5 months after the end of tunnel advance.

4.2.3.6 Additional Geotechnical Instrumentation

Settlement and tilt measurements were made on various buildings along the tunnel route by contractor and construction manager personnel during construction of the tunnels. Building settlements were found to be minimal, of the order of 1 inch maximum, and the detailed data was therefore not made a part of this study.

4.3 Structural Instrumentation

Structural responses to the applied loads were monitored using "sister bar" strain gages inbedded into selected segments at the casting yard. Twenty-four segments comprising four complete rings (excluding the key segments) were instrumented in this way. The "sister bars" consist of a piece of #4 reinforcing rod specially machined and fitted with resistance type strain gages. These bars were then placed at selected locations in the segments. Bonding between the concrete and the sister bar produced strains in the gages proportional to the concrete deformations. All electrical cables were cast into the segments with their ends terminating in flush mounted metal boxes. This eliminated all protrusions and minimized the potential for damage during handling and erection. Figure 19 is a detail of the sister bar installation. The strain gages were read periodically with portable readout equipment prior to erection. After segments were erected the gages were connected to an automatic data logger which had the capability of reading 60 channels every 20 seconds. Details of the location and types of equipment and the data gathering procedures are presented in section 7.3.1 of this report.

In order to develop a relationship between the shield jacking procedures and the associated strains as recorded by the sister bars, the shields' hydraulic system was instrumented. The instrumentation consisted of pressure transducers located in each of the four hydraulic lines supplying pressure to the four jacking quadrants. The transducers were also monitored automatically by the logger.

4.4 Geometric Instrumentation

Post erection liner distortions encompass ring diameter changes, longitudinal and circumferential joint movements, and segment rotations. To monitor these movements, several types of instruments were used. A specially designed extensometer was manufactured (Figure 20) to measure tunnel diameters, since the tunneling machine precluded direct diameter measurements. Joint movements were monitored by the use of a dial caliper with a centerpoint attachment (Figure 21)

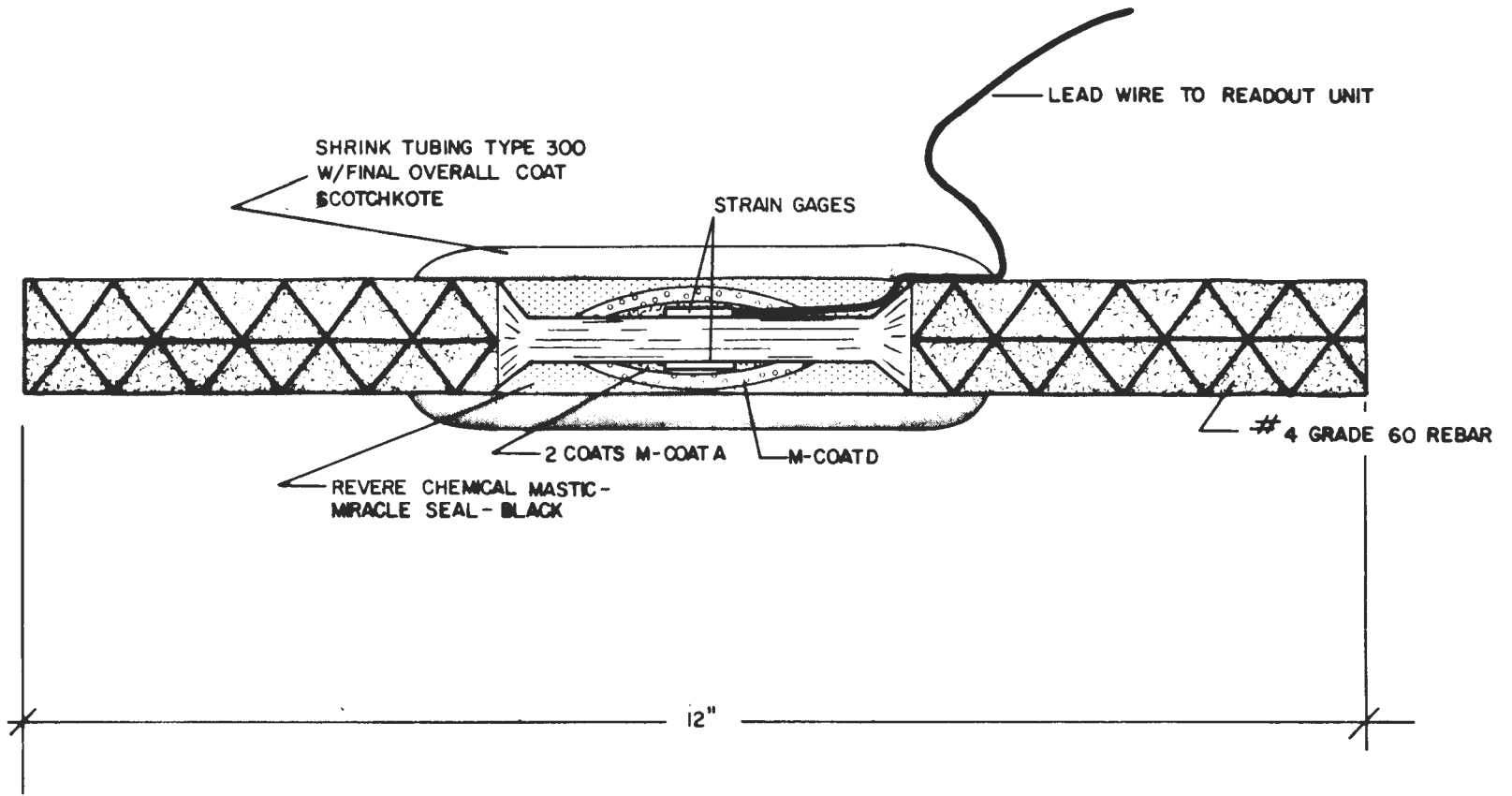

38

FIGURE 19. SCHEMATIC OF SISTER BAR WATERPROOFING

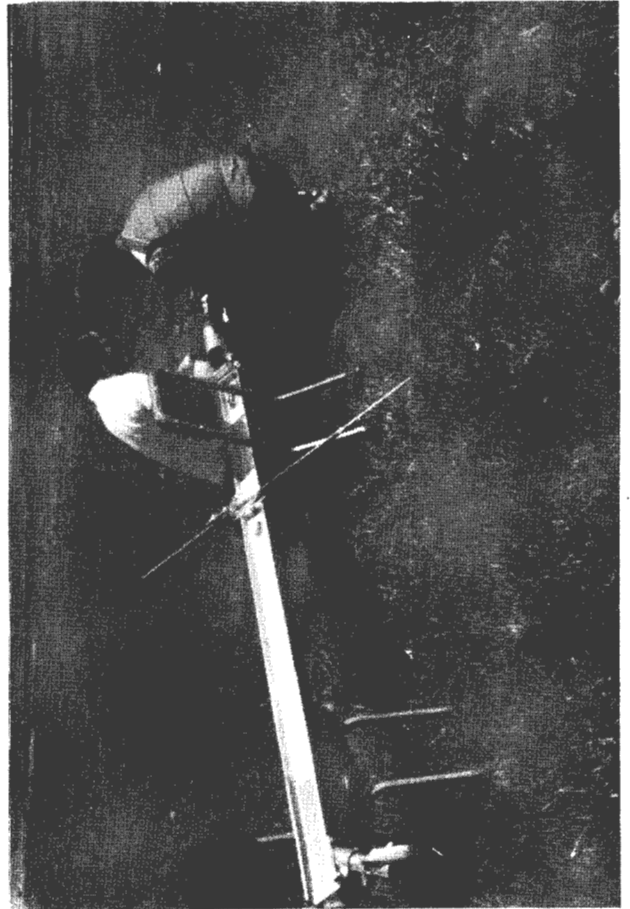
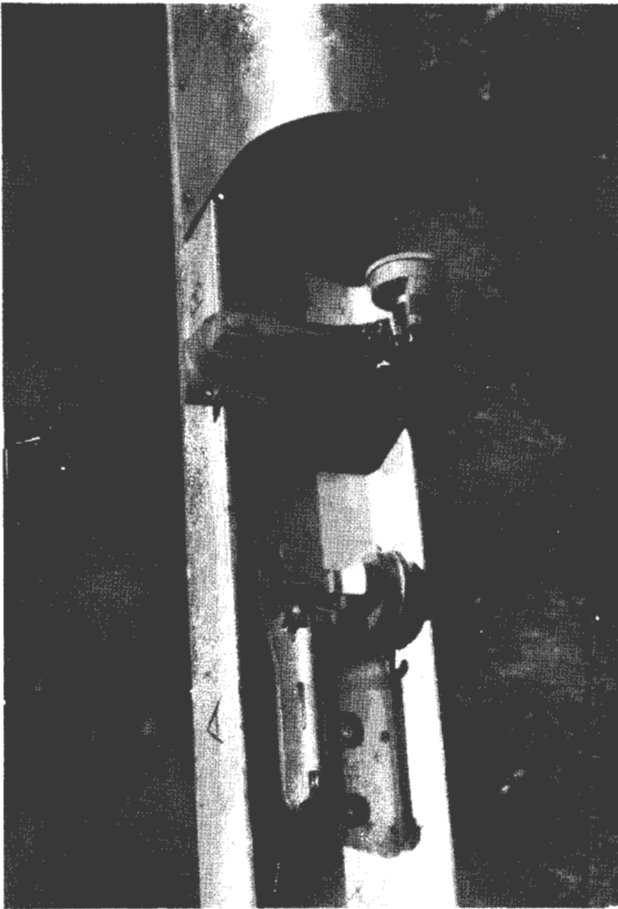
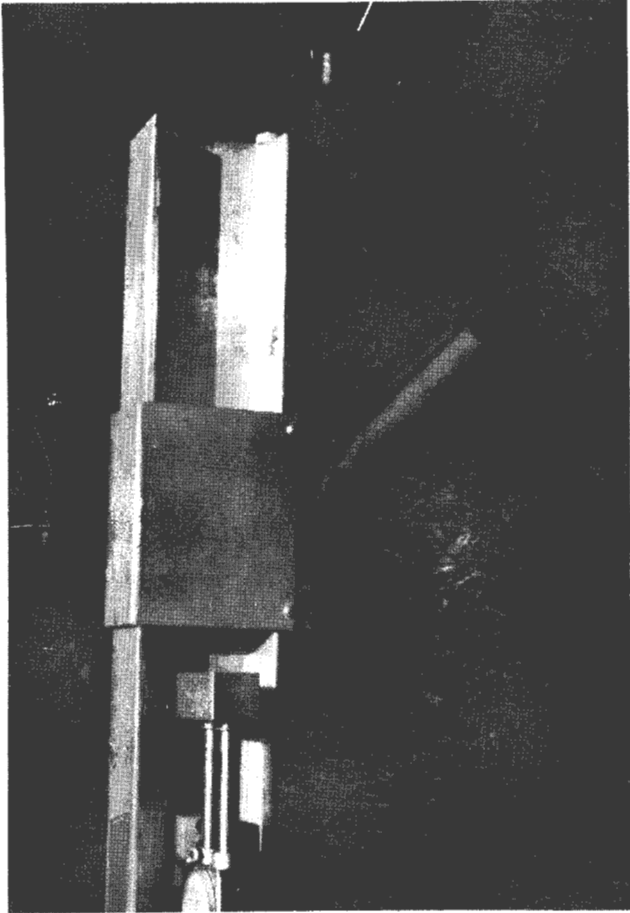

FIGURE 20. EXTENSOMETER

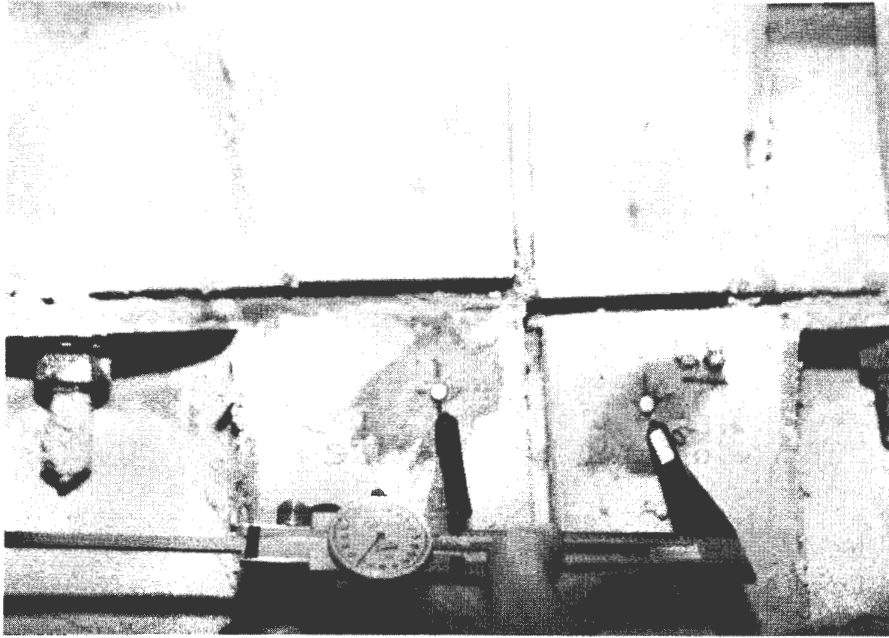

FIGURE 21. DIAL CALIPER FOR JOINT MEASUREMENT

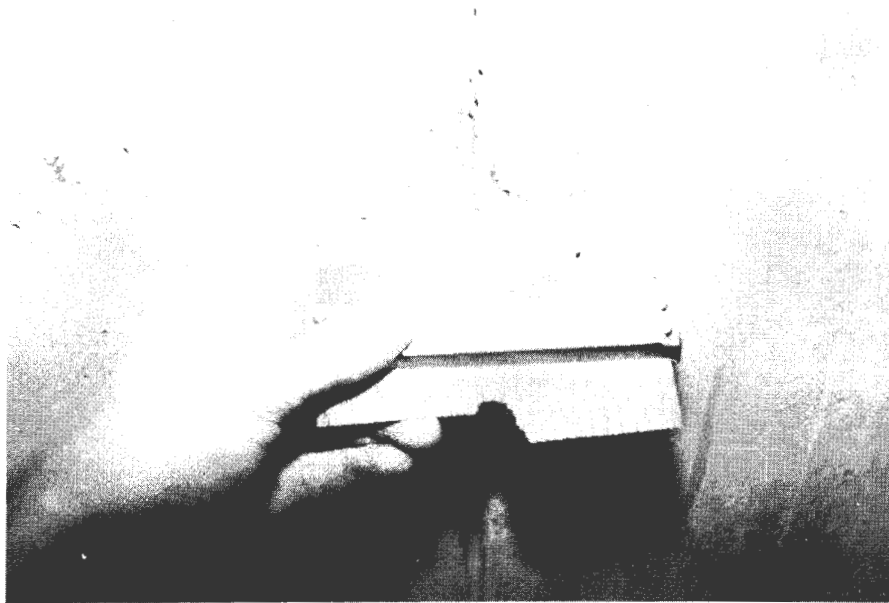
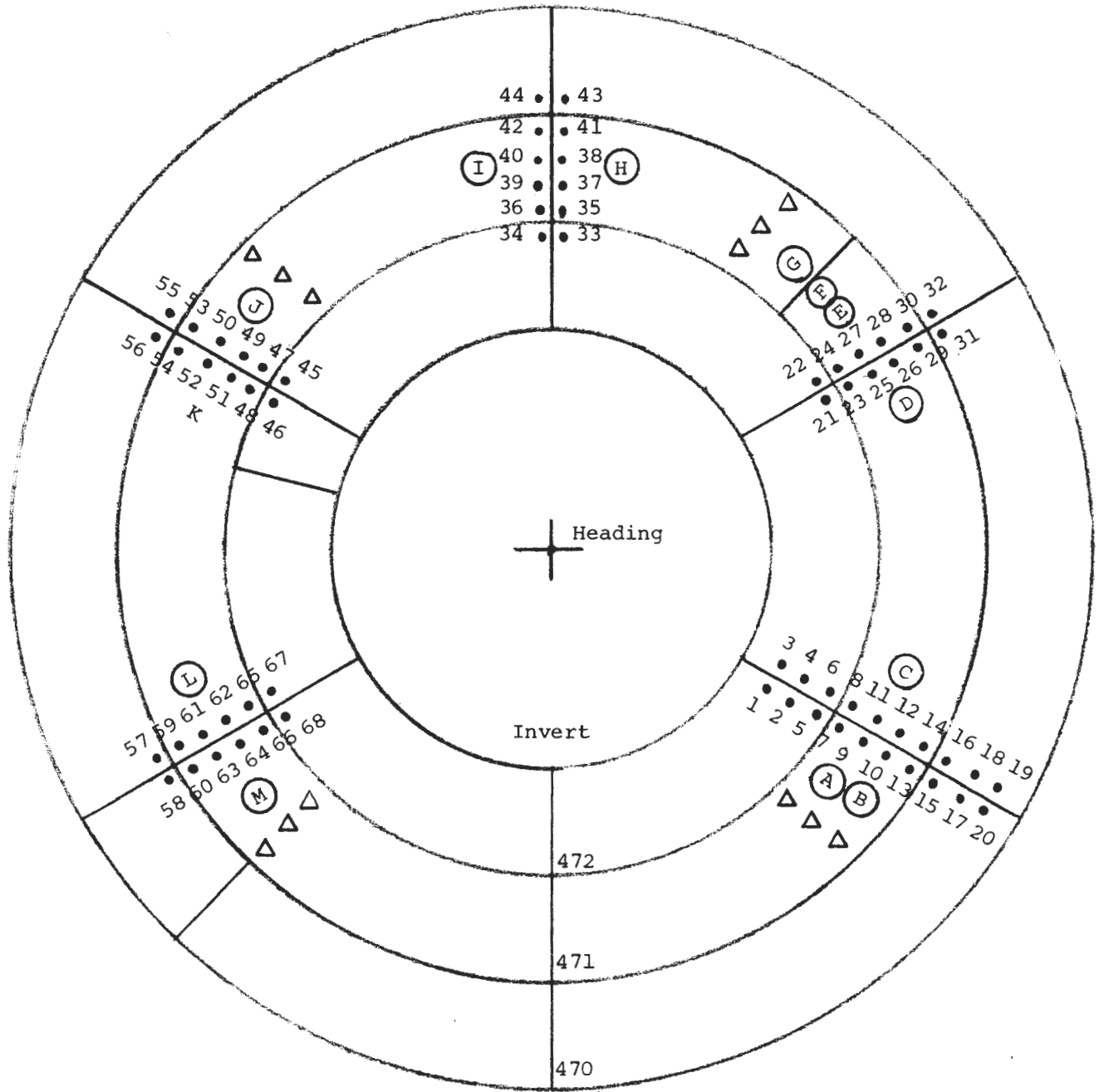

FIGURE 22. CONTOUR GAGE FOR JOINT OFFSET MEASUREMENT

and segment rotation was monitored by means of tilt plates located at the segment edges. In addition, later tunnel diameter measurements were obtained by taping. Joint offsets were recorded by means of a contour gage (Figure 22). Figure 23 indicates the location of reference points used to obtain these data. The results obtained from the geometric instrumentation are discussed in Section 7.3.1.2.



- △ = Extensometric Ball
- ⓐ-Ⓜ = Tilt Plate
- = Demec Point

FIGURE 23. LOCATION OF GEOMETRIC INSTRUMENTATION POINTS

5.0 GEOTECHNICAL SETTING

5.1 Geologic References in Bid Documents

The geotechnical subsurface data for the Lexington Market Line Tunnels, which were made part of the bid documents, are contained in the following reports by the General Soils Consultant (Robert B. Balter Company, Owings Mills, MD) and the Final Designer (Parsons, Brinckerhoff, Quade and Douglas, Inc., New York, NY):

- "Baltimore Regional Rapid Transit System - Phase I, Section A, Lexington Market Section, Geotechnical Data, Volume I" by Robert B. Balter Company, July 1976.
- "Baltimore Regional Rapid Transit System - Phase I, Section A, Lexington Market Section, Geotechnical Data, Logs with Core Photographs, Volume II" by Robert B. Balter Co., July 1976.
- "Baltimore Regional Rapid Transit System - Phase I, Section A, Lexington Market Section, Geotechnical Data Review" by Robert B. Balter Co., July 1976.
- "Baltimore Regional Rapid Transit System, Lexington Market Section, Contract Number NW-02-05-D, Design Summary Report" by Parsons, Brinckerhoff, Quade and Douglas, Inc., December 1976.

5.2 General Geologic Description

The Baltimore City area is divided into two main physiographic provinces. The Piedmont Province makes up approximately the northwestern half of the city and generally consists of relatively deep soils formed by weathering of the underlying Precambrian and Early Paleozoic basement rock. The Coastal Plain Province makes up the southeastern half of the city and generally consists of Cretaceous and Pleistocene sedimentary deposits which overlie the Precambrian and Early Paleozoic basement rock formations. The boundary between these two formations is usually denoted as the "fall-line" although the boundary is actually a transition zone of considerable width rather than a well defined line.

The Lexington Market Tunnels are located in the Coastal Plain Province. The sediments in this area are known as the Potomac Group and were deposited during a depression of the old land surface at the close of the Jurassic Period. In the immediate area of the project, the sedimentary deposits are predominantly of the Patuxent formation and consist of interbedded sand, gravel and clay. The sands and gravels are chiefly of quartz mineralogy while the clays are mainly a mixture of illite and kaolinite. The formation is generally light in color.

The Coastal Plain sediments in most of the Baltimore area are underlain by highly crystalline metamorphic schists, gneisses and amphibolites of Precambrian and Early Paleozoic ages. The rock in the project area is generally classified as the Carroll Gneiss member of the James Run formation.

5.3 Anticipated Subsurface Conditions Along the Tunnel Route

The subsurface data obtained prior to tunnel construction primarily consisted of the information obtained from the borings performed during three geotechnical investigations. A total of 27 hollow stem auger borings were performed along the tunnel route using a variety of sampling equipment including 2 inch and 3 inch OD split-spoon samplers, Denison samplers and double tube core barrels yielding 2.06 inch diameter rock core samples. A total of 12 falling head borehole permeability tests were performed in the borings in the vicinity of the tunnel boundaries. Ten piezometers were also installed in various boreholes along the route.

The boring location plan is shown on Figures 12 through 18. Figure 24 is the interpretative subsurface profile along the outbound tunnel centerline as constructed by Robert B. Balter, Inc., the general soils consultant, from the exploratory boring data.

Laboratory testing on the samples obtained from the borings included 106 natural moisture contents, 122 grain-size analyses, 34 Atterberg limits, 5 specific gravity tests, 5 unconfined compression tests, and 6 swell tests.

The soil strata shown on the profiles in Figure 24 is composed of the sedimentary Cretaceous soils (designated with a C), overlying the residual soils (designated with an R) which were derived from weathering of the underlying gneiss bedrock. These soil types were subdivided into the following designations:

C-1 and C-1a: Very dense sand and gravel in various gradations with low fines content (less than 12% passing #200 sieve). The C-1a soils are of a uniform gradation. The standard penetration resistance (N value) in these strata generally ranged from 40 to over 100 blows/foot.

C-2 and C-2a: Very dense sand and gravel in various gradations with moderate to high fines content (more than 12% passing #200 sieve). The C-2a soils are the more coarsely graded gravels. The standard penetration resistance in these strata generally ranged from 25 to over 100 blows/foot.

C-3: Sedimentary soil consisting mostly of dense silt and usually occurring as lenses in the C-1 and C-2 series of granular Cretaceous soils described above.

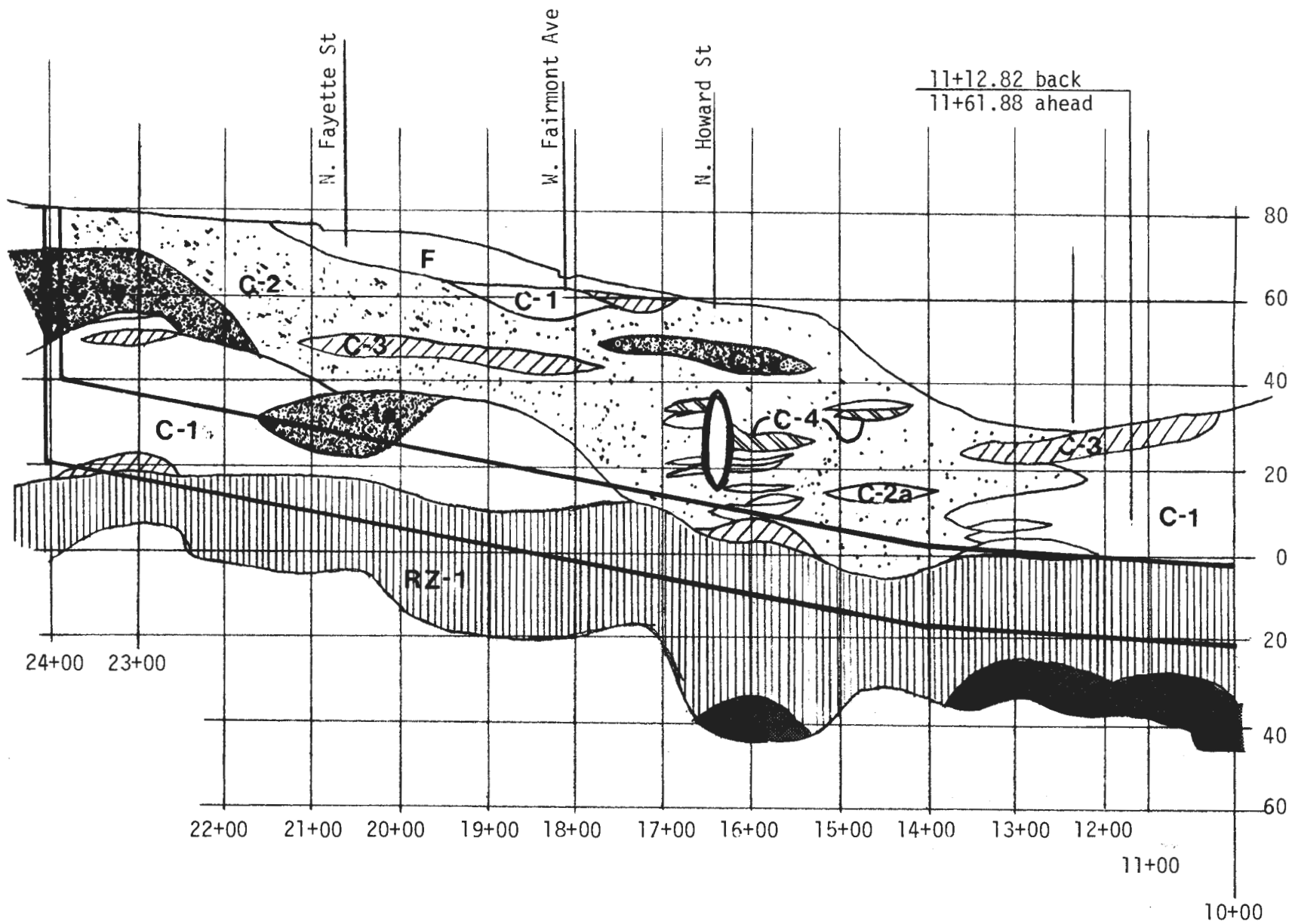

Scale: 1" = 160' Horz
1" = 33' Vert

FIGURE 24. OUTBOUND PROFILE

RS: These materials have been formed from either the in-situ decomposition of the parent rock or the reworking of residual material. This material is basically soil-like and does not normally exhibit visible remnant rock structure. It may contain rock fragments but they are usually friable and small. Based on our examination of the samples and our experiences, the strength characteristics of these materials are similar to cohesive sediments, and little additional strength remains from the structure of the parent material. These materials are often difficult to distinguish from similar sediments, especially when apparent reworking has occurred during geologic history. The design characteristics have been established based on penetration resistance, plasticity, and our experience.

RZ-1: These materials are considered as transitional between the Residual Soil (RS) and the less decomposed Residual Zone #2 (RZ-2). They have been derived by the in-situ decomposition of the parent formation with soil-like components and partially weathered and/or fresh rock components. RZ-1 materials usually retain some of the cohesion of the parent rock and usually exhibit visible remnant rock structure such as schistosity and relict joints. The degree of visible remnant rock structure is variable but generally becomes more obvious with increasing depth. These materials can usually be sampled by soil sampling techniques. In most, but not all cases, the Standard Penetration Test results are greater than 100 blows per foot. In borings NWA-10, 101, 102, 103, 105, 107 and 109, the RZ-1 material was electively sampled with coring equipment in order to provide a continuous sample. The constituents of this zone are described as soils based on their grain size and plasticity characteristics after the material was disaggregated by hand or using mortar and pestle.

Although there is considerable variability in the RZ-1 materials, they appear to divide into two main groups. One group, usually within the upper regions of the RZ-1 material but of variable depth, is composed of primarily white to tan lean clays and silts sometimes containing appreciable amounts of sand. The other group of RZ-1 materials are generally darker in color including brown, blue, green and gray. They range from cohesive, having an almost soap-like texture, to very coarse grained granular materials. In some cases, they appear to consist of small rock-like fragments bonded together in a cohesive fashion. Partially decomposed and fresh rock fragments have been found in some samples. It is considered that such fragments could be found anywhere within the zone.

Because of their remnant rock structure, the RZ-1 materials are expected to act as cohesive materials even though this characteristic is not apparent from

the grain size and plasticity. Borehole samples recovered rock fragments ranging between the #10 sieve and approximately 1.5 inches. However, it is likely that the partially weathered and/or fresh rock components will have highly irregular dimensions, depending on the discontinuities in the original rock mass through which weathering progressed. Experience indicates that this material can exhibit wide variations in density, moisture content and strength within short distances. This zone exhibits heterogeneity in strength and hardness because of the differential weathering response and decomposition characteristics of the materials. Our evaluation of the conditions of these materials, based on examination of the samples, indicates that they will tend to act as hard, dense, slightly cohesive to cohesive soils throughout most of the zone. The lighter colored materials frequently exhibit a laminar structure and are often friable. The darker materials are typically hard crumbly soil to soft rock-like material and will probably be difficult to excavate in places where they are very hard and where rock fragments are encountered. Also, these materials become very hard when dry so that they could vary substantially from their in-situ conditions. RZ-1 materials should generally be removable with power hand tools. Design characteristics were established based on unconfined compression test results (NWA-2 @ 58', NWA-2 @ 66', NWA-7 @ 64', NWA-7 @ 72', NWA-11 @ 61'), penetration resistance, plasticity, our experience, and test results from adjacent design sections.

RZ-2: Materials in this zone are rock-like, having been derived in-situ by partial decomposition of the parent formation with partially weathered and/or fresh rock components. These materials usually retain rock structure and considerable strength derived from the parent rock. The RZ-2 materials are commonly heterogeneous with respect to weathering ranging from decompositions throughout the entire body to partial decomposition throughout the material. RZ-2 materials cannot usually be disaggregated by manual means and they are described with rock terminology and notation of soil-like matrix or filler when appropriate. Materials in this zone usually require rock sampling techniques for obtaining specimens from boreholes. Similarly, rock excavation techniques including limited blasting may be required to remove this material. Material classified as RZ-2 was encountered in borings NWA-1, 6, 10, 102, 103, 104, 105, 107 and 108.

Rock: The rock encountered was composed of gneiss with some local pegmatite intrusions. The gneiss commonly exhibited broken and jointed zones. For the most part, the broken zones had no filling material while the joints had either no filler or siderite as a filler. In boring NWA-13, a broken, weathered zone was penetrated which may indicate the presence of a shear zone. Although rock is not anticipated to be a predominant factor during construction, the rock

horizon was encountered at levels as close as 3 to 5 feet below the proposed top of rail in the vicinity of borings NWA-106 and NWA-105. Unconfined compression tests performed by the GSC for various other projects in this formation indicate values ranging from 400 to 2100 KSF, depending primarily on the mineralogy of the test specimen.

Fill: Surficial, man-made fills were encountered at many locations along the alignment. These materials are included as one layer on the subsurface profile but are given distinct design parameters based on their classification. No strength testing was performed on the fill materials. Design characteristics have been estimated from the description of the materials and the penetration resistance.

Although the residual materials have been categorized into the RS, RZ-1 and RZ-2 zones, the transitions between them are frequently not a sharp boundary as may be inferred from the boring logs. The distinctions between the zones are qualitative with reliance on sample inspection and judgment. Also, one or more zones may not be present above the basement rock at all locations.

Groundwater elevations are variable along the tunnel route with many perched water tables reported. The water levels generally tend to follow the contour of the Cretaceous-residual boundary and were reported to vary from approximately the spring line elevation near the Lexington Market end of the project to approximately 12 to 15 feet above the tunnel crowns near Charles Center.

Falling head borehead permeability tests, grain-size analyses, water injection tests and laboratory grout injection tests were all performed on selected samples of the Cretaceous soils. Owing to the variability between the test procedures and especially the variability of the fines content in the different Cretaceous soil strata, the permeability values for these strata differed greatly. As reported by the Final Designer, the permeability for the "average" soil based on grain-size analyses was concluded to be about 3×10^{-4} cm/second with an uncertainty factor of at least ± 3 times this value. The range of permeabilities from borehole tests in the C-1, C-2 and C-3 soils varied from 1.2×10^{-4} to 3.1×10^{-6} cm/second in the "average" soils. The laboratory grout injection tests show a range in permeability between 10^{-4} and 0.5×10^{-5} cm/second in the Cretaceous soils, but these results were reported to be questionable based on the testing procedures used.

5.4 Actual Subsurface Conditions Encountered Along the Tunnel Route

During driving of both the steel-lined and concrete-lined tunnels for the Lexington Market Line, a log sheet was generated by the Construction Manager's

inspector for each liner ring installed. As each ring was being erected, the tunnel inspector would record grout volumes, shove pressures and target positions; and would sketch and briefly describe the geologic materials that were exposed in the face of the shield. These geologic observations were supplemented by periodic observations made by members of Parson's Geotechnical Staff and the S.O.G. team at various times during the construction of both tunnels. Based on the inspector's logs, S.O.G. observations and interpretations based on the original subsurface profiles, the geologic profile encountered at the face during tunnel driving was constructed and is shown on Figures 25 to 47. The profile constructed for the outbound concrete-segment-lined tunnel shows more detail due to the greater frequency of observations made by members of the S.O.G. team during advance of this tunnel.

The geology encountered during the advance of both tunnels generally agreed with what was anticipated from the borings. Tunneling progressed as expected except when RZ-2 material was encountered in the invert as described below. RZ-1 material was found at the face for practically the entire route, with usually more than half of the face composed of this residual soil. In general, more RZ-1 material was encountered than originally anticipated especially along the lengths from approximately Stations 10+00 to 14+00 and Stations 17+25 to 18+50 in both tunnels, where the entire face consisted of RZ-1 silty clay and clayey sand. The RZ-1 material consisting of gray green silty clay exhibited some remnant rock structure with many relict healed joints and much gneissic banding. Block samples of the residual soil were obtained at the face of the outbound tunnel between Stations 22+73 and 17+04. Unconfined compression tests performed on these block samples indicated a range in undrained shear strengths of 0.9 to 13.3 tsf. The majority of shear strength values were in the 2 to 5 tsf range for RZ-1 material, with the higher values probably obtained from material which would be classified as RZ-2. RZ-2 material was encountered in the invert between approximately Station 17+25 and 18+00 in both tunnels. The strength properties of the RZ-2 material varied over a wide range. The RZ-2 found in the outbound tunnel could be excavated with the hydraulic spade on the shield while the material in the inbound tunnel (later classified as RX) required blasting between approximately Station 17+50 and 17+75 so that the shield could progress.

No major groundwater inflow was encountered at the face in either tunnel. However, some groundwater seeps were noted at the face in both the dewatered and compressed air sections of each tunnel. These seeps were generally noted at the contact between the Cretaceous sediments and the residual soils. Although water

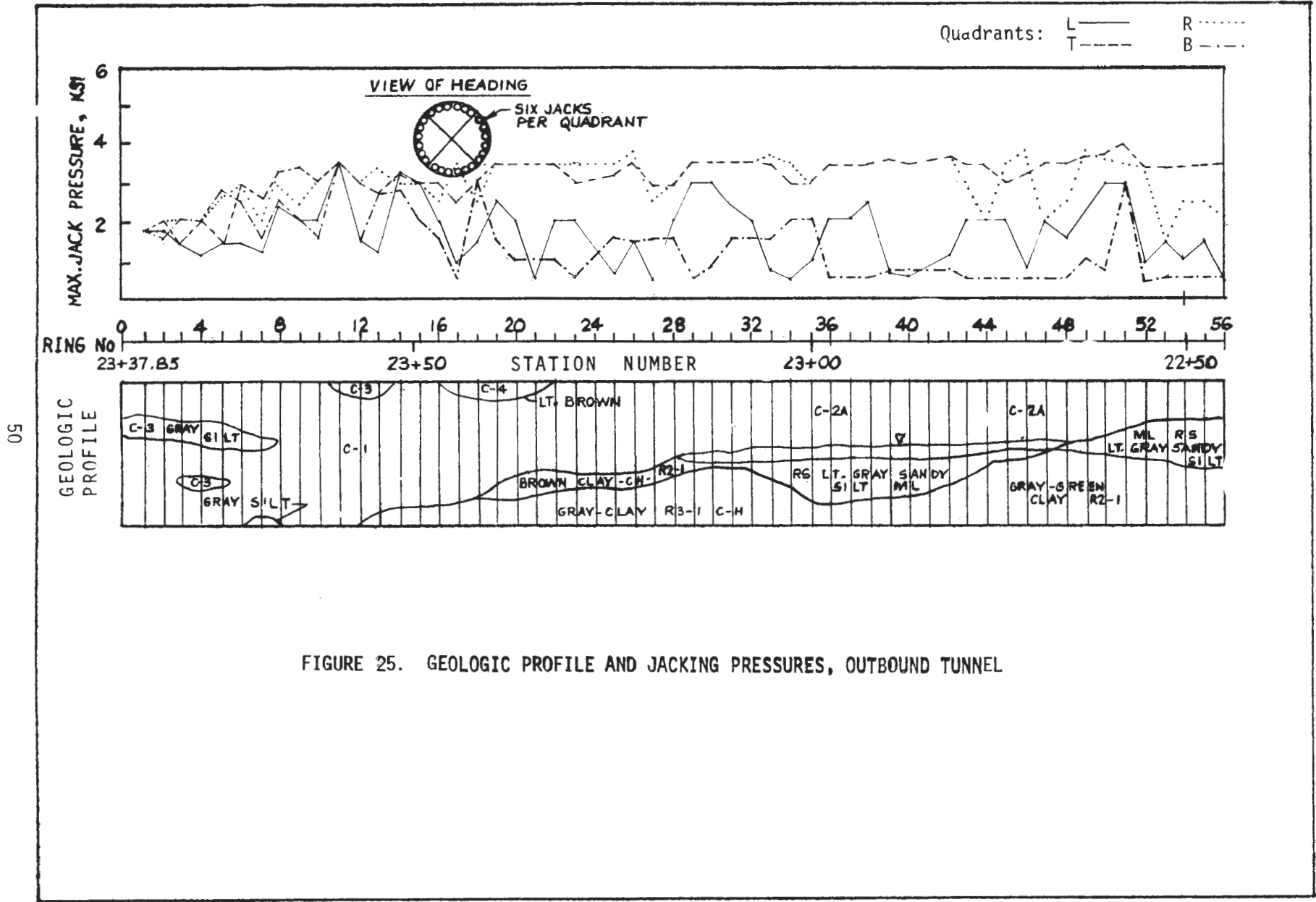

FIGURE 25. GEOLOGIC PROFILE AND JACKING PRESSURES, OUTBOUND TUNNEL

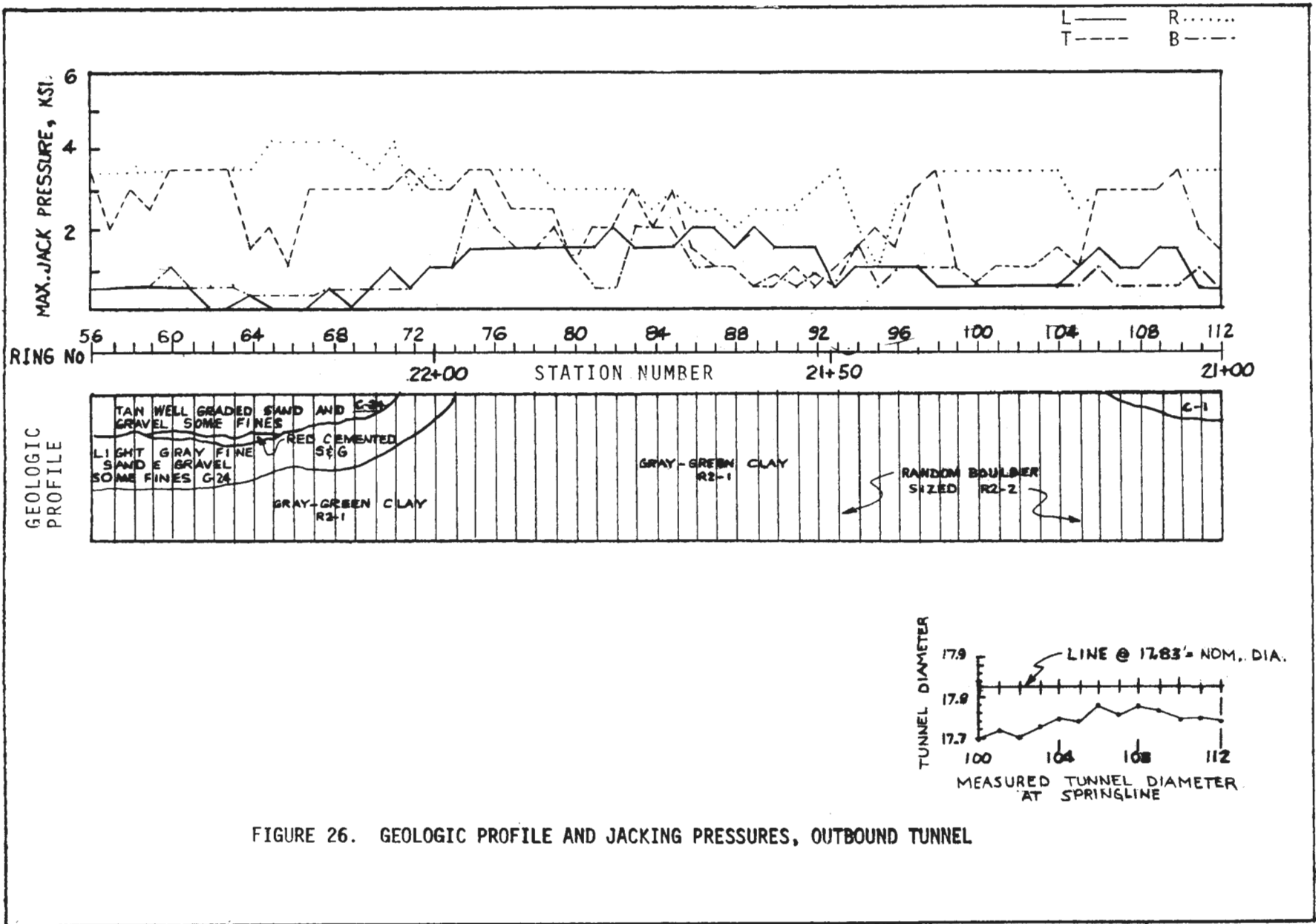
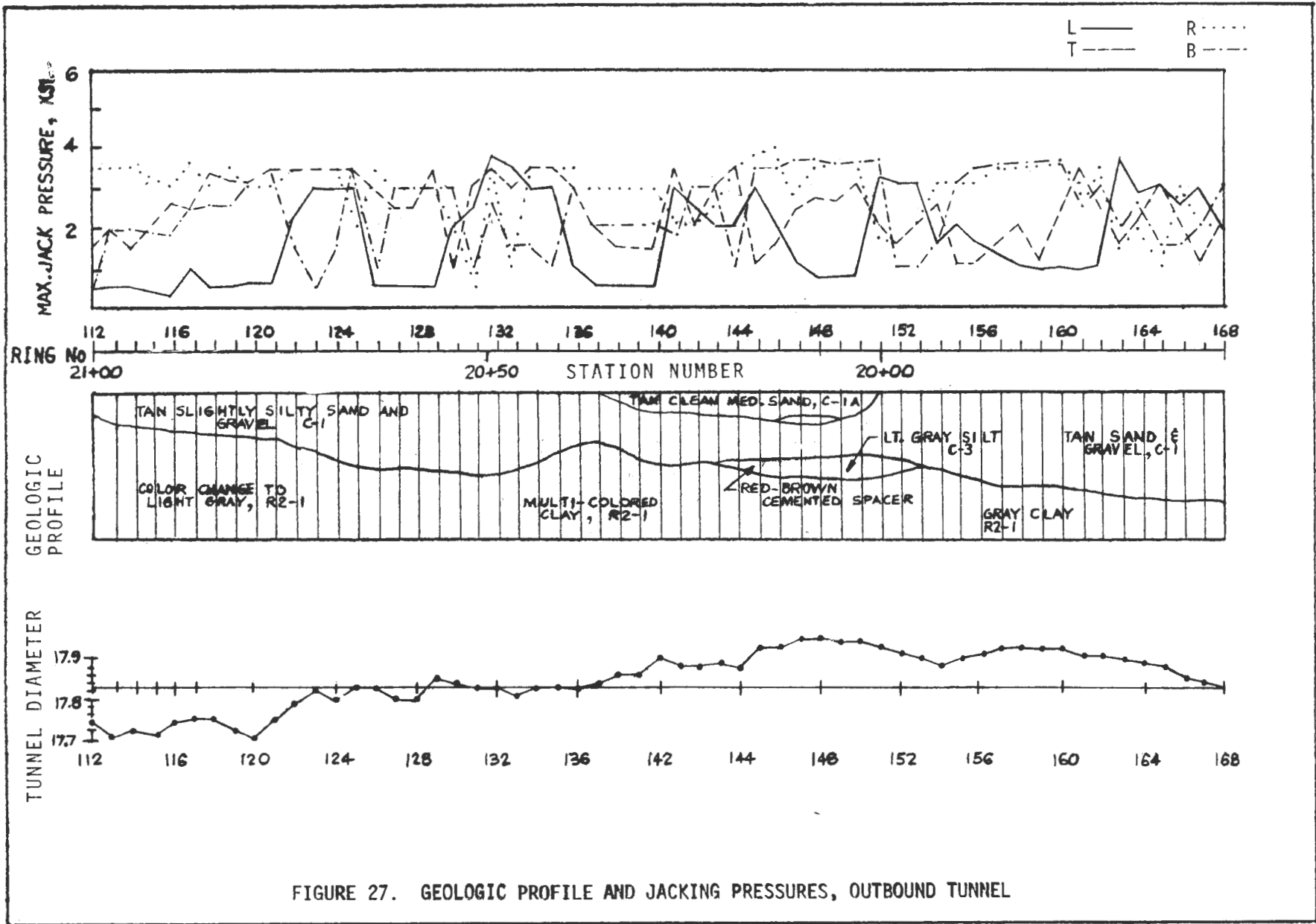

FIGURE 26. GEOLOGIC PROFILE AND JACKING PRESSURES, OUTBOUND TUNNEL



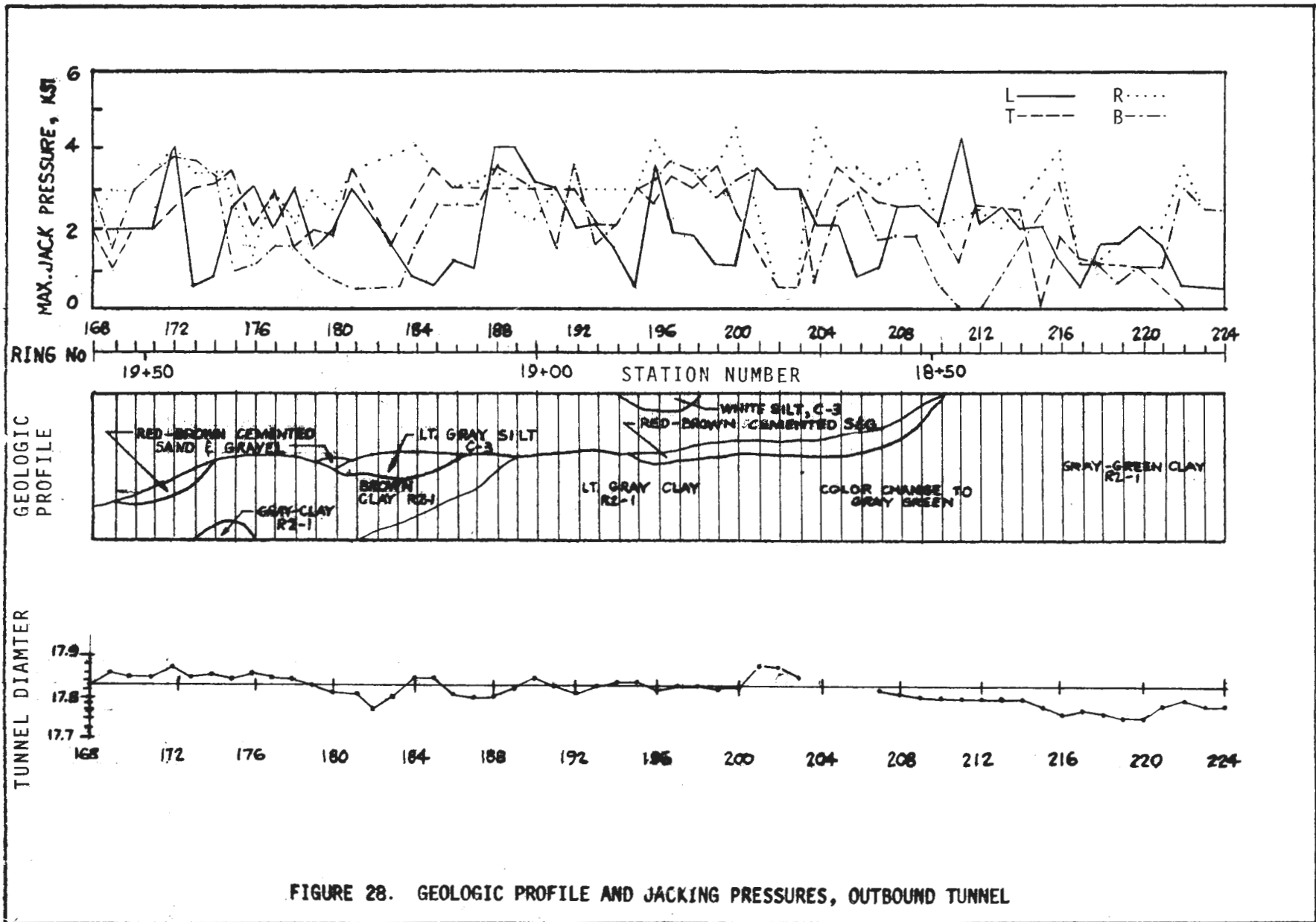

FIGURE 28. GEOLOGIC PROFILE AND JACKING PRESSURES, OUTBOUND TUNNEL

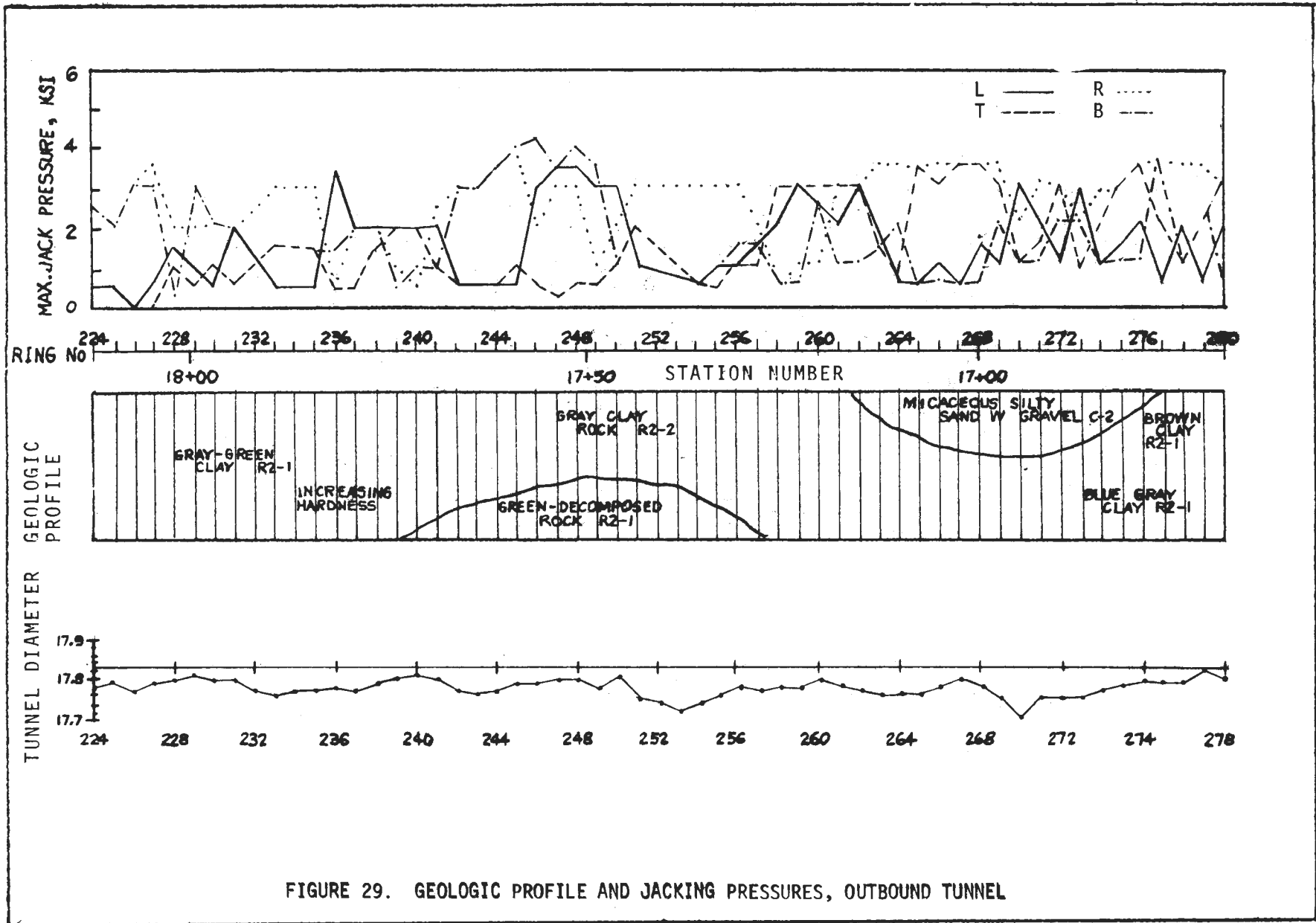
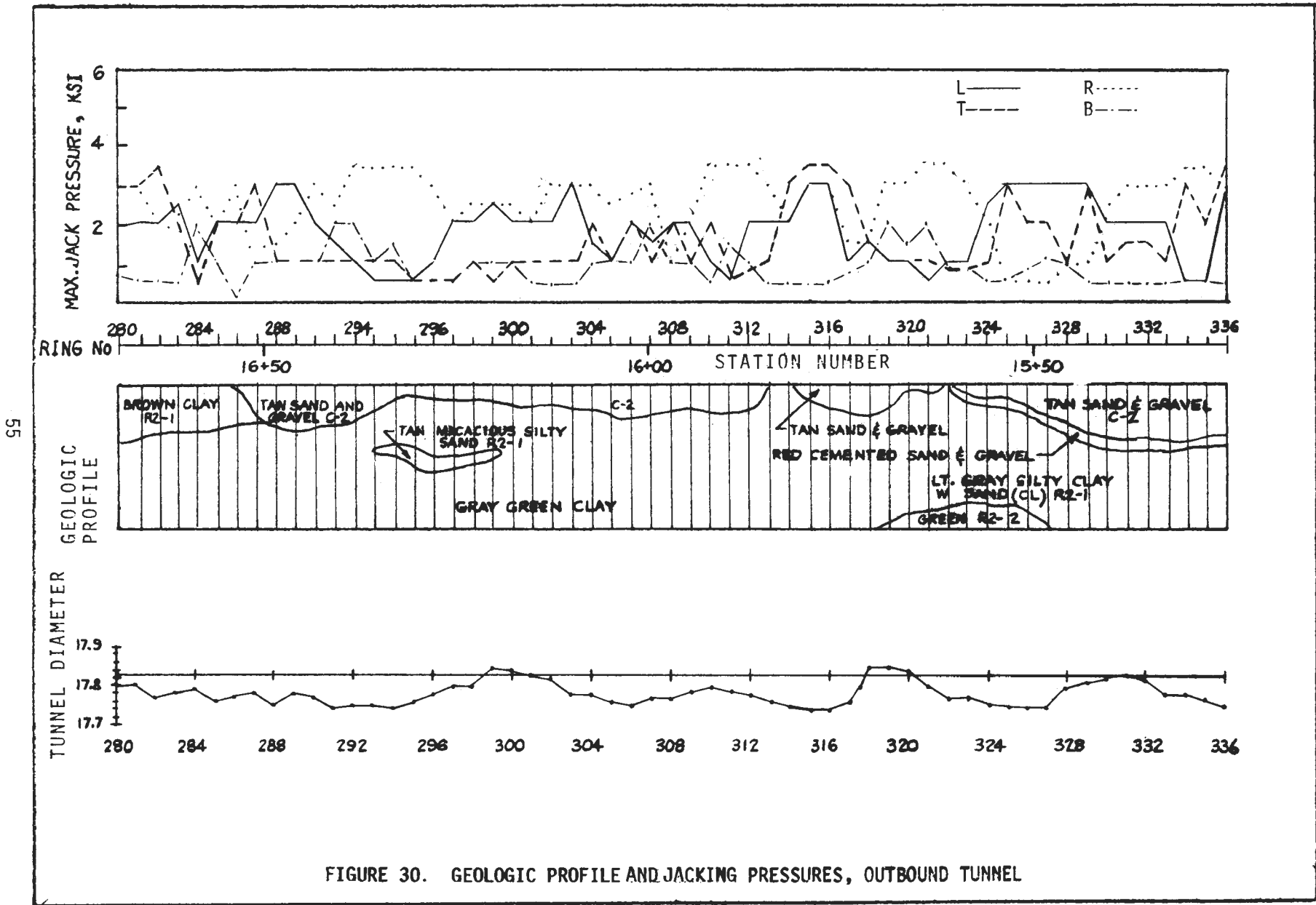

FIGURE 29. GEOLOGIC PROFILE AND JACKING PRESSURES, OUTBOUND TUNNEL



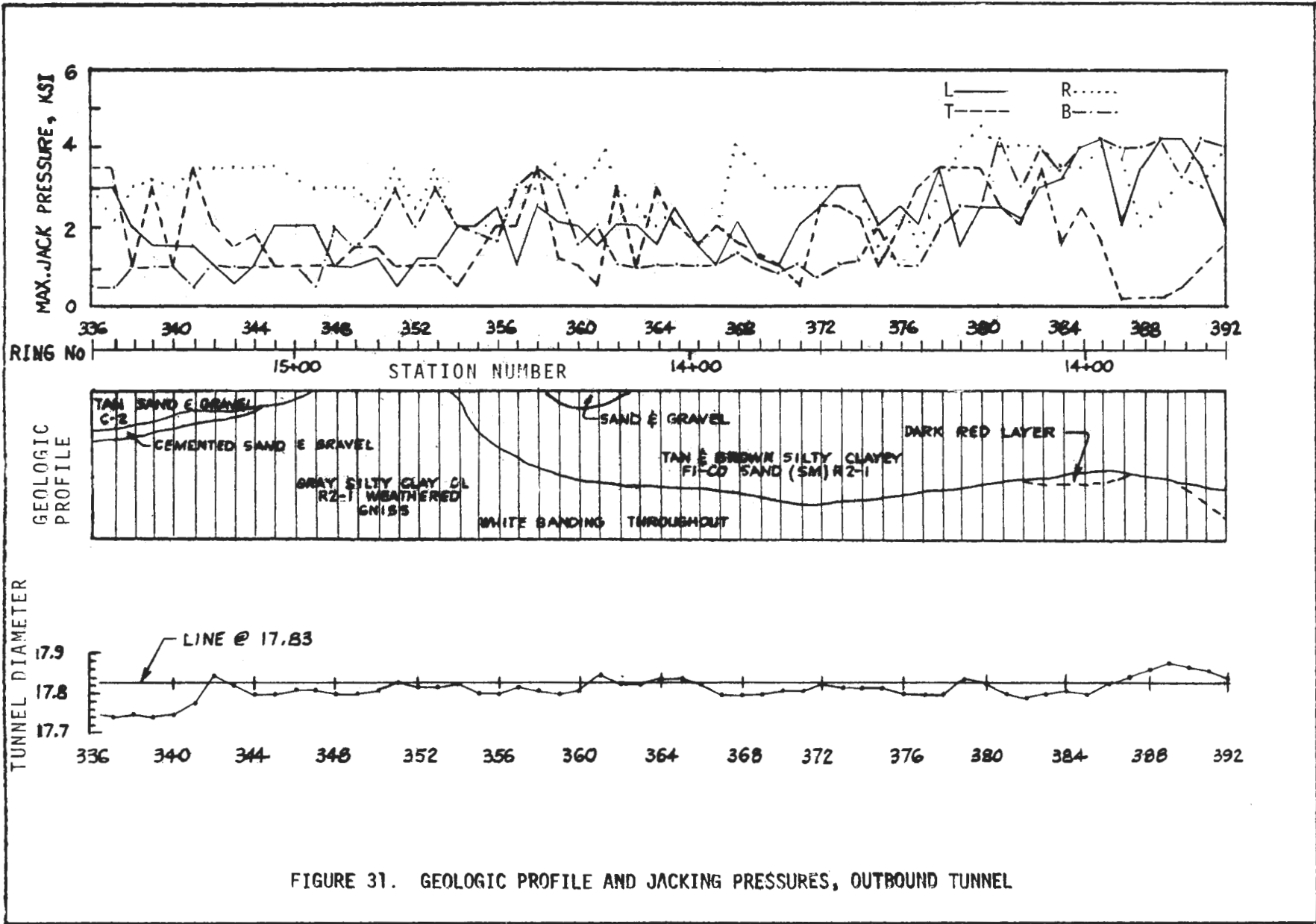
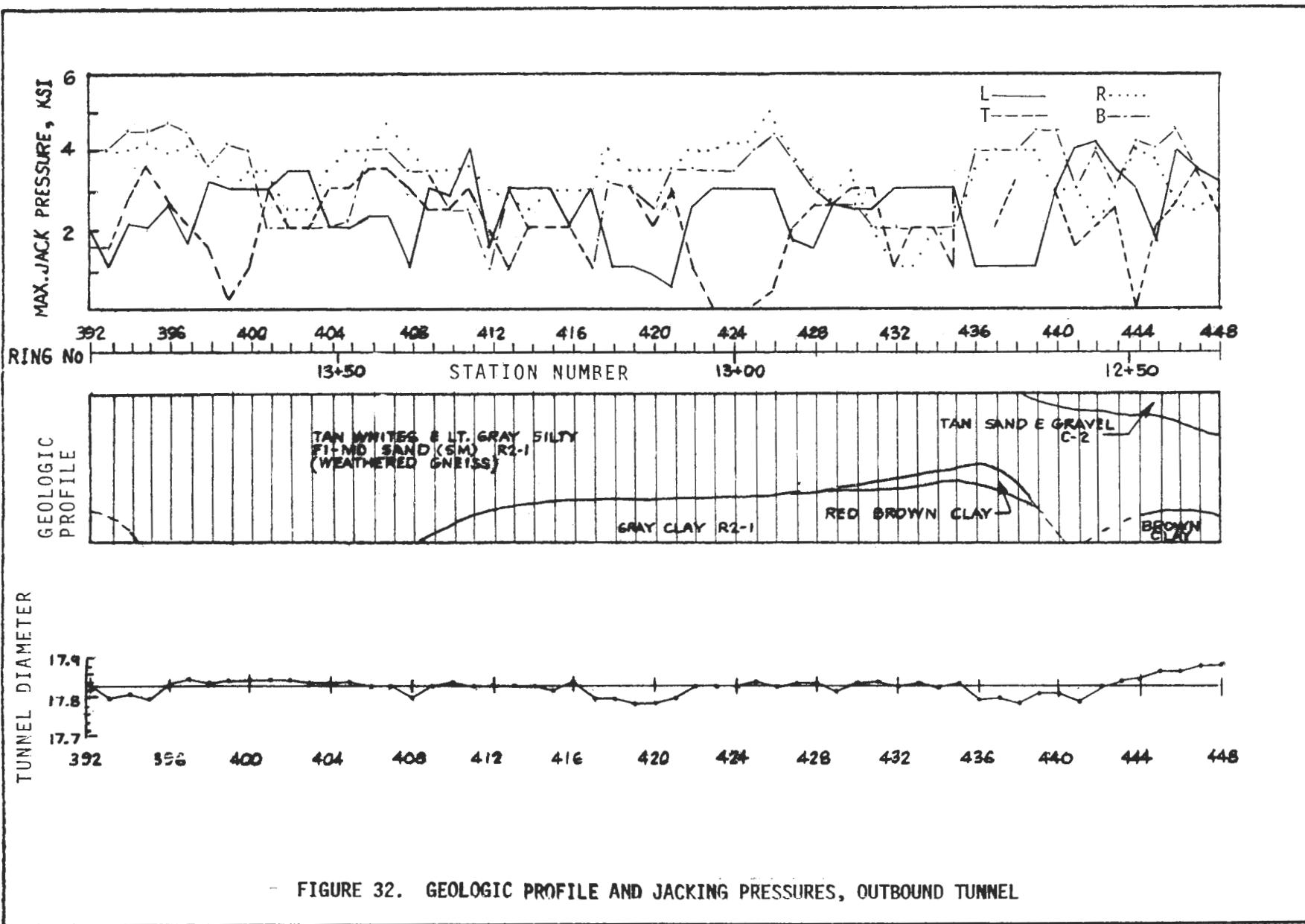

FIGURE 31. GEOLOGIC PROFILE AND JACKING PRESSURES, OUTBOUND TUNNEL



- FIGURE 32. GEOLOGIC PROFILE AND JACKING PRESSURES, OUTBOUND TUNNEL

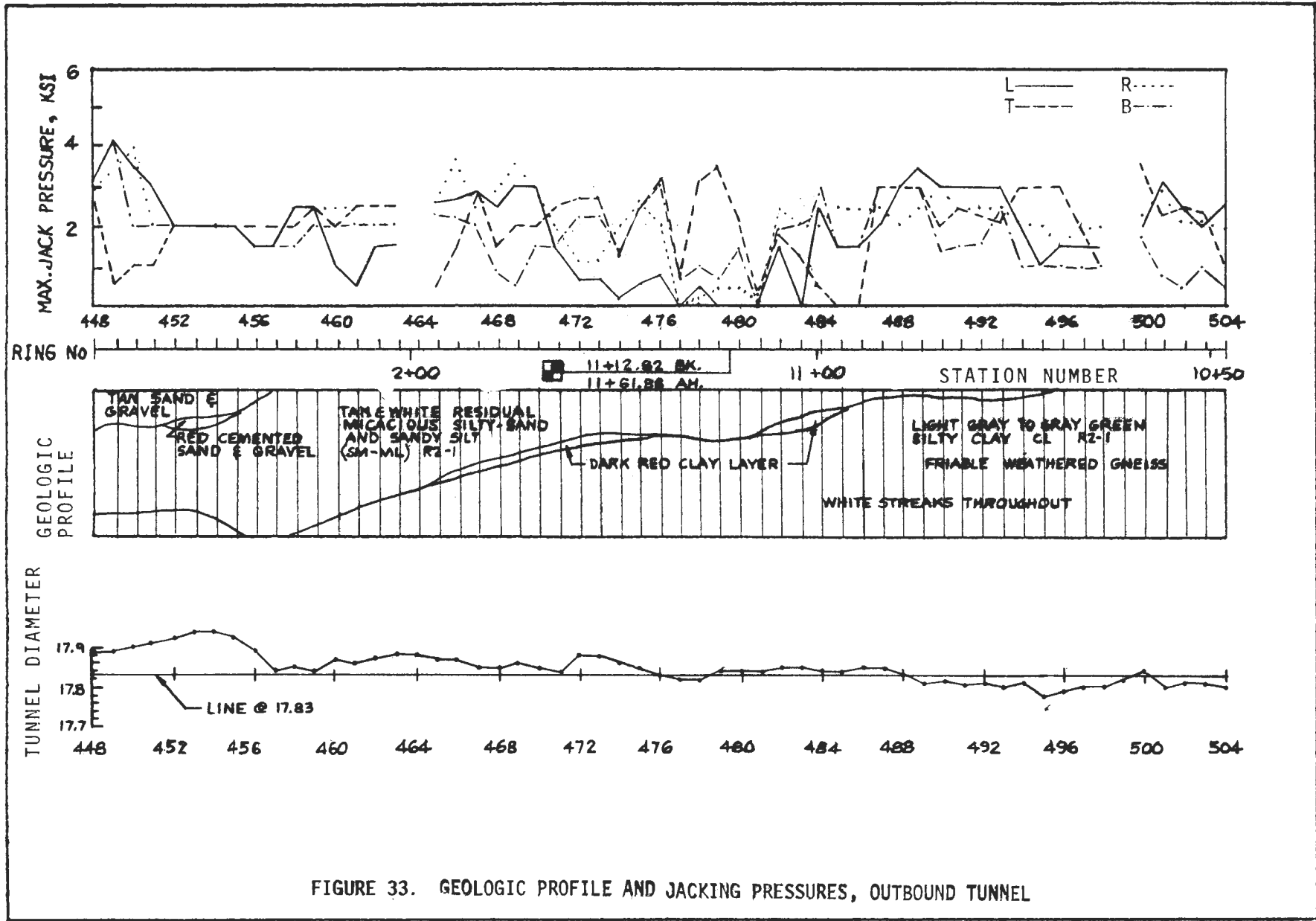

FIGURE 33. GEOLOGIC PROFILE AND JACKING PRESSURES, OUTBOUND TUNNEL

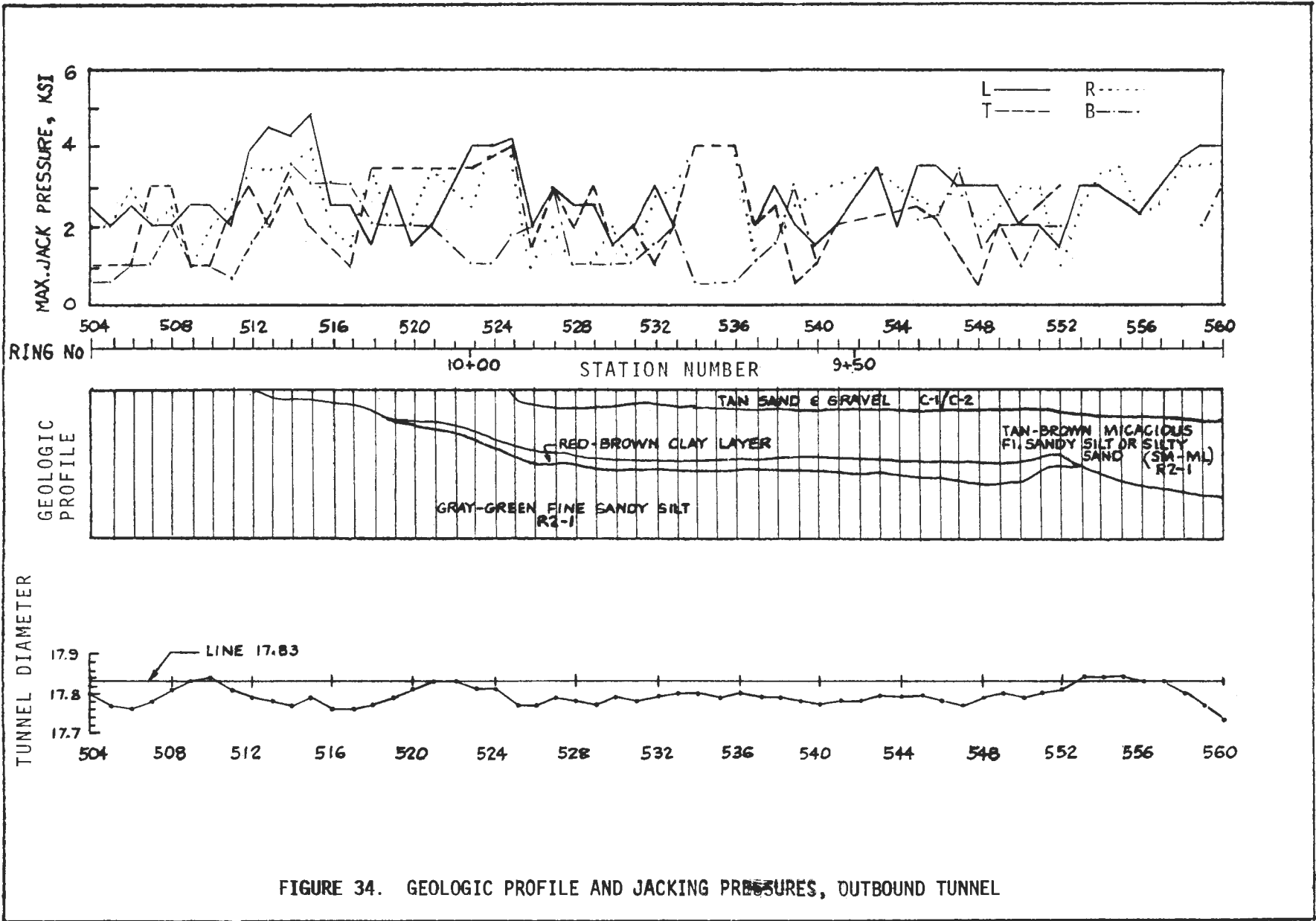
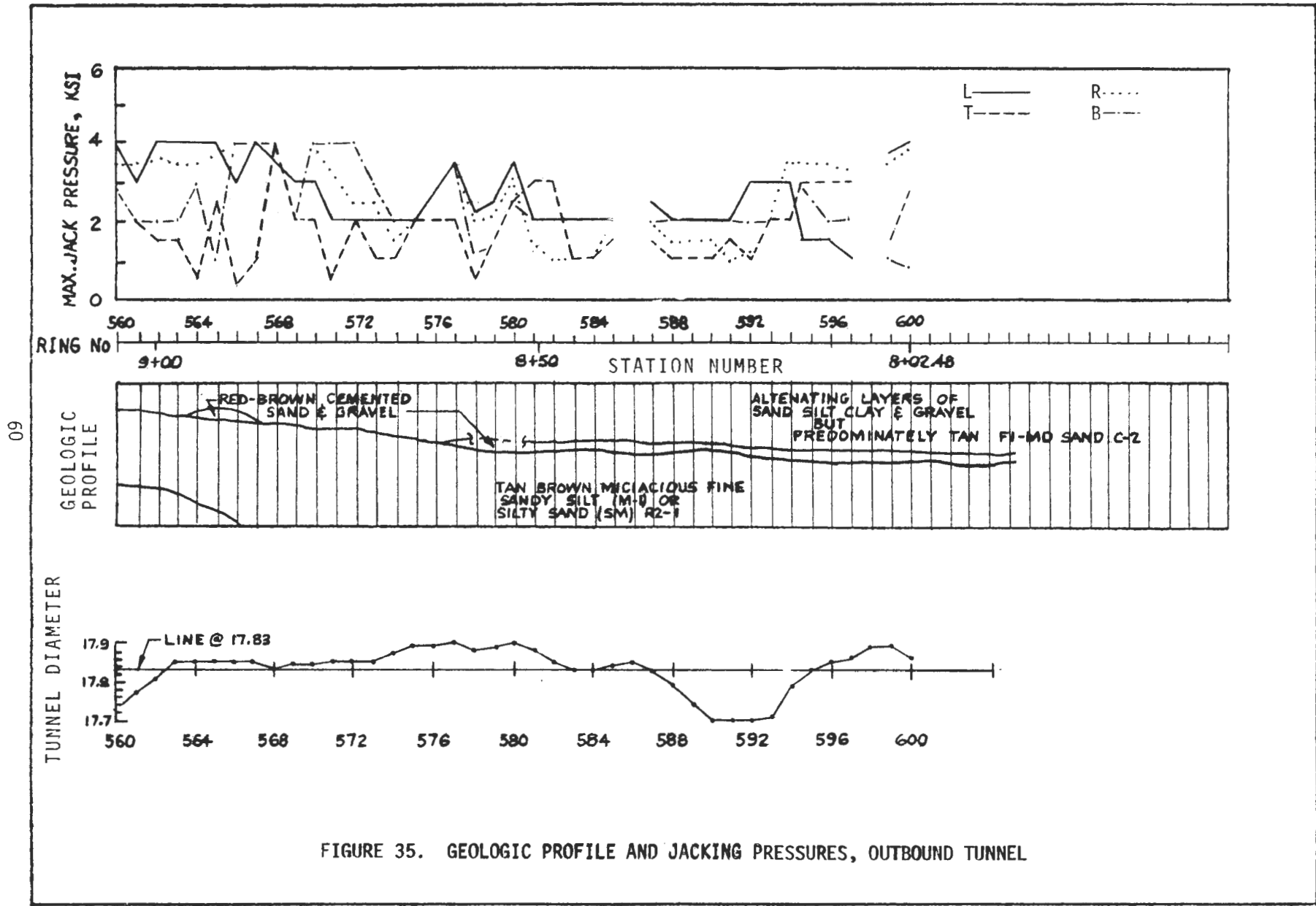

FIGURE 34. GEOLOGIC PROFILE AND JACKING PRESSURES, OUTBOUND TUNNEL



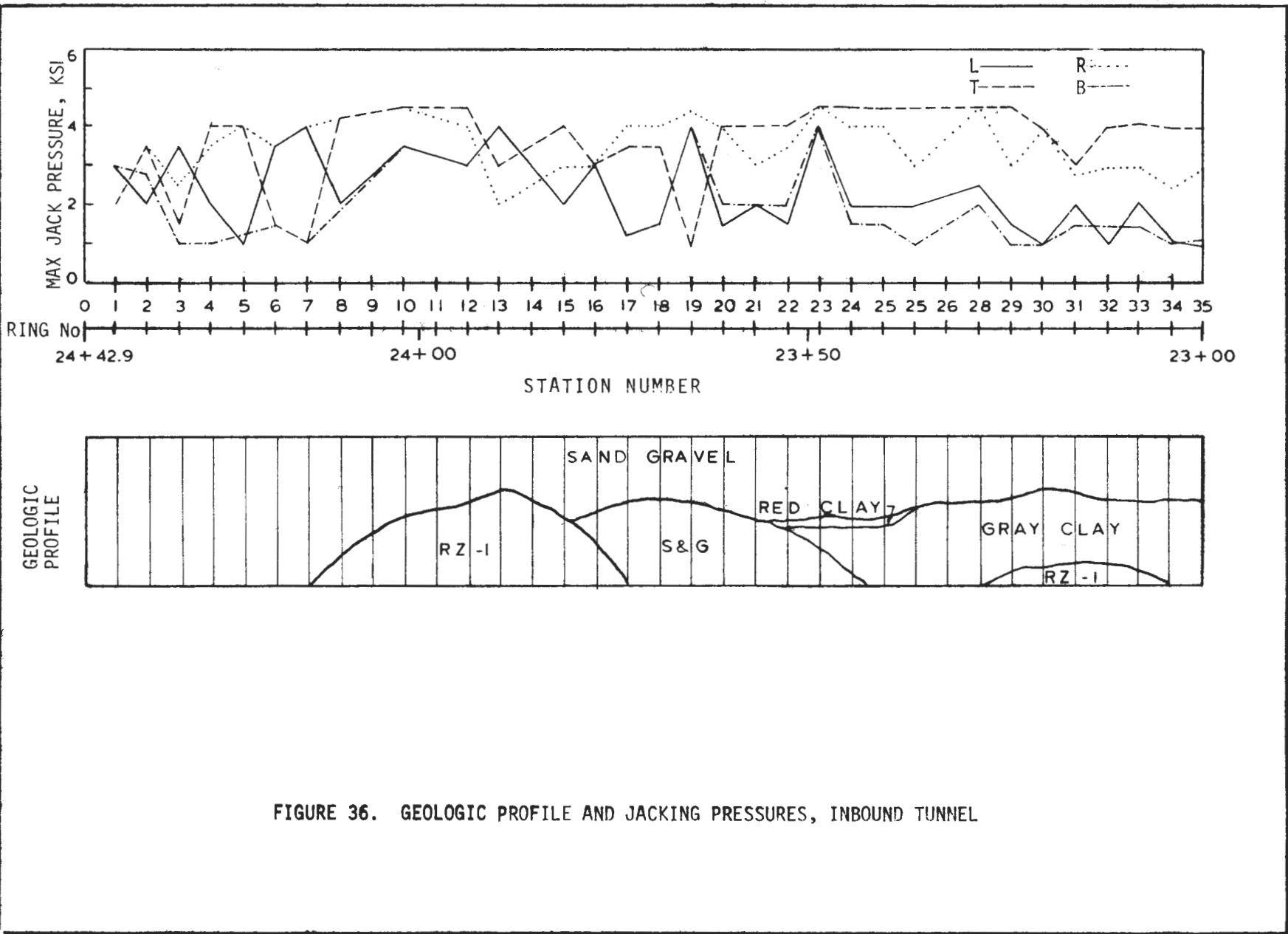

FIGURE 36. GEOLOGIC PROFILE AND JACKING PRESSURES, INBOUND TUNNEL

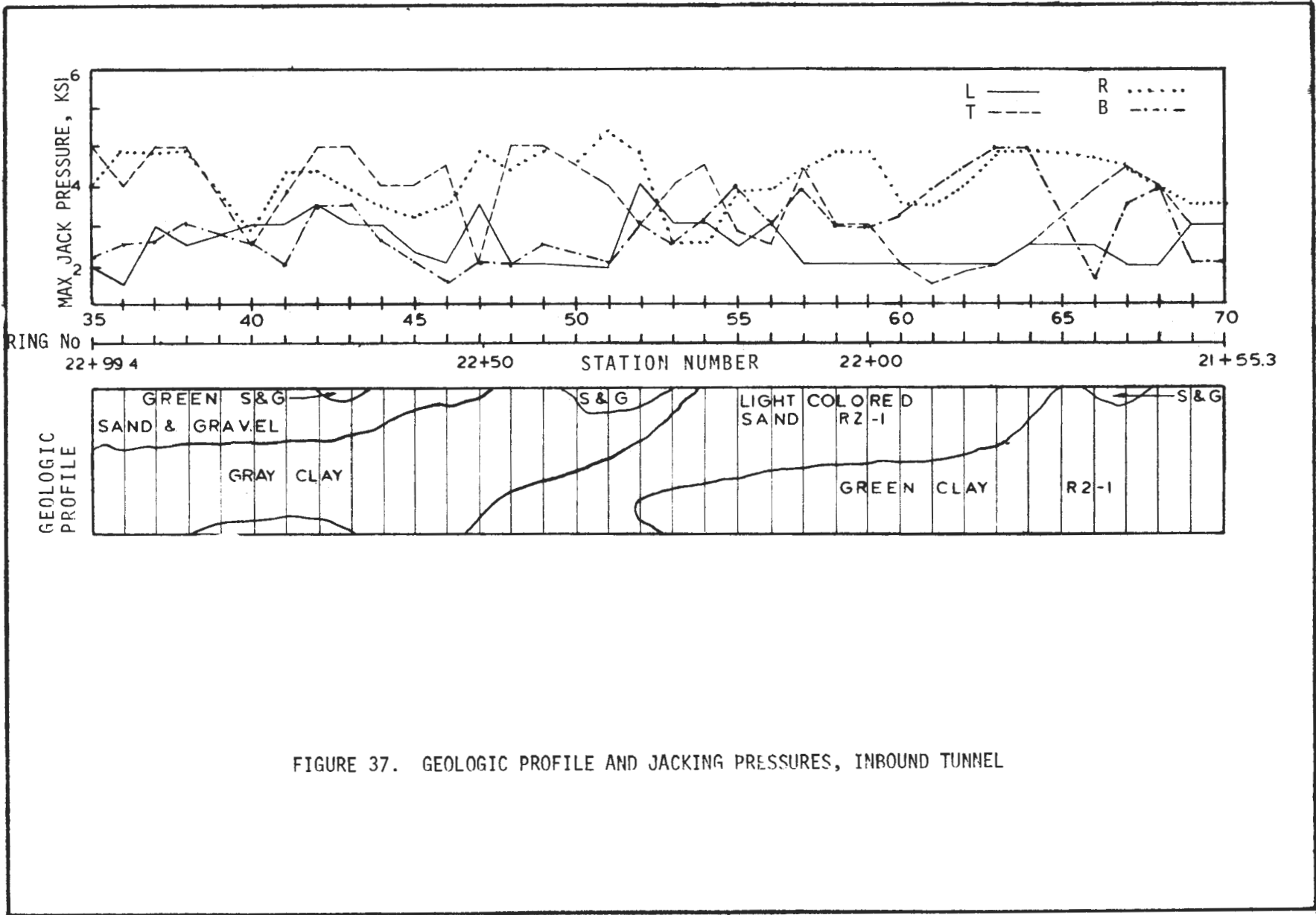

FIGURE 37. GEOLOGIC PROFILE AND JACKING PRESSURES, INBOUND TUNNEL

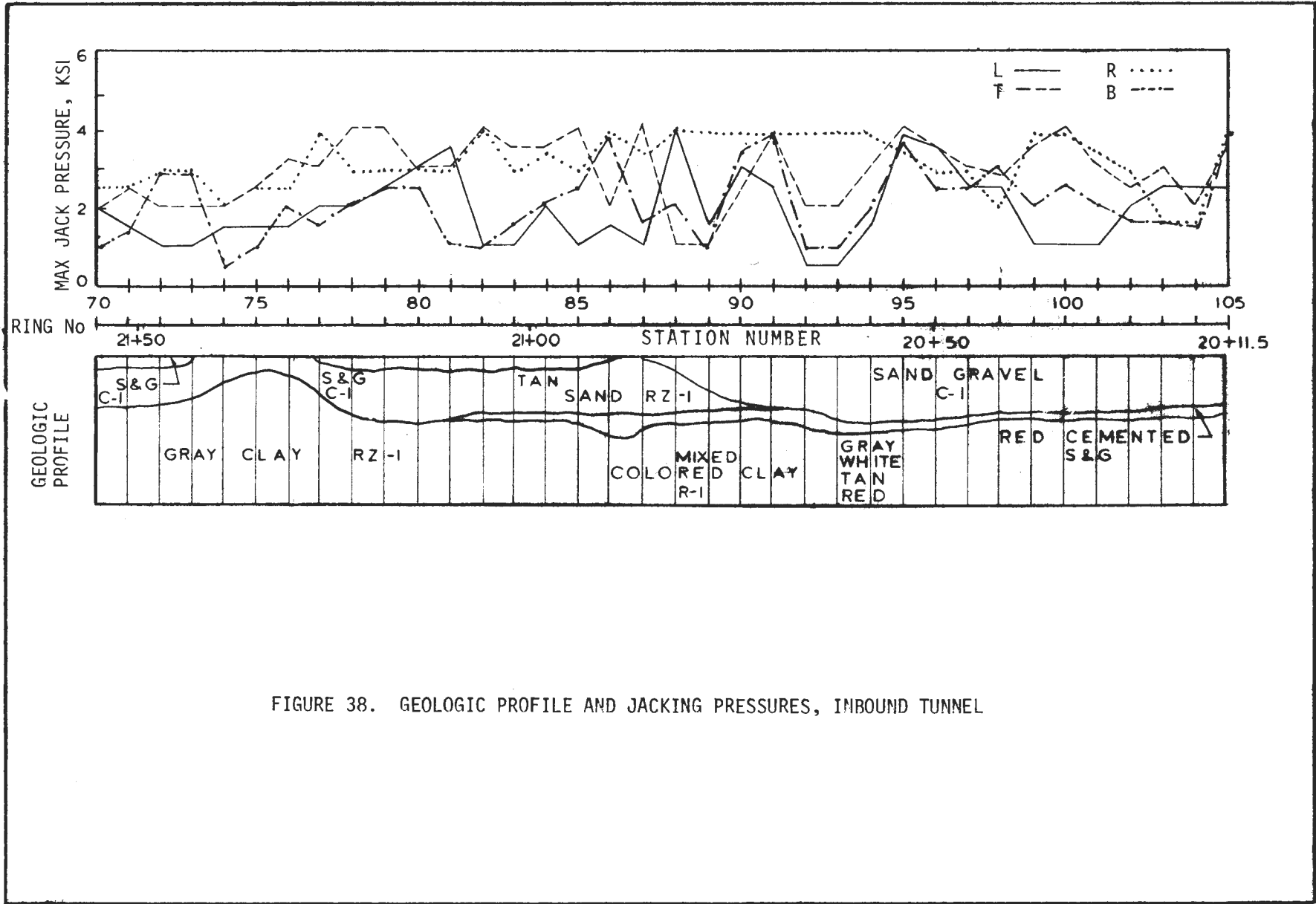

FIGURE 38. GEOLOGIC PROFILE AND JACKING PRESSURES, INBOUND TUNNEL

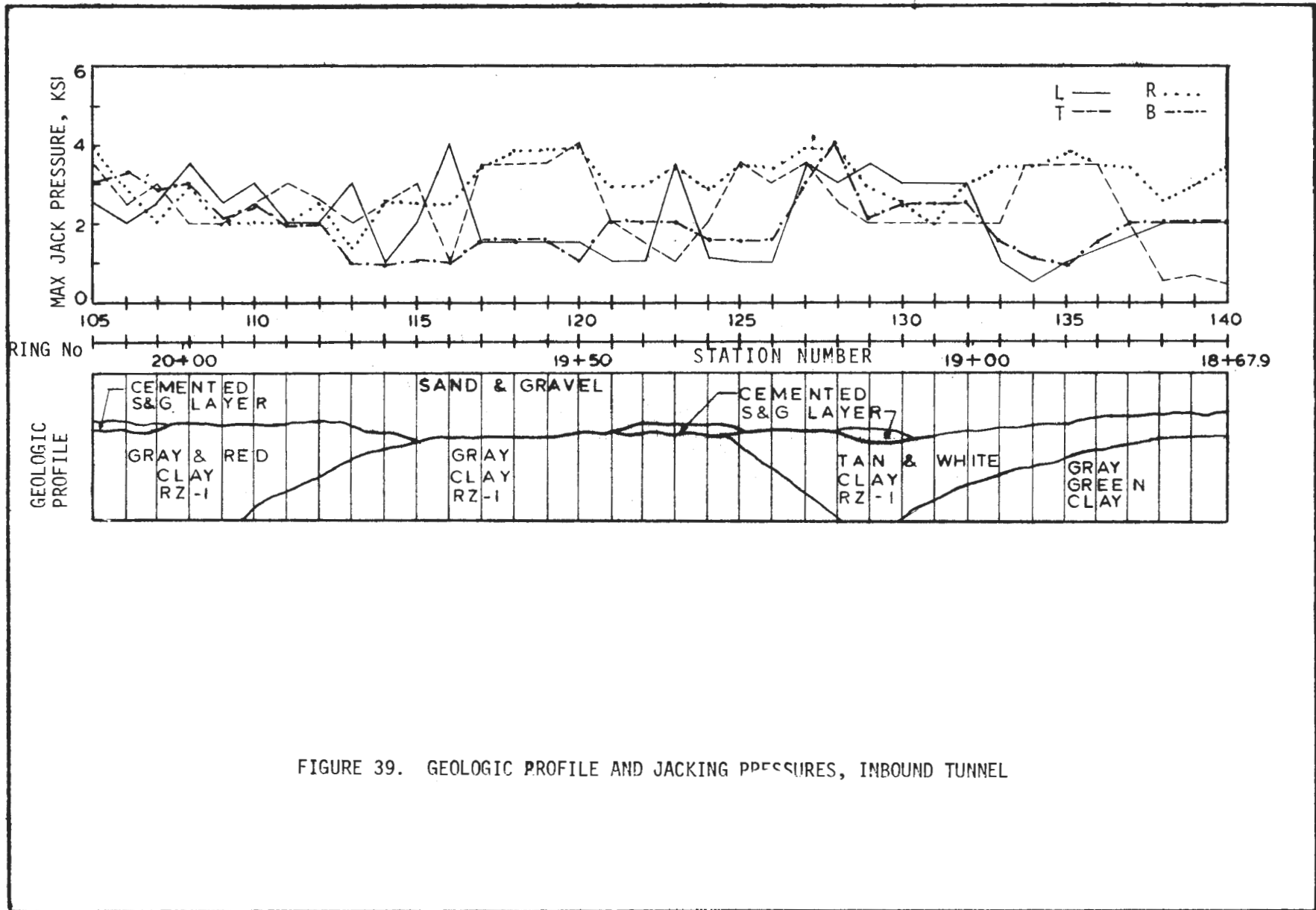

FIGURE 39. GEOLOGIC PROFILE AND JACKING PRESSURES, INBOUND TUNNEL

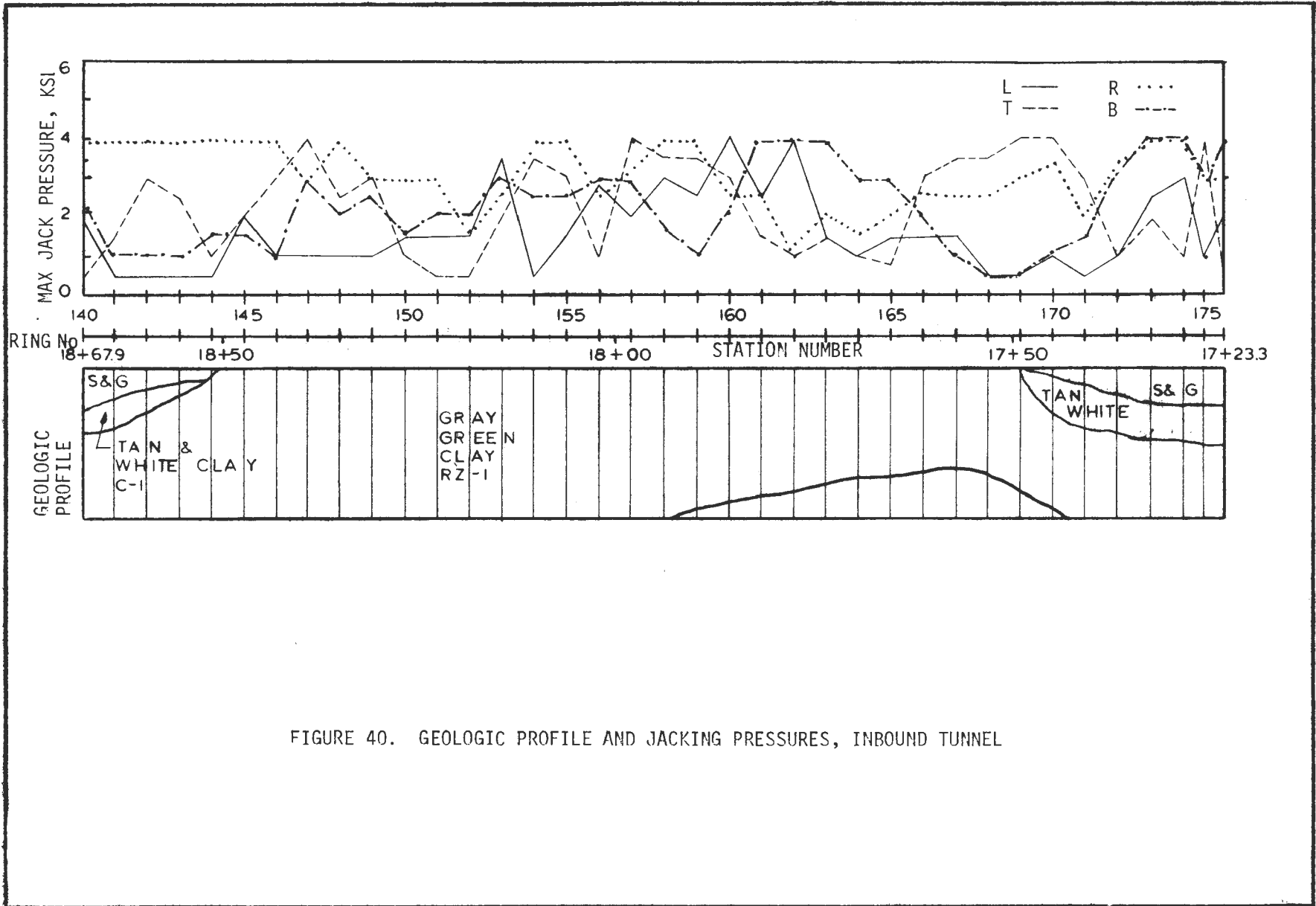

FIGURE 40. GEOLOGIC PROFILE AND JACKING PRESSURES, INBOUND TUNNEL

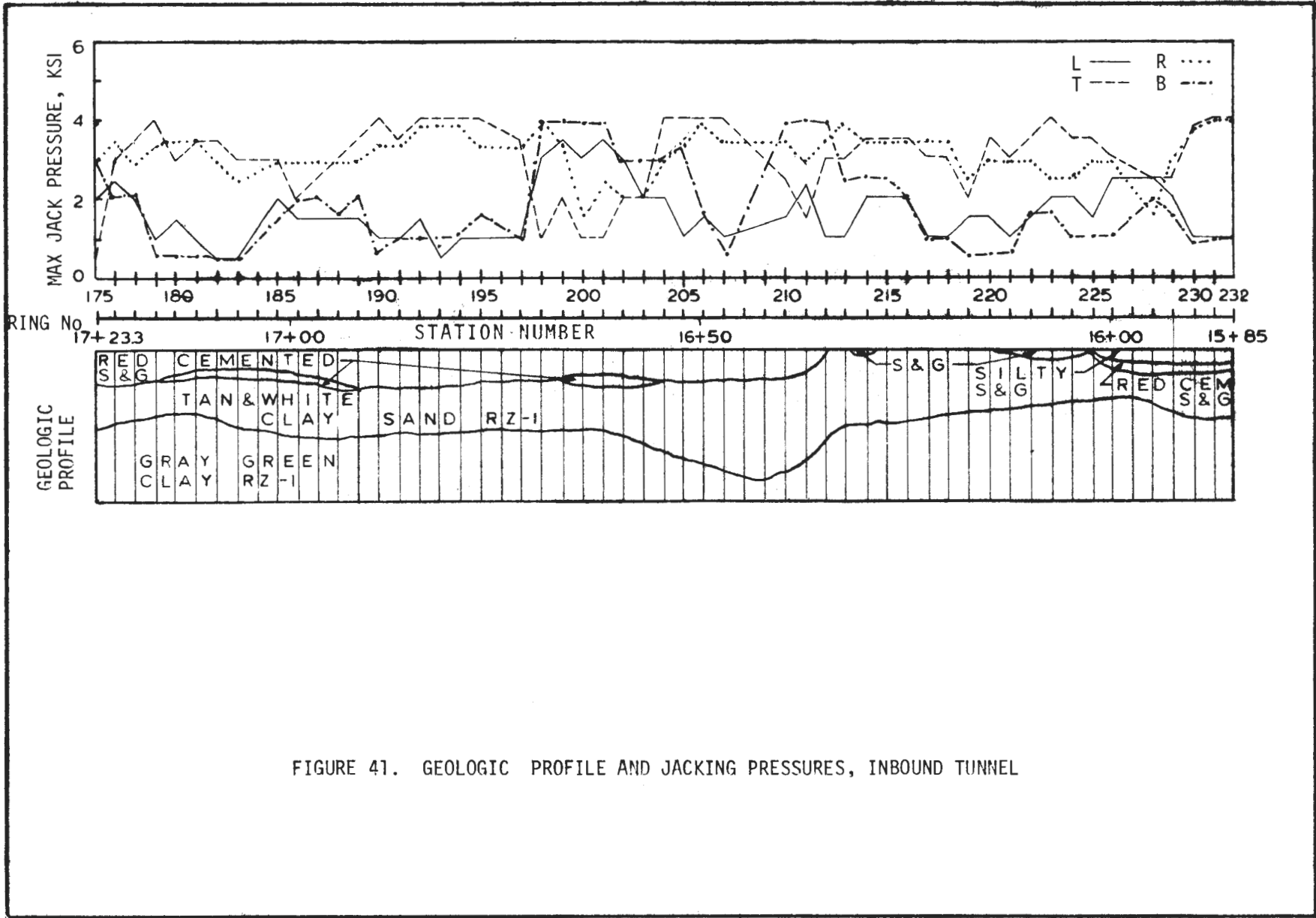

FIGURE 41. GEOLOGIC PROFILE AND JACKING PRESSURES, INBOUND TUNNEL

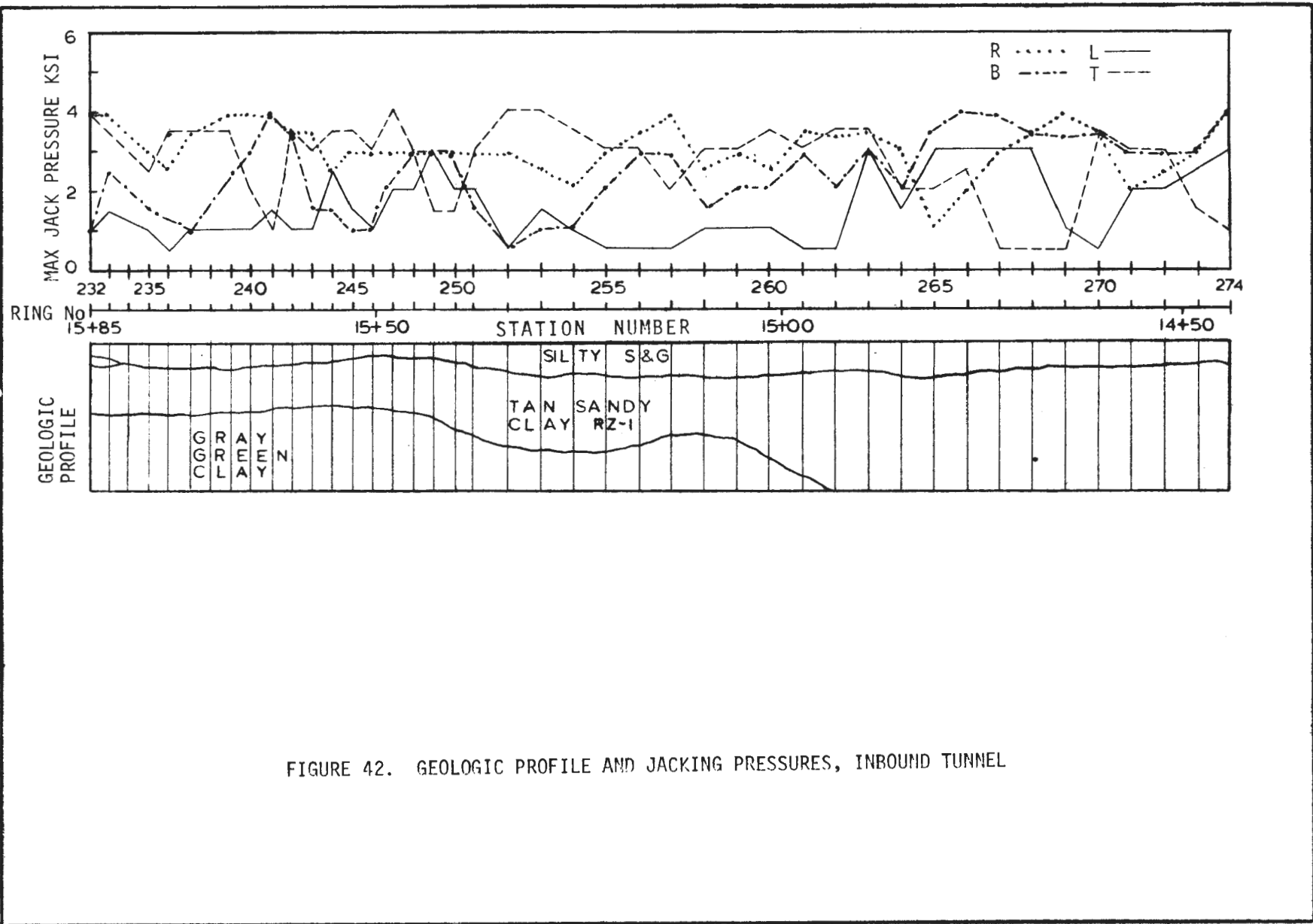

FIGURE 42. GEOLOGIC PROFILE AND JACKING PRESSURES, INBOUND TUNNEL

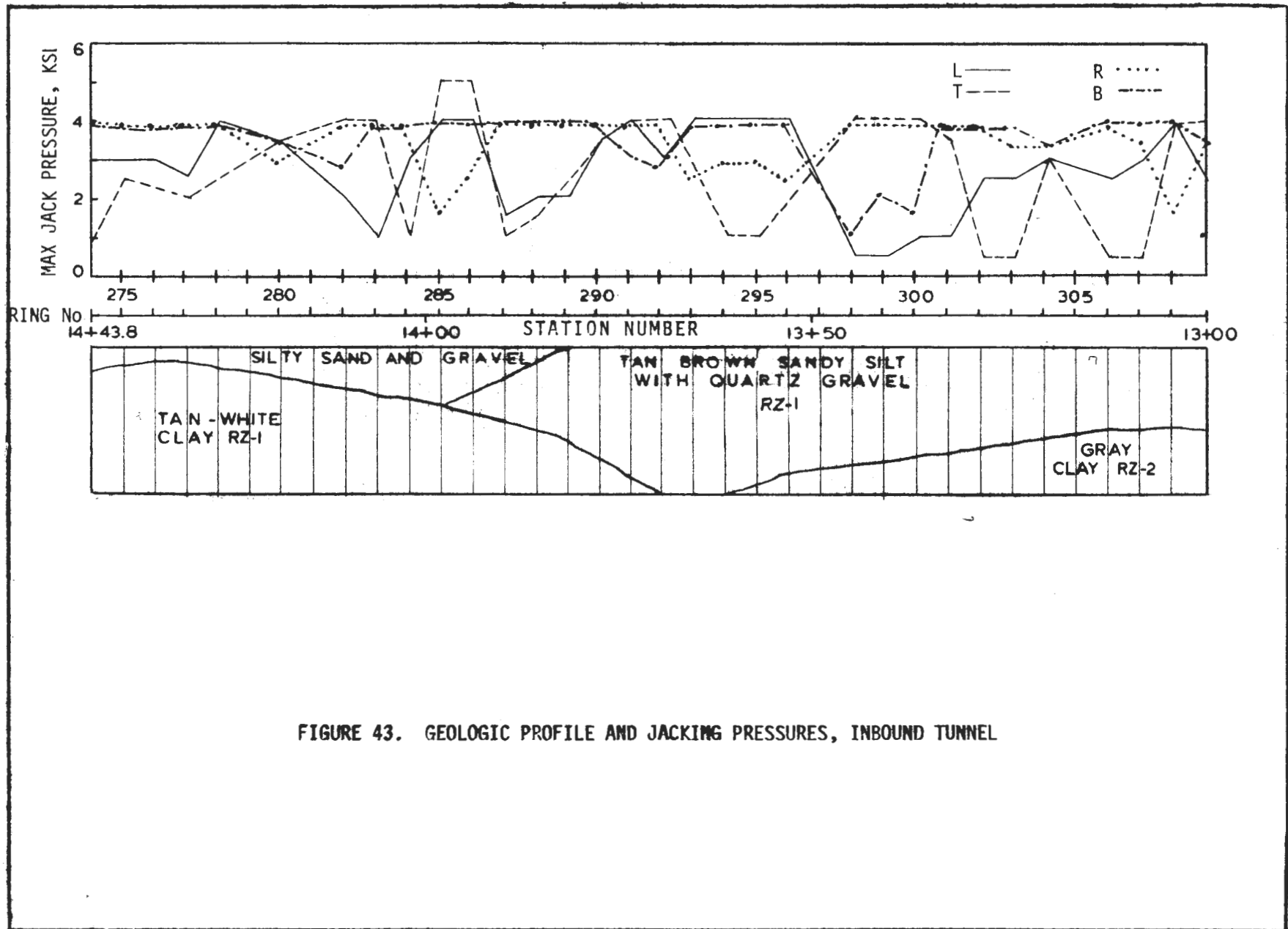

FIGURE 43. GEOLOGIC PROFILE AND JACKING PRESSURES, INBOUND TUNNEL

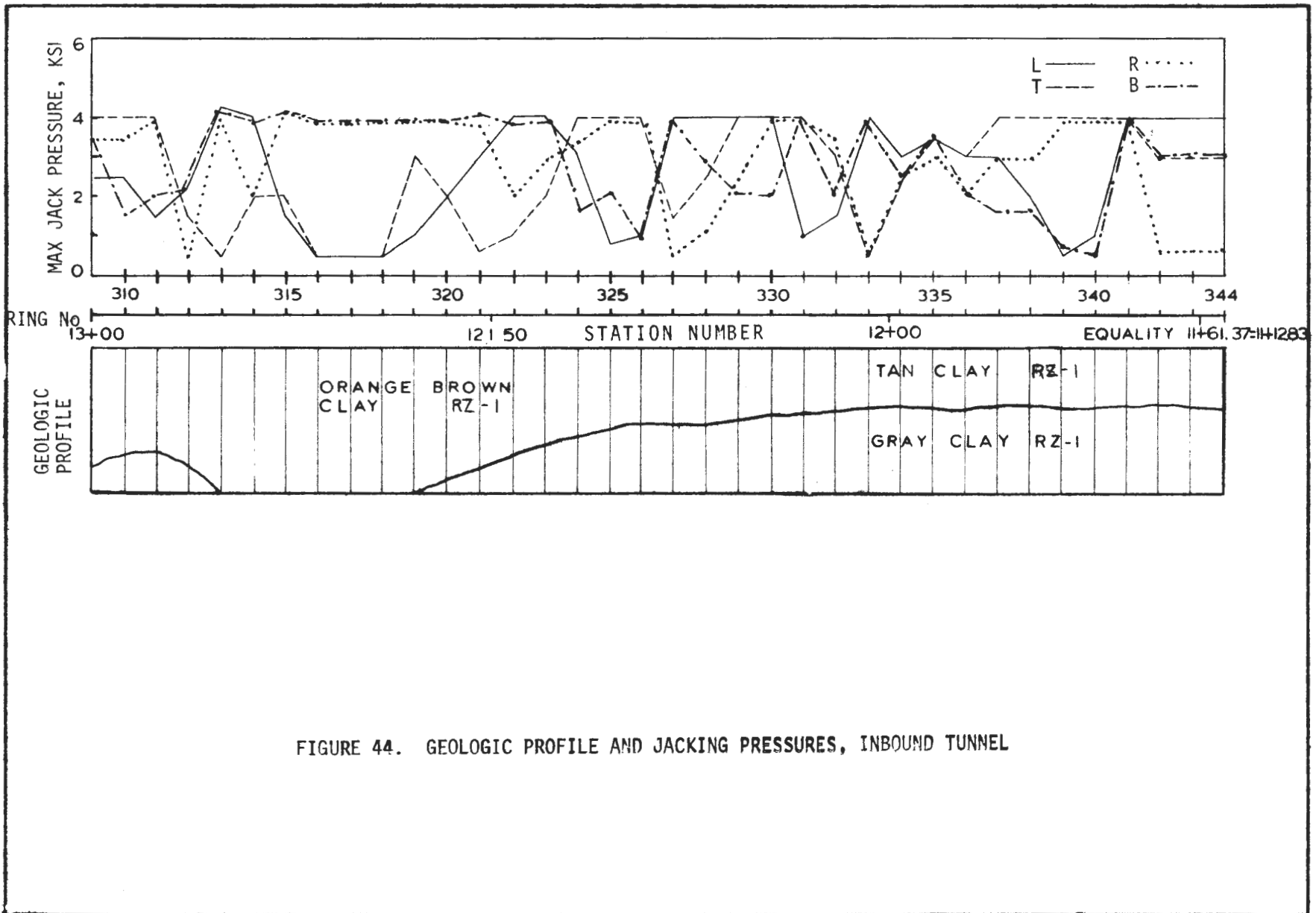

FIGURE 44. GEOLOGIC PROFILE AND JACKING PRESSURES, INBOUND TUNNEL

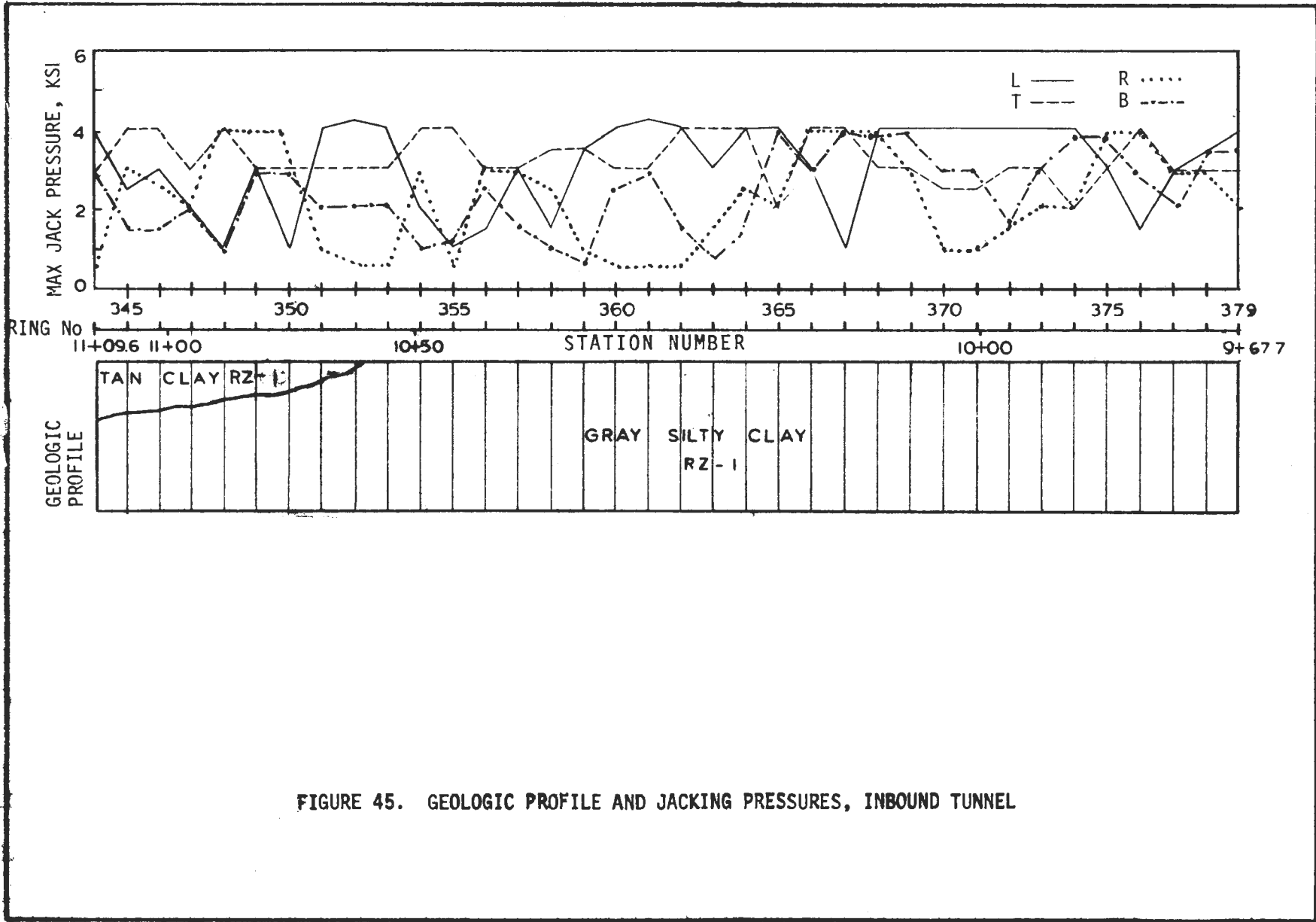

FIGURE 45. GEOLOGIC PROFILE AND JACKING PRESSURES, INBOUND TUNNEL

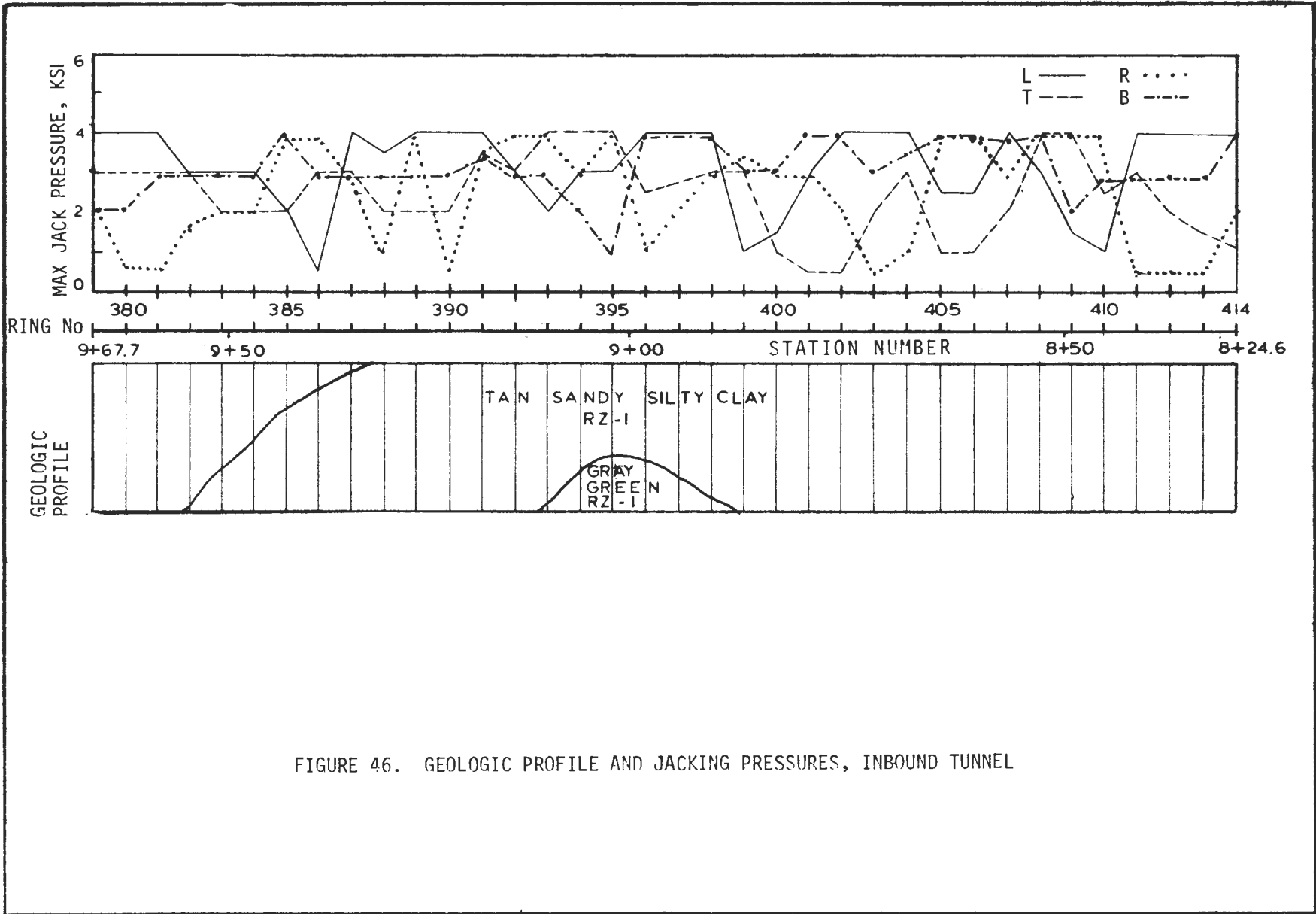

FIGURE 46. GEOLOGIC PROFILE AND JACKING PRESSURES, INBOUND TUNNEL

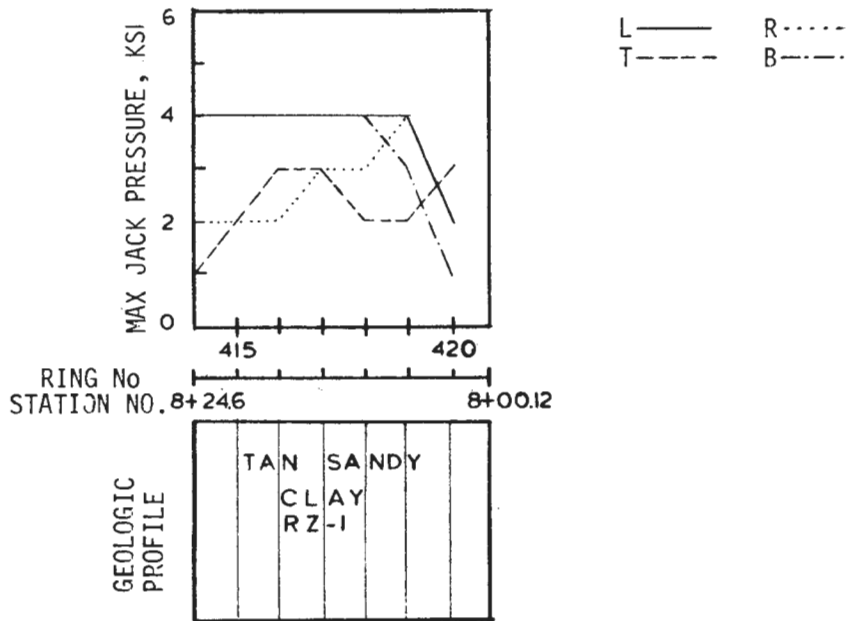

FIGURE 47. GEOLOGIC PROFILE AND JACKING PRESSURES, INBOUND TUNNEL

seepage through clean granular soils can lead to running ground conditions at the face in these soils, no major ground losses at the face were reported for either tunnel. A small soil run accompanied by some water inflow and a small drop in tunnel pressure was noted in the concrete tunnel at approximately Station 16+00. Approximately 8 to 12 cubic yards of C-2 sand and gravel ran into the tunnel near the crown at this location.

PART II. TECHNICAL PERFORMANCE

6.0 STEEL PLATE LINED TUNNEL

6.1 Design and Manufacture

6.1.1 General

The geology and groundwater conditions expected to be encountered during the construction of the Lexington Market Tunnels, as described in Section 5.0 of this report, and the necessity of minimizing settlement of building foundations along the tunnel route, resulted in the adoption of a shield and compressed air method of tunnel construction.

In selecting a lining system, consideration was given to the potentially feasible and economical systems available. Particular attention was given to ribs and lagging, and segmental linings of either steel, precast concrete, or cast iron. Steel ribs with timber lagging were ruled out for several reasons. The timber lagging and possibly any hay that would be needed for ground control presented a fire hazard under compressed air. It was also concluded that the cost advantage of this system would be offset by the necessity of having to place a secondary concrete lining while the tunnel was still under air pressure. Additionally if leakage became a problem the secondary lining would have to be placed as close to the shield as possible causing congestion at the heading and a drastic decrease in the heading advance rate.

During 1976 when the Design Summary Report⁽¹²⁾ was released the reliability of suppliers to deliver cast iron linings was in doubt. Therefore, although cast iron was technically feasible, it was not included as an alternative lining system. The remaining systems, fabricated steel and precast concrete, were the two alternative tunnel linings chosen. A segmented steel liner was chosen as the system to be used in the inbound tunnel. (Reference 12 states the steel lining was to be used in the outbound tunnel. This was subsequently changed to the inbound tunnel.)

6.1.2 Design Load Considerations

The theories, assumptions, and the detailed calculations are contained in References 10 and 11. A brief discussion of the factors considered in developing the various design loads is presented in the following paragraph for convenience.

Water Pressure: From Charles Center Station (Station 8+00) to Station 16+00, a design hydrostatic water pressure of 2750 psf was recommended.

From Station 16+00 to Lexington Market Station (Station 24+00) a hydrostatic pressure decreasing from 1900 psf to 900 psf was recommended. These recommendations include the effects of water table fluctuations of approximately 6 feet.

Earth Loads: From Station 8+00 to Station 16+00 the earth loads were calculated assuming the ground responded as a cohesive soil. The effect of soil arching was taken into consideration, but was assumed to be only partially developed due to the presence of several deep basements in this section of the system. Therefore, an effective vertical earth pressure of 2500 psf was recommended.

From Station 16+00 to Station 24+00 full arching was assumed to develop in the predominantly granular soils of this section and an effective vertical earth pressure of 1500 psf was recommended.

Grouting Pressure: A radial pressure of 2900 psf acting around the entire circumference of the lining plus a localized pressure of 1450 psf over a 60° arc were recommended for design purposes. This is equivalent to a pump pressure of approximately 30 psi.

Jack Forces: Jacking forces required to overcome skin friction while tunneling through cohesionless material were estimated to be approximately 1700 tons. Forces required to advance the shield through cohesive soil were estimated assuming a shield equipped with and without an overcutting bead. Forces of approximately 700 tons and 1500 tons were estimated for a shield with and without a bead respectively. In addition, a force of 250 tons was the estimated requirement to overcome soil bearing capacity along the shield cutting edge when advancing the tunnel through cohesive soil. Steering problems which might necessitate uneven jack forces were estimated to double the estimated forces required during a straight drive.

Based on these expected forces and assuming a shield equipped with 20 jacks, reference 10 concluded that "straight drive single jack force would be about 85 tons, but the maximum jack force could reach a magnitude of 170 tons." In actuality a shield equipped with 24 - 125 ton capacity jacks successfully advanced both tunnels.

6.1.3 Fabricated Steel Plate Liner Design

Each of the fabricated steel rings consisted of five segments plus a key. The required fabrication and construction tolerances are detailed on Figure 48.

The contract specification limited leakage to a value not to exceed 0.07 gpm per 100 linear feet of tunnel, and not to exceed 0.05 gpm for any 10 foot section. The gasket system designed to meet this specification consisted of a molded

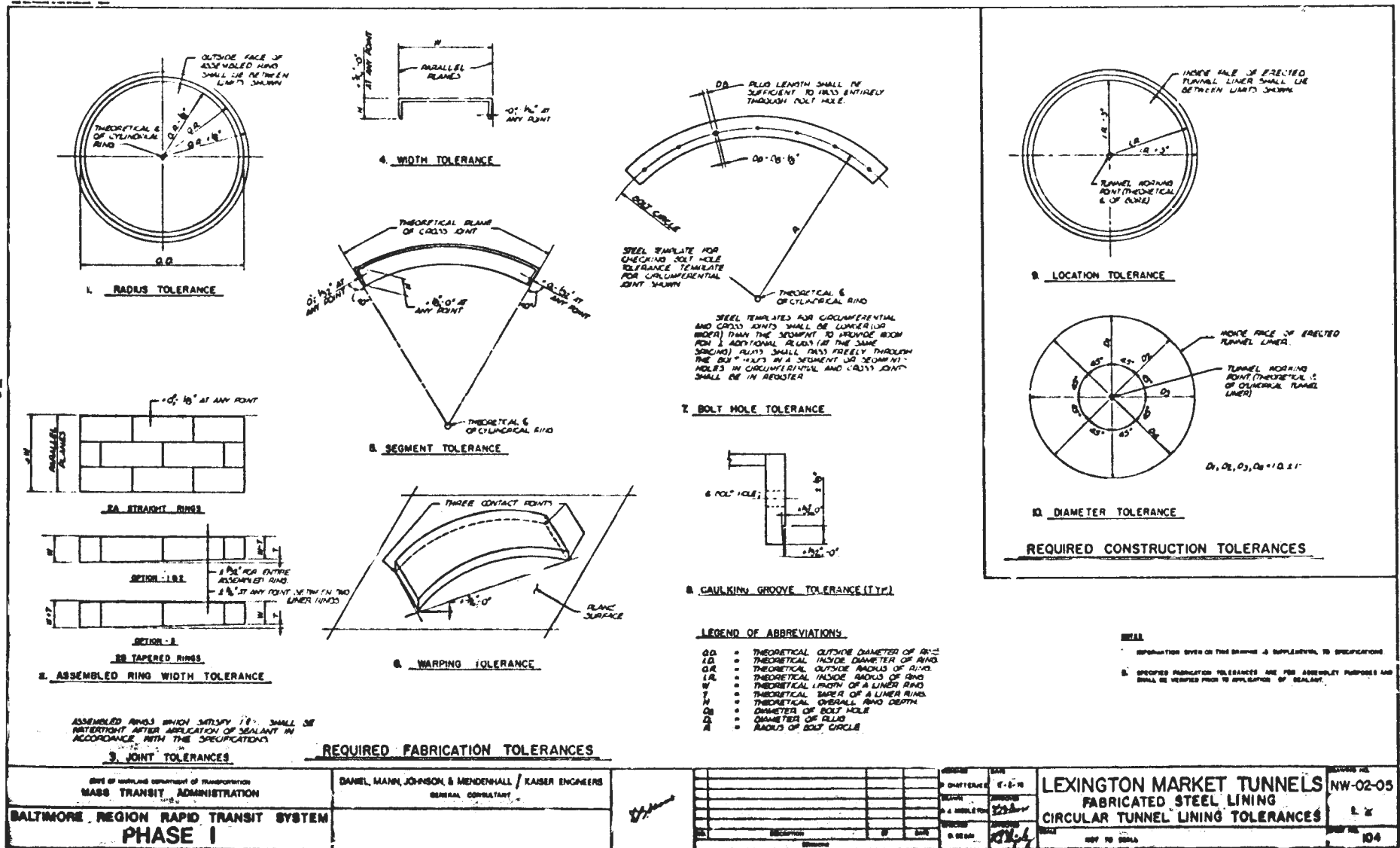

FIGURE 48. FABRICATION AND CONSTRUCTION TOLERANCES

epoxy gasket applied by the manufacturer to two sides of each segment. The ungasketed sides mated with gaskets of adjacent segments. To protect the liner from corrosively active soils and to provide cathodic protection from any stray electrical current, a 16 mil thick coal tar epoxy coating was applied to the earth face and an inorganic zinc silicate coating was applied to the interior surface.

The 48 inch segments were fabricated from 24 inch rolled channel sections. The two 24 inch channels were welded to a center rib (T-section) and longitudinal and radial stiffeners were added to accommodate the design loads. The segments were a modification of rolled channel segments successfully used in the WMATA D-4A tunnel.

To facilitate construction of the two cross passages special rings were designed and erected at the cross passage locations in both the steel and concrete lined tunnels. When tunneling was completed excavation of the cross passages commenced. The specially designed rings enabled the contractor to remove segments while maintaining the structural stability of the tunnels.

To minimize noise and vibration the steel as well as the concrete tunnels incorporated a floating slab as part of the final invert slab over a portion of their lengths.

6.2 Tunneling and Liner Erection Procedures

The first line tunnel to be driven was the inbound tunnel. Originally this was to be the precast-lined demonstration tunnel, however at the contractor's request steel lining was permitted and alternatively, the precast demonstration liner was switched to the outbound tunnel.

Tunnel excavation was to begin at the workshaft near the intersection of Lexington and Eutaw Streets and proceed south and east along a primarily curved alignment to the contract limits of the Charles Center Station.

6.2.1 Basic Tunneling Equipment

The shield assembly was originally built to Traylor and Associates' specifications by the Robbins Company, for use on the Washington, DC metro. It was successfully used on WMATA Sections F-2a and G-1, and was overhauled and fitted with a new skin for the Lexington Market Tunnel. The shield assembly and trailing gear are illustrated in Figure 49.

Features:

- An hydraulic digger spade broke out material and fed it up a loading apron to a conveyor. The conveyor carried material upward and to the rear of the trailing equipment where it was dumped into waiting 6 cubic yard muck cars.

SYMBOLS

- SL - Spring Line
- BT - Breasting Table
- GS - Grout Seal
- WP - Work Platform
- TJ - Thrust Jacks
- BD - Breasting Door (4)
- EX - Excavator Spade
- CS - Conveyor System
- GM - Grout Mixer
- GP - Grout Pump
- TR - Thrust Ring
- EA - Erector Arm (2)
- TG - Trailing Gear
(Hydraulic & Electric Power Supply)

Dim.	Nominal	
	ft/in	m
D-1	19'11"	6.1
L-1	7'5"	2.3
L-2	7'5"	2.3
L-3	21'7"	6.6
H	5'6"	1.7
T ₁	0'1"	.025
T ₂	0'3"	.076
N	1'10"	.56

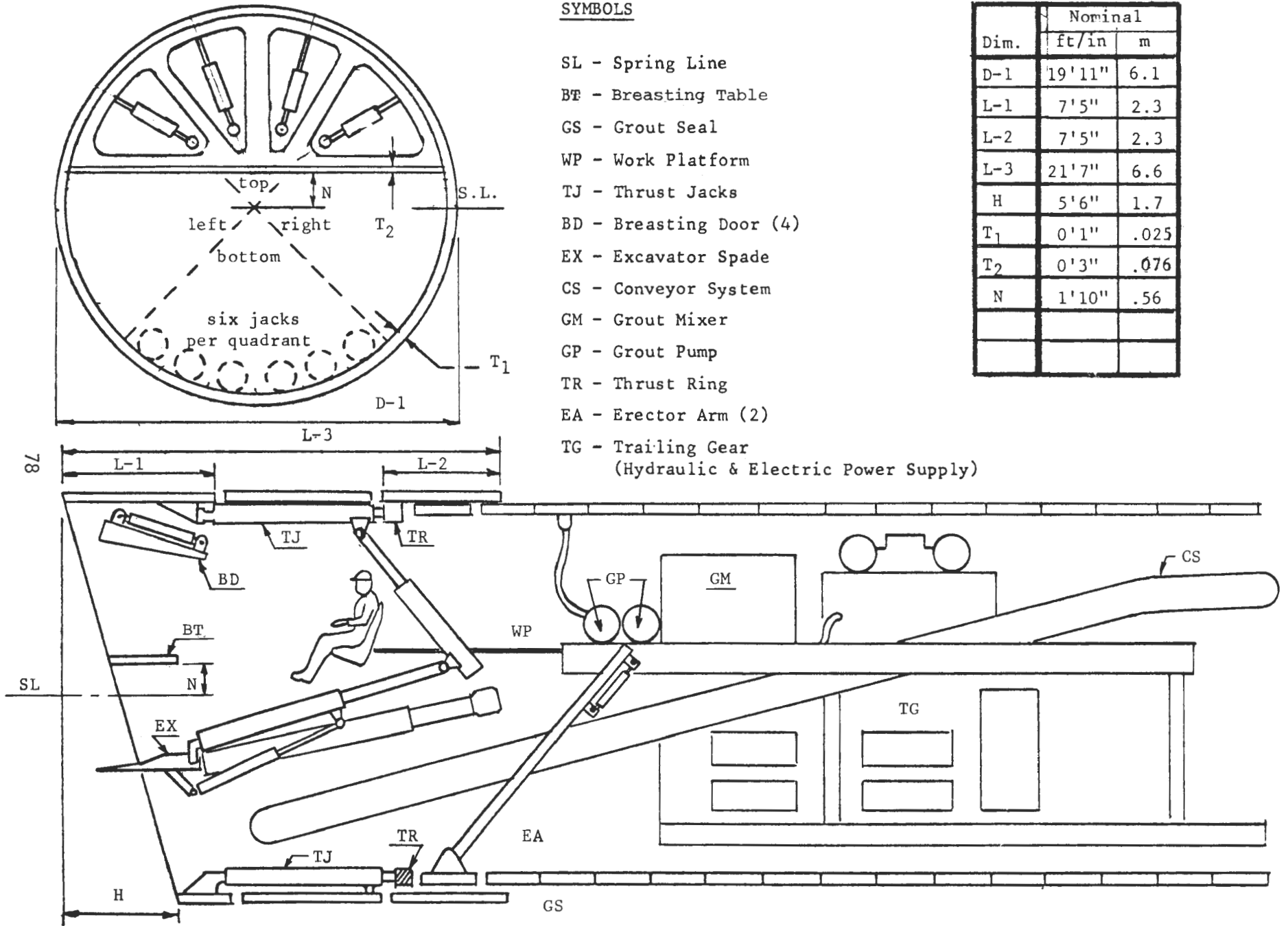

FIGURE 49. TUNNELING MACHINE ASSEMBLY

- The trailing gear was mounted on a sliding platform which could move with the shield as the tunnel advanced. The platform was equipped with tracks on either side of the trailing equipment so that rail cars could deliver construction materials close to the heading and muck cars to the excavator conveyor.

- The hydraulic powered erector arms mounted on each side of the trailing gear were used to unload segments from flat cars and move them into position for assembly. Also included was a diaphragm type grout pump for backfilling the assembled rings.

- The shield was equipped with four hydraulically operated breasting doors (Figure 50). The shield was articulated (required by specifications) to facilitate steering and was equipped with 24-125 ton jacks. It was also equipped with a spring steel-rubber backed tail seal to prevent water and grout from entering the tunnel between the shield and the liner.

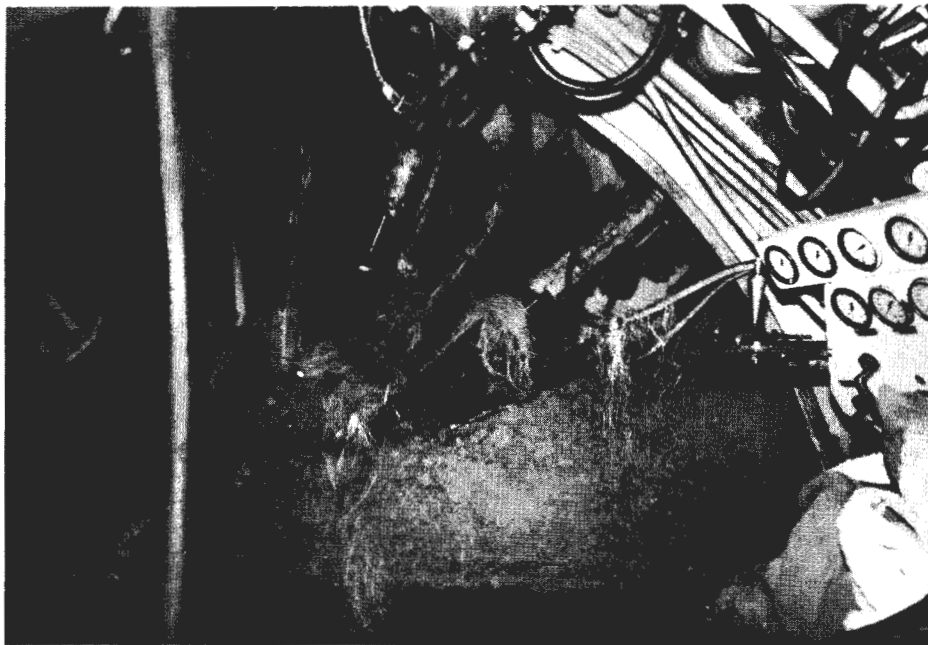

FIGURE 50. HYDRAULIC BREASTING DOORS IN USE

- Power was supplied to the shield by three hydraulic pumps, each with 3 phase, 480 volt motors of 60 HP, total 180 HP. The excavator was supplied by four hydraulic pumps having a total of 285 HP.

- Transportation in the tunnel was by rail. The locomotives were 10 ton electric (battery) powered vehicles. Switching was possible either on the heading platform or at a second switching platform located just beyond the air lock.

● Only one air lock was used, which passed men, materials and equipment into and out of the compressed air tunnel (Figures 51 and 52).

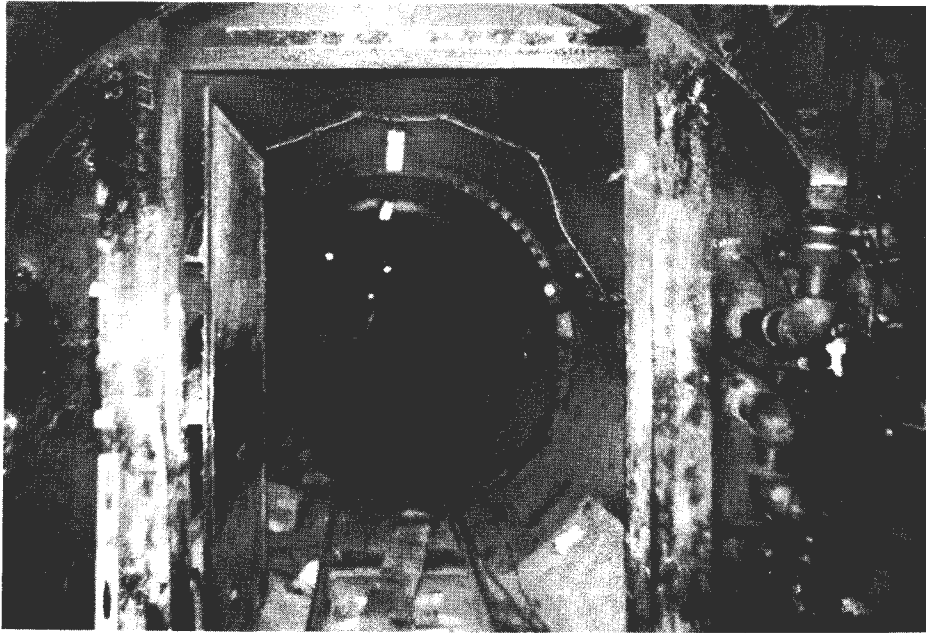

FIGURE 51. AIRLOCK



FIGURE 52. AIRLOCK

- A small batching plant was located in the shaft area for proportioning the materials that were used in the backfilling grout (see Figure 53).

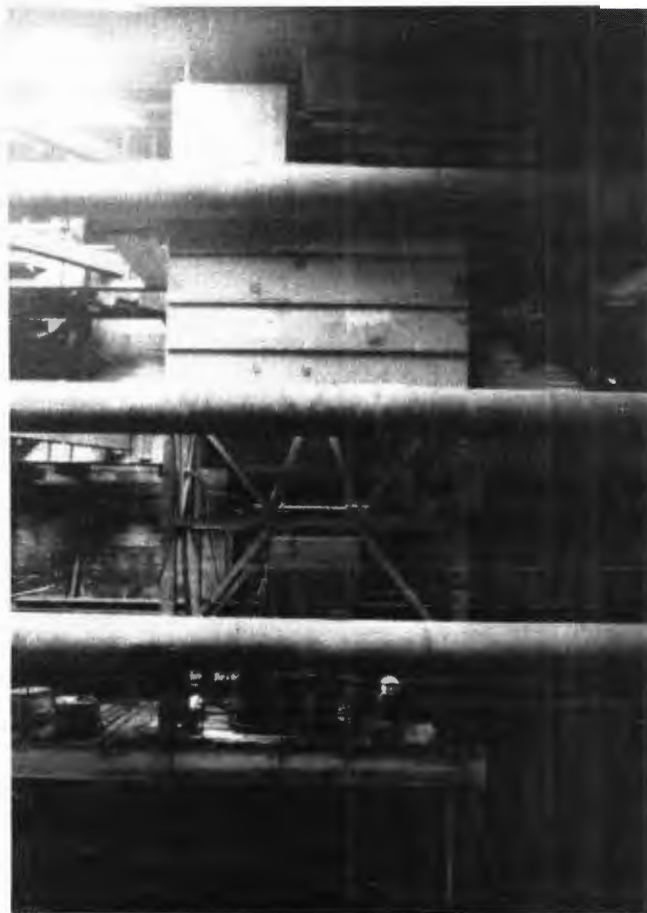

FIGURE 53. GROUT BATCHING PLANT

- The tunneling operations were serviced by a 100 ton Crawler Crane (Manitowac 3900) at the work shaft.

- A battery of electric air compressors of various size and manufacture, housed in a separate building at the worksite, supplied high pressure air for powering tools and equipment, and low pressure air for tunnel support.

- Yard equipment consisted of a Cat 966 front end loader for loading tunnel muck into trucks for removal from the site, a 20T hydraulic crane, 2 fork lifts and the usual complement of welders, pumps, pick-up trucks and incidental tools and equipment.

6.2.2 Tunneling Methods and Procedures

Setting up for tunneling started with the construction of a concrete cradle in the invert of the workshaft, on which to build and launch the shield. A

reaction ring made of structural steel members was then erected to provide jacking resistance for initial shove.

The shield was then assembled on the cradle and prepared for the initial shove. Figure 54 shows the reaction ring and assembled shield on the cradle for the outbound tunnel. The soldier beams were then cut and the shield carefully advanced into the portal face as lagging was removed.

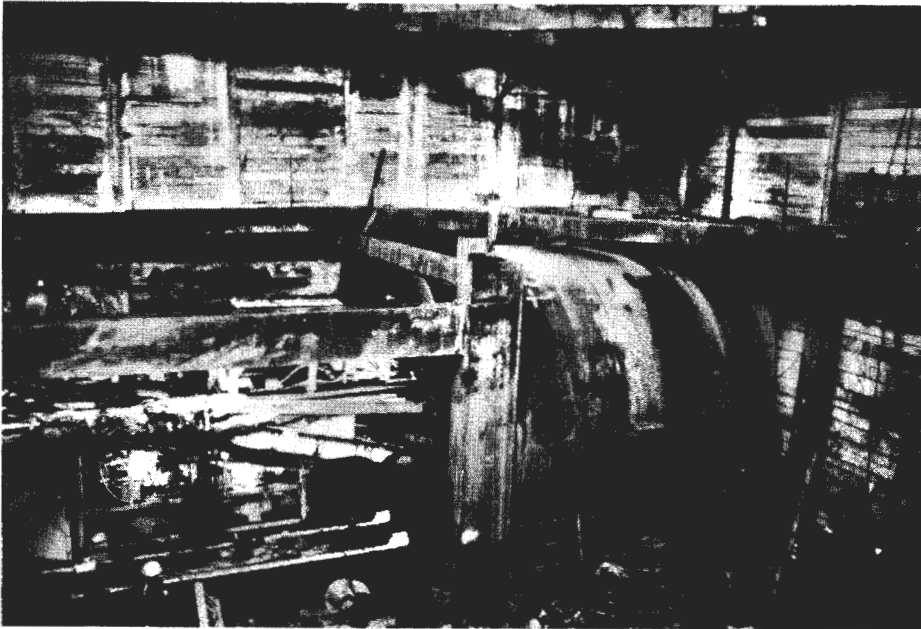

FIGURE 54. SHIELD AND REACTION RING ASSEMBLED FOR INITIAL SHOVE

"False" or "umbrella" rings of steel plate were erected in the shaft area ahead of the erection ring as each succeeding shove progressed, in order to provide continuing surface for the shield to jack against. Figure 55 shows these false rings which were subsequently removed when the shield was sufficiently advanced.

The contractor then drove about 275 feet of tunnel through ground in which the water table had been lowered by a deepwell dewatering system. At this point, tunneling was stopped while a bulkhead and airlock were installed. The remainder of the tunnel was driven under compressed air with maximum pressure of 12 psi.

A typical excavation cycle was as follows:

- The shield was shoved four feet while excavating with the digger arm from center. Muck was transported to the rear of the assembly by conveyor where it was dumped (end delivery) into 6 cubic yard muck cars.

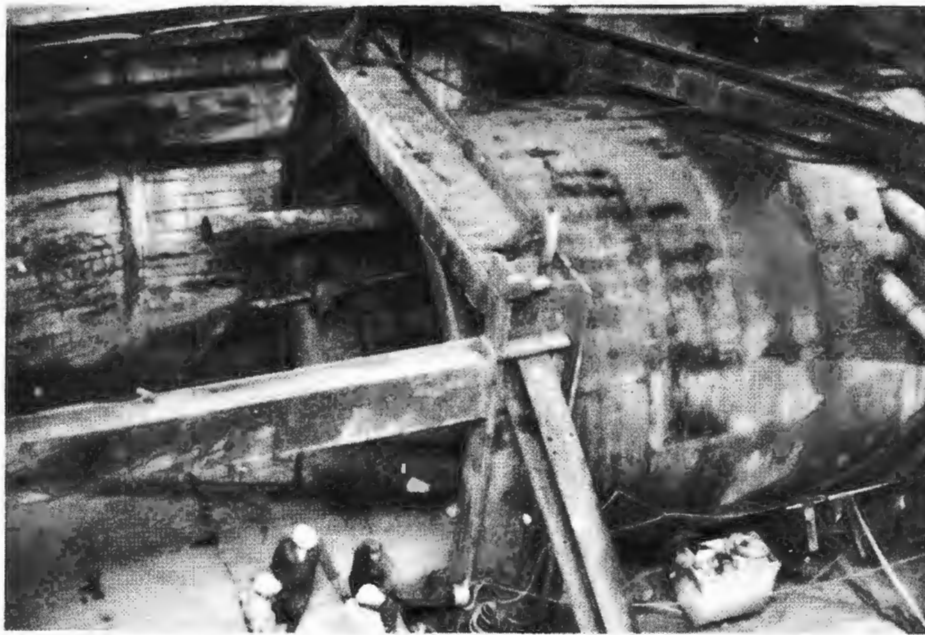

FIGURE 55. FALSE RINGS

- The jacks and push rings were retracted at the end of the shove and the liner ring was assembled after being brought to the face on flat cars at the front of the returning muck trains.

- The track switch assembly was employed to place a carload of segments on either side of the shield back-up equipment. This allowed both erector arms to be used independently and simultaneously to build the ring. The ring was assembled by bolting individual segments to the previous ring. The erector arm was clamped to the center web of the segment which was then lifted from the flat car. The segment was pivoted by hand and positioned into place by the erector arm where it was bolted to the previously placed segments (see Figure 56).

- Thrust jacks were then repressurized and the cycle repeated.

- Backfill grout was injected through grout holes in the liner to fill the annular space between the soil and the liner. Full grouting was maintained up to the tail of the shield. The shield tail seal permitted this to be done with minimal loss of grout into the tunnel work area.

- Four operators were used on the shield; two operated the shield itself, occupying stations at separate controls at the front of the machine. One controlled the thrust jacks and the breasting doors, the second operated the excavator. In addition, an operator was needed to run the conveyor, and another for the shield mounted grout pump. The shield operators also ran their respective erector arms on either side of the shield during the ring erection cycle.

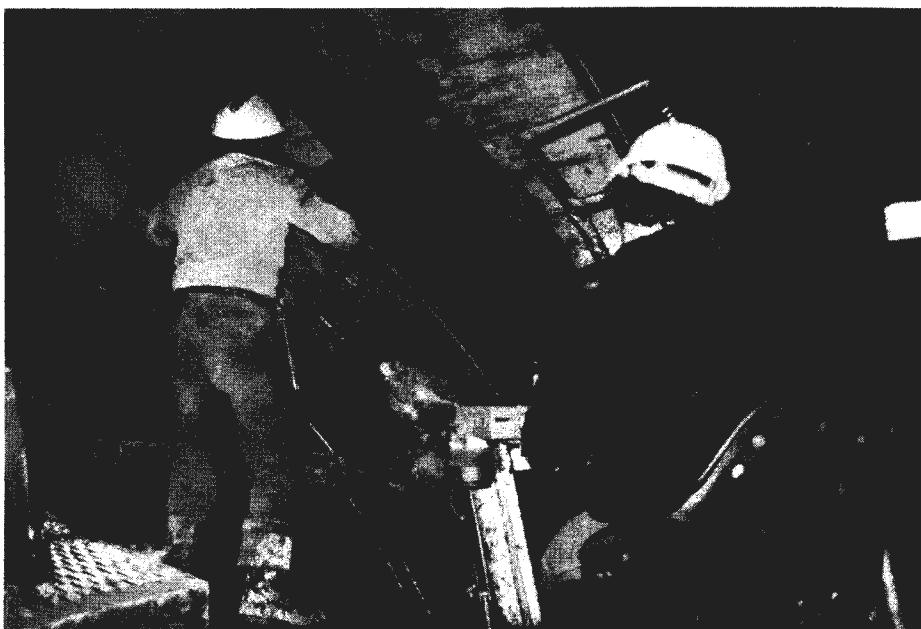

FIGURE 56. RING #273 ON INBOUND TUNNEL

- Two trains were used for normal operations, requiring two motormen. Brakemen were not required. Two muck cars per train were normal with a supply car at the head of each train. The supply car might be a flat car with segments, utility line pipe, or other construction materials, or it might be the grout car which transported the premixed backfill grout to the heading.

- The guidance system for the shield consisted of a laser and target system, augmented by a plumb-bob and grid located at the operator's controls. The laser was mounted on supports located from 100-500 feet behind the tunnel face and aimed at a predetermined alignment and gradient. The laser beam was directed to two targets mounted on the shield assembly, on which were traced two computer paths. By matching the laser beam to its path on each target, the shield operator could maintain alignment (see Figure 57).

- A plumb bob suspended over a gridded target allowed the operator to determine the pitch and/or roll of the machine itself; a necessity for proper steering.

- The railroad track and utility lines were extended during the ring erection cycle when the track was not in use.

The muck lock was sized so that the locomotive and three rail cars could pass in or out together. The usual train consisted of the locomotive, two muck cars, and one flat car for supplies. The locomotive operator would pull the train into the lock but would not remain with it. Once compression or decompression took place,

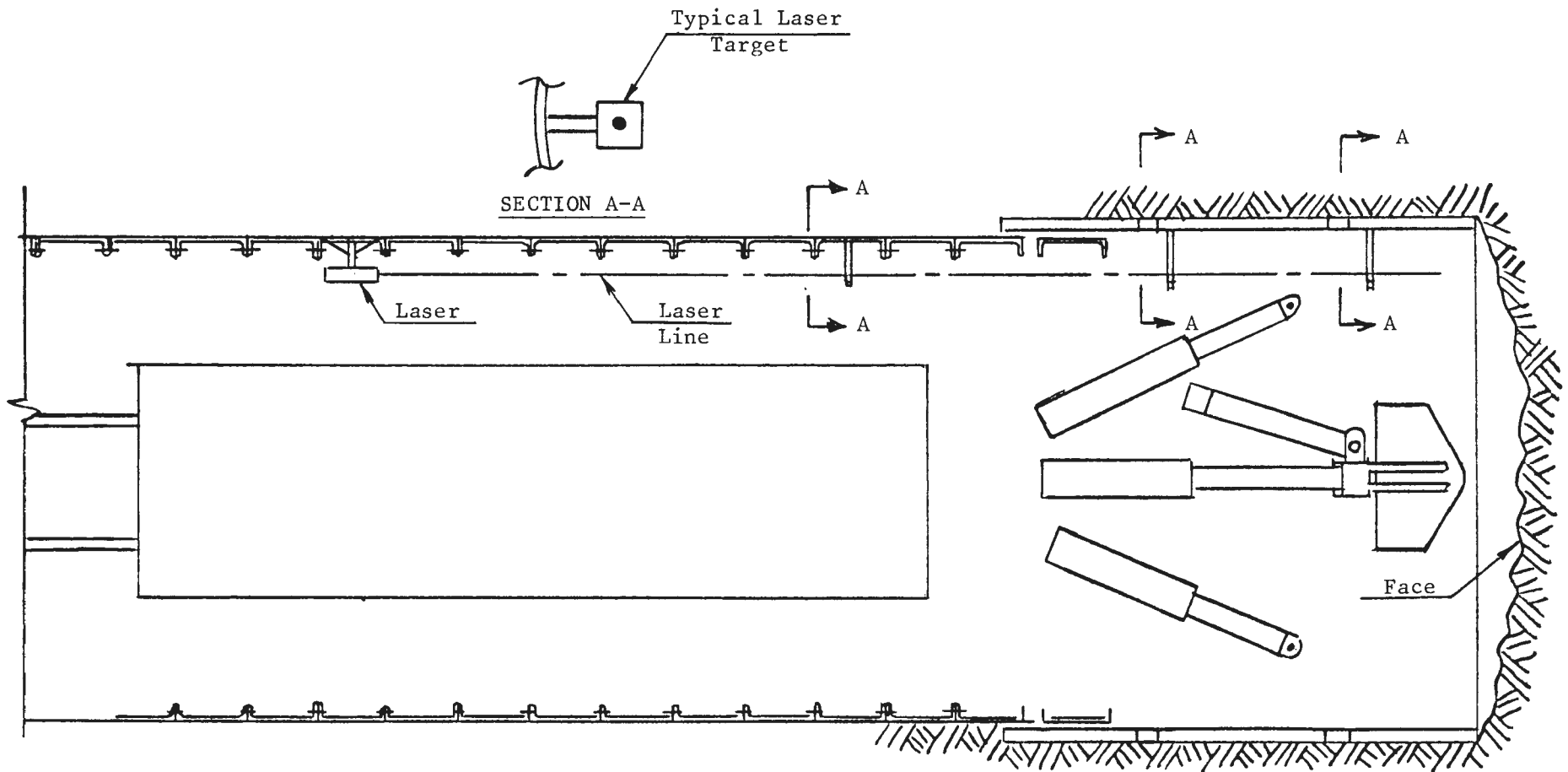

FIGURE 57. LASER CONTROL PLAN VIEW

another operator would be waiting on the other side of the bulkhead to board the train and remain with it to its destination. Consequently, three motormen were needed for 2 trains (2 inside, 1 outside) but time was saved since the train could be decompressed in only a few seconds, while decompression time for personnel at 12 psi is 3 minutes minimum.

The muck cars were large steel "buckets" sitting on a flat car frame. To empty them, a sling was lowered by the shaft crane and hooked to the muck car bucket. The bucket was then lifted from the shaft and dumped into a three sided muck bin, where the material was loaded by a 966 front end loader into trucks for off-site removal (see Figures 58 and 59).

The B&O railroad tunnel was underpassed without incident, although the contractor was required to work continuously in this area, rather than his customary 2 shift/day, 10 hours/shift routine.

The only major departure from the above routine transpired in mid-December, 1978, when the shield encountered rock at the face. At about Station 17+75, this material became too hard for practical excavation with the mechanical excavator and it became necessary to shut down the operation and consider alternate methods. Approval for blasting was quickly forthcoming. The air pressure was reduced to atmospheric, the shield equipment matted and protected and careful blasting began. The shield was advanced approximately 25 feet in this manner before blasting was terminated and construction could proceed again in normal fashion.

Ultimately, the tunnel excavation reached its southern terminus at the limits of the future Charles Center Station. The tunnel face was bulkheaded off with steel beams and timber lagging, and the tunneling equipment dismantled and removed. The shield skin itself was left in place, there being no practical way to remove it.

The remaining work to be done in this tunnel consisted of sealing water leaks, concreting the invert and installation of cross-passages.

Watersealing was a fairly simple matter. The liner plate bolts were simply tightened until the leaks were sealed.

Invert concreting operations were done in a conventional manner, starting from the extreme end of the tunnel and proceeding toward the work shaft in a systematic manner. The railroad track was first removed in sections as the work progressed. Next the invert was cleaned with the assistance of a compressed air blow pipe. Form, reinforcing steel, drain pipe and other embedded items were then



FIGURE 58. MUCK CAR BEING LIFTED UP THE SHAFT



FIGURE 59. MUCK CAR BEING DUMPED INTO BIN

installed and the concrete placed. Generally, placements were made in one lift and in bulkheaded sections 150 to 200 feet long. Concrete was transported to the site by transit mix trucks and supplied to the operation by a hydraulic concrete pump through a downhole from street to tunnel. Photographs of the concreting operations are shown in Figures 60, 61 and 62.

Construction of the crosspassages will be discussed in a later section,

6.3 Production Analysis -- Steel Lined Tunnel

A wealth of production related data associated with the tunnel driving operations were available and accumulated. Data considered to be of most interest to readers of this report has been analyzed, tabulated and presented in Figure 63. Graphic plots of advance rates and efficiency relationships are also provided, to aid in visualizing the trends in these important production factors.

The production tabulation chart is to a large degree, self explanatory, and use or interpretations of the data may vary according to the interest of the reader. A few words of explanation, however, will be useful.

Working Day: Column #1 simply lists the progressive working days during which the tunnel excavation operation was underway and production data accumulated.

Advance: Columns 2-5 list the rates of advance of the heading in terms of the number of rings per day and in lineal feet per day. The first two columns present those figures for each day while the second two columns are the cumulative averages since start of operations.

Cycle Times: Columns 6-14 present a breakdown of the observed tunnel cycle times. Again, the first set of numbers are the daily averages while the second set are cumulative averages of all cycles from the beginning of operations.

Muck Volume: Columns 15 and 16 are the daily and cumulative averages for muck volume removed per lineal foot of tunnel. No real meaning should be given the day-to-day variation in quantities, as the volumes were measured by recording the number of 6 cubic yard muck cars filled during each shove. This is subject to some short term error, which becomes insignificant by the completion of the operation. The cumulative average appears to approach (asymptotically) a final value of about 13.4 cubic yard/lf.

Since this value represents loose volume and since the theoretical in-place volume of the excavated bore is calculated to be about 11.3 cubic yard/lf, the "swell" or "fluff" factor is calculated to be about $\frac{13.4}{11.3} = 1.19$, or plus 19% as sometimes expressed.

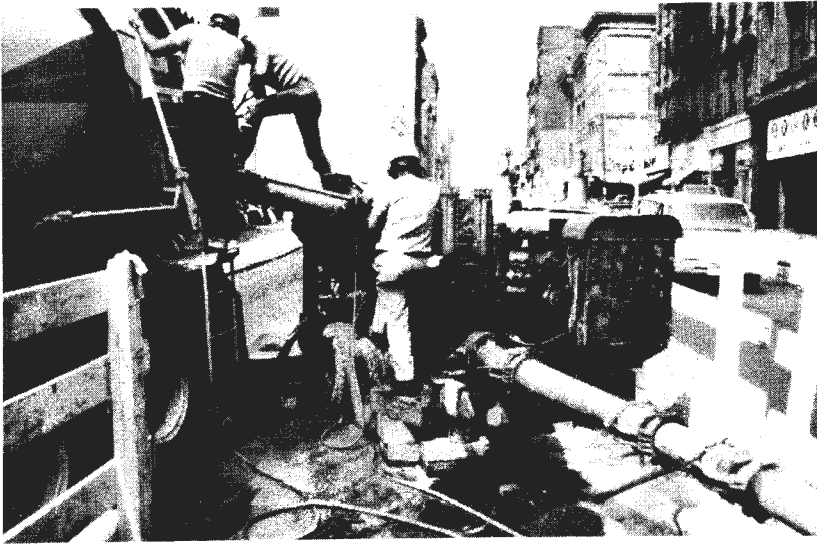

FIGURE 60. SURFACE
CONCRETING OPERATIONS

FIGURE 61. TUNNEL CONCRETING
OPERATIONS

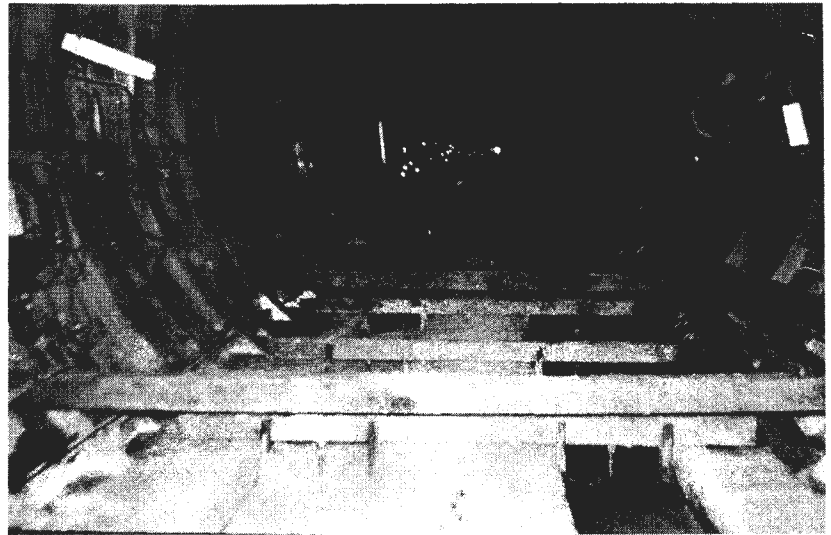

FIGURE 62. TUNNEL CONCRETING
OPERATIONS

Legend: Wrk Day = Working Day No.
 RG = No. of Rings
 LF = Lin.Ft.Advance
 SHV. = Shoving Time (Minutes)
 ERT = Erection Time (Minutes)
 LT = Lost Time (Minutes)

DT = Downtime (Minutes)
 Muck = Ave. Volume Removed in Loose C.Y./L.F.
 Grut = Backfill Grout
 Gross Efficiency = $\frac{SHV + ERT}{Tot.Time} \times 100$
 Working Efficiency = $\frac{SHV + ERT}{Tot.Time (-) D.T.} \times 100$

Underground Technology Development Corporation

STEEL TUNNEL

WRK DAY	ADVANCE				CYCLE TIMES										MUCK YD/LF		GRUT CF/LF		EFFICIENCY	
	DAILY		AVG/DAY		DAILY AVERAGE					ACCUM. AVERAGE					DAY	ACUM	DAY	ACUM	(ACCUM.)	
	RG	LF	RG	L.F.	SHV	ERT	LT	DT	TOT	SHV	ERT	LT	DT	TOT	MUCK	MUCK	GRUT	GRUT	GROSS	WORK
1	1	4.0	1.0	4.0	220	70	850	0	220	70	850	0	1140	0.0	0.0	0.0	0.0	25.4%	25.4%	
2	1	4.0	1.0	4.0	90	90	960	0	155	80	905	0	1140	0.0	0.0	21.8	10.9	20.6%	20.6%	
3	1	4.1	1.0	4.0	30	60	1050	0	113	73	853	0	1140	0.0	0.0	0.0	7.2	16.4%	16.4%	
4	2	8.2	1.3	5.1	120	130	320	0	116	96	700	0	912	10.4	4.2	18.4	11.7	23.2%	23.2%	
5	2	7.9	1.4	5.6	90	130	335	15	109	106	596	4	814	9.5	5.7	15.3	12.7	26.3%	26.5%	
6	1	5.4	1.3	5.6	180	90	630	240	118	104	600	34	855	8.3	6.1	15.0	13.1	25.9%	26.9%	
7	1	4.0	1.3	5.4	165	90	825	0	123	102	672	30	887	13.5	6.9	22.3	14.1	25.4%	26.3%	
8	2	7.3	1.4	5.6	168	143	0	328	131	110	517	84	841	6.8	6.9	13.4	14.0	28.6%	31.8%	
9	5	20.3	1.8	7.2	84	60	45	39	116	94	369	70	650	11.7	8.4	14.2	14.0	32.4%	36.3%	
10	3	12.2	1.9	7.7	117	70	93	100	116	90	326	75	607	10.9	8.8	11.6	13.7	34.0%	38.8%	
11	3	12.7	2.0	8.2	33	47	300	0	105	84	322	65	576	7.6	8.6	10.0	13.2	32.9%	37.0%	
12	1	4.2	1.9	7.9	0	80	1060	0	100	84	354	62	601	11.4	8.7	11.0	13.1	30.7%	34.2%	
13	4	16.4	2.1	8.5	69	78	105	34	96	83	317	58	554	9.1	8.8	11.6	12.8	32.3%	36.0%	
14	4	16.3	2.2	9.1	105	95	55	30	97	85	284	54	519	13.1	9.3	15.8	13.2	35.0%	39.0%	
15	4	16.5	2.3	9.6	74	69	21	121	94	83	254	62	492	12.9	9.8	12.4	13.1	36.0%	41.1%	
16	2	8.1	2.3	9.5	55	105	410	0	92	84	262	58	497	14.3	10.0	15.8	13.3	35.5%	40.2%	
17	4	16.3	2.4	9.9	48	59	21	158	88	82	239	68	476	14.2	10.4	17.2	13.7	35.6%	41.5%	
18	5	20.6	2.6	10.5	64	85	55	24	85	82	219	63	449	13.4	10.7	15.3	13.8	37.2%	43.3%	
19	6	24.6	2.7	11.2	65	54	56	15	83	79	200	58	419	14.6	11.2	13.5	13.8	38.6%	44.7%	
20	3	12.8	2.8	11.3	73	83	133	90	82	79	196	59	417	14.1	11.4	12.6	13.7	38.7%	45.1%	
21	7	28.8	3.0	12.1	70	31	53	9	81	74	180	54	388	14.6	11.7	14.3	13.8	39.8%	46.2%	
22	4	16.4	3.0	12.3	91	90	75	30	82	75	174	52	382	14.6	11.9	13.5	13.8	40.9%	47.4%	
23	5	20.6	3.1	12.7	106	55	39	28	83	73	164	51	371	14.0	12.0	17.6	14.0	42.2%	48.8%	
24	4	16.5	3.1	12.8	111	88	56	30	85	74	158	49	367	16.0	12.3	15.3	14.1	43.3%	50.1%	
25	6	24.5	3.2	13.3	78	64	19	28	84	73	148	48	354	10.8	12.1	17.8	14.4	44.6%	51.6%	
26	5	20.4	3.3	13.6	94	53	42	39	85	72	142	47	346	16.5	12.4	13.3	14.3	45.3%	52.5%	

FIGURE 63(a). PRODUCTION ANALYSIS -- STEEL

Underground Technology Development Corporation

STEEL TUNNEL

WRK DAY	ADVANCE				CYCLE TIMES										MUCK YD/LF		GRUT CF/LF		EFFICIENCY	
	DAILY		AVG/DAY		DAILY AVERAGE					ACCLUM. AVERAGE					DAY	ACCLUM	DAY	ACCLUM	(ACCLUM.)	
	RC	LF	RC	L.F.	SHV	ERT	L T	D T	SHV	ERT	L T	D T	TOT	MUCK	MUCK	GRUT	GRUT	GROSS	WORK	
27	5	20.5	3.4	13.8	117	45	35	31	87	71	136	46	340	12.9	12.4	13.7	14.3	46.3%	53.6%	
28	7	28.4	3.5	14.4	82	51	30	0	86	69	128	43	327	15.2	12.6	11.7	14.1	47.5%	54.8%	
29	6	25.3	3.6	14.7	52	60	46	32	84	69	124	43	319	12.3	12.6	12.7	14.0	47.9%	55.3%	
30	7	28.5	3.7	15.2	51	47	52	12	82	67	119	41	309	12.4	12.6	13.0	14.0	48.4%	55.7%	
31	4	16.5	3.7	15.2	35	38	183	30	81	66	121	40	308	10.9	12.5	13.6	13.9	47.6%	54.7%	
32	10	41.1	3.9	16.0	47	49	17	2	78	65	113	37	293	12.8	12.6	13.6	13.9	48.7%	55.8%	
33	7	28.9	4.0	16.4	44	46	42	30	76	64	109	37	286	13.1	12.6	13.3	13.9	48.9%	56.2%	
34	8	32.7	4.1	16.9	45	61	37	0	74	64	105	35	278	13.0	12.6	13.4	13.9	49.7%	56.8%	
35	5	20.6	4.1	17.0	57	65	43	63	74	64	103	36	276	12.8	12.6	13.4	13.8	49.8%	57.2%	
36	8	33.0	4.3	17.5	57	51	30	6	73	63	99	34	269	15.3	12.8	16.0	14.0	50.5%	57.8%	
37	3	12.2	4.2	17.3	122	52	77	130	74	63	99	36	271	15.7	12.8	14.0	14.0	50.4%	58.1%	
38	4	16.3	4.2	17.3	74	55	156	0	74	63	100	35	272	14.7	12.9	11.9	13.9	50.2%	57.7%	
39	1	4.2	4.1	17.0	85	20	1035	0	74	62	106	35	277	5.7	12.8	11.9	13.9	49.2%	56.3%	
40	1	4.1	4.1	16.6	75	55	1010	0	74	62	112	35	282	8.8	12.8	13.4	13.9	48.2%	55.0%	
41	4	16.4	4.0	16.6	78	58	144	6	74	62	112	34	282	14.6	12.8	13.2	13.9	48.2%	54.8%	
42	8	32.9	4.1	17.0	54	49	31	8	73	62	109	33	276	12.4	12.8	13.2	13.8	48.8%	55.4%	
43	4	9.8	4.1	16.8	46	63	26	178	72	62	107	36	277	14.7	12.8	11.9	13.8	48.4%	55.7%	
44	15	37.5	4.4	17.3	21	55	20	0	68	61	100	33	263	12.5	12.8	11.3	13.7	49.3%	56.4%	
45	10	24.6	4.5	17.5	34	48	18	45	67	60	96	34	257	15.4	12.9	11.1	13.6	49.5%	57.0%	
46	13	31.7	4.7	17.8	40	44	11	15	65	59	91	33	248	15.9	13.0	15.2	13.7	50.2%	57.8%	
47	6	15.0	4.7	17.7	28	57	155	0	64	59	93	32	248	25.6	13.2	12.9	13.7	49.8%	57.2%	
48	11	27.1	4.9	17.9	33	46	25	0	63	59	89	30	241	16.8	13.4	15.5	13.7	50.4%	57.6%	
49	10	24.7	5.0	18.1	35	52	9	19	62	58	86	30	236	17.0	13.5	12.7	13.7	50.9%	58.2%	
50	2	5.0	4.9	17.8	33	63	385	90	61	59	88	30	239	26.4	13.5	12.0	13.7	50.2%	57.5%	
51	6	14.5	4.9	17.7	32	43	20	95	61	58	87	32	237	10.8	13.5	13.2	13.7	50.0%	57.7%	
52	6	25.0	4.9	17.9	50	53	87	0	60	58	87	31	236	13.2	13.5	11.6	13.6	50.1%	57.7%	

FIGURE 63(b). PRODUCTION ANALYSIS -- STEEL

Underground Technology Development Corporation

STEEL TUNNEL

WRK DAY	ADVANCE				CYCLE TIMES										MUCK YD/LF		GRUT CF/LF		EFFICIENCY		
	RG	DAILY		AVG/DAY		DAILY AVERAGE					ACCLIM. AVERAGE					DAY MUCK	ACUM MUCK	DAY GRUT	ACUM GRUT	(ACCLIM.)	
		LF	RG	L.F.	SHV	FRT	L T	D T	SHV	FRT	L T	D T	TOT	GROSS	WORK						
53	6	24.5	5.0	18.0	64	58	27	41	60	58	85	31	235	11.3	13.4	15.1	13.7	50.3%	58.1%		
54	7	28.5	5.0	18.2	61	55	42	5	60	58	84	31	233	14.7	13.5	13.6	13.7	50.7%	58.4%		
55	8	33.0	5.1	18.5	69	47	27	0	61	58	83	30	231	15.6	13.5	13.0	13.6	51.3%	58.8%		
56	6	24.6	5.1	18.6	72	45	61	12	61	57	82	29	230	14.4	13.6	11.8	13.6	51.4%	59.0%		
57	8	32.9	5.1	18.8	47	39	51	6	61	57	81	29	227	10.9	13.5	14.9	13.6	51.6%	59.1%		
58	11	45.3	5.2	19.3	43	39	22	0	60	56	79	28	223	11.7	13.4	12.8	13.6	52.1%	59.4%		
59	8	32.6	5.3	19.5	47	33	33	30	60	56	78	28	221	12.1	13.4	15.0	13.6	52.1%	59.6%		
60	8	32.3	5.3	19.7	45	59	38	0	59	56	77	27	219	11.7	13.3	15.8	13.7	52.5%	59.9%		
61	6	24.6	5.3	19.8	58	39	93	0	59	55	77	27	218	15.1	13.4	13.6	13.7	52.4%	59.7%		
62	8	32.4	5.4	20.0	45	46	51	0	59	55	77	26	217	11.9	13.3	12.7	13.7	52.6%	59.8%		
63	10	40.5	5.4	20.3	46	44	25	0	58	55	75	25	214	12.4	13.3	11.3	13.6	53.0%	60.1%		
64	7	28.2	5.5	20.5	41	41	52	29	58	55	75	25	213	11.9	13.3	10.4	13.5	53.0%	60.1%		
65	10	40.3	5.5	20.8	41	41	25	8	58	54	73	25	210	12.4	13.2	13.7	13.5	53.2%	60.4%		
66	9	37.0	5.6	21.0	64	36	27	0	58	54	72	24	208	12.2	13.2	13.8	13.5	53.6%	60.7%		
67	12	48.5	5.7	21.4	35	34	26	0	57	53	71	23	204	12.6	13.2	14.4	13.6	53.9%	60.9%		
68	11	44.9	5.8	21.8	43	32	21	8	57	53	69	23	201	12.8	13.2	10.6	13.5	54.2%	61.1%		
69	12	49.0	5.9	22.2	42	36	15	2	56	52	68	22	198	14.9	13.2	14.0	13.5	54.6%	61.5%		
70	9	37.0	5.9	22.4	48	46	29	3	56	52	67	22	197	16.5	13.3	13.1	13.5	54.9%	61.7%		
71	7	24.4	5.9	22.4	45	43	58	18	56	52	67	22	196	18.7	13.4	13.7	13.5	54.8%	61.7%		

BREAKDOWN BY RING SIZE												
30 IN. RINGS												
9	77	8.6	20.8	32	50	38	30	150	16.7	13.2	55.0%	68.6%
48 IN. RINGS												
62	343	5.5	22.6	61	52	73	20	206	13.0	13.5	54.8%	60.7%

92

FIGURE 63(c). PRODUCTION ANALYSIS -- STEEL

Grout Volume: Columns 17 and 18 are the daily and cumulative averages for the cubic feet of grout per lineal foot of tunnel used to backfill the annular space behind the liner.

Efficiency: The final two columns present the cumulative efficiency of the tunneling operation expressed in two ways. Gross efficiency is the productive work time expressed as a percentage of the total work time including down time and lost time. Working efficiency is the productive work time expressed as a percentage of the total available work time (total time less down time). This relationship gives one a feeling for the proportion of incidental lost time experienced, which is a measure of the productivity of the men, the planning and the procedure itself, with equipment factored out. Since a portion of this tunnel was driven with 30" rather than 48" wide rings and on a 24 hour/day rather than a 20 hour/day basis, a separate breakdown of the final production data for each condition is provided as well, at the end of the overall tabulation.

A plot of the cumulative advance rates in the steel lined tunnel is given in Figure 64. It should be noted that a steady improvement in production was exhibited throughout the job, with no signs of a leveling off by the completion of the operation. The dip in production in the middle of the chart reflects the period when operations were slowed by the mixed face conditions.

Figure 65 is a plot of the cumulative production efficiency relationships developed from the cycle studies. An "availability" curve is included which is a plot of the amount of time available to do productive work expressed as a percent of the total time. This plot provides a convenient method of evaluating several important production factors. For instance, the area above the availability curve represents down time, which can be related to equipment reliability, while the area between the availability curve and the gross efficiency curve represents the operation lost time.

More analysis of these data is provided in Section 8.1, where comparative production relationships of the steel and the precast concrete lined tunnels are discussed.

6.4 Geometric Data

Although only a limited amount of study was planned for the steel lined tunnel, some basic geometric data were accumulated. Departures from the planned line and grade reached a maximum of 0.32 feet (under 4 inches), which was considered to be within acceptable limits.

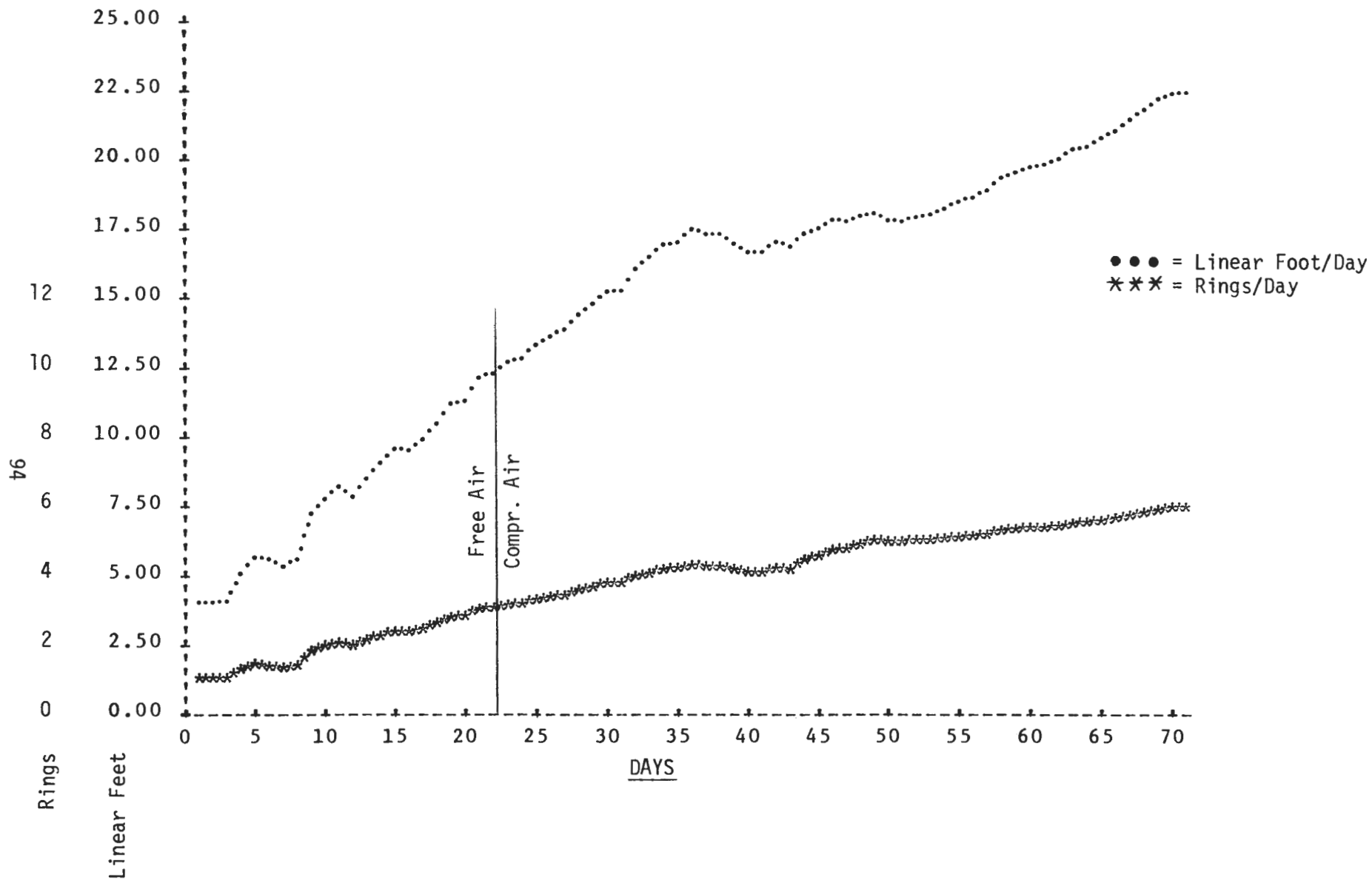

FIGURE 64. TUNNELING PRODUCTION -- CUMULATIVE AVERAGE ADVANCE RATES, STEEL LINED TUNNEL

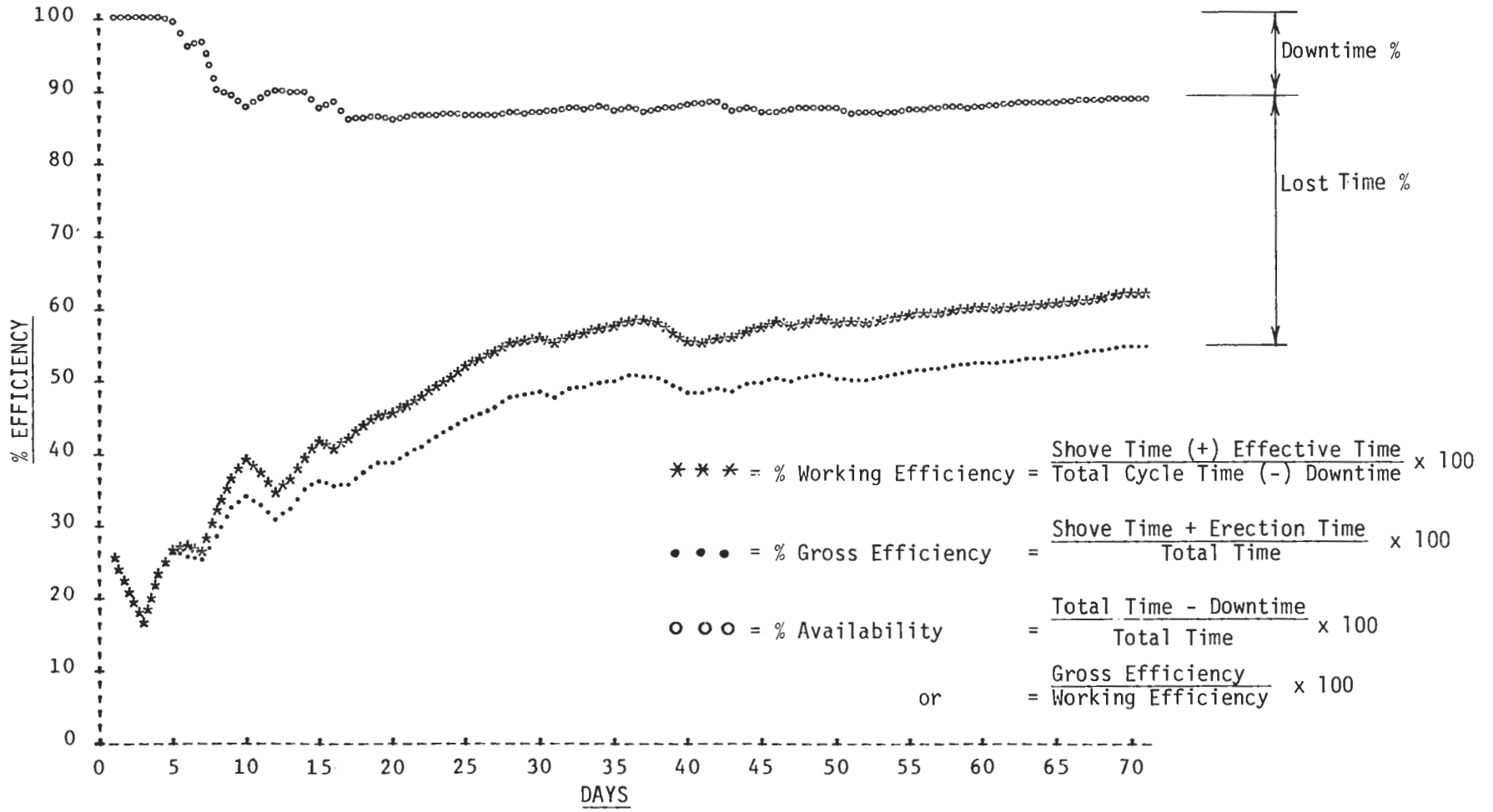

FIGURE 65. CUMULATIVE PRODUCTION EFFICIENCY RELATIONSHIPS, STEEL LINED TUNNEL

Analysis of representative sampling of horizontal diameters showed a standard deviation of 0.066 feet (about 3/4 inch) from the mean diameter. Maximum deviation (from mean) observed was 0.168 feet (about 2 inches). This translates to about 4 inches between maximum and minimum diameters.

6.5 Geotechnical Influences and Responses

It should be noted that the various displacements measured along the inbound tunnel route were subject to a range of error depending on the monitoring instrument used. The accuracy of the measurements made for the various displacements is controlled by the instrument in the measuring system with the lowest resolution and repeatability. Thus, the displacements that are reported in the following sections of the report are accurate to within the following ranges:

<u>Type of Instrument</u>	<u>Range of Error</u>
MDS	± 0.12 in.
D.S.	± 0.12 in.
Surface Settlement	± 0.12 in.
Inclinometer	± 0.30 in. per 100 ft

6.5.1 Soil Displacement

6.5.1.1 Vertical Movements

During the advance of the inbound steel liner plate tunnel, soil displacements near the tunnel were monitored by the MDS's and inclinometers installed along the route.

The MDS's located on the tunnel centerline all indicated that maximum soil movement occurred at the deepest anchor located within 2 feet of the tunnel crown. The measured maximum downward movements of these deep anchors are shown in the following table:

<u>Instrument Number</u>	<u>Vertical Displacement Δv (in.)</u>	<u>Comments</u>
MDS-2	3.4	Located in free air section; soil at crown and approximately upper 50% of face was C-1 sand and gravel, remainder RZ-1.
MDS-8	2.0	Free air section; C-1 at crown and upper 50% face, remainder RZ-1.

<u>Instrument Number</u>	<u>Vertical Displacement δv (in.)</u>	<u>Comments</u>
MDS-13	0.7	Compressed air section; C-1 at crown and upper 10 to 50% of face, remainder RZ-1.
MDS-15	1.7	Compressed air section; C-1 at crown and upper 50 to 60% of face, remainder RZ-1.
MDS-19	1.2	Compressed air section; RZ-1 cohesive soil full face.
MDS-23	1.0	Compressed air section; RZ-1 full face.

Based on this data the following observations can be made concerning the deep anchor movements:

- The largest movements occurred in the free air section of the drive. While this could be due to some groundwater inflow in this section, it is more likely that these larger movements were due to the startup procedures and learning period for the tunnel crew which is intrinsic to all tunnel work.
- The percentages of noncohesive granular soil at the face had a large influence on the amount of deep settlement that occurred over the advancing tunnel. This is reflected in the small movements of the anchors in MDS-13, 19 and 23 relative to the anchors in MDS-2, 8 and 15. The latter instruments were located at points where the face of the tunnel was composed of 50 to 60% noncohesive sediments as compared to less than 10% for the former instruments. This measured phenomena is most likely due to the noncohesive soils' greater tendency to move into the excavation, since they have negligible standup strength when unconfined.
- The deep settlement readings indicate there were no apparent time dependent movements occurring after the liner was installed. Due to the granular deposit above the tunnel, it was expected this would be the case.
- The other three anchors in each MDS, at positions of approximately 12, 22, and 23 feet above the crown, all showed decreasing subsoil movement approaching the ground surface as the soil displacement and volume changes were spread out over a larger area.
- The MDS instruments located off the inbound tunnel centerline all indicated diminishing downward movement in all anchors. This is due to the decrease in soil movement at locations increasingly distant from the tunnel, which is also reflected in the surface settlement profiles as discussed in Section 6.5.3 below.

6.5.1.2 Horizontal Movements

The inclinometers located adjacent to the inbound tunnel indicated horizontal soil movement into the tunnel excavation after passage of the heading.

The maximum displacement measured in inclinometers I-8, 9, 12, 13, 14 and 15 ranged from 0.14 inches to 0.33 inches, within the excavation limits. These horizontal movements into the excavation tended to dissipate from above the crown of the tunnel to the ground surface for all of the six inclinometers except I-9 which indicated fairly uniform horizontal movement to the ground surface. Figure 66 shows the inclinometer profile for horizontal movement perpendicular to the tunnel centerline at I-14 after passage of the inbound heading.

6.5.2 Volume Losses

Soil displacements are generally a result of the volume of ground lost during tunnel advance. This lost ground is generated by (1) loss of material at the tunnel face, (2) overexcavation of the tunnel opening due to projections on the shield which may be filled by collapsing soils, (3) an annular void which forms as the smaller diameter liner emerges from the larger diameter shield and which may also be filled by collapsing soil, and (4) long-term losses that may occur due to compression of the soil around the tunnel and/or deflection of the liner.

An approximate method of estimating the volume of lost ground per unit length of tunnel has been proposed by Cording et al⁽²⁾. The volume loss is estimated from the deep settlement measured over the tunnel crown by the following empirical formula:

$$V_L = 2\delta_v(R+y)$$

- V_L = volume of ground lost per unit length of tunnel
- δ_v = settlement at a point located directly over the tunnel at a distance y above the crown
- R = radius of the tunnel
- y = distance from crown to settlement point ($y \leq 6$ feet)

Using the formula and maximum measured displacements over the inbound centerline presented in Section 6.5.1, the ground losses were estimated at each MDS location. They are presented in the table below. The volume loss is also presented as a percentage of the gross tunnel volume per unit length of tunnel, $\%V_L$. It should be noted that these volume losses are total losses resulting from a combination of the factors presented at the beginning of this section.

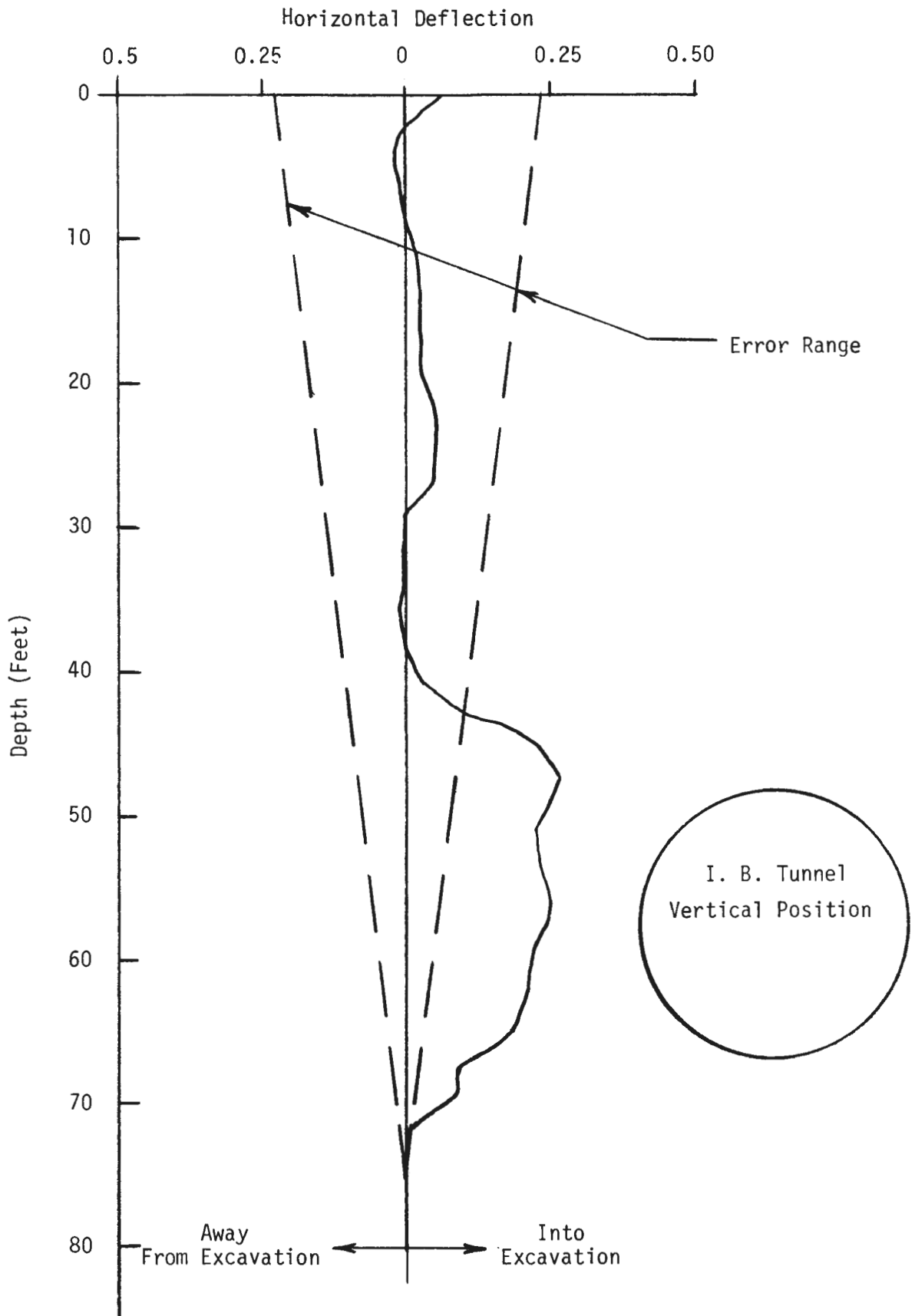

FIGURE 66. INCLINOMETER-14 MOVEMENT PERPENDICULAR TO I.B. TUNNEL CENTERLINE

Location	Volume of Lost Ground V_L (ft ³)	% V_L
MDS-2	12.2	3.9
MDS-8	7.3	2.3
MDS-13	2.7	0.9
MDS-15	6.2	2.0
MDS-19	4.2	1.3
MDS-23	3.5	1.1

Since these volume loss estimates were based on the MDS deep anchor movements presented in Section 6.5.1, the observations made in that section may be made concerning volume changes relative to construction experiences and geology: ground losses were largest at the start of the job in the dewatered portions and where the face was composed to a large percent of the Cretaceous sands and gravels.

Except for MDS-2, these estimated ground losses are all approximately equal to or less than the 1.5 to 2% originally estimated by the tunnel designer. The higher losses at MDS-2 can be attributed to the initial learning period and/or possible soil disturbance due to the proximity of the shaft.

6.5.3 Surface Settlement

The surface settlements resulting from the advance of the inbound steel tunnel were generally small along the tunnel route, with the maximum displacements occurring near the tunnel centerline. The largest surface movements were measured in the first 75 feet of the inbound drive where surface settlements of approximately 1.2 inches and 0.6 inches were recorded. For the remainder of the inbound tunnel advance, the maximum surface settlements measured were generally less than 0.25 inches.

The surface settlement profile which occurs along a line perpendicular to the axis of a soft ground tunnel has been shown for many tunnels to be similar in shape to a normal probability curve (for example, tunnels for WMATA, BART, Toronto, London, etc.). Schmidt⁽³⁾ and Peck⁽⁴⁾ used the properties of the probability curve to describe the characteristics of the settlement troughs measured for tunnels. The volume of the settlement trough (V_S) having the same shape as a probability curve is:

$$V_S = 2.5 i \delta_{\max}$$

where δ_{\max} = maximum measured surface displacement

i = horizontal distance from the point of maximum settlement to the point of inflection on the probability curve

The geometry of the surface settlement trough, assuming a probability curve distribution, is shown on Figure 67.

The shape of some of the surface settlement troughs obtained during the advance of the inbound tunnel generally tended to resemble a probability curve. Schmidt(3) suggested obtaining the point of inflection (i) by plotting the log of the settlement versus the distance squared from the centerline and reading off the value of i at $0.61\delta_{\max}$. Knowing the value of i, the normal probability curve may be plotted by using the following equation of the gaussian error function.

$$\delta = \delta_{\max} \exp \left(- \frac{x^2}{2i^2} \right)$$

where δ_{\max} = maximum measured surface displacement

x = horizontal distance measured from the centerline of the trough perpendicular to the tunnel axis

i = horizontal distance from the centerline of the trough to the point of inflection

This construction has been used for the surface settlement data obtained at the cross lines at Stations 22+90 and 22+60 outbound and is shown on Figure 68.

The approximate volume of each of the settlement troughs at these two locations obtained using the above equation and the measured settlement values is 0.95 ft^3 or $V_s\% = 0.3$, with $i = 18$ feet.

The surface settlement profiles measured at Test Section B along cross lines X, Y and Z are shown on Figure 69. These settlement troughs were the best defined along the route because of the large number of points along each cross line. A normal probability curve can be used to approximate the shape of the three settlement profiles. Settlement troughs for cross lines X and Z are basically symmetric about the inbound tunnel centerline, while the settlement trough for cross line Y is offset about 15 feet to the south of the centerline. The reason for this effect is not apparent. It should also be noted that although surface settlement points were located beyond 70 feet north of the inbound centerline on cross line Y (see Figure 69), they are not thought to be representative of the settlement trough shape because of their location in the median planter as described in Section 4.3.

Using the equation for the volume of the settlement trough and the graphical method of obtaining i presented above, the following approximate values are obtained at cross lines X, Y, and Z:

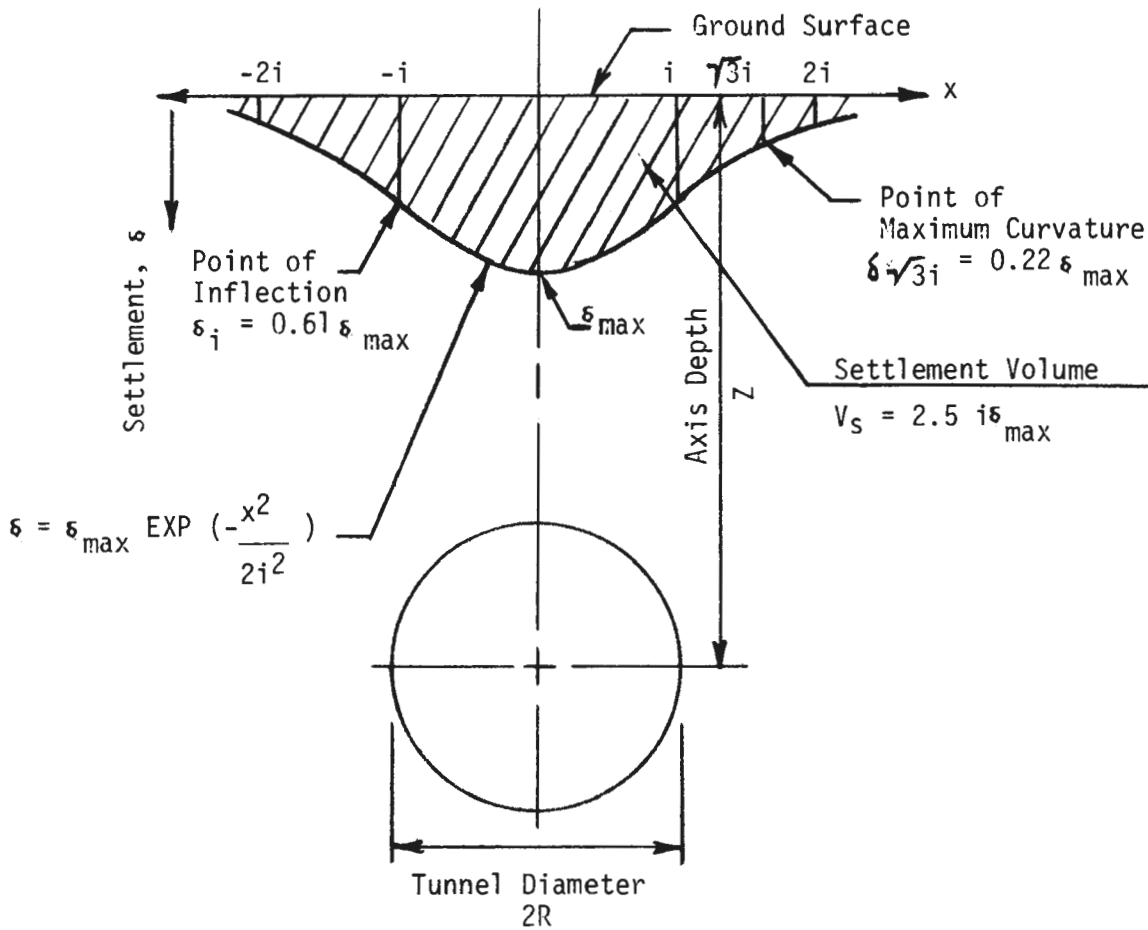

FIGURE 67. PROPERTIES OF ERROR FUNCTION OR NORMAL PROBABILITY CURVE AS USED TO REPRESENT CROSS-SECTION OF SETTLEMENT TROUGH ABOVE TUNNEL (AFTER PECK, 1969)

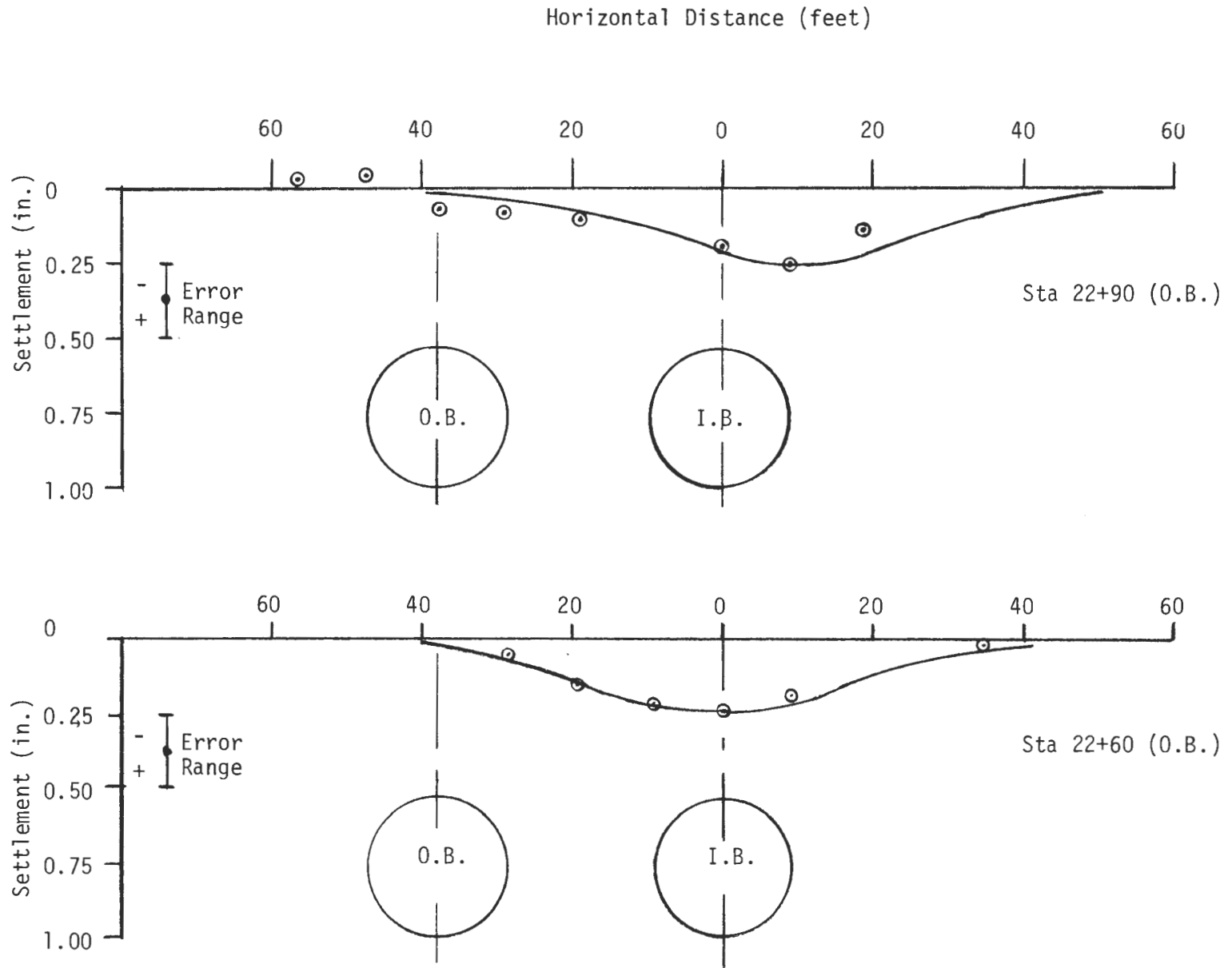

FIGURE 68. SURFACE SETTLEMENT PROFILES, INBOUND TUNNEL ONLY, TEST SECTION B

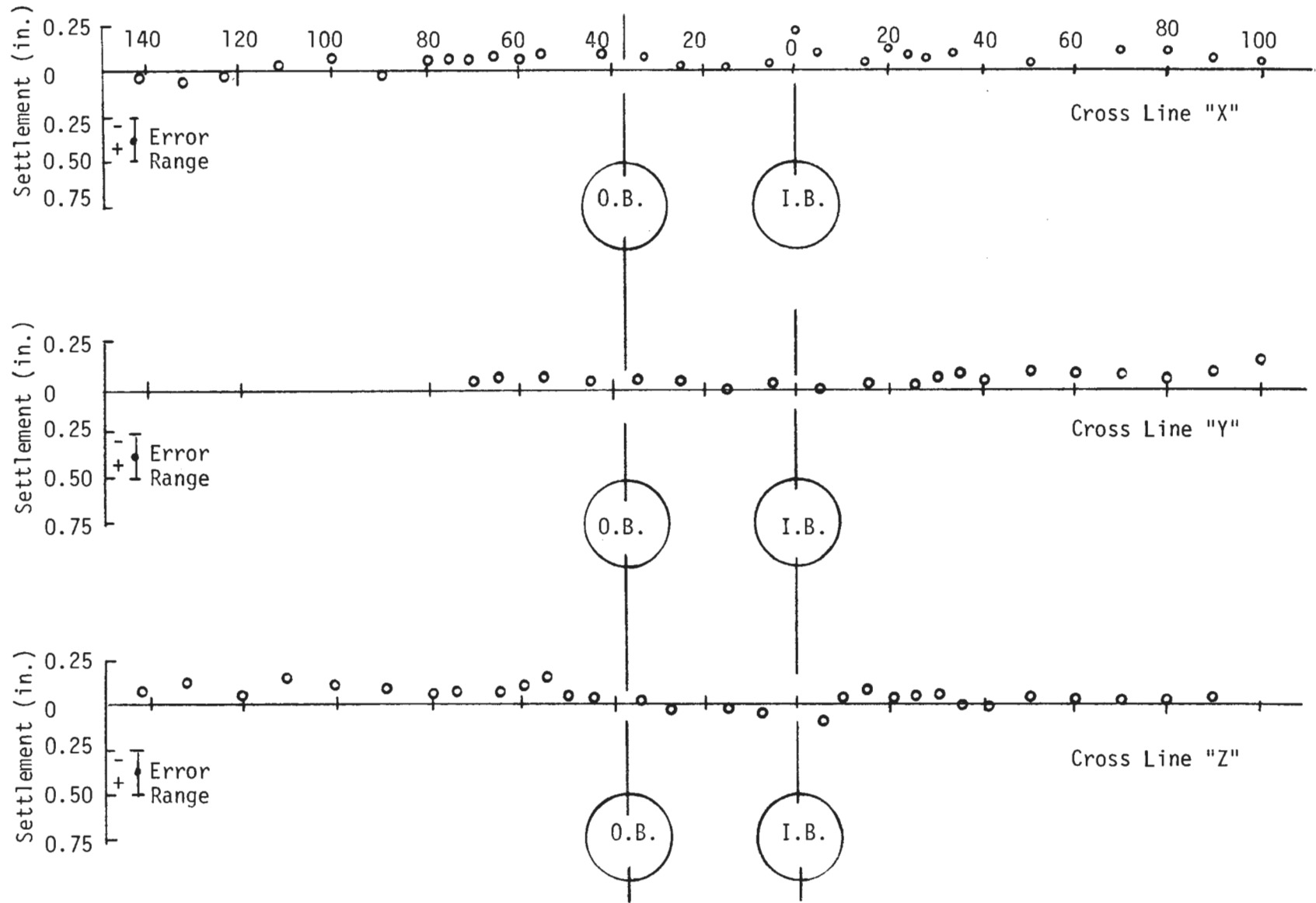

FIGURE 69. SURFACE SETTLEMENT PROFILES, TEST SECTION B

Cross Line	Settlement Trough Volume (V_S) ft ³	% V_X	i
X	1.0	0.3	19 ft
Y	1.5	0.5	19 ft
Z	1.1	0.35	20 ft

Figure 70 is the dimensionless chart for trough width proposed by Peck⁽⁴⁾. The point for the three cross lines in Test Section B, based on an i value of 19 feet falls in the zone representing the behavior of soft to stiff clays. This is somewhat outside of the zone that would be expected for the soil conditions along the inbound tunnel. The reason for the wider troughs may be the small soil deformations, as evidenced by the relatively minor surface settlements at these locations, which are probably more elastic than plastic in nature and thus tend to spread out over a wider area.

Except at the locations just discussed, the other surface settlement profiles along the tunnel route tended to be less well defined due to the limited number of monitoring points on each cross line.

Figure 71 shows a plot of the ground surface settlement along the centerlines of the tunnels. It may be seen that as the tunnel crew became more experienced and the tunnel went under compressed air, the surface settlements decreased.

6.5.4 Comparison of Soil Volume Lost (V_L) and Volume of Settlement Trough (V_S)

In elastic ground, the volume of soil which is lost into a tunnel can be expected to cause a settlement trough of equal volume at the ground surface. This response has generally been noted to be true in tunnels driven in clay. However, in granular soils volume changes can develop. In dense granular soil, the soils above the shield can expand and become looser as they ravel into the voids created by the construction. The expansion of the soil causes the volume of the settlement trough at the ground surface to be less than the volume of ground lost into the tunnel. In loose granular soil, the opposite could be expected to occur whereby the soil would decrease in volume and become denser above the tunnel, creating a settlement trough whose volume is greater than the volume of soil lost

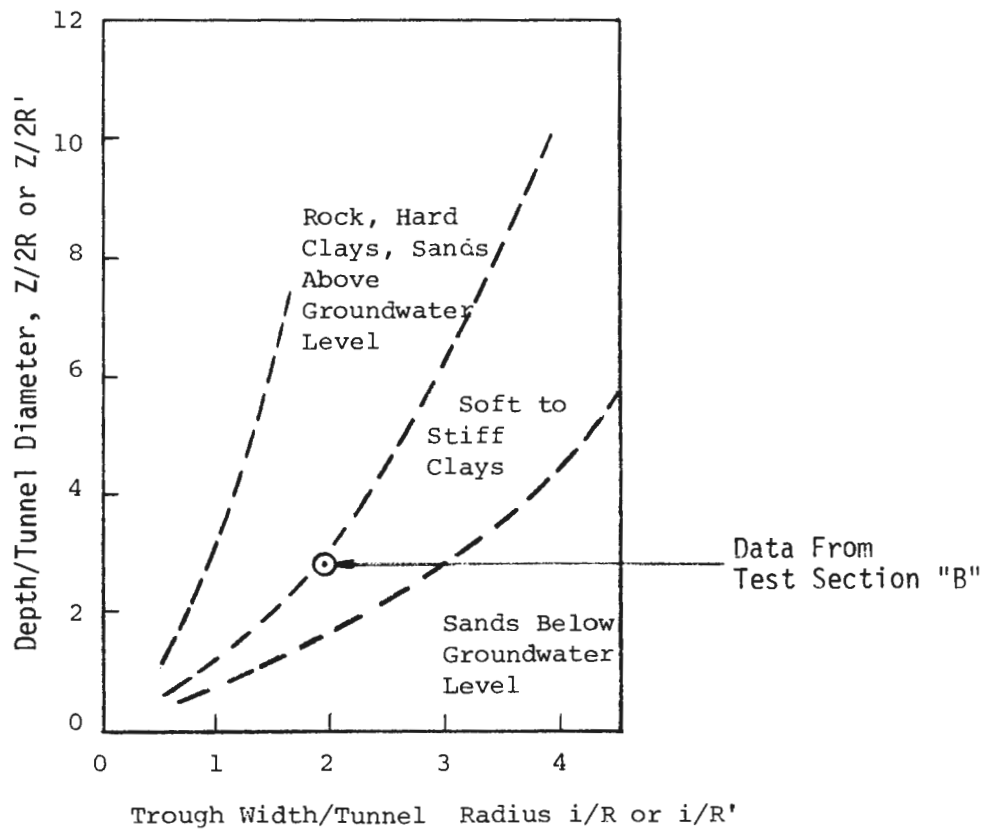

FIGURE 70. COMPARISON OF WIDTH OF SETTLEMENT TROUGH WITH PECK (1969)

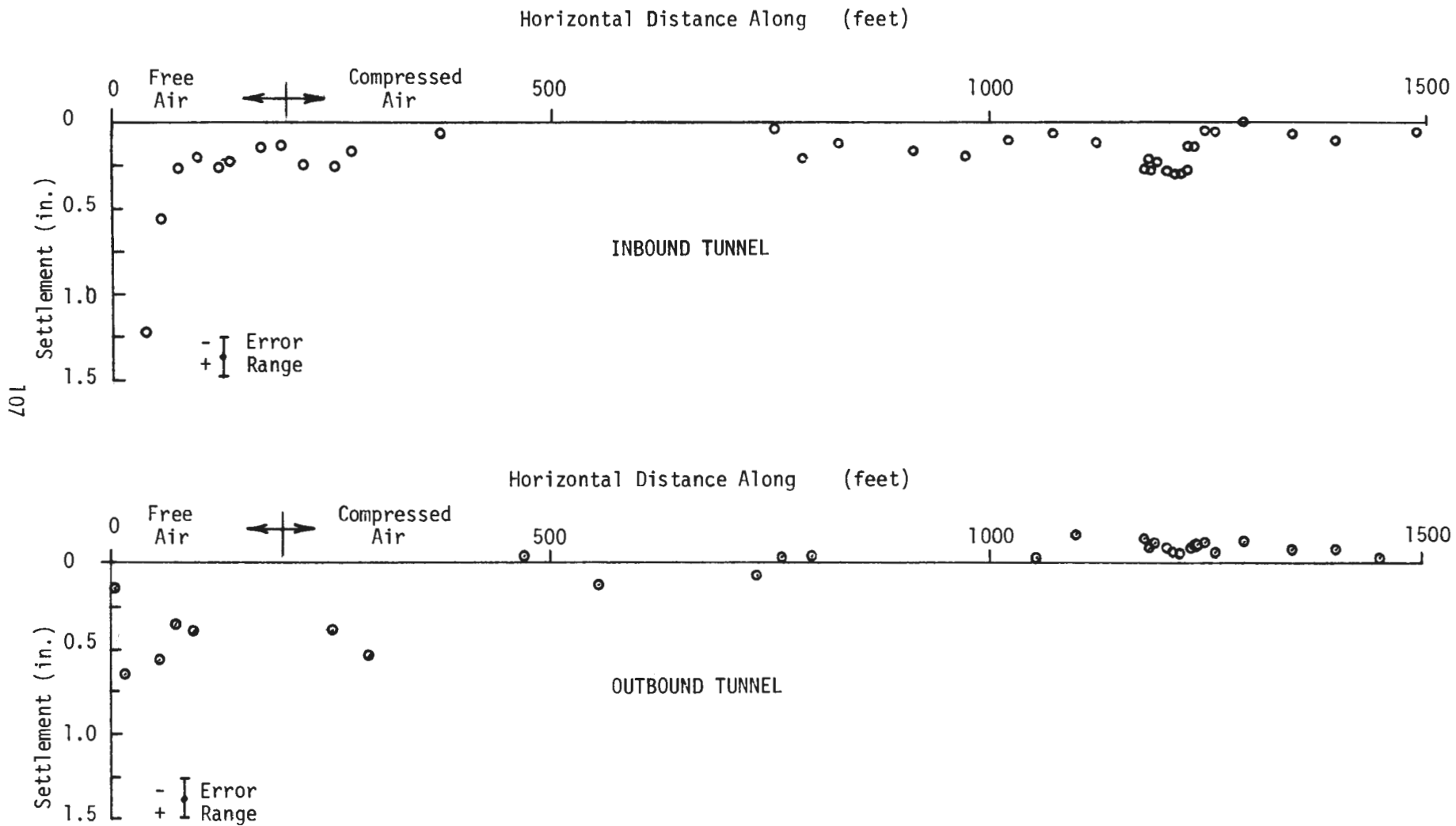

FIGURE 71. SURFACE SETTLEMENT PROFILES ALONG CENTERLINE

into the tunnel. Compression of the soil (V_C) due to stress increases in the soil at the tunnel springline may also occur, tending to offset the effects of the expansion. With these adjustments made, the total volume of the settlement trough may be expressed by the following equation:

$$V_S = V_L = V_E + V_C$$

At two locations (cross lines X and Y) in Test Section B and at Station 22+60 outbound, where both V_L and V_S could be estimated, the volume of the ground surface settlement trough was about 25%, 45% and 15%, respectively, of the volume of the ground lost into the inbound tunnel. This is based upon the actual measured values and does not include the error ranges. Therefore, it appears that substantial volume expansion has occurred in the dense granular soils above the inbound tunnel, accounting for over 50% of the volume lost into the tunnel at these two locations. Based on similar $\%V_L$ at the other MDS locations other than at the very start of the drive and the general small surface settlements along the entire inbound route, it appears that significant volume expansion (V_E) has occurred in the dense Cretaceous granular soils above the inbound tunnel for most of its length.

In addition, based on the measured downward vertical movement of approximately 0.25 inches measured by the deep anchors located at the tunnel springline in the MDS's adjacent to the tunnel, it appears that some volume decrease may have occurred (V_C) due to stress increases in the soils at the springline. These volume decreases would tend to increase the surface settlement volume, thus making the volume expansion that much greater to compensate for the additional volume decrease. It should be noted that some of this soil movement measured at the springline elevation could partially be due to lateral soil movement into the tunnel excavation.

6.5.5 Groundwater Response

The water levels measured in the piezometers along the tunnel route generally indicated a drop of 2 to 7 feet as the inbound tunnel heading passed the instrument, followed by a recovery of 50% to 100% of this drop after the tunnel heading had passed about 200 to 400 feet beyond the instrument. This occurred in both the dewatered and compressed air sections of the inbound tunnel.

Very little response was noted in most of the 14 piezometers as the advancing tunnel face approached their locations. However, an interesting, but unexplained, groundwater response can be seen in the data presented for PZ-11,

12, and 13 at Test Section B on Figure 72 for the inbound tunnel advance. The groundwater level had been very stable in all three piezometers at about El + 10 to +11 for approximately nine months prior to the inbound approach near these instruments. When the face of the approaching pressurized tunnel was approximately 250 feet from the instruments, the water levels increased approximately 4.5 to 6.0 feet. The levels then dropped back to the preconstruction levels of about El + 10 as the face passed the instruments and continued to decrease another 4 to 5 feet as the face continued to advance. The levels recovered about 2 feet after the inbound tunnel had holed through and the air was turned off. This unique response may be due to some continuous fissures or joints in the RZ-1 soils in this area, which transmitted the tunnel air pressure well ahead of the advancing face.

6.5.6 Jack Pressures and Air Consumption

The variation in jack pressures for the four quadrants was primarily due to the shield configuration and to the use of the breasting doors, which were capable of significantly altering the resultant resistance forces on the shield. Geology also had an effect. Lower jacking pressures were sometimes observed when RZ-1 was encountered because there was less friction mobilized along the skin of the shield.

There was no apparent correlation between geology and air consumption for the inbound tunnel.

6.6 Leakage and Sealing

Contract specifications required that leakage of groundwater through the liner of the completed structure should not exceed 0.07 gpm per 100 linear feet of tunnel. To meet this requirement, a sealing system was designed for the steel liner joints which consisted of two parts. First, a compression gasket made of a molded epoxy material was installed on two mating surfaces of each segment in such a way that all joints contained a single thickness of compression gasket. A cross-section schematic of the joint detail is shown in Figure 73.

Provisions for a secondary sealing system consisted of a groove along the inner face of the segment joints which could be packed with a caulking material (the traditional lead caulking was specified). Installation of this secondary sealing was not mandatory except in local areas where the compression seal failed to waterproof the joint.

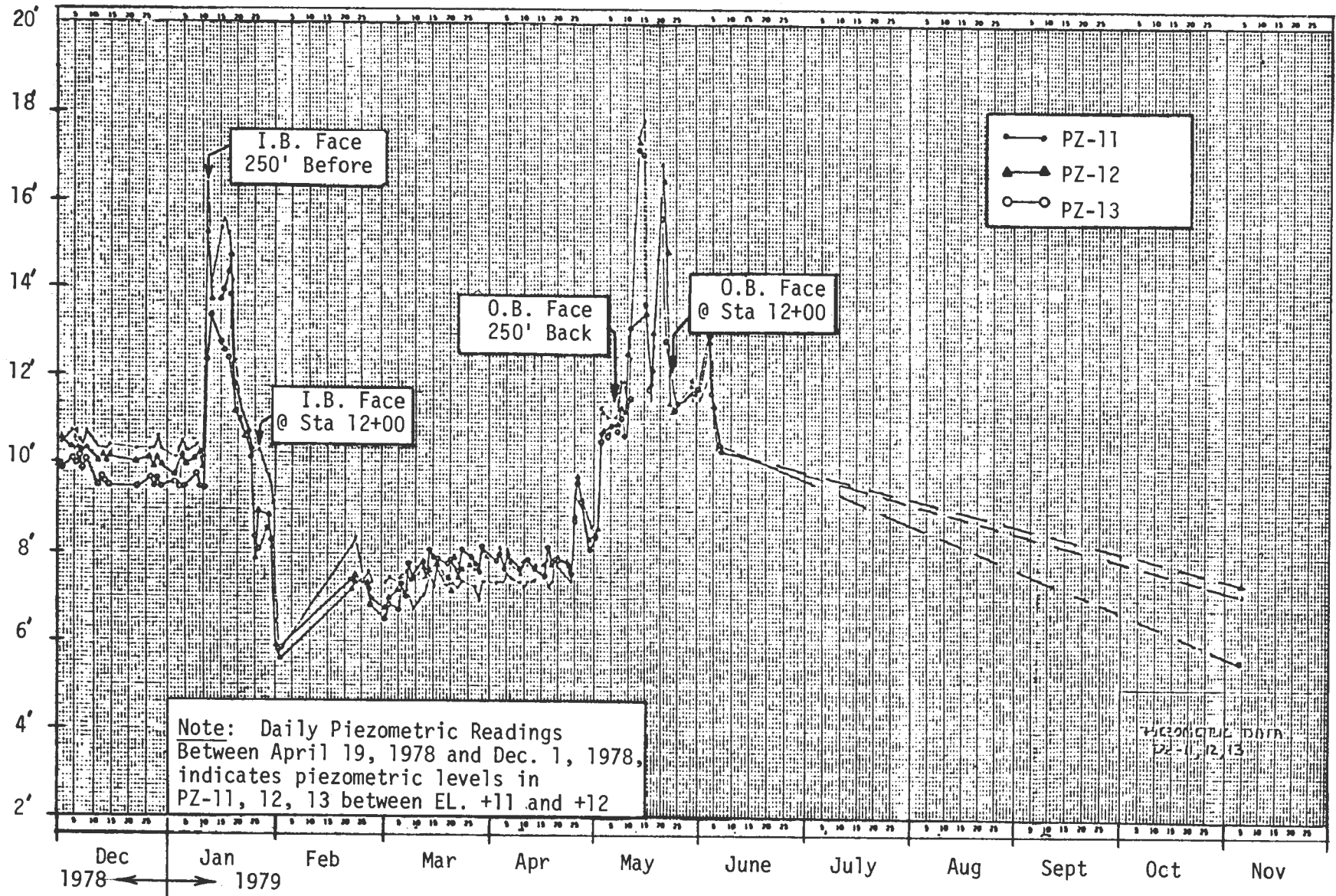

FIGURE 72. PIEZOMETRIC DATA -- PZ-11, PZ-12, PZ-13

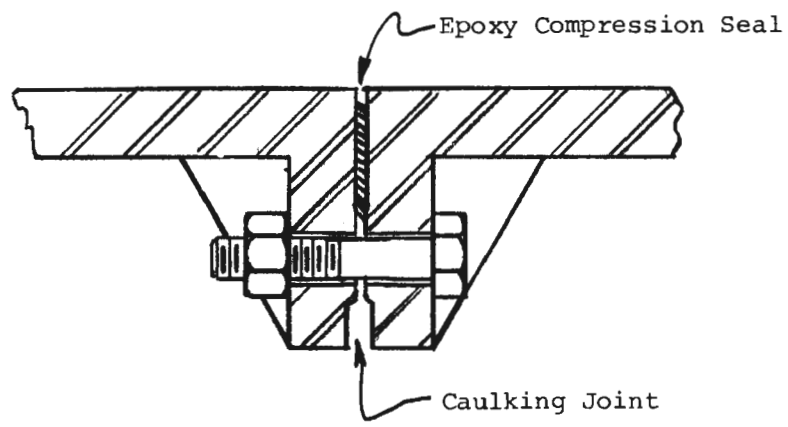
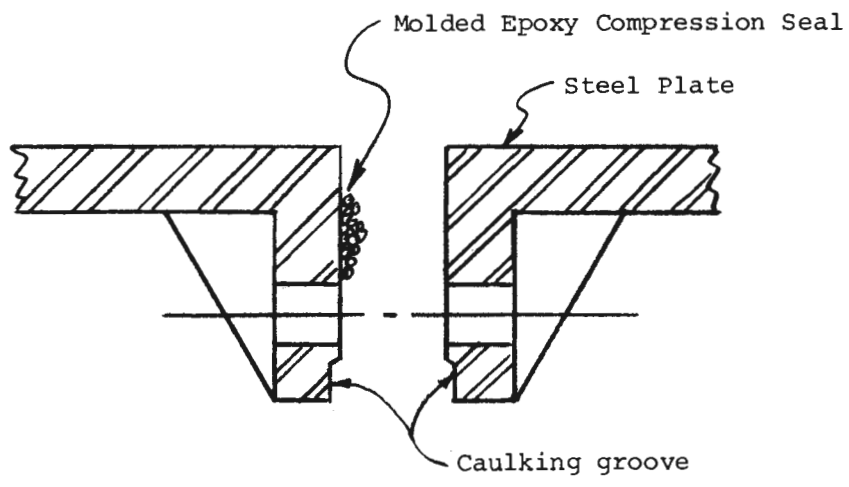

FIGURE 73. SCHEMATIC OF JOINT SEALING SYSTEM FOR STEEL LINERS

Because of the compressed air technique used in tunneling, there was little evidence of leakage through the liner during excavation. After excavation was completed and the tunnel returned to "free air", some leakage began to appear. Monitoring of the total water flows from the tunnel and the inflows at the bulk-headed face indicated that initial flows through the liner, before any remedial action was taken, amounted to about 7 gallons per minute. Over the total length of 1590 l.f., this translated to about 0.4 gpm per 100 l.f. of tunnel.

These inflows were made up of well defined leaks at specific locations, rather than a gradual moistening at all joints. This is an important observation because it indicates that the leakage was probably due to localized damage or other installation condition, rather than failure of the system itself to perform. This conclusion is supported by the fact that the only remedial action necessary to fully seal off the inflows was the simple expedient of tightening the liner bolts in the vicinity of the leak. No caulking of the joint grooves was done.

Another interesting observation concerns the sealing action at corners of segments. Even with staggered joints these are considered difficult to seal. Since the compression seal was not extended around the corners of the segments, there was further speculation that these might be a problem. Indeed, the majority of leaks that were observed developed in these areas. It appears, however that the steel segment joints could be tightened sufficiently by retorquing to compress and extrude the joint seal into these areas and seal off the flows.

6.7 Problems and Remedial Action

The only problems of any consequence which pertain to this study are those mentioned in earlier sections, namely, the encountering of mixed face rock conditions requiring blasting, and the waterleaks which developed in the liner joints.

The former should be considered an inherent risk in this type of construction. Subsurface geologic conditions can only be determined accurately at specific borehole locations. Interpreting what lies between them is still only an educated guess under the present state of the art.

The latter condition was anticipated and within reasonable limits. The remedial action too, was simple and effective.

The absence of major problems should not be considered unusual or surprising. The employment of a competent construction team together with the use of well developed construction techniques ensured that the problems encountered would be anticipated and effective solutions available.

6.8 Comments

From the standpoint of soil loss and resulting settlement, the inbound tunnel construction proceeded quite satisfactorily. Except at the very start of the drive, the volume of ground loss was less than originally expected and the surface settlements were much less than anticipated by the tunnel designers. These favorable geotechnical responses are due to both the stability of the cohesive residual soil and dense granular soils under air pressure and to the quality workmanship which the construction personnel exhibited during tunnel driving.

It should be noted that many of the volume estimates are based on relatively small measured displacements, which in many cases are of the same magnitude as the error band. Therefore, the values reported for the geotechnical responses must be evaluated considering the ranges of measurement error possible.

7.0 PRECAST CONCRETE LINED TUNNEL

7.1 Design

The geologic conditions and the design load recommendations have been presented in Section 5 of this report. In designing the precast segments to accommodate the expected loads, a conservative approach was adopted due to the pioneering nature of the project. Therefore, emphasis was placed on system reliability rather than structural economy. An additional design requirement was imposed upon the concrete segments, a requirement for compatibility with steel liner. Designing the concrete system so that steel rings could be bolted to them, provided an additional measure of safety. In the event unforeseen problems caused the use of concrete rings to be discontinued, the compatibility requirement would allow the contractor to substitute steel rings without major difficulties.

Since the tunnel was to be subjected to a permanent groundwater pressure, the reliability of the joint sealing system was a major concern. Due to the relatively short tunnel length, limited time available for an adequate development and testing program, and the concern for gasket reliability, the decision was made to adopt an existing proven system. The sealing system chosen (detailed in Section 7.3.4 of this report) had been successfully used in the Munich subway under more severe conditions than those expected for this project.

The bolting system, primarily provided to ensure uniform compression of the rubber gasket, has several other purposes. The short bolts in the transverse joints (Figure 74) are for initial compression of the rubber gasket and to mate the radial edges of the segments during construction. It was expected that ring compression resulting from the applied earth loads would provide adequate compression of the gasket eliminating the need for transverse bolts in the completed tunnel. However, since their salvage value was less than the cost of removing them they were left in place.

The 14" longitudinal bolts ensure that the rubber gasket is compressed along the circumferential joint. The long bolts also act as dowels connecting adjacent rings. The final designer had envisioned that the segment joints would be staggered by two bolt pockets from ring to ring. Staggering the joints, together with using dowel-like longitudinal bolts, would restrain uninhibited rotation of the transverse joints.

Another function of the longitudinal bolts was to maintain correct contact between rings under the effects of non-uniform heavy jack forces. Driving the tunnel around a curve would result in larger loads on the outside sections of

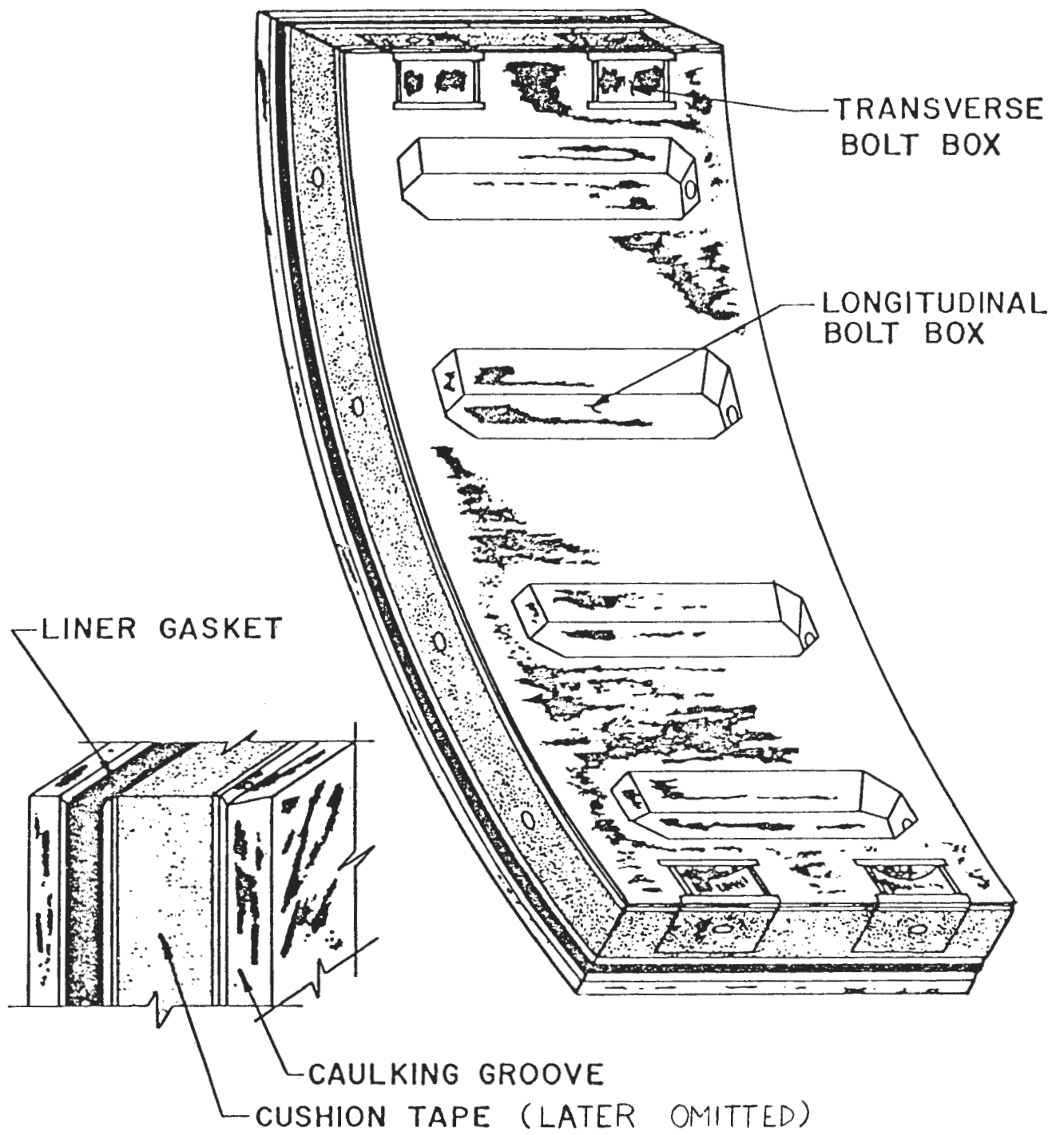

FIGURE 74. BOLTED PRECAST SEGMENTED CONCRETE LINER SEGMENT

the tunnel. This eccentric load would tend to compress the area of contact between rings and at the same time tend to force the rings apart along the contact surface opposite to the eccentrically applied load. If the contact surface was allowed to separate in this manner, the rubber gasket might not remain sufficiently compressed to prevent leakage. To resist the required bolt tension a strong reinforced concrete section was needed, and 6 inch concrete flanges were incorporated into the design. The six inch flanges necessitated the use of long (14 inch) bolts.

The reinforcing steel was designed to handle stresses under the segments' weight, to distribute jacking forces, and to resist bending stresses.

To check the design, a series of laboratory tests was conducted. The test sections were loaded to destruction in several instances and the results were used to modify the design. A second series of tests was performed on the modified segments, which proved acceptable. Details of the testing program and the results are presented in Reference 13.

7.2 Construction

7.2.1 Fabrication and Segment Preparation

The precast segments were manufactured by Buchan Concrete Tunnel Segments, Ltd., Brooklyn, New York.

Forty-nine molds were used in the casting operation. Seven entire rings could be cast simultaneously, using seven molds of each of the seven distinct ring segments. Production casting started on October 25, 1978 and after a brief learning period, the production capacity of 49 segments a day was soon reached and maintained for the duration of the contract. The segments were cast 5 days a week, Monday thru Friday and Saturday was reserved for stripping the forms, setting up for the next casting and coating the earth side of the segments with coal tar epoxy.

Table 2 is a summary of the casting yard activities and production rates. This table is based on the time sheets obtained from the casting yard for a five week period, starting Monday, February 26, 1979 and ending Saturday, March 31, 1979. After casting and curing, the segments were transported to the construction site storage yard in Baltimore, Maryland, via flat bed tractor trailer trucks. Generally, 20 segments, each weighing about 2100 pounds, were loaded on a truck. The segments were transported on edge and each truck was also, generally, loaded with the same type of segment, i.e., all number 4 segments or all number 1 segments. (See Figure 75).

Activity	Monday thru Friday			Saturday Only		
	Average Crew Size	Average Time Hours	Average No. of Units	Average Crew Size	Average Time Hours	Average No. of Units
Clean Forms	7.28	31.33	49.0 molds			
Fabricate Re-Bar	Cages	6.25	44.84 cages	0.4	6.0	5.0 cages
	Parts	3.64		0.8		
Transportation & Preparation of Re-Bar Cages	2.96	22.98	49.0 cages			
Mold Repair	2.28	8.12	--			
Batching Concrete	1.96	6.00	34.0 yd ³			
Placement of Concrete	Casting	9.48	49.0 segm.			
	Finishing	5.48				
Strip and Set Up	9.96	52.20	49.0 molds	4.2	22.4	49.0 molds
Transport to Curing	3.00	11.87	49.0 segm.			
Cure	2.00	2.00				
Epoxy Coating	2.00	16.00	98.0 segm*	2.0	18.0	147.0 segm.
Transport to Storage	3.00	11.78	49.0 segm.			
Loading for Transport Off Site	1.56	10.42	29.2 segm.			
Quality Control	1.0	7.02	--			
Supervision	1.0	7.02	--	1.0	5.35	

Notes:

* On Tuesdays only.

TABLE 2. CASTING YARD ACTIVITY RECORD

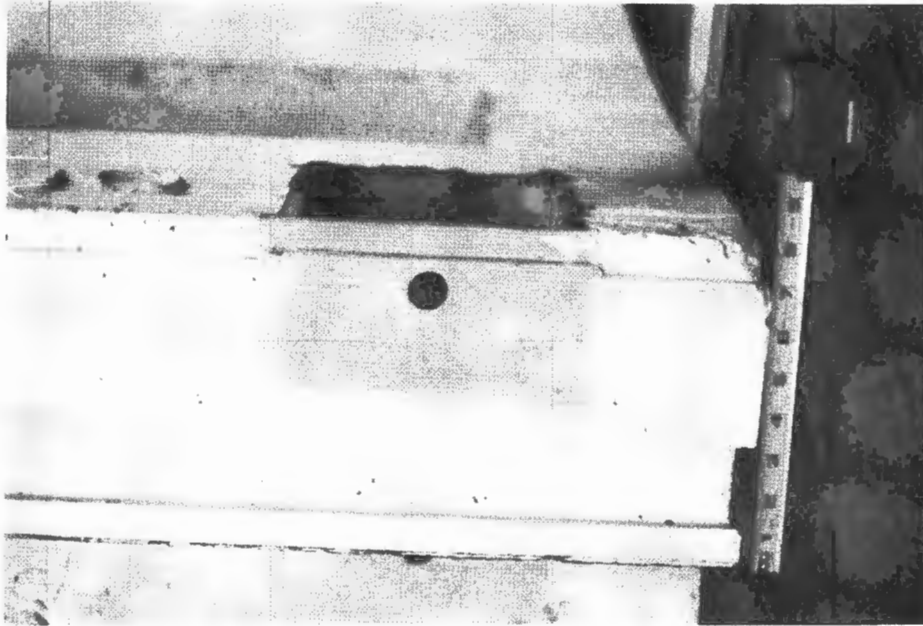

FIGURE 75. PRECAST SEGMENT AS DELIVERED

When the segments arrived at the Baltimore storage yard, they were unloaded and stacked in proper sequence, the gaskets were placed after the grooves were prepared, and finally, the segments were transported to the tunnel shaft. In order to minimize handling and decrease segment preparation time, the contractor varied methods used to perform these separate tasks until he developed the sequence described in the following paragraphs.

A fork lift equipped with padded lifting arms was used to remove the segments from the flat bed truck and transport them to a stacking area. The stacking area consisted of segregated stacks of each of the seven types of segments, arranged in a semi-circle. A hydraulic boom crane was positioned in the center of the circle enabling it to reach all seven segments by swinging the boom. The segments were lifted and stacked, as directed by a groundcrew, in proper sequence for the designated type of ring to be assembled. The segments were stacked, seven high, concave upward, and separated by 4 by 4 wooden spacers. The key segment was always on top of the stack. The segments were then transported to the preparation building by fork lift. (See Figure 76).

Inside the preparation building gasket grooves were prepared and gaskets were placed. This procedure was modified as construction progressed. A brief description of the initial and final procedures used is as follows:



FIGURE 76. ONE OF SEVERAL METHODS USED FOR LIFTING SEGMENTS

The specific items in the gasket system included the liner gasket, cushion tape, and two epoxy resin based compounds designated primer and final epoxy. The liner gasket in conjunction with the epoxy resin compounds were designed to provide a water tight seal for the joints between concrete segments. The function of the cushion tape was to provide a more uniform bearing surface on adjacent segments to minimize the possibility of segment damage due to localized stress concentrations.

Preparation of the segments consisted of the following four steps:

Step 1. The segment gasket grooves and adjacent surfaces were cleaned and ground with electric grinders. This step cleaned and removed excess concrete which usually was located at the segment corners. It also exposed any air bubbles hidden just below the surface.

Step 2. Preparing the gasket groove was a two part process intended to cut off the two sources of seepage around the gaskets. The first source is the inherent porosity of the concrete which can allow water to seep around the gasket through the concrete itself. This source of water seepage was avoided by impregnating the concrete surface in the gasket groove and approximately 1 inch to either side with the primer epoxy. The second source is interface (gasket/concrete) leakage.

Step 3. After the primer was applied and allowed to "set", the final epoxy was applied and allowed to dry. The gasket was then installed by first fitting both narrow ends into the gasket groove, then rolling the side sections into place, working toward the middle of the segment. Since the segment is curved the gasket tended to pop out of the middle section and usually had to be held in place with tape.

Step 4. The final stage was to apply the cushion tape. The tape was supplied in rolls with adhesive on one side covered by protective paper. The tape was applied to the segment edges between the caulking groove and the rubber gasket. Since the tape was almost as wide as this space, holes had to be cut in the tape to avoid covering the bolt holes. In addition, since the tape was straight and the segment edges were curved the tape had to be cut into several small segments to adequately cover the segment edge. (Figure 77).

This was the procedure recommended by the gasket supplier and adopted by the contractor for the initial segments prepared and used. The following changes were adopted during the first 10% of tunnel construction.

The cushion tape along the longitudinal (parallel to the tunnel axes) joint was eliminated on March 8, 1979. This change commenced with ring #14 and was in effect for the remainder of the tunnel. On approximately March 16, 1979, the cushion tape was eliminated from along the circumferential joints. Rings #45 through #600 (last ring in the concrete tunnel) were affected by this change. On approximately March 22, 1979, the epoxy coating procedure was revised. The final epoxy coat was applied first, filling in the surface irregularities along the gasket groove. Then the primer coat was applied to the gasket groove and adjacent areas. When the primer coat was tacky to the touch the gasket was inserted into the groove. The contractor felt this procedure provided the same waterproofing protection with the added benefit of providing a method of adhering the gasket to the groove. The change in the order of applying the epoxies affected rings #55 through #600 (see Figure 78).

7.2.2 Construction Procedures

7.2.2.1 Tunneling Equipment for Precast Liners

The equipment for driving the precast liner tunnel was basically the same as that used for the steel tunnel (see Section 6.2.1). Some modifications were made to the segment erecting equipment, notably the erector arms and the thrust ring, in order to accommodate the concrete segments.

Since the concrete segments were heavier than the steel, and also more susceptible to damage from rough handling, it was necessary to increase the size

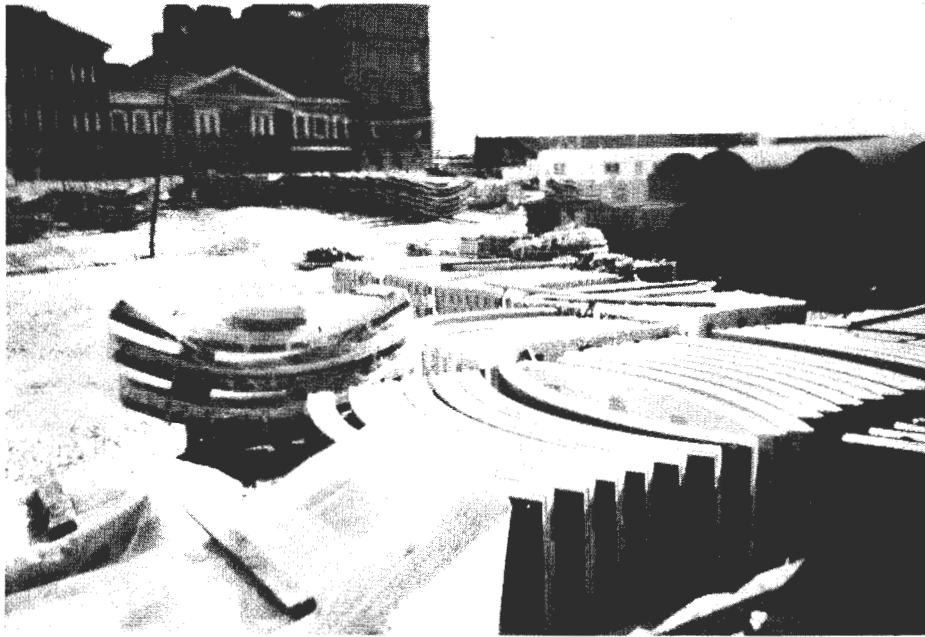

FIGURE 77. STORAGE OF SEGMENTS IN CONSTRUCTION YARD BEFORE AND AFTER INSTALLATION OF JOINT MATERIALS

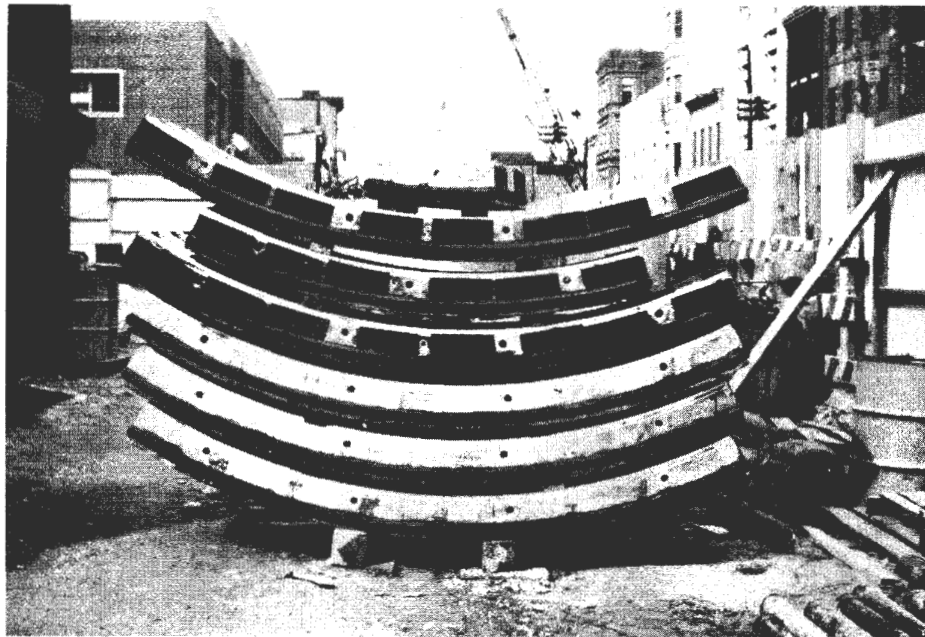

FIGURE 78. SEGMENTS AT WORK SHAFT READY FOR INSTALLATION IN TUNNEL

of the hydraulic cylinders on the erector arms. This slowed down the response of the arms, providing the operator with smoother and more certain control of segment positioning.

The most significant modification was that made to the thrust ring used in the concrete tunnel. In the steel tunnel the thrust ring was retracted and a new liner ring was bolted directly to the preceding liner ring. The thrust ring was then used to advance the shield for the next ring. In the concrete tunnel, the new liner ring was first assembled on the thrust ring, then moved back as a unit to be bolted to the previous liner ring.

The thrust ring actually consisted of three separate rings. The rearmost ring consisted of six segmented pads. The pads could be rotated along the circumference of the ring a few degrees either clockwise or counterclockwise by means of small hydraulic jacks. The pads contained aligning pins used to position the concrete segments on each pad before the segments were bolted to the thrust ring. The middle ring could be moved horizontally or vertically a few inches by means of another set of small hydraulic jacks. The ability to maneuver the newly completed ring horizontally, vertically and circumferentially, a few degrees was used when aligning and bolting it to the existing tunnel liner. The forward-most-ring was the main thrust ring used as a bearing surface for the 24 125-ton jacks.

Special mention should be made of the tail seal used by the contractor to seal the space between the tunnel liner and the tail shield. The ability to fill the annular space behind the lining with grout or other backfill material immediately as it leaves the shield is known to be a major factor in minimizing ground settlement above the tunnel. In the past, this has been a difficult thing to do because of poor success in developing a convenient sealing system to prevent the inflow of grout to the working area through the space between tail shield and liners. Efforts in this respect have ranged from packing rings, styrofoam or other materials into the void, to the use of mechanical, elastic or inflatable seals attached to the tail shield, all with their attendant problems.

The biggest problem with tail seals has not been in creating an effective seal, but rather in seal replacement due to short life. The abrasive action of the liner surface on the seal as well as the crushing effects that can occur between tail shield and liner during directional changes can quickly damage a seal and destroy its ability to perform. Changing a seal during tunneling operations can be time consuming, expensive and risky in many cases, since the shield must be pulled forward to expose the seal, thus reducing ground support in the immediate area. Consequently, past efforts to maintain full grouting at the shield tail have not been highly successful.

Traylor and Associates became aware of a seal which had been developed and used successfully in Europe and subsequently purchased a set for this project. The seal, shown in Figures 79(a), 79(b) and 80, consists of a spring steel sealing element, backed by a rubber filler of specific cross section, which is designed to allow it to deform without damage, even at the maximum deflection which can occur, considering all possible relative movements of the shield and liner. In addition, with this cross section design, increased grouting pressure will cause a proportionate increase in pressure of the seal against the liner, or a tighter seal. Spring steel construction protects the moving surface of the seal from the abrasive action of the liner.

The success of this seal on the project was both an important factor in the success of the demonstration project and a highlight in its own right as a significant advance in the state of the art.

The following comments by the general contractor about the practical use of the seal are an important "hands on" evaluation.

"Both the ethafoam and the permanent grout seals are effective in sealing the annular space. Since the majority of the annular space is filled before the tail leaves the segment, the ethafoam seal has a distinct advantage in very loose granular soils. However, a thin tail is necessary for this to be effective.

In most cases, the soil will stand long enough to allow a permanent seal, located at the rear of the tail, to be equally as effective as ethafoam. Additionally, the grouting operation is more efficient in both time and labor when the permanent seal is used, since the ethafoam seal requires installation and maintenance at every ring.

The permanent seal is preferred in most applications for the following reasons:

- It effectively seals annular spaces as small as 1 inch and as large as 5 or 6 inches.

- It is locally repairable and even completely replaceable with little effort under all but the worst soil conditions.

- It allows the I.D. of the tail to be reduced at a point behind the erection area. This provides sufficient room in the erection area to assemble segment rings without interference between the tail and the segments. This is important in preventing damage to precast segments. A corresponding I.D. reduction is not possible when the ethafoam is used."

7.2.2.2 Tunneling Methods for Precast Liner

The seven segments of the ring to be erected were transported to the heading via two flat-bed railroad cars. The cars were positioned on either side of the

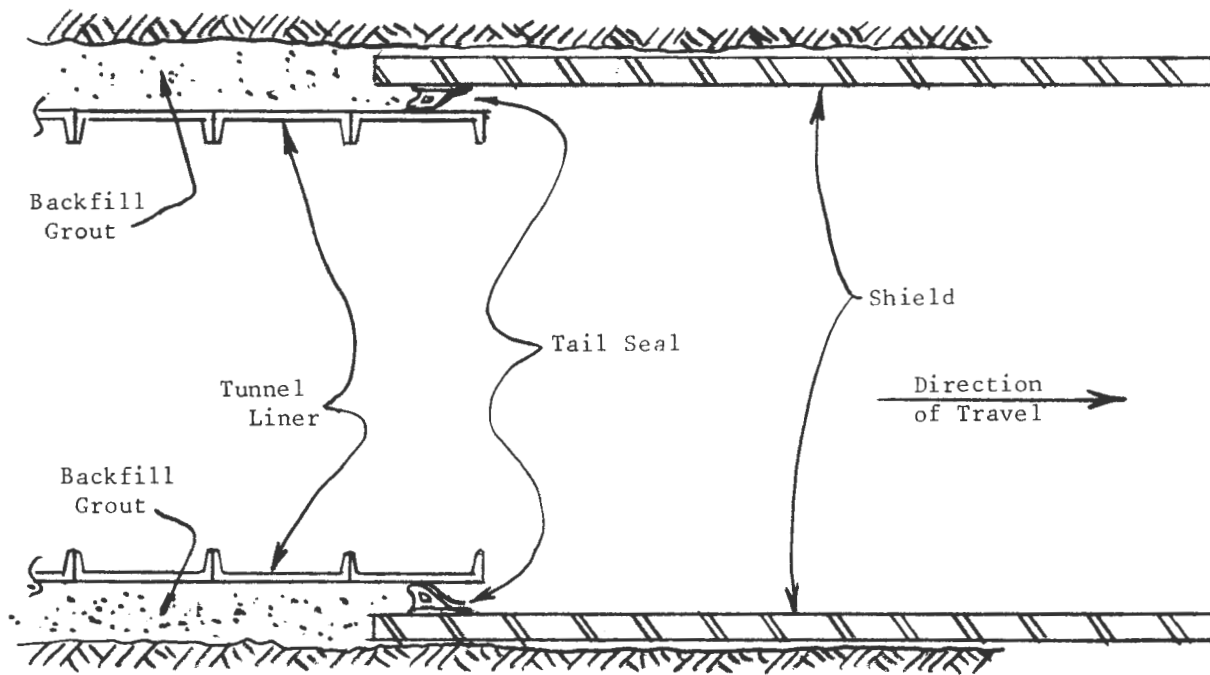

FIGURE 79(a). TAIL SEAL SCHEMATIC, N.T.S.

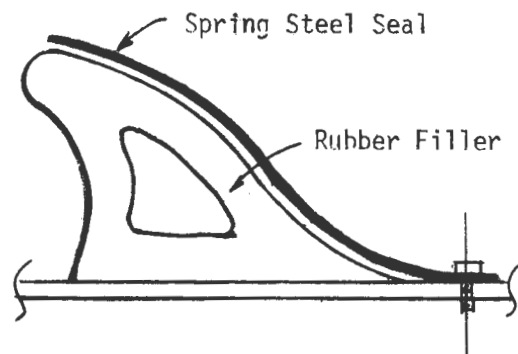

FIGURE 79(b). TAIL SEAL CROSS-SECTION, N.T.S.



FIGURE 80. PHOTO OF INSTALLED SEAL

conveyor with the segments stacked three high, concave upward and separated by two pieces of 4 x 4 inch lagging. The key segment was on top of one of the stacks. The shield operator and the excavator operator would then swivel their chairs around to face the concrete segments and the hydraulic control for the right and left erector arms, respectively. Laborers would screw a lifting plug into the center grout hole of the top segment. A ring on a swivel assembly of the erector arm was maneuvered onto the lifting plug and bolted in place. Since the segment was connected to the lifting arm by a free swinging swivel connection, the segment could not be mechanically rotated with respect to the connection and would hang freely.

In order to maneuver the segment into place, one or more laborers added their weight to a segment corner or edge. Starting at the invert the segments were aligned and bolted onto the jiggling ring using the aligning pins located on the segmented pads. After adjacent segments were connected to the segmented pads, the pads were then jacked toward each other along the circumference. This action compressed the rubber gaskets along their common longitudinal joint. With the gaskets compressed, the longitudinal bolts were placed and tightened. This process was repeated until the key segment was wedged in, completing the ring. Since the key was the last segment to be placed and was on top of the stack when erection began, it had to be moved twice. Usually the erector arm picked it up and placed it on the catwalk until the rest of the ring was completed. Then the erector arm removed it from the catwalk and placed it. Having to move the key segment twice resulted in some inefficiency (see Figures 81 through 86).

After the ring was completely erected on the thrust ring, the entire assembly was shoved back and bolted to the existing lining. Alignment of the longitudinal bolt holes was accomplished by hydraulic jacks capable of moving the jiggling ring horizontally, vertically and circumferentially. After the proper alignment was made, the longitudinal bolts were inserted and tightened with pneumatic wrenches. At the same time shoving and excavation began for the next ring. Grouting was started for the preceding rings as soon as the tail of the shield passed by the grout plug during the next cycle, (i.e., when the ring to be grouted was second from the heading).

Excavation, mucking and the forward advance of the shield generally occurred at the same time. This process continued until sufficient advance had been made to facilitate erection of the next ring.

The forward advance was not one continuous motion, but was stopped periodically when the muck train was full, and was resumed when the muck train

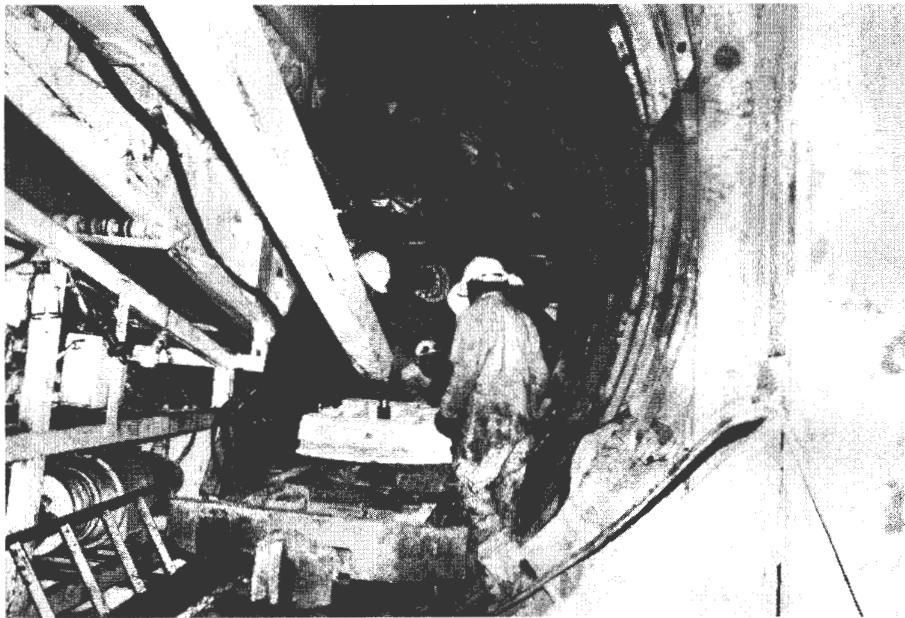

FIGURE 81. LIFTING SEGMENT WITH ERECTOR ARM



FIGURE 82. ROTATING SEGMENT MANUALLY FOR INSTALLATION



FIGURE 83. LIFTING SEGMENT INTO POSITION ON JIG RING

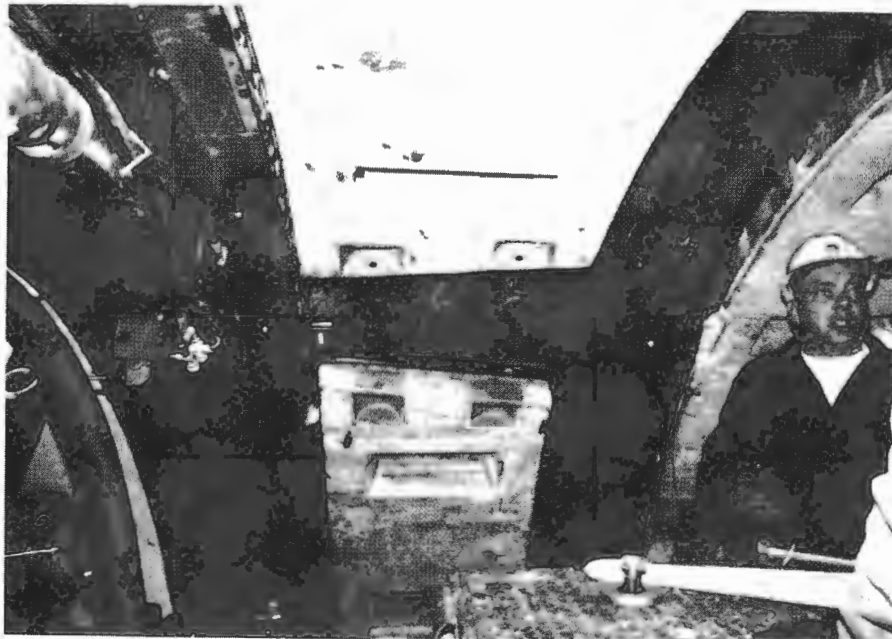

FIGURE 84. SEGMENTS MOUNTED ON JIG RING AWAITING KEY SEGMENT

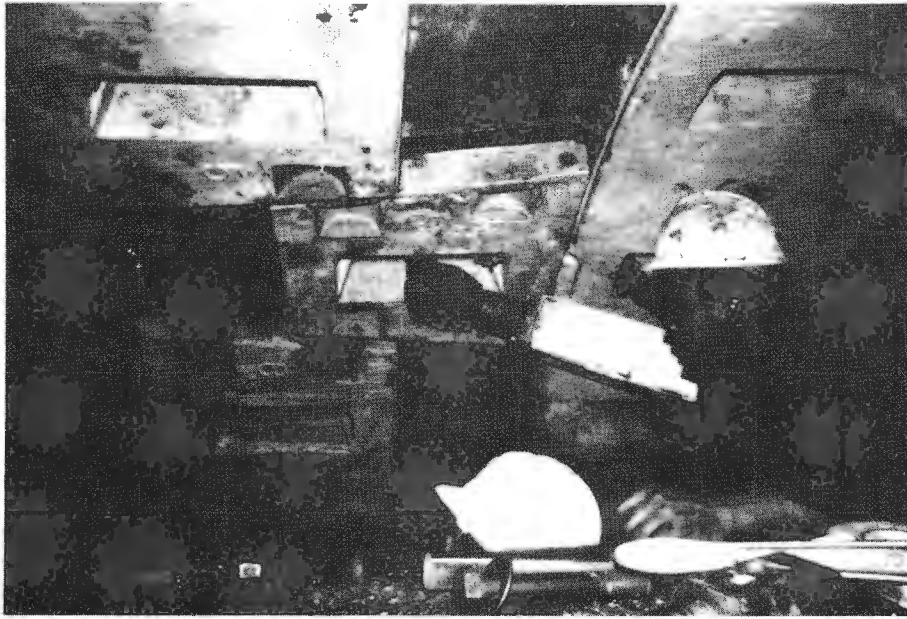

FIGURE 85. INSTALLATION OF KEY SEGMENT



FIGURE 86. PUSHING ASSEMBLED RING BACK TO
CONNECT WITH PREVIOUS RING

returned empty. Since a muck train consisted of a locomotive and two six cubic yard muck cars and it took an average of thirty-six cubic yards of muck for a complete shove, the shield advance was stopped an average of twice per cycle.

When the forward advance was sufficient for erecting the next ring, the shove was stopped and the thrust ring was retracted. Retracting the thrust ring generally took only a few seconds. The main concern during this step was to provide a uniform withdrawal of the aligning pins as they were retracted from the concrete segments. If the thrust ring was skewed, with respect to the plane of the ring, the aligning pins would gouge the bolt holes spalling off fragments of the concrete liner.

As in the steel tunnel, the first 275± feet of precast tunnel was driven in free air in the dewatered section. Excavation was then halted while the air lock and bulkhead were installed. The remainder of the tunnel was then driven under compressed air. Problems with hard rock in the invert in the area of Station 17+75± failed to materialize and the excavation proceeded to completion with only two minor incidents. These involved situations where significant damage occurred to the precast liners. They are described in Section 7.3.3.

Upon completion of tunnel excavation, the heading was again bulk-headed off and excavation began on the two cross passages. This was handmining work and began with the removal of special knock-out segments built into the precast concrete liner. Temporary structural steel braces were erected in the main tunnel adjacent to the cross passage openings to maintain roof support during this construction.

Steel squaresets with tight timber lagging were used as temporary support in the cross passage drifts.

The drifts were fully excavated and supported, to the steel lined tunnel before any of the corresponding steel segments were removed.

A pictorial account of this operation is provided in Figures 87 through 92.

7.2.2.3 Production Analysis - Precast Lined Tunnel

As with the steel lined tunnel, a proliferation of production related data was accumulated during the tunneling operations for the precast lined tunnel. This data was collated, analyzed and finally tabulated into a form intended to present the basic production information of greatest interest to the users of this study. The tabulation is presented in Figure 93.

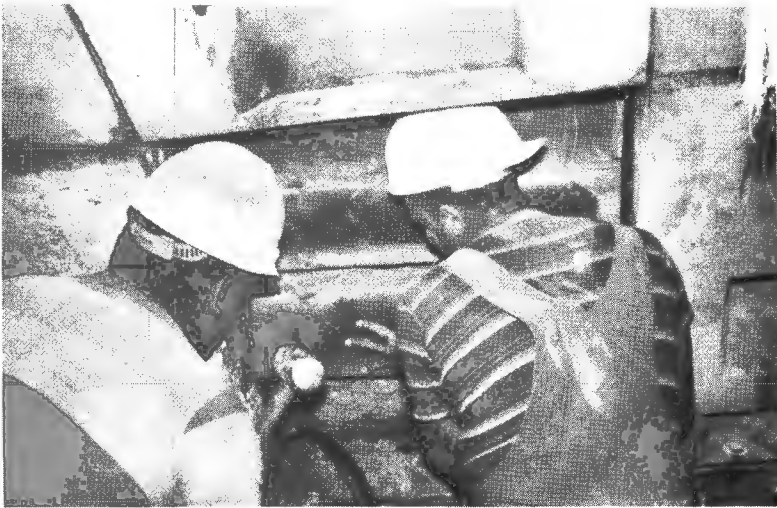

FIGURE 87. REMOVING KNOCK-
OUT SEGMENTS AND BREASTING
OFF.

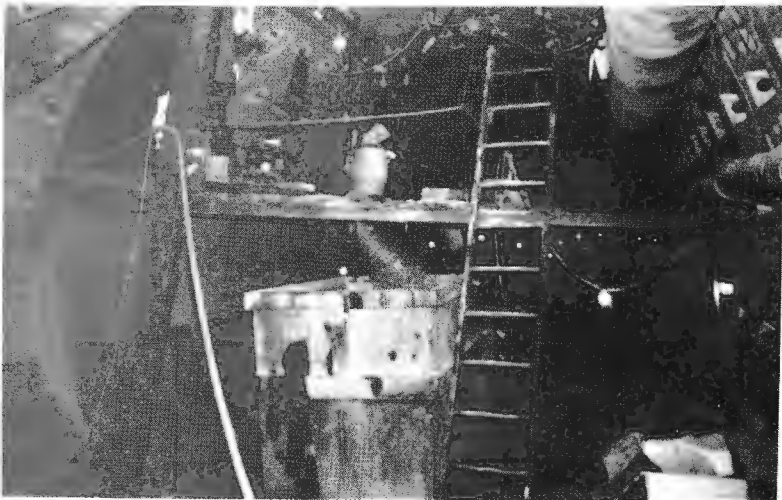

FIGURE 88. DRIFT OPENING
FOR CROSS PASSAGE.



FIGURE 89. CROSS PASSAGE
EXCAVATION IN PROGRESS.



FIGURE 90. TEMPORARY BRACING DURING EXCAVATION OF CROSS PASSAGES.



FIGURE 91. INTERSECTION OF CROSS PASSAGE WITH PRECAST-LINED TUNNEL.



FIGURE 92. INTERSECTION WITH STEEL LINER.

Legend: Wrk Day = Working Day
 RG = No. of Rings
 LF = Lin.Ft. of Advance
 SHV = Shoving Time (minutes)
 ERT = Erection Time (minutes)
 LT = Lost Time (minutes)

DT = Downtime (minutes)
 MUCK = Ave. Volume Removed in Loose cy/lf
 GRUT = Backfill Grout

$$\text{Gross Efficiency} = \frac{\text{SHV} + \text{ERT}}{\text{Total Time}} \times 100$$

$$\text{Working Efficiency} = \frac{\text{SHV} + \text{ERT}}{\text{Tot.} - \text{DT}} \times 100$$

CONCRETE TUNNEL

WRK DAY	ADVANCE				CYCLE TIMES										MUCK YD/LF		GRUT CF/LF		EFFICIENCY	
	DAILY		AVG/DAY		DAILY AVERAGE				ACCLIM. AVERAGE						DAY	ACIM	DAY	ACIM	(ACCLIM.)	
	RG	LF	RG	LF	SHV	ERT	LT	DT	SHV	ERT	LT	DT	TOT	MUCK	MUCK	GRUT	GRUT	GROSS	WORK	
1	2	5.1	2.0	5.1	133	110	315	13	133	110	315	13	570	10.0	10.0	0.0	0.0	42.5%	43.5%	
2	2	5.1	2.0	5.1	105	155	00	370	110	133	203	131	645	6.5	8.2	12.2	6.1	39.0%	55.4%	
3	1	2.5	1.7	4.2	650	200	15	430	225	146	165	233	775	9.6	8.5	12.0	7.2	47.9%	63.2%	
4	2	5.2	1.8	4.5	83	105	0	483	184	134	118	303	745	13.1	9.8	15.4	9.6	42.8%	73.0%	
5	2	5.1	1.8	4.6	68	195	183	153	158	148	133	275	714	9.4	9.7	9.8	9.7	42.8%	69.7%	
6	2	5.1	1.8	4.7	255	153	0	313	176	143	109	282	715	12.2	10.2	14.7	10.6	45.4%	74.8%	
7	2	5.1	1.9	4.7	78	138	270	85	161	147	134	252	633	12.9	10.6	13.4	11.9	44.4%	69.7%	
8	4	10.3	2.1	5.4	48	149	40	53	134	147	112	205	538	14.6	11.5	14.0	12.4	47.1%	71.6%	
9	4	10.2	2.3	6.0	51	143	25	0	118	148	107	166	538	20.0	13.1	16.2	13.1	43.4%	71.4%	
10	6	15.4	2.7	6.9	78	95	19	25	109	136	87	134	467	14.2	13.4	13.0	13.1	52.5%	73.8%	
11	8	18.9	3.2	8.0	61	79	23	6	98	123	72	105	338	18.8	14.5	13.9	13.3	55.5%	75.3%	
12	7	18.0	3.5	8.8	37	91	31	20	88	118	65	91	362	17.2	15.0	14.4	13.5	56.8%	75.8%	
13	4	11.7	3.5	9.1	47	103	58	153	84	116	65	96	362	15.7	15.1	12.0	13.3	55.5%	75.6%	
14	6	15.4	3.7	9.5	61	105	0	75	82	115	57	94	348	13.0	14.8	12.7	13.2	56.6%	77.4%	
15	2	5.7	3.6	9.2	103	115	285	68	82	115	66	93	356	15.1	14.8	12.3	13.2	55.5%	75.0%	
16	8	20.4	3.9	9.9	41	68	52	8	77	103	64	82	332	15.7	14.9	11.5	13.0	56.1%	74.4%	
17	9	23.5	4.2	10.7	52	68	40	0	74	104	61	71	310	14.8	14.9	15.5	13.3	57.3%	74.4%	
18	11	28.2	4.6	11.7	35	65	19	0	69	99	55	62	284	14.7	14.9	12.3	13.2	58.8%	75.1%	
19	11	28.3	4.9	12.6	37	76	15	0	65	96	51	54	266	14.2	14.8	14.0	13.3	60.5%	76.1%	
20	11	28.3	5.2	13.4	24	75	16	3	61	94	47	49	250	12.7	14.6	16.4	13.6	61.6%	76.6%	
21	10	25.8	5.4	13.9	22	58	29	6	57	91	45	45	238	13.7	14.5	14.7	13.7	62.0%	76.5%	
22	6	15.4	5.5	14.0	42	58	91	0	56	89	48	43	236	9.4	14.3	15.6	13.8	61.6%	75.3%	
23	11	28.3	5.7	14.6	48	55	14	0	56	86	45	39	226	15.1	14.3	12.2	13.7	62.7%	76.0%	
24	9	23.1	5.8	15.0	38	71	18	0	54	85	43	37	219	12.5	14.2	13.2	13.6	63.6%	76.4%	
25	11	28.3	6.0	15.5	32	48	24	0	53	82	42	34	211	11.4	14.0	11.3	13.5	64.1%	76.4%	
26	13	33.4	6.3	16.2	32	47	12	2	51	80	39	32	202	12.2	13.9	13.5	13.5	64.8%	76.9%	

FIGURE 93(a). PRODUCTION ANALYSIS -- CONCRETE.

CONCRETE TUNNEL

WRK DAY	ADVANCE				CYCLE TIMES										MUCK YD/LF		GRUT CF/LF		EFFICIENCY	
	DAILY		AVG/DAY		DAILY AVERAGE					ACCLM. AVERAGE					DAY	ACCLM	DAY	ACCLM	(ACCLM.)	
	RG	LF	RG	L.F.	SHV	FRT	L T	D T	TOT	SHV	ERT	L T	D T	TOT	MUCK	MUCK	GRUT	GRUT	GROSS	WORK
27	12	30.8	6.5	16.7	23	50	22	0	49	77	38	29	194	11.7	13.7	13.5	13.5	65.2%	76.9%	
28	14	36.0	6.8	17.4	25	54	17	0	48	76	37	27	187	10.7	13.5	12.5	13.4	65.9%	77.1%	
29	10	25.7	6.0	17.7	26	62	24	18	46	75	36	27	184	8.9	13.3	9.5	13.2	66.0%	77.2%	
30	8	20.1	6.0	17.8	45	46	47	5	46	74	36	26	183	13.1	13.3	14.4	13.2	65.9%	76.8%	
31	8	20.0	7.0	17.0	21	53	44	58	45	73	37	27	183	10.2	13.1	14.0	13.3	65.1%	76.4%	
32	4	11.7	6.9	17.7	38	50	197	0	45	73	40	27	184	12.1	13.1	13.2	13.3	64.1%	74.9%	
33	1	1.7	6.7	17.2	50	40	985	65	45	73	44	27	189	21.2	13.2	19.4	13.3	62.6%	72.9%	
34	5	12.8	6.6	17.1	42	57	129	0	45	72	46	26	190	15.0	13.2	12.8	13.3	62.1%	72.0%	
35	1	2.6	6.5	16.7	46	50	1044	0	45	72	50	26	194	16.2	13.2	11.5	13.3	60.7%	70.1%	
36	9	23.1	6.6	16.8	54	56	28	10	46	72	49	25	192	13.5	13.2	12.3	13.2	61.1%	70.4%	
37	10	25.7	6.6	17.1	51	48	22	9	46	71	48	25	189	15.6	13.3	11.4	13.2	61.5%	70.7%	
38	9	23.2	6.7	17.2	50	52	22	2	46	70	47	24	187	18.1	13.5	9.7	13.0	61.9%	71.0%	
39	14	35.4	6.9	17.7	49	36	17	1	46	68	46	23	183	15.6	13.6	13.2	13.0	62.5%	71.5%	
40	14	36.0	7.1	18.2	48	48	0	6	46	67	43	22	179	17.5	13.8	10.6	12.9	63.5%	72.4%	
41	20	51.4	7.4	19.0	38	34	0	0	46	66	41	21	173	16.3	14.0	12.1	12.9	64.7%	73.4%	
42	10	25.7	7.5	19.1	59	59	13	0	47	65	40	20	172	17.7	14.1	11.9	12.8	65.3%	73.9%	
43	10	25.7	7.5	19.3	55	45	18	0	47	65	39	19	170	18.7	14.2	13.9	12.9	65.7%	74.1%	
44	12	30.8	7.6	19.5	27	49	16	28	46	64	38	20	168	14.0	14.2	13.8	12.9	65.7%	74.3%	
45	12	30.6	7.7	19.8	35	53	13	0	46	64	37	19	166	15.7	14.3	14.1	12.9	66.1%	74.6%	
46	14	35.9	7.8	20.1	31	50	17	4	45	63	36	18	163	13.7	14.2	14.2	13.0	66.5%	74.8%	
47	13	33.5	8.0	20.4	28	49	11	2	45	63	36	18	161	13.4	14.2	15.1	13.1	66.8%	75.1%	
48	12	30.5	8.0	20.6	41	42	15	0	45	62	35	17	159	13.0	14.2	16.1	13.2	67.2%	75.3%	
49	12	30.8	8.1	20.8	32	56	12	3	44	62	34	17	157	13.2	14.1	14.8	13.2	67.5%	75.6%	
50	13	33.0	8.2	21.1	34	54	10	2	44	62	34	16	155	12.7	14.1	14.5	13.2	68.0%	75.9%	
51	9	23.2	8.2	21.1	33	50	42	31	44	61	34	17	155	15.3	14.1	13.8	13.3	67.6%	75.7%	
52	10	25.8	8.3	21.2	46	60	15	24	44	61	33	17	155	14.0	14.1	15.1	13.3	67.8%	76.0%	

FIGURE 93(b). PRODUCTION ANALYSIS -- CONCRETE

CONCRETE TUNNEL

WRK DAY	ADVANCE				CYCLE TIMES										MUCK YD/LF		GRUT CF/LF		EFFICIENCY			
	DAILY		AVG/DAY		DAILY AVERAGE					ACCLM. AVERAGE					DAY	ACLM	DAY	ACLM	(ACCLM.)			
	RG	LF	RG	L.F.	SHV	ERT	L	T	D	T	SHV	ERT	L	T	D	T	TOT	MUCK	MUCK	GRUT	GRUT	GROSS
53	10	25.7	8.3	21.3	32	51	29	20		43	61	33	17	155			13.5	14.1	13.4	13.3	67.7%	75.0%
54	8	20.5	8.3	21.3	61	54	9	25		44	61	33	17	154			12.3	14.1	15.4	13.3	67.8%	76.2%
55	9	22.1	8.3	21.3	55	63	11	1		44	61	32	17	154			16.3	14.1	17.3	13.4	68.2%	76.5%
56	13	33.4	8.4	21.5	30	48	16	3		44	61	32	16	152			12.6	14.1	14.5	13.5	68.4%	76.6%
57	5	12.8	8.3	21.4	28	56	11	25		43	61	33	16	153			8.4	14.0	18.4	13.5	67.9%	76.1%
58	8	19.6	8.3	21.3	31	50	42	20		43	60	33	16	153			15.3	14.0	10.1	13.6	67.8%	75.9%
59	10	25.5	8.4	21.4	40	45	28	1		43	60	33	16	152			13.2	14.0	16.7	13.7	67.9%	75.9%
60	11	28.3	8.4	21.5	40	46	16	12		43	60	32	16	151			11.9	14.0	16.1	13.7	68.0%	76.0%
61	12	30.7	8.5	21.7	36	44	16	3		43	59	32	16	150			12.9	13.9	17.4	13.8	68.2%	76.2%
62	9	23.0	8.5	21.7	46	46	23	12		43	59	32	16	150			13.6	13.9	16.5	13.8	68.3%	76.2%
63	11	28.2	8.5	21.8	31	42	27	13		43	59	32	16	149			13.6	13.9	14.5	13.9	68.2%	76.2%
64	11	28.1	8.5	21.9	44	49	9	7		43	59	31	15	148			13.2	13.9	14.9	13.9	68.5%	76.4%
65	11	28.2	8.6	22.0	18	49	29	7		42	58	31	15	147			11.1	13.9	12.6	13.9	68.4%	76.3%
66	11	28.1	8.6	22.1	28	50	14	15		42	58	31	15	147			13.2	13.9	14.3	13.9	68.5%	76.4%
67	11	28.2	8.7	22.2	26	52	18	9		42	58	31	15	146			11.5	13.8	16.3	13.9	68.5%	76.5%
68	11	28.2	8.7	22.3	28	52	24	0		41	58	31	15	145			13.2	13.8	14.2	13.9	68.7%	76.5%
69	9	19.1	8.7	22.2	23	48	50	5		41	58	31	15	145			14.5	13.8	13.1	13.9	68.5%	76.2%

FIGURE 93(c). PRODUCTION ANALYSIS -- CONCRETE

The tabulation format is the same as that presented earlier for the steel lined tunnel, but will be briefly summarized again for the readers' convenience.

Working Days:	Column #1
Advance Rates:	Columns 2-5. Daily and cumulative averages, in rings/day and lf/day.
Cycle Times:	Columns 6-14. Daily and cumulative averages.
Muck Volumes:	Columns 15 and 16. Daily and cumulative averages in loose cy/lf. Note that the final average volume for this tunnel is slightly larger than that of the steel tunnel, the theoretical volume is 11.6 cy/ft. The "swell" or "fluff" factor for the soil then is $\frac{13.8}{11.6}$ or 1.19, which agrees with that calculated for the steel tunnel.
Grout Volumes:	Columns 17 and 18. Daily and cumulative backfill grout quantities in cu.ft./lf of tunnel.
Efficiency:	The last two columns represent the efficiency of the tunneling operations. The <u>Gross Efficiency</u> is the cumulative productive work time expressed as a percentage of total cycle time. The <u>Working Efficiency</u> is the cumulative productive work time expressed as a percentage of <u>available</u> work time (total time less downtime).

The cumulative tunnel advance rates for the precast lined tunnel in terms of both rings per day and lineal feet per day is plotted in Figure 94. One can see a rapid improvement in production rates during construction of the first half of the tunnel, with a continued but less rapid rate of improvement during the last half at the construction period. Production was still improving at the end of the operation. The implication is that a greater tunnel length is necessary to develop the full production potential for the given conditions. Thus, the learning curve exceeds the length of the construction period.

Figure 95 is a plot of the cumulative operating efficiency relationships developed from the production studies. An "availability" curve is included, which is a plot of the amount of time available for productive work as a percentage

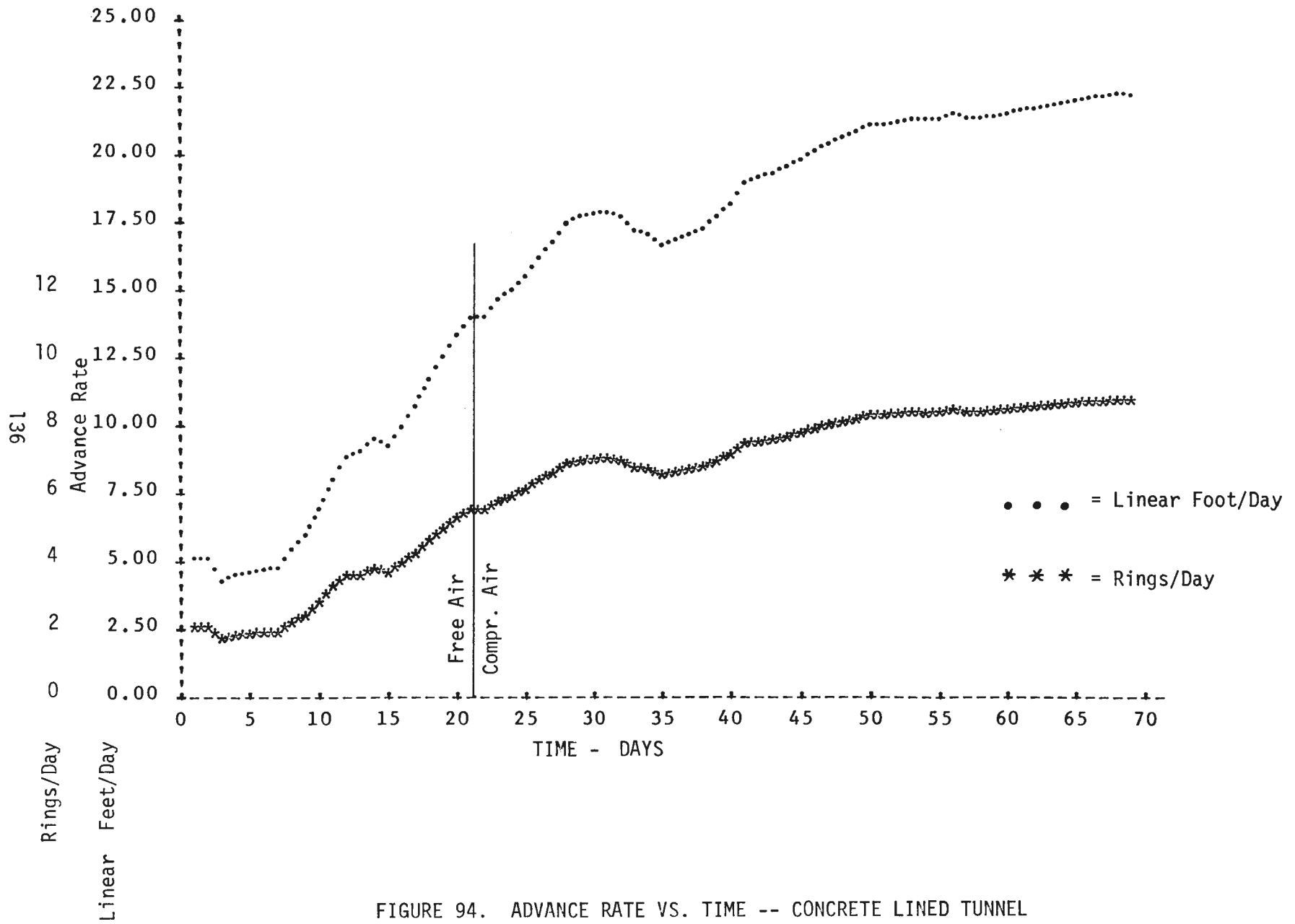

FIGURE 94. ADVANCE RATE VS. TIME -- CONCRETE LINED TUNNEL

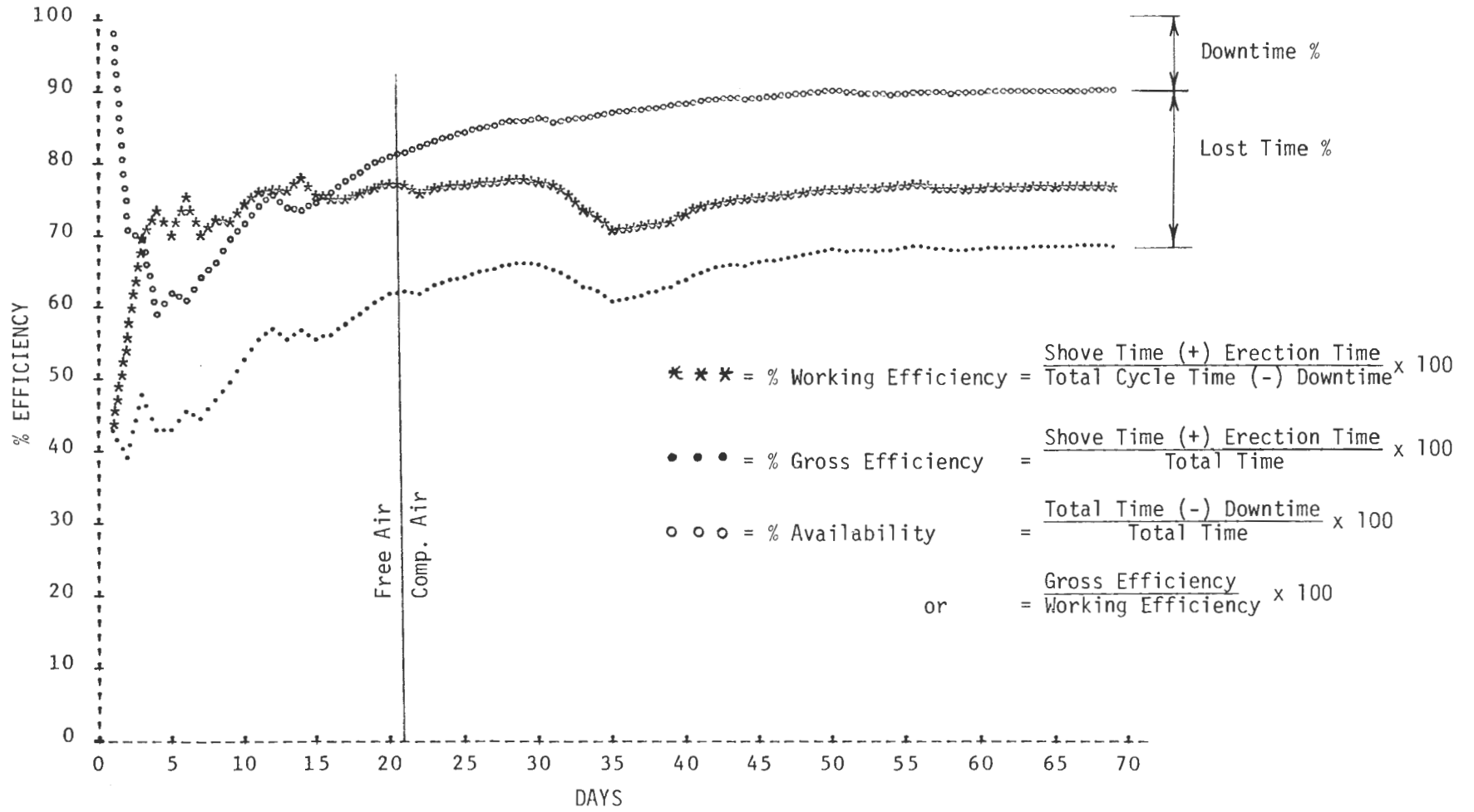

FIGURE 95. PRODUCTION EFFICIENCY RELATIONSHIPS VS. TIME -- PRECAST CONCRETE TUNNEL.

of total production time. This can be used to determine such production criteria as the relative downtime experience, which is indicative of equipment reliability and is represented by the area above the availability curve. Furthermore, the area between the availability curve and the Gross Efficiency curve represents the lost time experienced in the operation. This is indicative of the inherent inefficiencies built into the operation as well as the "human factor" considerations.

Further analysis of this production data will be presented in Section 8.1, dealing with a comparative analysis of steel and precast concrete liners.

7.3 Performance Analysis

7.3.1 Structural Instrumentation and Analysis

The structural instrumentation package was planned to provide an indication of the spatial motion of the individual segments used in the liner rings; of the general movement of the rings; and of the stress levels developed in the liner. The way in which the various instrumentation was installed and the results obtained are covered under separate headings in the following paragraphs. Detailed examination of the data led to a close examination of loading conditions on the liner. From this, a set of boundary conditions was postulated and a model developed for prediction of liner stresses and deflections. We shall begin by describing the model for liner loading.

7.3.1.1 Loading of the Concrete Liner

The Lexington Market precast liner was installed in the manner shown in Figure 96(a). A shield with digger attachment was equipped with a thrust ring which connected directly to the liner through a pinned and bolted joint. The thrust ring moved longitudinally in the tunnel, thrusting against the installed liner to obtain the reaction force necessary to drive the shield forward. Periodically, the thrust ring was disconnected from the lining, retracted into the tailshield where new segments were assembled on it, and then forced against the liner as the new ring was bolted in place.

Liquid grout was injected into the annular void left by the tailshield to provide immediate support for the ground. (The liner was sealed against the tailshield to prevent leakage of grout into the main tunnel area.) A relatively thin grout was used, and this had properties which caused the liner to appear to be immersed in liquid. Buoyancy forces thus exerted a continuous load of intensity W_B (equal to the weight of grout displaced by the liner per foot of length) along the tunnel axis. This is depicted in Figure 96(b).

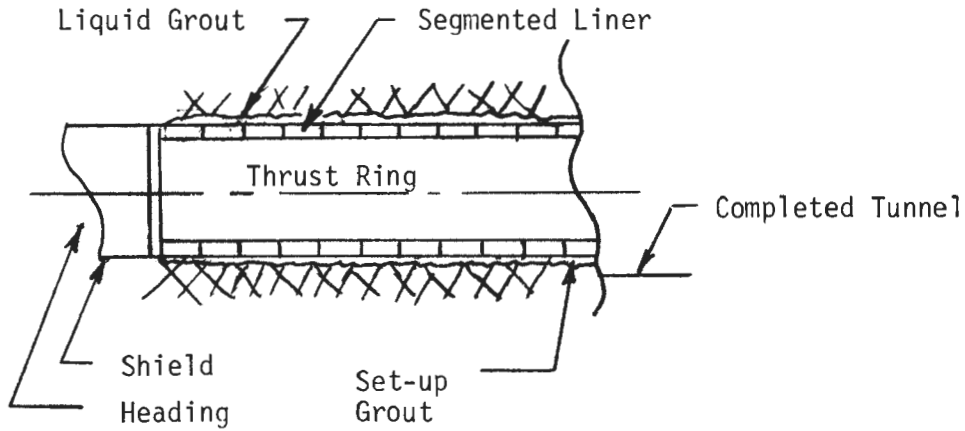

(a)

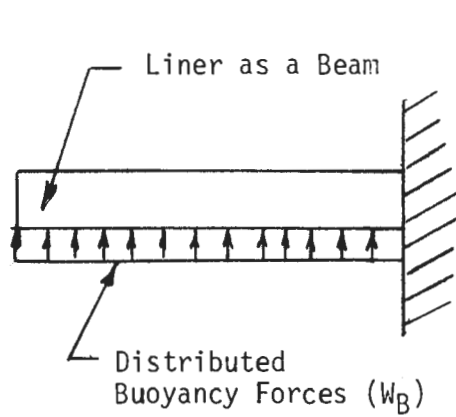

(b)

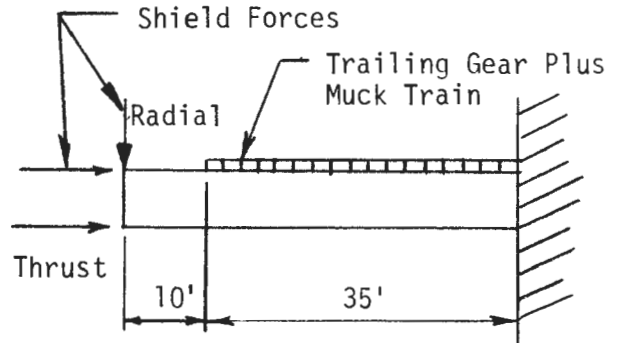

(c)

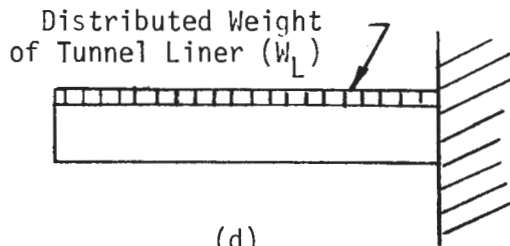

(d)

FIGURE 96. SCHEMATIC OF PRECAST SEGMENTED CONCRETE LINER INSTALLATION WITH ITS PRINCIPAL LOAD COMPONENTS.

The trailing gear with the muck train riding the Jacobs floor also exerts a load on the liner which is distributed along the tunnel axis by skids resting on the tunnel invert. This may be represented as a small, distributed load on the liner, Figure 96(c).

The third important distributed load is the weight of the liner itself, Figure 96(d). For all practical purposes, this is a vertical loading of intensity W_L (equal to the weight per foot of the liner assembly).

During the liner erection cycle described earlier, the liner undergoes two distinct loading patterns, Figure 97. When the liner is attached to the shove ring, Figure 97(a), it receives a thrust force T_S , a moment, M_S , due to eccentric loading from the thrust jacks, and distributed loads W_T , W_L and W_B as described above. Since the thrust ring has very limited radial travel, it constrains the liner by a radial force R_S at the thrust ring. To the right in Figure 97(a) grout has set up, and the liner may be considered to be a cantilevered beam, built in at that point.

Under the combined loading, the axis of the tunnel liner assumes the configuration shown. Critical points of that configuration are shown in Figure 98(a). At point "A", the liner reaches its peak radial displacement. The slope of the centerline is parallel to the tunnel alignment at that location. Point "B" is the location of peak axial tensile stresses in the top fibers of the liner. This peculiarity enables strain gages in the liner to show the existence of tensile longitudinal stresses, even when the liner is being loaded compressively by the thrust jacks. Point "C" is a flexure point at which the moment changes from + to - and the tensile stresses move from the top fibers to those at the tunnel invert. Thereafter, tensile stresses in the lower fibers of the liner increase until they reach a maximum at point "D" where the grout has set up.

Under the loading pattern of Figure 97(b), the end of the tunnel liner is not constrained radially by the thrust ring. When this occurs the liner axis curves upward in the manner followed by a uniformly loaded cantilever beam. Tensile stress in the bottom fiber and compressive stress in the top fiber vary from maximums at point "E" to 0 at point "F", Figure 98(b).

Thrust and moment forces applied by the thrust ring to the liner will cause variable stresses in the liner which may or may not dominate the stresses generated by the distributed radial loads mentioned above. In general, at light thrust loads, the axial compressive stresses induced by the thrust ring will be smaller than or of the same order as the stresses induced by the distributed loads. Sudden steering corrections introduce moments and radial forces which may

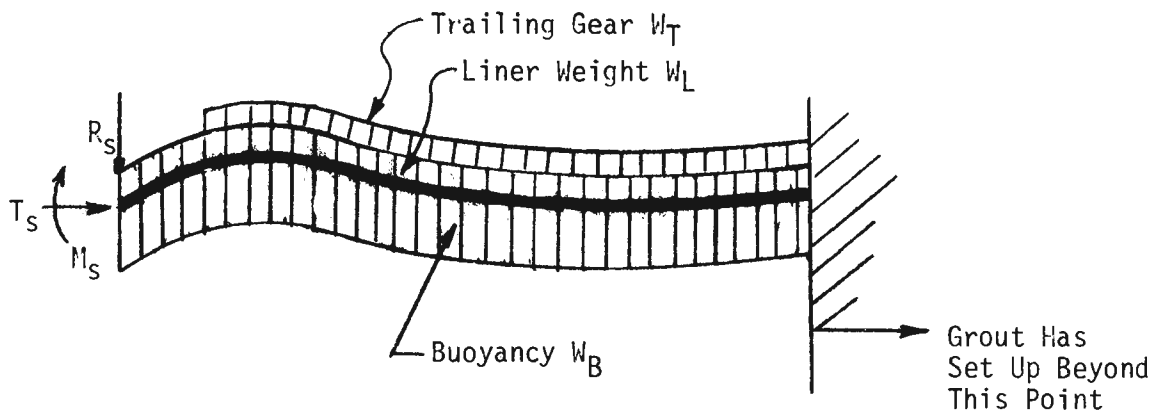

WITH LOADING RING ATTACHED TO LINER
 (a)

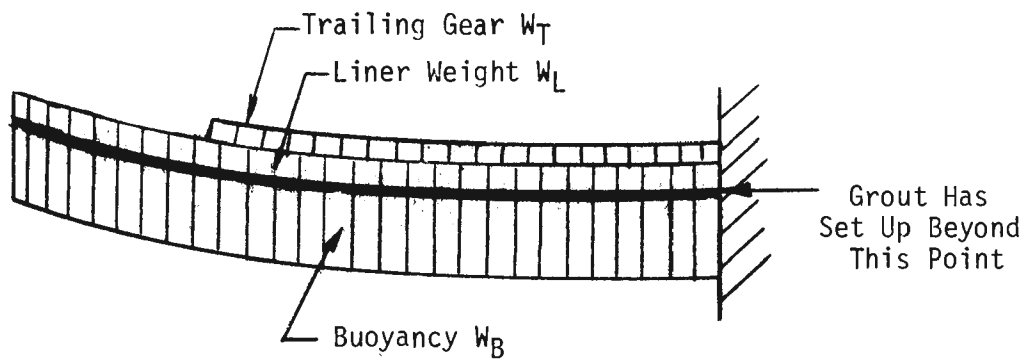

WITH LINER FREE FROM LOADING RING
 (b)

FIGURE 97. SCHEMATIC CONFIGURATION OF LOADING ON PRECAST, SEGMENTED CONCRETE TUNNEL LINERS.

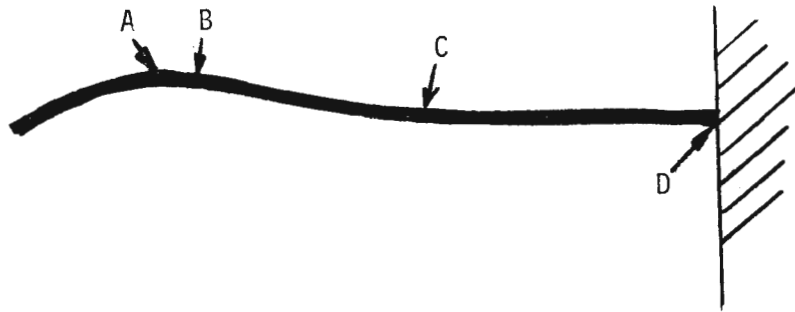

(a)



(b)

FIGURE 98. CRITICAL POINTS ON LINEAR AXIS UNDER POSTULATED LOADING CONDITIONS

generate higher or lower stresses than those caused by the distributed loads, depending upon the severity of the directional change. Heavy, uniform thrust loads tend to produce more uniformly compressive axial stresses which dominate the others.

The actual configuration of the tunnel liner will depend upon several factors. It is, of course, directly related to the length of the "cantilever", which is determined by the speed at which grout will set up compared with the rate of advance of the heading. Our measurements indicate that the grout used probably sets up to a point at which it makes a "built in" section of liner in 1-2 days.

Configuration is also directly related to the flexibility of the liner. A liner having more flexibility will develop greater radial displacements for equal load and stress conditions than one whose section inertia makes it very stiff. For a "beam" made up of a number of segments, which is the way the liner is constructed, flexibility appears to be a strong function of the properties of individual joints. Tensile stresses are carried across joints by bolts, which make the beam considerably more flexible than solid concrete walls. Likewise, when two adjacent liner rings have angular displacements of their planes relative to each other, concrete in the vicinity of the gasket groove is stressed beyond its compressive strength and crushes locally, giving the equivalent of added flexibility. The net flexibility of the liner as a beam is also influenced by relative movements along bolted joints in both the axial and tangential directions.

Typical radial displacements for the Lexington Market precast tunnel liner are of the order of a few tenths of an inch for the attached configuration, and 0.5-1.0 for the free configuration. Tensile and/or compressive stresses typically will be in the 100 to 2000 psi range, depending upon location relative to the end of the liner. Tensile stresses at the high end of this range are great enough to cause local cracking of individual segments. Observations that such cracks sometimes develop in liner rings located quite far back from the thrust ring agree with the predictions of the model that peak stresses are high enough to cause failure and they occur some distance from the end of the liner "beam".

In succeeding sections further agreement between the predictions of the model and experimental data will be discussed.

7.3.1.2 Geometric Measurement

One of the fundamental questions concerning liner performance is related to deflection. "How much did the tunnel cross sections change between initial installation and final configuration?" Experimental data to answer these questions were obtained from three different sources, an extensometer, tilt plates, and direct

measurement methods. Before presenting the data, it is appropriate to describe the measurement systems employed.

7.3.1.2.1 Ball Extensometer

Ideally, one would make diametral measurements directly by stretching a tape between opposite points on the liner. Unfortunately, this cannot be done in the region of interest at an appropriate time. The trailing gear of the tunneling shield occupies a major fraction of the central area of the tunnel. It precludes making "straight through" measurements, requiring the development of alternative means. This led to the ball extensometer concept.

The ball extensometer measurement system utilizes four steel balls spaced at approximately 90° intervals around the periphery of the test ring. Ball number 1 is located 50° away from the invert center. Ball numbers 3, 5, and 7 are located as shown in Figure 100. An extensometer, Figures 20 and 99, has end clamps which attach it firmly to two adjacent balls and a linear scale which enables the user to measure the distance between them. In addition, it has a second linear measuring attachment which extends outward to a point on the periphery of the liner ring located approximately halfway between the balls. The points of contact for the latter are "2", "4", and "6" in Figure 100. The overall arrangement, together with the measurements made, are illustrated in Figure 101. From these measurements, using appropriate trigonometric relationships, the spatial location of Points 1 through 7 may be calculated.

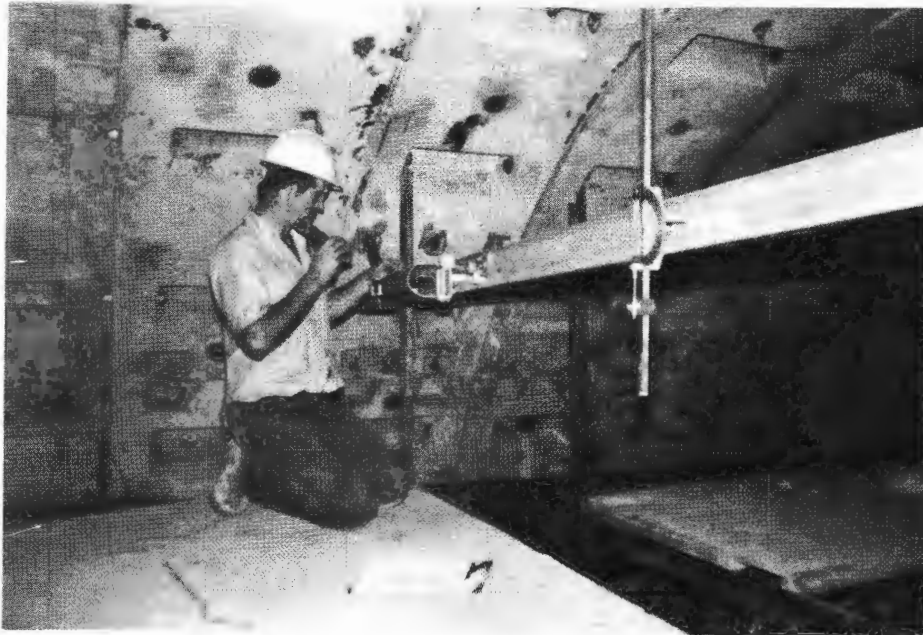

FIGURE 99. EXTENSOMETER

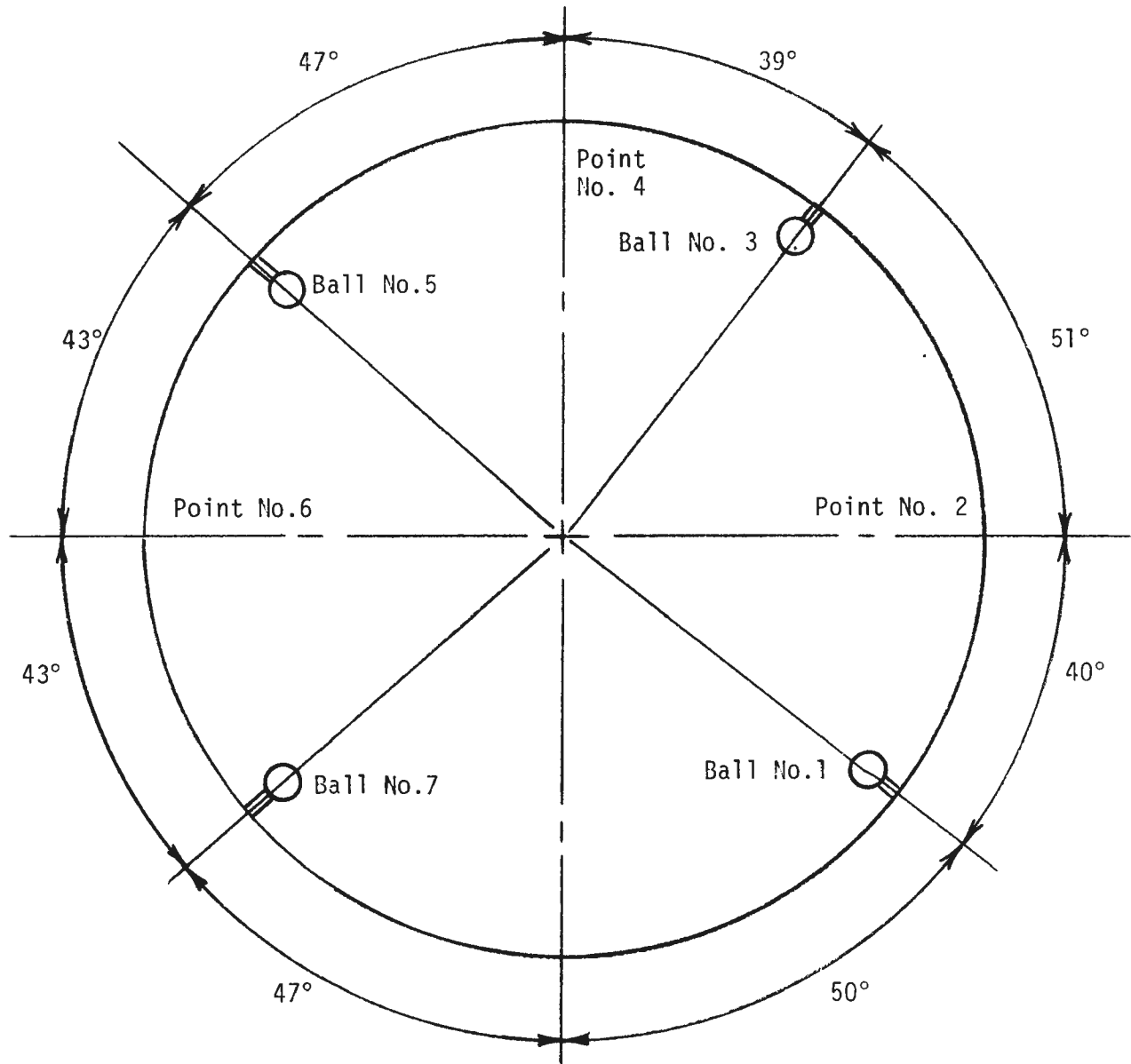

FIGURE 100. ANGULAR LOCATIONS OF EXTENSOMETER BALLS.

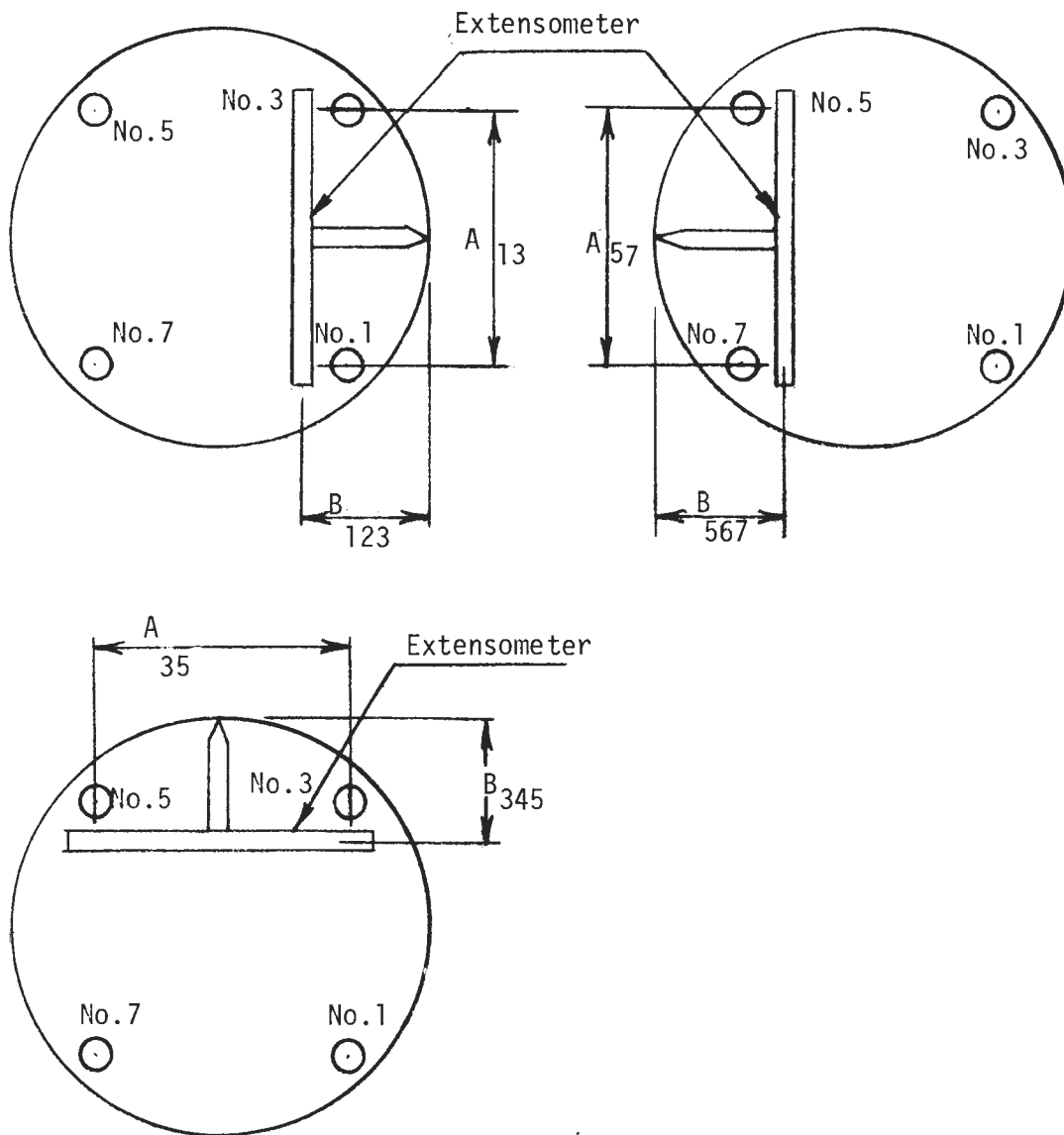

FIGURE 101. SCHEMATIC ARRANGEMENT OF BALL EXTENSOMETER MEASUREMENT SYSTEM.

In order to facilitate presentation of results, we have employed a defined reference circle on which all radii are measured. The radius of the reference circle has been arbitrarily chosen to be one half the nominal diameter of the tunnel. The center of the reference circle has been located to coincide approximately with the center of the ring.

Extensometer measurements were made in conjunction with each shove, and used to calculate the spatial locations of each of the reference points. Error envelopes were superimposed on each measurement and a ring configuration selected which fit within all envelopes^(a).

The most probable configuration for ring 471 based on its first measured position and on its final position are shown in Figure 102. Note that the radial displacement scale is greatly exaggerated (by a factor of 70:1 approximately) compared with the reference radius. The plot shows that segments as originally placed varied by a maximum of 0.25 inches from a perfect circle. This is a variation of 1/4% on the nominal radius (8.915'). Construction techniques which maintain this level of accuracy are considered to be very good. The final position is even more nearly circular. Liner movements required to move from the configuration of the first measured position to that of the final position agree qualitatively with measured ground movements as indicated by inclinometer-12.

7.3.1.2.2 Tilt Plate System

In the tilt plate system, a group of ceramic plates are fastened to the ends of the segments of the test ring. See Figure 103.

Each plate is anchored by an epoxy bond. A measuring instrument capable of accurately measuring the angle between a given tilt plate and the vertical is held against each plate in succession. The data obtained gives an indication of the way in which the segments move during successive advances of the tunneling shield.

Returning to Figure 102, it may be noted that segment number 1 (the 60° segment with reference point number 1 on it) must rotate counterclockwise to move from its first measured position to its final position. Both the direction of rotation and the angular rotation shown in the figure agree with measured tilt plate values. Indeed, tilt plate data was taken into account in selecting the most likely configurations of ring number 471.

- (a) An error envelope defines the range of values which a given measurement may be expected to have. Thus a measured value of 8.915' known to be accurate to $\pm 0.01'$ would have an envelope lying between 8.905' and 8.925'.

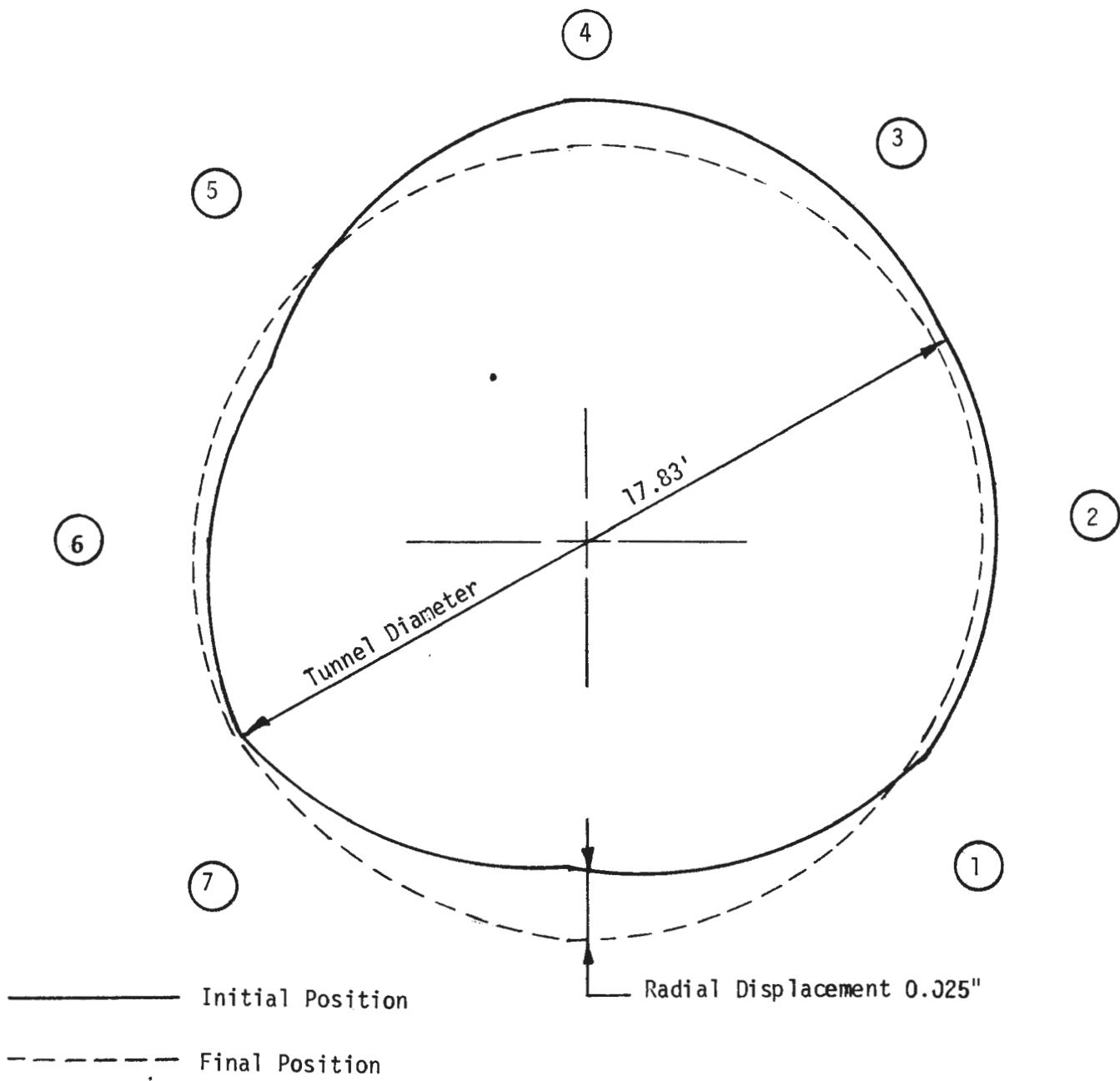

FIGURE 102. POLAR DIAGRAM OF MEASURED RING CONFIGURATION
 TEST SECTION "B" RING 471 (Note Exaggeration of Displaced
 Scale. Maximum Radial Displacement of Segments = 0.25";
 Tunnel Diameter = 17.83')

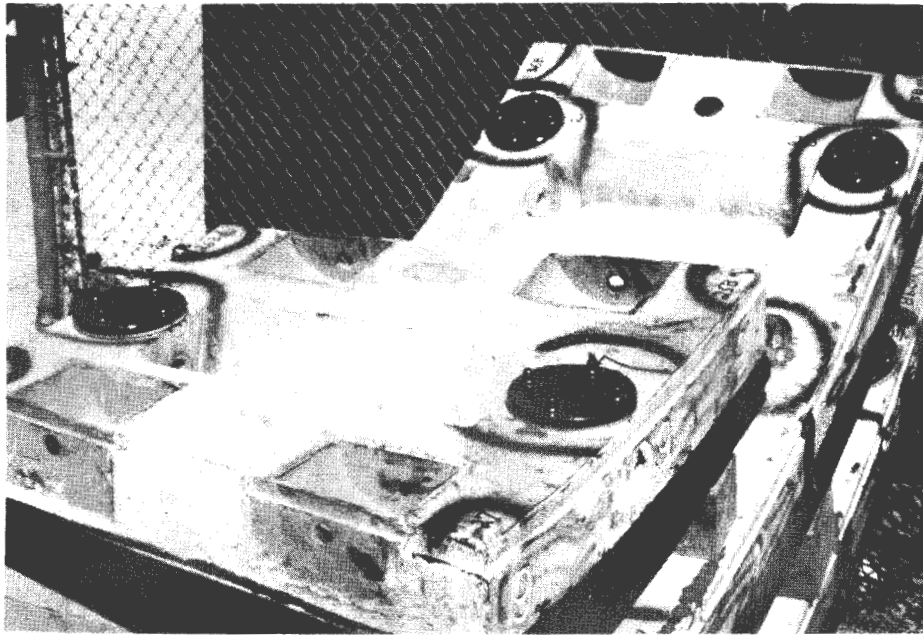

FIGURE 103. TILT PLATE.

Other data from the extensometer and the tilt plates agree to within the expected range of accuracy with the exception of that for segment number 6. Since very little tilt plate data was obtained for segment number 6^(b), this lack of agreement is not considered to be serious.

7.3.1.2.3 Direct Methods

The UTD survey party brought a reference elevation from the tunnel construction shaft to Test Section B. With this control, it was possible to employ a surveyor's level and rod to obtain elevations for the extensometer balls and the crown. Supplementary horizontal offsets were obtained for the balls by employing a plumb bob and scale. These measurements were used as check values to verify the accuracy of the extensometer data. In all cases there was agreement to within the limits of the error envelope between direct measurement data obtained in this way and calculated values from the extensometer.

Subsequently, after the shield had advanced sufficiently to remove interference from the central area of Test Section B, taped diameter measurements

(b) Tilt plates were broken on this segment shortly after the test ring was installed.

were made in several positions. These, too, were in general agreement with the ring configurations adopted as most likely based on all data obtained.

7.3.1.2.4 Conclusions

A series of geometric measurements were made to determine the probable configurations taken by the test ring subsequent to installation. Although these were taken by several independent methods, they were found to agree in most details with the predicted configurations. This leads to the conclusion that the predictions are an accurate representation of what happened with ring number 471. General observations of many other rings in the tunnel lead to the conclusion that ring 471 is representative of what happened throughout the precast segmented concrete lined tunnel.

Average radial changes between the first measured position and the final position are estimated to be of the order of 0.011 feet. This corresponds to a loss of ground of 0.15 cu.ft. per ring, which is considered to be negligible. It is concluded that precast segmented concrete liner does not have significant diametral distortion which would exceed that of other liners.

7.3.1.3 Caliper Extensometer Measurements

Movement of adjacent liner segments relative to each other provides an indication of the geometric changes taking place in the liner as it adjusts to the loads imposed on it. One of the experimental methods used to obtain data on these changes was the use of caliper extensometer measurements at several joints. The setup for caliper extensometer measurements is illustrated schematically in Figure 104 with a photo of a typical installation given in Figure 21. As shown in Figure 104, four measurement points were located on each segment in the joint region.

Each point was equipped with a conical recess into which a caliper point could be inserted with repeatable locational accuracy. A gage equipped with two caliper points and a means of measuring the distance between them was employed to obtain the distances AB, CD, EF, GH, CF, and DE. These distances could be used to calculate the movement of each segment relative to the segments adjacent to it. Two types of movement were evaluated.

First, from measurements made at those joints equipped with caliper points, (there were none on the invert joint) the net change in circumference was found. This would be equal to the sum of the increases (decreases) in distances "AB" and "GH" (Figure 104) for all joints in the ring. For ring 471, Test Section B, this net change in circumference was calculated to be -0.037", corresponding to a net decrease in radius of 0.006" between installation and final configuration. Conclu-

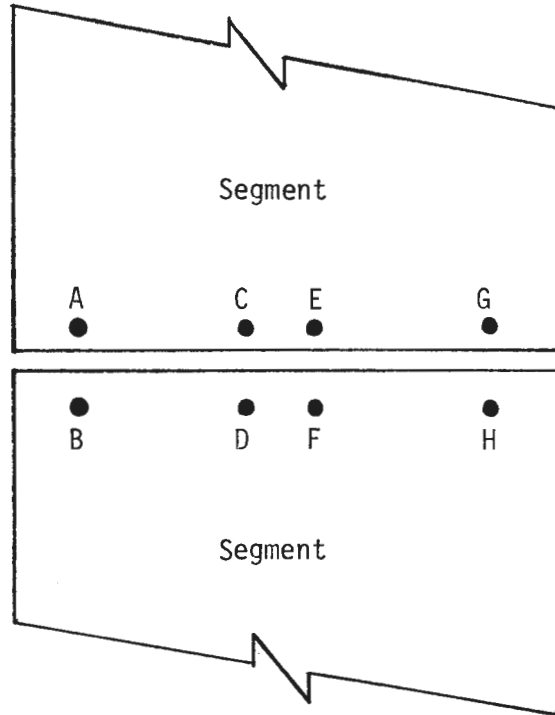

FIGURE 104. SCHEMATIC LAY-OUT SHOWING LOCATION OF CALIPER EXTENSOMETER POINTS

sions based on indirect measurements of tunnel diameter were that there was a net decrease in radius of 0.012". These two predictions, made on the basis of completely independent measurements, are remarkably close, and well within the expected range of accuracy of the measuring systems.

The second type of movement calculated was the angular movement of each segment in a ring with respect to its neighbors. This gives an indication of the way in which the plane of the ring was distorted with respect to a plane perpendicular to the tunnel alignment at the location of that particular ring. To obtain this, we divided the differential changes between distance AB and GH (Figure 104) by the distance between them ($AG \approx BH$). This was the angle through which the adjacent segments had turned relative to each other, expressed in radians. The results of the analysis for a sequence of shoves are illustrated in Figure 105. The figure shows a development of the ring. Each line between two plotted points represents one segment. The amount by which it lies above an adjacent section (i.e., the plotted value of its end points on the "y" axis) measures distance from the tunnel face measured along the tunnel axis. At the beginning, (shove A), Joint 4, which is at the tunnel roof, is ahead of Joint X, which is in the invert. This is equivalent to having tilted the plane of the ring so that its top elements are closer to the tunnel face than its bottom elements. The sequence of shoves which follows shows how the distances of the top segment relative to the bottom segment gradually change, until, at shove E, the entire ring is plane.

We have calculated the differential position of the bottom segment relative to the top segment for a sequence of 18 shoves at Test Section "B". These are shown in Figure 106. A comparison of this figure with the curves showing displacement and slope of the liner axis predicted by the model (see Section 7.3.1.1) shown in Figure 107 shows a striking similarity. Both show that the plane of the ring (theoretically perpendicular to the liner axis) will start in an inclined position at the thrust ring and gradually tilt until it becomes parallel to the tunnel face at approximately shove 7. Thereafter, it tilts in the other direction at an increasing rate, reaching a maximum negative slope at approximately the 12th or 13th shove, and gradually returning to a position parallel to the face by shove 18. This provides further confirmation that the loads and deflections predicted by the model are consistent with experimental observations.

The caliper extensometer data has been analyzed to show the position of the four jacking quadrants during the 18-shove sequence described earlier. Results are plotted in Figure 108 and may be interpreted as follows.

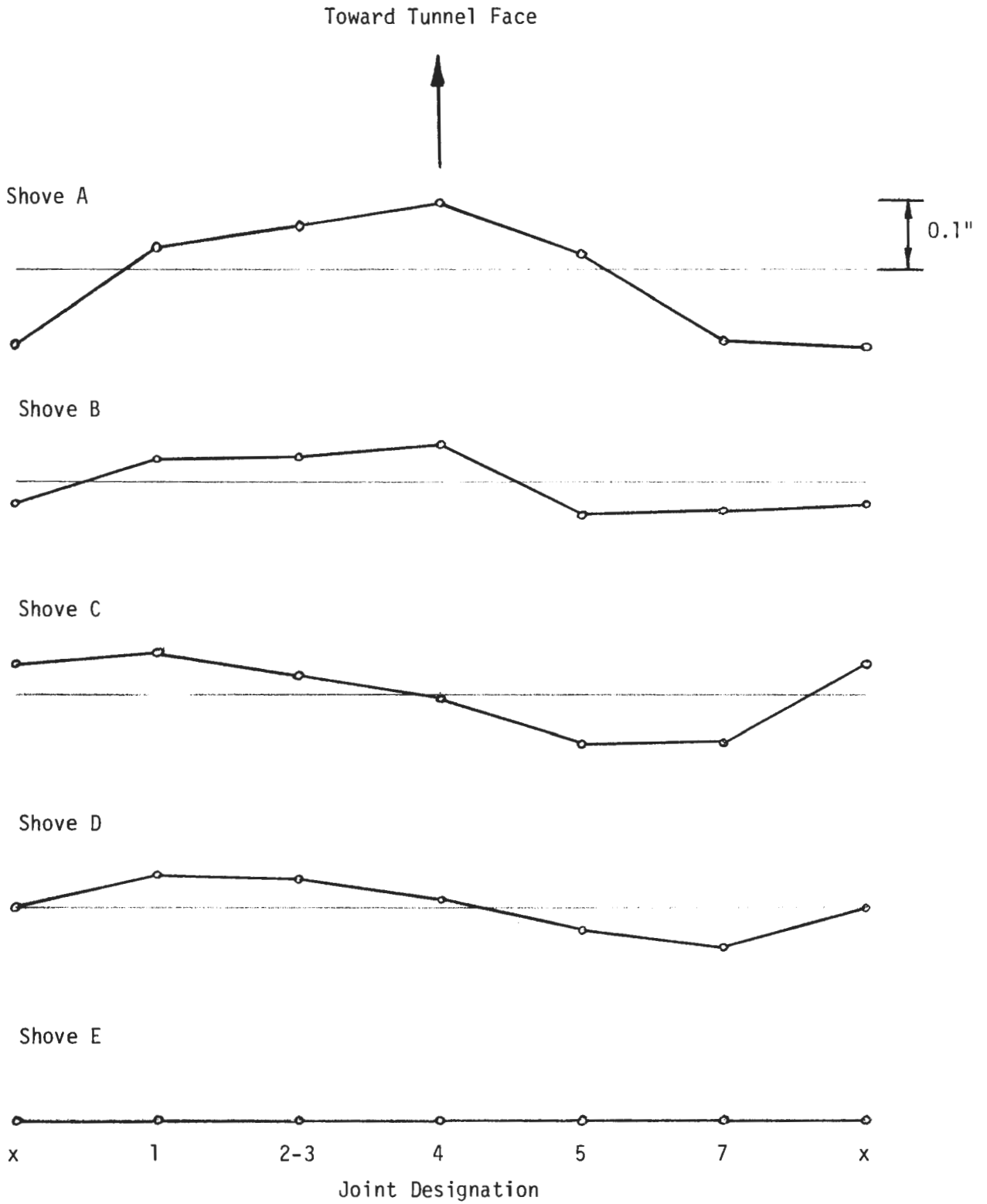
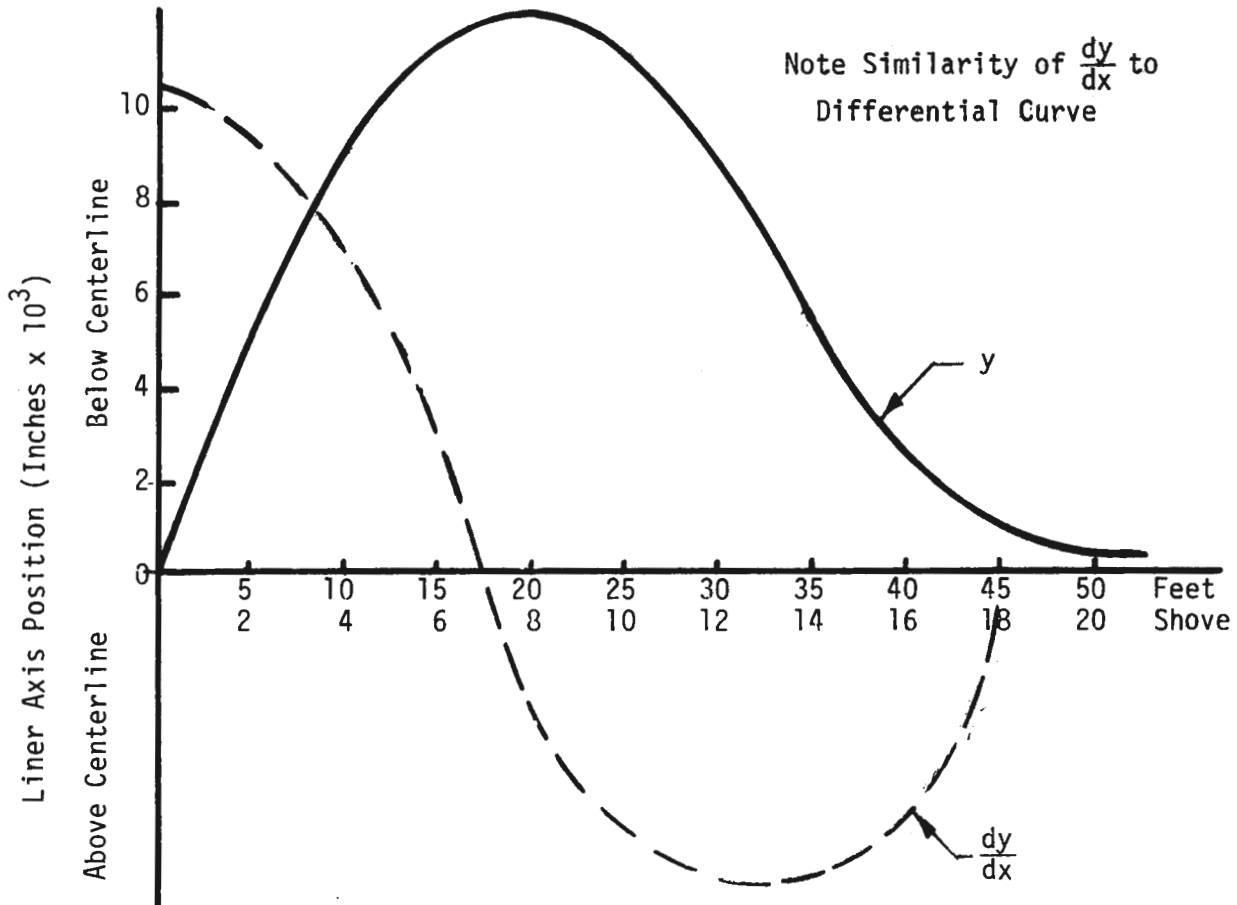
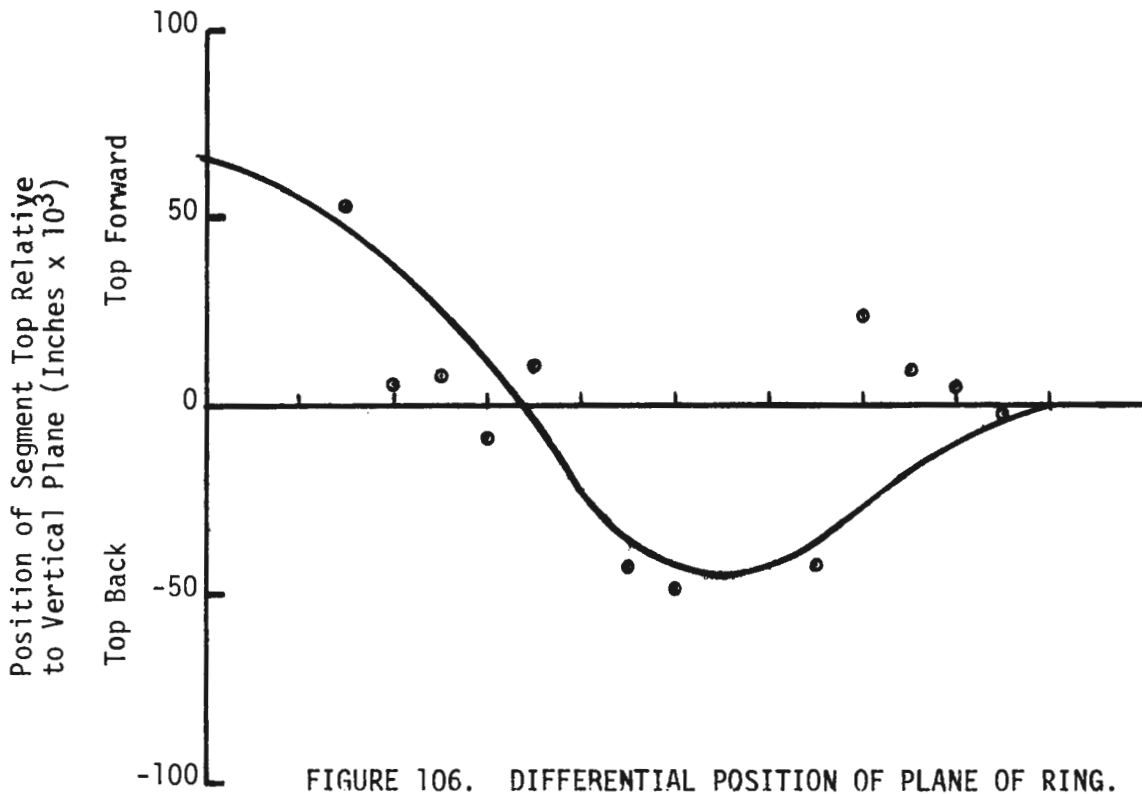

FIGURE 105. SCHEMATIC REPRESENTATION OF SEGMENT MOVEMENTS IN ONE RING DURING FIVE CONSECUTIVE SHOVS



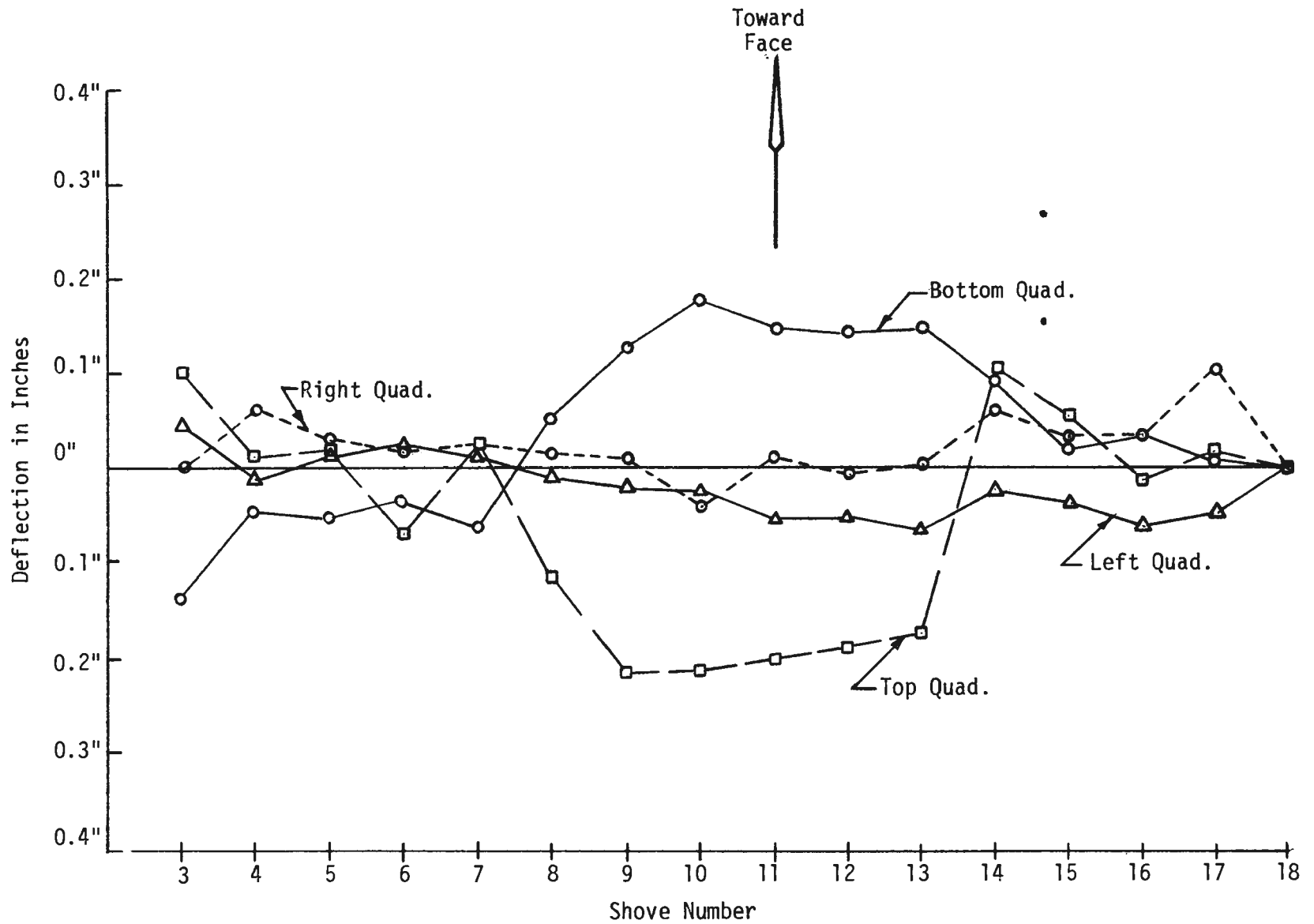

FIGURE 108. POSITIONS OF SEGMENTS IN THE JACKING QUADRANTS AS A FUNCTION OF SHOVE POSITION.

The right quadrant position does not have significant excursions away from or toward the tunnel face throughout the 18 shove sequence. Likewise, the left quadrant does not move significantly from its normal position. On the average, the right quadrant is nearer the face than the left, and this would be expected, since the tunnel alignment curves to the left throughout the period shown on the figure. (The minor excursions appear to be due to two causes, (1) steering corrections, and (2) measurement errors. Of the two, the steering corrections are predominant.)

The bottom and top quadrants show significant trends, which agree quite well with predictions based on the liner loading model. If we visualize distortion of the tunnel liner axis as shown in Figure 98(a), (Section 7.3.1.1), and consider the inclination of a plane perpendicular to that axis and traveling along it, it would behave as follows. Near the face, perhaps during shoves 1-7, the plane would be tipped forward, i.e., the top quadrant would be nearer the face than the bottom quadrant. (Shove 7 of Figure 108 corresponds to point "A" in Figure 98(a). After point "A" the bottom quadrant will be increasingly closer to the face than the top quadrant until it reaches a maximum, after which the two quadrants will gradually return to a position of equal distance from the face. The positions shown in Figure 108 provide a graphic illustration of segment movements, thereby helping the reader to visualize the motion of the segments in each jacking quadrant resulting from the construction process.

7.3.1.4 Strain Measurements

Introduction. Strain gage instrumentation was employed in three modes to obtain basic information about the loading and stress distribution in the liner. It was planned that the information obtained would provide future designers with an understanding of liner loading conditions, together with data upon which to base later designs. The modes were (1) as pressure transducers to provide information about hydraulic pressures, and hence about ram loads; (2) for longitudinal strain measurements in the liner segments; and (3) for circumferential strain measurements in the liner rings. Each of these will be discussed under separate headings.

7.3.1.4.1 Ram Forces

The tunnel shield was propelled by 24 hydraulic rams. Each ram had an 8" diameter piston and was rated at 125 tons capacity at 5000 psi hydraulic pressure. The rams were centered at the bolt pockets of the segments. However, this spacing was relatively unimportant because their thrust was exerted on the lining through a heavy thrust ring. The thrust ring had a built-up T-section, 24" in depth and

made from 3" plate. It was attached to an 8" x 8" steel erecting ring. A cross section of the assembly is shown schematically in Figure 109.

The rams were coupled hydraulically in groups of 6 which acted in each of four quadrants and were used for steering. The top quadrant was centered on the shield and extended 45° to either side of top center. Other quadrants were located at the left, right and bottom positions. All rams in each quadrant received approximately equal pressure at any instant of time. Ram pressures were measured by electrical pressure transducers, one in the hydraulic line feeding the rams in each quadrant. Repeatability, and hence predicted accuracy of the transducers was measured by calibration against a load cell and found to be of the order of ± 350 psi corresponding to an accuracy of $\pm 17,500$ pounds in predicted ram loads. Frictional forces in the mechanical components of the system account for significant and variable force levels, so the overall accuracy obtained is believed to be reasonable under the given measurement conditions.

Due to the fact that the shield advanced under highly irregular stick-slip frictional conditions, hydraulic pressures varied considerably during a normal shove. Variation during a typical shove, number 471, is shown in Figure 110. Because of this variation, and also because peak pressures are of primary interest, thrust ring forces were calculated in all runs on the basis of peak pressures. The calculated single ram loads developed at peak pressure conditions are given for shoves #472-482, and 489, in Figure 111(a) through (d).

It should be noted that the loads transmitted by the thrust ring to the liner do not change abruptly at the quadrant boundaries as suggested by the curves of Figure 111. Thrust ring stiffness will tend to distribute the forces, and it appears likely that force levels transmitted in the vicinity of quadrant boundaries will be intermediate between the two values given for the respective quadrants.

7.3.1.4.2 Longitudinal Strain

A total of 48 strain gages were installed parallel to the tunnel axis at Test Section B. They were installed in a typical segment as shown in Figure 112. The gages were allocated to three rings, #470, 12 gages; #471, 24 gages; and #472, 12 gages. The locations of all 48 gages are shown in Figure 113.

Because of their distribution around the segmented rings, it was planned that they would provide a complete data base on the longitudinal strains, stresses, and moments being developed in the rings at each stage of construction. Unfor-

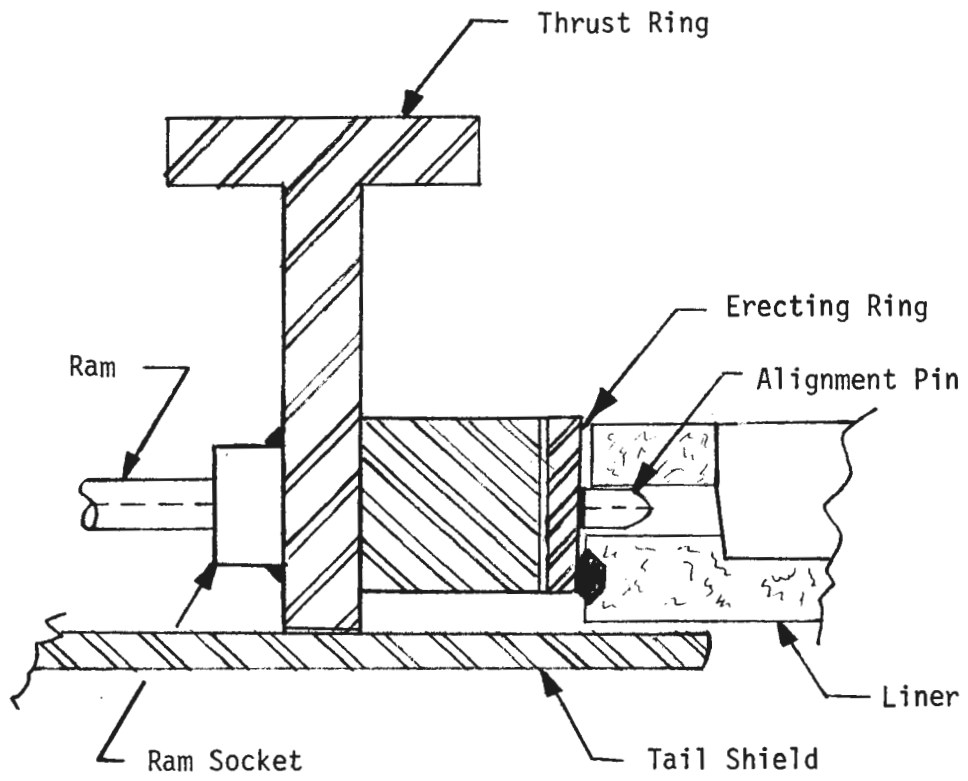

FIGURE 109. SCHEMATIC DETAIL OF THRUST RING ASSEMBLY

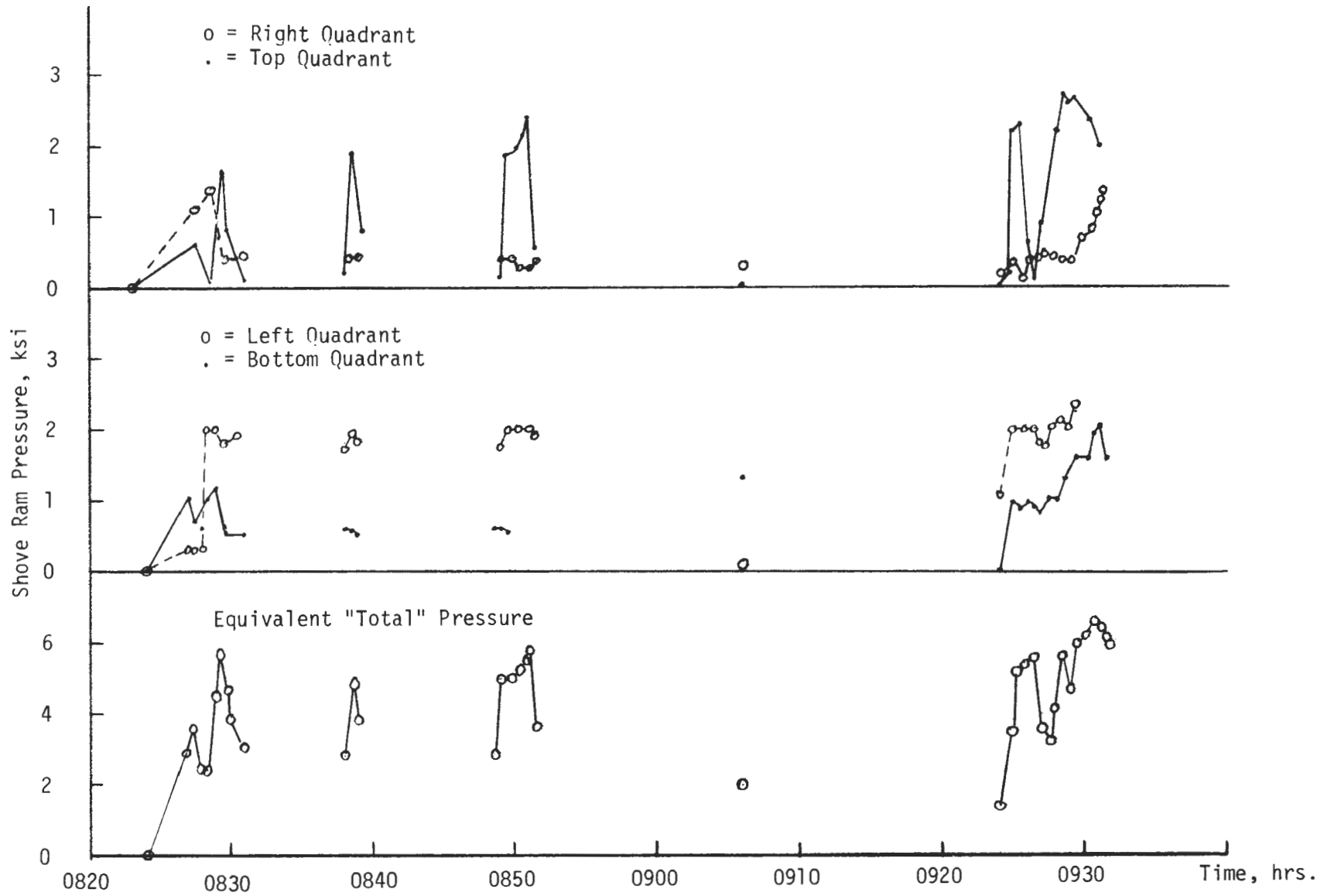

FIGURE 110. VARIATION OF SHOVE PRESSURES WITH TIME DURING SHOVE #471.

FIGURE 111(a). QUADRANT RAM LOADS (SINGLE RAM)
CALCULATED FROM MEASURED HYDRAULIC PRESSURE.

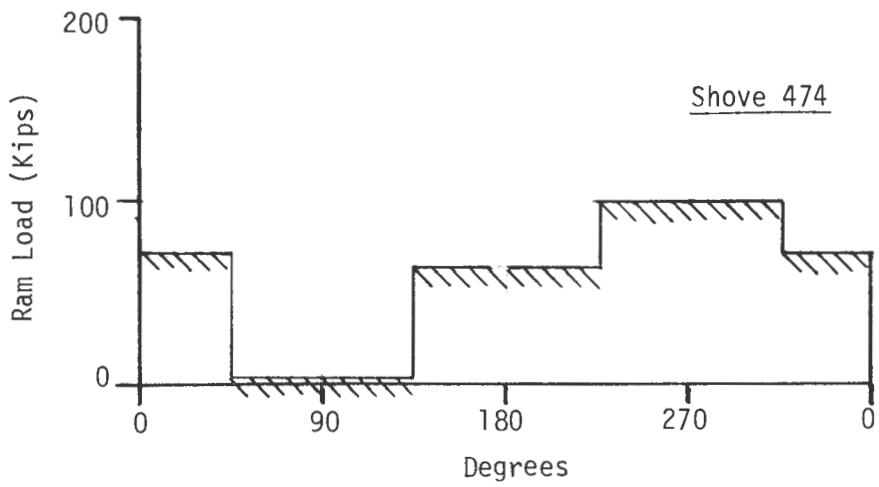
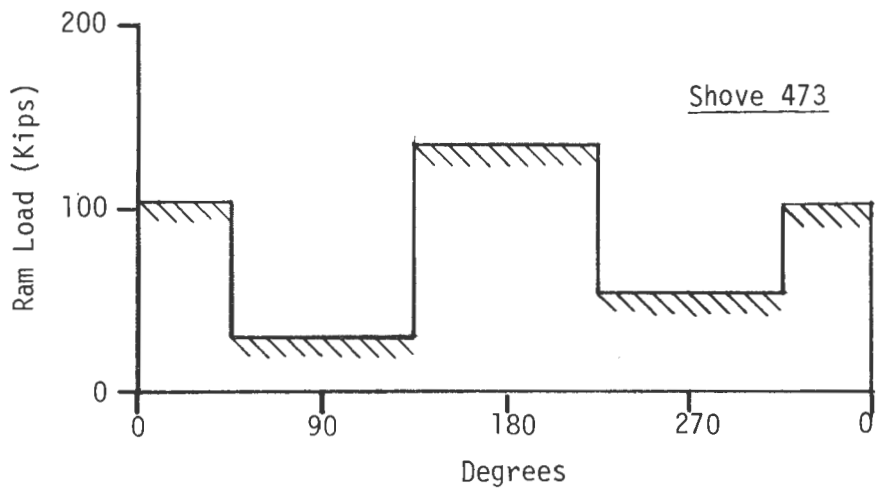
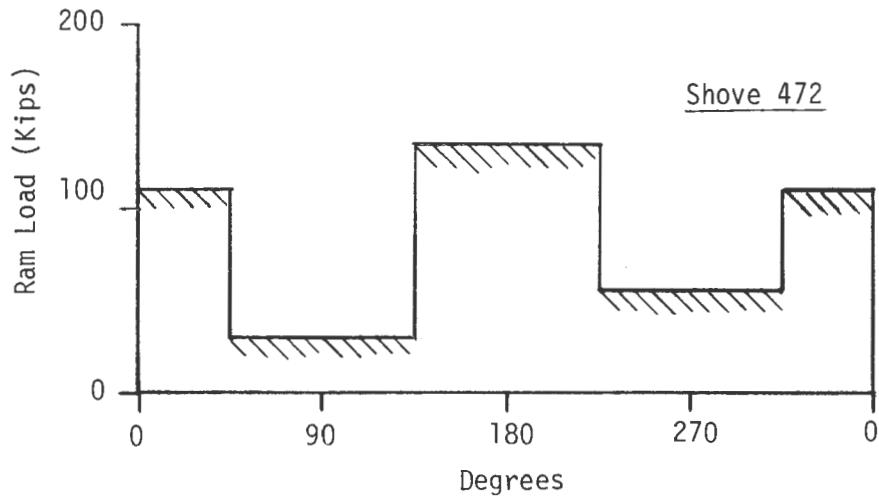

FIGURE 111(b). QUADRANT RAM LOADS (SINGLE RAM)
CALCULATED FROM MEASURED HYDRAULIC PRESSURE.

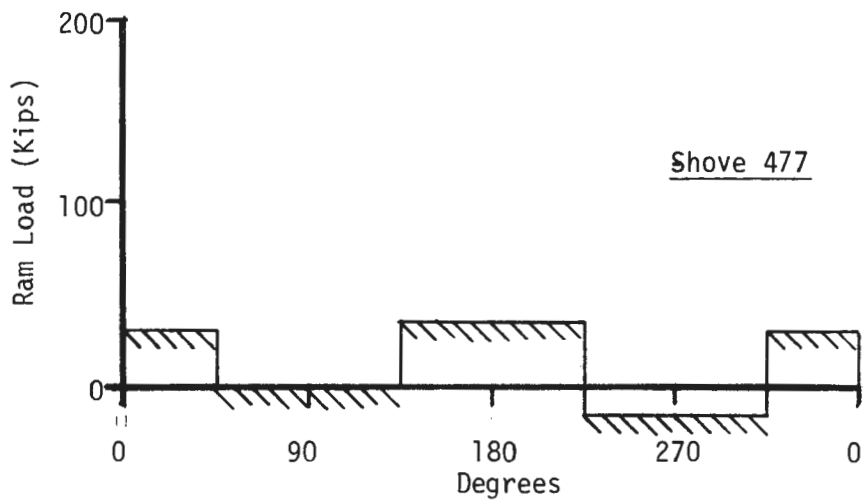
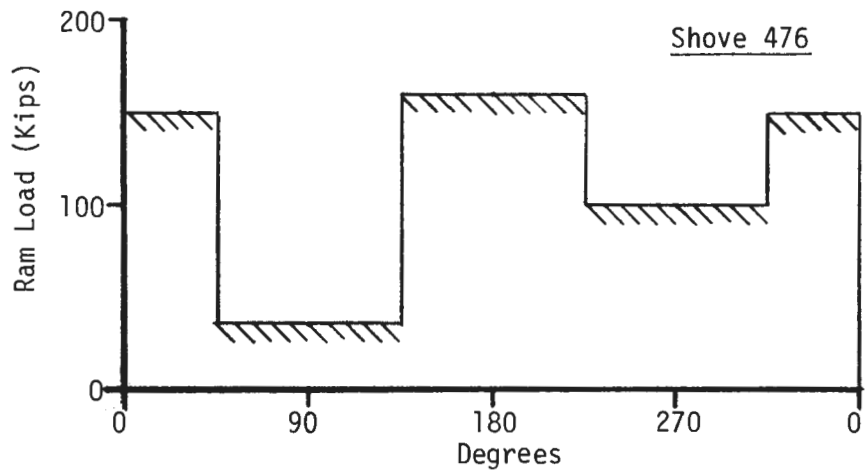
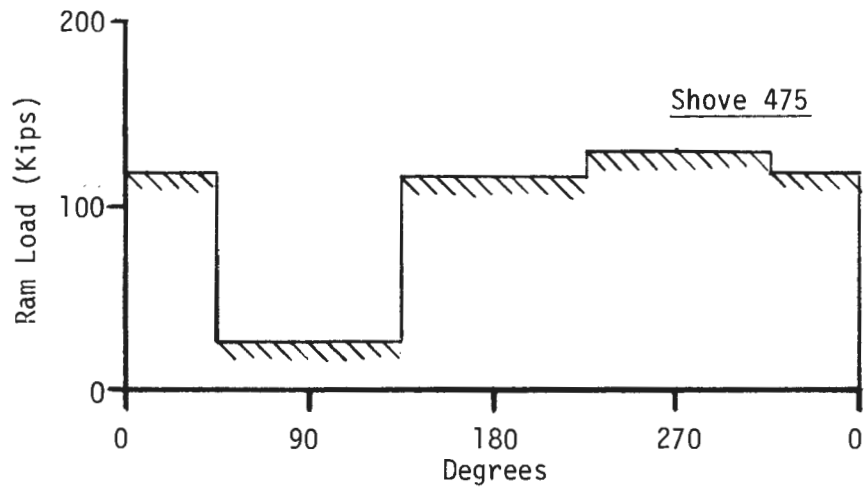

FIGURE 111(c). QUADRANT RAM LOADS (SINGLE RAM)
CALCULATED FROM MEASURED HYDRAULIC PRESSURE.

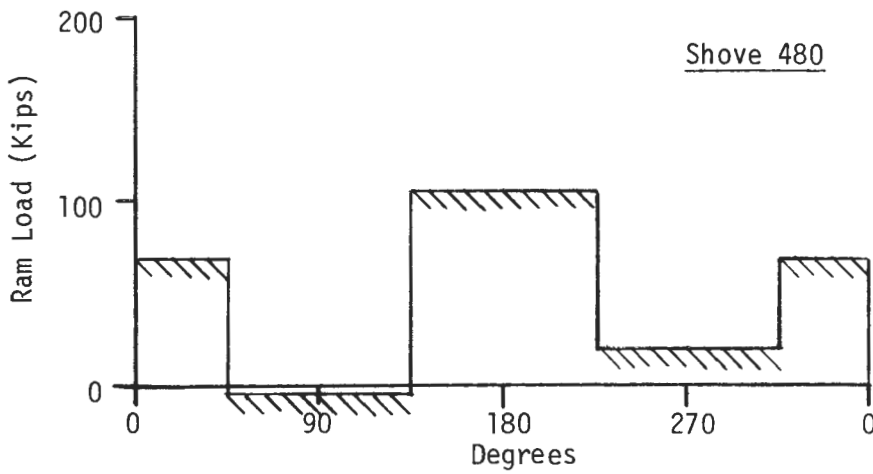
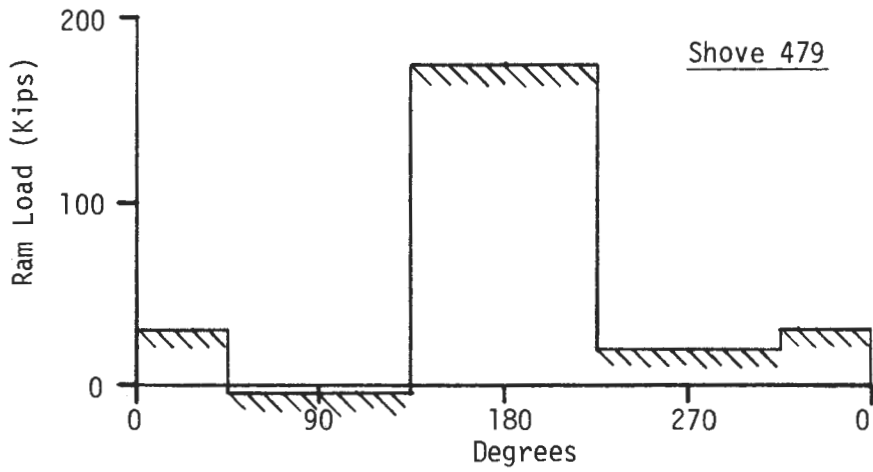
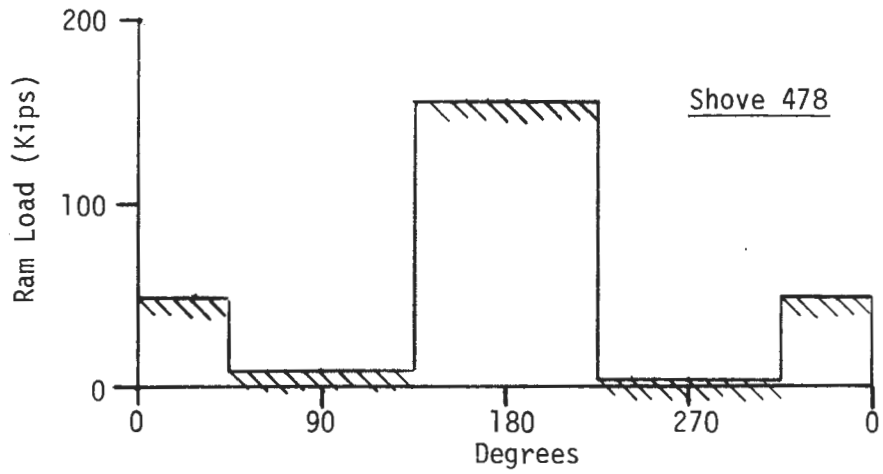
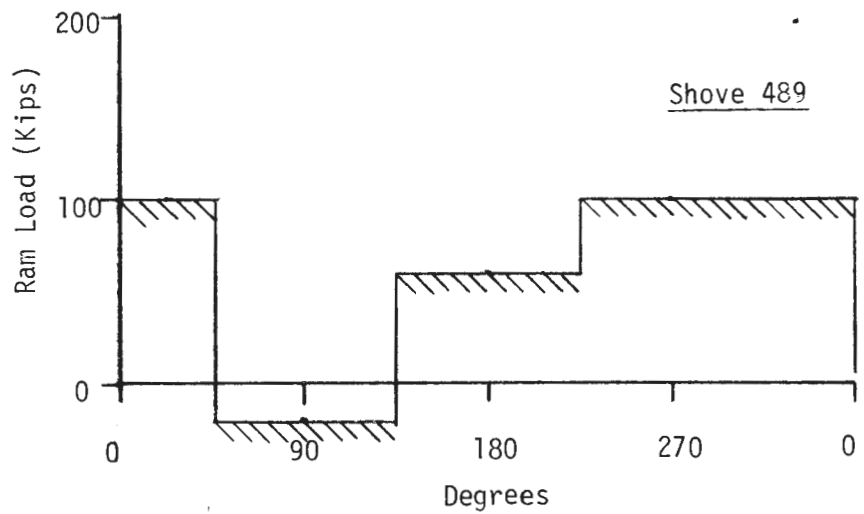
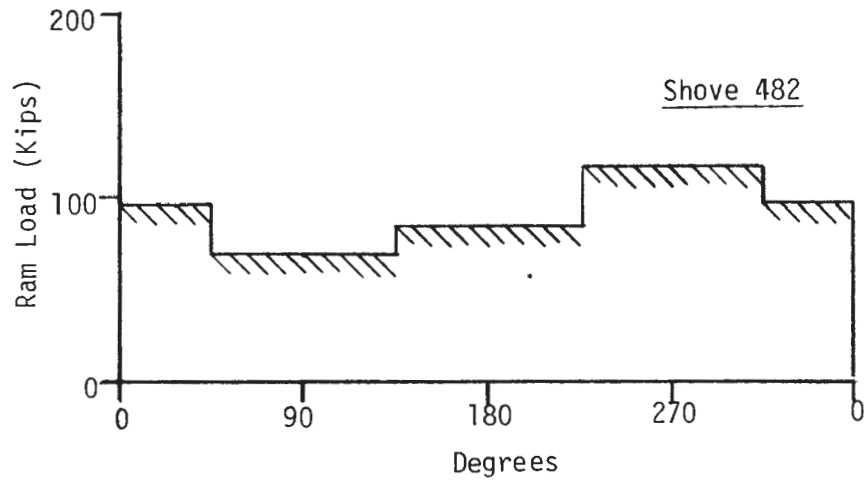
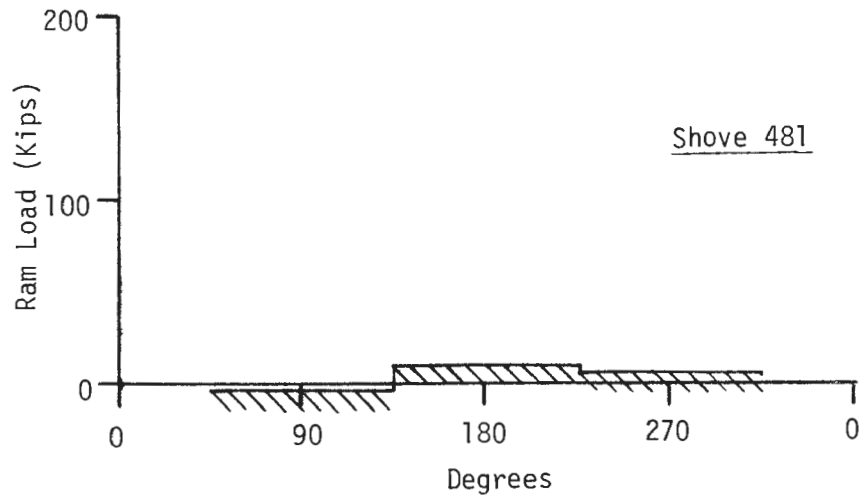

FIGURE 111(d). QUADRANT RAM LOADS (SINGLE RAM)
CALCULATED FROM MEASURED HYDRAULIC PRESSURE.



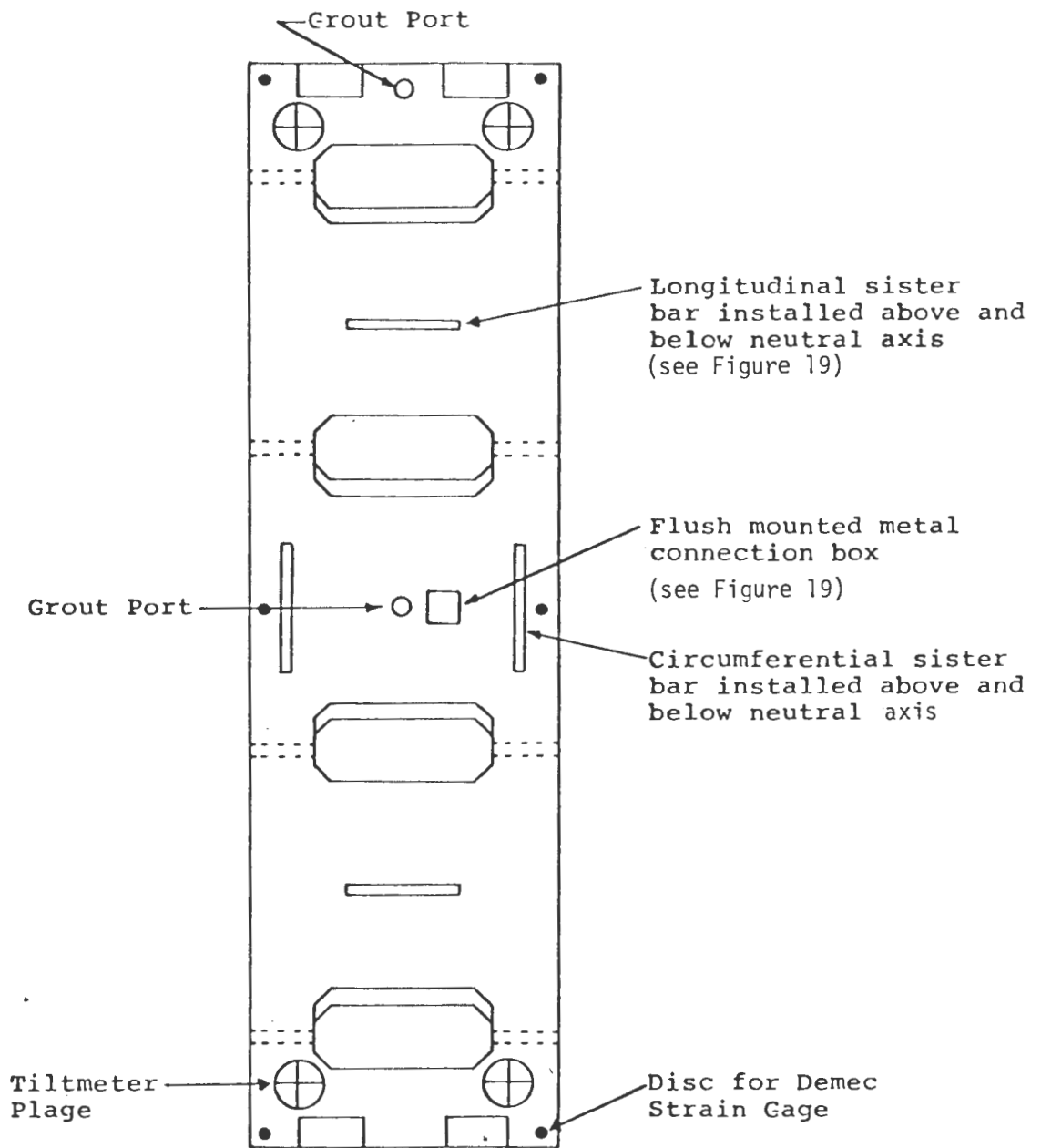

FIGURE 112. STRUCTURAL INSTRUMENTATION LOCATION.

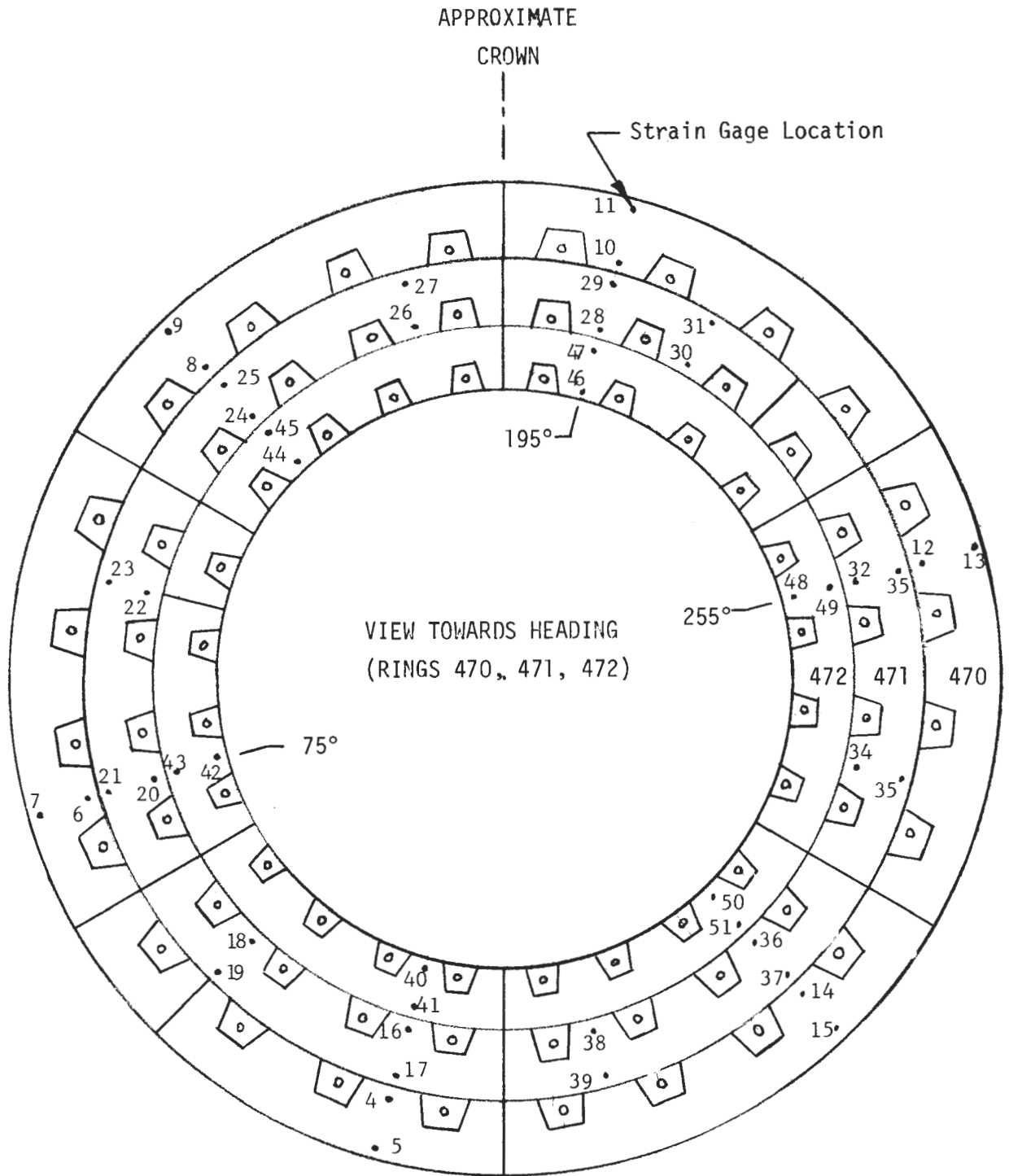

FIGURE 113. RING AND STRAIN GAGE CONFIGURATION AT TEST SECTION B.

tunately, because of the hostile environment in which the instrumentation was installed and used, only 23 gages were found to perform in a completely reliable manner. Data from these gages has been used in the analysis. Fortunately, these appear to be adequate for the intended purpose.

Each strain transducer was cast into its designated position in a segment. The transducer, called a "sister bar" is illustrated in Figure 19. A section of #4 grade 60 reinforcing bar was machined to a necked down configuration as shown in the figure. Strain gages were mounted on the neck and connected to lead wires which terminated at a connection box in the segment (see Figure 112). When the strain gages were in place, several epoxy coatings were applied, and a waterproof barrier built up to protect the gages during later immersion in wet concrete. Once the concrete has set, with the sister bar in place, the ends of the bar bond to the concrete, so they travel with it and give an accurate indication of the strain experienced by the concrete adjacent to the necked down section.

The strain gage instrumentation was attached to an automatic data logger, which also received inputs from the hydraulic pressure transducers. A complete cycle of readings required approximately 20 seconds to complete. Thus, individual strain readings were obtained on the average of 3 times per minute throughout each shove.

Repeatability (accuracy) of the sister bar measurements was found to be $\pm 30 \mu\text{in/in}$. This corresponds to an accuracy of load determination of $\pm 25,000 \text{ lb.}$ per 1/4 segment. (The load per 1/4 segment has been used because there are 4 rams per concrete segment (6 rams per quadrant), so that the load per ram and per 1/4 segment are comparable on a 1 to 1 basis).

An analysis of the reinforced concrete section with strain gages in place indicates that tensile stresses of the order of 500 psi, corresponding to the tensile fracture strength of 6000 psi concrete, will be reached at an indicated segment tensile load of approximately 50,000 lb. When a transverse tensile crack develops, it may be expected to spread quickly across the section. Thereafter, tensile loads will be carried by the rebars in tension, and the true loads will be less than the indicated (strain measurement) loads by a factor of 16.5 because of differences in section moduli, moduli of elasticity, and load carrying area for steel vs. reinforced concrete. In subsequent data reduction, whenever an indicated tensile load at a section has exceeded 50,000 lb., we have thereafter reduced the tensile loads indicated by the involved strain gages by a factor of 16.5.

In order to compare the ram loads with the loads experienced in the liner, we have examined data from the left, right and top quadrants of the liner at Test Section B. Strain gages #6 and 7, ring #470, 42 and 43, ring #472 were used for the left quadrant. As shown in Figure 113, the rings are in series on either side of ring #471, so we have assumed that the force obtained by averaging the force levels indicated for rings #470 and 472 is the longitudinal force existing in the liner at a particular time. In Figure 114 are given plots of ram force and force in the quarter segment for a series of shoves for which accurate data is believed to exist. On the figure, the shaded curve represents ram force. The width of the shaded portion above and below the centerline represents the estimated measurement error, $\pm 17,500$ lb.

Also plotted on Figure 114 are the forces indicated by the sister bars in the liner segments. These are shown as a dot representing the measured data point, with a vertical line through it representing the estimated measurement error, $\pm 25,000$ lb. As seen in the figure, every shove between #473 and 481 has an overlap between the ram and the segment forces when the error range is included. This suggests that this region of the liner, which is nearly centered on the left quadrant of the thrust ring, receives ram forces on essentially a 1 to 1 basis. Beyond shove #481, at shove #482, and 489, the only other positions for which data is available, segment force is somewhat lower than ram force. This suggests that there is some ram force attenuation with increasing distance along the liner, perhaps related to wall friction. Part of the decrease may also be due to the basic tensile stress pattern introduced in the liner below springline as predicted by the analytical model (see Section 7.3.1.1).

Comparable data for gages #12, 13, 32, 33, 48 and 49 are plotted in Figure 115. These gages are located at the 255° position in rings #470, 471 and 472, and are in series for force transmission so that their average should represent a good approximation to the strains (and, by computation, the longitudinal forces in the liner) at that location. They are nearly centered on the right ram quadrant. Eight of the first nine shoves (473-481) show overlap of the error ranges of the rams and segments, indicating essentially a 1 to 1 relationship between ram force and segment load. At shoves #482 and 489, the average segment forces again drop below ram forces, indicating attenuation, which is probably caused by the conditions mentioned earlier.

Figure 116 gives the corresponding information for the top quadrant, (195° position). Gages #10, 11, 28, 29, 46 and 47 are involved. As shown by the analytical model (Section 7.3.1.1) this part of the liner is subjected to tensile loading during the early shoves, and is subjected to more relative motion between

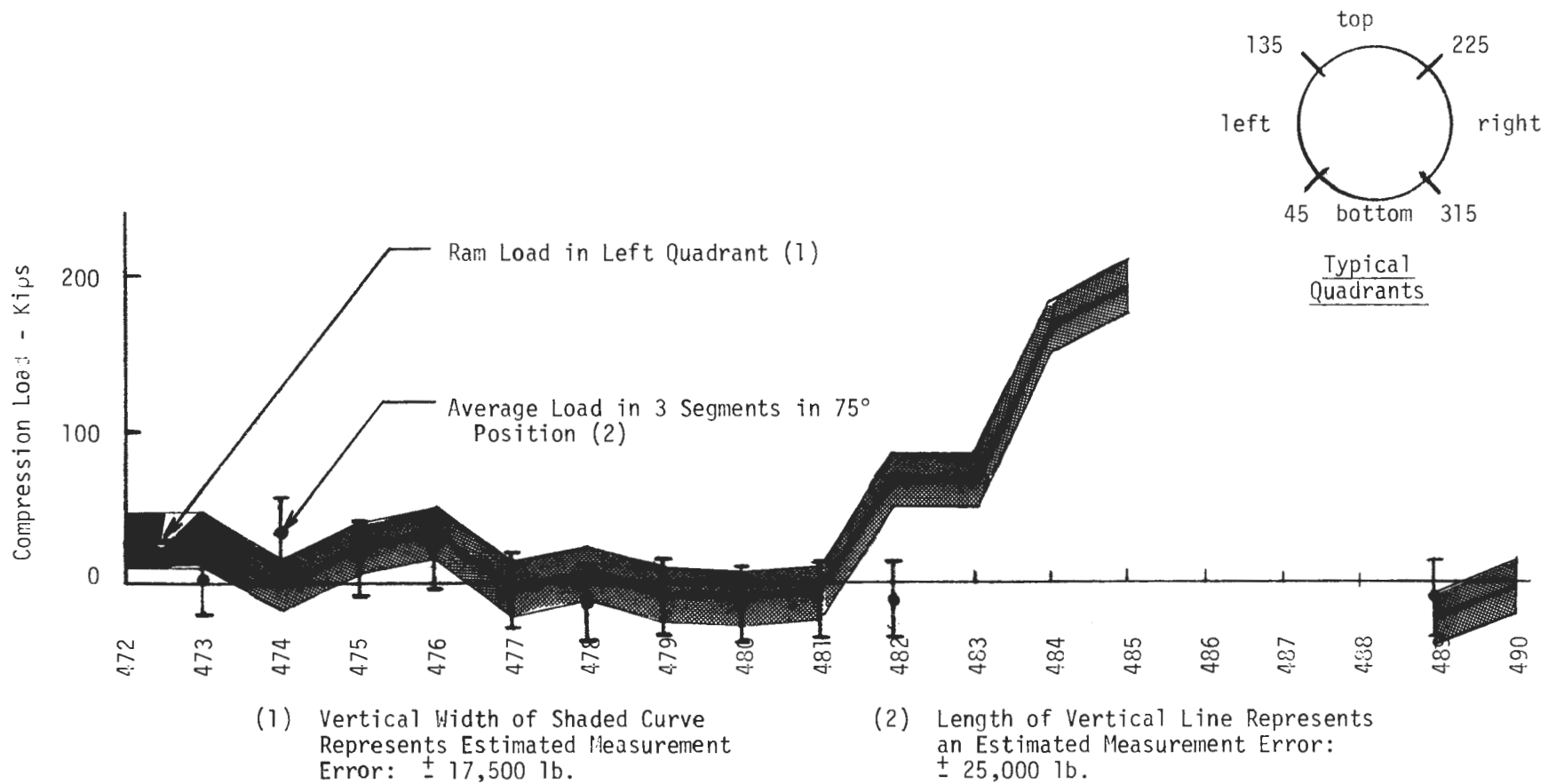
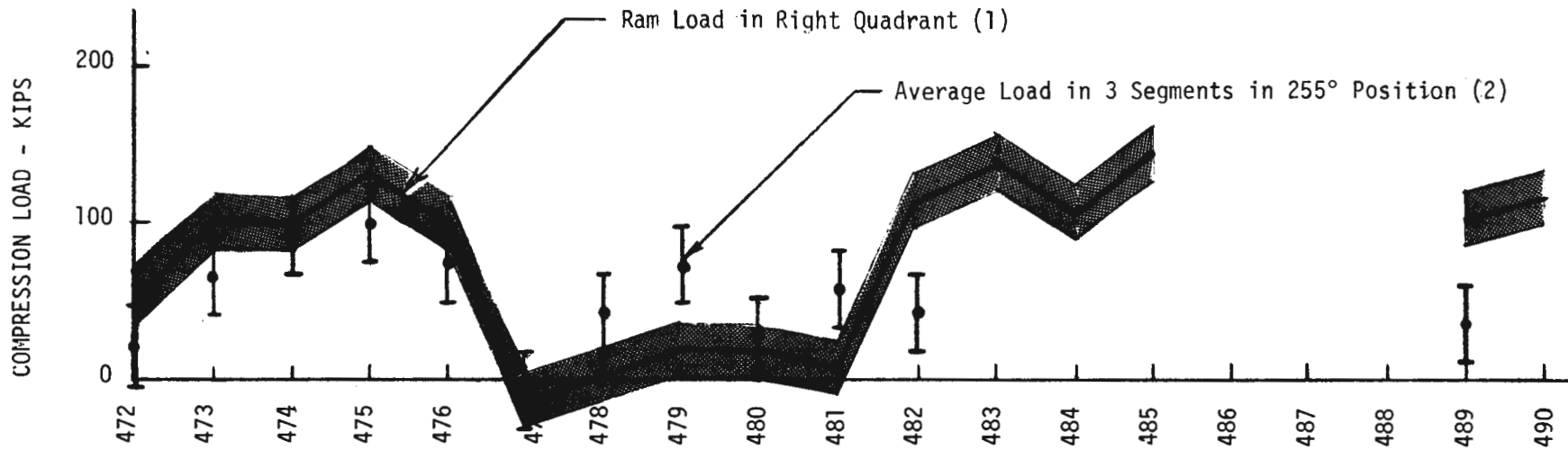

FIGURE 114. COMPARISON OF SEGMENT LOADS WITH RAM LOADS IN LEFT QUADRANT.



(1) Vertical Width of Shaded Curve
Represents Estimated Measurement
Error: $\pm 17,500$ lb.

(2) Length of Vertical Line Represents
an Estimated Measurement Error:
 $\pm 25,000$ lb.

FIGURE 115. COMPARISON OF SEGMENT LOADS WITH RAM LOADS IN RIGHT QUADRANT.

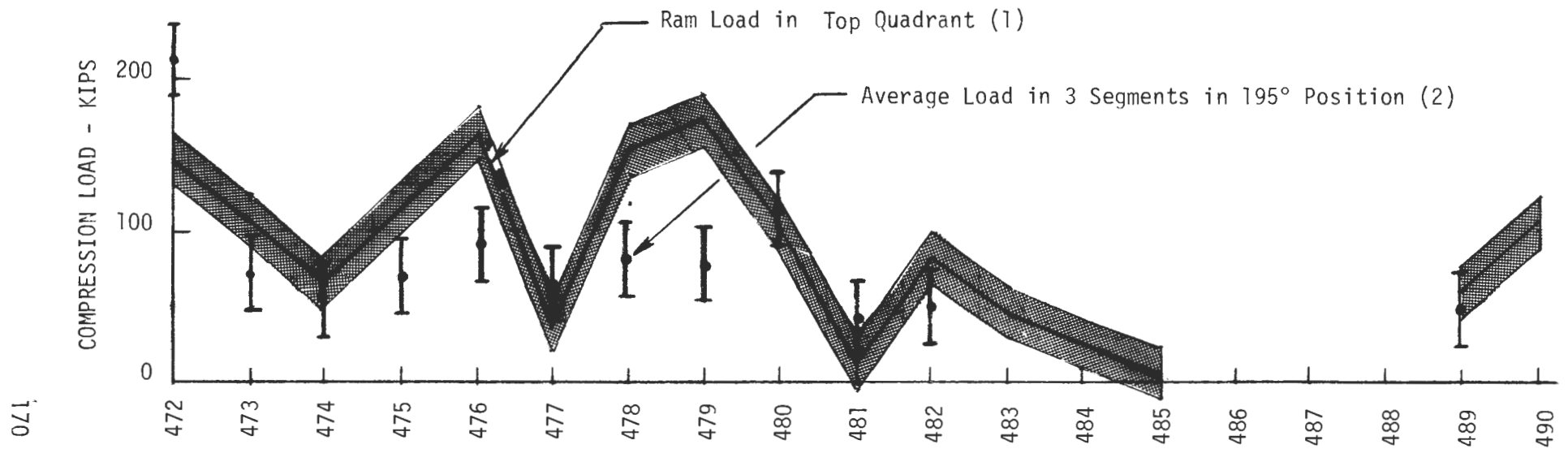

(1) Vertical Width of Shaded Curve Represents Estimated Measurement Error: $\pm 17,500$ lb.

(2) Length of Vertical Line Represents an Estimated Measurement Error: $\pm 25,000$ lb.

FIGURE 116. COMPARISON OF SEGMENT LOADS WITH RAM LOADS IN TOP QUADRANT.

adjacent rings. Both of these factors will tend to reduce the compressive load indicated by the segment strain gages below the ram load, and will tend to introduce a response lag as the segment positions readjust. This trend is shown by the data. Of the first 10 points (shove #473-482), 3 clearly fall outside the range which indicates a 1 to 1 ratio with ram force. All 3 of these fall below ram force levels. Segment force levels for shove #479-482 follow closely the pattern established by ram force during shoves #478-481. This indicates that segment force lags ram force by one shove, and is probably associated with the rearrangement of segments which takes place as the liner adjusts to its combined loading conditions.

The above data gives one reasonable confidence that liner forces, on the average, are of the same order of magnitude or lower than ram shove forces. Near the heading, as expected, ram and segment forces seem to match on a 1 to 1 basis, within the limits of experimental error. Of the 8 segment load data points which do not agree to within the limits of experimental error, only two indicate a segment load greater than the corresponding ram force.

Individual strain gages, as contrasted to the averages used above, indicate a wider spread. Two cases will be considered. Case A, which includes all of the strain gages except those in ring #470 at 255° (gages 12 and 13) is plotted in Figure 117. In the plot, ram load minus segment load is plotted for each position (left, right, and top quadrants) for shoves 473-482 and 489. When this value is positive, ram load exceeded segment load, indicating some attenuation as the load was carried back from ring to ring. When it is negative, indicated segment load exceeded ram load.

The limits of measurement error are shown on the plot, and from these it is apparent that in most cases segment load is approximately equal to ram load. For about 30% of the data points, this is not so. Those in which ram force exceeds segment force are of no particular interest, since they are easily explained by frictional effects, segment movements, etc. Also, they do not represent a threat to the integrity of the liner, since they fall below minimum segment design loads. The remaining four points, labeled 1 through 4 in Figure 117 require more careful scrutiny.

Point 1, shove #474, in which the gages at 75° show the segment load to be 70,000 lb. greater than the ram load, occurs at the end of a long decrease in ram force. At shove #471, (not shown), ram force was 70,000 lb., and thereafter it descended to a low of 2000 lb. at shove #474. Forces in the other three quadrants

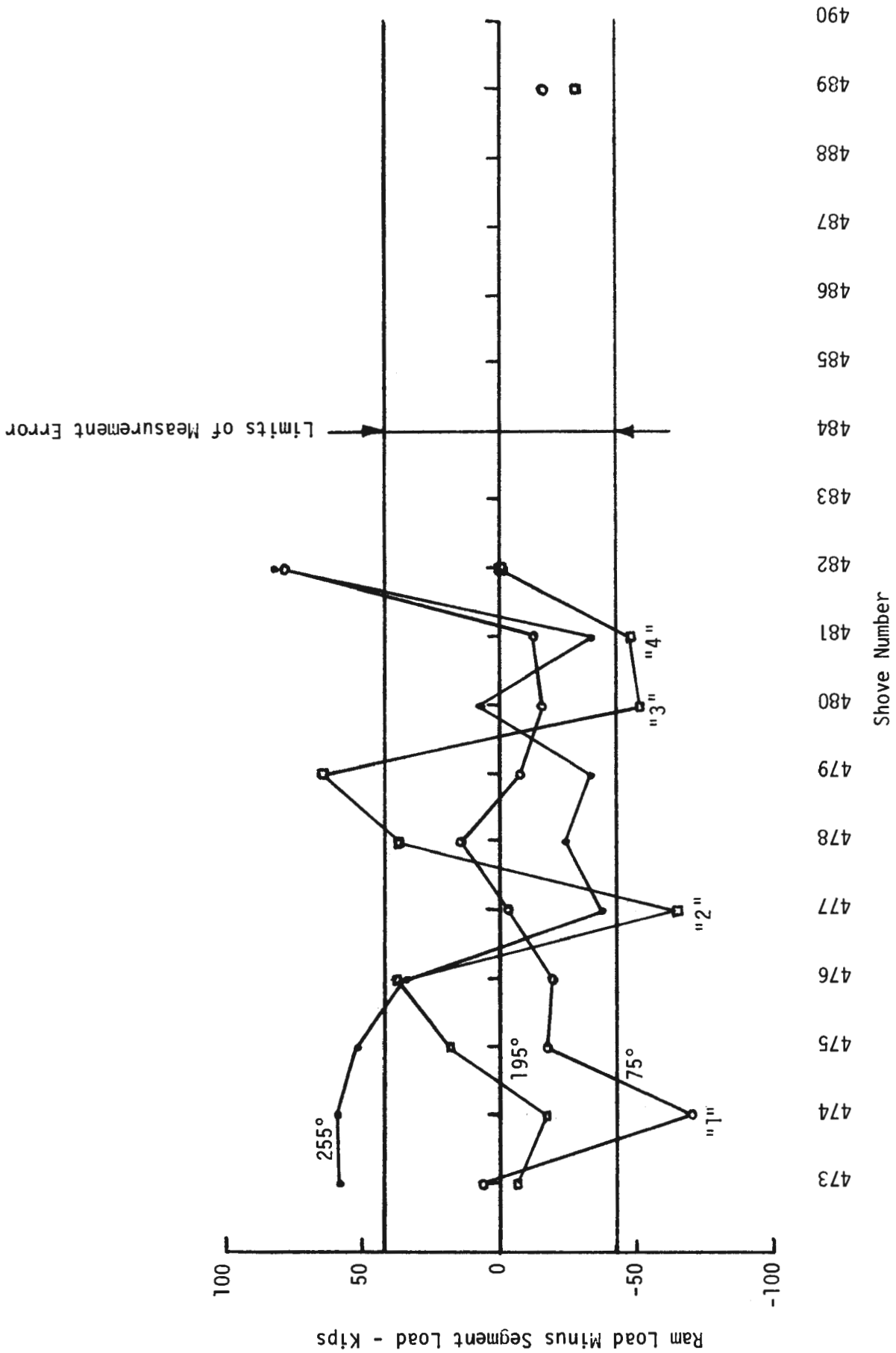

FIGURE 117. EXCESS OF RAM LOAD OVER SEGMENT LOAD IN LEFT, RIGHT AND TOP QUADRANTS.

were of the order of 100,000 lb. at shove #474, and these probably influenced the force levels felt by the segment at 75° because of the stiffness of the thrust ring. Thus, the combination of carryover forces from other quadrants, together with hysteresis effects as the pressure was dropped at 75°, offer a reasonable explanation for the fact that segment forces exceed jacking forces at Point 1.

Point 2, shove #477, in which the gages at 195° show the segment load to be greater than the ram force by 65,000 lbs., also occurs at the end of a major drop in ram force from 162,000 lb. to 37,000 lb. Hysteresis probably played a dominant role here, because other quadrants had relatively low ram forces at the time. The 102,000 lb. peak load shown in the segment is significantly below the peak ram load (162,000 lb.) from which the force reduction started, and hence does not pose a threat to the integrity of the lining.

Points 3 and 4, shoves #480 and 481, in which the gages at 195° show the segment load to be greater than the ram force by 51,000 lb. and 48,000 lb., respectively, occur in conditions very comparable to those of point 2 discussed above. Their peak loads, 156,000 lb. and 53,000 lb., respectively, are well below the peak ram force, 173,000 lb. from which the ram force reduction began.

From the above discussion, it is concluded that the trends shown in Case A are understandable and of no importance to setting the boundary conditions for liner design. A liner designed to handle peak ram loads would have been adequate for any of the excess load points mentioned. Indeed, excess loads appear, in these cases, to have been generated by earlier ram loads or heavy ram loads in other quadrants and hence are not due to multiplication of load at the time of ram application. They never exceed the loads which generated them.

Case B is more complex. The differential between ram forces and segment forces for this, ring #470 at the 255° position, is plotted in Figure 118. Segment loads equal to approximately twice the ram load are recorded for that position, while loads for corresponding points on rings #471 and 472 are light and medium, respectively, both being below normal ram force. When such a large discrepancy exists between the indicated loads on adjacent contacting segments, there is a strong possibility that the cause is located at the contacting surfaces. No cushion tape was used between adjacent segments in Test Section B, so any surface irregularities, either from outside contamination or from the shape of the surfaces themselves, would result in hard, localized contact.

One possible configuration which would produce the conditions observed is illustrated in Figure 119. It is assumed in the figure that four force concentration points occur as shown by the shaded areas. Ring #469 contacts the right

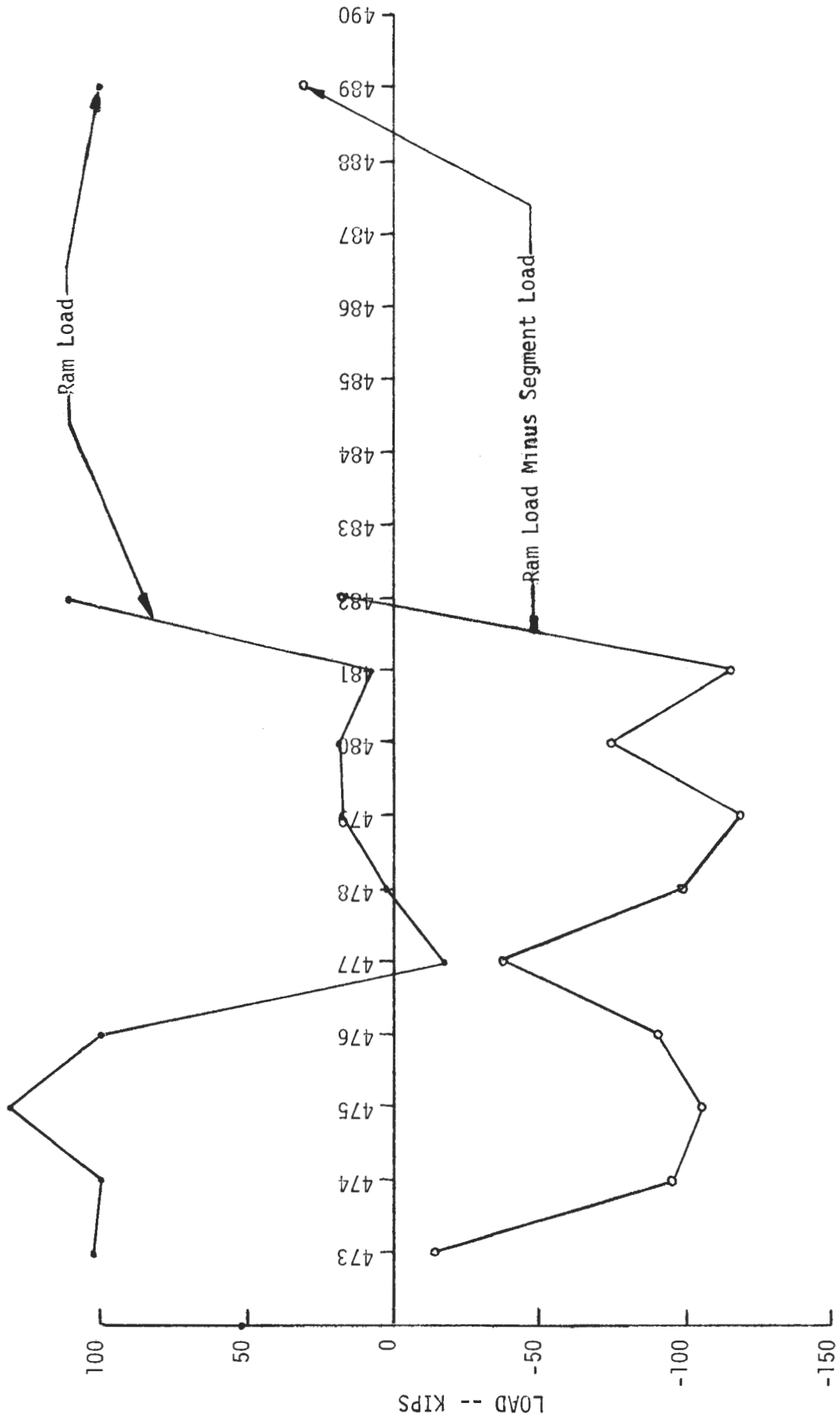
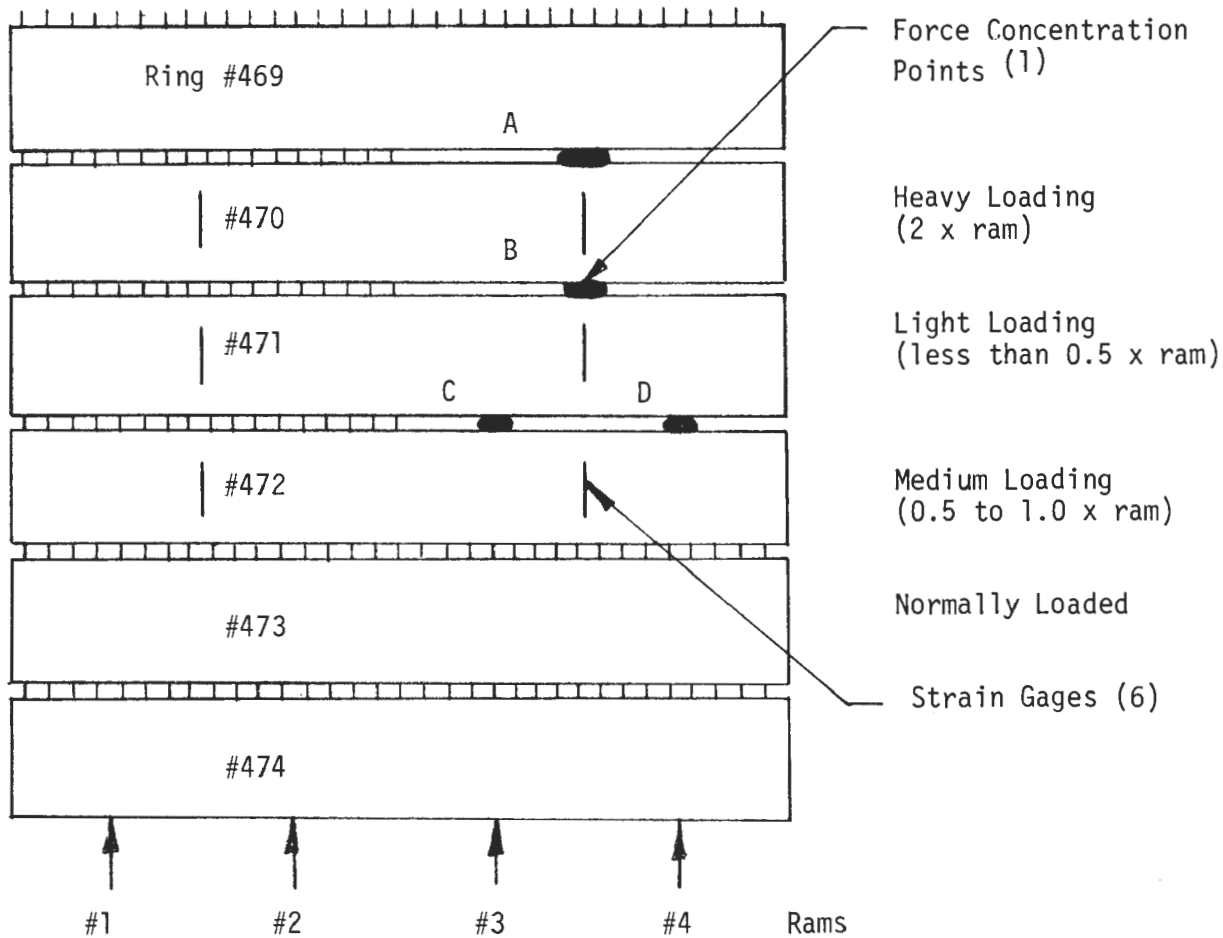

FIGURE 118. RAM/SEGMENT LOAD DIFFERENTIAL AND RAM LOAD FOR STRAIN GAGES NUMBERS 12 AND 13, RING 470 AT 255°



(1) Force concentration points are high points of contact caused either by surface irregularities in the segments or by contamination of the mating surfaces with tunnel muck or other foreign material.

FIGURE 119. STRAIN GAGE FORCE LEVEL INDICATIONS UNDER UNSYMMETRICAL LOADING CONDITIONS

half of ring #470 at a single point, "A". Ring #470 in turn contacts ring #471 at a single point, "B". Points A and B are aligned over the longitudinal strain gages. These gages "see" a segment load equal to twice ram load. Ring #471 contacts ring #472 at two high points, "C" and "D". Since "C" and "D" are not aligned with "B", the strain gages "see" a relatively low segment load. Ring #472 is uniformly supported by ring #473, so the force transfer across to points "C" and "D" sets up a medium level of strain in the gages of ring #472. By shifting the positions of points "A", "B", "C" and "D" relative to each other and relative to the strain gages at the 255° position, different strain patterns can be set up, including the ones described by our data.

An analysis of the possible arrangements which might occur without causing a bending failure in the segment suggests that segment loads can be equal approximately to twice ram loads without serious consequences. The observed data for ring #470 at the 255° position shows the segment loads to be of the order of twice the ram loads, lending credibility to this prediction. Also, the fact that average loads measured for the three rings are nearly equal to ram loads suggests that an overall balance of forces exists as would be expected with anomalies occurring only at individual points in the loading system.

The implications of the above discussion are as follows:

(1) A system which is to be installed with concrete-to-concrete contact should be designed to handle local loading conditions equal to at least twice those which would be imposed in a system having uniform load distribution.

(2) The employment of a contact stress distribution system (equivalent to cushion tape but without its shortcomings related to lateral shear) is likely to reduce the peak stresses induced in a segment under equivalent ram loads.

7.3.1.4.3 Circumferential Strain

Circumferential strain gages were installed in the segments of ring #471 at Test Section B as illustrated in Figure 112. The primary purpose of these gages was to obtain data from which the moments and stresses induced in the liner by ground loads could be calculated.

The instrumentation consisted of 24 sister bars, four in each of six segments. Readings were taken periodically, using a Vishay Model Number P-350A-K portable strain gage readout unit. Early readings (taken during the first 18 shoves following installation of ring #471), showed the stress levels in the segments to be nominal. This would be expected, given the modest ground loading levels coupled with the hydrostatic conditions of loading in the newly pumped grout.

Readings taken at a later time were found to indicate somewhat higher stress levels, probably associated with changed loading conditions. The latter are believed to have developed as the liner-soil-grout system adjusted to steady state conditions. In all cases, stresses were found to be within an acceptable range and were not judged to merit further analysis at this time.

7.3.2 Geotechnical Analysis, Test Sections A and B

7.3.2.1 Test Section A

7.3.2.1.1 General

As shown on Figure 24 and Figures 25 to 47, the top 40% to 50% of the soils encountered within the excavation limits at Test Section A (Outbound Sta 21+00) generally consisted of dense C-1 sand and gravel with the lower two feet cemented. The remainder of the face was made up of the underlying gray RZ-1 silty clay. No ground water inflow or running ground was noted as the tunnel heading passed through this zone.

7.3.2.1.2 Soil Displacements

MDS-14 was located over the centerline of the outbound tunnel with its deepest anchor located within 2 feet of the tunnel crown. The apparent measured maximum downward movement of this anchor was 1.1 inches as the outbound heading passed beneath it. The measured movements of the three shallower anchors in the MDS were all of similar magnitude: each was slightly over 0.5 inches, with no attenuation toward the ground surface.

The three shallow anchors in nearby MDS-15, which are located over the inbound tunnel some 35 feet from the outbound tunnel, indicated downward soil movement of 0.25 inches to 0.35 inches, with the largest movement measured in the shallowest anchor. This may be because the uppermost anchors are within the zone of influence of the outbound (concrete) tunnel whereas the lower anchors are not.

7.3.2.1.3 Volume Losses

As noted in Section 5.0 soil volume losses are a result of many factors which take place during construction. Using the formula proposed by Cording et al.,⁽²⁾ an approximate ground loss of 4.2 ft³ or 1.3% of the tunnel volume (%V_L) was calculated for the outbound tunnel as it passed beneath MDS-14. This was generally less than or equal to the volume losses calculated for the inbound tunnel in the compressed air section.

7.3.2.1.4 Surface Settlements

The measured surface settlement profile resulting from the advance of the outbound tunnel only at Test Section A is shown on Figure 120. Surface settlements were not recorded for this cross line during passage of the inbound tunnel. The maximum measured vertical displacement occurred between the two tunnels, with the trough wider than those generally measured during the inbound advance.

The volume of the settlement trough is estimated to be about 3.3 ft^3 or as a percentage of the tunnel volume, $\%V_S = 1.1\%$, with $i = 32$ feet.

7.3.2.1.5 Comparison of V_L and V_S

The volume of the surface settlement trough ($\%V_S = 1.1$) at Test Section A for the outbound tunnel was very close to the volume of soil lost ($\%V_L = 1.3$) as the tunnel passed. This can be compared to the ground losses and surface settlements which were measured as the inbound tunnel passed cross line X in Test Section B, as presented in Section 6.5.4. The $\%V_L$ for the inbound tunnel at this location was also estimated to be 1.3%. However, $\%V_S$ was only 0.3%. The reason for this difference was explained in Section 6.5.4 as resulting from a volume expansion of the dense granular soil above the tunnel, compensating for part of the soil volume lost into the tunnel. Assuming that the phenomena also occurred at Test Section A as the inbound tunnel was excavated, the soil in the vicinity of the inbound tunnel would have expanded prior to the driving of the outbound tunnel. Therefore, when the outbound tunnel was mined in this area, the loosened granular soils above the tunnel apparently did not experience a significant additional volume expansion. This effect is also evidenced by the shape of the settlement trough which is shifted toward the inbound tunnel where less volume expansion could occur due to the looser state of the soil. Some compression of the soil pillar between the tunnels due to increased stresses in the pillar may also have contributed to the larger trough centered between the two tunnels.

7.3.2.1.6 Groundwater Response

No significant groundwater response was noted in PZ-10 as the outbound tunnel passed.

7.3.2.2 Test Section B

7.3.2.2.1 General

As shown on Figures 24 and 33, the soils within the outbound excavation limits at Test Section B (Outbound Sta 11+90) consisted of all RZ-1 material with

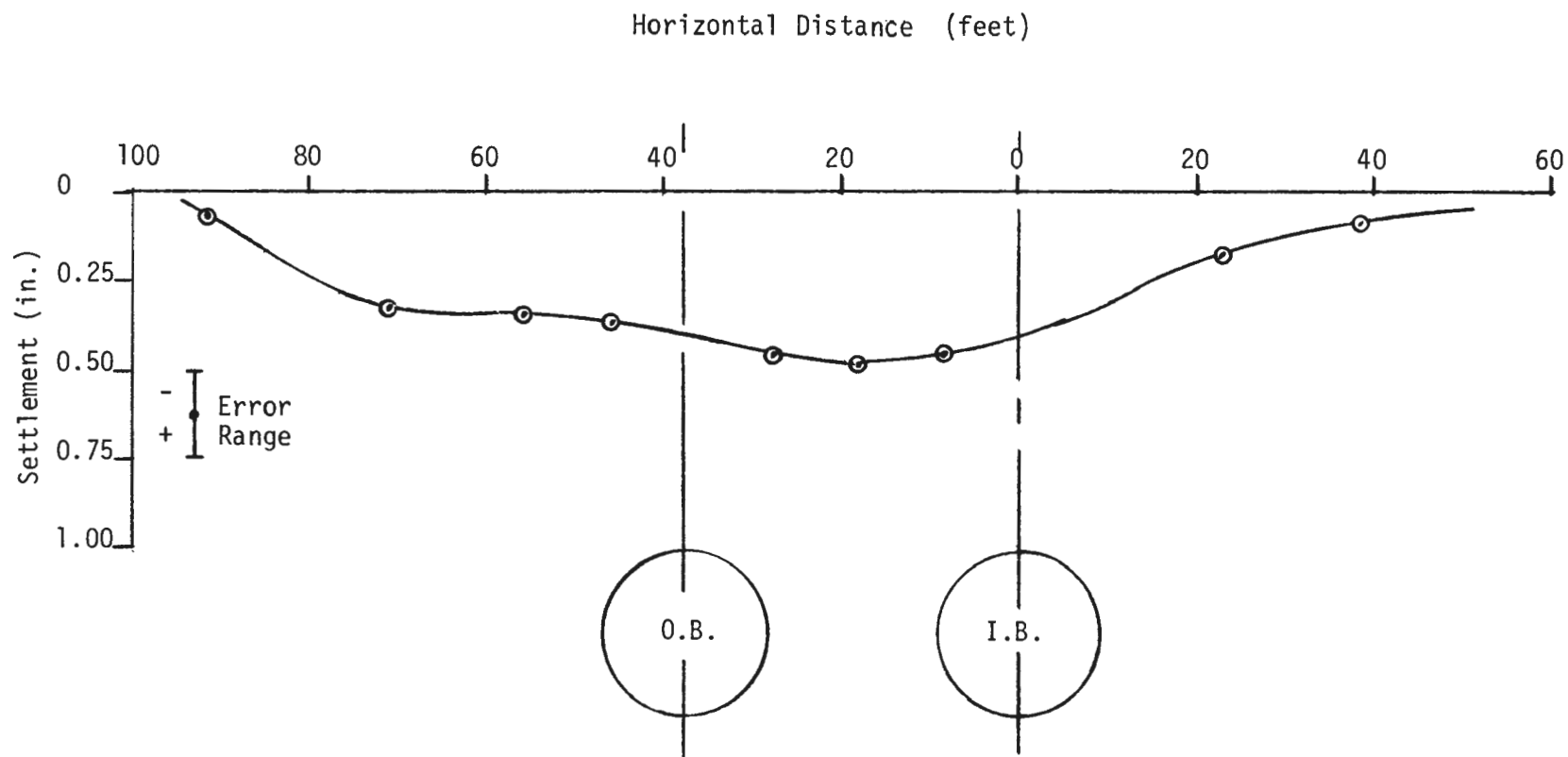

FIGURE 120. SURFACE SETTLEMENT OUTBOUND TUNNEL ONLY, TEST SECTION A

the top 30 to 80% made up of dense tan and white silty sand and sandy silt underlain by hard gray-green silty clay. No groundwater inflow or running ground was observed as the tunnel heading passed through this area.

7.3.2.2.2 Vertical Soil Displacements

MDS-17 and 21 located on the outbound tunnel centerline at cross lines X and Y, respectively, indicated that maximum vertical soil movements occurred at the deepest anchor located within 2 feet of the outbound crown as the heading passed. The maximum downward displacements measured by these deep anchors were 0.4 inches and 0.55 inches, respectively. The three anchors above the deepest anchor in MDS-17 and 21 all indicated measured downward movements of approximately 0.3 inches.

The MDS's located adjacent to the outbound tunnel all indicated measured downward movements of approximately 0.3 inches in practically all anchors. The reason for this uniform response is not apparent.

DS-7 located over the outbound centerline at cross line Z indicated measured downward soil movement as the outbound tunnel passed beneath the instrument of about 0.3 inches at a depth of 20 feet. This was similar to the soil movement measured at a depth of 20 feet in MDS-17 and 21.

As noted in Section 6.5, frequent readings were made of the MDS's in Test Section B as the outbound heading passed through this area. This enabled the plotting of the deep anchor movements for MDS-17 and 21 as the outbound tunnel progressed beneath them. This data is presented on Figures 121 and 122. As shown on these plots, a small portion of the anchor movements occurred ahead of the leading edge of the shield, followed by the largest portion of the movement occurring over the shield. As the liner emerged from the tail of the shield, more downward movement occurred at MDS-21, with additional movements taking place over the tunnel liner at both MDS-17 and 21 as the shield progressed. These observations will be discussed further in Section 7.3.5.

7.3.2.2.3 Horizontal Soil Displacements

Inclinometers I-10, 11 and 12 located adjacent to the outbound tunnel in Test Section B, all indicated very small horizontal soil movement into the tunnel excavation after passage of the outbound heading. The maximum measured apparent displacement of 0.18 inches near the invert was measured in I-12 with maximum measured displacements of less than 0.1 inches monitored in I-10 and 11. These small apparent movements all tended to dissipate above the crown of the

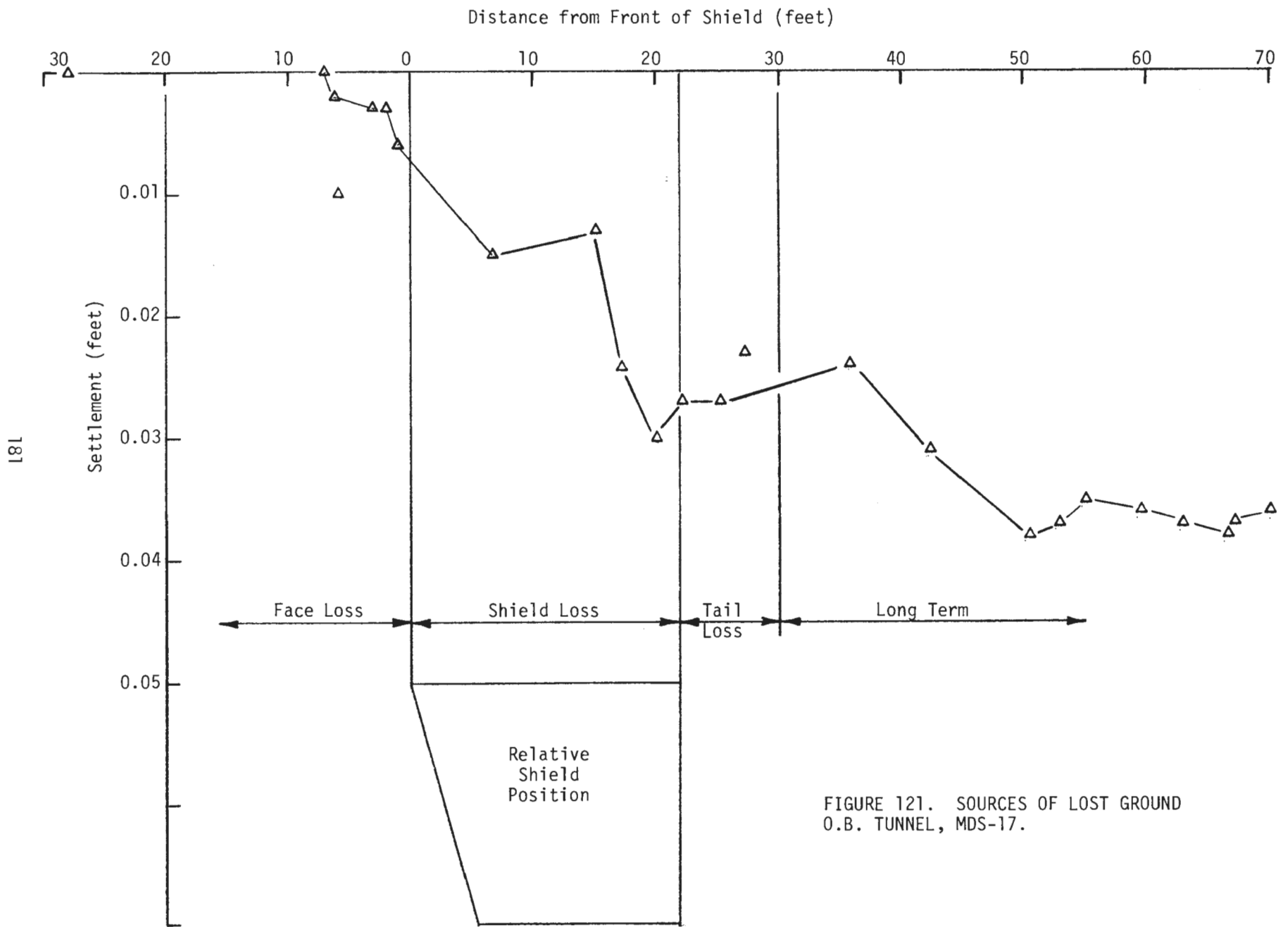

FIGURE 121. SOURCES OF LOST GROUND
O.B. TUNNEL, MDS-17.

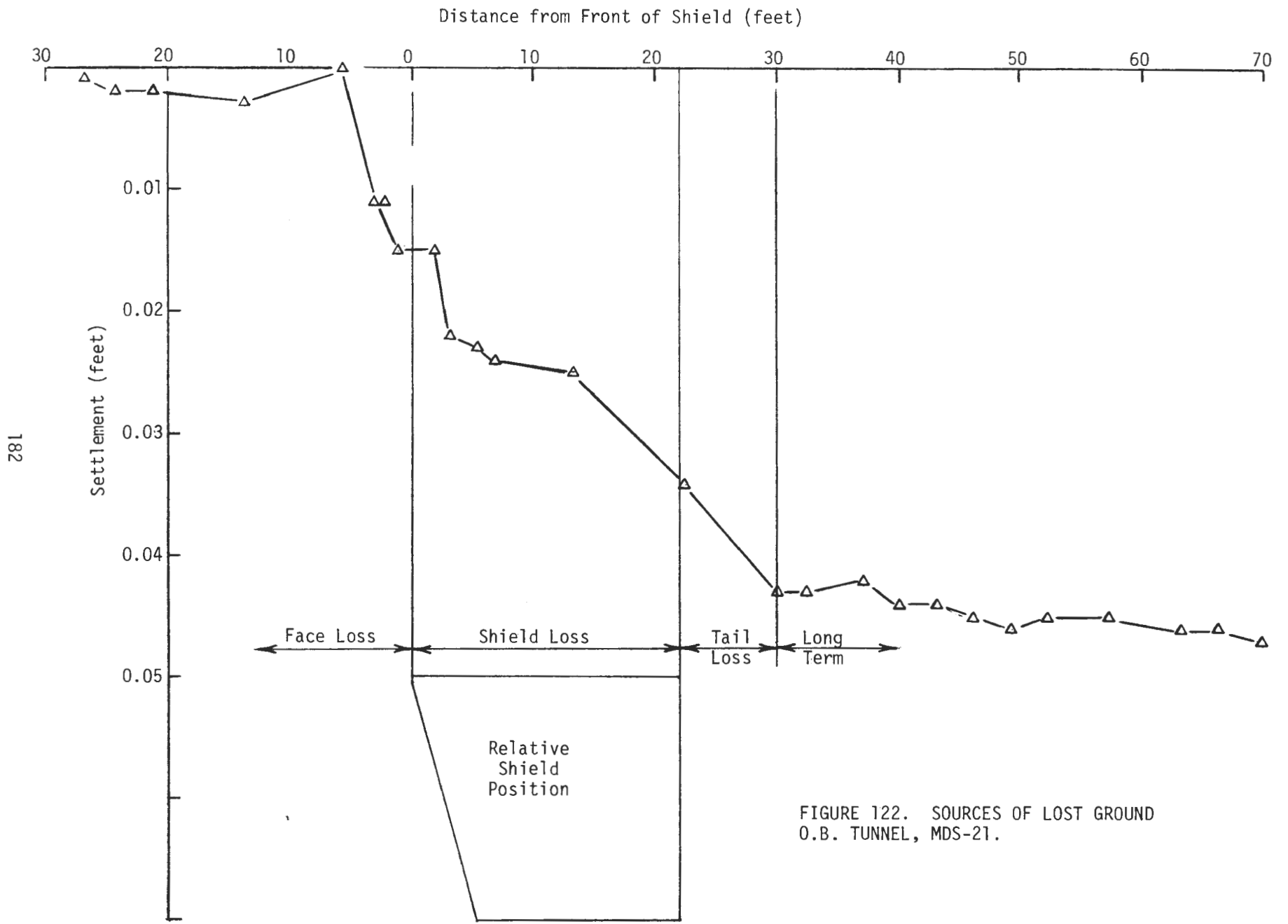

FIGURE 122. SOURCES OF LOST GROUND
O.B. TUNNEL, MDS-21.

tunnel. Figure 123 is a plot of the I-12 inclinometer profile for movement perpendicular to the tunnel centerline due to passage of the outbound heading.

7.3.2.2.4 Volume Losses

Using the formula presented in Section 6.5.4, the volume of ground lost due to excavation of the outbound tunnel at MDS-17 and 21 is 1.5 and 2.0 ft³ or 0.5% and 0.6% of the gross tunnel volume, respectively. These were about one-half of the volume losses calculated for the adjacent inbound tunnel as it progressed through Test Section B.

As briefly discussed in Section 7.3.5, it was possible to make a detailed plot of deep anchor movements as the heading progressed past these two locations and, therefore, determine where the lost ground was generated during construction. The sources of lost ground during the shield advance were discussed in Section 6.5.4 and the plots on Figures 121 and 122 have been divided into areas which coincide with these sources, similar to the analysis presented by MacPherson et al.⁽⁵⁾ From these figures the following estimate of the sources of lost ground may be made:

<u>Source of Loss</u>	<u>Percentage of Total Loss</u>	
	<u>At MDS-17</u>	<u>At MDS-21</u>
Face	16	33
Shield	46	44
Tail	0	16
Long-Term	38	7

The largest portion of ground loss occurred over the shield as the soil above the tunnel moved in to fill the void caused by overexcavation of the shield bead. The differences in percent contributions of the other sources of lost ground at the two locations may be due to such things as local soil type or an ungrouted pocket near the anchor.

7.3.2.2.5 Surface Settlement

The surface settlement profiles measured for the three cross sections all indicated essentially no surface settlement as the outbound heading passed through Test Section B. In fact, the survey measurements indicate a slight rise in the ground surface as the outbound tunnel passed, which can most likely be attributed to measurement error considering the ± 0.12 inch accuracy of the survey. See Figure 69 for the surface settlement data due to the outbound tunnel excavation at cross lines X, Y, and Z.

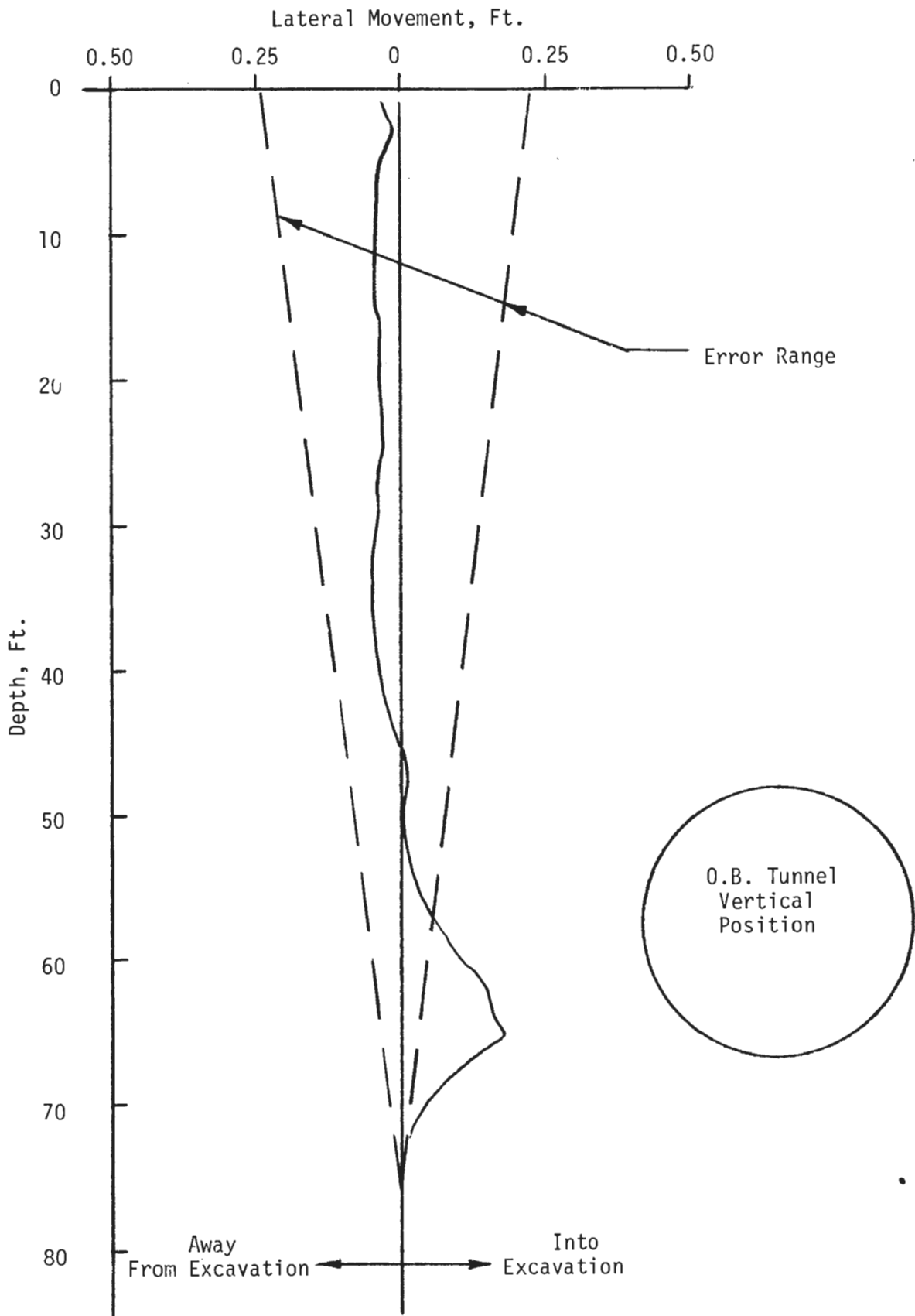

FIGURE 123. INCLINOMETER-12 MOVEMENT PERPENDICULAR TO O.B. TUNNEL CENTERLINE.

7.3.2.2.6 Comparison of V_L and V_S

It should be restated that downward displacements of about 0.3 inches were measured for the shallower anchors in MDS-17 and 21 and at DS-7. These movements would indicate that some soil displacement was progressing to the ground surface, as had occurred over the inbound tunnel where the shallow MDS anchor movements were of similar magnitude. Therefore, the apparent lack of surface settlement cannot be readily explained.

The calculated percent volumes of lost ground at MDS-17 and 21 were quite small ($\%V_L = 0.5$ and 0.6% , respectively). These small volumes of lost ground can partially account for the apparent very small to negligible surface settlements in the area. It would also seem that some volume expansion has taken place in the soils over the outbound tunnel to produce the apparent negligible settlement measured.

7.3.2.2.7 Groundwater Response

The response of the groundwater in P-11, 12, and 13 can be seen on Figure 72. The approaching pressurized outbound tunnel caused a groundwater rise of 9 to 10 feet, followed by a drop of about 7 feet as the face passed the instruments. The final measurements made on these piezometers in November 1979, approximately five months after passage of the outbound heading, indicated that the levels had returned to approximately the pre-outbound construction elevation of +7 feet. This level is approximately 3.5 feet lower than the level measured the previous November, before any tunnel construction activity for Charles Center Station and/or leakage into the tunnels.

7.3.3 Other Structural Observations

7.3.3.1 Cracking and Spalling Observations

Damage that was observed can be divided into 3 categories:

- that during and due to handling
- damage during installation
- damage after installation

7.3.3.1.1 Damage During Handling

Segments were handled and re-handled 5 times (on the job) before reaching the heading:

- unloading from truck and stacking
- moving segments into preparation shop
- moving segments out and restacking
- moving from storage yard to construction shaft site
- lowering down the shaft to the train for transportation to the heading

During this time, they experienced damage (broken corners, gouges and spalled edges) due to impact against each other and to gouging by the forks of the forklift. Typical examples are shown in Figures 124, 125 and 126.

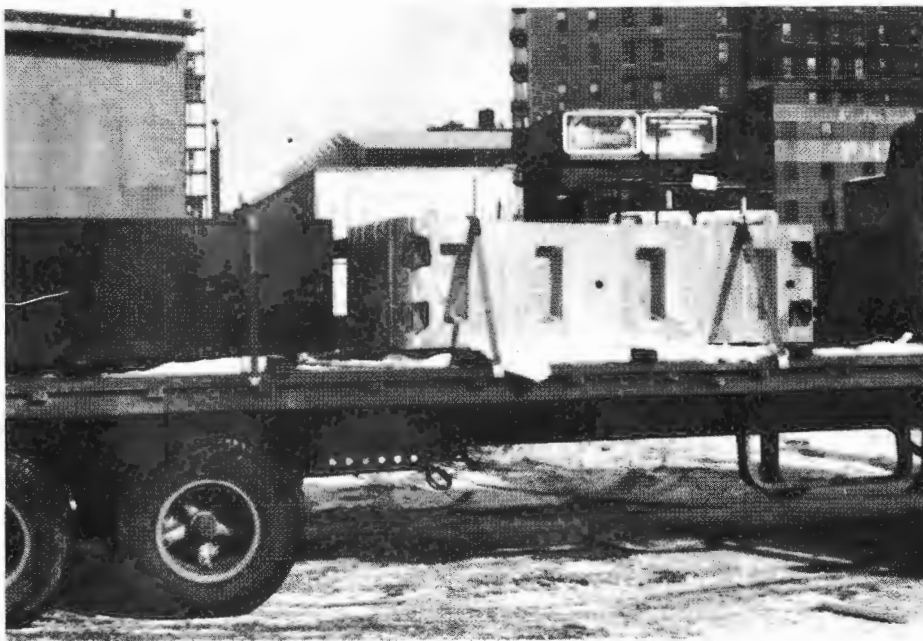

FIGURE 124. SEGMENTS IN TRANSPORT

7.3.3.1.2 Damage During Installation

When mounted on the erector arm, segments were sometimes awkward and difficult to control. They were subjected to impact with equipment and previously installed lining, which caused some additional damage. Being more brittle than the steel liner, they could not withstand the same rough installation technique without being damaged. Conditions improved as the crew gained experience, and installation damage was reduced.

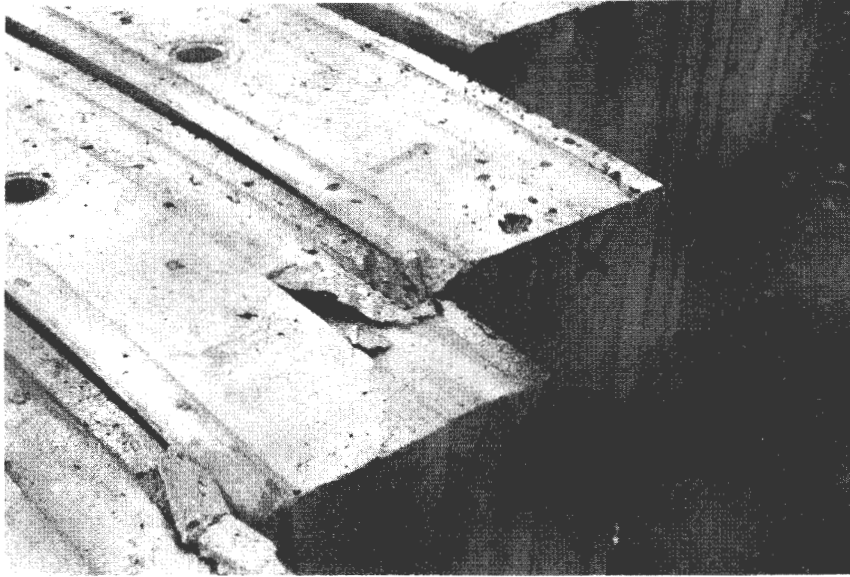

FIGURE 125. SEGMENTS DAMAGED DURING HANDLING



FIGURE 126. DAMAGE CAUSED BY FORKLIFT

Because of damage from the thrust ring face, additional thicknesses of rubber padding were added to the steel surface of the thrust ring, with little apparent relief. Finally, the padding was removed altogether and the steel-to-concrete surface seemed to work best.

Damage was also caused by withdrawal of alignment pins (Figure 127). Uneven retraction of the thrust ring caused the aligning pin to contact the wall of the bolt hole with tremendous leverage, causing a spall.

Damage in the contact area between segments was experienced, especially in the 2nd and 3rd rings back from the face during the early stages of the project. As crews became more proficient in aligning rings, this no longer occurred. Also, at about this time, the cushion tape was eliminated.

7.3.3.1.3 Post Erection Failure

These cases were by far the most serious.

Immediate Failure. There were two instances where this occurred, one of which was clearly a result of the construction process, and the second of which cannot be fully explained.

The first incident occurred on ring #202 and was evidenced by a visible and audible cracking in the top and right side of the ring at the time the shield was shoving. It was subsequently established that a directional correction had been made to the shield of such magnitude that the trailing edge was forced against the liner. The force of the shield jacks combined with leverage of the relative lengths of jacking point and shield length created very large localized loading on the ring at this point. Since the ring is designed to support fairly uniform loading, it failed.

The second dramatic failure took place in rings #447 to #451. While shoving for ring #451, cracking began at the invert of ring #447. The failure progressed up both sides at a nominal 45° angle to include rings #448, #449 and #450. Later, after ring #451 was installed, it too began to crack and spall in the same manner.

This damage was severe, not just surface or cosmetic. Figures 128 through 132 show the complete crushing of segments, shearing of liner bolts and offsetting of circumferential joints.

No single, uncontestable explanation has been found for the observed failure, although several possibilities exist. One theory is that failure was initiated by an "ironbound" condition in the invert at ring #447, similar to that at ring #202 as explained above. The lack of full support in the localized area could then have caused the failure of the rings that followed. It is difficult

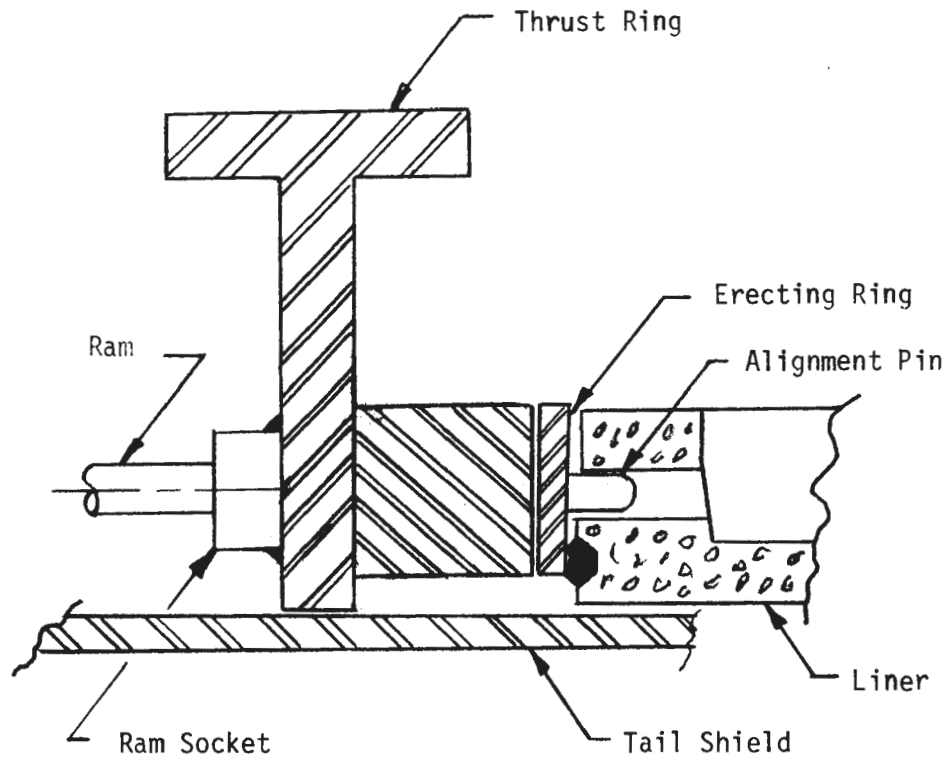

FIGURE 109 (REPEATED). SCHEMATIC DETAIL OF THRUST RING ASSEMBLY

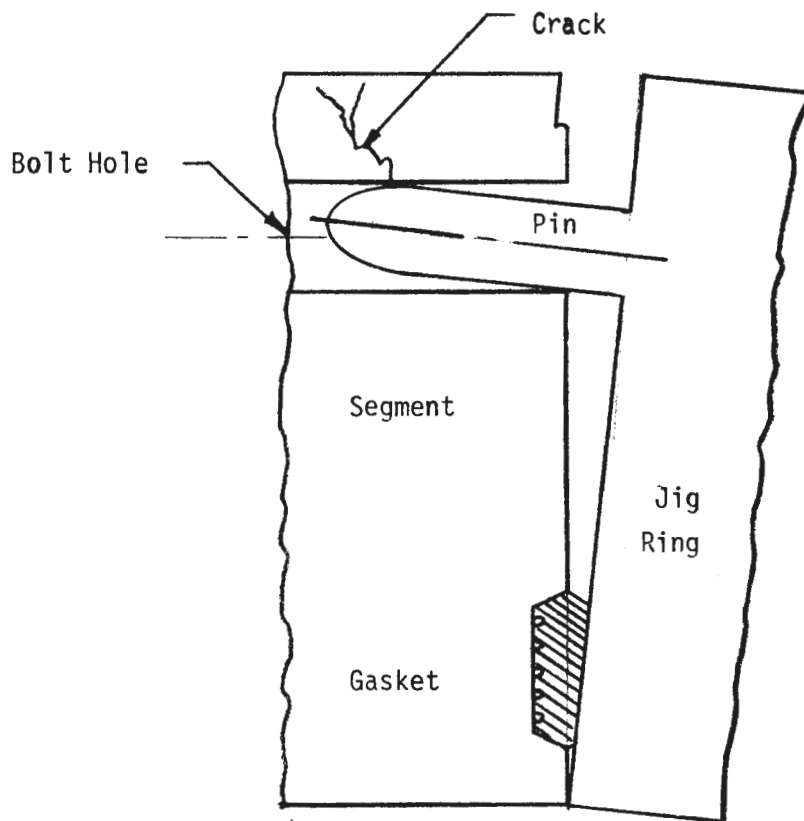

FIGURE 127. CRACK AND SPALL CAUSED BY EXTRACTION OF JIGGING RING



FIGURE 128. SEVERE RING FRACTURING AT RINGS #447-451



FIGURE 129. SEVERE RING FRACTURING AT RINGS #447-451.



FIGURE 130. FRACTURE OF RING #449.



FIGURE 131. FRACTURE OF RING #448.



FIGURE 132. EXPOSED REBAR IN RING #450.

to believe, however, that this would not occur until several rings beyond, when the jacking stresses in the area of initial failure had dissipated to a low value.

Other explanations which have been offered include the possibility of one or more defective segments, a rock, metal tool or other hard foreign object falling down and becoming wedged in the joint between the rings as they were installed, or perhaps some other unknown departure from the normal construction procedure at that time. Analysis of jacking thrust vs. liner stresses later available from Test Section "B" demonstrated the possibility of stress intensification when foreign objects are present (Figure 119), some conditions of which might have caused the observed failure. In any event, the failure has been documented, and may be assumed to be a possibility in future segmented concrete linings, regardless of its specific cause.

Long-Term Failure. The second type of post-erection damage was probably the most significant to this study for several reasons. First, it caused some alarm because it continued for several months after the tunnel excavation and lining had been completed. For a time this seemed to suggest the possibility of a long-term maintenance and repair problem associated with the liner.

Second, it led to subsequent investigations which resulted in new understandings of some properties and actions of the precast liner which would not otherwise have been discovered.

Third, it raised new questions and new issues which, although they were outside the scope of this study, will be important to future users of precast liner.

Early in construction, the erection-type of damage predominated to the extent that any post-erection distress was not readily apparent. Later, after the installation techniques had improved so that most rings were well aligned and undamaged, cracking and spalling began to appear far behind the heading operations. This damage took three general forms:

Type I: A deep wedge shaped spall at a bolt pocket along the circumferential joint on one side only. Usually this would be within 45° of the springline, and would extend along the joint above and below the bolt pocket as much as 2 feet in a shallow, narrow spall, exposing the rebar (see Figure 135, details A₁ and A₂).

Type II: A shallow spall along the circumferential joint but not necessarily at the bolt pocket (see Figure 135, details A₃).

Type III: A crack across the segment, parallel to the tunnel axis and always at a longitudinal bolt pocket location (see Figures 133 and 134).



FIGURE 133. LONGITUDINAL SEGMENT CRACK



FIGURE 134. LONGITUDINAL SEGMENT CRACK.

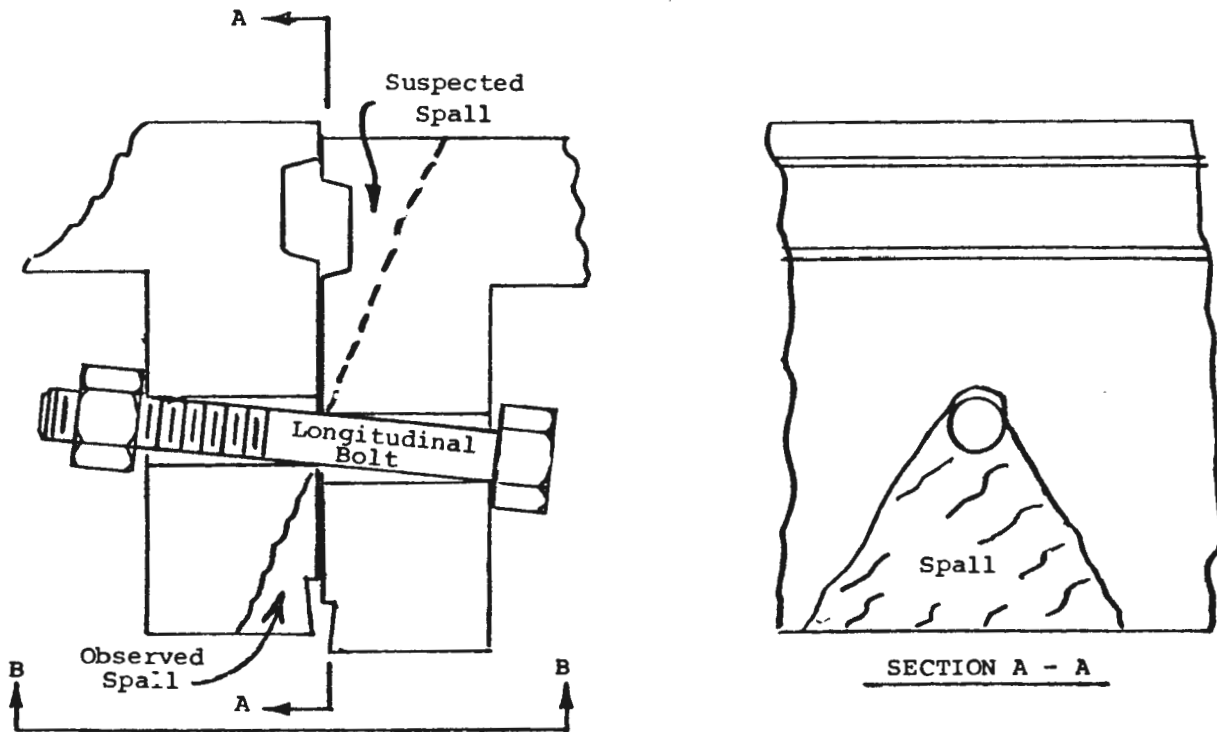
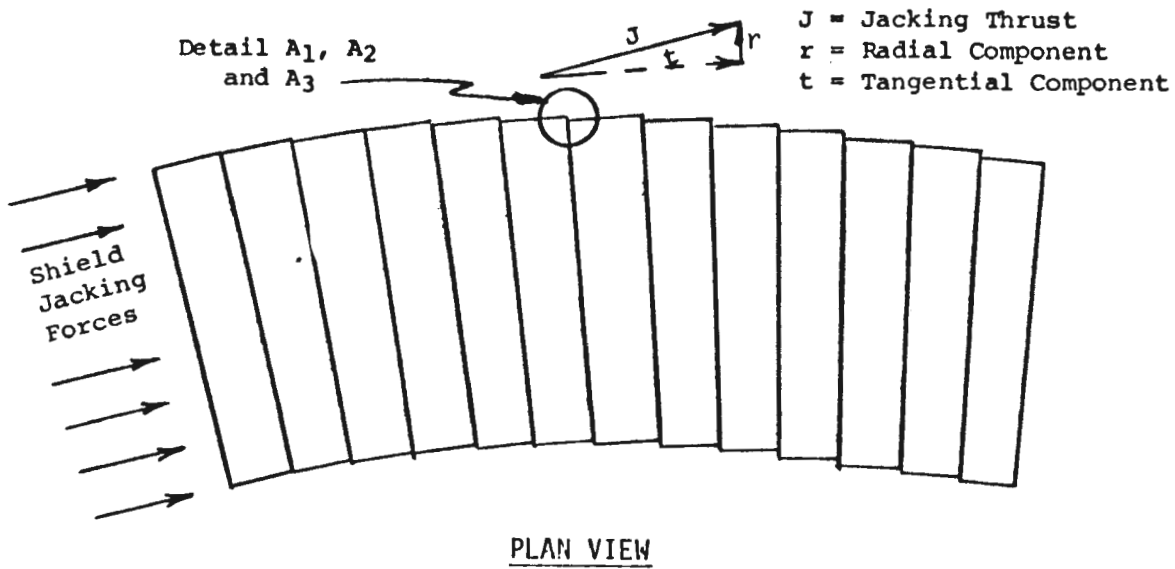

DETAIL A₁
 Spalls At Bolt
 Pockets Due To
 Relative Ring
 Movement

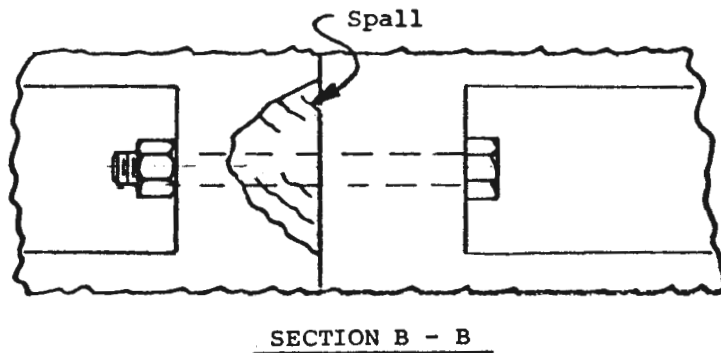
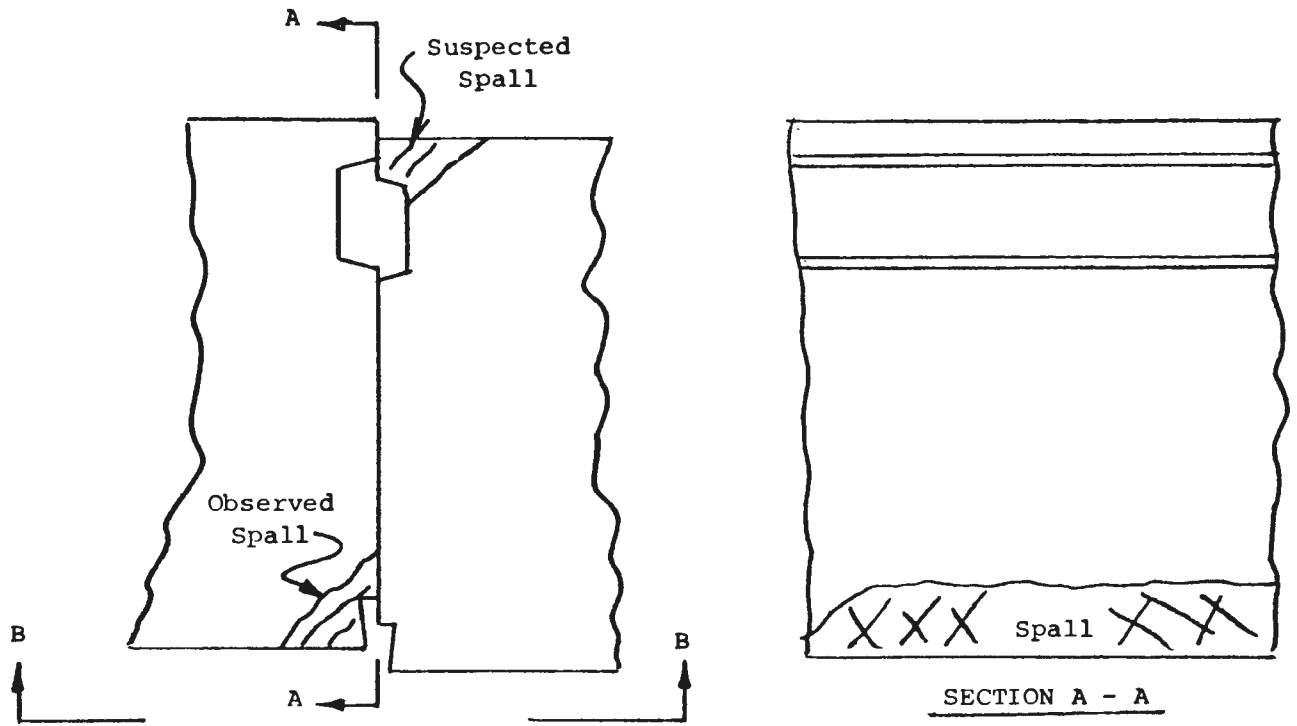

FIGURE 135(a). SCHEMATIC REPRESENTATION OF LOCALIZED SEGMENT DAMAGE



DETAIL A₂
 SPALLING BETWEEN BOLT-POCKETS

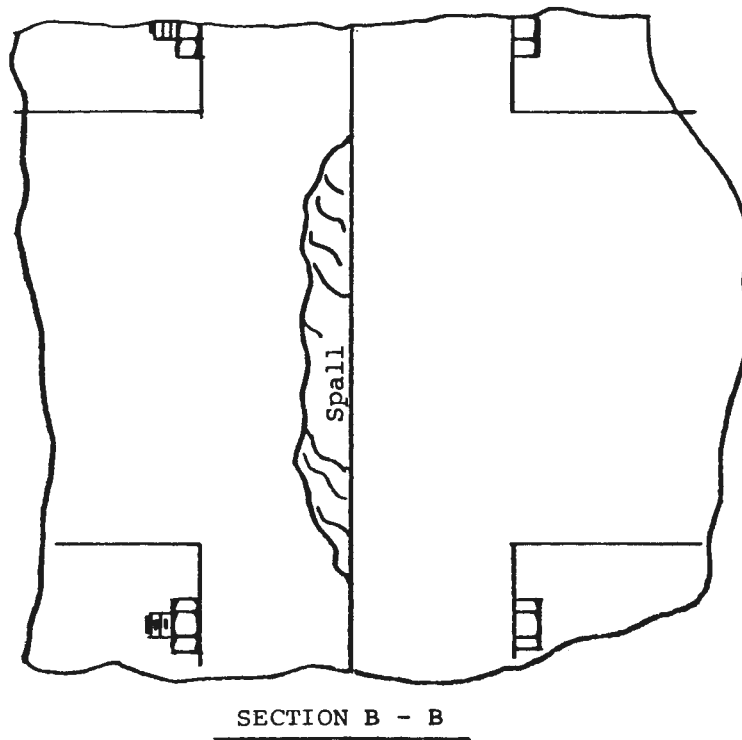
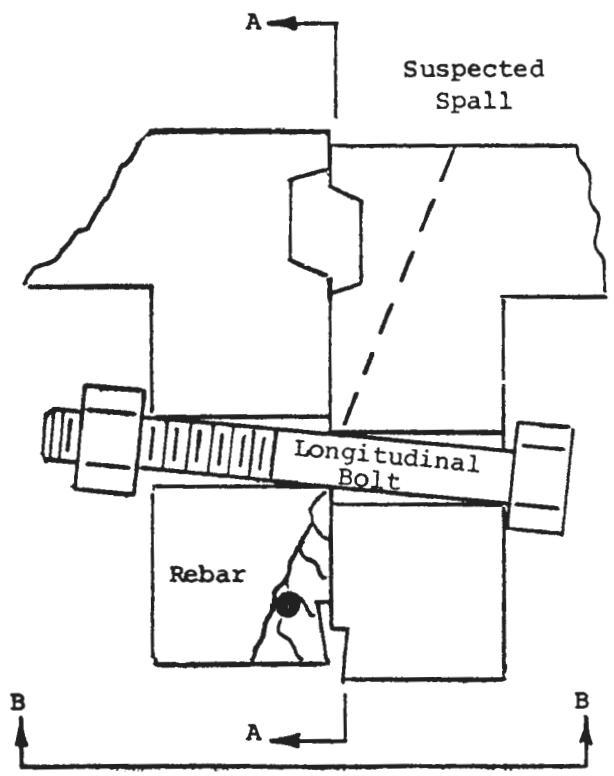
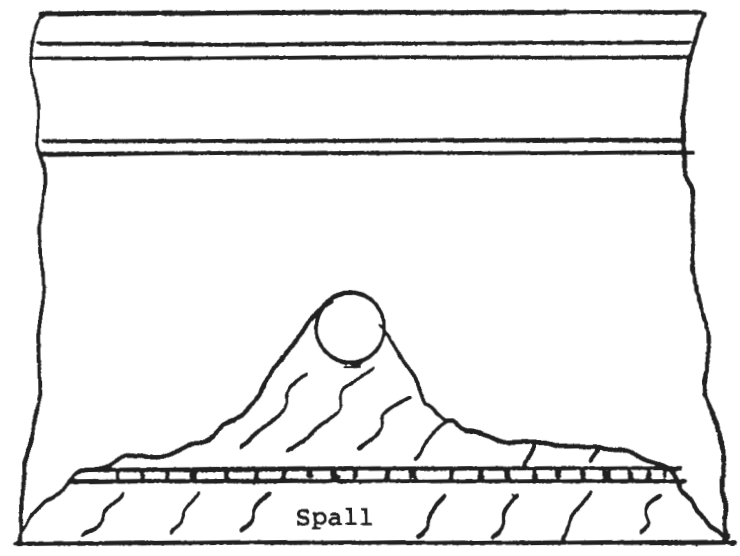

FIGURE 135(b). SCHEMATIC REPRESENTATION OF LOCALIZED SEGMENT DAMAGE



DETAIL A₃

Bolt Pocket Spall Extended
Along Joint By Leverage
On Rebar



SECTION A - A

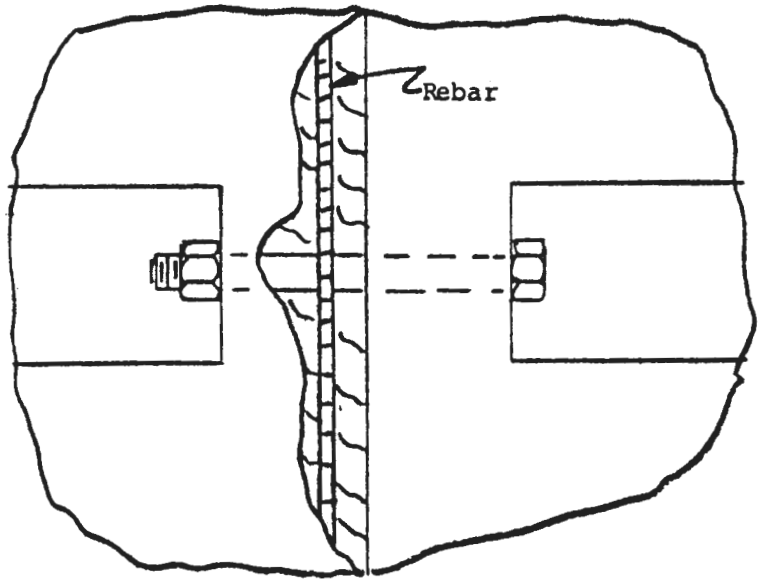

SECTION B - B

FIGURE 135(c). SCHEMATIC REPRESENTATION OF LOCALIZED SEGMENT DAMAGE

In view of the significance and potential consequences of this unanticipated condition, an intensive effort was made to document the extent and causes of the damage. Periodic inventories of segment damage throughout the tunnel were made and their results plotted against the damage recorded just after installation. Figure 136(a) through (f) is such a computer plot showing damage observed 3 months after the tunnel was completed and bulkheaded, compared to that immediately after ring erection. Arbitrarily weighted values were given to the type of damage, as explained in the figure legend, in order to provide a quantitative as well as qualitative perspective. The difference between the two curves at any given ring is representative of the damage experienced by that ring subsequent to installation.

A systematic monitoring of geometric dimensions was also begun. This quickly began to turn up evidence that continued ring movement was taking place long after the installation of the ring. From the relationship that they exhibited to ring damage, these movements fell into two categories; (1) relative displacement from ring to ring, as measured by joint offsets, and (2) overall distortion, as measured by ring diameters. An obvious correlation was demonstrated between the relative joint displacements and the spalling damage, types I and II above, and between the ring diameter changes and the type III cracking damage of the rings.

Throughout the curved section of the tunnel, a systematic lateral displacement of adjacent rings had occurred. Predominantly, this displacement was to the outside of the curve. The result was an established pattern of joint offsets in a radial direction, in the area above and below springline on both sides of the tunnel. Offsets of as much as 0.8 inches were measured where initially the rings were erected nominally flush.

This type of movement had not been anticipated, since design considerations assumed that the bolt tension would create a frictional force between adjacent rings sufficient to resist any differential radial displacement. Clearly, this was not the case. It appears that forces resulting from the radial component of the jacking thrusts, and perhaps other forces not yet known, acted asymmetrically on the rings after installation to cause this relative movement.

Figure 135(a) illustrates the effects of this relative displacement.

After the first 250-300 l.f. of tunnel, nearly all of the joint spalling was accompanied by a radial joint offset. Furthermore, virtually all of the spalls occurred on the recessed side of the joint. Consideration of these observations leads us to the conclusions demonstrated in Figure 135, details A₁ and A₃, as to the probable cause of type I and type II spalling, respectively.

In areas where spalls occurred along the joint between bolt pockets (type II), it appeared that the lateral displacement built up combined compressive

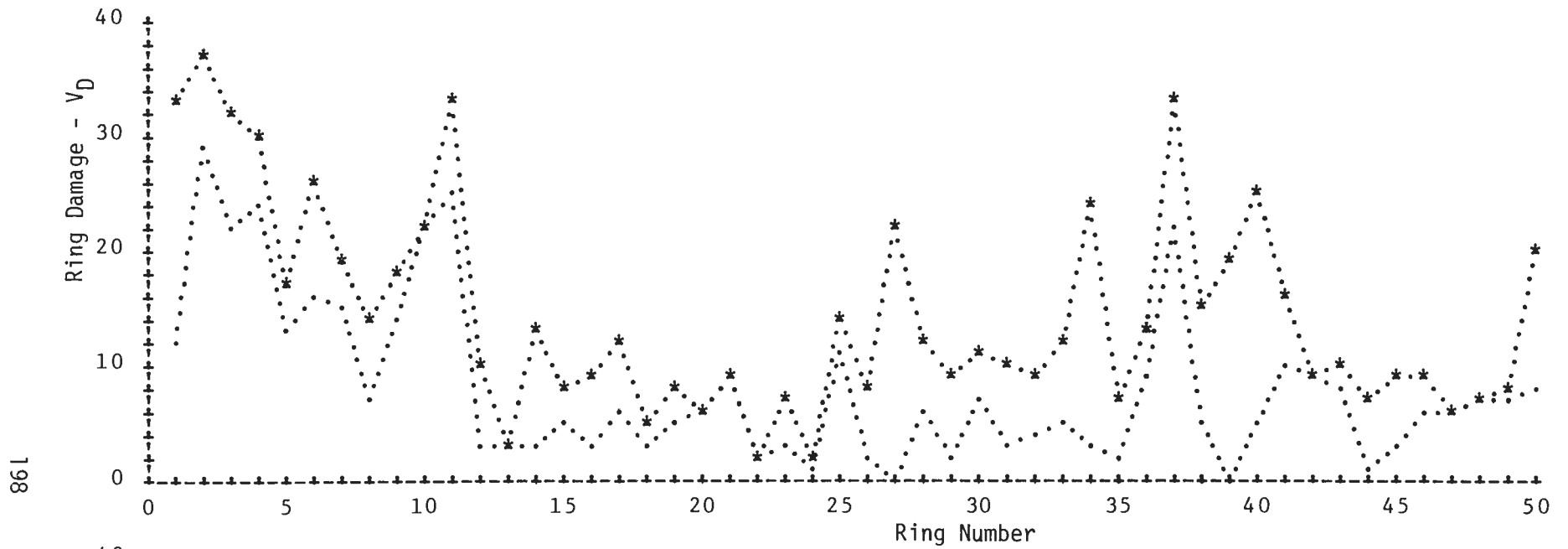

$$V_D = (S \times W_S) + (S_R \times W_R) + (C \times W_C)$$

where V_D = value plot for ring damage

S = number of spalls/ring

S_R = number spalls with rebar exposed/ring

C = cracks in ring

W = severity rating

$W_C = 1$

$W_S = 2$

$W_R = 3$

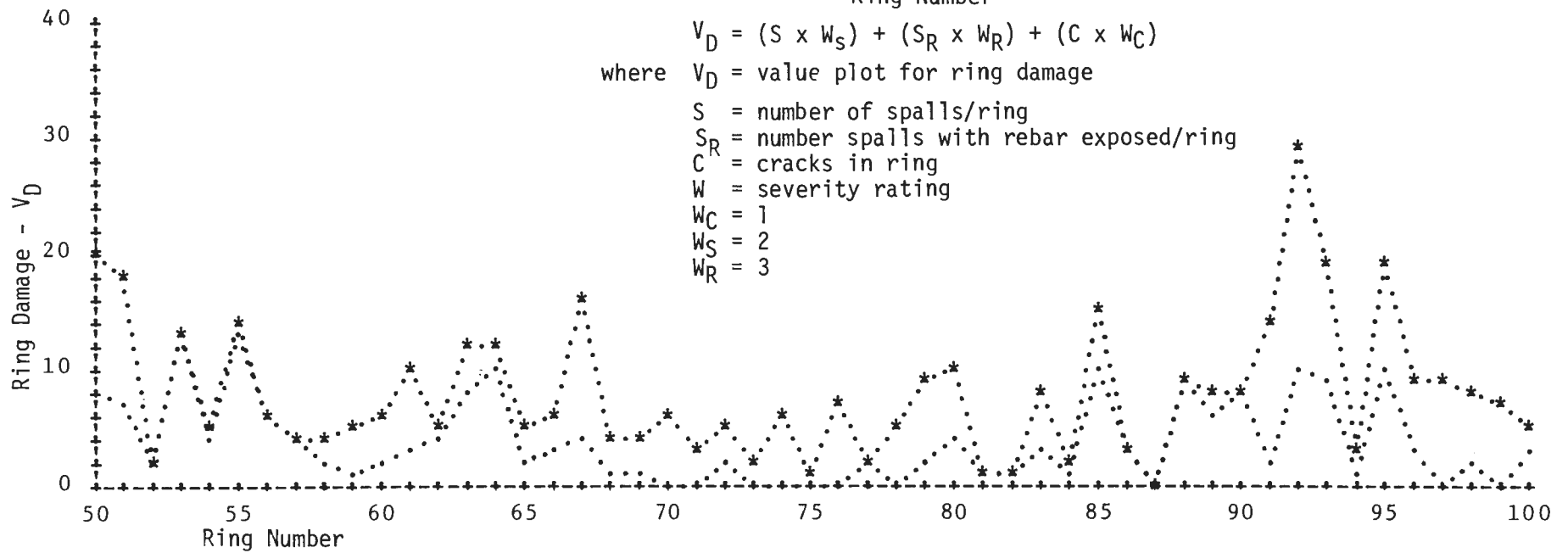

FIGURE 136(a). RING DAMAGE

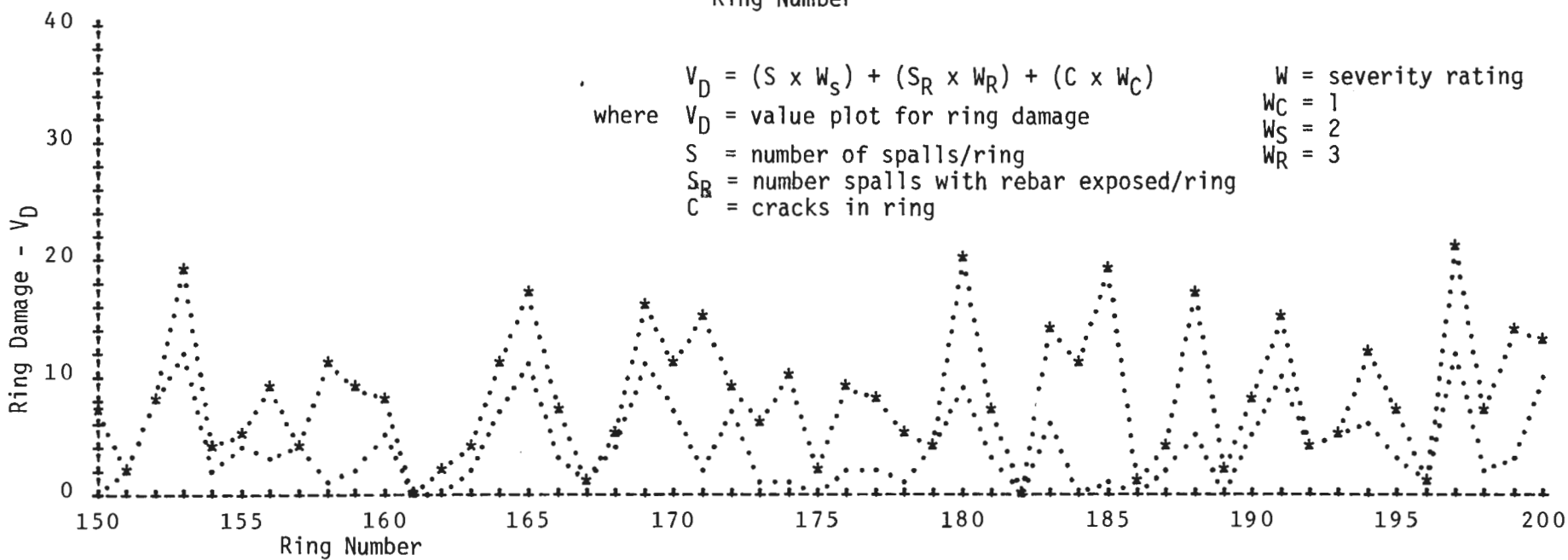
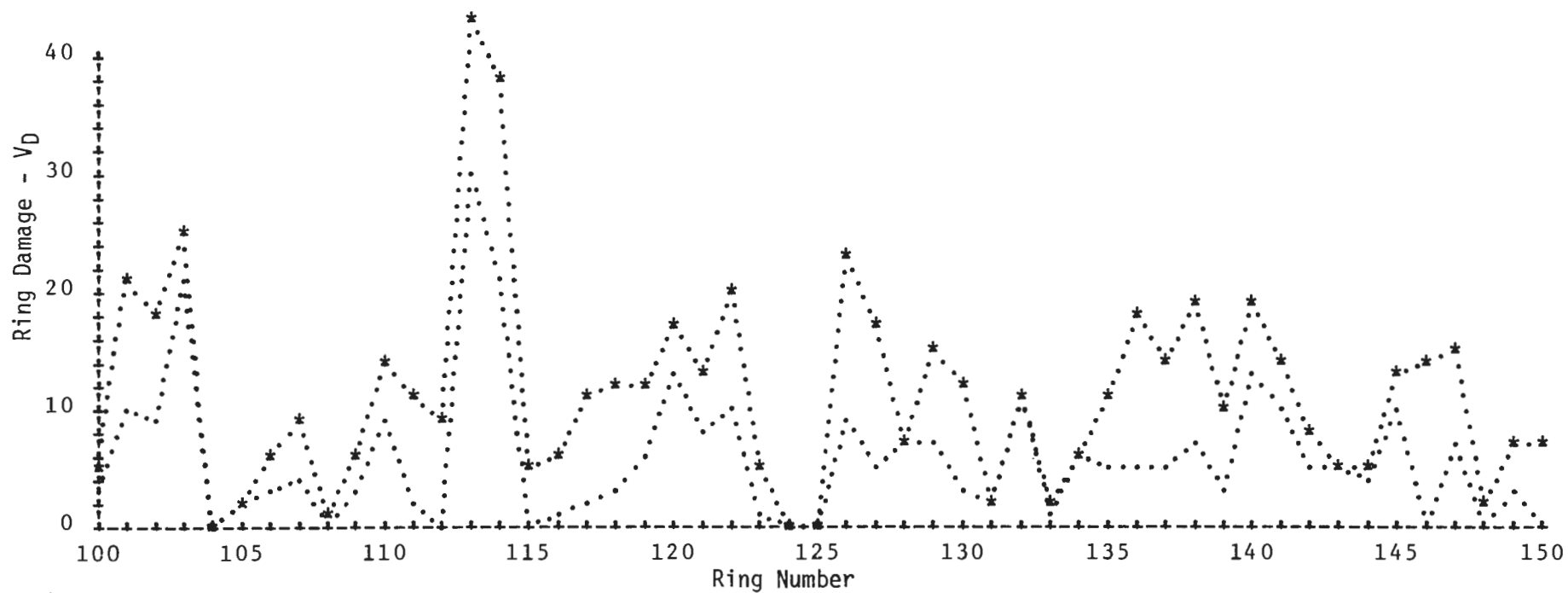
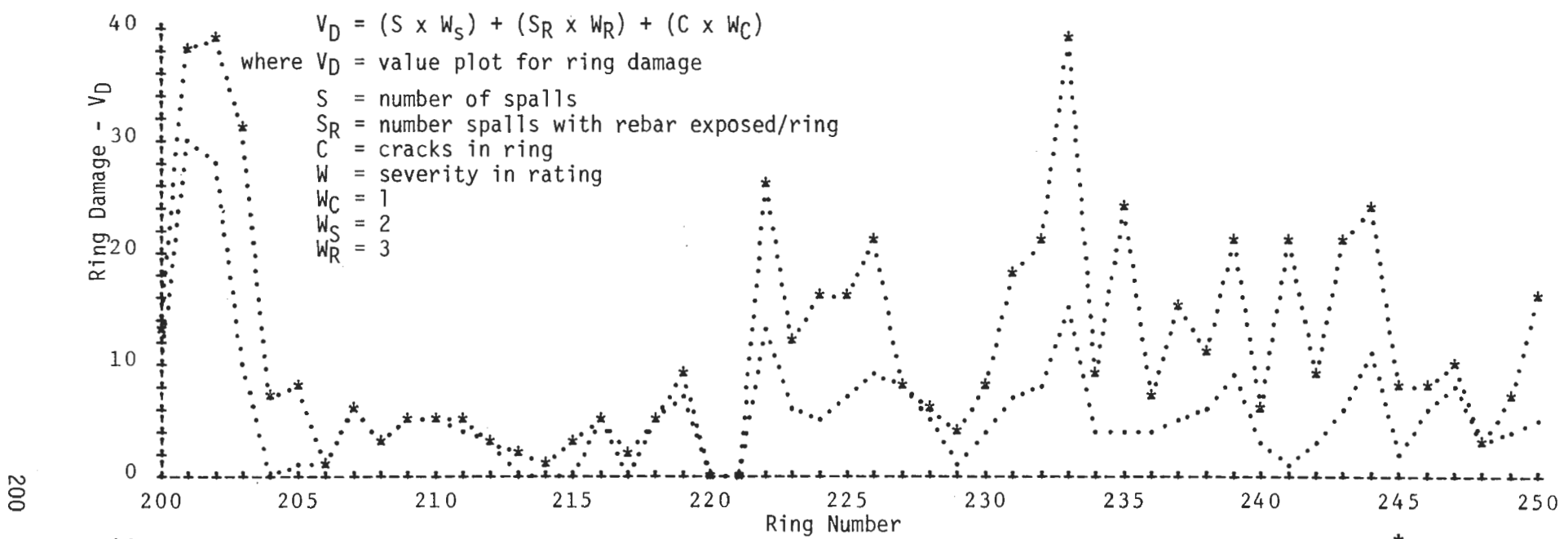

FIGURE 136(b). RING DAMAGE



200

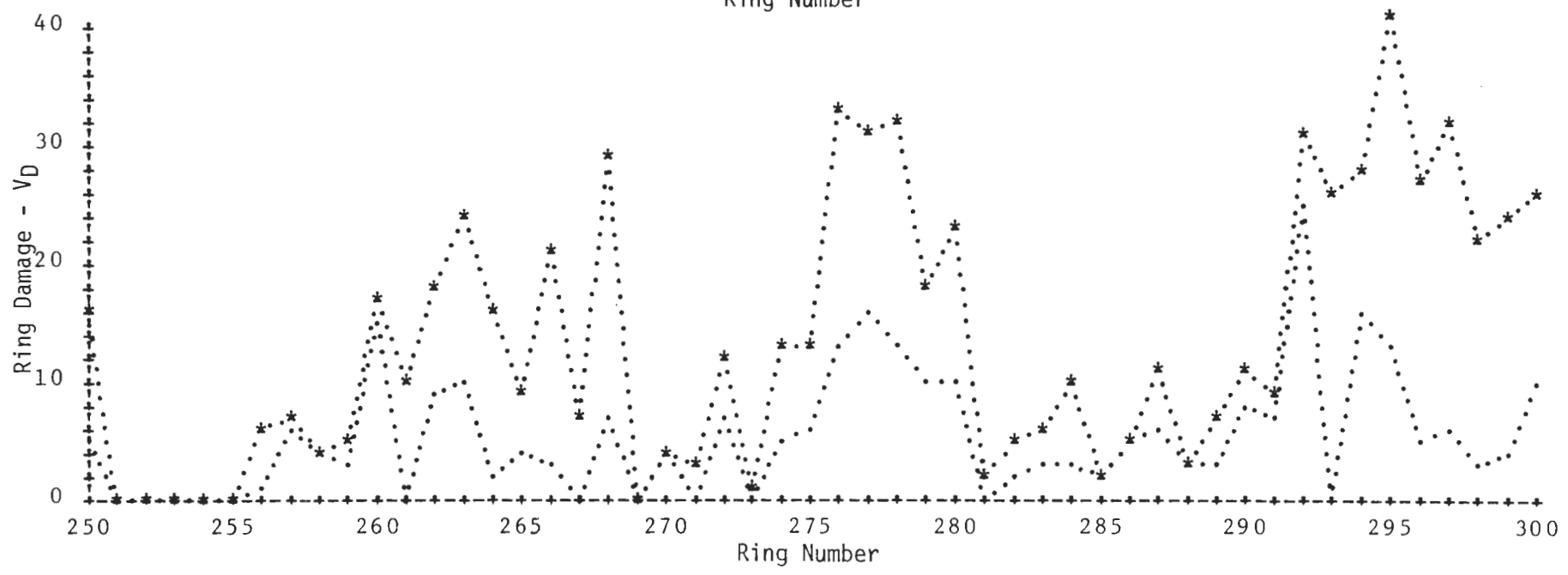
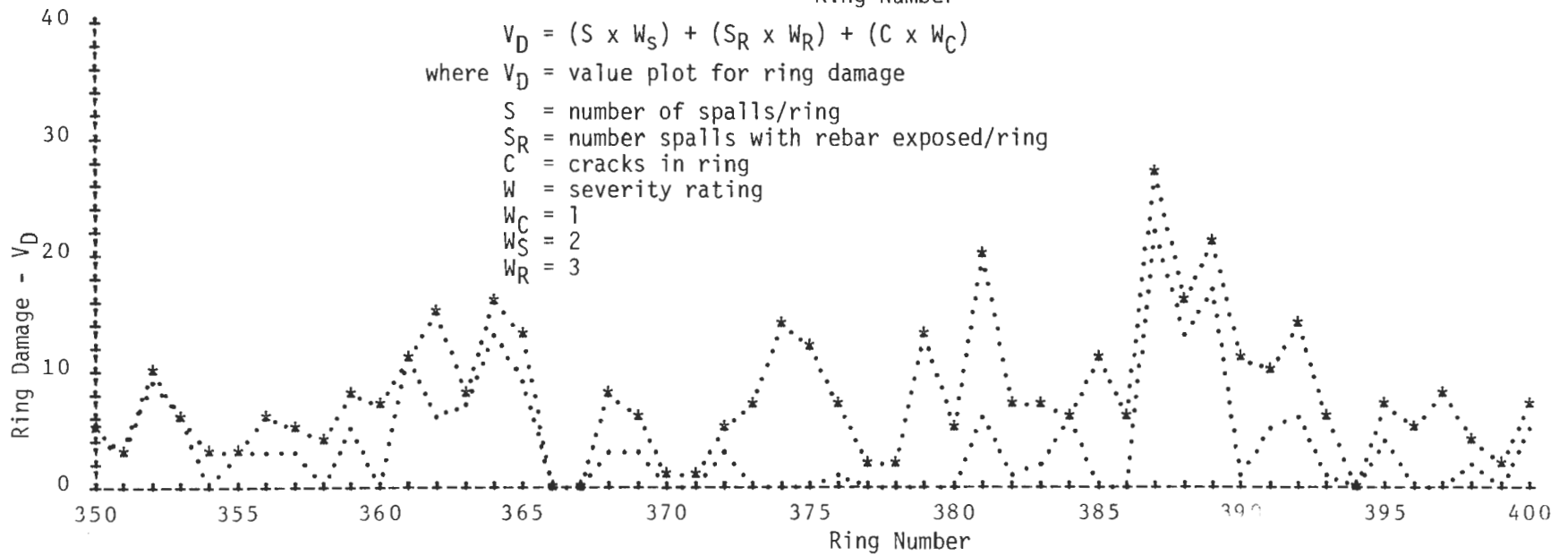
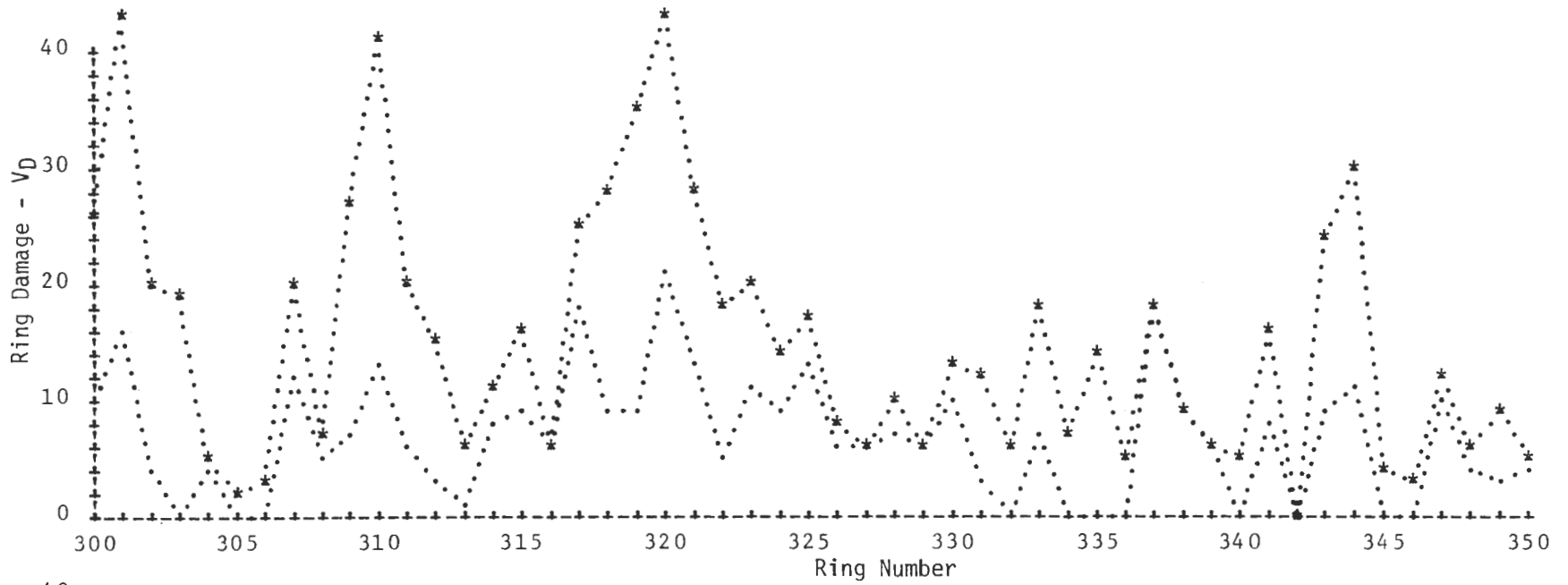
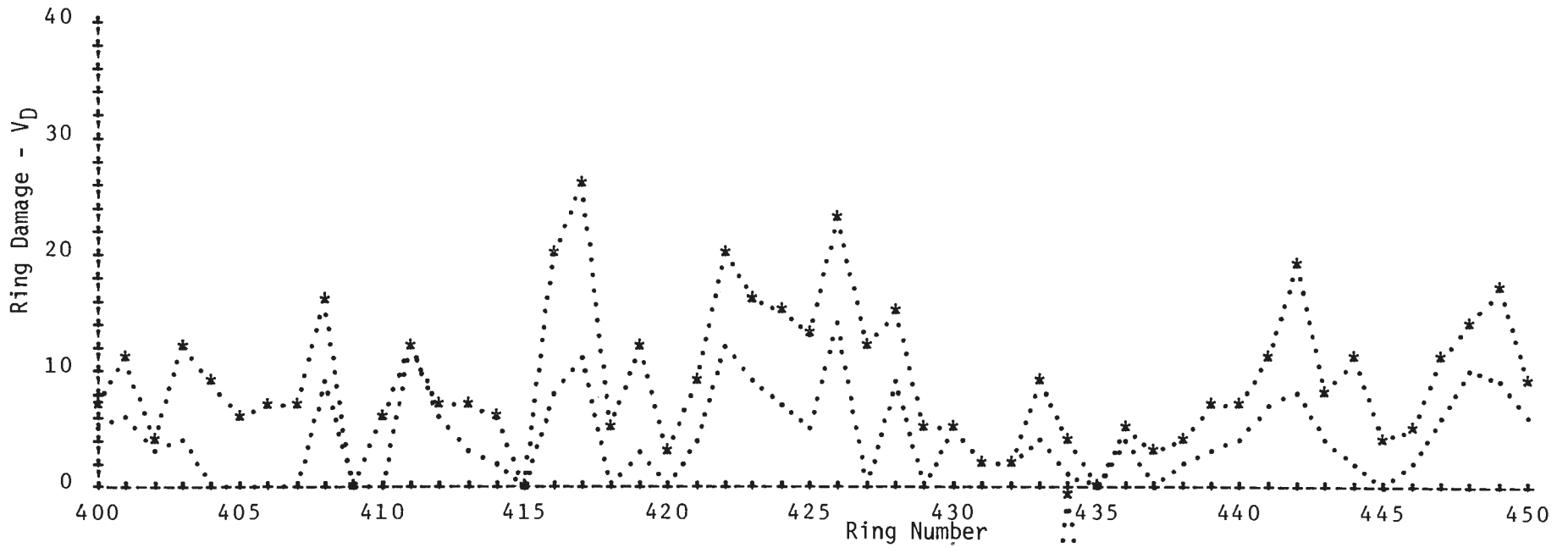

FIGURE 136(c). RING DAMAGE



$$V_D = (S \times W_S) + (S_R \times W_R) + (C \times W_C)$$
 where V_D = value plot for ring damage
 S = number of spalls/ring
 S_R = number spalls with rebar exposed/ring
 C = cracks in ring
 W = severity rating
 $W_C = 1$
 $W_S = 2$
 $W_R = 3$

FIGURE 136(d). RING DAMAGE



$$V_D = (S \times W_S) + (S_R \times W_R) + (C \times W_C)$$
 where V_D = value plot for ring damage
 S = number of spalls/ring
 S_R = number spalls with rebar exposed/ring
 C = cracks in ring
 W = severity rating
 $W_C = 1$
 $W_S = 2$
 $W_R = 3$

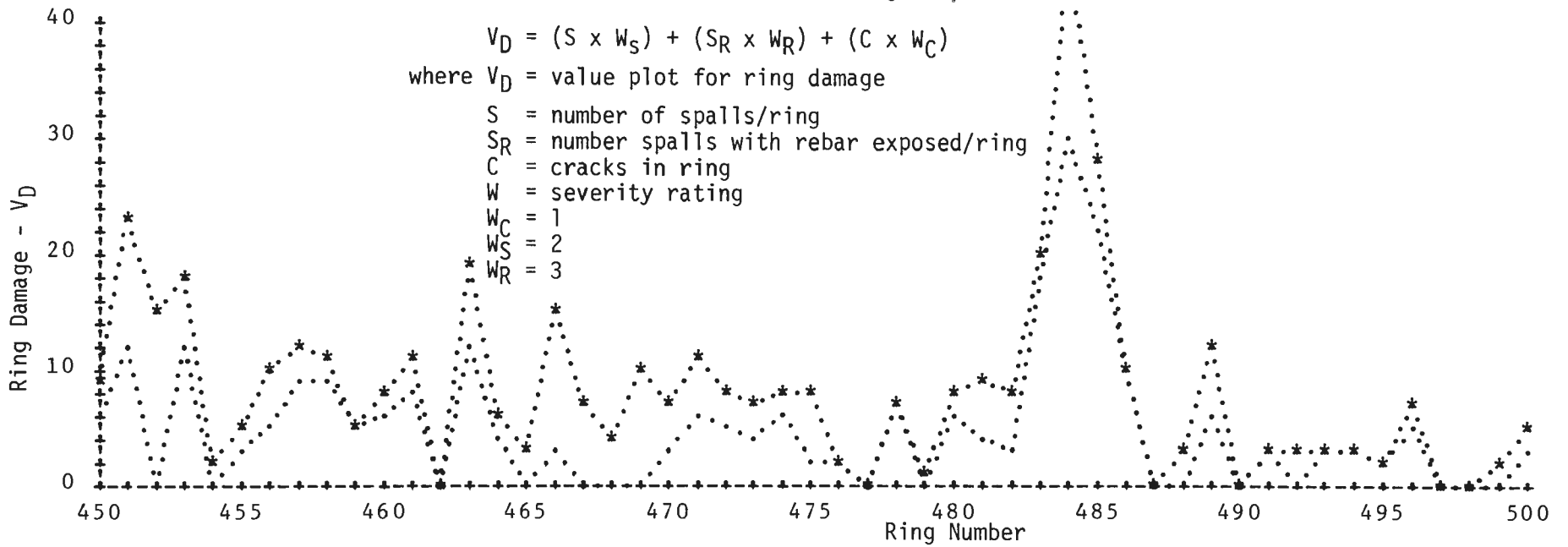
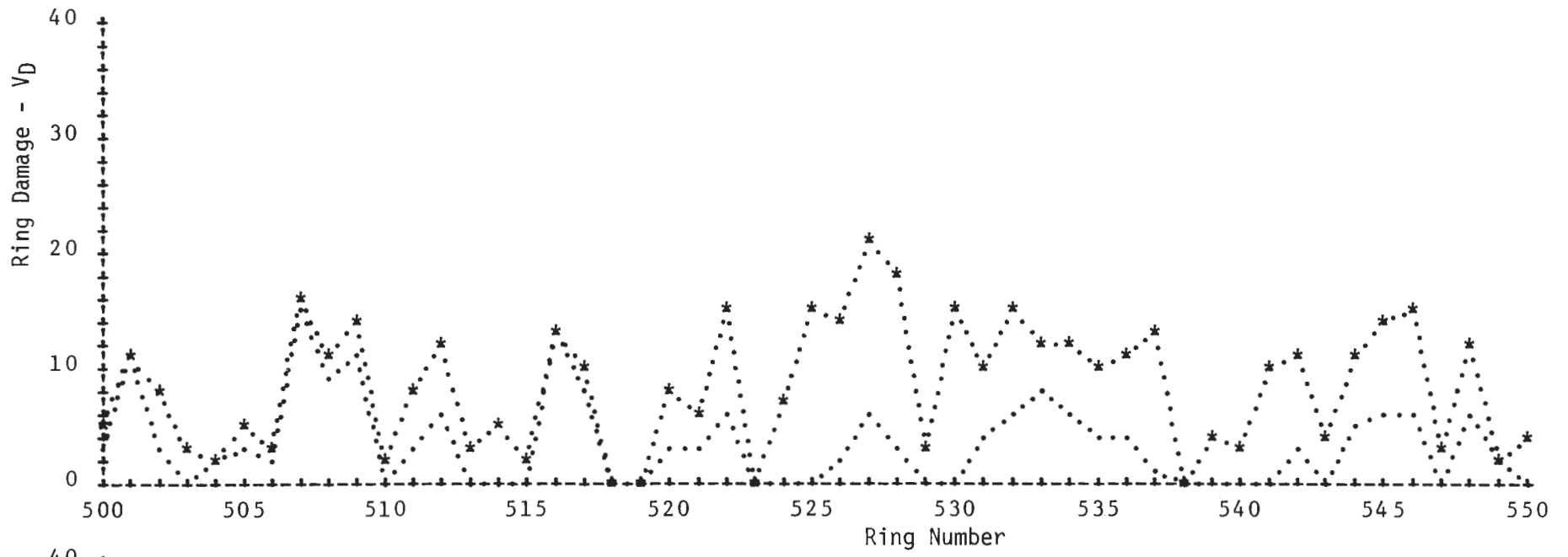

FIGURE 136(e). RING DAMAGE



$$V_D = (S \times W_S) + (S_R \times W_R) + (C \times W_C)$$
 where V_D = value plot for ring damage
 S = number of spalls/ring
 S_R = number spalls with rebar exposed/ring
 C = cracks in ring
 W = severity rating
 $W_C = 1$
 $W_S = 2$
 $W_R = 3$

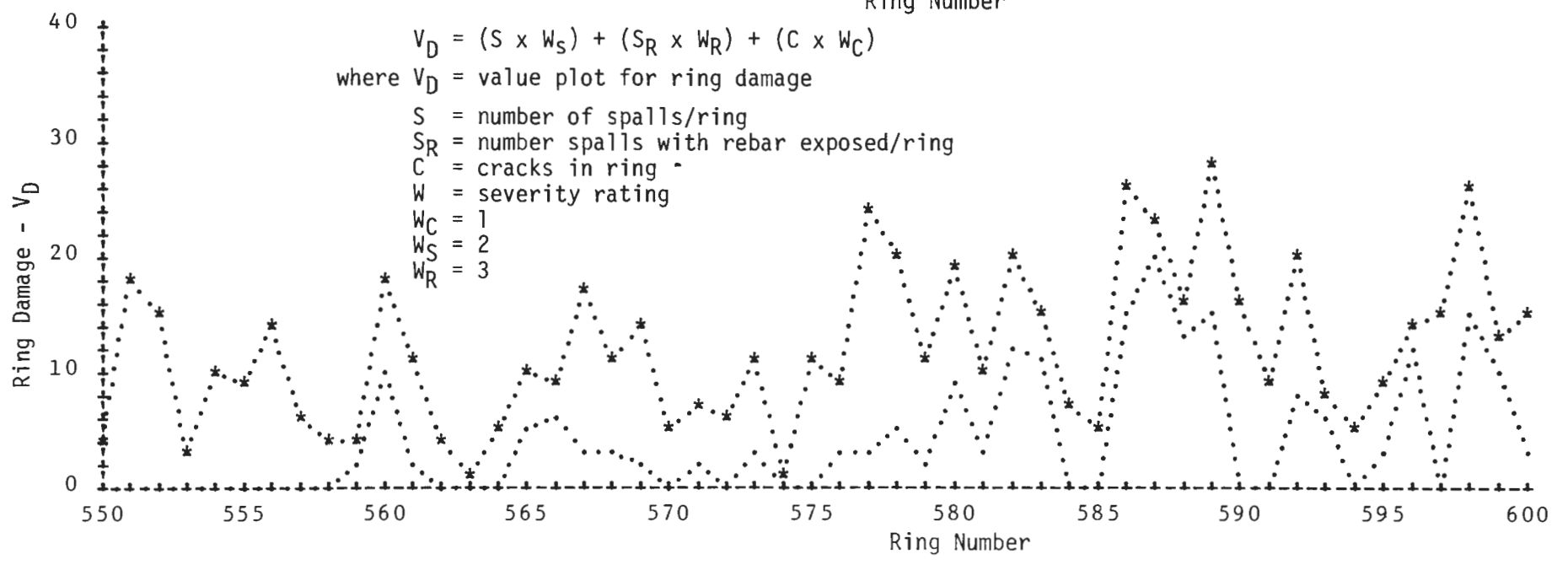

FIGURE 136(f). RING DAMAGE

and frictional forces at the joint which finally exceeded the shear resistance through a section of the recessed segment. The result was local spalling of the edge of the segment along the joint.

A more common and pronounced effect was the spalling adjacent to a longitudinal bolt pocket. Here, as shown in Figure 135, Detail A₁, the relative displacement caused the liner bolts to "skew" in the bolt holes. When the clearance tolerance between bolt and hole was reached, the total displacement forces of the ring began to build up quickly in a concentrated load the width of the bolt diameter. It then took very little additional ring displacement to cause the type I spall shown in Detail A₁.

A variation of this type I spall is shown in Detail "A₂". A reinforcing bar was located along the radial joint of the segment and between the longitudinal bolt and the inner surface of the segment. As continued radial joint displacement occurred, this bar served to extend the surface spalling along the joint by as much as 2 feet above and below the initial spall.

The consequence of the visible spalling is ostensibly one of aesthetics and probably not of real structural concern. What is of concern, however, is the probability that this same type of damage is occurring on the back surface of the segment. In the likely event that this is true, the gasket groove would, in each case, be damaged, destroying the watersealing capability at that location.

Though we were not able to physically observe the suspected damage to the buried faces of the segment, the experience of the drilling and grouting personnel who were sealing the leaks confirmed the existence of this type of damage.

Although the type III cracking damage was by far the least common of the three, it was particularly puzzling. The cracks were definitely a moment-type failure and the opening of the cracks toward the inner, or visible surface of the segment suggested an inward flexural displacement. This is the type most often associated with earth-loading failures. Yet, other data suggested that earthloading was well within expected limits.

Diameter measurements ultimately confirmed that the rings were experiencing an ovaling or elongation of either horizontal or vertical axis over a range of 2.5 inches [(+) or (-) 1.25" from theoretical]. Further, the connection of the flexural cracking with the shortening of the nearest axis was demonstrated.

Explanation of this distortion phenomenon is not fully apparent. One theory would tie it to the radial ring displacement discussed earlier. The radial forces would tend to displace the inner radius (closest to center of curve) more than the outer radius, causing an effect similar to "kinking" in a rubber hose.

A second explanation notes a general relationship to the geology in the mixed face tunnel. Figures 27 and 35 show that elongation of the vertical axis tends to occur in the cohesive residual material while elongation of the horizontal axis is more common in the less cohesive sand and gravel.

Fortunately, liner movement ceased damage between 4 and 6 months after tunnel excavation and no further damage was observed.

7.3.4 Sealing Systems, Watertightness

The sealing system specified for the precast concrete liner was intended to provide protection against ground water inflows through the joints between the segments and through any cracks that might develop in the segments. For the latter case, a coating of coal tar epoxy was specified for the exterior (earth contact) side of the segments. The purpose was to seal any shrinkage or other minor cracking that might develop through the segment section.

The joint sealing problem was less simple and was a major concern. As mentioned in the earlier design discussion, due to the relatively short tunnel length, the limited time available for the design and the testing of an adequate system and the concern for reliability, the decision was made to adopt an existing proven system. The system selected was the segment gasketing system provided by UTD Corporation. This system had most recently been used successfully to seal a mile long, precast lined subway tunnel under the Isar River in Munich, West Germany, where hydrostatic ground water pressures of between 1 and 2 atmospheres were experienced.

The basic components of this system, shown in Figure 137, consist of a groove about 2" wide which extends completely around the mating surfaces of each segment and into which is placed a continuous neoprene rubber gasket of the cross-sections shown. When the liner is assembled, the gasket surfaces of adjacent segments are matched and then held in compression by the torquing of the liner bolts, forming a tight seal. The neoprene ribs are calculated to provide a compression space for the gasket material and are matched to the manufacturing tolerance of the segments so that when mating segment surfaces are in full contact at maximum negative tolerance limits, the gaskets will just be fully compressed into the rib spaces provided. The purpose of this is to prevent spalling of the segment at the gasket groove due to lateral forces exerted by the gaskets.

The gaskets were manufactured in frames which were about 2% smaller than the gasket groove perimeter of the segment in which they would be installed.

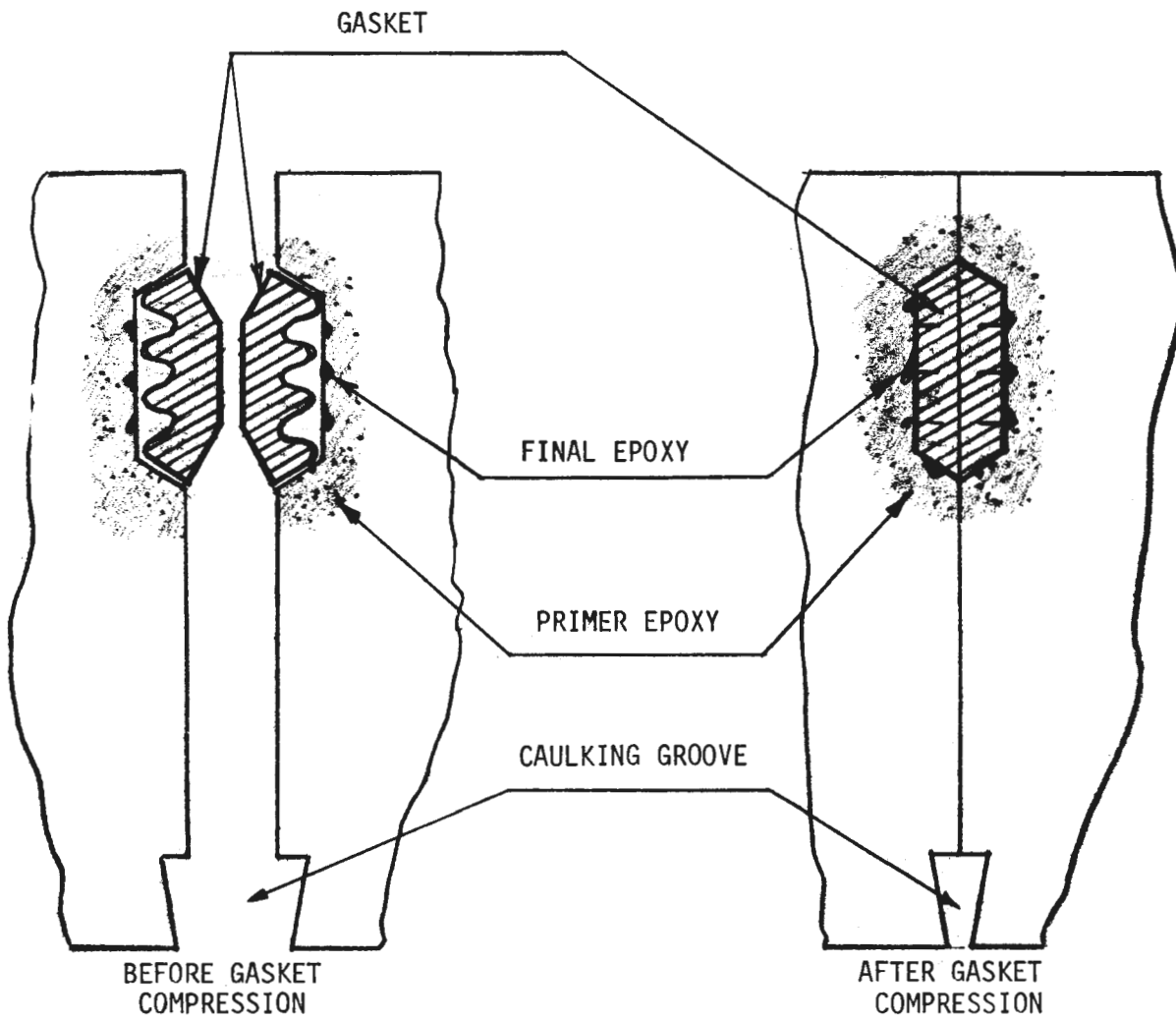

FIGURE 137. PRECAST LINER JOINT SEALING SYSTEM

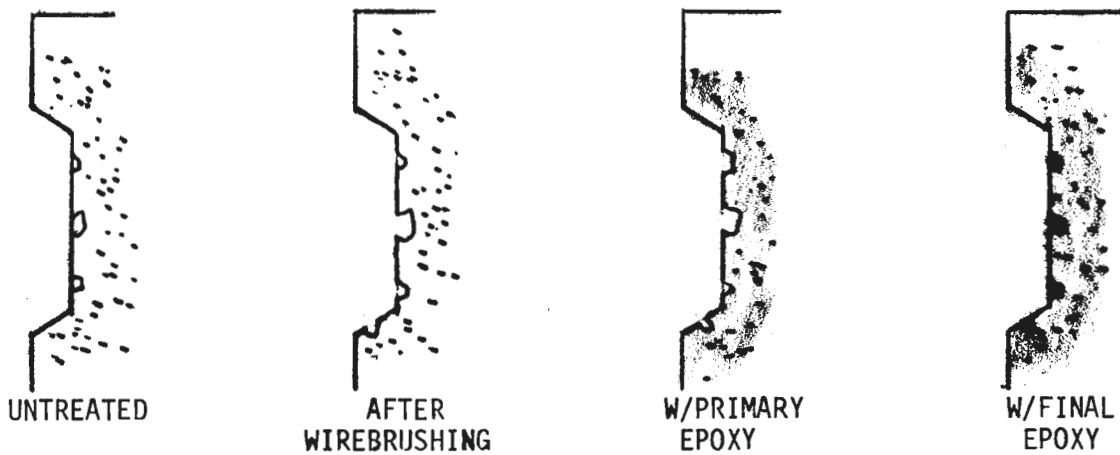

FIGURE 138. PRE-SEALING OF GASKET GROOVE

The purpose was to provide a pretension which would hold the gasket in its groove when installed. The corners of the gasket frames were cut on a mitre and vulcanized to match the segment corner, thus providing better sealing characteristics where the corners of two or more segments might come together.

This system also called for treatment of the gasket groove surface in order to prevent seepage between the gasket and the concrete surface, or through the concrete itself. Since concrete is a porous material, and since the casting process normally leaves a concentration of air bubbles at the formed surfaces, a special process was required to eliminate this source of seepage. This consisted of three steps for preparing the gasket groove prior to installation of the gasket (Figure 138):

- First the joint surface was wire brushed to open up any air bubbles just below the surface.
- Next an epoxy sealer of high viscosity was applied to the groove and adjacent area by brush or cloth to permeate and seal the small air pockets and pores in the concrete.
- Finally a stiff epoxy sealer was applied to the groove surfaces to seal the larger air bubbles. This was carefully troweled off flush with the surface in order to prevent reduction of the groove area which might result in over-compression of the gasket.

As a back-up or remedial measure, a caulking groove was also provided along the inner edge of the joint for use if needed (see Figure 137).

Preparation of the joints and installation of the gasket was to be done at the jobsite. The contractor constructed a special building at his storage yard so that this operation could be done under controlled conditions, protected from the elements. Two minor problems occurred during this operation which caused the contractor some annoyance. First, due to the length and curvature of the segments, the gasket had a tendency to roll out of the groove at the midpoint of the segment. This was solved, first by applying strips of duct tape over the installed gasket. These were later removed at the heading just prior to segment installation. Later, the contractor installed the gasket while the sealing epoxy was still tacky. The adhesive action of the epoxy held the gasket in place, eliminating the use of the duct tape. The second problem was that the gasket grooves were sometimes not cleanly cut. Collections of grout, spattered concrete or imperfections resulting from damage from blockouts sometimes encroached into the gasket groove, reducing the required cross-section. In this case, the contractor employed hand grinders to open the grooves up to their required dimensions.

Leakage studies during the period of tunnel excavation were not practical. Because of the compressed air technique used for tunneling, water inflows through the liner were virtually non-existent. There was some concern, however, because of the damage to the gasket groove area observed during handling and installation (see Section 7.3.3.1), that there was a potential for significant leakage at the joints.

Subsequent monitoring after the tunnel was returned to atmospheric pressure, however, relieved those concerns. One major leak existed through the crushed segment at rings #449-450, which produced about 7 gpm. Leakage through the remainder of the tunnel liner was measured at approximately 9 gpm, over 1530 l.f., this amounts to 0.6 gpm per 100 l.f., which was comparable to that observed in the steel tunnel. It was not possible to determine what portion of that amount was made up of leaks through cracked or damaged segments and what portion was attributable to the joint sealing system. In any event, the total inflow was so small that the question is academic.

Final sealing, where necessary, was accomplished by localized epoxy grouting, as discussed in Section 7.4

One common misunderstanding concerning the sealing system should be discussed at this point. Many people assume that the tight casting tolerances specified for mating surfaces of the precast segments are a requisite for the joint sealing system. This is not true. According to the gasket supplier, the gasket is designed to meet the given tolerances, rather than vice versa. Determination of the casting tolerances is a structural consideration. The major consideration is to create an even contact surface between segments, thus avoiding concentrated point loading which could cause local failures under jacking loads. The effect on sealing is a secondary one, the reduction of seeps that might occur through cracks resulting from such damage.

7.3.5 Geotechnical Influences and Responses

The following observations were made relative to the geotechnical data that was collected for the outbound tunnel construction in other than Test Sections A and B.

7.3.5.1 Soil Displacements

7.3.5.1.1 Vertical

The maximum soil movements monitored by the four MDS's outside of the test section were all measured at the deepest anchor located just above the tunnel crown. The maximum downward movements of these deep anchors are shown in Table 3, along with the MDS data from Test Sections A and B.

TABLE 3. MAXIMUM DOWNWARD MOVEMENTS, TEST SECTIONS A AND B

Instrument Number	Vertical Displacement (inches)	Comments
MDS-1	2.9	Free air section; C-1 at crown and upper 50% of face; remainder RZ-1
MDS-4	1.6	Free air section; C-1 at crown and upper 50% of face, remainder RZ-1
MDS-10	1.1	Compressed air section; C-1 at crown and upper 5 to 10% of face, remainder RZ-1
MDS-12	0.3	Compressed air section; C-1 and C-1a at crown and upper 50% of face, remainder RZ-1
MDS-14	1.1	Compressed air section; C-1 at crown and upper 40% of face, remainder RZ-1
MDS-17	0.4	Compressed air section; RZ-1 full face
MDS-21	0.5	Compressed air section; RZ-1 full face

The observations which can be made based on this data are generally similar to those made for the steel liner plate tunnel presented in Section 6.5. In short, the greatest movements of the deep anchors occurred at the start of the drive. However, smaller movements were recorded over the outbound tunnel relative to adjacent sections on the inbound tunnel. It would appear that since essentially the same tunnel crew was used on each tunnel, the experience gained on the first tunnel reduced the initial learning period for the second. Although not as well defined as in the inbound tunnel, it also generally appears that the smaller the amount of granular material in the face, the smaller the soil movements above the tunnel.

The three shallower anchors in MDS-1, 4, 10 and 12 all indicated attenuating soil movement approaching the ground surface. MDS-13, located adjacent to the outbound tunnel indicated downward movement of about 0.3 in. in the three anchors above the crown. This is similar to what was observed in the MDS's adjacent to the outbound tunnel in Test Section B.

7.3.5.1.2 Horizontal

Inclinometer I-6 showed measured horizontal movement of up to 0.3 in. into the outbound excavation which decreased only slightly from the

crown to the ground surface. Inclinator I-7 indicated approximately 0.15 in. of measured horizontal movement away from the outbound excavation, with no decrease of movement toward the ground surface. The largest horizontal movement for either tunnel was measured at I-16, where up to 0.38 in. of movement into the outbound excavation was recorded.

7.3.5.1.3 Volume Losses

Using the formula presented previously, the volumes of lost ground were estimated at each MDS location and are presented below:

Location	Volume of Lost Ground V_L (ft ³)	% V_L
MDS-1	10.7	3.4
MDS-4	6.0	1.9
MDS-10	3.9	1.2
MDS-12	1.0	0.3

The observations made for the deep anchor movements presented in Section 6.5 can also be made for these lost soil volume estimates. It can also be noted that except at MDS-1 these estimated ground losses are less than or equal to the 1.5% to 2% originally estimated by the tunnel designer.

7.3.5.1.4 Surface Settlements

The measured surface settlements resulting from the advance of the outbound tunnel were generally small for the first 400 feet of the drive and negligible for the remainder. The maximum displacements generally occurred above the outbound centerline, with the largest settlement of about 1.8 in. measured near MDS-2 at the start of the advance. For the remainder of the drive, the maximum surface settlements were less than 0.5 in. with many measurements indicating essentially no surface settlement over the outbound tunnel. Figure 139 is a plot of the ground surface settlements due to the outbound advance only, measured along the centerline of the outbound tunnel for the entire route.

The surface settlement troughs measured along the various crosslines not included in the two test sections tended to resemble the probability curve shape discussed in Section 6.5.3. Figure 140 shows the settlement profiles at Sta 22+90 and 21+00 (O.B.), which were two of the better defined troughs. The volumes of these settlement troughs (% V_S) at these two locations were

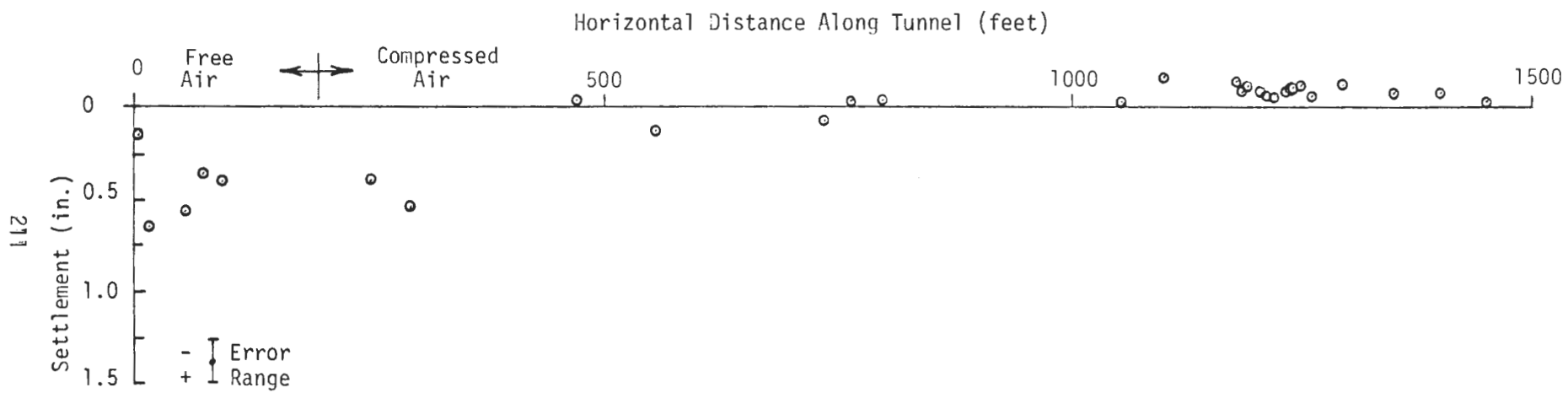

FIGURE 139. SURFACE SETTLEMENT CENTERLINE, OUTBOUND TUNNEL

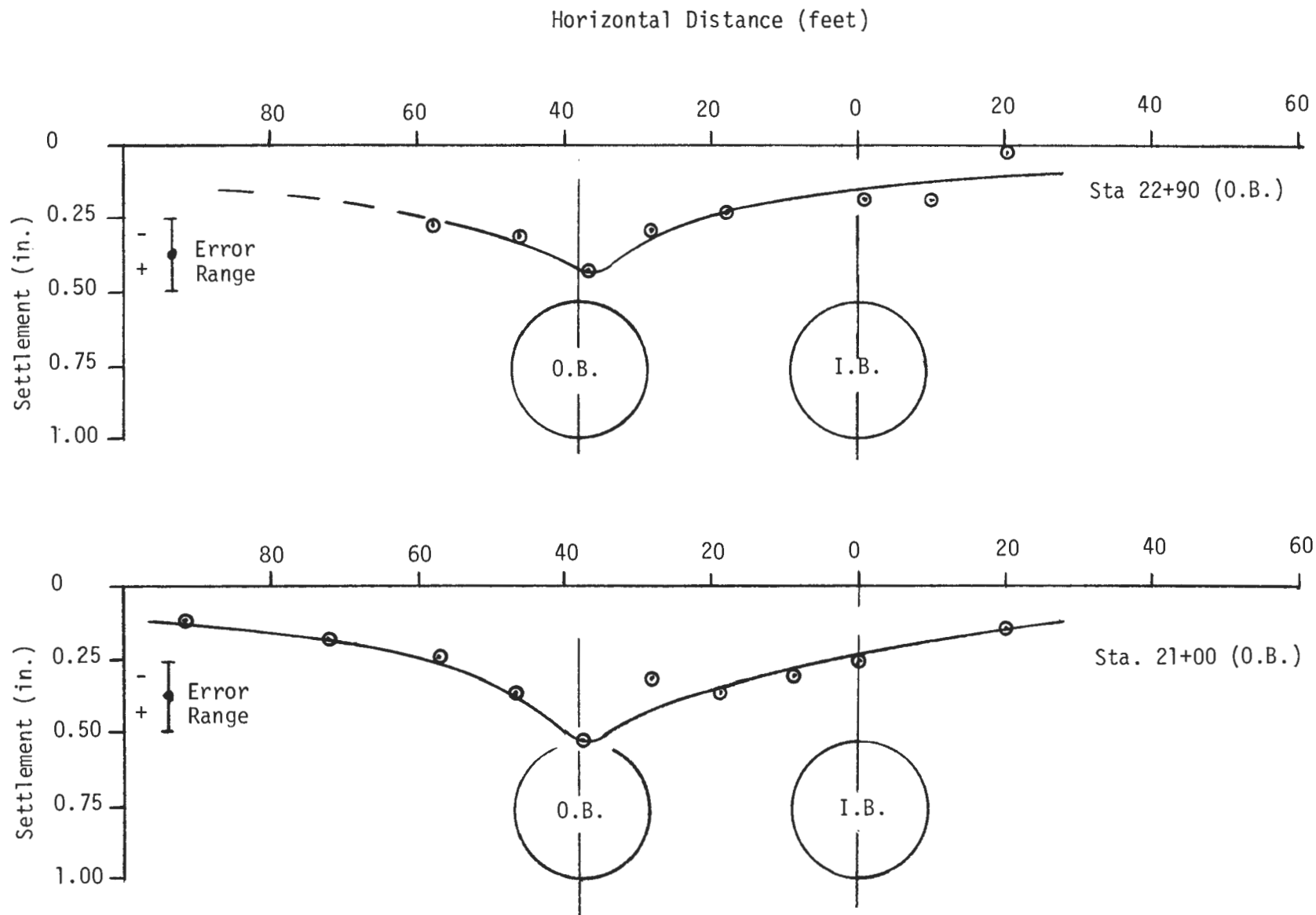

FIGURE 140. SURFACE SETTLEMENT TROUGHS, OUTBOUND TUNNEL ONLY

calculated to be approximately 0.7% and 0.8%, respectively. Extrapolation of the profile at Sta 22+90 was required due to a lack of settlement data to the west of the tunnel. It should also be noted that the settlement crossline at 21+00 is not perpendicular to the tunnel axis, but is skewed at about 25°.

7.3.5.1.5 Comparison of V_L and V_S

At Sta 22+90 and 21+00 the surface settlement trough volume was about 40% of the volume of soil which was estimated to have been lost into the outbound tunnel excavation based on the measured deep anchor movements in MDS-4 and 10. Therefore, it appears that at these locations substantial volume expansion has occurred in the granular soil above the tunnel. Based on the small to negligible settlements measured over most of the outbound tunnel route, with the major exceptions at the start of the drive and at Test Section A, it appears that volume expansion occurred in the dense granular soil overlying the outbound tunnel for most of its length.

7.3.5.1.6 Ground Water Response

Except for the response of the piezometers in Test Section B, as discussed in Section 7.3.2, no definitive response was apparent in the other piezometers during construction of the outbound tunnel.

7.3.5.1.7 Jack Pressures and Air Consumption

The variation in jack pressures for the four jack quadrants of the outbound shield seemed to be independent of the geology encountered. Also, there was no apparent correlation between geology and air consumption for the outbound tunnel.

7.3.5.1.8 Comments

Considering the generally small deep soil movements and surface settlements and small observed ground losses, the performance of the outbound tunnel during construction appears to have been quite satisfactory. As in the inbound steel lined tunnel, the favorable geotechnical responses can be attributed to both the stability of the soils through which the tunnel was mined and to the quality of workmanship provided by construction personnel.

It should be noted that many of the volume estimates are based on relatively small measured displacements, which in many cases are of the same magnitude as the error band. For this reason, values reported for the geo-

technical responses must be taken to be an indication that small ground movements occurred, but not as an absolute indication of the nature of those movements.

7.4 Remedial Action

Repair of the concrete segments started when the tunnel "holed through" and the bulkhead was completed. The first step in the remedial program was a field inspection of the outbound tunnel, conducted on July 2, 1979. The purpose of the inspection was to appraise the condition of the tunnel and to develop remedial procedures.

The procedures developed consisted of (1) removal and replacement of 9 severely damaged segments under compressed air, (2) treatment of all cracks and leaky joints after removal of the air pressure, and (3) coating of remaining spalls with epoxy to prevent further deterioration.

The repairs began by jack-hammering out the damaged segments. As sections of segment were removed, wood lagging was used to prevent run-ins as needed. A chase was raked out along the earth side of exposed segment edges and bentonite panels were set into the chase. Additional bentonite panels were placed to provide full coverage of the exposed area.

Prefabricated rebar cages were placed in the locations from which the segments had been removed. Bolts were inserted from adjacent segment bolt holes to structurally connect the segment to be cast to the existing tunnel. Where adjacent segments had been removed, the rebar cages were doweled together.

The segments were then cast in place using a standard 4 ksi concrete mix. Interior forming was used for casting along the sides of the tunnel. Figure 141 illustrates the locations of the removed segments.

In addition to the segments noted in Figure 141, a segment in ring #202 was removed and cast in place as described above. After these repairs were completed, the air pressure in the tunnel was gradually reduced to atmospheric over a period of approximately 24 hours.

As air pressure was reduced leaks began to appear along the tunnel. Most of the leaks consisted of seeps along the tunnel walls and dripping from the crown area.

All of the leaks were sealed using a low viscosity chemical gel. The procedure consisted of injecting the gel through injection ports (5/8 inch in diameter) drilled through the concrete segments in the leaking areas as shown in Figures 142 and 143. The ports generally were drilled near the segment edges. Once the injection ports were drilled, a hole packer, with a mixture nozzle

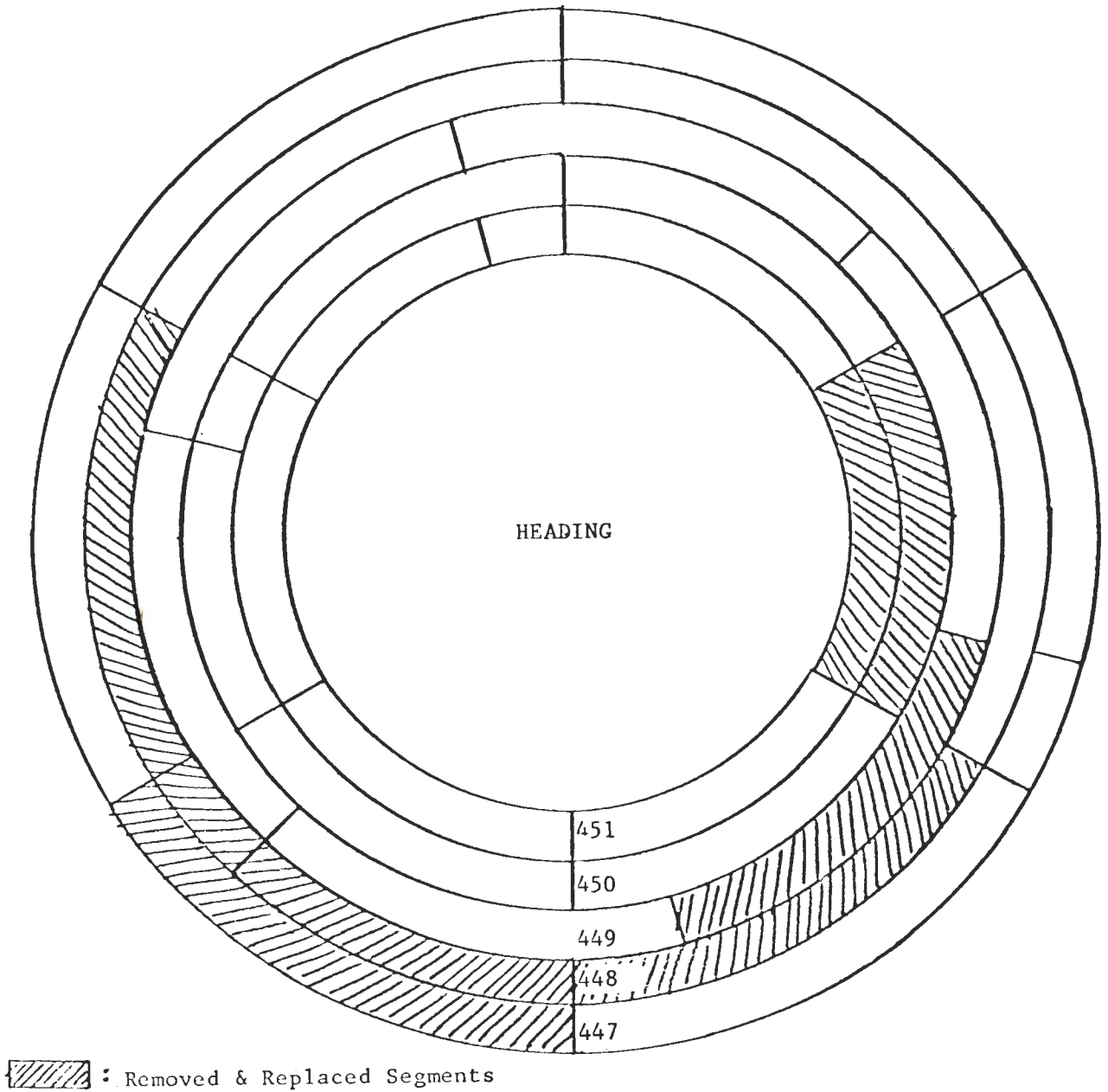

FIGURE 141. LOCATION OF REMOVED SEGMENTS

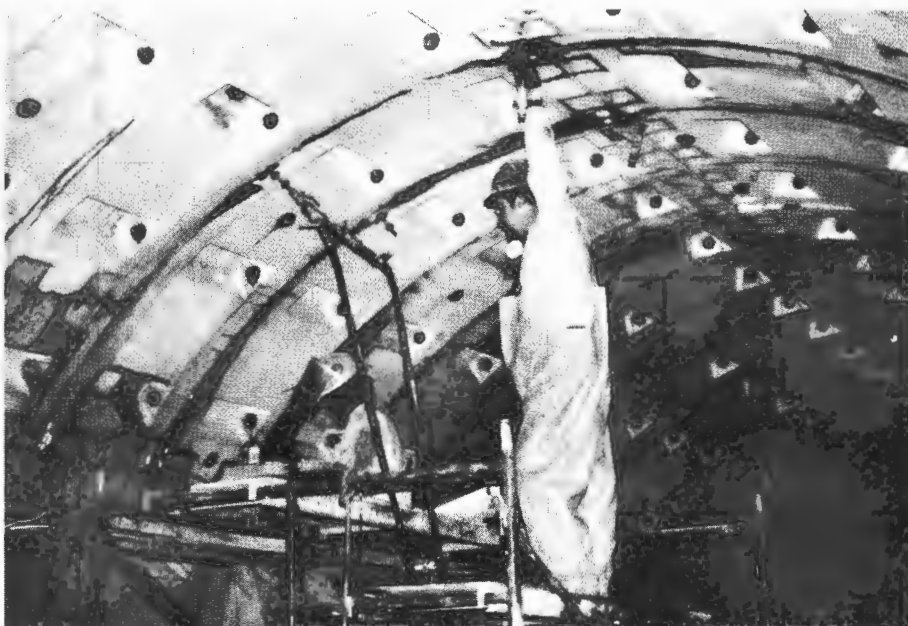

FIGURE 142. GROUTING OF LEAKS IN OUTBOUND TUNNEL

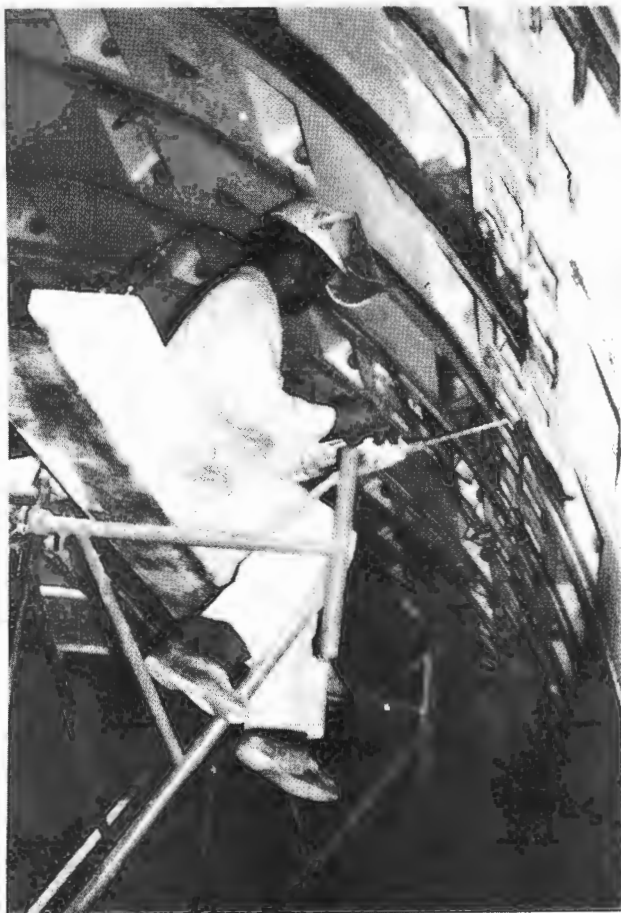

FIGURE 143. GROUTING OF LEAKS IN OUTBOUND TUNNEL

attached, was inserted into the port. A two part acrilimade gel was pumped in controlled amounts to the mixture nozzle through separate lines. Mixing occurred in the nozzle, after which the gel was injected.

The gel time was controlled by the amount of catalyst (ammonium persulfate) used. Gel times generally ranged between 20 and 30 seconds. The pumping pressure varied between 0 and 75 psi. The amount of grout was limited to a maximum of 10 gallons per port and was stopped at lower amounts when the grout flowed from an adjacent port. Since the grout was a clear liquid, an orange dye was used as a tracer. Generally, the three-man crew sealed an average of 5 rings per 8-hour day using an average gel quantity of 35 gallons per ring. Although there remained some moist areas along the tunnel the grouting procedure essentially reduced the inflow of water along the entire length of tunnel to zero.

After all leaks were sealed the remaining remedial action consisted of protecting the exposed reinforcing steel and the spalled concrete surfaces. It was concluded that the spalls did not present a problem structurally, but that the exposed steel and concrete should be protected to minimize further deterioration. The procedure used was to (1) chip out any loose concrete, (2) wire brush the exposed steel and spalled concrete, (3) apply a coating of zinc rich primer paint to the exposed steel, and (4) coat the painted rebar and the spalled concrete with two applications of moisture insensitive epoxy resin coating.

8.0 CONCLUSIONS OF PERFORMANCE EVALUATION

8.1 Comparative Evaluation of Precast vs. Steel Liner

The following statements summarize the conclusions of our comparative evaluation.

- Ground Support. Both precast and steel liners performed satisfactorily with respect to ground loss and surface settlement. In general, the performance of the Lexington Market tunnel liners equaled or exceeded that of other liners in soil whose performance is known.

- Fabrication. Both lining systems can be fabricated to the required dimensional tolerances within the present state of the art.

- Handling and Transportation. Concrete is more subject to damage and must therefore be handled and transported more carefully. Concrete segments are heavier than steel segments and may require heavier handling and transportation equipment.

- Preparation. The preparation of concrete segments at the construction site is more involved than that of steel segments. This may affect relative costs.

- Water Sealing. Both systems can be sealed adequately when used below the water table. Present limitations may be of the order of 100 feet, hydrostatic head, after which seals must be augmented by additional waterproofing. The long-term capabilities of the sealing systems are not known for periods exceeding 10 years, although accelerated laboratory tests indicate that lives of 50-100 years should be attainable.

- Installation. Precast liner segments are more susceptible to damage than steel and hence require more care during installation. This does not necessarily affect production rates adversely. See below.

- Production Rates. Production rates (feet/day) for precast liner appear to be comparable to those for steel, based on the Lexington Market experience. See Figures 144 and 145. Production is influenced by many factors, including learning curve position, muck removal, segment size, and methods of handling and assembly. When these are taken into account, precast liner is expected to compare very favorably with steel.

- Liner Stresses. Liner segments are subjected to a variety of known and unknown loading conditions which produce both compressive and tensile stresses. Precast concrete, being weaker in tension, is more vulnerable and must be designed with greater factors of safety than steel or, alternatively,

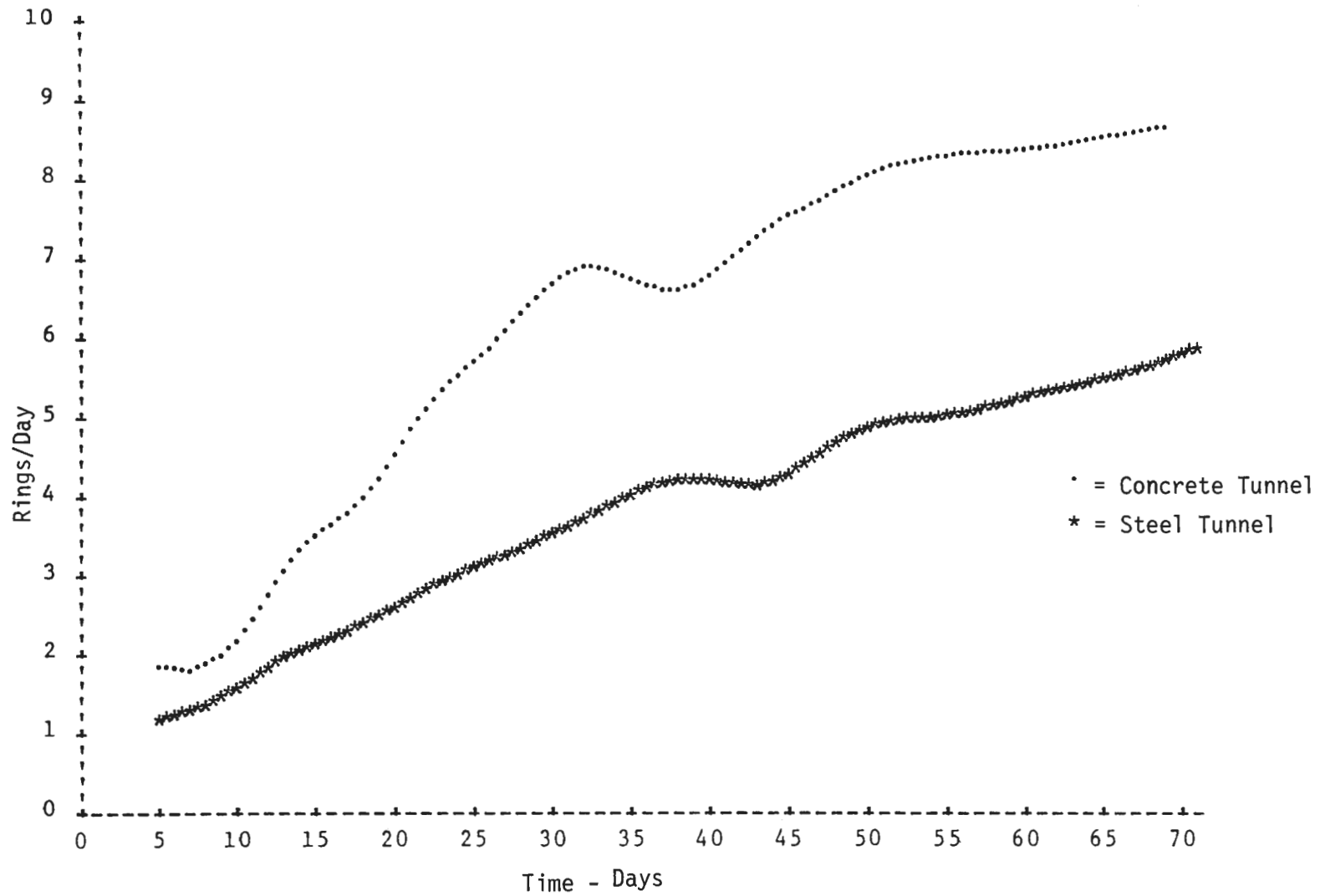

FIGURE 144. TUNNEL PRODUCTION -- RINGS/DAY MOVING AVERAGE OF 5 DAYS
PRECAST AND STEEL TUNNELS

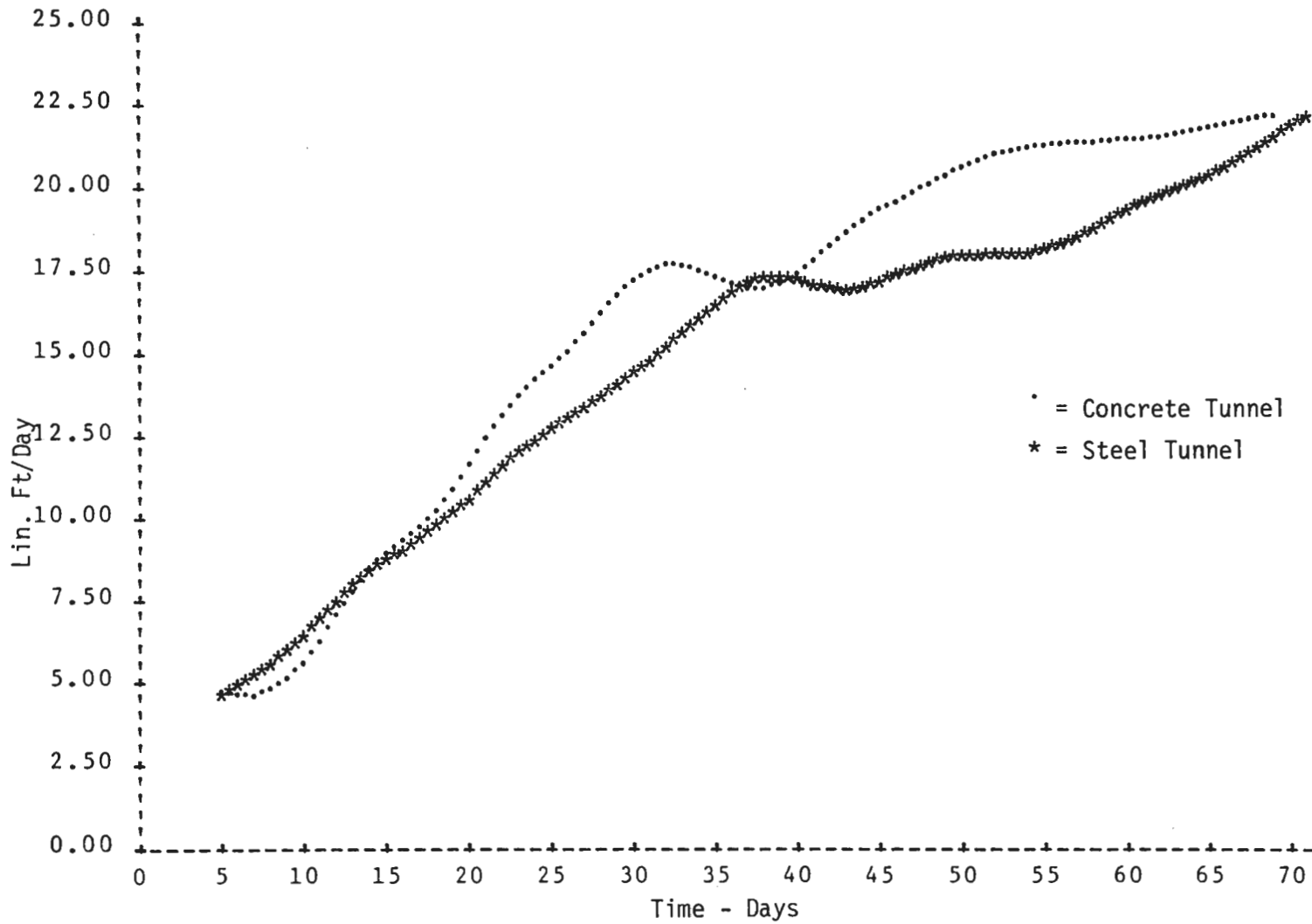

FIGURE 145. TUNNEL FOOTAGE PRODUCTION -- LIN.FT./DAY
MOVING AVERAGE OF 5 DAYS PRECAST AND STEEL TUNNELS

with protective configurations, if cracks and the problems associated with them are to be avoided (see following sections).

- Repairs. Precast lining is generally more difficult to repair than steel. Leakage repairs in the concrete system must be made by grouting whereas only tightening of liner bolts was required for the steel system. Fractures in precast lining may require complete segment replacement whereas the steel liner can be welded. In spite of these differences, repair of precast lining is not considered to be a serious problem.

The following comments, offered by the general contractor, are pertinent to performance evaluation:

"The two necessary ingredients for successful installation of precast segmented concrete liner are immediate grouting and erection of the liner in close to theoretical configuration. This effects equal distribution of thrust and soil loading, and helps to assure good radial and longitudinal jointing which is essential to water tightness. I am convinced that when these procedures are followed, and all joints are closed to at least 1/16", 95% of the leakage problems will be eliminated. The quality of construction required to do these things properly is possible, but requires confidence on the part of the contractor that he can do it and his total commitment to seeing that his field forces will make it work.

By using the jiggling ring, we re-established the theoretical circle and the plane of the radial joint with the installation of each new ring. This alignment was then held by immediate full circle grouting. There was never a need for outside forces (hog rods or wedging of annular space at springline) to maintain diameter control."

8.2 Findings for Improving Precast Performances

Our findings are grouped in three categories, each of which is presented under separate heading.

8.2.1 Design

- Protective Configuration. This involves designing each segment in such a manner that it (1) avoids loading of vulnerable areas such as the segment edges, and (2) forces the loads to be concentrated in locations best able to resist them, i.e., the centroid of the load carrying section.

- Increased Liner Thickness. An increase in liner thickness will reduce the proximity of the rebar to surfaces, thereby making the liner less subject to damage.

- Standardization. Standardization of design configurations within the USA (or even within each transit system) will help to assure uniformity and improve the general level of performance of precast concrete liner segments.

8.2.2 Fabrication

- Production Tooling. The rate at which segments can be cast and their final quality is strongly influenced by the tooling used. Good tooling will hold repeatable close tolerances and will allow production to have a quick turnaround. This helps to assure uniformly high quality of the finished segments. Careful planning and adequate expenditures for good production tooling will be repaid many times over at the job site.

- "Cast in Place" Gasket. The development of techniques by which the gasket can be cast into the concrete at fabrication should lead to better control of sealing system performance, reduced labor at the construction site and reduced overall costs.

8.2.3 Installation

- Special Handling Equipment. The vulnerability of the precast segment to handling damage engendered by the properties of the concrete and the extra weight of the lining should be fully taken into account in equipment design. Special fixtures and equipment should be developed for use both in the yard and in the tunnel to protect segments against accidental impact damage.

- Optimized Assembly Procedures. Thought should be given to developing assembly procedures at the heading which will minimize the number of extra movements made in transferring the segment from the transport car to the finished liner and fastening it in place.

- Fasteners. The number and type of fasteners required to hold liner segments in place, both at assembly and in the lining after it is in place should be evaluated. Precast fastening methods are time consuming, have expensive components, and sometimes induce damage in individual segments.

8.3 Limitations With Respect to Local Environment

- Water. At the present state of the art, the precast sealing system appears to be capable of dealing with hydrostatic pressures up to about 100 feet of water. This is not a serious limitation for most transit tunnel applications, nor is it considered to be a technological barrier. If the need arises, the range can be augmented by secondary sealing, or by soil treatment, or extended by suitable research and development of new primary sealing systems.

- Ground Conditions. The precast liner system should be useable in the majority of ground conditions encountered in rapid transit tunnels. The determining factor in most cases will be cost rather than technical performance. An exception may be in squeezing ground or in formations capable of developing highly localized loads which will produce large moments in the circumferential direction.

PART III. TECHNICAL STUDY -- COST

9.0 CONSTRUCTION COST ANALYSIS

Our discussions of cost in this report will deal with those costs of construction relating solely to the construction contractor's portion of the work. Costs for construction management, section design, rights-of-way or other administrative costs to the owner, though legitimate costs of construction, are not within the realm or scope of this study.

In analyzing the contractor's construction costs, it is necessary to understand the components from which they develop. A convenient system for understanding and analyzing these costs, particularly where comparisons are to be made, is the general system which has evolved within the construction industry for the preparation of bid estimates. This system is based on breaking the total project down into categories and sub-categories of like effort until a level of detail is reached which provides a clear understanding of its origin and make-up. For our purposes, this process would begin with the defining of the three general cost categories which make up the contractor's bid, which are:

Direct Costs
Indirect Costs
Margin

Direct Costs. These are costs which can specifically or "directly" be attributed to the building of a portion of the project. Consequently, these direct costs may be broken down into tasks or work items of similar nature, usually representative of the bid items such as the sinking of a shaft or underpinning of a building. Subsequent levels of subtasks can usually be defined until ultimately the basic elements of effort represented by each manhour, equipment hour, unit of material used, and the unit cost thereof have been identified.

Indirect Costs. These are overhead, administrative and general expense costs which cannot be directly attributed to a specific construction task, but rather are distributed among several tasks, or even the overall project. An example of this might be the costs of owning and operating a compressor which would serve several construction operations simultaneously. Other examples would include the office staff, engineering, management and safety personnel,

bond and insurance premiums, and legal fees. These items also, can be broken down into elemental units of quantity and cost for comparison, if necessary.

Margin. Margin is the amount by which the estimated cost to the contractor is increased in order to arrive at the bid price. It is made up of two components which are profit and contingency funds. Profit, of course, is the amount that the contractor wishes to realize after all costs are paid. Contingency funds are those amounts which the contractor feels he must include to cover inherent unknowns in order to insure his anticipated profit. Generally, the amount of margin is influenced by a complex set of conditions which may conform to statistical guidelines in the long-term, but are impossible to predict on a job-by-job basis.

This study will deal with only the contractor's costs, (direct and indirect), and will not attempt to address issues of margin, profitability and risk.

9.1 Direct Costs

As mentioned earlier, the direct costs include only that labor, material and equipment effort incorporated into or expended on the actual construction portion of the work. An independent estimate by the S.O.G. places the amount of these direct costs as-bid at about \$11,835,000±. Knowing that the bid price was 17,514,970, and assuming a balanced bid, we can make some preliminary judgments about the anticipated direct costs of the bid items with which we are concerned.

A balanced bid means that the "mark-up" (indirect cost plus margin) is distributed to the bid items in proportion to their respective direct costs. The exception to this is the case where bid items are provided for indirect costs such as mobilization. In this case, the mobilization bid price was fixed by contract at \$2,000,000, therefore the estimated amount of mark-up to be distributed to direct cost bid items was \$17,514,970 (-) \$11,835,000 (-) \$2,000,000 or \$3,680,000±. The "spread factor" or amount by which each bid item direct cost was multiplied in order to determine the bid price of the item would be:

$$\frac{\$11,835,000 + \$3,680,000}{\$11,835,000} = \underline{\underline{1.31094}}$$

Conversely, dividing the known bid price of each item by this factor should give us the approximate item direct cost, assuming again a balanced bid. Table 4 presents the theoretical direct costs as developed from the bid prices

TABLE 4. THEORETICAL AS-BID DIRECT COSTS

Bid Item Number	Description	Bid Quantity	Bid Prices		As-Bid Direct Cost	
			Unit	Total	Unit	Total
236	Earth tunnel with precast segmented concrete liners	1530 lf. ⁽¹⁾	\$3024/lf	4,626,729	\$2307/lf	3,529,315
237	Earth tunnel with segmented steel liners	1590 lf. ⁽¹⁾	\$3024/lf	4,808,160	\$2307/lf	3,667,719
239	Lead caulking - tunnel liner joints	9900 lf.	\$3.00/lf	29,700	\$2.29/lf	22,655
TOTALS:				9,464,580	7,219,689	

(1) As amended prior to construction.

for the comparative steel/precast liner items with which we will be concerned. These are the three bid items directly influenced by the relative quantities of steel or precast liner and, of the 59 bid items, they appear to represent about 61% of the anticipated project direct costs as-bid.

Next we might look at the actual direct costs as documented by jobsite records and observations. Table 5 summarizes these costs for work items roughly analogous to the bid items above. In addition, the computed costs for the mobilization effort to install and dismantle the respective shields, trailing gear, airlocks and bulkheads have been included so that one can get an overview of all costs directly related to these items.

Certain assumptions were made in assembling these costs which should be stated for the reader's benefit. Foremost is the manner in which the direct costs for the crew and equipment which supported the underground operations (i.e., shaft crane, surface support crew, etc.) were distributed to the work items. Since there were times when several different underground operations were underway simultaneously, all serviced by the same support crew, it was not practical to attempt to prorate this cost among all of the activities. Since the tunnel driving operation was by far the dominant activity the majority of the time, it was arbitrarily decided that the cost of support crew and equipment, where not specifically stated otherwise, would be distributed to the appropriate tunnel driving operation in progress at the time. This may tend to inflate the computed cost of these items slightly while reducing the cost of such lesser items as secondary watersealing of joints, invert concrete operations, removal of track and invert clean-up.

It would be appropriate to examine the sources of the more significant costs presented in Table 5 in greater detail. By far, the largest of these are the costs associated with the actual driving of the tunnels. Let us look at the precast lined tunnel first.

Precast Lined Tunnel. The total direct cost for driving and lining the precast tunnel was calculated to be about \$3,309,000. This breaks down percentage-wise as follows:

Labor	-	17%
Equipment Costs	-	13%
Expendable Supplies	-	2%
Permanent Material	-	64%
Subcontracts	-	4%

TABLE 5. ACTUAL DIRECT COSTS OF TUNNELING OPERATIONS

Description	Direct Labor Ins & Tax	Equipment		Supplies	Permanent Material	Subs	Total Direct Cost	
		Operating Costs	Rental				Unit	Total
Earth Tunnel w/Precast Liner (1530 lf) Mobilize Tunnel	\$198,000	\$ 51,000	\$ 71,000	\$ 17,000	---	\$ 23,000	(\$235)	\$360,000
Drive & Line Tunnel	559,000	170,000	252,000	60,000	2,128,000	140,000	(2163)	3,309,000
Secondary Water Sealing	2,000					40,000	(27)	42,000
Total Direct Costs 1530 lf.	\$759,000	\$221,000	\$323,000	\$ 77,000	\$ 2,128,000	\$203,000	\$(2425)	\$3,711,000
Earth Tunnel w/Steel Liner (1590 lf) Mobilize Tunnel	\$242,000	\$ 65,000	\$ 93,000	\$ 17,000	---	\$ 20,000	(\$275)	\$437,000
Drive & Line Tunnel	461,000	144,000	218,000	42,000	2,485,000	140,000	(2194)	3,490,000
Secondary Watersealing	3,000	---	---	1,000	---	---	(3)	4,000
Total Direct Costs 1590 l.f.	\$706,000	\$209,000	\$311,000	\$ 60,000	\$2,485,000	\$160,000	\$(2472)	\$3,931,000

Permanent materials are by far the predominant cost component. This item consists almost exclusively of the liner segments and related material. An evaluation of the probable costs of these items is summarized as follows:

Segment Cost, FOB Jobsite

Concrete	(Material Only)	\$ 70,000
Reinforcing Steel	(Material Only)	145,000
Inbedded Items	(Material Only)	180,000
Cost of Forms	(Molds)	400,000
Labor & Equipment for Rebar Cages		255,000
Labor & Equipment to Pour, Cure & Finish		290,000
Freight from Plant to Jobsite		90,000
Mark-Up (O/H & Profit) @ 25%		357,000
Total Cost for Segments:		\$1,787,000
<u>Joint Materials</u>		\$ 255,000
Total Permanent Materials for Liner:		\$2,042,000

The next largest cost components are the labor and equipment costs for driving and lining the tunnel. These costs are determined by the make-up (number, classification, size, type) of the crew and equipment spread used in doing the work, the unit cost of each and the duration, or time required to complete the operation.

The duration of the tunneling operation was 70 working days, consisting of two, 10-hour shifts per day. Typical crew and equipment spreads for this operation are shown in Tables 6 and 7.

The remaining cost components from Table 5 are expendable supplies (2% of direct cost and subcontracts, 4% of direct cost). Expendable supplies are self-descriptive and consist of materials not included in the finished work such as railroad ties, ventilation line, spikes, lights, and so forth. The primary subcontract items were the off-site muck hauling, the electrical installations and the grout-sealing of leakage in the lining.

Special mention should be made of several of the tasks whose costs are included in this tunnel driving item.

Segment Preparation. A crew consisting of a foreman, 3 to 4 laborers and an operator, along with a forklift tractor were used on day shift for about

TABLE 6. TYPICAL HEADING CREW -- PRECAST LINED TUNNEL

<u>Description</u>	<u>Shift</u>		<u>Graveyard</u>
	<u>Day</u>	<u>Swing</u>	
Labor: Shifter	1	1	--
Motorman	2	2	--
Shield & Excavator Oper.	2	2	--
Conveyor Operator	1	1	--
Grout Pump Operator	1	1	--
Miner/Laborers	4	4	--
Lock Tenders	1	1	--
Heading Engineer	1	1	--
Heading Mechanic	1	1	--
	—	—	—
Total:	14	14	

Equipment:

Shield, Excavator and Assembly	1	1
10 Ton Locomotives	2	2
Grout Car	1	1
Muck Cars - 6 cy	6	6
Flat Cars	2	2

TABLE 7. TYPICAL SHAFT AND SURFACE SUPPORT CREW FOR
DRIVING PRECAST LINED TUNNEL

<u>Description</u>	<u>Shift</u>		<u>Graveyard</u>
	Day	Swing	
Labor: Crane Operator	1	1	--
Oiler	1	1	--
Grout Plant Operator	1	1	--
Top Laborer	2	1	--
Bottom Laborer	2	2	--
Loader Operator	1	--	--
Compressor Operator	1	1	1
Utility Operator	1	--	--
Teamster	1	1	--
Pump Man	--	--	1
Mechanic/Welder	2	1	--
Master Mechanic	1	--	--
	—	—	—
Total:	14	9	2
Equipment:			
100 Ton Shaft Crane	1	1	--
Grout Plant	1	1	--
2-1/2 cy Wheel Loader	1	--	--
Compressor Bank - High or Low Air	1	1	1
Fork Lift	1	--	--
20 Ton Hydraulic Crane	1	--	--
Lo-Boy Truck	1	--	--
Misc. Pumps, Welders, etc.	1	1	1

4-1/2 months to install the joint materials on the segments. The costs for labor, equipment and expendable supplies were determined to be about \$47,000.

Repair of Segment Damage. This was done while other tunnel operations were in progress, so costs for related shaft and surface support were not available, however the direct costs for the repair crews' operations were estimated to be about \$18,000.

Sealing of Leaks. Technical Grout Services of Hyattsville, MD was the subcontractor employed to grout off the water leaks in the liner. Costs for this operation were determined to be about \$42,000.

Steel Lined Tunnel. The total direct cost for driving and lining the steel lined tunnel was calculated to be about \$3,490,000 as shown in Table 5. This breaks down percentagewise as follows:

Labor	13%
Equipment Costs	10%
Expendable Supplies	2%
Permanent Materials	71%
Subcontracts	4%

Again, the predominant cost component is the permanent materials items which is primarily the cost of the liner and accessories. Of the \$2,485,000 permanent materials cost, about \$2,400,000 is estimated to apply to the liner materials.

The duration for the driving of the tunnel was 69 work days. This is adjusted to 65 work days for comparison purposes, when allowing for delays associated with the unforeseen rock excavation conditions. The composition of the crew and equipment spreads were virtually identical to those for the precast lined tunnel.

9.2 Indirect Costs

These are the administrative and general expense costs associated with the overall project operations rather than specific features of the job. Since they incorporate such elements as the salaries of permanent staff, support of home office overhead and other fixed daily costs, they are often more influenced by the duration rather than the magnitude of the project. This can be an important consideration in any evaluation of the relative cost merits of comparative construction techniques, since there are circumstances where savings in project indirect cost due to a faster construction method can offset its higher direct cost.

The contractor's total indirect costs were projected at \$2,880,000. These costs are less easily documented than the direct costs and are therefore based to a certain extent on estimates and general industry standards, where specific documentation was not available. They should, then, be considered representative, based on jobsite evidence, rather than fully definitive and site specific.

The breakdown of indirect costs by category is as follows:

Salaries:

Management & Supervisory	\$620,000	
Engineering	275,000	
Office & Accounting	214,000	
Safety & First Aid	103,000	1,212,000
	<u> </u>	
General Site and Office Expense		1,299,000
General Vehicle Operation		40,000
General Plant		239,000
Bond Premiums		90,000
		<u> </u>
Total Indirect Costs:		\$2,880,000

The actual duration of 30 months, rather than the original contract period of 24 months was used to evaluate the indirect costs. Averaged over this period of time, the indirect costs amounted to about \$96,000/month.

Because of the many and complex relationships beyond the scope of this study which influence the indirect cost of this type of project, we will limit our comparative analyses in the following sections to the more definable direct costs.

10.0 COMPARATIVE COST ANALYSIS: THE STEEL AND PRECAST CONCRETE LINED TUNNELS

This project has presented a unique opportunity to document actual construction costs for these two systems under very similar conditions of geology, geometric size and length, function and time frame. Such a rare situation for a field demonstration simplifies the comparative evaluation tremendously by balancing out many of the variables, thereby reducing the number of relative conditions that must be examined. Still, the cost influencing factors for the two tunnels were by no means equivalent, and a one-to-one relationship between corresponding cost components cannot be assumed. One must allow for the dissimilarities as well, in order to achieve the proper perspective on the relative costs demonstrated on this project.

Such a comparison would begin with a tabulation of direct costs for corresponding tasks, as in Table 8, prorated on a unit price per tunnel foot, in order to compensate for the difference in length of the respective tunnels.

Other dissimilarities which one must consider and possibly compensate for in making valid comparisons are:

1. Escalation costs relating to the different periods in time that the respective operations were in progress.
2. One-time-only costs associated with attempting a new untried technique for which there was no experience precedent.
3. The benefits accrued to the second tunnel by virtue of experience gained in driving the first tunnel.

The escalation differences in this case are nominal and can be ignored. Most of the work was accomplished within the annual labor contract period. Permanent material and subcontract prices would normally be established as fixed prices early in the project. Equipment operating invoice costs (fuel, oil, repair parts) and expendable supplies could escalate over the construction period, but since they are a very small portion of the costs to begin with (less than 5%) any reasonable escalation would be insignificant.

One-time-only costs associated with the "experimental" aspects of the project might be more appropriate to a discussion of the owner's costs, where bid prices might reflect an inflated allowance for risk of the unknown. We are dealing with actual cost experience which should represent the true nature of the work. It is possible that there might be some once-only costs in the purchase price of the precast segments and related material, since this was bid as a fixed price to the contractor. Any attempt to quantify such amounts, however, would be purely speculative.

TABLE 8. DIRECT COSTS PER TUNNEL FOOT
INBOUND (STEEL) AND OUTBOUND (PRECAST) TUNNELS

<u>Item</u>	<u>Inbound (Steel)</u>	<u>Outbound (Precast)</u>	<u>Cost Precast VS. Steel</u>
<u>1. Mobilize Tunnel Operation</u>			
Labor	\$152/1f	\$130/1f	(-) \$22/1f
Equipment	99/1f	79/1f	(-) 20/1f
Expendable Supplies	11/1f	11/1f	-0-
Permanent Materials	-0-	-0-	-0-
Subcontracts	13/1f	15/1f	(+) 2/1f
Total:	\$275/1f	\$235/1f	(-) \$40/1f
<u>2. Driving & Lining Tunnel</u>			
Prepare Segments @ Jobsite	-0-	\$ 31/1f	(+) \$ 31/1f
Production Labor	290/1f	333/1f	(+) 43/1f
Production Equipment	228/1f	269/1f	(+) 41/1f
Expendable Supplies	26/1f	37/1f	(+) 11/1f
Permanent Materials - Liner Cost	1509/1f	1334/1f	(-) 175/1f
- Other	54/1f	56/1f	(+) 2/1f
Subcontract - Electric & Hauling	88/1f	91/1f	(+) 3/1f
Repair Damaged Segments	-0-	12/1f	(+) 12/1f
Secondary Watersealing	3/1f	27/1f	(+) 24/1f
Total:	\$2198/1f	\$2190/1f	(-) \$ 8/1f
<u>3. Total Tunneling Direct Costs</u>	\$2473/1f	\$2425/1f	(-) \$48/1f

Finally, we might examine the cost benefits which accrued to the outbound or precast lined tunnel as a result of experience gained by the crew in driving the inbound tunnel. To begin with, we would have difficulty in explaining the difference in mobilization costs in any other way. The equipment was virtually identical, yet the set-up costs for the outbound tunnel appear to be about 15% lower.

Secondly, if we refer to the curves of Figures 64 and 94 (Sections 6 and 7) we can see that the shake down period for crew and equipment for the steel tunnel was considerably longer than that for the precast tunnel. Consequently, the production efficiencies for the steel tunnel lagged its counterpart proportionately throughout their respective operations for its duration. A compensatory shift in the curve to equalize the operations would benefit the steel tunnel by about four days, affecting the labor and equipment costs for this item proportionately.

Table 9 incorporates these adjustments into a tabulation of comparative costs which are more representative of the actual relationship of the two techniques on this project.

We can conclude that for the given conditions of this project, the overall costs of tunneling with steel lining and tunneling with precast segmented concrete lining were about the same, at least within the accuracy of our data. However, it appears that the cost of purchasing the precast liner was substantially less than the steel, while the cost of using it was equal or greater.

It is of interest to examine how these relationships might compare as the cost parameters are varied from those of this project.

TABLE 9. ADJUSTED DIRECT COSTS PER TUNNEL FOOT
INBOUND (STEEL) AND OUTBOUND (PRECAST) TUNNELS

<u>Item</u>	<u>Inbound (Steel)</u>	<u>Outbound (Precast)</u>	<u>Cost Precast VS. Steel</u>
1. <u>Mobilize Tunnel Operation</u>	\$255/1f	\$255/1f	-0-
2. <u>Drive and Line Tunnel</u>			
Prepare Segments @ Jobsite	-0-	31/1f	(+)\$ 31/1f
Production Labor	272/1f	333/1f	(+) 61/1f
Production Equipment	214/1f	269/1f	(+) 55/1f
Expendable Supplies	26/1f	37/1f	(+) 11/1f
Permanent Materials - Liner	1509/1f	1334/1f	(-) 175/1f
- Other	54/1f	56/1f	(+) 2/1f
Subcontr. - Electrical & Hauling	88/1f	91/1f	(+) 3/1f
Repair Damaged Segments	-0-	12/1f	(+) 12/1f
Secondary Watersealing	3/1f	27/1f	(+) 24/1f
	-----	-----	-----
Total Drive & Line:	\$2166/1f	\$2190/1f	(+)\$ 24/1f
3. <u>Total Tunneling Direct Cost</u>	\$2421/1f	\$2445/1f	(+)\$ 24/1f

11.0 COST PROJECTIONS - STEEL VS. PRECAST CONCRETE LINED TUNNELS UNDER OTHER CONDITIONS

At this point, we have defined the construction costs of steel and precast concrete lined tunnel for only one of an infinite number of conditions. Surely, this is not a representative sampling from which we can extrapolate valid and specific costs for all conditions. We hope to have gained some insights, however, into the factors to which each system is particularly cost sensitive. Perhaps with a few well chosen examples we can examine how the relative costs compare as those factors change, and from this, make some observations as to the type of situation best suited to each.

The most obvious influencing parameter and the first that we will consider is the length of tunnel. We have observed from the production curves in Sections 6 and 7 that production rates in both tunnels were still improving when the tunnel driving was completed. A longer tunnel length then, should improve the production related costs of both the steel and precast tunnels. Furthermore, we have determined that nearly 25% (\$400,000) of the cost of the precast segments for this project consisted of manufacturing the molds for forming the segments. It has been suggested that these molds have a practical life which greatly exceeds the demands of this project. Given a greater tunnel length, the cost per foot for this one-time-only expense would be reduced.

Example #1

Let us assume a tunnel length of 10,000 l.f. while maintaining all other factors constant. Extrapolating from the production curves of Figures 64 and 94, it appears that the average production for the steel lined tunnel should level off at about 32 lf/day, while the precast tunneling operation might peak at about 28 lf/day. Durations and costs for the two operations would be as follows:

<u>Steel Lined Tunnel</u>	<u>1590 feet</u>	<u>10,000 feet</u>
Durations	61 days	313 days
Production Rate	26.1 lf/day	32 lf/day
Production Costs (Labor & Equip)	\$486 /lf	\$396 /lf
Net Savings Over 10,000 l.f.	\$90/lf	
<u>Precast Concrete Lined Tunnel</u>	<u>1590 feet</u>	<u>10,000 feet</u>
Durations	70 days	357 days
Production Rate	21.8 lf/day	28 lf/day
Production Costs (Labor & Equip)	\$602 /lf	\$469 /lf
Net Savings Over 10,000 l.f.	\$133/lf	

Additional savings to the precast concrete liner tunnel resulting from extended write-off of form costs would be: $(\$400,000/1530) - (\$400,000/10,000) = \$221/1f$. or about 19% of the segment costs.

Discussions with the joint material supplier indicate that a similar proportionate savings in these materials would be appropriate as well. This would amount to about $(\$255,000/1530) \times 19\% = \$32/1f$. It is not apparent that this type of savings would be available in the case of the steel liner.

The net savings for each tunnel for this example would be:

Steel Liner	\$90/1f
or	\$900,000 in 10,000 1f
Precast Liner	\$386/1f
or	\$3,860,000 in 10,000 1f

It seems clear that the precast liner would have a decided edge from the cost standpoint as tunnel lengths are increased beyond 1500 1f.

Example #2

Now let us assume that, with the tunnel length established at 10,000 1f., we increase the precast segment width to 48 inches, similar to the steel segments. This measure should nearly equalize production rates in the two tunnels. We will allow \$100,000 to build up the erecting gear for heavier segments.

The adjusted production costs would now be $\$469/1f \times \frac{28}{32} = \$410/1f$. Costs per tunnel foot for the heavier erecting equipment, using zero salvage would be \$10/1f. Net savings to the precast tunnel costs would be $\$469/1f (-) \$420/1f = \$49/1f$ or \$490,000 in 10,000 1f.

It appears then, that the precast segments would also demonstrate a more favorable cost position relative to the steel liner if compared on a similar ring-width basis.

Example #3

As a final example, let us assume the same conditions as examples 1 and 2, but with different geologic conditions. From the test section data, we have determined that the earth loads on the segments are small in relation to the jacking forces of the shield. Variation in geologic conditions then, should have little effect on the manufacturing costs of the precast or steel segments, except for extreme cases or where much higher jacking pressures are required. Any cost benefits for more favorable geology or penalties for less favorable geology would accrue more or less equally to both steel and precast concrete lined tunnels.

Similarly, hydrologic conditions would only affect the comparative cost relationships of the two systems in extreme cases if at all, since the watersealing abilities of each were comparable.

Other cost projections which might be of interest, though not within the realm of practicality in this study would be the influence of time on the comparative costs. This would involve such considerations as projected escalation of the manufacturing costs of steel versus precast concrete lining. Another time-related factor might be the relative maintenance costs of the two systems over their projected useful lives. Such attempts would be purely speculative and inconclusive based on the data available from this study.

12.0 CONCLUSIONS OF COST EVALUATIONS

12.1 Comparative Findings

In earlier sections, we have evaluated the relative cost merits of steel versus precast segmented concrete tunnel liner for this demonstration project and for other soft ground tunneling conditions. Our conclusions are as follows:

1. For this project, the costs of manufactured materials for the precast concrete liner were somewhat lower than those for the steel liner, while the cost of installation was higher.
2. In each case, the costs of liner materials amounted to more than 60% of the total direct tunneling costs, making this a likely area for significant cost savings.
3. There is a high mobilization cost associated with the precast liner manufacturing operation which creates a high cost sensitivity to the factor of tunnel length. This is not as pronounced in the case of fabricated steel segments in which tooling is used for other products as well. Consequently, while the relative costs were nearly equal for this project, the cost advantages of precast liner increase rapidly as tunnel lengths exceed 1500 lf., and decrease for shorter lengths. For 10,000 lf. of tunnel, the precast liner system used on this project would enjoy an approximate \$3,000,000 cost advantage over its steel counterpart.
4. The use of precast concrete tunnel liner in water bearing ground is a new technique to the U.S. tunneling industry. As members of the industry apply their skills to its design, manufacture and installation, improvements can be expected in all of these areas. These improvements can be expected to reduce costs in future applications.

12.2 Findings for Improving Precast Concrete Liner Costs

In the previous section, it was suggested that continued use of precast concrete tunnel liners will promote increased cost benefits as the state of the art improves. These can be realized in the form of increased efficiencies in the processes of manufacturing and installing the segments, or through refinements in design which simplify these processes. We will discuss each of these areas in the light of observations made on this project.

12.2.1 Design

Design decisions have a pronounced effect on subsequent precast concrete tunnel liner costs. In this respect, all stages of design are important, from preliminary planning to preparation of final drawings. Early planning decisions, which establish the length of each contract, can have significant cost conse-

quences. Later decisions, made as the details are developed, impact ease of manufacture, handling and assembly, as well as the need for subsequent repairs.

Standardization of design is another important cost consideration. By utilizing the same design throughout a system, one provides an opportunity for the precaster to expect a higher salvage value for his segment molds, a savings which competition will force him to pass on to the contractor, and secondarily, the owner. From the installation standpoint, the expense of modifying tunneling equipment (or building new) from project to project to accommodate varying designs will also be reduced or eliminated by standardization.

Design modifications which might improve the performance of the segments in the ways suggested in Section 8 would also improve the cost aspects by reducing the amount of segment repair and secondary waterproofing costs.

From what we now know, there appears to be merit in carefully evaluating the cost trade-offs of increasing segment thickness in order to reduce the amount and complexity of the reinforcing steel in the segments. The steel bolt pockets might also be eliminated, with added reductions in fabrication costs.

The views of the segment manufacturer and the contractor are very worthy of consideration at this point. Both were careful to state that the design was sound, functional and appropriate for this project, but that there were lessons to be learned which could reduce future precast tunnel costs. The manufacturer felt that for 10,000 lf. of tunnel (as in our example 1, Section 10.0) and given the opportunity to incorporate some minor changes of which he is now aware, he could manufacture the segments for about two-thirds of his current cost.

The contractor also suggested some ideas for a more economical design. Among these were casting dowel holes into the segments to reduce spalling, and construction-proofing the gaskets by using double gaskets (for back-up) and casting them into the segment.

12.2.2 Fabrication

Fabrication costs will undoubtedly be reduced as experience and technology advance. Probably the greatest opportunity for savings will be in developing early strength more rapidly so that the segments can be stripped

and the molds re-used on a faster cycle. Currently, the great expense of the segment molds makes their more efficient utilization, in any way possible, a primary goal.

12.2.3 Installation

Installation costs are, to a great extent, dependent on the design. Greater tunnel lengths, for example, would permit justification of investment in more specialized equipment built specifically for use with precast segments. This could improve overall costs both by increasing production rates and by reducing the damage repair and secondary sealing requirements.

Greater skills in installation will probably be achieved through the slower process of experience, i.e., trial and error. U.S. tunnel contractors have historically improved their performance in new areas through innovation in construction methods. This process may be expected to occur as precast segmented liner is more widely used.

PART IV. SUMMARY OF STUDY FINDINGS

13.0 SUMMARY OF PERFORMANCE AND COST EVALUATIONS

The primary conclusion of this report is that the precast concrete tunnel liner used on the Lexington Market Tunnel Project was satisfactory from both performance and economic standpoints. Further, it has been determined that precast concrete liner provides a viable economic alternative to steel liners for the general case of transit tunnels in waterbearing soils, without compromising functional performance. Finally, an expanded set of interrelationships between precast liner design, manufacture and installation were documented which should:

1. Benefit performance and cost of future generations of precast tunnel liners, and
2. Highlight areas in which to concentrate future study and development efforts.

13.1 Design Aspects

It is clear that the precast liner design can be the single most influential factor in liner performance and cost. The Lexington Market design performed particularly well, especially for a prototype system. Some refinements which are suggested by the findings of this report are:

1. Design each segment to have a protective configuration in which critical components such as gasket grooves are located where they cannot be easily damaged by the impacts occurring during normal handling.
2. Reduce the complexity of the segment reinforcing steel. Possible ways to do this are to increase the segment thickness, thereby reducing the rebar requirement and/or using a welded wire fabric rather than reinforcing bars.
3. Design joint configuration so that segment-to-segment contact is only possible over the middle or inner portion of joint cross sections, thereby eliminating high stresses at the joint extremities, where shear resistance is minimal.
4. The clear distance of any rebar which passes over or under a segment bolt, from the joint surface should be at least equal to the distance between that bolt and the rebar.

5. Standardization is a key word for a method such as precast concrete lining with relatively high tooling costs. Any changes which will reduce the amount of tooling or provide opportunities for prolonged utilization of existing tooling should be highly cost effective. This can mean designating (or permitting) a standard design for an entire system rather than project by project. It can also include such lesser considerations as utilizing a single, universal tapered section, as in Baltimore, rather than requiring a separate ring configuration for each directional change.

13.2 Fabrication Aspects

The precasting of concrete is a well developed technology in this country with an adequate number of suppliers in most urban areas where rapid transit tunnels are going to be constructed. The unique features of this use of precasting however, are the close fabrication tolerance requirements and the large volume requirements. The list of suppliers with both the technical capability and the capacity to meet the production requirements is more limited. This is a consideration for both owner and contractor in planning or bidding a project.

For the supplier, the high tooling costs generally place the emphasis on form turn around. The added expense of shift premium and overtime pay is generally a bargain if it permits more castings per day from each form. This reduces the number of forms which must be purchased in order to meet production demands.

Similarly accelerated curing by permissible methods effects the same benefits.

13.3 Installation Aspects

Liner installation and tunnel excavation operations are so interdependent that when we speak of either, we invariably must include the other. The findings of this study are, that for the given conditions of design and construction, the precast concrete segments were less expensive to manufacture but more costly to install than steel. The savings benefits for precast vs. steel were found to accrue more rapidly with increased tunnel length than the installation cost penalties, thereby projecting net savings for precast over steel for longer tunnels.

An objective then, is to close the gap in installation costs, thus increasing net savings. This can be accomplished in part by some of the design modifications mentioned previously. The rest must come from development of equip-

ment and techniques specifically suited to handling, installing and tunneling with precast segmented liner. These must accomplish two objectives:

1. Permit tunneling, particularly ring installation, to be accomplished as rapidly with precast concrete segments as with steel segments; and
2. Eliminate the high cost of remedial repair of concrete segment damage and water leaks resulting from installation methods. This will be accomplished by improved equipment and by the experience factor as the technique comes into more general use. However, one must stress the care that must be exercised in such areas as segment handling or shield alignment control to avoid the "ironbound" condition which can be disastrous for the precast concrete liner.

Of particular importance, from a performance standpoint, the construction specifications should require the following:

1. Good and complete grouting behind the rings as they are erected; and
2. Good erection procedures which will assure erection of the liner rings as nearly to theoretical configuration as possible.

PART V. RECOMMENDATIONS FOR FUTURE STUDY

14.0 THE 5-YEAR STUDY

This study period only covered the construction program and related aspects of the demonstration project. It would be desirable to provide for systematic reporting and analysis of the long-term performance of the Lexington-Market tunnel.

Such a program would begin with the establishment of a special cost reporting system in which operation and/or maintenance costs for this section of the subway system would be isolated from the remainder of the system. Further segregation of the costs according to inbound (steel) or outbound (precast) should be maintained. Finally, the costs for each tunnel should be distributed according to task; i.e., realign track, seal water leaks, etc. Similarly, written records should be kept describing any maintenance, repair, renovation or other work performed on the tunnels during the five year study period.

A team of (at least two) qualified individuals should be appointed, either from the owner's forces or an outside group, to make an annual inspection of the two tunnels, analyze the special record files and report on their relative performance. The field inspection should include logging and recording the number and severity of any leaks which may have developed or damage which may have been experienced by either liner. Particular attention should be directed toward the performance of segment repairs which were made during construction of the tunnels, in order to establish recommendations for future work.

The annual reports resulting from this review should include updated cost and performance charts for the entire post-construction period along with such life cycle cost conclusions as may be apparent at that time. Particular mention should be made of any new or unanticipated circumstances relating to the precast liner and special investigations recommended if appropriate.

We do not suggest further efforts be made to measure long-term strains, deformations or other physical properties of the lining. These properties appear to have stabilized during the construction period and further efforts would require new instrumentation and inordinate expense.

15.0 ONGOING STUDY OF SPECIAL PROBLEMS

It was pointed out in earlier sections of this report that a significant amount of continued cracking and spalling was observed in sections of the precast concrete lined tunnel for a period of several months after completion of construction. This condition seemed to be associated with a long-term shifting of the liner segments and eventually stabilized. The reasonable assumption is that differential locked-in construction stresses caused the movement, and once equilibrium was reached, the movement and subsequent damage ceased.

This could not be documented as a fact, however, so measures should be taken to monitor segment damage frequently over the first six months of operation. The question concerning the possibility of an inherent property of the precast concrete liner system which might be triggered by impact loading from the trains or by other external factors to create a serious ongoing maintenance problem should be answered as fully and as quickly as possible.

REFERENCES

1. Berkmyer, J.; "System Study of Precast Concrete Tunnel Liners", DOT-TST-75-102.
2. Cording, E. J.; W. H. Hansmire; H. H. MacPherson; P. A. Lenyini; and A. P. Vanderohi, Displacements Around Tunnels in Soil, DOT-TST 76T-22, August 1976.
3. Schmidt, B., Settlements and Ground Movements Associated with Tunneling in Soil, Ph.D. Thesis, University of Illinois, Urbana, 1969.
4. Peck, R. B., "Deep Excavations and Tunneling in Soft Ground," Seventh International Conference of Soil Mechanics and Foundation Engineering, Mexico City, State-of-the-Art Volume.
5. MacPherson, H. H.; J. W. Critchfield; S. W. Hang; and E. J. Cording, Settlement Around Tunnels in Soils: Three Case Histories, UMTA-IL-06-0043-78-1, March 1978.
6. Hansmire, W. H., Field Measurements of Ground Displacements About a Tunnel in Soil, Ph.D. Thesis, University of Illinois, 1975.
7. Sozio, Luis E., "Settlements in a Sao Paulo Shield Tunnel," Tunnels and Tunneling, Sept. 1978, pp. 53-55.
8. Schmidt, B., "Predictions of Settlements Due to Tunneling in Soils: Three Case Histories," 1974 RETC Proceedings, Vol. 2.
9. Eisenstein, Z. and S. Thompson, "Geotechnical Performance of a Tunnel in Till," Canadian Geotechnical Journal, Vol. 15, No. 3, August 1978.
10. Parsons, Brinkerhoff, Quade and Douglas, Inc., "Final Report on Earth Loads and Construction Loads on Tunnel Lining," August, 1975.
11. Parsons, Brinkerhoff, Quade and Douglas, Inc., "Amendment to Final Report on Earth Loads and Construction Loads on Tunnel Lining," June, 1976.
12. Parsons, Brinkerhoff, Quade and Douglas, Inc., "Baltimore Rapid Transit Lexington Market Tunnels Design Summary Report," December, 1976.
13. Parsons, Brinkerhoff, Quade and Douglas, Inc., "Precast Concrete Segmented Tunnel Liners, Design Research and Development Report," Volume I and II, December, 1976.
14. "Baltimore Regional Rapid Transit System - Phase I, Section A, Lexington Market Section, Geotechnical Data, Volume I" by Robert B. Balter Company, July 1976.
15. "Baltimore Regional Rapid Transit System - Phase I, Section A, Lexington Market Section, Geotechnical Data, Logs with Core Photographs, Volume II" by Robert B. Balter Co., July 1976.
16. "Baltimore Regional Rapid Transit System - Phase I, Section A, Lexington Market Section, Geotechnical Data Review" by Robert B. Balter Company, July 1976.



APPENDIX

LETTERS



DANIEL, MANN, JOHNSON, & MENDENHALL KAISER ENGINEERS
Division of Henry J. Kaiser Company
A JOINT VENTURE

April 17, 1981

Mr. Frank Hoppe
Mass Transit Administration
109 East Redwood Street
Baltimore, Maryland 21202

Subject: Draft Report - Special Study of Precast Concrete
Tunnel Liner, Lexington Market Tunnels, dated
April 30, 1980 (Received April 14, 1981)

Dear Mr. Hoppe:

We have reviewed the subject report and offer the following comments from the designers viewpoint:

GENERAL

The overall report is a good reference document and we believe that it provides considerable information for those who want to know more about precast concrete liner for transit tunnels.

Since DMJM/KE was not directly involved in the monitoring program once the design documents were completed, we would like to state that the conclusion reached in the report reflects the thinking of people who prepared the report, and not that of the General Consultant, DMJM/KE, or the Design Consultant, PBQ&D.

DESIGN RELATED

During the design phase, all of the questions related to structural integrity of the liner were investigated in the laboratory environment. The only thing left was to test the liner segment under actual installation conditions. The data collected has proven that most of the design considerations related to installation problems are caused by two important factors:

- . quality control methods used by the manufacturer of the segments.
- . installation procedures and the method used for adapting the erection ring to the concrete segment dimensions.

We are pleased to note that the procedure of assembling the concrete segments into a ring on the shield as a template before fastening it to the preceding liner ring was very innovative and very successful. Among other advantages, it overcame the inherent problem of accumulation of dimensional errors which would have occurred had succeeding liner rings been assembled by fastening them directly to the preceding rings.

In the Section 8.0, the authors of the report have reached conclusions and have made recommendations to improve the design. We take exception to a few of those listed in Section 8.2.1., and they are listed here:

Increased Liner Thickness: We disagree with this recommendation on the grounds that arrangement of rebar and its requirements are dictated by handling and practical construction consideration for the bolt pocket requirements and not only the design requirements. To address the question of thickness vs. damages of the segments, one must analyze:

- . structural integrity of segment;
- . erection sequence requirements;
- . practical construction - precasting techniques; and,
- . type of reinforcement used.

Standardization: It is unclear how the standardization of design configurations could affect the level of performance of concrete liner segments. We believe the performance of the liner is largely based on the quality control specified during the manufacturing process and not in the design process.

In the Section 8.1., the subject of limitations with respect to local environment deals with water (leakage problem) and ground conditions in a superficial manner.

In this section of the report, it was implied that the Baltimore experience proved that precast lined transit tunnels can be used under conditions of almost limitless groundwater head. The statement was made that joints can be constructed to prevent intrusion of groundwater up to 100-foot head and beyond. While this may be theoretically true, and may even be achievable under laboratory conditions, we do not believe that this position should be taken considering practical field conditions and the present state of the art. While we agree that the gasket and joint used in Baltimore has proved moderately successful, it should be recognized that some difficulties occurred and that the concrete lined tunnel, under relatively low groundwater heads, proved to be more susceptible to leakage than the steel lined tunnels subjected to much higher heads.

In this regard, we believe that a better position to take would be one of cautious optimism. We think that the conclusion should be that precast concrete lined tunnels for transit use can eventually be developed to exclude groundwater intrusion caused by significant heads, but that such applications should be approached cautiously and slowly by first proving practicality of tunnels subjected to moderate heads.

The other aspect of the report deals with the construction, and we believe that it stands on its own merit.

Mr. Frank Hoppe
April 17, 1981
Page Three

It has been a pleasure being a part of this UMTA demonstration project, and we hope that future property owners, designers, and builders will benefit from this Baltimore experience.

Sincerely,

DANIEL, MANN, JOHNSON, & MENDENHALL/
KAISER ENGINEERS

A handwritten signature in cursive script, appearing to read "E. A. Tillman". The signature is written in dark ink and is positioned above the typed name.

E. A. Tillman
Project Manager
General Consultant

DBD:EAT/db

