

Report No. FAA-RD-80-107

LEVEL

12

AD A091156

STUDY OF HELIPORT AIRSPACE AND REAL ESTATE REQUIREMENTS

A.G. DeLucien

F.D. Smith

PACER Systems, Inc.
1755 S. Jefferson Davis Highway
Arlington, Virginia 22202



DTIC
SELECTED
NOV 3 1980

August 1980

FINAL REPORT

Document is available to the U.S. public through
the National Technical Information Service,
Springfield, Virginia 22161.

DDC FILE COPY

Prepared for

U.S. DEPARTMENT OF TRANSPORTATION
FEDERAL AVIATION ADMINISTRATION
Systems Research & Development Service
Washington, D.C. 20590

80 11 03 234

NOTICE

This document is disseminated under the sponsorship of the Department of Transportation in the interest of information exchange. The United States Government assumes no liability for the contents or use thereof.

Technical Report Documentation Page

1. Report No. 18 FAA-RD-80-107	2. Government Accession No.	3. Recipient's Catalog No.	
4. Title and Subtitle 9 Study of Heliport Airspace and Real Estate Requirements.		5. Report Date 11 August 1980	6. Performing Organization Code SSED/FSG 12
7. Author 10 A. G. DeLucien, F. D. Smith		8. Performing Organization Report No. 14 PAR-037-80 15	10. Work Unit No. (TRAIS)
9. Performing Organization Name and Address PACER Systems, Inc., Suite 510 1755 South Jefferson Davis Highway Arlington, VA 22202		11. Contract or Grant No. DOT-FA-79WAI-019 15	13. Type of Report and Period Covered 9 Final Report, March 1980 to July 1980
12. Sponsoring Agency Name and Address U.S. Department of Transportation Federal Aviation Administration Systems Research and Development Service Washington, D.C. 20591		14. Sponsoring Agency Code FAA/ARD-330	
15. Supplementary Notes			
16. Abstract This report documents the review and evaluation of real estate and airspace requirements as set forth in applicable U.S. heliport design criteria. International criteria are reviewed to discern their rationale for various requirements. Helicopter performance during normal and failure-state operations is analyzed. The suitability of current criteria is examined with respect to various operational profiles. Modifications to current criteria are suggested which would accommodate various operational requirements and varying levels of terminal instrument procedures capability. Recommendations include a revised heliport classification scheme with corresponding changes to real estate and airspace criteria for IFR operations; helicopter performance chart standardization for flight manuals with specific data requirements; consideration of obstacle clearance for failure-state operations; additional criteria for offshore facilities; and revised criteria for elevated heliports/ helipads. <i>A</i>			
17. Key Words Helicopter, Heliport, Real Estate, Airspace, Obstacle Surfaces, Terminal Instrument Procedures, Criteria		18. Distribution Statement This document is available to the U.S. public through the National Technical Information Service, Springfield, Virginia 22161.	
19. Security Classif. (of this report) UNCLASSIFIED	20. Security Classif. (of this page) UNCLASSIFIED	21. No. of Pages 148	22. Price

404135
1
B

METRIC CONVERSION FACTORS

Approximate Conversions to Metric Measures			Approximate Conversions from Metric Measures					
Symbol	When You Know	Multiply by	To Find	Symbol	When You Know	Multiply by	To Find	Symbol
LENGTH								
in	inches	2.5	centimeters	cm	millimeters	0.04	inches	in
ft	feet	30	centimeters	cm	inches	0.4	inches	in
yd	yards	0.9	meters	m	feet	3.3	feet	ft
mi	miles	1.6	kilometers	km	meters	1.1	yards	yd
					kilometers	0.6	miles	mi
AREA								
m ²	square inches	6.5	square centimeters	cm ²	square centimeters	0.16	square inches	in ²
ft ²	square feet	0.09	square meters	m ²	square meters	1.2	square yards	yd ²
yd ²	square yards	0.8	square meters	m ²	square kilometers	0.4	square miles	mi ²
mi ²	square miles	2.6	square kilometers	km ²	hectares (10,000 m ²)	2.5	acres	ac
	acres	0.4	hectares	ha				
MASS (weight)								
oz	ounces	28	grams	g	grams	0.035	ounces	oz
lb	pounds	0.45	kilograms	kg	kilograms	2.2	pounds	lb
	short tons (2000 lb)	0.9	tonnes	t	tonnes (1000 kg)	1.1	short tons	st
VOLUME								
cup	teaspoons	5	milliliters	ml	milliliters	0.03	fluid ounces	fl oz
fl oz	tablespoons	15	milliliters	ml	liters	2.1	pints	pt
c	fluid ounces	30	milliliters	ml	liters	1.06	quarts	qt
pt	cup	0.24	liters	l	liters	0.26	gallons	gal
qt	pint	0.47	liters	l	cubic meters	35	cubic feet	ft ³
gal	quart	0.35	liters	l	cubic meters	1.3	cubic yards	yd ³
ft ³	gallon	3.8	cubic meters	m ³				
yd ³	cubic feet	0.03	cubic meters	m ³				
	cubic yards	0.76						
TEMPERATURE (exact)								
°F	Fahrenheit temperature	5/9 (after subtracting 32)	Celsius temperature	°C	Celsius temperature	9/5 (then add 32)	Fahrenheit temperature	°F

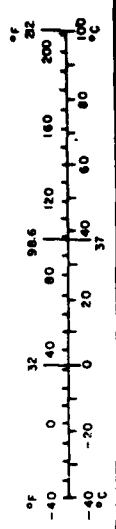
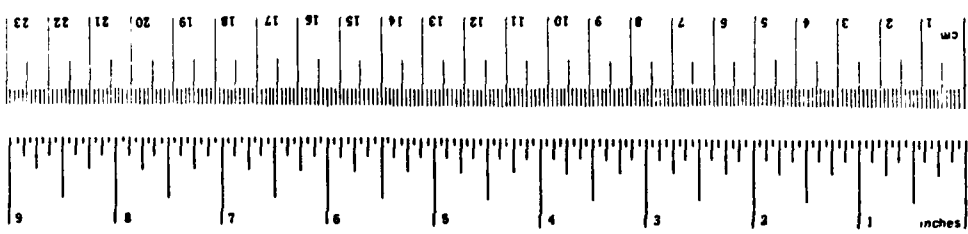

*1 in = 2.54 (exactly). For other exact conversions, and more detailed tables, see NBS Mon. Publ. 286, Units of Length and Measure, Price \$2.25, SO Catalog No. C13.10.286.

TABLE OF CONTENTS

<u>Section</u>		<u>Page</u>
1	<u>INTRODUCTION</u>	
1.1	GENERAL	1- 1
1.2	BACKGROUND	1- 2
2	<u>ANALYSIS OF U.S. HELIPORT REQUIREMENTS</u>	
2.1	INTRODUCTION	2- 1
2.2	GENERAL OBSTRUCTION STANDARDS	2- 1
2.3	GENERAL AIRPORT REQUIREMENTS	2- 5
2.3.1	Airport Classification Scheme	2- 5
2.4	GENERAL HELIPORT REQUIREMENTS	2- 8
2.4.1	Heliport Classification Scheme	2-11
2.5	HELIPORT AIRSPACE REQUIREMENTS	2-12
2.5.1	VFR Airspace Requirements	2-12
2.5.2	IFR Airspace Requirements	2-13
2.5.3	Offshore Helicopter Facility Requirements	2-21
2.6	HELIPORT REAL ESTATE REQUIREMENTS	2-21
2.6.1	VFR Real Estate Requirements	2-22
2.6.2	IFR Real Estate Requirements	2-22
2.6.3	Requirements for Failure-State Operations	2-23
2.7	U.S. ARMY HELIPORT AND HELIPAD CRITERIA	2-24
2.7.1	Categories of Helicopter Landing Facilities	2-25
2.7.2	Terminology and General Requirements	2-26
2.7.3	Heliport Criteria	2-29
2.7.4	Helipad Criteria	2-29

TABLE OF CONTENTS

<u>Section</u>	<u>Page</u>
2.8	FINDINGS AND CONCLUSIONS 2-31
3	<u>REVIEW OF INTERNATIONAL HELIPORT CRITERIA</u>
3.1	INTRODUCTION 3- 1
3.2	OVERVIEW OF SELECTED REAL ESTATE AND AIRSPACE REQUIREMENTS 3- 1
3.2.1	United Kingdom 3- 1
3.2.2	Canada 3- 5
3.2.3	Japan 3- 8
3.2.4	International Civil Aviation Organization (ICAO) 3-12
3.3	COMPARISON WITH U.S. CRITERIA 3-14
3.3.1	Licensing and Mandatory Compliance with Criteria 3-14
3.3.2	Heliport Classifications and Categories. . . . 3-15
3.3.3	Performance Considerations 3-17
3.3.4	Failure-State Operations 3-20
3.3.5	Takeoff and Landing Areas 3-26
3.3.6	Approach and Departure Areas 3-26
3.3.7	Lateral Obstacle Protection 3-28
4	<u>RATIONALE FOR HELIPORT DESIGN CRITERIA MODIFICATIONS</u>
4.1	INTRODUCTION 4- 1
4.2	OPERATIONAL PROFILES FOR HELIPORTS 4- 1
4.2.1	VFR Takeoff and Departure 4- 2
4.2.2	IFR Takeoff and Departure 4- 3
4.2.3	VFR Approach and Landing 4- 4

TABLE OF CONTENTS

<u>Section</u>		<u>Page</u>
4.2.4	IFR Approach and Landing	4- 4
4.3	IMPLICATIONS OF HELICOPTER PERFORMANCE ON HELIPORT CRITERIA	4- 5
4.3.1	Helicopter Takeoff & Departure Performance .	4- 6
4.3.2	Helicopter Approach & Landing Performance .	4-17
4.3.3	Application of Performance Charts to Heliport Operations	4-18
4.3.4	Summary and Conclusions	4-22
4.4	ALTERNATIVES FOR HELIPORT DESIGN CRITERIA . .	4-22
4.4.1	Real Estate for Takeoff and Departure . . .	4-22
4.4.2	Airspace for IFR Departure	4-24
4.4.3	Real Estate for VFR Approach and Landing. .	4-24
4.4.4	Real Estate for IFR Approach and Landing. .	4-25
4.4.5	Alternative PAR Missed Approach Surface . .	4-25
4.4.6	Criteria for Elevated Heliports	4-26
4.4.7	Surfaces for Offshore Helicopter Landing Facilities	4-26
4.4.8	Guidelines for Establishing Forced Landing Areas	4-27
4.4.9	Criteria for Curved Flight Paths.	4-27
4.4.10	Heliport Classification Requirements. . . .	4-28
5	<u>RECOMMENDATIONS</u>	
5.1	HELIPORT CLASSIFICATION SCHEME	5- 2
5.2	DEFINITIONS	5- 3
5.3	HELICOPTER PERFORMANCE CHARTS	5- 3
5.4	REAL ESTATE REQUIREMENTS	5- 4
5.4.1	Flight Test Data Requirements	5- 4

Accession For	
NTIS GRA&I	<input checked="" type="checkbox"/>
DTIC TAB	<input type="checkbox"/>
Unannounced	<input type="checkbox"/>
Justification	
By _____	
Distribution/	
Availability Codes	
Dist	(Avail and/or Special)
A	

TABLE OF CONTENTS

<u>Section</u>	<u>Page</u>
5.4.2	Visual Heliport Acceleration Distances . . . 5- 4
5.4.3	Instrument Heliport Acceleration Distances. 5- 5
5.4.4	Heliport Deceleration Distances 5- 5
5.5	STANDARD INSTRUMENT DEPARTURE CRITERIA 5- 5
5.6	AIRSPACE REQUIREMENTS. 5- 5
5.6.1	Instrument Departure Heliport 5- 6
5.6.2	Modified PAR Missed Approach Criteria . . . 5- 6
5.7	FAILURE-STATE OPERATIONS 5- 6
5.7.1	Clarification of Real Estate Requirements . 5- 6
5.7.2	Guidelines for Forced Landing Areas 5- 6
5.8	CRITERIA FOR OFFSHORE FACILITIES 5- 7
5.8.1	Mobile Drilling Unit Requirements 5- 7
5.8.2	Additional Criteria for Offshore Facilities 5- 7
5.9	ADDITIONAL CRITERIA FOR ELEVATED HELIPORTS/HELIPADS 5- 7
5.10	CRITERIA FOR CURVED FLIGHT PATHS 5- 7
Appendix A	DEFINITIONS AND TERMINOLOGY. A- 1
Appendix B	SELECTED U.S. ARMY DESIGN CRITERIA B- 1
Appendix C	SELECTED HELICOPTER PERFORMANCE CHART APPLICATIONS C- 1
REFERENCES	R- 1

LIST OF ILLUSTRATIONS

<u>Figure</u>		<u>Page</u>
2-1	Notice Requirements Related to Heliports.	2- 4
2-2	Civil Airport Imaginary Surfaces.	2- 6
2-3	Relationship of Heliport Surfaces	2-10
2-4	Imaginary Surfaces for Heliports.	2-14
2-5	Perspective of Copter-Only Non-Precision Final Approach Surfaces	2-16
2-6	Copter-Only Non-Precision Final Approach Segment Data.	2-17
2-7	Copter-Only Missed Approach Surfaces.	2-18
2-8	Copter-Only Precision Approach Radar Obstacle Surfaces	2-20
3-1	Perspective of Heliport Criteria, Performance Group A, U.K.	3- 3
3-2	Perspective of Heliport Criteria, Performance Group B, U.K.	3- 4
3-3	Perspective of Heliport Surfaces, Canada.	3- 6
3-4	Perspective of Heliport Surfaces, ICAO.	3-13
4-1	Performance Requirements for 8:1 Climb Gradient . . .	4- 8
4-2	Distance for Acceleration to Various Airspeeds. . .	4-11
4-3	Example Helicopter Performance Chart	4-20
C-1	Maximum Torque Available, 30 Minute Limit, UH-1H . .	C- 3
C-2	Hover Power Required, UH-1H	C- 5

LIST OF TABLES

<u>Table</u>	<u>Page</u>
2-1	Summary of Recommended Heliport Design Criteria. . . 2- 9
2-2	Selected Criteria for U.S. Army Heliports. 2-30
2-3	Selected Criteria for U.S. Army Helipads 2-32
3-1	Criteria for Curved Takeoff/Approach Areas, Canada . 3- 7
3-2	Characteristics of Land Heliports, Japan 3- 9
3-3	Characteristics of Water Heliports, Japan 3-10
3-4	Heliport Obstacle Surfaces, Japan 3-11
3-5	Comparison of International Obstacle Surface Slopes 3-27
4-1	Best Climb Performance (Normal State Operations) . . 4-9
4-2	Category A Performance Data, Aerospatiale SA-330J. . 4-13
4-3	Category A Performance Data, Bell 212. 4-14
4-4	Category A Performance Data, Sikorsky S-76 4-15

ABBREVIATIONS

AGL	Above Ground Level
AIM	Airman's Information Manual
CAA	Civil Aviation Authority (U.K.)
CDP	Critical Decision Point
CFR	Code of Federal Regulations
CTOD	Continued Take-Off Distance
DER	Departure End of Runway
DH	Decision Height
DME	Distance Measuring Equipment
FAA	Federal Aviation Administration
FAF	Final Approach Fix
FAR	Federal Aviation Regulations
GPI	Ground Point of Intercept
HIGE	Hover In Ground Effect
HOGE	Hover Out of Ground Effect
H-V	Height-Velocity
ICAO	International Civil Aviation Organization
IFR	Instrument Flight Rules
IGE	In Ground Effect
ILS	Instrument Landing System
IMC	Instrument Meteorological Conditions
ITO	Instrument Takeoff
KIAS	Knots Indicated Airspeed
MAP	Missed Approach Point
MDA	Minimum Descent Altitude
MLS	Microwave Landing System
NDB	Non-Directional Beacon
OEI	One Engine Inoperative
OGE	Out of Ground Effect
OIS	Obstacle Identification Surface
PAR	Precision Approach Radar
R/C	Rate of Climb
RFM	Rotorcraft Flight Manual
RNAV	Area Navigation
ROC	Required Obstacle Clearance
RTOD	Rejected Take-Off Distance
TACAN	Tactical Air Navigation
TERPS	Terminal Instrument Procedures
TERPS Handbook	U.S. Standard for Terminal Instrument Procedures (FAA Handbook #8260.3B)

ABBREVIATIONS (Cont)

U.K.	United Kingdom
VFR	Visual Flight Rules
VMC	Visual Meteorological Conditions
VOR	VHF Omni-Directional Radio Range
WAT	Weight, Altitude and Temperature

LIST OF SYMBOLS

v	Velocity
V_{TOSS}	Takeoff safety speed
V_y	Airspeed for best rate of climb, knots
g	Acceleration due to gravity (32.2 ft/sec ²)

SECTION 1
INTRODUCTION

1.1 GENERAL

The objective of this study is to review and evaluate the design criteria for heliport primary and approach surfaces established by Federal Aviation Regulations (FAR) and identified in the Heliport Design Guide, Advisory Circular AC 150/5390-1B (Reference 1). Other appropriate real estate and airspace requirements were reviewed, and additional or supplemental heliport criteria are recommended which accommodate instrument procedures. The instrument-oriented recommendations are more compatible with actual helicopter performance characteristics and consistent with applicable criteria contained in the U.S. Standard for Terminal Instrument Procedures (TERPS), FAA Handbook 8260.3B (Reference 2). Appropriate Federal Aviation Regulations were reviewed (References 3 through 12) and pertinent parts are analyzed with respect to their impact on the subject criteria.

Additionally, normal and failure-state helicopter operational parameters are examined; and real estate and airspace requirements for both are compared in the event that other than normal operational flight profiles are to be considered in developing criteria. The suitability of current criteria for failure-state operation is examined.

International heliport criteria are examined and the philosophy applied in the development of each is discussed where appropriate. Specific recommendations are provided for appropriate levels of additional real estate or airspace.

1.2 BACKGROUND

In 1960, there were less than 400 heliports reported in the United States, half of them concentrated in two states. At present the number has increased roughly ten-fold to about 3300 heliports in the U.S.. More than half are concentrated in five states, and a full two-thirds are accounted for by ten states. The latest statistical data indicate that nearly 300 are rooftop, and the rest are ground level. More than 400 are public-use, a number of them commercial heliports operated much like on-airport, fixed base operations. Hospital heliports number nearly 700, and there are more than 2300 (non-hospital) private or personal-use heliports.

As the number of heliports increased, guidelines were developed for real estate and obstacle clearance needs for approach/departure, touchdown and maneuver area, etc., and were issued as the first Heliport Design Guide in November 1969. The Guide was revised in August 1977 to its present status. Some of the changes included: adoption of three classifications for non-Federal Heliports with specified dimensional criteria; introduction of recommended runway separation between airport-based helicopter takeoff and landing areas and runways; a new hospital heliport markings standard to prevent conflict with the American Red Cross symbol; updated fire protection requirements of the National Fire Protection Association; and addition of recommendations for the design of permanently fixed offshore helicopter facilities located in U.S. waters.

Because the number of heliports, and helicopters using them, are continually increasing, there is a need to reexamine the real estate and airspace needs which will allow operators to maximize the utilization of helicopters at their varying levels of capability while maintaining an appropriate level of safety. This includes operations under both visual and instrument meteorological conditions (VMC and IMC).

SECTION 2
ANALYSIS OF U.S. HELIPORT REQUIREMENTS

2.1 INTRODUCTION

This section reviews the primary and approach surface requirements for heliports as set forth in FAR Part 77 (Reference 8) and amplified in the Heliport Design Guide. Areas are identified with potential inconsistency relative to obstacle clearance requirements contained in the TERPS Handbook.

A number of obstacle surface criteria are reviewed, analyzed and compared. They include: general obstruction standards and airport requirements; offshore helideck requirements for mobile drilling units and fixed structure facilities; heliport requirements (other-than-offshore) with respect to real estate requirement; and airspace requirements for both visual and instrument flight rules (VFR and IFR) operations.

Modifications to present design criteria are recommended to accommodate various levels of instrument approach capability in a manner analogous to the airport design requirements contained in FAR Part 77.

2.2 GENERAL OBSTRUCTION STANDARDS

The Federal Aviation Regulations Part 77, Objects Affecting Navigable Airspace, establishes the standards for determining obstructions in navigable airspace. Accordingly, it sets forth requirements and administrative procedures to determine the effect on the safe and efficient use of airspace that any obstructions might have.

For both VFR and IFR terminal area operations, obstacle clearance surfaces are prescribed. The FAR establish basic, imaginary surfaces to determine first what is considered to be an obstacle and, then which of those constitute obstructions to air navigation. They generally apply to VFR operations and establish a foundation on which surfaces for IFR procedures are further developed.

All approved procedures for instrument approach and departure of aircraft to and from takeoff and landing areas that are conducted within specified terminal obstacle clearance and departure areas are established in conformity to the applicable criteria set forth either in the TERPS Handbook or the FAA Handbook 8260.19, Flight Procedures and Airspace (Reference 13). In establishing those instrument approach and departure criteria, the involvement of existing obstacles on the type of instrument procedure proposed is one of the primary considerations. Accordingly, the standards of FAR Part 77 applicable to terminal instrument procedures were developed so as to be based on the same obstacle clearance concept that was used to formulate the applicable criteria of TERPS and the FAA Handbook 8260.19.

With respect to the scope of this research, Part 77, Subpart C, Obstructions Standards, is of principal concern, as it "establishes the standards for determining obstructions to air navigation. It applies to existing and proposed manmade objects, objects of natural growth, and terrain. The standards apply to the use of navigable airspace by aircraft and to existing air navigation facilities, such as an air navigation aid, airport, Federal airway, instrument approach or departure procedure, or approved off-airway route." Of concern to this study, Subpart C specifically defines: Standards for determining obstructions (para. 77.23); civil airport imaginary surfaces (para. 77.25); and airport imaginary surfaces for heliports (para. 77.29). Each of these will be addressed separately.

A brief explanation of the interrelationship of obstacles and obstructions will aid materially in understanding the real estate and airspace requirements discussed in this report. In the development of all types of instrument approach procedures under TERPS and departure procedures under FAA Handbook 8260.19, the method of establishing each such procedure is basically the same. The existing obstacles, including objects that are manmade, the terrain features, and the navigational facilities involving a particular approach or departure area are carefully analyzed, after which a prescribed plane, which is commonly referred to as an obstacle clearance plane, is established for that particular phase of flight. In order to

insure maximum safety to all aircraft operators who may use that particular terminal instrument procedure, applicable FAA criteria are then applied to provide an additional layer of airspace above the prescribed obstacle clearance plane.

In applying the standards of Part 77 to this type of airspace structure, any object that does not exceed the obstacle clearance plane is classified as an obstacle; but any object that penetrates the prescribed obstacle clearance plane is classified as an obstruction, and subject to aeronautical study to determine whether or not it is a hazard to air transportation or air commerce.

In first determining if an object is an obstacle, the criteria in FAR Part 77 is applied from Subpart B, Notice of Construction or Alteration. It requires persons to report any proposed construction or alteration of objects within specific guidelines. Of concern to this study are those for heliports contained in Paragraph 77.13 of that Subpart, and summarized in Figure 2-1 (Notice Requirements Related to Heliports).

With respect to terminal area operations of helicopters at heliports, Paragraph 77.23 establishes that an existing object is, and a future object would be, an obstruction to air navigation if it is of greater height than:

- 500 feet above ground level (AGL) at the site of the object;
- A height within a terminal obstacle clearance area, including an initial approach segment, a departure area, and a circling approach area, which would result in the vertical distance between any point on the object and an established minimum instrument flight altitude within that area or segment to be less than the required obstacle clearance;

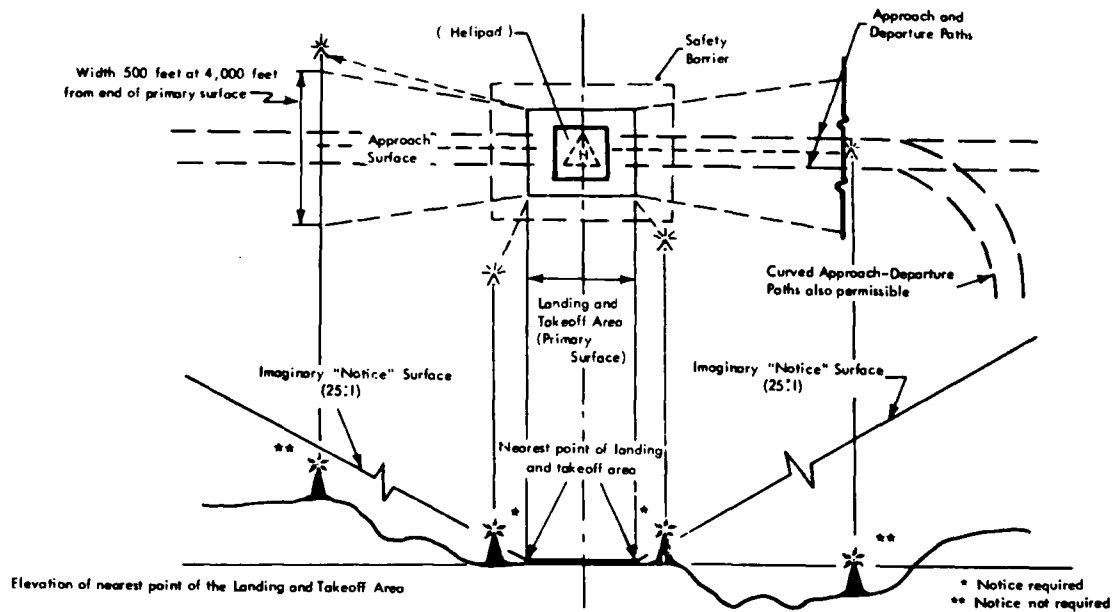

SUBPART B - NOTICE OF CONSTRUCTION OR ALTERATION

§77.13 (a)(2)-A notice is required for any proposed construction or alteration that would be of greater height than an imaginary surface extending outward and upward at the following slope:

(iii) 25 to 1 for a horizontal distance of 5,000 feet from the nearest landing and takeoff area of each heliport, available for public use and listed in the Airport Directory of the current Airman's Information Manual or in either the Alaska or Pacific Airman's Guide and Chart Supplements, is under construction and is the subject of a notice or proposal or file with the FAA and except for military heliports, it is clearly indicated that that heliport will be available for public use, or operated by a Federal Military agency.

Figure 2-1. Notice Requirements Related to Heliports.

- Surface of a takeoff and landing area of an airport or any imaginary surface established under paragraphs 77.25, 77.28 or 77.29. However, no part of the take-off or landing area itself will be considered an obstruction.

These basic obstruction standards apply to all situations, airport or heliport, and determine what objects can be classified as an obstruction in addition to any other surfaces which might be established.

2.3 GENERAL AIRPORT REQUIREMENTS

In 1960, when there were only about 350 heliports reported in the U.S., airports had already become well established, and airport obstacle surface requirements were firmly in existence. It was not until the late 1960s that heliports received any detailed attention or documentation with respect to obstacle surfaces and design criteria. Today, the criteria in Reference 1 are only recommendations, advisory in nature, with the exception of the imaginary obstacle surfaces as specified in FAR Part 77 and reproduced in Reference 1.

Airport requirements, having matured over a substantial period of time, represent a relatively well-developed obstacle surface standard. For that reason, they deserve some scrutiny. In order to facilitate a comparison of heliport surfaces with airport-related requirements contained in Part 77, the latter are presented here. Figure 2-2, Civil Airport Imaginary Surfaces, summarizes the obstruction surfaces for the various classifications of airports.

2.3.1 Airport Classification Scheme

Fundamental to the obstacle surfaces for airports is a runway classification scheme which accounts for the general construction or physical characteristics of the runway, and the intended use to include type of

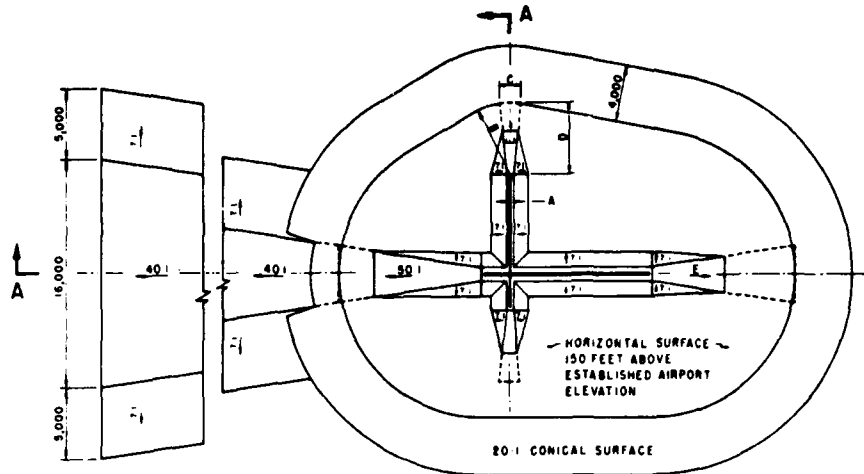

DIM	ITEM	DIMENSIONAL STANDARDS (FEET)					
		VISUAL RUNWAY		NON-PRECISION INSTRUMENT RUNWAY		PRECISION INSTRUMENT RUNWAY	
		A	B	A	C	D	
A	WIDTH OF PRIMARY SURFACE AND APPROACH SURFACE WIDTH AT INNER END	250	500	500	500	1,000	1,000
B	RADIUS OF HORIZONTAL SURFACE	5,000	5,000	5,000	10,000	10,000	10,000
		VISUAL APPROACH		NON-PRECISION INSTRUMENT APPROACH		PRECISION INSTRUMENT APPROACH	
		A	B	A	B		
C	APPROACH SURFACE WIDTH AT END	1,250	1,500	2,000	3,500	4,000	16,000
D	APPROACH SURFACE LENGTH	5,000	5,000	5,000	10,000	10,000	#
E	APPROACH SLOPE	20:1	20:1	20:1	34:1	34:1	#

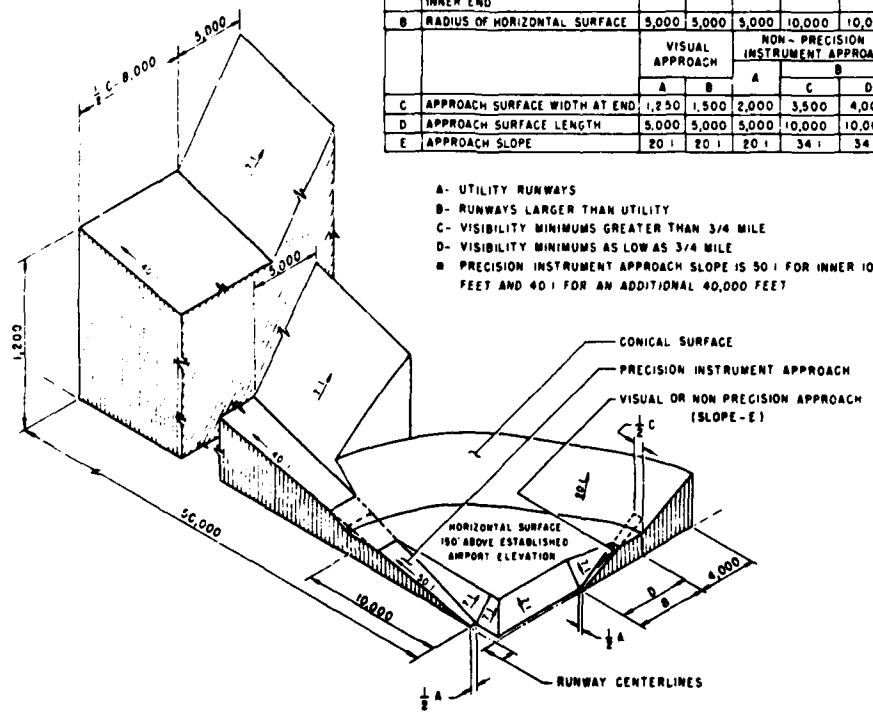

- A- UTILITY RUNWAYS
- B- RUNWAYS LARGER THAN UTILITY
- C- VISIBILITY MINIMUMS GREATER THAN 3/4 MILE
- D- VISIBILITY MINIMUMS AS LOW AS 3/4 MILE
- # PRECISION INSTRUMENT APPROACH SLOPE IS 50:1 FOR INNER 10,000 FEET AND 40:1 FOR AN ADDITIONAL 40,000 FEET

Figure 2-2. Civil Airport Imaginary Surfaces.

instrument procedures. Obstacle surfaces vary, based on the airport classification, as shown in Figure 2-2. In order to enhance the understanding of the surfaces depicted, applicable definitions of interest are offered, reproduced verbatim from FAR Part 77, paragraph 77.2:

Nonprecision Instrument Runway: a runway having an existing instrument approach procedure utilizing air navigation facilities with only horizontal guidance, or area type navigation equipment, for which a straight-in nonprecision instrument approach procedure has been approved, or planned, and for which no precision approach facilities are planned, or indicated on an FAA planning document or military service military airport planning document.

Precision Instrument Runway: a runway having an existing instrument approach procedure utilizing an Instrument Landing System (ILS), or a Precision Approach Radar (PAR). It also means a runway for which a precision approach system is planned and is so indicated by an FAA approved airport layout plan; a military service approved military airport layout plan; any other FAA planning document, or military service military airport planning document.

Utility Runway: a runway that is constructed for and intended to be used by propeller drive aircraft of 12,500 pounds maximum gross weight and less.

Visual Runway: a runway intended solely for the operation of aircraft using visual approach procedures, with no straight-in instrument approach procedure and no instrument designation indicated on an FAA approved airport layout plan, a military service approved military airport layout plan, or by any planning document submitted to the FAA by competent authority.

2.4 GENERAL HELIPORT REQUIREMENTS

Current real estate and airspace requirements for heliport obstacle clearance are derived from the FAR, U.S. Coast Guard regulations, the TERPS Handbook, and the Heliport Design Guide. They are variously applied in developing obstacle clearance for both VFR and IFR operations, for offshore helicopter landing facilities, and in determining real estate requirements with respect to takeoff and landings areas.

The Heliport Design Guide contains general and technical information pertaining to the establishment or improvement of a heliport. Its guidance is advisory in nature and is based on sound operating practices in effect at the time of publication. When Federal aid is involved in the development of a heliport, the design criteria contained in the guide are the standard for complying with certain requirements of the Airport and Airway Development Act of 1970.

Although generally advisory in nature, Reference 1 does contain certain criteria which are mandatory. It should be noted that it reproduces heliport imaginary surfaces from FAR Part 77, paragraph 77.29, which are used to identify which obstacles are considered obstructions. These will be addressed in subsequent discussions, along with real estate requirements and requirements for offshore facilities.

To facilitate these discussions, a summary of the recommended criteria contained in the guide is presented in Table 2-1. It should be noted that the criteria do not apply to offshore facilities, which will be discussed separately. Figure 2-3, Relationship of Heliport Surfaces, depicts how the surfaces and areas summarized in Table 2-1 generally relate to each other. The real estate and airspace requirements will be addressed in later discussions.

TABLE 2-1
SUMMARY OF RECOMMENDED HELIPORT DESIGN CRITERIA

DESIGN FEATURE	HELIPORT CLASSIFICATION		COMMENT
	PUBLIC-USE	PRIVATE-USE PERSONAL-USE	
	DIMENSION		
TAKEOFF & LANDING AREA Length, width, diameter	1.5 x helicopter overall length		To preclude premature obsolescence, consider the possibility of larger helicopters in the future.
TOUCHDOWN PAD Length, width, diameter	1.5 x rotor diameter		Elevated touchdown pads less than 1.5 rotor diameters in size may subject using helicopters to operational penalties due to loss of rotor downwash ground effect. Minimally sized touchdown pads are not encouraged, but may be used in cases of economic or aesthetic necessity. Touchdown pads less than one rotor diameter in size should have additional nonload-bearing area for downwash ground effect.
Minimum ground-level Length, diameter Width	2.0 x wheelbase 2.0 x tread	1.5 x wheelbase 1.5 x tread	
Minimum elevated Length, diameter Width	1.0 rotor dia. 1.0 rotor dia.	1.5 x wheelbase 1.5 tread	
PERIPHERAL AREA Recommended width Minimum width	1/4 helicopter overall length 10 feet (3 m)		An obstacle-free area surrounding the takeoff and landing area. Keep the area clear of parked helicopters, buildings, fences, etc.
TAXIWAY Paved width	Variable, 20-foot (6 m) minimum		Paved taxiways are not required if helicopters hover taxi.
PARKING POSITION Length, width, diameter	1.0 x helicopter overall length		Parking position should be beyond the edge of the peripheral area. Parked helicopters should not violate the 2:1 transitional surface.
PAVEMENT GRADES Touchdown pad, taxiways, parking positions	2.0 percent maximum		
OTHER GRADES Turf shoulders, infield area, etc.	Variable, 1-1/2 to 3 percent		A 10-foot (3 m) wide rapid runoff shoulder of 5 percent slope is permitted adjacent to all paved surfaces.
CLEARANCES, ROTOR TIP TO OBJECT Taxiways, parking positions	10-foot (3 m) minimum		Consider possibility of larger helicopters in the future.
HELICOPTER PRIMARY SURFACE Length, width, diameter Elevation	1.5 x helicopter overall length Elevation highest point takeoff & landing area.		Imaginary plane overlying the takeoff and landing area. Area to be free of all obstacles.
HELICOPTER APPROACH SURFACE Number of surfaces Angular separation Length Inner width Outer width Slope	Two 90° min., 18° preferred 4,000 feet (1,220 m) 1.5 x helicopter overall length 500 feet (152 m) 8:1		Protection for helicopter approaches and departures. The surface should not be penetrated by any objects that are determined to be hazards to air navigation.
HELICOPTER TRANSITIONAL SURFACE Length Width Slope	Full length of approaches and primary surface. 250 feet (76 m) measured from approach & primary surface centerline. 2:1		Surface should not be penetrated by objects.

NOTE: Above criteria does not apply to offshore helicopter facilities.

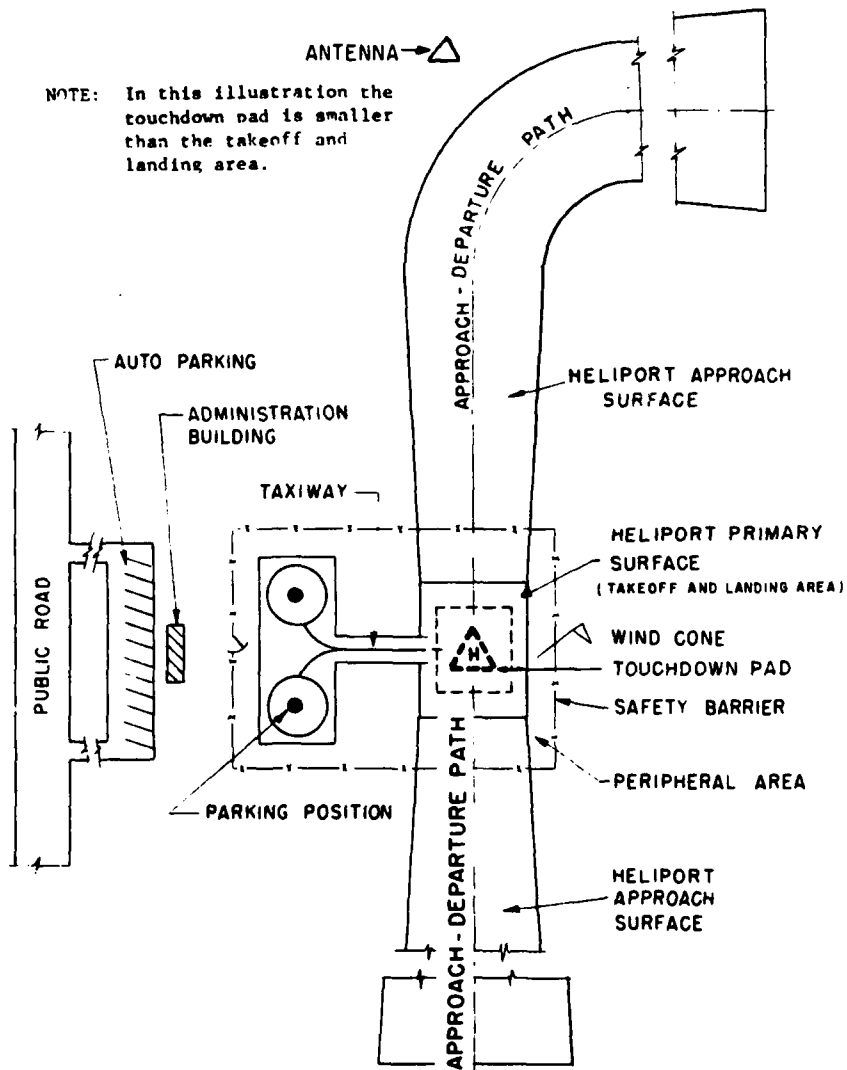

Figure 2-3. Relationship of Heliport Surfaces.

2.4.1 Heliport Classification Scheme

The terms used to classify United States heliports are descriptive of the class of user allowed to conduct flight operations from the facility. When the first Heliport Design Guide was published, heliports were classified as either military, Federal or non-Federal. As the popularity of heliports increased, the need developed for further classification, and in 1977 the terms "public-use, private-use and personal-use" were adopted to classify non-Federal heliports. The terms are consistent with the terminology of FAR Part 157 (Reference 12) and are also descriptive of the types of heliport usage. An additional term was introduced in Reference 1 for clarification purposes - "helicopter landing site".

The terms of classification are briefly defined below, developed from Reference 1, to enhance the understanding of later discussions. More detailed definitions, as they appear in Reference 1, are contained in Appendix A of this report.

Military Heliport applies to a heliport facility operated by one of the uniformed services. They are developed in accordance with the design criteria of the applicable service and generally prohibit non-military usage.

Federal Heliport applies to a heliport facility operated by a non-military agency or department of the U.S. Government.

Public-Use Heliport applies to a heliport facility that is open to the general public and does not require prior permission of the owner to land. It may be owned by a public agency, an individual or a corporation, and is listed in the Airman's Information Manual (AIM) Airport Directory.

Private-Use Heliport is a heliport facility that restricts usage to the owner, persons authorized by the owner, a specific type of user, or that requires prior permission of the owner to land.

Personal-Use Heliport applies to a heliport facility that is used exclusively by the owner. It is owned by individuals, companies or corporations.

Helicopter Landing Site applies to a location or clear area that is not a designated heliport, wherein a decision to land is made by the pilot who must weigh appropriate considerations and accept full responsibility for the decision. For the most part, these are one-time, temporary or infrequent operations, and the landing site should not be considered a heliport.

2.5 HELIPORT AIRSPACE REQUIREMENTS

Airspace requirements for heliports involve the application of obstacle surfaces emanating from the vicinity of the heliport, as the takeoff and landing area itself. They vary from VFR to differing levels of IFR operation and, in turn, help to define real estate requirements which will be addressed later in this report. VFR surfaces are contained primarily in the Heliport Design Guide (Reference 1), while IFR surfaces are contained in the TERPS Handbook (Reference 2).

2.5.1 VFR Airspace Requirements

With respect to heliports, only VFR surfaces are elaborated on in Reference 1 and in FAR Part 77. Any objects penetrating the surfaces defined therein are considered obstructions and must be evaluated to determine if they are hazards to air navigation. Requirements for IFR operations are addressed only insofar as Reference 1 advises that the TERPS Handbook applies in determining criteria for heliports which desire instrument procedures.

Three obstacle surfaces are provided for VFR operations in Reference 1, and duplicate those found in Part 77. They are: primary surface, approach surface, and transitional surface. Note that, by definition,

Reference 1 allows that the approach surface serves a two-fold function and, in effect, is an approach-departure surface. Figure 2-4, Imaginary Surfaces for Heliports, depicts and provides a perspective of those surfaces.

The dimensional drawing in Figure 2-4, excerpted from Reference 1, can be somewhat misleading. It is useful to recognize that the angles which correspond to the slopes are 7.1 and 26.6 degrees for the 8:1 and 2:1 slopes respectively. Further, the height at the outer end of the approach slope (4000 feet from the takeoff and landing area) is 500 feet. For the outer edge of the transitional surfaces, adjacent to the takeoff and landing area, the maximum height is 125 feet. Any objects which are below these surfaces, or outside their limits, are not considered obstructions to air navigation unless they are higher than 500 feet AGL.

2.5.2 IFR Airspace Requirements

Reference 1 cites the TERPS Handbook as providing the criteria for obstacle surfaces for heliports with instrument procedures. In the past, these have received little attention as only a very small number of heliports exist that have developed approved instrument approaches. Less than 50 are currently approved, and the largest share of those are private-use heliports, primarily supporting offshore operations.

It should be understood from the outset that the TERPS Handbook provides (through Chapter 11, Helicopter Procedures) the criteria for Copter-Only approaches only to heliports with respect to Non-Precision approaches and Precision Approach Radar. The criteria for precision Copter-Only approaches using ILS are for approaches to runways. Therefore, this section addresses only those criteria which apply to heliports. Recommendations for ILS and Microwave Landing System (MLS) criteria will be addressed separately.

Because this study is concerned with requirements in the vicinity of heliports, the only criteria or requirements addressed will be for final approach segment, missed approach segment, and departure segment. These are found in Reference 2.

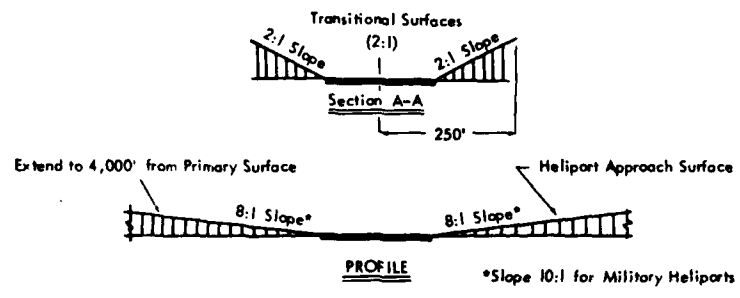
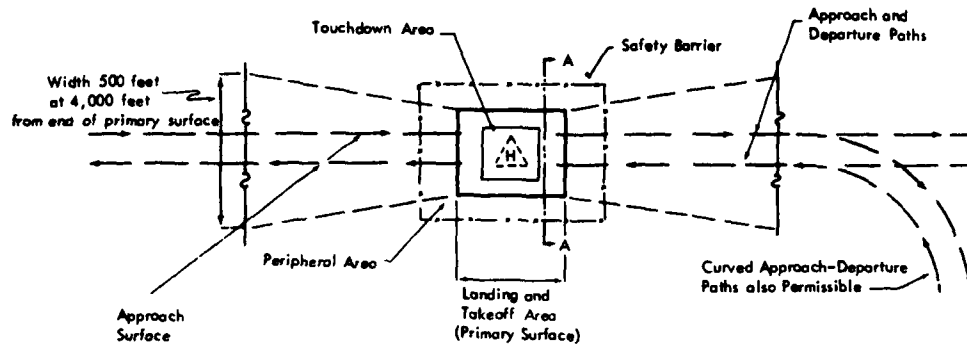

ACCEPTABLE RANGE OF ANGLES BETWEEN APPROACH-DEPARTURE PATHS
WHEN MORE THAN ONE APPROACH-DEPARTURE PATH IS PROVIDED

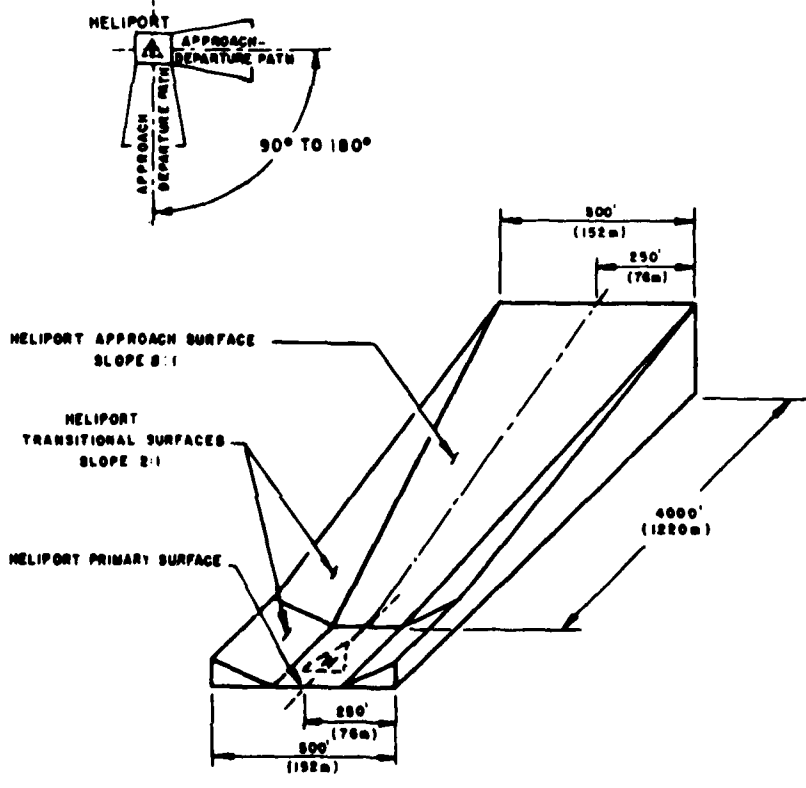

Figure 2-4. Imaginary Surfaces for Heliports.

Figure 2-5, Perspective of Copter-Only Non-Precision Final Approach Surfaces, provides a dimensional presentation of the final approach segment criteria for non-precision approaches. From a final approach fix (FAF), the helicopter descends to a minimum descent altitude (MDA) which assures a required obstacle clearance (ROC). The ROC varies from 250-350 feet in the Primary Area depending on the type of approach, except for arc approaches which maintain an ROC of 500 feet.

Specific dimensions and ROCs for the final approach segment are identified in Figure 2-6, Copter-Only Non-Precision Final Approach Segment Data. The width of the segment increases further away from the facility. Although the Missed Approach Point (MAP) was shown in Figure 2-5 to be at the narrow end, it can be located at either end in constructing an approach; but placing it at the wider end of the surface could result in a higher MDA because of the larger area which requires obstacle clearance.

In Figure 2-6, it should be noted that the final approach segment lengths (D_1) are the minimum lengths allowed and vary according to the angle at which the final approach course is intercepted when a final approach fix is provided. Also included are the criteria for area navigation (RNAV) approaches which are contained in Advisory Circular AC90-45A, Approval of Area Navigation Systems for Use in the U.S. National Airspace System (Reference 14). The "fix displacement area" referred to in Figure 2-6 is variable, and is derived from waypoint displacement areas defined in tables contained in Reference 14. Their size varies with distance and azimuth from the facility and is generally consistent with the other VOR/DME criteria in Figure 2-6.

Missed approach criteria are presented in Figure 2-7, Copter-Only Missed Approach Surfaces. These surfaces apply to all missed approaches and the width at the MAP is the same as the final approach segment areas. Note that the missed approach surface begins below the MAP at the same height as the controlling obstacle in the final approach surface. Restated, it begins at the bottom of the primary area block of ROC airspace, such that the MDA is above the start point of the missed approach surface by a

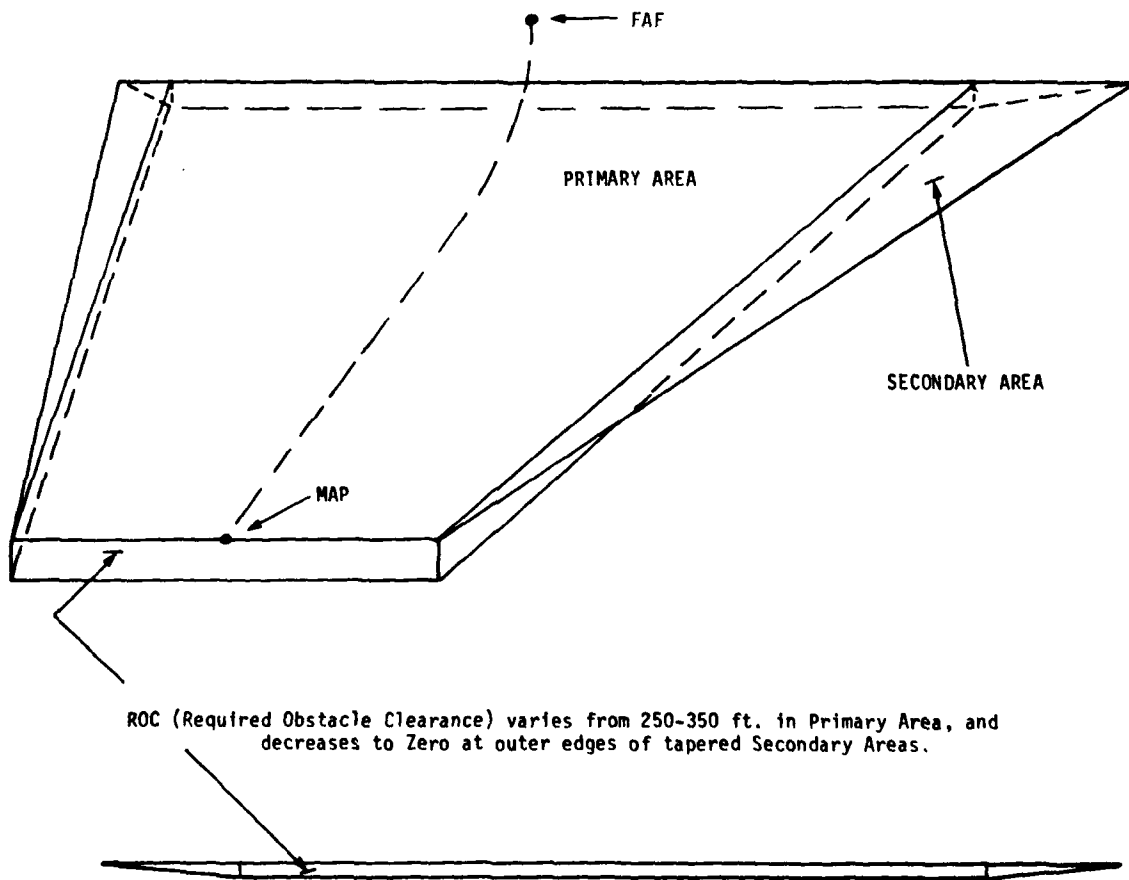
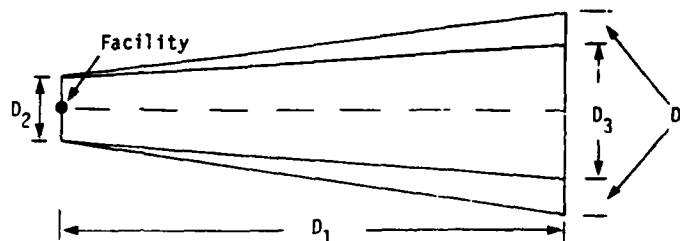

Figure 2-5. Perspective of Copter-Only Non-Precision Final Approach Surfaces.



Type of Approach	ROC	D ₁	D ₂	D ₃	D ₄
VOR (no FAF)	300'	5	2	4	0.67
VOR (with FAF) TACAN & VOR/DME (radial)	250'	1 (30°) 2 (60°) 3 (90°)	2 2 2	5 @ 30 5 @ 30 5 @ 30	1 @ 30 1 @ 30 1 @ 30
TACAN & VOR/DME (arc)	500'	UNK	8	8	2 constant
NDB (no FAF)	350'	5	2.5	4.25	0.67
NDB (with FAF)	300'	1 (30°) 2 (60°) 3 (90°)	2.5 2.5 2.5	5 @ 15 5 @ 15 5 @ 15	1 @ 15 1 @ 15 1 @ 15
2-D RNAV (AC90-45A)	250'	1 - 5 (10-60°)	fix dplcmnt area	4	1 constant

* all distances in nautical miles, D₁ are minimum lengths with intercept angles.

* constant D₄ means secondary area has same width at FAF and MAP ends.

Figure 2-6. Copter-Only Non-Precision Final Approach Segment Data.

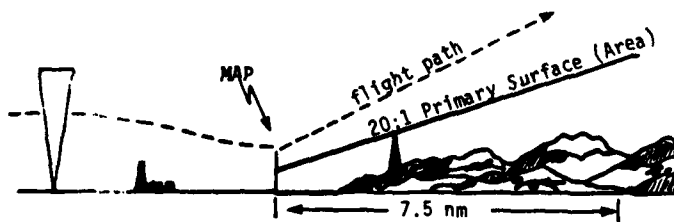
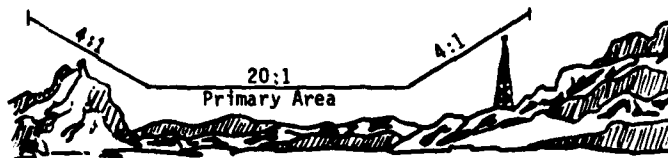
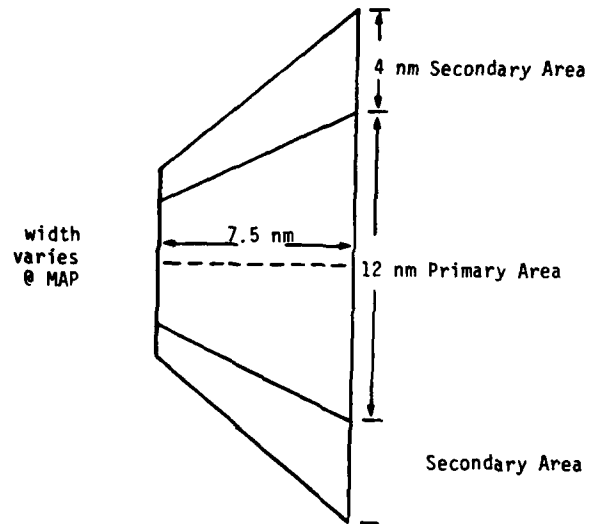

Figure 2-7. Copter-Only Missed Approach Surfaces.

height equal to the required obstacle clearance. The Copter-Only missed approach primary surface is based on a slope of one-half that for fixed wing (20:1 versus 40:1) because of the slower speeds (90 knots or less) at which Copter-Only procedures, by definition, are flown.

Departure procedures have yet to be developed for heliports, but criteria for airports are being introduced as Chapter 12 of the TERPS Handbook in Change 1. They call for a 40:1 "obstacle identification surface" (OIS) that begins at the "departure end of the runway" (DER) at a height of up to 35 feet above the DER. This is consistent with normal fixed wing balanced field length criteria.

Change 1 to the TERPS Handbook includes some changes to Chapter 11, Helicopter Procedures, but none of them affect Departure Procedures. Thus, by inference, a 40:1 slope and other criteria from Chapter 12 would also apply to heliports. However, it would seem appropriate that, given proper performance guidelines, a departure slope consistent with the current missed approach slope for helicopters could be introduced. This is discussed later under recommendations.

Airspace requirements for precision approaches to heliports do not exist for ILS or MLS, as Copter-Only approaches to that type landing system are for approaches to runways only. The TERPS Handbook does, however, contain criteria for PAR approaches at heliports.

With respect to PAR criteria, heliport obstacle surfaces for approach angles of less than three degrees are the same as those applied to fixed wing approaches. For approach angles from 3 to 12 degrees, obstacle surface slopes vary, and are shown in Figure 2-8. It should be noted that Chapter 11 suggests that, although criteria are offered for approach angles up to 12 degrees, the angle selected should be no greater than that required to provide obstacle clearance. It further cautions against implementation of the steeper angles by stating that "angles greater than 6 degrees shall not be established without authorization of the approving authority."

FINAL APPROACH GLIDE SLOPE – SURFACE SLOPE ANGLES.
 Par. 1162.b.

Glide Slope Angle (Degrees)	Less Than 3	3	4	5	6	7	8	12
Section 2 obstacle clearance surface gradient (degrees)	*	1.65	2.51	3.37	4.23	5.09	5.95	9.39

NOTE: This table may be interpolated.

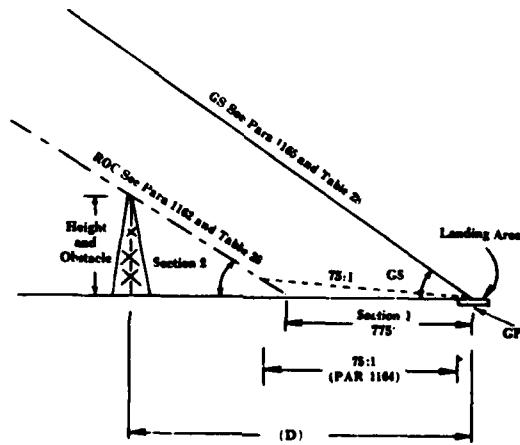

FINAL APPROACH AREA SURFACE AND OBSTACLE CLEARANCE. Paragraphs 1162 and 1164.

Figure 2-8. Copter-Only Precision Approach Radar Obstacle Surfaces.

2.5.3 Offshore Helicopter Facility Requirements

Offshore helicopter facilities include both fixed and mobile offshore drilling structures. Fixed structures are addressed in Reference 1, whereas criteria for mobile units are established in the U.S. Coast Guard's Code of Federal Regulations (CFR) 46 Parts 108 and 109 (Reference 15). Both provide guidance or criteria for landing and takeoff areas, and touchdown pads, based effectively on aircraft size, rotor diameter, and weight. Clear sectors of 180 degrees are used for airspace requirements as the elevated offshore structures do not normally have a problem with obstacles along an approach-departure path. The one area not addressed in either Reference 1 or 15 is obstacle surface requirements for rigs in a cluster.

2.6 HELIPORT REAL ESTATE REQUIREMENTS

The current real estate criteria for heliports, as identified in Reference 1, are derived through several factors: the operational profiles or requirements of the using helicopters, to include their performance capabilities; airspace requirements and their associated obstacle surface slopes; and obstacle surfaces designated in the vicinity of the heliport takeoff and landing area itself. There are three basic types of heliports considered in Reference 1: ground-level, elevated and offshore. Each has distinct requirements or circumstances which affect the ability to provide both real estate and/or airspace.

Ground level heliports, by far the most widespread, present the most difficult environmental situation with respect to providing adequate real estate and airspace for helicopter operations. Consequently, their real estate requirements are clearly defined and form the basic requirements which are extended to elevated heliports. The criteria for offshore heliports is limited to obstacle clearance on the takeoff and landing area with a 180 degree approach/departure sector.

2.6.1 VFR Real Estate Requirements

Reference 1 recommends a takeoff and landing area which is 1.5 times the overall length of the largest helicopter expected to use the facility. The touchdown pad within that area can be slightly smaller, needing only to accommodate the landing gear foot print of the using helicopter with a reasonable margin. An additional, obstacle-free, peripheral area surrounds the takeoff and landing area having a recommended width of one-quarter the overall helicopter length with a minimum width of 10 feet.

The approach-departure path surfaces begin at the takeoff and landing area boundary and extend outward, creating minimal real estate requirements as the surface rises at a slope of 8:1. The slope of this surface would permit a 50-foot obstacle to be located 400 feet from the edge of the takeoff and landing area, a 25-foot obstacle 200 feet away, etc.

2.6.2 IFR Real Estate Requirements

The real estate requirements for heliports changes only slightly as instrument procedures are introduced. The basic VFR criteria remain, and are changed only in the case of heliports with a PAR approach. Reference 1 establishes the VFR requirements or criteria, and identifies the TERPS Handbook (Reference 2) as the determinant of IFR obstacle surfaces. In applying the IFR obstacle surfaces, expanded real estate requirements for IFR operations develop when the ground-level point of origin of a surface is displaced from the takeoff and landing area.

For non-precision approaches, no additional real estate requirements are imposed. The non-precision approach scenario calls for descent to an MDA and, upon gaining visual reference at or before the missed approach point, a visual approach is made to the heliport within the airspace protected by the VFR obstacle surfaces.

For precision approaches to heliports using the standard Instrument Landing System or the future Microwave Landing System, no criteria exist. The ILS criteria contained in Chapter 11 of Reference 2 are for Copter-Only approaches to a runway. These could not appropriately be applied directly to heliports because they are supported by several additional obstacle surfaces which are peculiar to airports (i.e., the horizontal and conical surfaces). Neither those surfaces nor their concept were adopted in the basic heliport design criteria. Criteria for MLS are still under development for both airports and heliports.

Instrument approaches to heliports using PAR are the only instrument procedures which presently affect real estate requirements. Figure 2-8 depicted the heliport PAR criteria from Reference 2, and identified a ground-level point of origin for the final approach obstacle surface which is displaced 775 feet from the approach path's Ground Point of Intercept (GPI) which is at the center of the heliport takeoff and landing area. This establishes an additional real estate requirement to accommodate the 775 foot area. Further demands may be imposed depending on the angle of the approach surface (e.g., the steeper the surface, the less the resulting real estate requirement).

Instrument departures from heliports are not addressed in either of References 1 or 2. There is, however, an operational requirement for this. The air traffic control system currently allows helicopters to depart from other than airports, initiate an IFR flight plan, and enter into IMC conditions. This can be accomplished from a wide variety of locations that range from helicopter landing sites in remote areas to downtown heliports. Heliports served by an approved Copter-Only approach are logical sites for preplanned or published Copter-Only departure procedures.

2.6.3 Requirements for Failure-State Operations

An additional, potential requirement for real estate manifests itself in the form of forced landing areas. Consideration of emergency situations during approach and departure at heliports is only generally treated in

Reference 1, and not addressed in the other U.S. documents reviewed. The only time forced landing areas are discussed in Reference 1 is in addressing approach-departure paths. There, it states that "areas suitable for an emergency landing are desired along the approach-departure path unless the heliport is used exclusively by multi-engined helicopters with proven capabilities to continue flight with one engine inoperative."

The implication is that, to consider failure-state operations, some additional real estate should be available on a continuing basis to assure suitable forced landing areas. This is not, however, a requirement, as is the case with the obstacle surfaces reproduced from FAR Part 77.

2.7 U.S. ARMY HELIPORT AND HELIPAD CRITERIA

Any review of heliport design criteria would not be complete without including the requirements of the largest single user of helicopters in the country. Pertinent helicopter landing facility criteria were extracted from the U.S. Army technical manual, TM 5-803-4, Planning of Army Aviation Facilities (Reference 16). It contains the real estate and airspace requirements for a variety of fixed-wing and helicopter landing facilities.

The criteria are discussed here to demonstrate an approach to developing requirements which has matured over a number of years of extensive helicopter utilization. Although military resources (for heliport development) are significantly different than what is typically available for non-military facilities, the Army criteria discussed here could be said to represent an idealized or optimum set of requirements, given unlimited real estate or resources. They are included in this report as an excellent example of helicopter landing facility criteria.

2.7.1 Categories of Helicopter Landing Facilities

Reference 16 makes a clear distinction between the types of facilities, based on intended utilization. They are: heliport, helipad and hoverpoint. The latter is excluded from this discussion as it is constructed to provide a "reference point for air traffic control personnel for the arrival and departure control of helicopters".

Both heliports and helipads are permanent facilities. Each is sub-categorized according to type of intended utilization, and a classification scheme can be constructed as follows:

HELIPORT	Visual
	Instrument (Interim)
HELIPAD	Visual
	Instrument (Interim)
	Limited-Use

In both cases, increased real estate and airspace is required for instrument operations.

With respect to instrument criteria, Reference 16 makes note of anticipated improvements in instrumentation in a clarification of the "Interim" status noted above. That statement is quoted here to underscore those expectations; and how they appear to impact the Army's attitude toward developing helicopter facilities with instrument approach capability:

"Facility and clearance criteria concerned with instrument procedures for helicopters are labeled "INTERIM". These criteria have been developed in conjunction with the recent establishment of instrument procedures (TM 95-226, Reference 2) based on the existing state-of-the-art instrumentation. The INTERIM designation will be used until more sophisticated instrumentation, now in development, is produced which will refine approach corridors and may reduce land requirements

considerably below those indicated herein. During this interim period the fixed-wing runway and instrument procedures will be used by helicopters at existing airfields. Helicopter instrument landing facilities will only be developed at isolated heliports or land pads where military mission dictates the requirement for this capability."

It is useful to recognize that decisions to develop a heliport versus a helipad are based largely on the level of activity and physical characteristics of the site. Heliports typically apply to facilities normally required for the support of aviation units at major (division-type) installations, and are developed with a full complement of operations, maintenance and administrative services. They may also be adopted for use at other types of installations such as training centers or schools, hospitals, depots and arsenals.

Helipads in sizes from 40 to 100 feet square are normally authorized for "isolated sites, for support of infrequent operational requirements, for sites which cannot physically support (limitations of land and/or airspace) or economically justify an airfield/heliport development, or at airfield/heliports with high air traffic density which require one or more helipads for establishment of safe aircraft traffic control patterns". This type of facility best approximates the needs of civilian heliport operations, and selected criteria for the various sub-categories of Army helipads will be documented below.

2.7.2 Terminology and General Requirements

Certain terms used by the Army are at variance with those contained in the Heliport Design Guide; either in direct contrast, or expanded consistent with the Army approach/philosophy towards developing helicopter landing facility criteria. Pertinent definitions and terminology are included here, extracted from Reference 16, to enhance the understanding of the Army criteria discussed in subsequent paragraphs.

"APPROACH-DEPARTURE ZONE: A trapezoidal area, symmetrical about the extended runway centerline and expanding outward from the ends of the landing area of runways and helipads, or the clear area of hoverpoints. Provided for the 'straight-in' approach/'straight-out' departure to insure a satisfactory level of safety and regulation for aircraft."

"HELICOPTER RUNWAY: A prepared surface used for the landing and takeoff of helicopters requiring a ground run." (It should be noted, that helipads are "designed and constructed for the vertical takeoff and landing of helicopters.")

"HELIPORT: A group of facilities designed for takeoff, landing, servicing and parking of rotary-wing aircraft."

"LANDING AREA: The cleared and fine graded area symmetrical about the runway or helipad. The area usually consists of a prepared landing surface, shoulders, overruns, and the specified clearance areas to permit safe aircraft landings and takeoffs." (With respect to helipads, these are referred to as "clear landing area".)

"TAKEOFF SAFETY ZONE: A clear graded area within the limits of the approach-departure zone, contiguous to the landing area at the takeoff end of the runway. This area should be free of obstructions, both natural and manmade, rough graded to permit recovery of aircraft that are aborted during takeoff, and should be under control of the installation commander." (These areas are at the takeoff end of each approach-departure zone and are "provided as an emergency landing area in event of an engine failure.")

With respect to general requirements, certain elements of the Army criteria bear mention. For both heliports and helipads, several items make

repeated demands for real estate for all configurations and sub-categories of landing facilities.

Grading of clear areas is extensive and well-defined, emphasizing the importance of minimizing adverse effects on aircraft performance. In the case of helicopter runways and taxiways at heliports, lateral cleared areas are "rough-graded to the extent necessary to reduce damage to aircraft in the event of erratic performance." The "clear landing area" associated with an instrument helipad, in addition to being clear of obstructions, is to be "rough-graded to the extent necessary to reduce damage to helicopters in the event of an emergency landing." The takeoff safety zone defined above, which varies in size for heliports and helipads, also requires grading and places additional demands on real estate requirements.

Hoverlanes and taxiways are allowed substantial real estate. Taxiway size forces no restrictions on the size of helicopters intending to use the facility, providing 100 feet lateral clearance from centerline (more than twice the overall length of the largest helicopter, the S-64 Skycrane). For parking areas and aprons, dedicated to specific categories of helicopters, the same concept applies -- the width of hoverlanes/taxiways serving the sections of parking areas and aprons is at least twice the overall length of the largest helicopter assigned to that area.

Selected real estate and airspace requirements for heliports and helipads are summarized in the following sub-sections. The criteria are presented in tabular format with data most pertinent to the study shown. Because the Army criteria are considered by the authors to be an excellent example of heliport/helipad design requirements, appropriate portions of Reference 16 are extracted and included as Appendix B, Selected U.S. Army Design Criteria. Applicable chapters were reproduced in the hopes that they may serve civilian operators as a supporting reference in addition to the recommendations of the Heliport Design Guide.

2.7.3 Helicopter Criteria

The criteria for permanent heliports are the most demanding in terms of real estate. This is not unexpected, as they are intended to serve a relatively high density of traffic at major installations. Pertinent real estate and airspace requirements are presented in Table 2-2, Selected Criteria for Permanent U.S. Army Heliports.

The most significant contrast to civil criteria is the Army approach to development of a heliport runway. The basic dimensions are 75 by 450 feet, with lateral obstacle clearance from runway centerline of either 150 or 375 feet for visual and instrument heliports respectively. The basic length is based on sea level, standard day conditions, and is corrected for temperature and altitude.

From the basic 450 feet length at mean sea level, the following formulae are applied:

"An increase of 10% for each 1,000 feet in altitude above 2,000 feet will be made. A temperature correction of 4% will be added for each 10°F., above 59°F., for the average daily maximum temperature for the hottest month."

2.7.4 Helipad Criteria

Flight activities at Army helipads most closely approximate the desired or intended operational uses of the civilian sector. The helipad characteristics differ from heliports in that the runway is replaced by a landing pad with a surrounding "clear landing area", and the takeoff safety zone is smaller in the case of non-IFR helipads.

Three types of helipads are provided for by the criteria contained in Reference 16. The type to be developed is dependent upon the operational requirements of the mission, and are defined verbatim below:

TABLE 2-2
SELECTED CRITERIA FOR PERMANENT U.S. ARMY HELIPORTS

	<u>Visual</u>	<u>Instrument</u>
<u>RUNWAY</u> minimum length (ft)		450 (a)
width (ft)		75
Shoulder, width (ft)		25
Lateral Obstacle Clearance from runway centerline (ft)	150	375
<u>OVERRUN</u> length (ft)		75
width (ft)		125
<u>APPROACH - DEPARTURE ZONE</u>		
Obstacle Surface (slope)	10:1	25:1 (b)
Inner Width (ft)	300	750 (c)
Outer Width (ft)	600	8,000
Length (ft)	1,500	25,000 (d)
<u>TAKE-OFF SAFETY ZONE</u>		
Length (ft)	1,000	
Width (ft)	same as approach - departure zone	
<u>TRANSITIONAL SURFACES</u> slope	2.1	4.1

- (a) Basic dimensions, corrected for temperature and elevation.
- (b) Begins 775 ft from GPI.
- (c) Constant 750 ft. from GPI to beginning of obstacle surface, then flares.
- (d) Measured from GPI.

"INSTRUMENT (Interim) HELIPAD: These criteria will be used when IFR capability is a requirement of the military mission and no other instrumented heliport or airfield is located within commuting distance of the base of operations."

"STANDARD VFR HELIPAD: These criteria may be used for visual flight operations at locations where only occasional operations are required at special locations such as hospitals, headquarters buildings, missile sites, etc. or at airfields where one or more helipads may be required for purpose of separating operations of numerous small (OH, UH and AH type) helicopters from fixed-wing and/or medium and heavy helicopter traffic."

"LIMITED-USE HELIPAD: These criteria will be used for development of helicopter landing facilities when either there exists an instrumented landing facility (fixed-wing or rotary-wing) which can be utilized or whenever there is no mission requirement, either existing or future, which requires a separate instrumented helicopter landing facility."

Pertinent real estate and airspace requirements are presented in Table 2-3, Selected Criteria for U.S. Army Helipads.

2.8 FINDINGS AND CONCLUSIONS

This section generally summarizes the findings and conclusions of an analysis of existing U.S. heliport criteria and requirements, and their comparison with airport criteria. These findings form the basis from which the recommendations for modifications to heliport criteria will be developed in Section 4 and proposed in Section 5.

There is no requirement or criteria for heliports to have varied obstacle surfaces to accommodate different types of instrument approaches,

TABLE 2-3
SELECTED CRITERIA FOR PERMANENT U.S. ARMY HELIPADS

	<u>Limited-Use</u>	<u>Standard VFR</u>	<u>(Interim) IFR</u>
<u>LANDING PAD</u>			
Dimensions, square (ft)	40-100	100	
Shoulders, width (ft)	25	25	
<u>CLEAR LANDING AREA (CLA)</u>			
Dimensions, square (ft)	120-150	300	---
Except IFR --- Length (ft)	---	---	1,550
Width (ft)	---	---	750
<u>TAKEOFF SAFETY ZONE</u>			
Length (ft)	500		included in CLA
Width (ft)	coincides with approach - departure zone		
<u>APPROACH - DEPARTURE ZONE</u>			
Slope (run:rise)	10:1		25:1
Length	1,500		24,225
Inner Width	same as CLA		same as CLA
Outer Width	500	600	8,000
<u>TRANSITIONAL SURFACE</u>			
Slope (run:rise)	2:1		4:1

except for the PAR final approach surface identified in the TERPS Handbook. With respect to airports, it was found that: the width of primary areas increases for instrument procedures, and is the same for both precision approaches and non-precision approaches with visibility at or below 3/4 mile; the outer width of the approach area increases as the difficulty of the instrument approach increases; and the length of the approach area surface doubles for airports having instrument approach procedures.

Heliport surfaces as established by FAR Part 77, and reproduced in Reference 1, do not include horizontal and conical surfaces such as those prescribed for airports under the same FAR.

Heliport classifications address the nature of control exercised on their use, not the type of operations for which their use is suitable. Particularly, they have no classification scheme for the various types of instrument procedures, as do airport classifications under FAR Part 77.

No unique criteria for instrument departures from heliports are contained in either of References 1 or 2. The only criteria available are those published for airports in Chapter 12 of Reference 2.

Reference 1 contains no criteria for helicopter landing facilities on mobile offshore units, but does reference the appropriate U.S. Coast Guard office which establishes those requirements.

Reference 1 is purely advisory in nature, except when federal funding is involved, with the exception of heliport obstacle surfaces reproduced from FAR Part 77.

Forced landing areas in the vicinity of approach-departure paths are only generally addressed in Reference 1, and no provision exists for requiring their existence.

No real estate or airspace criteria exist for precision approaches to heliports using ILS or MLS.

There are no criteria for Copter-Only instrument departures contained in Reference 2.

There is no requirement for real estate to accommodate acceleration to V_{TOSS} (Take-Off Safety Speed) or minimum IFR speed.

Additionally, a review of the U.S. Government Airport/Facility Directory (Reference 17) was made for background information; and it was found that:

- No public-use heliport in the conterminous United States is reported to have a published Standard Instrument Approach Procedure (SIAP).
- There was no indication of whether heliports were ground-level or elevated.
- There was no statement made for those heliports which require pilots to receive a flight check prior to using the facility.
- There appears to be no requirement for a heliport diagram to assist pilots in preparing for arrival at a heliport for the first time.
- Information regarding the recommended or designed approach-departure paths is not identified in any fashion (such as: placement of paths, heading information, or whether a curved path is required).
- Although obstacle clearance at heliports is developed to accommodate the "largest helicopter expected to use the facility" (Reference 1), there is no indication in the Directory as to what would be the largest helicopter protected from obstacles.

SECTION 3
REVIEW OF INTERNATIONAL HELIPORT CRITERIA

3.1 INTRODUCTION

This section contains a review and analysis of certain heliport requirements from other nations having significant helicopter activity. The criteria reviewed are from the United Kingdom (U.K.), Canada, and Japan; and the International Civil Aviation Organization (ICAO). The purpose of the review was to discern the philosophies of these nations in determining real estate and airspace requirements for heliports.

3.2 OVERVIEW OF SELECTED REAL ESTATE AND AIRSPACE REQUIREMENTS

The selected criteria contrasted significantly with those of the United States. Overall, they were more restrictive, requiring greater amounts of both real estate and airspace than what is currently recommended in Reference 1 and FAR Part 77.

Certain criteria from the selected countries and ICAO considered pertinent to this study are included here to establish a basis for later comparison. The underlying philosophies will be discussed and contrasted to U.S. requirements in subsequent discussions.

3.2.1 United Kingdom

The Civil Aviation Authority (CAA) of the U.K. has developed in draft form a document entitled Helicopter Performance Code of Practice (Reference 18) which contains both helicopter performance requirements and heliport real estate and airspace requirements. The heliport criteria vary, depending on helicopter performance. In establishing their criteria, the U.K. differentiates between those helicopters which have a performance capa-

bility such that, in the event of failure of a power unit, it will be possible to continue the flight or land back on the take-off area (Group A) and those helicopters which have no engine-out capability and are obliged to land immediately following failure of a power unit (Group B).

The heliport criteria for both Group A and Group B helicopter performance categories are addressed. Group A is the most demanding and is similar in approach to the Category A performance prescribed in FAR Part 29 -- Airworthiness Requirements: Transport Category Helicopters (Reference 7). The heliport real estate and airspace requirements for both performance groups are depicted in Figures 3-1 and 3-2 (Perspective of U.K. Heliport Criteria, Performance Group A and B, respectively).

Of particular interest are the requirements for takeoff areas. Both performance groups have requirements for an area to accelerate to climb speed and apply helicopter performance from the Rotorcraft Flight Manual (RFM) in determining the size of these areas.

In the case of the more restrictive Group A, both a Continued Takeoff Distance (CTOD) and Rejected Takeoff Distance (RTOD) are computed; and the greatest of the two distances defines the end of an obstacle-free takeoff area. In computing the CTOD, allowance is made for delay in recognizing engine failure by applying a Power Unit Failure Point and a Decision Point; then determining the distance required to accelerate to Takeoff Safety Speed (v_{TOSS}) or climb to 50 feet. In computing the RTOD, the distance required to come to a full stop following an engine failure is determined.

Criteria for Group B, although changing terminology somewhat, provides a Horizontal Acceleration Area for acceleration to climb speed and the subsequent Takeoff Area accommodates an initial climb to 100 feet above the heliport elevation.

All of these areas are effectively free of obstacles, although there is a proviso which, for certain segments of real estate, allows obstacles

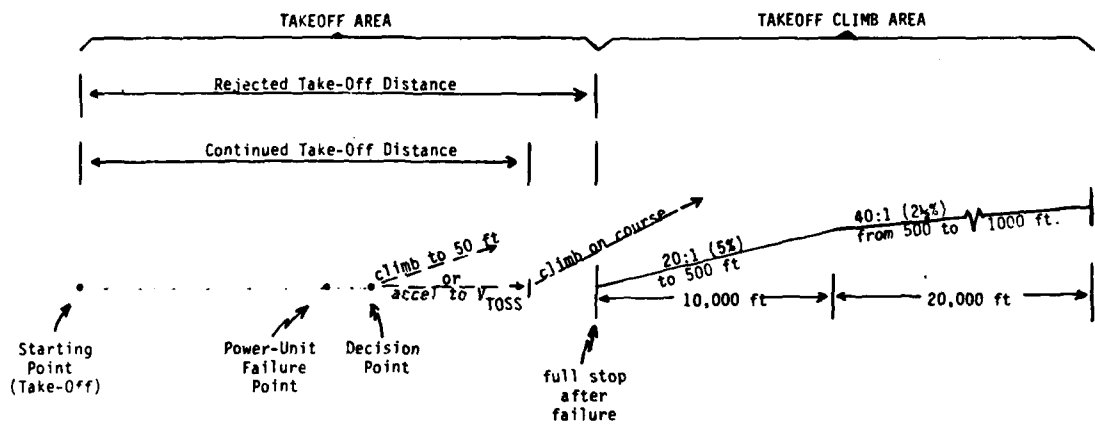

Figure 3-1. Perspective of Heliport Criteria,
Performance Group A, U.K.

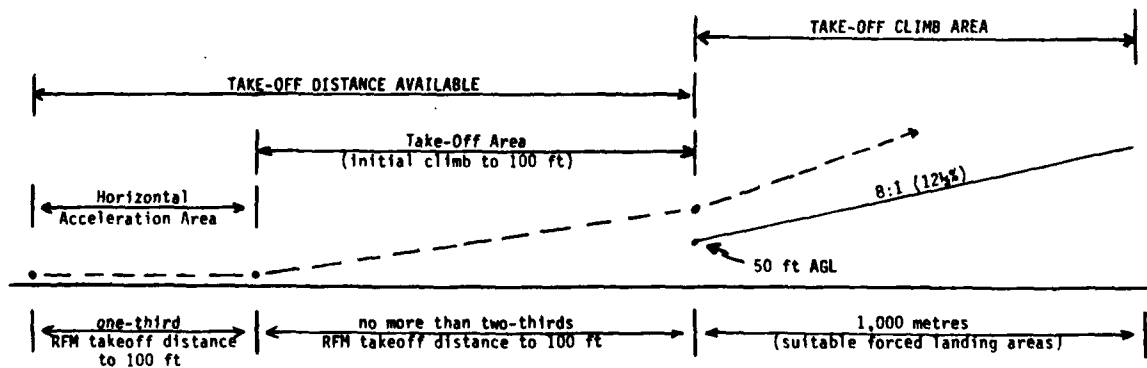

Figure. 3-2. Perspective of Heliport Criteria,
Performance Group B, U.K.

that are considered insignificant because of their size or frangibility. For both performance groups, suitable forced landing areas are required throughout approach and departure between the heliport environment and the enroute altitude.

3.2.2 Canada

The Canadian Ministry of Transport, Air, provided an advance copy of its new heliport regulations, Heliport and Helideck Design Criteria (Reference 19), which is expected to be issued shortly. Pertinent obstacle surfaces and criteria are presented here, reproduced from Reference 19, in Figure 3-3 (Perspective of Take-Off/Approach Areas and Surfaces, Canada) and Table 3-1 (Criteria for Curved Take-Off/Approach Area, Canada).

It should be noted that Canada introduced Heliport Classifications based not on the type of user (i.e., public versus private), but on the kind of operations: Day VMC; Day/Night VMC; and Day/Night IMC. The surfaces depicted vary considerably from U.S. criteria. For VMC operations, airspace requirements are noticeably steeper, and smaller for Day VMC, and become shallower and more expansive as the category of operation becomes more demanding. However, take-off and landing areas in all cases are larger than U.S. criteria.

The requirements contained in Table 3-1 represent the most precise criteria for developing curved approach/departure paths of all documents reviewed. Note that directional change, turn radius, and width at inner gate all change in conjunction with the heliport classification.

More criteria for the Canadian design guide are planned, but details were unavailable for the study. With respect to discerning the approach to determining criteria, it should be noted that an attachment to the design guide is to be developed entitled "Guidelines for Downtown Helicopter Flight Routes."

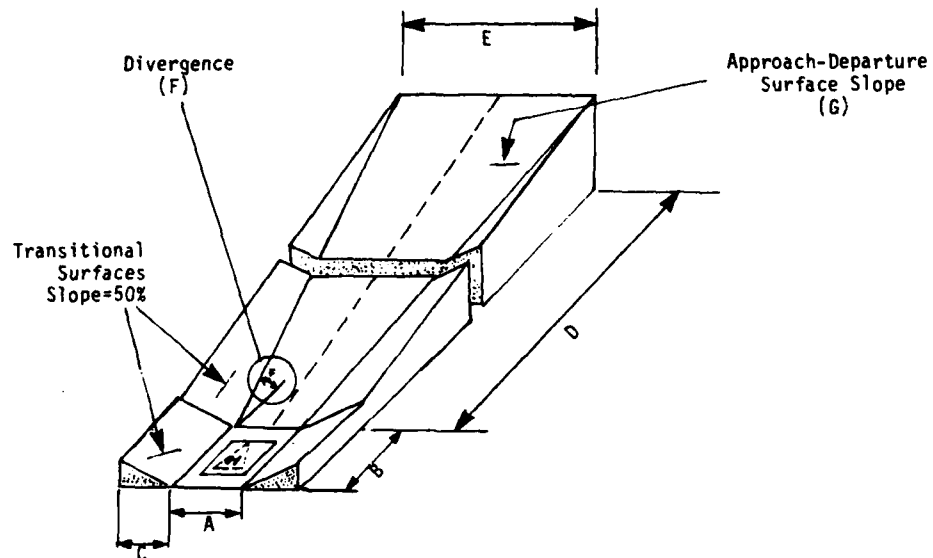

HELIPORT CLASS (FLT OPNS)	A	B	C	D	E	F	G
H-1 (VMC DAY)	200'	200'	N/A	800'	200'	N/A	25%
H-2 (VMC DAY/NIGHT)	400'	400'	100'	4,000'	1,200'	10%	20%
H-3 (IMC DAY/NIGHT)	800'	800'	150'	10,000'	3,800'	15%	2.5%

Figure 3-3. Perspective of Heliport Surfaces, Canada.

TABLE 3-1
CRITERIA FOR CURVED TAKEOFF/APPROACH AREAS, CANADA

Directional Change	120° Max	90° Max
Radius of Turn on Centre Line	Larger of 200 ft (H-1), 400 ft (H-2); or, width of inner gate	Larger of 800 ft or width of inner gate
Width at Inner Gate	Width of inner edge plus 20% of distance to inner gate	Width of inner edge plus 30% of distance to inner gate
Width at Outer Gate	1.5 X radius of turn	1.5 X radius of turn
Elevation of Outer Gate	As per inner gate	As per inner gate
Combined Length (Excluding Curved portion)	800 feet H-1 4000 feet H-2	10,000 feet
Slope	25% H-1 20% H-2	2.5 per cent
Divergence	20% (H-2 only)	15 per cent
Final Width	Width at outer gate plus 20% of remaining distance. (H-2 only)	Width at outer gate plus 30% of remaining distance

3.2.3 Japan

The Japanese criteria are mandatory in nature because aviation law in that country requires that all heliports be licenced as an aerodrome. Categories are specified for both land and water heliports, based on the performance capabilities and characteristics of the type helicopters to use the facility. The real estate and airspace requirements increase with aircraft size; and Category A designed for the heaviest or largest helicopters for both land and water heliports.

The Japanese criteria, maintaining terminology consistent with its nonheliport regulations, specifies requirements for a runway and/or landing strip, within which the takeoff and landing area is located. The physical characteristics for heliports are depicted in Tables 3-2 and 3-3 (land and water heliports, respectively). In the case of land heliports, the runway is surrounded by a landing strip which provides an obstacle free area on both sides of the runway as well as an "over-run" on each end. The water heliports consist only of a large landing strip.

Table 3-4 depicts obstacle surface criteria. Approach areas and surfaces are established in similar manner to other countries, but with slopes that are noticeably shallower. Japan is the only nation studied which did not establish transitional surfaces extending laterally from its approach/departure surfaces. Instead, a circular Horizontal Surface lies in a plane 150 feet above the heliport elevation. No provision could be found for designing curved approach/departure paths.

TABLE 3-2
CHARACTERISTICS OF LAND HELIPORTS, JAPAN

	Class	A	B	C	D
R U N W A Y	Width	30 m (100 ft) or more	20 m (66 ft) or more	15 m (50 ft) or more	1.2 times more than the width of projected area of aircraft to be used
	Max. longi- tudinal slope	2%			
	Max. lateral slope	2.5%			
L A N D I N G	Length	length of runway plus 15 m (50 ft) at each end of runway			1.2 times more than the length of projected area of aircraft to be used
	Width	50 m (164 ft) or more	40 m (130 ft) or more	30 m (100 ft) or more	1.2 times more than the width of projected area of aircraft to be used
	Max. longi- tudinal slope	2%			
S T R I P	Max. lateral slope	2.5%			
	Width	15 m (50 ft) or more	9 m (30 ft) or more	6 m (20 ft) or more	
T A X I W A Y	Max. longi- tudinal slope	3%			
	Max. lateral slope	3%			
	Distance between the edge of taxi- way and fixed obstacle	15 m (50 ft) or more	12 m (40 ft) or more	9 m (30 ft) or more	

Note. - The dimensions of each category of heliport are prescribed for a certain range. It is necessary that for an actual site the dimensions be determined case by case, taking into account temperature, altitude and the geographical conditions involved.

Type of Heliport	Category	Length of runway or landing strip
Land Heliport (Length of Runway)	A	90 m (300 ft) or more
	B	40 m (130 ft) to 90 m (300 ft)
	C	15 m (50 ft) to 40 m (130 ft)
	D	15 m (50 ft) or more, or 1.2 times or more than the length of projected area of aircraft to be used

TABLE 3-3
CHARACTERISTICS OF WATER HELIPORTS, JAPAN

Category	A	B
Width of Landing Strip	50 m (164 ft) or more	30 m (100 ft) or more
Width of Taxiing Channel	30 m (100 ft) or more	20 m (66 ft) or more
(Length of Landing Strip)	100 m (330 ft) or more	50 m (164 ft) to 100 m (330 ft)

TABLE 3-4
HELIPORT OBSTACLE SURFACES, JAPAN

Approach/Departure Surfaces

Type	Category	Length of Approach Area	Slope of Approach Surface
Land Heliport	A	2 000 m (6 600 ft)	1:20
	B	1 500 m (5 000 ft)	1:10
	C	1 000 m (3 300 ft)	1:10
	D	2 000 m (6 600 ft) or less, or length specified by the Minister of Transportation	1:10 or more and 1:4 or less, or slope specified by the Minister of Transportation
Water Heliport	A	2 000 m (6 600 ft)	1:20
	B	2 000 m (6 600 ft) or less, or length specified by the Minister of Transportation	1:10 or more and 1:4 or less, or slope specified by the Minister of Transportation

Note. - The "Approach Area" is a symmetrical trapezoid, the shorter parallel side of which is the same as the end of the landing strip. Each non-parallel side of the approach area extends outwards at an angle of 15° with respect to the extended centre line of the landing strip.

Horizontal Surfaces

Type of Heliport	Category	Radius of Horizontal Surface
Land Heliport	A	800 m (2 600 ft)
	B	600 m (2 000 ft)
	C	400 m (1 300 ft)
	D	800 m (2 600 ft) or less, or radius specified by the Minister of Transportation
Water Heliport	A	800 m (2 600 ft)
	B	600 m (2 000 ft) or less, or radius specified by the Minister of Transportation

Note. - The horizontal surface is a circular area lying in a horizontal plane 45 m (150 ft) above the reference point of the heliport, the radius of which is measured from this point and has the value shown in Table 1-5.

3.2.4 International Civil Aviation Organization (ICAO)

The ICAO criteria are contained in its Heliport Manual (Reference 20) and are advisory in nature, intended to provide guidance within the organization where none had previously existed. It is the result of a survey of member nations and contains: ICAO recommendations; and criteria submitted by the United Kingdom, United States and Japan. The Canadian criteria were still under development at the time of the ICAO survey.

The ICAO recommendations, depicted in Figure 3-4, provide a landing and takeoff area equal in length to Japan's Category A runway length plus landing strip longitudinal over-run, and slightly wider. Approach/Departure surface and transitional surfaces were established with slopes identical to the U.S. criteria.

It should be noted that the criteria for physical dimensions and characteristics, and obstacle surfaces, from the United Kingdom were not included in the ICAO Heliport Manual. All other U.K. requirements were included (i.e., construction and load-bearing requirements, firefighting and safety equipment, lighting and marking, etc.). The U.K. Helicopter Performance Code of Practice is still in draft form and is being applied internally within the CAA.

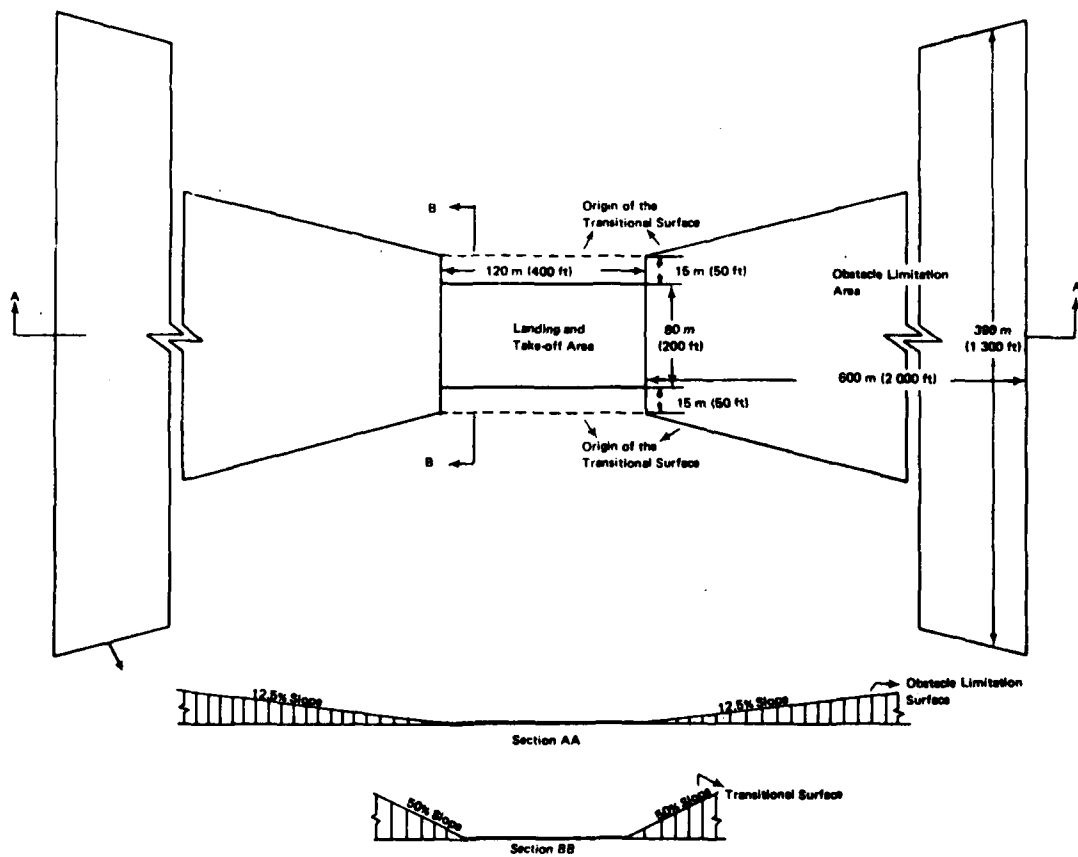

Figure 3-4. Perspective of Heliport Surfaces, ICAO.

3.3 COMPARISON WITH U.S. CRITERIA

This sub-section discusses the areas in which major or significant differences were found between the reviewed international criteria and the current U.S. criteria. It was found that the philosophy or approach to developing real estate and airspace requirements differed considerably from one country to the next and involved the full range of applicable parameters. These differences will be discussed in terms of:

- licensing and mandatory compliance;
- heliport classifications and categories;
- performance considerations;
- failure-state operations;
- takeoff and landing areas;
- approach and departure areas; and
- lateral obstacle protection.

Each of these areas will be discussed below, expanding on the specific international criteria presented earlier in this section.

3.3.1 Licensing and Mandatory Compliance with Criteria

There are no heliport licensing requirements in the United States other than those which might be required by local or regional authorities. The design criteria contained in Reference 1 are advisory in nature and must be complied with only when federal funds are used in the development of a public heliport. This effectively means that most heliports, including public heliports developed through private funding, need comply only with the obstacle surface criteria contained in FAR Part 77, unless non-federal requirements have been imposed locally (such as city or state laws).

The ICAO Heliport Manual does not require the licensing of heliports, nor does it specifically state that member states develop heliports in compliance with its standards. The stated purpose of the manual is to

"provide guidance on design of heliports as no Standards or Recommended Practices on the subject exist in any Annex." Thus, it is construed to be advisory in nature.

Japanese aeronautical law classifies heliports as a type of aerodrome, requiring that the establishment of a heliport is subject to approval by the Minister of Transportation, the same as an aerodrome for fixed-wing aircraft. Thus, it must be in compliance with Japan's heliport criteria.

In Canada, the uniform application of its criteria are generally mandatory; but may be modified if compensated for by an acceptable change in operational profile. Reference 18 explicitly forewarns users of the document to the need for operational considerations, by stating that "where deviations can be justified and are approved by the Director General, Civil Aeronautics, the amended criteria will normally be accompanied by some off-setting operational procedure, restriction or constraint."

The United Kingdom does not require a license for all heliports. Part III of its Helicopter Performance Code of Practice concedes that "the majority of Public Transport Group B operations will be conducted at unlicensed sites for the foreseeable future." It does, however, instruct operators assessing the suitability of a site for use that they should "ensure that certain criteria are met in order that the Performance Rules of Part II can be observed for operations at the site." By requiring operations in accordance with Performance Rules, the CAA effectively establishes voluntary compliance with site selection criteria.

3.3.2 Heliport Classifications and Categories

It was found that the United States criteria was the only one with a classification scheme based on ownership and/or access to the heliport (i.e., public, private and personal-use). Further, changing the classification makes no difference in obstacle surface requirements. The ICAO

guidance makes no mention of heliport classifications, but does suggest that in selecting dimensions for landing and take-off area the performance characteristics of the helicopters to be served should be considered.

The Japanese heliport classification system is based on the length of the runway for land heliports and on the landing strip for water heliports. The standards for heliport categories are promulgated in accordance with the class of helicopter they are to serve.

With respect to land heliports, Japan established four categories (A through D). The first three apply strictly to the class of helicopter, as identified below:

Category A: large (such as BV-107, S-61)

Category B: medium (such as S-62, S-58)

Category C: small (such as Bell 47)

The Category D heliports, according to Reference 20, were established "with a view to making helicopter operations permissible within the minimum limitations which the Minister of Transportation deems safe, taking into consideration the intended use, geographical conditions, etc., of the site." It is emphasized that Category D "would be used where the standard requirements of Categories A, B and C could not be completely satisfied and might result in conditions or restrictions being imposed on the use of the heliport." Further, it allows for flexibility in dealing with future helicopters having significantly different performance capabilities or characteristics. It should be noted that the landing strip size for Category D is not necessarily smaller than that for Category C.

With respect to water heliports, only two categories are used. Category A is established for large helicopters, and Category B for "other than large" helicopters. The latter is similar to that for Category D land heliports.

Canada developed three classifications for land heliports. They are based not on helicopter performance, but on the level of difficulty of the operation, and are presented below:

- H₁ Day VMC
- H₂ Day/Night VMC
- H₃ Day/Night IMC

Both the area and slope of obstacle surfaces change depending on the class of heliport.

The United Kingdom related its heliport criteria directly to the performance of helicopters to use the facility. Two sets of site selection criteria, with appropriate real estate and airspace requirements, were specified in Reference 18: Performance Group A and B. Both referred to multi-engine helicopters, with Group A requiring specific one-engine inoperative performance capabilities, and Group B the least restrictive in terms of both performance requirements and heliport criteria. Performance requirements are clearly specified in the Code of Practice Glossary of Terms and is discussed in the following sub-section.

3.3.3 Performance Considerations

All documents reviewed made reference or allusion to the need for considering the performance capabilities of the helicopters to use the facility. Only Canada and the United Kingdom, however, offered specific guidance as to how this might be achieved.

With respect to Canada, a performance capability study is required to determine if standard real estate and airspace requirements are sufficient. This is applied in addition to the different criteria already established for each heliport classification. The requirement is stated below:

"TEMPERATURE/ELEVATION ACCOUNTABILITY. Where a study of the flight manual performance data of the critical helicopter indicates that the reference temperature of the heliport is such that the effect on the density altitude could be a factor, the dimensions and slopes specified in Tables I to V must be adjusted."

The requirement is expanded by the definitions of critical helicopter and reference temperature provided in the Canadian design guide, and reproduced verbatim here:

"CRITICAL HELICOPTER: The helicopter whose operational requirements are most demanding with respect to the determination of lengths, widths and other physical characteristics of heliport design."

"HELIPORT REFERENCE TEMPERATURE: The monthly mean of the maximum daily temperature for the hottest month of the year (the hottest month being that which has the highest mean daily temperature). This temperature should be averaged over a period of years."

Further consideration of performance is implied in the definitions of Category A and B helicopters, reproduced below:

"CATEGORY A HELICOPTER: A (multi-engine) helicopter, the take-off performance of which can be determined and scheduled so that, in the event of a single engine failure at any time after take-off, the helicopter can, return and stop safely on the landing area, or continue the take-off and climb without ground effect, at a steady rate of climb of not less than 100 feet per minute."

"CATEGORY B HELICOPTER: A single or multi-engine helicopter which, in the event of an engine failure, can be landed safely at any point along the flight path."

However, Chapter 1 (Definitions) is the only reference to these performance categories within the document; and no application is made elsewhere.

The United Kingdom is more precise in stating performance criteria. The Helicopter Performance Code of Practice establishes Performance Groups A and B for multi-engine helicopters. Distinctly separate real estate and airspace criteria are established for each.

In addition, for each of the two performance groups, the CAA defines what are termed the "WAT (Weight, Altitude, Temperature) Curves/Limits." The definitions are reproduced below from the Code of Practice:

"For Group A helicopters the take-off and landing WAT curves indicate maximum weights appropriate to altitude and temperature at which the helicopter's one engine inoperative net climb performance is:

- (i) a rate of climb of at least 100 feet per minute, from a height of 50 feet at the end of the Continued Take-Off Distance Required to a height of 500 feet, and at least 50 feet per minute from the height of 500 feet to a height of 1000 feet above the take-off surface, and
- (ii) such that the net flight path remains above a profile having a gradient of 3% from a height of 50 feet at the end of the Continued Take-Off Distance Required to a height of 500 feet, and a gradient of 1 1/2% from the height of 500 feet to a height of 1000 feet above the take-off surface."

The WAT limits for Group B helicopters differ, depending on whether it was certificated under U.K. or U.S. regulations. The definitions for both are reproduced below:

"For Group B helicopters certificated to BCARs the WAT limit is the maximum weight appropriate to altitude and temperature at which the sum of the forward acceleration and the gradient of climb, at each point in the take-off path, is equivalent to a gradient of climb of at least 8%, all engines operating.

"For Group B helicopters certificated to USA, FARs, the WAT limit is reflected in the maximum certificated weight and is the maximum weight at which the helicopter can hover, at a height appropriate to the take-off technique:

- (a) at 4000 feet in the standard atmosphere for a piston-engined helicopter, or
- (b) at 2500 feet at a temperature of 90oF for turbine-powered helicopters."

The nearest that current U.S. Rotorcraft Flight Manuals come to the Canadian and British approach to performance criteria is the density altitude limitations contained therein. FAR 27 and 29 specify basic certification criteria for helicopters, but does not contain requirements explicitly for operations at heliports.

3.3.4 Failure-State Operations

The depth to which the U.S. considers failure-state situations (such as engine failures) is minimal in comparison with the criteria of the other nations reviewed. As mentioned earlier, the only time that forced landing areas are discussed in Reference 1 is in addressing approach-departure paths. There, it states that "areas suitable for an emergency landing are desired along the approach-departure path unless the heliport is used exclusively by multi-engined helicopters with proven capabilities to continue flight with one engine inoperative."

In all cases, including ICAO, the various international criteria required that suitable forced landing areas be available throughout the approach and departure. Also, each required more obstacle-free real estate than the U.S. for the takeoff and landing areas. The reason for these differences may be the underlying U.S. philosophy that obstacle surfaces

and procedures are designed to accommodate normal operations. The United States historically has generally developed failure-state performance criteria only for multi-engine aircraft through certification requirements. With respect to helicopters, this means FAR 27 and 29.

The most sophisticated or advanced approach to providing for failure-state conditions was found in the U.K. criteria. Their Performance Groups, detailed in the previous sub-section, are only an introduction to their handling of failure-state operations. The most prominent elements of their philosophy are addressed here.

The Helicopter Performance Code of Practice addresses failure-state operations in two ways: First, by providing sufficient obstacle-free real estate in takeoff/landing areas to accommodate engine failures, including continued or rejected takeoffs; and, second, requiring suitable forced landing areas throughout the helicopter transition between the enroute and heliport environments. The latter is in direct contrast to FAR 91 which makes exception for approach and takeoff at heliports.

With respect to takeoff and landing areas, the criteria specified for Performance Group A are the most precise, and include a number of elements intended to accommodate failure-state operations. Of interest are:

- Continued Take-Off Distance;
- Rejected Take-Off Distance;
- Power Unit Failure Point; and
- Decision Point.

The definitions, as provided in the Code of Practice, are offered here to clarify their intent and identify the U.K. philosophy.

"CONTINUED TAKE-OFF DISTANCE REQUIRED:

The distance required from the starting point, following a power unit failure at the Power Unit Failure Point, to continue to the Decision Point and then to continue the takeoff, reaching the

take-off safety speed V_2 or a height of 50 feet whichever is the greater."

"REJECTED TAKE-OFF DISTANCE REQUIRED:

The distance required from the starting point, following a power unit failure at the Power Unit Failure Point, to continue to the Decision Point and then come to a stop."

"POWER UNIT FAILURE POINT:

For the determination of takeoff and landing performance, the point at which sudden, complete failure of a power unit is assumed to occur."

"DECISION POINT:

For the determination of takeoff performance, the latest point at which, as a result of power unit failure or some other contingency, the pilot may be assumed to discontinue a takeoff.

For the determination of landing performance, the latest point at which, as a result of power unit failure or some other contingency, the pilot may be assumed to initiate the missed approach."

The Code of Performance included the last two definitions to allow consideration of reaction time to an engine failure. Specifically, it distinguished between the two in order to take into account "the delay which occurs before a power unit failure can be detected."

The previous definitions are applied in the Site Criteria where the continued and rejected takeoff distances together comprise the Takeoff Area. The criteria specify that the RTOD should be free from obstacles. The CTOD will include the RTOD if smaller, "but may contain beyond the end of any RTOD available, objects which may be considered insignificant due to size and/or frangibility."

The criteria further specify that the bearing strength of the RTOD should be sufficient to support the most demanding helicopter intended to use the site. With respect to the use of waterways for takeoff areas, it makes exception only insofar as the RTOD and CTOD "may consist partly or wholly of water provided that the helicopters using the area have permanent built in buoyancy, and that the areas can be kept clear of transient obstacles such as shipping during helicopter operations."

The criteria for Performance Group B, although they do not use the same continued and rejected takeoff distance approach, assure obstacle-free areas in a Horizontal Acceleration Area. In addition to this, the subsequent Takeoff Climb Area is required to contain "spaces suitable for an emergency landing and over which a helicopter can continue to climb from a height of at least 100 feet towards its enroute altitude."

The Site Criteria expands on the meaning of suitable emergency landing areas in its definition of obstacles under Takeoff Climb Area. It offers a unique approach to obstacle clearance requirements and is reproduced below from the Code of Practice.

"OBSTACLES:

Objects within the area should be sufficiently widely spaced to meet the emergency landing capability. For example, an object 70 feet high should have a cleared space 165 metres long beyond it, one 50 feet high a space of 120 metres, reducing to 105 metres for a 30 foot obstacle and 60 metres for any smaller objects.

Ideally the area should be free from objects, but where this cannot be achieved the area should be so aligned as to include only those obstacles which are conspicuous by their size, shape or colour. Telephone lines may be discounted if they are located close to houses, hedgerows, trees, etc., but overhead electricity lines are not considered acceptable."

Approach areas must have forced landing areas based on the general requirement for emergency landing areas. But the Site Criteria provide further guidance for Group B operations in its specifications for the Inner Approach Area, which is a mirror image of the Horizontal Acceleration Area except for length. Its length is specified as "long enough to accommodate for any helicopter to be used at the site the 'Emergency Landing Distance Required from 100 feet' specified in the Flight Manual or other approved performance data for the relevant operating weights and ambient conditions."

With respect to obstacles within that area, the final one-third must be free of all obstacles. However, in the initial two-thirds of the length in the direction of landing, "obstacles are acceptable provided they are insignificant due to size and/or fragility."

Obstacle limitation surfaces in the Japanese criteria also reflect a concern for failure-state operations. In the case of Category A heliports (large helicopters), a slope of 20:1 was considered necessary to "ensure safe operations in the case of an engine failure on takeoff by multi-engined aircraft." The adoption of transitional surface slopes of 4:1 considered that "landings by autorotation are possible from any direction." The latter statement may not be true of all helicopters, since the autorotative descent angles for a number of helicopters is as steep as 20 to 25 degrees for a typical autorotation profile.

It is appropriate to make one final comment with respect to failure-state operations. While the U.S. criteria afford little protection from the consequences of engine failure in a single engine helicopter; close to 10% of all serious helicopter accidents in the United States each year involve either engine failure or malfunction. Further, to quote the FAA inputs to the ICAO Heliport Manual, "it should be noted that the 2- to 5-place helicopters currently comprise about 95 percent of the civil helicopter fleet, and that the large transport type helicopters are used primarily by the scheduled helicopter airlines." That underscores the fact that the overwhelming majority of helicopters in the U.S. are single-engine helicopters. It appears appropriate, then, to entertain the possibility of considering

that provision for suitable forced landing areas for engine failure in single-engine helicopters be required.

Although Reference 1 makes scant referenced to forced landing areas, the FAA inputs to the ICAO Heliport Manual (developed after publication of the current issue of the U.S. Heliport Design Guide) expand on the topic. In its discussion of operational safety, the FAA states that approach-departure paths should be "over terrain which affords emergency landing areas in relation to the proposed altitudde of the helicopter and its autorotative performance. This provision is necessary for all but multi-engined helicopters capable of flight on one engine."

The discussion on operational safety also addresses the types of forced landing areas. In addition to such desirable as beaches, golf courses, etc., other recommended paths were identified as those over highways and freeways. It is suggested that these should not be considered suitable forced landing areas for two reasons: first, because of the inability to assure that they are clear when needed; and, second, the fact that many states have local ordinances which forbid the use of public highways for emergency landing sites.

Although forced landing areas are not treated precisely in the U.S. documents and regulations, the FAA does appear to take reasonable consideration of the need for the most part. In the ICAO manual, the FAA indicated that several heliports had been "forced to cease operations due to elimination of emergency landing areas by construction or change in land use." However, there have been cases where the FAA has approved landing facilities having approach-departure paths without continuous forced landing capabilities.

3.3.5 Takeoff and Landing Areas

The real estate requirements for takeoff and landing became apparent in the earlier discussion of performance considerations. By way of review, the U.S. criteria, if applied to their minimums, require a helicopter to accelerate forward while climbing along a departure path gradient of 7.4 degrees. This is impossible unless a helicopter is loaded below its maximum gross weight and is capable of a vertical climb while out of ground effect of better than 100 feet per minute.

All international criteria reviewed provided a nearly level takeoff and landing area of sufficient size to permit acceleration in ground effect to at least "effective translational lift" airspeeds of 15 to 25 knots. This provides a margin of power which appears sufficient for continued acceleration with a climb gradient above departure surfaces.

3.3.6 Approach and Departure Areas

In all cases, approach and departure areas were mirror images with respect to length, width and obstacle surface slope or gradient. There was no appreciable difference in the lengths and outer widths of the areas.

Of particular interest is the difference in slopes selected. The various obstacle surface slopes are presented in Table 3-5 for each country, with heliport classifications indicated where appropriate.

TABLE 3-5
COMPARISON OF INTERNATIONAL OBSTACLE SURFACE SLOPES

	<u>Category</u>	<u>Run:Rise</u>	<u>Gradient</u>
CANADA	H1	(4:1)	25 %
	H2	(5:1)	20 %
	H3	(40:1)	2.5 %
JAPAN	Land A	20:1	5 %
	Land B	10:1	10 %
	Land C	10:1	10 %
	Land D	10:1 - 4:1	10-25 %
	Water A	20:1	5 %
	Water B	10:1 - 4:1	10-25 %
ICAO	N/A	(8:1)	12.5 %
UNITED KINGDOM	Group A	20:1*	5 %
	(* 0-500 ft, ** 500-1000 ft)	40:1**	2.5 %
	Group B	8:1	12.5 %
UNITED STATES	N/A	8:1	12.5 %

3.3.7 Lateral Obstacle Protection

All criteria provide additional obstacle protection laterally for all maneuver areas associated with heliports. This is done in a number of ways: level, clear areas adjacent to the helipad itself; side or transitional surfaces extending laterally from maneuver areas; and, in the case of Japan, a circular, horizontal surface overlying the heliport area.

The United States, Canada and ICAO adopted transitional surfaces having slopes of 2:1 (50%) which extend laterally until reaching several hundred feet. The United Kingdom applied a 4:1 slope to 150 feet above heliport elevation for Group A, and a considerably steep slope of 1:1 to 100 feet for Group B. The Japanese criteria alone contained both horizontal and transitional surfaces, and are discussed below.

The transitional surface for all categories of Japanese heliports was established having a slope of 4:1. Their rationale for adopting such a comparatively shallow slope was that it was "considered necessary to prevent unnavigable vortices developed by objects (especially massive objects) adjacent to the transitional surface from affecting heliport operations."

Japan was the only country applying a horizontal surface. It was defined as a circular area lying in a horizontal plane 150 feet above the reference point of the heliport, and from which the radius of the surface is measured. The radii varied from 1300-2600 feet for land heliports and 2000-2600 feet for water heliports.

SECTION 4

RATIONALE FOR HELIPORT DESIGN CRITERIA MODIFICATIONS

4.1 INTRODUCTION

This section contains the rationale for developing recommended modifications to the real estate and airspace requirements contained in References 1 and 2. It also introduces specific alternatives to current heliport design criteria which will be used as a basis for recommendations in Section 5. Several are of a general nature, which impact documents or regulations other than the above references, and were addressed when peripheral areas were recognized which could easily be impacted in the course of this research.

The emphasis of this research is on real estate requirements for heliports. This includes any criteria which indirectly affect or help determine the real estate needs associated with the implementation or development of heliports. Also, peripheral areas are addressed where shortcomings were observed and it was felt that constructive recommendations could be made to improve heliport criteria in general.

4.2 OPERATIONAL PROFILES FOR HELIPORTS

In order to determine the actual real estate and adjoining airspace necessary at heliports, a number of operational profiles are offered here which generally define possible maneuver requirements for using helicopters. They are useful in identifying the components of real estate and airspace criteria. Several scenarios are presented for each of the applicable flight phases which occur in the vicinity of heliports, and are based primarily on helicopter performance capabilities.

4.2.1 VFR Takeoff and Departure

In determining appropriate real estate requirements for heliports, several questions must be addressed: Should a maneuver area be developed within which helicopters can accelerate to a predetermined or preferred speed before initiating a climb? Should the maneuver area consider aborted takeoffs and allow for deceleration maneuvers, such as the "balanced field length" concept presently applied to certain airports? There are two alternative scenarios which are applicable.

The first is dictated by existing obstacle surface criteria. It should be noted that the obstacle surfaces for approach-departure paths from the heliport begin at the edge of the takeoff and landing area. This means that the horizontal area available prior to initiating any climb (to meet departure surface slopes) is limited to the size of the takeoff and landing area. Further, it leaves little room for acceleration prior to climb if the minimum size area is used. Thus, the departing helicopter must have some vertical climb capability if it is to immediately initiate a climb at an 8:1 slope or steeper.

The second scenario involves a departing helicopter which has neither the vertical climb capability needed, nor the capability to perform an out-of-ground-effect (OGE) hover. In this case, it would be necessary to provide some level acceleration area. The area should be able to support level acceleration to one of a number of appropriate speeds: the onset of "effective translational lift" (typically 15 to 25 knots); Takeoff Safety Speed (V_{TOSS}) for multi-engine helicopters; best rate/angle of climb airspeed; or recommended climb speed. "Effective translational lift" is defined as that point at which the pilot can sense a reduction in power required as airspeed increases.

Additionally, with respect to the second scenario, an appropriate deceleration distance should be included if aborted takeoffs are to be accommodated. This could be done through development of a "balanced heliport area" concept similar to balanced field length requirements currently in use for fixed wing aircraft.

4.2.2 IFR Takeoff and Departure

There are no criteria at present which specifically define real estate or airspace requirements for IFR takeoff and departure from heliports. The only criteria which exist are the basic VFR surfaces for heliports, i.e., the 8:1 approach-departure path slope. The possible takeoff and departure profiles from a heliport under, or into, instrument meteorological conditions can be summarized in two scenarios which are somewhat similar to the VFR profiles described in the previous paragraphs.

The first is dictated by present regulations for civilian users, and involves a nearly level acceleration (while maintaining visual reference to the heliport environment) to a minimum IFR airspeed prescribed in the Rotorcraft Flight Manual (RFM) for the helicopter in question. The scenario requires a level acceleration area to the mandated minimum speed. Additional distance would also be required if deceleration distances are determined necessary for aborted takeoffs.

The second scenario describes a common military takeoff profile termed an "Instrument Takeoff" (ITO) and referred to as a "jump-type" takeoff in civilian circles. It is suitable, and occasionally is used, for takeoff under zero (or nearly so) ceiling and visibility conditions. The helicopter pilot executes the takeoff solely with reference to instruments while positioned in the takeoff area with landing gear on the ground. There are variations in technique from one military service to another, but the most severe is identified here. This scenario involves a near-vertical departure for approximately the first 100 feet and then a simultaneous acceleration to climb airspeed while maintaining a steep climb gradient. Power used is on the order of 20 percent or more above hover-in-ground-effect (HIGE) power until subsequent power reduction upon reaching climb airspeed to achieve the desired rate of climb. This scenario maintains the helicopter well within the current available VFR real estate and airspace. However, it is not consistent with procedures designed to ensure a safely rejected takeoff in the event of an engine failure.

4.2.3 VFR Approach and Landing

The imaginary surfaces presently required through FAR Part 77, and reproduced in Reference 1, are compatible with the "normal approach" angle taught in helicopter flight training schools of 8 to 10 degrees. This concept is further supported by the approach/landing profile identified in a NASA Technical Note, which was analyzed in a recent study of helicopter performance in the terminal environment, FAA Report No. FAA-RD-80-59 (Reference 21). In that study, it was found that the typical VFR approach, when considering commercial operations with passengers on board, adopted an angle of 6 to 9 degrees and rarely became as steep as 12 degrees. The average was just on the shallow side of the "normal approach" at approximately 8 degrees. This is compatible with the 8:1 approach path (7.1 degrees) currently in use.

This is within the parametric performance capabilities of current helicopters when ambient wind conditions are favorable. However, should downwind or quartering tailwind conditions be encountered during approach, there is the possibility that helicopters could encounter settling with power. Attempts to recover from the condition by executing a go-around or missed approach could require more airspace than is available from the 8:1 departure path surface.

One approach to overcoming the possibility of settling with power is by providing additional airspace to accommodate a shallower approach angle, in combination with increased real estate for deceleration. This would permit a shallow approach, with its attendant reduced power requirement, to a landing area which allows deceleration while in ground effect.

4.2.4 IFR Approach and Landing

Operational profiles for IFR approach and landing to heliports are effectively the same as for fixed wing except for a deceleration to zero ground speed at the takeoff and landing area of the heliport. The only

other differences relate to certain, helicopter-unique characteristics: airspeeds, approach and climb angles, maneuverability, and operational environment. The unique environment (operations in remote areas, city-center, etc.) is a direct consequence of the performance capabilities.

Many helicopters are capable of mixing in with routine fixed-wing traffic, including instrument approaches with airspeeds as high as 150 knots. However, Copter-Only approaches are executed at Category A airspeeds (90 knots or less), and generally have smaller approach and missed approach areas with steeper gradients, reflecting performance differences. The basic construction of airspace is the same.

The actual procedures for approach and missed approach are the same for helicopters until transition to VMC at the MAP. Once at the MAP a helicopter which has transitioned to VMC then continues with a visual approach and landing; for the purpose of this discussion, to a heliport supported by the basic (VFR) obstacles surfaces from FAR Part 77.

The VMC continuation underscores the helicopter's capabilities, and is the major reason for unique operational environments. After VMC transition, pilots can utilize a combination of helicopter-unique characteristics by making a relatively steep (compared to fixed-wing) approach, while simultaneously decelerating to a zero groundspeed hover, several feet above the touchdown point. Maneuverability is further enhanced by the capability of nearly immediate power changes (direct lift response of the rotors to collective changes) and the ability to make greater-than-standard-rate turns at all airspeeds through zero with little fear of stalling.

4.3 IMPLICATIONS OF HELICOPTER PERFORMANCE ON HELIPORT CRITERIA

The performance characteristics of the IFR certificated helicopters discussed in Reference 21 were reviewed in the context of heliport design criteria and instrument procedures which may become associated with heliport facilities. Several requirements documents and associated ampli-

fying guides interact in defining practical operating modes, but the implications of these interactions are not made manifest to practitioners whose interests focus in a single aspect of the problem. There is a paradox among multi-engine helicopters which must have an assured climb rate of 150 feet per minute following failure of one engine and the climb gradients of 8:1 associated with heliport design criteria and 20:1 associated with helicopter terminal instrument procedures.

The purpose of this sub-section is to illustrate, with the performance characteristics of real helicopters, some of the problems which may arise from consideration of only singular aspects of the problem. These problems may be resolved by stipulation of appropriate procedural limitations in the operating manuals used by helicopter operators, but enlightenment may avoid the creation of problems which, post facto, can only yield to suboptimal solution at the expense of the operators and, ultimately, the served public. Two problem categories will be addressed which are very separate in operational context but which are linked by heliport design -- landing and takeoff performance.

4.3.1 Helicopter Takeoff and Departure Performance

Reference 21 previously considered the impact of helicopter performance characteristics on helicopter terminal instrument procedures. This discussion will not restate Reference 21, but rather will draw on the performance analyses already conducted as a baseline for more detailed discussion and broader consideration. It has already been shown that combinations of weight, altitude, and temperature (WAT) exists which are within the approved normal operating envelopes of existing helicopters that preclude climb gradients compatible with helicopter TERPS. The unique helicopter requirements defined in TERPS permit missed approach procedures that require helicopter climb gradients of 20:1. These gradients cannot be consistently satisfied by helicopter capabilities; but it was found that a "rule of thumb" for planning, using hover out-of-ground effect (HOGE) capability as a guideline, could assure adequate climb capability.

When considering heliport design requirements which permit approach and departure gradients up to 8:1, the rule of thumb breaks down and no convenient proxy may be readily found in the flight manuals. Figure 4-1 depicts the variation of rate-of-climb (R/C) required to achieve an 8:1 gradient with groundspeed. For no wind conditions, substitutions of climbing airspeed for groundspeed yields a good approximation of the necessary R/C. Flight manuals can then be consulted to see whether capability exists to satisfy the needed gradient. Table 4-1 gives rate of climb, airspeed for best rate of climb (V_y) and the associated gradient for the helicopters reviewed in Reference 21.

The climb gradients themselves are not difficult to achieve in most normal circumstances, but the transition from hovering flight to oblique climbing flight is not covered by References 6 and 7 in certification requirements, nor is data apparently volunteered within most flight manuals to define performance capability. With reference to Figure 4-1, note that 8:1 requires a 100-200 foot per minute R/C in the 8-16 knot groundspeed regime. This is the flight regime in which most helicopters experience the onset of "effective translational lift", i.e., that point at which the pilot can sense a reduction in power required as airspeed increases. Because power required diminishes very little before the onset of "effective translational lift", a 100-200 foot per minute R/C at that point is tantamount to an equivalent vertical climb capability. Provision in the flight manuals of vertical climb charts would provide sufficient data for the pilot to determine if an 8:1 climb gradient is achievable without first translating to V_y .

Variation of Rate of Climb with Groundspeed Necessary
to Maintain an 8:1 Climb Gradient

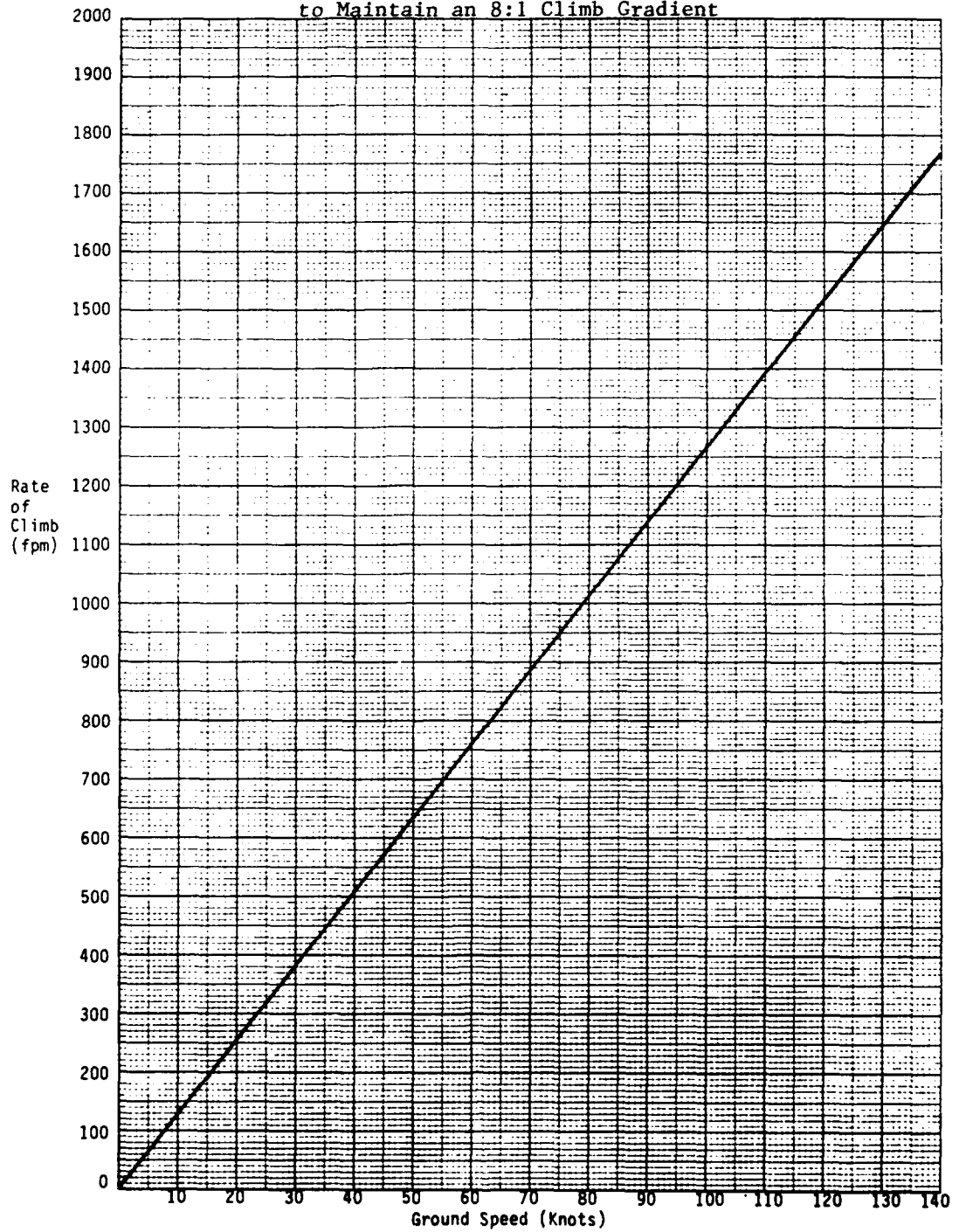

Figure 4-1. Performance Requirements for 8:1 Climb Gradient.

TABLE 4-1
BEST CLIMB PERFORMANCE
 (Normal-State Operations)

<u>HELICOPTER</u>	<u>(STANDARD DAY)</u>			<u>(STANDARD DAY + 20°C)</u>		
	<u>Climb Rate</u>	<u>Airspeed</u>	<u>Gradient</u>	<u>Climb Rate</u>	<u>Airspeed</u>	<u>Gradient</u>
A	1190	70	5.87	1125	72	6.44
B	1380	65	4.66	1220	67	5.49
C	1500	70	4.62	1460	72	4.92
D	1625	58	3.47	1170	60	5.09
E (VFR)	1150	52	4.47	540	52	9.76
E (IFR)	800	80	10.08	780	83	10.69
F	1075	58	5.37	1075	60	5.56
G	1310	75	5.71	600	78	13.05
H	1250	82	6.57	600	85	14.27
I	1150	65	5.63	950	67	7.09
J	1950	80	4.03	1625	83	5.06
K	1775	72	3.98	1425	74	5.19

All data is for sea level at maximum gross weight.

Climb Rate = Rate of Climb (fpm), R/C.

Airspeed = True Airspeed (knots) for Best Rate of Climb, Vy.

Gradient = Run:Rise for the Vy - R/C combination.

Certification requirements of both References 6 and 7 address these points by requiring a minimum climb capability of 6:1 for sea level standard day and demonstration of distance required to clear a 50 foot obstacle. These certification requirements do not, however, reflect the possibility that heliport design permits obstacles under an 8:1 slope which originates at the edge of the heliport primary area and may interfere with acceleration before climbing to clear obstacle.

Figure 4-2 gives distances required to accelerate to various airspeeds. The rotation angle used as a parameter is the tilt relative to hover position that the rotor must go through to initiate acceleration at the associated rate. Figure 4-2 is computed on the assumption that the acceleration is level and is maintained at the indicated constant rate after initiation. The onset of "effective translational lift" ensures that power will be available to sustain the acceleration.

The takeoff problem is compounded when one considers engine failure. References 6 and 7 are essentially equivalent in performance requirements for Normal Category Rotorcraft and Transport Category B Rotorcraft. Both categories must be operated in such a manner that a landing can be made safely at any point along the flight path if an engine fails. Transport Category A, however, requires demonstration of one engine inoperative (OEI) flight capability which must be attained while over the takeoff area. (The manufacturer may specify the size of the takeoff area for the procedure with which he demonstrates compliance.)

FAA approved flight manuals for three aircraft certified as Transport Category A were reviewed to gain appreciation of the procedures used and the performance characteristics pertinent thereto. These aircraft are the Aerospatiale SA 330J Puma, the Bell 212, and the Sikorsky S-76 Spirit. (Data presented in Reference 21 for the Sikorsky S-61 and the Boeing Vertol 107 were obtained from military flight manuals, which do not address takeoff techniques relevant to Transport Category A performance. The remaining helicopters are all Normal or Transport Category B.) These three helicopters employ variations on two basic takeoff techniques to satisfy Category A certification requirements.

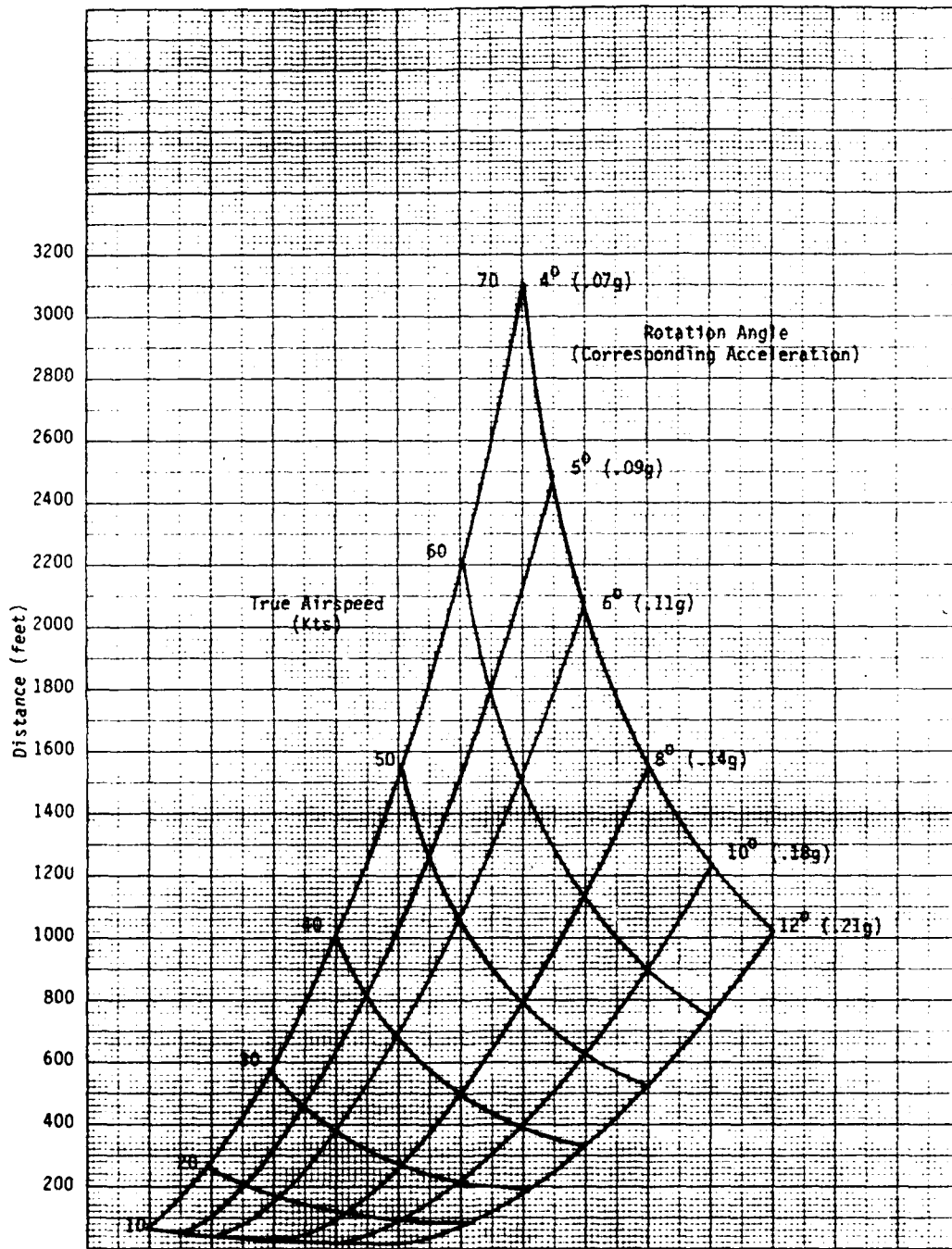

Distance Required to Accelerate to Various Airspeeds for Various Initial Rotation Angles (Acceleration Rate Assumed Held Constant Throughout Maneuver)

Figure 4-2. Distance for Acceleration to Various Airspeeds.

The first technique, called "normal" herein, involves acceleration in level flight or oblique climbing flight. A critical decision point (CDP) is defined such that an engine failure which occurs before CDP results in a safe landing on the takeoff area; and an engine failure after CDP results in a continued OEI flight climbing at the manufacturer's selected takeoff safety speed (V_{TOSS}). This procedure results in traverse over the ground from the initial hover to the completion of a rejected takeoff. The maximum distance traversed is identifiable from flight manual data as the rejected takeoff distance which may vary with weight, altitude and temperature. (Rejected takeoff distance is recorded only for abort decisions which are made at the CDP.)

The second technique, called "vertical" herein, involves a vertical climb until altitude is sufficient to permit a descending acceleration to V_{TOSS} . During the vertical climb phase, the aircraft is moved backward sufficiently to maintain visual contact with the takeoff area. An altitude above the takeoff area is the defined CDP. Any engine failure prior to reaching the CDP height results in an immediate descent to an OEI landing at the point of takeoff. Upon reaching CDP a descending acceleration to V_{TOSS} is immediately initiated. Thus, any engine failure after CDP results in single engine flight accelerating in a descent until V_{TOSS} is attained; then a climbout at V_{TOSS} is commenced.

The vertical procedure requires a marked reduction in takeoff weight which degrades the helicopter's disposable load. If IFR flight is planned, fuel requirements for an alternate airport plus reserves may dominate the operator's weight tradeoff and result in a disposable load reduction that almost entirely impacts the payload fraction. Thus, from the operators' and customers' viewpoint, the vertical procedure is economically less desirable than the normal procedure.

Tables 4-2, 4-3 and 4-4 present data relative to Category A performance for the three helicopters reviewed. The Aerospatiale Puma and Bell 212 provide procedures and performance data for both normal and vertical Category A takeoffs; the Sikorsky Spirit provides procedures and data for only the normal Category A takeoff.

TABLE 4-2
CATEGORY A PERFORMANCE DATA
AEROSPATIALE SA-330J

CHARACTERISTICS IN COMMON

Minimum IFR Airspeed	55 KIAS
Minimum IFR Climb Speed	65 KIAS
V _y (at sea level)	70 KIAS
Maximum Gross Weight	16,300 lb.
Altitude Limit	8,200 ft. (H _p)

CHARACTERISTICS FOR NORMAL CATEGORY A TAKEOFF PROCEDURES

Critical Decision Point Height Not defined

<u>Conditions at Sea Level</u>	<u>Std Day</u>	<u>Std Day + 20°C</u>
Gross Weight	16,300 lb.	16,300 lb.
V _{TOSS}	35 KIAS	61 KIAS
Rejected Takeoff Distance	1,000 ft.	1,700 ft.
R/C at V _{TOSS} with OEI (2-1/2 min rating)	520 fpm	150 fpm
Climb Gradient (V _y) with OEI (2-1/2 min rating)	6.8:1	42.6:1
R/C at V _y with OEI (30 min rating)	650 fpm	300 fpm
Climb Gradient at V _y with OEI	5.5:1	21.3:1

CHARACTERISTICS FOR VERTICAL CATEGORY A TAKEOFF PROCEDURES

Critical Decision Point Height 85 ft.
Heliport Minimum Size Not Specified

<u>Conditions at Sea Level</u>	<u>Std Day</u>	<u>Std Day + 20°C</u>
Gross Weight	14,900 lb.	14,900 lb.
V _{TOSS}	35 KIAS	47 KIAS
Distance to Gain 200 ft.	700 ft.	1,080 ft.
Procedural Gradient to 200 ft.	3.5:1	5.4:1
R/C at V _{TOSS} with OEI (2-1/2 min rating)	870 fpm	530 fpm
Climb Gradient at V _{TOSS} with OEI	4.1:1	9.3:1
R/C at V _y (30 min rating)	900 fpm	600 fpm
Climb Gradient at V _y	7.9:1	12.2:1

TABLE 4-3
CATEGORY A PERFORMANCE DATA
BELL 212

CHARACTERISTICS IN COMMON

Minimum IFR Airspeed	(Bell STC)	40 KIAS
	(Sperry STC)	50 KIAS
Recommended Climb Speed		70 KIAS
V _y (at sea level)		55 KIAS

CHARACTERISTICS FOR NORMAL CATEGORY A TAKEOFF PROCEDURES

Maximum Gross Weight		11,100 lb.
Critical Decision Point Height		35 feet
V _{TOSS}		55 KIAS

<u>Conditions at Sea Level</u>	<u>Std Day</u>	<u>Std Day + 20oC</u>
Gross Weight	11,200 lb.	10,000 lb.
Rejected Takeoff Distance	2,300 ft.	2,300 ft.
R/C at V _{TOSS} (V _y) with OEI (30 min rating)	290 fpm	290 fpm
Climb Gradient at V _{TOSS} (V _y) with OEI	19.2:1	19.9:1

CHARACTERISTICS FOR VERTICAL CATEGORY A TAKEOFF PROCEDURES

Altitude Limit	2,500 ft (H _p)
Heliport Minimum Size	72 ft. x 150 ft.
Maximum Gross Weight	10,000 lb.
Critical Decision Point Height	160 ft.
V _{TOSS} (55 KIAS max)	30 KIAS plus wind

<u>Conditions at Sea Level</u>	<u>Std Day</u>	<u>Std Day + 20oC</u>
Gross Weight	10,000 lb.	9,600 lb.
Distance to Gain 200 ft.	1,275 ft.	1,500 ft.
Procedural Gradient to 200 ft.	6.4:1	7.5:1
R/C at V _{TOSS} (30 KIAS) with OEI (30 min rating)	360 fpm	150 fpm
Climb Gradient (30 KIAS) with OEI	8.5:1	21.0:1
R/C at V _y (30 min rating)	600 fpm	475 fpm
Climb Gradient at V _y	9.3:1	12.1:1

TABLE 4-4
CATEGORY A PERFORMANCE DATA
SIKORSKY S-76

CHARACTERISTICS IN COMMON

Minimum IFR Airspeed	60 KIAS
V_y (at sea level)	73 KIAS
Maximum Gross Weight	10,000 lb
Altitude Limit (density altitude)	6900 ft

CHARACTERISTICS FOR NORMAL CATEGORY A TAKEOFF PROCEDURES

Critical Decision Point Height (35 KIAS)	40 ft
V_{TOSS}	52 KIAS

<u>Conditions at sea level</u>	<u>Std Day</u>	<u>Std Day +20oC</u>
Gross Weight	10,000 lb	10,000 lb
Rejected Takeoff Distance	1410 ft	1480 ft
ROC at V_{TOSS} with OEI (2-1/2 min rating)	1550 fpm	1450 fpm
Climb Gradient with OEI (2-1/2 min rating)	3.4:1	3.8:1
ROC at V_y with OEI (30 min rating)	1250 fpm	1100 fpm
Climb Gradient with OER (30 min rating)	5.9:1	7.0:1

Neither vertical Category A Takeoff Procedures nor Performance Listed

These tables are constructed to first provide data for aircraft characteristics which are common to all tabulated procedures, followed by those data which are peculiar to specific procedures but common to a variety of weight, altitude and temperature combinations. Finally, data peculiar to specific WAT conditions have been listed for two temperature conditions at sea level, standard day and 20° warmer than standard day. For each of these conditions the maximum useable takeoff weight has been selected.

The procedures involved assume immediate increase in power of the remaining engine to its maximum one engine inoperative (OEI) rating. In two cases this is a 2-1/2 minute rating and the remaining case a 30 minute rating. Climb gradients at V_{TOSS} have been computed based on the highest OEI rating available. Climb gradients at best rate of climb airspeed (V_y) have been computed at the highest, usable long duration power setting (in these cases, 30 minute ratings). Flight manuals provide a ground distance to gain 2000' height above takeoff for the vertical takeoff procedure. From these data, climb gradients were computed which represent the net effects of the procedure in attaining a height of 200 feet.

A wide spread of capability is evident from the data. Two data sets actually involve the certification limit R/C of 150 feet per minute. These are the Puma normal takeoff on a hot day (standard plus 20°C) and the Bell vertical takeoff under the same conditions. It is clear from these data that the basic 8:1 heliport criteria cannot be met up to the applicable 500 foot limit.

Should an engine failure occur after entering IMC, the Puma would be incapable of a 20:1 missed approach gradient at V_y and the Bell would not be able to achieve it at V_{TOSS} but could at V_y . In these two examples the certification performance criteria are met, but the performance is inadequate to satisfy the limiting heliport departure gradients and, in one case, the IFR missed approach gradient for this failure-state condition.

It is implicit, from this small sample of WAT conditions, that preplanning will always be required to ensure that performance will be compatible with actual conditions. Actual conditions may not, and need not, be as demanding as heliport design criteria imply. Favorable wind improves the climb gradient from a fixed level of aircraft performance, and heliport surroundings may not generate a need to better an 8:1 gradient. In fact, if a heliport were planned at the outset for all-weather helicopter use, it is most likely that far better obstacle clearance would prevail along some potential approach and departure paths than the limiting 8:1 heliport design criterion implies, as a result of the influence TERPS criteria would have on site selection and orientation.

A distinct difference in philosophy is evident between Bell and Aerospatiale in their respective vertical procedures. Bell uses a greater height at CDP than Aerospatiale and is willing to accept the minimum required OEI R/C. This implies that the vertical procedures WAT tradeoffs are limited solely by the certification requirement. On the other hand, Aerospatiale, in the Puma flight manual, states that WAT will be limited by the ability to hover in ground effect with OEI (2 feet wheel height). This more conservative approach permits a lower height at CDP and supports much better climb performance in their vertical Category A takeoff procedure.

4.3.2 Helicopter Approach and Landing Performance

Landing performance data were reviewed, but no significant impact could be found for either normal or OEI operating modes. Helicopter performance during landing is entirely compatible with any heliport for which takeoff performance is adequate. Thus, takeoff considerations should dominate both heliport and flight planning.

4.3.3 Application of Performance Charts to Heliport Operations

The critical nature of performance which is discussed in the preceding paragraphs, underscores the importance of performance charts as tools for pre-planning by pilots. Without such tools, it is impossible to accurately determine the capabilities of the helicopter (and/or the required performance) with respect to meeting the obstacle clearances afforded by the real estate and airspace which has been set aside.

Unfortunately, these tools are offered neither completely nor consistently in the rotorcraft flight manuals for various model helicopters. Some give the pilot most of the data needed, but they are usually scattered throughout the performance and other sections and require an arduous process to develop answers to what should be simple questions. Others give insufficient data and leave the pilot unable to adequately determine the helicopters capabilities.

To safely conduct operations in and out of heliports, a pilot must be able to answer a number of questions. The answers vary with different weight, altitude and temperature (WAT) conditions. The questions include:

- Can he climb out at an angle which is steeper than the obstacle surface slope? What is the best climb angle achievable for the current WAT conditions? What airspeed and rate of climb must be maintained to achieve that? Further, is there enough room to accelerate to that airspeed before initiating the climb?
- For an instrument departure with low ceilings, is there enough room to accelerate to minimum IFR airspeed, or to the recommended IFR climb speed? What rate of climb can be expected? Will the gradient at that rate of climb and airspeed be sufficient to climb steeper than the departure obstacle surface slope?
- For an instrument approach, will he be able to climb out steeper than the missed approach surface in the event of a go-around?

The answers to these questions are rarely available to pilots in the cockpit. They can only be derived from knowledge of the power required to achieve the needed level of performance, and knowledge of the power available for the applicable WAT conditions. Only then can a pilot determine if the capabilities are sufficient to meet the performance requirements.

The earlier discussions of performance emphasized several key points. Helicopters can maintain or exceed a 20:1 (IFR) climb gradient (if already at V_y) if there is sufficient power to hover OGE, and an 8:1 (VFR) gradient (while accelerating from a zero airspeed hover) if there is sufficient power to make an OGE vertical climb of 150 fpm. If those two capabilities can be determined quickly by the pilot, then he can be assured of the performance capability to satisfy the current IFR and VFR obstacle surfaces at heliports. But first, the power required for each, plus the total power available, must be known.

The idea of depicting power required for ICE and OGE hover is not new. Most flight manuals contain such information. The U.S. Army has developed a particularly useful format for computation and display of these data which can be readily expanded and adapted to the needs of civil operators.

Figure 4-3 provides an example of such an expanded format. It depicts a methodology with which pilots can easily determine the power available and the power required to meet the critical climb gradients identified above. Everything necessary to use the charts is available to the pilot in the cockpit: weight and balance data, pressure altitude by setting the altimeter at 29.92-in Hg, and temperature from the Outside Air Temperature (OAT) gage.

One set of Army performance planning charts (UH-1H) is reproduced in Appendix C, with the explanations on use of the chart extracted from the corresponding operator's manual. The example chart presented as Figure 4-3 was constructed using a fictitious helicopter to facilitate an explanation of how it could be applied.

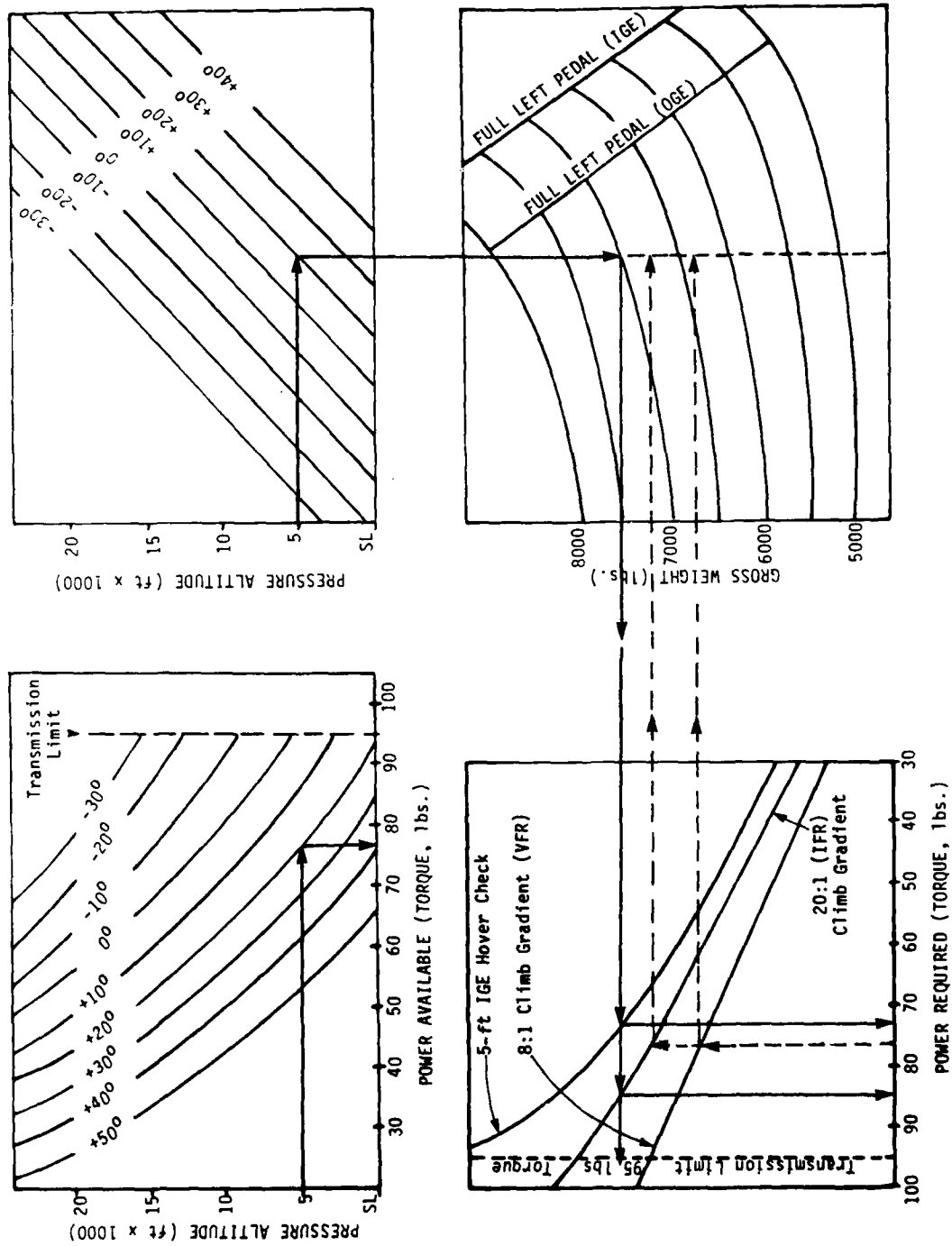

Figure 4-3. Example Helicopter Performance Chart.

The example helicopter has a basic empty weight of 5000 lbs., with a maximum gross weight (GW) of 8000 lbs.; and its transmission is limited to 95 pounds per square inch (psi) of torque. The example WAT conditions are 5000 feet pressure altitude (PA), +20°C OAT, and 7000 pounds GW.

The maximum power available for various altitudes and temperatures is determined using the upper left graph. The remaining three are used to determine power required for various WAT combinations for IGE hover, and minimum climb gradients of 20:1 (IFR) and 8:1 (VFR). The power requirement for IGE hover is included to permit an assurance check of calculations without having to make extreme power applications or hover OGE.

To determine the maximum power available, enter the upper left graph at 5000 feet PA and move right until intercepting the +20°C line. Read the maximum available torque of 78 psi directly below.

To determine the power required, starting with the top right graph, enter at 5000 feet PA and move right to the +20°C line. Move down until intercepting the 7000 lbs. GW curve, then move left to intercept the desired power required curve, and read torque required directly below. For 7000 lbs. GW, 72 psi torque is required for IGE hover, 85 psi for a 20:1 climb gradient, and torque in excess of the transmission limit would be required for an 8:1 climb gradient. However, the maximum available torque is 78 psi, so there is not sufficient power available (and, therefore, no capability) to sustain either a 20:1 or an 8:1 climb gradient.

The pilot can quickly determine necessary GW adjustments to achieve those capabilities by using the process in reverse. Enter the power required graph from the bottom (dotted line) at the maximum torque available of 78 psi and intercept the power required curve for the desired level of performance (using all available power). Move right until intercepting the PA/OAT extension to determine the highest allowable GW for the desired performance. For the example case: to attain an 8:1 gradient capability, helicopter weight must be reduced to 6300 lbs.; and to attain 20:1 gradient capability, a weight reduction to 6750 lbs. is all that is necessary.

4.3.4 Summary and Conclusions

It is apparent from the review of performance data that the Helicopter Design Guide should not confine itself to the basic requirements of FAR Part 77. A far better service would be provided if the guide alerted its readers to the desirability of a sufficient takeoff area to permit safe rejected takeoffs of the "normal" type, and the necessity for more stringent obstacle clearance requirements if IFR service may be contemplated.

Further, the inadequacy of performance data in a consistent and thorough manner forces pilots to operate without any assurance that they have the performance to exceed obstacle surfaces.

4.4 ALTERNATIVES FOR HELIPORT DESIGN CRITERIA

As the review of performance data indicated, there are a number of conditions and situations in which helicopter performance is not compatible with current real estate and airspace requirements. This is especially true of takeoff and departure performance, and becomes critical with respect to failure-state operations with a failed engine.

The following sub-sections offer and discuss specific alternatives to heliport design criteria. For each the rationale for developing recommended modifications to real estate and airspace requirements is presented. These alternatives will be used as the basis for the recommendations contained in Section 5.

4.4.1 Real Estate for Takeoff and Departure

If the heliport real estate requirement for VFR takeoff and departure is to be maintained in its present form, helicopter performance capability must be such that not only Hover-Out-of-Ground Effect (HOGE) but an OGE

vertical climb is possible. This will require the development of a series of performance charts, standard for all Rotorcraft Flight Manuals, which will allow helicopter operators to determine the power available and vertical rate of climb attainable for the prevailing weight, pressure altitude and temperature conditions.

Without the ability to easily calculate the helicopter's capability (or lack of it) to maintain a flight profile within obstacle free areas, then additional real estate would be required to allow a level acceleration to various airspeeds. The selection of those airspeeds would depend on the type of departure.

For VFR operations, real estate should be set aside for a level acceleration to an "effective translational lift" airspeed which will accommodate all helicopters currently in use, plus a margin of 10 knots. This will permit sufficient capability to climb at an angle steeper than the 7.1 degrees required of present VFR departure path surfaces.

For IFR operations, the real estate requirement should be extended to provide for level acceleration to an airspeed which will accommodate the recommended IFR climb airspeeds of all helicopters currently certified for IFR operation, plus a margin of 10 knots. In support of these criteria, go-no-go wind guides should be developed to identify those ambient wind conditions which would preclude the ability to maintain a flight profile within obstacle free airspace -- specifically, downwind or quartering tailwind conditions.

The real estate requirements for takeoff and departure should be identified for both VFR and IFR. The area required can be termed the "Helicopter Maneuver Area."

4.4.2 Airspace for IFR Departure

The following alternative would satisfy the airspace requirements of an IFR heliport classification. It is based on performance capabilities documented in Reference 21.

An obstacle identification surface (OIS) having a slope of 20:1 is suggested which originates from ground level at the departure end of the heliport maneuver area identified under 4.4.1. The use of any heliport designated an Instrument Departure Heliport would require that the Rotorcraft Flight Manual contain a performance chart to calculate HOGE capability to ensure the ability to maintain a flight profile within the obstacle free airspace provided by the OIS. The general construction of standard instrument departure areas should be consistent with the requirements of Chapter 12 of Reference 2, with departure area size developed based on Category A airspeeds and less. The major change would be in the use of a 20:1 slope for the OIS.

4.4.3 Real Estate for VFR Approach and Landing

In the event that a heliport has only a single approach-departure corridor, the possibility of downwind landings has been accepted. Normally, this would not be approved for an area of typically high winds that are predominantly downwind. If a maximum downwind limit cannot be specified for such heliport operations, then a landing area should provide for an approach with forward airspeed and then decelerate in ground effect. This avoids an OGE high power requirement during the approach as the helicopter airspeed passes through effective translational lift, zero airspeed, and then rearward flight, during a descent. Such a condition would be very conducive to settling with power.

Consistent with the heliport maneuver area concept introduced earlier, the real estate requirements for the approach end of that area should be able to accommodate level deceleration from at least 40 knots to a zero

groundspeed hover at the center of the takeoff and landing area. This is consistent with the maneuver requirements for avoiding potential settling with power when limited to operating in downwind conditions.

4.4.4 Real Estate for IFR Approach and Landing

It was noted in the earlier analysis of heliport requirements that no additional real estate requirements were imposed for increasing levels of instrument approach capability. Current VFR obstacle surfaces appear to be compatible with helicopter performance capabilities following a transition from the missed approach point of a non-precision approach. It is recommended, however, that real estate requirements be increased for heliports with precision instrument approach capability.

Notwithstanding that current ILS criteria apply to approaches to runways only, and that MLS criteria are still under development, the development of discrete real estate requirements should be planned to facilitate the inclusion of those types of precision approaches in the future. It is expected that the real estate required would be little more than that required for a "heliport maneuver area", and its deceleration area, described earlier.

4.4.5 Alternative PAR Missed Approach Surface

It was found that Reference 2 permitted the PAR missed approach surface to originate prior to the ground point of intercept (GPI) to gain relief from obstacles in the missed approach area when the missed approach surface would begin at the GPI (normal point of origin). By relocating the origin of the missed approach surface to a point on the final approach surface, beneath the MAP, obstacle clearance cannot be necessarily assured in the event of (inadvertent) re-entry into IMC after an initial transition to VMC.

It appears appropriate for the origin of the missed approach surface for both the PAR and other precision approaches to heliports be maintained at the GPI (center of the takeoff and landing area). Of principal concern is that heliports do not have the length of relatively obstacle-free area extending beyond the missed approach point, as do airports.

4.4.6 Criteria for Elevated Heliports

Criteria for elevated heliports/helipads currently consist of surfaces identical to ground-level heliports. Because of the critical nature of operations in congested areas (congestion being a primary reason for establishing an elevated helipad) a more indepth consideration of failure-state operations and performance is felt necessary. Category A procedures address elevated heliports, but no obstacle (surface) protection applies other than that contained in FAR Part 77. Since procedures do involve descent below the rooftop, such obstacle clearance would seem appropriate.

Accordingly, it is suggested that negative approach-departure surfaces could be implemented which would allow for obstacle-free, continued operation of multi-engine helicopters with one engine inoperative, and consideration of the failure at any point along the entire approach-departure path. Negative surfaces should begin at the boundary of the takeoff and landing area and have a slope sufficient to permit acceleration in a descent to single-engine climb speed from the most critical decision point during both takeoffs and landings.

4.4.7 Surfaces for Offshore Helicopter Landing Facilities

It was noted earlier that offshore landing facilities implied an obstacle-free zone or sector which traversed 180 degrees from the takeoff and landing area. It is suggested that the VFR and IFR approach-departure and transitional surfaces presently contained in Reference 1 be applied to offshore facilities. This is especially critical when the offshore structure of intended landing is in a cluster.

Further, the application of those surfaces should be extended such that transient surface vehicles and transient mobile offshore drilling units be restricted from adopting a stationary position, or traversing, within the defined approach-departure area of an offshore helicopter landing facility.

4.4.8 Guidelines for Establishing Forced Landing Areas

Consistent with the need for forced landing areas identified in Reference 1, it is desirable to establish a requirement that areas suitable for emergency landing be established along approach-departure paths. In defining the placement or location of these areas, a parametric summary of autorotative capabilities of helicopters can be applied to provide a measure for determining the suitability of the locations of available forced landing areas.

Forced landing areas should be available along the approach-departure path such that an autorotative landing could be made to subsequent areas along the entirety of the path (4000 feet). The forced landing areas should be no farther from the centerline than a series of arcs drawn to identify the limits of a descent angle of 15 to 30 degrees from the height of the baseline approach-departure path surface. This would approximate the autorotative descent angle for the lower airspeed ranges associated with approach and landing within 4000 feet of touchdown.

4.4.9 Criteria for Curved Flight Paths

At present there are no published criteria which establish turning radii for curved approach-departure path corridors. Criteria should be established to ensure consistency from one approach to the next, and so operators using procedures can be informed of the basis upon which their obstacle clearance is predicated. It is suggested that turning radius calculations should be based on standard rate or double-standard rate turns executed at 60-90 knots inclusive.

4.4.10 Heliport Classification Requirements

The heliport classification scheme currently contained in Reference 1 makes no distinction between heliports intended for visual and instrument operations. It is suggested that this be done, and that varying levels of instrument capability be addressed. Proposed classifications are:

- Visual Heliport
- Non-Precision Instrument Heliport
- Precision Instrument Heliport
- Instrument Departure Heliport

The fourth classification was proposed because the need exists to establish designated heliports from which helicopters can enter the IFR environment under limited ceiling and visibility conditions with an appropriate level of safety. Uncomplicated procedures can be developed and published for suitable heliports as Copter-Only Standard Instrument Departures (SIDs). Not to have an instrument departure classification, and the attendant obstacle clearance, inclines helicopter pilots to conduct marginally safe or uncertain operations. Without an approved instrument departure, a pilot must take a chance on obstacle clearance; or perhaps modify a takeoff procedure to climb out at less than the minimum IFR airspeed to avoid known obstacles.

SECTION 5
RECOMMENDATIONS

This section summarizes the recommendations developed in the course of this study and are of several types. Some propose modifications to the criteria contained in the Heliport Design Guide (Reference 1) to ensure that heliports have sufficient real estate and airspace to permit operations which are consistent with helicopter performance capabilities and operational requirements. Others recommend changes which will clarify the intent of certain criteria and improve the level of safety of operations at heliports.

Where appropriate, specific recommendations are parenthetically cross-referenced to the applicable, numbered sub-sections of this report. This was done to afford the reader quick reference to the supportive rationale and analysis contained herein.

5.1 HELIPORT CLASSIFICATION SCHEME

Further classifications are recommended for heliports (in addition to those currently contained in Reference 1) to enable application of discrete obstacle surfaces dependent on the type of operation, rather than the type of user. Proposed definitions are:

Visual Heliport means a heliport intended solely for the operation of helicopters using visual approach procedures, with no helicopter instrument approach or departure procedure, and no instrument designation indicated on any heliport planning document recognized by the FAA.

Non-Precision Instrument Heliport means a heliport having an existing instrument approach procedure utilizing air navigation facilities with only horizontal guidance, or area type navigation equipment, for which a straight-in non-precision instrument approach procedure has been approved or planned, and for which no precision approach facilities are planned or indicated on any heliport planning document recognized by the FAA. It may or may not have an approved instrument departure.

Precision Instrument Heliport means a heliport having an existing instrument approach procedure utilizing an Instrument Landing System (ILS), the future Microwave Landing System (MLS), or a Precision Approach Radar (PAR). It also means a heliport for which a precision approach system is planned and is so indicated by a heliport planning document recognized by the FAA. It may or may not have an approved instrument departure.

Instrument Departure Heliport means a heliport which may or may not have an instrument approach procedure, but has been developed and is approved for instrument departures by an FAA-approved Copter-Only Instrument Departure Procedure.

(Reference: 4.4.10)

5.2 DEFINITIONS

It is recommended that certain terms with definitions be added to Reference 1 to introduce several concepts which should prove useful in establishing future operations of Category A helicopters in populous or congested areas. The concepts are defined below.

Heliport Maneuver Area: An obstacle-free level area, surrounding or contiguous to the takeoff and landing area, to be used for the necessary maneuvering of helicopters during takeoff/departure and approach/landing. It provides real estate for the acceleration and deceleration of using helicopters, and varies in size with the heliport classification. (References: 4.4.1, 4.4.3)

Balanced Heliport: With respect to Performance Category A helicopter operations, a heliport with a heliport maneuver area of sufficient size to permit either an aborted takeoff or a continued climb can be executed, following an engine failure at the most critical decision point for all helicopters authorized to use the facility. (References: 4.2.1, 4.3.1)

5.3 HELICOPTER PERFORMANCE CHARTS

It is recommended that standards be developed for helicopter performance charts to be included in all rotorcraft flight manuals, having an identical or similar format. These performance charts should consist of Weight, Altitude and Temperature (WAT) Curves which would allow easy determination of, at a minimum, the following:

Airspeed for Best Angle of Climb, and the climb rate for that speed, when no vertical climb or HOGE capability exists. For multi-engine helicopters, it should be available for both normal operation and one engine inoperative (OEI).

Acceleration Distances required to reach selected, appropriate airspeeds such as the airspeeds for best climb angle, recommended IFR climb, and minimum IFR airspeed.

Vertical Climb Capability in terms of rate of climb for zero airspeed at the various WAT combinations. For multi-engine helicopters a chart should also be included for OEI operation.

Hover Performance to allow determination of hover capability for both in and out of ground effect, to include the power required and available at the various WAT combinations.

(References: 4.3.3, Appendix C)

5.4 REAL ESTATE REQUIREMENTS

Consistent with the heliport maneuver area concept introduced in 5.2, it is recommended that the FAA consider implementing revised real estate requirements for future public-use heliports. This would involve application of a Heliport Maneuver Area to all heliport classifications identified under 5.1.

5.4.1 Flight Test Data Requirements

Flight testing should be conducted to determine acceptable rates of acceleration and deceleration for takeoff and landing. These would be used to determine the dimensions of Heliport Maneuver Areas for the following heliport classifications.

5.4.2 Visual Heliport Acceleration Distances

The Heliport Maneuver Area should be of sufficient length to permit acceleration to a reference effective translational lift (ETL) airspeed

which would include all helicopters currently certificated for operation in the U.S., plus 10 knots.

(Reference: 4.4.1)

5.4.3 Instrument Heliport Acceleration Distances

The Heliport Maneuver Area should be of sufficient length to permit acceleration to a reference airspeed (to include all helicopters currently certificated for IFR operation in the U.S.) which would permit each subject helicopter to execute a level acceleration to its published Recommended IFR Climb Airspeed.

(Reference: 4.4.1)

5.4.4 Heliport Deceleration Distances

For all classifications (Section 5.1) of heliports, having only one approach-departure path, it is recommended that the Heliport Maneuver Area also be of sufficient length to allow an IGE deceleration to a zero ground speed hover from 40 knots.

(Reference: 4.4.3)

5.5 STANDARD INSTRUMENT DEPARTURE CRITERIA

It is recommended that criteria for Copter-Only Instrument Departures be developed to permit departures from heliports during marginal ceiling and visibility conditions.

5.6 AIRSPACE REQUIREMENTS

The following paragraphs recommend changes to heliport airspace requirements through modification of approach-departure surfaces. No changes are recommended for Visual Heliports or Non-Precision Instrument Heliports, if appropriate performance charts are available to the pilot.

5.6.1 Instrument Departure Heliport

It is recommended that for heliports having an approved instrument departure, the departure surface have a slope of 20:1. The surface should originate from the reference heliport elevation at the departure end of a Heliport Manuever Area of the size described in 5.4.3. The performance charts described in 5.3 should be available to the pilot.

(Reference: 4.4.2)

5.6.2 Modified PAR Missed Approach Criteria

It is recommended that authority to relocate the origin of the missed approach surface for PAR approaches as specified in Chapter 11 of Reference 2 be changed to require that the surface originate at the GPI.

(Reference: 4.4.5)

5.7 FAILURE-STATE OPERATIONS

Several recommendations are offered here to enhance the level of safety with respect to operations following an engine failure for both single and multi-engine helicopters.

5.7.1 Clarification of Real Estate Requirements

It is recommended that the FAA issue clarification of the requirements for forced landing areas. Specifically, does the FAR Part 91.79 exception for takeoff and landing allow the operation of heliports having no forced landing areas? If not, then the desirability of forced landing areas along heliport approach-departure paths, as indicated by Reference 1, should be strengthened to either provide greater emphasis or require that they be available at all heliports which serve single-engine helicopters

(Reference: 2.6.3)

5.7.2 Guidelines for Forced Landing Areas

It is recommended that guidance or criteria be developed, and provided in Reference 1, for assessing the suitability of forced landing areas along heliport approach-departure paths.

(Reference: 4.4.8)

5.8 CRITERIA FOR OFFSHORE FACILITIES

Two recommendations are made, one to help consolidate, and the other to change, design criteria for offshore helicopter landing facilities.

5.8.1 Mobile Drilling Unit Requirements

It is recommended that the FAA, rather than reference the U.S. Coast Guard as a source for offshore criteria in Reference 1, coordinate the inclusion and reproduction of the current, applicable portions of CFR 46, Parts 108 and 109, into Reference 1.

5.8.2 Additional Criteria for Offshore Facilities

It is recommended that the visual and instrument obstacle surfaces and areas for ground-level heliports be applied to both fixed and mobile offshore helicopter landing facilities.

(Reference: 4.4.7)

5.9 ADDITIONAL CRITERIA FOR ELEVATED HELIPORTS/HELIPADS

It is recommended that, for other-than-offshore facilities, as a supplement to existing requirements, additional, negative obstacle surfaces be established for elevated heliports/helipads. These negative surfaces should have a slope sufficient to permit acceleration in a descent to single-engine climb speed from the most critical decision point during both takeoff and landing by multi-engine helicopters.

(Reference: 4.4.6)

5.10 CRITERIA FOR CURVED FLIGHT PATHS

It is recommended that criteria be included in Reference 1 which establishes the maximum curvature of approach-departure paths based on a double-standard-rate turn at 60 knots.

(Reference: 4.4.9)

APPENDIX A
DEFINITIONS AND TERMINOLOGY

The research reported in this document involved review and analysis of a number of criteria, regulations and related publications which comprised a data base of considerable scope, and also is international in nature. In order to enhance the clarity and understanding of the discussions contained in this report, pertinent definitions of terms are offered here. Where appropriate, they are reproduced verbatim and the source identified.

EFFECTIVE TRANSLATIONAL LIFT (ETL): The point at which the pilot can sense a reduction in power required as airspeed increases. The onset of ETL typically occurs at 15-25 knots airspeed for most helicopters.

GROUND EFFECT: An improvement in flight capability that develops whenever the helicopter flies or hovers near the ground or other surface. It results from the cushion of denser air built up between the ground and the helicopter by the air displaced downward by the rotor. (Reference 1)

HELIPORT: An area of land, water, or structure used or intended to be used for the landing and takeoff of helicopters. (FAR Part 1)

HELIPORT CLASSIFICATION: The terms used to classify United States Heliports are descriptive of the class of user allowed to conduct flight operations from the facility. (Reference 1)

Federal Heliport. The term "Federal heliport" is applied to heliport facilities operated by a nonmilitary agency or department of the United States Government. Most Federal heliports are operated

by the Departments of Agriculture (DOA) and Interior (DOI). DOA and DOI heliports are located in national forests or national parks and are used to carry out departmental responsibilities for land management and fire suppression activities. Generally, DOA and DOI heliports are restricted to departmental usage.

Public-Use Heliport. The term "public-use heliport" is applied to any heliport that is open to the general public and does not require prior permission of the owner to land. However, the extent of facilities provided may limit operations to helicopters of a specific size or weight. A public-use heliport may be owned by a public agency, an individual, or a corporation so long as it is open for public use. Public-use heliports are listed in the Airman's Information Manual (AIM) and may be depicted on appropriate aeronautical charts.

Private-Use Heliport. The term "private-use heliport" is applied to any heliport that restricts usage to the owner or to persons authorized by the owner. Most private-use heliports are owned by individuals, companies, or corporations. However a heliport designated as "private-use" may be owned by a public body. In this case, the private-use classification is applicable because the facility is restricted to a specific type of user, such as the police department, or because the owner requires prior permission to land. Hospital heliports are considered private-use facilities since operations are normally restricted to medical-related activities. Private-use heliports are not listed in the AIM but may be depicted on aeronautical charts.

Personal-Use Heliport. The term "personal-use heliport" is applied to any heliport that is used exclusively by the owner. Personal-use heliports are owned by individuals, companies, or corporations. Personal-use heliports are not listed in the AIM but may be depicted on aeronautical charts.

Helicopter Landing Site. As noted previously, helicopters are capable of being operated into cleared areas only slightly larger than the helicopter itself. It is this versatility that enables the pilot of a helicopter to land at the scene of an accident, on the roof of a burning building, near a construction site, etc. In each case the decision to land is made by the pilot who must weigh the operational necessity for the landing against the helicopter's performance capabilities, physical limitations of the site, and his or her piloting skills. For the most part, these are one-time, temporary, or infrequent operations, and the landing site should not be considered a heliport.

HELIPORT APPROACH SURFACE: The approach surface begins at each end of the heliport primary surface with the same width as the primary surface, and extends outward and upward for a horizontal distance of 4,000 feet where its width is 500 feet. The slope of the approach surface is 8 to 1 for civil heliports and 10 to 1 for military heliports. (FAR Part 77)

HELIPORT ELEVATION: The elevation of the takeoff and landing area and the heliport primary surface.

HELIPORT PRIMARY SURFACE: The area of the primary surface coincides in size and shape with the designated takeoff and landing area of a heliport. This surface is a horizontal plane at the elevation of the established heliport elevation. (FAR Part 77)

HELIPORT TRANSITIONAL SURFACES: These surfaces extend outward and upward from the lateral boundaries of the heliport primary surface and from the approach surfaces at a slope of 2 to 1 for a distance of 250 feet measured horizontally from the centerline of the primary and approach surfaces. (FAR Part 77)

INSTRUMENT FLIGHT RULES (IFR): Rules that govern the procedures for conducting instrument flight.

OBSTACLE: Any object which does not exceed an obstacle clearance plane.

OBSTRUCTION: An object which penetrates a prescribed obstacle clearance plane or surface.

PARKING AREA (Apron or Ramp): A defined area on the heliport intended to accommodate helicopters for purposes of loading or unloading passengers or cargo, refueling, parking, or maintenance.

PERIPHERAL AREA: An obstruction-free area adjacent to the takeoff and landing area serving as a safety zone.

RUNWAY: A defined rectangular area, on a land airport, prepared for the landing and takeoff run of aircraft along its length (FAA Glossary). For the purpose of FAR Part 77, any clearly defined strip, pathway or lane designated by appropriate authority for the landing and takeoff of aircraft is considered to be a runway, even though its surface consists of water, turf, dirt or similar unprepared surface. (FAR Part 77, Preamble, P-15)

RUNWAY CLASSIFICATIONS: With respect to imaginary surfaces for obstacle clearance at airports, the FAR establishes certain classifications of runways based on operational considerations. Depending on their utilization, each type of runway may have different obstacle surfaces. Definitions of types pertinent to this study are reproduced below verbatim from FAR Part 77.

Non-Precision Instrument Runway means a runway having an existing instrument approach procedure utilizing air navigation facilities with only horizontal guidance, or area type navigation equipment, for which a straight-in non-precision instrument approach procedure has been approved, or planned, and for which no precision approach facilities are planned, or indicated on an FAA planning document or military service military airport planning document.

Precision Instrument Runway means a runway having an existing instrument approach procedure utilizing an Instrument Landing System (ILS), or a Precision Approach Radar (PAR). It also means a runway for which a precision approach system is planned and is so indicated by an FAA approved airport layout plan; a military service approved military airport layout plan; any other FAA planning document, or military service military airport planning document.

Utility Runway means a runway that is constructed for and intended to be used by propeller driven aircraft of 12,500 pounds maximum gross weight and less.

Visual Runway means a runway intended solely for the operation of aircraft using visual approach procedures, with no straight-in instrument approach procedure and no instrument designation indicated on an FAA approved airport layout plan, a military service approved military airport layout plan, or by any planning document submitted to the FAA by competent authority.

TAKEOFF AND LANDING AREA: A designated area on the heliport which is coincident with the heliport primary surface and the boundaries of which are used to establish the FAR Part 77.29 imaginary surfaces. These surfaces are used for determining obstructions to air navigation. As such, it is the heliport area from which helicopter departures and approaches are intended to originate or terminate.

TAXIWAY: A designated, but not necessarily paved, path or route for helicopters to taxi from one heliport area to another.

TERMINAL INSTRUMENT PROCEDURES (TERPS): Procedures for instrument approach and departure of aircraft to and from civil and military airports.

TOUCHDOWN PAD: The load-bearing portion of the heliport's designated takeoff and landing area on which a helicopter may alight.

VISUAL FLIGHT RULES (VFR): Rules that govern the procedures for conducting flight under visual conditions.

APPENDIX B
SELECTED U.S. ARMY DESIGN CRITERIA

This appendix contains pertinent helicopter landing facility criteria from the U.S. Army technical manual, TM 5-803-4, Planning of Army Aviation Facilities (Reference 16). The criteria reproduced here were discussed in Section 2.7 of this report. They are included here because they are considered by the authors to be an excellent example of heliport/helipad design requirements.

The applicable helicopter-oriented chapters are reproduced here in the hopes that they may serve civilian operators as a supporting reference in addition to the recommendations of the Heliport Design Guide. The chapters of Reference 16 which are presented in this appendix are:

- Criteria for Permanent Army Heliports;
- Criteria for Permanent Army Helipads and Heliports; and
- Criteria for Determining Obstructions to Air Navigation at Army Heliports and Landing Pads.

Definitions of terms and discussions of rationale are contained in Section 2.7 and should sufficiently enhance the readers' understanding of these extracted criteria.

CHAPTER 5

CRITERIA FOR PERMANENT ARMY HELIPORTS

RUNWAYS

1. Length-----450 feet
at mean sea level

An increase of 10% for each 1,000 feet in altitude above 2,000 feet will be made. A temperature correction of 4% will be added for each 10° F., above 59° F., for the average daily maximum temperature for the hottest month.

2. Width-----75 feet

Unless otherwise specified.

3. Longitudinal grades-----1% maximum

Grade must be continuous for entire length. Grading requirements are dictated by the operational limitations of the helicopter, the need for adequate surface drainage, and the necessity for exercising economy measures in the development of a heliport site. Consistent with these factors and because the runway lengths are computed on the basis of generally level pavements, longitudinal sloping of runways will be held to the minimum possible. Grades of edges of runways and shoulders of runways and taxiway intersections will be held to a minimum.

4. Transverse grade-----0.5% minimum
1.5% maximum

Not mandatory at runway intersections.

5. Shoulder width-----25 feet

These areas are provided for emergency use of aircraft and for dust and erosion control. Shoulder areas will be compacted to a minimum of 90% of CE 55 maximum density as determined

by (Military Standard) MIL-STD-621A, test method 100. Stabilization for dust and erosion control will be adequate for preventing displacement of shoulder materials by blast of rotor blades. Vegetative cover, coarse-graded aggregate, liquid palliatives, or a double bituminous surface treatment may be used. A base course 4 inches thick of California Bearing Ratio (CBR) 40+ material determined by test method 101, MIL-STD-621A, will be used when double bituminous surface treatment is specified.

6. Shoulder transverse grade-----5% first 10 feet
followed by 2%
minimum to 3%
maximum

Shoulders will slope away from runway.

7. Lateral clearance-----150 feet, visual
375 feet, instrument

Lateral clearance will be measured perpendicularly, each side, from the runway centerline to fixed and/or movable obstacles. Fixed obstacles include buildings, trees, rocks, terrain irregularities, and any other feature constituting a possible hazard to moving aircraft. Movable obstacles include moving and parked aircraft, vehicles, railroad cars, etc. The prescribed clearances apply with equal force to aprons, hardstands, parallel taxiways, roads, highways, railroad tracks, drainage headwalls and drainage ditches.

8. Cleared areas, grade in any direction-----5% maximum

Width of cleared areas depends on runway width involved. Lateral cleared areas are areas between runway shoulders and lateral clearance lines limiting placement of building construction and other obstacles with respect to runway centerline. These areas will be rough-graded to the extent necessary to reduce damage to aircraft in the event of erratic performance.

TAXIWAYS

- 9. Width-----40 feet
- 10. Longitudinal grades (including shoulders)-----2% maximum
- 11. Transverse grade-----0.5% minimum
1.5% maximum
- 12. Shoulder width-----25 feet

Same remarks as those for item 5.

- 13. Transverse grade, shoulders-----5% first 10 feet
followed by 2%
minimum to 3%
maximum

Shoulders will slope away from taxiways.

- 14. Lateral clearance-----100 feet minimum

Lateral clearance will be measured perpendicu-
larly from the taxiway centerline to fixed
and/or movable obstacles. For definition of
fixed and/or movable obstacles see remarks in
item 7.

- 15. Cleared areas, grade in any direction-----5% maximum

Lateral cleared areas are between taxiway
shoulders and clearance lines limiting
placement of building construction and other
obstacles with respect to taxiway shoulder
edge. These areas will be rough-graded to
the extent necessary to reduce damage to
aircraft in event of erratic performance.

PARKING AREAS AND APRONS

- 16. Pavement junction fillet-----25 feet minimum radius
- 17. Separate parking areas-----See Figure 5-A

18. Mass parking aprons-----See chapter 7

Mass parking apron requirements for helicopter units of less than company size will be determined in accordance with procedures shown in chapter 7.

19. Taxiway widths:

Medium and Heavy Helicopters (CH-47 & CH-54)-----180 feet, interior
110 feet, exterior

*Heavy Lift Helicopters (future)-----210 feet, interior
125 feet, exterior

*(See Note 3 Table 7-1)

20. Hoverlane width-----120 feet

OH, UH and AH helicopters.

21. Shoulder width-----25 feet minimum

Same remarks as those for item 5. Shoulder will be provided along permanent edges unless otherwise specified.

22. Pavement grade, in any direction-----0.5% minimum
1.5% maximum

Pavement gradients exceeding minimum specified are intended for those areas where design of expansive pavement to accommodate unusual runoff dictates such a requirement. Economic factors imposed by difficult terrain features may also require the use of steeper gradients. Arbitrary use of gradients in excess of actual or reasonable requirements is not within the intent herein. For example, in designing so-called "sawtooth" surface drainage patterns, extreme care must be exercised to prevent use of steep grades or rapid grade changes at relatively short intervals. Such surface irregularities aggravate normal flexing of helicopter blades while taxiing and may result in damage to aircraft.

23. Transverse grade of shoulders-----5% first 10 feet,
then 2% minimum
to 3% maximum

Shoulders will slope away from pavement.

24. Lateral clearance-----75 feet

From rear and sides of aprons to fixed and/or movable obstacles where "own-power" aircraft movement is involved. For definitions of fixed and movable obstacles see remarks for item 7. The 75-foot minimum apron clearance does not apply to edges of apron where "own-power" taxiing is prohibited and manual movement is mandatory (See Figure 4-A). An 80-foot minimum clearance will be provided to other aircraft parking aprons.

ENGINE RUNUP APRONS

25. When required for helicopter runway will conform to criteria contained in items 24 through 28, chapter 4.

OVERRUN

26. Length-----75 feet minimum

Design of overrun same as for runway shoulder in remarks, item 5.

27. Width-----125 feet

Width of runway plus shoulders

28. Longitudinal grade-----continuation of last 100 feet of runway.

29. Transverse grade-----2% minimum
3% maximum

APPROACH-DEPARTURE ZONE

VISUAL PROCEDURES

30. Clearance surface slope ratio-----10:1

Begins at the outer edge of the landing area at the centerline elevation of the overrun. Minimum vertical clearance above public highway, railroad or property line 50 feet.

31. Length-----1,500 feet

Approach-departure zones and surfaces will be extended at a width of 600 feet, where required, in order to reach helicopter operating levels above 150 feet.

32. Width-----variable

At end of landing area - 300 feet. At outer end, 600 feet.

APPROACH-DEPARTURE ZONE
INSTRUMENT PROCEDURES (INTERIM)

33. Clearance surface slope ratio-----25:1

Begins at 775 feet from Ground Point of Intercept (GPI)

34. Length-----25,000 feet

Distance is measured from the GPI at the same elevation as the landing area for 775 feet and than the approach surface is carried on a 25:1 slope to the outer limit. Minimum clearance over public highway, railroad or property line is 50 feet.

35. Width-----variable

Width is 750 feet at the GPI and for 775 feet longitudinally, and then flares uniformly to a width of 8,000 feet at the outer end of the Approach-Departure Zone, 25,000 feet from the GPI.

TAKEOFF SAFETY ZONE

36. Length-----1,000 feet

37. Width-----same as approach-departure zone

An area at the takeoff end of each approach zone under control of the command and free of obstacles, provided as an emergency landing area in event of engine failure.

TRANSITIONAL SURFACE

38. Slope ratio-----2:1 visual
4:1 instrument

Vertical height of vegetation and other fixed
or movable obstacles and/or structures will
not penetrate the transitional surfaces.

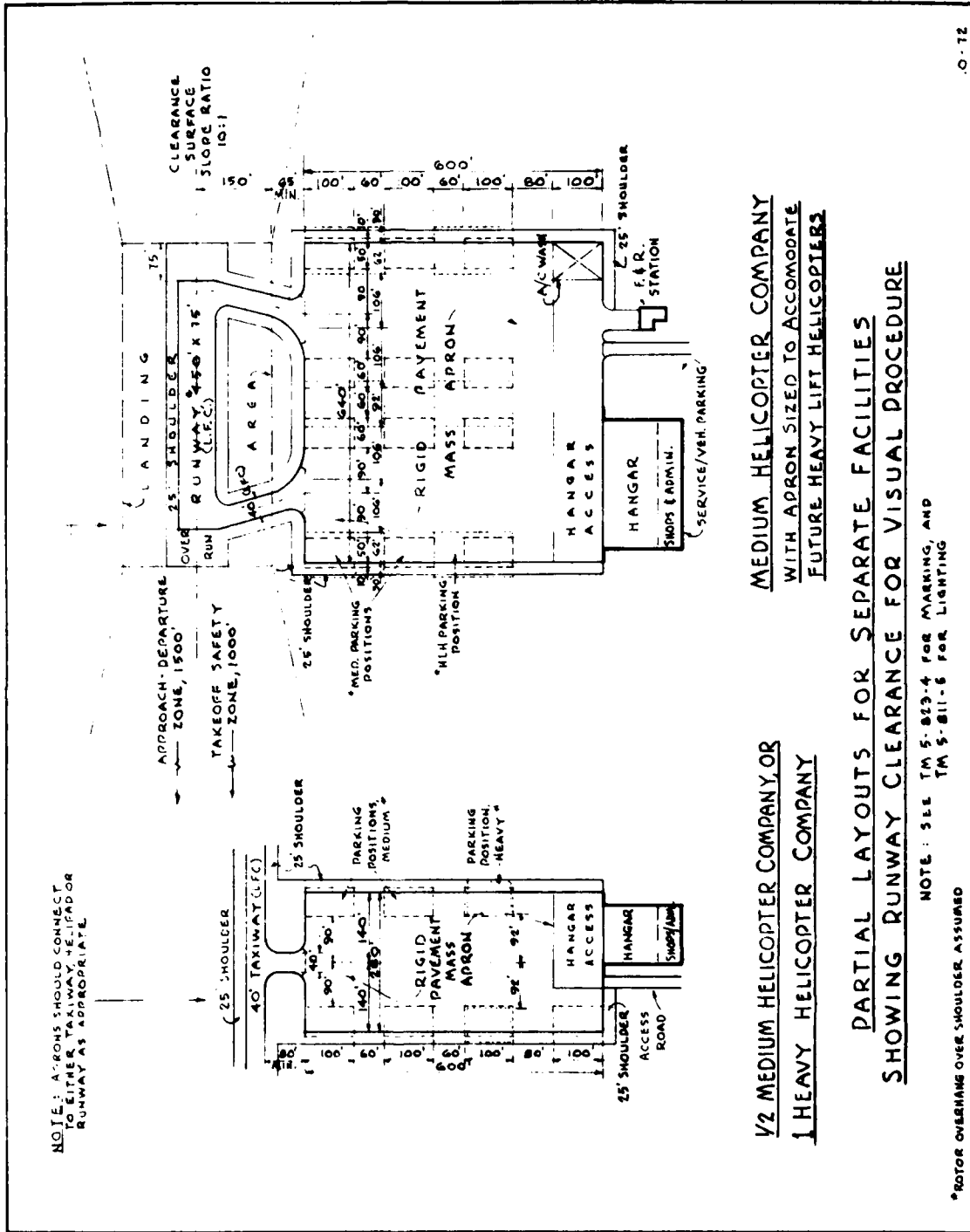

5-8

Figure 5-A

B-9

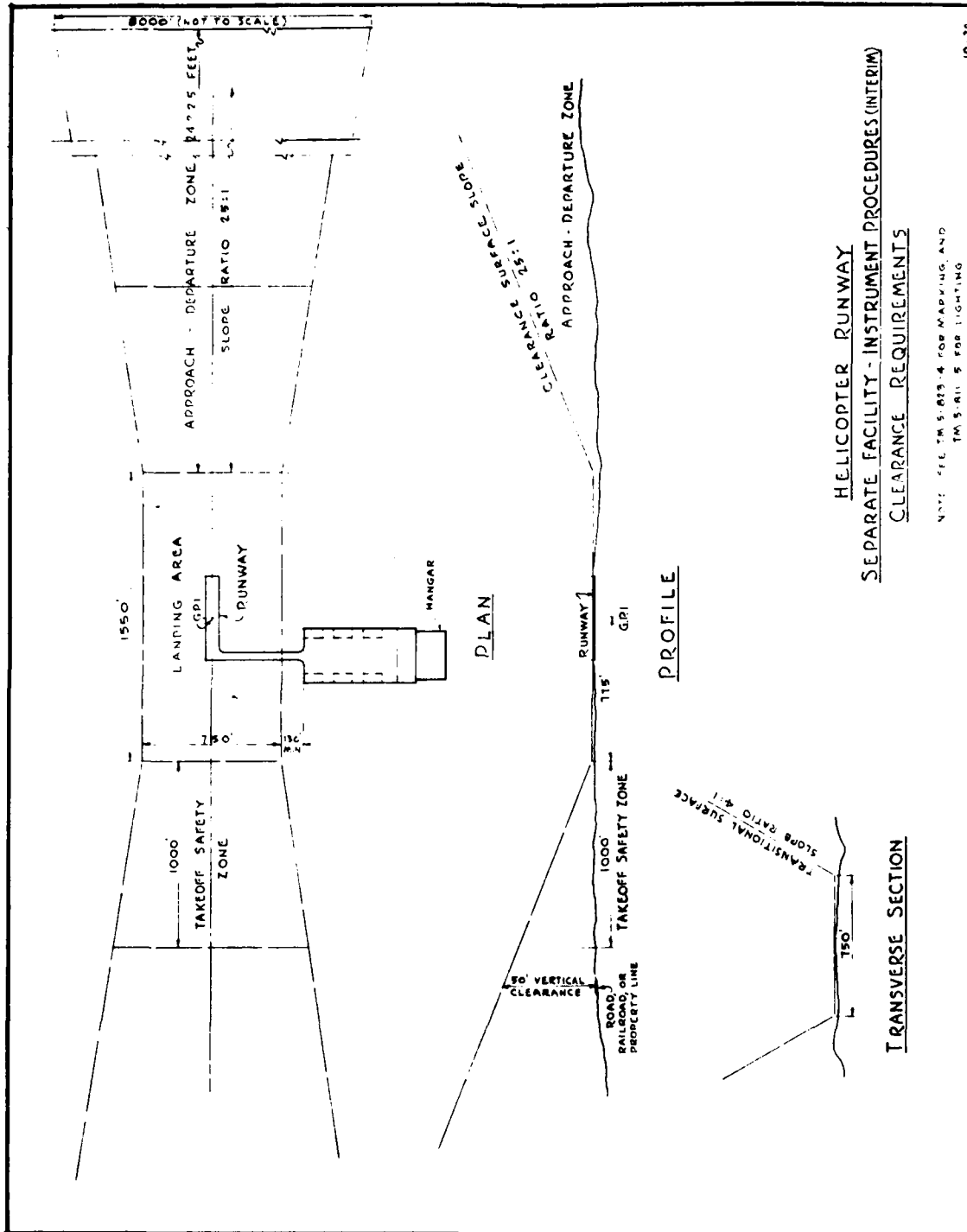

Figure 5-B

CHAPTER 6

CRITERIA FOR PERMANENT ARMY HELIPADS AND HOVERPOINTS

GENERAL

Three types of helipads are provided for by criteria contained in this Chapter. The type to be developed is dependent upon the operational requirements of the mission. These types are:

a. Instrument (interim) helipad. These criteria will be used when IFR capability is a requirement of the military mission and no other instrumented heliport or airfield is located within commuting distance of the base of operations.

b. Standard VFR helipad. These criteria will be used for development of helicopter landing facilities when either there exists an instrumented landing facility (fixed-wing or rotary-wing) which can be utilized or whenever there is no mission requirement, either existing or future, which requires a separate instrumented helicopter landing facility.

c. Limited use helipad. These criteria may be used for visual flight operations at locations where only occasional operations are required at special locations such as hospitals, headquarters buildings, missile sites, etc. or at airfields where one or more helipads may be required for purpose of separating operations of numerous small (OH, UH and AH type) helicopters from fixed-wing and/or medium and heavy helicopter traffic (See Figure 4A).

LANDING PAD

- 1. Size-----Instrument (Interim) 100 by 100 feet
 Std. VFR 100 by 100 feet
 Limited Use 40 by 40 to 100 by 100 feet
- 2. Grade-----0.5% minimum-1.5% maximum
 Grade of pad will be in one direction
- 3. Shoulders-----width 25 feet
 Grade 5% first 10 feet than
 2% minimum to 3% maximum

Shoulders will be provided unless otherwise specified. These areas are provided for emergency use of aircraft and for dust and erosion control. Shoulder areas will be compacted in accordance with (Military Standard) MIL-STD-621A, test method 100. Stabilization for dust and erosion control will be adequate for preventing displacement of shoulder materials by blast of rotor blades. Vegetative cover, coarse-graded aggregate, liquid palliatives, or a double bituminous surface treatment may be used. Shoulders will drain away from the helipad.

CLEAR LANDING AREA

4. Sizes-----Instrument (Interim) 750 by 1,550 feet
Std. VFR 300 by 300 feet
Limited Use 120 by 120 feet minimum
150 by 150 feet maximum
5. Grades-----Variable

For Std. VFR and Limited Use areas 2% minimum and 3% maximum outside of the shoulder area to limits of the landing area.

For Instrument (Interim) same as above for an area within the limits of 300 by 300 feet around the helipad and its shoulders, and for the balance of the clear landing area it shall be kept clear of obstructions and rough graded to the extent necessary to reduce damage to helicopters in event of an emergency landing.

APPROACH-DEPARTURE ZONES

6. Clearance surface slope ratio-----Instrument (Interim) 25:1
Std. VFR and Limited Use 10:1

Surface slope ratio begins at the outer edge of the clear landing area and at the same elevation as the landing pad.

7. Length-----Instrument (Interim) 24,225 feet
Std. VFR and Limited Use 1,500 feet

Approach-departure zones will be measured along the extended center line commencing at the outer end of the clear landing area. Approach-departure zones and clearance surfaces for Limited Use and Std. VFR helipads, will be extended at a width of 500 feet and 600 feet respectively where required to reach helicopter operating levels above 150 feet.

8. Width-----The width of the inner end of each approach-departure zone will be equal to the width of the respective clear landing area. The zones will flare equidistant each side of center line to the following:

Instrument (Interim) 8,000 feet
Std. VFR 600 feet
Limited Use 500 feet

TRANSITIONAL SURFACE

9. Slope ratio-----Instrument (Interim) 4:1
Std. VFR and Limited Use 2:1

Vertical height of vegetation and other fixed or movable obstacles will not extend above the transitional surfaces.

TAKEOFF SAFETY ZONES

10. Length-----Std. VFR and Limited Use 500 feet
Instrument (Interim) (Included within the clear landing area)
11. Width-----Coincides with the respective approach-departure zone

Area at takeoff end of each approach-departure zone under control of the command and free of obstacles, provided as an emergency landing area in event of engine failure.

HOVERPOINT

12. Hoverpoint-----30-foot dia.

A circular paved area, domed to six inches in the center and used as a reference point by air traffic control personnel for arrival and departure control of helicopters. Hoverpoints are not intended for landing, except in emergency situations. The same criteria set forth in preceding Items 6 through 11 as applicable to Limited Use Helipads are required. When multiple hoverpoints are required they should be identified by numeric or alphabetic marking. In instances where it is propitious to designate a hoverpoint on an existing aircraft pavement surface, the construction of the six-inch dome will be omitted.

13. Clear area-----120 by 120 feet minimum
150 by 150 feet maximum

Grade of clear area to conform with criteria in preceding Item 5 as specified for Limited Use Helipad.

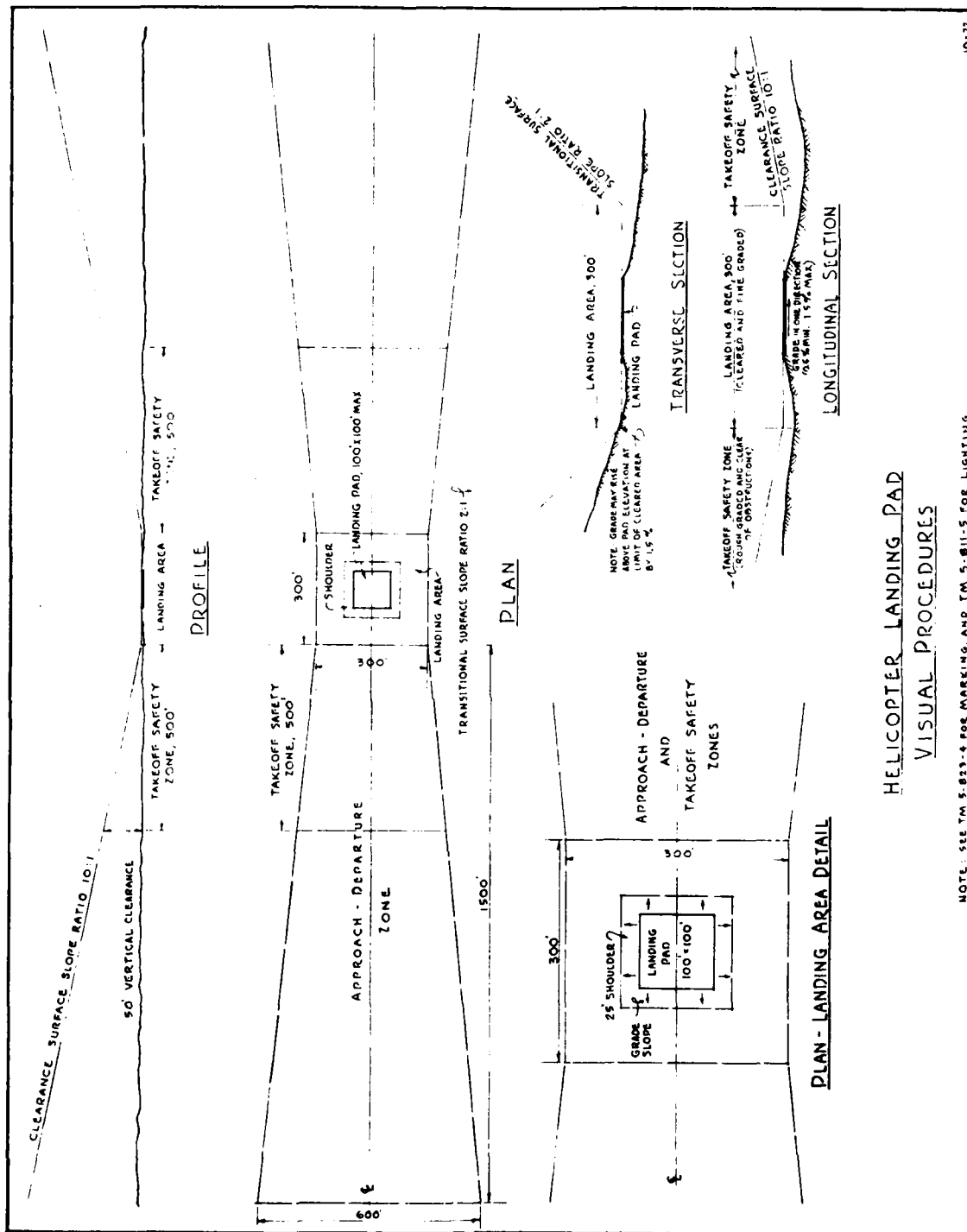

10-72

NOTE: SEE TM 5-823-4 FOR MARKING, AND TM 5-811-5 FOR LIGHTING

HELICOPTER LANDING PAD
VISUAL PROCEDURES

PLAN - LANDING AREA DETAIL

Figure 6-A

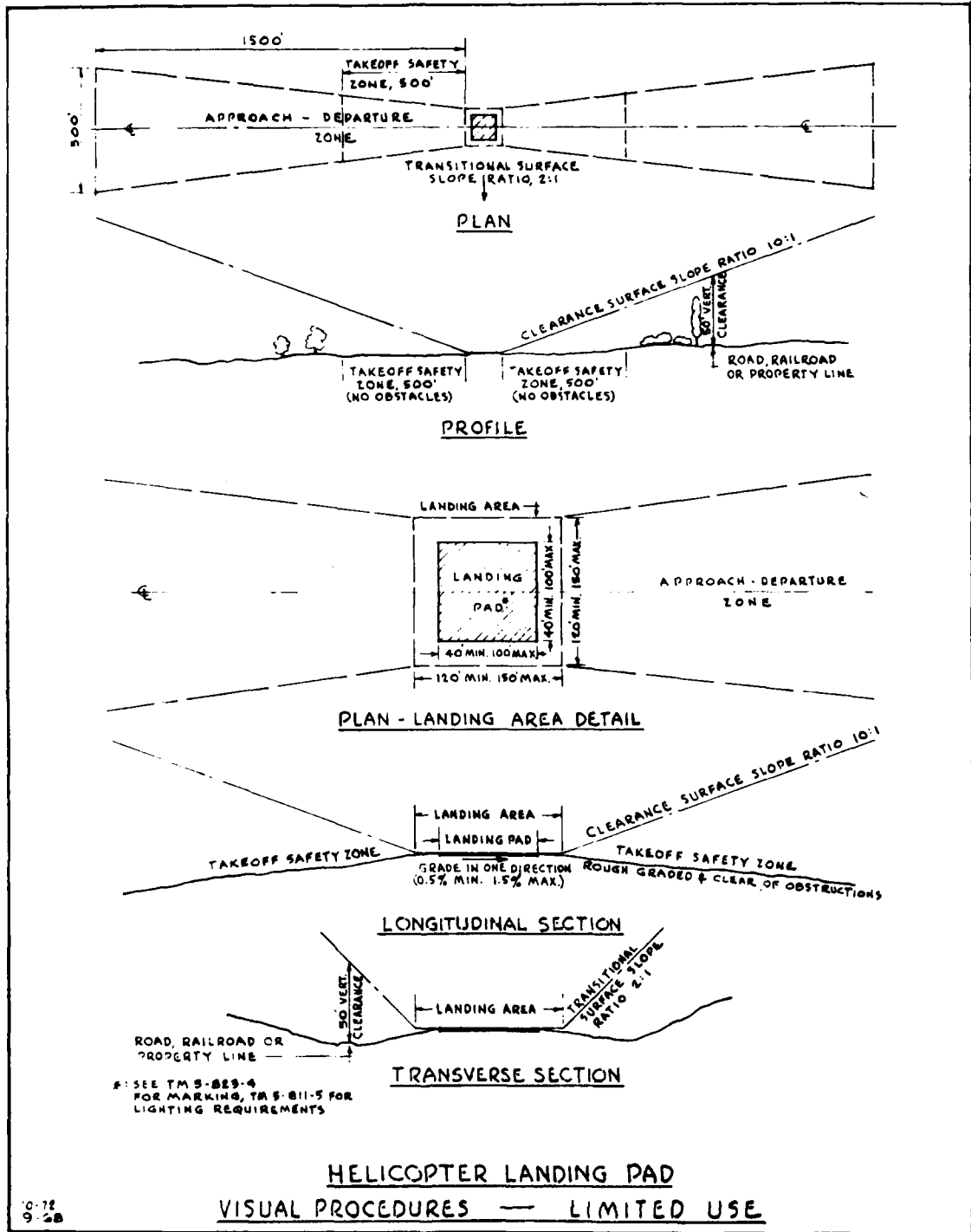
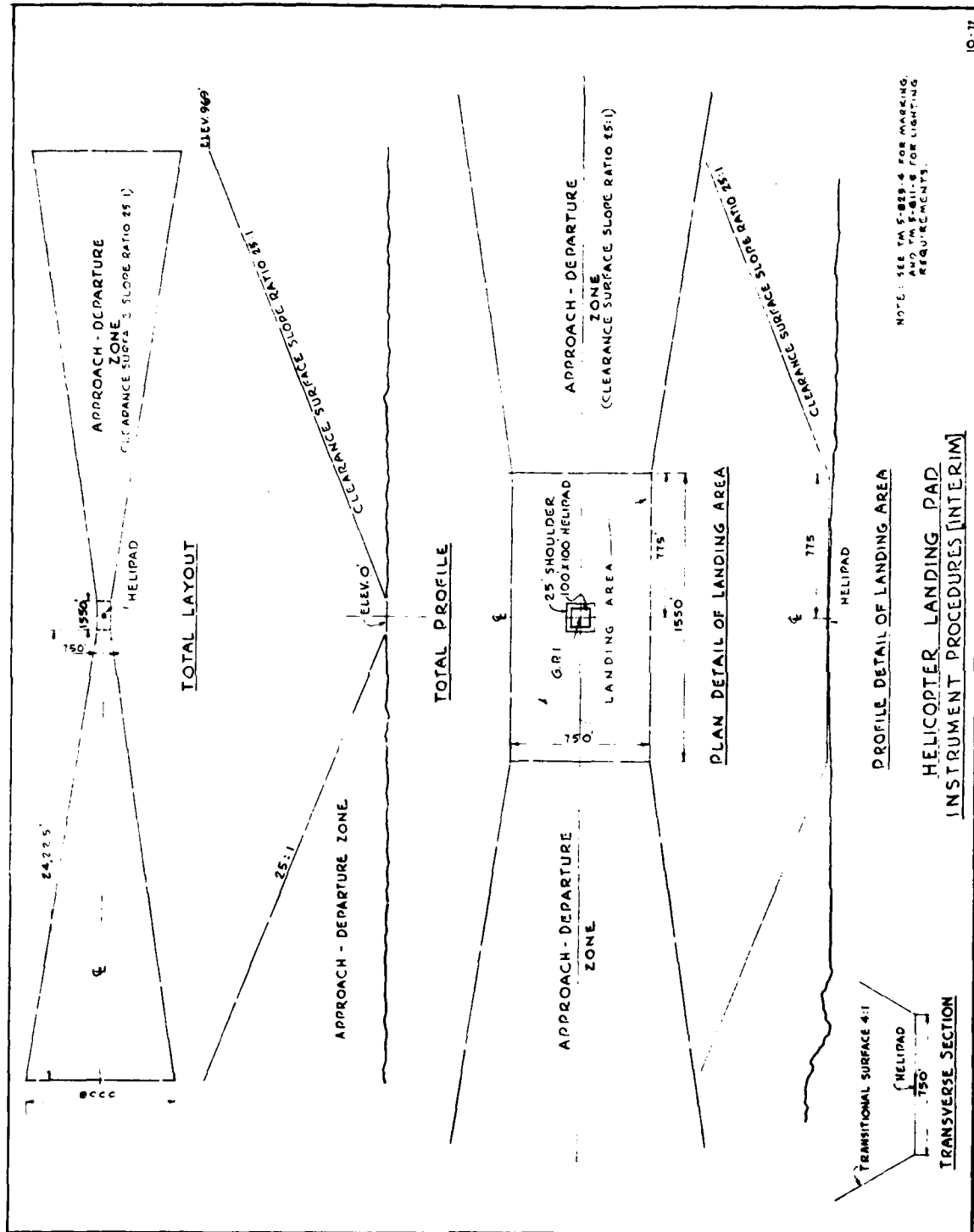

Figure 6-B

6-6

B-16



10-12

Figure 6-C

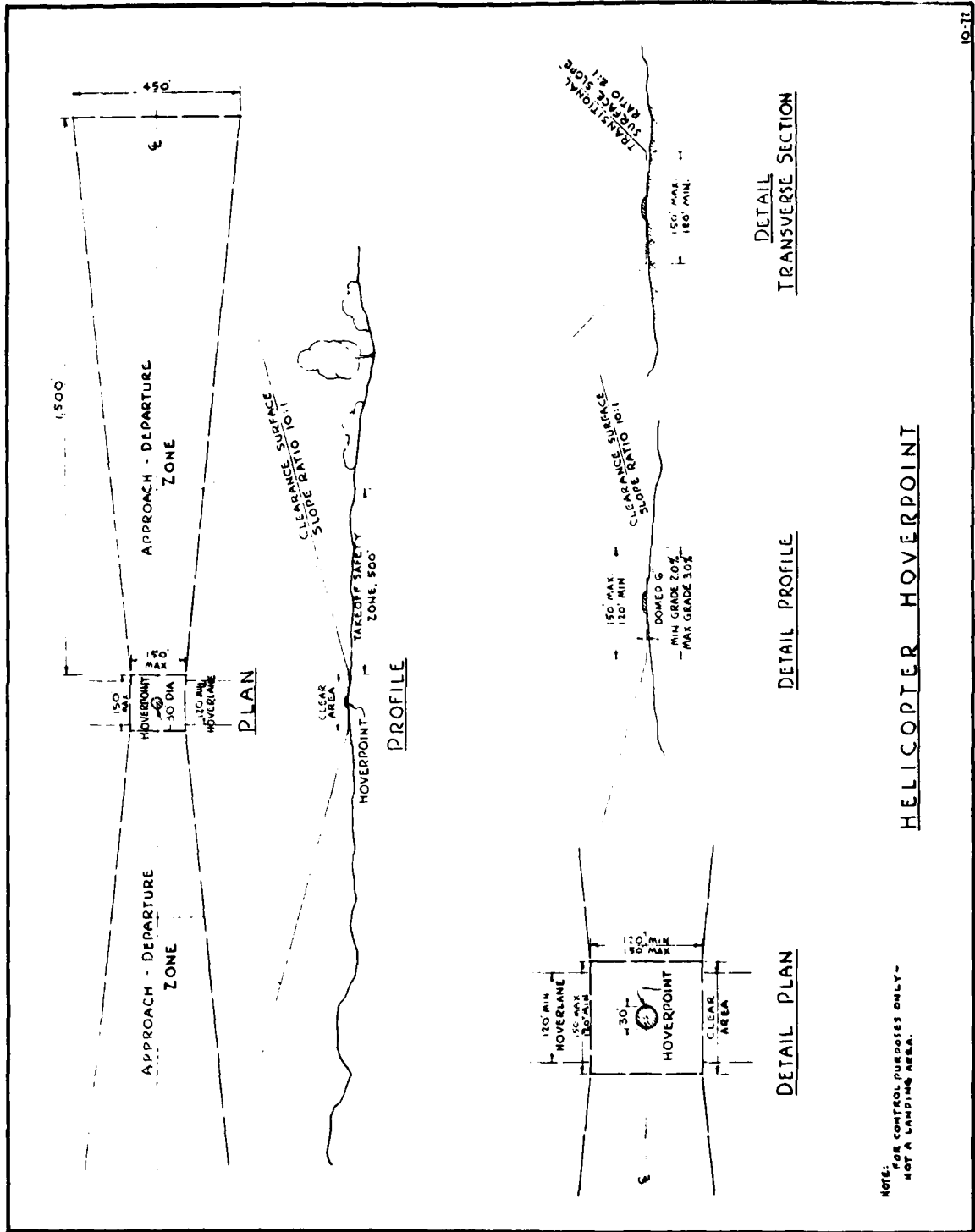

10-72

HELICOPTER HOVERPOINT

NOTE:
FOR CONTROL PURPOSES ONLY.
NOT A LANDING AREA.

6-8

Figure 6-D

CHAPTER 9

CRITERIA FOR DETERMINING OBSTRUCTIONS TO AIR
NAVIGATION AT ARMY HELIPORTS AND LANDING PADS

9-1. GENERAL.

Any natural object or man-made structure that protrudes above the planes or surfaces defined below, or exceeds the limiting heights aboveground described in paragraph 9-3, is considered an obstruction to air navigation.

9-2. DEFINITIONS.

Figures 9-A, 9-B and 9-C illustrate the following definitions. If conflict exists between the definitions and the illustration, the definition will govern.

a. Approach-departure clearance surface (Visual). An imaginary, inclined plane above the limits of the approach-departure zone, symmetrical about the extended centerline, beginning at the end of the landing area at the centerline elevation of the landing area edge. The approach-departure clearance surface rises at a slope ratio of 10:1 until an elevation of 150 feet above the established heliport or landing pad elevation is reached. Where the approach-departure zone ends within the limits of the horizontal surface of an airfield, the approach-departure clearance surface will meet the airfield horizontal surface at a point 150 feet above the established airfield elevation. At separate helicopter facilities, the approach-departure clearance surface will extend horizontally to the limits of that surface, and then continue on a 10:1 slope ratio until the minimum enroute altitude is reached. The width at the outer end of the first 1,500 feet of the approach-departure surface and beyond will be 600 feet for a heliport runway or standard VFR helipad, and 500 feet for a Limited Use helipad or hoverpoint until the minimum enroute altitude is reached.

b. Approach-departure clearance surface (Instrument-interim). An imaginary inclined plane above the limits of the approach-departure zone, symmetrical about the extended centerline, beginning at the end of the landing area at the centerline elevation of the nearest landing area edge. The approach-departure clearance surface rises at a slope ratio of 25:1 for a horizontal distance of 24, 225 feet. The width at the outer end of the clearance surface will be 8,000 feet.

c. Established heliport or landing pad elevation. The elevation, in feet above mean sea level, of the highest point on the landing area that is used, or intended to be used for takeoff and landing operations.

d. Transitional surfaces. These imaginary planes connect the landing area and the approach-departure clearance surface to the airfield horizontal surface, or extend to a prescribed horizontal distance beyond the limits of the horizontal surface. Each surface is measured outward and upward at a slope ratio of 2:1 for visual procedures and 4:1 for instrument procedures, at right angles to the runway or landing pad centerline.

e. Horizontal Surface (Instrument procedure-interim). An imaginary level plane circular in shape, located 150 feet above established airfield elevation, defined by scribing an arc with a radius of 4,600 feet about the center point of the landing pad or helicopter runway.

9-3. LIMITING HEIGHTS ABOVEGROUND IN HELIPORT AREAS.

In addition to requirements set forth in the preceding paragraphs, objects will be considered obstructions to air navigation (unless special aeronautical study indicates otherwise) if they are more than 500 feet aboveground or fall in the following categories:

a. Objects in the approach-departure zone and below the applicable clearance surface slope ratio that are more than 100 feet above the ground or 100 feet above the elevation at the approach end of the runway, landing pad or hoverpoint.

b. Objects protruding above heliport extended approach-departure clearance surface beyond limits of standard approach-departure zone (1,500 feet) which will be governed by airfield airspace clearance criteria.

9-4. REMOVAL OF OBSTRUCTIONS.

Natural objects and man-made structures determined to be obstructions to air navigation, and under Government control, will be removed where both feasible and economical. Where such removal is not feasible or economical, obstructions will be lighted and marked in accordance with national standards contained in current issue of FAA Advisory Circular AC 70/7460, or in accordance with the Standardization Agreement appropriate to the foreign area in which the facility is located.

9-5. PROTECTION OF AIRSPACE.

Control over the use of land not under jurisdiction of the Department of the Army in order to prevent erection of obstructions to air navigation will be accomplished by:

a. Real estate action securing control of the necessary airspace by fee purchase or easement acquisition; or

b. Zoning coordination with local authorities.

c. Federal Aviation Regulation Part 77.

9-6. EXCEPTIONS.

Deviations from these provisions for protection of navigable airspace and obstruction clearances will not be permitted without written approval of the Department of the Army. Requests by the using service for such deviations will be submitted through channels to HQDA(DAEN-MCE-P) WASH D.C. 20314.

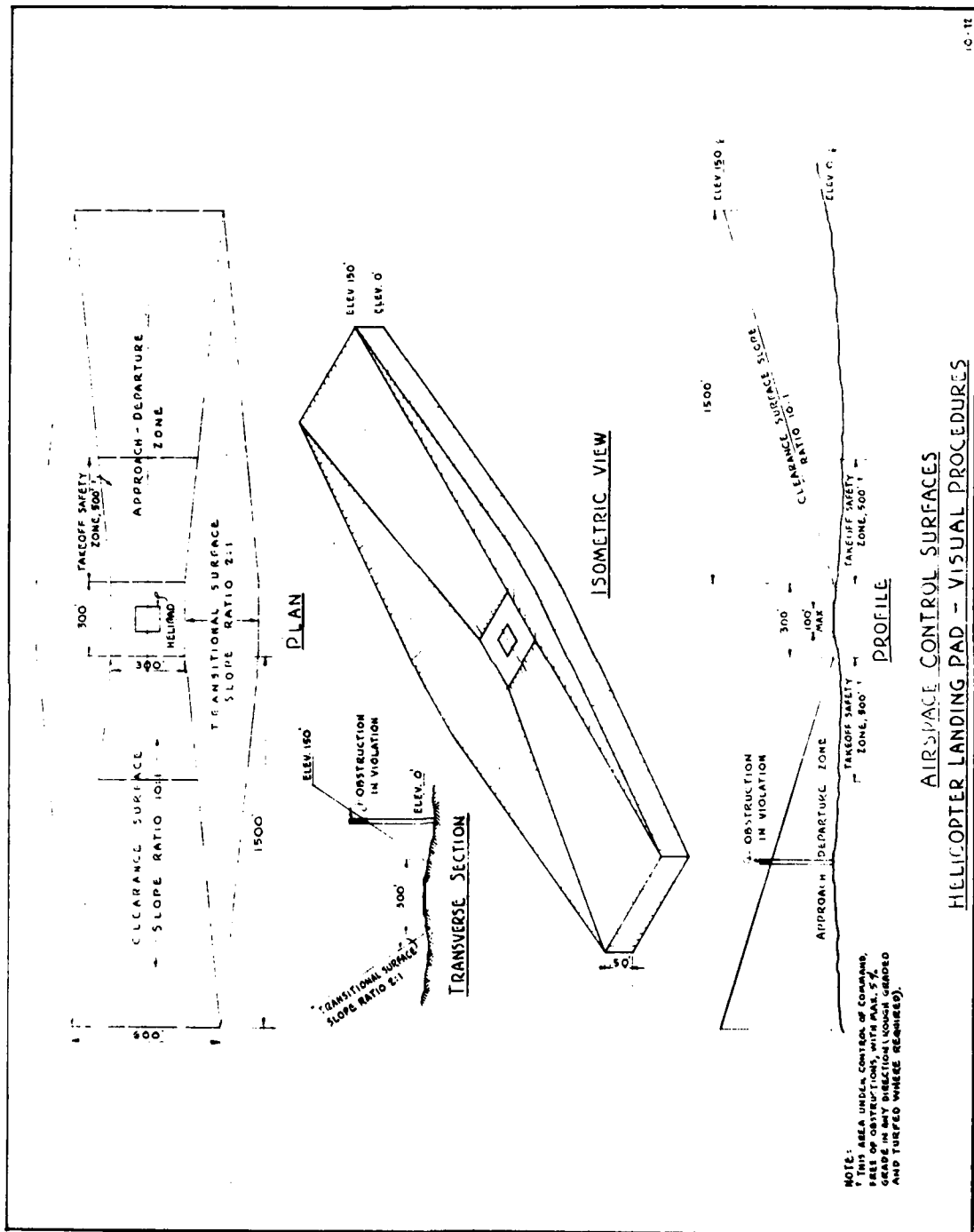

9-4

Figure 9-A

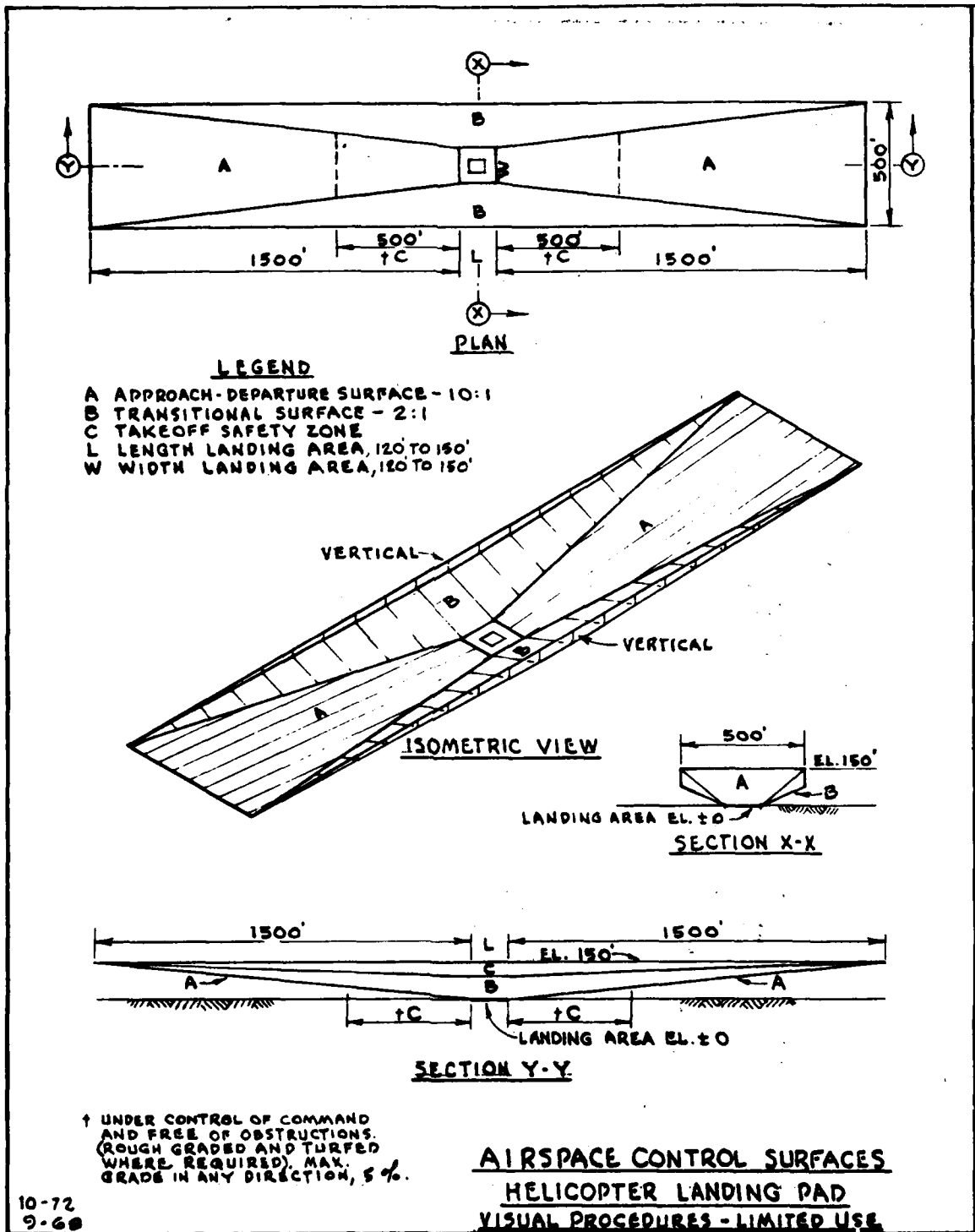
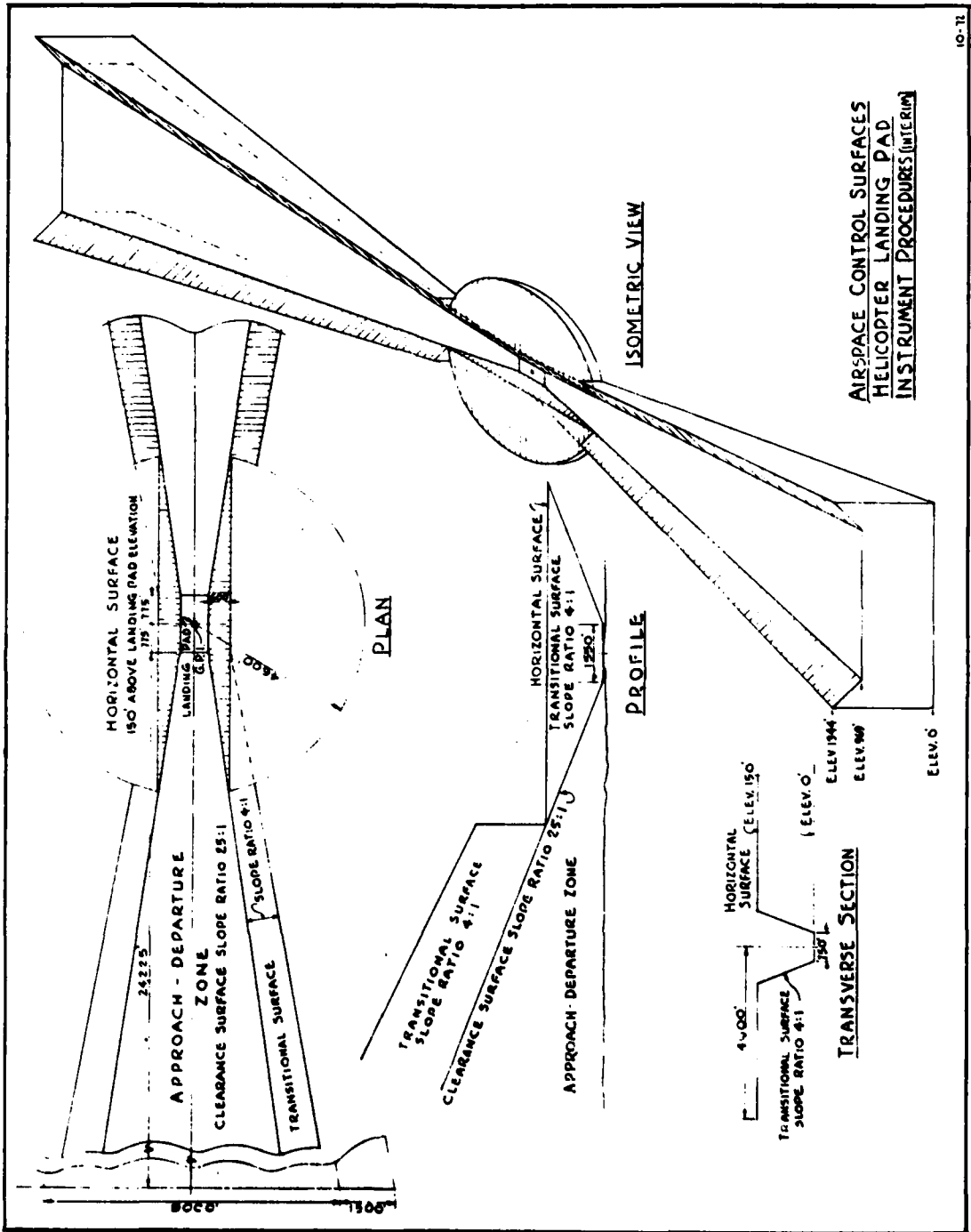

Figure 9-B



10-71

9-6

Figure 9-C

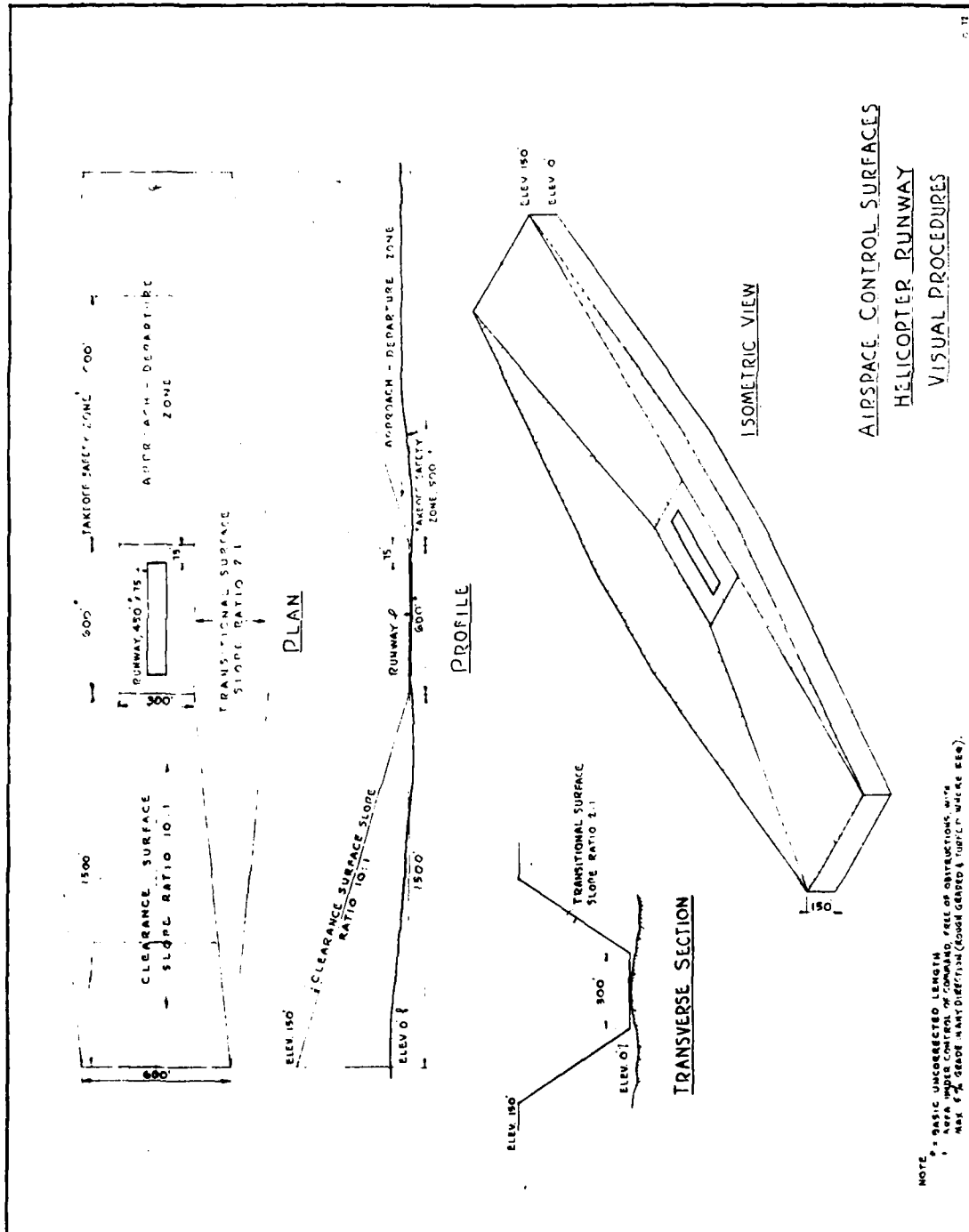
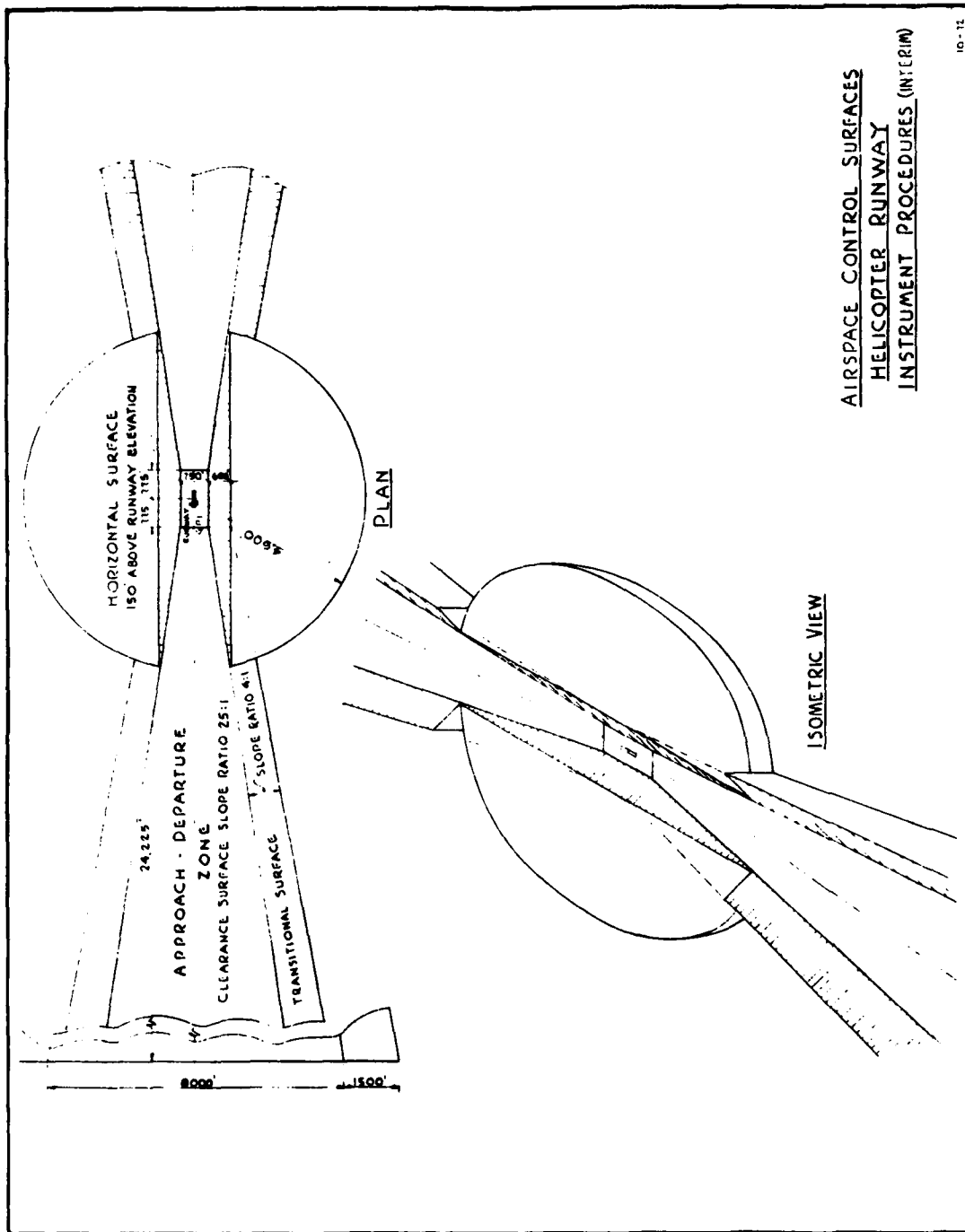

Figure 9-D



9-8

Figure 9-E

APPENDIX C
SELECTED HELICOPTER PERFORMANCE CHART APPLICATIONS

This appendix contains a discussion of a performance chart developed by the military. It serves here as an example of the ease with which helicopter performance capabilities and limitations can be determined by the pilot in terms of power available versus power required for real-time WAT (weight, altitude and temperature) combinations for both takeoff and landing. The data derived through these charts could be used as a baseline against which an additional chart could be available to quickly determine each of the essential performance data requirements recommended in section 5.2 of this report.

The discussion is extracted from the UH-1H (Bell 205) Operator's Manual (Reference 22) and reproduced verbatim. Figure C-1 is used to determine power available, and Figure C-2 to determine power required.

4-18. Maximum Torque Available Chart 30 Minute Limit (UH-1H).

a. *Chart Description.* The torque available chart shows the effects of altitude and temperature on torque available. The lower half of chart provides a means of accounting for the individual engine calibration factors. Maximum torque available for a 30-minute limit (Figure 14-21) is determined either by the N1 limit or by the transmission torque limit of 49 PSI (calibrated torque). Maximum torque available precludes the use of bleed air.

b. *Use of Chart.* Since torque available and indicated torque may change from aircraft to aircraft, calibrated torque must be found and used. Use examples on Figure 14-21 to find the indicated and calibrated torque available. Indicated torque is used in flight and calibrated torque is used with other performance charts. Use the lower half of the chart to convert calibrated torque to indicated torque, or vice versa.

c. *Calibration Factor.* The calibration factor (Data Plate Torque), obtained from the engine data plate (as shown in Figure 14-21) or from the engine acceptance records, is the indicated torque pressure at 1125 ft-lbs actual output shaft torque, and is used to correct the error of individual engine torque indicating system.

d. *Conditions.*

(1) *Rotor/Engine Speed.* Speeds of 324 rotor/6600 engine RPM have been chosen for considerations of rotor performance, directional control, and maximum rotor energy in the event of engine failure.

(2) *Airspeed.* Engine inlet air pressure decreases slightly above 60 knots; therefore, torque available decreases from one to two PSI at high speeds.

(3) *Fuels.* Engine performance is based on JP-4 fuel. Other allowable fuels may change torque available slightly.

e. *Installation Losses.* The following losses are included in the torque available charts.

(1) *Engine Inlet Temperature Rise of 1° C For All Flight Conditions.* Prolonged downwind hovering causes only intermittent increases in inlet air temperature.

(2) *Inlet Pressure Loss.* The presented torque available is for the barrier filter and particle separator inlet configuration. The louvers and bellmouth configuration improve the torque available slightly. Slight dirtiness of the filters has no measurable effect on performance. Until the AIR FILTER light activates, torque decrease will be less than 1 PSI.

(3) *Compressor Bleed Air.* The compressor bleed air used to drive the left fuel boost pump and oil cooler fan has been included on all torque available charts. Additional bleed air used for other accessories will decrease torque available.

(4) *Exhaust Losses.* The standard UH-1H tail pipe causes no loss. If the infrared suppressor or muff heater tail pipes are used, a torque decrease can be expected. These losses are not presently known.

MAXIMUM TORQUE AVAILABLE 30 MINUTE LIMIT

ANTI-ICE AND BLEED AIR OFF

MAX TORQUE
UH-1H
T-53-L-13

324 ROTOR/8600 ENGINE RPM JP-4 FUEL TAS 0-60 KNOTS

INSTALLATION LOSSES INCLUDED

WANTED

INDICATED TORQUE
CALIBRATED TORQUE

KNOWN

PRESSURE ALTITUDE - 3500 FT
OAT - 37°C
CALIBRATION FACTOR - 59.0

METHOD

ENTER PRESSURE ALT HERE
MOVE RIGHT TO OAT
MOVE DOWN TO CAL FACTOR
MOVE LEFT, READ INDICATED
TORQUE - 38 PSI

FOR CALIBRATED TORQUE
CONTINUE DOWN THRU
CAL FACTOR, READ
CALIBRATED TORQUE - 39.5 PSI



CALIBRATION
FACTOR
(Data Plate Torque)

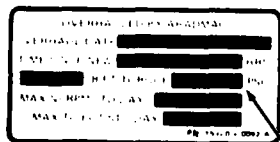

CALIBRATION
FACTOR
(Data Plate Torque)

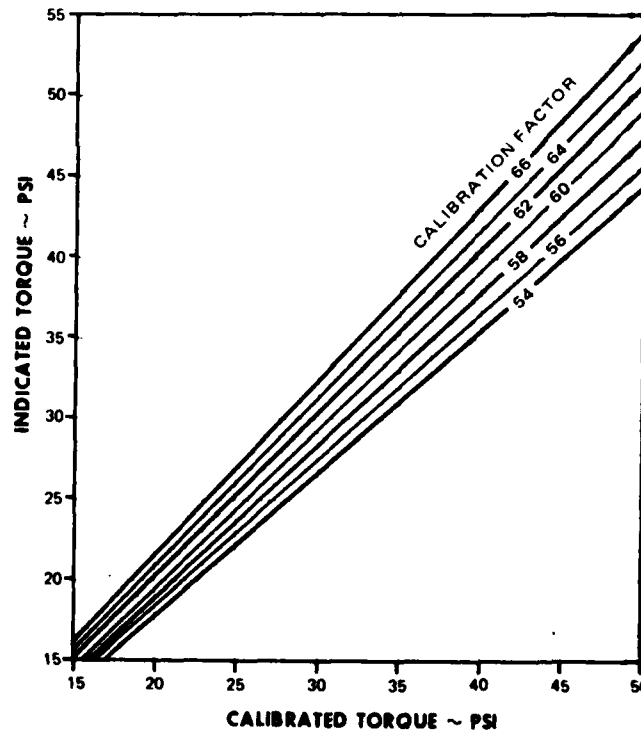
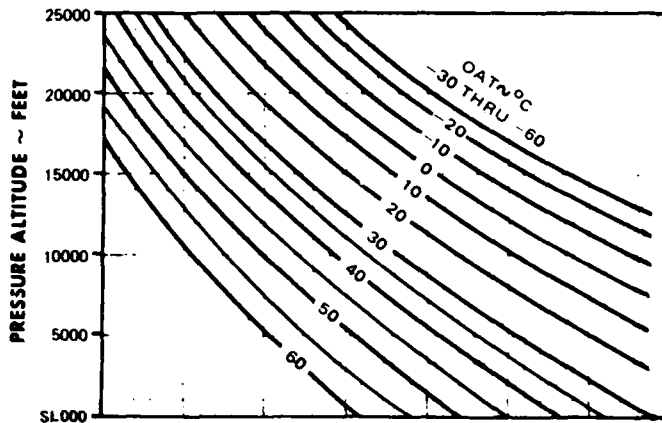

DATA BASIS: CALCULATED FROM MODEL SPEC 104.33, 6 MAY 1966, CORRECTED FOR INSTALLATION LOSSES
BASED ON FLIGHT TEST, ASTA-TDR 06-04, NOVEMBER 1970

Figure C-1. Maximum Torque Available, 30-Minute Limit, UH-1H.

4-19. Hover Chart.

a. *Chart Description.* The hover chart shows the torque required to hover at given conditions of skid height, gross weight, altitude, and temperature. Maximum skid height, gross weight, altitude, or temperature can also be found by entering maximum torque available from Figure 14-21.

b. *Use of Charts.* Example IV-1 on Figure 14-22 shows the method for finding calibrated torque required to hover. Example IV-1 may also be used to determine or check gross weight by computing the torque required at a given skid height for several gross weights near the estimated gross weight and then using a hover check. For example, if conditions are: Pressure altitude = 8500 feet, OAT = 25°C, and skid height = 4 feet; then 9500 lb = 46 PSI, 9000 lb = 43 PSI, and 8500 lb = 39.7 PSI. If the hover check required 44 PSI, gross weight would be approximately 9200 lb.

Example IV-2.

WANTED: Maximum hover gross weight.

KNOWN: Pressure Altitude=6000 feet.
OAT = 35°C.
Maximum Calibrated Torque Available = 37 PSI (From Figure 14-21).
Desired Skid Height = 5 feet.

METHOD: On Figure 14-2 enter pressure altitude on top left scale, move right to OAT, move down. Next, enter torque available on left bottom scale, move up to skid height, move right. Where line from skid height intersects line from OAT, read gross weight = 8200 lb.

Example IV-3

WANTED: Maximum hover skid height.

KNOWN: Pressure Altitude=3000 feet.
OAT = 30°C.
Maximum Calibrated Torque Available = 44 PSI (From Figure 14-21)
Gross Weight = 9000 lb.

METHOD: On Figure 14-2 enter pressure altitude on top left scale, move right to OAT, move down to gross weight, move left to maximum torque available, and read skid height = 16 feet.

c. *Directional Control.* At heavy weights or high altitudes, directional control may be marginal or inadequate. Above the SAFE PEDAL MARGIN line, there will be insufficient directional control to safely hover, takeoff, and land at some wind direction and speed. At the FULL LEFT PEDAL - OGE line, full left pedal will be required in calm wind while hovering OGE. At the FULL LEFT PEDAL - 2 FEET line, full left pedal will be required to hover in calm wind at two feet.

d. Conditions.

(1) *Rotor/Engine Speed.* Speeds of 324 rotor/6600 engine RPM were chosen primarily for considerations of directional control. Rotor speeds below 324 RPM require more left pedal and the remaining pedal margin becomes less effective.

(2) *Winds.* The hover chart is based on calm wind conditions. Adequate data is not available to completely define the effects of wind on hovering performance. However, as head wind speeds increase above translational lift speed, torque required to hover decreases rapidly. Out of ground effect hovering performance improves more rapidly and to a greater extent than IGE performance as head wind speed increases. Since surface wind speed and direction cannot be accurately predicted, hover performance should be based on calm winds. If winds are present, the helicopter should be hovered into the wind.

(3) *Surfaces.* All IGE hover data is based on hovering over a level surface. If the type of surface/terrain over which hovering is to be conducted is known to be steep, uneven, covered with high vegetation, or the type of terrain is unknown, the mission should be planned to provide OGE hover capability.

324 ROTOR/6800 ENGINE RPM

HOVER
CALM WIND

LEVEL SURFACE

HOVER
UH-1D/H
T53-L-9/11/13

EXAMPLE IV - 1

WANTED

TORQUE REQUIRED TO HOVER

KNOWN

PRESSURE ALTITUDE - 8500 FT
OAT - 25°C
GROSS WEIGHT - 8400 LB
DESIRED SKID HEIGHT - 4 FT

METHOD

ENTER PRESSURE ALTITUDE HERE
MOVE RIGHT TO OAT
MOVE DOWN TO GROSS WEIGHT
MOVE LEFT TO SKID HEIGHT
MOVE DOWN, READ TORQUE
REQUIRED TO HOVER - 38.5 PSIG

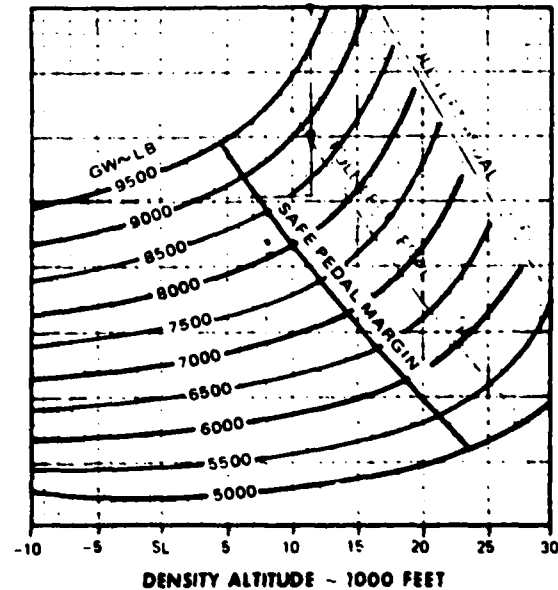
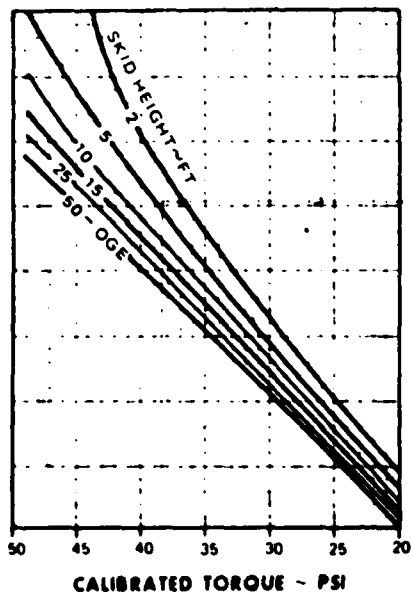
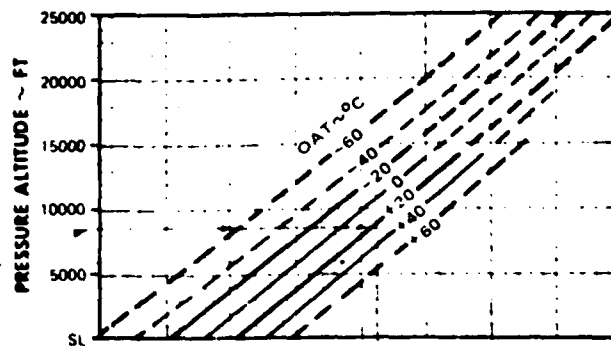

DATA BASIS: DERIVED FROM YUH 1H FLIGHT TEST, ASTA TDR 66 04, NOVEMBER 1970

Figure C-2. Hover Power Required, UH-1H.

REFERENCES

1. ANON: Heliport Design Guide, Advisory Circular AC 150/5390-1B, Dept. of Transportation, Federal Aviation Administration, Washington, D.C., August 1977.
 2. ANON: U.S. Standard for Terminal Instrument Procedures (TERPS), FAA Order 8260.3B, Dept. of Transportation, Federal Aviation Administration, Washington, D.C. July 1976. Also officially adopted by U.S. Army as Technical Manual TM 95-226, with same title.
 3. ANON: Advisory Circular Checklist and Status of Federal Aviation Regulations, Advisory Circular AC 00-2, Dept. of Transportation, Federal Aviation Administration, Washington, D.C., January 1980.
 4. ANON: Status of Federal Aviation Regulations, Advisory Circular AC-00-44, Dept. of Transportation, Federal Aviation Administration, Washington, D.C., January 1980.
- ANON: Federal Aviation Regulations (FAR), Dept. of Transportation, Federal Aviation Administration, Washington, D.C., all changes through July 1980. Selected FAR Parts identified below:
5. FAR Part 1 — Definitions and Abbreviations.
 6. FAR Part 27 — Airworthiness Standards: Normal Category Rotorcraft.
 7. FAR Part 29 — Airworthiness Standards: Transport Category Rotorcraft.
 8. FAR Part 77 — Objects Affecting Navigable Airspace.
 9. FAR Part 91 — General Operating and Flight Rules.
 10. FAR Part 121 — Certification and Operations of Scheduled Air Carriers with Helicopters.
 11. FAR Part 135 — Air Taxi Operators and Commercial Operators of Small Aircraft.
 12. FAR Part 157 — Notice of Construction, Alteration, Activation, and Deactivation of Airports.
 13. ANON: Flight Procedures and Airspace, FAA Handbook 8260.19, Dept. of Transportation, Federal Aviation Administration, Washington, D.C., February 16, 1970 through Change 14.
 14. ANON: Approval of Area Navigation Systems for Use in the U.S. National Airspace System, Advisory Circular AC 90-45A, Dept. of Transportation, Federal Aviation Administration, Washington, D.C., February 1975.

15. ANON: Requirements for Mobile Offshore Drilling Units, Dept. of Transportation, U.S. Coast Guard, Code of Federal Regulations (CFR) 46, Parts 108 and 109.
16. ANON: Planning of Army Aviation Facilities, TM 5-803-4, Headquarters, Dept. of the Army, Washington, D.C., 31 October 1973.
17. ANON: Airport/Facility Directory, U.S. Government Flight Information Publication, National Ocean Survey, Riverdale, MD 20840, 15 May 1980.
18. ANON: Helicopter Performance Code of Practice, Civil Aviation Authority, London, England; Interim Draft version received May 1980.
19. ANON: Heliport and Helideck Design Criteria, Department of Transport, Air Branch, Ottawa, Ontario, Canada; Advance Copy, April 1980.
20. ANON: Heliport Manual, First Edition, ICAO Document No. 9261-AN/903, International Civil Aviation Organization, Montreal, Quebec, Canada, April 1979.
21. DeLucien, A.G.; Green, D.L.; Price, H.R.; Smith, F.D.; Study of Helicopter Performance and Terminal Instrument Procedures, FAA Report No. FAA-RD-80-58, Dept. of Transportation, Federal Aviation Administration, Washington, D.C., June 1980.
22. ANON: Operator's Manual, Army Model UH-1D/H Helicopters, TM 55-1520-210-10, Headquarters, Dept. of the Army, Washington, D.C., 25 August 1971, through Change 20.